

Prefeasibility report for the Port of Itajai

Sedimentation and alignment study



MSc project group TU Delft
Hydraulic Engineering
June 2010



General notice to the reader:

In the academic programme for Hydraulic Engineering we have in the 4th year (i.e. in the first year of the Master Programme) the requirement that students should do in a group of four to six persons a so-called "groupwork". It is also called "Master Project". During this groupwork they should make a full design of something. The work should be integral, starting with terms of reference, and ending with the real design. This can be a structure, but also it can be a harbour lay-out, a policy plan design, etc. The total time available for the project is in the order of two months and will provide 10 European Credits. It has to be practical and applied.

It is certainly not an M.Sc. thesis assignment (the thesis work is individual, 6 months and more focussed on research or advanced design work on details). But it is also not an apprenticeship, internship or traineeship where the student has to work together with a group of experienced people. For this groupwork they have to solve the problem on their own (of course with guidance).

This report is the result of such a Master Project. This report has been assessed by staff of TU Delft. It has been provided with a passing mark (i.e. a mark between 6 and 10 on a scale of 10), and consequently considered sufficient for publication.

However, this work has not been fully corrected by TU Delft staff and therefore should be considered as a product made in the framework of education, and not as a consultancy report made by TU Delft.

The opinions presented in this report are neither the opinions of TU Delft, neither of the other sponsoring organisations.

Department of Hydraulic Engineering
Delft University of Technology

Prefeasibility report for the Port of Itajaí

Sedimentation and layout study

Final Report, MSc Project Hydraulic Engineering

Itajaí, Brazil, June 2010

Project group 'Itajaí 2010'

S.B. Devillé	<i>1142801</i>
E.M. Hooning	<i>1211234</i>
M.S. de Jong	<i>1222643</i>
O.L.M. Sturm	<i>1236601</i>
M.J. Verhage	<i>1179314</i>

Supervisor

Ir. H.J. Verhagen

Delft University of Technology,
Faculty of Civil Engineering and Geosciences, Section Hydraulic Engineering

Preface

The multidisciplinary project is part of the MSc-program Hydraulic Engineering of the faculty of Civil Engineering, at the Delft University of Technology. Students have the opportunity to do a research and design study in a group abroad. The aim of this project is to come up with a solution for an actual civil engineering problem as a team, by applying knowledge obtained during the previous years. The time period for this project is 10 weeks.

In the period of April until June 2010, the project group “Itajaí 2010” from the TU Delft has performed a study for the Port of Itajaí, Brazil. The study deals with both the lay out of the harbour as the sedimentation processes that occur in het harbour basin.

For this project we would like to thank the Port of Itajaí for the opportunity to carry out this project, especially the commercial director R. Grantham and the technical engineer A. Pimentel for their input for our research. W. Agacci we want to thank for his translating work. We would also like to thank our Brazilian supervisor A. Klein for his guidance during our project and the University of UNIVALI for their hospitality and support. We want to thank above all M.E. da Costa Gama and D. Silva de Aguiar Miranda. Furthermore we are grateful to the input we got from Mr. W. Joos from APM Terminals Itajaí, Mr. F.R. van der Velden from van Oord, Ms. M. Pitrez dos Santos and Mr. M. Kuhn from Environmental Issues of the Port of Itajaí, and from the pilot Mr. A. da Rocha, which was really useful for our project.

From the TU Delft we thank our supervisor Ir. H.J. Verhagen for arranging the project and setting up the contacts in Brazil, as well as our advisers Dr. Ir. C.J. Sloff, Dr. Ir. E. Mosselman and Prof. Ir. H. Ligteringen for their counsel. We would like to thank Deltares for letting us use a free copy of the software SOBEK, especially dhr. S. de Wit who helped us to understand and work with SOBEK. Also we thank HKV for their advice, in particular Dr. Ir. B.G. van Vuren and Dr. F. Huthoff.

Last but not least we are very grateful to our sponsors for making this great learning experience possible.

Itajaí, June 2010.

Project Group “Itajaí 2010”

Seppe Devillé
Evert Hooning
Matthijs de Jong
Olga Sturm
Mirella Verhage

Sponsors

This project is made possible by our sponsors, for which we are very grateful. Many thanks to:

Head sponsors



 **Royal Boskalis Westminster nv**



Sponsors



Partners

Iv-Groep B.V.

Van Oord Dredging and Marine Contractors

Summary

In southern Brazil, in the province of Santa Catarina, the port of Itajaí is situated. The port is located at the mouth of the river Itajaí-Açu, about 3 km inland. The Port of Itajaí is very important for both the local and national economy because of its role in foreign trade, and due to this prominent role in the community many stakeholders are involved. To allow larger vessels into the harbour of Itajaí there has been a constant process of deepening the approach channel and the harbour basin. In order to compete with surrounding harbours it is important to allow safe navigation of larger vessels as this results in greater cargo handling at lower cost. Due to recent developments the Port of Itajaí is investigating the possibility to receive vessels with a length of 300 m overall, 45 m beam and 14 m draught.

The Port of Itajaí is facing two different kinds of problems, one concerning the alignment and the other concerning sedimentation. In order to deal with the problems the current situation was mapped. The river, sea and harbour characteristics are given; river discharges, flood events, harbour development, harbour lay out, tide, wind and wave direction.

At this moment the approach channel of the harbour deals with some imperfections, which makes it difficult, sometimes even impossible, for the design vessel to sail through the channel. Also the current turning circle is a problem as turning of the new design vessel will be extremely difficult and the safety is questionable. With a cost-benefit analysis the best possible location for a larger turning basin is determined and a number of changes for the alignment are given.

Without human interventions the estuarine system would be in a dynamic equilibrium. The bathymetry would adjust to varying conditions and oscillate around this dynamic equilibrium depth. This is the depth for which the average annual sedimentation is zero. When the natural dynamic equilibrium is disturbed as a result of deepening the estuary, the system will try to restore itself. This causes sedimentation and maintenance dredging is required to maintain the newly dredged areas. The volume of the required maintenance dredging depends on the extent of the disturbance in relation to the equilibrium situation. A larger deepening will lead to smaller flow velocities and therefore to higher sedimentation rates.

The sedimentation that occurs in the Itajaí-Açu estuary is a complex ensemble of processes, which is influenced by processes at the boundary conditions. The two most important processes are the tidal fluctuations and river discharge. To gain insight in the wet system, hand calculations and a 1D-computer model were made. The effect of a number of human interventions on the Itajaí-Açu river are determined with hand calculations. With the 1D-modelling software, SOBEK, the effects of the planned dredging are determined.

At this moment the harbour of Itajaí has an expensive dredging program with a water injection dredger, in order to keep the depth on the required level. The yearly amount of dredged material is on average 2.000.000 m³ and this process costs the Port of Itajaí 16.200.000 R\$ per year. It is clear that because of the current upstream deepening of the river and the planned deepening of the harbour the

sedimentation process in the harbour basin will change. From a commercial point of view it is very interesting to search for other solutions to keep the river at the required depth besides dredging. There are four main principal solutions to reduce the sedimentation of the harbour basin: reduce the sediment production, reduce the transport capacity of the river, increase the flow velocity and redirect the sediment. All these possibilities have a positive effect on the sedimentation in the harbour. Reducing the transport capacity of the river with the use of a sand trap is expected to have the most effect.

Table of Contents

Summary	1
1 Introduction	7
2 Problem description.....	9
3 Stakeholders	10
4 Characteristics of the river.....	15
4.1 River Management.....	15
4.2 Classification	15
4.3 Dams	16
4.4 Discharge.....	16
4.5 Rain	17
4.6 Floods.....	17
5 Characteristics of the sea.....	18
5.1 Wind climate	18
5.2 Offshore wave climate	18
5.3 Bathymetry	19
5.4 Shallow water.....	19
5.5 Tide.....	19
5.6 Storm surge.....	22
5.7 Longshore current.....	22
6 Characteristics of the harbour	23
6.1 Economic value	23
6.2 Throughput	23
6.3 Shipping.....	24
6.4 Layout.....	25
6.5 Ship manoeuvring	27
6.6 Hinterland connections.....	28
6.7 Service level	29
6.8 Storage areas	29

Prefeasibility report for the Port of Itajaí

6.9	Planned projects	30
6.10	Checking the dimensions	30
7	Optimisation of the alignment.....	34
7.1	Outer approach channel	34
7.2	Northern breakwater	35
7.3	Inner approach channel and harbour basin.....	35
7.3.1	East bend.....	35
7.3.2	West bend	36
7.4	Turning circle.....	36
7.5	Cost benefit analysis turning circle	38
7.6	Rough cost estimation	39
7.7	Summarizing.....	40
8	Sedimentation of harbour basin	42
8.1	Origin.....	42
8.2	Sediment control.....	43
8.3	Sediment characteristics.....	43
8.4	Dynamic equilibrium	44
8.5	Transport modes.....	44
8.6	Sedimentation.....	45
8.7	Sedimentation studies	46
8.8	Sedimentation modelling.....	47
9	Hand calculations.....	48
9.1	Calculation method.....	48
9.2	Topography	49
9.3	Results.....	50
9.4	Summarizing.....	57
10	SOBEK.....	58
10.1	Initial situation	58
10.2	Calibration.....	60
10.3	Topography	60
10.4	Results.....	63

Prefeasibility report for the Port of Itajaí

11	Dredging.....	66
11.1	River upstream.....	66
11.2	Planned dredging.....	66
11.3	Maintenance dredging.....	67
12	Possible solutions sedimentation	68
12.1	Reduce the sediment production	68
12.2	Reduce transport capacity of the river	69
12.3	Increase the flow velocity	70
12.4	Redirect the sediment.....	71
12.5	Summerizing	71
13	Conclusion.....	73
13.1	Alignment study.....	73
13.2	Sedimentation study.....	73
14	Recommendations.....	75
14.1	Obtain local data.....	75
14.2	Alignment study.....	76
14.3	Sediment study	77
14.4	The future	78
15	Post script.....	79
16	Reference list	80
16.1.1	Articles	80
16.1.2	Books.....	81
16.1.3	Internet	81
16.1.4	Interviews.....	82
Appendix A: Stakeholders		84
Appendix B: River.....		85
Appendix C: Sea.....		88
Appendix D: Harbour.....		101
D.1	General.....	101
D.2	Checking the dimensions.....	105

Prefeasibility report for the Port of Itajaí

Appendix E: Optimalization alignment.....	116
Appendix F: Sedimentation of harbour basin.....	130
Appendix G: Theories of river engineering.....	132
G.1 Stationary flow.....	132
G.2 Sediment transport formula.....	133
G.2.1 Theory of Van Rijn.....	133
G.2.2 Theory of Engelund and Hansen.....	134
G.3 Effects of interventions.....	135
G.4 Sand trap.....	136
G.5 Widening of a part of a river.....	139
G.6 Bends.....	141
Appendix H: Hand calculations.....	142
H.1 Original situation.....	143
H.2 Dredging up to -12m.....	144
H.3 Current situation.....	145
H.4 Future situation 1.....	146
H.5 Future situation 2.....	147
Appendix I: SOBEK.....	150
Appendix J: Dredging.....	162
Appendix K: Possible solutions sedimentation.....	165

1 Introduction

In southern Brazil, in the province of Santa Catharina, the Port of Itajaí is situated. The port is located at the mouth of the river Itajaí-Açu, about 3 km inland. The Port of Itajaí is very important for both the local and national economy because of its role in foreign trade. The law 8630 of 25/2/1993 proposed to modernize port activities, redefined some roles and allowed the partnership between public ports and private sectors. Due to this partnership the investments in port areas by private companies increased and ports became more important for the national economy. The effects of these cooperation's are already visible: the country's commercial trade has grown and there are economic and social developments in the region of the ports. Moreover, the government has sought to invest in infrastructure of ports and encourage partnerships in this economic segment. Economic analysts have widely accepted as a thesis, the fact that the main obstacle to the expansion of Brazil's participation in international trade is to seek balanced port costs, coupled with modernization techniques and the administrative and operational practices consistent with international standards. Within this scenario, it is natural that the Port authority of Itajaí seeks for opportunities to optimize the performance of its activities. In order to do so, the port infrastructure should be competitive, as well as the load handling. There has been a constant deepening of the approach channel and the harbour basin to allow the safe navigation of larger vessels, resulting in greater cargo handling at lower cost.

The river is used for discharge of the rain, inland water transport, industry, agriculture and fishery. The river contains a lot of sediment causing problems for the Port of Itajaí. Due to the low velocities in the turning basin the sediment can settle down, leading to reduction of workability of the port. Next to that there is also the tide which has a big influence on the harbour basin.

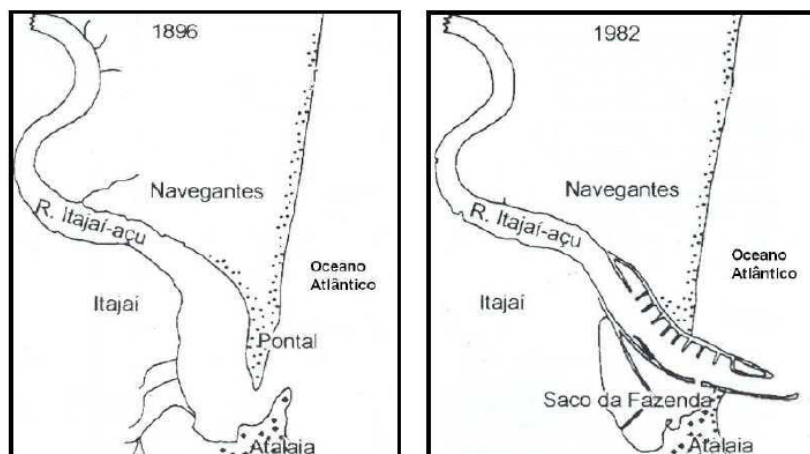

figure1-1: development of Port of Itajaí

The Port of Itajaí is facing two different kind of problems, one concerning the alignment and the other concerning sedimentation. In the next page a more detailed problem description is given and also the general approach method is described. The next chapter describes the interests of the stakeholders and their relationship with each other. In order to deal with the problems the current situation is mapped, see chapter 5, 6 and 6. In these chapters the river, sea and harbour characteristics are given; river discharges, flood events, harbour development, harbour layout, tide, wind and wave direction. Chapter 7 deals with the new suggested alignment for the approach channel and a new location for the turning circle. Chapter 8 deals with sedimentation processes that occur in the harbour basin. The different processes are described and information is given on sediment characteristics. Chapter 9 shows some hand calculations and in chapter 10 are the results of the SOBEM model presented. In chapter 11 the current dredging program and future plans are described. In chapter 12 a number of measures are suggested to reduce the amount of sedimentation in the harbour basin. Finally, in chapter 13 and 14, the conclusions and recommendations are given. The appendices, found at the end of this report, contain used data, explanation of used theory and other background information.

2 Problem description

- In order to accommodate the most modern and largest container vessels, the current state of the harbour basin and alignment is not sufficient.
- The (sediment) discharge of the river has a negative effect on the workability of the harbour basin, especially after a flood.

To deal with these problems the current situation has to be mapped, including the upstream part of the river and the seaward side. A number of research questions have been composed. Some concerning the general situation, some concerning the alignment of the harbour and the other questions are related to the sedimentation problem. This study will give the Port of Itajaí an overview of possible measures and suggested changes in order to make the harbour ready for a flourishing future. The goal of the study is to answer those questions and hand in a pre-feasibility study to the Port of Itajaí. The project will be executed in cooperation with the University of Itajaí, UNIVALI, which will give support and accompaniment where needed. The conclusions of this study will help the Port of Itajaí with further decision-making about the problems they are facing. Recommendations and suggestions will be made concerning helpful future studies.

- Who are the stakeholders, what are their interests and who is responsible for workability of the harbour?
- How does the wet system work and what are the effects for the harbour?
- What will be the optimal alignment of the harbour concerning the current urban development?
- What are the effects of deepening the upstream part of the river for the sedimentation of the harbour?
- What are the effects of deepening the harbour basin and approach channel for the sedimentation of the harbour?
- What are possible measures in order to change/reduce sediment transport and create a stable situation requiring minimal maintenance?
- Which of the proposed measures fit the requirements of the Port of Itajaí and other stakeholders best and is most cost effective?

3 Stakeholders

The Port of Itajaí has to deal with many stakeholders, resulting in a complex process of decision making. Before describing the different parties and their mutual relations, an overview of the structure is given as an organization chart in figure 3-1.

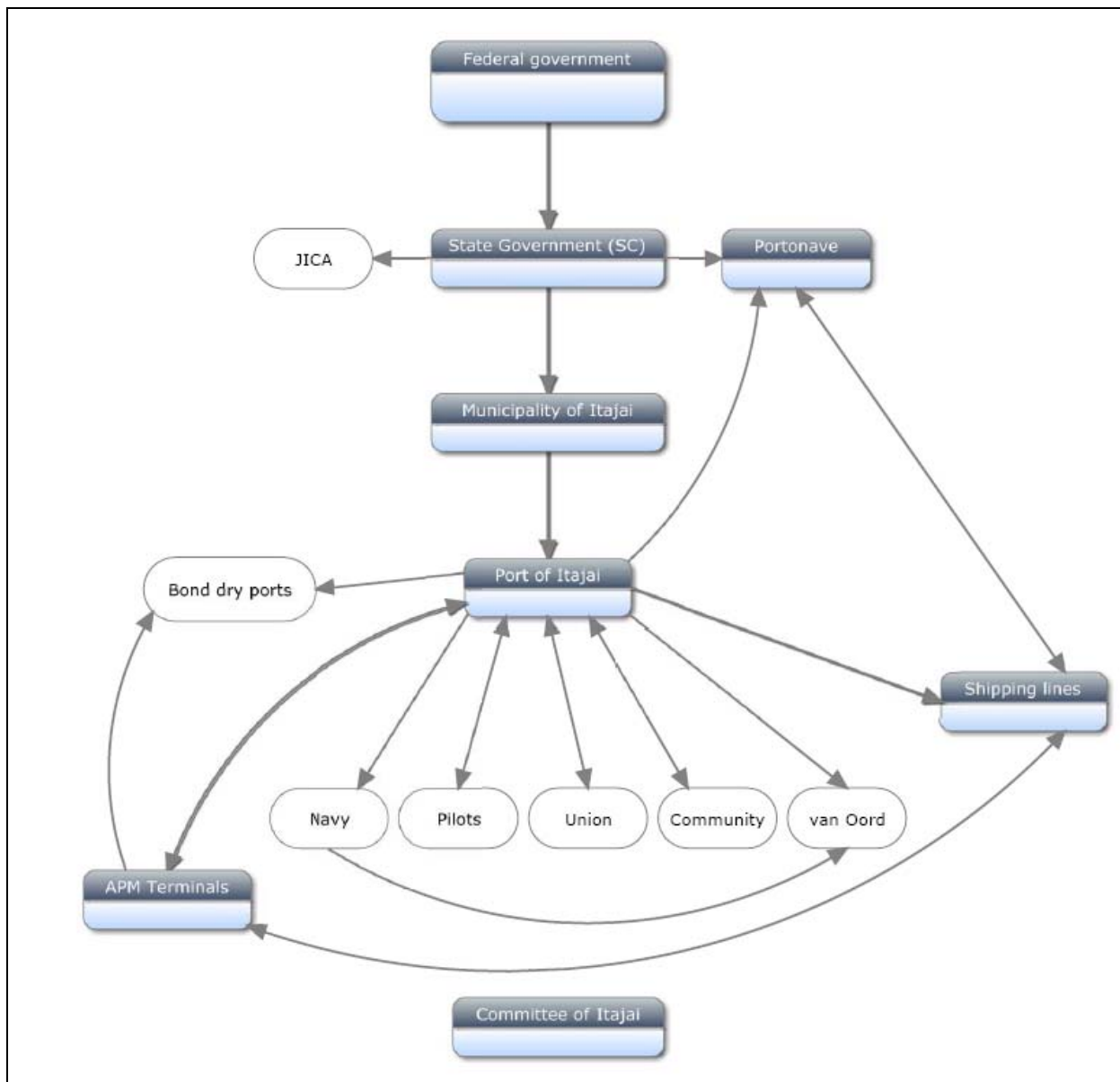

figure 3-1: organization chart

- Brazilian political structure

Brazil is a federation composed of 26 states, one federal district (which contains the capital city, Brasilia) and municipalities. States have autonomous administrations, collect their own taxes and receive a share of taxes collected by the federal government. Each state has a governor and a unicameral legislative body elected directly by their voters. For common justice there are independent Courts of Law.

However, states have less autonomy to create their own laws than in the United States. The states and the federal district may be grouped into the following regions: North, Northeast, Central-West, Southeast and the South. Municipalities of Brazil are administrative divisions of the states of Brazil. The Brazilian regions are merely geographical, not political or administrative divisions, and they do not have any specific form of government. Although defined by law, Brazilian regions are useful mainly for statistical purposes, and also to define the application of federal funds in development projects. Municipalities, as the states, have autonomous administrations, collect their own taxes and receive a share of taxes collected by the Union and state government. Each has a mayor and an elected legislative body, but does not have a separate Court of Law.

- Federal government

According to the federal government a harbour is a public utility. Therefore the federal government is the owner of the land and the properties, but it can decide to grant a concession to a private company to use the land for a certain period. Therefore some of the bigger ports in Brazil are run directly by the federal government, through a so called dock company. Examples of such ports are Santos, Rio de Janeiro and Salvador de Bahia.

Recently a new law has been declared stating the following: if a landowner along a waterway wants to start a business (terminal/port), he has to show the federal government the plan is viable (economic studies, nautical studies, etc.). The federal government can decide to put the plan up for a bid, for which everyone can enter, and the winner gets the permission to build. If the original landowner doesn't win the bid, the winner has to pay the landowner for the land, the performed studies, and so forth. This law will always be applied, unless the landowner can prove he is a manufacturer of something and need a harbour solely to export his own goods. Then the federal government will give him the permission without further notice.

The federal government funds projects concerning the harbour's infrastructure on a large scale, like the deepening to 14m and rebuilding the collapsed berths of the Port of Itajaí. This is because of the concession. There is also an emergency fund; in the case of Itajaí this is used to pay for the upstream dredging project which has as goal flood prevention.

- State government

The federal government granted concession for some of the harbours in Brazil to state governments, for example Paranagua, São Francisco do Sul and Rio Grande. In the case of the Port of Itajaí there is no direct link between the state and the harbour. The federal government granted a concession to the city of Itajaí and not to the State of Santa Catarina.

- JICA

Japan International Cooperation Agency (JICA) was ordered by the state government of Santa Catarina to study the possibilities of flood control along the Rio Itajaí-Açu. One of the recommendations of JICA

was dredging an upstream part of the river; the project is being executed funded by the federal government.

- Portonave

Portonave is the terminal at the northern bank of the harbour basin, so at the side of the city of Navegantes. This terminal has its own contracts with certain shipping lines, but obviously has to make use of the channel, which is controlled by the Port of Itajaí. The Port of Itajaí is the authority that decides the order of berthing, etc. and gives permission to vessels to come in. Furthermore the maintenance dredging, also for the Portonave side, is done by the Port of Itajaí. To compensate for this maintenance all the vessels passing the channel (regardless of where they will berth) have to pay for the use of the channel. This amount is slightly more than for vessels going to the Port of Itajaí.

Another issue is the fact that the organized port area touches the Portonave terminal at the west, as can be seen in appendix A, figure A-1. Within the organized area of the port there are certain obligations. For instance, every operating ship is obliged to order labour from the union pool, which is union labour, expenses, etc. If the terminal is outside the organized port area, it is free to hire its own labour. But when a ship is in the western berth of Portonave, it touches the organized port area. The union says the ship is inside, so on board the ship they demand their union labour. Because Portonave and the Port of Itajaí are using the same waterway cooperation is needed. Plans for future changes in the harbour basin and turning circle should be made in collaboration.

- Municipality of Itajaí

The Port of Itajaí is the only harbour of Brazil for which the federal government granted a concession to a city, the city of Itajaí. This means there is a strong, if not direct link between the community hall and the Port of Itajaí. This has effect on the staff of the Port of Itajaí, after local elections the staff is often subject to change.

- Port of Itajaí

As mentioned above, the Port of Itajaí works from a concession given by the federal government to the city of Itajaí. This means there's a concession of 25 years, renewed for another 25. The federal government will fiscalise, so the auditors will have to comply with certain requirements, where the land and the properties belongs to the federal government. Also any construction made during the concession time will at the end reverts in favour of the federal government. Then, according to the terms of the concession the Port of Itajaí is obliged to lease out a part of the port operations to private operators. Teconvi/APM Terminals has a lease by the Port of Itajaí; they pay to the Port of Itajaí. The lease is paid for the use of the land and by moves: there is a price for the use of the land and a price for every container moved. The Port of Itajaí is responsible under the terms of the concession for the maintenance of the channel, breakwaters, etc. in general: maintenance of the infrastructure. The plan is, according to the concession, that the Port of Itajaí has to lease out and that the port authority has to step out of the operation. In the past all operations on shore were under the responsibility of the port authority. A port operator hired labour from the Union on board of the ship and the Port of Itajaí hired

labour on the shore side. Later the port operators hired all the labour, so the port authorities already got out of that. This was about ten years ago. After Teconvi came, the influence of the port authority was further withdrawn. At this moment the Port of Itajaí is still responsible for storage in the part of the port that has not been leased, but no cargo handling is done by the Port of Itajaí. All the cargo handling in the whole port area is now done by Teconvi/APM Terminals.

- Bond dry ports

The Bond dry ports are the storage- and distribution areas for containers around Itajaí. They are controlled by the customs and they provide the needed containers on time according to the wishes of the terminal they deliver to, whether these are import-, export- or empty containers. The containers leave or arrive at the bond dry port by truck.

- Navy

The navy handles security issues and checks the guaranteed depth dredged by Van Oord as stated in the contract of the Port of Itajaí and Van Oord.

- Pilots

The local pilots take over the manoeuvring of the vessels during entering and leaving the port. The pilots give feedback on possible manoeuvres in the future and help setting up and evaluating any nautical studies done.

- Teconvi/APM Terminals

As mentioned before, a part of the harbour is leased to Teconvi/APM Terminals and pays the Port of Itajaí for the port use, see figure A-2 in appendix A. APM Terminals bought 100% of the shares of the Teconvi terminal in 2007 and so now the lease of the terminal belongs to Teconvi/APM Terminals. Teconvi/APM Terminal is fully responsible for the layout, organization and use- and types of equipment within their part of the port. They make contracts with the shipping lines and decide what containers to store within their area (import or export) and make arrangements with the bond dry ports that all these containers arrive and leave the terminal on time. Due to the fact that the port is a concession and all the land, etc. actually belongs to the government whenever the concession should end, investments are done very carefully. Currently, because of the collapse of the APMT2 berth there is an agreement that Teconvi/APM Terminals can use berth 4 of the public area, see figure A-2 in appendix A. There is a plan to also privatise the public area of the port. Teconvi/APM Terminals is really interested in taking over this area as there is a real shortage of space/storage area (square meters per berth). It is currently well under international standards.

- The Union

The Union has a strong position within the port, because, as mentioned before, according to the concession all the labour that works within the organized port area has to be hired from the Union.

- The community

As the Port of Itajaí, directly or indirectly, generates a lot of jobs in and around Itajaí it has an enormous influence on the community. But also the community can influence the port largely on certain decisions. I.e. nuisance can cause serious problems to the port's workability.

- Shipping lines

The shipping lines are the customers of the terminals. They close contracts to open trade lines with the terminal, generating production and income for the terminal. When such a contract ends, or the terminal doesn't meet the demands of the shipping line, the shipping line can decide to leave the terminal or even the concerning port. If shipping lines are going to use larger ships on certain trading lines in the future, the terminals needs to convince the port authority to assess their infrastructure in order to see if accommodate of these vessels is possible. And the port authority in its turn needs to convince the federal government to fund any improvements to this infrastructure, if needed.

- Van Oord

This is the company that is responsible for the maintenance dredging of the harbour, contracted by the Port of Itajaí. The guaranteed depth stated in the contract is the depth that always has to be available for shipping. This guaranteed depth is checked by the navy.

- Committee of Itajaí

This committee exists for 11 years. They are responsible for the catchment area and the tributaries of the river Itajaí-Açu. It is a membership of people representing public and private organizations in charge of guiding the use and protection of water. It consists of people from federal- and state government agencies, water users, municipality, universities, ngo's and civil society organizations. The proxy of the committee is to promote joint actions of defence against drought and floods and ensuring the provision of adequate water for all users. These objectives will be achieved by combating and preventing pollution, soil erosion and silting of watercourses and the protection of reverie environments.

4 Characteristics of the river

4.1 River Management

The province of Santa Catarina has a complex set of rivers, which all together form the Itajaí-Açu. The watershed of the river is about 15.500 km². This river system has to drain a large amount of water, especially during rainy periods with high intensive rainfall. The river discharges can be very high. The river management of the Itajaí-river is done by the Committee of Itajaí. This organization is responsible for the catchment area, for the Itajaí-river and its tributaries. The committee promotes joint actions of defence against drought and floods and ensures the provision of adequate water for all users. These objectives will be achieved by combating and prevention pollution, soil erosion and silting of watercourses and protection of the river environment. The committee is a collegiate body with an advisory and deliberative regional level, linked to the State Board of Water Resources (CERH). Besides this committee there is also a water agency which goal is to protect the valley against floods.

4.2 Classification

The Itajaí-Açu river can be divided in three parts, each which their own characteristics.

- High Itajaí-Açu

This part of the river has a small slope, a meandering course and a length of 26 km. Its spring is at the confluence of the sub-basins Itajaí East and the Itajaí South, at Salto Pylonen in the province of Santa Catarina.

- Middle Itajaí-Açu

The middle part of the river is the steepest part and has a length of 93 km. The flow gets stronger going from Salto Pylonen to Salto Weissbach. Most of the sediment has its origin in this part. Due to the steepness the flow velocities are high and erosion occurs.

- Low Itajaí-Açu

The lowest part of the river has the mildest slopes and ends at the Atlantic Ocean. The length of this part of the river is about 80 km.

In figure 4-1 the complete overview of the watersheds, the total area of 15.500 km², can be seen. The blue part is the Itajaí-Açu river, called the Itajaí Valley. The other rivers all mouth in the Itajaí-Açu river.

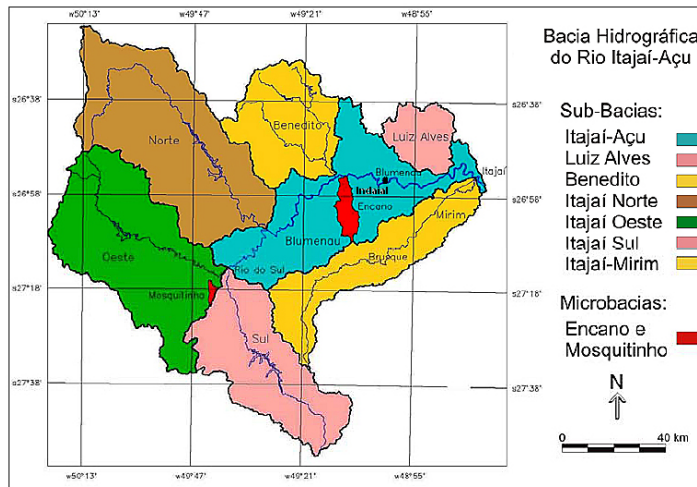

figure 4-1: watersheds of Itajaí-Açu river

4.3 Dams

There are three dams in the province of Santa Catharina; near Ituporanga, Taio and Joseph Boiteux. See appendix B, figure B-1. The main purposes of the dams are preventing flood (especially during heavy rainfall) and controlling the flow through the hinterland. The reservoir of the dam of Taiois, the most western located dam, has a capacity of 83 million m³. The dam of Ituporango, the southern dam, has a capacity of 93,5 million m³. The most northerly dam, Jose Boiteux, is the biggest with a capacity of 357 million m³.

4.4 Discharge

In the tables below overviews of discharges are given. Since 1934 the discharge of the Itajaí-Açu River is measured at Indaial. The Agência Nacional de Energia Elétrica is situated at Indaial and collects data about the river at this location. Indaial is 90 km upstream from the mouth of the river. The discharge at the mouth of the river is about 40% higher than the discharge measured at Indaial station [Jansen, 2000]. This increased discharge is due to the contribution of two rivers debouching in the main river (Rio Itajaí Mirim and Rio Luiz-Alves). In appendix B, figure B-3 gives a discharge-depth relation at Indaial, measured from 2000 till 2005.

Q [m ³ /s]	Indaial	Itajaí
Minimum	40	56
Maximum	2000	2800
Average	270	378
Peak	5000	7000

table 4-1: discharger at Indaial and Itajaí

River	Average Q [m ³ /s]
Rio Luiz-Alves	16,2
Rio Itajaí-Mirim	38,7

table 4-2: discharges at branches

4.5 Rain

Rainfall is the most important supply of water for the river. The total average rainfall for the period 1999-2008 was 1113 mm/year. figure 4-2 gives an overview of the distribution of rainfall per month over this period. In a period with extreme rainfall, the capacity of the river will be too small and floods will be the result.

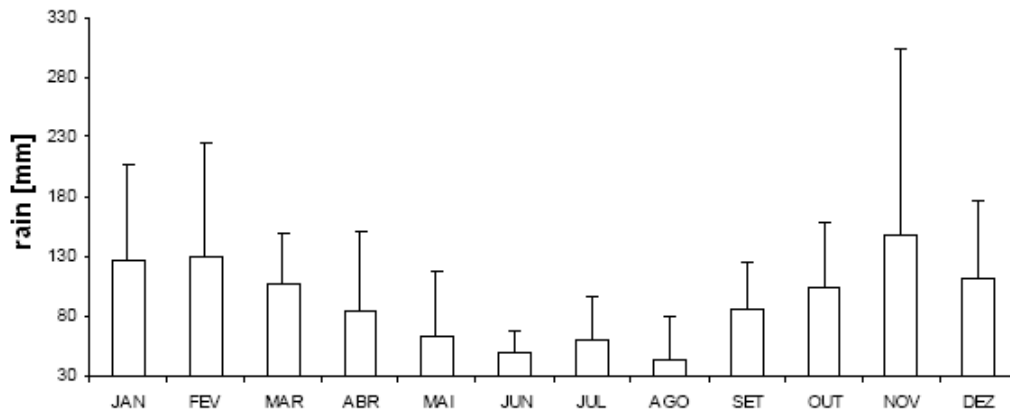

figure 4-2: distribution of rainfall per month in 1999-2008

4.6 Floods

In 2008 a big flood occurred. For many days it rained intensively with as result several landslides, which created mudflows into the river. An area of 6.700.000 m² was eroded. The combination of high discharges and a high sediment concentration created a lot of problems downstream. In the harbour basin a large amount of sediment settled and at the inner bend the average depth was reduced to 7 meter. Due to the high velocities the outer bend eroded till 22 meter. Another problem that occurred due to the high velocities was the partly damaged breakwater. At the interface of the river flow and the waves from the sea the forces were extreme.

In 2010 Hidrotopo made a probabilistic calculation on the frequency of a flood with the collected data of river discharges near Indaial. In appendix B figure B-4, results of this study are shown.

A group of Japanese engineers [JICA] is already a few years busy with a flood study on the Itajaí valley. In order to do so the river system is being mapped and analysed. The results off this study are expected in 2011.

5 Characteristics of the sea

5.1 Wind climate

The past years multiple studies were performed on the Itajaí valley. Determining the wind and wave climate is a returning item in those studies. It is not clear which data is used in the most recent study done in 2010 by Hidrotopo, however there is a reference to the study of 2006 performed by Alkyon: 'nautical study for the Port of Itajaí and Navegantes'. The conditions of wind, waves and flows were determined in order to use as a boundary condition for a subsequent manoeuvring study. This data on wind and wave climate is the best available and the most complete; therefore it is assumed that this data can be used as input for this study.

The offshore observations on the wind and wave climate were retrieved from Alkyon's in-house database HydroBase.net, from satellite observations and from a global hind cast model. The climates are represented in the form of exceedance tables and wind and wave roses. Appendix C figure C-1 shows the annual offshore wind rose, which represents the wind climate for Itajaí. The total number of observations selected is 150543. The wind rose shows that winds up to 11,0m/s come from northeast direction. Slightly higher winds with speeds of 14,0m/s come from the southwest. There are quite significant winds up to 11,0m/s coming from the north and south. The joint probability of the wind occurrence classified according total speed and direction is presented in appendix C, table C-1.

Appendix C figure C-2 shows the wind speed exceedance from the representative open sea wind climate at Itajaí for the offshore wind directions from north to south.

5.2 Offshore wave climate

In order to determine the offshore wave climate, three data sources were compared. Data from the HydroBase database, satellite data and data obtained by a hind cast model. Appendix C: figure C-3, figure C-4 and figure C-5.

The directionality of the different data sets was compared. The hind cast model and the satellite data looked fairly consistent specially compared with the ship observation data. Assumed was that the ship observations underestimate the swell components and the satellite data underestimates the wind sea component. This assumption is consistent with the data shown in the wind rose, the north-easterly direction displays strong contribution to the wind climate.

Secondly, the comparison between those three data sets was undertaken by looking at the wave height exceedance curves, appendix C figure C-6. The hind cast model and satellite data agree fairly well, but the ship observations seem to underestimate the wave heights.

The ship observations were discarded for the rest of the study, because it is less conservative than the other data and it seems to be swell dominated. The hind cast model and the satellite data agree fairly well, but the hind cast model is more complete in the sense that it provides more wave period information. Therefore, the hind cast model was selected as a base for the study of Alkyon and for this study.

Appendix C, table C-2 and table C-3 display the joint probabilities of occurrence for wave height and wave period per directional sector.

5.3 Bathymetry

Appendix C, figure C-7 shows the bathymetry map which was used for the SWAN model.

5.4 Shallow water

The offshore wave climate was transformed into shallow water conditions by applying the SWAN model. This model included refraction, local wave generation and dissipation by breaking and bottom friction. The transformed wave climate with a water depth of 20 m is presented in the form of a wave rose in appendix C, figure C-8. The joint probability of occurrence of the wave height over the directions is presented in appendix C, table C-4. The two main wave directions are 60°N and 90°N, for those directions the wave penetration inside the harbour is the most significant. Another conclusion of the Alkyon study was the fact that refraction plays a very little role in most of the sea area. The mean wave direction changes only in the last few kilometres from the shore. Past the breakwaters there is little wave activity.

In appendix C figure C-9, one of the results is shown, for which a significant wave height, H_s of 2 m is found in shallow water.

5.5 Tide

- Vertical tide

The specific water level fluctuations due to the vertical tide at Itajaí consist mainly of a semi-diurnal tide (period ca. 12 hr. 25 min.) with daily inequality. This means that two high waters per tidal day occur (lunar day; 24 hr. 50 min.), with a higher high tide and a lower low tide each day. The 'form factor' of the tide, which is the ratio of the principal semi-diurnal components divided by the sum of the principal diurnal components $((M2+S2)/(O1+K1))$ has a value of 0,4, calculated by Schettini et al. [1996]. The astronomical tide is strongly influenced by local shallow water harmonics; of the 32 with respect to DHN provided by the tide gauge station of the Port of Itajaí, 14 are shallow water harmonics, generated by the deformed tidal wave which deforms during its advance on the continental shelf and its penetration in the estuary of the Itajaí-Açu river system [Schettini, 2002]. The mean tidal range is 0,8 m, with a minimum range of 0,3 m and a maximum range of 1,2 m during spring tide periods.

The Admiralty Tide Tables (or Nautical Chart No. 1801 of DHN) give the following figures with respect to tidal levels (relative to Chart Datum = CD); appendix C, figure C-10:

MSL = mean sea level = 0.6 m

MHWS = mean high water spring = 1.0 m

MHWN = mean high water neap = 0.6 m

MLWN = mean low water neap = 0.5 m

MLWS = mean low water spring = 0.2 m

From registrations in the period 1999 to 2004 the highest and lowest water levels are found to be respectively 1,91 m above and 0,53 m below CD.

On a larger timescale the sea level has several other variations, generated by astronomical, oceanographic and atmospheric processes, which propagate as waves in the ocean until they reach the coast. Mainly responsible for the meteorological component of the oscillation of the water level are the atmospheric pressure and wind shear stress, of which the latter is considerably more important. The wind can dam the tide, or reduce it and atmospheric pressure may also raise the level (low pressure) or suppress it (high pressure). On the Southeast coast of Brazil positive fluctuations of the mean sea level are related to the Ekman transport towards the coast, caused by southerly winds, which tend to accumulate ('stack') water against the coastline. When at the same time cold fronts pass, the meteorological tide can be about 1m above the astronomical tide level.

From the mouth of the river Itajaí-Açu to the mouth of the river Itajaí Mirim, the tidal wave propagation has a synchronous behaviour. The effects of the reduced cross-sectional area of the river are compensated by frictional effects. In this case, the energy and height of the tidal wave are conserved, but there is a phase delay in the order of 10 or 20 minutes and the speed is around 9,5 m/s. The tidal wave propagates approximately 70 km upstream, as oscillations in water level of up to 15 cm are recorded during periods of spring tide at the city of Blumenau.

For an arbitrary period of two months (56 days, beginning 01-01-2010) the predicted vertical tide (Tidal elevation) at Itajaí is shown in appendix C, figure C-10. The prediction, coming from <http://tbone.biol.sc.edu/tide/>, is made by an application called XTide. The algorithm that XTide uses to predict tides is the same used by the National Ocean Service in the U.S and uses special data from each and every location for which one wants to predict tides. XTide reads these data from harmonics files like World Vector Shoreline data, etc. The accuracy of the predictions of this method is found to be more than acceptable. Also the tidal elevation during one day of springtide (02-05-2010) and one day of neap tide (08-01-2010) are added in respectively appendix C, figure C-11 and figure C-12.

In order to allow large vessels in the Port of Itajaí a tidal window is selected. The description of the tidal window can be found in paragraph 6.10.

○ Horizontal tide

As a result of the vertical tidal elevation there is a horizontal flow in and out of the harbour basin, called horizontal tide. The velocities of the horizontal tide are important for a ship manoeuvring and therefore Alkyon applied two numerical flow models to generate relevant information for their nautical study. One of those studies was a 3D-model made with the software 'Delft-3D'.

The tide used in the 3D-model represents the period from 9 to 10 April 2005. Figure C-13 and figure C-14 in appendix C show the simulated (depth averaged) flow velocities for four locations along the access channel at 3,9 km; 2,5 km; 1,3 km and 0,5 km. The velocities are given for a number of discharges and the maximum flow velocities at the access channel (inside breakwaters) are in the order of 0,4 to 0,5 m/s for conditions with low river runoff. With a low river runoff there is a change in flow direction due to the difference between ebb and flood conditions. For higher river runoff the maximum flow velocities increase to 1,6 to 2,0 m/s and the flow direction is continuously seaward. If the discharge of the river is higher than 1000 m³/s the local flow conditions are dominated by the river, otherwise by the sea.

From the model simulation it can be observed that in the (wide and deep) harbour basin the flow pattern is rather complex, especially for conditions with relative low river runoff. Under these conditions the salt and fresh water interaction, with a salt wedge near the bed, generates a complicated 3D-flow pattern. During flood conditions the inflow of water is mainly realized in the bottom layers by the denser salt water, whereas in the surface layer the flow velocities are small. During ebb conditions the outflow of fresh water is in general through the surface layers, in the near bed layers the flow is pointing in another direction. Further upstream the flow directions are all in the same direction.

	Tide dominated (Q<1000m/s)	River dominated (Q>1000m/s)
Flow direction	Tide depended	Always out flowing
Highest velocities	Flood: bottom layer, northern limit	Southern banks
	Ebb: surface layer, southern limits	
	Curves: outer bend	
Lowest velocities	Flood: surface	Northern banks, counter clockwise
	Ebb: bottom	
	Curves: inner bend	

table 5-1: horizontal tide

In table 5-1 an overview is given for the different processes that occur in the harbour basin as a result of interacting between river discharges and vertical tide. If the tide is dominant the flow direction depends on the tide creating a horizontal tide. This flow differs in horizontal and vertical space.

In 2010 Hidrotopo has also preformed a 3D-flow study, see appendix C figure C-15. The goal of the study was to determine the possible effects dredging till a depth of 14m has on the system. The figure shows the effect on the flow velocity in different tidal stages.

5.6 Storm surge

During a severe storm the waves generated at open sea will be much higher than normal. Depending on the shape of the coast under consideration, the direction of the wind during the storm and the strength of the wind, the still water level (SWL), can be piled up along the coast. This piling-up of the water level is called surge. The storm surge at Itajaí can be considerable, but there are no measurements available on the exact water levels and frequency of occurrence. However, the storm surge seems to be in the order of the tidal elevation.

5.7 Longshore current

As a result of tidal forcing, wind forces and obliquely incoming waves a longshore current can be generated. The longshore current is counteracted by friction forces, which are expressed in terms of the bottom shear stresses. In the Acquaplan of 2009 a number of simulations were made on the longshore current along the coast of Itajaí. Appendix C figure C-16, figure C-17, figure C-18 and figure C-19 show some of those results.

The velocity direction of the sea depends on the tidal phase. During flood the velocity direction is to the North and during ebb the direction is to the South. Because the Port of Itajaí is situated in a bay the longshore current largely depend on bathymetry, local wind conditions and local wave conditions. For certain tide and wind conditions a vortex can be generated, the longshore current can be reversed and there is no real dominant direction.

6 Characteristics of the harbour

6.1 Economic value

Due to the strategic location, Itajaí is one of the main centres of distribution of goods from the state of Santa Catarina. It serves as an important link between production and consumption centres. In 2008 the harbour was responsible for approximately 65% of the total export of goods in Santa Catarina. The local economy of Itajaí depends strongly on the fishing industry and commercial harbour activities. The city has a complex network of fishing, landing, processing and canning of vegetables, fish and there are a lot of maritime agencies and other companies related to maritime services. The fishing alone has 3000 direct jobs, with a fleet of 200 industrial vessels. Harbour activities accounts for more than 50% of the tax revenue, in addition it's generating employment directly and indirectly.

6.2 Throughput¹

The port of Itajaí takes care of about 43% of all import and export of the state of Santa Catarina, which relates to a share of ca. 4% of that of the whole of Brazil. In 2009 the import and export rates of the port where respectively 38% and 62%. Expectations are that these rates will converge to a fifty-fifty situation. The port of Itajaí mostly exports meat (49,8%), foodstuffs (11,5%) and metal mechanical (15,3%) and imports mainly electronics (39,5%), textiles (22,6%) and chemicals (17,5%). Most of the export products go to the Netherlands (12%), the USA (11%) and Russia (10%). The goods that are imported come mostly from China (33%), the USA (12%) and Germany (7%).

In 2008 the annual throughput of the port of Itajaí was 693.580 TEU's. Due to the collapsing of the two berths of the APM/Teconvi terminal this was reduced in 2009 to 593.359 TEU's. The current expectation is that the annual throughput of 2010 will exceed the 2008 figures.

The monthly amount of calls (which varies along the years, market given) is around 90/95 entering the harbour area, including the upstream terminals outside the Port of Itajaí's area. From these calls approximately 35 are assigned to the APM/Teconvi terminal and 55 to the Portonave terminal. This distribution can change in the future depending on market demand. The amount of TEU's per call is approximately 750. Due to the restriction in the harbour's depth the vessels are partly loaded.

¹ If not otherwise stated, the numbers used here are from 2009

6.3 Shipping

Different types of vessels frequented the port of Itajaí.

- Container ships

In 2008, 1007 vessels frequented the waterway of the Rio Itajaí-Açu. 88% of this total was linked to containerized cargo handling. The length of these vessels was between 180 m and 253 m with a draught between 9,8 m and 12,5 m.

The public port and port complex is frequented by several services of major shipping lanes in the international maritime trade as the Far East, east and west coasts of North America, Europe, Africa, Middle East and others. Owners who climb the waterway of the Rio Itajaí on their regular routes are: Hamburg Sud, MSC, P&O and Maersk Sealand Nedloyd.

- Reefer

This kind of vessel is used to transport frozen goods and has a low frequency of arrival at the harbour. The numbers of 2008 show a capacity of these vessels between 6386 and 7685 DWT, a length between 120 m and 145 m and a maximum draught between 7,4 m to 7,9 m.

- General Dry Cargo Ships

These vessels are used to transport all sorts of dry cargo. The General Dry Cargo Ships also visit the harbour with a low frequency and transport mainly wood. The capacity varies between 15000 DWT to 22300 DWT, with a full-length between 14 m and 190 m and a draught between 6 m to 10 m.

- Future shipping trends²

In the process of globalization, containerization has contributed to the growth of international trade. Because of its providing security, relatively low cost and ability to access markets in any region of the planet containers are and will be in the future the standard. Through a network with highly integrated and efficient routes, services, feeders and transshipment there is a connection between different parts of the world. More and more Brazilian harbours are included in these international shipping routes. Since 2005 the share in international trade has grown enormously for Brazil and the expectations are that this growth will continue.

The future trend of the main lines seems to be the use of larger vessels for the Asian-Europe line and smaller vessels will be used for the north-south line. Vessels frequent Itajaí will have a maximum capacity of 3750 TEUs to 6000 TEUs, a draught that needs 14,0m depth and without handling equipment on board. The dimensions of this vessel would have a length of 300m overall, 45m beam and 14m draught. In order to compete with the surrounding harbours in the region it is important to decrease the service level so that the waiting time for the vessels won't get too long.

²Prof. ir. H. Ligteringen

6.4 Layout

In this section the layout of the harbour will be described. At first glance a division can be made in the wet and dry layout.

- Wet layout

The wet layout can be split in the outer approach channel, inner approach channel and the harbour basin. See appendix D figure D-4 for current layout of harbour.

- Outer approach channel (19+00 – 49+20)

The entire approach channel, so inner and outer, concerns a one way channel. The alignment of the outer approach channel is approximately 260° and covers a length of 3,0 km from the isobathymetric depth contour line of 12,5 m till the harbour entrance at the breakwaters. The width of the outer approach channel takes into account not only a 'basic width', but also the effects of wind, current and waves require additional width, but also does the lack of visibility, etc. The current width of the outer approach channel varies between 120 and 200 m. The current depth of the outer approach channel is ca. 12,5 m with respect to CD.

Within the outer approach channel there can be made a distinction between:

- Fully exposed section of outer channel (19+00 – 39+40)

The outer channel is subject to wave action, which is usually moderate and approaches the harbour from Northeast or Southeast. Width = 120 m, depth = 12,5 m to 12 m.

- Entrance section of outer channel (39+40 – 49+20)

The entrance to the port is flanked by two non-symmetrically placed breakwaters. The south breakwater head is set 400 m further into the sea than the northern head. Currents play a role at the entrance: the flow is reported to deflect to the north, creating a cross-current component. Once past the breakwaters the cross-current plays no significant role. Due to elimination of the sheltering by the breakwaters, outbound vessels can suddenly be subjected to wave action, cross currents and wind. This can cause a (additional) drift angle and therefore requires extra width to adjust the vessel to this new situation. Therefore the width of this section is increased in tapers, which have a width of 50 m and a length of 500 m each, appendix D figure D-5. The depth of this section is 11,0 m.

- Inner approach channel (49+20 – 75+50)

The inner approach channel starts at the entrance of the breakwaters and ends at the harbour basin. In this section the river varies in width and includes a couple of bends. Again separate sections can be distinguished:

- Curved section of inner channel (49+20 – 56+00)

At the beginning of the entrance the channel starts to make a gentle right curve, with a radius in the order of 3 km. The width of this section at the entrance, between the breakwaters is 120 m and the depth is 12 m.

- Inner channel east bend. (56+00 – 62+80)

In this section the gentle curve that commenced at the entrance becomes a much tighter bend, with a radius of about 1 km. The width here is ca. 140 m and the depth 11,5 m.

- Inner channel straight section (62+80 – 69+60)

This is a short straight section connecting the two channel bends with a width of 120 m and a depth of 11,5 m.

- Inner channel west bend. (69+60 – 75+50)

This again is a very tight bend, this time with a radius of approximately 1,2 km. The width at the beginning at this section is 155 m and is limited due to the presence of the passenger terminal here. Special care has to be taken when manoeuvring through this bend when a cruise vessel is moored. Just after the passenger terminal the channel narrows to 120 m at the end of the bend it widens again, forming the beginning of the harbour basin. The depth is 11,5 m.

- o Harbour basin (75+50 – 87+95)

The basin has a length of approximately 1 km and varies in width, with initially a maximum width of 425 m. The basin is flanked at the North and South bank by respectively the Portonave and APM/Teconvi terminals. The depth of the basin varies but has an average depth of 10,5 m. Close to the quay walls there cannot be dredged due to the danger of instability. At the Western boundary the Southside is shallower and the North side is deeper due to sedimentation caused by the secondary flow in the river bend. In the centre of the harbour basin a turning basin with a radius of 360 m is situated.

- Dry layout

The dry layout consists of the facilities along the banks of the river flanking the harbour basin and approach channel.

Following the river from East to West, at first the river is flanked by the two breakwaters. Constructed around 1930 and of which the southern extends ca. 400 meters more into the sea than the northern one. Further upstream, throughout the east bend and the beginning of the straight section, there are groins covering the northern bank. Due to these groins the velocities in the channel are high enough to avoid sedimentation. Where the groins end there is a marina (Marina do Centro) on the northern bank. On the southern bank of the straight section and on the west bend several organisations have their offices, buildings and jetties:

- IBAMA is an organisation that carries out research and measurements along the river concerning environmental issues.
- The Navy handles security issues and checks the navigable depth of the channel.
- The pilots board in-, and outbound vessels to take over the manoeuvring.
- The passenger terminal is used to receive cruise vessels and give shelter to passengers entering, leaving and waiting for the vessel. There are plans to build another passenger terminal on the southern bank, more downstream.
- The Itajaí – Navegantes ferry has two small ferries crossing the river continuously bringing cars, pedestrians, bikes, etc. from one side of the river to the other.
- The local fishing boats of Itajaí use the fishing terminals to unload their catch and stay moored for the night. Plans to move the fishing terminals further upstream of the river, outside the harbour area have been made.

An overview of the location of these organisations is given in figure D-6 in appendix D.

Finally on the banks of the actual harbour basin the quay walls of both the APM/Teconvi terminal (Southern bank) and the Portonave terminal are located, see also appendix D figure D-6.

6.5 Ship manoeuvring

Due to the layout of the harbour ship manoeuvring is difficult. In 2008 Alkyon performed a nautical study on the limitations for safe manoeuvring with a partly loaded 5600 TEU Container Carrier. These vessels have a length of 275 m, a beam of 40 m and a draught of 10,5 m. Currently these vessels are sailing upstream. The bathymetry of the river has not changes since the study was performed; therefore the critical points are still present.

- Fully exposed section of outer channel

The tugs need to be connected to the vessel in this section of the approach channel in order to have it available for the entrance section. Normally 2 tugs are needed and 3 if the length of the ships is more than 250 m. With wave conditions higher than 1,5 m tug use is impossible. There are wave conditions which limit the accessibility of the harbour, the directions of which are 30°N, 90°N, and 150°N. This is due to the sensitivity of the current container vessels to resonance to waves from the quarters. This can result in extreme heave, and thus requiring a larger under keel clearance.

- Entrance section

At the passage of the breakwaters, multiple course corrections have to be applied in order to keep the vessel centred in the channel. With high river discharge the transverse currents make the entrance manoeuvres more difficult. In the case the river current exceeds 4 knots no manoeuvring procedure can be fulfilled at all. In this section of the approach channel tugs are needed to reduce the speed and to steer the vessel. Outbound the vessel starts to accelerate here. The width between the breakwaters is not a problem, but the fact that there is a bend directly after the entrance section makes it useful to enlarge the width.

- Curved section of inner channel

In arrival with high discharge the vessel approaches the southern side of the channel. Outbound the tugs are released here.

- East bend

Both the tugs and higher main engine revolutions are used to increase the rate of turn in the east bend. The velocities in the east bend are high during rains. The past 5 years the velocities change more rapidly when it starts to rain, as a result of urban development. The width of the channel is just sufficient for feasible manoeuvring.

- Straight section of inner channel

The straight section is used to position the vessel for the next river bend. Inbound the forward tug attaches here. Outbound the forward tug releases towline here.

- West bend

Both the tugs and higher main engine revolutions are used to increase the turn rate in the west bend. During arrival the stern of the vessel generally gets close to the northern side of the channel just before entering the harbour basin. During departures the vessel tends to get close to the southern side of the channel. It is common that the vessel and the tugs feel the mud at the bottom of the river. This makes steering hard especially when steering is the most needed; the tugs often cannot deliver the required force in this case, therefore turning takes a long time. The width of the channel in the west bend is limited for this vessel. In particular when there is a cruise ship berthed at the cruise terminal. Due to the primary waves, secondary waves and the set-down related to a passing container ship the cruise ship starts moving horizontally and with increasing beam of the expected container ships there is a real possibility mooring lines of the cruise vessel will not be able to withstand the accompanied forces and break.

- Harbour basin

The layout of the harbour basin does not cause difficulties for the turning of the vessels till a length of approximately 235 m. Larger problems can be expected if vessels are berthed on both sides of the river, because the effective diameter of the turning basin is then reduced to 320 m. It is deemed not feasible to turn the vessel between two moored vessels for its very limited safety margin. Tug capacity is limited in case of strong wind conditions from northerly or southerly directions. One tug at the side is not sufficient to keep the vessel in position in beam-on winds. The higher flow rates at the southern side of the basin can be used to assist the turning of the vessel. The high engine power of the vessel is beneficial for the rapid acceleration of the vessel on the approach of the west bend. Also at large current velocities the drift of a vessel along the river axis can cause problems.

In July 2008 Alkyon performed a nautical study for the port of Navegantes for safe navigation of Monte-Class Container Carriers. One of the conclusions was that navigation should not be done for river discharges exceeding 500 m³/s and a favourable tidal window should be selected. This tidal window should consider an Under Keel Clearance of at least 1,5 m. Also, the outer approach channel should be widened to 160 m. Similarly, the west river bend should be widened on both sides of the river. If possible the inner channel should be widened to 140-160 m. The passage through the channel should be made with the over ground speed not exceeding 5,5 knots. So far the conclusions of this study have not been executed.

6.6 Hinterland connections

The city of Itajaí is connected to other parts of the State Catarina and Brazil by 4 roads. The city is the most important traffic junction of the State and therefore there is a lot of traffic, including cargo

transport for the harbour. The ministry of transport has the plan to separate traffic flow by destination in order to make the port better accessible and reduce the nuisance. This plan is in an early stage and has not yet been tendered. Currently there is also a plan to make a railway to transport frozen chicken to the hinterland. This plan is also in an early stage and the expectations are that it takes 10 to 15 years to complete the project.

6.7 Service level

The last years the import and export rate of the Port of Itajaí has grown enormously. The origin characteristics of the harbours of Santa Catarina were built in the years 1930-1950, technically classified as a first generation harbour. These harbours were designed in order to exchange general cargo and not for efficient container handling. For this reason the Port of Itajaí, were and still is modernized and renovated to meet the market demand for the international cargo trade.

- Approach channel

Currently the approach channel is a one way channel, and that will probably remain in the future because there is no room for expansion. It is possible that multiple vessels are berthed at the same time but there can sail only 1 vessel in the inner and outer channel. Some berths are located partly in the turning circle, when a vessel is berthed at one of those berths this is no reason not to use the turning circle. Another limitation for the approach channel is the fact that there is a tidal window, see paragraph 6.10.

- Cargo handling

Upstream there are multiple terminals located that are all responsible for their own handling equipment and terminal layout. The Port of Itajaí has no influence on the service levels at the quays but it does give permission and assigns a vessel to a particular berth (this can be a berth at the APM/Teconvi or Portonave terminal) and vessels who want to sail upstream have to pay the Port of Itajaí for using the approach channel. UNTACT of the UN body recommended an occupation level of 60% of the harbour infrastructure, to avoid queues. Vessels will not frequent a harbour with a high waiting time because of the costs, making them less competitive in foreign markets. The APM/Tenconvi terminal has an occupation rate that is far beyond the recommended rate, the waiting time is therefore long. This is however due to the fact that two berths collapsed during the 2008 flood. As these berths are currently being rebuilt, it is to be expected that the occupation rate for this terminal will decline once the four berths can be used again.

6.8 Storage areas

In the surroundings of Itajaí a lot of bounded dry ports and logistical support facilities are situated. These areas are needed to fill and empty containers, store empty containers and clear customs, so the containers can be brought to the designated terminal and loaded on a vessel rather quick. Due to the

great amount of meat exported by the Port of Itajaí many of these bound dry ports have huge refrigerated warehouses to store the meat.

6.9 Planned projects

In order to compete with other harbours the service time and waiting time of the Port of Itajaí have to be reduced. Therefore a number of projects are planned.

- Deepening of the approach channel and harbour basin till -14m and widening of the entrance
- Connection of the direct access road to the port

6.10 Checking the dimensions

The current and future dimensions of the approach channel and of the harbour basin and berths area will be checked for both current and future design vessel. Although the design parameters are to some extent interdependent, they will be treated separately here. In appendix D the calculations can be found.

- Approach channel
 - Alignment

In this case of course the local geometry and bottom conditions of the Rio Itajaí-Açu play the most important roles in the alignment of the actual inner approach channel. There might be a possibility to change the alignment of the outer approach channel and enlarge the radius of some bends in the inner approach channel. These possibilities will be discussed later.

- Channel Width

A sailing ship makes a sinusoidal track and thus covers a 'basic width', which is about 1,5 times the ship's beam. The effects of wind, current and waves require additional width, but so does the lack of visibility. Moreover certain margins are needed, which depend on the type of channel bank and the type of cargo. The PIANC Working Group has developed a method for concept design, which accounts for all these aspects, see appendix C.2:

$$W_{outer} = 1.7B + 2B + 2 * 0.5B = 4.7B$$

Currently the outer approach channel is 120 m wide, so the channel would be safe for vessels with a beam of $120/4.7=26$ m. This is less than the beam of the former design ship ($B=37$ m), and thus manoeuvring such a vessel is hard for the pilot, if even possible. This will result in a slower manoeuvre, longer service time and hence more costs. In the new situation, with the outer approach channel having a width of 160 m and designing for a ship of 45 m wide, the width should be $4.7*45=211,5$ m. So also in this situation the channel is too narrow. Widening to a width of 210m should be advised.

The required width for the inner approach channel can be calculated with same method:

$$W_{outer} = 1.7B + 0.8B + 2 * 0.5B = 3.5B$$

In the present situation ($B_{inner\ channel}=120\ m$, $B_{design\ ship}=37\ m$), the width of the inner channel is nearly sufficient, as $120/3.5=34\ m$.

For the future, the inner channel having a width of 160 m and a design ship of 45 m wide, the width of the inner channel is also sufficient, as $3.5*45=157,5\ m$.

The entrance of the breakwaters currently has a wide of 120 m. In order to allow the design vessel through the breakwaters the width should be extended to about the width of the inner channel, which is 157,5 m. At the moment the northern breakwater is set back, giving the entrance a width of 128 m, which will cause difficulties for navigation for the design vessel.

Of course remarks should be made on the above mentioned: the guidelines used are applied for the initial design and should be checked and refined by Fast Time Simulation. Particularly useful would be a comparison of the duration of the approach manoeuvres at various given channel widths. This will give insight in the relationship of widening the channel against the gain in service time. Also a check on the feasibility of manoeuvring for an increasingly wide ship at a given channel width can be valuable for future perspective.

- Channel depth

The depth of approach channels depend on a number of factors, used formula:

$$d = D - T + s_{max} + r + m$$

The value T is introduced when a port decides to introduce a tidal window. The values of s_{max} , r and m together form the gross under keel clearance (UKC). They may be estimated on the basis of experience; $s_{max}=0,5\ m$, $r=H_s/2$. m has a value depending on the type of soil along the channel for soft mud, 0.5 m for a sandy bottom and 1.0 m for a hard soil or rock.

An interview with a pilot showed that for the new container vessels the combined effect of heave, pitch, roll and yaw can easily take up an UKC of 1,5 m to 2 m for the governing wave directions (the 'quarters'). This UKC corresponds with the earlier mentioned values of $s_{max}=0.5\ m$ and $m=0,5\ m$, and $r=1\ m$ (so a significant wave height $H_s=2\ m$, which is in line with the actual wave climate at the outer approach channel), see paragraph 5.2. The calculations below will also be done for wave directions from the quarters because the modern container vessels are particularly sensitive for waves from the quarters, which give the greatest wave induced motions to the vessel.

The depth of the outer channel is currently about 12 to 12,5 m. Taking into account an UKC of 2 meters and the current tidal window of $T=0.6\ m$ gives a required depth of $d=10,5-0,6+2=11,9\ m$, so the depth is sufficient.

The inner channel generally has a depth of 11,5 m. Due to the reduced wave action and the bed consisting of mud, an UKC of 1,5 m is chosen here. This gives a required depth of 10,9 m, so also here the depth is ok.

From calculations it follows that the depth for the future situation (depth of outer approach channel 14.5 m, depth of inner approach channel 14 m and a design ship with a draught of 14 m) is not enough to accommodate the new design ship when it is fully loaded. For this situation a tidal elevation is required of $T=1,5$ m, which does not occur here, see paragraph 5.5 about the tide. Therefore a calculation is made giving the percentage of loading of the design ship vs. the tidal elevation needed to accommodate the ship in this loading condition. Comparing this with the tidal data an extra graph is included showing the percentage of time the port can receive the ship in that particular loading condition.

As the results show, for the outer approach channel an operational time of 100% can only be achieved with a tidal window of +0,1 m CD and a 65% loaded design ship (giving for a 6000 TEU ship $0.65 \cdot 6000 = 3900$ TEU). Depending on the wishes of the harbour, terminals and shipping lines, a suitable choice of tidal window can be made.

This spread sheet can also be used to evaluate larger design ships (if expected in the future), or other depths of the approach channel, appendix D figure D-11.

- Port Basin and berth areas
 - Port basin

The port basin should give sufficient width for the safe towing in and towing out of the vessels, whilst other berths are occupied. The width can be determined using the requirements, appendix D figure D-12. Hence a width of approximately $5B+100$ m is required, which for the new design ship, with a beam of 45 m, results in a basin width of 325 m. This width is present throughout the basin.

- Turning circle

The turning basin, from where vessels are turned (whether before or after berthing) in the right direction to leave the port again (facing East), is situated inside the harbour basin and currently has a diameter of 360 m. This is considered too small to safely turn a ship over 235 m length with two vessels moored at each side of the basin. Pilots think it is possible to turn a vessel of 300 m (so the new design vessel) if there are no vessels moored at the berths north and south of the turning circle, but there is very little margin for error and so the safety is questionable. Also such a tight fit will take much more time, increasing service times and thus waiting times. It is crucial to enlarge the turning basin in order to allow the new design vessel into the harbour.

- Quay length

In the case of the Port of Itajaí, as can be seen in appendix D, figure D-13. the quays walls actually consist of two separate sections, each containing two berths. Section 1, containing berth 1 and 2 has a length of approximately 500 m. Section 2, containing berth 3 and 4, has a length of ca. 485 m.

In this case the maximum length of the ships berthing can be for section 1: 256 m and for section 2: 247 m.

To accommodate larger ships of 300 m in the future, there is no possibility to keep 4 berths with the current length of the quay walls. The number of berths will be reduced to two. One in section 1 and one in section 2. As the required quay length $L_q = 300 + 2 * 15 = 330 < 500m$ and $< 485m$ the length of these sections is more than sufficient to accommodate the new design vessel.

At this moment it is possible that a vessel of 300 m is moored and at the same time 2 smaller vessels are moored. Currently once a week a vessel of 300 m is moored and the future expectation is that this number won't increase, thus there are no problems expected towards the quay length.

7 Optimisation of the alignment

At this moment the approach channel of the harbour deals with some imperfections, which makes it difficult, sometimes even impossible, for the design vessel to sail through the channel. Also the current turning circle is a problem. Turning of the design vessel will be extremely difficult and the safety is questionable. These imperfections will be pointed out and possible adjustments will be made to realize a safer navigation. The requirements stated in paragraph 6.10, based on the design guide of PIANC/IAPH, will be applied to optimize the channel alignments and turning circle. The given wind-, wave- and current data, as stated in chapter 5, are used as design parameters.

7.1 Outer approach channel

For the outer channel two problems occur. First of all it is difficult to navigate through the entrance section due to the hydraulic conditions of the sea. Secondly, the longshore current passing Itajaí builds up sandbanks near the northern breakwater, which result in quicker sedimentation of the approach channel.

Taking the hydraulic condition data into account the preferable direction of the approach channel can be analyzed, based on the best entrance conditions for vessels. At the moment the angle of the outer approach channel, seen from the entrance, is 83°N, which has a small angle with the dominant wave directions, see figure E-2 in appendix E. In accordance with paragraph 5.2, the wave directions that limit the accessibility of the harbour are 30°N, 90°N, and 150°N. The wind rose shows that the dominant wind directions come from the northeast and the southwest. Finally, the cross currents are directed north and south. These are of lesser importance because of the low cross current velocities due to the sheltering. See figure E-2 and figure E-3 in appendix E for an overview of the wind directions and the directions of the cross currents.

As stated in the report of PIANC some requirements can be made concerning the approach channel. It is important to attain the shortest channel length, to avoid bends close to the port entrance and to have a small angle between the approach channel and the wave direction. Considering the hydraulic conditions at the outer channel with a wave direction of 90°N, it can be favourable for the manoeuvrability to place the entrance of the outer channel in an angle of around 100°N instead of 83°N, see figure E-1 in appendix E. With this change the rate of turn a vessel has to make in the curved section and east bend in the inner channel will be strongly reduced compared to the current situation (see appendix E figure E-4). This will make navigation more feasible and there will still be a small angle with the wave direction. Also one of the main purposes of the breakwaters, sheltering the entrance section from waves, is not jeopardized with the new alignment as can be seen in appendix E, figure E-7-, figure E-8 and figure E-9. The sheltering is identical for the current and the suggested alignment. Although the dominant directions of the cross wind are somewhat less favourable for the suggested alignment, there are some directions with only slightly lower velocities taking a great share of the total wind distribution that are

less favourable for the current alignment. This taken into account, plus the fact that the largest wind speeds are not considered to be very high, it can be reasonable to say the 'net disadvantage' due to cross winds for both alignments can be considered zero. Both of the alignments have a small angle with the cross currents and there is no significant difference. Also the velocities of the cross currents are so low that they can be neglected.

So in terms of wave direction and cross currents there is no difference between the current and the suggested alignment, for wind a minor preference for the latter and for manoeuvrability a strong preference for the suggested alignment.

Should the suggested alignment be implemented, there are a number of adjustments necessary: the channel needs to be dredged conform the new alignment and the southern breakwater needs to be placed in a slightly different angle/rotated (see appendix E figure E-5). It is important to mention that implementing the new alignment of the outer channel only makes sense if the alignment of the east bend will also be changed according to the recommendations stated later on. This is because the combined effect of the changes to the east bend (larger radius of the bend) and the alignment of the outer channel are greater than that of the two separately. An overview of the entrance section (with the tip of the southern breakwater rotated) is shown in appendix E figure E-6.

7.2 Northern breakwater

The second problem concerning the formation of a sandbank can be solved by extending the northern breakwater. In the current situation the by-passing sand can react in the formation of a vortex, which transports sand from the northern adjacent coastline into the access channel. This requires excessive maintenance dredging which can result in high costs. By extending the northern breakwater this problem can be solved.

7.3 Inner approach channel and harbour basin

For the inner approach channel and harbour basin some difficulties arise, mostly caused by the bends in combination with a small width of the channel. The most critical parts are the eastern bend in the river, which has a small radius, the western bend, which has a small width due to the presence of the cruise terminal and also experiences a flow pushing the bypassing vessels to the northern river bank. Finally there is at this moment no space for a larger turning circle in the harbour basin, which is necessary to allow the design vessel. These different sections and the accompanied suggested improvements will be treated separately below.

7.3.1 East bend

By changing the alignment of the outer channel, as described above, it will be easier to make the turn in the eastern bend. Besides that, the bend can also be less tight by reducing the length of the groynes in

the north and placing the channel more to the north. This will also give more space in order to widen the channel in this section, which is necessary considering the calculated dimensions in paragraph 6.10. However, by shortening the groynes the flow width of the channel increases and the flow velocities through the channel will be lower and thus has a negative effect on the sedimentation. To maintain the flow condition in this section there will be a need for a flow width reducing structure on the south side of the river, i.e. groynes. In figure E-4 of appendix E an overview of the east bend in the new alignment is given, and in figure E-5 necessary adjustments.

As mentioned before, improving the alignment of the east bend is only useful if the alignment of the outer channel will be changed too. If this is not the case, the effect on the manoeuvrability of a vessel through this bend is negative. Furthermore, a study has to be done on the possible alternatives for the 'flow width reducing structure' that will need to be placed on the south side of the channel.

7.3.2 West bend

After the east bend follows the straight section. For this section PIANC suggests that the length is $\geq 5 L$, depending on the radius of the bends. In the present situation the straight part is only around 700m, which is rather small but could be sufficient if the east- and west bend become gentler. Also increasing the width of this section will make manoeuvring more feasible. This can be reached by moving some of the terminals/jetties on the southern bank to another location. Especially the passenger terminal reduces the manoeuvrability through the west bend. Moving this terminal further downstream creates room to reduce the rate of turn of the west bend and also reduces the risk of the cruise vessel being damaged when moored when a container vessel passes. The recommended alignment of the west bend and the necessary structures needed to be removed to implement this alignment are shown in appendix E figure E-10 (in this figure also the new turning circle at location C, see below, is already shown).

7.4 Turning circle

The last concern is the size of the turning circle in the harbour basin. Because the effective diameter of the turning basin is 360m and the length of the design vessel is 300m, turning will be extremely difficult and unsafe, if not impossible. Also there cannot be another vessel moored at one of the berths north or south of the turning circle at the same time, for this will reduce the effective diameter of the turning circle even more (also see paragraph 6.10). Because the width of the harbour basin is restricted by the quay walls of the Port of Itajaí's and Portonave's terminal, there is no space within the current harbour basin to accommodate a larger turning basin. Therefore the new turning circle will need to be situated more upstream or downstream of the harbour basin. There are four possible locations as can be seen in figure E-11 of appendix E.

- Location A

The turning circle is located on the upstream side of the harbour basin. When the design vessel enters the basin it has to sail for another 1,5 km before it can turn. The circle can be placed at a location where

only rural, unconstructed land needs to be removed, see appendix E figure E-12. Then again, this land is used as green compensation for the port of Portonave, so it can actually not be touched. Another environmental issue is the consequence it will have for the flow in the river. The width of the river has to be enlarged by more than 200 meters, which will reduce the flow in this area significantly and cause more sedimentation. This will lead to much higher maintenance costs for the turning circle. Lastly, for safety reasons it is also wise to replace the shipping companies on the other side of the river.

- Location B

Turning circle B is situated just upstream of the harbour basin in the bend, see in appendix E figure E-13. A good reason for placing the circle here, is that only rural, unconstructed land needs to be removed. The main disadvantages are the high sedimentation of this area and the difficulty of turning due to the strong current in the bend. The sedimentation is not only caused by the widening of the river, also secondary flow will play an important part. The outer bend will be deepened out, while the inner bend will get more sedimentation. A lot of dredging is necessary for the maintenance of the turning circle. For this location it is recommended that the shipping company opposite the river should be removed.

- Location C

This location is just before entering the harbour basin. To realize this location some fishing companies and an area at Navegantes, including houses and a supermarket, has to be removed, see appendix E figure E-14. It is also necessary to place the ferryboat at another position. The advantage is that maintenance costs are low and only a small area needs to be taken away. Replacing the fishing companies is not only helpful for placing the turning circle, this will also lead to a better navigation route for the design vessel. The problem on the other hand is that the inhabitants of Navegantes who live in the critical area must be bought out. Momentarily, there is a lot of discussion about this location. The first estimation is that the construction costs for realizing this turning basin will be very high but maintenance cost will be lower than the other locations.

- Location D

This location is situated around 2,0 km after entering the breakwaters. The free space is a good reason to place the turning circle here, see appendix E figure E-15. However, it is required to take away a few groynes and houses on the side of Navegantes. Also the small marina of Navegantes, situated behind the groynes, needs to make way for the turning circle and thus has to be placed somewhere else. The groynes, which are located here to increase the flow in this section of the river, need to be replaced by other flow increasing structures. Secondly, buying out the inhabitants of Navegantes in the required area will be expensive. And most importantly, the design vessel needs to sail backwards for almost 2,0 km, until it reaches the harbour basin. This is a great distance and almost impossible, taking into account the flow of the river.

7.5 Cost benefit analysis turning circle

A cost-benefit analysis is a qualitative economic decision making tool; the costs and benefits of different options are compared with each other to come to a conclusion. In table 7-1 a cost benefit analysis is given for the four possible location of the turning circle as described above. The analysis is very qualitative and further study is advised.

	Costs			Benefits		
	dredging costs	loss of land	loss of buildings	maintenance costs	ship manoeuvring	environment
Location A	--	--	0	-/--	-	--
Location B	--	--	0	--	-/--	--
Location C	-	-	--	-	+	-
Location D	-	-	-	-	--	-

++: very positive, +: positive, 0: neutral, -: negative, -- very negative

table 7-1: cost benefit analysis location turning circle

There is no real good option for the location of the turning circle because of the urban development on the banks of the river. So for every possible location concessions have to be made, for some more than for others.

Considering the possibilities, circles B and D are no good options. The maintenance costs of location B are very high and ship manoeuvring is hard due to (secondary) flow in the bend. Another large disadvantage of this location is the fact that land with high environmental value will be lost. When Portonave was constructed a part of the agreement was that the negative environmental impact should be compensated. This compensation was made in the form of land, next to the new harbour where urbanisation is not allowed. For both location A and B a part of this land will be lost and of course this have to be compensated. Location D is not feasible due to the long distance the vessel needs to sail backwards, see paragraph 7.4.

Location A has comparable disadvantages as location B but is slightly better, mostly due to the reason that it is easier for the vessel to turn here, as it is not in a bend. Option C is the only location which has scored a positive point. Also this option has a lot of disadvantages, but the ship manoeuvring is the best and that is of great importance for a turning circle. The biggest problem for this option is the loss of buildings, which is a difficult point to overcome politically. However, this location is the best option compared with the other possibilities and therefore afford has to be made.

7.6 Rough cost estimation

A first rough cost estimation of the suggested alignment changes is given below in table 7-2; in appendix E the costs can be found in more detail. Further studies are needed to get more reliable numbers.

Five changes can be distinguished:

- Deepening and widening dredging
- New location for turning circle
- Alignment change of the outer channel until the east bend
- Alignment change of the east bend until the west bend
- Extending the northern breakwater

	Costs
Deepening and widening dredging approach channel and turning circle ³	64.340.000
Alignment from the outer channel until the east bend	79.600.000
Extending the northern breakwater	30.000.000
Alignment from the east bend until the west bend	8.000.000
Turning circle, location C	100.000.000
	281.940.000

table 7-2: rough cost estimation for the suggested alignment changes [R\$]

To allow the design vessel with a length of 300 m into the harbour, it is necessary to deepen and widen the approach channel to respectively 14,0 m and 160,0 m. In a recent study done by Hidrotopo the estimated costs for dredging this approach channel will be ca. R\$ 64.340.000.

The east bend is a bottleneck for the ships when sealing into the harbour. By adjusting the alignment, it will become much more feasible for ships to go through the channel. The plans for moving the northern breakwater are completed and will definitely be executed; therefore the costs are not included in the total cost estimation (R\$ 17.500.000). One of the highest cost for this suggested alignment changes comes from rotating the southern breakwater, which is estimated around ca. R\$ 35.000.000. Next to that the dredging of the outer channel will also be expensive, taking into account that the channel width needs to be enlarged to 210 m. The total cost also includes dredging, adjustment of the groyne length and flow width reducing structure on the south side.

For the West bend the costs are significantly lower, however the result is of slightly less importance. Currently there are plans to buy the fishing companies out, which will be around R\$ 2.000.000. Another important modification to improve the accessibility of this section for the design vessel is to replace the passenger terminal. The total costs for removing and replacing the terminal to another location are estimated on R\$ 6.000.000.

³The plans of widening and deepening dredging are completed already and will definitely be executed, therefore this costs will not be taken in account in the total cost estimation

The last suggested change is the extension of the northern breakwater to avoid the formation of sandbanks. By extending this breakwater the sandbanks will not be of any hinder to the approach channel. The costs for this alteration areca. R\$30.000.000.

The cost to construct the new turning circle at location C is estimated at ca. R\$ 100.000.000. This value includes the costs for buying out the house owners and companies.

7.7 Summarizing

An overview of the total channel alignment containing all the proposed improvements versus the old alignment is given in figure 7-1. A big advantage of the suggested changes in the alignment is that they can be realised in stages. However, in order to receive the design vessel at least the turning basin has to be enlarged and the approach channel has to be deepened. There is no point in changing the alignment of the approach channel as long as the problem of the turning basin is not solved, and therefore the construction of a larger turning basin needs the highest priority. The plans for widening and deepening dredging of the harbour basin and approach channel are completed already and will definitely be executed. In principal the harbour can receive the design vessel when the deepening and widening dredging are carried out and an enlarged turning basin is realised. The harbour will be able to receive vessels in a larger array of meteorological conditions, however the safety of ship manoeuvring is questionable. By realising the alignment changes for the east and west bend the safety can be increased and probably a slight gain in service time of the channel can be realised.

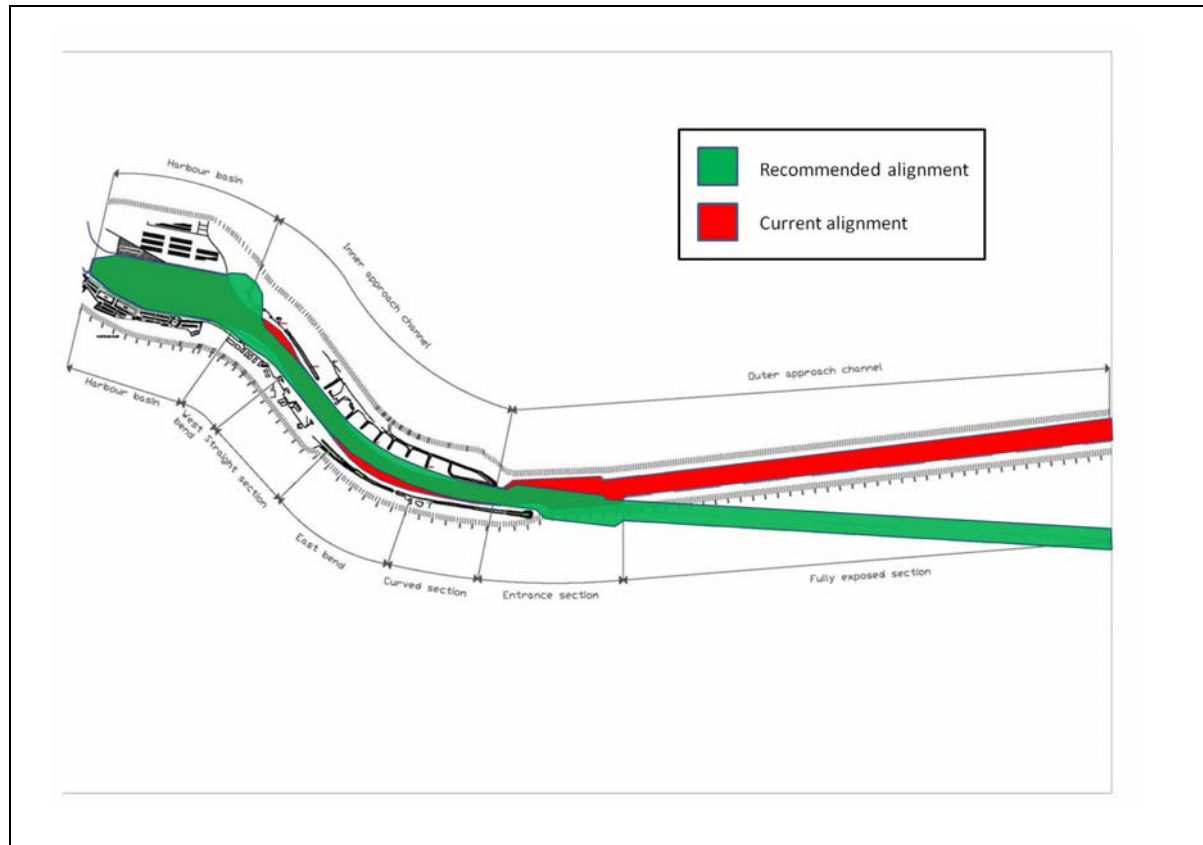

figure 7-1: overview total alignment including suggested alignment changes (green) vs. old alignment (red)

As mentioned before, improving the alignment of the east bend is only useful if the alignment of the outer channel will be changed too. If this is not the case, the effect on the manoeuvrability of a vessel through this bend is negative. This suggested change is expensive, but has a very positive effect on the ship manoeuvring. Additionally, from a construction and commercial point of view, it is convenient that the majority of the implementation of the outer channel's new alignment can be done without disturbing port operations as the current outer channel can be used simultaneously.

The problem concerning the formation of a sandbank can be solved by extending the northern breakwater. In the current situation the by-passing sand can react in the formation of a vortex, which transports sand from the northern adjacent coastline into the access channel. This requires excessive maintenance dredging which can result in high costs. By extending the northern breakwater with ca. 200m this problem can be solved. The costs for the maintenance dredging of this part of the approach channel is included in the annual R\$ 16.2 million spent on maintenance dredging, so it is not known what the actual costs for this section alone are. Therefore it is difficult to give an estimation whether it is beneficial to extend the breakwater or to leave it as it is.

For the suggested alignment for the west bend it is necessary to remove some structures. This alignment change is less expensive than the suggestion for the east bends but has also less positive influence on the safe ship manoeuvring.

8 Sedimentation of harbour basin

8.1 Origin

The Itajaí-Açu river can be divided in three sections, see figure 8-1:overview Itajaí-Açu riverfigure 8-1. Each part has its own characteristics, influencing the sedimentation processes.

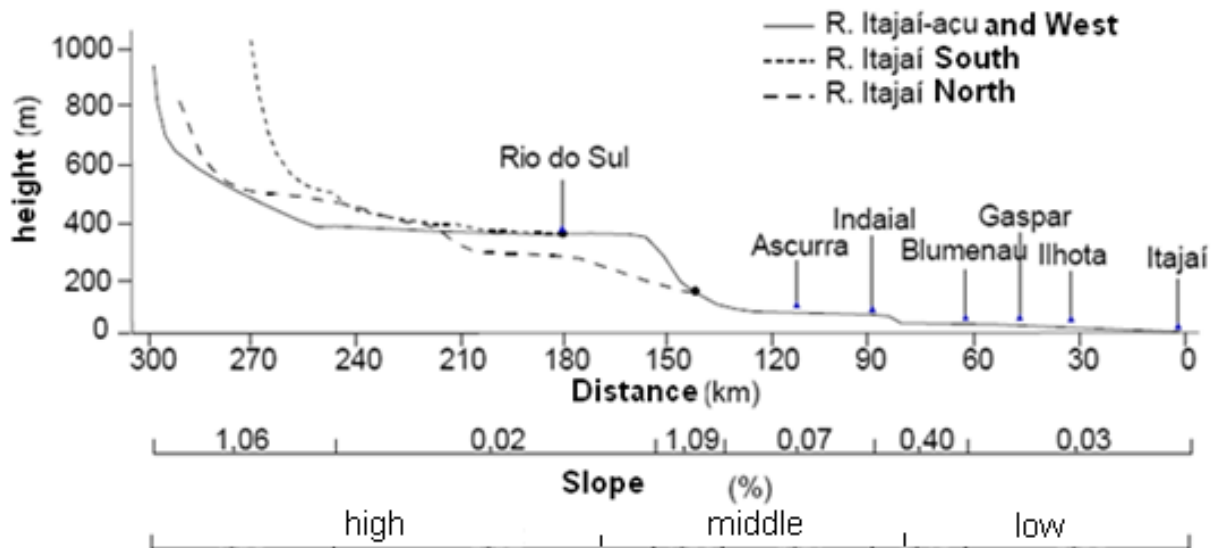

figure 8-1:overview Itajaí-Açu river

- High Itajaí-Açu

The Itajaí- West, -South and - North all flow into the Itajaí-Açu. The West and the South have a relative small eroding power compared with the Itajaí North, due to the low flow velocities. The river Itajaí-North has a bigger flow velocity and a looser riverbed, which results in more erosion.

- Middle Itajaí-Açu

In this part of the valley there is a change in the bottom. Here the river flows over metamorphic rocks of granulite from Santa Catarina. There are several tributaries coming from steep, higher parts. Because of this steepness these rivers have high erosion power and high discharges. A lot of sediment is transported into the Itajaí-Açu.

- Low Itajaí-Açu

The lower valley of the Itajaí-Açu is characterized by rocks, especially gneiss and other metamorphic rocks. In this area the river widens, where there are floodplains and alluvial plains. Here there is a lower flow velocity, so the river transports less sediment. The sediments consist primarily of sand, silt and clay.

The steepest part of the Itajaí-Açu river is between Indaial and Blumenau and has on average the largest production of sediment, as showed in table 8-1. The last decade a number of measurements were made. Measurements of the concentration show that the sediment concentration in Blumenau is much higher than in Indaial. Thus a lot of erosion occurs between these two stations. Other measurements show that the amount of sediment from the Itajaí-Mirim is largely dependent on the discharge; this is less the case for the Itajaí-Açu.

	Sub-basin	Sediment concentration equation [mg/l]	n	Average production of sediment 1980-1989 [ton/ha/year]	Average production of sediment 1990-1999 [ton/ha/year]	Area [km ²]
Brusque	Itajaí-Mirim	$C = 2,9314 * Q - 1,3463$	66	1,21	1,38	1.240
Indaial	Itajaí-Açu	$C = 0,2576 * Q + 12,777$	91	1,45	1,27	11.150
Blumenau	Itajaí-Açu	$C = 0,2452 * Q + 173,59$	24	2,94	3,32	11.800

table 8-1: sediment information (1980-1989)

8.2 Sediment control

At this moment the sediment control is segmented, which means there is no central approach. The Port of Itajaí is controlling the sediment in the harbour itself, the harbour is responsible for the maintenance dredging. There is no cooperation with parties who are controlling the sediment upstream. The sediment control of the harbour is maintained by Van Oord. This company is also responsible for dredging the upstream part of the western border of the harbour basin, which will definitely affect the sedimentation in the harbour basin, see chapter 11.

8.3 Sediment characteristics

In the study of Sistema Capricornius some characteristics of the sediment are found. The points where the samples were taken are known, see appendix Ffigure F-1, but at what depth in the water column they were taken is not clear. According to the study, the sediment contains different elements, such as sand (75,3%), silt (20,4%), clay (4,2%) and gravel (0,1%). The mean diameter of the sediment at the mouth of the river is 0,12mm with a standard deviation of 1,24mm. The density is 1,844g/cm³ with a porosity of 51,6%. Despite the intense activity of sand mining along the estuary, there are no studies to quantify the contribution of sandy sediments and their transport through the estuary to the coastal zone.

In a study performed by Alkyon in 2005, an average diameter for suspended sediment was found of 50 to 70 µm. Using the relation between particle size and settling velocity [Winterwerp, 1999], the median settling velocity is determined between 0,05 to 0,2m/s.

JICA [1989], paragraph 4.6 about floods, found a diameter for the bottom sediment between 0,4 and 1,5mm. This diameter is found in the upstream part of the Itajaí-Açu river. In this study the river will be modeled till 60 km upstream where the same diameter will be used as was found by JICA.

8.4 Dynamic equilibrium

Without human interventions the estuarine system would be in a dynamic equilibrium. The bathymetry would adjust to varying conditions and oscillate around this dynamic equilibrium depth. This is the depth for which the average annual sedimentation is zero. When the natural dynamic equilibrium is disturbed as a result of deepening of the estuary, the system will try to restore itself. This causes sedimentation and maintenance dredging is required to maintain the newly dredged areas. The volume of the required maintenance dredging depends on the extent of the disturbance in relation to the equilibrium situation. A larger deepening will lead to smaller flow velocities and therefore to higher sedimentation rates.

8.5 Transport modes

The sedimentation that occurs in the Itajaí-Açu estuary is a complex ensemble of processes, which is influenced by processes at the boundary conditions. The two most important processes are the tidal fluctuations and river discharge. The concentration of sediment depends on the actual flow of the river, especially for suspended load. During a period of low discharges the sediment concentration is also low and due to the reduced velocities there is little erosion upstream. The relation between discharge and sediment concentration is non-linear. In appendix F, figure F-2 a quadratic relation between discharge and suspended sediment concentration is assumed. When the river discharge is high, the concentration is also high, but due to the high velocities the sedimentation rate is low. The highest rate of sedimentation is found when there is an average river discharge.

A distinction can be made between sedimentation processes that occur in the outer channel and processes that occur in the inner approach channel and harbour basin.

- Outer approach channel

The outer approach channel is dredged out of the sandy seabed. The water depth of the seabed naturally ranges from about 5 m in the harbour access to 12 m at the end of the outer channel.

- Near breakwaters

The sediment characteristics that are found in the approach channel near the breakwaters, the entrance section, agree with those found within the harbour basin. It is likely that the sediments have the same source.

- Fully exposed section

In this part of the outer approach channel sediments are found, which have different characteristics than those found inside the harbour basin. This is a reason to believe that the sediments originate from sediment transported along the shoreline, due to the alongshore current.

- Inner approach channel and harbour basin

Transport modes in this part of the river delta are caused by four mechanisms.

- Fluctuations of the water level due to the tide

Due to the presence of tide at sea there is a fluctuation of the water level in the harbour. The amount of water that flows in and out of the harbour can be calculated by multiplying the water level fluctuation with the wet area. This process mainly takes place in the inner approach channel.

- Horizontal vortices due to the tide

When the horizontal tide flows into the harbour, a vortex is formed. Due to this vortex, the relatively clean water from inside the turning basin and berths is exchanged for water from the outside. The amount of water exchange depends on the flow rate and the layout of the delta. This process mainly takes place in the inner approach channel.

- Currents induced by density difference

There is also an exchange of water due to the density difference between the water in- and outside the harbour. Salt water is denser than fresh water and a salt tongue is formed. On the interface mixing takes place, for which the amount of mixing depends on the mixing factor f_M . The figure F-3 in appendix F gives a schematic overview of the forces and mixing process that occurs due to the density difference.

- River flow

Fresh water, which can contain large concentrations of sediment, flows continuously through the turning basin and berths. The flow varies between almost zero to more than 1000 m³/s. During a medium flow rate deposition of sediments occurs in the harbour basin.

The figure 8-2 gives an overview of the processes that occur and influence the water exchange in the harbour basin.

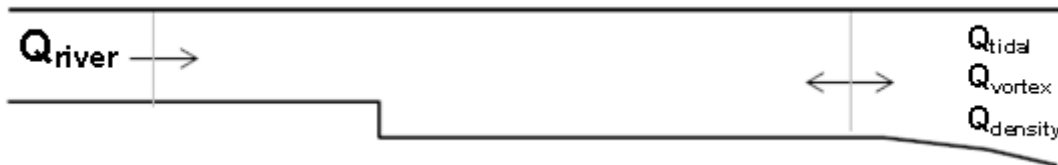

figure 8-2: transport modes in harbour basin

8.6 Sedimentation

As a result of the different transport in the harbour basin a lot of sediment passes the harbour basin and approach channel. Within the harbour basin the flow velocities are reduced because of the larger cross-section and the wave conditions are weak, causing a partly deposition of the suspended sediments. The amount of deposition depends on the amount of water exchanged and the amount of sediment this water contains.

$$\text{deposition of sediments} = \alpha * V * c$$

α = dimensionless factor not depending on fall speed, flow parameters and geometry [-]

V = volume of water exchange [m³/s]

c = sediment concentration in water [kg/m³]

In March 2010 Hidrotopo made a number of calculations with this conceptual model for several river flows in a range between 100 and 840 m³/s. The goal of this study was to determine the contribution of each mechanism to the total sedimentation rate. Concluded was that the exchange of water due to density difference and due to horizontal vortex are small compared to the contributions of tide and river flow. This is because of the fact processes due to density difference and horizontal vortex mainly takes place near the entrance and less around the harbour basin. Tide and river flow are the two most important processes to obtain when estimating the impact of deepening the approach channel and the harbour basin on the sedimentation rate. In table 8-2 there is an overview given for which situation the tide is dominant and for which situations the river is dominant.

Tide influence	River influence
Lower river discharge ($Q < 200 \text{ m}^3/\text{s}$)	High river discharge ($Q > 1000 \text{ m}^3/\text{s}$)
Low suspended solid discharge ($< 10 \text{ ton/day}$)	High suspended solid discharge ($> 10.000 \text{ ton/day}$)
High conservation rate of sediment	Low conservation rate of sediment
Erosion and deposition during spring tide peaks	Strong erosion of independent phase of the tide
Residual transport of sediment upstream	Parallel transport downstream
Import of sediment from the inner shelf and decrease in the volume estuarine	Export of sediment to the inner shelf and volume increase estuarine

table 8-2: river – tide influence dominant

8.7 Sedimentation studies

Hidrotopo preformed a study in 2010 on the amount of sedimentation as a result of dredging the depth of the approach channel and harbour basin till 14m. 4 methods are used to determine the amount.

- method 1 & 2

These methods are based on Eysink-Vermaas. Eysink-Vermaas is used for predicting sedimentation rates in dredged channels and basins in an estuarine environment. It is a formula for a slow decline of suspended transport (by a drop of vertical concentration) above a sand fall. The question whether erosion or sedimentation may be expected in a dredged channel can only be judged by comparing the total sediment influx into the channel with the sediment outflux capacity. Sedimentation in the formula of Eysink-Vermaas is mostly caused by the transport capacity. The differences in flow speed are very important.

- method 1

An insight into the effect of dredging the harbour basin from -12m till -14 m is achieved. In this model a constant flow and a constant width of the channel is assumed.

- method 2

A more detailed approach of the deepening form -12m to -14m. The tidal differences and the different widths of the channel are taken into account. The differences in flow speed are caused by the geometry

of the channel. So this more detailed model gives more accurate information of the expected new situation. An increase of sedimentation of approximately 25% is expected.

- method 3

This method is based on extrapolating previous studies and historic data. Both a linear and an exponential extrapolation are made.

- method 4

A less accurate method to determine the effect of deepening the channel is to determine the relation between the amount of sediment and the volume of the dredging cut, based on experience. The ratio between the deepening dredging of the harbour and the maintenance dredging of the harbour is calculated. The increased volume of cut for the channel from 14,0 m depth is approximately 28% of the volume of cut for channel from 12,0 m depth. Therefore, the increased sedimentation the channel depth is also 28%.

The four methods above provide a description of the amount of sedimentation as it will occur in the basin and the channel of the harbour itself after the deepening up to -14m. Method 1 and Method 2 provide probably the most accurate data. However, the new upstream depth (from the harbour up to 9.5 km upstream) is not taken into account. Methods 3 & 4 are not very accurate methods, because of the use of a very simple approach; these serve only as a first indication.

8.8 Sedimentation modelling

To gain insight in the total system, hand calculations and a 1D-model are made. The hand calculations are made to determine the effect of a number of human interventions on the Itajaí-Açu river, both existing and planned interventions. In order to make the calculations the situation is simplified and the values that are used are average, constant values.

With the 1D-modelling software, SOBEK, the effects of the planned dredging are determined. The 1D-model gives insight in the sedimentation processes and the effect the interventions have on the dredging program of the harbour. However, the model that will be used is a simple 1D-model and therefore the results will give an indication of the expected sedimentation rates rather than real hard quantified numbers that can be directly implemented in a technical solution.

9 Hand calculations

Over the years different human interventions have taken place in the Itajaí-Açu river. The river is widened and deepened to expand the harbour and receive larger vessels. Each intervention leads to a new equilibrium situation for the river on the long term.

It is important to know the effect of each of these human interventions on the river because of the influence it has on the amount of sedimentation in the harbour basin. Although the lower part of the river is a very complex environment with the influence of the tide, in this first calculation, the river is approached as a 1D-river, with a uniform and stationary flow. In these hand calculations the Itajaí-Açu river is schematized as a straight canal with a shallow, rectangular cross-sections. In this case the steady flow, which has a mean value over the depth of the canal, can be described by the continuity equation and the equation of motion.

In a simplified composition of the reality the most important interventions are mentioned and the effects are worked out. Due to simplification certain processes are neglected, for example the salt wedge, cohesive behaviour of sediments, bank erosion and tributaries are not taken into account. The values that are used for the calculations are average values. So for example discharge, bed roughness, and the width of the river over certain distances will not fluctuate.

9.1 Calculation method

To describe and to make hand calculations of a shallow channel with rectangular cross sections, there is a continuity equation and an equation of motion required in the x-direction. Also a transport capacity formula is needed. In the calculations below the transport capacity formula of Engelund and Hansen is applied (see appendix G.2 and G.3). To calculate the water profiles the theory of Bélanger is used. The approach of Bresse is applied to calculate the distortions in the backwater curve.

The continuity equation is expressed as:

$$\frac{d(uh)}{dx} = 0$$

and the momentum equation in x-direction is expressed as:

$$u \frac{du}{dx} = g i_b - g \frac{dh}{dx} - \frac{g}{C^2} \frac{u^2}{h}$$

Based on the critical depth (Fr=1)

$$h_g = \left(\frac{q^2}{g} \right)^{1/3}$$

and the equilibrium depth by Chézy,

$$h_e = \left(\frac{q^2}{C^2 i_b} \right)^{1/3}$$

these equations are used for deriving the formula of Bélanger. For small Froude numbers, this formula has the following formulation:

$$\frac{dh}{dx} = i_b \left[\frac{h_e^3}{h^3} \right]$$

By Bresse there is a method derived, making use of halving the distortions in the backwater curve, to determine the water depths:

$$h = h_e + (h_b - h_e) \left(\frac{1}{2} \right)^{\frac{-x_d - x_b}{L_{1/2}}}$$

with $L_{1/2}$ · $L_{1/2}$ is 'half-length'

$$L_{1/2} = \frac{0.24h_e}{i_b} \left(\frac{h_b}{h_e} \right)^{4/3}$$

The above formulas form a guideline for the calculation of a certain area of interest. The water depths on different places in a river can be calculated.

9.2 Topography

The effects of the different human interventions, resulting in four different topographies, are compared: the original situation without human interventions; the current situation where the harbour is dredged; future situation 1 with deepening dredging upstream and finally the situation where there has been deepening dredging upstream and deepening dredging of the harbour, future situation 2. See table 9-1 and figure 9-1. table 9-1: overview human interventions

	Approach channel	Harbour basin	Upstream harbour basin - Br101
Original situation	-	-	-
Current situation	deepening dredging till 12m	deepening dredging till 12m	-
	maintenance dredging till 12m	maintenance dredging till 12m widening	
Future 1	deepening dredging till 12m	deepening dredging till 12m	deepening dredging
	maintenance dredging till 12m	maintenance dredging till 12m widening	maintenance dredging
Future 2	deepening dredging till 14m	deepening dredging till 14m	deepening dredging
	maintenance dredging till 14m	maintenance dredging till 14m widening	maintenance dredging

table 9-1: overview human interventions

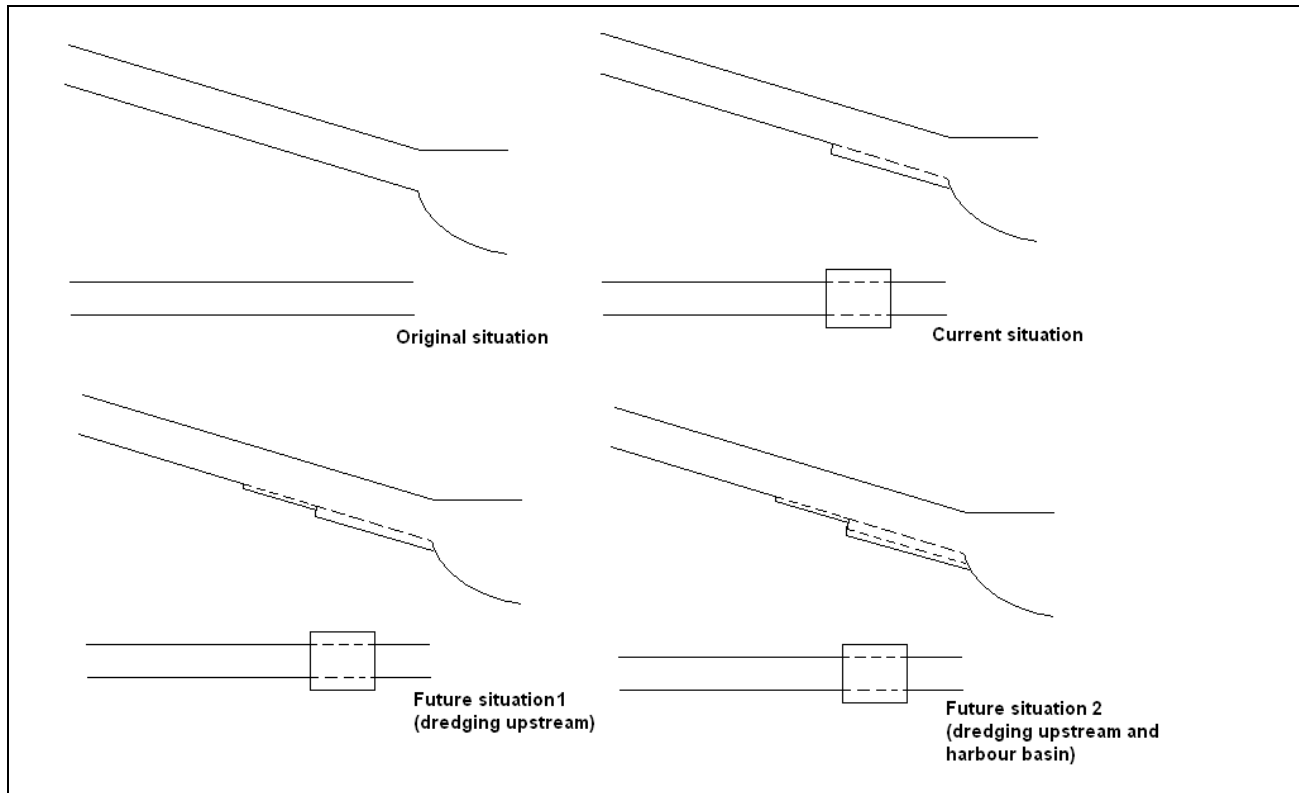

figure 9-1: overview of human interventions on the Itajaí-Açu river

9.3 Results

For the calculations only the part of the Itajaí-Açu river between Blumenau to the mouth of the river is considered. Blumenau is chosen as boundary because upstream of Blumenau a part of the river has a slope of 0.0022 m/m, which creates a supercritical flow ($Fr > 1$). Therefore it is impossible to make hand calculation upstream Blumenau.

The mean sea level is at +0.6 CD. In the calculations the tide is neglected and this value is assumed to be a constant value in the four different situations. In the calculations there are three interventions that are used one or more times. These interventions are deepening dredging, maintenance dredging and the widening of the river.

- Deepening dredging

Deepening dredging is a temporary intervention, after some time the river will turn back to its original situation.

- Maintenance dredging

Maintenance dredging ensures that the created situation becomes a permanent change in the river. Maintenance dredging is the extraction of sediments from the river. In this way the maintenance dredging causes a less steep slope of the river bed in the river downstream from this point. It also causes a bed step at the riverbed at the point where the sediments are extracted from the river.

- Widening of the river

The widening of the river influences the riverbed. Due to the widening the flow velocity decreases, which results in the settling of more sediment, causing sedimentation in the widened part of the river. Because of this sedimentation the riverbed rises locally and a bed step in the river is formed. The widening of the river is a local intervention, it causes an increase of the local bed-slope for the widened part of the river.

For a general description of each of these interventions for a general river, see also appendix G. The changes for the river that could be expected (on the short and on the long term) are shown.

- Dredging

It is important to understand that, to make these calculations, the amount of sediment extraction had to be estimated. From the Van Oord reports the amount of sedimentation in the harbour basin is known. Because of the strong schematisation and the neglecting of local processes a much smaller sedimentation will be found by these hand calculations. A factor 3.25 less than in the reality is found. This factor will also be applied on the future situations. At this moment the sedimentation rates in future situations are not know. The amount of maintenance dredging is roughly estimated for these parts of the calculation. In further research this value will get a more founded/realistic value.

- Bed-step

Due to a certain intervention in the river system, locally some characteristics of a river will change. These interventions can also have a global effect over a certain distance of the river. Over this distance the river bed can for example go up or down. In this way, an intervention can cause a bed-step of the river bottom. In these calculations different bed-steps are presented. The bed-steps are presented very abrupt. In reality the bed-steps won't be so abrupt. Probably the transition will be spread more over a certain distance.

- The original situation

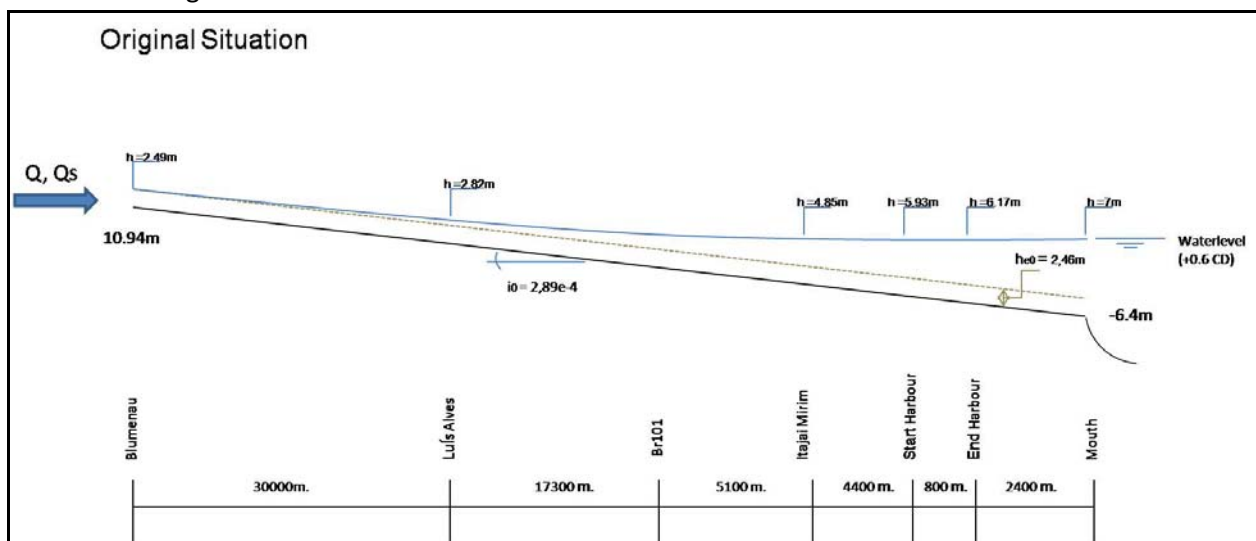

figure 9-2: original situation, no interventions

In the original situation, before human intervention, the mouth of the river had a depth of around 7m. There is a backwater curve, from the mouth of the river going to the equilibrium depth h_e further upstream. In Blumenau the depth of the river is almost equal to the equilibrium depth.

o Current situation

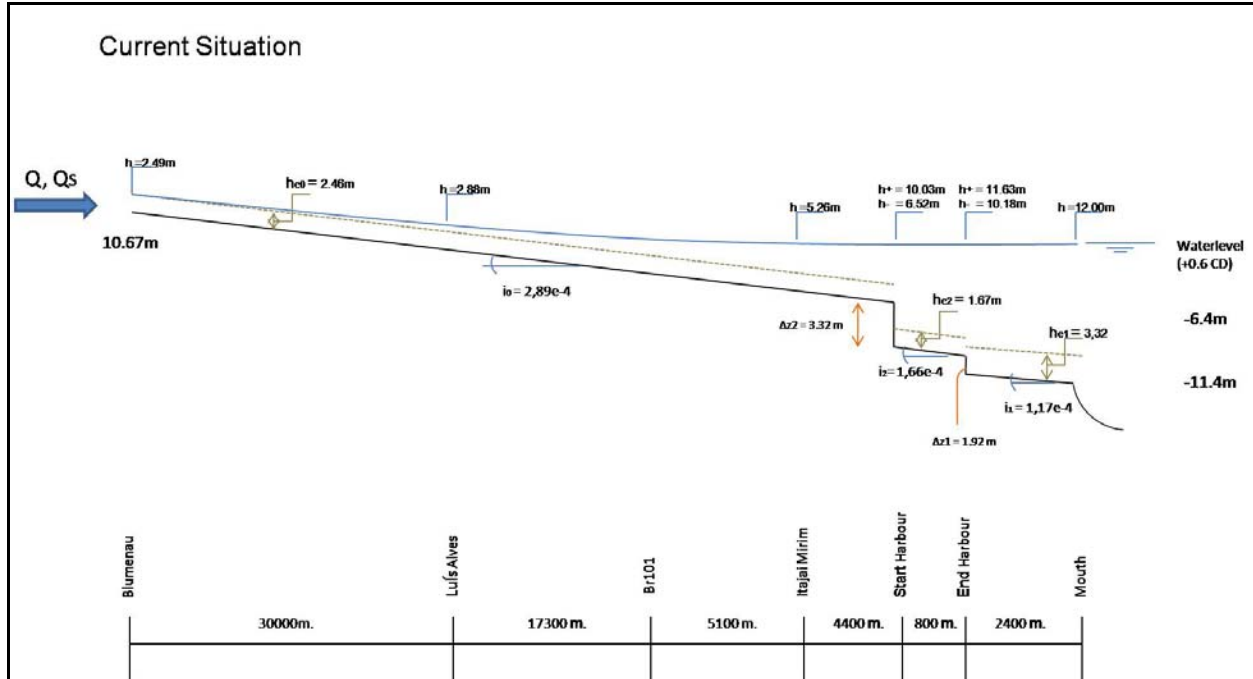

figure 9-3: current situation; deepening, maintenance dredging and widening of harbour area

Three important human interventions were implemented in order to change the original situation of the river to the current situation of the river Itajaí-Açu:

1. *deepening dredging from the mouth of the river up to the harbour basin*

2. *maintenance dredging from the mouth of the river up to the harbour basin*

In this situation this process starts at the start of the harbour basin. In this way the maintenance dredging causes a less steep slope of the river bed in the river downstream from this point. It also causes a bed step at the riverbed at the start of the harbour.

3. *widening of the river in the harbour basin*

The widening of the river is done to create space for the turning circle.

In the calculations there is chosen to apply first the deepening and the maintenance dredging and after that the widening of the river is applied. As explained, as a result of the widening, the river-bed goes up locally. The river-bed-step Δz_1 is formed, at the end of the harbour basin. The widening of the river is a local intervention, which causes an increase of the local bed-slope for the widened part of the river, the harbour basin. This results in the final bed step at the start of the harbour: Δz_2 . Δz_2 is actually a combination of the bed step that is formed by the maintenance dredging, the rise of the river bed caused by the local widening of the river and the increased bed slope in the widened part of the river.

The deepening of the river from the mouth of the river to the more upstream point, the start of the harbour basin, results in bigger water depths in this part of the river. Naturally the river will show a backwater curve from the mouth of the river to the upstream part. Far upstream the river will approach the equilibrium depth. From the mouth of the river going upstream the water depth will decrease. In the figure 9-4 the depth of the river is shown at different places.

The interventions from the mouth of the river up to the start of the harbour resulted in a change of the local slope and the local equilibrium depth. Upstream, from the start of the harbour up to Blumenau the values of the slope and of the equilibrium depth didn't change. The occurring water depth increased a little bit. Further on, upstream from the start of the harbour up to Blumenau, the whole river bed is lowered with $10.94 - 10.67 = 0.27$ meters. This is caused by the fact that the riverbed in the downstream harbour area shows less steep slopes than in the original situation.

- Future situation 1

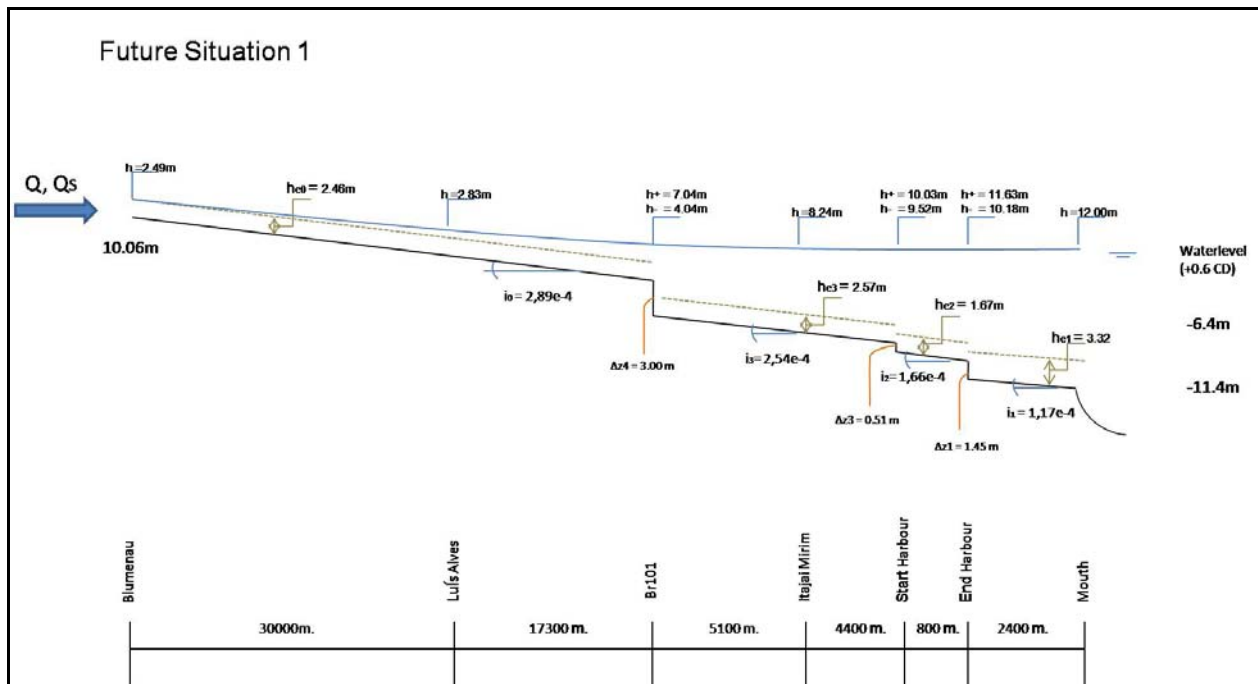

figure 9-4: future situation 1; deepening and maintenance dredging upstream

At this moment an upstream part of the river is being dredged over a length of 9,5km. This results in future situation 1:

1. *upstream deepening dredging from the start of the harbour to about the highway Br101*



figure 9-5: overview

2. *upstream maintenance dredging from the start of the harbour to about the highway Br101*

The maintenance dredging is approached as the extraction of sediments in the river at the bridge of the Br101 highway. In this way the maintenance dredging causes a less steep slope of the river bed in the river downstream from this point. It also causes a bed step at the riverbed at Br101: Δz_4 . In the picture also bed step Δz_3 is shown. This bed step is quite small compared with bed step Δz_2 in the current situation. This is because of the deepening dredging of 3m of the upstream part from the start of the harbour.

The deepening of the river upstream will take out a part of the amount of sediment that is transported by the river flow. Because of this, in the harbour basin and in the inner approach channel there will settle down less sediment. In this calculation the configuration of the harbour area did not change, because the maintenance dredging in the harbour area is adjusted to the new situation. Also the water depths in this part of the river did not change as can be seen in the figure 9-4. In this part of the river also the slope and the equilibrium depth didn't change.

The deepening of the river from the start of the harbour to the more upstream point at Br101 results in bigger water depths in this part of the river. It results in changes of the local slopes and the local equilibrium depth.

Upstream from Br101 up to Blumenau the values of the slope and of the equilibrium depth did not change. The occurring water depth decreased a little bit. Further upstream the river will approach the equilibrium depth. In figure 9-4, the depth of the river is shown at different places.

From Br101 up to Blumenau, the whole river bed is lowered with $10.94 - 10.06 = 0.88$ meters compared with the original situation. Compared with the current situation the riverbed will be lowered with about $10.20 - 10.06 = 0.14$ m. This is caused by the fact that the riverbed in the dredged area will show less steep slopes and by the fact that the riverbed in the new deepened upstream river area also shows less steep slopes.

In the search for the sediment control in the harbour, this human intervention is an important one. This intervention can be implemented as a sand trap. The harbour should take advantage of it. For general information about a sand trap, see appendix G.4.

There is an important note according this possible sand trap. Normally the river bed is just lowered over some distance to create a sand trap:

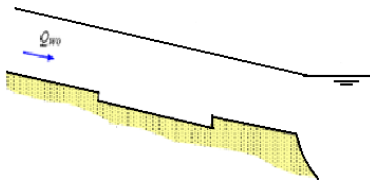

figure 9-6: schematized sand trap

After the sand trap the riverbed will go up again. In the case of the Itajaí-Açu the 'sand trap' has a little different configuration. At the end of the 'sand trap' the riverbed doesn't go up, because the end of the sand trap is located at the start of the harbour basin. At the start of the harbour basin the bed-level of the river will go down instead of going up. There has to be figured out what consequences this has for the sand trap and possible measures to maintain the sand trap function. With higher discharges, the bed-load transport is generated more easily, because it is not blocked at the downstream point.

○ Future situation 2

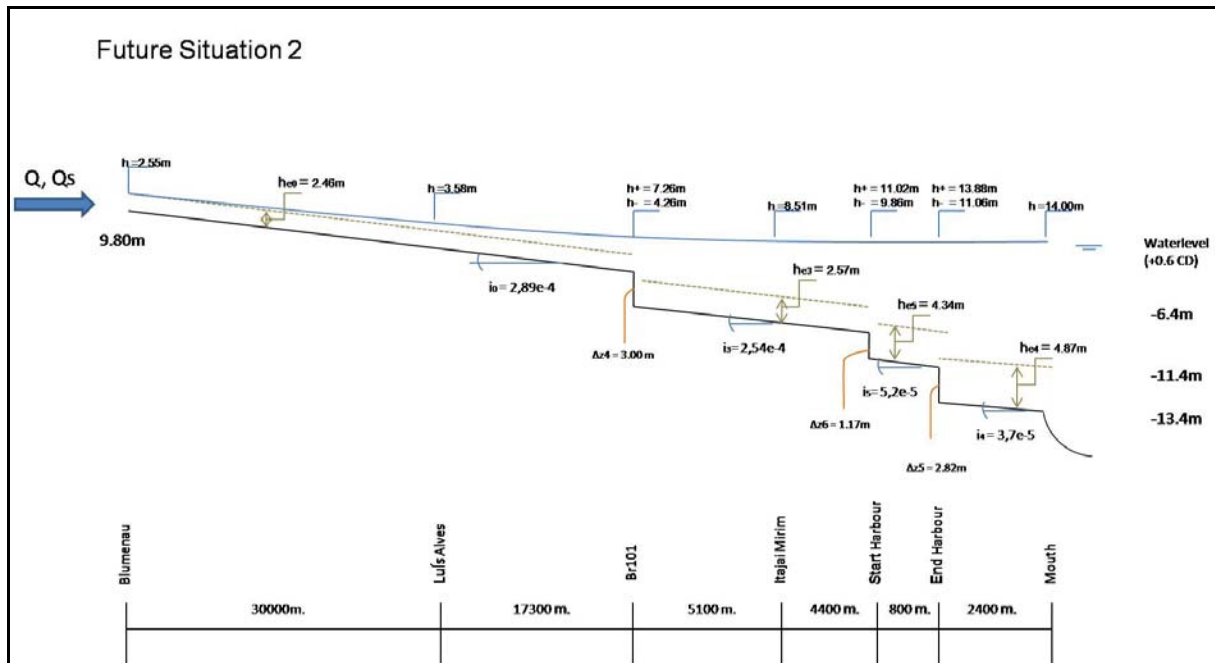

figure 9-7: future situation 2; deepening and maintenance dredging of harbour area

To arrive at the future situation 2, two important human interventions have to be implemented:

1. *Deepening dredging from the start of the harbour to the mouth of the river up to 14m. Water depth*
2. *Maintenance dredging from the start of the harbour up to the mouth of the river to keep the new configuration*

The maintenance dredging causes a less steep slope of the river bed in the river downstream from this point. It also causes a bed step at the riverbed at the start of the harbour: Δz_6 . Bed step Δz_6 is actually a combination of the bed step that is formed by the maintenance dredging, the rise of the river bed caused by the local widening of the river and the increased bed slope in the widened part of the river.

The deepening of the river from the start of the harbour to the mouth of the river results in bigger water depths in this part of the river. In figure 9-7, the depth of the river is shown at the different locations. In future situation 2 the depth of the harbour basin and the river downstream is increased. The interventions from the mouth of the river up to the start of the harbour resulted in a change of the local slope and the local equilibrium depth.

From the start of the harbour up to Blumenau the values of the different slopes and of the equilibrium depth didn't change. The occurring water depth upstream increased a little. Further upstream the river will approach the equilibrium depth.

From Br101 up to Blumenau, the whole river bed is lowered with $10.94 - 9.80 = 1.14$ meters compared to the original situation. Compared to the current situation the riverbed will be lowered with about $10.20 - 9.80 = 0.40$ m. Compared to the future situation $10.06 - 9.80 = 0.26$ m the riverbed will be lowered with about $10.20 - 9.80 = 0.40$ m. This is caused by the fact that the riverbed in the dredged area will show less steep slopes than before.

9.4 Summarizing

Bed Step [m]	End Harbour	Start Harbour	Br101
	x=2400	x=3200	x=12700
original situation	-	-	-
current situation	$\Delta z_1=1,92$	$\Delta z_2=3,04$	-
future situation 1	$\Delta z_1=1,92$	$\Delta z_3=0,51$	$\Delta z_4=3,00$
future situation 2	$\Delta z_5=2,82$	$\Delta z_6=1,17$	$\Delta z_4=3,00$

table 9-2: calculated steps in bed level

Equilibrium Depth [m]	Mouth River - End Harbour	End Harbour - Start Harbour	Start Harbour - Br101	Br101 - Blumenau
	x=0 - x=2400	x=2400 - x=3200	x=3200 - x=12700	x=12700 - x=60000
original situation	2,46	2,46	2,46	2,46
current situation	3,32	1,67	2,46	2,46
future situation 1	3,32	1,67	2,57	2,46
future situation 2	4,87	4,34	2,57	2,46

table 9-3: calculated equilibrium depth

Bed Slope [m/m]	Mouth River - End Harbour	End Harbour - Start Harbour	Start Harbour - Br101	Br101 - Blumenau
	x=0 - x=2400	x=2400 - x=3200	x=3200 - x=12700	x=12700 - x=60000
original situation	0,000289	0,000289	0,000289	0,000289
current situation	0,000117	0,000166	0,000289	0,000289
future situation 1	0,000117	0,000166	0,000254	0,000289
future situation 2	0,000037	0,000052	0,000254	0,000289

table 9-4: calculated bed slope

Reference Level River Bed [m]	Mouth River	Blumenau
	x=0	x=60000
original situation	-6,40	10,94
current situation	-11,40	10,67
future situation 1	-11,40	10,06
future situation 2	-13,40	9,80

table 9-5: calculated reference level river bed

These calculations give a general idea of the expected changes; it gives insight in certain processes and can be used as a starting point for further research. The values that are calculated should not be seen as hard values. Therefore more detailed calculation in a 1D-, 2D- or 3D-numerical model is needed. In this study also a 1D-model is made in SOBEK. Processes as tide and salt intrusion are (partly) taken into account by this numerical program. The calculated dimensions and values shown here will be calibrated in SOBEK, so more can be said about the reality of certain results that are shown in these calculations.

10 SOBEK

The goal of this study is to give a general idea of the consequences that deepening of the river has on the sedimentation in the harbour basin. A 1D-model will be used because it is easy to apply, gives good results for tide levels, discharges and long term morphology. The disadvantages of this kind of model are: poor results for local currents and a lack of information on lateral morphology. So far, for a first estimation a 1D-model is a good choice, but for further studies a 3D-model is highly recommended.

SOBEK is the name of a highly sophisticated software package, which in technical terms is a one-dimensional open-channel dynamic numerical modelling system, equipped with the user shell and which is capable of solving the equations that describe unsteady water flow, salt intrusion, sediment transport, morphology and water quality. In less technical terms SOBEK can be described as a flexible, powerful and reliable tool to simulate and solve problems in river management, flood protection, design of canals, irrigation systems, water quality, navigation and dredging. For this study SOBEK-RE was used, a program which can model 1D-flows in estuaries. Morphology changes can be monitored with this program.

10.1 Initial situation

The most reliable results would be generated by modelling the entire wet system including all the features of the Itajaí-Açu river in reality. However, this is not possible in a 1D-model and also not necessary for the goal of this study. So simplifications are needed. Some of these simplifications are described below:

- Length

A simplification in the modelled length of the Itajaí-Açu river is made because upstream of Blumenau (26 km. from Blumenau) a part of the river has a slope of 0.0022 m/m, which creates a supercritical flow ($Fr > 1$). It is not possible to model supercritical flows in SOBEK. So the river is modelled till 60 km upstream (mouth of the river till Blumenau).

- Bends

The Itajaí-Açu river is meandering and therefore contains a lot of bends. For simplification reasons the model contains no bends.

- Cross-sections

In reality the cross-section of the river varies continuously, especially in width. For simplification reasons the model contains only three different cross-sections, with a rectangular shape. The river upstream till the harbour basin has a constant cross-section with a width of 200 m. The harbour basin has a width of 355 m and the approach channel has a width of 150 m.

- Bed level

The bed levels of the approach channel and harbour basin are measured on a regular basis by the navy. The average slope can be calculated with those numbers, $1,0 \cdot 10^{-4}$ m/m. In the current situation the river upstream is not dredged and therefore there is a step in the bed level. Upstream of this step the bed levels are measured so the bed level can be determined; the step in the bed level as a result of downstream dredging is 5 m. Upstream this bed step a slope of the river of $2,89 \cdot 10^{-4}$ m/m is assumed.

- Upstream boundary condition

The discharges of the Itajaí-Açu river is measured at Indaial. As mentioned before, in chapter 4, the discharges at the mouth of the river are about 40% higher. This increase is the result of some tributaries debouching in the main river. The average discharges of the largest of these rivers, the Alves and Mirim are known, and implemented in the model. The upstream boundary condition is a discharge and is set at $270 \text{ m}^3/\text{s}$, which is the average discharge of the Itajaí-Açu, measured at Indaial.

Upstream there is also a sediment load entering the river and this value is based on measurements.

- Downstream boundary condition

At the downstream boundary the river flows into the sea, so the downstream boundary is a water level variation as a result of the tide. Mean sea level is set 0,6m above chart datum. The period of the tide is M2-tide, so a period of 12 hours and 25 minutes. The amplitude of spring tide is 0,4 m with a phase of $6,28 \text{ rad/s}$. This results in a frequency of $1,406 \cdot 10^{-4} \text{ m}^{-1}$. The sediment load entering the river downstream is assumed to be the half of the value upstream based on assumptions Alkyon made in their studies. The salt concentration is assumed to be $34,15 \text{ kg/m}^3$. The length of salt intrusion set at 60000m because the effects of the tide, and thus the backwater curve is noticeable till Blumenau (see paragraph 5.5). After comparing the results of model runs with and without tide, there was no significant difference. This is probably due to the fact a water level elevation is given as boundary condition, and not a discharge in and out of the estuary (it is not possible to use discharges as both upstream and downstream boundary condition due to the computational numerical methods the program uses). Because no differences were found, for computation time reasons, the tide boundary is left out in the final runs.

- Tributary

In the model two tributaries enter the main river. The average discharge of the Alves and the Mirim are known from measurements. The sediment load of the Mirim is known but not the load of the Alves. In the model it is assumed that the load of the Alves is the half of the sediment load of the Mirim.

- Dredging

To keep the bed level of the approach channel and the harbour basin at the desired depth maintenance dredging is required. The amount of sediment that is dredged is known from Van Oord data. Because the model is a very simplified image of the reality the amount of sediment that enters the harbour basin and approach channel can be different than in reality. It is possible that the amount of sediment will be changed after calibration.

10.2 Calibration

The calibration of the model is based on the assumption that the initial bed levels will not change in time, there is a sediment balance. Due to simplification the sedimentation in the model is different than in reality. Different input values are examined and adjusted in order to get a somewhat constant bed level profile over the length of the river. As the values are much different than the usual values of European rivers and the uncertainty is great, SOBEK had many difficulties finding an equilibrium situation. Therefore the bed level will appear to be not stable in the final results, which is of course taken into account in the conclusions.

- Time and grid

The computation time step is taken as 12:00 hours. For stability and accuracy reasons the computation grid distance has a value of 100 m. The total run time is 50 years, allowing enough time for the system to reach a somewhat steady situation.

- Dredging

As stated before the sedimentation of the harbour basin is different than the sedimentation that occurs in reality, due to simplification. Therefore the amount of dredged material is different. The bed level of the harbour basin is somewhat stable, for the 50 years run time with a dredge value of $2,9 \cdot 10^{-5} \text{ m}^2/\text{s}$. The bed level of the inner approach channel is somewhat stable with a value of $3 \cdot 10^{-8} \text{ m}^2/\text{s}$.

10.3 Topography

In the final model, the runs of four different topographies are compared: the current topography (figure 10-1), the current topography upstream with deepening dredging in the harbour (figure 10-2), the current topography of the harbour with deepening dredging upstream (figure 10-3) and finally the situation where there has been deepening dredging upstream and deepening dredging of the harbour (figure 10-4). These model runs with individual topographies will further be referred to as respectively run 1, run 2, run 3 and run 4. In all these runs the amount of maintenance dredging is constant, so the effect of the changed topography on the sedimentation can easily be compared. The schematizations of the different topographies are shown below (not on scale).

Prefeasibility report for the Port of Itajaí

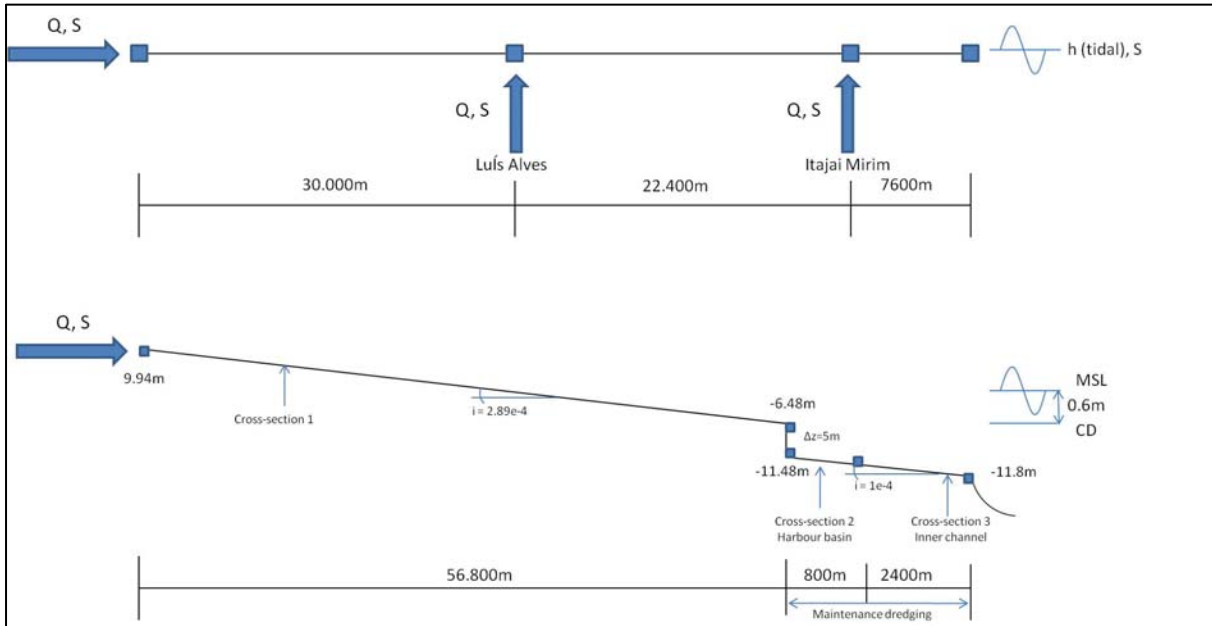

figure 10-1: current topography

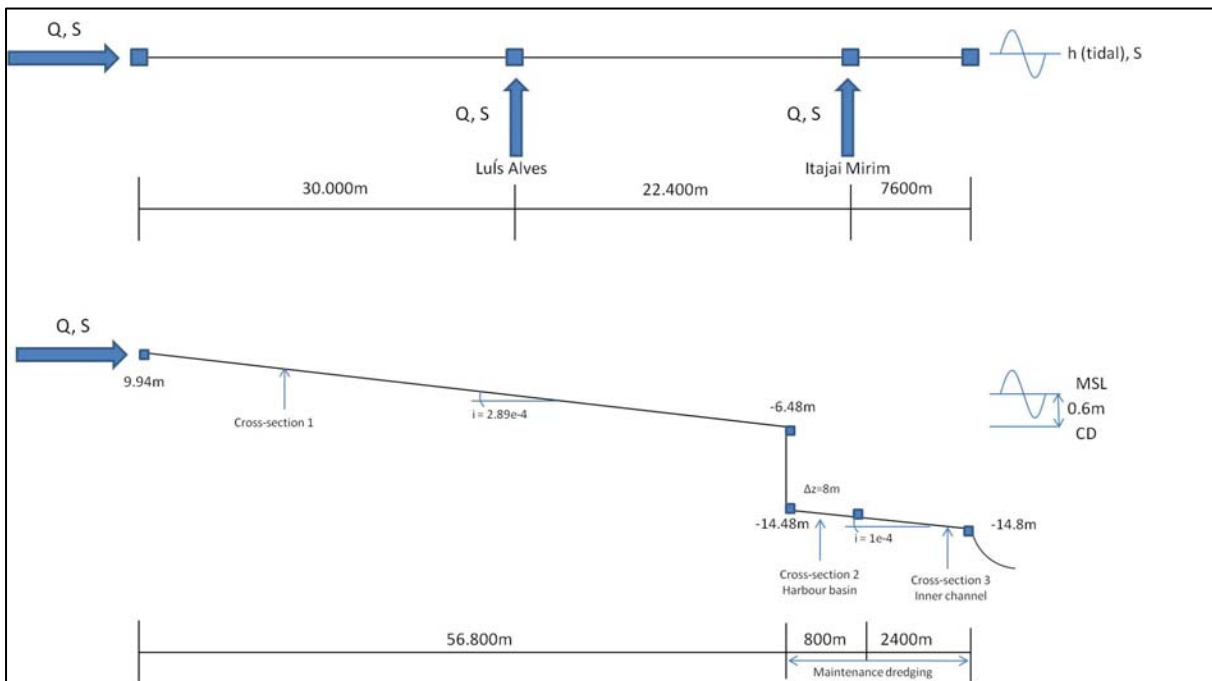

figure 10-2: deepening dredging harbour

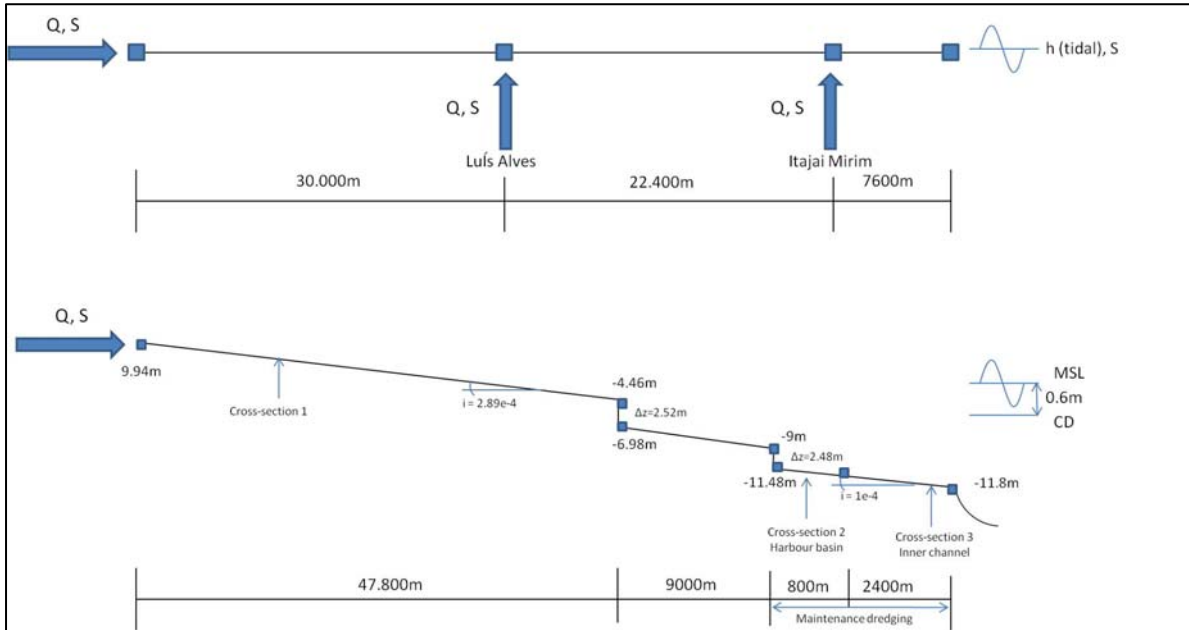

figure 10-3: deepening dredging upstream

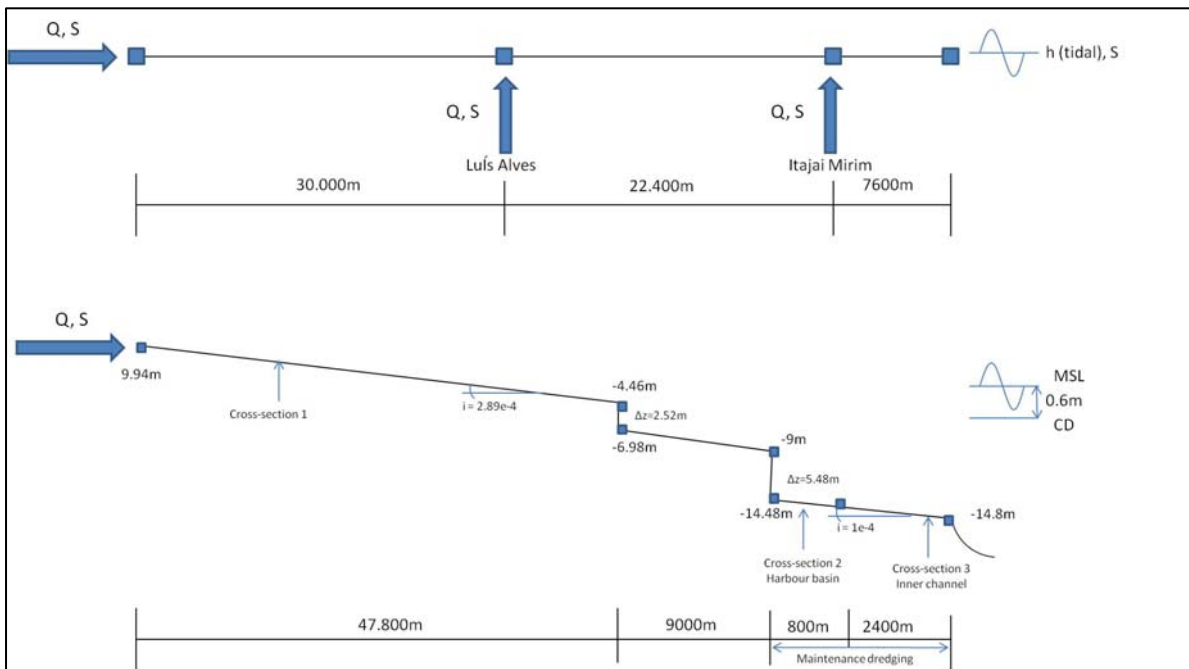

figure 10-4: deepening dredging harbour and upstream

10.4 Results

In the results of the model runs, it can be seen that the bed level upstream isn't stable in the 50 years of computation time as would be expected. This is probably because the program cannot cope with the imposed variables, and hence does not reach a stable situation with these variables. However, after calibration, this is the closest it comes to a stable situation and thus this difference with respect to the reality has to be taken into account when making calculations and drawing conclusions. Also, regardless of the amount of maintenance dredging in the harbour basin, it can be seen that there occurs sedimentation on the transition from the upstream part (having cross section 1) and the harbour basin (having cross section 2). This sedimentation occurs probably due to the abrupt change in depth and width. In reality this bar does not have the chance to develop because of the maintenance dredging of the harbour basin and approach channel. In the calculations this extra sedimentation will be taken into account. The evolution of the bed level upstream and the development of the bar over the first four years of the simulation are shown in figure 10-5.

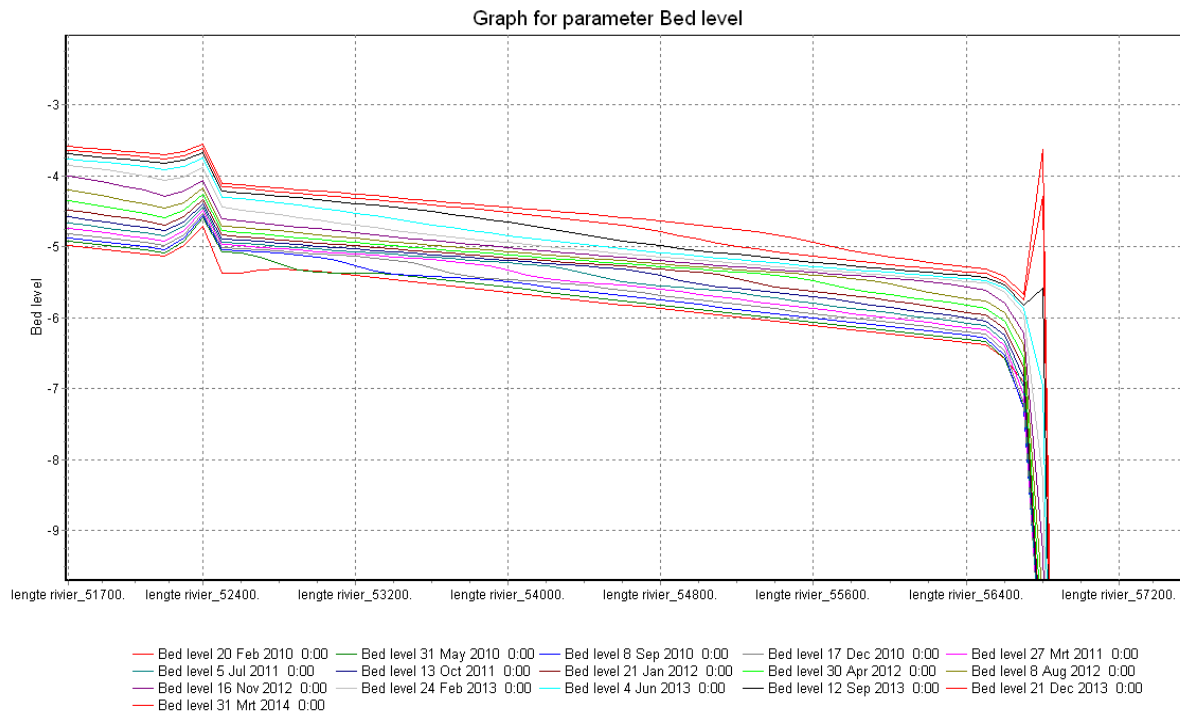

figure 10-5: bed level 2010 till 2014, location x = 51700m till 57200m

The total results of the 50 years model runs are shown in appendix I. The shown sediment volumes in the tables are calculated by computing the area of the sedimentation in the harbour basin and multiplying this with the corresponding width. One has to understand these are only indicators; it gives an order of magnitude of the sedimentation and cannot be taken as the truth, due to the many simplifications made.

In the results of run 1 (appendix I, figure I-1, figure I-2 and table I-1) it can be seen that there is a great deal of sedimentation in the harbour basin. The sedimentation volume of the bar and in the harbour

basin created in 50 years is $3.081.845 \text{ m}^3$. In the model maintenance dredging is implemented. Without this process the total sedimentation volume would be ca. $48.473.775 \text{ m}^3$ for the total run of 50 years. This amounts to a sedimentation rate of $969.475,5 \text{ m}^3$ per year. The current maintenance dredging program of Van Oord removes an annual volume of approximately 2 million cubic meters of sediment (see chapter 11).

The results of the model should correspond herewith, but differ with a factor 2. It is however fairly acceptable as this can once more be ascribed to the simplifications made, the uncertainty of some variables and the limitations of the software to implement certain physical processes. This factor 2 should be kept in mind with all of the following model run results.

Run 2's results (appendix I, figure I-3, figure I-4 and table I-2) are quite similar as those of run 1. The volume of the bar and the sediment in the harbour basin created in 50 years is now however $4.071.552,5 \text{ m}^3$. Comparing this with the $3.081.845 \text{ m}^3$ from run 1 gives an increase of ca 30% of sedimentation when deepening the harbour. This rate of increase is very reasonably in accordance with the expectations (increase of ca. 25%) that Hidrotopo had in their report of 2010 (see chapter 8).

Looking at the results of run 3 (appendix I, figure I-5, figure I-6 and table I-3), it is clear that after some time the deepened part of the river upstream is completely filled up, which is not surprising, and a large trench has developed in the harbour basin.

This trench occurs due to the fact the implemented maintenance dredging in the model already starts at the beginning of the simulation. At the beginning there is hardly any sediment supply to the harbour basin, as it nearly all settles in the deepened section and so the maintenance dredging just removes sediment from the bed of the harbour basin causing the formation of the trench. Hence it actually embodies the sediment deficit caused by the deepened section.

There is a decrease in sedimentation volumes, including maintenance dredging, between run 3 and run 1, respectively $36.880.575 \text{ m}^3$ and $48.473.775 \text{ m}^3$. Comparing those results show a decrease of nearly 24% of sedimentation volume in the harbour basin when the river upstream is deepened.

Similarly as described above, the results of run 4 (appendix I, figure I-7, figure I-8 and table I-4) are compared with the results of run 2. The volumes of respectively $35.838.870 \text{ m}^3$ and $49.419.482 \text{ m}^3$ show there is a decrease in sedimentation in this situation as well. Now this decrease is 27%.

Summarizing, keeping the explained remarks on the model results in mind, there will be a 30% increase in sedimentation in the harbour basin when the harbour basin is deepened and no deepening is carried out upstream. If deepening dredging is carried out on the river's first 9 km upstream of the harbour basin a decrease of approximately 25% will occur. It might be wise to investigate the possibility to carry out some maintenance dredging in this part, keeping the harbour basin 'clear' of sediment for longer, eliminating the problems caused to ship maneuvering.

	Sedimentation rate of change [%]
Run 2	30
Run 3	-24
Run 4	-26

table10-1: changes compared with run 1

11 Dredging

To ensure that the Port of Itajaí can receive vessels with increasing dimensions there has been a continuous process of deepening and widening the approach channel and harbour basin. These deepening and maintenance dredging activities are being executed for some decades, see appendix J, table J-1. Until 1998, dredging was carried out with a suction hopper dredger. Since 1998 dredging was done by the use of Water Injection Dredging (WID). The last years the maintenance dredging was done by the Dutch dredging company Van Oord at a rate of 2.000.000 m³/year operated 365 days a year for R\$ 16.200.000/year.

11.1 River upstream

After the flood of 2008 one of the proposals JICA made was to dredge a part of the river over a length of 9,5km to increase the flow capacity of the river. A hydrological study was performed to determine the total flow going into the Itajaí-Açu river, based on a return time of 50 and 100 years. The area upstream was split up in 13 sections, see appendix J figure J-1. Comparing the results of the flow capacity of each river section with the design flow, it appeared that for both return periods only 3 sections (11, 12 and 13) meet the design standard, so dredging seems necessary. The total volume of clay and sand to be dredged according to the tender given out by the federal government is 1.617.695,33 m³. Van Oord won the bid on the tender and is currently dredging the upstream part of the river using a trailing suction hopper and a water injection dredger. The dredged material is dumped at sea in the disposal areas, see appendix J figure J-3. The project covers only deepening dredging and there are no plans to maintain this new situation, so after some time the original dynamic equilibrium will be returned.

11.2 Planned dredging

At the moment the federal government has written out a tender for dredging the approach and the harbour basin of the Port of Itajaí till 14 m.

- Approach channel

The outer approach channel will be dredged till circa 14,5 m for a span of 4,9 km offshore to the entrance of the breakwaters. The width of the outer approach channel will be increased from 120-200 m to 160-260 m. The inner approach channel has to be dredged till 14 m and will be widened. No dredging activities may be performed 20m or less from the banks or berths, in order not to cause damage to the structures or existing facilities in its vicinity.

- Turning basin

The lay-out of the turning basin will not change, only the depth will be increased till 14 m, no dredging activities may be performed 20 m, or less from the berths.

The total volume of sand and clay that needs to be dredged is ca. 6.268.981.06 m³ for a total calculated price of R\$ 65.000.000, paid by the federal government. The work will take approximately 7 months and have to be executed by a medium or large self-carrier dredger [Hidrotopo 2010]. An environmental issue assessment has been performed on the project.

11.3 Maintenance dredging

Based on the results coming from the SOBEK model, there will be a 30% increase in sedimentation in the harbour basin when the harbour basin is deepened. This means that there is more maintenance dredging necessary, which will lead to higher costs. However, currently the river's first 9 km upstream of the harbour basin is being dredged till a depth of 9 m. Taking this into account there will be a decrease in sedimentation in the harbour basin of approximately 25%; the largest part of the sedimentation will occur in the dredged section upstream, leaving less sediment to settle in the harbour basin. Subsequently, the amount of maintenance dredging which is required to keep the harbour basin at the required will also reduce. As the price for dredging is usually based on the number of cubic meters of sediment needed to be removed, it is likely maintenance dredging costs for the Port of Itajaí will also decline in the order of 25%, expecting a decrease to an amount of approximately R\$ 1.000.000 per month. It should be noted however, that to keep a low rate of sedimentation in the harbour basin there will be some maintenance dredging necessary in the upstream part of the river as well. As the main function of this part of the river is flood protection, and thus is the responsibility of the state government, the maintenance dredging costs of this section should for the majority be paid by the state government. But as this maintenance dredging is beneficial for both parties, however, this should be discussed by the Port of Itajaí and the state government.

12 Possible solutions sedimentation

As mentioned before, an estuarine system would be in a dynamic equilibrium without human interventions. The natural bathymetry would adjust to varying conditions and oscillate around this dynamic equilibrium depth. With this depth the average annual sedimentation would be zero. The present equilibrium situation is disturbed as a result of deepening the estuary; therefore the system tries to restore itself which causes sedimentation. To get insight in sedimentation processes it is very important to have good knowledge of local morphological conditions, for example: bed material, settling velocities, suspended solids and transport rates.

At this moment, the harbour of Itajaí has an expensive dredging program with a water injection dredger in order to keep the depth on the required level. The yearly amount of dredged material is on average 2.000.000 m³ and this process costs the Port of Itajaí R\$ 16.200.000 per year. It is clear that because of the current upstream deepening of the river and the planned deepening of the harbour basin and approach channel the sedimentation process in the harbour basin will change. From a commercial point of view it is very interesting to search for other solutions to keep the river at the required depth besides dredging. There are a number of ways to influence the sedimentation processes in the harbour basin.

12.1 Reduce the sediment production

- Run-off

The origin of the sediment, which is transported by the rain into the river, can be found on the land surface area. Proper land use and management can substantially reduce the problems related to run-off. The design of hydraulic structures as for example terracing, debris dams and slope fixation can offer solutions.

In the case of the Itajaí-Açu river the exact origin of the sediment is not known, therefore it is hard to change the amount of run-off. There are rough numbers available on the contribution of run off to the total sediment between Indaial and Blumenau, which is about 0,17-0,42%, table K-1 and table K-2 in appendix K. So in order to reach significant changes in the total sediment the exact location of the origin has to be known and a large area has to be managed. There are also extreme run-off events, in the past there have occurred a number of landslides as a result of heavy rainfall. It is very hard to manage these extreme circumstances. However, it is good to collect more information on events like this.

- Tributaries

Tributaries increase the amount of sediment in the main river.

The tributary Itajaí-Mirim near the harbour basin has a high concentration of sediment in relation with the discharge, compared to the Itajaí-Açu. With a mean discharge of both rivers, the ratio sediment concentration versus discharge of Itajaí-Açu is about 0,70 and the ratio sediment concentration versus discharge of Itajaí-Mirim is about 2,94. See appendix K table K-3.

It is useful to do more research on reducing the amount of sediment of this tributary because of the high ratio. A weir can be a solution to trap the sediment from the tributaries before entering the Itajaí-Açu.

- Bed and bank erosion

Erosion of the banks and the bottom of the river also contributes to the total amount of sediment. There are multiple causes for this kind of erosion. One of them is high discharges through bends. The amount of sediment can be decreased by:

- Creating a solid bottom layer to realize a better bed protection
- Creating stronger banks by different methods, i.e. reforestation or creating vegetated buffer strips.
- Bottom vanes: these screens are placed in the outer bend of the river under a small angle of the mainstream. This creates a spiral flow which is contrary to the normal spiral flow in river bends. As a result less asymmetric cross-sections are created, either a shallower outer or a deeper inside curve. With the bottom vanes the depth of the river will be maintained.

The measures described above are good to solve local problems. At this moment it is not clear which bends give a large contribution to the total amount of sediment and therefore it is hard to say if these solutions will have a positive effect on the amount of sedimentation in the harbour basin.

Another cause of bed and bank erosion can be the slope of the river. The sediment concentration increases between Indaial and Blumenau; from 110 mg/l to 266 mg/l at a mean discharge. See table K-2 in appendix K for the sediment rates based on an average year. In this part of the river a lot of sediment enters the river and there is a very steep slope of 0,004. In this case probably bed protection would be a good solution to reduce the sediment load.

12.2 Reduce transport capacity of the river

- Sand trap

The principle of a sand trap is to reduce the flow velocity by increasing the cross section (width and/or depth). The sediments will settle down in this sand trap, resulting in a lower sediment concentration downstream of the sand trap. In the end, there will be less sediment conducted to the mouth of the river, because the sand trap catches the sediment. The sand trap works best when bottom transport is more dominant than wash load. For this river it is not known which type of sediment transport is dominant.

At this moment an upstream part of the river is being deepened for flood security reasons. This section can also be used as a sand trap, if the depth is maintained. It is wise to look for the possibilities to combine both functions with JICA and their plans to make room for the river as flood protection.

- Sediment filter

Another way to catch the sediment is with a filter. This filter has the properties to pass water and not the grains to catch the sediment.

This solution is very expensive and further studies are needed to determine the effectiveness of a sediment filter in the case of the Itajaí-Açu river.

12.3 Increase the flow velocity

- Discharge

Due to the high velocities during high discharges the transport capacity of the water flow increases. Settled sediment will be picked up and transported further downstream and a large amount of sediment will flow into the sea. Therefore high discharges have a negative effect on sedimentation, which has a positive effect on the harbour basin.

One of the characteristics of the Itajaí-Açu river is that a mud layer at the bottom arises when there is a period of low discharges. The layer can have a thickness in the order of decimetres. With high discharges this layer is washed away into the sea. In the case of Itajaí, discharges can be influenced by the three dams upstream, which are built for flood regulation. So it is worthwhile to look for a possible cooperation.

- Hydraulic structure

In order to increase the flow velocity of the river, a hydraulic structure can be placed in the water. An example of a flow increasing structure is a groyne. This structure creates a smaller cross section in the channel, which will lead to a higher flow velocity and less sedimentation.

In case of the Itajaí-Açu river these structures have already been applied at the entrance of the channel and are beneficial for the flow velocity and sedimentation. It is possible that placing groynes upstream will also have a positive effect on the flow and sedimentation but further research is needed.

- Alignment

The location of sedimentation depends strongly on the alignment of the river. For example in a bend where the sediments settle down in the inner bend.

Direct upstream of the harbour basin is a sharp bend. As a natural process a lot of sediment settles down at the inner bends, at the Navegantes side. Erosion will take place at the outer bend, at the Itajaí side. This erosion process will be prevented by placing bottom protection. In order to reduce the sedimentation at the Navegantes side as much as possible the alignment of the bend needs to be smoothed. No big alignment changes are possible because of the urban development; therefore optimisations can only be done on a local scale. In figure 12-1 the effect of smoothing the bend on the flow pattern is shown. In bends streamlines are not able to follow the sudden change in the alignment of the river. Therefore a vortex is formed. Due to the new suggested layout the streamlines are able to follow the bend better and therefore the vortex is closer to the Navegantes side, resulting in less sedimentation and a more constant flow.



figure 12-1: flow around bend

Another option to counteract the process of the natural flow of water in bends is the use of bottom vanes. A big advantage of bottom vanes is maintaining the depth of the river. This can decrease the amount of dredging. If measures are taken in river bends, sedimentation in the inner bend can be reduced. It is difficult to predict the impact of this measure on the harbour basin, because it depends on a lot of factors. It is known that the effect of bottom vanes is very limited; it has only a local effect.

12.4 Redirect the sediment

With the use of a side channel or sewage system is it possible to divert the sediment from the harbour basin.

In the past there had been ideas about a bifurcation channel, to prevent flooding. It would have been a good idea to combine this with the redirection of the sediment. However, the location one had in mind for this channel is now taken by the city of Navegantes. A lot of houses and buildings are constructed here nowadays. There is no good alternative location to make a side channel. So the redirection of sediment by a side channel will be very expensive to realize and isn't the best idea to prevent sedimentation in the harbour basin.

12.5 Summerizing

As described above there are four main principal solutions to reduce sedimentation of the harbour basin; reduce the sediment production, reduce transport capacity of the river, increase the flow velocity and redirect the sediment. A further division was made and possible measures were described. In table12-1 an overview of these described sediment-reduction-measures is given. In the table an indication of the effect and costs of each measure can be found. On this scale it is not possible to give

any hard numbers; a lot of research has to be done. It is clear that a number of measures can be taken, which will have a positive effect on the sedimentation of the harbour basin.

	Solution	Effect	Costs
Run-off	proper land use and management	?	?
Tributaries	weir	+	-
Bed and bank erosion	bed and bank protection	++	--
Sand trap	--	++	-
Sediment filter	--	+	--
Discharge	cooperation dams	+	0
Hydraulic structure	groynes	0	-
Redirect the sediment	bifurcation channel	+	---
Alignment	bend flow smoothening	?	-

?: study needed, ++: very positive, +: positive, 0: neutral, -: negative, -- very negative

table12-1: overview sediment reduction measures

Further study is needed in order to say more about the effect and the cost of the measures concerning the run-off sediment and the alignment in order to increase the flow velocity. Decreasing the contribution of the tributaries is a good option. This option is also not so expensive. Bed and bank protection and a sand trap are measures which have a significant influence on the sedimentation. This measure is relatively cheap if it is possible to use the currently dredged upstream part of the river. If cooperation is possible there are only maintenance costs. A sediment filter is a good, but relative expensive measure. Influencing the discharge with the upstream dams works well and does not have to cost anything, more research is definitely worthwhile. Constructing groynes upstream has no significant effect on sedimentation and off course this measure costs money. The last measure is very expensive and will not have a very positive effect on the sedimentation and therefore no further study is advised.

So concluding a sand trap, bed and bank protection, discharges regulations and a weir for the tributaries are measures which are worth more attention in further studies. It is strongly recommendable to do a study to determine which parts of the river give the largest contribution to the total sediment load and so where measures need to be taken.

13 Conclusion

To allow larger vessels into the harbour of Itajaí there has been a constant process of deepening the approach channel and the harbour basin. In order to compete with surrounding harbours it is important to allow safe navigation of larger vessel, this results in greater cargo handling at lower cost. Due to recent developments the Port of Itajaí is investigating the possibility to receive vessels with a length of 300 m overall, 45 m beam and 14 m draught.

13.1 Alignment study

At this moment the approach channel of the harbour deals with some imperfections, which makes it difficult, sometimes even impossible, for the design vessel to sail through the channel. Also the current turning circle is a problem as turning of the new design vessel will be extremely difficult and the safety is questionable. There are plans to deepen and widen the approach channel and harbour basin, the future dimensions are checked for the new design vessel using the PIANC method and suggestions on the alignment are made.

Calculations show that with the draught of the design vessel an operational time of 100% for the outer approach channel can only be achieved with a tidal window of +0,1 m CD and a 65% loaded design vessel. Also it is found that the width of the approach channel and turning circle do not meet the requirements of the PIANC method. A number of suggestions on the alignment are made in order to comply with these requirements and allow safe navigation of the design vessel. There is however no point in changing the alignment of the approach channel as long as the problem of the turning basin is not solved, and therefore the construction of a larger turning basin needs the highest priority. In principal the harbour can receive the design vessel when the deepening and widening dredging is carried out and an enlarged turning basin is realised; however the safety of ship manoeuvring is questionable. By realising the alignment changes for the east and west bend the safety can be increased and probably a slight gain in service time and accessibility of the channel can be realised.

The suggested alignment changes for the approach channel consist of improving the alignment of the east bend in combination with the outer approach channel and the alignment of the west bend. This suggested change of the east bend is more expensive than those of the west bend but it has a more positive effect on the ship manoeuvring.

The suggested alignment changes can be realised in stages, minding the turning basin has to be realised first. The total costs of the changes are roughly estimated at R\$ 281.940.000.

13.2 Sedimentation study

Without human interventions the estuarine system would be in a dynamic equilibrium. The bathymetry would adjust to varying conditions and oscillate around this dynamic equilibrium depth. This is the depth for which the average annual sedimentation is zero. When the natural dynamic equilibrium is disturbed as a result of deepening the estuary, the system will try to restore itself. This causes sedimentation and

maintenance dredging is required to maintain the newly dredged areas. The volume of the required maintenance dredging depends on the extent of the disturbance in relation to the equilibrium situation. A larger deepening will lead to smaller flow velocities and therefore to higher sedimentation rates.

The sedimentation that occurs in the Itajaí-Açu estuary is a complex ensemble of processes, which is influenced by processes at the boundary conditions. The two most important processes are the tidal fluctuations and river discharge. The concentration of sediment depends on the actual flow of the river, especially for suspended load. During a period of low discharges the sediment concentration is also low and due to the reduced velocities there is little erosion upstream.

To gain insight in the wet system, hand calculations and a 1D-computer model are made. The effect of a number of human interventions on the Itajaí-Açu river are determined with hand calculations. The height of the created bed steps, the equilibrium depth, the change in bed slope and the new reference level of the river bed are determined. In order to make the calculations, the situation is simplified and the values that are used are average, constant values.

With the 1D-modelling software, SOBEK, the effects of the planned dredging are determined. A 1D-model is used because it is easy to apply, gives good results for tide levels, discharges and long term morphology. The disadvantages of this kind of model are: poor results for local currents and a lack of information on lateral morphology. So far, for a first estimation a 1D-model is a good choice, but for further studies a 3D-model is highly recommended. The results of SOBEK show there will be a 30% increase in sedimentation in the harbour basin when the harbour basin is deepened and no deepening is carried out upstream. If deepening dredging is carried out on the river's first 9 km upstream of the harbour basin a decrease of approximately 25% will occur.

At this moment, the harbour of Itajaí has an expensive dredging program with a water injection dredger in order to keep the depth on the required level. The yearly amount of dredged material is on average 2.000.000 m³ and this process costs the Port of Itajaí R\$ 16.200.000 per year. It is clear that because of the current upstream deepening of the river and the planned deepening of the harbour the sedimentation process in the harbour basin will change. From a commercial point of view is it very interesting to search for other solutions to keep the river at the required depth besides dredging.

There are four main principal solutions to reduce sedimentation of the harbour basin; reduce the sediment production, reduce transport capacity of the river, increase the flow velocity and redirect the sediment. All these possibilities have a positive effect on the sedimentation in the harbour of which the sand trap measure is expected to have the most effect.

14 Recommendations

This study gives a number of suggestions for alignment changes and determines the effect and order of magnitude of planned dredging works. Possible solutions are pointed out which can influence the sedimentation process in the harbour basin in a positive way. However, on all these topics further study is needed and more data should be collected. There is a lot unknown of the Itajaí-Açu river, this is especially the case for the upstream part of the river.

14.1 Obtain local data

In the challenge for a better control of the sedimentation process it is very important to get insight in the different variables that influence the process. For further research it is important to look at the whole system of the river and not only consider the harbour. One of the most important aspects for further study is to obtain more information of local data. There are certain areas where extra attention is needed:

- At this moment there is too little knowledge about the river upstream. Around Indaial and Blumenau hardly any research is performed. There is no data on cross sections or the exact amount of sediment that flows through the river. The sediment concentration data that is available is measured at the water surface and its development over the water column is not known. It is known that between Indaial and Blumenau a lot of sediment goes into suspension, which makes further research even more important. If the characteristics of this area are known, the sediment load here can be reduced by measures, resulting in less sediment carried by the river into the harbour basin.
- Of the Itajaí-Mirim it is known that it's contribution is 5 – 10 % of the suspended sediment load of the Itajaí-Açu. It is not completely clear how much of this sediment settles down in the harbour. However, it is still worth doing more research for possibilities in reducing this load, so it won't enter the harbour basin.
- In the stratified estuary a high-density salt wedge exists. This salt wedge makes the situation in the harbour basin a complex one. The flow in this part of the river is different than in any other parts of the river. Because of the salt wedge, in the near-bed region relatively high near-bed densities will occur and relatively low near-surface densities will occur. Stratified flow will result in damping of turbulence because turbulence energy is consumed in mixing of heavier fluid from a lower level to a higher level against the action of gravity. After the dredging upstream, the salt wedge will be able to further penetrate into the estuary. At this moment little information is known on this phenomenon. Further research is useful especially when the influence increases with the planned dredging. The distance of penetration of the salt wedge and the influence on the sedimentation process can only be modelled by a 2D-, or a 3D-model.

- The sediment in the harbour basin partly consists of cohesive particles. The sediments occur as aggregates instead of single particles. When the particles are in aggregates they will settle down faster. Once they are in the estuary they are in a very complicated environment. The contribution of this cohesive material on the sedimentation process is not known. Also little is known on the high density mud layer; the development or the propagation is unclear. Because of the very high concentrations of the sediment in this mud layer, more knowledge about this mud layer could lead to better management of the sedimentation process.
- Information about the bed form of the bottom is lacking. The bed form contributes to the dynamic roughness of the alluvial bed. More insight in the bed forms delivers more information about the way the sediment is transported along the bottom of the river and the flow of the water through the river.
- Bends in the river also have an important contribution to the sedimentation process. Especially the bend just before the harbour can be interesting to model and see if certain measures can lead to fewer problems in the asymmetric sedimentation that occurs at the moment. To make calculations taking the bends into account a 2D- or a 3D-model should be used.

It is clear that a lot of research is needed to get more insight in the processes that occur in the harbour. Measures have to be taken in order to collect the required data. With the required data, scale models or more detailed numerical models can be made. Important aspects as the salt wedge, river flow in bends, flocculation of sediment are processes that play an important role in the sedimentation process in the harbour basin and cannot be modelled in a 1D-model.

14.2 Alignment study

During the course of this study a couple of recommendations regarding the overall alignment of the approach channel and harbour basin were made. These findings are an important part of the total recommendations.

- The PIANC guidelines which are used to check the dimensions of the approach channel and harbour basin are applied for the initial design and the outcomes should be checked and refined by Fast Time Simulation. Particularly useful would be a comparison of the duration of the approach manoeuvres at various given channel widths and river flows. This will give insight in the relationship of widening the channel against the gain in service time. Also a check on the feasibility of manoeuvring for an increasingly wide ship at a given channel width and river flow can be valuable for future perspective.
- For the suggested alignment changes of the east bend it is suggested to shorten the groynes to create more space. However, by shortening the groynes the flow width of the channel increases and the flow velocities through the channel will be lower and thus has a negative effect on the sedimentation. To maintain the flow condition in this section there will be a need for a flow width reducing structure on the south side of the river, i.e. groynes. A study has to be done on

the possible alternatives for the 'flow width reducing structure' that will need to be placed on the south side of the channel.

- From the cost-benefit analysis followed that the best location for the new turning basin would be location C. The biggest problem for this option is the loss of buildings, which is a difficult point to overcome politically. However, this location is the best option compared with the other possibilities, based on a cost-benefit analysis.
- The problem concerning the formation of a sandbank can be solved by extending the northern breakwater. Currently this sand is dredged away. It is not clear what the actual costs of this dredging will be. Therefore it is difficult to give an estimation whether it is beneficial to extend the breakwater or to leave it as it is, further study is suggested.

14.3 Sediment study

- In the study a 1D-model was used because it is easy to apply, gives good results for tide levels, discharges and long term morphology. The disadvantages of this kind of model are: poor results for local currents and a lack of information on lateral morphology. So far, for a first estimation a 1D-model is a good choice, but for further studies a 3D-model is highly recommended.
- Although in this study no further special attention is given to the flood of 2008, it is recommended to try to collaborate with JICA, to bring the interests of the harbour under their attention. JICA has done a lot of research according the flood. In the problems according such a flood it is also possible to model such a disaster with a 3D-model.
- The SOBEK results show that if deepening dredging is carried out on the river's first 9 km upstream of the harbour basin a decrease of approximately 25% will occur. It might be wise to investigate the possibility to carry out some maintenance dredging in this part, keeping the harbour basin 'clear' of sediment for a longer time, eliminating the problems caused to ship manoeuvring.
- A number of sediment reduction measures can be applied for the Itajaí-Açu river. A sand trap, bed and bank protection, discharges regulations and a weir for the tributaries are measures which are worth more attention in further studies. It is strongly recommendable to do a study to determine which parts of the river give the largest contribution to the total sediment load and so where measures need to be taken.
- In order to deal with the sedimentation in the harbour basin knowledge on these processes is very important, therefore it is strongly recommended to start an intensive cooperation with UNIVALI. The professors of the university have a lot of knowledge on these processes and the

university has much useful data. Students could do a part of the recommended study as part of their study; making measures or analyse data.

14.4 The future

In the above recommendations there are two main problems that need extra attention, because of their importance. Solving these first will have the most positive effect on the future of the port. The Port of Itajaí is facing these problems and needs to handle. These two problems both need their own approach:

1) Alignment – turning circle

The biggest challenge lies in the near future for the management of the Port of Itajaí. It is very important to make the right choices according this subject as soon as possible: the realization of a bigger turning circle. If time is wasted according this issue, it will lead to major problems for the Port of Itajaí. And if it fails, the harbour will not be able to keep their leading position in the market. This will have a big influence on the local economy of Itajaí and its surroundings. It is clear that the solution has to be found in a political play: it will be a long and difficult political issue. Both Portonave and Navegantes at one side and the Port of Itajaí on the other side will have to agree on the location, the finances etc. All the effort should be made to overcome these problems and to realize this bigger turning circle.

2) Sedimentation – sand trap and 3D-model

It is clear that further research will give more knowledge about the physical processes that influence the harbour system. Especially more sophisticated models will be the tool to gain insight and to get more in control of the situation. From a management point of view this is very important, because it will lead to solutions that will reduce the maintenance costs. It will also give the harbour management a better control of the variables and uncertainties they have to deal with in their goal to make the harbour as efficient as possible. The Port authorities should think of a plan to keep a good overview according the different rapports and studies they have ordered in the past and they will make in the future, so work will not be done twice and results will not be lost.

At the moment, the most important issue according this further research is the approach of the upstream dredging as a sand trap: There should be made a 3D-model, taking into account both the river and the sea side; the mud flow, the salt wedge and the tide should be included. The other aspect according the sand trap is a practical one: The Port of Itajaí has to realize that a big opportunity lies here. The Port of Itajaí should be sure that this part of the river is maintenance dredged on a regular basis. The management of the Port needs to be sure that the maintenance dredging is done in such a way that the sediments are taken out of the river, so they won't be able to enter the harbour basin. As the main purpose of the upstream deepening dredging is flood control, it is useful for the Port to investigate if the costs for maintenance dredging in this part can be (partly) paid by the state government.

15 Post script

At the end of a challenging ten weeks of hard work on this project it is useful to reflect our experiences and acknowledge that during our project we faced some problems. Some of them had to do with the cultural differences and the way of approaching problems and others had to do with working in a team.

The first week of our project we gave a presentation at the port to some of the employees and to Dhr. Klein. The goal of this presentation was to make clear what the harbour could expect from our study so there wouldn't be any disappointments. At the end there was a little discussion, after that it was for both parties clear which research questions would be answered and what kind of study was to be expected. This presentation was a good kick off for the research.

In the first weeks many reports needed to be analyzed, as there was a lot of data available on the present situation. However there was still plenty of data missing, i.e. little research has been done on the river upstream. Therefore many assumptions had to be made, which was not so easy because of a lack of experience.

Off course modeling the system into SOBEK took more time than expected and was sometimes very frustrating. With a regular updated time planning this problem was tackled and in the end there was enough time to process the results.

During the project working in a team turned out to be more difficult than thought before. Different ways of approaching problems and lack of communication gave sometimes problems. But with a regular updated planning and a weekly talk the problems were solved.

16 Reference list

16.1.1 Articles

Acquaplan Tecnologia e Consultaria Ambiental, April 2009; *Estudo de impacto ambiental eia da dragagem para aprofundamento do canal de acesso e da bacia de evolucao do porto organizado de Itajai, SC.*

Alkyon, March 2007; *Nautical study for Port of Itajai and Port of Navegantes.*

Alkyon, January 2008; *Manoeuvring simulations with 5600 TEU Container Carrier for the port of Navegantes.*

Alkyon, May 2008; *Sedimentation study, Port of Itajai/Navegantes. Additional sedimentation at Itajai as a result of Portonave and channel deepening.*

Eysink, W.D. ,&Vermaas, H.,1983; *Computational methods to estimate the sedimentation in dredged channels and harbour basins in estuarine environment*, Delft Hydraulics Publication No. 307

Governo do estado de Santa Catarina, September 2009; *Obra emergencial da dragagem e estabilizacao do rio Itajai-Acu.*

Helpdesk SOBEK-RE; *Morphology and Sediment Transport, Technical Reference*, Delft: Deltares

Helpdesk SOBEK-RE; *User manual*, Delft: Deltares

Helpdesk SOBEK-RE; *Salt Intrusion, Technical Reference*, Delft: Deltares

Hidrotopo, July 2009; *Estudo de viabilidade de dragagem e derrocagem do canal de acesso e bacia de evolucao para a cota de 14,5m.*

Hidrotopo, August 2009; *Cálculo das dimensões do canal de acesso e bacia de manobra do porto de Itajai no estar de Santa Catarina(14,0-14,0).*

Hidrotopo, December 2009; *Projeto básico recuperação e recuperação e reforçodo guia-corrente Norte do porto de Itajai.*

Hidrotopo, March 2010; *Projecto basico de dragagem do canal de acesso ao porto de Itajai – SC para a cota de 14,0 metros.*

Japan International Cooperation Agency (JICA), October 1989; *Feasibility study on the flood control project in the lower Itajai river basin.*

Ministerio dos Transportes, 2008; *Estudo de viabilidade do projeto de dragagem do porto de Itajai – SC.*

PIANC Working Group II-30; *Approach channels, a guide for design*

PIANC Working Group 43; *Minimising Harbour Siltation*.

Schettini, C.A.F., & Toldo, E.E., *Journal of Coastal Research*, 2006; *Fine sediment transport modes in the Itajaí-Açu Estuary*.

Schettini, C.A.F., Centro de Ciências Tecnológicas da Terra e do Mar, March 2002; *Caracterização Física do Estuário do Rio Itajaí-Açu*

16.1.2 Books

Battjes, J.A., 2006; *Short Waves*, TU Delft

Branco, J.O., & Lunardon-Branco, M.J., & Belletto, V.R., 2009; *Estuário do Rio Itajaí-Açu, Santa Catarina: Caracterização Ambiental e Alterações Antrópicas*. Univali, Itajaí-SC

Crosato, A.; *Morphological response at the reach scale*. UNESCO-IHE, Delft

de Vriend, H.J., & Havinga, H., & Visser, P.J., & Wang, Z.B., March 2010; *River Engineering*. TU Delft

Schriek, G.L.M., 2001; *Bed, bank and shoreline protection*. TU Delft

Stelling, G.S., & Booij, N., August 1999; *Computational modelling flow and transport*. TU Delft

Van der Schriek, G.L.M., January 2010; *Dredging Technology*. TU Delft

van Rijn, L. C., 2005, *Principles of sedimentation and erosion engineering in rivers, estuaries and coastal seas*. TU Delft

Verhagen, H.J., & d'Angremond, K., & van Roode, F.; *Breakwaters and closure dams*. TU Delft

Verheij, H.J., & Stolker, C., & Groenveld, R., February 2008; *Inland Waterways*. TU Delft

Verruijt, A., & van Baars, S., 2005; *Grondmechanica*. TU Delft

16.1.3 Internet

<http://www.deinfra.sc.gov.br/barragens/situacao-em-tempo-real/>; status of dams in real time.

<http://tbone.biol.sc.edu/tide/>; tidal elevation

<http://wikipedia.org>; general information

http://www.worldlingo.com/ma/enwiki/nl/Coastal_management

16.1.4 Interviews

Carvalho, J.L.B. ;*Professor of Physical Oceanography at UNIVALI in Itajaí*

da Rocha, A.; *Pilot of Port of Itajaí*

Grantham, R.; *Commercial director Port of Itajaí*

Joos, W.; *Manager director APM Terminals of Itajaí*

Kuhn, M., &Pitrez dos Santos, M.; *Environmental issues manager of Port of Itajaí*

Smits, M.C.J.; *Project Engineer at Royal Haskoning*

Van der Velden, F.; *Project manager of maintenance dredging project for Port of Itajaí and deepening dredging project of upstream part of river Itajaí-Açu*

Appendix

Appendix A: Stakeholders



figure A-1: organized area of Port of Itajaí

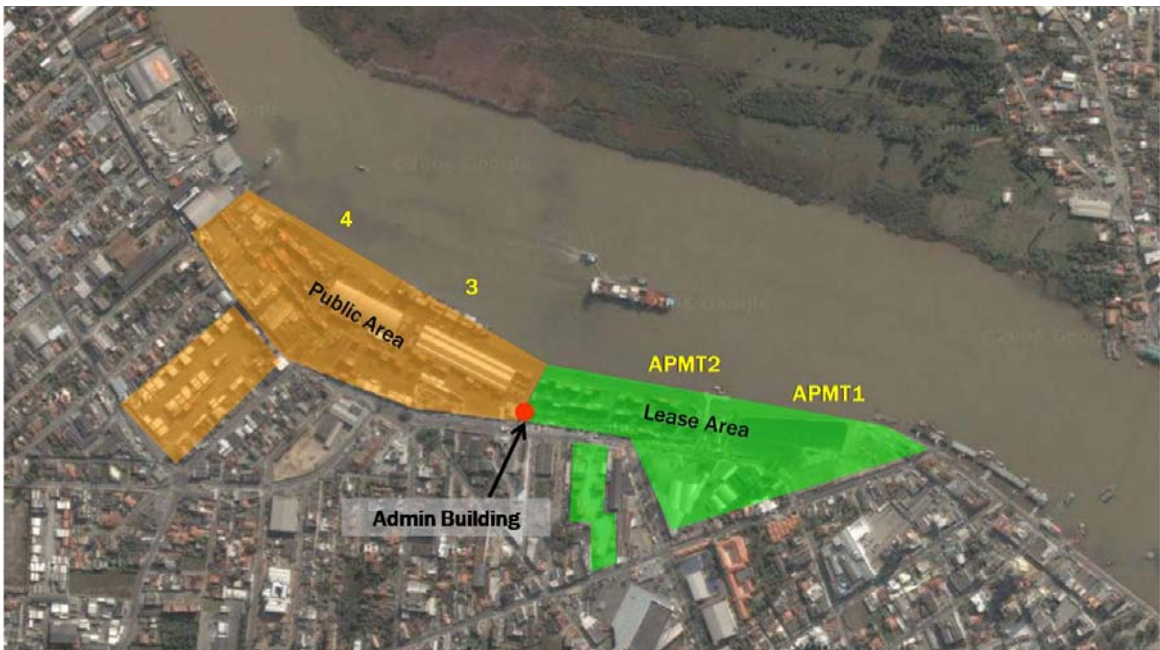

figure A-2: Port of Itajaí

Appendix B: River

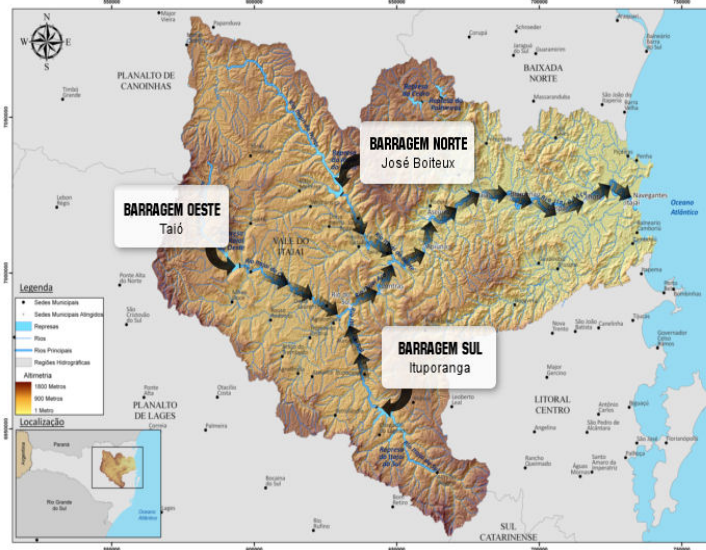

figure B-1: location of dams

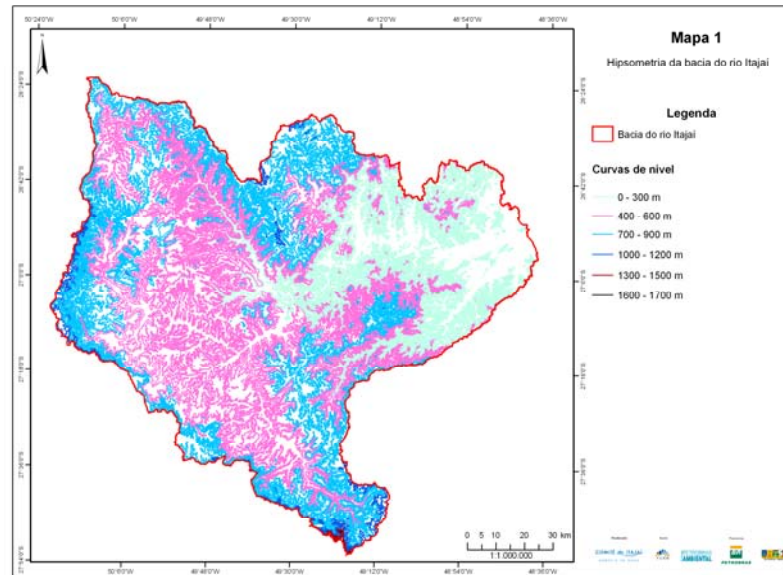

figure B-2: elevation map

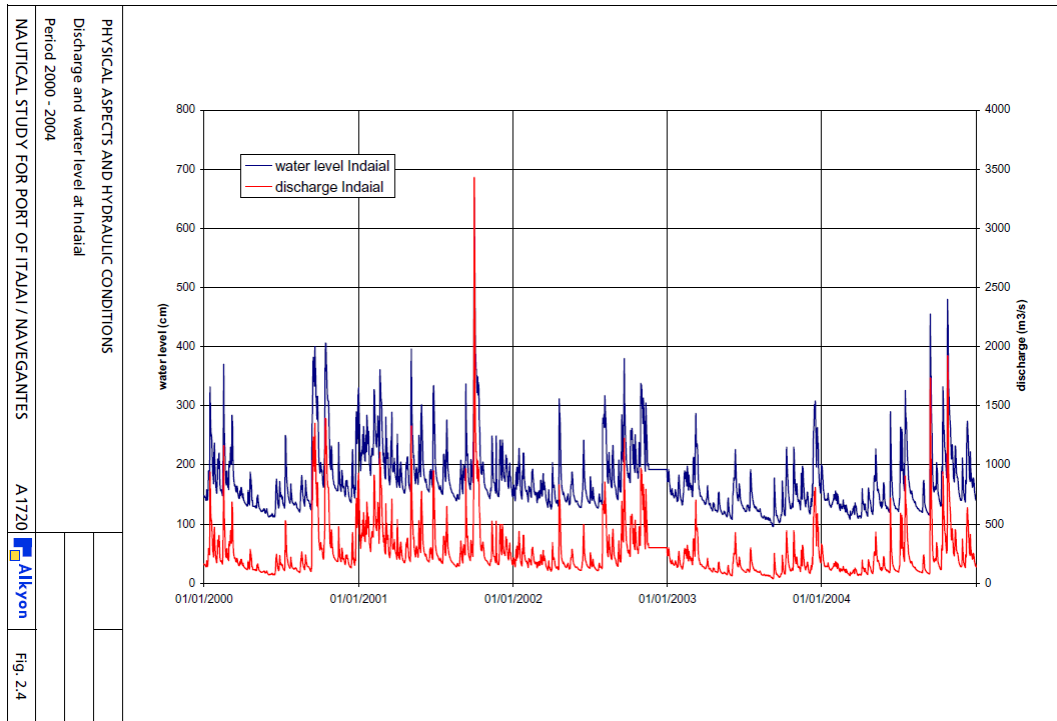

figure B-3: discharge-depth relation at Indaial;2000-2005

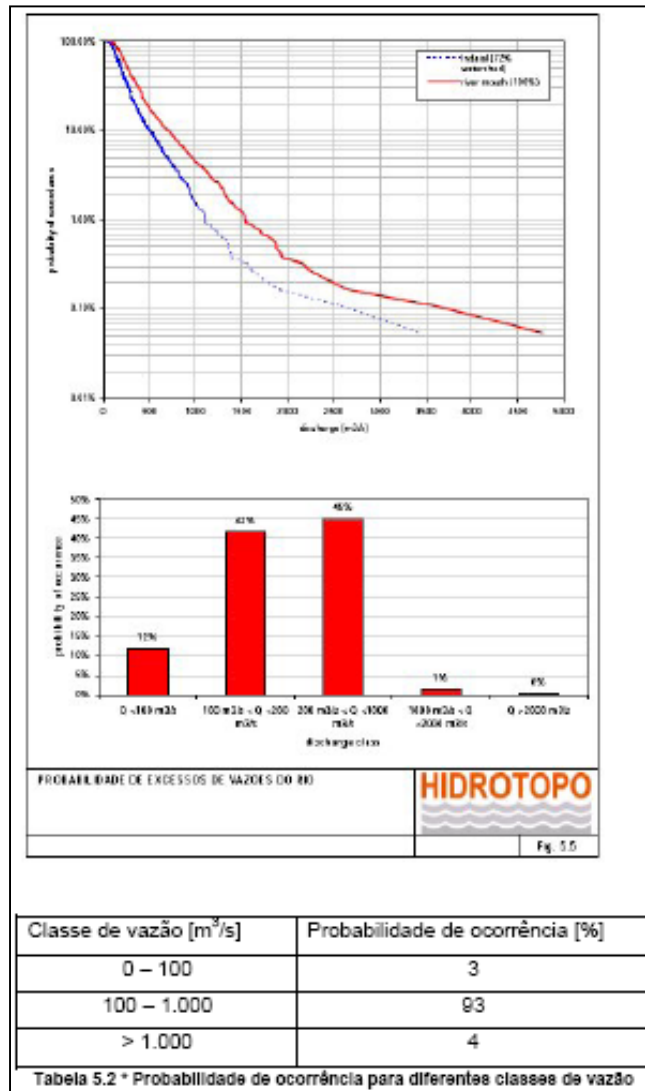

figure B-4: probability of flood occurrence

Appendix C: Sea

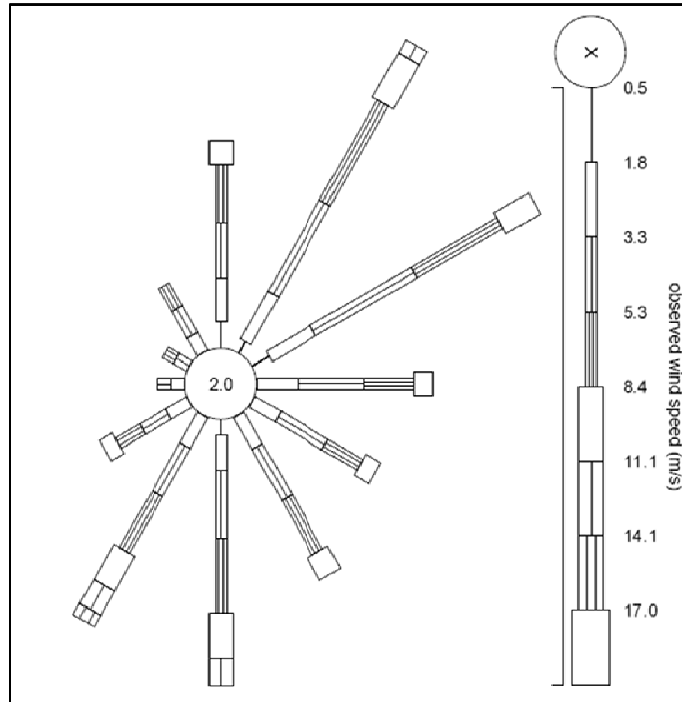

figure C-1: offshore wind rose - ship observations

U (m/s)	wind direction (Deg)													Total
	-15 to 15	15 to 45	45 to 75	75 to 105	105 to 135	135 to 165	165 to 195	195 to 225	225 to 255	255 to 285	285 to 315	315 to 345		
<.5	1.86	.02	.03	.01	.00	.01	.01	.01	.01	.00	.00	.01	.01	1.99
.5 1.8	1.10	.54	.82	.45	.30	.42	.61	.40	.34	.16	.20	.32	.32	5.65
1.8 3.3	1.85	2.31	2.16	1.71	1.23	1.52	1.50	1.48	1.03	.55	.49	.85	.85	16.67
3.3 5.3	2.30	4.40	4.85	2.83	2.33	2.47	2.87	2.33	1.24	.59	.64	1.30	1.30	28.13
5.3 8.4	2.42	4.83	4.14	2.03	1.69	2.63	3.11	2.74	1.19	.45	.52	1.10	1.10	26.85
8.4 11.1	1.04	2.12	1.64	.79	.71	1.07	1.93	1.68	.61	.22	.15	.32	.32	12.29
11.1 14.1	.30	.65	.46	.31	.17	.45	1.11	1.16	.29	.09	.05	.12	.12	5.15
14.1 17.0	.09	.20	.18	.06	.04	.15	.43	.54	.19	.01	.02	.03	.03	1.93
17.0 21.0	.04	.07	.05	.03	.02	.05	.19	.24	.09	.02	.01	.01	.01	.82
21.0 24.5	.	.01	.06	.00	.01	.01	.02	.01	.02	.	.01	.	.	.15
24.5 28.5	.01	.04	.04	.01	.03	.01	.01	.03	.01	.	.	.02	.02	.21
28.5 33.0	.	.02	.	.01	.01	.01	.04	.	.	.0109
33.0 >	.01	.01	.01	.	.01	.	.01	.01	.02	.0107
Total	11.00	15.23	14.43	8.23	6.53	8.80	11.84	10.64	5.04	2.11	2.08	4.07	4.07	100.00

Season: All year
 Period: 1960 to 1997
 Location: Itajaí-offshore (x = 312.25, y = -27.00)
 Source: Ship observations
 No. of obs: 150543
 Type of data: Wind
 Tidal phase: undefined level
 Record: Offshore wind Season: All year

table C-1: joint probability of occurrence (%) of the offshore wind in Itajaí - ship observations

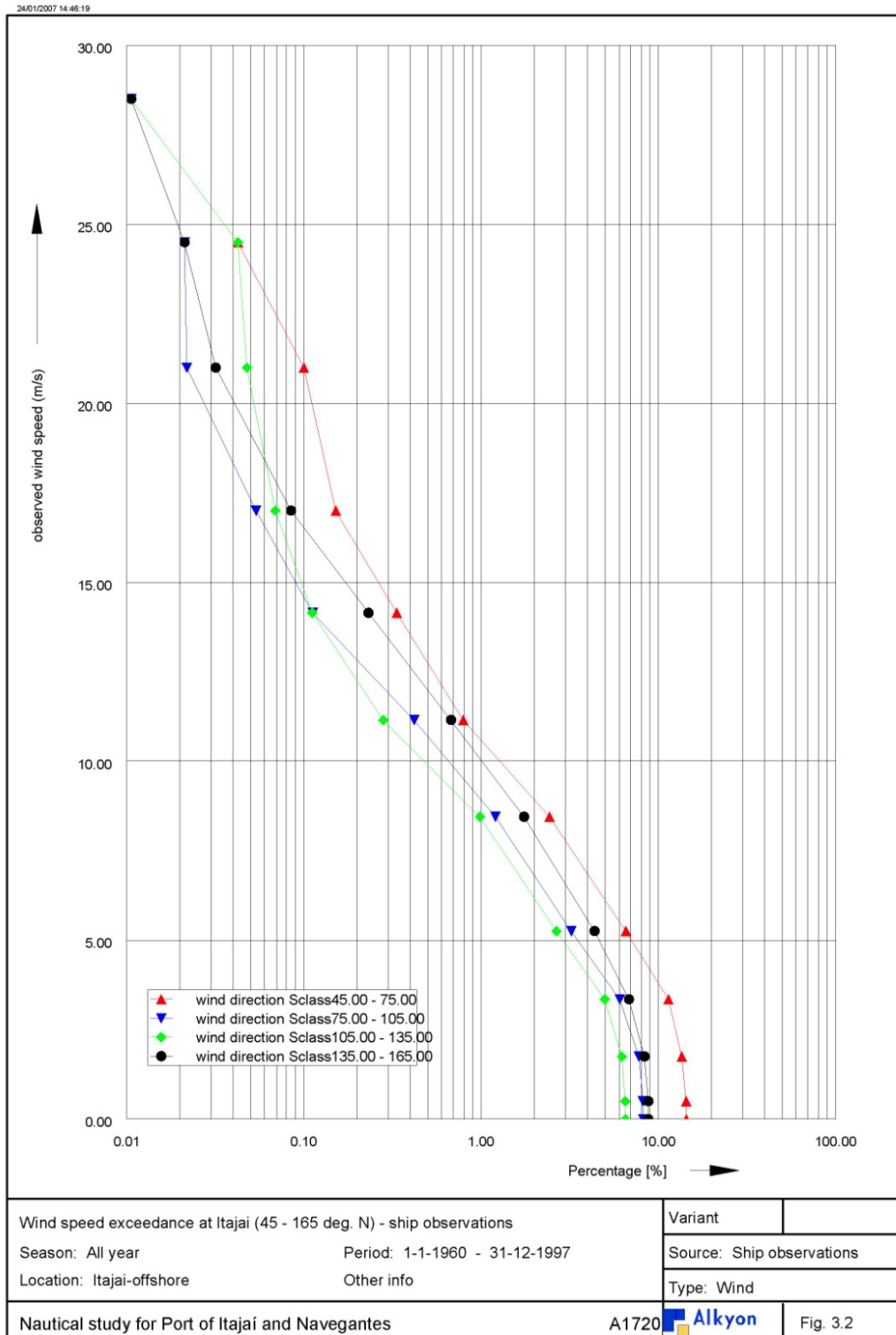

figure C-2: wind speed exceedance at Itajaí - ship observations

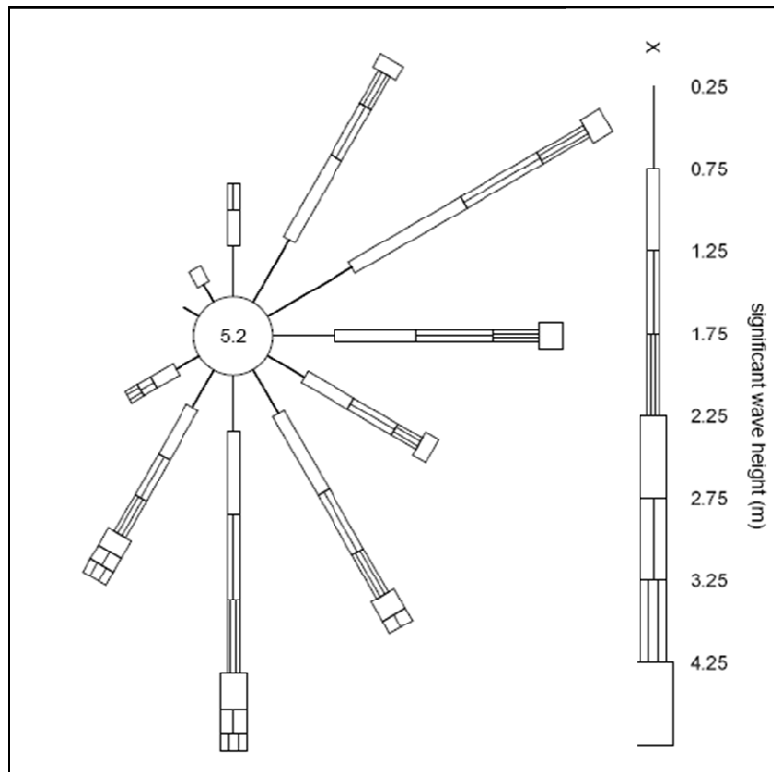

figure C-3: offshore wind rose – ship observations

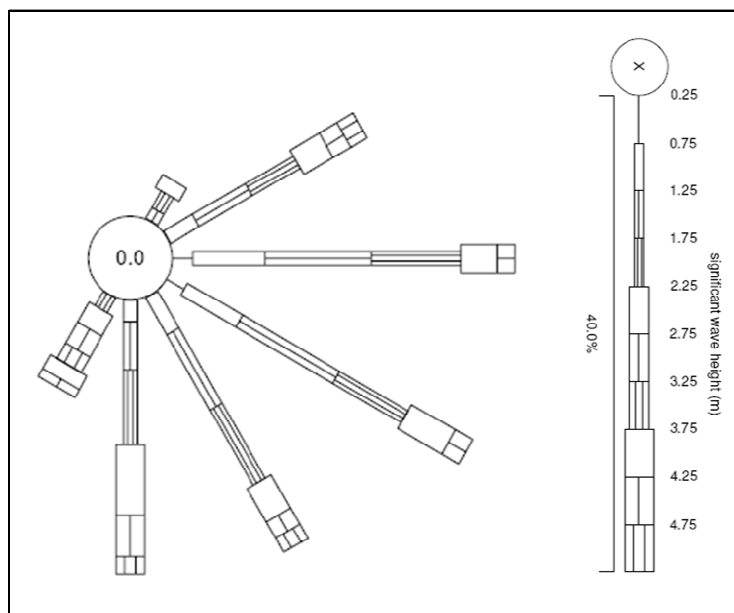

figure C-4: offshore wind rose – ship observations

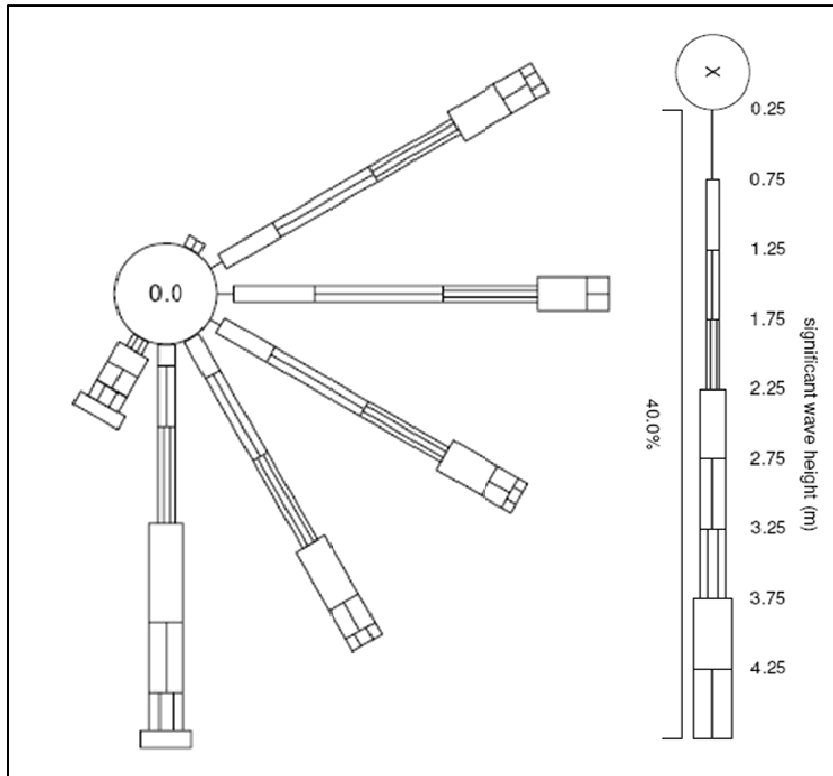

figure C-5: offshore wind rose – hindcast model

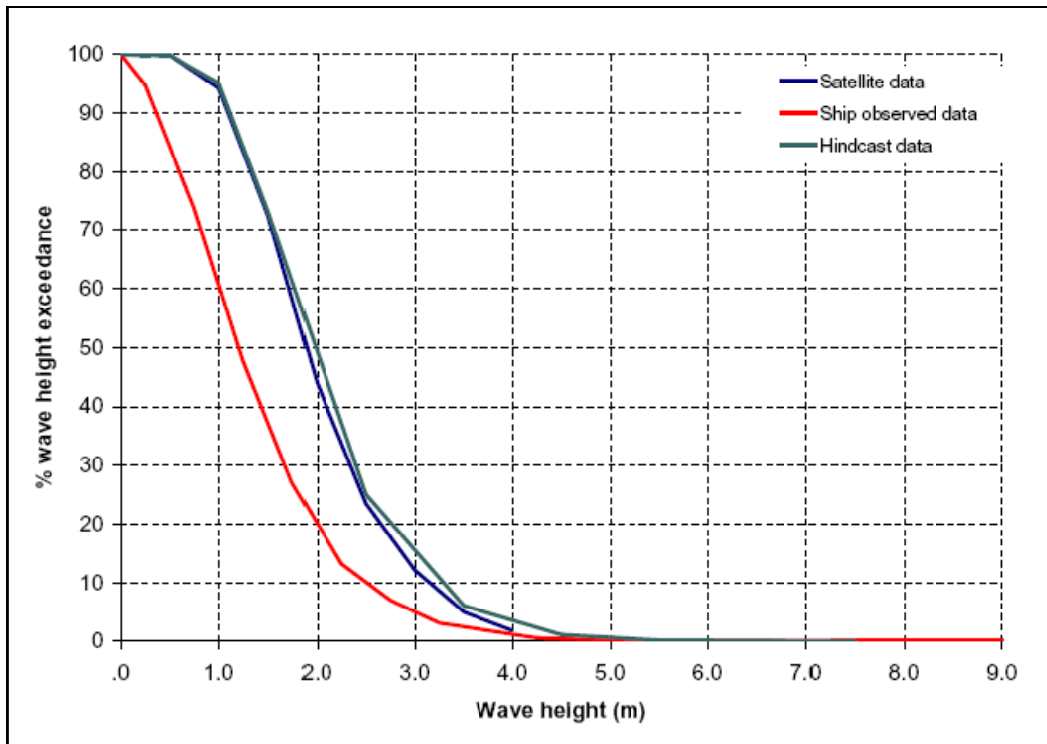

figure C-6: comparison of wave height exceedance – ship observations, satellite data, hindcast model

Prefeasibility report for the Port of Itajaí

Hs (m)		wave direction (Deg)												Total	
		-15 to 15	15 to 45	45 to 75	75 to 105	105 to 135	135 to 165	165 to 195	195 to 225	225 to 255	255 to 285	285 to 315	315 to 345		
Lower	Upper														
<	.25	.00	.00	.02	.01	.00	.03	.08							.14
.25	.75	.04	.12	.75	2.06	2.83	7.30	6.32							19.42
.75	1.25	.08	.55	3.75	5.67	4.70	6.32	1.69							22.77
1.25	1.75	.02	.57	6.18	8.23	7.00	8.48	.68							31.17
1.75	2.25	.00	.34	4.09	4.79	3.86	4.69	.08							17.86
2.25	2.75		.08	1.70	1.68	1.34	1.31	.00							6.11
2.75	3.25		.01	.32	.69	.38	.29								1.99
3.25	4.25		.00	.18	.20	.09	.06								.54
4.25	5.25					.00	.00								.00
5.25	6.25														
6.25	7.25														
7.25	8.25														
8.25	9.25														
9.25	10.25														
10.25	11.25														
11.25	12.25														
12.25	13.25														
13.25	14.25														
14.25	15.25														
15.25	>														
Total		.15	1.68	17.30	23.33	20.21	28.48	8.86							100.00

Season: All year
 Period: 1960 to 1997
 Location: Itajaí-20m depth (x = -48.55, y =-26.92)
 Source: Hindcast model
 No. of obs.: 100021
 Type of data: Highest of sea & swell
 Tidal phase: undefined level
 Record: HINDCAST offshore data to 20m depth contour Season: All year

table C-2: joint probability of occurrence (%) of the offshore wave height at Itajaí - hindcast model

Tp (s)		wave direction (Deg)												Total	
		-15 to 15	15 to 45	45 to 75	75 to 105	105 to 135	135 to 165	165 to 195	195 to 225	225 to 255	255 to 285	285 to 315	315 to 345		
Lower	Upper														
<	2.5														
2.5	3.5														
3.5	4.5	.00	.01	.03	.00	.00	.00	.00							.04
4.5	5.5	.03	.12	.23	.05	.01	.02	.02							.49
5.5	6.5	.07	.56	3.25	1.75	.73	.63	.32							7.31
6.5	7.5	.04	.69	7.08	6.32	3.61	3.13	.97							21.83
7.5	8.5	.01	.25	4.71	7.91	6.17	6.54	.98							26.58
8.5	9.5		.04	1.71	4.85	5.38	7.73	.66							20.38
9.5	10.5		.00	.29	1.79	3.32	6.77	.03							12.20
10.5	11.5			.01	.43	1.69	4.14								6.27
11.5	12.5				.07	.82	2.15								3.04
12.5	13.5				.02	.52	.76								1.30
13.5	14.5					.34	.09								.43
14.5	15.5					.11	.00								.12
15.5	>														
Total		.15	1.68	17.30	23.20	22.72	31.96	3.00							100.00

Season: All year
 Period: 1960 to 1997
 Location: Itajaí-20m depth (x = -48.55, y =-26.92)
 Source: Hindcast model
 No. of obs.: 100021
 Type of data: Highest of sea & swell
 Tidal phase: undefined level
 Record: Season: All year

table C-3: joint probability of occurrence (%) of the offshore wave height at Itajaí - hindcast model

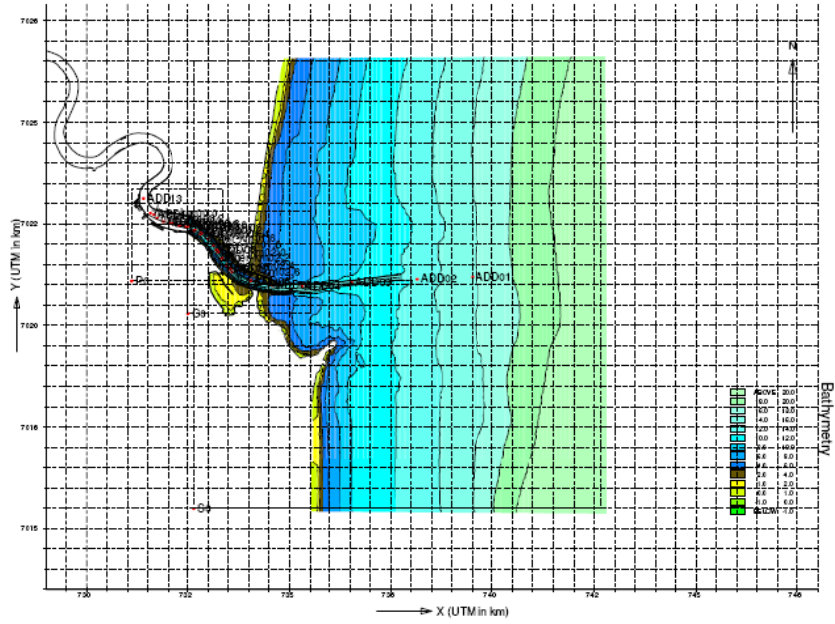

figure C-7: bathymetry map

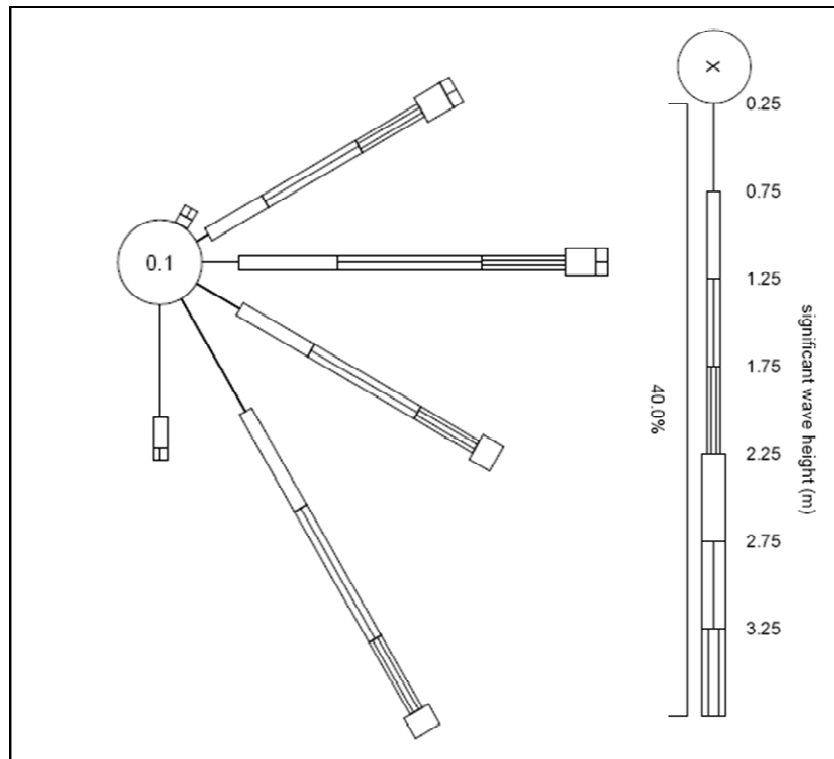

figure C-8: wave rose at 20m water depth - satellite data

Prefeasibility report for the Port of Itajaí

Hs (m)		wave direction (Deg)											Total		
		-15 to 15	15 to 45	45 to 75	75 to 105	105 to 135	135 to 165	165 to 195	195 to 225	225 to 255	255 to 285	285 to 315		315 to 345	
< .25	.25	.00	.00	.02	.01	.00	.03	.08							.14
.25	.75	.04	.12	.75	2.06	2.83	7.30	6.32							19.42
.75	1.25	.08	.55	3.75	5.67	4.70	6.32	1.69							22.77
1.25	1.75	.02	.57	6.18	8.23	7.00	8.48	.68							31.17
1.75	2.25	.00	.34	4.09	4.79	3.86	4.69	.08							17.86
2.25	2.75		.08	1.70	1.68	1.34	1.31	.00							6.11
2.75	3.25		.01	.62	.69	.38	.29								1.99
3.25	4.25		.00	.18	.20	.09	.06								.54
4.25	5.25					.00	.00								.00
5.25	6.25														
6.25	7.25														
7.25	8.25														
8.25	9.25														
9.25	10.25														
10.25	11.25														
11.25	12.25														
12.25	13.25														
13.25	14.25														
14.25	15.25														
15.25	>														
Total		.15	1.68	17.30	23.33	20.21	28.48	8.86							100.00

Season: All year
 Period: 1960 to 1997
 Location: Itajaí-20m depth (x = -48.55, y = -26.92)
 Source: Hindcast model
 No. of obs.: 100021
 Type of data: Highest of sea & swell
 Tidal phase: undefined level
 Record: HINDCAST offshore data to 20m depth contour Season: All year

table C-4: joint probability of occurrence (%) of the wave at 20 m water depth - hindcast model

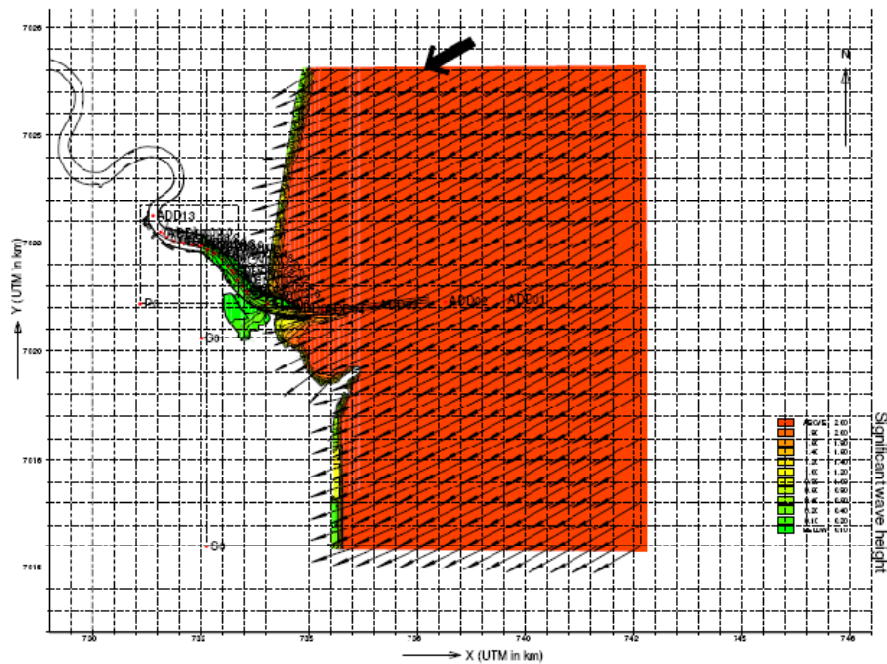

figure C-9: results of SWAN model

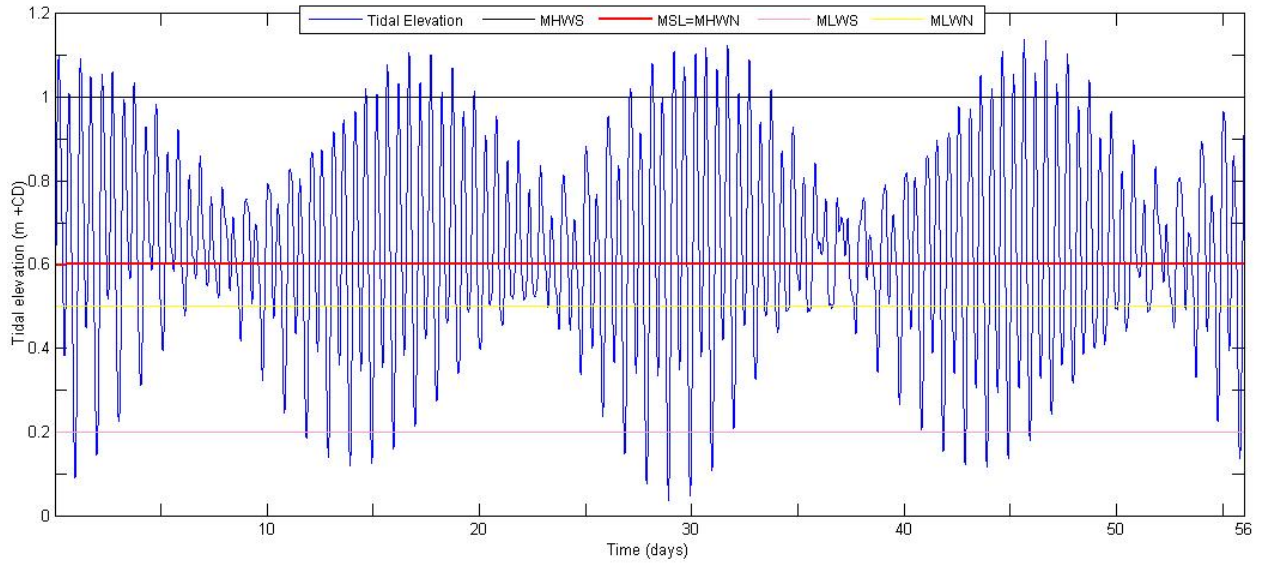

figure C-10: tidal elevation 2 months

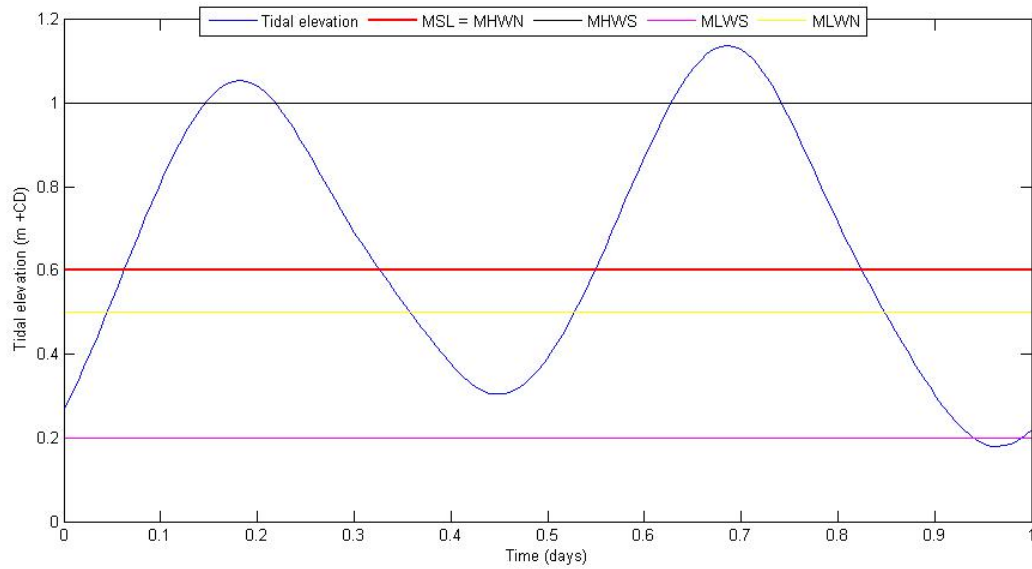

figure C-11: tidal elevation 1 day – spring tide

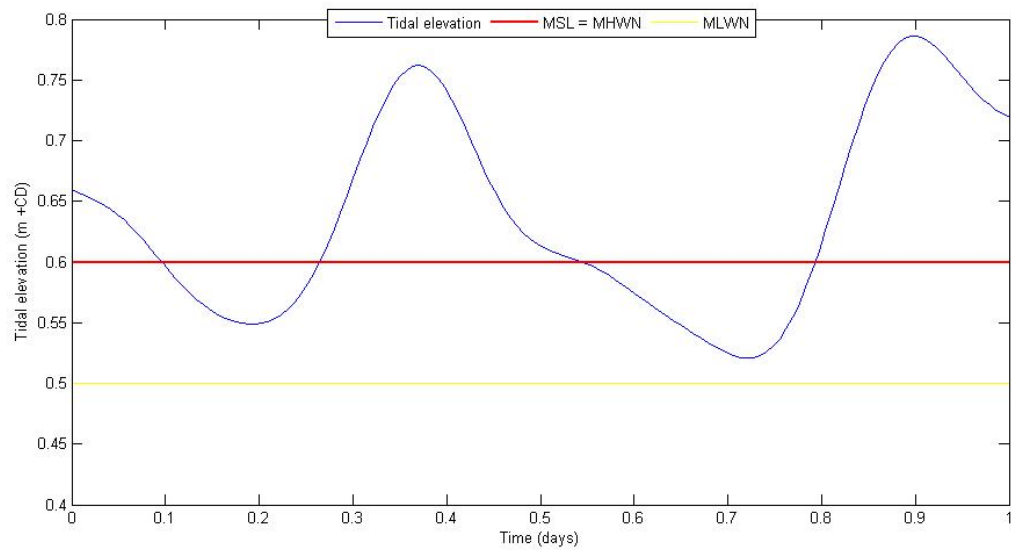

figure C-12: tidal elevation 1 day – neap tide

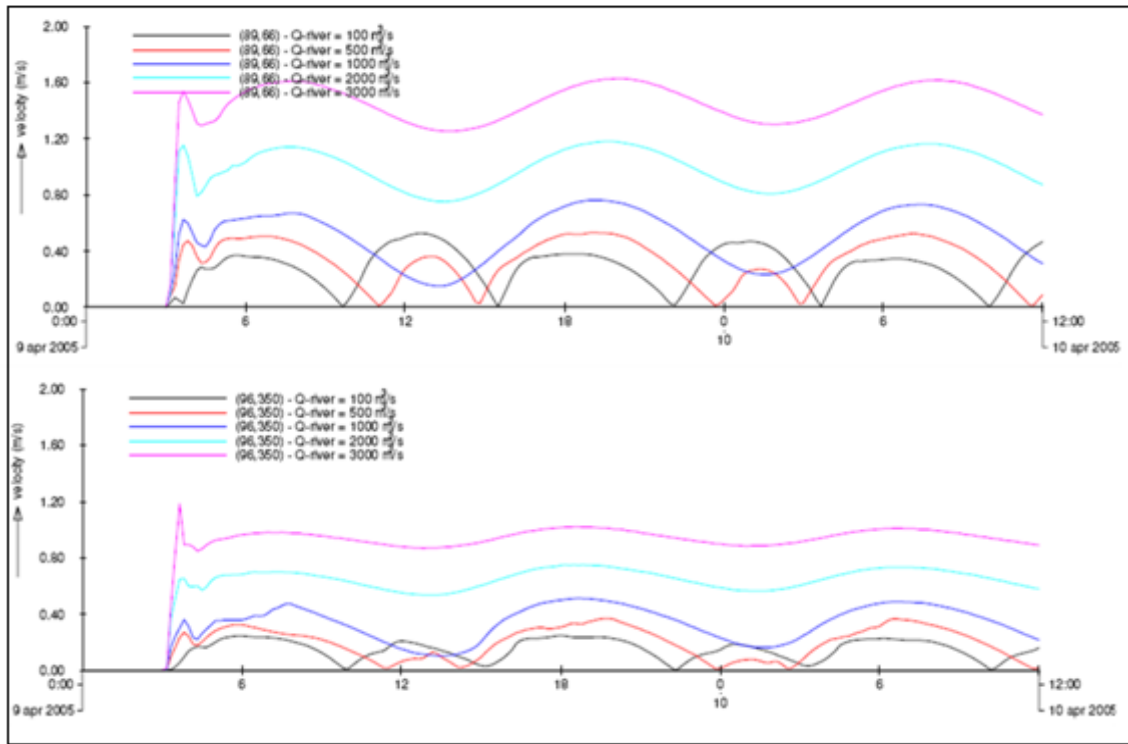

figure C-13: flow velocities in (89,66) and (98,173) - results of 3D-flow simulation

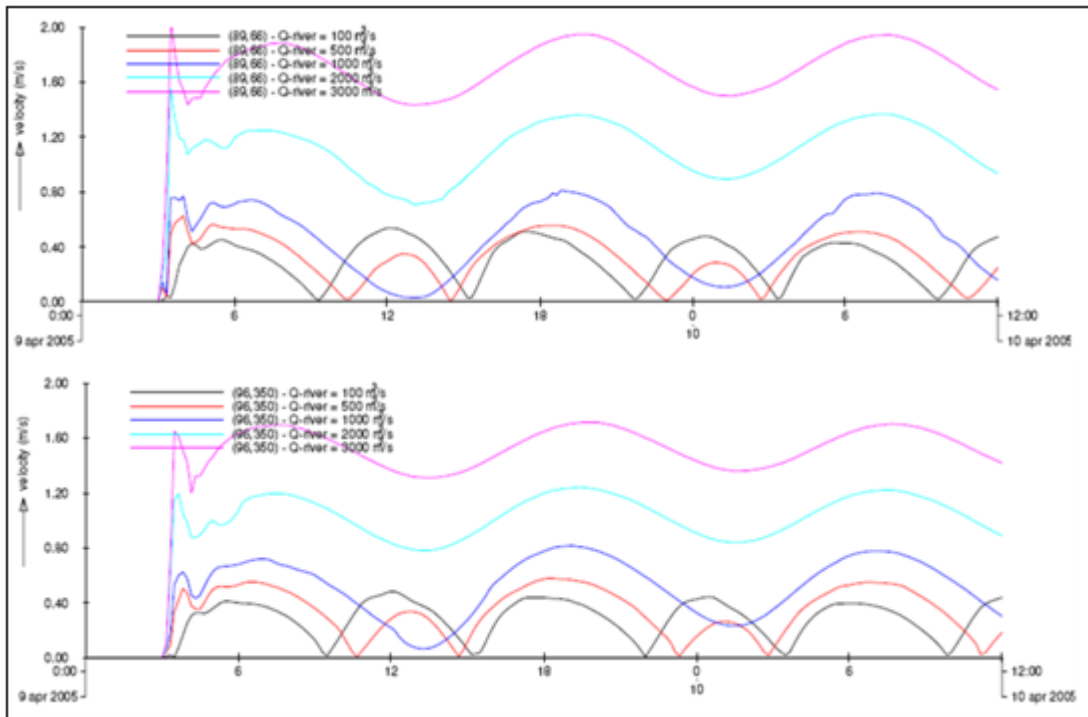

figure C-14: flow velocities in (96,277) and (96,350) - results of 3D-flow simulation

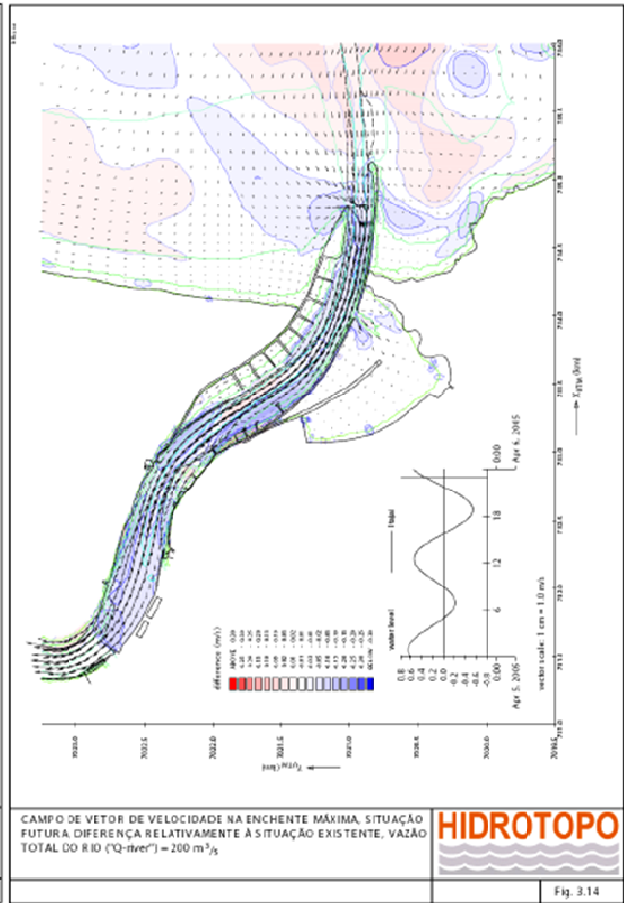
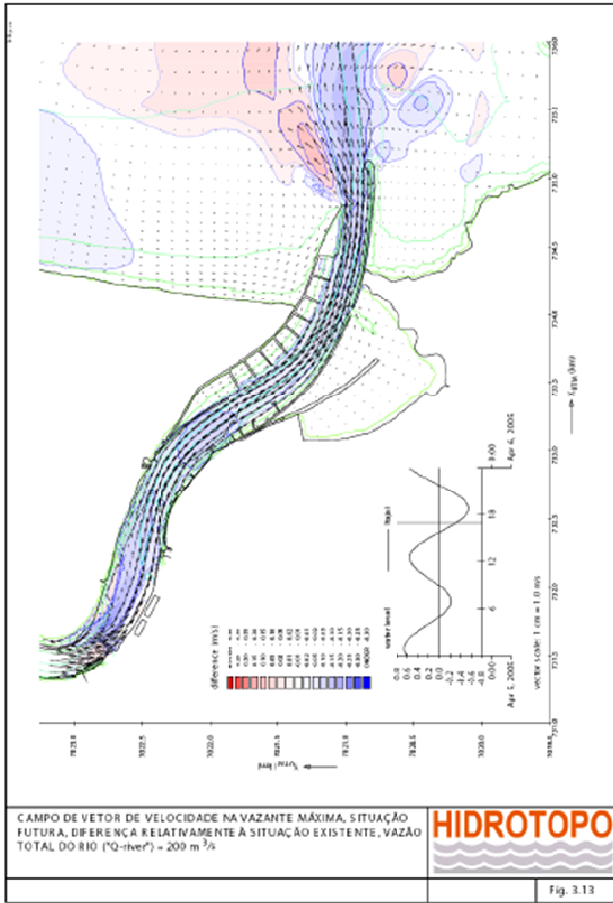

figure C-15: 3D-flow simulation - Hidrotopo

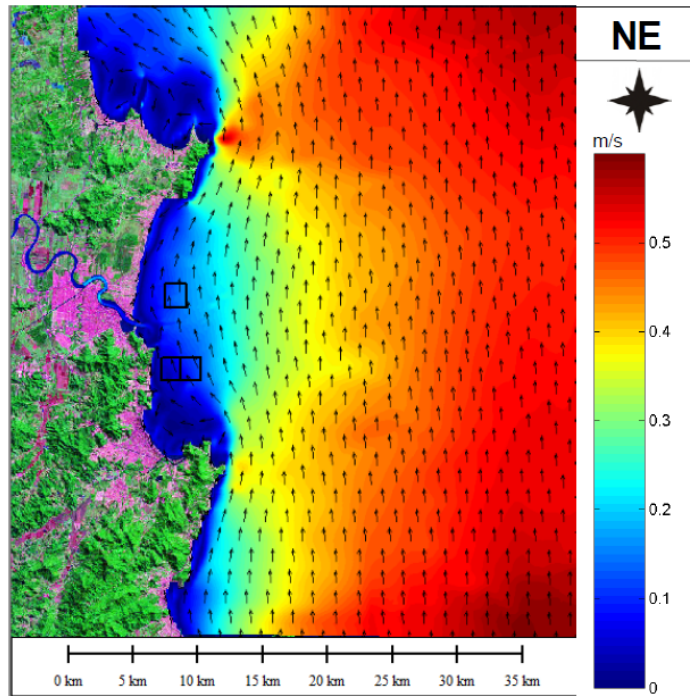

figure C-16: velocity field on the scenario with wind north east (NE) and flood tide. Observe the values of current velocities in the order of 0.2m/s north.

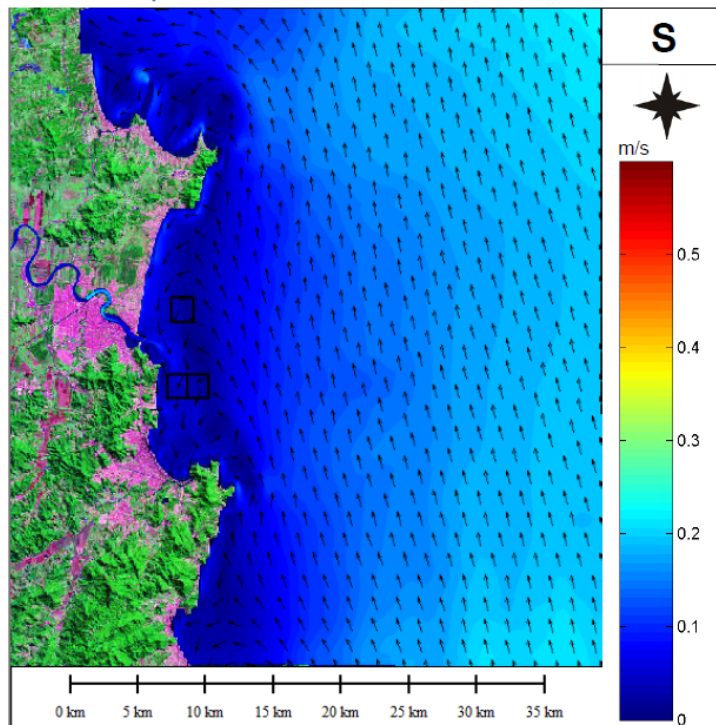

figure C-17: velocity field on the scenario with southerly winds (S) with flood tide. It is observed the formation of a vortex off the Mariners and Brava beaches, providing the reversal of currents to the south. The speeds are about 0.2m/s.

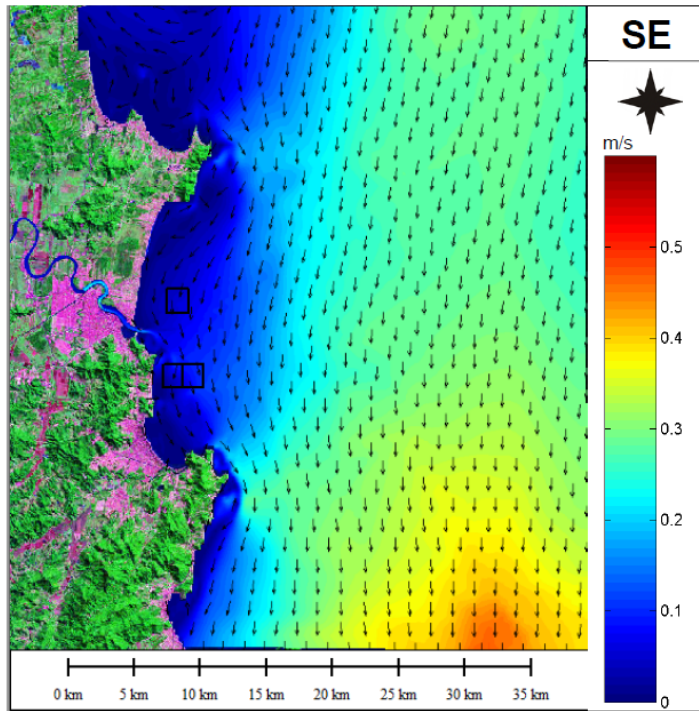

figure C-18: velocity field on the scenario with wind southeast (SE) and ebb tide. Observe the current parallel to the coastline to the south, with approximately 0.2 m/s.

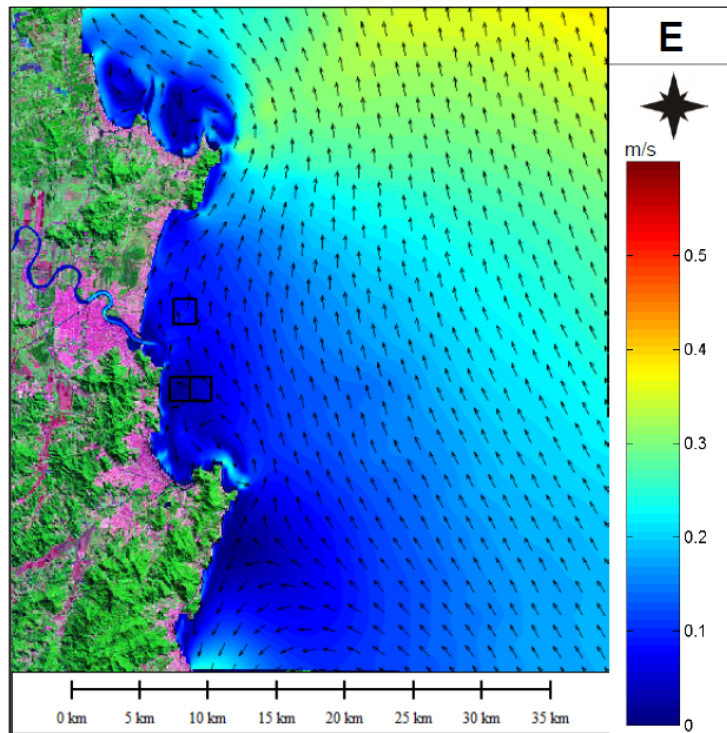

figure C-19: velocity field on the scenario with wind east (E) and flood tide. Observe the current parallel to the coastline in the north with 0.2m/s.

Appendix D: Harbour

D.1 General

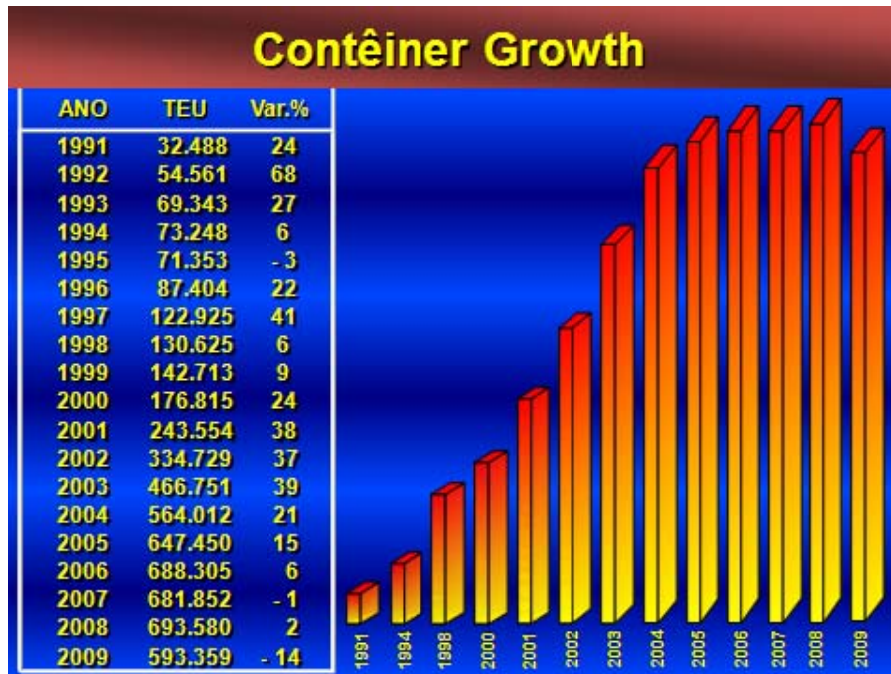

figure D-1: container growth

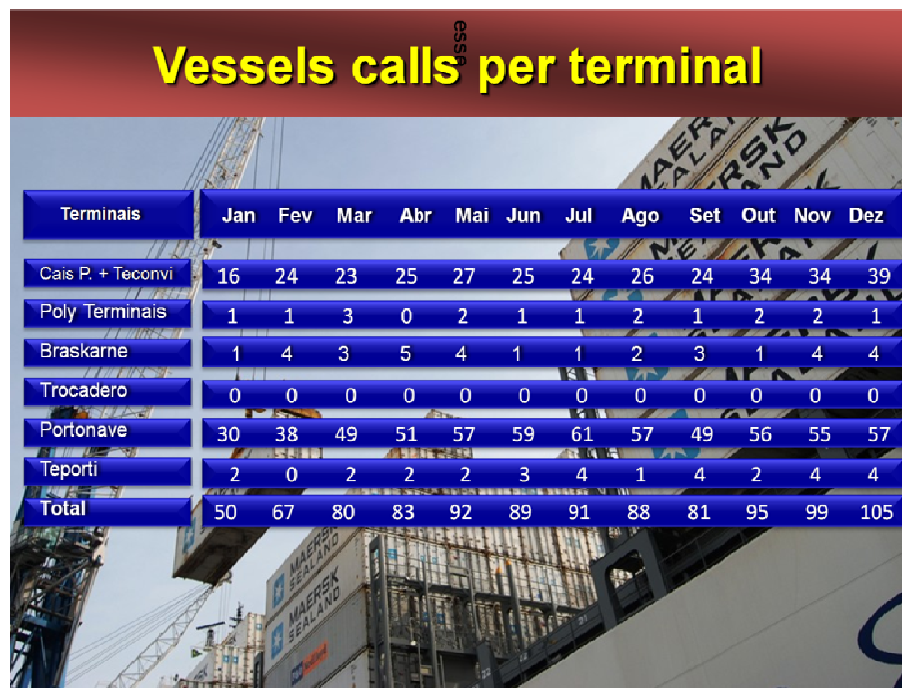
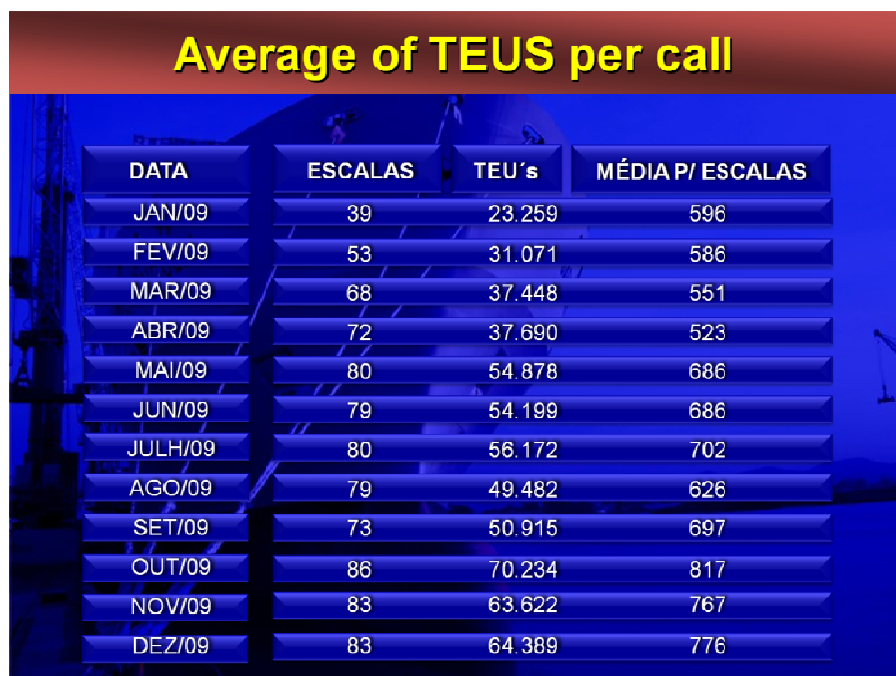

figure D-2: vessels calls per terminal

The image shows a table titled "Average of TEUS per call" overlaid on a background image of a port at night. The table has four columns: "DATA", "ESCALAS", "TEU's", and "MÉDIA P/ ESCALAS". The data rows represent months from January to December 2009. The values for "ESCALAS" range from 39 to 86, "TEU's" from 23,259 to 70,234, and "MÉDIA P/ ESCALAS" from 596 to 817.

DATA	ESCALAS	TEU's	MÉDIA P/ ESCALAS
JAN/09	39	23.259	596
FEV/09	53	31.071	586
MAR/09	68	37.448	551
ABR/09	72	37.690	523
MAI/09	80	54.878	686
JUN/09	79	54.199	686
JULH/09	80	56.172	702
AGO/09	79	49.482	626
SET/09	73	50.915	697
OUT/09	86	70.234	817
NOV/09	83	63.622	767
DEZ/09	83	64.389	776

figure D-3: average of TEUs per call

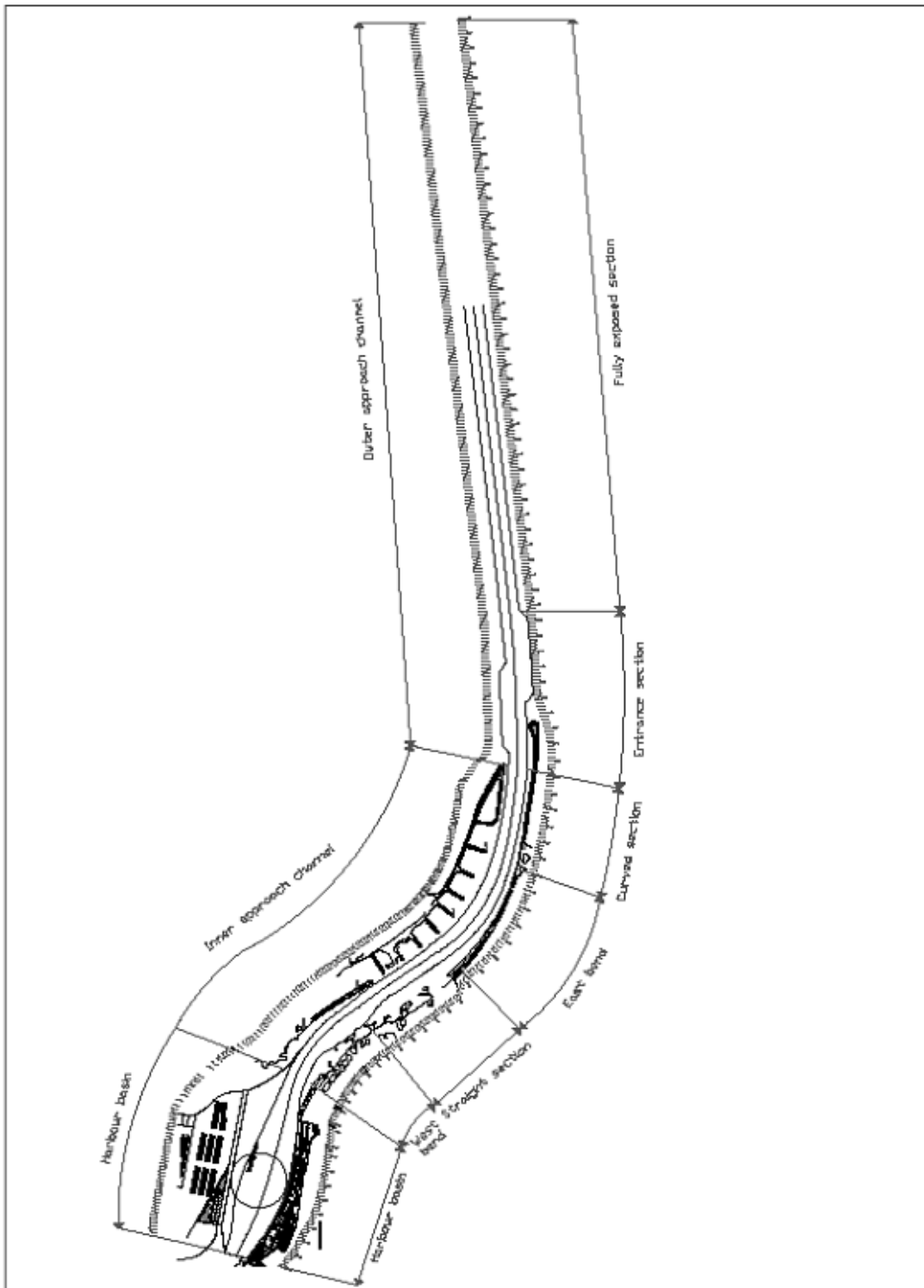

figure D-4: overview current layout of harbour

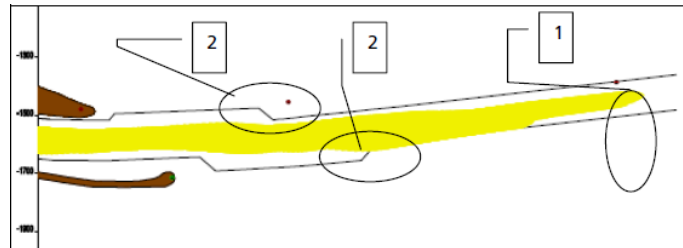

figure D-5: tapers in layout outer channel



figure D-6: overview organisations along the southern bank

D.2 Checking the dimensions

- Approach channel

In this section the three design parameters; alignment, width and depth will be checked for the current and future situation for both current and future design vessel. Although the design parameters are to some extent interdependent, they will be treated separately here.

The International Navigation Association (PIANC) has published a Guide for Design of Approach Channels, which provides a valuable reference (PIANC, 1997). Some of the material described below is taken from this report, without further reference.

- Alignment

The following (sometimes conflicting) requirements apply to the alignment of an approach channel:

- The shortest possible length taking into account wave, wind and current conditions
- Minimum cross-currents and cross-wind
- Small angle with dominant wave direction
- Minimize number of bends and avoid bends close to port entrance
- The need to avoid obstacles or areas of accretion which are difficult or expensive to remove or require excessive (and hence costly) maintenance dredging

In this case of course the local geometry and bottom conditions of the Rio Itajaí-Açu play the most important roles in the alignment of the actual inner approach channel. There might be a possibility to change the alignment of the outer approach channel and enlarge the radius of some bends in the inner approach channel. These possibilities will be discussed later.

- Channel Width

A sailing ship makes a sinusoidal track and thus covers a 'basic width', which is about 1.5 times the ship's beam. The effects of wind, current and waves require additional width, but so does the lack of visibility. Moreover certain margins are needed, which depend on the type of channel bank and the type of cargo. The PIANC Working Group has developed a method for concept design, which accounts for all these aspects; see table D-1.

Width component	Condition	Width (m)
Basic width (W_{BM})	$1.25 D < d < 1.5 D$	1.6 B
	$d < 1.25 D$	1.7 B
Additional width (W_i)		
▪ prevailing cross-winds	15 - 33 kn	0.4 B
	33 - 48 kn	0.8 B
▪ prevailing cross-current	0.2 - 0.5 kn	0.2 B
	0.5 - 1.5 kn	0.7 B
	1.5 - 2.0 kn	1.0 B
▪ prevailing long current	1.5 - 3 kn	0.1 B
	> 3 kn	0.2 B
▪ prevailing wave height	1 - 3 m	1.0 B
	> 3 m	2.2 B
▪ aids to navigation	VTS	0
▪ seabed characteristics	good	0.1 B
	soft	0.1 B
▪ cargo hazard	hard	0.2 B
	medium	0.5 B
	high	1.0 B
▪ separation distance (W_p)	8 - 12 kn	1.6 B
▪ bank clearance (W_B)	5 - 8 kn	1.2 B
	sloping edge	0.5 B
	steep, hard embankment	1.0 B

table D-1: PIANC method to determine required width

For straight sections the channel width is described by the following equation:

$$W = W_{BM} + \sum W_i + 2W_B$$

The additional width in a bend depends on rudder angle, water depth/draught ratio and the availability of tug assistance. The swept path of the ship in bends amounts to 0.35B assuming a rudder angle of 20° and a water depth of 1.25D. For smaller under keel clearance this additional width further decreases to 0.2B at $d=1.1D$. It is common practice to only apply additional width in case the adjoining straight leg has a minimum width W_{BM} . No additional width in the bend is required when width additions for wind current, etc. are included.

Outer approach channel:

Basic width (W_{BM})	$d < 1,25 D$	→	1.7B
Prevailing cross-winds:	15 - 33kn	→	0.4B
Prevailing cross-current:	0.4kn	→	0.2B
Prevailing long current:	>3kn	→	0.2B
Prevailing wave height:	1 -3m	→	1.0B
Aids to navigation:	good	→	0.1B
Seabed characteristics:	soft	→	0.1B
Cargo Hazard:	none	→	0.0B +
Total additional width (W_i)			2.0B
Bank clearance (W_B)	sloping edge	→	0.5B

So $W_{outer} = 1.7B + 2B + 2 * 0.5B = 4.7B$

Currently the outer approach channel is 120m wide, so the channel would be safe for vessels with a beam of $120/4.7=26\text{m}$. This is less than the beam of the former design ship ($B=37\text{m}$), and thus manoeuvring such a vessel is hard for the pilot, if even possible. This will result in a slower manoeuvre, longer service time and hence more costs.

In the new situation, with the outer approach channel having a width of 160m and designing for a ship of 45m wide, the width should be $4.7*45=211,5\text{m}$. So also in this situation the channel is too narrow. Widening to a width of 210m should be advised.

For the inner approach channel:

Basic width (W_{BM}):	$d < 1,25 D$	→	1.7B
Prevailing cross-winds:	15 - 33kn	→	0.4B
Prevailing cross-current:	0kn	→	0.0B
Prevailing long current:	>3kn	→	0.2B
Aids to navigation:	good	→	0.1B
Seabed characteristics:	soft	→	0.1B
Cargo Hazard:	none	→	0.0B
			0.8B

Bank clearance (W_B) sloping edge → 0.5B

So $W_{inner} = 1.7B + 0.8B + 2 * 0.5B = 3.5B$

In the present situation ($B_{inner\ channel}=120\text{m}$, $B_{design\ ship}=37\text{m}$), the width of the inner channel is nearly sufficient, as $120/3.5=34\text{m}$.

For the future, the inner channel having a width of 160m and a design ship of 45m wide, the width of the inner channel is also sufficient, as $3.5*45=157,5\text{m}$.

The entrance of the breakwaters currently has a width of 120m. In order to allow the design vessel through the breakwaters, this section is currently widened to 128m, for which pilots believe it is feasible. However, due to the reason that the outer channel must have a width of 210m, a width of 128m between the breakwaters will cause major difficulties for the navigation of the design vessel. Considering an inner channel of 157,5m, the channel width between the breakwaters should be extended to this width as well. Here for the alignment of the breakwaters should be checked in order to realise this width, which will be done later on in this study.

Of course remarks should be made on the above mentioned: the guidelines used are applied for the initial design and should be checked and refined by Fast Time Simulation. Particularly useful would be a comparison of the duration of the approach manoeuvres at various given channel widths. This will give insight in the relationship of widening the channel against the gain in service time. Also a check on the

feasibility of manoeuvring for an increasingly wide ship at a given channel width can be valuable for future perspective.

- Channel depth

The depth of approach channels depend on a number of factors:

- Draught of the design ship, i.e. the ship with the largest draught, which may enter the port fully loaded
- Other ship-related factors such as the squat (sink age due to the ship's speed) and trim (unevenness keel due to loading conditions) and the vertical response to waves
- Water level, mostly related to tidal levels
- Channel bottom factors, including the variation in the dredged level and the effects of siltation after maintenance dredging

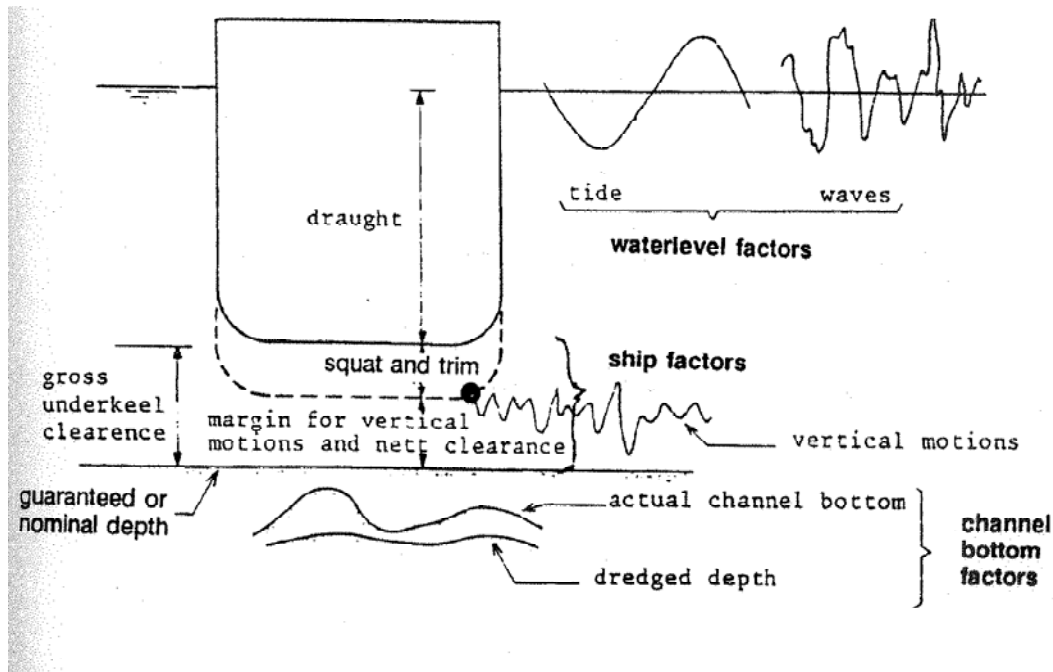

figure D-7: determining required depth for approach channel

To determine the various factors separately the following formula is used:

$$d = D - T + s_{\max} + r + m$$

In which:

- d = guaranteed depth (with respect to CD)
- D = draught design ship
- T = tidal elevation above DHN, below which no entrance is allowed
- s_{\max} = maximum sink age (fore or aft) due to squat and trim
- r = vertical motion due to wave response
- m = remaining safety margin or net under keel clearance

The value T is introduced when a port decides to introduce a tidal window. The values of s_{\max} , r and m together form the gross under keel clearance (UKC). They may be estimated on the basis of experience; $s_{\max} = 0,5\text{m}$, $r = H_s/2$. m has a value depending on the type of soil along the channel for soft mud, $0,5\text{m}$ for a sandy bottom and $1,0\text{m}$ for a hard soil or rock.

An interview with a pilot showed that for the new container vessels the combined effect of heave, pitch, roll and yaw can easily take up an UKC of $1,5\text{m}$ to 2m for the governing wave directions (the 'quarters'). This UKC corresponds with the earlier mentioned values of $s_{\max} = 0,5\text{m}$ and $m = 0,5\text{m}$, and $r = 1\text{m}$ (so a significant wave height $H_s = 2\text{m}$, which is in line with the actual wave climate at the outer approach channel), see paragraph 5.2, in main report. The calculations below will also be done for wave directions from the quarters because the modern container vessels are particularly sensitive for waves from the quarters, which give the greatest wave induced motions to the vessel.

The depth of the outer channel is currently about 12 to $12,5\text{m}$. Taking into account an UKC of 2 meters and the current tidal window of $T = 0,6\text{m}$ gives a required depth of $d = 10,5 - 0,6 + 2 = 11,9\text{m}$, so the depth is sufficient.

The inner channel generally has a depth of $11,5\text{m}$. Due to the reduced wave action and the bed consisting of mud, an UKC of $1,5\text{m}$ is chosen here. This gives a required depth of $10,9\text{m}$, so also here the depth is ok.

For the future situation (depth of outer approach channel $14,5\text{m}$, depth of inner approach channel 14m and a design ship with a draught of 14m) it is clear the depth is not large enough to accommodate the new design ship when it is fully loaded, as

$$d = D - T + s_{\max} + r + m$$

$$14,5 = 14 - T + 2$$

gives a required tidal elevation $T = 1,5\text{m}$, which does not occur, see paragraph 4.5, Tide, in main report. Therefore a calculation is made giving the percentage of loading of the design ship vs. the tidal elevation needed to accommodate the ship in this loading condition. Comparing this with the tidal data an extra graph is included showing the percentage of time the port can receive the ship in that particular loading condition. For this calculation a draught of 10m is used for the 'empty loading condition'¹, $s_{\max} = 0,5\text{m}$, $m = 0,5\text{m}$ and $r = 1\text{m}$ for the outer approach channel and $s_{\max} = 0,5\text{m}$, $m = 0,3\text{m}$ and $r = 0\text{m}$ for the inner channel. Tidal elevations lower than $-0,5\text{m}$ CD are excluded because they are not relevant. See figure D-9 and figure D-10.

¹ After consulting MSc. K. Wagner, marine engineer

As the results show, for the outer approach channel an operational time of 100% can only be achieved with a tidal window of +0,1m CD and a 65% loaded design ship (giving for a 6000TEU ship $0.65 \cdot 6000 = 3900\text{TEU}$). Depending on the wishes of the harbour, terminals and shipping lines, a suitable choice of tidal window can be made.

This spreadsheet can also be used to evaluate larger design ships (if expected in the future), or other depths of the approach channel, figure D-10.



figure D-8: draught versus tidal elevation – outer approach channel

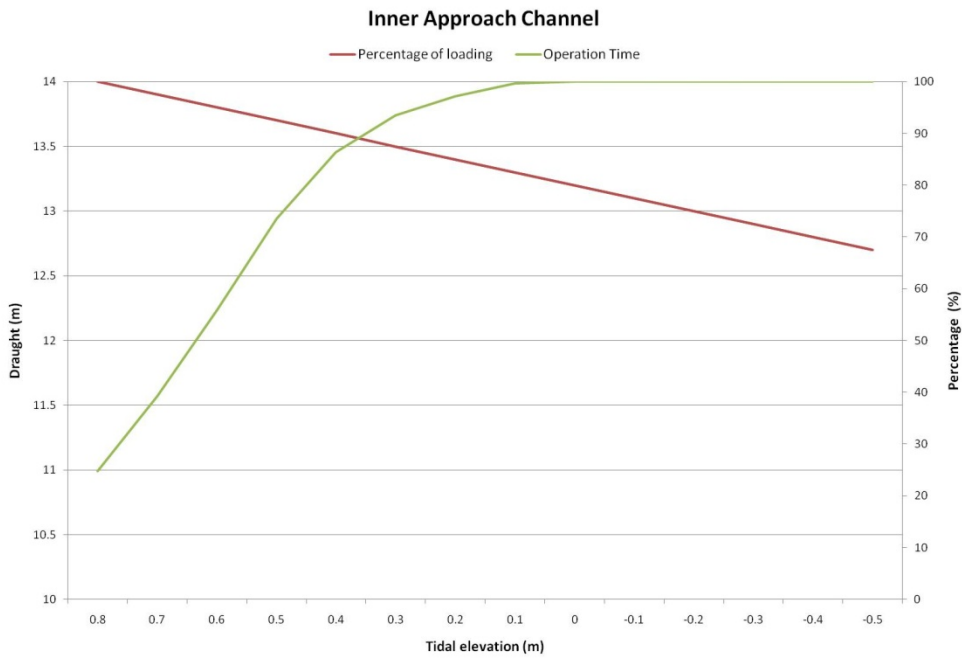

figure D-9: draught versus tidal elevation – inner approach channel

- Port basin and berth areas
 - Port basin

The port basin should give sufficient width for the safe towing in and towing out of the vessels, whilst other berths are occupied. The width can be determined using the requirements in figure D-11. Hence a width of approximately $5B+100\text{m}$ is required, which for the new design ship, with a beam of 45m, results in a basin width of 325m. This width is present throughout the basin.

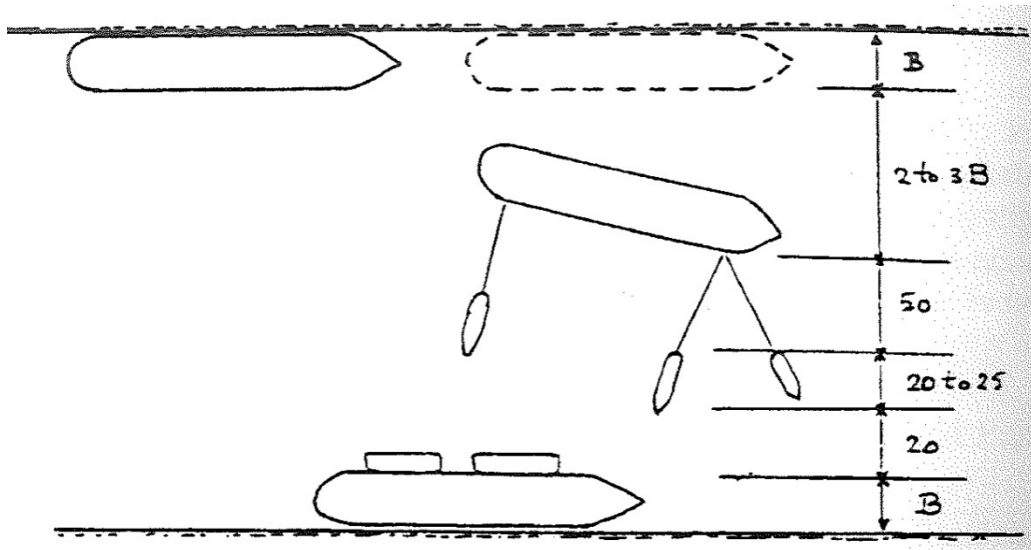

figure D-11: determining required basin width

- Turning circle

The turning basin, from where vessels are turned (whether before or after berthing) in the right direction to leave the port again (facing East), is situated inside the harbour basin and currently has a diameter of 360m. This is considered too small to safely turn a ship over 235m length with two vessels moored at each side of the basin. Pilots think it is possible to turn a vessel of 300m (so the new design vessel) if there are no vessels moored at the berths north and south of the turning circle, but there is very little margin for error and so the safety is questionable. Also such a tight fit will take much more time, increasing service times and thus waiting times. It is crucial for allowing the new design vessel to find a way to enlarge the turning basin.

- Quay length

For a single berth the quay length is determined by the length of the largest vessel frequently calling at the port, increased with 15m extra length fore and aft for the mooring lines. For multiple berths in a straight continuous quay front the quay length is based on the average vessel length (\bar{L}_s , which is $0.8 \cdot \text{LOA}$), as follows:

$$L_q = 1.1 * n * (\bar{L}_s + 15) + 15$$

This allows for a berthing gap of 15m between the ships moored next to each other and an additional 15m at the two outer berths. The factor 1.1 follows from a study carried out by UNCTAD.

In the case of the Port of Itajaí, as can be seen in figure D-12 the quays walls actually consist of two separate sections, each containing two berths. Section 1, containing berth 1 and 2 has a length of approximately 500m. Section 2, containing berth 3 and 4, has a length of ca. 485m.

In this case the maximum length of the ships berthing can be:

Section 1:

$$L_q = 1.1 * n * (\bar{L}_s + 15) + 15$$

$$500 = 1.1 * 2 * (\bar{L}_s + 15) + 15$$

$$\bar{L}_s = 205m = 0.8 * LOA \rightarrow LOA = \frac{205}{0.8} = 256m$$

Section 2:

$$L_q = 1.1 * n * (\bar{L}_s + 15) + 15$$

$$485 = 1.1 * 2 * (\bar{L}_s + 15) + 15$$

$$\bar{L}_s = 198m = 0.8 * LOA \rightarrow LOA = \frac{198}{0.8} = 247m$$

To accommodate larger ships of 300m in the future, there is no possibility to keep 4 berths with the current length of the quay walls. The number of berths will be reduced to two, one in section 1 and one in section 2. As the required quay length $L_q = 300 + 2 * 15 = 330 < 500m$ and $< 485m$ the length of these sections is more than sufficient to accommodate the new design vessel. In this case, concerning only the length of the quay walls, theoretically even ships up to a length of $500 = LOA + 2 * 15 \rightarrow LOA = 470m$ for section 1 and $485 = LOA + 2 * 15 \rightarrow LOA = 455m$ for section 2 could be allowed.

At this moment it is possible that a vessel of 300m is moored and at the same time 2 smaller vessels are moored. Currently once a week a vessel of 300m is moored and the future expectation is that this number won't increase, so there are no problems expected towards the quay length.

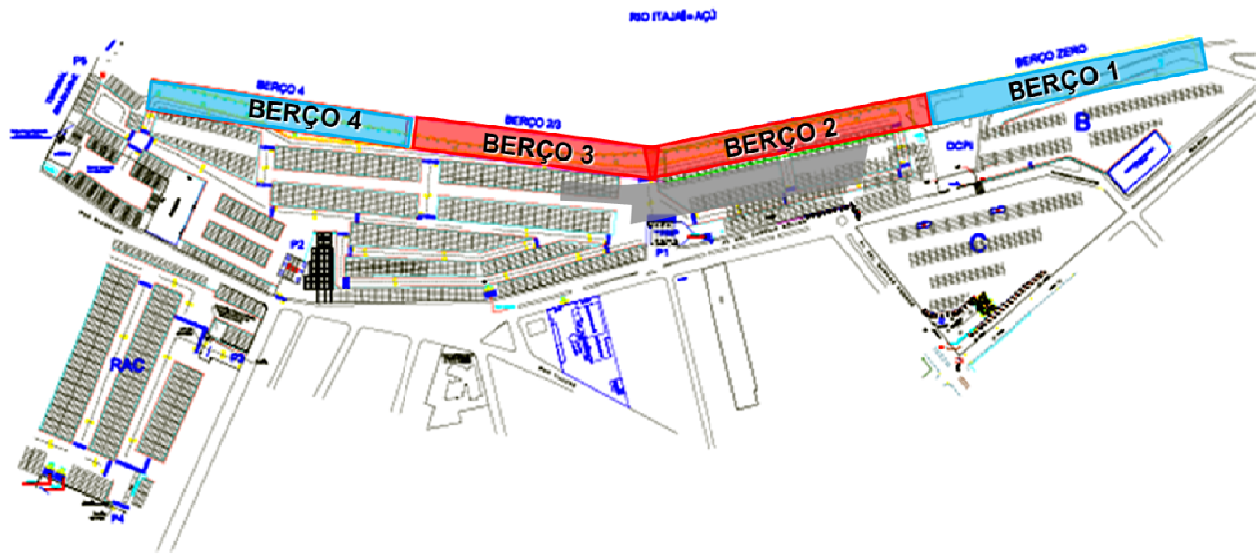

figure D-12: overview of berths

Appendix E: Optimization alignment

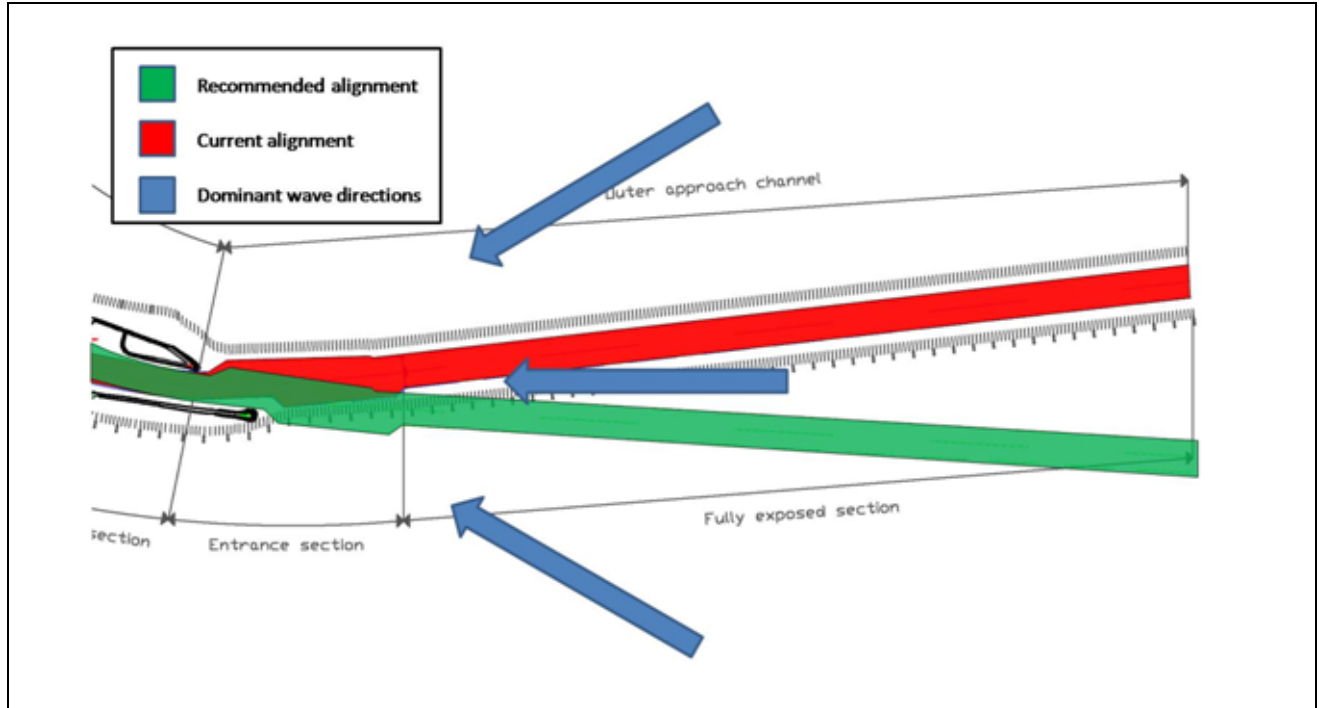

figure E-1: outer channel alignment + dominant wave directions

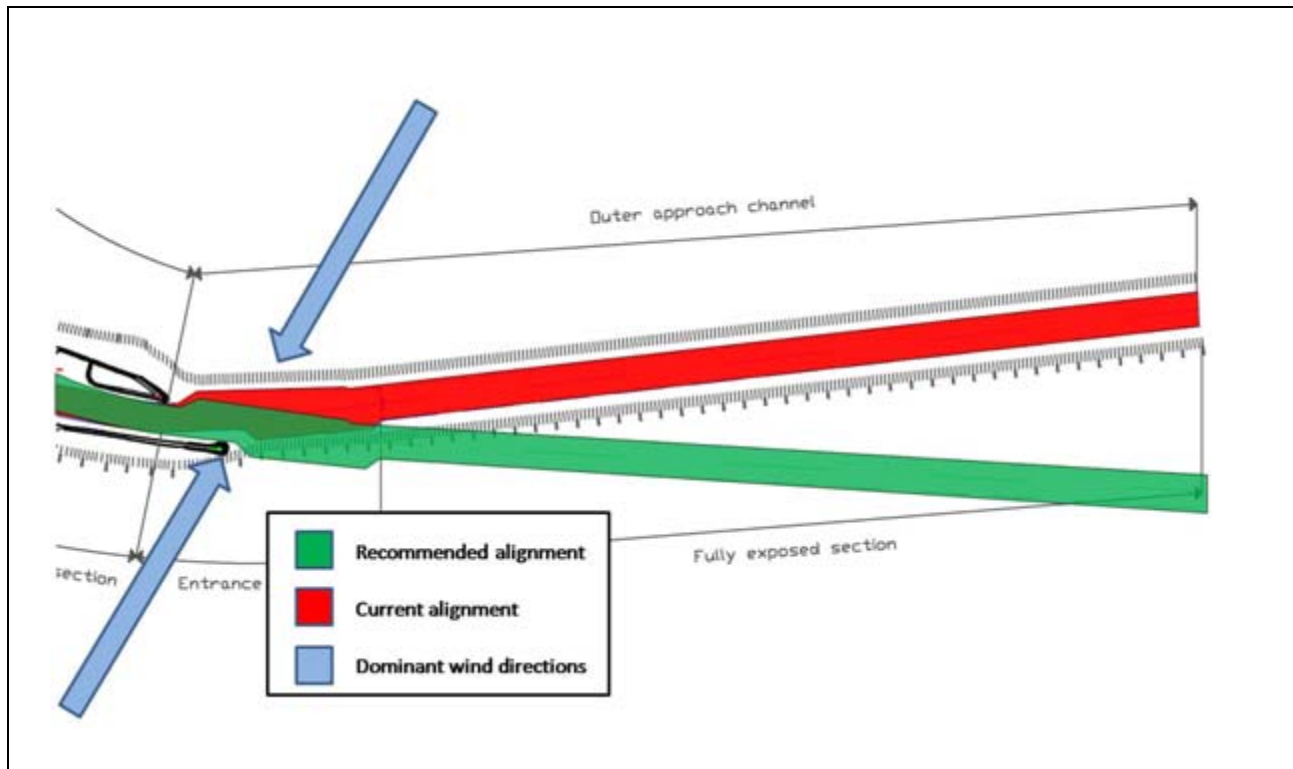

figure E-2: outer channel alignment + dominant wind directions

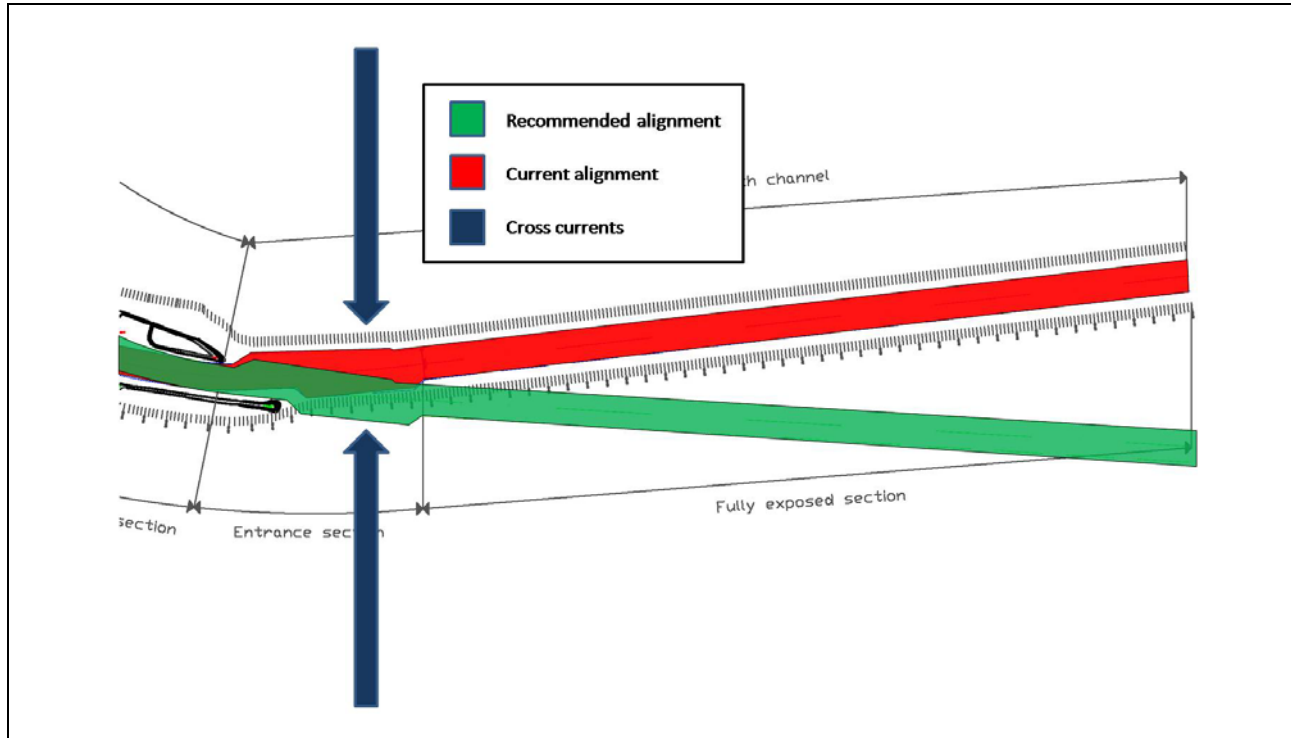

figure E-3: outer channel alignment + cross currents

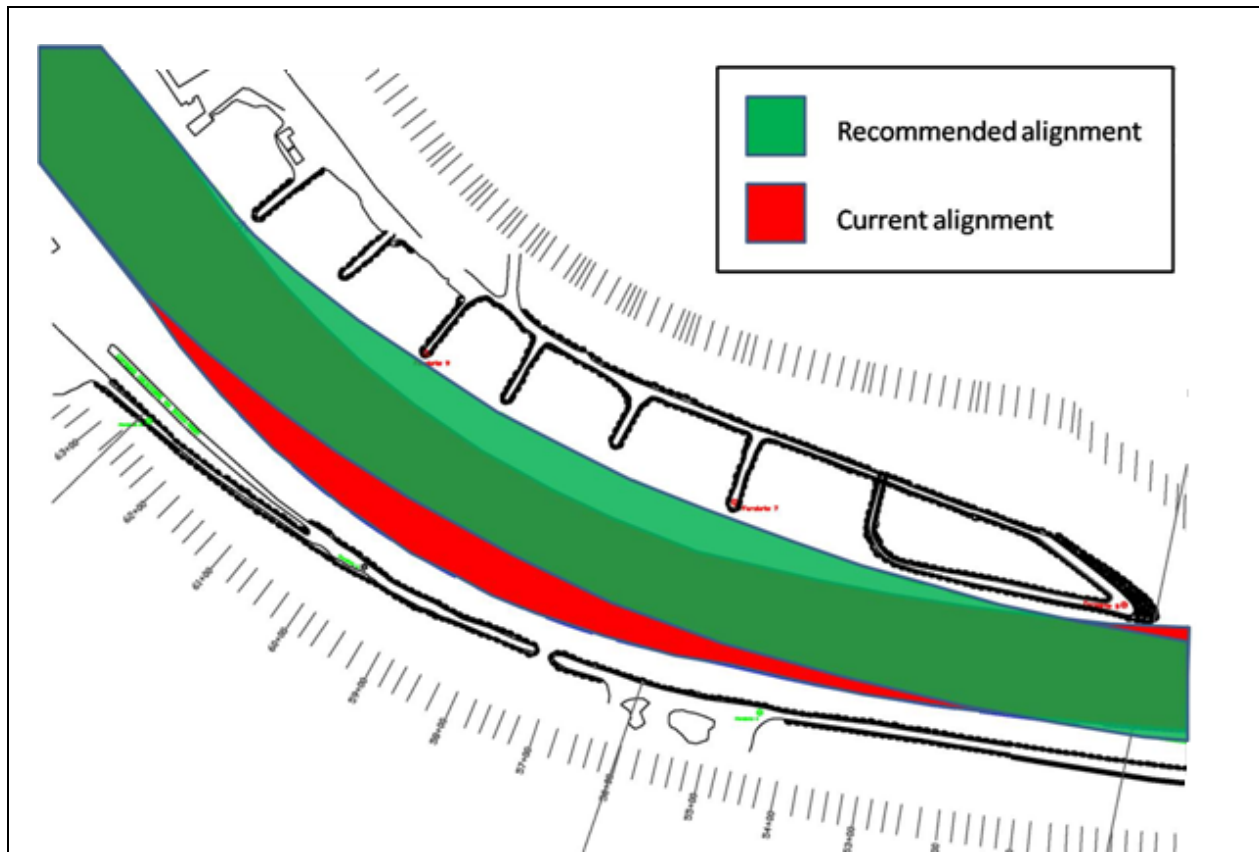

figure E-4: inner channel east bend alignment

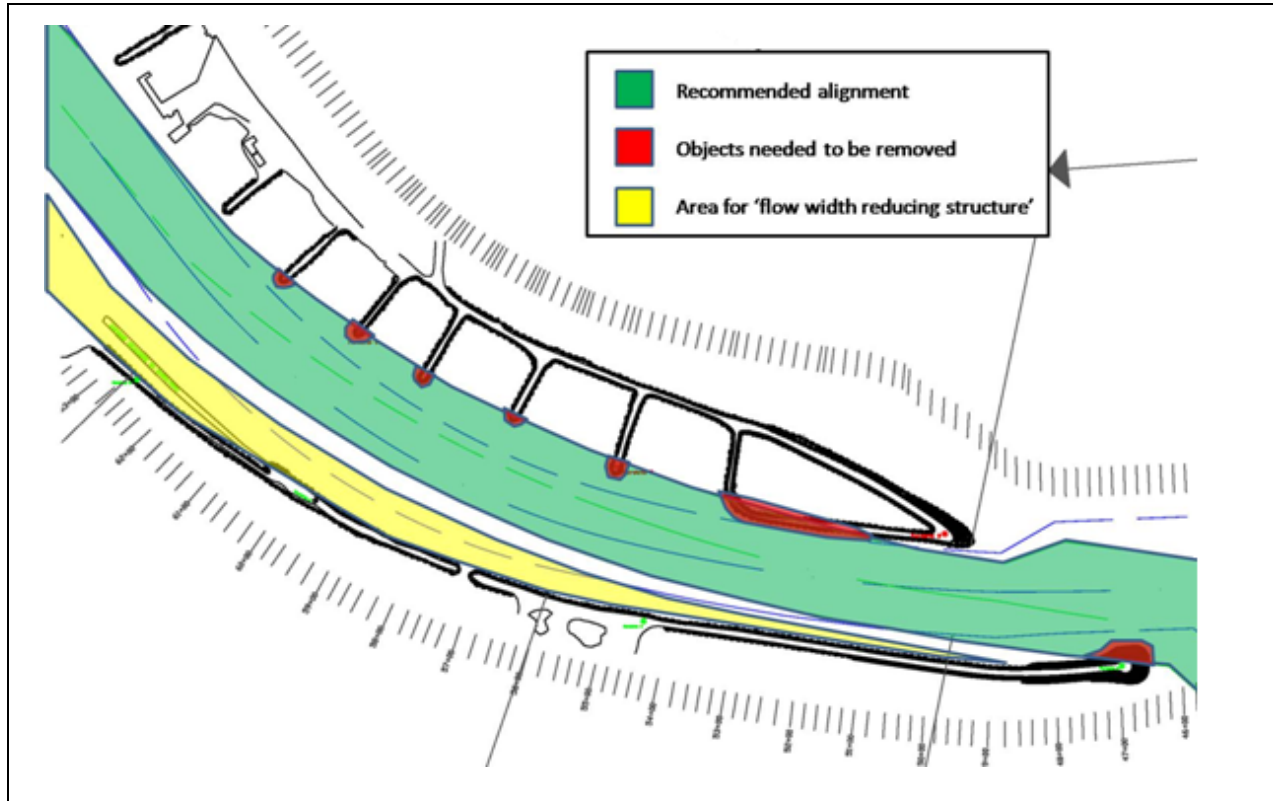

figure E-5: implementation recommended alignment east bend

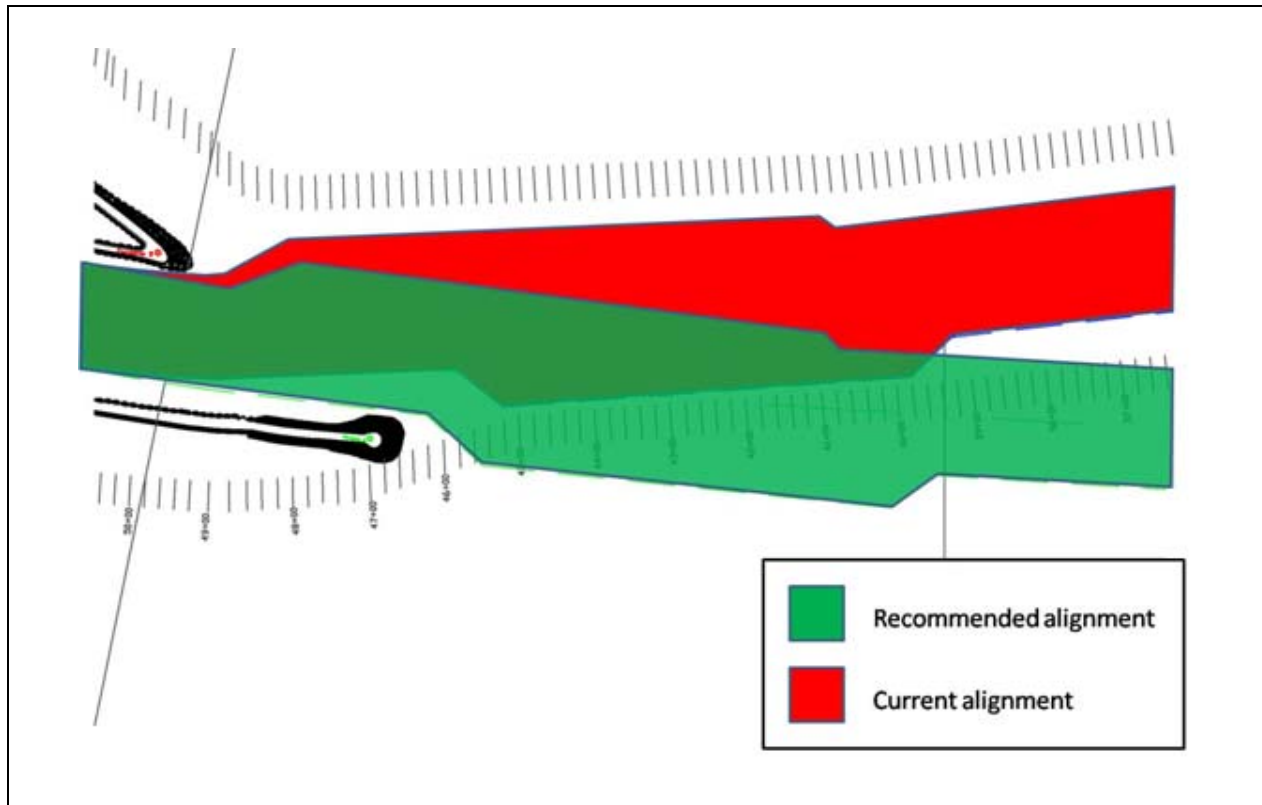

figure E-6: alignment entrance section

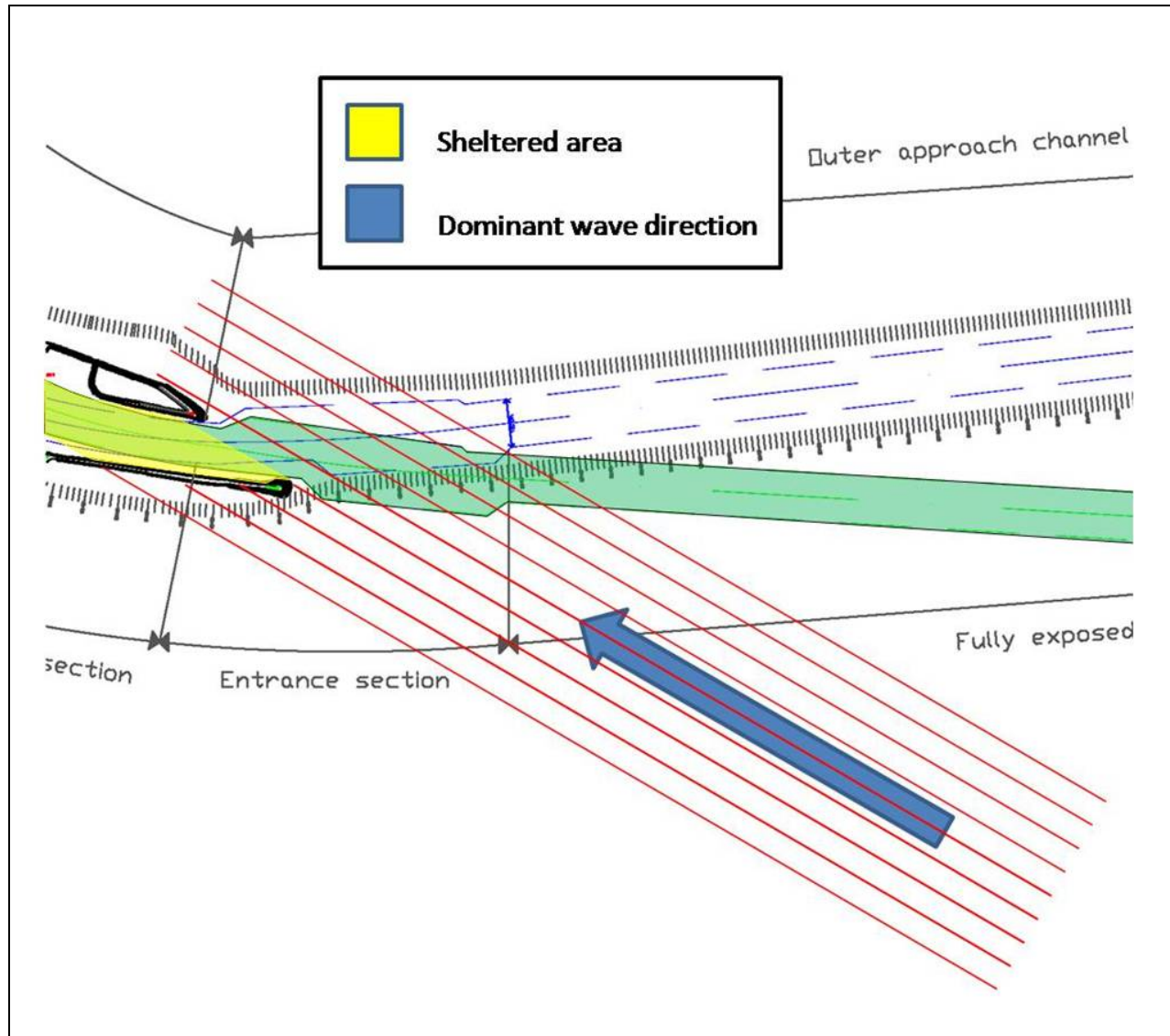

figure E-7: wave sheltering 1

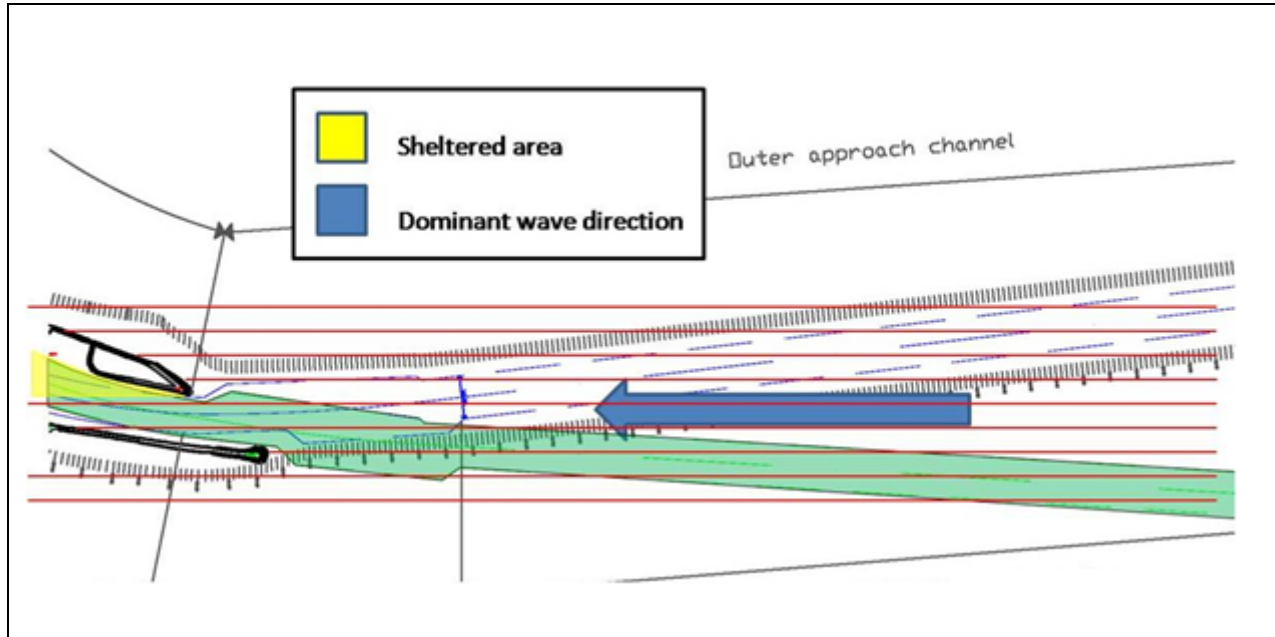

figure E-8: wave sheltering 2

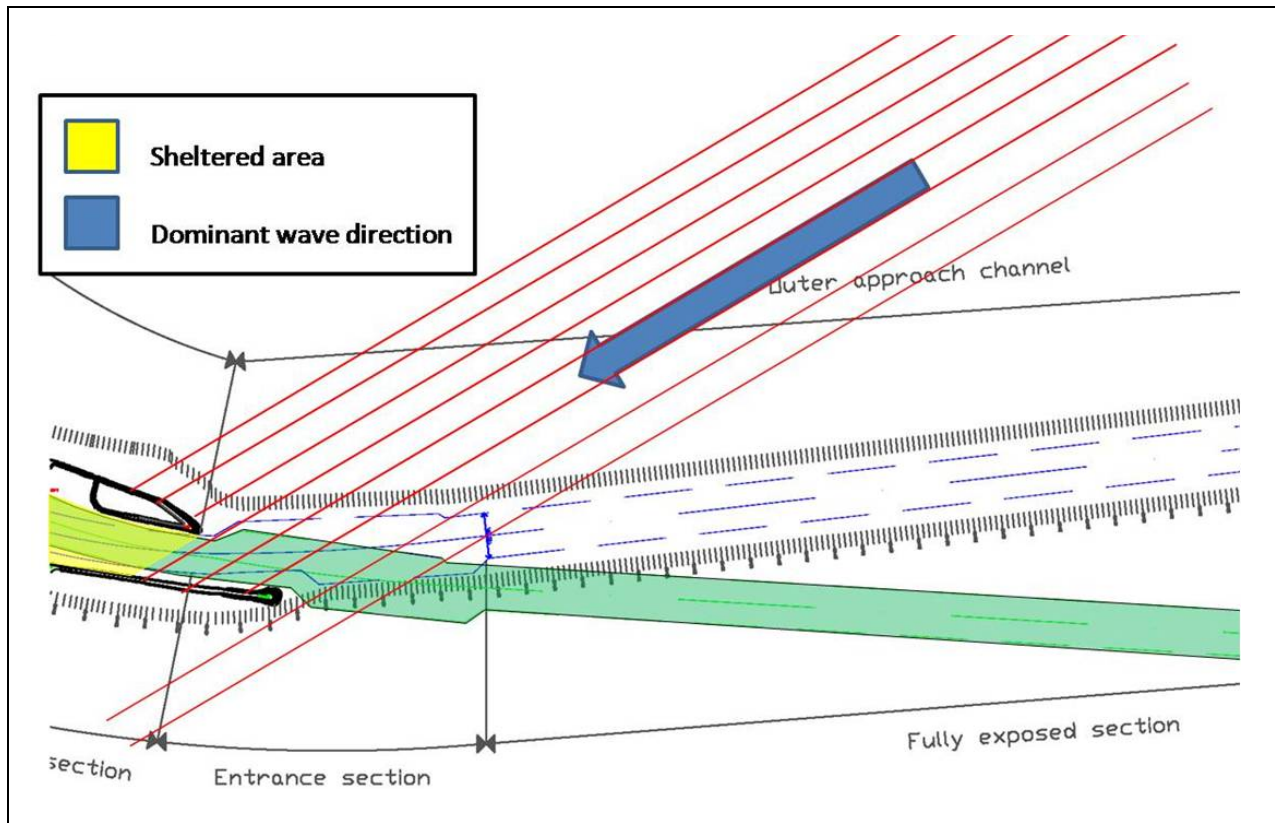

figure E-9: wave sheltering 3

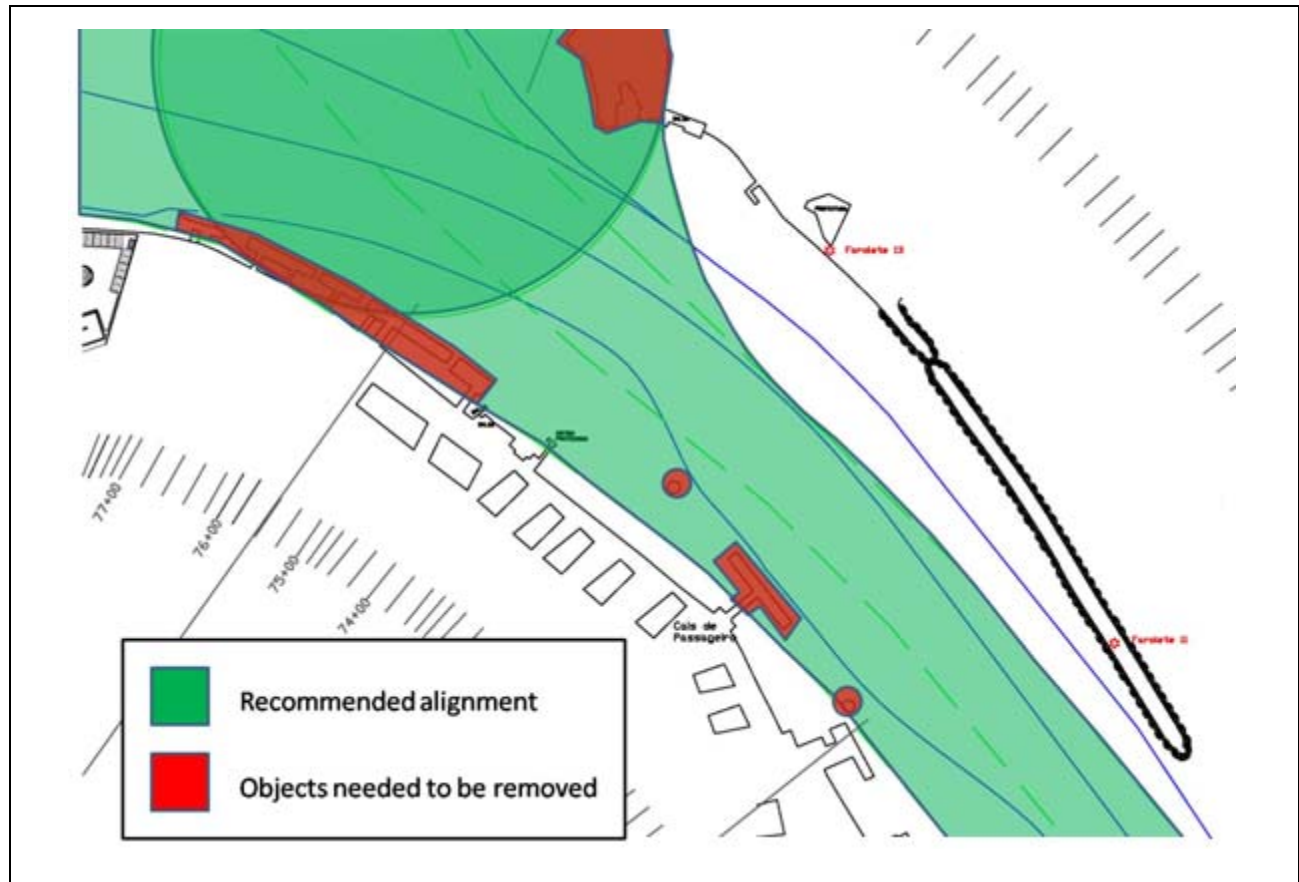

figure E-10: west bend alignment

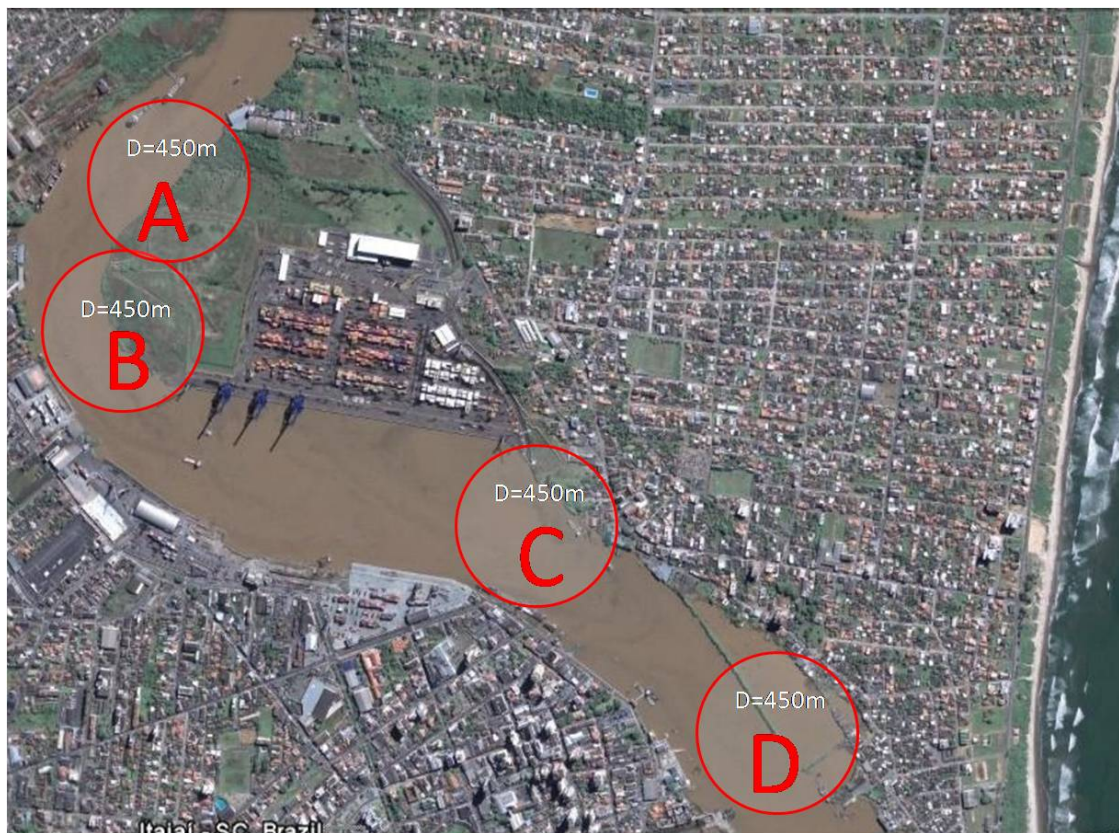

figure E-11: locations turning circle

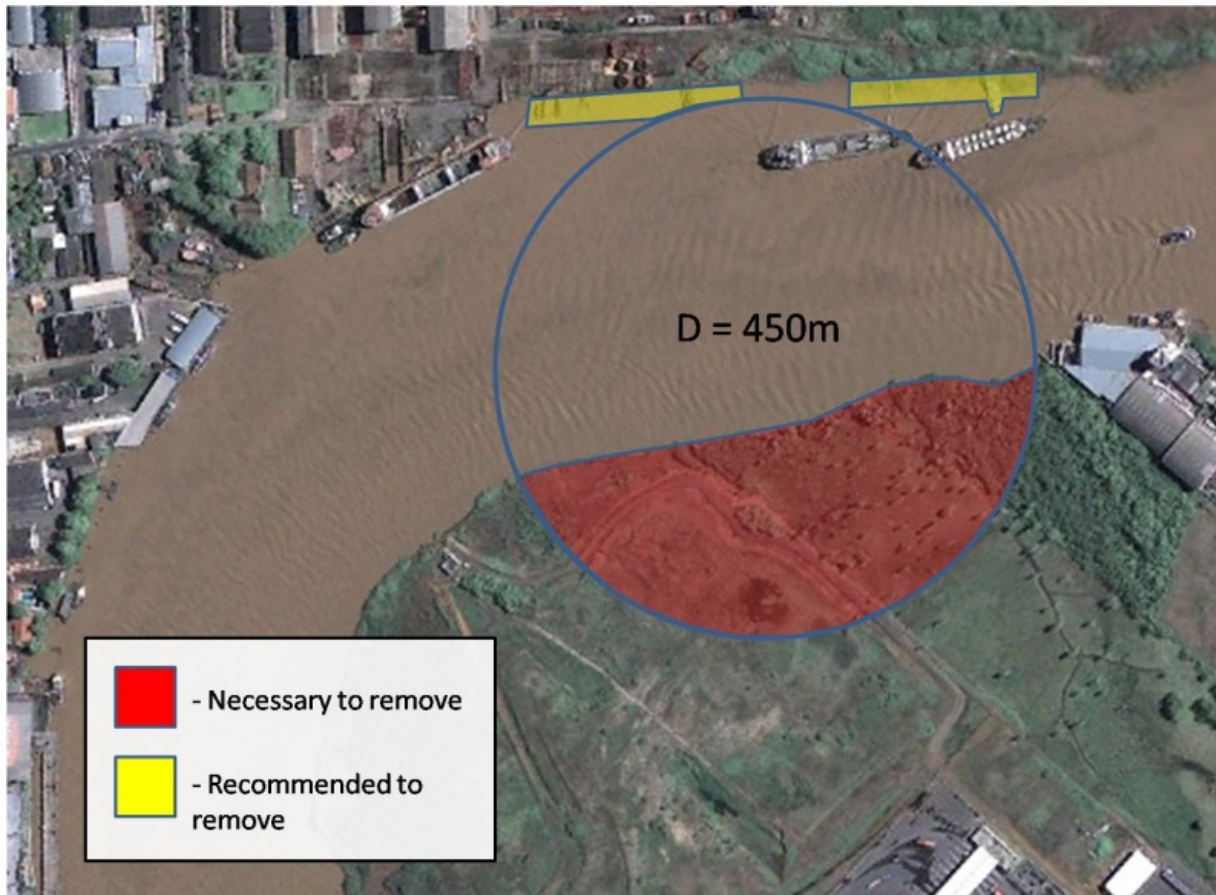

figure E-12: location A turning circle

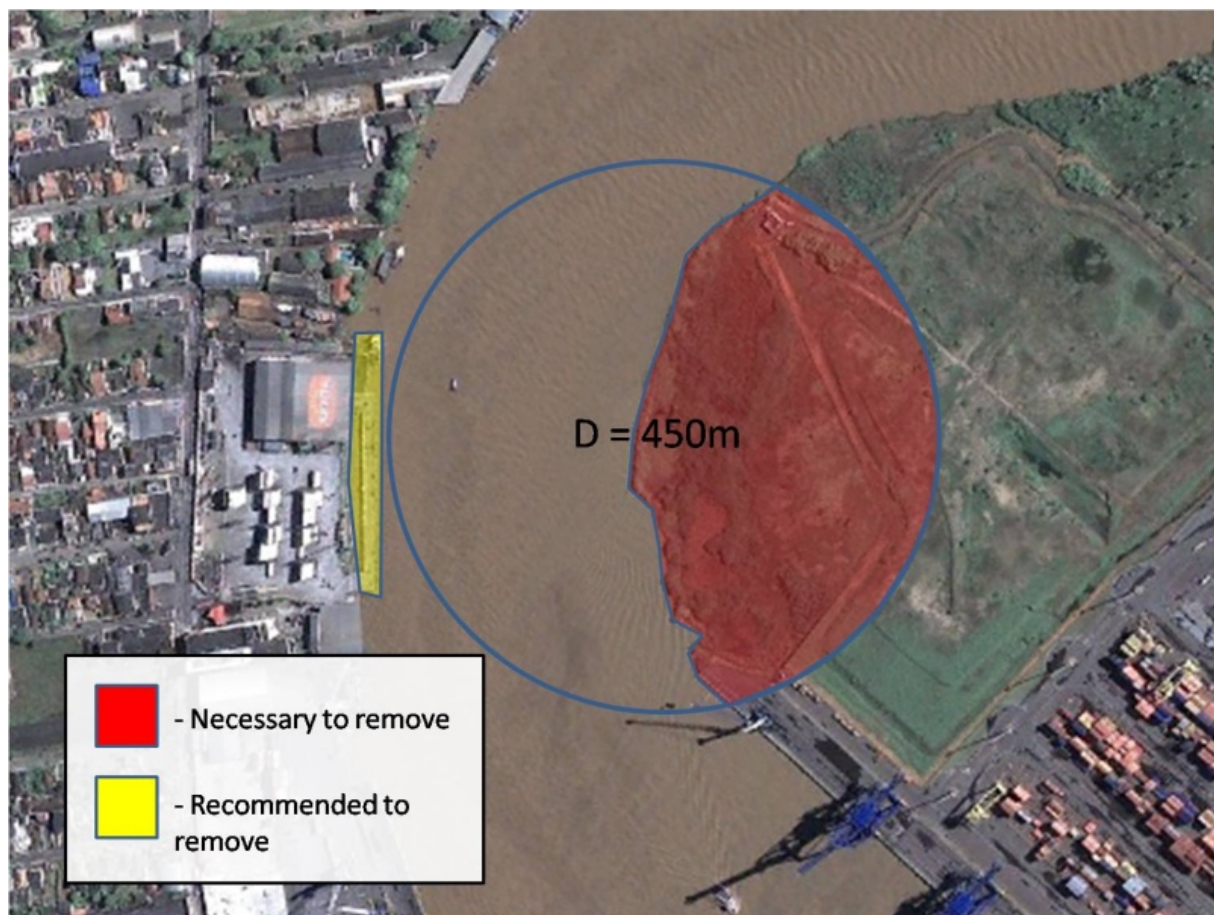

figure E-13: location B turning circle

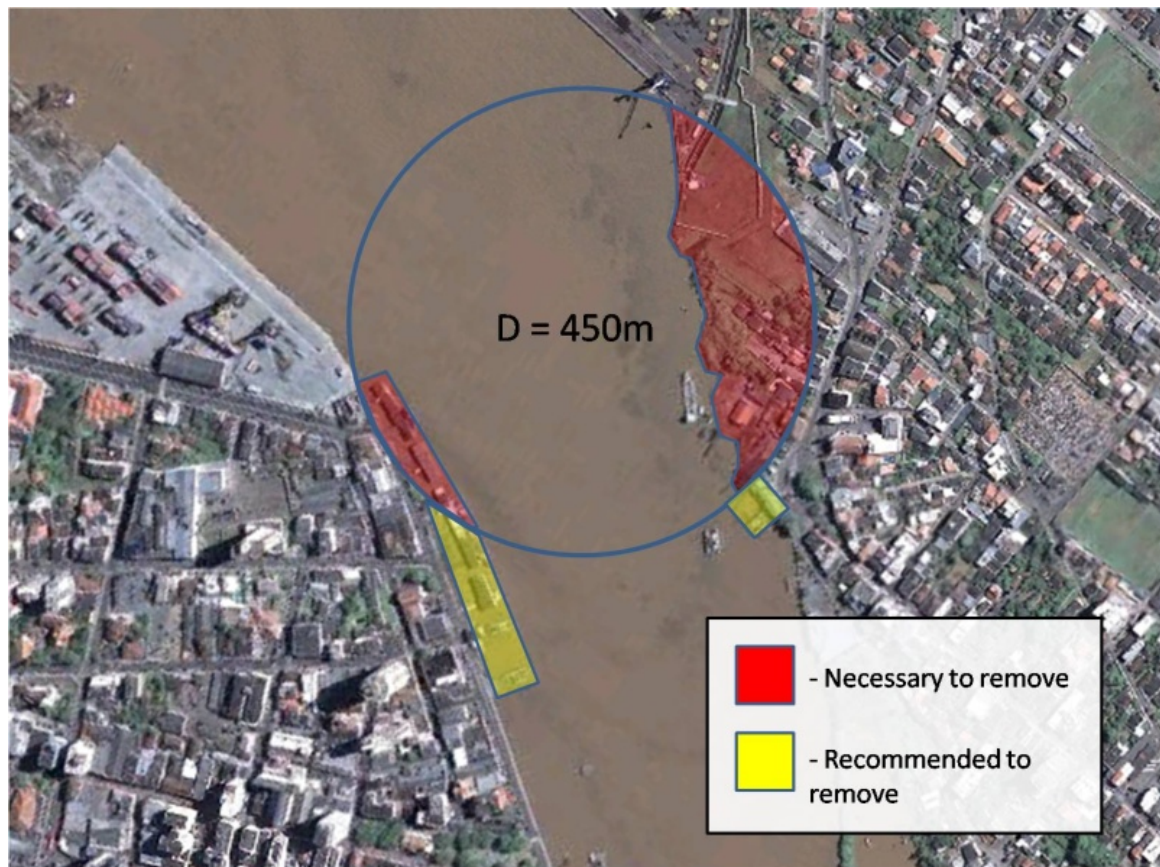

figure E-14: location C turning circle

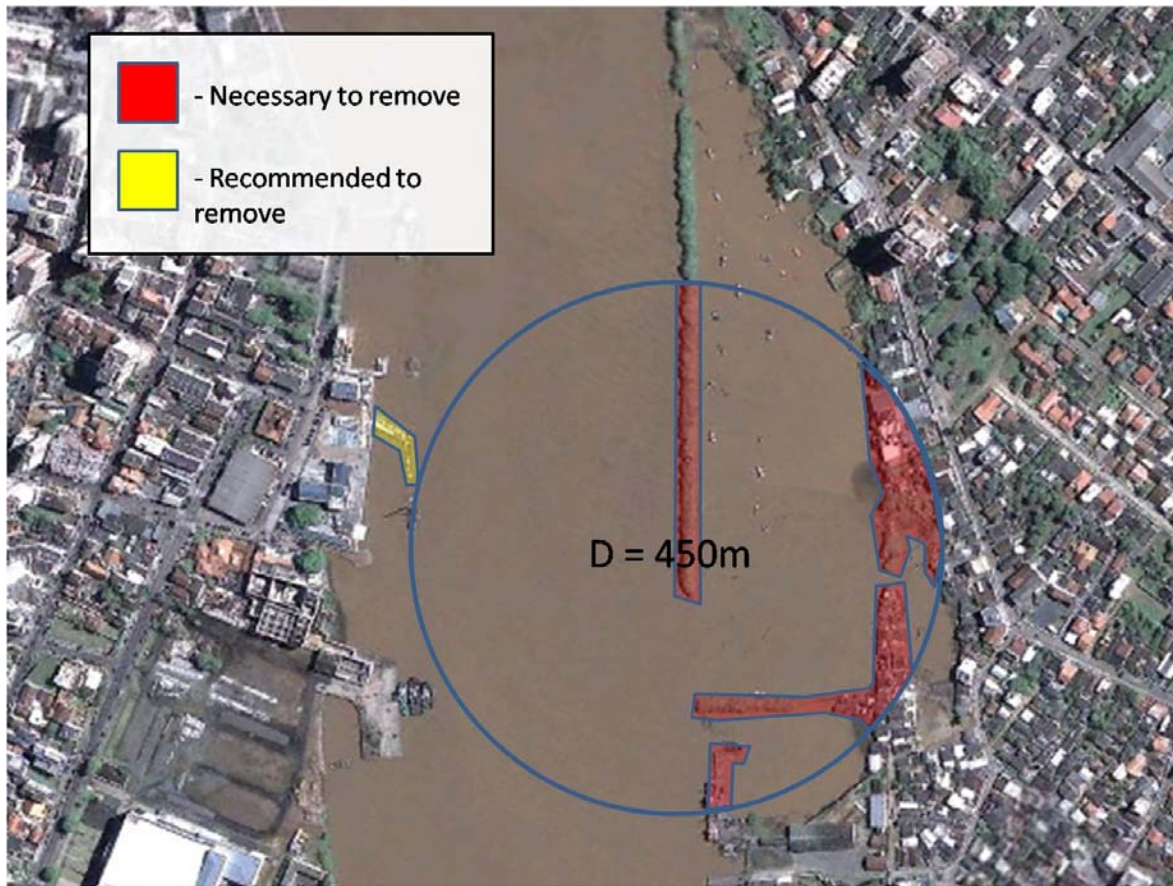

figure E-15: location D turning circle

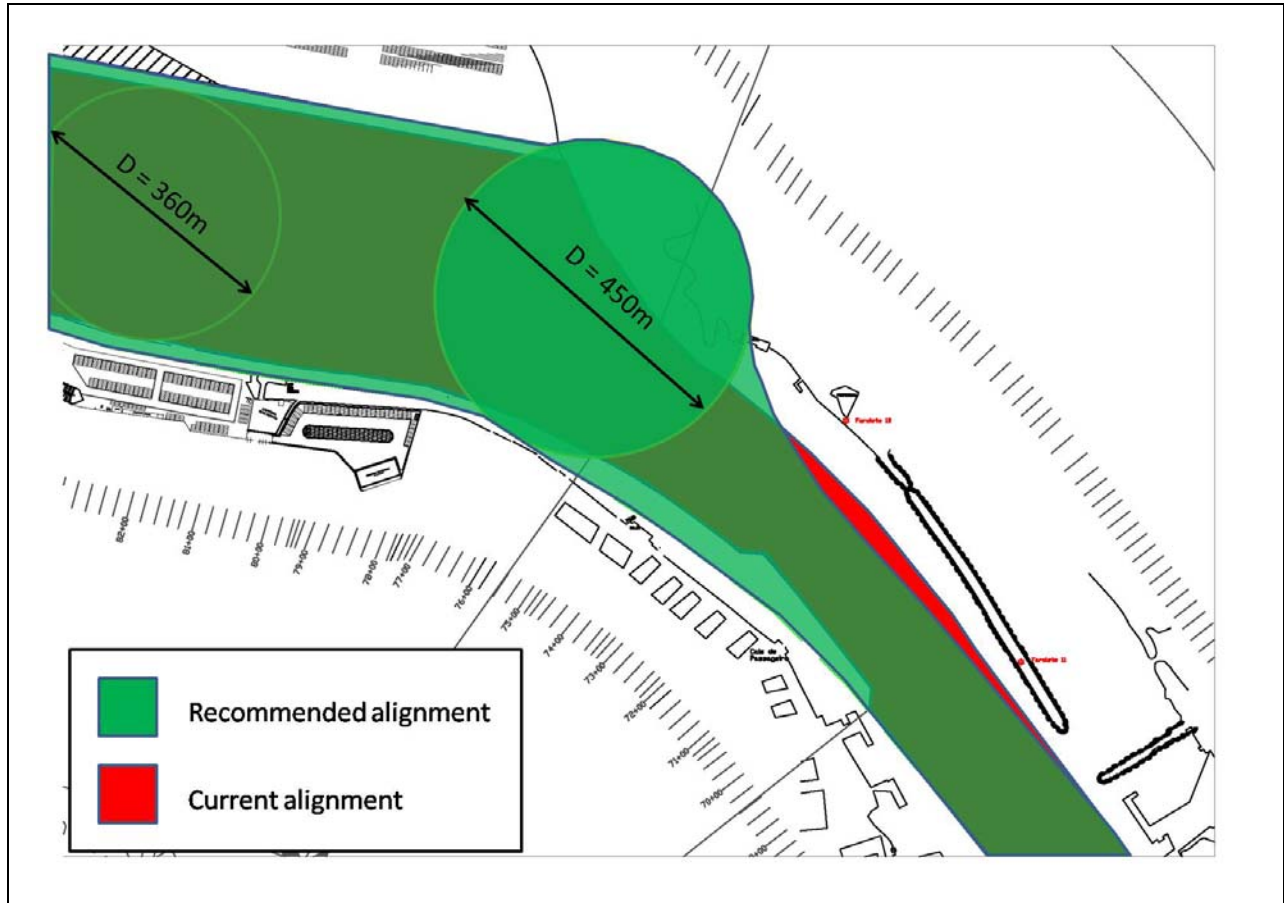

figure E-16: implementation turning circle location C

Prefeasibility report for the Port of Itajaí

Deepening and widening dredging approach channel and turning circle²		
Dredging:		
Price of dredging (sand)	49.060.573	
Price of dredging (clay)	13.199.830	
Mobilization	1.037.630	
Demobilization	1.037.630	
		64.340.000
Alignment from the outer channel until the east bend		
Dredging:		
Dredging new outer channel*	38.520.000	
Mobilization	1.037.630	
Demobilization	1.037.630	
		40.600.000
Turning the southern breakwater*		35.000.000
Adjust groyne length*		1.500.000
Flow width reducing structure on the south side*		2.500.000
		79.600.000
Extending the northern breakwater		
Extending northern breakwater*		30.000.000
Alignment from the east bend until the west bend		
Remove/replace the passenger terminal*		6.000.000
Buy out/removing shipping companies*		2.000.000
		8.000.000
Turning circle, location C		
Dredging and preparing the area of Navegantes*		100.000.000
		100.000.000
		R \$ 281.940.000

table E-1: cost estimation of the suggested alignment changes [R \$]

² The plans of widening and deepening dredging are completed already and will definitely be executed, therefore this costs will not be taken in account in the total cost estimation

- Dredging new outer channel **R \$ 38.520.000**
The dredging costs are assumed to be R\$ 7,85 /m³ for sand [HIDROTOPO]. Assumed that it is only sand, a total volume of 4.907.500m³ sand needs to be dredged to realise this approach channel.
- Turning the southern breakwater **R \$ 35.000.000**
The cost estimation of turning the southern breakwater is based on the costs for moving the northern breakwater (R\$ 17.500.000). The southern breakwater has a larger core than the northern so for the first cost estimation it is assumed that the costs are two time greater.
- Adjust groyne length **R\$ 1.500.000**
6 groynes need to be shortened; the cost estimation is based on mobilization, volume that needs to be removed and demobilization.
- flow width reducing structure on the South side **R\$2.500.000**
This cost estimation is based on information from a catalogue on coastal management. For the flow width reduction groyne will be constructed, there are around 4 groynes needed. Information from the catalogue states R\$ 600.000/groyne.
- Extending northern breakwater **R \$ 30.000.000**
The cost of a breakwater depends on a number of things, such as wave conditions, water depth, ground type and the availability of construction material in the surroundings. For a first cost estimation R\$ 150.000/m will be used. In order to solve the problems with the sandbanks near the northern breakwater the breakwater needs to be extended for 200 m.
- Remove/replace the passenger terminal **R \$ 6.000.000**
The passenger terminal needs to be bought out and replaced. There are plans to replace the passenger terminal to another location, in order to release this companies has to be bought out.
- Buy out/removing shipping companies **R \$ 2.000.000**
Estimation made by the engineer of the Port of Itajaí. Currently, the port is negotiating with the shipping companies.
- Dredging and preparing the area of Navegantes **R \$ 100.000.000**
Estimation made by the engineer of the Port of Itajaí. The total costs are so high, because a number of house owners and companies have to be bought out, in order to realize the turning circle. The costs estimation include every aspect, i.e. buying out the houses, removing the land, dredging and constructing a new quay wall.

Appendix F: Sedimentation of harbour basin



figure F-1: location of samples

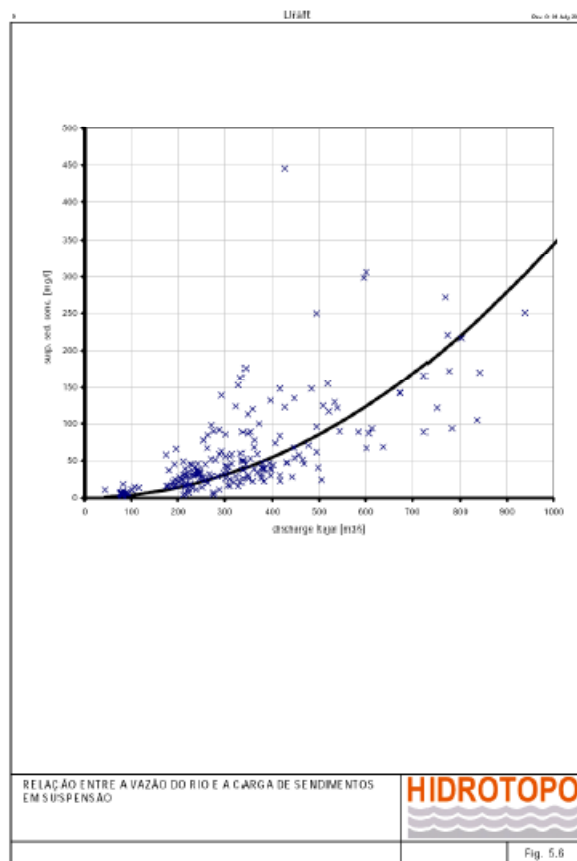
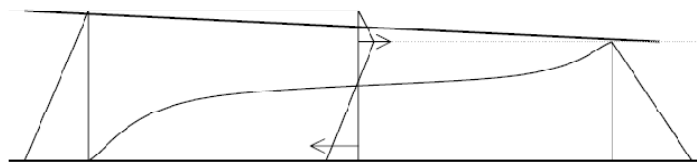
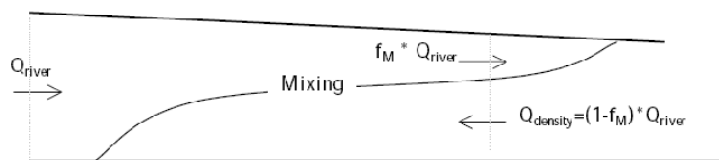

figure F-2: relation between discharge and suspended sediment concentration



a) Equilibrium of forces in the salt wedge.



b)

figure F-3: mixing of fresh and salt water

Appendix G: Theories of river engineering

In this chapter of the appendix there are explained several theories and formulas, which are used in the report.

G.1 Stationary flow

To describe and to make hand calculations of a shallow channel with rectangular cross sections, there are required a continuity equation and an equation of motion in the x-direction. The continuity equation is expressed as:

$$\frac{d(uh)}{dx} = 0$$

and the momentum equation in x-direction is expressed as:

$$u \frac{du}{dx} = g i_b - g \frac{dh}{dx} - \frac{g}{C^2} \frac{u^2}{h}$$

Based on the critical depth

$$h_g = \left(\frac{q^2}{g} \right)^{1/3}$$

and equilibrium depth by Chézy,

$$h_e = \left(\frac{q^2}{C^2 i_b} \right)^{1/3}$$

these equations are used for deriving the formula of Bélanger. for small Froude numbers, this formula has the following formulation:

$$\frac{dh}{dx} = i_b \left[\frac{h_e^3}{h^3} \right]$$

By Bresse there is a method derived, making use of halving the distortions in the backwater curve³, to determine water depths:

$$h = h_e + (h_b - h_e) \left(\frac{1}{2} \right)^{\frac{-x_a - x_b}{L_{1/2}}}$$

with $L_{1/2} \cdot L_{1/2}$ is 'half-length'

$$L_{1./2} = \frac{0.24 h_e}{i_b} \left(\frac{h_b}{h_e} \right)^{4/3}$$

The above formulas form a guideline for the calculation of a certain area of interest. The water depths on different places in a river can be calculated.

³ A backwater curve is the longitudinal profile of the water surface in an open channel where the water surface is raised above its normal level by a natural or artificial obstruction. The backwater half-length is used to scale the length of the backwater effects. The total length of the backwater effects is much larger than double the backwater half length, because the curve is asymptotic.

G.2 Sediment transport formula

There are different sediment transport formulas. Most of them are based on observations in laboratory tests. There are three kinds of transport formulas:

- formulas for bed-load transport
- formulas for suspended load transport
- formulas for total load transport

In the river Itajaí-Açu there is a lot of bed transport and also a lot of suspended sediment transport. The formula that has to be used in this situation will be a total load transport formula. Examples of total load transport formula are Van Rijn and Engelund and Hansen.

Both formulas are used in SOBEK for calibrating the model. Below, both sediment transport formulas are explained.

G.2.1 Theory of Van Rijn

This formula makes a distinction between bed-load and suspended load. These loads together give the total sediment transport. Important parameters in this formula are the bed shear stress and the grain size diameter.

The range for application of this formula is:

$$\begin{aligned} 1 &\leq d \leq 20 && [m] \\ 0.5 &\leq u \leq 2.5 && [m / s] \\ 100 &\leq D_{50} \leq 2000 && [\mu m] \end{aligned}$$

The total sediment transport load will be: $s = s_b + s_s$

The formula for the bed load is as follows: $\frac{s_b}{u_m d} = \frac{1}{1 - \varepsilon} 0.005 \left(\frac{u_m - u_c}{\sqrt{g \Delta D_{50}}} \right)^{2.4} \left(\frac{D_{50}}{d} \right)^{1.2}$

The formula for the suspended load is: $\frac{s_s}{u_m d} = \frac{1}{1 - \varepsilon} 0.012 \left(\frac{u_m - u_c}{\sqrt{g \Delta D_{50}}} \right)^{2.4} \left(\frac{D_{50}}{d} \right) D_g^{-0.6}$

In which D_g is a dimensionless grain size parameter defined as: $D_g = D_{50} \left(\frac{g \Delta}{v^2} \right)^{1/3}$.

u_m = flow velocity

d = depth

s_b = bed-load transport per unit of width

s_s = suspended-load transport per unit of width

ε = packing factor of bed material

u_c = critical flow velocity for sediment transport

The critical flow velocity for sediment transport can be computed as follows:

$$\text{For } 100 \leq D_{50} \leq 500 [\mu m] \rightarrow u_c = 0.19 D_{50}^{0.1} \log \left(\frac{12R}{3D_{90}} \right)$$

$$\text{For } 500 \leq D_{50} \leq 2000 \rightarrow u_c = 8.50 D_{50}^{0.6} \log \left(\frac{12R}{3D_{90}} \right)$$

G.2.2 Theory of Engelund and Hansen

Usually, this formula is used in rivers with fine sediment. The bed-load and the suspended load are integrated in the total formula.

The range for application of this formula is:

$$u_* / w_s > 1 \quad [-]$$

$$0.19 < D_{50} < 0.93 \quad [\text{mm}]$$

$$0.07 < \theta < 6 \quad [-]$$

To calculate the Shields parameter θ :

$$\theta = \frac{u_*^2}{\Delta g D_{50}}$$

The u_* can be calculated with the following formula:

$$u_* = \frac{\sqrt{g}}{C} u_m$$

The general transport formula:

$$s = m u_m^n$$

$$\text{In which } m = \frac{0.05}{\sqrt{g} C^3 \Delta^2 D_{50}} \quad [\text{s}^4 / \text{m}^3]$$

The degree of non-linearity n for Engelund and Hansen is 5.

If sand settles down it will take in more place, because of the porosity in the sand:

$$s = \frac{1}{1 - \varepsilon} m u_m^n$$

u_* = shear velocity

w_s = fall velocity sediment

θ = Shields parameter

u_m = average flow velocity in the main channel

ε = packing factor of bed material

G.3 Effects of interventions

In river engineering, there are several general formulas used for computing the effects of certain interventions like withdrawal of sediment, withdrawal of water and long constrictions. These general formulas are also called the ‘forget-me-nots’ and are used to get a first impression what the effects of an intervention will be.

Problem	Constant discharge	Variable discharge
Withdrawal of sediment ΔS and ΔV	$\frac{i_1}{i_0} = \left[1 - \frac{\Delta S}{S_0} \right]^{3/n}$ $\frac{h_1}{h_0} = \left[1 - \frac{\Delta S}{S_0} \right]^{-1/n}$	$\frac{i_1}{i_0} = \left[1 - \frac{\Delta V}{V} \right]^{3/n}$ with $V = \int_0^{\infty} S(Q) p(Q) dQ$
Withdrawal of water ΔQ or $p_0(Q) \rightarrow p_1(Q)$	$\frac{i_1}{i_0} = \frac{Q_0}{Q_0 - \Delta Q}$ $\frac{h_1}{h_0} = 1 - \frac{\Delta Q}{Q_0}$	$\frac{i_1}{i_0} = \left[\frac{\int_0^{\infty} Q^{n/3} p_0(Q) dQ}{\int_0^{\infty} Q^{n/3} p_1(Q) dQ} \right]^{3/n}$
Long constriction $B_0 \rightarrow B_1$	$\frac{i_1}{i_0} = \left[\frac{B_1}{B_0} \right]^{\frac{n-3}{n}}$ $\frac{h_1}{h_0} = \left[\frac{B_0}{B_1} \right]^{\frac{n-1}{n}}$	$B^{1-n/3} i^{n/3} \int_0^{\infty} Q^{n/3} p(Q) dQ = \text{constant}$ so $\frac{i_1}{i_0} = \left[\frac{B_1}{B_0} \right]^{\frac{n-3}{n}}$

table G-1: forget-me-nots for river interventions

The n in the formula is the degree of nonlinearity of the sediment transport formula.

G.4 Sand trap

A sand trap is formed by deepening dredging. The principle of a sand trap is to reduce the flow velocity by increasing the cross section (width and/or depth). The sediment transport capacity will decrease. The sediments will settle down in this sand trap, resulting in less concentration of sediment in the flow of the river downstream of the sand trap. In the end, there will be less sediment conducted to the mouth of the river, because the sand trap catches the sediment. The sand trap works best when bed load transport is more dominant than wash load. For this river it is not known which type of sediment transport is dominant. For bed load transport, the sand trap is very effective, but for wash load the sand trap is not efficient. Washload has no connection with the discharge of the river on the contrary, bed load transport does have a connection with the discharge. Below the classification of the sediment transport is shown.

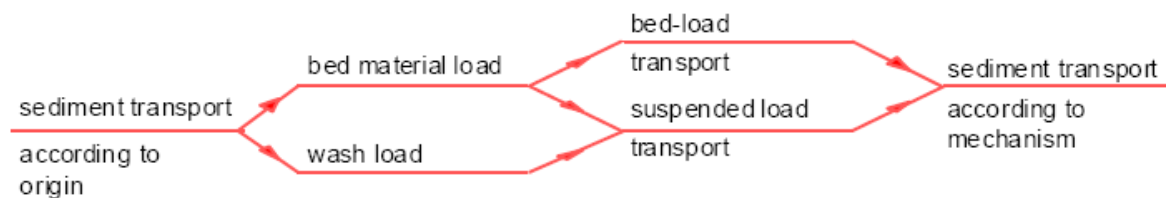

figure G-1: classification of the sediment transport

The sand trap can be seen as a continuous sediment extraction of the river, until the sand trap is filled up with sand again. The discharge will not change downstream, but the sediment transport will be reduced from S_0 to $S_1 = S_0 - \Delta S$. The quantity of sediment will be unchanged upstream of the sand trap, but deposition of the sediment in the harbour basin will be reduced.

The sand trap is gradually filled up with sediment in a natural way. After some time the river returns to its original configuration. The time scale of filling the sand trap can be calculated with: $T = \frac{L\Delta Z_b(1 - \varepsilon)}{q_s}$.

In the situation with the upstream dredging, according to this very simple formula, it would take a few years for the river to return to its former situation.

This is a first estimation of the time it will take, before the sand trap is filled up again. Not all the sediment will be able to settle down in the trap. Especially the suspended sediment will be hard to settle down. In practice the duration of the filling process is also influenced by the mud layer and the tidal influence. The configuration of the sand trap will change in time. At the boundaries of the trap, the shape will change, see the figure below. To keep the function of a sand trap (catch the sediment), maintenance has to be carried out.

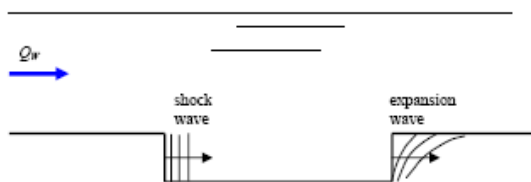

figure G-2: initial propagation and deformation of the sand trap

A basic situation of a sand trap is schematised below. It is an example of a normal sand trap in a straight river, in equilibrium.

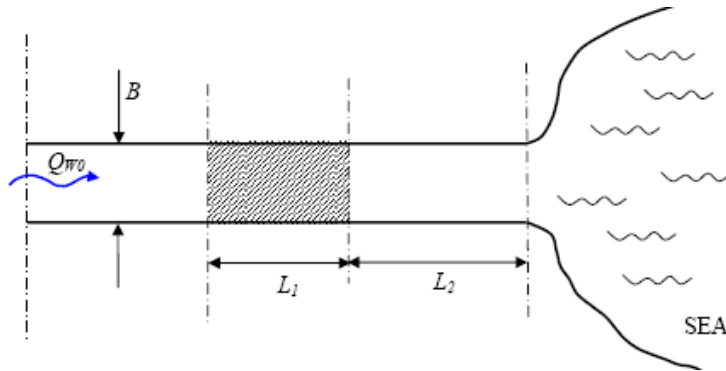

figure G-3: top view of river with a sand trap

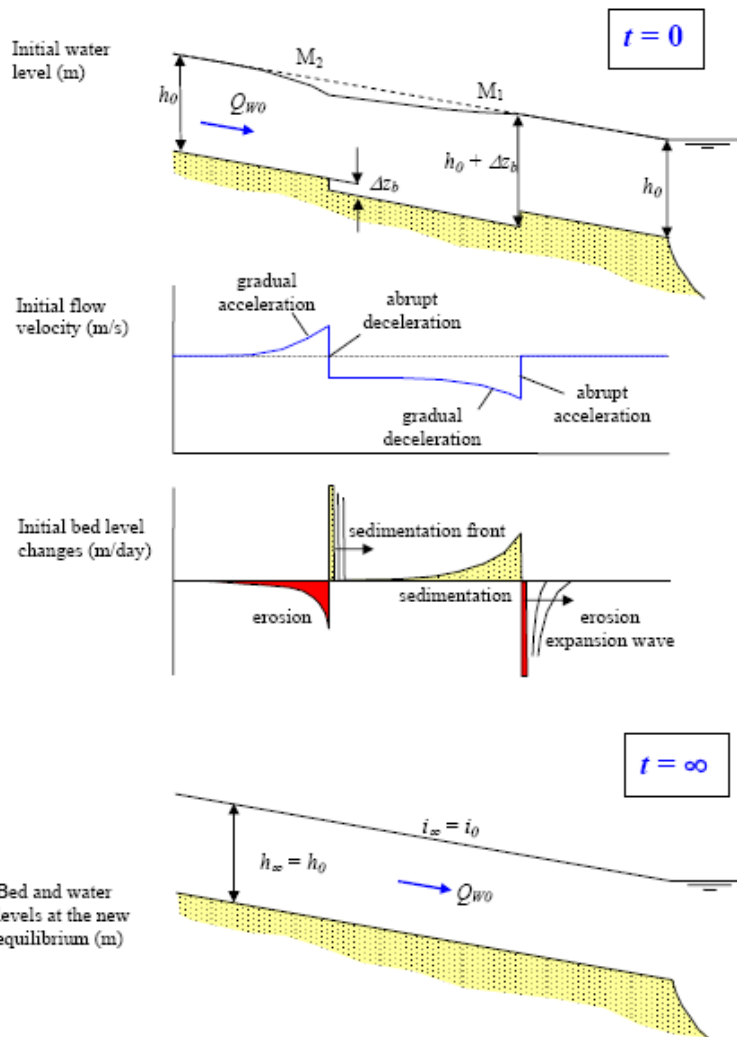

figure G-4: short and long term effects of a sand trap

The long term effects of this intervention: the sand trap is gradually filled up to its original configuration. Short term effects are erosion at the upstream boundary of the sand trap and sedimentation at the downstream boundary. At the long term, the water depth and the slope will not change.

In the situation of the harbour, there will be a more complicated situation. Downstream of the sand trap the bed level of the river is going down, because of the dredging program.

The following figures shows the schematised situation of the continuous dredging of sediment at an extraction point.

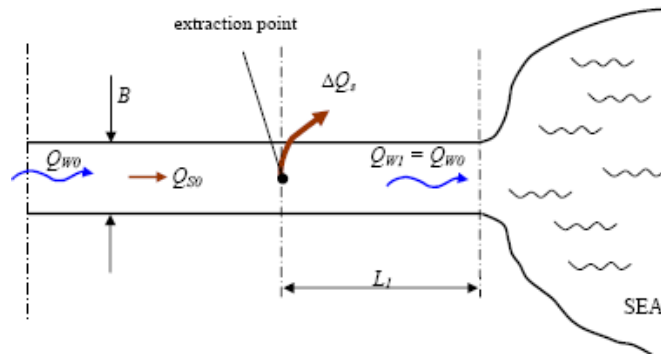

figure G-5: top view of a river with sediment extraction

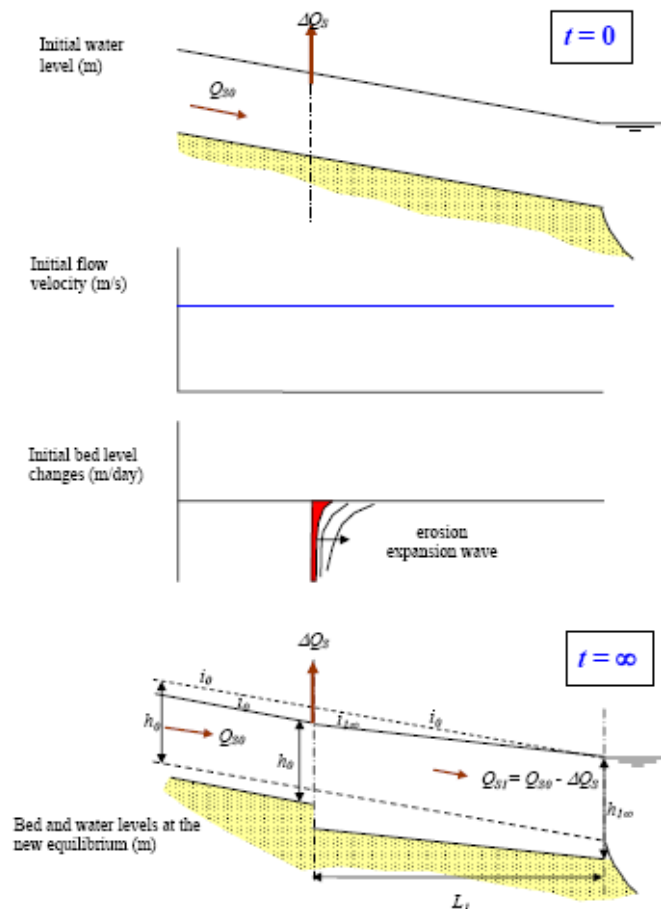

figure G-6: short and long term effects of sediment extraction

Long term effects are: decreasing of the bed slope and increasing of the water depth downstream of the extraction point.

G.5 Widening of a part of a river

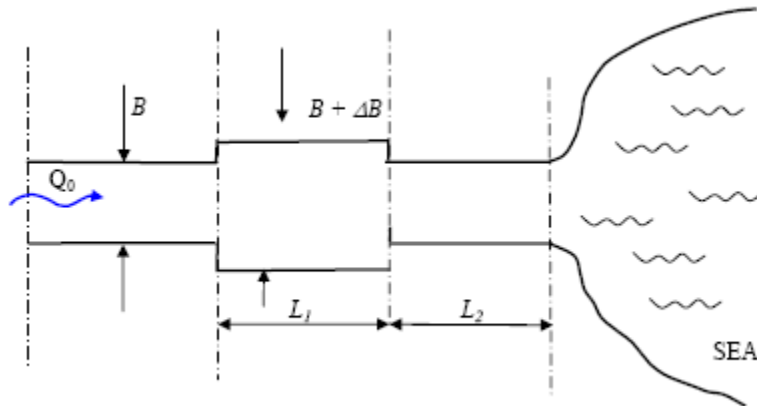

figure G-7: top view of a river with a widened part

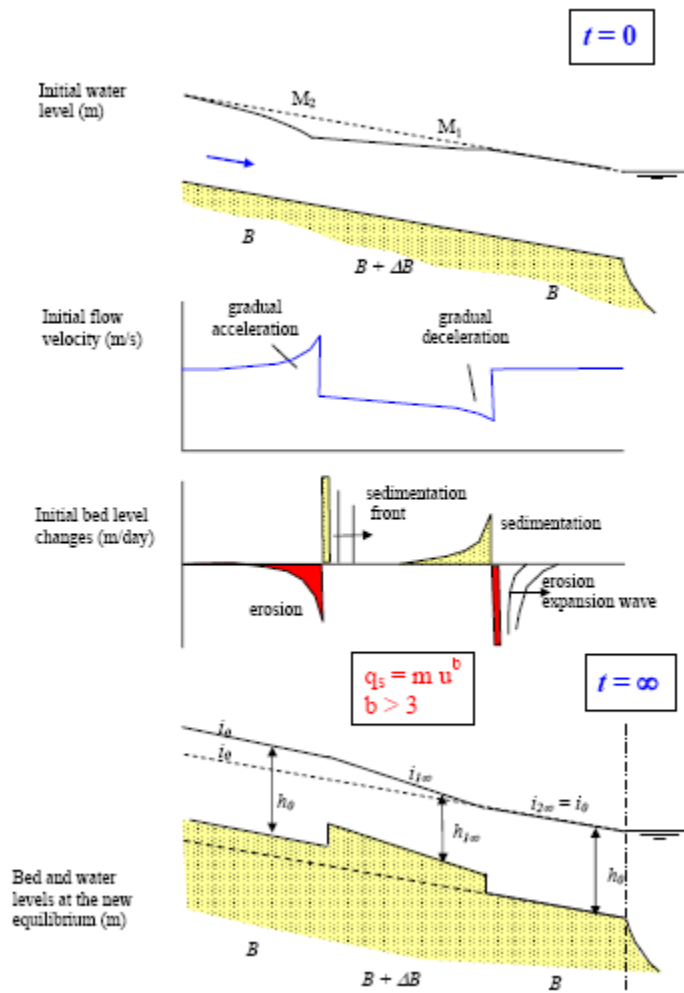

figure G-8: short and long term effects of widening of a river over a certain length

G.6 Bends

In river bends the water flow is disturbed. The centripetal acceleration $\frac{u^2}{r}$ is needed to make the water follow the curvature of the bend. The figure G-9 below shows the velocity field in the vertical. The centripetal acceleration together with the vertical structure of the downstream velocity $u(z)$, gives rise to a cross-stream circulation, often named secondary flow. When combined with the main (downstream) flow $u(z)$ this leads to a spiral flow.

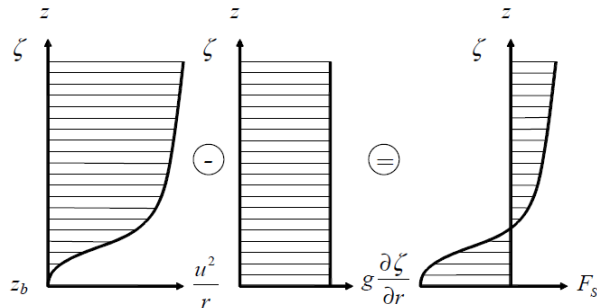

figure G-9: forces of the curvature-induced secondary flow

The flow velocity will increase in the outer bend, which causes erosion. In the inner bend the flow velocity will decrease, which will lead to accretion. These transformations will change the bed level. figure G-10 below shows what the effects are for the cross sections of the river. This process is a continuous process.

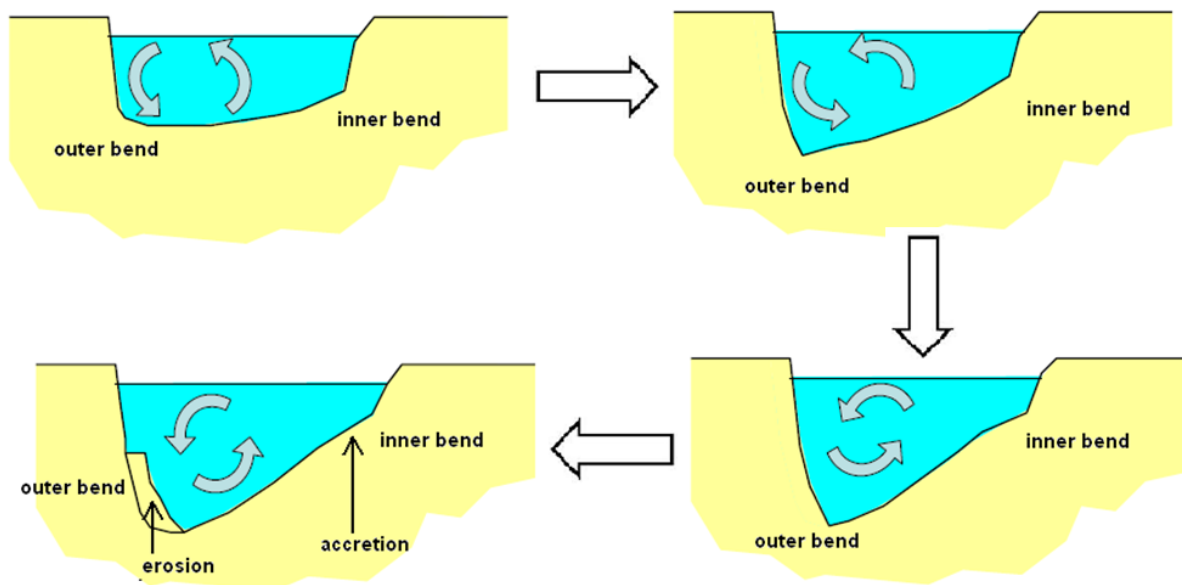

figure G-10: overview processes in bends

Appendix H: Hand calculations

In this calculation the Itajaí-Açu river is approached as a 1D-river with a straight and stationary flow. In the below calculations the transport capacity formulas of Engelund and Hansen are applied. For more details about this formula, see appendix G.2.2.

To calculate the water depths the theory of Belanger is used and the approach of Bresse is applied.

river Itajaí-Açu			
width river	B_{river}	150	m
width harbour	B_{harbour}	355	m
width river, after harbour	B_{river2}	150	m
slope river	i_b	0,000289	m/m
relative density	Δ	1,65	-
median diameter	D_{50}	0,0009	m
Chezy	C	30	$\text{m}^{1/2}/\text{s}$
gravity	g	9,81	m/s^2
fall velocity	w_s	0,05	m/s
fall velocity	w_s	0,2	m/s
degree of non-linearity	n	5	-
porosity	ϵ_p	0,516	-
theoretical depth	$h_{\text{original,mouth}}$	7	m
water depth mouth	h_{mouth}	12	m

table H-1: general data

	amount of sediment maintenance [m^3/year]
dredging current situation ^(*2)	600000
dredging in the future ^(*2)	620000
dredging river upstream ^(*2)	150000

table H-2: amount of sediment

Node *1) The Chézy factor has a higher value in reality. The Chézy value has its influence on all the different river characteristics. In this calculation it was the best way to increase the slope of the river, which occurs in reality. By decreasing the Chézy, a concession is done according the transport of sedimentation. If the Chézy value is chosen bigger, the amount of sedimentation transport would also be bigger.

Node *2) In the chapter 11, it's found that the amount of maintenance dredging in the current situation has an average of 2.000.000 m^3/year . In this 1D-hand calculation some important processes are neglected. In this hand calculation the amount of maintenance dredging will be a factor 3 to 5 times smaller than in reality occurs in a tidal basin (Nasner, 1992). Also the amount of maintenance dredging

in the future and the maintenance dredging in the river upstream will logically be smaller than occurs in reality. A factor 3.25 is found for the maintenance dredging in the current situation.

H.1 Original situation

	half length [m]
$i_b = i_0$	
$L_{1/2,0} = 0.24 * (h_{e0}/i_0) * (h_{\text{original,mouth}}/h_{e0})^{4/3}$	8239

Q [m ³ /s]	q [m ² /s]	h_{e0} [m]	U_0 [m/s]	u_* [m/s]	u_*/w_s [-]	u_*/w_s [-]	θ [-]
295	1,97	2,46	0,80	0,083	1,67	0,42	0,48

Engelund and Hansen	
$u_*/w_s > 1$	TRUE (only for small w_s)
$0,07 < \theta < 6$	TRUE
$0,19 \text{ mm} < D < 0,93 \text{ mm}$	TRUE
	Engelund and Hansen may be applied

				sediment transport	amount of sediment			amount of sediment including pores
		m	s_1 [m ² /s]	S_1 [m ³ /s]	S_1 [m ³ /year]	pore content	S_0 [m ³ /s]	S_0 [m ³ /year]
sediment transport	$s_1 = m * u_1^n$	0,000241	0,000018	0,003	83060	2,066	0,024	771612

	water depth [m]
h_{mouth}	12,00
$h_{\text{end harbour}} = h_{e1} + (h_{\text{mouth}} - h_{e1}) * (1/2)^{((x_{\text{end harbour}} - x_{\text{mouth}})/L_{1/2,1})}$	11,63
$h_{\text{start harbour}}^+ = h_{e1} + (h_{\text{end harbour}} - h_{e1}) * (1/2)^{((x_{\text{start harbour}} - x_{\text{end harbour}})/L_{1/2,1})}$	11,50
$h_{\text{start harbour}}^- = h_{e1} + (h_{\text{end harbour}} - h_{e1}) * (1/2)^{((x_{\text{start harbour}} - x_{\text{end harbour}})/L_{1/2,1})}$	6,50
$h_{\text{mirim}} = h_{e0} + (h_{\text{start harbour}} - h_{e0}) * (1/2)^{((x_{\text{mirim}} - x_{\text{start harbour}})/L_{1/2,0})}$	5,25
$h_{\text{alves}} = h_{e0} + (h_{\text{mirim}} - h_{e0}) * (1/2)^{((x_{\text{alves}} - x_{\text{mirim}})/L_{1/2,0})}$	2,88
$h_{\text{blumenau}} = h_{e0} + (h_{\text{alves}} - h_{e0}) * (1/2)^{((x_{\text{blumenau}} - x_{\text{alves}})/L_{1/2,0})}$	2,49

H.2 Dredging up to -12m

$i_b=i_0$			[m/m]
Forget-me-knots	$i_2/i_1=[B_1/B_0]^{(n-3)/n}$	i_1	0,000289
		i_2	0,000117
$L_{1/2,2}=0.24*(h_{e1}/i_1)*(h_{end\ harbour}/h_{e1})^{4/3}$	37683	[m]	

Q [m ³ /s]	q [m ² /s]	h_{e1} [m]	U_1 [m/s]	u_* [m/s]	u_*/w_s [-]	u_*/w_s [-]	θ [-]
295	1,97	3,32	0,59	0,062	1,24	0,31	0,26

Engelund and Hansen	
$u_*/w_s > 1$	TRUE (only for small w_s)
$0,07 < \theta < 6$	TRUE
$0,19\text{ mm} < D < 0,93\text{ mm}$	TRUE
	Engelund and Hansen may be applied

				sediment transport	amount of sediment			amount of sediment including pores
		m	s_1 [m ² /s]	S_1 [m ³ /s]	S_1 [m ³ /year]	pore content	S_1 [m ³ /s]	S_1 [m ³ /year]
sediment transport	$s_1=m*u_1^n$	0,000241	0,000018	0,003	83060	2,066	0,005	171612

	water depth [m]
h_{mouth}	12,00
$h_{end\ harbour}=h_{e1}+(h_{mouth}-h_{e1})*(1/2)^{((x_{end\ harbour}-x_{mouth})/L1/2,1)}$	11,63
$h_{start\ harbour}^+=h_{e1}+(h_{end\ harbour}-h_{e1})*(1/2)^{((x_{start\ harbour}-x_{end\ harbour})/L1/2,1)}$	9,70
$h_{start\ harbour}^-=h_{e1}+(h_{end\ harbour}-h_{e1})*(1/2)^{((x_{start\ harbour}-x_{end\ harbour})/L1/2,1)}$	9,57
$h_{mirim}=h_{e0}+(h_{start\ harbour}-h_{e0})*(1/2)^{((x_{mirim}-x_{start\ harbour})/L1/2,0)}$	6,53
$h_{alves}=h_{e0}+(h_{mirim}-h_{e0})*(1/2)^{((x_{alves}-x_{mirim})/L1/2,0)}$	5,27
$h_{blumenau}=h_{e0}+(h_{alves}-h_{e0})*(1/2)^{((x_{blumenau}-x_{alves})/L1/2,0)}$	2,89

H.3 Current situation (dredging up to -12m and widening harbour basin to 355m)

$i_b=i_0$			[m/m]
Forget-me-knots	$i_2/i_1=[B_1/B_0]^{(n-3)/n}$	i_1	0,000117
		i_2	0,000166
$L_{1/2,2}=0.24*(h_{e1}/i_1)*(h_{end\ harbour}/h_{e1})^{4/3}$	37683	[m]	

Q [m ³ /s]	q [m ² /s]	h_{e1} [m]	U_1 [m/s]	u_* [m/s]	u_*/w_s [-]	u_*/w_s [-]	θ [-]
295	0,83	1,67	0,50	0,052	1,04	0,26	0,19

Engelund and Hansen	
$u_*/w_s > 1$	TRUE (only for small w_s)
$0,07 < \theta < 6$	TRUE
$0,19\text{ mm} < D < 0,93\text{ mm}$	TRUE
	Engelund and Hansen may be applied

				sediment transport	amount of sediment			amount of sediment including pores
		m	s_2 [m ² /s]	S_2 [m ³ /s]	S_2 [m ³ /year]	pore content	S_2 [m ³ /s]	S_2 [m ³ /year]
sediment transport	$s_1=m*u_1^n$	0,000241	0,000007	0,00111	35096	2,066	0,002	72512

iteration bed step		s_1 [m ² /s]
h_{e4}	4,87	0,0000026
Δz_5	2,82	0,0000026

	[m/m]	$L_{harbour\ basin}$ [m]		[m]		[m]
i_4	0,000117	800		0,0938		
i_5	0,000166	800		0,13241		
			Δz	0,03860	Δz_2	3,04

Prefeasibility report for the Port of Itajaí

	Water depth [m]	
h_{mouth}	12,00	
$h_{\text{end harbour}}^+ = h_{e1} + (h_{\text{mouth}} - h_{e1}) * (1/2)^{\wedge}((x_{\text{end harbour}} - x_{\text{mouth}}) / L_{1/2,1})$	11,63	
$h_{\text{end harbour}}^- = h_{e1} + (h_{\text{mouth}} - h_{e1}) * (1/2)^{\wedge}((x_{\text{end harbour}} - x_{\text{mouth}}) / L_{1/2,1})$	10,18	bed step = Δz_1
$h_{\text{start harbour}}^+ = h_{e2} + (h_{\text{end harbour}} - h_{e2}) * (1/2)^{\wedge}((x_{\text{start harbour}} - x_{\text{end harbour}}) / L_{1/2,2})$	10,03	
$h_{\text{start harbour}}^- = h_{e2} + (h_{\text{end harbour}} - h_{e2}) * (1/2)^{\wedge}((x_{\text{start harbour}} - x_{\text{end harbour}}) / L_{1/2,2})$	6,52	bed step = Δz_2
$h_{\text{mirim}} = h_{e0} + (h_{\text{start harbour}} - h_{e0}) * (1/2)^{\wedge}((x_{\text{mirim}} - x_{\text{start harbour}}) / L_{1/2,0})$	5,26	
$h_{\text{alves}} = h_{e0} + (h_{\text{mirim}} - h_{e0}) * (1/2)^{\wedge}((x_{\text{alves}} - x_{\text{mirim}}) / L_{1/2,0})$	2,88	
$h_{\text{blumenau}} = h_{e0} + (h_{\text{alves}} - h_{e0}) * (1/2)^{\wedge}((x_{\text{blumenau}} - x_{\text{alves}}) / L_{1/2,0})$	2,49	

H.4 Future situation 1 (current situation + dredging upstream)

$i_b = i_0$			[m/m]
Forget-me-knots	$i_2 / i_1 = [B_1 / B_0]^{(n-3)/n}$	i_1	0,000289
		i_2	0,000254
$L_{1/2,2} = 0.24 * (h_{e1} / i_1) * (h_{\text{end harbour}} / h_{e1})^{4/3}$	14935	[m]	

Q [m ³ /s]	q [m ² /s]	h_{e1} [m]	U_1 [m/s]	u_* [m/s]	u_* / w_s [-]	u_* / w_s [-]	θ [-]
295	1,97	2,57	0,77	0,080	1,60	0,40	0,44

Engelund and Hansen	
$u_* / w_s > 1$	TRUE (only for small w_s)
$0,07 < \theta < 6$	TRUE
$0,19 \text{ mm} < D < 0,93 \text{ mm}$	TRUE
	Engelund and Hansen may be applied

				sediment transport	amount of sediment			amount of sediment including pores
		m	s_2 [m ² /s]	S_2 [m ³ /s]	S_2 [m ³ /year]	pore content	S_2 [m ³ /s]	S_2 [m ³ /year]
sediment transport	$s_1 = m * u_1^n$	0,000241	0,000066	0,00992	312733	2,066	0,002	646143

Prefeasibility report for the Port of Itajaí

	water depth [m]	
h_{mouth}	12,00	
$h_{\text{end harbour}}^+ = h_{e1} + (h_{\text{mouth}} - h_{e1}) * (1/2)^{((x_{\text{end harbour}} - x_{\text{mouth}}) / L_{1/2,1})}$	11,63	
$h_{\text{end harbour}}^- = h_{e1} + (h_{\text{mouth}} - h_{e1}) * (1/2)^{((x_{\text{end harbour}} - x_{\text{mouth}}) / L_{1/2,1})}$	9,70	bed step = Δz_1
$h_{\text{start harbour}}^+ = h_{e2} + (h_{\text{end harbour}} - h_{e2}) * (1/2)^{((x_{\text{start harbour}} - x_{\text{end harbour}}) / L_{1/2,2})}$	9,57	
$h_{\text{start harbour}}^- = h_{e2} + (h_{\text{end harbour}} - h_{e2}) * (1/2)^{((x_{\text{start harbour}} - x_{\text{end harbour}}) / L_{1/2,2})}$	9,06	bed step = Δz_3
$h_{\text{mirim}} = h_{e3} + (h_{\text{start harbour}} - h_{e3}) * (1/2)^{((x_{\text{mirim}} - x_{\text{sh}}) / L_{1/2,3})}$	7,79	
$h_{\text{br101}}^+ = h_{e3} + (h_{\text{mirim}} - h_{e3}) * (1/2)^{(x_{\text{br101}} - x_{\text{mirim}}) / L_{1/2,3}}$	6,62	
$h_{\text{br101}}^- = h_{e3} + (h_{\text{mirim}} - h_{e3}) * (1/2)^{(x_{\text{br101}} - x_{\text{mirim}}) / L_{1/2,3}}$	3,62	bed step = Δz_4
$h_{\text{alves}} = h_{e0} + (h_{\text{br101}} - h_{e0}) * (1/2)^{((x_{\text{alves}} - x_{\text{br101}}) / L_{1/2,0})}$	2,73	
$h_{\text{blumenau}} = h_{e0} + (h_{\text{alves}} - h_{e0}) * (1/2)^{((x_{\text{blumenau}} - x_{\text{alves}}) / L_{1/2,0})}$	2,48	

H.5 Future situation 2 (dredging upstream + dredging up to -14m harbour basin down to river mouth)

$S_{\text{new}} = S - \Delta S_{\text{sand trap}}$	621612	[m ³ /year]	
ΔS_{new}	530000	[m ³ /year]	
$h_{\text{mouth,new}}$	14	m	
Forget-me-knots	$i_4/i_1 = [1 - \Delta S_{\text{new}}/S_{\text{new}}]^{(3/n)}$	i_1	0,000117m/m
		i_4	0,000037m/m
	$i_5/i_2 = [1 - \Delta S_{\text{new}}/S_{\text{new}}]^{(3/n)}$	i_2	0,000166m/m
		i_5	0,000052m/m
$L_{1/2,4} = 0.24 * (h_{e4}/i_4) * (h_{\text{mouth,new}}/h_{e4})^{4/3}$	128504	m.	
$L_{1/2,5} = 0.24 * (h_{e5}/i_5) * (h_{\text{end harbour}}/h_{e5})^{4/3}$	93543	m.	

$S_{\text{new}} = S - \Delta S_{\text{sand trap}}$	621612	[m ³ /year]
ΔS_{new}	530000	[m ³ /year]
$h_{\text{mouth,new}}$	14	[m]

Prefeasibility report for the Port of Itajaí

Q [m ³ /s]	q [m ² /s]	h _{e4} [m]	u ₄ [m/s]	u* [m/s]	u*/w _s [-]	u*/w _s [-]	θ [-]
295	1,97	4,87	0,40	0,042149	0,84	0,21	0,12

Q [m ³ /s]	q [m ² /s]	h _{e5} [m]	u ₅ [m/s]	u* [m/s]	u*/w _s [-]	u*/w _s [-]	θ [-]
295	1,97	4,34	0,45	0,047279	0,95	0,24	0,15

Engelund and Hansen	
u*/w _s >1	TRUE (only for small w _s)
0,07< θ< 6	TRUE
0,19 mm < D < 0,93 mm	TRUE
	Engelund and Hansen may be applied

				sediment transport	amount of sediment			amount of sediment including pores
		m	s ₄ [m ² /s]	S ₄ [m ³ /s]	S ₄ [m ³ /year]	pore content	S ₄ [m ³ /s]	S ₄ [m ³ /year]
sediment transport	s ₄ =m*u ₄ ⁿ	0,000241	0,0000026	0,000031	979	2,066	0,000064	2023

iteration bed step		s [m ² /s]
h _{e4}	4,87	0,0000026
Δz5	2,82	0,0000026

	[m/m]	L _{harbour basin} [m]		[m]		[m]
i ₄	0,000037	800	=	0,0297 m		
i ₅	0,000052	800	=	0,04198 m		
			Δz	0,01224 m	Δz6	1,17

Prefeasibility report for the Port of Itajaí

	Water depth [m]	
$h_{\text{mouth,new}}$	14,00	
$h_{\text{end harbour}}^+ = h_{e1} + (h_{\text{mouth}} - h_{e1}) * (1/2)^{((x_{\text{end harbour}} - x_{\text{mouth}}) / L_{1/2,1})}$	13,88	
$h_{\text{end harbour}}^- = h_{e1} + (h_{\text{mouth}} - h_{e1}) * (1/2)^{((x_{\text{end harbour}} - x_{\text{mouth}}) / L_{1/2,1})}$	11,06	bed step = Δz_5
$h_{\text{start harbour}}^+ = h_{e2} + (h_{\text{end harbour}} - h_{e2}) * (1/2)^{((x_{\text{start harbour}} - x_{\text{end harbour}}) / L_{1/2,2})}$	11,02	
$h_{\text{start harbour}}^- = h_{e2} + (h_{\text{end harbour}} - h_{e2}) * (1/2)^{((x_{\text{start harbour}} - x_{\text{end harbour}}) / L_{1/2,2})}$	9,86	bed step = Δz_6
$h_{\text{mirim}} = h_{e3} + (h_{\text{start harbour}} - h_{e3}) * (1/2)^{((x_{\text{mirim}} - x_{\text{start harbour}}) / L_{1/2,3})}$	8,43	
$h_{\text{br101}}^+ = h_{e3} + (h_{\text{mirim}} - h_{e3}) * (1/2)^{(x_{\text{br101}} - x_{\text{mirim}}) / L_{1/2,3}}$	7,12	
$h_{\text{br101}}^- = h_{e3} + (h_{\text{mirim}} - h_{e3}) * (1/2)^{(x_{\text{br101}} - x_{\text{mirim}}) / L_{1/2,3}}$	4,12	bed step = Δz_4
$h_{\text{alves}} = h_{e0} + (h_{\text{br 101}} - h_{e0}) * (1/2)^{((x_{\text{alves}} - x_{\text{br101}}) / L_{1/2,0})}$	3,55	
$h_{\text{blumenau}} = h_{e0} + (h_{\text{alves}} - h_{e0}) * (1/2)^{(x_{\text{blumenau}} - x_{\text{alves}}) / L_{1/2,0}}$	2,55	

Appendix I: SOBEK

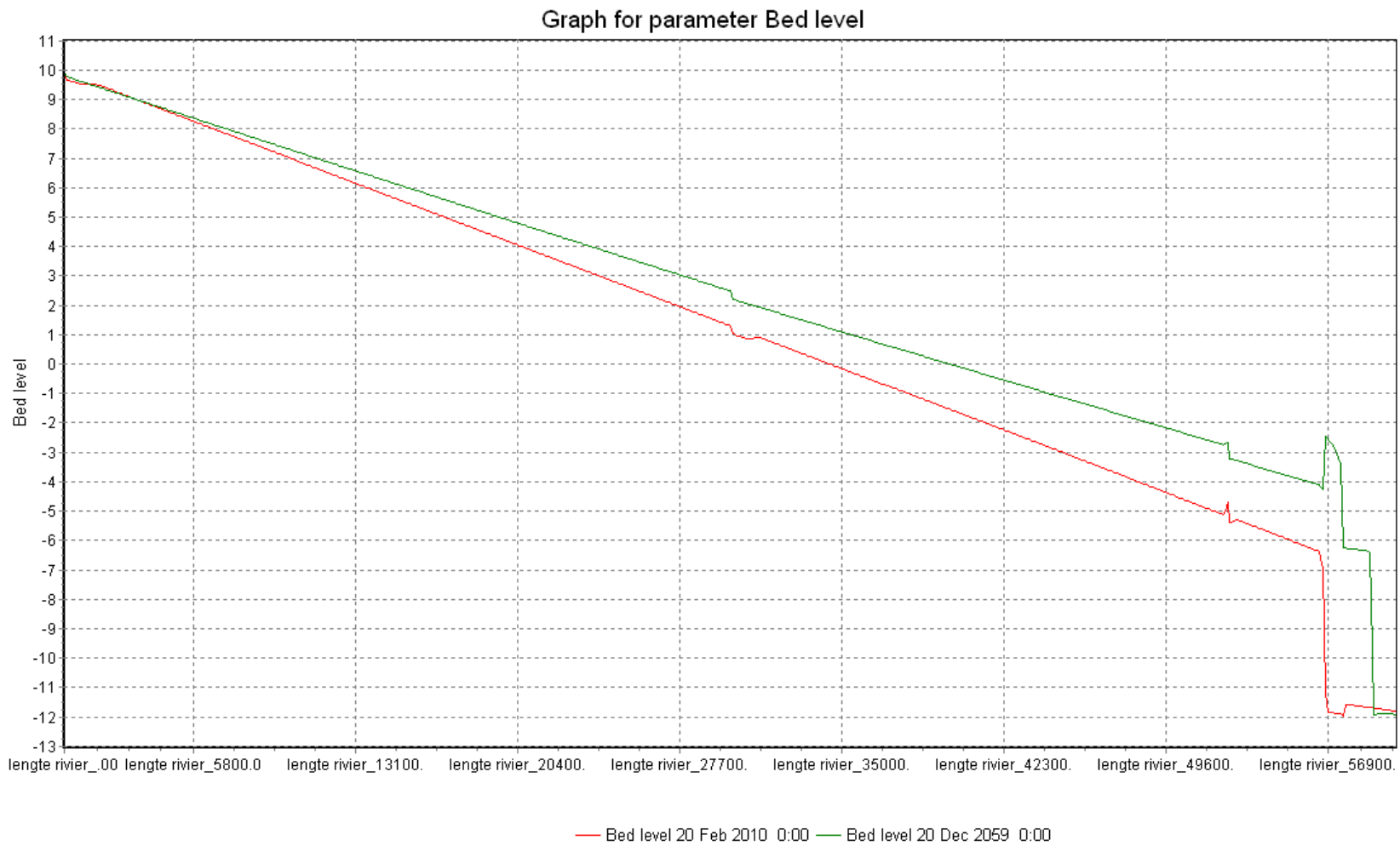

figure I-1: 50 years result run 1

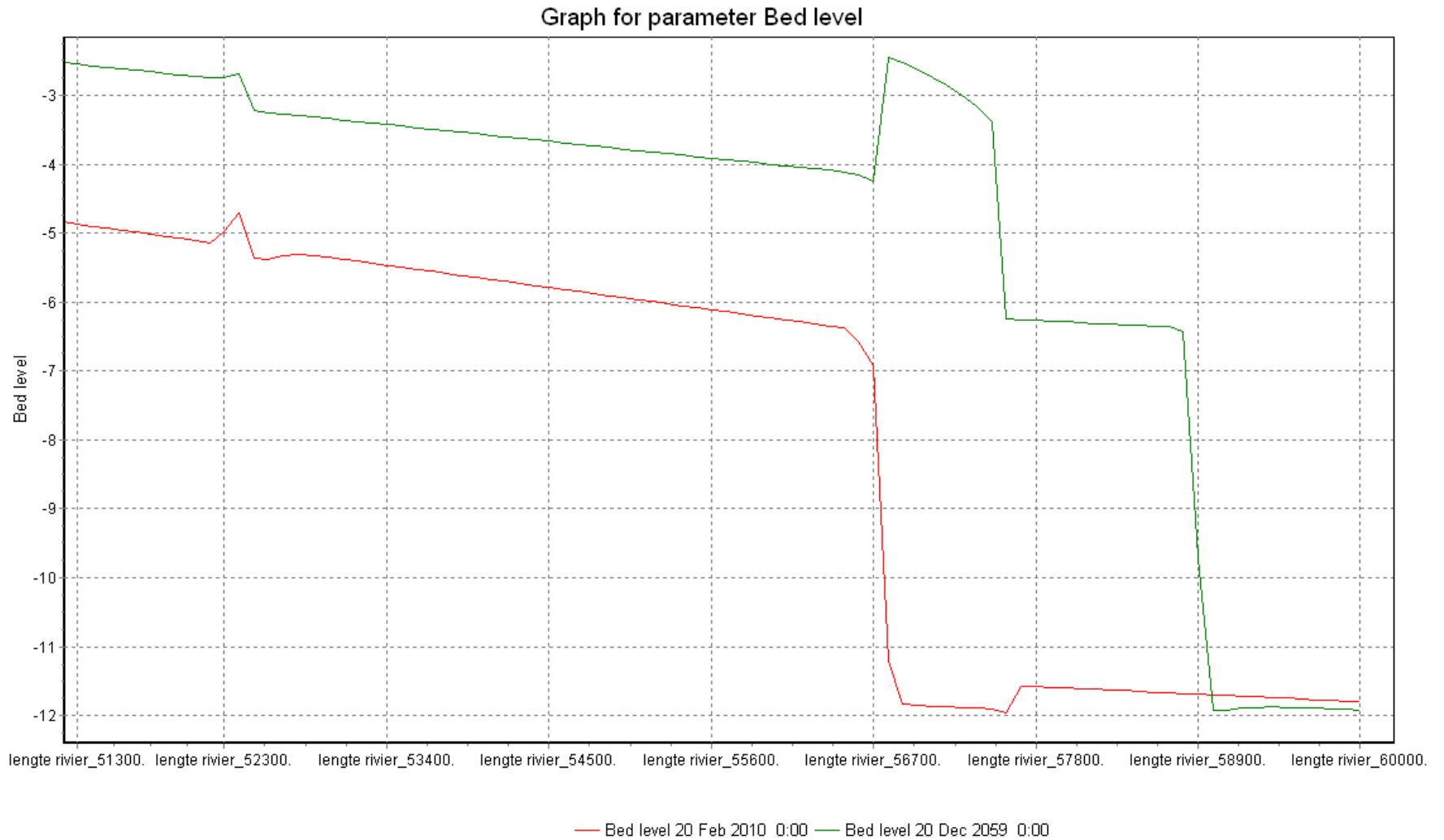

figure I-2: harbour basin 50 years result run 1

Prefeasibility report for the Port of Itajaí

	Bed level 20 Feb 2010 0:00	slope	Bed level 20 Dec 2059 0:00	slope		Original layout,
0	9.934999		9.934999			
100	9.650809	0.0028419	9.771426	0.00163573	volume 1	448800
200	9.630067	0.00020742	9.746645	0.00024781		
300	9.609634	0.00020433	9.721856	0.00024789	volume 2	116795
400	9.589484	0.0002015	9.697065	0.00024791		2012850
500	9.570072	0.00019412	9.672278	0.00024787		952200 +
600	9.552502	0.0001757	9.647491	0.00024787		3081845
700	9.538503	0.00013999	9.622707	0.00024784		2633045
800	9.529899	8.604E-05	9.597932	0.00024775	dredging (1000m)	45727200
900	9.527678	2.221E-05	9.573156	0.00024776	dredging 2 (2400m)	113529.6
1000	9.531523	-3.845E-05	9.548381	0.00024775		
1100	9.539874	-8.351E-05	9.523611	0.0002477	Total (50 years)	48473775
1200	9.542933	-3.059E-05	9.498843	0.00024768	Total (1 year)	969475.5

table I-1: part of exported data run 1

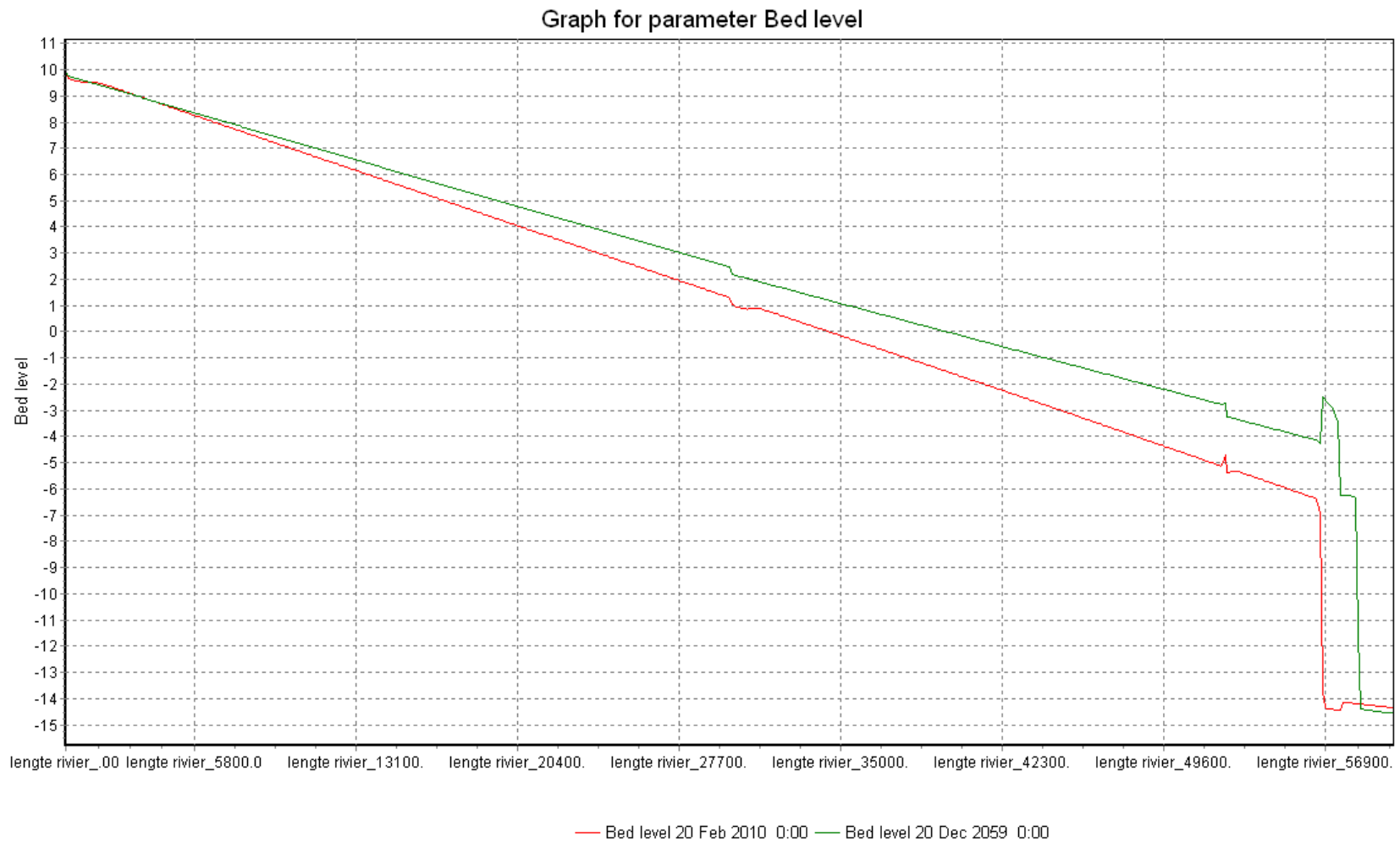

figure I-3: 50 years result run 2

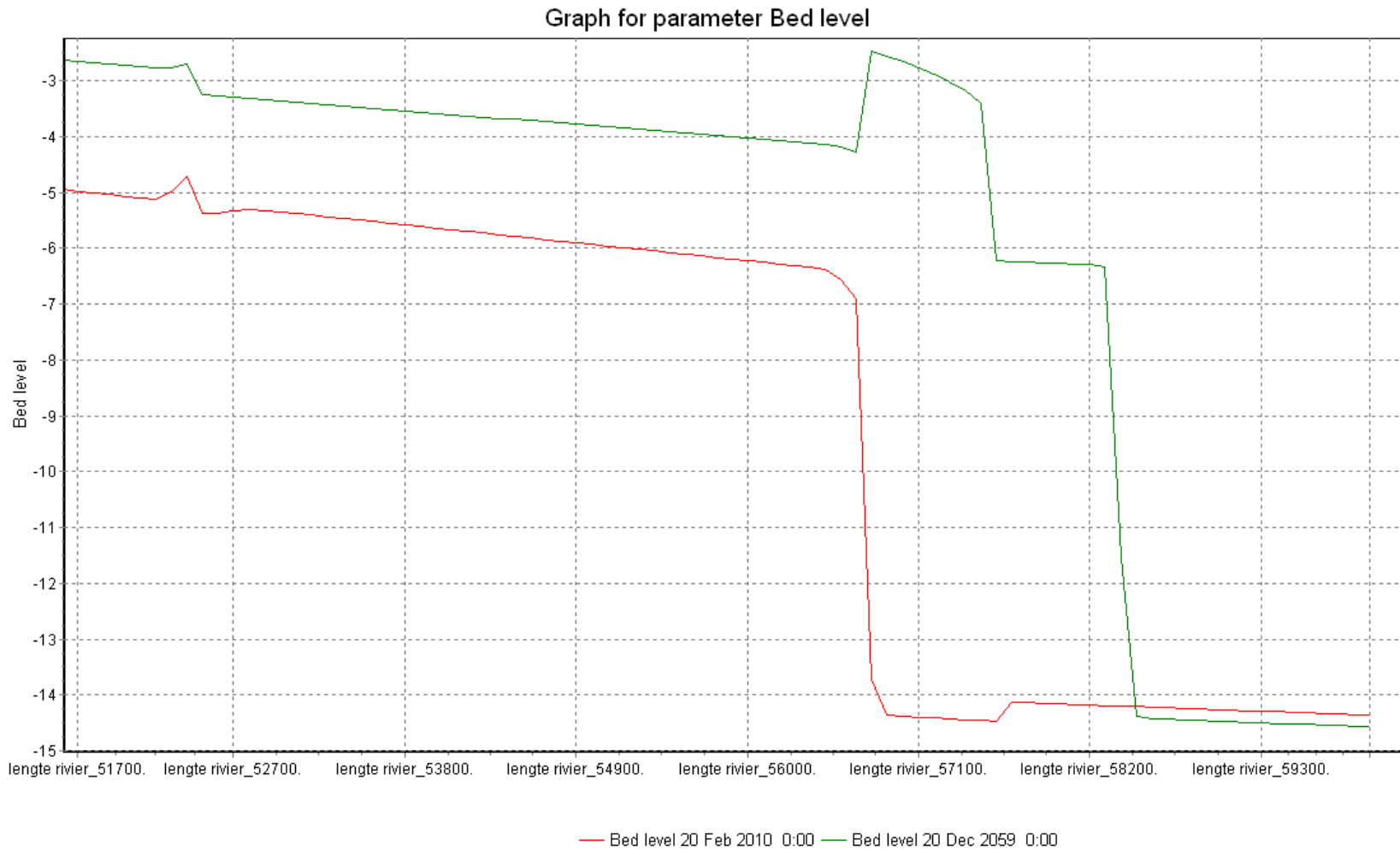

figure I-4: harbour basin 50 years result run 2

Prefeasibility report for the Port of Itajaí

	Bed level 20 Feb 2010 0:00	slope	Bed level 20 Dec 2059 0:00	slope		deepening dredging in harbour basin
0	9.934999		9.934999			
100	9.650804	0.00284195	9.758815	0.00176184	volume 1	492800
200	9.630061	0.00020743	9.734042	0.00024773		
300	9.60963	0.00020431	9.709261	0.00024781	volume 2	115552.5
400	9.589484	0.00020146	9.68448	0.00024781		3010400
500	9.570071	0.00019413	9.6597	0.0002478		945600 +
600	9.552498	0.00017573	9.634925	0.00024775		4071552.5
700	9.5385	0.00013998	9.610151	0.00024774		3578753
800	9.529894	0.00008606	9.585382	0.00024769	dredging (1000m)	45727200
900	9.527678	0.00002216	9.560612	0.0002477	dredging 2 (2400m)	113529.6
1000	9.531522	-0.00003844	9.535847	0.00024765		
1100	9.539871	-0.00008349	9.511084	0.00024763	Total (50 years)	49419482
1200	9.542932	-0.00003061	9.486323	0.00024761	Total (1 year)	988389.64

table I-2: part of exported data run 2

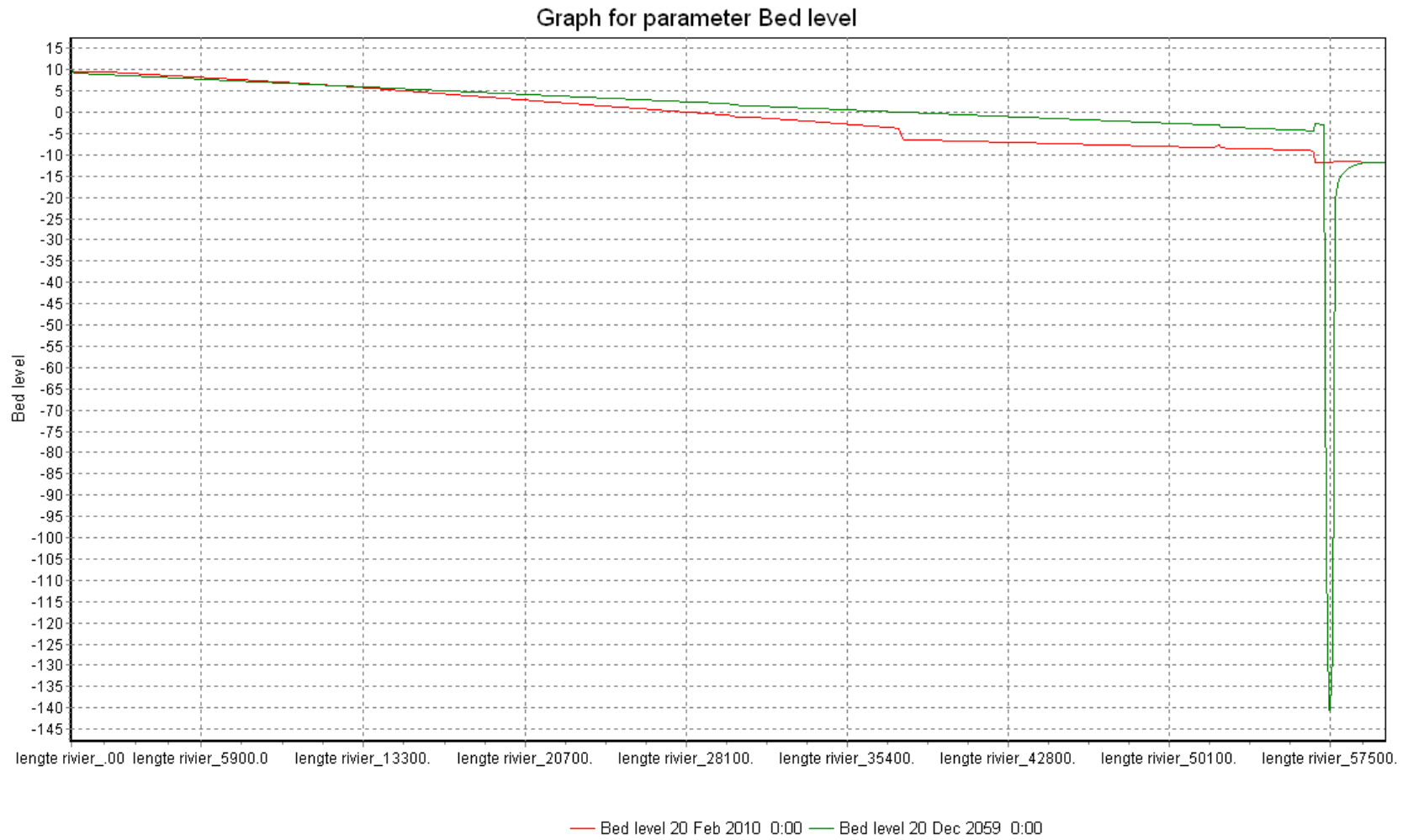

figure I-5: 50 years result run 3

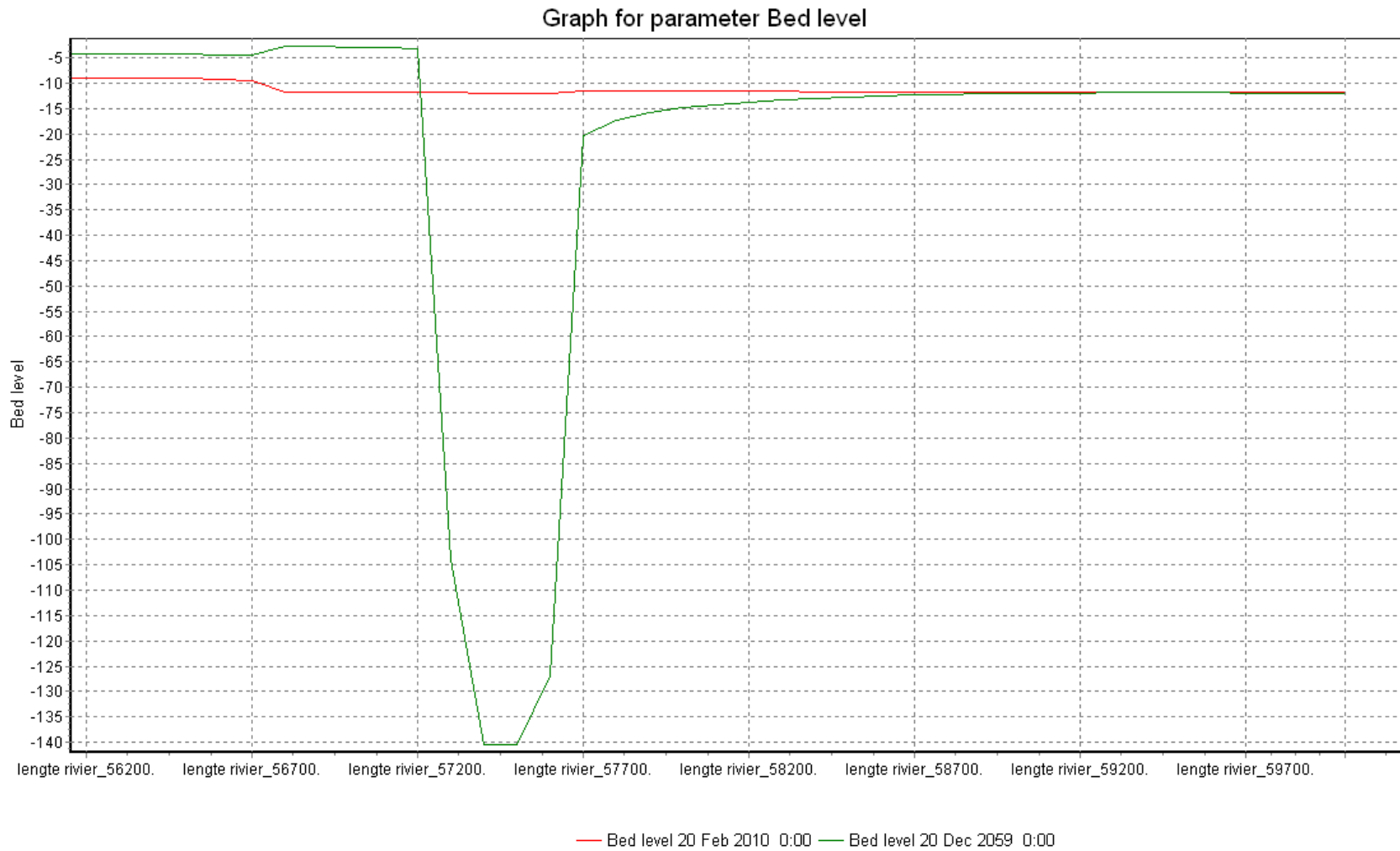

figure I-6: harbour basin 50 years result run 3

Prefeasibility report for the Port of Itajaí

	Bed level 20 Feb 2010 0:00	slope	Bed level 20 Dec 2059 0:00	slope		Deepening dredging upstream
0	9.934999		9.934999			
100	9.571784	0.00363215	9.190689	0.0074431		
200	9.555442	0.00016342	9.165736	0.00024953	volume	32660
300	9.539577	0.00015865	9.140766	0.0002497		1245340
400	9.523904	0.00015673	9.115793	0.00024973		-10238155 +
500	9.508737	0.00015167	9.090826	0.00024967		-8960155
600	9.494998	0.00013739	9.065866	0.0002496		
700	9.484179	0.00010819	9.04091	0.00024956	dredging (1000m)	45727200
800	9.477856	0.00006323	9.015956	0.00024954	dredging 2 (2400m)	113529.6
900	9.476936	0.0000092	8.991012	0.00024944		
1000	9.481195	-0.00004259	8.966073	0.00024939	Total (50 years)	36880575
1100	9.489551	-0.00008356	8.941144	0.00024929	Total (1 year)	737611.49

table I-3: part of exported data run 3

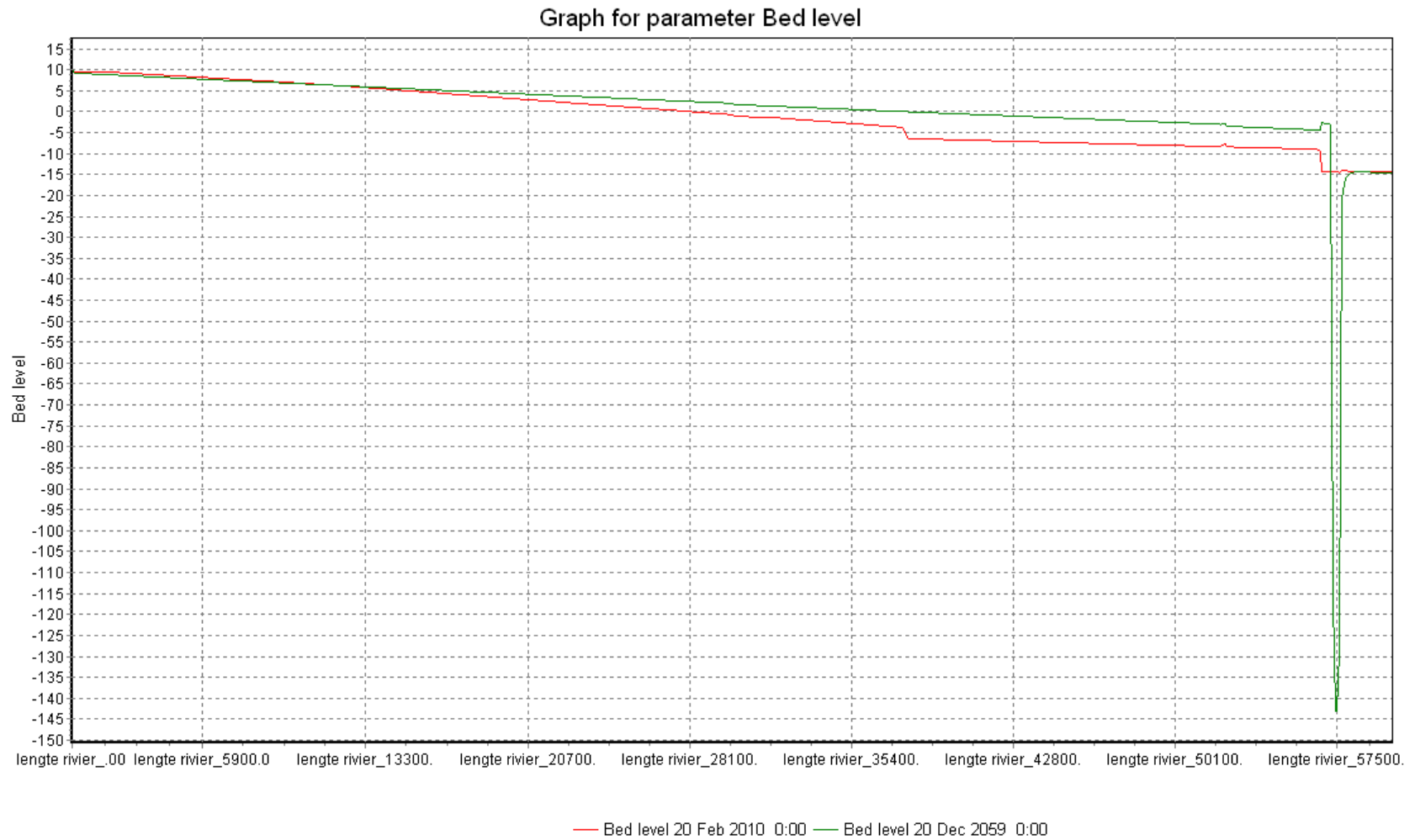

figure I-7: 50 years result run 4

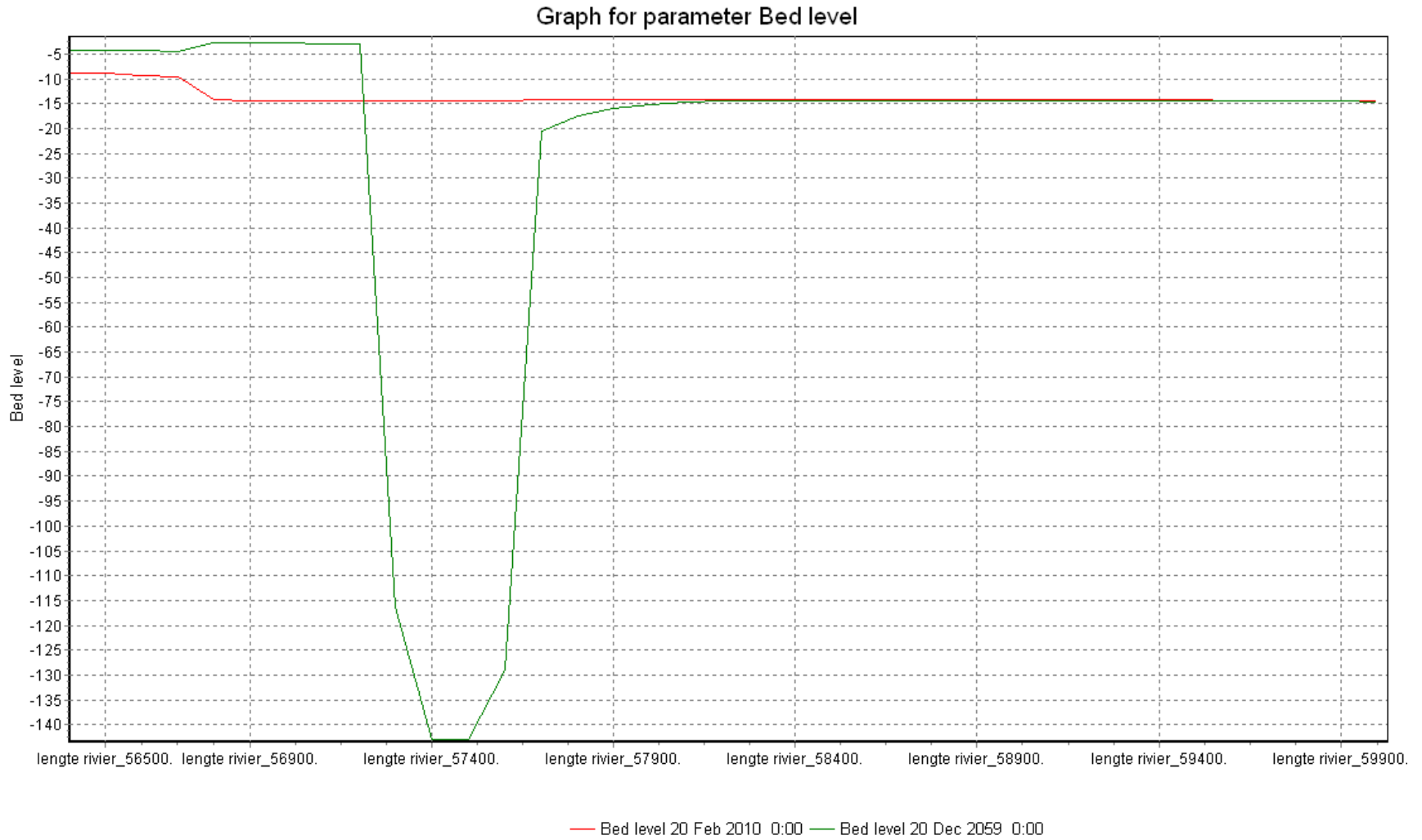

figure I-8: harbour basin 50 years result run 4

Prefeasibility report for the Port of Itajaí

	Bed level 20 Feb 2010 0:00	slope	Bed level 20 Dec 2059 0:00	slope		Deepening dredging harbour and upstream
0	9.934999		9.934999		volume	32660
100	9.571777	0.00363222	9.182459	0.0075254		1604600
200	9.555432	0.00016345	9.157507	0.00024952		-11639120 +
300	9.539573	0.00015859	9.132539	0.00024968		-10001860
400	9.523902	0.00015671	9.107567	0.00024972		
500	9.508735	0.00015167	9.082598	0.00024969	dredging (1000m)	45727200
600	9.494996	0.00013739	9.057636	0.00024962	dredging 2 (2400m)	113529.6
700	9.484178	0.00010818	9.032681	0.00024955		
800	9.477851	0.00006327	9.007732	0.00024949	Total (50 years)	35838870
900	9.476932	0.00000919	8.982791	0.00024941	Total (1 year)	716777.39

table I-4: part of exported data run 4

Appendix J: Dredging

Ano	Volume Dragado	Und	Origem dos Recursos	Profundidade	Und	Tolerância	Und	Classificação	Obs:
1958	200,000.00	m³	Ministério dos Transportes	6.50	m	0.50	m	Manutenção	Canal Ext
1971	120,989.00	m³	Ministério dos Transportes	6.00	m	0.50	m	Manutenção	Bacia
1971	174,100.00	m³	Ministério dos Transportes	6.00	m	0.50	m	Manutenção	Canal Int
1971	196,800.00	m³	Ministério dos Transportes	6.00	m	0.50	m	Manutenção	Canal Ext
1972	1,034.00	m³	Ministério dos Transportes	6.00	m	0.50	m	Manutenção	Bacia
1972	45,000.00	m³	Ministério dos Transportes	6.00	m	0.50	m	Manutenção	Canal Int
1978	531,378.00	m³	Ministério dos Transportes	7.00	m	0.50	m	Aprofundamento	Canal Ext
1978	396,164.00	m³	Ministério dos Transportes	7.00	m	0.50	m	Manutenção	Canal Int
1978	358,133.00	m³	Ministério dos Transportes	7.00	m	0.50	m	Manutenção	Bacia
1980	43,147.00	m³	Ministério dos Transportes	8.00	m	0.50	m	Aprofundamento	Canal Ext
1980	232,772.00	m³	Ministério dos Transportes	8.00	m	0.50	m	Manutenção	Canal Int
1980	197,999.00	m³	Ministério dos Transportes	8.00	m	0.50	m	Manutenção	Bacia
1982	241,004.00	m³	Ministério dos Transportes	8.05	m	0.50	m	Aprofundamento	Bacia
1982	237,058.00	m³	Ministério dos Transportes	8.05	m	0.50	m	Manutenção	Canal Int
1982	106,573.00	m³	Ministério dos Transportes	8.05	m	0.50	m	Manutenção	Canal Ext
1989	172,000.00	m³	Ministério dos Transportes	8.05	m	0.50	m	Manutenção	-
1990	1,596,694.00	m³	Ministério dos Transportes	8.10	m	0.50	m	Aprofundamento	-
1991	528,512.00	m³	Próprios	8.10	m	0.50	m	Aprofundamento	-
1992	842,610.97	m³	Próprios	8.10	m	0.50	m	Manutenção	-
1993	841,180.00	m³	Próprios	8.10	m	0.50	m	Manutenção	-
1994	53,927.00	m³	Próprios	8.10	m	0.50	m	Manutenção	-
1995	796,870.00	m³	Próprios	8.10	m	0.50	m	Manutenção	-
1996	2,250,000.00	m³	Próprios	8.15	m	0.50	m	Manutenção	-
1997	898,787.00	m³	Próprios	8.15	m	0.50	m	Manutenção	-
1998	1,500,000.00	m³	Próprios	9.15	m	0.50	m	Aprofundamento	-
1998	1,102,530.00	m³	Próprios	10.00	m	0.50	m	Manutenção e Aprofundamento	Man:1102530 Aprof:2177470
1999	1,234,345.21	m³	Próprios	10.00	m	0.50	m	Manutenção	Canal Ext, Int e Bacia
2000	2,000,000.00	m³	Próprios	10.00	m	0.50	m	Manutenção	Canal Ext, Int e Bacia
2001	1,870,000.00	m³	Próprios	10.00	m	0.50	m	Manutenção	Canal Ext, Int e Bacia
2002	1,800,000.00	m³	Próprios	10.00	m	0.50	m	Manutenção	Canal Ext, Int e Bacia
2003	1,893,750.00	m³	Próprios	10.00	m	0.50	m	Manutenção e Aprofundamento	Man:1800000 Aprof:93750
2004	1,850,430.04	m³	Próprios	10.00	m	0.50	m	Manutenção	Canal Ext, Int e Bacia
2005	1,800,000.00	m³	Próprios	10.00	m	0.50	m	Manutenção	Canal Ext, Int e Bacia
2006	4,373,679.00	m³	Próprios/União	11,00 e 12,00	m	0.30	m	Manutenção e Aprofundamento	Man:1102530 Aprof:2873679
2007	2,265,000.00	m³	Próprios	11,00 e 12,00	m	0.30	m	Manutenção	11,00 (int e bacia) / 12,00 (ext)

table J-1: history of dredging in the Port of Itajaí



figure J-1: river upstream divided in sections



figure J-2: dredged area upstream

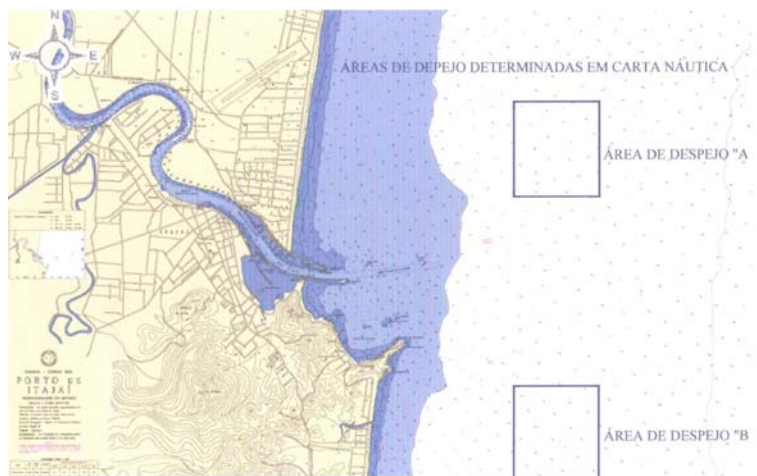

figure J-3: disposal area dredged material

Appendix K: Possible solutions sedimentation

	Sediment concentration equation [mg/l]	Av. production of sediment [ton/ha/year]	Av. production of sediment [ton/km ² /year]	Av. production of sediment [ton/ha/year]	Av. production of sediment [ton/km ² /year]	Area [km ²]	Production of sediment [kg/year]
Indaial	$C = 0,2576 * Q + 12,777$	1,45	145	1,27	127	11,15	1.416.050
Blumenau	$C = 0,2452 * Q + 173,59$	2,94	294	3,32	332	11,8	3.917.600
							5.504.777

table K-1: run off sediment production at Indaial and Blumenau (1980-1989)

Itajaí-Açu	Concentration formula	Q [m ³ /s]	Concentration [mg/l]	Density [kg/m ³]	Sediment transport [kg/s]	Sediment transport [kg/year]
Indaial	$C = 0,2576 * Q + 12,777$	378	110,15	0,11	41,64	1.313.051.818
Blumenau	$C = 0,2452 * Q + 173,59$	378	266,28	0,266	100,65	3.174.167.048

table K-2: total sediment production at Indaial and Blumenau

Itajaí-Mirim	Concentration formula	Q [m ³ /s]	Concentration [mg/l]	Density [kg/m ³]	Sediment transport [kg/s]	Sediment transport [kg/year]
Brusque	$C = 2,9314 * Q - 1,3463$	112,10	327,26	0,327	36,66	1.156.005.691

table K-3: sediment load Itajaí-Mirim

