

Digital Solutions for a Circular Façade Economy

A conceptual framework of a Façade's Product Passport to facilitate decision-making at its End of Service (EoS).

MASTER THESIS – P5 REPORT

BUILDING TECHNOLOGY MASTER TRACK

Faculty of Architecture and the Built Environment

First Mentor: Dr. Michela Turrin, AE+T-Design Informatics

Second Mentor: Ph.D. Juan Azcarate, AE+T-Façade Design

External Supervisor: Monique Fledderman, VMRG

Internal Advisor: Prof.Dr.Ir. P.J.M. van Oosterom

Student: Abhishek Holla | 5109906

Acknowledgments

Before acknowledging the support from my mentors, friends, and family, I would like to thank TU Delft Façade Research Group and VMRG for initiating this fascinating topic, which has had a drastic impact on my understanding of the Dutch Metal Façade Industry. There could not have been a better platform for me to gain this insight and knowledge, which I look forward to implementing in the future.

However, this body of research would not be possible without the support of my mentors, peers, friends, and family. Firstly, I would like to thank my main mentor, Dr. Michela Turrin, for her insightful and open-minded approach to this rather unconventional research topic for the master track. She not only allowed me to sculpt my direction during this research, but the gentle nudges from time to time greatly helped in grounding the research with a strong scientific base. Also, I thank her for allowing me to assist her during the MEGA course, where some of the lectures and discussions were relevant for this research, for which I am incredibly grateful. I would like to extend my sincere thanks to my second mentor, Juan Azcarate, for the various discussions around this subject area and practical inputs, which helped me define the deliverables of this research. His background experience and knowledge from a more Construction management perspective were essential to approach such an immensely vast topic. I am also deeply grateful to my external supervisor Monique Fledderman from the VMRG, for the prompt coordination throughout the research topic. The continuous in-depth feedback and support helped me speed with the Dutch Façade Market and its current practices. She has a very open mind and has a very strong practical knowledge of this subject area and therefore could share valuable data and putting me in touch with relevant stakeholders throughout the project. The project wouldn't have reached this level of maturity if it wasn't for this continued support. Lastly, I would like to thank Peter van Oosterom, my internal advisor, for the insightful discussions that helped me align the topic into an existing body of research that helped define this study's scientific novelty. These suggestions and insights have been an eye-opener into a completely different domain.

Apart from my graduation committee, several people have had an indirect influence on this research. Firstly, I would like to thank Stingo Huuderman, who was open to sharing many insights and information about the development of Cirling, its features, technicalities, and shortcomings. I would also like to thank Gerrit Bentenhuis from the VMRG, who helped me understand the nuances of certifications in the Façade Industry and providing me with all the necessary material. I would like to thank Professor Marcel Bilow and Professor Ulrich Knaack for giving me critical feedback, which helped me inform this research defined from a Façade Design perspective. Lastly, I would like to thank all the company representatives listed in Chapter 12 who made time to fill out the survey and agreed to share their valuable insights during the interviews. Firstly, this experience has left me humbled, firstly about how open companies in the Netherlands are towards innovation and research. Secondly, it shed light on the intricate and robust collaboration between academia and industry in the Netherlands, which I am incredibly grateful to be part of during this research.

Apart from this, I would like to thank all my friends back in India and my family who stayed with me throughout the research through the various ups and downs during this pandemic. I don't think I would be writing this in such high spirits if it weren't for you guys. Concerning my research, I would like to thank my friends and colleagues Neha for the discussions about circularity frameworks for reuse and Anagha for knowledge-based decision-making and for the constant encouragement during these conversations. Cheers to you both, and I look forward to many more discussions in this fascinating subject. A shoutout to my room mates and dear friends Vicente and Lucas and extended roommates Anastasia, Aditya, Leonardo, Twinkle, and Inaka, who have been there for me with the occasional random banter and insightful conversations throughout these strange and isolating times. I would also like to thank my partner Shrunga for being my support system and providing valuable inputs on the visualizations of the project. There are also some people I would like to thank, who have been indirectly responsible for even choosing Delft. Ar. Karun Kumbara, for enabling me to develop an interest in Circular Architecture way before joining Delft or even learning about the subject through the various innovative projects built with him over the years. My sister Mithila and her partner Sharath for motivating me to pursue this Master Track. Lastly, Elly and Ester from the Dagpo Educational Fund enabled me to visit TU Delft in 2017, completely changing my perspective of technical education in Europe. It has been a tremendous journey, and I wouldn't have made it so far without this initial seed and impression of studying in the Netherlands if it weren't for you two. Thanks a lot!

Executive Summary

The target of the Dutch government going fully circular by 2050 will happen parallel to the transitioning towards implementing Industry 4.0 Technology. With this context, several companies across the Netherlands have launched initiatives to tackle this challenge with innovative methods and technology. VMRG, a Dutch Metal Façade Association, who, in collaboration with TU Delft Façade Research group, has launched pilot projects that integrate Industry 4.0 Technology and Circular Business models to assist the transitioning of the Dutch Façade Industry to be more Circular. However, as Industry-wide cooperation and awareness are crucial for this transition, it was essential to adapt these technologies by considering stakeholders who have little or no awareness of these concepts. Additionally, although these initiatives intend to accelerate the Circular transition, there was a lack of a framework to address the main objective, i.e., retaining the maximum value of a façade at its end of life.

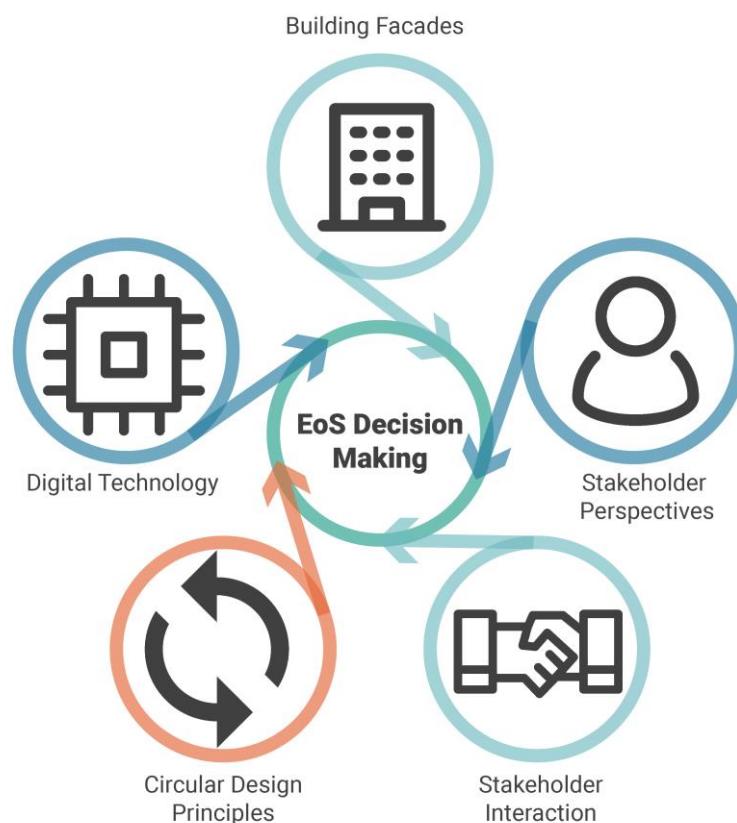

Therefore, this research attempts to bridge these gaps by creating a framework that, instead of focusing exclusively on Digital Methods and Technology, emphasized stakeholder perspectives on Circularity, current industry practices, business models, and general functioning of the Dutch Façade industry. Hence part of the research is to bring together and refine existing frameworks towards the needs of the Dutch Metal Façade Industry, and part of the research is suggestive in areas where no frameworks existed. Furthermore, given the current trends of industry stakeholders from diverse domains constantly coming up with new initiatives, the conceptual approach of the thesis was essential to enable them to interpret it from the perspective of their domain and refine their initiatives to be more grounded towards the main objectives of Circularity. To ensure the framework is practically understood, it is developed around one façade typology, i.e., Unitized Metal Facades, and demonstrated using a case study. The demonstration also explains the main shortcomings of the industry practices and creates a reference to adapt to other façade typologies and eventually into other building components.

Abstract

In the Dutch government attempting to become fully circular 2050, VMRG, a Dutch Metal Façade Association, has initiated several pilot projects. Two of the most prominent ones are Cirliq, an asset management platform for documenting building facades, and FaSA (Façade Service Applicate), a collective of stakeholders aiming to use drones and image recognition technology predict the maintenance requirement of facades. There are also attempts to extend the producers' responsibility by developing new business models in collaboration with TU Delft, resulting in developing a Façade Leasing Business model. However, despite these several initiatives and the emergence of new technology to facilitate them, there was still a lack of clarity on how they can be integrated to collect, organize and use façade information to enable decision-making at its End of service.

The first steps of the research involved conducting a literature review on the current state of the art in Circularity, the façade industry, and digital technology in the lifecycle of a façade. A preliminary framework was generated that conceptually maps out the information generated in the lifecycle of a façade, a data structure to store this information, and a conceptual framework for a façade product passport. Based on this preliminary framework, several hypotheses were tested and validated or refuted using surveys and interviews, which helped develop a more detailed framework. This contains detailed process maps of stakeholder roles in the supply chain of the façade, the digital methods used, and information exchanged in the process.

Several criteria are identified by referring to additional literature that can influence the End of Service (EoS) scenario of a façade and are categorized and arranged into decision trees, which eventually can form a framework for a computational tool. These are then grouped into modules which, when processed together, results in a decision. The criteria were then co-related to the information currently exchanged by the stakeholders to determine what is most crucial to making a decision. During this process, it was found that most information required to make a decision is un-processable by computational methods; firstly, they are in unstructured data formats such as documents, and secondly, the necessary criteria to make a decision are subjective and still need human interpretation. Therefore, the decision-making framework can either be used to evaluate existing facades scheduled for demolition or determine the crucial information to be entered in the passport for facades that are not yet constructed.

The entire framework from information capture, organization, and end-of-life decision-making is then demonstrated with information received of the CiTG Façade in the TU Delft campus as part of the Façade Leasing project TU Delft. During this evaluation, it was found that several essential information about the façade not available, and hence the façade was evaluated by assuming industry-standard processes and references to external databases such as the Granta Edu Pack. Information that is available and information generated is noted, which indicates the most crucial information required for EoS Decision making. During the EoS assessment process, while the façade can be disassembled and reused, it can be done early to design a new building, as it had fixed non-modular dimensions. Many conditions have to be considered, mainly regarding sizing, geometry, positioning, and structural system of the façade while designing the building for the CiTG façade to be reused. It was also found that recycling and energy recovery of the façade is only possible if the separation between the aluminum profiles and the thermal barrier is achieved. Although specific modules such as the condition assessment and the performance assessment could not be thoroughly carried out, a table with results of the assessments is generated and therefore acts as a starting point of how this framework can eventually be used and adapted to assess different facades. This framework can be eventually be developed in an iterative manner which can expand it to cater to multiple façade typologies and eventually forming a basis for an EoS assessment tool. All the research questions are answered at the end, acting as a summary of findings. As this research is just a starting point for further in-depth research, conclusions are made regarding recommendations to the Dutch Metal Façade industry and the following possible research stages.

Contents

| | |
|--|-----------|
| ACKNOWLEDGMENTS | 3 |
| EXECUTIVE SUMMARY | 4 |
| ABSTRACT | 5 |
| CONTENTS | 6 |
| LIST OF ABBREVIATIONS | 8 |
| 1 Research Framework..... | 10 |
| 1.1 Background..... | 11 |
| 1.2 Problem statement..... | 13 |
| 1.3 Objectives..... | 14 |
| 1.4 Research Question | 14 |
| 1.5 Design Question..... | 14 |
| 1.6 Methodology..... | 15 |
| 1.7 Relevance..... | 18 |
| 2 THE CIRCULAR FAÇADE ECONOMY | 20 |
| 2.1 Circularity in Building Facades | 21 |
| 2.2 The Circular Lifecycle of a Façade | 29 |
| 2.3 Circular Business models..... | 31 |
| 2.4 Conclusions | 34 |
| 3 MATERIAL PASSPORTS | 35 |
| 3.1 Definition..... | 36 |
| 3.2 Contents | 36 |
| 3.3 Applications in the lifecycle of a building | 39 |
| 3.4 Information Infrastructure..... | 39 |
| 3.5 Influence on stakeholder involvement..... | 42 |
| 3.6 Overview Current platforms in the Market | 43 |
| 3.7 Conclusions | 46 |
| 4 DIGITAL TWINS | 47 |
| 4.1 Context..... | 48 |
| 4.2 Definition..... | 48 |
| 4.3 Components of Digital Twins | 49 |
| 4.4 Uses in the Lifecycle of a Façade | 50 |
| 4.5 Evolution of Digital Twins | 51 |
| 4.6 Limitations..... | 52 |
| 4.7 Conclusions | 53 |
| 5 PRELIMINARY FRAMEWORK | 54 |
| 5.1 Product Levels to Information Levels | 55 |
| 5.2 Framework for Façade Product Passports..... | 55 |
| 5.3 Long List and Data Template for Façade Product Passports | 58 |
| 5.4 Conclusions | 59 |
| 6 SURVEY AND INTERVIEW ANALYSIS | 60 |
| 6.2 Analysis framework for Surveys and Follow-up interviews | 61 |
| 6.3 Analysis of Independent interviews..... | 69 |
| 7 FRAMEWORK FOR A CONCEPTUAL INFORMATION MODEL | 71 |
| 7.1 Processes, Stakeholders, and Information Exchange | 71 |
| 7.2 Information infrastructure for façade passports..... | 81 |
| 8 FRAMEWORK FOR THE END OF SERVICE (EoS) ASSESSMENT PROCESS | 86 |
| 8.1 EoS Assessment in the lifecycle of a façade..... | 87 |
| 8.2 EoS Assessment process and stakeholders involved | 88 |
| 8.3 EoS Assessment Method | 89 |
| 8.4 Typology Selection Module..... | 91 |
| 8.5 Design for Disassembly (DfD) Module..... | 94 |

| | | |
|-----------|---|------------|
| 8.6 | Condition Assessment Module | 99 |
| 8.7 | Recyclability and Toxicity Module..... | 102 |
| 8.8 | Performance Assessment Module..... | 102 |
| 8.9 | Reuse/Remanufacturing parameters | 103 |
| 8.10 | Conclusions | 111 |
| 9 | DEMONSTRATION OF THE FRAMEWORK..... | 112 |
| 9.1 | Case Study | 112 |
| 9.2 | Information received | 113 |
| 9.3 | Inclusions and Exclusions | 114 |
| 9.4 | Identification of Database Instances | 114 |
| 9.5 | Identification of Processes and connections | 116 |
| 9.6 | Database Structuring | 116 |
| 9.7 | Demonstration of Data templates | 118 |
| 9.8 | EoS Assessment | 124 |
| 9.9 | Conclusions | 134 |
| 10 | ANSWERING RESEARCH QUESTIONS..... | 135 |
| 10.1 | Research Questions | 135 |
| 10.2 | Design Questions | 143 |
| 11 | CONCLUSIONS | 146 |
| 12 | SURVEY AND INTERVIEW RESPONDENTS..... | 148 |
| 12.1 | List of Survey respondents | 148 |
| 12.2 | List of interviewees..... | 148 |
| 13 | REFERENCES | 148 |
| 14 | LIST OF FIGURES | 151 |
| 15 | APPENDIX..... | 155 |
| 15.1 | Positioning process of the research topic based on literature collected | 155 |
| 15.2 | Preliminary lifecycle stakeholder map | 156 |
| 15.3 | Preliminary Material Passport framework | 156 |
| 15.4 | Preliminary Decision Models for EoS Assessment process..... | 157 |
| 15.5 | Results of the Survey | 160 |
| 15.6 | List of interview questions | 164 |
| 15.7 | List of Survey Questions per stakeholder..... | 167 |
| 15.8 | Long list of Façade Passports..... | 170 |
| 15.9 | Sources of EoS assessment criteria | 177 |
| 15.10 | Auxiliary research on Industry Foundation Classes (IFC): | 178 |
| 15.11 | Auxiliary Research on Façade Product certifications | 179 |
| 15.12 | Stages of NEN 2767 Condition measurement process | 180 |

List of Abbreviations

BIM: Building Information Modelling
DT: Digital Twin
VDC: Virtual Design Construction
PSS: Product Service System
AI: Artificial Intelligence
IoT: Internet of Things
CE: Circular Economy
MP: Material passport
CDW: Construction and demolition waste
DFD: Design for Disassembly
VR: Virtual Reality
AR: Augmented Reality
RFID: Radio Frequency Identification
IT: Information Technology
DBFMO: Design, Build, Finance, Maintain, Operate
MFA: Material Flow Analysis
MCI: Material Circularity Indicator
LCA: Lifecycle Analysis
API: Application Programming Interface
IFC: Industry Foundation Classes
AEC: Architecture Engineering and Construction
LOD: Level of Detail
STEP: Standard for the Exchange of Product Data
IDS: Information Delivery Specification
MVD: Model View Definitions
EoS: End of Service
EoL: End of Life
FPP: Façade Product passport

1 Research Framework

The chapter overviews the background information, problem statement, research questions, and the methodology employed for the research.

1.1 Background

The Circular Economy arose from the necessity of utilizing waste flows more effectively, reducing our demand for raw materials. Then, a UK based charitable organization actively working on frameworks for the circular economy concept defines it as follows: "A circular economy is restorative and regenerative by design and aims to keep products, components, and materials at their highest utility and value at all times, distinguishing between technical and biological cycles." At present, the building industry mainly concerns the technical cycles and the increasing use of bio-based materials, which would eventually dominate the biological cycles. As seen in Figure 1, the system diagram indicates the biological and technical cycle's material flows in a circular economy.

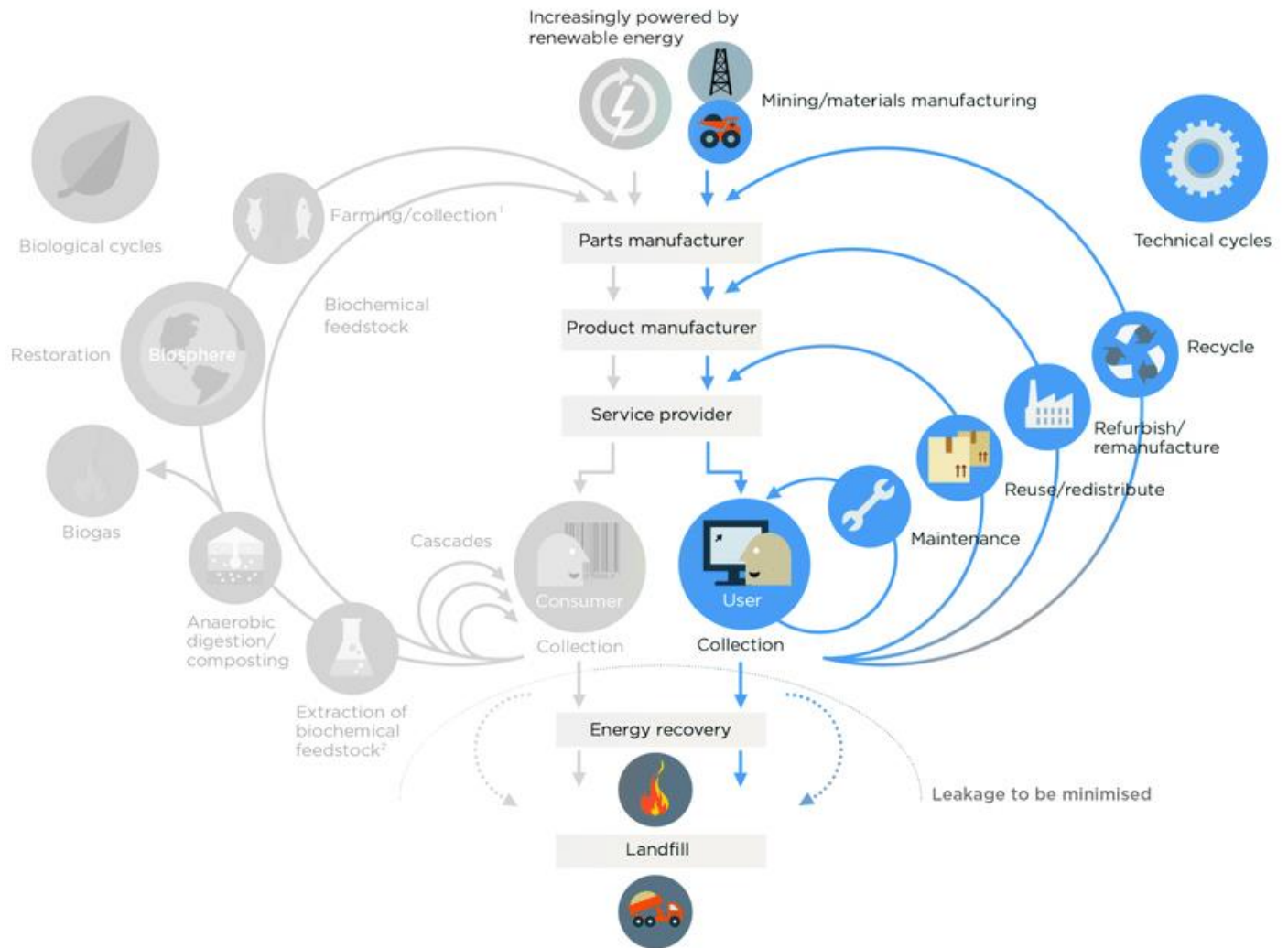

Figure 1: System Diagram of the Circular Economy indicating the technical cycles. Source: Adapted from EMF

There are many different ways of enabling circular material flows in the building industry. For example, the 9R Framework by Potting, Hekkert, and Worrell (2017), as seen in Figure 2, details some of the strategies organized in a hierarchy based on their value. These strategies can either be employed during the design, operation phase, or end-of-life of a project. According to a report by (Deloitte, 2017), which aimed at investing the current CDW management practices in EU member states detailed in Figure 3, the Netherlands is recycling 86% of the recovered construction waste (CDW). But there are ongoing efforts to move towards more circular strategies with a roadmap to go fully circular by 2050. These goals need to be achieved in parallel to the fourth Industrial Revolution (Industry 4.0), which includes an increased effort towards

automation, connectivity, and Artificial Intelligence-driven technologies in the manufacturing industry and is expected to extend into the construction industry.

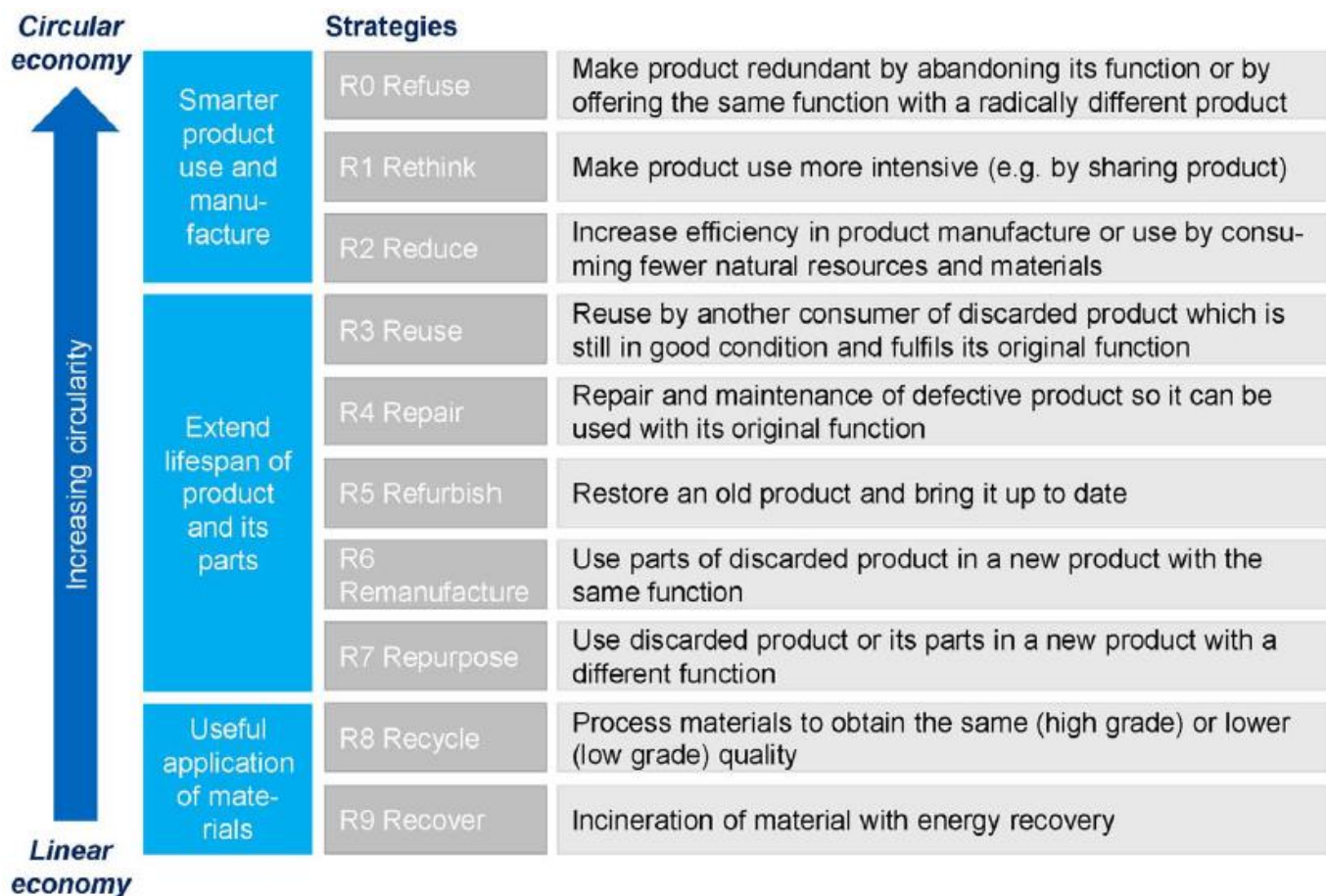

Figure 2: The 9R Framework adapted from Potting et al. (2017)

Therefore, the advantage of emerging technology such as big data Processing, IoT, and Sensor technology to facilitate the shift towards implementing Circular Strategies is unquestioned. One such business model, developed by T.U. Delft and several other partners are aimed at supplying building Facades as a service rather than a product. This would ensure manufacturers retain full ownership of the product throughout the Lifecycle, which has many associated benefits in achieving circular goals. VMRG, the Dutch Metal Façade Industry branch organization, and other industry partners, including T.U. Delft has initiated several pilot projects to facilitate the implementation of these business strategies. For example, A façade Identification system (FIS) project was initiated by VMRG, which has resulted in a web-based application, 'Cirlingq,' which acts as an asset management platform to monitor the health of buildings and facades and determine its value. The platform enables information about buildings and building objects to be located and stored in a centralized platform for various stakeholders to use, including companies that have leased out facades as a service. This would result in a database of information termed a 'Material Passport,' a key facilitator for transitioning to the Circular Economy as it serves as an inventory of information about all components in a project. Another initiative, termed Façade Service Application (FaSA), has also been developed with 39 other partners to support data collection for facades' maintenance using emerging survey technology such as photogrammetry and thermal imaging and processing them using AI to predict the condition of a façade. Therefore, these technological applications can be seen as early integrations of Industry 4.0 technologies to achieve circular building.

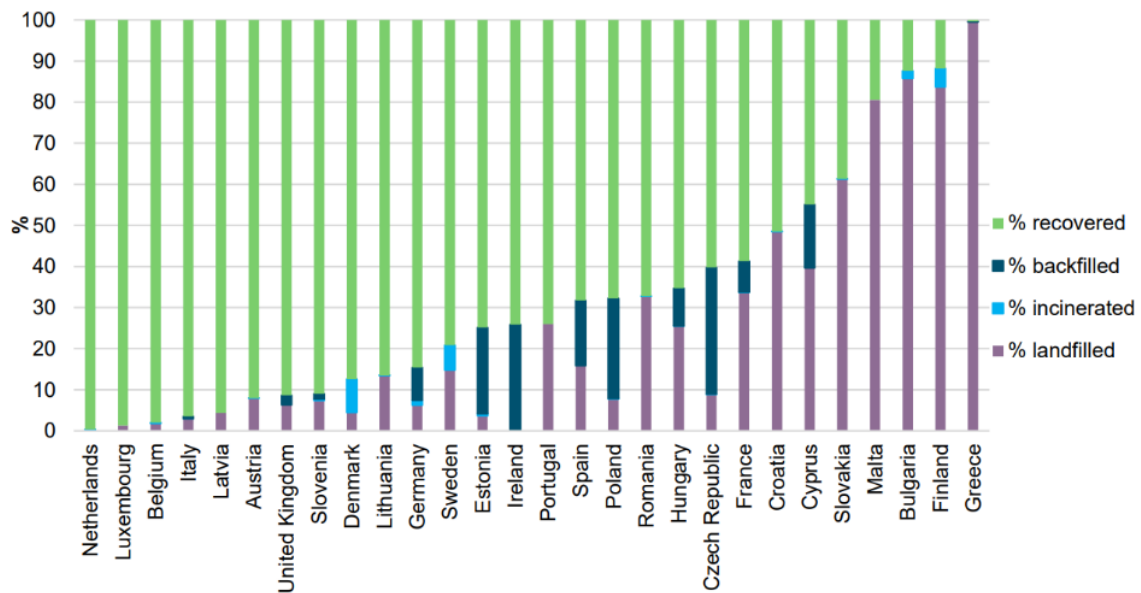

Figure 3: Waste Management summary of EU nations (2012). Source: (Deloitte, 2017)

1.2 Problem statement

Despite numerous technological developments around the Circularity of Buildings, there is little or no literature on determining the best re-life option for a façade. This becomes crucial, especially since dependence on high recycling rates is not sustainable in the long run to achieve a fully circular economy. The statistics in Figure 3 only indicate the weight of materials being recycled, but there is not much data on the embodied emissions of the recycling process. Recycling materials with high embodied energy such as aluminum, steel, or glass can continually contribute to CO2 emissions, and hence other strategies to extend the product's lifespan have to be employed. According to the 9R framework developed by Potting et al. (2017), this implies a shift towards reuse, remanufacturing, refurbishing, repurposing, repairing, and maintaining facades.

Also, in the quest for monetizing their efforts, most current platforms focus on one specific set of stakeholders based on the business it is being used for. For example, passport platforms are often combined with asset management functionalities, which only focus on recording product information and its value, not on the information required to determine its end destination after its service life. Information is also usually linked to the building using BIM Models via IFC files. But considering that IFC's have been developed only since the '90s, it can be said that most current facades, which according to Alba-Concepts (2020), will be replaced between 2020-2095, have been constructed at a time when there was very little BIM implementation. Another issue is that BIM was not intended to work with real-time data as the current usage is majorly for design, construction, maintenance, and stakeholder collaboration, which do not require real-time capability (Bruno, De Fino, & Fatiguso, 2018). Therefore, a solution needs to be developed for recording information about buildings that are being demolished and with almost no BIM implementation while also offering solutions to transition towards integrating Industry 4.0 technology. Therefore, independent methods of organizing façade information have to be addressed.

Therefore, the objective of material passports should also be directed towards storing information that indicates what materials are present and assists in decision-making at its End of service. A framework is required to map out the various information required to be present in the passport and specify a method of collecting and organizing this information, more from the industry's perspective, considering their implementation level with these technologies. The framework must be kept conceptual to ensure that stakeholders from the distinctive and diverse domains can interpret it and use it for various initiatives.

1.3 Objectives

In order to tackle these challenges, the main objective of the thesis is *to develop a framework to collect, organize and store information exchanged in the lifecycle of a metal façade to facilitate decision making about its re-life at its End of service.*

Sub-objectives

- Identify what kind of information is generated and exchanged by various stakeholders in the c lifecycle of a façade product.
- To determine how this information can be acquired, structured, and organized.
- To identify the information required to determine the various re-life options of a façade.
- To demonstrate the proposed framework using a case study.

1.4 Research Question

How can a conceptual framework be developed to collect, organize and store the information exchanged in the circular lifecycle of a Unitized metal façade to enable decision making about its re-life at its End of service (EoS)?

Sub-Questions

1. What are the various stages in the circular lifecycle of a Unitized metal façade, and who are the main stakeholders involved?
2. What kind of information is being exchanged between stakeholders during the circular lifecycle of a façade?
3. How can the information generated during the lifecycle of a facade be acquired, organized, and stored in a Façade Product passport?
4. What kind of information about a façade is required to determine the various re-life options of a façade and how can it be stored in a façade product passport?

1.5 Design Question

How can the information about the metal frame of the CiTG façade be collected, organized, and stored to enable decision making at its End of service (EoS)?

Sub-Questions

1. What kind of data is currently available about the CiTG façade, and what information can be extracted from it?
2. How can this information be structured and organized using the proposed Façade Product passport framework?

- How can the information contained in the Façade Product passport of the CiTG façade be used to generate a decision at its End of service?

1.6 Methodology

The research method employed consists of state-of-the-art literature reviews, surveys, and interviews with industry stakeholders, integrating the findings into the proposed framework and demonstrating them using a case study. An overview of the Research process is shown in Figure 4.

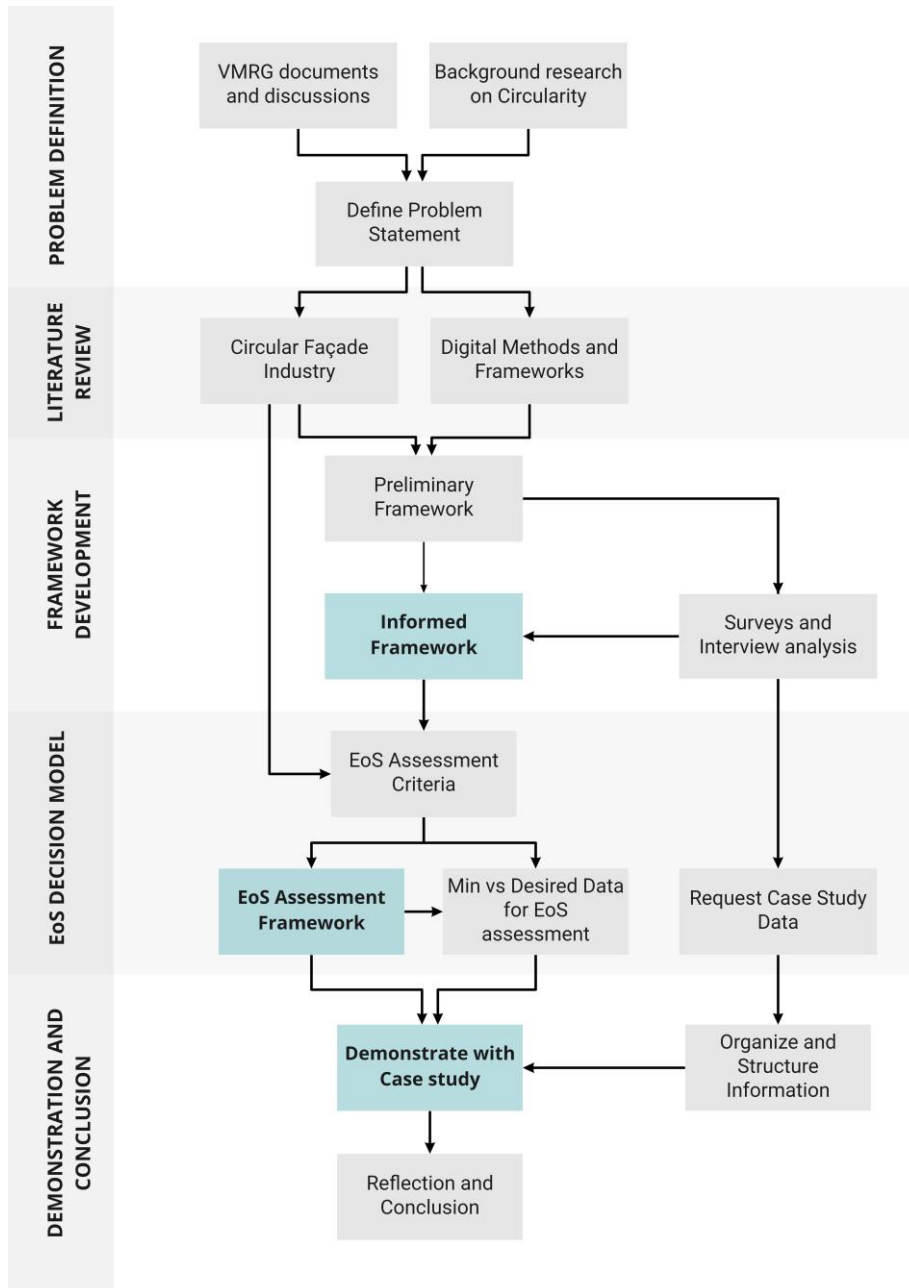

Figure 4:

Research methodology. Source: Author

1.6.1 Literature Reviews

Since the research objective was to define a framework based on current developments in the industry, the literature review aimed to be more exploratory and descriptive to familiarize with the various subjects involved. The standard search terms for the Digital methods and Technologies included: Digital frameworks, Digital Twins, Smart Manufacturing, Industry 4.0, with an affix of search terms such as 'Circular Economy,' 'Design,' 'Manufacturing,' 'Logistics', 'Supply Chain

Management," 'Building Industry.' Search terms for Circular Façade Economy Included: 'Circular Economy,' 'Design for Disassembly,' 'Circularity evaluations,' 'Reuse of Facades', etc. The research material included previous thesis' reports, Ph.D. results, Thesis reports of other universities, and various Journals and was organized into groups into BIM, Circular Business Models, Circular Economy, Digital Frameworks, Digital Twins, Circularity Evaluations, building facades, and Material Passports as shown in Figure 5.

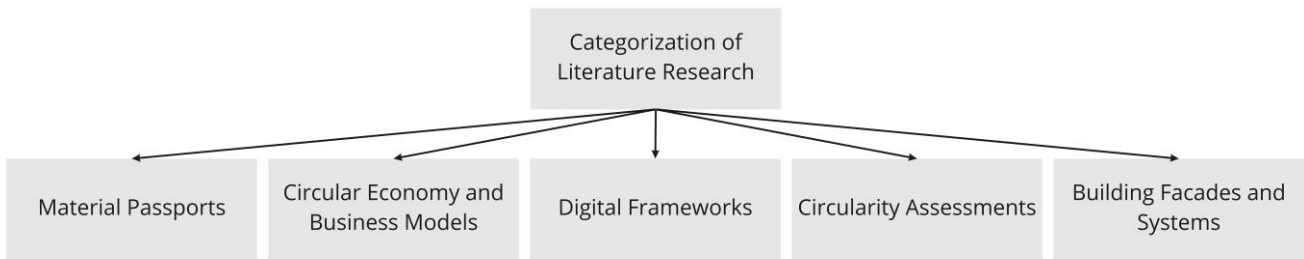

Figure 5: Categorization employed for the Literature research. Source: Author

1.6.2 Survey and Interviews

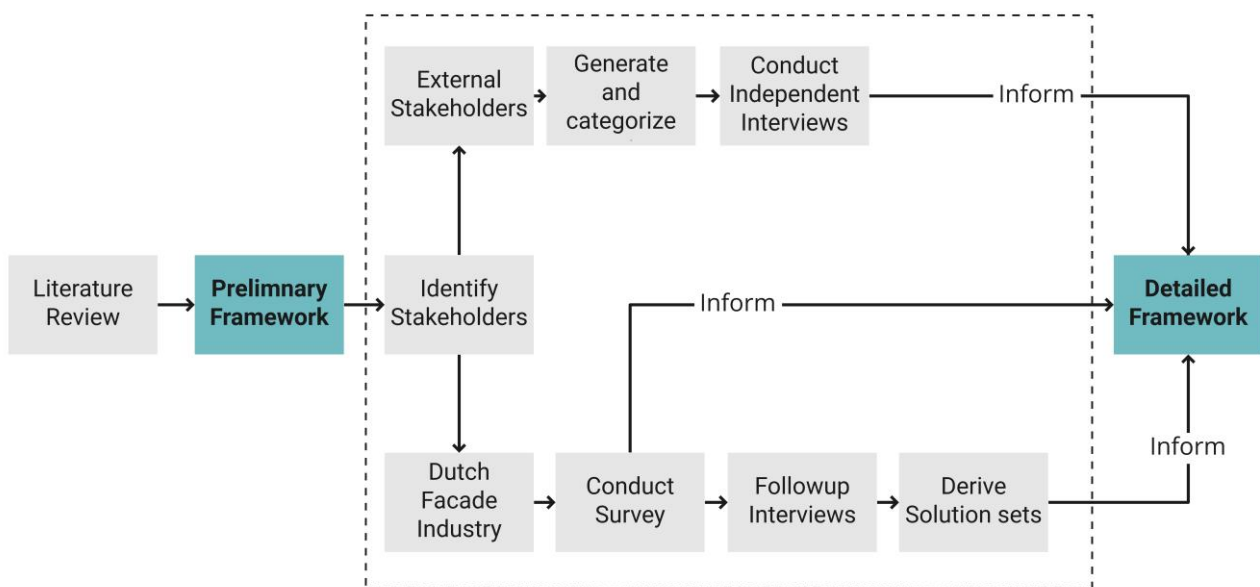

Figure 6: Flow chart of the survey and interview process employed. Source: Author

Chapter 1.1 established the ongoing transitioning of the Dutch Façade industry towards a more circular model. As the framework proposal was to be developed from the industry's perspective, surveys and interviews become the main body of the work to understand who are the stakeholders, what are processes they are involved in, and to what level digital technologies are used in context with the circularity. The results of these interviews would help develop and define the model and ensure it is practically applicable in the context of the Dutch Façade Industry. Figure 6 gives an overview of the Survey and interview methodology. A preliminary framework was outlined by integrating the results of the literature review and certain hypotheses. The survey and interviews helped validate or refute these hypotheses, and the results could then be used to generate a more integrated and detailed framework based on the industry's current state while also taking into account some of the drawbacks. Different questions were generated for each stakeholder, and results were interpreted based on their roles in the survey and categorized into several themes. First, the survey was released, and after receiving the results, follow-up interviews were conducted. Parallely independent interviews of stakeholders outside the Dutch Metal Façade Industry, but linked to Facades' Circularity, helped understand more contextual aspects. Some of the key findings of the interviews are used to inform the detailed model.

1.6.3 Process maps and Decision trees

Process maps and decision trees become crucial methods to map out the outputs of the research. This is mainly due to the strategic level approach of the research topic where the focus is not on one façade or one stakeholder but instead approached at a pan-industry scale. The main body of this research involves extensive mappings, which serve as a framework to develop an industry-wide conceptual information model for the circular façade industry. Figure 7 and 8 schematically indicate examples of both.

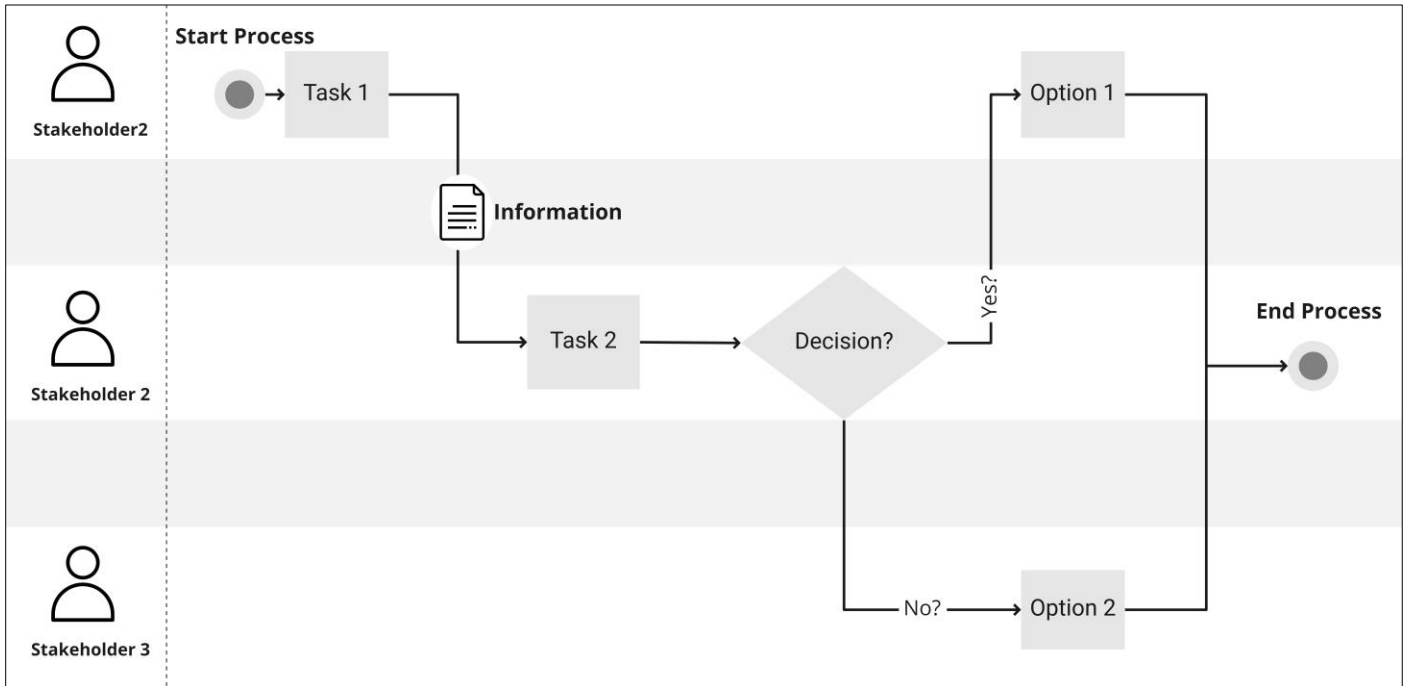

Figure 7: Example of a Process map. Source: Author

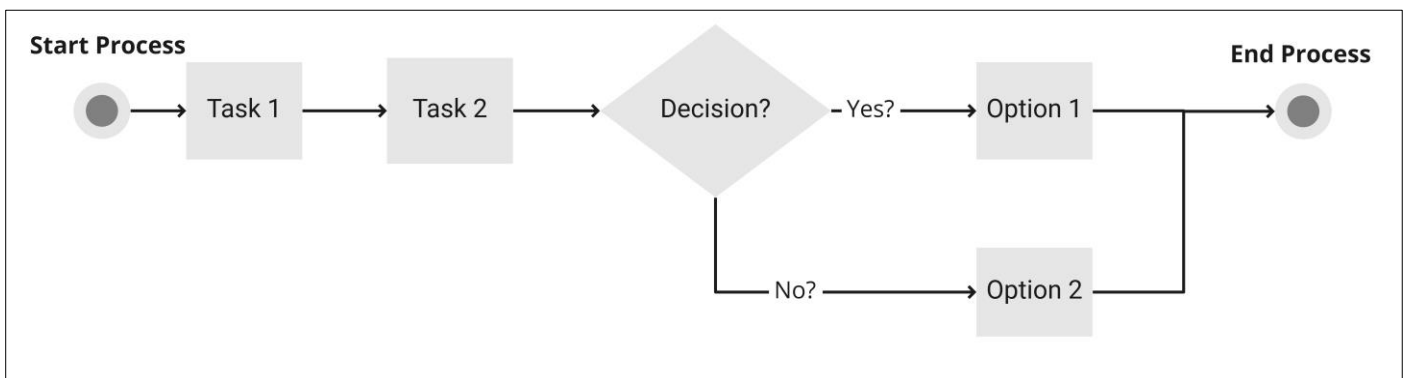

Figure 8: Example of a Decision Tree. Source: Author

1.6.4 Limitations

- As it addresses multiple domains and subject areas, the research can only address them at a strategic level, requiring aspects of it to be conceptual. Although this is done deliberately to ensure stakeholders from diverse domains can follow the research and derive inferences, there is still a risk due to a lack of testing.
- As it attempts to document the current industry practices via interviews and surveys, the research method depends on the individual stakeholders being aware of the discussed concepts and willing to share information. Therefore, there is a risk of biased results, especially from those who are already active in various circularity initiatives from those who are not.

- Mapping out contradicting perspectives from different industry stakeholders sometimes makes it difficult to define the best solution. In such cases, the only option is to keep these results more descriptive and open to interpretation.
- Due to the diversity in Façade Typologies and drastic differences in materials, clustering of components, functionality, and other characteristics, the framework is developed with only a focus on Unitized Metal Façade Systems and is tested with only one case study. Therefore, more time and effort are required to validate and refine the framework by testing it out with additional case studies of the same type and, eventually, multiple façade systems.
- The research topic itself is dynamically evolving in the industry, with many players developing new and innovative methods to approach this subject area. But unfortunately, as these overlap business practices, there is very little scientific literature in the public domain, and the few white papers developed around this topic are carefully crafted to hide confidential information, which gives the stakeholders a competitive advantage. Therefore, there is a risk of this research not being completely up to date with current findings and know-how of the industry.
- Although the subject is centered around the Circular Economic, all economic considerations, such as Co2 Tax, material costs, construction costs, etc., have not been considered. Therefore, the actual economic implications of the proposed processes and solutions cannot be evaluated, and the feasibility is unknown.

1.6.5 Timelines

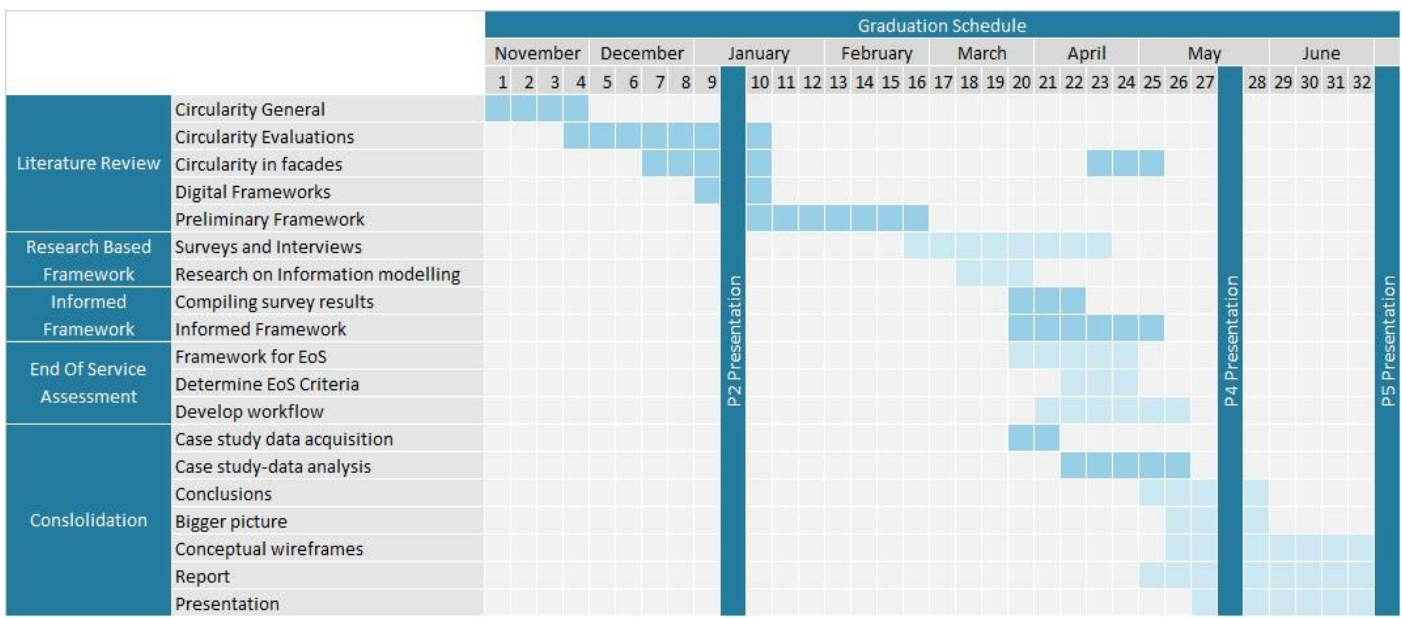

Figure 9: Timeline of the research

1.7 Relevance

1.7.1 Professional relevance

As the research was conducted in collaboration with a company, the results are directly applicable to various industry stakeholders. Firstly, when material passports become a regulation, outputs from the research (data templates) can directly help different stakeholders determine their responsibilities when entering façade information. The research also attempts to specifying a framework where the Façade Architecture, Data Structure, and stakeholder responsibilities are brought together in a way that is communicable to stakeholders in various domains. For example, the various process maps and decision trees generated in the study can be used as a medium to engage with professionals in the IT industry, such as software developers and data scientists, who can use them further to develop detailed digital methods and frameworks. Lastly, since material passports would eventually become universal for all building parts, the thesis can serve

as a framework for a repeatable model that can map out material information for other façade types or other building components and determine stakeholder responsibilities of the respective industries.

1.7.2 Societal relevance

With every industrial revolution, there has been a constant replacement of people in redundant, repetitive, and risky jobs with machines in the quest for efficiency. This trend would continue onto the current ongoing revolution (Industry 4.0), with automation and AI replacing numerous jobs across various industries. While this can be looked at as a downside, efficient designing of systems and identifying new areas and disciplines can give rise to more jobs that are less tedious and redundant, to ones that are more creative and require analytical thinking. Within this paradigm, the new jobs would mean that embedding experiences and knowledge of industry experts into software systems is crucial to ensure the technology goes to serve the purpose it is designed for. Therefore, appropriate working methods need to be established to provide this can happen seamlessly and reduce the dissonance between IT and the Building Industry. The project attempts to identify ways to bridge these differences and define this method by studying the actual conditions of the Dutch metal façade industry and mapping stakeholder perspectives and processes.

Material passports are also crucial for enabling a circular economy, thereby indirectly reducing the overall CO2 levels. The decision-making framework to determine higher values of re-life apart from recycling ensures this reduction can happen at a more accelerated phase. With the eventual implementation of the CO2 tax, digitally linked material passports could pave the way for calculating the CO2 levels per material in each stage of the supply chain. Apart from this, information on materials can also directly impact human health. As more and more people now live inside buildings and conditioned spaces more than ever before, identifying toxic materials would go a long way in protecting human health. For example, if passports were already implemented, a map of all the buildings with high asbestos content could help make fast decisions and ensure people's lives are not at risk. This is just one of the several possibilities passports could benefit society, provided frameworks are created with a human-centric approach.

1.7.3 Scientific Relevance

The research is positioned between three main focus areas within the Building Technology Graduation studio, i.e., Façade Design, Circular Building Products, and Design Informatics. During the literature research, it was understood that there was very little existing conducted on the exact content and structure of material passports. Even if there are passport platforms in the market, the frameworks of these platforms are kept confidential by companies. Almost no research currently links material passports with the actual industry stakeholders responsible for entering and maintaining the information. The present research aims to bridge these gaps and connect them to academia by using the study conducted on circular design principles, evaluation methods, and business models. It attempts to use the available research and organize them using process maps and decision trees, forming a body of knowledge that can eventually be used for further study or developing a conceptual information model. The thesis's conceptual and descriptive approach can ground further in-depth research required on data structures, digital tools, circular design strategies. The research framework can serve as a template for future research with a similar intent on other Building Components and materials.

2 The Circular Façade Economy

With the Netherlands planning to go fully circular by 2050, various industry stakeholders in the Dutch metal Façade Industry are working on new and innovative solutions to tackle this challenge. This chapter focuses in detail on why we need to go circular, the parameters that influence it, how it can be measured, the business models, and the stakeholders involved in what can be now termed as the Circular Façade Economy.

2.1 Circularity in Building Facades

2.1.1 Requirement of Circularity in Building Facades

It is well established that different parts of the building have different lifetimes, based on the materials. Brand (1994) illustrates this as the shearing layers of change where facades have a lifespan of 20+ years as compared to the main structure of the building, which is assigned a range from 30-300 years as shown in Figure 10. This lower lifespan can be attributed to wear and tear due to exposure to weather or repair/replacement of the façade to adapt to new trends, energy regulations, or changing internal functions of the building. This aspect has resulted in a lot of growing interest in making building facades more Circular. Design for Disassembly (DfD) is one way to achieve a circular building, which ensures materials can be separable from each other at the End of life. When viewing these shearing layers by Brand, with the perspective of the building being circular, it can be presumed that each of the layers needs to be separable from each other. This approach has resulted in modern building constructions, especially facades, move towards prefabricated building techniques.

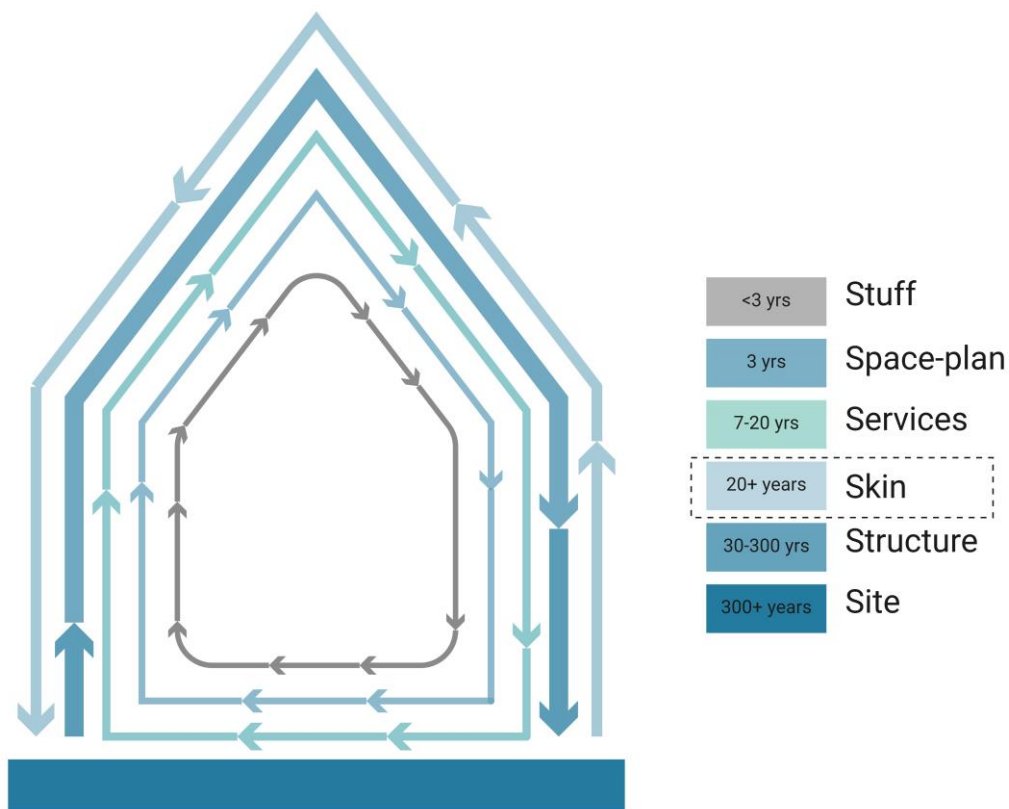

Figure 10: Layers of a building and its respective lifespans. Source: Author, Adopted from Brand (1994)

Prefabrication can be mainly attributed to the high precision, complexity, and detailing in the contemporary façade. Although, other building parts can have tolerances in centimeters, tolerances in building facades are in millimeters (Klien, 2013). Apart from the lower lifespan, facades can contribute to at least 20% of the cost of construction, can have a surface to floor area ratio of around 40% for most tall buildings (Parker, Wood, 2013), and serves as an external protection layer with a host of functions as detailed in Figure 11, which results in a complex, intricate assembly of materials. The parameters mentioned above and a drastic impact on operational energy, and therefore the impact of facades in the building's overall footprint can be quite significant. Therefore, the need to develop new façade systems with circularity principles and evaluate current facades and ensure it is reused at its highest value and least impact on the environment becomes essential.

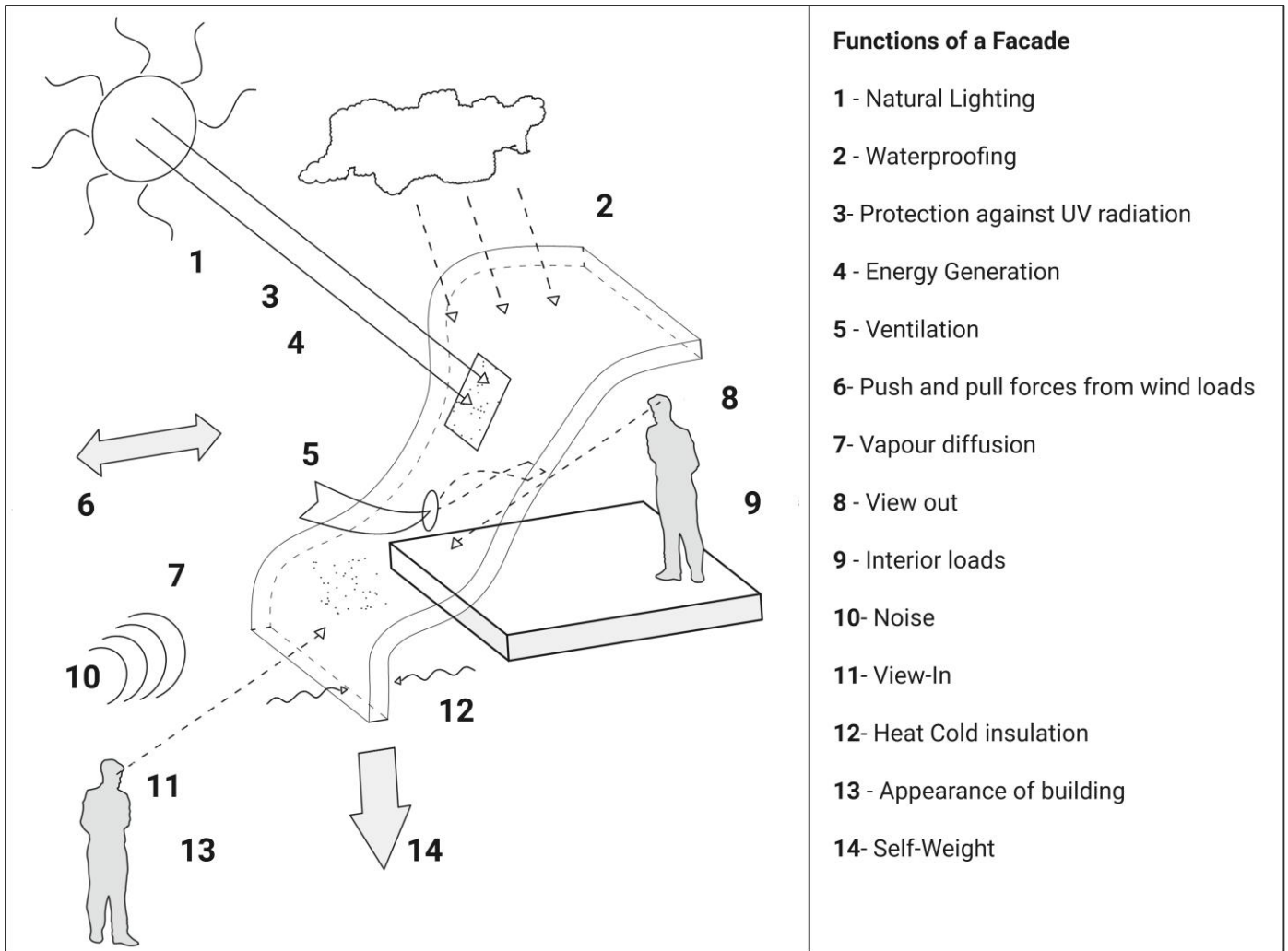

Figure 11 : Common Functions of a facade. Source: Adapted from Knaack, Klein, Bilow, and Auer (2007)

2.1.2 Methods to Measure Circularity

According to Corona, Shen, Reike, Rosales Carreón, and Worrell (2019), circularity indicators can be essential in increasing public awareness. A need for indicators was also raised by the European Commission's action plan (E.C., 2015) as follows: "to assess progress towards a more circular economy and the effectiveness of action at E.U. and national level, it is important to have a set of reliable indicators." The tools can help all the stakeholders, such as academics, industrialists, politicians and decision-makers to be more aware of C.E. principles and manage the transition at different systemic levels.

Several circularity indices and measurement frameworks have been established. Each methodology considers different inputs and is calculated using formulas or an online/offline computational tool. Most of these indices aim to represent the level of Circularity in a product with a value from 0 to 1 (Corona et al., 2019). These indices can be used either for labeling products based on performance metrics or to instigate regulatory change. The assessments can be addressed at different spatial levels, such as macro, meso, and micro. These levels can correspond to different evaluation methods and techniques (Saidani, Yannou, Leroy, & Cluzel, 2017).

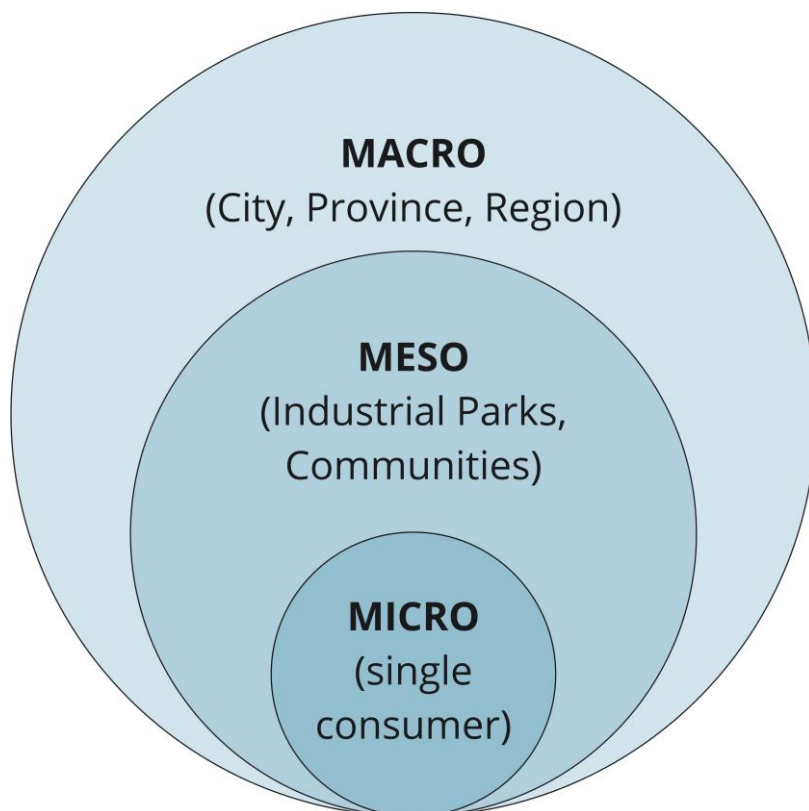

Figure 12: Different spatial levels of evaluating Circularity as defined by Saidani et al. (2017). Source: Author

2.1.3 Comparisons of different Indices

According to Linder, Sarasini, and van Loon (2017), there is a need for a robust assessment method and a requirement to consolidate the different options and compare them for strengths and weaknesses. Linder et al. (2017) compared different tools to identify weaknesses and aim to derive a new metric for quantifying product-level circularity. The main contribution is to clarify the fuzzy logic of current indicators and understand their usability in an organized manner (Linder et al., 2017). They assessed the various tools to Construct Validity, reliability, Transparency, Generality, and Aggregation Principles, and the results are summarized in Figure 13. The results found that none of the metrics they compared score well on all criteria. Although MFA and MCI provide useful starting points, the methods seem problematic during accurate quantification of the inputs (Linder et al., 2017). Although the Eco-Efficient Value Ratio ranks the highest, the differences between the results are not significant enough to rule out the other indicators.

| Indicator | Construct Validity | Reliability | Transparency | Generality | Aggregation Principles | Total Score |
|----------------------------------|--------------------|-------------|--------------|------------|------------------------|-------------|
| Eco Efficient Value Ratio | 1 | 1 | 2 | 3 | 3 | 10 |
| Material Circularity Indicator | 2 | 1 | 1 | 3 | 2 | 9 |
| Circular Economy Index | 1 | 3 | 3 | 1 | 0 | 8 |
| Repro | 1 | 1 | 2 | 2 | 1 | 7 |
| Material Reutilization Part(C2C) | 2 | 0 | 1 | 3 | 1 | 7 |

Figure 13: Adaptation of the table using numerical values. Source: adapted from Linder et al. (2017)

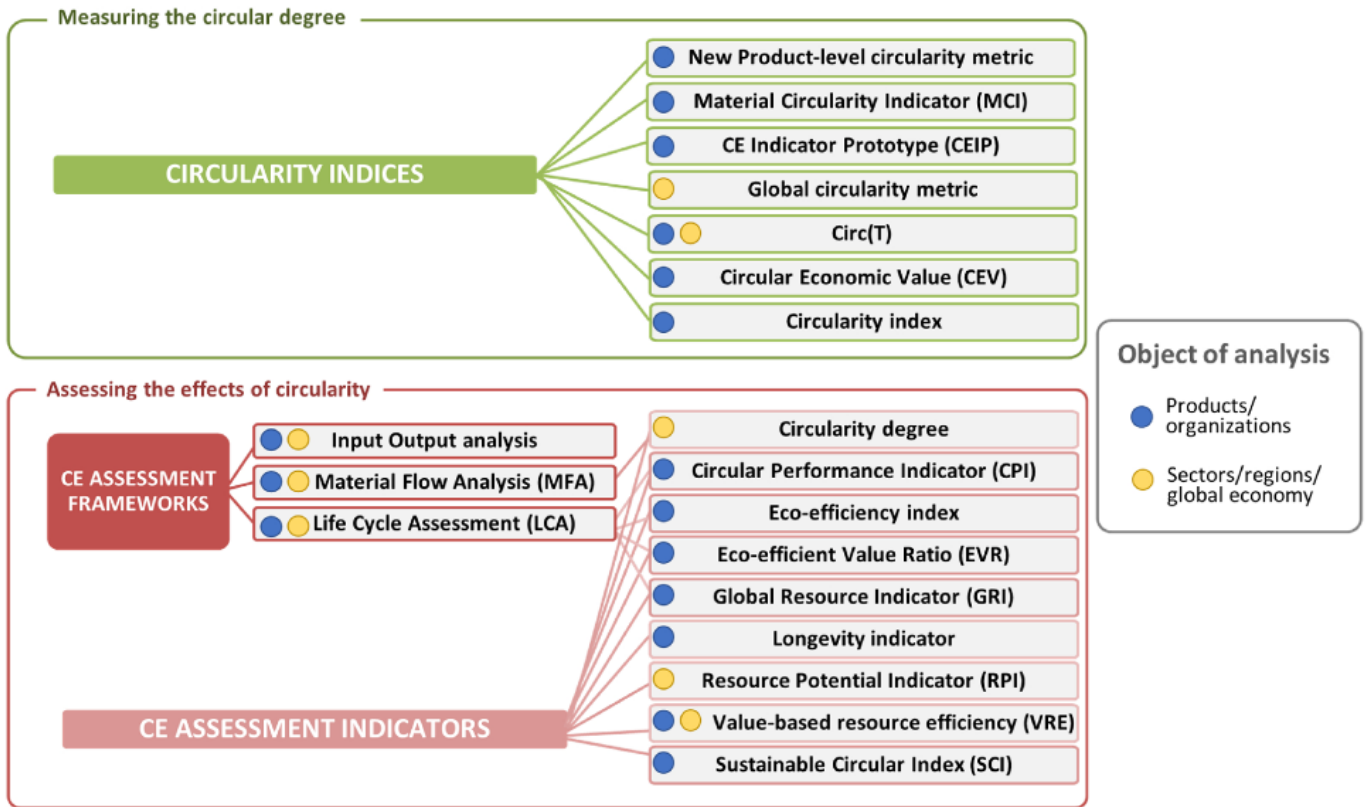

Figure 14: Classification of the reviewed metrics. Source: Corona et al. (2019).

Linder et al. (2017) defined a new evaluation method called the Product level Circularity metric, which is based on product parts' economic value as a basis for aggregating recirculated and non-recirculated elements into a combined measure for product circularity. However, even this new method had its limitations, as evaluated by Corona et al. (2019), who categorized various assessment methods into two groups: assessment indices and assessment tools, as shown in Figure 14. The first group, called 'Circularity measurement Indices, provides one value ranging from 0 to 100%, representing the circularity degree. The second group, termed 'Circularity Assessment Tools', was analyzed to contribute strategies to the principles of Circular Economic and was further subdivided into CE Assessment Indicators and CE assessment Frameworks. All these different methods are evaluated for their environmental, ecological, and societal considerations. The criteria were evaluated for the level of fulfillment as partial, total, or no fulfillment. These ratings were converted to points and tabulated, as shown in Figure 15. The results of the research are summarized in Figure 16 and Figure 17.

| Rating System | |
|-------------------------------------|---|
| No Fulfillments | 0 |
| Partial, or can be extended to fill | 1 |
| Fulfilled | 2 |

Figure 15: Rating system based on the fulfillment level of the metrics which are compared. Source: Author

| Indicator | Source | Resources | Emissions | Material Waste | Recycle Share | Durability and Utility | Jobs | Value Added | Social Well Being | Total Score |
|---|--------------------------|-----------|-----------|----------------|---------------|------------------------|------|-------------|-------------------|-------------|
| Circ(T) or Cumulative Service Index | (Pauliuk et al., 2017) | 1 | 0 | 2 | 1 | 2 | 0 | 0 | 0 | 6 |
| Material Circularity Indicator (MCI) | (EMF, 2015) | 1 | 0 | 2 | 1 | 2 | 0 | 0 | 0 | 6 |
| Circular Economic Value (CEV) | (Fogarassy et al., 2017) | 1 | 0 | 2 | 2 | 0 | 0 | 0 | 0 | 5 |
| Product-level circularity metric | (Linder et al., 2017) | 1 | 0 | 0 | 1 | 0 | 0 | 1 | 0 | 3 |
| Circularity index | (Cullen, 2017) | 1 | 0 | 2 | 0 | 0 | 0 | 0 | 0 | 3 |
| Circular Economy Indicator Prototype (CEIP) | (Cayzer et al., 2017) | 1 | 0 | 1 | 1 | 0 | 0 | 0 | 0 | 3 |
| Global circularity metric | (De Wit et al., 2018) | 1 | 0 | 0 | 1 | 0 | 0 | 0 | 0 | 2 |

Figure 16: Results of the evaluation of circularity indices, ranked from highest to lowest fulfillment levels. Source: adapted from Corona et al. (2019).

| Assessing effects of circularity | | | | | | | | | | |
|---|--|-----------|-----------|----------------|---------------|------------------------|------|-------------|-------------------|-------------|
| Indicator | Source | Resources | Emissions | Material Waste | Recycle Share | Durability and Utility | Jobs | Value Added | Social Well Being | Total Score |
| Life Cycle Assessment (LCA) | (ISO, 2006a) | 2 | 2 | 2 | 2 | 2 | 1 | 1 | 1 | 13 |
| LCA- Eco-efficient Value Ratio (EVR) | (Scheepens et al., 2016) | 2 | 2 | 2 | 1 | 2 | 2 | 0 | 0 | 11 |
| Input Output analysis | (Leontief, 1970) | 1 | 2 | 2 | 2 | 0 | 1 | 2 | 0 | 10 |
| LCA- Eco-efficiency index (EEI) | (Laso et al., 2018b) | 2 | 2 | 0 | 0 | 2 | 2 | 0 | 0 | 8 |
| Sustainable Circular Index (SCI) | (Azevedo et al., 2017) | 1 | 0 | 0 | 1 | 2 | 2 | 1 | 0 | 7 |
| LCA- Global resource indicator (GRI) | (Adibi et al., 2017) | 2 | 0 | 2 | 1 | 2 | 0 | 0 | 0 | 7 |
| Material Flow Analysis | (Haupt et al., 2017), (Busch et al., 2017) | 1 | 0 | 2 | 1 | 0 | 0 | 1 | 0 | 5 |
| Value Based Resource Efficiency | (Di Maio et al., 2017) | 2 | 0 | 0 | 0 | 0 | 0 | 2 | 0 | 4 |
| LCA- Circular Performance Indicator (CPI) | (Huysman et al., 2017) | 1 | 0 | 2 | 0 | 1 | 0 | 0 | 0 | 4 |
| Reuse Potential Indicator | (Park and Chertow, 2014) | 1 | 0 | 2 | 0 | 0 | 0 | 0 | 0 | 3 |
| Longevity Indicator | (Franklin-Johnson et al., 2016) | 1 | 0 | 0 | 0 | 2 | 0 | 0 | 0 | 3 |

Figure 17: Results of the evaluation of assessment frameworks, ranked from highest to lowest fulfillment levels. Source: adapted from Corona et al. (2019).

The results show that none of the metrics address all the criteria they have identified, and the differences in the total results are quite drastic. They attribute this issue to an oversimplified and varied understanding of the concept of

circularity. The criticality of resources is not taken into account. Therefore, social and environmental parameters are not considered and therefore fail to represent the issues such as scarcity and emission levels (Corona et al., 2019). LCA has shown a high potential to assess Circularity's goals at the product and service level among all assessment methods. However, this directly contradicts (Linder et al., 2017) position on circularity evaluations being purely focused on the circular economy concepts and not be boarded to accommodate other requirements.

Saidani, Yannou, Leroy, Cluzel, and Kendall (2019), evaluated 55 indicators from diverse sources. Their goal was to propose a taxonomy of circular indicators as different indicators could be used for different purposes. Even Saidani et al. (2019) conclude the lack of reliability of most current indicators as they state, to provide a more holistic approach and address the three pillars of sustainability, i.e., Social, Economic, and Environmental parameters. The research resulted in an excel tool that can be used to identify the different metrics. The data inputs required and other parameters where subjective comparisons can be made. A set of Inputs as shown in Figure 18, are asked to be entered, for which results are tabulated. Using the excel tool, a preliminary search was conducted to identify potential methods, usage, and required data. The results are tabulated in Figure 19.

| Input type | Options |
|--|-------------------------------------|
| <p>*Circular Economy Implementation Level* Are you focused on the circularity of a component, products, materials (micro), industrial symbiosis, eco-park, value chain (meso), of a region or nation (macro)?</p> | Micro Macro Meso |
| <p>*Circularity Perspective (Retro- or Pro-)* Are you interested in knowing actual and effective circularity performances (retrospective) or potential performances of circular practices, e.g., during product development (prospective)?</p> | Retrospective Potential |
| <p>*Circularity Performance* Are you willing to evaluate the intrinsic performance of your circularity loops (recirculation of resources) or the impacts/consequences of circular practices on sustainability performance?</p> | Intrinsic Impacts |
| <p>*Circularity Loop* Are you considering a particular loop/class of the circular economy (i.e., Maintain & Prolong; Reman. & Reuse; Recycle)?</p> | All Loops Reman/Reuse Recycle |
| <p>*Dimensionality* Are you looking more particularly for a tool with a single and unique indicator or a framework including a set of multiple indicators?</p> | Single Multiple |
| <p>*Type & Format* What kind of assessment framework linked to the C-indicators would you prefer to use?</p> | Formulas Computation tool |
| <p>*Transversality* Are you looking for a generic tool(s)/indicator(s) that could be applied for a wide variety of products/organizations or more specific ones designed for a particular industrial field?</p> | Generic Specific |

Figure 18: Input options of the excel tool to find suitable indicators. Source: adapted from a tool developed by Saidani et al. (2019).

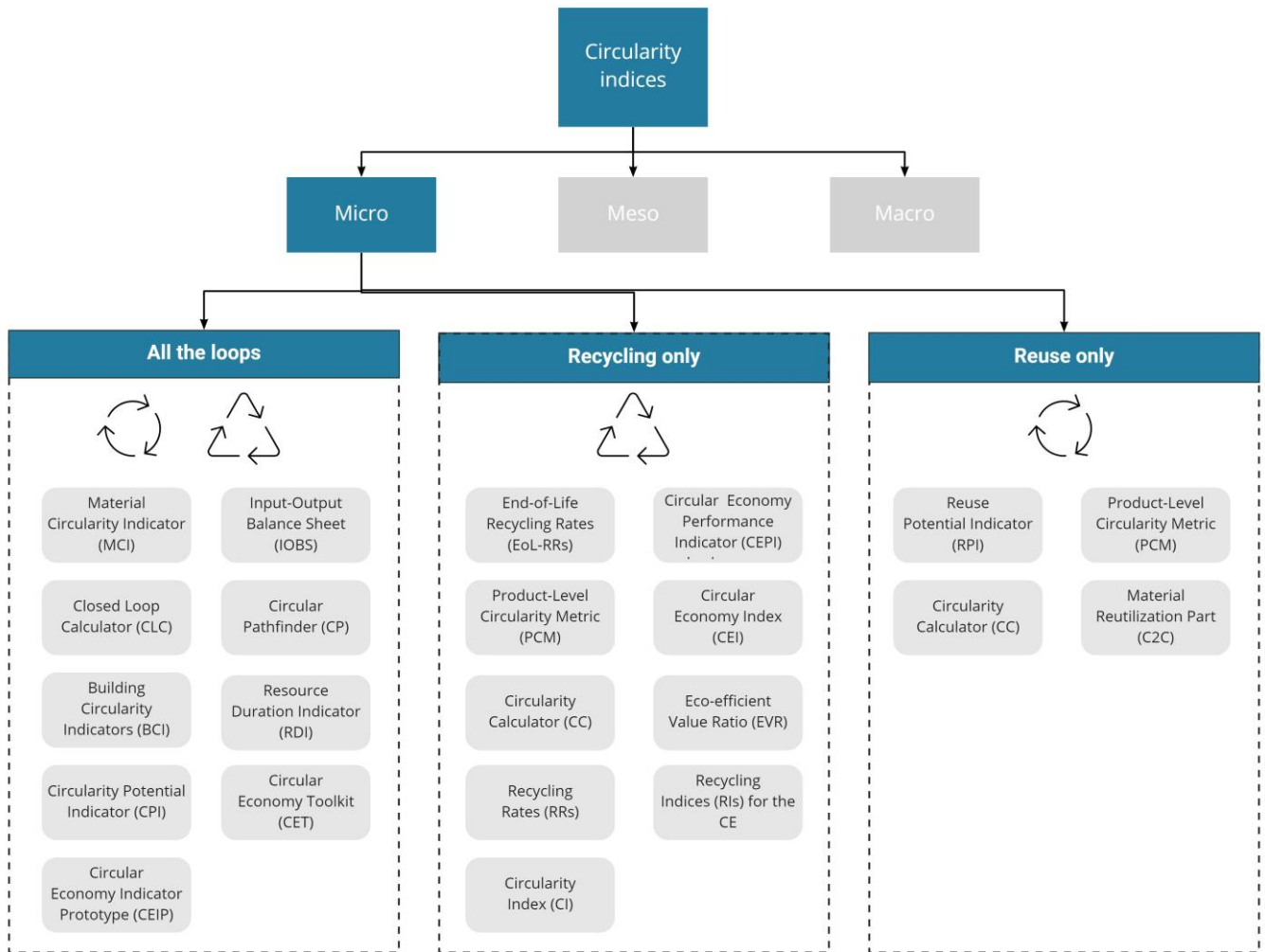

Input info for Indices calculations

| | | | | |
|--|--|--|---------------------------------------|-------------------------------|
| Virgin/non virgin content | Material that enters the recycling process | % of material recycled at EoL | Cost of production | Material Composition |
| Packaging data | Recycled material flows at EOL | Technology deployment for EoL processing | Qualitative info on product lifecycle | End of life pathways |
| Weighting of materials | Value/Cost of material | Resources for installation | Life cycle inventory | Material type input |
| Lifetime earned and recycled lifetime earned | Recyclable/Non recyclable ratio | Production data | Resources for Maintenance | Business practices |
| Intensity of product use | Recycling efficiency | Disassembly possibilities. | Bill of materials | Information on toxic elements |

Figure 19: Categorization of results from the excel tool and summarization of all the required data input for performing the calculations. Source: Author.

2.1.4 Mapping influence of design criteria in circularity of facades

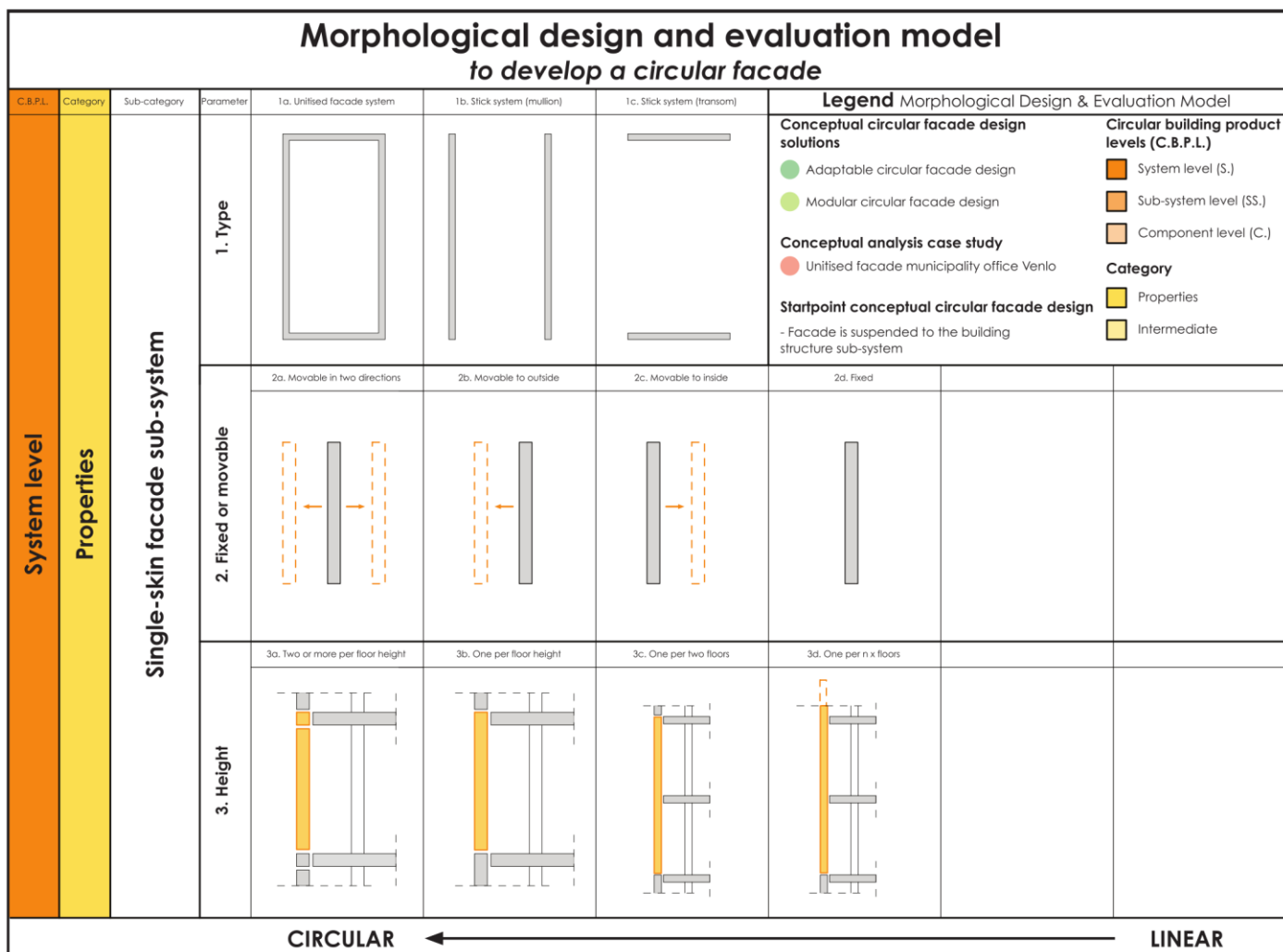

Figure 20: The Morphological design and evaluation model indicating a facade's circularity based on 21 properties. Source: Beurskens & Bakx (2015)

As shown in Figure 19, many indicators require information that is sometimes hard to distill down to measurable values. For example, the requirement of disassembly possibilities or installation methods and reuse potential overlap aspects of building design and, therefore, can be highly subjective. To tackle this issue and develop a practical framework, the morphological matrix developed by (Beurskens, Ritzel, Durmisevic, Lichtenberg, & Durmisevic, 2016) overviews 21 criteria can influence to what degree a façade is circular or linear. Each façade is categorized into subsystems and components and is further divided and identified. Disassembly schemes with the component/element name, product levels, clustering, and type of connections are developed. These factors are analyzed through the model as shown in Figure 20 and evaluated at the system, sub-system, and component levels against 21 criteria indicating relative Circularity or linearity. Although the result cannot be quantified numerically, it can still be used as a practical framework to determine criteria that make a façade circular and indicate the high level of subjectivity associated with circularity in building facades.

2.1.5 Conclusions

While it is evident that there is more than one method for evaluating Circularity, and none of them cover the concepts in full, the vast number of assessments available indicates significant progress in developing methods to analyze. A good indicator needs to be specified through the entire lifecycle of products, from design, production, consumption, and End of life (EEA, 2016). Even during this research, it was identified that most of these tools are only available upon request to the authors, and some are not offered without a financial incentive (e.g., C2C), which brings a degree of the unreliability of the

indicators. In order to compute indicators accurately, there is a requirement for the various need of data all along the value chain (Saidani et al., 2019). Potting et al. (2017) also state that most of this information cannot be extracted easily and, therefore, must be provided by actors in the supply chain. According to (Rahla , Braganca, & Mateus, 2019), with the increase of data sources, there essentially would be an emergence of Big Data which can drastically change how circularity assessments are made. While several industries such as automotive, aeronautical, logistics have already integrated the utilization of big data into their operations, the building industry has only begun to scratch the surface of the various potentials it has to offer. This can be attributed to the somewhat fragmented market space, where most businesses are too small or conservative in implementing new methods and technologies, or there is not much demand. But what is clear is that with Big Data, new datasets can emerge at the micro-level, which can therefore help assess circularity performance of products, components, and materials in the entire lifecycle(Saidani et al., 2019).

2.2 The Circular Lifecycle of a Façade

2.2.1 Forward Logistics Processes

The different phases of an architectural project, as shown in Figure 21. Although the technical Lifecycle of a façade technically starts at stage 6, when the parts are being manufactured and installed, the material selection, which has a significant impact on the Lifecycle of the facade, can start at the early stages design, i.e., stage 2 or 3. The decisions were taken during the concept, and technical design stages can contribute to 80% of the environmental impact of the building (Morini, Ribeiro, & Hotza, 2019). Depending on the contract structure, a façade designer and producer can be involved at an earlier or later stage of the project, which can also impact the overall quality. The Lifecycle of a typical façade is shown in Figure 22.

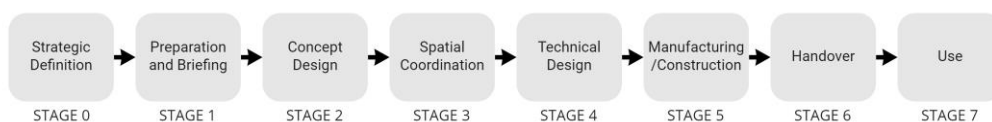

Figure 21: Stages of a construction project. Adapted from RIBA (2020, p. 40)

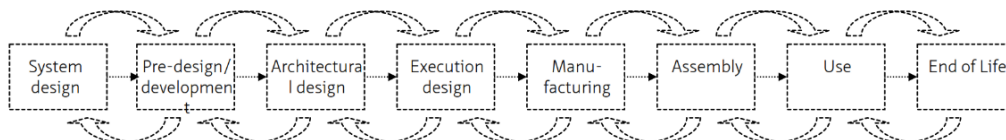

Figure 22: The Design and construction process for a curtain wall. Source (Klien, 2013, p. 40)

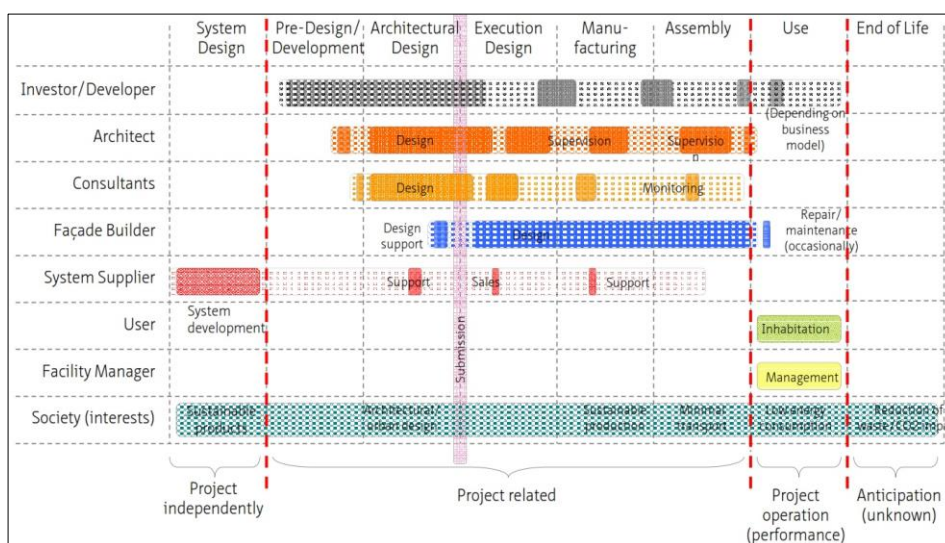

Figure 23: Stakeholder involvement in the lifecycle of a façade. Source: Klien (2013)

Different stakeholders are involved in various stages of the building, again highly dependent on the structure of the contract, but a general overview is given in Figure 23. While the involvement of stakeholders during the design stage is significantly high, it is interesting to see no stakeholder involved at the End-of-life stage. This was confirmed by Klien (2013) during interviews with different façade builders, who seemed to show a poor understanding of the stages after End of life. The interviews have shown that most façade builders do not understand the proper End of life of a façade.

2.2.2 Reverse Logistics Processes

According to (Schultmann and Sunke, 20015), reverse logistics processes can be categorized into the collection, inspection, sorting, reprocessing, and redistribution. A more detailed reverse logistics derived from the Butterfly diagram is illustrated in Figure 24. Apart from this, there is no other frameworks to determine the reverse logistics process of a building façade as new stakeholders are constantly defining new ways to deal with facades at its End of Service.

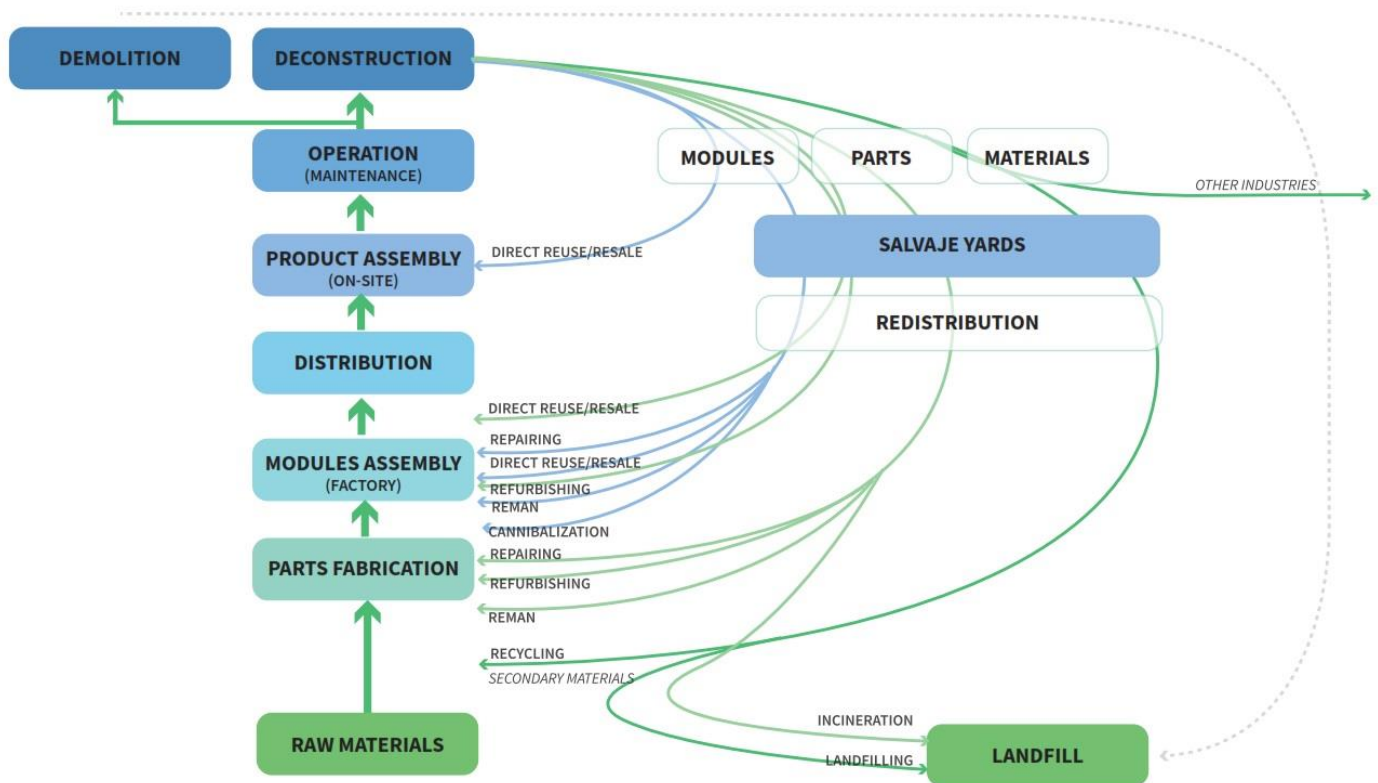

Figure 24: Facade Reverse logistics based on the Butterfly diagram. Source (J.M.Leos, 2020)

2.2.3 Stakeholder involvement

The involvement of stakeholders in a typical lifecycle of a façade was indicated in Chapter 2.2. which more generalized and primarily forward logistics processes. Circular Business models or contracts would also require additional stakeholders even in the reverse logistics process. Typically, a logistics manager appointed during the End-of-life stage takes care of transportation, storage, and distribution of building components. However, more stakeholders such as a building demolisher, collector, and recycling companies can also be involved (Heinrich & Werner, 2019).

Moreover, the implications of Circular thinking extend beyond the stakeholders of the building industry. They can also include the end-users, city inhabitants, regulatory bodies, infrastructure providers, and countless others (Azcarate-Aguerre, den Heijer, & Klein, 2018) and therefore can differ based on location and contract the model employed, regulations, and project type. A more generalized list of the different actors is formulated in Figure 25 based on an extensive material passports framework developed by Heinrich and Werner (2019) and stakeholders identified in Chapter 2.2. Specific actors

involved in P.S.S-based contracts for facades can be considered a subset of this list. The grouping is done based on each stakeholder's roles in the lifecycle of the façade and can be refined further based on other parameters.

| STAKEHOLDERS INVOLVED IN THE CIRCULAR ECONOMY OF FACADES | | | | | |
|--|--|-----------------------------|-------------------|-----------------------|------------------------|
| Sl. No | Stakeholders outside the facade industry | Stakeholders for Operations | Planners | Forward Logistics | Reverse Logistics |
| 1 | Government | Facility Manager | Architects | Raw Material Supplier | Recycling plant |
| 2 | Building User | Building Administrator | Consultants | Manufacturer | Deconstruction company |
| 3 | Owner | | Engineers | Installers | Material Warehouses |
| 4 | Banks/Financers | | Surveyors | Logistics | Material Traders |
| 5 | Insurance | | Assessors | Suppliers | Urban Miners |
| 6 | | | Façade Designers | System Suppliers | |
| 7 | | | Project manager | Construction company | |
| 8 | | | Project developer | | |

Figure 25: Stakeholders Involved in the Circular Lifecycle of a Building. Source: adapted from Heinrich and Werner (2019, p. 51)

2.3 Circular Business models

2.3.1 General Overview

As the current building and manufacturing industry implements a linear process, long-term collaboration between stakeholders such as suppliers, contractors, and clients is not promoted (Azcárate-Aguerre et al., 2018). There would be numerous challenges for designers and business strategists to ensure the transformation from a linear to a more circular model. (Bocken, Bakker, & de Pauw, 2015). Therefore, to implement a circular façade economy, there is no doubt that most of the innovation can be driven by an appropriate business strategy. According to (Chesbrough, 2010), the exact product innovation implemented through different business models can lead to different economic outcomes. This logic is equally valid with circular business models. Bocken et al. (2015) categorize these business models into two main categories, slowing product loops, and closing product loops, as shown in Figure 26. Slowing resource loops deal with keeping the products we have in use for longer and closing loops deal explicitly with closing the loop between post use and production.

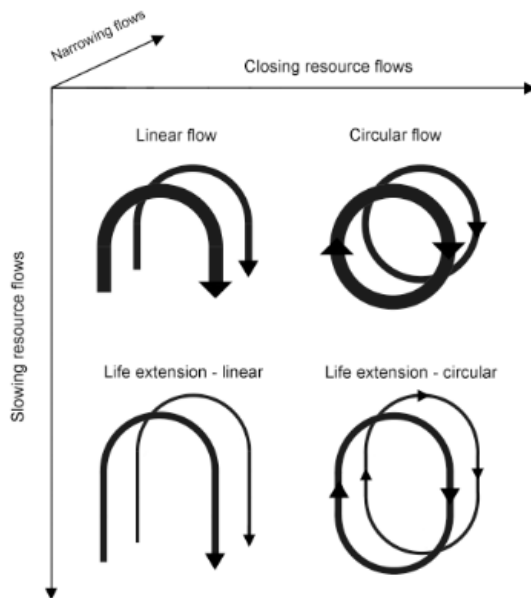

Figure 26: Categorization of Circular Business models. Source: Bocken et al. (2015)

While the table as shown in figure 27 gives an overview of the different business models, there could also be collaborations between companies with different business strategies to create an industrial symbiosis. For example, although mainly

concerned about extending the value of resources, a recycle bank can also collaborate with Access and a performance-based company to receive material that is scheduled to be discarded.

| Business model to slow product loops | | | | | |
|---------------------------------------|--------------------------|---|-----------------------------|---|---|
| Sl. No | Strategy | Definition | | Elements | Examples |
| 1 | Access and performance | Providing capability or services to satisfy user needs without needing to own products | Value proposition | Value Proposition: Delivery of service | 1.Car sharing 2.Document management (Xerox) 3. Tuxido hire 4.Phone leasing |
| | | | Value creation and delivery | Value Creation and delivery: hassle of service and maintenance is taken over by retailer. | |
| | | | Value capture | Value capture: pricing per unit of service | |
| 2 | Extending product value | Exploiting residual value of products, from manufacturing to customers and back to manufacturing. | Value proposition | Value Proposition: exploit residual value, by repair, remanufacturing etc. | 1.Automotive-remanufacturing parts 2.gazelle offering consumers cash for electronics 3.Clothing return initiatives 4.Reused material markets |
| | | | Value creation and delivery | Value creation: Take back systems to enable consistent product returns (collaborate with retailers, logistic companies and collection points) | |
| | | | Value capture | Value capture: Reduced material costs can lower overall cost. | |
| 3 | Encourage sufficiency | Solutions which actively seek to reduce user consumption by increasing durability, upgradability, service warranties etc. | Value proposition | High quality durable products, with high levels of service (repairable, reusable). No "build-in obsolescence" | 1.premium brands such as 2.vitscoe Patagonia 3.Energy service companies |
| | | | Value creation and delivery | Non consumerist approach. Sell what is needed | |
| | | | Value capture | Often a premium model, high price per product can justify volumes | |
| Business model to Close product loops | | | | | |
| Sl. No | Strategy | Definition | | Elements | Examples |
| 1 | Extending resource value | Exploiting the residual value of resources: collection/ sourcing of waste materials/ resource to energy etc.. | Value proposition | Exploiting residual value of resources | 1.Recycle bank 2.Interface - collecting and 3. supplying fishing nets as raw 4. material for carpets 5.Kalundborg Eco-Industrial Park |
| | | | Value creation and delivery | New collaborations and take back systems | |
| | | | Value capture | Use wasted resources and create new value | |
| 2 | Industrial Symbiosis | A process-oriented solution concerned with using residual outputs from one process as feedstock from another, benefitting from geographical proximity of businesses | Value proposition | Process oriented solution, converting residue from one process to feed stock to another across close businesses | AB Sugar, waste = value practices |
| | | | Value creation and delivery | collaborative agreements to reduce costs across the network | |
| | | | Value capture | joint cost reduction and potential creation of new business lines on former waste streams | |

Figure 27: Overview of Different Business models and examples. Source: adapted from (Bocken et al., 2015)

2.3.2 Facades as a Product Service System

As per Azcárate-Aguerre (2014), in the typical business model, the client would be the owner of the façade but would not have the technical know-how of how to maintain it, and therefore, facades can go neglected during the operation phase. In a Product Service System (PSS), the producer can ensure they can provide service for the whole period for a lower price. In a typical PSS-oriented business model, all stakeholders are tied materially and financially to the building's optimum performance throughout its service life, including the End of service decision making (Azcárate-Aguerre et al., 2018). These business models would fall under the Access and Performance category or the encourage sufficiency models as per the categorization in Figure 27. The value addition can either be that facades are supplied as a pay-per-service or designed with durable material to reduce maintenance costs or a combination of both. In either case, servicing is carried out by the supplier through its use as part of the contract. One of the main reasons is that the performance of a façade or a mechanical system in a building depends on the performance of each of the individual systems and their similar life spans. Therefore, employing such business models would change stakeholders' engagement terms responsible for designing and manufacturing facades. Facades would be more robust, efficient, serviceable, and possibly integrated with mechanical systems. Due to most modern façade components' modular nature, they are interchangeable, enabling clients, service providers, and manufacturers to make short-term decisions with lower investments (Azcárate-Aguerre, 2014).

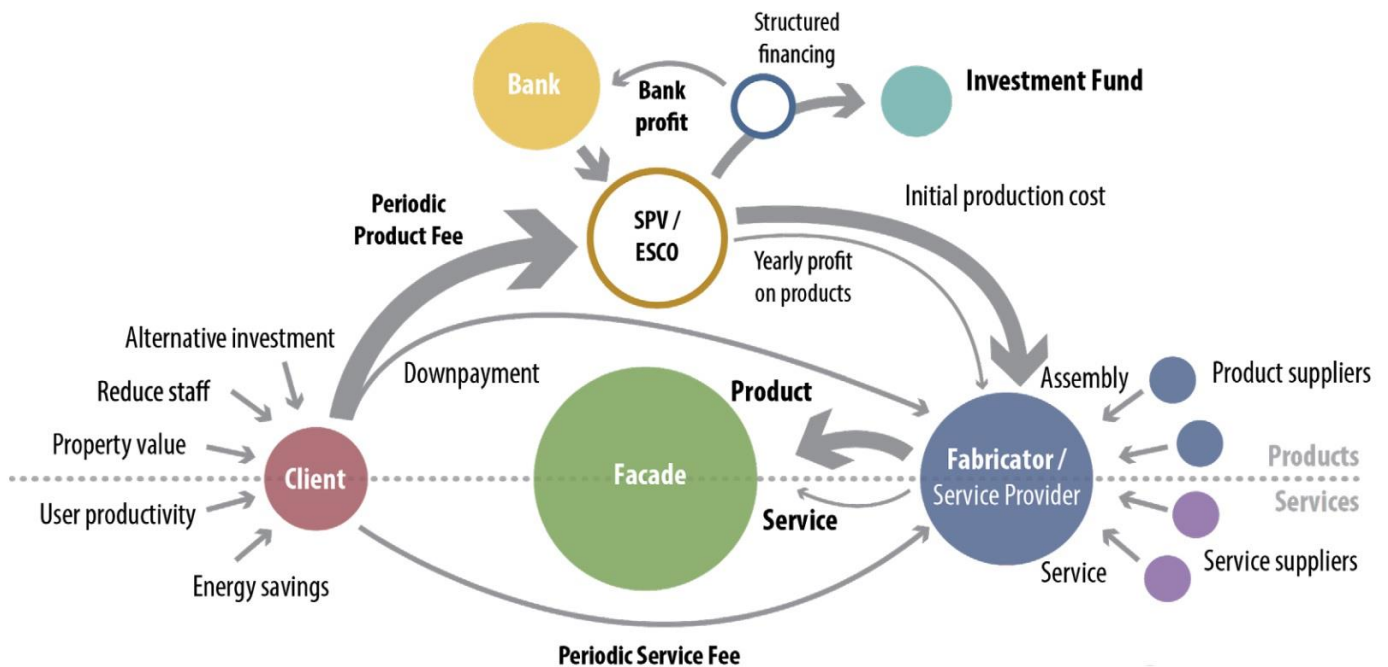

Figure 28: Stakeholder framework for the Façade Leasing Project. Source: Azcarate et al. (2018)

A truly Circular PSS System needs to extend a typical DBFMO contract (Design, Build, Finance, Maintain and Operate), which many new builders operate with. While employing such a business model would require redesigning current facades, including how building services are structured, it could be a high capital route to facilitate circular principles. An alternative model can be developed where the remanufacturing is done by an enterprise that collects façade parts from various sources, remanufactures, and re-sells them in the open market at a competitive price.

2.4 Conclusions

The chapter addressed the context of why implementing circular principles in building facades is crucial and challenging. For successful implementation, the Lifecycle of a façade must include forward and reverse logistics processes, which results in a circular lifecycle of a façade. Various stakeholders are involved at different stages of the Lifecycle bound together by circular business models and contracts. While in traditional contracts, technical stakeholders who know the façade disconnect from the project even before the use stage, business models such as a Product Service System (PSS) can ensure stakeholder interaction through the use stage and at the End of life. Figure 29 summarizes the findings and positions business models as per the present situation and where the industry needs to transition to VMRG's service levels to extend the producer's responsibility.

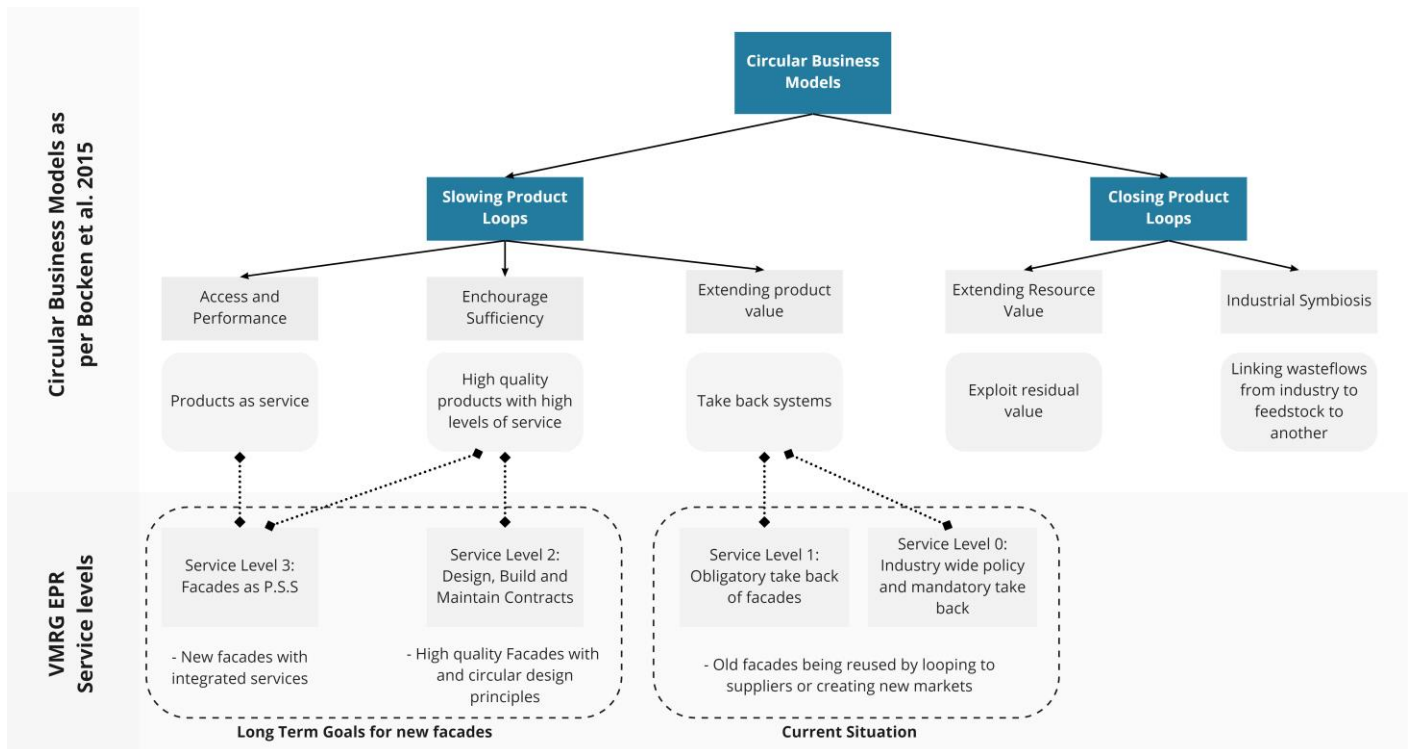

Figure 29: Categorization of Business models which can be explored under the Circular Facade Economy. Source: Author

3 Material Passports

Irrespective of which Circular Business model is implemented and what responsibilities are assigned for each stakeholder, material passports become essential for successfully integrating these strategies. It is a tool to ensure the end destination of the material is known throughout the supply chain so that appropriate decisions can be taken. For this, many industry stakeholders have already begun implementing and using Material Passports. Since the concept is fairly new, the chapter gathers information about passports and the technological framework required to implement them.

3.1 Definition

As defined by Mullhall et al. (2017, p. 3), "Material Passports are digital sets of data describing defined characteristics of materials and components in products and systems that give them value for present use, recovery, and reuse." They are part of a larger group of data sets, such as the building cadastre of a region or city. They are differentiated from building passports and energy passports, as shown in Figure 307. The nature of application and scale characterizes the differences between them. Material passports describe characteristics focusing on the value of materials in reuse or recovery (Heinrich & Werner, 2019), energy passports can be used to communicate the energy performance of a building (Virta, Hovorka, & Lippo, 2012), and building passports can be used to capture information on building quality as well as environmental properties and performance data (Blum, 2001). Essentially material passports become a tool for tracking materials and documenting the residual value and is a powerful component to support circular building initiatives.

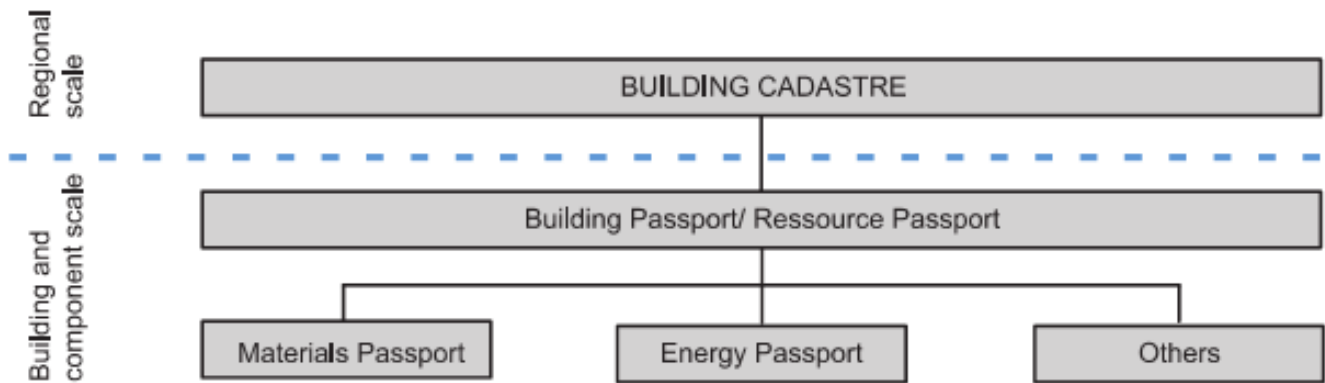

Figure 30: Classification of Materials Passports. Source: Heinrich and Werner (2019)

3.2 Contents and categorization

Although several platforms claim to act as a material passport, without standardization of the information content, it is less likely to be used for the intended purpose. Due to the diversity of construction techniques used in the entire building, standardization can be difficult. But essentially, they could be considered an extension of an ingredients list with additional information such as material health, disassembly, positioning, location, reverse logistics, etc. (Luscuere, 2017). Heinrich and Werner (2019) released an extensive document titled "Materials Passports – Best Practice," which indicates an extensive list of the various possible information that it can contain. Based on this extensive list, an overview of the different information included is generated, as shown in Figure 31 and described as follows:

1. **Identifiers:** These refer to various Unique identification systems used to identify the particular component in the building.
2. **Manufacturers Data:** These refer to data sets relating to production-related information, which can be subcategorized as administrative data, such as registrations, dates, etc., and technical data, which have more specific details about production processes and so on.
3. **Monitoring data:** These refer to data collected once the product is installed and operational. It can be structural fatigue, thermal properties such as temperature, anything that would help understand the wear and tear of the product to predict its maintenance, performance, or expected lifespan.
4. **Logistics:** Data used during the transportation of material from different nodes of the supply chain.

5. **Certifications:** Contains All the various certifications and standards the material needs approval from
6. **Material Properties:** These are technical information on the various properties of materials such as thermal, optical, structural, building physics, biological, etc.
7. **Environmental assessments:** These can be values extracted from databases or eco inventories or calculated based on inputs from other data within the material passport. Examples are LCA ratings, Circularity indices, Carbon footprint, and so on, depending on the standard employed by the organization or country.
8. **Design Data:** These refer to information generated by stakeholders which define the design criteria of the building façade. These could be stored in unstructured formats such as images and pdf drawings to structured formats such as numerical values and 3d Digital Models.

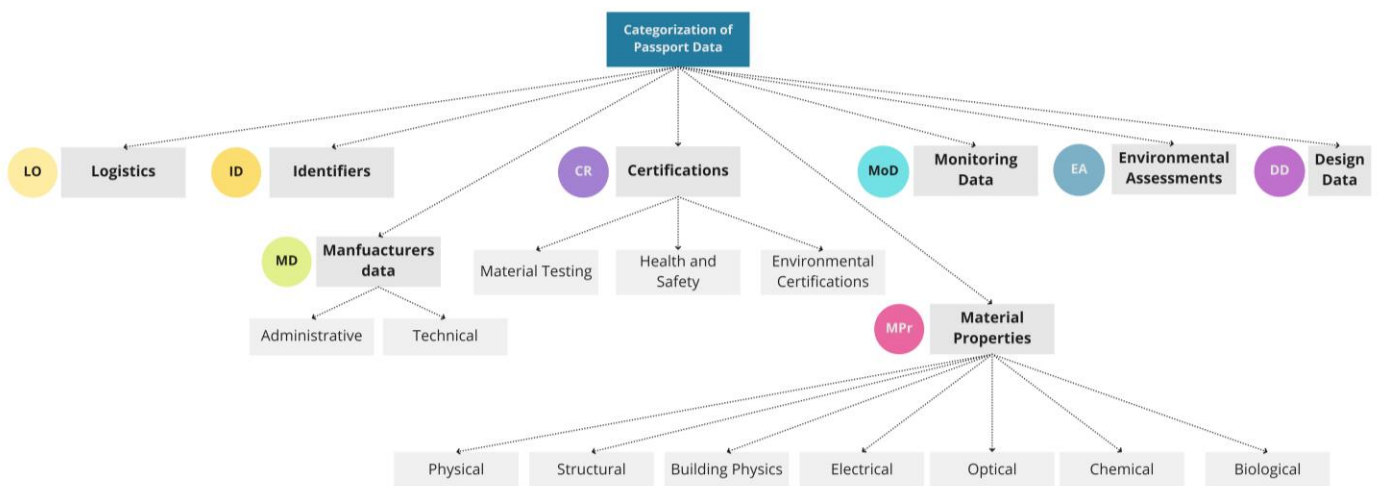

Figure 31: Categorization of the contents of the material passport. Source: partially adapted from (Heinrich & Werner, 2019)

According to Honic, Kovacic, and Rechberger (2019), information such as recycling potential, separability, and accessibility must also be included in a material passport. While recycling potential of a façade or a material can be calculated using one of the Circularity indicators listed out in chapter 2.1.1, how materials are separable for each other and how they can be accessed is more qualitative in the form of drawings/diagrams or a visual indication of location within a building. The location and context are extremely crucial to determine the end-of-life scenarios (Luscuere, 2017). This could be an Identifier linked to a central BIM Model or multiple consistent, unique identifiers listed in multiple drawings. An example of the contextual information in Building facades is the systematization models developed by Durmisevic (2006), shown in Figure 32, who developed these schemes to demonstrate the various factors that make a building transformable. These can also represent assembly and disassembly sequences and interconnectivity between various components, as shown in Figure 33. An automated way of generating these systems by creating these relational diagrams from the BIM Model using graph theories and social network analysis is also proposed by Denis, Temmerman, and Rammer (2017) but yet to be implemented.

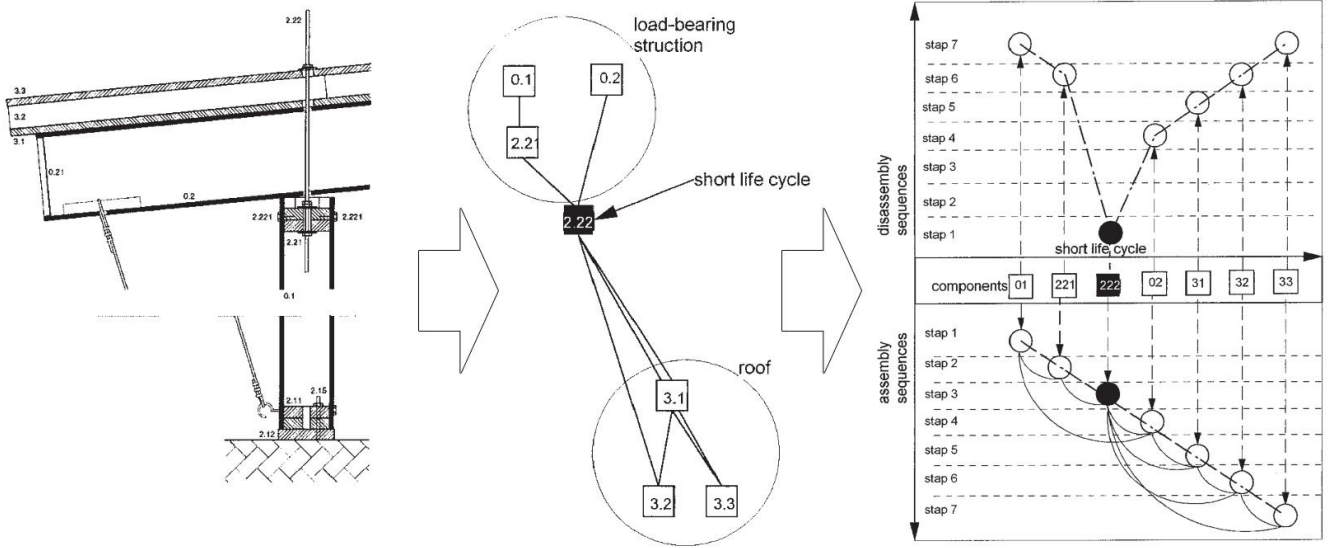

Figure 32: Systematization of Facades for assembly/disassembly sequencing. Source: Adapted from Durmisevic (2006)

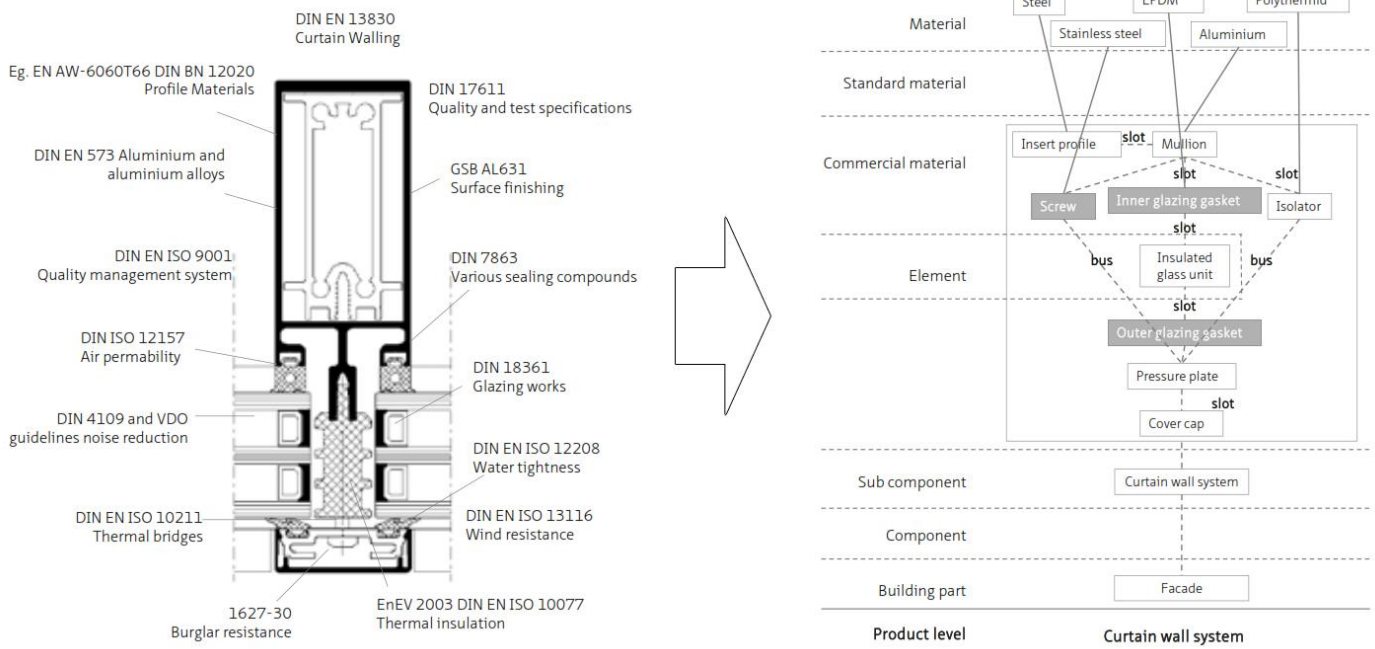

Figure 33: 1-Drawing a typical Curtain wall, two the product levels and relational diagram, 3- comparisons of product profiles of multiple facades studied as part of the research. Source: adapted from Klien (2013)

3.3 Applications in the lifecycle of a building

The detailed specification of materials during the building design and construction phase is a major factor determining the level of re-usability of materials at the End of life (Akanbi et al., 2017). The uses and users of materials passports can differ in different parts of the lifecycle of a product. According to Copeland and Bilec (2020), who mapped out the uses of a Material passport in the lifecycle of a building, during early design stages, the Materials Passports can serve as an optimization and a decision support tool; during tendering and documentation stages, the passports can become part of the inventory giving an overview of the various materials and components. Depending on the implementation level and information included in the passport, they can also be used during the supply chain and logistics process for tracking location in the supply chain and within the building and is a useful component for construction and site management (Heinrich & Werner, 2019). During the use phase, they can record maintenance schedules, service life, and live performance monitoring. Finally, the passports with all the aggregated data about materials can help decide the best possible reverse logistic strategy for the end-of-life stage.

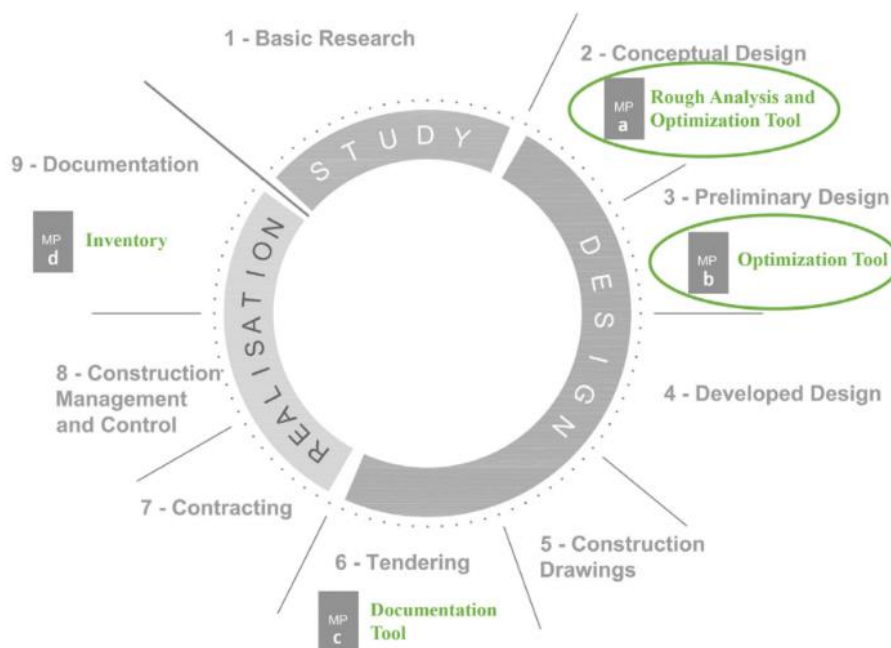

Figure 34: Uses of material Passport in various stages. Source: Copeland and Bilec (2020)

3.4 Information Infrastructure

3.4.1 Data acquisition

Different stakeholders involved in the value chain are responsible for the input of data. The methods can be either manual or automatically generated. Nonetheless, within each stakeholder group, one person needs to be responsible for the data collection method, such as an MP consultant as it to have specific know-how in data management and handling, building materials, eco indicators, and relevant repositories (Honic, Kovacic, Sibenik, & Rechberger, 2019). One study has explored the automated generation of material passports using laser scanners, ground-penetrating radar, and BIM (Honic, Kovacic, Gilmuridinov, & Wimmer, 2020). Other forms of automated data collection are explored using links to databases with a standardized nomenclature, live readings of connected sensors via IoT (Internet of things), and RFID scans for location-specific information.

3.4.2 Data Processing

Here the data from the various sources are then categorized and organized as a database. The processing component can happen on either side of the data storage component. On the input side, the processing would mainly include

algorithms used to link the various data sources, create relations, and perform other calculations required for information display. On the output side, the processing will be customized based on each stakeholder's needs. Data visualization, analytics, AI, and machine learning algorithms can be considered possible processing at the output end.

3.4.3 Data Storage

For the storage component, many papers refer to the use of blockchain technology. This would ensure transparency and security, as it allows for changes as a transaction ledger is maintained for every change by a stakeholder (Heiskanen, 2017). Due to their decentralized nature, the data here is safer from manipulation than it could ever be in a centralized platform (Arup, 2019). Therefore, it will provide the entire stakeholder network to know who made what change at a particular time. RFID information can also be stored in a blockchain to track the location of the material throughout its lifecycle (Copeland & Bilec, 2020). A material passport should allow confidential data to only be accessible to specific users determined by its owner, usually the manufacturer (Copeland & Bilec, 2020). There are cases where the information is important but does not need to be fully transparent to all stakeholders, as long as the evaluation of the information can be presented transparently (Luscuere, 2016).

Another criterion to consider is the level of detail the information needs to be documented. As buildings can be broken down into several product levels, a similar information clustering can be applied to material passports. Material passports can be scaled down or scaled up based on four levels of products, ingredients, subcomponents, products, and systems, and relations between them need to be defined (Mullhall et al., 2017). An example of this aggregation of relation applied in a material passport data structure is illustrated in Figure 35.

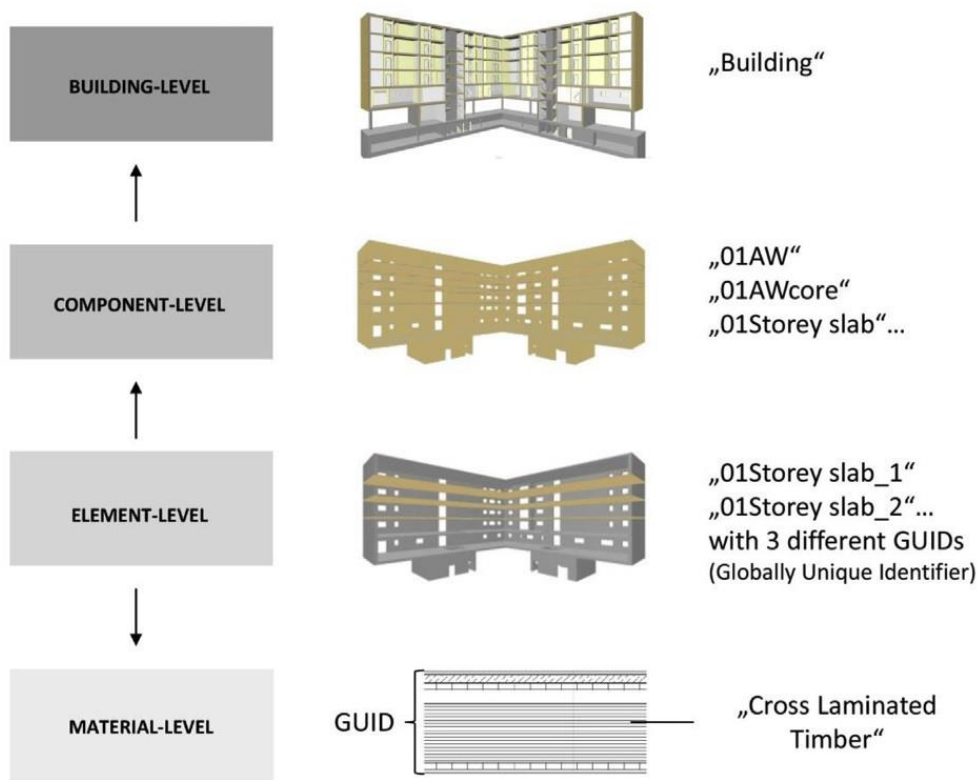

Figure 35: Example of Product levels employed in a BIM-Based material passport. Honic, Kovacic, Sibenik, et al. (2019)

3.4.4 Data visualization

Material Passport companies such as Madaster, Cirliq, and Circular Cloud have already employed a web-based API to access information. An Application Programming Interface (API), as defined by Mullhall et al. (2017, p. 7), is "a series of

protocols and tools to enable systems to communicate with the platform. A web-based platform's advantage is that access to the platform can be from any given location, so stakeholders from all locations can use it.

3.4.5 Examples of Material Passport Use

While looking into current examples of material passports, it was found that scientific literature on frameworks for material passports is sparse, and information on implemented passports is kept confidential for competitive advantages. Therefore, papers were referred to who define digital methods to create a 'local' material passport for their respective research. Honic, Kovacic, Sibenik, et al. (2019) defined a workflow where a BIM Supported material passport was created to assess building materials' recycling potential and environmental impacts. Revit was used as a BIM software for modeling, and Building One (BO), a material inventory and analysis tool as an addon, was used for data management, as shown in Figure 36. BO was used as an external data handling program due to a lack of direct data handling in the BIM software package. A modeling guide based on the Austrian Norm "Digital Building Documentation: BIM-Level 3BiM" was used as a BIM model reference. A control tool, in this case, the Solibri model checker, checks the BIM model to verify if predefined elements are used as per the norm.

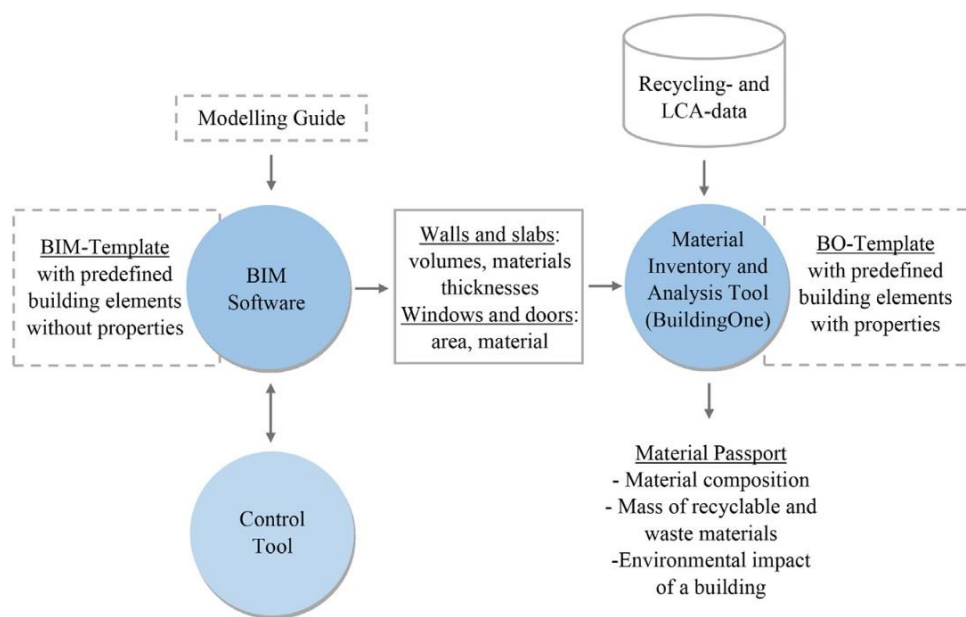

Figure 36: Workflow employed for a BIM-Based material Passport. Source: Honic, Kovacic, Sibenik, et al. (2019)

Based on this workflow, several inferences were made, such as

1. Matching data from different sources can be time-consuming and requires specific knowledge, requiring an additional stakeholder termed MP consultant.
2. The limitations of using predefined elements help better categorize and match data but limit the design space.
3. Building elements are mono-layered to keep the design space open, but this would lead to inaccuracy, and the approach is most suited for early design-based evaluations.

3.5 Influence on stakeholder involvement

While material passports can be described as an equivalent of a nutritional label, they can do more than just be an ingredients list as they can contain data from different sources and provide information to different sources (Luscuere, 2017). This becomes one of the most critical aspects of the material passport, as not every stakeholder requires all the information simultaneously. Additionally, it also requires a stakeholder interaction framework and a standardized technological framework. Copeland and Bilec (2020) developed a data stakeholder management framework for creating a BIM-based material passport, as shown in Figure 37. They propose an additional stakeholder, an MP consultant responsible for the data entry and linking databases to the BIM Model. The workflow they propose includes data references from eco inventories and external libraries, they stress harmonizing data between eco inventories, the building elements specifications, and product declaration data. This is to ensure data can be linked more seamlessly with an automated process. A strong collaboration between MP consultants, designers, and BIM managers are needed.

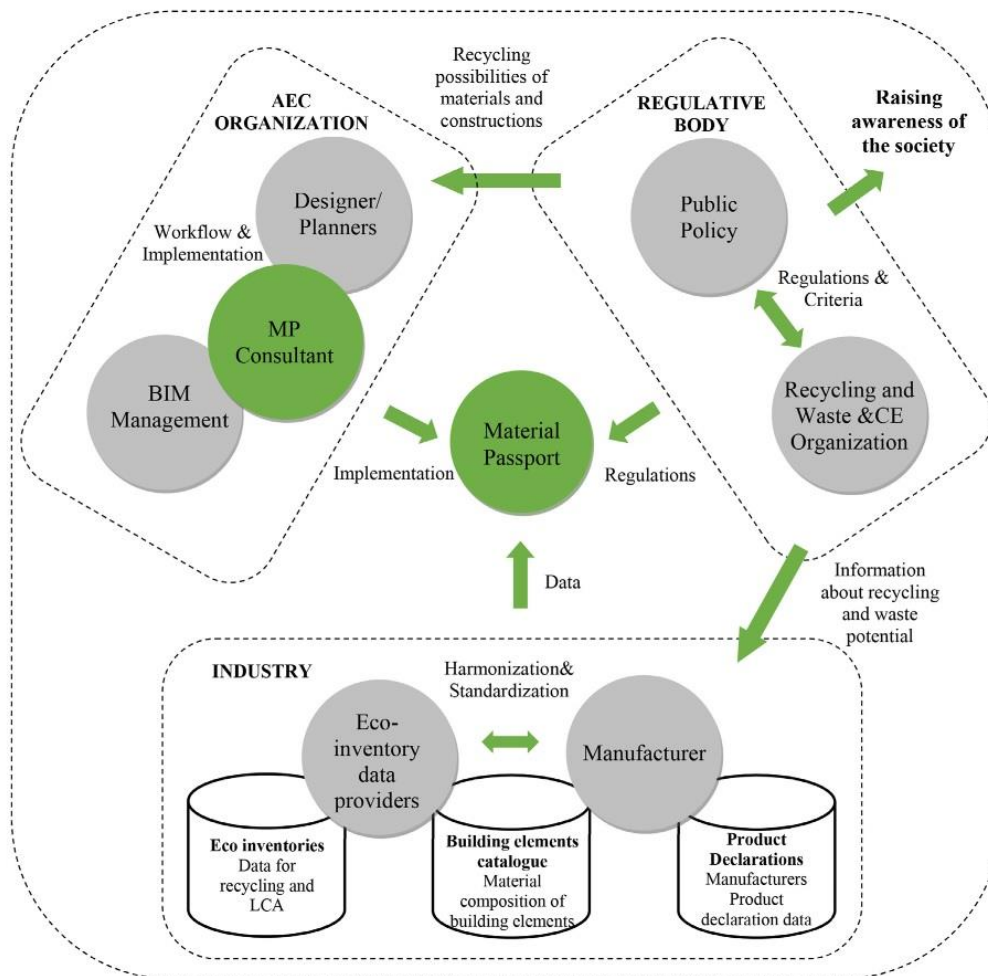

Figure 37: Introduction of a material passport consultant as a mediator for linking data between the designer and BIM manager. Source: Copeland & Bilec (2020)

Private enterprises own most material passports that are active. The exact details of how the passport works are not easily accessible. However, a conceptual framework for this is proposed by Mullhall et al. (2017), as shown in Figure 38. It breaks down the passport into three components, data, input, processing, and output of customized passports. There is a Data Input with different sources, a data processing component that works as a web-based platform, and the generation of customized material passports for various stakeholders to use.

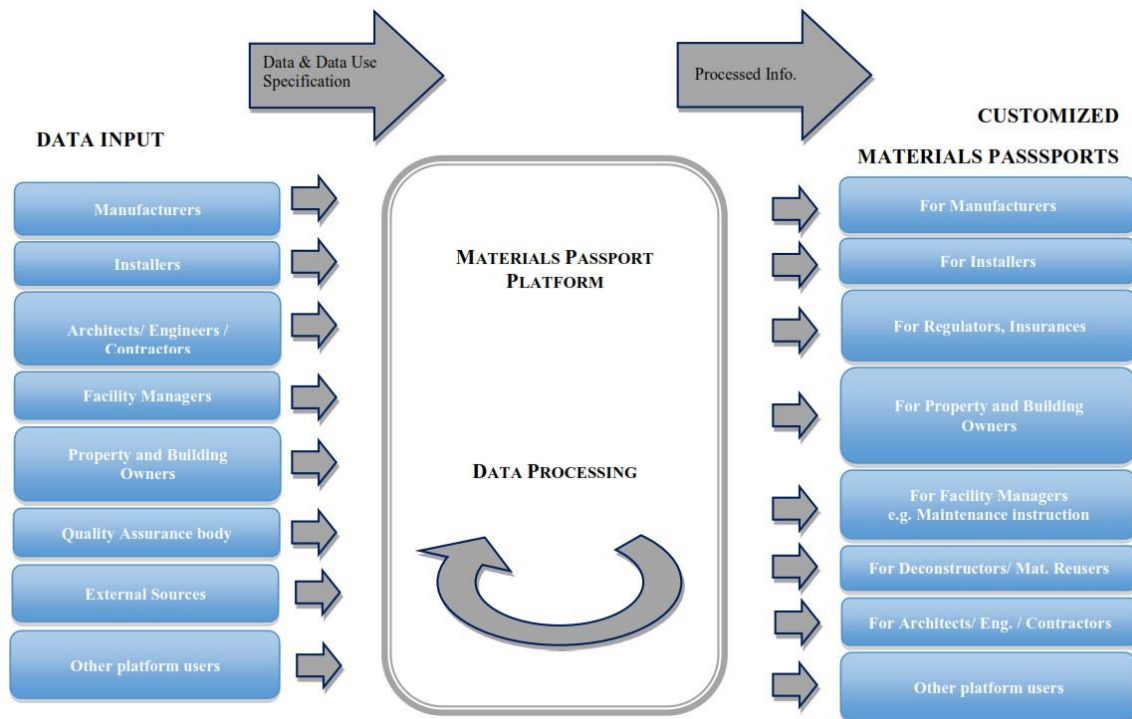

Figure 38: Conceptual framework for a material passport. Source: Mullhall et al(2017).

3.6 Overview Current platforms in the Market

3.6.1 Madaster

The Madaster material passport is among the most widely known passport platforms in Europe. The platform has a BIM model as an input where necessary quantities of materials are extracted. Additional options are provided for stakeholders to modify the information or enrich the BIM model within the platform. Furthermore, the information is organized into the different Shearing layers as per Brand, thereby giving an account of the quantity of materials each building layer consists of. Lastly, it also uses the Material Circularity Indicator (MCI) to assess how circular or linear each layer and/or material is within the building.

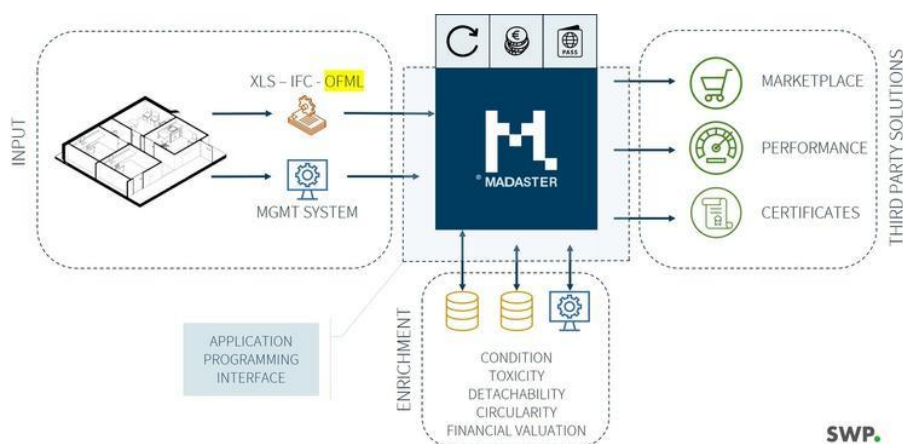

Figure 39: Framework of the Madaster Material Passport Platform. Source: www.duurzaam-ondernemen.nl



Figure 40 Screenshot of the Madaster platform with the layers of the building. Source: thenewbuilders.nl

3.6.2 Cirliq

Cirliq resulted from the Façade Identification System(FIS) project, a pilot initiated by VMRG, the Dutch Metal Façade association. It is similar to Madaster in the sense of the overall logic of the passport. A BIM model is entered as a base information layer, and additional data can be added and/or enriched to this BIM model. But instead of organizing the building into shearing layers, the data structure is dependent on how the IFC models are structured. In order to regulate this structure, IFC standards are shared with the potential users of the platform, as shown in Figure 42. There are also possibilities of linking live information from sensors and/or QR code scans documenting the current status of each component of the building. Currently, Cirliq is mainly used as an asset management platform to store information about Façade components and other live equipment and ensure timely maintenance.

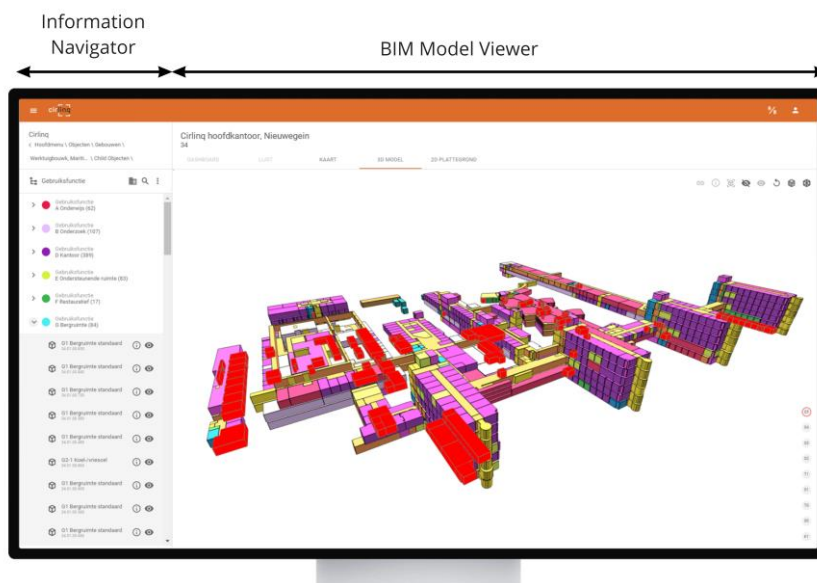

Figure 41: General Overview of the Cirliq Platform. Source: cirliq.nl

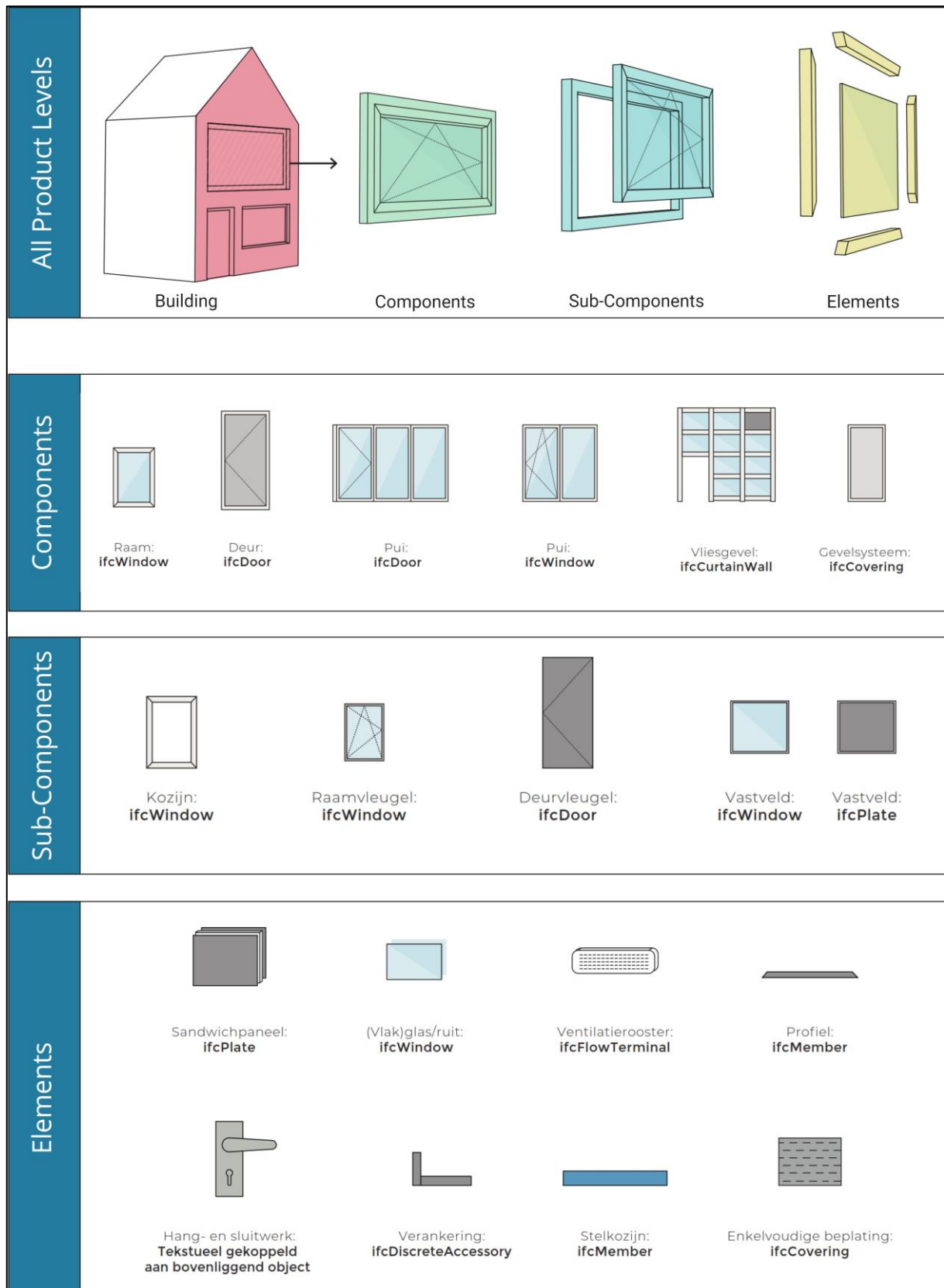

Figure 42: Modelling guidelines for Cirliq by ILS GEVEL. Source: Adapted from VMRG.nl

3.7 Conclusions

From the various literature review shown, it is clear that a material passport is more than just a collection of data sets and has far-reaching technological implications. And hence an exact boundary of what is a material passport cannot be defined. However, what can be established from the above is that a material passport can:

1. Have a standardized data entry method, mutually agreed upon by all stakeholders or standardized at a national level.
2. Different sources of information can be connected via an IoT network and integrated into a cloud-based platform.
3. Information can be collected and viewed in different product levels and interlinked as a relational database.
4. Blockchain technology can manage and store the information to record and track changes, ensuring transparency while maintaining security.
5. Data can be edited, accessed, and visualized using a web-based API where the front-End GUI can be customized to the stakeholder's needs.
6. It can be used as a tool to influence different stages of a lifecycle of a façade.

4 Digital Twins of the supply chain

The chapter looks at gaining a basic understanding of digital twins and their use across the entire supply chain. As material passports, defined in the previous chapter, focus on capturing and recording information of a Building. With the increased use of Iota devices in the building industry, the passport also becomes a platform to record dynamic information and act as a Digital Twin. The Tu Delft Façade leasing project (J. A. Azcarate, Klien, & Heijer, 2019) is an example of this. As per the inferences on Circularity Indices from Chapter 2.1.3, a lot of information to determine the circularity of a façade depends on information from different actors in the supply chain. Therefore, eventually, passports need to contain information generated by all actors in the supply chain, which is where envisioning a Digital Twin of the entire supply chain becomes crucial in the long run.

4.1 Context

Boje, Guerriero, Kubicki, and Rezgui (2020) state that the dynamics of human interaction with built assets increase, there is often a limitation of existing Building management systems based on BIM, which need to respond adapt better to the user's needs. A Digital Twin (DT) could be a possible solution towards ensuring these needs are met. BIM can be viewed as a starting point for developing a DT, which acts as a 3D reference model, and the DT can be used for various applications (Boje et al., 2020). Industry 4.0 implies establishing direct communication and coordination links between several automated production operations along the value stream, resulting in autonomous production processes (Sacks, Brilakis, Pikas, Xie, & Girolami, 2020). A DT is an evolutionary step in manufacturing capable of bridging manufacturing to Industry 4.0 Principles (Rosen, von Wichert, Lo, & Bettenhausen, 2015). These methods can control lean construction principles, prioritize efficient production processes with minimal variations, and use resources.

4.2 Definition

There are several definitions of a Digital Twin as it is not a domain-specific technology, unlike BIM. In the context of the Building Industry, the definition given by Qi and Tao (2018) states, "Digital twin works especially with real-time data fed by the sensor systems to record and analyze the real-time structural and environmental parameters of a physical asset to perform highly accurate digital twin simulation and data analytics."

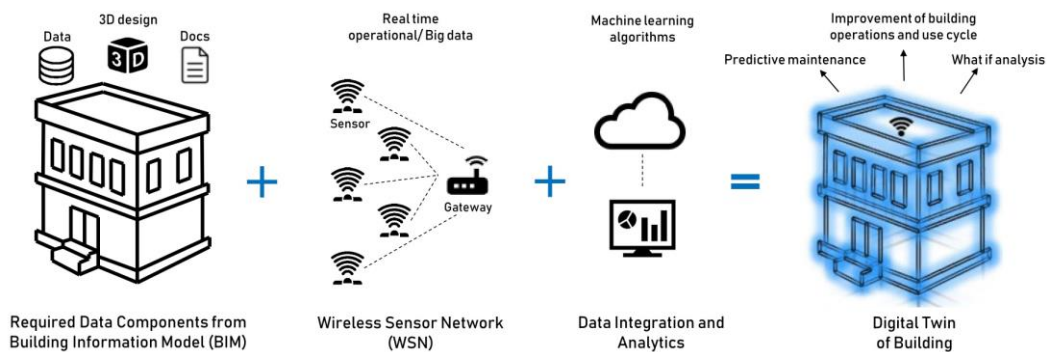

Figure 43 - Digital Twin, perceived as an extended intelligent version of a BIM Model. Source: Khajavi, Motlagh, Jaribion, Werner, and Holmstrom (2019)

A distinction needs to be made between a Digital Model, Digital Shadow, and Digital Twin. While Digital twin refers to simulating a product, detecting its performance, and mapping out its real-world interactions, they can be also be used as a functional description of a component, product, or system with the relevant operational data (Boschert & Rosen, 2016). Therefore, digital Twins are also considered a 'System of Systems, which can help communicate data in a scalable, effective, and intelligent manner (Boje et al., 2020). Figure 44 shows the three stages in the evolution of a Digital Model towards developing a DT (Tchana, Ducellier, & Remy, 2019).

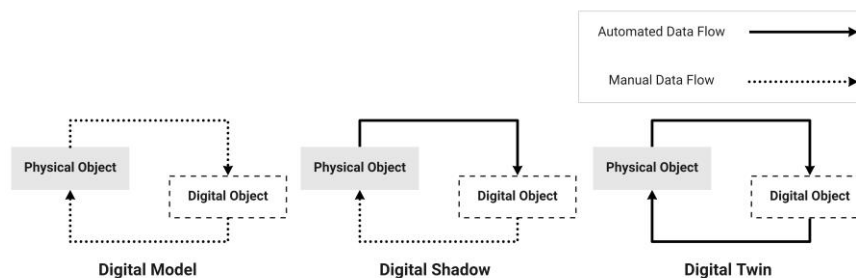

Figure 44 - Digital Twin as an evolutionary system derived from a Digital Model. Source: Tchana et al. (2019)

The digital model does not have any form of data exchange between the physical object. The Digital shadow records data from the physical object in an automated manner, using various devices, and sends the data back to be written in the database. In the Digital twin, data flows between the physical object and the digital object seamlessly. In this case, modifications in a digital object can modify attributes of a physical object, while the twin tries to simulate the physical object in real-time. Moreover, Digital twins need not be realistic representations of the physical object but instead abstractions that are more suited for the use case (Arup, 2019).

4.3 Components of Digital Twins

Integrating a wireless sensor network (WSN) integration and data analytics is required (Tao et al., 2018). Therefore, the digital twin can be a common platform that can be used by different stakeholders and can be looked at as a result of an integration of 3d simulations, IoT devices, 4g and 5g networks, Blockchain, Cloud Computing, and AI (Arup, 2019). Boje et al. (2020) break down the main DT's components into three simple parts, as indicated in Figure 45. The "physical part" collects actual data and is sent for processing; the "virtual part" can help in discovering this information and manage the "physical" (Boje et al., 2020).

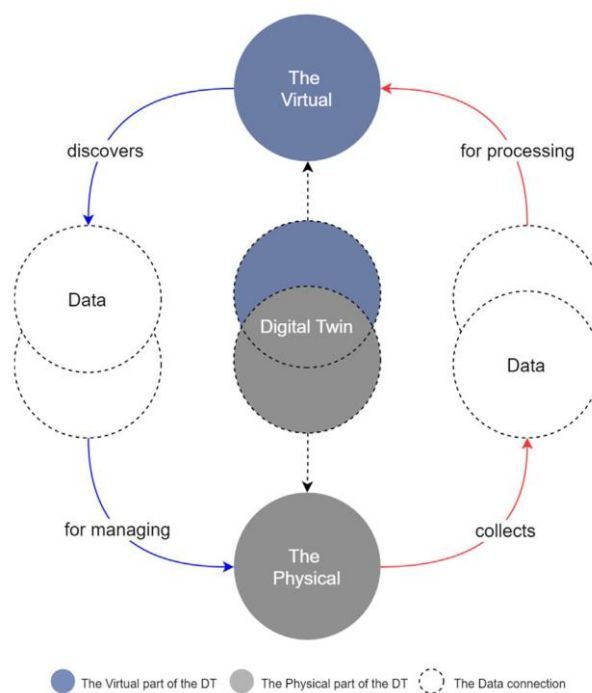

Figure 45: Components of a Digital Twin. Source: Boje et al. (2020)

The exact subcomponents of the physical, virtual, and the data can be particular to the intended use case as DT is far-reaching. The data connection is referred to as exchanging information between the physical and virtual, enabled by advanced sensing, the Internet of Things (IoT), high-speed networking, and advanced analytics (Sacks et al., 2020). The data used in the communication between the physical and digital in manufacturing and construction can account for big data (Qi & Tao, 2018). Visualization also plays a crucial role in digital twins, which can be more three-dimensional from images and video to Augmented Reality (AR) and Virtual Reality (VR), while raw data in other sources are mostly limited to tables, charts, graphs, and files (Qi & Tao, 2018). Like the physical object, the data linked to a digital twin can evolve and mature over its lifecycle. A scheme of this is indicated in Figure 46. It indicates the digital twin's birth much before the physical twin, starting at the conceptual design stage. The difference between Digital Twin used for design stages, as opposed to a BIM model, is that with a Digital Twin, there is a possibility of modeling in a dynamic virtual environment which is replicating physical reality fed through with accurate environmental data fed by sensors, with methods to predict the behavior of the designed component, as opposed to modeling in a static virtual environment.

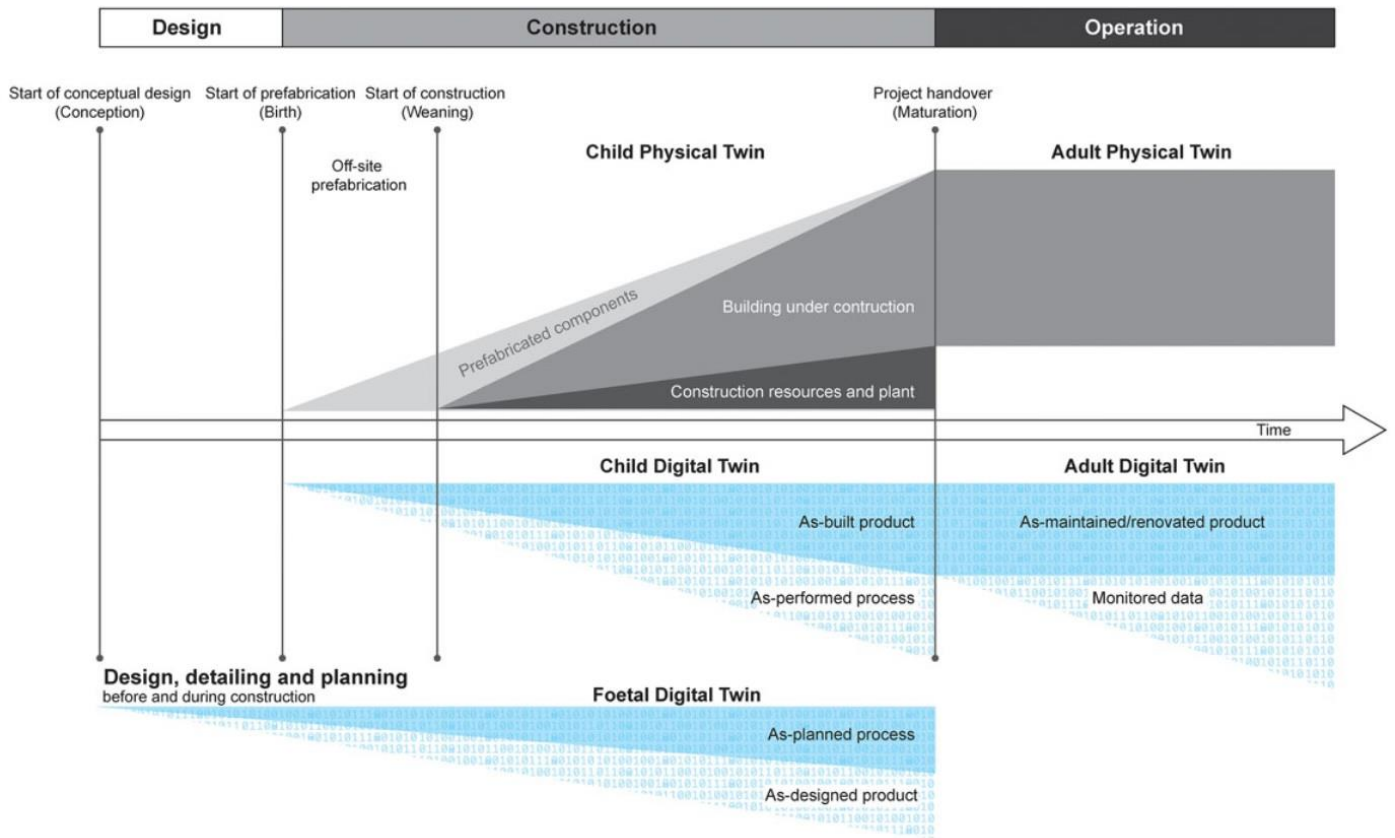

Figure 46: Lifecycle of a Digital Twin compared to a typical Building Lifecycle. Source: Sacks et al. (2020).

4.4 Uses in the Lifecycle of a Facade

While DT implementation is only beginning to open to the building industry, there is a lack of relevant literature, mainly on the façade industry. Therefore, literature studies on Digital twins used in manufacturing for key examples to equate it to the façade industry. This argument holds good considering the extensive nature of prefabrication expected in a circular building, with a more production-line approach.

1. Design Stage

During the design phase, the digital twin, in this case, placed in a virtual environment, can enable iterative optimization of the design enabling real-time adjustments and improvements to achieve a personalized product design (Qi & Tao, 2018). Simulations can be augmented with real data using sensors, therefore improving accuracy. Data from sensors can be fed into this virtual world for augmented simulation environments for improving accuracy and fidelity (Boschert & Rosen, 2016). This will help verify the functionality of the product, its behavior, determining the manufacturability reducing the amount of testing and verification required (Qi & Tao, 2018)

2. Manufacturing Stage

The design can be fed into a smart workshop in the manufacturing stage, where the entire process can be optimized using a DT (Rosen et al., 2015). Here, a virtual factory model will have all the geometric and logistical information of the different equipment, materials, tools, and a production plan (Tao et al., 2017). DT, combined with BIG data using a hyper network,

can enable supply-demand matching and scheduling (Tao, Cheng, Cheng, Gu, et al., 2017), helping find the required resources and integrated analysis planning (Alonso et al., 2019). This is the most effective use of a digital twin, in the context of circular building methods, which can help in moving towards a supply-driven demand, where a constant check of available resources is made, and optimized pathways for production processes are created, rather than a demand-driven supply which can give rise to exploitation of resources.

3. Construction Stage

During the construction stage, digital twins can help monitor activities, such as adherence to the master plan or time-based activities such as material supply, location of works, and equipment (Sacks et al., 2020). Simulations can be used to achieve optimized planning or other construction management objectives (Boje et al., 2020). Real-time tracking of the supply chain and data collection methods can greatly improve stakeholder interactions during a project's construction. They can also perform risk assessment analysis, optimize pathways in the supply chain, and automatically schedule the pickup and drop-off actions until the end destination.

4. Use and operation phases

During the use stage, the Digital Twin is connected to the physical twin through a network of sensors (Qi & Tao, 2018), which can help perform various performance monitoring or create automated maintenance schedules of spaces, components, or equipment. Real-time reflection can be achieved through learning and optimization by facility managers in the use phase of the building life cycle (Khajavi et al., 2019).

5. End of life

Based on the uses mentioned in the above stages, it can be presumed that the digital twin would have an aggregated data log of the different activities in the Lifecycle, which can help make judgments or decisions about the correct End of life. This would highly depend on the nature and quality of the data available. Therefore, there are considerable advantages in BIM slowly transitioning towards Digital Twin while retaining its knowledge domain and technology to integrate A.I. and IoT. This would facilitate the change from more static, closed data with multiple interoperability issues towards more linked data (Boje et al., 2020).

An overview of the various uses and features of the Digital Twin in the Circular Lifecycle of a façade is given in Figure 47.

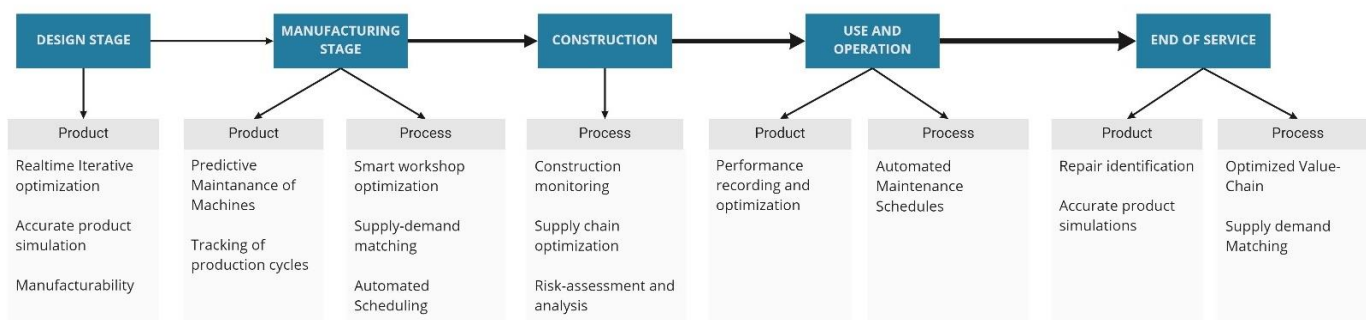

Figure 47 - Overview of uses and features of a Digital Twin. Source: Author with adaptation from various sources.

4.5 Evolution of Digital Twins

Like most technologies, Digital Twins are still at early stages and are expected to evolve. Boje et al. (2020) predict that the eventual merge between virtual models and sensing would converge on a common semantic web platform, where

interpretability or differences in standards among various stakeholders becomes no longer an issue. Therefore, this would reduce the reliance on IFC data structures, and DTs would progress towards implementing a more flexible framework such as Linked Data (LD) and Web Ontology Language (OWL). Boje et al. (2020) propose the evolution of a Construction Digital Twin in three stages, as illustrated in Figure 48. Initially, the DT is a more improved version of BIM used for construction with live data monitoring. The next stage involves the use of IoT devices with monitoring platforms with a standard web language. The last stage, or the third generation, can be completely autonomous with data acquired by AI agents(Boje et al., 2020).

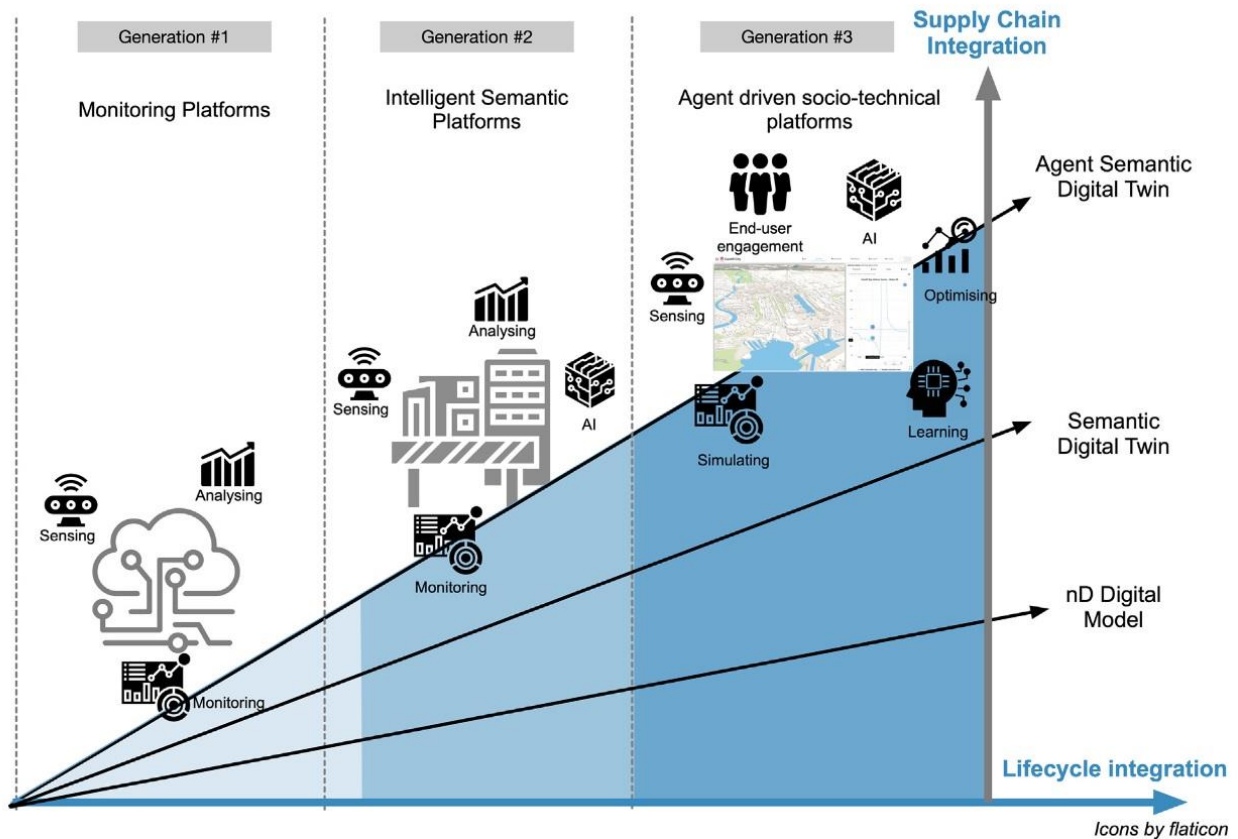

Figure 48 - 3 Tier evolution of the Construction Digital Twin. Source: (Boje et al., 2020).

Similar evolutionary characteristics can be considered for Digital Twins applicable for other uses, starting with just monitoring platforms or mere Digital Shadows and evolving towards an Agent Driven Socio-technical platform.

4.6 Limitations

Although Digital Twins can offer numerous potentials to the building industry, especially in facilitating circular economy goals, implementing digital twins would require overcoming technical, social, organizational, and commercial barriers.

1. The use of digital twins can lead to a large amount of data, which needs to be processed with additional data to extract useful information. (Floridi, 2013).
2. Implementing such systems is difficult in the conservative construction industry, as there are already difficulties integrating BIM workflows seamlessly for construction projects (Sacks et al., 2020).

4.7 Conclusions

Based on the above review, it is evident that moving towards Digital Twins' development can be very useful for streamlining all processes in a project's lifecycle. Aspects such as real-time data monitoring and recording are already being tested in buildings and RFID tracking in logistics companies to monitor packages' locations. Researchers have confirmed merging these varied applications into a common semantic platform where all systems are interconnected and data can be exchanged in all supply chain nodes. Therefore, it is inevitable that these Industry 4.0 concepts would go a long way in enabling data transparency and acquisition systems, thereby facilitating the implementation of Circular principles.

With this context, we must also recognize that most of the construction industry is still lagging in implementing BIM in a holistic platform, and the concept of material passports is barely being considered due to the lack of value addition to the way our economies are structured. While this is expected to change with the implementation of CO2 tax and other new business models, a specific transition needs to occur for which frameworks must be developed. The frameworks need to keep conceptual considering the context to ensure they are adaptable for drastic technological developments over the years. Although Digital Twins, combined with Agent-driven AI systems, are a potential future for the interconnected nature of products, processes, and systems, the proposed conceptual framework can be interpreted in both directions serving as a transitory tool rather than defining the end goal.

5 Preliminary framework

Based on the research on the Circular Façade Industry and the information in material passports, a primary framework was established to proceed with the remaining research. The preliminary framework was essential to identify how the different components of the façade industry and information exchange come together and the key limitations to be addressed in the surveys and interviews.

5.1 Product Levels to Information Levels

Building facades can be grouped into different product levels. Klien (2013) identified a total of 8 levels. The standards set by the VMRG as part of their information delivery specifications identified four levels. Platform-CB'23 (2020) mentions seven levels, two of which correspond to objects beyond the building scale. However, they mention additional customization required to categorize the different product levels. Therefore, to follow a standard reference for the remaining part of the research, the logic specified by Eekhout (2008) in his hierarchical range of products was used as a starting point and adapted for façade products. Figure 49 shows the product levels employed and referenced in this research.

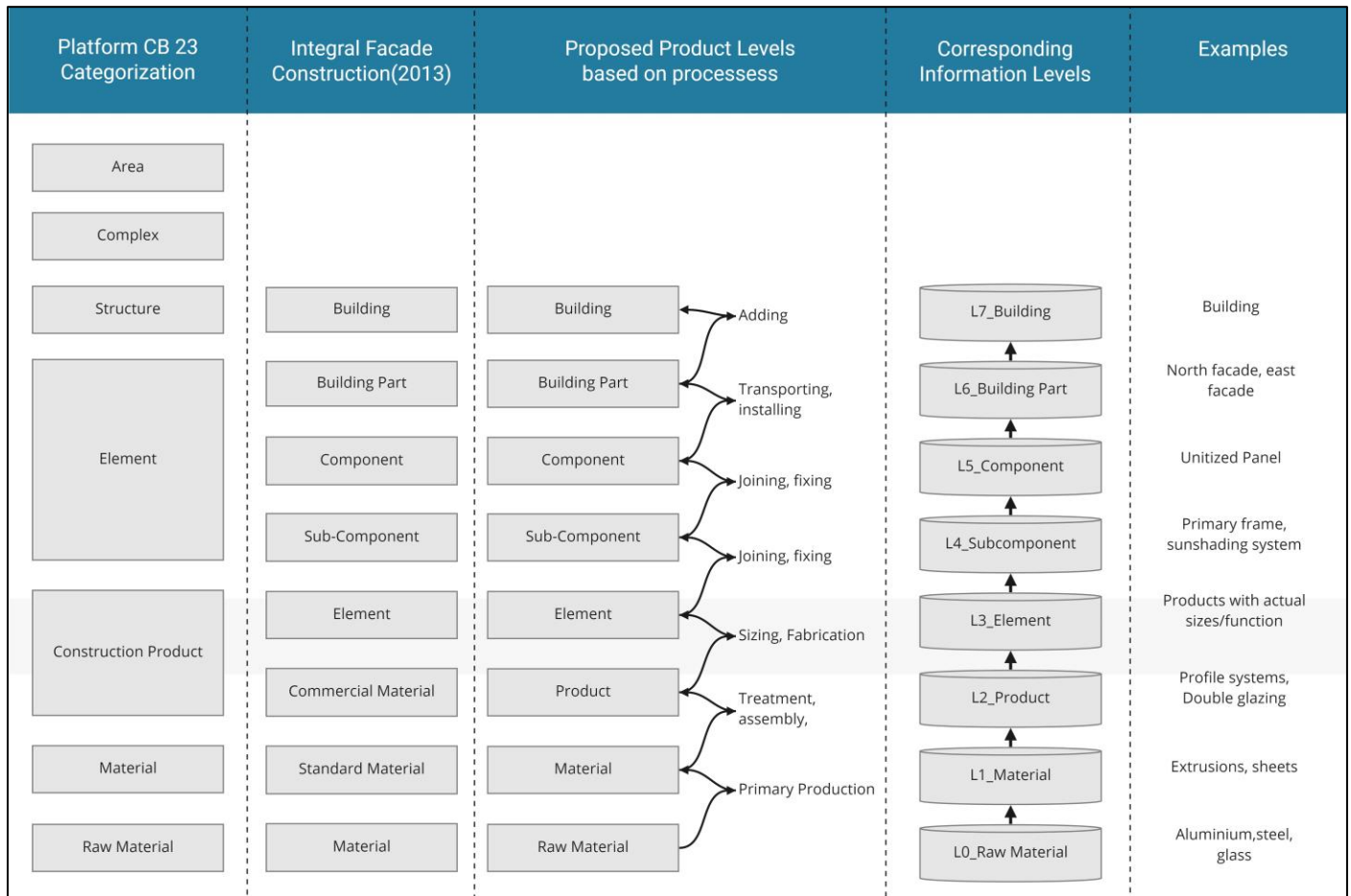

Figure 49: Diagram indicating pre-existing definitions of product levels in the facade and the proposed product and information level relationships. Source: Author

5.2 Framework for Façade Product Passports

In order to determine an industry-wide framework for material passports, it is essential to create a lifecycle stakeholder data map shown in Figure 50. Based on the literature research, this diagram represents all the various intricacies involved in the circular lifecycle of the façade and the possible stakeholders involved in it. Also, based on the passport contents and categorization mentioned in Chapter 3.2, the map indicates the possible data flows which currently happen at various stages for performing the different processes. Based on the information categorization, product levels, and long passports, a conceptual framework for a Façade Product passport is created, as shown in Figure 51. This is organized similarly to the framework proposed by Mullhall et al. (2017) indicated in Chapter 3.4.

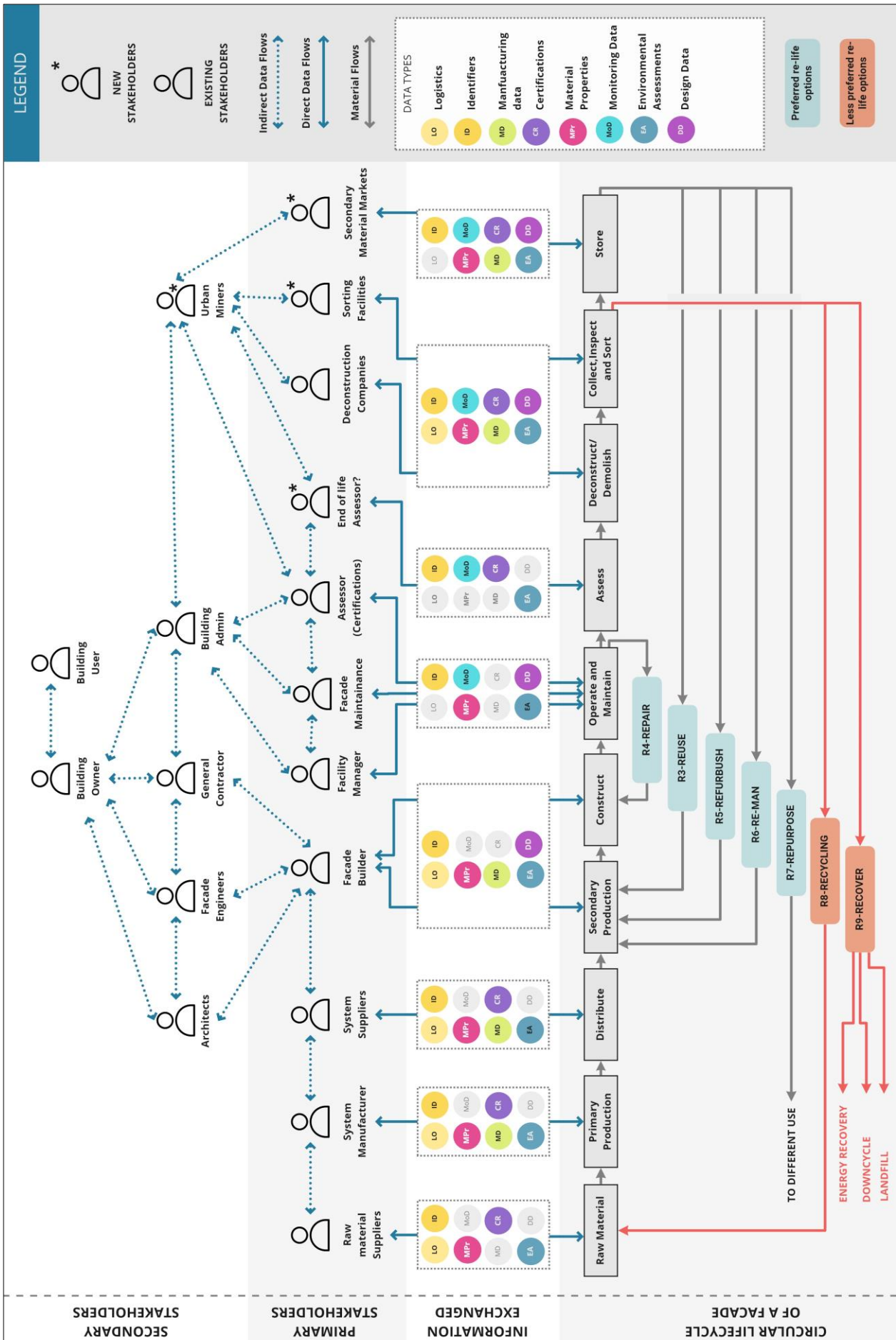

Figure 50: The stakeholder lifecycle and data map of the circular lifecycle of a facade. Source: Author

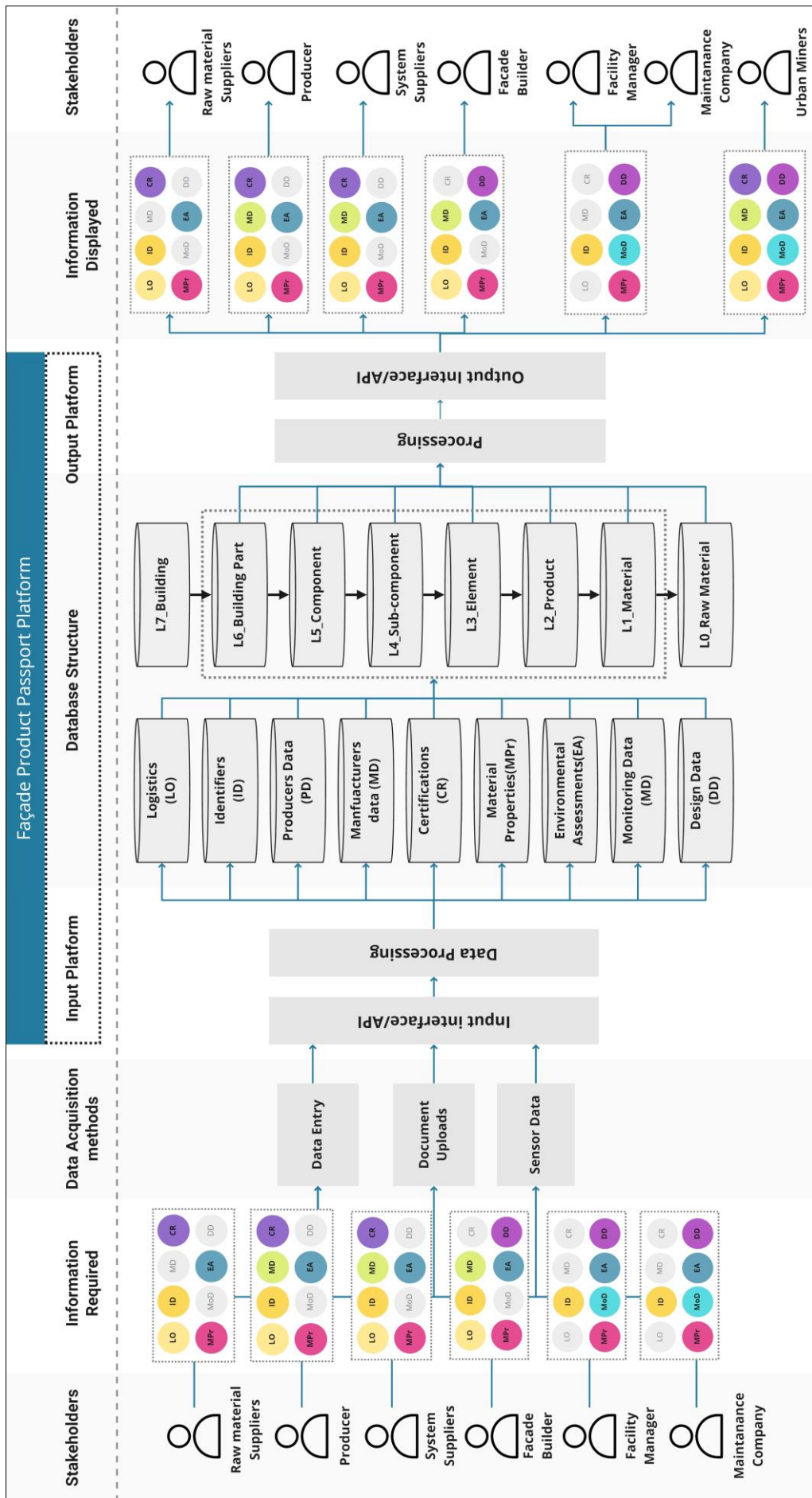

Figure 51: A preliminary framework for a facade product passport and its uses. Source: Author

5.3 Long List and Data Template for Façade Product Passports

Based on the basic framework developed by (Heinrich & Werner, 2019), market research of data on façade products and the various certifications applicable for each product, a long list with the various information contained within a Façade Product Passport was created. A small section of the long list is shown in Figure 52. Each data item can be categorized with multiple criteria shown in Figure 53. The categorization is essential to demonstrate the amount of variability present in the information about façade product passports. About 151 items identified in this long list would require such an approach, and therefore, alternate methods of automatically extracting information may need to be identified.

| Product | Data Item | Unit | Type | Source | Product Level | Categorization | Standard |
|-----------------------|--|-----------|--------------|--------------|------------------------|---------------------|-----------------------------|
| General | 3D Model | No unit | Drawings | Manual Input | All levels | Design data | NA |
| Profiles | Ability to release | Pass/Fail | Multi-option | CE | L2_Product | Material Properties | EN 179, EN 1125 |
| Sandwich panels | Abiotic depletion potential for fossil resources(ADPF) | Check | Value | EPD | L1_Material/L2_Product | Environmental Data | NA |
| Profiles | Air Permeability | Class | Text | CE | L2_Product | Material Properties | Product standard EN 14351-1 |
| General | Analysis Drawings | No unit | Drawings | Manual Input | All levels | Design data | NA |
| Insulated Glass Units | Application conditions | No unit | Text | CE | L1_Material/L2_Product | Manufacturing Data | NA |
| Profiles | Behavior between different climates | Class | Text | CE | L2_Product | Material Properties | Product standard EN 14351-1 |
| General | BIM Model | No unit | Drawings | Manual Input | Multilevel | Design data | NA |

Figure 52: An excerpt from the long list of information that a Façade Product passport can contain. Source: Author

| Organization type | Item | Description |
|-------------------|---------------------|--|
| by Type | Document | Information contained in the form of Pdf's. It could be graphical, textual or others |
| | Drawings | CAD files, 3d Models etc. |
| | Value | A number with a unit |
| | Text | Readable character strings. Also applies to certification Codes etc. |
| | Multi-option | Value which are part of a multi-option list |
| | Multiple | Information which have a combination of two or more data types |
| by Source | Brochure | Data items retrieved from company brochures on websites |
| | CE | CE marking of products which are publicly available |
| | Docu-Center | Online document center of companies which requires login information |
| | EPD | The environmental Product Declaration |
| | Manual Input | Information which has is manually generated per project |
| by Product Level | L0_Raw Material | The product/information levels mentioned in previous chapter |
| | L1_Material | |
| | L2_Product | |
| | L3_Element | |
| | L4_Subcomponent | |
| | L5_Component | |
| | L6_Building Part | |
| L7_Building | | |
| by Categorization | Design Data | Categorization of adapted from Heinrich & Werner, 2019 |
| | Environmental Data | |
| | Identifiers | |
| | Logistical Data | |
| | Manufacturing Data | |
| | Material Properties | |

Figure 53: Criteria used to organize the long list of Façade product passports. Source: Author

5.4 Conclusions

The preliminary framework summarizes the various aspects required to develop a conceptual information model. It provides a basis on which further research can be carried out. Firstly, a framework to categorize product levels was determined based on actual processes in the context of the façade industry, as shown in Figure 49 in Chapter 5.1. Next, a long list was prepared (Appendix 15.8) after analyzing information about three main façade products. This long list categorized the information into different criteria and provided a basis for further investigation into the exchange between stakeholders. The lifecycle stakeholder data map (Figure 50, Chapter 5.2) and the Façade Product passport framework (Figure 51, Chapter 5.2) gives an overview of how FPP's could be used throughout the supply chain and what information is possibly exchanged at a conceptual level. It provides a basis for further validation and detailing what exact piece of information is exchanged in the façade industry from which further analysis can be done as to what can be contained in a passport and how it can be used for the end of life.

Based on the literature reviews, the following summarizes the different phases involved in a circular lifecycle of a façade.

1. **Design Phase:** The phase involves translating the client's and architects' requirements into a manufacturable façade.
2. **Forward Logistics:** The stage involves converting the design into a manufacturable, usable product installed on the building.
3. **Operate and Maintain:** Stage involving using the façade in the building and maintaining it to ensure its longevity.
4. **EoL Assessment:** While not recognized formally as a phase currently as the Circular Façade Economy is still in the early stages of development, this phase is proposed to be a part where information is collected about the façade and decisions are taken about how the material is treated with its highest value.
5. **Reverse Logistics:** The stages after the EoL assessment involve deconstructing the façade and sending the materials to its end destination or the beginning of its second life.

In a fully circular model, the design phase and the EoL assessment are explicitly connected, and due to that, the forward and reverse logistics are also connected and inform each other. For example, decisions taken at the EoL assessment of a façade can influence the design decision process, depending on whether the façade is reused, recycled, remanufactured, etc. Similarly, the reverse logistics of the façade, i.e., the actual act of deconstructing the façade and sending it for reuse, recycling, and so on, can influence the forward logistics processes of a façade when the material is recirculated in the supply chain. For example, a Façade Engineer or builder decides to use material with higher recycled content or reuse a façade component.

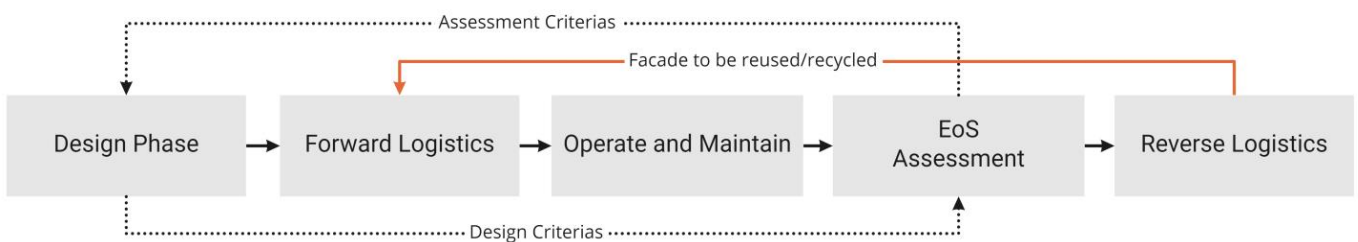

Figure 54: Summarized version of the circular lifecycle of a façade and their inter-relationships. Source: Author.

6 Survey and Interview Analysis

The interviews were conducted to extract more subjective aspects about the implementation of Digital tools in information exchange and collection and to understand the stakeholders' specific roles in the industry. While the results can be more quantitative, the results and inferences are descriptive and qualitative. Therefore, the interviews were instrumental in defining the framework throughout the research.

6.1.1 Profile of Interviewees and Survey Respondents

For the survey and follow-up interviews, members of VMRG were the primary respondents as they are directly involved in the engineering, manufacturing, and assembly of the façade. Although around 80 VMRG partners and members were contacted using the monthly newsletter and a personalized email for the survey, only nine responded. Their roles are shown in Figure 55. For the independent interviews, stakeholders outside the Dutch metal façade industry but with expertise relevant to the research context are contacted. The surveys and interviews were conducted with sensitivity to confidentiality, and therefore the names of the stakeholders are not revealed at any point in the main body of the research. A complete list of survey respondents and interviewees is shown in Chapter 12. To further understand how the stakeholders interact during the lifecycle of a façade, additional questions were asked to form a basic profile of who is responsible for what task and how the roles are defined. These inferences are directly mapped in the Framework for a conceptual model in Chapter 7.

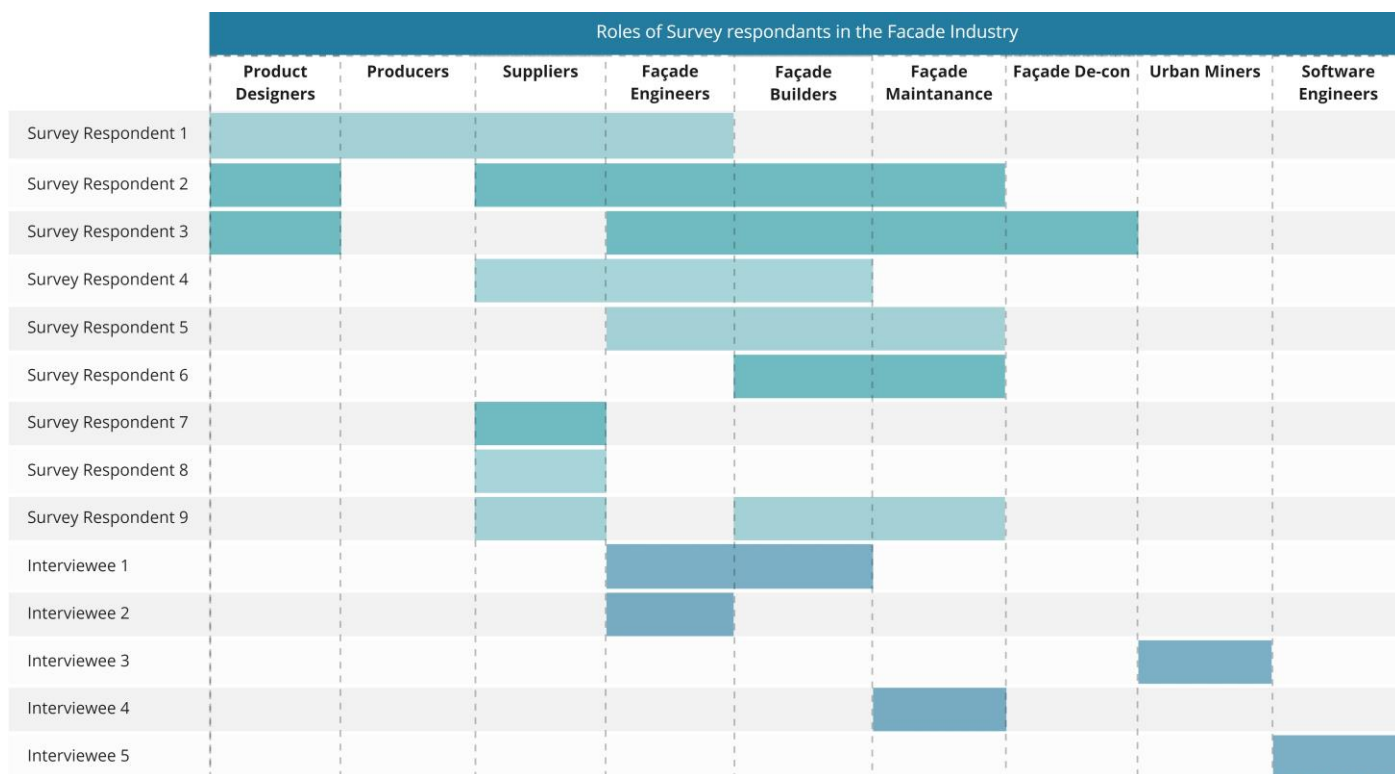

Figure 55: Roles of the survey respondents in the lifecycle of the façade. Source: Author

6.2 Analysis framework for Surveys and Follow-up interviews

As mentioned in Chapter 1.6.2, the results of the surveys and the follow-up interviews are grouped into six main categories, each one informing different aspect required to develop the framework. Figure 56 gives an overview of the different themes into which the questions are organized, and Appendix 15.7 gives the entire list of questions categorized under each theme. The main results of the survey per question are summarized in Appendices 14.5.3 and 14.5.5.

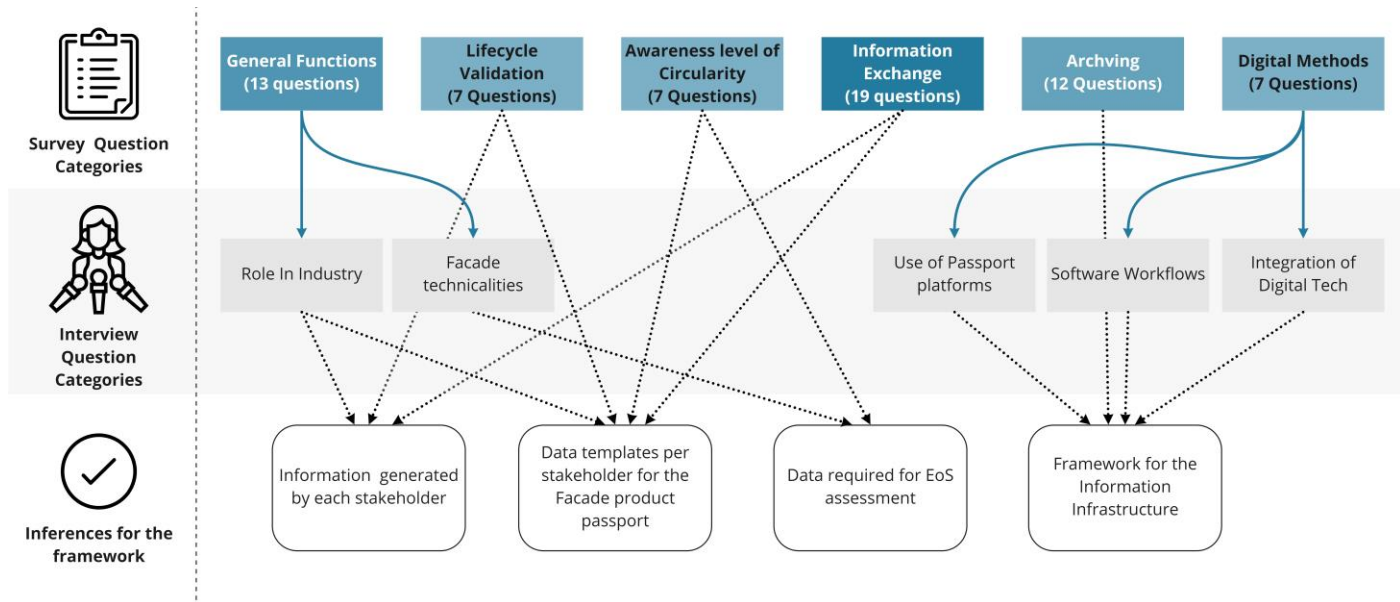

Figure 56: Categorization of questions and use of the results in the proposed framework. Source: Author.

6.2.1 General Functions

These refer to questions regarding their role and functions in the lifecycle of a façade. The preliminary framework developed in Chapter 5.2 is generated only based on literature reviews. It was essential to validate certain aspects, especially those in charge of product selection and how companies actively develop new products. The general hypothesis was that either Façade Engineers or Façade builders have maximum control over façade products. However, what was inferred is that these stakeholders only serve as advisors and the architect or the building owner most likely takes the final decision. The majority of respondents also mention selecting products based on suppliers they already know. While the apparent reason behind that was not asked for, it gives an idea that companies are limited in choice for façade product selection.

| General Functions | | | | |
|-------------------|---|--|--|---|
| Ref. Question | Hypothesis/Question | Result | Interpretation | Key point for consideration |
| Survey 1.3 | Products selection is controlled by Façade Engineers as they have maximum understanding of the architects requirements as well as the technical requirements of the consultant. | The hypothesis is false. Product selection is heavily influenced by the architects and building owners, who have lesser in-depth knowledge of façade products in the market. | Difficult to ensure the most circular product is used, unless architects or building owners are informed well. | Product selection influenced by non-Technical* Stakeholders |
| Survey 2.16,3.1 | Façade engineers and/or builders try to opt for products or materials from suppliers they are comfortable working with. | The hypothesis is true | The resulting façade becomes highly dependent on the diversity network of the façade builder/engineer. | Façade builders working with a limited number of known suppliers |
| Interview Q:52 | Façade Engineers specify façade products | The hypothesis is false. Façade Engineers try not to specify products as the could limit the involvement of the façade builders. | Although façade engineers do not specify products, they need to be aware of possibilities in the current market. | Lack of a consistent information about façade products in the market. |

Figure 57: Analysis of the general functions of stakeholders. Source: Author

Inferences to be incorporated in the framework:

The current processes in which a product selection is made are purely dependent on the individual stakeholders' awareness level and, therefore, may not be sustainable in the long term. If more façade products are reused, information about these products needs to be displayed as alternates when new product selections are made. This is very important, especially as the interviews have shown that non-technical stakeholders such as architects, general contractors, or building owners are most influential in making product selections. They need to be shared with the correct information in an easily understandable way, comparable so that better product selections are made during the design of a façade.

6.2.2 Awareness level of Circular principles

Here, a general assessment was made to determine how much the industry is aware of circular design principles, how much they are implementing them, and whether they lack the know-how. The tabulation of the hypothesis made and the results are shown in Figure 58.

| Awareness level of Circular Principles | | | | |
|--|---|--|--|--|
| Ref. Question | Hypothesis/Question | Result | Interpretation | Key point for consideration |
| Survey 2.4 | DFD is a common practice considering the amount of prefabrication associated with Metal based façade systems. | The hypothesis is false. Majority stakeholders are either unaware or do not make use of DFD in their regular projects. | Facades rely heavily on adhesives for watertightness, and lack of knowhow of market for more circular façade products. | Low level of Implementation of Circular Design principles. |
| Survey 2.8 | Co2 Emissions, Recycled content and other environmental impacts of facades are hardly considered at design stage. | The hypothesis is true. Majority of stakeholders indicate such considerations are done in specific cases, and mostly when clients demand it. | Added time required to make these calculations make it a labor intensive task. | Are not able take into account environmental Impacts, due to time constraints. |
| Survey 3.22 | Unsure about the stakeholders stance on extended producer responsibility. | Most stakeholders want to take more responsibility, but lack awareness how. | Possibly due to still ambiguity of how Circularity can affect their work process, and lack of information on how other companies are approaching it. | Companies are willing to take responsibility, but lack an awareness |

Figure 58: Analysis of the level of awareness and implementation of Circular principles in the Dutch Façade Industry. Source: Author

While there is currently a low level of implementing circular design principles, most companies indicate interest in taking more responsibility. However, they also indicate that they currently lack the know-how of how what can be done to implement these design principles.

Inferences to be incorporated in the framework:

One way to improve the lack of awareness of implementing circular design principles is to facilitate open and transparent information exchange. This is one of the crucial aspects of a thriving circular economy. If companies can safely share information about various circular principles they have used in new and innovative projects, the companies who lack awareness can improve their current methods. The specificities of data security, patents, and trademarks hinder this, and therefore careful investigation needs to be done about what information can be shared.

6.2.3 Stakeholder Interaction

These questions are directed towards understanding the roles and interactions of stakeholders involved in the lifecycle of a façade. A pattern of how stakeholders interact can help determine which stakeholder can be responsible for producing what kind of information. The tabulation of the hypothesis made and the results are shown in Figure 59.

| Stakeholder Interaction | | | | |
|-------------------------|---|---|---|---|
| Ref. Question | Hypothesis/Question | Result | Interpretation | Key point for consideration |
| Survey 1.1 | Certain stakeholder roles such can be grouped due to shared responsibilities. | Not a single supplier has shown continuous involvement in the supply chain. | A focused business model is easier to manage and more successful in this market, rather than taking in all roles in the supply chain. | Unpredictable pattern of stakeholder engagement. |
| Survey 2.3 | Some amount of engineering is done inhouse by stakeholders. | The hypothesis is true. Advanced calculations are outsourced. | | Subcontracting complex tasks is a common trend. |
| Survey 3.2 | Logistics is mostly outsourced. | The hypothesis is true | | |
| Interview Q.34 | Unsure if stakeholders who claim manufacture products(profiles etc.) manufacture it themselves. | Companies who claim to manufacture, outside the production to third party manufacturing plants. | As they subcontract these to third parties, they have less traceability of raw material source and quality standards | No stakeholder has direct connection to the raw material source |

Figure 59: Analysis of the stakeholder interaction in the Dutch Façade Industry. Source: Author

Based on the results, it is evident that it becomes difficult to pinpoint which company plays what role in every project due to the low sample size. Even terms such as “Product Manufacturer” or “System Supplier” seem to mean different things to different stakeholders. Some companies claimed to be product manufacturers and, in the interview, indicate that they only design the products such as profiles, gaskets, etc., and the actual manufacturing is subcontracted. This was even after the answer choices had mentioned each role. Hence a clear result of a pattern of engagement of stakeholders cannot be established.

Inferences to be incorporated in the framework:

A clear pattern of engagement of stakeholders in the lifecycle of a façade could not be established. Hence the roles of each stakeholder are referred to in this research, and the framework is explicitly stated to ensure there is no ambiguity.

6.2.4 Information Exchange

These questions were generated to understand what kind of information is being exchanged, the quality of the information, any agreements they use to ensure consistency, and what information they are willing to share. The tabulation of the hypothesis made and the results are shown in Figure 60.

| Information Exchange | | | | |
|--------------------------------|---|---|---|--|
| Ref. Question | Hypothesis/Question | Result | Interpretation | Key point for consideration |
| Survey 3.9 | Few stakeholders develop as-built drawings of the façade | The hypothesis is partially true. As-built drawings are drawn mostly upon request. | Data stored about façades in the archive cannot be considered to be fully accurate and needs additional verification. | Lack of accuracy in data currently stored in Facades. |
| Survey 2.12 | No stakeholder has standardized agreements of information exchange formats | The hypothesis is partially true. Most stakeholders have agreements for only exchanging BIM formats and LOD levels which are also customized per project. | As digital workflows vary quite drastically from company to company it would be difficult to draw out these agreements. | Lack of Information Exchange standards. |
| Survey 3.15 | Uncertainty of what information is shared with client/building owner | Drawings and 3d Models are most certainly shared. But not the Bill of Materials. | Clients/building owner are less technical and a lot of information is of no value to them | |
| Survey 3.16 | Stakeholders would be open to share more information at the facades end of life | The hypothesis is true. | Confidential information is less valuable after 15-20 years and they are more happy that their facades are processed at a high level. | Confidential information less valuable to stakeholders over-time. |
| Survey 2.5 | Information mentioned in system manufacturer websites not sufficient to make a product selection. | The hypothesis is partially true. Costs, lead time and sometimes digital drawings are often asked for. | Cannot make an interpretation due to small sample size. | - |
| Survey 2.9 and Interview Q 100 | Uncertainty of what information is shared for onsite installation and coordination | 2d Drawings for details, 3d model or BIM for coordination, software with ERP functions for coordinating other tasks. | Standardizing this information would be difficult considering uniqueness of project and stakeholders involved. | Difficult to standardize information required for onsite processes. |
| Interview Q 102 | Most companies do not have a standardized way of documenting assembly logic of a façade. | Most coordination happen through oral communication and 2d drawings. It is mostly required when subcontracting to third parties. | As companies choose limited products from suppliers, the onsite team is already trained to know how to plan/assemble facades. | Lack of a accessible method of recording assembly logic of facades at a component level. |

Figure 60: Analysis of the information exchanged in the Dutch Façade Industry. Source: Author

Based on the results, it was clear that there are not many information standards present currently. This makes it harder to pinpoint which stakeholder is responsible for extracting what information.

Inferences to be incorporated in the framework:

There is a high variance in how each stakeholder records façade information, especially when there are no information exchange standards. As this façade information can be accessed in the future, it becomes crucial to develop and implement these to ensure information can be accessed quickly during the End of Service of a Façade.

6.2.5 Documentation methods

These questions mainly refer to how companies use documentation as part of their workflow, what they store, and their thoughts on a central platform to store information about façade products. While it was found that most companies do store all their project information such as drawings, documents, calculations, bills of materials, etc., its accessibility by third-party viewers is still debatable.

| Documentation methods | | | | |
|--|--|---|---|--|
| Ref. Question | Hypothesis/Question | Result | Interpretation | Key point |
| 2.6 | Façade Builders and Engineers locally store supplier information, as information in the websites are often not enough or not easy to access for quick referencing. | The hypothesis is true. | Companies prefer curating and customize data for their internal work, to make it easier to integrate with their own digital workflows. | Companies curate product information for their internal workflows. |
| 2.3 and Interview Q.77 | Unsure about the readability of archived information. | There is a lack of quality of information and lack of consistency. | While there is a lot of information, it would be time consuming to access this easily. It would mean you need more Leadtime for this to happen. | Processing archived data is time consuming and tedious. |
| 4.1,4.4,4.5 and Interview Q. 46, 78 and 61 | Uncertain if façade maintenance companies store information about maintenance history per façade product | Only companies who are experimenting with QR codes, or RFID's have this data, but not the rest. | As façade maintenance is not prioritized, there is a lack of standardized way of recording information. | Lack of recording of maintenance data at a product level. |
| Interview Q 64,96 | Uncertain if a standardized database of façade products would be useful to make selections and whether manufacturers are open to do this. | While façade Engineers do indicate a use for this, system producer claims it would be difficult to do so considering huge variation in the context in which the façade will be installed. | Comparing façade products would require high level of categorization of facades and testing methods | Difficult to compare façade products. |

Figure 61: Analysis of documentation methods used in the Dutch Façade Industry. Source: Author.

Inferences to be incorporated in the framework:

The inferences here are similar to findings under Information Exchange methods. Similar to how data templates need to be set for each stakeholder, additional documentation standards need to be set to ensure the information archived by companies is readable and accessible to any stakeholder. Although many companies are reluctant to share this information, they do fail to realize that the guarantee of their company existing for the duration of the façade is questionable, and it can be assumed that the information generated by them is almost always going to be read by a third-party external evaluator at the end of service.

6.2.6 Digital Methods

These questions were generated to understand the implementation of digital methods and technologies in the façade industry. Questions ranged from design workflows to manufacturing and tracking, and tracing methods of façade products. The tabulation of the hypothesis made and the results are shown in Figure 62.

| Digital Methods | | | | |
|-------------------------------------|---|---|---|--|
| Ref. Question | Hypothesis/Question | Result | Interpretation | Key point for consideration |
| 3.3,1.7 and Interview Q85,92,93 | BIM is more commonly used across the entire supply chain | The Hypothesis is false. Very low implementation of BIM post design stage and almost no use during the maintenance stage. | Cost and time of making detailed brim models are relatively high. Maintenance Data is not recorded part by part, but rather a checklist for the entire building | Use of BIM stops after detailed design stage. |
| 3.21 and Interview Q 19,82,67 | Companies make use of an internal ID system which is traceable internally, but not after its installed on the building. | The hypothesis is partially true. Only front runners experimented on a few projects with RFID's and QR codes. | Companies who are manually writing down ID's or stickers are not able to trace back the manufacturer of the subcomponent for old projects. QR codes and RFID's also lack details about tracing the subcomponents. | No identification of components and subcomponents which can be traced to a drawing. |
| 1.12 and Interview Q.15 | Low level of automation and use of Emerging Digital methods and technologies | The hypothesis is true. Some companies only indicate possibility of partial automation. | Full automation and smart manufacturing is still challenging due to manual labor intensive tasks involved in metal facades. | Lack of automation in manufacturing processes. |
| 2.1 and Interview Q.91 | Unsure how BOM's are generated | Most of BOM data is coming from an ERP software or customized façade design software. Base level quantities(number of elements etc.) is referred from BIM | - | BOM data is generated from the ERP |
| 4.7 and Interview Q. 94,11,37,68,86 | Unsure if companies are thinking of migrating to a cloud server | Most companies have a physical server and only a few are considering going to the cloud. | High costs and the image of the cloud being a secure place for data are the main limiting factors. | Cloud based storage is advantageous, but market is still reluctant. |
| Interview Q.92 | Unsure about the usability of BIM models received from architects or general contractors. | Façade Engineers claim to redo the BIM model in most cases to suit their internal requirements. | Duplication of data exists due to lack of trust in human generated information. | Duplication of data even with use of BIM |
| Interview Q. 18,103,88,38 | Unsure if Façade Passports can supplement a companies day to day work processes | Companies claim that passport info can help them mostly with recording maintenance data. | Considering high level of complexity involved in their digital workflows, passports would not supplement their current work processes. | Passports not as useful in the forward logistics of a façade as much as the reverse logistics. |

Figure 62: Descriptive analysis of the digital methods used in the Dutch Metal Façade Industry. Source: Author.

Apart from this, various software used by each company was extracted to identify all the different software relevant to develop the framework is detailed in Figure 63, along with their functionalities.

| List of Software Used by Survey Respondents | | | | |
|---|-------------------|-------------------------------------|--|---------------------------------------|
| Sl/No | Software Name | Type | Description | Stakeholders |
| 1 | Revit | Building Information Modelling(BIM) | Mostly used as a medium to exchange façade information with architects. It only serves as a base mode to visualize and link basic façade data. | Façade Engineers and Builders |
| 2 | Solibri | | | |
| 3 | SimpleBim | | | |
| 4 | Autocad | Computer Aided Design(CAD) | As this is used to make all the digital drawings of the façade. Cad software can range from simple drawing platforms, to software which are customized to design products and components such as Autodesk Inventor or Solid works. | All |
| 5 | Inventor | | | |
| 6 | BricsCAD | | | |
| 7 | Solidworks | | | |
| 8 | Engraving | Computer Aided Manufacturing(CAM) | Software used to control machines which produce the different components of the façade product. | Product producers and Façade Builders |
| 9 | Camplus | | | |
| 10 | Metalix | | | |
| 11 | Navision-Propos | Enterprise Resource Planning(ERP) | Software which map the digital drawings, 3d Model and all related documents and it to the Bill of Materials, costs, managing orders and linking it to the Supply Chain Management Program. | Product Producersand Façade Builders |
| 12 | SAP LEAN | | | |
| 13 | PMF | | | |
| 14 | Janisoft | Façade Development | Software's which are used to make detailed Façade Drawings based on an inventory of profiles in the market. The output of the software can directly be linked to a CAM software, thereby facilitating the manufacturing. | Façade Builders |
| 15 | Orgadata Logikal | | | |
| 16 | Consignment | Inventory tracking | Software similar to a supply chain management, but mostly focused on the logistics | Product Procers |
| 17 | Solidworks PDM | Product Data Management | Software which organize all the data per project, in some cases they are connected to the CAD, BIM software to ensure auto updating as well as organized based on the component hierarchy. | Façade Builders |
| 18 | Mepla | Structural Analysis | Software to analyze structural performance of façade components. | Façade Builders |
| 19 | SAP | Supply Chain Management(SCM) | Helps in managing the logistics processes within the company and between companies. | Product Producers |
| 20 | Physibel | Thermal Analysis | Thermal flow analysis software used for determining performance of façade frames | Façade Engineers and Builders |
| 21 | Bisco | | | |
| 22 | Trisco | | | |
| 23 | Voltra | | | |
| 24 | Vitrages Decision | | | |
| 25 | WinSLT | Thermal Analysis for glazing | Thermal analysis software specifically designed for glass windows and facades | Façade Engineers and Builders |

Figure 63: Categorization and description of the list of software used by survey respondents. Source: Author

Inferences to be incorporated in the framework:

As the key points in this category are mostly descriptive merely to understand the current workflows employed, it will inform the mapping of the current industry workflows and develop the information infrastructure proposed in Chapter 7.2.

6.3 Analysis of Independent interviews

Independent interviews were also assessed similarly as the Survey and Follow-up interviews. However, due to these interviewees' specialized and diverse roles, the questions were mostly generated to conduct a descriptive analysis of their roles. Following are the results of the interviews categorized into respective themes.

6.3.1 Technicalities of Façade Maintenance

The questions were mostly directed towards understanding the technical aspects concerning the maintenance of facades.

| Technicalities of Façade Maintenance | | | | |
|--------------------------------------|--|--|--|---|
| Ref. Question | Hypothesis/Question | Result | Interpretation | Key point for consideration |
| Survey 9 | Uncertainty of the role of structural fatigue in the maintenance of a façade. | According to the interviewee, there is very less influence of structural fatigue, unless the facades are placed in critical conditions such as cantilevers where there is more movement. | Although structural fatigue seems to play a small role, it is important to understand the loading conditions it is designed for and has been subjected to. | Load cases of a façade is crucial information needed for assessment. |
| Survey 43 | Uncertainty of whether Lifespan of profiles can be predicted with a visual inspection. | Interviewees indicated that although predictions can be made about the coating, not much can be inferred about the base material. | Visual inspections can be done for preliminary checking, additional inspections and tests need to be carried for special cases. | Visual inspections will need to be supplemented with testing wherever possible. |

Figure 64: Descriptive analysis of the technical aspects of facade maintenance. Source: Author.

6.3.2 Digital Condition Assessments

These questions were focused on the level to which condition assessments can be done digitally. As these companies use the NEN 2767 framework to generate a condition rating of façade components, questions about handling the subjectivity associated with those ratings are generated. The results showed that, to a large extent, the condition assessments could be automated as long as the defects are visible. In cases where there is ambiguity, human input is required.

| Digital Condition Assessments | | | | |
|-------------------------------|--|---|---|--|
| Ref. Question | Hypothesis/Question | Result | Interpretation | Key point for consideration |
| Survey 59 | Understanding the level of automation in assessing the condition of facades. | Any defect identifiable by the naked eye during a visual inspection have the possibility of an automatic assessment, if the algorithm has a history of that defect. | As training the algorithm is still in progress, it is currently still difficult to estimate what specific issues can be detected remotely and what needs manual inspection. | Human input for remote assessments still required for maximizing accuracy. |
| Survey 58,59 | NEN 2767 assessments are highly subjective | The hypothesis is true. | While the condition assessment can give a base picture of what parts are in good condition, it harder to determine more subjective aspects. | |

Figure 65: Descriptive analysis of digital condition assessment methods. Source: Author.

6.3.3 Information Exchange at EoS

As the EoS of a façade, in most cases, is extremely uncertain, especially when numerous industries are trying to define new ways to approach it, here the questions are mainly to get a basic idea of what it looks like currently. One of the main issues identified during the interviews is the low quality of information present at the End of Life of a building. Almost no information is available for most buildings. Also, there seems to be very little time between the notification of the demolition and the actual demolition date, so there is not much time to generate the information required to make proper assessments. Although the information extracted with these methods can be quite rough, they indicate which buildings are worth investigating further. The only drawback with these methods is that information that cannot be captured visually using photographs has to be generated manually. This refers to information such as dimensions, type of material, connection details, etc., which is crucial in material reuse.

| Information Exchange at End of Life | | | | |
|-------------------------------------|--|---|--|--|
| Ref. Question | Hypothesis/Question | Answers by Interviewees | Interpretation | Key point for consideration for consideration for |
| Survey 42 | Understanding what information is currently used to communicate the condition of a façade. | Photographs and a description of the issues faced. | As there is no accurate data sources, for accurate assessments additional information needs to be generated. | Need more time to assess sufficiency of information. |
| Survey 31 | Understanding the level of documentation available during the end of life phase of a building. | no information apart from Existing data sources such as street view, or the 3d Model from 3dbag platform. | | |
| Survey 35 | Unsure what information is currently used to recirculate products. | Currently information is generated per material in terms of quantity, quality, connection type and the rough sizes. | Approximation is a key trend when it comes to end of life assessments considering the lack of information. | Rough assessments can be made even with lower information quality. |
| Survey 53,54,55 | Understanding the information which can be generated using photogrammetry. | Street and Aerial Images, Thermal Imaging, 3d Point cloud of building, list of materials, areas, measurements, total lengths and the condition assessment outputs. | - | - |
| Survey 35,56 | Uncertainty of what information is desired during use and end of life stage. | Information which cannot be assessed visually such as type of material/coating, cross-section of profiles, connection types etc. are useful to make better decisions. | More information provided in a consistent manner can greatly improve their current work practices. | Information which cannot be captured visually has to be generated. |

Figure 66: Descriptive analysis of information exchange in the Dutch Façade Industry. Source: Author.

7 Framework for a Conceptual Information Model

The following chapter addresses mapping out the various processes involved in the lifecycle of a façade based on the results of the surveys and interviews.

7.1 Processes, Stakeholders, and Information Exchange

7.1.1 Design Phase

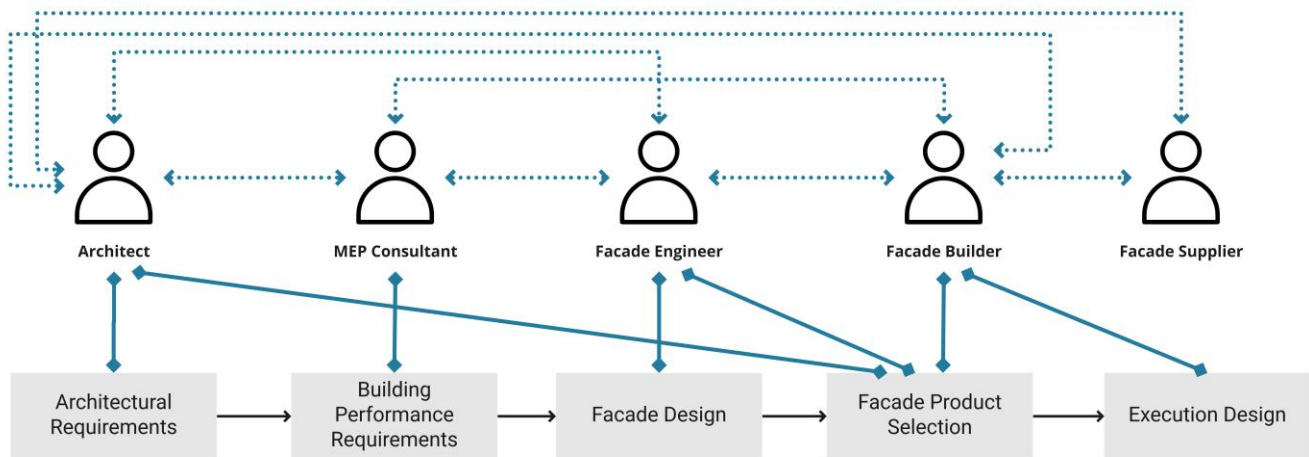

Figure 67: Stages and stakeholders involved in the design phase of a façade. Source: Author.

The design phase of the façade involves mainly the interaction between the architect, façade engineer, façade consultant, façade builder, and the building owner. The architect and the building owner are mainly considered non-technical stakeholders as they are less knowledgeable about façade systems. Therefore, their roles mostly approve the different phases based on costs, architectural requirements, and logistics.

Figure 67 gives an overview of the different stakeholders involved in the design process of a façade and their interactions indicated as red lines. The exact steps required to arrive at an executable design are shown in the form of a process map, as shown in Figure 69. These can vary depending on the agreements between the various stakeholders and the level of information exchange standards.

Digital workflows in the Design Phase

Based on the software described by interviewees, a rough workflow outline can be identified as follows. The initial design phases are carried out using CAD and BIM Software. Specific parts of the façade are analyzed either by a façade consultant or an appointed MEP consultant. Depending on the results of the analysis, the design is modified. Once the required performance results are achieved, it is then handed over to the façade builder, where a similar process is carried out in a more detailed manner. The last stages will involve feeding the detailed CAD drawings into a cam software for production, or when companies are developing unitized windows, it is sent to a Façade Configurator such as Orgadata Logikal, outputs of which can directly feed into the CNC machines.



Figure 68: Software workflow used in the Design and execution stage of a Façade. Source: Author

Information Exchanged and workflows used in the Design phase:

As per the result in Interview 2.12, although many stakeholders indicate the use of exchange standards, it was confirmed that these are mainly applicable for BIM models specifying the Level of Details (LOD). No other additional standards are employed. Therefore, the actual information exchange could only be inferred based on 2.9, 3.10, and 4.5. As Architects and MEP consultants were not part of the survey or interviews, not much can be inferred from the data exchange at the early design stage. But based on interviews with Façade Engineers, it is inferred that depending on the project and the architect, either a BIM model of the design or drawings are provided. In this case, Façade Engineers claim to redraw the building design to suit their internal workflows and standards. This would also mean sometimes recreating their own BIM Model. In addition, they receive information such as performance requirements in the form of a document or report from the MEP engineer, and these act as input for the façade design process.

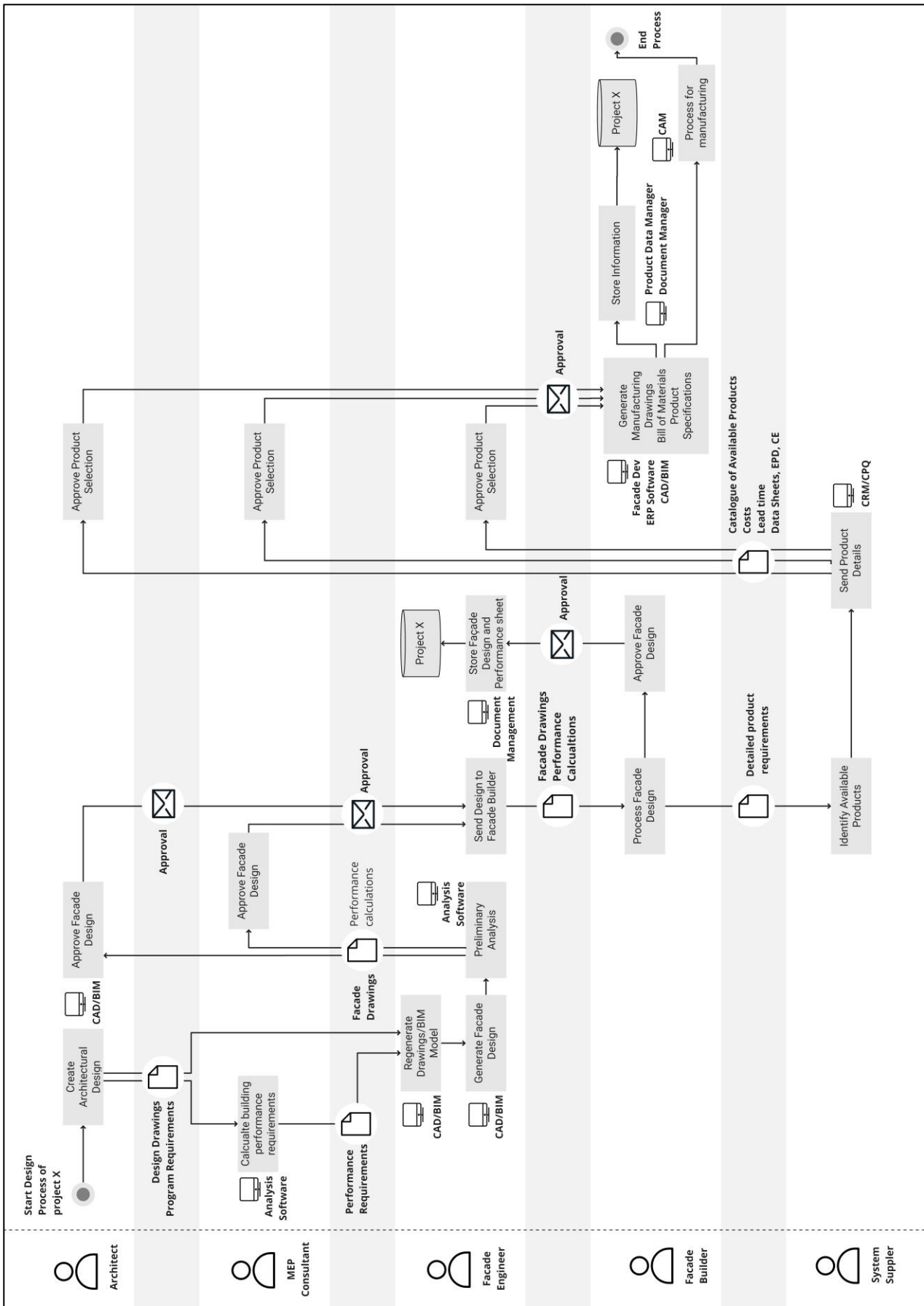

Figure 69: Process map with information exchanged in the design phase of a facade. Source: Author

7.1.2 Forward Logistics Phase

The main production stages of a façade can be categorized into raw material extraction, product production, Product distribution, Façade assembly, and construction, use and maintain as shown in Figure 70. The stages are generalized irrespective of the material and can have slight variations from material to material.

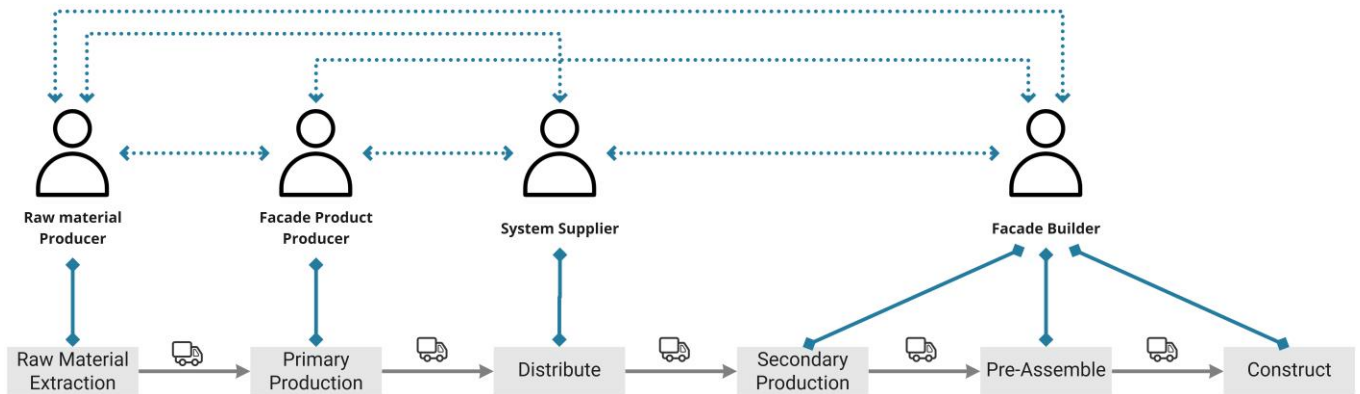

Figure 70: Overview of the Forward logistics process and the stakeholder interaction framework. Source: Author

While the production stages are more or less similar, the stakeholder engagement in these processes is highly dynamic and varies based on each stakeholder's business model. This was confirmed in the interviews as well. As per interview results 20, 72, and 98, subcontracting is quite common in the industry. Therefore logistics, transportation, and manufacturing processes such as aluminum extrusions, thermal breaks, gaskets, etc., are done by entirely different industries and only combined to form a profile system by the Façade Product Manufacturer. As the details of these manufacturers are kept confidential by product manufacturers, details of information exchange between them are outside the scope of this research.

Process and Information Exchanged:

The initial process of the forward logistics phase happens parallel to some of the design phases as Raw material extraction and primary production is not precisely done per order but happens continuously. The supply is increased or decreased based on multiple orders the Product manufacturer receives. Nonetheless, in the context of analyzing these phases based on a series of events in a particular project, the forward logistics process can start when an order is placed to the façade supplier, as detailed in the last stages of Figure 69. The processes involved in the forward logistics phase are detailed in Figure 71.

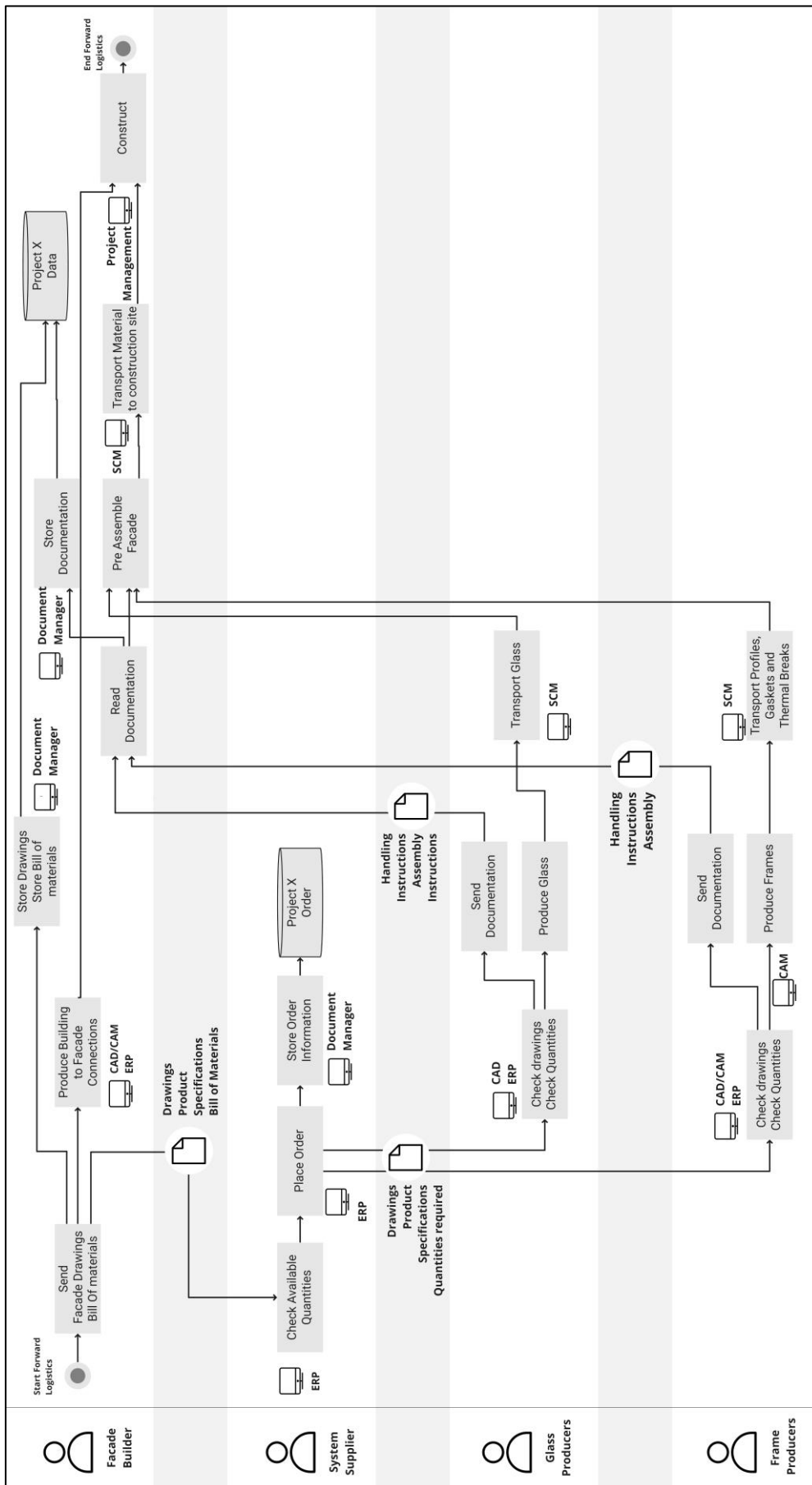

Figure 71: Process map with the information exchanged during the forward logistics process of a facade. Source: Author.

Software workflows:

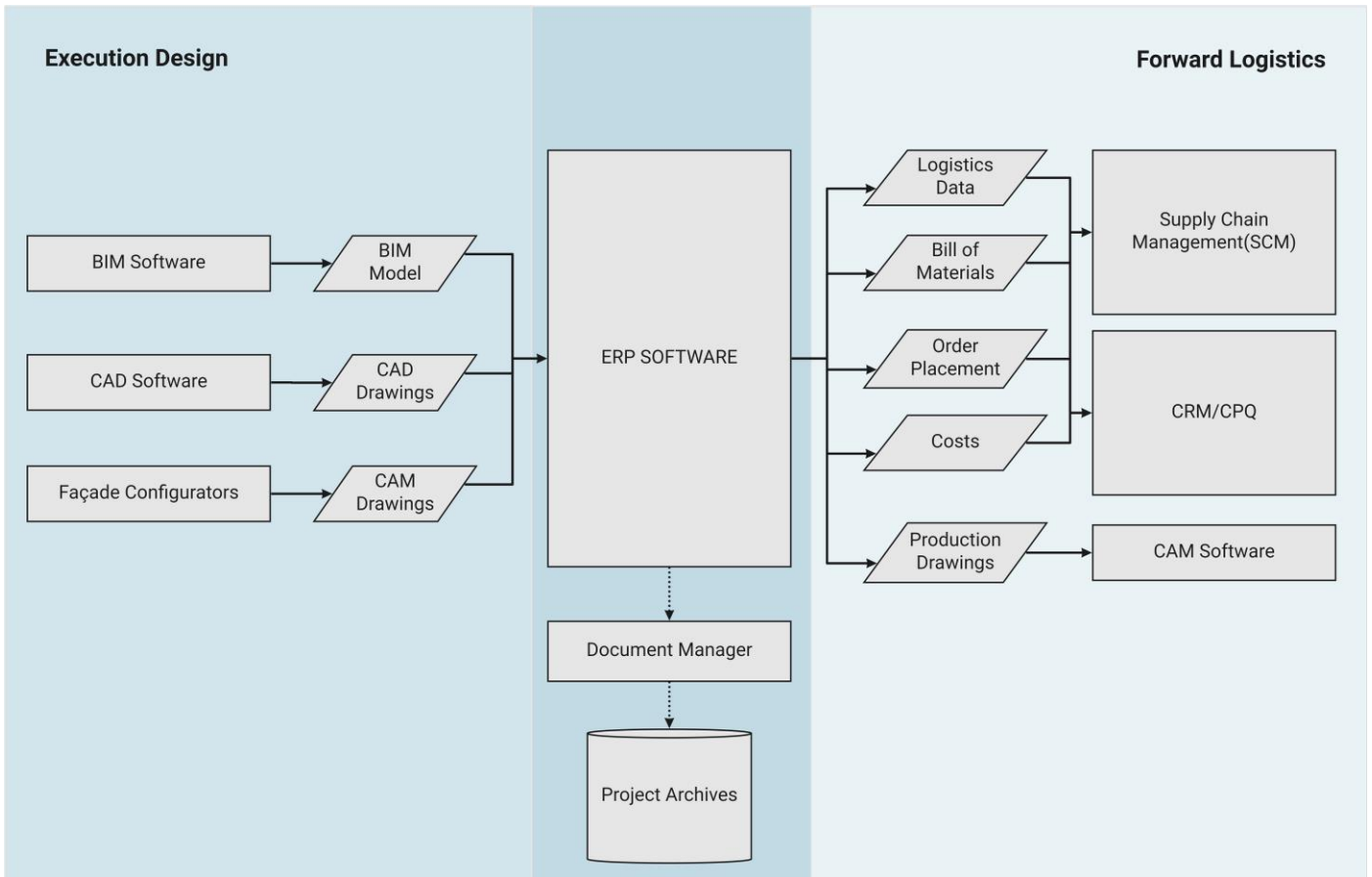

Figure 72: Overview of the digital workflow used between the design and forward logistics phase. Source: Author

The workflows involved in the forward logistics phase overlap with the execution design and are mostly connected by the ERP software, linking data used by different departments and the project's design data. For example, all the parts needed for a façade are identified and are linked to information such as production process, costs, logistics requirements, etc. Many stakeholders indicate ERP transitioning from CAD/BIM software to supply chain management from which onsite logistics and other aspects are carried out.

7.1.3 Operate and Maintain Phase

After the façade has been constructed currently, three contractual models can be isolated based on current developments in the Dutch Façade Industry.

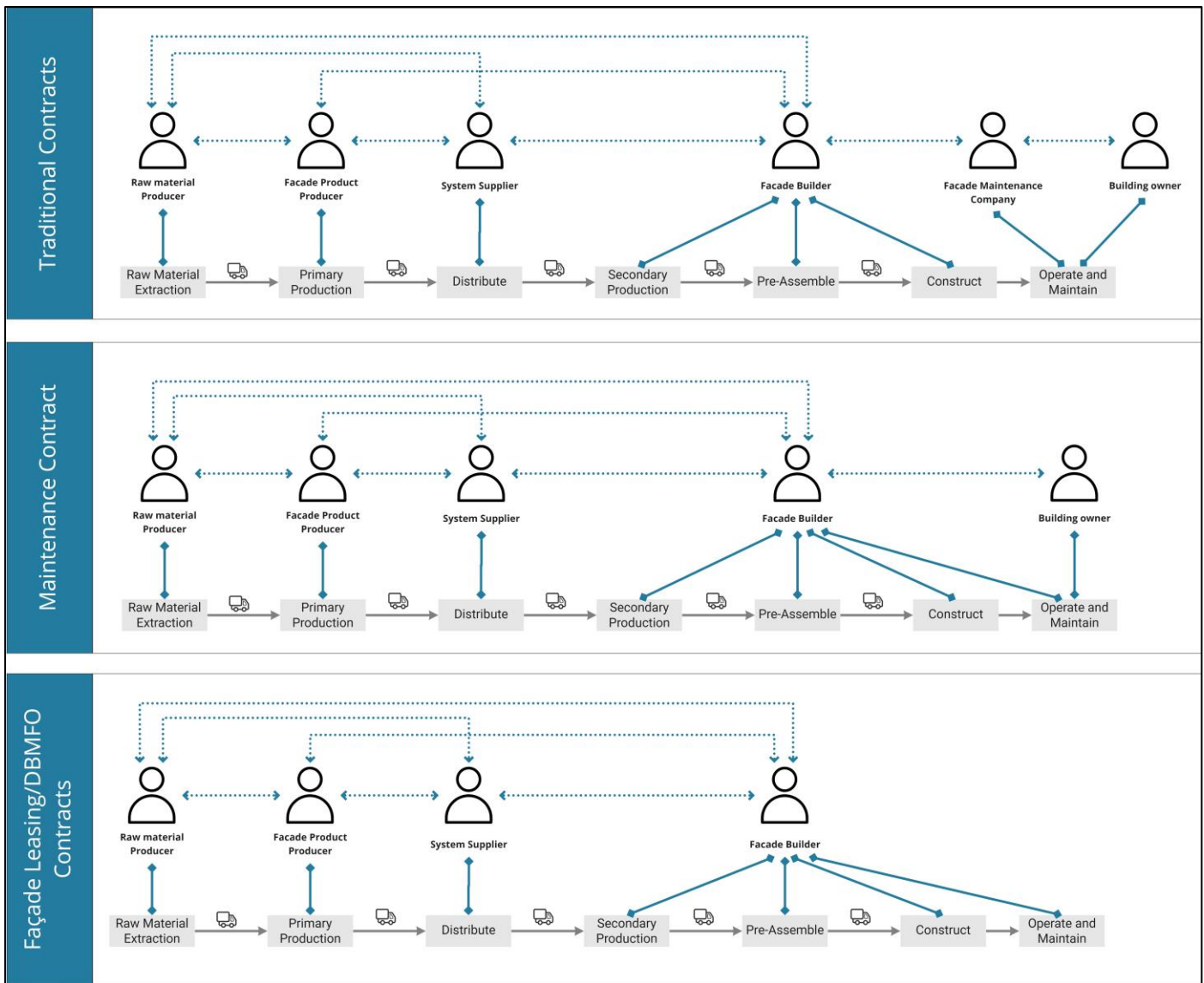

Figure 73: Stakeholder interaction comparisons based on different contractual models. Source: Author.

1. Without Maintenance Contracts: In the most typical case, the façade is handed over to the building owner, with very little information, without any maintenance contracts. Here maintenance work is carried out ad-hoc and in cases where there is a defect in the façade which has to be solved. Moreover, during these situations, the Owner contacts the maintenance company specialized in fixing that particular defect.

The level of digitization is deficient in this scenario. Usually, the building owner makes a notification with the maintenance company using a photograph of the defect. Then, the maintenance company identifies it remotely or physically, determines the appropriate maintenance procedure, and carries it out based on the client's approval. Therefore, it can be inferred that there are no records of maintenance history apart from the email communications between the owner and the company.

2. With maintenance contracts:

Here the building owner may appoint a specialized maintenance company who carries out the maintenance in contact with the façade builder. Scenario 1 applies in the case where the owner identifies the defect before the routine maintenance. Otherwise, Scenario 2 in Figure 73 is applicable when the company carries out its routine maintenance. Here again, there is just a predetermined checklist where aspects such as Mechanisms of Doors, Structural Stability,

Water and Airtightness, and the coating condition are checked for the entire building. Once the routine inspection is completed, the checklist is filled in and uploaded to the document manager. No documentation is carried out of the exact location of the defect, nature of the defect, etc., apart from the email communication.

3. Design, Build and Maintain contracts: The second approach is when the company that installs the façade, either a façade builder or even a supplier/product manufacturer, is responsible for the maintenance. So, all the necessary documentation is with the company itself. This is similar to the first model, except that the maintenance contract is given to the company which installed it.

As all the necessary documentation of the faced is already with the façade builder, there is not much information between the building owner and the façade builder. Therefore, a checklist with a standardized template is used to evaluate the façade. Nevertheless, this checklist is done for the entire building and not mapped per component or building location.

4. Façade Leasing model:

The third option, which is still in a very early stage of development as only a few industry stakeholders have started implementing this, is to lease the façade to the building owner. It could be similar to the Design, Build and Maintain contracts, but the difference is that the façade is not sold but rather leased to the building owner. J. Azcarate et al. (2018) have demonstrated that this model successfully ensures the longevity of a façade and provides financial merit to companies for produce high-quality circular facades. As the DBMFO and Façade Leasing contracts are recent developments, there is a higher implementation level of emerging Digital Methods. Companies have started using QR codes to identify the various façade elements in the building, and the performance data of the façade is monitored and recorded. The QR codes also correspond to a BIM model, and with platforms such as Cirling, the maintenance logs can be maintained based on individual façade elements. Here sensors can record live information such as temperature, humidity, CO2 levels, which can therefore be used to monitor the performance of the façade. Apart from that, for openable doors and windows, the number of opening and closing cycles is essential to record as it determines when the hinges and locks can fail. For buildings that do not have a BIM model or documentation, maintenance requirements can be assessed using Photogrammetry techniques, where certain defects can be identified. There is also the use of the NEN 2767 metrics to quantify the condition of a façade, and in the case of using photogrammetry, the entire process can also be automated using AI.

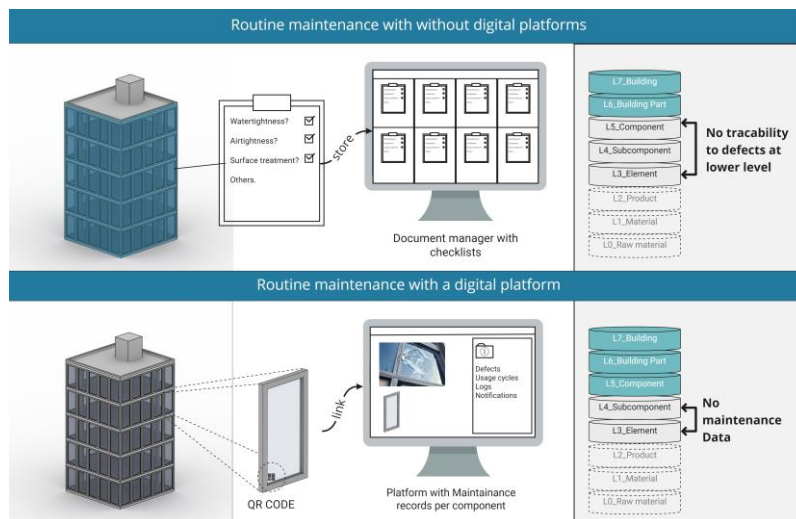

Figure 74: Illustration comparing the maintenance process carried out currently with and without a maintenance platform. Source: Author.

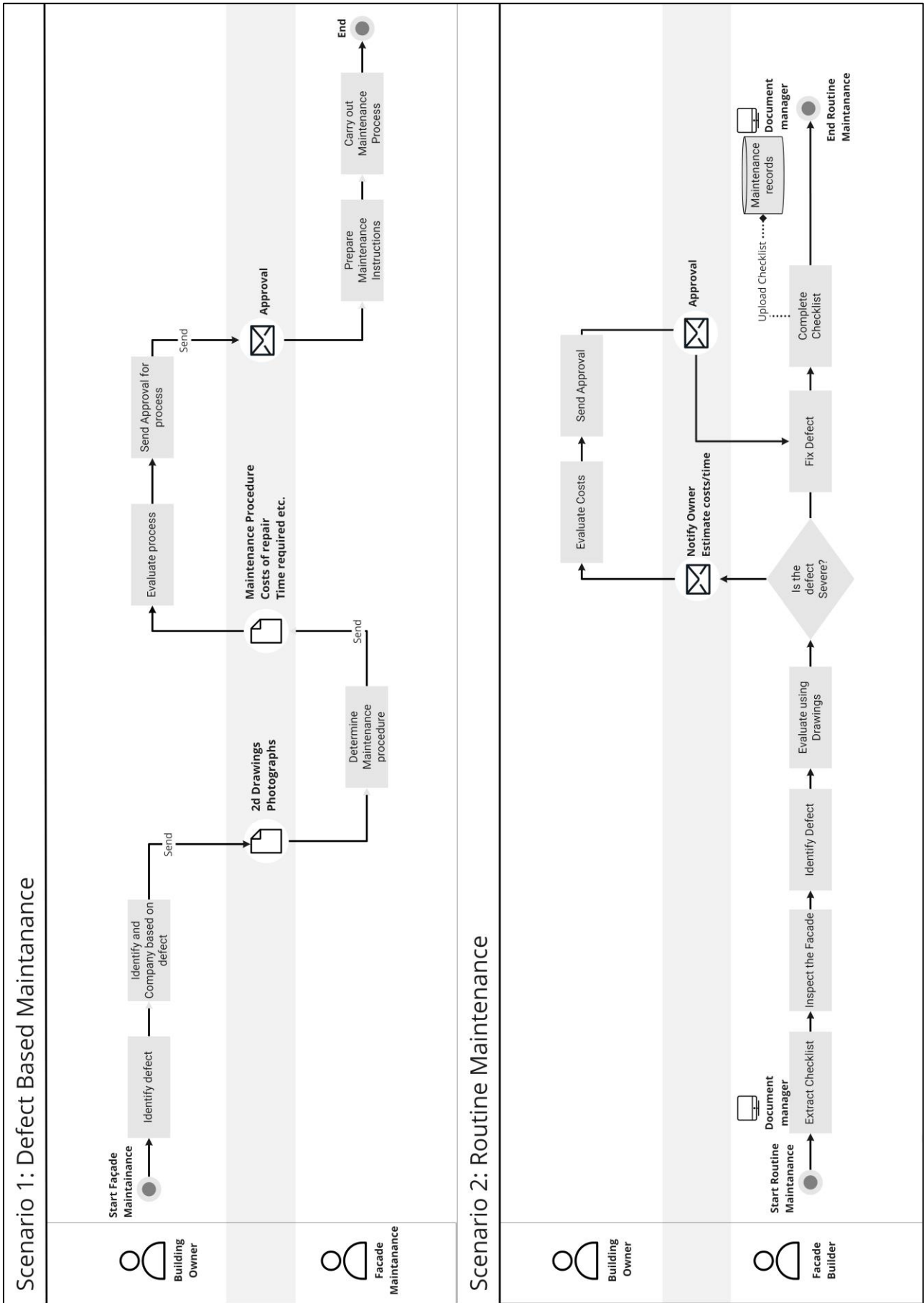

Figure 75: Process maps arisons between defect-based maintenance and routine maintenance without a digital platform. Source: Author.

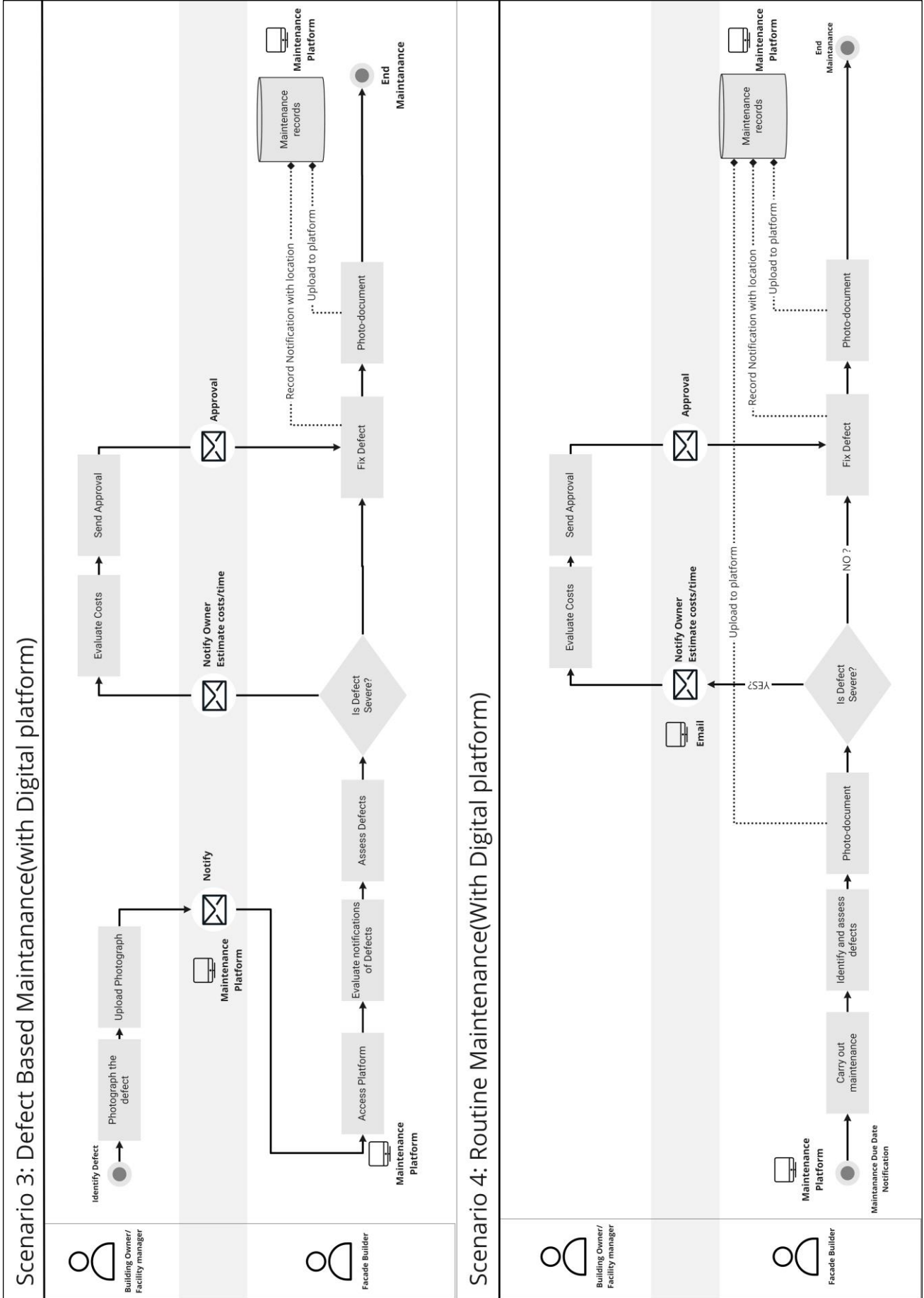

Figure 76: Process maps between Defect based maintenance and routine maintenance with a digital platform. Source: Author.

As companies have already indicated product information being archived locally, including long-term data (Survey result Q 2.15, Q 3.14), their eventual migration to cloud-based servers can be considered a starting point for automating the process of updating passport information. Additional tools can be developed as an extension to an ERP or PDM software which can allow every company to link information to the façade product passport instead of manually entering them for every project.

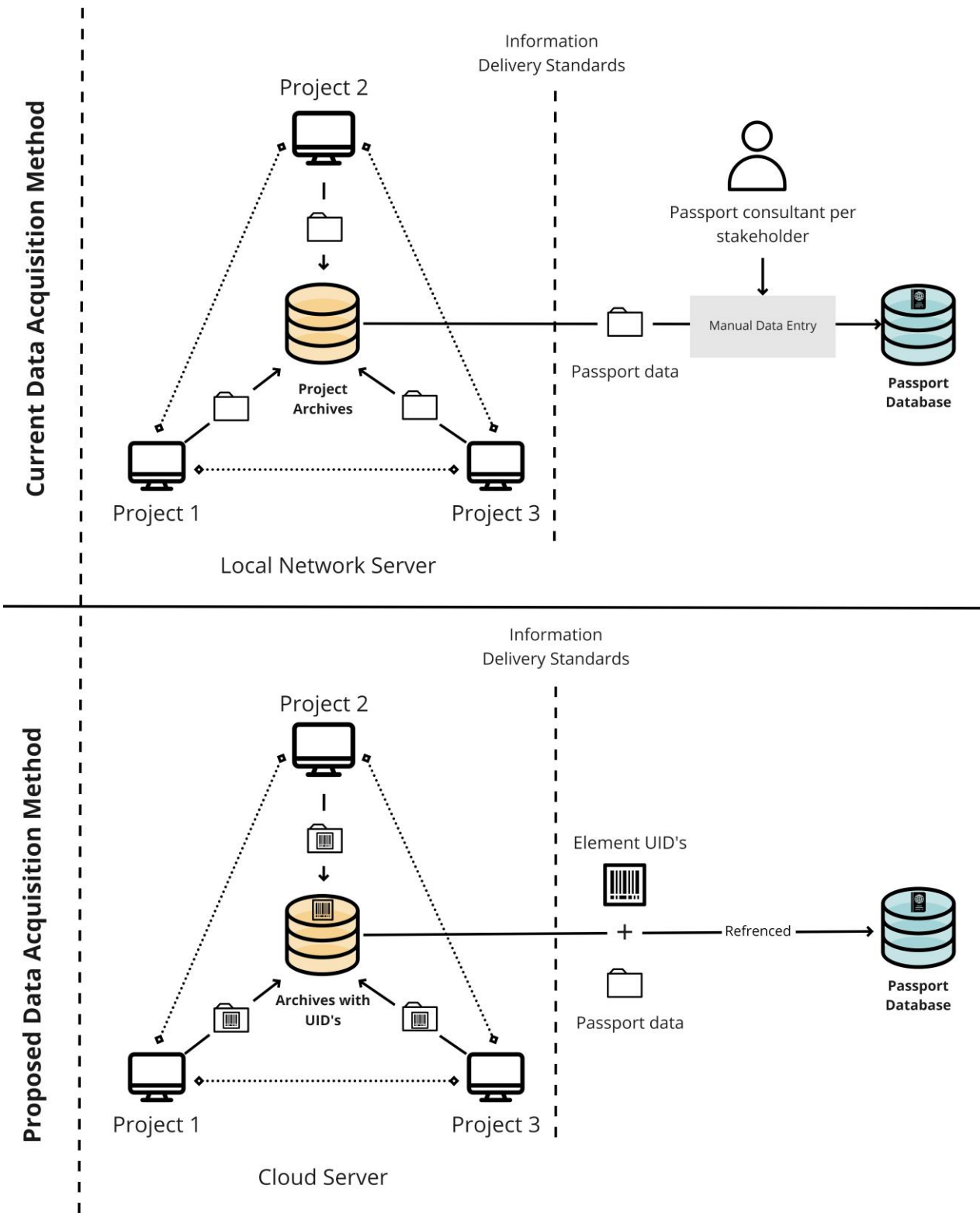

Figure 78: Comparison of the existing and proposed data acquisition methods. Source: Author.

7.2.2 Data Structure

The database structure based on product levels was already proposed in Chapter 5.4. Each level in the database has different sets of information, which refers to information from the level below. As these different levels of information are generated at different stages of the supply chain, the stakeholder's responsibility is to supply information to which level of the database can be established. Nevertheless, as we want to reduce the number of times stakeholders manually enter information into the platform and ensure validity and accuracy, the different levels can be distributed into different databases, as shown in Figure 78. Specifics of the different datasets are detailed below.

1. Database of Raw Materials: This refers to a database that contains information about Raw Materials. While there are already many such databases, for example, the Granta Edu Pack or the National Environmental Database, its information has to be verified Nationally based on actual raw material sources per country. Additionally, as these databases are expected to migrate to the cloud, each material must have a UID so that Passport platforms can directly reference all the relevant information from them. A method to also extract industry average values for costs and material properties also need to be created. Figure 79 shows an overview of the material datasheets of aluminum as displayed in the Granta Edu Pack.

Aluminum alloy, wrought (6061, T4)

Datasheet view: All Architecture Show/Hide Find Similar



Figure caption
Aluminum is primarily found as part of the building enclosure. Shown here in the form of building cladding (Kiasma, Helsinki; Steven Holl, Architect).

The material
Aluminum was once so rare and precious that the Emperor Napoleon III of France had a set of cutlery made from it that cost him more than silver. But that was 1860, today, nearly 150 years later, aluminum spoons are things you throw away - a testament to our ability to be both technically creative and wasteful. Aluminum, the first of the 'light alloys' (with magnesium and titanium), is the third most abundant metal in the earth's crust (after iron and silicon) but extracting it costs much energy. It has grown to be the second most important metal in the economy (steel comes first), and the mainstay of the aerospace industry. This record describes for the series of wrought Al alloys that rely on age-hardening requiring a solution heat treatment followed by quenching and ageing. This is recorded by adding TX to the series number, where X is a number between 0 and 8 that records the state of heat treatment.
2000 series: Al with 2 to 6% Cu -- the oldest and most widely used aerospace series.
6000 series: Al with up to 1.2% Mg and 1.3% Si -- medium strength extrusions and forgings.
7000 series: Al with up to 8% Zn and 3% Mg -- the Hercules of aluminum alloys, used for high strength aircraft structures, forgings and sheet. Certain special alloys also contain silver.
This record is typical of the 6000 series of age-hardening aluminum alloys.
An alternative name for Aluminum in many countries is **Aluminium**.

Compositional summary ⓘ
2000 series: Al + 2 to 6% Cu + Fe, Mn, Zn and sometimes Zr
6000 series: Al + up to 1.2%Mg + 0.25% Zn + Si, Fe and Mn
7000 series: Al + 4 to 9% Zn + 1 to 3% Mg + Si, Fe, Cu and occasionally Zr and Ag

General properties

| | | | | | |
|---------|---|--------|---|--------|--------|
| Density | ⓘ | 2.69e3 | - | 2.73e3 | kg/m³ |
| Price | ⓘ | * 2.25 | - | 2.79 | USD/kg |

Material form that data applies to

| | | |
|-------|---|---|
| Bulk | ⓘ | ✓ |
| Sheet | ⓘ | ✓ |

Building system

| | | |
|----------------|---|---|
| Superstructure | ⓘ | ✓ |
| Enclosure | ⓘ | ✓ |
| Interiors | ⓘ | ✓ |
| Services | ⓘ | ✓ |

Mechanical properties

| | | | | | |
|--|---|--------|---|-------|----------------------|
| Young's modulus | ⓘ | 68 | - | 71.5 | GPa |
| Shear modulus | ⓘ | 25.6 | - | 26.9 | GPa |
| Bulk modulus | ⓘ | * 66.6 | - | 70 | GPa |
| Bending modulus | ⓘ | * 68 | - | 71.5 | GPa |
| Poisson's ratio | ⓘ | 0.33 | - | 0.343 | |
| Yield strength (elastic limit) | ⓘ | 92.6 | - | 108 | MPa |
| Tensile strength | ⓘ | 206 | - | 240 | MPa |
| Compressive strength | ⓘ | * 92.6 | - | 108 | MPa |
| Bending strength | ⓘ | * 103 | - | 124 | MPa |
| Elongation | ⓘ | 16 | - | 23 | % strain |
| Hardness - Vickers | ⓘ | 74 | - | 87 | HV |
| Fatigue strength at 10 ⁷ cycles | ⓘ | * 91.1 | - | 106 | MPa |
| Fracture toughness | ⓘ | * 30 | - | 36 | MPa.m ^{0.5} |
| Mechanical loss coefficient (tan delta) | ⓘ | * 1e-4 | - | 0.002 | |

Thermal and combustion properties

| | | | |
|---------------------------------|---|-----------------|------------|
| Thermal conductor or insulator? | ⓘ | Good conductor | |
| Thermal resistivity | ⓘ | 0.0055 - 0.0065 | m.°C/W |
| Thermal expansion coefficient | ⓘ | 23.4 - 24.6 | µstrain/°C |
| Specific heat capacity | ⓘ | 934 - 972 | J/kg.°C |
| Melting point | ⓘ | 580 - 650 | °C |
| Maximum service temperature | ⓘ | 130 - 150 | °C |
| Flammability | ⓘ | Non-flammable | |
| Emissivity | ⓘ | 0.02 - 0.216 | |

Figure 79: Screenshot of Granta Edu Pack, an example for a Raw Material Database. Source: Granta Edu Pack.

2. Database of Façade Products: This refers to a database where all facade products in the market are categorized, and a unique ID is provided for each of them. Currently, no such database exists, and information has to be extracted from individual stakeholder websites. While this works for their advertising, there are cases where products not being sold in the market are missing in these portals. So, when a façade is reused after 20-30 years and if the relevant product information is not present on the company's website, it becomes necessary to have an additionally verified portal to store product-level information. BIMObject, a database for BIM models uploaded by companies, currently acts as an informal product database, as shown in Figure 80.

Window Art System, Unit examples

Unique ref.: Window_Art_System
 Brand: Jansen AG
 Product family: Steel windows, non-insulated
 Product group: Economy 50
 Depth (mm): 50
 Date of publishing: 2019-11-20
 Edition number: 1
 Type: Object (single object)

[Download \(4\)](#)

Materials / surface finish

- Bright
- Strip galvanised steel

Window types / opening types

Figure 80: Example of a Product database. Source: bimojbeet.com

3. Façade Builders Project Archive: This refers to the cloud-based archive proposed in Figure 78, where all relevant information about a project is stored in the cloud by the Façade Builder. As discovered in the survey, most façade builders archive information about their projects, including long-term data, but is not designed in a way where external parties can access the necessary information. Irrespective of archiving standards of each company, once Project archives move to the cloud, specific sets of information based on a nationally regulated standard can be referenced into the passport instead of a passport consultant or the façade builder manually entering each of this information.

4. Relationships between Database Levels: Between each level of the database, certain relationships are established. These relationships can either indicate manufacturing processes, logistical processes, or construction processes. The responsibility of which processes are carried out is in the stakeholder's scope in charge of the process. For example, the extrusion process of raw material to aluminum profiles is in the scope of the Façade Product manufacturer. Therefore, they ideally determine all the required information about the extrusion process, such as extrusion location, energy consumed, CO₂, and other standards and regulations employed. Nevertheless, due to the complexity involved in calculating these parameters per profile can be pretty complex, the actual values can again be referred from other external databases, which in this research is termed as a "Process Database." Whether this exists as in an independent database, where industry averages are compiled and stored, or combined with other databases such as a National Environmental Database is beyond the scope of the present research. Nonetheless, the concept of having unique Identifications for each of these processes with relevant information can be taken into account to avoid laborious data entry and duplication. Compiling this into a database by considering all industry averages and referencing it into the passport databases could reduce the amount of data entry work by stakeholders and give a validated method of comparing different façade options. Nevertheless, it is to be noted that these databases are required mainly in the transitioning period from the current state of the industry to a complete transition to Industry 4.0, where real-time data about processes in the supply chain can be extracted, eliminating the need for industry averages.

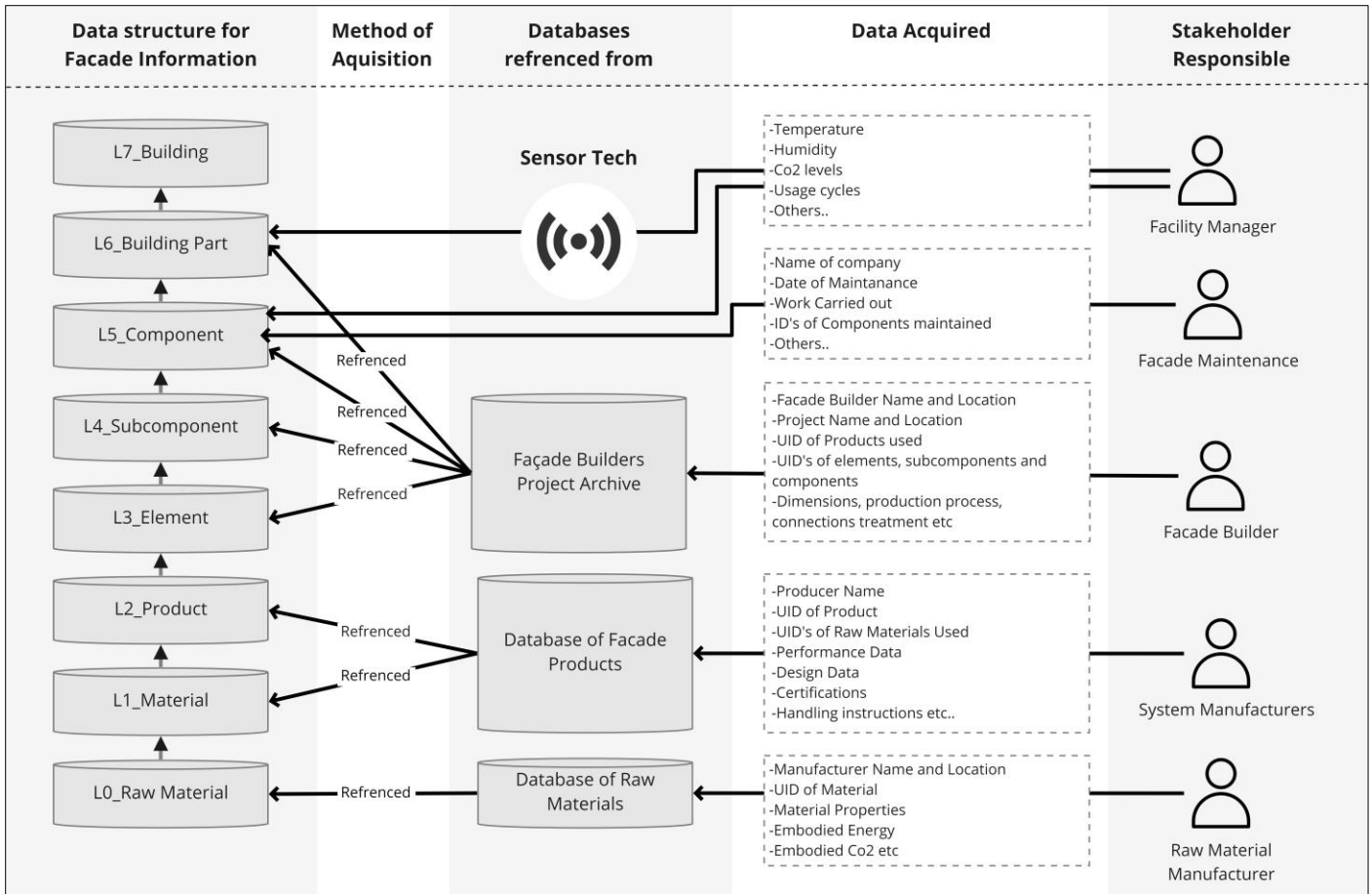

Figure 81: Overview of the proposed distributed database method of data acquisition. Source: Author

7.2.3 Proposed Digital Workflow

In the early design stage, architects and façade engineers can access information about various products in a transparent and validated manner, which can help them make better choices of products for their façade. This can be easily communicated with the façade builders, and data exchange between the façade builders and engineers can be streamlined. During the detailed design stage, façade builders can use the same unique ID in their drawings, and information about the product is referenced constantly and seamlessly. Once the design is completed, the Bill of Materials also contains these unique IDs with their references, and during the manufacturing, all the components are identified using the same ID.

7.2.4 Conclusions

The chapter focuses on the different processes involved in the lifecycle of a façade, and the information exchanged between them. The results are generated using inputs received from stakeholders during the interviews, combined with understanding the software's functionality used by stakeholders. As per Chapter 7.2.1, the ERP software becomes a critical element of connecting different data generated to the project's supply chain. Most stakeholders also indicate the use of either a Project Document Manager, which also does this somehow. This way, information about each component of a façade is linked centrally and can be traced throughout the supply chain.

8 Framework for the End of Service (EoS) Assessment process

The following chapter defines a framework for performing an End of Service (EoS) assessment of a façade. While this phase does not exist as a mandatory stage in the lifecycle of a facade, the interviews and recent developments showed an increased interest in this stage if façade information is made available. With sufficient data about facades, it could open a whole new domain of consulting companies specializing in performing this assessment.

8.1 EoS Assessment in the lifecycle of a façade

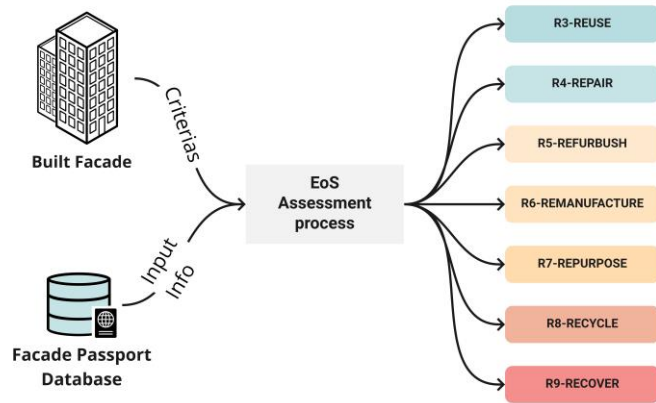

Figure 82: A conceptual overview of the inputs and outputs of the EoS Assessment process. Source: Author

The primary purpose of the assessment is to determine the best possible re-life scenario for the façade based on the information available about it. Re-life options R3 to R9 as per the 9R framework (Potting et al., 2017) are considered for this end-of-life decision making. Figure 82 schematically indicates the primary function of the EoS Assessment phase. Until Product Passports become a regulation, the EoS assessment process can be considered a separate lifecycle stage for existing buildings being demolished. This is because additional time is required to gather the required information, mostly stored in unstructured formats such as documents, organize them, and manually analyze them to perform the assessment. Eventually, as passports become regulated and more structured information is made available, automated information processing can be done using processing algorithms, and assessments can be carried out during the operation phase. Figure 83 gives an overview of this aspect, indicating two scenarios.

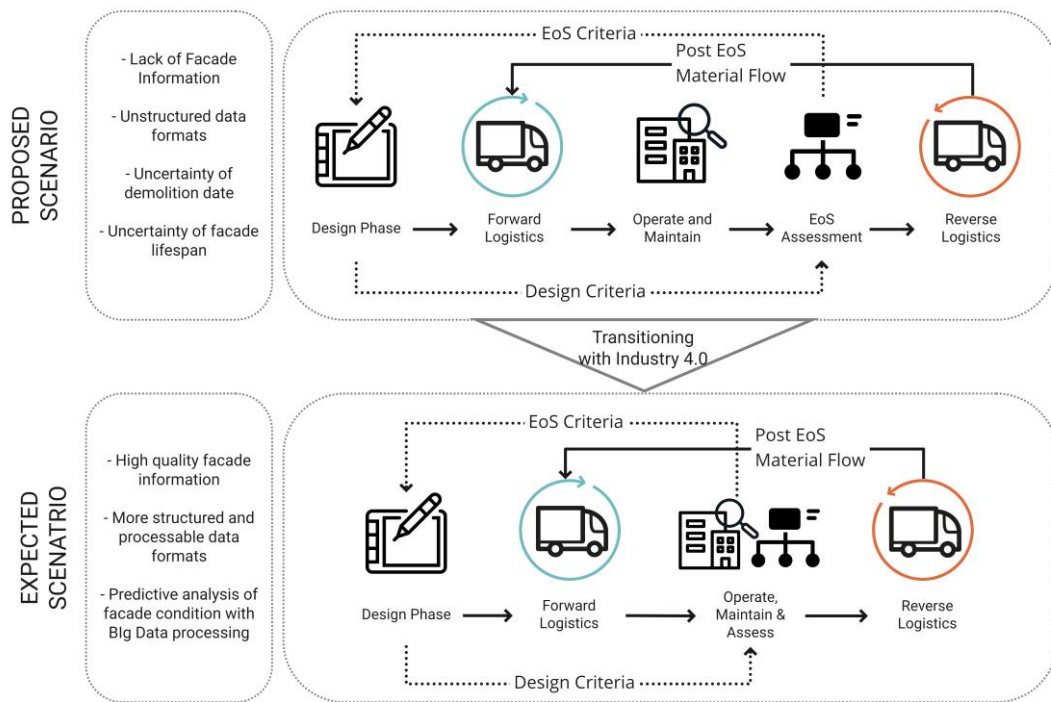

Figure 83: Schematic diagram of the typical progression of the assessment phase to merge and occur during the operation of a building. Source: Author.

8.2 EoS Assessment process and stakeholders involved

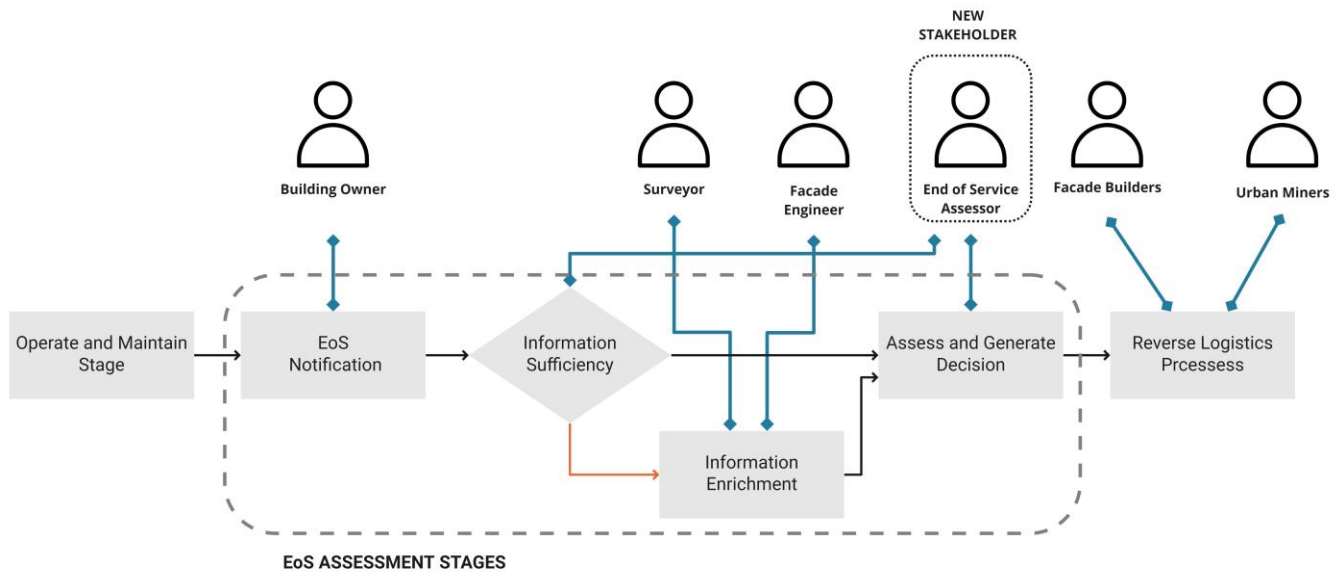

Figure 84: Processes and stakeholders at the End-of-Life Assessment process for existing buildings. Source: Author

The EoS assessment process can be broken into four main sub-stages for existing buildings, as shown in Figure 84. A new stakeholder termed “End of Service assessor” must be established as no current stakeholder fulfills this role. Their primary function would be to evaluate sufficient information about the building and perform the required assessment. These assessments could be carried out in collaboration with Urban Miners, Façade Maintenance Companies, and Façade Builders, depending on the experience level of the assessor and the specific expertise required based on the condition of the facade. Depending on the legal aspects and business models, the EoS assessor can be part of the municipality or a private organization such as an Urban Mining company, a façade Builder, or an independent third-party consulting company that performs these assessments projects across the Netherlands.

Stage 1: EoS Notification

The assessment process can start as soon as the building owner notifies the local municipality or relevant authorities of a possible demolition project. However, as per interviews, this usually happens quite close to the actual demolition date, and therefore, there is not much time to carry out a thorough assessment. Therefore, as mentioned in Chapter 8.1, until we reach the preferred scenario where Product passports are regulated, and structured information is available, regulation needs to be passed to ensure the authorities' notification is made a few months in advance so the assessment can be done can be carried out.

Stage 2: Information Sufficiency

Here the information available from the Building Owner or Façade Product passports are assessed against a Data Template to ensure all the information required to perform an assessment is available for processing. If the specific essential information is missing, the stakeholder notifies a surveyor or consults a Façade Engineer to analyze the data and generate the information required.

Stage 3: Information Enrichment

This stage involves generating information that is missing from the passport and is required for the assessment. Depending on the state of the information available, this process could last from a few weeks to several months and can involve various techniques like Photogrammetry, Material Testing, Laser Scanning, Survey/Documentation, and other methods.

Stage 4: Assess and Generate Decision

Once the required information is organized according to the Data Structure and Templates indicated in Chapter 7.2.2, the information can be processed to generate a decision per the assessment framework proposed in the subsequent chapters. Based on the decision rendered, the EoS assessor can notify the relevant stakeholder to carry out the reverse logistics process, and more importantly, whether it is valuable for the façade to be deconstructed or demolished.

8.3 EoS Assessment Method

8.3.1 Criteria for Assessment

There is no comprehensive framework already developed to determine the EoS of a façade, a few existing literature works focusing on aspects that could influence the EoS assessment were referred to. These are Alba-Concepts (2019) which indicate a methodology to identify a detachability index for building products, Durmisevic (2006), which focuses on criteria that influence the Disassembly of a Building, Beurskens, Rltzen, Durmisevic, Lichtenberg, and Durmisevic (2016), who focused on developing a set of criteria to determine to what extent a façade is linear or circular and lastly the NEN 2767 which looks at measuring the condition of a façade which were commonly referred to by EoS stakeholders such as maintenance companies and Urban miners during the interviews conducted. Since the frameworks are in a very early stage of development and have not been tested extensively, a certain level of flexibility is considered to adapt and appropriate it for the EoS assessment processes. A list of criteria used and the respective sources/ descriptions are detailed in Appendix 15.9. The criteria can either be in the form of schematic parameters or numerical values and are described as follows:

- 1. Conditional Values and criteria:** These refer to criteria from which a clear output decision can arrive, and there is not much room for human interpretation. They can also eventually be evaluated using processing algorithms with the availability of more structured information.
- 2. Descriptive criteria and Values:** These are criteria in the form of numerical values which do not influence the output decision in any manner. They mainly describe aspects of the façade which are highly subjective for a human to make a decision.

Figure 85 schematically indicates the categorization of these criteria and how they have been addressed in the decision trees.

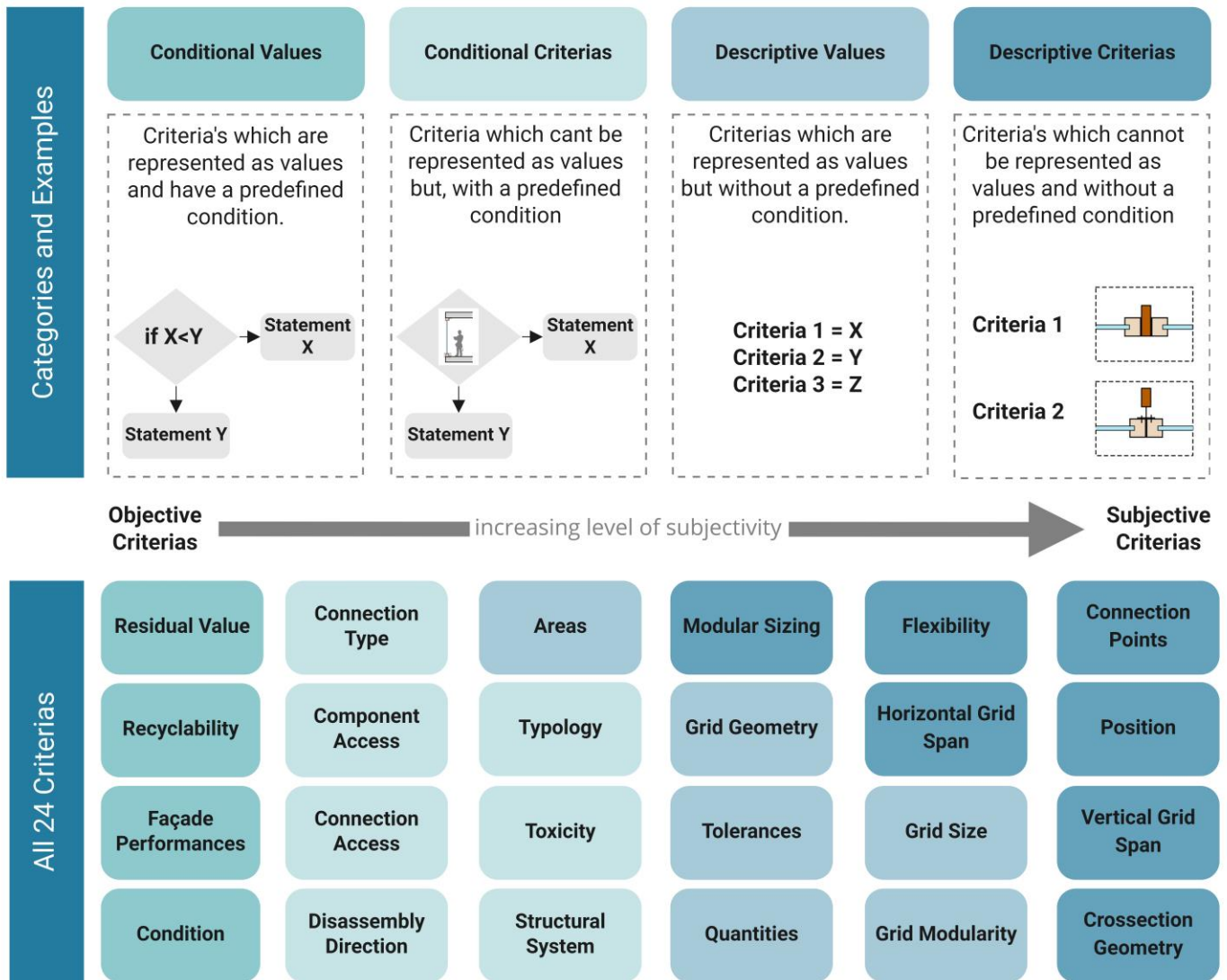

Figure 85: Categorization of Assessment Criteria based on the level of subjectivity. Source: Author

8.3.2 EoS Assessment modules

The different criteria were organized into decision trees which can act as a model or framework which can be further developed into a computational tool. These are crated in an iterative process, with a perspective of assessing for the highest re-life value, i.e., reuse, and depending on its qualification/disqualification, the lower levels are evaluated as shown in Figure 86. Several preliminary decision trees were developed as shown in Appendix 15.4 and refined using the case study detailed in Chapter 9.

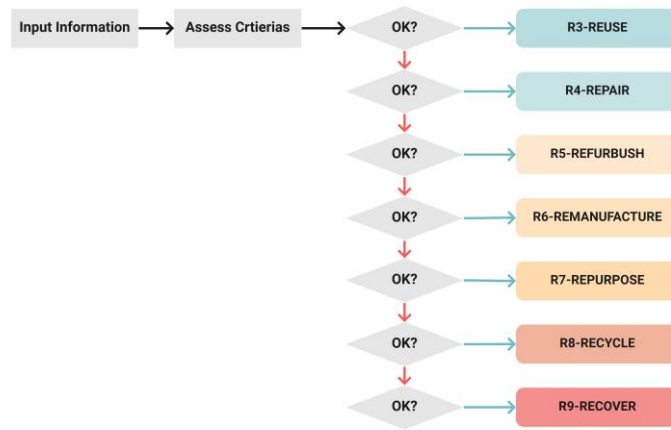

Figure 86: The organizing logic used to develop the EoS Assessment Framework. Source: Author

Once a comprehensive decision tree was developed, it was split into smaller trees organized into different assessment modules, as shown in Figure 87. The assessment modules are also organized as an overarching decision tree and split wherever a false statement redirecting the façade to a lower re-life value. The modules are also organized to group similar assessment criteria together. When sufficient information is ideal, all modules are processed linearly, resulting in a decision. The further the façade qualifies in this decision tree; the more chances of the façade being reused a higher re-life value.

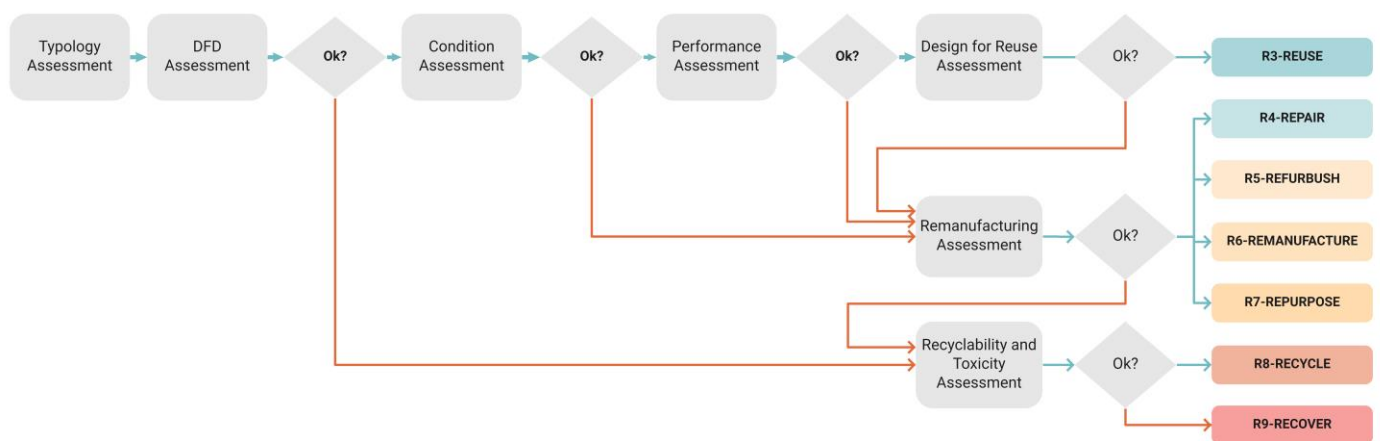

Figure 87 Overview of the assessment modules in the end-of-life assessment process.

8.4 Typology Selection Module

8.4.1 Typology Selection Criteria

The first module looks into determining the typology of the given façade. In this case, the term “typology” is mainly governed by the product architecture and how components are clustered into the different product levels and their respective functions. The main typologies considered here would be between a Unitized Façade and a Stick system, but more typologies can be eventually identified with additional case studies. It is essential to understand how the components are clustered and how much they contribute to the actual function of the façade, as they can dictate the criteria considered in the remaining modules. For example, in a Unitized Façade system, the performance of the entire panel with all the materials becomes crucial to evaluate at first. In contrast, in a stick system, assessment can begin from the element level and then go to a subcomponent level if all the elements qualify against the given criteria. Figure 88 gives a schematic overview comparing information access level based on façade typology.

8.4.2 Influence of Façade Typology on Assessment Process

Based on how components are clustered and interdependent, the assessment process can begin at different Product/Information Levels. For example, suppose the Façade is Unitized, during the assessment process. In that case, it's important to evaluate the entire unitized module, i.e., at the component level (highlighted in blue in Figure 89), as it is preferable to reuse an entire unitized panel instead of the individual components. So, information such as the condition, performance, and other criteria at a component level becomes more important for assessment. Only if there are specific criteria that disqualify the assessment, information at the lower levels is accessed.

And if the façade is a mullion or a transom system, since there is no clustering of products at a component or subcomponent level, as seen in Figure 88, the assessment must be carried out at an element level. Then, based on the result, higher and lower database levels need to be accessed.

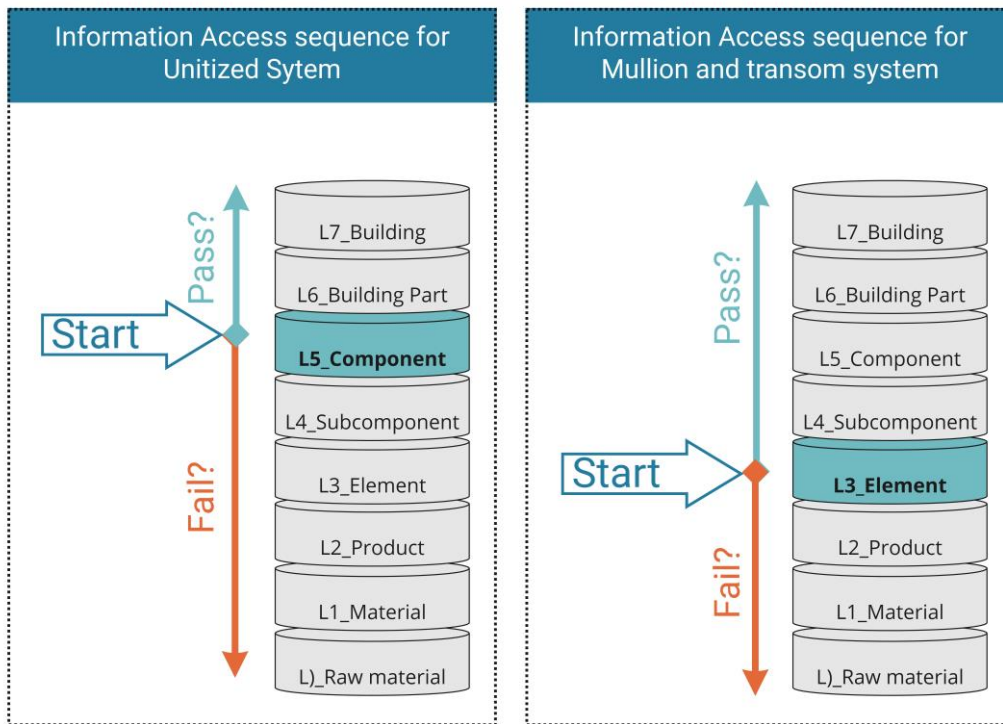

Figure 88 Schematic diagram indicating access levels of the database based on the clustering of a facade. Source: Author.

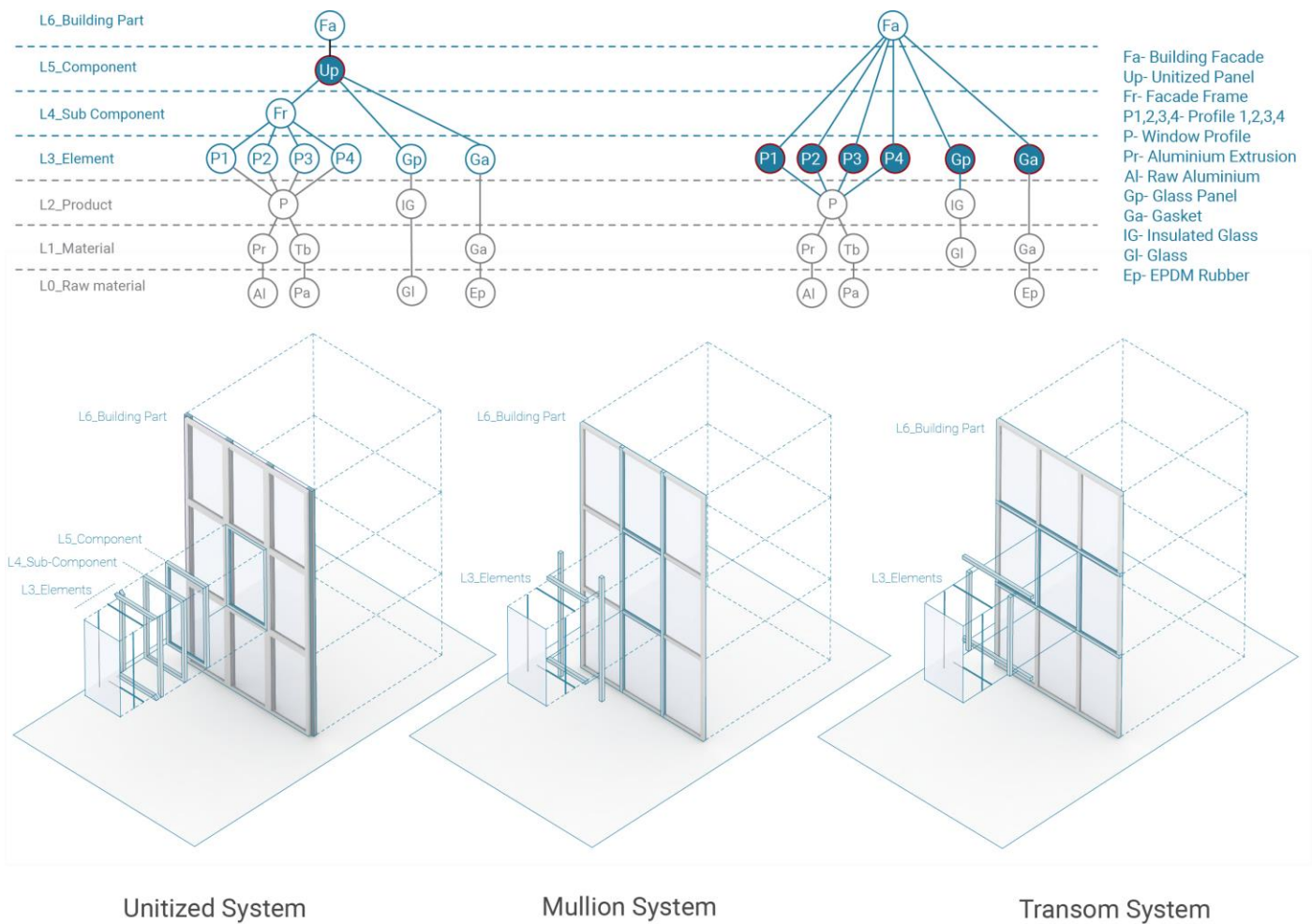

Figure 89: Schematic diagram indicating the relationship between facade typologies and clustering of materials. Source: Author

8.4.3 Information required

All necessary information to give a clear picture of the architecture of the façade, such as mounting of frames, glass, gaskets, and connections to the building, is required to evaluate the typology or the clustering. Connection types also become crucial to evaluate whether they are fixed/ removable etc. As per the present scenario in the industry, this can be identified using 2d elevations, 2d plans, a vertical and horizontal section that shows the entire component.

| Information Required for Typology Assessment | Possible Formats | Data Provided By | Product level |
|--|----------------------------------|------------------|-------------------|
| Spanning of mullions | Façade elevation | Façade Builder | Building Part |
| Spanning of transoms | | Façade Builder | Building Part |
| Element to element connections | Horizontal and Vertical Sections | Façade Builder | Component/element |
| Façade to Building Connections | | Façade Builder | Component/element |

Figure 90: Overview of the information required for the Typology selection module. Source: Author

8.4.4 Process

The process of typology assessment is fairly simple. If the façade frame elements are continuous and span between floors, it can be considered a stick system, and if the façade frame elements are disconnected and form modules, then it

can be considered a unitized system. An overview of the flowchart for the typology assessment is shown in Figure 91.

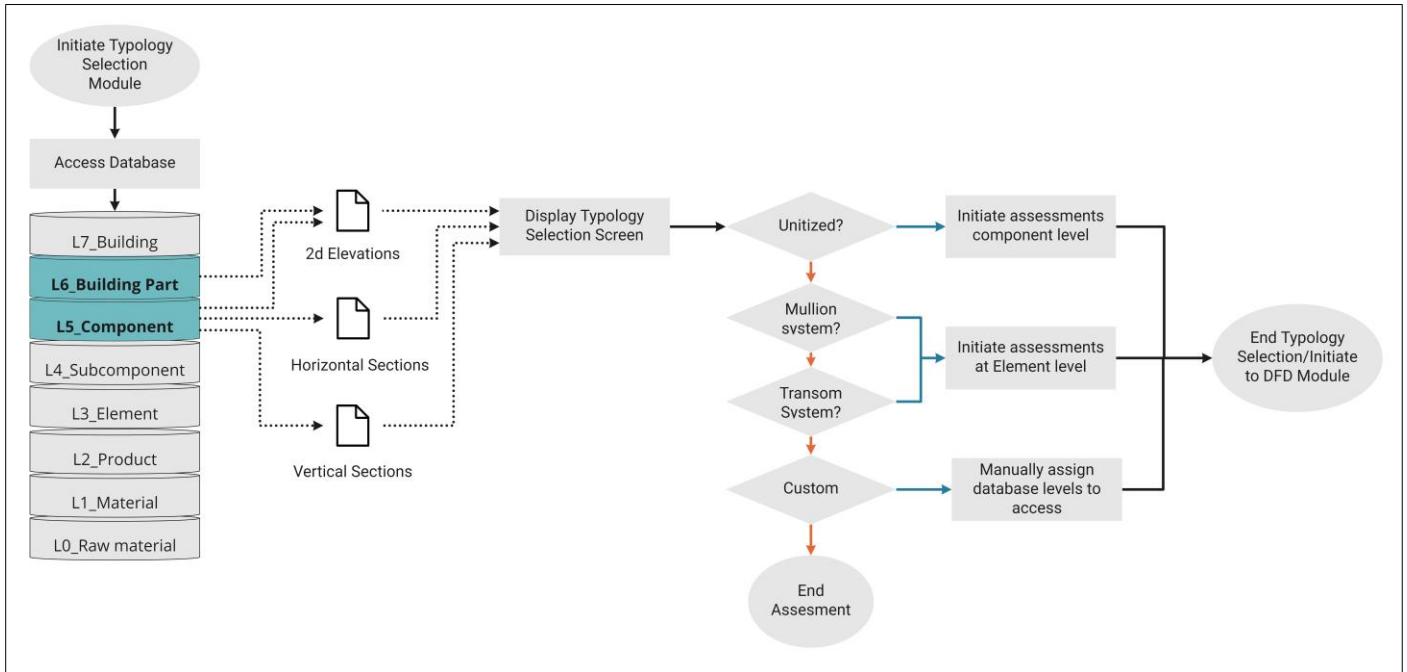

Figure 91: Flowchart of the typology assessment module. Source: Author

8.5 Design for Disassembly (DfD) Module

The next module looks into the extent to which the façade can be disassembled from the building and whether there is a requirement for additional remanufacturing and repair of the façade.

8.5.1 DfD Criteria

The main criterion to be assessed in this module is the level of separability of the façade. In a unitized system, it is crucial to ensure the entire panel is separable from the building without damage (Component to Building part connection), as it would be reused as a whole. On the other hand, if the panel is not removed from the building, separability between the lower levels, i.e., Subcomponent to Element, is essential. The main criteria identified to check whether the façade can be removed are Component Accessibility, Disassembly direction, Connection type, and Connection Accessibility. Refer to Appendix 15.9 for the description of each these criteria.

DfD Criteria

Component Accessibility

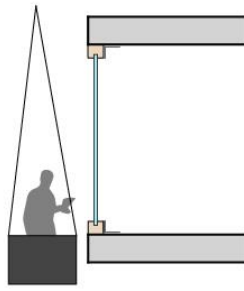

Outside

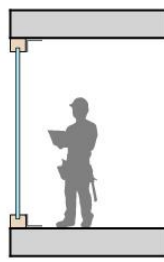

Inside

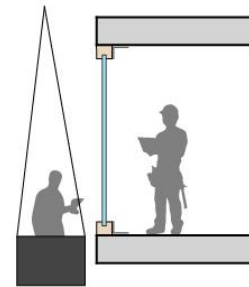

Both-Sides

Disassembly Direction

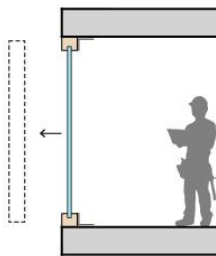

Outside

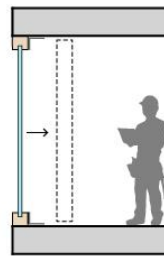

Inside

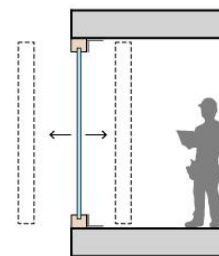

Both-Sides

Connection Type

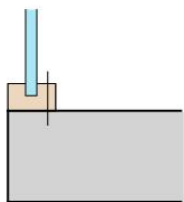

Direct

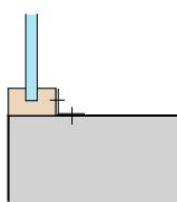

Indirect

Connection Accessibility

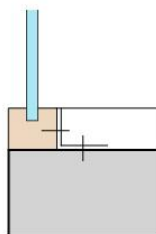

With Damage

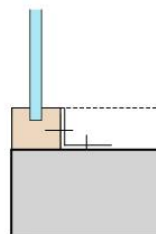

Without Damage

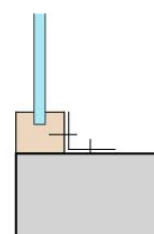

Without Actions

Figure 92: Schematic overview of the criteria to be assessed in the DfD module. Source: Author, Partially adopted from Beurskens et al. (2016) and Alba-Concepts (2019)

8.5.2 Information required

For determining the component accessibility, information of the building and context is crucial, such as the presence of a BMU unit, the possibility of installing a scaffolding, the presence of elevators within the building, and whether there is permission by the building owner of accessing the building internally is required. In addition, detailed drawings at a component or element level are necessary to determine the disassembly direction, connection type, and connection accessibility. Additional information such as understanding the assembly/disassembly sequence at an element or component level would greatly speed up the assessment process. This could be in the form of schematic 2d or 3d drawings, or with the emergence of BIM 4D, could be detailed 3d animations.

| Information Required for DfD Assessment | Possible Formats | Data Provided By | Product level |
|--|--------------------------------|------------------|-------------------|
| Building to façade component connection | 2d Sections of components, 2d | Façade Builder | Component/element |
| Element to element connections | Elevations, 2d Plans, Assembly | Façade Builder | Component/element |
| Component to component connections | Sequence, 3d Model | Façade Builder | Component/element |
| Residual values of materials | Table with Values | Façade Builder | Component/element |
| Size of components | | Façade Builder | Component/element |
| Weight of components | | Façade Builder | Component/element |
| Presence, capacity and accessibility to elevator | Floor plan of building | Building Owner | Building |
| Presence of Building Maintenance Unit | Section of building | Building Owner | Building |
| Accessibility for scaffolding | Photographs of building | Building Owner | Building |

Figure 93: Information required and stakeholder responsibility for DfD module. Source: Author.

8.5.3 Process

1. Disassembly Direction and Accessibility

The first process is to determine which directions the façade can be removed from the building. This would depend on whether the Façade components are accessible via scaffolding, a Building maintenance unit, or internally via elevator. Also, based on the size and assembly sequence of the façade, the direction in which it can be removed is crucial to understand. While it can be considered obvious that the direction in which the façade is removed is the same as the direction it is installed, scaffolding may not be feasible at the time of demolition. This could be due to neighboring plots, how much it affects the functioning of surrounding roads or the overall cost-effectiveness. Hence both aspects have to be evaluated separately. Once the results of these are matched, the accessibility of the connections is assessed. This is derived from the Disassembly Index developed by Alba-Concepts (2019). Connections are categorized into accessible without actions, accessible with recoverable damage, and accessible with much damage. If the criteria fail this, the façade is directly transferred to recyclability assessment.

2. Process: Connection Type

Here an assessment has to be done about how exactly the connection is made, especially whether it is a direct or indirect connection and whether the façade can be separated from the connection or not. If it is a direct removable connection, then the façade already qualifies this criterial. If it is an indirect connection series of decisions have to be taken to determine whether the third element is a connector or any other material and whether it is separable from the façade or not. When the third element is not separable from a façade, then the element is considered part of the façade for further evaluation. If the criteria fail, the façade is automatically redirected to a lower level of reuse, i.e., recycling.

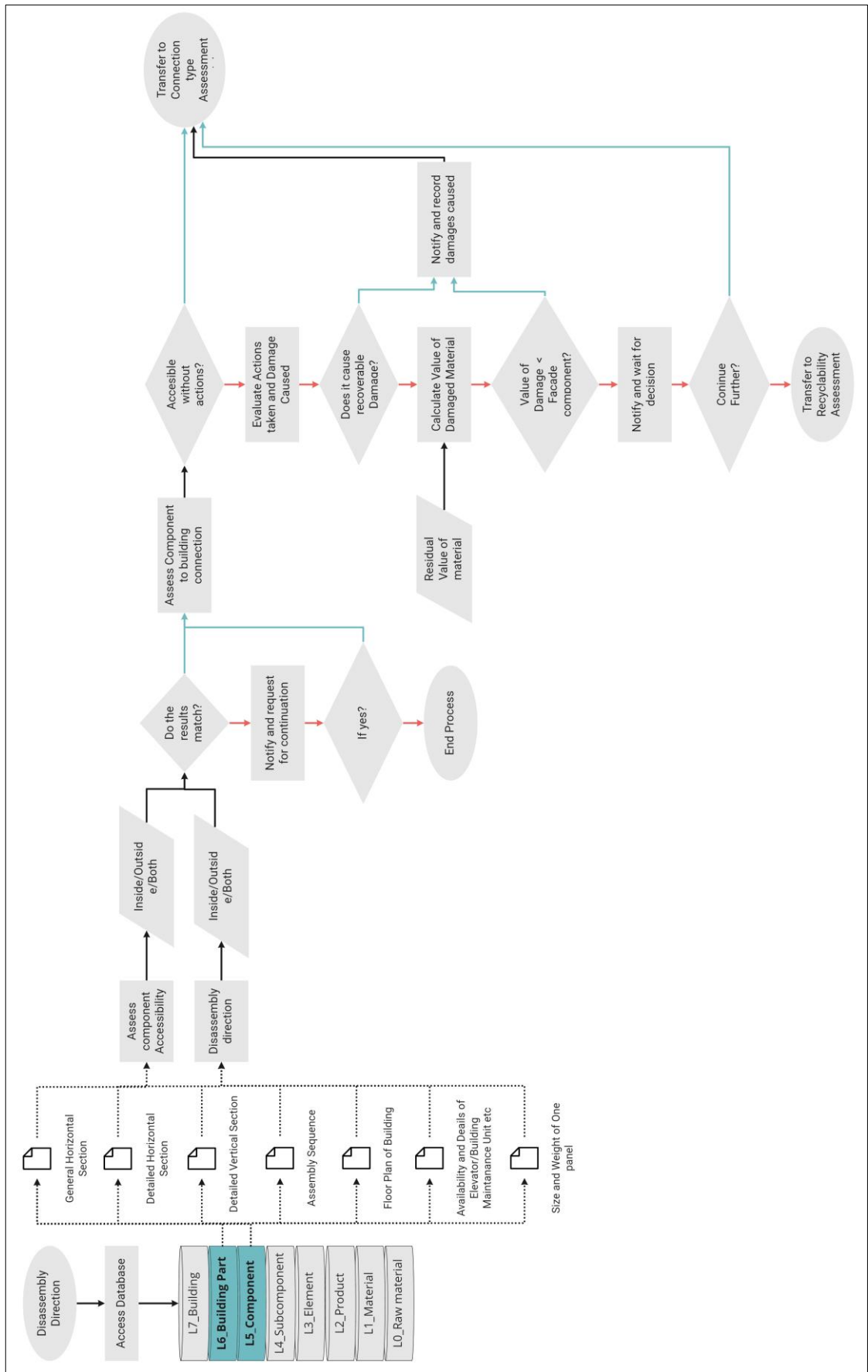

Figure 94: Decision tree of the accessibility and disassembly criteria as part of the DfD module. Source: Author.

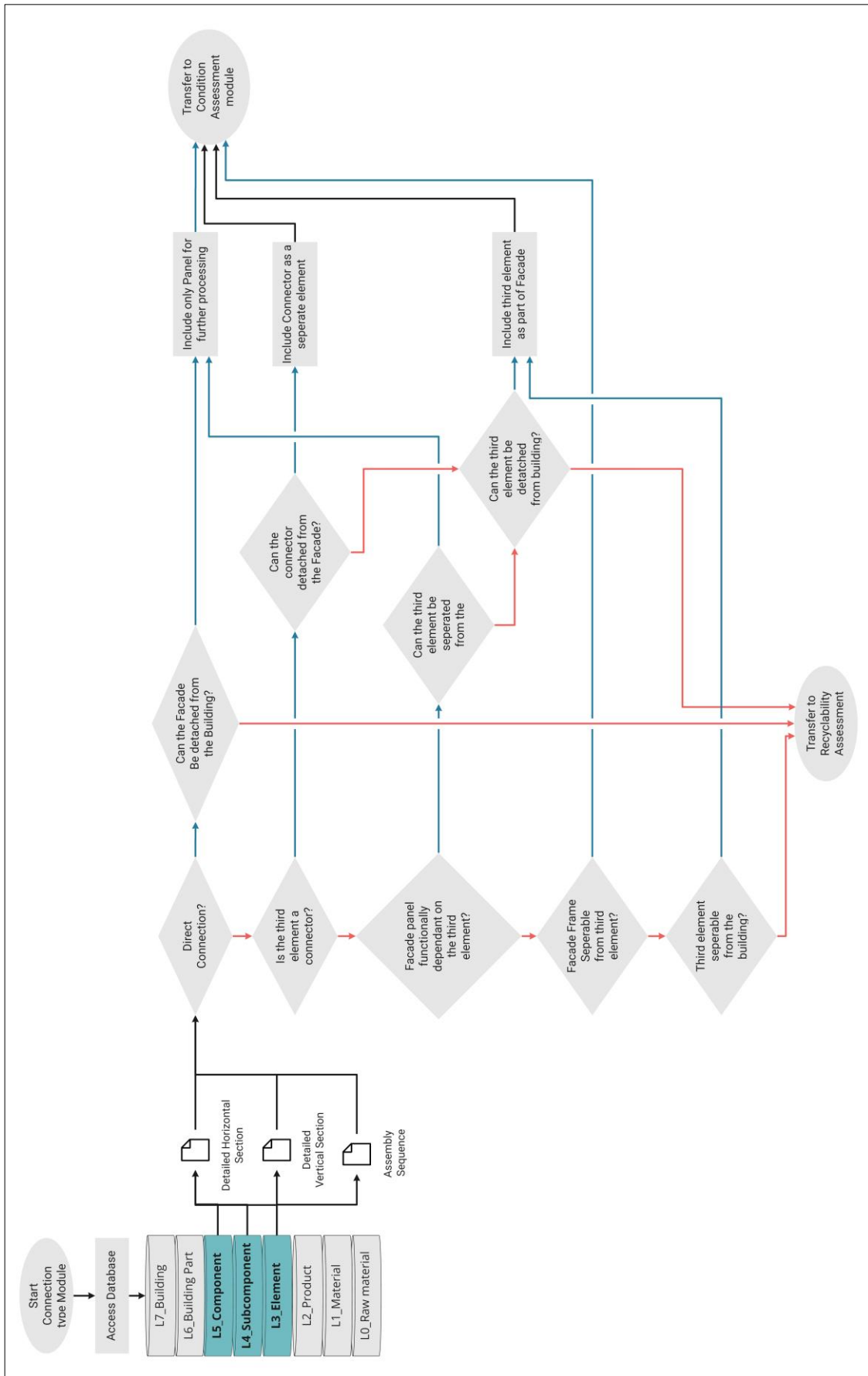

Figure 95: Decision tree of the connection type criteria as part of the DfD module. Source: Author.

8.6 Condition Assessment Module

This model performs assessments that involve checking the quality and the condition of the product during scheduled demolition. The NEN 2767, currently used to quantify a façade during the maintenance stage, can be a starting point. Nevertheless, as there are stages in this method that are highly subjective, and there is still a lack of standard of to what detail level the assessment has to be carried out, it can be considered that this method can be used to assess the façade from a material or product level to the façade level.



Figure 96: Overview of the condition assessment process of facades using emerging technology. Source: facadeserviceapplicatie.nl

8.6.1 Criteria

A Brainstorming conducted in 2019 by FaSA regarding facades of high-rise buildings involved identifying the various defects associated with Metal Profiles and are shown in Figure 97. Surface Defects refer to issues that do not drastically affect the profile's performance and may not require a complete replacement. Structural Defects can affect the performance of the profile and sometimes may require complete replacement, and Performance-based defects directly influence the performance of the façade.

| Common types of Defects in Aluminium Profiles | | |
|---|--------------------|---|
| Surface Defects | Structural Defects | Performance Based |
| Pollution | Dents | Water tightness |
| Contamination | Scratches | Air tightness |
| Cracks | Cracking | Structural Fatigue |
| Gloss reduction | Connection Play | Water retention/Drainage |
| Chalking | Impact Damage | |
| Leakage Marks | Corrosion | |
| Colour Degradation | Dried out gaskets | |
| Dirt in water slots | Cracked gaskets | |
| Thickness of coating | | |
| Metal surface contamination | | |
| Assesed through high resolution photographs, photogrammetry with minimum requirement of onsite | | Requires onsite inspection/Testing |

Figure 97: Overview of common defects in Aluminum profiles. Source: VMRG Workshop.

8.6.2 Information required

Maintenance companies confirmed that most defects are detectable through high-resolution photographs. Software company Interviewee 5 also uses high-resolution imagery captured using drones, street view images, and other sources to categorize the defects into various levels of severity. However, during the interview, they identified that human input is constantly required to ensure prediction accuracy. Therefore, additional information such as a maintenance history of the façade categorized at a component level would help cross-verify the visual assessment. It can also help in determining defects that are not easily detected by photographs.

| Information Required for Condition Assessment | Possible Formats | Data Provided By | Product level |
|---|-----------------------------|--------------------|-------------------|
| Current defects on the façade | High resolution photographs | Façade Maintenance | Component/element |
| | Aerial View Photographs | Façade Maintenance | Component/element |
| | Street View Photographs | Façade Maintenance | Component/element |
| Thermal Defects, leaks | Infrared Photographs | Façade Maintenance | Component/element |
| Type of defect, id of component, date of defect | Maintenance Log | Façade Maintenance | Component/element |
| ID of component, Location of Defect | Drawings, 3d Model, lists | Façade Maintenance | Component/element |
| Sizes of defects | Drawings, 3d Model, lists | Façade Maintenance | |
| Thermal Performance History | Outside/Inside temperatures | Facility manager | Component/element |
| Sizes of components | 2d Drawings | Façade Builder | Component/element |

Figure 98: Overview of information required and stakeholders responsible for condition assessment. Source: Author

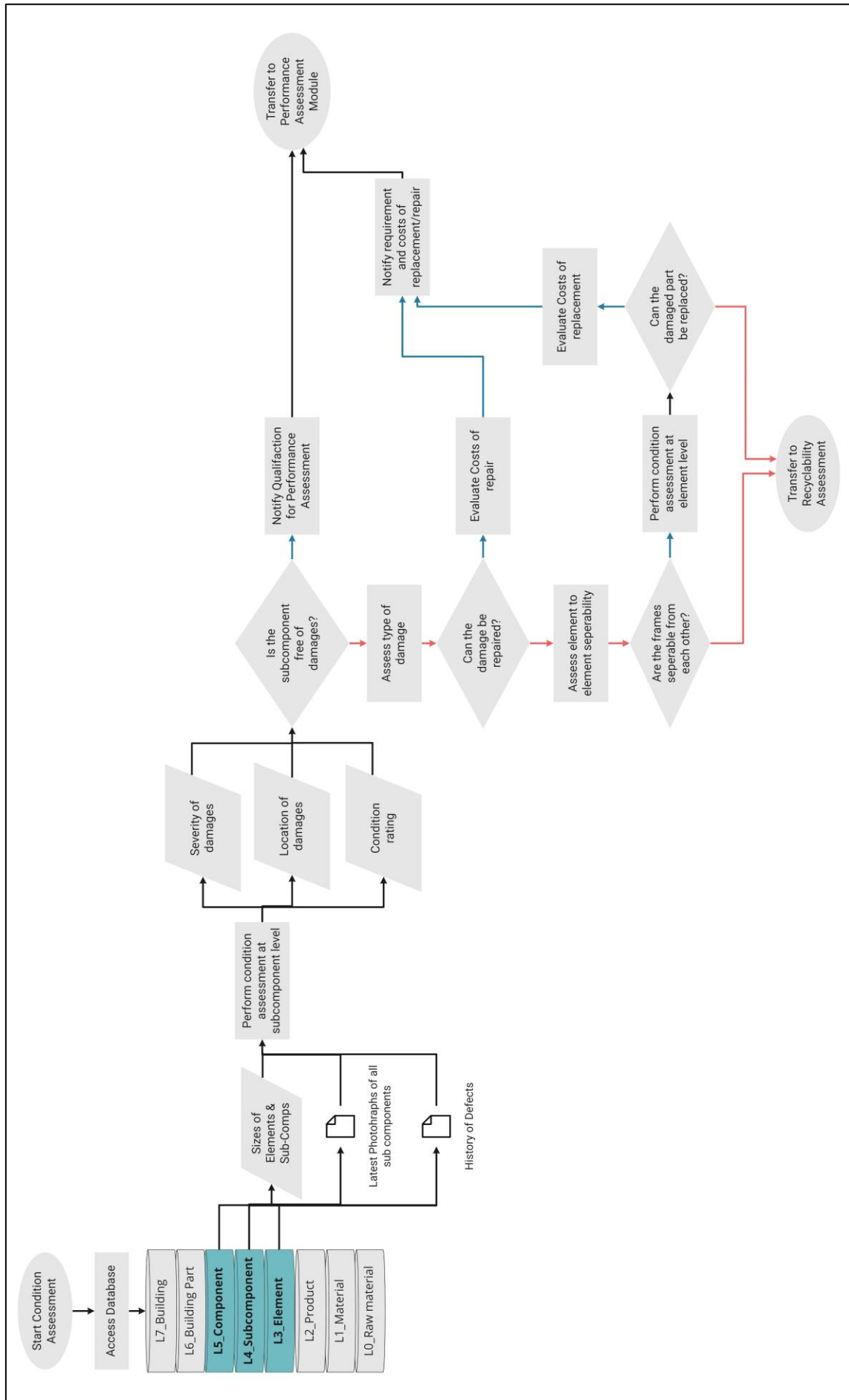

Figure 99: Decision tree of the condition assessment process. Source: Author

8.7 Recyclability and Toxicity Module

8.7.1 Criteria for evaluation

This module is processed only when the facade disqualifies all the other re-life options. The only criteria which need to be determined are whether the type of material is recyclable or not. This can be easily determined by the datasheet of each of the façade materials. If the element cannot be easily recycled, additional checks about whether the elements contain toxic materials or contaminated are assessed. This can only be done through physical inspections. If it passes these criteria, it is approved for landfilling/backfilling.

8.7.2 Information required

| Information Required for Recyclability | Possible Formats | Data Provided By | Product level |
|--|-------------------|------------------|---------------|
| Material composition | Table with values | Product Producer | Raw material |
| Presence of toxic elements | Table with values | Product Producer | Raw material |
| Recyclability | Boolean | Product Producer | Raw material |
| Calorific value | Value | Product Producer | Raw material |

Figure 100: Overview of information required for recyclability assessment. Source: Author.

8.8 Performance Assessment Module

8.8.1 Criteria

Defects that influence the performance of the façade and require additional testing need to be assessed using a test method. Nevertheless, remote assessments can be carried out much more quickly if sufficient monitoring data about the façade is known. For example, temperature sensors on the interior and exterior monitored over a long time can indicate the thermal performance of the façade. If there was a history of this issue, logs maintained would indicate the frequency of the issue, thereby influencing how the issue is rectifiable. The main performative parameters can be deduced from the array of standards a façade has to pass to ensure it is reusable. These values are usually derived during the testing of the façade product in the production phase and are usually indicated in CE marking. Some standards are calculated for the entire façade, as per the requirement of the building decree, and these are proven in the form of calculations. Standards become a crucial element in determining to what extent the façade can be reused. While the list in Figure 101 gives an overview of current standards and regulations known, these can change quickly, and relevant datasets of facade standards need to be maintained and updated.

8.8.2 Information required

The following is a list of information required for the assessment of Façade Performance. Due to pay-per-access clauses to access many standards, not all the minimum values could be identified.

| Min Performance criteria to be Employed | | | | | | | |
|---|--|----------------|------------------------|--------------------|----------|-----------------|----------------------|
| Sl no | Performance requirement | Type | Value | Unit | Criteria | Standards Body | Test Method |
| 1 | Thermal Insulation solid part | Rc Value | 4.5 | m ² K/W | Max | Building Decree | NEN 1068 |
| 2 | Thermal Insulation individual Door/windows | U value | 2.2 | W/m ² K | Max | Building Decree | NEN 1068 |
| 3 | Thermal Insulation Façade glazing | U value | 1.65 | W/m ² K | Max | Building Decree | NEN 1069 |
| 3 | Air permeability | Pressure | 10 | Pa | Min | Building Decree | NEN-EN 1026. |
| 4 | Water Tightness | Pressure | 150 | Pa | Min | Building Decree | NEN-EN 1027 |
| 5 | Burglary resistance | Class | ? | Not Accessible | Min | ? | NEN 5096:2012 |
| 6 | Impact resistance | Class | ? | Not Accessible | Min | ? | ? |
| 7 | Wind resistance | Class | ? | Not Accessible | Min | ? | ? |
| 8 | Fire Resistance of doors/windows | Class | ? | Not Accessible | Min | ? | NEN 1634-2:2008 |
| 9 | Fire resistance of façade | Time/Class | 60 | minutes | Min | Building decree | NEN 6069,NEN-EN 1364 |
| 9 | Acoustic performance | Resistance | 20 | Db | Min | Building Decree | NEN EN 14351-1 |
| 10 | Wind load resistance(max deflection) | Max Deflection | H/200 if H<3m | mm | Max | Eurocode | NEN EN 12211,13116 |
| | | | D <5mm if H >3m N 7.5m | mm | Max | Eurocode | NEN EN 12211,13117 |
| | | | H/250 if H>7.5m | mm | Max | Eurocode | NEN EN 12211,13118 |
| 11 | Horizontal load resistance | Max Deflection | L/200 if L<3m | mm | Max | Eurocode | EN 13830 |
| | | | D<5mm+L/300 if L>3m | mm | Max | Eurocode | EN 13830 |

Figure 101: Overview of information required for evaluating performance values of a façade. Source: Author.

8.9 Reuse/Remanufacturing parameters

If the assessment process, if the Façade clears all the assessment modules during the assessment process, it is scheduled for reuse or remanufacturing mainly based on the condition score of the façade determined in the conditional assessment stage. In such a scenario, the requirements of the second building are also required to determine if the façade can be reused. As all design requirements, these requirements can comprise specific parameters, quantifiable as values or highly subjective, which are not quantifiable. A simple example would be the height of the module vs. the subdivision geometry of the façade. While the floor-to-floor height is a functional requirement of the façade, the subdivision geometry depends on the appearance of the façade or the program of the building, etc., which is not quantifiable. A set of criteria affect both the design of the building and the design of the façade are determined and categorized as shown in Figure 102.

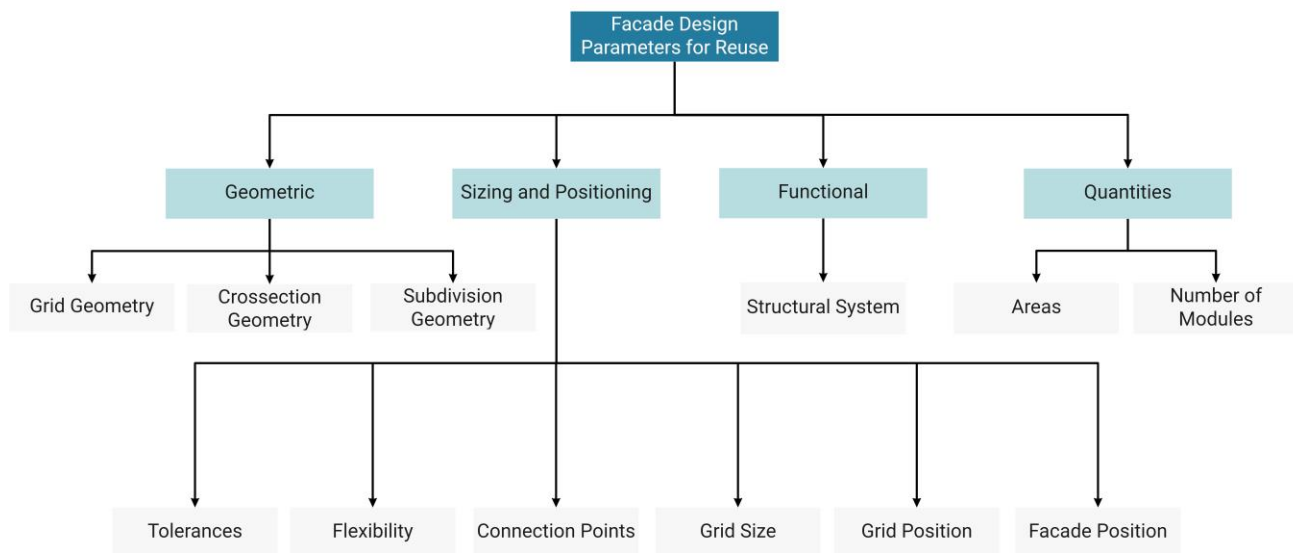

Figure 102: Summary of Parameters which affect the design of the façade and the building at reuse. Source: Author

Depending on how fixed or flexible these parameters are either in the building and in the façade, the façade can be proposed to be reused in three main scenarios listed in the next subchapter.

8.9.1 Geometric parameters

Aspects about the geometric properties of the façade, which influence how the façade fits with the building, are considered. The geometry of the unitized panel can be characterized based on the geometry of the grid, the geometry of its subdivisions, and the geometry of the cross-sections. These aspects become the main elements to consider whether a façade is suitable for reusing or not, as visually, it becomes the most dominant factor. The geometry of the façade and how it overlaps and fits with neighboring components can also be considered criticality can significantly influence the installation sequence of the façade and how the air/water tightness layers are installed. An overview of the geometric parameters for reuse is shown in Figure 103.

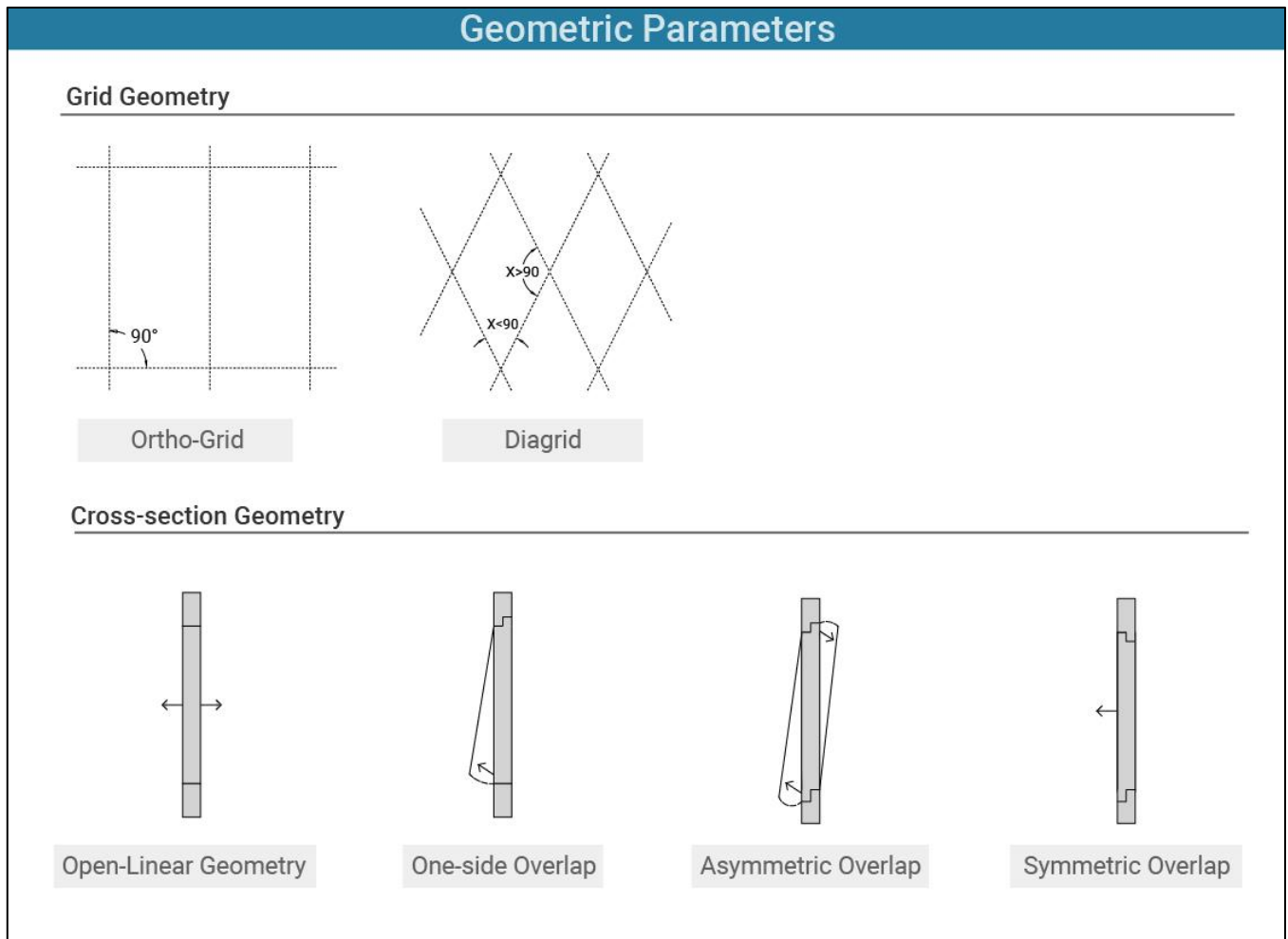

Figure 103: Overview of the geometric parameters for reuse assessment. Source: Author, partially adapted from multiple sources as mentioned in Appendix 15.9

8.9.2 Sizing and positioning parameters

These are parameters relating to the dimensions of the façade component. These parameters affect how the façade fits into the building and how they are positioned. Figure 104 and 105 gives an overview of all the Sizing and positioning parameters for reuse assessment.

1. Tolerances: Tolerances between façade components and between the components and the building indicate to what extent the façade elements can be adjusted on-site to suit the dimensional requirements. The tolerances are given between the façade frame and the connector and between the connector and the building.

2. Dimensional Flexibility: Indicates to what extent the sizes of the façade components are adjustable or not in the case of higher flexibility. If the sizes are fixed, it becomes more difficult to reuse the façade as the receiving building needs to have the same size. If it is more flexible/adaptable, then more buildings can be suited for the same.

3. Connection Points: Positions, where the façade can be connected to the building are required to determine whether the same is possible in the designed building. In the case of an existing building, it becomes the main determining factor whether the façade would fit the building, and in the case of a new building that is being designed, the connection positions can be taken into account during the design phase itself.

4. Grid size: The Grid size of the façade along with the connection positions is also a crucial piece of information to determine if the façade is suitable or not. In some cases, the grid size may determine the reuse of the façade, as specific grid sizes may not work with the building concept or the spanning of the structural system. In other cases, it can also be an aesthetic choice.

5. Grid position (Horizontal and vertical Spanning): The vertical and horizontal grid spans of the façade can either be adjusted to the structural grid or independent. This parameter can be influenced by how the façade appears and how it relates to the functions within the building, especially when different rooms require different façade typologies.

6. Position of façade: The position of the façade directly influences the grid size and the connection type parameters. If the façade position is in front of the building, a degree of tolerance can be accounted for when spanning the façade elements, and additional elements can be used to ensure the old façade fits the building. If the position is spanning between floor slabs, this aspect becomes a bit more limited.

7. Modular Sizing: This parameter refers to whether a standard measurement system is employed across a façade. Sizing the elements in a module makes it easier to computationally determine design options and therefore could increase the chance of the façade being reused. New buildings can also consider this module size as a design input to ensure the façade is reusable in the proposed building.

8. Grid Modularity: This refers to the number of similar panels sizes the façade has. The lesser the number of unique types, easier it can be for the façade to find a new building or a building to be designed around the façade parameter. For example, if all panels are of a standard size, it becomes easier to design the width and height of the building which receives the façade.

Sizing and Positioning Parameters

Grid Size and Connection points

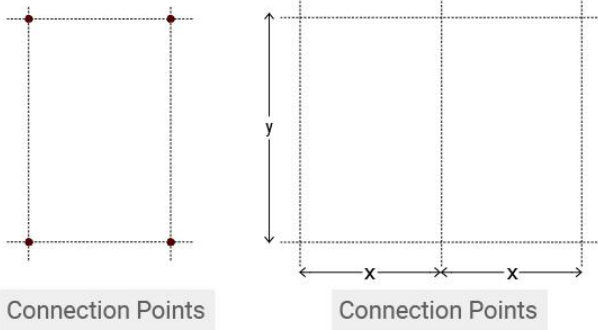

Modular Sizing

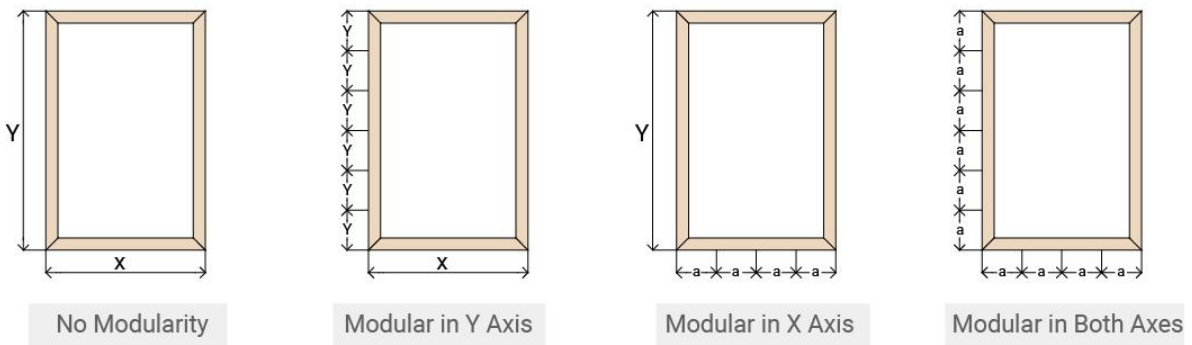

Vertical Spanning

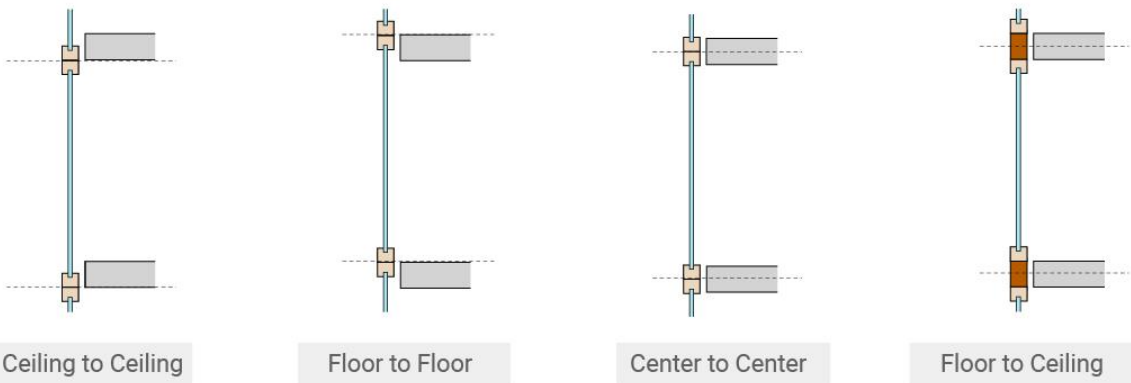

Dimensional Flexibility

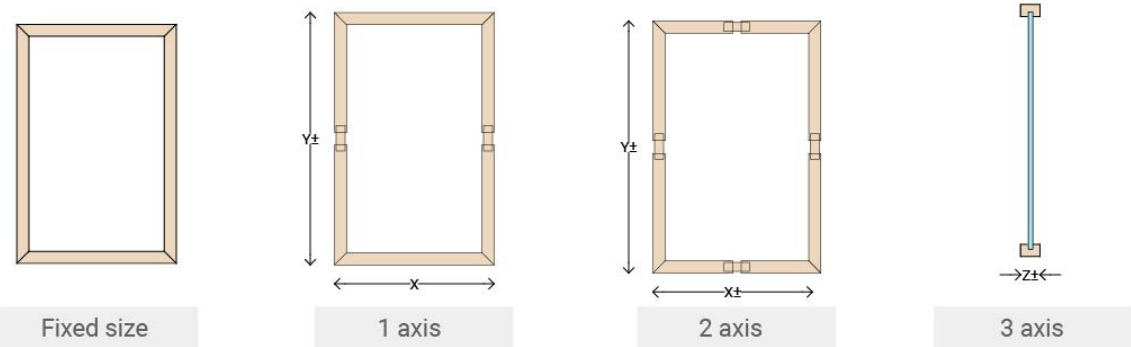
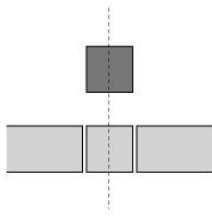

Figure 104: Sizing and positioning parameters for Reuse Assessment. Source: Author, partially adapted from multiple sources as mentioned in Appendix 15.9

Sizing and Positioning Parameters

Horizontal Spanning



Clear Width

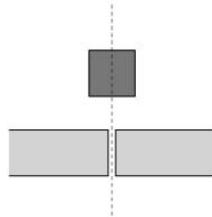

Center to Center

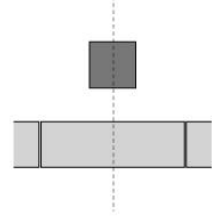

Offset

Facade Position

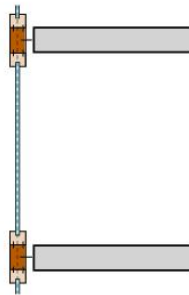

Outside

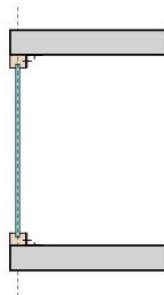

In-Plane

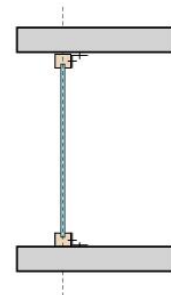

Recessed

Tolerances

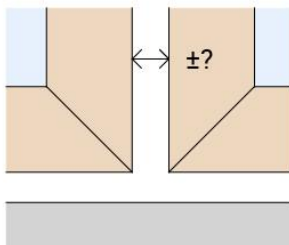

Component to Component

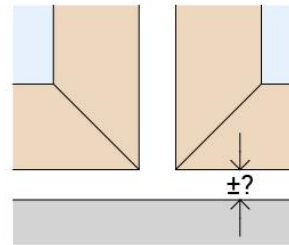

Building to Component

Grid Modularity

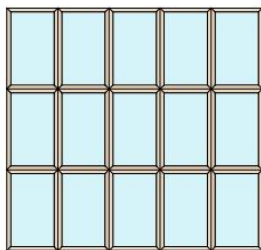

One Type

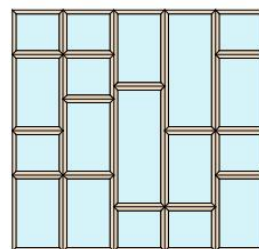

Multiple Types

Figure 105: Sizing and positioning parameters for Reuse assessment. Source: Author, partially adapted from multiple sources as mentioned in Appendix 15.9

8.9.3 Functional parameters

These are more technical aspects of the functionality of the façade in the building. These parameters have slight overlaps with criteria established in the earlier stages of assessment, mainly the performance parameters and connection type. The structural system refers to whether the façade element is self-supporting or it needs additional supports etc. The structural system of the façade and the structural system of the new building has to be compatible. If the façade is not self-supporting and needs an additional structure, it is important to have an idea of the structural system employed in the building currently to know either an additional support structure can be installed integrated with the new building design.

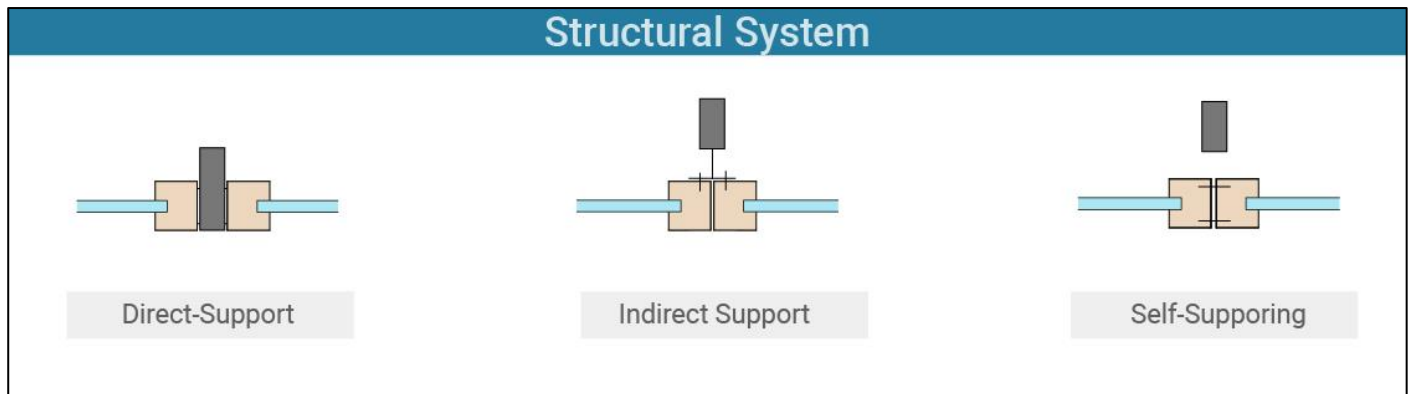

Figure 106: Functional Parameters for reuse Assessment. Source: Author, partially adapted from multiple sources as mentioned in Appendix 15.9.

8.9.4 Quantities

This refers to how many of the reusable façade components or panels are available. As per the interviews with Interviewee 3, it was understood that it is almost impossible to find a second life to materials where the exact number of materials from one building would match the other. There may be a shortage or an excess, and therefore it is crucial to understand the quantities of the façade available. How this parameter influences the reusability depends on the costs and value of the façade and how easily it can be reused in the new building. Quantities are measured by surface areas and the number of modules. The number of modules can be categorized based on types, functions, and sizes. The categorization method can vary from building to building. For example, in a building with multiple types of façade modules such as openable, closed, etc., the categorization can be made. When the building has similar types but various sizes, the categorization can be made on the actual sizes.

8.9.5 Scenarios of façade Reuse

If all the assessment modules are processed and the façade qualifies for reuse, an additional step needs to be taken to identify the best scenario in which the façade can be reused. This would also depend on the market situation, what buildings are being developed currently, what other facades are scheduled and available for reuse, and numerous other parameters, for which further elaboration is necessary. Although this additional "matching" stage is not part of the scope of this thesis, three different scenarios can be hypothesized based on the criteria defined and the design of the assessment modules as indicated below and schematically illustrated in Figure 107.

1. Matching the Building to the Façade: This scenario holds good when the building is still in the early stage, which means the parameters which affect the design of the building are still flexible and can adapt or infer the parameters from the façade which is proposed to be reused, i.e., "Matching the building to the Façade." When parameters of the façade are stored in the passport database, architects, façade engineers and/or facade engineers can use them to determine if a particular façade suits their requirements. Based on the parameters of the selected façade, they can dictate the design of the building adapt to the parameter of the façade.

Example Case with the parameter of Grid size: If we take a simple example of the grid size of the selected façade, it automatically determines the floor-to-floor height of the building to ensure the façade can be reused. So, the architect or façade engineer ensures the building uses this parameter to ensure the floor-to-floor height matches that of the selected façade. While this is just one example, these can extend onto the other parameters listed in Figure 107.

2. Two-way matching: This scenario is considered feasible when the design parameters of the selected façade and the design parameters of the building are still flexible. Here the building already has a set of predetermined criteria but still can adapt to the façade. It holds good for the parameters of the selected façade as well. While certain aspects of the selected façade can be fixed, if the façade is designed to be circular, there could still be certain parameters that are modifiable to suit the building design. In such a case, a two-way matching is set to happen.

Example Case with the parameter of Grid size: Again, if we take into account the grid size of the façade, and if it is considered to be modifiable in the X-axis, and the building has already determined the height of the façade, they can select a façade of the required height and modify the X-axis dimensions based on what is required.

3. Matching the façade to the building: The third scenario is when the building parameters are highly specific and therefore are in the late design stage, or is a building already built. In this case, many of the building parameters can be fixed, which searches for those parameters in a façade highly specific.

Example case with Grid Size: So, In the case of grid size, as the floor-to-floor height is already predetermined and fixed and so is the structural grid and possible even the internal walls, a façade that exactly matches the building grid is more likely to be reused therefore creating a scenario for the Façade Being matched to the building requirements.

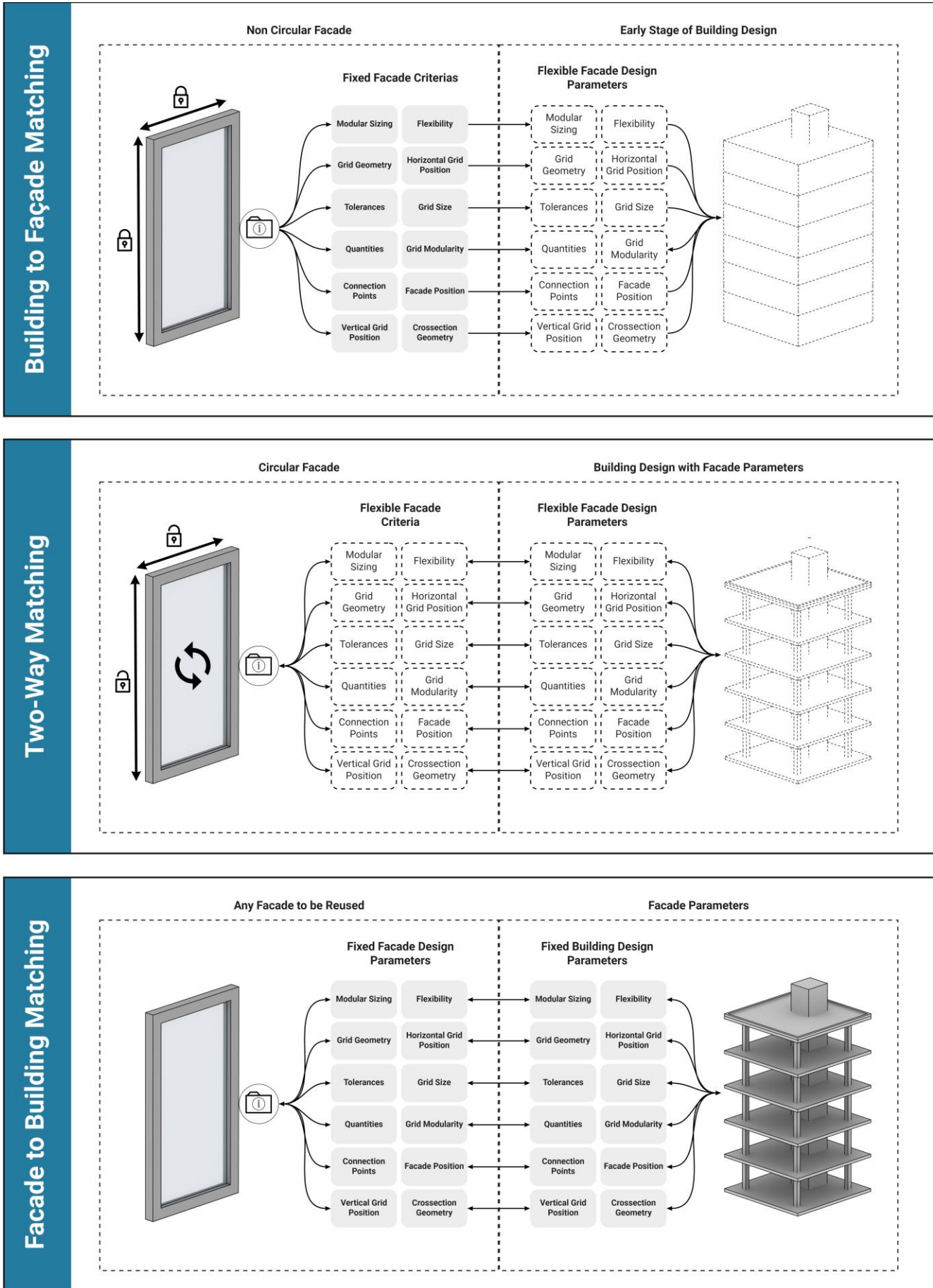

Figure 107: Various scenarios for reuse of a facade. Source: Author.

8.10 Conclusions

The EoS assessment framework was developed mainly to understand the crucial information required in the Façade Product Passport. A context in which the assessment would occur was identified, and the various sub-stages between the Operation and Reverse logistics phases were detailed. The EoS assessment framework was subdivided into smaller modules categorized based on the interdependency of the parameters. The information required for the processing was identified based on the Interviews and Surveys. A series of conditional statements give an overview of the qualification of each module. These can be automatically assessed if the information to these questions and provided beforehand. Another method is to have a platform that can display the necessary information and the question to sequentially guide the assessor to generate a decision. Based on the information required, the processable and non-processable information is identified as follows.

Digital drawings and 3d Modules are processable to an extent where areas, volumes, and quantities are extracted, and additional parametrization is required to ensure the logic in which the models are put together can be identified. Another option is to pre-categorize the façade typologies so that EoS assessment can be carried out faster. With the advancement in parametric design, the logic of the façade can be deciphered with minimum information, which is already in a processable state. Parameterizing certain information about a façade can go a long way in speeding up the end-of-life decision process. A similar approach can be employed for façade systems with a clearer structure, such as an instance tree. While the instance tree works in cases where the façade has a clear hierarchy of elements, these trees have to be developed for multiple façade types to define an appropriate method of classifying the façade into product levels.

9 Demonstration of the Framework

9.1 Case Study

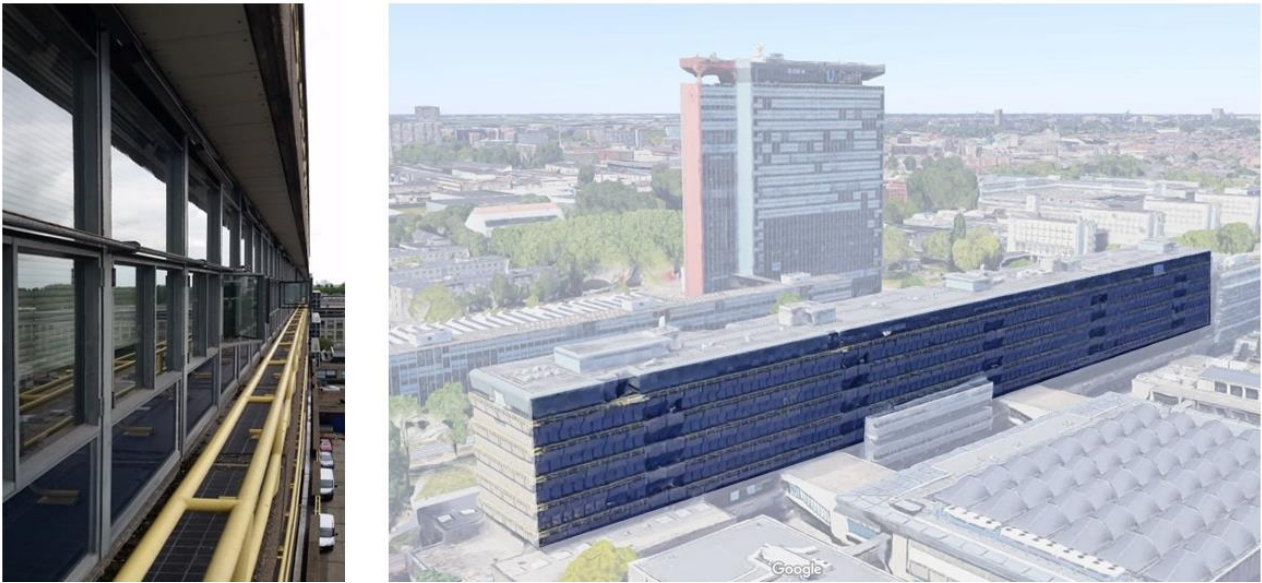

Figure 108: Photograph of the CiTG East Facade(left), aerial Image of the CiTG Building East Facade(right). Source: Facade Leasing group(left), Google(right)

In order to practically approach the entire framework, a case study façade was chosen to be documented and assessed. The building Façade renovation developed by Alkondor for the Civil Engineering Building in TU Delft was proposed to be evaluated. The façade design was carried out as part of a renovation project, aiming to improve the energy performance and, in this process, also implement a product service business model. Although the leasing model was not fully implemented, the technology required to make it feasible, such as collecting real-time data, tracking maintenance schedules using a QR code, and offloading it into a digital platform such as Cirling, is done is active as summarized in Figure 109. As the Façade Builder is one of the leading companies in the Circular Façade Industry of the Netherlands, it can serve as a relatively good benchmark in terms of documentation standards employed at the highest level.

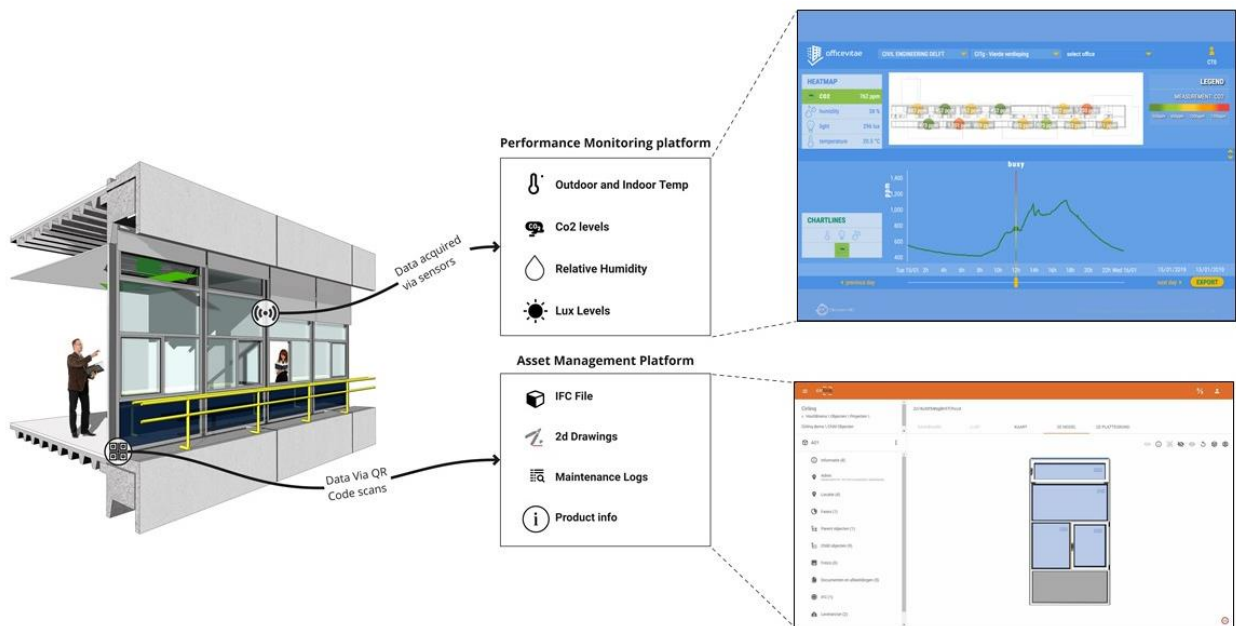

Figure 109: Image with the overview of the CiTG Façade Prototype proposed by Alkondor. Source: J. A. Azcarate et al. (2019)

9.2 Information received

The table below (Figure 110) gives an overview of the various documents received from the façade builder. As there were confidentiality issues, access to the data contained in the Cirliq and the monitoring platform could not be made. Hence the evaluation is carried out only based on the information officially received via email.

| Information received from Facade Builder of CiTG Project | | | |
|--|-----------------|---------------------|----------------------|
| Document received | Format received | Type of information | Product level |
| Map with approach route | Document | Graphics | NA |
| Supplier List | Document | Table with text | NA |
| Installation of window seals | Document | Drawings | Component |
| Structural calculations of frames and anchors | Document | Drawings and values | Subcomponent |
| 2d Elevations of façade | Document | Drawings | Building Part |
| 2d Elevation of Components(per unitized panel) | Document | Drawings | Component |
| 2d Horizontal section 1:2 | Document | Drawings | Subcomponent/Element |
| 2d Vertical Section 1:2 | Document | Drawings | Subcomponent/Element |
| Fabrication Instructions(system details) | Document | Graphics | Product |
| CE Certificates(per unitized panel) | Document | Table with values | Product |

Figure 110: Overview of information received from the Facade Builder. Source: Author

After evaluating the available information, additional information was extracted from the system manufacturer's website. The name of the company and the products used are kept confidential. The company had a document center where various information about each façade product is compiled and stored and is only accessible through an account. Also, different sets of information are shown for different roles in the industry. This has less to do with confidentiality but more to do with the curation of information. For example, an architect does not need to know fabrication instructions where a façade builder does not need to know more marketing level information. Nonetheless, the creation of the account entailed that information contained within it cannot be shared, and hence for the remaining part of the case study, the exact product name is kept confidential. Figure 111 indicates the various documents contained in the system manufacturers website.

| Information received from System Manufacturers Website | | | | | |
|--|---------------------|----------|-------------------|---|---------------|
| Document received | Data Created By | Format | Type | Information Extracted | Product level |
| Product Brochure | System Manufacturer | Document | Table with values | U value | Product |
| | | | | Basic depth | |
| | | | | Sound Insulation | |
| | | | | Water tightness | |
| | | | | Air permeability | |
| | | | | Wind resistance | |
| | | | | Corrosion protection | |
| | | | | Standards of calculation methods used | |
| Fabrication Instructions(system details) | System Manufacturer | Document | Drawing | Installation instructions of elements | Product |
| | | | Table with values | Max glass weight supported by gaskets | |
| | | | Drawing | Max glass weight supported by adhesive | |
| | | | | Compatible adhesives/sealants | |
| Environmental Product Declaration | System Manufacturer | Document | Table with values | Installation of ventilator frames | Component |
| | | | | Drainage positions | |
| | | | | Glass installation methods | |
| | | | | Weight of elements per 1.23X1.48 m module | |
| | | | | Performance values | |
| | | | | Reference service life | |
| | | | | Transportation utilization | |
| Waste at end of life | | | | | |
| Environmental Impacts | | | | | |
| Resource Use | | | | | |
| Output flows and waste categories | | | | | |

Figure 111: Overview of information received from the system manufacturer's website. Source: Author

While these sets of information give a good indication of the actual quality of information available, for the case study, additional information was extracted from J. A. Azcarate et al. (2019), such as construction photographs.

9.3 Inclusions and Exclusions

As evaluating the entire façade would be unfeasible given the limited time available for the research and the lack of processable data, such as CAD drawings, 3d Models, etc., a boundary condition had to be set up. Moreover, the objective is not to get too detailed into the nuances of the Façade Design, but demonstrate the use of the framework or evaluate how good circular or not the façade is, but instead use it as a medium to demonstrate the documentation method required for the framework.

They have been excluded from the framework since significantly less information about glass and gaskets and slightly different supply chains. In addition, movable and/or motorized components are also excluded as including them would require even movable parts such as hinges and motors. Therefore, the demonstration is carried out only with the main outer frame of one of the Unitized Module as shown in Figure 112.

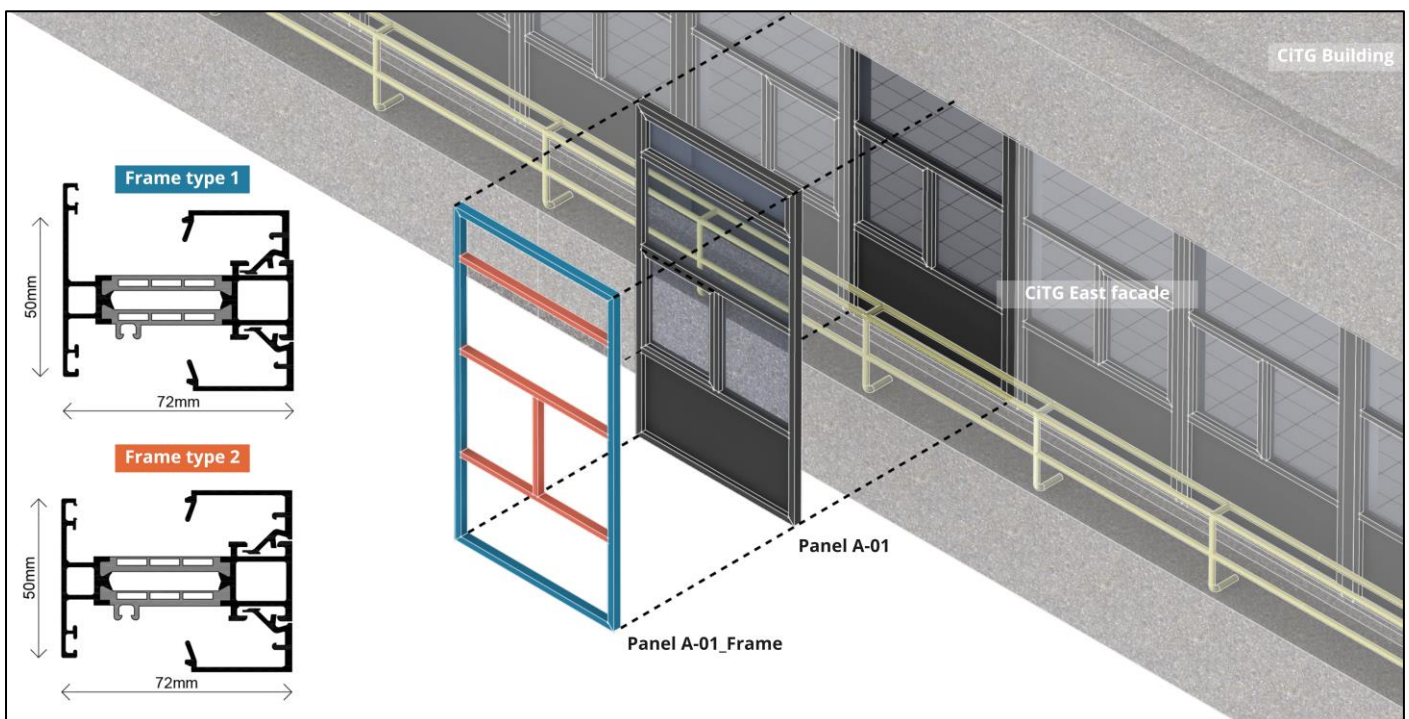

Figure 112: Parts from the CiTG Panel A-01 included for the demonstration. Source: Author

9.4 Identification of Database Instances

Component Level: Each unitized Panel is named with a Unique Id as per the original nomenclature used in the drawings received by the façade builder.

Sub-Component Level: Each part connected is considered a subcomponent. For example, all the frames connected with the connectors become a sub-component, or two sheets of glass forming a double-glazed unit, etc. They are referred by the Name of the component with an extension of which part. For example, the outer frame of Panel A01 is named PanelA01_Frame

Element Level IDs” At a component level, all the frames are cut to size based on the different edge conditions and how it connects to the neighboring frame. All Vertical Frames are Named as V1, V2, V3, and horizontal ones as H1, H2, H3, etc. Each element is given a unique name even if it shares the same geometry or length, as they have a unique position in the building and therefore have different neighboring materials and connection characteristics and is essential to record each of these as a unique instance in the project. The connectors are named based on the elements it connects. For example, connector V1_H5 connects elements V1 and H5.

Product Level IDs: When a combination of the profiles and thermal breaks are connected, they form a frame categorized as Frame type 1 and Frame type 2. These products are part of the family and are used in the CiTG façade as the outer frame. Frame type 2 is used in the intermediate members. There is no information on the connections or details, a generic L and an I shape have been assigned and given a name Connection type 1, 2, and 3.

Material level Id's: At a material level, AP_1, AP_2, AP_3 and AP_4, and AP_5 are the five types of different aluminum extrusions used in the outer frame façade. These are part of the product family. TB_1 and TB_2 are the thermal breaks that connect the different profiles.

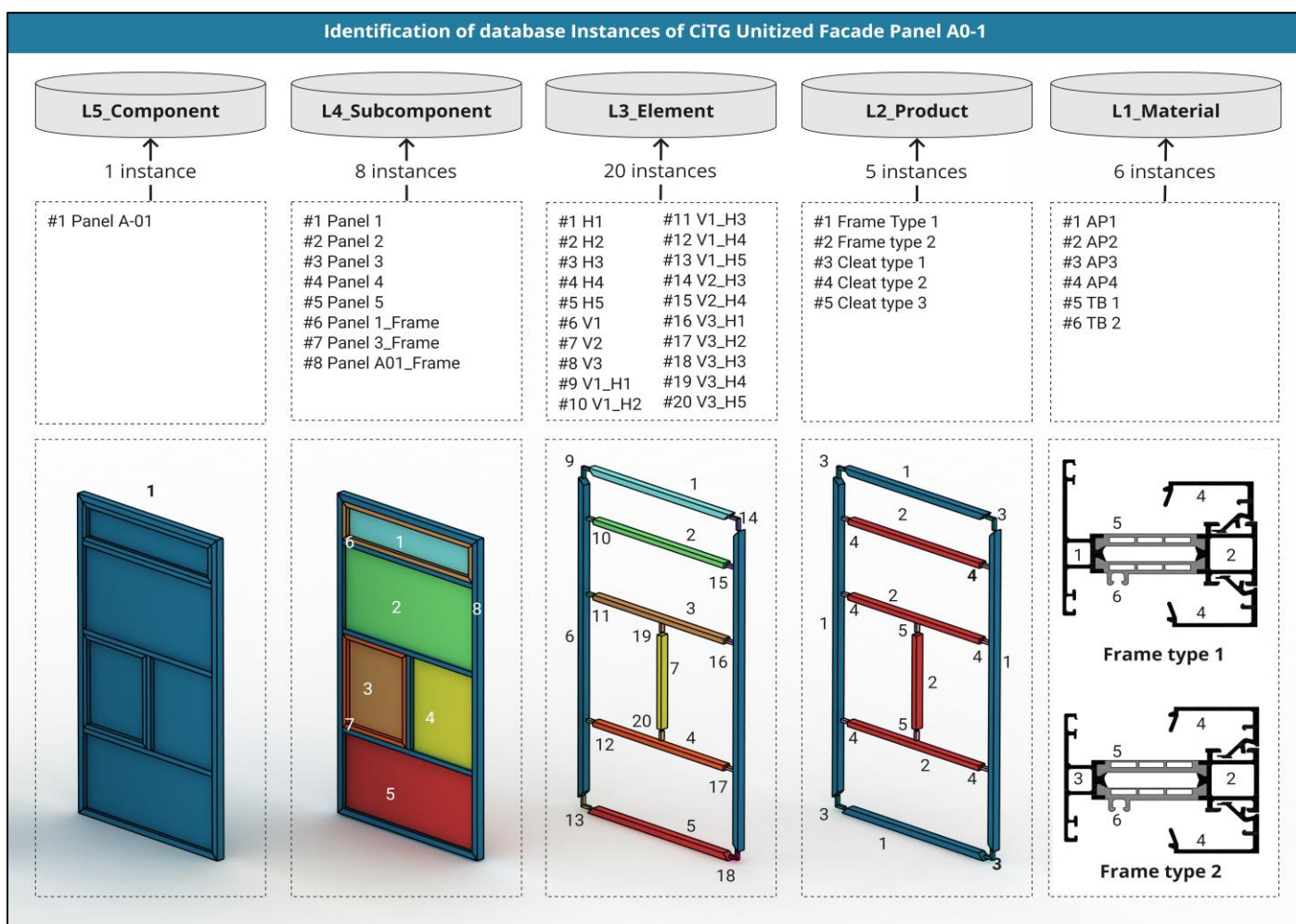

Figure 113: Identifications of the different parts in the CiTG Facade Frame. Source: Author.

9.5 Identification of Processes and connections

The information of the different processes is stored in the Process Database, and they are referenced in the Façade Product database using the following Identifications.

| Inventory of Processes | | | |
|------------------------|--------------|---------------------|---------------------|
| Sl.no | Id | Process Name | Ref Raw Material ID |
| 1 | PA_Extrusion | Polyamide Extrusion | PA66_25% GF |
| 2 | AL_Extrusion | Aluminium Extrusion | AL-6061-T6 |
| 3 | AL_Pcoat | Powder Coating | Aluminium 6061 |

Figure 114: List of identifiers in the Process Database. Source: Author

The information of the various connections can also be stored in the process database and is referenced in the Façade Product passport using the following IDs.

| Inventory of Connections | |
|--------------------------|------------------|
| Sl.no | Type |
| 1 | Bolt |
| 2 | Screw |
| 3 | Anchor |
| 4 | Nail |
| 5 | Silicon |
| 6 | Hard Compound |
| 7 | Soft Compound |
| 8 | Crimp |
| 9 | Click |
| 10 | Pin Connection |
| 11 | Silicon Adhesive |
| 12 | Tape |
| 13 | Rolled-In |
| 14 | Fitted |
| 15 | Glued |

Figure 115: List of identifiers of connection types in the Process database. Source: Author

9.6 Database Structuring

The product levels defined in Chapter 5.1 are used to organize the parts of the façade and therefore indicate how the information is also structured in the database. Additionally, between each database level, processes are used in the connections referencing information from the process database. The processes can be either connections, manufacturing procedures, transportation, or other aspects. Therefore, the Data structure somehow represents the way the façade is organized and indicates the supply chain dynamics and history of each component. The transitioning datasets are termed primary, secondary, and tertiary processes based on which stage the processes are carried. Figure 116 gives a brief overview of how parts of the CiTG Façade are structured into Product/Information levels.

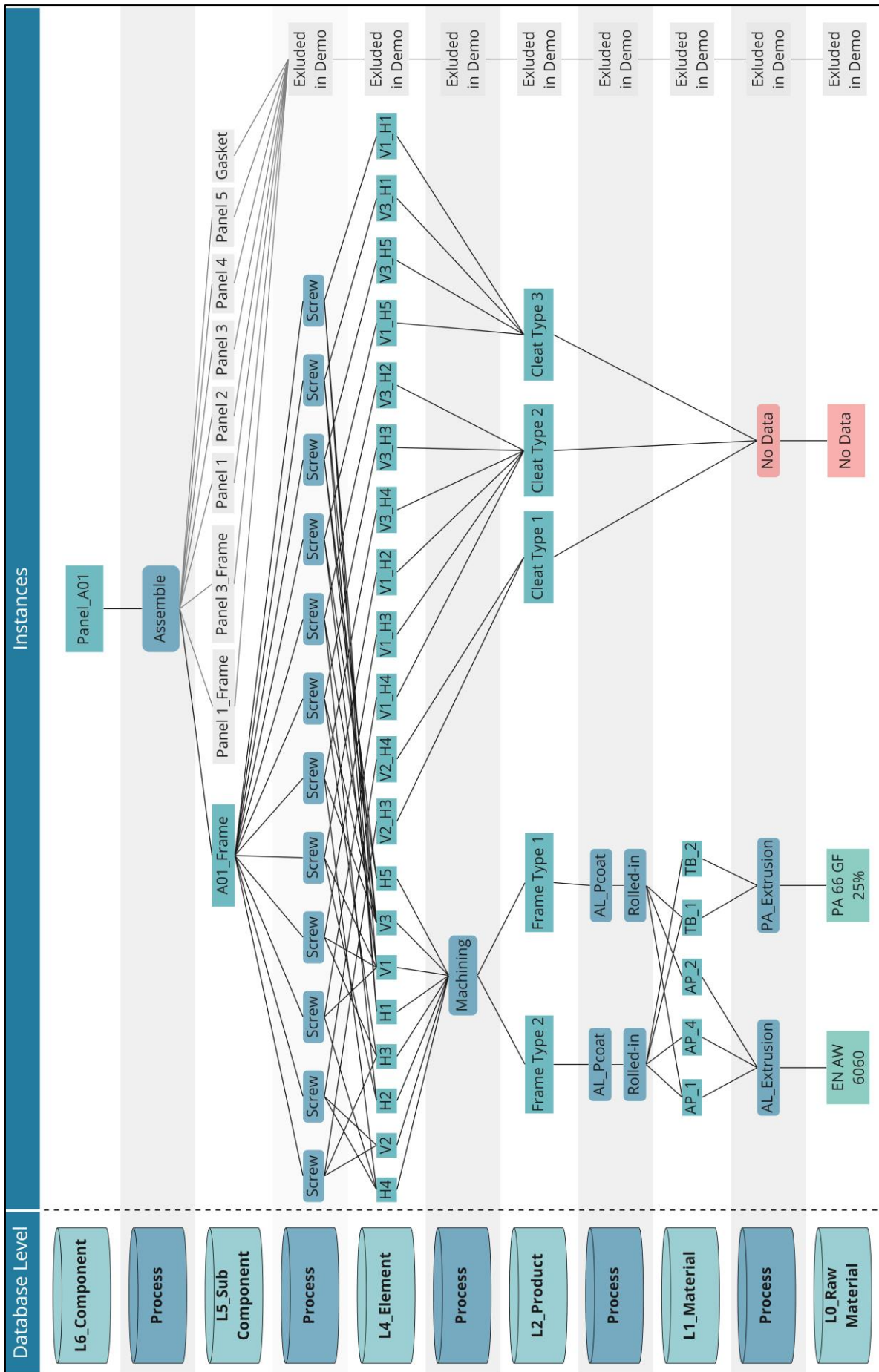

Figure 116: Organization of the CITG Facade frame parts into product levels. Source: Author.

9.7 Demonstration of Data templates

The information in the different product levels is demonstrated using mock dashboards, as shown in the following figures. Each snapshot pertains to information in one level of the database and specifies a particular data template. The available information, or needs additional calculations, is indicated with <no data>, <requires calculations>. Fields that require manual entry by the stakeholder responsible are encased within quotation marks.

9.7.1 Process Database

The process database can contain information relevant to evaluating the façade, such as the Co2 Footprint or the Energy. Currently, many databases already provide this information. Identifying which database is more suited for Façade manufacturing is a complex subject and is not relevant. What is stressed is a universal acceptance of a particular database and referencing of information from these databases using Unique IDs. For example, information about the extrusion of polyamide in the agreed-upon, if identified as "PA_Extrusion," when referenced in the Façade Passport, values of its energy and Co2 and water consumption, or other required information can already be referenced into the Façade Product Database.

| Process ID: AL_Extrusion | | | | |
|--------------------------|--------|----------------|-------|-------|
| Sl.no | Item | Attribute type | Value | Unit |
| 1 | Energy | Value | 6.98 | MJ/kg |
| 2 | Co2 | Value | 0.523 | kg/kg |
| 3 | Water | Value | 6.37 | L/kg |

Figure 117: Information contained within the identifier 'AL_Extrusion' in the Process database. Source: Author.

9.7.2 Connection Database

Similarly, a database of connections can have information such as assembly and disassembly time, based on industry averages, required material, detachability index, or the type of connection, either Direct, Indirect, etc. So, if a particular component is connected to another using a screw, the relevant information can be referenced using the Identifier "Screw" in the Façade Product Passport.

| Connection ID: Screw | | | | | |
|----------------------|---------------------|--------------------|-----------|---------|--------------|
| Sl.no | Name | Attribute type | Value | Unit | Source |
| 1 | Assembly time | Value | 6.5 | seconds | Stevels,2015 |
| 2 | Disassembly type | Multi Option Value | Removable | NA | NA |
| 3 | Material Required? | Boolean | Yes | NA | NA |
| 4 | Detachability Index | Value | 0.8 | NA | Alba Concept |
| 5 | Connection type | Multi Option Value | Direct | NA | NA |

Figure 118: Information Contained within the identifier "Screw" in the process database. Source: Author

9.7.3 L0_Raw Material Database

The raw material database contains information regarding the material properties before it is formed into any product. The source of the raw material and its properties is not mentioned in any documentation received from the Façade Builder. The data is gathered as per industry standards and using the Granta Edu Pack database. However, the more important aspect for this research is the various fields of information rather than the actual values. These can serve as base information for the product development process and are referenced in higher levels of the database. The exact fields are as indicated in Figure 120, which documents information on Aluminum, and Figure 119 which documents information on Polyamide.

| Material ID : AL-6061-T6 | | | | |
|--------------------------|--------------------------------|----------------|-------------------|------------|
| Category | Attribute | Attribute type | Value | Unit |
| Manufacturers Data | Name of material | Text | Aluminium 6061,T6 | NA |
| | Manufacturer Name | Text | "insert name" | NA |
| | Date | Date | "insert date" | Date |
| | Manufacturer Location | Text | "insert location" | NA |
| | Year of Dataset | Date | "insert year" | Date |
| | Cost | Currency | "insert cost" | Eur |
| | Alloy ID | Text | ENAW6060-T6 | Class |
| Material Composition | Aluminium | Value | 95.8-98.6 | % |
| | Chromium | Value | 0.04-0.35 | % |
| | Copper | Value | 0.15-0.4 | % |
| | Iron | Value | 0-0.7 | % |
| | Magnesium | Value | 0.8-1.2 | % |
| | Manganese | Value | 0-0.15 | % |
| | Silicon | Value | 0.4-0.8 | % |
| | Titanium | Value | 0-0.15 | % |
| | Zinc | Value | 0-0.25 | % |
| | Other | Value | 0-0.15 | % |
| Physical Props | Density | Mass Density | 2700 | kg/m3 |
| | Lifetime | Value | 50 | years |
| | Hardness | Value | 76 | HV |
| Mechanical Properties | Hardness | Value | 40 | HB |
| | Youngs Modulus | Value | 70 | GPa |
| | Yeild Strength | Value | 175 | MPa |
| | Tensile Strength | Value | 222 | MPa |
| | Compressive Strength | Value | 175 | MPa |
| | Shear Modulus | Value | 27 | GPa |
| | Bulk Modulus | Value | 73 | GPa |
| | Possions Ratio | Value | 0.335 | NA |
| Thermal Properties | Thermal Conductivity | Value | 150 | W/m.°C |
| | Maximum Service Temperature | Value | 174 | °C |
| | Specific Heat Capacity | Value | 972 | W/m.°C |
| | Thermal Expansion Co-Efficient | Value | 24.6 | µstrain/°C |
| Environmental Properties | Recyclable? | Boolean | Yes | NA |
| | Biodegradable? | Boolean | No | NA |
| | Combustible? | Boolean | No | NA |
| | Critical Elements | Boolean | Yes | NA |
| | Primary Energy | Value | 199.5 | MJ/kg |
| | Co2 Footprint | Value | 5.57 | kg/kg |
| | Water Usage | Value | 706 | l/kg |

Figure 119: Information in the identifier Aluminum 6061 at L0_Raw Material Level. Source: Own, Values adapted from Granta Edu Pack.

| Material ID : PA66_25% GF | | | | |
|---------------------------|--------------------------------|----------------|-------------------|------------|
| Category | Attribute | Attribute type | Value | Unit |
| Manufacturers Data | Name of material | Text | Polyamide Type 66 | NA |
| | Manufacturer Name | Text | "insert name" | NA |
| | Date | Date | "insert date" | Date |
| | Manufacturer Location | Text | "insert location" | NA |
| | Year of Dataset | Date | "insert year" | Date |
| | Cost | Currency | "insert cost" | Eur |
| | Polymer Code | Text | PA66-GF20-FR | NA |
| Material Comp | Polymer Code | Value | 75 | % |
| | Frame Retardant | Value | 15 | % |
| | Glass fiber | Value | 25 | % |
| Physical Props | Density | Mass Density | 1470 | kg/m3 |
| | Lifetime | Value | 50 | years |
| | Hardness | Value | 118 | HB |
| Mechanical Properties | Youngs Modulus | Value | 7.28 | GPa |
| | Yeild Strength | Value | 117 | MPa |
| | Tensile Strength | Value | 112 | MPa |
| | Compressive Strength | Value | 128 | MPa |
| | Shear Modulus | Value | 2.47 | GPa |
| | Bulk Modulus | Value | 8.2 | GPa |
| | Possions Ratio | Value | 0.36 | NA |
| | Thermal Conductivity | Value | 0.453 | W/m.°C |
| | Maximum Service Temperature | Value | 130 | °C |
| | Specific Heat Capacity | Value | 1430 | J/m.°C |
| Thermal Props | Thermal Expansion Co-Efficient | Value | 91.8 | µstrain/°C |
| | Recyclable? | Boolean | No | NA |
| | Biodegradable? | Boolean | No | NA |
| Environmental Properties | Combustible? | Boolean | Yes | NA |
| | Critical Elements | Boolean | No | NA |
| | Primary Energy | Value | 117 | MJ/kg |
| | Co2 Footprint | Value | 5.57 | kg/kg |
| | Water Usage | Value | 706 | l/kg |

Figure 120: Information in identifier PA66_25% GF at L0_Raw Material Level. Source: Own, Values adapted from Granta Edu Pack for representation purposes.

9.7.4 L1_Material database

At the material level, Aluminum and Polyamide's raw materials have already gone through the primary production process and have more geometric information such as size, cross-section, and a predefined use case in the building. Nevertheless, these databases can also exist independently as information at the Material level is produced by System Manufacturers, who do not influence the actual design of the Façade. As per the framework proposed in Chapter 7.2.2, if material information is accessed in the Database of the Façade Product, product-related information such as location in the building or instance tree view will not be present. The demonstration in Figure 122 is when the information is accessed in a Façade Product passport. An instance tree view helps navigate the various façade components and can represent how the different parts in the façade are connected. Additional information such as the 2d cross-section and 3d view can be displayed.

Data Template for Materials:

| Material ID: AP_1 | | | | | |
|---------------------|-------|----------------------------|----------------|----------------------------|------|
| Category | SL.no | Attribute | Attribute type | Value | Unit |
| Manufacturers Data | 1 | Raw material ID | Text | AL-6061-T6 | NA |
| | 2 | Common Name | Text | Aluminum Profile | NA |
| | 3 | Manufacturer Name | Text | "Company Name" | NA |
| | 4 | Manufacturer Location | Text | "Location" | NA |
| | 5 | Year of Dataset | Date | "Insert date" | NA |
| | 6 | Cost | Value | "insert cost" | Eur |
| Physical Properties | 7 | Crosssection Area | Value | 176.59 | mm2 |
| | 8 | Manufactured Lengths | Value | 6000 | mm |
| | 9 | Width | Value | 25 | mm |
| | 10 | Height | Value | 22 | mm |
| | 11 | Wall Thickness | Value | 16 | mm |
| | 12 | Weight | Value | 2860.758 | kg |
| Design Data | 13 | Crosssection Drawing | Graphic | Link to 2d Drawing | NA |
| | 14 | Crosssection 3d | Graphic | Link to 3d Model | NA |
| | 15 | Associated Façade Products | ID | Frame type1,Frame type 2 | NA |
| | 16 | Associated Connections | ID | Rolled in, Screwed, Bolted | NA |
| Database references | 22 | Process 1 | ID | AL_Extrusion | NA |
| | 23 | Process 2 | ID | Transportation Method | NA |
| | 24 | | | | |
| | 25 | | | | |

Figure 121: Data Template for Material Level Information. Source: Author.

Passport Viewer

EoS Assessment

Building Part
Component
Sub_Component
Element
Product
Material
Raw Material

Instance Tree View

Displaying details of Material : AP_1

Material View

Properties

| | | |
|---------------------|-----------------------|--------------------|
| IDs | Instance ID | AP_1 |
| | Common Name | Aluminium Profile |
| Manufacturers Data | Manufacturer Name | Company XYZ |
| | Manufacturer Location | <Location> |
| | Year of Dataset | DD/MM/YY |
| | Cost | <insert cost> |
| | Process 1 | AL_Extrusion |
| Physical Properties | Crosssection Area | 0.011m2 |
| | Manufactured Lengths | 6000 mm |
| | Width | 25 mm |
| | Height | 22 mm |
| | Wall Thickness | 1.1 mm |
| Design Data | Weight | 178.2kg |
| | Crosssection Drawing | Link to 2d Drawing |
| | Crosssection 3d | Link to 3d Model |

Figure 122: Schematic dashboard with material level information with the instance tree view. Source: Author

DIGITAL SOLUTIONS FOR A CIRCULAR FAÇADE ECONOMY

120

9.7.5 L2_Product Database

Information in the product database is also by the system manufacturer and can be viewed from an independent Product database and the Façade Product Passport when used in a building. Figure 123 shows an overview of the different information contained within it. Here additional information such as how the instances in the Material Database are connected can also be displayed.

| Product ID: Frame Type_1 | | | | |
|--------------------------|-----------------------|----------------|--------------------|-------|
| Category | | Attribute type | Value | Unit |
| Manufacturers Data | ID | Text | Frame Type_1 | NA |
| | Common Name | Text | Window Frame | NA |
| | Manufacturer Name | Text | "Company Name" | NA |
| | Manufacturer Location | Text | "Location" | NA |
| | Year of Dataset | Date | "Insert date" | NA |
| | Cost | Value | "Insert cost" | Eur |
| Database references | L1_Material | ID | AP_1 | NA |
| | L1_Material | ID | AP_2 | NA |
| | L1_Material | ID | TB_1 | NA |
| | L1_Material | ID | TB_2 | NA |
| | Process Database | ID | AL_Pcoat | NA |
| | Process Database | ID | AL_Rolled in | NA |
| Physical Properties | Crosssection Area | Value | 0.04 | m2 |
| | Manufactured Lengths | Value | 6000 | mm |
| | Width | Value | 60 | mm |
| | Height | Value | 50 | mm |
| | Wall Thickness | Value | 16 | mm |
| | Weight | Value | 648 | kg |
| Design Data | Crosssection Drawing | | Link to 2d Drawing | |
| | Crosssection 3d | | Link to 3d Model | |
| Performance Values | Thermal Insulation | Value | 12 | W/m2K |
| | Air permeability | Value | 4 | Class |
| | Water Tightness | Value | 9A | Class |
| | Burglary resistance | Text | RC 2 | Class |
| | Impact resistance | Text | No Data | Class |
| | Sound Reduction | Value | 25 | dB |
| Logistics | Wind Resistance | Value | Class C5/B5 | Class |
| | Distance Travelled | Value | "Insert distance" | kms |

Figure 123: Data Template for Product Level Information. Source: Author.

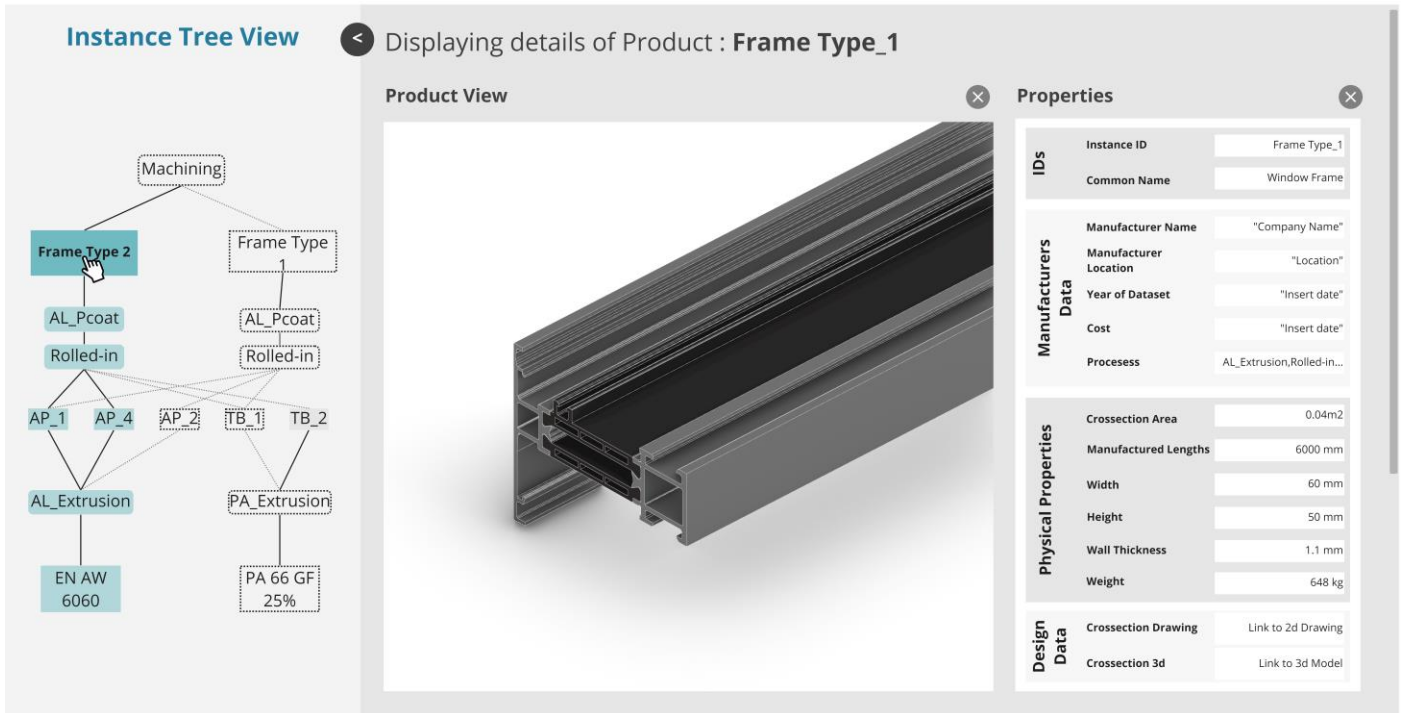

Figure 124: Overview of Facade Product Passport Dashboard at Product Level. Source: Author

9.7.6 L3_Element Database

In the element database, the specified product is modified and used in the building. Figure 125 indicates the various information which is contained. Not all information is displayed, but the category, connected "instances" already specifies the different sources from which the information is referenced.

| ID: V1 Location: Element Database(L3) | | | | |
|---|-----------------------|----------------|--|------|
| Category | Item | Attribute type | Value | Unit |
| Manufacturers Data | ID | Text | V_1 | NA |
| | Common Name | Text | Primary Mullion | NA |
| | Manufacturer Name | Text | "Company Name" | NA |
| | Manufacturer Location | Text | "Location" | NA |
| | Year of Dataset | Date | "Insert date" | NA |
| | Cost | Value | "Insert cost" | Eur |
| Database references | L2_Database | ID | Frame Type_1 | NA |
| | Process Database | ID | PA_Fine Machining, AL_Powdercoating, Rolled-in | NA |
| Physical Properties | Crosssection Area | Value | 967 | mm2 |
| | Length | Value | 3120 | mm |
| | Depth | Value | 25 | mm |
| | Face Width | Value | 60 | mm |
| | Weight | Value | 322 | kg |
| Design Data | Crosssection Drawing | Graphics | Link to 2d Drawing | NA |
| | 3d model | Graphics | Link to 3d Model | NA |
| | Fabrication Drawing | Graphics | Link to 2d Drawing | NA |
| | Location in Building | Graphics | Link to 2d Drawing | NA |
| | Location in Component | Graphics | Link to 2d Drawing | NA |

Figure 125: Data Template for Element Level Information. Source: Author.

Instance Tree View

```

graph TD
    S1[Screw] --- M[Machining]
    S2[Screw] --- M
    S3[Screw] --- M
    S4[Screw] --- M
    M --- H2[H2]
    M --- H3[H3]
    M --- H1[H1]
    M --- V1[V1]
    M --- V3[V3]
    M --- H5[H5]
    M --- V2[V2]
    M --- FT2[Frame Type 2]
    M --- FT1[Frame Type 1]
    FT2 --- AL_Pcoat2[AL_Pcoat]
    FT1 --- AL_Pcoat1[AL_Pcoat]
    AL_Pcoat2 --- R2[Rolled-in]
    AL_Pcoat1 --- R1[Rolled-in]
    R2 --- AP1[AP_1]
    R2 --- AP4[AP_4]
    R2 --- AP2[AP_2]
    R1 --- TB1[TB_1]
    R1 --- TB2[TB_2]
    AP1 --- AE[AL_Extrusion]
    AP4 --- AE
    AP2 --- AE
    TB1 --- PE[PA_Extrusion]
    TB2 --- PE
    AE --- ENAW[EN AW 6060]
    PE --- PA66[PA 66 GF 25%]
    
```

Displaying details of Element : V_1

Element View

Properties

| | | |
|---------------------|-----------------------|------------------------------------|
| IDs | Instance ID | V_1 |
| | Common Name | Primary Mullion |
| Manufacturers Data | Manufacturer Name | "Company Name" |
| | Manufacturer Location | "Location" |
| | Year of Dataset | "Insert date" |
| | Cost | "Insert date" |
| | Processes | AL_Extrusion,Rolled-in,... |
| Physical Properties | Crossction Area | 0,04m2 |
| | Length | 3120mm |
| | Width | 60 mm |
| | Height | 50 mm |
| | Wall Thickness | 1.1 mm |
| Design Data | Weight | 336 kg |
| | Crossection Drawing | Link to 2d Drawing |
| | Crossection 3d | Link to 3d Model |

Figure 126: Overview of Facade Product passport Dashboard at the Element level. Source Author

9.8 EoS Assessment

9.8.1 Information Sufficiency check

All the information received from Alkondor was categorized in Chapter 9.2 and evaluated against the information required to perform the EoS assessment as per the proposed framework in Chapter 8.4 to Chapter 8.9. The result was categorized as not available, available, partially functional, and not applicable with comments. The crucial parts were the material composition of all the elements, connections of building façade to component, and element to element from the various information missing. Although the EoS framework proposed is ordered sequentially, independent parts can be executed to see if assessments can be made on specific modules.

| Information Required for Condition Assessment | Product level | Sufficiency | Comments |
|--|-------------------|----------------------|--|
| Current defects on the façade | Component/element | Not Available | Condition assessment has to be carried out. |
| | Component/element | Not Available | |
| | Component/element | Not Available | |
| Thermal Defects, leaks | Component/element | Not Available | |
| Type of defect, id of component, date of defect | Component/element | Not Available | |
| ID of component, Location of Defect | Component/element | Not Available | |
| Sizes of defects | Component/element | Not Available | |
| Thermal Performance History | Component/element | Not Available | |
| Sizes of components | Component/element | Sufficient | Can be determined based on component drawings |
| Information Required for DfD Assessment | Product level | Sufficiency | Comments |
| Building to façade component connection | Component/element | Partially Sufficient | Only detail available, not positions and points. |
| Element to element connections | Component/element | Not Available | |
| Component to component connections | Component/element | NA | Not required as components are separated with third element |
| Residual values of materials | Component/element | NA | There's no calculation method developed for this yet and therefore cannot be expected. |
| Size of components | Component/element | Sufficient | |
| Weight of components | Component/element | Sufficient | Can be calculated |
| Presence, capacity and accessibility to elevator | Building | NA | Not required as there is scaffolding access |
| Presence of Building Maintenance Unit | Building | NA | Not required as there is scaffolding access |
| Accessibility for scaffolding | Building | Sufficient | Could be determined based on previous construction planning |
| Assembly Sequence | Component/element | Not Available | |
| Information Required for Typology Assessment | Product level | Sufficiency | Comments |
| Spanning of mullions | Building Part | Sufficient | |
| Spanning of transoms | Building Part | Sufficient | |
| Element to element connections | Component/element | Not Available | |
| Façade to Building Connections | Component/element | Sufficient | |
| Information Required for Recyclability | Product level | Sufficiency | Comments |
| Material composition | Raw material | Not Available | |
| Presence of toxic elements | Raw material | Not Available | |
| Recyclability | Raw material | Not Available | |
| Calorific value | Raw material | Not Available | |

Figure 127: Information Sufficiency check of CiTG Façade Data for EoS assessment process. Source: Author.

9.8.2 Generating missing information

1. Material composition, recyclability, toxic elements, and calorific value: While this information may have been already part of the Cirling platform, it still could not be accessed due to confidentiality issues. As it is an industry standard to use Aluminum 6060/6061 for profiles and Polyamide PA 66 for the thermal break, this was used as a reference to generate the material information from the Granta Edu Pack. However, there are no specific details in any of the documents

received about the polyamide or the exact tempering process of the aluminum, the kind of coating used, and the respective manufacturers. Therefore, all details were generated by using the Granta Edu Pack database for material-level information.

2. Element-to-element connections: Based on an industry-standard detail, it is assumed that different types of cleats are used for the corner and the intermediate connectors, which are riveted to the façade frame. Even though these cleats are known to be made of aluminum, the alloy and material composition are still unknown and cannot be generated.

9.8.3 Assessment Modules

1. Design for Disassembly: To assess whether it is possible to disassemble the façade, all drawings related to building to connection are required. In the CiTG building, these are the vertical and horizontal sections. As there are no actual assembly/disassembly sequence drawings received, Figure 129 indicates the possible disassembly steps required. The photograph with the scaffoldings indicates that the component is accessible from the outside.

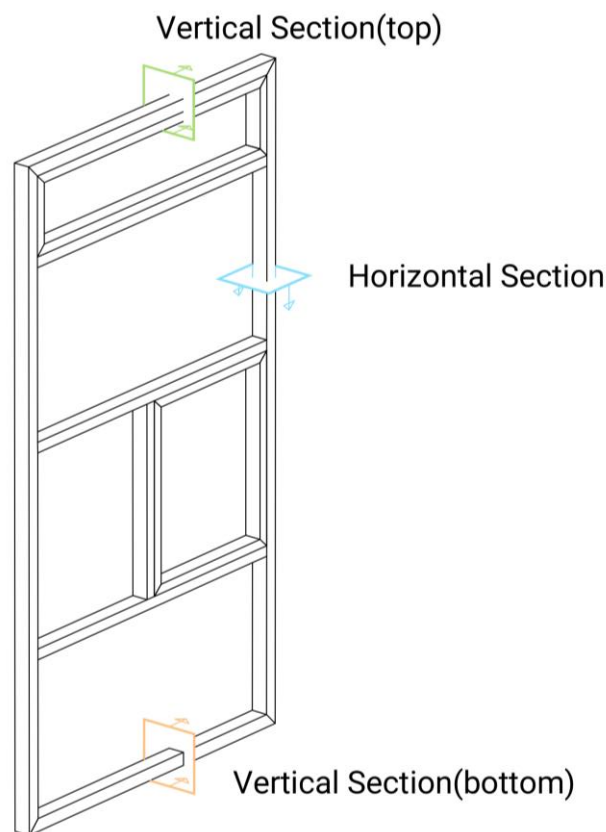
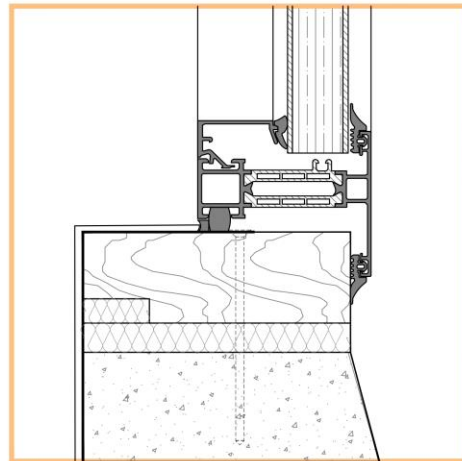
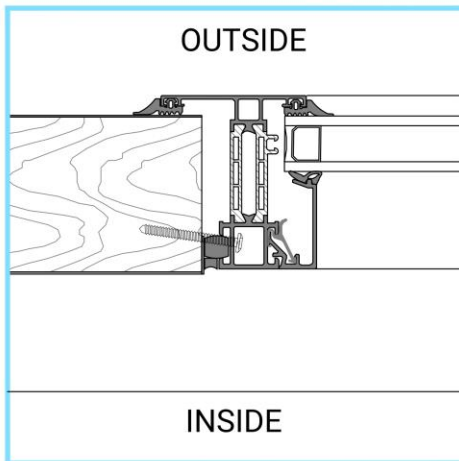
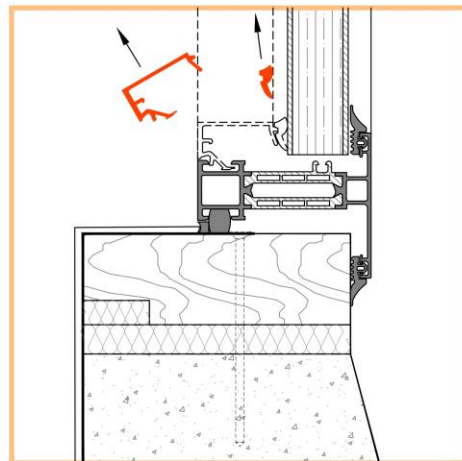
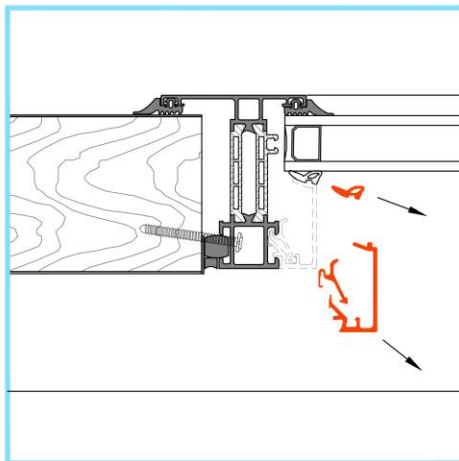

Figure 128: 3d View showing the Horizontal and Vertical sections used to demonstrate the Assessment modules. Source: Author.

Existing Condition



STEP 1:
Removal of Glazing Beading



STEP 2:
Removal of glass and Panelling

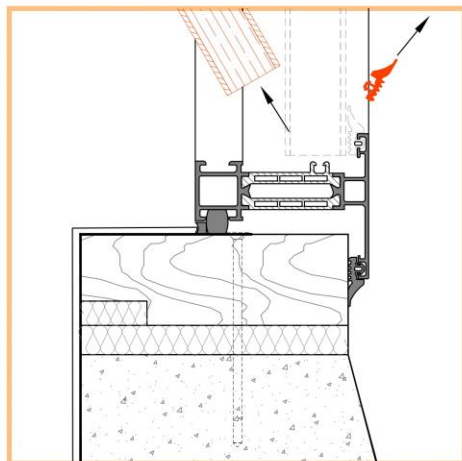
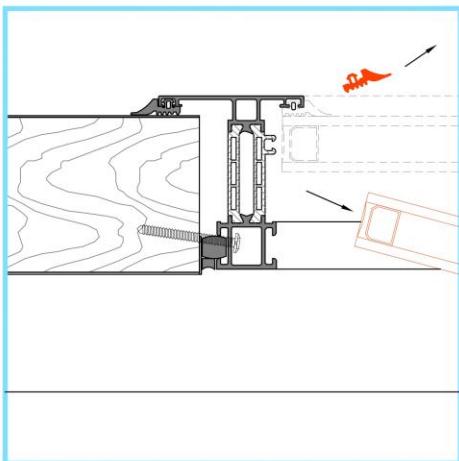
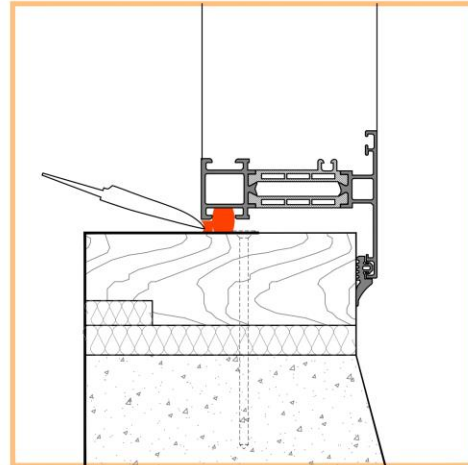
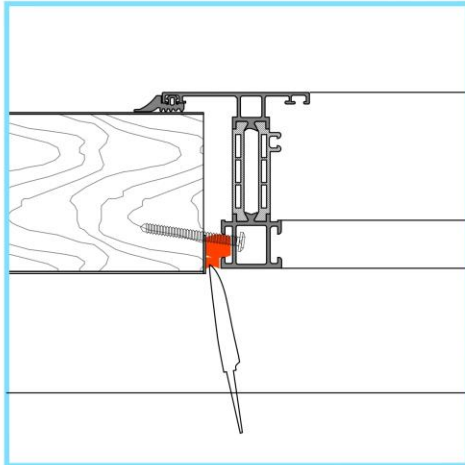
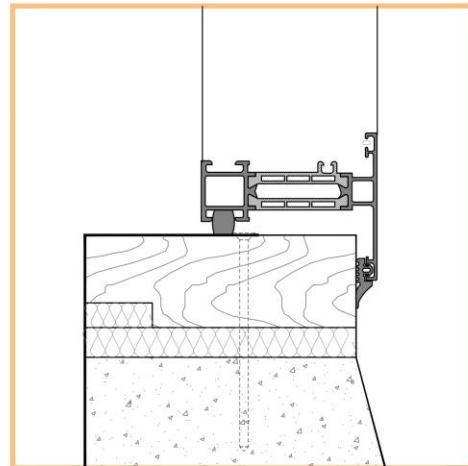
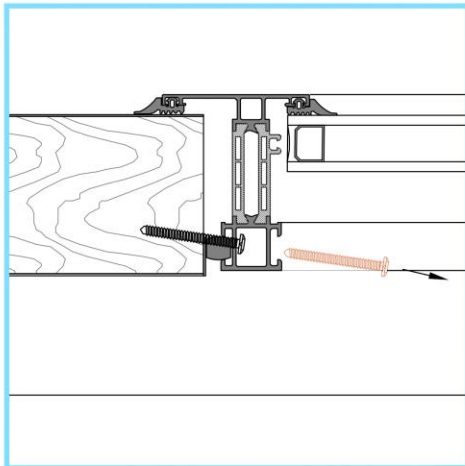

Figure 129: Disassembly Sequence of the CiTG Facade Frame. Source: Author

STEP 4:
Scrapping off Sealants



STEP 5:
Removal of Fixing Screws



STEP 6:
Removal of Outer Frame

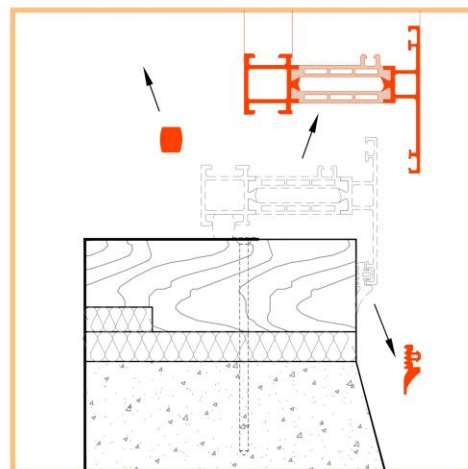
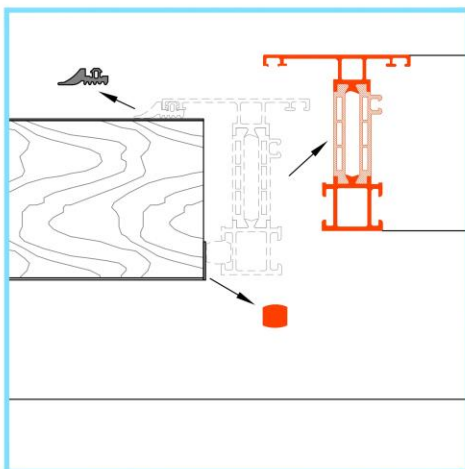

Figure 130: Disassembly sequence of the CiTG Facade Frame. Source: Author.

2. Condition Assessment: This requires high-resolution pictures, for processing and a standardized calculation method NEN 2767 is used and therefore not in the scope of the research. It can be assumed that all elements are in good condition with no severe defects.

3. Recyclability and toxicity: Based on information extracted from the Granta Edu Pack, the Aluminum profiles are recyclable, but the Polyamide extrusions are not. This is because of the Glass Fiber Content. So different process of separating the aluminum from the polyamide has to be employed. Since the two profiles are rolled in, a method to separate the two has to be developed.

4. Performance Data: This part could not be fully assessed as information about all the current standards a Façade has to employ is not publicly available in a centralized location. Navigating between the different calculation methods, testing methods, and extracting the minimum values required is a tedious task, and many of the standards have a pay-per-access clause. Therefore, it could not be summarized. Moreover, many values are categorized as classes and not as values, making it difficult to assess. There are conversion charts to enable this but are not available for all the values required. For structural performances, calculation sheets from Alkondor were studied, but navigating through this document was also tedious, especially when there is no summarized result which specifies whether the minimum standard is reached or not. No calculations are received for the thermal performance assessment, so only the System Manufacturers website values could be used. This can be used to assess the façade at an elementary level and has been evaluated. The details of the different values required for evaluation and what could be evaluated are given in Figure 131. Although the performance evaluation is not conclusive, the investigation further reinforces the requirement of information accessibility and standardization of material information.

| EoS Assessment summary of the CiTG Outer Frame | | | | |
|--|--|--|--|--|
| Assessment Module | Criteria | Result | Evaluation | Comments |
| DFD | Typology of façade | Unitized System with glass installed separately | Assessed as a Unitized system | |
| | Subcomponent accessibility | Outside | | Via scaffolding |
| | Disassembly direction | Outside | | Geometry of façade indicates disassembly can be done towards the outside. |
| | Connection type | Indirect | Façade can be disassembled | The façade is connected to a wooden post which is connected to the main building |
| | Assess component to building connection | Accesible without damage | | The façade connection is screwed to the wooden post which is accesible |
| | Connection type | Indirect connection seperable from the façade | | The façade is dependant on the wooden post and the sill to be installed |
| Condition assessment | Damanges | No Damage | Façade is free of damage | Assumed there is no damage due to lack of data |
| Recyclability and toxicity | Recyclability | Materials are sortable, only aluminium is recyclable | Profiles are recyclable, not polyamide | The seperation between the profiles and the polyamide is still uncertain, but current recycling trends of the façade industry suggests that it is possible to do so. |
| Performance Data | Thermal Insulation solid part | NA | NA | Not applicable as only the outer frame is evaluated |
| | Thermal Insulation individual Door/windows | 1.2W/m2K | Pass | Pass |
| | Thermal Insulation Façade glazing(average) | - | NA | Not applicable as only the outer frame is evaluated |
| | Air permeability | Class 4 | No result | Conversion required from Pa To class |
| | Water Tightness | Class 9A | Pass | 9A=600pa |
| | Burglary resistance | Up to RC2 | No result | Minimum standard to be followed is unknown |
| | Wind resistance | Class C5 | No result | No result can be established as the criterial involves the |
| | Fire Resistance of doors/windows | Unknown | No result | condition of neighbouring materials and the minimum |
| | Fire resistance of façade | Unknown | No result | standard to be followed is unknown. |
| | Acoustic performance | 45 dB | Pass | - |
| | Wind load resistance(max deflection) | Unknown | No result | The structural calualtion document does not have the result summerized and hence cannot be evaluated. |
| | Unknown | No result | | |
| Horizontal load resistance | Unknown | No result | | |

Figure 131: EoS Assessment summary of the CiTG Outer frame. Source: Author

9.8.4 *Design Parameters for Reuse*

In order to evaluate the reuse parameters of the façade, the exact drawings used to assess the DfD criteria of the façade are used.

1. Geometric Parameters: To evaluate the grid geometry, the front elevation of the façade indicates an orthogonal grid. The cryosection geometry indicates the facade as asymmetric overlapping towards the outside. The subdivision geometry can also be evaluated using the front elevations. While the sizes are not explicitly mentioned in any drawings, they can be evaluated by digitizing the drawing and scaling it.

Sizing and Positioning

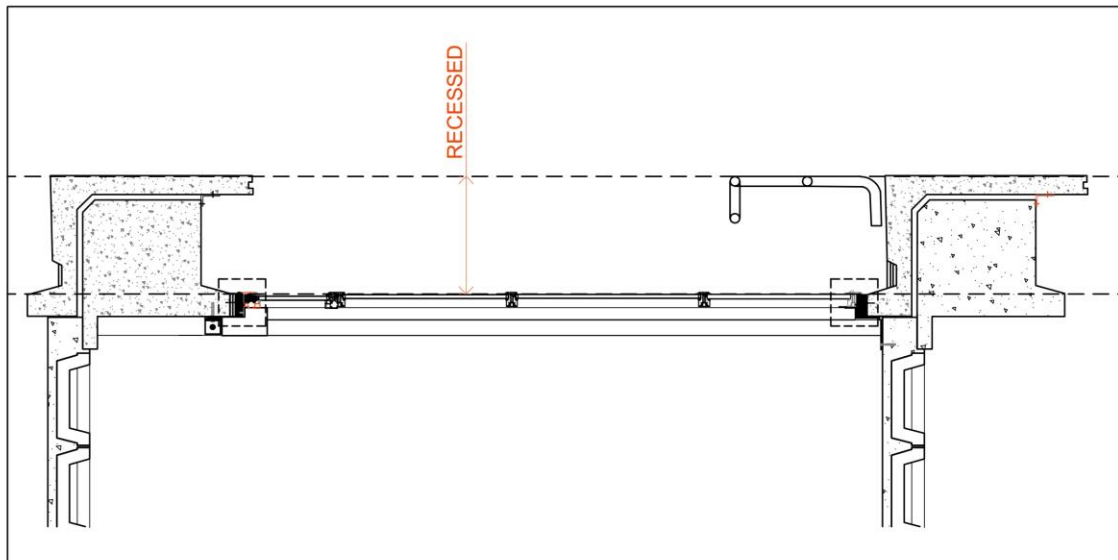

Facade Position

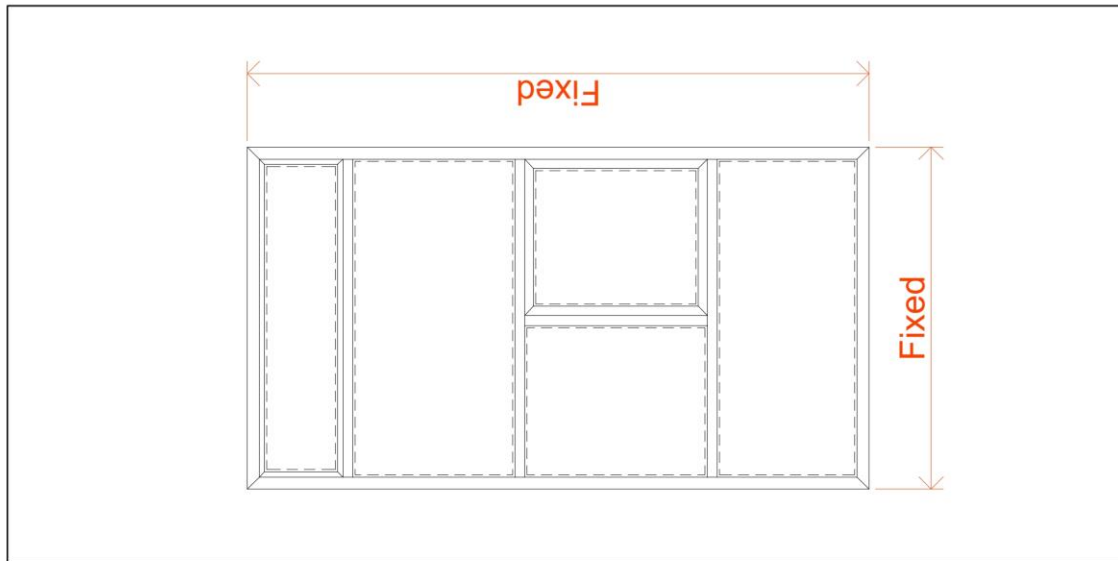

Dimensional Flexibility

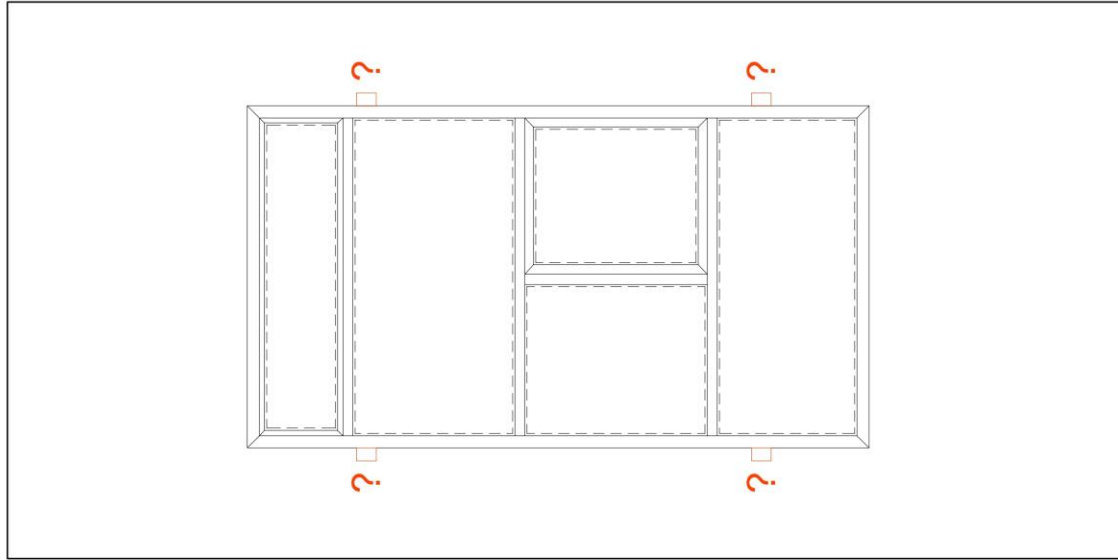

Connection Points

Figure 132: Evaluating the CiTG Facade based on existing information. Source: Author

GEOMETRIC PARAMETERS

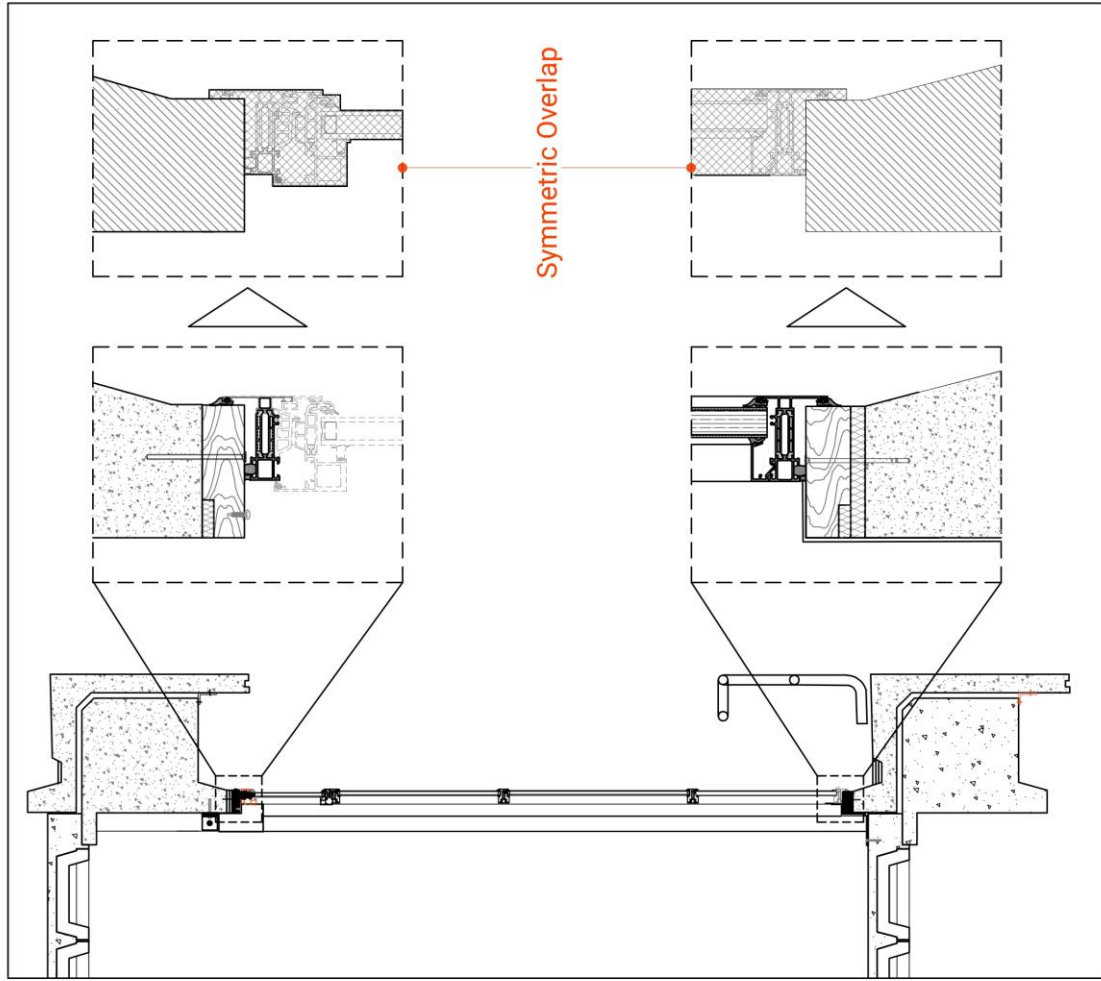

Cross-Section Geometry

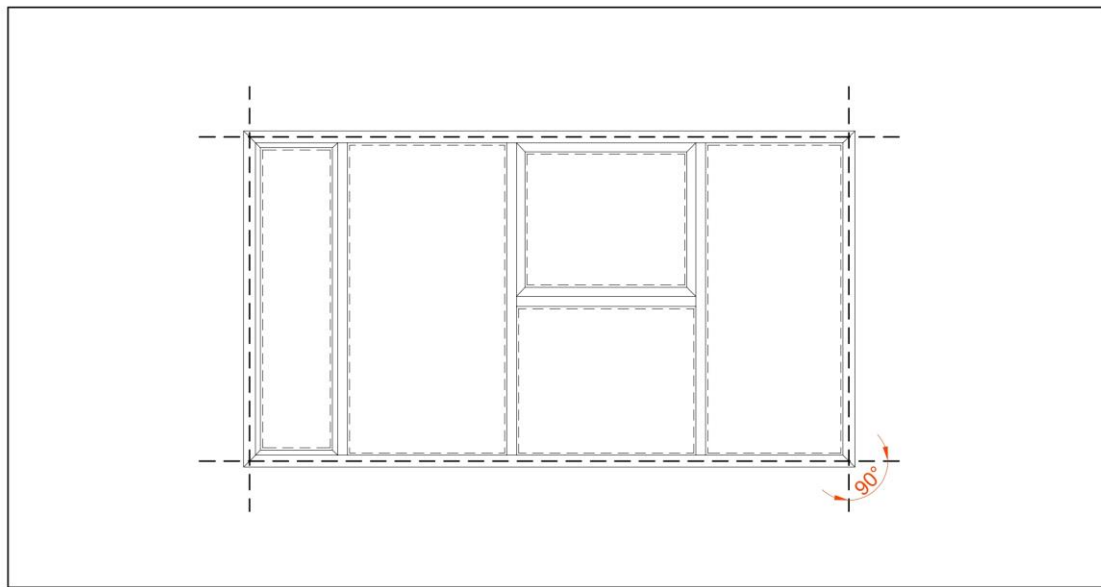

Grid Geometry

Figure 133: Evaluation of Geometric Parameters of the CiTG Facade Frame. Source: Author

VERTICAL AND HORIZONTAL TOLERANCES

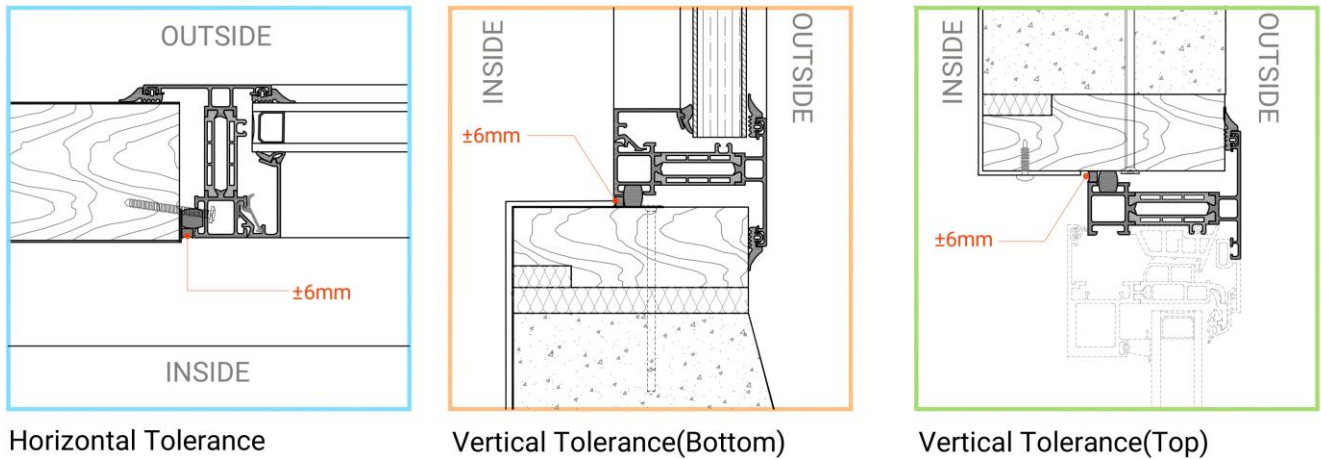

Figure 134: Overview of the Sizing and Positioning Parameters of the CiTG facade Frame. Source: Author

2. Sizing and Positioning: The cross-section drawing was studied to evaluate the positioning of the façade frame. The Façade is in an open position. No form of dimensional flexibility is indicated in any of the drawings. None of the drawings mention the tolerance and the locations where the façade is connected to the building. While tolerance data can be inferred from the digital version of the document, as shown in Figure 135, connection points can only be inferred after a physical inspection. The overall size of each panel is given in the elevation drawings. Functional Parameters: The horizontal section indicates a support structure required to fix the façade frame. So, the Façade is structurally dependent on a third element, as shown in Figure 135.

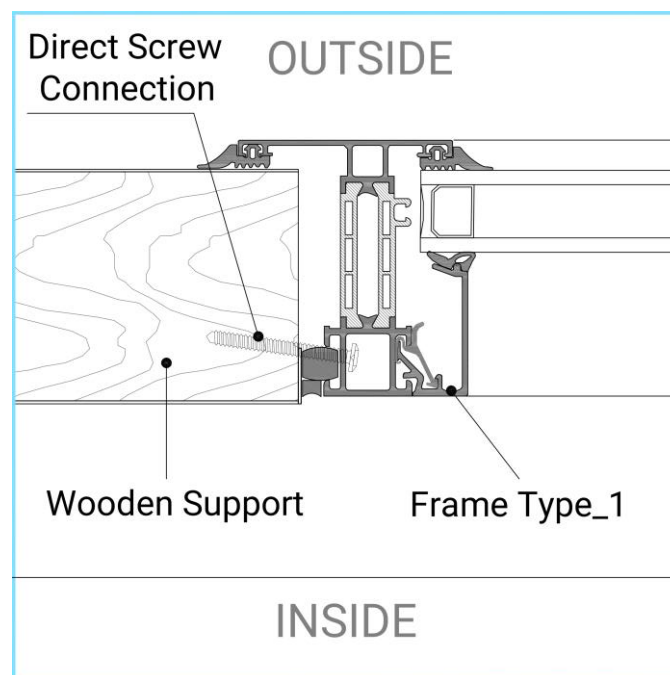

Figure 135: Overview of the Functional parameters of the CiTG Facade Frame. Source: Author

4. Quantities: Bill Of materials of the façade was not received, and no digital copy of the entire elevation of the façade is also given. Therefore, the surface areas of the façade could not be evaluated. Nevertheless, the elevation drawings also

contained the quantity of each of the different panels and, combined with the sizes, rough areas of each module can be estimated. It needs to be noted that these areas are excluding the support structures used for mounting the façade frame.

5. Summary of Design Parameters: Figure 136 summarizes all the parameters required to be evaluated when considering reusing this façade in a new building. Finding a suitable building for this façade system would be difficult because the façade is dependent on the connection type. The façade requires an additional support structure of a specified thickness, and the sizes of the façade frames vary across the building and are not modular. Therefore, a new building has to be designed to match the building, which means the inventorizing the façade, mapping it into a database of products, and made accessible to architects in the early design stage is crucial.

| Assessment Module | Criteria | Result | Evaluation | Comments |
|------------------------|---|----------------|------------|---|
| Function | Structural system | Direct support | | The wooden post is directly connected to the façade frame |
| Dimensional | Crosssection Geometry | See Drawing | | |
| | Grid geometry | Orthogonal | | Building should require an orthogonal grid |
| | Subdivision Geometry | See Drawing | | |
| Sizing and Positioning | Subcomponent grouping | Multiple types | - | |
| | Façade Position | Recessed | - | |
| | Dimensional Flexibility | None | | Facade sizes are not modifyable, and needs the new building to be designed with exact sizes to fit the façade modules |
| | Component to component toerlances | No data | | |
| | Element to Element Tolerances | No data | | |
| | Building to façade component tolerances | No data | | |
| | Connection points | See Drawing | | |
| Sizes | A01 | 1725X3129 | | |
| | A01-1 | 1697X3129 | | |
| | A02 | 1725X3129 | | |
| | A02-1 | 1697X3129 | | |
| | A03 | 1067X3129 | | |
| | A04 | 1545X3129 | | |
| | A04-1 | 1229X3129 | | High degree of variability, lack of modular sizing |
| | A05 | 1699X3129 | | |
| | A07-2 | 1000X1300 | | |
| | A07-1 | 2150X1300 | | |
| | A07 | 2129X1224 | | |
| | A06-1 | 1699X3129 | | |
| | A06-1 | 1699X3129 | | |
| | A05 | 1699X3129 | | |
| Areas | A01 | 895.98915 | | |
| | A01-1 | 100.888347 | | |
| | A02 | 895.98915 | | |
| | A02-1 | 100.888347 | | |
| | A03 | 126.868434 | | |
| | A04 | 183.70359 | | |
| | A04-1 | 7.691082 | | |
| | A05 | 106.32342 | | |
| | A07-2 | 2.6 | | |
| | A07-1 | 2.795 | | |
| | A07 | 2.605896 | | |
| | A06-1 | 42.529368 | | |
| | A06-1 | 63.794052 | | |
| | A05 | 106.32342 | | |
| Number of Modules | A01 | 166 | | |
| | A01-1 | 19 | | |
| | A02 | 166 | | |
| | A02-1 | 19 | | |
| | A03 | 38 | | |
| | A04 | 38 | | |
| | A04-1 | 2 | | Less quantities of certain odd sizes, harder for finding suitable match. Unique sizes with low quantities are not preferable. |
| | A05 | 20 | | |
| | A07-2 | 2 | | |
| | A07-1 | 1 | | |
| | A07 | 1 | | |
| | A06-1 | 8 | | |
| | A06-1 | 12 | | |
| | A05 | 20 | | |

Figure 136: Summary of Design Parameters of the CiTG facade frame for reuse evaluation. Source: Author.

9.9 Conclusions

By evaluating the decision modules, certain vital conclusions can be made to improve the information delivery standards of relevant stakeholders.

1. A template to navigate calculation sheets along with summarized values would go a long way in extracting relevant information.

2. Although VMRG, on their website, has defined all the performance requirements for a façade, an additional step needs to be made to categorize these standards based on the façade typology. Also, a tool can be developed so that Façade Engineers and Façade Builders can enter relevant calculations and determine whether the current standards are matched. Such a tool can be made modular so that it can adapt to changing standards.

3. Documentation standards are essential for EoS assessment. Even if standards are difficult to employ, stakeholders must set up data templates to ensure summarized versions of the most crucial information are categorized and stored in the Façade Product Passport. The EoS Assessment Framework is a starting point for the development of such a template.

10 Answering research Questions

10.1 Research Questions

How can a conceptual framework be developed to collect, organize and store the information exchanged in the lifecycle of a Unitized metal façade to enable decision making at its end of service (EoS)?

The answer to this central question is structured in a series of sub-questions that are read sequentially. Sub question 1 identifies the stakeholders involved in the lifecycle of a façade and specifies their roles. All the stakeholders in the lifecycle of a façade directly or indirectly influence the End of Service condition of a façade in the supply chain, and a thorough mapping of it is required to ensure the framework addresses these influences. Sub Question 2 addresses the stakeholder interaction during the lifecycle stages to determine the information exchanged in this process. Sub Question 3 looks at how this information can be acquired, stored, and organized and provides a framework for Façade Product passports. Lastly, sub-question 4 looks in-depth into the decision-making process and identifies the information required to make a decision. This would then help determine the crucial information necessary for the decision-making process.

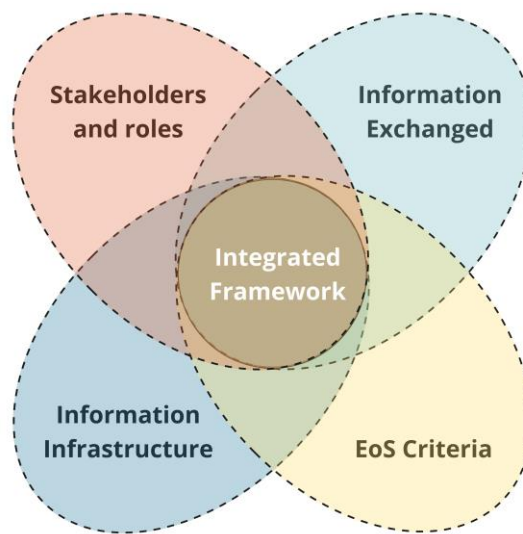

Figure 137: Schematic diagram of the main aspects considered for the development of the framework. Source: Author.

In the present research, these four parts of the conceptual framework are addressed strategically, identifying and bringing together these four diverse topics in a novel way, thereby creating a framework. While defining the important points in each part and defining a research methodology defines how a framework can be created. However, it also means that the framework isn't completed. The process has to be repeated with additional refinement and involving disciplines concerning façade design and manufacturing and information technology and in collaboration with academia who are constantly developing new methods of evaluating Façade systems. The method needs to be also repeated to take into account multiple façade typologies other than a Unitized Metal façade and map out the influence of all the other materials such as glass, rubber gaskets, silicone sealants, and the connections to the building. This reputation can be done with the present research as a framework and eventually progress towards a more robust framework to achieve the main goals of the Circular Façade Economy.

The detailed answers to each sub-questions that address the different areas of the framework are defined below.

1. What are the various stages in the circular lifecycle of a Unitized metal façade, and who are the main stakeholders involved?

Klien (2013) identifies the stages involved in producing a façade as detailed in Chapter 2.2.1, along with the stakeholders involved in each stage. These stages can be split into a Design Phase and the forward logistics phase when the façade transforms from a digital drawing to a manufactured product. After the Operate and maintain phase, termed the Reverse Logistics phases of a Facade, the stages are less defined due to the lack of existing frameworks. J.M.Leos (2020) defines this based on the Butterfly Diagram by EMF, as shown in Chapter 2.2.2. Other than that, there is still ongoing work on which stakeholder is responsible for the Reverse logistics process and can vary a lot based on the different contractual models employed. VMRG, the Dutch metal Façade association, is currently defining different service levels. Here the Producer of the Façade is made responsible for the reverse logistics phases based on the different Business models as shown in Figure 27, in Chapter 2.3. While this is being implemented and is yet to become an industry standard, current market trends indicate that new stakeholders such as Urban Miners, independent demolition/deconstruction companies, material warehouses, and even online marketplaces are directly and indirectly responsible for the reverse logistics phases of a façade.

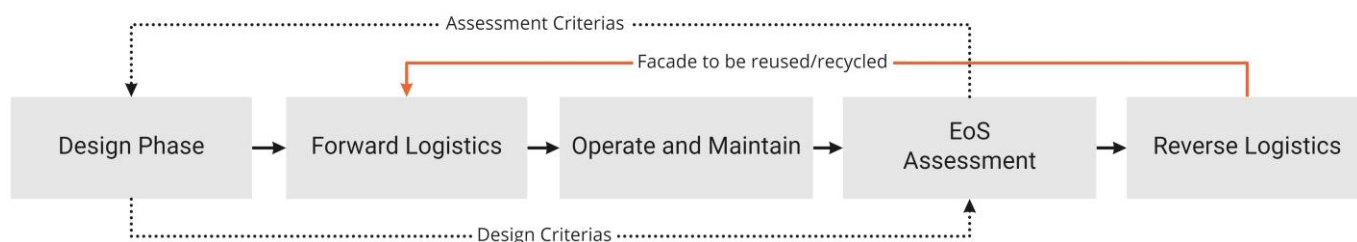

Figure 138: Schematic overview of the Lifecycle of a facade. Source: Author.

Apart from the forward and reverse logistics phases, an additional phase is introduced during this research, i.e., the End of Service (EoS) assessment stage. This stage is necessary to be introduced in the lifecycle of a façade, as currently, there isn't sufficient time to determine the best use case of a façade before its deconstruction. Multiple stakeholders confirmed this during the interviews. Therefore, by combining all of the phases mentioned above, a summarized scheme of the Circular Lifecycle of a façade is indicated in Figure 128, with the more detailed one mapped in the Lifecycle-stakeholder-data map in Figure 50, Chapter 5.2. The stakeholders are categorized as primary and secondary stakeholders in the Lifecycle-stakeholder data map depending on their involvement with the material flows. Primary stakeholders directly handle the material, such as manufacturing, processing, transportation, assembly, etc. Indirect stakeholders are mainly decision-makers who direct the material flows based on certain regulations, standards, or business models.

The following is an overview of the stakeholder roles in the Circular Façade Industry as understood during this research.

- 1. Raw Material Provider:** The stakeholder is involved in the early stage of a facade's lifecycle, mining raw materials and supplying them to manufacturing companies. No stakeholder who was surveyed or interviewed in the survey identified themselves with this role.
- 2. Product/System Manufacturer:** The system manufacturer designs the products and oversees the production of the various components which are required for his product. For example, the actual act of converting the raw material to a particular shape may be carried out by a company subcontracted by the system manufacturer. However, the assembly of the different materials which make up a system is done within the System Manufacturers facility. Essentially the system manufacturer collects different materials from various material manufacturing industries to make up their product.
- 3. Product/System Supplier:** The system supplier is in charge of taking orders from different clients, managing the logistics of collecting the materials from the product manufacturer and supplying it to the building site, or a Façade Builders workshop role is explained later. In many cases, the system supplier becomes a mediator between the system manufacturer and the client and advises which products are more suited for the project.

4. Façade Engineer: The façade engineer works closely with architects and MEP consultants, extracts their requirements, and converts them into a façade design through additional calculations and analysis. The façade design will have specifications of the materials used and how they are assembled schematically with proof that the desired performance values are achieved. They then hand over this information to the façade builder and oversee converting the detailed design to something that can be executed.

5. Façade Builder: The façade builder is in charge of converting a detailed façade design into a built façade. In order to carry this out, companies organize themselves into three different departments, i.e., the execution design team, manufacturing team, and the onsite team. The execution design team converts the design received from a façade designer to a fully buildable façade. Then, detailed calculations are carried out of each component based on regulations for approval. Once this is approved and depending on how the façade itself is designed, the manufacturing team orders the required façade products from the system supplier and modifies them to suit their requirements, and this can be in the form of sizing shaping and joining different elements together. Finally, the façade builder takes the pre-assembled components and installs them on the construction site. Sometimes the façade parts are already pre-manufactured by the system manufacturer and are sent directly to the construction site.

6. Façade Maintenance: Companies that inspect the façade and provide solutions to maintain and repair a façade based on defects. The façade maintenance can be a sub-team of façade builders or System manufacturers but can also exist as independent companies specializing in specific maintenance processes.

7. Building Owner: The person or company who initiates the project and, depending on the business model employed, is also in charge of financing the project.

8. Facility Manager: The person or company appointed by the building owner, who oversees the maintenance operations of a façade.

8. Urban Miner: Urban mining is a comprehensive specialization with very diverse roles. Based on survey and interviews, it was identified that they actively seek out buildings which are scheduled for demolition. Next, they identify the materials in these buildings and determine their value in the market. Based on this evaluation, they find suitable companies interested in using these materials and facilitating the transaction of these companies. In this process, they work with or appoint several smaller companies to carry out different tasks. Therefore, the business models employed can vary from case to case.

9. Façade Deconstruction: This role is currently not fulfilled by any stakeholder, but in general, it refers to companies who are aware of the technicalities involved in the assembly of a façade, such as a Façade builder, and therefore can carefully disassemble the façade into its constituent parts retaining the value of the material after its End of service.

10. General Contractor: Company responsible for the construction works of the building onto which the façade is installed. In many cases, the general contractor becomes a point of contact for architects to identify suitable façade builders, engineers, and suppliers. Nevertheless, his role would mainly be to ensure that the building is built according to specifications and is in a condition to receive the façade by continuously coordinating with the façade builder.

11. Architects: The company or person responsible for designing the building and determining the preliminary requirements of a façade. The available sizes, functions, geometries, and aesthetic appearance. In later stages, they become significant in deciding the façade system, among the options the façade supplier presents.

12. EoS Assessor: An End of Service assessor is a person or a company, either part of the Urban mining group or an independent regulatory body which assesses a façade to determine the highest value. As opposed to an urban miner, the EoS assessor is more aware of the technicalities of façade deconstruction and reuse.

12. Software companies: Due to the high level of digitization of the industry, software companies are slowly being integrated with the lifecycle of a façade. Currently, these are mostly asset management platforms, material passport platforms, and Digital Condition assessment platforms.

2. What kind of information is being exchanged between stakeholders during the circular lifecycle of a façade?

As no existing literature exists, at least in the public domain which addresses this subject, the answer to this question had to be generated from multiple sources based on a general study of the Façade Market. The first and most obvious sources are looking into manufacturer websites to determine what information has been displayed. Three of the most common products used in most buildings were identified and used, i.e., Sandwich panels, Aluminum Profiles, and Insulated Glass Units. This information is contained in brochures, CE markings, and EPD's. A long list of passport information (Appendix 15.8) is compiled using these sources and reference to a framework created by Heinrich and Werner (2019), which was also used to categorize this information. To determine information exchanged by other stakeholders in the lifecycle of a façade, surveys and interviews were the main methods used. The survey was designed with questions related to information exchange and software used, and during interviews, in-depth analysis and understanding of software workflows were determined. Also, questions related to what tasks are outsourced and what tasks are done in-house are noted. Process maps were generated of each lifecycle stage of a façade detailed in Chapter 7.2. In these process maps, the main information generated and used by stakeholders is mapped out corresponding to the actual task. A summarized list of the various information exchanged by stakeholders is tabulated in Figure 139. It needs to be noted that these results only give a partial understanding of all the information exchanged, as these were identified in the survey with stakeholders of very diverse expertise. But for the present research, this can be determined to be sufficient as it points out the main information recognized by these stakeholders more frequently and therefore can be considered the minimum information exchanged between them. A detailed study has to be carried out with a dedicated survey only focusing on information exchange with preferably larger sample size to arrive at a more comprehensive answer.

| Document received | Generated by | Phase of Project |
|---|---------------------------------|--|
| Desing drawings | Architect | Design Phase |
| Program of requirements | Architect | |
| Façade Detailed Drawings | Façade Engineer | |
| Façade Performance Calculations(prelimnary) | Façade Engineer | |
| Detailed Product requirements | Façade Builder | |
| Manufacturing drawings | Façade Builder | |
| Bill of Materials | Façade Builder | |
| Product Specifications | Façade Builder | Forward Logistics |
| Façade Assembly Notes/Instructions | Façade Builder | |
| Product Brochures and documentation | System Supplier | |
| CE Ratings of Façade Products | System Supplier | |
| EPD of Façade Products | System Supplier | |
| Bill of Materials with costs of products | System Supplier | |
| Handling Instructions | System Supplier | |
| Product Assembly instructions | System Supplier | Operate and Maintain Phase |
| Photographs of Façade Defects | Building Owner/Facility Manager | |
| Maintanance Procedure | Façade Maintanance | |
| Costs of repair | Façade Maintanance | Operate and Maintain Phase, End of Service |
| Condition rating of elements | Urban Miners, Software company | |

Figure 139: Summary of Information Exchanged during the lifecycle of a Façade derived from the Process maps. Source: Author

3. How can the information generated during the lifecycle of a facade be acquired, structured, and organized in a Façade Product passport?

Now that the information exchanged, collected, and stored in the lifecycle of a façade is already mapped in the previous research question, it is essential to categorize how the same can be done in a Façade Product Passport. This would contribute to defining the Information Infrastructure of the Façade Product passport from the perspective of the domain. The research question is answered sequentially as follows

Data Structuring and Organization:

Many existing frameworks specify a data structure for Material Passports as what has been termed in this research as information levels. However, none of the frameworks specifically address Facades, so the information levels in a Façade have to be determined. Klien (2013) identified seven levels based on several transformations. For the present research, these transformations are mapped out based on the lifecycle of the Façade itself. Therefore, these levels become snapshots of information at different stages of a façade as defined in Chapter 5.1 and shown in Figure 49. An illustrated version of this is indicated in Figure 140. As the quality of the information in the passport platform increases from unstructured to structured formats, instead of these levels being snapshots of different stages, it can transform. The simplest example of this transformation would be the weight of a façade part. At the lower levels, only the weight of the individual component is recorded, and at higher levels, when objects are connected, the weight of all the objects in the lower levels is added up. Many such values can undergo this transformation, but instead of just an additive function in weight, other predefined can be used, based on the type of transformation to material undergoes. Defining this transformation of information is not in the scope of the research but is partially addressed during the case study demonstration.

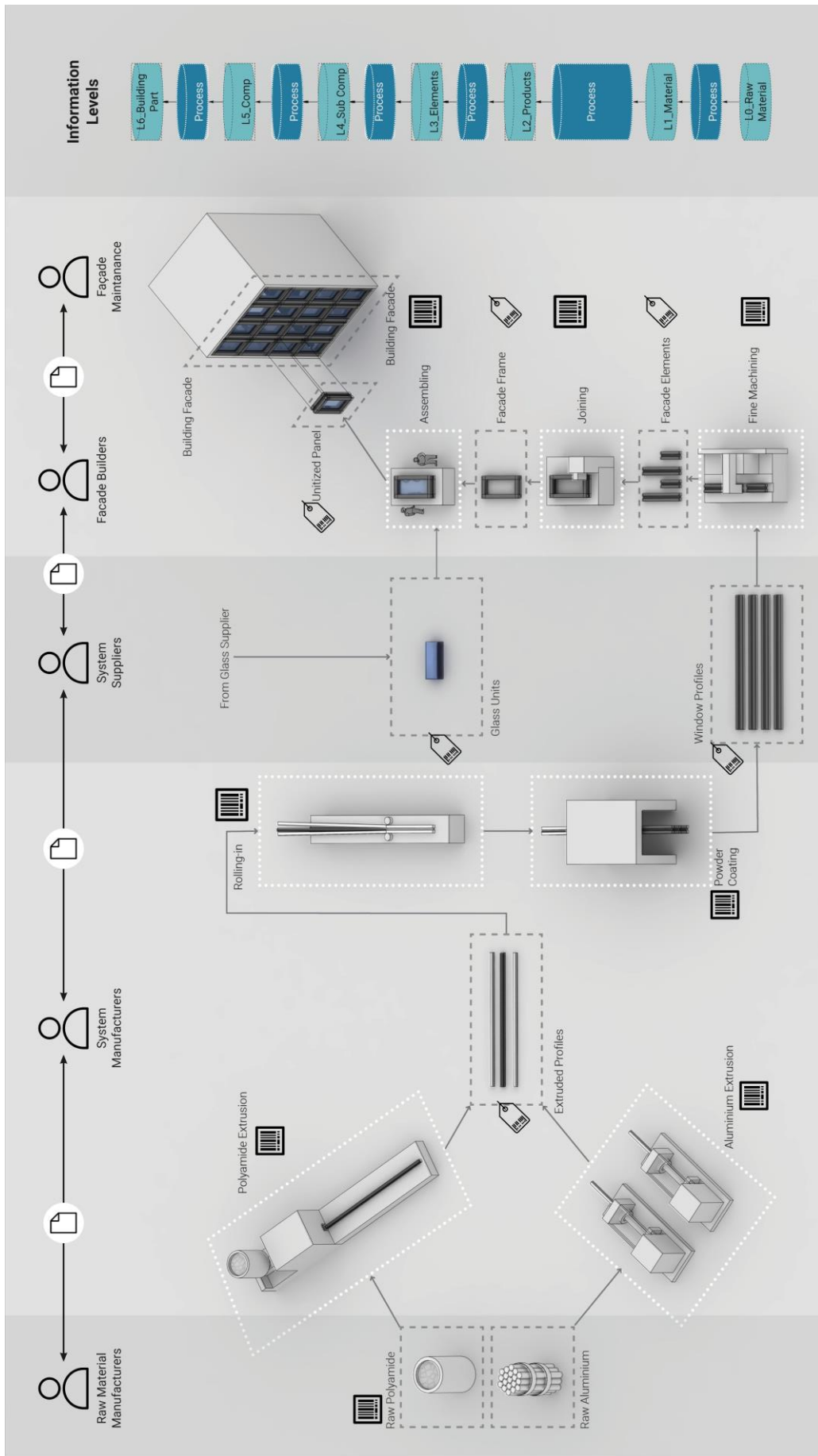

Figure 140: Information levels determined based on the lifecycle of a Unitized Façade. Source: Author.

Data Acquisition:

Currently, present trends (such as the Cirling and/or Madaster platform) indicate the use of Passport Platforms by one stakeholder at the end of the supply chain responsible for collecting information from all the previous stages. This makes it impossible to trace the information to the stakeholder in case certain aspects are not valid. To tackle this, a preliminary framework is defined in Chapter 5.2, Figure 51, which indicates the use of multiple stakeholders entering the respective information into the passport platform. But it defines a manual method of collecting information. However, in the long run, manual data entry is not sustainable considering the vast amount of information required to enter a Façade Product passport. Therefore, alternatives had to be identified. During the interviews, it was identified that many stakeholders use Document Managers to store and record information they generate and exchange, and are usually stored in a Local Network Server. It was also identified that while some stakeholders are already considering an eventual migration to the cloud. With this transitioning to the cloud, it becomes possible to link different sets of information from individual stakeholder archives to the Façade Product passport, ensuring the information is constantly updated. A similar set of information can be grouped into distributed databases, and a regulating body can control what information is stored in these individual databases. The long list of Passport information also gives an account of which stakeholder is responsible for what information, as indicated in Appendix 15.8. These databases, which would use blockchain technology, will generate unique IDs for each information generated by the stakeholder in the supply chain.

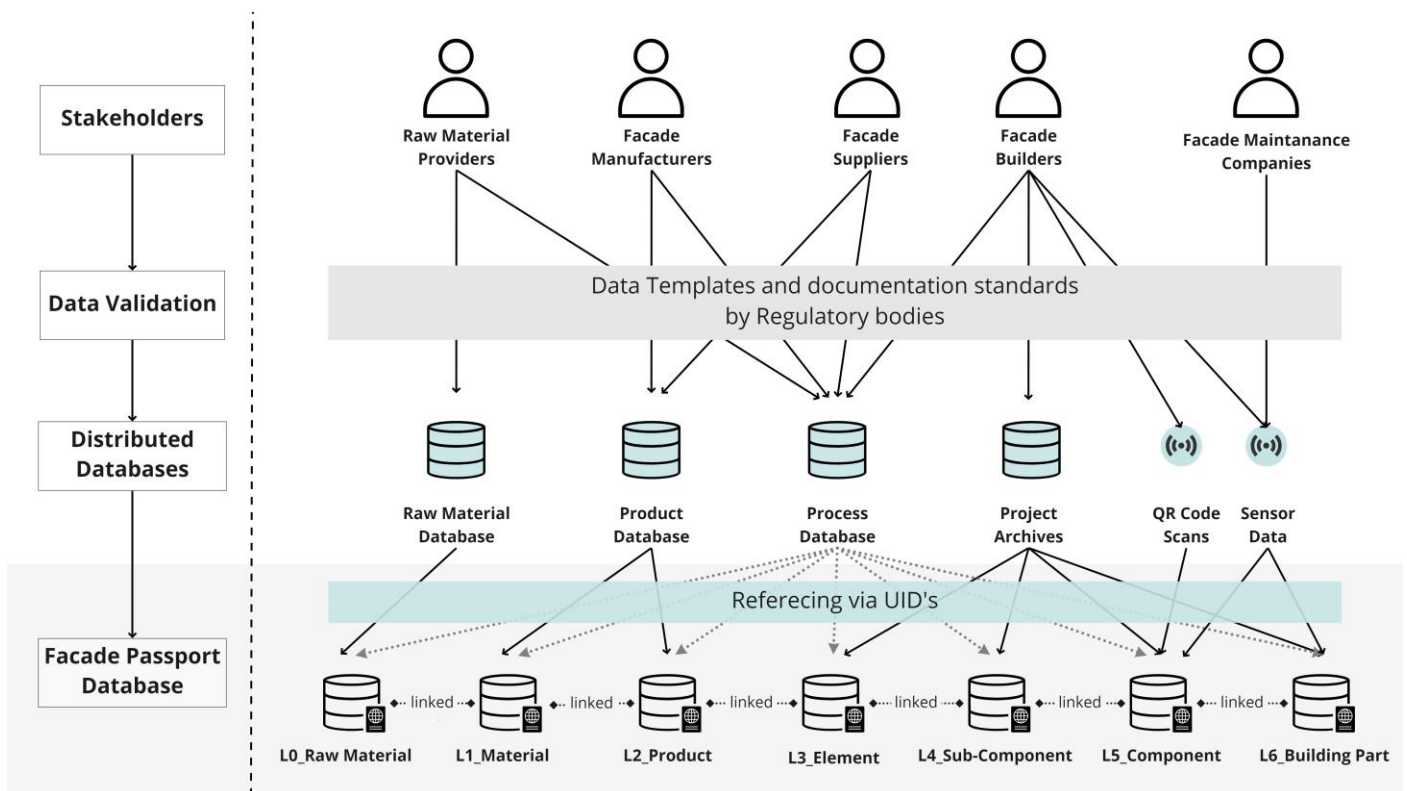

Figure 141: The Framework for facade product passports. Source: Author.

Data Storage:

As the framework's technological implications are outside the research's boundary condition, not much can be specified about the kind of infrastructure required to store passport formation. However, as elaborated in chapter X, most existing literature and frameworks mention blockchain use due to increased data security and transparency.

4. What kind of information about a façade is required to determine the various re-life options of a façade and how can it be stored in a façade product passport?

In order to determine the information required at EoS, the assessment process had to be first mapped out while parallelly looking into what information was generated during the lifecycle of a façade. The various criteria which influence the end of life decision-making are derived from Alba-Concepts (2019), Durmisevic (2006), and Beurskens et al. (2016). During this process, it was identified that many parameters which influence the circularity of a façade in the design stage also have a strong relation to parameters that determine if a façade can be reused, recycled, or remanufactured at its EoS. Apart from this, it was also identified that there is a level of subjectivity associated with determining these criteria and therefore, not all are automatically processable using computational methods. Hence the criteria had to be categorized based on subjectivity, and specific methods are applied to process each category as shown in chapter XX. Criteria that are more objective are processable using computational algorithms, and therefore a decision can be made, and subjective criteria are kept descriptive for the assessor to decide. These criteria are then organized using several decision trees through a back-and-forth iterative process while parallelly testing it with a case study. As shown in Figure 86, this organization is done by evaluating the façade for the highest EoS value, i.e., Reuse, and only if certain criteria in the decision tree fail are they evaluated for lower re-life values. Once the decision trees are finalized, they are further subdivided into smaller modules where the façade is redirected to a lower re-life value, as shown in Figure 87. After this process, the information required for each step in each decision tree is identified while referring to the information generated by stakeholders in the lifecycle of a façade. By using this, a summarized list of information required for the EoS assessment is Generated, as shown in Figure 142.

| Information Required for Condition Assessment | Possible Formats | Data Provided By | Product level |
|--|---|--------------------|-------------------|
| Current defects on the façade | High resolution photographs | Façade Maintenance | Component/element |
| | Aerial View Photographs | Façade Maintenance | Component/element |
| | Street View Photographs | Façade Maintenance | Component/element |
| Thermal Defects, leaks | Infrared Photographs | Façade Maintenance | Component/element |
| Type of defect, id of component, date of defect | Maintenance Log | Façade Maintenance | Component/element |
| ID of component, Location of Defect | Drawings, 3d Model, lists | Façade Maintenance | Component/element |
| Sizes of defects | Drawings, 3d Model, lists | Façade Maintenance | |
| Thermal Performance History | Outside/Inside temperatures | Facility manager | Component/element |
| Sizes of components | 2d Drawings | Façade Builder | Component/element |
| Information Required for DfD Assessment | Possible Formats | Data Provided By | Product level |
| Building to façade component connection | 2d Sections of components, 2d Elevations, 2d Plans, Assembly Sequence, 3d Model | Façade Builder | Component/element |
| | | Façade Builder | Component/element |
| | | Façade Builder | Component/element |
| Element to element connections | Table with Values | Façade Builder | Component/element |
| Component to component connections | | Façade Builder | Component/element |
| Residual values of materials | | Façade Builder | Component/element |
| Size of components | | Façade Builder | Component/element |
| Weight of components | | Façade Builder | Component/element |
| Presence, capacity and accessibility to elevator | Floor plan of building | Building Owner | Building |
| Presence of Building Maintenance Unit | Section of building | Building Owner | Building |
| Accessibility for scaffolding | Photographs of building | Building Owner | Building |
| Information Required for Typology Assessment | Possible Formats | Data Provided By | Product level |
| Spanning of mullions | Façade elevation | Façade Builder | Building Part |
| Spanning of transoms | | Façade Builder | Building Part |
| Element to element connections | Horizontal and Vertical Sections | Façade Builder | Component/element |
| Façade to Building Connections | | Façade Builder | Component/element |
| Information Required for Recyclability | Possible Formats | Data Provided By | Product level |
| Material composition | Table with values | Product Producer | Raw material |
| Presence of toxic elements | Table with values | Product Producer | Raw material |
| Recyclability | Boolean | Product Producer | Raw material |
| Calorific value | Value | Product Producer | Raw material |

Figure 142: List of Information required for EoS Assessment process. Source: Author

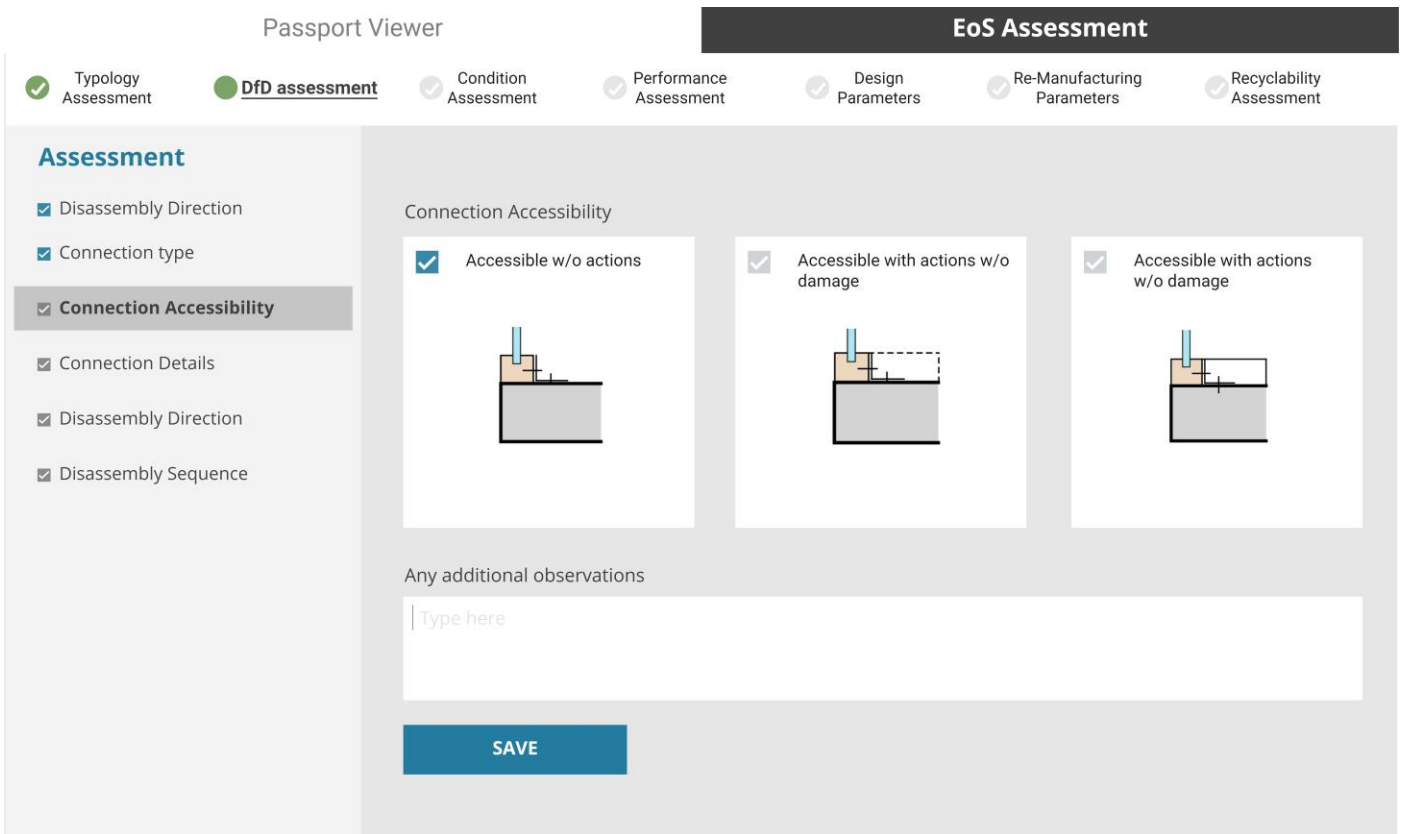

Figure 143: Schematic overview of the EoS assessment platform for enriching the passport with subjective design criteria. Source: Author

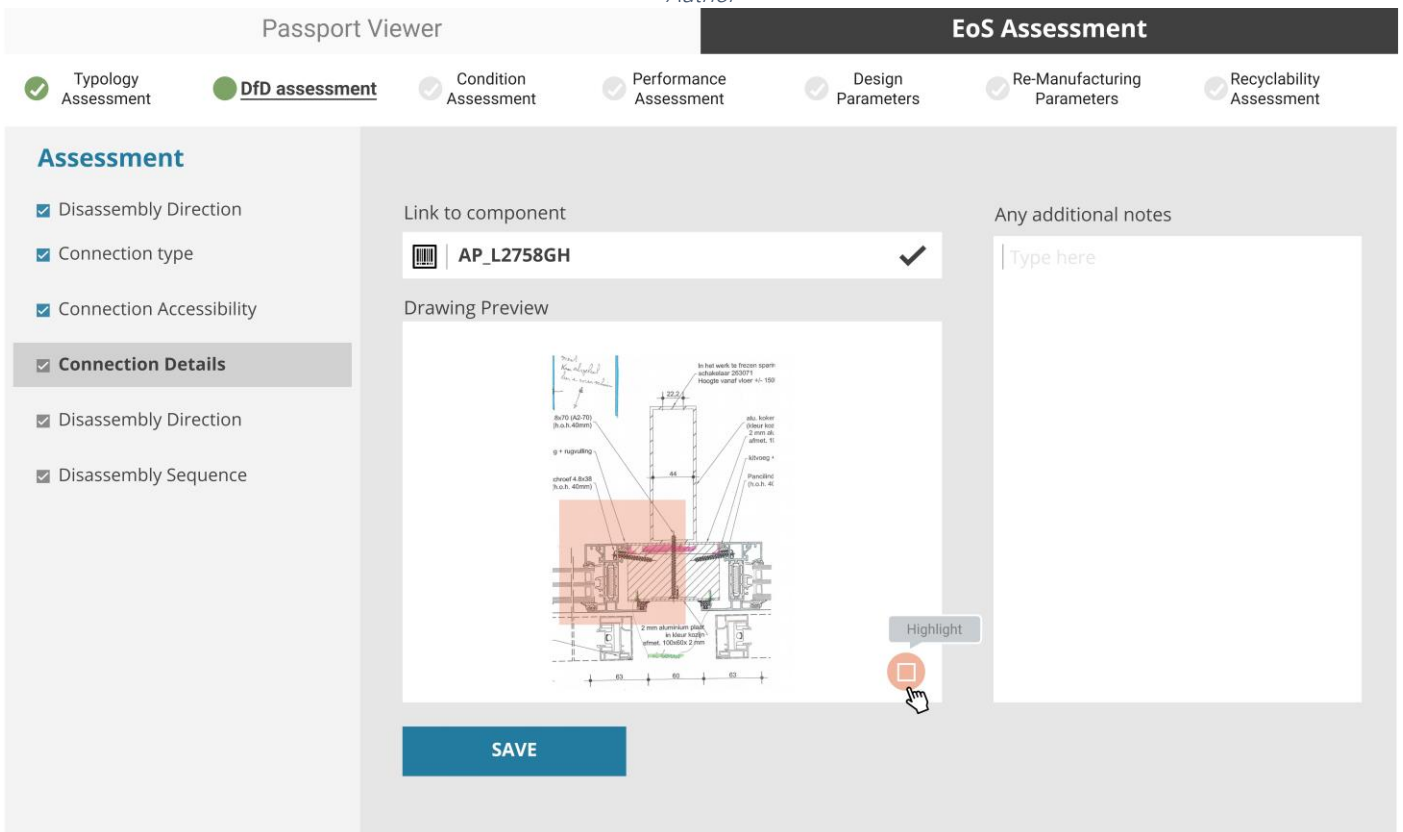

Figure 144: Schematic overview of the EoS assessment platform linking the subjective design criteria to the information in the passport platform. Source: Author.

10.2 Design Questions

How can the proposed conceptual framework organize the CiTG Façade to enable decision-making at its End of Service?

The main design question is answered similarly to the main research question. The first stage was collecting and identifying the information available, which is answered in Sub Question 1. The next stage is to organize and store the information as per the proposed data structure, which is answered in Sub Question 2, and lastly, the information is processed using the EoS decision-making model to determine the best re-use scenario of the CiTG Façade, from which additional reflection and conclusions are derived.

The individual findings of the sub-questions can be summarized in the Database Dashboards as shown in Chapters 9.7.4, 9.7.5 and 9.7.6. In addition, as shown in Chapter 9.6, an instance tree acts as a graphic where the database can be navigated and indicates the relationships of each instance in the façade and what information is referenced from the levels below each instance.

The EoS assessment explained in Sub question 3 is inconclusive as sufficient information was not present to process it. As the main objective is to demonstrate How an assessment can be carried out, having a conclusive answer isn't part of the research question. The findings of the EoS assessment are summarized in the EoS assessment dashboard, which can be summarized to be used in two situations as described below and shown in Figure 145.

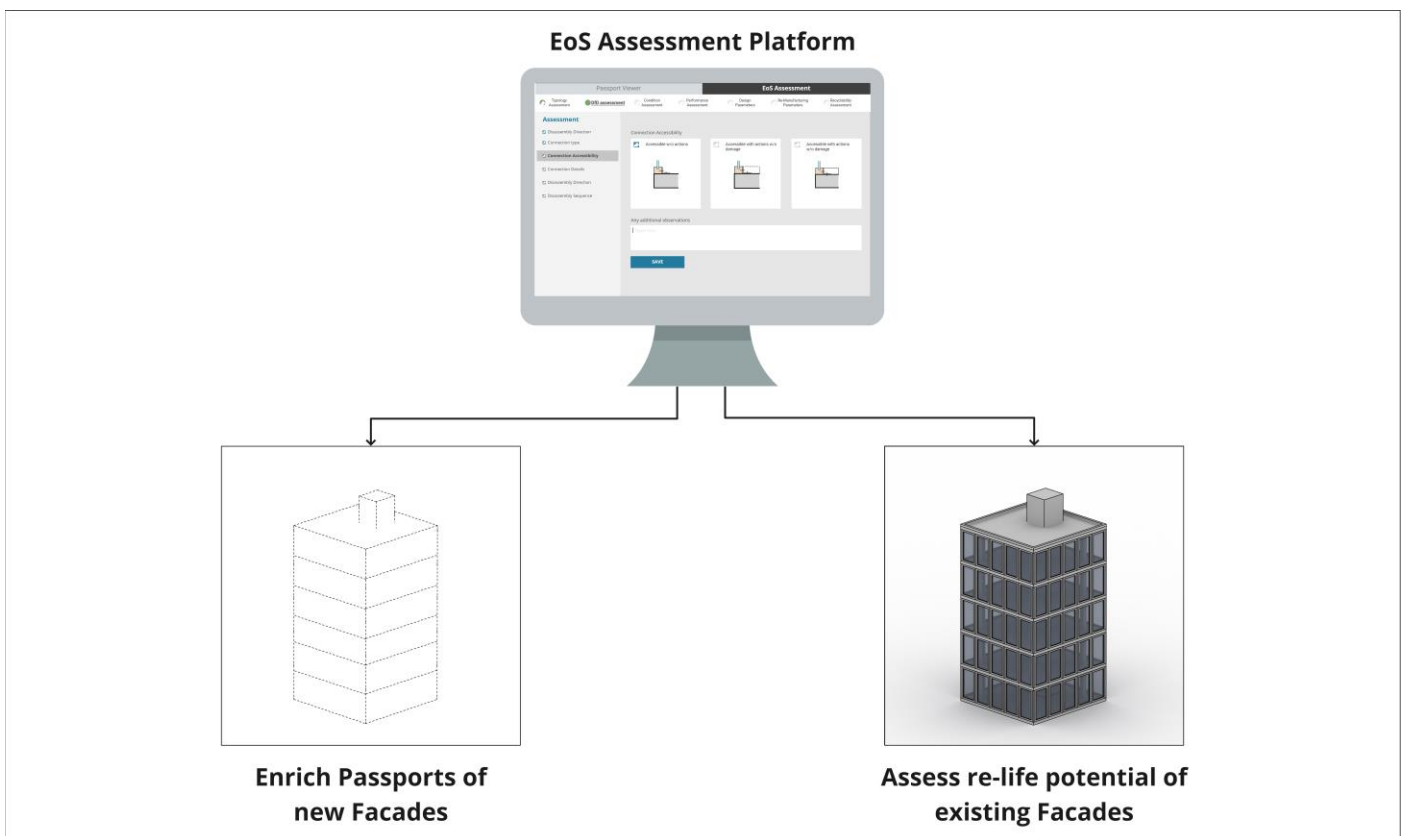

Figure 145: Uses of the EoS Assessment Platform. Source: Author.

1. Existing Buildings: The assessment dashboard navigates the user through the various assessment modules for existing buildings that need to be assessed. Depending on the available information quality, specific sets of information can be referenced and parallelly linked to each criterion for future use. At each screen, different assessment modules are displayed with spaces for humans to make a decision. In addition, areas, where information is processable can be automatically assessed.

2. For new buildings: For buildings that are yet to be demolished, information is already pre-linked to the respective criteria to enable an EoS assessor to easily assess the façade in 10-20 years. Also, the criteria for each façade are already pre-entered and based on the condition assessment and the performance assessment, which can have different outputs depending on the time of assessment, the final decision can be generated. The detailed answers to each of the sub-questions are as follows:

1. What kind of data is currently available about the CiTG façade, and what information can be extracted from it?

The following documentation was requested to Alkondor to use in the case study demonstration.

1. Drawings with product specifications
2. 3d/BIM model
3. Technical data sheets of the products used (CE mark, EPD or brochures or links)
4. Additional drawings to explain the assembly/disassembly instructions.
5. Design notes/construction instructions.
6. Results of analysis/calculations (structural, thermal, environmental, etc.) carried out during design of the facade
7. Maintenance data/records.

The information which was received from them has been categorized in Chapter 9.2. The missing information from the requested list was mainly maintenance data, 3d models, and digital versions. Drawings with design notes were handwritten in Dutch and hence were not decipherable. It may or may not have contained assembly and disassembly instructions, but it is clear that these partial drawings are not prepared as per their standard documentation set and therefore have not been considered. Apart from the information received from the Façade builder, additional information was extracted about the façade profiles from the system manufacturers' websites. The information specific to the exact façade model was not available on any website, and information on a similar product variant is referred for the research process. As the drawings are primary documents, it was not possible to measure anything from them. The drawings had to be redrawn to scale, and dimensions, etc., were derived from it. Since the case study was used in the research by J.M.Leos (2020), digital versions of the drawings generated could be retrieved.

2. How can this information be structured and organized using the proposed Façade Product passport framework?

Different data sets are created in an excel file to demonstrate the framework, each representing the various product levels already determined in Chapter 9.7. Higher product levels are not considered for evaluation as they are outside the boundary condition set for the research, which is only to process the façade frame. Processable information such as values, dimensions, weight, names, etc., are displayed in fields and organized according to the categories mentioned in Chapter 3.2. For non-processable information such as drawings and documents, links can be displayed, redirecting the user to the specific information. Most of the current information is in an unstructured format (i.e., drawings and documents). These are, for example, assembly instructions, handling instructions, calculation sheets, certifications, etc. For such documents, links can be given to either view or download the different documents, specific to the product level it caters to. Here the model viewer can redirect to where the component or the building part is located to access the different links.

3. How can the proposed EoS Decision making framework be used to process the information in the Façade Product passport of the CiTG façade to generate a decision at its end of service?

As per the information sufficiency check-in Chapter 9.8.1, it was noted that not all the information required to perform the end of service assessment is available. Therefore, the EoS assessment could not be processed sequentially, but each module of the EoS Decision model was processed individually based on the information available. Chapter 9.8.3 gives an overview of all the criteria which were evaluated and the respective results. The end-of-life assessment suggests that the

Façade can be disassembled. The condition assessment could not be carried out, as there was no information, the implementation of technology required to perform the condition assessment is beyond the scope of this research. The performance assessment could not be thoroughly evaluated due to additional calculations needed for standards and the lack of a summarized data that certifies the façade employing relevant standards.

If the façade is in good condition and the performance values are as per current standards, it can be scheduled for reuse. In this case, the CiTG façade is more likely to be used in the early design stage, where the building design has to be matched to the façade, as indicated in chapter 8.9.5. When assessing the CiTG façade frame, it was found that while the aluminum extruded parts (AP_1, AP_2, AP_3, AP_4, AP_5) can be recycled, the thermal breaks (TB1_TB2) cannot be recycled as it contains glass fibers. An intermediate step is required to separate the aluminum and polyamide, and currently, there isn't an industry-standard process that enables this separation without damage to either of the components.

11 Conclusions

11.1.1 Recommendations to the Dutch Metal Façade Industry

The present research evaluated the current state of the art in the Dutch metal facade industry and identified the stakeholders, digital workflows, information exchange, and determined what is helpful at the end of life. Based on the research, conclusions are based on recommendations to the industry on several aspects listed below. However, this research is incomplete, and many more steps have to be taken to ensure a smooth transition to a Circular Façade Economy.

11.1.2 Information Exchange Guidelines

1. Accessibility of information: A standardized method of documenting façade information has to be developed for the entire industry, which specifies the information to be delivered and the format in which the information is organized. Therefore, a template can be created to access the relevant information required for assessment, and this template can be incorporated in the data structure and the passport viewer, redirecting the user to relevant information for assessment.

2. Notification of Façade Demolition: As is not much time between the moment in which a building is notified for demolition and the actual demolition process, it limits the quality of assessment which can be carried out. A possible solution is to ensure any building with a Metal Façade with a predefined minimum area of a façade has to notify the concerning bodies several months in advance to ensure the required EoS assessment is carried out. It also gives time for Urban miners to link the correct stakeholders to ensure the materials are reused at the highest value.

3. Harmonization of information formats across EU: As per chapter 8.9.5, several scenarios for reusing a façade are identified. In many cases, there is a change a suitable building is not found within the Netherlands, or the standards employed here disqualifies the façade to be reused. However, if the pool of available buildings is done pan-EU, there is a higher chance that a suitable building is found and the façade gets reused. In these cases, it could be beneficial if the main façade documentation is either translated or in a translatable format (such as a PDF).

Some stakeholders mention the willingness to share more information only at the EoS stage as per Survey result 3.16, and some mention, they want to be involved in the EoS process, which means they can process the information. 4. Data Transparency: Most stakeholders are concerned about sharing information that hinders their competitive advantage. This is a barrier for the circular façade economy, especially when facades need to be reused. Nevertheless, since a lifecycle of a façade is at least 10-20 years, this would highly depend on the company structure and business models employed at that time. Therefore, option one can be explored, where an embargo period is specified for façade information.

11.1.3 Design Guidelines

Many of the design criteria mentioned in Chapter 8.3.1, along with circular design principles developed by Beurskens et al. (2016) and Durmisevic (2006), can be considered for developing new façade systems. The criteria identified in Alba-Concepts (2019), although it helps in determining how detachable a building component is, gives criteria on how a facade can be designed. However, one of the main aspects found during the research is the high degree of customization present in current aluminum façade profiles and the high degree of variability in the product types. This could be attributed to the rate at which new products are being developed, which is less than two years, according to Survey Result 5.9. While innovation cannot be limited, one aspect to consider is reducing the amount of customization in a façade product. This ensures that any façade builder or façade deconstruction company can easily disassemble the façade, even if the necessary information is not present. This would mean using more standardized and simplified sections and connection systems and requiring less customized tools to assemble or disassemble the façade.

11.1.4 Moving forward

The framework is one of the first attempts to bridge various diverse topics together. It can be considered only a starting point to further progress in the entire development and implementation of Façade Product Passports, End of Life assessment frameworks, and eventually a fully autonomous Digital Twin of the entire Supply chain of the Façade Industry. With this vision in perspective, some critical next steps are identified for further continuation of this research.

1. Developing an Information model of Façade Product Passports: While the current project highlights the various aspects that need to be considered from the industry's perspective, the first next step would be to move towards developing an information model with the defined product levels and stakeholder interactions. This would mean defining classes, relationships, and attributes based on the longlist elaborated in Appendix 15.8

2. Completing case study documentation: Due to several limitations, including confidentiality, the CiTG Façade frame was not thoroughly documented in the framework intended. Therefore, complete documentation and demonstration of this framework would require several months as each element in the façade has to be categorized, organized, and structured in the product level logic. As TU Delft is partially involved in this, it could be a research topic to develop a database structure for the CiTG Façade to ensure all the required information at all the levels of the products are accessible. As mentioned earlier, currently, the information is recorded per component, and subcomponent information and the logic in which the façade is assembled are missing.

3. Repetition of the model on other similar facades: Due to time constraints, the framework was only tested on one façade typology, and therefore, feedback from this exercise cannot yet be fully incorporated. Other facades also need to be evaluated using this framework to determine more criteria that influence the EoS decision to further improve and refine this.

4. Developing new models for different facade typologies: The framework is only developed for a Unitized Façade system. The decision trees behind the framework can be drastically different when assessed for other façade typologies. Therefore, new models may need to be developed and evaluated. Facades already documented in the Technoldege Façade Design course form a strong basis for evaluating different façade types.

5. Database-driven computational workflows: The framework presents a new opportunity to develop workflows where predefined information about products such as size, geometry, connection type, grid size, and all the design parameters enlisted in Chapter 8.3.1 can be present in a database of a Façade Product passport. Current parametric design workflows mostly start with new parameters being defined at the beginning of every project. However, with a Circular Design approach, especially with reuse, workflows need to be developed to generate a façade configuration with predefined parameters from existing databases of Facades.

12 Survey and Interview respondents

12.1 List of Survey respondents

| Survey respondents | |
|------------------------|-------------|
| Name | Location |
| Metaglas Groep | Netherlands |
| Agentor N.V | Netherlands |
| Alkondor | Netherlands |
| Koninklijk Boon Edam | Netherlands |
| Hydro Building Systems | Netherlands |
| Aldowa B.V | Netherlands |
| Jansen by ODS, | Netherlands |
| Schedlebouw B.V, | Netherlands |
| Unkown Respondant | - |

12.2 List of interviewees

Following is the list of interviews which were held entirely keeping in mind the Coronavirus Pandemic.

| List of interviewees (followups in light blue+independent in grey) | | |
|--|---|---|
| Name | Role | Company |
| Stingo Huuderman | Project Coordinator Data and Circular Business Innovation | New Horizon Urban Mining B.V, Netherlands |
| Simon Pierce | Associate Director | Eckersley O'Callaghan, United Kingdom |
| Niels Dijkstra | Business Development and Customer Success Manager | Spotr, Netherlands |
| Gerrit Buitenhuis | Coordinator Technology, Innovation and Quality | VMRG, Netherlands |
| Ron Jacobs | Brand and Sustainability Manager | Jansen by ODS, Netherlands |
| Martijn Veerman | Specialist Circular Facades | Alkondor Hengelo BV, Netherlands |
| Janneke Verkerk | Senior Building Physics Engineer | Schedlebouw B.V, Netherlands |
| Nicky Tossings | Project Design Manager | Schedlebouw B.V, Netherlands |
| Heske Groendaal | Managing Director | Metaglass B.V, Netherlands |
| Antigoni Lampardi | Engineer | Aldowa, Netherlands |
| Misja van Hattum | Engineer | Aldowa, Netherlands |
| Frank Framau | Account Manager | Aldowa, Netherlands |

13 References

References

- Alonso, R., Borrás, M., Koppelaar, R. H. E. M., Lodigiani, A., Loscos, E., & Yöntem, E. (2019). SPHERE: BIM Digital Twin Platform. *Proceedings*, 20(1). doi:10.3390/proceedings2019020009
- Arup. (2019). Digital Twin: Towards a meaningful Framework.
- Azcárate-Aguerre, J. (2014). Façades as a Product-Service System: The potential of new business-to-client relations in the facade industry.
- Azcárate-Aguerre, J., den Heijer, A., & Klein, T. (2018). Integrated façades as a Product-Service System – Business process innovation to accelerate integral product implementation. doi:10.7480/jfde.2018.1.1840

- Azcarate, J., Klein, T., den Heijer, A., Vrijhoef, R., Ploeger, H., & Prins, M. (2018). Façade Leasing: Drivers and barriers to the delivery of integrated Façades-as-a-Service.
- Blum, A. (2001). "Building-Passport" - A tool for quality, environmental Awareness and Performance in the Building Sector
- Bocken, N., Bakker, C., & de Pauw, I. (2015). Product design and business model strategies for a circular economy.
- Boje, C., Guerriero, A., Kubicki, S., & Rezgui, Y. (2020). Towards a semantic Construction Digital Twin: Directions for future research. *Automation in Construction*, 114. doi:10.1016/j.autcon.2020.103179
- Boschert, S., & Rosen, R. (2016). Digital Twin—The Simulation Aspect. In P. Hehenberger & D. Bradley (Eds.), *Mechatronic Futures: Challenges and Solutions for Mechatronic Systems and their Designers* (pp. 59-74). Cham: Springer International Publishing.
- Brand, S. (1994). *How Buildings Learn: What Happens After They're Built*.
- Bruno, S., De Fino, M., & Fatiguso, F. (2018). Historic Building Information Modelling: performance assessment for diagnosis-aided information modelling and management. *Automation in Construction*, 86, 256-276. doi:<https://doi.org/10.1016/j.autcon.2017.11.009>
- Chesbrough, H. (2010). Business Model Innovation: Opportunities and Barriers. *Long Range Planning*, 43(2), 354-363. doi:<https://doi.org/10.1016/j.lrp.2009.07.010>
- Copeland, S., & Bilec, M. (2020). Buildings as material banks using RFID and building information modeling in a circular economy. *Procedia CIRP*, 90, 143-147. doi:10.1016/j.procir.2020.02.122
- Corona, B., Shen, L., Reike, D., Rosales Carreón, J., & Worrell, E. (2019). Towards sustainable development through the circular economy—A review and critical assessment on current circularity metrics. *Resources, Conservation and Recycling*, 151. doi:10.1016/j.resconrec.2019.104498
- Deloitte. (2017). Resource Efficient Use of Mixed Wastes Improving management of construction and demolition waste.
- Denis, F., Temmerman, N. D., & Rammer, Y. (2017). The potential of graph theories to assess buildings' disassembly and components' reuse: How building information modelling (BIM) and social network analysis (SNA) metrics might help Design for Disassembly (DfD)?
- Durmisevic, E. (2006). Transformable Building Structures.
- EEA. (2016). Circular economy in Europe.
- Heinrich, M., & Werner, L. (2019). Materials Passports- Best Practice.
- Honic, M., Kovacic, I., Gilmutdinov, I., & Wimmer, M. (2020). *Scan to BIM for the Semi-Automated Generation of a Material Passport for an Existing Building*.
- Honic, M., Kovacic, I., & Rechberger, H. (2019). Improving the recycling potential of buildings through Material Passports (MP): An Austrian case study. *Journal of Cleaner Production*, 217, 787-797. doi:10.1016/j.jclepro.2019.01.212

- Honic, M., Kovacic, I., Sibenik, G., & Rechberger, H. (2019). Data- and stakeholder management framework for the implementation of BIM-based Material Passports. *Journal of Building Engineering*, 23, 341-350. doi:10.1016/j.jobbe.2019.01.017
- Khajavi, S. H., Motlagh, N. H., Jaribion, A., Werner, L. C., & Holmstrom, J. (2019). Digital Twin: Vision, Benefits, Boundaries, and Creation for Buildings. *IEEE Access*, 7, 147406-147419. doi:10.1109/access.2019.2946515
- Klien, T. (2013). Integral Facade Construction: Towards a new product architecture for curtain walls.
- Laakso, M., & Kiviniemi, A. (2012). The IFC Standard: A Review Of History Development And Standardization.
- Linder, M., Sarasini, S., & van Loon, P. (2017). A Metric for Quantifying Product-Level Circularity. *Journal of Industrial Ecology*, 21(3), 545-558. doi:10.1111/jieec.12552
- Luscuere, L. M. (2017). Materials Passports: Optimising value recovery from materials. *Proceedings of the Institution of Civil Engineers - Waste and Resource Management*, 170(1), 25-28. doi:10.1680/jwarm.16.00016
- Morini, A. A., Ribeiro, M. J., & Hotza, D. (2019). Early-stage materials selection based on embodied energy and carbon footprint. *Materials & Design*, 178, 107861. doi:<https://doi.org/10.1016/j.matdes.2019.107861>
- Mullhall, D., Hansen, K., Luscuere, L., Zanatta, R., Willems, R., Bostrom, J., & Elfstorm, L. (2017). Frameworks for Material Passports. In.
- Qi, Q., & Tao, F. (2018). Digital Twin and Big Data Towards Smart Manufacturing and Industry 4.0: 360 Degree Comparison. *IEEE Access*, 6, 3585-3593. doi:10.1109/access.2018.2793265
- Rahla , K. M., Braganca, L., & Mateus, R. (2019). Obstacles and barriers for measuring building's circularity.
- Rosen, R., von Wichert, G., Lo, G., & Bettenhausen, K. D. (2015). About The Importance of Autonomy and Digital Twins for the Future of Manufacturing. *IFAC-PapersOnLine*, 48(3), 567-572. doi:<https://doi.org/10.1016/j.ifacol.2015.06.141>
- Sacks, R., Brilakis, I., Pikas, E., Xie, H. S., & Girolami, M. (2020). Construction with digital twin information systems. *Data-Centric Engineering*, 1. doi:10.1017/dce.2020.16
- Saidani, M., Yannou, B., Leroy, Y., & Cluzel, F. (2017). How to Assess Product Performance in the Circular Economy? Proposed Requirements for the Design of a Circularity Measurement Framework. *Recycling*, 2(1). doi:10.3390/recycling2010006
- Saidani, M., Yannou, B., Leroy, Y., Cluzel, F., & Kendall, A. (2019). A taxonomy of circular economy indicators. *Journal of Cleaner Production*, 207, 542-559. doi:10.1016/j.jclepro.2018.10.014
- Tao, F., Cheng, J., Qi, Q., Zhang, M., Zhang, H., & Sui, F. (2018). Digital twin-driven product design, manufacturing and service with big data. *The International Journal of Advanced Manufacturing Technology*, 94(9), 3563-3576. doi:10.1007/s00170-017-0233-1
- Tao, F., Cheng, Y., Cheng, J., Zhang, M., Xu, W., & Qi, Q. (2017). Theory and technologies for cyber-physical fusion in digital twin shop-floor 数字孪生车间信息物理融合理论与技术. *Computer Integrated Manufacturing Systems*, 23, 1603-1611. doi:10.13196/j.cims.2017.08.001
- Tchana, T., Ducellier, G., & Remy, S. (2019). Designing a unique Digital Twin for linear infrastructures lifecycle management.
- Virta, M., Hovorka, F., & Lippo, A. (2012). Building passport as a tool to evaluate sustainability of building.

Uncategorized References

Alba-Concepts. (2019). Report Measurement Method: Detachability For GPR Bbuilding And BREEAM-NL

Alba-Concepts. (2020). Exploration of producer responsibility for Facade construction.

Azcarate, J. A., Klien, T., & Heijer, A. d. (2019). Facade Leasing Demonstrator Project. Technical Delivery Report. (Final Published Version).

Beurskens, P., Ritzel, M., Durmisevic, E., Lichtenberg, J., & Durmisevic, E. (2016). A morphological design and evaluation model for the development of circular facades

Eekhout, M. (2008). Methodology for product development in architecture.

J.M.Leos, J. (2020). Facade Reverse Logistics- Acheiving Circularity by applying reverse logistics strategies for curtain walls and window facade constructions.

Platform-CB'23. (2020). Passports for the Construction Sector. *Version 2.0*.

Potting, J., Hekkert, M., & Worrell, E. (2017). Circular Economy Measuring Innovation In Product Chains.

14 List of Figures

| | |
|---|----|
| FIGURE 1: SYSTEM DIAGRAM OF THE CIRCULAR ECONOMY INDICATING THE TECHNICAL CYCLES. SOURCE: ADAPTED FROM EMF | 11 |
| FIGURE 2: THE 9R FRAMEWORK ADAPTED FROM POTTING ET AL. (2017) | 12 |
| FIGURE 3: WASTE MANAGEMENT SUMMARY OF EU NATIONS (2012). SOURCE: (DELOLITE, 2017) | 13 |
| FIGURE 4: RESEARCH METHODOLOGY. SOURCE: AUTHOR | 15 |
| FIGURE 5: CATEGORIZATION EMPLOYED FOR THE LITERATURE RESEARCH. SOURCE:AUTHOR | 16 |
| FIGURE 6: FLOW CHART OF THE SURVEY AND INTERVIEW PROCESS EMPLOYED. SOURCE: AUTHOR..... | 16 |
| FIGURE 7: EXAMPLE OF A PROCESS MAP. SOURCE: AUTHOR..... | 17 |
| FIGURE 8: EXAMPLE OF A DECISION TREE. SOURCE: AUTHOR | 17 |
| FIGURE 9: TIMELINE OF THE RESEARCH..... | 18 |
| FIGURE 10: LAYERS OF A BUILDING AND ITS RESPECTIVE LIFESPANS. SOURCE: AUTHOR, ADOPTED FROM BRAND (1994) | 21 |
| FIGURE 11 : COMMON FUNCTIONS OF A FACADE. SOURCE: ADAPTED FROM KNAACK, KLEIN, BILOW, AND AUER (2007)..... | 22 |
| FIGURE 12: DIFFERENT SPATIAL LEVELS OF EVALUATING CIRCULARITY AS DEFINED BY SAIDANI ET AL. (2017). SOURCE: AUTHOR..... | 23 |
| FIGURE 13: ADAPTATION OF THE TABLE USING NUMERICAL VALUES. SOURCE: ADAPTED FROM LINDER ET AL. (2017) | 23 |
| FIGURE 14: CLASSIFICATION OF THE REVIEWED METRICS. SOURCE: CORONA ET AL. (2019)..... | 24 |
| FIGURE 15: RATING SYSTEM BASED ON THE FULLFILLMENT LEVEL OF THE METRICS WHICH ARE COMPARED. SOURCE: AUTHOR | 24 |
| FIGURE 16: RESULTS OF THE EVALUATION OF CIRCULARITY INDICES, RANKED FROM HIGHEST TO LOWEST FULFILLMENT LEVELS. SOURCE: ADAPTED FROM CORONA ET AL. (2019). | 25 |
| FIGURE 17: RESULTS OF THE EVALUATION OF ASSESSMENT FRAMEWORKS, RANKED FROM HIGHEST TO LOWEST FULFILLMENT LEVELS. SOURCE: ADAPTED FROM CORONA ET AL. (2019)..... | 25 |
| FIGURE 18: INPUT OPTIONS OF THE EXCEL TOOL TO FIND SUITABLE INDICATORS. SOURCE: ADAPTED FROM A TOOL DEVELOPED BY SAIDANI ET AL. (2019). | 26 |
| FIGURE 19: CATEGORIZATION OF RESULTS FROM THE EXCEL TOOL AND SUMMARIZATION OF ALL THE REQUIRED DATA INPUT FOR PERFORMING THE CALCULATIONS. SOURCE: AUTHOR. | 27 |
| FIGURE 20: THE MORPHOLOGICAL DESIGN AND EVALUATION MODEL INDICATING A FACADE'S CIRCULARITY BASED ON 21 PROPERTIES. SOURCE: BEURSKENS & BAKX(2015) | 28 |
| FIGURE 21: STAGES OF A CONSTRUCTION PROJECT. ADAPTED FROM RIBA (2020, P. 40) | 29 |
| FIGURE 22: THE DESIGN AND CONSTRUCTION PROCESS FOR A CURTAIN WALL. SOURCE (KLIEN, 2013, P. 40) | 29 |
| FIGURE 23: STAKEHOLDER INVOLVEMENT IN THE LIFECYCLE OF A FAÇADE. SOURCE: KLIEN (2013) | 29 |
| FIGURE 24: FACADE REVERSE LOGISTICS BASED ON THE BUTTERFLY DIAGRAM. SOURCE (J.M.LEOS, 2020)..... | 30 |
| FIGURE 25: STAKEHOLDERS INVOLVED IN THE CIRCULAR LIFECYCLE OF A BUILDING. SOURCE: ADAPTED FROM HEINRICH AND WERNER (2019, P. 51) | 31 |
| FIGURE 26: CATEGORIZATION OF CIRCULAR BUSINESS MODELS. SOURCE: BOCKEN ET AL. (2015)..... | 31 |
| FIGURE 27: OVERVIEW OF DIFFERENT BUSINESS MODELS AND EXAMPLES. SOURCE: ADAPTED FROM (BOCKEN ET AL., 2015)..... | 32 |

| | |
|---|----|
| FIGURE 28: STAKEHOLDER FRAMEWORK FOR THE FAÇADE LEASING PROJECT. SOURCE: AZCARATE ET AL. (2018) | 33 |
| FIGURE 29: CATEGORIZATION OF BUSINESS MODELS WHICH CAN BE EXPLORED UNDER THE CIRCULAR FAÇADE ECONOMY. SOURCE: AUTHOR..... | 34 |
| FIGURE 30: CLASSIFICATION OF MATERIALS PASSPORTS. SOURCE: HEINRICH AND WERNER (2019) | 36 |
| FIGURE 31: CATEGORIZATION OF THE CONTENTS OF THE MATERIAL PASSPORT. SOURCE: PARTIALLY ADAPTED FROM (HEINRICH & WERNER, 2019) | 37 |
| FIGURE 32: SYSTEMATIZATION OF FACADES FOR ASSEMBLY/DISASSEMBLY SEQUENCING. SOURCE: ADAPTED FROM DURMISEVIC (2006) | 38 |
| FIGURE 33: 1-DRAWING A TYPICAL CURTAIN WALL, TWO THE PRODUCT LEVELS AND RELATIONAL DIAGRAM, 3- COMPARISONS OF PRODUCT PROFILES OF MULTIPLE FACADES STUDIED AS PART OF THE RESEARCH. SOURCE: ADAPTED FROM KLIEN(2013) | 38 |
| FIGURE 34: USES OF MATERIAL PASSPORT IN VARIOUS STAGES. SOURCE: COPELAND AND BILEC (2020) | 39 |
| FIGURE 35: EXAMPLE OF PRODUCT LEVELS EMPLOYED IN A BIM-BASED MATERIAL PASSPORT. HONIC, KOVACIC, SIBENIK, ET AL. (2019) | 40 |
| FIGURE 36: WORKFLOW EMPLOYED FOR A BIM-BASED MATERIAL PASSPORT. SOURCE: HONIC, KOVACIC, SIBENIK, ET AL. (2019) | 41 |
| FIGURE 37: INTRODUCTION OF A MATERIAL PASSPORT CONSULTANT AS A MEDIATOR FOR LINKING DATA BETWEEN THE DESIGNER AND BIM MANAGER. SOURCE: COPELAND & BILEC(2020) | 42 |
| FIGURE 38: CONCEPTUAL FRAMEWORK FOR A MATERIAL PASSPORT. SOURCE:MULLHALL ET AL(2017). | 43 |
| FIGURE 39: FRAMEWORK OF THE MADASTER MATERIAL PASSPORT PLATFORM. SOURCE: WWW.DUURZAAM-ONDERNEMEN.NL..... | 43 |
| FIGURE 40 SCREENSHOT OF THE MADASTER PLATFORM WITH THE LAYERS OF THE BUILDING. SOURCE: THENEWBUILDERS.NL | 44 |
| FIGURE 41: GENERAL OVERVIEW OF THE CIRLIQ PLATFORM. SOURCE: CIRLIQ.NL | 44 |
| FIGURE 42: MODELLING GUIDELINES FOR CIRLIQ BY ILS GEVEL. SOURCE: VMRG.NL | 45 |
| FIGURE 43 - DIGITAL TWIN, PERCEIVED AS AN EXTENDED INTELLIGENT VERSION OF A BIM MODEL. SOURCE: KHAJAVI, MOTLAGH, JARIBION, WERNER, AND HOLMSTROM (2019) | 48 |
| FIGURE 44 - DIGITAL TWIN AS AN EVOLUTIONARY SYSTEM DERIVED FROM A DIGITAL MODEL. SOURCE: TCHANA ET AL. (2019)..... | 48 |
| FIGURE 45: COMPONENTS OF A DIGITAL TWIN. SOURCE: BOJE ET AL.(2020) | 49 |
| FIGURE 46: LIFECYCLE OF A DIGITAL TWIN COMPARED TO A TYPICAL BUILDING LIFECYCLE. SOURCE: SACKS ET AL. (2020). | 50 |
| FIGURE 47 - OVERVIEW OF USES AND FEATURES OF A DIGITAL TWIN. SOURCE: AUTHOR WITH ADAPTATION FROM VARIOUS SOURCES. | 51 |
| FIGURE 48 - 3 TIER EVOLUTION OF THE CONSTRUCTION DIGITAL TWIN. SOURCE: (BOJE ET AL., 2020). | 52 |
| FIGURE 49: DIAGRAM INDICATING PRE-EXISTING DEFINITIONS OF PRODUCT LEVELS IN THE FACADE AND THE PROPOSED PRODUCT AND INFORMATION LEVEL RELATIONSHIPS. SOURCE: AUTHOR..... | 55 |
| FIGURE 50: THE STAKEHOLDER LIFECYCLE AND DATA MAP OF THE CIRCULAR LIFECYCLE OF A FACADE. SOURCE: AUTHOR..... | 56 |
| FIGURE 51: A PRELIMINARY FRAMEWORK FOR A FACADE PRODUCT PASSPORT AND ITS USES. SOURCE: AUTHOR | 57 |
| FIGURE 52: AN EXCERPT FROM THE LONG LIST OF INFORMATION THAT A FACADE PRODUCT PASSPORT CAN CONTAIN. SOURCE: AUTHOR | 58 |
| FIGURE 53: CRITERIA USED TO ORGANIZE THE LONG LIST OF FACADE PRODUCT PASSPORTS. SOURCE: AUTHOR..... | 58 |
| FIGURE 54: SUMMARIZED VERSION OF THE CIRCULAR LIFECYCLE OF A FACADE AND THEIR INTER-RELATIONSHIPS. SOURCE: AUTHOR..... | 59 |
| FIGURE 55: ROLES OF THE SURVEY RESPONDENTS IN THE LIFECYCLE OF THE FACADE. SOURCE: AUTHOR | 61 |
| FIGURE 56: CATEGORIZATION OF QUESTIONS AND USE OF THE RESULTS IN THE PROPOSED FRAMEWORK. SOURCE: AUTHOR. | 62 |
| FIGURE 57: ANALYSIS OF THE GENERAL FUNCTIONS OF STAKEHOLDERS. SOURCE: AUTHOR..... | 62 |
| FIGURE 58: ANALYSIS OF THE LEVEL OF AWARENESS AND IMPLEMENTATION OF CIRCULAR PRINCIPLES IN THE DUTCH FACADE INDUSTRY. SOURCE: AUTHOR | 63 |
| FIGURE 59: ANALYSIS OF THE STAKEHOLDER INTERACTION IN THE DUTCH FACADE INDUSTRY. SOURCE: AUTHOR..... | 64 |
| FIGURE 60: ANALYSIS OF THE INFORMATION EXCHANGED IN THE DUTCH FACADE INDUSTRY. SOURCE: AUTHOR..... | 65 |
| FIGURE 61: ANALYSIS OF DOCUMENTATION METHODS USED IN THE DUTCH FACADE INDUSTRY. SOURCE: AUTHOR. | 66 |
| FIGURE 62: DESCRIPTIVE ANALYSIS OF THE DIGITAL METHODS USED IN THE DUTCH METAL FACADE INDUSTRY. SOURCE: AUTHOR. | 67 |
| FIGURE 63: CATEGORIZATION AND DESCRIPTION OF THE LIST OF SOFTWARE USED BY SURVEY RESPONDENTS. SOURCE: AUTHOR..... | 68 |
| FIGURE 64: DESCRIPTIVE ANALYSIS OF THE TECHNICAL ASPECTS OF FACADE MAINTENANCE. SOURCE: AUTHOR..... | 69 |
| FIGURE 65: DESCRIPTIVE ANALYSIS OF DIGITAL CONDITION ASSESSMENT METHODS. SOURCE: AUTHOR..... | 69 |
| FIGURE 66: DESCRIPTIVE ANALYSIS OF INFORMATION EXCHANGE IN THE DUTCH FACADE INDUSTRY. SOURCE: AUTHOR. | 70 |
| FIGURE 67: STAGES AND STAKEHOLDERS INVOLVED IN THE DESIGN PHASE OF A FACADE. SOURCE: AUTHOR. | 71 |
| FIGURE 68: SOFTWARE WORKFLOW USED IN THE DESIGN AND EXECUTION STAGE OF A FACADE. SOURCE: AUTHOR | 72 |
| FIGURE 69: PROCESS MAP WITH INFORMATION EXCHANGED IN THE DESIGN PHASE OF A FACADE. SOURCE: AUTHOR..... | 73 |
| FIGURE 70: OVERVIEW OF THE FORWARD LOGISTICS PROCESS AND THE STAKEHOLDER INTERACTION FRAMEWORK. SOURCE: AUTHOR..... | 74 |
| FIGURE 71: PROCESS MAP WITH THE INFORMATION EXCHANGED DURING THE FORWARD LOGISTICS PROCESS OF A FACADE. SOURCE: AUTHOR..... | 75 |
| FIGURE 72: OVERVIEW OF THE DIGITAL WORKFLOW USED BETWEEN THE DESIGN AND FORWARD LOGISTICS PHASE. SOURCE: AUTHOR..... | 76 |
| FIGURE 73: STAKEHOLDER INTERACTION COMPARISONS BASED ON DIFFERENT CONTRACTUAL MODELS. SOURCE: AUTHOR. | 77 |

| | |
|---|-----|
| FIGURE 74: ILLUSTRATION COMPARING THE MAINTENANCE PROCESS CARRIED OUT CURRENTLY WITH AND WITHOUT A MAINTENANCE PLATFORM. SOURCE: AUTHOR..... | 78 |
| FIGURE 75: PROCESS MAPS ARISONS BETWEEN DEFECT-BASED MAINTENANCE AND ROUTINE MAINTENANCE WITHOUT A DIGITAL PLATFORM. SOURCE: AUTHOR..... | 79 |
| FIGURE 76: PROCESS MAPS BETWEEN DEFECT BASED MAINTENANCE AND ROUTINE MAINTENANCE WITH A DIGITAL PLATFORM. SOURCE: AUTHOR. | 80 |
| FIGURE 77: A SCREENSHOT OF THE SOLIDWORKS PDM TREEHOUSE MODEL NAVIGATOR. SOURCE: JAVELIN TECHNOLOGIES..... | 81 |
| FIGURE 78: COMPARISON OF THE EXISTING AND PROPOSED DATA ACQUISITION METHODS. SOURCE: AUTHOR. | 82 |
| FIGURE 79: SCREENSHOT OF GRANTA EDU PACK, AN EXAMPLE FOR A RAW MATERIAL DATABASE. SOURCE: GRANTA EDU PACK. | 83 |
| FIGURE 80: EXAMPLE OF A PRODUCT DATABASE. SOURCE: BIMOBJECT.COM | 84 |
| FIGURE 81: OVERVIEW OF THE PROPOSED DISTRIBUTED DATABASE METHOD OF DATA ACQUISITION. SOURCE: AUTHOR | 85 |
| FIGURE 82A CONCEPTUAL OVERVIEW OF THE INPUTS AND OUTPUTS EXCEPTED FROM THE EoS ASSESSMENT PROCESS. SOURCE: AUTHOR..... | 87 |
| FIGURE 83: SCHEMATIC DIAGRAM OF THE TYPICAL PROGRESSION OF THE ASSESSMENT PHASE TO MERGE AND OCCUR DURING THE OPERATION OF A BUILDING. SOURCE: AUTHOR. | 87 |
| FIGURE 84: PROCESSES AND STAKEHOLDERS AT THE END-OF-LIFE ASSESSMENT PROCESS FOR EXISTING BUILDINGS. SOURCE: AUTHOR | 88 |
| FIGURE 85: CATEGORIZATION OF ASSESSMENT CRITERIA BASED ON THE LEVEL OF SUBJECTIVITY. SOURCE: AUTHOR | 90 |
| FIGURE 86: THE ORGANIZING LOGIC USED TO DEVELOP THE EoS ASSESSMENT FRAMEWORK. SOURCE: AUTHOR..... | 91 |
| FIGURE 87 OVERVIEW OF THE ASSESSMENT MODULES IN THE END-OF-LIFE ASSESSMENT PROCESS..... | 91 |
| FIGURE 88 SCHEMATIC DIAGRAM INDICATING ACCESS LEVELS OF THE DATABASE BASED ON THE CLUSTERING OF A FACADE. SOURCE: AUTHOR. | 92 |
| FIGURE 89: SCHEMATIC DIAGRAM INDICATING THE RELATIONSHIP BETWEEN FACADE TYPOLOGIES AND CLUSTERING OF MATERIALS. SOURCE: AUTHOR | 93 |
| FIGURE 90: OVERVIEW OF THE INFORMATION REQUIRED FOR THE TYPOLOGY SELECTION MODULE. SOURCE: AUTHOR..... | 93 |
| FIGURE 91: FLOWCHART OF THE TYPOLOGY ASSESSMENT MODULE. SOURCE: AUTHOR | 94 |
| FIGURE 92: SCHEMATIC OVERVIEW OF THE CRITERIA TO BE ASSESSED IN THE DfD MODULE. SOURCE: AUTHOR, PARTIALLY ADOPTED FROM BEURSKENS ET AL. (2016) AND ALBA-CONCEPTS (2019) | 95 |
| FIGURE 93: INFORMATION REQUIRED AND STAKEHOLDER RESPONSIBILITY FOR DfD MODULE. SOURCE: AUTHOR. | 96 |
| FIGURE 94: DECISION TREE OF THE ACESIBILITY AND DISASSEMBLY CRITERIA AS PART OF THE DfD MODULE. SOURCE: AUTHOR..... | 97 |
| FIGURE 95: DECISION TREE OF THE CONNECTION TYPE CRITERIA AS PART OF THE DfD MODULE. SOURCE: AUTHOR. | 98 |
| FIGURE 96: OVERVIEW OF THE CONDITION ASSESSMENT PROCESS OF FACADES USING EMERGING TECHNOLOGY. SOURCE: FACADESERVICEAPPLICATIE.NL . | 99 |
| FIGURE 97: OVERVIEW OF COMMON DEFECTS IN ALUMINUM PROFILES. SOURCE: VMRG WORKSHOP. | 99 |
| FIGURE 98: OVERVIEW OF INFORMATION REQUIRED AND STAKEHOLDERS RESPONSIBLE FOR CONDITION ASSESSMENT. SOURCE: AUTHOR | 100 |
| FIGURE 99: DECISION TREE OF THE CONDITION ASSESSMENT PROCESS. SOURCE: AUTHOR..... | 101 |
| FIGURE 100: OVERVIEW OF INFORMATION REQUIRED FOR RECYCLABILITY ASSESSMENT. SOURCE: AUTHOR. | 102 |
| FIGURE 101: OVERVIEW OF INFORMATION REQUIRED FOR EVALUATING PERFORMANCE VALUES OF A FACADE. SOURCE: AUTHOR..... | 103 |
| FIGURE 102: SUMMARY OF PARAMETERS WHICH AFFECT THE DESIGN OF THE FAÇADE AND THE BUILDING AT REUSE. SOURCE: AUTHOR..... | 103 |
| FIGURE 103: OVERVIEW OF THE GEOMETRIC PARAMETERS FOR REUSE ASSESSMENT. SOURCE: AUTHOR..... | 104 |
| FIGURE 104: SIZING AND POSITIONING PARAMETERS FOR REUSE ASSESSMENT. SOURCE:AUTHOR..... | 106 |
| FIGURE 105: SIZING AND POSITIONING PARAMETERS FOR REUSE ASSESSMENT. SOURCE: AUTHOR..... | 107 |
| FIGURE 106: FUNCTIONAL PARAMTERS FOR REUSE ASSESSMENT. SOURCE: AUTHOR..... | 108 |
| FIGURE 107: VARIOUS SCENARIOS FOR REUSE OF A FACADE. SOURCE: AUTHOR. | 110 |
| FIGURE 108: PHOTOGRAPH OF THE CITG EAST FACADE(LEFT), AERIAL IMAGE OF THE CITG BUILDING EAST FACADE(RIGHT). SOURCE: FACADE LEASING GROUP(LEFT), GOOGLE(RIGHT)..... | 112 |
| FIGURE 109: IMAGE WITH THE OVERVIEW OF THE CITG FACADE PROTOTYPE PROPOSED BY ALKONDOR. SOURCE: J. A. AZCARATE ET AL. (2019) | 112 |
| FIGURE 110: OVERVIEW OF INFORMATION RECEIVED FROM THE FACADE BUILDER. SOURCE: AUTHOR | 113 |
| FIGURE 111: OVERVIEW OF INFORMATION RECEIVED FROM THE SYSTEM MANUFACTURER'S WEBSITE. SOURCE: AUTHOR..... | 113 |
| FIGURE 112: PARTS FROM THE CITG PANEL A-01 INCLUDED FOR THE DEMONSTRATION. SOURCE: AUTHOR..... | 114 |
| FIGURE 113: IDENTIFICATIONS OF THE DIFFERENT PARTS IN THE CITG FACADE FRAME. SOURCE: AUTHOR. | 115 |
| FIGURE 114: LIST OF IDENTIFIERS IN THE PROCESS DATABASE. SOURCE: AUTHOR | 116 |
| FIGURE 115: LIST OF IDENTIFIERS OF CONNECTION TYPES IN THE PROCESS DATABASE. SOURCE: AUTHOR..... | 116 |
| FIGURE 116: ORGANIZATION OF THE CITG FACADE FRAME PARTS INTO PRODUCT LEVELS. SOURCE: AUTHOR. | 117 |
| FIGURE 117: INFORMATION CONTAINED WITHIN THE IDENTIFIER 'AL_EXTRUSION' IN THE PROCESS DATABASE. SOURCE: AUTHOR | 118 |
| FIGURE 118: INFORMATION CONTAINED WITHIN THE IDENTIFIER "SCREW" IN THE PROCESS DATABASE. SOURCE: AUTHOR | 118 |
| FIGURE 119: INFORMATION IN IDENTIFER PA66_25% GF AT LO_RAW MATERIAL LEVEL. SOURCE: OWN, VALUES ADAPTED FROM GRANTA EDU PACK FOR REPRESENTATION PURPOSES. | 119 |

| | |
|--|-----|
| FIGURE 120: INFORMATION IN THE IDENTIFIER ALUMINUM 6061 AT LO_RAW MATERIAL LEVEL. SOURCE: OWN, VALUES ADAPTED FROM GRANTA EDU PACK..... | 119 |
| FIGURE 121: DATA TEMPLATE FOR MATERIAL LEVEL INFORMATION. SOURCE: AUTHOR..... | 120 |
| FIGURE 122: SCHEMATIC DASHBOARD WITH MATERIAL LEVEL INFORMATION WITH THE INSTANCE TREE VIEW. SOURCE: AUTHOR | 120 |
| FIGURE 123: DATA TEMPLATE FOR PRODUCT LEVEL INFORMATION. SOURCE: AUTHOR..... | 121 |
| FIGURE 124: OVERVIEW OF FACADE PRODUCT PASSPORT DASHBOARD AT PRODUCT LEVEL. SOURCE: AUTHOR..... | 122 |
| FIGURE 125: DATA TEMPLATE FOR ELEMENT LEVEL INFORMATION. SOURCE: AUTHOR. | 122 |
| FIGURE 126: OVERVIEW OF FACADE PRODUCT PASSPORT DASHBOARD AT THE ELEMENT LEVEL. SOURCE: AUTHOR | 123 |
| FIGURE 127: INFORMATION SUFFICIENCY CHECK OF CITG FAÇADE DATA FOR EOS ASSESSMENT PROCESS. SOURCE: AUTHOR. | 124 |
| FIGURE 128: 3D VIEW SHOWING THE LOCATION OF THE HORIZONTAL AND VERTICAL SECTIONS USED TO DEMONSTRATED THE ASSESSMENT MODULES. SOURCE: AUTHOR. | 125 |
| FIGURE 129: DISASSEMBLY SEQUENCE OF THE CITG FACADE FRAME. SOURCE: AUTHOR | 126 |
| FIGURE 130: DISASSEMBLY SEQUENCE OF THE CITG FACADE FRAME. SOURCE: AUTHOR..... | 127 |
| FIGURE 131: EOS ASSESSMENT SUMMARY OF THE CITG OUTER FRAME. SOURCE: AUTHOR | 128 |
| FIGURE 132: EVALUATING THE CITG FACADE BASED ON EXISTING INFORMATION. SOURCE: AUTHOR..... | 130 |
| FIGURE 133: EVALUATION OF GEOMETRIC PARAMETERS OF THE CITG FACADE FRAME. SOURCE: AUTHOR..... | 131 |
| FIGURE 134: OVERVIEW OF THE SIZING AND POSITIONING PARAMETERS OF THE CITG FACADE FRAME. SOURCE: AUTHOR | 132 |
| FIGURE 135: OVERVIEW OF THE FUNCTIONAL PARAMETERS OF THE CITG FACADE FRAME. SOURCE: AUTHOR..... | 132 |
| FIGURE 136: SUMMARY OF DESIGN PARAMETERS OF THE CITG FACADE FRAME FOR REUSE EVALUATION. SOURCE: AUTHOR. | 133 |
| FIGURE 137: SCHEMATIC OVERVIEW OF THE LIFECYCLE OF A FACADE. SOURCE: AUTHOR. | 136 |
| FIGURE 138: SUMMARY OF INFORMATION EXCHANGED DURING THE LIFECYCLE OF A FACADE DERIVED FROM THE PROCESS MAPS. SOURCE: AUTHOR... | 138 |
| FIGURE 139: INFORMATION LEVELS DETERMINED BASED ON THE LIFECYCLE OF A UNITIZED FACADE. SOURCE: AUTHOR. | 140 |
| FIGURE 140: THE FRAMEWORK FOR FACADE PRODUCT PASSPORTS. SOURCE: AUTHOR. | 141 |
| FIGURE 141: LIST OF INFORMATION REQUIRED FOR EOS ASSESSMENT PROCESS. SOURCE: AUTHOR | 142 |
| FIGURE 142: SCHEMATIC OVERVIEW OF THE EOS ASSESSMENT PLATFORM FOR ENRICHING THE PASSPORT WITH SUBJECTIVE DESIGN CRITERIAS. SOURCE: AUTHOR..... | 143 |
| FIGURE 143: SCHEMATIC OVERVIEW OF THE EOS ASSESSMENT PLATFORM LINKING THE SUBJECTIVE DESIGN CRITERIAS TO THE INFORMATION IN THE PASSPORT PLATFORM. SOURCE. AUTHOR..... | 143 |
| FIGURE 144: USES OF THE EOS ASSESSMENT PLATFORM. SOURCE: AUTHOR. | 144 |
| FIGURE 145: PRELIMINARY LIFECYCLE-STAKEHOLDER DIAGRAM. SOURCE: AUTHOR | 156 |
| FIGURE 146: PRELIMINARY MATERIAL PASSPORT FRAMEWORK. SOURCE: AUTHOR..... | 156 |
| FIGURE 147: EOS ASSESSMENT CRITERIA CONSIDERED AND SOURCES REFERENCED FROM. SOURCE: AUTHOR. | 177 |
| FIGURE 148 - STRUCTURE OF AN IFC DATA MODEL. SOURCE: LAAKSO AND KIVINIEMI (2012)..... | 178 |
| FIGURE 149: THE SPATIAL TREE OF THE IFC FILE. SOURCE: WIKI.OSARCH. | 178 |
| FIGURE 150: TYPES OF CERTIFICATIONS AND METHODS EMPLOYED IN THE FAÇADE INDUSTRY. SOURCE: AUTHOR | 179 |
| FIGURE 151: CERTIFICATIONS OF VARIOUS PRODUCTS IN THE LIFECYCLE STAGES. SOURCE: AUTHOR..... | 179 |
| FIGURE 152: OVERVIEW OF CERTIFICATIONS REQUIRED FOR A FAÇADE PRODUCT. SOURCE: AUTHOR..... | 180 |
| FIGURE 153: STAGES OF NEN 2767 CONDITION MEASUREMENT PROCESS. SOURCE: AUTHOR | 180 |

15 Appendix

15.1 Positioning process of the research topic

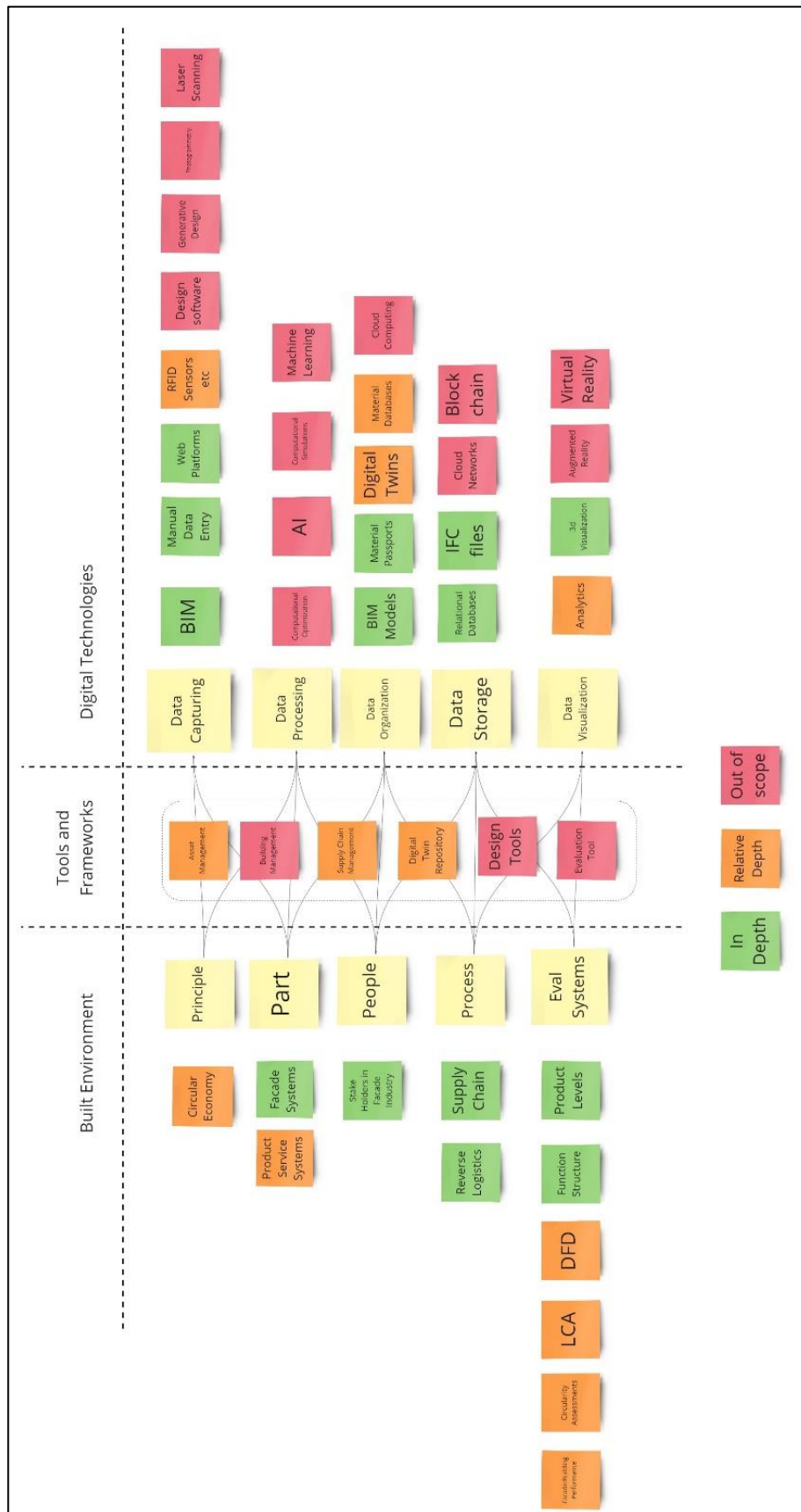

15.2 Preliminary lifecycle stakeholder map.

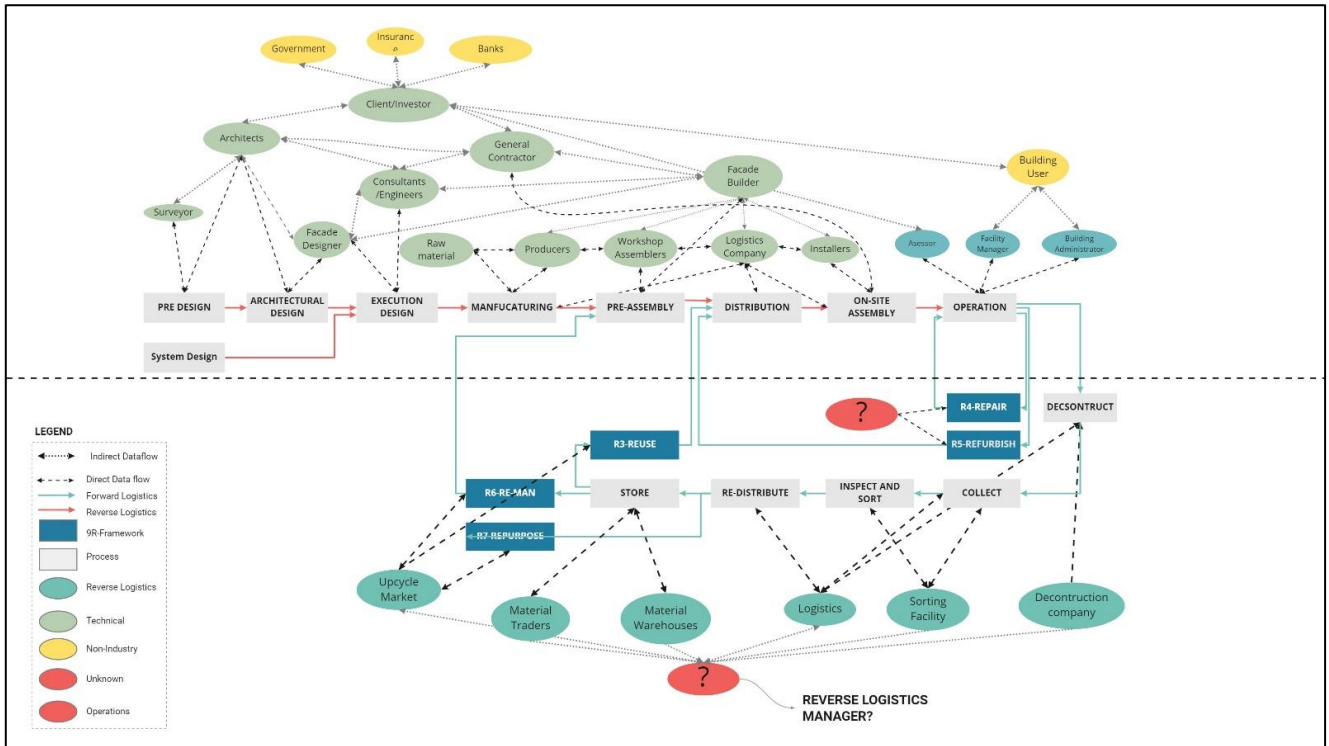

Figure 146: Preliminary Lifecycle-Stakeholder Diagram. Source: Author

15.3 Preliminary Material Passport framework

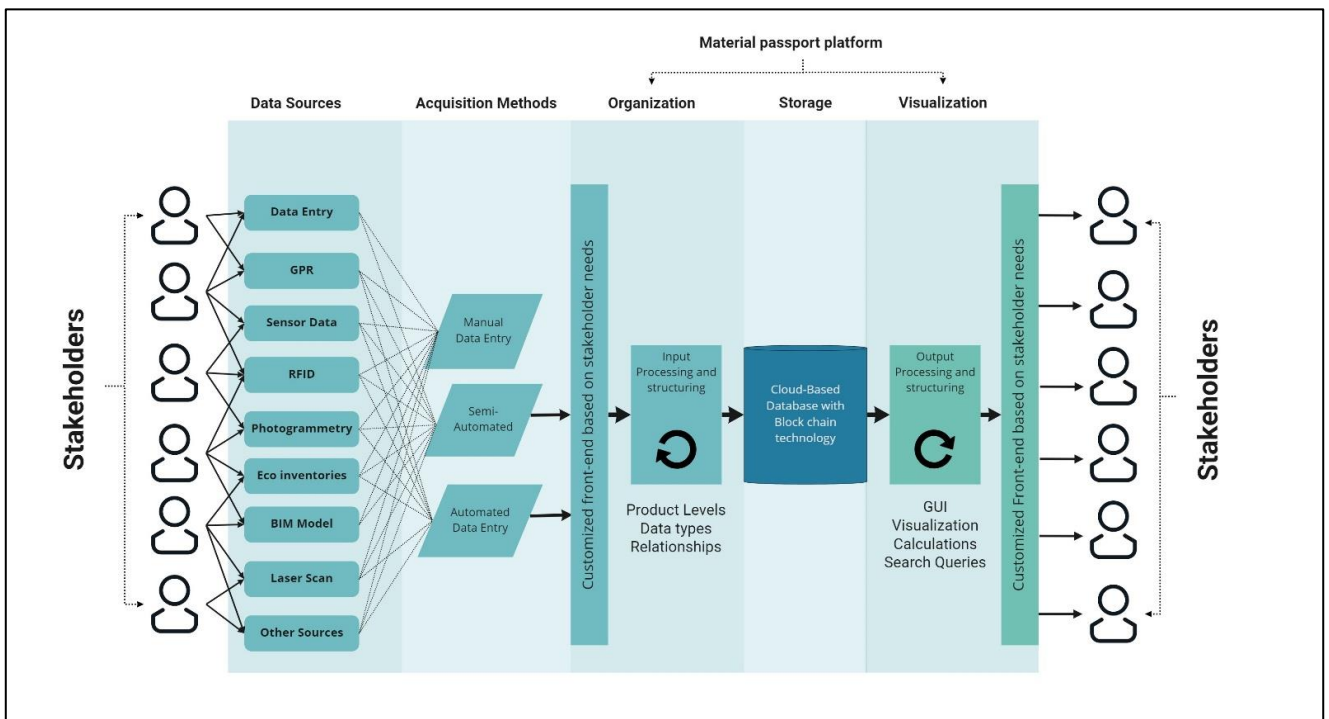
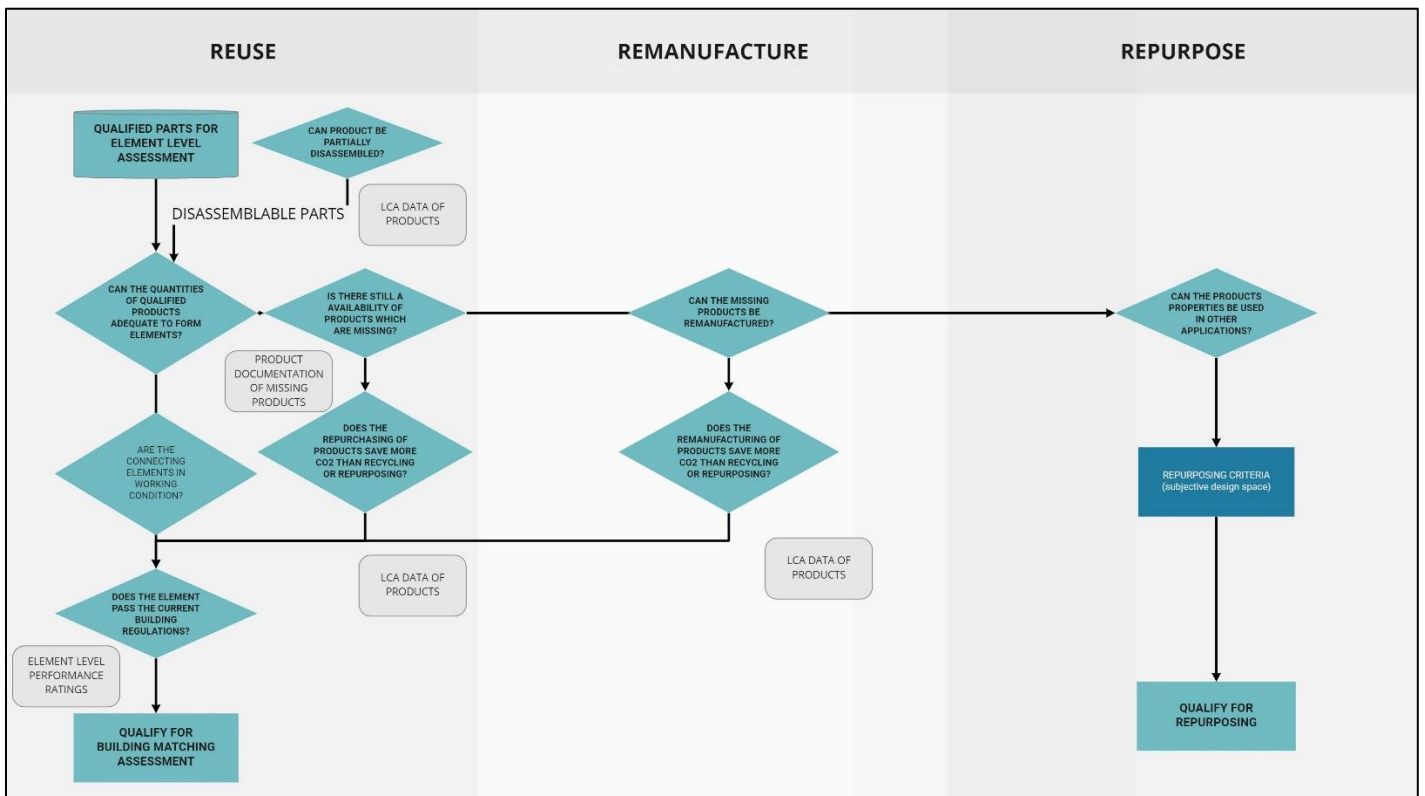
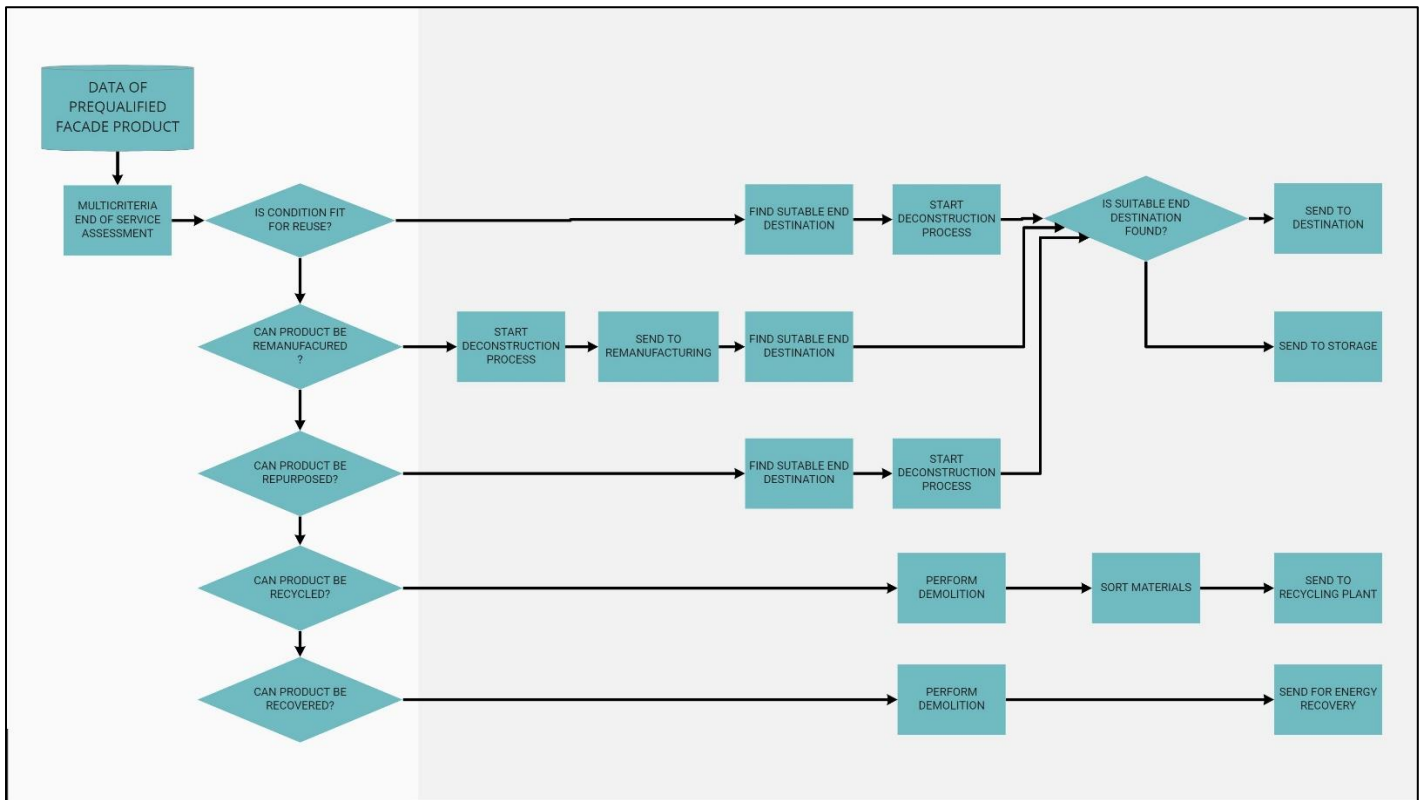
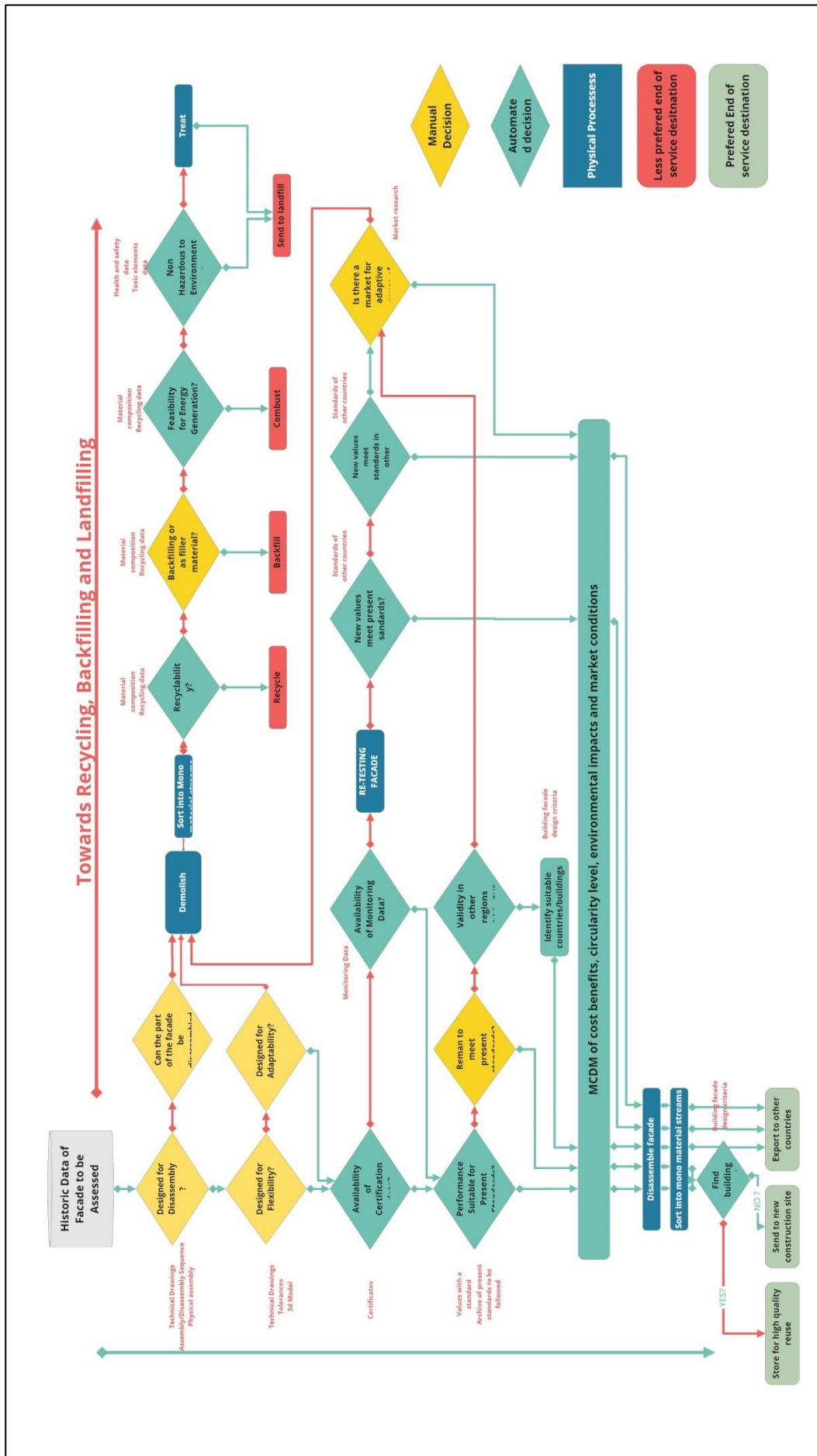
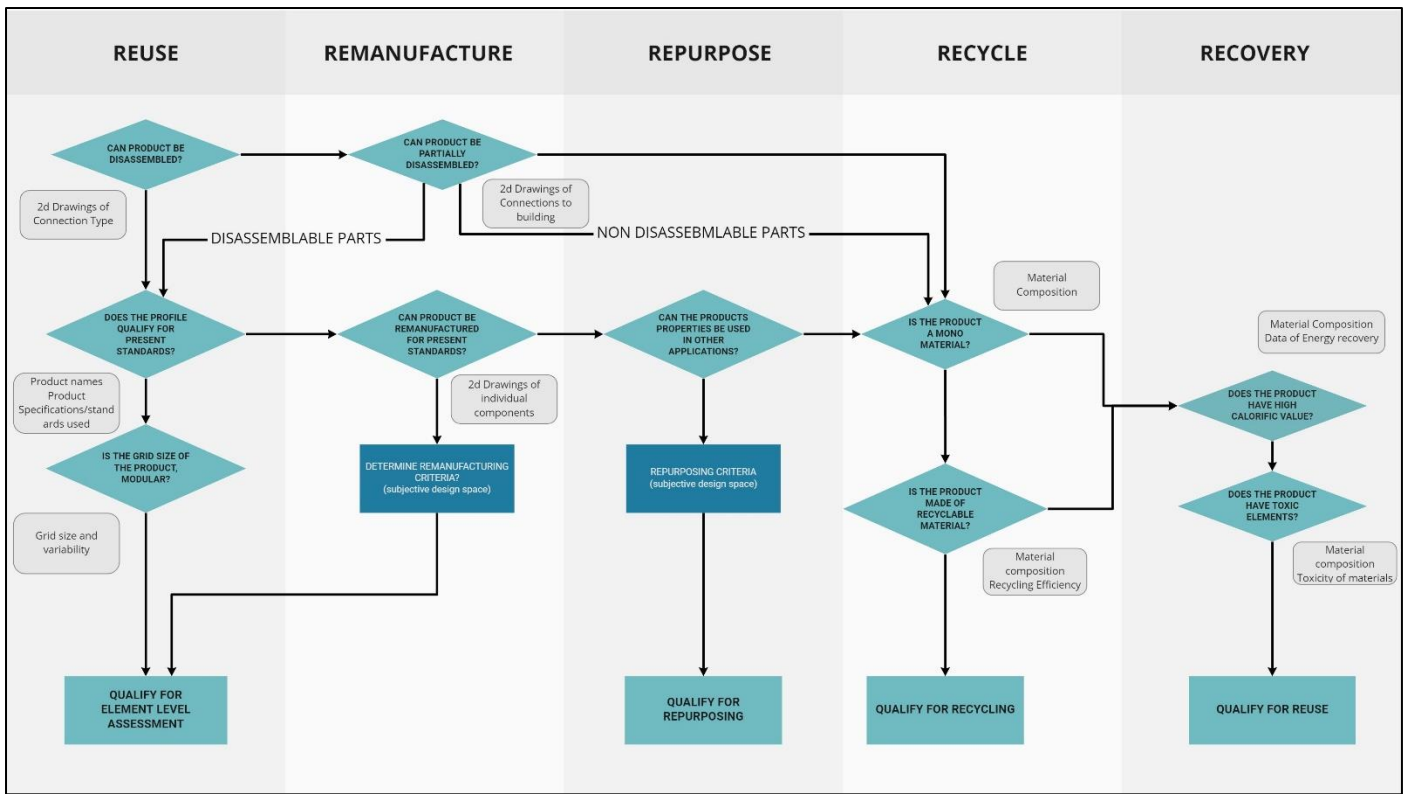

Figure 147: Preliminary Material Passport Framework. Source: Author

15.4 Preliminary Decision Models for EoS Assessment process







15.5 Results of the Survey

15.5.1 Survey Results: General

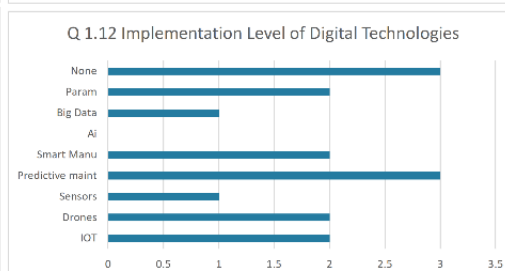
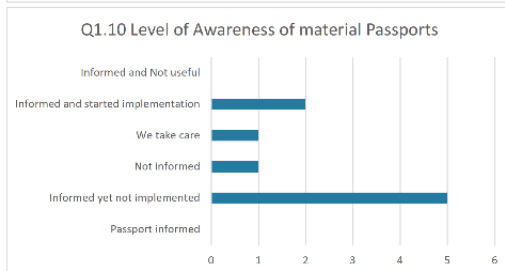
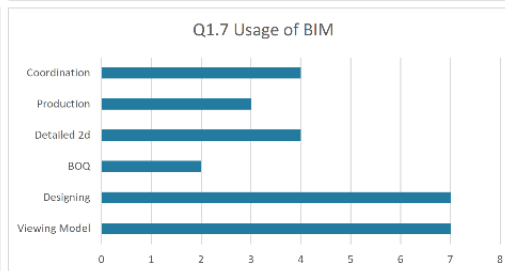
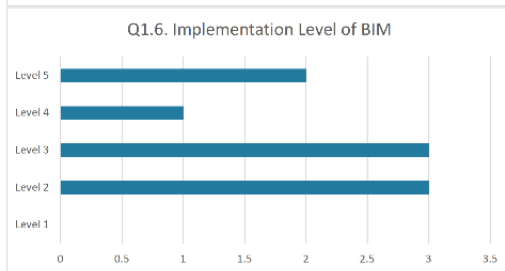
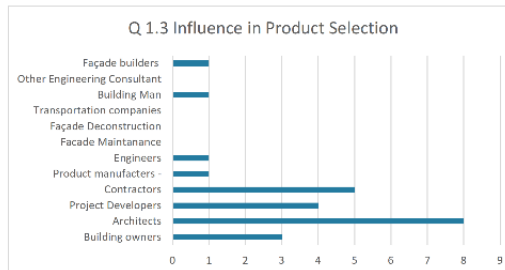
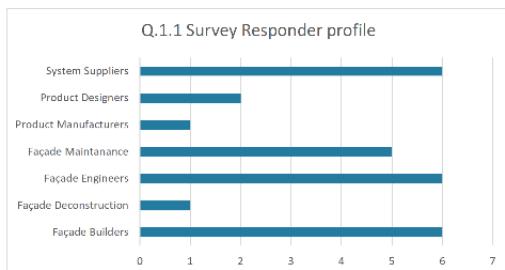

15.5.2 Façade Engineers/Consultants

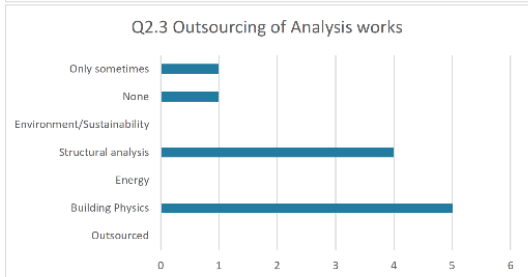
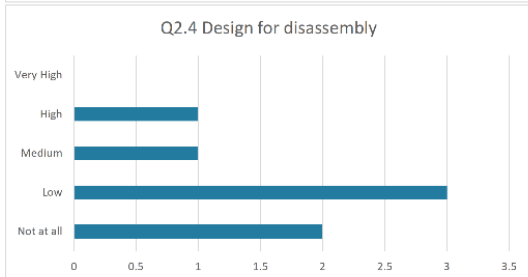
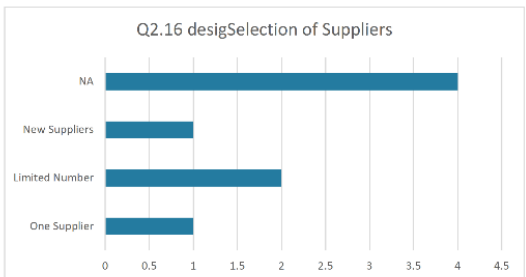
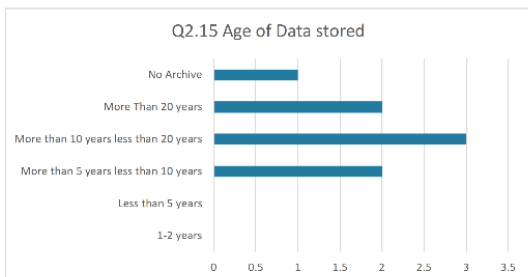
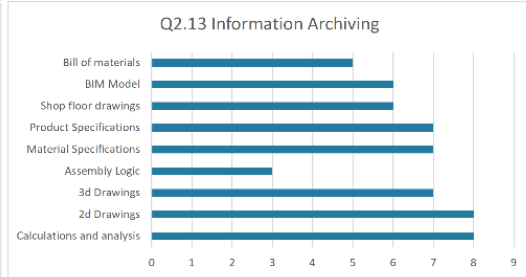
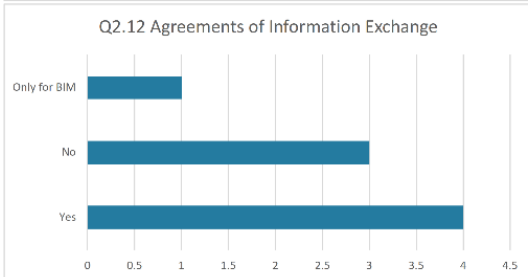
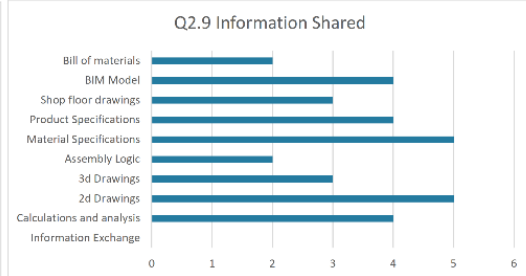
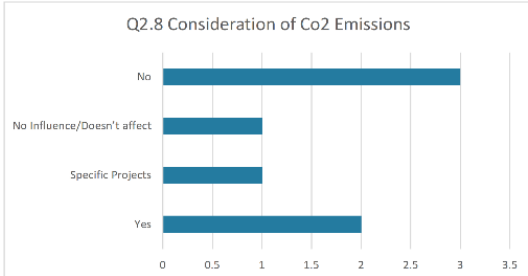
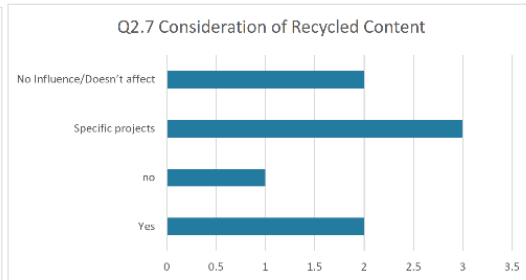
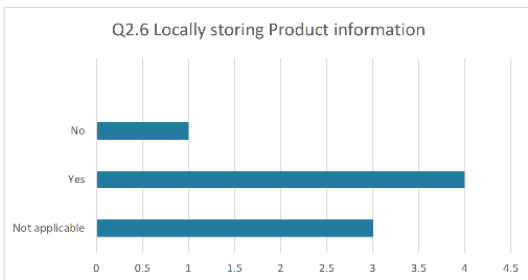

15.5.3 Survey Results: Façade Builders

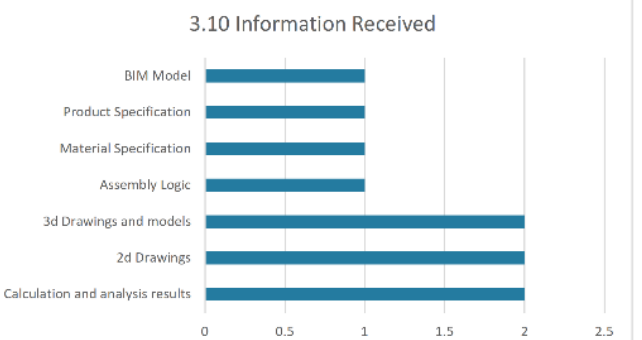
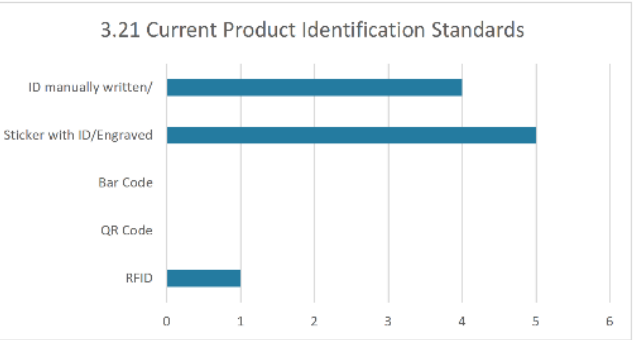
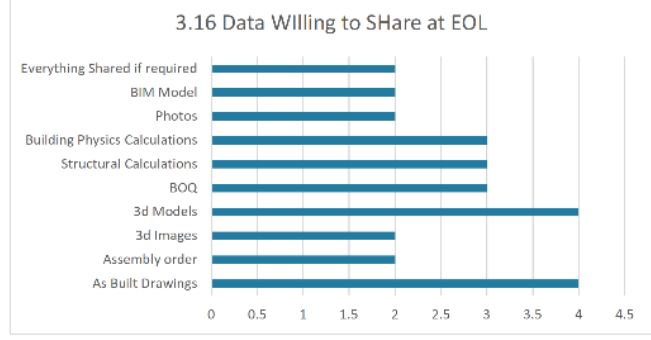
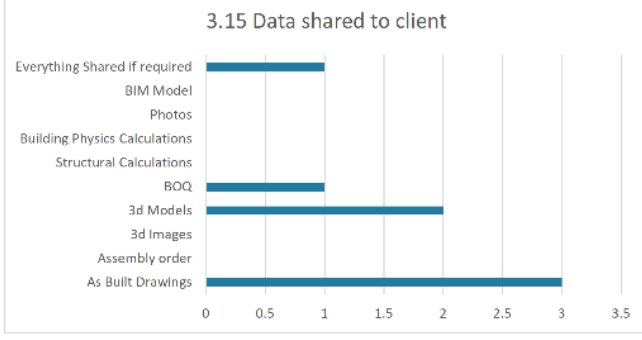
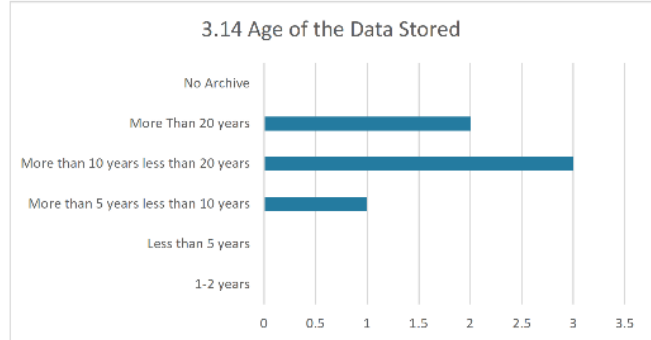
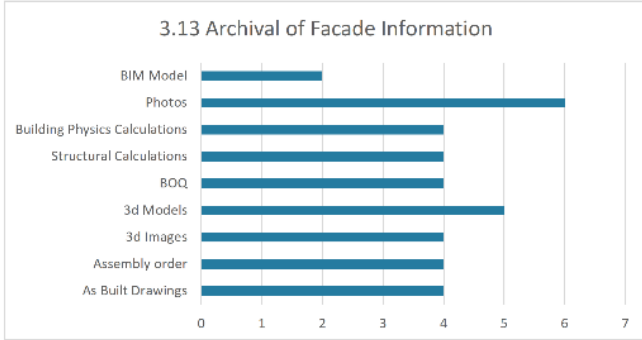
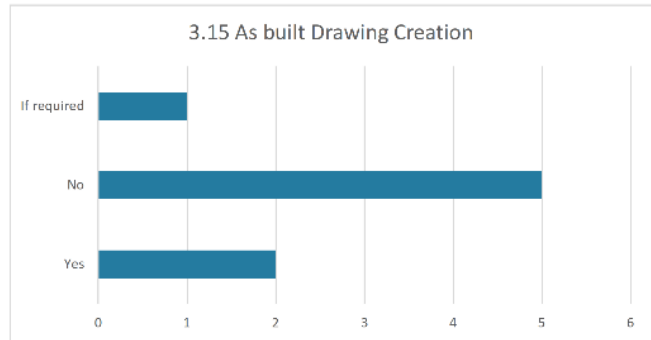
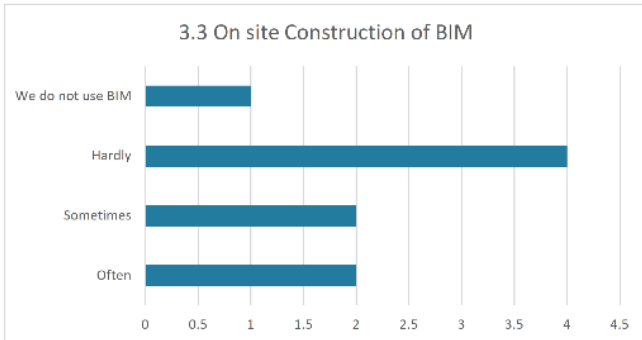

15.5.4 Survey Results: Façade maintenance

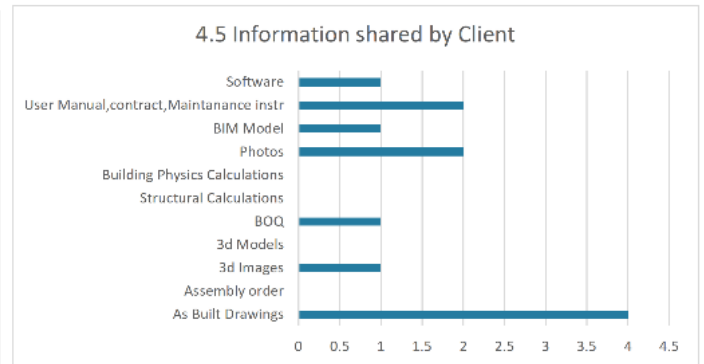
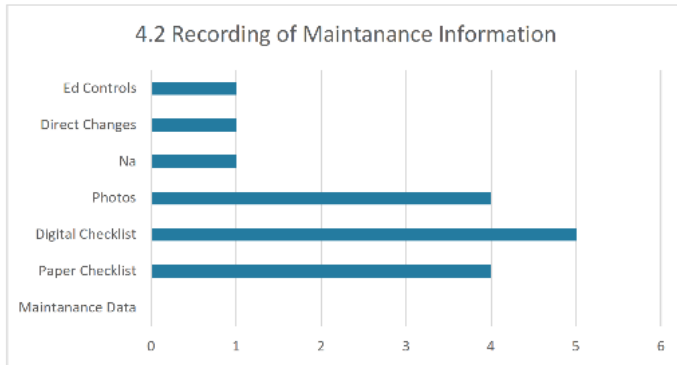
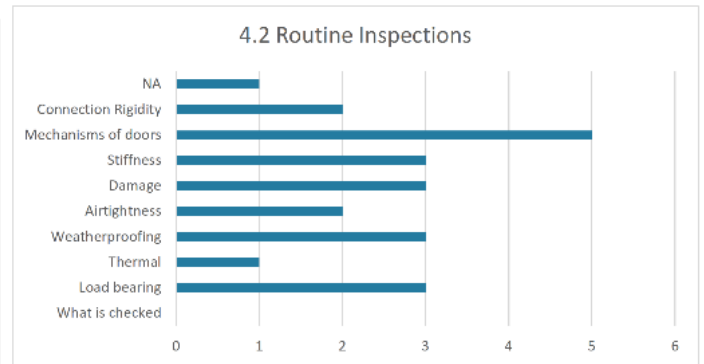
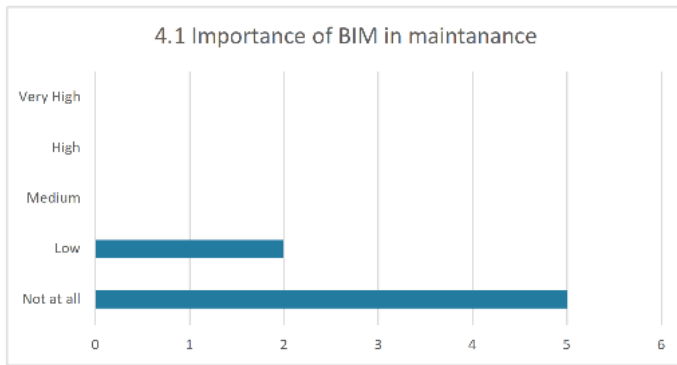

15.5.5 Survey Results: Façade Product Manufacturers

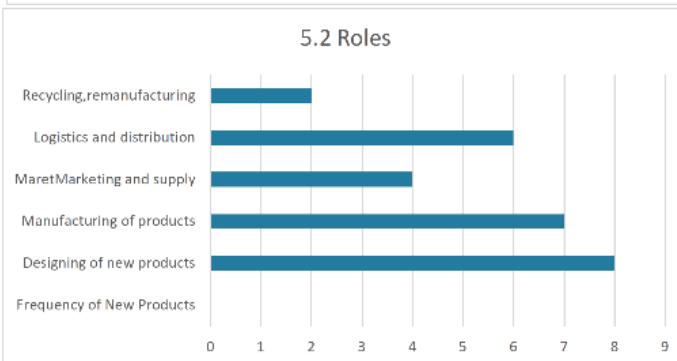
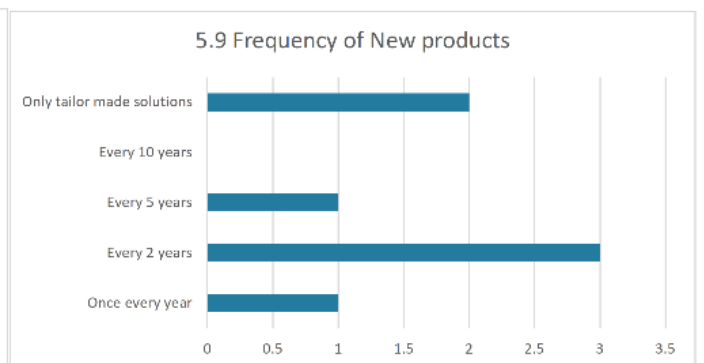
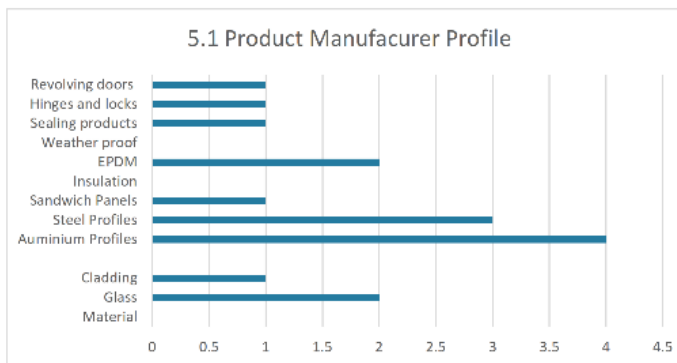

15.6 List of interview questions

| Interview Questions | | | | |
|---------------------|---|---------------|-------------|-----------------------------|
| Q. No | Question asked | Interviewee | Type | THEME |
| 1 | What roles in the façade industry is your company involved in? | Interviewee 1 | Independent | Role in the Industry |
| 2 | Do you specify façade products in your drawings? | Interviewee 1 | Independent | General Functioning |
| 3 | In your experience, who is responsible for selecting and specifying the suitable façade product for a project? | Interviewee 1 | Independent | Role in the Industry |
| 4 | Is there additional analysis carried out after the façade products are chosen for a project? | Interviewee 1 | Independent | Role in the Industry |
| 5 | Is there an agreement set for this information exchange of what needs you expect, what the contractor expects from you, and what you expect from the contract? | Interviewee 1 | Independent | Information Exchanged |
| 6 | To what extent are you already implementing some circular design principles in current projects? Such as design for disassembly, or recycled content, etc.? | Interviewee 1 | Independent | Awareness of Circularity |
| 7 | So, in a way, a database of material specs, recycled content, and environmental data can be helpful for this? | Interviewee 1 | Independent | Information Exchanged |
| 8 | And what about other principles, like, design for disassembly? And, you know, ensuring materials are separable? Do you guys fit into that? | Interviewee 1 | Independent | Awareness of Circularity |
| 9 | Do you think structural fatigue plays a big role in the lifecycle of a façade profile? For example, would it be structurally usable after 20-30 years? | Interviewee 1 | Independent | Facade Technicalities |
| 10 | Do you think this information can, for example, be extracted through sensor data? | Interviewee 1 | Independent | Integration of Digital Tech |
| 11 | How is your office currently storing data? Is it on the cloud or in a physical server? | Interviewee 1 | Independent | Data Storage and Archiving |
| 12 | Can you explain a bit about your workflow? From AutoCAD, SimpleBIM, solid works and metalix etc. | Interviewee 2 | Independent | Software workflows |
| 13 | Are the quantities coming from solid works or the BIM model? | Interviewee 2 | Independent | Software workflows |
| 14 | Do you need to give additional inputs in metalix, apart from sending the dxf or the step file? | Interviewee 2 | Independent | Software workflows |
| 15 | You mentioned the use of smart manufacturing and big data. Can you elaborate a bit on how do you use this? Are you also progressing towards full automation in the future? | Interviewee 2 | Independent | Integration of Digital Tech |
| 16 | You mentioned that you don't use BIM for maintenance. So, I am curious whether you record information about the maintenance of a building? | Interviewee 2 | Independent | Data Storage and Archiving |
| 17 | You also mentioned the use of the tool called EDI controls. Can you elaborate a bit more on how you use it? | Interviewee 2 | Independent | Software workflows |
| 18 | Do you see the utility of material passports in your day-to-day workflow? | Interviewee 2 | Independent | Software workflows |
| 19 | You mentioned you use a sticker or engraving. Is this traceable or identifiable later as well? | Interviewee 2 | Independent | Integration of Digital Tech |
| 20 | What kind of information are you keeping track of when you subcontract your logistics? | Interviewee 2 | Independent | Information Exchanged |
| 21 | How accessible is your current archiving system? For example, would a person who doesn't know your projects be able to find specific information about a particular component when looking through your data? | Interviewee 2 | Independent | Data Storage and Archiving |
| 22 | How close to the as-build condition is this information? Do you expect many changes? | Interviewee 2 | Independent | Information Exchanged |
| 23 | How easily disassemble are your components? Can a different façade builder extract information? | Interviewee 2 | Independent | Facade Technicalities |
| 24 | You mention the use of agreements for information. Can you elaborate on what agreements are set? And what kind of stakeholders do you have these agreements with? | Interviewee 2 | Independent | Information Exchanged |
| 25 | How do you use CRM software, but can you explain how it helps your organization and the main data points extracted from it? | Interviewee 2 | Independent | Software workflows |
| 26 | What is your role in the Façade Industry? | Interviewee 3 | Independent | Role in the Industry |
| 27 | What is your role in the company? | Interviewee 3 | Independent | Role in the Industry |
| 28 | Who are the main stakeholders you interact with? | Interviewee 3 | Independent | Role in the Industry |
| 29 | Are you physically in contact with the material at any point, such as extraction, storage, etc., or is coordination between stakeholders the main role? | Interviewee 3 | Independent | Role in the Industry |

| | | | | |
|----|--|---------------------|-------------|----------------------------|
| 30 | Do you have any kind of storage facilities for storing extracted material? | Interviewee 3 | Independent | Role in the Industry |
| 31 | What kind of documentation do you receive during the scheduled demolition of a building? | Interviewee 3 | Independent | Information Exchanged |
| 32 | Do you maintain an archive of the checklist used to evaluate a building, and is it done per project or material? | Interviewee 3 | Independent | Data Storage and Archiving |
| 33 | When you communicate with the stakeholders, what kind of information is exchanged? | Interviewee 3 | Independent | Information Exchanged |
| 34 | What kind of digital methods are used to exchange this information? | Interviewee 3 | Independent | Information Exchanged |
| 35 | Is geometric information being extracted and communicated with your stakeholders? | Interviewee 3 | Independent | Information Exchanged |
| 36 | How much do you think your work can be remotely carried out in the near future? | Interviewee 3 | Independent | Software workflows |
| 37 | Does your company currently use a cloud-based network or a physical network? | Interviewee 3 | Independent | Data Storage and Archiving |
| 38 | How would material passports benefit your role as an Urban Miner? | Interviewee 3 | Independent | Software workflows |
| 39 | Can you mention a bit about your company and what you do? | Interviewee 4 | Independent | Role in the Industry |
| 40 | Are tests you carry out to understand the condition of the material done off-site or on-site? | Interviewee 4 | Independent | General Functioning |
| 41 | Do you also take up maintenance contracts from building owners or facility managers? | Interviewee 4 | Independent | Role in the Industry |
| 42 | What kind of information is provided to you by the customer? | Interviewee 4 | Independent | Information Exchanged |
| 43 | Can you assess the condition and predict the lifespan of a product by visually analyzing it? | Interviewee 4 | Independent | Facade Technicalities |
| 44 | Can you perform a remote assessment of a product without going to the site by using photographs? | Interviewee 4 | Independent | General Functioning |
| 45 | What are the aspects or defects for which you have to be physically present? | Interviewee 4 | Independent | General Functioning |
| 46 | Do you have the maintenance history of a particular project, and is information about the condition of individual products also recorded? | Interviewee 4 | Independent | Data Storage and Archiving |
| 47 | What kind of defects would require you to replace an entire component? | Interviewee 4 | Independent | Facade Technicalities |
| 48 | Do you use NL2767 or any other metrics to measuring conditions? | Interviewee 4 | Independent | General Functioning |
| 49 | Do you use physical or digital checklists? | Interviewee 4 | Independent | Software workflows |
| 50 | If there is a dent or damage to aluminum, do you repair them? | Interviewee 4 | Independent | Facade Technicalities |
| 51 | What does your company do, and which stakeholders are your clients? | Interviewee 5 | Independent | General Functioning |
| 52 | Can you elaborate in detail on the steps in which your company gets involved with collecting maintenance information? | Interviewee 5 | Independent | General Functioning |
| 53 | What are the main data outputs you can get from your platform? | Interviewee 5 | Independent | Software workflows |
| 54 | When humans are deploys on-site, if they make a photograph, is it referenced to the base model in XYZ coordinates, or is it stored as an additional image in the project? | Interviewee 5 | Independent | Software workflows |
| 55 | Does your current system able to extract detailed geometric information of the façade product? | Interviewee 5 | Independent | Software workflows |
| 56 | If the Façade industry were obliged to produce more qualitative information, what would most benefit from improving your current process? | Interviewee 5 | Independent | Information Exchanged |
| 57 | How long does it take to process all this information? | Interviewee 5 | Independent | General Functioning |
| 58 | How do you currently take into account the knowledge of industry experts in your AI model? What is the process used to map this? | Interviewee 5 | Independent | Software workflows |
| 59 | In the NEN 2767, which aspects are automated and what aspects are manually generated? | Interviewee 5 | Independent | Software workflows |
| 60 | What is limiting you from giving a higher warranty on your profiles? | Survey Respondent 2 | Follow-up | Facade Technicalities |
| 61 | How do you go about storing information about the maintenance of a façade? | Survey Respondent 2 | Follow-up | Facade Technicalities |
| 62 | What are the main failure points that occur during the routine inspection of a façade? | Survey Respondent 2 | Follow-up | Facade Technicalities |
| 63 | What would be the main concerns if one of your windows were proposed to be reused in a new building with exact dimensions? Are there any specific issues with the profile? | Survey Respondent 2 | Follow-up | Facade Technicalities |
| 64 | What are your thoughts about a central database or a platform to locally store and view all information of façade products in a market so | Survey Respondent 2 | Follow-up | Data Storage and Archiving |

| | | | | |
|----|--|---------------------|-----------|-----------------------------|
| | that façade engineers, architects, etc., can compare different products and make better choices? | | | |
| 65 | What is the main information you share with your clients, and what information do you withhold when the customer wants to choose your façade? | Survey Respondent 2 | Follow-up | Information Exchanged |
| 66 | How are you planning to incorporate Industry 4.0 technologies such as IoT, AI, and interconnected manufacturing machines? | Survey Respondent 2 | Follow-up | Integration of Digital Tech |
| 67 | You mentioned that you track your products in the supply chain using a manually written ID; how do you trace it within your manufacturing plant? | Survey Respondent 2 | Follow-up | Integration of Digital Tech |
| 68 | Are there plans to go to the cloud to have this information archived in the cloud database? | Survey Respondent 2 | Follow-up | Integration of Digital Tech |
| 69 | What do you think are the challenges of upgrading an existing profile to adapt to new standards? Or do you think recycling is a better option? | Survey Respondent 2 | Follow-up | Facade Technicalities |
| 70 | When you create a new product, what are the key technical considerations take into account? | Survey Respondent 2 | Follow-up | Facade Technicalities |
| 71 | Is it possible to remanufacture an existing façade to be able to approve it for present standards? | Survey Respondent 2 | Follow-up | Facade Technicalities |
| 72 | Your company says that you work with metal profiles and glass. Which parts are subcontracted, and what is internally manufactured? | Survey Respondent 2 | Follow-up | Stakeholder Interaction |
| 73 | Do you customize Façade Panels for every project? Do you create new documentation sets for each project? | Survey Respondent 3 | Follow-up | Information Exchanged |
| 74 | What kind of documentation is created to assemble the façade on-site? | Survey Respondent 3 | Follow-up | Information Exchanged |
| 75 | Why do you opt for more customized products, is it aesthetics or because of complexity? | Survey Respondent 3 | Follow-up | Facade Technicalities |
| 76 | What challenges do you face when it comes to reusing and recycling apart from maintenance? | Survey Respondent 3 | Follow-up | Facade Technicalities |
| 77 | What kind of information do you store about projects, and is this information easily accessible by an external third-party façade engineer? | Survey Respondent 3 | Follow-up | Data Storage and Archiving |
| 78 | What kind of information do you store about maintenance, and is it recorded at a product level? | Survey Respondent 3 | Follow-up | Data Storage and Archiving |
| 79 | Do you collect this information at an overall level or per panel/product? | Survey Respondent 3 | Follow-up | Information Exchanged |
| 80 | Can you give me an overview of the entire digital workflow used in your company? | Survey Respondent 3 | Follow-up | Software workflows |
| 81 | What kind of files or information is exchanged between your own program and SAP? | Survey Respondent 3 | Follow-up | Software workflows |
| 82 | What is the relation between the identification in the software to the identification marked physically on the component itself? | Survey Respondent 3 | Follow-up | Software workflows |
| 83 | Are the models manually made for every component? | Survey Respondent 3 | Follow-up | Software workflows |
| 84 | Can the information you showed in your software be displayed in other third-party software, or is it proprietary to the particular software package? | Survey Respondent 3 | Follow-up | Software workflows |
| 85 | How would BIM supplement this entire process? | Survey Respondent 3 | Follow-up | Software workflows |
| 86 | Are there possibilities being discussed migrating to the cloud? | Survey Respondent 3 | Follow-up | Integration of Digital Tech |
| 87 | How are assembly and sequences are coordinated? | Survey Respondent 3 | Follow-up | Information Exchanged |
| 88 | Do you think anything is missing in your current workflows that can be fulfilled by a material passport platform? | Survey Respondent 3 | Follow-up | Use of Passport Platforms |
| 89 | Suppose you propose reusing facade elements from a previous project; what are the main aspects to look out for? | Survey Respondent 6 | Follow-up | Facade Technicalities |
| 90 | What information are you willing to share if your facade is proposed to be reused later on after 10-20years? | Survey Respondent 6 | Follow-up | Information Exchanged |
| 91 | How do you go about generating a Bill of Materials to order material? Is it linked via BIM or other software? | Survey Respondent 6 | Follow-up | Software workflows |
| 92 | Do you redo the BIM model or use the same Model received from an architect? | Survey Respondent 6 | Follow-up | Software workflows |
| 93 | To what level of detail are the BIM Models made? Are they detailed enough to be sent for production, or additional drawings have to be made? | Survey Respondent 6 | Follow-up | Software workflows |

| | | | | |
|-----|--|---------------------|-----------|-----------------------------|
| 94 | Do you store information in a network server or a cloud-based database? | Survey Respondent 6 | Follow-up | Integration of Digital Tech |
| 95 | Do you use the QR code to track the material during logistics and transportation? | Survey Respondent 6 | Follow-up | Integration of Digital Tech |
| 96 | Do you think a central nationally approved database of CE verified facade products helps make better products? | Survey Respondent 6 | Follow-up | Data Storage and Archiving |
| 97 | Do you store information about your projects in your database? | Survey Respondent 6 | Follow-up | Data Storage and Archiving |
| 98 | Is the analysis work (structural and thermal) for Facades subcontracted or done in-house? | Survey Respondent 6 | Follow-up | Stakeholder Interaction |
| 99 | Who are your clients, and what information do you receive from them? | Survey Respondent 6 | Follow-up | Information Exchanged |
| 100 | What information is shared with the facade builder for on-site processes, and how is this information shared? | Survey Respondent 6 | Follow-up | Information Exchanged |
| 101 | Do you need to generate additional 2d Drawings apart from the BIM Model? | Survey Respondent 6 | Follow-up | Information Exchanged |
| 102 | How is assembly logic communicated with the facade builders? | Survey Respondent 6 | Follow-up | Information Exchanged |
| 103 | As your company uses Cirlinq, I wanted to know what you currently use it and what processes you think it's useful for? | Survey Respondent 6 | Follow-up | Software workflows |

15.7 List of Survey Questions per stakeholder

| Survey Questions | | |
|--|--------------------------------|-------------|
| Timestamp | Category | Stakeholder |
| 1.1 What are the services your company carries out in the Dutch Facade Industry? | Lifecycle validation | General |
| 1.10 Material or Product passports are being implemented in many projects to record a building's materials. To what level is your company currently informed about the use of these passports? | Awareness level of Circularity | General |
| 1.11 How well is your organization informed about the Cirlinq platform initiated by VMRG? | Awareness level of Circularity | General |
| 1.12 Please list the advanced digital technologies your company has experimented with or incorporated into your workflow | Digital Methods | General |
| 1.2 Who are the stakeholders your company is coordinating with for carrying out these services? | Lifecycle validation | General |
| 1.3 From your point of view, who has the maximum influence in product selection for a façade? | General Functions | General |
| 1.4 Please list out the various CAD Software use by your company presently. Answer Not relevant if it doesn't apply to you. | Software use | General |
| 1.5 Please list out other software's used for your company for general purposes such as Workflow Management, Planning, Work preparation, Resource Management, Sales and Order Management, quality management etc.? | Software use | General |
| 1.6 To what extent is Building Information Modelling (BIM) implemented in your company | Digital Methods | General |
| 1.7 If you use BIM Software, what are the various functions you use it for? | Digital Methods | General |
| 1.8 If your company currently does not use Building information modeling (BIM), can you list the main reasons? | Digital Methods | General |
| 1.9 Please list out the document management system used to archive information on your completed projects. | Archiving | General |
| 2.1 Can you list out the Software use for generating the Bill of Materials (BOM) of a facade? | Software use | Engineers |
| 2.10 What are the methods in which the information mentioned above is exchanged? | Information Exchange | Engineers |
| 2.11 Do you often encounter problems with the conversion of electronic formats between you and the client? | Information Exchange | Engineers |

| | | |
|---|--------------------------------|----------------|
| 2.12 Do you have agreements for the format and method of data exchange with your clients, i.e., facade builders, architects or others? | Information Exchange | Engineers |
| 2.13 What kind of information on completed projects do you store for future reference, or at least during the guarantee period? | Archiving | Engineers |
| 2.14 Would you appreciate an industry-wide standardized approach for exchanging documents or data with your clients? | Information Exchange | Engineers |
| 2.15 How old is the oldest project which has been digitally stored? | Archiving | Engineers |
| 2.16 Do you specify façade products from a single supplier for all projects or different suppliers in each project? (For a particular material) | General Functions | Engineers |
| 2.2 Can you list out the various analyses carried out by your company for a typical facade (structural, building physics, acoustics, etc.) and list the software programs used for the same? (Entry format: 'Analysis type' - 'Software program') | General Functions | Engineers |
| 2.3 What kind of analysis work for a façade design is outsourced to external consultants? | Lifecycle validation | Engineers |
| 2.4 How much does your company prioritize design for disassembly (DFD) when you engineer a facade? | Awareness level of Circularity | Engineers |
| 2.5 According to you, is the technical information given on the product manufacturer's website sufficient to select a product for a particular façade project? (Apart from cost implications) | | Engineers |
| 2.6 Do you organize and store information received from product manufacturers so that you can easily refer it to your projects? | Archiving | Engineers |
| 2.7 Do you take into account the recycled content of materials when choosing Facade Products for a project? | Awareness level of Circularity | Engineers |
| 2.8 Do you consider Environmental impacts such as Co2 Emissions or Embodied Energy when choosing Facade Products for a project? | Awareness level of Circularity | Engineers |
| 2.9 What kind of information is exchanged with the façade builder during the construction of a façade? | Information Exchange | Engineers |
| 3.10 What kind of information does your company receive from the façade engineer? (Please skip the question if you have answered in the previous section) | Information Exchange | Façade Builder |
| 3.11 According to you, is the information on the product manufacturer's website sufficient to choose the right façade product for a particular project? (Skip if you already answered in the previous section) | Information Exchange | Façade Builder |
| 3.12 Does your company store information about façade products (profiles, gaskets, glass, etc.) to speed up your projects' product selection process? (Skip if you already answered in the previous section) | Archiving | Façade Builder |
| 3.13 What kind of information do you store after a project is completed? (Drawings, photographs, calculations others) | Archiving | Façade Builder |
| 3.14 How old is the oldest project in which you have digitally archived the information mentioned above? (Skip if you answered it in the previous section) | Archiving | Façade Builder |
| 3.15 What kind of information is shared with the client/building owner after the project is completed? | Information Exchange | Façade Builder |
| 3.16 What kind of information about your projects would you be willing to share to take necessary steps at their end of life? | Information Exchange | Façade Builder |
| 3.17 What information about your projects would you be willing to share with architects and other façade engineers if your façade has to be reused in a new project? | Information Exchange | Façade Builder |
| 3.18 If you do not wish to share the information, please state the reason below? | Information Exchange | Façade Builder |
| 3.19 How many years of Guarantee do you give your clients for construction defects or other maintenance-related issues? | General Functions | Façade Builder |

| | | |
|---|--------------------------------|-----------------|
| 3.2 Can list out the Software used for generating the Bill of Materials of a facade? (Please skip the question if you have answered in the previous section) | Software use | Façade Builder |
| 3.20 How does your company handle logistics and transportation? | Lifecycle validation | Façade Builder |
| 3.21 What are the current techniques to identify and track Façade components from the manufacturing plant to the construction site? | General Functions | Façade Builder |
| 3.22 To what level do you take responsibility to ensure recycling/reusing your own product? | Awareness level of Circularity | Façade Builder |
| 3.3 Do you currently use BIM models to coordinate the on-site construction process? | Digital Methods | Façade Builder |
| 3.4 What software programs are used within the factory or workshop to control the machines and their processes? | Software use | Façade Builder |
| 3.5 What software programs are used for logistics and supply chain management? | Software use | Façade Builder |
| 3.6 Can you list out any methods or software (such as Just in Time Delivery Procedures) applied in your company to synchronize Orders between you, your suppliers, and your client? | Software use | Façade Builder |
| 3.7 What are methods in which the assembly sequences of a façade are coordinated with your team who are in the construction site? (2d drawings, 3d drawings, verbal communication, photographs, etc.) | Information Exchange | Façade Builder |
| 3.8 What do you think is lacking in your company's present digital infrastructure to ensure a project is executed efficiently? | Digital Methods | Façade Builder |
| 3.9 Do you make a new drawing after the construction is completed with all the changes (as-built drawing)? | Archiving | Façade Builder |
| 4.1 How important is Building Information Modelling in your company for performing maintenance activities on a façade? | Digital Methods | Maintenance |
| 4.2 What are the main aspects which are inspected and recorded during routine maintenance of the facade? | General Functions | Maintenance |
| 4.3 What are the various methods your company employs when inspecting a facade? (Photographs, drone images, visual inspection, etc.) | Information Exchange | Maintenance |
| 4.4 How do you document the maintenance history of the facade? For example, repair of parts, replacement of damaged parts, leakages. | Archiving | Maintenance |
| 4.5 What kind of information is handed over to you by your clients for performing maintenance activities on a facade? | Information Exchange | Maintenance |
| 4.6 What additional information do you record before starting the maintenance process and documenting the facade's existing condition? (Example photographs, detailed drawings, etc.) | Archiving | Maintenance |
| 4.7 How do you store information of past projects for future reference or for recording purposes? | Archiving | Maintenance |
| 4.8 How old is the oldest project of which maintenance information has been stored? | Archiving | Maintenance |
| 4.9 What sort of information is required used to predict the lifespan of various façade products? (Mainly Insulated Glass, Profiles, gaskets, and panels) | General Functions | Maintenance |
| 5.1 Please select the façade products your company is known for | Lifecycle validation | System Supplier |
| 5.10 What software does your company use for product design? Skip the question if your company does not design products | Software use | System Supplier |
| 5.11 What software programs are used within the manufacturing plant to control the machines and their processes? (Please skip if your company does not manufacture any products) | Software use | System Supplier |
| 5.12 What software programs are used for logistics and supply chain management? | Software use | System Supplier |
| 5.13 Can you list out any their methods or software's (such as Just in Time Delivery Procedures) applied in your company to synchronize Orders between you, your suppliers, and your client? | Software use | System Supplier |

| | | |
|---|--------------------------------|-----------------|
| 5.14 What are the current techniques to identify and track Facade components from the manufacturing plant to the construction site? | General Functions | System Supplier |
| 5.15 Which is the oldest product in your current product line, and how old is it? | General Functions | System Supplier |
| 5.16 How old is the oldest product for which you have the EPD, CE marking, or other technical information? | General Functions | System Supplier |
| 5.17 To what level do you take responsibility to ensure recycling/reusing your own product? | Awareness level of Circularity | System Supplier |
| 5.18 What are the designed lifespans of the various products in your company? (Format: product name - no of years) | General Functions | System Supplier |
| 5.19 How many years of Guarantee do you give for your products? | General Functions | System Supplier |
| 5.2 What are the different stages of a project your company is involved in? | Lifecycle validation | System Supplier |
| 5.3 Which stakeholder makes up the majority of your clientele at the moment? (Choose 1 or 2) | Lifecycle validation | System Supplier |
| 5.4 Apart from EPD and CE marking and data on your brochures, what additional information do you share with your clients to help them choose your products? | Information Exchange | System Supplier |
| 5.5 What format is the above-mentioned information shared? | Information Exchange | System Supplier |
| 5.6 Do you often encounter problems with the conversion of electronic formats between you and your client? | Information Exchange | System Supplier |
| 5.7 Is there an agreement with your clients about the format used for exchanging and storing data? | Information Exchange | System Supplier |
| 5.8 Would you appreciate a standardized approach for exchanging documents or data with your clients? | Information Exchange | System Supplier |
| 5.9 How often are new products designed and released in the market? | General Functions | System Supplier |

15.8 Long list of Façade Passports

| Product | Data Item | Unit | Type | Source | Product Level | Categorization | Standard |
|---------|-----------------------------|--------------------|----------|--------------|------------------------|---------------------|------------|
| General | Thermal Transmittance | W/m ² K | Value | CE | L1_Material/L2_Product | Material Properties | EN 13165 |
| General | Structural Analysis Results | No unit | Document | Manual Input | Multilevel | Design data | Unknown |
| General | Thermal Analysis results | No unit | Document | Manual Input | Multilevel | Design data | Unknown |
| General | Thermal Flow results | No unit | Document | Manual Input | Multilevel | Design data | Unknown |
| General | Reaction to fire | Class | Text | CE | L1_Material/L2_Product | Material Properties | EN 13501-1 |
| General | Fire resistance | Class | Text | CE | L1_Material/L2_Product | Material Properties | EN 13501-2 |
| General | Quality assurance | No unit | Text | Brochure | L2_Product | Manufacturing Data | NA |
| General | Air permeability | g/m ² | Value | CE | L1_Material/L2_Product | Material Properties | EN 12114 |
| General | Density | kg/m ³ | Value | Brochure | L1_Material/L2_Product | Material Properties | NA |
| General | Width | mm | Value | Brochure | L1_Material/L2_Product | Material Properties | NA |
| General | Location in building (AN) | No unit | Multiple | Manual Input | L7_Building | Design data | NA |

| | | | | | | | |
|---------|-------------------------------------|------------------------------------|--------------|--------------|------------------------|---------------------|---------|
| General | BIM Model | No unit | Drawings | Manual Input | Multilevel | Design data | NA |
| General | Design Notes | No unit | Drawings | Manual Input | L6_Building Part | Design data | NA |
| General | Function Tree | No unit | Drawings | Manual Input | L5_Component | Design data | NA |
| General | Instance tree | No unit | Drawings | Manual Input | L5_Component | Design data | NA |
| General | UID's | No unit | Text | Manual Input | All levels | Identifiers | NA |
| General | Installation instructions | No unit | Document | Brochure | L1_Material/L2_Product | Manufacturing Data | NA |
| General | 3D Model | No unit | Drawings | Manual Input | All levels | Design data | NA |
| General | Technical Drawings | No unit | Drawings | Manual Input | L5_Component | Design data | NA |
| General | Coating | Specification | Text | EPD | L1_Material/L2_Product | Material Properties | NA |
| General | Output flows | Check | Value | EPD | L1_Material/L2_Product | Environmental Data | NA |
| General | Global warming potential | kg Co2 Equivalent/FU | Value | EPD | L1_Material/L2_Product | Environmental Data | NA |
| General | Waste production | kg/FU | Value | EPD | L1_Material/L2_Product | Environmental Data | NA |
| General | Processing Co2 | kg/kg | Value | EPD | L1_Material/L2_Product | Environmental Data | NA |
| General | Water consumption | m3/FU | Value | EPD | L1_Material/L2_Product | Environmental Data | NA |
| General | Energy consumption | MJ/FU | Value | EPD | L1_Material/L2_Product | Environmental Data | NA |
| General | Nonrenewable resource consumption | MJ/Fu | Value | EPD | L1_Material/L2_Product | Environmental Data | NA |
| General | Processing Energy | MJ/kg | Value | EPD | L1_Material/L2_Product | Environmental Data | NA |
| General | Hazardous substances | No unit | Text | CE | L1_Material/L2_Product | Environmental Data | NA |
| General | Material composition | % | Value | EPD | L1_Material/L2_Product | Material Properties | NA |
| General | Biodegradability Declaration issued | Biodegradable or non-biodegradable | Multi-option | CE | L1_Material/L2_Product | Material Properties | Unknown |
| General | Valid until | Date | Value | EPD | L1_Material/L2_Product | Manufacturing Data | NA |
| General | Cost of material | Euro/kg? | Value | Manual Input | Multilevel | Manufacturing Data | NA |
| General | Cost of production | Euro/kg? | Value | Manual Input | Multilevel | Manufacturing Data | NA |
| General | Working Drawings | No unit | Drawings | Manual Input | All levels | Design data | NA |
| General | Distance Travelled | kms | Value | Manual Input | All levels | Logistical Data | NA |
| General | Color | No unit | Text | Brochure | L1_Material/L2_Product | Material Properties | NA |
| General | Product Level | No unit | Value | Manual Input | All levels | Identifiers | NA |
| General | RFID Number | No unit | Text | Manual Input | All levels | Identifiers | NA |
| General | Packaging requirements | No unit | Document | Brochure | L1_Material/L2_Product | Logistical Data | NA |
| General | Current Location | No unit | Multiple | Manual Input | L5_Component | Logistical Data | NA |
| General | Location History | No unit | Multiple | Manual Input | L5_Component | Logistical Data | NA |
| General | Packaging notes | No unit | Document | EPD | L1_Material/L2_Product | Logistical Data | NA |
| General | EPD prepared by | No unit | Text | EPD | L1_Material/L2_Product | Manufacturing Data | NA |
| General | EPD registration number | No unit | Text | EPD | L1_Material/L2_Product | Manufacturing Data | NA |

| | | | | | | | |
|-----------------------|--|--------------------|----------|--------------|------------------------|---------------------|-----------------------------|
| General | General description | No unit | Document | EPD | L1_Material/L2_Product | Manufacturing Data | NA |
| General | Manufacturer | No unit | Text | EPD | L1_Material/L2_Product | Manufacturing Data | NA |
| General | Owner of declaration | No unit | Text | EPD | L1_Material/L2_Product | Manufacturing Data | NA |
| General | Product name | No unit | Text | EPD | L1_Material/L2_Product | Manufacturing Data | NA |
| General | Production process | No unit | Document | EPD | L1_Material/L2_Product | Manufacturing Data | NA |
| General | Certificates | No unit | Text | Brochure | L1_Material/L2_Product | Manufacturing Data | NA |
| General | General notes | No unit | Text | Brochure | L1_Material/L2_Product | Manufacturing Data | NA |
| General | Handling | No unit | Document | Brochure | L1_Material/L2_Product | Manufacturing Data | NA |
| General | Live Monitoring results | No unit | Value | Manual Input | Multilevel | Design data | Unknown |
| General | Guarantee Period | Years | Value | Manual Input | L5_Component | Material Properties | NA |
| General | Service life | Years | Value | EPD | L1_Material/L2_Product | Material Properties | NA |
| General | Weight | kg | Value | CE | L1_Material/L2_Product | Material Properties | NA |
| General | Impact resistance | Class | Text | CE | L1_Material/L2_Product | Material Properties | EN 12600 |
| General | Product Specific Handling Instructions | No unit | Document | DocuCentre | L2_Product | Manufacturing Data | NA |
| General | CAD File of Product | No unit | Drawings | DocuCentre | L2_Product | Manufacturing Data | NA |
| Insulated Glass Units | Energy transmission the | % | Value | CE | L2_Product | Material Properties | EN 410 |
| Insulated Glass Units | Light Transmission | % | Value | CE | L2_Product | Material Properties | EN 410 |
| Insulated Glass Units | Energy reflection (Ree/Rei) | % | Value | EPD | L2_Product | Material Properties | EN 410 |
| Insulated Glass Units | Energy transmittance (ET) | % | Value | EPD | L2_Product | Material Properties | EN 410 |
| Insulated Glass Units | Light reflection (Rle/Rli) | % | Value | EPD | L2_Product | Material Properties | EN 410 |
| Insulated Glass Units | Light transmittance | % | Value | EPD | L2_Product | Material Properties | EN 410 |
| Insulated Glass Units | Rw(C,Ctr) | dB | Value | EPD | L2_Product | Material Properties | EN 12758 |
| Insulated Glass Units | Sound reduction Rw | dB | Value | CE | L2_Product | Material Properties | EN 140-3 |
| Insulated Glass Units | G value | No unit | Value | CE | L2_Product | Material Properties | EN 410 |
| Insulated Glass Units | Solar Factor | No unit | Value | EPD | L2_Product | Material Properties | EN 410 |
| Insulated Glass Units | Ug value | No unit | Value | EPD | L2_Product | Material Properties | EN 410 |
| Insulated Glass Units | U value W/m2K | W/m ² K | Value | CE | L2_Product | Material Properties | EN 673 |
| Insulated Glass Units | Solar Energy Transmittance | Class | Text | CE | L2_Product | Material Properties | Product standard EN 14351-1 |
| Insulated Glass Units | UV stability/durability | hrs. | Value | CE | L2_Product | Material Properties | EN ISO 12543-4 |
| Insulated Glass Units | Dimensional tolerances | mm | Value | CE | L1_Material/L2_Product | Material Properties | NA |
| Insulated Glass Units | Nominal thickness | mm | Value | CE | L1_Material/L2_Product | Material Properties | NA |
| Insulated Glass Units | Spacer Thickness | mm | Value | CE | L1_Material/L2_Product | Material Properties | NA |
| Insulated Glass Units | Thickness tolerance | mm | Value | CE | L1_Material/L2_Product | Material Properties | NA |

| | | | | | | | |
|-----------------------|--|----------------------------------|--------------|--------------|------------------------|---------------------|-----------------------------|
| Insulated Glass Units | Glass 1 | Specification | Text | CE | L1_Material/L2_Product | Material Properties | NA |
| Insulated Glass Units | Glass 2 | Specification | Text | CE | L1_Material/L2_Product | Material Properties | NA |
| Insulated Glass Units | Maximum glass size | WXH mm | Value | CE | L1_Material/L2_Product | Material Properties | NA |
| Insulated Glass Units | Burglary resistance | Class | Text | EPD | L2_Product | Material Properties | Class EN 356 |
| Insulated Glass Units | CPC classification | No unit | Text | EPD | L2_Product | Manufacturing Data | 37115 "safety glass" |
| Insulated Glass Units | Product/CE/DoP Code | No unit | Text | CE | L1_Material/L2_Product | Manufacturing Data | NA |
| Insulated Glass Units | Application conditions | No unit | Text | CE | L1_Material/L2_Product | Manufacturing Data | NA |
| Insulated Glass Units | Vapor Diffusion | Sd | Value | CE | L2_Product | Material Properties | Unknown |
| Insulated Glass Units | Refractive index | No unit | Value | CE | L2_Product | Material Properties | Unknown |
| Insulated Glass Units | PCR | Reference to Standard | Text | EPD | L2_Product | Material Properties | EN 15804 |
| Insulated Glass Units | Responsible sourcing | Reference to Standard | Text | EPD | L2_Product | Material Properties | Iso 14001 |
| Insulated Glass Units | Health and Safety | Reference to Standard | Text | EPD | L2_Product | Material Properties | ISO 16000 |
| Insulated Glass Units | Fire resistant interlayer | Weight % | Value | EPD | L1_Material/L2_Product | Material Properties | NA |
| Insulated Glass Units | Gas | Weight % | Value | EPD | L1_Material/L2_Product | Material Properties | NA |
| Insulated Glass Units | Material Composition-Glass | Weight % | Value | EPD | L1_Material/L2_Product | Material Properties | NA |
| Insulated Glass Units | Material Composition-PVB interlayer | Weight % | Value | EPD | L1_Material/L2_Product | Material Properties | NA |
| Insulated Glass Units | Material Composition-Butyl Sealant | Weight % | Value | EPD | L1_Material/L2_Product | Material Properties | NA |
| Insulated Glass Units | Material Composition-Desiccant | Weight % | Value | EPD | L1_Material/L2_Product | Material Properties | NA |
| Insulated Glass Units | Material Composition-Sealant polysulfide | Weight % | Value | EPD | L1_Material/L2_Product | Material Properties | NA |
| Insulated Glass Units | Material Composition-Spacer bar | Weight % | Value | EPD | L1_Material/L2_Product | Material Properties | NA |
| Insulated Glass Units | Transparency | Transparent, Opaque, Translucent | Multi-option | CE | L2_Product | Material Properties | NA |
| Post designed product | Analysis Drawings | No unit | Drawings | Manual Input | All levels | Design data | NA |
| Post designed product | Outer dimensions | WXH mm | Value | CE | All levels | Material Properties | NA |
| Post designed product | Location In building (GR) | No unit | Drawings | Manual Input | All levels | Identifiers | NA |
| Profiles | Sound reduction | dB | Value | Brochure | L2_Product | Material Properties | EN ISO 140-3 |
| Profiles | Rw (acoustic performance) | dB | Value | CE | L2_Product | Material Properties | Product standard EN 14351-1 |
| Profiles | Thermal insulation | W/m ² K | Value | Brochure | L2_Product | Material Properties | EN 12412-2 |
| Profiles | Thermal transmittance | W/m ² K | Value | CE | L2_Product | Material Properties | Product standard EN 14351-1 |
| Profiles | Ventilation | Check | Value | CE | L2_Product | Material Properties | Product standard |

| | | | | | | | |
|----------|--|-----------|--------------|------------|------------|---------------------|-----------------------------|
| | | | | | | | EN 14351-1 |
| Profiles | Waterproofing | Class | Text | CE | L2_Product | Material Properties | EN 12208 |
| Profiles | Wind resistance | Class | Text | CE | L2_Product | Material Properties | EN 12210 |
| Profiles | Resistance to Use | Class | Text | CE | L2_Product | Material Properties | EN 12400 |
| Profiles | Water tightness | Class | Text | CE | L2_Product | Material Properties | Product standard EN 14351-1 |
| Profiles | Air Permeability | Class | Text | CE | L2_Product | Material Properties | Product standard EN 14351-1 |
| Profiles | Depth of frame | mm | Value | Brochure | L2_Product | Material Properties | NA |
| Profiles | Possible thicknesses | mm | Value | Brochure | L2_Product | Material Properties | NA |
| Profiles | Profile cross-section | No unit | Document | Brochure | L2_Product | Manufacturing Data | NA |
| Profiles | Product Name | No unit | Text | Brochure | L2_Product | Manufacturing Data | NA |
| Profiles | Ability to release | Pass/Fail | Multi-option | CE | L2_Product | Material Properties | EN 179, EN 1125 |
| Profiles | Max Weight of Glass | kg | Value | Brochure | L2_Product | Material Properties | NA |
| Profiles | Loadbearing capacity of safety devices | Pass/fail | Multi-option | CE | L2_Product | Material Properties | Product standard EN 14351-1 |
| Profiles | Resistance to transverse shear stress | Class | Text | CE | L2_Product | Material Properties | EN 13115 |
| Profiles | Torsion resistance | Class | Text | CE | L2_Product | Material Properties | EN 13115 |
| Profiles | Resistance to wind load | Class | Text | CE | L2_Product | Material Properties | Product standard EN 14351-1 |
| Profiles | Operating forces | Class | Text | CE | L2_Product | Material Properties | Product standard EN 14351-1 |
| Profiles | Mechanical strength | Class | Text | CE | L2_Product | Material Properties | Product standard EN 14351-1 |
| Profiles | Bullet resistance | Class | Text | CE | L2_Product | Material Properties | Product standard EN 14351-1 |
| Profiles | Explosion resistance | Class | Text | CE | L2_Product | Material Properties | Product standard EN 14351-1 |
| Profiles | Resistance to repeated opening and closing | Class | Text | CE | L2_Product | Material Properties | Product standard EN 14351-1 |
| Profiles | Behavior between different climates | Class | Text | CE | L2_Product | Material Properties | Product standard EN 14351-1 |
| Profiles | Burglar resistance | Class | Text | CE | L2_Product | Material Properties | Product standard EN 14351-1 |
| Profiles | Product Specific Installation Instructions | No unit | Document | DocuCentre | L2_Product | Manufacturing Data | NA |

| | | | | | | | |
|-----------------|---|-----------------------|--------------|--------------|------------------------|---------------------|----------|
| Profiles | Thermal Transmittance (U value) | W/m ² K | Value | CE | L2_Product | Material Properties | Unknown |
| Profiles | Thermal Conductivity (K value) | W/mm | Value | CE | L2_Product | Material Properties | Unknown |
| Profiles | Water Tightness | Class | Multi-option | CE | L2_Product | Material Properties | Unknown |
| Profiles | Heat transfer Coefficient | Btu | Value | CE | L2_Product | Material Properties | Unknown |
| Profiles | Product Manufacturer Name | No unit | Text | CE | L2_Product | Manufacturing Data | NA |
| Profiles | Product Manufacturing Date | No unit | Value | CE | L2_Product | Manufacturing Data | NA |
| Profiles | Product Manufacturer Registration Number | No unit | Text | CE | L2_Product | Manufacturing Data | NA |
| Profiles | Material Composition | No unit | Text | CE | L2_Product | Material Properties | NA |
| Profiles | Toxic Elements | No unit | Text | CE | L2_Product | Material Properties | Unknown |
| Profiles | Untreated/Treated | Treated or Untreated | Multi-option | CE | L2_Product | Material Properties | NA |
| Profiles | Maximum Service Life | Years | Value | CE | L2_Product | Material Properties | Unknown |
| Profiles | Minimum Service Life | Years | Value | CE | L2_Product | Material Properties | Unknown |
| Profiles | Shear Modulus | Gpa | Value | CE | L2_Product | Material Properties | Unknown |
| Profiles | Youngs modulus | Mpa | Value | CE | L2_Product | Material Properties | Unknown |
| Profiles | Water Absorption | % | Value | CE | L2_Product | Material Properties | Unknown |
| Profiles | Year of dataset | Date | Value | CE | L2_Product | Manufacturing Data | NA |
| Profiles | Recycled Content | % | Value | Manual Input | L2_Product | Environmental Data | NA |
| Profiles | Unique Identification Number | No unit | Text | Manual Input | L2_Product | Identifiers | NA |
| Sandwich panels | U value | W/m ² K | Value | EPD | L1_Material/L2_Product | Material Properties | Unknown |
| Sandwich panels | Thermal permeability | Class | Text | CE | L2_Product | Material Properties | EN 10077 |
| Sandwich panels | Water permeability | Class | Text | CE | L2_Product | Material Properties | EN 12865 |
| Sandwich panels | Water vapor Permeability | Permeable/Impermeable | Multi-option | CE | L1_Material/L2_Product | Manufacturing Data | NA |
| Sandwich panels | Density of insulation | kg/m ³ | Value | CE | L2_Product | Material Properties | EN 1602 |
| Sandwich panels | Max Length | m | Value | Brochure | L1_Material/L2_Product | Material Properties | NA |
| Sandwich panels | Rc Value | m ² K/W | Value | Brochure | L1_Material/L2_Product | Material Properties | NA |
| Sandwich panels | Thickness overall | mm | Value | Brochure | L1_Material/L2_Product | Material Properties | NA |
| Sandwich panels | Thickness of insulation | mm | Value | CE | L1_Material/L2_Product | Material Properties | NA |
| Sandwich panels | Thickness of outer sheet | mm | Value | EPD | L1_Material/L2_Product | Material Properties | NA |
| Sandwich panels | The thickness of the inner sheet | mm | Value | EPD | L1_Material/L2_Product | Material Properties | NA |
| Sandwich panels | Abiotic depletion potential for fossil resources (ADPF) | Check | Value | EPD | L1_Material/L2_Product | Environmental Data | NA |
| Sandwich panels | Cover width | mm | Value | EPD | L1_Material/L2_Product | Material Properties | NA |
| Sandwich panels | Unique Id of product | No unit | Text | CE | L1_Material/L2_Product | Manufacturing Data | NA |

| | | | | | | | |
|-----------------|---|-----------------------|-------|-----|------------------------|---------------------|----------|
| Sandwich panels | Certifications applicable | No unit | Text | EPD | L1_Material/L2_Product | Manufacturing Data | NA |
| Sandwich panels | Coating certifications | No unit | Text | EPD | L1_Material/L2_Product | Manufacturing Data | NA |
| Sandwich panels | Paint coating | No unit | Text | EPD | L1_Material/L2_Product | Manufacturing Data | NA |
| Sandwich panels | Metallic coating | No unit | Text | EPD | L1_Material/L2_Product | Material Properties | NA |
| Sandwich panels | Harmonized standard | Reference to Standard | Text | CE | L2_Product | Material Properties | EN 14509 |
| Sandwich panels | Panel weight | kg | Value | EPD | L1_Material/L2_Product | Material Properties | NA |
| Sandwich panels | Wrinkling strength in the span | Mpa | Value | CE | L2_Product | Material Properties | EN 14509 |
| Sandwich panels | Wrinkling strength elevated temp | Mpa | Value | CE | L2_Product | Material Properties | EN 14509 |
| Sandwich panels | Wrinkling strength central support | Mpa | Value | CE | L2_Product | Material Properties | EN 14509 |
| Sandwich panels | Elevated wrinkling strength at the central support | Mpa | Value | CE | L2_Product | Material Properties | EN 14509 |
| Sandwich panels | Wrinkling strength Internal Façade in the span | Mpa | Value | CE | L2_Product | Material Properties | EN 14509 |
| Sandwich panels | Wrinkling strength (internal face) in the span | Mpa | Value | CE | L2_Product | Material Properties | EN 14509 |
| Sandwich panels | Wrinkling strength (internal face) at the central support | Mpa | Value | CE | L2_Product | Material Properties | EN 14509 |
| Sandwich panels | Shear modulus of the core | Mpa | Value | CE | L2_Product | Material Properties | EN 14509 |
| Sandwich panels | Shear Strength | Mpa | Value | CE | L2_Product | Material Properties | EN 14509 |
| Sandwich panels | Tensile Strength | Mpa | Value | CE | L2_Product | Material Properties | EN 1609 |
| Sandwich panels | Compressive strength of the core | Mpa | Value | CE | L2_Product | Material Properties | EN 826 |

15.9 Sources of EoS assessment criteria

| Criteria affecting EoS assessment and their sources. | | | |
|--|---|--|---|
| Criteria | Source | Location in Source | Description |
| Connection Access | Alba-Concepts (2019) | Accessibility connection criteria. | How accessible are the connections of the façade. |
| Flexibility | Beurskens et al. (2016) | Adapted from 17, 18 and 19 (figure 3) | Whether the façade dimensions can be modified. |
| Disassembly Direction | Beurskens et al. (2016) | Adapted from 21 and 22 (figure 3) | Direction in which the façade can be disassembled. |
| Connection Points | Beurskens et al. (2016) | Adapted from 21 and 22 (figure 3) | Positions where the façade is connected to the building |
| Horizontal Grid Span | Beurskens et al. (2016) | Adapted from 6 (figure 3) | How the façade grid spans in the vertical direction |
| Crosssection Geometry | Beurskens et al. (2016) | Adapted from 7 (figure 3) | The schematic overlap of the façade onto the building. |
| Position | Beurskens et al. (2016) | Adopted from 4. Building structure Position (figure 3) | Placement of the façade with respect to the building. |
| Vertical Grid Span | Beurskens et al. (2016) | Adopted from 5. Position Vertical (figure 3) | How the façade grid spans in the vertical direction |
| Defects | NEN 2767 | NA | The various defects which the façade has at EoS |
| Connection Type | Durmisevic (2006) | Figure 5.21 connection types. | How the façade is connected to the building |
| Façade Performances | Building Decree and other standards | NA | Whether the façade meets the minimum performance values as per standards |
| Component Access | Author's adaptation | NA | What are the possible ways in which the façade can be accessed. |
| Modular Sizing | Author's adaptation | NA | How modular are the dimensions of the façade frame. |
| Areas | Author's adaptation | NA | Surface area of the façade which is being assessed |
| Residual Value | Author's adaptation | NA | The value of the façade or façade element, at the EoS stage. No framework currently exists to map this out. |
| Grid Modularity | Author's adaptation | NA | The number of repeated elements in the façade |
| Tolerances | Author's adaptation | NA | A dimension indicating how much the façade can move or adapt with respect to the building |
| Grid Size | Author's adaptation | NA | Dimensions of the façade grid |
| Grid Geometry | Author's adaptation | NA | Geometry of the façade grid |
| Recyclability | Author's adaptation | NA | Whether a recycling process exists for the given material |
| Quantities | Author's adaptation | NA | The number of façade units of a particular size |
| Structural System | Author's adaptation | NA | Whether the façade requires an additional support or not |
| Toxicity | Author's adaptation | NA | Whether the façade materials have high toxic content. |
| Typology | Beurskens et al. (2016) and Durmisevic (2006) | Typology definition: 1 from Beurskens et al. (| Determines type of façade, and product architecture |

Figure 148: EoS Assessment Criteria considered and sources referenced from. Source: Author.

15.10 Auxiliary research on Industry Foundation Classes (IFC):

IFC (Industry Foundation Classes) represents the data core of BIM. It represents an open and standardized data model to ensure interoperability between BIM software in the Building Industry (Laakso & Kiviniemi, 2012). As data building elements in a BIM model are structured as an IFC data model, and most current material passport platforms use this data structure to access specific elements, it becomes crucial to understand its architecture. An IFC data model comprises layers with a controlled referencing hierarchy, as shown in Figure 125. The Domain Layer contains models for processes specific to different AEC industry domains, such as structural engineering, HVAC, architecture, etc. The interoperability is more common and generic and can be distributed across the different domains, for example, the IFC wall, Beam-Column stair, etc. IFC Kernel represents some of the most abstract entities, such as groups, processes, products, and relationships between entities. The central aspect is that between the layers can only happen downwards, which implies that the lowest layer (i.e., resource layer) is independent and cannot reference any layer above it, as shown in Figure 125.

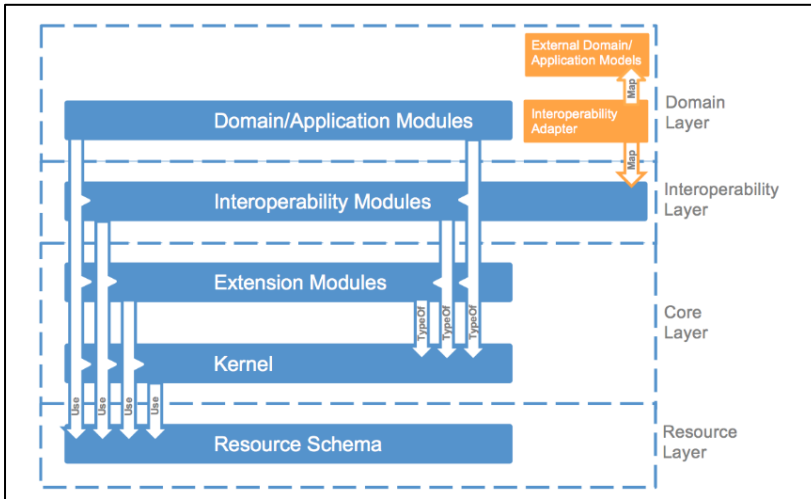

Figure 149 - Structure of an IFC data model. Source: Laakso and Kiviniemi (2012)

Essentially an IFC file would comprise of IFC Entities, which have the project's information and are referenced from a combination of the Different layers, which give each entity several objects and properties. As indicated in Figure 126, a spatial tree indicates this relationship and organizational structure for a typical wall and column represented in a building.

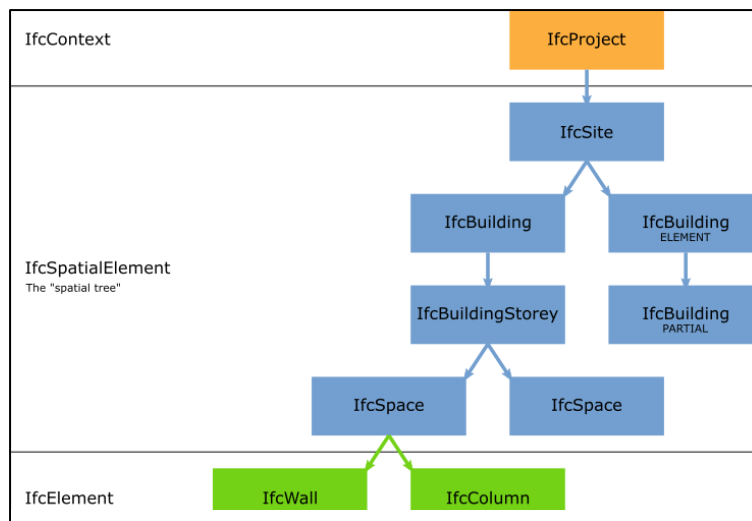

Figure 150: The spatial tree of the IFC file. Source: Wiki.OsArch.

15.11 Auxiliary Research on Façade Product certifications

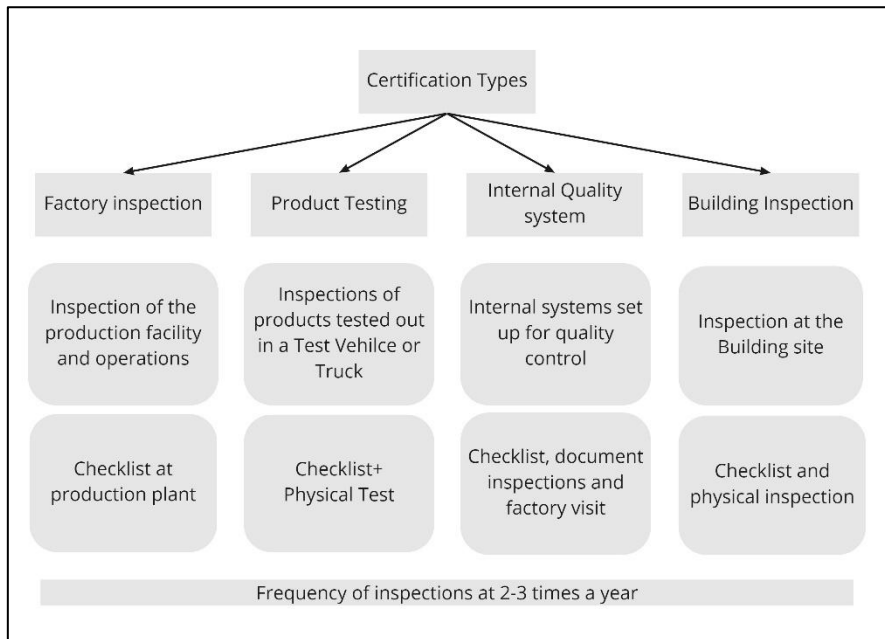

Figure 151: Types of Certifications and Methods employed in the Façade Industry. Source: Author

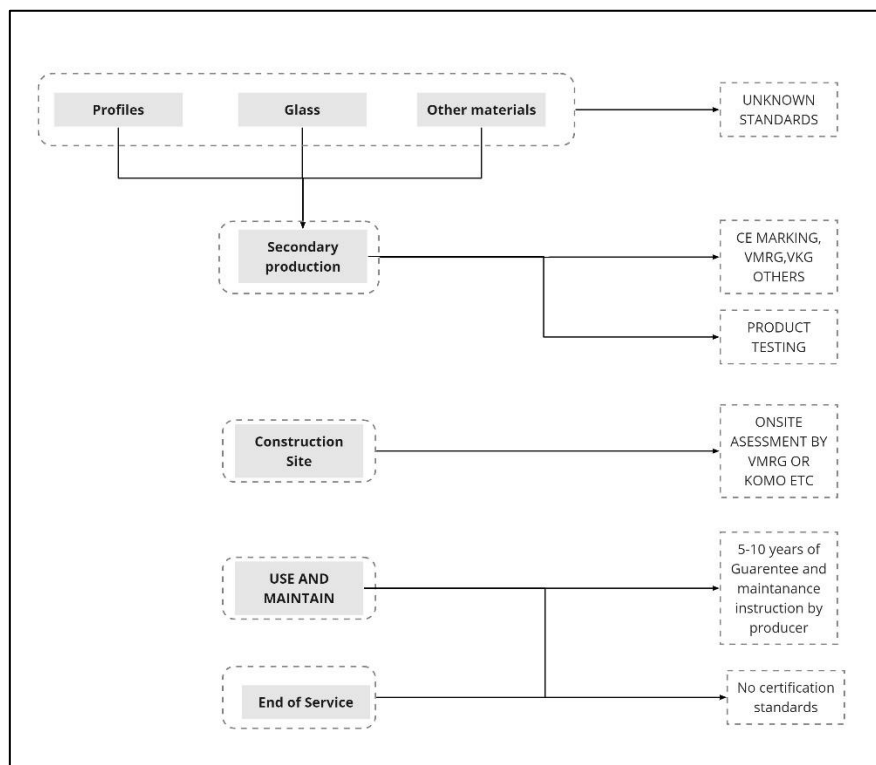

Figure 152: Certifications of Various products in the lifecycle stages. Source: Author

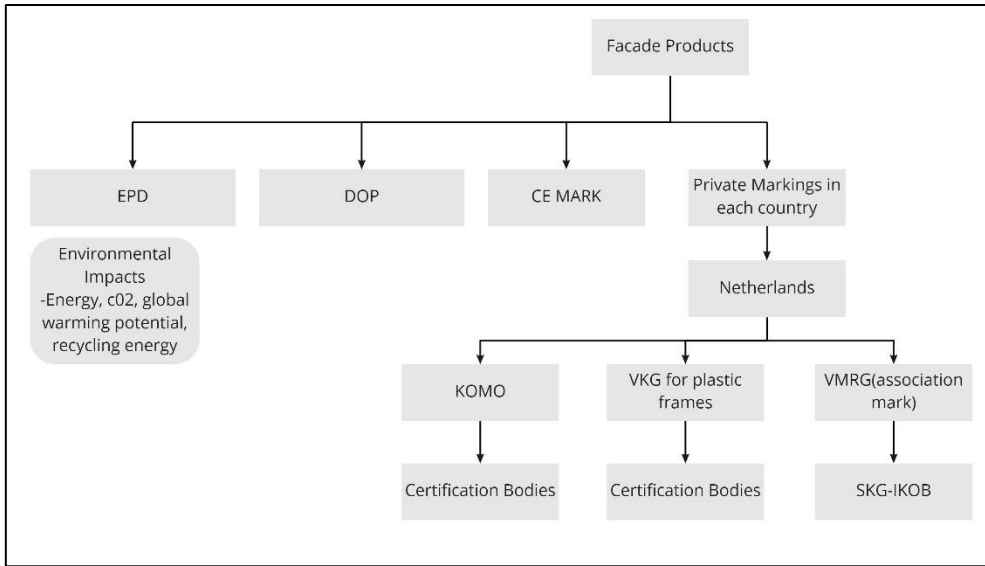

Figure 153: Overview of certifications required for a façade product. Source: Author

15.12 Stages of NEN 2767 Condition measurement process.

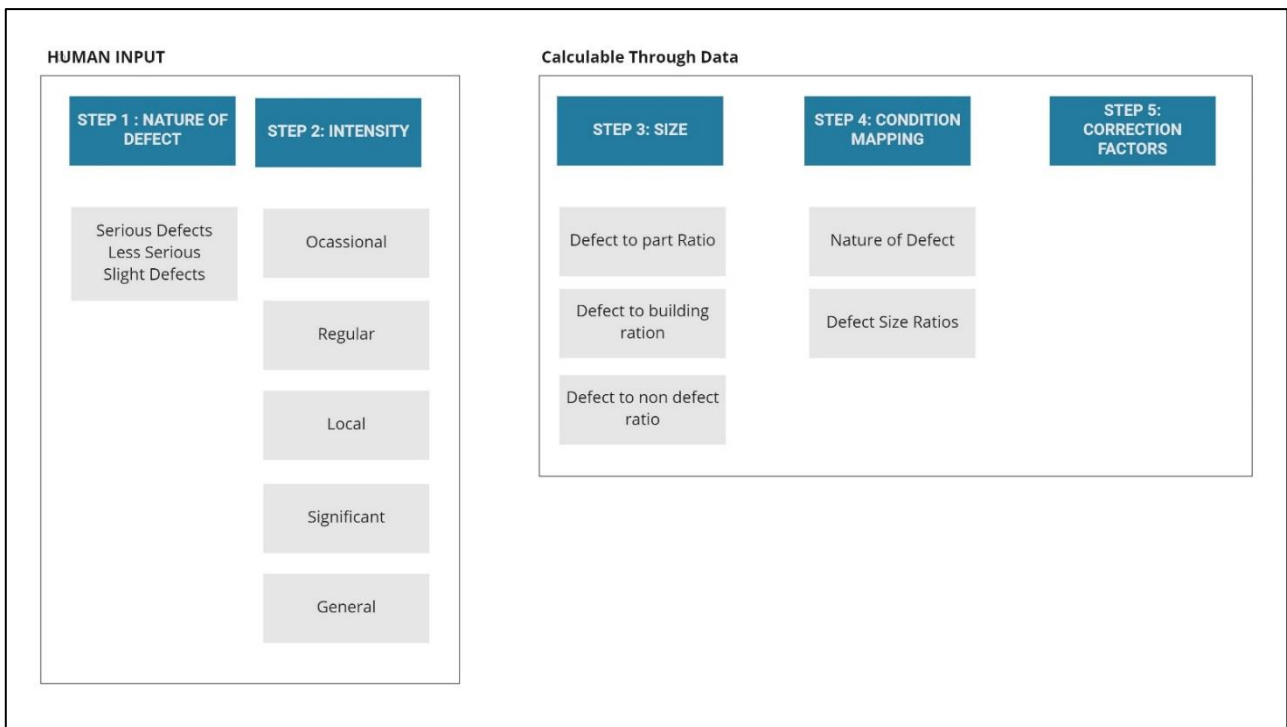

Figure 154: Stages of NEN 2767 condition measurement process. Source: Author