

**Document Version**

Final published version

**Citation (APA)**

He, C., Yang, Z., Zhang, P., Li, S., Naeimi, M., & Li, Z. (2022). A Finite Element Thermomechanical Analysis of Polygonal Wear. In A. Orlova, & D. Cole (Eds.), *Advances in Dynamics of Vehicles on Roads and Tracks II - Proceedings of the 27th Symposium of the International Association of Vehicle System Dynamics, IAVSD 2021* (pp. 533-541). (Lecture Notes in Mechanical Engineering). Springer. [https://doi.org/10.1007/978-3-031-07305-2\\_53](https://doi.org/10.1007/978-3-031-07305-2_53)

**Important note**

To cite this publication, please use the final published version (if applicable).  
Please check the document version above.

**Copyright**

In case the licence states "Dutch Copyright Act (Article 25fa)", this publication was made available Green Open Access via the TU Delft Institutional Repository pursuant to Dutch Copyright Act (Article 25fa, the Taverne amendment). This provision does not affect copyright ownership.  
Unless copyright is transferred by contract or statute, it remains with the copyright holder.

**Sharing and reuse**

Other than for strictly personal use, it is not permitted to download, forward or distribute the text or part of it, without the consent of the author(s) and/or copyright holder(s), unless the work is under an open content license such as Creative Commons.

**Takedown policy**

Please contact us and provide details if you believe this document breaches copyrights.  
We will remove access to the work immediately and investigate your claim.

***Green Open Access added to TU Delft Institutional Repository***

***'You share, we take care!' - Taverne project***

**<https://www.openaccess.nl/en/you-share-we-take-care>**

Otherwise as indicated in the copyright section: the publisher is the copyright holder of this work and the author uses the Dutch legislation to make this work public.



# A Finite Element Thermomechanical Analysis of Polygonal Wear

Chunyan He<sup>(✉)</sup>, Zhen Yang, Pan Zhang, Shaoguang Li, Meysam Naeimi, and Zili Li

Section of Railway Engineering, Delft University of Technology, Stevinweg 1, 2628 CN Delft,  
The Netherlands  
C.he-1@tudelft.nl

**Abstract.** Polygonal wear is a common type of damage on the railway wheel tread, which could induce wheel-rail impacts and further components failure. This study presents a finite element (FE) thermomechanical model to investigate the causes of wheel polygonal wear. The FE model is able to cope with three possible causes of polygonal wear: thermal effect, initial defects, and structural dynamics. To analyse the influences of the three causes on wheel-rail contact stress and wear depth, different material properties (i.e., elastic, elasto-plastic, thermo-elasto-plastic with thermal softening), and wheel profiles (i.e., round and polygonal) were used in the FE model. The simulation indicates that a high temperature up to 264.20 °C could be induced by full-slip wheel-rail rolling contact when the polygonal profile is used. The thermal effect, similar to that induced by tread brake, may then have a significant influence on wheel-rail contact stress and wear depth. In addition, the involvement of initial defects, i.e., polygonal profile, causes wheel-rail impact contact and remarkably increases the contact stress and wear. By reliably considering all the three possible causes, the proposed FE model is believed promising for further explaining the generation mechanisms of wheel polygonal wear.

**Keywords:** Polygonal wear · Finite element model · Thermal effect · Initial defects

## 1 Introduction

During the past 30 years, polygonal wear has been investigated using experimental and numerical methods, and different views on the generation mechanism have been presented. In summary, the proposed causes of the polygonal wheels are divided into three categories: 1) thermal effect from block braking system [1–4], 2) initial defects on the wheels [5–7], and 3) resonance of the train/track system [8–14]. The polygonal wear generation can, however, not be fully understood by only considering one or two potential causes [13]. Comprehensively considering all the three causes is desirable.

The explicit finite element method (FEM) has been proven reliable to model wheel-rail contact with arbitrary geometry [15] and handle dynamic effects [16] and thermal effect [17]. The explicit FEM is thus employed in this study, which could simultaneously

deal with initial defects, thermal effect, and wheel/rail structural dynamics. The contact solution of the dynamic model with an elastic material in the steady-state is verified against the results obtained with Hertz contact theory and Kalker's program CONTACT. Simulations with different material types and wheel profiles are conducted to investigate the influence of the thermal effect and initial defects on the wheel-rail contact stress distributions and consequent wear.

## 2 Modelling

### 2.1 Finite Element (FE) Models

A FE dynamics model is developed (shown in Fig. 1) according to the parameters of the V-Track test rig [18]. The solution procedure includes four steps are: 1. Modelling of the V-Track rig (pre-processing in ANSYS); 2. Static equilibrium of the wheel loading on the rail (implicit solution); 3. Dynamic rolling of the wheel along the rail (explicit solution); 4. Results output (Post-processing with Matlab). The implicit-explicit sequential analysis (steps 2 and 3) can effectively mitigate initial dynamic excitation.

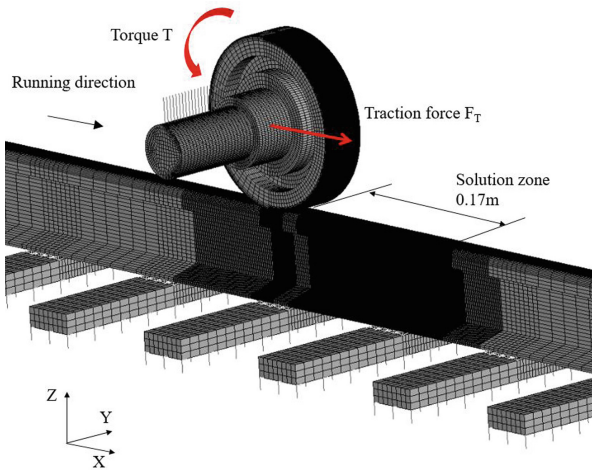

**Fig. 1.** 3D FE wheel/rail dynamics model

The pre-processing includes the geometry modelling, discretization, definition of contact pair, the input of the boundary conditions, and other parameters, e.g., material properties, loads, initial conditions. The total length of the rail model is 3.07 m including a solution zone with a length of 0.17 m. The rail model is connected to sleepers by fastenings. A wheel with a radius of 0.065 m (1/7 scaled) and a half axle is modelled with solid elements. The carbody and bogie simplified as lumped mass elements are connected to the wheel axle with spring-damper elements which represented the first suspension. To conduct the static equilibrium, longitudinal and lateral degrees of freedom of the wheel are constrained, and the gravity load is applied.

The implicit-explicit sequential analysis is conducted to simulate the wheel rolling along the rail. The longitudinal constraint of the wheel is released in the explicit model. Besides, the nodal displacements are obtained by the static equilibrium, which is an initial condition for the explicit model. Initial translational velocity (3.6 m/s) and angular velocity of the wheel (55.54 rad/s) are specified in the model. Modifying the traction force and the torque could influence the wheel and rail rolling sliding state. The case when the wheel runs in a steady-state is developed for the verification in Sect. 3. In this case, a traction force along the running direction is applied to the center of the wheel, a negative torque that comes from the motor is applied to the axle, which is shown in Fig. 1. Positive torque is applied to the wheel to simulate the acceleration condition in Sect. 4. To evaluate the thermal effect and initial defects on the wear depth, four types of materials are employed in the FE model, which is shown in Table 1. Elastic-thermal material means the material could conduct heat but it is always in an elastic state. The bilinear material type is applied to the FE model to calculate the contact solutions with plastic deformation. When the von Mises stress is beyond the yield strength, plastic deformation occurs. Based on the elasto-plastic model, thermal softening is considered in the FE model. Temperature-dependent yield strength, Young’s modulus, and other parameters (e.g., parameters related to heat conduction) are applied in this study, as reported in [19].

**Table 1.** Material parameters of the model

Type	Parameters	Value/units
Elastic material	Young’s modulus, $E$	210/Gpa
	Poisson’s ratio, $\nu$	0.3
Elastic-thermal material	Young’s modulus, $E$	210/Gpa
	Poisson’s ratio, $\nu$	0.3
	Thermal parameters [19]	
Elasto-plastic material	Young’s modulus, $E$	210/Gpa
	Poisson’s ratio, $\nu$	0.3
	Yield stress, $\sigma_y$	483MPa
	Tangent modulus, $G$	21Gpa
Thermo-elasto-plastic with thermal softening	Mechanical and thermal parameters in [19]	

The thermomechanical coupled progress is shown in Fig. 2. Based on the actual temperature, plastic work, material properties, thermal expansion are calculated in the mechanical solver. Based on the current geometry, the heat-related parameters are calculated in the thermal solver. Then, temperature-dependent contact results could be obtained.

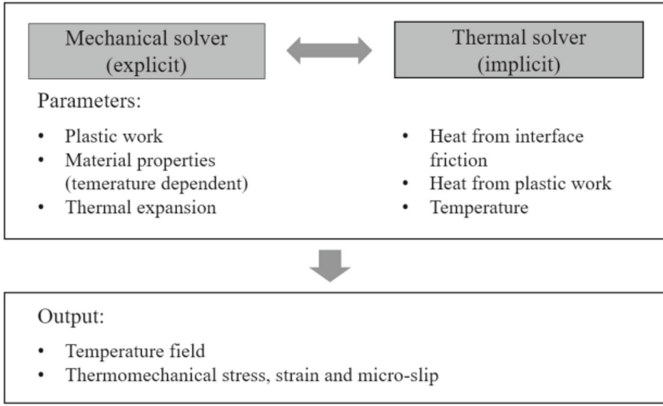

**Fig. 2.** Thermomechanical coupled simulation

**2.2 Polygonal Wheel Profile in the FE Models**

According to the profile test in the literature [14], the polygonal wheel can be treated as a combination of harmonic waves which have different wavelengths and amplitudes. Usually, some harmonic waves are obvious on the tread, which could be noticed and investigated independently. Arbitrary profiles of the wheel can be implemented in the FE model, which is an advantage of the FE model in studying the influence of the initial defects. The profile of the wheel can be modified as Eq. (1).

$$R_p = R + A \cdot \sin(N \cdot \theta) \tag{1}$$

where  $R$  is the radius of a wheel without polygonal wear.  $R_p$  is the wheel radius with polygonal wear. Sine waves are used to simulate the wavy profile on the tread.  $N$  is the order of the polygonal wear, which means the number of the harmonic waves along the whole tread’s circumference.  $A$  means the amplitude of the wave.  $\theta$  is the corresponding angle on the circumference of the wheel. The polygonal profile of the wheel will be used in the FE models when investigating the wear depth in Sect. 4.

**2.3 Simulation Cases for the Polygonal Wear**

In total, eight simulation cases (Table 2) are included in this paper to investigate the thermal effect on the wear depth. All the models are under the same boundary conditions, but the profile and the material type vary in these models. The initial profile of the wheel is ideally round for each case (cases 1 to 4), while a polygonal profile is applied for each case (cases 5 to 8). 68 order of polygonal wear is applied, in line with the measured wear pattern of the V-Track wheel. The elastic material is applied in each case (cases 1, 2, 5, 6), while elasto-plastic material is used in each case (cases 3, 4, 7, 8). Thermal softening of the material is considered in each case (case 4 and case8). However, the wear depth of the wheel on the V-Track is relatively small due to the short running distance and higher hardness than that of the rail. The amplitude of the harmonic wave is set as 0.029mm (1/7 scaled), which is consistent with the field measurement [20].

**Table 2.** Simulation cases

Profile	Round		Polygonal	
	Case	Name	Case	Name
Elastic	1	Model E	5	Model E-POL
	2	Model ET (thermal)	6	Model ET-POL (thermal)
Elasto-plastic	3	Model EP	7	Model EP-POL
	4	Model EPT (thermal)	8	Model EPT-POL (thermal)

### 3 Verification

The model E was verified against Hertz contact theory and the boundary element-based CONTACT program because the Hertzian theory and CONTACT deal with steady-state linear elastic contact without the consideration of the thermal effect. Normal contact stress could be obtained with all of them, shear stress could be gained by using the CONTACT program and the FE model. Contact pressures on the surface of rail calculated with the three methods are shown in Fig. 3. Traction bound (i.e., normal pressure times friction coefficient) and the shear stress on the surface of the rail from the FE model and CONTACT program are presented in Fig. 4. Figure 5 shows the nodes in the slip and adhesion area from the FE model and CONTACT program. It can be concluded that the contact solutions from the FE model agree well with the results from the other methods.

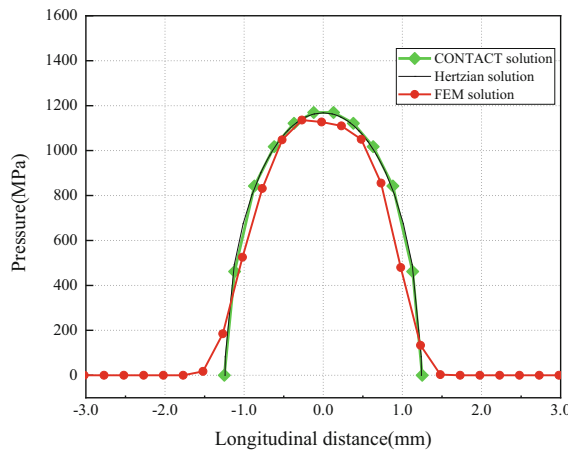

**Fig. 3.** Contact pressures along the longitudinal axis of the contact patch

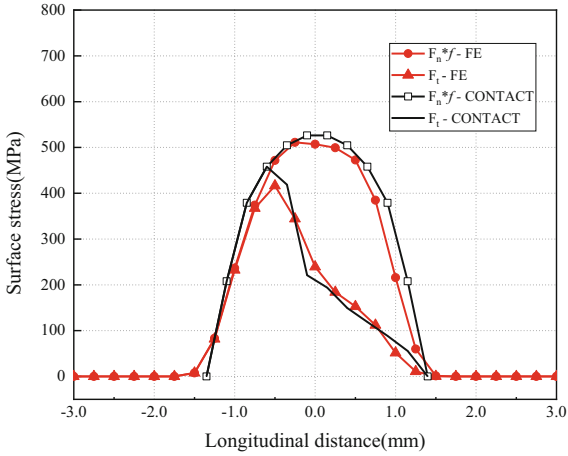

Fig. 4. Traction bonds and shear stresses along the longitudinal axis of the contact patch

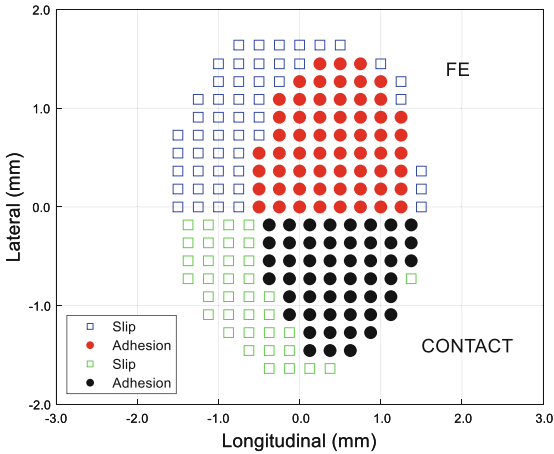

Fig. 5. Comparison of the adhesion-slip region of the FE model and CONTACT program

## 4 Simulation Results

### 4.1 Contact Pressure on the Surface

The contact pressure is a critical parameter to solve the wear depth in the contact patch. To explain the thermal effect and the initial defects on the contact pressure, the simulations from eight cases (Table 2) are conducted. In each case, the wheel accelerates from the initial speed along the rail with a positive torque of 162.50 N·m, which simulates wheel-rail rolling under a full sliding condition.

Normal contact pressure results are shown in Fig. 6. Figure 6(a) shows the contact pressures with the initially round profile. The maximum contact pressures calculated with

the elastic models (i.e., models E and ET) are higher than those calculated with elasto-plastic models (i.e., models EP and EPT), and the pressure distributions are symmetrical in the elastic models, but asymmetric (the peak value shifts forward) in the elasto-plastic models, all corresponding well to the results reported in the literature [15, 21, 22]. Comparing the results calculated with and without the consideration of thermal effect, i.e., model E vs model ET and model EP vs model EPT, we can see that the influence of the friction heat is not significant in Fig. 6(a). Figure 6(b) shows the results calculated with the models considering the initially polygonal profile. As expected, the peak contact pressures calculated with the elasto-plastic models (i.e., models EP-POL and EPT-POL) are lower than those calculated with the elastic models (i.e., models E-POL and ET-POL) in Fig. 6(b). It can, however, be interestingly observed that the contact pressure increases when comparing the results obtained with the models EP-POL and EPT-POL, suggesting that the thermal effect may take a much more pronounced effect when both the temperature-dependent material properties and initial irregularities are considered in the model.

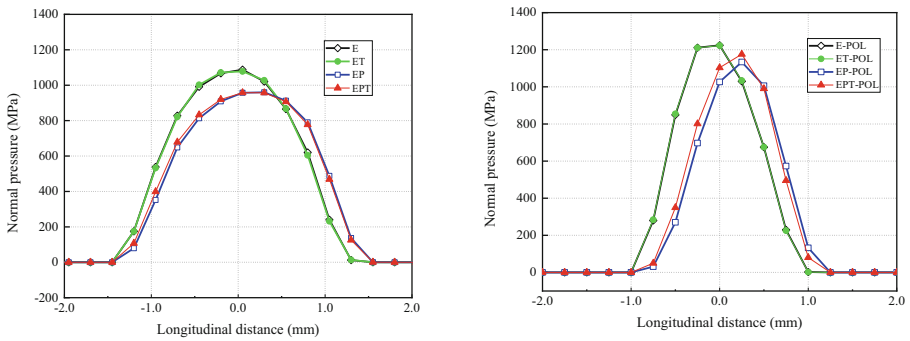
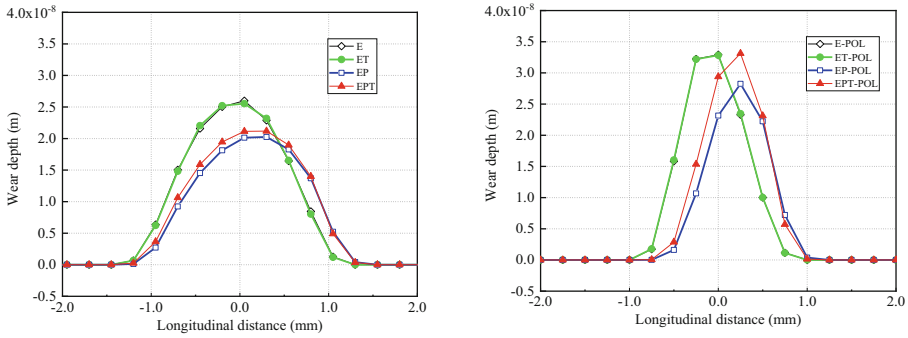

**Fig. 6.** Normal pressures on the wheel surface (a) models with initially round profile, (b) models with polygonal profile

## 4.2 Wear Simulation

The Archard's wear model [23] is employed to obtain the wear depth in the contact patch of the wheel.

As shown in Fig. 7(a), the trend of the wear depth is consistent with the contact pressure. It can be seen that wear depths of the elastic models (i.e., models E, ET) are higher than those in elasto-plastic models (i.e., models EP, EPT). Comparing the results obtained with the models EP and EPT, the influence of the frictional heat on the wear depth is slight with the round profile. However, larger wear depth when considering the initial polygonal profile and the thermal effect (i.e., model EPT-POL) could be obtained compared to the model EP-POL. The highest temperature of the wheel in the model EPT is 179.85°C, while the highest temperature in the model EPT-POL is 264.20°C. Higher temperature influences the material properties and contact geometry and induces a significant influence on the wear depth. The thermal effect is suggested to be considered in the simulations with high creepage or/and impacts.



**Fig. 7.** Wear depths in the contact patch (a) models with initially round profile, (b) models with polygonal profile

## 5 Conclusions and Future Work

In this paper, a finite element thermomechanical model is proposed, which is able to investigate three main causes of the polygonal wear: thermal effect, initial defects, and structural dynamics. To figure out the influences of the three causes on wheel-rail contact stress and wear depth, different material properties and wheel profiles were applied in the FE model. Based on the simulation results, the following conclusions are drawn:

- 1) The FE contact solutions with elastic material and round profile are verified against the Hertz contact theory and the CONTACT program. The contact solutions from the model E agree well with those from the other methods.
- 2) The involvement of initial defects, i.e., polygonal profile, causes wheel-rail impact contact and significantly increases the contact stress and wear.
- 3) The simulations indicate that a high temperature up to  $264.20^{\circ}\text{C}$  could be induced by full-slip wheel-rail rolling contact when the polygonal profile is used. The thermal effect, similar to that induced by tread brake, may then have a significant influence on wheel-rail contact stress and wear depth. The thermal effect is suggested to be considered in the simulations on wear with high creepage or/and impacts.

The contact solutions at the crest of the polygonal profile are presented in this paper. The difference of the contact solutions between the crest and the trough of the polygonal profile would be investigated in the future to examine the evolution of the polygonal wear. Besides, thermal effect simulations are conducted in this work, but the validation of some parameters should be done in future work.

## References

1. Kaper, H.: Wheel corrugation on Netherlands railways (NS): origin and effects of “polygonization” in particular. *J. Sound Vib.* **120**(2), 267–274 (1988)
2. Vernersson, T.: Thermally induced roughness of tread-braked railway wheels: part 1: brake rig experiments. *Wear* **236**(1–2), 96–105 (1999)

3. Gallardo-Hernandez, E.A., Lewis, R., Dwyer-Joyce, R.: Temperature in a twin-disc wheel/rail contact simulation. *Tribol. Int.* **39**(12), 1653–1663 (2006)
4. Sundh, J., Olofsson, U.: Relating contact temperature and wear transitions in a wheel-rail contact. *Wear* **271**(1–2), 78–85 (2011)
5. Rode, W., Müller, D., Villman, J.: Results of DB AG investigations ‘out-of-round wheels’. In: Proceedings Corrugation Symposium-Extended Abstracts, IFV Bahntechink (1997)
6. Snyder, T., Stone, D., Kristan, J.: Wheel flat and out-of round formation and growth. In: Proceedings of the 2003 IEEE/ASME Joint Railroad Conference (2003)
7. Ye, Y., Shi, D., Krause, P., et al.: Wheel flat can cause or exacerbate wheel polygonization. *Veh. Syst. Dyn.* **58**(10), 1575–1604 (2020)
8. Meywerk, M.: Polygonalization of railway wheels. *Arch. Appl. Mech.* **69**(2), 105–120 (1999)
9. Andersson, C., Johansson, A.: Prediction of rail corrugation generated by three-dimensional wheel-rail interaction. *Wear* **257**(3–4), 423–434 (2004)
10. Johansson, A., Andersson, C.: Out-of-round railway wheels—a study of wheel polygonalization through simulation of three-dimensional wheel-rail interaction and wear. *Veh. Syst. Dyn.* **43**(8), 539–559 (2005)
11. Wu, Y., Du, X., Zhang, H., et al.: Experimental analysis of the mechanism of high-order polygonal wear of wheels of a high-speed train. *J. Zhejiang Univ. Sci. A.* **18**(8), 579–592 (2017)
12. Cai, W., Chi, M., Wu, X., et al.: Experimental and numerical analysis of the polygonal wear of high-speed trains. *Wear* **440**, 203079 (2019)
13. Tao, G., Wang, L., Wen, Z., et al.: Experimental investigation into the mechanism of the polygonal wear of electric locomotive wheels. *Veh. Syst. Dyn.* **56**(6), 883–899 (2018)
14. Tao, G., Wang, L., Wen, Z., et al.: Measurement and assessment of out-of-round electric locomotive wheels. *Proc. Inst. Mech. Eng. F: J. Rail Rapid Transit.* **232**(1), 275–287 (2018)
15. Yang, Z., Boogaard, A., Wei, Z., et al.: Numerical study of wheel-rail impact contact solutions at an insulated rail joint. *Int. J. Mech. Sci.* **138**, 310–322 (2018)
16. Yang, Z., Deng, X., Li, Z.: Numerical modeling of dynamic frictional rolling contact with an explicit finite element method. *Tribol. Int.* **129**, 214–231 (2019)
17. Naeimi, M., Li, S., Li, Z.: Thermomechanical analysis of the wheel-rail contact using a coupled modelling procedure. *Tribol. Int.* **117**, 250–260 (2018)
18. Naeimi, M., Li, Z., Petrov, R.H., et al.: Development of a new downscale setup for wheel-rail contact experiments under impact loading conditions. *Exp. Tech.* **42**(1), 1–17 (2018)
19. Talamini, B., Gordon, J., Perlman, A.B.: Investigation of the effects of sliding on wheel tread damage. In: ASME International Mechanical Engineering Congress and Exposition (2005)
20. Liu, X., Zhai, W.: Analysis of vertical dynamic wheel/rail interaction caused by polygonal wheels on high-speed trains. *Wear* **314**(1–2), 282–290 (2014)
21. Wei, Z., Li, Z., Qian, Z., et al.: 3D FE modelling and validation of frictional contact with partial slip in compression-shift-rolling evolution. *Int. J. Rail Transp.* **4**(1), 20–36 (2016)
22. Zhao, X., Li, Z.: A three-dimensional finite element solution of frictional wheel-rail rolling contact in elasto-plasticity. *Proc. Inst. Mech. Eng. Part J: J. Eng. Tribol.* **229**(1), 86–100 (2015)
23. Archard, J., Hirst, W.: The wear of metals under unlubricated conditions. *Proc. Math. Phys. Eng. Sci.* **236**(1206), 397–410 (1956)