

Solution space concept

Human-machine interface for 4D trajectory management

Klomp, R. E.; Riegman, R.; Borst, C.; Mulder, M.; van Paassen, M. M.

Publication date

2019

Document Version

Accepted author manuscript

Published in

Proceedings of the 13th USA/Europe Air Traffic Management Research and Development Seminar 2019, ATM 2019

Citation (APA)

Klomp, R. E., Riegman, R., Borst, C., Mulder, M., & van Paassen, M. M. (2019). Solution space concept: Human-machine interface for 4D trajectory management. In *Proceedings of the 13th USA/Europe Air Traffic Management Research and Development Seminar 2019, ATM 2019: 17/06/19 - 21/06/19 Vienna, Austria*

Important note

To cite this publication, please use the final published version (if applicable).
Please check the document version above.

Copyright

Other than for strictly personal use, it is not permitted to download, forward or distribute the text or part of it, without the consent of the author(s) and/or copyright holder(s), unless the work is under an open content license such as Creative Commons.

Takedown policy

Please contact us and provide details if you believe this document breaches copyrights.
We will remove access to the work immediately and investigate your claim.

Solution Space Concept: Human-Machine Interface for 4D Trajectory Management

R. E. Klomp, R. Riegman, C. Borst, M. Mulder, M. M. van Paassen
Control and Simulation, Faculty of Aerospace Engineering
Delft University of Technology (TU Delft)
Delft, The Netherlands

Abstract

The current evolution of the ATM system, led by the SESAR programme in Europe and the NextGen programme in the US, is foreseen to bring a paradigm shift to the work of the air traffic controller. Rather than the current primarily tactical control method, one aims for the introduction of more strategic, 4D (space and time) trajectory management. In both programmes a central role is foreseen for the human operator, aided by higher levels of automation and advanced decision-support tools. Previous work has shown promising results in the design of such automated support tools, however, issues with controller acceptance and intuitiveness were found to be key for their overall acceptability. This paper presents a concept decision-support tool for 4D trajectory management that aims to overcome these issues by directly visualizing action-relevant solution spaces. Rather than imposing a certain control strategy, the solution space visualizes all possible control actions, regardless of their optimality. Results of preliminary validation experiments with partial implementations of the solution space representation demonstrated the viability of the concept, but also highlighted areas for improvement.

I. INTRODUCTION

The current evolution in the Air Traffic Management (ATM)-system is expected to result in a situation where high-precision, gate-to-gate, four-dimensional (4D, i.e., space and time) trajectories for aircraft, stored in automated support tools, will form the basis for the work of the human controller. This new form of Air Traffic Control (ATC) implies a fundamental shift in the work of the Air Traffic Controller (ATCo), one that will no longer be possible without the aid of advanced automated support- and decision-making tools.

Although considerable research has been devoted to explore this future approach of ATC with 4D trajectory support, a definite breakdown of the distribution of roles and coordination between the human operator and automation is not yet well defined. When a human operator is expected to continue to fulfill ‘the central role’ in the future ATM system, the acceptability and ease of use of the automation tools and human-machine interface are of crucial importance. In the past, many prototypes in advanced computer-based support have not been embraced by the ATC community [1]–[3]. According to Westin *et al.* [1], controller acceptance played a critical role, where acceptance is driven by how much the support tool conforms or matches with the skills and strategies of humans. Thus the challenge remains how to design a decision-support tool that facilitates 4D trajectory management, whilst accounting for the controllers’ expertise and strategies.

One of the tasks in which the controller is foreseen to remain to play an essential role is in *tactical 4D trajectory management* that entails monitoring and revising trajectories in

real-time. Although airspace use and route-allocation will be structured and optimized beforehand to achieve optimal system performance in terms of safety, efficiency and productivity, it are the *unforeseen* separation provisions, sequencing, weather and changing airspace constraints which *inevitably* require (small, tactical) changes in the pre-planned trajectories.

In this paper, a novel human-machine interface concept is introduced to support controllers in 4D perturbation management. Different from other prototypes, our *solution space* displays focus on portraying solution spaces (instead of problem areas) that form the boundaries for safe actions, regardless of optimality. These solution spaces – constructed by automation – enable controllers to observe the full range of control actions, and allow them to utilize robust control strategies that are close to current-day practices (i.e., ‘4D vectoring’). Given the use of automation to *show* action-relevant constraints rather than *issue* specific actions, flexibility and adaptation in control will be facilitated in a way that keeps the controllers *in full control* and solve 4D problems in their unique, creative, and self-driven way. Human-in-the-loop experiments conducted with partial implementations revealed the solution space concept’s viability, but also areas for improvement.

II. PREVIOUS WORK: HIPS

In previous studies, various decision-support tools for 4D trajectory management have been investigated and prototyped for pilots and controllers [4]–[13]. These range from highly automated tools that provide a set of automated conflict resolution options to advisory-level tools that highlight probable conflicts or ‘conflict areas’.

One of the most elaborate studies was performed by the PHARE consortium in the late 90’s, and yielded the Highly Interactive Problem Solver (HIPS) concept. Although the initial outset was to provide controllers with highly automated conflict resolution tools, that idea was discontinued at an early stage due to controllers’ opposition [8]. Subsequently, an approach was adopted that allowed the controller to modify the trajectory, and show the outcome of the modifications overlaid on the radar screen in the form of ‘avoidance zones’. These avoidance zones visualized areas in the sector along the current trajectory of a selected aircraft where conflicts could occur due to modifications of the flightplan. After each trajectory modification (routing, altitude, speed), the avoidance zones would be updated to reflect the impact of that modification. A screenshot of the HIPS interface is shown in Fig. 1.

Although HIPS was a novel tool and has been well-received by the research community, the final project report highlighted a number of findings and issues with the interface [8]. The avoidance zones did not always correctly represent the controller’s perception of the nature and severity of the problems.

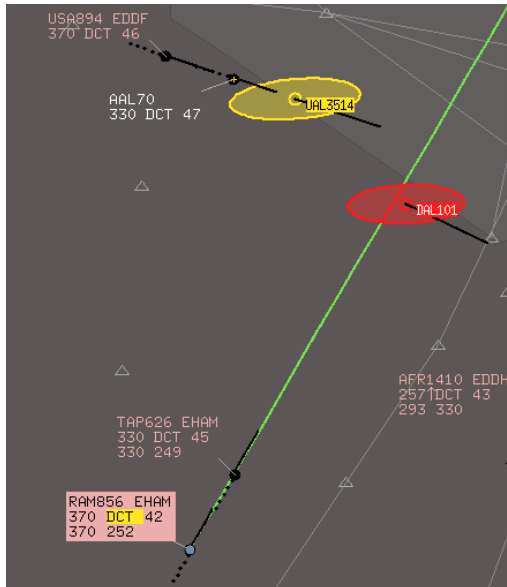

Fig. 1: PHARE HIPS display showing red and yellow avoidance zones along the planned route of selected aircraft RAM856 (taken from [14]).

Sometimes there could be inconsistencies between the conflict detection algorithms and the problem-solver tool, resulting in ambiguous information causing controller distrust. The main conclusion was that *controller acceptance* and *interface intuitiveness* were crucial for the acceptability of any future ATC decision-support tool.

III. SOLUTION SPACE CONCEPT

A. Theoretical motivation

The success of the envisioned future ATM system will hinge on three important challenges that need to be addressed. The first challenge is determining *how far* the next generation ATM system should and *can be automated*. Given the more complex nature of data link driven 4D trajectory management, the need for more automation support is clear. However, the ATM community acknowledges that fully automating the ATM system is nearly impossible, leading to the consensus that humans should remain the ultimate responsible for operational safety. But at what levels of autonomy and authority should automation mingle in the work of humans? The answer to this question leads to the second challenge; Is it possible to exploit the advantages of automation whilst *maintaining a competent and skilled human workforce*? Third and finally, any new technology aimed at taking over (parts of) work from trained professionals will *need to be accepted by the users* as articulated in PHARE studies and others [1].

The solution space concept aims to overcome above-mentioned challenges by putting emphasis in the design of the support tool(s) on visualizing the physical and intentional *boundaries on actions* to controllers, instead of having a computer algorithm provide a single, optimized control action. That is, automation uses flight data (from digital data links) to calculate and visualize ‘solution spaces’, but lets the operator decide on a specific course of action within the available action space. This design philosophy is inspired by Ecological Interface Design [15], [16], which aims to make work domain

constraints (e.g., laws of physics) salient on an interface in such a way that people can directly perceive the space of possibilities and act upon it by utilizing their own expertise and skills. This concept is geared towards moving humans closer to the decision and control loops and provide a deeper insight into the constraints governing their work, which all can help to preserve and perhaps even extend existing expertise. Acceptability research indicates that technology should acknowledge the individual differences between humans, and thus provide support that matches the individual user [17]. Our solution space concept is indeed individual-sensitive as it does not directly dictate what actions a controller must perform, but rather enables her to solve problems in her own way.

B. Scope

The design of the integrated solution space concept is initially focused on real-time, tactical 4D trajectory re-planning, by a single air traffic controller in a single sector. We assume that the airspace- and route allocation have been planned, optimized, and de-conflicted *a-priori*. The controller task is then to revise trajectories in cases where operational perturbations such as delays, hazardous weather, and restricted airspace result in conflicting, unsafe, or infeasible trajectories. For this concept, only en-route traffic has been considered that passes through the sector from a set of predefined entry waypoints to exit waypoints in zero-wind conditions. Emphasis has been placed on supporting control actions that adhere to the original planning as much as possible, to prevent cascading effects in adjacent sectors. That is, the lateral and vertical trajectory manipulations have been designed such that the sector exit parameters (e.g., exit location, time, and altitude) remain unchanged.

C. Physical control space

The onset of the solution space concept is to facilitate flexibility and adaptation in control, allowing humans to reason about, and come up with creative solutions for challenging problems. The set of feasible control actions in air traffic control is, however, first and foremost bounded by the laws of physics. In terms of manipulating 4D trajectories, while adhering to the imposed metering constraints, flight dynamics and aircraft performance play a crucial role.

1) Horizontal solution space

In order to meet the original Required Time of Arrival (RTA) at the sector exit fix, any lateral deviation from the originally planned straight trajectory will require the aircraft to fly faster as a result of the added track miles (see Fig. 2). However, the speed envelope within which an aircraft can operate is physically limited by the lower maneuvering speed (V_{min}) and upper maximum operating speed, or Mach buffet limit (V_{max}). The combination of the fixed RTA and the speed envelope bound the physical area in which an aircraft can be rerouted.

Fig. 2 shows how an increase in speed affects the horizontal rerouting options of an aircraft to its time-metered position fix. The figure shows that, without considering turn dynamics, all rerouting options for a given speed increase (thus, also equal added track miles) lie on an ellipse with the aircraft and fix as focal points. For example, the intermediate waypoint WP_A will split the original track into two equal-speed segments, and will require the aircraft to fly 10 knots faster to meet the fix RTA. All intermediate waypoints that lie on that ellipse result in the same track length and thus aircraft speed. A waypoint

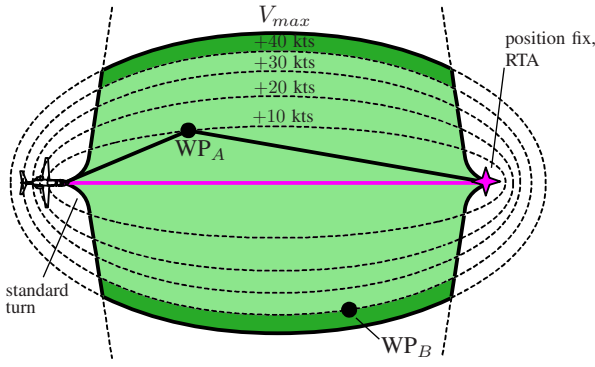

Fig. 2: HSS: Horizontal Solution Space.

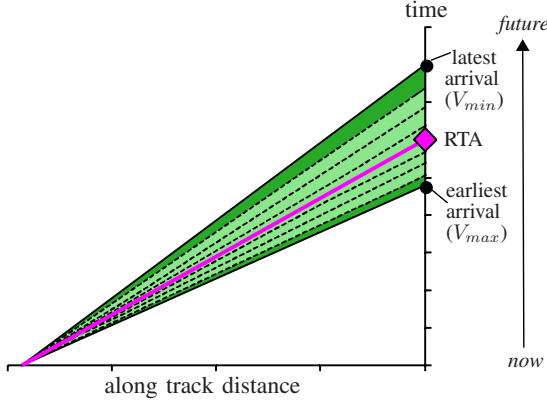

Fig. 3: TSS: Time-based Solution Space.

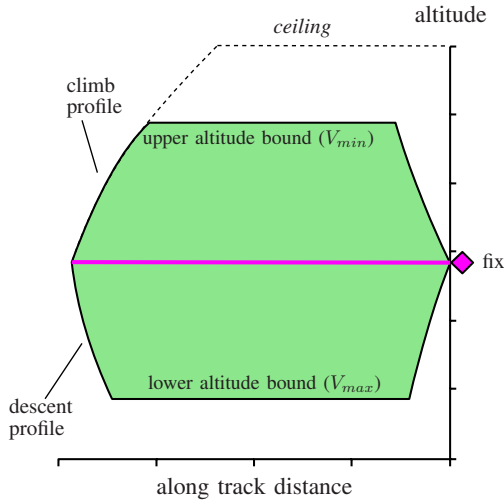

Fig. 4: VSS: Vertical Solution Space.

that results in a larger deviation from the original track, for instance WP_B , results in a higher required speed that in this case is close to V_{max} . By taking the ellipse that results from flying at V_{max} as a basis, and taking into account a standard turn in the direction toward the metering fix, the green shaded lateral solution space as shown in Figure 2 can be constructed.

2) Time-based solution space

When fixing the original lateral trajectory of an aircraft, its solution space can also be evaluated and expressed in the time domain. A useful way to visualize this is a Time-Space Diagram (TSD) [18], as illustrated in Fig. 3. Here, the predicted time at any point along the trajectory is plotted

against the along track distance to go to the metering fix. The zero position on the horizontal axis represents 'zero miles to go to the metering fix', and the zero position on the vertical time-axis represents 'now'. The trajectories of moving aircraft are then portrayed as sloped lines in the TSD. The slope of the line represents the speed of the aircraft at that point along the trajectory. A faster speed will result in a shallower slope (the aircraft will arrive earlier at the metering fix), and vice versa, a slower speed will result in a steeper slope. Any curved portions of the trajectory indicate that the aircraft is undergoing a speed change (i.e., acceleration or deceleration).

Similar to the horizontal solution space, the time-based solution space is constrained by V_{min} and V_{max} , resulting in the latest and earliest possible arrival time, respectively. It is important to realize that the horizontal solution space, Fig. 2, and time-based solution space, Fig. 3 are linked. That is, introducing a delay (i.e., flying slower) in the TSD will widen the horizontal solution space, and flying faster will reduce the horizontal possibilities.

3) Vertical solution space

The vertical solution space is bound by the aircraft speed envelope and atmospheric effects. Current aircraft speed control is performed by maintaining a constant indicated airspeed (IAS) below the crossover altitude and a constant Mach number above the crossover altitude. The exit time at the metering fix is, however, directly dependent on the aircraft ground speed. Due to the decreasing air density at higher altitudes, flying at the same IAS at higher altitudes will result in a higher ground speed and thus an earlier arrival time at the metering fix. When changing to constant Mach number, the true airspeed (and thus ground speed assuming zero-wind conditions) will increase at a slower rate when climbing. Further, climb performance is limited at higher altitudes, bounding the maximum operational altitude at which the aircraft may operate (i.e., operational ceiling).

Given that 4D trajectory management imposes *absolute* time constraints at waypoints, solely increasing the altitude along the trajectory implies that the aircraft has to reduce its IAS to comply with the RTA when below the crossover altitude. Assuming that the aircraft will also have to reach the fix at the original planned altitude, the vertical solution space can be visualized in a Vertical Solution Display (VSD) as illustrated in Figure 4.

D. Intentional constraints

In many control systems, a set of rules, operating limits, and other intentional provisions are introduced to assure overall safety and efficiency of operations due to uncertainty. Typically, in tactically controlled ATC sectors, the safety provision for positive separation between two aircraft is set to 5 nautical miles laterally and 1,000 feet vertically. Any breach of this space is seen as a 'loss of separation' between aircraft.

In the scenario of fully mature trajectory-based air traffic control, the intent of all aircraft is broadcast, updated, and distributed to ATC centers and other airspace users. Therefore, an accurate prediction is available to the automation of the position of all traffic at any given point ahead in time. This information can be used to determine whether any control action within the physically feasible solution space will lead to a loss of separation, or not.

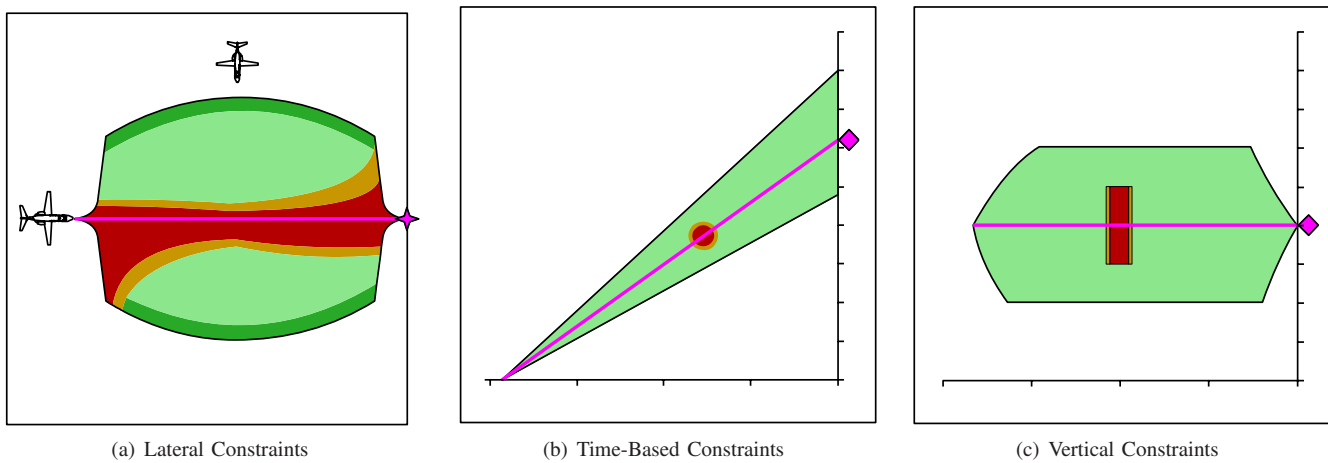

Fig. 5: Constraints mapped on the solution Space.

1) Lateral constraints

As illustrated in Fig. 2, placing an intermediate waypoint at a discrete point inside the lateral solution space will lead to a new trajectory consisting of two segments that are flown with a higher speed. By comparing this new trajectory to the predicted trajectories of all other traffic it can be automatically determined whether this path will lead to a loss of separation.

When similar checks are performed for all possible control actions within the lateral solution space, avoidance (or *unsafe*) zones can be determined and overlaid on the solution space as shown in red in Fig. 5(a). In short, placing an intermediate waypoint at any point inside the lateral solution space, but outside an avoidance zone, will lead to a new trajectory that is both feasible in terms of performance and is predicted to satisfy the lateral safety margins. Note that in the case illustrated in the figure, the current trajectory of the aircraft passes through an avoidance zone, indicating that a loss of separation is predicted to occur if no action is undertaken.

To account for uncertainty in the flight path predictions, an additional intentional lateral separation buffer can be added to the existing 5NM as shown in amber in Fig. 5(a). Any control action within this separation buffer will lead to a situation in which passing traffic will be in close vicinity of the separation minimum and requires caution. In addition, the shape of this buffer also hints at how the avoidance zone propagates throughout the solution space. That information can help the controller to make a more informed judgement when considering a particular control action.

2) Time-based constraints

When the lateral path of an observed aircraft is fixed, for each position along that trajectory (fixed point in space), it can be automatically determined whether other traffic will be within 5NM horizontally, and 1,000ft vertically of that position at a certain point in time. By performing this check for all points along the trajectory, time-based avoidance zones can be generated and overlaid on the vertical solution space as shown in Fig. 5(b). It is important to note that as long as the lateral and vertical path of the observed aircraft are left unchanged, the size and shape of these zones remain unchanged, irregardless of the speed of the aircraft along that path.

A predicted loss of separation is indicated when the time-space trajectory of the aircraft passes through an avoidance

zone, as shown in the figure. A loss of separation in the time-based solution space implies that there is also a loss of separation in the horizontal solution space, and vice versa. Finally, similarly as for the horizontal solution space, additional intentional separation zones can be generated and visualized to account for uncertainty.

The location of the avoidance zones in the time-based solution space gives an indication about the overall crossing sequence of the other traffic. If an avoidance zone is located beneath the time-space trajectory, other traffic is predicted to pass *in front* of the observed aircraft. If an avoidance zone is above the trajectory, the traffic will pass *behind*.

The geometry of the avoidance zone itself also provides information about the geometric nature of the crossing; a horizontally symmetrical avoidance zone indicates a 90 degree crossing. Zones slanted towards the direction of the time-space trajectory (i.e., to the right in Fig. 5(b)) indicate more in-trail crossings, and zones slanting away from the trajectory indicate more head-on crossings. This can better be observed in Fig. 6.

3) Vertical constraints

Vertical avoidance zones are computed and overlaid on top of the vertical solution space in a similar manner as in the TSD. Assuming that the lateral trajectory and the speed along that trajectory are fixed, it can be determined for each point along that trajectory if other traffic will be within 5NM at a certain altitude. Here, also, a loss of separation is indicted when the vertical trajectory passes through a vertical avoidance zone as shown in Fig. 5(c). Predicted losses of separation imply that there is a mutually inclusive avoidance zone present in the lateral, time-based, and vertical solution space.

E. Integrated display concept

Fig. 6 shows the lay-out of the integrated solution space display concept. The left-hand side of the display is reserved for the Planview Display (PVD), the TSD is located on the top-right side, and the VSD on the bottom-right side.

The typical workflow of using the integrated display is shown in Fig. 7. When no aircraft is selected, the PVD acts as a traditional ATC radar screen, showing a top-down view of the traffic. In this case, no solution spaces are visualized on the PVD, and the TSD and VSD are empty. In this display state, aircraft that are predicted to have a loss of separation

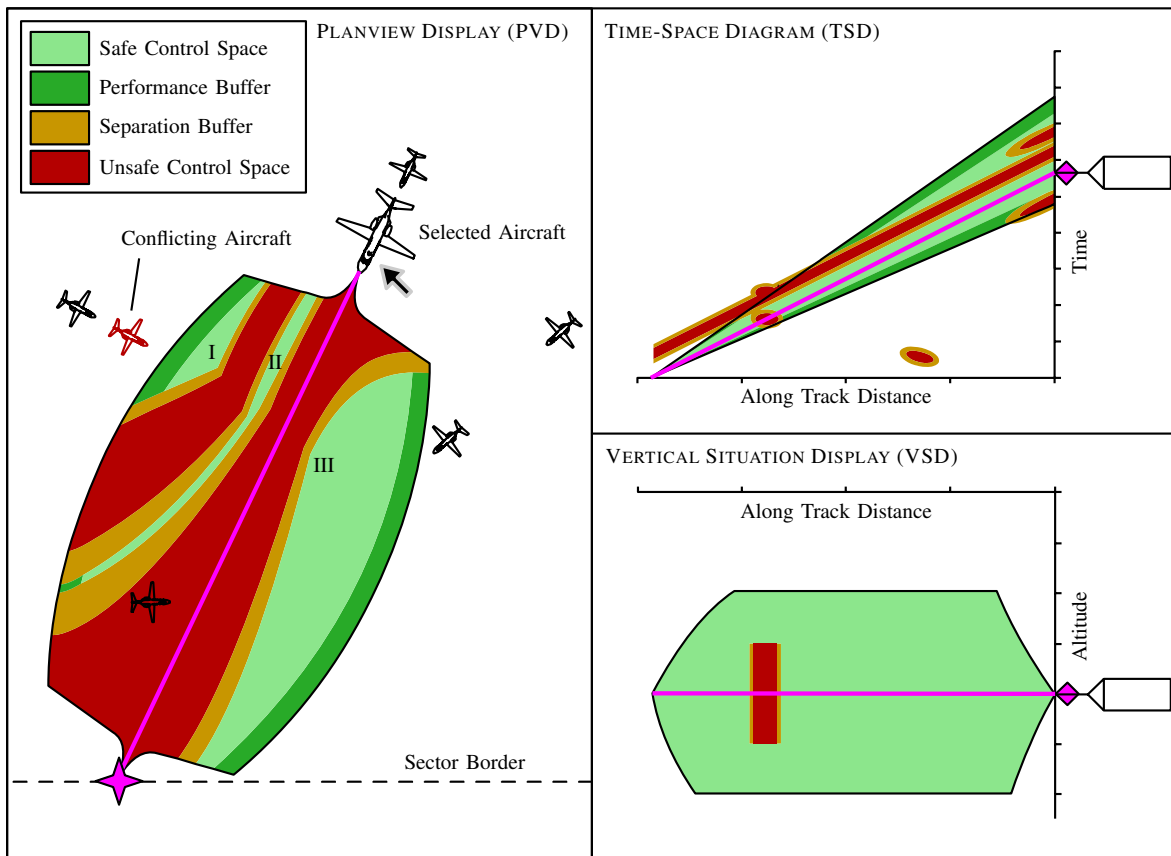

Fig. 6: Overview of the integrated solution space display concept.

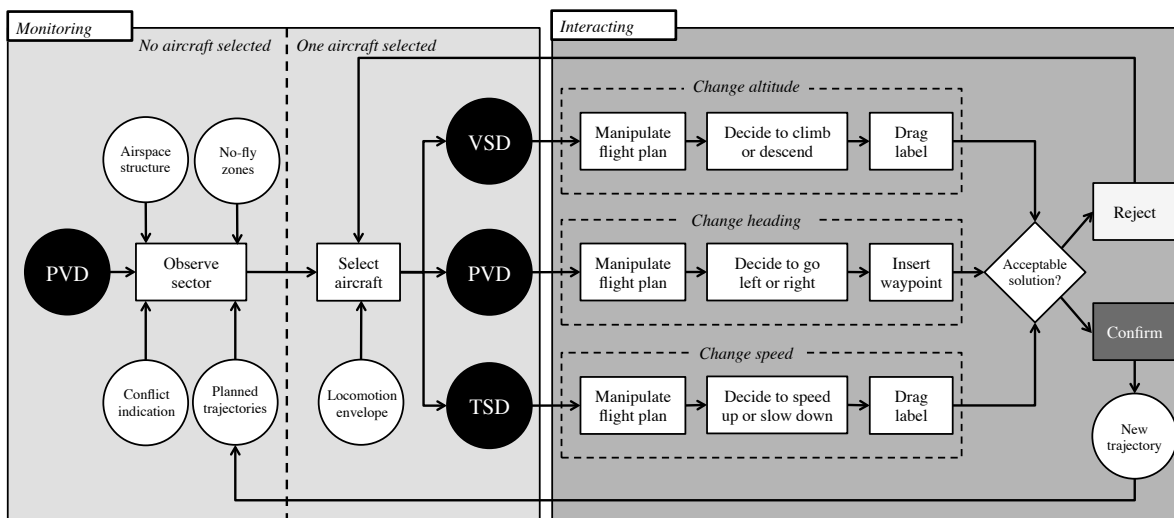

Fig. 7: Workflow of the integrated solution space concept.

can be highlighted on the PVD. By hovering over a conflicted aircraft with the mouse cursor, the other aircraft causing the conflict (can be one or more) are also highlighted.

If the controller has identified that a trajectory manipulation is required, she can select an aircraft of her choice on the PVD. Upon clicking the chosen aircraft, the horizontal, time-space, and vertical trajectories and solution spaces are visualized

in real-time *on all three* sub-displays. In this display state, hovering with the mouse cursor over an avoidance zone in the PVD, TSD, or VSD will highlight the aircraft that causes that zone on the PVD. This enables a controller to mentally ‘connect’ the information shown on the three displays.

Manipulating the trajectory of the selected aircraft can be done *in each of* the three displays. These manipulations loosely

correspond to current-day ATC strategies, namely changing the flight direction (PVD), speed (TSD) and/or altitude (VSD). The integrated concept also allows for combined control actions. The solution space visualizations are all *coupled* due to the time and altitude constraint on the metering fix.

The following paragraphs illustrate how the interactions on the PVD, TSD and VSD work both in isolation and in combination to manipulate the trajectory.

1) Horizontal manipulations

Fig. 8(a) shows the solution space on the PVD for a selected aircraft in a crossing conflict with other traffic. The image shows that the controller has the option to either reroute the selected aircraft in front or behind the other traffic. Fig. 8(b) shows how the controller can select a suitable location for waypoint placement by clicking on the solution space with a mouse. Once the location is selected, the aircraft trajectory is split in two equal speed segments, and a new solution space is constructed for both path segments as shown in Fig. 8(c). If the controller is satisfied with the control action, she can execute the trajectory and send it to the aircraft for execution.

Note that the horizontal solution space does not limit the allowed control actions by the controller, however, when a location is selected in the avoidance zone, this will lead to a new trajectory that is still in conflict with the traffic. Similarly, the controller can select to place a waypoint outside of the solution space all together, but that will lead to the aircraft not adhering to the metering constraint at the fix (i.e., delay).

When observing the possible horizontal trajectory modifications in the more complex scenario of Fig. 6, the controller could choose to either steer the selected aircraft behind both crossing aircraft (I), steer the aircraft to fly between the crossing aircraft (II), or steer the aircraft in front of the crossing traffic (III). It can be deduced from the solution space that, in this case, a preferred solution in terms of safety and efficiency would be to steer in front.

2) Time-Space manipulations

Fig. 9(a) shows the solution space on the TSD for a selected aircraft in a crossing conflict with other traffic. The figure shows that the conflict can be resolved by expediting or delaying the aircraft to the conflict location, resulting in it passing either in front or behind the traffic. Fig. 9(b) shows how the controller can select a suitable location inside the solution space to create an intermediate waypoint along the current lateral trajectory. The time-space trajectory is then split into two segments as shown in Fig. 9(c), for which new solution spaces are generated. here, the first segment is flown at a slower speed (sloped steeper), and the second at a faster speed in order to meet the constraint at the metering fix. The selected aircraft will thus pass behind the traffic, also shown by the avoidance zone that is located under the time-space trajectory. The intermediate waypoint will also show up on the lateral route in the PVD.

The controller could also choose to resolve the conflict by delaying or expediting the aircraft along its entire trajectory by dragging the aircraft label on the time-axis up or down. However, then, the time constraint at the metering fix will be violated. Note that it is not possible to place a waypoint outside of the time-space solution space because the selected aircraft cannot fly faster or slower than its maximum and minimum speed. As mentioned above, the horizontal solution space on the PVD will grow when delaying the aircraft and shrink when expediting the aircraft.

When observing the time-space solution space in the more complex scenario of Fig. 6, a number of things can be observed. The trailing aircraft causes a stretched avoidance zone above the time-space trajectory of the selected aircraft. Thus, delaying the selected aircraft is likely to cause an ‘overtake’ conflict. The two avoidance zones at the end of the time-space trajectory (attached to the time axis) are caused by the two aircraft that are planned to exit the sector at the same metering fix. The two crossing aircraft cause avoidance zones at the same point along the trajectory, but at different times. From the TSD it can be concluded that the only feasible control option that respects all constraints is to steer the selected aircraft *between* the crossing aircraft. This, however, will lead to a trajectory that lies close to, or even comes within the intentional separation buffer to other traffic.

3) Vertical manipulations

Fig. 10(a) shows the solution space on the VSD for a selected aircraft in a crossing conflict with another aircraft. From the figure it can be observed that the conflict can be resolved by climbing over or descending under the conflict zone. To implement a solution, the flight label on the altitude axis can either be dragged up (i.e., climb) or down (i.e., descent). Fig. 10(b) shows what the display looks like when dragging the label up.

Upon dragging the label, two intermediate waypoints are automatically created along the flight trajectory – one representing the top of climb and one representing the top of descent. These two waypoints will also be shown on the PVD and TSD. The label cannot be dragged beyond the upper and lower bound of the envelope, because these boundaries are coupled with the speed envelope under the assumption that the time constraint at the metering fix must be met. Note that delaying the aircraft using the TSD makes the upper bound of the vertical solution space to move down, because the aircraft has to fly slower relative to the ground. Similarly, when expediting the aircraft by using the TSD, the lower bound on the VSD will move up.

Finally, the usage of the VSD is slightly inconsistent with that of the TSD. Dragging the label in the TSD will result in a violation of the metering constraint, but this is not the case when dragging the label in the VSD. This has been a deliberate design choice for this prototype, but can easily be adjusted or changed in future implementations.

F. Real-time Implementation

A prototype of the integrated solution space concept has been implemented in an ATC simulator, and validated that it is possible to visualize the solution space representations in real time. In this implementation, the computation of the solution space is performed using the Graphics Processing Unit (GPU), and computations are done for each on-screen pixel. No performance issues were found when running on a current consumer desktop computer, and using a 30”, 2560 x 1600 pixel display at 60Hz.

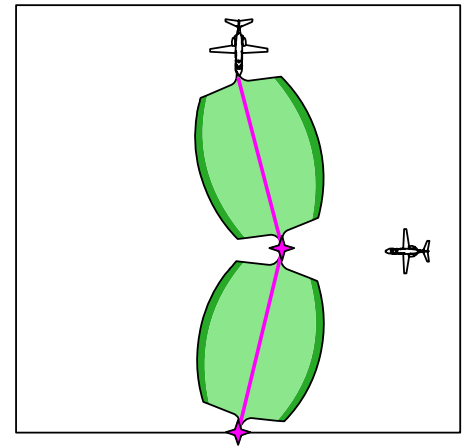
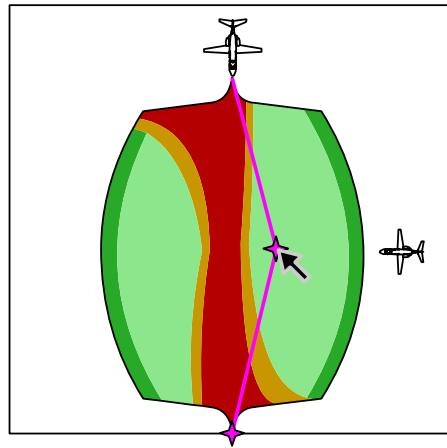
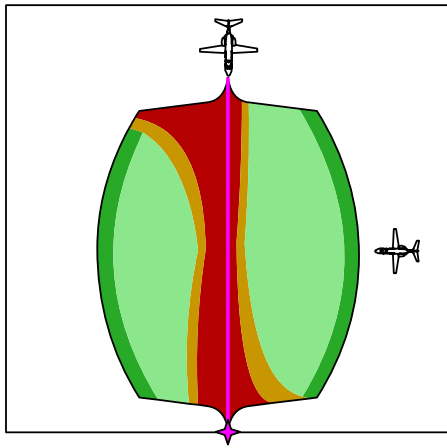

Fig. 8: Manipulations on the PVD.

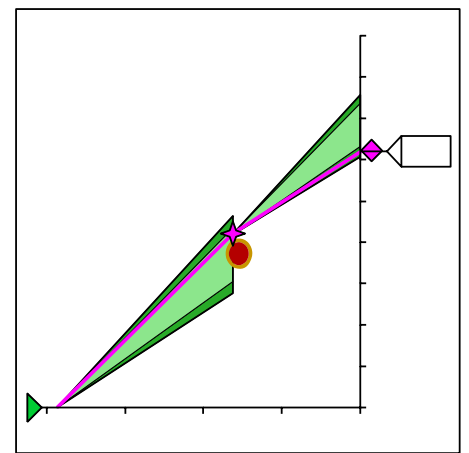
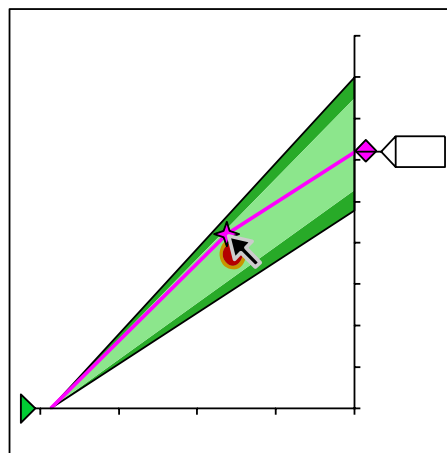
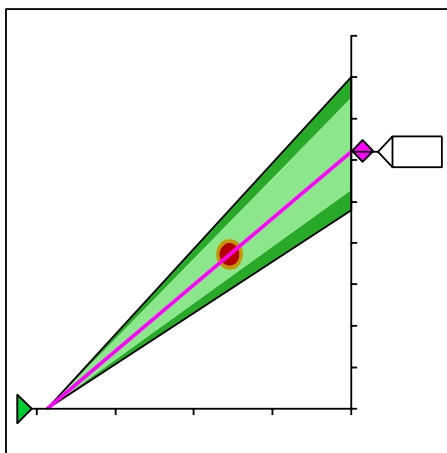

Fig. 9: Manipulations on the TSD.

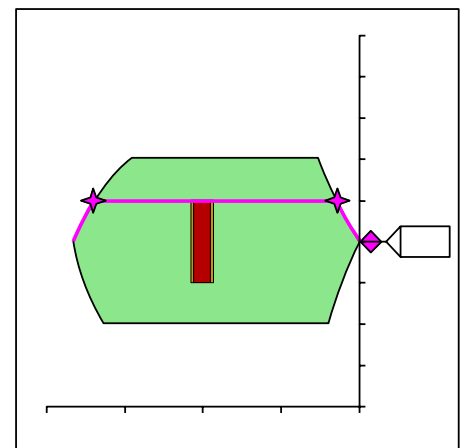
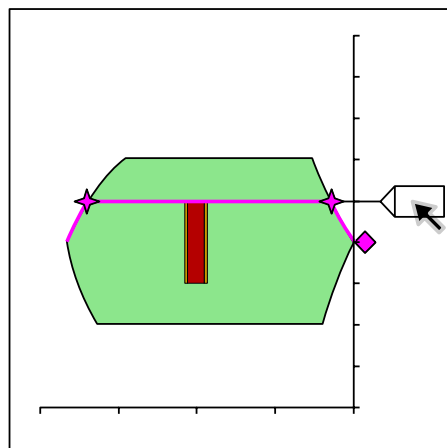
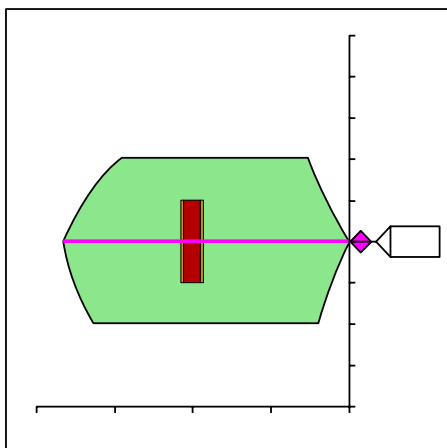

Fig. 10: Manipulations on the VSD.

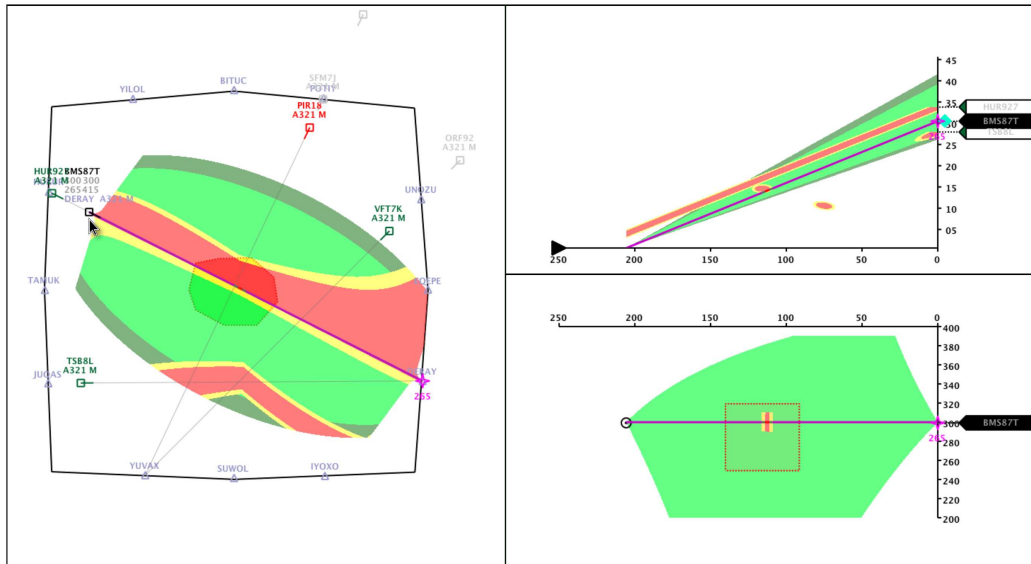

Fig. 11: Screenshot of the computer-based implementation of the Integrated Solution Space concept, featuring a no-fly zone (with altitude restrictions) in the center of the sector.

IV. PRELIMINARY VALIDATION RESULTS

The three interfaces of the Solution Space concept for 4D perturbation management have been under development and have undergone a series of partial evaluations since 2011.

In [19], initial versions of the TSS and VSS prototypes were developed and evaluated in an experiment reflecting ‘area control’ in which inbound aircraft had to be sequenced and merged. This evaluation, performed with four active air traffic controllers, four retired controllers and four domain experts validated the viability of these concepts. The traffic scenarios under evaluation were reminiscent of the situation in The Netherlands, where area control and (initial) arrival management are intertwined due to relatively small sector sizes. The results indicated that the TSS is effective in supporting controllers with managing (time-based) separation in arrival management. However, due to the continuous descent profiles of the inbound aircraft, the VSS was found to be less useful for this task because of the limited options for control. Further, no significant differences were found in the use of the TSS and VSS between the three participant groups.

In [20], the HSS was evaluated in an experiment where participant groups with different levels of expertise needed to resolve perturbations in the horizontal plane only. The sector geometry was reminiscent of a FABEC airspace covering Belgium that is relatively large in ‘length’ (East-West axis), but narrow in ‘width’ (North-South axis). A sector’s geometry significantly influences the size and shape of the available solution spaces for aircraft. Taken together with the number of crossing routes and sector disruptions, in the form of delayed aircraft entering the sector and/or the presence of a no-fly zone, the HSS concept was validated across a wide range of complexity factors influencing the efficiency and safety of control actions.

The results of this experiment showed that use of the HSS mainly depended on the expertise of the controller. That is, expert controllers were found to more pro-actively manage

the traffic and follow control strategies that were inherently more robust than novice controllers. Here, novice controllers often chose for ‘tight’ solutions that minimized path deviations, but left little room for resolving future disturbances. Expert controllers, however, indicated that they had relatively low trust in the visualizations alone, resulting in more conservative control actions that adopted larger safety (i.e., separation) margins. These led to the explicit visualization of ‘intentional’ separation buffers in the HSS to accommodate ‘uncertainties’. A follow-up experiment using the same scenarios showed that by including the visualization of these buffers, the robustness of control actions by novice participants migrated closer to that of the experts.

Recently, a preliminary feasibility evaluation of the integrated concept as presented in this paper has been conducted, again in an en-route setting, but now featuring an even larger FABEC sector that could also be suitable for multi-sector planning concepts (Fig. 11). Since the emphasis of the experiment was put on evaluating the VSS, all traffic initially started at the same flight level and traffic conflicts (i.e., due to delayed aircraft entering the sector) could then be solved either in the horizontal plane (HSS), vertical plane (HSS) or the time domain (TSS), depending on a participant’s preference. Although the data of the latest experiment are still being processed, the initial results indicate that participants mainly used the VSS and HSS to solve conflicts and disregarded the TSS. Participants also varied in the ways they used the VSS and HSS. Some participants adopted a proactive control strategy where they used the VSS to structure traffic streams on different altitude layers by putting each aircraft on a specific stream on a designated flight level upon sector entry. In that way, those participants were able to reduce their experienced (mental) workload, despite that this strategy led to more control actions than necessary. Other participants only used the VSS to solve conflicts when they appeared, thereby adopting a strategy focused on minimizing their (physical) control effort.

As such, the results seem to be similar to those of the previous experiments where the common denominator is that all controllers of different expertise/experience levels are able to successfully exercise their own preferred control strategies in resolving perturbations.

The choice for the preferred type of manipulation by controllers (i.e., HSS, TSS, or VSS) was found to be largely coupled to the specific task conditions. For example, in merging tasks for inbound traffic, the spacial trajectories of aircraft are mostly fixed, making manipulations in the TSS more favourable. In an en-route environment, the VSS becomes a more favourable weapon of choice since resolving perturbations involving crossing traffic is easiest by changing altitudes. As such, the integrated Solution Space concept for 4D trajectory management could be useful for different teams of controllers, ranging from approach toward upper area controllers.

To conclude, the experiments also showed that the complexity of the interfaces, that may be initially intimidating for controllers, remains a point of attention. When one aims to support full flexibility in control, this is inevitable however, since a more complex task (i.e., 4D trajectory management) requires the opposite of a simple, trivial interface [21]. Indeed, an important take-away from our experiments is that much training is needed and *required* before controllers understand – and with that *appreciate* – the solution space concept, and before they start to fully exploit the potential of the visualizations. When bringing the concept closer to reality by adding constraints imposed by wind fields, trajectory uncertainties and airline preferences, new empirical insights will be gathered in finding the right balance between providing more domain insight versus displayed complexity and interface usability.

V. CONCLUSION

The goal of the Solution Space concept for 4D trajectory management described in this paper is to support air traffic controllers in resolving perturbations in a way that allows them to exercise their own preferred control strategies. The gist of this concept is portraying the available solution areas in position and time, without instructing them what to do. Initial validations indicated the viability of the concept and have gained controllers acceptance. For future developments, the concept will be improved by adding more constraints (i.e., wind fields, trajectory uncertainties and airline preferences) that will bring the concept closer to reality. This, however, does require a careful balance between visualizing operational complexity against the concept's usability.

REFERENCES

- [1] C. A. L. Westin, C. Borst, and B. G. Hilburn, "Strategic Conformance: Overcoming Acceptance Issues of Decision Aiding Automation?" *IEEE Trans. on Human-Machine Systems*, vol. 46, no. 1, pp. 41–52, 2016.
- [2] M. Bekier, B. R. Molesworth, and A. Williamson, "Tipping point: The narrow path between automation acceptance and rejection in air traffic management," *Safety Science*, vol. 50, no. 2, pp. 259–265, feb 2012.
- [3] M. Bekier and A. M. Williamson, "Why Air Traffic Controllers Accept or Refuse Automated Technology," in *16th International Symposium on Aviation Psychology*, 2011, pp. 615–620.
- [4] B. J. A. Van Marwijk, C. Borst, M. Mulder, M. Mulder, and M. M. Van Paassen, "Supporting 4D Trajectory Revisions on the Flight Deck : Design of a Human-Machine Interface," *The International Journal of Aviation Psychology*, vol. 21, no. 1, pp. 35–61, 2011.
- [5] M. S. Eby, "A self-organizational approach for resolving air traffic conflicts," *The Lincoln Laboratory Journal - Special issue on air traffic control*, vol. 7, pp. 239–254, 1994.

- [6] H. Idris, R. Vivona, J.-L. Garcia-Chico, and D. Wing, "Distributed traffic complexity management by preserving trajectory flexibility," in *2007 IEEE/AIAA 26th Digital Avionics Systems Conference*, 2007, pp. 1–13.
- [7] H. Idris, D. Delahaye, and D. Wing, "Distributed Trajectory Flexibility Preservation for Traffic Complexity Mitigation."
- [8] M. J. Whiteley and I. Wilson, "PHARE Advanced Tools Problem Solver," Eurocontrol, Brussels, Belgium, Final Report DOC 98-70-18, Aug. 1999.
- [9] T. Prevot, P. U. Lee, N. Smith, and E. A. Palmer, "ATC Technologies for Controller-Managed and Autonomous Flight Operations," *AIAA Guidance, Navigation and Control Conference, San Francisco, California, USA*, Aug. 2005.
- [10] J.-P. Nicolaon, G. Dean, and W. Miller, "An overview of ARC 2000 version 3 from the operational point of view," EEC, Bretigny-sur-Orge, France, Tech. Rep. 286, 1995.
- [11] L. Goldmuntz, J. T. Kefaliotis, L. A. Kleiman, R. A. Rucker, S. L. , and D. Weathers, "The AERA concept," DOT/FAA, Washington D.C., USA, Tech. Rep. FAA-EM-81-3, 1981.
- [12] W. P. Niedringhaus, "A mathematical formulation for planning automated aircraft separations for AERA 3," DOT/FAA, Washington D.C., USA, Tech. Rep. DOT/FAA/DS-89/20, 1989.
- [13] H. Erzberger, T. A. Lauderdale, and Y. C. Chu, "Automated conflict resolution, arrival management, and weather avoidance for air traffic management," in *Proceedings of the Institution of Mechanical Engineers, Part G: Journal of Aerospace Engineering*. Institution of Mechanical Engineers, 2012, pp. 930–949.
- [14] M. van Gool and H. Schroter, "PHARE Final Report," Eurocontrol, Brussels, Belgium, Tech. Rep. DOC 99-70-09, 1999.
- [15] K. J. Vicente and J. Rasmussen, "Ecological Interface Design: Theoretical Foundations," *IEEE Transactions on Systems, Man, and Cybernetics*, vol. 22, no. 4, pp. 589–606, 1992.
- [16] C. M. Burns and J. Hajdukiewicz, *Ecological Interface Design*. CRC Press, 2004.
- [17] B. G. Hilburn, C. A. L. Westin, and C. Borst, "Will Controllers Accept a Machine That Thinks Like They Think? The Role of Strategic Conformance in Decision Aiding Automation," *Air Traffic Control Quarterly*, vol. 22, no. 2, pp. 115–136, 2014.
- [18] M. Tielrooij, A. C. In 't Veld, M. M. Van Paassen, and M. Mulder, "Development of a Time-Space Diagram to Assist Air Traffic Controllers in Monitoring Continuous Descent Approaches," in *Air Traffic Control*, M. Mulder, Ed. Sciyo, 2010, ch. 7, pp. 135–147.
- [19] R. E. Klomp, M. Mulder, M. M. Van Paassen, and M. J. Roerdink, "Redesign of an inbound planning interface for air traffic control," in *AIAA Guidance, Navigation, and Control Conference*. American Institute of Aeronautics and Astronautics, aug 2011.
- [20] R. E. Klomp, C. Borst, M. M. Van Paassen, and M. Mulder, "Expertise Level, Control Strategies, and Robustness in Future Air Traffic Control Decision Aiding," *IEEE Transactions on Human-Machine Systems*, vol. 46, no. 2, pp. 255–266, 2015.
- [21] C. Borst, J. M. Flach, and J. Ellerbroek, "Beyond Ecological Interface Design: Lessons From Concerns and Misconceptions," *IEEE Transactions on Human-Machine Systems*, vol. 45, no. 2, pp. 164–175, 2015.

Rolf Klomp received the M.Sc. degree (2010) in aerospace engineering from the Delft University of Technology, The Netherlands, where he is currently working towards the PhD degree at the section Control and Simulation for his research on ecological 4D trajectory-based controller decision-support tools.

Rick Riegman received his M.Sc. degree (2018) in aerospace engineering from the TU Delft. He designed and integrated the Vertical Situation Display into the solution space concept.

Clark Borst received the M.Sc. degree (cum laude) and Ph.D. degree from TU Delft, in 2004 and 2009, respectively. He is currently an Assistant Professor in aerospace human-machine systems. His work and research interests include developing and evaluating decision-support tools and automation for aviation applications using Ecological Interface Design principles.

M. M. (René) van Paassen received the M.Sc. degree (cum laude) and Ph.D. degree from TU Delft, in 1988 and 1994, respectively. He is currently an Associate Professor with the section Control and Simulation, Aerospace Engineering, TU Delft, working on human-machine interaction and aircraft simulation.

Max Mulder received the M.Sc. degree and Ph.D. degree (cum laude) from TU Delft, in 1992 and 1999, respectively. He is currently a Full Professor and the Head of the section Control and Simulation, Faculty of Aerospace Engineering, TU Delft. His research interests include cybernetic and cognitive systems engineering approaches to human-machine interface design.