

Document Version

Final published version

Licence

CC BY

Citation (APA)

Smith, R., van de Loo, J., van den Boomen, M., Khakzad, N., Jan van Heck, G., & Wolfert, A. R. M. (2019). Long-term availability modelling of water treatment plants. *Journal of Water Process Engineering*, 28, 203-213. <https://doi.org/10.1016/j.jwpe.2019.01.021>

Important note

To cite this publication, please use the final published version (if applicable). Please check the document version above.

Copyright

In case the licence states "Dutch Copyright Act (Article 25fa)", this publication was made available Green Open Access via the TU Delft Institutional Repository pursuant to Dutch Copyright Act (Article 25fa, the Taverne amendment). This provision does not affect copyright ownership. Unless copyright is transferred by contract or statute, it remains with the copyright holder.

Sharing and reuse

Other than for strictly personal use, it is not permitted to download, forward or distribute the text or part of it, without the consent of the author(s) and/or copyright holder(s), unless the work is under an open content license such as Creative Commons.

Takedown policy

Please contact us and provide details if you believe this document breaches copyrights. We will remove access to the work immediately and investigate your claim.

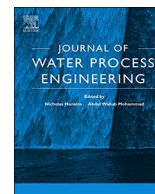

Long-term availability modelling of water treatment plants

Roland Smit^{a,b}, Jasper van de Loo^{a,b}, Martine van den Boomen^{b,*}, Nima Khakzad^c,
Geert Jan van Heck^{a,b}, A.R.M. (Rogier) Wolfert^b

^a Waternet, Amsterdam, the Netherlands

^b Faculty of Civil Engineering and Geosciences, Delft University of Technology, the Netherlands

^c Faculty of Technology, Policy, and Management, Delft University of Technology, the Netherlands



ARTICLE INFO

Keywords:

Availability
Water treatment plants
Deterioration
Repairable systems

ABSTRACT

Water treatment plants (WTPs) are characterised as complex configurations of repairable and deteriorating components. Previous studies have mainly focused on the average or steady-state availability of such systems while ignoring inherent characteristics like degradation. The current research proposes a two-level hierarchical model for long-term availability analysis of WTPs. To do so, at the component level, a condition-based technique (semi-Markov) or a failure-based technique (non-homogeneous Poisson process) is proposed based on the type and amount of available data while at the system level a reliability block diagram can be used to combine the component-level availabilities. The application of the methodology has been demonstrated on a real case study in the Netherlands.

1. Introduction

The water sector provides essential services to the public, including the production and supply of drinking water, and collection and treatment of wastewater. To do this, the water sector relies on treatment plants and infrastructure networks located in urban and rural areas. These assets have generally a long life, often over 50 years, and the majority of the spent utilities relates to these assets [1].

In many countries, water infrastructures are aging and their condition is deteriorating [2]. Although drinking and surface water quality is improving in many countries, leakage, infrastructure failure and the associated cost are still high [3]. During the first decade of the 21st century, many customers, for instance in Australia and England, have been affected by insufficient supply capacity and reliability and increasing water bills [4,5].

Large sums of money are involved in the management of water systems [2]. Water sector decision-makers have to decide how to spend this money efficiently so as to maintain the services at the required level both in the short and long terms.

Water treatment plants (WTPs) form an essential part of the

drinking water and wastewater systems and can be characterised with three features: (i) they are complex systems consisting of a multitude of components; (ii) their components experience deterioration, that is, their performance decreases due to ageing; (iii) WTPs are repairable systems, i.e., given some components failure they can keep operating without a complete system shutdown and replacement.

Asset management is seen as one of the promising methods for the management of complex and asset-intensive companies. Asset management is about managing the lifecycle of physical assets [6–9], with the aim of providing present and future required service levels in the most cost effective way [7]. It provides a coherent set of tools and methods for operation, maintenance and investment activities for the assets [10]. An important objective of asset management is providing and optimising maintenance strategies.

The effectiveness of maintenance strategies can be evaluated by means of asset performance indicators. Well-known indicators are reliability, availability and maintainability. Reliability is defined as the probability of an asset not failing in a predefined period of time. Reliability provides a measure of the frequency of failures and does not take the downtime into account. Maintainability of an asset can be

Abbreviations: ARA, arithmetic reduction of age; ARI, arithmetic reduction of intensity; ARP, alternating renewal process; CDF, cumulative distribution function; CTMC, continuous-time markov chain; DBN, dynamic bayesian network; DFT, dynamic fault tree; FTA, fault tree analysis; HPP, homogeneous poisson process; ITS, inverse transform sampling; LCC, life cycle costing; MCS, Monte Carlo simulation; MDP, Markov decision process; MLE, maximum likelihood estimation; NHPP, non-homogeneous poisson process; PDF, probability density function; PLP, power law process; QRP, quasi-renewal process; RBD, reliability block diagram; SMDP, semi-Markov decision process; SMP, semi-Markov process; VAP, virtual age process; WTP, water treatment plant

* Corresponding author at: Building 23, Stevinweg 1, Delft 2628 CN, the Netherlands.

E-mail address: m.vandenboomen@tudelft.nl (M. van den Boomen).

<https://doi.org/10.1016/j.jwpe.2019.01.021>

Received 4 October 2018; Received in revised form 21 January 2019; Accepted 29 January 2019

Available online 11 February 2019

2214-7144/ © 2019 Elsevier Ltd. All rights reserved.

defined as its ability to be retained in or restored to a specified condition, given the use of prescribed procedures and resources. Availability is the probability of an asset being in a functional state as a result of previous failures and repairs. In fact, availability accounts for both reliability and maintainability, and therefore is a more informative index for evaluating WTPs as it is not the continuous operation of WTPs (as an indication of reliability) or their ease of maintenance (as an indication of maintainability) but their overall operational time (as an indication of availability) that matters.

Availability can be expressed in different forms, such as mission availability, average availability and instantaneous availability. The instantaneous availability is a time-variant variable, and due to its ability to account for deterioration of assets is considered in the current research. Conversely, average availability cannot properly deal with deteriorating assets as it provides an average value. Furthermore, WTPs are continuous production systems and therefore mission availability does not apply.

Maintenance strategies can be divided into corrective maintenance, preventive maintenance and improving maintenance [11]. Recently, there has been a trend from corrective maintenance to preventive maintenance [12,13], which itself can further be distinguished into scheduled maintenance and predictive maintenance. Scheduled maintenance is a well-known type of maintenance based on operation or calendar time, while predictive maintenance is undertaken based on the current state and the estimated remaining lifetime of an asset.

In order to ensure that WTPs deliver the service levels required by the society, the facility managers will have to provide and continuously optimise maintenance strategies based on a proper assessment of their effect on the WTP's long-term availability. To this end, methodologies would be required for assessing the instantaneous availability of complex systems with repairable and deteriorating components.

2. Literature review

The literature does not provide many studies that describe methodologies for availability assessment of WTPs. However, numerous studies concern methodologies for comparable systems. The consulted studies are discussed and evaluated through four criteria:

- Is the methodology able to model repairable components?
- Is the methodology able to model deteriorating components?
- Is the methodology able to model complex system configurations?
- Is the methodology able to model the instantaneous availability?

Regarding the foregoing criteria, some works incorporate complexity in their methodology, but do not consider instantaneous availability or repairable and deteriorating components [14,15]. Other works present methodologies for repairable systems but do not consider the instantaneous availability, deterioration, or complexity of the system [16–20]. Those which consider deterioration, however, do not deal with complexity, repairability, or instantaneous availability [11]. Table 1 provides an overview of all the discussed literature and how they relate to the afore-mentioned four criteria.

As can be seen from Table 1, only one of the consulted studies covers all the four criteria. Cai et al. [35] obtained the reliability and availability of subsea blowout preventers based on a dynamic Bayesian network approach. However, their method only deals with moderate complexity (i.e. series and parallel structures) and not high complexity (e.g. k-out-of-n redundancy and bridge structures) as often seen in WTPs. This study is therefore aimed at proposing a methodology that can handle all the aforementioned four criteria. Section 3 describes the techniques used to develop the methodology and how they are combined. Section 4 presents the application of the methodology to a WTP. Section 5 is devoted to the discussion of the methodology and the results while section 6 provides the conclusions.

3. Methodology

In this study, a two-level hierarchical model is proposed to combine several modelling techniques. The two main advantages of a hierarchical modelling approach are: (i) it reduces the model complexity, and (ii) it enables the identification of critical components or sub-systems [21]. First, modelling at system level is dealt with in Section 3.1 using reliability block diagram (RBD). Section 3.2 provides a flowchart for selecting the most optimal model at component level while Section 3.3 demonstrate the application of the selected methodologies to the components. The structure of the methodology is given in Fig. 1.

3.1. System availability modelling

In order to compute the system availability based on the components' availability, combinatorial models can be used. Reliability Block Diagram (RBD) is one of the most widely used combinatorial models [22]. With an RBD, the system availability $A(t)$ can be calculated as a function of the components availability $A_i(t)$. This can be expressed as:

$$A(t) = \psi(A_1(t), A_2(t), \dots, A_n(t)) \quad (1)$$

where the structure function ψ depends on the system configuration [23]. For independent components, the structure function of an RBD can be obtained by deriving the minimal path sets [23–27].

Fig. 2 shows the RBD of a system consisting of three components in parallel, followed by three components in series. By using the minimal path sets the following system availability function can be obtained:

$$A(t) = (A_1 + A_2 + A_3 - A_1A_2 - A_1A_3 - A_2A_3 + A_1A_2A_3) A_4A_5A_6$$

3.2. Model selection

At component level two different models can be used: a condition-based model (SMP model) and a failure-based model (NHPP model). For each component the asset manager must decide which model to apply. It should be noted that there is a distinction between the model selection for current use and the model selection for optimal use. The former is purely based on the data that is currently available, whereas the latter is related to the type of data that should be recorded in the future aiming at optimal availability modelling. The flowchart in Fig. 3. presents the model selection for optimal use.

- First, to determine if the NHPP model could be used, the question is whether sufficient failure events could be recorded. In the case of components of high reliability which do not frequently fail, sufficient failure data cannot be recorded and the answer would be 'no'. If the components experience failure, the question arises here is whether the failures have been recorded, and if so, whether they are sufficient. According to Rigdon and Basu [28], at least five failure events have to be recorded in order to use the NHPP model. If less than five failures events are recorded, more events should be recorded until there are sufficient data for using the NHPP model. However, one should take into account the time it would take to record sufficient failure events. If it is not reasonable to wait long enough to have sufficient events recorded, the NHPP model should not be chosen.
- Second, to determine if the SMP model can be applied, the asset manager must find out if sufficient condition data could be recorded. For components for which condition monitoring is not possible at all (either continuous or periodic) the SMP model cannot be applied. If the condition can be monitored for the concerned component, the next question is whether sufficient condition data can be collected within reasonable time. If not, the SMP model is not the optimal choice.

Table 1
Overview of the consulted literature.

Year	Reference	Method	Which criteria is considered by the methodology?			
			Repairable system	Deterioration	Complex configuration	Instantaneous availability
2001	[11]	SMP		X		
2002	[27]	SMP, CTMC	X	X		X
2003	[22]	Hierarchical model (Markov process)	X			
2004	[20]	Hierarchical model (Markov process)	X			X
2005	[12]	SMDP	X	X		
2006	[31]	Hierarchical model (Markov process + FTA)	X	X	X	
2006	[13]	Markov process	X	X		
2008	[6]	ARP	X			
2008	[32]	Hierarchical model (Markov process + FTA)	X	X	X	
2008	[17]	Markov process	X	X		
2008	[18]	NHPP	X	X		
2009	[23]	FTA	X		X	
2009	[14]	SMDP	X	X		
2009	[28]	QRP	X	X		X
2010	[29]	Markov process	X	X		X
2010	[7]	Fuzzy Bayesian method	X		X	
2010	[33]	NHPP, MCS	X	X		
2012	[25]	Markov process (+ RBD)	X			
2012	[15]	SMP	X	X		
2013	[24]	Hierarchical model (CTMC + RBD)	X	X	X	
2013	[35]	DBN	X	X	X	X
2013	[16]	SMP	X	X		
2013	[4]	RBD, FTA			X	
2014	[8]	MDP + RBD	X		X	
2014	[34]	(N)HPP, MCS, (ARP)	X	X		
2015	[30]	ARP	X	X		X
2015	[19]	VAP	X	X		
2015	[21]	DBN		X	X	
2015	[5]	FTA			X	
2016	[26]	Hierarchical model (Markov process + DFT)	X		X	
2016	[9]	FTA	X		X	
2018	[10]	Minimal path sets	X			

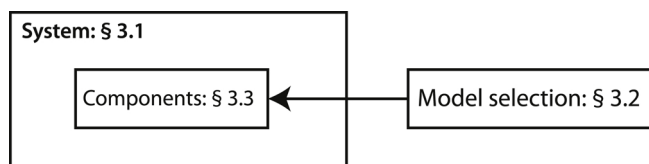

Fig. 1. Structure of the methodology.

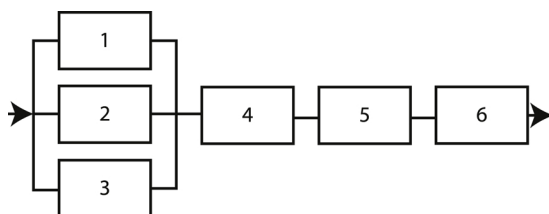

Fig. 2. RBD for a combined system consisting of parallel and serial sub-systems.

The methodology depicted in Fig. 3 facilitates the choice between two different techniques for modelling component availability over time. If both techniques can be applied to a component, model selection should be based on economic considerations. On the other hand, if neither of the models can be applied, the component average availability as the ratio of the total downtime to a defined period of time can be used as input data to the RBD to calculate the system availability. For example, consider a pump which has failed five times over the last ten years, and the average downtime as a result of failure has been estimated as two days. This would result in an average availability of 0.997 for the pump. Clearly, this does not provide any information regarding deterioration and maintenance but assures all components are included in the RBD.

3.3. Component availability modelling

The modelling approach at the component level is illustrated in Fig. 4, where two different techniques are proposed: the semi-Markov process (SMP) and the non-homogeneous Poisson process (NHPP). SMP results in a condition-based model, while NHPP results in a failure-based model. For both models, the uptimes and downtimes of components are generated via inverse transform sampling (ITS), where one uptime and one downtime form a cycle. The distribution of the uptimes depends on whether SMP or NHPP is selected while the downtimes are assumed to be lognormal for both models. Finally, the availability is modelled over time using Monte Carlo simulation.

3.3.1. Semi-Markov process

The conventional Markov process is characterised by exponentially distributed holding times, meaning the transition probabilities are constant in time and independent of how long the component has been in a certain state. This limitation can be relaxed via SMP, in which the holding times are described by non-exponential distributions [29,30]. For many real-life situations this is a more realistic way of modelling deterioration and therefore the SMP has been more adapted for availability modelling [29,31–35].

However, SMP (as all types of Markov models) is not well equipped for modelling complex systems. The number of states grows exponentially with the size of the model leading to the notorious state-space explosion problem [36]. Nevertheless, SMP can deal with deterioration and reparability of system components and thus still applicable to the availability modelling of components within a complex system.

In SMP, the uptimes are often described by Weibull distribution [32,37–41]. This is a well-known assumption in the field of reliability engineering as it can fit a wide range of distributions by varying its

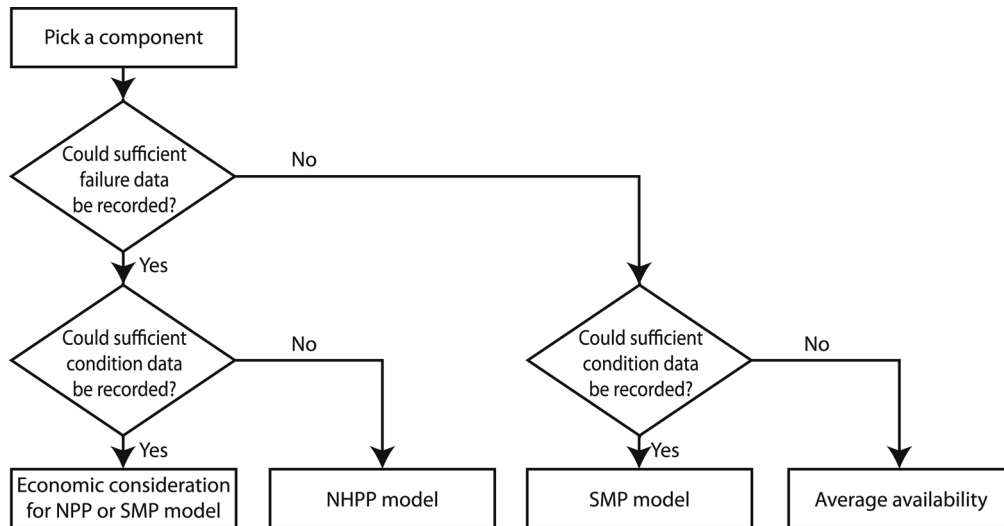

Fig. 3. Flowchart for optimal model selection at component level.

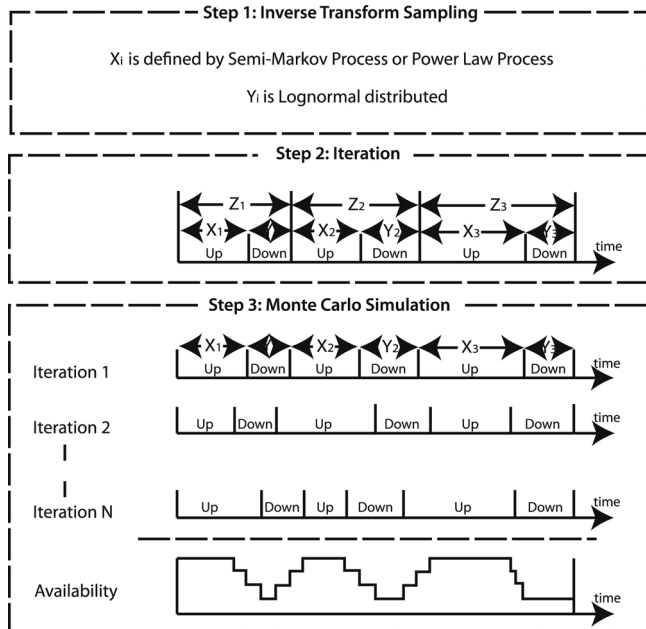

Fig. 4. Approach for availability modelling at component level.

parameters [29]. The probability density function (PDF) of a two-parameter Weibull distribution is given by:

$$f(t) = \frac{\beta}{\theta} \left(\frac{t}{\theta}\right)^{\beta-1} \exp\left(-\left(\frac{t}{\theta}\right)^\beta\right) \quad \forall t > 0 \tag{2}$$

where β = shape parameter; θ = scale parameter; and t = time. Given a dataset, the parameters can be estimated using the Maximum Likelihood Estimation (MLE) method [42,43].

3.3.2. Non-homogeneous poisson process

NHPP is known for its ability to model repairable systems [44,45]. Specifically, it can deal with repairable systems which deteriorate over time. Different types of NHPP exist, among which the power law process (PLP) is very popular [44] with the same failure rate (intensity function) of Weibull distribution:

$$\lambda(t) = \frac{\beta}{\theta} \left(\frac{t}{\theta}\right)^{\beta-1} \quad \forall t > 0 \tag{3}$$

When $\beta > 1$, PLP resembles a deteriorating system, where the times

between failures become stochastically smaller. When $\beta = 1$, PLP resembles a system subject to random failure, and PLP changes to a homogenous Poisson process whereas for $\beta < 1$, the times between failures become stochastically larger, and PLP resembles an improving system. PLP has been used to model the failure patterns of a variety of deteriorating systems such as power systems [46], machineries [18,49–51], and water mains [47].

Although PLP can model repairable and deteriorating components, it cannot be used to aggregate the failure of different components, and is thus not suitable for failure assessment of systems. Besides, when modelling failures, PLP does not consider downtimes and thus cannot model instantaneous availability. This latter drawback could be alleviated by including the downtimes via lognormal distribution.

In order to find out whether a component is deteriorating, a trend test such as the Laplace trend test or the MIL-HDBK-189 test should be applied to the component’s failure data [48]. If the data do not show a trend, a homogeneous Poisson process (HPP) should be applied instead of a NHPP or PLP. Furthermore, to find out if multiple components deteriorate in a similar fashion, a likelihood ratio test may be employed. Rigdon and Basu [45] provide such tests for both the HPP and the PLP.

3.3.3. Distribution of downtimes

The inclusion of downtimes is required for computations regarding availability. With the SMP model this is realised through involving downtimes for specific states that correspond to non-availability. With the NHPP model this could be achieved through cycles of alternating up- and downtimes. For the downtimes the lognormal distribution is used, which is a commonly chosen distribution for repairs [24,27]. The PDF of the lognormal distribution is given by:

$$f(t) = \frac{1}{(\sqrt{2\pi}\sigma^2)t} \exp\left(-\frac{(\ln(t) - \mu)^2}{2\sigma^2}\right) \quad \forall t > 0; -\infty < \mu < \infty; \sigma > 0 \tag{4}$$

where μ = scale parameter, σ = shape parameter, and t = time. The parameters can be estimated using the MLE method [48].

3.3.4. Inverse transform sampling

One iteration within the Monte Carlo simulation consists of consecutive cycles of up- and downtimes. Simulation of the individual up- and downtimes is done via inverse transform sampling (ITS). The general approach in ITS is to use the distribution function of a random variable, take its inverse cumulative density function (CDF) and

generate random numbers according to this inverse CDF by using the uniform distribution [49]:

- Let $F(x)$ be any invertible CDF of continuous random variable x
- Take $F(x) = U$, where U is a random generated number from the continuous uniform distribution $U[0, 1]$
- Then: $X = F^{-1}(U)$

Applying ITS, the availability can be modelled for one iteration for both the SMP and the NHPP models.

3.3.5. Monte Carlo simulation

With the simulation of one iteration only the instantaneous availability according to that single iteration can be modelled. Therefore, Monte Carlo simulation is applied to combine the results of many single iterations. A discrete time space is used and for each point in time the average of the availability amounts over n iterations is computed. The availability of the i^{th} iteration at time t is given by $A_i(t)$, which is a binary measure depending on whether the iteration at t belongs to an uptime ($A_i(t) = 1$) or a downtime ($A_i(t) = 0$). The result approximates the stochastic availability of a component, which is defined as the probability of the component being available at t [50,51]:

$$A(t) = P(A(t) = 1) = \frac{\sum_{i=1}^n A_i(t)}{n} \quad (5)$$

4. Application of the methodology

The application of the methodology which was developed in the previous section is demonstrated through a water facility in the Netherlands. The facility's main drinking water treatment plant is called Leiduin. Since complete and unambiguous data is not available within the managing company, data for the SMP and NHPP techniques has been elicited using experts.

4.1. System description

The focus in this case study is on a sub-system consisting of three consecutive process steps: rapid sand filtration, ozonation and softening (Fig. 5). Pumps and valves that are relevant to the availability of the water treatment plant as a whole are included in the case study as well. The interest of Leiduin's asset managers lies in the development of the availability over a time period of 30 years. Due to constraints in the pre-treatment process, the concerned sub-system of Leiduin has a maximum production capacity of 2400 m³/h. In the present study, the term availability for both the system and its components is specified as the 'probability that the system (or component) is up and able to meet the maximum production capacity'. Consequently, every component is either in an 'available state' or 'unavailable state'.

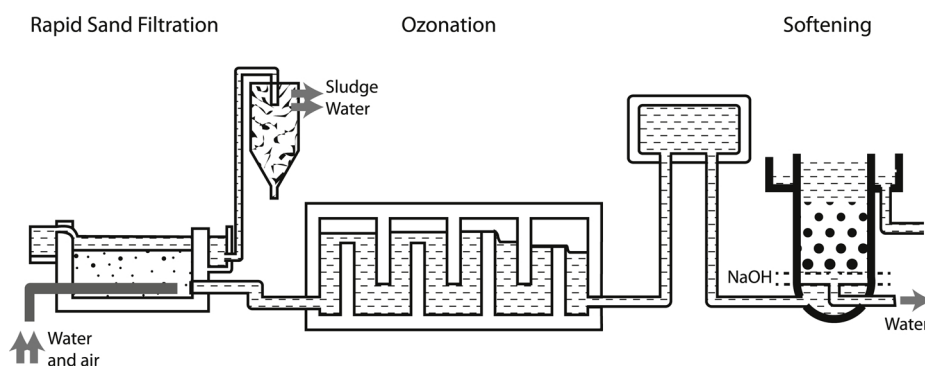

Fig. 5. Treatment steps in the sub-system of Leiduin (www.waternet.nl).

4.1.1. Rapid sand filtration

The first treatment step of the considered system is the rapid sand filtration, consisting of six filters. These filters take out suspended particles in the water. These filters have to be periodically backwashed in order to unclog. Each filter has a maximum capacity of 600 m³/h, resulting in a total maximum capacity of 3600 m³/h. Since the sub-system's overall production capacity is constrained to 2400 m³/h, the rapid sand filtration needs at least 4 out of 6 installed filters to be working in order to meet the maximum production capacity. From the sand filters the water flows through pipelines to the ozonation step.

4.1.2. Pipelines

Pipelines connecting the different treatment steps are part of the system as well. However, discussions with the site personnel uncovered that no failures are known for the pipelines on site, and therefore they are assumed to have an availability of 1, and will not be addressed in the subsequent sections.

4.1.3. Ozonation

The next treatment step is the ozonation, which is a disinfection step to kill off bacteria, viruses and pesticides. The treatment takes place in a multi-chambered cellar, where the water is brought into contact with the ozone. Leiduin has two ozone streets, Ozone street 1 and 2. These streets consist of an ozone generator, a cooling system, a multi-chambered cellar and an ozone dispensing system. Each of the ozone streets can handle 2800 m³/h, and thus able to meet the maximum production capacity alone.

4.1.4. Pumps

After the ozonation, the water is pumped to the softening process. Ozone street 1 is connected to Pumps 1 and 2 while Ozone street 2 is connected to Pumps 3 and 4. Both pumping units have a parallel configuration in order to provide redundancy. Each pump has a capacity of 2500 m³/h, which is sufficient to meet the maximum production capacity.

4.1.5. Valve

Valves are used to direct flows of water through the pipeline system. In the present sub-system one important valve is present. The valve is located between the ozone streets and the pumps. The valve makes it possible to bypass the water flow from Ozone street 1 to Pumps 3 and 4 and from Ozone street 2 to Pumps 1 and 2. The capacity of the valve is 3600 m³/h in either direction.

4.1.6. Softening reactors

Water is then pumped to the softening reactors. In the softening reactors the water comes into contact with sodium hydroxide, letting calcium precipitate on sand grains. When the grains increase in size, they sink to the bottom and are subsequently drained from the

Table 2
Model selection per component.

Component	Model selection
Rapid sand filters	NHPP
Ozone streets	SMP
Pumps	SMP
Valves	Average availability
Softening reactors	NHPP

softening reactor. There are four softening reactors in total, each with a maximum production capacity of 800 m³/h. In order to meet the maximum production capacity of the sub-system (2400 m³/h), at least 3 of the 4 softening reactors need to be operating at full capacity. After this softening process step the water flows towards the next treatment step, the carbon filtration, which is not included in this case study.

4.2. Selection of appropriate techniques at component level

After the identification of the sub-system's components, the next step is selecting the appropriate technique (SMP, NHPP, or neither) for assessing each component's availability using the flowchart in Fig. 3. The rapid sand filters are taken as an example for applying the flowchart. It is assumed that for the rapid sand filters sufficient failure events have been recorded over the past years (this proposes both SMP and NHPP as potential techniques). Besides, according to the plant operators and asset managers, it is practically not possible to determine the condition of the filters (this rules out SMP as an option). As such, the NHPP model could be used to model the availability of the rapid sand filters. Following the same procedure, appropriate techniques for the other components can be identified as in Table 2.

4.3. Availability assessment of components

4.3.1. Availability of rapid sand filtration

MIL-HDBK-189 test and Laplace test are applied to the data of the rapid sand filters. These suggest there is no trend in the data of any of the filters (Appendix A), indicating that the rapid sand filters can be modelled by an HPP, which is similar to an NHPP with $\beta = 1$. In order to find out if the data from all the filters can be pooled together, a likelihood ratio test can be performed. This test measures the equality of the filters based on the failure data. The outcome of the test at a significance level of $\alpha = 0.05$ does not reject the equality of the filters, meaning the data from all filters can be pooled. Since the filters are modelled via HPP, only the parameter θ has to be estimated ($\beta = 1$). The repair time data of all the filters is assumed to identically follow a lognormal distribution. The parameters of both the HPP model (up-times) and the lognormal distribution (downtimes) are calculated using the MLE approach as in Table 3.

These parameters of the lognormal distribution are used for the NHPP model. The availability of a rapid sand filter has been depicted in Fig. 6. At the beginning, the availability of the sand filter is equal to 1.0 (initial condition) but soon descends to a steady amount of about 0.987. This steady availability is consistent with the HPP and its random failure behaviour.

4.3.2. Availability of ozonation unit

Four discrete upstates are assumed for the ozone streets: state 1

Table 3
Parameter estimations for the NHPP model of the rapid sand filtration.

Uptimes (HPP)		Downtimes (Lognormal)	
θ	β	μ	σ
683.12	1	4.89	0.98

corresponds to the same as new and state 4 refers to the last deterioration state before failure. The condition of both the ozone streets can be monitored continuously. When an ozone street is monitored to be in state 4, maintenance is performed immediately. However, the condition improvement due to maintenance decreases over time. The first three repair actions for an ozone street return its condition back to state 2. The 4th, 5th and 6th repairs result in state 3. Then, the 7th repair action is a perfect repair (renewal), so afterwards the ozone street is assumed to be the same as new. This procedure is repeated thereafter so the next repair can be seen as the first repair of a new cycle. One downstate (state 5) is assumed to describe all repair actions. The parameters for the holding time distributions can be estimated using MLE as presented in Table 4. Fig. 7 shows the availability of one of the ozone streets, modelled with the SMP model.

It should be noted that the distribution parameters of the holding time of state 4 cannot be estimated. When an ozone street enters state 4, a repair action is performed immediately so the holding times are cut off. In the SMP model the holding time for state 4 is always equal to one day, not influencing the model outcome.

4.3.3. Availability of pumps

Similar to the ozone streets, four discrete upstates are assumed and the condition can be monitored continuously. When a pump is monitored to be in state 4, maintenance is performed, the influence of which decreases over time. The first five repair actions for a pump return its condition to state 2. This type of imperfect repair is described by a downstate as state 5. The 6th repair action is a perfect repair (renewal), bringing the pump back to state 1 (same as new). The equivalent downstate is referred to as state 6. The parameters for the holding time distributions can be estimated using MLE as listed in Table 5. Fig. 8 shows the availability of a single pump. For the same reasons as for the ozonation unit, the holding time distribution for state 4 of the pumps cannot be estimated.

4.3.4. Availability of softening reactors

The trend tests suggest that there is a trend in the failure data of the softening reactors (Appendix A). In order to find out if the data from all reactors can be pooled together a likelihood ratio test is performed. The likelihood ratio test fails to reject the equality of the failure data of the softening reactors. It is yet unknown if the trend in the data is signalling a deteriorating system or an improving system. Therefore, the parameters of the NHPP model have to be estimated via MLE. The parameter β confirms that the data follows a deteriorating trend, since the 95% confidence interval of β is greater than 1.0 (Table 6). The availability of a softening reactor has been displayed in Fig. 9. The availability behaviour is consistent with a deteriorating NHPP where due to its minimal repair the uptimes are stochastically decreasing with time, leading to an ever-decreasing availability.

4.4. Availability assessment of the system

Based on the system description in Section 4.1, the system can be modelled using a RBD as shown in Fig. 10. Based on the availability of its components, the system availability can be computed by deriving the minimal path sets for the different types of configurations in the RBD. The system availability (Fig. 11) clearly shows a deteriorating behaviour, where the availability declines over time.

5. Discussion

From an asset manager's point of view, the aim is to optimise the system configuration and maintenance strategy in order to satisfy the availability demands in the most cost-efficient way. This challenge has caused a shift from preventive and corrective maintenance towards predictive, condition-based maintenance. To evaluate changes to the system configuration or maintenance strategies it is important to gain

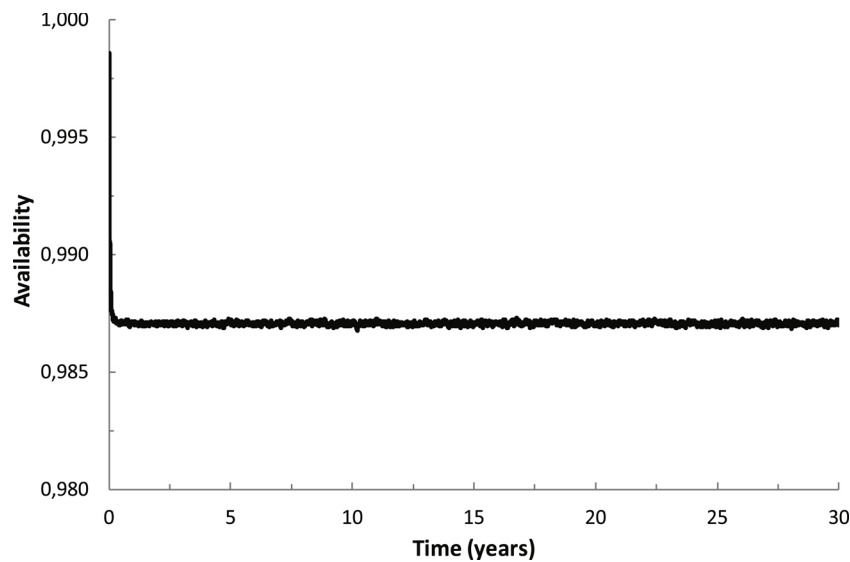

Fig. 6. Instantaneous availability over 30 years for rapid sand filter.

Table 4
Parameter estimations for SMP model of the ozone streets.

State	Distribution	Parameter			
		β	θ	μ	σ
1	Weibull	11.15	100.46	–	–
2	Weibull	5.47	80.76	–	–
3	Weibull	2.36	72.77	–	–
4	–	–	–	–	–
5	Lognormal	–	–	1.02	0.29

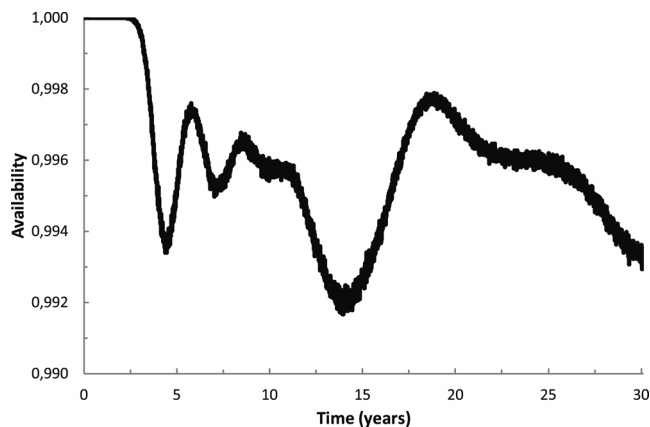

Fig. 7. Instantaneous availability over 30 years for ozone street.

Table 5
Parameter estimations for SMP model of the pumps.

State	Distribution	Parameter			
		β	θ	μ	σ
1	Weibull	4.38	52.33	–	–
2	Weibull	3.49	39.89	–	–
3	Weibull	3.91	30.17	–	–
4	–	–	–	–	–
5	Lognormal	–	–	0.35	0.56
6	Lognormal	–	–	3.03	0.08

insights about the system availability over time, decreased by asset deterioration and increased via maintenance actions. The proposed methodology has been developed with the aim of assisting asset managers of WTPs in this regard.

An important feature of the methodology is that it is data driven. The SMP model is based on condition data, so it is important to know if and how the condition of assets can be determined. For some assets it is possible to monitor the condition continuously, which would be the ideal situation, whereas for other assets the condition can only be determined through periodic inspections. Aiming for uniform condition monitoring a standard, such as the Dutch NEN-2767 standard [52], could serve as a guideline to asset managers. The NHPP model, on the other hand, is driven by failure data. It must be well defined when an asset has failed and the recording of failures needs to be accurate and uniform. In case of data scarcity, it is possible to use expert judgement as input for the modelling at component level. Many models for expert judgement elicitation exist in the literature. Cooke and Goossens [53] discuss two models for critical infrastructures.

Likewise, the information regarding the performed maintenance actions must be well registered. Information on the type of active maintenance strategy, the influence of a maintenance action on the asset condition, and the time it takes to perform the maintenance action are of significant importance for accurate availability modelling. Without a proper definition and collection of condition data, failure data and maintenance actions, adoption of the methodology by asset managers and other users might prove difficult. Subsequently, the proposed methodology can be used as a demonstration of the usefulness and importance of collecting data in producing tangible insights into temporal availability of assets and asset systems.

The present study can further be improved by relaxing some of the simplifying assumptions made in the development of the methodology. First, it is assumed that components deteriorate and/or fail independently, which is inevitable if the system is to be modelled using RBD technique. This assumption seems to be simplistic since in real-life systems there would be dependencies between components due to common-cause failures or load-sharing (in parallel sub-systems). A solution could be the application of (dynamic) Bayesian belief networks [17,50,54,55] to account for conditional dependencies, which can be pursued in future works.

Second, it should be noted that this study focusses on availability modelling, which is a first step in the optimisation process of maintenance strategies and system configurations. The next step would be the conducting a cost-benefit analysis, in order to ensure an affordable

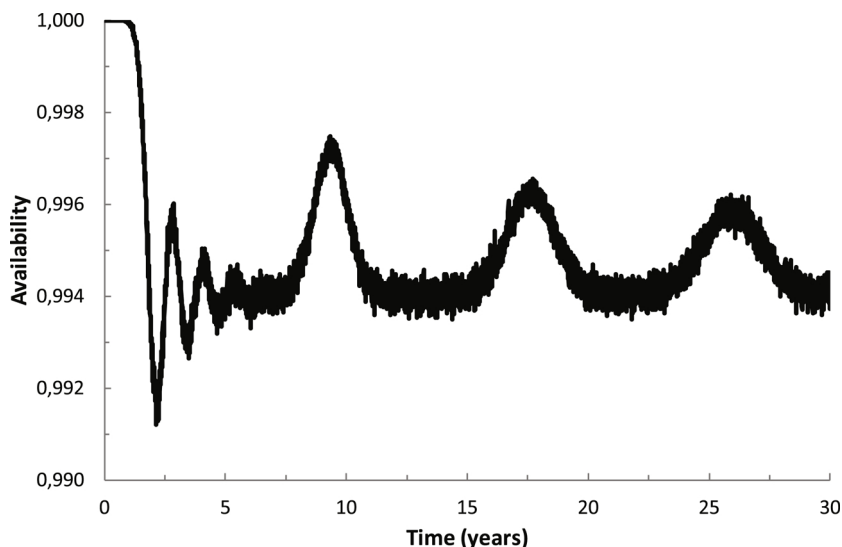

Fig. 8. Instantaneous availability over 30 years for pumps.

Table 6
Parameter estimation for the NHPP model of the softening reactors.

Parameter	Value	Confidence bounds 95%	
β	2.84	2.13	3.54
θ	4748.71	Not applicable	
μ	4.00		
σ	1.81		

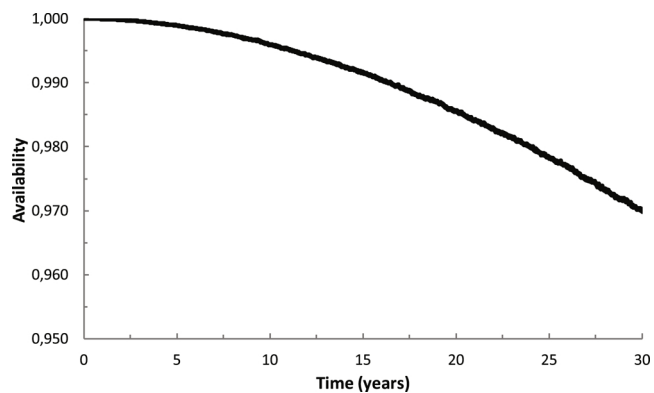

Fig. 9. Instantaneous availability over 30 years for softening reactors.

high availability. In this regard, the Semi-Markov Decision Process (SMDP) – as an extension of the SMP model - could be used to find optimal maintenance strategies [33,56,57] and Life Cycle Costing (LCC) techniques could be applied for discounting future revenue and expenses of maintenance strategies in the NHPP model [58].

Third, with the SMP model multiple condition states can be included, where each condition state is corresponding to a value for the instantaneous availability of the concerned component. In the proposed methodology this instantaneous availability is assumed to be a binary variable (either 1 or 0). Therefore, an extension to the SMP model could be the inclusion of intermediate values for the instantaneous availability. This would allow the modelling of partly available (or

degraded) components as a result of deterioration. For example, within a WTP this could be relevant for different types of filters experiencing degrees of clogging and thus not working with 100% efficiency.

Fourth, inclusion of other types of models at the component level could relax some assumptions. For the NHPP model the application of imperfect repair models, such as Virtual Age Process (VAP) models are recommended to be investigated [59–61]. They relax the assumption of minimal repair for the NHPP model (or perfect repair for the HPP model). VAP models such as the Arithmetic Reduction of Intensity (ARI) and the Arithmetic Reduction of Age (ARA), introduced by Doyen and Gaudoin [59] fit well with the Power Law Process used in the NHPP model. One should keep in mind, however, that with the generalisation to imperfect repair models, demands on data become more challenging as in addition to failures and repair times, the effect of repairs on the asset has to be estimated too.

6. Conclusions

In order to ensure water availability to society, asset managers of WTPs are in need for tools to assess long-term availability. Complex configurations and repairable and deteriorating assets are inherent characteristics of these plants. However, methodologies capable of modelling the instantaneous availability and simultaneously addressing reparability and deterioration of WTP are lacking.

Therefore, the current research presents a two-level model for assessing the instantaneous availability of WTPs: (i) choosing between a condition-based technique (SMP) and a failure-based technique (NHPP) at the component level, and (ii) application of a RBD to calculate the availability at the system level. The proposed methodology is exemplified by a case study of a Dutch WTP, where data has been elicited from experts. Assessing the availability of the components and the system, it was shown that the WTP was presenting a deteriorating behaviour over a 30-year period.

This research has relied on the simplifying assumption of independent deterioration and failure of components. Therefore, the performance of the developed methodology can further be improved by applying more sophisticated techniques than RBD so that conditional dependencies can be accounted for.

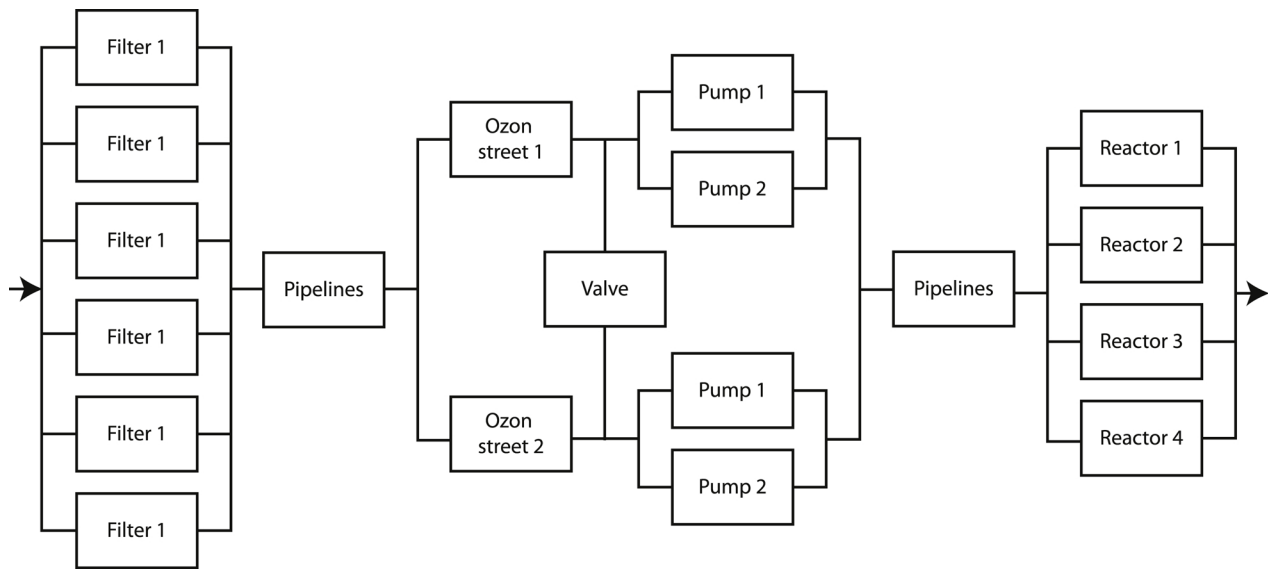

Fig. 10. Reliability Block Diagram of the water treatment facility.

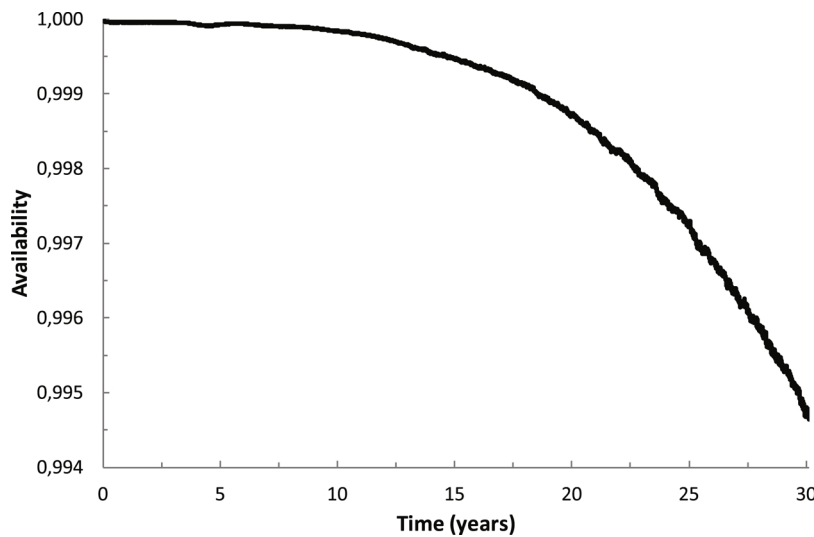

Fig. 11. Instantaneous availability of the water treatment facility over 30 years.

Appendix A

Trend test statistics from the NHPP models

The trend tests work as follows: for the Laplace test there is no trend if the test statistic falls within the interval bounds corresponding to the chosen significance level of the standard normal distribution. Thus, a significance level of $\alpha = 0.05$ means that the interval bounds are about -1.96 and $+1.96$.

For the MIL-HDBK-189 test, if the test statistic falls within the interval bounds for a chosen significance level, there is no trend in the data. The interval bounds of this test are data specific and are included within [Tables A1 and A2](#).

Table A1

Trend test statistics on the data of the rapid sand filtration.

Filter	MIL-HDBK-189 Trend Test			Laplace Trend Test Test statistic	Outcome of tests ($\alpha = 0.05$)
	Test statistic	Lower bound	Upper bound		
1	32.17	16.79	46.98	0.03	No trend in data
2	35.78	19.81	51.97	-0.97	No trend in data
3	45.55	22.88	56.90	-1.79	No trend in data
4	44.85	27.57	64.20	-0.91	No trend in data
5	44.85	22.88	56.90	0.36	No trend in data
6	44.07	19.81	51.97	-0.46	No trend in data

Table A2
Trend test statistics on the data of the softening reactors.

Reactor	MIL-HDBK-189 Trend Test			Laplace Trend Test	Outcome of tests ($\alpha = 0.05$)
	Test statistic	Lower bound	Upper bound	Test statistic	
1	11.47	18.29	49.48	6.81	Trend in data exists
2	15.35	22.88	56.90	3.95	Trend in data exists
3	3.870	12.40	39.36	12.60	Trend in data exists
4	12.33	15.31	44.46	8.24	Trend in data exists

References

- [1] R.E. Brown, B.G. Humphrey, Asset management for transmission and distribution, *IEEE Power Energy Mag.* 3 (3) (2005) 39–45.
- [2] EPA, EPA's 2007 Drinking Water Infrastructure Needs Survey and Assessment, (2009).
- [3] F.Z. Blaha, Jian, main breaks, *Drinking Water Res.* 20 (4) (2010) 27–28.
- [4] National Water Commission, Urban Water in Australia: Future Directions, NWC, Canberra, 2011.
- [5] U.K. Water, How Water Prices Are Set, (2013).
- [6] T. Van der Lei, P. Herder, Y. Wijnia, Asset Management: the State of the Art in Europe From a Life Cycle, Springer, 2014.
- [7] Institute of Public Works Engineering Australasia, International Infrastructure Management Manual, National Asset Management Steering (NAMS) Group, 2011.
- [8] British Standards Institution, PAS 55-1: Asset Management. Part 1: Specification for the Optimized Management of Physical Assets, (2008).
- [9] International Union of Railways, Guidelines for the Application of Asset Management in Railway Infrastructure Organisations, (2010).
- [10] The Institute of Asset Management, Asset Management – an Anatomy, (2015).
- [11] R.K. Mobley, An Introduction to Predictive Maintenance, Butterworth-Heinemann, 2002, <https://doi.org/10.1016/b978-0-7506-7531-4.x5000-3>.
- [12] PwC, Mainnovation, Predictive Maintenance 4.0: Predict the Unpredictable, (2017).
- [13] S. Wu, P. Do, Editorial, *Reliab. Eng. Syst. Saf.* 168 (2017) 1–3, <https://doi.org/10.1016/j.ress.2017.09.004>.
- [14] K. Bourouni, Availability assessment of a reverse osmosis plant: comparison between reliability block diagram and fault tree analysis methods, *Desalination* 313 (2013) 66–76, <https://doi.org/10.1016/j.desal.2012.11.025>.
- [15] M. Taheriyoun, S. Moradinejad, Reliability analysis of a wastewater treatment plant using fault tree analysis and Monte Carlo simulation, *Environ. Monit. Assess.* 187 (1) (2015) 4186, <https://doi.org/10.1007/s10661-014-4186-7>.
- [16] H. Maciejewski, D. Caban, Estimation of repairable system availability within fixed time horizon, *Reliab. Eng. Syst. Saf.* 93 (1) (2008) 100–106, <https://doi.org/10.1016/j.ress.2006.10.016>.
- [17] L. Görkemli, S.K. Ulusoy, Fuzzy Bayesian reliability and availability analysis of production systems, *Comput. Ind. Eng.* 59 (4) (2010) 690–696, <https://doi.org/10.1016/j.cie.2010.07.020>.
- [18] Q. Ahmed, F.I. Khan, S.A. Raza, A risk-based availability estimation using Markov method, *Int. J. Qual. Reliab. Manag.* 31 (2) (2014) 106–128, <https://doi.org/10.1108/ijqrm-04-2012-0056>.
- [19] I.-H. Choi, D. Chang, Reliability and availability assessment of seabed storage tanks using fault tree analysis, *Ocean. Eng.* 120 (Supplement C) (2016) 1–14, <https://doi.org/10.1016/j.oceaneng.2016.04.021>.
- [20] R.M.A. Velásquez, J.V.M. Lara, Reliability, availability and maintainability study for failure analysis in series capacitor bank, *Eng. Fail. Anal.* 86 (2018) 158–167, <https://doi.org/10.1016/j.engfailanal.2018.01.008>.
- [21] D. Tang, K.S. Trivedi, Hierarchical computation of interval availability and related metrics, *Dependable Systems and Networks, 2004 International Conference on* (2004), <https://doi.org/10.1109/dsn.2004.1311940>.
- [22] S. Distefano, A. Puliafito, Dynamic reliability block diagrams vs dynamic fault trees, *Reliability and Maintainability Symposium, 2007. RAMS'07. Annual* (2007), <https://doi.org/10.1109/rams.2007.328095>.
- [23] R.-T. Wang, Reliability evaluation techniques, in: J. Mathew, R.A. Shafiq, D.K. Pradhan (Eds.), *Energy-Efficient Fault-Tolerant Systems*, Springer New York, New York, NY, 2014, pp. 11–97, https://doi.org/10.1007/978-1-4614-4193-9_2.
- [24] A. Birolini, *Reliability Engineering: Theory and Practice*, Springer, 2017, <https://doi.org/10.1007/978-3-662-54209-5>.
- [25] M.C. Kim, Reliability block diagram with general gates and its application to system reliability analysis, *Ann. Nucl. Energy* 38 (11) (2011) 2456–2461, <https://doi.org/10.1016/j.anucene.2011.07.013>.
- [26] S. Mejjaoui, R.F. Babiceanu, Minimal path sets models for reliability computation of wireless sensor networks, *Systems Conference (SysCon)*, 2016 Annual IEEE (2016), <https://doi.org/10.1109/syscon.2016.7490565>.
- [27] M. Rausand, A. Hoyland, *System Reliability Theory: Models, Statistical Methods, and Applications Vol. 396*, John Wiley & Sons, 2004.
- [28] S.E. Rigdon, A.P. Basu, Mean squared errors of estimators of the intensity function of a nonhomogeneous Poisson process, *Stat. Probab. Lett.* 8 (5) (1989) 445–449, [https://doi.org/10.1016/0167-7152\(89\)90025-4](https://doi.org/10.1016/0167-7152(89)90025-4).
- [29] M. Black, A. Brint, J. Brailsford, A semi-Markov approach for modelling asset deterioration, *J. Oper. Res. Soc.* 56 (11) (2005) 1241–1249, <https://doi.org/10.1057/palgrave.jors.2601967>.
- [30] A. Scheidegger, T. Hug, J. Rieckermann, M. Maurer, Network condition simulator for benchmarking sewer deterioration models, *Water Res.* 45 (16) (2011) 4983–4994, <https://doi.org/10.1016/j.watres.2011.07.008>.
- [31] V.S. Barbu, A. Karagrigoriou, A. Makrides, Semi-Markov modelling for multi-state systems, *Methodol. Comput. Appl. Probab.* 19 (4) (2017) 1011–1028, <https://doi.org/10.1109/ares.2014.60>.
- [32] O. Thomas, J. Sobanjo, Semi-Markov models for the deterioration of bridge elements, *J. Infrastruct. Syst.* 22 (3) (2016) 04016010, [https://doi.org/10.1061/\(asce\)is.1943-555x.0000298](https://doi.org/10.1061/(asce)is.1943-555x.0000298).
- [33] C.L. Tomasevicz, S. Asgarpoor, Optimum maintenance policy using semi-Markov decision processes, *Electr. Power Syst. Res.* 79 (9) (2009) 1286–1291, <https://doi.org/10.1016/j.epr.2009.03.008>.
- [34] R. Vinayak, S. Dharmaraja, Semi-Markov modeling approach for deteriorating systems with preventive maintenance, *Int. J. Performability Eng.* 8 (5) (2012) 515.
- [35] L. Wang, L. Cui, J. Zhang, J. Peng, Reliability evaluation of a Semi-Markov repairable system under alternative environments, *Commun. Stat.-Theory Methods* 45 (10) (2016) 2938–2957, <https://doi.org/10.1080/03610926.2014.894062>.
- [36] M. Lanus, L. Yin, K.S. Trivedi, Hierarchical composition and aggregation of state-based availability and performability models, *IEEE Trans. Reliab.* 52 (1) (2003) 44–52, <https://doi.org/10.1109/tr.2002.805781>.
- [37] D. Dolas, M. Jaybhaye, S. Deshmukh, Estimation of the system reliability using weibull distribution, *Int. Proc. Econ. Dev. Res.* 75 (2014) 144.
- [38] K. Fung, A. Jardine, Weibull parameter estimation, *Microelectron. Reliab.* 22 (4) (1982) 681–684, [https://doi.org/10.1016/s0026-2714\(82\)80180-7](https://doi.org/10.1016/s0026-2714(82)80180-7).
- [39] J.W. Kim, G. Choi, J.C. Suh, J.M. Lee, Optimal scheduling of the maintenance and improvement for water main system using Markov decision process, *IFAC PapersOnLine* 48 (8) (2015) 379–384, <https://doi.org/10.1016/j.ifacol.2015.08.211>.
- [40] Y. Kleiner, Scheduling inspection and renewal of large infrastructure assets, *J. Infrastruct. Syst.* 7 (4) (2001) 136–143, [https://doi.org/10.1061/\(asce\)1076-0342\(2001\)7:4\(136\)](https://doi.org/10.1061/(asce)1076-0342(2001)7:4(136)).
- [41] T. Seki, S. Yokoyama, Robust parameter-estimation using the bootstrap method for the 2-parameter Weibull distribution, *Ieee Trans. Reliab.* 45 (1) (1996) 34–41, <https://doi.org/10.1109/24.488914>.
- [42] R. Ross, Bias and standard deviation due to Weibull parameter estimation for small data sets, *Ieee Trans. Dielectr. Electr. Insul.* 3 (1) (1996) 28–42, <https://doi.org/10.1109/94.485512>.
- [43] R. Srinivasan, R.M. Wharton, Confidence bands for the weibull distribution, *Technometrics* 17 (3) (1975) 375–380, <https://doi.org/10.2307/1268077>.
- [44] H. Ascher, H. Feingold, *Repairable Systems Reliability: Modeling, Inference, Misconceptions and Their Causes*, M. Dekker, New York, 1984.
- [45] S. Rigdon, A. Basu, *Statistical Methods For The Reliability Of Repairable Systems*, Wiley Series in Probability and Statistics, John Wiley & Sons, New York, 2000.
- [46] C.A. Gonzalez, A. Torres, M.A. Rios, Reliability assessment of distribution power repairable systems using NHPP, *Transmission & Distribution Conference and Exposition-Latin America (PES T&D-LA)*, 2014 IEEE PES (2014), <https://doi.org/10.1109/tde-la.2014.6955225>.
- [47] P.D. Rogers, Prioritizing water main renewals: case study of the Denver water system, *J. Pipeline Syst. Eng. Pract.* 2 (3) (2011) 73–81, [https://doi.org/10.1061/\(asce\)jps.1949-1204.0000082](https://doi.org/10.1061/(asce)jps.1949-1204.0000082).
- [48] N.T. Thomopoulos, *Statistical Distributions: Applications and Parameter Estimates*, Springer, 2017, <https://doi.org/10.1007/978-3-319-65112-5>.
- [49] E. Zio, *The Monte Carlo Simulation Method for System Reliability and Risk Analysis Vol. 39*, Springer, 2013, <https://doi.org/10.1007/978-1-4471-4588-2>.
- [50] M. Neil, D. Marquez, Availability modelling of repairable systems using Bayesian networks, *Eng. Appl. Artif. Intell.* 25 (4) (2012) 698–704, <https://doi.org/10.1016/j.engappai.2010.06.003>.
- [51] Q. Qiu, L. Cui, H. Gao, Availability and maintenance modelling for systems subject to multiple failure modes, *Comput. Ind. Eng.* 108 (2017) 192–198, <https://doi.org/10.1016/j.cie.2017.04.028>.
- [52] NEN, *NEN 2767 Condition Assessment Built Environment*, (2017).
- [53] R.M. Cooke, L.H. Goossens, Expert judgement elicitation for risk assessments of critical infrastructures, *J. Risk Res.* 7 (6) (2004) 643–656.
- [54] B. Cai, Y. Liu, Y. Ma, Z. Liu, Y. Zhou, J. Sun, Real-time reliability evaluation methodology based on dynamic Bayesian networks: A case study of a subsea pipe ram BOP system, *ISA Trans.* 58 (2015) 595–604, <https://doi.org/10.1016/j.isatra.2015.06.011>.

- [55] B. Cai, Y. Liu, Y. Zhang, Q. Fan, S. Yu, Dynamic Bayesian networks based performance evaluation of subsea blowout preventers in presence of imperfect repair, *Expert Syst. Appl.* 40 (18) (2013) 7544–7554, <https://doi.org/10.1016/j.eswa.2013.07.064>.
- [56] D. Chen, K.S. Trivedi, Optimization for condition-based maintenance with semi-Markov decision process, *Reliab. Eng. Syst. Saf.* 90 (1) (2005) 25–29, <https://doi.org/10.1016/j.ress.2004.11.001>.
- [57] R. Srinivasan, A.K. Parlikad, Semi-Markov decision process with partial information for maintenance decisions, *Ieee Trans. Reliab.* 63 (4) (2014) 891–898.
- [58] L. Crow, Methods for reducing the cost to maintain a fleet of repairable systems, *Reliability and Maintainability Symposium*, 2003. Annual (2003), <https://doi.org/10.1109/rams.2003.1182021>.
- [59] L. Doyen, O. Gaudoin, Classes of imperfect repair models based on reduction of failure intensity or virtual age, *Reliab. Eng. Syst. Saf.* 84 (1) (2004) 45–56, [https://doi.org/10.1016/s0951-8320\(03\)00173-x](https://doi.org/10.1016/s0951-8320(03)00173-x).
- [60] M.L.G. De Toledo, M.A. Freitas, E.A. Colosimo, G.L. Gilardoni, ARA and ARI imperfect repair models: estimation, goodness-of-fit and reliability prediction, *Reliab. Eng. Syst. Saf.* 140 (2015) 107–115, <https://doi.org/10.1016/j.ress.2015.03.035>.
- [61] P.A.P. Ramírez, I.B. Utne, Decision support for life extension of technical systems through virtual age modelling, *Reliab. Eng. Syst. Saf.* 115 (2013) 55–69.