

CARTRIDGE+

CONCEPT DESIGN OF A SMART CARTRIDGE ECOSYSTEM FOR PHARMACEUTICAL 3D PRINTING

CONTEXT:

A SIGNIFICANT CHALLENGE IN HEALTHCARE IS THE PREVALENT 'ONE-SIZE-FITS-ALL' APPROACH TO MEDICATION, WHICH OFTEN FAILS TO ADDRESS THE DIVERSE NEEDS OF INDIVIDUAL PATIENTS. HOWEVER, THE ADOPTION OF ADVANCED TECHNOLOGIES, SUCH AS THE DOSER'S RX1 3D PRINTER, IS PROMPTING A SHIFT IN PHARMACEUTICAL MANUFACTURING. WHILE THE TABLET PRINTING PROCESS REMAINS IN ITS DEVELOPMENTAL STAGES, IT PRESENTS OPPORTUNITIES FOR FURTHER OPTIMIZATION.

OBJECTIVE:

THE PRIMARY OBJECTIVE OF THIS STUDY WAS TO ENHANCE THE EFFICIENCY OF THE TABLET PRINTING PROCESS USING DOSER'S RX1 3D PRINTER.

METHODOLOGY:

A DETAILED ANALYSIS WAS UNDERTAKEN TO THOROUGHLY UNDERSTAND THE OPERATIONAL CONTEXT OF THE PRINTER, THE INTRICACIES OF THE PRINTING PROCESS, AS WELL AS THE NECESSARY PRE-PRINTING AND POST-PROCESSING PROCEDURES. THIS ANALYSIS FACILITATED THE IDENTIFICATION OF ALL RELEVANT PROCESS VARIABLES, ISOLATING THOSE FACTORS MOST CRITICAL FOR EFFICIENCY. EXPERIMENTS WERE CONDUCTED USING ACTIVE PHARMACEUTICAL INGREDIENT (API) AND PLACEBO FORMULATIONS, WITH THE FINDINGS VALIDATED THROUGH AN INDEPENDENT THIRD-PARTY LABORATORY.

RESULTS:

THE OPTIMIZED PROCESS SUCCESSFULLY REDUCED THE TOTAL TABLET PRINTING TIME BY NEARLY 50%.

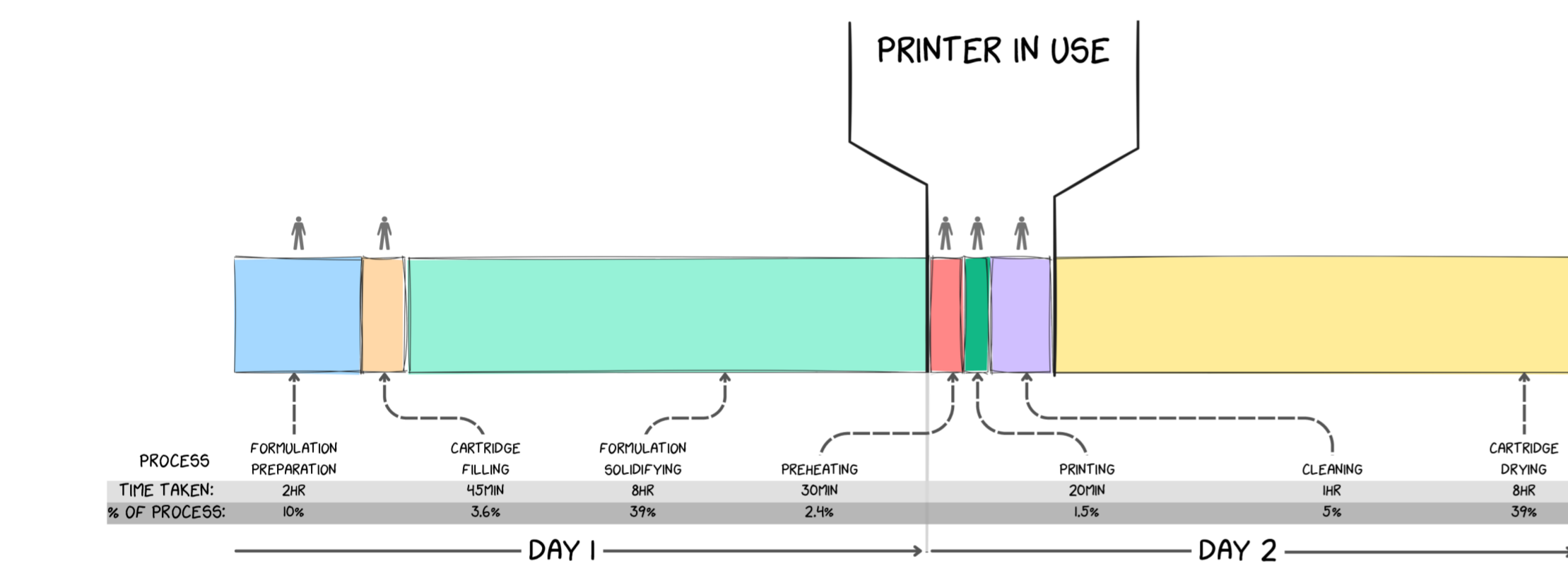

OLD PROCESS

TIME TO PRINT: 12 HOURS
HUMAN INTERVENTION: 5 TASKS
TOTAL PROCESS TIME: 25 HOURS

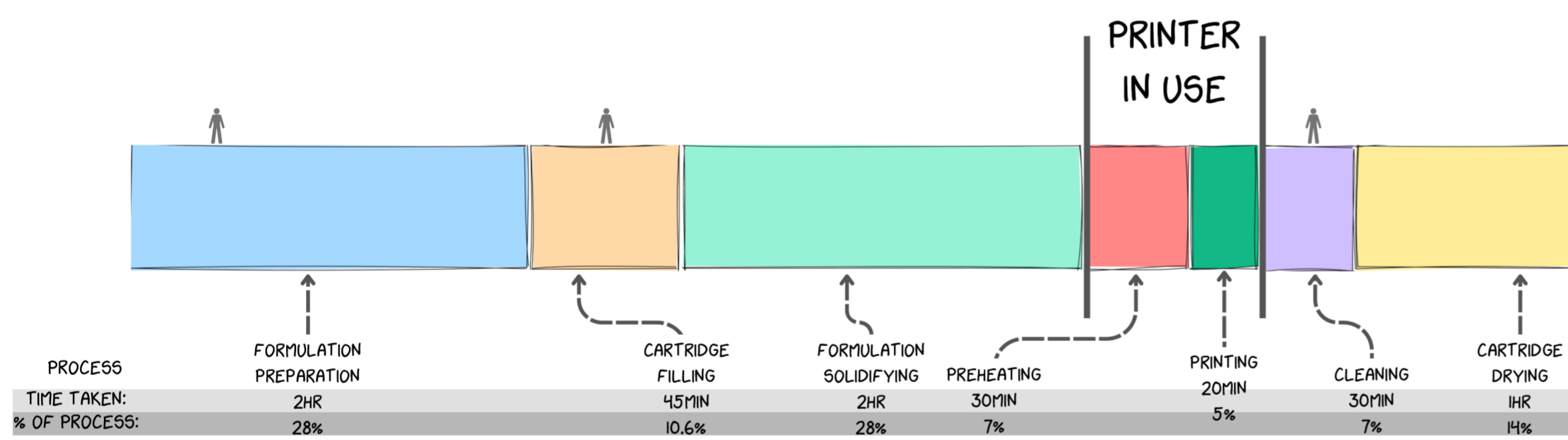

PROPOSED PROCESS

TIME TO PRINT: 6 HOURS
HUMAN INTERVENTION: 3 TASKS
TOTAL PROCESS TIME: 8 HOURS

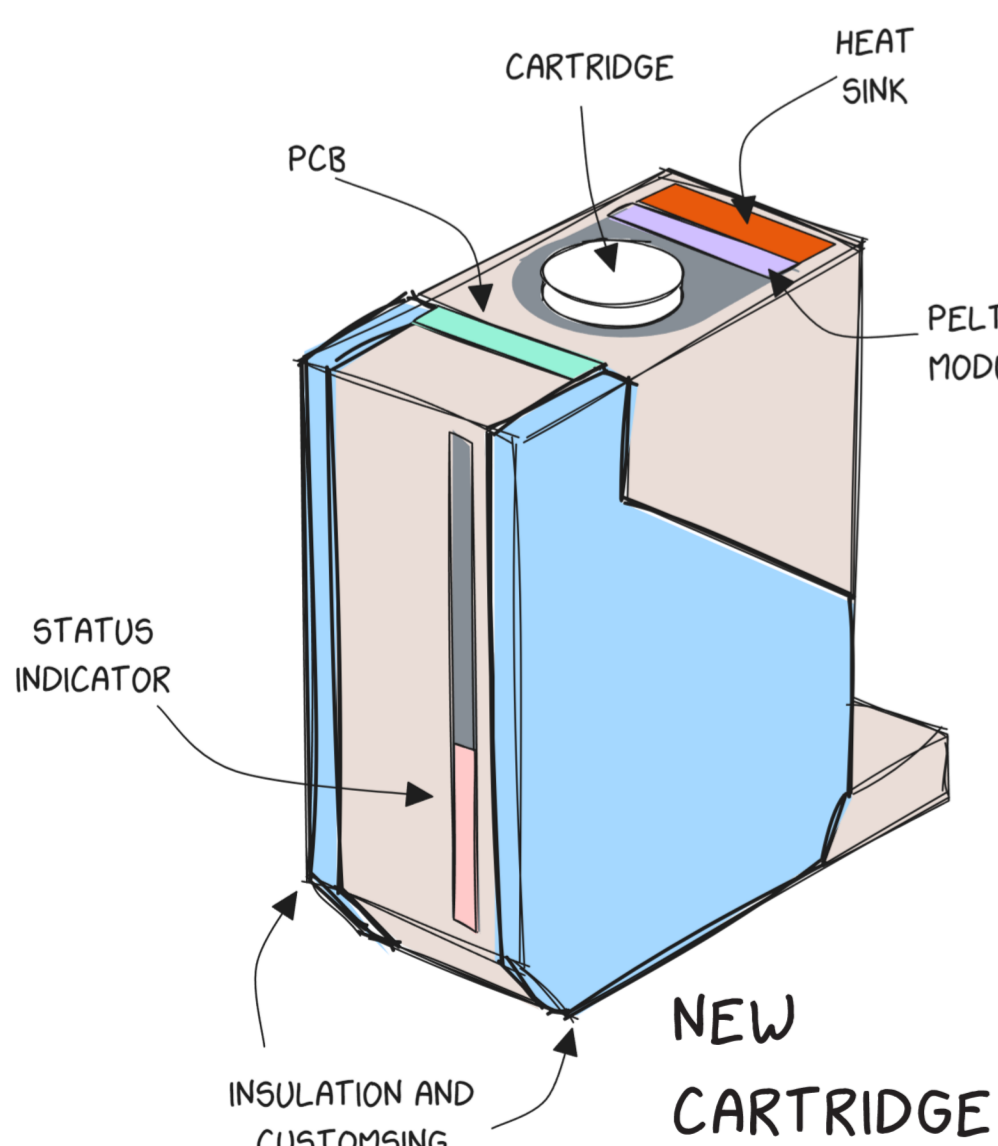
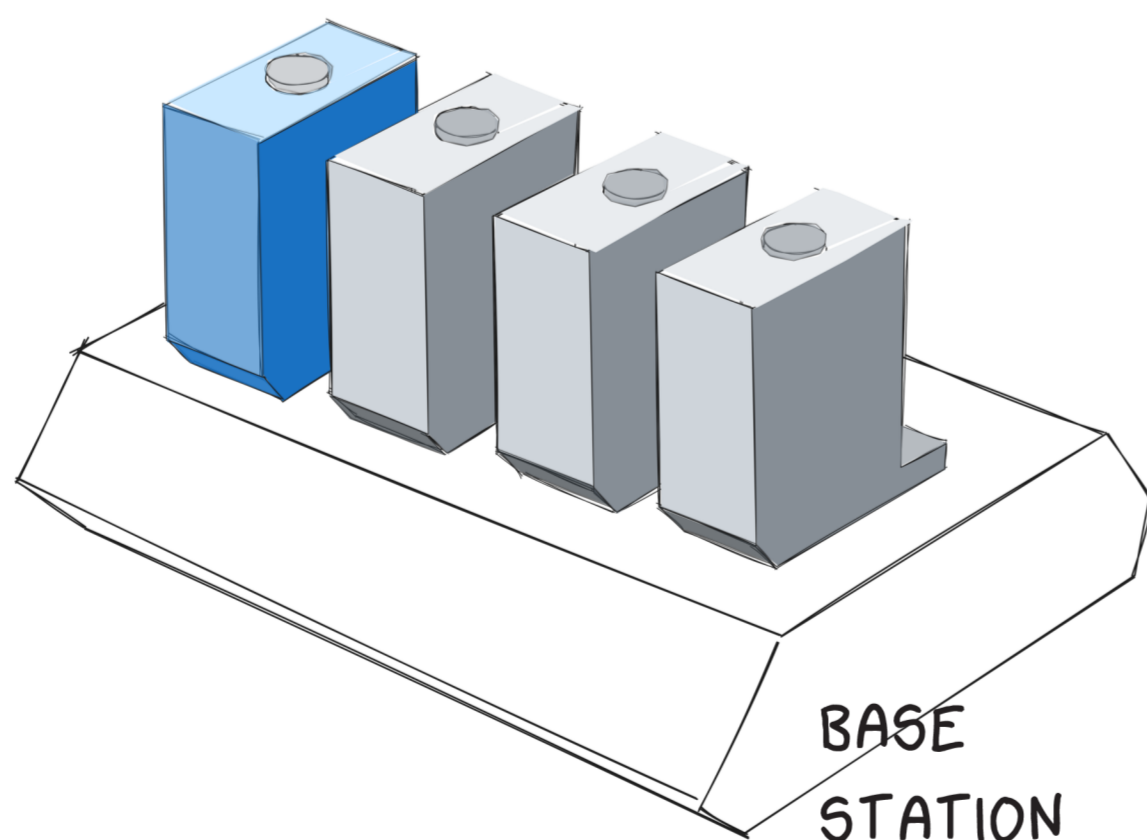
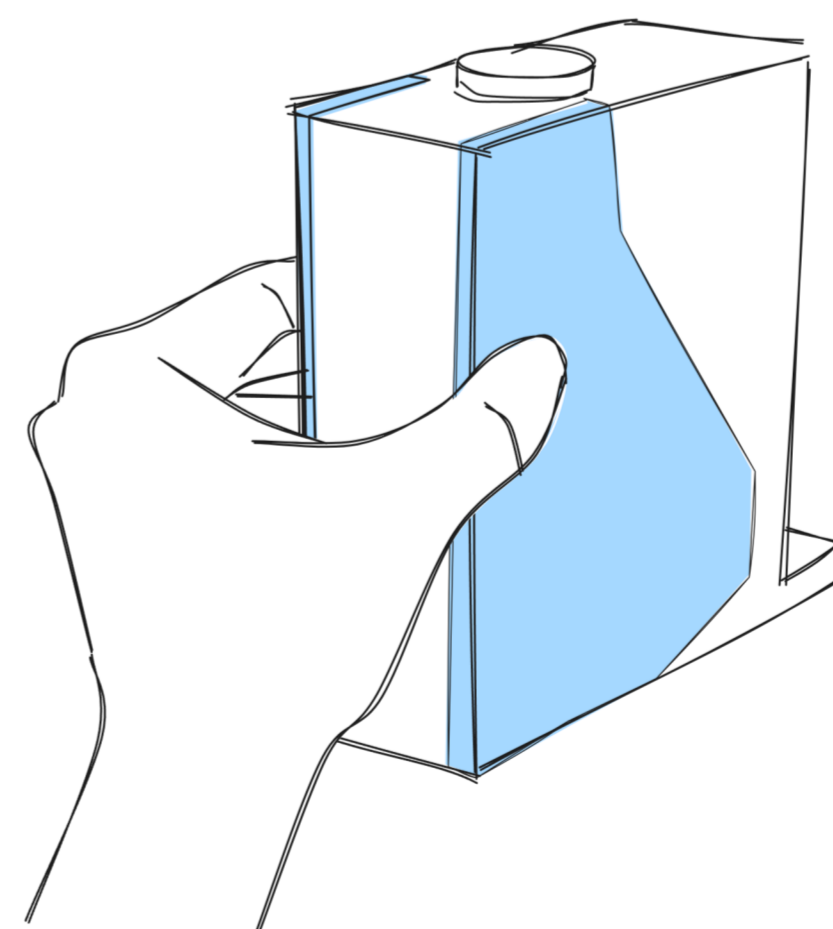
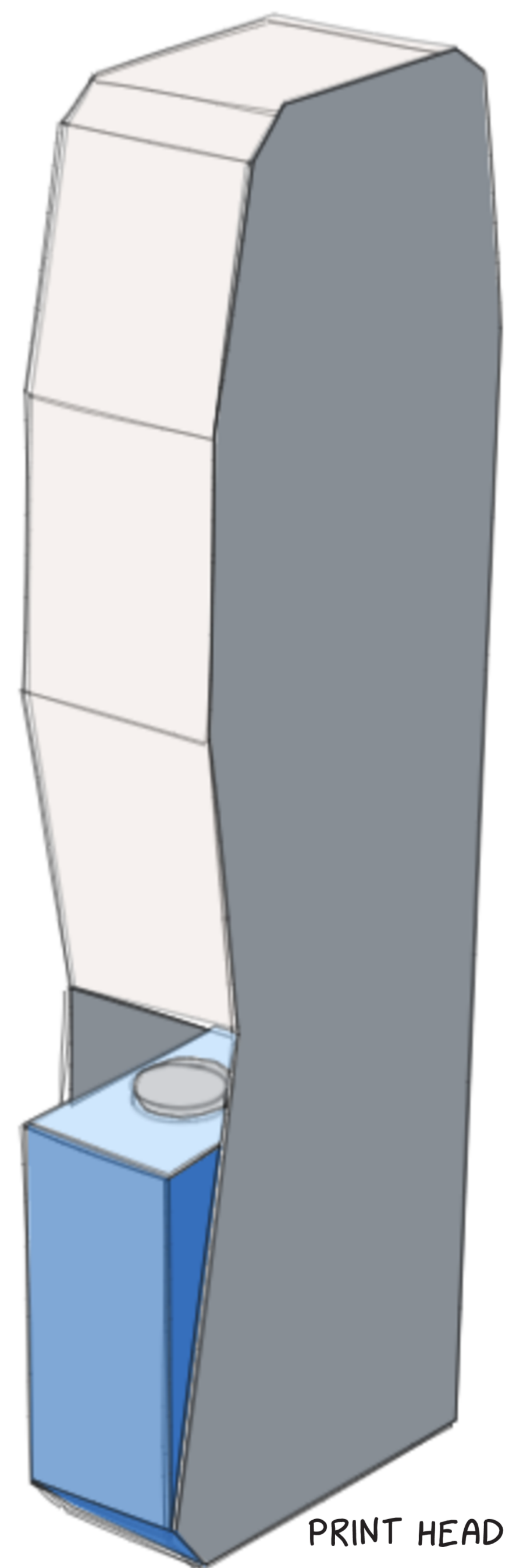

Rohan Sandeep Rege
Cartridge +
August 2024
Integrated Product Design (MVE-IPD)

Committee Dr.ir. A.J. Jansen - Chair
Dr.ir. V. Mishra - Mentor
Ir. T. Nijenhuis - Company Mentor
Company Doser B.V.

