

Realising a floating city

Appendix

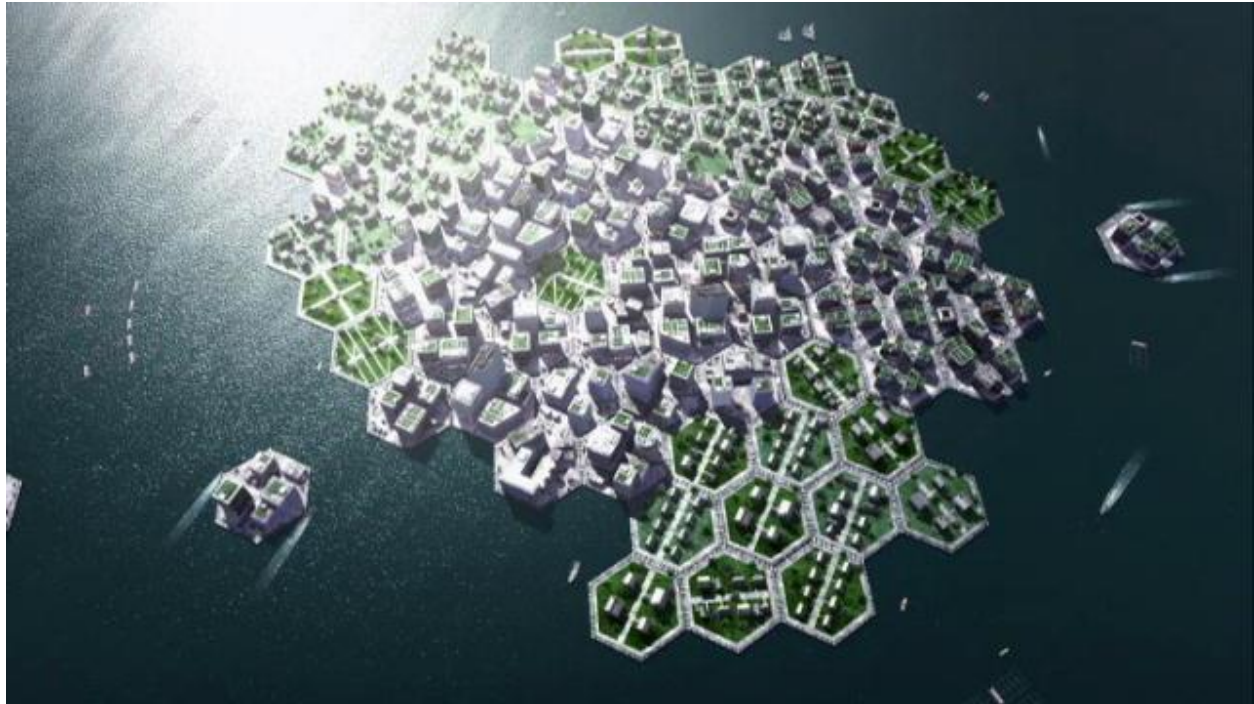

Source: <http://www.discovery.com/tv-shows/other-shows/videos/mega-engineering-floating-new-orleans/>

Date

30-06-2015

Author

K.K.M. Ko

Master program

Delft University of Technology
Civil Engineering and Geosciences,
Specialisation Hydraulic Structures

Graduation committee

Prof. Dr. Ir. S.N. Jonkman
Ir. W.F. Molenaar
Dr. Ir. P.C.J. Hoogenboom
Ir. K. Czapiewska

Delft University of Technology
Delft University of Technology
Delft University of Technology
Deltasync

Table of Contents

1	Appendix 1: Reference projects	2
2	Appendix 2: Types of floating structures.....	7
3	Appendix 3: Floating principles and mechanics	14
4	Appendix 4: Multi-criteria evaluation for platform design.....	21
5	Appendix 5: Load definition	25
6	Appendix 6: Static stability calculations	37
7	Appendix 7: Connection types	45
8	Appendix 8: Structural analysis.....	57

1 Appendix 1: Reference projects

An actual project of a floating city is not realised yet. But the floating city concept can be based on several other floating structure projects.

1.1 Offshore platforms

Offshore projects are extending to large water depths throughout the years, making the original offshore platforms which are founded on the sea bottom not feasible anymore. With large water depths, it is economic more beneficial to use floating structures. Floating structures are used in the offshore industry since 1970. Floating structures in the offshore industry are usually huge floating platforms or ship shaped platforms.



Figure 1: Thunder Horse PDQ¹

Thunder Horse PDQ

Type: Semi-submersible oil platform

Location: Mississippi Canyon

Year of completion: 2005

Cost: US\$ 5 billion

Owner: BP plc and ExxonMobil

Length: 136 m

Beam: 112 m

Draught: 30 m

Special note: World's largest offshore installation of its kind



Figure 2: Perdido²

Perdido

Type: Spar oil platform

Location: Gulf of Mexico

Year of completion: 2010

Cost: US\$ 3 billion

Owner: Shell

Water depth: 2.450 m

Special note: World's deepest floating oil platform

¹ http://en.wikipedia.org/wiki/Thunder_Horse_PDQ

² <http://www.shell.com/global/aboutshell/major-projects-2/perdido.html>

1.2 Floating houses and villages

Most of the people around the world live on firm land, but there is also a minority of people living on water at some places. Some folks are living on water for quite some centuries. Like in South-East Asia, people have lived on water for more than thousand years. Examples are the floating villages in Cambodia, Vietnam, Thailand, Indonesia and China. These floating villages consists of little wooden houses or tents made on a wooden platform to keep the house floating. The floating villages in Cambodia are to be found in the Siem Reap province, where it is inhabited by fishermen tribes.



Figure 3: Floating village in Cambodia ³

A new concept for floating houses originated in North America.⁴ The company International Marine Floatation Systems Inc. (IMFS) introduced a new technology of constructing real estate on water in the early 1980's. This floating system is based on a core of polystyrene foam (EPS, Expanded Poly Styrene) with a concrete shell around it. EPS is a light weight material which gives great floating capabilities. This floating system gives the possibility to build on water and results in less draught so it can even be used in more shallow waters. The development of this floating system contributed to the formation of large floating quarters in the cities Seattle and Vancouver.



Figure 4: Floating house made by IMFS in Seattle ⁵

³ http://en.wikipedia.org/wiki/Siem_Reap

⁴ <http://www.floatingstructures.com/>

⁵ <http://www.floatingstructures.com/gallery/floating-homes/rosenstock/>

1.3 Floating bridges and infrastructure

Floating bridges (or pontoon bridges) already exist since ancient times. In ancient China and the Greek-Roman era, pontoon bridges consisted of a row of small boats with wooden planks on top of the boats. These were temporarily pontoon bridges usually for military purposes. Permanent floating bridges nowadays are usually used for sheltered waters where it is considered economically less feasible to use a bridge with anchored piers. Floating bridges are compatible to be used for highways.

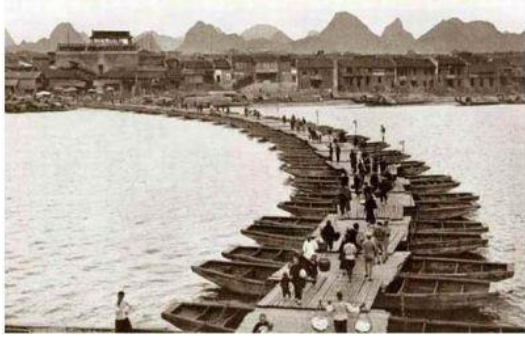

Figure 5: Ancient pontoon bridge made of small boats



Figure 6: Nordholland Bridge⁶



Figure 7: Homer M. Hadley Memorial Bridge (left) and Lacey V. Murrow Memorial Bridge (right)⁷

Nordholland Bridge

Type: Combined cable-stayed and pontoon bridge

Location: Hordaland, Norway

Year of completion: 1994

Cost: NOK 910 million (\approx US\$ 130 million)

Total length: 1.614 m

Height: 99 m

Longest span: 172 m

Clearance below: 32 m

Material: Concrete

Homer M. Hadley memorial Bridge

Location: Seattle, Washington

Year of completion: 1989

Total length: 1.771 m

Special note: World's 5th longest floating bridge

Lacey V. Murrow Memorial Bridge

Location: Seattle, Washington

Year of completion: 1940

Cost: US\$ 9 million

Total length: 2.020 m

Special note: World's 2nd longest floating bridge

⁶ http://en.wikipedia.org/wiki/Nordholland_Bridge

⁷ http://en.wikipedia.org/wiki/Homer_M._Hadley_Memorial_Bridge

1.4 Floating wave attenuators

Breakwaters are usually bottom founded and thus very large heavy structures. In cases of very deep waters, it is economically more feasible to apply floating breakwaters as floating breakwaters require less space and material. As the function of a breakwater is to dampen/absorb wave forces, it is quite difficult to design a floating breakwater because of dynamic responses due to wave actions. Floating breakwaters are attached to the seabed with mooring lines.



Figure 8: Pier extension floating breakwater in Monaco⁸

Pier extension floating breakwater in Monaco

Type: Floating caisson
Location: Port Hercule, Monaco
Year of completion: 2002
Cost: € 123 million
Total length: 352 m
Height: 19 m
Width: 28 m
Draught: 16 m
Water depth: 55 m
Material: Concrete

1.5 Floating utility structures

Very large floating structures are also used for other utilities and facilities like parking garages, emergency centres, airports, fire stations, restaurants etcetera.



Figure 9: Installation of a mega-float IT base⁹

Mega-float IT base

Type: Mega-float
Location: Kanagawa Yokosuka City, Japan
Year of completion: 2001
Total length: 200 m
Width: 100 m
Height: 2 m
Water depth: 4 m
Material: Concrete

⁸ <http://www.fdn-engineering.nl/#!/floating-breakwater-in-monaco/c1w36>

⁹ http://www.srcj.or.jp/html/megafloat_en/data/da_index.html



Figure 10: Floating airport runway¹⁰

Floating airport runway

Type: Modular mega-floats (4 large steel pontoons)
Location: Tokyo Bay, Japan
Year of completion: 2000
Total length: 1000 m
Width: 60 m
Height: 3 m
Material: Steel



Figure 11: Floating emergency rescue base¹⁰

Floating emergency rescue base

Type: Mega-float
Location: Tokyo Bay, Japan
Year of completion: 2003
Length: 80 m
Width: 24 m
Height: 4 m
Material: Steel

¹⁰ <http://www.eng.nus.edu.sg/core/Report%20200402.pdf>

2 Appendix 2: Types of floating structures

There are two types of floating structures suitable for a floating city, namely the semi-submersible-type and the pontoon-type. Semi-submersible-type structures are platforms raised above the water level using columns or structural elements. This way, the platform is protected against the severe wave environment. Semi-submersible-type structures are mainly used in the offshore industry.

Pontoon-type floating structures are structures that float in the water like vessels and without any fixed attachment to the sea bed. Basically just like ships constructed as large platforms. Pontoon-type floating structures are mostly suitable for use in calm waters, often inside a cove or a lagoon and near the shoreline. Large pontoon-type floating structures have been termed Mega-Floats by Japanese engineers (or Very Large Floating Structures 'VLFS' in general). As a general rule of thumb, Mega-Floats are floating structures with at least one of its length dimensions greater than 60 m. There are several advantages and disadvantages for pontoon-type structures compared to semi-submersible-type structures and land reclamation.

The advantages of pontoon-type structures are:

- Large dimensions
- The larger the structure is, the more stable it floats
- Easy to prefabricate and then towed to destination
- Cost effective when the water depth is large
- Environmental friendly as they do not damage the marine eco-system (directly), or silt-up deep harbours or disrupt the tidal/ocean currents
- Easily removed or expanded
- The facilities and structures on VLFS are protected from seismic shocks
- No suffer from differential settlement

The disadvantages are:

- Very vulnerable to wave actions
- Very vulnerable to currents
- Needs to be moored by a superstructure to prevent it from moving around
- Although large dimensions can be achieved, several floating structures are usually needed to create a floating city.
- Complicated connections between the floating structures

There are several methods to realise pontoon-type structures. Caissons are the standard pontoon-type structure. Other than caissons, pontoon-type structures consists of a platform made of concrete or lightweight material backed up by a floating mechanism. Examples are aircushion supported platforms and platforms based on a core of polystyrene foam (EPS, Expanded Poly Styrene) with a concrete shell around it.

2.1 Caissons

A caisson is in fact a large concrete box. In civil engineering a caisson could be defined as a retaining watertight case in order to keep out water during construction, but also for more permanent purposes. These caissons are always part of a larger structure, such as a breakwater, substructure or foundation. Most of the time, caissons are pre-fabricated and transported to their final position at a later moment in time. Caissons are able to float in water, although the structure is huge and heavy it still manages to float. The draught is usually very large. Due to the floating capability, caissons can be used as a floating platform. Since the twentieth century, concrete caissons are used as foundations for floating structures. In 1922 the concrete caisson made its introduction as foundation for a floating house and since then it is by far the most used foundation for floating structures. There are two main types of caissons distinguished in civil engineering: standard caissons and pneumatic caissons. In some literature also an 'open caisson' type is mentioned: more or less a standard caisson without a bottom plate.

The standard concrete caisson is a closed concrete box with concrete walls, bottom and top. Larger caissons have also got concrete inner walls. This has two reasons: decreasing the spans and partitioning for safety in case of leakage. The enclosed air compartments give the concrete caisson its buoyancy. The superstructure can be placed on top of the caisson, but the internal space can also be used just like an underground facility. The concrete caisson with its thick bottom and walls results in a rather massive system, this results in high self-weight, which is beneficial for weight stability, but results in a large draught and small buoyant capacity, which strongly limits the weight of the superstructure. The standard caisson is by far the most used floating foundation for floating houses and floating utility buildings.

Advantages:

- Many experience in the development of the structure
- Large weight stability
- Internal space available
- Relatively cheap
- High durability/low maintenance

Disadvantages:

- Little buoyant capacity
- Large draught
- Sinkable

The difference between the standard caisson and the pneumatic caisson is that the pneumatic concrete has no bottom section. The buoyancy must come from the enclosed air between water and concrete top. Usually the air pressure is enlarged by high pressure air pumps. Airtightness is very important as this system will fail if the enclosed air can escape. This floating system is in fact not very suitable as floating body for floating structures, since it has very low buoyancy and it is a somewhat risky system. But a useful combination of this construction type with some other lightweight floating material could improve this system by a lot.

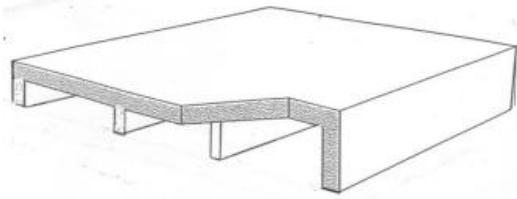

Figure 12: Pneumatic caisson

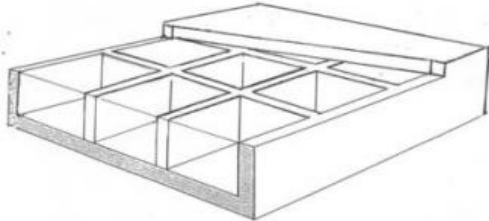

Figure 13: Standard caisson

2.2 Floating structures made from concrete and EPS

In the early 1980's International Marine Floatation Systems Inc. (IMF) introduced a new technology of constructing real estate on water by making use of the very light polystyrene foam (EPS, expanded polystyrene). The big advantage of this system is that no expensive dock or assembly hall is needed; it can be constructed on the open water where the structure finally belongs. This system is based on a core of EPS and a concrete shell. The system thanks it is buoyancy on the EPS, with a density of only 20 kg/m^3 , which is 50 times lighter than water. The concrete has a purpose for strength, stiffness and protection of the EPS. The IMF system made construction on water possible. When the construction is finished using this method, it results in a reversed concrete tray which is in fact a pneumatic caisson, but now the space is filled with EPS instead of air or aircushions. The structure becomes unsinkable, because there are no possibilities of water accumulation while the spaces in the structure are filled with EPS.

The EPS-concrete system gives a much lighter structure than the standard caisson system because far less concrete is needed. This is because the EPS system does not need a concrete floor, unlike the standard caisson system. On top of this, the walls can be made thinner too, because an eventual leakage will not result in water accumulation and sinking of the structure. The EPS supports the deck directly, so the deck can also be thinner. By the direct support of EPS, less beams or inner walls will be needed for strength purposes. Because the EPS acts as an elastic foundation, all the loads are distributed and transferred directly to the concrete shell. While in case of caissons, the loads are distributed via inner walls or columns and the floor has to be sufficient thick to handle the stresses. The difference of this load distribution is sketched in Figure 15. Due to these savings on concrete, a low self-weight and draught is achieved. However, a low self-weight and draught also contributes to a less stable system compared to the caisson. Another note, EPS has not such great strength capabilities as concrete. So when used in a heavy environment with a lot of waves and external loads, more concrete is needed to back up the structural strength of the structure. A more functional drawback of this system is the inaccessibility of the floating body. Because the floating body is filled with EPS, there is no space left for installations, pipes, 'underground' (storage) area etc. To accommodate these facilities, the superstructures have to be constructed higher than the ground level of the floating platform. This leads to an even higher cost for the realization of this floating system.

Advantages:

- Unsinkable
- Low self-weight, high buoyant capacity
- Small draught
- High durability/low maintenance
- Construction on water possible
- Different shapes relative easy possible
- works insulating

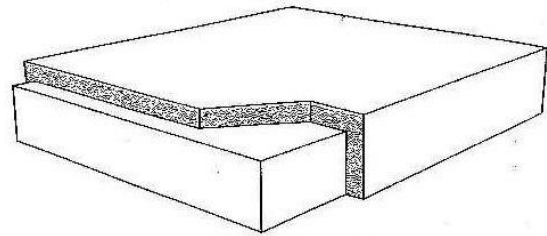

Figure 14: EPS floating body with a concrete shell

Disadvantages:

- No internal space
- Less stable compared with caissons
- Lack of structural strength
- Expensive material

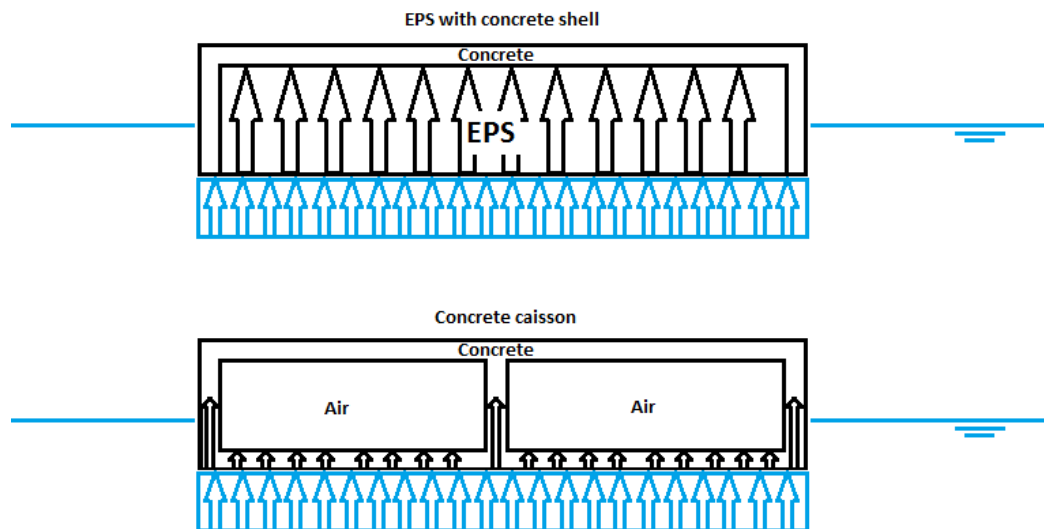

Figure 15: Load distribution of caissons with and without EPS

As mentioned that the EPS floating body with a concrete shell lacks structural strength, some new forms of this system are developed. One of the new applications of EPS with concrete is to make a concrete skeleton to increase the stiffness of the floating structure, while the compartments are filled with EPS for maximum floating capability. The cubes of EPS can be made in such a form, that they also function as a mold for the concrete skeleton. An impression of such a system is illustrated in Figure 16. With the adding of more concrete, this system is slightly heavier than the original concept. The ratio of concrete and EPS can be further increased by using concrete inner walls instead of just a skeleton framework. The use of EPS is already expensive, but with the adding of more concrete and more complicated construction methods, these systems are maybe not very economical feasible.

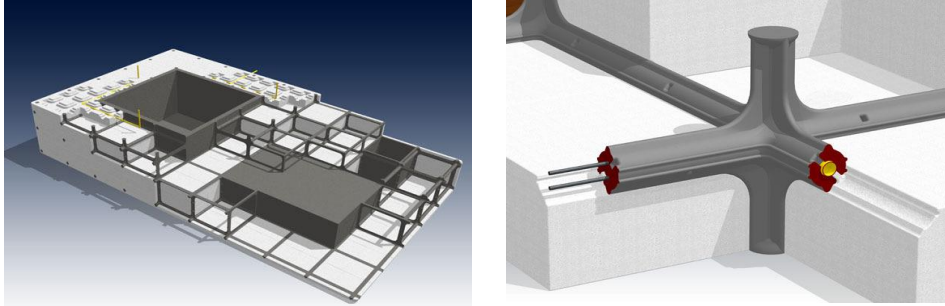

Figure 16: EPS floating system with a concrete framework (Koekoek, 2010)

2.3 Floating steel structures

Steel is the most used material in offshore industry. Floating bodies made of steel can have any shape. Rectangular steel pontoons or other shapes are possible, like steel tubes welded to each other.

Steel floating bodies can have small wall thicknesses, which results in a small self-weight, which gives high buoyancy. But this also results in small weight stability, but this can be simply counteracted by adding ballast weight. The big disadvantage of steel is that it is susceptible to corrosion, so it needs a lot of maintenance. The reason why steel structures are only temporarily is because the long term effects of the aggressive environment will cause rapid and severe corrosion to the structure.

Advantages:

- Many experience in the development of the structure
- Internal space available
- Low self-weight, high buoyant capacity
- Small draught
- Different shapes easily possible to construct

Disadvantages:

- High maintenance needed
- Relative expensive
- Poor weight stability
- Sinkable
- No insulation



Figure 17: House on floating steel tubes ¹¹

¹¹ http://archrecord.construction.com/innovation/1_TechBriefs/0310Watervilla.asp

Another use of steel for floating structures is illustrated in Figure 18. This system is just like the EPS floating body with a concrete shell. The difference is that the floating body is now replaced by hollow steel cylinders. The air locked in the steel cylinders functions as dampers for wave-action or water level rise. The water movement ensure that the air is put into motion and not the platform itself. The cylinders are in open connection with each other on the upper side. In this way, the air travels through the whole system. However, this is not really a system that is only possible with steel. The main focus of this system is the use of hollow cylinders to ensure the floating and stability of the structure. These hollow cylinders can also be made from other materials, which is actually more likely because of the vulnerability of steel in aggressive wet environment.

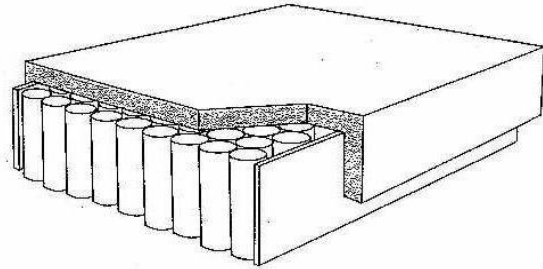

Figure 18: Concrete shell with hollow steel cylinders

2.4 Aircushion supported platforms

For floating there can be made use of air cushions. Generally these air cushions will be made of plastics. The great advantage of air cushions is their flexible buoyancy. Aircushions are flexible in the means that the air in the cushion can be precisely controlled to give the preferred floating capability in different situations. Like when the floating structure is tilting, the aircushions on the tilting side can be filled up with more air to get the structure back in initial equilibrium. The disadvantage is the lack of having an own shape make them less reliable, and the risk of leakage is also higher with cushion systems and the consequences will be more critical. Aircushion supported platforms are in fact pneumatic caissons but with the use of air cushions to provide the extra floating capability.

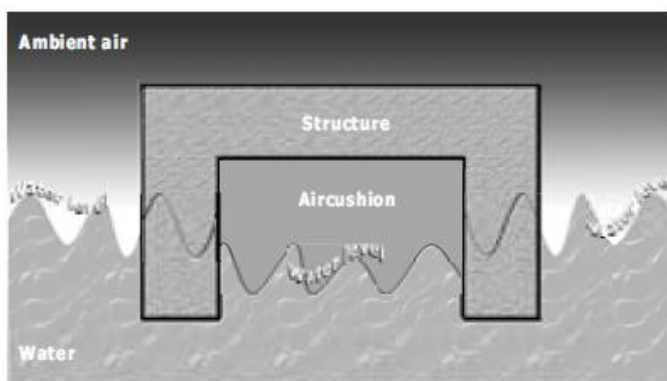

Figure 19: Aircushion supported platform (Kessel, 2010)

It is proved that aircushions work reliably as supporting structures. Often aircushion pontoons are used to stabilize the floating process of other floating structures, like when caissons are being towed to their destination. Research is done for floating structures which rely solely on aircushions (Kessel, 2010). The outcome is that aircushions are more suitable as supporting elements to stabilize the floating structure when subjected to waves.

2.5 Semi-submersible structures

Semi-submersible-type structures are platforms raised above the water level using columns or structural elements. This way, the platform is protected against the severe wave environment. Semi-submersible-type structures are mainly used in the offshore industry. A semi-submersible structure is in the offshore industry often a MODU (Mobile Offshore Drilling Unit) designed with a platform-type deck which contains equipment for drilling purposes and other machinery supported by pontoon-type columns that are submerged into the water. The design concept of partially submerging the rig lessens the rolling and pitching movements of the structure because the structures have good stability and sea keeping characteristics. There are two main types of semi-submersibles, based on the way the rig is submerged in the water: bottle-type and column-stabilized semi-submersibles.

Bottle-type semi-submersibles consist of bottle-shaped hulls below the platform which can be submerged by filling the hulls with water, see Figure 20. Originally, this type of semi-submersible structure was submersible. The bottles were then fully submerged till they reached the ocean floor. But later on, engineers realized that the rig would maintain its stabilization even if the bottles were partially submerged. This way, the rig could go into deeper waters because it didn't need to rely on the ocean floor anymore. Although, mooring lines are now needed to keep the semi-submersible structure in its place. The column-stabilized semi-submersible design is derived from the bottle-type semi-submersible structure. The column-stabilized semi-submersible structure consists of a platform with two horizontal hulls connected via cylindrical or rectangular columns, see Figure 21. Submerging this type of structure is achieved by partially filling the horizontal hulls with water until the rig has submerged to the desired depth. Mooring lines are also needed to keep this type of semi-submersible structure in its place.



Figure 20: Ship transporting a bottle-type semi-submersible ¹²



Figure 21: Column-stabilized semi-submersible structure ¹³

¹² www.oil-electric.com

¹³ http://www.rigzone.com/training/insight.asp?insight_id=338&c_id=24

3 Appendix 3: Floating principles and mechanics

How does a structure made from heavy construction material float? The most important element which causes structures to float is the buoyancy. Buoyancy is a simple principle which is described by the principle of Archimedes. The buoyant force combined with the weight of the structure defines the draught and the freeboard of the structure. If the structure is able to float, then it still has to be checked on stability and tilt/rotation. A wide body with a small draught gives the best static stability. By enlarging the width and length, the stability of the structure increases.

3.1 Buoyancy

Vertical forces establish equilibrium if the buoyant force (upward force) equals the weight of the floating body (downward force). This buoyant force has the same magnitude as the weight of the displaced volume of fluid (Archimedes' principle: a floating body displaces its own weight of fluid):

$$F_A = \rho * g * V$$

With: F_A = Buoyant force/Archimedes force
 ρ = Density of fluid
 g = Acceleration due to gravity
 V = Volume of displaced fluid

A vertical equilibrium is usually reached if the element is floating. A vertical equilibrium is also reached if the element is resting on the bottom of the water body. If there is no equilibrium of forces, a completely immersed element will move upward or downward until an equilibrium state is reached. An element will move upward if the buoyancy is more than the total weight of the buoyant force. When this buoyant force equals the weight of the element, it then stops moving upward (the element is floating). On the other hand, an element will sink if the weight of the element exceeds the buoyant force. The bottom will resist the downward directed force and will stop the element from moving down. This equilibrium principle (Archimedes' principle) is shown in Figure 22. Simplified, it states that there is equilibrium of forces when the buoyant force (F_A) is equal to the weight of the element (F_G). Archimedes' principle can be formulated as follows: Apparent immersed weight = weight – weight of displaced fluid.

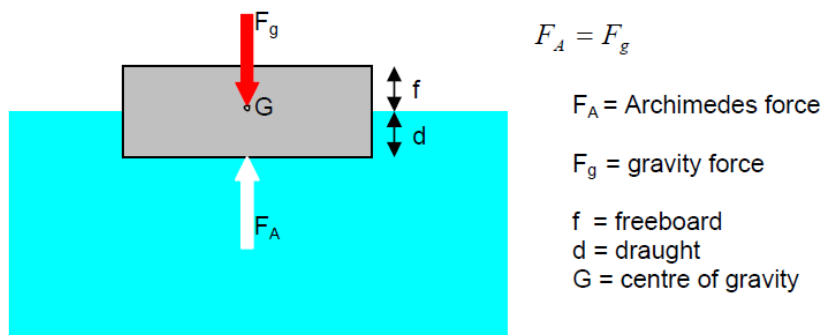

Figure 22: Buoyancy force

3.2 Draught and freeboard

The draught of a floating structure is its depth in the water. In case of a floating body with a flat and level bottom plane and vertical walls the draught is equal as the depth of its bottom plane. In case of tilt, the term draught is used both for the average depth of the bottom of the structure, as well as for the largest depth of the floating body. Of course, common sense is that the structure is floating if the draught is less than the height of the structure. So it is convenient to keep the draught small to prevent the structure from sinking. However, a larger draught also means more stability.

The part of a floating body that is above the water surface is called the freeboard. In other words, the freeboard is the height of the floating body minus the draught. A convenient requirement for the freeboard is that the freeboard is larger than the mean wave height. With a sufficient large freeboard, waves won't collapse on the surface of the floating structure. See Figure 22 which indicates the draught and the freeboard.

3.3 Rotation/tilt

Rotation is a circular movement of the floating body, causing the floating body to tilt to one side. Rotation occurs when an eccentric load (be it a horizontal or vertical load) or a moment is acting on a floating body. The eccentric load or moment causes a displacement on one side of the structure which leads to an opposite displacement on the other side of the structure, given the structure is (infinite) stiff. One side of the floating structure will get a larger draught and the opposite side will get more freeboard. In other words, one side of the floating structure will get deeper into the water and the opposite side will rise out of the water.

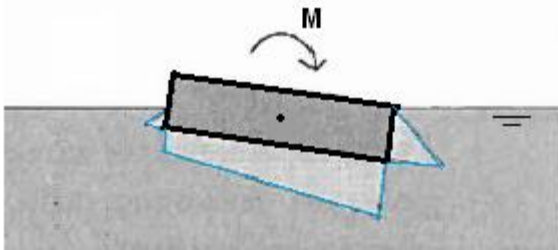

Figure 23: Water pressures on a floating body caused by rotation

As it is stated with the principle of Archimedes, the buoyant force increases as more volume is displaced. The part of the structure with a larger draught has more water pressure (see Figure 23) and thus a higher buoyant force, causing a counteracting moment to offset the tilt. This counteracting moment can bring the floating body in equilibrium again.

Rotation/tilt is caused by eccentric loads or moments acting on the floating body. These loads vary from permanent loads caused by heavy structures to dynamic loads caused by wind and waves. The tilt caused by heavy structures (on one side, thus eccentric) can be countered with ballast or another heavy structure on the opposite side of the floating body. Another solution to counter the tilt caused by heavy structures is to change the shape of the floating body such that the buoyant force is bigger on the side of the heavy structure. This can be done by increasing the draught. It is a lot more difficult to counteract the tilt caused by wind and waves. As these loads come from all directions, there is no such a solution as to use ballast or a larger draught to offset the tilt. These loads are dynamic and variable, so the solution must also be flexible and adaptive to the situation. In case of using ballast, the ballast has to be movable to adjust to the side which is tilting. This can be done with ballast tanks or water cellars for example. In case of

increasing the buoyancy, the buoyancy under the floating body must be adjustable to the amount of tilt caused. Buoyancy can be adjusted by air cushions for example. It is best to have zero rotation/tilt to achieve maximum comfortable living on top of the floating structure. But such movements cannot always be prevented, so the requirement is to have minimum rotation/tilt as possible. A reasonable requirement is that the floating structure must maintain an obliquity of 1% or less. An obliquity of 1% means that the tilted deflection is 1% of the length of the structure in the direction it is tilting.

3.4 Static stability

When the loads or moments causing the mentioned rotation and tilt are taken away and the floating body manages to return to its original position due to the buoyant force, the floating body is stable. Stability is the behaviour of when a body in equilibrium is brought out of its initial equilibrium. There are three possibilities of stability:

- The body is called stable when it returns to its initial equilibrium position.
- The body is called unstable when it won't return to its initial equilibrium position and in worse case; the body keeps drifting further away from the initial equilibrium position.
- The body is called neutrally stable when it manages to find a new equilibrium position.

These three possibilities of stability are sketched in Figure 24. On the left, the ball is unstable as it rolls off the hill as soon as you bring it out of its initial position. In the middle, the ball is stable as it always rolls back to its initial position. On the right, the ball is neutrally stable as it will find a new equilibrium position once it stops rolling.

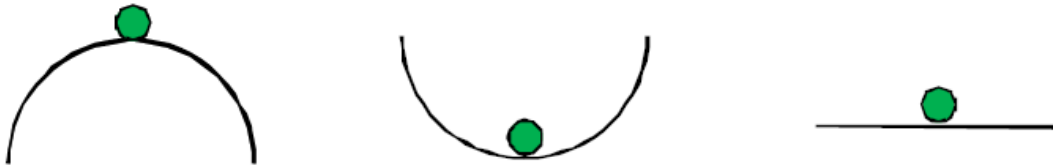

Figure 24: Principle of stability

Stability is thus very important for floating structures. When a floating structure is not stable (unstable), the body will tilt and in worse case capsize and ultimately sink. A neutrally stable floating structure occurs when there is tilt, but the body stays in this tilting equilibrium. Technically seen, this is okay as the structure is still stable. But it causes discomfort for the facilities and people on top of the floating structure. So this indicates that a floating structure must be perfectly stable and not otherwise. Even in the case of a stable floating structure, the mechanism of returning to the initial equilibrium may not occur too frequently. For example, a rocking ship will cause seasickness to the passengers on board. In case of a floating city, the citizens will live uncomfortable when the floating structure keeps getting out of and back to the initial equilibrium. This can be interpreted as 'sensitivity to tilting'.

3.4.1 Metacentric height

A measure of the resistance to tilting is given by the 'metacentric height'. The cross-section of a floating element to illustrate the metacentric height is seen in Figure 25.

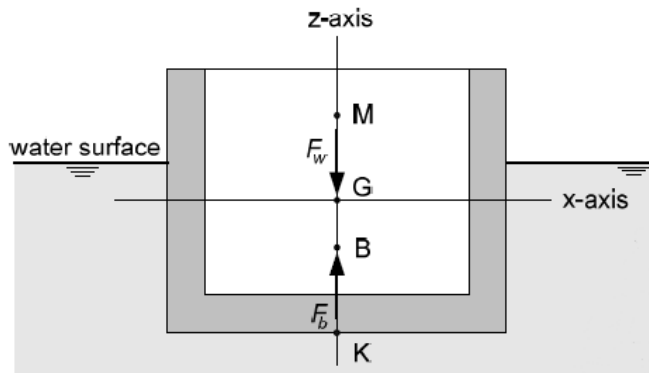

Figure 25: Stability of a floating element

Point B indicates the centre of buoyancy. This is the point where the buoyant force (F_b) is applied. In other words, it is the centre of gravity of the displaced water. Point B is found halfway between the water surface and the bottom of the floating element (in case the floating element is rectangular shaped). Point G indicates the centre of gravity of the floating element and at the same time as the rotation point. Point M indicates the metacentre of the floating element. This is the point of intersection of the axis of symmetry, the z-axis and the action line of the buoyant force.

The distance of point G to point M (the line segment GM) is called the metacentric height. If the metacentric height is positive, it indicates that the floating element is stable. The larger the metacentric height is, the more stable the structure is. To achieve a large metacentric height, the point of gravity should be as low as possible and the metacentre should be as high as possible. A low centre of gravity suggests good weight stability and a high metacentre suggest good shape stability. The meaning of good shape stability lies in the shifting of the centre of buoyancy (point B) in case the floating element rotates. Theoretically, if the metacentric height is larger than 0, the body is stable. The floating body is unstable if the metacentric height becomes smaller than 0. In practice, a metacentric height larger than 0.50 m is recommended.

3.4.2 Shape stability

The base of shape stability lies in the shifting of the centre of buoyancy, when the structure rotates. The more the centre of buoyancy shifts and can shift with a certain rotation, the higher the metacentre will be, so the more stable the floating structure will be. A rectangular floating body is more stable than other shapes like cylinders or triangular shapes. This is because when a floating element rotates, a rectangular shaped body displaces the most water. A study about the shape of floating elements can be found in the thesis 'How high can you float' (Winkelen, 2007). From this study, it is concluded that the width to depth ratio is decisive for the shape of floating elements. By enlarging the width of the structure, the stability increases a lot. This means that a wide body with a small draught gives the best stability in general. A problem arises when the draught is relatively large, for example in case of a high-rise building on the floating body. The centre of gravity of the floating body will move up, resulting in a smaller metacentric height for the floating body, see Figure 26 (note that the metacentric height of the most right structure is negative since the point of gravity lies higher than the point of metacentre, resulting in an unstable situation). But when the floating body is given a large enough width, the point of metacentre will move up which results in a larger metacentric height, see Figure 27.

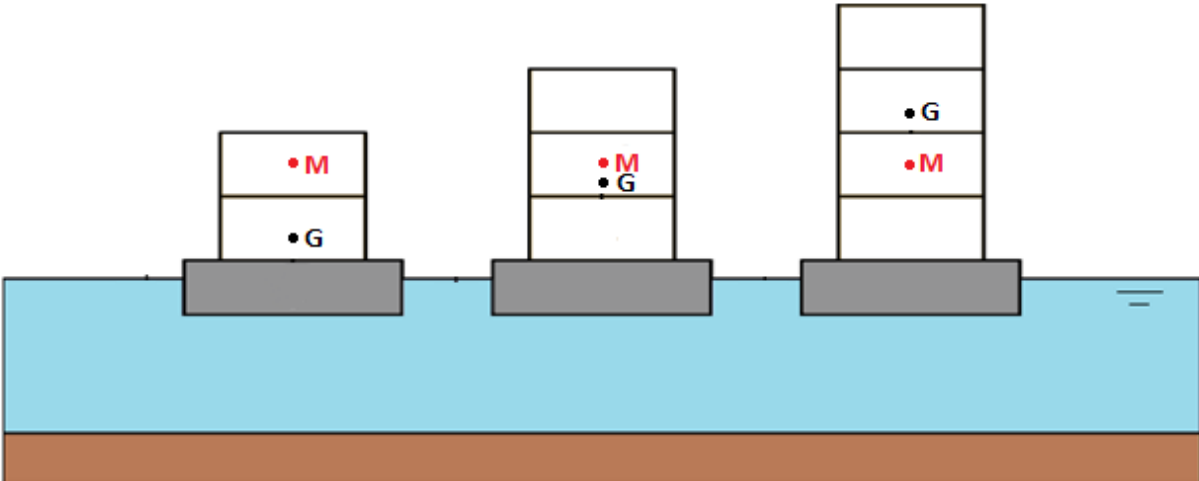

Figure 26: Metacentric height of high-rise floating structure

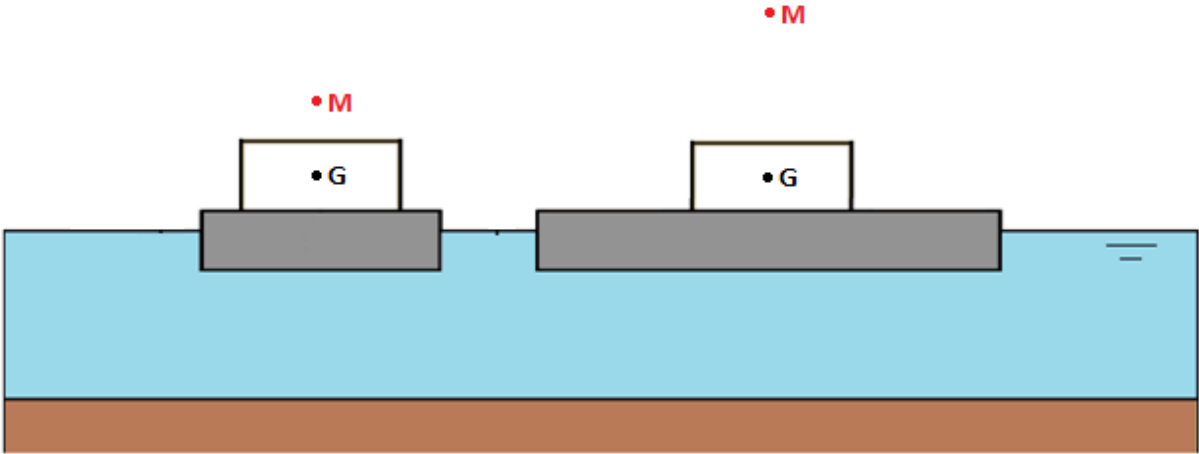

Figure 27: Metacentric height with wider floating element

3.5 Dynamic stability

Static stability concludes the stability when the floating element is subjected by static loads like the deadweight of a building. It was mentioned that rotation/tilt also occurs when the floating element is subjected by wind and wave loads. These loads are however not static, but dynamic. These dynamic loads cause the floating element to constant move around or rotate. Each movement or rotation has its own definition, see Figure 28:

Translations

- Surge; movement in x-direction
- Sway; movement in y-direction
- Heave; movement in z-direction

Rotations

- Roll; rotation around x-axis
- Pitch; rotation around y-axis
- Yaw; rotation around z-axis

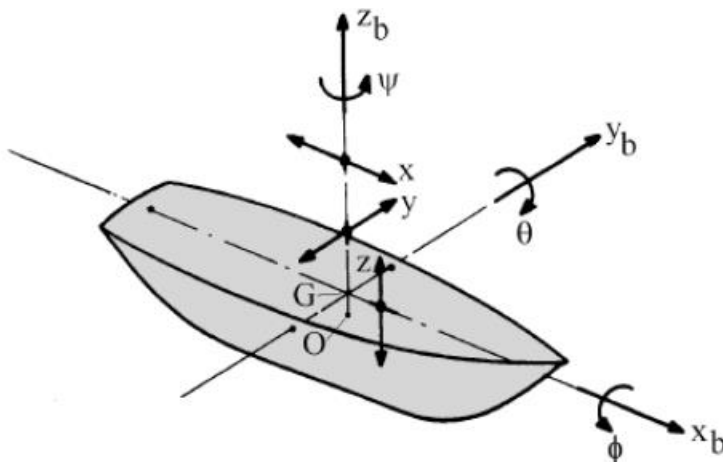

Figure 28: Movements and rotations of a floating element (CT3330 lecture notes)

3.5.1 Surge and sway

Surge and sway (the translations in x- and y-direction) will mostly not be a huge problem as these translations can be more or less prevented by moorings. When a floating element is moored by a stiff mooring structure, the surge and sway is even not noticeable. When the floating element is moored by tension cables, then the surge and sway effects are only significantly minimized. The real objective of tension cable moorings (or moorings in general) is to keep the surge and sway to a minimum and to keep the floating element in place without drifting away. If the dimensions (length or width) of a floating element are too small compared to the length of the waves or swell, the element will start swaying on the waves. In practice, the following rule of thumb is being used (dependent on the direction of the wave or swell): $L_{wave} < 0.7 * L_{element}$; $L_{wave} < 0.7 * W_{element}$

Where L_{wave} = wave length

$L_{element}$ = length of element

$W_{element}$ = width of element

3.5.2 Heave

Heave is the vertical motion of a floating element. Floating structures follow the height change of the water level. So tides and (swell) waves put a floating structure in vertical motion, also called heave oscillation. This vertical motion can't be prevented by means of mooring structures, as the water is the foundation for the floating element. The advantage of the vertical motion in conjuncture with the water level is that there will be no problems with sea level rise. This was one of the reasons to go for floating houses/city. Problems arise when the heave turns into roll or pitch movements.

3.5.3 Roll and pitch

Roll and pitch are in fact the same, the difference is that pitch is rotating in the longest direction and roll is rotating in the less wide direction. If a floating element has a static rotation, this is called tilt. Tilt can be caused by static eccentric loads or moments. The same as with tilting, it is convenient to minimise the deflections cause by roll and pitch to an obliquity of 1%.

3.5.4 Dynamic oscillation

Worse than just swaying on the waves or swell is the movement of a floating element if the period of the water movement comes close to the natural oscillation period of the floating element. This will cause increasing sway/roll/pitch and large movements. To prevent this, the natural oscillation period of the floating element must be larger than the oscillation period of the waves/swell. The natural oscillation period of a floating element can be calculated by using the metacentric height. The metacentric height is in turn dependent on the width/length of the floating element.

$$\text{Natural oscillation period } T_0 = \frac{2\pi * j}{\sqrt{h_m * g}}$$

$$\text{Polar inertia radius } j = \sqrt{\frac{I_{polar}}{A}} \quad , A \text{ is the area of concrete in a vertical cross-section}$$

$$\text{Polar moment of inertia } I_{polar} = I_{xx} + I_{zz} \quad , I_{xx} \text{ is polar moment of inertia around the z-axis}$$

I_{zz} is polar moment of inertia around the x-axis

4 Appendix 4: Multi-criteria evaluation for platform design

To choose the most suitable design, a few criteria must be concluded which the designs should fulfil. Each criteria has an own value of importance for the design, this is implemented in a weight factor for the criterion. And so, each design will be given a score for each criteria and the design with the highest score will be chosen. This method is also known as the multi-criteria evaluation.

The score given for each criterion is in the range of 1 till 5, where a score of 1 contributes to bad quality concerning the criterion and a score of 5 contributes to a very good quality concerning the criterion. The weight factor for each criterion is in the range of 1 to 4.

4.1 MCE criteria

The following criteria are used in the multi-criteria evaluation to choose a suitable design:

- Sea keeping
- Number of connections needed
- Number of different platforms needed
- Efficient space usage
- Growth
- Circular layouts
- Dynamic geography
- Water experience

Sea keeping

Sea keeping is referred to the ability to keep the floating community suitable to live on. Suitable means that it has to be safe and comfortable to live on the floating structures. The floating community has to be able to adapt for survival on high seas and extreme conditions should such phenomena's take place. To an extent, the sea keeping is coupled with the safety, so that is why a weight factor of 4 is given to this criterion. A score of 1 would indicate that the platforms in the design have poor stability and a score of 5 would indicate that the platforms in the design have a very good stability.

Growth

The term 'growth' is quite self-explanatory and it is about the possibilities for the floating community to grow into a larger community. Different forms, sizes and configurations of the individual platforms lead to different growth formations and possibilities. A score of 1 is given if the floating community is difficult to expand and a score of 5 is given if the floating community is easy to expand. The floating community must start on a small scale and steadily grow into a floating community worthwhile to be called a city. A weight factor of 3 is given as the possibility of growth is necessary.

Circular layouts

The configuration of the platforms should enable circular layouts in order to efficiently fit behind a breakwater structure if ever needed. A circle has the shortest perimeter for a given area. A breakwater structure contributes to the safety of the floating community, so a weight factor of 3 is given to this criterion. A score of 5 is given to configurations which easily enable circular layouts and a lower score would indicate that the platform is more difficulty to be constructed in a circular layout.

Number of connections needed

The connections between individual platforms to form a larger floating community are quite expensive and difficult to design. To reduce the complexity and costs of the concept, it is convenient to use as less as possible connections. A score of 1 is given if the configuration of the floating community requires a lot of connections and a score of 5 is given if the configuration of the floating community requires fewer connections. As said, the number of connections directly contributes to the complexity and costs of the floating community. Thus a weight factor of 3 is given to this criterion.

Number of different platforms needed

For production purposes, the individual floating structures should be uniform shaped to keep down the construction costs. Repetition of an element offers an increasing learning cycle in the construction and thus to a lowering of the required man-hours. Uniform shapes also simplify the configuration possibilities. The form of the platform should be easy to construct. A platform is convenient and quick to construct if it has no ordinary curves or angles. A score of 5 is given if a design is able to use just one kind of floating platform and a lower score would indicate that the design requires different platform forms. Again, the uniformity of the platforms contributes directly to the complexity and costs of the floating community. Thus a weighting factor of 2 is given to this criterion (slightly less important than the number of connections needed because the costs of the connections are much higher).

Efficient space usage

The area available on top of the platform should be efficiently used. The prices per square meter are very expensive because the platform itself will be very expensive. So spacing should not be wasted as it would be cost ineffective. The value of the platform would decrease if the shape of the platform allows a lot of wasted spacing. This criterion has an indirect effect on the cost and value of the platform, so a weight factor of 2 is given to this criterion. A score of 5 is given if the space on the platform can be efficiently used and a lower score would indicate that the platform is less efficient in the spacing.

Dynamic geography

The dynamic geography refers to the freedom of moving inside the floating community with one's own house as an individual, or even moving away from the community with a group of inhabitants. This dynamic geography can be achieved by different types of configurations. A score of 1 would indicate that the platforms in the design have poor freedom of manoeuvrability and a score of 5 would indicate that the platforms in the design have a very good freedom of manoeuvrability. Compared to the other criteria, the dynamic geography is less important and thus a weight factor of 1 is given to it. The dynamic geography is less important because it concerns the comfort ability of the inhabitants and not the functionality of the platform.

Water experience

The experience of the water in a floating community can be subdivided into two categories: visual and physical experience. The water experience is more to give the feeling and image of living on water. This has very little to do with the functionality of the platforms, so a weight factor of 1 is given to this criterion. It is difficult to give a score to this criterion because there is no such argument as good or bad water experience. It is more about the balance of the space for water and the space available to live on (the platforms). When the platform shape allows a lot of houses to be built at the water side, a score of 5 will be given and a lower score is given if less building can be built at the water side.

4.2 MCE grading

The multi-criteria evaluation is taken for the designs in figure 39, 40 and 42. In short, the multi-criteria evaluation is based on the different shapes (square, pentagon and hexagon shape) of the individual platforms. First the explanation for the given scores in the MCE is discussed.

Sea keeping: The symmetry of the platform also contributes to the sea keeping. The pentagon shaped platform needs to carefully consider its (asymmetric) loads to keep its sea keeping ability. While the square and hexagonal shaped platforms are easier to keep the balance by just equalling the loads around the symmetry axis. The pentagon shaped platform has one symmetry axis, which is why a score of 3 is given. The square and hexagon shaped platforms have multiple symmetry axis's to balance the loads.

Growth: The design with the square shaped platforms is very straightforward and the growth of this floating community is simply achieved by adding more platforms in all ways possible. The other two designs achieve growth by adding (complex) clusters of platforms, so growth is very dependent on the layout of the floating community.

Circular layouts: The pentagon shaped platforms achieve a smoother curved circular layout than with the hexagon shaped platforms. This is because the pentagon shaped platforms have a larger interacting angle with other platforms. It is self-explanatory that square shaped platforms are not good for circular layouts.

Number of connections: When looking at the number of connections in each design, it can be thought that the more sides the platform has, the more connections there are needed. But this is not all; the number of connections depends also on the angle of two interacting platforms. Square shaped platforms need 3 platforms to achieve a 90 degrees 'curve' and 5 platforms to achieve a centre with 4 different directions. The connections in the design with pentagon shaped platforms are very dependent on the layout, so it is not always the design with the least or the most connections. The hexagonal shaped platform uses a maximum of 4 sides to connect to other platforms. When more sides of a hexagon are connected to each other, then a composite type configuration would be realised which is not favourable.

Different platforms needed: It is clear that the design with the pentagon shaped platforms can only be realised with other platform shapes. The square and hexagon shaped platform can also be used in combination with other platform shapes, but it is not mandatory.

Efficient space usage: The space usage on a square shaped platform is maximised. Houses and buildings are always more or less square shaped, so they fit really well on a square shaped platform. The more corners or wider/smaller angles a platform has, the less efficient space usage is. Not much can be built on the corners of the pentagon and hexagon shaped platforms. The score for each shape decreases with increasing corners.

Dynamic geography: Regarding the dynamic geography, the pentagon shaped platform has scored the worst because the shape allows only certain formations with other platforms. So it is quite difficult to freely adjust the configuration of the platforms to each individual. On the other hand, the square and hexagonal shaped platforms are symmetric from all sides, so it is easier to configure the floating community in different ways without worrying about whether the platforms are going to fit to each other.

Water experience: The more sides the platform has, the more sides there is to build houses near the water. The score given to each shape increases with the amount of sides the shape has.

Table 1 presents the MCE and the result is that the hexagonal shaped platforms are the most suitable option.

	Weight factor	Square shape		Pentagon shape		Hexagon shape	
Sea keeping	4	5	20	3	12	5	20
Growth	3	5	15	3	9	3	9
Circular layouts	3	1	3	5	15	4	12
Number of connections	3	1	3	4	12	3	9
Different platforms needed	2	5	10	1	2	5	10
Efficient space usage	2	5	10	4	8	3	6
Dynamic geography	1	5	5	1	1	5	5
Water experience	1	3	3	4	4	5	5
Total score			69		63		76

Table 1: MCE

5 Appendix 5: Load definition

The possible loads acting on the floating platform are divided into dead and live loads. Dead loads are loads which won't change (very much) over time and live loads are loads which change under different circumstances.

The dead load of the floating city consists of the following loads:

- Dead weight platform
- Dead weight super structure

The live load of the floating city consists of the following loads:

- Load of the inhabitants
- Storage load
- Traffic load
- Wave load
- Wind load
- Current load

5.1 Dead load

The floating structure itself has a certain dead load to begin with. The weight of the floating structure determines the draught of the structure and thus the floating capability. Dead load on top of the floating structure includes loads from buildings, facilities and infrastructure. More weights on top of the floating structure results in a larger draught. Also, these static loads need to be well distributed to prevent rotation and tilt of the floating structure. The dead weight of the platform and the super structures are dependent on the design of the floating city.

5.1.1 Dead weight platform

The dead weight of the platform depends on the amount of material that is used to construct the platform. The platform is made of concrete with reinforcing and/or pre-stressing steel. With the assumed thicknesses for the slabs and walls of the platform, the volume and thus the weight of the concrete can be estimated. The exact amount of reinforcement is not calculated in this stage as it is considered that the weight of the concrete is governing in the total weight of the platform. However, the density of concrete is taken as 25 kN/m^3 (thus including the weight of the steel reinforcement) to give a better estimation of the dead weight of the platform.

The dead weight of the platform is variable dependent on the amount of material and thus the dimensions of the platform and the thicknesses of the slabs/walls. The only dimension which has to be confirmed is the height of the platform.

5.1.2 Dead weight super structures

The permanent loads indicated as dead weight from the super structures are mainly from housings and buildings. For this thesis, two different load cases are set up: a case with high-rise buildings and a case with low-rise buildings. One platform has to accommodate 250 inhabitants. To maximize space usage, it is best to opt for high-rise buildings where all inhabitants live in. Of course this is a very extreme case as there is enough space on one platform to utilize low-rise buildings.

5.1.2.1 High-rise building

Assume all the 250 inhabitants would live in one flat/apartment. And assume each floor can house approximately 16 inhabitants with 75 m² of living space for each resident. The amount of floors in the apartment would then be $\frac{250}{16} = 15.6 \approx 16$ floors. Assuming each floor has a height of 3 m, the total height of the building would be $16 * 3 = 48 \text{ m} \approx 50 \text{ m}$. An example of the footprint of such a high building is seen in Figure 29. The building footprint is $25 * 60 = 1500 \text{ m}^2$, but other designs for the building with different dimensions are also possible. The most standard building is taken to give a general idea about the stability and strength of the platform in this thesis. It is known for sure that the platform would tilt if a large eccentric force (dead weight of the building) acts on the platform. So that is why the building is placed in the centre of the platform.

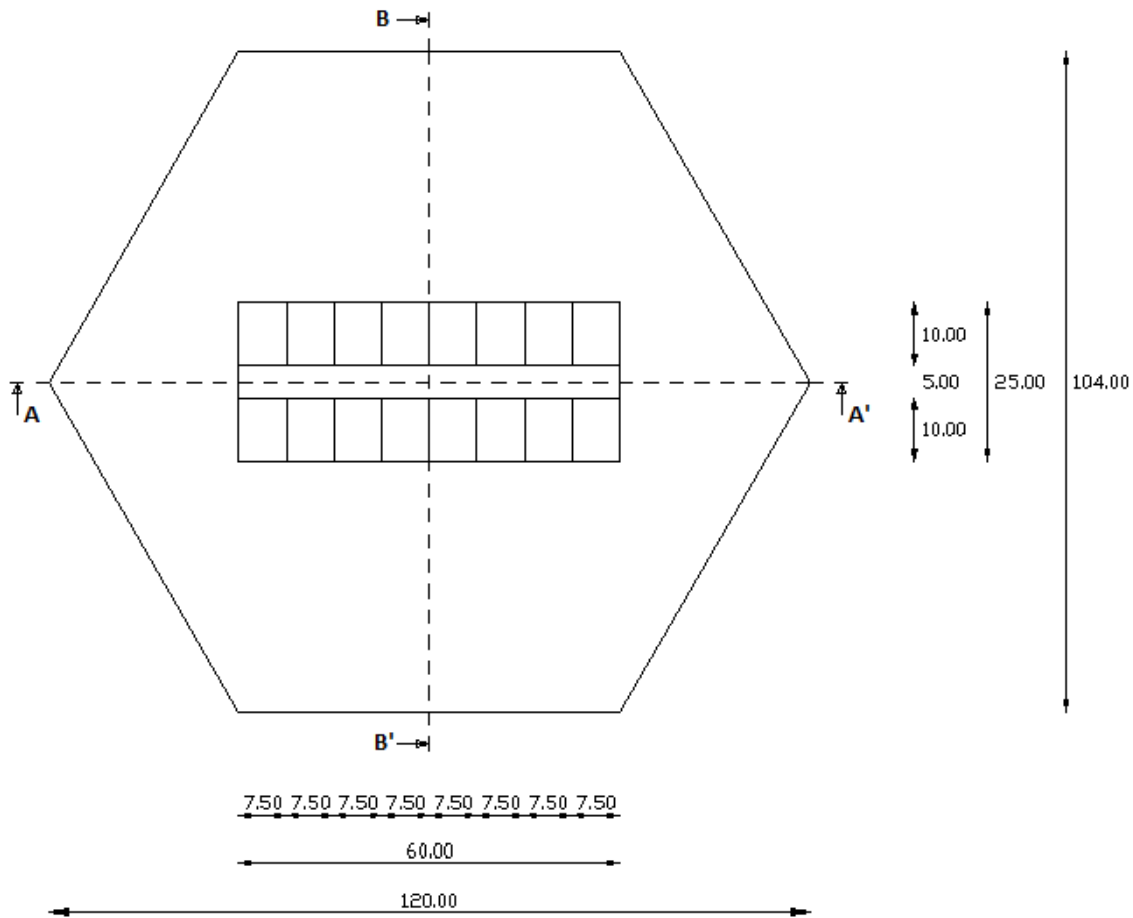

Figure 29: Footprint of the high rise building on the platform

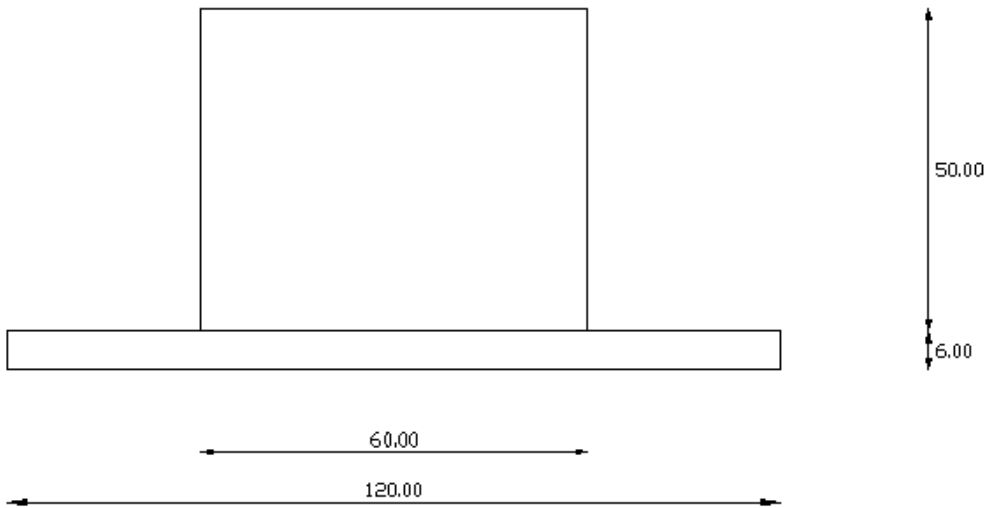

Figure 30: Cross-section AA'

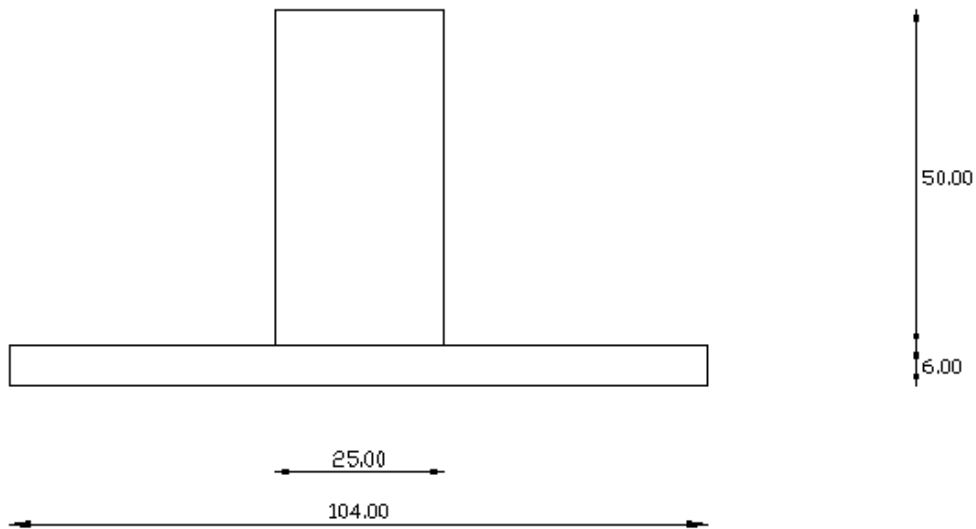

Figure 31: Cross-section BB'

Cross-section BB' is governing for stability calculations because a smaller width of the platform results in a smaller shifting of the centre of buoyancy when the platform rotates. The more the centre of buoyancy shifts and can shift with a certain rotation, the higher the metacentre will be, so the more stable the floating structure will be. In other words, the stability increases a lot by enlarging the width of the floating structure. Thus a smaller shifting of the centre of buoyancy gives a significantly smaller metacentric height and that is why the stability calculations should focus on this cross-section.

5.1.2.2 Low-rise buildings

The total area available for housing was estimated to be 50% of the platform space, thus 4677 m². With an apartment with a footprint of 1500 m², there is still a lot of space left for housings. So it is actually not very necessary to build such a high building, but it is certainly an option if preferred or needed.

Another option would be to utilise the maximum area available on the platform and see how high the buildings then would be. Assume 50% of the platform space (4677 m²) is fully used for housings. It doesn't matter how the houses and buildings are arranged, but the idea is to have a distributed load over the entire platform with apartments of the same height; see the arched area in Figure 32. Again, the cross-section with the smallest width is chosen because this cross-section is governing for stability calculations.

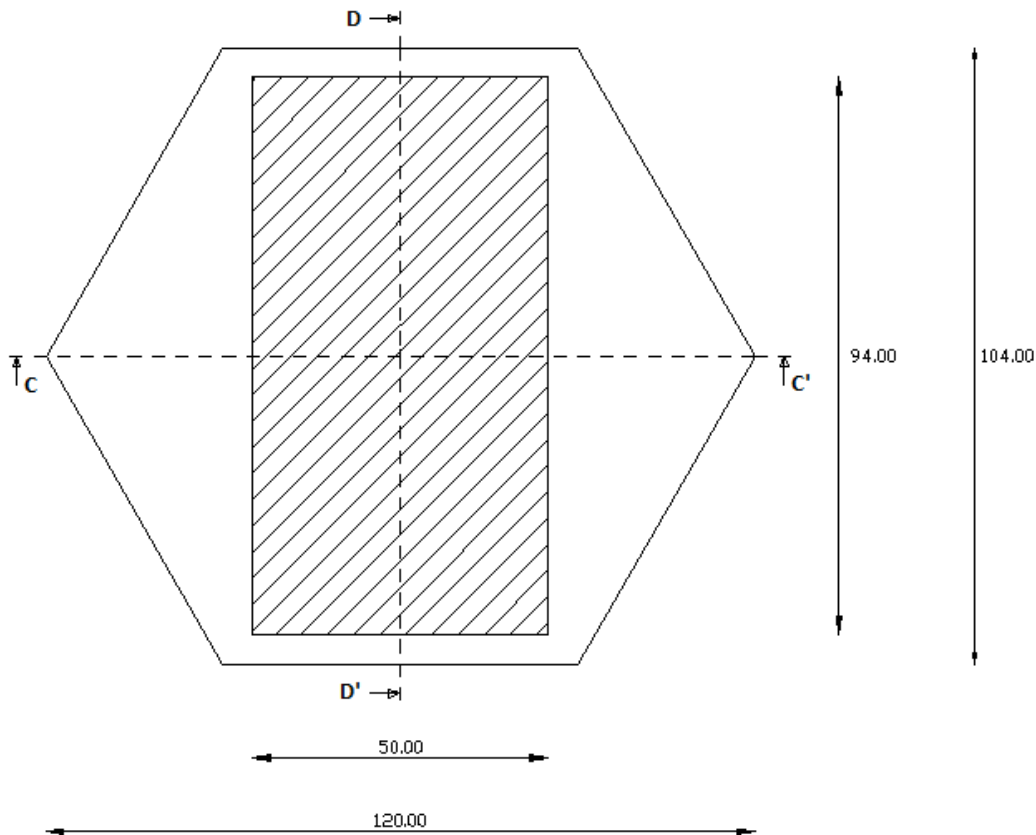

Figure 32: 50% of the platform area for housing

4677 m² of housings over a full length of 94 m (5 m on each side for sidewalks etc.) results in a $\frac{4677}{94} \approx 50$ m wide strip on the platform. The amount of inhabitants living on one floor would be $\frac{4677 \text{ m}^2}{75 \text{ inhabitants/m}^2} \approx 62$ inhabitants. The average amount of floors of all the housings to accommodate all 250 inhabitants would be $\frac{250}{62} \approx 4$ floors, with each floor having a height of approximately 3 m the average height results in $4 * 3 = 12$ m.

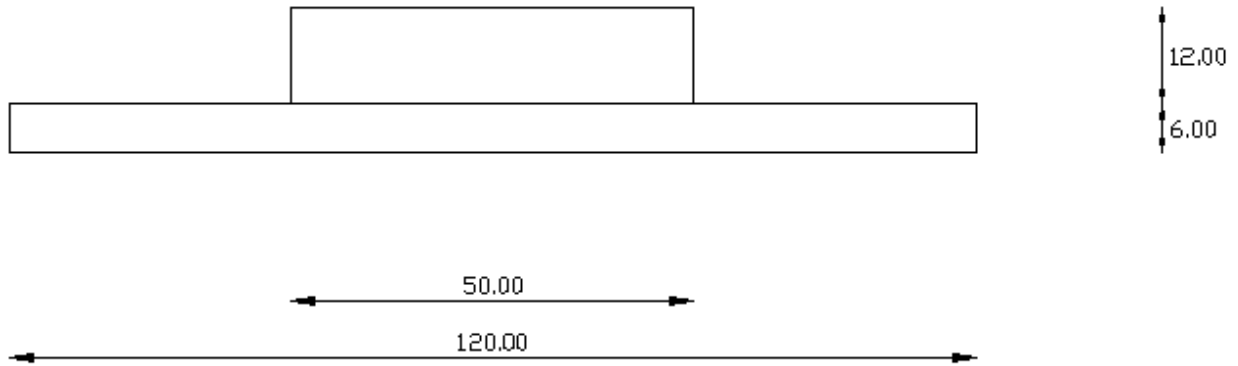

Figure 33: Cross-section CC'

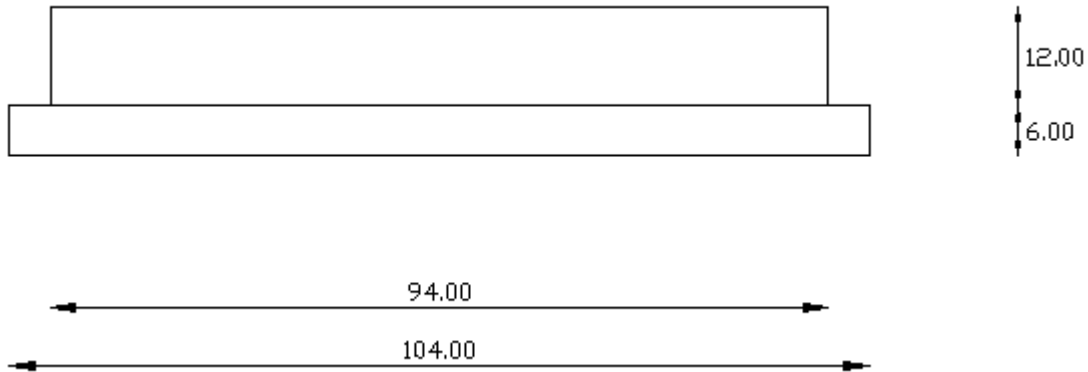

Figure 34: Cross-section DD'

5.1.2.3 Load cases

The dead weight of the super structures in the two load cases can now be estimated. The loads are not accurately calculated because this would involve a whole study about the composition of the super structure itself. The focus of this thesis is about the design of the floating platform, so an estimation of the dead weight of the super structure suffices.

From now on, case 1 is referred to the platform with the high-rise building in the centre and case 2 is referred to the platform with the distributed low-rise buildings. The average dead weight of a building can be estimated to be around 5 kN/m^2 .^[14] This is the dead weight of a single floored house, so for a multi-story building this dead weight must be multiplied by the amount of floors. However, the upper floors would only be roughly 70%^[15] of this weight because the first floor has the most compartments to support the weight of the floors above.

So for case 1, the dead weight of the super structure is $(5 + 16 * (0.7 * 5)) * 60 * 25 = 91500 \text{ kN}$.
 The dead weight of the super structure of case 2 is $(5 + 4 * (0.7 * 5)) * 50 * 94 = 89300 \text{ kN}$.

¹⁴ <https://law.resource.org/pub/bd/bnbc.2012/gov.bd.bnbc.2012.06.02.pdf>

Estimation is made through Table 2.2.2 by roughly adding all the different compartments.

¹⁵ http://eurocodes.jrc.ec.europa.eu/doc/WS2008/EN1991_2_Malakatas.pdf

Of course it is less likely to have just one high-rise building for all the inhabitants on a platform or to have all the houses be distributed into one rectangular area. Urban architecture plays a big role to determine the exact dead loads caused by the super structures. The cases mentioned are more or less extreme situations. When the strength and stability requirements suffice for the extreme cases, then other cases would likely to suffice the requirements too.

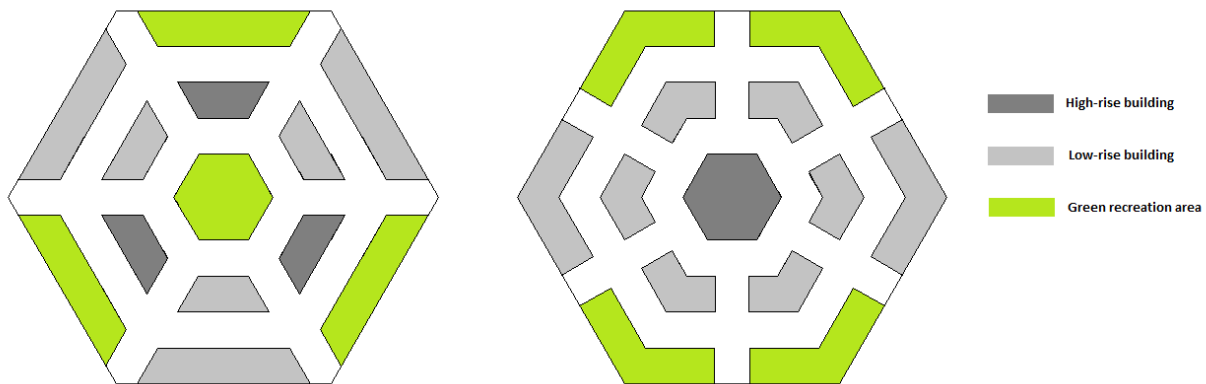

Figure 35: Sketch examples of urban architecture for one platform

5.2 Live load

Other than the dead load, the platform is also subjected to live loads. Live loads are loads which change under different circumstances. Some examples of live loads on the platform are the storage load, traffic load, load of the inhabitants, wave load, current load, wind load, water pressure and buoyancy.

5.2.1 Load of the inhabitants

The load caused by the inhabitants on the platform is actually defined as the live load of the super structure. These live loads are produced by the use and occupancy of a building. Loads include those from human occupants, furnishings, non-fixed equipment, storage, and construction and maintenance activities. These live loads are estimated at $4.79 \text{ kN/m}^2 \approx 5 \text{ kN/m}^2$.^[16]

For case 1, the live load is estimated to be $(5 + 16 * (0.7 * 5)) * 60 = 3660 \text{ kN/m}$.

The live load of case 2 is estimated to be $(5 + 4 * (0.7 * 5)) * 50 = 950 \text{ kN/m}$.

5.2.2 Storage load

The inside of the floating platform can be either used as a storage facility. The storage load is thus dependent on the kind of goods stored in the platform. Water is more or less the most simple and heavy storage medium with a weight of 1000 kg/m^3 . Each compartment in the platform has dimensions of $15 * 13 * 4 \text{ m}$ in this thesis, this results in a storage load of $\frac{15 * 13 * 4 * 10}{15 * 13} = 40 \text{ kN/m}^2$.

The storage load is not always equally distributed along the whole platform. It may occur that there will be more storage at one side of the platform resulting in an asymmetric load distribution. The tilting of the platform would then increase for sure. To illustrate an extreme case of this unfavourable asymmetric loading, the load on only one side of the platform is considered:

$$Q_{storage} = 40 * 60 = 2400 \text{ kN/m}$$

¹⁶ <https://law.resource.org/pub/bd/bnbc.2012/gov.bd.bnbc.2012.06.02.pdf>
Table 2.3.1 the live load for multi-family houses

5.2.3 Traffic load

The traffic load on the platform is heavily dependent on the design of the infrastructure. The traffic load doesn't act on the whole platform, but only where there is infrastructure. The same is as the storage load where it may occur that on one side of the platform there is more traffic than on the other side, resulting in tilting of the platform. Again, the traffic load is taken asymmetric to illustrate such an extreme case. The load is also dependent on the amount of traffic lanes. As the first traffic lane (the most right lane in European standard) has the most traffic and the second and third lanes would have less traffic. According to Eurocode EN 1991-2:2003 E, the distributed load on the first traffic lane can be estimated to be 9 kN/m^2 and the load on the second and higher lanes can be estimated to be 2.5 kN/m^2 .^[17]

5.2.4 Wave load

It was assumed that waves with a wave height of 4 m are applied for the general design of the floating platform. Other characteristics with this wave height of 4 m are the wave length of 76.5 m and the wave period of 8.6 s. With this information, the wave load can be calculated.

Waves play a big role on floating structures. We can distinguish a horizontal effect of the waves that is relevant for the mooring constructions and a vertical effect that is relevant for the load on the underside of the floating structure.

5.2.4.1 Horizontal wave load

As a result of different wave motions in the surroundings of the floating structure, there may be a pressure difference caused. This pressure difference can be caused if there is on one side of the floating structure a wave crest, while on the other side of the structure a wave trough is located as shown in Figure 36. This makes the total horizontal pressure not in balance anymore. There will be a net resultant horizontal force, causing the floating structure to move. This net horizontal force is to be taken up by a mooring construction.

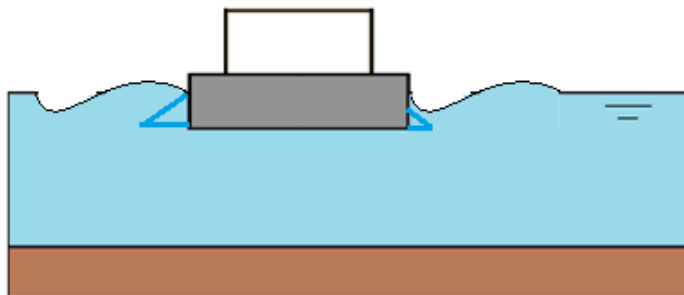

Figure 36: Unbalance of the horizontal pressure due to waves

When waves approach a (floating) structure, two things can happen: the waves break on the structure or the waves are reflected.

In case of a reflected wave, a reflection can be partially or fully. The effect of reflection is that the wave height increases around the structure. A vertical wall of a structure reflects 100% of the incoming wave energy, whereas a gentle slope on the structure will reflect less. In other words, the wave height during impact on the vertical wall is twice the incoming wave height. However, a floating structure doesn't act as a complete vertical wall. The sides of the floating structure may be vertical, but as the structure is afloat,

¹⁷ <https://law.resource.org/pub/eur/ibr/en.1991.2.2003.pdf> Table 4.2

the waves will partially pass under the floating structure. This means that a part of the wave energy will not be reflected and thus the reflected wave height is not twice the incoming wave height.

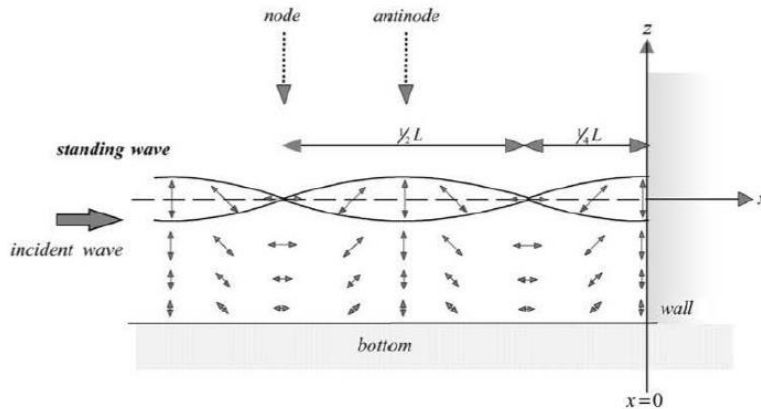

Figure 37: Reflection of a wave against a vertical wall

There are several ways to estimate the wave load. All these methods calculate the load of non-breaking waves on a (vertical) wall. This should give a fair estimation of the static wave load subjecting the floating platform as the sides of the platform are in fact large (floating) walls. The five methods to calculate the wave load are:

- Rule of thumb; for preliminary estimate
- Linear wave theory; for preliminary and final design phase
- Method of Sainflu; for preliminary design phase and often used in practice
- Method of Rundgren; for final design phase
- Method of Goda; for final design phase

The method of the linear wave theory is chosen because the design of the platform in this thesis is still the preliminary design phase. The linear wave theory is chosen because it gives a more accurate calculation compared to the method of Sainflu which is rather simple and often used in practice. The (horizontal) force per linear meter according to the linear wave theory can be calculated with:

$$F_{wave} = \rho g H_w * \left(\frac{\exp(k*d) - \exp(-k*d)}{2*k*\cosh(k*d)} + \frac{H_w}{2} \right)$$

Where, H_w = wave height [m]
 k = wave number [m^{-1}]
 d = water depth [m]

The water depth in the case of a floating platform is actually the draught.

5.2.4.2 Wave impact

The phenomenon of wave breaking is that the crest of a wave starts to collapse. As a wave is running into shallower water, the wave crest will increase until it can't maintain the speed and mass of the water particles and thus resulting in a collapsing/breaking wave. Breaking waves deliver huge horizontal impact loads on the floating structure. The shape of the breaking wave and the possible air that is caught in between the structure and the breaking wave has a large influence on the maximum wave shock and the course of the pressure distribution in time. The load due to breaking waves has a dynamic character. Due to collision between the wave and the structure, a transfer of impulse takes place. At the moment of impact, a relative high pressure occur which only lasts for a very short time (in the order of 1/100 seconds, see Figure 38). Because of the short time span, this pressure is not very representative for the stability of

a floating structure (due to the inertia of mass). This dynamic pressure is more important for the strength of the structure. There are several models to roughly estimate the load of this dynamic impact. Most notably are the models of Minikin; CERC (1984, broken waves) and Goda-Takahasgi.

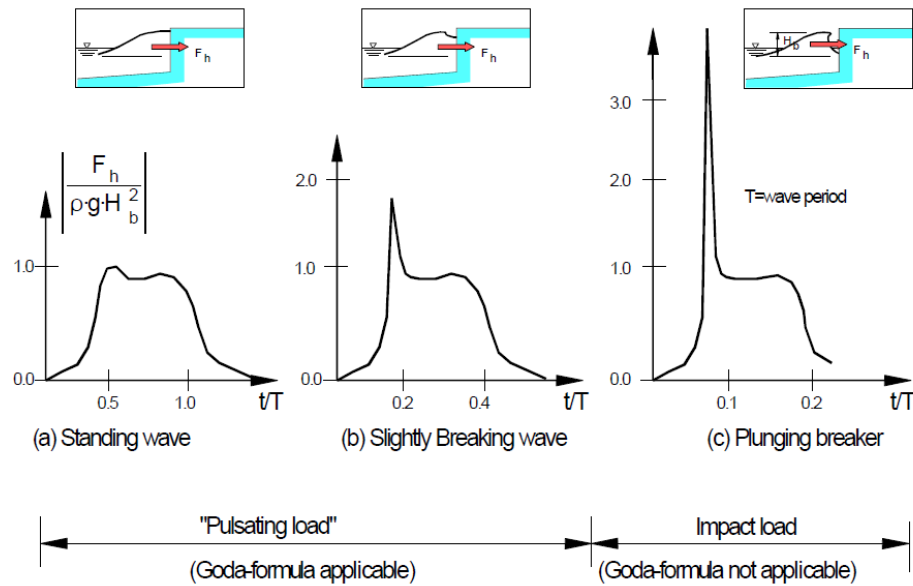

Figure 38: Impact load of a breaking wave

5.2.4.3 Vertical wave load

Waves also have vertical impacts on floating structures. Particularly long swell or tidal waves. Swell waves are long period wind waves generated by local wind, but the waves have travelled away from the local wind area. These long waves have long periods. In general, a floating body will have time enough to follow the movements of the water plane. Therefore the body will not experience great response motions due to swell. As short waves have great horizontal impact on floating structures, long waves act more as a sudden (partial) elevation of the water surface. As seen in Figure 39, a floating structure subjected to long waves will only be partially founded on the water surface. This results in hogging and sagging moments. These moments occur in the floating structure as the structure now acts as a beam on one or multiple discontinuous foundations. To calculate the internal forces and deformations for floating structures, the water can be schematized as an elastic support. However, water results in a very soft elastic support with a low k -value of 10 kN/m^3 . This means that a floating structure will heavily subside in the water and is strongly susceptible to vertical movement and tilting. The structural design and stiffness of the structure must be designed to take these unfavourable moments.

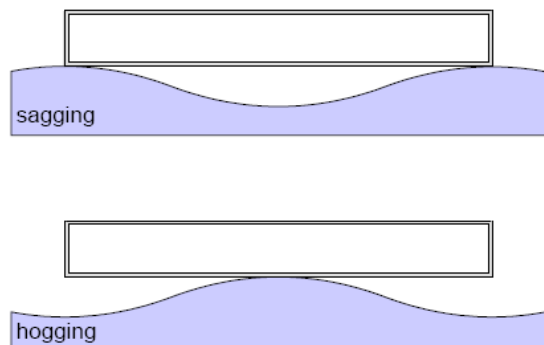

Figure 39: Effects of long waves on floating structures

The movements (roll, pitch, yaw, etcetera) caused by waves (dynamic loads) are the resulting movements when the floating structure is considered (infinite) stiff. The response of floating structures is often largely elastic (depends on material) and very different from ships. The modeling of the floating foundation is often compared to that of a slender beam resting on an elastic foundation. The length of the beam which gets affected when a force is applied is determined by a formula proposed by Suzuki and Yoshida (1996):

$$\lambda_c = 2 * \pi * \sqrt[4]{\frac{EI}{k_c}}$$

Where, EI is the bending stiffness of the beam; λ_c is the characteristic length; k_c is the spring constant of the hydrostatic restoring force.

If the characteristic length is larger than the length of the structure, the structure behaves as a rigid body, else it behaves elastically. Also, if the wavelength is smaller than the length of the structure, the response alternates with a length of λ_c and the load effect cancels each other. However, if the wavelength is greater than the length of the structure, the response becomes significant.

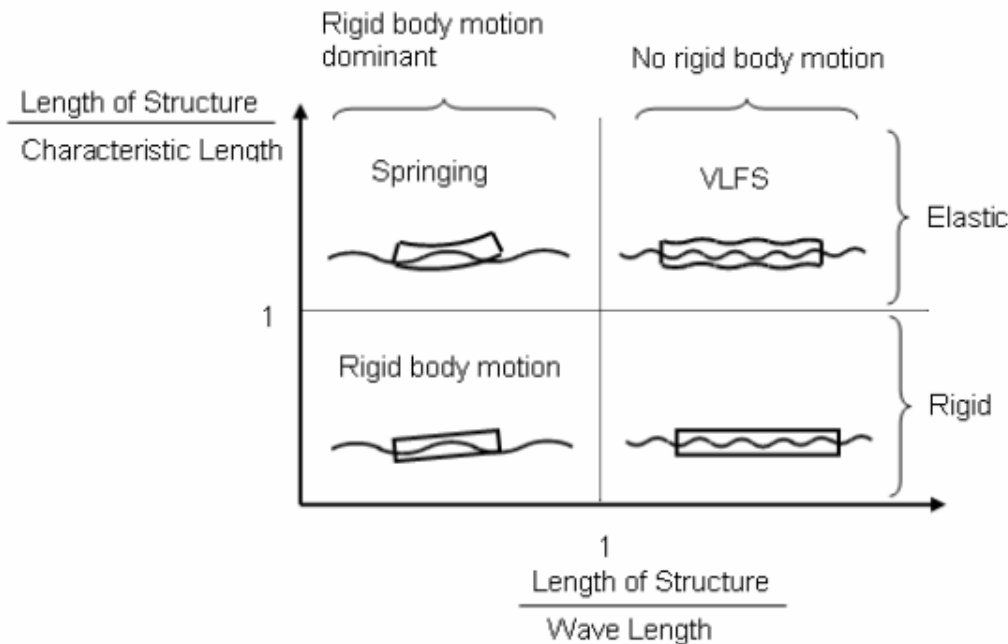

Figure 40: Structure length versus wave length (Parwani, 2013)

The response of floating structures to wave action is thoroughly investigated by E.V. Koutandos, Th.V. Karambas and C.G. Koutitas from the 'Journal of Waterway, Port, Coastal and Ocean Engineering'.¹⁸ The report contains copyright, so the contents are not published in this thesis. However, the study is about developing a finite difference numerical model and being tested for the investigation of the hydrodynamic behaviour of the vertical forces acting on fixed-heave-motion floating breakwaters. One of the conclusions is that the length/width ratio and the draught/depth ratio are very decisive for the performance of the floating breakwater. Also, resonance phenomena occur when the period of the incoming wave is close to the natural oscillation period of the floating breakwater.

18

https://www.google.nl/url?sa=t&rct=j&q=&esrc=s&source=web&cd=1&ved=0CC0QFjAA&url=http%3A%2F%2Fwww.researchgate.net%2Fpublication%2F236009577_Floating_breakwater_response_to_waves_action_using_a_Boussinesq_model_coupled_with_a_2dv_elliptic_solver%2Ffile%2F3deec521ee5e89b428.pdf&ei=IC3pUv39Asmg0QX7-YHQDA&usg=AFQjCNEgwiKnFDURAnjmJ8ih3PWLK3gFcg&bvm=bv.60157871,d.d2k&cad=rja

5.2.5 Current load

Uniform current causes a drag force on a fixed body in the direction of the current and it causes a lift force on the body perpendicular to the direction of the current. Water can flow underneath the floating platform. Therefore, drag and lift forces will be smaller than on a fixed object such as a bridge pile (cylinder). The floating platform is assumed to be a very large flat plate with its longitudinal axis rather parallel to the direction of the current. The resulting force on the platform can be estimated with the Morison equation:

$$Q_{current} = \rho g \frac{u_c^2}{2g} = \frac{1}{2} \rho * u_c^2 * C_d$$

Where, u_c = current velocity [m/s]
 C_d = drag coefficient [-]

The drag coefficient can be estimated with the Reynolds number:

$$Re = \frac{u_c * W}{\nu} = \frac{1.0 * 104}{1.0 * 10^{-6}} = 104 * 10^6$$

Where, W = width [m]
 ν = viscosity [m²/s]

The drag coefficient for a hexagon with this Reynolds number is 1.0 according to Figure 41.

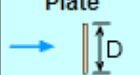
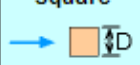
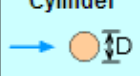
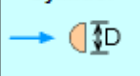
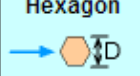
Shape	Area, A	Reynolds Number, Re	Drag Coefficient C_D
 Plate	bD**	$> 10^4$	2.0
 Square	bD	$> 10^4$	2.1
 Cylinder	bD	$< 10^5$ $> 5 \times 10^5$	1.2 (Laminar) 0.3 (Turbulent)
 Semicircular Cylinder	bD	$> 10^4$	1.2
 Hexagon	bD	$> 10^4$	1.0

(**Note: b is the length into the page)

Figure 41: Drag coefficients for different shapes ¹⁹

$$Q_{current} = \frac{1}{2} * 1025 * 2.5^2 * 1.0 = 3203 \text{ N/m}^2 \approx 3.2 \text{ kN/m}^2$$

The total load due to the current depends on the area perpendicular to the current. Thus the width and the still unknown draught are required to estimate the current force.

¹⁹ https://ecourses.ou.edu/cgi-bin/ebook.cgi?doc=&topic=fl&chap_sec=09.1&page=theory

5.2.6 Wind load

The wind load consists of a static wind pressure part which depends on the height and location of the structure, and a dynamic part. The dynamic part of the wind load consists of wind gusts in various directions. The behaviour of wind around a building is very complex, so for simplification reasons only the static part is considered.

Same as the current load, wind loads also cause a drag and lift force on structures subjected to wind. The equation to calculate the pressure of a given wind velocity is also obtained by the Morison equation. The difference with the wind load compared to the current load is that the drag coefficient changes depending on the height of the structure. The wind pressure decreases at a lower height. The decrease of the wind pressure is more like an exponential function, but for simplification reasons a linear decreasing function is assumed.



Figure 42: Wind load in reality versus assumption of the wind load acting on a building

Wind surrounds the whole building and the drag coefficient also changes depending on the side of the building, see Figure 43. The drag coefficient actually depends on the geographic location.

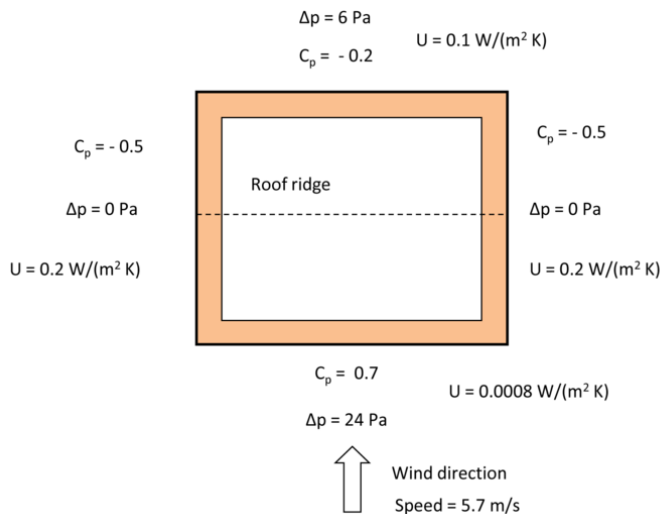

Figure 43: Example of drag coefficients on a building (top view) ²⁰

$$\text{Case 1: } Q_{wind} = \frac{1}{2} * 1.225 * \left(\frac{56}{3.6}\right)^2 * 0.7 * 60 = 6240 \text{ N/m}^2 \approx 6.0 \text{ kN/m}$$

$$\text{Case 2: } Q_{wind} = \frac{1}{2} * 1.225 * \left(\frac{56}{3.6}\right)^2 * 0.7 * 50 = 5200 \text{ N/m}^2 \approx 5.0 \text{ kN/m}$$

²⁰ http://en.wikipedia.org/wiki/File:Wind_pressure_coefficients_for_low_rise_building.png

6 Appendix 6: Static stability calculations

6.1 Draught calculation

Vertical forces establish an equilibrium if the buoyant force equals the weight of the floating platform including all the additional loads on the platform. If the platform is able to float, then the desired vertical equilibrium is reached. The vertical equilibrium gives a result on how high the construction height of the platform must be.

With the assumed thicknesses, the concrete volume of the platform and thus the weight of the platform can be calculated. The draught of the platform is calculated by adding the weight of the platform and the additional vertical loads and then dividing through the buoyant force.

$$D = \frac{F_v}{F_{buoyancy}} = \frac{F_v}{A * \rho_w}$$

Where, D	= draught	[m]
F_v	= total vertical load	[kN]
$F_{buoyancy}$	= buoyant force	[kN/m]
A	= area of the hexagon	[m ²]
ρ_w	= density of water	[kN/m ³]

The estimated platform size was a hexagon with sides of 60 m. The buoyant force of the platform relies on the area of the hexagon. A larger area means larger buoyant force resulting in a smaller draught.

With the known dimensions of the platform and the assumed thicknesses of the walls, the total volume of concrete needed for the platform is known. Concrete volume multiplied with the concrete density results in the weight of the platform. The buoyant force is the area of the platform multiplied with the water density. With all the vertical loads now known, the draught can be calculated with the aforementioned formula = $\frac{F_v}{F_{buoyancy}}$.

Dimensions platform										
Side	m	30,00	40,00	50,00	60,00	70,00	80,00	90,00	100,00	120,00
Length	m	60,00	80,00	100,00	120,00	140,00	160,00	180,00	200,00	240,00
Width	m	51,96	69,28	86,60	103,92	121,24	138,56	155,88	173,21	207,85
Area	m ²	2338,27	4156,92	6495,19	9353,07	12730,57	16627,69	21044,42	25980,76	37412,30
Height (outer)	m	35,00	22,00	16,00	14,00	12,00	11,00	10,00	10,00	9,00
Height (inner)	m	33,00	20,00	14,00	12,00	10,00	9,00	8,00	8,00	7,00
Thicknesses										
Outer walls	m	1,00	1,00	1,00	1,00	1,00	1,00	1,00	1,00	1,00
Inner walls	m	0,50	0,50	0,50	0,50	0,50	0,50	0,50	0,50	0,50
Bottom slab	m	1,00	1,00	1,00	1,00	1,00	1,00	1,00	1,00	1,00
Deck	m	1,00	1,00	1,00	1,00	1,00	1,00	1,00	1,00	1,00
Concrete volume										
Outer walls	m ³	5940,00	4800,00	4200,00	4320,00	4200,00	4320,00	4320,00	4800,00	5040,00
Inner walls	m ³	7619,19	6656,92	6087,31	6441,23	6387,31	6666,23	6741,23	7556,92	8039,77
Bottom slab	m ³	2338,27	4156,92	6495,19	9353,07	12730,57	16627,69	21044,42	25980,76	37412,30
Deck	m ³	2338,27	4156,92	6495,19	9353,07	12730,57	16627,69	21044,42	25980,76	37412,30
Total	m ³	18235,73	19770,77	23277,69	29467,38	36048,45	44241,61	53150,06	64318,45	87904,36
Vertical forces										
Density concrete	kN/m ³	25,00	25,00	25,00	25,00	25,00	25,00	25,00	25,00	25,00
Weight platform	kN	455893,20	494269,15	581942,19	736684,46	901211,34	1106040,13	1328751,61	1607961,15	2197609,07
Weight building	kN	91500,00	91500,00	91500,00	91500,00	91500,00	91500,00	91500,00	91500,00	91500,00
Live load building	kN	91500,00	91500,00	91500,00	91500,00	91500,00	91500,00	91500,00	91500,00	91500,00
Storage load	kN	124800,00	124800,00	124800,00	124800,00	124800,00	124800,00	124800,00	124800,00	124800,00
Buoyancy										
Density water	kN/m ³	10,25	10,25	10,25	10,25	10,25	10,25	10,25	10,25	10,25
Buoyancy force	kN/m	23967,25	42608,45	66575,70	95869,01	130488,38	170433,80	215705,28	266302,81	383476,05
Draught	m	31,86	18,82	13,36	10,89	9,27	8,30	7,59	7,19	6,53
Freeboard	m	3,14	3,18	2,64	3,11	2,73	2,70	2,41	2,81	2,47

Table 2: Quantifying the platform size

Table 2 shows the different side lengths of the hexagon in relation to the draught. As already stated, larger platforms results in smaller draughts. The chosen 60 m side length is a usable length as the draught is still significant small compared to platforms with sides of 30 or 40 m.

Case 1

A first estimation of the construction height was 6 m. This construction height results in a draught of 9.02 m and thus a 'freeboard' of -3.02 m, see Table 3. The draught of the platform exceeds the construction height, which means that the platform is completely under water and it will sink. Therefore, the construction height needs to be increased. Table 4 shows the draught and freeboard of different construction heights. In this table, it can be seen that the draught fulfils the requirement when the construction height is larger than 10 m. However, the freeboard is then 0.04 m and the freeboard must also be of sufficient height for extra safety, additional loads and to keep the deck dry and safe from wave attacks.

Dimensions platform										
Side	m	60.00	60.00	60.00	60.00	60.00	60.00	60.00	60.00	60.00
Length	m	120.00	120.00	120.00	120.00	120.00	120.00	120.00	120.00	120.00
Width	m	103.92	103.92	103.92	103.92	103.92	103.92	103.92	103.92	103.92
Area	m ²	9353.07	9353.07	9353.07	9353.07	9353.07	9353.07	9353.07	9353.07	9353.07
Height (outer)	m	6.00	7.00	8.00	9.00	10.00	11.00	12.00	13.00	14.00
Height (inner)	m	4.00	5.00	6.00	7.00	8.00	9.00	10.00	11.00	12.00
Thicknesses										
Outer walls	m	1.00	1.00	1.00	1.00	1.00	1.00	1.00	1.00	1.00
Inner walls	m	0.50	0.50	0.50	0.50	0.50	0.50	0.50	0.50	0.50
Bottom slab	m	1.00	1.00	1.00	1.00	1.00	1.00	1.00	1.00	1.00
Deck	m	1.00	1.00	1.00	1.00	1.00	1.00	1.00	1.00	1.00
Concrete volume										
Outer walls	m ³	1440.00	1800.00	2160.00	2520.00	2880.00	3240.00	3600.00	3960.00	4320.00
Inner walls	m ³	2147.08	2683.85	3220.61	3757.38	4294.15	4830.92	5367.69	5904.46	6441.23
Bottom slab	m ³	9353.07	9353.07	9353.07	9353.07	9353.07	9353.07	9353.07	9353.07	9353.07
Deck	m ³	9353.07	9353.07	9353.07	9353.07	9353.07	9353.07	9353.07	9353.07	9353.07
Total	m ³	22293.23	23189.99	24086.76	24983.53	25880.30	26777.07	27673.84	28570.61	29467.38
Vertical forces										
Density concrete	kN/m ³	25.00	25.00	25.00	25.00	25.00	25.00	25.00	25.00	25.00
Weight platform	kN	557330.63	579749.86	602169.09	624588.32	647007.55	669426.78	691846.00	714265.23	736684.46
Weight building	kN	91500.00	91500.00	91500.00	91500.00	91500.00	91500.00	91500.00	91500.00	91500.00
Live load building	kN	91500.00	91500.00	91500.00	91500.00	91500.00	91500.00	91500.00	91500.00	91500.00
Storage load	kN	124800.00	124800.00	124800.00	124800.00	124800.00	124800.00	124800.00	124800.00	124800.00
Buoyancy										
Density water	kN/m ³	10.25	10.25	10.25	10.25	10.25	10.25	10.25	10.25	10.25
Buoyancy force	kN/m	95869.01	95869.01	95869.01	95869.01	95869.01	95869.01	95869.01	95869.01	95869.01
Draught	m	9.02	9.26	9.49	9.73	9.96	10.19	10.43	10.66	10.89
Freeboard	m	-3.02	-2.26	-1.49	-0.73	0.04	0.81	1.57	2.34	3.11

Table 3: Draught calculation case 1

Note that the live load of the building and the storage load is converted to kN instead of kN/m.
The live load of the building is multiplied by 25 m (the width of the building): $3660 * 25 = 91.500 \text{ kN}$
The storage load is multiplied by 52 m (half of the width of the platform): $2400 * 52 = 124.800 \text{ kN}$

Construction height [m]	Draught [m]	Freeboard [m]
6	9.02	-3.02
7	9.26	-2.26
8	9.49	-1.49
9	9.73	-0.73
10	9.96	0.04
11	10.19	0.81
12	10.43	1.57
13	10.66	2.34
14	10.89	3.11

Table 4: Construction height, draught and freeboard relation of case 1

When increasing the height of the platform, the weight of the platform also increases. The increase of the weight of the platform in turns increases the draught. The relation of increasing the load on the platform and the increase of the draught is more or less linear, see Figure 44. The slope of the function is very gentle, which means that an increase in the vertical load leads to a small increase of the draught.

The weight of the platform with a construction height of 13 m equals 714.265 kN. The weight of the platform with a construction height of 14 m equals 736.684 kN. An increase of 1 m in construction height leads to $736.684 - 714.265 = 22.419 \text{ kN}$ extra load. In other words, adding 22.419 kN leads to an increase of $10.66 - 10.89 = 0.23 \text{ m}$ in the draught. Theoretically, when another building like in case 1 is built on the platform (91.500 kN) the draught would increase with $\frac{91.500}{22.419} * 0.23 = 0.94 \text{ m}$. A load like this is already quite big and it can thus be safely assumed that the draught of the platform will not increase drastically when extra vertical loads on the platform appears. Not all vertical loads are applied yet in this thesis, so for extra insurance a platform height of 14 m can be chosen. The freeboard (marge for the draught) is then 3.11 m . With extra vertical loads equalling $2 * 91.500 = 183.000 \text{ kN}$ results in a freeboard of $3.11 - 2 * 0.94 = 1.23 \text{ m}$ which is still an acceptable marge.

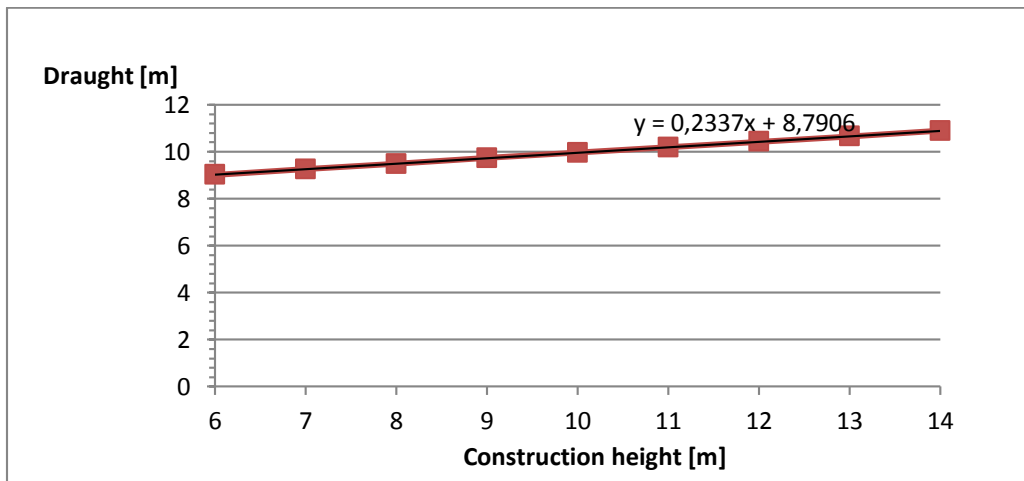

Figure 44: Relation construction height and draught case 1

Case 2

The load of case 2 is slightly lower than in case 1, but the height of the platform assumed first (6 m) would definitely not suffice in this case too.

Dimensions platform										
Side	m	60.00	60.00	60.00	60.00	60.00	60.00	60.00	60.00	60.00
Length	m	120.00	120.00	120.00	120.00	120.00	120.00	120.00	120.00	120.00
Width	m	103.92	103.92	103.92	103.92	103.92	103.92	103.92	103.92	103.92
Area	m ²	9353.07	9353.07	9353.07	9353.07	9353.07	9353.07	9353.07	9353.07	9353.07
Height (outer)	m	6.00	7.00	8.00	9.00	10.00	11.00	12.00	13.00	14.00
Height (inner)	m	4.00	5.00	6.00	7.00	8.00	9.00	10.00	11.00	12.00
Thickesses										
Outer walls	m	1.00	1.00	1.00	1.00	1.00	1.00	1.00	1.00	1.00
Inner walls	m	0.50	0.50	0.50	0.50	0.50	0.50	0.50	0.50	0.50
Bottom slab	m	1.00	1.00	1.00	1.00	1.00	1.00	1.00	1.00	1.00
Deck	m	1.00	1.00	1.00	1.00	1.00	1.00	1.00	1.00	1.00
Concrete volume										
Outer walls	m ³	1440.00	1800.00	2160.00	2520.00	2880.00	3240.00	3600.00	3960.00	4320.00
Inner walls	m ³	2147.08	2683.85	3220.61	3757.38	4294.15	4830.92	5367.69	5904.46	6441.23
Bottom slab	m ³	9353.07	9353.07	9353.07	9353.07	9353.07	9353.07	9353.07	9353.07	9353.07
Deck	m ³	9353.07	9353.07	9353.07	9353.07	9353.07	9353.07	9353.07	9353.07	9353.07
Total	m ³	22293.23	23189.99	24086.76	24983.53	25880.30	26777.07	27673.84	28570.61	29467.38
Vertical forces										
Density concrete	kN/m ³	25.00	25.00	25.00	25.00	25.00	25.00	25.00	25.00	25.00
Weight platform	kN	557330.63	579749.86	602169.09	624588.32	647007.55	669426.78	691846.00	714265.23	736684.46
Weight building	kN	89300.00	89300.00	89300.00	89300.00	89300.00	89300.00	89300.00	89300.00	89300.00
Live load building	kN	47500.00	47500.00	47500.00	47500.00	47500.00	47500.00	47500.00	47500.00	47500.00
Storage load	kN	124800.00	124800.00	124800.00	124800.00	124800.00	124800.00	124800.00	124800.00	124800.00
Buoyancy										
Density water	kN/m ³	10.25	10.25	10.25	10.25	10.25	10.25	10.25	10.25	10.25
Buoyancy force	kN/m	95869.01	95869.01	95869.01	95869.01	95869.01	95869.01	95869.01	95869.01	95869.01
Draught	m	8.54	8.78	9.01	9.24	9.48	9.71	9.95	10.18	10.41
Freeboard	m	-2.54	-1.78	-1.01	-0.24	0.52	1.29	2.05	2.82	3.59

Table 5: Draught calculation case 2

Note that the live load of the building and the storage load is converted to kN instead of kN/m.

The live load of the building is multiplied by 25 m (the width of the building): $950 * 50 = 47.500 \text{ kN}$

The storage load is multiplied by 52 m (half of the width of the platform): $2400 * 52 = 12.480 \text{ kN}$

The relation between the draught and construction height are seen in Table 6 and Figure 45.

Construction height [m]	Draught [m]	Freeboard [m]
6	8.54	-2.54
7	8.78	-1.78
8	9.01	-1.01
9	9.24	-0.24
10	9.48	0.52
11	9.71	1.29
12	9.95	2.05
13	10.18	2.82
14	10.41	3.59

Table 6: Construction height, draught and freeboard relation of case 2

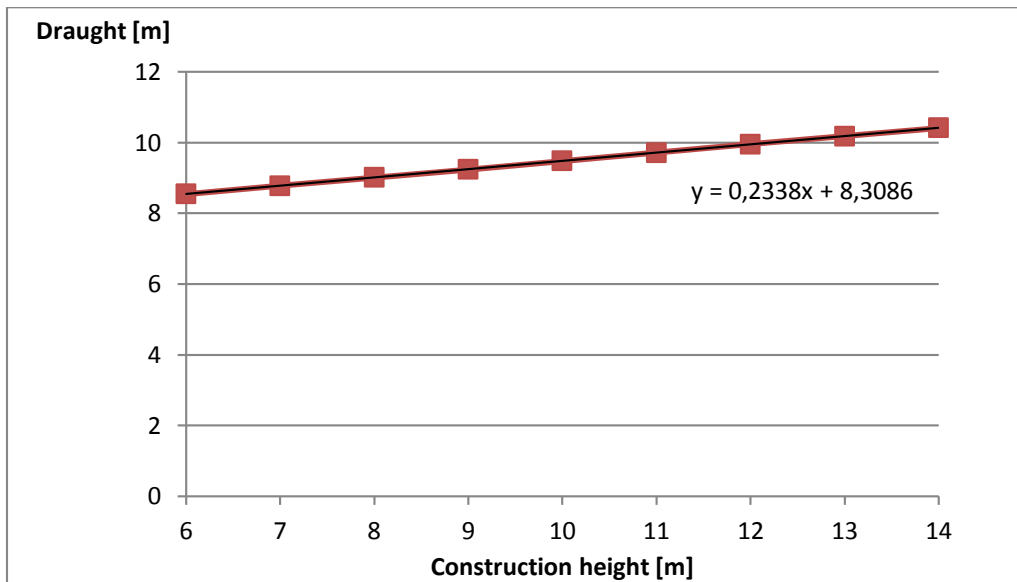

Figure 45: Relation construction height and draught case 2

The slope of the function is more or less the same as the function in case 1. So in this case, an increase in the vertical load leads to a small increase of the draught too. The prediction of the platform height of 14 m with a freeboard of 3.59 m is maybe a bit too high for this case. Such a large platform height would only be necessary if it is sure that really huge vertical loads are going to be on the platform. So a construction height of 13 m with a draught of 10.18 m is chosen for load case 2.

A special note, the freeboard must actually be large enough to keep the deck dry from waves. With a wave height of 4 m, the freeboard must actually be at least 4 m. But this would economically be not feasible as the platform would gain too much weight and material and thus increasing the costs. On top of the platform, provision need to be taken to keep the waves from the deck, like barriers for example.

6.2 Metacentric height

The platform is tilting because of the horizontal loads and the asymmetric storage load. And when the platform is tilted, the dead and live load of the super structure moves out of the symmetry-axis (z-axis) and thus contributes to the rotation of the platform. However, the centre of buoyancy also shifts and should be counteracting the moments caused by the external loads and the loads of the super structure. Horizontal loads also include the wave load and the current load. But because these loads act on the platform, the distance of these loads to the centre of gravity (arms) are small and thus negligible.

To determine the equilibrium of the moments, the platform must be given a tilting position and the buoyancy force should restore the platform to its initial position. The requirement of the tilting position for comfortable living on the platform is to have a maximum skewness of 1%. This means that the platform may rotate $\frac{0.01}{360} * 2\pi = 0.57^\circ$ at maximum.

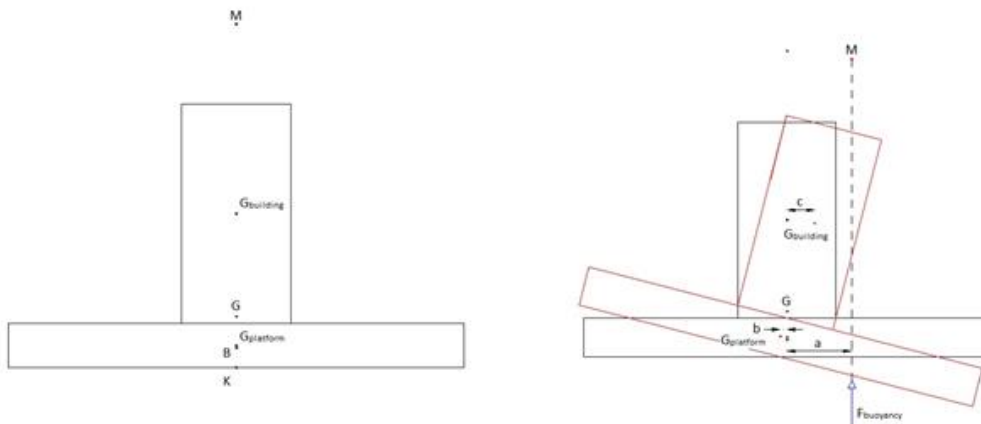

Figure 46: Sketch of the metacentric height and the displacement of the centre of buoyancy

A measure of the resistance to tilting is given by the 'metacentric height'. The distance of point G to point M (the line segment GM) is called the metacentric height. If the metacentric height is positive, it indicates that the floating element is stable. The larger the metacentric height is, the more stable the structure is. The metacentric height can be determined with the following formula:

$$h_m = GM = KB + BM - KG$$

Where, GM	= metacentric height	[m]
KB	= distance between centre of buoyancy and bottom of the platform	[m]
KG	= distance between centre of gravity and bottom of platform	[m]
BM	= distance between centre of buoyancy and metacentre	[m]

$$KB = \frac{1}{2} * D$$

$$KG = \frac{\sum(G_i * e)}{\sum G} \quad e = \text{centre of gravity of element } i \quad [\text{m}]$$

$$BM = \frac{I}{V_w} \quad I = \text{moment of inertia} \quad [\text{m}^4]$$

$$I = \frac{5\sqrt{3}}{16} * z^4 \quad V_w = \text{volume of displaced water} \quad [\text{m}^3]$$

$$z = \text{length of one side of hexagon} \quad [\text{m}]$$

The platform is considered to be statically stable when the metacentric height equals 0.5 or more. Note that horizontal loads are not included in the calculation of the metacentric height. The metacentric height is about the static stability due to the weight of the platform and the super structure on top of it. Both the dead load and the live load of the buildings are taken into account.

	Case 1	Case 2
KB	5.45 m	5.09 m
KG	13.37 m	8.51 m
BM	68.84 m	73.68 m
GM (h_m)	60.92 m	70.26 m

Table 7: Static stability calculation results

The distance between the centre of buoyancy and metacentre (BM) in both cases is very large. This is because the platform has very large dimensions. Larger dimensions results in a larger shift of the centre of buoyancy when the platform is tilted. Looking at Figure 46, the horizontal shift of the centre of buoyancy (a) is determined with $a = \varphi * h_m$. This is only applicable when the rotation φ is very small, which is the case now. Likewise, the horizontal shift of the centre of gravity of the building (c) can be determined: $c = \varphi * |GG_{building}|$

$|GG_{building}|$ is the distance between the centre of gravity and centre of gravity of the building. The horizontal shift of the centre of gravity of the platform (b) can be neglected as this shift is very small. With these distances known and their loads, a momentum balance can be made of the platform when it is tilted:

	Case 1	Case 2
Arm a	34.90 m	40.26 m
Moment buoyancy	36.457.017 kNm	39.284.634 kNm
Arm c	14.69 m	6.01 m
Moment building weight	-2.687.610 kNm	-822.271 kNm
Arm storage load	26.00 m	26.00 m
Moment storage load	-3.244.800 kNm	-3.244.800 kNm
Arm wind load	33.97 m	37.82 m
Moment wind load	-7.642 kNm	-1.702 kNm
Total moment	30.516.964 kNm	35.215.860 kNm

Table 8: Moment calculation

Because of the tilting, the water pressure on both sides of the platform would increase and decrease because of the change of the draught on each side. But the rotation φ is very small, so these changes in the draught are neglected and the resulting moment caused by the horizontal water pressure equals zero. The negative signs in Table 8 indicate that the moment is an overturning moment and the moments with a positive sign are restoring moments.

In both cases, the total moment is nearly equal to the moment due to buoyancy. The moment due to buoyancy is far greater than the other moments because of the large metacentric height. The platform will quickly restore itself to its initial position when it is forced in tilting.

7 Appendix 7: Connection types

First, there are two main types of connections possible for floating structures:

- Connections which leaves space between two adjacent platforms
- Connections which does not leave space between two adjacent platforms

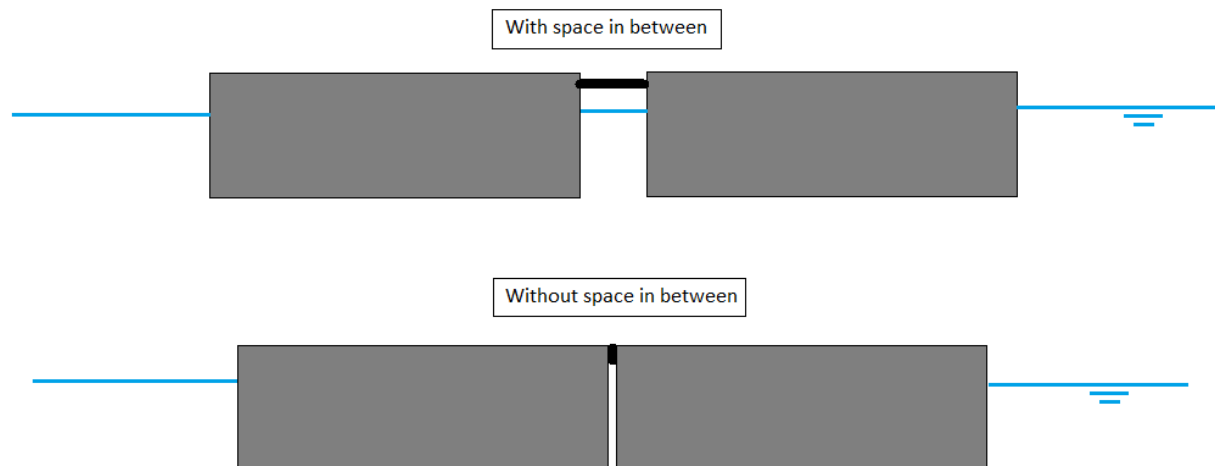

Figure 47: Two main types of connections

The connections which leaves space between two adjacent platforms are more like a bridge connection. The connections mostly do not restrict movements in the vertical direction (heave motions). When heave motions are not of great concern for the floating platforms, this type of connection is preferred as the heave motions of one platform will not affect the heave motions of the adjacent platform, so the two platforms can freely move in vertical direction completely independent from each other. This is because the connection does not transfer any vertical forces as the connection is in fact a beam with two hinges at each end. The main failure mechanism of the connection will be because of torsion, which is induced by relative roll and yaw motions.

Aside from the structural aspects, the use of connections with intermediate space between platforms also have aesthetic reasons. Like if each platform got a different owner, then the connection sort of acts like a border between the two territories. Due to the distance between the platforms, it is more difficult to move from one platform to the other. Specially designed infrastructure or bridges are always needed, which leads to larger investments for a large scale floating community. The infrastructure and bridges will be more expensive than regular structures because they have to withstand the internal forces due to the motions of the platforms too.

Depending on the desired movement restriction(s), there are different sub-types within the two main type connections. There are six degrees of freedoms for the connections to restrict, each of these degrees of freedom can be either rigid, compliant or fully released. This makes a total combination of 6 times 3 is 18 sub-types of connections possible. Although there are theoretically 18 possible combinations of movement restrictions, it is considered to always prevent the relative surge and sway motions. The relative surge and sway motions are the most basic motions and they need to be resisted to prevent the platforms from drifting away from each other. Note that the connections must prevent the relative surge and sway motions, thus the horizontal displacements of the platforms relative to each other. The

moorings attached to the platforms are there to resist the overall surge and sway motions of the whole floating community.

The most common sub-types of connections used in practice are the following:

- Fully flexible
- Vertical free (allowing relative heave)
- Hinged connection
- Fully rigid connection

When movements are restricted, large forces and moments are introduced into the platform and the connection. The choice/requirements of restricting certain degrees of freedom also greatly depends on the structural design of the connection and the platform.

Fully flexible connection

A fully flexible connection in fact does not restrict any major movements. This means that such connections have no structural value when certain movements are undesired. Undesired movements are usually prevented by the moorings when fully flexible connections are used. These connections are mostly used for transportation of cars and pedestrians (like a bridge) or ducts and cables etcetera. Fully flexible connections are common sub-types within the main category of connections with an intermediate distance between the platforms.

Vertical free connection (allowing relative heave)

By allowing relative heave motions between platforms, the vertical internal forces are greatly decreased in the connections and the platform. Relative heave motions are frequently occurring due to waves and/or unequal vertically imposed loads. When heave motions are not of great concern for the floating platforms, this type of connection is preferred as the heave motions of one platform will not affect the heave motions of the adjacent platform, so the two platforms can freely move in vertical direction completely independent from each other. Also because of the decrease in the internal vertical forces, the connection can be constructed lighter and simpler.

Hinged connection

When relative heave is undesirable but relative pitch is allowed, a hinged connection is used. A hinged connection has the structural property to only transfer shear and normal forces and no moments. A pure hinged connection allows relative pitch, but with more degrees of freedom it is also possible to allow certain roll and/or yaw movements to further decreasing the internal forces. An example of a hinged connection is the McDermott MOB connection system.

Fully rigid connection

When all relative movements are undesired, a fully rigid connection is to be used. Rigid connections prevent relative motions, but they also contribute to the decrease of the overall movement of the platforms. This is because the coupled floating platforms can be approximated as a single platform when rigidly connections are used. The combined length of the platforms will more likely be larger than the wavelength. If the length of the structure is greater than the wavelength, the heave response becomes significant smaller.

The connections without intermediate distance between the platforms are able to restrict movements in all directions, making these types of connections very rigid compared to connections with intermediate distance between the platforms. These connections are already designed to take on high internal loads and are therefore easier to be made rigid compared to the other type of connection. As a rigid connection is the most favourable for the floating city concept (all movements are undesired for maximum living comfort ability), it is chosen to only elaborate the connections without intermediate distance between the platforms.

A rigid connection is possible and preferred as long as the internal forces stay within the limits of the strength of the connection and platforms. When the internal forces exceed the strength of the connection or platform, failure occurs and it is better to allow more movements to reduce the internal forces. In most cases, the moments in the connection will be the largest in rigid connections. So if possible, it is best to apply semi-hinged connections to reduce the internal moments. This is only applicable when the roll, pitch and yaw movements of the platforms are within comfortable range for the floating city. An overview of the possible connections for floating platforms to be discussed is shown in the figure below.

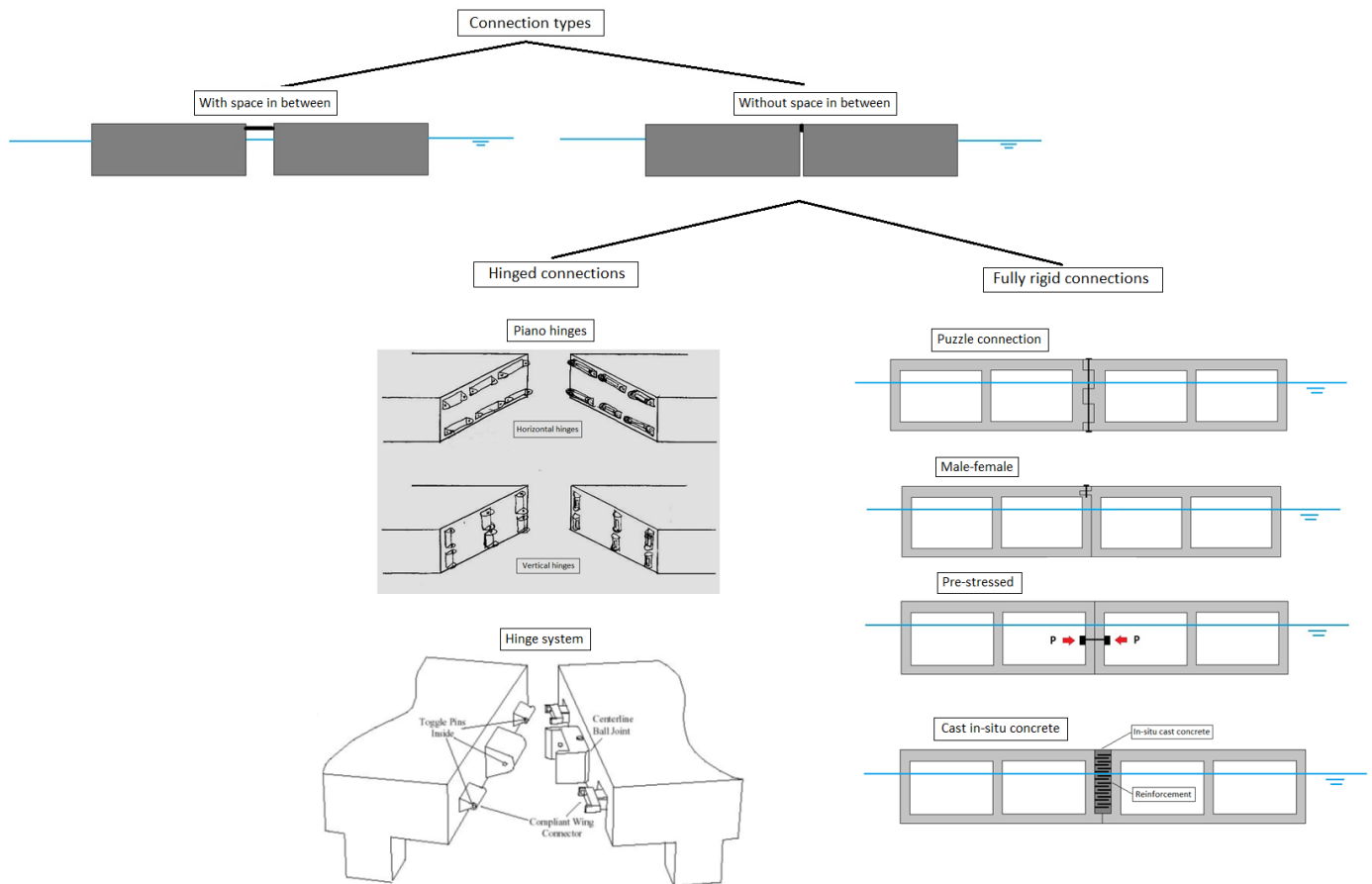

Figure 48: Overview of possible connections for floating platforms

When relative heave is undesirable but relative pitch is allowed, a hinged connection is used. A hinged connection has the structural property to only transfer shear and normal forces and no moments. A pure hinged connection allows relative pitch, but with more degrees of freedom it is also possible to allow certain roll and/or yaw movements to further decreasing the internal forces. An example of a hinged connection is the McDermott MOB connection system.

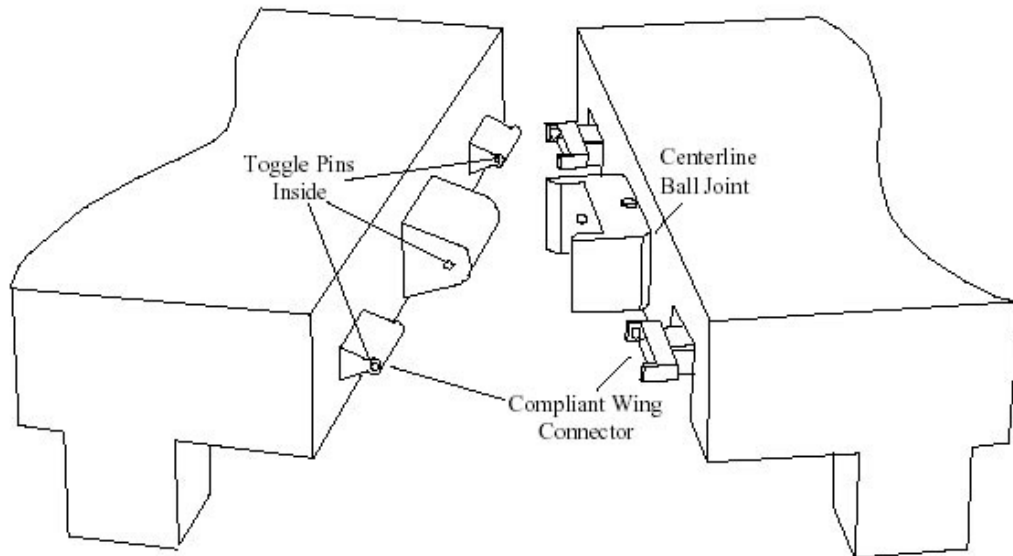

Figure 49: McDermott hinge connection (Koekoek, 2010)

Although the McDermott MOB connection is a hinged connection and is categorized as a connection without intermediate distance between the platforms, there is still a significant gap between the platforms because of the presence of the connection itself. This could be dangerous for the inhabitants on the floating community so this is seen as a disadvantage of this system. Another disadvantage would be that this connection uses quite expensive materials and labour as the connection must be specially fabricated.

7.1 Steel hinges

When relative heave is undesirable but relative pitch is allowed, a hinged connection is used. A hinged connection has the structural property to only transfer shear and normal forces and no moments. A pure hinged connection allows relative pitch, but with more degrees of freedom it is also possible to allow certain roll and/or yaw movements to further decreasing the internal forces. An example of a hinged connection is the McDermott MOB connection system.

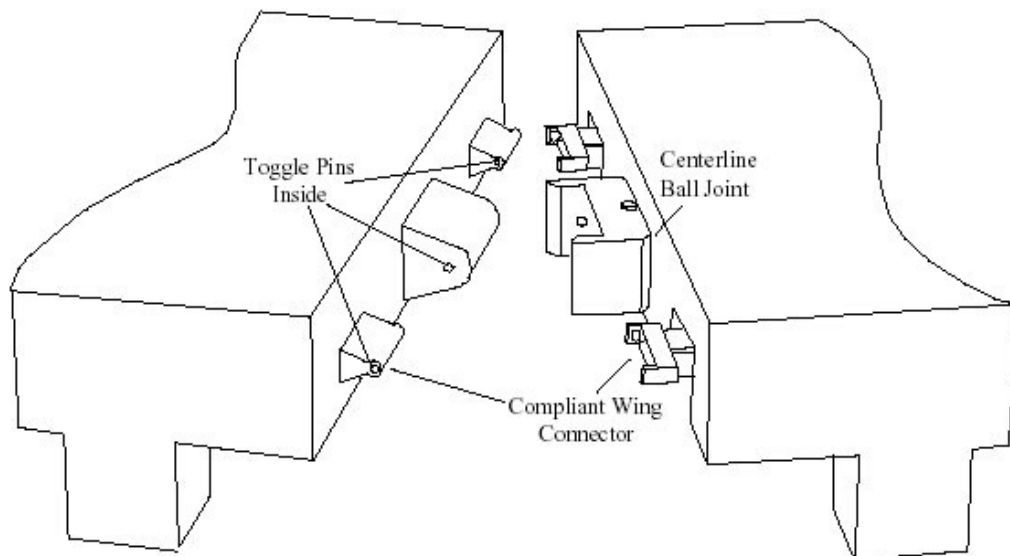

Figure 50: McDermott hinge connection (Koekoek, 2010)

Although the McDermott MOB connection is a hinged connection and is categorized as a connection without intermediate distance between the platforms, there is still a significant gap between the platforms because of the presence of the connection itself. This could be dangerous for the inhabitants on the floating community so this is seen as a disadvantage of this system. Another disadvantage would be that this connection uses quite expensive materials and labour as the connection must be specially fabricated.

Deriving from the McDermott MOB connection system, a simpler hinged connection can be made with a row of horizontal or vertical steel hinges. When two or three rows of steel hinges are used, more relative motions will be restricted. By distributing the connections over the sides, the rigidity increases and point loads decrease. A combination of horizontal and vertical steel hinges results in a fully rigid connection. The steel hinges are locked to each other by a steel bar/tube. This bar/tube is easier to insert for vertical steel hinges. The steel hinges can have quite large dimensions depending on the dimensions of the platform.

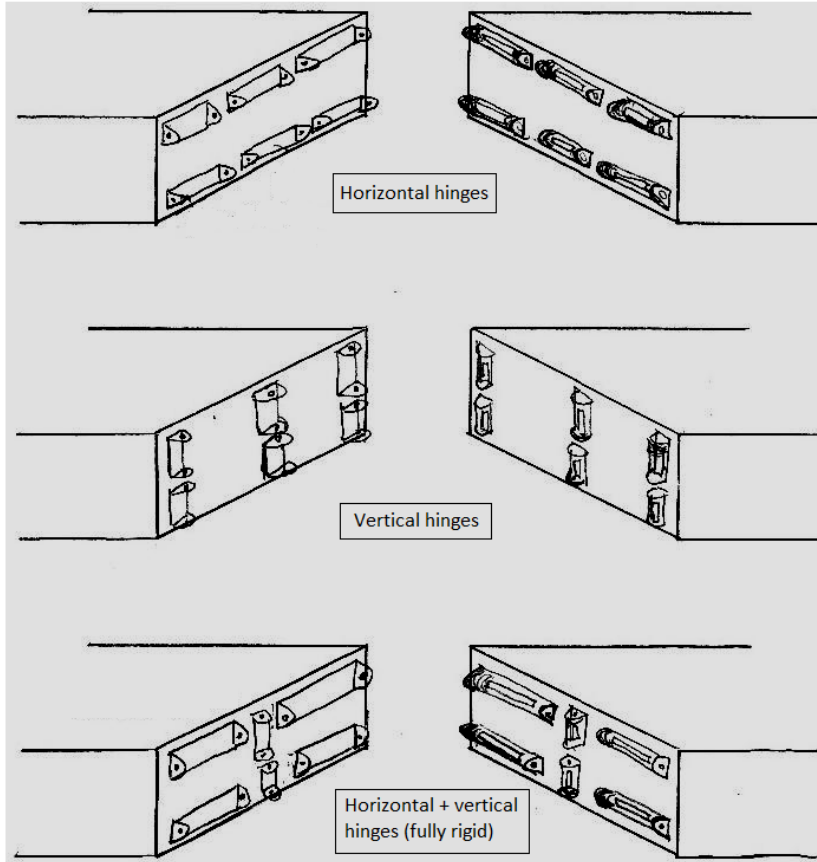

Figure 51: Steel hinged connection (Rooij, 2006)

Heave and pitch motions will hinder the coupling procedure. This is especially the case when a horizontal bar/tube is inserted into the hinges. Unlike other connection types, hinged connections have no means of self-alignment function as the protruding hinges are in the way. This means that the coupling procedure should be executed during calm environment circumstances.

Compared to concrete, steel is relative more expensive. Also, steel is more prone to corrosion and fatigue which means that the connections need to be maintained quite often. So more costs are involved.

7.2 Puzzle connection

These connections are actually different shaped edges of the platforms which fit on the opposite platform, just like how puzzle pieces work. When the platforms are connected to each other by pins or bolts fitting into the shaped edges of the platform, the connection becomes a fully rigid connection type. The puzzle type connection is in fact a vertical or horizontal free connection, depending on the shapes on the edge of the platform. Vertical shapes gives free movement in vertical direction while horizontal shapes give does not restrict sway movements. But with the adding of bolt/pins, the remaining degree of freedom can be restricted.

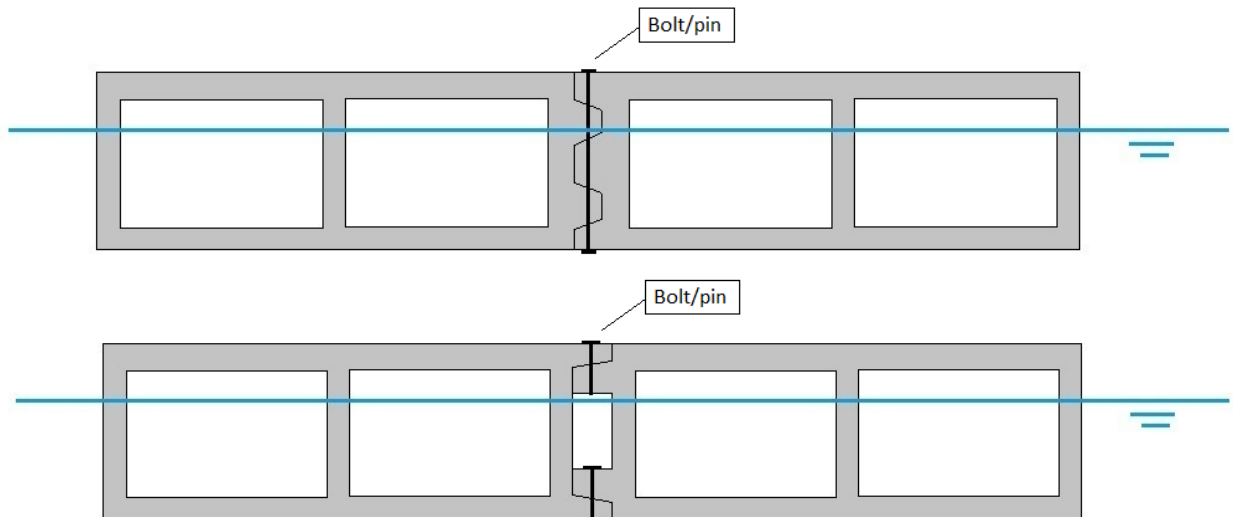

Figure 52: Puzzle type connection with bolt/pin, side view (horizontal shapes)

The protruding edges are mostly referred as teeth or studs and they can have different shapes like rectangular, trapezoidal or being rounded. The teeth/studs can be continues over the height or length/width of the platform or they can be interrupted. Continues teeth/studs need extra ridges and cavities for self-alignment to achieve an easy execution, so that the bolts/pins can be inserted accurately.

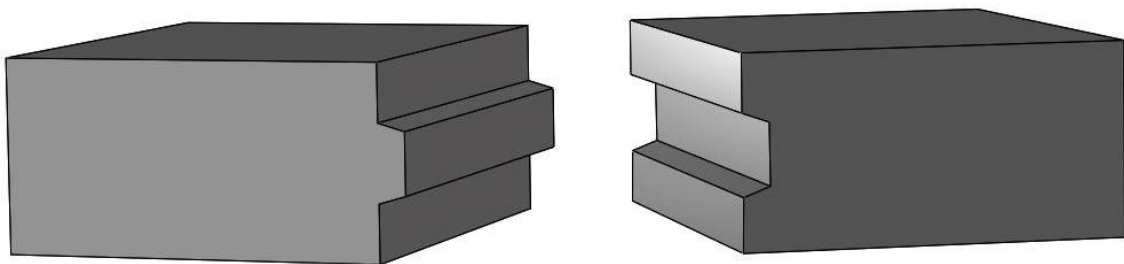

Figure 53: Continues teeth/studs

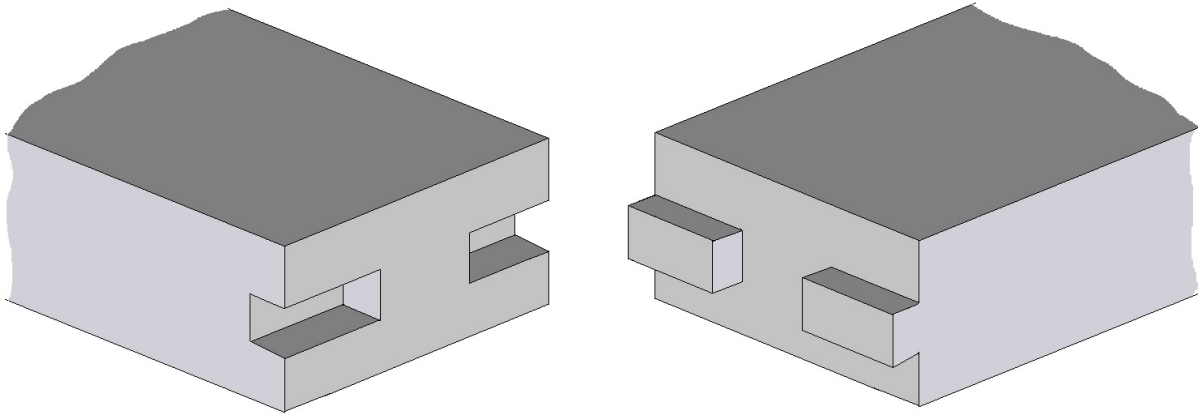

Figure 54: Interrupted teeth/studs

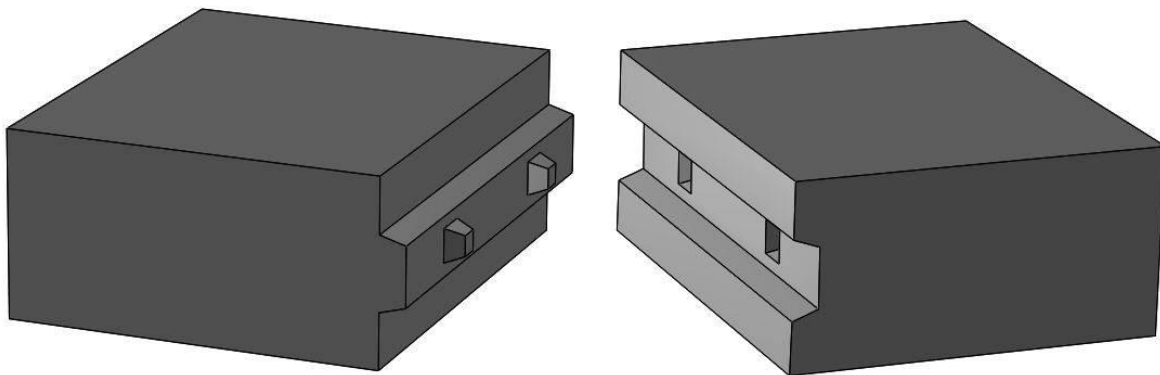

Figure 55: Continues teeth/studs with extra ridges and cavities for self-alignment

The puzzle type connection is a simple, solid and sturdy connection. The connectors are heavily built and can introduce large forces. The protruding teeth/studs will endure impacts from heave and pitch motions. The bolts/pins will mostly endure the surge and sway movements. The connection is quite durable because it is made of concrete. And due to the properties of concrete, the connection can bear high (compression) loads. The strength of the concrete teeth/studs can further be improved by reinforcement bars or pre-stressing steel.

Regarding the coupling procedure, the connection should be slid or shoved in place and then locked with bolts/pins immediately. This can be done very accurately, especially with the help of a ballast system which can control the vertical position of the platform.

7.3 Male-female connection

The male-female connection is in fact also a puzzle type connection. The male-female connection is only much simpler because of less material used for the connection. But also because of the less material used, this connection is great to be used when the draught of the platform is small as this connection cannot be executed near the underside of the platform. This connection would be more like a hinged connection when the draught of the platform is large.

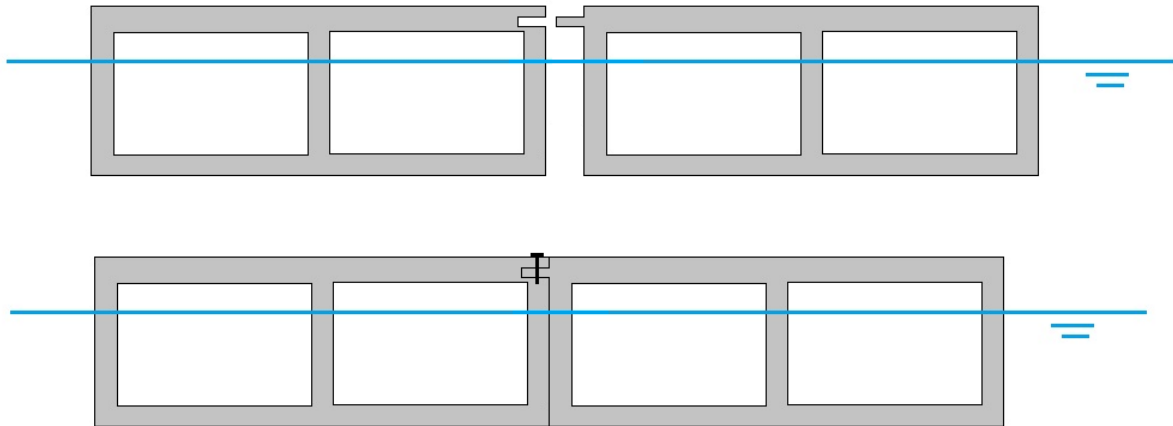

Figure 56: Male-female connection

An example of such a male-female connection already being realised is the Flexifloat connection. The Flexifloat Construction System is a connection system for portable, interlocking modular steel barges. The Flexifloating connection system is easy and quickly executed without the need of special equipment. The steel barges and connections of the Flexifloat system were designed for road transport by standard highway trucks and trailers.

The main advantage of this system is the ease of execution. However, this system faces difficulties during execution when the wave circumstances are too rough or the draught of the floating elements are uneven. Other disadvantages would be the durability as the Flexifloat concerns steel elements which are prone to corrosion.

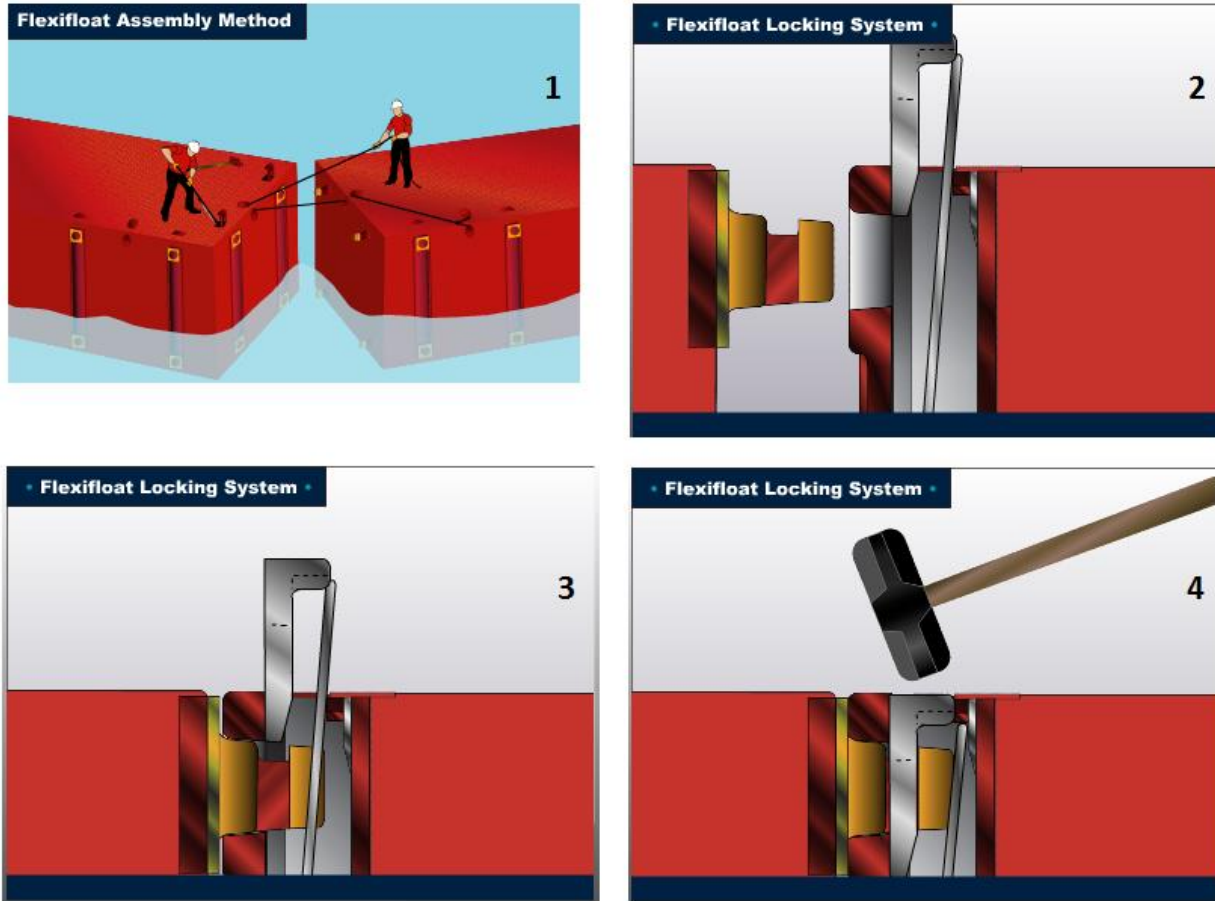

Figure 57: Flexifloat connection system ²¹

7.4 Hooks and cables

Hooks and cables are the simplest solution to keep the platforms together. But the simplicity also leaves this kind of connections less strong, rigid and reliable compared to other connection types.

7.5 Magnets

Magnets have a very strong attracting force which is very suitable to be used as a connection type for floating platforms. However, a lot of energy is required to keep all the magnets working and when there is a power outage all the platforms will be disconnected.

²¹ www.flexifloat.com

7.6 Pre-stressed connection

Floating platforms can be connected to each other by transiting cables or rods through the floating bodies and then tensioning the cables/rods. This way the cables/rods are pre-stressed and they exert a pre-stressing force on the structure. When the pre-stressing cables/rods are in the lower part of the floating body, the pre-stressing force will cause the platform to bend upwards. Without pre-stressing, the platform would bend and deform under the dead and vertical variable loads. So the upward bending due to the pre-stressing force compensates the downward bending due to vertical loads, this is the very principle of pre-stressing and is illustrated in Figure 59. However, for this principle to work on multiple platforms, the connection between the two platforms must be very strong and rigid. An alternative would be to pre-stress a cable/rod between the outer walls of the platforms only.

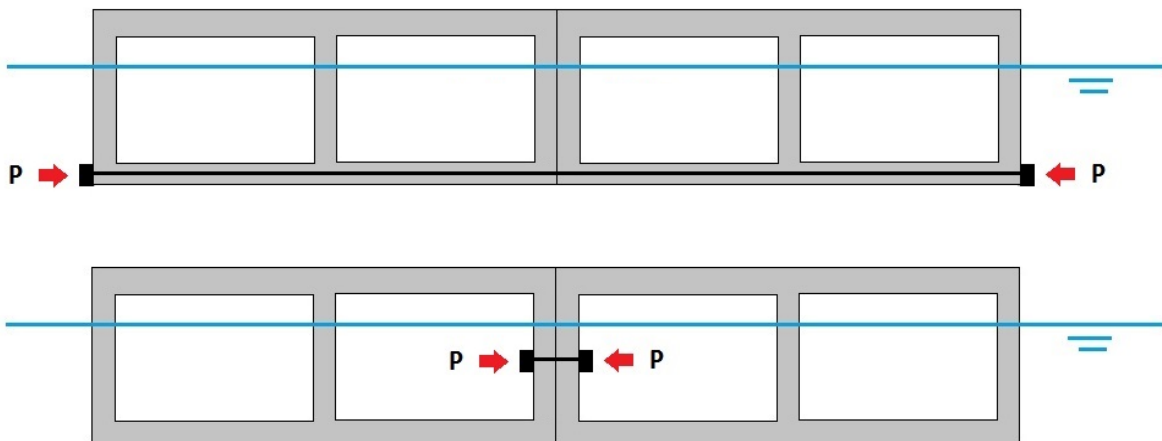

Figure 58: Pre-stressed connection

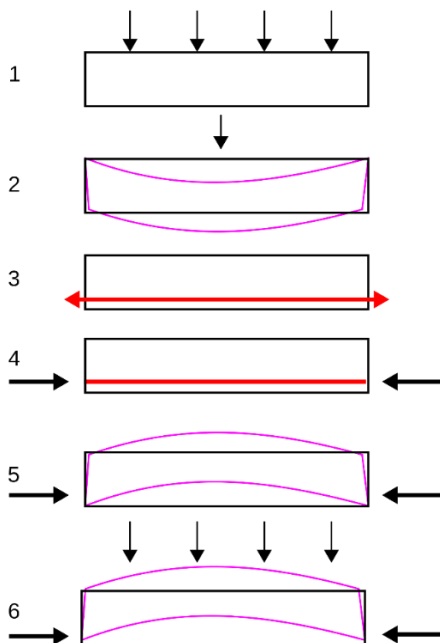

Figure 59: Principle of pre-stressing ²²

²² http://en.wikipedia.org/wiki/Prestressed_concrete

Main disadvantage of this kind of connection is the difficulty of execution since (salt) water may not enter the ducts where the cables/rods lie during pre-stressing, this will cause corrosion of the rods and affect the strength. Also, this type of connection is not able to be detached easily once applied.

7.7 Cast in-situ concrete connection

A very simple and straightforward method is to permanently connecting platforms to each other by casting concrete in between the platforms. The strength of the cast connection can be improved by reinforcement bars or even pre-stressing steel. The platforms should be temporarily hold together with other methods while the concrete is cast and be ready. Another problem would be the environment of the location of the floating city. Concrete needs a specific temperature and humidity during the whole process to achieve good quality concrete.

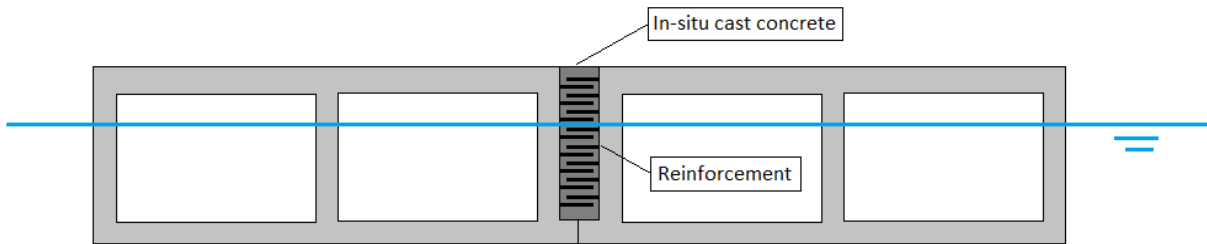

Figure 60: In-situ cast concrete connection

7.8 Pneumatic/hydraulic jacks

The company Mega-Float in Japan designed a disconnect-able connection which uses pneumatic/hydraulic jacks. The connection failed at an attempt of constructing a floating runaway in Japan, which means that this connection easily fails at high loads. The complicated connection is also very expensive which makes this type of connection not suitable for the floating city concept.

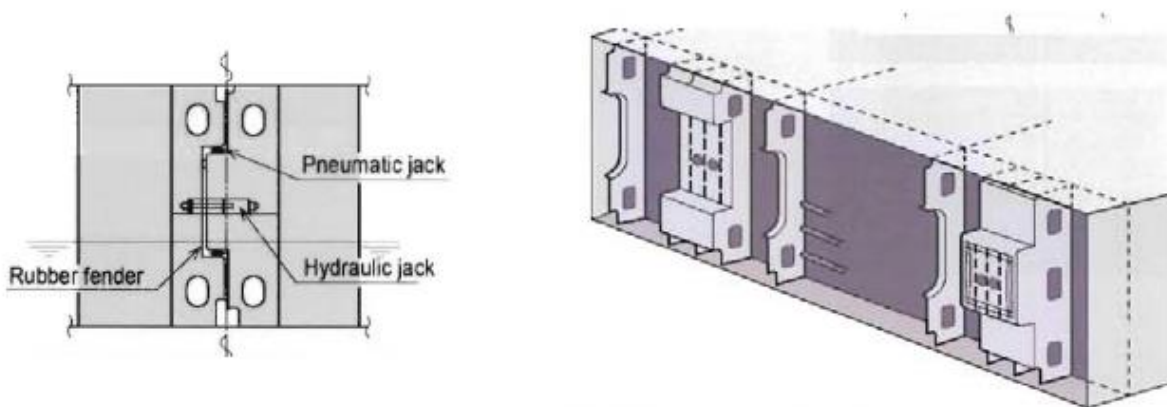

Figure 61: Hydraulic/pneumatic jack connection

8 Appendix 8: Structural analysis

8.1 Frequency comfort levels

The dynamic analysis provides information about the movements of the platforms when loaded by a wave load. These movements (heave, sway, roll etcetera) can cause discomfort of living on the platform. There are several ways to determine the comfort level for the inhabitants. However, all these methods are not 100% accurate as many factors play a role in determining the vibration nuisance, like:

- Intensity
- Frequency
- Duration of action
- Frequency of occurrence
- Location
- Direction
- Position of the body
- Health of inhabitants
- Activity
- Secondary effects (slamming, jingling etc.)

In the Netherlands, the limit values for vibration nuisance are derived from:

- TNO
- DIN 4150 part 2 1975 (pre-norm)
- ISO 2631

TNO

The limits for the permissibility of vibrations for humans according to TNO are given in Figure 62. The figure is derived from a TNO report BI-67-107 drawn up by H. van Koten on the basis of ISO 2631. In this graph, there are several levels of 'noticeability' of the vibration nuisance. Depending on the accelerations of the structure and the occurring frequency, the level of 'noticeability' can be determined.

DIN 4150 (pre-norm 1975)

The DIN 4150 limits for vibration nuisance were stated in Germany. Similarly as the TNO graph, the DIN graph also states a few different levels of vibration nuisances. The difference is that the DIN graph is also dependent on the following:

- Location of the vibration (type of area)
- Time of day
- Frequency of occurrence

ISO 2631

ISO 2631 uses simple graphs and formulas compared to TNO and DIN 4150. Only three different levels are being distinguished:

- Limit I (reduced comfort boundary): An acceptable limit value of the vibration level for everyday activities.
- Limit II (fatigue-decreased boundary): Repeatedly vibration nuisance at which persons shows signs of fatigue.
- Limit III (exposure limit): Maximum tolerable vibration nuisance for humans

Between the methods of TNO, DIN 4150 and ISO 2631, in practice it is preferred to use the graphs of TNO and DIN 2631 as ISO 2631 has a shallower distinction between nuisance levels. DIN 4150 is preferred when the assessment of vibration nuisance is for well-described situations. In this thesis, the graph of TNO will be used to determine the comfort level of vibration nuisances.

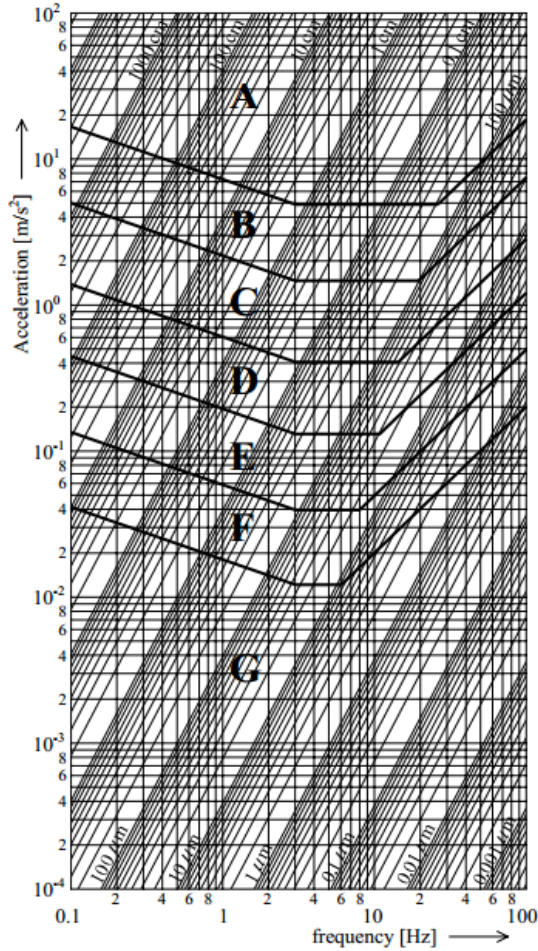

description of noticeability	admissibility for people in buildings	global judgement of influence on structures	examples
A unbearable	inadmissible	possible collapse	emergencies
B unpleasant quickly tiresome	inadmissible	local damage	sudden pulling up of a car
C strongly noticeable	hardly admissible	cracking of masonry	elevators trams
D clearly noticeable	rough manual labour	Introduction of light cracking	start of seasickness
E noticeable	short periods in houses	no influence on normal buildings	
F hardly noticeable	long periods in houses	no influence	
G not noticeable		no influence	

Figure 62: Limits to accelerations according to TNO (CIE4140 Dynamics of structures lecture notes)

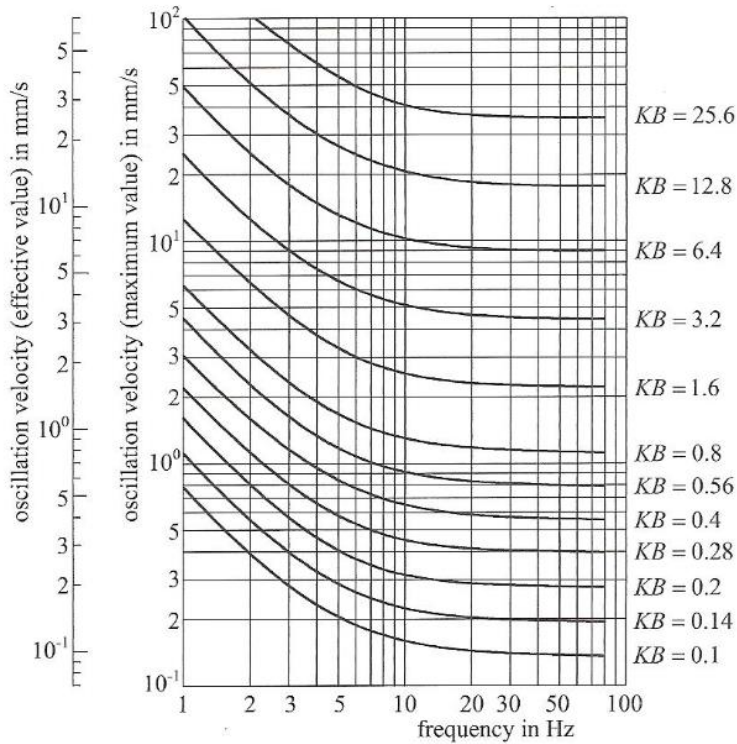

	1	2	3	4
	Baugebiet ¹⁾	Zeit	<i>KB</i> -Anhaltswerte dauernd und mit Unterbrechungen wiederholt zutretenden Erschütterungen	seltener auftretende Erschütterungen
1	Reines Wohngebiet (WR) Allgemeines Wohngebiet (WA) Wochenendhausgebiet (SW) Kleinsiedlungsgebiet (WS)	tage	0.2 (0.15) ²⁾	4
		nachts	0.15 (0.1) ²⁾	0.15
2	Dorfgebiet (MO) Mischgebiet (MI) Kerngebiet (MK)	tage	0.3 (0.2) ²⁾	8
		nachts	0.2	0.2
3	Gewerbegebiet (GE) (gilt auch für Büroräume)	tage	0.4	12
		nachts	0.3	0.3
4	Industriegebiet (GI)	tage	0.6	12
		nachts	0.4	0.4
5	Sondergebiet nach Nutzungsart und Wohnungsarten (SO)	tage	0.1 bis 0.6	4 bis 12
		nachts	0.1 bis 0.4	0.15 bis 0.4

¹⁾ Die Baugebiete entsprechen der Verordnung über die bauliche Nutzung der Grundstücke (Baunutzungsverordnung - Bau NVO -) vom 28.11.1988 (BGBl. I S.1237 und 1989 S.11). Weicht die tatsächliche bauliche Nutzung im Einwirkungsbereich der Anlage erheblich von der im Bebauungsplan festgesetzten baulichen Nutzung ab, so ist von der tatsächlichen baulichen Nutzung unter Berücksichtigung der vorgesehenen baulichen Entwicklung des Gebietes auszugehen.

²⁾ Das Einhalten der in Klammern angegebenen Werte ist insbesondere bei horizontalen Erschütterungen von Gebäuden bei Frequenzen unterhalb von etwa 5 Hz anzustreben.

Figure 63: Limits to velocities according to DIN 4150 (CIE4140 Dynamics of structures lecture notes)

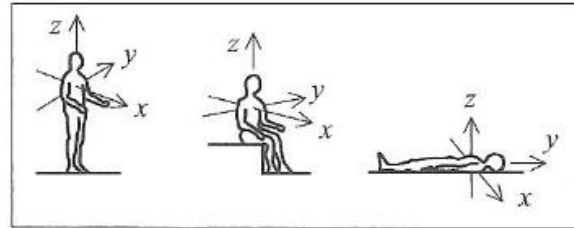
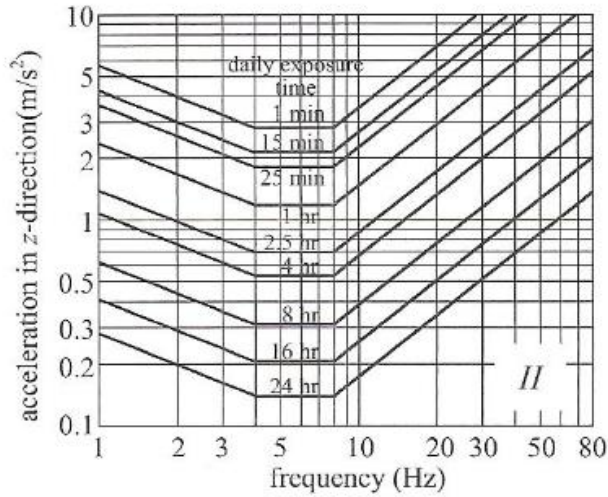

$$a_{eff} = \sqrt{\frac{1}{T} \int_0^T a^2(t) dt}$$

Limit I

This limit is obtained by division of the above formulae by 3.15

Limit II

See the figures

Limit III

This limit is obtained by multiplication of the above formulae by 2

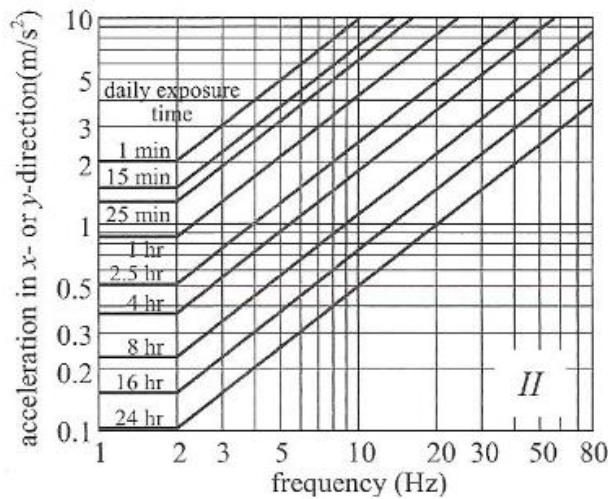

Figure 64: Limits to accelerations according to ISO 2631 (CIE4140 Dynamics of structures lecture notes)

8.2 Equation of motion set-up for 1 mass-spring system

The floating platform can be schematized as a rigid, infinite stiff block founded on vertical and horizontal springs. These kinds of schematizations are called mass-spring systems. In reality, the platform is not infinitely stiff and hogging/sagging moments occur, but these are neglected for now and are to be calculated in the structural design of the platform. The springs represent the 'stiffness' of the water which are used to indicate the hydrostatic forces on the floating platform. Furthermore, the platform is excited by a sinusoidal motion which represents the vertical wave motion.

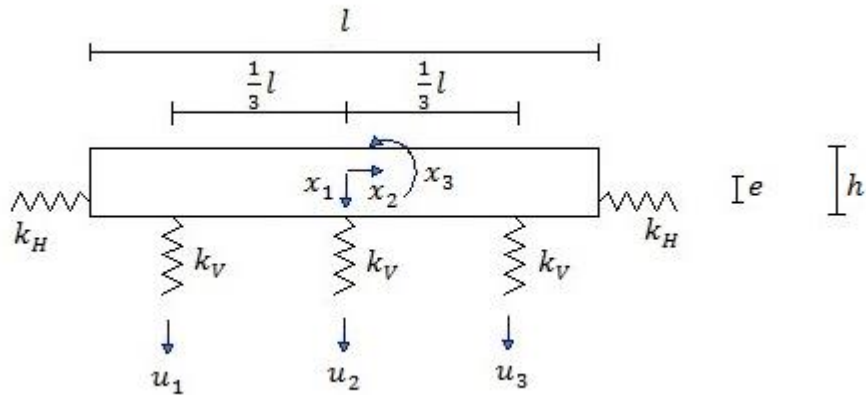

Figure 65: Floating structure schematised as a mass-spring system

In Figure 65: k_V = spring stiffness of water in vertical direction
 k_H = spring stiffness of water in horizontal direction

l = length of floating structure
 e = eccentricity of water mass on the sides (half of the draught)

Vertical wave motions:
 $u_1(t) = H_s \sin(\omega(t - \Delta t))$
 $u_2(t) = H_s \sin(\omega t)$
 $u_3(t) = H_s \sin(\omega(t + \Delta t))$

The hydrostatic forces act on the whole underside of the platform, so it would be logical to assume that the springs should be represented as a continuous spring system. However, for the convenience and understanding of the calculations it is chosen to represent the hydrostatic forces with 3 individual springs.

The vertical spring stiffness of the water can be calculated with the principle of Archimedes:

$$F_{buoyancy} = \rho_w g V = \rho g * A * D$$

$$\frac{F_{buoyancy}}{D} = k = \rho_w g * A$$

Where:

- $F_{buoyancy}$ = Buoyant force/Archimedes force
- ρ_w = Density of fluid
- g = Acceleration due to gravity
- V = Volume of displaced fluid
- A = Bottom area of structure
- D = Draught

This value of the vertical spring stiffness is divided by 3 to obtain the spring stiffness of each individual spring. The horizontal spring stiffness of the water is calculated in a same approach.

To determine the displacements and forces on the floating structure, the displacement method is used to set up the equations of motion. The positive motions are in the directions of x_1 , x_2 and x_3 depicted in Figure 65. The movements in x_1 , x_2 and x_3 direction are the heave, sway and roll motion respectively. The displacements in the directions of x_1 , x_2 and x_3 are displayed in the figures below.

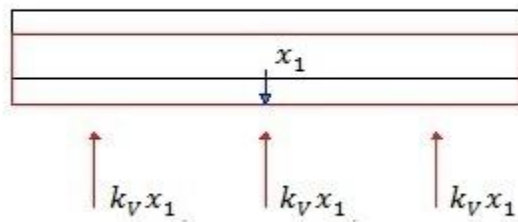

Figure 66: Motion in x_1 direction (heave)



Figure 67: Motion in x_2 direction (sway)

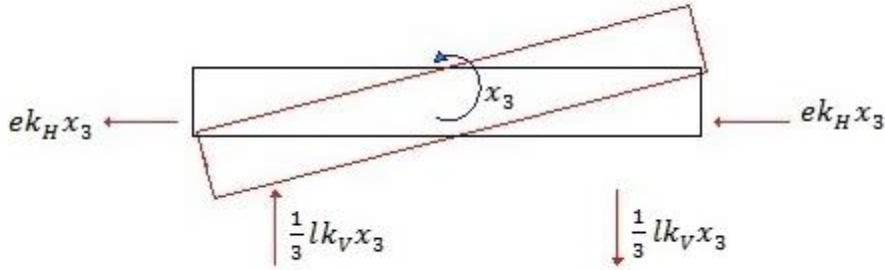

Figure 68: Motion in x_3 direction (roll)

With the displacement method, each direction of the body (degree of freedom) is given a displacement to see what forces acts on the body. According to Newton's law, the equation of motion for each direction can be set up by collecting the respective forces.

Vertical force equilibrium:

$$M\ddot{x}_1 = -k_V(x_1 - u_1) - k_V(x_1 - u_2) - k_V(x_1 - u_3) + \frac{1}{3}lk_V x_3 - \frac{1}{3}lk_V x_3$$

Horizontal forces equilibrium:

$$M\ddot{x}_2 = -k_H x_2 - k_H x_2 - ek_H x_3 - ek_H x_3$$

Momentum equilibrium:

$$J\ddot{x}_3 = ek_H x_2 + ek_H x_2 - e^2 k_H x_3 - e^2 k_H x_3 - \frac{1}{3}lk_V \left(x_1 + \frac{1}{3}lx_3 - u_1\right) + \frac{1}{3}lk_V \left(x_1 - \frac{1}{3}lx_3 - u_3\right)$$

After some mathematically ordering, the equation of motion is presented as follows:

$$M\ddot{x}_1 + 3k_V x_1 = k_V(u_1 + u_2 + u_3)$$

$$M\ddot{x}_2 + 2k_H x_2 + 2ek_H x_3 = 0$$

$$J\ddot{x}_3 + 2ek_H x_2 + \left(2e^2 k_H + \frac{2}{9}l^2 k_V\right) x_3 = \frac{1}{3}lk_V(u_1 - u_3)$$

The set of equation of motions can be written in matrix form see below.

$$\begin{bmatrix} M & 0 & 0 \\ 0 & M & 0 \\ 0 & 0 & J \end{bmatrix} * \begin{bmatrix} \ddot{x}_1 \\ \ddot{x}_2 \\ \ddot{x}_3 \end{bmatrix} + \begin{bmatrix} 3k_V & 0 & 0 \\ 0 & 2k_H & 2ek_H \\ 0 & 2ek_H & 2e^2 k_H + \frac{2}{9}l^2 k_V \end{bmatrix} * \begin{bmatrix} x_1 \\ x_2 \\ x_3 \end{bmatrix} = \begin{bmatrix} k_V(u_1 + u_2 + u_3) \\ 0 \\ \frac{1}{3}lk_V(u_1 - u_3) \end{bmatrix}$$

Aside from the vertical spring stiffness of the water, the floating structure is being moored with anchors to the bottom of the sea which are also schematized as springs.

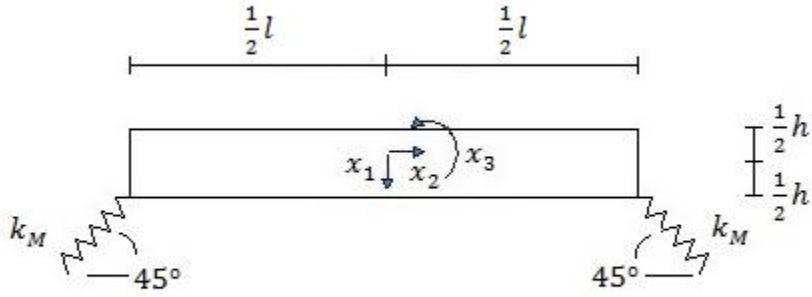

Figure 69: 1 mass-spring system with moorings only

In Figure 69: $k_M =$ spring stiffness of mooring line
 $l =$ length of floating structure
 $h =$ height of the floating structure

For the spring stiffness of the chains, the Law of Hooke is being used: $k_M = \frac{EA}{l_M}$, where EA is the stiffness of the mooring line (2110 MN) and l_M is the length of the mooring line.

The displacement method is again applicable to this situation, see the figures below.

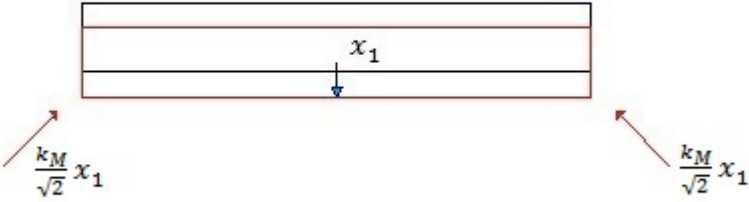

Figure 70: Motion in x_1 direction (heave)



Figure 71: Motion in x_2 direction (sway)

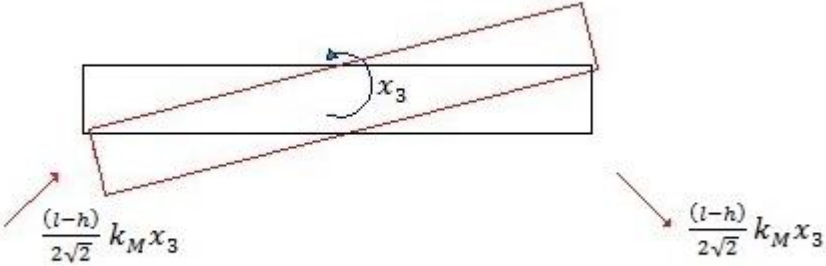

Figure 72: Motion in x_3 direction (roll)

The elongation/shortening of the springs due to the x_3 rotation is a bit tricky to determine as the corners of the structure have both a horizontal and vertical displacement. Each displacement gives a different elongation and shortening of the spring. The net elongation/shortening of the spring is the difference of the elongation/shortening of each displacement. The horizontal and vertical displacements can be converted to an elongation/shortening of the spring respectively $\frac{1}{2}hx_3$ and $\frac{1}{2}lx_3$. The net elongation/shortening of the spring is then: $\frac{1}{2}lx_3 - \frac{1}{2}hx_3 = \frac{(l-h)}{2\sqrt{2}}x_3$

The equation of motion for this mass-spring system is as follows:

Vertical force equilibrium:

$$M\ddot{x}_1 = \frac{1}{\sqrt{2}} \left(-\frac{k_M}{\sqrt{2}}x_1 - \frac{k_M}{\sqrt{2}}x_1 + \frac{k_M}{\sqrt{2}}x_2 - \frac{k_M}{\sqrt{2}}x_2 + \frac{(l-h)}{2\sqrt{2}}k_Mx_3 - \frac{(l-h)}{2\sqrt{2}}k_Mx_3 \right)$$

Horizontal force equilibrium:

$$M\ddot{x}_2 = \frac{1}{\sqrt{2}} \left(\frac{k_M}{\sqrt{2}}x_1 - \frac{k_M}{\sqrt{2}}x_1 - \frac{k_M}{\sqrt{2}}x_2 - \frac{k_M}{\sqrt{2}}x_2 + \frac{(l-h)}{2\sqrt{2}}k_Mx_3 + \frac{(l-h)}{2\sqrt{2}}k_Mx_3 \right)$$

Momentum equilibrium:

$$J\ddot{x}_3 = \frac{1}{\sqrt{2}} \left(\frac{1}{2}l\frac{k_M}{\sqrt{2}}x_1 - \frac{1}{2}l\frac{k_M}{\sqrt{2}}x_1 + \frac{1}{2}h\frac{k_M}{\sqrt{2}}x_1 - \frac{1}{2}h\frac{k_M}{\sqrt{2}}x_1 + \frac{1}{2}l\frac{k_M}{\sqrt{2}}x_2 + \frac{1}{2}l\frac{k_M}{\sqrt{2}}x_2 - \frac{1}{2}h\frac{k_M}{\sqrt{2}}x_2 - \frac{1}{2}h\frac{k_M}{\sqrt{2}}x_2 - \frac{1}{2}l\frac{(l-h)}{2\sqrt{2}}k_Mx_3 - \frac{1}{2}l\frac{(l-h)}{2\sqrt{2}}k_Mx_3 + \frac{1}{2}h\frac{(l-h)}{2\sqrt{2}}k_Mx_3 + \frac{1}{2}h\frac{(l-h)}{2\sqrt{2}}k_Mx_3 \right)$$

All the terms are multiplied with $\frac{1}{\sqrt{2}}$ to split the diagonal forces into a horizontal and vertical component.

After some mathematical ordering, the equation of motion is presented as follows:

$$M\ddot{x}_1 + k_Mx_1 = 0$$

$$M\ddot{x}_2 + k_Mx_2 - \frac{l-h}{2}k_Mx_3 = 0$$

$$J\ddot{x}_3 - \frac{(l-h)}{2}k_Mx_2 - \frac{(l-h)(h-l)}{4}k_Mx_3 = 0$$

The set of equation of motions can be written in matrix form see below.

$$\begin{bmatrix} M & 0 & 0 \\ 0 & M & 0 \\ 0 & 0 & J \end{bmatrix} * \begin{bmatrix} \ddot{x}_1 \\ \ddot{x}_2 \\ \ddot{x}_3 \end{bmatrix} + \begin{bmatrix} k_M & 0 & 0 \\ 0 & k_M & -\frac{l-h}{2}k_M \\ 0 & -\frac{(l-h)}{2}k_M & -\frac{(l-h)(h-l)}{4}k_M \end{bmatrix} * \begin{bmatrix} x_1 \\ x_2 \\ x_3 \end{bmatrix} = \begin{bmatrix} 0 \\ 0 \\ 0 \end{bmatrix}$$

In combination with the equation of motion due to the water buoyancy, the stiffness matrix K of the system including water buoyancy and moorings can be constructed:

$$K = \begin{bmatrix} 3k_V + k_M & 0 & 0 \\ 0 & 2k_H + k_M & 2ek_H - \frac{l-h}{2}k_M \\ 0 & 2ek_H - \frac{(l-h)}{2}k_M & 2e^2k_H + \frac{2}{9}l^2k_V - \frac{(l-h)(h-l)}{4}k_M \end{bmatrix}$$

With the addition of the added mass, the equations of motion are as following in matrix form:

$$\begin{bmatrix} M_{platform} + M_{building} + M_z & 0 & 0 \\ 0 & M_{platform} + M_{building} + M_y & M_{buildingz} \\ 0 & M_{buildingz} & J + M_\theta \end{bmatrix} + \begin{bmatrix} 3k_V + k_M & 0 & 0 \\ 0 & 2k_H + k_M & 2ek_H - \frac{l-h}{2}k_M \\ 0 & 2ek_H - \frac{(l-h)}{2}k_M & 2e^2k_H + \frac{2}{9}l^2k_V - \frac{(l-h)(h-l)}{4}k_M \end{bmatrix} = \begin{bmatrix} k_V(u_1 + u_2 + u_3) \\ 0 \\ \frac{1}{3}lk_V(u_1 - u_3) \end{bmatrix}$$

The displacements of the platform are obtained by assuming the steady-state response of the structure; this can be done with the help of the program Maple.

The steady-state response is a solving method to obtain the amplitudes of the displacements as a function of the frequency. The displacements of the structure (in this case x_1 , x_2 and x_3) are given an assumption in the form of the external excitation (in this case u_1 , u_2 and u_3).

$$\begin{aligned} u_1(t) &= H_s \sin(\omega(t - \Delta t)) \\ u_2(t) &= H_s \sin(\omega t) \\ u_3(t) &= H_s \sin(\omega(t + \Delta t)) \end{aligned}$$

The terms u_1 and u_3 can be written in a sine and cosines form by implementing it in the Taylor series to get rid of the Δt in the sine function:

$$\begin{aligned} u_1 &= H_s * (\sin(\omega t) - \cos(\omega t) * \omega \Delta t) \\ u_3 &= H_s * (\sin(\omega t) + \cos(\omega t) * \omega \Delta t) \end{aligned}$$

The vertical displacement x_1 is assumed to be identical to this function, but with a yet unknown amplitude A_1 and B_1 : $x_1(t) = A_1 * \sin(\omega t) + B_1 * \cos(\omega t)$. By substituting this assumed function for x_1 (and x_2 and x_3 likewise) into the equation of motions, a total of 6 unknown amplitudes (A_1 , A_2 , A_3 , B_1 , B_2 and B_3) can be obtained as a function of the frequency.

```

> restart:
>
> x1:=A1*sin(w*t)+B1*cos(w*t):
> x2:=A2*sin(w*t)+B2*cos(w*t):
> x3:=A3*sin(w*t)+B3*cos(w*t):
>
> u1:=Hs*sin(w*(t-dt)):
> u2:=Hs*sin(w*t):
> u3:=Hs*sin(w*(t+dt)):
>
> u1:=Hs*(sin(w*t)-cos(w*t) *w*dt):
> u2:=Hs*(sin(w*t) ):
> u3:=Hs*(sin(w*t)+cos(w*t) *w*dt):
>
> eq1:=(Mplatform +Mbuilding +Mzwater)*diff(x1,t,t)
+ (3*kV+kM)*x1 -kV*(u1+u2+u3) = 0:
> eq2:=(Mplatform +Mbuilding +Mywater)*diff(x2,t,t)
+Mbuilding*z*diff(x3,t,t) +(2*kH+kM)*x2 +(2*e*kH-(1-h)*kM/2)*x3
= 0:
> eq3:=(J +Mthetawater)*diff(x3,t,t) +Mbuilding*z*diff(x2,t,t)
+(2*e*kH-(1-h)*kM/2)*x2 +(2*e^2*kH+(2/9)*1^2*kV-((1-h)*(h-
1))*kM/4)*x3 -(1/3)*1*kV*(u1-u3) = 0:
>
> collect(expand(eq1),{cos(w*t),sin(w*t)});
      (-B1 Mzwater w2 - B1 w2 Mbuilding - B1 w2 Mplatform + B1 kM
      + 3 B1 kV) cos(w t) + (-A1 Mzwater w2 - A1 w2 Mbuilding
      - A1 w2 Mplatform + A1 kM + 3 A1 kV - 3 Hs kV) sin(w t) = 0

> eq11:=-B1*Mzwater*w^2-B1*w^2*Mbuilding-
B1*w^2*Mplatform+B1*kM+3*B1*kV=0:
> eq12:=-A1*Mzwater*w^2-A1*w^2*Mbuilding-
A1*w^2*Mplatform+A1*kM+3*A1*kV-3*Hs*kV=0:
>
> collect(expand(eq2),{cos(w*t),sin(w*t)});
      (-Mplatform B2 w2 - Mbuilding B2 w2 - Mywater B2 w2
      - Mbuilding z B3 w2 + 2 kH B2 + kM B2 + 2 e kH B3
      +  $\frac{1}{2}$  kM h B3 -  $\frac{1}{2}$  kM l B3) cos(w t) + (-Mplatform A2 w2
      - Mbuilding A2 w2 - Mywater A2 w2 - Mbuilding z A3 w2
      + 2 kH A2 + kM A2 + 2 e kH A3 +  $\frac{1}{2}$  kM h A3 -  $\frac{1}{2}$  kM l A3)
      sin(w t) = 0

```

```

> eq21:=-Mplatform*B2*w^2-Mbuilding*B2*w^2-Mywater*B2*w^2-
Mbuilding*z*B3*w^2+2*kH*B2+kM*B2+2*e*kH*B3+(1/2)*kM*h*B3-
(1/2)*kM*l*B3=0:
> eq22:=-Mplatform*A2*w^2-Mbuilding*A2*w^2-Mywater*A2*w^2-
Mbuilding*z*A3*w^2+2*kH*A2+kM*A2+2*e*kH*A3+(1/2)*kM*h*A3-
(1/2)*kM*l*A3=0:
>
> collect(expand(eq3), {cos(w*t), sin(w*t)});
      (
      -JB3 w^2 - Mthetawater B3 w^2 - Mbuilding z B2 w^2 + 2 e kH B2
      + 1/2 kM h B2 - 1/2 kM l B2 + 2 e^2 kH B3 + 2/9 l^2 kV B3
      + 1/4 h^2 kM B3 - 1/2 h kM l B3 + 1/4 kM l^2 B3
      + 2/3 l kV Hs w dt) cos(w t) + (
      -JA3 w^2 - Mthetawater A3 w^2
      - Mbuilding z A2 w^2 + 2 e kH A2 + 1/2 kM h A2 - 1/2 kM l A2
      + 2 e^2 kH A3 + 2/9 l^2 kV A3 + 1/4 h^2 kM A3 - 1/2 h kM l A3
      + 1/4 kM l^2 A3) sin(w t) = 0

> eq31:=-J*B3*w^2-Mthetawater*B3*w^2-
Mbuilding*z*B2*w^2+2*e*kH*B2+(1/2)*kM*h*B2-
(1/2)*kM*l*B2+2*e^2*kH*B3+(2/9)*l^2*kV*B3+(1/4)*h^2*kM*B3-
(1/2)*h*kM*l*B3+(1/4)*kM*l^2*B3+(2/3)*l*kV*Hs*w*dt=0:
> eq32:=-J*A3*w^2-Mthetawater*A3*w^2-
Mbuilding*z*A2*w^2+2*e*kH*A2+(1/2)*kM*h*A2-
(1/2)*kM*l*A2+2*e^2*kH*A3+(2/9)*l^2*kV*A3+(1/4)*h^2*kM*A3-
(1/2)*h*kM*l*A3+(1/4)*kM*l^2*A3=0:
>
>
sol:=solve({eq11,eq12,eq21,eq22,eq31,eq32},{A1,A2,A3,B1,B2,B3}):
> assign(sol);
>
> g:=9.81: rho:=1025: l:=104: b:=60: h:=14: d:=11: e:=1.5:
z:=32: dwater:=100:
> Mplatform:=736684/g*1000: J:=Mplatform*(l^2/12+h^2/12):
> Mbuilding:=2*91500/g*1000:
> Mzwater:=0.5*rho*3.14*b*(1/2)^2: Mywater:=0.5*rho*3.14*b*d^2:
Mthetawater:=rho*3.14*((1/4)^4+(d/2)^2*(d/2+4)^2)*b:
> kV:=(rho*g*l*b)/(3*1000): kH:=(rho*g*b*d)/1000: EA:=2110:
lm:=sqrt(2*dwater^2): kM:=(EA/lm)*1000:
> Hs:=4/2: T:=8.6: Lwave:=76.5: c:=Lwave/T: dt:=(1/3)*(1/c):
>

```

```
> plot(max(abs(A1),abs(B1)),w=0..0.05,0..10,title="Amplitude
frequency response of vertical displacement
(x1)",labels=["frequency w [rad/s]","Amplitude
[m]"],labeldirections=["horizontal","vertical"]);
```

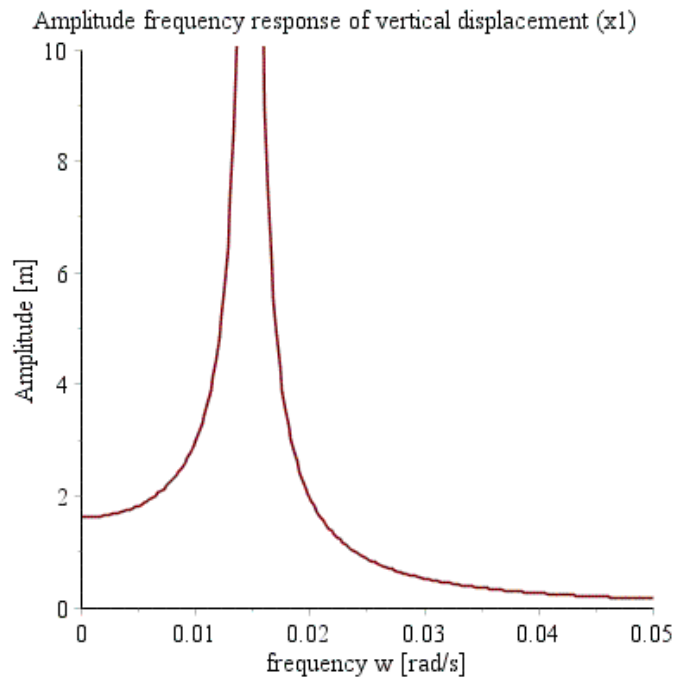

```
> plot(max(abs(A2),abs(B2)),w=0..0.05,0..5,title="Amplitude
frequency response of horizontal displacement
(x2)",labels=["frequency w [rad/s]","Amplitude
[m]"],labeldirections=["horizontal","vertical"]);
```

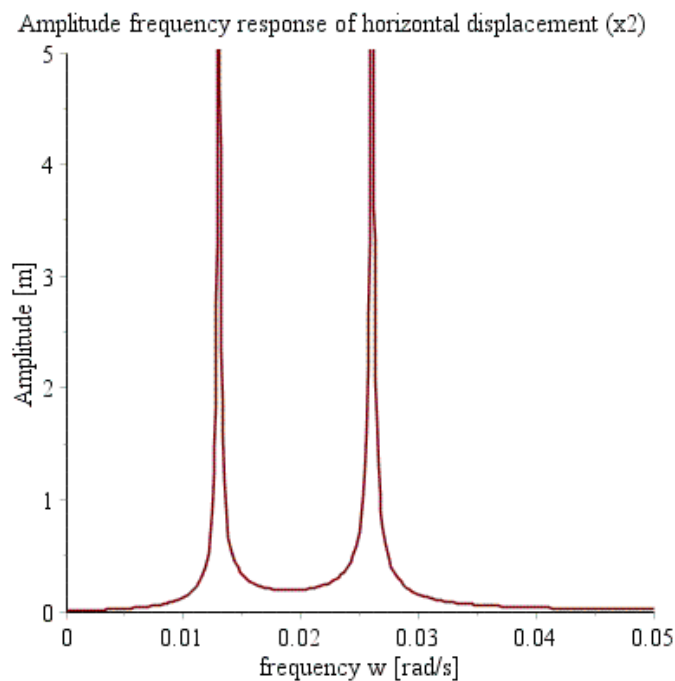

```
> plot(max(abs(A3),abs(B3)),w=0..0.05,0..3,title="Amplitude
frequency response of rotational displacement
(x3)",labels=["frequency w [rad/s]","Amplitude
[rad]"],labeldirections=["horizontal","vertical"]);
```

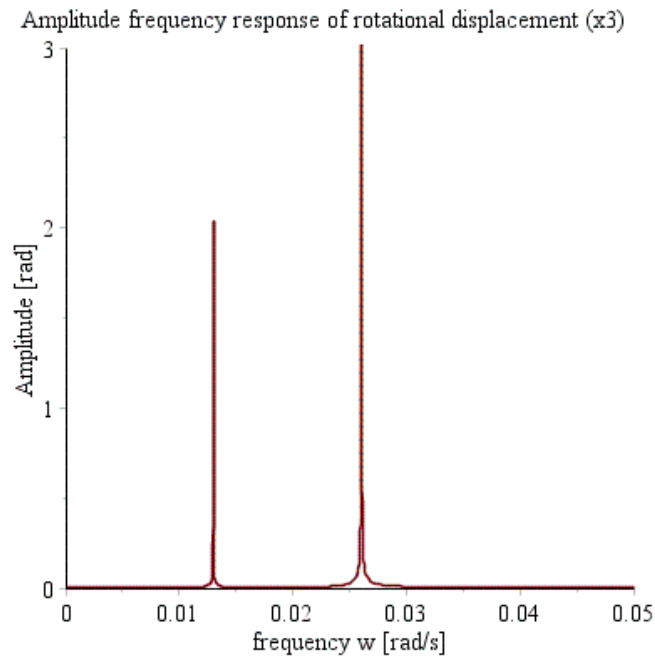

```
> A1; A3;
```

$$\frac{2.509790400 \cdot 10^5}{3.548344102 \cdot 10^8 \omega^2 - 10550 \sqrt{2} - 62744.76000} + \frac{8.137853755 \cdot 10^8 \omega}{5.676705031 \cdot 10^{12} \omega^2 - 1.810801305 \cdot 10^9 - 769095000 \sqrt{2}}$$

```
> plot(A1, \omega); plot(A3, \omega);
```

The amplitudes of the graphs go to infinite at the following frequencies:

0.0148 rad/s for the vertical motion.

0.0130 rad/s and 0.0260 rad/s for the horizontal motion.

0.0130 rad/s and 0.0260 rad/s for the rotational motion.

To check whether the steady-state solution is correct, these frequencies should be close to the natural frequency of the platform. The natural frequency of the platform is obtained by solving the equation of motion but without any external forces/displacements. So in this case u_1 , u_2 and u_3 are 0.

```

> M := Matrix([[M_platform + M_building + M_z, 0, 0], [0, M_platform + M_building + M_y, M_building·z], [0, M_building·z, J + M_θ]]);
M := 
$$\begin{bmatrix} M_{\text{platform}} + M_{\text{building}} + M_z & 0 & 0 \\ 0 & M_{\text{platform}} + M_{\text{building}} + M_y & M_{\text{building}} z \\ 0 & M_{\text{building}} z & J + M_{\theta} \end{bmatrix}$$
 (1)
> K := Matrix([[3·kv + km, 0, 0], [0, 2·kh + km, 2·e·kh -  $\frac{(l-h)}{2}$ ·km], [0, 2·e·kh -  $\frac{(l-h)}{2}$ ·km, 2·e2·kh +  $\frac{2}{9}$ ·l2·kv -  $\frac{(l-h)·(h-l)}{4}$ ·km]]);
K := 
$$\begin{bmatrix} 3 kv + km & 0 & 0 \\ 0 & 2 kh + km & 2 e kh - \frac{1}{2} (l - h) km \\ 0 & 2 e kh - \frac{1}{2} (l - h) km & 2 e^2 kh + \frac{2}{9} l^2 kv - \frac{1}{4} (l - h) (h - l) km \end{bmatrix}$$
 (2)
>
> A := -M·ω2 + K;
A := 
$$\begin{bmatrix} -\omega^2 (M_{\text{platform}} + M_{\text{building}} + M_z) + 3 kv + km & 0 & 0 \\ 0 & -\omega^2 (M_{\text{platform}} + M_{\text{building}} + M_y) + 2 kh + km & -\omega^2 M_{\text{building}} z + 2 e kh - \frac{1}{2} (l - h) km \\ 0 & -\omega^2 M_{\text{building}} z + 2 e kh - \frac{1}{2} (l - h) km & -\omega^2 (J + M_{\theta}) + 2 e^2 kh + \frac{2}{9} l^2 kv - \frac{1}{4} (l - h) (h - l) km \end{bmatrix}$$
 (3)
> with(linalg):
> CharacteristicEQ := collect(det(A), ω):
> g := 9.81 : ρ := 1025 : l := 104 : w := 60 : h := 14 : d := 11 : e := 1.5 : z := 32 : dwater := 100 :
M_platform :=  $\frac{736684.46}{g}$  · 1000 : M_building :=  $\frac{2 \cdot 91500}{g}$  · 1000 : M_z :=  $\frac{1}{2} \rho \cdot 3.14 \cdot \left(\frac{l}{2}\right)^2 \cdot w$  : M_y :=  $\frac{1}{2} \rho \cdot 3.14 \cdot d^2 \cdot w$  : M_θ :=  $\rho \cdot 3.14 \cdot \left(\left(\frac{l}{4}\right)^4 + \left(\frac{d}{2}\right)^2 \cdot \left(\frac{d}{2} + 4\right)^2\right) \cdot w$  :
J := M_platform ·  $\left(\frac{l^2}{12} + \frac{h^2}{12}\right)$  :
kv :=  $\frac{\rho \cdot g \cdot l \cdot w}{3 \cdot 1000}$  : kh :=  $\frac{\rho \cdot g \cdot w \cdot d}{1000}$  : EA := 2110 : lm := sqrt(2 · dwater2) : km :=  $\frac{EA}{lm}$  · 1000 :
> solve(CharacteristicEQ, ω);
-0.01296611583, 0.01296611583, -0.01479445621, 0.01479445621, -0.02597537107, 0.02597537107 (4)

```

The frequencies where resonance would occur for a system loaded by waves of 4 m are quite close to the natural frequencies of the system, so the steady-state solution is correct.

8.3 Equation of motion set-up for 2 mass-spring system

The floating platform can again be schematized as a rigid, infinite stiff block founded on vertical and horizontal springs (hydrostatic forces) and diagonal springs (moorings). And again, the platform is excited by a sinusoidal motion which represents the vertical wave motion. The connection is now schematized as a structural hinge although it should be a fully rigid connection. When the connection is schematized as a rigid connection in the model, then the two platforms will act as one rigid beam so there will be no difference with the 1 mass-spring system. Due to the hinge, there will be a difference in the displacement method compared to the 1 mass-spring system.

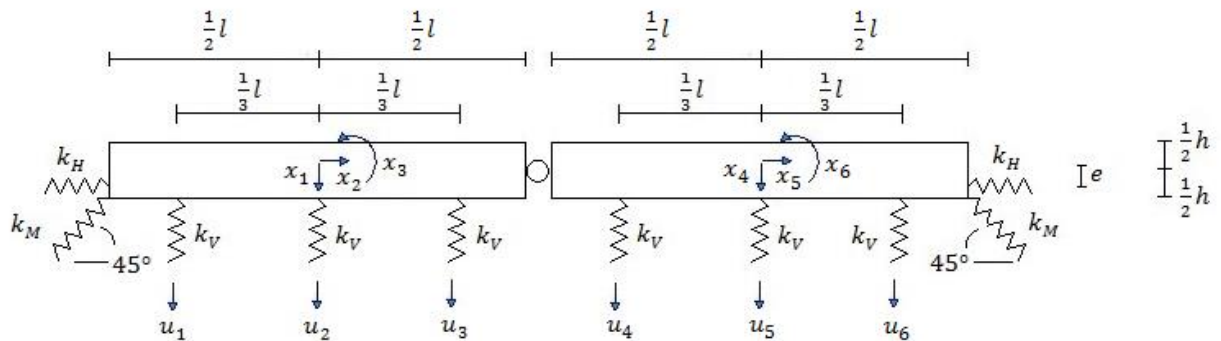

Figure 73: 2 mass-spring system model

In Figure 73: k_V = spring stiffness of water in vertical direction
 k_H = spring stiffness of water in horizontal direction
 k_M = spring stiffness of mooring line

l = length of floating structure
 h = height of floating structure
 e = eccentricity of water mass on the sides (half of the draught)

Vertical wave motions:
 $u_1(t) = H_s \sin(\omega(t - \Delta t))$
 $u_2(t) = H_s \sin(\omega t)$
 $u_3(t) = H_s \sin(\omega(t + \Delta t))$
 $u_4(t) = H_s \sin(\omega(t + 2\Delta t))$
 $u_5(t) = H_s \sin(\omega(t + 3\Delta t))$
 $u_6(t) = H_s \sin(\omega(t + 4\Delta t))$

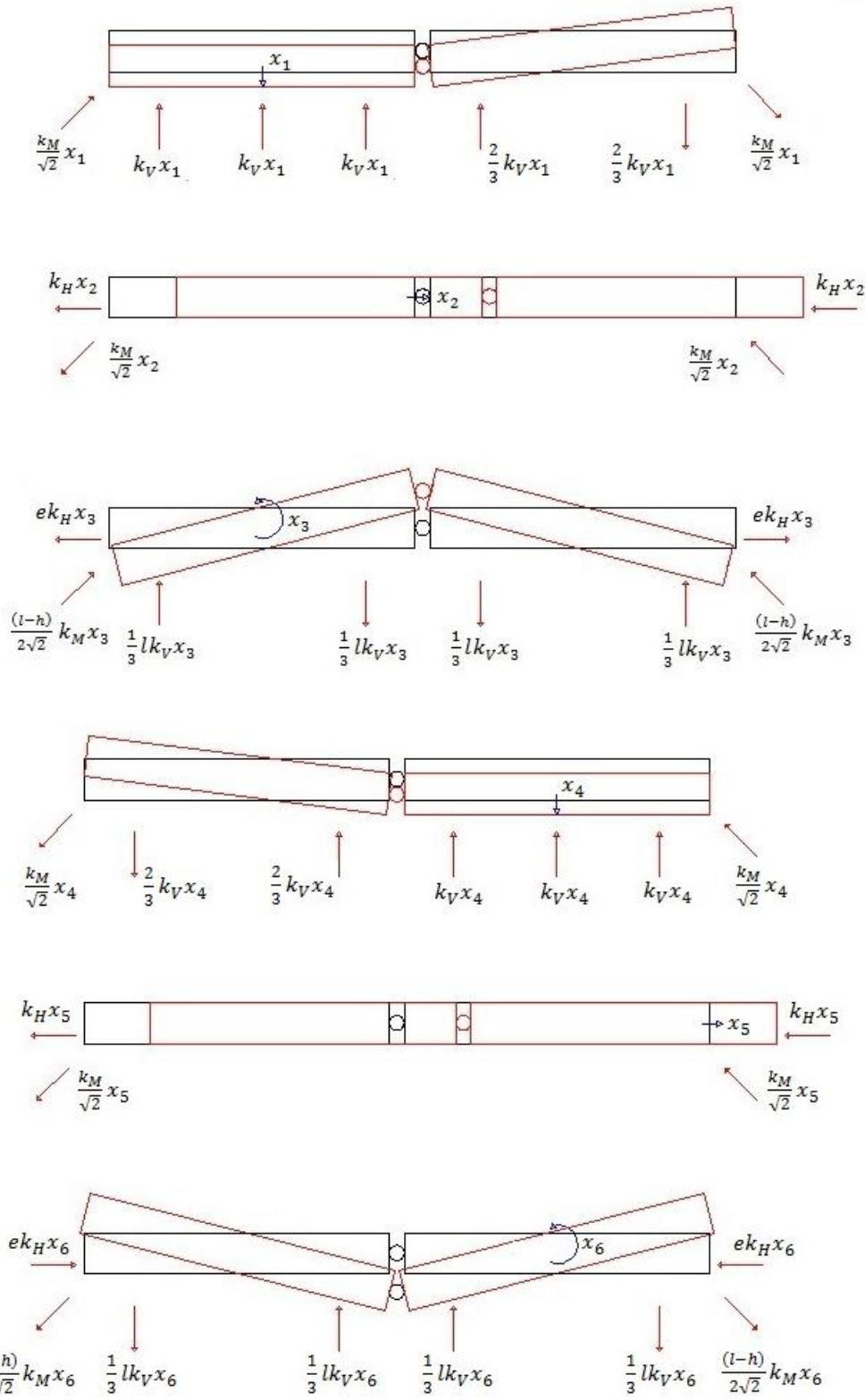

Figure 74: Displacement method 6 degrees of freedom system

By collecting all the forces acting on one body for each degree of freedom, the equation of motion can be set up.

Vertical equilibrium on left platform:

$$\sum M_1 \ddot{x}_1 = -3k_V x_1 - \frac{1}{\sqrt{2}} \frac{k_M}{\sqrt{2}} x_1 + \frac{1}{\sqrt{2}} \frac{k_M}{\sqrt{2}} x_2 + \frac{1}{3} l k_V x_3 - \frac{1}{3} l k_V x_3 - \frac{1}{\sqrt{2}} \frac{(l-h)}{2\sqrt{2}} k_M x_3 + \frac{2}{3} k_V x_4 - \frac{2}{3} k_V x_4 + \frac{1}{\sqrt{2}} \frac{k_M}{\sqrt{2}} x_4 + \frac{1}{\sqrt{2}} \frac{k_M}{\sqrt{2}} x_5 + \frac{1}{3} l k_V x_6 - \frac{1}{3} l k_V x_6 + \frac{1}{\sqrt{2}} \frac{(l-h)}{2\sqrt{2}} k_M x_6 + k_V u_1 + k_V u_2 + k_V u_3$$

Horizontal equilibrium on left platform:

$$\sum M_1 \ddot{x}_2 = \frac{1}{\sqrt{2}} \frac{k_M}{\sqrt{2}} x_1 - k_H x_2 - \frac{1}{\sqrt{2}} \frac{k_M}{\sqrt{2}} x_2 - e k_H x_3 + \frac{1}{\sqrt{2}} \frac{(l-h)}{2\sqrt{2}} k_M x_3 - \frac{1}{\sqrt{2}} \frac{k_M}{\sqrt{2}} x_4 - k_H x_5 - \frac{1}{\sqrt{2}} \frac{k_M}{\sqrt{2}} x_5 + e k_H x_6 - \frac{1}{\sqrt{2}} \frac{(l-h)}{2\sqrt{2}} k_M x_6$$

Momentum equilibrium on left platform:

$$\sum J_1 \ddot{x}_3 = -\frac{1}{3} l k_V x_1 + \frac{1}{3} l k_V x_1 - \frac{1}{2} l \frac{1}{\sqrt{2}} \frac{k_M}{\sqrt{2}} x_1 + \frac{1}{2} h \frac{1}{\sqrt{2}} \frac{k_M}{\sqrt{2}} x_1 - e k_H x_2 + \frac{1}{2} l \frac{1}{\sqrt{2}} \frac{k_M}{\sqrt{2}} x_2 - \frac{1}{2} h \frac{1}{\sqrt{2}} \frac{k_M}{\sqrt{2}} x_2 - 2 * \frac{1}{3} l \frac{1}{3} l k_V x_3 - e^2 k_H x_3 - \frac{1}{2} l \frac{1}{\sqrt{2}} \frac{(l-h)}{2\sqrt{2}} k_M x_3 + \frac{1}{2} h \frac{1}{\sqrt{2}} \frac{(l-h)}{2\sqrt{2}} k_M x_3 + 2 * \frac{1}{3} l \frac{2}{3} k_V x_4 + \frac{1}{2} l \frac{1}{\sqrt{2}} \frac{k_M}{\sqrt{2}} x_4 - \frac{1}{2} h \frac{1}{\sqrt{2}} \frac{k_M}{\sqrt{2}} x_4 - e k_H x_5 + \frac{1}{2} l \frac{1}{\sqrt{2}} \frac{k_M}{\sqrt{2}} x_5 - \frac{1}{2} h \frac{1}{\sqrt{2}} \frac{k_M}{\sqrt{2}} x_5 + 2 * \frac{1}{3} l \frac{1}{3} l k_V x_6 + e^2 k_H x_6 + \frac{1}{2} l \frac{1}{\sqrt{2}} \frac{(l-h)}{2\sqrt{2}} k_M x_6 - \frac{1}{2} h \frac{1}{\sqrt{2}} \frac{(l-h)}{2\sqrt{2}} k_M x_6 - \frac{1}{3} l k_V u_1 + \frac{1}{3} l k_V u_3$$

Vertical equilibrium on right platform:

$$\sum M_2 \ddot{x}_4 = \frac{2}{3} k_V x_1 - \frac{2}{3} k_V x_1 + \frac{1}{\sqrt{2}} \frac{k_M}{\sqrt{2}} x_1 - \frac{1}{\sqrt{2}} \frac{k_M}{\sqrt{2}} x_2 + \frac{1}{3} l k_V x_3 - \frac{1}{3} l k_V x_3 - \frac{1}{\sqrt{2}} \frac{(l-h)}{2\sqrt{2}} k_M x_3 - 3k_V x_4 - \frac{1}{\sqrt{2}} \frac{k_M}{\sqrt{2}} x_4 - \frac{1}{\sqrt{2}} \frac{k_M}{\sqrt{2}} x_5 + \frac{1}{3} l k_V x_6 - \frac{1}{3} l k_V x_6 + \frac{1}{\sqrt{2}} \frac{(l-h)}{2\sqrt{2}} k_M x_6 + k_V u_4 + k_V u_5 + k_V u_6$$

Horizontal equilibrium on right platform:

$$\sum M_2 \ddot{x}_5 = \frac{1}{\sqrt{2}} \frac{k_M}{\sqrt{2}} x_1 - k_H x_2 - \frac{1}{\sqrt{2}} \frac{k_M}{\sqrt{2}} x_2 + e k_H x_3 - \frac{1}{\sqrt{2}} \frac{(l-h)}{2\sqrt{2}} k_M x_3 - \frac{1}{\sqrt{2}} \frac{k_M}{\sqrt{2}} x_4 - k_H x_5 - \frac{1}{\sqrt{2}} \frac{k_M}{\sqrt{2}} x_5 - e k_H x_6 + \frac{1}{\sqrt{2}} \frac{(l-h)}{2\sqrt{2}} k_M x_6$$

Momentum equilibrium on right platform:

$$\sum J_2 \ddot{x}_6 = -2 * \frac{1}{3} l \frac{2}{3} k_V x_1 - \frac{1}{2} l \frac{1}{\sqrt{2}} \frac{k_M}{\sqrt{2}} x_1 + \frac{1}{2} h \frac{1}{\sqrt{2}} \frac{k_M}{\sqrt{2}} x_1 - e k_H x_2 + \frac{1}{2} l \frac{1}{\sqrt{2}} \frac{k_M}{\sqrt{2}} x_2 - \frac{1}{2} h \frac{1}{\sqrt{2}} \frac{k_M}{\sqrt{2}} x_2 + 2 * \frac{1}{3} l \frac{1}{3} l k_V x_3 + e^2 k_H x_3 + \frac{1}{2} l \frac{1}{\sqrt{2}} \frac{(l-h)}{2\sqrt{2}} k_M x_3 - \frac{1}{2} h \frac{1}{\sqrt{2}} \frac{(l-h)}{2\sqrt{2}} k_M x_3 + \frac{1}{3} l k_V x_4 - \frac{1}{3} l k_V x_4 + \frac{1}{2} l \frac{1}{\sqrt{2}} \frac{k_M}{\sqrt{2}} x_4 - \frac{1}{2} h \frac{1}{\sqrt{2}} \frac{k_M}{\sqrt{2}} x_4 - e k_H x_5 + \frac{1}{2} l \frac{1}{\sqrt{2}} \frac{k_M}{\sqrt{2}} x_5 - \frac{1}{2} h \frac{1}{\sqrt{2}} \frac{k_M}{\sqrt{2}} x_5 - 2 * \frac{1}{3} l \frac{1}{3} l k_V x_6 - e^2 k_H x_6 - \frac{1}{2} l \frac{1}{\sqrt{2}} \frac{(l-h)}{2\sqrt{2}} k_M x_6 + \frac{1}{2} h \frac{1}{\sqrt{2}} \frac{(l-h)}{2\sqrt{2}} k_M x_6 - \frac{1}{3} l k_V u_4 + \frac{1}{3} l k_V u_6$$

After some mathematically ordering, the equation of motion is presented as follows:

$$\sum M_1 \ddot{x}_1 + \left(3k_V + \frac{k_M}{2}\right) x_1 - \frac{k_M}{2} x_2 + \frac{(l-h)}{4} k_M x_3 - \frac{k_M}{2} x_4 - \frac{k_M}{2} x_5 - \frac{(l-h)}{4} k_M x_6 = k_V(u_1 + u_2 + u_3)$$

$$\sum M_1 \ddot{x}_2 - \frac{k_M}{2} x_1 + \left(k_H + \frac{k_M}{2}\right) x_2 + \left(ek_H - \frac{(l-h)}{4} k_M\right) x_3 + \frac{k_M}{2} x_4 + \left(k_H + \frac{k_M}{2}\right) x_5 + \left(-ek_H + \frac{(l-h)}{4} k_M\right) x_6 = 0$$

$$\sum J_1 \ddot{x}_3 + \frac{(l-h)}{4} k_M x_1 + \left(ek_H - \frac{(l-h)}{4} k_M\right) x_2 + \left(\frac{2}{9} l^2 k_V + e^2 k_H + \frac{(l-h)^2}{8} k_M\right) x_3 + \left(-\frac{4}{9} l k_V - \frac{(l-h)}{4} k_M\right) x_4 + \left(ek_H - \frac{(l-h)}{4} k_M\right) x_5 - \left(\frac{2}{9} l^2 k_V + e^2 k_H + \frac{(l-h)^2}{8} k_M\right) x_6 = \frac{1}{3} l k_V (u_1 - u_3)$$

$$\sum M_2 \ddot{x}_4 - \frac{k_M}{2} x_1 + \frac{k_M}{2} x_2 + \frac{(l-h)}{4} k_M x_3 + \left(3k_V + \frac{k_M}{2}\right) x_4 + \frac{k_M}{2} x_5 - \frac{(l-h)}{4} k_M x_6 = k_V(u_4 + u_5 + u_6)$$

$$\sum M_2 \ddot{x}_5 - \frac{k_M}{2} x_1 + \left(k_H + \frac{k_M}{2}\right) x_2 - \left(ek_H x_3 - \frac{(l-h)}{4} k_M\right) x_3 + \frac{k_M}{2} x_4 + \left(k_H + \frac{k_M}{2}\right) x_5 + \left(ek_H - \frac{(l-h)}{4} k_M\right) x_6 = 0$$

$$\sum J_2 \ddot{x}_6 + \left(\frac{4}{9} l k_V + \frac{(l-h)}{4} k_M\right) x_1 + \left(ek_H - \frac{(l-h)}{4} k_M\right) x_2 - \left(\frac{2}{9} l^2 k_V + e^2 k_H + \frac{(l-h)^2}{8} k_M\right) x_3 - \frac{(l-h)}{4} k_M x_4 + \left(ek_H - \frac{(l-h)}{4} k_M\right) x_5 + \left(\frac{2}{9} l^2 k_V + e^2 k_H + \frac{(l-h)^2}{8} k_M\right) x_6 = \frac{1}{3} l k_V (u_4 - u_6)$$

The mass and stiffness matrices can be constructed as follows:

$$M := \begin{bmatrix} M_{pl} + M_{bl} + M_{zl} & 0 & 0 & 0 & 0 & 0 \\ 0 & M_{pl} + M_{bl} + M_{yl} & M_{blz} & 0 & 0 & 0 \\ 0 & M_{blz} & J_{pl} + M_{\theta l} & 0 & 0 & 0 \\ 0 & 0 & 0 & M_{p2} + M_{b2} + M_{z2} & 0 & 0 \\ 0 & 0 & 0 & 0 & M_{p2} + M_{b2} + M_{y2} & M_{b2z} \\ 0 & 0 & 0 & 0 & M_{b2z} & J_{p2} + M_{\theta 2} \end{bmatrix}$$

$$K := \begin{bmatrix} 3k_V + \frac{1}{2} k_M & -\frac{1}{2} k_M & \frac{1}{4} (l-h) k_M & -\frac{1}{2} k_M & -\frac{1}{2} k_M & -\frac{1}{4} (l-h) k_M \\ -\frac{1}{2} k_M & kh + \frac{1}{2} k_M & ek_H - \frac{1}{4} (l-h) k_M & \frac{1}{2} k_M & kh + \frac{1}{2} k_M & -ek_H + \frac{1}{4} (l-h) k_M \\ \frac{1}{4} (l-h) k_M & ek_H - \frac{1}{4} (l-h) k_M & \frac{2}{9} l^2 k_V + e^2 k_H + \frac{1}{8} (l-h)^2 k_M & -\frac{4}{9} l k_V - \frac{1}{4} (l-h) k_M & ek_H - \frac{1}{4} (l-h) k_M & -e^2 k_H - \frac{2}{9} l^2 k_V + \frac{1}{8} (l-h)^2 k_M \\ -\frac{1}{2} k_M & \frac{1}{2} k_M & \frac{1}{4} (l-h) k_M & 3k_V + \frac{1}{2} k_M & \frac{1}{2} k_M & -\frac{1}{4} (l-h) k_M \\ -\frac{1}{2} k_M & kh + \frac{1}{2} k_M & -ek_H + \frac{1}{4} (l-h) k_M & \frac{1}{2} k_M & kh + \frac{1}{2} k_M & ek_H - \frac{1}{4} (l-h) k_M \\ \frac{4}{9} l k_V + \frac{1}{4} (l-h) k_M & ek_H - \frac{1}{4} (l-h) k_M & -\frac{2}{9} l^2 k_V - e^2 k_H - \frac{1}{8} (l-h)^2 k_M & -\frac{1}{4} (l-h) k_M & ek_H - \frac{1}{4} (l-h) k_M & \frac{2}{9} l^2 k_V + e^2 k_H + \frac{1}{8} (l-h)^2 k_M \end{bmatrix}$$

The displacements of the platform are obtained by assuming the steady-state response of the structure; this can be done with the help of the program Maple just like with the 1 mass-spring system.

```

> restart:
>
> x1:=A1*sin(w*t)+B1*cos(w*t):
> x2:=A2*sin(w*t)+B2*cos(w*t):
> x3:=A3*sin(w*t)+B3*cos(w*t):
> x4:=A4*sin(w*t)+B4*cos(w*t):
> x5:=x2:
> x6:=(x1-x3*1/2-x4)/(1/2):
>
> u1:=Hs*sin(w*(t-dt)):
> u2:=Hs*sin(w*t):
> u3:=Hs*sin(w*(t+dt)):
> u4:=Hs*sin(w*(t+2*dt)):
> u5:=Hs*sin(w*(t+3*dt)):
> u6:=Hs*sin(w*(t+4*dt)):
>
> u1:=Hs*(sin(w*t)-cos(w*t)*w*dt):
> u2:=Hs*(sin(w*t)):
> u3:=Hs*(sin(w*t)+cos(w*t)*w*dt):
> u4:=Hs*(sin(w*t)+cos(w*t)*2*w*dt):
> u5:=Hs*(sin(w*t)+cos(w*t)*3*w*dt):
> u6:=Hs*(sin(w*t)+cos(w*t)*4*w*dt):
>
> F1:=kH*(x2+x3*(h/2-e)):
> F2:=kM*((x1+x3*1/2)/sqrt(2)-(x2+x3*h/2)/sqrt(2)):
> F3:=kV*(u1-x1-x3*1/3):
> F4:=kV*(u2-x1):
> F5:=kV*(u3+x1+x3*1/3):
>
> eq3:=(Mplatform +Mbuilding1 +Mywater)*diff(x2,t,t)
+Mbuilding1*z*diff(x3,t,t) +H +F1 -F2/sqrt(2) = 0:
> eq4:=(Mplatform +Mbuilding1 +Mzwater)*diff(x1,t,t) +V -F5 -F4
-F3 +F2/sqrt(2) = 0:
> eq5:=(J +Mthetawater)*diff(x3,t,t) +Mbuilding1*z*diff(x2,t,t)
-V*1/2 +F5*1/3 -F3*1/3 +F2/sqrt(2)*1/2 -F2/sqrt(2)*h/2 +F1*(h/2-
e) = 0:
>
> F6:=kV*(u4-x4-x6*1/3):
> F7:=kV*(u5-x4):
> F8:=kV*(u6-x4+x6*1/3):
> F9:=kM*((x4-x6*1/2)/sqrt(2)+(x5+x6*h/2)/sqrt(2)):
> F10:=kH*(x5+x6*(h/2-e)):
>
> eq6:=(Mplatform +Mbuilding2 +Mywater)*diff(x5,t,t)
+Mbuilding2*z*diff(x6,t,t) -H +F10 +F9/sqrt(2) = 0:
> eq7:=(Mplatform +Mbuilding2 +Mzwater)*diff(x4,t,t) -V -F6 -F7
-F8 +F9/sqrt(2) = 0:

```

```

> eq8:=(J +Mthetawater)*diff(x6,t,t) +Mbuilding2*z*diff(x5,t,t)
-v*1/2 -F6*1/3 +F8*1/3 -F9/sqrt(2)*1/2 +F9/sqrt(2)*h/2
+F10*(h/2-e) = 0:
>
> collect(expand(eq3+eq6), {cos(w*t), sin(w*t)});

> eq9:=-2*(Mplatform+Mywater)*B2*w^2-
(Mbuilding1+Mbuilding2)*B2*w^2+Mbuilding2*z*w^2*(-
2*B1/l+2*B4/l+B3)-Mbuilding1*z*w^2*B3-2*kH/l*B1*e+2*kH/l*B4*e-
1/2*kM/l*B4*h+kM*B4+kH/l*B1*h+2*kH*B2-kM*B1+1/2*kM/l*B1*h-
kH/l*B4*h+kM*B2=0:
> eq10:=-2*(Mplatform+Mywater)*A2*w^2-
(Mbuilding1+Mbuilding2)*A2*w^2+Mbuilding2*z*w^2*(-
2*A1/l+2*A4/l+A3)-Mbuilding1*z*w^2*A3+kH/l*A1*h-2*kH/l*A1*e-
1/2*kM/l*A4*h-
kH/l*A4*h+2*kH/l*A4*e+2*kH*A2+1/2*kM/l*A1*h+kM*A4+kM*A2-kM*A1=0:
> collect(expand(eq4+eq7), {cos(w*t), sin(w*t)});

> eq11:=-1/2*kM*B3*h-(Mplatform+Mbuilding2+Mzwater)*B4*w^2-
9*kV*Hs*w*dt+1/2*kM/l*B1*h+1/2*kM*1*B3-
1/2*kM/l*B4*h+kV*B1+kM*B4-
(Mplatform+Mbuilding1+Mzwater)*B1*w^2+3*kV*B4=0:
> eq12:=1/2*kM*1*A3+kM*A4-1/2*kM*A3*h-6*kV*Hs-
(Mplatform+Mbuilding1+Mzwater)*A1*w^2+3*kV*A4-
(Mplatform+Mbuilding2+Mzwater)*A4*w^2+1/2*kM/l*A1*h+kV*A1-
1/2*kM/l*A4*h=0:
> collect(expand(eq5-eq8), {cos(w*t), sin(w*t)});

> eq13:=4/9*kV*1*B4+2*kH*B3*e^2-3/4*kM*B4*h+1/2*kM*1*B4-
1/2*kM*1*B3*h-2*kH/l*B4*h*e-
2*kH*B3*h*e+2*kH/l*B1*h*e+2*J/l*B1*w^2+1/4*kM*1^2*B3-
2*J/l*B4*w^2-2*J*B3*w^2-
1/4*kM*h^2/l*B1+1/4*kM*h^2*B3+1/4*kM*h^2/l*B4+1/4*kM*h*B1+1/2*kH
*B3*h^2-1/2*kH/l*B1*h^2-
2*kH/l*B1*e^2+2/9*kV*1*B1+4/9*kV*1^2*B3+1/2*kH/l*B4*h^2+2*kH/l*B
4*e^2+(Mbuilding2-Mbuilding1)*z*B2*w^2+2*Mthetawater*w^2*(B1/l-
B4/l-B3)=0:
> eq14:=-
1/2*kM*1*A3*h+2/9*kV*1*A1+1/2*kH/l*A4*h^2+4/9*kV*1^2*A3+1/2*kM*1
*A4+1/4*kM*1^2*A3-
3/4*kM*A4*h+1/4*kM*h*A1+2*kH/l*A1*h*e+1/4*kM*h^2*A3-
2*kH/l*A4*h*e+1/2*kH*A3*h^2+2*kH*A3*e^2-
2*kH/l*A1*e^2+2*kH/l*A4*e^2+4/9*kV*1*A4-
2*kH*A3*h*e+2*J/l*A1*w^2-1/2*kH/l*A1*h^2-2*J/l*A4*w^2-

```



```

1/4*kM*h^2/l*A1+1/4*kM*h^2/l*A4-2*J*A3*w^2+(Mbuilding2-
Mbuilding1)*z*A2*w^2+2*Mthetawater*w^2*(A1/l-A4/l-A3)=0:
> collect(expand(eq5-eq7*1/2),{cos(w*t),sin(w*t)});

> eq15:=-1/2*kM*1*B2+1/4*kM*h*B2+1/8*kM*h^2*B3-3/2*kV*1*B4-
kH*B2*e+kH*B3*e^2+2/9*kV*1^2*B3+1/4*kM*B4*h+1/2*kH*B2*h-
1/2*kM*1*B4+1/2*kM*1*B1+31/6*kV*1*Hs*w*dt-
1/2*kM*h*B1+1/4*kH*B3*h^2-1/8*kM*1*B3*h-J*B3*w^2-
kH*B3*h*e+2/3*kV*1*B1+1/2*1*(Mplatform+Mbuilding2+Mzwater)*B4*w^
2-Mbuilding1*z*B2*w^2-Mthetawater*B3*w^2=0:
> eq16:=-
1/2*kM*1*A2+3/2*kV*1*Hs+1/4*kM*h*A2+2/9*kV*1^2*A3+1/2*kH*A2*h-
kH*A2*e-1/8*kM*1*A3*h+1/8*kM*h^2*A3-3/2*kV*1*A4+2/3*kV*1*A1-
1/2*kM*1*A4+1/2*1*(Mplatform+Mbuilding2+Mzwater)*A4*w^2+1/4*kM*A
4*h-1/2*kM*h*A1+kH*A3*e^2-J*A3*w^2+1/2*kM*1*A1+1/4*kH*A3*h^2-
kH*A3*h*e-Mbuilding1*z*A2*w^2-Mthetawater*A3*w^2=0:
>
>
sol:=solve({eq9,eq10,eq11,eq12,eq13,eq14,eq15,eq16},{A1,A2,A3,A4
,B1,B2,B3,B4}):
> assign(sol);
>
>
> g:=9.81: rho:=1025: l:=104: b:=60: h:=14: d:=11: e:=1.5:
z:=32: dwater:=100:
> Mplatform:=736684/g*1000: J:=Mplatform*(l^2/12+h^2/12):
> Mbuilding1:=2*91500/g*1000: Mbuilding2:=2*91500/g*1000:
> Mzwater:=0.5*rho*3.14*b*(l/2)^2: Mywater:=0.5*rho*3.14*b*d^2:
Mthetawater:=rho*3.14*((l/4)^4+(d/2)^2*(d/2+4)^2)*b:
> kV:=(rho*g*1*b)/(3*1000): kH:=(rho*g*b*d)/1000: EA:=2110:
lm:=sqrt(2*dwater^2): kM:=(EA/lm)*1000:
> Hs:=4/2: T:=8.6: Lwave:=76.5: c:=Lwave/T: dt:=(1/3)*(1/c):
>
>
> plot(max(abs(A1),abs(B1)),w=0..0.05,0..50,title="Amplitude
frequency response of vertical displacement (x1) of first
platform",labels=["frequency w [rad/s]","Amplitude
[m]"],labeldirections=["horizontal","vertical"]);

```

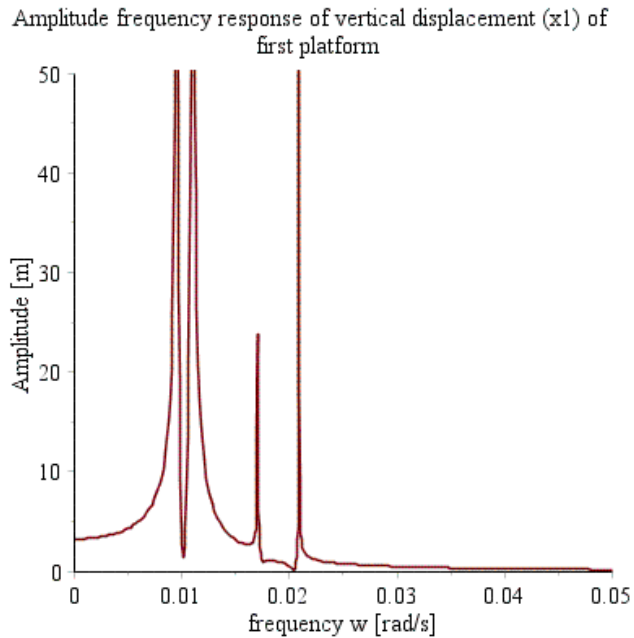

>

```
> plot(max(abs(A2),abs(B2)),w=0..0.05,0..50,title="Amplitude
frequency response of horizontal displacement (x2, x5) of both
platforms",labels=["frequency w [rad/s]","Amplitude
[m]"],labeldirections=["horizontal","vertical"]);
```

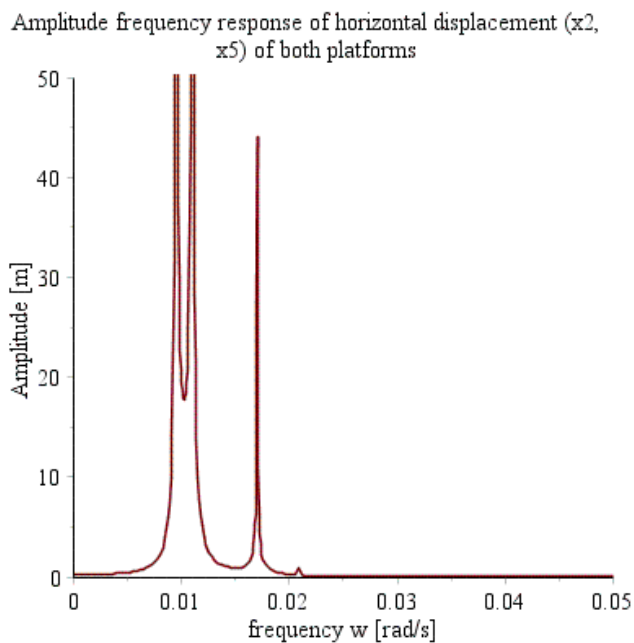

```
> plot(max(abs(A3),abs(B3)),w=0..0.05,0..50,title="Amplitude
frequency response of rotational displacement (x3) of first
platform",labels=["frequency w [rad/s]","Amplitude
[rad]"],labeldirections=["horizontal","vertical"]);
```

Amplitude frequency response of rotational displacement (x3)
of first platform

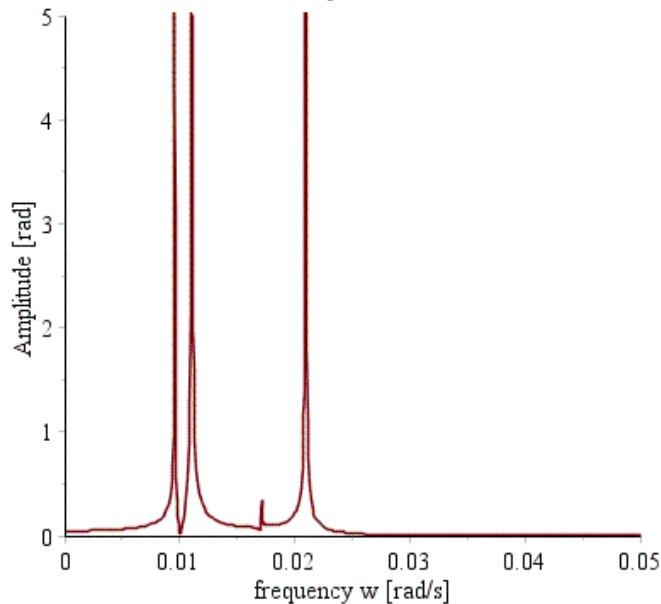

```
> plot(max(abs(A4),abs(B4)),w=0..0.05,0..50,title="Amplitude
frequency response of vertical displacement (x4) of second
platforms",labels=["frequency w [rad/s]","Amplitude
[m]"],labeldirections=["horizontal","vertical"]);
```

Amplitude frequency response of vertical displacement (x4) of
second platforms

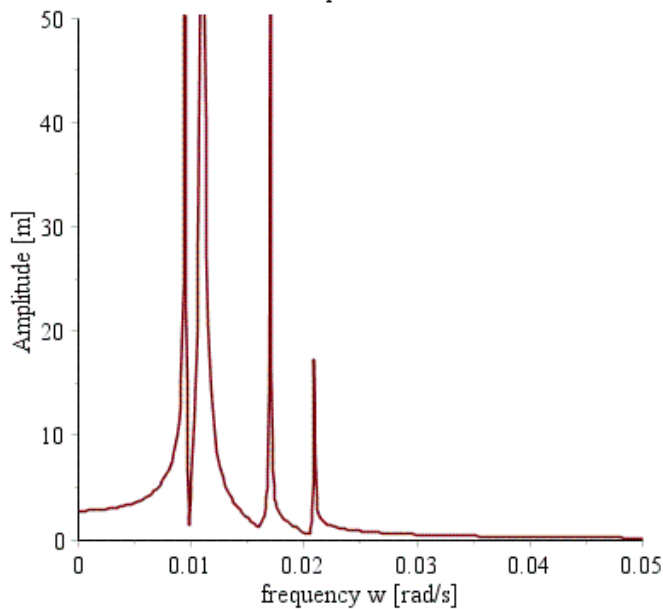

```
> A6:=(A1-A3*1/2-A4)/(1/2):
> B6:=(B1-B3*1/2-B4)/(1/2):
> plot(max(abs(A6),abs(B6)),w=0..0.05,0..5,title="Amplitude
frequency response of rotational displacement (x6) of second
platform",labels=["frequency w [rad/s]","Amplitude
[rad]"],labeldirections=["horizontal","vertical"]);
```

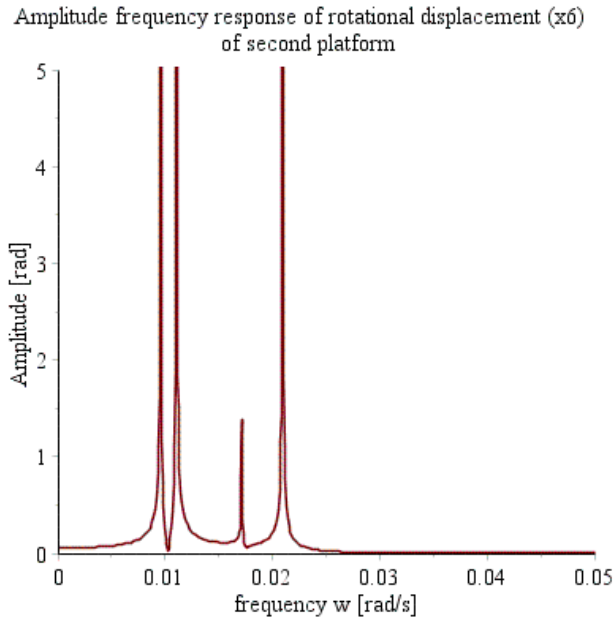

The amplitudes of the above graphs go to infinite at the following frequencies:

$$\omega_1 = 0.008 \text{ rad/s}$$

$$\omega_2 = 0.012 \text{ rad/s}$$

$$\omega_3 = 0.017 \text{ rad/s}$$

$$\omega_4 = 0.022 \text{ rad/s}$$

The assumed wave height of 4 m with a wave period of 8.6 s contributes to a wave frequency of $\frac{2\pi}{8.6} = 0.73 \text{ rad/s}$ which is far away from the resonance frequency of the platforms.

The maximum value for the vertical motion with a wave frequency of 0.73 rad/s is:

$$x_1 = 0.00066 \text{ m} = 0.66 \text{ mm}$$

$$x_4 = 0.0060 \text{ m} = 6 \text{ mm}$$

The maximum value for the horizontal motion with a wave frequency of 0.73 rad/s is:

$$x_1 = 0.00034 \text{ m} = 0.34 \text{ mm}$$

The maximum value for a vertical displacement due to rotation with a wave frequency of 0.73 rad/s is:

$$x_3 = x_6 = 0.00006 \text{ rad} \rightarrow 0.00006 * \text{length} = 0.00006 * 104 = 0.00624 \text{ m} = 6.24 \text{ mm}$$

These motions are executed at the following accelerations:

$$a_1 = 0.00035 \text{ m/s}^2 \text{ (vertical motion of first platform)}$$

$$a_2 = 0.00018 \text{ m/s}^2 \text{ (horizontal motion of both platforms)}$$

$$a_3 = a_6 = 0.00003 \text{ rad/s}^2 \rightarrow 0.00003 * \text{length} = 0.00003 * 104 = 0.0031 \text{ m/s}^2 \text{ (vertical acceleration due to rotation of both platforms)}$$

$$a_4 = 0.0032 \text{ m/s}^2 \text{ (vertical motion of second platform)}$$

Result is that the first platform has the same displacements and accelerations as in the 1 mass-spring system. The second platform attached to the first platform is having larger displacements than the first platform, in the order of 10 times bigger. But the displacement of the second platform is still very small and not noticeable.

8.4 Results of different load scenarios

The displacements and accelerations of the 2 mass-spring system is solved for the specific condition of equal symmetric loading and the wave conditions with 4 m wave height, 8.6 s wave period and 76.5 m wave length. Other situations are imaginable for instance higher wave heights, larger wave periods (tsunami), eccentric loading, different amount of moorings etcetera. The results for each scenario is acquired by using the same Maple calculation file as the 2 mass-spring system, but only certain variables are changed. In all the scenarios, the various results should not exceeds the following values.

Output	Limit
Acceleration a	< 0.04 m/s ²
$\sigma_{\text{connection}}$	< 500000 kN/m ²
F_{mooring}	< 22070 kN

Table 9: Output limits

A note at the limitation of the displacements. It is several times stated in this thesis that the relative displacements between platforms should not be too large as this will cause damage to any structures which are at the intersection of two platforms (e.g. roads, lines, pipes etcetera). The (rigid) connection should bear all the forces which are caused by the displacements. So the criteria for the relative displacement between platforms is translated into the strength of the connection $\sigma_{\text{connection}}$.

8.4.1 Larger single platforms

The hexagonal platform is given sides of 120 m instead of 60 m, thus doubling the dimensions. Due to the larger dimensions, a lot more weight is present in the form of dead load and added water mass. The main reason why such low displacements and accelerations are achieved is because of the dimensions of the platforms. By increasing the dimensions of the platforms, the motions and accelerations decrease drastically. This quantifies the statement that if the length of the structure is greater than the wavelength, the heave response becomes significant smaller. All output values are within the limits.

	Larger platforms
Variables:	
Platform length	208 m
Platform width	120 m
Wave height	4 m
Wave period	8.6 s
Wave length	76.5 m
Results:	
x_1	$4.56 \cdot 10^{-4}$ m
x_2	$8.30 \cdot 10^{-5}$ m
x_3	$3.70 \cdot 10^{-5}$ rad
x_4	$7.34 \cdot 10^{-3}$ m
x_6	$3.70 \cdot 10^{-5}$ rad
a_1	$2.43 \cdot 10^{-4}$ m/s ²
a_2	$4.40 \cdot 10^{-5}$ m/s ²
a_3	$2.00 \cdot 10^{-5}$ rad/s ²
a_4	$3.91 \cdot 10^{-3}$ m/s ²

a_6	$2.00 \cdot 10^{-5} \text{ rad/s}^2$
$\sigma_{\text{connection}}$	167 kN/m^2
$F_{\text{mooring, heave}}$	77 kN
$F_{\text{mooring, pitch}}$	38 kN

Table 10: Results for a larger platform in the 2 mass-spring system

However, a larger system is already achieved when multiple platforms are connected to each other through a rigid connection. So there is not a huge benefit of increasing the dimensions of the single platforms. In fact, larger single platforms are more difficult to construct and difficult to transport and larger internal forces occur due to the weight of the platform. In chapter 4 it is proven that a hexagonal shaped platform with sides of 60 m is the optimal dimension.

8.4.2 Tsunami wave

A tsunami wave in deep waters is not characterised by its wave height, but by its large wave length and period. When a tsunami wave approaches very shallow water (ea. the shore) the tsunami can increase to several meters height as 30 m. Even breakwaters specially constructed to withstand a destructive crashing wave of 30 m height has a high probability of failure. There is no way that the floating community can survive such a tsunami wave whenever the floating community is going to be situated in really shallow waters, so this situation will not be elaborated. When the floating community is going to be situated in waters with a water depth of several kilometres, the wave height of a tsunami is several centimetres and the tsunami wave will cause no problems. The input of the tsunami characteristics in the model fits a tsunami wave in intermediate shallow water as the water depth in this model is just 100 m deep. This is the most interesting situation with a tsunami wave to observe the behaviour of the floating community.

Variables:			
Wave height	4 m	2 m	0.20 m
Wave period	1200 s	1200 s	1200 s
Wave length	200000 m	200000 m	200000 m
Results:			
x_1	4.38 m	2.19 m	0.22 m
x_2	0.46 m	0.23 m	0.023 m
x_3	0.066 rad	0.033 rad	0.0033 rad
x_4	3.61 m	1.81 m	0.18 m
x_6	0.081 rad	0.041 rad	0.0041 rad
a_1	$1.20 \cdot 10^{-4} \text{ m/s}^2$	$6.00 \cdot 10^{-5} \text{ m/s}^2$	$6.00 \cdot 10^{-6} \text{ m/s}^2$
a_2	$1.27 \cdot 10^{-5} \text{ m/s}^2$	$6.33 \cdot 10^{-6} \text{ m/s}^2$	$1.27 \cdot 10^{-7} \text{ m/s}^2$
a_3	$1.82 \cdot 10^{-6} \text{ rad/s}^2$	$9.09 \cdot 10^{-7} \text{ rad/s}^2$	$1.82 \cdot 10^{-7} \text{ rad/s}^2$
a_4	$9.90 \cdot 10^{-5} \text{ m/s}^2$	$4.95 \cdot 10^{-5} \text{ m/s}^2$	$9.90 \cdot 10^{-6} \text{ m/s}^2$
a_6	$2.22 \cdot 10^{-6} \text{ rad/s}^2$	$1.11 \cdot 10^{-6} \text{ rad/s}^2$	$2.22 \cdot 10^{-7} \text{ rad/s}^2$
$\sigma_{\text{connection}}$	$3.30 \cdot 10^5 \text{ kN/m}^2$	$1.65 \cdot 10^5 \text{ kN/m}^2$	16513 kN/m^2
$F_{\text{mooring, heave}}$	38154 kN	19077 kN	1907 kN
$F_{\text{mooring, pitch}}$	38534 kN	19267 kN	1924 kN

Table 11: Results for the 2 mass-spring system when a tsunami occurs

The large displacements causes large connection and mooring forces. But another problem is, how fast can the platforms rise with the rising water level? If the water elevates 4.74 m and the platforms do not respond fast enough, a 4.74 m column of water will be on the platform which causes the platforms to sink because of the extra mass. This problem is illustrated in Figure 75. On the other hand, if the platform rises too fast, citizens will notice the displacement and become uncomfortable.

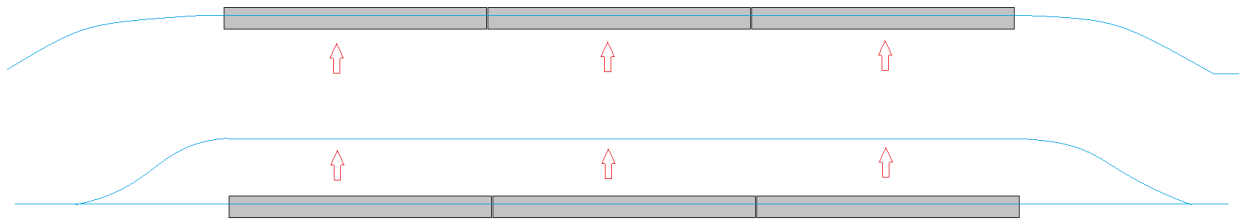

Figure 75: Rising water level due to tsunami wave

From the results it is seen that the accelerations of the displacements are very low. This means that citizens will not notice the 4.38 m elevation of the floating community. The floating community will rise with a speed of $\frac{2\pi}{1200} * 4.38 = 0.023 \text{ m/s}$. The water elevation due to the tsunami wave will rise with a speed of roughly $\frac{4}{1200} = 0.0033 \text{ m/s}$. This means that the platforms are able to respond fast enough to a large water elevation.

Due to the long wave length and the long wave period of the tsunami, the platforms will have displacements almost equal to the wave height as expected. Resonance of the system actually takes place. The problem with large heave motions is that the moorings will endure a very large force, which can even exceed the current Minimum Breaking Load of 22070 kN for moorings with a rope stiffness of 2110 MN. Less stiff moorings can cope better with large displacements but cannot bear large forces. A mooring line with a rope stiffness of 557 MN and a Minimum Breaking Load of 5647 kN also fails during the occurrence of a tsunami wave. And even if the mooring lines do not break, the platforms with mooring lines will maintain at the original water level while other platforms will rise with the water level, see the following figure.

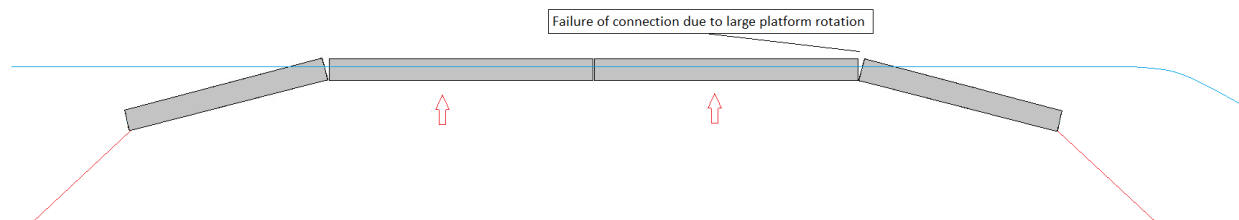

Figure 76: Elevation of platforms when mooring lines do not break

A solution to prevent the mooring lines from breaking and to prevent the problem illustrated in Figure 76 is to have an adjustable mooring line system. Such a system should extend the mooring line only whenever a very large heave motion is detected. The mooring lines are then extended and locked into their new length which is suitable for the new water depth.

Overall, the main conclusion about the occurrence of a tsunami wave is that failure totally depends on the wave height of the tsunami wave. With smaller wave heights (tsunami wave in very deep waters) the heave motion is considerable smaller which leads to smaller connection and mooring forces.

8.4.3 Severe wave conditions

A wave condition with 4 m high waves is already quite a rough situation. But the results of a 4 m wave height stated that the system is perfectly in balance. So the same calculation is run with even more severe wave conditions, higher waves, larger wave length and period. The condition is just not as worse as a tsunami wave. Result is that the displacements and accelerations of the platforms are still within a perfect safe margin.

	Severe waves
Variables:	
Platform length	104 m
Platform width	60 m
Wave height	15 m
Wave period	14 s
Wave length	212 m
Results:	
X ₁	0.0066 m
X ₂	0.0012 m
X ₃	2.18*10 ⁻⁴ rad
X ₄	0.021 m
X ₆	2.18*10 ⁻⁴ rad
a ₁	1.32*10 ⁻³ m/s ²
a ₂	2.50*10 ⁻⁴ m/s ²
a ₃	4.39*10 ⁻⁵ rad/s ²
a ₄	4.33*10 ⁻³ m/s ²
a ₆	4.39*10 ⁻⁵ rad/s ²
σ _{connection}	1965 kN/m ²
F _{mooring, heave}	227 kN
F _{mooring, pitch}	104 kN

Table 12: Results for the 2 mass-spring system with more severe waves

Although the platforms are still dynamically in balance, wave heights of 15 m crashing on the platforms are not a good sign. In general, the freeboard of a floating structure should be larger than the occurring wave height. In this case, the freeboard of the platform is 3.11 m. Even in the basic situation (wave height of 4 m), the waves will overtop the platforms. It is not feasible to make a platform with a freeboard of over 15 m just to keep the deck dry. At the edges of the platforms should be a barrier like construction to keep wave overtopping at a minimum. Or another solution is to never let such high waves occur around the floating community by enclosing the floating community behind a breakwater.

8.4.4 Shallow water depth

What if the first floating community is going to start near shore instead of in deeper waters? Will the platforms behave identical to the platforms in deeper water? The variable of water depth is not a determining input in the stiffness matrix of the 2 mass-spring system. The water depth is only hidden in the length of the mooring line and the effect of a mooring line on the displacements is minimal. However, there is another way to cope with a shallow water depth in the model. A floating structure in shallow water experiences less displacements of the surrounding waters (added water mass) because the displacing water will hit the bottom of the sea and cancelling this effect. So in the calculations, the added water masses are neglected. This reduces a lot of weight on the platforms which results in larger displacements compared to the basic situation in deeper water. The displacements are indeed at least a factor 2 larger when the added water mass is neglected, but the values are still within acceptable range.

	Shallow water
Variables:	
Wave height	4 m
Wave period	8.6 s
Wave length	76.5 m
Water depth	20 m
Results:	
x_1	$2.51 \cdot 10^{-3}$ m
x_2	$1.37 \cdot 10^{-3}$ m
x_3	$2.13 \cdot 10^{-4}$ rad
x_4	0.022 m
x_6	$2.13 \cdot 10^{-4}$ rad
a_1	$1.34 \cdot 10^{-3}$ m/s ²
a_2	$7.33 \cdot 10^{-4}$ m/s ²
a_3	$1.13 \cdot 10^{-4}$ rad/s ²
a_4	0.011 m/s ²
a_6	$1.14 \cdot 10^{-4}$ rad/s ²
$\sigma_{\text{connection}}$	1993 kN/m ²
$F_{\text{mooring, heave}}$	1151 kN
$F_{\text{mooring, pitch}}$	507 kN

Table 13: Results for the 2 mass-spring system in shallow water depth

8.4.5 Eccentric loading

An extreme example of eccentric loading is applied where one platform bears the load of 2 high rise buildings and the other platform has no additional loads. This is the only case where the heave motions of both platforms are not equal anymore. However, the difference is still very small and it gives no other special differences compared with the basic situation and all the other values are within the limitations. Eccentric loads on one platform compared to another platform should not give issues on the stability. And even if they did, asymmetric loads can be compromised with ballast very easily.

	Eccentric load
Variables:	
Wave height	4 m
Wave period	8.6 s
Wave length	76.5 m
Water depth	100 m
$M_{\text{building1}}$	$2 * M_{\text{building1}}$
$M_{\text{building2}}$	$0 * M_{\text{building2}}$
Results:	
x_1	$6.66 * 10^{-4}$ m
x_2	$1.99 * 10^{-4}$ m
x_3	$6.30 * 10^{-5}$ rad
x_4	$6.29 * 10^{-3}$ m
x_6	$6.30 * 10^{-5}$ rad
a_1	$3.55 * 10^{-4}$ m/s ²
a_2	$1.06 * 10^{-4}$ m/s ²
a_3	$3.40 * 10^{-5}$ rad/s ²
a_4	$3.36 * 10^{-3}$ m/s ²
a_6	$3.36 * 10^{-5}$ rad/s ²
$\sigma_{\text{connection}}$	725 kN/m ²
$F_{\text{mooring, heave}}$	63.30 kN
$F_{\text{mooring, pitch}}$	28.48 kN

Table 14: Results for the 2 mass-spring system with eccentric loads

8.4.6 Change in mooring lines

In the basic situation, the mooring lines were stiff enough to withstand the (very low) mooring forces. To reduce the costs for the moorings, less thick and thus less stiff mooring lines can be used. A diameter of 76 mm is chosen which contributes to a Minimum Breaking Load of 5647 kN and an axial stiffness of 557 MN. Again, the mooring forces are still safe under the Minimum Breaking Load as the displacements are still small and the same as the basic situation. It can be concluded that the role of the moorings can be neglected in the mass-spring system as the moorings do not contribute to a decrease of the displacements. All the values for the displacements and accelerations are indeed not changed even when no moorings are applied in the model. The moorings are there to make sure the floating community does not drift away from its location due to repeated displacements.

	No moorings	Less stiff moorings
Variables:		
Wave height	4 m	4 m
Wave period	8.6 s	8.6 s
Wave length	76.5 m	76.5 m
Water depth	100 m	100 m
Mooring line stiffness	0	557 MN
Results:		
x_1	$6.63 \cdot 10^{-4}$ m	$6.63 \cdot 10^{-4}$ m
x_2	$3.45 \cdot 10^{-4}$ m	$3.45 \cdot 10^{-4}$ m
x_3	$6.00 \cdot 10^{-5}$ rad	$6.00 \cdot 10^{-5}$ rad
x_4	$5.99 \cdot 10^{-3}$ m	$5.99 \cdot 10^{-3}$ m
x_6	$0.60 \cdot 10^{-4}$ rad	$0.60 \cdot 10^{-4}$ rad
a_1	$3.54 \cdot 10^{-4}$ m/s ²	$3.54 \cdot 10^{-4}$ m/s ²
a_2	$1.84 \cdot 10^{-4}$ m/s ²	$1.84 \cdot 10^{-4}$ m/s ²
a_3	$3.00 \cdot 10^{-5}$ rad/s ²	$3.00 \cdot 10^{-5}$ rad/s ²
a_4	$3.20 \cdot 10^{-3}$ m/s ²	$3.20 \cdot 10^{-3}$ m/s ²
a_6	$3.00 \cdot 10^{-5}$ rad/s ²	$3.00 \cdot 10^{-5}$ rad/s ²
$\sigma_{\text{connection}}$	725 kN/m ²	725 kN/m ²
$F_{\text{mooring, heave}}$	0	17
$F_{\text{mooring, pitch}}$	0	8

Table 15: Results for the 2 mass-spring system with different mooring stiffness's

8.4.7 Combination of unfavourable situations

From the results of previous scenarios, it can be concluded that significant larger displacements are achieved by more severe wave conditions (tsunami), a shallow water depth, and eccentric loading of the platforms. In each scenario, the results on the displacements and accelerations were mostly under their limited values. When all these scenarios are occurring at the same time (which is not a rare scenario) the displacements, accelerations and forces of the platforms do not show any dangerous values. Only a vertical displacement of 0.095 m is achieved for the second platform, which seems a little bit higher than usual. The larger displacement leads to significant larger stresses in the connection, but this is just solved by making a stronger connection with more reinforcement bars and pre-stressing steel. The stresses even do not exceed the tensile strength of concrete.

	Unfavourable
Variables:	
Wave height	15 m
Wave period	14 s
Wave length	212 m
Water depth	20 m
Mooring line stiffness	557 MN
$M_{\text{building1}}$	$2 * M_{\text{building1}}$
$M_{\text{building2}}$	$0 * M_{\text{building2}}$
Results:	
x_1	0.025 m
x_2	$3.29 * 10^{-3}$ m
x_3	$9.16 * 10^{-4}$ rad
x_4	0.095 m
x_6	$8.91 * 10^{-4}$ rad
a_1	$5.16 * 10^{-3}$ m/s ²
a_2	$6.62 * 10^{-4}$ m/s ²
a_3	$1.84 * 10^{-4}$ rad/s ²
a_4	0.019 m/s ²
a_6	$1.79 * 10^{-4}$ rad/s ²
$\sigma_{\text{connection}}$	8680 kN/m ²
$F_{\text{mooring, heave}}$	1323 kN
$F_{\text{mooring, pitch}}$	558 kN

Table 16: Results for the 2 mass-spring system with all unfavourable situations

8.4.8 Results comparison

Overall, it can be safely assumed that the floating platforms are inhabitable under all circumstances. The main reason why such low displacements and accelerations are achieved is because of the dimensions and the masses of the platforms. If the length of the structure is greater than the wavelength, the heave response becomes significant smaller. Resonance and thus large displacements occur when wave periods larger than 195 s are present, just like in the situation with a tsunami. And with the low occurring displacements, the connection and mooring forces remain very small. In fact, the moorings have no influence on the total mass-spring system.

	Basic situation	Tsunami	Severe waves	Larger platforms
Variables:				
Platform length	104 m	104 m	104 m	208 m
Platform width	60 m	60 m	60 m	120 m
Wave height	4 m	4 m	15 m	4 m
Wave period	8.6 s	1200 s	14 s	8.6 s
Wave length	76.5 m	200000 m	212 m	76.5 m
Results:				
x ₁	6.63*10 ⁻⁴ m	4.38 m	0.0066 m	4.56*10 ⁻⁴ m
x ₂	3.45*10 ⁻⁴ m	0.46 m	0.0012 m	8.30*10 ⁻⁵ m
x ₃	6.00*10 ⁻⁵ rad	0.066 rad	2.18*10 ⁻⁴ rad	3.70*10 ⁻⁵ rad
x ₄	5.99*10 ⁻³ m	3.61 m	0.021 m	7.34*10 ⁻³ m
x ₆	0.60*10 ⁻⁴ rad	0.081 rad	2.18*10 ⁻⁴ rad	3.70*10 ⁻⁵ rad
a ₁	3.54*10 ⁻⁴ m/s ²	1.20*10 ⁻⁴ m/s ²	1.32*10 ⁻³ m/s ²	2.43*10 ⁻⁴ m/s ²
a ₂	1.84*10 ⁻⁴ m/s ²	1.27*10 ⁻⁵ m/s ²	2.50*10 ⁻⁴ m/s ²	4.40*10 ⁻⁵ m/s ²
a ₃	3.00*10 ⁻⁵ rad/s ²	1.82*10 ⁻⁶ rad/s ²	4.39*10 ⁻⁵ rad/s ²	2.00*10 ⁻⁵ rad/s ²
a ₄	3.20*10 ⁻³ m/s ²	9.90*10 ⁻⁵ m/s ²	4.33*10 ⁻³ m/s ²	3.91*10 ⁻³ m/s ²
a ₆	3.00*10 ⁻⁵ rad/s ²	2.22*10 ⁻⁶ rad/s ²	4.39*10 ⁻⁵ rad/s ²	2.00*10 ⁻⁵ rad/s ²
σ _{connection}	725 kN/m ²	3.30*10 ⁵ kN/m ²	1965 kN/m ²	167 kN/m ²
F _{mooring, heave}	63.30 kN	38154 kN	227 kN	77 kN
F _{mooring, pitch}	28.48 kN	38534 kN	104 kN	38 kN

Table 17: Results of different situations, part 1

	No moorings	Eccentric load	Shallow water	Unfavourable
Variables:				
Wave height	4 m	4 m	4 m	15 m
Wave period	8.6 s	8.6 s	8.6 s	14 s
Wave length	76.5 m	76.5 m	76.5 m	212 m
Water depth	100 m	100 m	20 m	20 m
Mooring line stiffness	0	2110 MN	2110 MN	557 MN
Results:				
x ₁	6.63*10 ⁻⁴ m	6.66*10 ⁻⁴ m	2.51*10 ⁻³ m	0.025 m

x_2	$3.45 \cdot 10^{-4}$ m	$1.99 \cdot 10^{-4}$ m	$1.37 \cdot 10^{-3}$ m	$3.29 \cdot 10^{-3}$ m
x_3	$6.00 \cdot 10^{-5}$ rad	$6.30 \cdot 10^{-5}$ rad	$2.13 \cdot 10^{-4}$ rad	$9.16 \cdot 10^{-4}$ rad
x_4	$5.99 \cdot 10^{-3}$ m	$6.29 \cdot 10^{-3}$ m	0.022 m	0.095 m
x_6	$0.60 \cdot 10^{-4}$ rad	$6.30 \cdot 10^{-5}$ rad	$2.13 \cdot 10^{-4}$ rad	$8.91 \cdot 10^{-4}$ rad
a_1	$3.54 \cdot 10^{-4}$ m/s ²	$3.55 \cdot 10^{-4}$ m/s ²	$1.34 \cdot 10^{-3}$ m/s ²	$5.16 \cdot 10^{-3}$ m/s ²
a_2	$1.84 \cdot 10^{-4}$ m/s ²	$1.06 \cdot 10^{-4}$ m/s ²	$7.33 \cdot 10^{-4}$ m/s ²	$6.62 \cdot 10^{-4}$ m/s ²
a_3	$3.00 \cdot 10^{-5}$ rad/s ²	$3.40 \cdot 10^{-5}$ rad/s ²	$1.13 \cdot 10^{-4}$ rad/s ²	$1.84 \cdot 10^{-4}$ rad/s ²
a_4	$3.20 \cdot 10^{-3}$ m/s ²	$3.36 \cdot 10^{-3}$ m/s ²	0.011 m/s ²	0.019 m/s ²
a_6	$3.00 \cdot 10^{-5}$ rad/s ²	$3.36 \cdot 10^{-5}$ rad/s ²	$1.14 \cdot 10^{-4}$ rad/s ²	$1.79 \cdot 10^{-4}$ rad/s ²
$\sigma_{\text{connection}}$	725 kN/m ²	725 kN/m ²	1993 kN/m ²	8680 kN/m ²
$F_{\text{mooring, heave}}$	0	63.30 kN	1151 kN	1323 kN
$F_{\text{mooring, pitch}}$	0	28.48 kN	507 kN	558 kN

Table 18: Results of different situations, part 2