

Antechamber to the Bosphorus.
In point, line, surface.

by Matilda Luisa Hoffmann

*Transient Liquidities along the New Silk Road II
Borders&Territories graduation studio 2022/2023*

introduction

waiting

research

site, context, conditions

design

waiting experience
material, structure, assembly

reflection



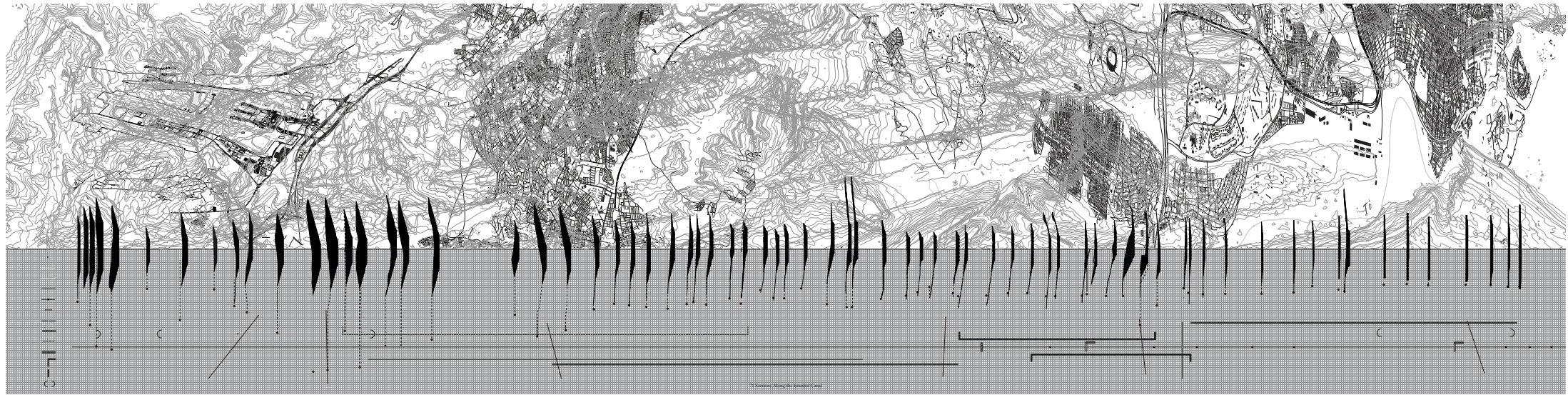

// collective map [drawing: infrastructure and congestion]



Ömer

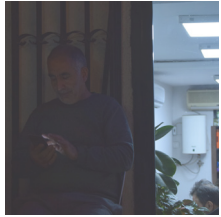

Sakal



İlayda



Süleyman



Dondu



Mehmet I.



Sinan



Mehmet II.



Mustafa

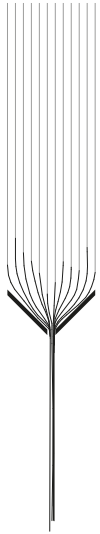

constriction

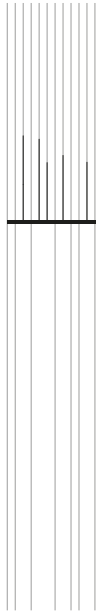

barrier

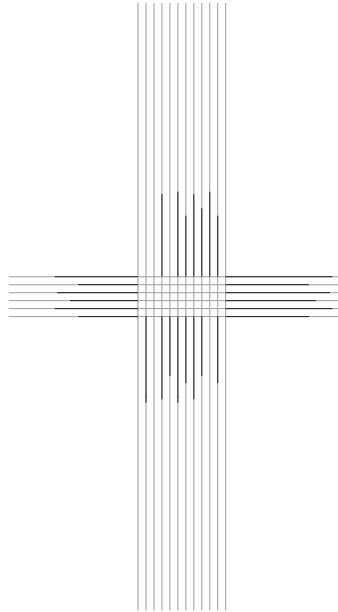

crossing

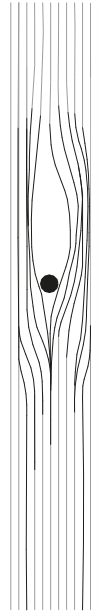

obstacle

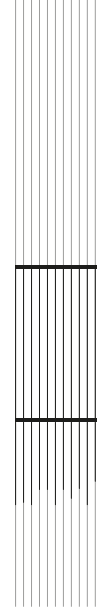

lock

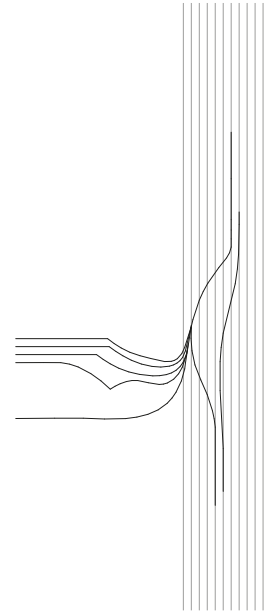



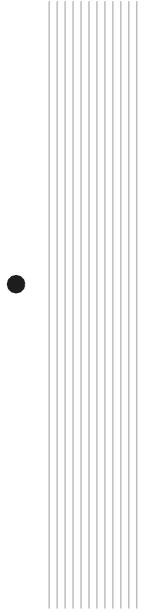































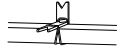























transit



godot

Estragon: "Let's go."
Vladimir: "We can't."
Estragon: "Why not?"
Vladimir: "We're waiting for Godot."

Beckett S., 1952. *En attendant Godot*

//distraction	 //A 01	 //B 02	 //C 01	 //D 01	 //E 01	 //F 01	 //G 01	 //H 01	 //I 01	 //J 01	 //K 01	 //L 01	 //M 01	 //N 01	 //O 01
//comfort	 //A 02	 //B 02	 //C 02	 //D 02	 //E 02	 //F 02	 //G 02	 //H 02	 //I 02	 //J 02	 //K 02	 //L 02	 //M 02	 //N 02	 //O 02
//barrier	 //A 03	 //B 03	 //C 03	 //D 03	 //E 03	 //F 03	 //G 03	 //H 03	 //I 03	 //J 03	 //K 03	 //L 03	 //M 03	 //N 03	 //O 03
//information	 //A 04	 //B 04	 //C 04	 //D 04	 //E 04	 //F 04	 //G 04	 //H 04	 //I 04	 //J 04	 //K 04	 //L 04	 //M 04	 //N 04	 //O 04

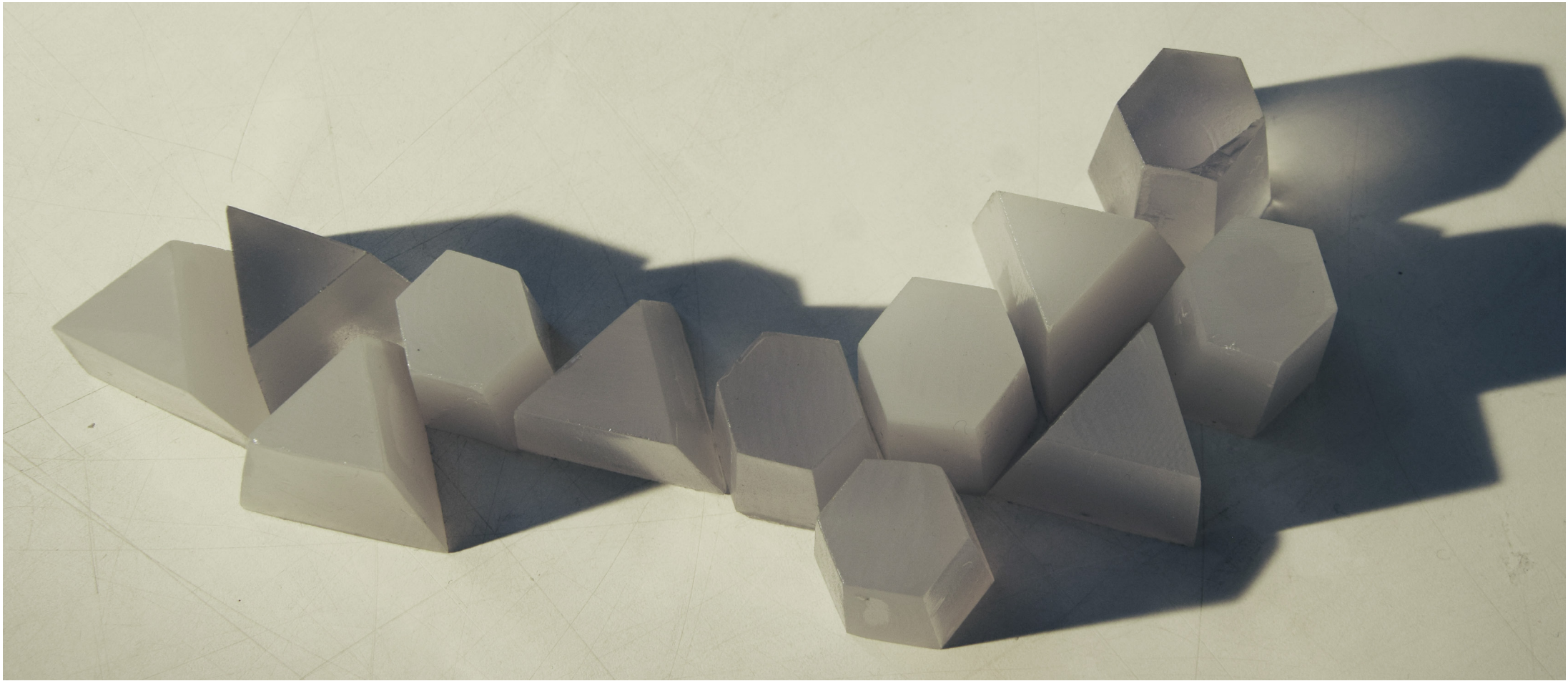

// Modi Operandi [Assemblage exercise 'Form']

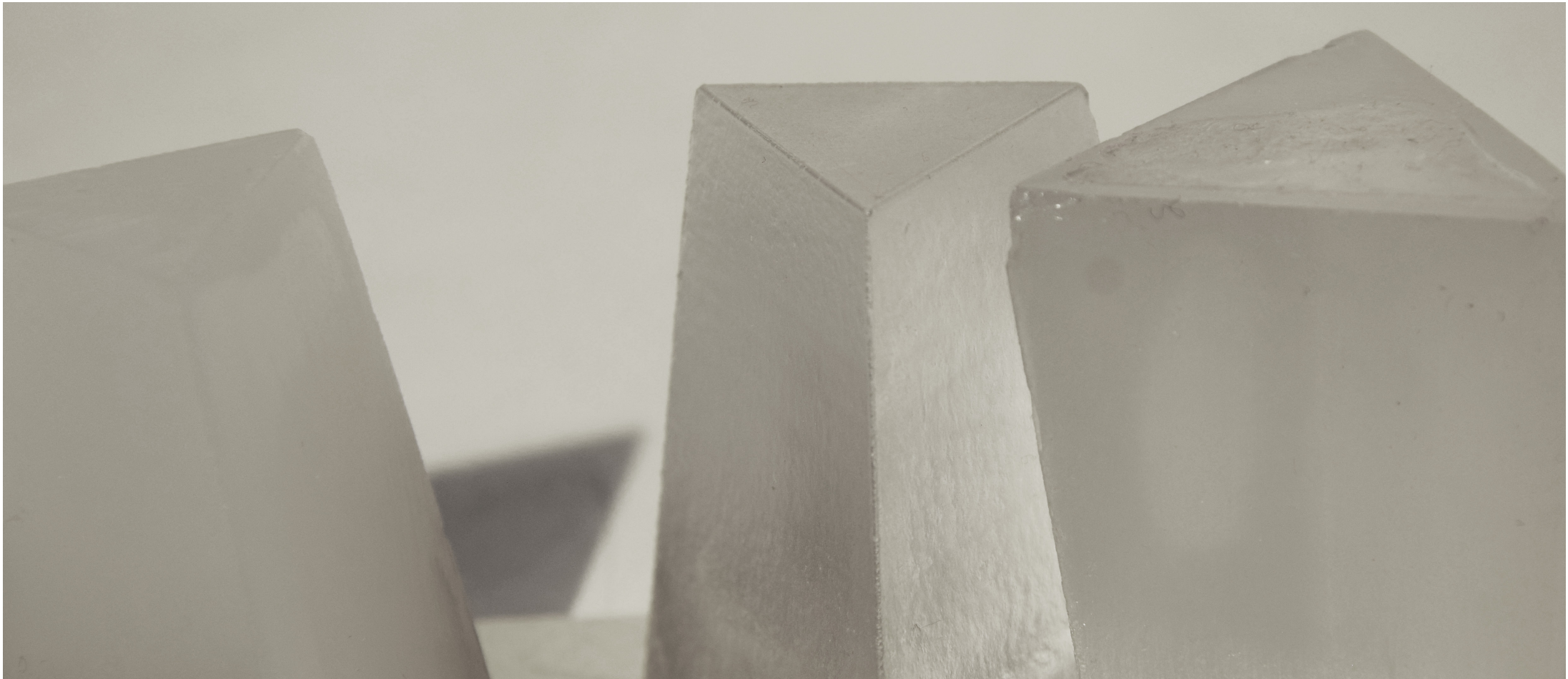

// Modi Operandi [Assemblage exercise 'Form']

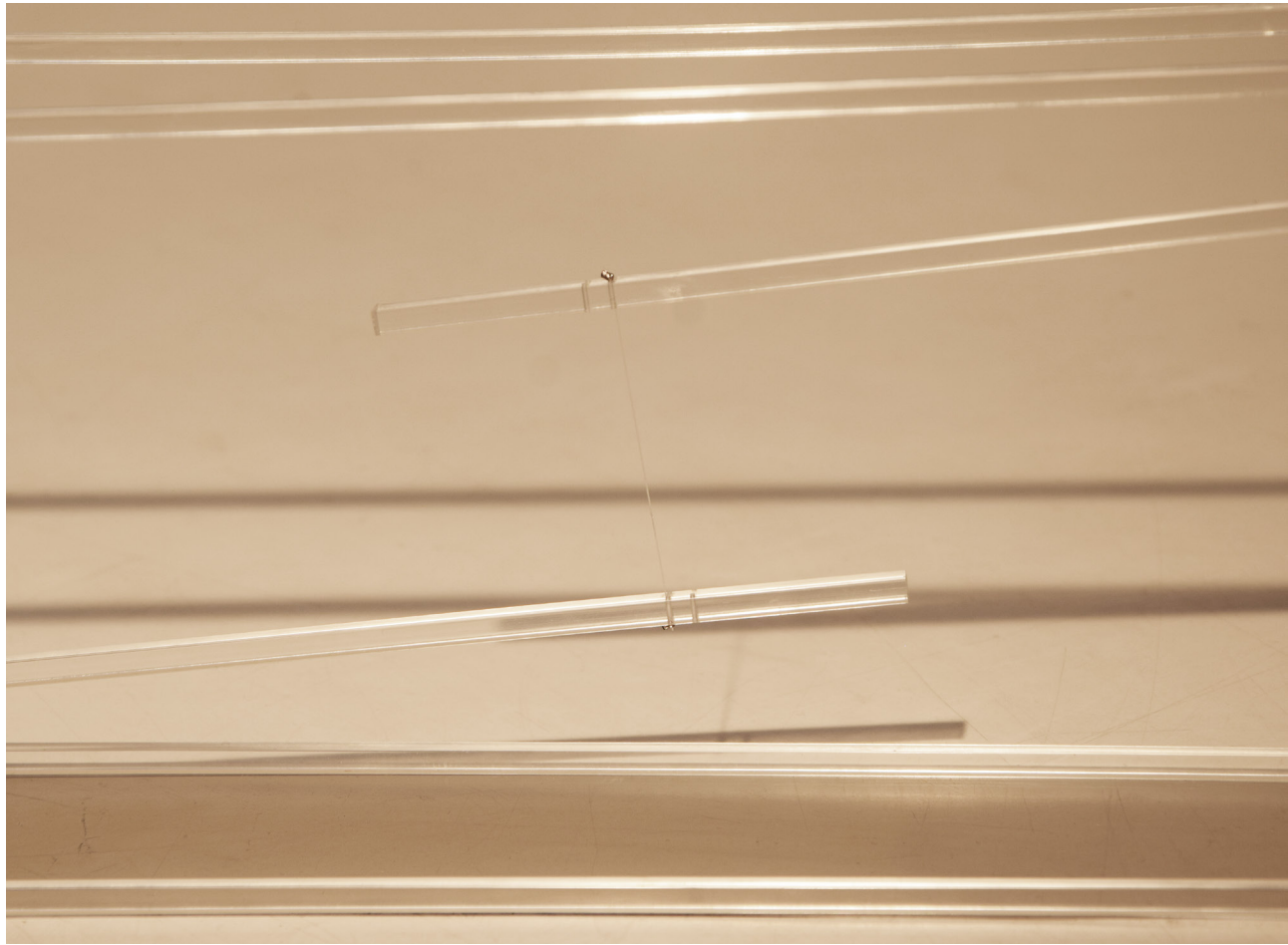
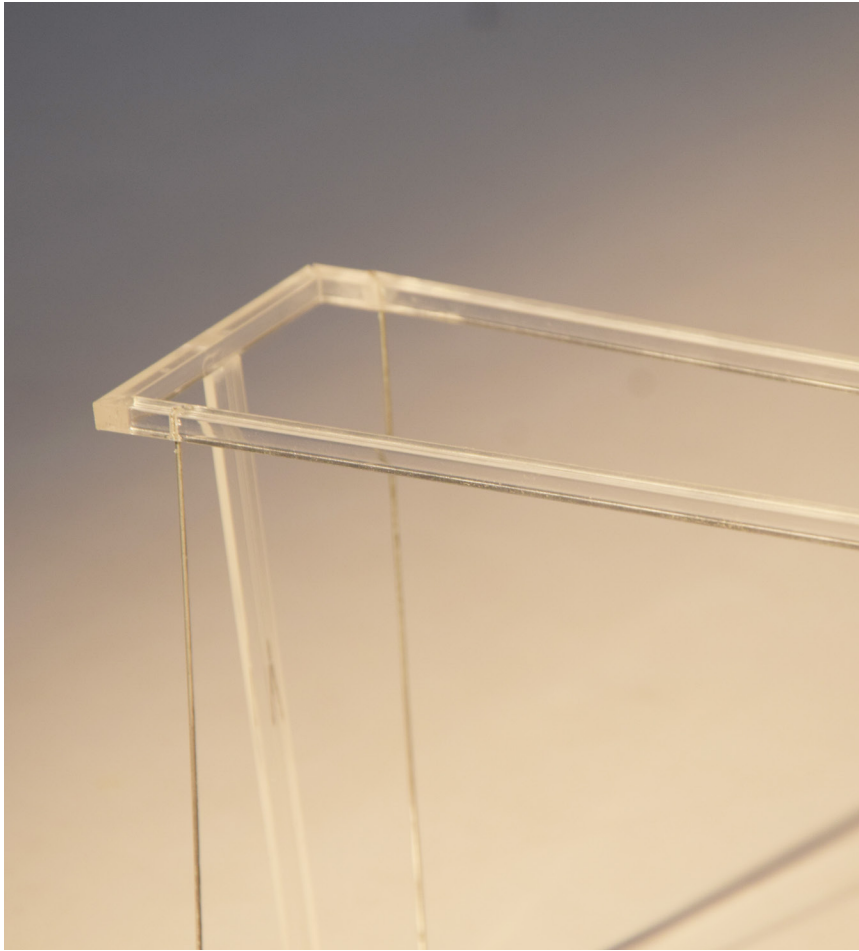

// Modi Operandi [spatial situations exercise 'Program']

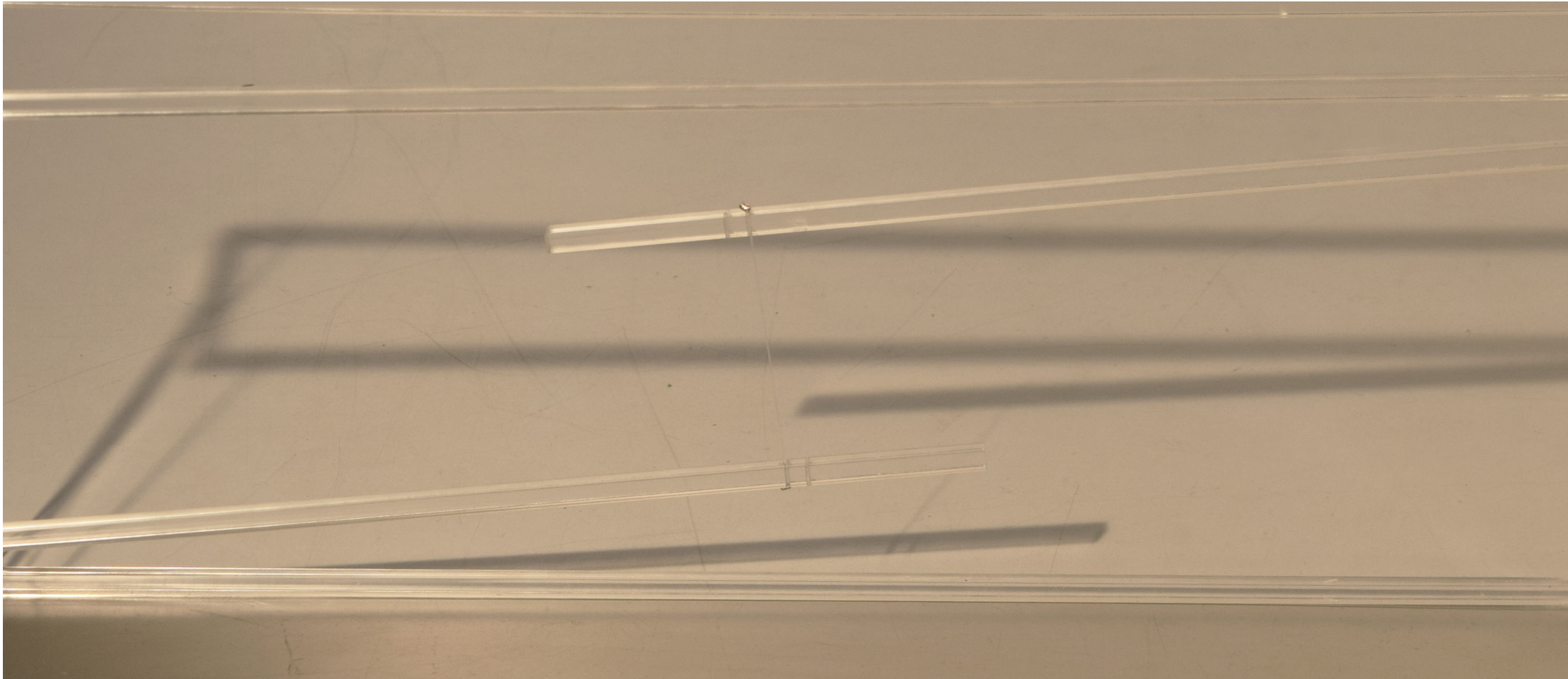

// *Modi Operandi [spatial situations exercise 'Program']*

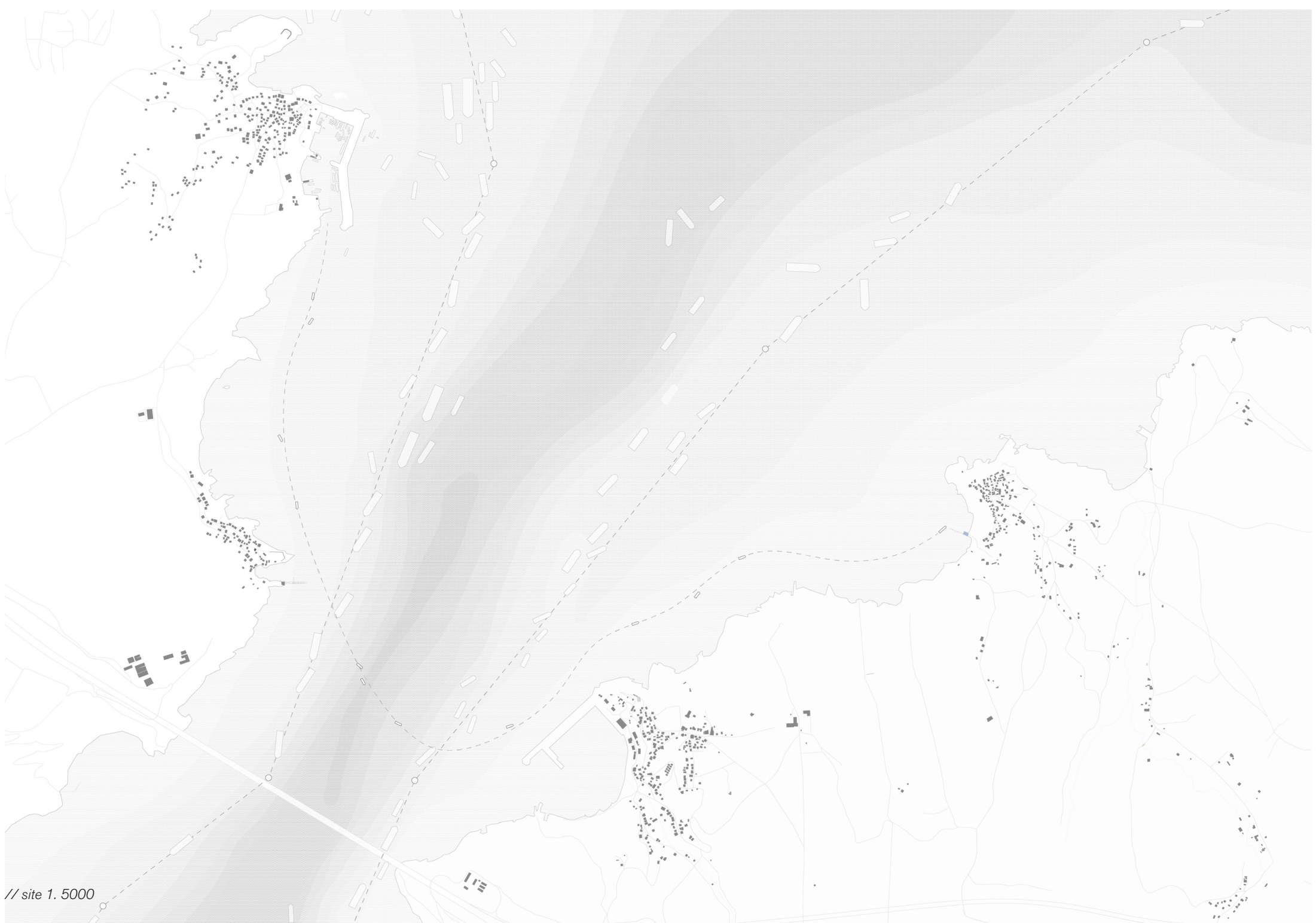

// site 1. 5000

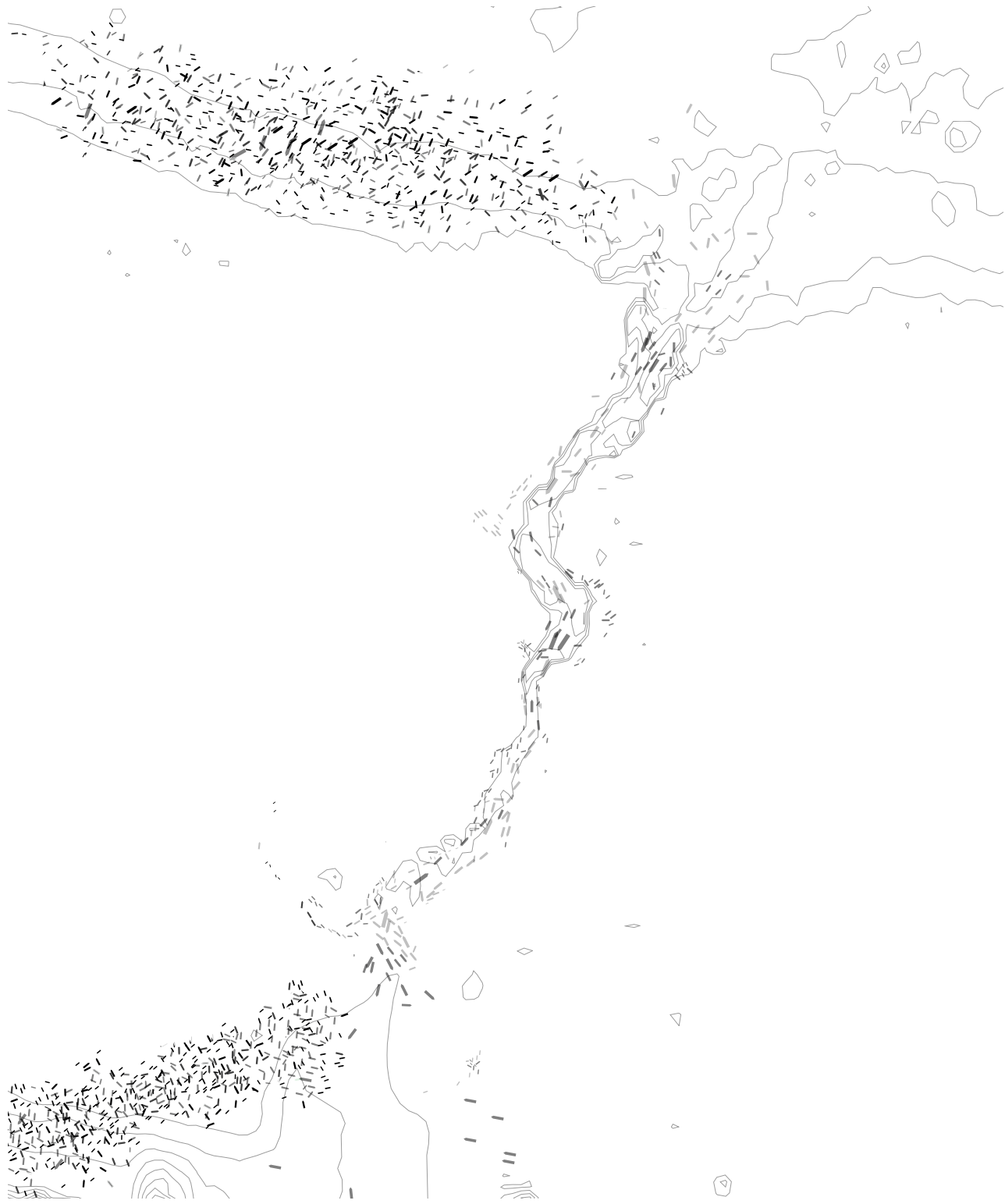

// waiting vessels

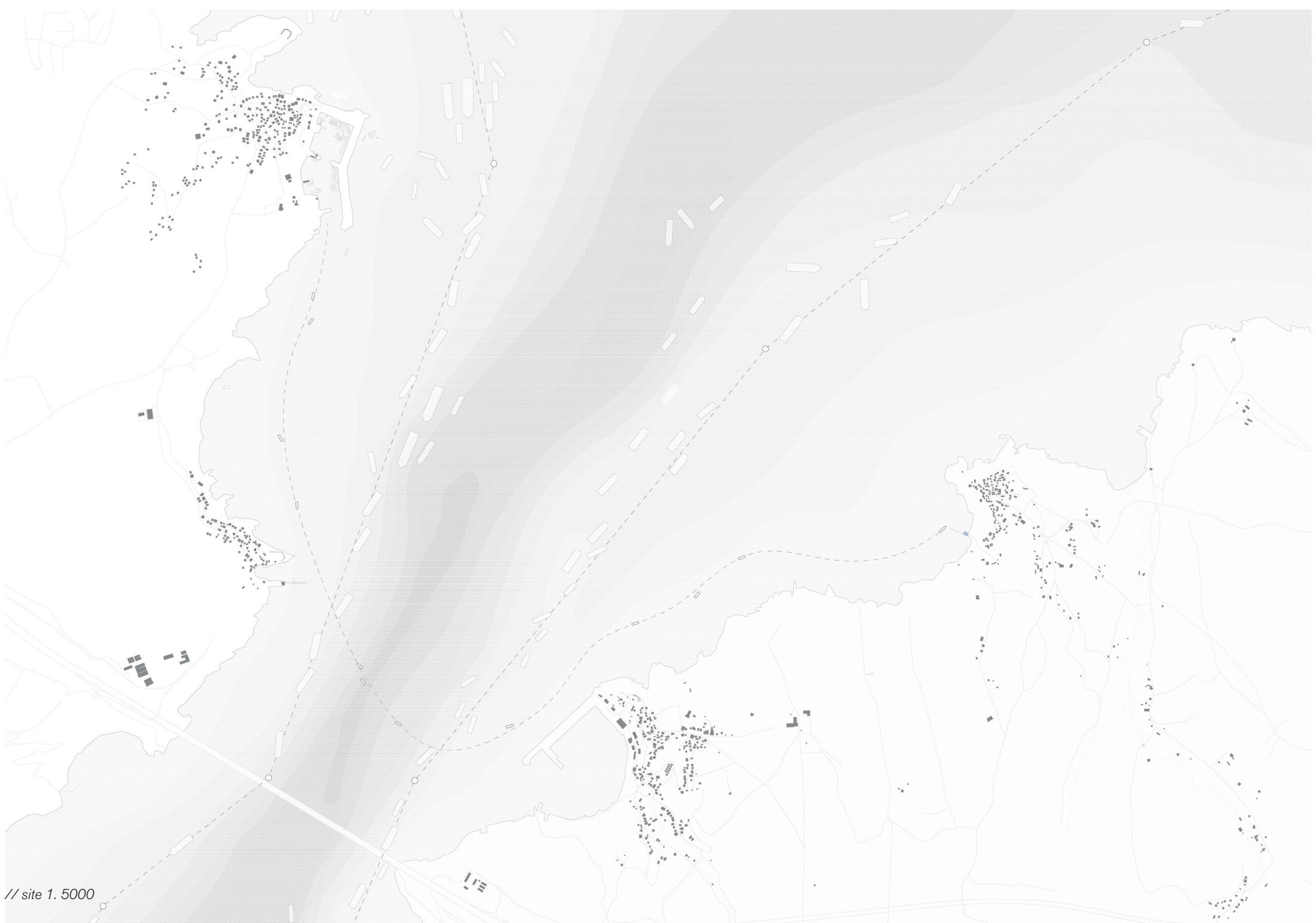

// site 1. 5000



terminal

pier

tower

We look to the street for diversion.

We look further off to the water for something larger – to reassure ourselves that all is right with the world.

The view, no matter how distant, takes on a spiritual meaning. The window which looks on to the Bosphorus becomes an altar (...); the chairs, sofas and dining tables in the living room are all arranged to face the sea. (...)

Windows on the ships watch Istanbul, while windows on the shore watch the ships.

*The Boy Who Watched the Ships Go By.
Orhan Pamuk, 1998.*

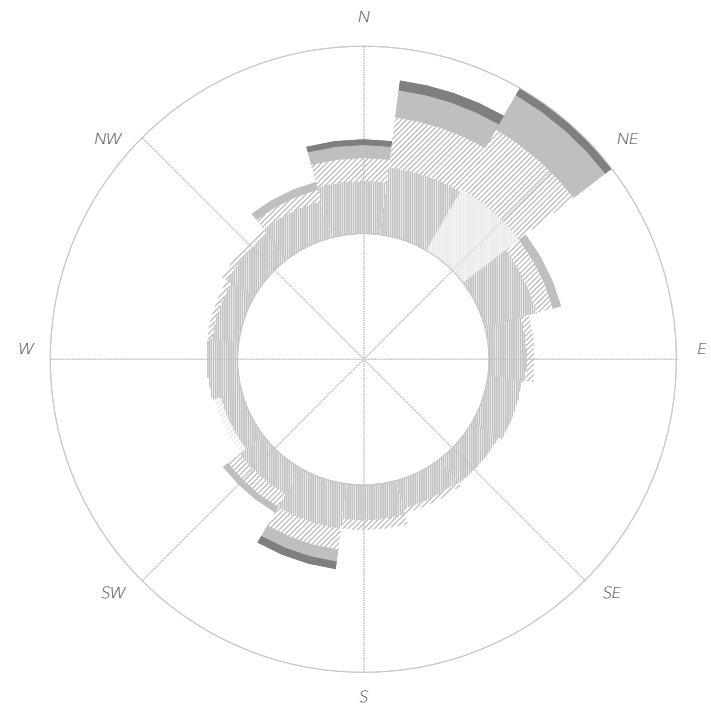
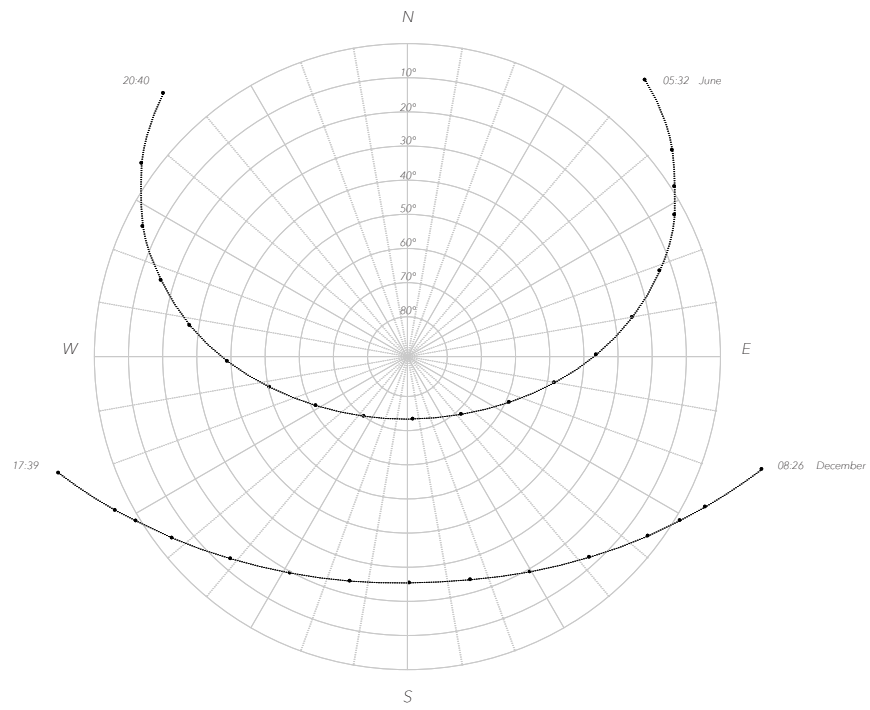

8-12 knots 12-17 knots 17-23 knots 23-35 knots

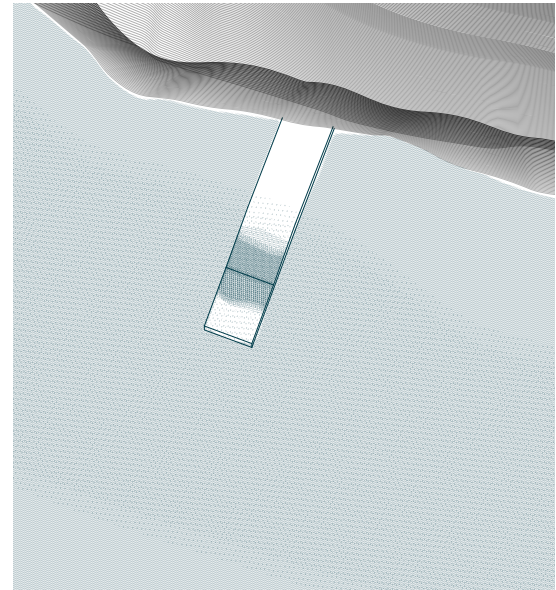
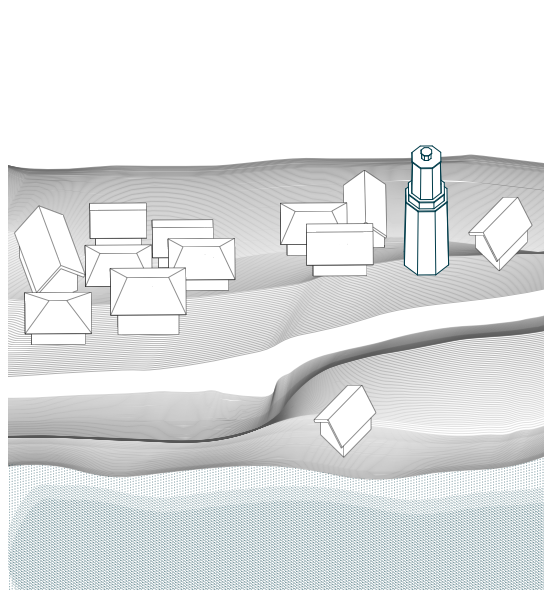
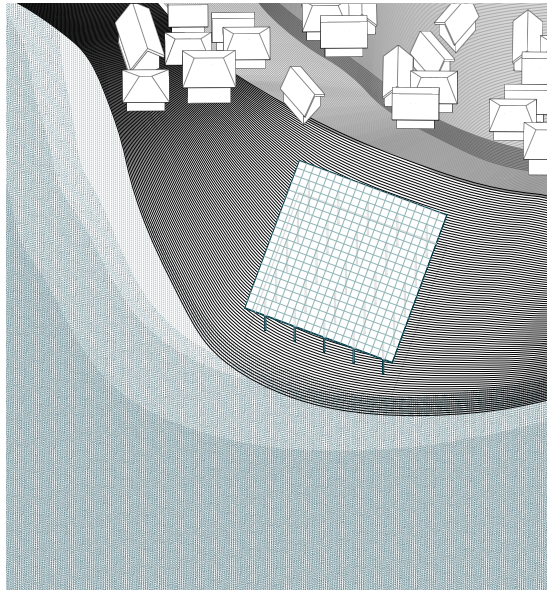

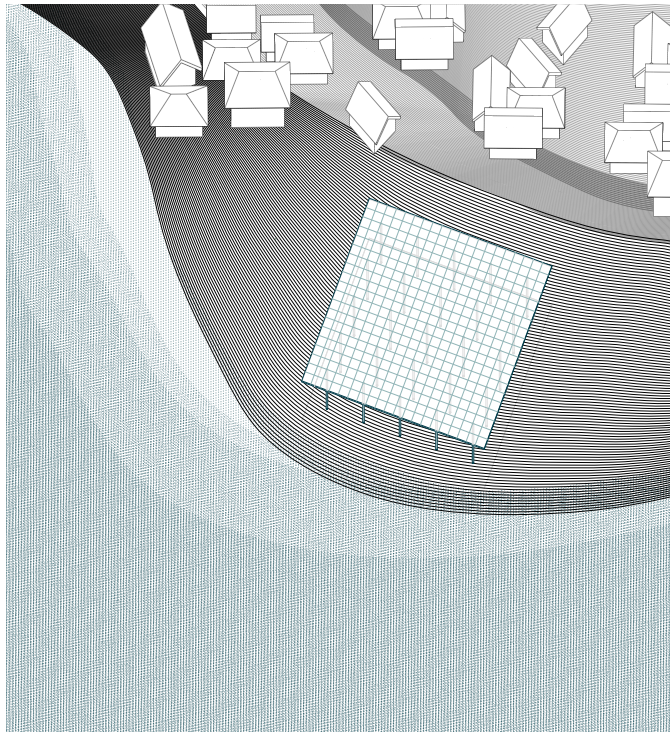



// site photo

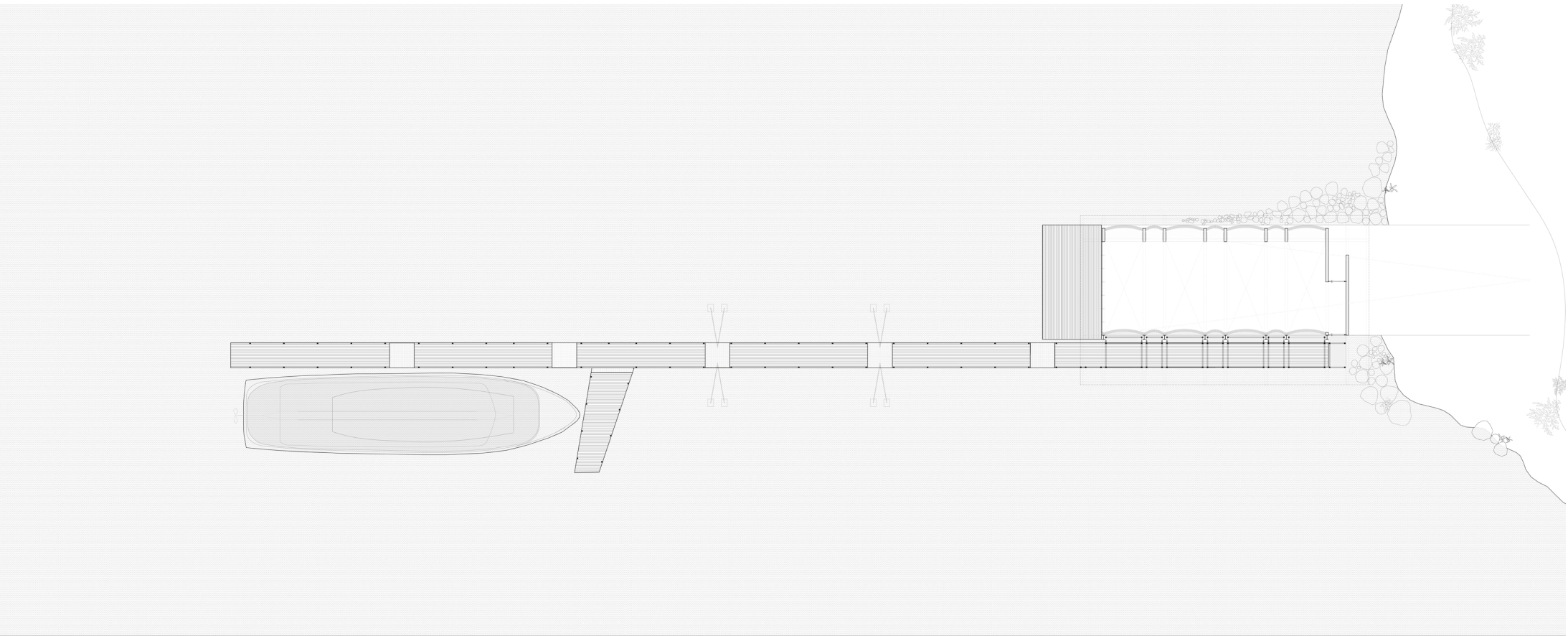

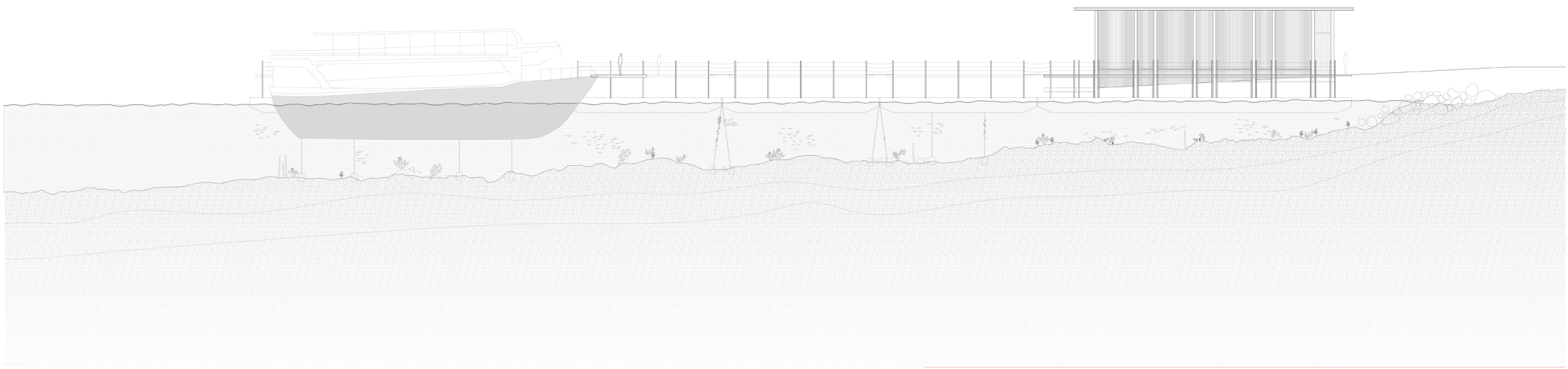

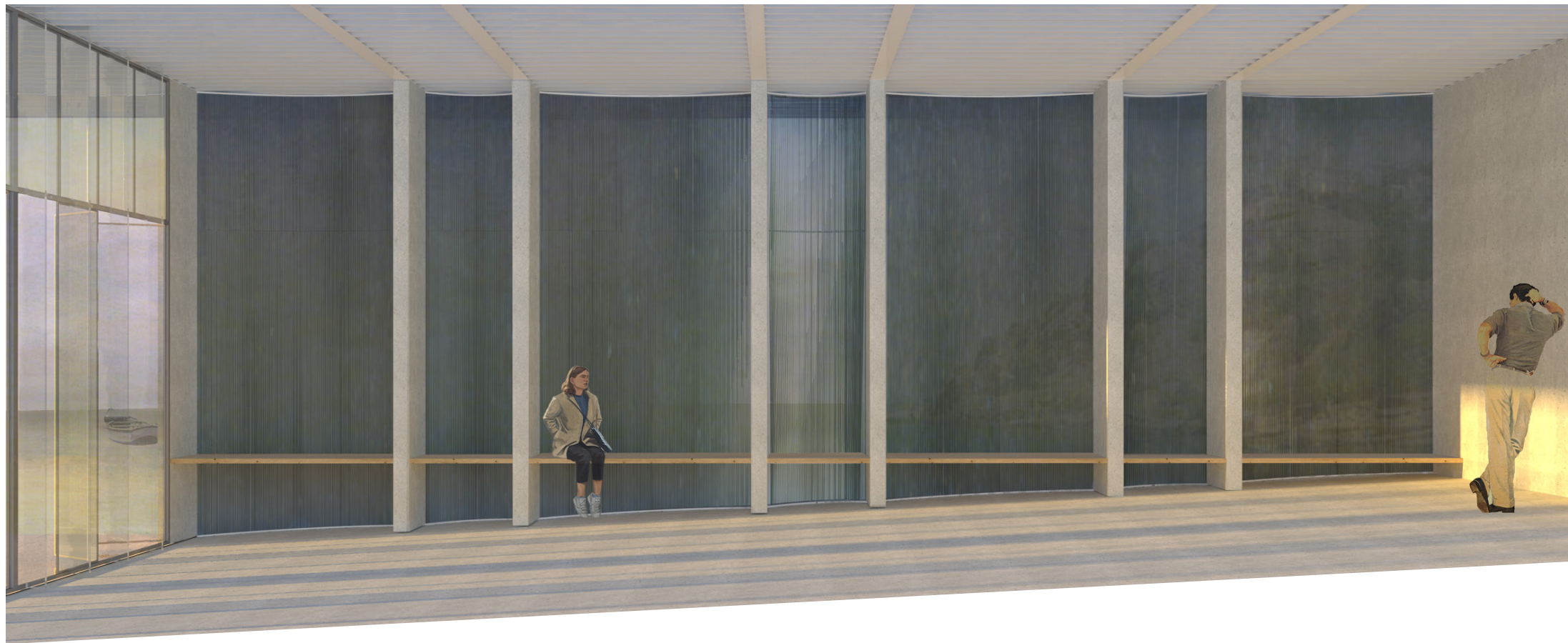

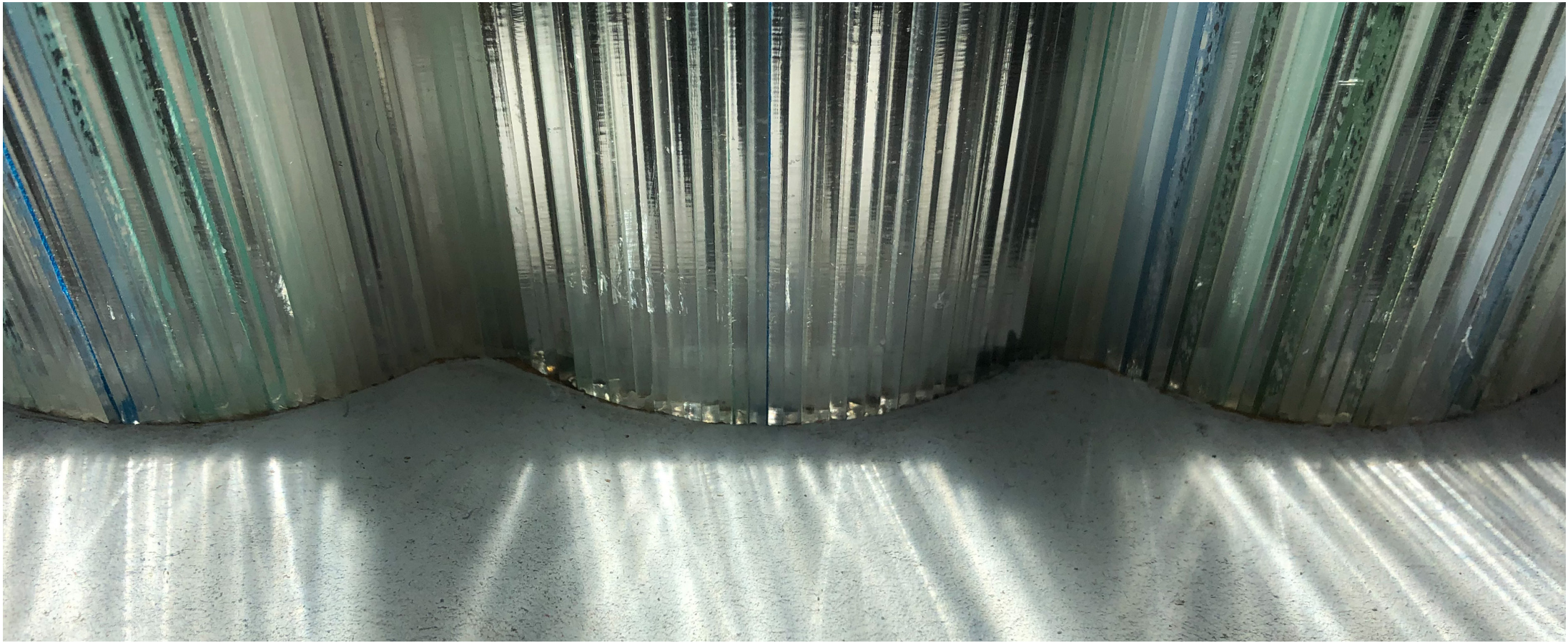

// corner workshop

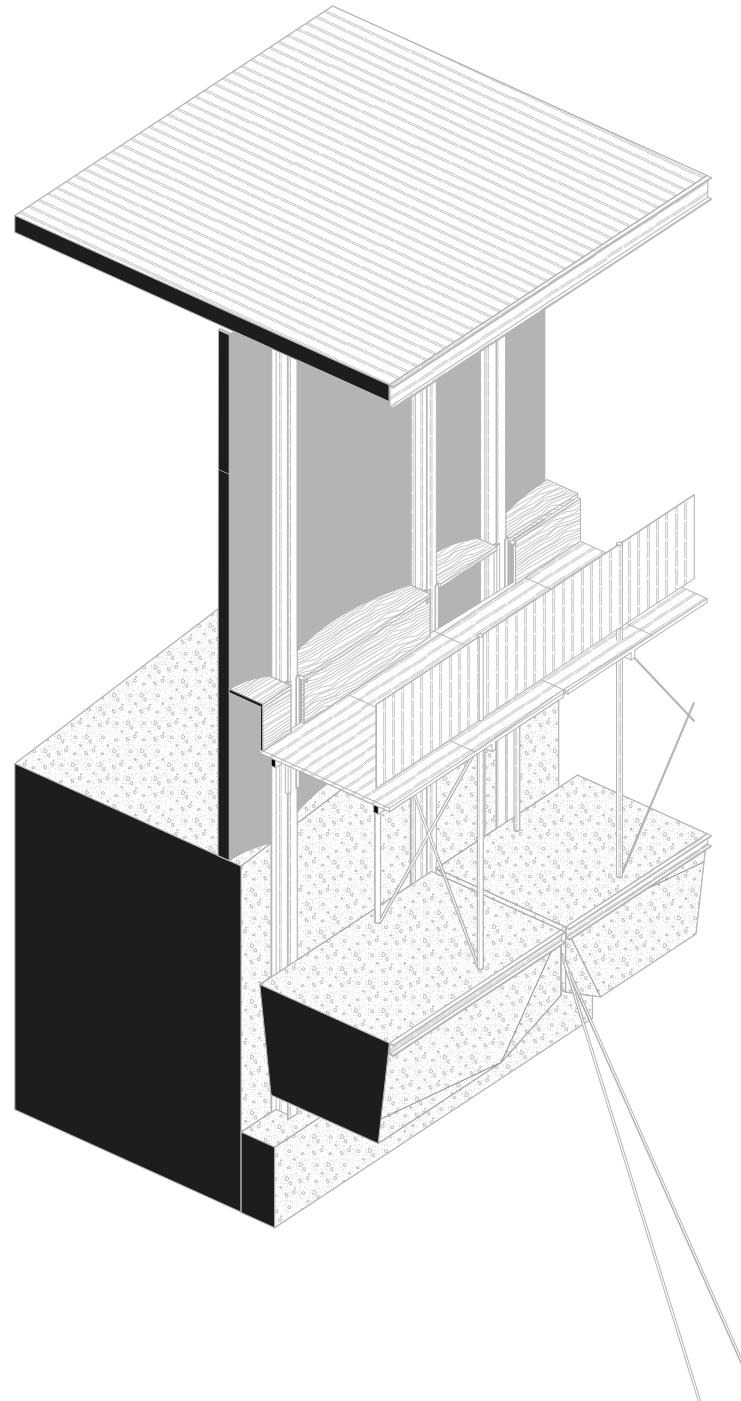

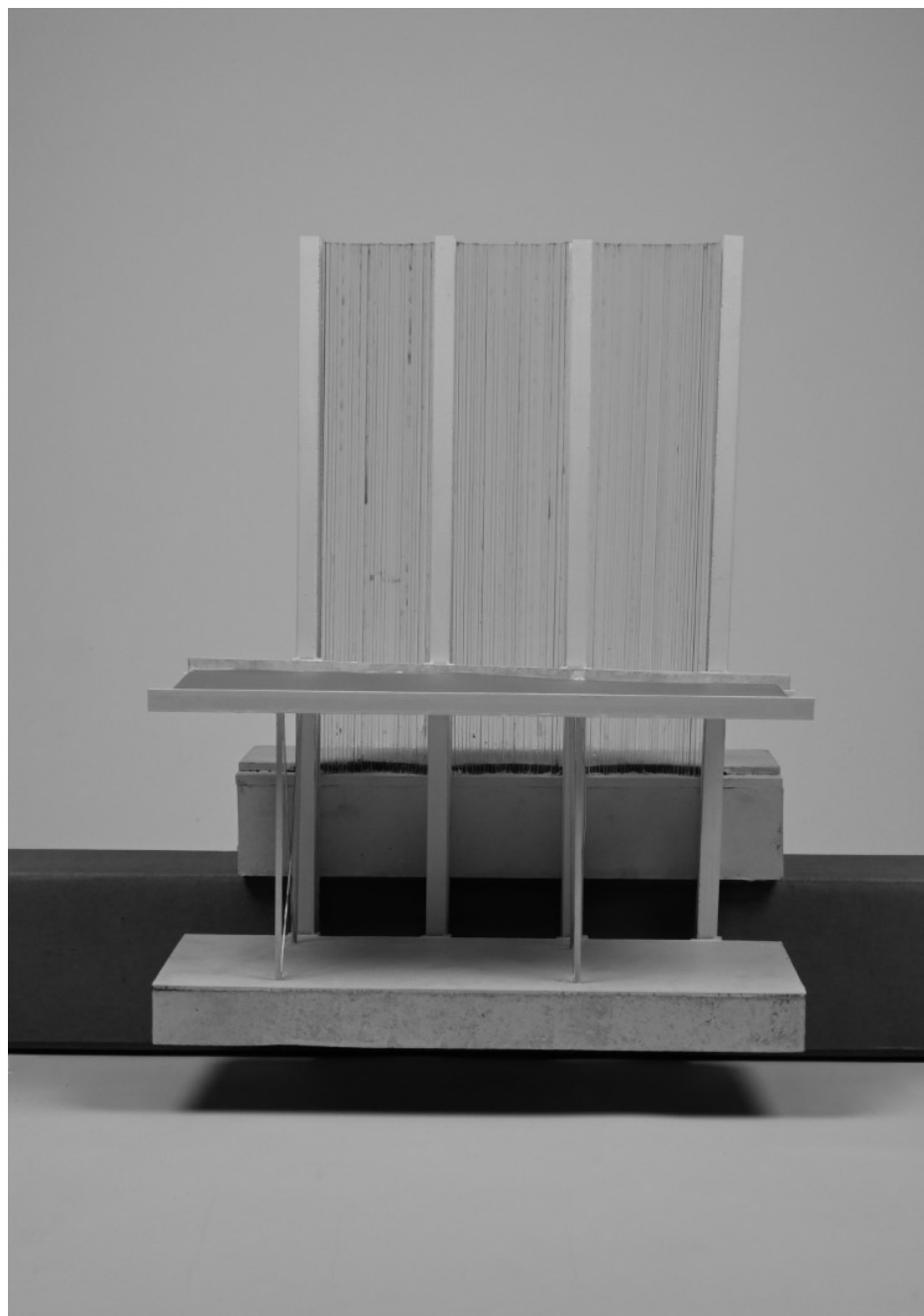

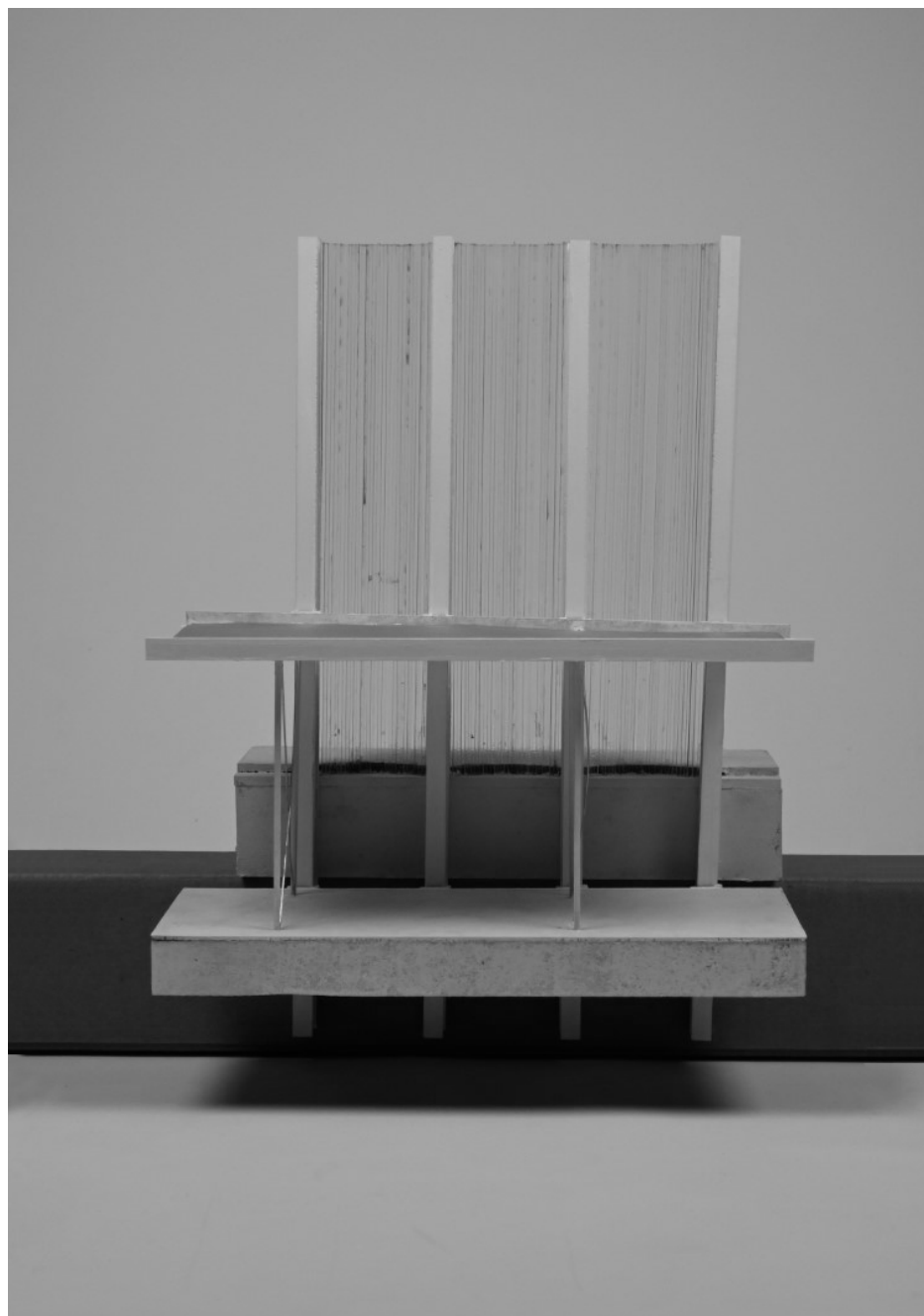

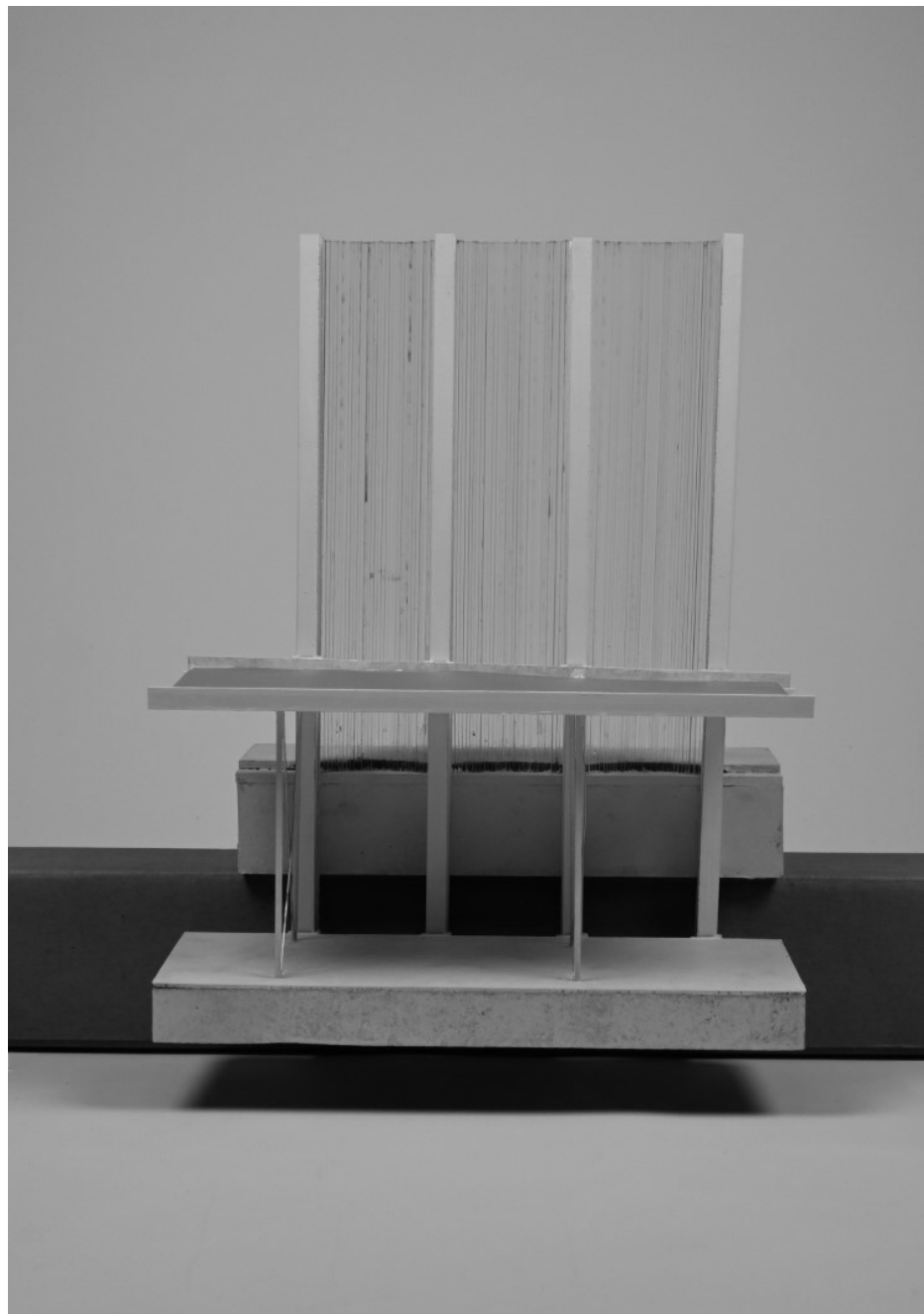

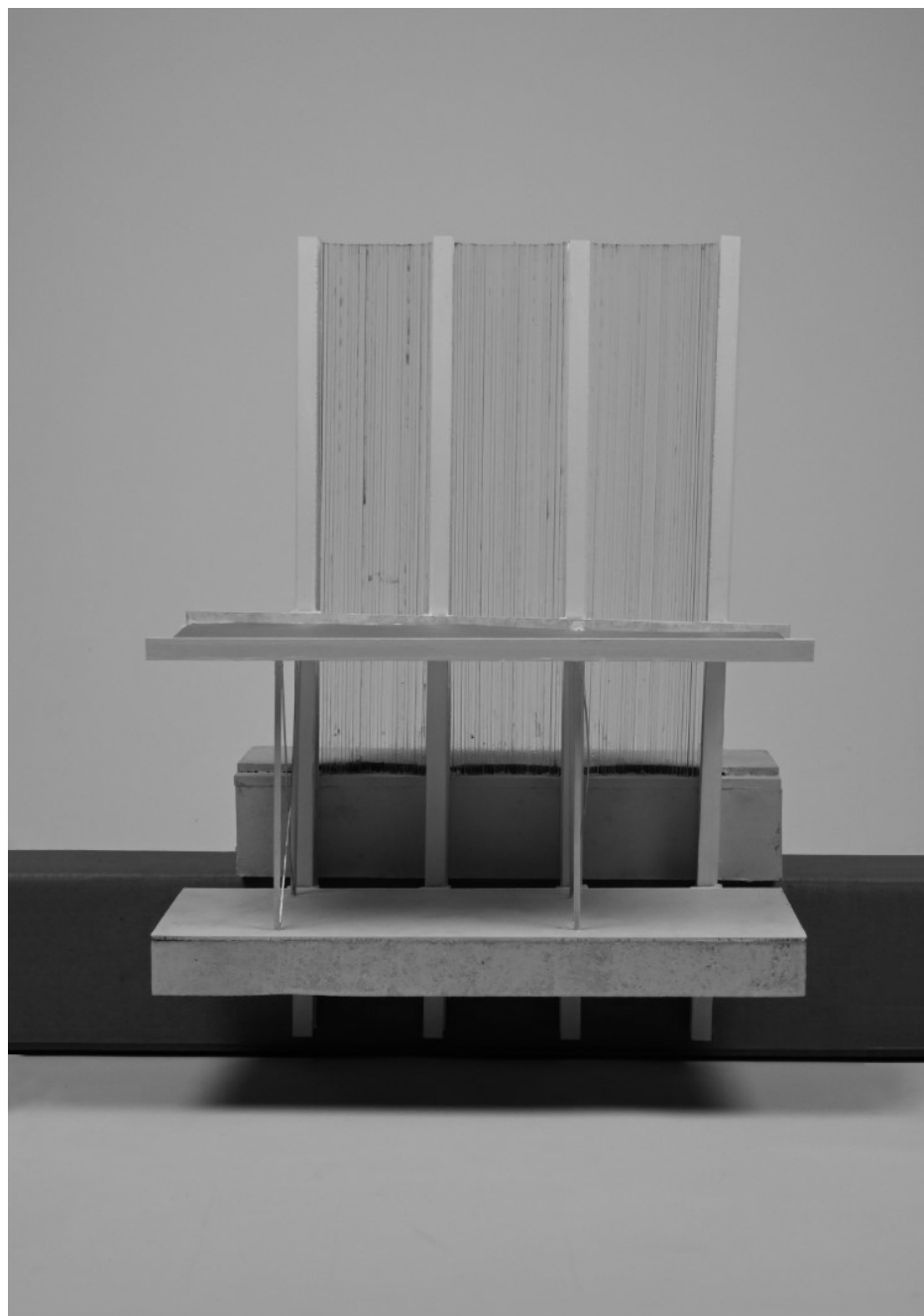

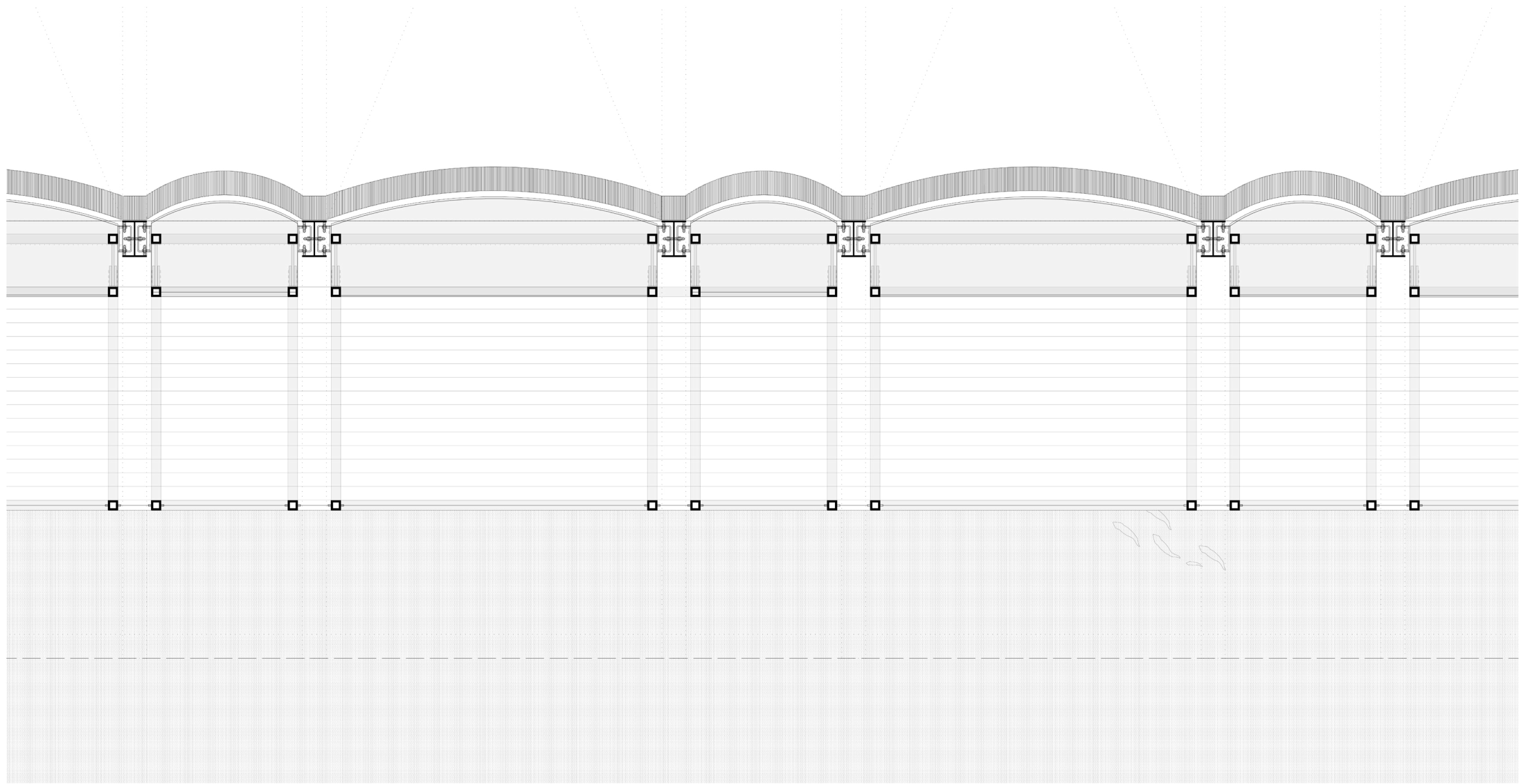

// fragment horizontal section 1.10

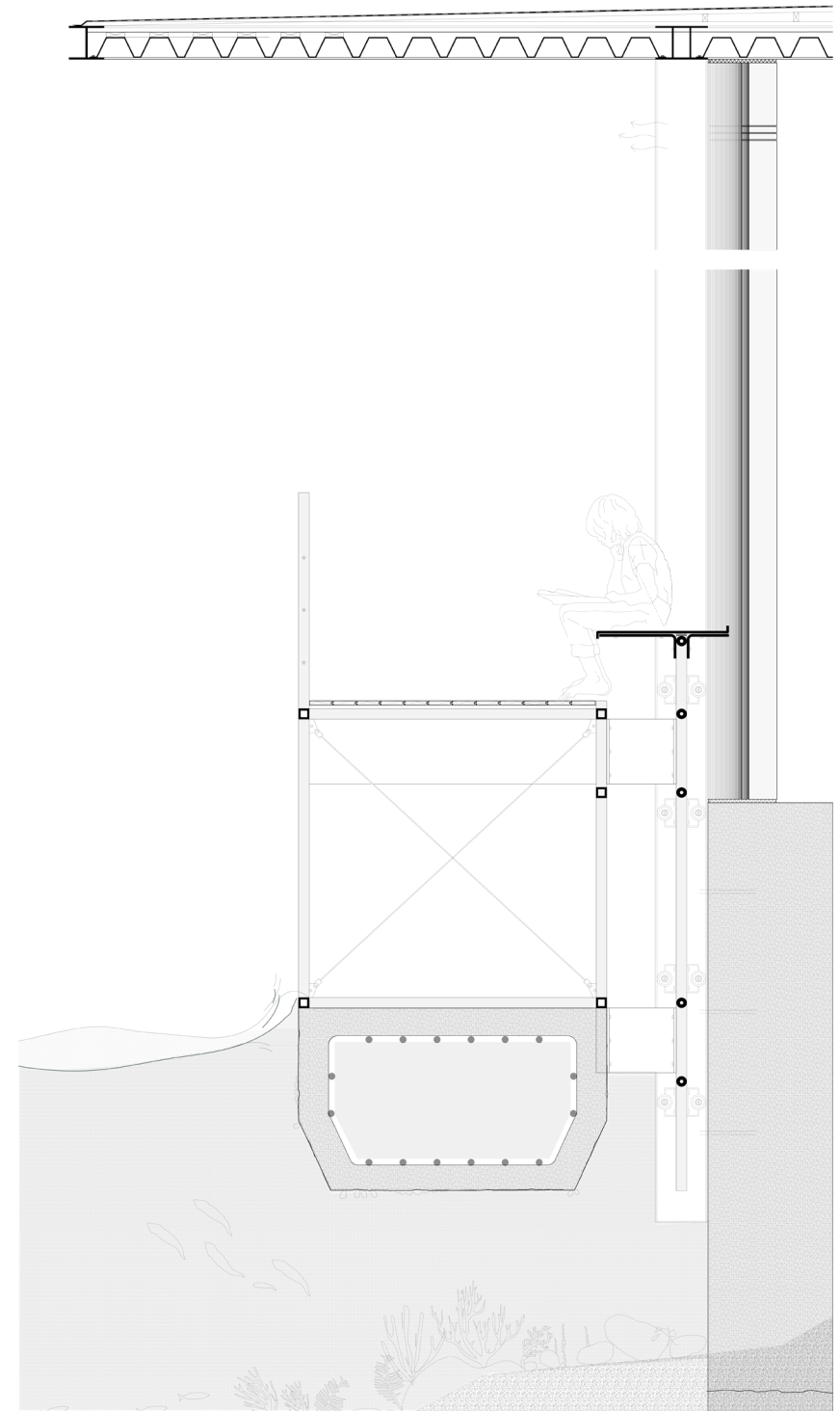

// fragment facade elevation, vertical section 1.10

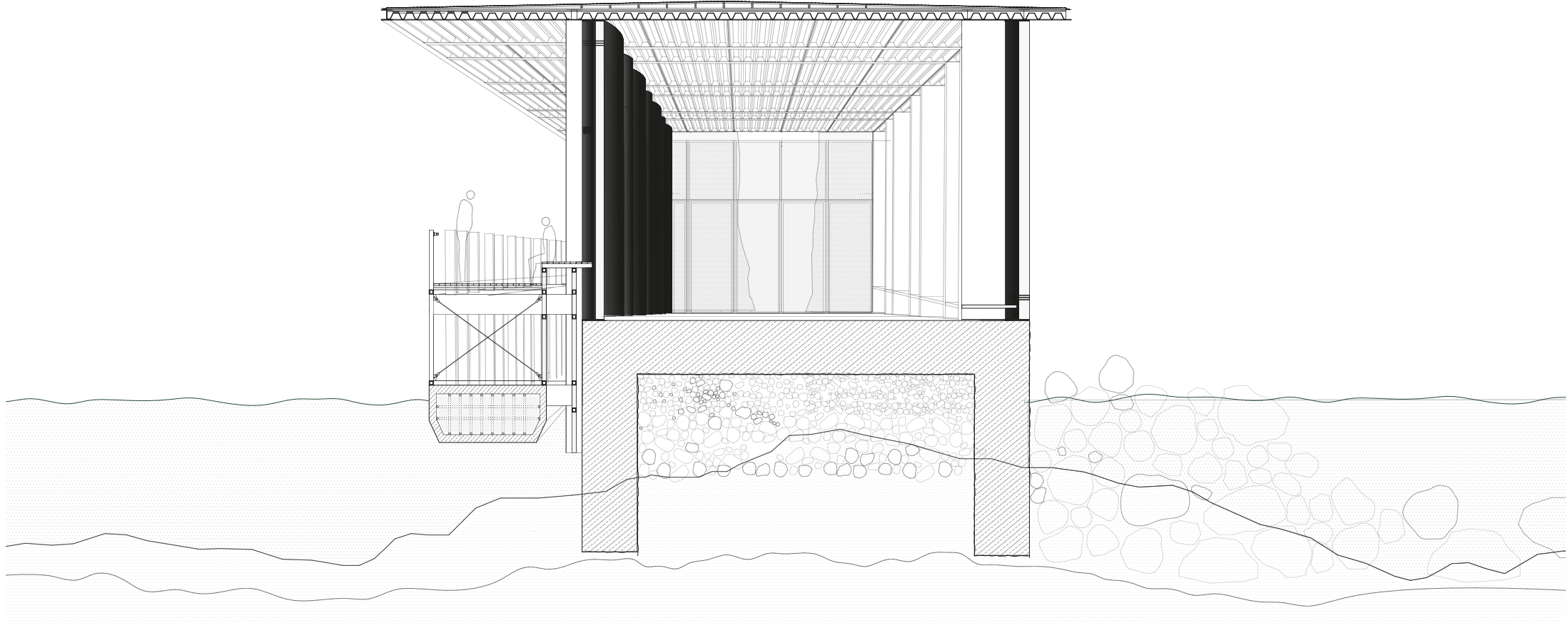

// perspective section 1.50



terminal

pier

tower

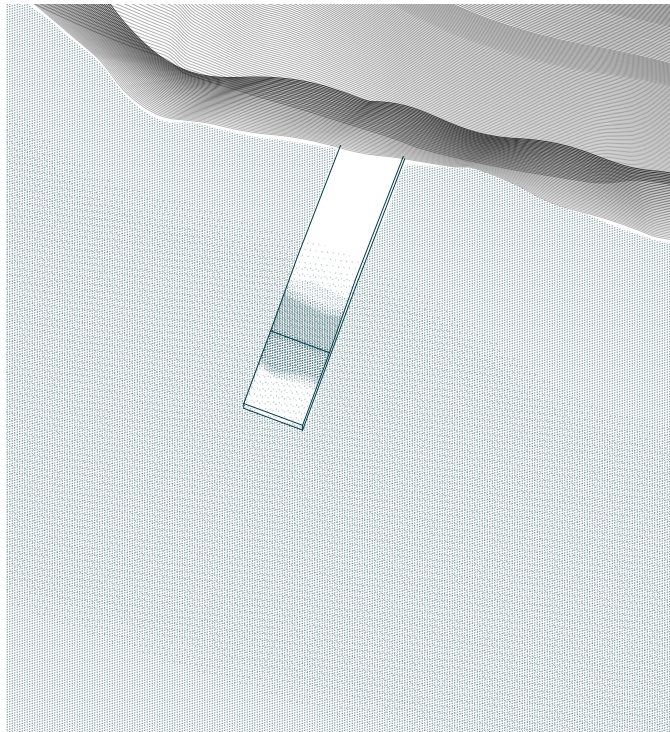



// site map 1.500



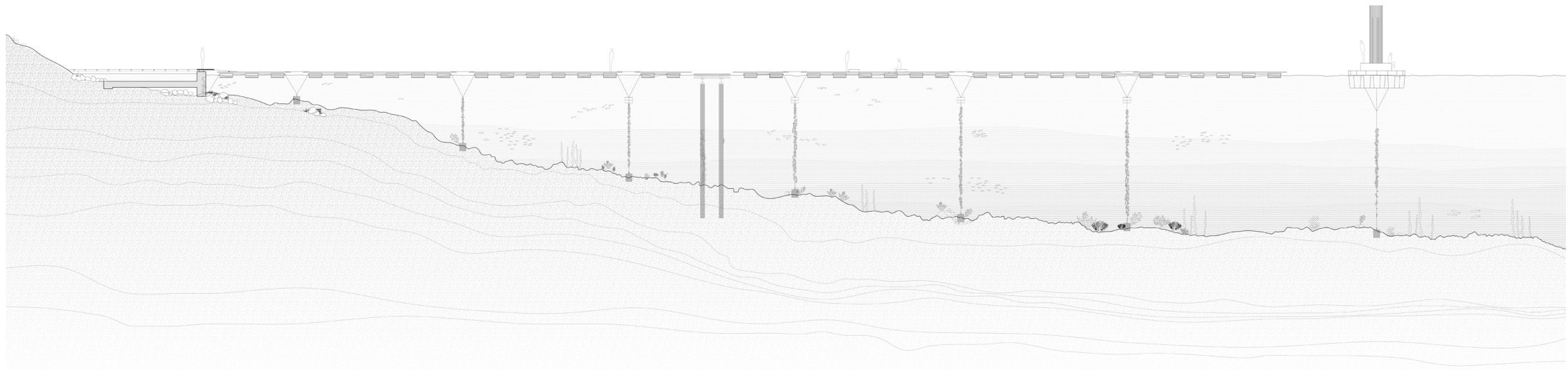

// elevation 1.100

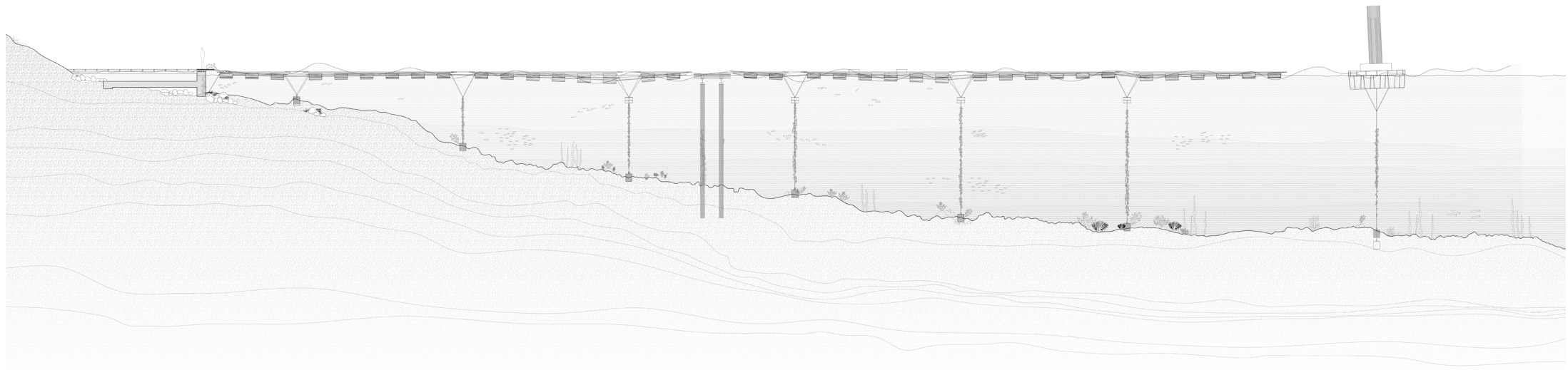

// elevation 1.100

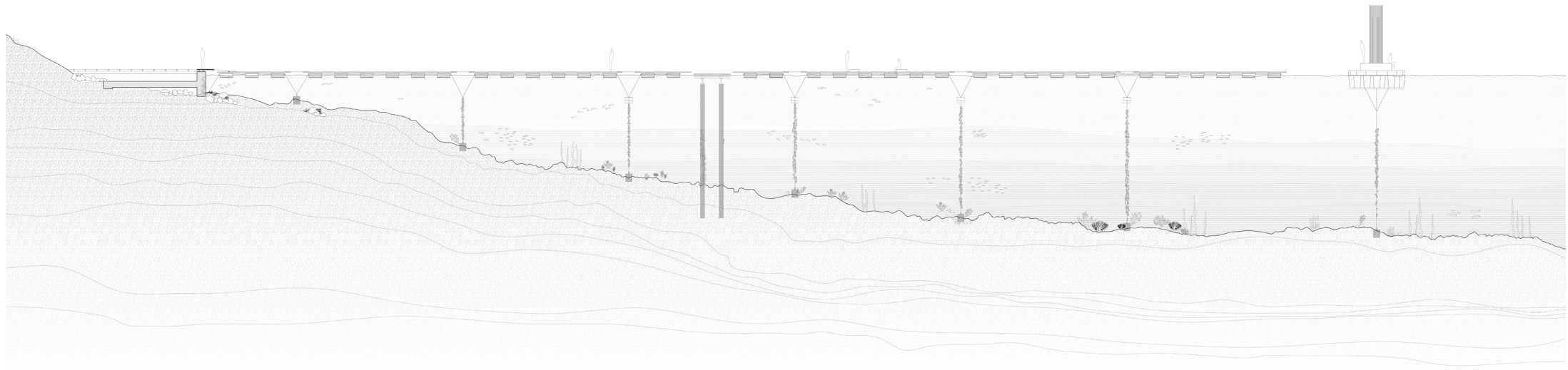

// elevation 1.100

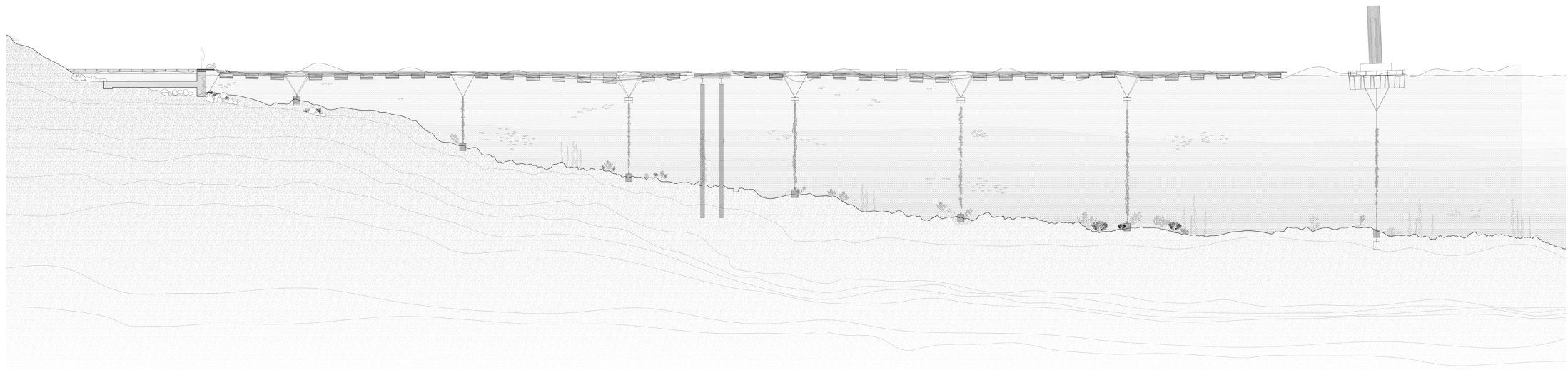

// elevation 1.100



fertilized eggs,
0,5mm



newly-hatched free
swimmers



d-shape larvae



metamorphic larvae

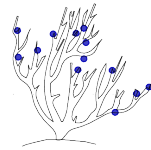

natural
progression



harvest spat



first seeding

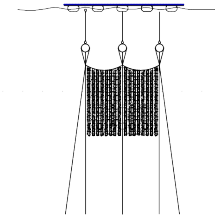

reseeding

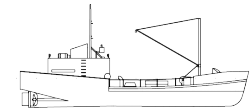

harvest



mature mussel

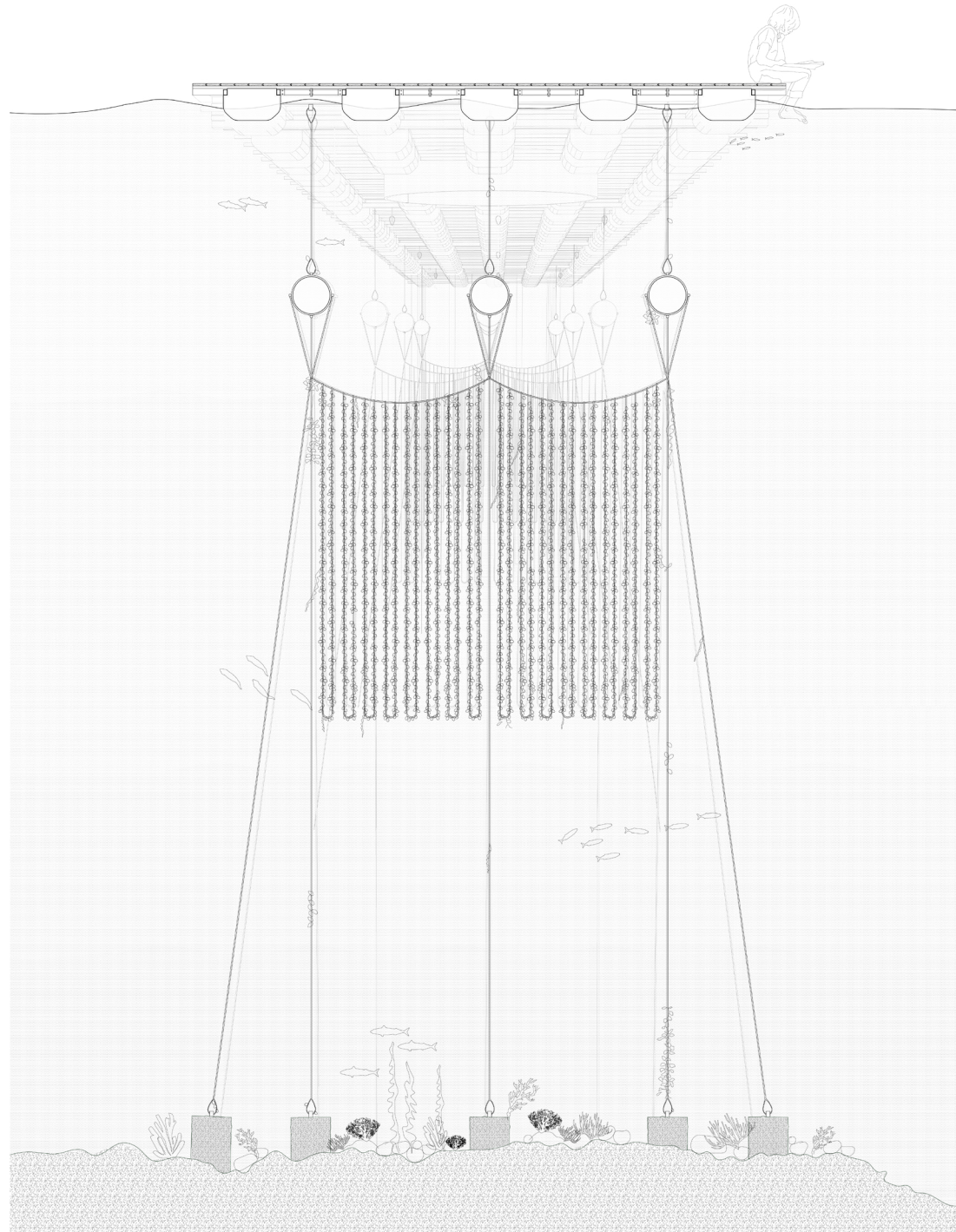

// perspective section 1.20

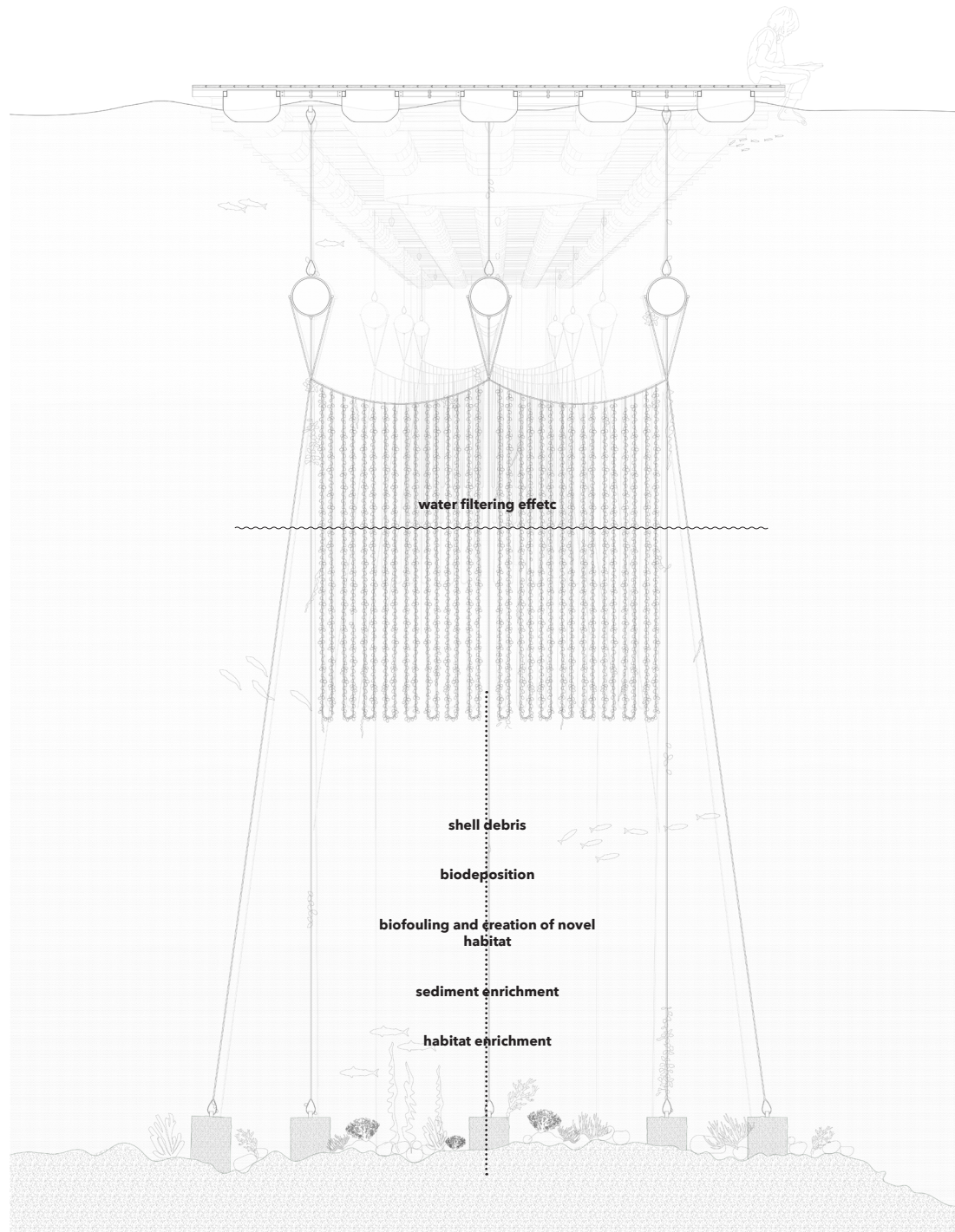

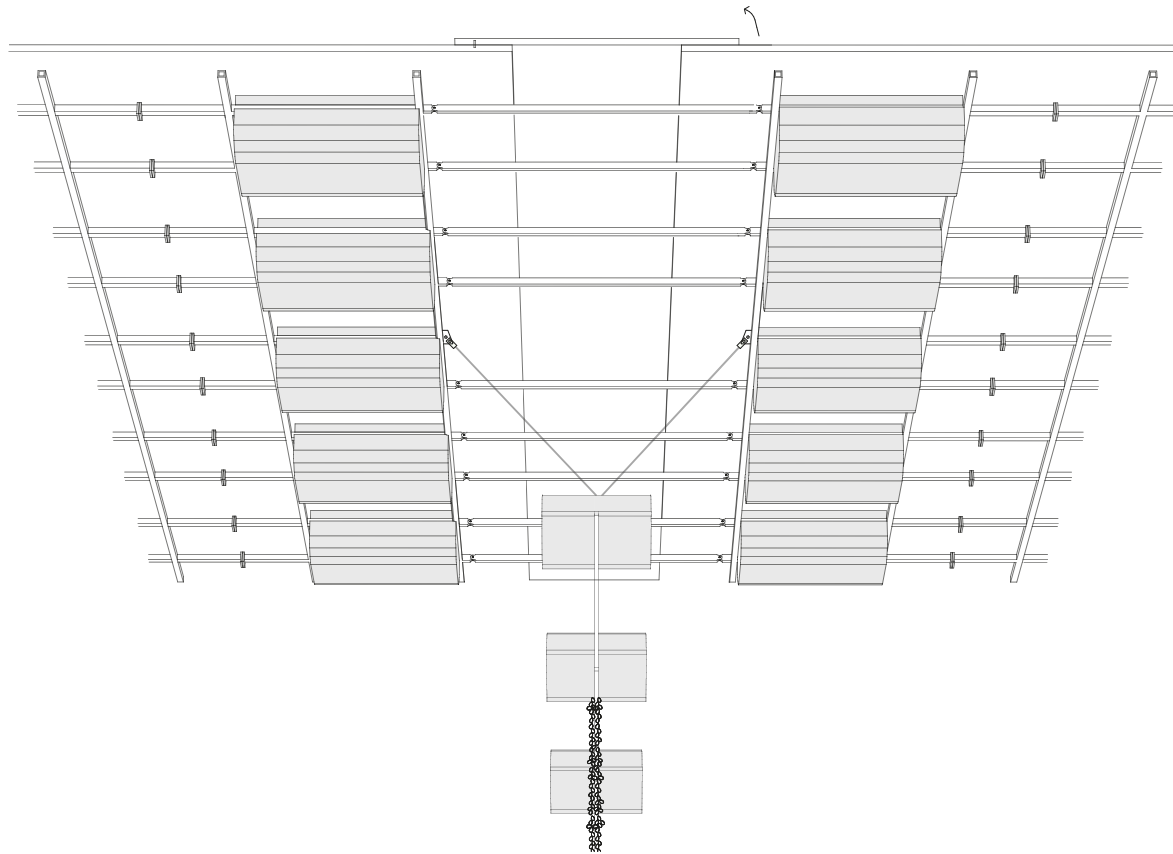

// pier, connection principle



terminal

pier

tower

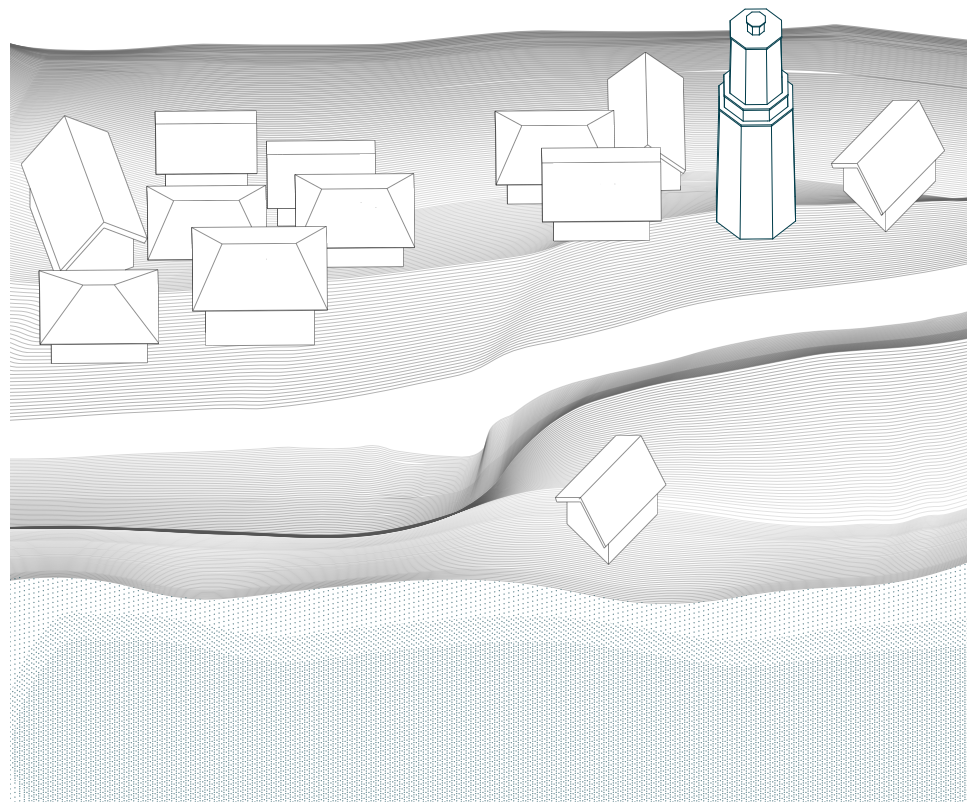



// tower [photo: existing building, Rumeli Feneri]

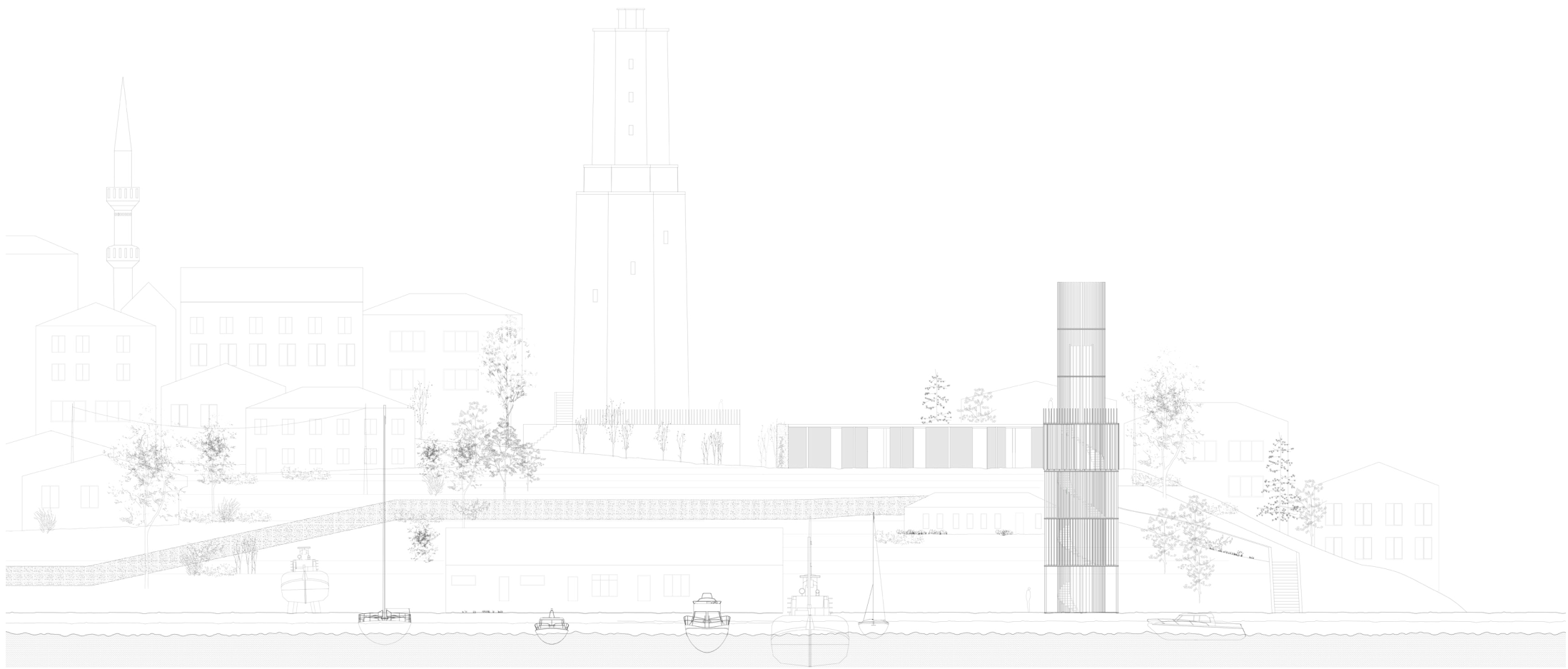

// elevation 1.100

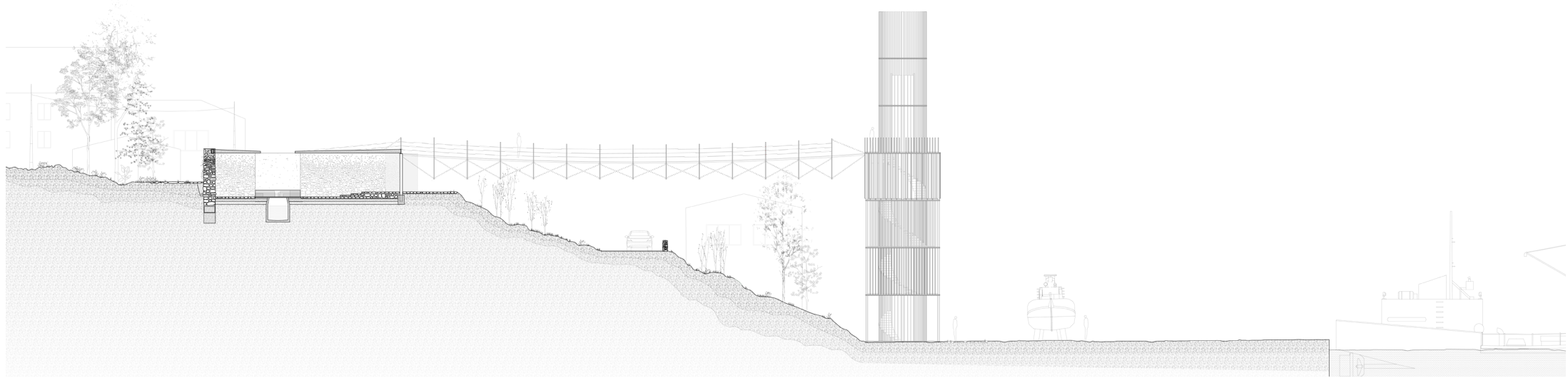

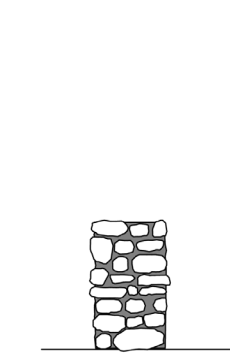

existing stone wall



disassembled stones

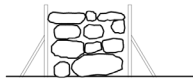

assembly base

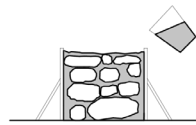

fill with mortar

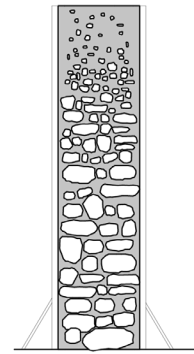

assembly new wall

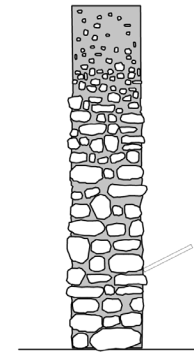

remove formwork and knock free







// plan 1.100



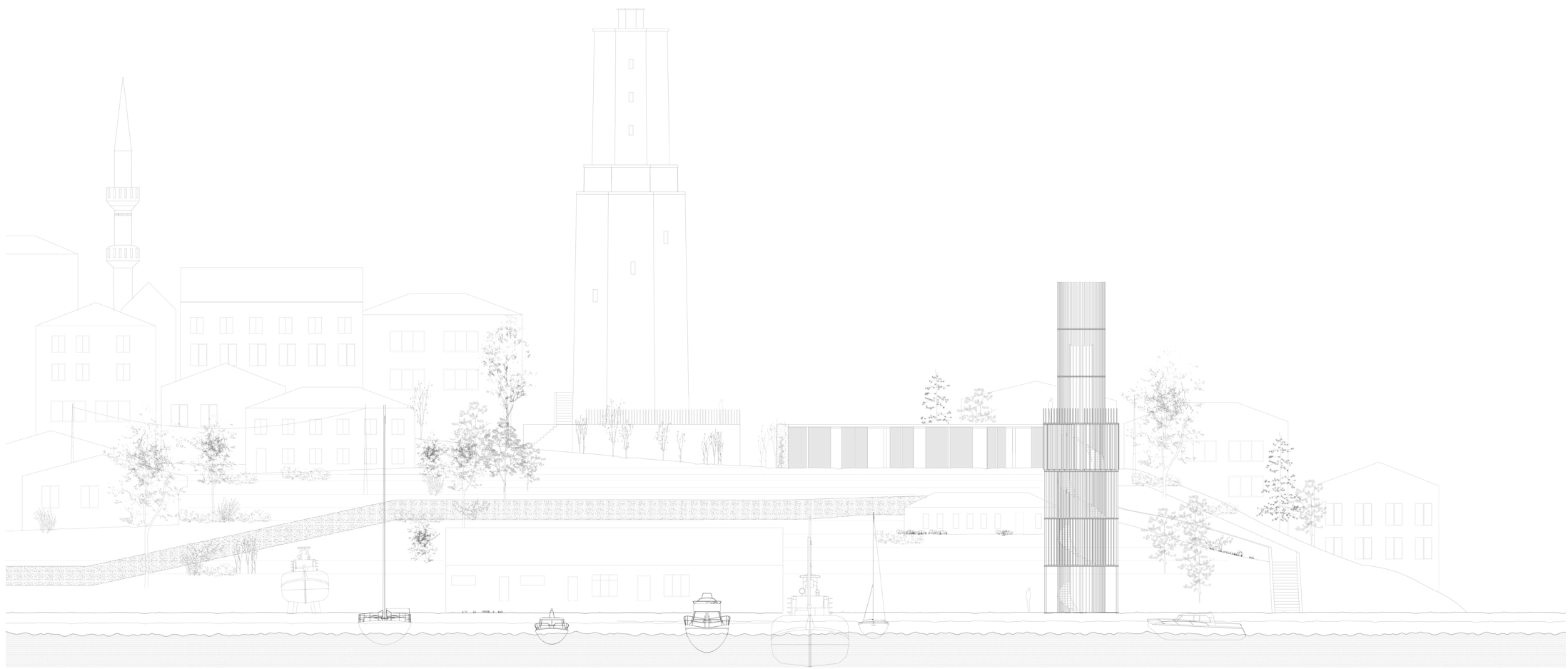

// elevation 1.100

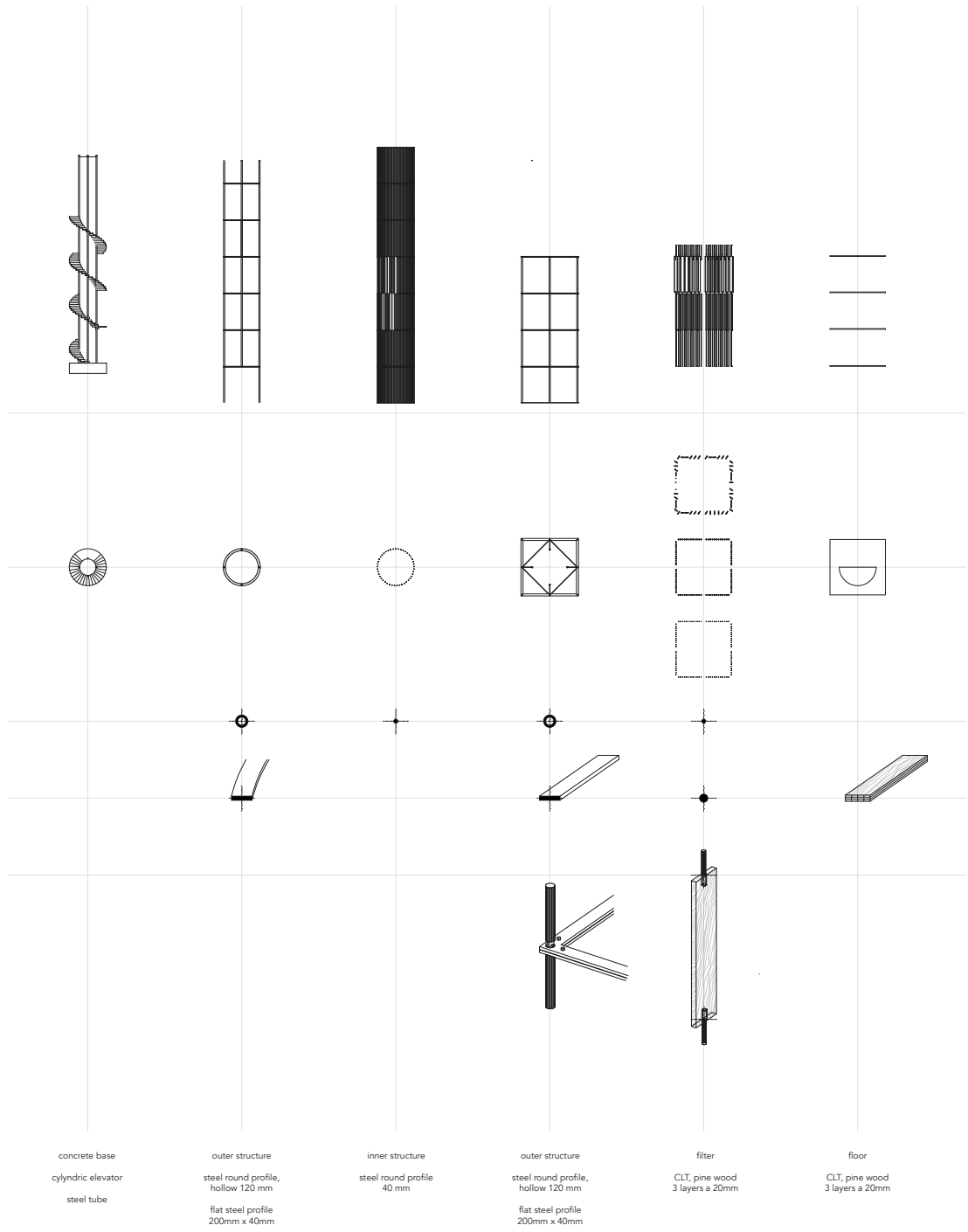

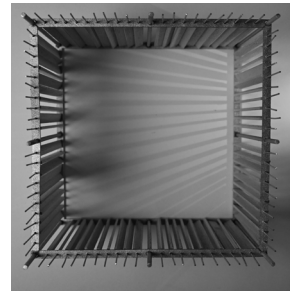
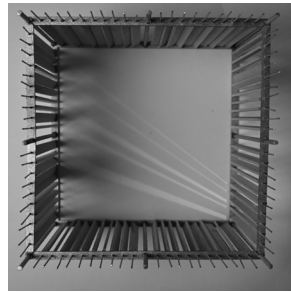
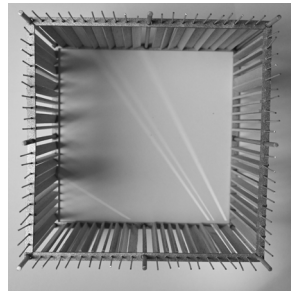
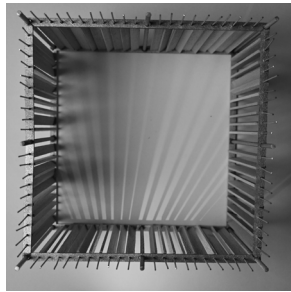
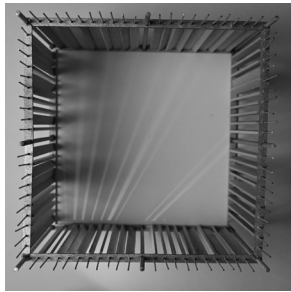
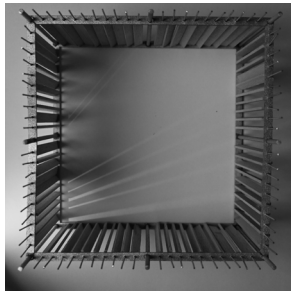
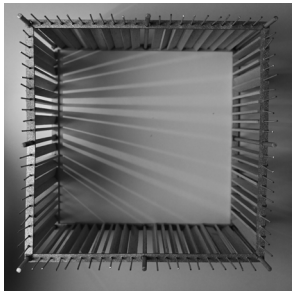

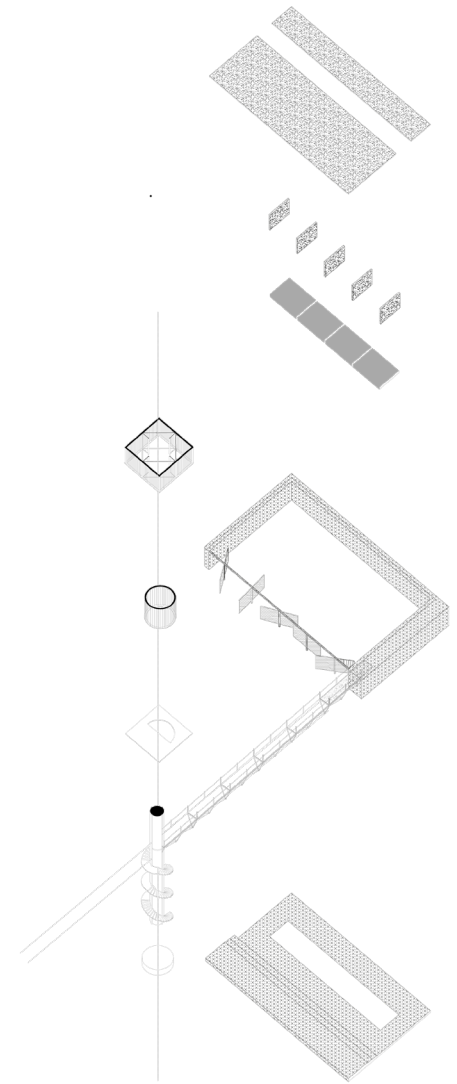
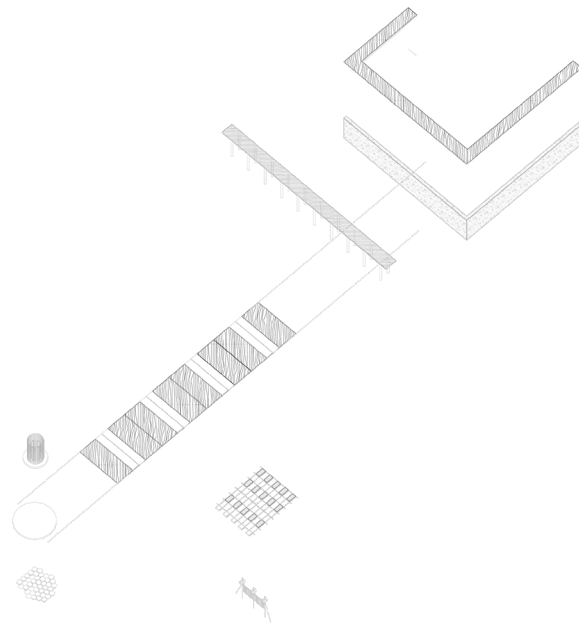
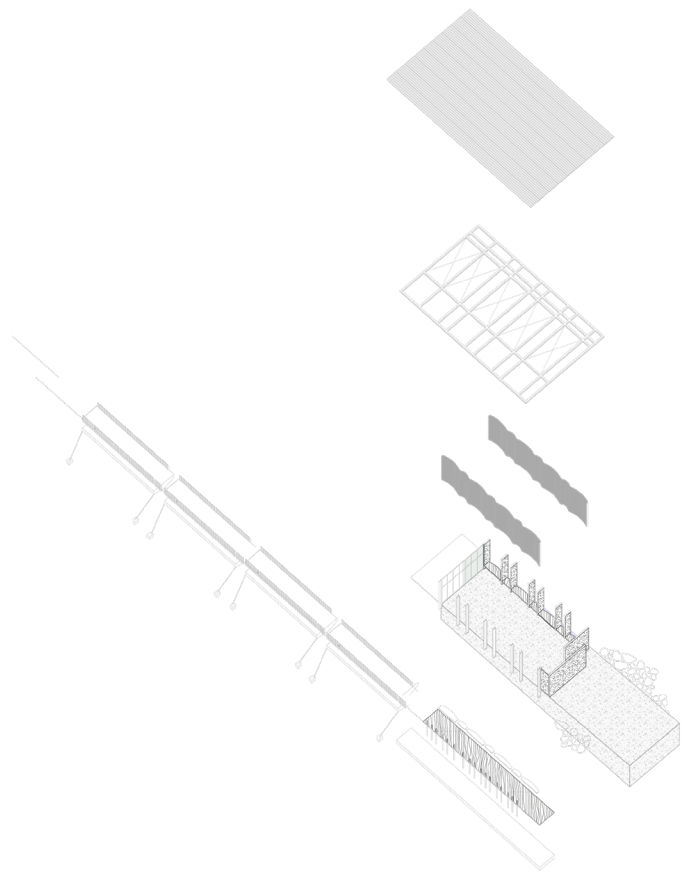

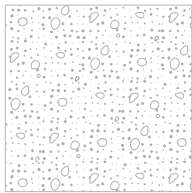

(existing) concrete,
concrete caissons

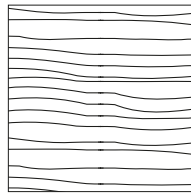

weathering, local
pine wood

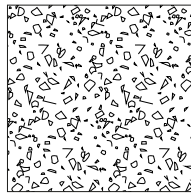

sea stone,
concrete-like material
based on oyster shells

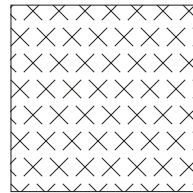

reused stones from
old walls, tuff stone,
layered, bound with
shell mortar

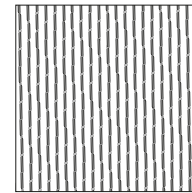

stapled glass, reusing
old glass plates, of
different colours and
sizes

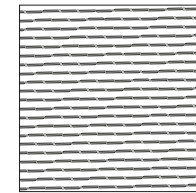

steel, linseed oil-based
anti-corrosion
nanocomposite
coating



waiting

for godot
for the fish
for the rain
for the passage
for the ferry
for the tide
for the waves
for the growth
for the change
for the wind
for the light
for the traffic
for the night
for transit
for someone
for the event
for passengers
for the lock
for the obstacle
for the barrier
for the weathering
for the sound
for the time
for the customer
for adaptation
for a signal
for the seasons
for an information
for a letter
for the end

thank you.