



MAFUNDI EXPO

Frank Reitsma - Explorelab - TU Delft - fereitsma@me.com



Frank Reitsma - Explorelab - TU Delft - fereitsma@me.com

P5 PRESENTATION

07 - 07 - 2017



RESEARCH



DESIGN



TECHNOLOGY





INTRODUCTION

“Generally, African cities are characterised by low densities, peripheral sprawl, economies dominated by informal activities and widespread informal settlements with limited services. The proportion of urban residents living in informal settlements is higher in Africa as a region than any other part of the world.”

UN-Habitat (2009): Global Report on Human Settlements: Backgrounder on Urban Informality.

THE URBANISATION OF POVERTY

[ANIMATION]

THE CONTEXT



RESEARCH

The thesis revisits the ideas of John F.C. Turner who in the 1960s argued that the success of government housing strategies in this context, depends on the alignment of government action with the priorities and forces of popular settlement



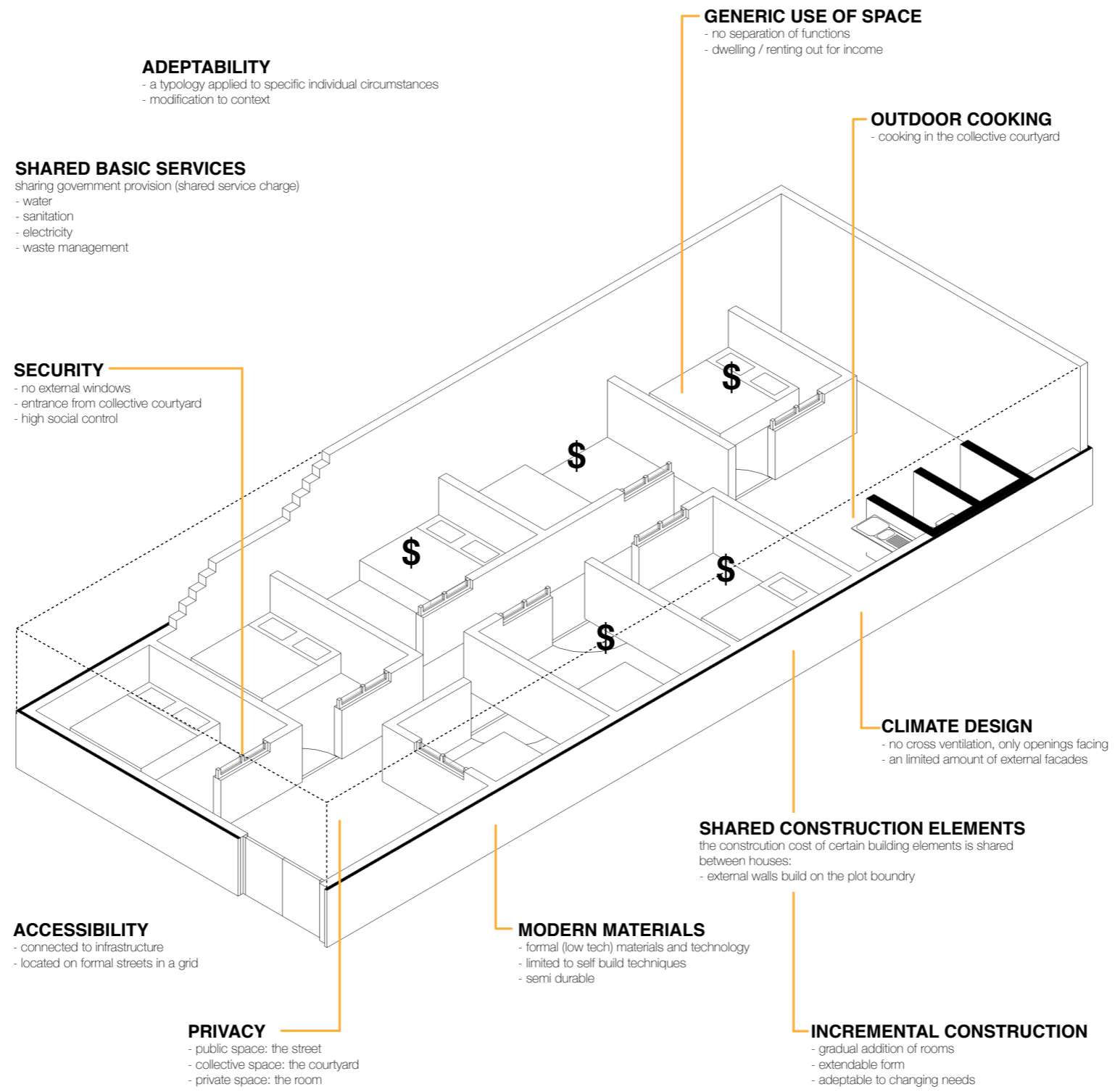









































HYPOTHESIS



ANALYSIS OF HOUSING STRATEGIES

HOUSING STRATEGY OVERVIEW













SELF HELP / PROVIDING / ENABLING

		location	paradigm	legality	initiator
SELF HELP					
	squatting and informal sale				SELF
	informal rent				SELF
PROVIDER PARADIGM					
	formal housing estates				GOV \$\$\$
	formal apartments				GOV \$\$\$
ENABLER PARADIGM					
	extended formal housing				SELF
	sites and services				GOV
	core housing				GOV
	cooperative partnerships				NGO
	settlement upgrading				GOV NGO
	in-situ half housing				GOV
	assisted informal multi-story housing				SELF

80 / 118

STRATEGY EVALUATION FRAMEWORK

CRITERIA BASED ON GOVERNMENT AND INHABITANT PRIORITIES

INHABITANT PRIORITIES		
COSTS	 informal construction	low
	does the strategy allow for the incremental payment of housing construction?	
	 informal rent	mid
	does the strategy allow for the workings of the informal rental system?	
	 taxes	mid
	is inhabitant able to avoid paying taxes (service charges) in the strategy?	
CONTROL	 location	high
	is the housing located near existing jobs / social structures?	
	 control over construction	high
	does the inhabitant control the building process (incremental) and product?	
QUALITIES	<input checked="" type="checkbox"/> high value formal housing	low
	is inhabiting the housing more likely than renting it out / selling it on for its high value?	
	<input checked="" type="checkbox"/> social implications	low
	Is the social status of the housing and materials satisfactory?	
GOVERNMENT PRIORITIES		
COSTS	 formal construction	high
	does the strategy allow the government not to provide housing construction?	
	 infrastructure provision	high
	does the strategy allow the government not to provide infrastructure?	
	 basic service provision	high
	does the strategy allow the government not to provide basic services?	
	 secure tenure provision	high
	does the strategy allow the government not to provide tenure security?	
CONTROL	 location	low
	is the housing located in an area determined by the government?	
	 control over construction	low
	does the government control the building process (instant) and product?	
	 consolidation time	low
	does the strategy have an adequate consolidation time?	
QUALITIES	<input checked="" type="checkbox"/> housing quality	mid
	does the strategy deliver an adequate quality of housing?	
	<input checked="" type="checkbox"/> urban density	mid
	does the strategy deliver an adequate urban density?	

81 / 118

RECOGNISING PRIORITIES

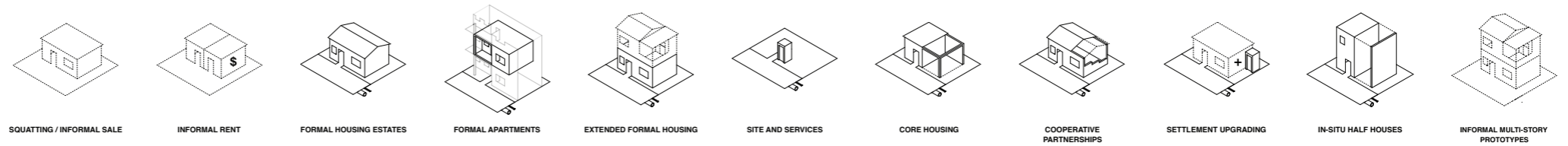

INHABITANT PRIORITIES

\$ informal construction does the strategy allow for the incremental payment of housing construction?	YES	-	NO	NO	YES	YES	50%	YES	YES	50%	YES
\$ informal rent does the strategy allow for the workings of the informal rental system?	YES	YES	NO	NO	YES	NO	NO	NO	YES	YES	YES
\$ vertical construction does the strategy facilitate vertical extension of the housing?	NO	NO	NO	NO	YES	NO	NO	NO	NO	YES	YES
\$ taxes is inhabitant able to avoid paying taxes (service charges) in the strategy?	YES	YES	NO	NO	50%	NO	NO	NO	NO	NO	YES
H location is the housing located near existing jobs / social structures?	YES	YES	NO	NO	YES	NO	NO	NO	YES	YES	YES
H control over construction does the inhabitant control the building process (incremental) and product?	YES	YES	NO	NO	YES	YES	50%	NO	YES	50%	YES
☑ high value formal housing is inhabiting the housing more likely than renting it out for it's high value?	YES	YES	YES	NO	YES	YES	YES	YES	YES	NO	YES
☑ social implications is the social status of the housing and materials satisfactory?	50%	50%	YES	YES	50%	NO	50%	YES	50%	YES	50%

GOVERNMENT PRIORITIES

\$ formal construction does the strategy allow the government not to provide housing construction?	YES	YES	NO	NO	YES	YES	50%	YES	YES	50%	YES
\$ infrastructure provision does the strategy allow the government not to provide infrastructure?	YES	YES	NO	NO	YES	NO	NO	NO	NO	NO	YES
\$ basic service provision does the strategy allow the government not to provide basic services?	YES	YES	NO	NO	YES	NO	NO	NO	NO	NO	YES
\$ secure tenure provision does the strategy allow the government not to provide tenure security?	YES	YES	NO	NO	YES	NO	NO	NO	NO	NO	YES
H location is the housing located in an area determined by the government?	NO	NO	YES	YES	YES	YES	YES	YES	NO	NO	NO
H control over construction does the government control the building process (instant) and product?	NO	NO	YES	YES	NO	NO	50%	YES	NO	50%	NO
☑ consolidation time does the strategy have an adequate consolidation time?	NO	NO	YES	YES	50%	NO	50%	50%	NO	YES	NO
☑ housing quality does the strategy deliver an adequate quality of housing?	NO	NO	YES	YES	50%	50%	YES	YES	50%	YES	50%
☑ urban density does the strategy deliver an adequate urban density?	NO	NO	NO	YES	50%	NO	NO	NO	NO	50%	50%

SELF HELP

PROVIDER PARADIGM

ENABLER PARADIGM

EVALUATION OF HOUSING STRATEGIES

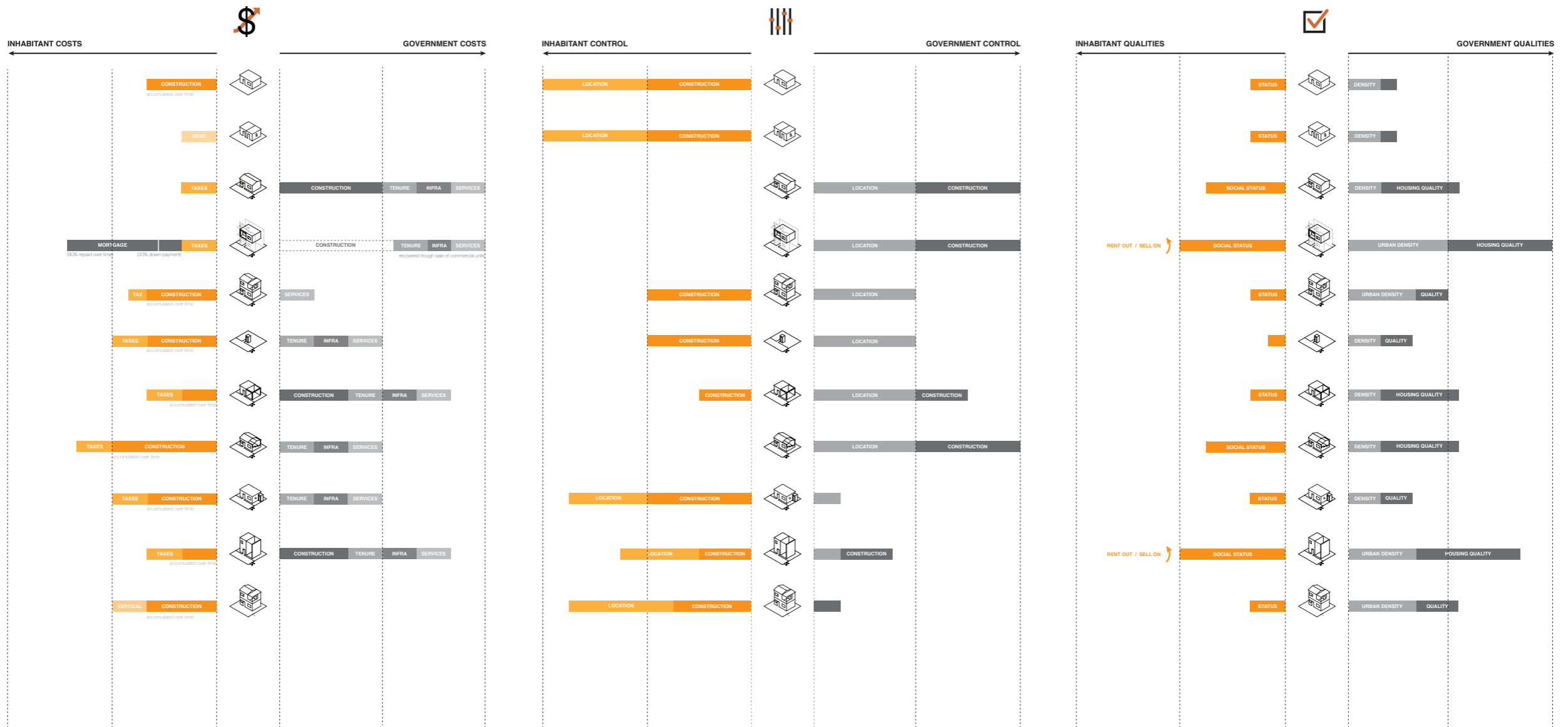

STRATEGY DECISION-MAKING TOOL

When housing is developed outside the formal systems, it may have all kinds of drawbacks, but the main point is that it is arranged to meet the priorities of its inhabitant.

PROVIDING NOR ENABLING

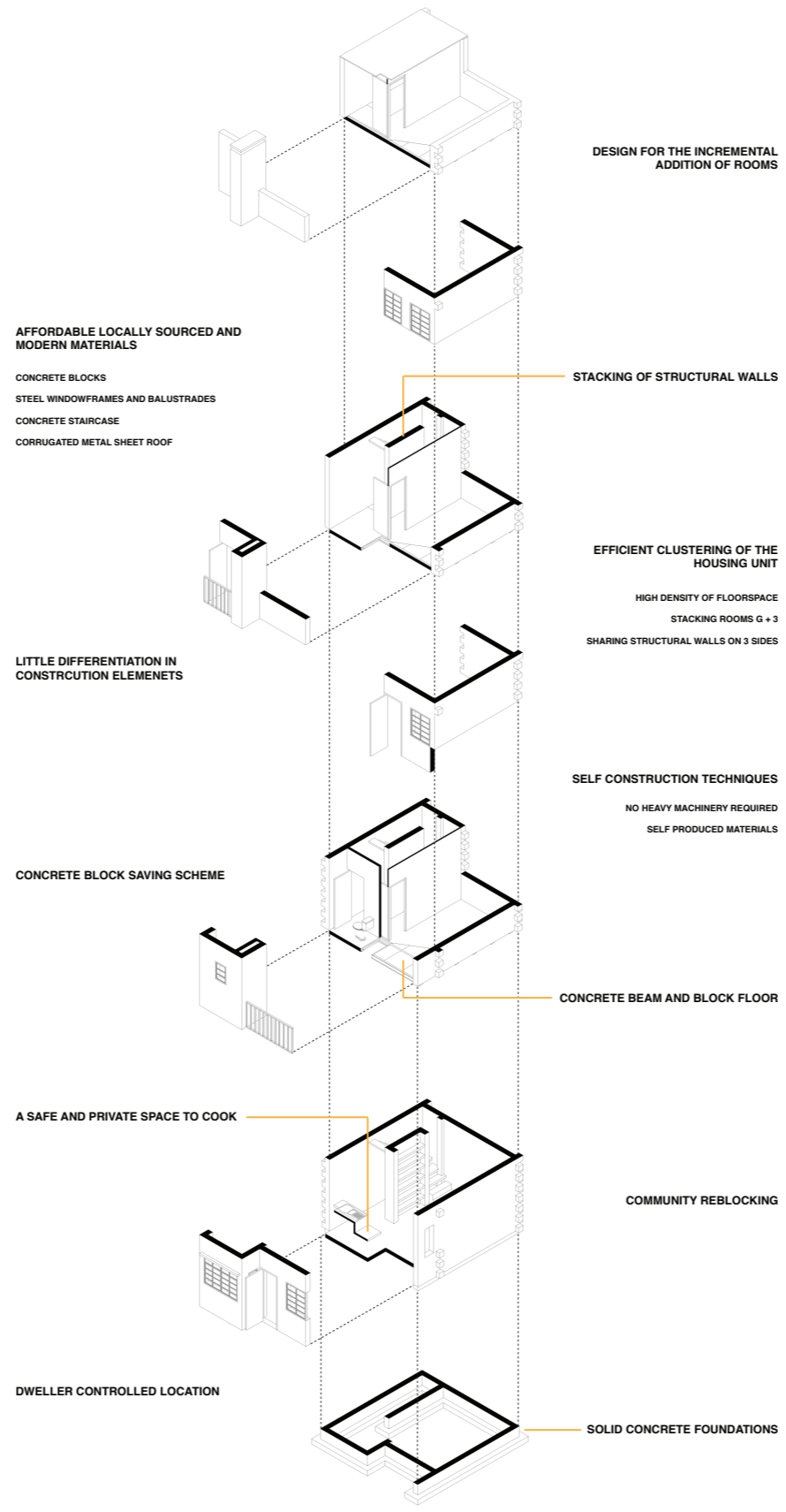

Generic guidelines from case studies of pilot projects that attempt to improve the housing quality and urban density of informal settlements in sub-Saharan Africa

RESEARCH PRODUCT



DESIGN

How to improve the urban density and housing quality of the informally produced rental housing in Dar es Salaam, Tanzania.

PROBLEM STATEMENT

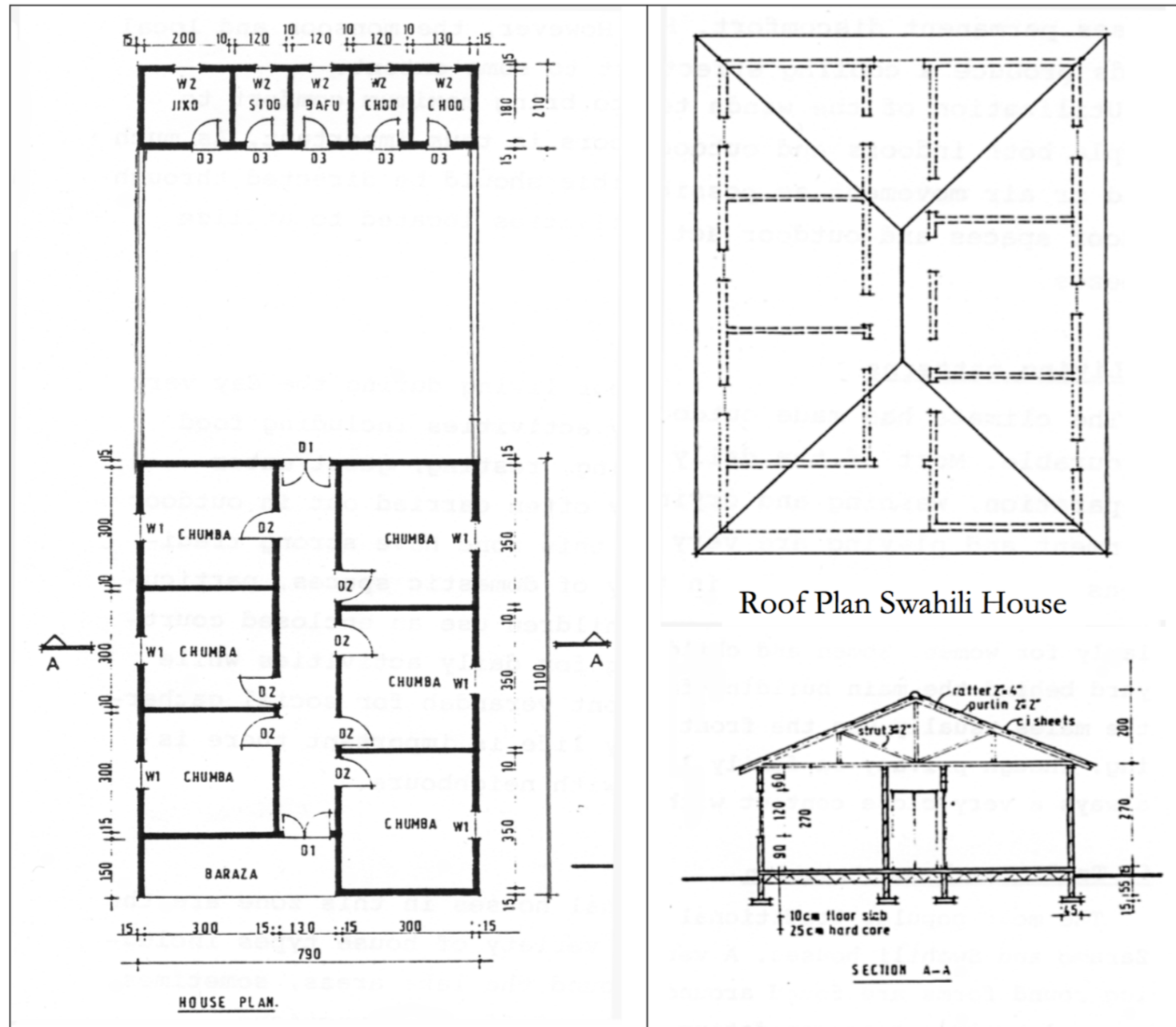
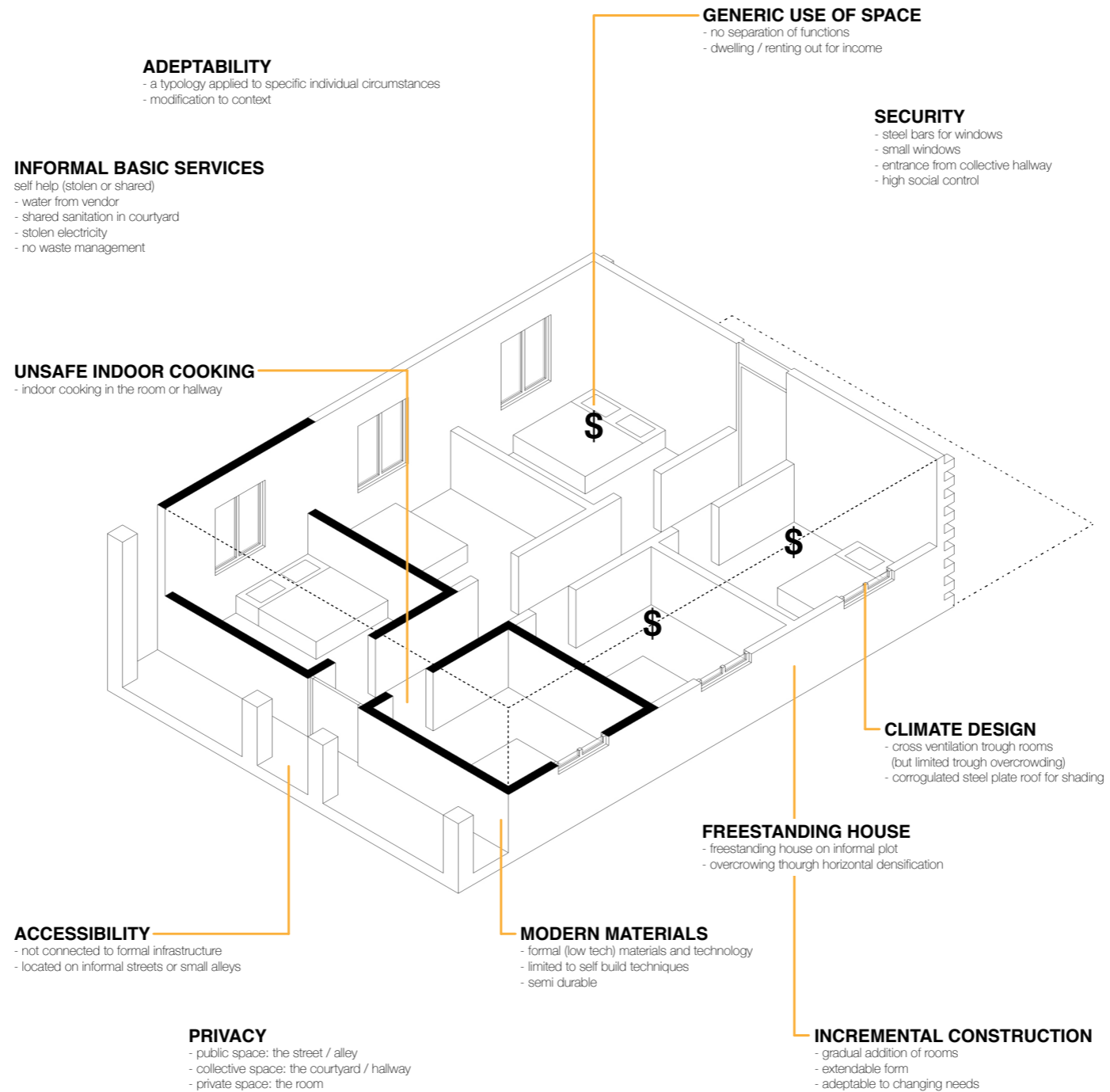

Figure 2.12: Typical urban Swahili house designed by National Housing Corporation. Plan, roof plan and section. Note the front veranda on the plan, each room is accessed through the corridor. Utilities are located at the backyard (Source: Nnkyia, 1984:79).

CORNERSTONE OF INFORMAL HOUSING



ANALYSIS OF THE URBAN SWAHILI HOUSE

[ANIMATION]

INFORMALLY PRODUCED HOUSING



Citywide Action Plan for Upgrading Unplanned and Unserviced Settlements in Dar es Salaam

UN HABITAT
FOR A BETTER URBAN FUTURE



Cities Alliance
Cities Without Slums

ANNEX 1

SUB-OUTCOME 3.3: QUALITY OF HOUSING STOCK IMPROVED

Outputs	Activities	Estimated budget (TZS)	Estimated budget (USD)	Responsible	Location
SHORT TERM					
Situation analysis/baseline survey of the city's housing stock with recommendations for technical assistance for housing improvements	Undertake baseline survey on current housing stock: quantity, quality, conditions, types, occupancy rates, building materials, sizes, tenure, services, annual needs of new housing units/backlog, assessment of existing building codes, standards and procedures	358,797,000	264,405		Citywide
Guidelines, standards and codes for development of new affordable housing	Develop, approve and adopt affordable building codes, standards and procedures (including issuance of building permits) for development of new housing units	44,879,700	33,073		Citywide
Guidelines, standards and codes for the upgrading of housing in unplanned areas	Develop and approve building codes, standards and processes for application to housing improvements in Upgrading unplanned settlements	44,879,700	33,073		Citywide
MEDIUM TERM					
Citywide housing development programme	Develop a citywide housing programme (based on provisions in the National Housing Policy)	31,439,850	23,169		Citywide
Houses in unplanned areas upgraded	Implement housing upgrading programme according to approved building codes, standards				Unplanned
Urban development control enforced	Develop and implement mechanism to enforce urban development control and strengthen municipal supervisory role in housing development	31,439,850	23,169		Citywide
Increased capacity of artisans and youth in housing improvement	Build the capacity of local artisans and youth in housing improvement in unplanned settlements (based on building codes and standards)	1,080,445,500	796,202		Citywide
Performance standards for building materials, technologies and designs	Collect and disseminate information (performance standards) on affordable building designs, materials and technology	31,439,850	23,169		Citywide
LONG TERM					
Houses in unplanned areas upgraded	Implement housing upgrading programme according to approved building codes, standards				Citywide
Availability of affordable building materials and skilled labour; local income generation	Undertake housing upgrading activities through youth and women groups (local production of building materials and supply of skilled labour)				Unplanned areas

SUB-OUTCOME 3.4: CITYWIDE HOUSING DEVELOPMENT EFFECTIVELY REGULATED

Outputs	Activities	Estimated budget (TZS)	Estimated budget (USD)	Responsible	Location
SHORT TERM					
Municipal Housing Sections established	Establish a Housing Section within the Urban Planning Department in each Municipality	492,000,000	362,564		Municipalities
Capacity needs assessment report for housing production by local artisans and youth	Identify capacity needs for local artisans and youth in housing improvement in unplanned settlements as per building codes and standards	44,879,700	33,073		Citywide
Strategy for improved development control	Identify gaps in mechanisms for enforcement of urban development control, including approved building codes and standards, and develop recommendations on how to strengthen municipal supervisory role in housing development	44,879,700	33,073		Citywide
MEDIUM TERM					
Municipal Housing Departments established	Establish a Housing Department in each Municipality by upgrading the Housing Sections set up during short-term phase				Municipalities
MEDIUM TO LONG TERM					
Housing development control established	Enforce housing development control				Citywide

65

CITYWIDE ACTION PLAN

1. "Collect and disseminate information (performance standards) on affordable building designs, materials and technology"
2. "Develop, approve and adopt affordable building codes, standards and processes for application to housing improvements in upgrading unplanned settlements (and for new housing units)"
3. "Identify capacity needs for local artisans and youth in housing improvement in unplanned and under serviced settlements as per building codes and standards"
4. "Build the capacity of local artisans and youth in housing improvement in unplanned settlements (based on building codes and standards)"

CITYWIDE ACTION PLAN

MAFUNDI EXPO

kupanua jengo ujuzi wako!

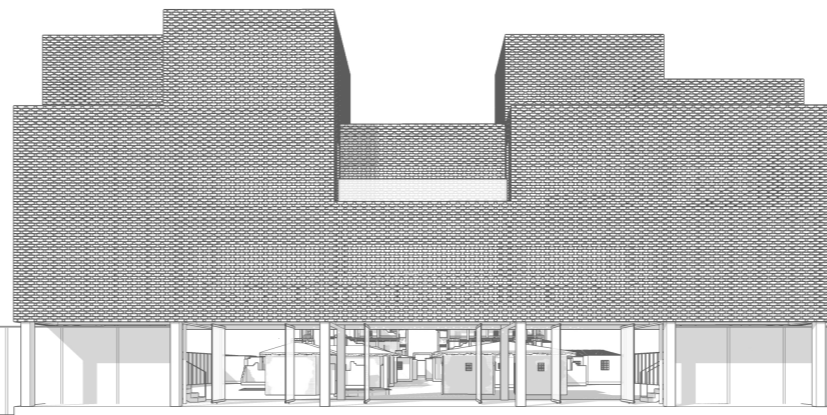

Ghana & Ohio rd. kuvuka - katika Golden Jubilee Tower



ADDRESSING THE MAIN ACTORS IN INFORMAL CONSTRUCTION



EXPOSITION ALONG A NARRATIVE ROUTE

a route narrates the mutations of the typical Swahili house over time: the past, the present and future tense of housing

CONCEPT



CONTEXT OF THE FORMAL CITY CENTRE



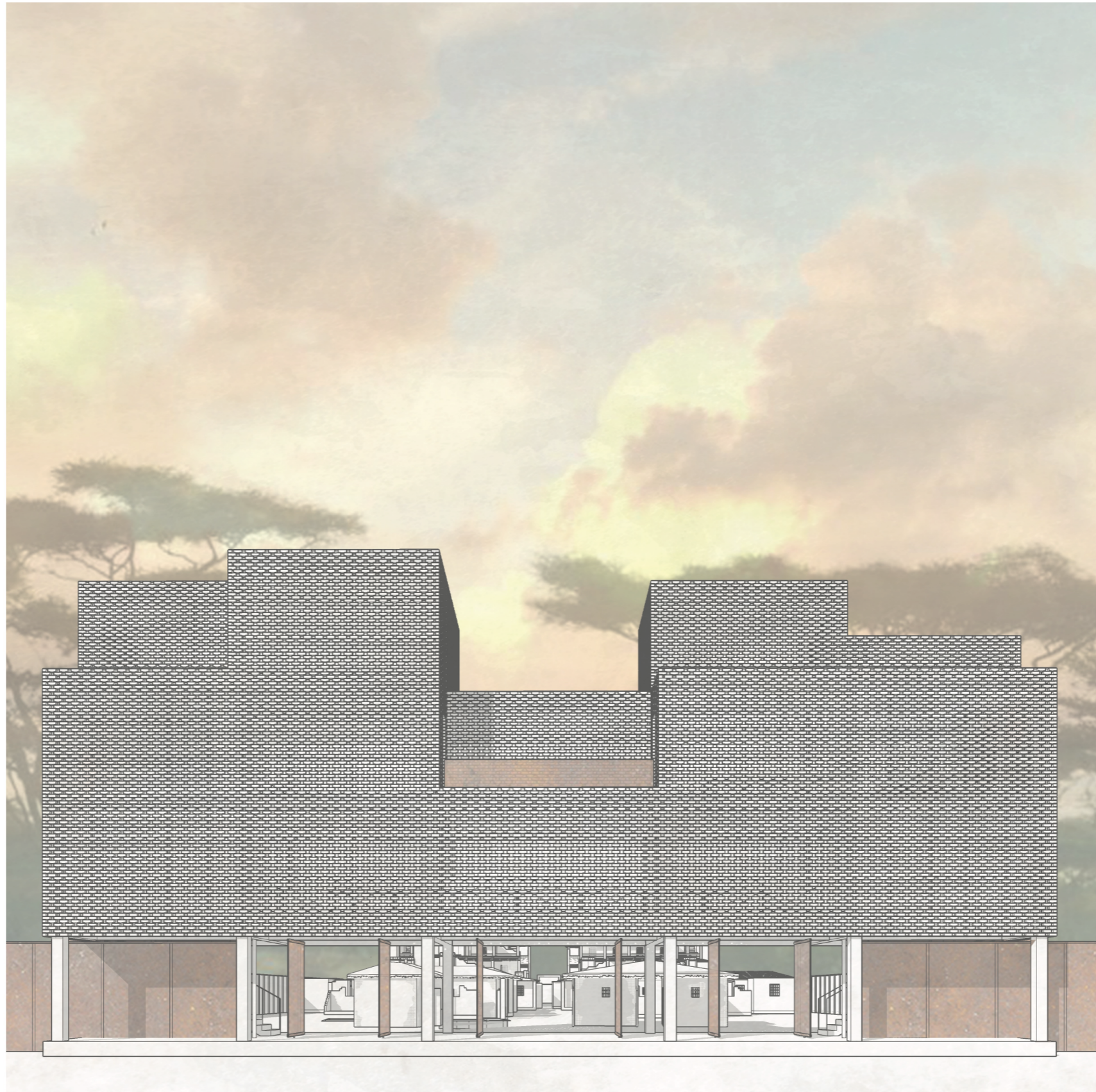

AN EXPOSITION ON HOUSING CONSTRUCTION

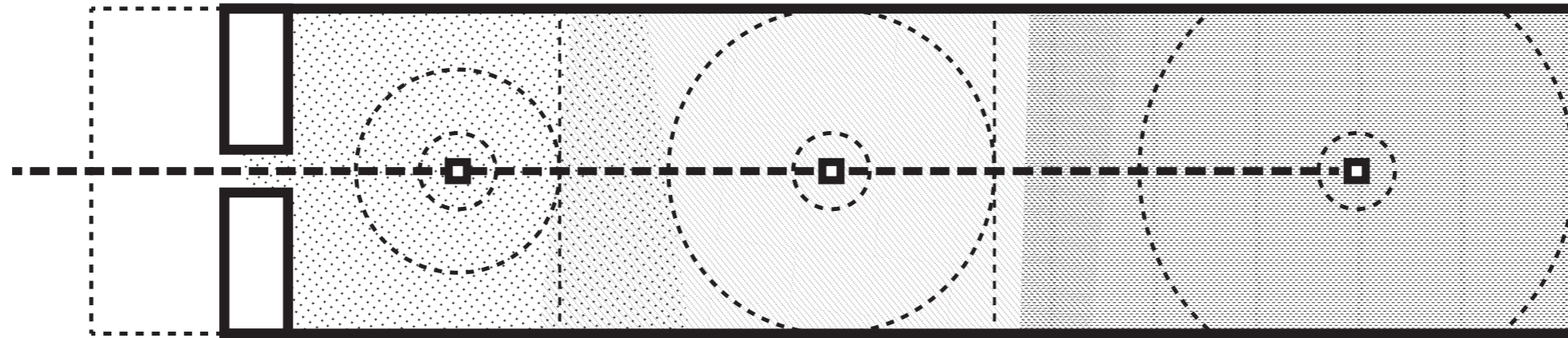

PAST

PRESENT

FUTURE

THEME



THE PAST TENSE

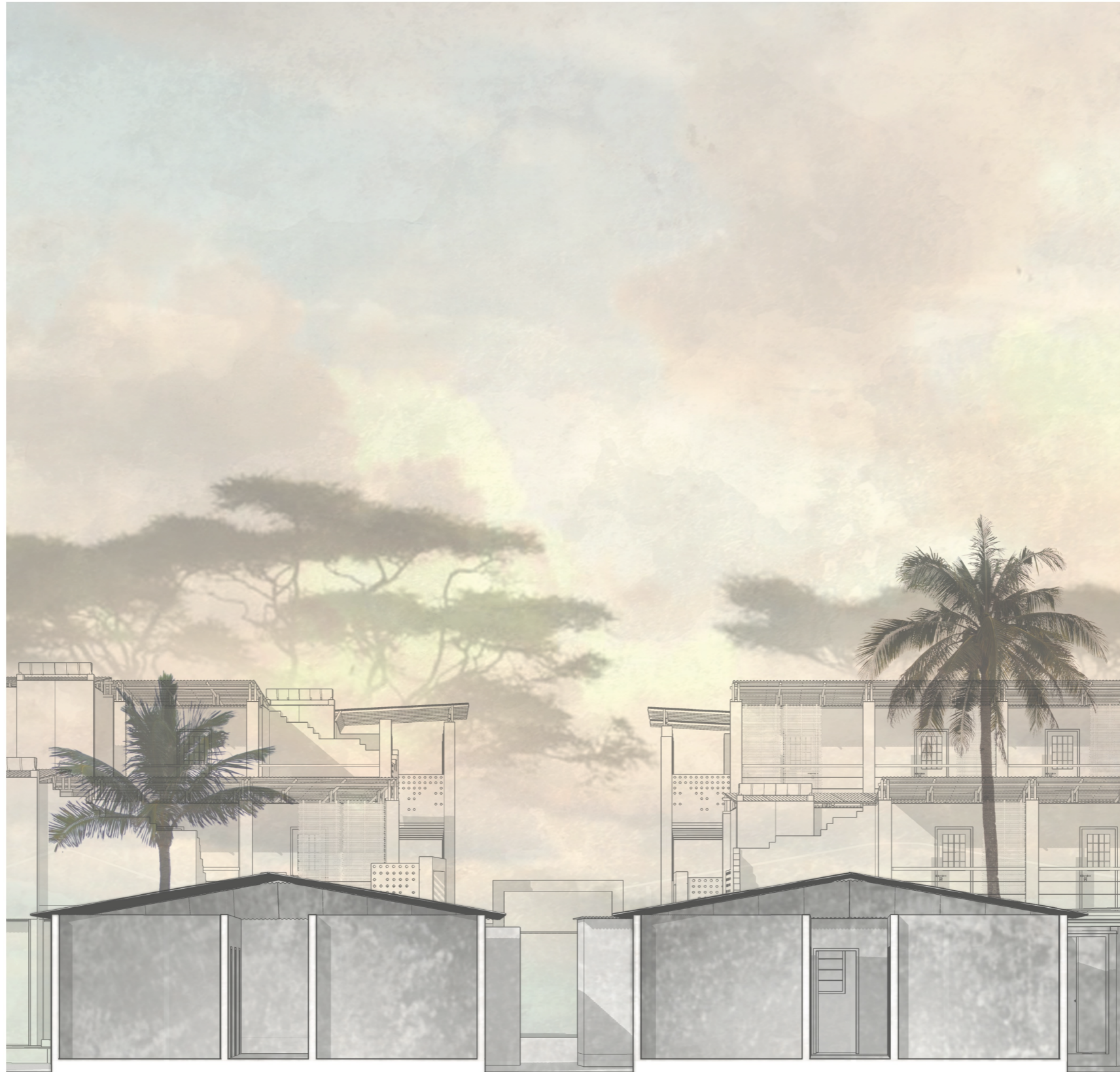

THE PRESENT TENSE

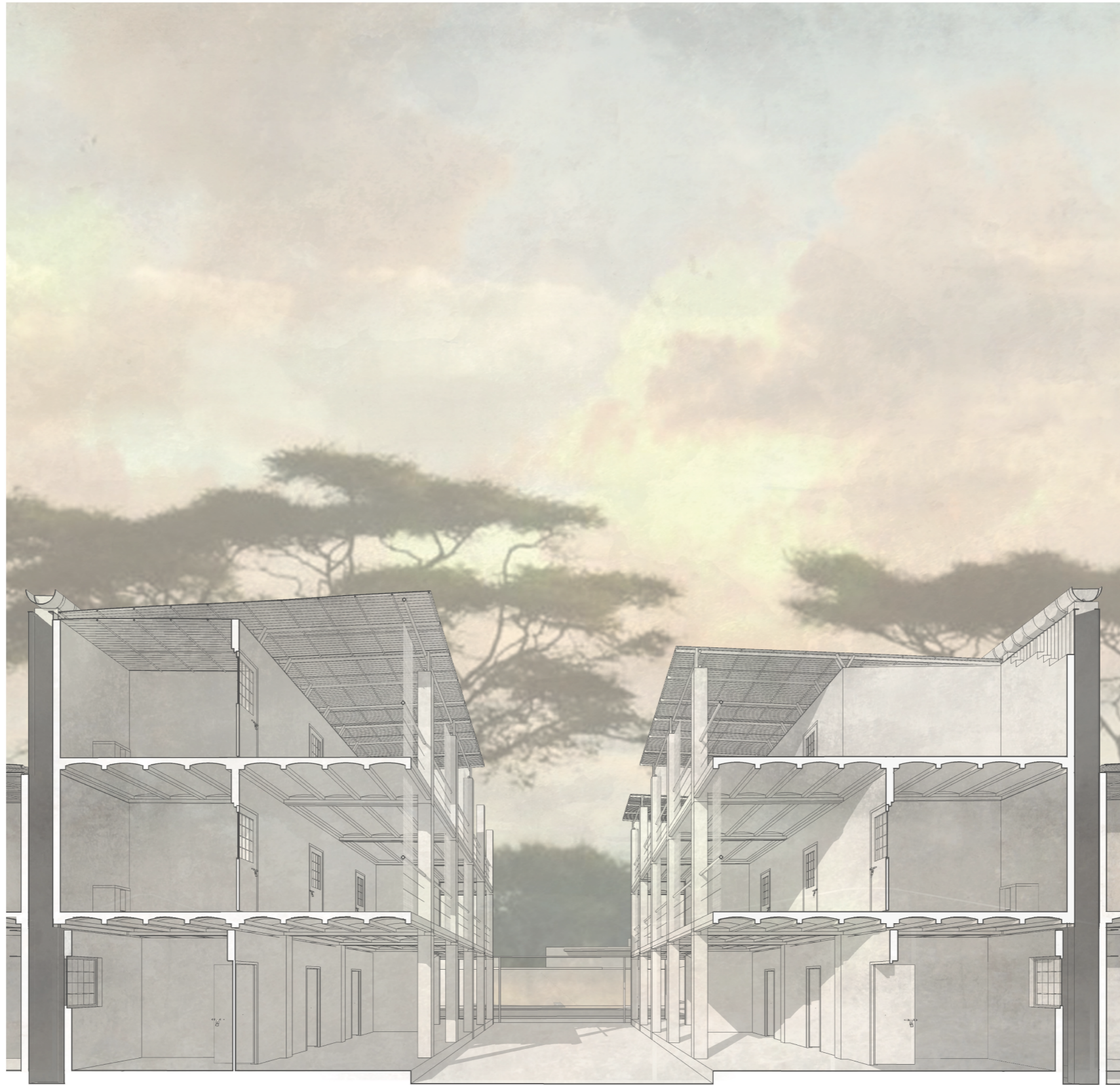

A FUTURE TENSE



ASPIRATIONAL ENTRANCE BUILDING

inspiring a new use for the materials that are currently utilised in the informal production of housing in the city

CONCEPT

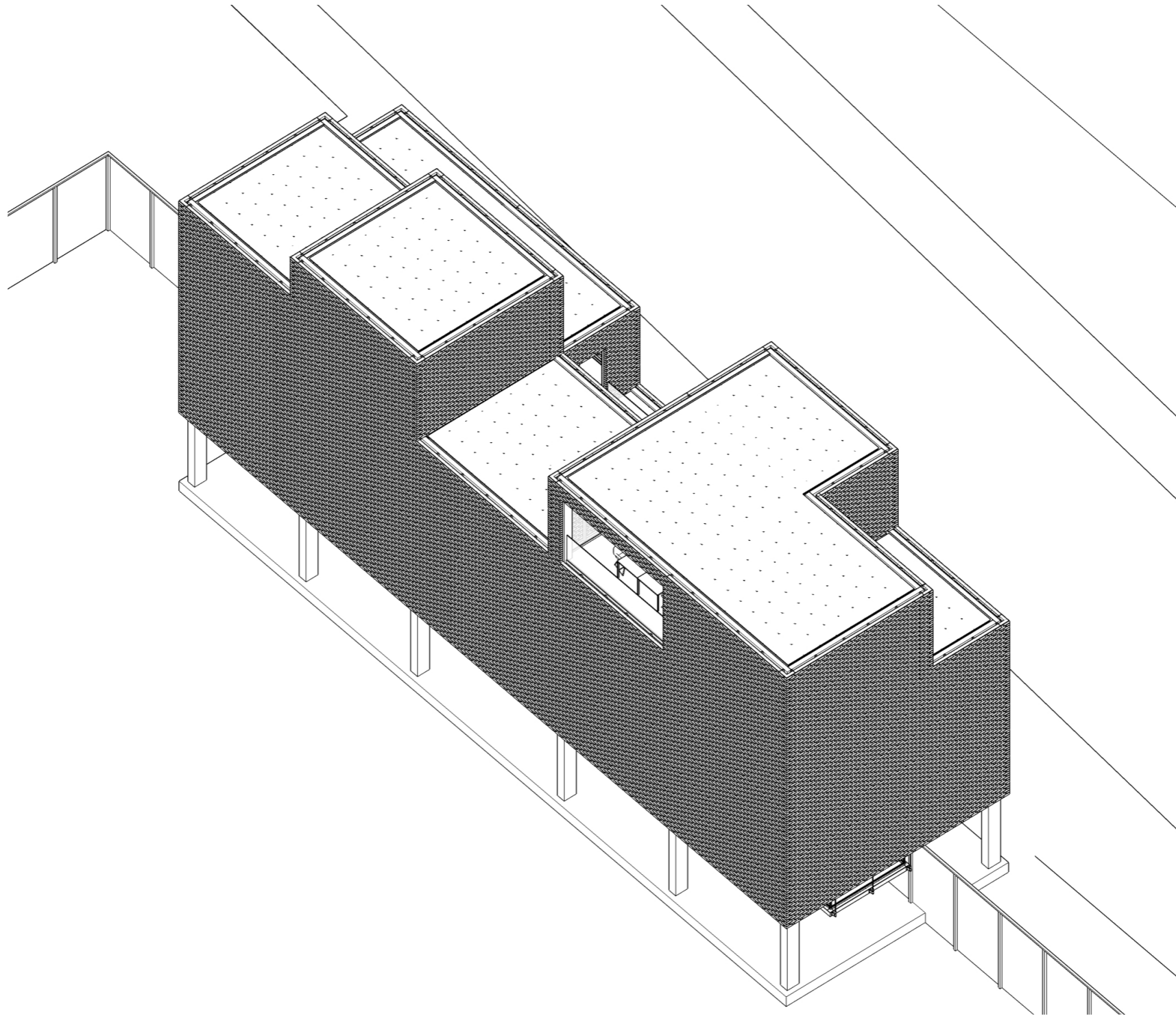

ENTRANCE BUILDING

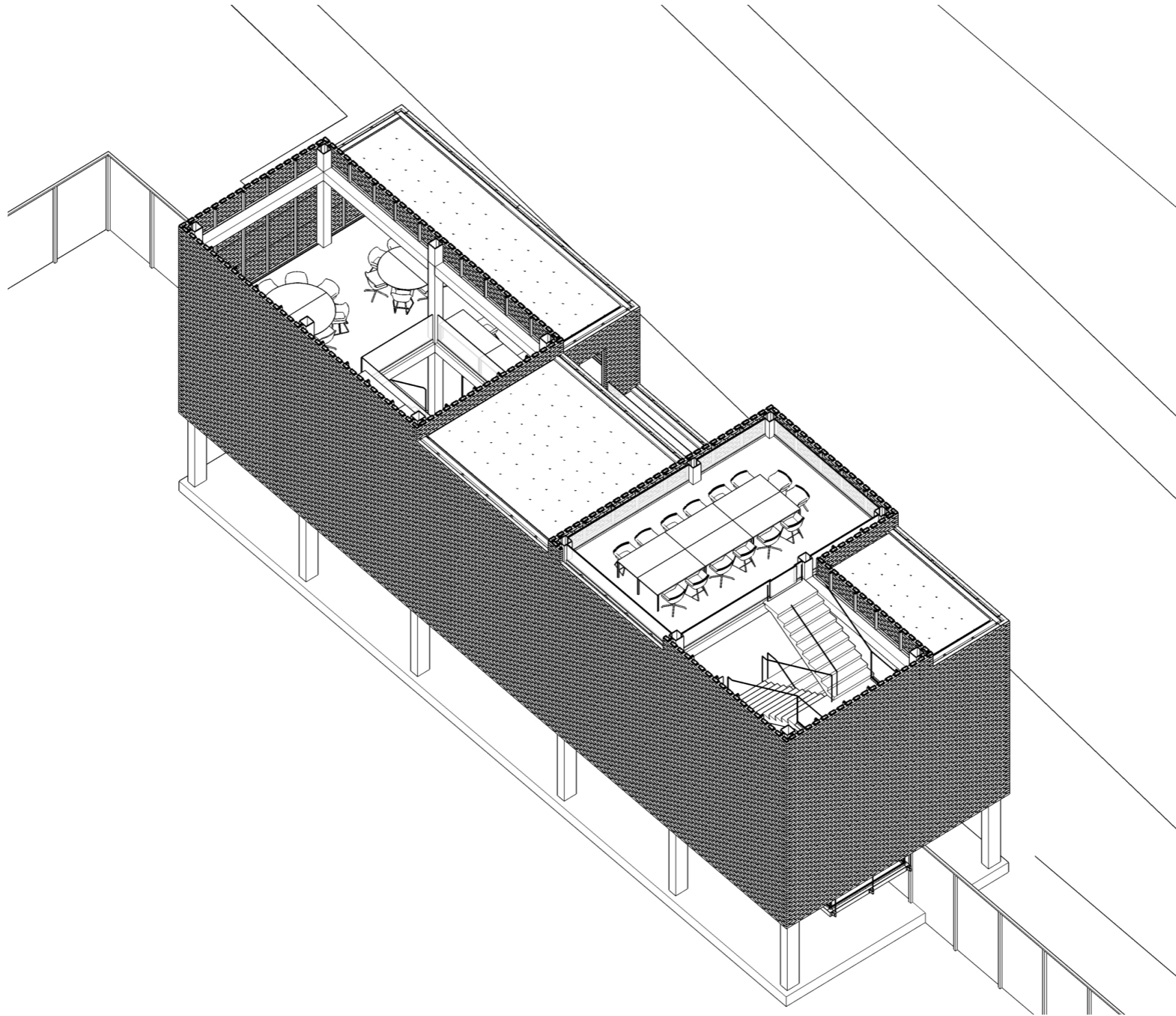

ENTRANCE BUILDING

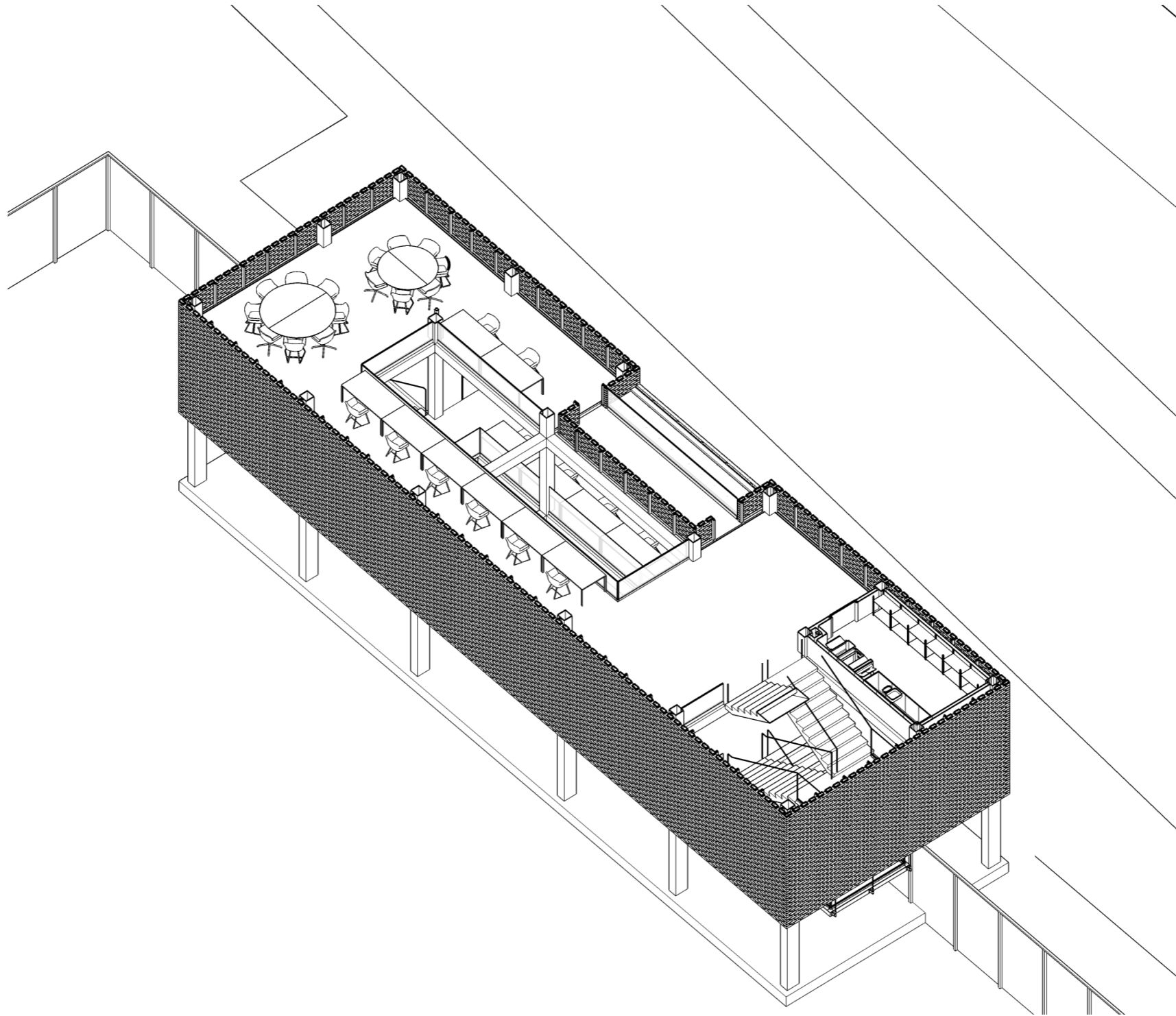

ENTRANCE BUILDING

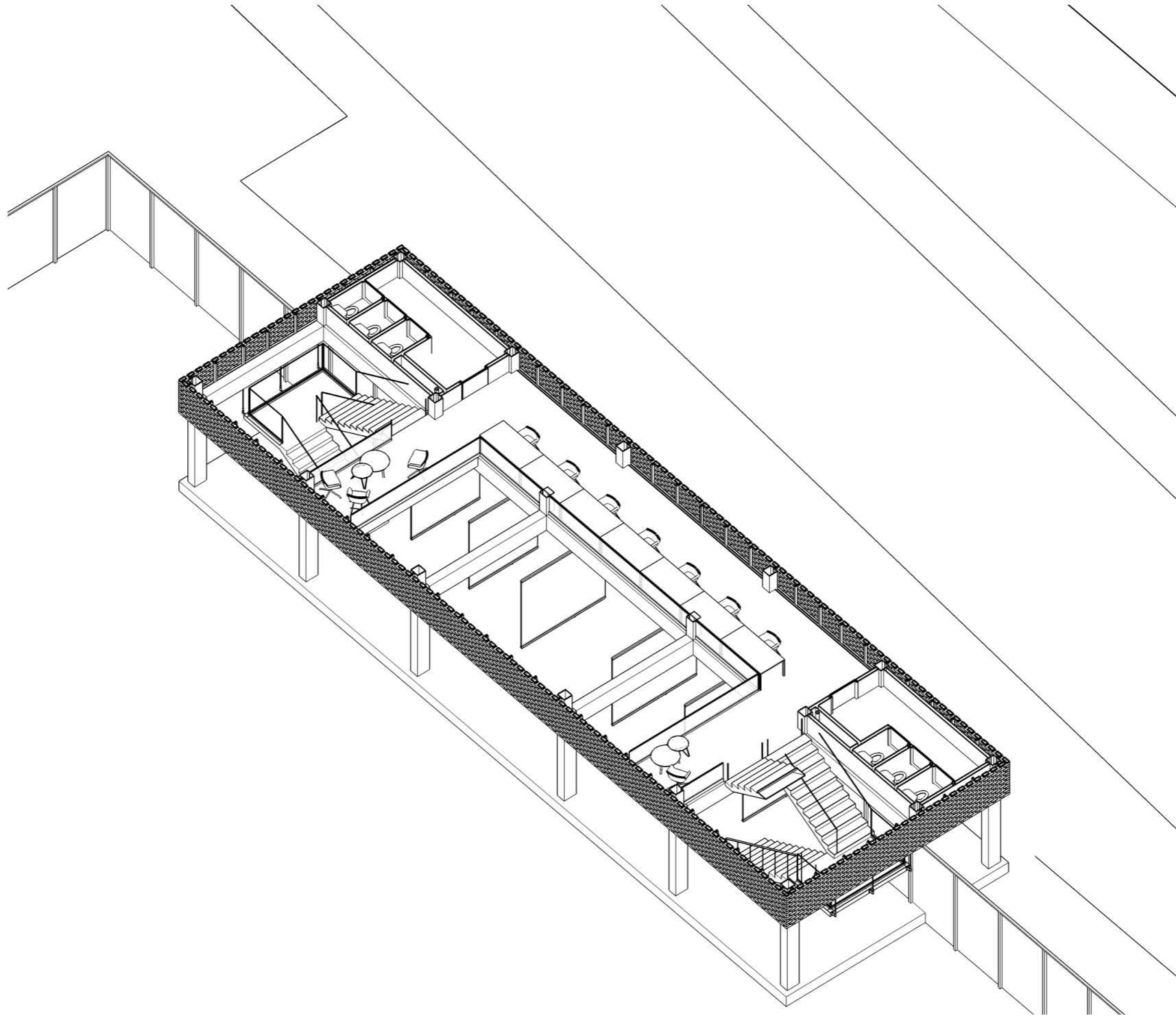

ENTRANCE BUILDING

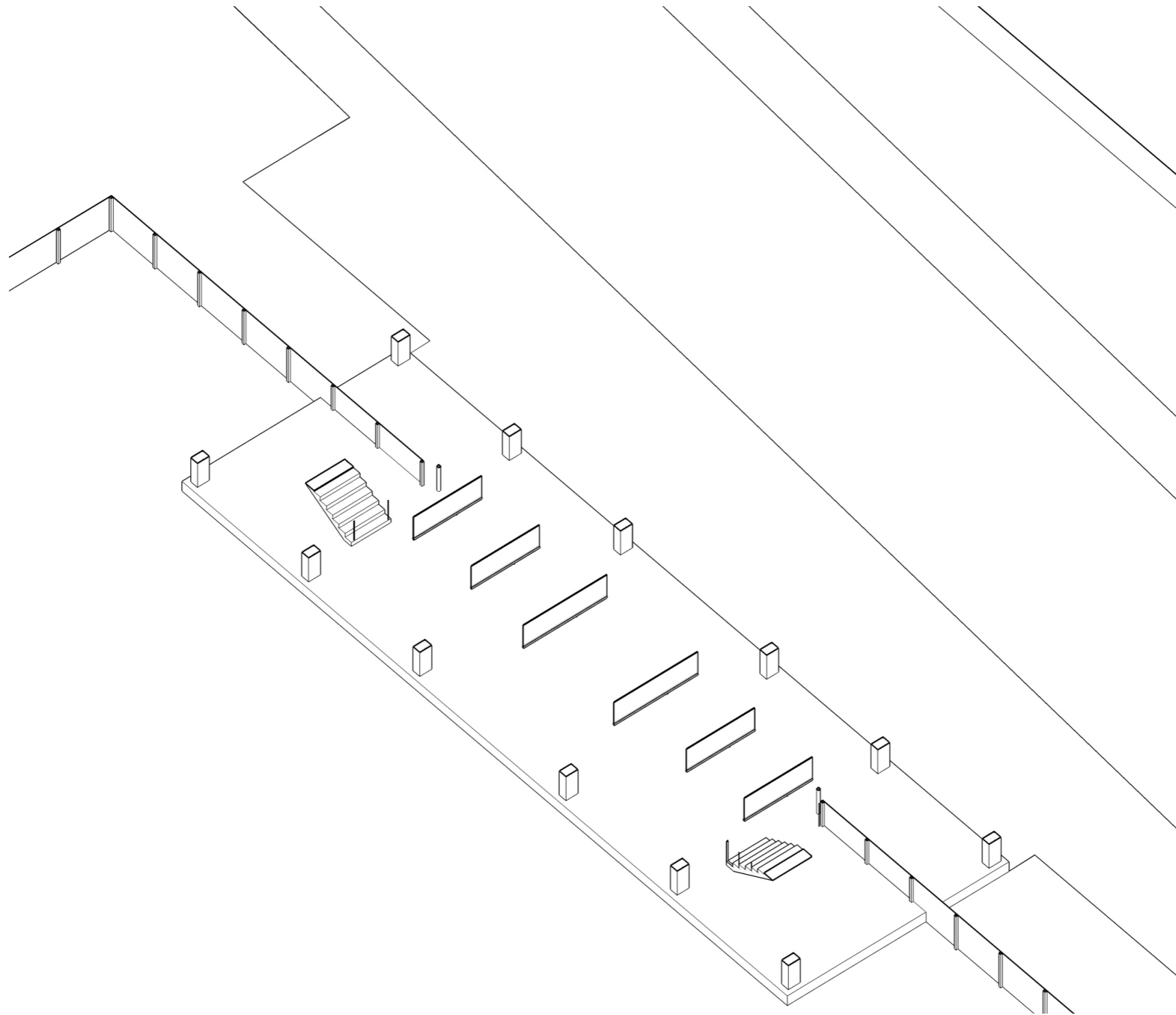

ENTRANCE BUILDING

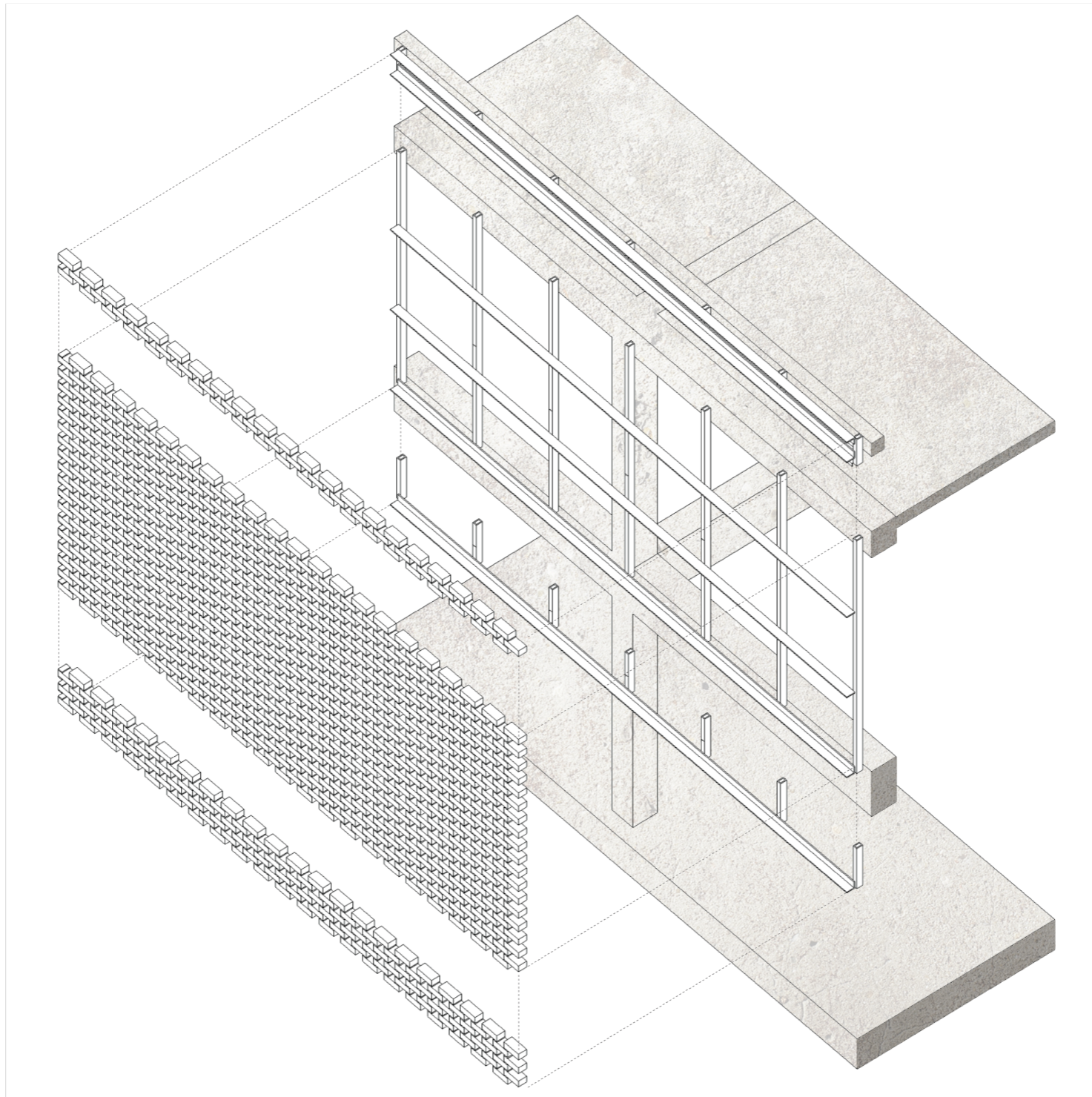

FACADE FRAGMENT



PERFORATED BORDER FENCE

the steel mesh fence surrounding the exposition provides framed views into the 'typical streets' of the exposition

CONCEPT

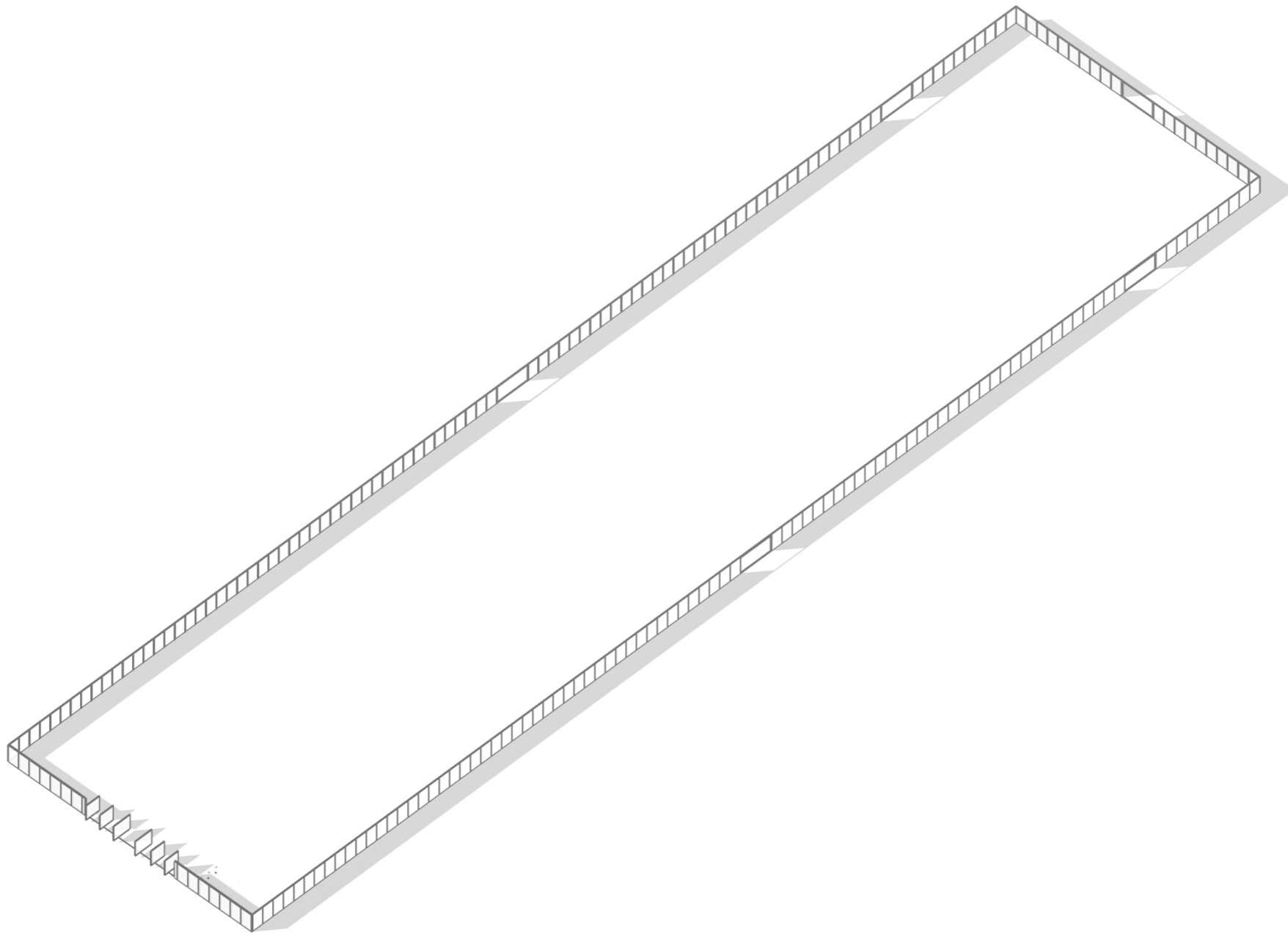

BORDER FENCE



FENCE REFERENCE

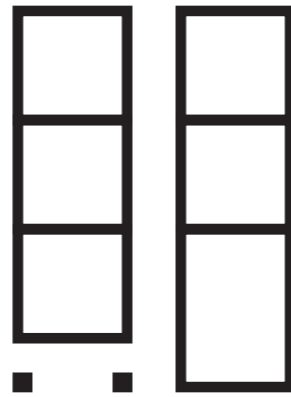

REDESIGN OF THE SWAHILI HOUSE

introducing a next phase to the informal process of housing: improving the dominant housing typology

CONCEPT

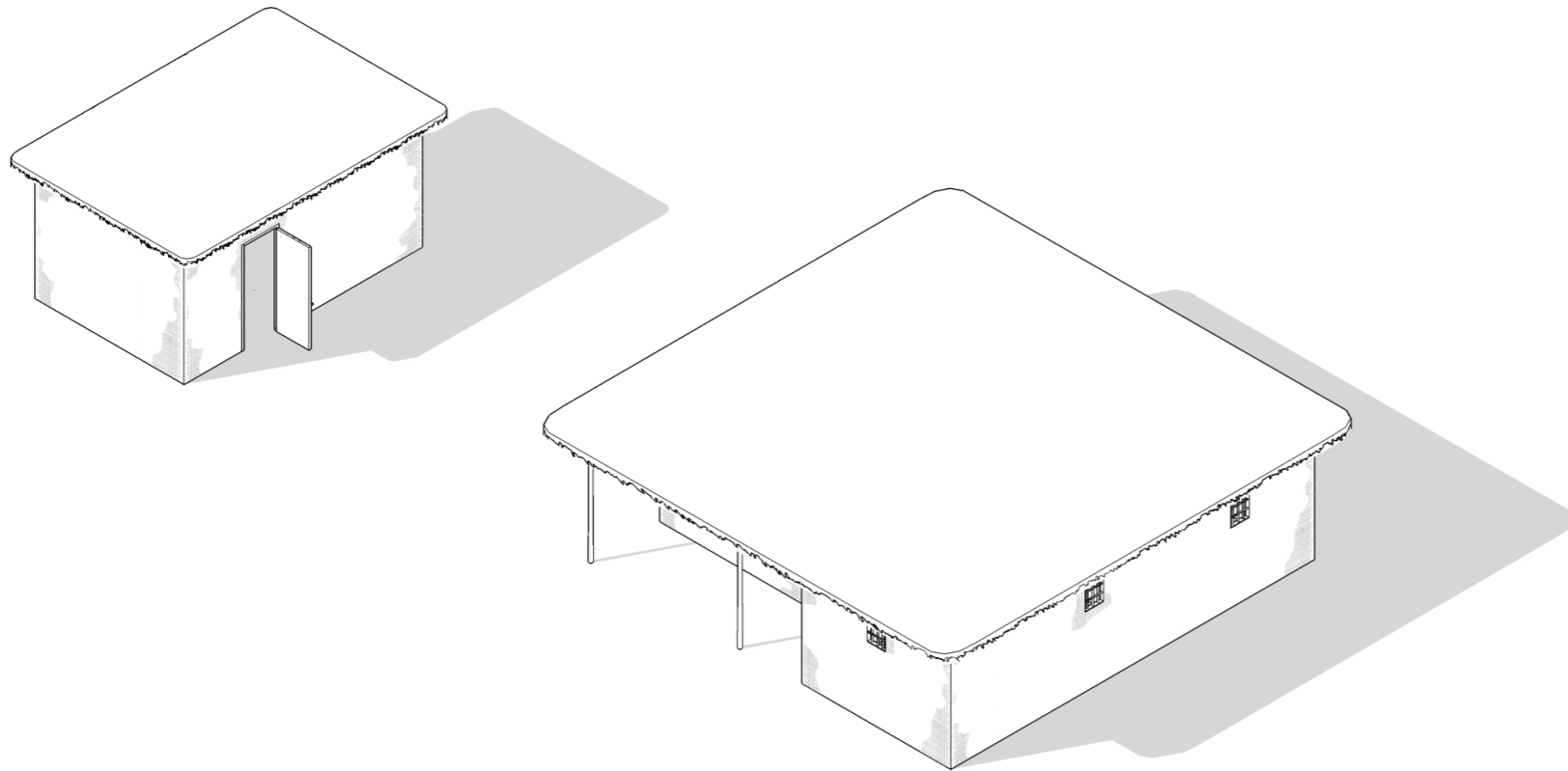

RURAL HOUSING CUSTOMS

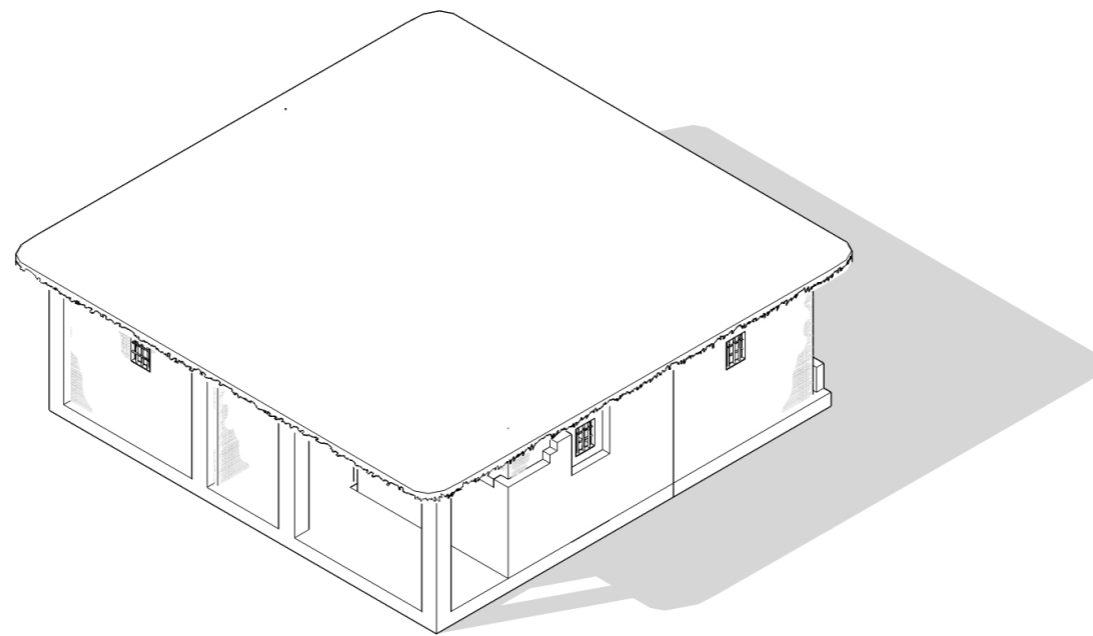

MODERNISING MATERIALS

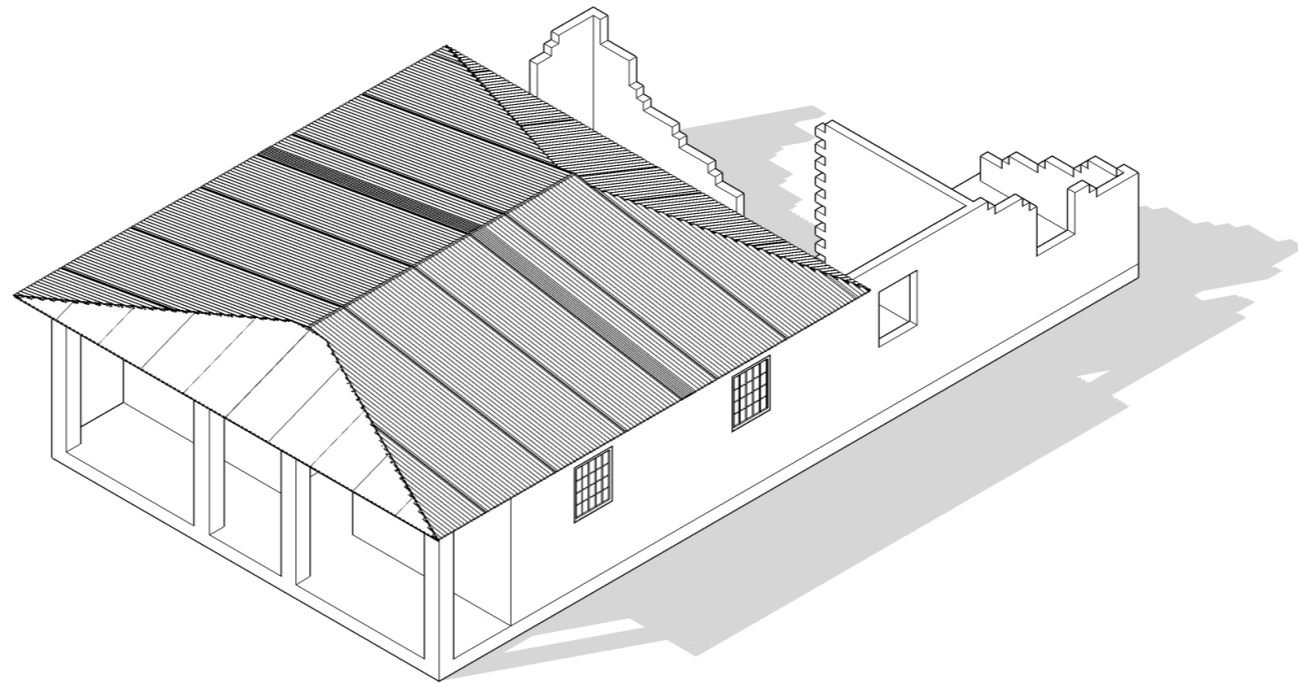

INCREMENTAL EXPANSION

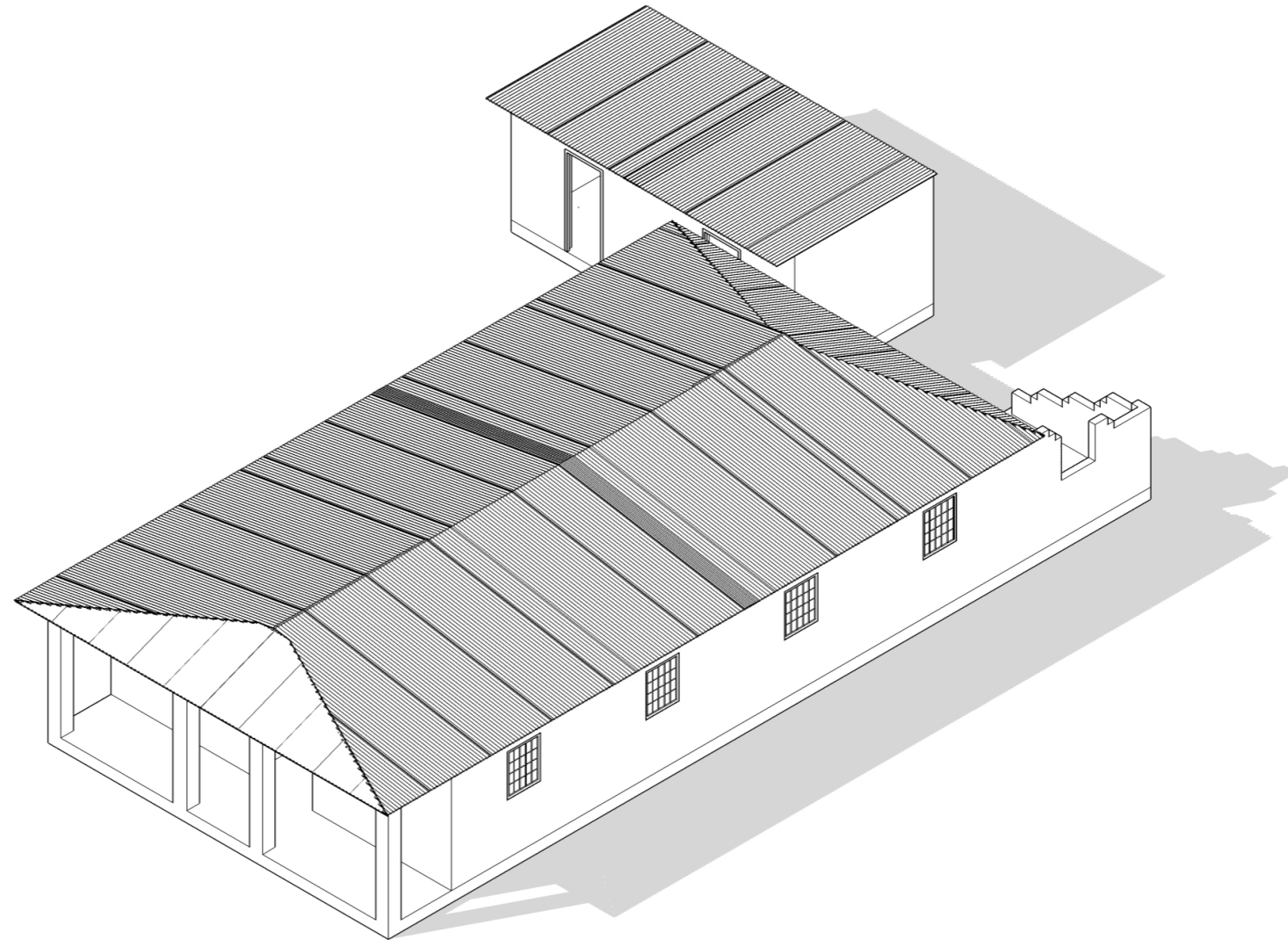

INVESTING IN LETTABLE ROOMS

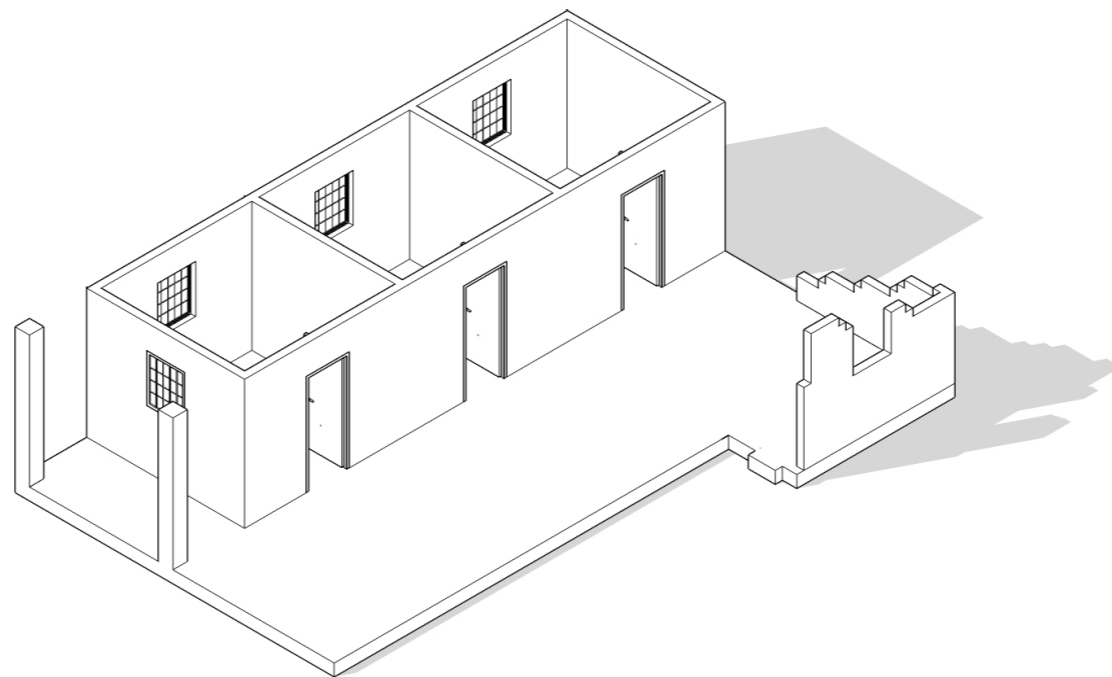

RECLAIMING OPEN SPACE

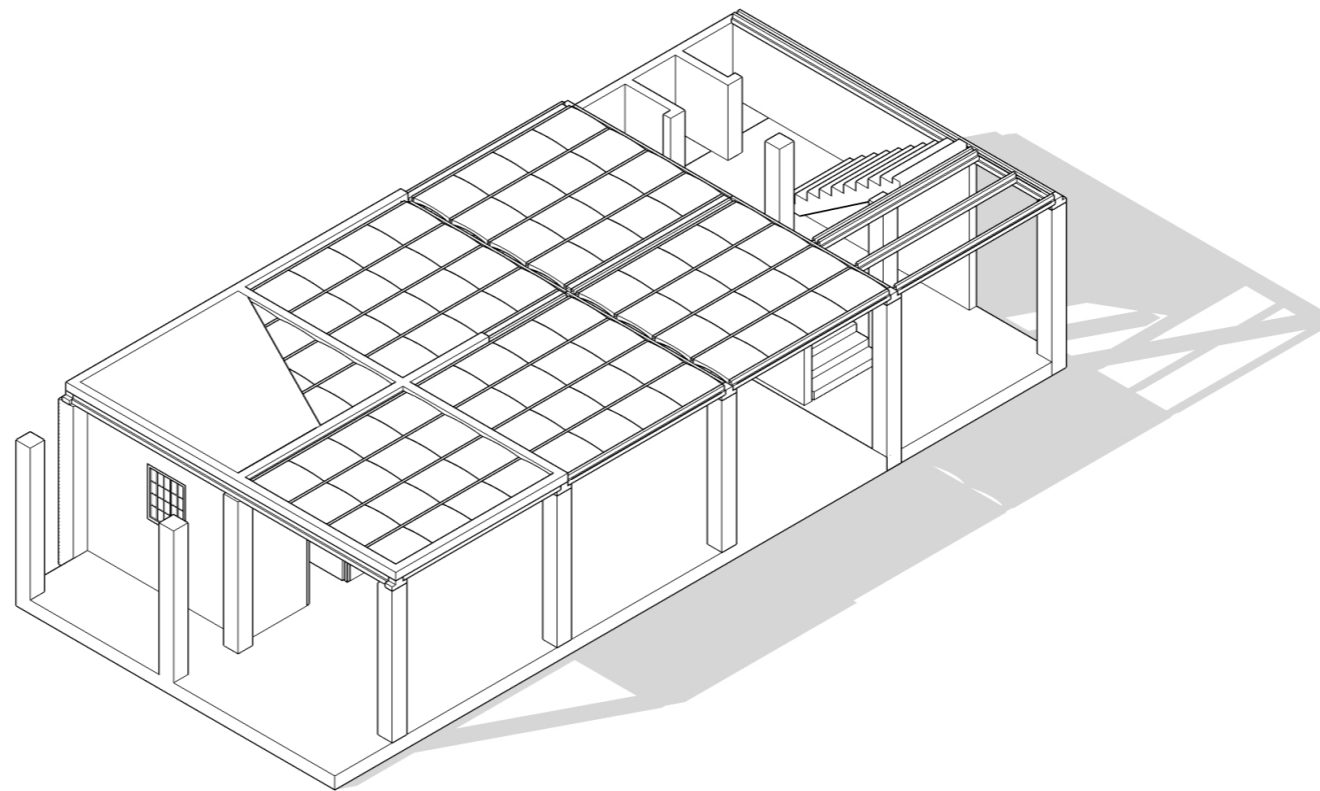

INTRODUCING VERTICALITY

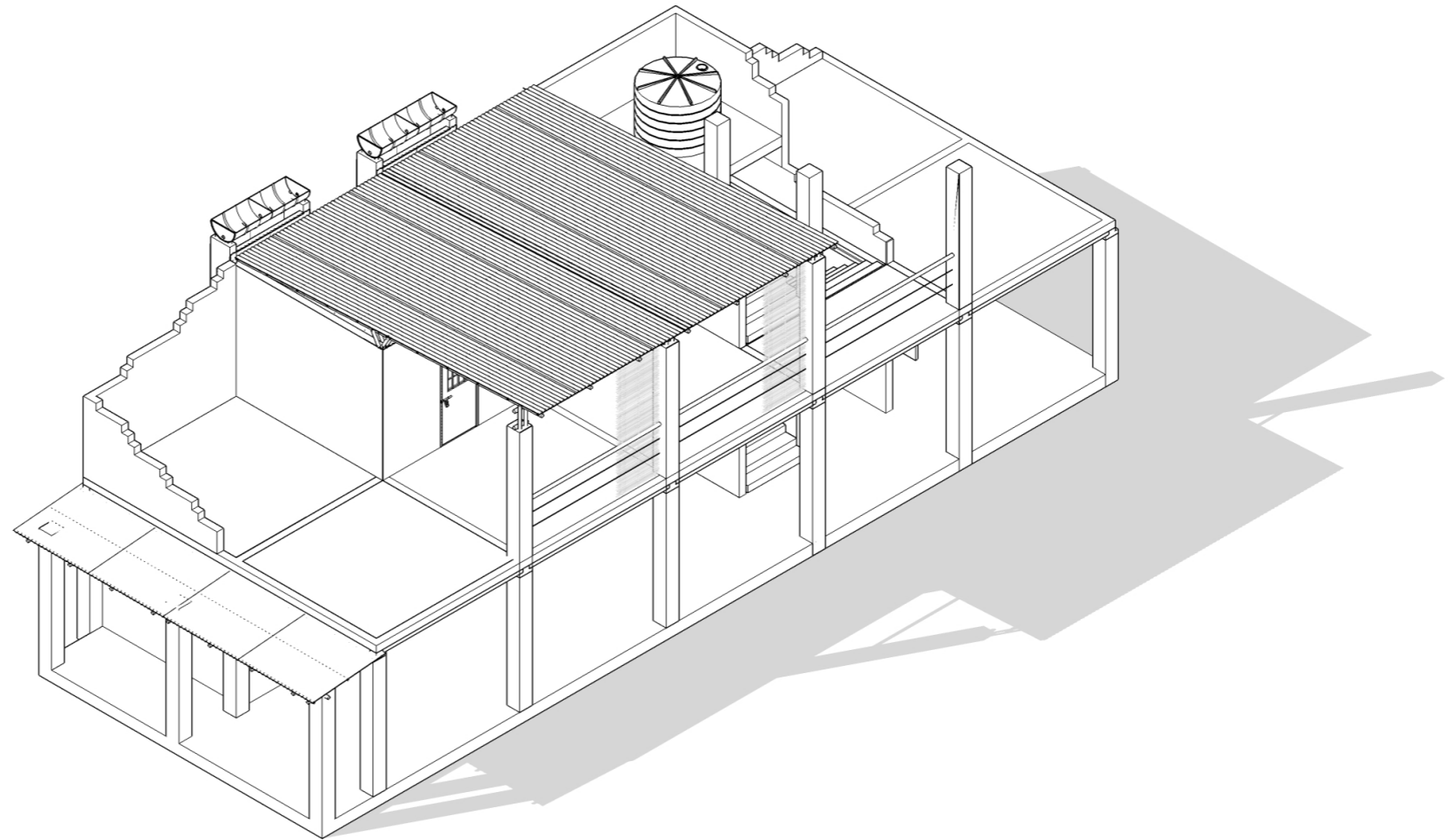

IMPROVING CLIMATIC QUALITIES

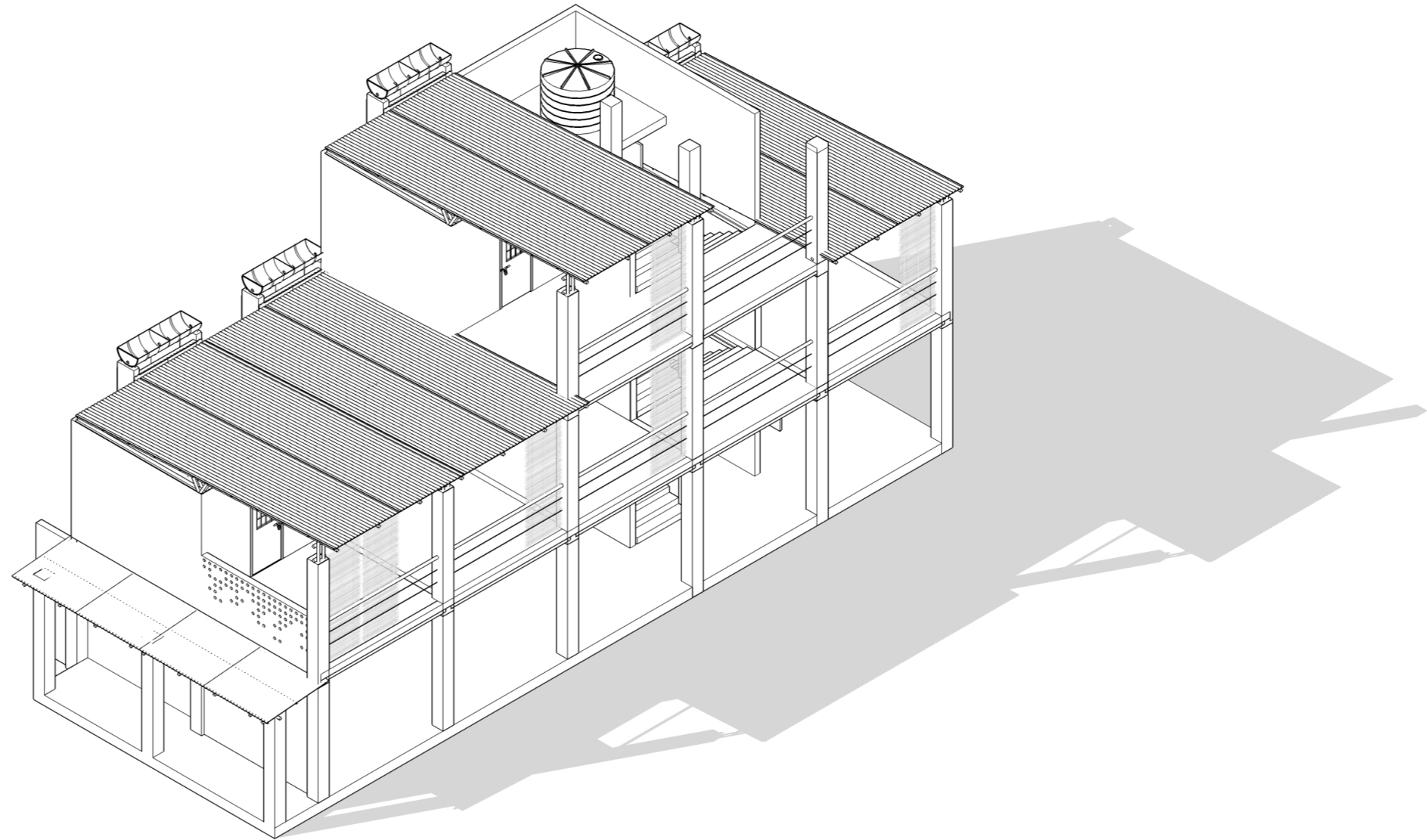

INCREMENTAL EXPANSION

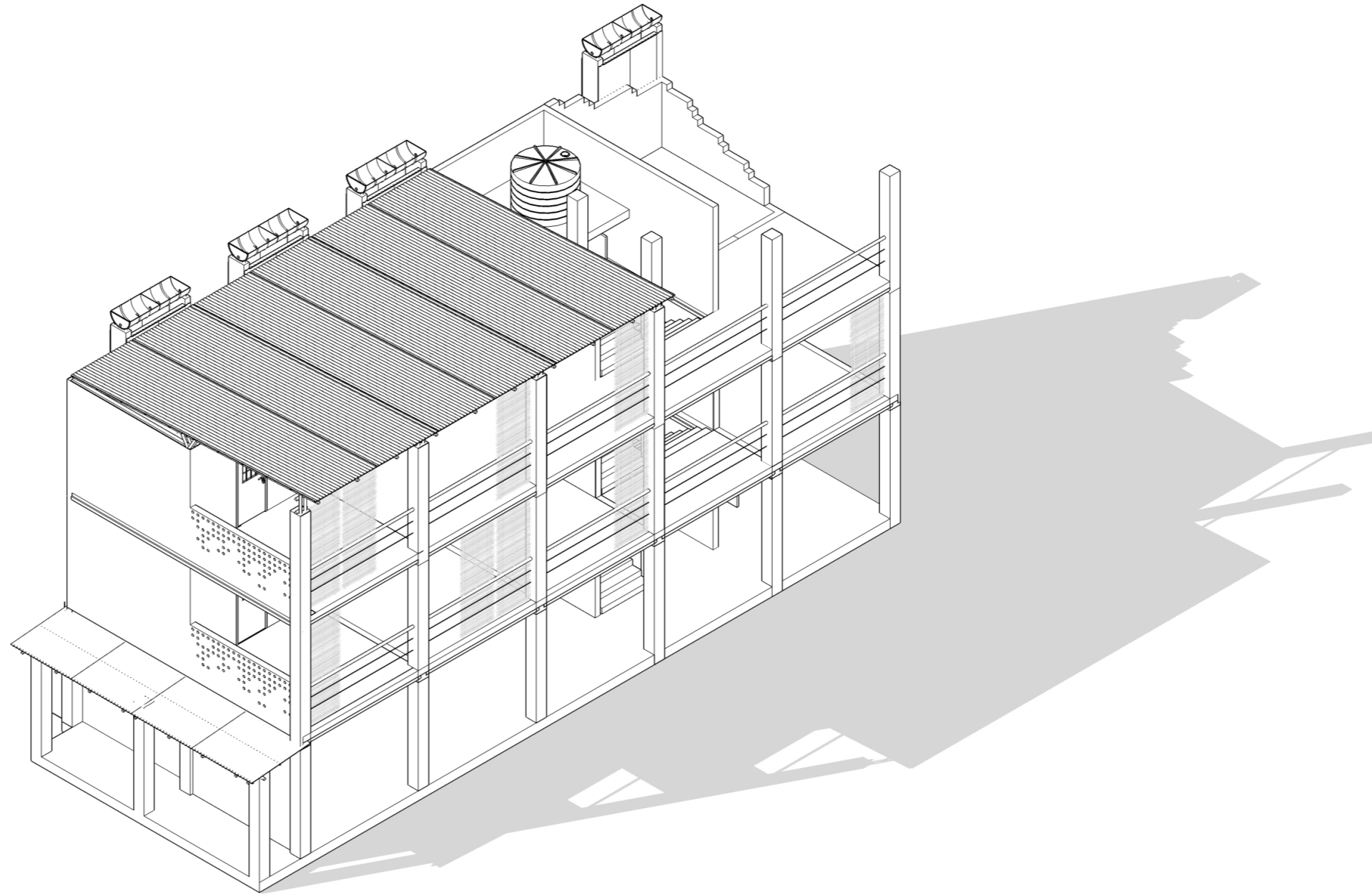

LETTABLE ROOMS AS AN INVESTMENT

Implementing the construction methods introduced in the EXPO, you will be able to:

- obtain **legal tenure** when you want to apply for it
- **increase** the amount of **lettable rooms** that can be build on your plot

VIABILITY OF THE STRATEGY

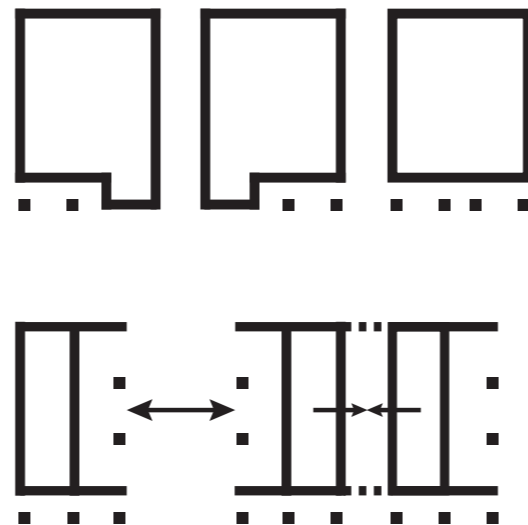

TRANSFORMATION OF THE URBAN FABRIC

the redesign of the Swahili house introduces to the informal settlement open courtyard spaces and closed off service alleys

CONCEPT

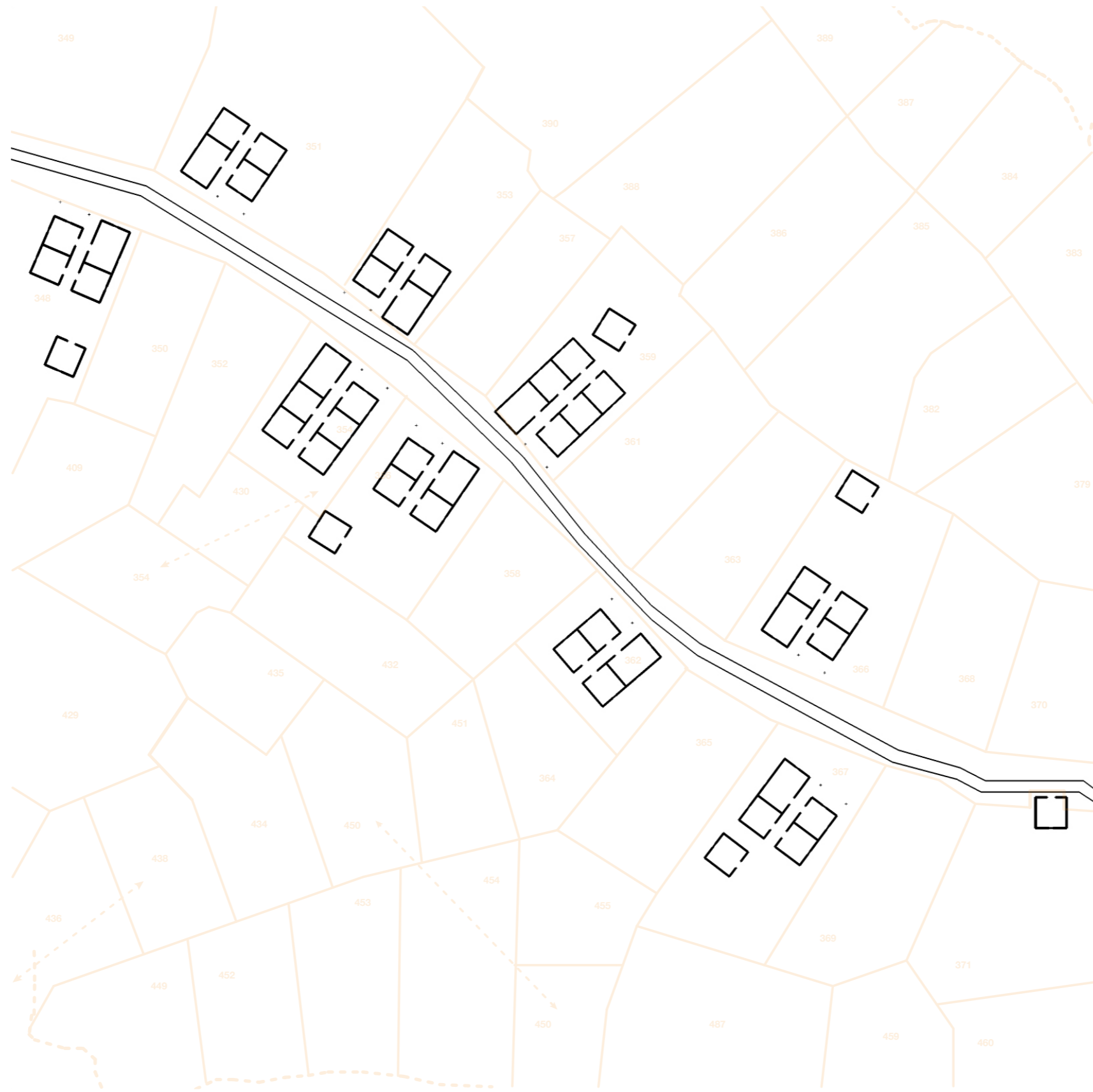

TRANSFORMATION OF THE URBAN FABRIC

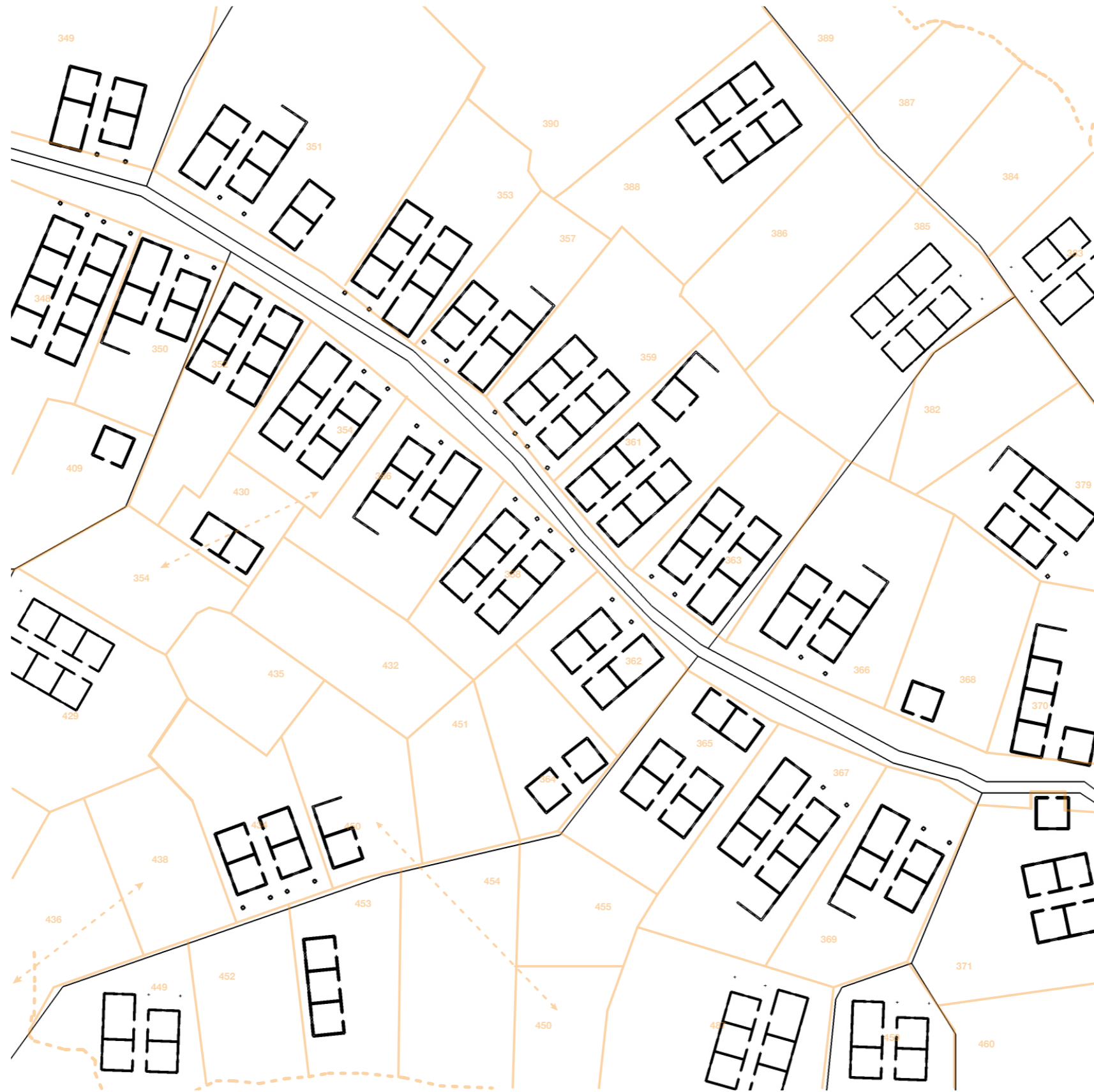

TRANSFORMATION OF THE URBAN FABRIC

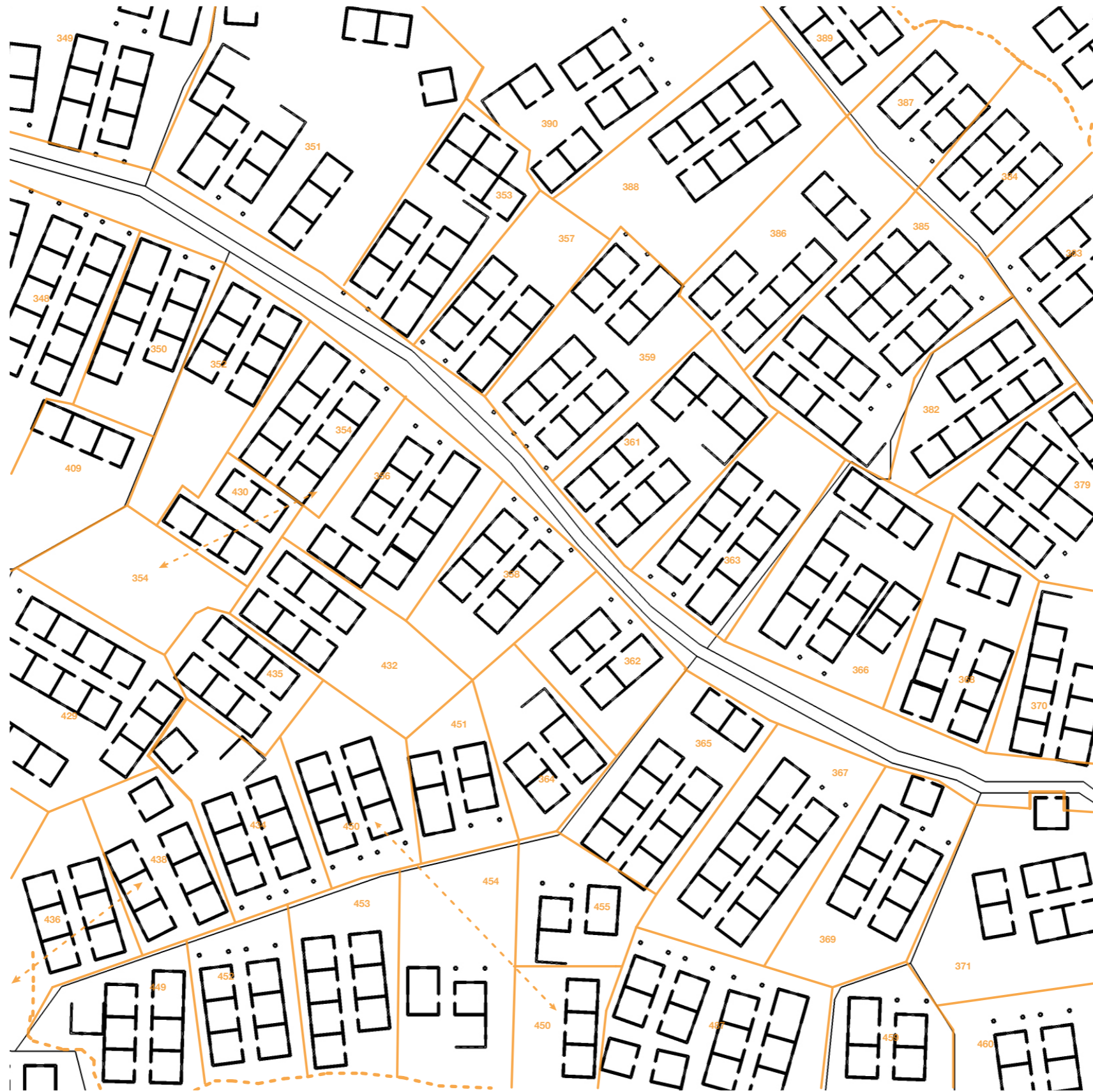

TRANSFORMATION OF THE URBAN FABRIC

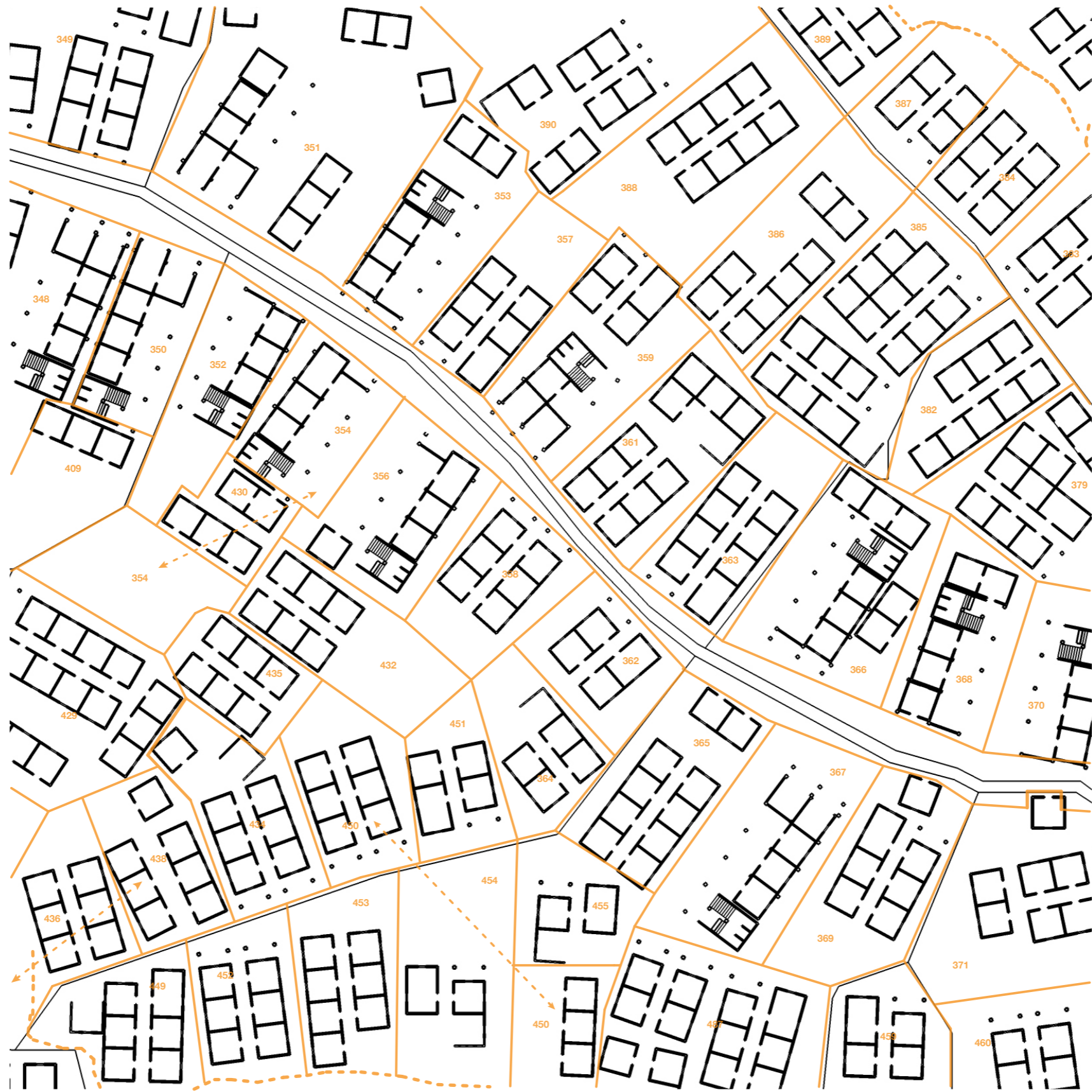

TRANSFORMATION OF THE URBAN FABRIC

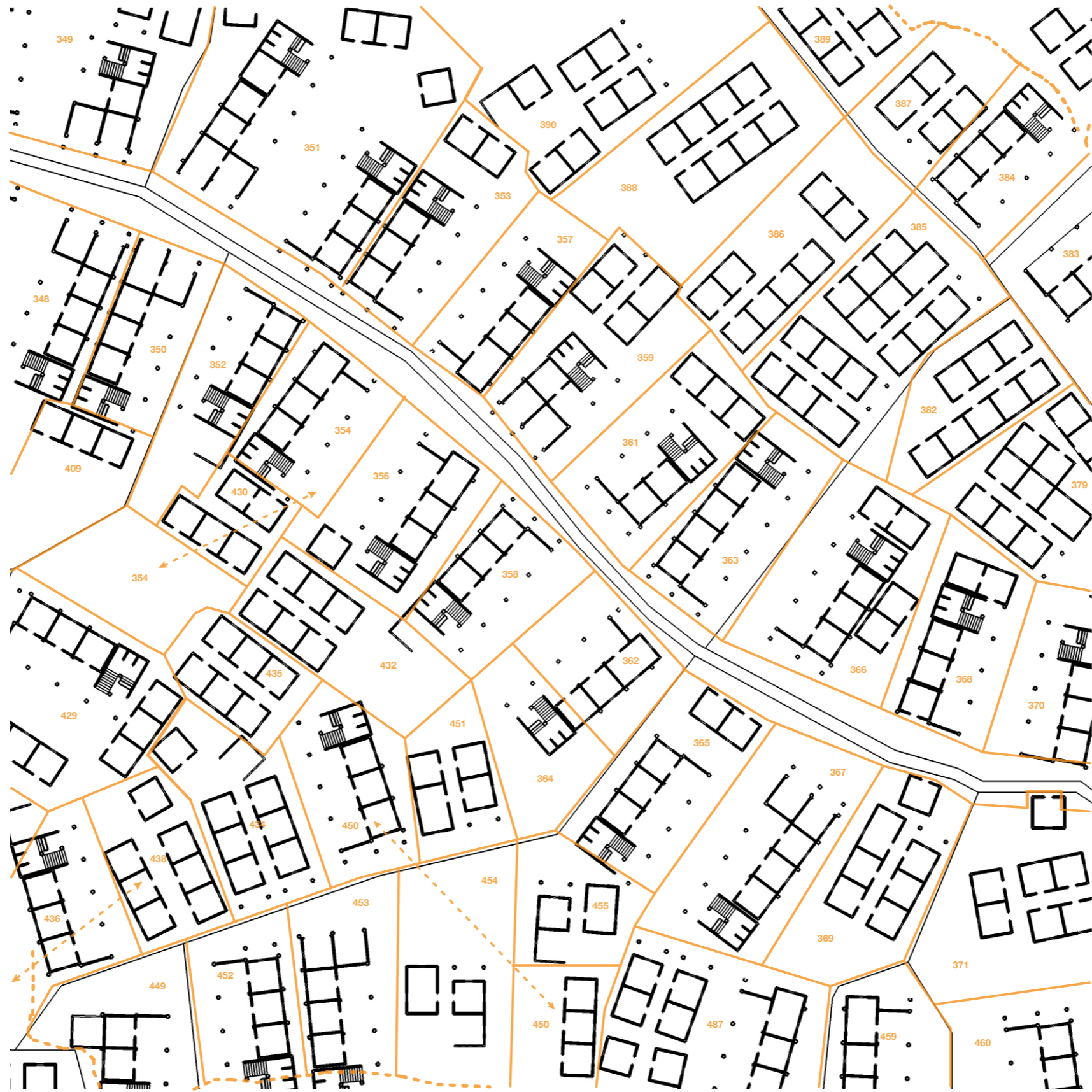

TRANSFORMATION OF THE URBAN FABRIC

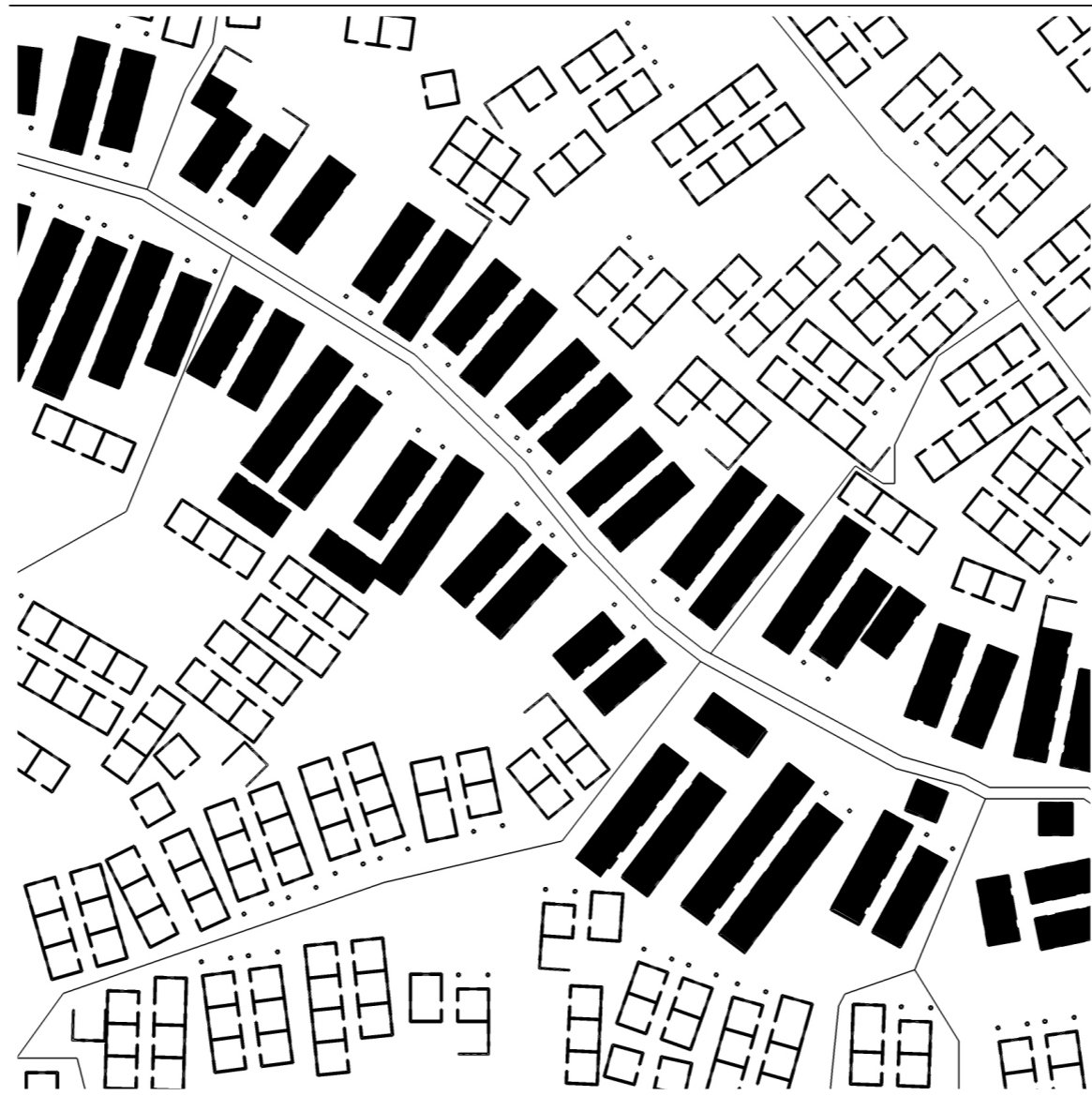

ABSTRACTED TRANSFORMATION

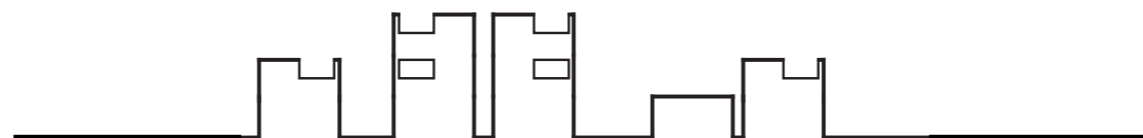
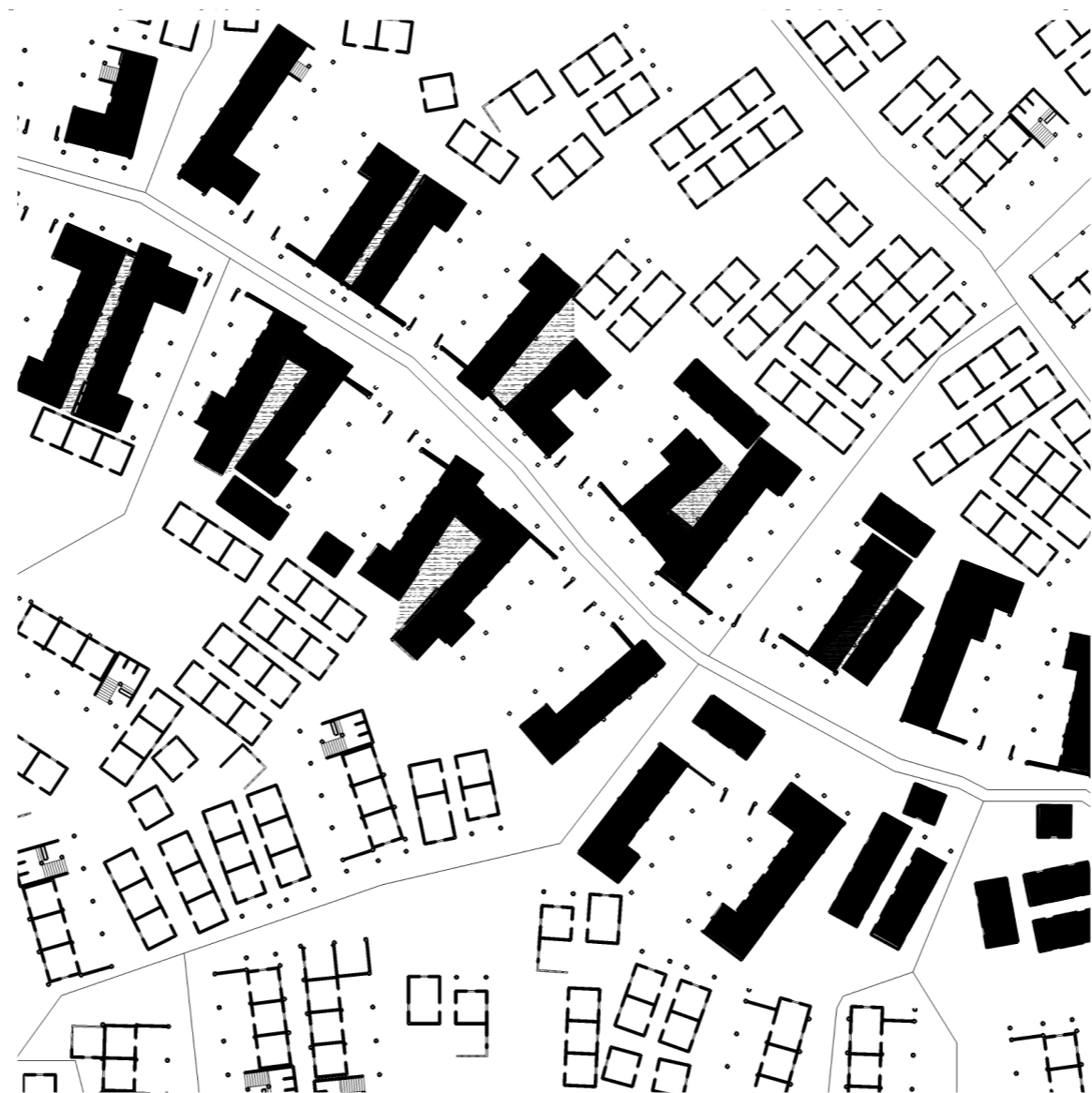

ABSTRACTED TRANSFORMATION



THE FIGURE OF THE GATE

irregularity in the form of the informal settlement is mitigated by the elements that border the open and enclosed alleys

CONCEPT

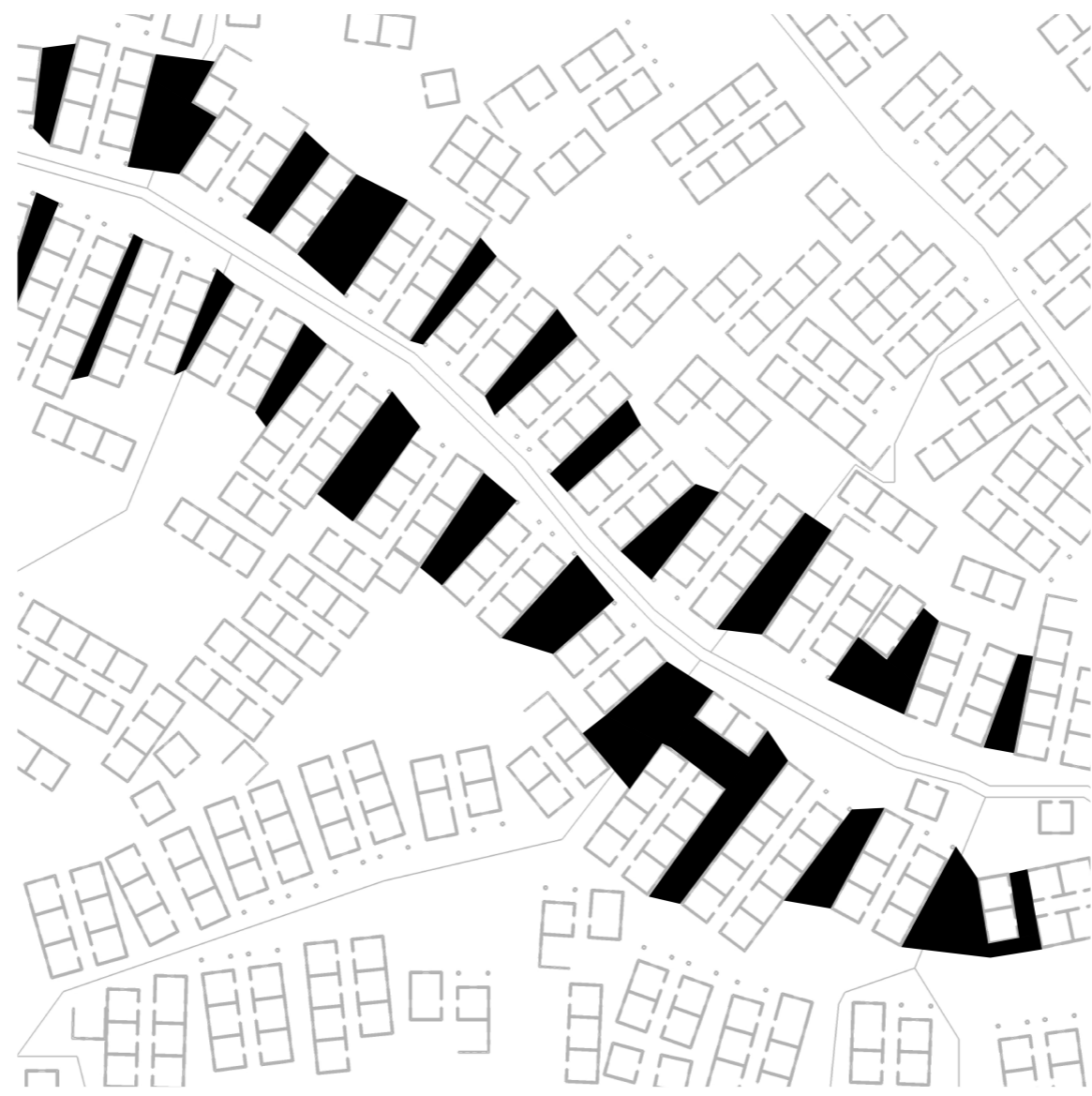

IRREGULARITY IN FORM

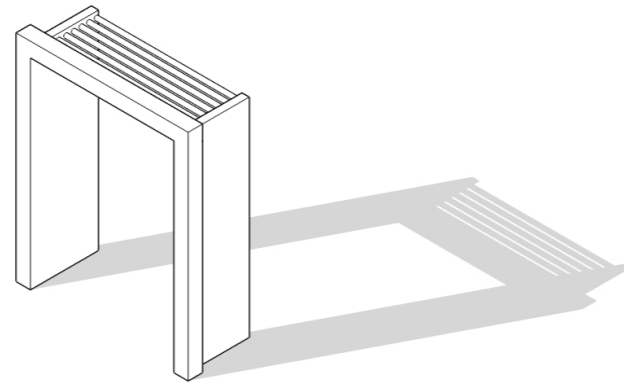

TOLLERANCES

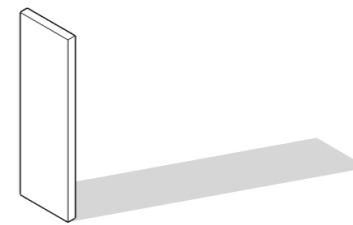
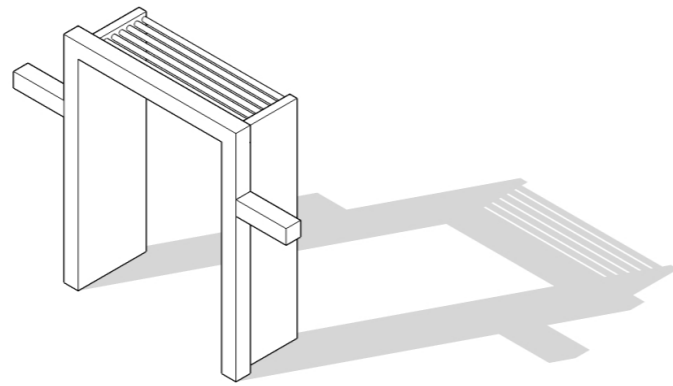

TOLLERANCES

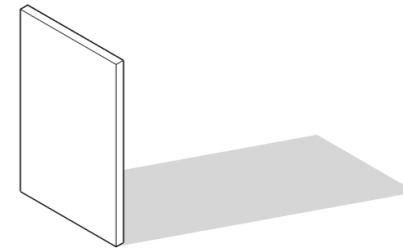
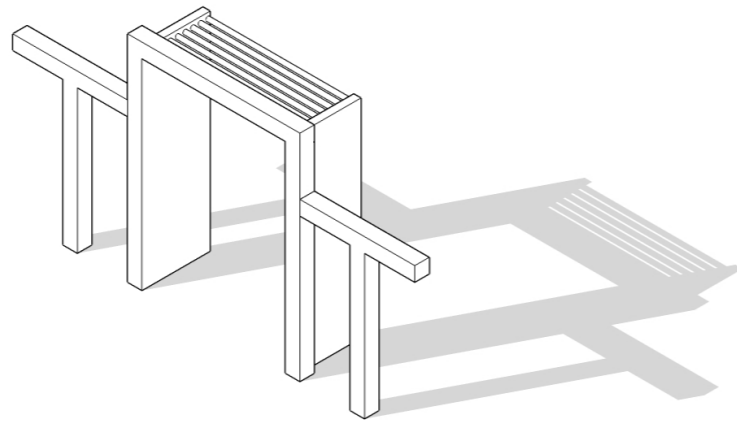

TOLLERANCES

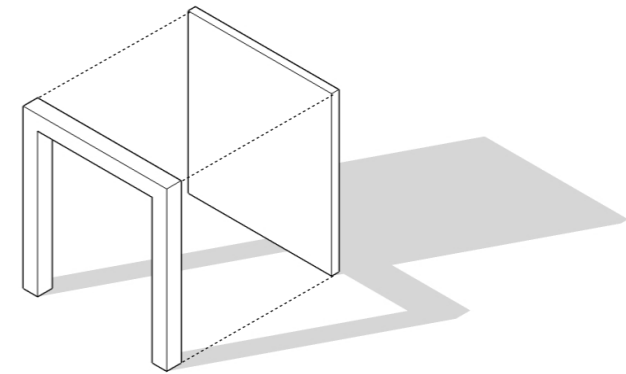
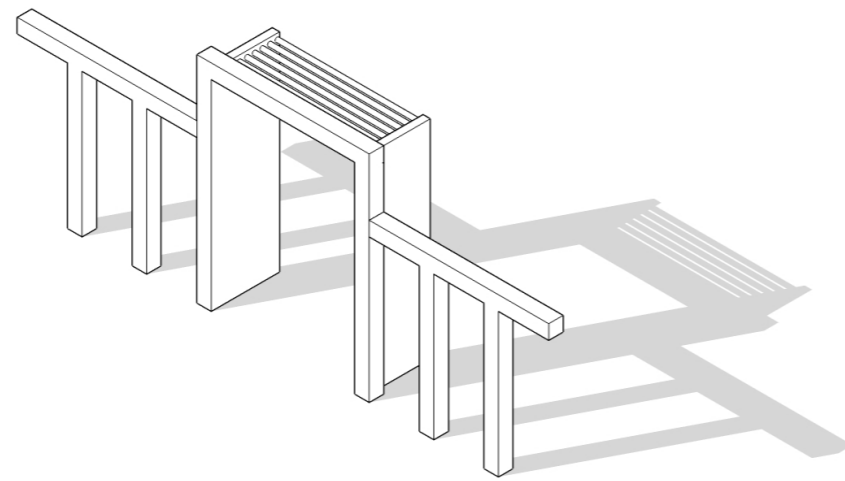

TOLLERANCES

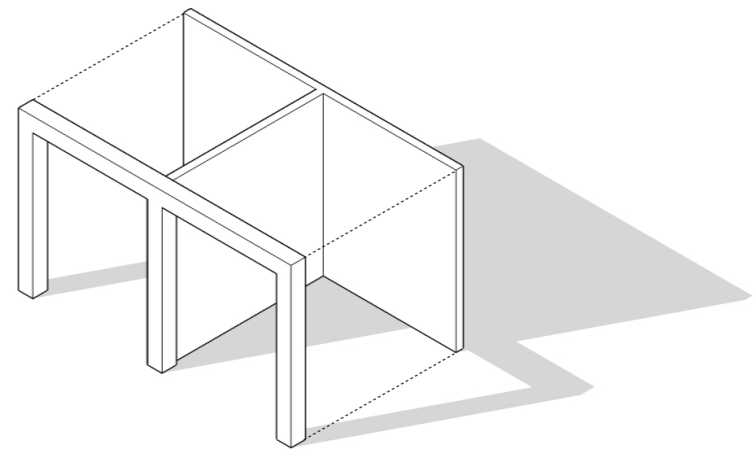
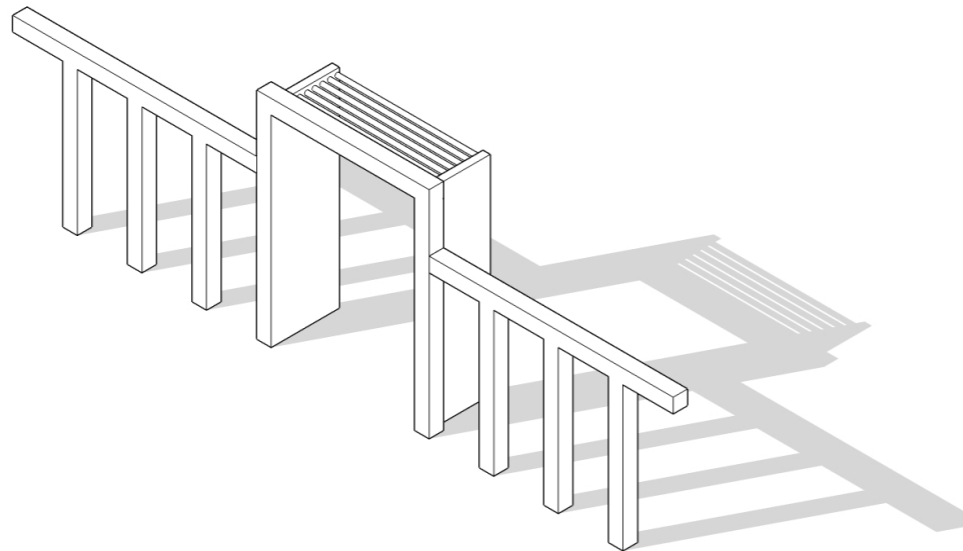

TOLLERANCES

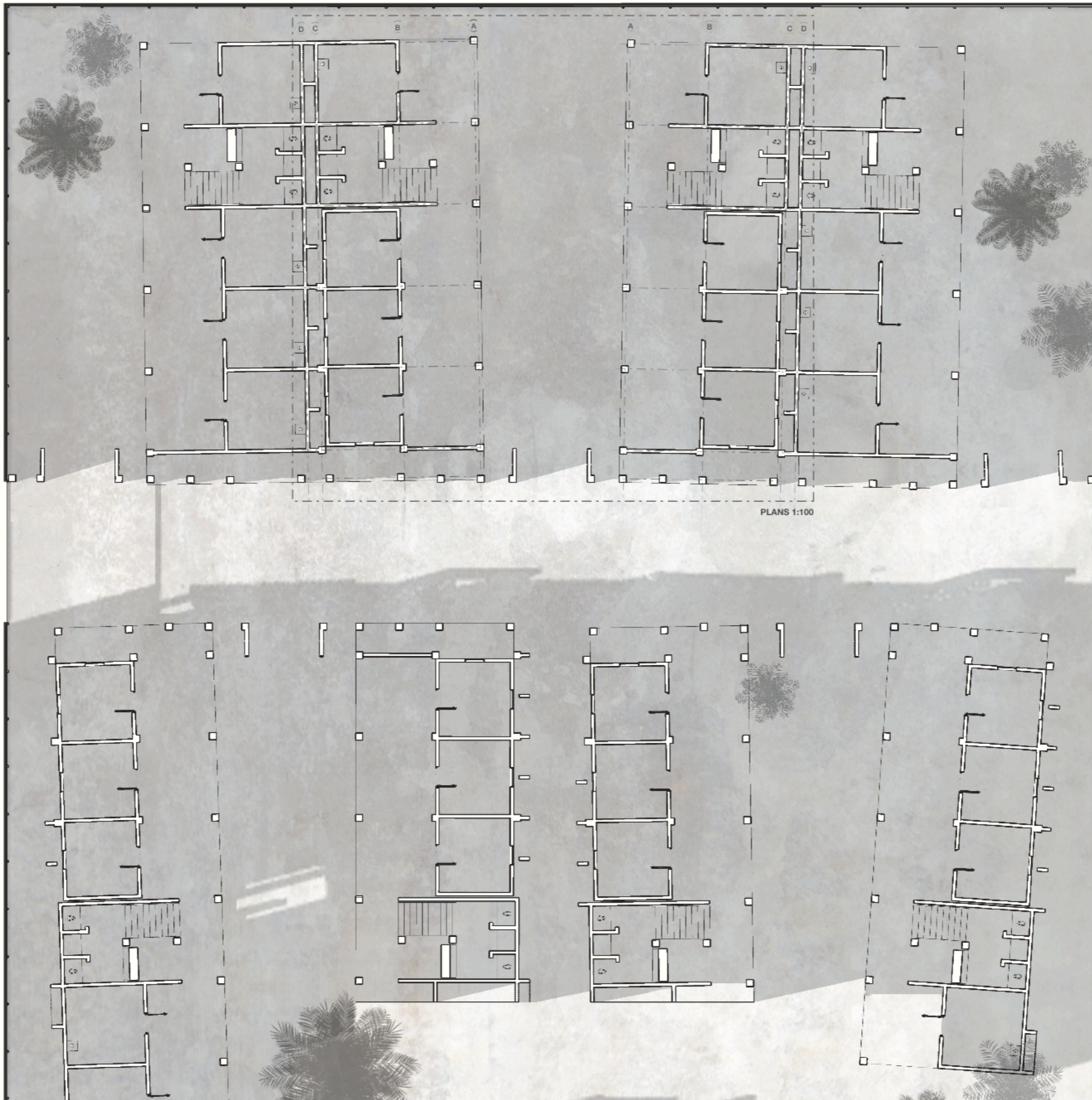

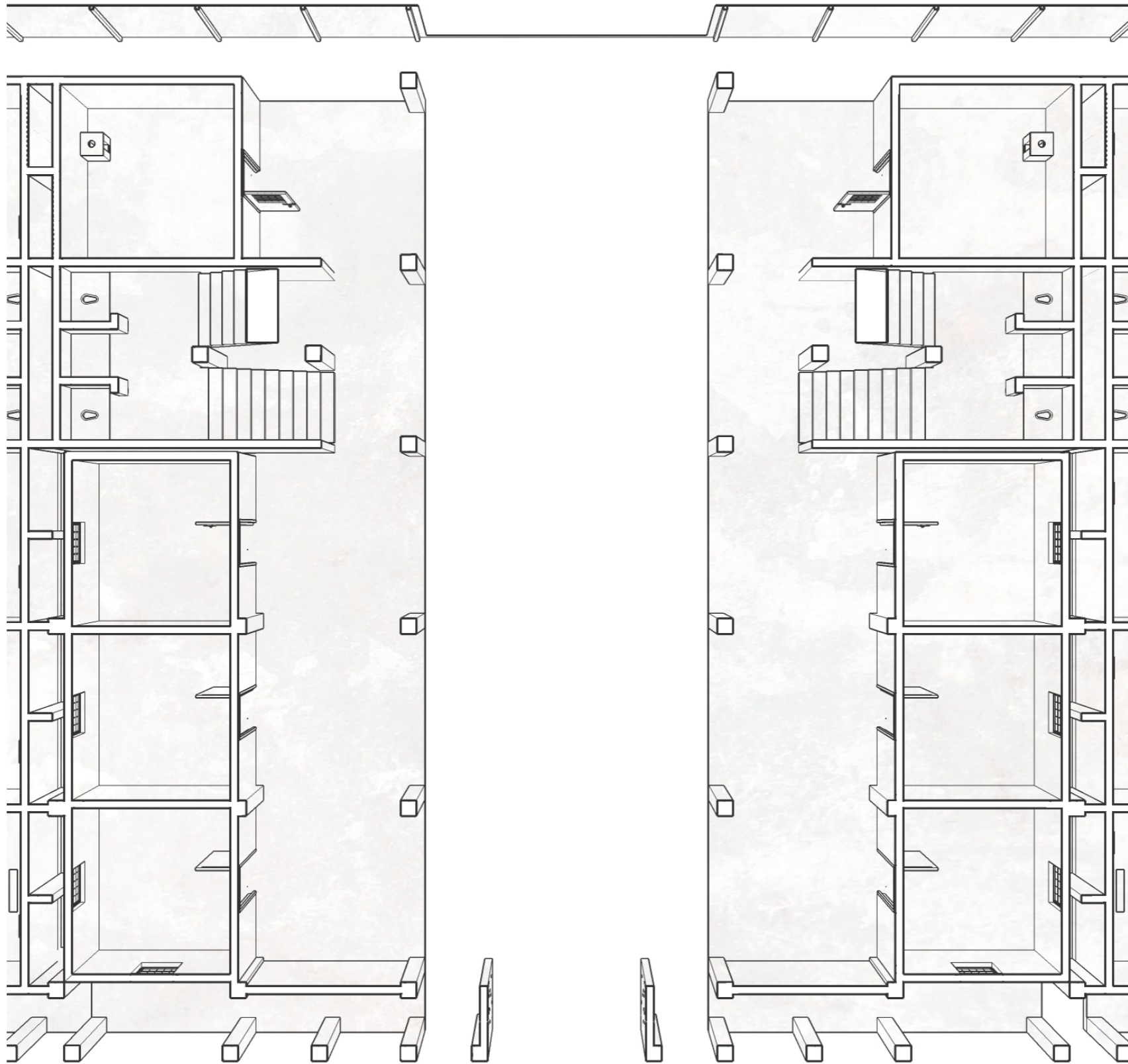

THE SWAHILI HOUSE TYPOLOGY

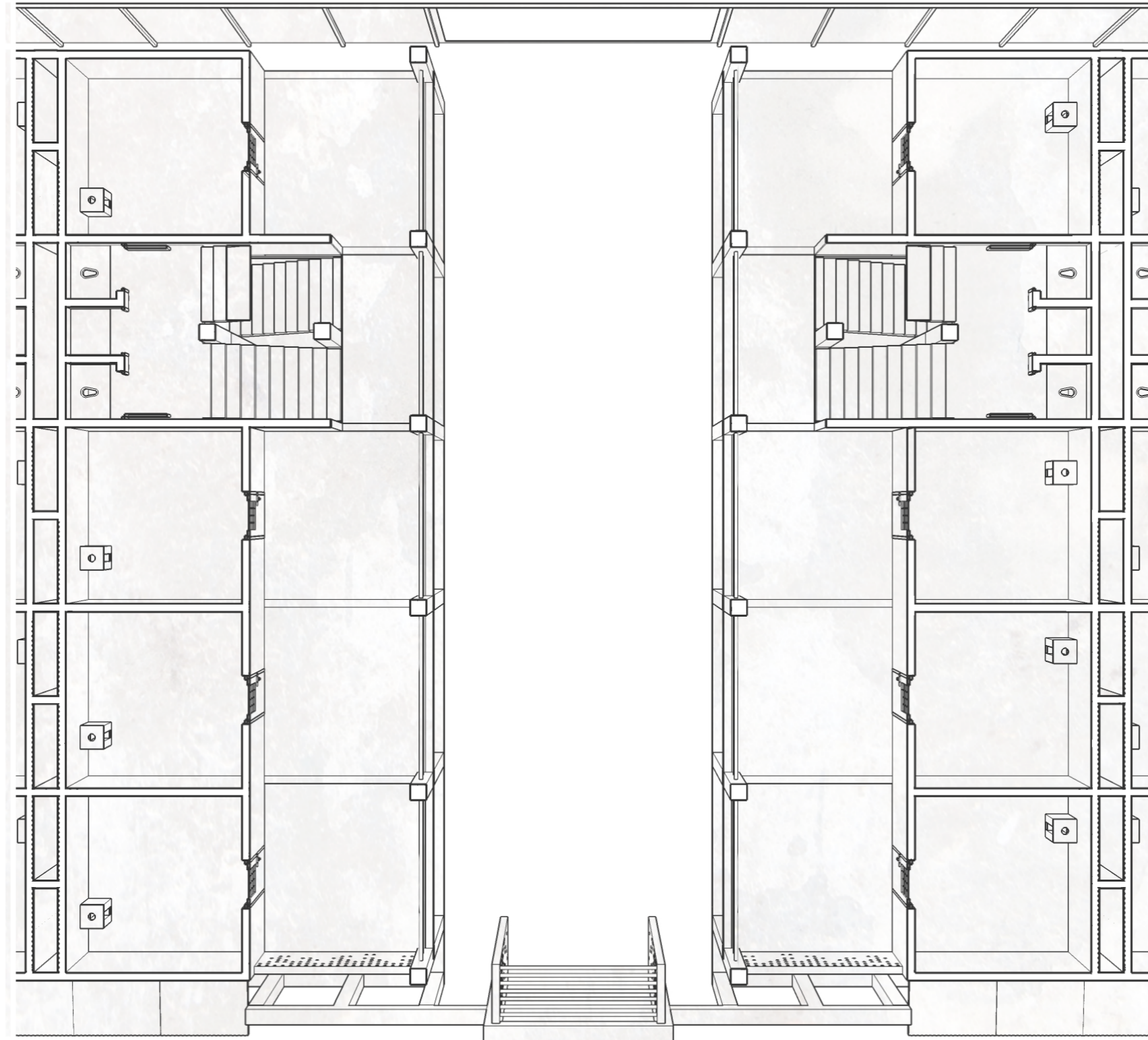

THE SWAHILI HOUSE TYPOLOGY

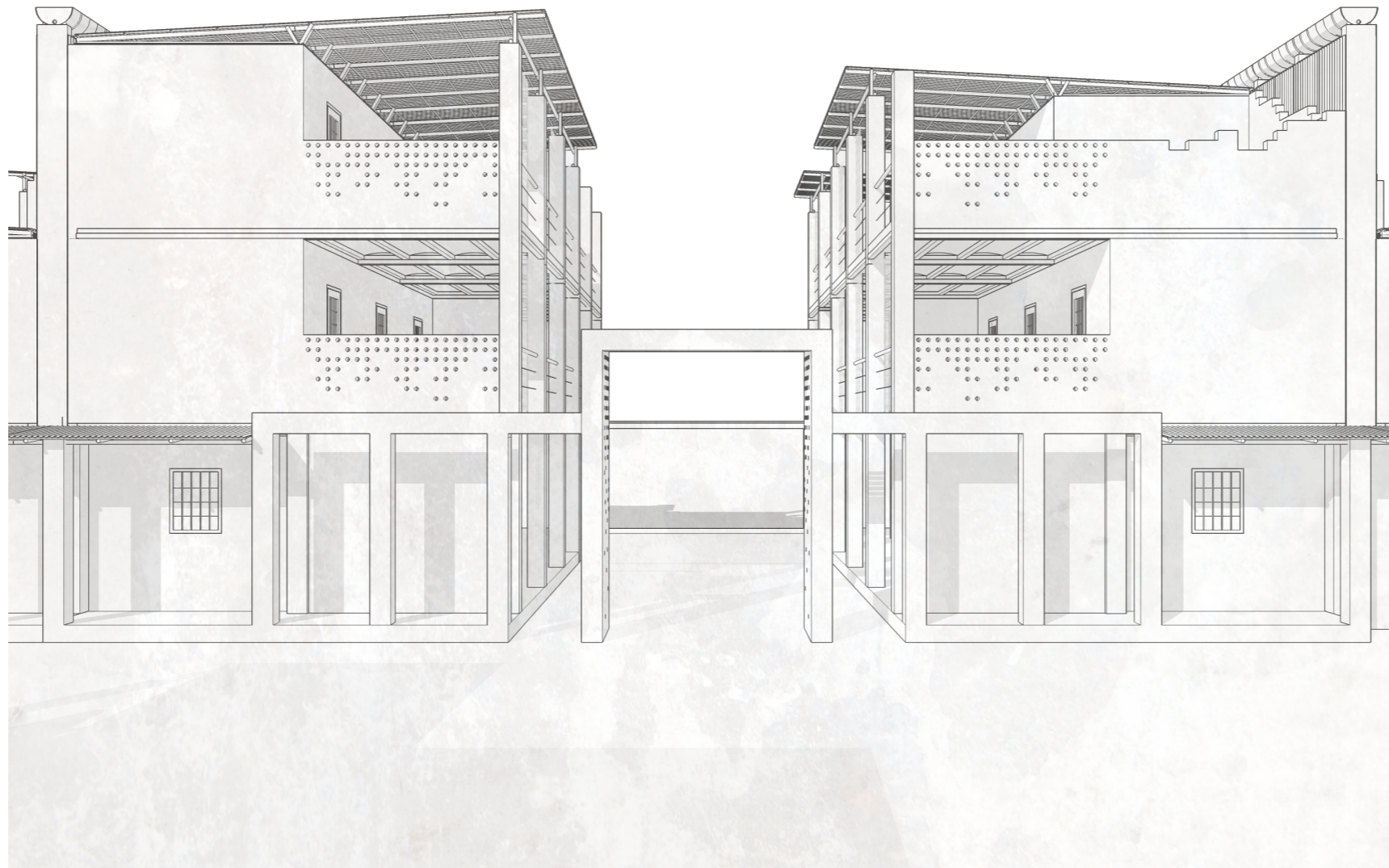

THE SWAHILI HOUSE TYPOLOGY

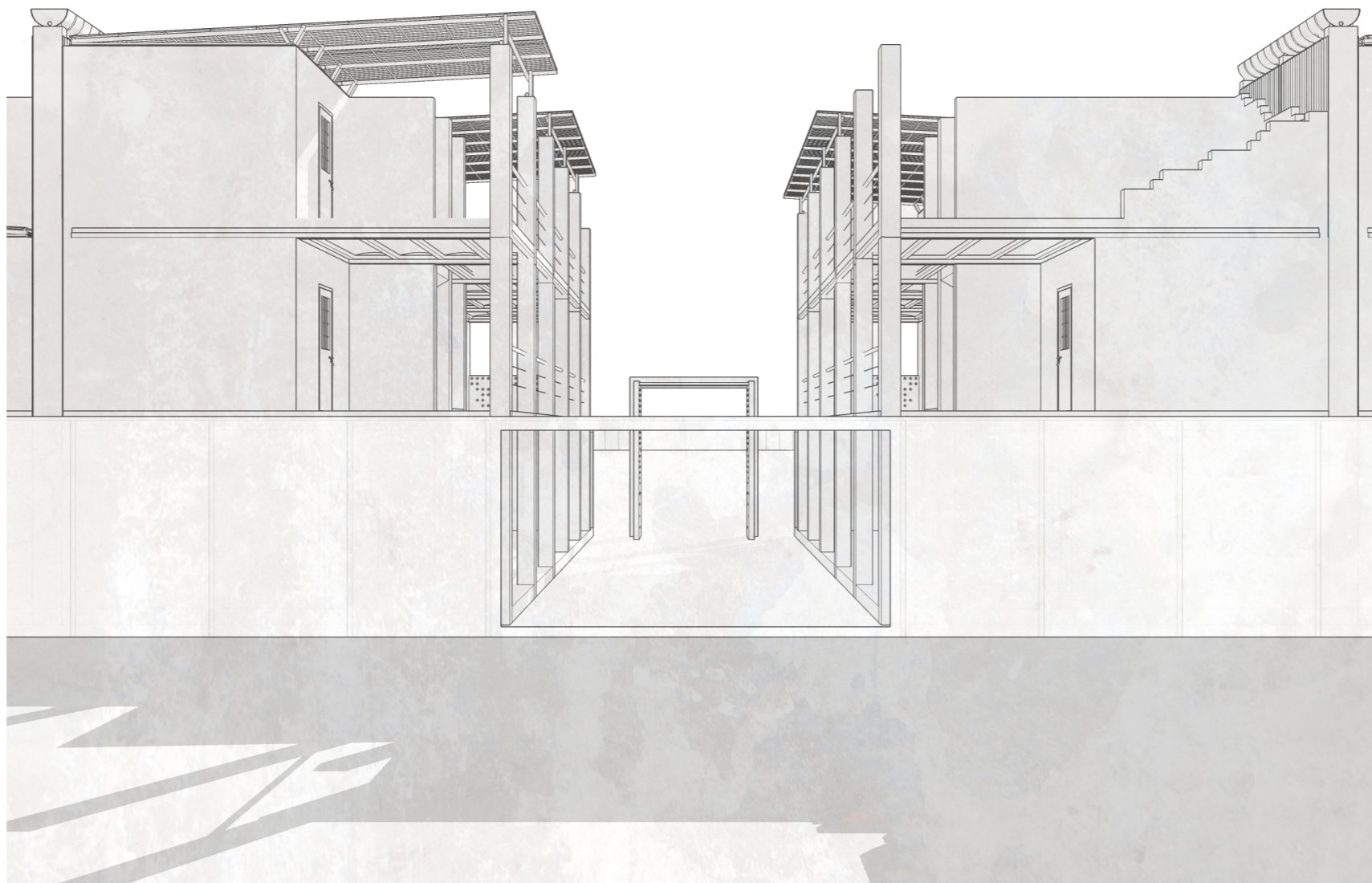

THE SWAHILI HOUSE TYPOLOGY



THE SWAHILI HOUSE TYPOLOGY



THE SWAHILI HOUSE TYPOLOGY



A SPATIAL HIERARCHY IN PRIVACY

the usage of the generic rooms in the typology is steered by a gradient from open to enclosed space

CONCEPT

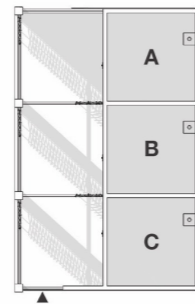
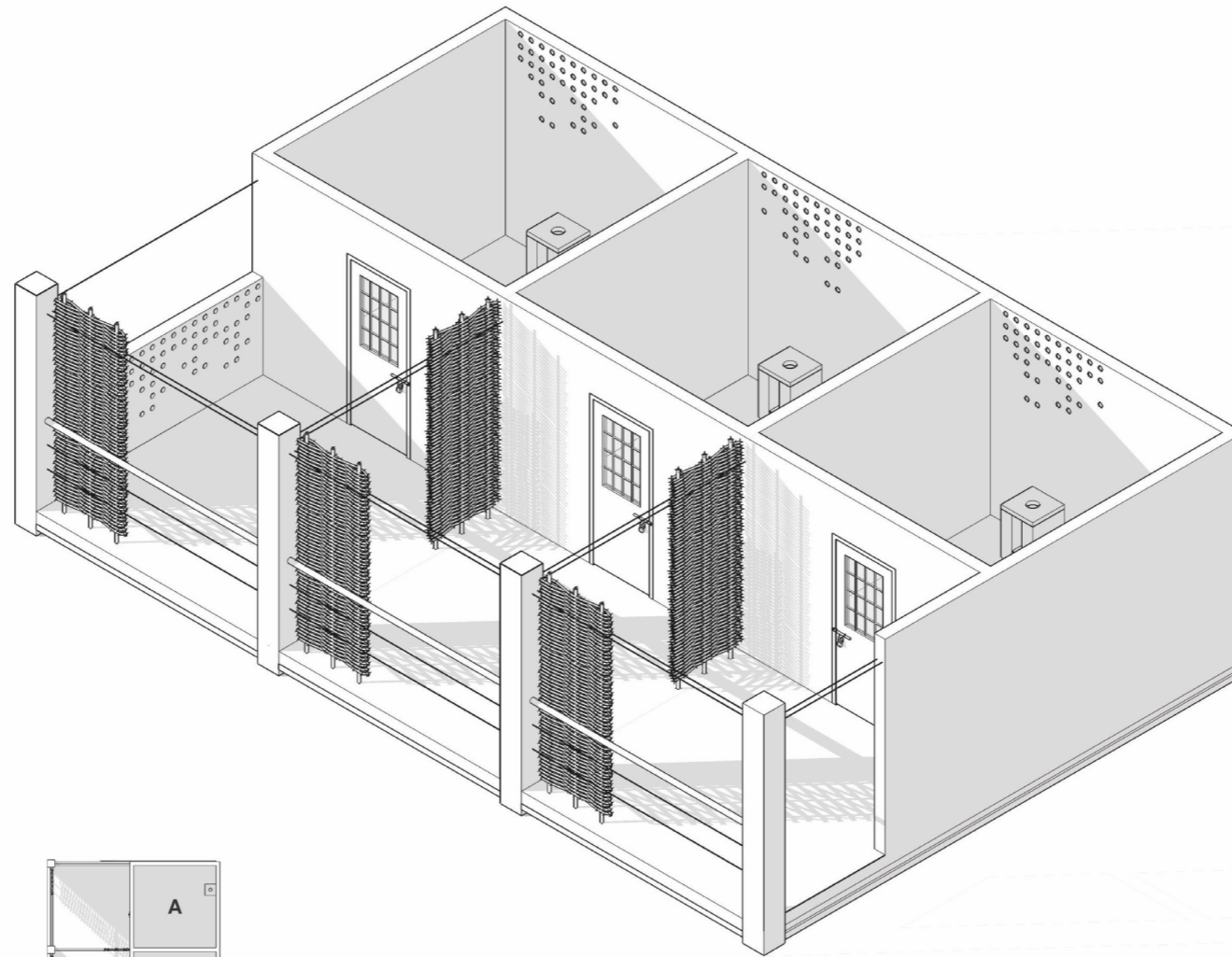

FLOOR INHABITED BY THREE HOUSEHOLDS

FLEXIBILITY IN USE

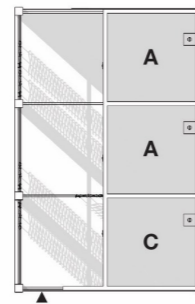
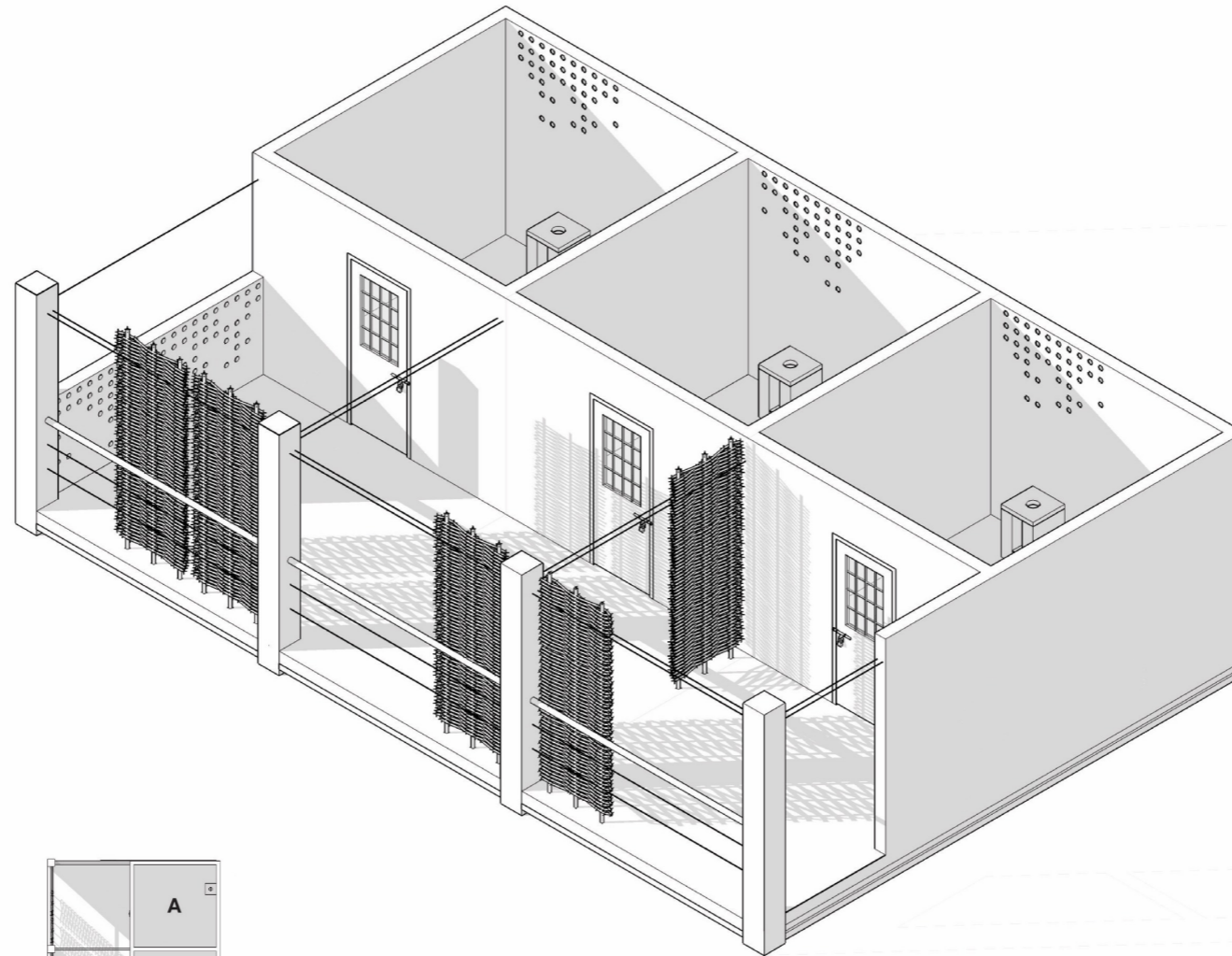

FLOOR INHABITED BY TWO HOUSEHOLDS

FLEXIBILITY IN USE

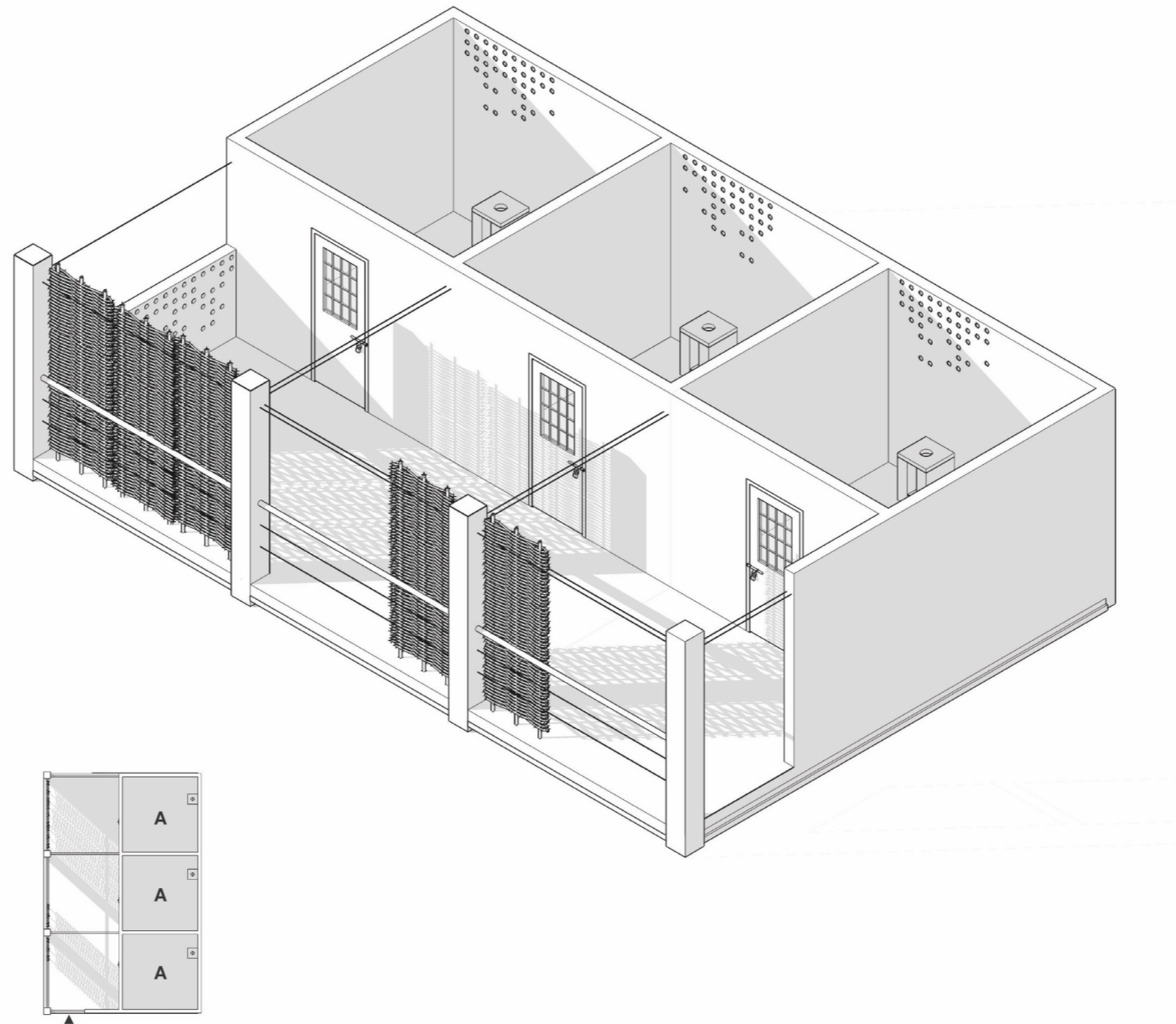

FLOOR INHABITED BY A SINGLE HOUSEHOLD

FLEXIBILITY IN USE

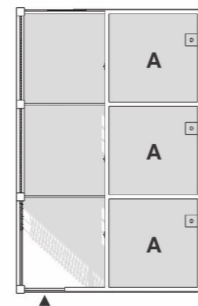
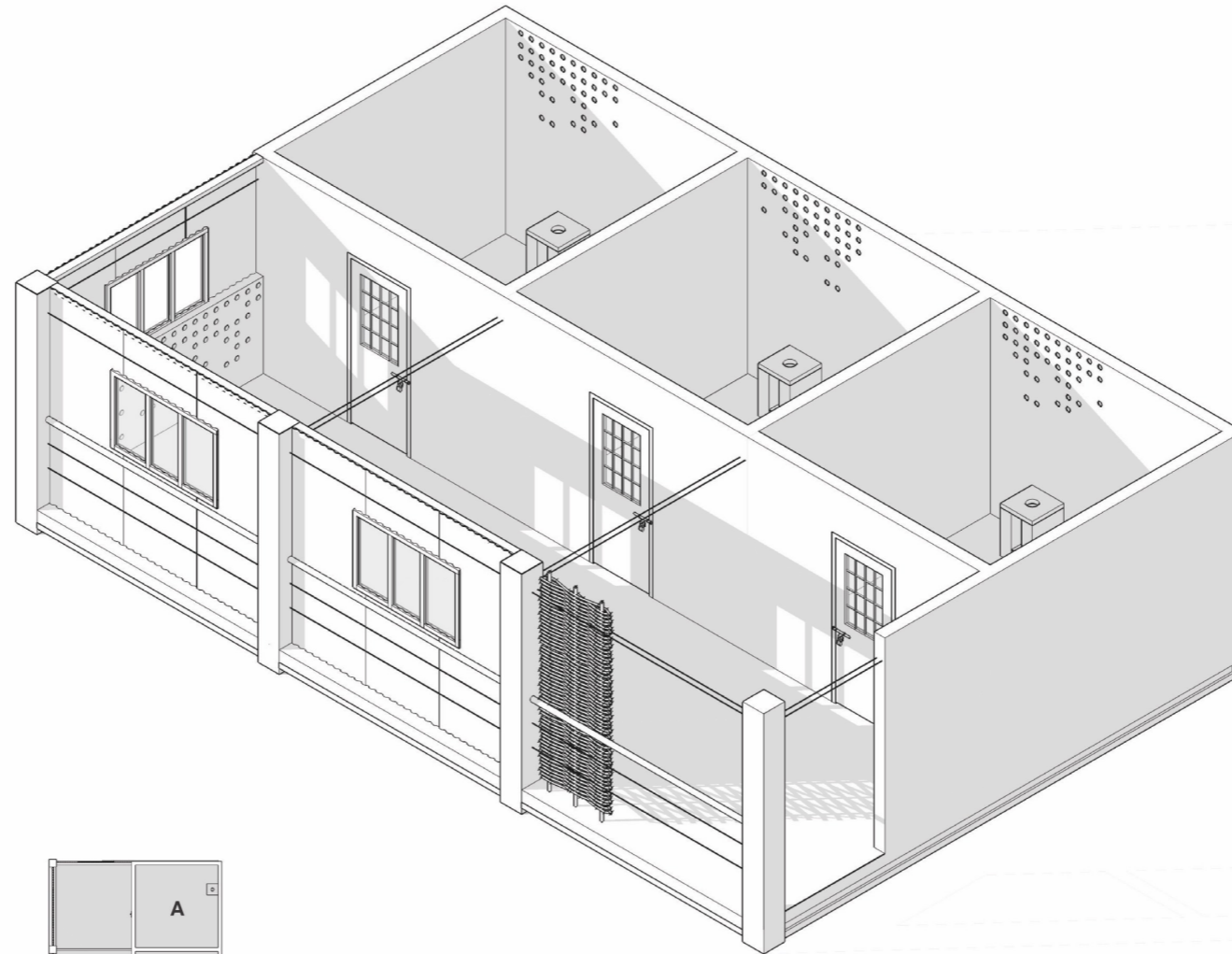

TRANSFORMATION TOWARDS A SEPARATION OF FUNCTIONS

FLEXIBILITY IN USE

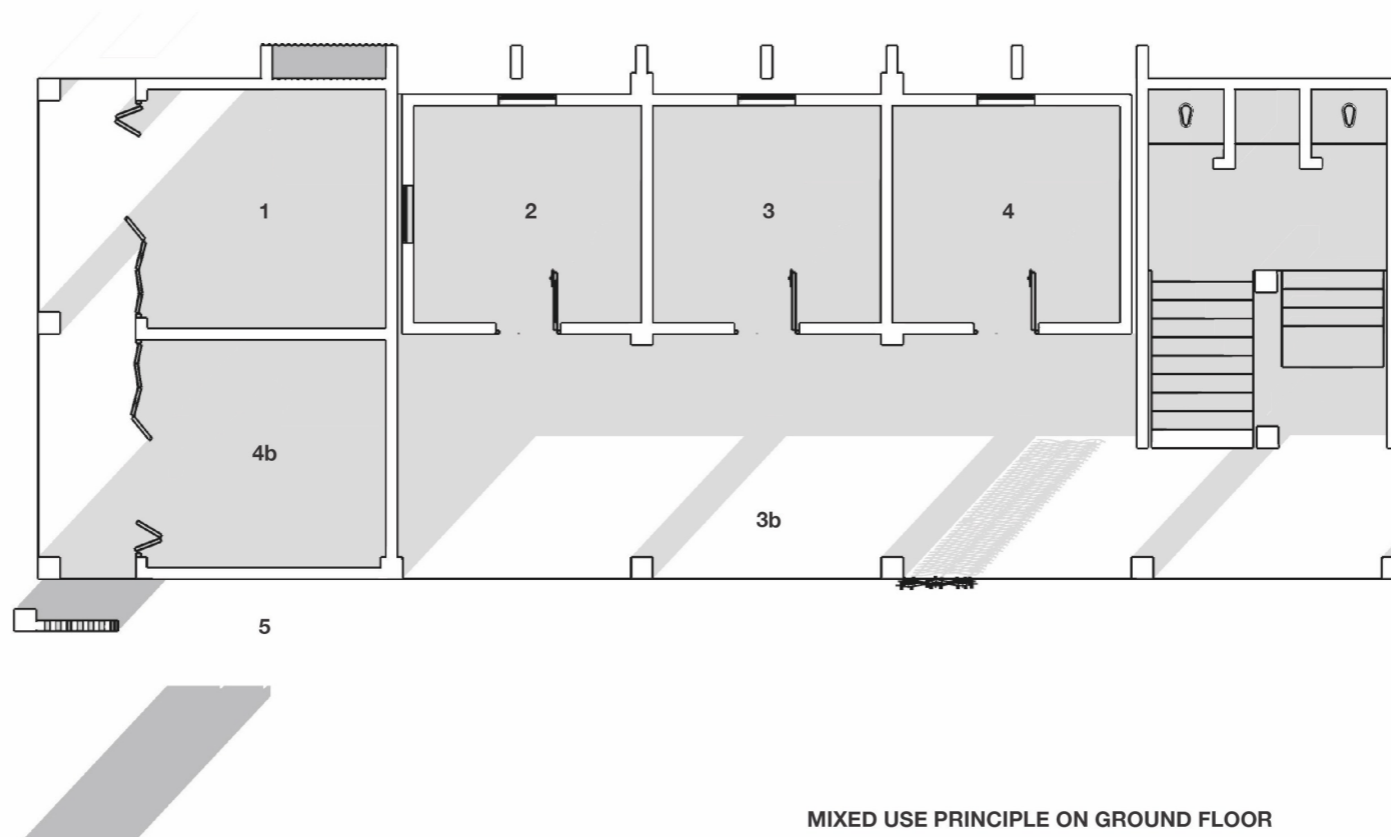

MIXED USE PRINCIPLE ON GROUND FLOOR

1	Tailor / garment shop	tenant rents a single room (shop)
2	Cinema	owner sells tickets at the door
3	Rental room	tenant rents a single room
3b	Mamalishe	informal food vendor
4	Rental room	tenant also rents a shop
4b	Butchers shop	tenant also rents a room
5	Kahawa vendor	coffee vendor

FLEXIBILITY IN USE

[ANIMATION]

USE OF SPACE



TECHNOLOGY

How to improve the structural and climatic qualities of informally produced rental housing in Dar es Salaam, limited to auto-construction methods and materials.

PROBLEM STATEMENT

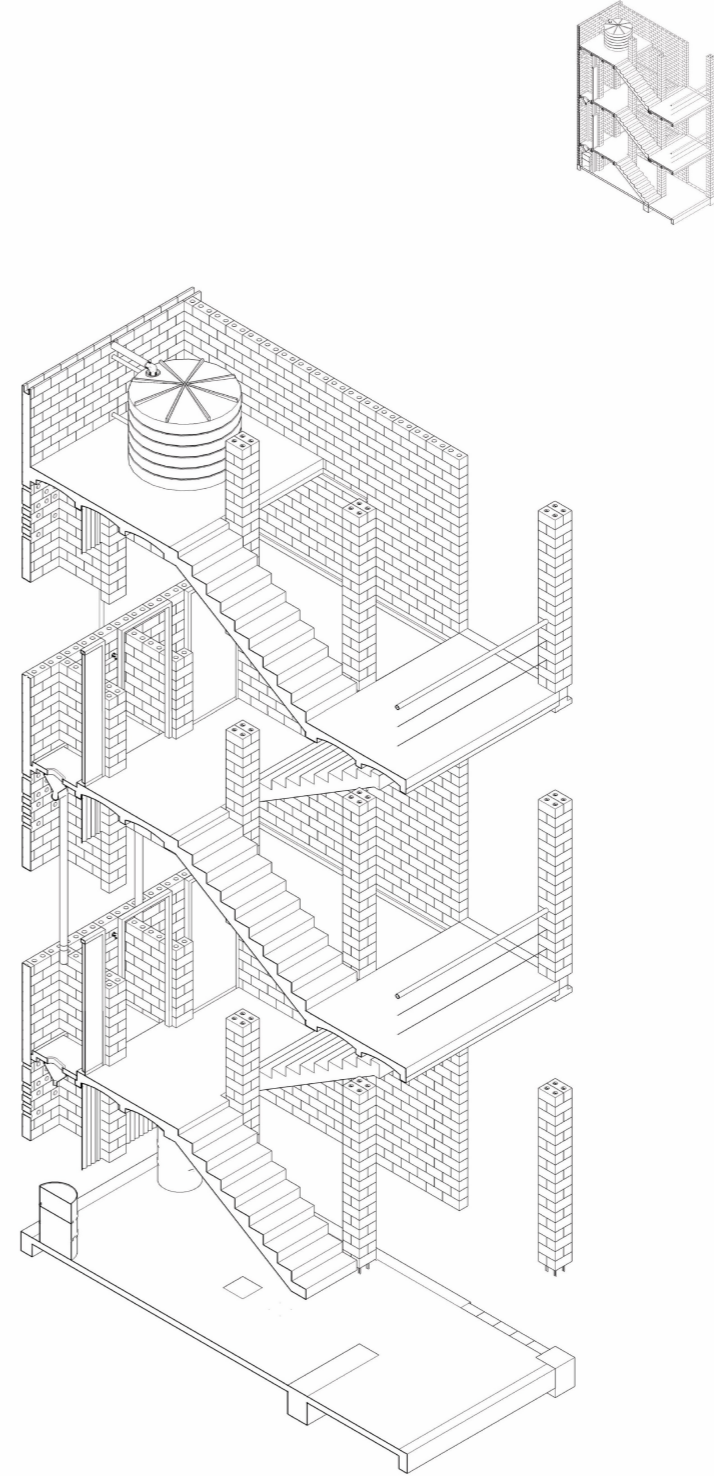
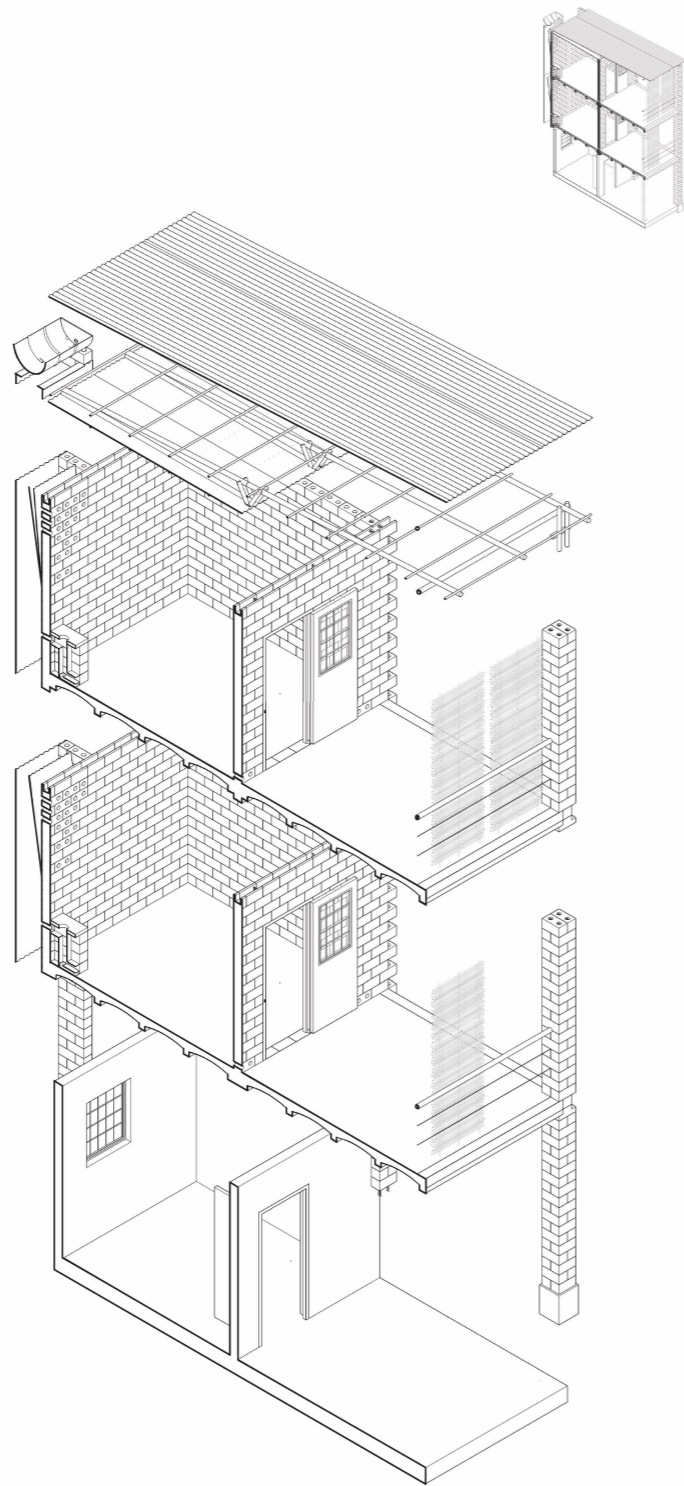

TYPICAL SECTIONS

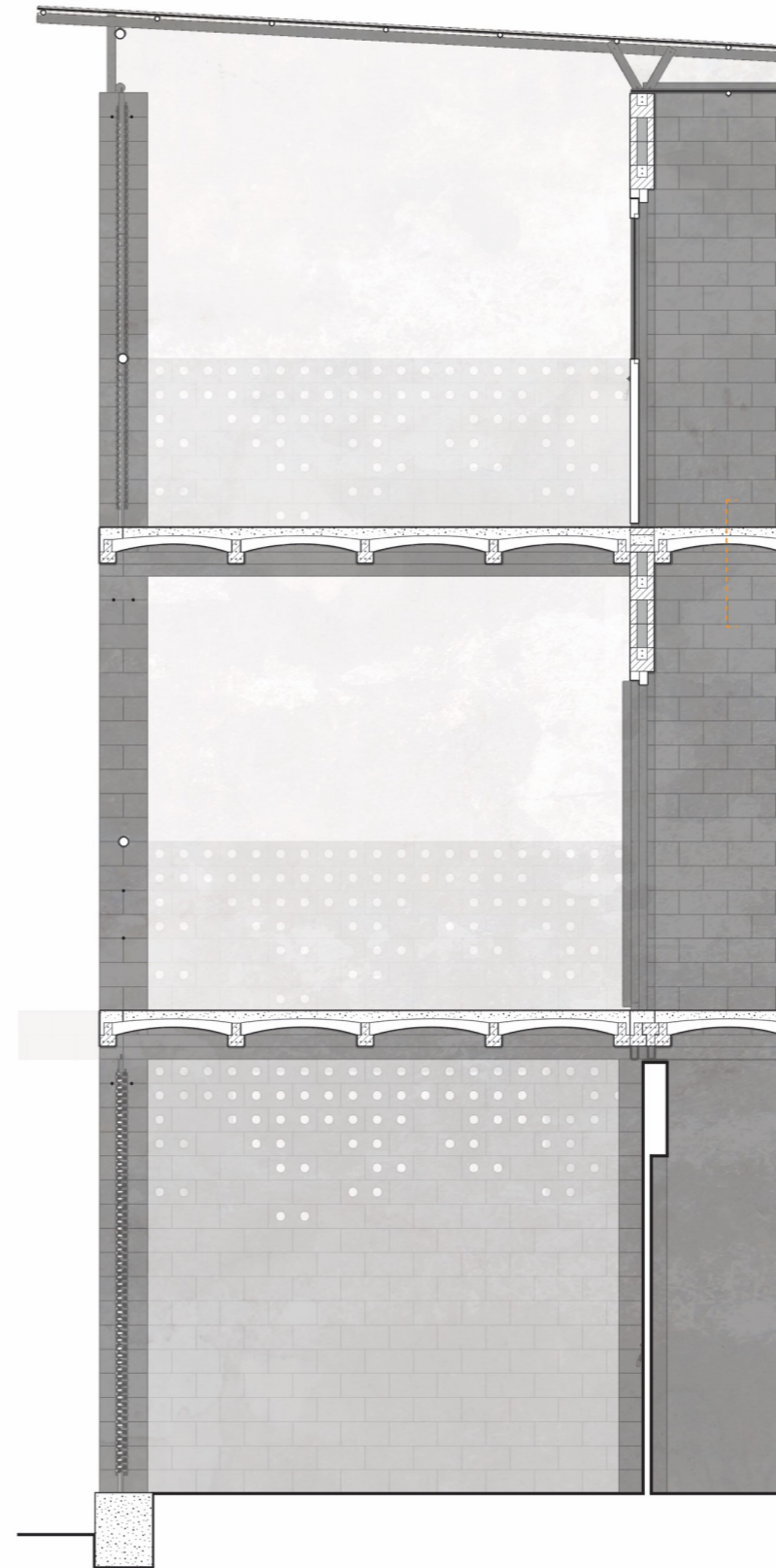

FACADE FRAGMENT



DESIGN FOR INCREMENTAL EXTENSION

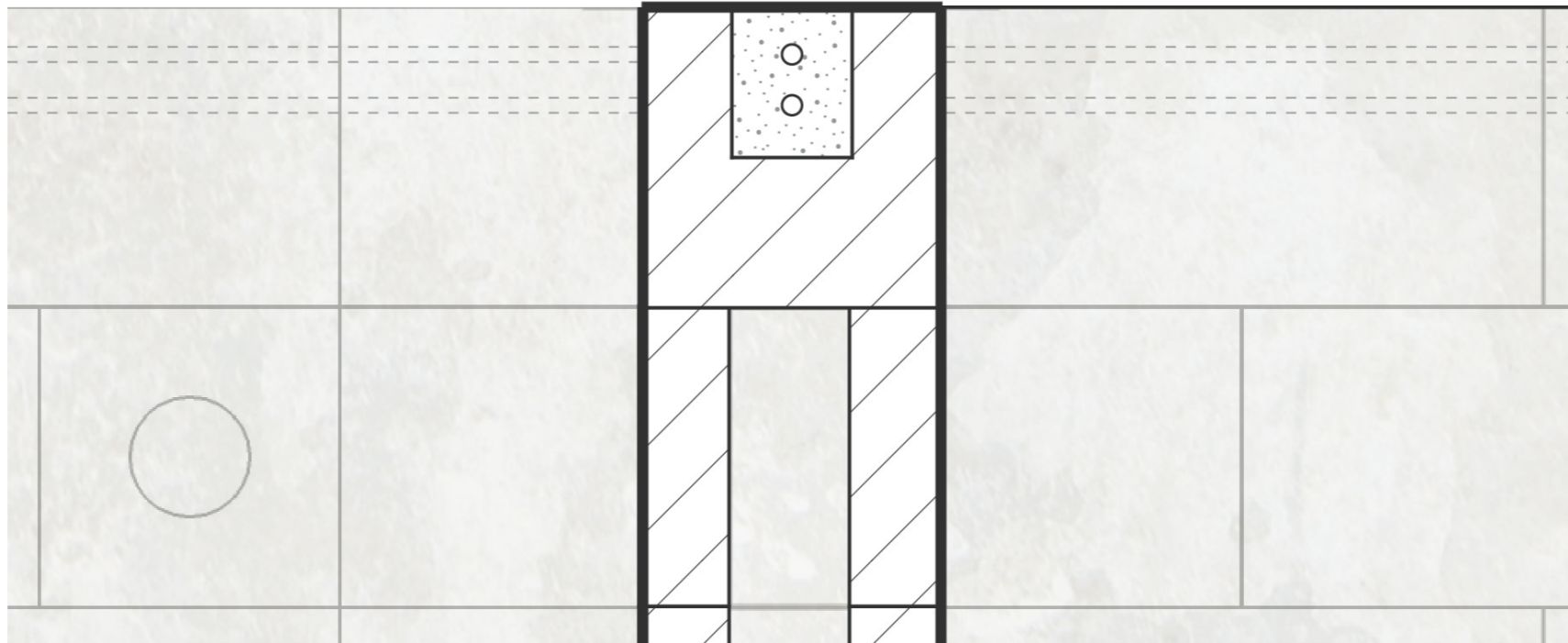

DESIGN FOR INCREMENTAL EXTENSION

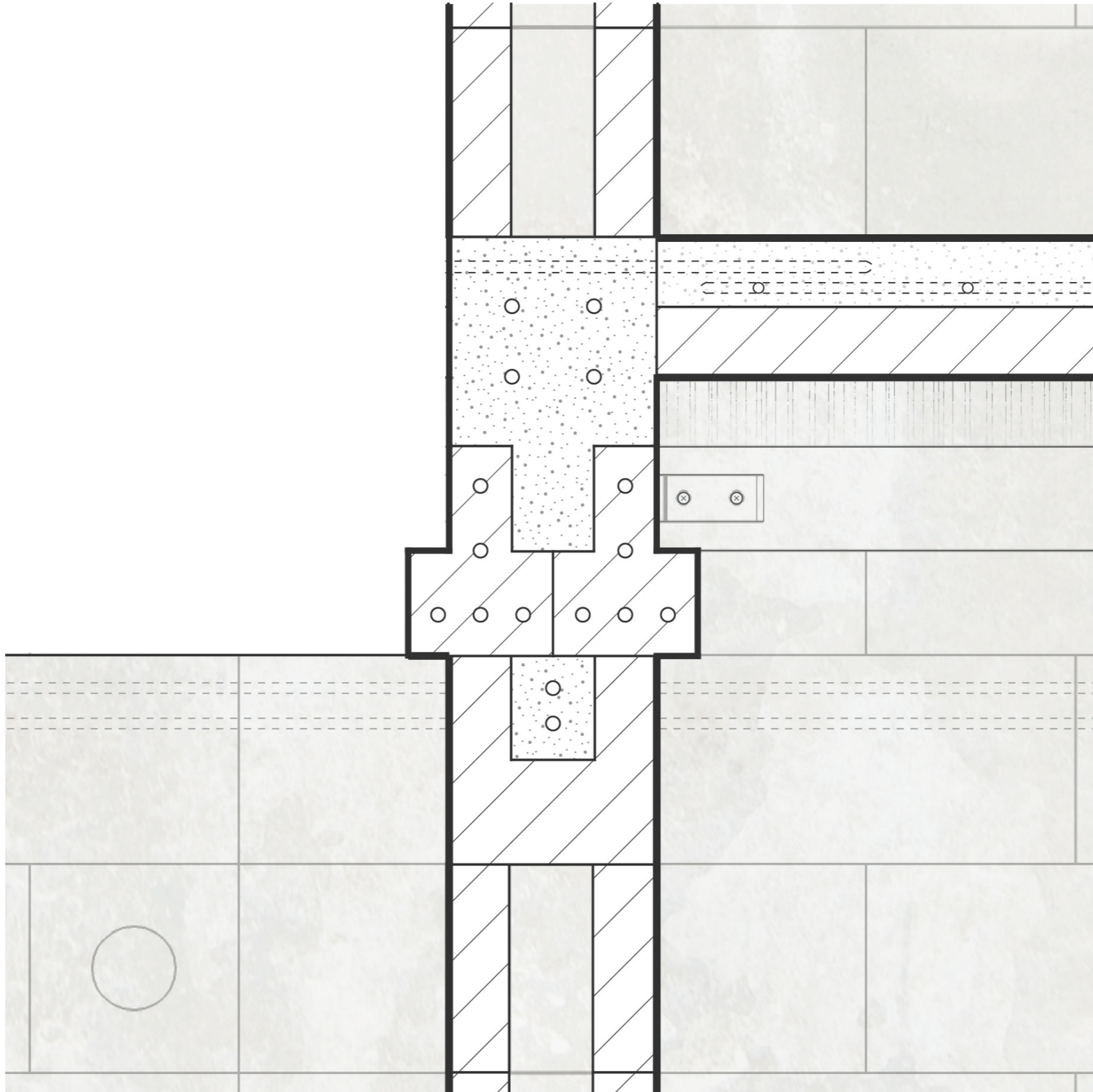

DESIGN FOR INCREMENTAL EXTENSION

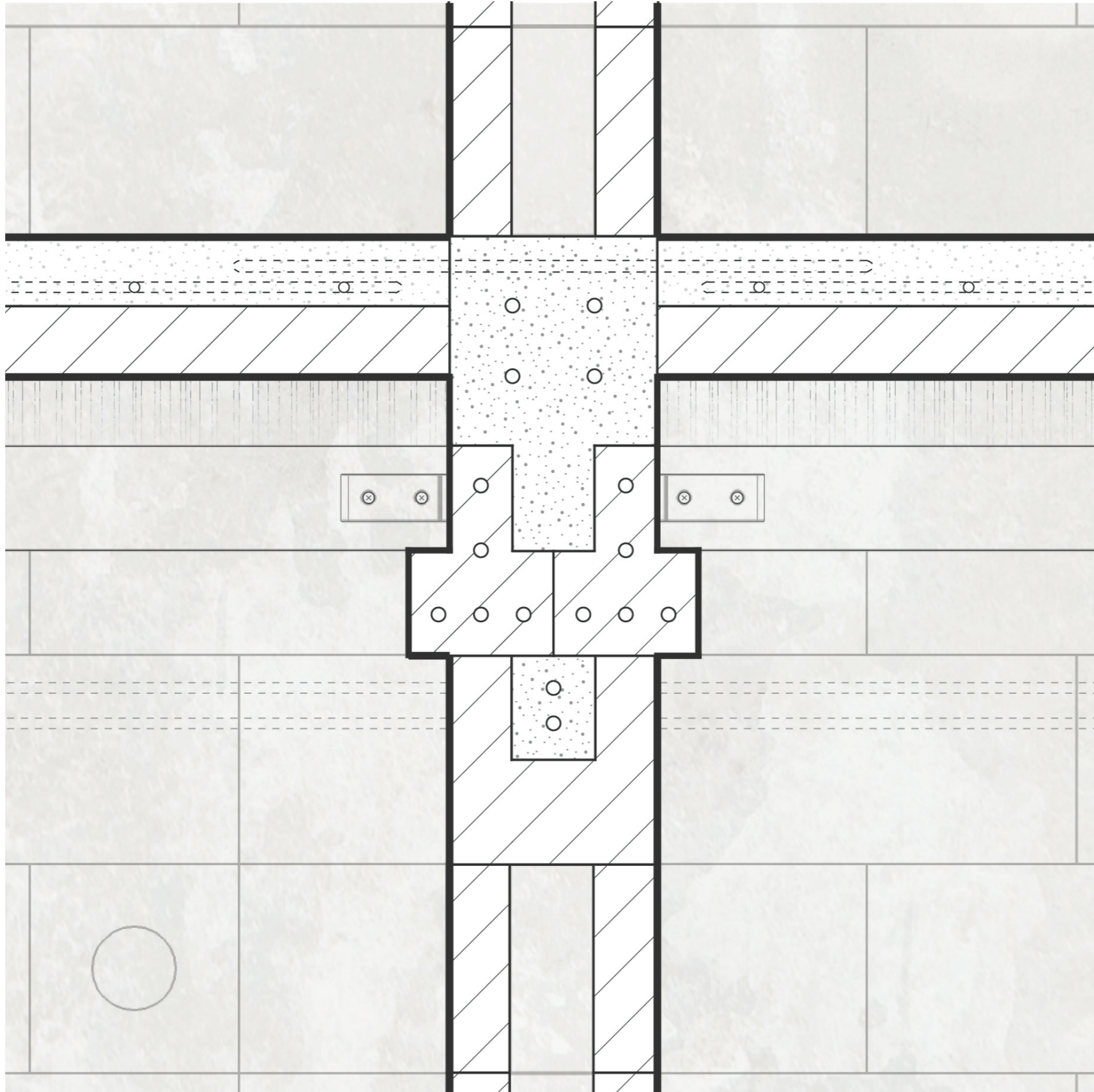

DESIGN FOR INCREMENTAL EXTENSION

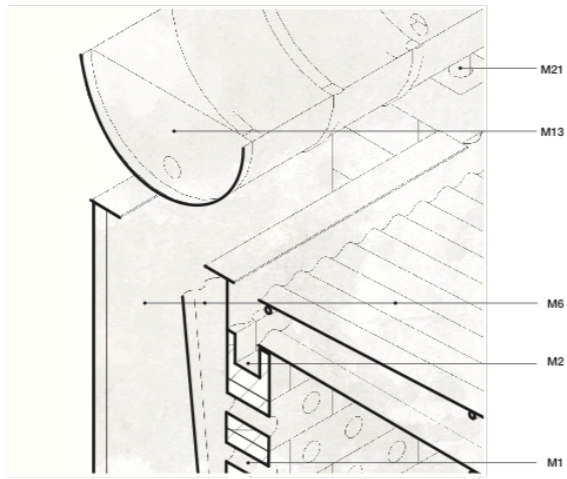

ROOF / CLIMATE CHIMNEY DETAIL

the windflow under the oil drum creates a venturi effect that enhances ventilation

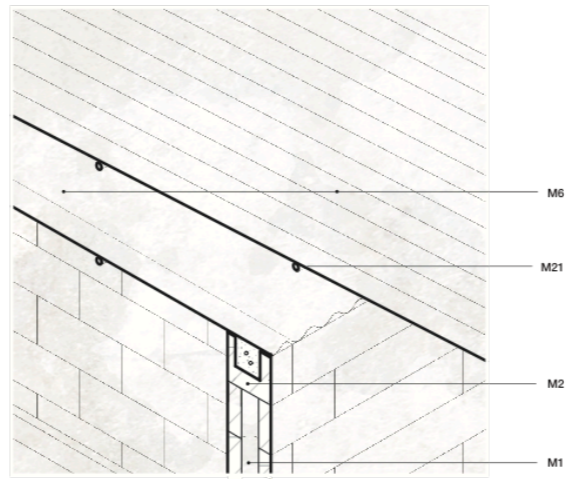

ROOF / PARTITION WALL DETAIL

a ventilated double roof lowers heat gain and provides a possibility for rainwater collection

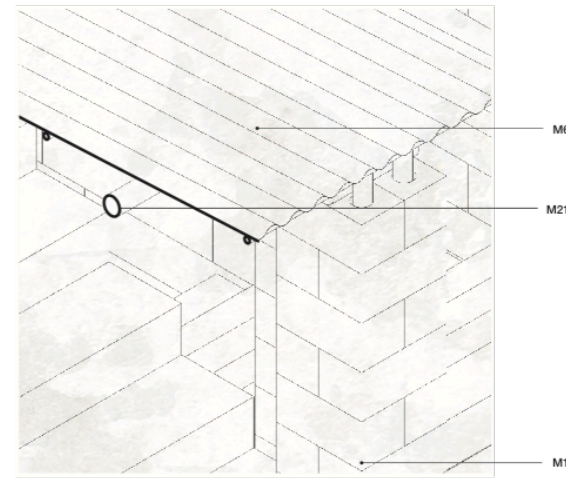

ROOF / COLUMN DETAIL

the double roof is supported by trusses constructed from wood branches and poles

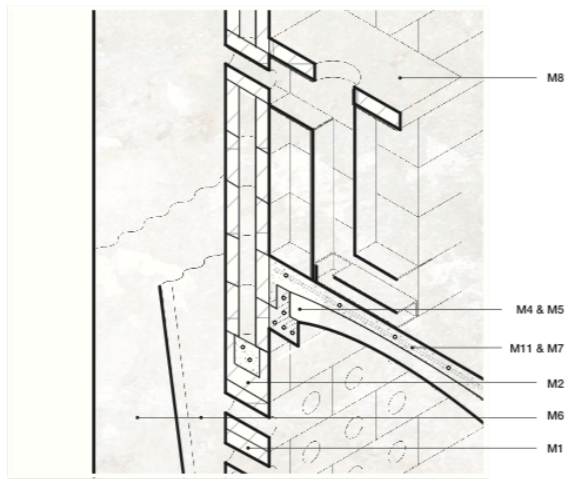

FIRST & SECOND FLOOR / CLIMATE CHIMNEY DETAIL

a shunt prevents polluted air from rocket stoves on lower floors from entering the room

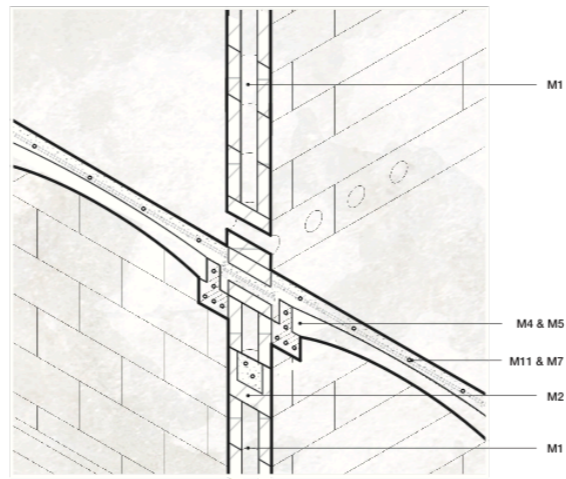

FIRST & SECOND FLOOR / PARTITION WALL DETAIL

a concrete topping connects the beam and block floors trough holes in the partition wall

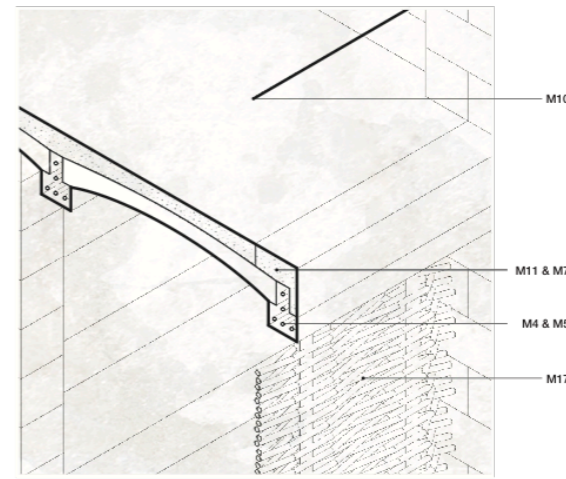

FLOOR EDGE DETAIL

high quality concrete is used to create the edge of the beam and block floor

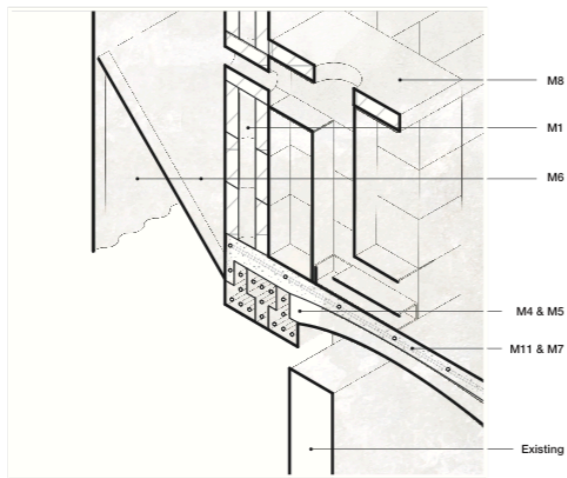

FIRST FLOOR / CLIMATE CHIMNEY DETAIL

this detail applies when the typology is built on top of an existing Swahili house

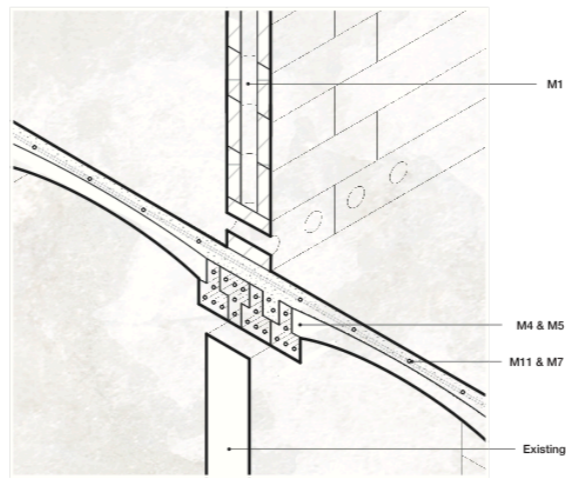

FIRST FLOOR / PARTITION WALL DETAIL

this detail applies when the typology is built on top of an existing Swahili house

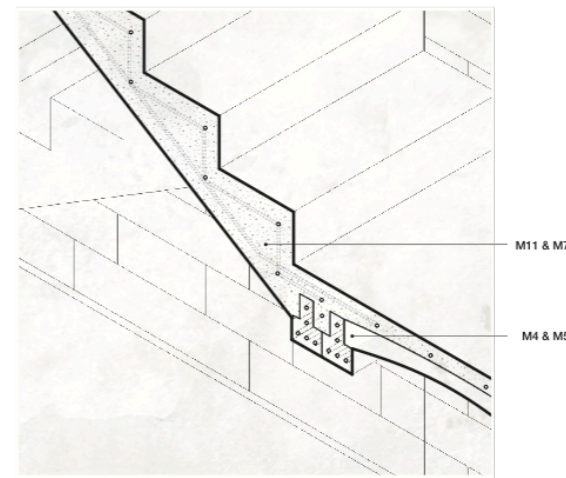

FIRST OR SECOND FLOOR / STAIRCASE DETAIL

where required in the construction, multiple T-beams are used to create strength zones

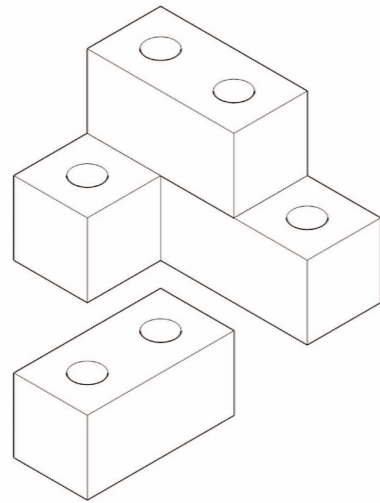

M1 HOLLOW SOIL CEMENT BLOCK

dimensions: 300 x 150 x 150 mm
min. 7 - 10 % cement in soil cement mixture

to test the strength of the soil cement blocks:
3-point bending test and the drop test

NEW
manual production with a standard block press
block press and moulds are sold at the EXPO

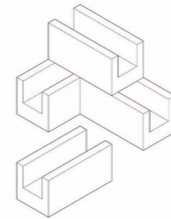
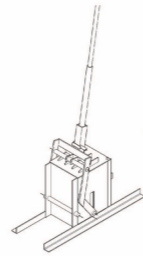

M2 U-SHAPED SOIL CEMENT BLOCK

300 x 150 x 150 mm
min. 7 - 10 % cement

NEW
manual production with soil cement block press

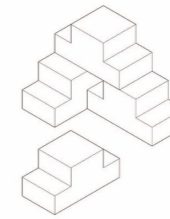

M3 T-SHAPED SOIL CEMENT BLOCK

300 x 150 x 150 mm
min. 7 - 10 % cement

NEW
manual production with soil cement block press



M4 PRECAST T-BEAM

3300 x 100 x 150 mm
steel reinforced

NEW
manual production with wood or steel moulds

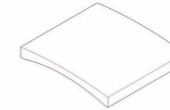

M5 PRECAST LANDI SLAB

750 x 660 x 100 mm
arched concrete slab

NEW
manual production with wood or steel moulds

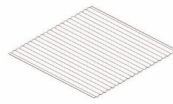

M6 CORRUGATED STEEL SHEET

galvanized corrugated plating
used as cheap and lightweight
roofing material

used in current practice

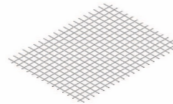

M7 REINFORCEMENT BAR

used as a net in the top layer of
the beam and block floor, or to
reinforce corners, lintels and
ring beams

used in current practice

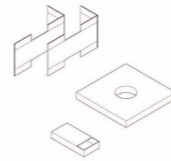

M8 ROCKET STOVE

two steel strips and a concrete
stove top can be combined
with soil cement blocks to form
a highly efficient rocket stove

NEW
drawings / parts sold in EXPO

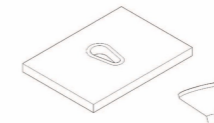

M9 SANITATION SLAB

a special concrete slab that fits
within the beam and block
system, allowing for a toilet
solution

NEW
drawings / parts sold in EXPO

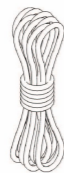
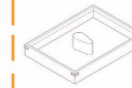

M10 ROPE

a flexible and cheap solution to
form a balustrade and to secure
the wattle panels and roof
trusses

used in current practice



M11 CONCRETE (IN SITU)

made with a different proportion
of cement according to strenght
requirements of the respective
element:

- foundations
- lintels
- ring beams
- top floor layers
- stairs

used in current practice

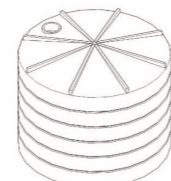

M12 WATER TANK 5000 Gal

for storing collected rainwater
capacity: 5000 Gallons

used in current practice

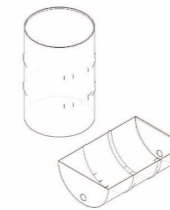

M13 OIL DRUM 55 Gal

used to facilitate a venturi effect
through a compression in the
airflow over the top of the
chimney

NEW
widely available product

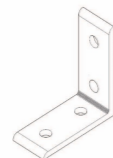

M14 METAL CORNER PROFILE

75 x 40 x 5 mm
used to secure T-beams and
balustrades in place

used in current practice

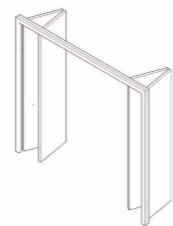

M15 FOLDING DOORS

shop doors that can fold away
to fully open the street facade
usually made from wood or
steel

used in current practice



M16 DOOR

wooden door with integrated
window: the window is made
from musquito gaze and
reinforcement bar, like in
current building practice

NEW
combination of products



M17 WATTLE PANEL

used to facilitate a private and
shaded environment on the
open deck space

customary building practice



[ANIMATION]



MAFUNDI EXPO

Frank Reitsma - Explorelab - TU Delft - fereitsma@me.com

THANK YOU



MAFUNDI EXPO

Frank Reitsma - Explorelab - TU Delft - fereitsma@me.com