

Self-driven MRDH

A Method to Assess the Impact of Automated Vehicles on Urban Liveability in the Rotterdam The Hague Metropolitan Region

Vincent Babes

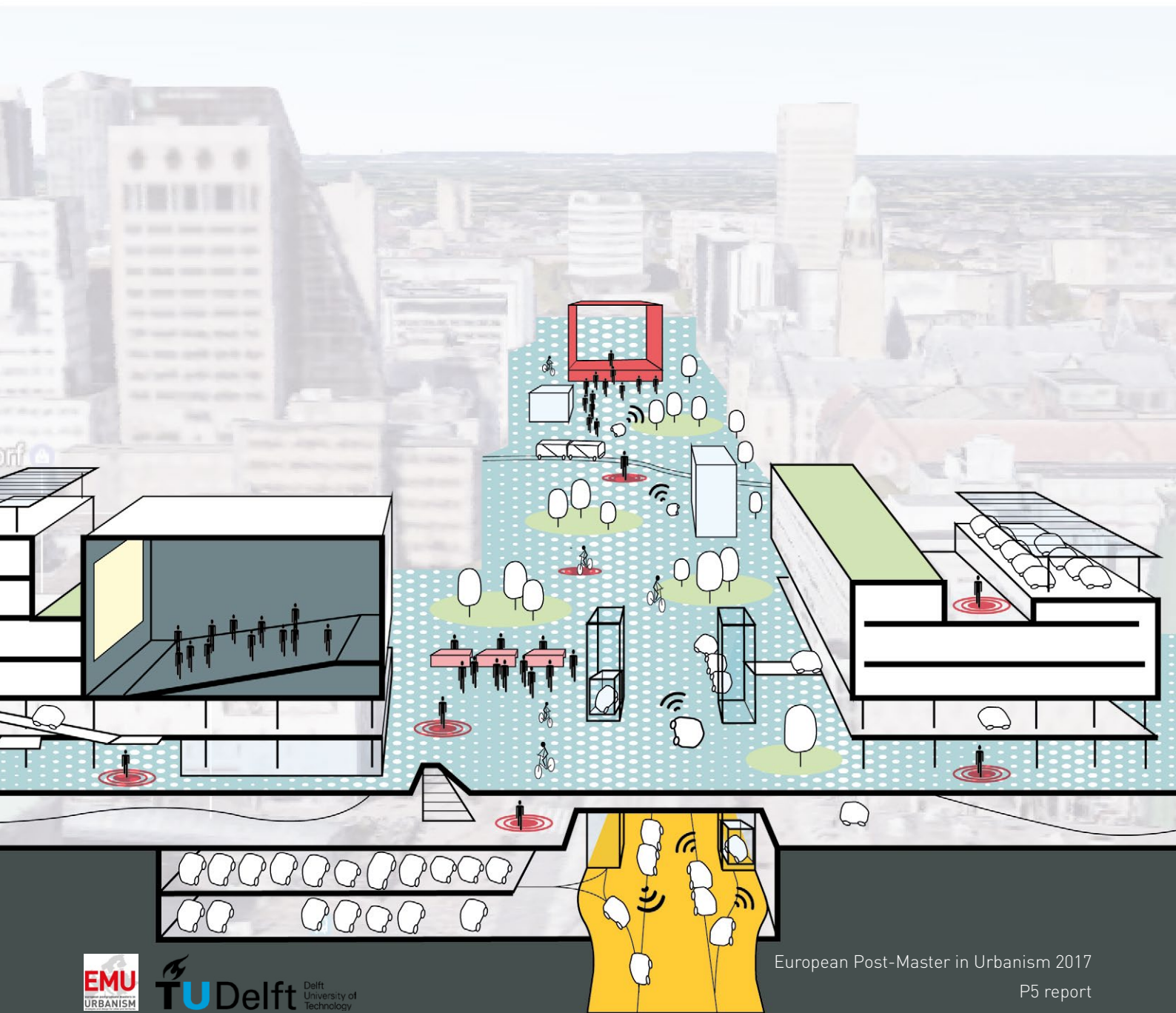

Self-driven MRDH

A Method to Assess the Impact of Automated Vehicles on Urban Liveability
in the Rotterdam The Hague Metropolitan Region

I dedicate this work to my parents for their wholehearted support of my EMU studies. Mulțumesc!

I would like to thank my mentors, Alexander Wandl, Luisa Calabrese and Paola Pellegrini, for their precious guidance, inspiration and encouragement throughout this graduation project. I would also like to thank all other teachers and colleagues who have offered their insight and advice. Special thanks to Birgit Hausleitner for the excellent organisation of the semester and the constant help provided.

Colophon

Self-driven MRDH. A Method to Assess the Impact of Automated Vehicles on Urban Liveability in the Rotterdam The Hague Metropolitan Region

European Post-Master in Urbanism (EMU)
Faculty of Architecture and the Built Environment
Delft University of Technology, The Netherlands

Frontiers graduation semester
June 2017
P5 report

Mentors
Dipl.ing. Alexander Wandl, TU Delft
Dr.ir. Luisa Maria Calabrese, TU Delft
Dr. Paola Pellegrini, Università Iuav di Venezia

Student
Aurel Vincent Babeş
4512804



Content

| | |
|---|-----|
| Summary | 9 |
| I. Research outline | 11 |
| I.1. Problem statement | |
| The impact of transport technology on the built environment | 12 |
| Automated vehicles in the context of mobility trends | 14 |
| Societal and scientific relevance | 16 |
| Forerunners not followers | 20 |
| I.2. Aims | |
| Definitions of liveability | 22 |
| Liveability criteria in the project | 24 |
| I.3. Research questions | 30 |
| II. Theoretical and analytical framework | 31 |
| II.1. Building a method: foresight and through-sight | |
| Scenario construction in urbanism | 32 |
| Transect analysis | 34 |
| Visionary urban sections | 36 |
| Conclusions: building a method | 38 |
| II.2. Literature review on automated vehicles | |
| General aspects of AV | 40 |
| AV in urbanism | 44 |
| Conclusions: spatial impacts of AV | 46 |
| II.3. Territorial analysis | |
| MRDH, a dynamic region | 52 |
| Mapping the mobility landscapes | 58 |
| Mapping the drivers: density and flows | 72 |
| Transect analysis and liveability indicators | 76 |
| Case study locations | 84 |
| III. Scenarios | 93 |
| III.1. Scenario construction: AV and MRDH in 2040 | |
| Hypotheses and drivers | 94 |
| Learning from the visionaries | 96 |
| Scenario 1: Clockwork Utopia | 98 |
| Scenario 2: Shared Patchwork | 100 |
| Scenario 3: Efficient Garden Region | 102 |
| Scenario 4: Infinite Randstad | 104 |

| | |
|---|-----|
| III.2. Scenario development: Clockwork Utopia and Infinite Randstad | |
| Mobility and lifestyle hypotheses | 106 |
| Drivers: organisation principles | 107 |
| Drivers: regional structure | 108 |
| Case study 1: City centre - Coolsingel, Rotterdam | 112 |
| Case study 2: Residential neighbourhood - Goeverneurlaan, The Hague | 120 |
| Case study 3: Urban edge - A13/Kruithuisweg, Delft | 128 |
| IV. Evaluation and reflection | 137 |
| IV.1. Scenario evaluation | |
| Mobility performance and impact | 138 |
| Natural and built environment | 139 |
| Society and economy | 140 |
| IV.2. Reflection | |
| Research, design and policy tasks foreseeing AV | 141 |
| Reflection on the methods | 142 |
| Forerunners not followers | 143 |
| References | 144 |

Summary

This project aims to build a spatial method to assess the impact of automated vehicles (AV) on liveability in the urban environment and to enable the urbanist to participate in the development of this technology as a forerunner. To reach this aim, it proposes to build a specific method, by combining scenario construction and transect analysis, and to test this method in the Rotterdam The Hague Metropolitan Region (MRDH).

Mobility revolutions in the past, such as the railways or the automobile, have not limited their effects solely on transport. They unravelled new lifestyles, new cityscapes and new patterns of using the territory. Automated vehicle technology, or driverless car in popular terms, has the potential to repeat a large-scale disruption on mobility. It is presumed to change the way people spend their time during traveling, their choice of location for living, working and other activities, the urban infrastructure and the whole structure of mobility patterns. However, current research on AV is focused on its technical and legal aspects, while the possible spatial effects are overlooked. Urbanism as a profession must understand the opportunities and risks entailed in AV. It must take an active role in the interdisciplinary discussion with engineers, policy makers and others on the development of this novel technology. In order to do so, it must have a goal and a method.

The main goal identified with the urban environment and mobility is liveability. The important point when designing with AV is to have an idea of what is a desirable environment for society. This approach is inspired by the great visionary planners of the 19th and 20th

centuries, but must not repeat their mistakes. It is neither a quest for a utopian society, nor is it about imposing automation as a solution to all problems. The desirable can be defined as a city region where the mobility system performs its main task – getting people and goods to their destinations – while offering a variety of choices, encouraging active mobility, ensuring accessibility for everyone and reducing air and noise pollution. Within the project, liveability is not solely defined by quantitative measures specific to ‘the most liveable city’ charts, but takes into consideration spatial qualitative aspects derived from urban design literature, too. These include the street section, walkability, accessibility, spatial variety, encounter opportunity and contact with the natural environment. All these terms can be strongly influenced by the future adoption of AV, into the better or the worse. The project aims to position the urbanist as a forerunner of technology, stressing the importance of liveability as a factor to be accounted in the development of automation.

How can urban planning and design tools lead to reaching liveability in different spatial scenarios of AV technology adoption? In building a method to work with AV, the project resorts to two specific instruments of urbanism: foresight and through-sight. Foresight is based on scenario construction, especially in the Dutch planning tradition. Through-sight builds on the urban sections drawn by visionaries such as Cerdà or Haussmann, and at a wider scale on the analysis method of territorial transect. By combining these two instruments in the framework of research-by-design, the networks (mobility) and the fields (built density, program, population etc.) of

the territory can be investigated in different possible futures of AV adoption.

The territory of the MRDH, because of its polycentric and heterogeneous spatial structure, its complex mobility patterns, but also its congestion and pollution issues, is an optimal testing ground for the proposed hypotheses.

The method was designed in the following way: first, two main driving forces of spatial change were extracted from the available literature on AV, density and separation of flows. Secondly, the territory of the MRDH was analysed through the prism of these drivers using the transect method. The transect was applied to the most intense metropolitan axis between the two urban cores Rotterdam and The Hague. On this axis, data regarding urban subzones, network accessibility and liveability data were superimposed to understand the connections between urban fabric, mobility and liveability on which the scenarios would be built. Further, three critical points in different settings were chosen for case studies: an urban centre, a residential area and an urban edge with motorway links.

The third and main step of the method is the scenario construction. Using the driving forces of density and separation of flows, and based on hypotheses available in literature regarding AV and the evolution of the region, four extreme scenarios were described: Clockwork Utopia, characterised by concentrated urbanity and AV separated from other flows; Shared Patchwork, characterised by concentrated urbanity and AV leading to merger of flows; Efficient Garden Region, characterised by dispersed urbanisation and separated flows; and Infinite Randstad, characterised by dispersed urbanisation and merged traffic flows. The scenarios were inspired by various theoretical models, visionary and realised projects. In the second stage of scenario construction, Clockwork Utopia (S1) and Infinite Randstad (S4) were selected for further development. For both scenarios, regional models of networks and urban fields were modelled, and the three

case study locations were analysed using the urban section. For each of the case studies a package of briefs, for urbanism, architecture and society, were proposed based on the liveability analysis, and the specific context of the scenario. The solutions in the section have a research-by-design character, used to test the resistances of the space and the technology, and to propose further directions of research.

Finally, the scenarios were evaluated using the liveability criteria at regional and local scales: mobility performance, natural and built environment, and society and economy. Among the main conclusions are that both scenarios include elements that can improve mobility at regional level, through efficiency and flexibility, respectively. Regarding the physical aspect of infrastructure, S1 performs better in the city centre and in high-speed environments, whereas S4 is superior in neighbourhoods or defined clusters. In terms of environment, S4 provides the better choice of living and working environments, including contact to nature, but imposes strong pressure on nature and the water system of the region. For society and economy, S1 is more capable of creating critical mass and concentration for activities that necessitate clustering, but S4 creates more opportunity for wider society, as well as accessibility to more marginal areas in the region. In short, S1 could be described as an extreme evolution of current trends, where AV has a propelling role, while S4 is a radical change effected by AV, creating new urban occupation patterns and lifestyles.

More than the resulting scenarios, this thesis offers a method for urbanists and architects to approach a new technology such as driving automation, and to be able to participate in the interdisciplinary discussion on the subject having in mind the ultimate goal of urban liveability.

I. Research outline

I.1. Problem statement

The impact of transport technology on the built environment

Mobility connects all the elements of human life: living, working, education, services, leisure and others, and occupies a considerable amount of time in itself. Mobility also corresponds to a large proportion of space in the city and territory. Specific modes of transport necessitate ever more dedicated rights of way, but also spaces to remain idle between uses, or to be maintained. Their technical characteristics are often dictating the form of the urban space, such as curve radii, street widths or the relation between buildings and streets. Mobility also impacts the environment and human health, through air and noise pollution, or through the choice of passive (auto vehicle) or active (cycling and walking) mobility. All these aspects impact liveability in the urban environment.

During the 19th century, railways and industrialisation led urban expansion beyond the old city limits, and in the second half of the 20th century the advent of the personal car transformed the previous city - agricultural land duality into a continuous city-territory, leaving only a relative concentration in the old urban cores. Increased speed and individual autonomy meant people could live and work in more distant locations, and a dense network of motorways to serve this purpose was developed and continues to be extended in the early 21st century. This process led to both very high concentrations of activities and dense infrastructures intertwined on multiple levels, as well as to extensive dispersion of the urban fabric.

Transport technologies also necessitated specific infrastructures which formed new typologies of urban environment: viaducts, train stations, flyovers, motorway

interchanges and parking lots. When existing urban areas were upgraded or new development was devised, the technological needs of mobility were primary in design decisions. Street profiles, railway tracks, areas reserved for higher speed roads and multi-level intersections became fixed objects around which the city was accommodated. In most cases, the inherent inertia of the city meant that these structures are maintained despite their negative impacts on their immediate surroundings and on the larger functionality of the city. There are very few exceptions, such as the removal of the railway viaduct in Delft by moving the railway tracks into a tunnel in 2015.

In recent years a new major change to mobility is being defined by automation. If innovation in technology enables automated vehicles to become an everyday reality, even by 2040 according to some estimates, what will be their impact on urban development and what typical infrastructures will it necessitate? Will these infrastructures have a positive impact on urban liveability or will technological necessity be the primary driver in their development? These are questions the urbanism profession must face in the coming years. By accepting the uncertainties of future technological development, this research project aims to lay down the path towards the possible answers.

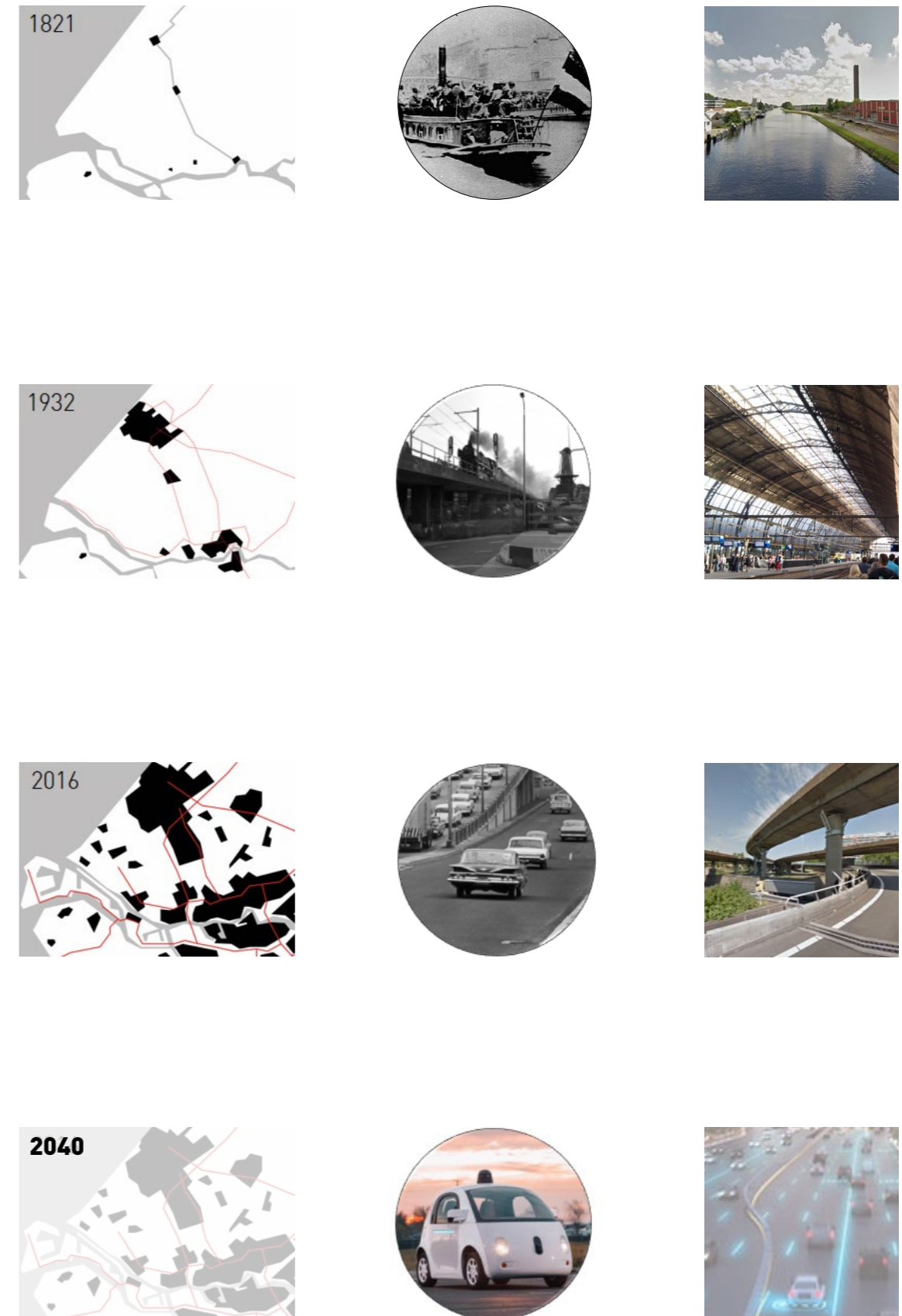

Figure 1. Inland waterway, rail and road transport influenced urban form and their infrastructures created specific urban environments. What will be the urban form and infrastructural environment of automated vehicles?

Image sources: www.tijdreis.nl, Google Street View, www.pinterest.com.

Automated vehicles in the context of mobility trends

While the context of smart mobility contains a number of innovative concepts such as car-sharing, integrated digital platforms, on-demand mobility, mobility as a service, or electric bicycles, the AV is projected to have a major impact on the physical urban space, and is estimated to become widely adopted in between 5 to 10 years from 2015 (Gartner, van Arem et al). The potentials of AV would be in the fields of lower emissions, road safety, better territorial and social coverage of mobility, and integration with other modes.

Automation is currently seen as part of the wider spectrum of ‘smart mobility’ (Jeekel, Corwin et al), however it is expected to take the leading technological driver position. Any study or research regarding automation in vehicles must consider the connected trends of the present, and incorporate them in methods such as scenario construction.

| Domains of smart mobility/ Societal Challenges on mobility | Urban mobility | IT in mobility | Globalization and freight | Energy and climate | Next generations |
|--|--------------------------------|---|---------------------------|--------------------|--|
| Vehicle Technology | Smart cycling | Automated driving | Power trains | Fuel technology | |
| | | Electric vehicles | Last-mile systems | | |
| | | Solar cars | | | |
| Intelligent Transport Systems | | Connected and cooperative driving | Truck Platooning | | |
| Data | Relationship with smart cities | Big data possibilities | IT matching supply-demand | | Real-time travel information |
| New Mobility Services | Integrated mobility services | Intelligent apps matching supply-demand | Urban logistics | Logistic services | Sharing economy concepts (car sharing, ride sharing) |

Figure 2. Smart mobility types classification. From Jeekel, JF (2016). Smart mobility and societal challenges: an implementation perspective, Technische Universiteit Eindhoven.

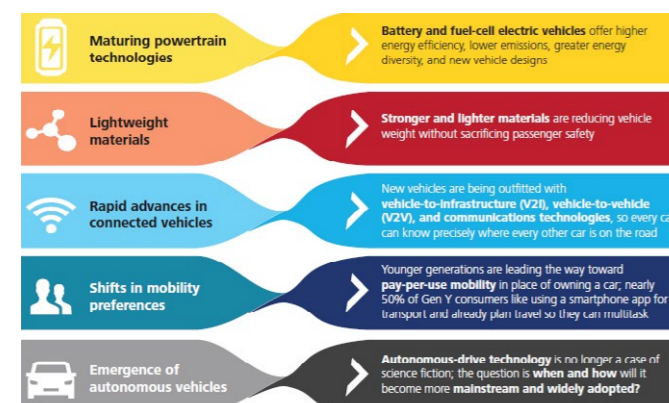

Figure 3. Trends in mobility. From Corwin, S, Vitale, J, Kelly, E & Cathles, E (2015). The future of mobility. How transportation technology and social trends are creating a new business ecosystem, Deloitte University Press.

SHARING PLATFORMS

INNOVATIVE PUBLIC TRANSPORT

SYNERGIES

CLEAN ENERGY

E-BIKES & CYCLING HIGHWAYS

Figure 4. Mobility trends. Image sources: www.uber.com, www.solaroad.nl, www.cbs.nl, www.verkeersnet.nl, www.bridj.com, www.archdaily.com, www.electricbike.com.

Societal and scientific relevance

Automated vehicles are a rapidly developing technology, with an expected entry into everyday service expected between 2020 and 2025 (Gartner, Milakis et al). There is a general enthusiasm of opinion regarding a possible driverless future of mobility, but also reversals and setbacks. These entail the initial reticence of larger automotive companies to pursue the novel technology, reticence of drivers to hand their safety and control to a machine, as well as a number of incidents, some of them fatal, during the testing of AV models. However, successful market introduction of limited driving automation features such as lane keeping, obstacle sensing, assisted and automated parking (Milakis et al), have demonstrated the positive features of automation and helped to form trust in the technology.

The main promised advantages of AV technology include: increased traffic safety, less pollution, increased traffic capacity, more efficient energy use, car sharing, less parking space occupied, better territorial and social coverage, increase work and leisure time of the driver. There are also doubts expressed about these impacts, for example the reduction in pollution per car might be cancelled by the increase in induced travel demand or faster driving, or the presence of re-positioning empty cars on the road (Milakis et al); others question the cost-related barriers to universal accessibility of the technology (Pulyaert). Numerous negative impacts are also envisioned by existing research: urban sprawl, more sedentary lives, increase in travel demand, energy consumption and pollution, unclear insurance and legal responsibilities, negative impact on public transport, and the loss of numerous mobility jobs.

The societal relevance of research in the field of AV and its effects on the city are to avoid foreseeable negative effects, and to aid an environmentally, socially and economically sustainable introduction of the technology,

but also to ensure that safety and efficiency measures are balanced and integrated with the quality of public space.

Whereas the technological, economic or legal aspects of AV are intensely studied by developers and public authorities, the spatial effects of AV represent a research gap. The premise of this lack of interest is probably based in the assumption and aspiration that AV will use the existing road network and imitate human behaviour as much as possible. In spatial terms, the increased safety of AV compared to human drivers is opposed to the possible need for a separate right of way if predicting human (pedestrian and cyclist) behaviour proves impossible to be safely incorporated in the technology. Because of these reasons, implementation of AV is currently limited to separated rights of way and highly controlled, isolated areas - airports, ports, business parks, railways, and motorways in the near future. The true interest lays in the impact of AV would have on the 'open' street network, where space is shared with other modes, and in large scale ownership/use by individuals. It is an urban planning and design specific task to explore the possibilities of AV and to seek synergies with energy shift, environmental benefits, social processes and ultimately urban liveability.

Current urban studies in AV focus mostly on the urban design, but have limited insight into other changes or a meaningful re-thinking of the way urban space is used. The scientific relevance is first the insight on an unexplored territory: how would AV affect the urban environment. The research can also build guidelines and principles of design for use to their parties such as designers and municipalities, learn from historical failures of similar technological disruptions.

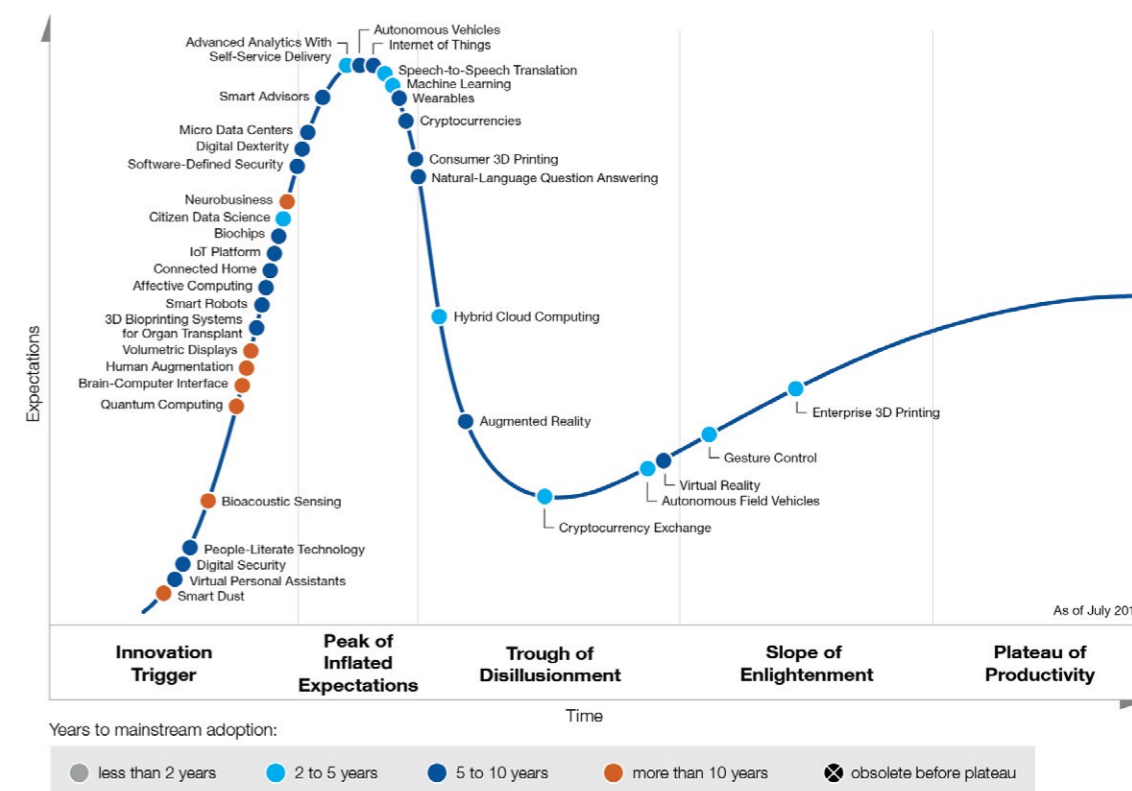

Figure 5. Emerging technology hype cycle 2015 by Gartner. Automated vehicles are prognosed to enter markets in 5 to 10 years. www.gartner.com



Figure 6. WEpods running between Ede and Wageningen, www.wepods.nl



Figure 7. Rotterdam port truck platooning, www.theguardian.com



Figure 8. Autonomous bus on line 500 in Capelle, Rotterdam, www.digitaltrends.com

Home Latest Topics Ministries Government Documents

Home > All topics > Mobility, public transport and road safety > Contents > Truck Platooning

Mobility, public transport and road safety

Overview Contents News Question and answer Documents

The Netherlands is the ideal testing ground

The Netherlands is an ideal location for testing self-driving vehicles and customised route information. The Netherlands has the following benefits as a proving ground:

- Our legislation already provides scope for testing self-driving vehicles on public roads. And vehicle manufacturers are pleased to have such opportunities;
- Various testing facilities are also available, such as the Road Transport Agency (RDW) test track, an innovation centre and cameras for monitoring driving behaviour;
- The Netherlands has a dense, well-maintained and interconnected road network;
- Knowledge institutions and companies have a lot of expertise in the area of transport technology;
- Dutch people accept self-driving vehicles better than people in other EU countries.
- The government supports all innovative developments in the area of transport and wants to be at the forefront of this internationally. Partnerships in this field between public authorities, companies and knowledge institutions have already proven successful. The [Optimising Use programme](#) contains many examples of measures that were the result of parties working together to find innovative solutions;

Figure 9. "The Netherlands as ideal testing ground" for AV, public policy initiative. From www.government.nl

EU 2016

The Netherlands EU Presidency 2016

Home Latest Events EU Presidency Media Documents NL FR DE

Home > Latest > News

Latest

Overview News Press releases

EU ministers to try out self-driving cars in Amsterdam

News item | 14-04-2016 | 14:36

The idea of self-driving cars might sound futuristic to some, but European transport ministers will put their faith in this technology.

Figure 10. The EU Amsterdam declaration on legislation enabling autonomous vehicles. From www.government.nl

Why is this important in the Netherlands and in the Rotterdam-The Hague Metropolitan Region (MRDH)? While the country is one of the most advanced in terms of environmental-friendly mobility such as cycling and public transport, still 73% of distances travelled by people nationally are by car (CBS). This causes severe congestion, especially in the MRDH, and leads to major emissions of NOx, PM10 and CO2 (CBS) which are damaging to the environment and public health.

AV technology can embrace the Netherlands' openness to innovation in technology and society, and profit from public authority's support for automation at regulative and governance level. Concomitantly, it can answer to locally specific problems such as congestion, pollution, traffic safety and environmental pressures of mobility and urbanisation.

The Netherlands are also particularly interested as a country in leading the innovation in the field of AV, and are promoting legislation change to enable AV across the European Union. There are also a number of pilot projects, such as by Rotterdam public transport company RTM, truck platooning exercises on motorways, a fully implemented driverless unloading truck system in the Port of Rotterdam, and a driverless bus line called WePods between Wageningen and Ede.

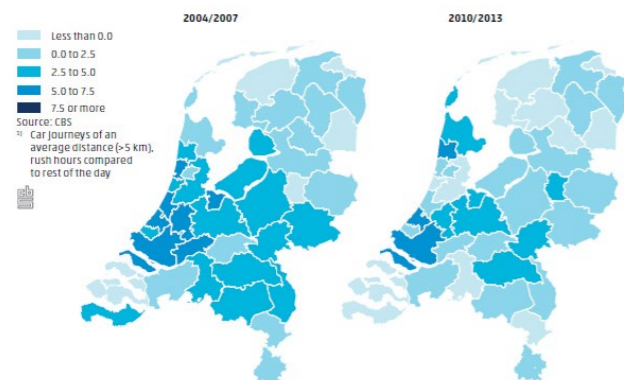

Figure 11. Evolution of lost travel time in the evening rush hour; Transport and mobility 2015.



Figure 12. Article about congestion on Dutch motorway, from www.dutchnews.nl

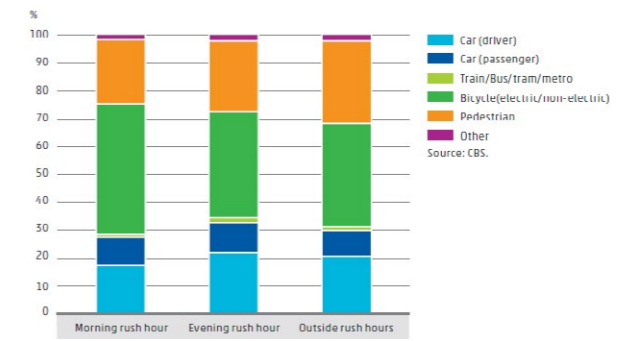

Figure 13. Journeys under 5km travelled by modal split in the Netherlands, idem.

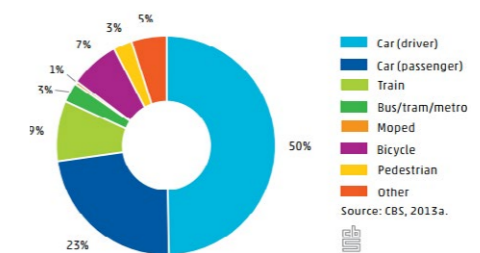

Figure 14. Passenger distance travelled by modal split in the Netherlands, idem.

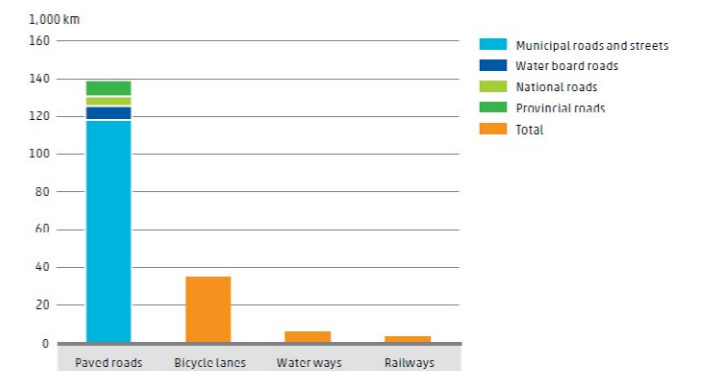

Figure 15. Area occupied by road infrastructure types in the Netherlands, idem.

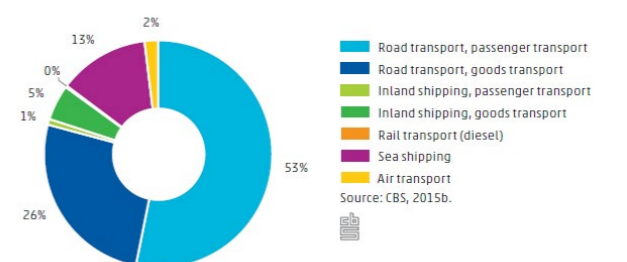

Figure 16. CO₂ emissions by transport mode in 2013 in the Netherlands, idem.

Forerunners not followers

Urbanism as a profession was born out of the necessity during the 19th century to accommodate cities to novel technologies of mobility and to improve living conditions of inhabitants in rapidly industrialising areas (Benevolo, 1963). The adoption of the automobile led to major changes in infrastructure, and emboldened and inspired members of the Modernist movement to re-think the city and imagine utopian urban models, which inspired the development of cities for the rest of the 20th century. The effects are universally known: spatial barriers, pollution, congestion. While these models received a strong and mostly well fundamented critique, the urbanism profession was gradually side-lined and replaced by others such as traffic engineers in the area of infrastructure planning. In many cases, the city was being remodelled for the technology. What if technology could be modelled around the city, with urbanists bringing an integrated approach that embodies environmental, social and economic sustainability? A unique opportunity in this direction is the possible future adoption of AV technology.

Technological determinism as a philosophical current from the late 19th century claims that technical development runs ahead of social developments. This theory may be partially true, but the urbanists of the time embraced the new technology and went further: they used them as a tool to pursue their own visions of society. They didn't simply follow technology but were forerunners of it, and their plans inspired the way technology subsequently developed and the way it was used in the urban environment. Haussmann, Cerda and other visionaries of the time drew plans and sections depicting not only a street profile to accommodate new types of mobility, but a new city, a new way of life for a new society.

While other professions are studying technical, legal and other aspects of AV, the spatial impact remains uncharted territory. The urbanism profession has the best profile to develop knowledge on this. In order to do so, it needs an *aim* and a *method*.

Where does the urbanist stand?

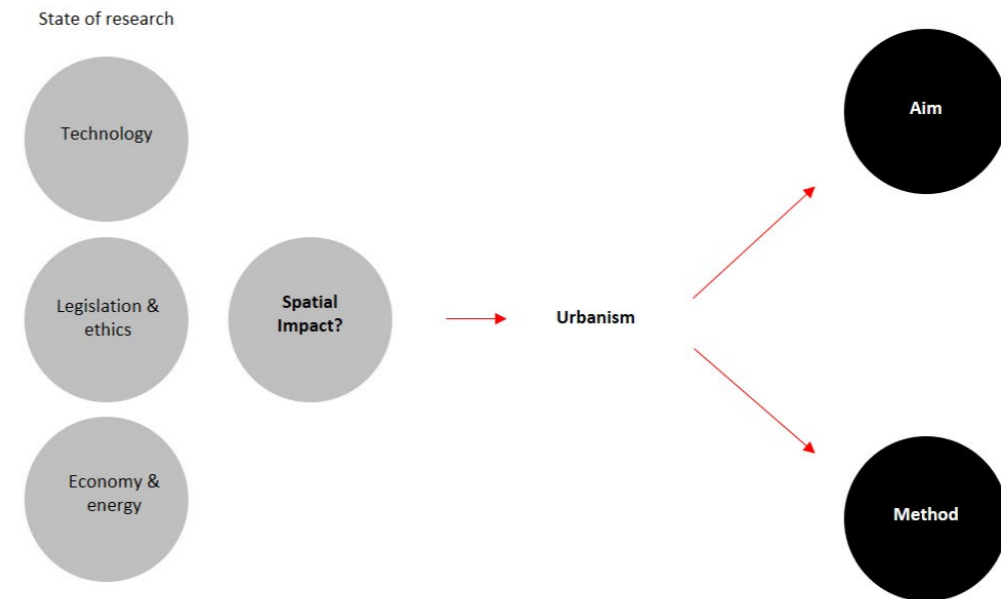

Figure 17. In order to produce a meaningful interdisciplinary contribution to the development of AV, urbanism must have an aim and a method specific to the profession.

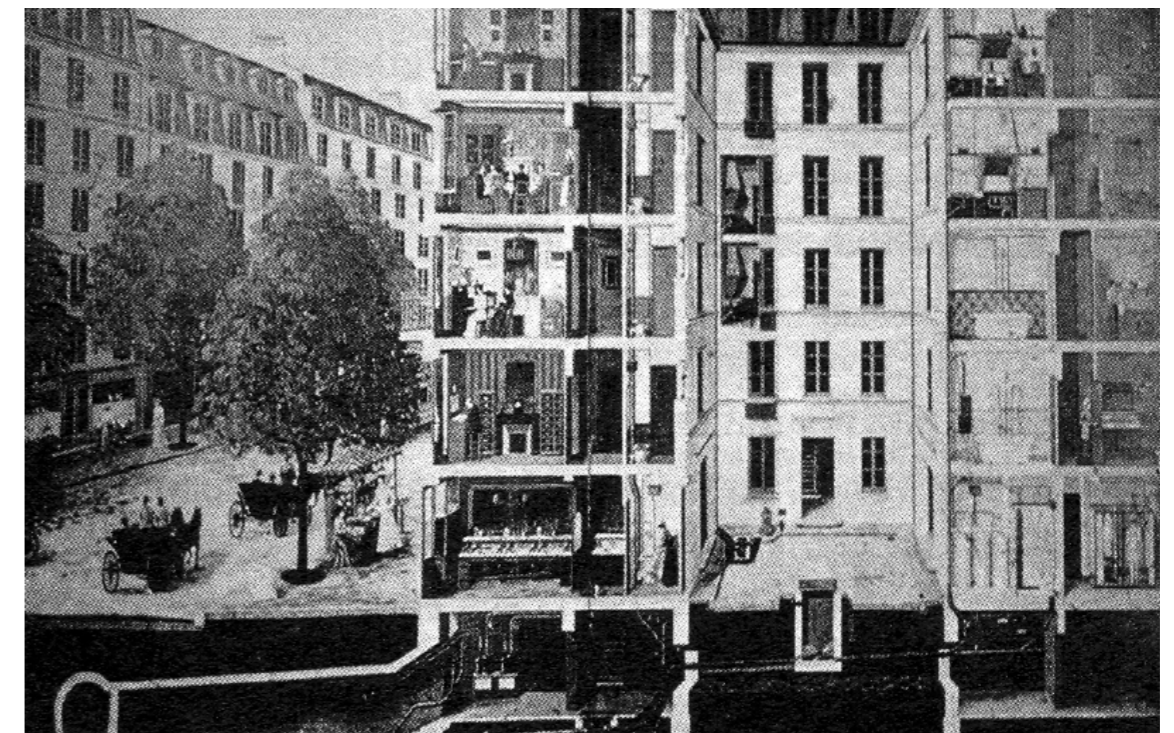

Figure 18. Baron Haussmann imagined not only a street section to accommodate modern facilities and hygiene, but also a new society - the bourgeoisie. Haussmann, Boulevard cross-section in Plan for Paris. From Calabrese, LC (2004). *Reweaving UMA*.

I.2. Aims

Definitions of liveability

In order to answer the spatial impact of AV question, urbanism needs an aim and a method. These have to be specific to the profession. If mechanical engineers explore the functioning of vehicles, IT engineers program the software, traffic engineers plan the rights of way, and policy makers debate responsibility and insurance issues, what is the subject matter for planners and designers?

One of the universally recognised goals of the urban planning and design profession is liveability. The primary aim of human settlements is to be inhabited, for people to live in them. All the other functions of a city - work, learning, leisure, mobility - are all subject to inhabiting. Therefore the most important attribute of a city, or region, is to perform its primary aim, to be liveable. Liveability is a specific attribute of the built environment; it has to answer a variety of issues, from socio-economic, health, ergonomics, to environment and behaviour, which are brought together by the act of planning and design.

Liveability can be defined in different ways. It is a focus subject not only for research, but also urban governance: cities compete in liveability indexes, and a certain pattern can be deducted from urban areas with the highest scores. This pattern includes in most cases: availability of various housing, work premises, education and healthcare facilities, efficient mobility, healthy living environment, safety and relative prosperity of the inhabitants. In order to form a definition to be used in this project, three definitions of liveability were studied.

First, there is an administrative definition of liveability, which is based on a clearly defined list of quantifiable criteria: number of housing units, number of facilities available within a certain travel time, degree of flood risk etc. One such example in the studied region is the Leefbaarometer indicator which measures liveability down to neighbourhood level in the Netherlands. Second, there is an academic definition of liveability which focuses on the human individual's perception of qualities such as health, security, inequality, social relationships, control, and contact with nature (van Dorst). Finally, there is an urban theory definition of liveability, which emphasises the physical qualities of the urban environment, namely walkability, accessibility, density, spatial variety and spaces for social or economic encounter opportunities (Jacobs, Gehl).

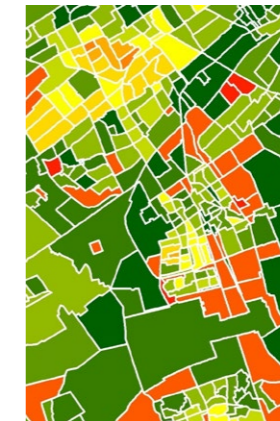

Figure 19. The administrative definition of liveability can be found in the Leefbaarometer or in National Strategy for cities in the Netherlands. It comprises quantifiable criteria categorised and universally accepted. Image source: www.leefbaarometer.nl

Administrative

- housing
- physical environment
- services
- population
- safety
- sufficient housing and work premises
- natural and cultural heritage

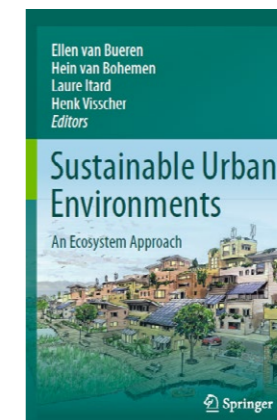

Figure 20. The academic definition of liveability comprises elements by which the individual relates to the urban environment. Source: Machiel van Dorst, *Liveability*.

Academic

- health and security
- material prosperity, income inequality, happiness inequality
- social relationships
- control
- contact with the natural environment



Figure 21. Urban theory definition of liveability accounts the individual's experience in the public space related to the spatial characteristics of the space. Source: Jane Jacobs, *Downtown is for People*; Jan Gehl, *Cities for People*.

Urban theory

- walkability
- accessibility
- density
- spatial variety
- encounter opportunities

Liveability criteria in the project

The project's own definition of liveability discerns between regional, or macro, criteria and local, or micro criteria. On both scales, the aspects of mobility, environment and society and economy are described. The liveability criteria are based on the definitions extracted from literature, synthesised in order to be applicable to the AV scenario evaluation in part IV of the project.

On the regional scale, mobility is defined through performance and impact. Performance is described as the capacity of the mobility system to answer the needs of people and businesses in terms of coverage - territorial and social, efficiency - energy and time, and modal choice - shared, private, active etc. Impact is mainly defined by air and noise pollution, especially of inhabited areas. The environment factor comprises the built and the natural components. The built environment liveability performance at regional level means to have sufficient and diverse, by type and location, housing and work premises across the territory. The natural component of regional liveability is composed of the availability of contact with open nature, as well as preserving natural heritage such as the Green Heart. The society and economy factor implies a variety of economic sectors having the proper spaces and accessibility, as well as jobs being available close to where people live.

On a local scale, mobility performance assumes proper accessibility and spatial integration of the urban environment for all users and as many modes as possible. Different user types should not impede others' accessibility, for example cars pedestrians. Mobility impact is more related to the individual's safety and perception of control. An elderly or disabled person should be able to use the space safely and in a comfortable way, even if the space is designed with a dynamic, young atmosphere in mind. The local scale natural and built environment criteria are the daily contact with nature close to home and work, and an urban fabric that enables desirable lifestyles, for example safe to raise children. Society and economy wise, the local criteria are sufficient and varied spaces for encounter, whether benches, sidewalks, cafes or shop windows, in order to foster social relationships and economic opportunities.

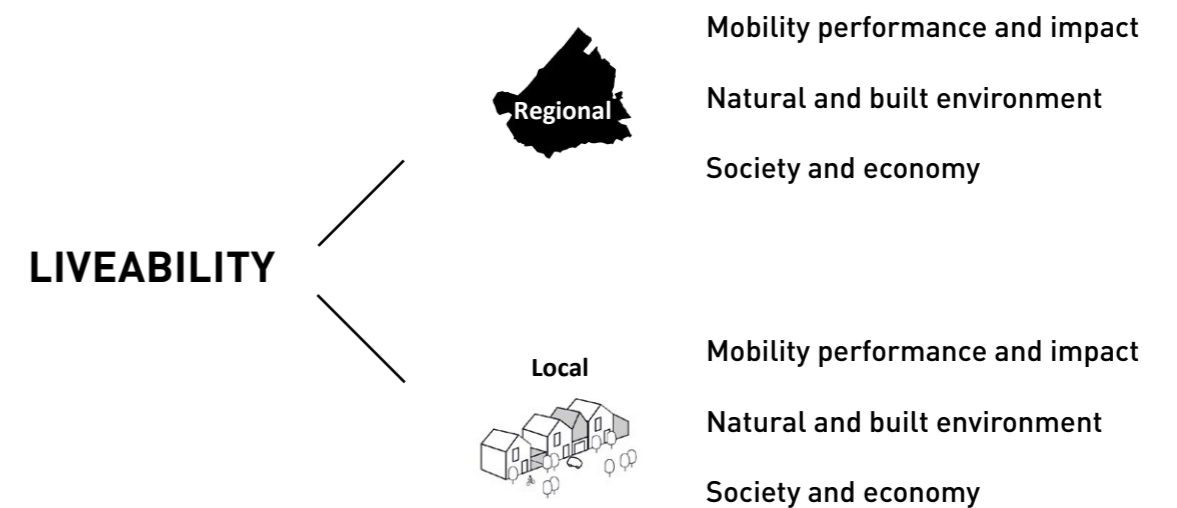

Figure 22. Liveability criteria used in the project are categorised into regional and local scale criteria. In both scales, the three levels of mobility, environment and society-economy are analysed.

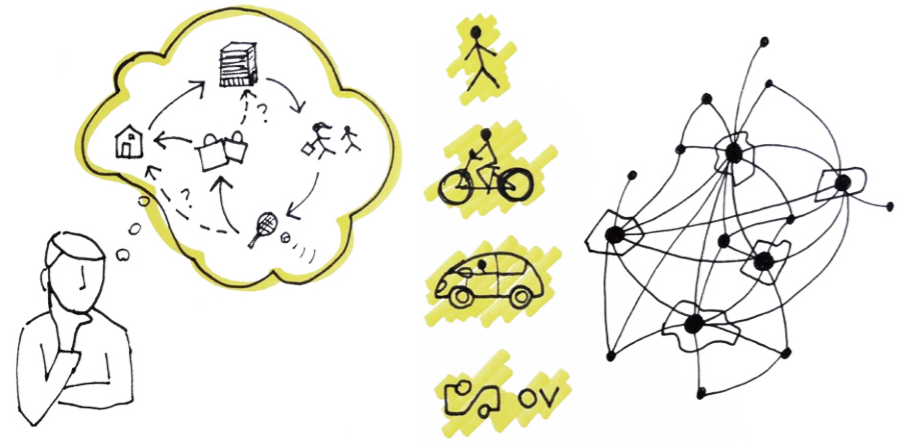

Figure 23. Mobility performance: coverage, efficiency and modal choice are ensured for everyone.

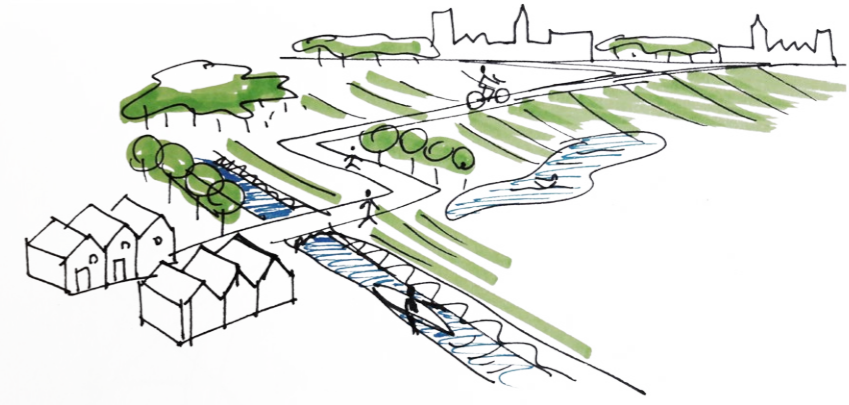

Figure 25. The urban form enables contact with open nature.



Figure 24. Mobility impact: air and noise pollution are reduced to minimum in inhabited areas.



Figure 26. Society and economy: housing and work premises are sufficient and diverse by type and location.

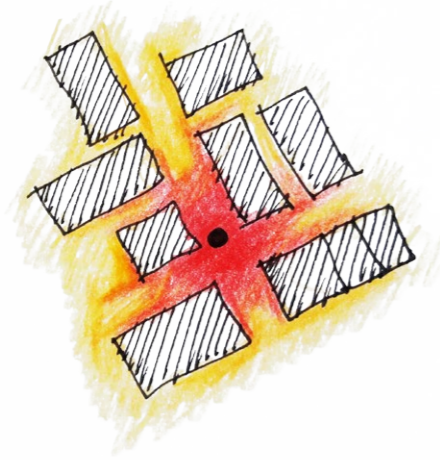

Figure 27. Mobility performance: accessibility and spatial integration in urban environment for all users.

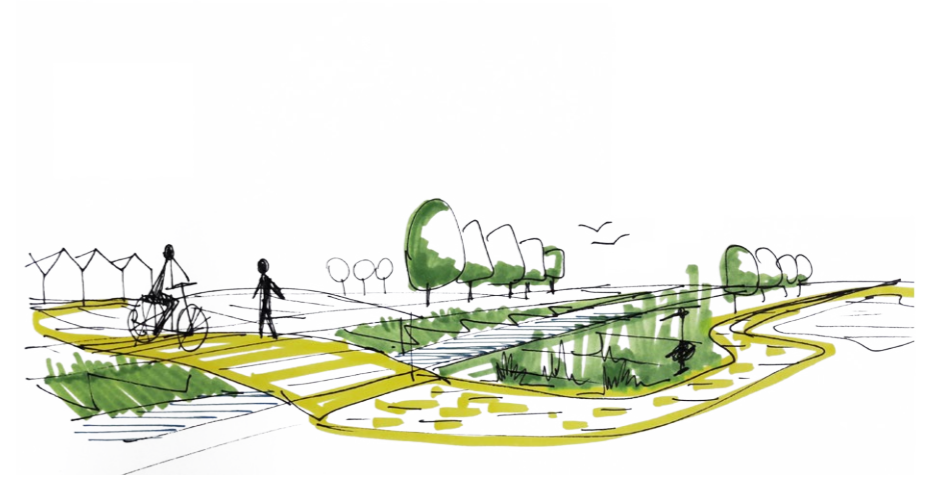

Figure 29. Environment: contact with nature in everyday life.

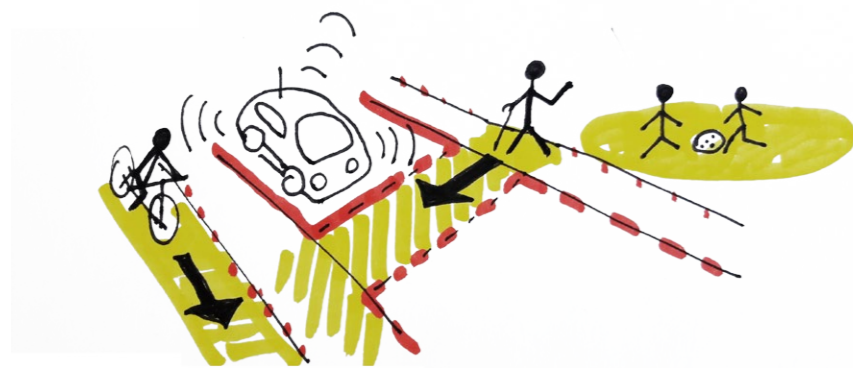

Figure 28. Mobility impact: control and safety for all categories of users, including elderly or children.



Figure 30. Society and economy: spaces for encounter such as benches, sidewalks, shop windows.

I.3. Research questions

This research project does not intend to plainly explore the possibilities of AV, but about claiming a position for urbanism in the interdisciplinary discussion on the development of the technology. It aims to achieve this by building a specific method. This method will be based on spatial scenarios describing the MRDH in extreme cases of driving automation evolution. It also bears in mind the aim of liveability as the ultimate goal of adopting the technology. In conclusion, the main research question is the following:

How can we assess the impact of automated vehicles on urban liveability through the use of spatial scenario construction?

What directions of research, design and policy should be followed in the future in order to enhance urban liveability in the context of automated vehicle adoption?

Are the tools specific to urbanism useful to assess the impact of automated vehicles on the urban environment?

How can the urbanist/architect be ahead of the times by imagining the living environments and lifestyles resulting from technological innovation?

These research questions are embedded in the EMU key issue of “Mobility and network cities”, and in the TU Delft Urbanism department research themes of “Design of the urban fabric” and “Metropolitan spatial structures”. It is also within the 3A agenda of the Faculty of Architecture and Urbanism at TU Delft, in the field of automation.

II. Theoretical and analytical framework

II.1. Building a method: foresight and through-sight

Scenario construction in urbanism

The methodology of the project is within a research by design approach in the understanding of the EAAE. Within this approach, the main method is scenario construction in the understanding of scenario as a base for discussion, in which the alternative to the present reality is imagined on the basis of radical spatial expressions (Vettoretto).

Scenario construction is also a “tradition” of Dutch urban planning, where envisioning the future was an always essential mean of organizing the territory (Salewski).

Scenarios are based on hypotheses, often radical, and consequent narratives of the future. The balance of rationality and imagination, of the quantifiable and the speculative is a core quality of the method. Scenarios can also be used as analytical devices in order to test developments, and depend strongly ‘on the research question, the employed models, the data used, and the transparency of the process’. (Salewski)

In this particular case, the scenarios are based on the main research questions, delivering a total of four possible scenarios of effects of AV technology in the MRDH: high-concentration territory with dissolved separation between traffic modes; high-concentration territory with total modal separation of traffic; low-density territory with dissolved separation of traffic modes; and a low-density territory with total modal separation of traffic. The scenarios are analysed and compared using a set of evaluation criteria based on urban liveability. The scenarios are developed in the form of territorial sections inspired from the theoretical framework case studies of historical visionary and realised projects.



Figure 56. Constant Nieuwenhuis, *New Babylon / Den Haag, 1964*. From Salewski, C (2012). *Dutch New Worlds. Scenarios in Physical Planning and Design in the Netherlands, 1970-2000*, 010 Uitgeverij, Rotterdam



Figure 57. *VROM Atelier Randstad 2040*, One Architecture, Matthijs Bouw, *Randstad 2040, 2008: Kuststad / Coast City*. idem.

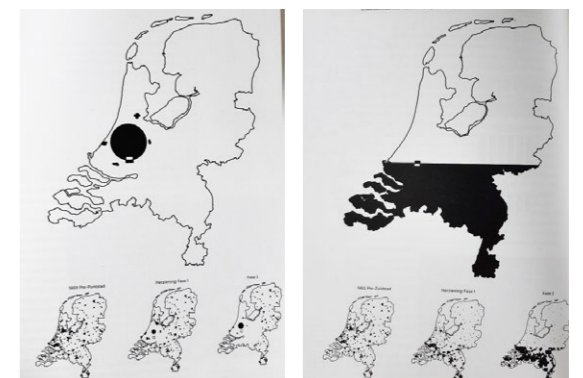

Figure 58. AIR-Alexander; OMA, *New Urban Frontiers, 1993: Point City and South City*. idem.

Visionary urban sections

The new urban situation created by the growing industrial city inspired a radical re-thinking of the city by the visionaries of the late 18th and throughout the 19th century. When Cerda competed for the enlargement plan for Barcelona, or when Haussmann received the task of redesigning the street network of Paris, they did not limit their projects to answering the task of new, wider streets. They dared to imagine new lifestyles for a new society that was forming at the time - the bourgeoisie. The new social model was represented in their drawings in the form of all-encompassing sections of the street and adjacent buildings. The section would detail all the novel technicalities such as the sewage and rainwater collection systems, but would also for the first time depict the activities on the street: carriage traffic was separated from pedestrian sidewalks, tree alignments would provide shade and a pleasant environment.

Moreover, the sections extend into the buildings, showing their relation with the street, but also the new layering of society reflected in the occupation of the different floors. Later, in the early 20th century new transport modes such as the tramway and the automobile inspired visionaries such as Sant' Elia, Corbett or Le Corbusier, to propose multi-leveled separations of traffic types, in the name of efficiency and technological breakthrough. These sections represent a model on which the scenarios on AV can build new questions. How will this innovation change the social patterns? What type of urban space can accommodate these changes? How will the inertia of the city enable these visions?

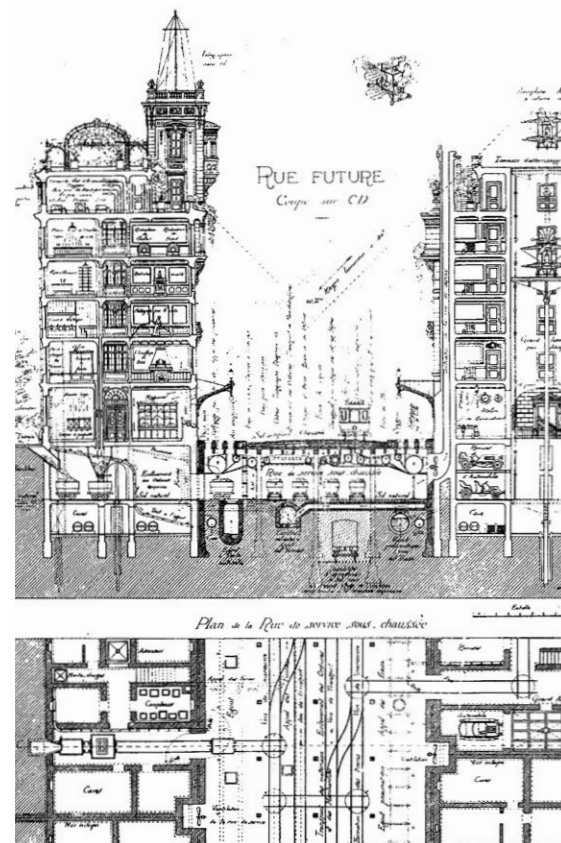

Figure 63. Eugene Henard, Rue Future, 1911. From Lewis, P, Tsurumaki, M & Lewis, DJ (2016). Manual of section, Princeton Architectural Press, New York.

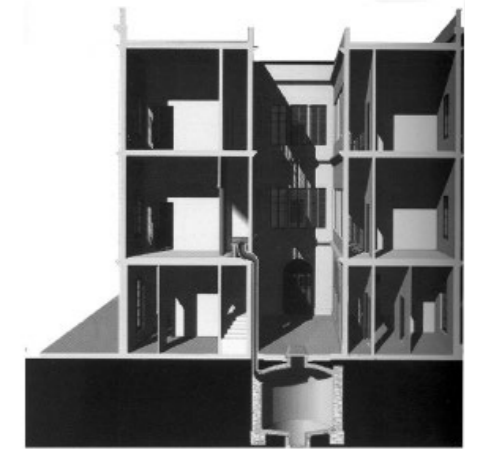

Figure 64. Idefons Cerda, Enlargement plan for Barcelona, 1859, typical section. From Calabrese, LC (2004). Reweaving UMA, doctoral thesis, Delft University of Technology.

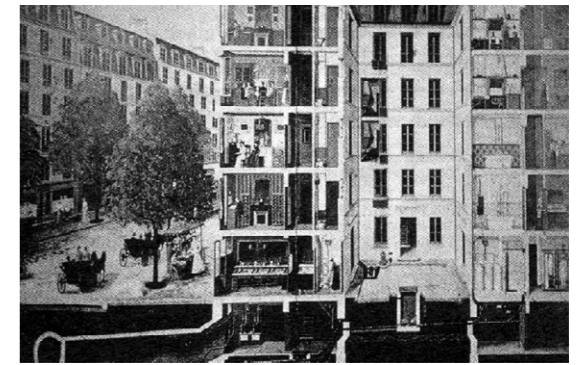

Figure 65. George-Eugene Haussmann, Plan for Paris, (1853-1877), boulevard and building section. idem.

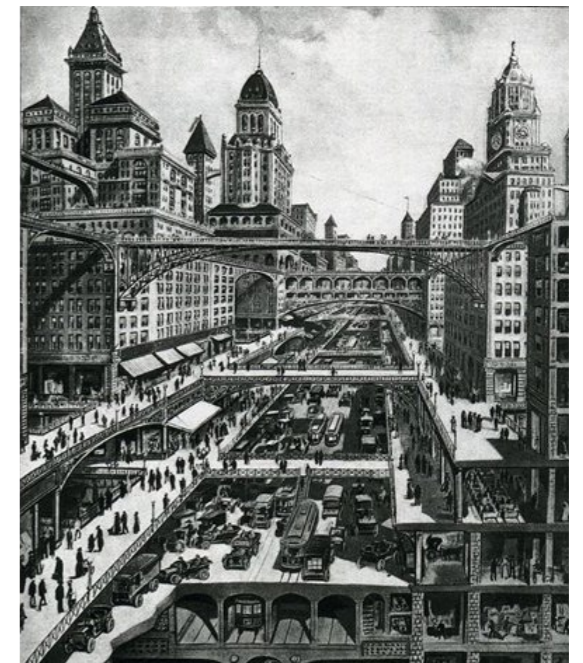

Figure 66. Harvey Wiley Corbett, City of the Future, 1913. From Lewis, P, Tsurumaki, M & Lewis, DJ (2016). Manual of section, Princeton Architectural Press, New York.

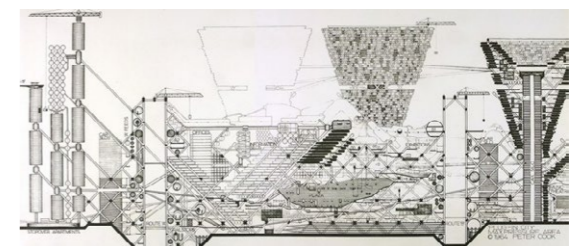

Figure 67. Peter Cook / Archigram, Plug-in City, 1964. Sustainance components section. idem.

Conclusions: building a method

Scenario construction, transect analysis and the visionary section are employed as tools to assemble a working method specifically designed for urbanism in order to assess the impact of a new technology on urban liveability. The method intends to be applicable regardless of the technology type and particular territory. This project exemplifies the method through evaluating the impact of potential large scale adoption of automated vehicles in the Rotterdam The Hague Metropolitan Region. The method is designed as follows (example of this project in brackets).

First, the available literature on the technology (AV) is studied and two categories of information are extracted: the main spatial driving forces (urban density and separation of flows) and the potential spatial impacts categorised by the driving forces (fields and networks).

Secondly, the territory (MRDH) is analysed, mapping the driving forces (fields and networks) and their current trends (urbanisation process and infrastructure development), as well as the elements subject to spatial impacts (mobility landscapes). Further, a representative transect of the region is selected, and divided into subzones using the driving forces (fields density and network accessibility), and selected liveability data (population, jobs, green area, pollution) is analysed on its length. Regional patterns are extracted and critical points are chosen for later case study.

The third and main step of the method is the scenario construction. Using the driving forces of density and separation of flows, and based on hypotheses available in literature regarding AV and the evolution of the region, four extreme scenarios are described. The scenarios are inspired by various theoretical models, visionary and realised projects. In the second stage of scenario construction, two radically opposing scenarios are selected for further development. For both scenarios, regional models of networks and urban fields are modelled, and the three case study locations are analysed using the urban section. For each of the case studies a package of briefs, for urbanism, architecture and society, are proposed, based on the liveability analysis, and the specific context of the scenario. The solutions in the section have a research-by-design character, used to test the resistances of the space and the technology, and to propose further directions of research.

Finally, the scenarios are evaluated using the liveability criteria at regional and local scales: mobility performance and impact, natural and built environment, and society and economy. The conclusions of this evaluation are translated into research, design and policy tasks for the future.

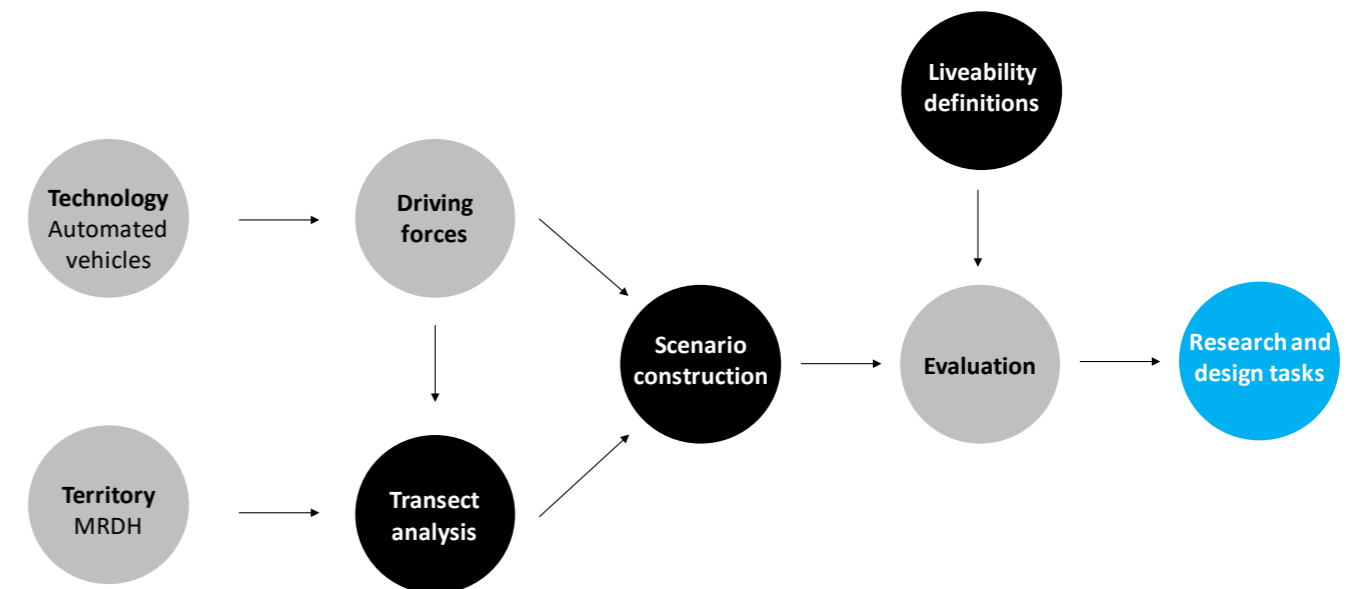

Figure 68. Methodology scheme.

II.2. Literature review on automated vehicles

General aspects of AV

Automated vehicles (AV) are an idea rooted in the 1950s, however it is only in recent years that the technology is mature enough to be properly tested and even introduced in commercial use. AV can be categorised in 5 levels, out of which levels 4 and 5 are considered ‘fully assisted’ and ‘fully automated’ (Milakis et al 2017), which are the levels of interest to this project due to the strong impact they might have on urban environment.

The effects of AV on the city and territory can be classified as first-order - street section, intersection functioning, parking, new infrastructures and new uses for obsolete infrastructures; second-order - land use and mobility choices; third-order: societal, economic and environmental impacts (Milakis et al 2017).

In research literature there are a number of generally accepted advantages and disadvantages, often stemming from the same characteristic, of potential AV adoption. One major advantage is territorial coverage of mobility, as automated vehicles could make marginal areas currently not served by public transport more economically accessible by driverless shared vehicles. AV could also bring wider social coverage, extending mobility for elderly, disabled and children, for example. Possibly the single largest opportunity of AV is to increase safety. Automation will mean less dangerous driving, more sensing of obstacles, and direct communication between all cars on the road, all of these conditioned by improving technology. AV are also prognosed to minimise lost time, especially looking for parking, as passengers are dropped off at their destination before the

AV self-parks or continues its journey to a further user. Car sharing could also lead to less cars on the road, and reduced parking needs in cities. Lower parking requirements could also make central developments more common and affordable. Nevertheless, smart driving and possibly imposing only electric cars within cities will drastically reduce toxic emissions, also boosted by less unnecessary braking and optimised route choices in rush hour. Within cities, AV would integrate and complement other transport modes, offering more variety and redundancy in the mobility system. Finally, individuals will benefit from increased work and leisure time as they are freed from driving.

Some of the aspects mentioned above can however be cancelled by the disadvantages some researchers are signalling. First, AV is feared to replicate the postwar effect of the automobile and cause a urban sprawl by encouraging longer commuting. Time spent in the AV will also mean unhealthier, more sedentary lifestyles. The previously mentioned advantages of fewer cars on the road and reduced pollution can also turn in the opposite direction. It is possible that the city is blocked by a vast number of AV looking to self-park. If electric cars are not developed concomitantly with automation, there's a strong chance that whatever energy saving from eco-driving is cancelled by the larger number of cars on the streets. It is also speculated that to maximise capacity, some AV may have ‘aggressive’ driving options to bypass congestion, thus polluting more in the end. By reaching to remote areas in cost-effective and attractive ways, AV, in convergence with ride-sharing applications, may harm the profitability of public transport

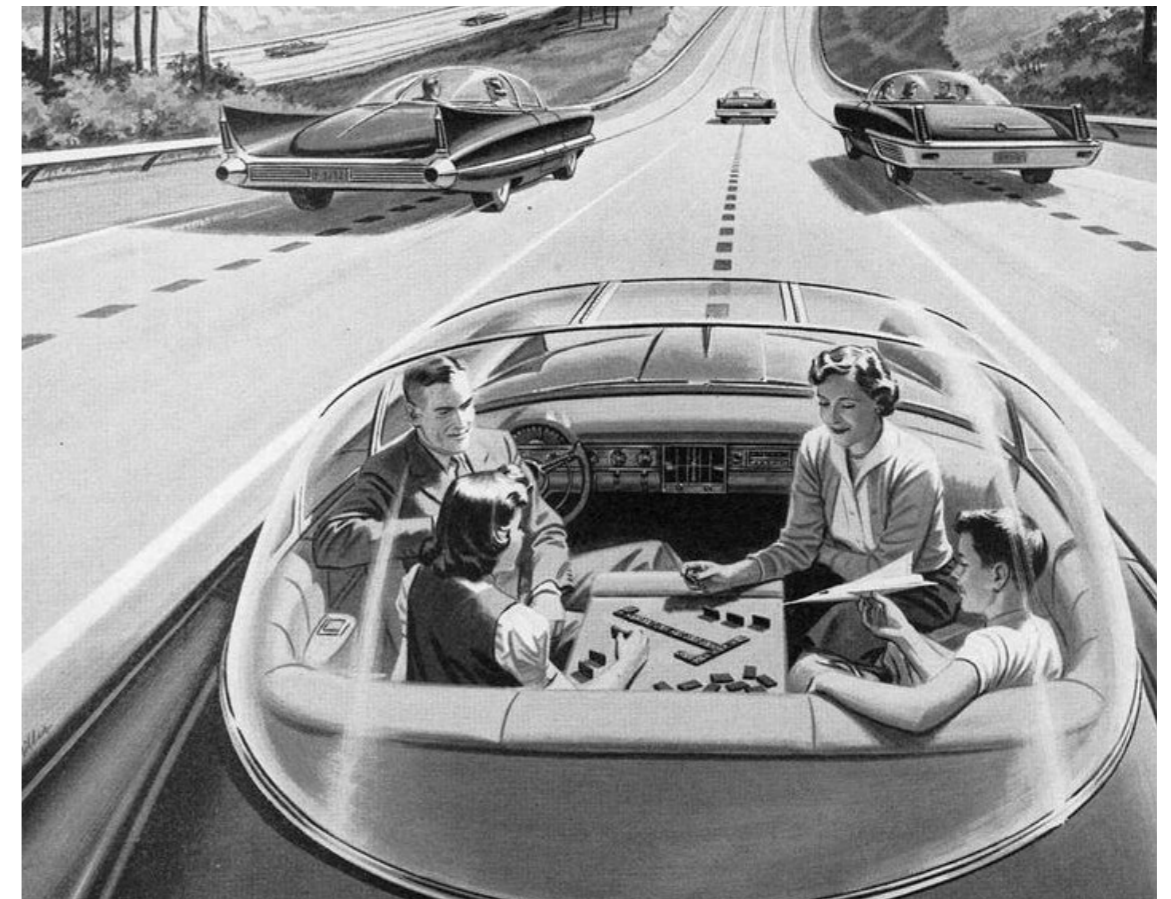

Figure 31. Automated vehicle as imagined in the 1950s, from American Power Company.

and even reduce its provision over time, some argue. Numerous driver jobs are also prone to be lost to automation, as commercial users - goods and people transport, taxis, trucks - are the first candidates to automation. Nevertheless, automation can also introduce unclarity and policy conflicts in the fields of legislation and insurance. Finally, for the individual's experience, AV might lower the value of personal time, even if that time could be spent otherwise.

There are a number of studies on the automated vehicles and their application in the Netherlands. Especially the study of AV's ripple effects is essential to understand the possibilities enabled by the technology. The studied effects include: on road capacity, mobility habits, and transport infrastructure; change in the value of personal travel time; ownership and sharing; location choices and land use; air pollution; road safety; social equity; economy; public health. The studies include a scenario research on AV in the Netherlands for 2030 and 2050 and

include four possible outcomes based on the drivers of technological development and government support. The conclusion is that the two scenarios involving a pro-active government are the most likely to be the outcome, with large scale adoption forecast to occur in 2025 for rapid technological development, respectively 2040 in the case of slower innovation. In both cases, demand management and regulations will be needed to curb traffic growth (Milakis, van Arem et al).

Figure 33. Scenario matrix about development of automated vehicles in the Netherlands. Milakis, D, Snelder, M, van Arem, B, van Wee, B & de Almeida Correia, GH (2015). Development of automated vehicles in the Netherlands: scenarios for 2030 and 2050, Research report, Delft University of Technology, p.39

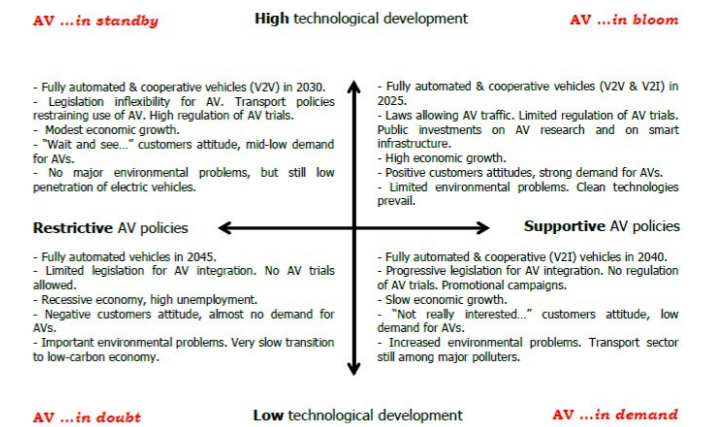

Figure 34. Potential value shifts. Corwin, S, Vitale, J, Kelly, E & Cathles, E (2015). The future of mobility. How transportation technology and social trends are creating a new business ecosystem, Deloitte University Press, p.19



- +
- SAFETY
- AUTONOMY
- TIME
- SHARING
- URBAN SPACE
- LOWER EMISSIONS



-
- URBAN SPRAWL
- ENERGY USE
- ETHICS
- HEALTH
- JOBS

Figure 32. Automated vehicles promise a series of advantages, most importantly increased safety and time saving. However, a number of disadvantages can also be envisioned, such as increased energy use or urban sprawl.

Figure 35. Physical infrastructure requirements to facilitate vehicle automation (E-essential; G2H-good to have; NE-not essential; ?-unknown). Farah, H (2016). State of Art on Infrastructure for Automated Vehicles, Research report, Transport & Planning, Delft University of Technology, p.47

| Physical Requirement | L1 | L2 | L3 | L4 _{loc} | L4 _{shuttle} | L5 |
|---|----|----|----|--|-----------------------|--|
| Lane markings | ? | E | E | E | NE | G2H |
| Sufficient friction coefficient | E | E | E | E | NE | G2H |
| Traffic signs | E | E | E | G2H | NE | NE |
| Lighting | ? | ? | ? | ? | ? | ? |
| Traffic signals at intersections in urban areas (vulnerable road users) | E | E | E | E | NE | E |
| Current standards for width (lane, shoulder, median, clear zone) | E | E | E | E | NE (can be reduced) | NE (can be reduced) |
| Emergency stop zones frequency | ? | ? | ? | ? | ? | ? |
| Current standards for sight distance | E | E | E | NE With connectivity, (can be reduced) | NE | NE with connectivity, (can be reduced) |
| Current standards for road curvature | E | E | E | ? | ? | ? |
| Current speed limits | E | E | E | NE with connectivity, (can be increased/dynamic) | Not essential | NE with connectivity, (can be increased/dynamic) |
| Transition areas | ? | ? | ? | ? | ? | ? |

AV in urbanism

Automated vehicles inspire architecture and urbanism research already, and there are projects imagining from regional to street scale impact of AV. Some projects consider the hypothesis that AV will lead to significant urban expansion (CAU, MIT), while others focus on the impact on street functioning. A few projects dare to re-think the barriers between cars and other street users enabled by technology. Other research,

in the Netherlands, is focused on the role of the urban motorway ringroad (Highway and City), but also looks at how the automated vehicle can play a role in energy production at the neighbourhood level. Different street sections are also studied and intermodal transfer hubs from mass transit to slow city centre mobility are imagined. Overall, research on AV is limited, but offers an interesting insight on future possibilities.



Figure 36. A future of automated vehicles are imagined in combination with Hyperloop technology. The Future of Suburbia, image by Matthew Spremulli, Center for Advanced Urbanism, MIT School of Architecture and Planning, 2016, news.mit.edu



Figure 37. UN Studio, The HUB, in Snelweg x stad, from www.bna.nl



Figure 38. TAB competition entry, Tallinn, from vision2015.tab.ee

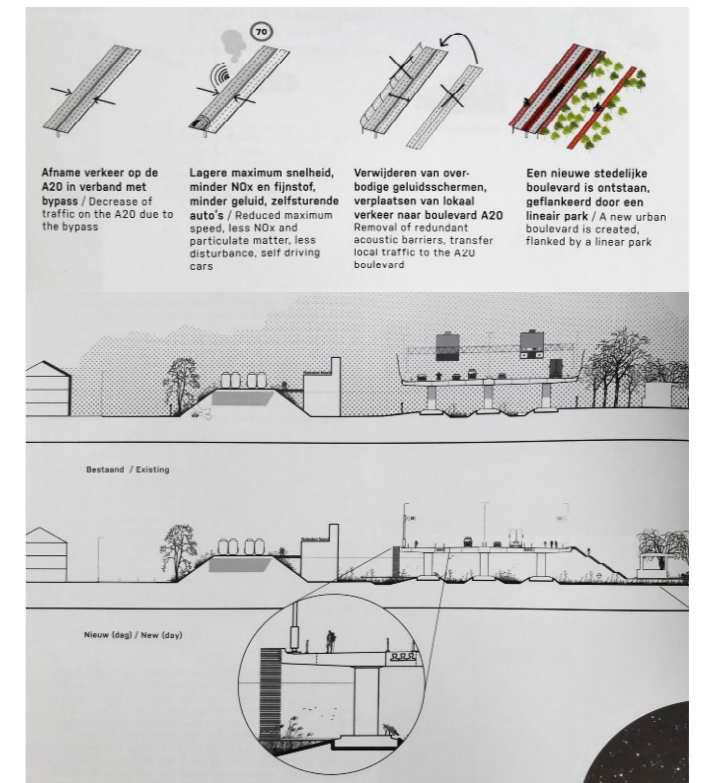

Figure 39. Urban motorway section research, From Boomen, van den, T, de Boer, H & Hinterleitner, J (eds, 2017). Highway x City: The Future of the Urban Ringroad, BNA Onderzoek, Amsterdam.

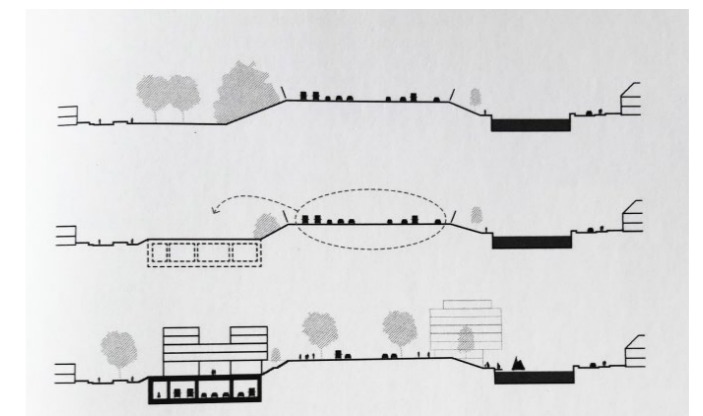

Figure 40. Strategy to move motorway underground. From Boomen, van den, T, de Boer, H & Hinterleitner, J (eds, 2017). Highway x City: The Future of the Urban Ringroad, BNA Onderzoek, Amsterdam.

Conclusions: spatial impacts of AV

To process the information regarding the spatial impacts of AV, a number of principles were drawn. The principles are categorised as impacts on the road, on networks and on fields. The first category describes use and physical changes occurring in the street section, intersections and road design. The network category comprises impacts on the urban sprawl, centralities, mobility system, but also the AV supporting system of parking

lots and energy charging points. Finally, the fields category includes the impacts on the built environment due to lower parking needs, as well as the spatial implications of restructuring the car-oriented economy.

AV IMPACT ON THE ROAD

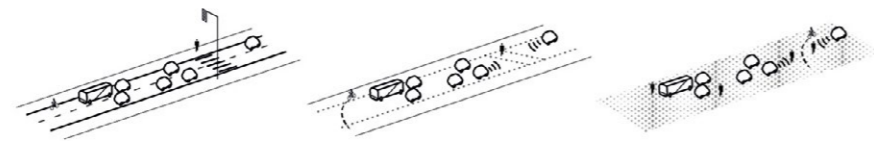

Figure 41. Smart sensing, shared space and dynamic street management may lead to increased safety and better public space quality.



Figure 42. High intensity traffic can be accommodated in the same road capacity, reducing the need for expansion.



Figure 43. Smart sensing will lead to seamless intersection management.

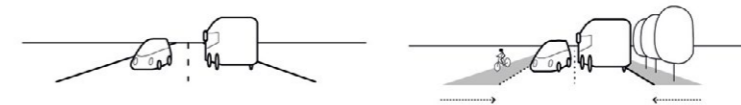

Figure 44. Precision of AV will lead to narrower car lanes, enabling new road design opportunities such as bike lanes or tree alignments on provincial roads.

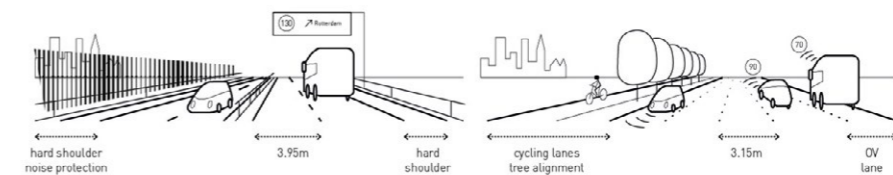

Figure 45. On motorways, automation will lead to lower investment needs, less pollution and better integration with the landscape.

AV IMPACT ON NETWORKS

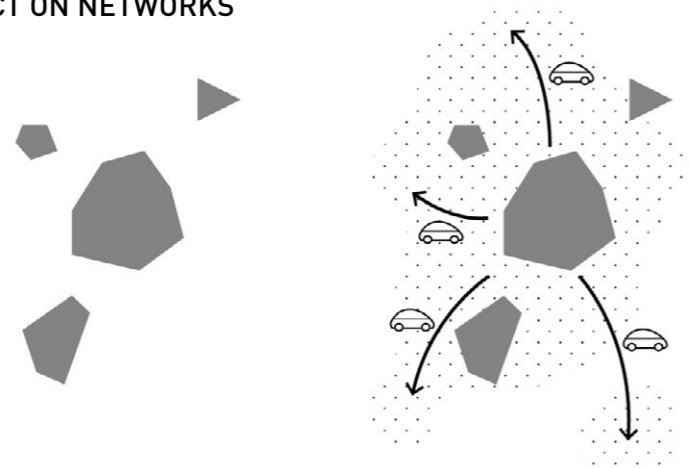

Figure 46. AV might lead to urban sprawl and lower density developments.

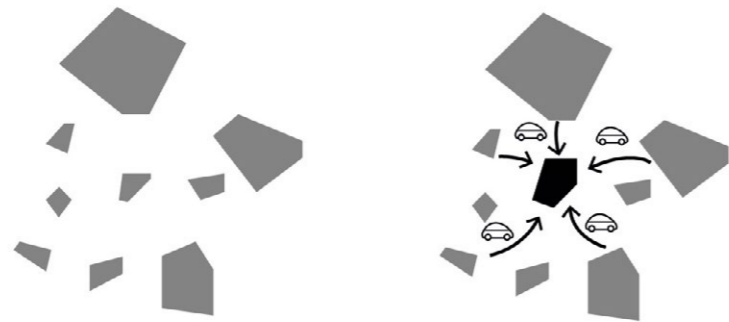

Figure 47. However, AV can also lead to new concentrations by making remote places more accessible.

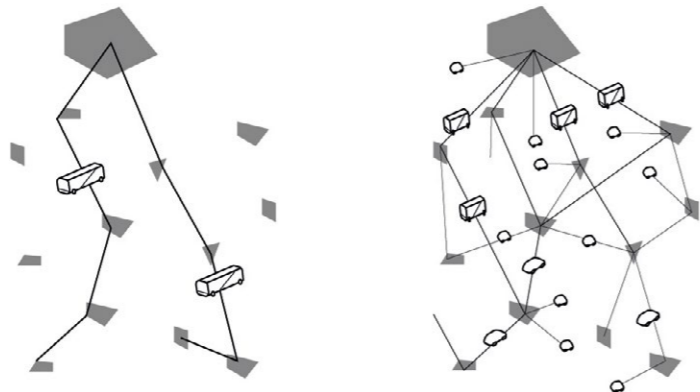

Figure 48. Public transport in low density rural areas will be improved with on-demand, economically sustainable shared services.

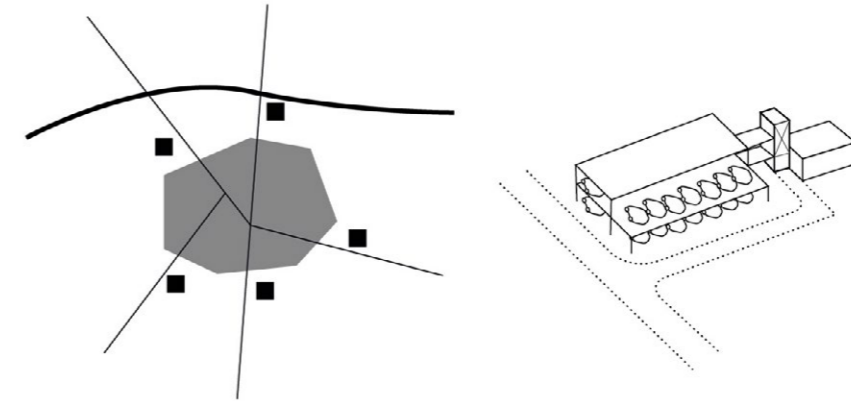

Figure 49. Parking racks and service points may appear on cheaper land on city edges for AV to self-park.

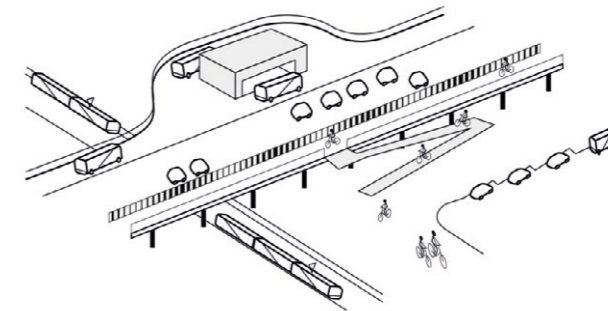

Figure 50. Synergy of high and low intensity transport modes will be strengthened in multi-modal hubs. Here travellers and commuters can transfer from long distance to local active mobility.

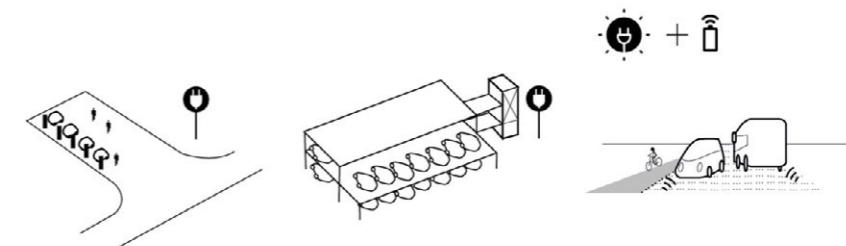

Figure 51. E-charging points, charge parking lots, solar roads with wireless charging and building-car synergy will change the energy use and related infrastructure.

AV IMPACT ON FIELDS

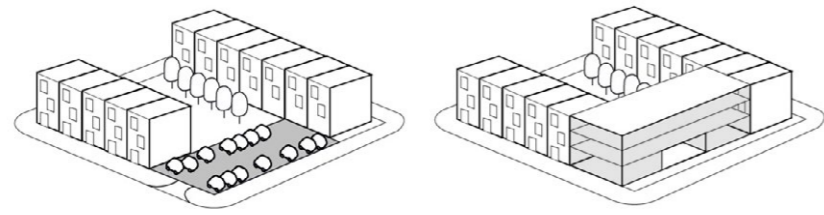

Figure 52. Less parking requirement due to sharing and city edge carparks enables higher density urban infill.

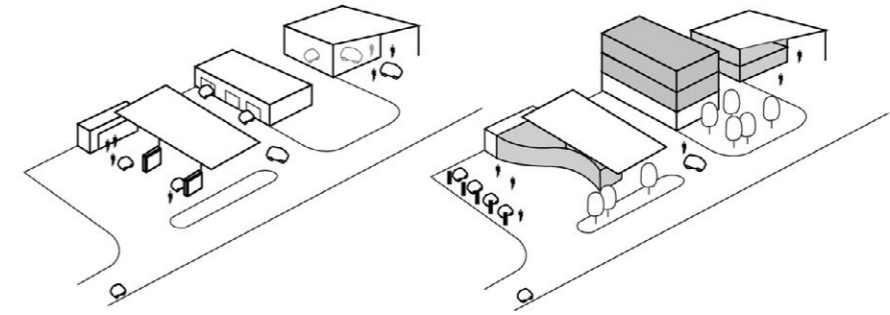

Figure 54. Restructuring of the car related economy may lead to new uses in attractive areas such as along arterial roads.

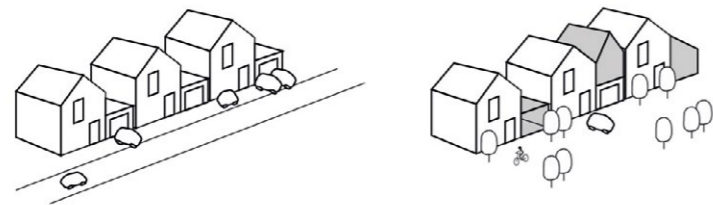

Figure 53. Reconversion of parkings and garages in residential areas to new uses.

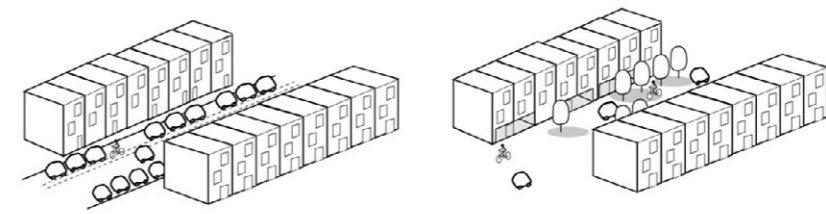

Figure 55. No on-street parking leads to more active, green, pedestrian- and cyclist-friendly streetscapes.

II.3. Territorial analysis

MRDH, a dynamic region

The Rotterdam The Hague Metropolitan region is one of the most densely populated and economically vital regions of Western Europe. The metropolitan region is part of the province Zuid Holland, and covers the largest part of it. Comprising the Southern pair of cities of the Randstad among its 23 member municipalities, it has a population over 2.2 million (MRDH, 2016). The region is covered 17% by water, 15% by buildings and almost 12% by roads, to have an image of its intense urbanisation. The region houses Europe's largest port, managed by the Port of Rotterdam authority, leading knowledge centres, such as TU Delft and Erasmus MC, as well as large glass house clusters in Westland and Pijnacker. Mobility wise, it is the most congested province of the Netherlands, unable to reduce its traffic jams unlike Amsterdam (CBS, 2015).

The region is also one of the most polluted in Europe, with pollution concentrated in the port and industry areas, as well as in the city centres, along motorways, and along the North Sea coast. It is also a very unbalanced region, with certain areas such as Westland and the port concentrating economic productivity, while the population is concentrated in the urban cores where there are numerous pockets of social, economic and ethnic isolation. The liveability figures officially provided (Leefbaarometer, 2016) underline this fact, showing that the lowest liveability ratings are in the industrial areas and urban centres.

The region has evolved along history driven by its mobility networks. Previously based mainly on shipping via inland waterways, from the end of the 19th century the cities of The Hague and Rotterdam grew exponentially driven by the role of capital, and by port activity, respectively. The railways have led an urban growth along the railways and have created their own infrastructural landscape comprised of train stations, viaducts and tunnels. Later, in the postwar period, when The Netherlands developed its motorway network, the cities of The Hague and Rotterdam expanded again (Rutte et al, 2014), as did the port which reached the coastline by the end of the century. The motorways brought with them a new lifestyle and became part of the urban environment as the city grew, causing pollution and congestion (van den Boomen et al, 2017).

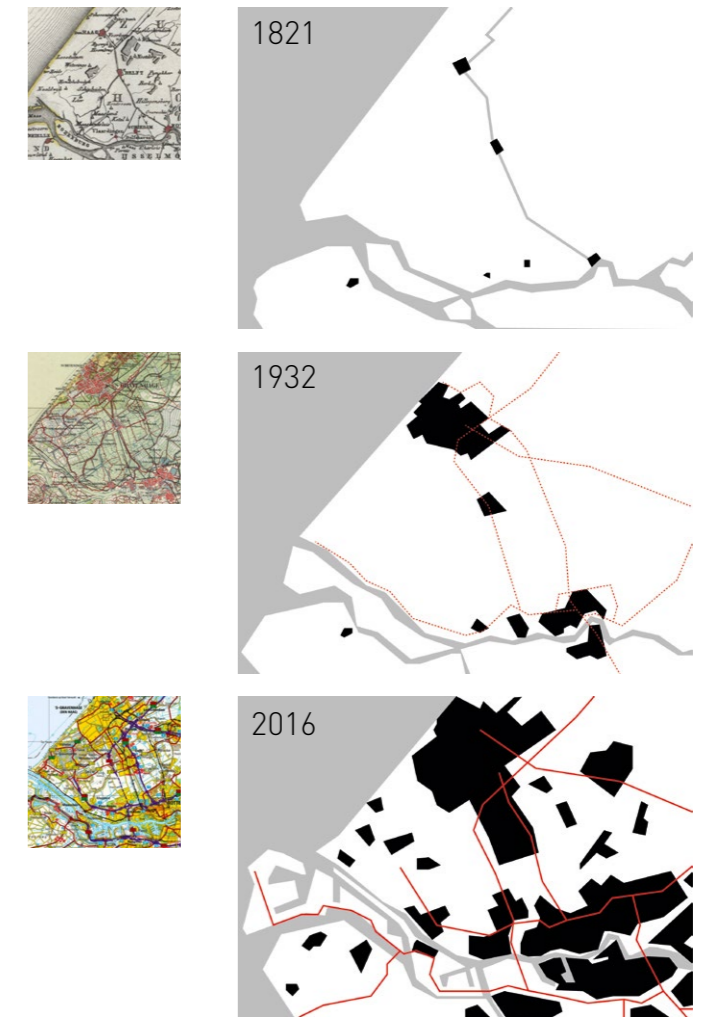

Figure 69. Historical maps and interpretation of urbanization and infrastructure in 1821 (canal), 1932 (railways) and in 2016 (motorways). From www.topotijdreis.nl

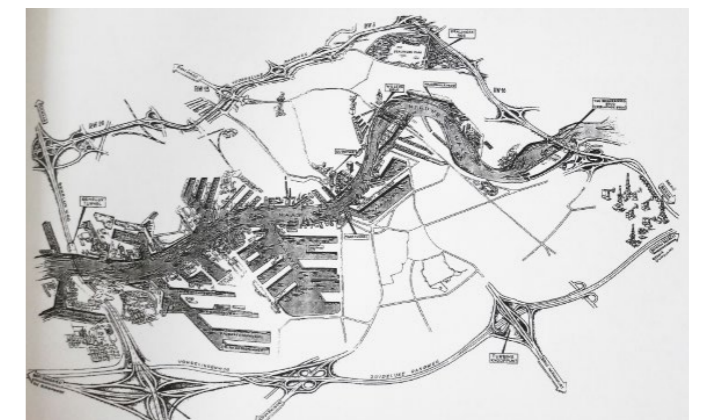
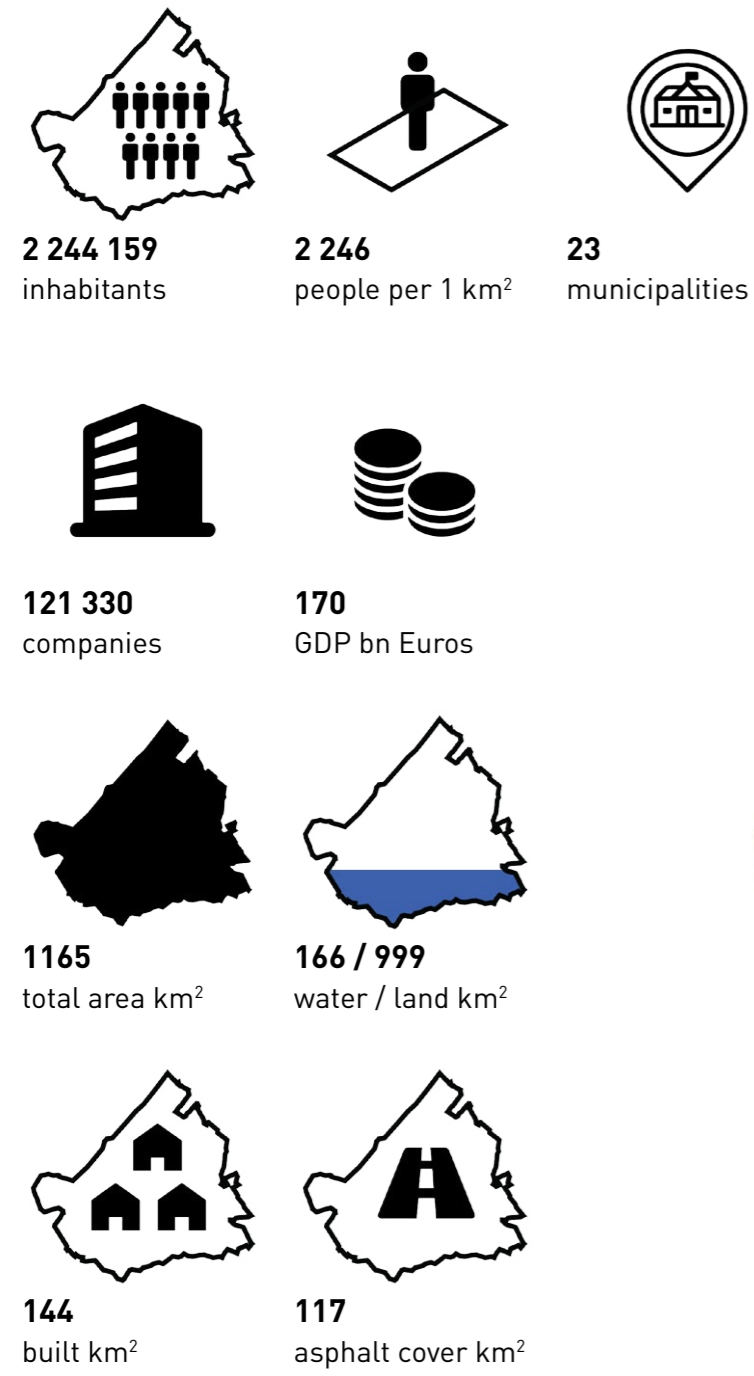

Figure 70. De diamond ring of Rotterdam, 1973. From Boomen, van den, T, de Boer, H & Hinterleitner, J (eds, 2017). Highway x City: The Future of the Urban Ringroad, p.77

Figure 71. MRDH general data and satellite map. MRDH is one of the most dense urbanised regions of Europe.



Data sources: OECD Territorial Reviews, Metropolitan Region Rotterdam The Hague; CBS, Wijk- en Buurkaart 2016; Kadaster Basisregistratie Topografie, Top10NL. Map source: Google Earth Pro satellite imagery.



The current trends of urbanisation observed can be categorised in trends of urbanisation and trend of mobility infrastructure. The population growth and increasing incomes over the last decades have led to demand for larger housing further away from the city centres. Large developments since 2005 can be seen in the medium sized cities of the region, such as Delft, Zoetermeer, Pijnacker, Berkel en Rodenrijs, Voorburg, or on the edge of Rotterdam. Largely the pattern followed is city edge and along infrastructure, especially after the construction of the Rotterdam-Schiphol high speed railway line.

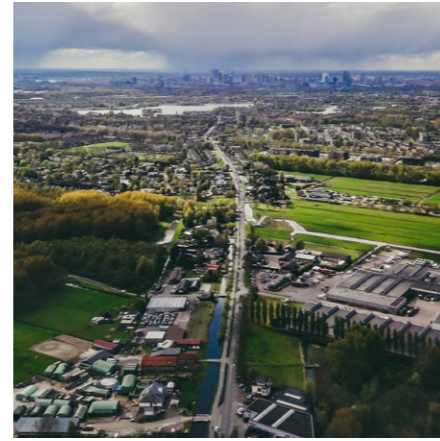
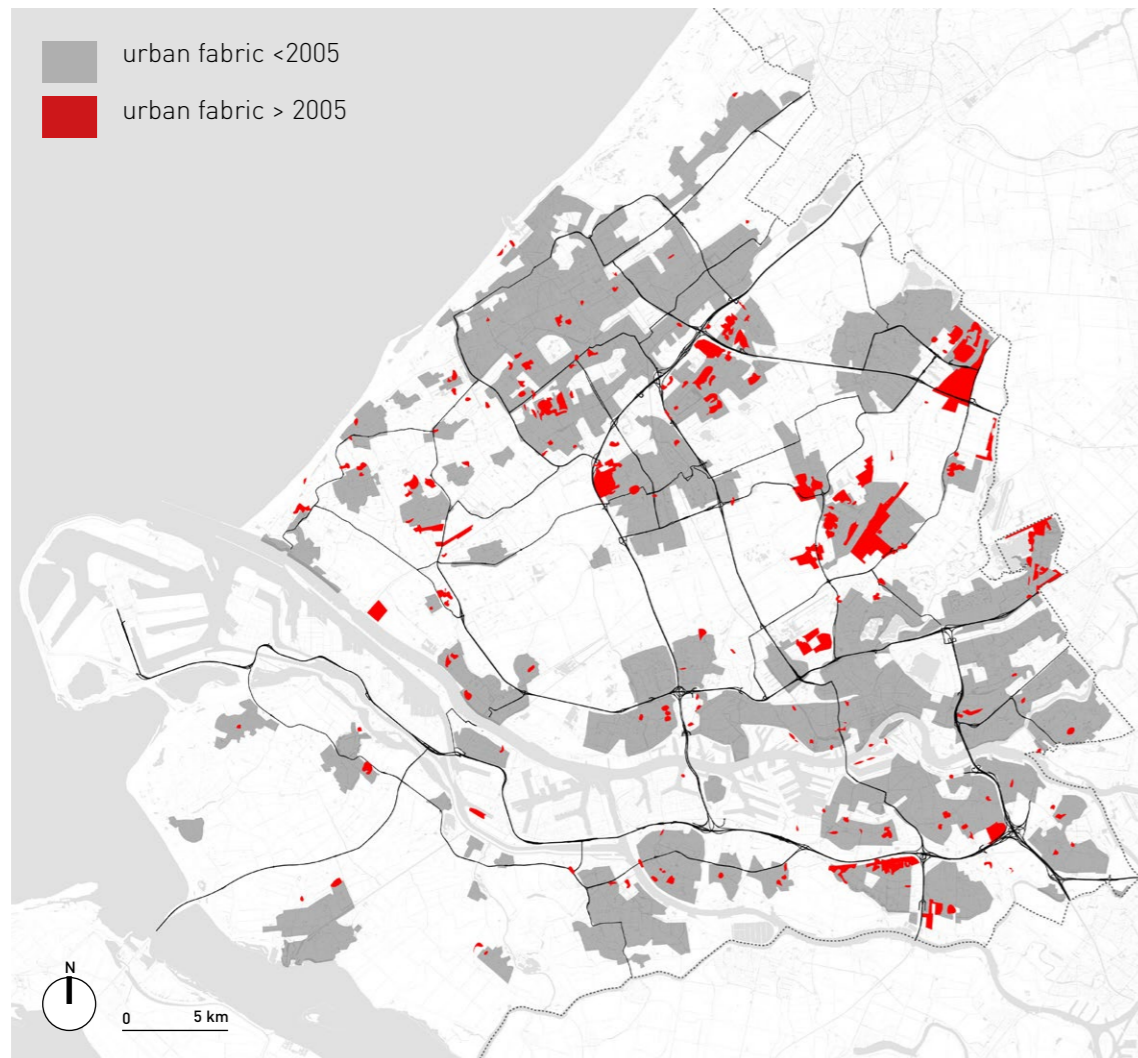

Figure 72. Urban expansion north of Rotterdam, aerial view, 2017. Photograph by author.

Figure 73. Urbanization after 2005. Data from Corine Land Cover 2012, CBS and code.waag.org



The trends of infrastructure development comprise both road and public transport investments. Public transport includes improving the accessibility to Scheveningen and Binckhorst by Randstadrail, increasing the railway capacity between the two large cores, and smaller AV feeder routes in campuses. The road investments are concentrated on improving connections over the Maas in Rotterdam and in the port, faster East-West connections in The Hague, but also to provide an extra bypass of Rotterdam as the A20 was engulfed by the city over time.

Figure 74. Projects under current implementation. Data and image sources: www.mrdh.nl; www.ns.nl; www.rijkswaterstaat.nl.

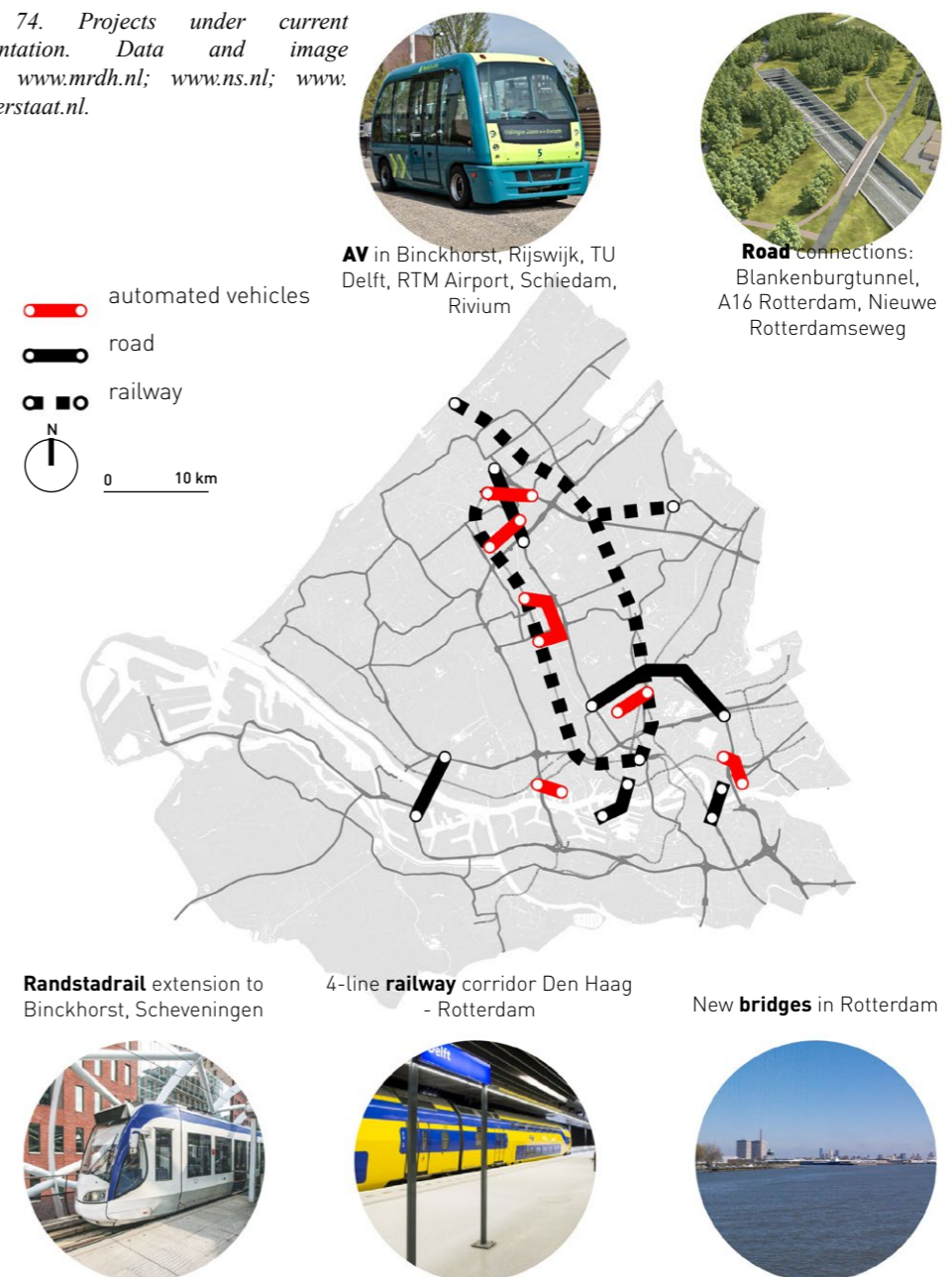

Mapping the mobility landscapes

In order to construct the scenarios, the mobility landscapes, which are going to be the ‘ingredients’ that change and develop due to AV implementation, must be mapped and analysed. This process was composed of on-site visits, selection according to the AV literature and mapping. The site photographs were taken during various field trips but also during daily travel. They help to understand the gabarits, materialities, local atmospheres of each element of the mobility landscape and to contemplate over how they can change or be replaced by AV adoption.

The elements of the mobility landscapes impacted by AV were categorised in four types: spaces of the car on the move, spaces of the car idle, spaces of no car and spaces of car economy.

The spaces of the car on the move represent all public roads open to motorised traffic and have two subcategories: controlled access fast roads, or motorways, and open access roads, or all other roads and urban streets. In total, they comprise over 8405 km in length, out of which 490 km are fast roads.

The spaces of the car idle are all parking spaces. These are also subcategorised in two types: on-street parking, which accounts for 12.5 km², and large parking lots which occupy 5.8 km². These surfaces are going to change the most radically in a full automation and sharing scenario, in which cars will not necessitate to be parked next to the destination or the user, as they would go on to self-park or to look for a next passenger.

The spaces of no car are cycling lanes and pedestrian areas. While most of these are probable to remain in their current status - as many cycling lanes and pedestrian city centre streets were invested in recently - the behaviour and functionality in these areas is interesting to understand in a shared space scenario in which AV would occupy the same surface with pedestrians and cyclists.

Finally, the spaces of the car related economy are important because this economy has a very large value and occupies important areas in the city. This category has three subtypes: gas stations, car sales and car maintenance.

The above elements will be used to describe the scenario developments as well as to map the network accessibility in the regional transect.



Figure 75. Motorway relation with peri-urban landscape. Photograph by author.



Figure 76. Self-service gas station. Photograph by author.



Figure 77. Residential street in Rotterdam. Photograph by author.



Figure 79. Cyclist and cars next to metro station, Rotterdam Zuid. Photograph by author.



Figure 78. Peculiar sights on local street next to motorway, Delft. Photograph by author.



Figure 80. Total separation of flows. Pedestrian sidewalk, cyclist lane and car lanes overpass railway on Kruithuisweg, Delft. Photograph by author.



Figure 81. Car and cycling lanes share same road surface. Delft. Photograph by author.



Figure 83. Multi-modal hub functions 24 hours, Rotterdam Centraal. How would city edge hubs be experienced? Photograph by author.



Figure 82. Inland waterways still mark their presence on newer modes of transport. How will today's modes impede automated traffic? Delft. Photograph by author.



Figure 84. Rotterdam Centraal. Could railway efficiency be replicated by AV on roads? Photograph by author.

Figure 85. Spaces of car on the road. From GIS based on 'wegen_lijn' and 'wegen_vlak' layers from top10nl, CBS 2015.

— Main road network
 — Local streets

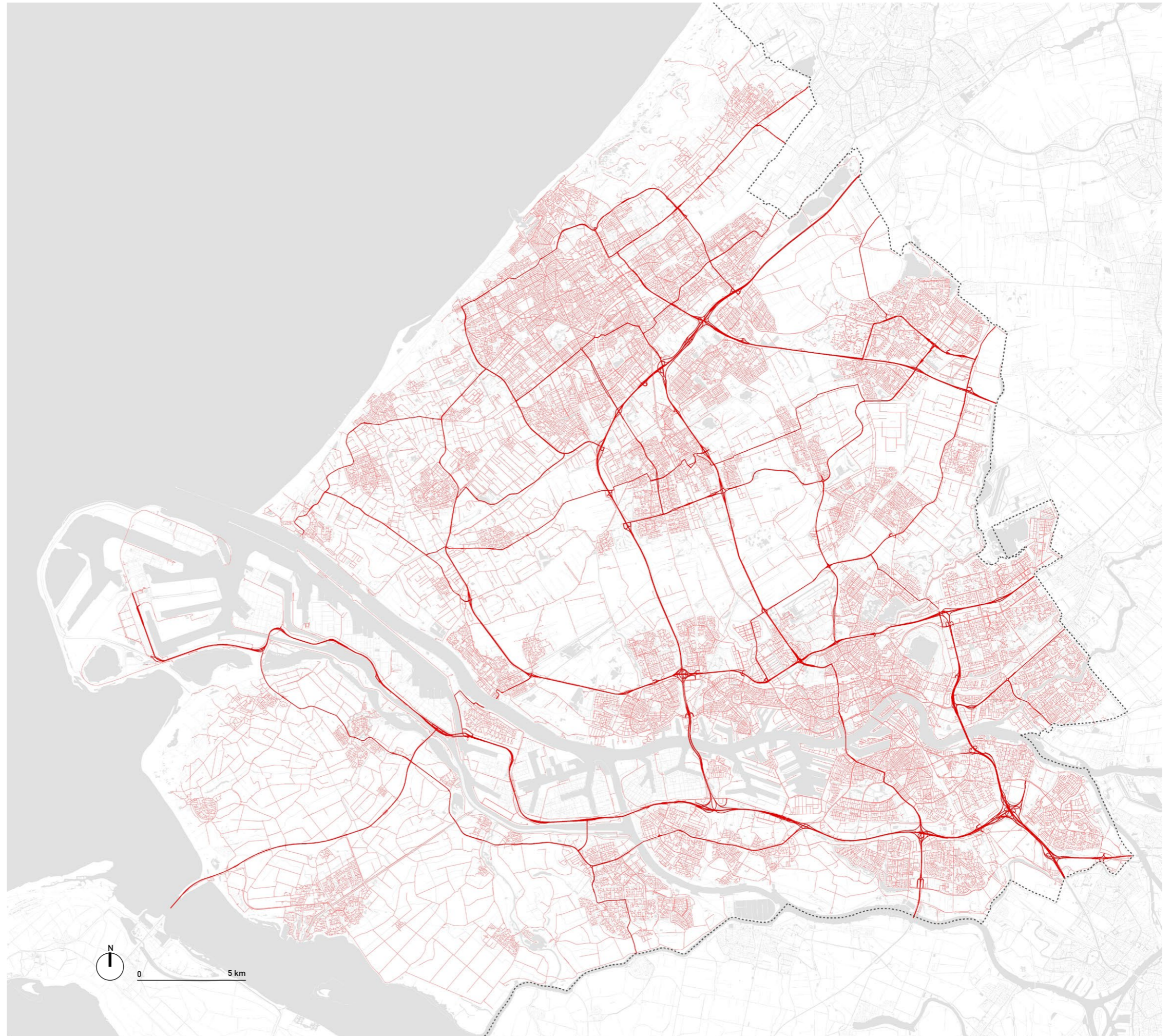

Main roads 490 km

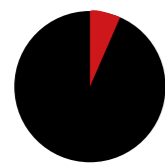

Secondary roads and urban streets 7915 km

Road network 8405 km

Figure 86. Surfaces occupied by road type. Measured in GIS based on 'wegen_lijn' and 'wegen_vlak' layers from top10nl, CBS 2015.

Figure 87. Spaces of the car idle. From GIS based on 'wegen_lijn', 'wegen_vlak' and 'gebouw' (typegebouw = 'parkdak') layers from top10nl, CBS 2015.

- Large parkings
- On-street parking

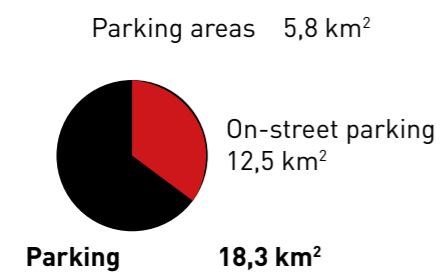
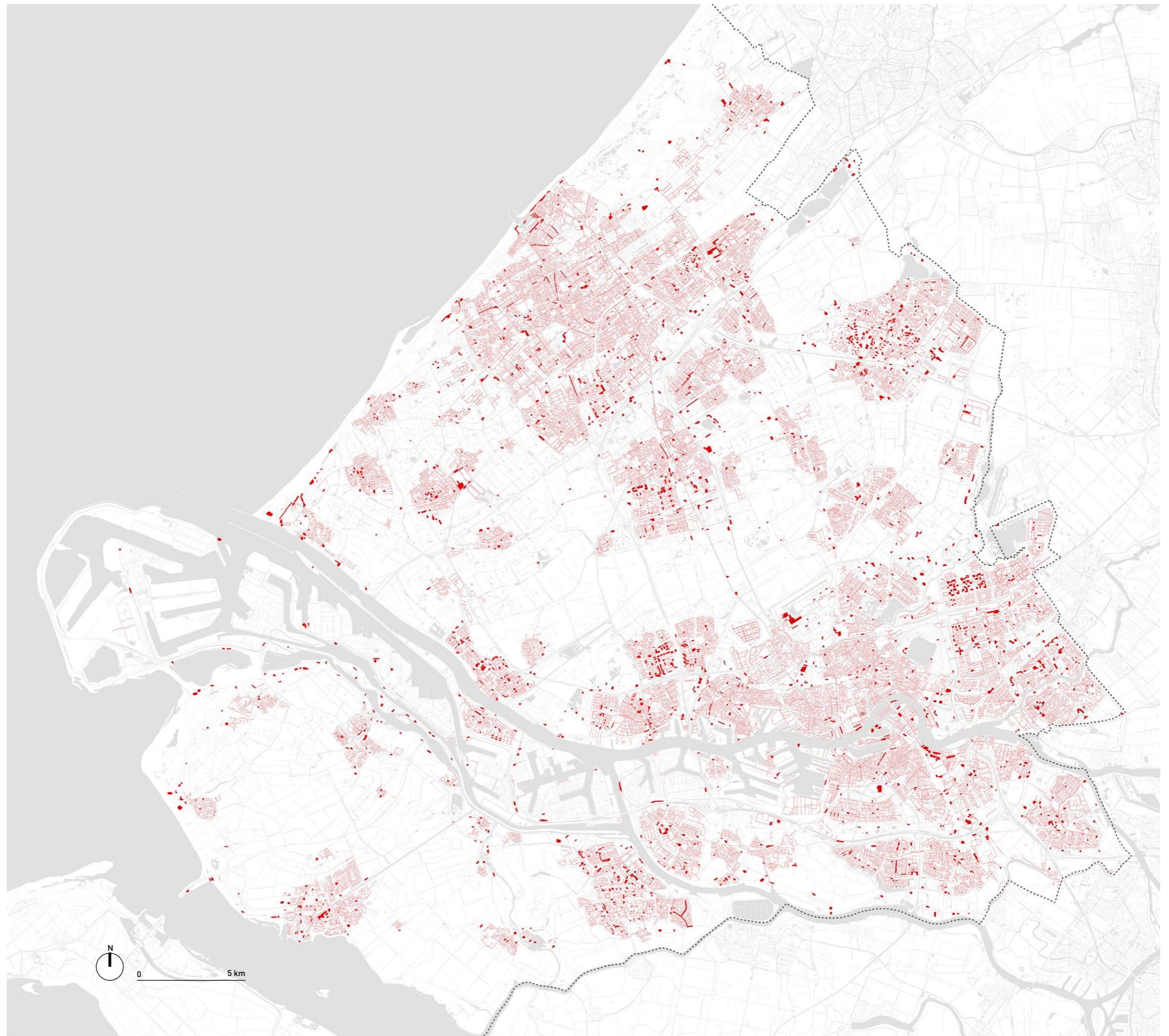

Figure 88. Surfaces occupied by parking types. Measured in GIS based on 'wegen_lijn', 'wegen_vlak' and 'gebouw' (typegebouw = 'parkdak') layers from top10nl, CBS 2015.

Figure 89. Spaces of no car - cycling and pedestrian infrastructure. From GIS based on 'wegen_lijn' and 'wegen_vlak' layers from top10nl, CBS 2015.

- Pedestrian areas
- Cycling infrastructure

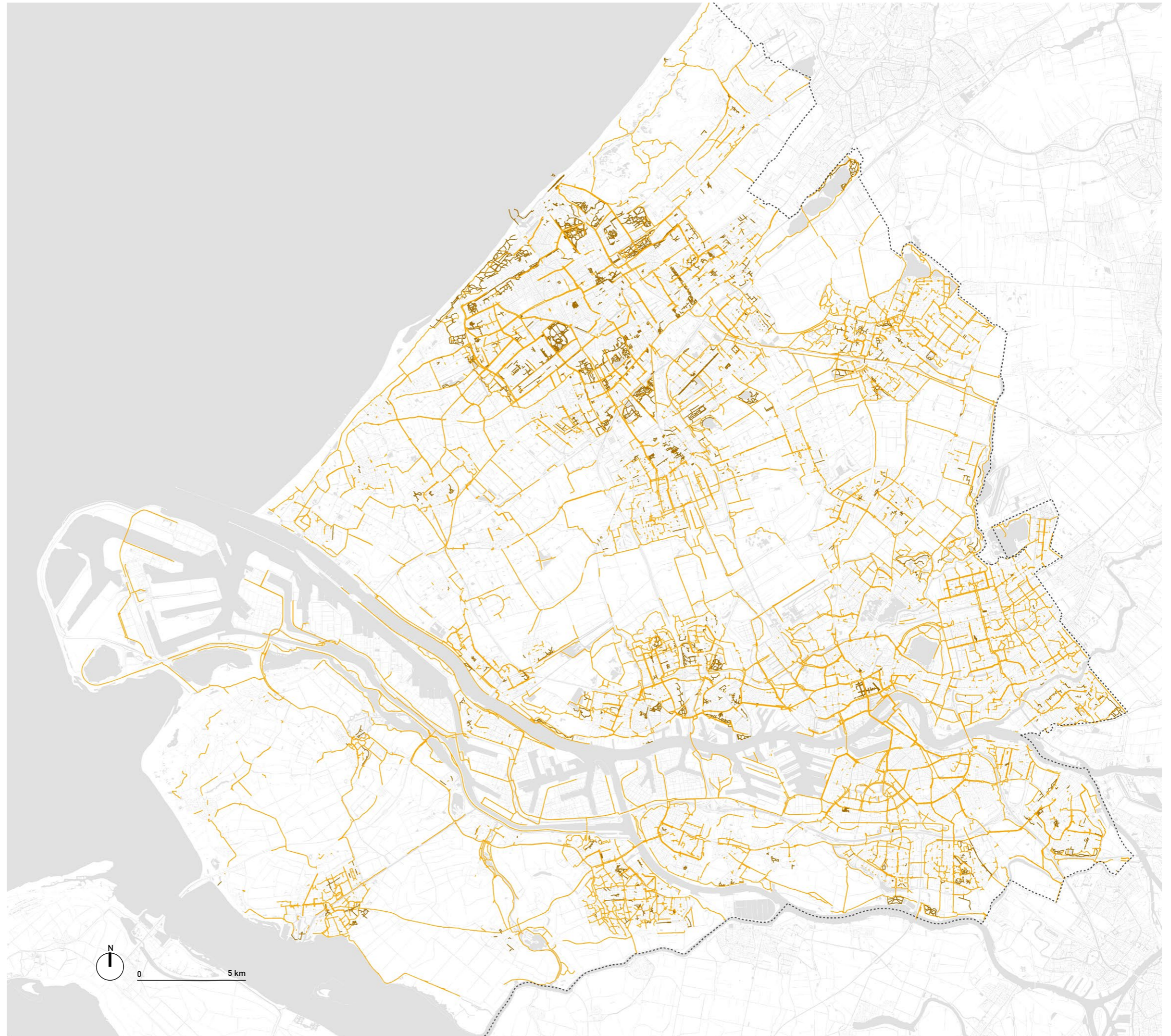
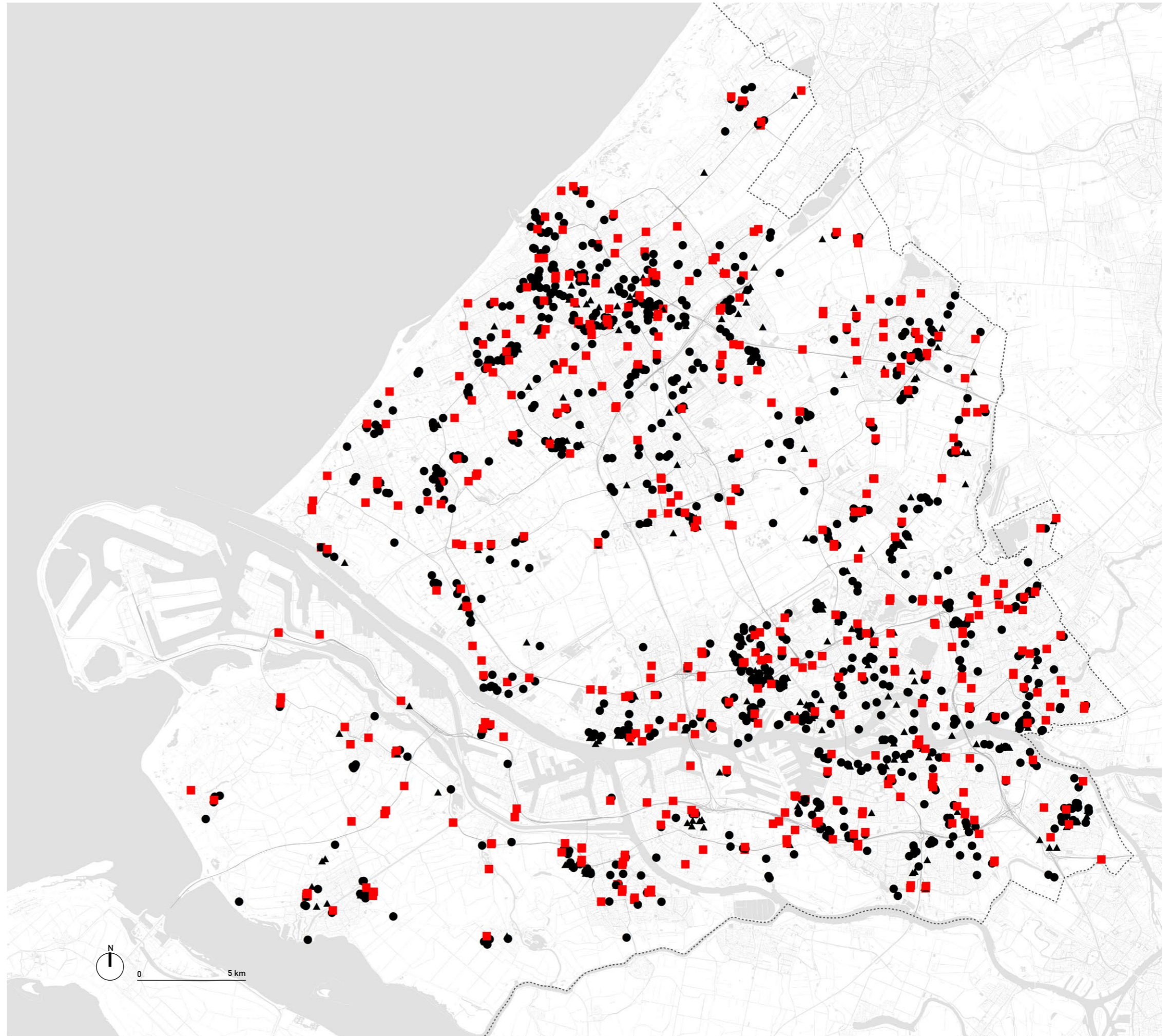

Figure 90. Car economy. Gas stations, car sales and car services represent a large part of the economy. What would replace them and what are the spatial consequences?
From GIS based on companies / BAG shapefile from CBS 2015.

- Fuel stations
- Car sales
- ▲ Car service



Mapping the drivers: density and flows

The two main driving forces of the post-AV adoption scenario, density and flows, were mapped and used later to describe transect subzones. The density map is a combination of built density variables (high/low) with human activity variables (population concentration / job concentration) resulting in five area types (see map). It can be observed on the map that the region already has a high density of buildings outside the urban cores, however these areas are mainly productive landscapes where jobs are attracted but little housing is available. Other areas are very dense as well, but only residential. Thus, there is a long and large amount of daily commute necessary for the region to function properly.

- High density + population concentration + job concentration
- High density + population concentration
- High density + job concentration
- Low density + population concentration
- Low density

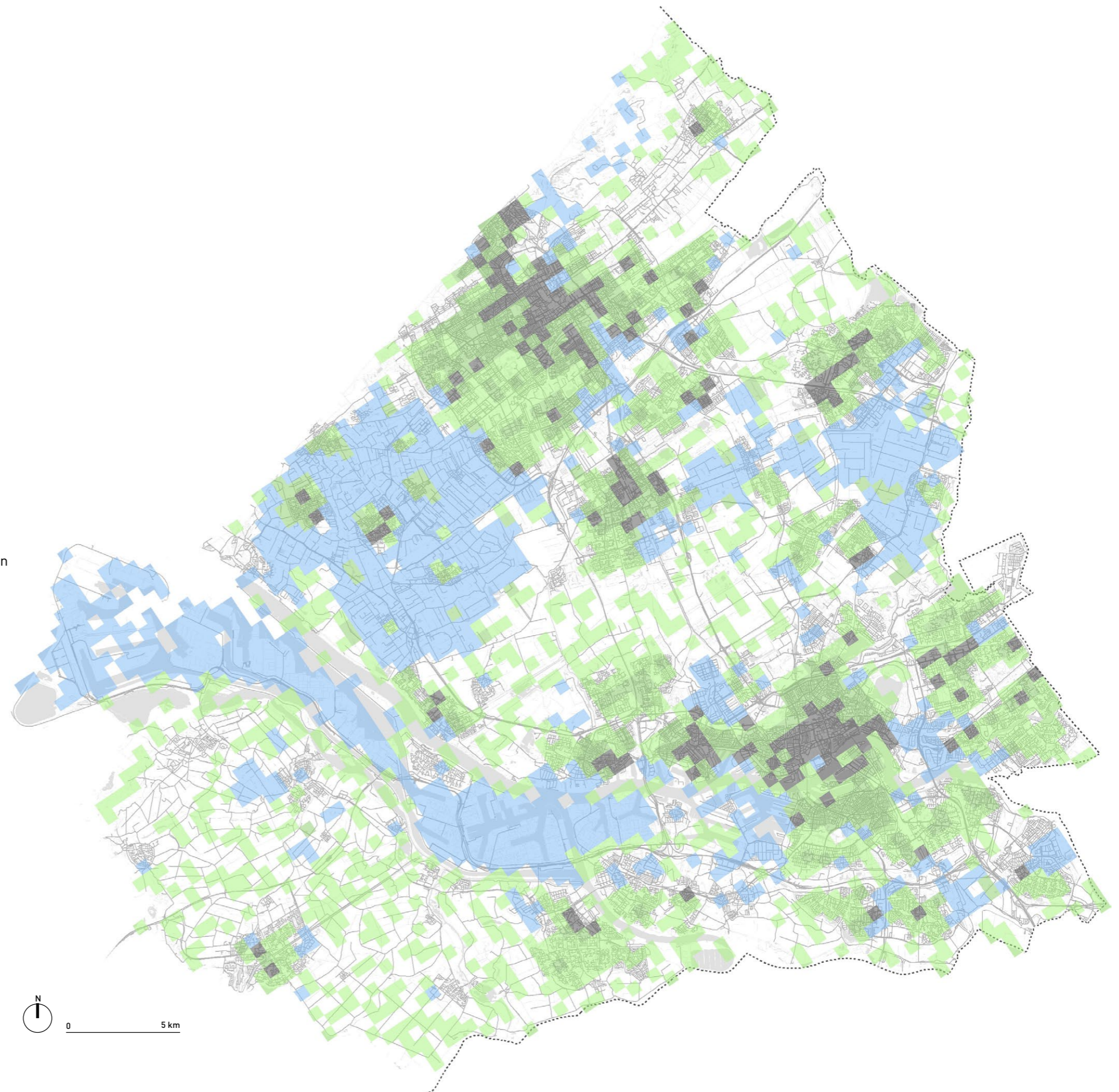

Figure 91. Densities and concentrations
 Data from Buurkaart 2016, Top10NL, CBS. Edited in ArcMap.
 Built density based on area of buildings from Top10NL weighed by floor amount (laagbouw = 2; hoogbouw = 10; kas, warehouse, dok = 1).
 Population concentration based on population density from Buurkaart 2016.
 Job concentration based on employee numbers in Bedrijven GIS data from CBS.

The network driver map is described as a combination of regional connectivity by main roads and high capacity public transport (rail, metro) systems, and local connectivity which is measured geometrically (betweenness distance) and empirically (activity concentration and areas of interest). The conclusion of the map is that there are numerous areas of local interest with poor regional connectivity, while there are many locally weakly integrated areas, but with strong regional links. This suggests an under-performing allocation of land use as well as the need for improved mobility options in certain defined urban areas.

- High regional integration by road
- High regional integration by public transport
- High local concentration
- High local integration
- Low integration



Figure 92. Modal integration and concentration analysis.
 Data from Top10NL, Google Maps. Edited in ArcMap.
 Regional integration by road based on 500 m network catchment area of main road network (hoofdwegen).
 Regional integration by public transport based on 500 m network catchment area of train (NS), metro (RET) and Randstadrail stations.
 High local concentrations based on 'areas of interest' in Google Maps.
 High local integration based on Urban Network Analysis of street network.

Transect analysis and liveability

The transect analysis is performed as an instrument in order to synthesize the characteristics of the region from the points of view of density and mobility and to focus the project on the main urban areas that would be affected by automated driving. The chosen transect is the most intense according to these criteria and the density-program matrix (fig.93). It represents the main metropolitan axis between The Hague and Rotterdam, stretching from the North Sea coast at Scheveningen, through the main cities, the Green Buffer and urban port, to the major infrastructure interchanges at Barendrecht to the South.

Three layers were studied along the transect: liveability fields, urban subzones and network accessibility. By superimposing these layers, regional patterns and critical points were observed. The transect is used to feed the scenario construction process in order to understand which inhabited areas would be impacted most in terms of liveability. The critical points were chosen in different subzones and to be characteristic of the transect as a whole, and they will serve as case study locations for the detailed scenario development.

Figure 93. Density-program matrix used to choose transect for analysis. Data from CBS and Corine Land Cover.



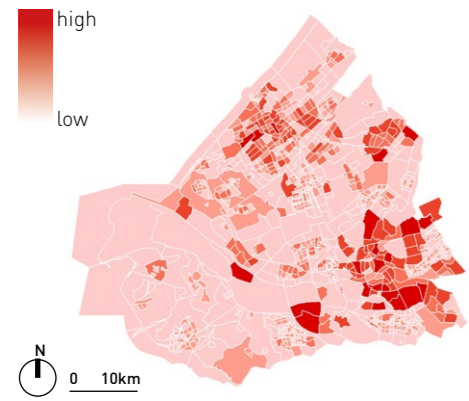

Figure 94. Population per neighbourhood (buurt), 2014. Data from CBS.

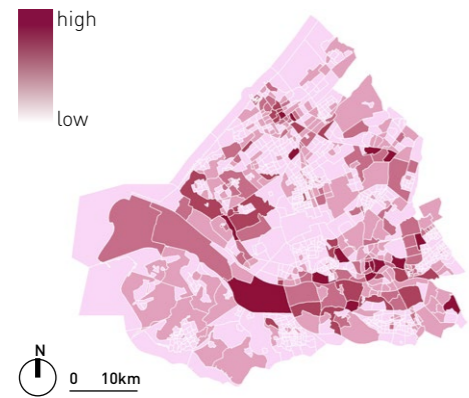

Figure 95. Number of jobs per neighbourhood (buurt), 2014. Data from CBS.

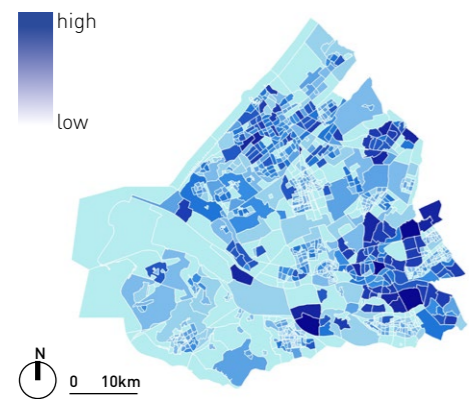

Figure 96. Number of cars per neighbourhood (buurt), 2014. Data from CBS.

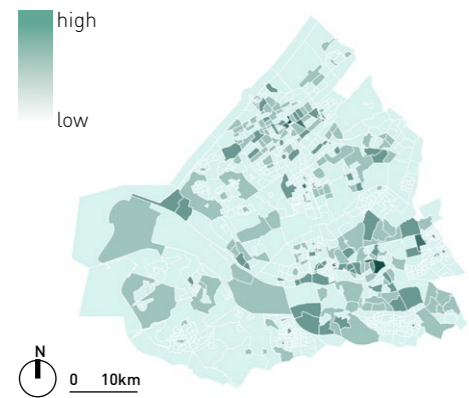

Figure 97. Number of public transport stops per neighbourhood (buurt), 2014. Data from CBS.

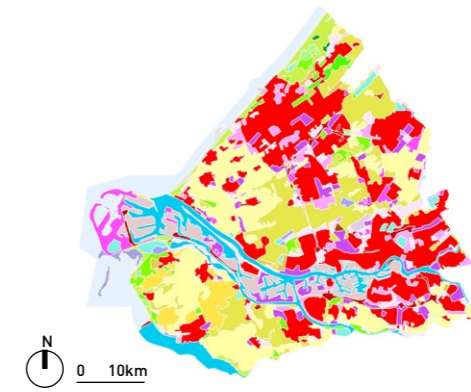

Figure 98. Corine Land Cover 2012. See Corine color code on p.77.

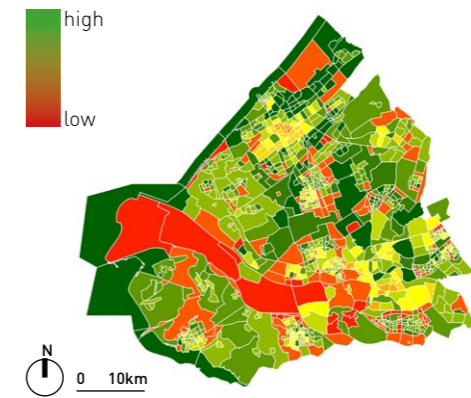

Figure 99. General life quality per neighbourhood (buurt), 2014. www.leeftaarnometer.nl

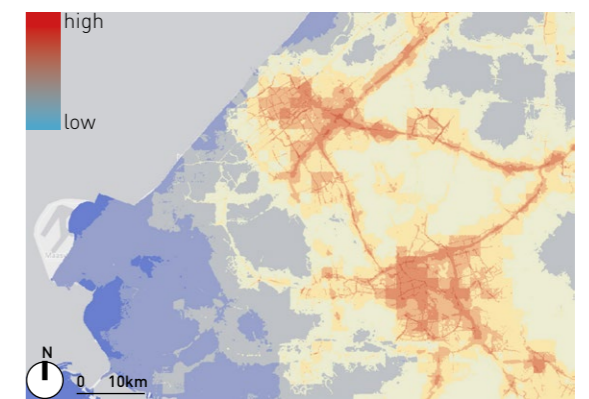

Figure 100. Soot emissions from road traffic, 2014. From www.leeftomgeving.nl

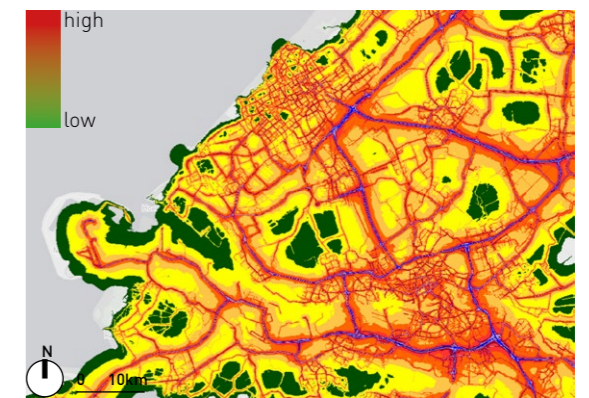

Figure 101. Noise pollution from road traffic, 2014. From www.leeftomgeving.nl

Figure 102. Built fabric



Figure 103. Green areas

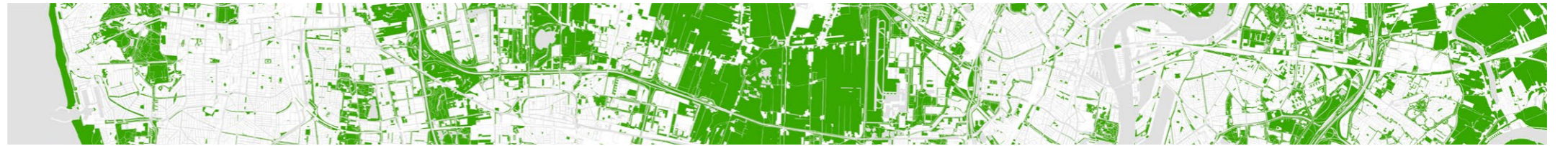

Figure 104. Car on the move: main road network



Figure 104.b. Car on the move: secondary network



Figure 104.c. Car idle: parking



Figure 105. Public transport



Figure 106. Cycling infrastructure



Figure 107. Pedestrian infrastructure

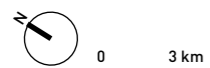

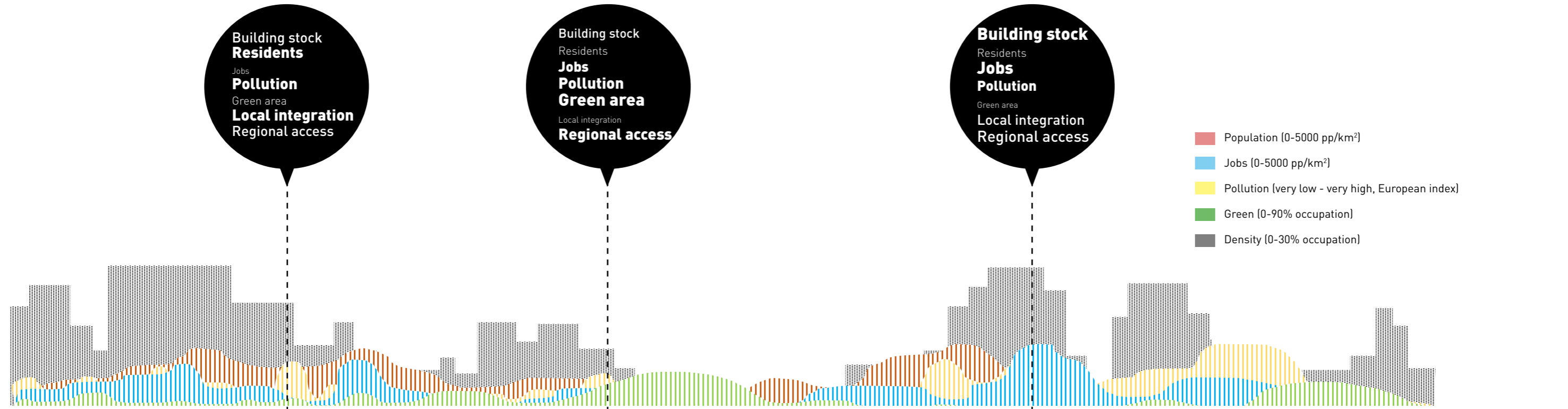

Figure 108. Transect analysis: fields of liveability. Just like following the altimetric line of a path in the territory, the transect reader can reveal the areas with highest discrepancies in liveability field values. The three highlighted points will be further analysed for case study at the local scale.



Figure 109. Transect analysis: fields of urban density. Inspired from Duany's 'smartcodes', the transect subzones of the MRDH present specific spatial and functional characteristics. The case study will highlight three different subzone types: urban centre, urban residential and undefined urban edge.

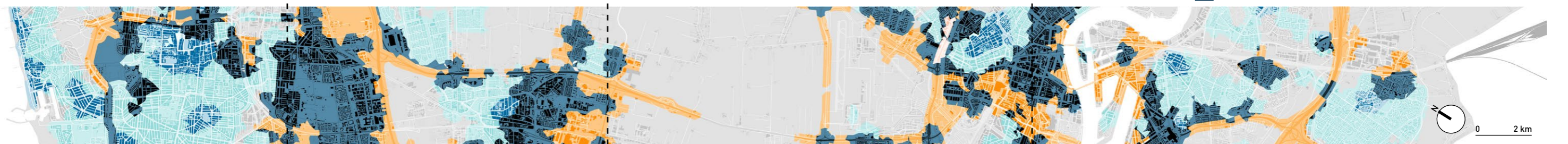
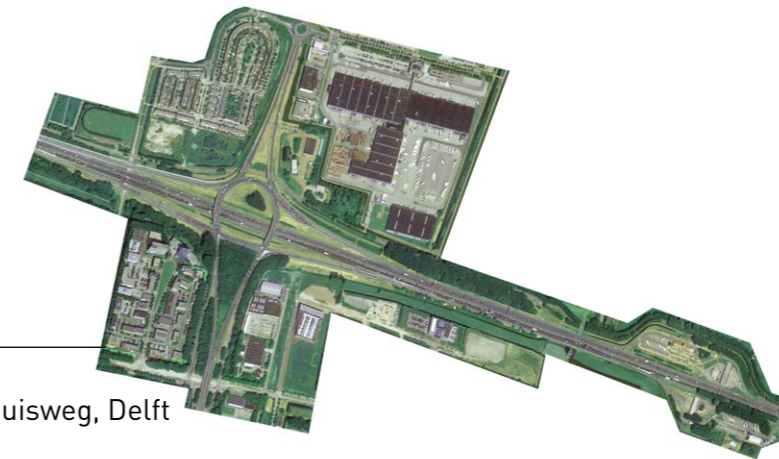

Figure 110. Transect analysis: network integration. Similar to the field subzones above, the network subzones indicate areas with different degrees of reachability.

Case study locations

Three critical subzone locations characteristic of the wider region were chosen to test the impact of automated vehicles implementation at the local scale. They are three environments of different character: urban centre, residential neighbourhood and urban edge, each with its specific problematics. The sites were analysed through the lens of critical liveability indicators, of the current structure of the built environment and of the mobility networks, and by that of the urban character of its main and secondary roads or public spaces. The locations will be used to develop scenarios at local level, by answering to specific design briefs of urbanism, architecture and society.



Urban edge
A13 / Kruithuisweg, Delft



Figure 111. Case study location on transect.



Residential neighbourhood
Gouverneurlaan, The Hague

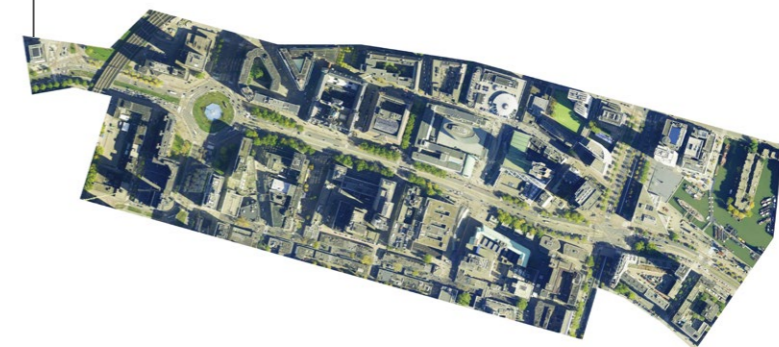

City centre
Coolingsingel, Rotterdam

City centre - Coolsingel, Rotterdam

Coolsingel is a major commercial artery of Rotterdam. The site is characterised by a high built density, high number of jobs and companies, as well as good regional and local integration. It also suffers from strong pollution, very scarce green areas and a low local population. The main street has a ‘full profile’ of tramway, car lanes, tree alignment, cycling lanes and sidewalks. Despite this, the street is not very lively itself. At the intersection with the main pedestrian street it features a commercial underpass that also serves as metro entrance. The side streets are closer to a shared space type and are more active.



Figure 112. View on main street Coolsingel. Google Street View.



Figure 113. View on secondary street Meent. Google Street View.



Figure 113. Current situation built density.

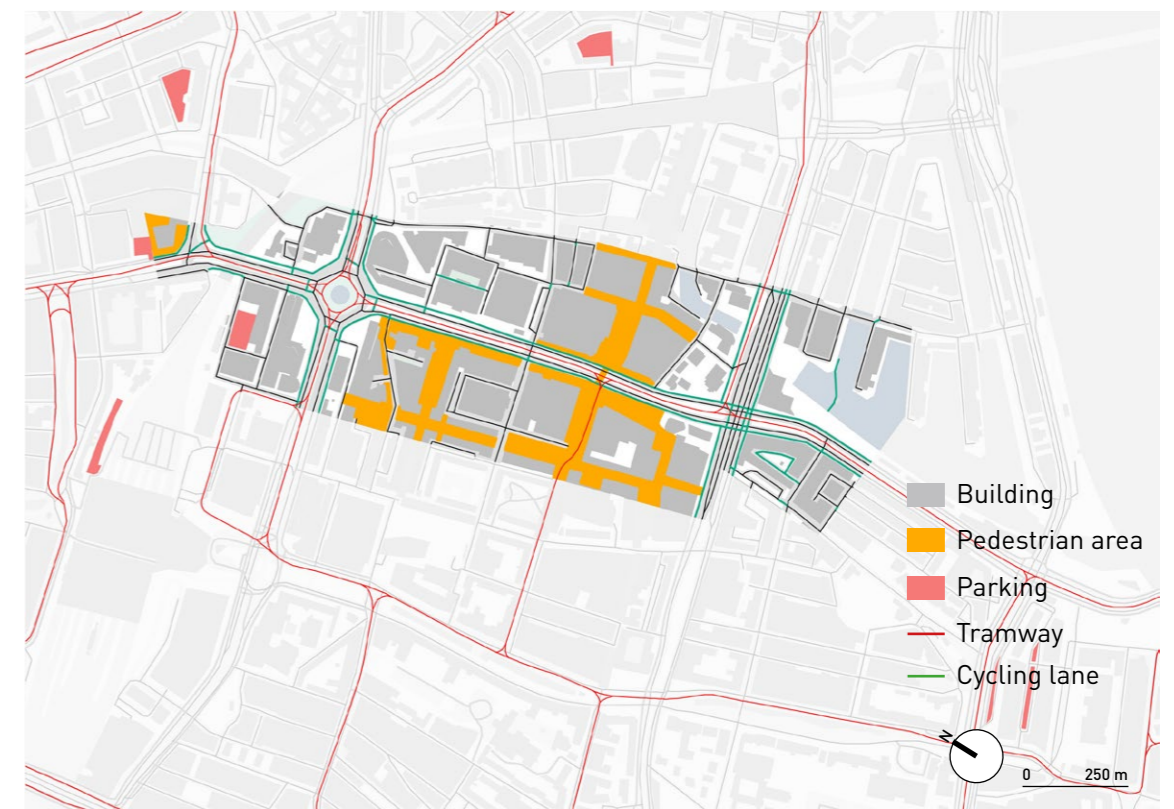

Figure 114. Current situation networks.

Residential neighbourhood - Goeveurlaan, The Hague

Goeveurlaan in The Hague is a residential neighbourhood characteristic for much of postwar Dutch urbanism. Continuous rows of housing with little or no commercial activity on the ground floor enclose a series of more private but much livelier terrace houses. The neighbourhood offers very few local jobs compared to the number of inhabitants, and pollution is moderately high. The main street is served by public transport and is relatively well connected locally and regionally, however not directly.



Figure 115. View on main street. Google Street View.



Figure 116. View on secondary street. Google Street View.

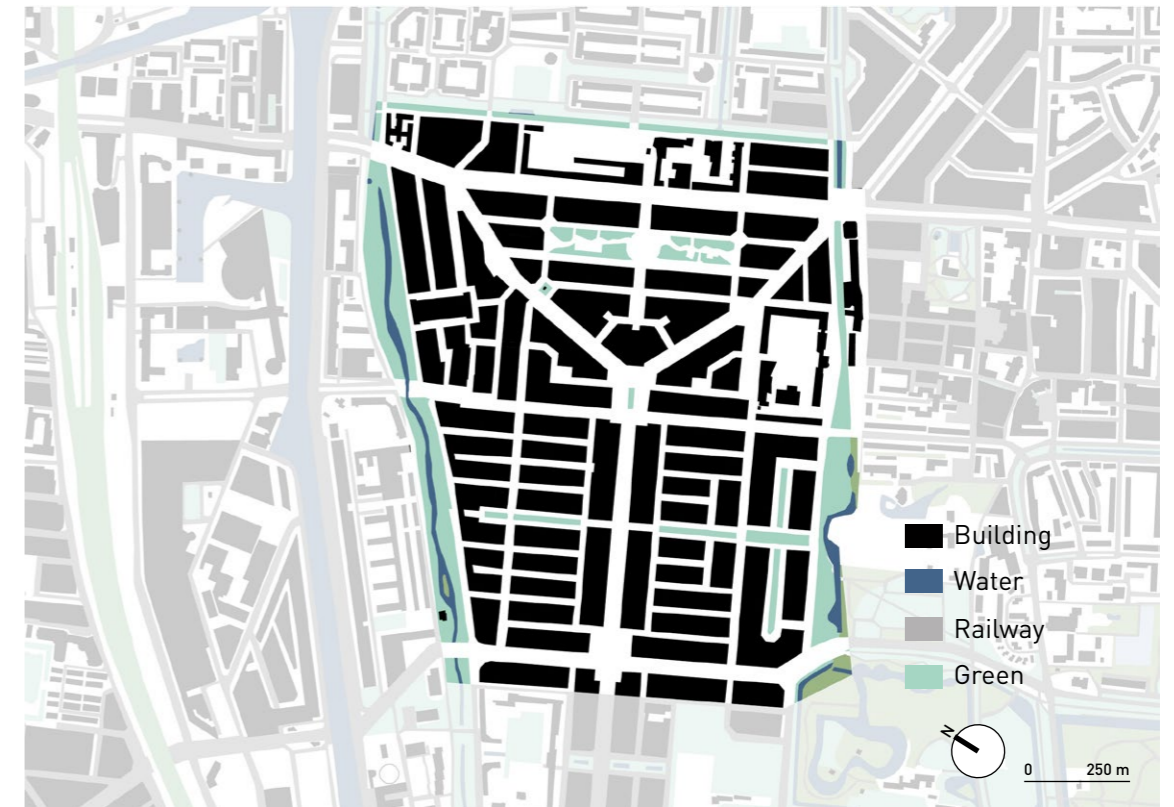

Figure 117. Current situation built density.

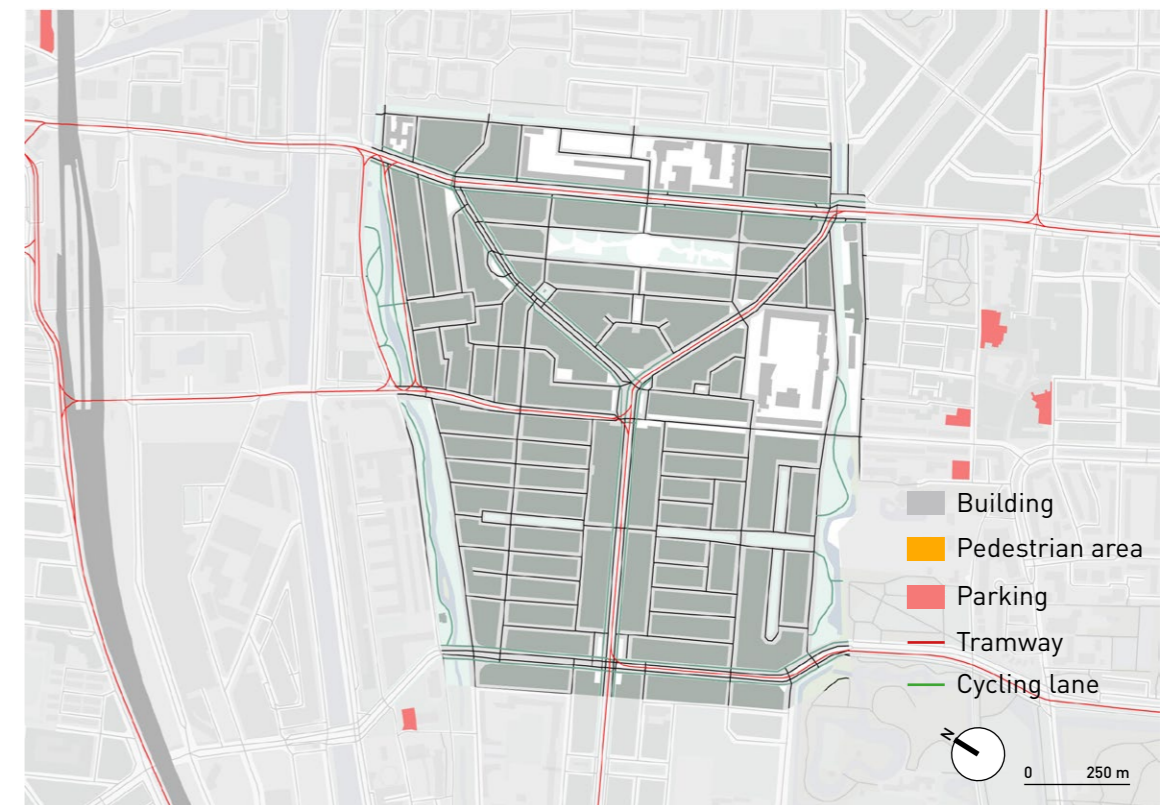

Figure 118. Current situation networks.

Urban edge - A13 / Kruithuisweg, Delft

The A13 / Kruithuisweg interchange is a major gateway to Delft from the direction of Rotterdam. It offers very high regional accessibility via the motorway but relatively low local integration. Because of its location it offers a very high number of companies and jobs, but also high road pollution. Functionally it is characterised by a mix of research centres, regular offices, logistic hubs, low density housing and sport facilities. It is built in low density and has vast areas of green space on the edge of the city.



Figure 119. View on A13 motorway. Google Street View.



Figure 120. View on secondary street. Google Street View.



Figure 121. Current situation built density.

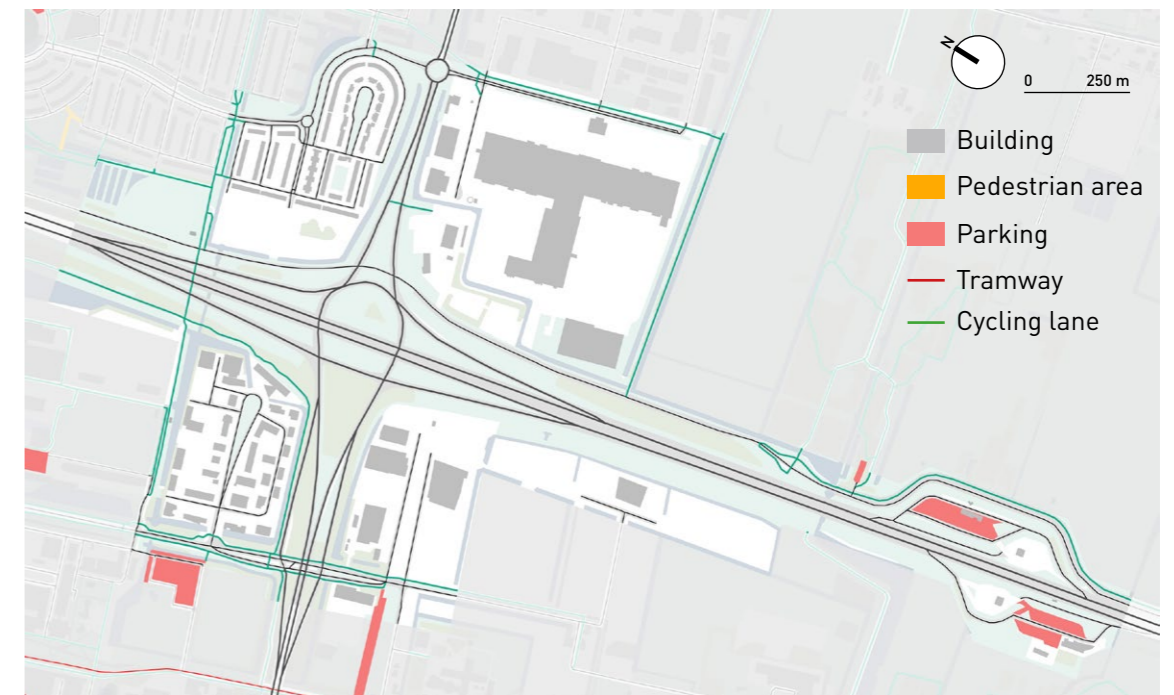

Figure 122. Current situation networks.

III. Scenarios

III.1. Scenario construction: AV and MRDH in 2040

Hypotheses and drivers

The third and main step of the method is the scenario construction. Using the driving forces of density and separation of flows, and based on hypotheses available in literature regarding AV and the evolution of the region, four extreme scenarios were described: Clockwork Utopia, characterised by concentrated urbanity and AV separated from other flows; Shared Patchwork, characterised by concentrated urbanity and AV leading to merger of flows; Efficient Garden Region, characterised by dispersed urbanisation and separated flows; and Infinite Randstad, characterised by dispersed urbanisation and merged traffic flows. The scenarios were inspired by various theoretical models, visionary and realised projects.

The year of the scenarios was chosen as 2040 as this is a moment when AV is presumed to be widely developed and available (Milakis et al 2017). The scenarios depart from the presumption that AV will be available starting in 2025 (Milakis et al 2017, Gartner 2015), thus allowing enough time for the technology to be developed and adopted by society, as well as public policy to be realigned to include AV.

The territorial hypothesis for the MRDH in 2040 was extrapolated from data for 2030 in official documents (MRDH, Government) and concludes that there should be 380.000 new housing units, as well as work premises for 80.000 new jobs.

Other hypotheses considered in all scenarios are that: commercial transport (truck, small delivery, bus, taxi) will be completely served by AV; AV will have at least a 50% share of individual cars; electric vehicles will have a share of at least 50% of all vehicles and 100% of public transport; soft technological trends such as smart mobility, sharing platforms, connected machines will continue to develop; other hard technologies will develop in parallel to AV such as electric bikes, electric cars, wireless battery charging, self-sustainable solar energy, solar roads; socio-economic trends like ageing society, automation, new job types, increased free time for all income categories, labour flexibility, fully digitalised society.

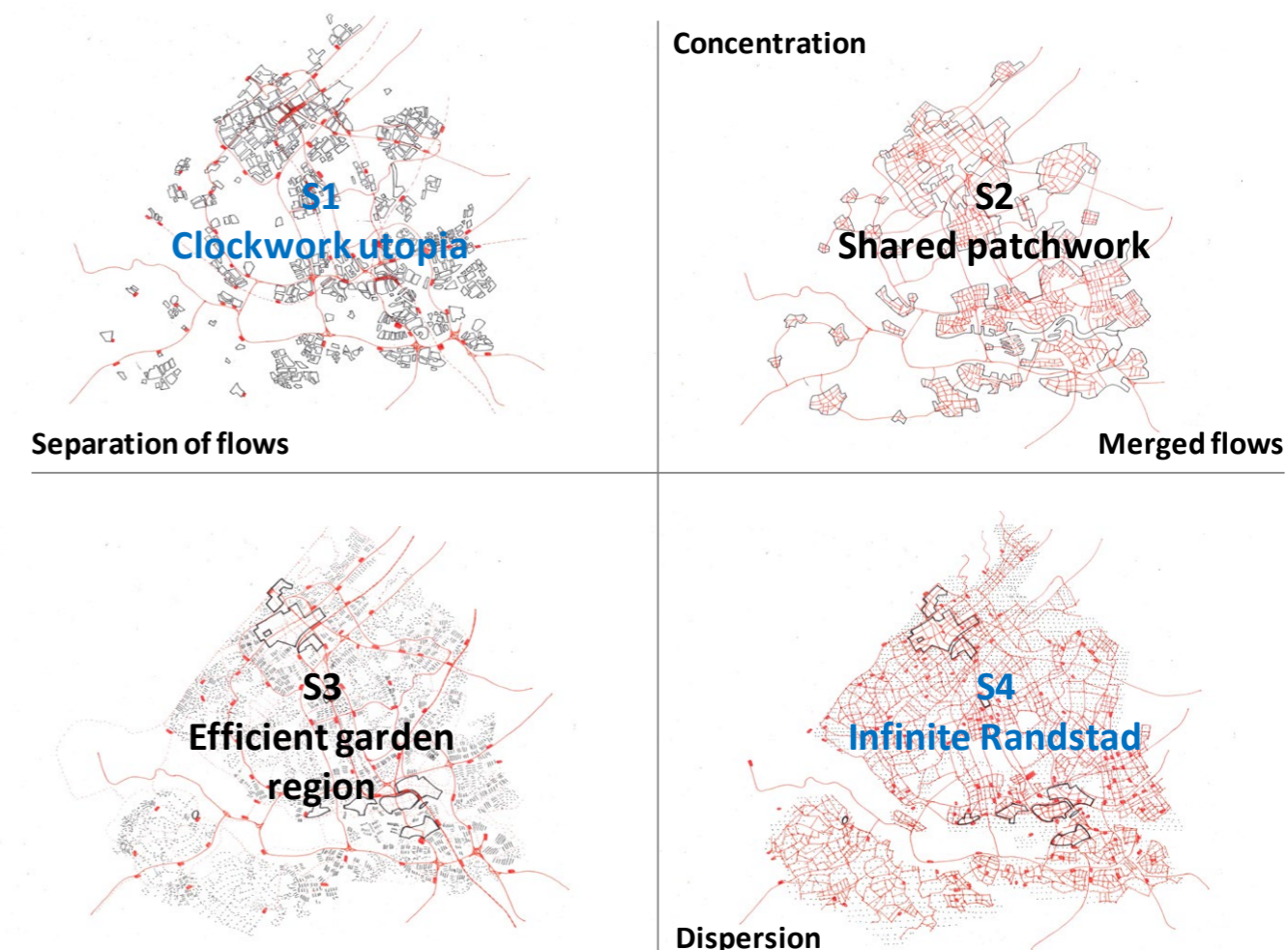

Figure 123. Scenario matrix scheme.



Figure 124. Hypotheses and drivers

Learning from the visionaries

Scenario 1. Clockwork Utopia



Harvey Wiley Corbett, City of the Future, 1913. From Lewis, P, Tsurumaki, M & Lewis, DJ (2016). Manual of section.



Le Corbusier, Ville Radieuse 1930. From Calabrese, LC (2004). Reweaving UMA.



Hong Kong organical separation of flows between 1960 and today. www.citieswithoutground.com

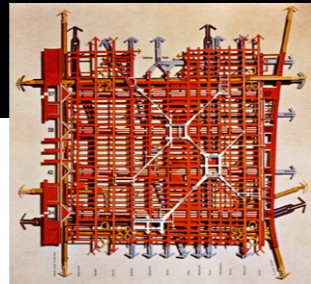

Yona Friedman, Urban Design Manhattan, 1969. From Yoos & James, The Multilevel Metropolis.

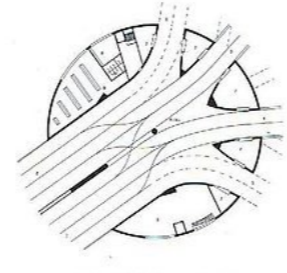

OMA, Zeebrugge Sea Terminal, 1988. www.oma.eu

concentration

REALISATION

PROJECT / VISION

THEORY



Ildefons Cerda, Enlargement plan for Barcelona, 1859. From Calabrese, L (2004). Reweaving UMA.

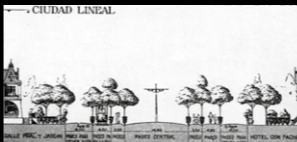

Arturo Soria y Mata, Ciudad Lineal, 1882. From Calabrese, LC (2004). Reweaving UMA.



Living street, Ghent, 2015. From www.leefstraat.be

Scenario 2. Horizontal Density

separated flows

merged flows

Figure 125. Visionary projects table, organised by scenario and type. Scenarios 1 and 4 link to most project/vision types, whereas scenarios 2 and 3 are connected to mostly theoretical models or realised projects. Therefore, scenarios 1 and 4 are the most interesting to develop in an explorative direction.



Geoffrey Jellicoe, Motopia, 1959.

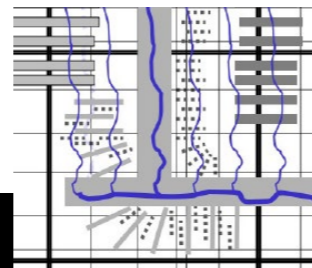

Regional model and activities model of the two networks strategy, Tjallingii, 2015.

THEORY

PROJECT / VISION

REALISATION

dispersion



Ebenezer Howard, Garden City, 1902.



Norman Bel Geddes, Futurama, 1939. www.tumblr.com

Scenario 3. Efficient Garden Region



Foster & partners, London Cycling Highways, 2015. www.fosterandpartners.com



Frank Lloyd Wright, Broadacre City, model, 1930. From www.moma.org

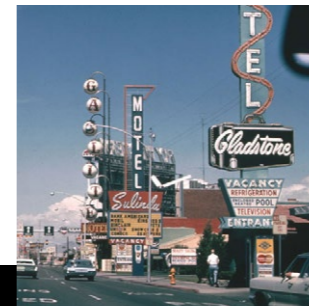

Robert Venturi, Denise Scott Brown, Learning from Las Vegas, 1972.

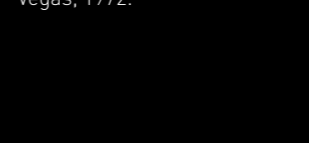

Andrea Branzi, Residential Park, No-stop City, project, plan. 1969. From www.moma.org



Robert Moses, Grand Central Parkway Queens, 1936. www.corbisimages.com

Scenario 4. Infinite Randstad



Future of suburbia, Matthew Sprenulli, Center for Advanced Urbanism, MIT, 2016.

Scenario 1: Clockwork Utopia

Characteristics:

- densification only in existing urban cores
- territory connecting dense no-car urban blocks
- AV clearly separated from other modes
- highly efficient public multimodal transport

Design problems to tackle:

- overcome spatial segregation between urban blocks
- design and locate the multimodal hubs
- accommodate growth in intensive densification
- ensure access to green and water in the cities

References:

- Ville Radieuse, 1930, Le Corbusier
- City of the Future, Corbett, 1913
- Urban Design Manhattan, Friedman, 1969
- Zeebrugge Sea Terminal, OMA, 1988
- Hong Kong skywalk network, Cities without ground

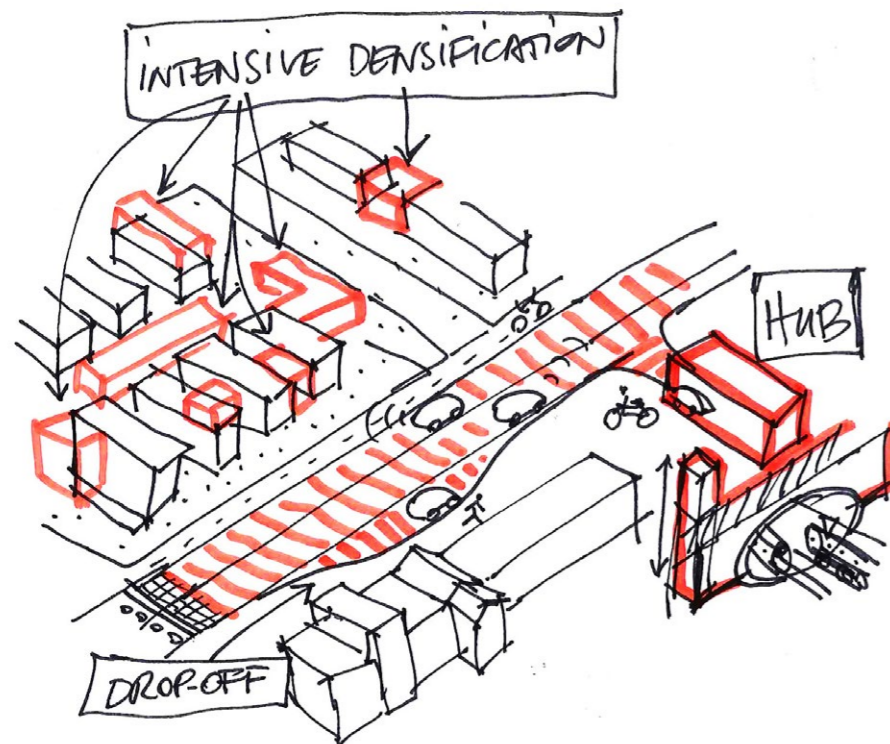

Figure 126. Clockwork Utopia zoom in to street level.

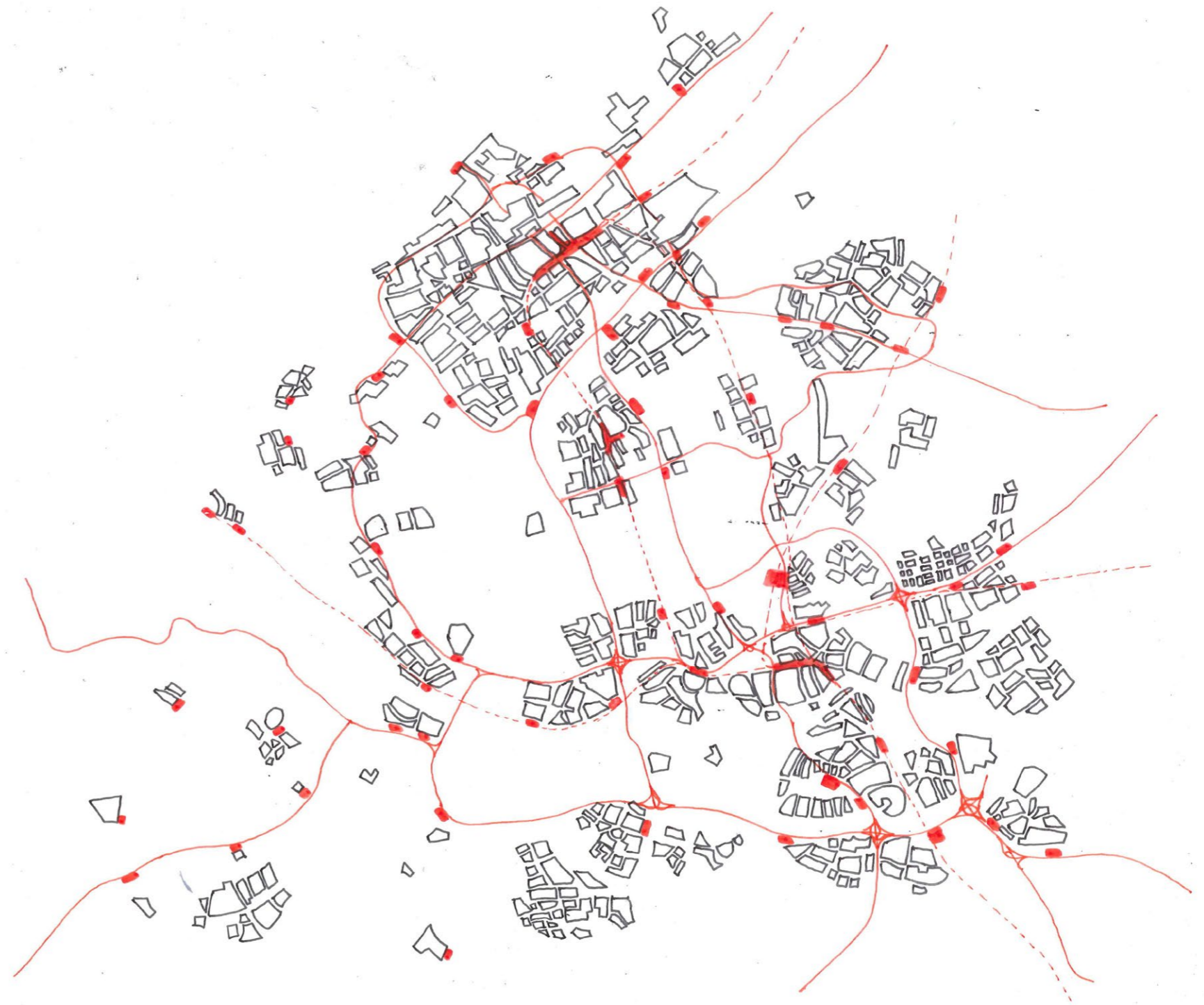

Figure 127. Clockwork Utopia concept map.

Scenario 2: Shared Patchwork

Characteristics:

- densification only in existing urban cores
- territory of clearly determined fabric types
- AV and all modes mixed everywhere, with few exceptions
- variety of public and private multimodal transport

Design problems to tackle:

- accommodate growth in intensive densification
- ensure access to green and water in the cities
- extents and quality of shared traffic spaces
- re-evaluate existing dedicated infrastructures

References:

- Enlargement plan for Barcelona, Cerda, 1859
- Ciudad Lineal, Soria y Mata, 1882
- Downtown is for people, Jane Jacobs, 1958
- Cities for People, 2010, Jahn Gehl
- Living street, Ghent, 2015

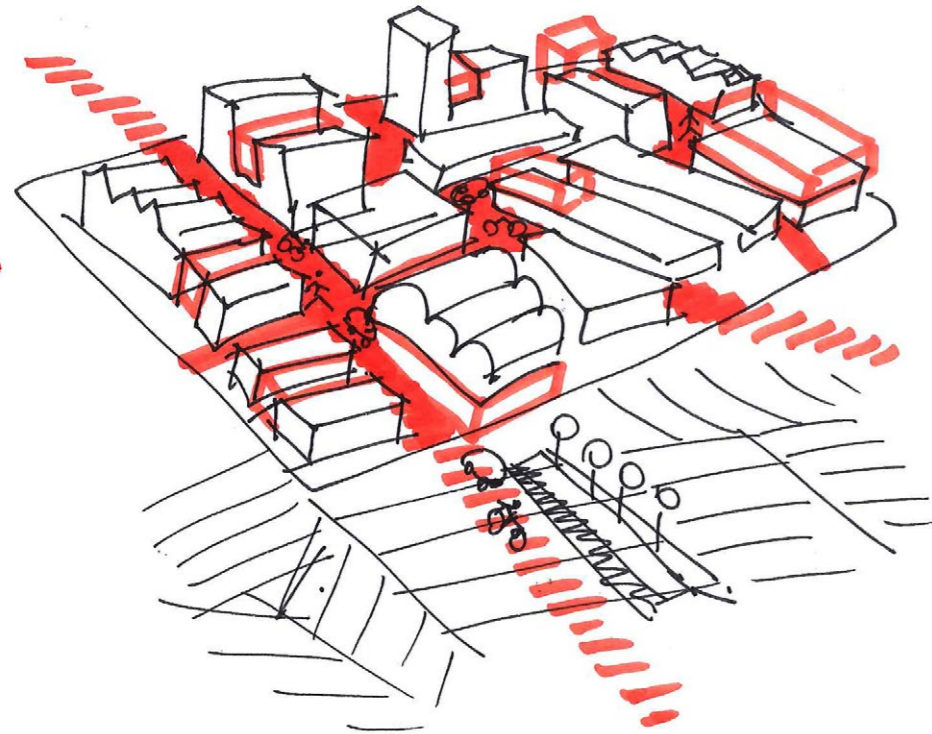

Figure 128. Shared Patchwork zoom-in sketch.

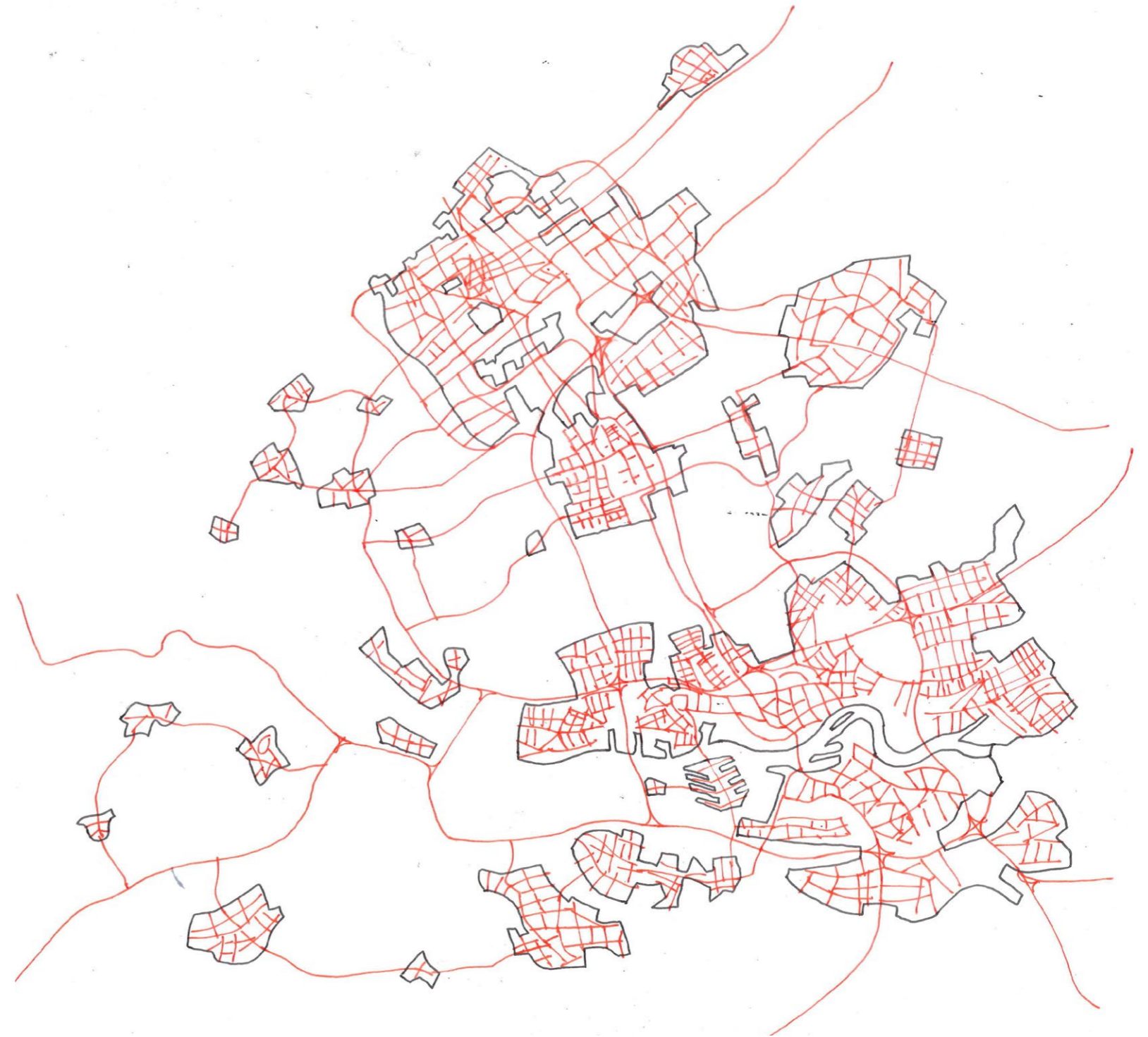

Figure 129. Shared Patchwork concept map.

Scenario 3: Efficient Garden Region

Characteristics:

- growth mainly outside existing urban cores
- mixed territory of rural areas and light urbanity
- AV clearly separated from other modes
- highly efficient fast and slow regional transport networks

Design problems to tackle:

- coexistence and synergy of fast and slow networks
- promote active mobility and multimodality
- overcome spatial segregation created by AV roads
- maintain continuity and proportion of green areas in the region

References:

- Garden City, Howard, 1902
- Futurama, Bel Geddes, 1939
- Motopia, Jellicoe, 1959
- London cycling highways, Foster, 2015
- Planning with water and traffic networks, Tjallingii, 2015

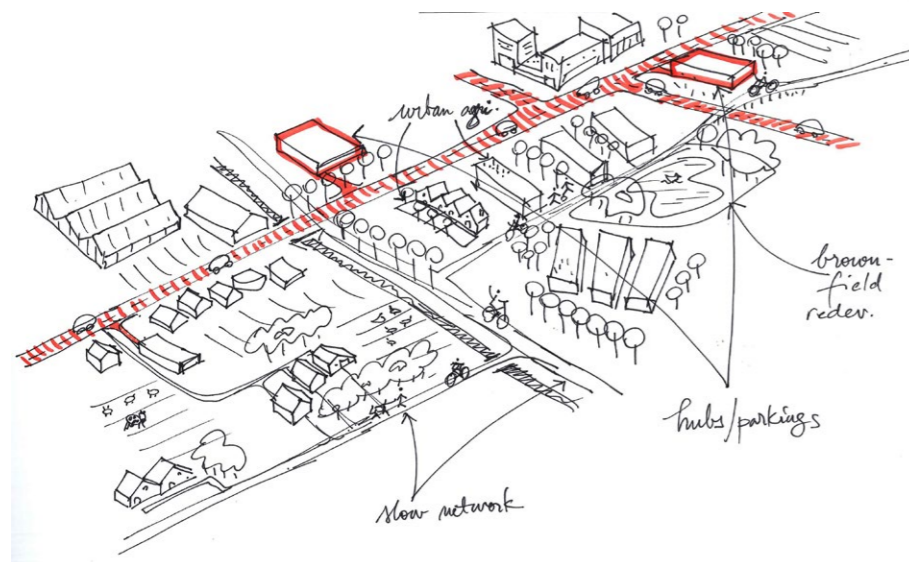

Figure 130. Efficient Garden Region zoom in sketch.



Figure 131. Efficient Garden Region concept map.

Scenario 4: Infinite Randstad

Characteristics:

- growth mainly outside existing urban cores
- low-density territory with spontaneous centralities
- AV and all modes mixed everywhere, with few exceptions
- isotropic accessibility with all transport means, low multimodality

Design problems to tackle:

- extents and quality of shared traffic spaces
- promote active mobility and multimodality
- re-evaluate existing dedicated infrastructures
- maintain continuity and proportion of green areas in the region

References:

- Broadacre City, 1932, Frank Lloyd Wright
- No-stop City, 1969, Andrea Branzi
- Learning from Las Vegas, Venturi and Brown, 1972
- Future of suburbia, MIT, 2016

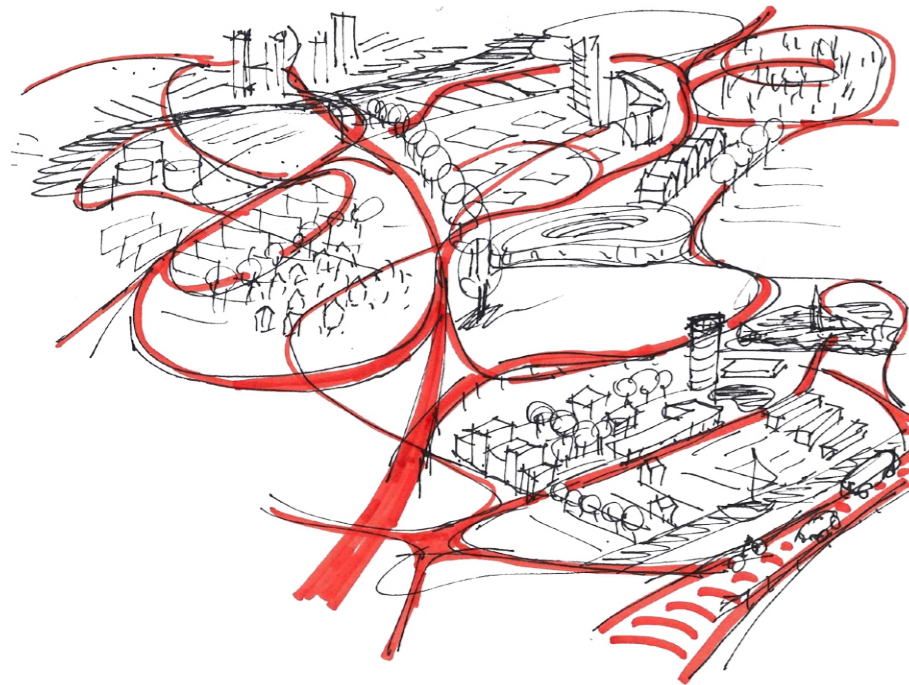

Figure 132. Infinite Randstad concept aerial view.



Figure 133. Infinite Randstad concept map.

III.1. Scenario development: Clockwork Utopia and Infinite Randstad

Mobility and lifestyle hypotheses

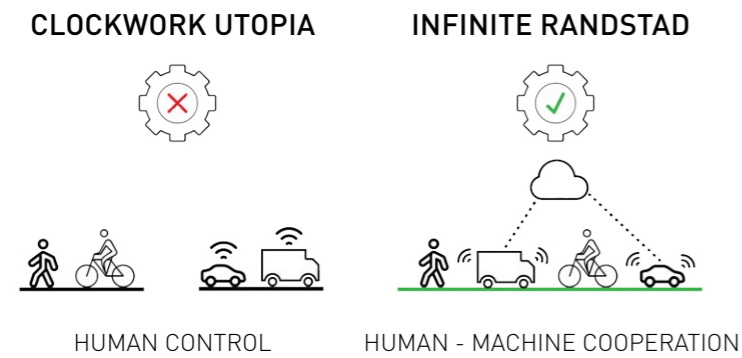

Figure 134. Tendency to control versus trust in technology: in S1 technology is not completely trusted thus separation of flows occurs. In S4, users share the same space of mobility due to proven safety.

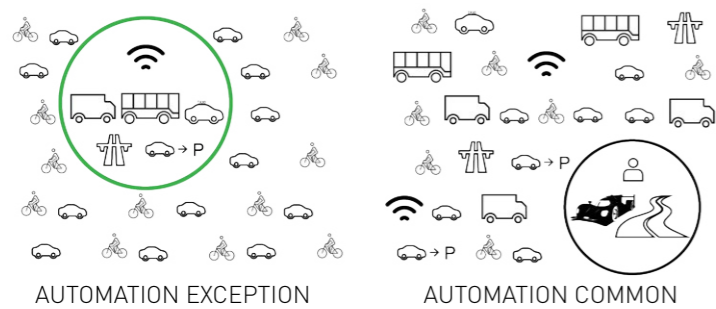

Figure 135. In S1, automation is a novelty slowly accepted and is mixed in traffic with traditional human-driven vehicles. In S4 automation is the norm and human driving is only for recreational purposes in special or scenic areas.

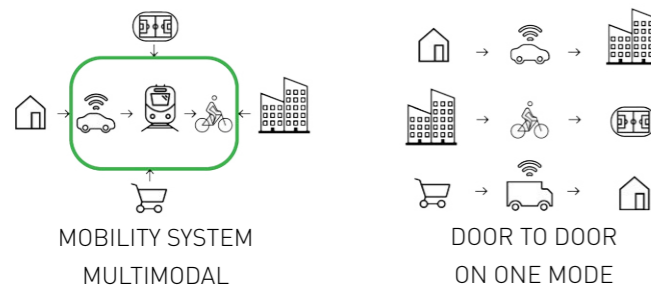

Figure 136. People in S1 use multiple modes of transport to reach their final destination, many of them being shared or active modes. In S4, it is convenient to travel door-to-door by one mode, reducing the need to transfer.



Figure 137. While in S1 travel time is mostly a publicly spent time - like today on public transport, in S4 travel time becomes private time and, without the need to drive, new activities can be accommodated.

Drivers: organisation principles

In Clockwork Utopia, separation of flows translates into grade-separated crossings for pedestrians and separate rights of way for cars, public transport and cyclists, whereas in Infinite Randstad, merged flows appear as shared space of the urban ground level, where all users are free to make their way as

AV has learned to follow and predict human behaviour. At a regional scale, concentration in the first scenario leads to clearly defined functional urban areas, with large open green spaces between cities, while in the second urban pattern is more dispersed and isotropic.

CLOCKWORK UTOPIA

INFINITE RANDSTAD

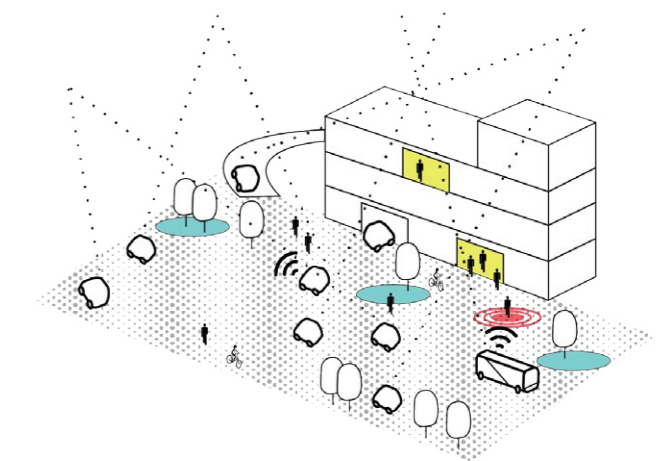
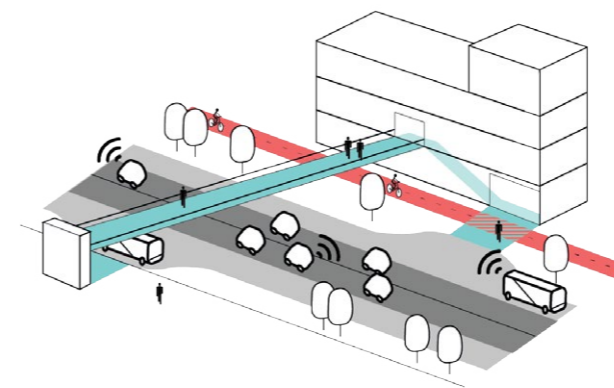

SEPARATION OF FLOWS

SHARED SPACE

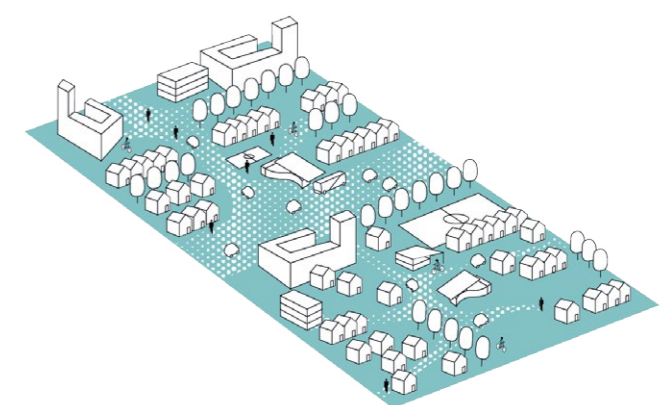
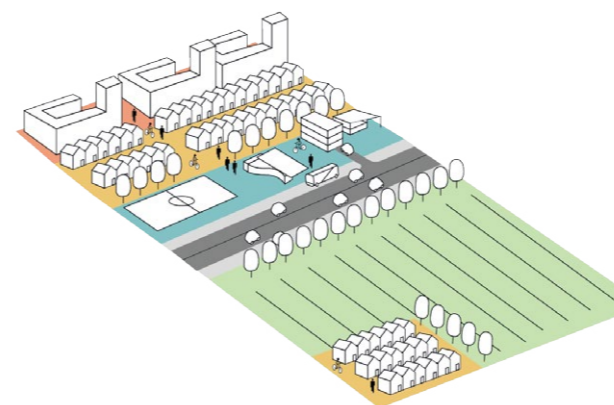

CONCENTRATION

DISPERSION

Figures 138-141. Axonometric diagrams of scenario driving forces: flows and density.

Drivers: regional structure

Field density and network structure follow distinct directions in the two scenarios. In the first, urban development is contained within city limits as intensive growth, whereas in the second, development is allowed closer to nature and in green/agricultural areas.

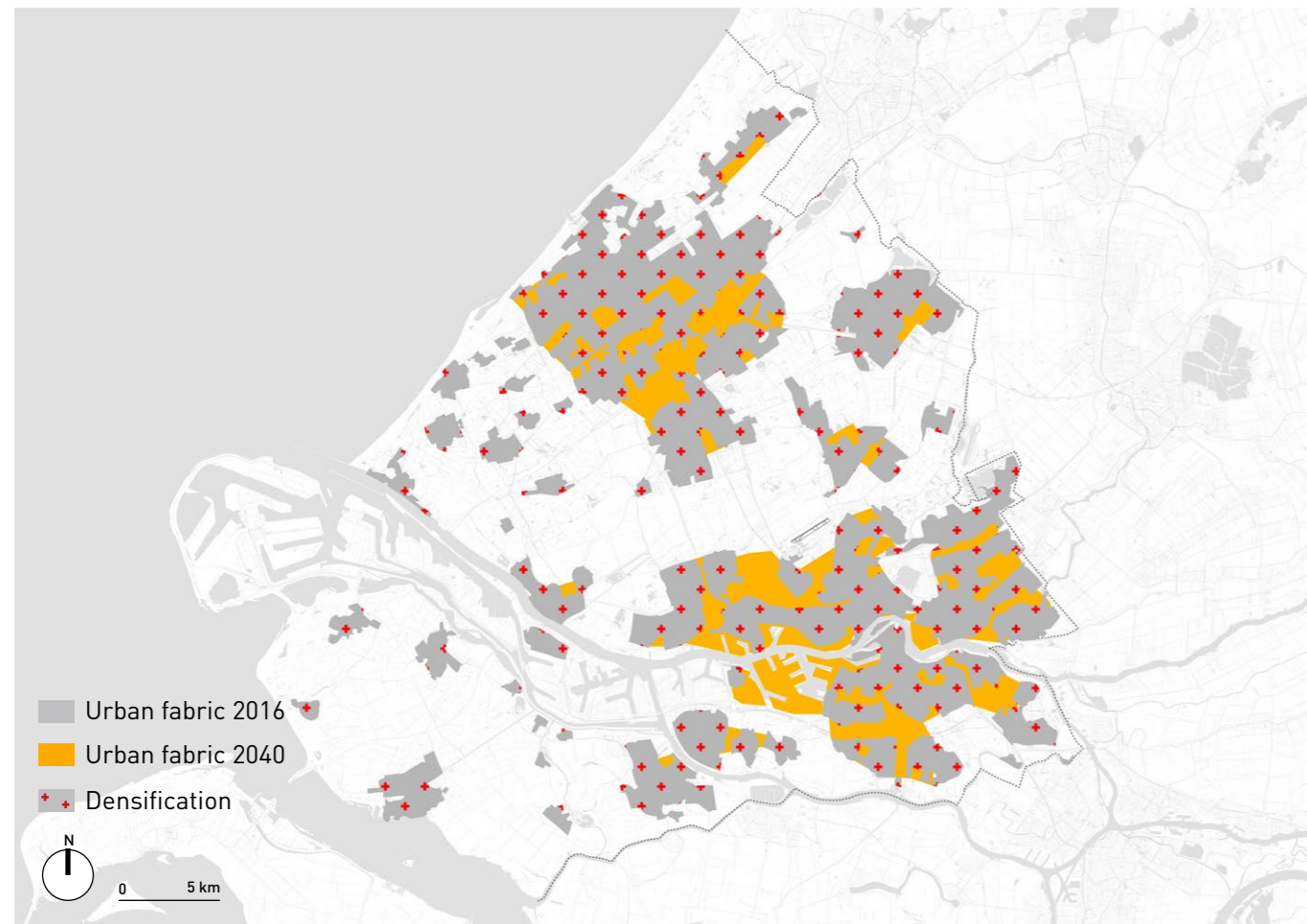

Figure 142. Urban fabric development in Clockwork Utopia. The two main cities Rotterdam and The Hague are re-inforced and merged with their neighbours. Large open spaces remain free between inhabited areas.

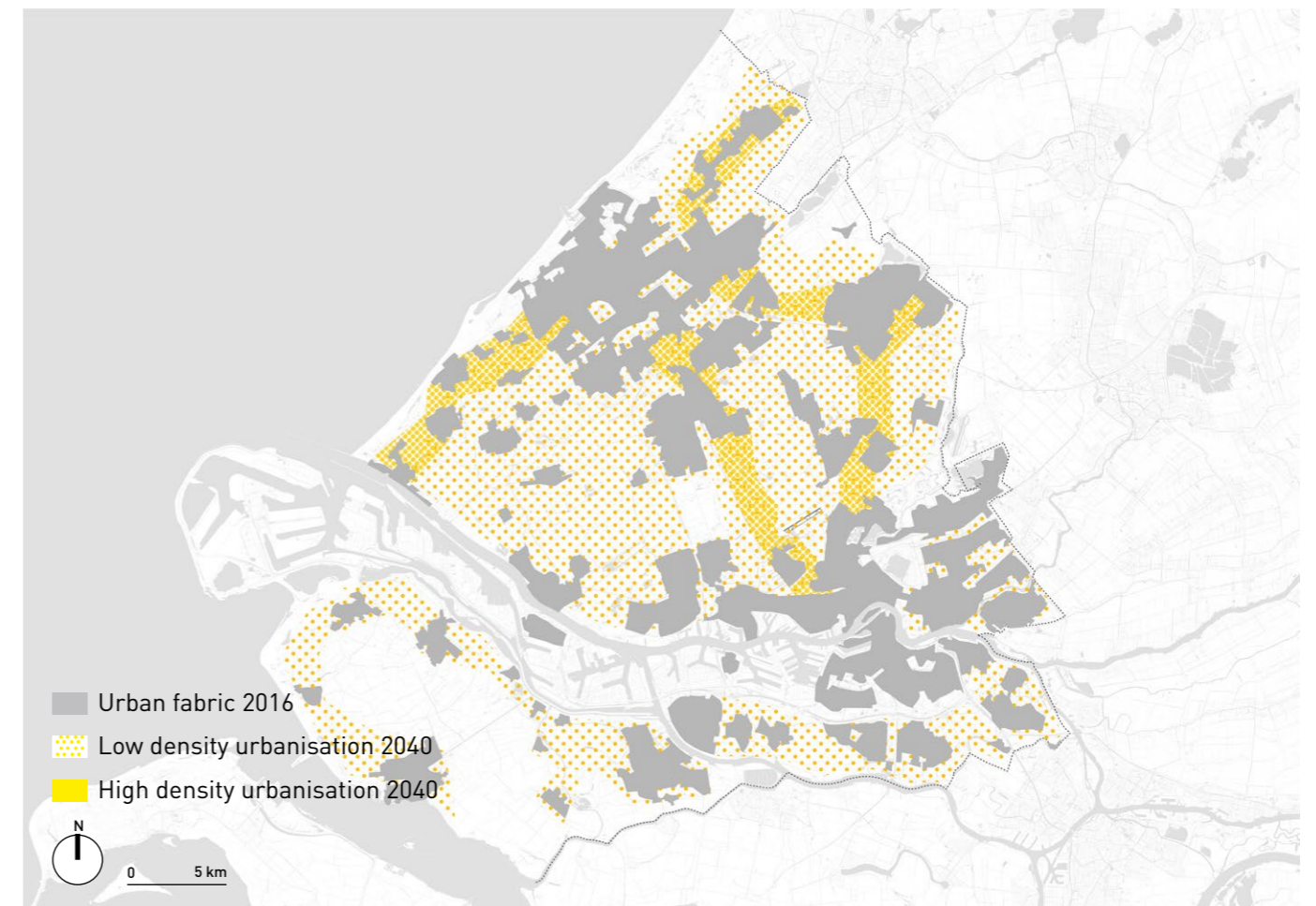

Figure 143. Urban fabric development in Infinite Randstad. Urbanisation is happening everywhere, enabled by fast mobility and technological development. New concentrations appear on the main connections between the cities, as well as along the North Sea coast.

These urban patterns are enabled by the mobility networks, as Clockwork Utopia is based on a hub-and-spoke structure of urban cells where transfer is necessary between modes of different speeds, while in Infinite Randstad point-to-point travel is more dominant enabled by the universal access of AV.

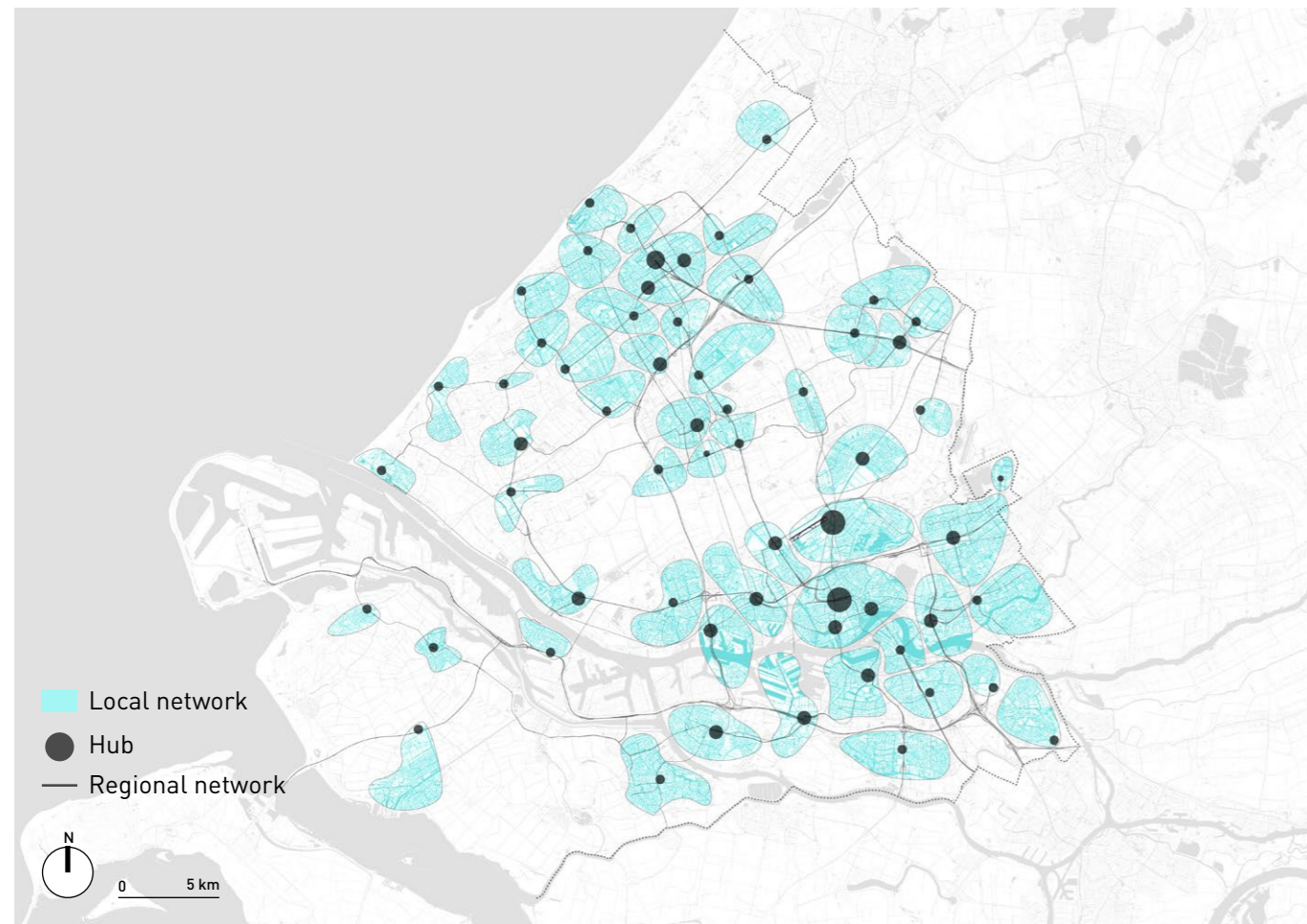

Figure 144. Mobility networks development in Clockwork Utopia. A hub-and-spoke system connects the main urban areas between them. Transfers from fast inter-hub travel by train, metro or car to slow, local modes - cycling, walking, neighbourhood shared pods - are made at large hubs which become centres of activity such as train stations today. Lightly or not urbanised areas remain marginally served by shared AV or e-bike.

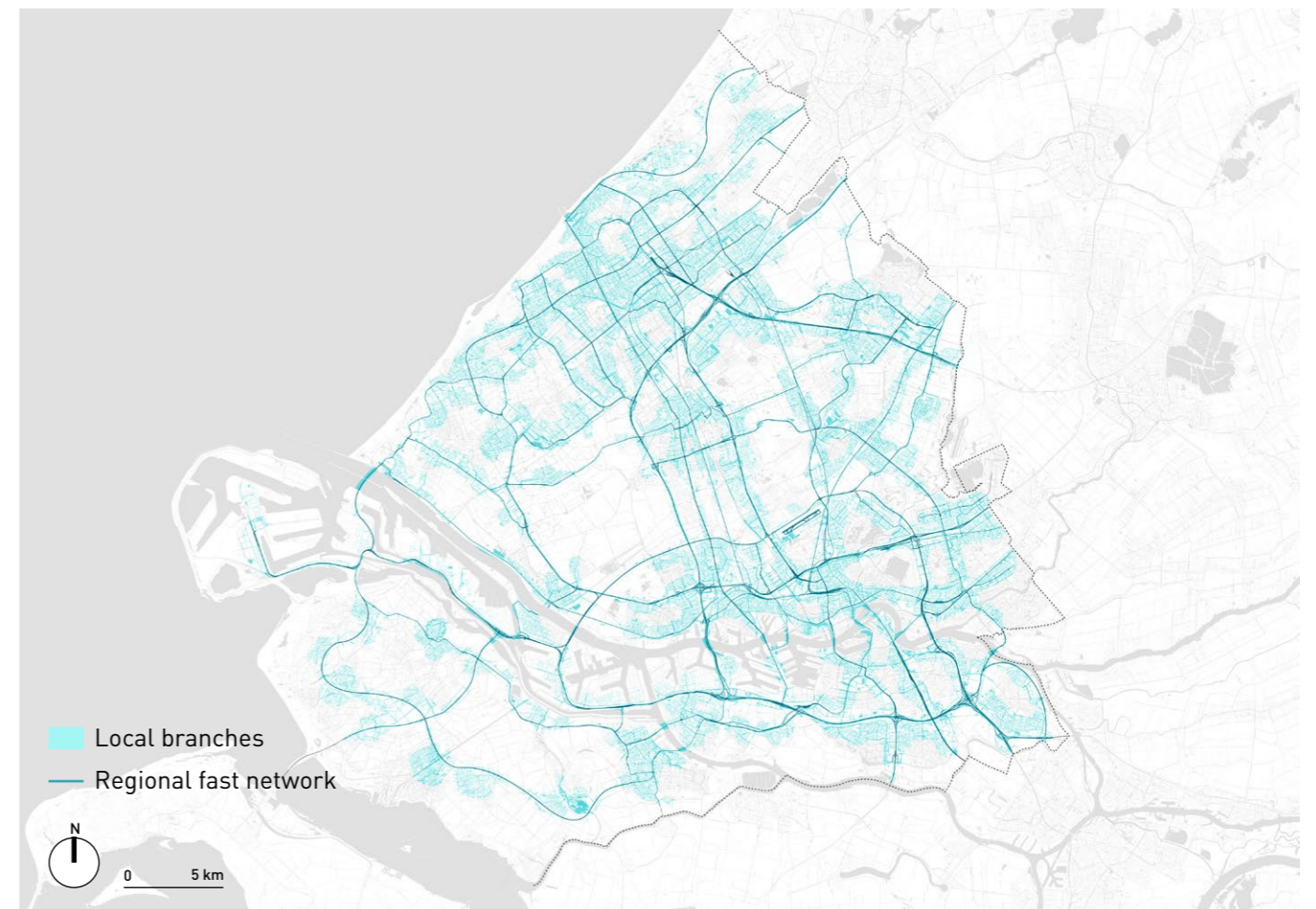

Figure 145. Mobility networks development in Infinite Randstad. Isotropy of the region is achieved by high speed corridors on existing motorways and new connections. These branch directly into inhabited areas to provide seamless accessibility. Due to spatial resistances of traditional urban fabric, development is re-focused on extra-urban corridors. A13, for example, becomes the MRDH boulevard (Deltametropool, OMA, 2002). Remote areas become easily accessible, driving residents out of the urban core to live closer to nature.

Case study 1: City centre - Coolsingel, Rotterdam Clockwork Utopia

The design trial is based on a brief from the under-performing liveability criteria - pollution, additional housing, additional green areas - and from the specific situation of the scenario - separated flows, design of the transfer point, added mixed uses, living in the city centre and spending the increased free time there.

The city centre is imagined as a place to live, but also to spend leisure time. The transfer point connects the ground level to public regional transport underground. These hubs create poles of activity on multiple levels. Bus and tram are merged into new automated pods transferring people quickly on reserved right of way through the city centre and dropping them off at clearly marked points.

Vehicles are not allowed to other streets with few exceptions, and only electric shared cars are permitted in the city centre. New building programs concur to solve the problem of flow separation by creating skywalks and integrating functions over multiple traditional urban blocks. Higher density means new buildings but also additions on top of existing ones. Parking is moved outside the city centre thus large amount of space becomes available. The street space freed up is used for bike lanes, larger sidewalks and trees. Living in the city centre becomes more appreciated and the increased leisure time means many more facilities appear for sports, culture and commerce.

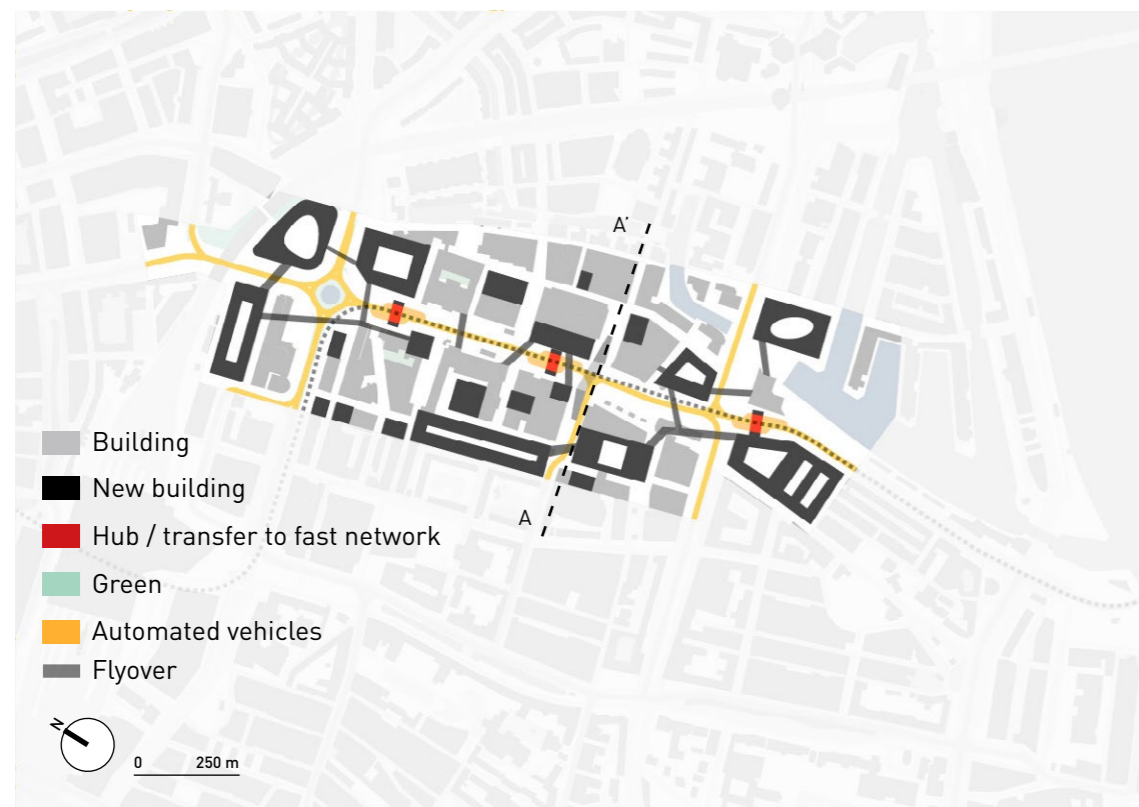

Figure 146. City centre site in Clockwork Utopia

Design brief:

URBANISM

- separate flows of different speeds
- reduce pollution
- design with energy
- design transfer space

ARCHITECTURE

- re-think transferia
- increase housing stock and mixed use
- incorporate green areas within/on buildings

SOCIETY & LIFESTYLE

- spend extra free time in the city
- live in the city centre
- alternate idiorhythms to use spatial resources more efficiently

Figure 147. City centre site in Clockwork Utopia

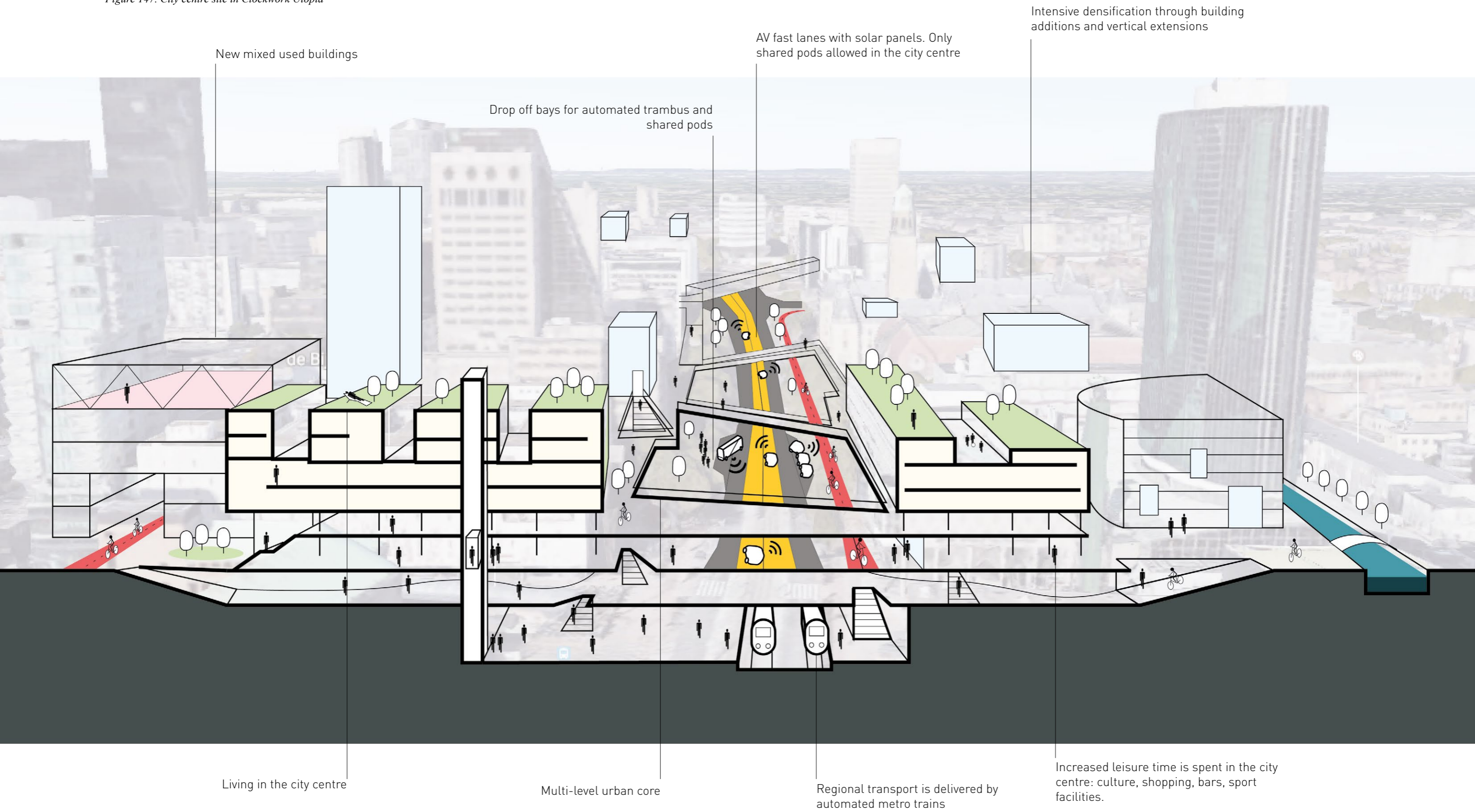

Case study 1: City centre - Coolsingel, Rotterdam Infinite Randstad

The design brief for this case study contains the following: shared urban ground level, reduce pollution, incorporated energy, green areas, improve fast connections, minimise ground occupied by automated vehicles, re-thinking the building-street relation, new programs in the freed up street space, design buildings with AV in mind, opportunities to spend the increased free time, make it easy to learn how to use the shared space, and adapt physical space to a digital society.

In this section the city centre is seen as a destination. Automated cars use the former metro tunnels to offer high speed, flexible regional connectivity. Elevators bring the automated cars from the regional subway to the street level where they transfer to low

speeds and shared space. If in the previous scenario people were performing the vertical movement to shift between different speeds, in this one automated vehicles take over the vertical movement and create a more seamless urban ground for people. Some automated vehicles also enter buildings for parking, delivery, disabled accessibility or just to provide an extra room. More diverse occupations are seen on the freed up street space: green areas, new light buildings, events and markets. Without traditional sidewalks and streets, and with vehicles inside buildings, the differences between outdoor and indoor become less visible. The continuous ground level is a smart surface which embeds energy production and distribution, connectivity and traffic safety.

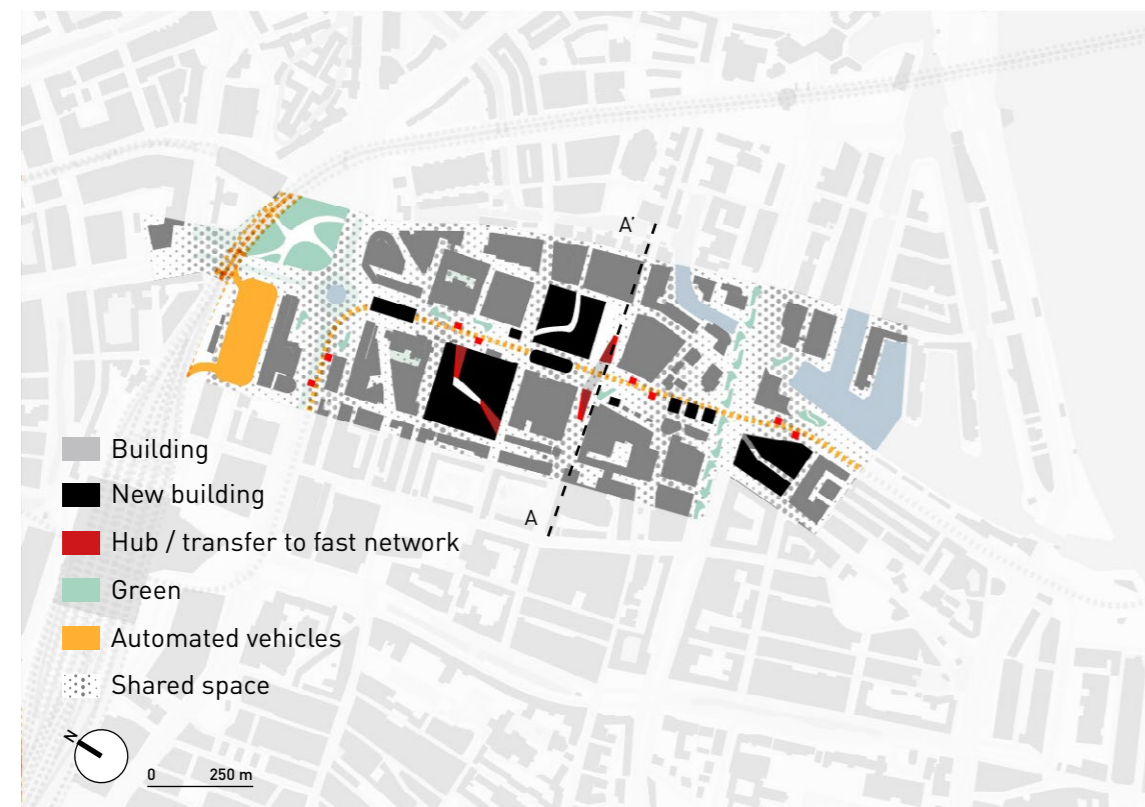

Figure 148. City centre site in Infinite Randstad.

Design brief:

URBANISM

- design the shared urban ground level
- reduce pollution
- design with energy
- increase ground-level green area
- improve fast regional connections
- minimise ground occupied by AV infrastructure

ARCHITECTURE

- re-think building-street relation
- new programs in excess road space
- incorporate technical needs of AV in buildings

SOCIETY & LIFESTYLE

- spend extra free time in the city
- learn to use shared space with AV
- digitalise socio-economic encounters

Figure 149. City centre site in Infinite Randstad.

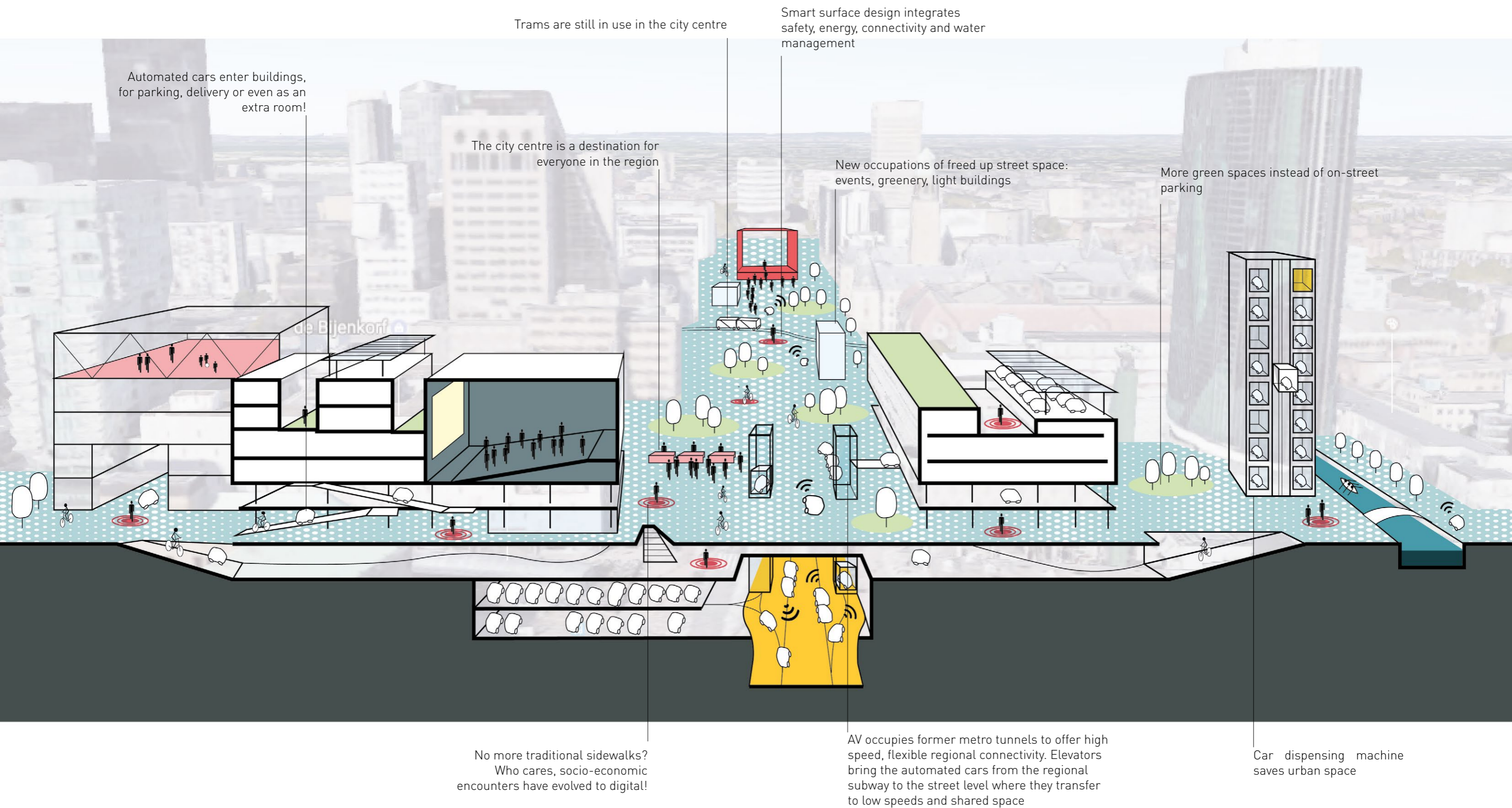

Case study 2: Residential neighbourhood - Goeverneurlaan, The Hague. Clockwork Utopia

This design answers to the following brief: the need to physically separate flows, reduce pollution, integrate energy, re-use parking, open ground floor to the street, densify housing, incorporate green areas into buildings, re-think garages and parking lots as social infrastructure, make it pleasant to live in a denser city, enable through design alternate idiorhythms.

The street's smart lanes are used mostly by shared pods, but individual AVs of residents are accepted. Pods stop at designated hubs which concentrate neighbourhood services on multiple levels, acting as a downsized version of the city centre. New housing and facilities for the growing population replace the existing fabric or are added on

top of existing buildings. Scarcity of space encourages multifunctionality and alternate idiorhythms for a new, flexible economy. Living denser is the new normal. Former parking space becomes building extension, bicycle lane or space for trees. Mini-parks and urban gardens appear on roofs. Old garages and parkings are refunctionalised in a neighbourhood-wide strategy to provide more housing and work premises.

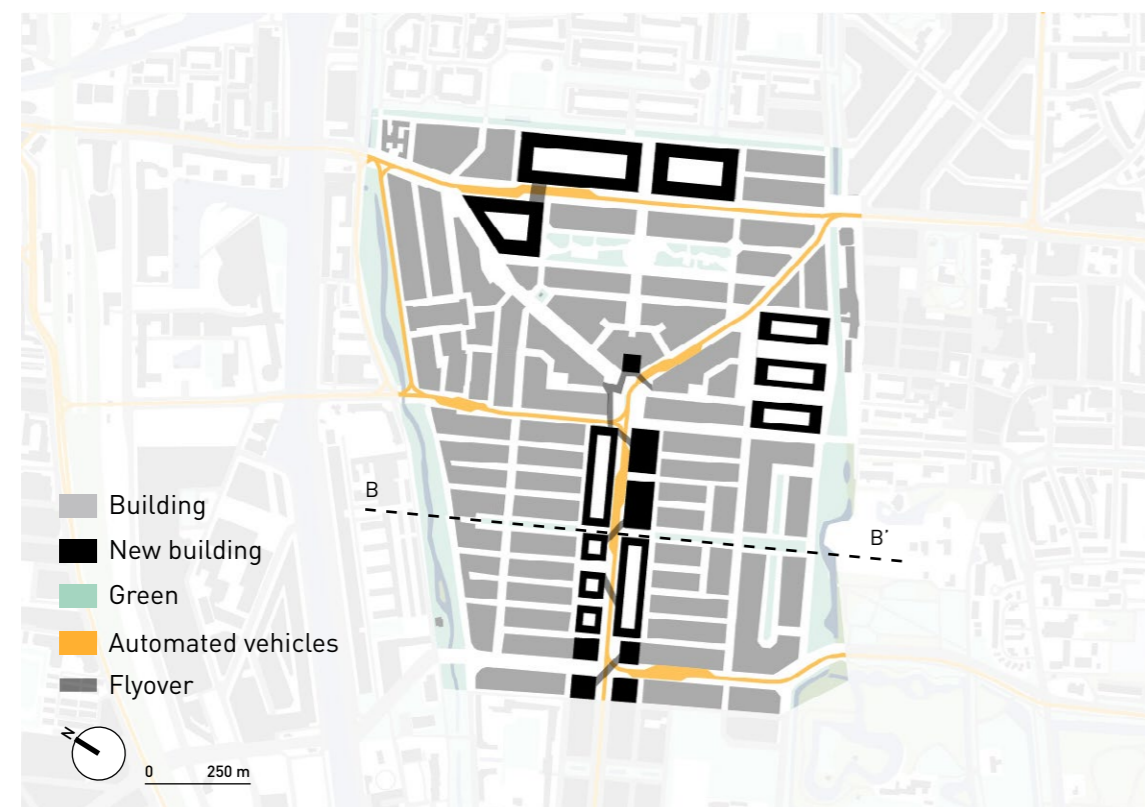

Figure 150. Residential site in Clockwork Utopia

Design brief:

URBANISM

- separate flows of different speeds
- reduce pollution
- design with energy
- re-assign former parking to other modes and green areas

ARCHITECTURE

- open ground floor to the street
- densify housing stock
- incorporate green areas and social facilities in design
- rethink garages and parkings

SOCIETY & LIFESTYLE

- live in a denser urban environment
- alternate idiorhythms to use spatial resources more efficiently

Figure 151. Residential site in Clockwork Utopia

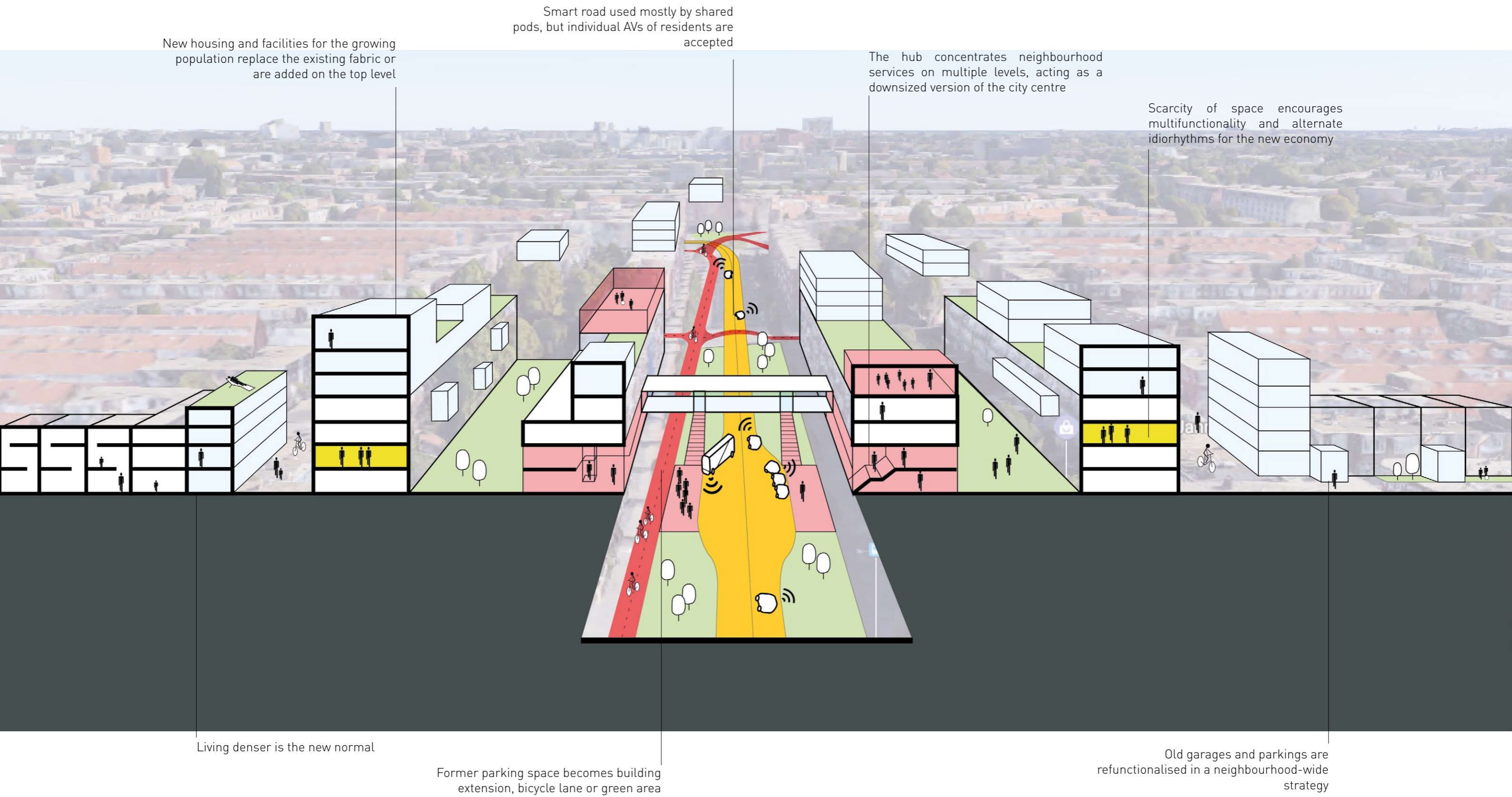

Case study 2: Residential neighbourhood - Goeverneurlaan, The Hague. Infinite Randstad

The design brief: design the shared ground level area, reduce pollution, design with energy, de-densify and increase green area, activate street, incorporate AV into buildings, add leisure spaces in buildings and around, DIY refunctionalised garages and parkings for family use, spend extra free time with family and community, enjoy nature 'around the corner', encourage active mobility and provide sport facilities.

Nature is 'around the corner'. There is room for large parks and sport fields in every neighbourhood like this one. People moved into new developments in the Randstad, so there is more room for public amenities. Homes, streets and automated vehicles are part of a single smart energy system which

maximises efficiency according to demand, using the resources alternately. Freed-up parking lots become hobby spaces, offices, student rooms or simply the family terrace. There is a vibrant community and family-centred life. Public and commercial uses occupy the ground floors to create a lively street. Automated vehicles are redesigned to be pedestrian friendly and are welcome as well. All shared space is designed for low speed and mixed use.



Figure 152. Residential site in Infinite Randstad.

Design brief:

URBANISM

- design the shared ground level area
- reduce pollution
- design with energy
- de-densify and increase green area
- activate street

ARCHITECTURE

- incorporate AV into buildings
- add leisure spaces in buildings and around
- DIY refunctionalised garages and parkings for family use

SOCIETY & LIFESTYLE

- spend extra free time with family and community
- enjoy nature 'around the corner'
- encourage active mobility, sports

Figure 153. Residential site in Infinite Randstad.

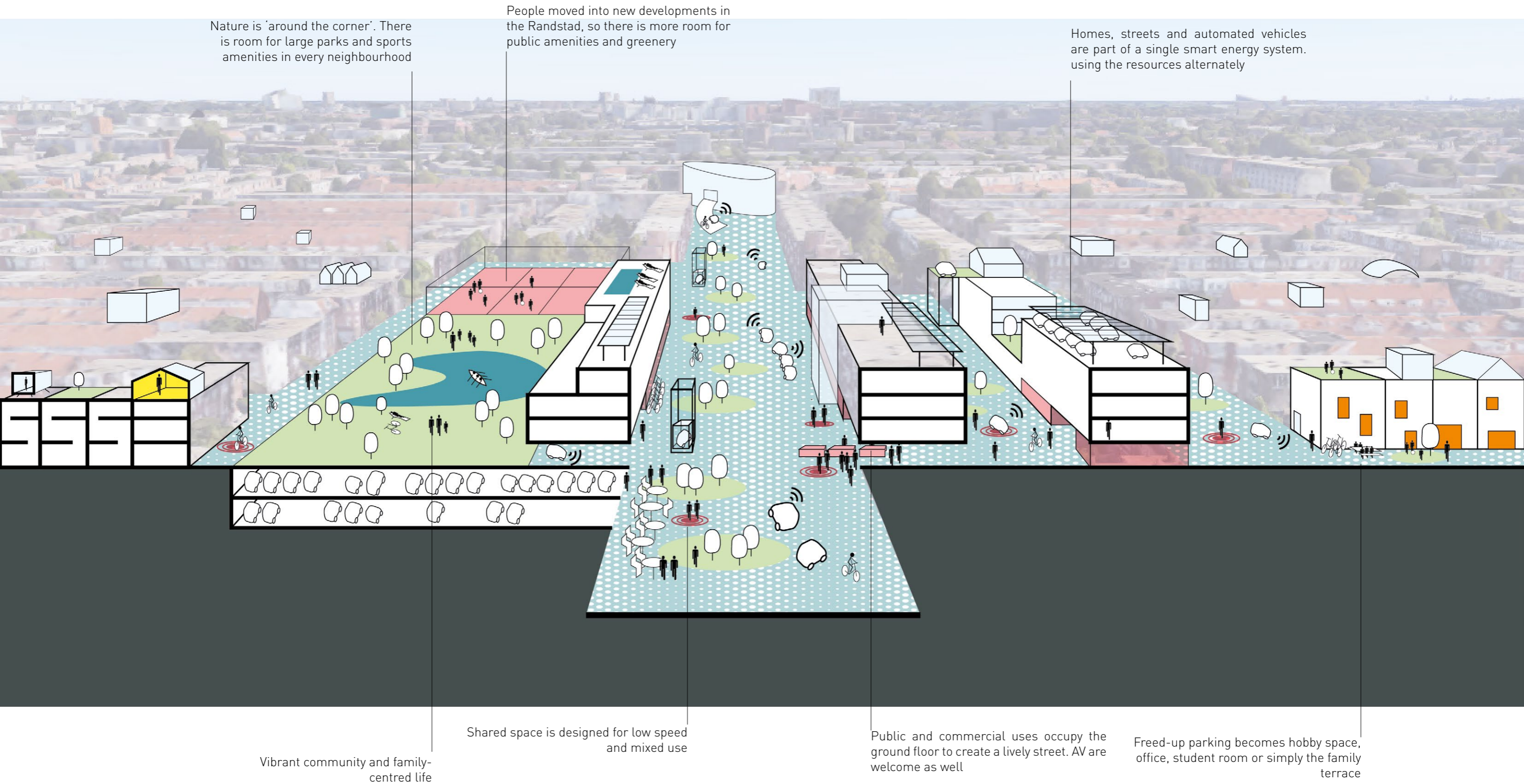

Nature is 'around the corner'. There is room for large parks and sports amenities in every neighbourhood

People moved into new developments in the Randstad, so there is more room for public amenities and greenery

Homes, streets and automated vehicles are part of a single smart energy system. using the resources alternately

Vibrant community and family-centred life

Shared space is designed for low speed and mixed use

Public and commercial uses occupy the ground floor to create a lively street. AV are welcome as well

Freed-up parking becomes hobby space, office, student room or simply the family terrace

Case study 3: Urban edge - A13 / Kruithuisweg, Delft Clockwork Utopia

The design brief: separate flows of different speeds, reduce pollution, design with energy, improve local connectivity, re-think role of motorway in mobility system, define the urban edge, new architectural programs as hub, AV parking and maintenance, incorporate green areas within/on buildings, spend free time in Green Heart, discover new activities that combine nature with technology, use urban edge as hub for innovation.

The motorway is integrated in the public transport system. City edge HUB connects people to public transport, individual automated vehicles, local transfer pods, bikes and e-bikes. It also acts as a gate to the city and offers multiple facilities. Parking and maintenance of urban pod fleet is located

outside high-demand urban land, but close to the hub. There is a denser built fabric within the urban limits, and the urban edge is intensified as the space for innovation and logistics. Ecoducts ensure safe crossing of the highway and ecosystem continuity. Urban residents enjoy 'open' nature on the city edge, where they can relax or practice new sports enabled by technology.

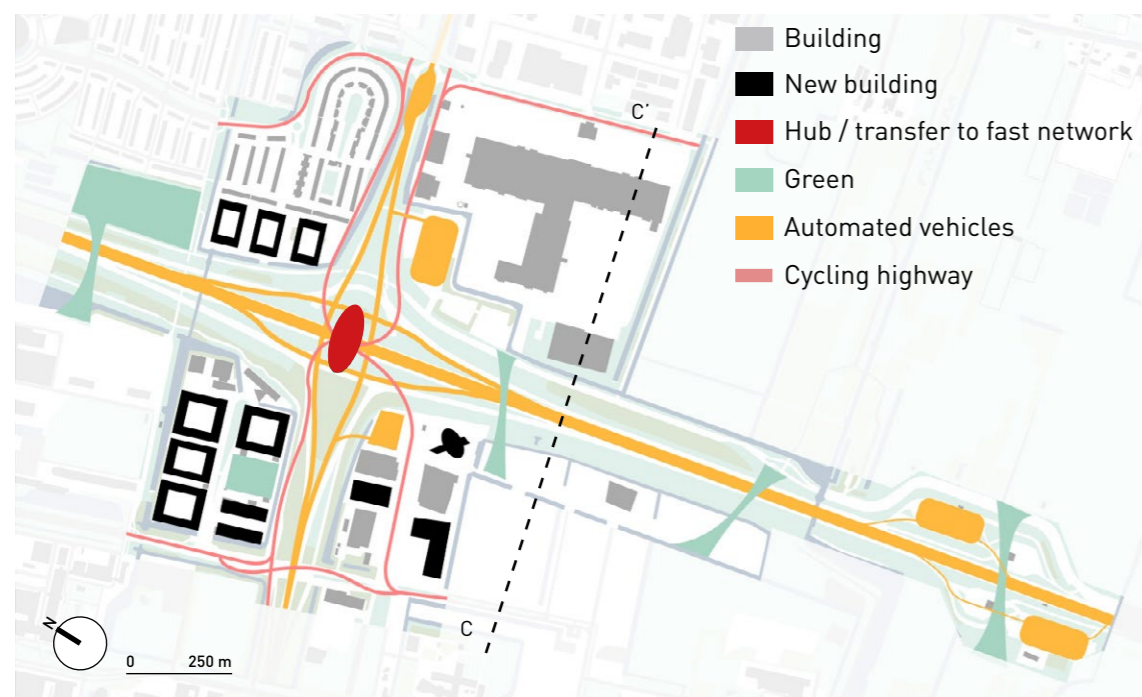

Figure 154. Urban edge site in Clockwork Utopia

Design brief:

URBANISM

- separate flows of different speeds
- reduce pollution
- design with energy
- improve local connectivity
- re-think role of motorway in mobility system
- define the urban edge

ARCHITECTURE

- new programs: hub, AV parking and maintenance
- incorporate green areas within/on buildings

SOCIETY & LIFESTYLE

- spend free time in Green Heart
- discover new activities that combine nature with technology
- use urban edge as hub for innovation

Figure 155. Urban edge site in Clockwork Utopia

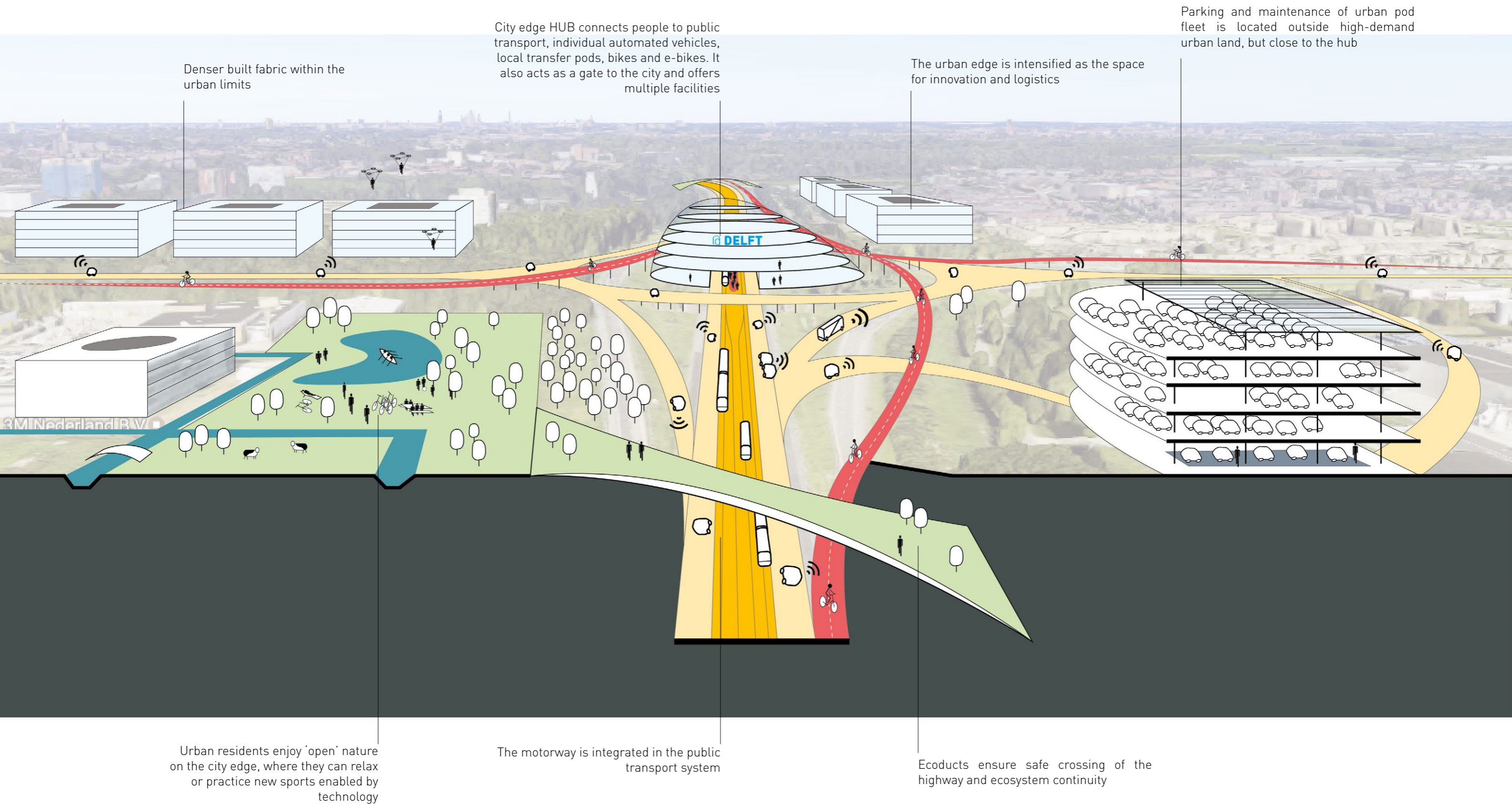

Case study 3: Urban edge - A13 / Kruithuisweg, Delft Infinite Randstad

The design brief: re-think role of the motorway in the metropolitan structure, reduce pollution, design with energy, improve local connectivity, new programs that define the metropolitan backbone, incorporate AV into buildings, re-think building perception and access for new speeds, adopt and adapt to high-speed living, incorporate activities into travel time, flexible schedules enabled by rapid regional connections.

A13 is the new 'Zuidrandstad Boulevard' offering a multi-speed metropolitan promenade from Zuidplein to Scheveningen. Direct access to regional infrastructure is possible for each building. New architectural typologies allow real door-to-door experience. Welcome to the drive-in office! New types

of vicinity are normal: office in the polder, house on the highway. Buildings, roads and cars are part of various smart energy systems. A flexible, connected society is multi-tasking and moving in the territory faster and more efficiently. High speed lifestyle means many activities are performed in the time and space of mobility. Mundane trips are rendered unnecessary by automation because drones are able to deliver most parcels from the main network into the territory.



Figure 156. Urban edge site in Infinite Randstad.

Design brief:

URBANISM

- re-think role of the motorway in the metropolitan structure
- reduce pollution
- design with energy
- improve local connectivity

ARCHITECTURE

- new programs that define the metropolitan backbone
- incorporate AV into buildings
- re-think building perception and access for new speeds

SOCIETY & LIFESTYLE

- adopt and adapt to high-speed living
- incorporate activities into travel time
- flexible schedules enabled by rapid regional connections

Figure 157. Urban edge site in Infinite Randstad.

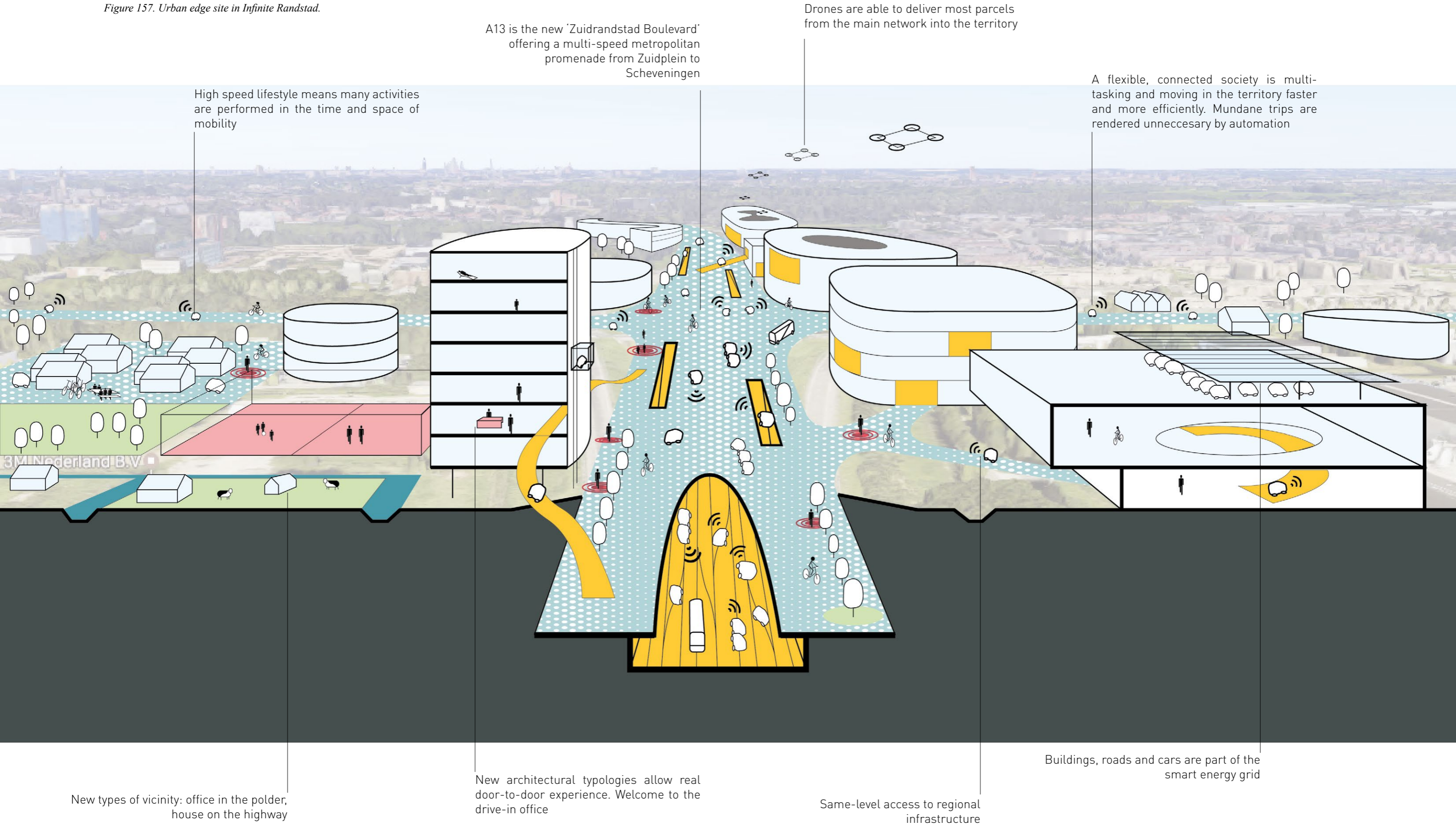

High speed lifestyle means many activities are performed in the time and space of mobility

A13 is the new 'Zuidrandstad Boulevard' offering a multi-speed metropolitan promenade from Zuidplein to Scheveningen

Drones are able to deliver most parcels from the main network into the territory

A flexible, connected society is multi-tasking and moving in the territory faster and more efficiently. Mundane trips are rendered unnecessary by automation

New types of vicinity: office in the polder, house on the highway

New architectural typologies allow real door-to-door experience. Welcome to the drive-in office

Same-level access to regional infrastructure

Buildings, roads and cars are part of the smart energy grid

IV. Evaluation and reflection

IV.1. Scenario evaluation

Mobility performance and impact

In the liveability definitions at I.2, mobility performance was defined on the regional level as the optimum coverage, efficiency and modal choice for travel, while the impact was defined as the lowest possible air and noise pollution. At local level, the performance was defined as good accessibility of various destinations for all user types, and the impact as safety and perception of control of the individual. The results for mobility performance and impact are mixed between the two scenarios.

Clockwork Utopia (S1) offers optimum coverage of all densely inhabited areas, however more remote areas are underserved. The city centre and the city edge are optimally served by high speed connectivity, while the residential area has to rely solely on the ground level medium speed urban pod service. Efficiency is best in the city centre, as congestion is avoided by allowing only shared pods inside the central limit. Modal choice is higher as you approach the hubs on the city edge, however in the urban core flexibility and accessibility need to be addressed. Cycling infrastructure is well developed in all subzones and sites. The regional impact of S1 is multi-faceted. On one hand, efficiency and allowing only shared electric pods in the city centre reduces air and noise pollution strongly. However, by concentrating activity and population in the urban limits means that mobility will also be concentrated within these. On the local scale, S1 has a divided performance, as not all destinations are possible to reach by all modes. Transferring is necessary, making travel more difficult for disadvantaged groups such as elderly and disabled. The impact of S1 on safety and control is generally positive, as separation

of flows minimises pedestrians and cyclists meeting cars on the same surface. The need to change levels in order to cross every AV special lane on the other hand might reduce pedestrian and cyclist comfort.

Infinite Randstad (S4) performs better in form of coverage and modal choice, through its isotropic condition. Efficiency however is questionable as not everywhere can different modes of greatly different speeds coexist. It can be said that shared space, where pedestrians and cyclists share the right of way with cars, functions very well in residential areas and campuses, but in city centres a limitation of the number of AV is needed to avoid congestion. To reach isotropy, also a large investment into a fast network is needed to bypass the ground level. In some areas, former railway and metro tunnels can be refurbished for AV, which would offer a higher flexibility by combining higher and lower speed travel on the same vehicle. Air and noise pollution would be more or less negatively impacted: AV could be limited to certain speeds by software around cities and at night, but on the other hand increased demand and a more decentralised network would increase travelled kilometres. The local impact of S4 is better for accessibility of all destinations by all modes. Safety, despite shared space, would not be significantly lower than S1 due to the much higher reliability of technology than human drivers. The perception on control for cyclists and pedestrians is unknown: it could be positive if social acceptance of AV is high, but an 'unfriendly' AV could also discourage people to really use the share space.

Natural and built environment

The environmental criteria of liveability for the project are availability and variety of living and working environments, and contact with quality nature, on a regional scale (e.g. green buffer) and at local scale (e.g. the neighbourhood park).

In S1, if growth is within cities there will be less travel and kilometres travelled, thus better for environmental quality in general. Denser cities would also mean less green space within the city, where green areas need to be moved into/on buildings. Nature however will be experienced on the city edge and in the green buffer where new activities and sports can function as attractors. Furthermore, energy use can be saved by less travel and a smaller urban footprint, but denser living also means there can be local concentrations of very high use of energy. The wide usage of transfer points also minimises changing speed environment for vehicles, thus vehicles can be optimised for high- or low-speed service type and result in less braking, thus fewer pm10 particle emissions. The CO₂ emissions will be reduced conditioned by the parallel development of performing and economical electric vehicles. The availability of housing and work premises might be limited by the urban limit constraints, and overcoming this through densification might reduce the offer of certain types of development such as family friendly environments or cheap low density industrial areas that many companies prefer and are essential in the local economic chain. Densification can also mean more improper vicinities would be created such as housing and industry.

In terms of environments, S4 provides the better choice of living and working environments, including contact to nature, but imposes strong pressure on nature and the water system of the region. However this can be offset by environmental technology innovation and the higher life

quality. This hypotheses is underlined by the leefbaarometer which gives heavier importance to proximity of nature and lack of pollution. Energy use increases with distances travelled but if electric cars are developed the impact can be offset. Also individual cars can use their batteries to fuel remote buildings and work as a smart energy grid. Urban growth can also lead to de-densification of inner cities and further to the addition of urban green spaces, increasing life quality in the city. However, this gain on the local scale could be cancelled on the regional scale by the loss of 'open' nature or the green buffer as a clear non-urbanised space between cities. Living in a lower density environment can also mean living outside the impact buffer of road pollution.

Society and economy

In terms of society and economy, the liveability criteria were considered that a variety of economic sectors having the proper spaces and accessibility, as well as jobs being available close to where people live on the regional scale, and sufficient and varied spaces for encounter, such as parks, sidewalks or commercial ground floors, in order to foster social relationships and economic opportunities on the local scale.

At the regional scale, S1 offers a denser environment suitable for a young metropolitan lifestyle, with mixed uses, walkable centres and cultural and leisure amenities, however it is debatable if this type of living environment is suitable for all societal groups. At best, it will cause an already ageing society to adopt younger lifestyles, at worst it might cause alienation. The contrast between S1 and S4 also puts into discussion whether automation might lead to a more urban, leisure oriented society, or to a more regional, productive one. In S1 there is less room for traditional productive environments, found on cheap land at the edge of cities. But will this still be an issue if mass customisation disrupts the whole process of production and everyone has a 3D printer at home? If mobility networks determine job location, there is also a reverse impact of commuting on the efficiency of these networks in terms of congestion, time lost and energy consumption. In terms of economy, it can also be speculated that a hub-and-spoke model will encourage a larger amount of backtracking on journeys, reducing efficiency and convenience and increasing energy consumption unnecessarily. Inside the urban cells, the encouraging of cycling and walking can offset these issues and lead to healthier society. At a local scale in S1, there can also be a discussion over whether large parts of the city centre should be closed to private/individual vehicles and transformed into mega-pedestrian zones. Would this not diminish the vitality, functional variety and

socio-economic resilience of the centre, transforming it rather into something similar to an amusement park? On the other hand, the separation of flows in S1 maintains the traditional sidewalks as a strong identity of pedestrian space where socio-economic encounter can occur.

S4 acts as a trigger for societal change. In the regional level, there are numerous and varied premises for work and living. Impulsed by a freely evolving territory, the economy is flourishing along the main roads and in spaces of concentration. The A13's redefinition as a metropolitan boulevard creates the premises for a new type of spatial experience. New architectural programs, shared space and automated vehicles can foster a culture characterised by speed, connectivity and innovation. At local scale, the de-densification of the centre along with the removal of on-street parking leads to more green areas and wider shared space areas usable by pedestrians. It is debatable how people will react and adopt, or not, the shared space and how this would influence economy such as main street shops. Will they lose their importance, or will they be renewed by a new spatial understanding due to automation?

For society and economy, S1 is more capable of creating critical mass and concentration for activities that necessitate clustering, but S4 creates more opportunity for wider society, as well as accessibility to more marginal areas in the region. In short, S1 could be described as an extreme evolution of current trends, where AV has a propelling role, while S4 is a radical change, with AV as trigger, creating new urban fabric patterns and lifestyles.

IV.2. Reflection

Research, design and policy tasks foreseeing AV

Following the evaluation according to the liveability criteria, the project makes a series of recommendations which can be put on the table by urbanism in the interdisciplinary discussion over the future of automated vehicles. These are in the form of a task book with three parts: research, design and policy tasks.

The research tasks devised for AV design are the following: to develop economical and performing electric vehicles in parallel to driving automation; to optimise vehicles for high- and low-speed environments to make them less polluting; find synergies between AV and railways and other modes; make AV pedestrian and cyclist friendly and safe. Other connected research directions include: how to solve conflicts of direction and speed on surfaces shared by AV with other users; research optimum size and gabarits of pedestrian zones/shared space; psychological acceptance of AV; work towards home-car-road smart energy systems; further research the impact on urban sprawl.

A number of design tasks for urbanism and architecture were devised: use design to improve safety of pedestrians in shared spaces; design the contact between surfaces belonging to different modes and speeds; address transfer hub accessibility and convenience for disadvantaged users; improve accessibility of residential pockets; add green spaces in dense urban fabric; design urban edge parks as attractors; if AV leads to economic disruptions, re-functionalise gas stations, car sales centres and maintenance garages, keeping in mind local economy and social networks; manage urban dispersion and water networks, resources; design shared

space to maintain sidewalk experience, social and economic encounter; design access of buildings to regional highways; and research the future section of today's motorways; new architectural programs that integrate AV; re-think parking, delivery, emergency vehicles access to buildings; re-design former on-street parking space into green, cycle lanes, pedestrian areas in innovative ways.

The task book is completed by policy tasks directly regarding AV for public authorities to consider: encourage shared and electric vehicles; limit city centre access to shared vehicles or consider charging a mileage fee, but ponder how this will impact the social and economic vitality of the area; trial railway reconversion to fast AV lanes; compel private transport operators to serve marginal areas in return for licence; provide space for car parking racks and maintenance on city edge to save central land; automatically limit speeds of AV in proximity of residential areas and at night. There are also a number of policy directions of secondary implication of AV: encourage active mobility through walkable urban environments and cycling infrastructure; set urban edge areas as 'innovation and fun' spaces to create alternative to city centre and commercial clusters; in densification scenario, keep certain areas low density and low price for key industries in the economic chain to have room to experiment and develop; in a dispersion scenario, encourage clustering of niche activities; create alternative job opportunities for people displaced by driving automation; design policies which encourage a balance between urban and ex-urban development in order to contain urban growth while offering a variety of housing and workplaces.

Reflection on the methods

The project started from a particular technological challenge and applied it to a site, not the opposite way which is typical to most urbanism projects. Therefore, **building a method** to assess a potentially high impact new technology gradually took a leading position in the aims of the project due to the future uncertainties of AV. It aimed at becoming a reusable method in other situations of technology and site.

Overall, the Dutch method of **scenario construction** is helpful in this particular case of multiple unknown parameters (AV development, social acceptance, other factors), but also challenging and limiting in reaching a clear result. It is especially difficult to discern developments where AV will have a direct impact, an impact in convergence with other trends, and developments completely independent of AV. As AV is a new technology, with implications into many branches of human life on which multiple opposing ideas are being circulated (Should we live in compact cities or closer to nature? Should we trust technology with human lives? etc.) Therefore, the methodological clarity of the scenario construction process was not ideal, and many choices had to be made subjectively or randomly. In addition, some developments of the driving forces could have led to similar outcomes, but the more different ones were chosen in order to widen the contrast between scenarios.

The **transect** method was useful in understanding the region in a simplified way, pointing out the liveability critical points and choosing the case study sites very methodically. While the transect enabled a focusing of the study on the impact of AV in main urban areas, it is also true that the chosen transect was a very specific metropolitan one, excluding other parts of the territory. From the urbanisation trend, it is the more marginal areas that are densifying at the strongest

rate. Thus, choosing the transect was also a choice between analysing the impact of AV on existing urban fabrics or on newly developing and future ones, with the choice being the former. The transect was also a time consuming method, as the same results could probably have been extracted from a traditional regional analysis of the data. Nevertheless, the elegance and the urbanism specificity of the method made it valuable to be included in the project structure.

Further, the visionary **urban section** proved a more useful method than initially thought in order to assess the research and design dilemmas arising with automation. The section is certainly the least identically replicable part of the whole method, due to its subjectivity and the background of each designer in part. In order to overcome this situation, a method of 10 options (Haddon 1970) was tried, however proved less efficient than the 'traditional' problem solving designer-at-work. The approach lead to exciting results as well as difficult questions from the architect/urbanist to the other professions regarding AV. In conclusion, the urban section should be considered as only an illustration of the search for answers.

Finally, the effects of the scenario construction are highly **contextualised** in the Netherlands: high share of cycling and active mobility, relatively short distances, commuting and multiple jobs in different places as part of the economic culture, the lack of a strong automobile industry, urban development limited by water management. However, the main Western trends of urbanisation are present: urban expansion, high share of road in modal split, a mix of traditional (city centres) and new (motorway junctions, industrial parks, city edges) activity concentrations. Thus **generalising** the results is possible but limited by the context factor.

Forerunners not followers

The urbanist should be a forerunner who starts the debate from what the technology should provide for the city, rather than a mere follower, continuously trying to catch up with innovation. In order to actively participate in the shaping of novel technologies, the urbanism profession must rely on its own aims and strengths: (1) focus on liveability, (2) use its own methods of foresight and through-sight, and (3) drive inspiration from the daring visionary projects of the past.

Confronted with the challenge of a novel technology such as automated vehicles and the impacts it might project on the urban environment, this project aimed to design a method using the instruments of spatial scenario construction, regional transect and urban section. The end result is a workable method, with its limitations described before, which offers a way to approach the old subject of mobility and the new subject of automation from an urban point of view, always having in mind liveability as the goal.

The scenarios resulting from this method offer a picture of the contrasting worlds a small technological change might lead to. Overall it cannot be said that any of the scenarios is better than the other, but that is not the aim of the research. The real aim is to explore new possibilities, as well as to point out the spatial resistances of the city and the technological resistances of automated vehicles which have to be overcome in order to reach liveability.

Just as Haussmann or Cerda, who started from edilitary and hygienic principles, imagined and created a new society through the Parisian boulevard, respectively the Barcelona block, the automated vehicle offers the 21st century urbanist the chance to build the premises for a new type of society, starting from the conditions to make a city liveable. What could be the new boulevard or block? Is shared urban ground level an answer? Or perhaps the digital cloud which gathers all the data to make the smart city function? Or maybe neither of these?

This thesis aimed not necessarily to give the answers to these questions - as any answer would have to be confirmed by reality and time in any case - but to open windows for the urbanist to imagine the future of the relationship between city and technology starting from liveability. A future for the self-driven, not driverless city.

References

Motivation & problem statement

Arem, van, B (2016) “Automated Driving and Societal Impacts: What about Ethics?”, lecture notes, *Workshop Ethics: Responsible Driving Automation*, Connekt, Delft, 15 March 2016, available from <http://repository.tudelft.nl/islandora/object/uuid:6beb9325-e8bc-445c-9c48-99b329128b13/datastream/OBJ/download> [28 March 2017].

Benevolo, L (1963) *The Origins of Modern Town Planning*, Editori Laterza, Bari, English translation by J Landry, MIT Press, Cambridge, Massachusetts, 1967.

Calabrese, LC (2004) *Reweaving UMA*, doctoral thesis, Delft University of Technology, available from <http://repository.tudelft.nl/islandora/object/uuid%3A369662a0-ed16-4545-970c2608375ee571?collection=research> [21 March 2017].

Corwin, S, Vitale, J, Kelly, E & Cathles, E (2015) *The future of mobility. How transportation technology and social trends are creating a new business ecosystem*, Deloitte University Press, available from <https://dupress.deloitte.com/dup-us-en/focus/future-of-mobility/transportation-technology.html?id=us:2el:3dc:dup1374:eng:cons:fom:dcpromo> [21 March 2017].

Mumford, L (1958) *The Highway and the City*, Harcourt Brace and World, New York.

Roe Smith, M & Marx, L (eds, 1995) *Does Technology Drive History? The Dilemma of Technological Determinism*, MIT Press, Cambridge, MA, London.

Stanford University (2016) *Artificial Intelligence and Life in 2030*, One Hundred Years Study on Artificial Intelligence, report of the 2015 Study Panel, available from https://ai100.stanford.edu/sites/default/files/ai_100_report_0831fnl.pdf [28 March 2017].

Statistics Netherlands (2015) *Transport and mobility 2015*, available from <http://download.cbs.nl/pdf/2015-transport-and-mobility.pdf> [21 March 2017].

Automated vehicles

Boomen, van den, T, de Boer, H & Hinterleitner, J (eds, 2017) *Highway x City: The Future of the Urban Ringroad*, BNA Onderzoek, Amsterdam.

Farah, H (2016) *State of Art on Infrastructure for Automated Vehicles*, Research report, Transport & Planning, Delft University of Technology, available from <http://knowledgeagenda.connekt.nl/bibliotheek/> [21 March 2017].

Heinrichs, D (2016) “Autonomous Driving and Urban Land Use”, in Maurer, M, Gerdes, JC, Lenz, B & Winner, H (eds) *Autonomous Driving. Technical, Legal and Social Aspects*, pp.213-231, doi: 10.1007/978-3-662-48847-8_11. Springer Berlin Heidelberg, available from https://link.springer.com/chapter/10.1007%2F978-3-662-48847-8_11 [21 March 2017].

Hooimeijer, F (2017) “In View of the Buffer Zone”, in Boomen, van den, T, de Boer, H & Hinterleitner, J (eds) *Highway x City: The Future of the Urban Ringroad*, BNA Onderzoek, Amsterdam.

Hyperloop One (2017) *Preparing for the Infinite Suburb. Q&A with Alan Berger and Joel Kotkin*, available from <https://hyperloop-one.com/blog/preparing-infinite-suburb> [6 June 2017].

Jeekel, JF (2016) *Smart mobility and societal challenges: an implementation perspective*, Technische Universiteit Eindhoven, available from https://pure.tue.nl/ws/files/24682463/Jeekel_2016.pdf [21 March 2017].

Milakis, D, van Arem, B & van Wee, B (2017) “Policy and society related implications of automated driving: a review of literature and directions for future research”, in *Journal of Intelligent Transportation Systems*, accepted manuscript, available from <http://dx.doi.org/10.1080/15472450.2017.1291351> [21 March 2017].

Milakis, D, Snelder, M, van Arem, B, van Wee, B & de Almeida Correia, GH (2015) *Development of automated vehicles in the Netherlands: scenarios for 2030 and 2050*, Research report, Delft University of Technology, available from <http://repository.tudelft.nl/islandora/object/uuid%3Ac22db456-b61a-4908-b2f-51d16d5708f8?collection=research> [21 March 2017].

Metropoolregio Rotterdam Den Haag (2016) *Investeringspakket Automatisch Vervoer Last Mile*, available from http://mrdh.nl/system/files/vergaderstukken_/10.3%20PvA%20AVLM_0.pdf [28 March 2017].

Puylaert, S (2016) *Social desirability and mobility impacts of early forms of automated vehicles*, Master thesis, Delft University of Technology, available from <http://repository.tudelft.nl/islandora/object/uuid:f651c2a0-59e5-4957-b85c-2557528de0e7/datastream/OBJ/download> [28 March 2017].

Liveability

Dorst, van, M (2012) “Liveability”, in Bueren, van, E, van Bohemen, H, Itard, L & Visscher, H (eds) *Sustainable Urban Environments. An Ecosystem Approach*, Springer Science+Business Media BV, Dordrecht.

Gehl, J (2010) *Cities for People*, Island Press, Washington.

Jacobs, J (1958) “Downtown is for People”, *Fortune*, April 1958, <http://www.fortune.com/2011/09/18/downtown-is-for-people-fortune-classic-1958/> [28 March 2017].

Leidelmeijer, K, Marlet, G, Ponds, R, Schulenberg, R, van Woerkens, C & van Ham, M (2014) *Leefbaarometer 2.0: Instrumentontwikkeling*, available from <http://doc.leefbaarometer.nl/resources/Leefbaarometer%202.0%20Instrumentontwikkeling%20CONCEPT.pdf> [28 March 2017].

Ministry of Infrastructure and the Environment (2013) *Summary National Policy Strategy for*

Infrastructure and Spatial Planning, The Hague, available from <https://www.government.nl/binaries/government/documents/publications/2013/07/24/summary-national-policy-strategy-for-infrastructure-and-spatial-planning/summary-national-policy-strategy-for-infrastructure-and-spatial-planning.pdf> [28 March 2017].

Transect method

Duany, A & Talen, E (2002) “Transect Planning”, in *Journal of the American Planning Association*, 68:3, 245-266, available from <http://dx.doi.org/10.1080/01944360208976271> [28 March 2017].

Secchi, B & Viganò, P (2009) *La ville poreuse: chantier 2*, competition entry project, Atelier International du Grand Paris, available from <https://www.ateliergrandparis.fr/aigp/conseil/studio/STUDIOlc02.pdf> [28 March 2017].

Talen, E (2002) “Help for Urban Planning: The Transect Strategy”, in *Journal of Urban Design*, 7:3, 293-312, available from <http://dx.doi.org/10.1080/1357480022000039349> [28 March 2017].

Wall, A (1999) “Programming the Urban Surface”, in Corner, J (ed) *Recovering Landscape. Essays in Contemporary Landscape Architecture*, Princeton Architectural Press, New York.

Scenario construction and evaluation

Haddon, W (1970) “On the Escape of Tigers. An Ecologic Note”, in *American J Public Health Nations Health*, 1970 Dec; 60(12); 2229-2234, available from <https://www.technologyreview.com/s/409370/on-the-escape-of-tigers/> [30 March 2017].

Salewski, C (2012) *Dutch New Worlds. Scenarios in Physical Planning and Design in the Netherlands, 1970-2000*, 010 Uitgeverij, Rotterdam.

Secchi, B (2010) “Projects, visions, scenarios”, in *Planum. The Journal of Urbanism*, n.21, 2/2010, available from <http://www.planum.net/projects-visions-scenarios> [28 March 2017].

Steinitz, C (2012) *A Framework for Geodesign*, Esri Press, California.

Vettoretto, L (2003) *Scenarios: an introduction, some case studies and some research prospects*, Università Iuav di Venezia.

Territorial analysis MRDH

Berghauer Pont, MY & Haupt, PA (2009) *Space, Density and Urban Form*, doctoral thesis, Delft University of Technology, available from <http://repository.tudelft.nl/islandora/object/uuid:0e8cdd4d-80d0-4c4c-97dc-dbb9e5eee7c2/datastream/OBJ/download> [28 March 2017].

CBS (2016) *Wijk- en Buurtkaart 2016*, available from <https://www.cbs.nl> [8 May 2017].

International Architecture Biennale Rotterdam (2015) *Atlas of Rotterdam Work Milieus*, atelier The Productive City.

Kadaster (2016) *Basisregistratie Topografie*, release Juni 2016, available from <https://www.kadaster.nl> [8 May 2017].

Metropoolregio Rotterdam Den Haag (2016) *Kernboodschap Regionaal Investeringsprogramma*, Werkgroep Public Affairs, available from http://mrdh.nl/system/files/vergaderstukken_/15.4%20v1-Bijlage_3_Public_Affairs_0.pdf [28 March 2017].

Ministry of Infrastructure and the Environment (2012) *35 Icons of Dutch Spatial Planning*, The Hague, available from <https://www.government.nl/binaries/government/documents/leaflets/2012/12/19/icons-of-dutch-spatial-planning/icons-of-dutch-spatial-planning.pdf> [28 March 2017].

Rutte, R & Abrahamse, JE (2014) *Atlas van de verstedelijking in Nederland*, Uitgeverij Thoth, Bussum.

Vroom, MJ & Meeus, JHA (eds, 1990) *Learning from Rotterdam*, Mansell Publishing Limited, London.

Case studies

Branzi, A (2006) *No-stop City: Archizoom Associati*, HYX, Orleans.

Calabrese, LC (2004) *Reweaving UMA*, doctoral thesis, Delft University of Technology, available from <http://repository.tudelft.nl/islandora/object/uuid%3A369662a0-ed16-4545-970c2608375ee571?collection=research> [21 March 2017].

Geddes, NB (1940) *Magic Motorways*, Random House, New York, available from <https://www.archive.org/stream/magicmotorways00geddrich> [6 June 2017].

Lewis, P, Tsurumaki, M & Lewis, DJ (2016) *Manual of section*, Princeton Architectural Press, New York.

Office for Metropolitan Architecture (1995) *A4 Corridor*, masterplan, Provincie Zuid-Holland, available from <http://oma.eu/projects/a4-corridor> [5 April 2017].

Pisano, C (2011) *Coloring the Patchwork Metropolis*, thesis, European Masters in Urbanism, Delft University of Technology, available from <http://repository.tudelft.nl/islandora/object/uuid:7cc06848-7ce8-4198-ad2e-13c659b60e13/datastream/OBJ/download> [28 March 2017].

Tjallingii, S (2015) “Planning with water and traffic networks. Carrying structures of the urban landscape”, in *Research in Urbanism Series*, 3(1), 57-80. doi:10.7480/rius.3.832, available from <http://rius.tudelft.nl/index.php/rius/article/view/832/1034> [21 March 2017].

Yoos, J & James, V (2016) “The Multilevel Metropolis”, in *Places Journal*, May 2016, <https://doi.org/10.22269/160518> [28 March 2017].

Zaandbelt, D & Rimmelzwaan, M (2010) *Atlas of Big Plans*, Delft University of Technology.

