

# SERENITEA

AN INTEGRATED PRODUCT DESIGN MASTER THESIS

---

EXPLORING MATERIAL-BASED OPPORTUNITIES AND SCENT INTEGRATION

IN TEA CLAY FOR VISUALLY IMPAIRED INCLUSIVE DESIGN

SYLVIA KO | DR. SEPIDEH GHODRAT | DR. STEFANO PARISI | MSc. JIWEI ZHOU

## ABSTRACT

Each year, 5.9 million tonnes of tea is consumed worldwide. However, this large consumption of tea also leads to large amounts of tea waste. Approximately 90% of steeped tea is being thrown away. This waste leads to problems such as environmental pollution. In order to combat this issue, Tea Clay was previously developed as a material made from wasted tea leaves. However, this material was not suitable for large scale implementation.

This project aims to explore the material-based opportunities for Tea Clay to be implemented on a larger scale. The Tea Clay has an envisioned implementation as a memory board game based on tactile and olfactory senses for visually and non-visually impaired people. The Material Driven Design method is used for developing the material further to fit this vision. Benchmarking has inspired the material to have a reprocessing step: creating bulk material that can later be reprocessed into the intended product. Through tinkering, a new material with added gelatine and water was created which can reshape the material once it has been steamed. The reprocessability of the material could benefit the availability of the material for product implementation. Material can be created at one place and sold to customers, who in turn steam the material and reshape it in different products. The reprocessability also facilitates recyclability at the product end of life.

Bending tests and hardness tests have shown that it has a similar Young's modulus and hardness as that of polypropylene and polyethylene, resulting in a material that is suitable for the substitution of conventional plastics. Experiential characterisation tests have proven that users are willing to interact with a novel material with appropriate background information. Knowing the material composition can stimulate them to be more accepting and embracing towards the material. Scent implementation is important for the intended product, as the scent should not disappear over time. A user test was conducted to test the scent duration and strength. Coating the material with essential oil has proven to keep the scent over a period of 4 weeks without much disappearance. The results of the material exploration both technically and experientially have come together in the design of a board game for visually and non-visually impaired people. This design aims at enhancing social interaction between visually and non-visually impaired through a game where everyone has a sense of collaboration and autonomy during game play and setup.

Overall, this study has demonstrated the potential of Tea Clay to be used as a waste composite material for product development. Future studies are still needed to further analyse the material properties of Tea Clay, and to validate its application in design for visually impaired people.

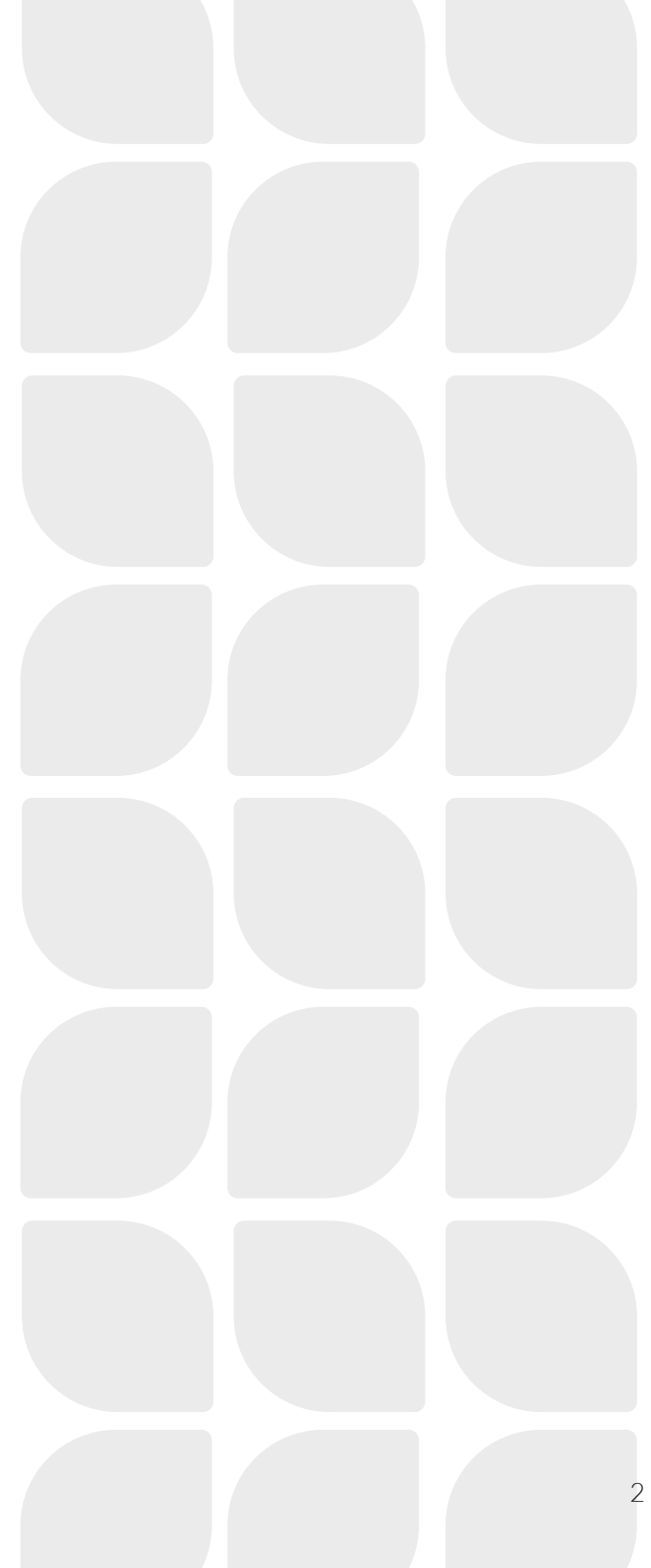

# TABLE OF CONTENTS

CHAPTER 1 INTRODUCTION & SCOPE	5	CHAPTER 4 PROJECT GOAL & OPPORTUNITIES	34
1.1 Tea Clay project	6	4.1 Processability	35
1.2 Material Driven Design Course	7	4.2 Demoulding	35
1.3 Serendipitea project	7	4.3 Deformation	35
1.4 Problem definition	9	4.4 Reprocessing	36
1.4.1 Processability	9	4.5 Scent implementation opportunities	37
1.4.2 Scent implementation problem	9	4.5.1 method 1: infusing	37
1.4.3 Visually Impaired People and their needs	9	4.5.2 method 2: spraying	37
1.5 Research questions	10	4.5.3 method 3: dipping	37
1.6 Research motivation	10	4.6 Material taxonomy	38
1.7 Methodology	11		
		CHAPTER 5 TINKERING	39
CHAPTER 2 LITERATURE REVIEW	12	5.1 Gelling agents	40
2.1 Tea	13	5.2 Beeswax	43
2.2 Bioplastics and manufacturing	14	5.3 Drying time	44
2.4 Scent implementation literature	15	5.4 Intermediate conclusions	46
2.4.1 Infusing	15	5.5 Processability and deformation	49
2.4.2 Blending	16	5.6 Reprocessing	50
2.4.3 Scenting	16	5.7 Scent implementation	52
2.4.4 Scent measurement	17	5.8 Shaping	53
2.5 Visually impaired people	18		
2.5.1 Board game design for VIP	19	CHAPTER 6 TECHNICAL CHARACTERISATION	55
2.6 Chapter conclusion	20	6.1 Shrinkage	56
		6.2 Shrinkage second test	58
CHAPTER 3 BENCHMARKING	21	6.3 Bending test	60
3.1 Tea waste	22	6.4 Hardness test	63
3.2 Coffee	25	6.5 Viscosity test	64
3.3 Waste resources	27	6.6 Chapter conclusion	66
3.4 Game solutions for visually impaired	30		
3.5 Chapter conclusions	33		

CHAPTER 7 EXPERIENTIAL CHARACTERISATION	67	CHAPTER 9 DISCUSSION	97
7.1 Goal	68	9.1 Results summary	98
7.2 Method	69	9.2 Contributions	99
7.3 Samples	70	9.3 Limitations & future studies	102
7.4 Participants	70	9.4 Personal reflection	104
7.5 Results	71		
7.5.1 Performative level	71	CHAPTER 10 CONCLUSION	105
7.5.2 Sensorial level	73		
7.5.3 Emotional level	75	REFERENCES	107
7.5.4 Interpretive level	77		
7.5.5 Focus groups	79		
7.6 Chapter conclusions	80		
CHAPTER 8 DESIGN	81		
8.1 Evaluation of Serendipitea	82		
8.2 Vision	83		
8.3 List of requirements	84		
8.4 Mood boards	85		
8.5 Conceptualising	87		
8.5.1 Game piece shape	87		
8.5.2 Game play	89		
8.5.3 Board design	90		
8.5.4 Rule book	90		
8.5.5 Storage	91		
8.5.6 Production process	93		
8.6 Concept validation	93		
8.6.1 Mechanical properties	93		
8.6.2 Mould design	95		
8.6.3 Prototyping	95		

The image shows three round, dark brown, textured objects, possibly made of wood or a similar material, arranged on a light brown cardboard surface. The objects have a rough, fibrous texture and some visible grain. One object is in the foreground, slightly to the right of the center, and is the most prominent. Two other objects are in the background, one to the left and one to the right, both slightly out of focus. The text 'CHAPTER 1 | INTRODUCTION & SCOPE' is overlaid in white, sans-serif font, centered horizontally and partially overlapping the objects. A vertical line separates the text into two columns.

CHAPTER 1 | INTRODUCTION  
& SCOPE

## 1.1

# TEA CLAY PROJECT

Tea has been consumed by people for many years. For some cultures, tea has become an integral part of their lifestyle. Sometimes the consumption of tea has symbolic meaning, such as spending time together. Other cultures have created ceremonies around tea. This could be about the serving, but also about the consumption. In many cases the tea leaves that are left after the consumption are discarded as waste. Tea leaves are usually used once since the flavours and aromas of the leaves will be diluted during the preparation of the beverage.

Using the tea waste, Zhou and Rhen created a patented material that is homogenous and has properties that resemble clay. The patent number is CN107964254A·2018-04-27 and consists of tea powder, a lignin fibre and a starch-modified adhesive. These components create a mixture of 4:1:1 ratio. The adhesive, otherwise called binder, contains plant starch, acetic acid solution, glycerin and water.

The adhesive is mixed and heated. The adhesive and water create a mixture that resembles glue. The fibre and tea powder are added and kneaded further. The kneading creates a homogenous mass that resembles clay. It can be shaped by hand, torn apart and joined together. It is moulded into various 3D printed moulds. The process is illustrated in figure 1.1. The material could be air dried for several days until the water has evaporated and the material has become solid.

The clay has the colour of the used tea leaves, and most importantly, it still carries the smell of the tea. According to Zhou and Ren, when the Tea Clay is wet, it has the plasticity and mouldability of normal clay. When it is dry, it has the workability and durability of wood (Zhou & Ren, 2018).

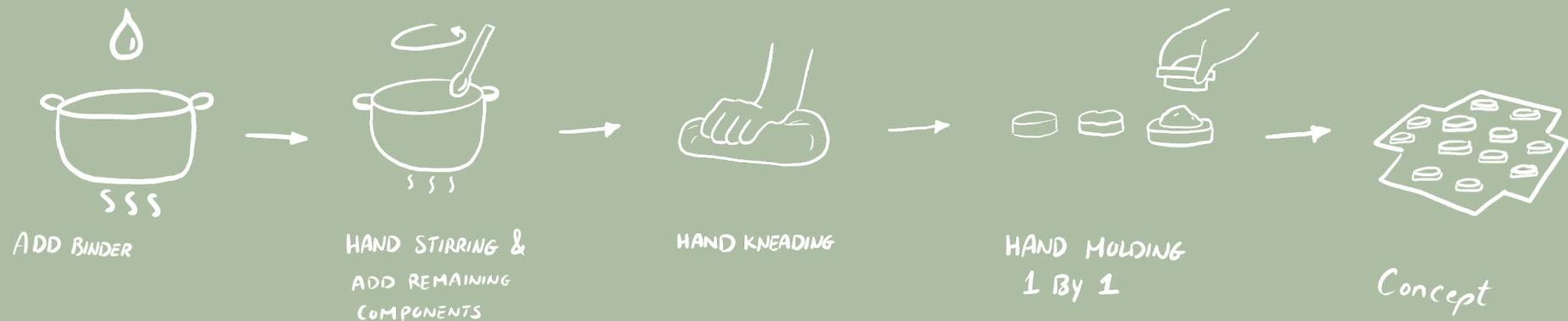

Figure 1.1: The process of creating Tea Clay

## 1.2 MATERIAL DRIVEN DESIGN COURSE

Material Driven Design is an Industrial Design Engineering master's elective course taught at the Delft University of Technology. The course revolves around the Material Driven Design Method created by Karana et al (2015), where the material is central in the design approach. The design is defined through technical and experiential characteristics (Karana et al., 2015). During the course, the students had to work with the Tea Clay material created by Zhou and Rhen. The outcomes were product concepts based on chosen material characteristics. The group of de Cocker, et al (2022) focussed on the material's ability to absorb and release scents. This resulted in the Serendipitea project (De Cocker et al., 2022).

## 1.3 SERENDIPITEA PROJECT

Serendipitea is a memory game based on scents for visually impaired children that is made from Tea Clay. In a traditional memory game, cards are laid on a table facing down. The players each take turns where they can flip two cards. If the symbol on the two cards is identical, the player may keep the cards. If the cards are not identical, they must be flipped down again. The player must now remember the content of the card and its location. As the game proceeds further, the players will have a memory on the location of each symbol and can then easily pair them together. Figure 1.2 is a concept drawing of Serendipitea. Serendipitea is focussed on bringing sighted and visually impaired individuals together in a game where they can both be good at.



Figure 1.2: Serendipitea concept drawing

Visually impaired children are unable to identify two identical symbols through sight. Serendipitea therefore uses the sense of smell and touch. The game has 8 pairs, which results in 8 different scents with 8 complementary textures. The range of scents were derived from popular tea blends in which tea is blended with another ingredient. The scents were incorporated into the material by adding them simultaneously with the tea powder in the process.

Figure 1.3 shows the modified recipe of Zhou and Rhen (2018) for Serendipitea.

The concept is created with 100% biobased materials. Tea Clay is very durable. It has withstood drop tests and mechanical tests to see if it was applicable in a user context. The box in which the Tea Clay objects come in serves simultaneously as the board of the game. At the end of life, the box can be discarded at the paper bin, and the Tea Clay objects can be composted.

The concept can operate in a similar way as a traditional memory game: 2 players will each take turn to choose two objects. They can smell and touch the objects and determine if they are identical or not. In case the player believes that the two objects are identical, the player can check this by using the braille code on the side of the object.

SERENDIPITEA RECIPE	
Binder	Dry ingredients
44% water	30% Tea
7% Plant- starch	7% Lignin fibre
4% Acetic acid solution	4% scent powder
4% Glycerin	

Figure 1.3: The composition of Serendipitea



Picture of Serendipitea, by author



## 1.4 PROBLEM DEFINITION

Serendipitea was as finalised as possible to fit within the curriculum and timeframe of the course. Extensive tinkering was performed to understand the material characteristics. However, when the concept is approached from a manufacturing point of view, there are some things that could be worked on if this concept would want to be taken one step closer to being produced. Users were involved in the experiential characterisation of the material, but there was no further research conducted on the needs of the intended user group for the product application.

### 1.4.1 PROCESSABILITY

The processing of Serendipitea is based on craft: When the dry ingredients are added to the binder, the material needs to be kneaded by hand. This procedure is unsuitable to be applied on an industrial scale. Next to the kneading, a lot of excess material will stick to the used equipment, such as the gloves, spatula and cooking pot. This results in a loss of material, as the end product will have less material compared to the materials that were used in the composition. The kneading of the material should therefore be removed in order to create a more streamlined production.

The moulding of the material into the moulds was based on manual labour. When too little material was put in the moulds or too little pressure was applied, air gaps would form in the sample. This has a negative effect on the structure and strength of the product.

### 1.4.2 SCENT IMPLEMENTATION PROBLEM

Different methods for implementing the scent have been researched, and the final concept uses dry particles that are blended into the material. These particles will release scent, but the scent can become weaker or disappear over time. This has not been accounted for during the concept creation. For the concept to be applicable in the predefined user context, the scent endurance is crucial. Currently, it is unknown how long the scent will last in the product. The scent has also not been quantified over time in the previous study.

Another problem for the scent implication is the moment when it is added. When the concept has 8 different scents, this would result in a repetition of 8 times, but each with a different scent ingredient. This is not very practical, as the preference would be to create as much material as possible and create differentiation later in the process compared to the beginning.

### 1.4.3 VISUALLY IMPAIRED PEOPLE AND THEIR NEEDS

The current concept was created with the Material Driven Design method: This method indicates that the material will be explored and developed, and a suitable product application will be chosen based on the material characteristics. Due to time constraints it was not possible to research the needs of the intended user group. The MDD method does facilitate the cohesion of technical, experiential and user aspects, but this was not executed well enough during the Serendipitea project. The current product was developed without any understanding what Visually Impaired People (VIP) need and value. Understanding this can create more meaningful design that comes from both the material characteristics and the user needs.



## 1.5 RESEARCH QUESTIONS

1. How can the current Tea Clay processing method be optimised to facilitate the upscaling of product manufacturing?
  - 1.1 What are the mechanical properties of Tea Clay?
2. Which scenting method could be best implemented during the final processing stage of a Tea Clay product?
3. How do product users respond to waste materials such as Tea Clay?
4. What are the difficulties faced by Visually Impaired People, and what are their needs for a board game design?

## 1.6 RESEARCH MOTIVATION

In this project, the upscaling opportunities of Serendipitea will be explored. A focus will be held on the material itself. The material should undergo modifications in its composition to achieve a better manufacturability. Another aspect is the smell encapsulation in the material. The outcomes of this project will be valuable for research in developing the material further. The outcomes of this project will also be valuable for other bio-based material that are in development, as currently most of the new bio-based materials are created under specific circumstances, and there are not many examples of such materials being widely used for commercial products. This project would serve as a case study in how methods of manufacturing and working towards envisioned material characteristics can be explored and applied on a new bio-based material. This project will also serve as a proof of concept for the Tea Clay itself. The outcomes of the project will bring

Tea Clay one step closer to being applicable in a product application.

The main opportunities are that currently many of the new bio-based materials are in the same stage as TeaClay, meaning that there is a need for such research to find out how these materials can take the next step in being able to be applied in consumer's lives.



## 1.7 METHODOLOGY

The Material Driven Design approach will be applied once again on the Serendipitea project. The MDD approach usually starts with an underdeveloped or emerging material. The process focuses on the material experience and technical aspects. Rather than designing a concept and applying a material to it, the process focuses on what the potentials are of the material, and what designs are therefore suitable. This enables the designer to have a better understanding of the material and to create meaningful concepts for society (Karana et al., 2015). This process is illustrated in figure 1.4. The first phase is the understanding of the material, which involves tinkering, technical and experiential characterisation, as well as benchmarking. Literature review and benchmarking will be leading the tinkering and scenting process. The tinkering phase will focus on changing the processing method and material composition, as well as implementing different scenting methods and testing its intensity. The outcomes could solve research questions 1 and 2. The technical characterisation will focus on the mechanical properties of the renewed material, and thus solve research question 1.1. The experiential characterisation will revolve around the people's interpretation of the material and how it can be best introduced to them to accept it, which solves research question 3. The benchmarking focusses on existing concepts, and can inspire to new manufacturing methods, as well as determining a need for the users. This research will use literature review and benchmarking to determine the difficulties faced by VIP and the existing board games that are currently available in order to design a product that is more adaptable to their needs. This would solve research question 4. This project is a redesign of Serendipitea, and the idea of a memory game for visually impaired people will not change. Material Driven Design is an iterative process, where the designer can go from step 4 to step 1 again. This project would thus be the second iteration round from a concept back to understanding the material, and back to redefining the concept. With this information, a redesign of Serendipitea can be created that is more suitable for large scale processing, and suits the needs of the users better.

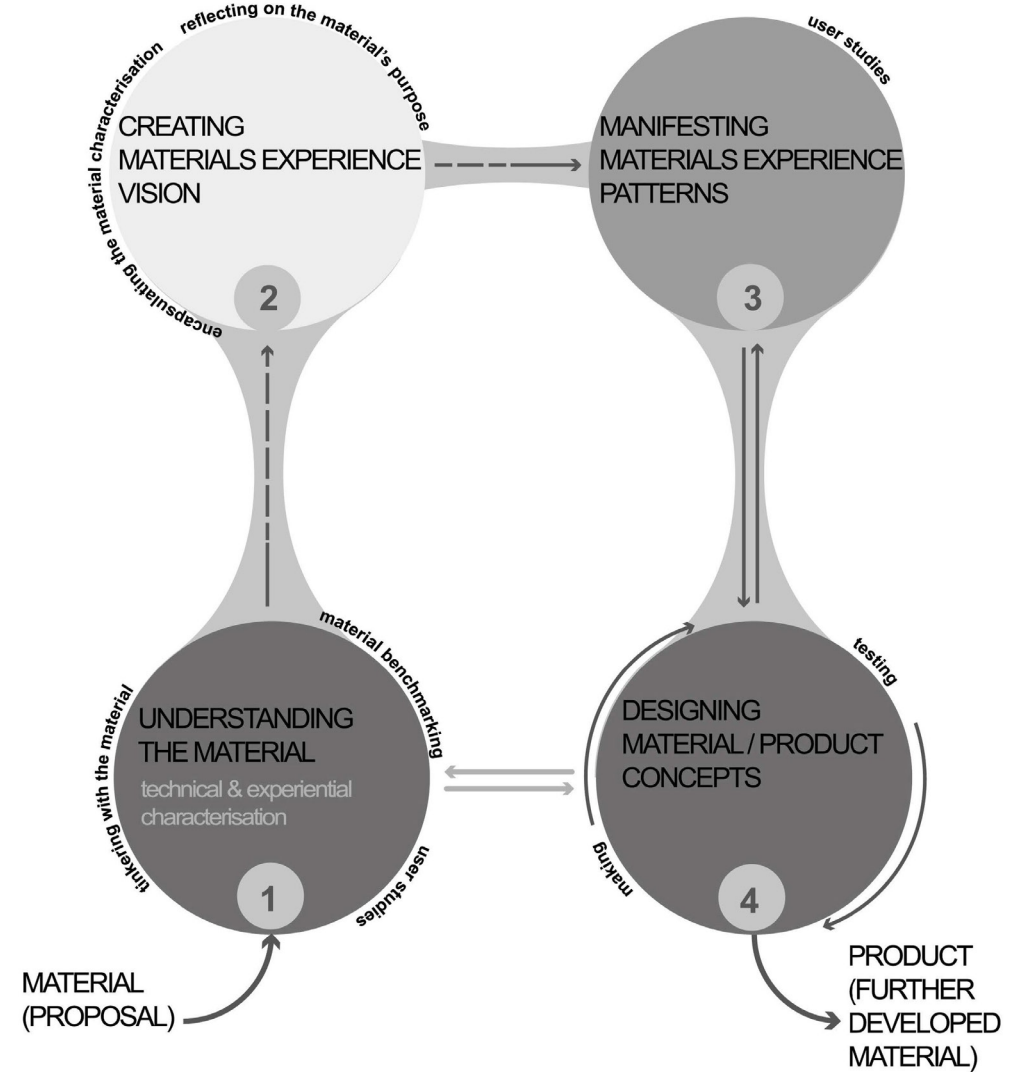

Figure 1.4: the Material Driven Design approach by Karana et al (2015)

A close-up, slightly blurred photograph of green tea leaves, likely oolong or a similar variety, filling the background of the top half of the page. The leaves are dark green with some lighter, silvery-green areas, and are scattered across the frame. The lighting is soft, highlighting the texture of the leaves.

## CHAPTER 2

## LITERATURE REVIEW

In this chapter, literature research will be conducted on several topics. Mainly, journal articles are sought via google scholar. This literature research also aims for understanding the core materials of the research. For example, understanding the history of tea, and why tea is being consumed, and understanding the development of bioplastics nowadays. These topics are harder to find in journal articles but could be found in books as well. Mostly, the areas of material science were consulted. Keywords such as tea bio composite, tea composition, bio composite manufacturing, measuring odour, visually impairment and visually impaired boardgames are used.

The origin of tea and its consumption will be discussed, following with the pressing problem of tea waste and its possible solutions. Further, current research into manufacturing of bioplastics will be researched to create an understanding of the possibilities for Tea Clay. Research about scent measurement and implementation techniques will stimulate the scent aspect of the project, determining whether it is possible to continue further development. As last, research about VIP regarding board games are discussed to create a better understanding of their needs and to draw design guidelines that are applicable for Serendipitea.

## 2.1 TEA

Tea has been consumed by humans for over more than 2000 years. Tea drinking originated in China but has since made its way into other cultures as well. In 2019, 5.9 million tonnes of tea are consumed yearly (Guo et al., 2021). The choice for consuming tea is based on many different aspects. Tea drinking contains sensory properties, such as the warmth and aroma. In many cultures, drinking tea is also part of their customs. Tea is widely available and relatively cheap, which then increases the consumption as well. Lastly, tea is believed to have medicinal purposes (Chen, 2002).

Tea is categorised in 3 groups. Green, oolong and black. Many people would believe that these are three different plants, while in fact they are all one. The manufacturing process differs, which results in different kinds of tea. Tea consists of dried leaves, but when oxidation occurs, the colour taste will change. Green tea is the least oxidated tea, with oolong being half fermented tea, and black tea being full fermented tea. The process for manufacturing tea includes spreading the leaves, fixing them, rolling them together and drying, with the fermented teas undergoing a fermentation and withering process as well (Xu & Chen, 2002).

The dried leaves are steeped with hot water. After brewing, the spent tea leaves are disposed. Manufactures of for example bottled, canned or instant drinks brew large amounts of tea and dispose the solid residue. This process results in 90% of tea leaves ending up in waste after brewing. Next to that, the catering industry such as hotels, restaurants and cafes use large amounts of tea to provide beverages to their customers. The disposal of this large amount of organic waste leads up to environmental pollution, intensive labour, and a great use of space. This can result in water and soil pollution. It is therefore important to provide a solution for the utilization of spent tea leaves. Research has been conducted wherein spent tea leaves can filter out certain chemicals in liquid solutions. Next to that, spent tea leaves are used for fillers in bioplastics. Bioplastics are biodegradable and are therefore more interesting to use for products compared to plastics made from fossil fuels. Conventional plastics remain longer in the environment, causing pollution. Many bioplastics have material characteristics that resemble that of conventional plastics. Studies on the use of tea leaves as a filler for bioplastics is still limited (Negi et al., 2022).

Picture of tea leaves drying, by author



## 2.2 BIOPLASTICS AND MANUFACTURING

Synthetic polymers have been used by people for many years and up until now, there did not seem to be a need for looking for an alternative. They can come in any shape, colour, and finish, and is applied in all everyday objects. They last for a long time and contain high mechanical properties. Additionally, synthetic polymers are highly affordable. These polymers existed since the last 70 years, and at that moment there did not seem to be a problem with their long life span. Society has come to the moment where the first polymers created 70 years ago are well past their usage, but the polymer itself has a low degradability and surpasses its user phase. Combined with a poor recycling system, many synthetic products end up in nature. Next to the poor degradability of the product, the resources for creating synthetic polymers are scarce and unrenowable. This altogether rises the need for new bioplastics made from renewable sources and with a better degradability. Biodegradable means that microorganism can degrade the material back to substances such as water and carbon (Cecchini, 2017).

Research has been conducted on starch based bioplastics, as starch can be derived from different sources. Starch has the ability to gelatinise when it has contact with water and heat, forming a viscous medium. Next to starch, the biopolymers need plasticisers such as water and glycerol to create flexibility. Additionally, a filler material is needed to create volume. This filler material is usually derived from cellulose, as the fibrous structure brings positive mechanical properties to the bioplastic. Starch based bioplastics take a shorter time to degrade, and currently represent 50% of commercially produced bioplastics (Das & Kalyani, 2023).

Starch based bioplastics have developed well over time, but they still do not possess the same qualities as synthetic polymers. One big disadvantage for many starch-based bioplastics is their hydrophilic properties, meaning they have a low water resistance compared to synthetic polymers. These starch-based polymers should therefore be coated, and ideally with a biobased coating. The research of Hendrawati et al (2021) focusses on using beeswax as a natural coating for sago-based bioplastics (Hendrawati et al., 2021). Beeswax is a natural hydrophobic material. It can be painted or sprayed (Kääriäinen et al., n.d.). It was proven that beeswax has a positive effect on the water resistance of a material, whilst still being biodegradable (Hendrawati et al., 2021).

The starch from these bioplastics usually come from edible sources, such as corn. This raises questions whether corn is a suitable source to substitute synthetic polymers. The idea to grow crops in order to create bioplastics from would mean that the problem gets shifted to another ecosystem, but in the long term it could face the same problems we have now (Cecchini, 2017).

Other research has been conducted on using waste resources to create bioplastics. One of the most common used waste products is coffee. The cultivation of coffee produces many byproducts, such as coffee fruit, husks, pulp and chaff. Next to that, there is waste after brewing coffee. The husks and pulp waste are now used for composting due to their high nutritional content or they are used for the production of biodiesel. Coffee chaff is a byproduct of roasting and there are not many applicable products for it yet. The spent coffee grounds after brewing contains 90% of the starting mass, which means that this waste is very large. Due to the different methods for brewing coffee and grinding the beans, the spent coffee grounds have different chemical compositions. A part of the spent coffee grounds is used for producing biodiesel or fuel pellets, and another part is used as a filler for bioplastics (Blinová et al., 2017).

Another application of spent coffee ground is researched by Sena da Fonseca et al (2014). Here, different rations of coffee ground were mixed with ceramics. Adding coffee ground in ceramics was hypothesised to increase the thermal properties of ceramics in building materials. The research concluded that significant amounts of spent coffee grounds could be used to increase the performance of ceramics. There was an improvement in thermal performance, and the coffee ground reduced the overall bulk density, and when the proportions of a waste material is done right, it can improve the workability of the material and are then capable for industrial processing (Sena da Fonseca et al., 2014). It is therefore important to note that bio-composites originating from waste also have the potential to outperform and enhance traditional materials.

## 2.4 SCENT IMPLEMENTATION LITERATURE

### 2.4.1 INFUSING

Tea has been scented for years. There are several methods for mixing tea with fragrances. One of the most traditional methods for creating scented tea is the production of jasmine tea. This method is unique to China and can be dated back to the Ming Dynasty. Jasmine tea production uses the ability of tea to absorb fragrances. Jasmine tea is green tea that is scented with fresh jasmine flowers. Jasmine tea production usually starts in the summer since that is the season when jasmine flowers are growing. The flowers need to be freshly plucked in the morning when the flowers have not opened yet. Different methods will be used for opening the flowers at the desired rate and time. Fresh closed flowers are put on sieves and shaken until they open. Another method is to put them in a controlled temperature, simulating the environment in which they would naturally bloom. The temperature regulation is very important, because the flowers can either remain closed in cold temperatures, or wither in hot temperatures.



After the flowers have been prepared for the scenting, the tea leaves and the flowers are placed in a room together. The flowers and leaves do not need to be mixed, as simply putting them next to each other can scent the leaves already. The flowers will release their scents, and the tea will absorb it. After some time, the tea leaves have become scented tea. It is usual for jasmine tea to be served without the flowers, but some manufacturers add the flowers as well to strengthen the scent and flavour of the tea. The quality of the scented tea depends on various factors such as the amount of flowers, scenting time and scenting temperature (An et al., 2022). There are many other examples of teas that are scented using this method. The scenting production comes from different regions of China. Lily scented tea is produced in the south-eastern provinces of China. The process is similar to jasmine tea. Fresh lily flowers are put together with tea leaves. The former releases its scents while the latter absorbs it. The lily flowers are packaged together with the tea leaves. This can enhance the quality, medicinal and edible value.

Rose scented tea is native to the Guangdong and Fujian provinces in China. The rose flowers undergo a freeze-drying method to remain their fragrance until they are ready to be scented with. After scenting, the leaves need to be dried. Microwaving the leaves can preserve the fragrance and stimulate the colour of the tea.

Honeysuckle tea uses pan fried green tea and honeysuckle flowers. The flowers and tea leaves are left in a sealed enclosure. They are separated through gauze and stacked in multiple layers. This stimulates the mixing of the scents. Afterwards, the flowers and tea leaves are packed together (Liu et al., 2022).

Photo by Anna Pou from Pexels: <https://www.pexels.com/photo/close-up-of-dry-leaves-8329249/>

## 2.4.2 BLENDING

Blending tea is the addition of fragrance ingredients to the tea leaves. The tea leaves and fragrances are steeped together during the preparation of the beverage. An example of this would be Tao of Tea's Blended Puer tea with ginger. Here, they indicate that their tea is blended, see figure 2.1 (Tao of Tea, n.d.-b). This method is very versatile because many combinations of teas and fragrances can be combined together. This also allows tea manufactures to come up with different combinations of fragrances. For example, Tao of Tea has created a chai blend with black tea, dried ginger, cinnamon, cloves and cardamon, see figure 2.2 (Tao of Tea, n.d.-a). This scenting method is similar to the current scenting method of Serendipitea.



Figure 2.1: Tao Of Tea Blended ginger Puer

## 2.4.3 SCENTING

Next to blended teas there are scented tea. Scented teas are created by coating the tea leaves in essential oils. This is more cost-effective alternative to scenting tea, as essential oil is used in smaller quantities to deliver a rich aroma compared to blending tea. A well-known example for scented tea is earl grey. Here, tea leaves are coated with bergamot essential oil (Tao of Tea, n.d.-c). See figure 2.3. The consumer can steep the tea and the oil fragrances will come free (Smith, 2016).



Figure 2.2: Tao of Tea Black tea blended with spices

Usually, a combination of scenting and blending is used. This could be due to enhancing the flavours of blending with scenting. An example of this is Tao of Tea's Rose Petal Black. Here, black tea and rose petals are blended, but it is also sprayed with rose essence (Tao of Tea, n.d.-d).



Figure 2.3: Tao of Tea green tea scented with bergamot oil



## 2.4.4 SCENT MEASUREMENT

Next to knowing how the scent can be applied, it is important to test which method will be the most successful in the product application. As scent decreases over time, it can cause the concept to lose one of its main functionalities. Without the scents, only one part of the game can be played.

Odours consist of Volatile Organic Compounds (VOC) that are released in the air. Released scent is often heterogenous, chaotic, turbulent and is only measurable for a limited time. The release of scent can be different from time to time, and it is difficult to indicate what the physical structure is of the scent that is released. Humans and animals detect odours with the use of their biological olfactory system. VOC float around in the air, and in order for humans and animals to detect them, they need to be carried by a medium to reach their sensing element. This is done by sniffing. The sniffing causes air to carry the VOC towards their sensing element (Kauer & White, 2009).

It is possible to quantify the odour that is released from a material. This is usually done with an olfactometer and human examiners. Odour is quantified with the Odour Threshold (OT). The olfactometer dilutes the odour of a sample with air. The human examiners must determine whether they can detect the odour or not. The dilutions will be increased every time when the odour is still detectable. The OT is reached at the moment when the odour cannot be detected anymore. The OT is therefore defined as the concentration at which the odour is still detectable by 50% of human examiners. The OT also gives a number of dilutions. This is defined as the Odour Concentration ( $ouE/m^3$ ).

Using human examiners and an olfactometer cannot always be used due to circumstances, for example, when an odour needs to be measured in a field study. Another method for quantifying and identifying odour is by using gas chromatography. Here, samples can be captured on cartridges with solvents where the odours can adhere to. The cartridges need to undergo thermal desorption before they can be analysed with the gas chromatograph (Capelli et al., 2013). An example of this is the research from Kesselmeier et al. (2000). Here, VOCs were measured at a remote tropical forest site in central Amazonia. Their method was to collect the VOCs on solid absorbent traps and use gas chromatography to identify, separate and quantify the VOCs. The results were a database of the different VOCs that were present in that area. Even low amounts of VOC were detectable and put in the database (Kesselmeier et al., 2000).

Recent developments are coming with Electrical Noses. E-noses can distinguish complex volatiles. They are for example used in the food industry to detect and identify spoilage. E-noses fulfil a quality control and assurance role. E-noses are designed to become an artificial smell receptor, as it should be able to identify, distinguish and quantify odours. However, E-noses are not very accurate in distinguishing odours, because they cannot fully mimic human receptors (Arakawa et al., 2023).

Commercial VOC sensors are commonly used for indoor air quality. A VOC sensor measures the Total VOC (tVOC) of the ambient environment. There is not much proof that a commercial VOC sensor can be used to quantify odours. A VOC sensor cannot distinguish different odours as well. This means that when it detects an odour, it can quantify the amount of VOC, but it cannot identify what the odour or odour composition is. Marinov et al (2021) has conducted research where the usage of low cost commercial VOC sensors could assess the indoor air quality. Indoor air quality is usually measured with CO<sub>2</sub> sensors, as a high presence of CO<sub>2</sub> suggest that there is a poor air circulation, and this could cause an increase in air pollutants.

As CO<sub>2</sub> sensors are used as indicators for air quality, VOC sensors were tested in order to see whether they can provide a more detailed assessment. 4 commercial VOC sensors were tested in combination with CO<sub>2</sub> sensors. The result was that the VOC sensors are sensitive to particular VOCs such as benzene, toluene and ethylbenzene, but not to other VOC's which are important for the assessment of indoor air quality. The conclusion was that VOC sensors could be potentially used for the assessment of indoor air quality instead of the traditional CO<sub>2</sub> method (Marinov et al., 2021).

This research creates more understanding towards the research from Van Dijken, et al.(2022). They have used a commercial VOC sensor to measure the scent release rate of their TeaClay samples with essential oils applied to the surface. First, their VOC sensor did not indicate a difference in VOC from the background environment and their sample. This would suggest that the VOC sensor is not sensitive to the type or amount of VOCs provided by the samples. Another issue was that some readings showed an increase in VOC after a few days of testing. This can be explained since VOCs are released in different quantities each time. This concludes that commercial VOC sensors cannot be a reliable source for quantifying the odour (Van Dijken et al., 2022).



## 2.5 VISUALLY IMPAIRED PEOPLE

According to the World Health Organisation, there are globally 2.2 billion people who have a visual impairment (World Health Organisation, 2023). Visual impairment means that an eye condition affects the vision of a person and that additional tools such as glasses cannot reverse the effect. Therefore, colour blindness or difficulty to perceive details in low lighted areas are also considered visual impairment. The WHO describes the rate of visual impairment based on their acuity, wherein a low acuity is labelled as “low vision”, and an even lower acuity is described as “blind”. This means that people who are labelled as blind can perceive some things, even though it is quite limited.

Even when blind people do perceive some things, it does make their daily life much harder. Children who have a visual impairment at a young age can have a lack of emotional, social, and cognitive development. And school aged children often experience lower levels of educational achievement (World Health Organisation, 2023).

VIP are often perceived as dependent and helpless, while according to them, this is a huge misconception. Visually impaired people value autonomy in their daily life. They feel frustrated due to the dependence of sighted individuals. An increase in autonomy stimulates social interaction and can give them a boost of confidence (da Rocha Tomé Filho et al., 2019). Especially people with a higher impairment have difficulties with social interaction and prejudice from strangers. But there is not enough proof that VIP are less capable in daily tasks than sighted individuals. A study from the Massachusetts Eye and Ear Infirmary have shown that people who are born blind can have heightened senses such as touch and smell, and that they have enhanced cognitive abilities such as memory and language, as their brain adapts to their lack of vision and instead works around it with other abilities (Bauer et al., 2017). It should be taken into account that this study limits to people who are born blind, but that according to the WHO, the majority of VIP do not fall in this category.

Photo by MART PRODUCTION: <https://www.pexels.com/photo/a-woman-in-brown-coat-walking-on-pathway-8327739/>

## 2.5.1 BOARD GAME DESIGN FOR VIP

But even when VIP do not have as severe dependencies as perceived by people, there is still a gap between the interaction of visual impaired and non-visual impaired. Board games can enhance relationships and stimulate social interaction, but there are not many games that are adaptable for VIP. Currently existing games make use of tangible and audible features, but there are not many examples of smell being implemented in games. A recent study suggests that smell has the ability to recall memories, but more importantly, that smell can nudge VIP to share these memories, resulting in a deeper social interaction (Feng et al., 2019). This could indicate that a game based on scents can perhaps bridge the gap between VIP and sighted players.

It is important to take certain needs into account when a game is being developed for VIP. A studies by Da Rocha Tomé (2019) has established adaptation guidelines for board games. Even when VIP have very low vision, they are still highly dependent on tactical feedback. It is therefore important create tactile patterns. These can serve for identification or describing of pieces. A tactile pattern can indicate if there are game pieces that belong to other players, or that there are different pieces with different functions in a game. Regarding the presence of different pieces, Da Rocha Tomé has expressed the importance to not make these objects ambiguous or unidentifiable. For example, instead of using brown colours chips to indicate that they are wooden logs, it is much better to create miniature pieces in the shape of a log. Colours for differentiating between pieces is unadvised, as the colours needs to be colour blind adapted, and must contain a high contrast for low vision people to be perceived well. It is always advisable to implement audible feedback in gameplay. This can stimulate social interaction, and helps the VIP to keep track of the game.

Regarding game pieces, they must have a storage compartment. This can help with visual impaired players to keep track of where pieces are, and that they cannot accidentally get lost. Small components must be fixed to prevent them from moving. Moved components can difficult the gameplay as they are highly dependent on their memory of a certain position. Fixing components can also prevent them from accidentally being knocked over. It is therefore also advisable to enlarge game elements. Next to actual game pieces, there are also guidelines for instructions. Written text must be accompanied with braille, and text should always have a high contrast with the background, as well as a large font with high readability (da Rocha Tomé Filho et al., 2019).



Photo by Tima Miroshnichenko from Pexels: <https://www.pexels.com/photo/girl-holding-a-book-while-sitting-on-sofa-6609525/>



Photo by lil artsy from Pexels: <https://www.pexels.com/photo/white-and-brown-ceramic-bowl-1793035/>

## 2.6 CHAPTER CONCLUSION

There is a need for spent tea leaves to be reused, both regarding the high consumption rate that happens nowadays, and because of the lack of applications that are currently happening. It is believed tea leaves can act as a filler for bio plastics, but the information on this is scarce. It is therefore important to continue the research into opportunities for manufacturing tea clay.

Bioplastics are in high need to reduce the usage of synthetic polymers. Bioplastics are better degradable and contain renewable materials. Most of the bioplastics are starch based, which has proven to be successful for commercial products, but has its limitations regarding water resistance and usage of a food source such as corn.

Even waste product bioplastics are still dependent on starch, as the food waste will only act as a filler. However, the usage of waste as a filler can decrease the usage of other materials and have a positive effect on the weight of the material. At the moment, it seems that starch plays an integral part in bioplastics and cannot be substituted yet due to its gelatinization process, but the development for waste products is urgent and therefore justifiable. It is however important to keep the usage of starch at a minimum.

The scent measurement insights have resulted that there are many intricate ways for determining odour quantity, but which are not applicable within this study and time frame. However, a qualitative study regarding can provide some insights in scent quality and can be helpful. This study will go simultaneously in the scent implementation techniques. The three techniques can serve as examples of how scent can be better implemented in Serendipitea.

The research towards visually impaired people and their needs draws a better picture of their social struggles and perceptions of themselves and others. They are often perceived as dependent, while they have frustration towards this and value independent tasks higher in their lives. This altogether also creates social difficulties. There is a perceivable gap between sighted individuals and VIP, and board games can come in to bridge the gap. There are guidelines created for designing board games for visually impaired, which contains guidelines not only for the game pieces itself, but also for the game board and instructions. These guidelines are useful during the design phase.



Benchmarking creates insight into existing projects from designers. This creates a good overview in methods that have been tried before, or even products that are still in their concept phase but have not reached consumer standards yet. Resources such as online databases will be consulted to collect information. Next to that, design magazines and company websites will be used. The MaterialDistrict exhibition is a yearly exhibition hosted by Material District, which is an online database. This exhibition was visited as well to look for existing projects. Keywords that were used during the search for products are: tea bioplastic, coffee bioplastic and waste bioplastics. The benchmarking will be conducted on biomaterials that are similar to tea.

It is well known that there are many products on the market made from coffee waste. It is therefore interesting to conduct research on the diversity of coffee ground products and their applications. Next to coffee waste, other waste products can be researched as well. The idea of benchmarking is to determine different production methods, and to see if the products are still at concept level or are already implemented in society. Benchmarking is also suitable for determining existing solutions for VIP regarding board games. These games are found with google search engine. Keywords for the search engine were board games for visually impaired people. These findings can create an understanding in solutions that are successful and what the user's needs are.

### 3.1

## TEA WASTE

Tea waste is like coffee grounds, as it is usually used as filler material for biobased plastics. Interestingly, the tea waste usually does not include a service design where the producer collects tea waste from its clients. The tea waste samples have a broader variety in products and processing, as they are not mainly used as a filler for injection moulding. The tea waste samples offer insight in different processing methods that could be used during this project.

Albert et al (2022) have also researched another processing method for Zhou and Rhen's composition. They were exploring the influence of water for a 3D printing application. They have found out that a 3 times increase of water can transform the material from a clay to a paste that can be printed. One thing worth mentioning is that the increase of water will result in more shrinkage compared to Zhou and Rhen's composition (Albers et al., 2022).

Another report from Van Dijken et al (2022) have researched the ability for Zhou and Rhen's composition to absorb scents. Their solution was to add essential oils to the dried Tea Clay composition. A VOC sensor was used to measure the endurance of the smells, but the results were inconclusive due to doubts in the accuracy of the sensor (Van Dijken et al., 2022).

Dust London combines grinded tea powder with Jesmonite, which is an eco-friendly binder (Home | Jesmonite, n.d.). It has similar properties to plaster, as it can be poured and is easily processable. (Hamar, n.d.)

Katherine Lopez created a clay with tea waste which is very similar to Zhou and Rhen's composition (Lopez, n.d.). The difference here is the lack of lignin fibre, and that Lopez's material needs to be dried in an oven. Lopez also created a variation that was extrudable. The material is extrudable in different thicknesses, and it is easily joined on the contact surfaces when it is wet. Her advice for water resistance is to add a bio resin coating to the material.

Fulden Gencel uses tea waste with gelatine to create a material that is mouldable by hand or pourable. The gelatine makes it possible for the material to be reheated after it has been dried. This creates a product life cycle, as the end product can be repurposed into a new product (Gencel, n.d.).

Sanskriti Gupta also approached tea waste with a gelling agent. The combination of gelatine and tea creates a thin, transparent bioplastic (Gupta, n.d.).

Lastly, Chazence creates different products made from used tea leaves. Their products look at the structure of the tea leaves, and creates fitting applications for them. Tea stalks are fibrous and create a stronger structure. However, the look and feel will be less uniform. Compressing the tea stalks makes wall panels that are both strong and do not require to be homogenous. The finer fibres of tea leaves are not suitable for wall panels, but when these fibres are compressed into thinner objects, packaging material or paper can be created (Chazence, n.d.).

Photo by Dust London via <https://luxiders.com/wp-content/uploads/2020/09/Webp.net-compress-image-2020-08-11T094045.505.jpg>





<b>Name</b>	Dust London	Tea Waste by Katherine Lopez	Tea Waste by Katherine Lopez	Tea waste by Cheng Cheng
<b>Composition</b>	Tea powder with Jesmonite	Tea powder, water, glycerine, starch, vinegar. For water resistance : add bioresin	Tea powder, water, glycerine, starch, vinegar.	Tea powder, corn starch, sodium alginate. For water resistance: add bioresin
<b>Material form</b>	Viscous	Homogenous mass	Homogenous mass	Homogenous mass
<b>Material fabrication</b>	Unknown	Mixed and heated, and afterwards heat treated until dry	Mixed and heated, and afterwards heat treated until dry	Mixed and heated
<b>Product processing</b>	Pouring in silicone moulds	Hand modelled	Extruded	Hand modelled
<b>Biodegradable</b>	Unknown	Yes	Yes	Yes
<b>Application</b>	Vases	Jewellery, model building Water resistant material is applicable for furniture	3D printing	Vases, candle holders
<b>Source</b>	(Dust London   Transforming Tea Waste into Homeware, n.d.)	(Tea Waste by Katherine Lopez – Future Materials Bank, n.d.)	(Tea Waste by Katherine Lopez – Future Materials Bank, n.d.)	(Tea Waste by Cheng Cheng – Future Materials Bank, n.d.)



Name Tea waste by Fulden Gencel

Composition Tea powder, water, glycerine, gelatine

Material form Viscous

Material fabrication Heated and mixed, and afterwards dried in the air

Product processing Shaped by hand or poured in mould

Biodegradable Yes

Application Table

Source (Tea Waste by Fulden Gencel – Future Materials Bank, n.d.)

Name Tea grounds bioplastic

Composition Tea grounds, water, gelatine, glycerol

Material form Viscous

Material fabrication Heating and mixing

Product processing Pouring into flat tray mould

Biodegradable Yes

Application Unknown

Source (Gupta, n.d.)

Name PrZence by Chazence

Composition Tea powder and tea stalks

Material form Fibrous

Material fabrication Unknown

Product processing Unknown

Biodegradable Yes

Application Wall panels, decorative panels

Source (Chazence, n.d.)

Name FmZence by Chazence

Composition Tea leaves fibres

Material form Fibrous

Material fabrication Compressing fibers together

Product processing Unknown

Biodegradable Yes

Application Packaging and paper

Source (Chazence, n.d.)



## 3.2

# COFFEE

Coffee ground is commonly used as a filler for biobased plastics. Several benchmarking samples are coffee ground mixed with biopolymers. Here, coffee grounds serve as a filler material, and they are embodied in bioplastics or resins. Coffee ground material are usually part of a service or systemic design. The Dutch company called Coffee Based is a B2B where they collect coffee grounds from companies, and returns it as coffee-based products, such as cups and plant pots (Coffee Based, n.d.). Such service designs in collaboration with companies is doable for coffee grounds, since companies produce a lot of coffee grounds that would otherwise go to waste. The return system makes it attractive and fulfilling for companies to establish a partnership with Coffee Based. Some samples use biodegradable plastic that is mixed with the coffee grounds. This will result in biodegradable end products as well. This working method is similar to that of Coffee Polymer. Here, they use different kinds of biodegradable polymer, and each with a different degrading method. By mixing coffee grounds with biodegradable granulate, several different products can be created. Short term use products are mostly made with biodegradable polymers that can degrade in nature, while long term products can degrade in a simulated waste processor (Coffee Polymer, n.d.). The question is here whether the company collects the material afterwards to ensure the correct waste disposal.

Big Circle studios has created a bio composite using coffee husk. In the coffee production world, coffee husk is also another waste material that comes from the large consumption of coffee. The coffee husk does not use bioplastics or resins, but agar agar and glycerol. The agar agar, glycerol and water are heated until the agar agar starts to thicken. Then, the coffee husk is added to the paste and mixed thoroughly. The mixture is scooped in moulds and dried (Big Circle Studios, n.d.). This working method has many similarities with Zhou and Rhen's composition. The wet ingredients are combined with a thickening agent, in this case agar agar, and heated. The heat transforms the mixture and then the coffee husk is added.

The Material Driven Design paper written by Karana et al (2015) uses a case study of coffee grounds to illustrate how the method works. Here, they created several different materials. It is interesting to see how coffee ground can have different material applications, and that each application is then transformed into a suitable product feature. Coffee ground tablets were made with seeds inside. The coffee grounds provide nutrients to the seed, creating a suitable growing environment. After the seeds are planted, the tablets can be discarded in organic waste. Next to that. A pot made from coffee grounds was made to house the soil and seeds. This case study shows the benefits of using MDD as a design method for creating valuable products from the material, technical and user perspectives (Karana et al., 2015).

Photo by OV-Design via <https://zwinc-magazine.nl/startups-in-the-spotlight-2/>

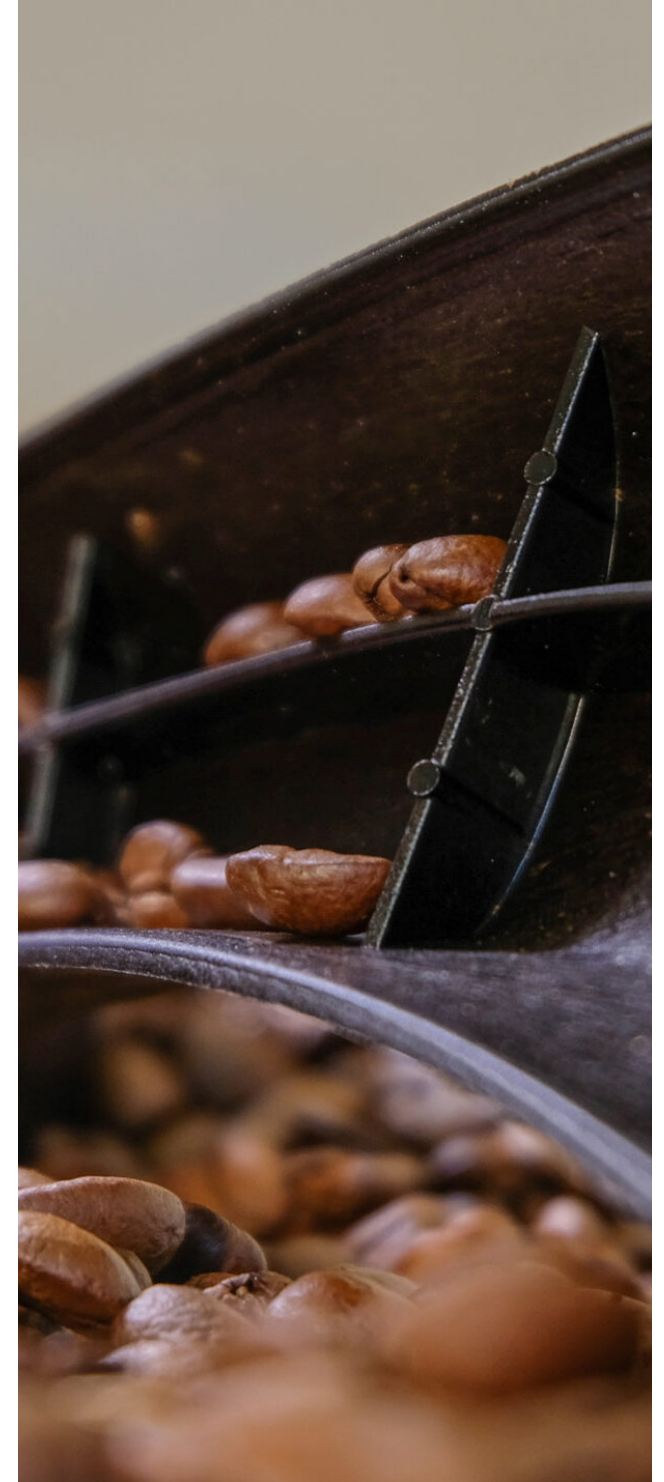



<b>Name</b>	Coffee Based Material	OV design- Espresso polymer	Coffee husk	Cof2grow
<b>Composition</b>	Coffee grounds and biopolymers	Coffee grounds and biopolymers	Coffee husk, agar agar, water, glyceorl	Coffee grounds, paper pulp and bio-based polyurethane
<b>Material form</b>	Flexible sheets or granulate	Granulate	Homogenous mass	Homogenous mass
<b>Material fabrication</b>	Unknown	Unknown	Heating wet ingredients, then adding coffee husk	Mixed with pulp, compressed and heated
<b>Product processing</b>	Vacuum forming the sheets Injection moulding the granulate	Injection moulding	Manual moulding and drying in air or oven	Compressed in moulds, or injection moulded
<b>Biodegradable</b>	Yes, only the injection moulded products	Yes, in simulated waste processor	Yes	Pulp can be recycled The polyurethane composite cannot
<b>Application</b>	Cups, pots, panels, notebooks	Long term products	Unknown	Seed package and pot
<b>Source</b>	(Coffee Based Material , n.d.)	(Coffee Polymer, n.d.)	(Big Circle Studios, n.d.)	(Karana et al,2015)

### 3.3

## WASTE RESOURCES

Waste resources are resources that are a byproduct of manufacturing and are always discarded as waste. One example of this would be saw dust. Saw dust exists after wooden products have been fabricated due to sawing or sanding. MDF plates are wooden plates that are created by adding synthetic resin to the wood particles and hot compressing it into plates. Next to saw dust, pulp chips, planer shavings, plywood trim are all used as material for the creation of MDF. The quality and size of the fibers determines the application of the plates. MDF made from planer shavings has more strength due to the long fibers, and they are usually used in construction work. While MDF made from saw dust has a finer structure but offers less strength. These are usually applied to lightweight furniture (Maloney, 1996). Next to traditional MDF plates, Woodio encases woodchips in resin based adhesives to create a new composite (Woodio®, n.d.). This method of enclosing waste materials in resin is suitable for every kind of waste, because the waste does not add much in the structural properties of the material. The resin will fill gaps between the waste material, causing the material to not be so porous. The resin will also determine the surface finish of the material, while the colour is determined by the waste resource. This is also visible in the material of Ottan materials (Ottan, n.d.)

Usually, waste resources also include food waste. Examples of this are eggs. Basse Stittqen uses eggs and dehydrates them into powder. With the crushed eggshells, everything can be heat pressed together. The protein in the egg white polymerizes and binds the solid materials together (Stittqen, n.d.). Another egg project is the one from Ana Otero. Eggshell powder, xanthan and water are mixed without heating. Xanthan is a polysaccharide that is commonly used as a binder in the food industry. Otero's material does not require the use of heat to bind the material (Otero, n.d.). Xanthan will thicken once it is mixed with the other ingredients. The material is suitable for 3D paste printing (Materiom, n.d.).

Nettle plants are considered to be weeds. Weeds need to be removed occasionally and are usually disposed of. Mairi Gillies has created a gelatine composite with nettle plant as main ingredient. The working method of this is similar to other bio composites: drying the main ingredient and grinding it into a powder, and then adding it to a heated binder (Gillies, n.d.).



Picture of Agriluma lamp, by author



Name	Woodchip by Woodio	Ottan Materials	Egg bioplastic	Eggshell paste for 3D printing
Composition	Wood chip and resin based adhesives	Food waste and bio resin	Egg	Eggshell powder, xanthan, water
Material form before application	Unknown	Unknown	Powder	Homogenous mass
Material fabrication	Unknown	Mixing	Heat pressing the powder together	Mixing the materials
Product processing	Compressing	Injection moulding	Unknown	Paste printing
Biodegradable	No	Unknown	Yes	Unknown
Application	Panels	Furniture	Cutlery and tableware	3D printing
Source	(Woodio®, n.d.)	(Ottan, n.d.)	(Stittgen, n.d.)	(Otero, n.d.)



<b>Name</b>	Nettle leaf gelatine composite	BioM by VanHier	Agriluma	Rumi
<b>Composition</b>	Nettle leaf, gelatine, glycerol, water	Grass, elephant grass and plantbased binder	Agrifood waste, and other unknown ingredients	Leaves, starch, glycerin, vinegar, water
<b>Material form</b>	Homogenous mass	Solid slabs/sheets	Unknown	Homogenous mass
<b>Material fabrication</b>	Mixed and heated	Hot compression	Unknown	Mixing the materials
<b>Product processing</b>	Poured into tray mould and left to dry	Thermoforming or cutting	Compression moulding	Manual moulding
<b>Biodegradable</b>	Yes	Yes	Yes	Yes
<b>Application</b>	Unknown	Furniture	Furniture	Stacking game
<b>Source</b>	(Gillies, n.d.)	(VanHier, n.d.)	(HighSociety studio, n.d.)	(Lopez, n.d.-a)

### 3.4 GAME SOLUTIONS FOR VISUALLY IMPAIRED

During the benchmarking of game solutions for VIP, it was noticeable that there was a difficulty finding good games. This is due to the lack of information channel, and lack of inclusive games. It was difficult to find resources where inclusive games were promoted and sold. It was noticeable that traditional games such as checkers or chess had undergone adaptations to make it more inclusive (MaxiAids, n.d.). Some resources would provide games that were not inclusive, but they offered DIY solutions to make them inclusive. An example of this is the game Quarto (Masters of Games, n.d.). The writer suggests modifications in which dark and light pieces can be distinguished. Velcro tape is advised for preventing pieces to be knocked over or moved involuntarily.

There are also sources where people suggest making their own inclusive board games. An example here is the “make your own tactile memory game”(Paths to Literacy, n.d.). Here, laser cut pieces of wood and tactile shapes are glued together to create a tactile memory game.

Lastly, there are a few sources where people rate commercial board games on their inclusiveness. It was noticeable that there were not many games that were fully inclusive for VIP. From a list of 221 reviewed games, only one game has managed to score full points (A+) on visual accessibility. Next to that 13 out of 221 games were rated A or A-. This shows the unavailability of visual accessible games on the market. The one game that has been granted full rates is the game called Nudge. The game provides a tactile playing board, a high contrast in colours between the playing chips and playing board, and tactile elements on the playing chips on one side, making it easy to distinguish between your own chips and the ones from your opponent (MeepleLikeUs, n.d.).

Lastly, there are also digital games for VIP. Apps on tablets or smartphones are usually visual. The Feelif creator is an electronic device that has the same abilities as a tablet but has a tactile screen with dots for navigation. With their own software, they can create games that are compatible with the dotted screen (Perkins School For The Blind, n.d.).

It is noticeable that all the games that were found are playable for non VIP. This shows that every game tries to compensate for the disability of the visually impaired person, but that none of the games revolve around this disability and make it a strength. As each game is playable for non VIP, it would mean that VIP are always the people who are in need of modification.



Photo by Yan Krukau: <https://www.pexels.com/photo/a-young-person-touching-drawings-on-a-braille-book-7694426/>

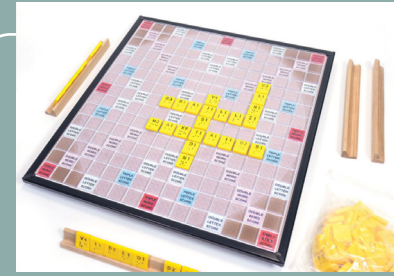

Name

Tactile checkers

Tactile chess

Braille Scrabble

Mancala

Type of game

Boardgame, 1 vs 1

Boardgame, 1 vs 1

Board game, multiple opponents

Board game, multiple opponents

Number of players

2

2

4

2 - 4

Inclusive elements

Tactile differentiation between tiles  
Peg holes  
High contrast  
Playable with non VIP

Tactile differentiation between tiles  
Peg holes  
Playable with non VIP

Tactile letters and braille  
Raised board edges for letters to not move  
Playable with non VIP

Physical elements  
No differentiation in pieces from each opponent  
Playable with non VIP

Exclusive elements

-

Black pieces do not have a contrast with board  
White and Black tower piece have the same tactile elements

-

-

Modifications needed

-

Adding other tactile elements  
Recolour board

-

-

Source

(MaxiAids, n.d.)

(MaxiAids, n.d.)

(MaxiAids, n.d.)

(Masters of Games, n.d.)

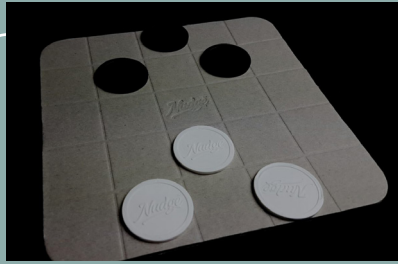

Name

Nudge

Type of game

Boardgame, 1 vs 1

Number of players

2

Inclusive elements

Tactile differentiation between tiles  
Board with tactile guides  
High contrast  
Playable with non VIP

Exclusive elements

-

Modifications needed

-

Source

(MeepleLikeUs, n.d.)

Quarto

Boardgame, 1 vs 1

2

Tactile differentiation between tiles  
Playable with non VIP

Difference between dark and light pieces is not tactile  
Pieces can fall

Place tactile elements on either dark or light pieces  
Velcro pieces to board

(Masters of Games, n.d.)

Make your own tactile memory game

Board game, 1 vs 1

2

Tactile shapes  
Playable with non VIP

-

A board where the pieces will not shift

(Paths to Literacy, n.d.)

Feelif

Digital game

2

Dotted screen  
Playable with non VIP

-

(Perkins School For The Blind, n.d.)



## 3.5 CHAPTER CONCLUSIONS

It can be concluded that there are not many commercially available products made from tea waste, while coffee waste has made its first steps into the consumer world. However, most of the coffee waste is just used as a filler in combination with bioplastics. As this is indeed one solution, it only decreases the use of bioplastics for a certain amount. Tea waste projects are still upcoming and are particularly in their research phase. However, the tea waste projects were more diverse in working method and have delivered insightful methods than just using it as a bio filler. Waste materials are also upcoming, and have some good results, but very little product applications. The research about games for VIP have showed how little progression there is in this field. People have to either create their own diy games, buy existing games and perform modifications, or look very extensively at the scarce amount of resources for games that are 100% suitable for VIP. The examples from this benchmarking can be used as guidelines in the design phase.

The benchmarking also showed how games are adapted to VIP, and that there are not many games that are made specifically for VIP. The feelif creator is an entire device created for VIP, but can also create the feeling of isolation as they need an entirely new device to be able to play games like others. It is therefore important to create a game specifically for VIP.



Picture of author at Material District exhibition, exploring samples for benchmarking, photo by Andrei Rosu



## CHAPTER 4

## PROJECT GOAL & OPPORTUNITIES

With the problem definition, literature review, benchmarking and material taxonomy, various project opportunities can be determined that will answer the research questions.

## 4.1

### PROCESSABILITY

Processability is the term used to define all aspects regarding the creation of the material. The material should be easily manipulated to create efficiency. This includes the ease and time the material allows to be processed when it is made. The method in which the material should be created is also very important. The current composition uses utensils to stir the ingredients, but at the time when the dry ingredients are added, gloves should be worn to knead the material. The kneading is needed to fully incorporate the dry ingredients and to create a homogenous mass. One project goal would be to create a better processability for the material. This would mean that the material should go towards a less viscous state. Less viscosity means that the kneading would become redundant and that the material can be created with utensils only.

Another improvement from a more viscous material would be the moulding process. An opportunity would be to make the material pourable. A pourable material means that the viscosity is lower. This will remove the kneading from the material creation process. A pouring method will also facilitate a faster production. An opportunity would be to tinker with the water amount, as Albers et al (2022) have proven that increasing the water amount can transform the material creation process from compression moulding to paste printing

## 4.2

### DEMOULDING

A lower viscosity could have an influence on the drying time of the material. Next to the drying time, there is a time that the material needs to be solid enough to hold the shape in which it is moulded without being in the mould. Taking the material earlier out of the mould will increase the drying time due to more contact with air and can prevent the growth of fungi. It is therefore favourable to take the material out of the mould as soon as possible. The demoulding time refers to the time the material needs to be solid enough to be taken out of the mould without deforming the shape. The goal is therefore to create a material that has a low demoulding time.

## 4.3

### DEFORMATION

Deformation is caused by the shrinkage of the material. Since water will evaporate during the drying process, this would mean that the material will shrink and could possibly deform. The current composition was deforming uniformly. However, when the processability is changed, the deformation could change too. Changing the composition can cause non uniform shrinkage that can lead to warping. The goal is therefore to create a material that deforms uniformly.

## 4.4

# REPROCESSING

The Serendipitea samples have plastic behaviour right after it has been created. The evaporation of water and the cooling down of the temperature will cause the material to be stiffer and eventually dry. The time at which the material can be moulded to a product is therefore limited to the temperature and water of the material.

Looking at Gencel's project, the tea waste there is endlessly recyclable. When there is waste material coming from the creation of the material, it can easily be remelted into a new product (Gencel, n.d.). This concept has some similarities with Desktop Metal's new manufacturing concept for 3D printing with metal. Here, metal powder is combined with wax and binding materials to create bars. These bars are heated until the wax deforms, and the material is 3D printable (Deep Dive: Bound Metal Deposition (BMD) | Desktop Metal, n.d.).

Combining the reuse of waste material and creating a solid state of the material to be processed further into the end product would be an opportunity for Tea Clay. If Tea Clay could be reprocessed, this would mean that the production can be streamlined. The material can enter a solid state before being remelted into the final product. This will create the possibility to mass produce the material without it being in the final form. Waste material that has dried out and would previously be labelled as unusable can be added at the remelting process to form a product. The other benefit is that proposing an intermediate state for the material can allow the scent application to happen after the material has been created. This will solve the problem in which the scent ingredient needed to be added at the beginning of the material production.

Ultimately, the ability to mass produce a solid material that can be repurposed into various products widens the opportunities for Tea Clay to be implemented for consumer products. Solid material can be produced at one location, and sold to different companies, who in turn create different products with it. As visible in the benchmarking, many companies who produce products made from waste materials develop the material themselves too. Having Tea Clay in a solid state is similar to selling granulate to companies who already have a injection moulding machine.

Illustration of reprocessable material being distributed from one manufacturer to different companies, who then create different concepts.

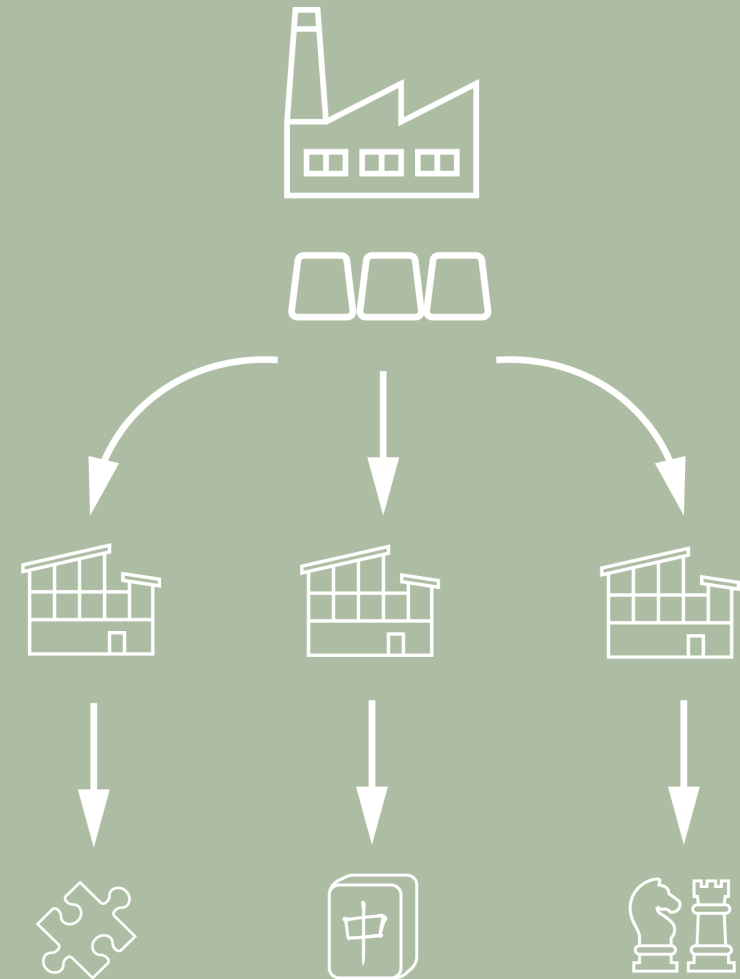

## 4.5 SCENT IMPLEMENTATION OPPORTUNITIES

Considering that the scent needs to be implemented at a later stage in the production of the product, different options can be explored. The solid state that is introduced in the chapter 4.4, Reprocessing can be used to implement scents.

### 4.5.1 METHOD 1: INFUSING

The first method is to infuse the solid state material with fresh flowers. Originally this would be done with a closed off box and fresh flowers. This method is similar to the infusing method for jasmine tea as was researched during the literature review. Using fresh flowers can complicate the process and can become time consuming. This method will therefore use dried flowers and steam the material with the flowers. Steaming can open up the flowers more and release scent. This method is illustrated in figure 4.1

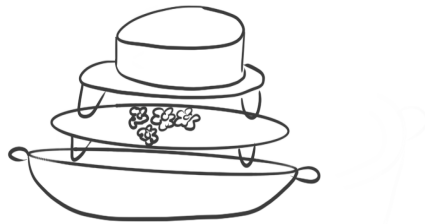

Figure 4.1: steaming Tea Clay with dried flowers

### 4.5.2 METHOD 2: SPRAYING

Another method is to spray the solid state material with essential oils. Essential oils are stronger than dried ingredients, and this method is deduced from the scenting method for tea leaves as described in the literature review. This method is illustrated in figure 4.2

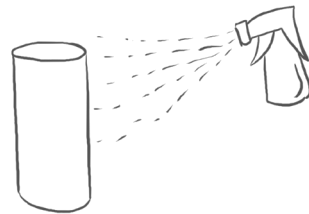

Figure 4.2: spraying TeaClay with essential oils

### 4.5.3 METHOD 3: DIPPING

The third method is to dip the TeaClay in beeswax mixed with essential oils. This idea occurred from The Chemarts cookbook (Kääriäinen et al., n.d.) where beeswax is introduced as a versatile material. It is bio based and hydrophobic. Applying beeswax on the outside of the samples could create a waterproof material. Beeswax is usually used for candles as well. These candles are melted beeswax that are mixed with essential oils. These candles usually hold their scent for a long time, and the scent will become stronger once the beeswax is melted again. This can create the opportunity to hold the scent longer on the product, or to create a product where the material needs to be rubbed in order to smell the scent. This method is illustrated in figure 4.3.

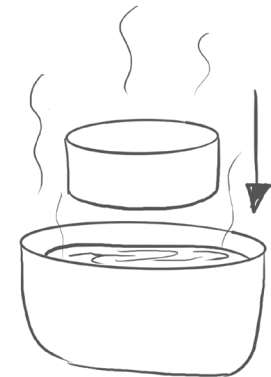

Figure 4.3: Dipping Tea Clay in melted beeswax with essential oil.

## 4.6

# MATERIAL TAXONOMY

Material taxonomy creates an overview of all the variables that will be taken into account during this project. The material taxonomy is shown in figure 4.4. The ingredients section shows the possible ingredients that can be tinkered with in order to achieve a better processing of the material. During benchmarking, several materials such as gelling agents and water could improve the processability. The process section shows the possible tinkering tests that can be conducted on the then renewed material. Primary shaping includes how the material is processed and shaped, while secondary process involves whether the material is reprocessable, entering a second process.

Ingredients such as gelling agents, beeswax and water can stimulate this. The structure section contains the structural composition of the material. Density is important to determine, as this can serve as a unit for comparison between other materials. The surface finish is linked to the user experience and can therefore be altered as well. Lastly, properties will convey the material properties in order to create an understanding of the type of material and if it would be a suitable replacement for standard materials such as plastics and wood.

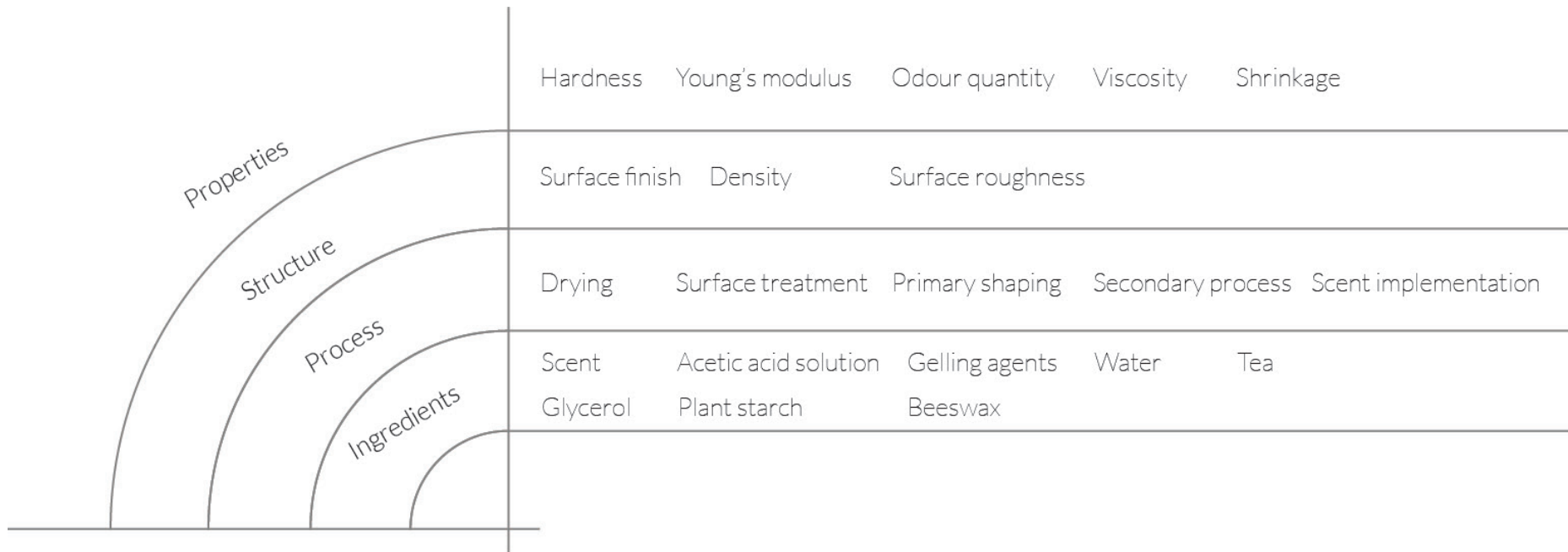

Figure 4.4: Material taxonomy that maps all the opportunities for TeaClay



## CHAPTER 5 | TINKERING

Tinkering is an explorative process wherein material qualities are researched. The process consists of creating and evaluating the material. In this chapter, tinkering was used for exploring different qualities of Tea Clay. The outcomes from the literature review, benchmarking and problem definitions are all starting points for tinkering. Please refer to appendix A: Tinkering for the full details of tests during this phase.

## 5.1

# GELLING AGENTS

### GOAL

In this tinkering entry, different types of gelling agents will be tried out in combination with Tea Clay. The goal of this tinkering entry will be to see if the material can be reprocessed once it has been made. This will be done by putting the dried samples in the oven, and seeing if the material can melt down into another mould, creating a new shape. This would prove that the material can be made in bulk, and that the processing of the material to product would become parallel to the creation of the material.

### METHOD

Gelatine, pectin and agar agar were all used in a ratio to the starch. It is believed that lignin fibre might interfere with possible results, as it can influence the processability of the material. Therefore, it was chosen to leave the fibre out of the composition. The compositions are in figure 5.1. After the samples have completely dried out, they were put in a preheated oven. The oven process took 3 different stages. The first stage is to put the oven at the melting temperature of the respective gelling agent. The samples will undergo 10 minutes of exposure to this temperature. The second stage is to put the oven at 70 °C. 70 degrees is the temperature at which the plant starch started to change phase. The second stage is to test whether the material can transition at this temperature as well. The third stage is to put the oven at 100 °C. This is the temperature where water starts to evaporate. This would serve as the ultimate temperature in which the samples could go before completely drying out.

Since water will evaporate from the samples during their drying process, it would be interesting to see what the effect would be to add water to the samples prior to heat exposure in the oven. The added water could facilitate the melting behaviour. The samples were soaked for 30 minutes in water. After this, the material should have absorbed some of the water, and the remaining water will be removed. The absorbed samples will be put in a preheated oven of 100 °C for 20 minutes. After the first 10 minutes, the samples will be checked.

GELATINE 1:1		GELATINE 1:2		GELATINE 1:3	
72%	Water	69%	Water	67%	Water
4%	Plant- starch	4%	Plant- starch	4%	Plant- starch
2%	Glycerin	2%	Glycerin	2%	Glycerin
2%	Acetic acid	2%	Acetic acid	2%	Acetic acid
16%	Tea	15%	Tea	15%	Tea
4%	Gelatine	8%	Gelatine	10%	Gelatine

---

AGAR AGAR 1:1		AGAR AGAR 1:2		AGAR AGAR 1:3	
72%	Water	69%	Water	67%	Water
4%	Plant- starch	4%	Plant- starch	4%	Plant- starch
2%	Glycerin	2%	Glycerin	2%	Glycerin
2%	Acetic acid	2%	Acetic acid	2%	Acetic acid
16%	Tea	15%	Tea	15%	Tea
4%	Agar agar	8%	Agar agar	10%	Agar agar

---

PECTIN 1:1		PECTIN 1:2		PECTIN 1:3	
72%	Water	69%	Water	67%	Water
4%	Plant- starch	4%	Plant- starch	4%	Plant- starch
2%	Glycerin	2%	Glycerin	2%	Glycerin
2%	Acetic acid	2%	Acetic acid	2%	Acetic acid
16%	Tea	15%	Tea	15%	Tea
4%	Pectin	8%	Pectin	10%	Pectin

Figure 5.1: the 3 gelling agents samples and the variations



## RESULTS

The agar agar samples were brittle and flaky when they were dried. The material structure and surface finish were both below standard, as it was apparent that they would not fit the project goals. Therefore, the agar agar samples have been disqualified for the tests.

Some observations for the samples would be that the gelatine samples have a fast drying time. The addition of gelatine causes the material to have a light shimmer to the outer surface. The pectin also had a fast drying time. See figure 5.2. Working with pectin was more difficult compared to the agar agar and gelatine, because pectin does not dissolve well in water. The working method for pectin was therefore different from the other gelling agents. The pectin and hot boiling water had to be put together in a jar and shaken vigorously, whereas the other gelling agents could be added simultaneously with the binder. Even at the end product, pieces of pectin were still present in the structure. See figure 5.3. The other gelling agents are therefore more favourable as they can be better integrated into the existing working method. However, the pectin samples do not deform as severe compared to the gelatine samples



Figure 5.2: the fast demoulding of pectin and gelatine samples.



Figure 5.3: : the pectin samples had visible pieces of pectin in the end product

The samples failed in being able to melt down. It could be due to the low amount of water that the gelling agents are not able to transform back to their viscous state. It was also noticed that the samples were not completely dried from the inside. When the gelatine samples were heat treated, the outer layer of the sample remained solid while the inside was liquid. See figure 5.4.



Figure 5.4: when the gelatine sample was heated, the outside remained solid, but the inside was liquid

This indicates that the outer layer has too less moisture to be able to melt, while the inside still has water encapsulated in the material. This result proves that water is an important factor if reprocessability wants to be achieved. The same results were achieved with the pectin samples. The same behaviours were observed for the pectin samples. The second test was to put the absorbed samples in a preheated oven. After 10 minutes, the samples were still moist on all sides. The bottom of the sample, which was in constant contact with the silicone mould, started to deform. When pressure was applied, the sample could deform. Heating the samples further results in the contact areas with the air solidifying again, since the moisture would be evaporated. However, the bottom area remained moist. The same behaviours were observed for the pectin samples.

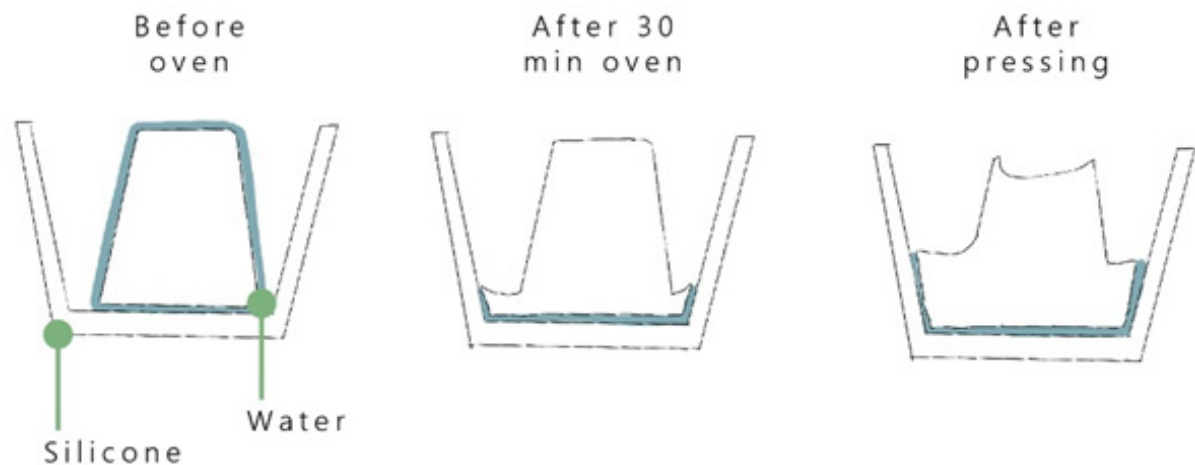

Figure 5.5 shows the procedure. Before the samples goes in the oven, the water is soaked in and around the material. After heat has been applied, the contact areas with air will have evaporated the water, but the water between the sample and the silicone becomes trapped. A bit of deformation will thus happen at the bottom. After 30 minutes, the upper part of the sample is soft and can be pressed on, causing deformation. The conclusion is that water is necessary to be able to transform the material back to its viscous state when heat is applied. The downside of heat application is that it will evaporate the water. If the sample is encapsulated in water, for example with a silicone container that does not permit the water to escape, the material could be completely melted down. Another approach would be to heat the samples in a climate chamber where moisture can be added to it through the air.

Figure 5.5: the results of heating water absorbed samples.

## 5.2

# BEE SWAX

### GOAL

In this tinkering entry, different ratios of beeswax will be tried out in combination with Tea Clay. The goal of this tinkering entry is to reduce the water evaporation, as beeswax is believed to hold hydrophobic qualities (Kääriäinen et al., n.d.). When more water is inside the sample, this could stimulate the rate at which it is able to be reprocessed through heat. The sample from this tinkering entry will go into the oven similar to the gelling agent samples.

### METHOD

A material composition was created according to the research from Dobrosielska et al. (2023). This research focussed on creating a biocomposite with PLA and diatomaceous earth and adding beeswax as a natural additive. In this research, the PLA serves as a binder, and the diatomaceous earth as filler. Using the same ratios between the binder, filler and beeswax, different percentages of beeswax were used in this tinkering entry. Dobrosielska uses the beeswax as a percentage of the weight from the binder. The percentages were 1% w/w and 2% w/w (Dobrosielska et al., 2023). This tinkering entry will also use a ratio between the binder and the beeswax, and the percentages will range from 1 to 5%. It is believed that a bigger range in percentages could result in more variable results that can be observed.

Beeswax has a melting temperature of 45 degrees. This would mean that it will melt in the binder when it is heated, since the binder starts to transform at 70 degrees. The compositions are in figure 5.6.

### RESULTS

Due to their high water content, the samples could not fully dry. It was noticed that there is a difference between drying time and the time the samples need to solidify enough before they can be taken out of the mould without deforming the shape. This will be labelled as the demoulding time. The longer the samples are within their mould, the more risk they will have in developing fungi due to the water content that cannot evaporate. See figure 5.7. Therefore, the beeswax samples could not undergo the reprocessing tests.

BEE SWAX 5 %		BEE SWAX 4 %		BEE SWAX 3 %	
72%	Water	73%	Water	74%	Water
4%	Plant- starch	4%	Plant- starch	4%	Plant- starch
2%	Glycerin	2%	Glycerin	2%	Glycerin
2%	Acetic acid	2%	Acetic acid	2%	Acetic acid
16%	Tea	16%	Tea	16%	Tea
4%	Beeswax	3%	Beeswax	2%	Beeswax

---

BEE SWAX 2 %		BEE SWAX 1 %	
74%	Water	74%	Water
4%	Plant- starch	4%	Plant- starch
2%	Glycerin	2%	Glycerin
2%	Acetic acid	2%	Acetic acid
16%	Tea	17%	Tea
2%	Beeswax	1%	Beeswax

Figure 5.6: the compositions of the beeswax ratios and methods.

## 5.3

### DRYING TIME

#### GOAL

It was apparent in the beeswax samples that the demoulding time is important for an industrial application. Not only will it prevent the risk of developing fungi, a faster demoulding time would mean that the samples have more contact area with air to be dried faster. This will speed up the processing time. Compared with the original composition and the scent modified composition, the demoulding time of those samples was significantly faster compared to the beeswax samples. Possible variables that influence the demoulding time would be the water amount of the beeswax. To determine which variables influence the demoulding time, another test setup was made.

Since the material solidifies due to the evaporation of water, this would mean that a higher water content results in a longer demoulding time. The samples that have been created by now have 3 times increase of water compared to the original composition created by Zhou and Rhen (Zhou & Ren, 2018). This water amount was chosen since Albers, et al. (2022) has established that an increase of water would result in a higher processability. While this may be true for extruding material, it is different for poured material. Extruded material has a bigger contact area to air compared to poured material. Extruded material does not need a mould to be shaped. The high amount of water was chosen because it would change the processing from moulding to pouring, but the demoulding time has not been accounted for. This tinkering entry will establish whether the water amount is a factor in the demoulding time.

Another opportunity for speeding up the demoulding time would be to add a solidifying agent. The hypothesis here is that the high amount of water can be solidified if there are more dried ingredients added to the mixture. This will make the mixture less viscous and could eventually speed up the demoulding time. In Zhou and Rhen's composition, lignin fibre was used. Lignin fibres can strengthen the material. This tinkering entry will research the effect of these fibres on the demoulding time.

It could also be a possibility that the addition of beeswax has a negative effect on the demoulding time. Beeswax was chosen due to its hydrophobic abilities. It could therefore occur that beeswax is holding the water too long in the samples, causing the demoulding time to increase and fungi to grow.

Figure 5.7: fungi growing on beeswax sample



## METHOD

In the previous beeswax samples, 72% of water was used. Two water ratios will be tested. Low water amount is the same water amount that was used in Zhou and Rhen's composition, which was 48% for this composition. Medium water amount means 120 ml of water will be used, which is 64% in this composition. The results of these three water variables can create a structured overview of the demoulding. Another sample will be created with the addition of lignin fibres. For this, 69% of water will be used, as this can serve as a comparison with the previous samples which were all created with 72% of water. To establish whether the beeswax has an influence on the demoulding time, a control group will be created. See figure 5.8 for the 4 variations.

All four samples will be moulded with the same mould as previous samples. The demoulding time is observed by attempting to demould the material at regular times.

LOW WATER		MEDIUM WATER		LIGNIN FIBRE		CONTROL	
48%	Water	64%	Water	69%	Water	72%	Water
8%	Plant- starch	5%	Plant- starch	4%	Plant- starch	4%	Plant- starch
4%	Glycerin	3%	Glycerin	2%	Glycerin	2%	Glycerin
4%	Acetic acid	3%	Acetic acid	2%	Acetic acid	2%	Acetic acid
32%	Tea	21%	Tea	15%	Tea	16%	Tea
4%	Beeswax	4%	Beeswax	4%	Beeswax	4%	Lignin fibre
				4%	Lignin fibre		

Figure 5.8: 2 beeswax samples with varying water percentages, and 2 samples with added lignin fibre

## RESULTS

It was apparent that the low water beeswax samples could be demoulded the fastest. The material could be demoulded twenty minutes after it had been moulded. It was easy to take it out of the mould, and the shape of the material did not deform during this process. The material had to be kneaded by hand and compression moulded. The low water content creates a faster transition to solidifying, which would result in a faster demoulding time.

The medium water beeswax sample had a significantly longer demoulding time. The samples could be demoulded after 4 days in the mould. It would be more beneficial if the material could be demoulded on the day of production. This will facilitate in a more streamlined production process.

The high water fibre and control group samples also had a demoulding time of 4 days. This would indicate that fibre cannot solidify the material enough, nor that beeswax holds the water longer in the samples to prevent them from demoulding sooner. A remark is that the samples have grown fungi. This is due to the increased water content compared to the other two samples and the long time in the mould.

## 5.4 INTERMEDIATE CONCLUSIONS

These tests, combined with the other tinkering entries, have given a spectrum in which the material behaves when it is in the processing phase. It is also becoming clearer what the influence is of each parameter for the processing, demoulding, shape of the material and reprocessing. Adding water can increase the processability but will take away the demoulding time. A long demoulding time has resulted in the growth of fungi. An increase in water also causes severe deformation, as water will always evaporate. The observed deformation is not only shrinkage, but also warping of the material. Some of the samples have deformed so much that they did not resemble the initial shape in which they were moulded. However, too less water will cause the material to be tough to work with, and the need of gloves to incorporate the ingredients to form a homogenous mass. Figure 5.9 and 5.10 show the difference in processing.



Figure 5.9: a low processable material, as it cannot be stirred and needs hands to knead and mould.



Figure 5.10: a highly processable material, as it can be stirred and poured into the desired shape.

In general, figure 5.11 visualises the effect of water on the material. Designers can use the axis to see which behaviour and product application they are aiming for, and what the side effects would be.

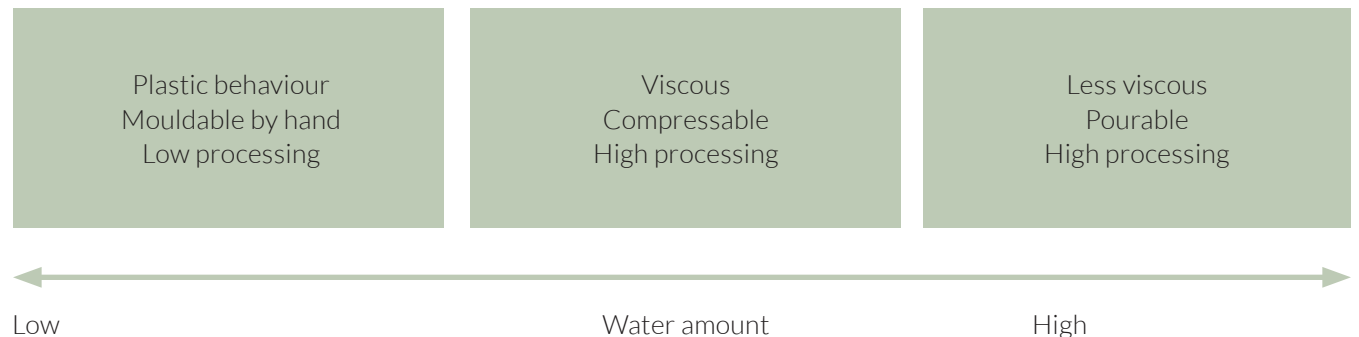

Figure 5.11: the perceived behaviour of the influence of water.

The samples have been put in an axis to create an overview of the performance on each project goal. This can be seen in figure 5.12. Since the reprocessing of the materials has not fully happened yet, there could not be made any conclusions on this.

On the left of the axis are the three project goals. Each sample will be evaluated based on observations that were made during the tinkering phase.

Low deformation = The dried shape of the material is very similar to the wet shape of the material

High deformation = The dried shape of the material is not similar to the wet shape of the material

Low processability = The material cannot be created with utensils only. The moulding of the material needs to be more careful in order to avoid air gaps and the plastic behaviour of the material is low as it is more viscous.

High processability = The material can be created with utensils only. The moulding of the material is going with ease and the moulded samples do not have many defects. The material is less viscous.

Low demoulding = The demoulding time is low, which means that the material can be quickly demoulded without damaging the shape.

High demoulding = The demoulding time is high, which means that the material needs a long time to be demoulded without damaging the shape.

Each sample that has been created in the tinkering phase by now has been added to this axis. The desired situation to have achieved the project goals would be a low deformation and demoulding, but a high processability. In the graph there is not a single sample that fits in the desired situation. However, two samples are standing out more.

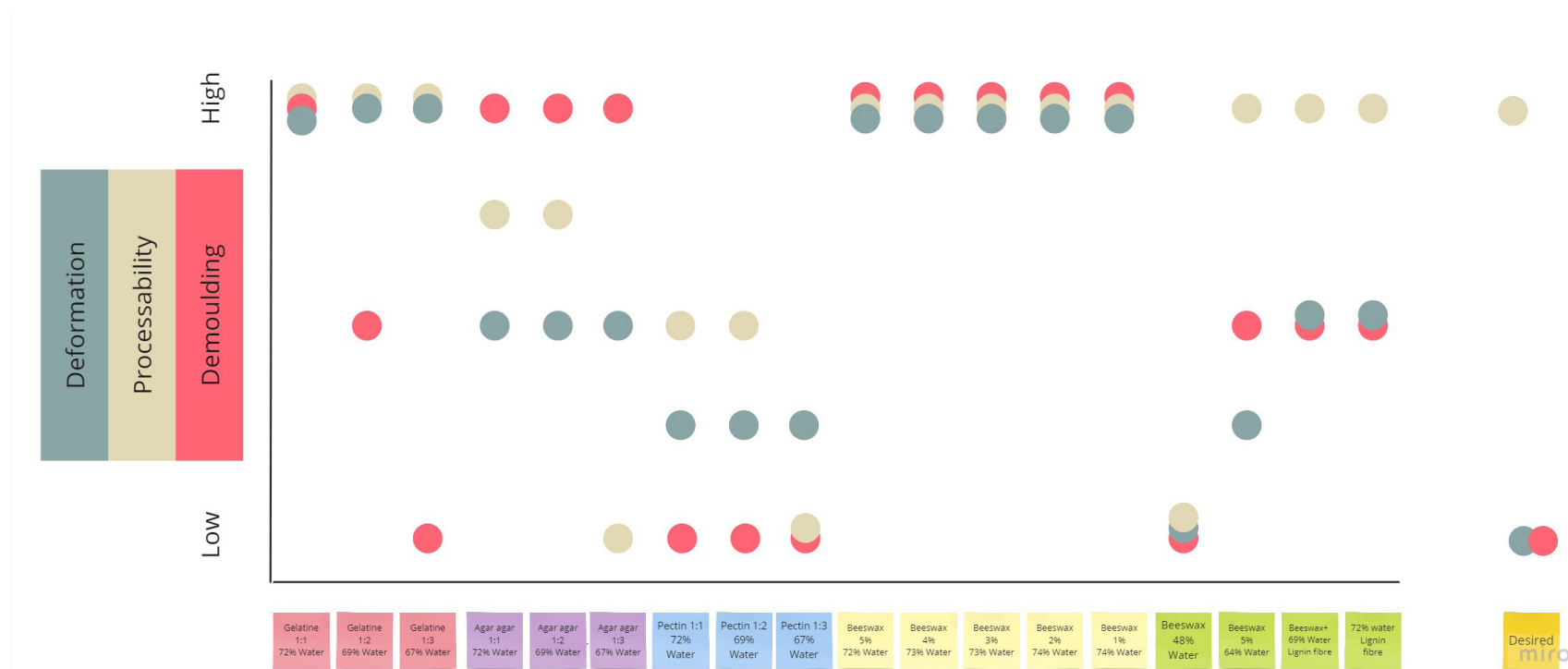

Figure 5.12: mapping the tinkering results based on deformation, processability and demoulding performances.

## GELATINE 1:3

The gelatine 1:3 sample was created with 3 times the amount of gelatine compared to plant starch and the usage of 67% of water. The gelatine caused the material to solidify quickly, creating a low demoulding time. The high amount of water caused the material to be less viscous when it was processed. The material could be scooped in the mould without excessively pressing the material together to compress it. The downside of the gelatine sample is that the deformation was more severe. It can be seen that the flat surfaces will start to shrink inwards, while the edges stay stiff. This is due to the outer layer of the material drying first and leaving the middle wet. The difference in moisture is causing the shrinkage to be directed inwards. The edges are more reinforced due to the geometry of the sample. Therefore, the edges can withstand the force of the inwards shrinkage more, but the flat surfaces are less stiff and are therefore going inwards. Figure 5.13 shows shrinkage in the samples. The right sample is more deformed compared to the left sample.

## BEESWAX 5%

The beeswax sample was created with 48% of water and 5% of beeswax. The demoulding time of the sample was fast due to the low amount of water. The low amount of water also caused the deformation to be minimal. However, the processing of the material required kneading for the incorporation of dry ingredients.

These two samples have achieved two out of the three project goals. Therefore, the next goal would be to tinker these two samples to fit for the third goal.



Figure 5.13: shrinkage occurs in flat surface that go towards the middle of the sample, as can be seen in the sample on the right.



## 5.5 PROCESSABILITY AND DEFORMATION

### GOAL

The gelatine 1:3 sample needs to have less shrinkage. This can be achieved by reducing the water amount but considering that the material should still be incorporated with utensils and compressed in the moulds. The beeswax sample needs to be less viscous for it to better processable. Here, an increase in water can be helpful.

### METHOD

The Beeswax 5% samples have been made with 48%, 64% and 69% water before. The previous conclusion was that 48% and 69% delivered unsatisfactory results. Therefore, increments between these values will be used to determine if it will increase the processability.

The gelatine 1:3 samples has been done with 72% water only. The gelatine samples will thus also be tested lower amounts of water. The deformation should be less severe, but the processability should not lower as well. Figure 5.14 shows the different ratios used.

GELATINE 40%		GELATINE 47%		GELATINE 53%	
40%	Water	47%	Water	53%	Water
7%	Plant- starch	6%	Plant- starch	5%	Plant- starch
3%	Glycerin	3%	Glycerin	3%	Glycerin
3%	Acetic acid	3%	Acetic acid	3%	Acetic acid
27%	Tea	23%	Tea	20%	Tea
20%	Gelatine	18%	Gelatine	16%	Gelatine
GELATINE 57%		BEESWAX 55%		BEESWAX 60%	
57%	Water	55%	Water	60%	Water
5%	Plant- starch	7%	Plant- starch	6%	Plant- starch
2%	Glycerin	3%	Glycerin	3%	Glycerin
2%	Acetic acid	3%	Acetic acid	3%	Acetic acid
20%	Tea	29%	Tea	24%	Tea
14%	Gelatine	3%	Beeswax	4%	Beeswax

Figure 5.14: gelatine and beeswax samples with water variations

### RESULTS

The beeswax 55% and 60% samples did not increase the processability. The samples still had to be kneaded by hand, while the 69% beeswax sample could be created without manual labour. However, the 69% beeswax sample had a low demoulding time. The conclusion is that beeswax is very hydrophilic and that there is a fine balance between the amount of water, drying time and processability. On the other hand, the 57% water gelatine sample has a fast demoulding time with a large amount of water. The ingredient incorporation was easily done without manual labour, and the material did not warp as severely as the 72% water sample. The 57% sample has slightly more deformation than the 53% sample, but the 53% sample has a less homogenous structure and surface as can be seen in figure 5.15. Since the deformation is minimal, it is chosen to prioritise the homogenous structure. Therefore, the 57% water ratio is chosen as the final material. Another interesting behaviour of the gelatine samples is the drying behaviour. The gelatine composition solidifies fast, making it fast demouldable. But the material is not solid, as it has gelatine properties. The material enters a state in which it is flexible, but stiff, resembling rubber, and can be described as a “gummy” state. This state of the material is very impact resistant, as the flexibility absorbs impacts. The gummy state is the solution to better demoulding. It makes the material solid enough that it can be demoulded within 30 minutes, freeing up the mould and increasing the drying time by letting the material have air contact on all sides. The gummy state is due to temperature and can stay in the state until the material has fully dried and solidifies.



Figure 5.15: left: 53% water, right: 57% water. The 57% water sample is more homogenous.

## 5.6 REPROCESSING

The gelatine 1:3 57% sample has achieved 3 of the project goals. Previously, the gelatine 1:3 67% water sample has undergone 3 heat treatment methods.

### METHOD 1

The hypothesis was that the gelatine would melt above 45 degrees, and that the material would transition to its processing state. There was no perceived change, even when the temperature increased. When the material inside was inspected, it could be seen that the inside has melted. This is due to water that has not evaporated yet during the drying process.

The same results happened when the samples have been put in a climate chamber at 70°C and 90% humidity. The outer layer remained solid, while the inside was liquid.



Figure 5.16: Inside of the material is liquid while the outside is hard

### METHOD 2

The addition of water has been tried to reprocess the samples during the heat treatment. The sample was soaked in water. It would absorb the water and afterwards be put in a preheated oven of 70 degrees. The water could moisten the material outside, but if it was left in the oven for too long, the outer layer would become dry again. After 30 minutes the material could be somewhat deformed, but there were still chunks of solid material inside. The material was not homogenous.



Figure 5.17: soaking the material in water and putting it in the oven

### METHOD 3

Another method was to add water to the material directly without soaking it. The material was granulated into smaller pieces and put in a new mould. The water loss due to evaporation was known, and the same amount of water was added back to the sample. The granulate and water was then put in a preheated oven of 70 degrees. The granulate absorbed the water in the oven, but the water did not evaporate. The water could moisten the granulate through to the core because of the smaller volume. After 30 minutes, the samples could be compressed into a new mould and dried. After drying, the samples were solid and adhered to each other.

This test used a small amount of granulate, which resulted in the new shape to be very thin. The strength of the material could therefore not be evaluated. The granulate was not homogenous, as there were still chunks of solid material inside. This could also explain the cracks of the material that occurred.



Figure 5.18: Granulated material and water in the oven

#### METHOD 4

It became apparent that a reprocessing method is needed where heat is applied and water is added to the sample. Steaming is a process where hot water evaporates whilst not in contact with the object, causing the steam to heat and moisten the object. Steaming occurs at a temperature of 100°C. The sample was steamed for 30 minutes. After 30 minutes, the outer layer did not seem to have melted, but the entire material was soft and deformable. The material texture was very homogenous and the material could be manipulated and reshaped. This can be seen in figure 5.19. The ultimate steaming time was then tested. Various samples of the same size and weight were put in the steamer for different time intervals. After the steaming, a 1 kg weight was put on the samples for 1 minute. This can be seen in figure 5.20. The resulting material would compress to a certain thickness. After drying, the thickness was measured. The results are in table 6.1. This table shows that the material is fully saturated with water after 25 minutes of steaming, meaning that when the material is industrialised, steaming should occur in this duration. This concludes that the composition of 57% water and 1:3 gelatine can be reprocessed if it is steamed for 25 minutes. Overall, steaming shows the highest potential as a reprocessing technique. It should be noted that these results are for this specific shape and samples. It could occur that the samples were not entirely dried, and could require the addition of water during steaming. In reality, it would be easier to granulate the Tea Clay. This will result in faster steaming times and more evenly distributed heat. This was not tested, but is taken as an assumption. A recommendation would be to test this hypothesis.

Sample	Steaming time	Thickness average
1	5 min	14,4 mm
2	10 min	10,2 mm
3	15 min	10,15 mm
4	20 min	9,25 mm
5	25 min	9,1 mm
6	60 min	9,15 mm

Table 5.1: 6 steaming times and thicknesses after pressing 1kg for 1 minute.



Figure 5.19: Steamed material that has been reshaped.

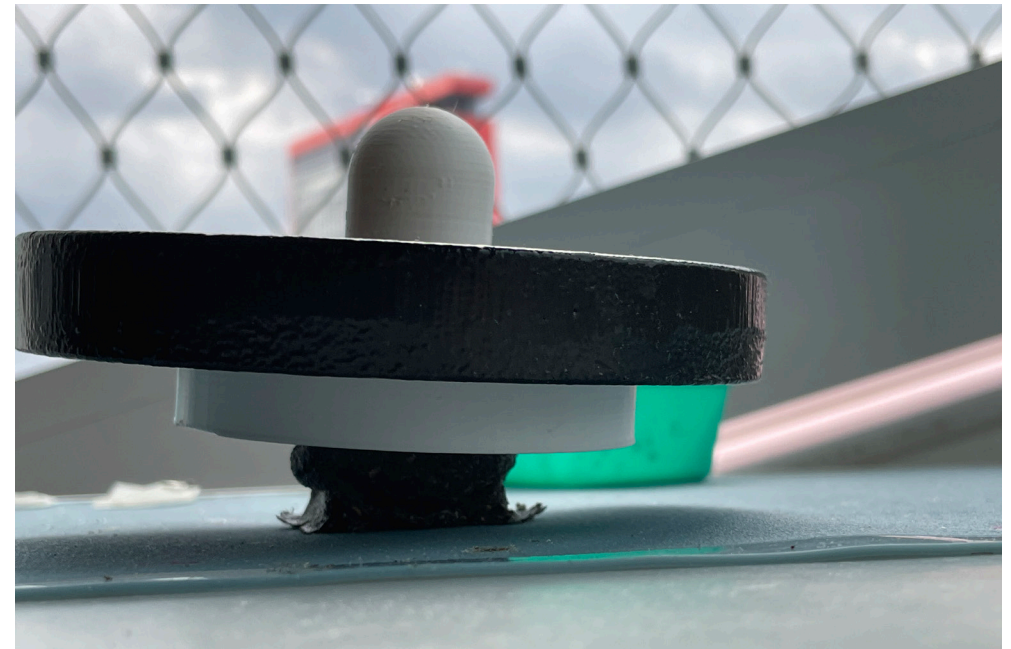

Figure 5.20: Steaming the material and deforming with 1 kg weight for 1 minute.

## 5.7 SCENT IMPLEMENTATION

The three methods for scenting have been described in Chapter 5: Project goal & opportunities, scent implementation. The rest of this paragraph will discuss the results from these tests and the conclusion.

As discussed in the literature review, it is difficult to determine the odour quantity. Gas chromatography, olfactometers and human examiners are all resources that are not available within the resources of this thesis project. In order to determine the strength and duration of the scent, a qualitative study was performed.

### GOAL

The goal of his study is to determine which scenting method produces the strongest odour that fades the least over time. This study also experiments with two different odours. The goal is to determine if there is a difference between different odours.

### METHOD

6 samples were created and scented with the three methods described in Chapter 5: Project goal & opportunities, scent implementation. The chosen scents were chamomile and roses. Dried flowers were used for scenting method 1, while essential oils were used for scenting methods 2 and 3. Three participants were asked to rate the odour strength of each sample from a scale of 1 to 10, where 1 is very weak and 10 is very strong. This was done for all 6 samples. Participants were also asked to rate the three scenting methods from strongest to weakest, and to pick one sample that was the strongest of all 6. This test was done over a time span of 4 weeks, where the participants had to repeat this process in week 1, 2 and 4. Prior to the scent rating, the participants were also asked to rate their own smelling capability of that day with a number between 1 to 5, where 1 means that they cannot smell anything, and 5 that they can smell very well that day. It was made sure that participants would get a different order in samples each week, to ensure that the first sample they would smell does not influence their rating. In between samples, participants were advised to smell coffee beans, as smelling too many samples can desensitise their nose. The coffee beans offers a palate cleanse. Consent forms were made for this research. The consent form can be found in appendix A: Tinkering, scenting.

## RESULTS

The full results are in appendix A: Tinkering, scenting. Each participant has indicated their smelling capability with a number at the beginning of each session. This number has been converted into a compensation factor. This compensation factors allows the participants to be compared to each other. For example, if a participant has a smelling capability of 3 out of 5, this will mean that the compensation factor is  $3/5$  or  $0,6$ . If the participant then rated a sample with a 7 out of 10, the compensation factor is multiplied with the rating, resulting in a rating of  $4,2$ . This compensation factor will make the data comparable between participants.

The result is that scenting method 2 with roses was the most successful over time. Figure 6.21 was created with each participant's rating, and the linear average results in a rating of 6 to 7 out of 10. Compared to the other samples, this was the highest score. Combined with the fact that each participant has expressed that the SR2 sample was the strongest in each session, it can be concluded that spraying the samples with essential oil is a very effective method for long term scent on the samples. Spraying the samples creates efficiency in the manufacturing process, as spraying can occur at any stage when the product is being shaped.

Another observation is that the participants were very dependent on the coffee beans provided, as they have exclaimed several times that they cannot smell the difference anymore. This indicates that the final concept could also contain an object to help aid a desensitized nose, but more research about this needs to be conducted.

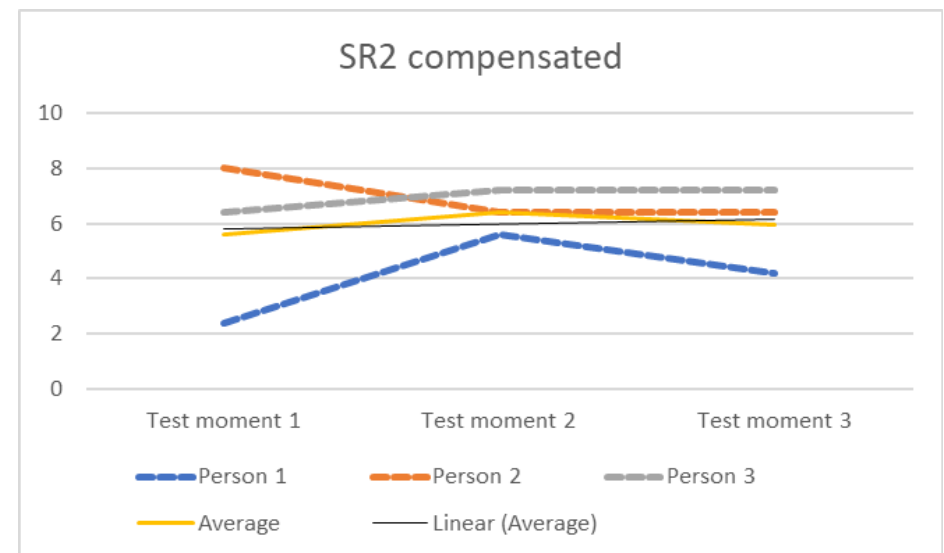

Figure 5.21: the compensated values of each participant, over 3 test moments, with an average and linear line.

## 5.8 SHAPING

### GOAL

Since the material composition and moulding method has changed, this could result in a different method for producing products as well. In Serendipitea, the material was similar to a clay, and could be moulded in 3D printed stamps. The material was suitable for taking various designs, as was apparent during Serendipitea's tinkering phase (De Cocker et al., 2022). Figure 5.22 shows moulds that were tested during the tinkering. Figure 5.23 shows how well the material could adapt to the shapes and the details it could convey. The goal of this tinkering entry is to test whether the renewed material still possesses the ability to transfer the details of stamps. Next to that, tests will be performed on changing the surface of the material with sanding.



Figure 5.23: the resulted Tea Clay of Serendipitea and the details



Figure 5.22: the 3D printed moulds for Serendipitea, concept phase

## METHOD

The material will be moulded in the same moulds that were used during the tinkering phase of Serendipitea. Next to that, other material samples will undergo sanding and coating treatments to evaluate what the material is capable of.

3 stamps will be used. The stamps were chosen on concave and convex shapes. The third stamp is a geometrical pattern.

Other samples will undergo sanding with sanding paper, a sanding machine and a vile. Next to that, the sanding machine will try to create rounded corners. One surface will undergo coating to see if it is applicable on the material. The coating that will be used is TruOil, which is used for gun stock finishes and guitars. It gives the wood a high shine and smooth surface.

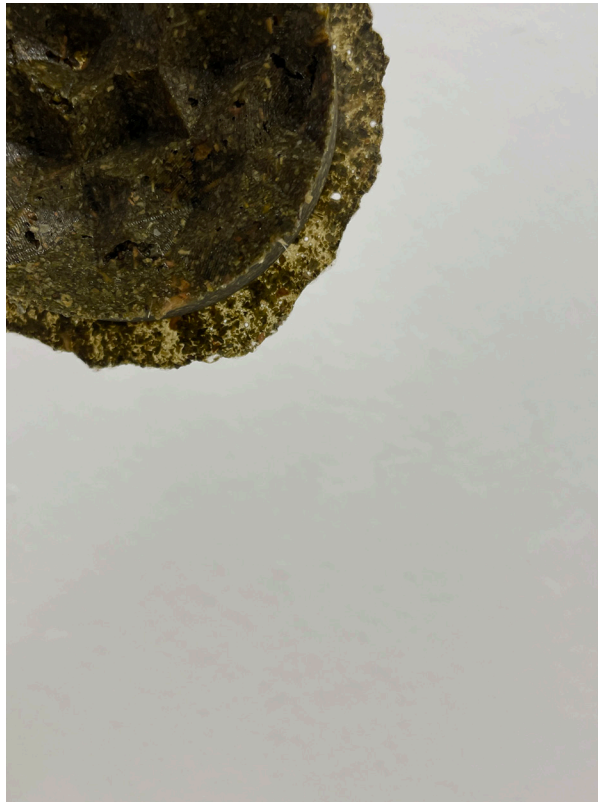

Figure 5.24: thin material becomes transparent



Figure 5.25: when dried, the thin material warps severely.



Figure 5.26: Sanded material and coated with TruOil

## RESULTS

The renewed material has the same capabilities of translating 3D printed moulds to its own surface. When the material becomes too thin, it has transparent capabilities, but due to the high amount of gelatine, this thin material will undergo severe warping. This can be seen in figure 5.24 and 5.25.

The material was able to be sanded with sandpaper, a sanding machine and a vile. The finer the sanding material, the smoother the material would be. The coating of the material was successful as well, as the material had a high shine to it. The addition of shine to the material should be considered as this can effect the perception of the material. Figure 5.27 shows the sanded material and the coated material. The material is easy to undergo surface treatment. Being able to sand the material means that the material is also suitable for CNC milling. This would indicate that patterns can be engraved on the material.

A photograph of a mechanical testing machine, likely a universal testing machine, with a specimen on a platform. The machine is dark grey or black. A blue tube is connected to the side. The specimen is a dark, irregular, porous material. The text 'CHAPTER 6' is overlaid on the left side of the image.

## CHAPTER 6

## TECHNICAL CHARACTERISATION

The gelatine composition has deviated from the original composition created by Zhou and Rhen (Zhou & Ren, 2018). As it is a new material, it would be insightful to determine some mechanical properties of the material. This can create a better understanding of the material and can propose other product applications. The technical characterisation will also determine whether the new material is suitable for the intended product application. Please refer to appendix B: Technical characterisation for more details on the tests executed.

## 6.1 SHRINKAGE

### GOAL

The material will undergo shrinkage as part of its drying process. Even as shrinkage is inevitable, it is preferable to understand the shrinkage behaviour and determine whether principles such as warping and ununiform shrinkage will occur.

It is also important to determine the shrinkage behaviour after reprocessing the sample. Reprocessing will add water to the material. The difference in shrinkage before and after reprocessing will determine whether the material is suitable for multiple lifecycles.

### METHOD

The dimensions for the moulds will be 30\*30\*36 mm. 14 samples will be created and the wet weight will be measured. After the material has dried for 4 days, the material will be weighted again. The dimensions of the 14 samples will be measured, determining the volume after drying.

Using  $\rho = m/v$ , the density can be calculated.

The density from the wet and dried weight are calculated after 4 days of drying, creating an average density change.

### RESULTS

The results are in table 6.1. Here, the conclusion can be drawn that the density after 4 days of drying is around 724 kg/m<sup>3</sup>, while the density of the material before drying was 740 kg/m<sup>3</sup>. The mass decreases with 40%, and the volume decreases with 38%. The density decreases with 2%. This indicates that the material shrinks uniformly.

	Wet			Dry			Difference			
Nr	Weight (kg)	Volume (m <sup>3</sup> )	D e n s i t y (kg/m <sup>3</sup> )	Weight (kg)	Volume (m <sup>3</sup> )	Density (kg/m <sup>3</sup> )	Weight (kg)	Volume (m <sup>3</sup> )	Density (kg/m <sup>3</sup> )	
1	0,024	3,24E-05	740,74	0,016	2,08E-05	769,23	-33,33	-35,80	3,85	
2	0,024	3,24E-05	740,74	0,014	2,02E-05	694,79	-41,67	-37,81	-6,20	
3	0,024	3,24E-05	740,74	0,014	2,02E-05	694,79	-41,67	-37,81	-6,20	
4	0,024	3,24E-05	740,74	0,014	2,03E-05	691,36	-41,67	-37,50	-6,67	
5	0,024	3,24E-05	740,74	0,016	2,42E-05	661,70	-33,33	-25,37	-10,67	
6	0,024	3,24E-05	740,74	0,014	1,89E-05	742,71	-41,67	-41,82	0,27	
7	0,024	3,24E-05	740,74	0,014	1,89E-05	742,71	-41,67	-41,82	0,27	
8	0,024	3,24E-05	740,74	0,014	0,000018	777,78	-41,67	-44,44	5,00	
9	0,024	3,24E-05	740,74	0,014	1,88E-05	745,00	-41,67	-42,00	0,57	
10	0,024	3,24E-05	740,74	0,014	1,74E-05	804,60	-41,67	-46,30	8,62	
11	0,024	3,24E-05	740,74	0,014	2,03E-05	691,36	-41,67	-37,50	-6,67	
12	0,024	3,24E-05	740,74	0,014	1,89E-05	742,71	-41,67	-41,82	0,27	
13	0,024	3,24E-05	740,74	0,014	1,95E-05	717,95	-41,67	-39,81	-3,08	
14	0,024	3,24E-05	740,74	0,014	2,11E-05	664,77	-41,67	-35,00	-10,26	
				Average	0,014	1,98E-05	724,39	-40,48	-38,91	-2,21
				STDEV	7,00E-04	1,59E-06	41,56	2,92	4,90	5,61

Table 6.1: 14 material samples with their wet weight, volume and density compared to their dried weight, volume and density.



The density ranges from 661 to 804 kg/m<sup>3</sup>. This range was put into Granta Edupack to compare the density with other materials (ANSYS Inc, 2021). The graph is shown in figure 6.1. In this graph, the density of Tea Clay is similar to that of bamboo and plywood, and heavier than that of softwood.

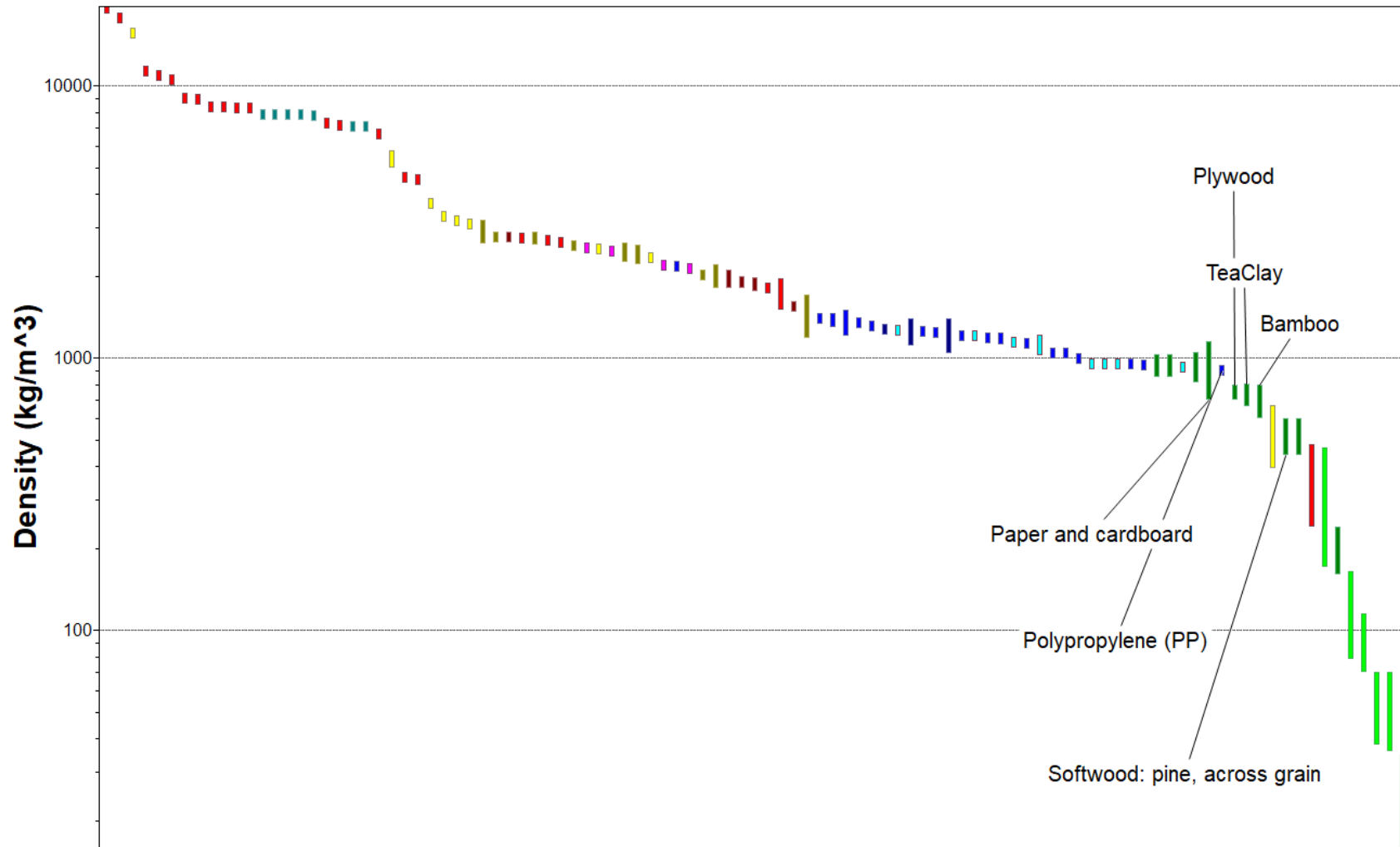

Figure 6.1: Tea Clay plotted in Granta Edupack based on density. (ANSYS Inc, 2021)

## 6.2 SHRINKAGE SECOND TEST

### GOAL

The shrinkage and density that was measured was after 4 days. The second test is to determine the shrinkage after steaming the samples. This can indicate the material performance in several recycling cycles.

### METHOD

8 samples will be created with a mass of 24 grams and a volume of 30\*30\*36 mm. The samples will be split in 2 groups of 4. The first group will be steamed after 4 days and dried for 2 weeks, while the second group will keep on drying for 2 weeks. The mass and volume will be measured, determining the density.

### RESULTS

The measurements for the steamed samples are in table 7.2. The wet weight, volume and density are measured at the moment when the material was made. The dried density is after steaming and letting it dry for 2 weeks. Here it is apparent that the mass decreases with 56%, and the volume decreases with 44%. This indicates that the shrinkage does not occur uniformly. The density has a decrease of 21%.

The measurements for the samples that were left to dry for 2 weeks are in table 6.3. The wet weight, volume and density are measured at the production moment. The dried density is measured after 2 weeks. It is shown that the mass decreases with 50%, and the volume with 43%. These numbers are similar to those of the steamed samples. The density changes with 11%.

Combined with the data of chapter 6.1 Shrinkage, a general conclusion on the behaviour cannot be drawn. There is not enough data to determine the effect of steaming on the density, and the density of a dried sample is also difficult to set. It is unclear when a sample is completely dry to measure the mass and volume of. This results in an open conclusion for the density and shrinkage. The recommendation is to redo all the tests and expand it with more samples. Due to the lack of time, this is not possible within this research. The results of "Shrinkage second test" are therefore observations but cannot contribute to the conclusions. However, the first shrinkage test occurred in an earlier moment in the project. The shrinkage of 40% that was perceived there has been used throughout the project as well as the perceived density. This means that some results are only binding to this research.

Picture of deforming samples, by author



Wet			Steamed			Difference from wet to steamed			
Weight (kg)	Volume (m <sup>3</sup> )	Density (kg/m <sup>3</sup> )	Mass (kg)	Volume (m <sup>3</sup> )	Density (kg/m <sup>3</sup> )	Mass (kg)	Volume (m <sup>3</sup> )	Density (kg/m <sup>3</sup> )	
2.40E-02	3.24E-05	740.74	1.24E-02	1.88E-05	661.33				
2.40E-02	3.24E-05	740.74	1.20E-02	1.73E-05	695.65				
2.40E-02	3.24E-05	740.74	1.06E-02	1.78E-05	596.76				
2.40E-02	3.24E-05	740.74	1.27E-02	1.90E-05	666.79				
						<b>Average</b>	-50.31%	-43.82%	-11.56%
						<b>ST.DEV</b>	3.35%	2.24%	4.88%

Table 6.2: wet and dried mass, volume and density after steaming.

Wet			Dried			Difference wet to dried			
Weight (kg)	Volume (m <sup>3</sup> )	Density (kg/m <sup>3</sup> )	Mass (kg)	Volume (m <sup>3</sup> )	D e n s i t y (kg/m <sup>3</sup> )	Mass (kg)	Volume (m <sup>3</sup> )	Density (kg/m <sup>3</sup> )	
2.40E-02	3.24E-05	740.74	1.05E-02	1.79E-05	585.28				
2.40E-02	3.24E-05	740.74	1.06E-02	1.80E-05	588.89				
2.40E-02	3.24E-05	740.74	1.01E-02	1.79E-05	562.69				
2.40E-02	3.24E-05	740.74	1.07E-02	1.80E-05	594.44				
						<b>Average</b>	-56.35%	-44.53%	-21.32%
						<b>St.DEV</b>	0.95%	0.086%	1.63%

Table 6.3: wet and dried mass, volume and density after drying for 2 weeks.

## 6.3

# BENDING TEST

### GOAL

A bending test can determine the Young's modulus, stresses and strains that occur in a material. Due to the nature of a bending test, the upper layer of the material will experience compression, while the lower layer of the material will experience tension. The Young's modulus can be compared with other materials, determining whether Tea Clay's strength is comparable and even replaceable for other materials such as plastics and woods.

### METHOD

#### Dimensions

The dimension for the bending test is according to NEN-EN-ISO 178, Plastics - Determination of flexural properties standards.

The standard specified samples of  $16 \pm 0.2 * 2 \pm 0.2 * 0.8 \pm 0.2$  (l\*w\*h).

The span will be  $16 * 0.8 = 12.8$  cm. The shrinkage of the material needs to be taken account. The shrinkage was determined to be 40%. This will be the scaling factor for the moulds to ensure that the shrunken material will have the specified dimensions. Three samples will be tested to ensure the data is valid and repeatable. The samples can be seen in figure 6.2.

#### Measuring instrument

The ZwickRoell machine was used for performing a three point bending test. With a 3 point bending test, the sample is typically a bar shape with 2 supports beneath it. A force will move from top to bottom, bending the material in the middle. As specified before, the distance between the two supports at the bottom is the span, which is 12.8 cm. The speed at which the machine moves is set for 10 mm per minute. The ZwickRoell for this test was set up to bend the material 10mm and measure the distance of the deformation and the force. Figure 6.3 shows the test setup.



Figure 6.2: the samples used for testing



Figure 6.3: the test setup for the 3 point bending test.

## RESULTS

Figure 6.4 shows the force and distance curves from all three samples. The full results are in appendix B: Technical characterisation, Bending.

### Series graph:

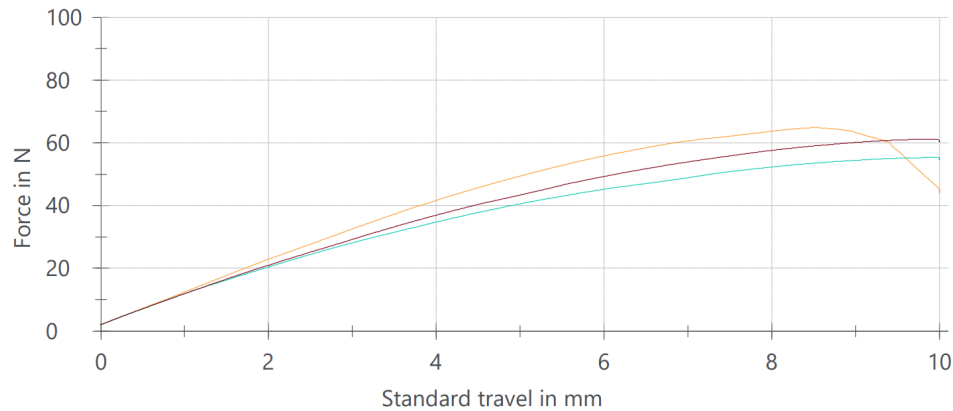

Figure 6.4: Force and displacement curves of 3 samples.

The curves are very similar, which shows that the data is coherent. The yellow curve starts decreasing around 9.6 mm travel. This is the moment when the sample started cracking. The other two samples did not crack during the bending test. One interesting observation is that all three samples were bended into a curve, but several days after the test, the samples have reformed back to their original shape, despite being bended and cracked. This is an interesting phenomenon that should have further research into.

### Statistics:

Series	$F_{max}$	dL at $F_{max}$	$F_{Break}$	dL at break	W to $F_{max}$	$a_0$	$b_0$	$S_0$	$t_{Test}$
$n = 3$	N	mm	N	mm	Nmm	mm	mm	mm <sup>2</sup>	s
$\bar{x}$	60,4	9,4	-	-	364,02	7,1	22	156,20	61,13
s	4,80	0,8	-	-	21,31	0,3464	0,000	7,62	0,04
v [%]	7,95	8,49	-	-	5,86	4,88	0,00	4,88	0,07

Figure 6.5: the average statistics of the bending tests

Figure 6.5 shows the statistics of the three samples. The average maximum force that could be applied on the middle was 60.4N, with a maximum deformation of 9.4 mm. A stress-strain curve is created to normalise the data. This can be seen in figure 6.6. A force-displacement curve conveys the sample size. This makes a stress-strain curve comparable with other materials, while a force-deformation curve is more specific to this test. The stress strain curve shows that the material behaves in an appropriate way comparable to plastics. The stress strain curve also indicates the maximum stresses and strains that the material can endure before breaking, as the samples could break at a force of 60.4 N.

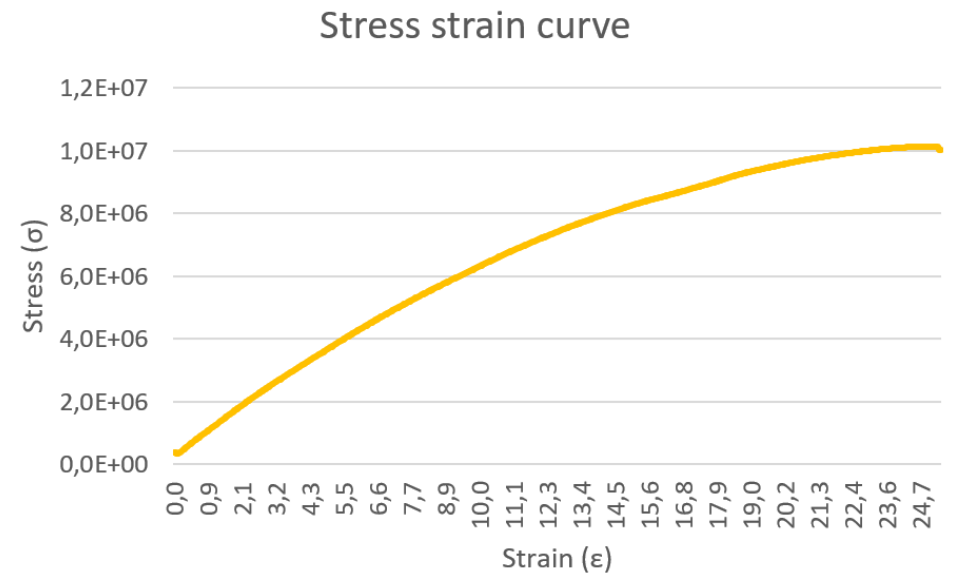

Figure 6.6: the stress strain curve

Using the formula for deflection, the young's modulus can be calculated.

$$\delta = \frac{F * L^3}{48 * E * I}$$

The deflection formula, where F = maximum force

L = Length of the sample

E= Young's modulus

I = Moment of Intertia

The moment of inertia (I) is dependent on the size of the cross section. Since this is a rectangle, the following formula can be used.

$$I = \frac{bh^3}{12}$$

Where b= the width and h= the thickness.

The calculations result in a Young's modulus of 835 MPa.

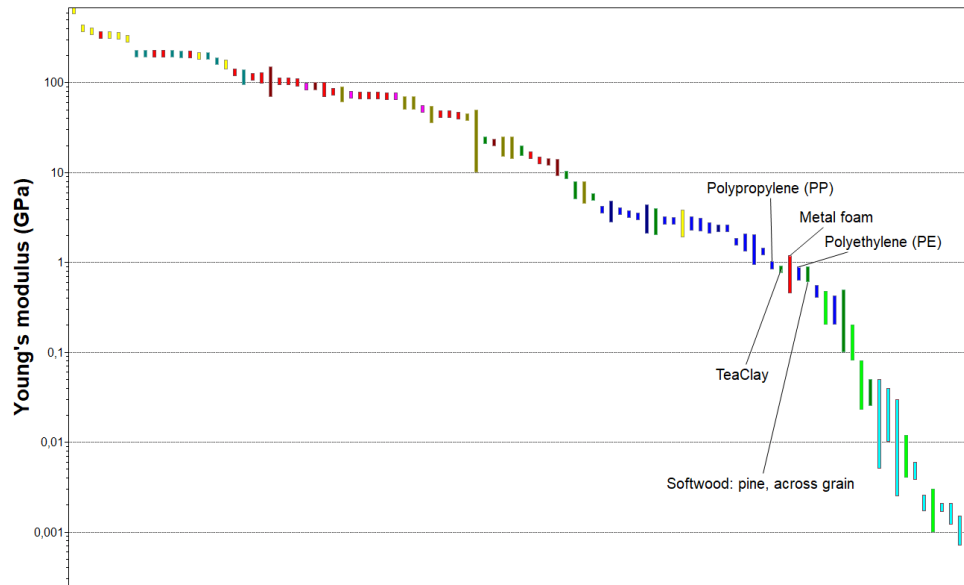

Figure 6.7: Tea Clay plotted in Granta Edupack based on Young's Modulus (ANSYS Inc, 2021).

Using Granta Edupack the young's modulus of Tea Clay can be plotted with other materials (ANSYS Inc, 2021). The result is visualised in figure 6.7. In this figure, it is apparent that Tea Clay has the same strength as several plastics such as polypropylene and polyethylene, and as well as soft woods.

With the density that was calculated at chapter 7.1 Shrinkage, the material was plotted together with its Young's Modulus in Granta Edupack (ANSYS Inc,2021). See figure 6.8. Here, it is apparent that tea clay falls under the natural materials, which is expected due to its material composition. Tea Clay does not fall within the polymers group due to its low density, however, the young's modulus of Tea Clay falls in the middle of the range of polymers. This indicates that Tea Clay performs similar to polymers, but that it is less dense. A lower density means that there is less mass needed to create the same volume, resulting in a lower material usage. This is a great advantage and proves that Tea Clay can serve as a substitute for polymer products, reducing the usage of polymers.

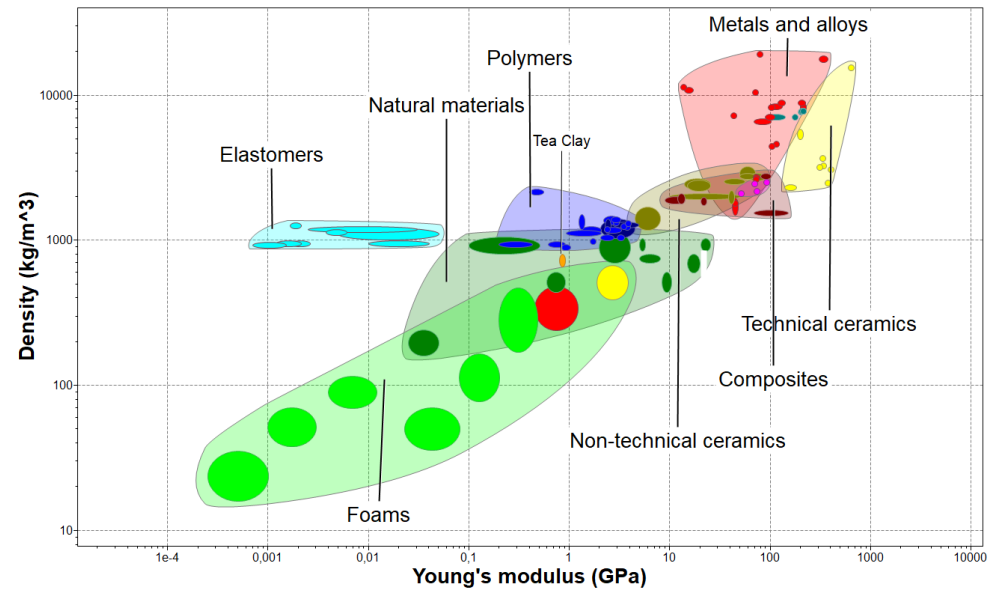

Figure 6.8: Tea Clay plotted in Granta Edupack based on Young's Modulus and density. (ANSYS Inc, 2021)

## 6.4

# HARDNESS TEST

### GOAL

The hardness of a material determines how well the material can withstand permanent deformation. The intended material usage was for a board game, which is an environment in which the material should withstand different forces, e.g people holding the material, squeezing it, poking it, dropping it. Determining the hardness of the material can therefore create an understanding how well the material is suitable for its intended use.

### METHOD

Hardness can be measured with different test setups. ISO 868: Plastics and ebonite - Determination of indentation hardness by means of a durometer (Shore hardness) was used for determining the hardness of the material. A durometer is a device that punctures into the material. The degree of indentation determines the hardness of the material. A durometer D was used in this test. A durometer D is usually used for hard rubbers or soft plastics, which resembles Tea Clay with gelatine the most. A slab with a minimum thickness of 4 mm needs to be prepared for the test. This was achieved by sawing the cross section of the material. The sawing produced rough finishes. Sanding paper was used to smoothen the surface and to assure that the sample was entirely flat

The durometer was performed on 5 randomly chosen locations , providing there was a minimum distance of 9 mm from the edge of the material. The 5 measurements were averaged to create the hardness of the material.

Figure 6.9 shows the durometer.

### RESULTS

The result of each test is in table 6.4. The hardness of Tea Clay is 50.4 shore with a standard deviation of 2.09. Shore 50.4 is similar to Low Density PolyEthylene (LDPE) with a shore of 40-50, Polypropylene, impact modified (PP) with a shore of 45 – 55 and Thermoplastic Starch (TPS) (Omnexus, n.d.). PP and LDPE are generally used for plastic products such as toys. This would indicate that Tea Clay is suitable for boardgame environments and interactions based on its hardness.

	Shore
Test 1	48
Test 2	51
Test 3	54
Test 4	50
Test 5	49
Average	50.4
Standard dev.	2.09

Table 6.4: the results of the durometer.



Figure 6.9: using a durometer to measure the hardness.

## 6.5

# VISCOSITY TEST

### GOAL

The viscosity of the material has been observed throughout the tinkering phase, but a value was not calculated. Determining the viscosity can better describe the material behaviour and indicate the relation between the moulding method and the viscosity. Therefore, a viscosity test using a rheometer will be performed in order to determine the viscosity of the material.

### METHOD

Viscosity tests cannot be conducted on solid materials. Therefore, the material needs to be created and put in an airtight bag. The bag will keep the material from solidifying. The material will enter the highly flexible gelatine state, but when heat is applied, the material will become viscous again. Three different water variations of the material will be tested. Testing different water variants can help conclude whether the results are accurate. The three water variations will be 40%, 67% and 72%. These can be seen in figure 6.10. The hypothesis is that the lower amount of water will result in a higher viscosity, while a higher amount of water will result in a lower viscosity. A rheometer will be used to determine the viscosity. The material is in its gelatinous state, and will transition to viscous when the environmental temperature of the rheometer has reached 70 degrees. The setup can be seen in figure 6.11.

	Water	Plant-starch	Acetic acid solution	Glycerin	Tea	Gelatine
VARIATION 1	40%	7%	3%	3%	27%	20%
VARIATION 2	57%	5%	2%	2%	20%	14%
VARIATION 3	67%	4%	2%	2%	16%	11%

Figure 6.10: the water variations and the compositions

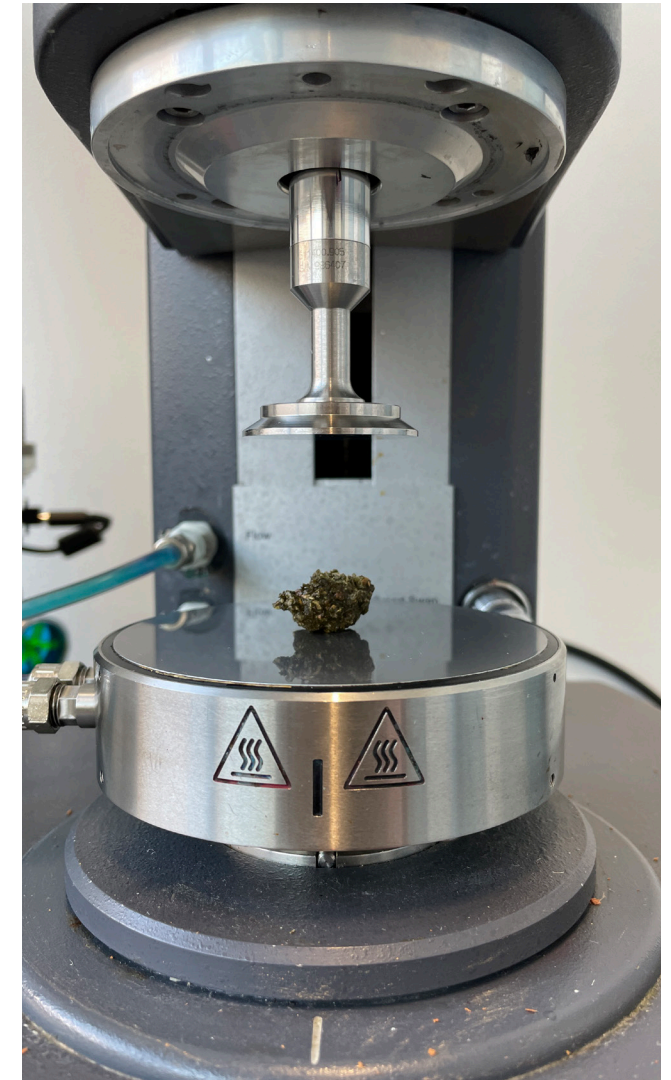

Figure 6.11: the rheometer and a material sample



## RESULTS

The idea was to test each sample once. However, the rheometer showed to be inaccurate in producing similar results for each sample. During the test, the material would dry and slip out of the rheometer, causing the obtained data to be inaccurate. After 5 measuring points the viscosity drops severely. This is due to the fact that the material was not in the machine anymore but has slipped out. This result also occurred at the other variants. This behaviour causes the measured average viscosity to be unrepresentable.

To be able to draw a conclusion, all test data needs to be reinterpreted. 3 shear rates will be observed from the obtained data, namely 1, 5 and 10 (1/s). The viscosities of these corresponding shear rates will be compared in order to draw a conclusion. It is believed that the perceived viscosity is a defusing process. This indicates that the strain changes with movement, which is a physical relationship. It is assumed that the viscosity and shear rate have an Arrhenius type relationship. Arrhenius's equation is used since it describes a temperature time dependent reaction, which then translates to a linear model. The slope of this equation shows the activation energy needed to activate the material system.

Table 6.5 shows the compared viscosities. The natural logarithm of each viscosity is taken. These values are plotted on a logarithmic scale, as can be seen in figure 6.12

The trendline and equation show that there is approximately a linear behaviour, with an  $R^2$  value of 0,94. The  $R^2$  value indicates the variance between the observed data and the values estimated by the trend line. This indicates that all samples behave in a similar way, and that thus the test results are consistent with the linear model. It is also noticeable that there is not a perceived difference between each viscosity. This indicates that the chosen water values are not variable enough for this test setup to perceive a change in viscosity. Thus, it was not possible for this test to determine the viscosity.

1/Shear rate	Viscosity (Pa.s)					
	40% water (1)	40% water (2)	67% water (1)	67% water (2)	67% water (3)	72% water
1	8,98	8,75	8,82	8,93	8,70	8,92
0,2	7,99	7,40	7,10	7,55	7,38	7,57
0,1	7,47	6,79	6,43	6,96	6,82	7,03

Table 6.5: Viscosity in natural logarithm and shear rate for each sample

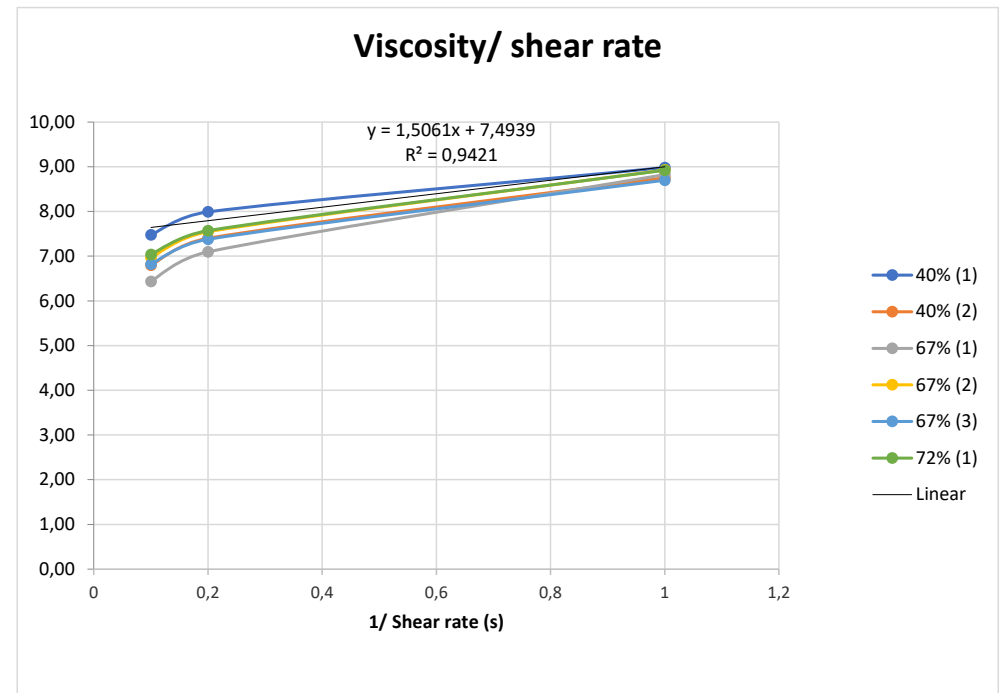

Figure 6.12: viscosity and shear rate graphs for all samples, on logarithmic scale

## 6.6 CHAPTER CONCLUSION

The shrinkage tests have indicated that the shrinkage happens uniformly in the first days of drying. However, shrinkage tests performed after 4 days have indicated different results. These tests were performed with less samples and could not conclude the shrinkage behaviour. It is therefore chosen to assume that the shrinkage occurs around 40%, and this is thus the value that will be used for mould design.

The bending tests have indicated that the material has a Young's modulus of 835 MPa. This is similar to thermoplastics such as polypropylene and polyethylene. The stress strain curve of the samples behaves similarly to other plastics. The stress strain curve also indicates the maximum stresses and strains that the material can endure before breaking. These can be essential for product implementation. The Young's modulus and density measured from the shrinkage test have been plotted with other materials to determine the comparability. It became apparent that Tea Clay is less dense than thermoplastics but contains the same strength. This indicates that Tea Clay can be a substitute for certain thermoplastic products, as it could also use less material due to its lower density. Hardness tests have also indicated that the material's impact resistance is similar to that of thermoplastics.

As last, viscosity tests were performed on the material with three water variations. The test results were invalid after a shear rate of 10 (1/s) as the material would dry up and slip out of the testing device. However, the results within 1 and 10 shear rate have indicated that the behaviour of the water variations is similar to each other. The measured viscosities have a limited variation. The three water variations were therefore not variable enough to perceive a difference. The viscosity of the material could not be indicated, but the testing method was valid as the three variations have performed similar behaviour.



Picture of the samples used for bending tests, by author



## CHAPTER 7

# EXPERIENTIAL CHARACTERISATION

Experiential characterisation describes the experiences that people have with a material. This is through several layers, such as the performative, sensorial, emotional and interpretive level. The performative level focusses on how people move, hold and touch the material. The sensorial level lets people describe material characteristics based on their experience: people can perceive a material as very hard, or very soft. The emotional level focusses on the emotions that the material evokes on the person. E.g., a person can feel comfortable due to the softness of a material.

The interpretive level is based on how the people perceive the material. If the material were a person, how would that person be described? A material can come across as aggressive, because it is very rough, or it can come across as playful, because it is malleable.

In this chapter, a user test was conducted to determine the experiential characterisation of the renewed material.

## 7.1

### GOAL

The benchmarking and literature review has determined that there are not many commercial products made from tea waste. It is therefore a very novel material and ingredient. This also means that there is little understanding to how people would perceive the material and what their opinions are. As the material is made from a waste material, it can happen that people have negative connotations with it. This can influence their behaviour towards the material. A big part for people to accept something new is for them first to understand it. Looking at the concept, it will most probably be sold online, or in a physical board game shop. The areas of interest for customers would be the packaging, physical attributes, name and description of the game.

The experiential characterisation serves as a great tool for exploring people's perceptions on the material. The material's goal is for it to be manufacturable and therefore commercially available. Using the experiential characterisation can help with delivering the information of the material composition, and creating guidelines as to how the material should look and feel. This altogether can guide them into interacting with the material in the intended way. Therefore, it is chosen to have one group of participants who are not informed about the material, and another group who is. By looking at the differences in responses, it can prove how important communication can be for new materials. The non-informed group can also be fully unbiased about how the material should look and feel according to them, but because they do not know the composition, it is interesting to determine what their perceptions are.

From the tinkering chapter, it was known that the material can take various shapes and surface qualities, ranging from smooth to rough. These surface qualities can also influence people's perception on the material. It is therefore also interesting to research people's perception on different surface qualities of the material. Altogether, the experiential characterisation method will help with how the material can be described to people, and how the material surface should be made for them to accept it.



Picture of hands exploring the material, by author

## 7.2

### METHOD

The MA2E41 toolkit will be used. This toolkit was developed by Camera and Karana and will guide the participants through all levels of experience for one sample. The tool also comes with a vocabulary where the participants can choose their emotions and interpretations from. Next to a vocabulary, interpretive pictures are given to the participants that can help them describe their interpretation. (Camera & Karana, 2018) 2 groups will be made, where one group is entirely not informed about the material, while the other group will receive an introduction. 10 participants will be divided in 2 groups. One group will be labelled as “non- informed group” and the other group will be labelled as “informed group”.

Since the concept is for VIP, being able to see the material can influence the entire experiential characterisation. Therefore, all the participants will interact with the material in a closed box, causing them not to be able to see the material. The setup can be seen in figure 7.1.. This research will not focus on the participant’s tendency to smell the samples, since this test was conducted during the Serendipitea project.

The “informed group” will receive the following information : “It is a new material made from wasted tea leaves, mixed with bio-based and largely available ingredients, even in domestic environment. It is safe to touch and interact with. The material will be used to create a board game for visually impaired people”.

The “non-informed group” will only receive the following information: “It is a new material made from bio based and largely available ingredients. It is safe to touch and interact with. The material will be used to create a board game for visually impaired people.”

The sensorial level contains certain material aspects that are impossible to answer when the participant cannot see the sample. These aspects have therefore been removed. All the participants will undergo the performative, sensorial, emotional and interpretive phases, which will be rounded up with a final reflection wherein the participants are asked three questions:

“What is the most pleasant quality of the material?”

“What is the most unpleasant quality of the material?”

“What is the most unique quality of the material?”

Figure 7.1: the test setup with a closed off box and curtain for the participants



## 7.3

### SAMPLES

2 samples will be made where one has a rough texture and the other one has a smooth texture. Roughness and smoothness can provide different opinions whilst being the same material. It can therefore offer interesting findings in this study. The samples will be made in circular disc shapes with a diameter of 3.5 cm. A disc has varying surface sizes and resembles the Tea Clay pieces that were used for Serendipitea. The samples can be seen in figure 7.2. The smooth sample will be extruded in a circular mould and covered up with a flat object to ensure that the top layer stays smooth (sample 1). The rough sample will be extruded in a circular mould and dried (sample 2). By not adding a flat piece, the top layer will remain rough. To ensure that people were not biased about the first sample they would experience, the sample order was randomised among the participants.

## 7.4

### PARTICIPANTS

10 participants were needed to conduct this test. The only criterium is that the participants must not have any pre knowledge about the material or project. If people have seen the material before, it could influence their experience. The participants were mostly students from IDE, as these were easily approachable and available within a short period of time. To draw out biases, the participant gender was also randomised but held equal among each group. The participants were presented with a consent form. During the performative level, the hands of the participants were recorded to capture certain actions they were performing on the sample. The other phases did not include recordings, as the participants' answers were immediately transcribed. A consent form was created for this research and can be found in appendix C: Experiential characterisation, consent form.



Figure 7.2: the samples that were used during the user test

## 7.5 RESULTS

The transcriptions of each participant are in appendix C: Experiential Characterisation.

### 7.5.1 PERFORMATIVE LEVEL

The participants were handed the sample in a closed off box. The participants were given 5 minutes to interact with the material and thinking out loud about their responses and thoughts. The facilitator asked deeper questions to stimulate reflection. For example, questions such as “I notice that you are rubbing the material with that your thumb, is there a reason for that?”

#### SAMPLE 1

The people were very playful with the samples. They started turning it around as a sign of fidgeting (figure a), sliding it around the table to test the resistance (figure b). Since the participants could not see the material, they performed several tests to see if they can figure out what it is. Figure c shows a participant trying to break the material. When they were asked how they would hold the material, all participants agreed that they would at least lay one finger on the biggest surface. They explained that the slight indent in the middle conveyed an ergonomic clue for them, making it easy to put a finger there whilst holding. Non-informed people would interact with the material in a similar way: They would turn it around, in a similar way as coin flipping (figure d), flick their fingers against it to test the hardness (figure e) and use many fingers and contact area to explore the material (figure f). The non-informed people were not as creative with their playability, but the actions they performed have resemblances to being curious about the material and trying ways to work with it.

#### INFORMED PARTICIPANTS

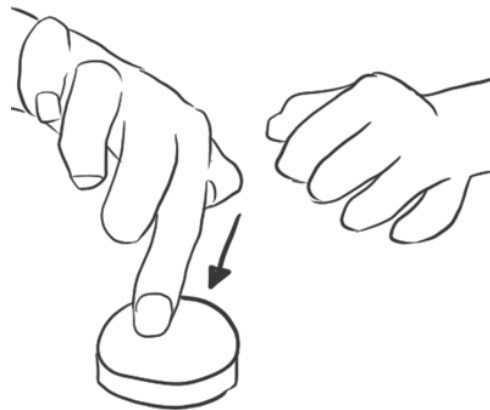
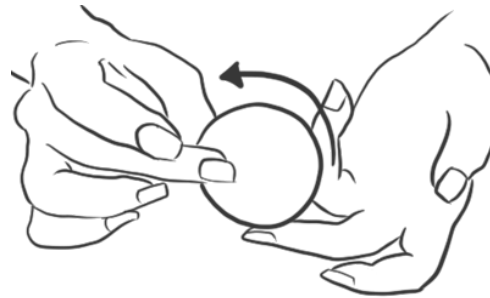

From top to bottom, figure (a), person turning the sample. Figure (b), person sliding the sample, figure (c) Person trying to break the material.

#### NON-INFORMED PARTICIPANTS



From top to bottom, figure (d), person turning the sample. Figure (e), person flicking the material, figure (f) person exploring the material.

## SAMPLE 2

The informed people were curious about the material, and usually used one hand to hold the material, and their index finger to explore the rough surface (figure g). Nails were used for scratching the surface. This was out of curiosity as well, as the participant wanted to test the hardness and brittleness of it, in order to get a better understanding of the material capabilities. (figure h). It was noticeable that the thumb was used for stroking the rough surface (figure i). When asked further about it, participants have expressed that their thumb can handle the roughness, and that their index finger is more used for exploring the small cavities. This is contrasting to sample 1, where all fingers were used for exploring.

The non-informed group was more confused about the material. Upon first interaction, they have expressed their surprise regarding the roughness and pointiness. Participants tried to connect meanings of the shape and characteristics together into a purpose, but have failed in doing so. Some participants thought that the material was a 3D printed part, as it felt just like that according to them. The roughness was seen as a failed 3D print. Regarding the purpose of the material, the participants had difficulties finding a good purpose, except for exfoliation. This is seen in figure j and k. When asked how they would hold the material, they preferred holding the sides, as these were smoother.

## INFORMED PARTICIPANTS



From top to bottom: figure g, using the index finger to explore. Figure h, scratching the material to test hardness, figure i, thumb used for stroking the material.

## NON-INFORMED PARTICIPANTS



From top to bottom: figure j, using the sample as exfoliator. Figure k, using the sample as exfoliator, figure l, holding the sample at the sides.



## 7.5.2 SENSORIAL LEVEL

The sensorial level is for people to rate certain material characteristics based on their perception. Some characteristics are measurable with mechanical tests, but the people's perception on it can deliver surprising insights. The results for the sensorial level are in the figures 7.3,7.4,7.5 and 7.6.

### INFORMED PARTICIPANTS

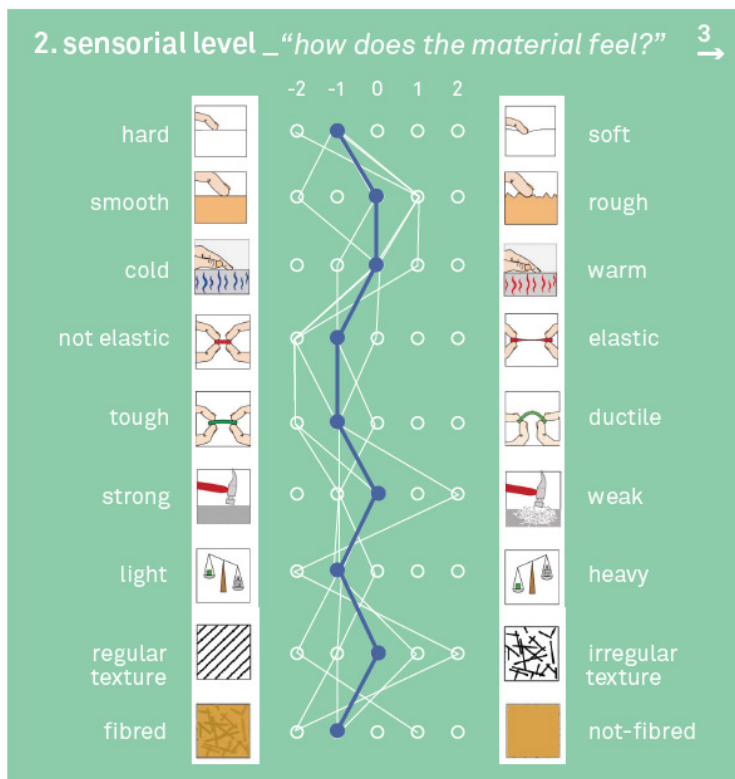

Figure 7.3 : the sensorial level answers for all informed participants on sample 1. The blue line indicates the average score.

## SAMPLE 1

When the informed group is compared to the non-informed group regarding sample 1, there is not much difference between the answers. It is noticeable that informed people have difficulty determining the regularity of texture, while non-informed people are more consistent. On the other hand, non-informed people find it difficult to rate the elasticity. It should be noted that it was perceived that not all participants tried to pull the material. The elasticity is therefore a characteristic that has not been tested well enough by participants.

### NON-INFORMED PARTICIPANTS

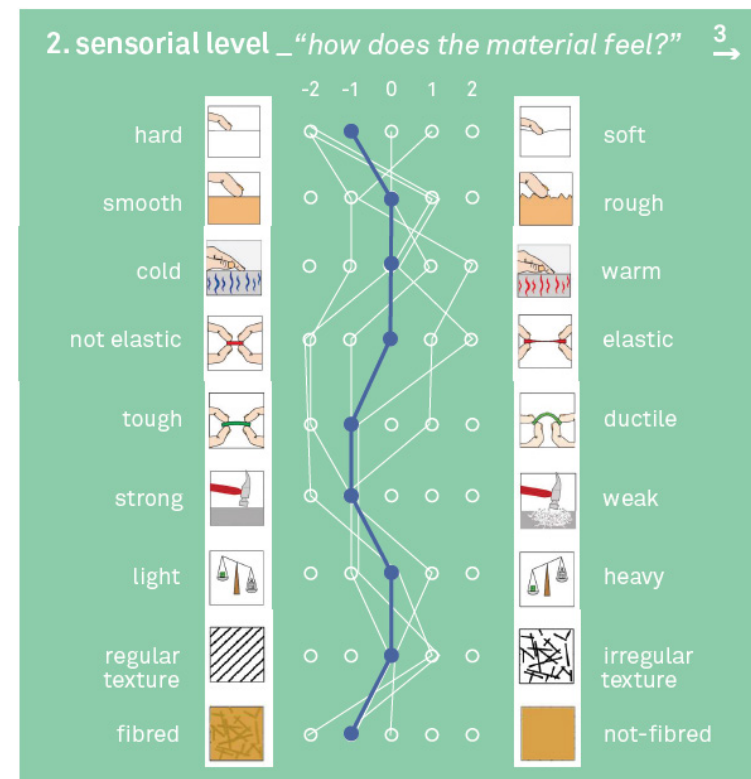

Figure 7.4 : the sensorial level answers for all non-informed participants on sample 1. The blue line indicates the average score.

## SAMPLE 2

For the second sample, it is noticeable that non-informed people perceive hardness, roughness and irregular texture as more extreme compared to informed people. It is understandable that non-informed people would rate this higher because they do not know the material composition. Informed people are more biased in their opinion, as they know it is made from tea, so that it would never be as hard as steel for example.

### INFORMED PARTICIPANTS

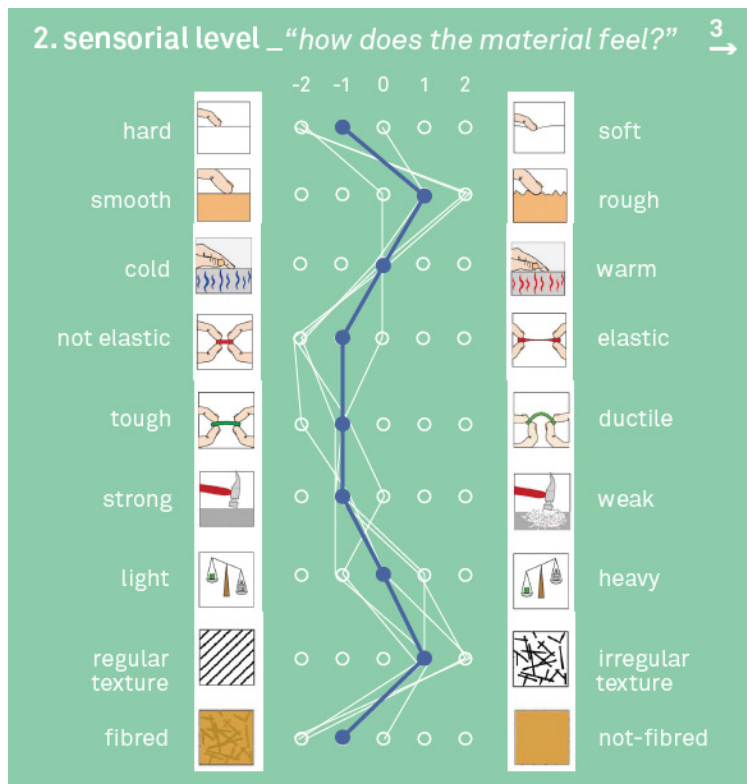

Figure 7.5 : the sensorial level answers for all informed participants on sample 2. The blue line indicates the average score.

### NON-INFORMED PARTICIPANTS

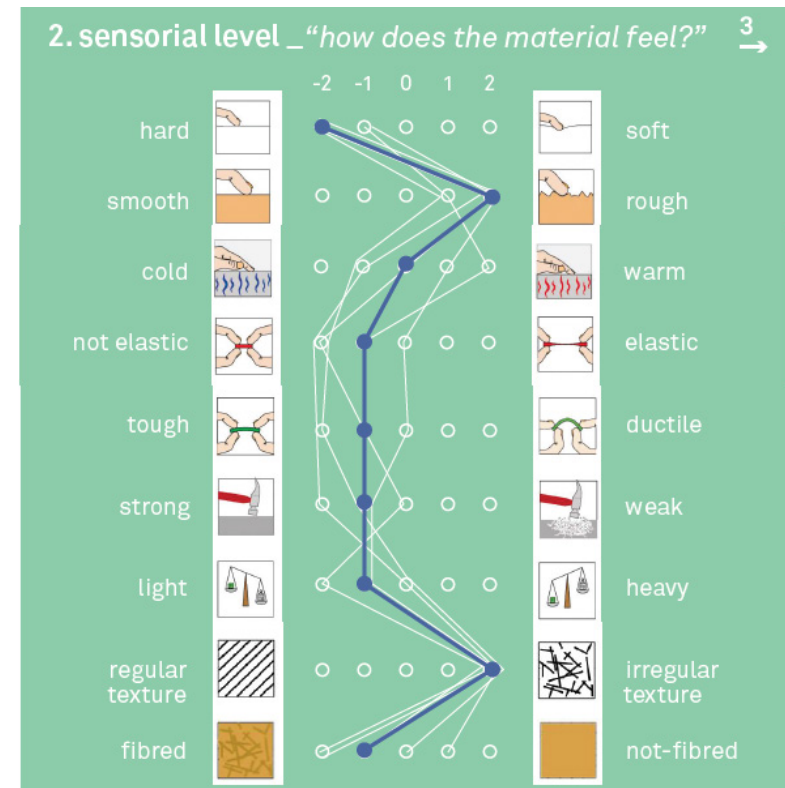

Figure 7.6 : the sensorial level answers for all non-informed participants on sample 2. The blue line indicates the average score.

### 7.5.3 EMOTIONAL LEVEL

The emotional level focusses on the emotions that the people perceive whilst interacting with the material. Emotions can be positive or negative and can have a varying intensity. A list of emotions is presented to the participants together with a graph where they can place how positive, negative and intense this emotion is. The answers of all participants have been counted and mapped out in one graph. The bubbles indicate emotions that have been mentioned multiple people. The single words are emotions that have been expressed once.

#### SAMPLE 1

The results from the informed participants for sample 1 are in figure 7.7. The informed group were curious about the material, even when they were aware that it was made of tea. It was this knowledge that made them curious as to how it was made, and how tea can be like the sample they had in front of them. The comfort that was experienced came from the smoothness of the material and the shape. The round shape and small size were comfortable to hold and interact with. The disappointment came from expectations that were not met. People expected a material from tea to be soft and malleable, which could enable certain interactions such as kneading. As the material was not like that, the participants experienced a mild disappointment.

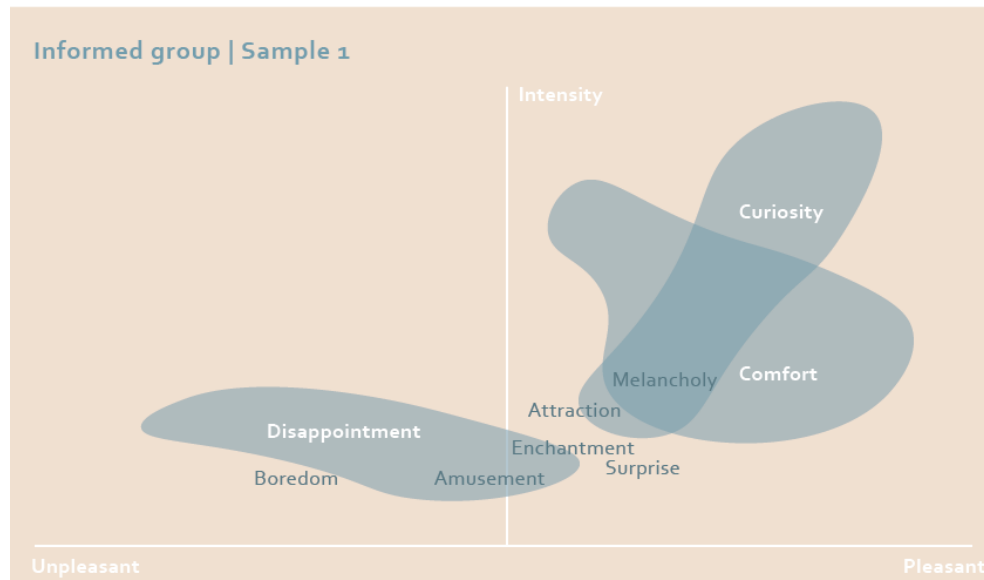

Figure 7.7: The perceived emotions of the informed participants on sample 1

Figure 7.8 shows the perceived emotions of non-informed participants on sample 1. The non-informed group also experience curiosity in different intensities. The curiosity came from the lack of knowledge about the material composition. Participants have expressed that they cannot place the material because it does not match with other materials that they are familiar with. "It feels like cork, but it is not entirely like cork" Such reference sentences were made for various materials, for example metal, plastic, wood and stone. The confidence was the toughness of the material that gave the participants a reassurance they can easily interact with the material. The amusement came from the small size and how easy it was to play with. Since the participants did not have any idea about the material composition, they remembered pleasant memories. "This material feels like those thick rubber tiles at the playground that I used to go as a kid, and that memory and that I am feeling this now is very amusing"

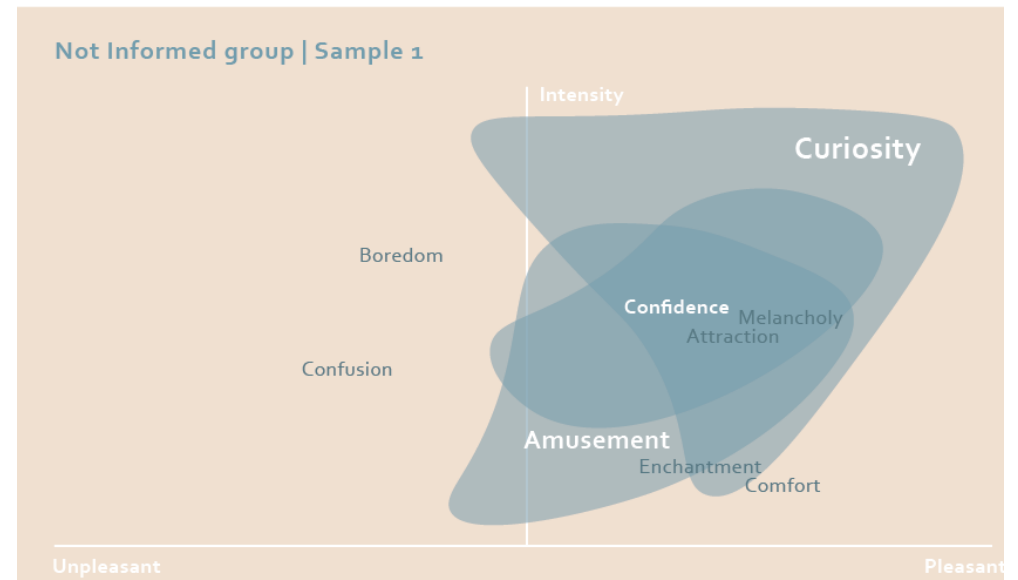

Figure 7.8: The perceived emotions of the non-informed participants on sample 1

## SAMPLE 2

Informed people experienced curiosity because the roughness of the material was different for them. They were curious how tea could achieve such roughness, because in their perception tea is soft and wet. This curiosity led participants to be eager to know the material better. This transpired to their surprise as well. The surprise came from the contrast between rough and smooth in one sample. The roughness of the material made the participants want to explore each little difference to create a better understanding. The reluctance came from the irregular shape and surface, as they were not entirely comfortable with this. They were afraid the material might be brittle, as the roughness meant to them that it was more fragile. On the other hand, the participants were also concerned if the roughness could hurt them.

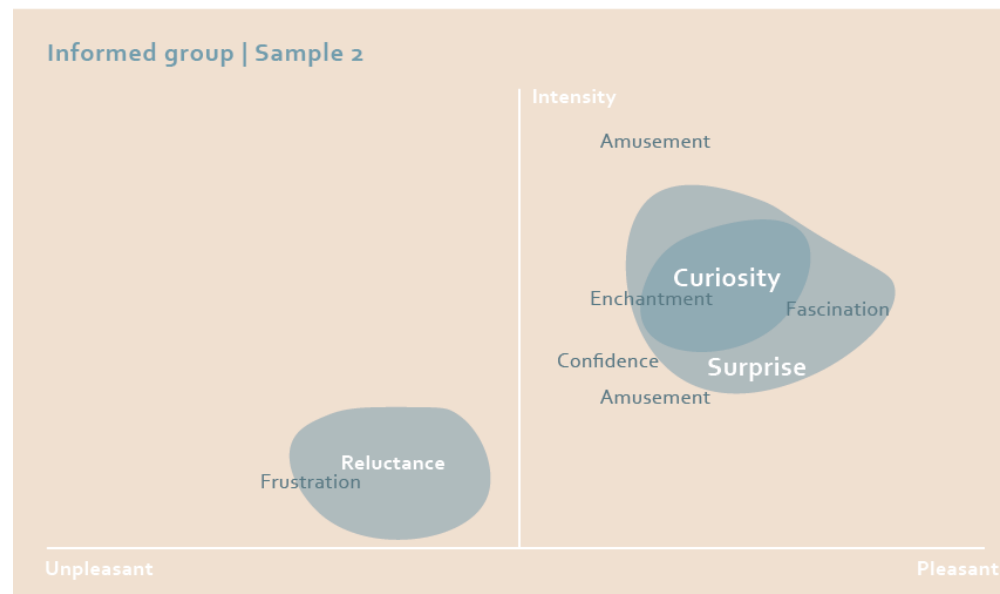

Figure 7.9 The perceived emotions of the informed participants on sample 2

The emotions of the non-informed people is mapped in figure 7.10. The non-informed people experienced curiosity for the same reasons as informed people. The surprise they felt because everything all together felt illogical to them. They did not know the material composition, and it does not match with any other material they know. Some participants who had experienced sample 1 first, mentioned the surprise in difference between two samples. Confusion erupted due to the illogical and mismatching features. Rejection occurred due to the roughness which was unpleasant. One participant has also associated the material with dirt, as it reminded them of other objects with similar roughness that they perceived as dirty and discomforting. This led to the participant's reluctance to interact with the material.

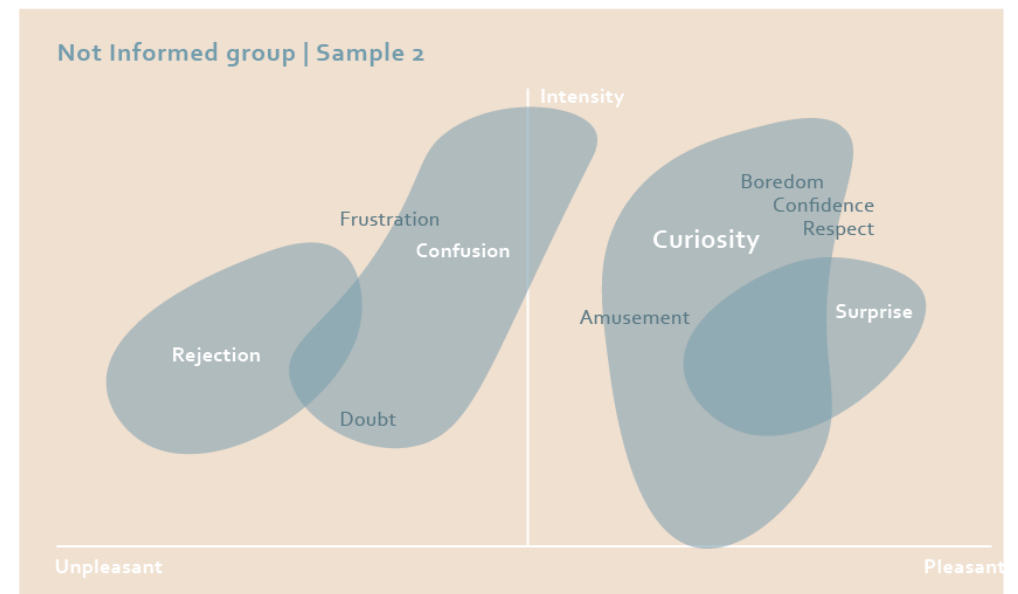

Figure 7.10: The perceived emotions of the non-informed participants on sample 2

## 7.5.4 INTERPRETIVE LEVEL

The interpretive level focusses on people's perception of the material and how they would describe it. A material can be perceived as futuristic, perhaps because of its shape or surface finish. A list of interpretations was given to the participants where they had to choose three from. The interpretations had a list of complimentary pictures that can help the participants to describe the reason behind their choice better. Some quotes of the participants explaining their choice were transcribed as well. Mood board with the pictures that were chosen the most and quotes of the participants were made. These mood boards are visualised in figure 7.11 and 7.12.

### SAMPLE 1

Informed participants have expressed that the first sample was toy-like, mostly due to the similarities in how children's toys are usually made. The shape and smoothness of it has also given participants a feeling of coziness. The interaction with the material has given them certain emotions and feeling that were also experienced when drinking a cup of coffee whilst being under a blanket. Participants have also chosen the words handcrafted and natural, as the sample was not entirely perfect. There were small dents and irregularities, but these were embraced and valued.

Non-informed participants had similar reactions to the material. However, some of them have expressed the material to be handcrafted due to the slight irregularity, whilst others have expressed it to be manufactured due to the symmetry and smoothness. The calming feeling of the material came forth from the smoothness similar to the white vases, with some slight irregularities that are embraced. The toy like feeling came forth from comes from happy and amusing memories that people have recalled during the test.



7.11: The interpretations of informed participants on sample 1.

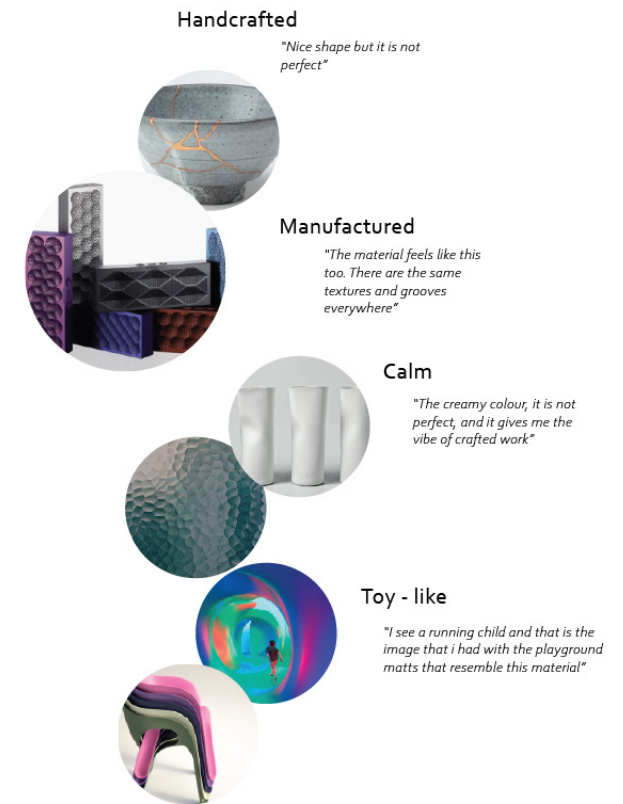

7.12: The interpretations of non- informed participants on sample 1.

## SAMPLE 2

Mood boards were created for sample 2 as well. These are in figure 7.13 and 7.14. Informed participants have expressed the sample to be strange. One participant said: "it is familiar, yet it does not make sense". The participants have constantly tried to connect the material characteristics with their own knowledge, but have expressed how it does not match entirely with their library of materials. This makes the material strange, even when they do know the composition of it. Participants have not mentioned for sample 1 to be strange. This is due to the extreme roughness that fall even further in their expectations about tea. A soft surface was still acceptable and slightly different from their perception. The handcrafted feeling comes from their knowledge that it is tea and that it seems to be mixed with other ingredients. However, the handcrafted feeling has never been associated with being less perfect.

The non-informed participants all agreed that the material was aggressive due to the roughness. The rough surface was very unstructured, which led participants to believe that it was done deliberately. Due to this, participants also believed that the material was more manufactured than handcrafted. As mentioned in the performative level, some participants believed that they were holding a piece of 3D printed plastic. The strangeness of the material comes forth from their inability to categorise it with their own preexisting knowledge.

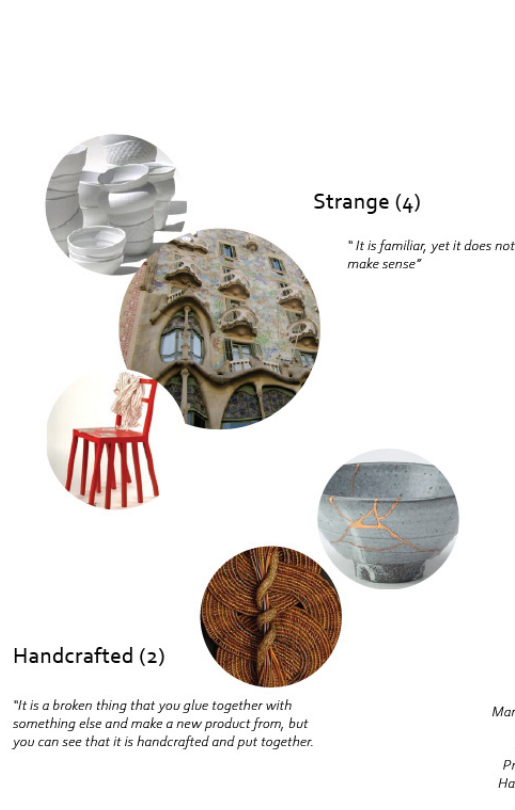

7.13: The interpretations of informed participants on sample 2.

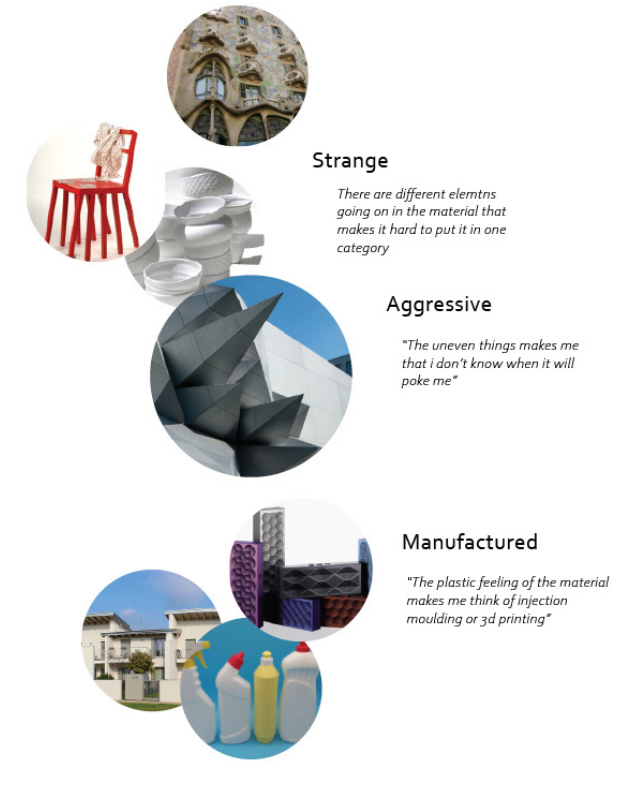

7.14: The interpretations of non-informed participants on sample 2.

## 7.5.5 FOCUS GROUPS

The participants were clustered together, and focus groups were created. This resulted in 4 focus groups. The 4 groups are illustrated in figure 7.15.

A majority of the participants wanted a good balance between variety and novelty. Sample 1 was very cozy and created pleasant emotions, but could also bore them due to the lack of variety. Sample 2 however was more strange because it had too many different aspects that did not fit together, but the participants liked exploring the rough surface as it kept them busy for a long time. This focus group was found between informed and non-informed participants.

Another large group were participants who had different expectations but kept on interacting, exploring, and understanding new values and meanings of the material. These participants were all informed people, and the expectations they built were towards having a material made from tea waste in their hands. They were usually surprised and curious how the material could have the hardness and roughness, whilst being made from tea.

One participant was in the non-informed group, but this lack of information did not matter, as the participant explored all the meanings and values of it without having a context. This participant focussed merely on the material itself and found beauty within it. The last group are participants who had difficulty finding value and meaning with the material. These participants were more practical oriented, and were seeking for the practicality of the material. These participants were non-informed about the material composition.

The focus groups are grouping slight remarks and characteristics of the participants, but this does not mean that the entire experience of the participant was as the focus group described. The participant who was more practical also appreciated other aspects of the material, such as that it has two contrasting sides. The focus groups are therefore for mapping user needs, but do not convey all the behaviours of the participants.

*"It is boring because there are not many irregularities. It is kind of that there is not much variety. You are done with it pretty fast"*

**The person who wants novelty and variety**



*"There is something accessible with the material. It is provoking but not in an unpleasant way."*

**The person who sees value in everything**



**The person who expected something else but is embracing it**

*"So I kept asking questions to build the expectations in my mind and to learn what it is. When I interacted with it, I tried to build an expectation in my mind."*



**The person who does not understand the material meaning and value**

*"It is very uneven. It is not stable no matter how I put it. The roughness feels less easy to use"*



Figure 7.15: the 4 focus groups created from the experiential characterisation results

## 7.6 CHAPTER CONCLUSIONS

The experiential characterisation test was performed to meet several goals.

### GOAL 1 CREATING GUIDELINES.

The first goal was to create guidelines as to how the material should look and feel. It was apparent that the material felt like a natural material, especially when people were rating sample 1. Assuming or knowing that the material is natural also caused people to have different expectations for the look and feel. They did not necessarily need it to be a perfect shape, or perfectly smooth. The natural deformations caused by drying were embraced and appreciated. They enjoyed the irregularities, because this seemed more natural to them, instead of artificial. This was also apparent in the interpretive level: "Handcrafted" was chosen by the participants, with pictures of broken bowls that were glued back together. This concludes that people can appreciate the irregularities of a natural material.

From the emotions and interpretive level, there is a correlation between participants feeling comfort and interpreting the material as cozy and calm. These are the design aspects that match with the idea of tea and can therefore be further used in the design phase.

The chosen size for the samples was good for most of the participants, as they can easily have it in one hand. Some participants expressed it to be slightly too big for their hands. The size of the samples can be used as a starting point for the final design.

### GOAL 2: DETERMINE THE IMPORTANCE OF INFORMING.

The second goal was to determine how informing people can change their perception and interaction with the material. It was expected that informing people about the material could create feelings of rejection, as it is made from waste materials. From the informed participants, it was apparent that this feeling never occurred. This concludes that participants might not perceive tea waste as actual waste that makes them have negative emotions. Instead, knowing the composition created a sense of curiosity and appreciation, because people are curious as to how the material could be made from tea.

Even when the material did not meet their expectations, they were positive about the outcome.

Non-informed participants perceived sensorial qualities as a bit more extreme. They felt that the roughness was extra rough compared to informed participants. This could be due to the lack of information and thus lack of reference point. From the emotional level it was apparent that they had pleasant emotions with sample 1, but that they would experience more negative and intense emotions compared to informed participants. The difference in perception between the two samples and groups was also apparent with the interpretive level: both groups perceived sample 2 as strange, but non-informed participants even described the sample as aggressive. Aggressive can be perceived as very negative interpretation, while informed participants might know the material composition and thus would not choose the word aggressive for it.

### GOAL 3: DETERMINE THE PERCEPTION ON DIFFERENT SURFACE QUALITIES.

From the performative level, it is apparent that the roughness of sample 2 can be difficult for people, as it is not comfortable. This was also described in the interpretive level. Looking at the sensorial level, the participants indeed rate sample 2 much rougher. However, participants have also expressed that the smoothness of sample 1 can be boring, while the irregularity of sample 2 was appreciated. There was also a notable difference in how people would interact with sample 2: they would explore it longer, trying to make sense of the shape. Caution should be made that when the design does not correlate to anything, that this can lead to frustration because participants are endlessly exploring it without getting a clue what it is. There should be a good balance between novelty and typicality: too much novelty leads to them finding it hard to appreciate, while too much typicality can bore them.

### GOAL 4: DETERMINE HOW THE MATERIAL CAN BE DESCRIBED TO PEOPLE.

From the focus groups, it is apparent that informing people can lead to their understanding and appreciation. The group who does not understand and accept the material were created from some participants of the non-informed group. This proves that the description given to people was enough to inform them well, and that the combination of material attributes such as surface finish and shape can guide them into having an open mind about the material.



# CHAPTER 8

# DESIGN



## 8.1 EVALUATION OF SERENDIPITEA

Following chapter 2.5, Visually Impaired People and 3.4, Game solutions for Visually Impaired, there are some adaptations needed for Serendipitea.

### 8.1.1 LACK OF COMMUNICATION AND TEAM PLAY

Serendipitea is a board game for two players, but the actual game play involves little interaction. Players are mostly playing for themselves, and the only moment when they think of the other player is to obstruct them by getting more matches. As was apparent in the literature review, social interaction is more difficult for VIP. A guideline for designing board games is therefore also to implement audible feedback from other players. In Serendipitea, players did not have to establish the amount of pairs they had already obtained. This can create ambiguity regarding the remaining amount of pairs when the players cannot see those.

### 8.1.2 IDENTIFICATION OF PIECES

Serendipitea uses 3 identifiers for users to identify pieces and call them a match. The first is the smell. If a smell of one sample is the same as another, they are a match. The second is touch. Each sample that had the same smell, also had the same tactile figure on top of it. The third is braille. Braille codes were placed on the sides of the game pieces and acted as the very last identifier. These were many identifiers and is making the components all together redundant. A player can also choose to only use touch to find pairs and will therefore not need the other identifiers. To stimulate social interaction, an idea would be to let players validate for each other. This builds a sense of trust.

### 8.1.3 LOSS OF FOCUS

As mentioned before, since there were three identifiers to play the game, players can choose to identify the pieces based on their own benefit. However, the idea of Serendipitea was to have a unique memory game based on tactile patterns and scent. The risk of players not choosing scent to match pairs is bigger when there are many other options to find pairs. An idea is therefore to split the scent and tactile characteristics, and letting players establish if they want to play a game solely on tactile or scent. This creates a more interesting dynamic in game set up, and will make neither of the characteristics redundant.

### 8.1.4 LACK OF STIMULATION

Serendipitea was a very straight forward game: game pieces were laid out and with an opponent, pairs had to be searched for. However, in literature review it was apparent that VIP felt they were dependent on sighted individuals, and that sighted individuals perceive VIP as helpless. To break this relationship, it is needed to bring the two groups together in collaboration and play. This can stimulate their interaction, and can help sighted individuals perceive VIP as equals and vice versa. An idea here is to let the players establish game rules and customise their own game. This creates a sense of team work.

## 8.2

### VISION

Combining the shortcomings of Serendipitea with the findings from the user tests, a vision can be created. A reflection of the four experiential stages is combined with the ultimate purpose for the game regarding its social impacts.



## 8.3 LIST OF REQUIREMENTS

### 8.3.1 PHYSICAL REQUIREMENTS

#### Game pieces

- Game pieces shall be roughly 5 \* 5 \* 2 cm.
- Tactile pattern on game pieces.
- Tactile pattern needs to be clear.
- Scent on game pieces is applied with essential oil.
- Difference in surface finishes can be used for differentiation.
- A game piece to aid a desensitized nose is needed.
- Pieces with same scent are stored together.
- Cozy and calm themes will be implemented in the shape of the game pieces. These themes are extracted from the two mood boards in chapter 9.3, Mood board.

#### Board

- Tactile pattern for navigation.
- Indents to prevent pieces from falling.
- Storage compartment is needed.
- Colour contrast between pieces and board.
- Board is simultaneously travel and storage case.
- The case is lightweight, and is under the 2 kg.
- The case is durable, and can withstand impacts of 4N without denting.
- The board has a rectangular grip.
- The board has navigation guidelines using braille, letters and numbers.

#### Rule book

- Rule book is provided with braille.
- Text size is 18 pt.
- Colours are contrasting.
- Colour blind compatible palette will be used.
- Contains information about material composition.

### 8.3.2 SOCIAL REQUIREMENTS

- Each player gets its own rule book.
- Players need to provide audible feedback.
- Players will validate for each other.
- Non VIP and VIP need equal chances to win.
- Non VIP and VIP need to communicate to establish game rules.

The calm and cozy interpretations were chosen by informed and non-informed participants during the experiential characterisation. These two interpretations are relevant to each other, and both convey a meaning that is favourable for the material.

Two mood boards are created to inspire the design process and shape of the material. See figure 8.1 and 8.2. The concept is renamed to Serenitea. Serenitea means peacefulness, as the look and feel should have calm and cozy features.

## Calm



Figure 8.1: the mood board created for “Calm”

# Cozy

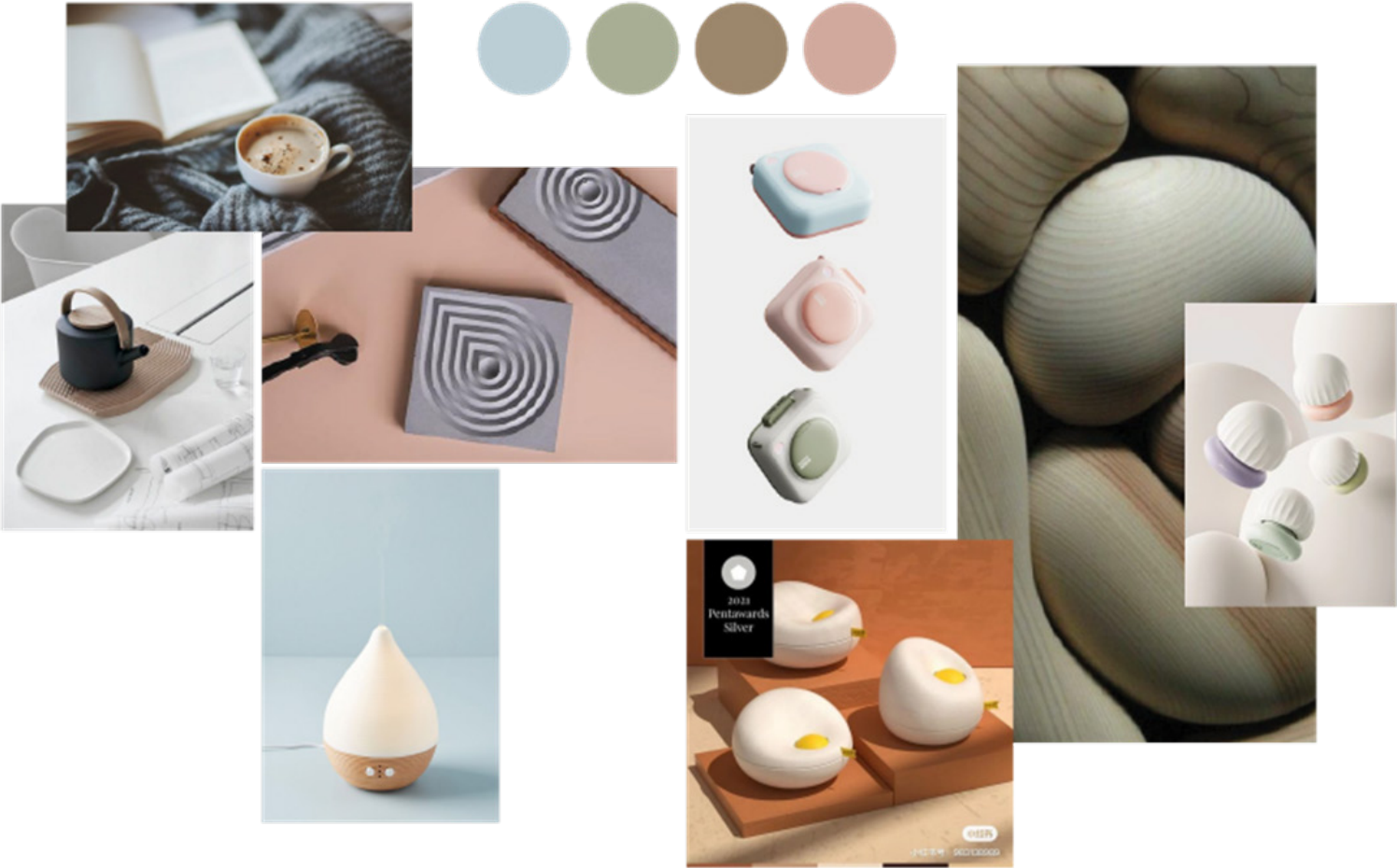

Figure 8.2: the mood board created for “Cozy”

Serenitea: the board game based on tactile and olfactory senses for both visually and non-visually impaired people.

### 8.5.1 GAME PIECE SHAPE

During the experiential characterisation phase, the participants have expressed their wish for the shape to be understandable in relation to the material. A round disc was not associated with a tea leaves material. One of the adaptation guidelines for VIP also mentioned that tokens in boardgames should be specific in its shape, and not only rely on colours to differentiate. Following on the mood board, the overall direction for the renewed board game should be calming, cozy and minimalistic.

Several shapes were drawn where these three words were conveyed in figures. These shapes are in figure 8.3

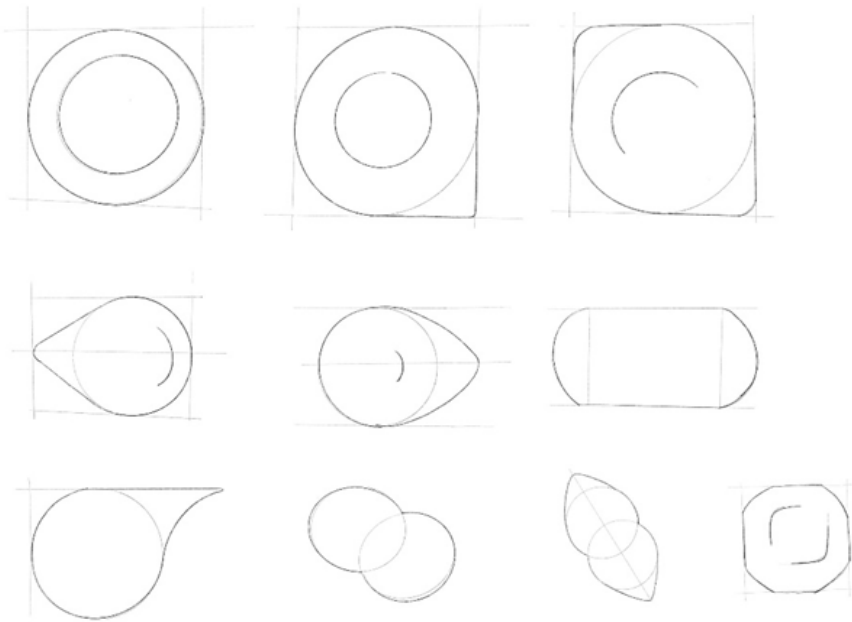

Figure 8.3: shape ideation for the game pieces, using calm, cozy and minimalistic.

Some shapes were selected to draw 3D versions of. This helped in getting a better understanding of how the shapes would be modelled for a board game. These shapes can be found in figure 8.4.

An important design criterion is that the board is a rectangular grid. While a honeycomb grid might look more intriguing, it can cause confusion during game play when the players cannot see well. A rectangular grid gives a better sense of the board.

Some shapes were put in a rectangular grid to see how they would look. Drawing them on a grid gave the insight that the shapes should be symmetrical, and that players should not depend on the orientation of the piece or their seating position to understand the material. Several more sketches can be found in appendix D: Design.

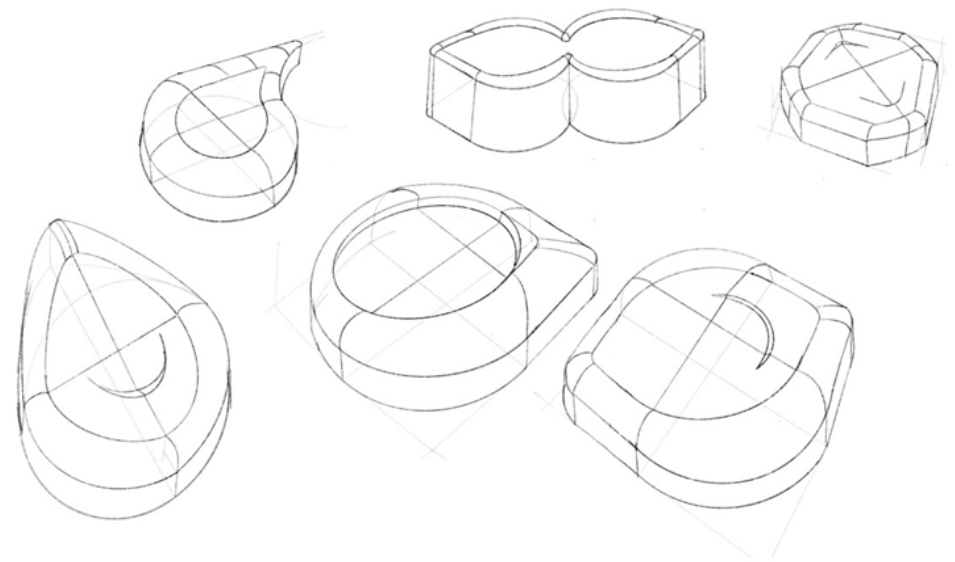

Figure 8.4: 3D drawings of several shapes

A shape was chosen that was symmetrical and easy to produce. The benefit of the chosen shape is that its orientation possibilities are limited. The shape also resembles a leaf, which can make the connection between shape and material composition more understandable, since Da Rocha Tomé et al (2019) has expressed that game pieces should not be ambiguous and accurately resemble something familiar (da Rocha Tomé Filho et al., 2019). Several patterns were drawn on the shape, to see if tactile pattern could be made, see figure 8.5. The shape showed to have a good versatility in the patterns that can be applied on it. The patterns are distinguishable and understandable compared to the patterns used in Serendipitea. There, the patterns were more randomly chosen and did not match in their visual style.

Figure 8.6 shows the 3D shape of the tile with an engraved tactile pattern. Big, rounded edges were chosen for the tile. In chapter 5.8: Shaping, it was established that straight edges can result in sharp corners. The sharpness was perceived as unpleasant by some participants during the experiential characterisation.

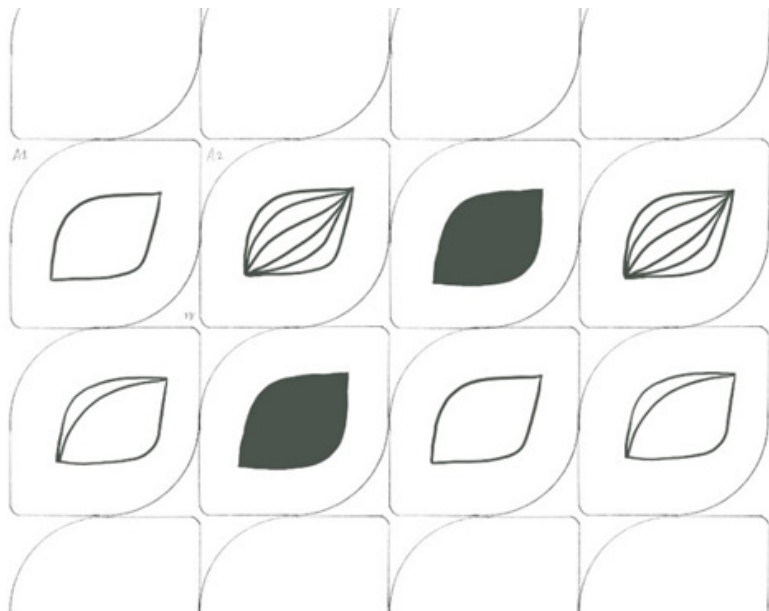

Figure 8.5: Different tactile patterns on the chosen shape.

The rounded edges also contribute to a more cozy and calm product characteristic, as is apparent from chapter 8.3: Mood boards. Next to that, it was apparent from chapter 5.8: Shaping, that the material can be easily sanded to create a smooth surface. This fits the cozy and calm mood boards as well, and will therefore be applied at the top of the piece. The test participants from the experiential characterisation test have also voiced their dislike towards the roughness of the unfinished product.

From the experiential characterisation it was apparent that the size of the samples (2.5 cm) was fitting nicely in the hands of most participants, with some of them finding it a bit too big. However, from the design guidelines given by Da Rocha Tomé et al (2019), it was established that game pieces for visually impaired people should be enlarged to make them more visible. Another aspect is that most participants used two hands to interact with the sample during the experiential characterisation, deeming the comment that it cannot fit nicely in one hand less important. The chosen size for the pieces is now 4,5 cm.

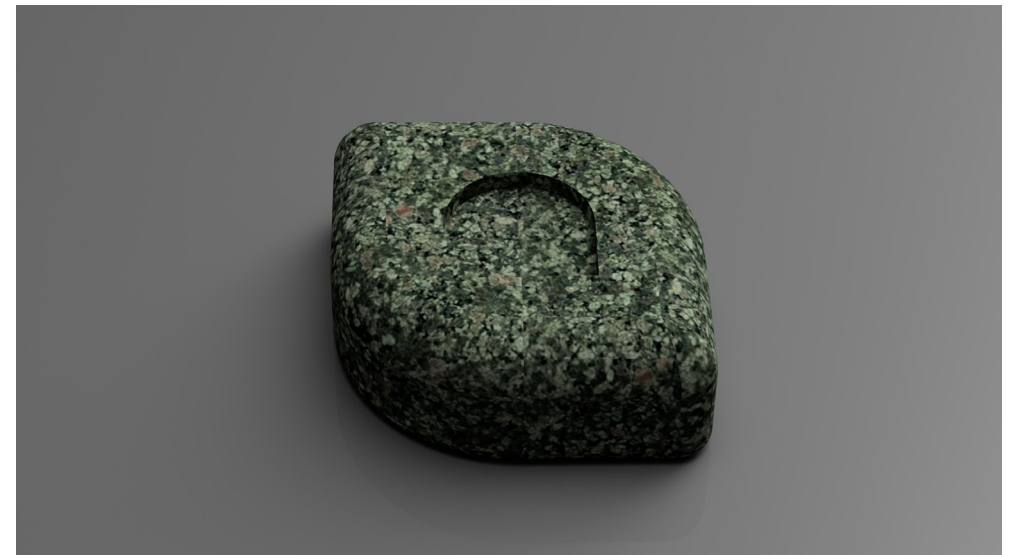

Figure 8.6: 3D render of the tile with a tactile pattern



### 8.5.2 GAME PLAY

The idea was to separate the scent and tactile patterns, so players can choose which version of the game they want to play. An idea is to apply scent on one side of the pieces, and have the tactile pattern on the other side. When players choose to play with tactile patterns, they can flip the tactile patterns to the top on the board. When they choose to play with scent, they can flip the pieces again. Or, even more interestingly, players can decide to play with a mix.

The side where the scent is applied will be concave, as in the research of De Cocker et al., 2022 it was established that concave objects gives people the tendency to smell it, as they can easily put their nose at it. (De Cocker et al., 2022). Figure 8.7 shows the two sides of the tile. The convex side will have the tactile pattern, while the concave side will have the scent.

In Serendipitea, 16 pieces were given, meaning there were 8 pairs to be obtained.

This resulted in a game duration of around 15 minutes. However, in the literature review it became apparent that VIP have a difficulty with creating autonomy and social interaction with sighted individuals. Giving players the option to choose between scent and tactile gives a feeling of autonomy. The next idea is to present 24 pieces (12 pairs) to the game, and letting the players decide which pieces will be played with. This creates another feeling of autonomy, teamwork and discussion. This tactic can be gamified as well, players can for example set a rule where they need to draw 4 pairs and discard two each. Creating more emphasis on the building of the game gives another playing experience that was not done in Serendipitea before.

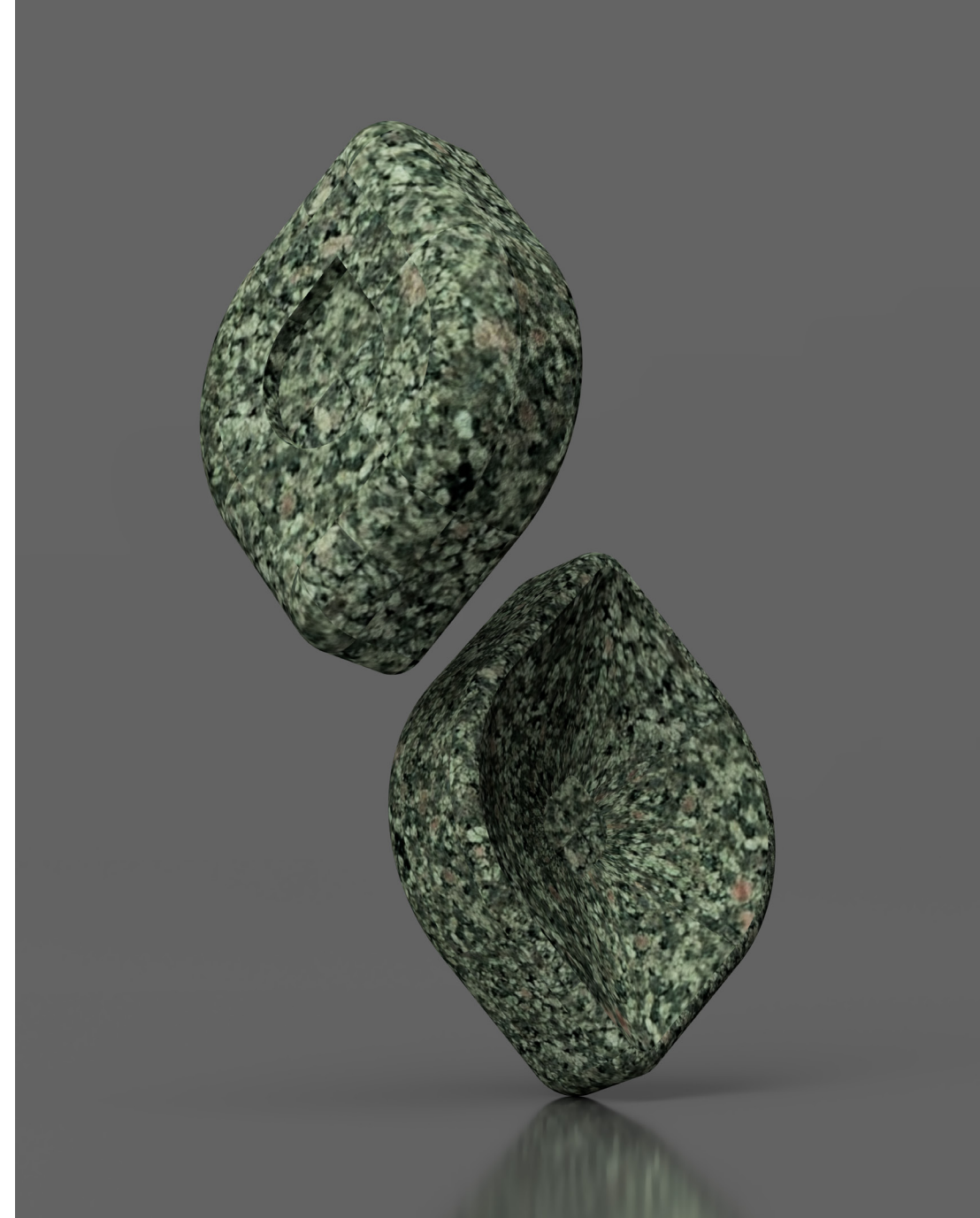

Figure 8.7: the concave and convex sides of the game piece

### 8.5.3 BOARD DESIGN

The navigation of the board is important for VIP, as they need to rely on precise locations during a memory game. These navigations can help them memorise a piece they explored, and can help them relocate the position in case they need to put the piece back. The navigation is done with both braille and letters. To not overcrowd the board, the indications are for each column and row. The grid is designed for two players to play opposite of each other. Hence, the navigation guidelines are mirrored horizontally. The grid can be seen in figure 8.8.

The benefit of the chosen shape is that it is symmetrical, meaning that there will be no confusion when it is placed differently on the board. This means that the player on the opposite side does not need to play upside down, as the tiles, tactile patterns and navigational guidelines are understandable from that side.

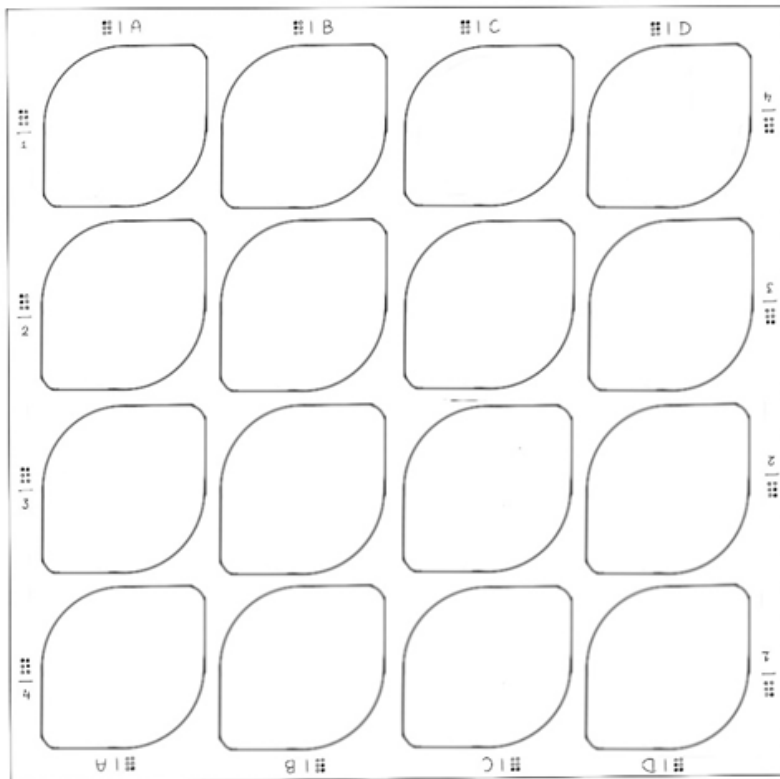

Figure 8.8: the navigational guidelines in braille, numbers and letters.

### 8.5.4 RULE BOOK

To give each player a sense of autonomy, each player will get its own rule book. This prevents sighted individuals from taking the lead in explaining the game and gives VIP the chance to read things themselves. All the pages of the rule book can be found in appendix D: Design, rulebook.

The rule book contains an introduction to the material and the concept, as well as game play suggestions, such as playing with scent, playing with tactile patterns, creating a mix, and setting up the board. The guidelines for rulebooks was used, such as that the font is chosen to be Times New Roman, as this is a clear font. The text size is chosen to be 18pt. This also influenced the size of the rule book in general. In order to create an inclusive environment, the rule book contains both braille and printed text. If one separate book in braille was provided to VIP, it would have caused a sense of distinguishment. By having each page containing both braille and printed text, the VIP will not have the idea that the design is made specifically for them, but that their needs are standard.

The rule book will make use of simple, straight to the point text, and illustrations to clarify the concept. These illustrations will be embossed for VIP to feel. Embossing the paper creates an added dimension in the rule book, namely that you can feel it as well. This concept is used as an advantage during the explanation of playing with tactile patterns: here, the illustration of the game piece is embossed, so that the players can immediately understand how tactile patterns are. See figure 8.9.

The same method is also applied to the introduction of scented game pieces. By scenting the paper on that page, the players will get another type of interaction with the book, and a better understanding of the concept.

#### Play with tactile

**You can play memory based on touch. Each tile has a pattern on it. By playing with tactile, you need to find tiles with the same tactile pattern**

Braille text explaining the tactile pattern concept, including instructions on how to identify and match patterns on the tiles.



Figure 8.9: the rule book page with explanation on how to play with tactile elements.

The introduction to the material is also included in the rule book, but kept very concise, as can be seen in figure 8.10. It discloses what the material composition is. The information that it is made in combination with biobased materials was left out, as this could be too specific for the rule book. The disclosure of the material composition should be described at the packaging of the material, and for example at the selling point, if it was sold on an online platform. This information is more important at the moment of purchase because it can persuade customers to buy the product when they are assured that it is safe.

**Serenitea is a memory game made from wasted tea leaves.**  
**These leaves come from drinking tea. Instead of throwing it away, they have been dried and made into a new game.**

Braille text representing the introduction of the material.



Figure 8.10: the rule book page with introduction of the material.

### 8.5.5 STORAGE

Game pieces with the same scent need to be stored together. There is not enough research to suggest that differently scented tea clay will not influence each other when stored together. The solution of Serendipitea was to wrap matching pairs in lotus leaves. However, these leaves would break over time, and did not hold the pieces together for a long time. It is therefore important that matching pieces are stored together and separated from other pairs. As the game play involves 12 pairs, the storage compartment should house 12 pairs. Since the game only involves 8 pairs, the remaining 4 pairs should be stored in the storage compartment.

Another problem is the storage of obtained pieces. In Serendipitea, the obtained pieces were put next to the board, but this can cause a risk of them being knocked over. It is therefore important to create a compartment where obtained pieces of each player can be kept during game play. Next to all this, the storage should also accommodate the rule books. Figure 8.11 shows the concept of the storage box.



Figure 8.11: the concept for the storage box, with 12 compartments for the pairs, and two for the rule books and acquired pieces.

The concept of the storage box has 12 compartments in which pairs can be stacked on top of each other. Next to that, there are two bigger compartment which will contain the rule books. During game play, the players can use the bigger compartment to put in obtained pairs. In the end, the players can easily count the pairs and determine the winner. The lid for this box will be the game board, which can slide into the box. Figure 8.12 shows the game board. The rule book will fit at the top of the storage, see figure 8.13.



Figure 8.12: the game board.



Figure 8.13: the rule books in the storage.

### 8.5.6 PRODUCTION PROCESS

As was seen in chapter 6.6: Reprocessing, it was suitable to steam the material in order for it to enter a second processing round. The benefit of having a material that can be reprocessed was discussed in chapter 4.4: Reprocessing. One manufacturer can supply Tea Clay, which then ends up at different companies who can produce Serenitea by steaming the granulate and injecting it in the mould. These companies can for example be board game manufacturers who buy the material. The process would be for them to steam the material until it is viscous, and injecting it into the silicone moulds. After 30 minutes, the material will enter the gummy state and can be taken out of the mould and left to dry on a drying rack. Drying can take a few days, but the process can be sped up if they have a dehydration chamber. The tactile patterns and smooth surface finish can be CNC milled. The scent can be applied by spraying it with a drop of essential oil.

The ability to reprocess the material can also benefit the life span of the product. If the product has any defects, it can be returned and reprocessed into new game pieces. The product can also be repurposed into new products when people do not wish to use it any further. There are many possibilities for the material, not only for it to become Serenitea, but also for it to become other components in other games.

Since the smell application occurs at the final stage of the process, it is therefore possible to return pieces with decreased smell and getting new fresher pieces in return. The logistics for this needs to be taken into consideration, but this does not fall within the scope of this project.

## 8.6 CONCEPT VALIDATION

### 8.6.1 MECHANICAL PROPERTIES

From the technical characterisation, it was concluded that the material has similar properties to Polypropylene and other conventional plastics. This can thus be used to evaluate the design based on its mechanical properties. It is important that the design does not fail during the usage of the product. Children should not be able to break the material. Children aged from 7 to 10 were chosen as the users of the game. Häger-Ross and Rösblad (2002) have conducted a studies with 504 children ranging from 4 – 16 years to research their gripping strength. Figure 8.14 shows a graph they provided that visualises the peak gripping strength of each age category (Häger-Ross & Rösblad, 2002). Considering the size and usage of the pieces, it is unlikely that children would perform other forces on the object rather than gripping. In the graph, it is visible that children aged 7 can perform strengths of 50 to 150 N, and children of 10 can perform strengths of 100 to 200 N.

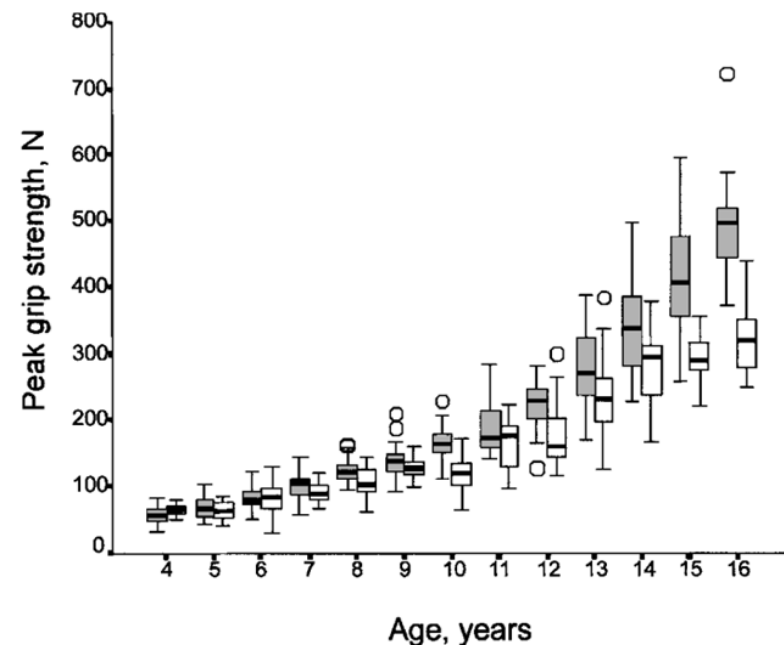

Figure 8.14: box plots of peak grip strength (N) of children aged 4 to 16 years

The 3D model of the piece has been assigned a material composition of polypropylene. A most likely scenario wherein the game piece can be broken is illustrated in figure 8.15. Children can attempt to hold the piece in both hands, and breaking it with their thumb. This scenario was deducted from the performative level, as participants have tried to break the given sample in a similar way.

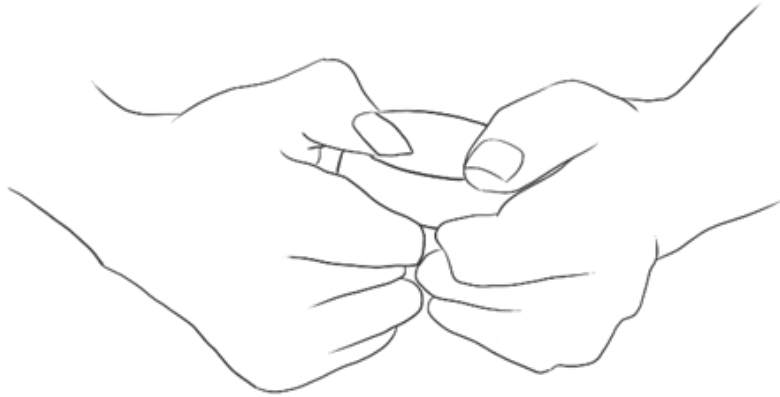

Figure 8.15: The scenario wherein the product can be attempted to be broken.



The scenario is simulated in a 3D modelling software, where the force applied to the middle is 200N. The results are in figure 8.16 and 8.17.

The results show that most of the stress is performed at the place where they hold it, but that the force is not big enough for break the material, as the highest stress is 9.15 MPa, while the Young's modulus of the material lies at 835 MPa, which means that material has resilience against the forces applied by children. This result was also perceived during the experiential characterisation tests. The samples had a thickness of 0.6 mm, and the participants did not manage to break the samples.

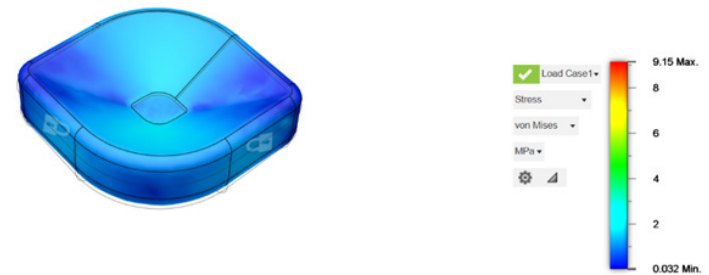

Figure 8.16: the bottom of the piece simulated with 200N load and the stresses that occur.

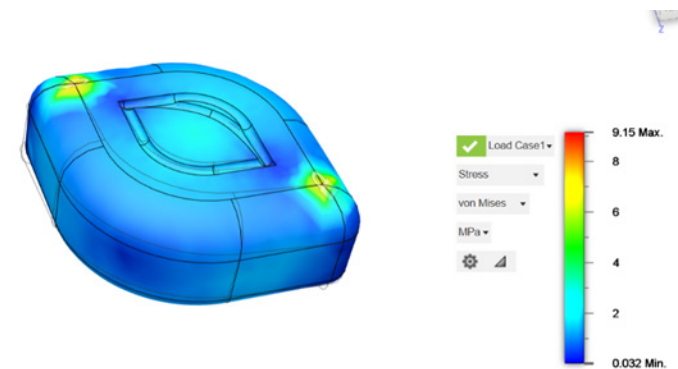

Figure 8.17: the top of the piece simulated with 200N load and the stresses that occur.

### 8.6.2 MOULD DESIGN

The tactile patterns on each game piece will be engraved with a CNC machine. This allows for a single, universal mould, and will allow the customisation of each pattern to happen at the last stage of production.

From chapter 6.1: Shrinkage, it was determined that the material shrinks uniformly with roughly 40%. This is considered with the mould design by enlarging the mould uniformly by 40%.

During the preparation of the experiential characterisation samples it was concluded that the material can be moulded at all edges, as was perceived in sample 1, and not only have 1 side rough and exposed such as sample 2. The chosen shape therefore also requires a 2 sides mould, with the parting line in the middle. See figure 8.18.

Ideally, the lower part of the mould should be made from silicone, as it allows the material in the mould to cool down faster, resulting in more efficiency during manufacturing. The flexibility of a silicone mould also allows material to be demoulded easier, while with a rigid mould there should be more care in how the material is demoulded. The material can be demoulded once it enters the gummy state. While this state is solid enough to keep the material stiff for demoulding, it is still prone to damage. For this project, a 3D printed mould will be used as this is faster than creating a silicone mould, but a recommendation would be to design a silicone mould.



Figure 8.18: A 2 sided mould

### 8.6.3 PROTOTYPING

A prototype of the concept will be created to test its design limitations. The game board will be laser cut, and the moulds will be 3D printed. 24 pieces of material will be produced. The material will be directly moulded in the moulds. The concept should be using reprocessed material, but this is not possible in this project due to time limitations. After the material has been moulded, demoulded and dried, it should be engraved. The CNC router available during this project was unable to attach the sample to the bed due to its concave bottom. However, there are CNC routers available that can clamp the material from the sides, or use a vacuum to hold the material at its place during the process. As these were not available at the moment, it was chosen to 3D print tactile moulds. These moulds will be filled with new material. Freshly made material has the ability to adhere to surfaces. The 24 tiles were stuck to the new material and left to dry. After a few hours the gelatinization will make it possible to demould the patterns. Sanding it needed to finish the surface of the material. Another method of laser engraving was also tried to create a tactile pattern. The results of this can be found in appendix D: Design, prototyping. Figure 8.19 shows the 3D printed patterns.



Figure 8.19: the 3D printed patterns

Laser engraving was not chosen as the final method for this prototype because it was unable to upscale to 24 pieces. The other down side of laser engraving is the result of burnt smell. This can affect the smell of the material and thus the game play.

The chosen method of 3D printed moulds for additional patterns have caused the tactile pattern to be very clear. The benefit of 3D printed patterns is that the thickness of the pattern can be regulated. The tactile pattern could have been included in the mould design first hand. However, it is still believed that CNC milling the material is the most suitable option as this creates versatility in the product outcome, as it will use 1 mould instead of 12 different ones.



Figure 8.20: the tiles with their tactile patterns.

The material can sometimes provide sharp edges. A sanding paper is used to sand off sharp edges, but not to remove the original roughness of the material. Some pieces have warped due to shrinkage, causing them to not lie flat on the table. These samples have been sanded to ensure they are stable on the table.

The tactile navigation system on the board has been tested out. Due to the prototyping limitations, it was not possible to CNC mill the board and thus create tactile braille elements. It was chosen to laser engrave these elements. This can be seen in figure 8.21. These laser engravings have shown difficulty with the orientation and use-cues of the board.



Figure 8.21: Laser engraved tactile patterns.

First it was chosen for players to have their navigation system on the top and left side, but the prototype has shown that this is not user friendly. The player needs to reach on the far end of the board to feel the elements. It is therefore better to have the elements on the bottom and on the right side, similar to the navigation system on tactile chess. During prototyping it also became apparent that users need a use cue to know the right orientation of the board. Two unrounded corners at each lower left bottom is placed to communicate the orientation. Users should therefore always have the unrounded corner on their left side. The new board can be seen in figure 8.22.

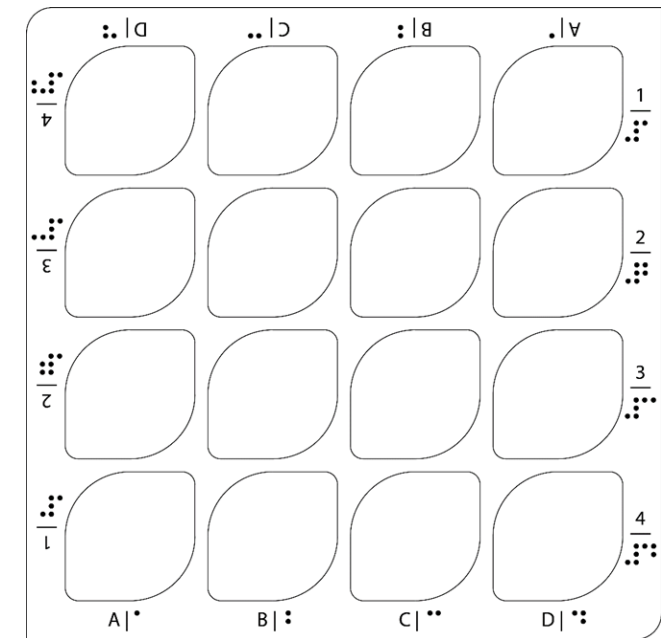

Figure 8.22: The new board navigation system





CHAPTER 9 | DISCUSSION

## 9.1 RESULTS SUMMARY

The outcomes of this study have provided different insights regarding the material-based opportunities and scent integration of Tea Clay in a board game for Visually Impaired. The newly developed material has an absence of lignin fibre, increased water content, and the addition of gelatine to provide a better processing, demoulding and deformation, as well as enabling reprocessing for the material. This indicates that the material has advanced in its manufacturing process compared to its earlier version, as there is less manual labour involved. The material is pourable instead of kneadable, which reduces the number of steps needed in the processing method. Pourable material also indicates that multiple samples can be created in a longer period of time. The demoulding time has remained constant despite its increased water content due to the introduction of gelatine which aids solidification of the material. The gelatine allows reprocessing of the material, which leads to flexibility in production time and location. The material has material characteristics that are similar to polypropylene and polyethylene, and that its hardness also shows similar results. The density of the material and strength proves that it is lighter than thermoplastics while having the same strength. This indicates that the material is a suitable replacement for these plastics as it does not require the usage of fossil fuels during manufacturing and its low density indicates that less material could be used. The introduction of a second processing step allows scenting to be applied as a last step in the process. This enables more flexibility in product manufacturing, as now different scents can be applied simultaneously and define the product. The scenting method that produced the most intense scent over time was spraying with essential oil. The scent intensity was constant over time. This indicates that this scenting method would be most durable during product implementation.

The experiential characterisation test has proven that users can have both pleasant and unpleasant feelings and interactions with the material based on its surface structure. The material has proven that it can have different product surfaces, and that it is easy to alter the surface structure both during processing and afterwards. This enables manipulation of the material to cater to the needs of the user. Design principles such as novelty vs typicality were qualities that were sought for in the material. These design principles can thus be applied to the material both during and after processing, resulting in a versatile material that can be integrated into society's needs. This indicates that the material is suitable for product applications regarding user acceptance.

Picture of the new material, by author

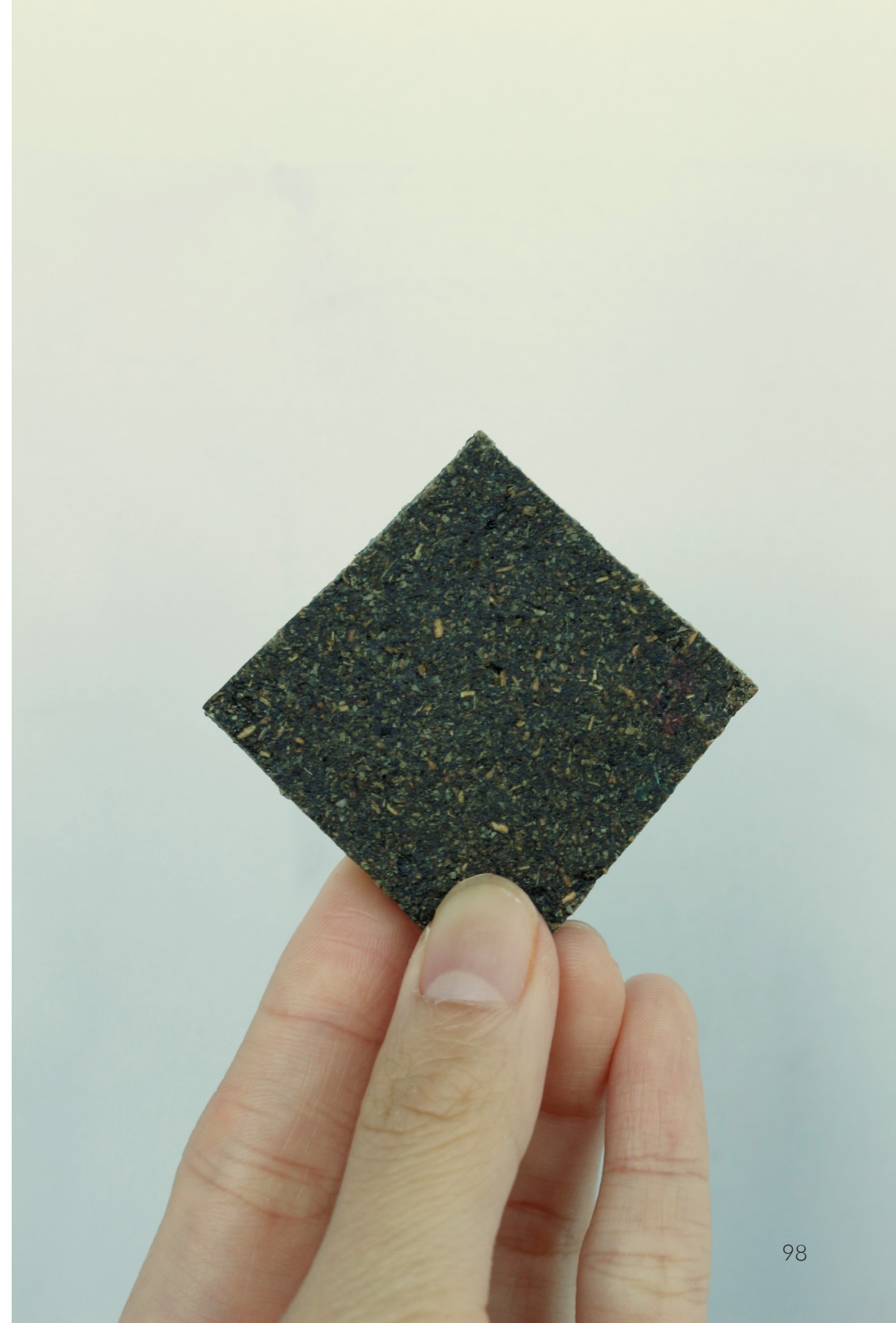

## 9.2 CONTRIBUTIONS

From the literature review it became apparent that 5.9 million tonnes of tea is consumed worldwide on a yearly basis. From this amount, 90% of the tea leaves becomes waste after brewing. Companies who produce bottled tea beverages for example will be facing big amounts of tea waste yearly. Currently, tea waste can be utilised for the filtering of chemicals in waste water, but there should be more research conducted towards the utilisation of spent tea leaves as a filler for bioplastics.

This report has researched ways for spent tea leaves to be utilised in the production of a bio-based material in order to be applied in a board game for visually impaired people. The results of this research have several contributions to the research questions that were formed.

### 1) HOW CAN THE CURRENT TEA CLAY PROCESSING METHOD BE OPTIMISED TO FACILITATE THE UPSCALING OF PRODUCT MANUFACTURING?

Tinkering, benchmarking, and literature methods were applied to develop a second iteration of the Tea Clay recipe that is processable in a larger scale production. The addition of water and gelatine, and the removal of lignin fibre, has allowed the material to become more viscous compared to the clay structure of Tea Clay. The viscous material is suitable for pressing in moulds. The new material has the ability to be reprocessed, creating a second processing step, but increasing the ease of production. Material can be processed and dried. The dried material can be shipped to product manufacturers who in turn steam the material for 25 minutes and compression mould it in their desired product. This increases the availability of the material. The addition of gelatine allows the material to quickly enter a gelatinous state due to cooling down. This gelatinous state allows for quick demoulding. The material can thus dry outside of a mould, allowing a fast workflow wherein moulds can be reused for the next round of material.

### 1.1) WHAT ARE THE MECHANICAL PROPERTIES OF TEA CLAY?

The new material has been tested on its technical properties. Bending tests with 3 samples have shown that the material can endure bending strengths of 60,4N. This resulted in a Young's modulus of 835 MPa. This is comparable to conventional plastics such as polypropylene or some soft woods. The hardness of the material has also been tested five times on one sample and resulted in an average hardness of shore 50.4. This is comparable to polypropylene that has been impact modified, and thermoplastic starch plastics. These results indicate that the new material is suitable for implementations in boardgames, as boardgames generally also use polypropylene and soft wood. Shrinkage has been tested on 14 samples to record its behaviour and to account for design guidelines for product implementation. The material shrinks uniformly but can undergo warping if the material is too thin, or if sharp edges are present in the design. Shrinkage occurs due to the dehydration of the material, and accounts for 40%. Mould designs should therefore be scaled with this factor to ensure that the end product will have the proper size.

The viscous and thus pourable material, combined with the quick demoulding due to the gelatinisation and the introduction of a solid state wherein bulk material can be created and reprocessed has allowed the processing method of Tea Clay to be translated to a larger scale production line. Next to that, the material has similar technical properties to conventional plastics and soft woods, ensuring that the product application of board games is feasible.

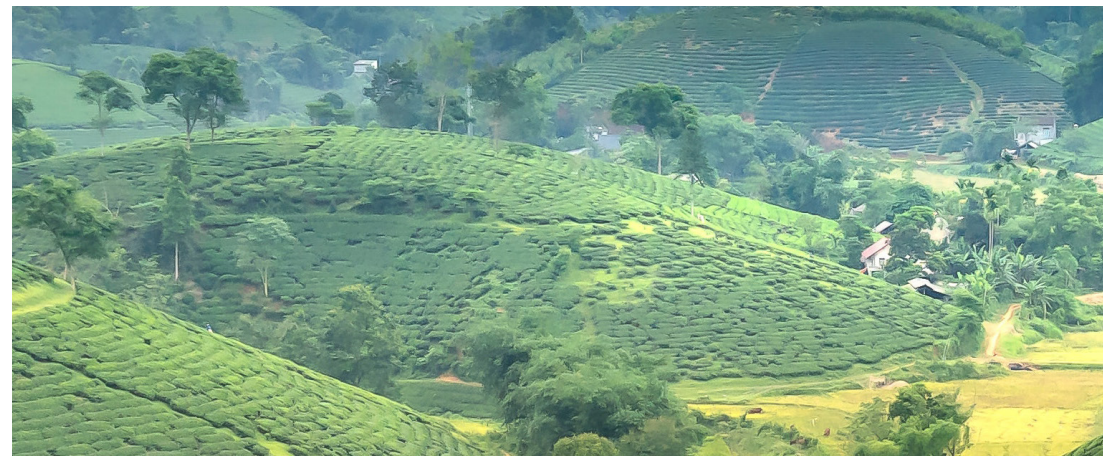

## 2) WHICH SCENTING METHOD COULD BE BEST IMPLEMENTED DURING THE FINAL PROCESSING STAGE OF A TEA CLAY PRODUCT?

The introduction of a second processing step allows new possibilities for the scenting of the material. In Serendipitea, the scent was applied at the processing of the material with scent powder. This is similar to the blending method discussed in chapter 2.4.2. New scenting methods were researched that would allow the material to be scented as the very last step of production, as this would allow more versatility in product manufacturing. Research has been conducted on different scenting methods and their durability over time. 3 participants tested 3 different methods of scenting over a time span of 4 weeks. The scenting methods were: 1) infusing with fresh flowers. This is similar to how jasmine tea is made by keeping tea leaves and jasmine flowers in a sealed space, allowing the tea to absorb the fragrances. 2) spraying with essential oil. This is called “scenting” and is usually done with earl grey tea, where bergamot essential oil is sprayed on tea leaves and steeped in water for consumption. 3) dipping in beeswax with essential oils. This is similar to how scented candles are produced. The beeswax was believed to prolong the scent duration. The result is that spraying in essential oils proved to provide the strongest scent over time, namely an average score of 6 out of 10 during the 4 weeks, with the least decrease. Scent can thus be implemented at a later stage during processing, allowing versatility in the product outcomes.

## 3) HOW DO PRODUCT USERS RESPOND TO WASTE MATERIALS SUCH AS TEA CLAY?

An experiential characterisation test that was conducted by 10 participants. It became apparent that informing people beforehand about the material composition can lead to positive interactions. The 5 participants who were non-informed about the material had no reference point to the material, which also made it easier for them to judge it. If the material was rough, it was perceived as aggressive.

Informed participants who interacted with the same material were not likely to create strongly negative interpretations for the material, probably due to their pre-knowledge of the material composition. Informed participants were more open to the material and started embracing its flaws. Knowing it was made from tea created the sense that it did not had to be perfect. The handcrafted and natural feeling were appreciated. Even irregularities that were found with such a material were embraced, as participants started to find it interesting to explore the naturally created patterns. Participants have even expressed that the irregularity and lack of symmetry in the material was more interesting to them compared to a entirely regular and symmetrical material. None of the participants have expressed disgust towards the material composition. It is believed that tea waste does not have a negative connotation such as regular waste.

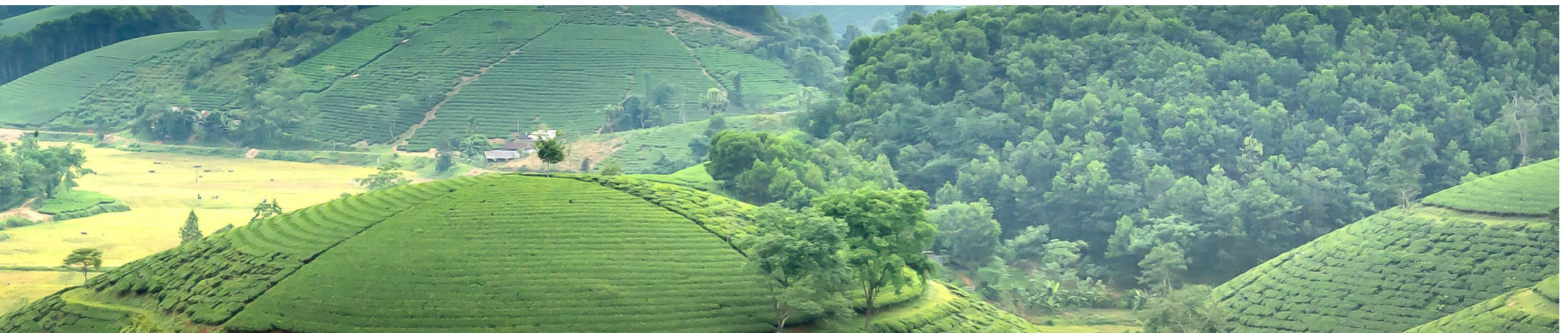

#### 4) WHAT ARE THE DIFFICULTIES FACED BY VISUALLY IMPAIRED PEOPLE, AND WHAT ARE THEIR NEEDS FOR A BOARD GAME DESIGN?

Young children with visual impairment can face difficulties such as a lack of emotional, social, and cognitive development. VIP are often perceived as helpless and dependent. According to them, this is a huge misconception as they value autonomy. They feel frustrated when they are dependent on sighted individuals. Having more autonomy can create a boost of confidence. Next to the frustrations by perceptions from sighted individuals, VIP also experience a lack of social interaction.

Board games are a good medium for engaging in social interaction. However, there are not many board games that are adaptable to VIP. Benchmarking has shown that a board game rating website has rated 1 game out of 221 which was fully accessible for VIP. Next to that, board games for VIP are usually classic games who have been adapted, board games who accidentally are VIP accessible, or VIP need to create their own games. This proves that there is not much development in the board game industry towards accessibility of VIP. VIP therefore have a need for social interaction with sighted individuals and board games that are accessible for them. They are in need of an environment wherein they can experience autonomy and an absence of prejudice.

As there are different types of visual impairment, it is therefore important to take all kinds of impairment into account. Game designs should be accessible for colour blind, low vision and blind. Colour blind people have a need for colour blind compatible colour palettes when colours are used. Low vision people have a need for bigger objects and fonts, and a high contrast between words, illustrations and game pieces and board. Blind people have a need for tactile elements.

To combine this all, game piece sizes need to be big, and as descriptive as possible. For example, instead of using coloured chips for indicating game pieces, it is more effective to use miniature figures as these have more tactile elements to be recognised by. Next to the shape of game pieces, there should be adequate considerations towards the size. When they are too small, they could get lost, and when they are too tall then could be knocked over. Game pieces should be grounded to the table, as well as boards and other game elements.

Rule books should contain both braille and written text in text size 18. A big contrast between words and background is advisable, and the usage of colour should be done sparingly.

#### OVERALL CONTRIBUTIONS

This project was founded based on a perceived gap: an existing Tea Clay material that has certain properties and abilities, and can be made into small concepts, but does not fit within the general picture of mass production. This project would thus focus on creating a material that can serve as a proof of concept that emerging materials can take the next step in being implemented. The material has indeed taken progression towards large scale implementation, but there are still details and values to be researched. However, it is believed that the results of this study can contribute to a first step towards implementation, and can also serve as a case study for other emerging materials.

This project has used the Material Driven Design method as a project guideline and could thus serve as another contribution towards the implementation of this method. However, the project has also developed its own path as it is the crossroad between materials science, design, technical aspects, user interaction and inclusive design. The project had to be able to adapt to these different subjects and therefore required different methods of approach. It is therefore believed that this project serves as a contribution to the design community as it can show that adaptation can bring out unexpected design findings. Unconventional methods such as steaming are found because of this adaptation method.

Benchmarking and literature research have shown the lack of product development for visually impaired. Not only is there a limitation of games accessible for them, but none of the board games also create a bridge between their social and physical needs. This project hopes to contribute to the development of similar future concepts as well, as the social problems that VIP are facing have been happening for a prolonged time.

## 9.3 LIMITATIONS & FUTURE STUDIES

Throughout the course of the study there were many findings that have shaped the redesign of the board game. The usage of gelatine was based on benchmarking examples and has proven to be a suitable application to allow reprocessing in the material. However, the gelatine does cause some deformation in the material. The deformation of the material was kept as minimal as possible to enable processability. User tests have indicated that the deformation is acceptable to them and that the material does not need to become perfect. However, during prototyping it became apparent that the deformation can also cause the product shape to be inconsistent. It is therefore recommended in future studies to research additional ingredients that can counter the deformation.

The steaming method that was chosen for this material has proved to be successful for reshaping the material. However, this was executed well for 3 out of 5 times during this study. This could be due to different material dryness, as it was unclear whether the material was fully dry. The steaming method has proved to be an interesting approach for reprocessing of material, but further research should be conducted wherein the material behaviour can be monitored better, and that thus a better conclusion can be drawn on the effectiveness of this method. The designed product application also uses granulate for steaming rather than small blocks. This can also alter the steaming conditions and time and should be researched in the future.

New ingredients were added to the material, but this study did not focus on the modification of ratios within the recipe, as the amount of tea powder, starch, glycerine, and acetic acid solution were not modified and tested. Modifying these quantities can also alter the material characteristics in different ways which could be interesting regarding the material processing.

The density of the material has been tested out with various tests, but each test has drawn a different conclusion on its deformation behaviour. Generally, the first observation is that the material shrinks uniformly for 40% during the first days of drying. It is unclear whether the shrinkage will become more severe after this. More samples and a thorough understanding of the material dryness is needed to research this behaviour.

The technical tests performed have used ISO standards regarding the hardness and bending properties of the material. It is recommended to perform cyclic loading tests on the material to determine its life span during use, as the material application is in a physical product.



Picture of the material shaped for Serenitea, by author

This study has researched the hardness and strength with processed material rather than reprocessed material, while the product application uses reprocessed material. The time limitations and difficulty during the drying process have influenced this decision. It is therefore important for future studies to research the reprocessed material on its technical aspects. This study also did not research the life span of the material itself. The material has proven to be able to be reprocessed, but it is unknown whether the material will deteriorate after several reprocessing cycles. This is important because it can predict how reusable the material can be. The density of the material should be researched again, as the results varied with different drying times.

The viscosity tests performed on the water variations have shown that the viscosity behaves similarly for all water variations. This indicates that the chosen variations were not variable enough to measure a significant difference. However, the consistency between the tests proves that the testing method is reliable. A future study with a wider variety of materials could perhaps disclose the viscosity of the material during production.

The scent application has proven to be successful within 4 weeks, but this time should be prolonged to measure the effect of the scenting method and to see whether it fits the lifespan of the product. Since the scenting method is applied on the surface of the material, it could become a problem when the material needs to be recycled into another product. The scent intensity after reprocessing should be measured and its influence on future product applications needs to be thought of. Tea Clay has the ability to absorb scents. It is therefore interesting to determine whether the game pieces in the board game storage box will influence each other, deeming the product unusable after a period of time.

This study did not involve a user study with VIP. This was done due to time constraints. The design outcomes have been adapted to literature and benchmarking examples of VIP products, but user tests can indicate points that were not thought of. It is therefore recommended to perform user studies with the concept and to initiate another design iteration based on these results.

Although this study has its limitations, it has proven that there is a possibility for emerging material to take a step closer towards production towards a real consumer product through the MDD method. User tests have indicated that they are accepting and willing to have products made of novel materials, and technical tests have proven that these materials can behave similarly to conventional plastics. This study is therefore a contribution towards emerging materials studies.



## 9.4 PERSONAL REFLECTION

During this project there were a lot of developments on a personal level. This project was chosen due to its working method. It was a well-balanced project between hands on working, direct evaluation, research and iteration. This is a working method that I have found out to work the best for myself, and this project has made me confident in applying my own method for finding results. I have realised that there is not a standard way for design. There are several roads that lead to Rome, and my road was through this process that I have done in 6 months. If another designer would have done this project, it would have been shaped entirely differently, but not for the worse or the better. It is just another way of approaching, interpreting and executing ideas. This is a lesson that I will use during my future career, as I have found out that since designers are so diverse, we should work together to combine ideas.

If there is one thing that I learnt quite late in the process, it would be asking for help. During this project I have had a lot of difficulty with the drying of the samples, causing severe delays in my schedule. It was in the very last week when I asked the lab staff members if we had a food dehydrator available. This person then suggested to use the climate chamber, and setting the humidity on 0, causing the moisture of the samples to be removed. At that moment, I realised that I should have asked for advice and help earlier on, as it would have saved a lot of time management stress. This was also the moment when I knew that I surely would want to work in an environment with several designers, as we can all help each other by seeing things the other did not see.

Another surprising outcome would be my development in conducting research. I have always liked to skim through research, since I valued prototyping and designing more than design thinking. It was therefore surprising when I realised that I enjoyed literature research and benchmarking a lot, and that I could spend a significant amount of time interpreting results. I believe that this is a skill that I learned to enjoy during this project. This has allowed me to perceive myself as a more versatile designer than I initially was.







CHAPTER 10

CONCLUSION

This study has shown the possibilities for Tea Clay as a novel material and its applications in product manufacturing. Literature review has shown that there is a need for tea to be repurposed, as approximately 5.9 million tonnes of tea are consumed yearly (Guo et al., 2021), and 90% of the steeped leaves are discarded (Negi et al., 2022). Bioplastics are more in demand since it became apparent that conventional plastics are surpassing their product lifetime and end up polluting the world. The development of bioplastics is currently focused on starch-based plastics, as these have proven to be the most successful in replacing conventional plastics. The downside of starch based plastics is their poor water resistance and their high demand of starch, as starch can be derived from food products that are otherwise used for consumption (Cecchini, 2017). The combination of the large amount of tea waste and the need for bioplastics manufactured from other resources make tea waste based polymers ideal materials to tackle both issues.

Benchmarking was conducted on existing bioplastics made from tea, coffee and other waste resources. Most of the materials are developed by designers and have proof of concepts, but not many materials are already implemented on large scale. Most of the large-scale materials are waste resources being encased in resin, or waste resources mixed with fossil fuel plastics. The benchmarking also served as inspiration for the material development. A concept by Gencel (n.d.) uses gelatine in the material which allows for the material to be remelted after application, resulting in a circular material. This idea of remelting material has thus been applied on Tea Clay in the form of reprocessing. Reprocessing is the modification of the material at a later stage during production. This allows the material to be created in bulk and sold to customers who in turn can create new material with it, resulting in the upscaling of the availability of the material.

Tinkering was performed to modify the material. A focus on the processing method, deformation, demoulding and reprocessing have led the development of the material. The increase of water and absence of lignin fibre combined with the addition of gelatine has created a material that is now pourable in moulds with little deformation and fast demoulding. Once the material has dried, it can be steamed to be moulded in its product application form.

Bending tests have proven that the material has a Young's modulus of 835 MPa, which is similar to polypropylene and polyethylene. Impacts tests have also indicated that the material is similar to conventional plastics, with a hardness of 50.4 Shore. This means that the material is suitable for a similar product application as that of conventional plastics. The measured density combined with the strength of the material indicate that the material is even lighter than conventional plastics. This is a benefit as this would indicate that less material could be used to produce the same type of products.

Scent implementation was chosen to be conducted at the last stage of production as this creates the most versatility in implementation. Three methods were tested with three participants in a time span of 4 weeks. The material has been steamed with dried flowers, sprayed with essential oil and dipped with beeswax mixed with essential oils. The participants ranked the scent strength from 0-10. The result is that spraying with essential oils has provided the strongest scent over time, with an average score of 6 which stayed constant over the four weeks.

User tests were performed to determine the user's opinion on waste materials and to determine if communication could modify their perception of the material. Two groups were tested where one group received information about the material composition and the other not. The result was that users who were informed about the material would be more accepting towards it. Even when the material did not meet their assumptions, they still embraced the material and looked at the pleasant qualities of it. Users who were not informed were sometimes a bit more difficult with understanding and accepting the material. This could be due to their lack of information causing their range of perceptions to be wider. The users all agreed that the material was more pleasant when it was smoother. It did not have to be perfect, as they enjoyed the handcrafted and asymmetrical qualities of the material.

Literature research was done for visually impaired people and their needs. VIP are often perceived as dependent, but according to them this is a misconception. VIP value autonomy and are therefore frustrated due to the dependence on sighted individuals (de Rocha Tomé Filho et al., 2019). This frustration pairs together with a difficulty regarding social interaction. Board games can enhance relationships and stimulate social interaction (Feng et al., 2019). Benchmarking in board games for VIP has shown that there are not a lot of existing products for them. Most of the games are traditional games which are adaptable for them, but there are no games specifically designed for visual impairment. Most of the games add tactile elements to the game, but none of them are specifically designed for VIP.

The results of this study have come together to the redesign of Serendipitea. The redesign, now called Serenitea, is more adapted to the social needs of VIP, namely that they need a game where they can interact with sighted individuals, while having full autonomy during setup and playing of the game. The material has adapted to the processing method of this concept, making it easier to create and upscale the production towards the market. The new scent implementation method and moment allows multiple tiles to be scented differently at once. Although this research has come to an end, it is only the beginning of a new era of emerging materials being implemented on large scale for social impacts.

# REFERENCES

Albers, E., Impelluso, L., & Kim, J. (2022). Tea Clay: Material characterisation. Material-Driven Design elective, Faculty of Industrial Design Engineering. Unpublished report.

An, H., Ou, X., Zhang, Y., Li, S., Xiong, Y., Li, Q., Huang, J., & Liu, Z. (2022). Study on the key volatile compounds and aroma quality of jasmine tea with different scenting technology.

Food Chemistry, 385, 132718. <https://doi.org/10.1016/J.FOODCHEM.2022.132718>

Arakawa, T., Iitani, K., Toma, K., & Mitsubayashi, K. (2023). Biosensors: Gas Sensors. Encyclopedia of Sensors and Biosensors: Volume 1-4, First Edition, 1–4, 478–504. <https://doi.org/10.1016/B978-0-12-822548-6.00066-2>

Bauer, C. M., Hirsch, G. V., Zajac, L., Koo, B.-B., Collignon, O., & Merabet, L. B. (2017). Multimodal MR-imaging reveals large-scale structural and functional connectivity changes in profound early blindness. PLOS ONE, 12(3), e0173064. <https://doi.org/10.1371/journal.pone.0173064>

Big Circle Studios. (n.d.). Coffee Husk/Chaff Biomaterial. Retrieved May 3, 2023, from <https://materiom.org/recipe/665>

Blinová, L., Sirotiak, M., Bartošová, A., & Soldán, M. (2017). Review: Utilization of Waste From Coffee Production. Research Papers Faculty of Materials Science and Technology Slovak University of Technology, 25(40), 91–101. <https://doi.org/10.1515/rput-2017-0011>

Camera, S., & Karana, E. (2018, June 28). Experiential Characterization of Materials: toward a toolkit. <https://doi.org/10.21606/drs.2018.508>

Capelli, L., Sironi, S., Del Rosso, R., & Guillot, J. M. (2013). Measuring odours in the environment vs. dispersion modelling: A review. Atmospheric Environment, 79, 731–743. <https://doi.org/10.1016/J.ATMOSENV.2013.07.029>

Cecchini, C. (2017). Bioplastics made from upcycled food waste. Prospects for their use in the field of design. The Design Journal, 20(sup1), S1596–S1610. <https://doi.org/10.1080/14606925.2017.1352684>

Chazence. (n.d.). Chazence. Retrieved May 20, 2023, from <https://www.zenceobject.com/%E5%89%AF%E6%9C%AC%E7%94%9F%E6%85%8B%E8%8C%B6%E6%9D%90-%E5%BB%BA%E9%80%A0%E7%B3%BB%E5%88%97>

Chen, M. (2002). Tea and health, an overview.

Cheng Cheng. (n.d.). Tea waste by Cheng Cheng. Retrieved April 25, 2023, from <https://www.futurematerialsbank.com/material/tea-waste-2/>

Coffee Based. (n.d.). Coffee Based Material. Retrieved May 19, 2023, from <https://materialdistrict.com/material/coffee-based-material/>

da Rocha Tomé Filho, F., Mirza-Babaei, P., Kapralos, B., & Moreira Mendonça Junior, G. (2019). Let's Play Together. Proceedings of the 2019 CHI Conference on Human Factors in Computing Systems, 1–15. <https://doi.org/10.1145/3290605.3300861>

Das, S., & Kalyani, M. I. (2023). From trash to treasure: review on upcycling of fruit and vegetable wastes into starch based bioplastics. Preparative Biochemistry & Biotechnology, 53(7), 713–727. <https://doi.org/10.1080/10826068.2022.2158470>

De Cocker, E., Van der Laan, F., & Ko, S. (2022). Tea Clay: Material characterisation. Material-Driven Design elective, Faculty of Industrial Design Engineering. Unpublished report.

Deep Dive: Bound Metal Deposition (BMD) | Desktop Metal. (n.d.). Retrieved May 3, 2023, from <https://www.desktopmetal.com/resources/deep-dive-bmd>

Dobrosielska, M., Dobrucka, R., Kozera, P., Brząkałski, D., Gabriel, E., Głowacka, J., Jałbrzykowski, M., Kurzydłowski, K. J., & Przekop, R. E. (2023). Beeswax as a natural alternative to synthetic waxes for fabrication of PLA/diatomaceous earth composites. *Scientific Reports*, 13(1), 1161. <https://doi.org/10.1038/s41598-023-28435-0>

Feng, A., Chen, Y. V., Li, R., & Ding, L. (2019). How smell can help visually impaired in health and well-being – a cognitive experiment. *The Design Journal*, 22(sup1), 371–386. <https://doi.org/10.1080/14606925.2019.1595426>

Gencel, F. (n.d.). Tea waste by Fulden Gencel – Future Materials Bank. Retrieved May 20, 2023, from <https://www.futurematerialsbank.com/material/tea-waste/>

Gillies, M. (n.d.). Nettle leaf. Retrieved May 3, 2023, from <https://materiom.org/recipe/382>

Guo, S., Kumar Awasthi, M., Wang, Y., & Xu, P. (2021). Current understanding in conversion and application of tea waste biomass: A review. *Bioresource Technology*, 338, 125530. <https://doi.org/10.1016/j.biortech.2021.125530>

Gupta, S. (n.d.). Tea Grounds Bioplastic. Retrieved May 21, 2023, from <https://materiom.org/recipe/692>

Häger-Ross, C., & Rösblad, B. (2002). Norms for grip strength in children aged 4-16 years. *Acta Paediatrica*, 91(6), 617–625. <https://doi.org/10.1080/080352502760068990>

Hamar, C. L. (n.d.). Dust London | Transforming Tea Waste into Homeware. Retrieved May 3, 2023, from <https://luxiders.com/dust-london/>

Hendrawati, N., Wibowo, A. A., Chrisnandari, R. D., & Adawiyah, R. (2021). Biodegradable foam tray based on sago starch with beeswax as coating agent. *IOP Conference Series: Materials Science and Engineering*, 1073(1), 012006. <https://doi.org/10.1088/1757-899X/1073/1/012006>

HighSociety studio. (n.d.). Agriluma. Retrieved April 25, 2023, from <https://materialdistrict.com/material/agriluma-agrimat/>

Home | Jesmonite. (n.d.). Retrieved May 3, 2023, from <https://jesmonite.com/>

Kääriäinen, P., Tervinen, L. M., & Vuorinen, T. (n.d.). The chemarts cookbook.

Karana, E., Barati, B., Politecnico, V. R., Milano, D., & Zeeuw Van Der Laan, A. (2015). Material Driven Design (MDD): A Method to Design for Material Experiences Mycelium Based Materials for Product Design View project TAMBALI FII: social and technological sustainability supporting Senagalese fishing-nautical sector View project. In *Article in International Journal of Design* (Vol. 9, Issue 2). [www.ijdesign.org](http://www.ijdesign.org)

Kauer, J. S., & White, J. (2009). Electronic Nose. *Encyclopedia of Neuroscience*, 871–877. <https://doi.org/10.1016/B978-008045046-9.01694-6>

Kesselmeier, J., Kuhn, U., Wolf, A., Andreae, M. O., Ciccioli, P., Brancaleoni, E., Frattoni, M., Guenther, A., Greenberg, J., De Castro Vasconcellos, P., De Oliva, T., Tavares, T., & Artaxo, P. (2000). Atmospheric volatile organic compounds (VOC) at a remote tropical forest site in central Amazonia. *Atmospheric Environment*, 34(24), 4063–4072. [https://doi.org/10.1016/S1352-2310\(00\)00186-2](https://doi.org/10.1016/S1352-2310(00)00186-2)

Liu, B., Zhang, J., Zhou, X., Deng, S., Du, G., Liu, B., Zhang, J., Zhou, X., Deng, S., & Du, G. (2022). Research Progress on the Health Benefits of Scented Tea. *Recent Advances in the Health Benefits of Tea*. <https://doi.org/10.5772/INTECHOPEN.106605>

Lopez, K. (n.d.-a). Rumi. Retrieved May 3, 2023, from <https://www.recyclingboerse.org/projekte/kunst-und-kultur/recycling-designpreis/designer-innen-2022/431-rumi>

Lopez, K. (n.d.-b). Tea waste by Katherine Lopez. Retrieved May 3, 2023, from <https://www.futurematerialsbank.com/material/tea-waste-3/>

Maloney, T. M. (1996, February). The family of wood composite materials. *Forest Products Journal*. <https://www.proquest.com/docview/214632589?fromopenview=true&pq-origsite=gscholar>

Marinov, M. B., Ganev, B. T., & Nikolov, D. N. (2021). Indoor Air Quality Assessment Using Low-cost Commercial Off-the-Shelf Sensors. *Proceedings of the 2021 6th International Symposium on Environment-Friendly Energies and Applications, EFEA 2021*. <https://doi.org/10.1109/EFEA49713.2021.9406260>

Masters of Games. (n.d.). Games for Blind people. Retrieved August 20, 2023, from <https://www.mastersofgames.com/cat/guide/games-for-blind-people.htm>

Materiom. (n.d.). Xanthan. Retrieved May 21, 2023, from <https://materiom.org/ingredient/223>

MaxiAids. (n.d.-a). Braille Scrabble. Retrieved August 20, 2023, from <https://www.maxiaids.com/product/deluxe-scrabble-game-braille-version>

MaxiAids. (n.d.-b). Tactile Checkers. Retrieved August 20, 2023, from <https://www.maxiaids.com/product/deluxe-checker-set>

MaxiAids. (n.d.-c). Tactile Chess. Retrieved August 20, 2023, from <https://www.maxiaids.com/product/large-table-top-chess-set-for-the-blind-or-those-with-low-vision>

MeepleLikeUs. (n.d.). Nudge - Accessibility teardown. Retrieved August 20, 2023, from <https://www.meeplelikeus.co.uk/nudge-2019-accessibility-teardown/>

Negi, T., Kumar, Y., Sirohi, R., Singh, S., Tarafdar, A., Pareek, S., Kumar Awasthi, M., & Alok Sagar, N. (2022). Advances in bioconversion of spent tea leaves to value-added products. *Bioresource Technology*, 346, 126409. <https://doi.org/10.1016/J.BIORTECH.2021.126409>

Omnexus. (n.d.). Omnexus Shore D hardness. Retrieved July 26, 2023, from <https://omnexus.specialchem.com/polymer-properties/properties/hardness-shore-d#:~:text=The%20Shore%20D%20Hardness%20test,hardness%20represents%20the%20harder%20material.>

Otero, A. (n.d.). Eggshell paste for 3d printing. Retrieved May 21, 2023, from <https://materiom.org/recipe/601>

Ottan. (n.d.). Ottan Materials. Retrieved May 3, 2023, from <https://materialdistrict.com/material/ottan-materials/>

OV Designs. (n.d.). Coffee Polymer. Retrieved April 25, 2023, from <http://www.ovdesigns.nl/coffee-polymer.html>

Paths to Literacy. (n.d.). Make your own tactile memory game. Retrieved August 20, 2023, from <https://www.pathstoliteracy.org/make-your-own-tactile-memory-game/>  
Perkins School For The Blind. (n.d.). Feelif memory game. Retrieved August 20, 2023, from <https://www.perkins.org/resource/feelif-memory-game/>

Sena da Fonseca, B., Vilão, A., Galhano, C., & Simão, J. A. R. (2014). Reusing coffee waste in manufacture of ceramics for construction. *Advances in Applied Ceramics*, 113(3), 159–166. <https://doi.org/10.1179/1743676113Y.0000000131>

Smith, K. (2016). *World atlas of tea*. Denise Bates.

Stittqen, B. (n.d.). Egg bioplastic. Retrieved May 21, 2023, from <https://materialdistrict.com/material/egg-bioplastic/>

Tao of Tea. (n.d.-a). 500 Mile Chai. Retrieved May 25, 2023, from <https://taooftea.com/product/500-mile-chai/>

Tao of Tea. (n.d.-b). Ginger Puer. Retrieved May 25, 2023, from <https://taooftea.com/product/ginger-puer/>

Tao of Tea. (n.d.-c). Green Earl Grey. Retrieved May 25, 2023, from <https://taooftea.com/product/green-earl-grey/>

Tao of Tea. (n.d.-d). Rose Petal Black. Retrieved May 25, 2023, from <https://taooftea.com/product/rose-petal-black/>

Van Dijken, M., De Reus, B., & Van Wolfwinkel, L. (2022). *Tea Clay: Material characterisation*. Material-Driven Design elective, Faculty of Industrial Design Engineering. Unpublished report.

VanHier. (n.d.). BioM. Retrieved May 3, 2023, from <https://van-hier.com/>

Woodio®. (n.d.). Woodchip by Woodio®. Retrieved May 21, 2023, from <https://www.futurematerialsbank.com/material/woodchip/>

World Health Organisation. (2023). Blindness and vision impairment. <https://www.who.int/news-room/fact-sheets/detail/blindness-and-visual-impairment>

Xu, ning, & Chen, Z. (2002). *Green tea, black tea and semi fermented tea*.

Zhou, J., & Ren, L. (2018). *Tea powder-containing degradable composite material and preparation method and application thereof* (Patent CN107964254A).





Industrial Design  
Engineering

## Appendix A: Tinkering

### Tinkering: gelling agents

#### Goal

Create different gelling agent ratios with the TeaClay recipe.

The basic recipe is:

180 ml water (75%) – this is found to create the most viscosity for the paste printing of TeaClay.

5 ml acetic acid solution (2.5%) – The acetic acid solution is needed to dissolve the starch.

5 ml glycerol (2.5%) – The glycerol creates flexibility in the material.

10 gr starch (4%) – The starch will gel when it is heated, and this incorporates the tea leaves.

40 gram (16%) tea leaves – At this moment, the tea leaves act as a filler material and as the fibres.

The basic recipe will be produced with different ratios of gelling agent. The ratio will be measured from the starch, as the starch is the other gelling component. Starch will gel when it is heated, but when it dries, it becomes hard like a composite.

	1:1	1:2	1:3
Gelatine			
Agar Agar			
Pectin			

Each recipe created 3 samples that were the same size and poured in a silicone mould.

#### Working method:

For the gelatine and agar agar:

Acetic acid solution, glycerol, water and starch were combined. In the pan, they were heated together with the gelatine or agar agar. The pan was stirred continuously until the mixture turned from white to transparent. The viscosity changed here as well. When this point is reached, the tea leaves were added and incorporated. The end product is poured or scooped in the mould.

For the pectin:

Water was boiled to 100 degrees. In a jar, the respective amount of pectin was added with the water amount from the basic recipe. The jar was closed off and shaken until the pectin dissolved. The pectin water was poured in the pan and the acetic acid solution, glycerol and starch were added with heat. The pan was stirred continuously. The mixture will turn more transparent and less viscous. The tea leaves were added and incorporated. The end product is poured or kneaded in the mould.

## Gelatine 1:1

The gelatine melted at 40 degrees Celsius. The mixture became transparent and viscous at 70 degrees. The mixture was **pourable** in the moulds and had a **long drying time**.



*figure 1: Gelatine 1:1, still white at 35 degrees*



*figure 2: Gelatine 1:1, turning transparent at 70 degrees.*



*figure 3: Gelatine 1:1, 70 degrees, turning more solid*



*figure 4: Gelatine 1:1: pourable in the mould*



#### Gelatine 1:2

The gelatine melted at 57 degrees Celsius. The mixture became transparent and viscous at 65 degrees. The mixture is first white and becomes transparent. The mixture was **pourable** in the moulds and had a **long drying time**.

#### Gelatine 1:3

The gelatine melted at 56 degrees Celsius. The mixture became transparent and viscous at 65 degrees.

The mixture was **pourable** in the moulds and had a **long drying time**.

#### Agar agar 1:1

It was unclear at what degree the agar agar melted, since the agar agar is more a powder and the gelatine were granules. The mixture was first white and turned transparent and viscous at 65 degrees. The mixture was **less viscous than gelatine**, and it resembled wet tea clay. It was still **mixable with the spatula**, but it had to be **scooped and compressed** in the moulds.

Due to the lack of agar agar, there could only be 1 sample made.



*figure 5: Agar agar at 67.6 degrees, already the same as gelatine 1:1 at 70 degrees*



*figure 6: Agar agar 1:1 looks thicker and starchier compared to gelatine*

### Pectin 1:1

The pectin mixture was yellow and did not really turn transparent. The measurement of 65-70 degrees was used. The mixture was **similar to 1:1 agar agar**. It was still mixable with a spatula. It has to be **scooped and compressed** in the moulds.



*figure 7: Pre mixing the pectin with hot water*



*figure 8: Pectin at 60 degrees*



*figure 9: Pectin with tea leaves*

#### Pectin 1:2

The pectin mixture was yellow and did not really turn transparent. The measurement of 65-70 degrees was used. The mixture was **similar to 1:1 agar agar**. It was still mixable with a spatula. It has to be **scooped and compressed** in the moulds.

#### Pectin 1:3

The pectin mixture was yellow and already very tough to work with. Stirring was hard. The measurement of 65-70 degrees was used. The more it was heated, the tougher it was to stir. When the tea was added, the mixture had not enough liquid to be stirred, so gloves were put on and the mixture was kneaded. This is similar to the original tea clay recipe with 60 ml water (44%). Afterwards, the material had to be **put in the mould by hand and compressed**. When the material was lifted from the pan, it was strong enough to hold onto itself.



*figure 10: Kneading the pectin*



*figure 11: The pectin 1:3 can hold onto itself when held in the air*

#### Agar Agar 1:1 (Smaakt brand)

The mixture was brown because of the agar agar. The added ingredient of vanilla made the cooking process smell better. The agar agar dissolves immediately in water, even when the temperature is not reached. It is not possible to see when the agar agar is melting. When the stirring is not being done continuously, there will be gel bubbles forming. They can be broken.



*figure 12: Gel pockets at 70 degrees, but the rest is still liquid*

At 70 degrees, the agar agar did not become like a gel, it is a viscous, powdery fluid. Comparable to honey when it has crystallised. The tea is mixable in the mixture. The material can be scooped in the mould. The density of the material is heavy enough that it can mend all the air pockets in the mould, and does not need additional pressing force to compress everything together.

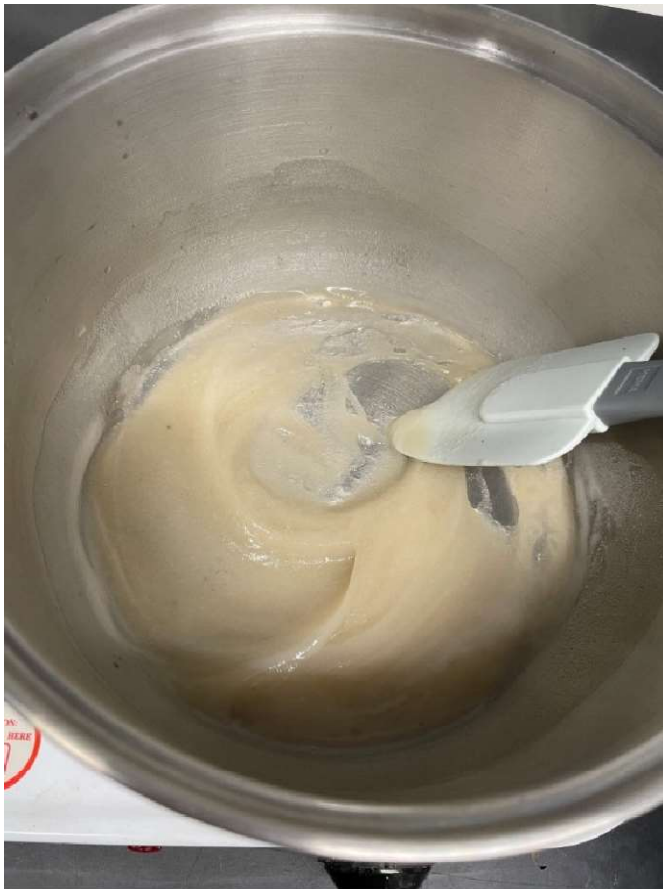

*figure 13: Some time later, the agar agar becomes a crystallised honey structure*



*figure 14: It then forms into a gel*

#### Agar agar (1:2)

The mixture was brown because of the agar agar. It dissolved immediately in water. The gel bubbles were not present this time. At 64 degrees, the mixture has become solid. It could be draped and did not spread as a liquid. The tea was mixable with the spatula, but it is noticeable that it became a white starchy mass that was mixed within the tea. The mass was very sticky to the spatula as well. When the mass on the spatula was held in the air, the mass did not fall down. The mass had to be scooped into the mould, but pressed to seal any air gaps.



*figure 15: Agar agar 1:2 sticking to spatula*



*figure 16: Agar agar 1:2*

### Agar Agar (1:3)

The mixture was even more brown compared to the other two ratios. At 55 degrees it was similar to agar agar 1:2 at 64 degrees. At 65 degrees, the agar agar 1:3 was like a paste with even less flexibility compared to the other ratios. It seemed like the mixture would dry even more when the 70 degrees would be reached, so the tea was added at 65 degrees. The tea was not mixable with the spatula, so gloves were used to knead the tea. The mass was uniform. And very flexible. It was easy to break a piece off, but that piece was very much like a paste that could be spread and compressed. When the mass was held at one point in the air, it did not break off or fall down. It had to be compressed into the moulds.



*figure 17: Agar agar 1:3 at 65 degrees is like a paste*



*figure 18: Kneading agar agar 1:3 with hands*



*figure 19: Agar agar 1:3 kneaded*

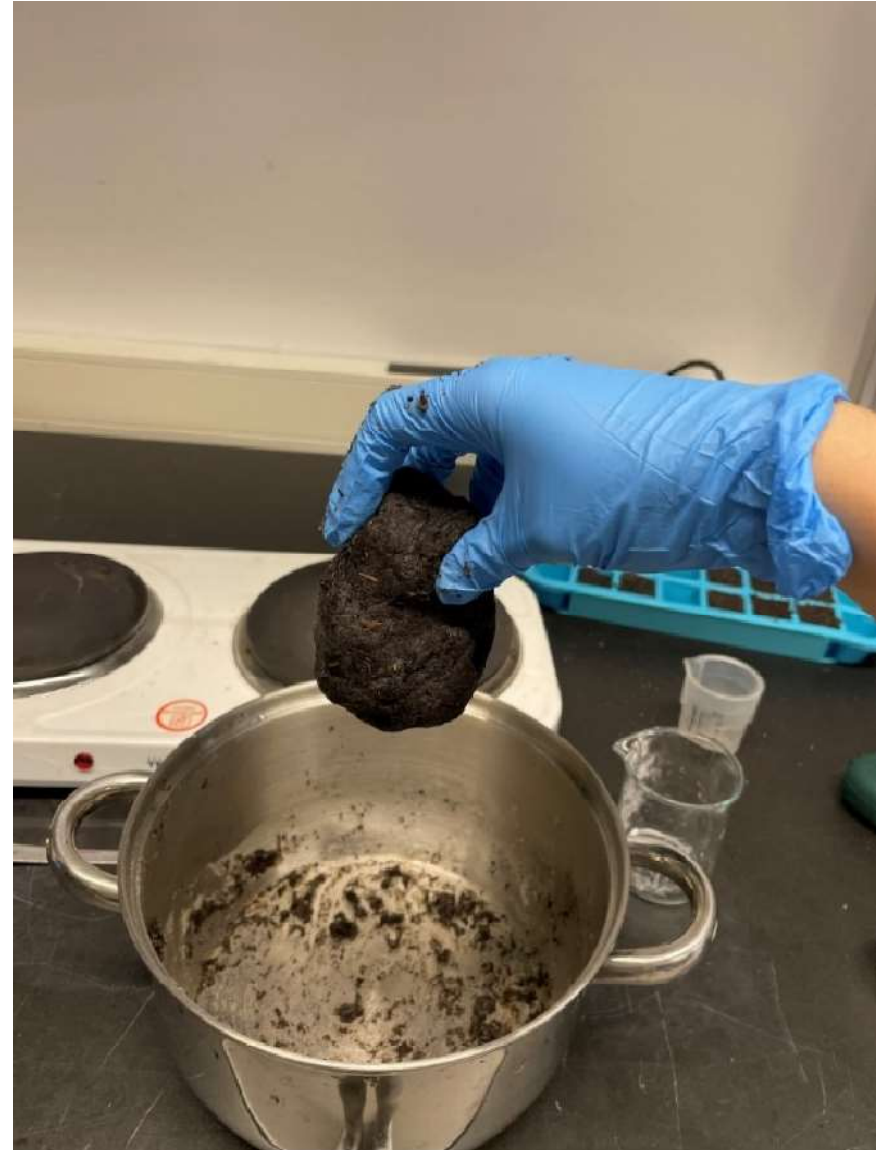

*figure 20: Agar agar 1:3 does not fall down*

Intermediate results



figure 21: The samples and labelled variations.



figure 22: The samples drying in their moulds



figure 23: the top dries first. The silicone enables ease of demoulding.



The contact area with air dries first, the rest does not dry in the mould. At the same day as the fabrication, several samples could be demoulded:



figure 24: The samples that could be demoulded the same day, plus the two gelatines ( a bit later)



figure 25: Gelatine has a very different surface finish compared to pectin



figure 26: A sample with a big piece of unmelted pectin



*figure 27: Gelatine samples and agar agar could break when trying to demould too early*



*figure 28: Gelatine samples that were demoulded earlier have a glossy finish, and freshly demoulded gelatine samples look like cake.*



figure 29: Shrinkage of gelatine samples



figure 30: Agar agar samples still drying after being in the mould for three days

### Shrinkage

The samples have been weighed after 4 days. The results are in table 1.

Gelatine 1:1 (gr)	Gelatine 1:2 (gr)	Gelatine 1:3 (gr)	Pectin 1:1 (gr)	Pectine 1:2 (gr)	Pectine 1:3 (gr)
9.6	9.0	9.6	11.7	10.4	14.5
8.5	10.1	8.6	9.5	10.8	13.6
10.3	8.1*	9.3	11.3	10.3	13.7
10.8	10.2				
<b>9.8</b>	<b>9.35</b>	<b>9.16</b>	<b>10.83</b>	<b>10.5</b>	<b>13.95</b>

table 1: The weighted samples before and after drying for 4 days.

It is noticeable that the pectin 1:3 has a higher average weight compared to the gelatine samples. Truth is that the wet material was not measured before it was put in the mould, so there could be some differences there. But, since the gelatine samples have shrunken the most compared to the mould, it could also be that the weight loss is due to water evaporation. An assumption could be that the gelatine samples evaporate water more compared to the pectin samples.

It is also apparent that the samples have undergone severe deformation due to shrinkage.

### Hardness

Hardness was not measurable because the samples were not uniform. The lack of uniformity is due to the shrinkage and the moulding of the samples. The sample needs to have a thickness of 4 mm minimal.

After the samples have been sawed, it was visible that the inside of the samples was not completely dry. A hardness test can only be performed if the sample is completely dry.



figure 31: samples sawed in slabs turned out to be not completely dried inside.

## Melting the samples

### Gelatine

Gelatine 1:1, 1:2 and 1:3 in silicone moulds and in a preheated oven of 45 degrees.

After ten minutes. No change.

Oven pre heated to 70 degrees.

After ten minutes. No change.

Then a hole was created in the samples, the inside was liquid. Compared to samples that were not put in the oven, those were not liquid.

Now, oven to 100 degrees and put in for 10 minutes, see if the water evaporates more, or that they finally melt. Would be useful to measure the weight after that.



figure 32: The samples in a different mould to be melted

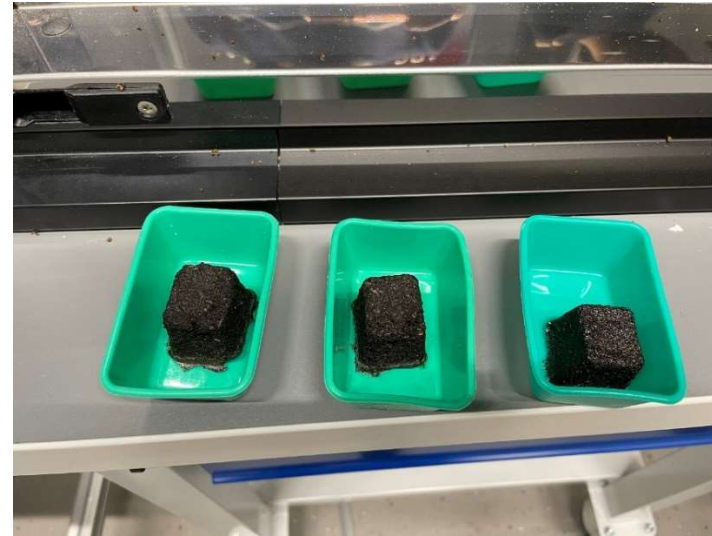

figure 33: Ten minutes 45 degrees



figure 34: Ten minutes 70 degrees



*figure 35: Holes could be poked, outer membrane is hard but inside not*



*figure 36: Inside is liquid*



*figure 37: Compared to gelatine that has not been in the oven, inside is not liquid, but it is like a paste.*

Figure 37 also confirms that the samples were not completely dried. This would allow the inside to be melted, as it contained water. Water is thus essential for the material to be able to be melted.

#### Gelatine soaked in water

It was apparent that the samples would need water to be able to melt. New gelatine samples of 1:1, 1:2 and 1:3 was completely immersed in water for 30 minutes. After the 30 minutes, the samples were taken out of the water and put in a preheated oven of 100 degrees for 10 minutes.

After the first 10 minutes, the outer membrane of the samples were starting to melt and dissolve. After 10 more minutes, the outer membrane has dried and hardened again. The bottom of the samples has melted. The material was not liquid, but more similar to the paste state in which it had been moulded. The top layer of the material was hard while the bottom remained soft. When a force was applied on the top, the material started deforming.



*figure 38: Gelatine 1:3 starting to lose its shape after some force was pressed on it.*

## Pectin

Pectin 1:1, 1:2 and 1:3 were 10 minutes in a preheated oven of 70 degrees. The samples did not deform.

The samples were 10 minutes in a preheated oven of 100 degrees. The samples did not deform.

The samples were 10 minutes in a preheated oven of 165 degrees. The samples did not deform.

## Pectin soaked in water

The pectin samples have been soaked in water for 30 minutes. After this, they were taken out of the water and placed in a bigger silicone mould into a preheated oven of 100 degrees for 10 minutes. After 10 minutes, the outer membrane of the pectin samples was starting to dissolve.

After 10 more minutes, the outer membrane of the pectin samples has hardened again, but the bottom of the samples has started to dissolve slightly. It was possible to deform the samples there. The pectin 1:2 broke in half. This is most probably due to the moulding technique. The assumption is that during moulding, the material had an air gap that was not sealed properly. This air gap would serve as the weak spot that would succumb first when the material is being heated.

## Conclusion

The conclusion is that from all the gelling agents, gelatine could be the most potential due to the ease of processing. The only downside of the gelatine samples is the severe deformation. The deformation is due to the water loss. A new method for containing the water loss needs to be found.

## Tinkering: beeswax

### Goal

Create different beeswax ratios with TeaClay

### Working method:

#### Alpha method

The alpha method is to add the beeswax and binder together in the pan. The contents are then heated until 70 degrees Celsius is reached. After this temperature has been reached, the tea powder is added to the mixture.

#### Beta method

The beta method is to heat the binder until it reaches 70 degrees in the pan. After 70 degrees has been reached, the beeswax and tea will be added and stirred until the beeswax has dissolved completely.

#### Alpha method 5%

180 ml water+ the rest of the binder, 5% w/w beeswax. And then add 40 grams of tea.

The beeswax melted at 70 degrees. The binder beeswax mixture was transparent and had an oily shine to it. When the tea was added, the mixture was like a liquid paste. The material could be scooped into the moulds without pressing too hard. It was noticeable that the material was gliding easier from the pan, spoon and silicone spatula. Each mould was filled with 22 grams of material.

#### Beta method 5%

180 ml water (72%)+ the rest of the binder, 5% w/w beeswax. And then add 40 grams of tea.



The binder has started to gel at 70 degrees. After this, the beeswax and tea were added simultaneously to the mixture. The mixture was stirred until the beeswax was seemingly dissolved. The mixture was a liquid paste. The material could be scooped into the moulds without pressing too hard. It was noticeable that the materials was gliding easier from the pan, spoon and silicone spatula. Each mould was filled with 23 grams of material.

#### Alpha method 4%

180 ml water (73%) + the rest of the binder, 4% w/w beeswax. And then add 40 grams of tea.

The beeswax melted at 70 degrees. The binder beeswax mixture was transparent and had an oily shine to it. When the tea was added, the mixture was like a liquid paste. The material could be scooped into the moulds without pressing too hard. It was noticeable that the material was gliding easier from the pan, spoon and silicone spatula. Each mould was filled with 23 grams of material.

#### Alpha method 3%

180 ml water (73%)+ the rest of the binder, 3% w/w beeswax. And then add 40 grams of tea.

The beeswax melted at 70 degrees. The binder beeswax mixture was transparent and had an oily shine to it. When the tea was added, the mixture was like a liquid paste. The material could be scooped into the moulds without pressing too hard. It was noticeable that the material was gliding easier from the pan, spoon and silicone spatula. Each mould was filled with 23 grams of material.

#### Alpha method 2%

180 ml wate (74%)r+ the rest of the binder, 2% w/w beeswax. And then add 40 grams of tea.

The beeswax melted at 70 degrees. The binder beeswax mixture was transparent and had an oily shine to it. When the tea was added, the mixture was like a liquid paste. The material could be scooped into the moulds without pressing too hard. It was noticeable that the material was gliding easier from the pan, spoon and silicone spatula. Each mould was filled with 25 grams of material.

#### Alpha method 1%

180 ml water (74%) + the rest of the binder, 1% w/w beeswax. And then add 40 grams of tea.

The beeswax melted at 70 degrees. The binder beeswax mixture was transparent and had an oily shine to it. When the tea was added, the mixture was like a liquid paste. The material could be scooped into the moulds without pressing too hard. It was noticeable that the material was gliding easier from the pan, spoon and silicone spatula. Each mould was filled with 23 grams of material.

#### Control Group

The binder was heated to 70 degrees. At this state, the binder turned transparent and started to gel. After this, the tea was added to the mixture. The material was liquid paste. It could be scooped into the moulds. Each mould was filled with 23 grams of material.

### Intermediate results

All the samples had a severe drying time, and could not be taken out of the mould without destroying the shape. Eventually, they could be removed from the mould. A moisture sensor was used to keep track of the drying time, but they took a very long time to harden.

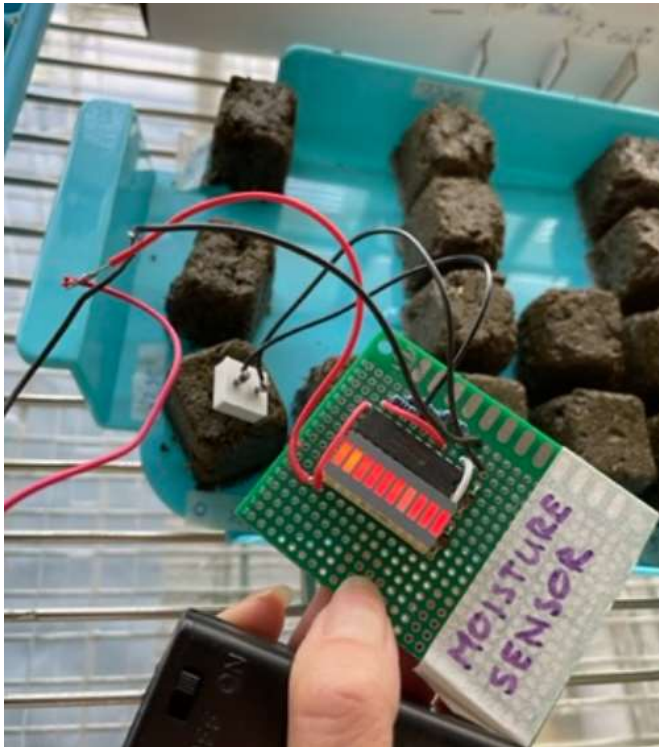

figure 39: moisture sensor was used to evaluate if the samples were dried.

### Conclusion

It is not clear what causes the severe drying time. It could be due to various factors. More research needs to be done in order to conclude this observation.

## Tinkering : Processability

### Goal

The beeswax samples from tinkering day 1/5 have an extremely slow drying time. This drying time was also experienced during the gelling agent samples. There are 2 drying times identified: 1) demoulding time: the time the sample needs to have hardened enough to be demoulded from the mould without breaking the material 2) the drying time: the time the sample needs to be completely dried, on the outside and inside.

The goal for this tinkering entry is to decrease the demoulding time in order to prevent mould and to stimulate a better workflow.



figure 40: Demoulding the samples too early can cause the samples to break

Demoulding times	
Gelatine 1:3	Day of fabrication
Pectin 1:1	Day of fabrication
Pectin 1:2	Day of fabrication
Pectin 1:3	Day of fabrication
Gelatine 1:2	Day after fabrication
Gelatine 1:1	Day after fabrication
Agar agar 1:1	4 days after fabrication
Agar agar 1:2	4 days after fabrication
Agar agar 1:3	4 days after fabrication
Original recipe	2 days after fabrication
Beeswax Alpha method 5%	2 days after fabrication ( 1 out of 4)
Beeswax Beta method 5%	2 days after fabrication (4 out of 4)
Beeswax Alpha method 4%	2 days after fabrication (2 out of 4)
Beeswax Alpha method 3%	2 days after fabrication (4 out of 4)
Beeswax Alpha method 2%	2 days after fabrication (2 out of 4)
Beeswax Alpha method 1%	2 days after fabrication (3 out of 4)

table 2: the demoulding time for the samples that have been created so far.

### Working method

There are two possibilities to increase the demounting time. One method is to decrease the water content. Less water content means that the drying time will be faster as there is less water to be evaporated. The other possibility is to introduce Lignin fibre back in the recipe, as Lignin fibre can act as a fibres structure that can make the entire structure of the material strong enough to be demoulded.

#### 60mL water

Ingredients:

60 ml water (48%)

10 grams starch (8%)

5 ml acetic acid solution (4%)

5 ml glycerol (4%)

This creates a total of 80 grams. Taking 5% of this for beeswax would result in 4 grams of beeswax.

Additional to this, 40 grams of tea will be added. (21%)

4 samples were moulded in the mould. Each sample weight 22 grams.

Furthermore, the material was put in a piping bag and extruded.



*figure 41: Structure of the heated binder of 60 ml water and 5% beeswax*



*figure 42: The material resembles clay and can be moulded by hand.*



*figure 43: The TeaClay had to be kneaded and moulded by hand. When the temperature was higher, the material was more sticky. After kneading several more times, it could form into one homogenous mass.*



*figure 44: The material had to be moulded by hand into the moulds*



*figure 45: The material could be extruded with a piping bag. The material was very tough, therefore it was hard to extrude*

120 mL water

Ingredients:

120 ml water (64%)

10 grams starch (5%)

5 ml acetic acid solution (5%)

5 ml glycerol (5%)

This creates a total of 140 grams. Taking 5% of this for beeswax would result in 7 grams of beeswax.

Additional to this, 40 grams of tea will be added. (21%)

4 samples were moulded in the moulds and weighed 20 grams.

The rest of the material was extruded using a piping bag.

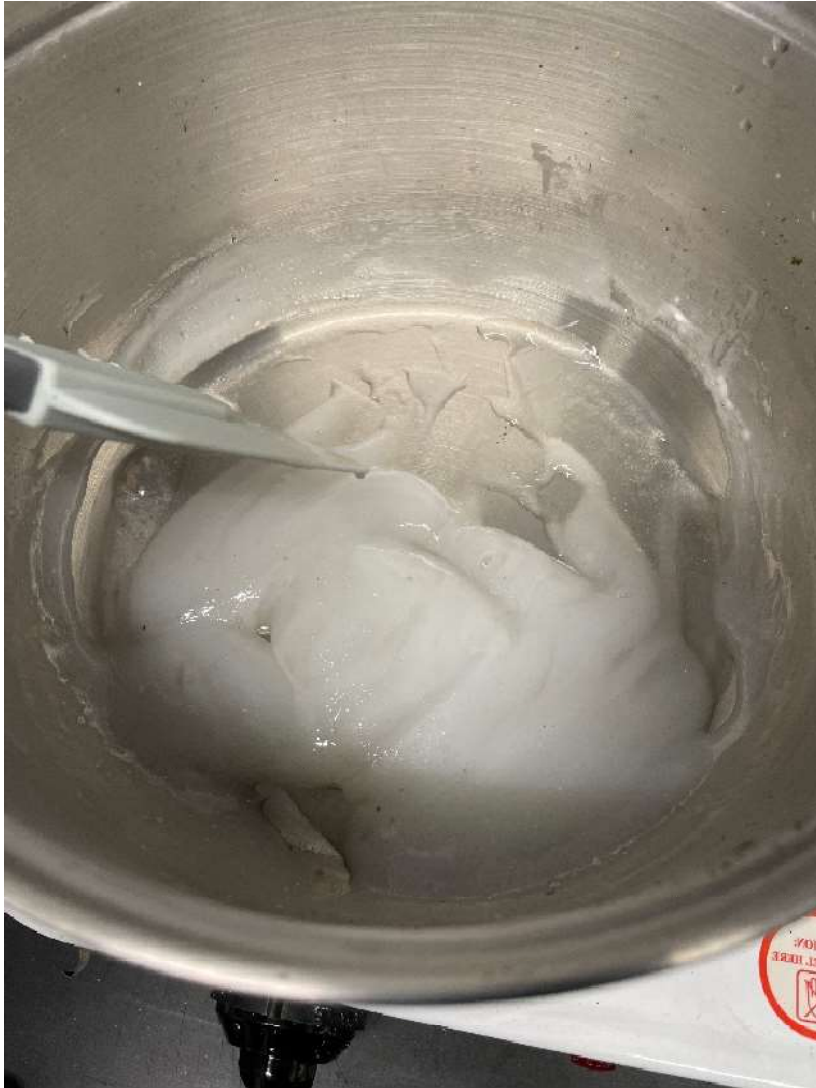

*figure 46: The heated binder with beeswax was gelling*



*figure 47: The binder with the tea resulted in a paste*



*figure 48: The material can be scooped in the mould*



*figure 49: Moulding the material was possible using spoons and pressing it in the mould*





*figure 50: The material was extrudable. It could not be moulded by hand because it stuck to the gloves.*

180 ml and Lignin fibre

Ingredients:

180 ml water (69%)

10 grams starch (4%)

10 grams of Lignin fibre (4%)

5 ml acetic acid solution(2%)

5 ml glycerol (2%)

This creates a total of 210 grams. As this recipe would result in a lot of material, the recipe was halved, but the ratios between the materials were kept the same.

90 ml water

5 grams starch

5 grams of Lignin fibre

2.5 ml acetic acid solution

2.5 ml glycerol

Taking 5% of this for beeswax would result in 5,25 grams of beeswax.

Additional to this, 20 grams of tea will be added.

4 samples were moulded in the moulds and weighed 20 grams.

The rest of the material was extruded using a piping bag.

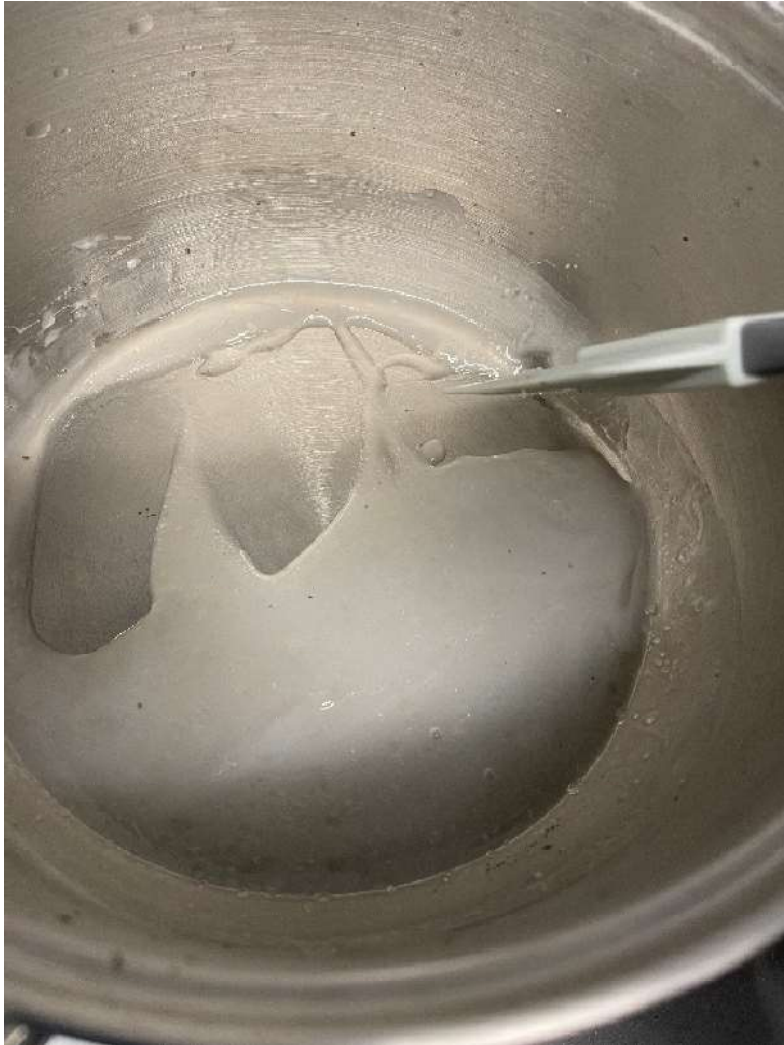

*figure 51: The binder is very fluid*



*figure 52: After adding tea to the binder*



figure 53: The material is easy to extrude.

### 180 ml

A control group needs to be made in order to know if the beeswax is causing the demoulding time to be slow. This would be the original recipe without Lignin fibre and with 180 ml water (72%)

## Intermediate results

### Shrinkage

#### 60 ml water (48%)

Wet weight	Dry weight	Water loss in %
4.6	2.4	48%
5.5	2.8	49%
6.5	3.4	47%
7.0	3.9	44%

table 3: the weight differences from wet to dry for 60ml water.

#### 120 ml water (64%)

Wet weight	Dry weight	Water loss in %
5	1.7	66%
3.9	1.3	66,67%
3.4	1.1	67%
3.8	1.3	66%
3.3	1.1	66.67%
4.1	1.4	66%

table 4: the weight differences from wet to dry for 120ml water.

#### 180 ml water & Lignin fibre (69%)

Wet weight	Dry weight	Water loss in %
4.6	1.4	69%
5.3	1.7	68%
4.4	1.4	68%
5.4	1.9	64%

table 5: the weight differences from wet to dry for 180ml and Lignin fibre water.

*Control group 180 ml water (72%)*

Wet weight	Dry weight	Water loss in %
3.8	1.1	71%
3.4	0.9	74%
4.1	1.0	76%
6.9	2.0	71%
3.9	0.7	82%

table 6: the weight differences from wet to dry for 180ml water.

Demoulding times	
Gelatine 1:3	Day of fabrication
Pectin 1:1	Day of fabrication
Pectin 1:2	Day of fabrication
Pectin 1:3	Day of fabrication
Gelatine 1:2	1 Day after fabrication
Gelatine 1:1	1 Day after fabrication
Agar agar 1:1	4 days after fabrication
Agar agar 1:2	4 days after fabrication
Agar agar 1:3	4 days after fabrication
180 ml water	2 days after fabrication
Beeswax Alpha method 5%	2 days after fabrication ( 1 out of 4)
Beeswax Beta method 5%	2 days after fabrication (4 out of 4)
Beeswax Alpha method 4%	2 days after fabrication (2 out of 4)
Beeswax Alpha method 3%	2 days after fabrication (4 out of 4)
Beeswax Alpha method 2%	2 days after fabrication (2 out of 4)

Beeswax Alpha method 1%	2 days after fabrication (3 out of 4)
Beeswax 60 ml (48%)	20 minutes after moulding
Beeswax 120 ml (64%)	4 days after fabrication
Beeswax 180 ml + Lignin fibre (69%)	4 days after fabrication (growing fungi)
180 ml (72%)	4 days after fabrication (growing fungi)

table 7: the perceived demoulding time for the samples created so far.

## Conclusion

The Lignin fibre does not facilitate faster demoulding time.

The beeswax does not cause the demoulding time to be severe, as the control group of 180 ml has a longer demoulding time than the beeswax samples.

The water amount is increasing the demoulding time. Less water means that the drying time is shorter, and that the material has a higher viscosity. More fluid material is causing more demoulding time.

## Tinkering : Processability v2

### Working method

#### Gelatine 1:3

The gelatine 1:3 samples had a low demoulding: this means that there was little time needed for the material to be taken out of the mould without damaging the shape. The gelatine was also good processable, as the material could be poured, and there were no air gaps in the material.

The downside of gelatine is the water shrinkage and therefore the deformation.

In this tinkering entry, the water amount will be tweaked. The recipe from Tinkering 19/4: gelling agents used a 1:3 ratio gelatine with 180 ml of water. Here, 30 grams of gelatine was used compared to the starch. Increments of 60 ml of water will be reduced.

This will result in the following recipes:

120 ml water 30 gram gelatine

60 ml water 30 gram gelatine

*60 ml water (40%)*

Observations:

The binder is liquid.

Adding tea leaves to the binder that is not like a gel.

The material had to be kneaded by hand, however, the material was very sticky and resulted in a lot of material loss on the gloves.

4 cubes were filled with each 26 grams. The rest of the material was spread on a silicone sheet to be dried. The sheet was solidified very fast,

but it was not dried at the bottom due to the silicone. However, it was solid enough.



figure 54: Gelatine with 60 ml water solidified fast.

#### *120 ml water (57%)*

The 120 ml water and gelatine also did not turn into a gel, but the mixed material with the tea leaves was liquid enough to be stirred with a spoon. 3 cubes were filled to 30 grams.

#### *Beeswax 60 ml (48%)*

The beeswax 60 mL samples had a low demoulding, as they could be demoulded immediately after processing. The processing was more tough, as the material was less mouldable and quite stiff. The deformation of the material was low, as the material still had a similar shape after it has been dried.

The downside of the beeswax samples is the processability.

In this tinkering entry, the water amount will be tweaked. In the recipe from Tinkering 4/5 processability, the recipe used 5% beeswax, 60 ml water, 10 gram starch, 5 ml acetic acid solution and 5ml glycerol. In this tinkering entry, increments of 20 ml of water will be made until 120 ml is reached. This will result in the following recipes:

80 ml water (55%)

100 ml water (60%)

*80 ml water (55%)*



*figure 55: beeswax causes the material to not stick to the pan*



*figure 56: Beeswax makes the wet material non stick.*

Something very noticeable with the beeswax samples is that the beeswax is creating a coating around the material, causing it not to stick to the pan or the equipment. The material is still very tough because moulding had to be done by hand.

4 cubes of 26 grams were filled.

There was also leftover material, so it was placed on a silicone sheet.



figure 57: The next day, which is 17 hours later, the material was still mouldable

#### 100 ml water (60%)

The 100 ml water beeswax samples were also the same regarding processability compared to 60 ml. It still had to be kneaded and moulded by hand. The recipe was executed. 3 moulds of 22 grams were filled.

## Intermediate results

### Demoulding time

Demoulding times	
Gelatine 1:3	Day of fabrication
Pectin 1:1	Day of fabrication
Pectin 1:2	Day of fabrication
Pectin 1:3	Day of fabrication
Gelatine 1:2	1 Day after fabrication
Gelatine 1:1	1 Day after fabrication
Agar agar 1:1	4 days after fabrication
Agar agar 1:2	4 days after fabrication
Agar agar 1:3	4 days after fabrication
180 ml water	2 days after fabrication
Beeswax Alpha method 5%	2 days after fabrication ( 1 out of 4)
Beeswax Beta method 5%	2 days after fabrication (4 out of 4)
Beeswax Alpha method 4%	2 days after fabrication (2 out of 4)
Beeswax Alpha method 3%	2 days after fabrication (4 out of 4)
Beeswax Alpha method 2%	2 days after fabrication (2 out of 4)
Beeswax Alpha method 1%	2 days after fabrication (3 out of 4)
Beeswax 60 ml (48%)	20 minutes after fabrication
Beeswax 120 ml (64%)	4 days after fabrication
Beeswax 180 ml + Lignin fibre (69%)	4 days after fabrication (growing fungi)
Beeswax 180 ml (72%)	4 days after fabrication (growing fungi)
Gelatine 60 ml (40%)	1.5 hour after fabrication



Gelatine 120 ml (57%)	1.5 hour after fabrication
Beeswax 80 ml (55%)	1 day after fabrication
Beeswax 100 ml (60%)	1 day after fabrication

table 8: the demoulding times for the samples created so far.

### Gelatine rubber

The gelatine that was leftover and spread on a silicone sheet had hardened faster than the cubes, because there was more contact area with the air. The sheet has a tough rubber trait. When hitting it with a hammer, it springs back to its original shape. When punctured with an object, it springs back to shape. The material is not fully dried yet when these observations were made. The material could be cut with a knife and scissors, and clean cuts could be made.



figure 58: the material hardened.



figure 59: A shallow cut being made in the material



figure 60: the material can be cut into squares, and has different surface qualities.

The material has the roughness in which it was moulded, but the other side, the side that was on the sheet, is smooth.

One particular observation is that the material surface is different compared to the original teaclay. The material feels more homogenous, and shrinkage is occurring more uniform.

### Conclusion

There is no difference between the demoulding time between the two gelatines, even if they have a different water amount. This means that the gelatine acts as a solidifier for the material. This result was also apparent with the 180 ml (72%) gelatine, but this gelatine sample experienced a lot of deformation. The 120 ml (57%) and 60 ml (40%) gelatine have less deformation, but the 60 ml (40%) gelatine is harder to process than the 120 ml (57%) gelatine. This means that the 120 ml (57%) is favourable opposed to the 60 ml or 180 ml.

The beeswax 80 and 100 ml did not succeed in increasing the processability.

## Tinkering: moldability

### Goal

There seems to be a balance between moldability and demoulding time. Therefore, it was interesting to research the ingredient that can influence the moulding time.

### Method

- 1) Original recipe: 60 ml water, 10 gram Lignin fibre, 10 gram starch, 5 ml acetic acid solution, 5 ml glycerol and 40 grams of tea
- 2) Beeswax: 60 ml water, 10 gram Lignin fibre, 10 gram starch, 5 ml acetic acid solution, 5 ml glycerol, 4 grams of beeswax and 40 grams of tea
- 3) Without Lignin fibre: 60 ml water, 10 gram starch, 5 ml acetic acid solution, 5 ml glycerol and 40 grams of tea
- 4) Extra water: 80 ml water, 10 gram Lignin fibre, 10 gram starch, 5 ml acetic acid solution, 5 ml glycerol and 40 grams of tea

Each recipe was fabricated and left on a silicone mat in the shape of a ball. Each ball weighed 50 grams. Time intervals were created at which the material would be broken apart and tried to be mended together. The material was marked as finished when the ball could not be mended together anymore.

	After 15 min	After 30 min	After 1 h	After 2 h
Original recipe	Yes	Yes	Yes	No
Beeswax	Yes	Yes	No	No
Without Lignin fibre	Yes	Yes	Yes	Yes
Extra water	Yes	Yes	Yes	Yes

table 9: Indications if the material was still shapable after some time.

In this table, the time stamps can be seen at which the 4 materials were tested. Yes means that the material could be broken and mended without much difficulty. Cracks would disappear and the material has a homogenous look. No means that the material could not be mended. Cracks were still appearing after kneading and the material does not have a homogenous look.

From this table some moldability times can be created:

Material	Time wherein it is still mouldable
Original recipe	1 h 45 min
Beeswax	45 min
Without Lignin fibre	3 h and 45 min
Extra water	3h and 45 min

table 10: moldability times of the materials.

It should be noted that a prolonged moulding time could also mean that the demoulding time could be increased, creating a reduction of the processability of the material. An increased demoulding time could also serve the risk of creating mould.

## Tinkering: Gelatine variations

### Goal

The gelatine 1:3 recipe has been tried out with 60 ml, 120 ml and 180 ml of water. To be more consistent in a similar way as the beeswax, the values in between should also be tested. The goal of this tinkering is to determine how the processability can be influenced by the water content.

### Method

Since it is clear that the 180 ml gelatine is not a favourable result, and the 120 ml is getting near the preferred result, it would make sense to only try

80 ml and 100 ml of water, creating a range from 60,80,100,120 and 180 ml.



figure 61: Gelatine variations

### Conclusion

The 80 ml sample was tough regarding processing, while the 100 ml sample was better. However, the surface quality of the 100 ml compared to the 120 ml is very different. The 120 ml is much smoother, while the 100 ml can have some defaults and roughness.



figure 62: Left is the 100 ml, right is the 120 ml.

The grind size of the tea should be the same. The 100 ml has more pores compared to the 120 ml.

## Tinkering: Reprocessing

It was apparent that there should be water present with the samples if they would need to be reprocessed. The gelatine 1:3 samples were already put in an oven before. The inside melted, and the outside not. Then, the samples were soaked in water and put in a heated oven. The outside started to degrade, but after too long in the oven, the water evaporated. The area that has been stuck between the sample and the silicone bottom remained having water, causing it to be melting there. The material was not deformed, but it could be reshaped.

### Working method

The first method is to put the gelatine sample in a climate chamber. Outside humidity is around 50-60%. A climate chamber can be put on 90% with 70 degrees Celsius for 30 minutes.

The second method is to granulate the beeswax and add the water that has been lost to the new mould and put it in the oven with the granulate.

The third method is to steam the sample. Steaming occurs at 100 degrees and the humidity is more apparent than a climate chamber.

### Results

The climate chamber has caused the material to be slightly deformable, but not entirely.

The granulate method has caused the material to be able to be shapen or compressed together.

The steaming method caused the entire material to be reshapable.

### Conclusions

The steaming method is the most promising and is proof that reprocessing is possible for the material.

## Tinkering: shaping

### Method

The new material behaves in a different way than Jiwei's material. Jiwei's material was resembling a clay: it could be kneaded and moulded into shapes. When big volumes were made, it would crack. In this tinkering entry, different shapes of the material will be tested.

- 1) Big volume – The material will be shaped in a ball and left to dry. It is important that the material will not crack
- 2) Shape details – The material will be shaped in a cube of 2.5\*2.5\*2.5 cm. It is important that the material will take the corners of the material well
- 3) Prints – The material will be pressed in a circular ring and a 3D print will be stamped on it. The 3D print has three variations: Concave rose design, convex rose design and concave spikes. The rose design is a random pattern that has some shallow details. The difference between concave and convex is to determine if the material is able to go into narrow moulds. The concave spikes is to determine if the material will take the shape of small pointed shapes.

## Intermediate results



*figure 63: pressing the tea clay with a mould.*

The spiked mould was pressed down on the material, and could not be removed. After the material has reached the gummy state, it could be removed.

The same could not be done with the rose stamps, because the shapes were not protruding enough. For the rose shapes, the material was laid on the shape. Gravity would cause the material to flow in the cavities.

A ball was created by just rolling the material together. Since the material does not have clay properties anymore, the rolling was not very possible because it would stick to the gloves. A ball was nevertheless shaped.

The materials were in the gummy state within an hour and the moulds could be removed.



*figure 64: All the figures were converted to the material*



*figure 65: geometric shapes were converted to the tealay.*



*figure 66: some details were not conveyed, especially if the mould had small gaps.*

Not all details were converted, such as very small cavities. This could probably be changed if the demoulding happened a bit later.



*figure 67: Still some finer details were missing.*



*figure 68: excess material created a thin material.*

The spiked figure had excess material that squeezed out. It became a very thin layer of material that has transparency.



*figure 69: the demoulded material conveyed the lines of the 3D printed mould.*

The gummy state has a shine and conveys the lines of the 3D printed mould as well. This is similar behaviour that was observed for Jiwei's material.

## Results

The material can be shaped in moulds and compression. The moulds will be downwards, and a tamper will be used to compress the material onto it.

When dried, the thin structure of the material curls due to high deformation.



*figure 70: the thin material warps when dried.*



## Tinkering : Steaming time

### Goal

The 120 ml (57%) gelatine 1:3 sample has been steamed for 30 minutes, and this created the possibility to deform the material. It is however not clear whether 30 minutes is the maximum, or that even more deformation could occur. There is also the “gummy state”, this happens within one hour of creating the material This gummy state has shape memory effects, and it is therefore interesting to know when the gummy state is achieved.

### Method

A tamper needs to be 3D printed for this experiment to compress the sample.

10 minutes

20 minutes

40 minutes

50 minutes

80 minutes

### Results

The gummy state is not within these time frames. The gummy state is a temperature and water balance. The temperature should be somewhere between 20 (room temperature) and 10 degrees. Steaming occurs at 100 degrees only. So, the gummy state would occur in the very first minutes when the sample is placed in the steamer.

A new test needs to be done where samples will be steamed from 5,10,15,20,25 and 30 minutes. A weight of 1kg will be put on the samples for 1 minute and the thickness of the material will be measured.

Therefore, 6 samples will be needed for this.

## Tinkering, saturation steaming

### Goal

The goal of this research is to determine the time that the teaclay needs in order to be saturated with water and able to be moulded after steaming. This is essential information for the production of teaclay

### Method

6 teaclay blocks of the same size and weight were used for this test. Each block will undergo different times for steaming. After the steaming time, the block will be compressed with a weight of 1 kg for 1 minute. After the material has properly dried, the thickness of the material can be measured.

The blocks will be steamed in the times of

5 minutes

10 minutes

15 minutes

20 minutes

25 minutes

## Results

Sample	Steaming time	Thickness average
1	5 min	14,4 mm
2	10 min	10,2 mm
3	15 min	10,15 mm
4	20 min	9,25 mm
5	25 min	9,1 mm
6	60 min	9,15 mm

table 11: the steaming times and respective thickness after compression.

This table illustrates the thickness of the sample. It is shown that the thickness does not vary much after 25 minutes of steaming compared to 60 minutes. It is therefore believed that 25 minutes is enough time to saturate the sample.

## Tinkering, Scenting

### Method

There are 3 methods for implementing scents.

- 1) Steam the material and dried scenting objects together, under each other.
- 2) Spray the material with essential oil
- 3) Dip the material in beeswax with essential oil



figure 71: sample dipped in beeswax with essential oil. Figure 66: sample steamed with dried flowers.

Two different scents will be used. The users have to evaluate the quality of the scent, and if they can distinguish the scents. This means that 6 samples have to be created.

Goal:

- 1) Determine perceived scent quality over time
- 2) Determine if different scents can be observed
- 3) Determine the best method for scenting : Best quality over time and best scent distinguishing.

Session 1: 14<sup>th</sup> of June

Session 2: 21<sup>th</sup> of June (1 week since creation)

Session 3: 12<sup>th</sup> of July ( 4 weeks since creation)

## Questions

Choosing participants:

- 1) On a scale of 0 to 5, how well can you smell through your nose ( 0 = not good, 5= very well)
- 2) How strong would you rate the scent ( 0 to 10) 0= I don't smell anything at all, 10 = The smell is very strong
- 3) Give the participant three of the same scent. "You have three samples in front of you. Which one would you rate as strongest smell and which one the weakest?"
- 4) Repeat step 3 with the other scent
- 5) Present all six samples to participant
- 6) Which one would you rate as the strongest from all?
- 7) Which one would you rate the least strong?

## Consent form

### STUDY DETAILS

The purpose of this study is to determine the user's perception on the smell of some samples. Several scenting techniques are used to scent the samples. The goal of the user is to indicate the strongest and least strongest smelling sample at 3 time moments. The participant will also be asked to rank the samples from strongest to least strongest.

### REGULATIONS

In case that you are experiencing symptoms that might be COVID-19, it is advised to stay home and notify the researcher as soon as possible. An alternative time can be planned according to your wellbeing.

### DATA WE WILL COLLECT

During the study, you are free to ask any questions. The researcher will answer these questions if the information does not influence the results. The data that we will collect are the speeches that the participants have shared during the research. These speeches will be transcribed immediately and treated as notes. Pictures will not be taken.

### HOW WE WILL USE YOUR DATA

Any data, recording or other personal information collected about you will be treated confidentially. Notes are used for internal purposes. Responses will also be anonymized.

### YOUR RIGHTS

Your participation in this study is voluntary. You can take a break or discontinue participation at any time without giving a reason.

## YOUR CONSENT

I give my consent:

- For Sylvia to use the notes for internal purposes
- For Sylvia to aggregate and anonymize my data to share study results externally

By signing below, you acknowledge that you are 18 years of age or older and have read and understood the information in this Research Consent Form.

X

X

## Results

The participants have expressed their ability to smell. This is a numeric value and can be used as a compensation factor. If a person rated their smelling capability with 4 out of 5, the compensation factor will be 0,8. This indicates that each value the participant has given for the strength of the sample will be multiplied by this factor. This normalises the data between the participants.

Each week, the participants have the same format for filling in their responses.

P1D1	Smelling capability (0 to 5)				
	2	Compensation factor		0,4	
	Odour rate (0-10)	Ranking Rate	Compensation value	Strong-est	Weak-est
SC1	3	3	1,2		
SC2	7	2	2,8		
SC3	5	1	2		
SR1	4	3	1,6		X
SR2	6	1	2,4	X	
SR3	8	2	3,2		

table 12: the table used for collecting data from respondents.

Graphs were created for each sample. With each participant's response and time of evaluation. The compensated values were taken. The average was drawn to illustrate the progression over time.

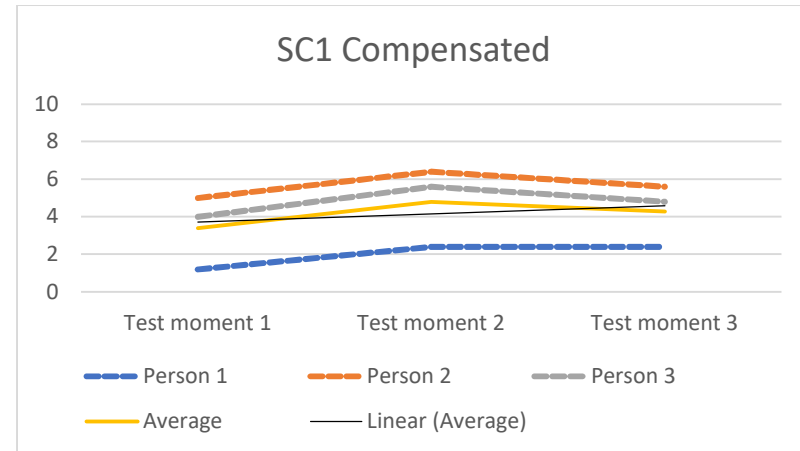

figure 72: Steaming teaclay with camomile flowers.

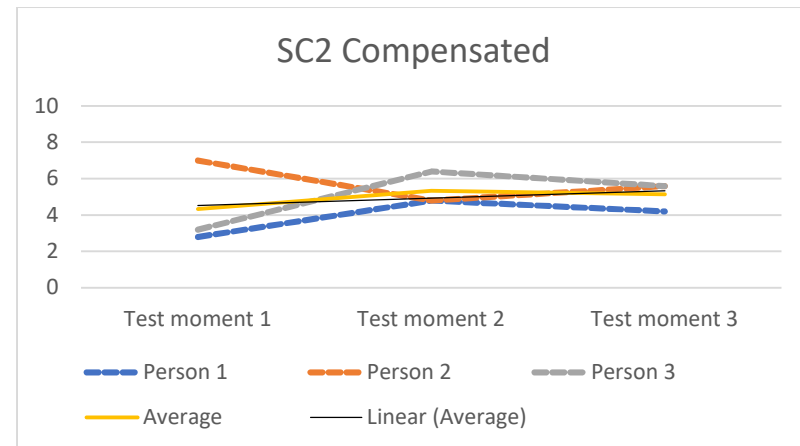

figure 73: spraying teaclay with camomile essential oil

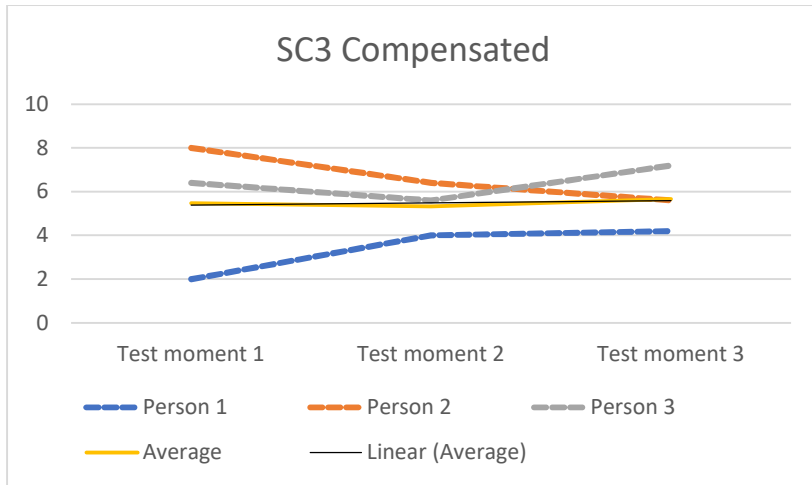

figure 74: dipping teaclay in beeswax with camomille essential oil

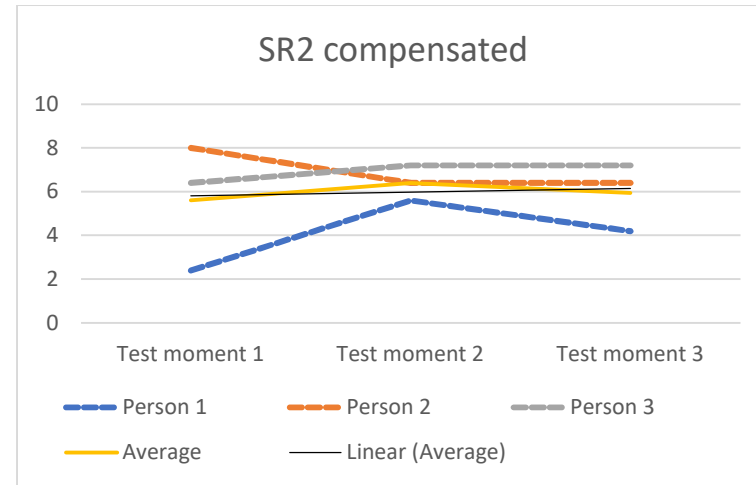

figure 76: spraying teaclay with rose essential oil.

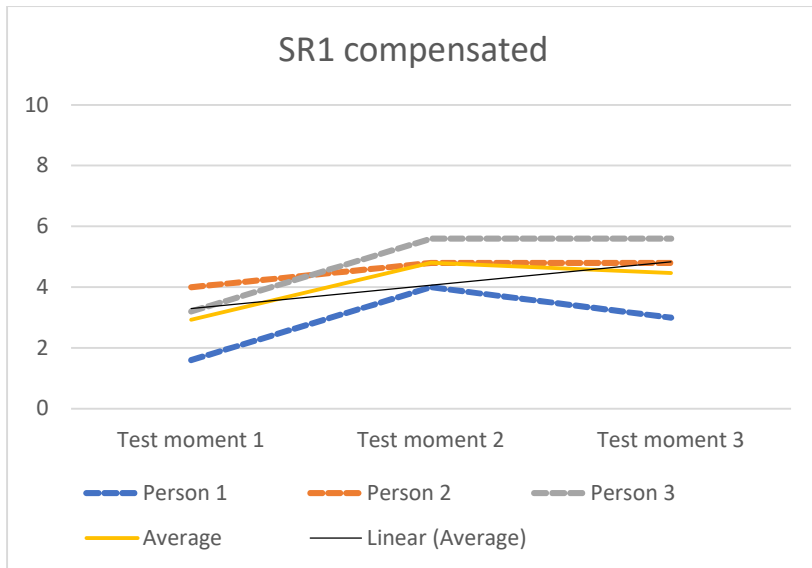

figure 75: steaming teaclay with dried roses.

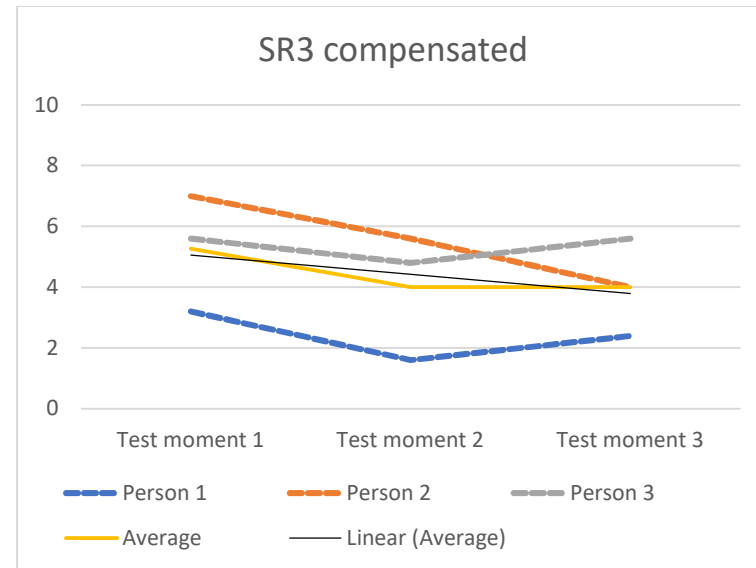

figure 77: dipping teaclay in beeswax with rose essential oil.

It can be seen that SR2 performs the best over time, with the least decrease and highest average score. It is interesting to see that SC2 performs differently, even when the scenting method is the same. This could be probably due to the scent itself. More research should be performed into different scents and their durations. Next to that, SR2 was chosen as the strongest sample by all participants, at each session.

## Appendix B: Technical characterisation

### Technical testing, bending

#### Goal

The bending test will provide stress, strain, elastic modulus and fracture toughness.

#### Method

3 samples will be created according to ISO 178 standards.

The samples will be 16\*2\*0,8 cm . Shrinkage is around 40%, so the moulds will have an increase of 40%.

#### Results

Zwick Z010

Make sure to set the end-switch on the machine such that the machine cannot crush itself!

Pre-load : 2 N

Test speed : 10 mm/min

#### Test results:

Legend No.	Date/Clock time	F <sub>max</sub> N	dL at F <sub>max</sub> mm	F <sub>Break</sub> N	dL at break mm	W to F <sub>max</sub> Nmm	a <sub>0</sub> mm	b <sub>0</sub> mm	S <sub>0</sub> mm <sup>2</sup>
1	31-7-2023 11:09:58	64,8	8,5	-	-	342,24	7,5	22	165,00
2	31-7-2023 11:28:23	55,3	10,0	-	-	364,99	6,9	22	151,80
3	31-7-2023 11:31:44	61,1	9,8	-	-	384,84	6,9	22	151,80

Legend No.	t <sub>Test</sub> s
1	61,10
2	61,18
3	61,10

#### Series graph:

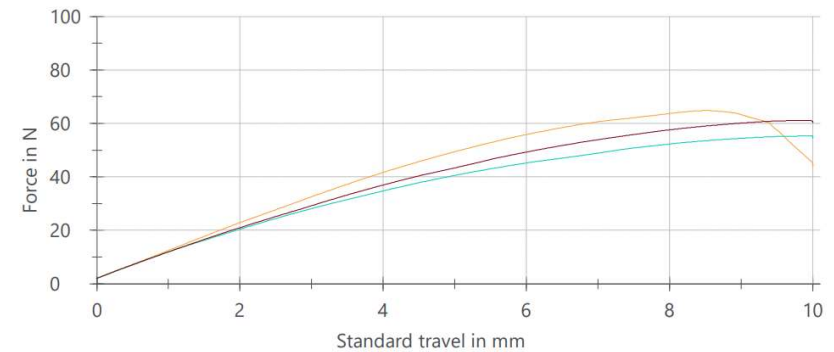

figure 78: the travel and force admitted on all three samples. The orange line breaks at around 9.6 mm travel.

#### Statistics:

Series	F <sub>max</sub> N	dL at F <sub>max</sub> mm	F <sub>Break</sub> N	dL at break mm	W to F <sub>max</sub> Nmm	a <sub>0</sub> mm	b <sub>0</sub> mm	S <sub>0</sub> mm <sup>2</sup>	t <sub>Test</sub> s
n = 3									
x	60,4	9,4	-	-	364,02	7,1	22	156,20	61,13
s	4,80	0,8	-	-	21,31	0,3464	0,000	7,62	0,04
v [%]	7,95	8,49	-	-	5,86	4,88	0,00	4,88	0,07

These results show that from 3 samples, one has broken and two not. The average maximum force is 60,4 N. The test was set up that it would only bend the samples 10 mm. The maximum force can be taken to calculate the Young's Modulus.



## Technical testing, hardness

### Goal

Determine the hardness of the material, to determine whether it has impact resistance and is comparable to other materials.

### Method

A slab of 4 mm thickness will be sawed from the cross section of the material. The slab will be sanded to make sure of an even surface. A durability tester D will be used on 5 different locations of the sample. An average of the 5 values will give the hardness of the material.

### Results

	Shore
Test 1	48
Test 2	51
Test 3	54
Test 4	50
Test 5	49
<b>Average</b>	<b>50.4</b>
<b>Standard dev.</b>	<b>2.09</b>

table 13: shore measurements at five different locations.

## Tinkering, viscosity

### Goal

The viscosity of the material is researched to have a better understanding of its behaviour.

### Method

A rheometer will be used to determine the viscosity of the material. A flow sweep will be used. The rheometer will be preheated to 70 degrees, because this is the temperature in which the material moulded.

### Results

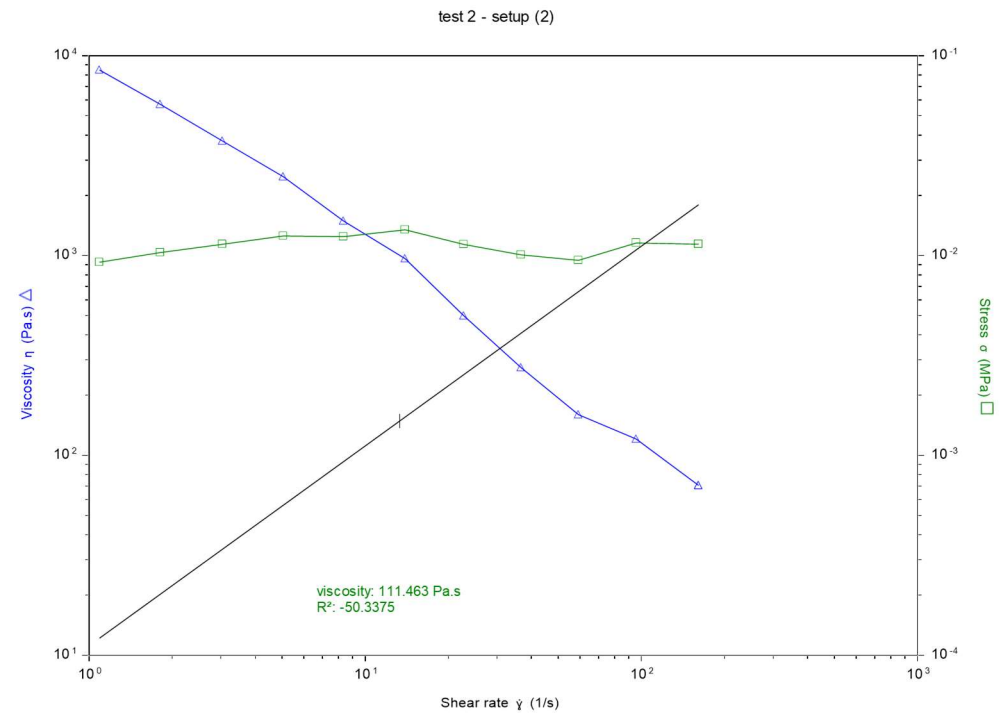

figure 79: viscosity and shear rate graph for 120 ml water sample.

Flow sweep - 1					
Stress	Shear rate	Viscosity	Step time	Temperature	Normal stress
MPa	1/s	Pa.s	s	°C	MPa
0,009259	1,09121	8485,41	34,9482	69,97	0,079082
0,010353	1,81215	5712,94	69,9904	69,98	0,079234
0,01139	3,04283	3743,3	105,199	70,02	0,079299
0,012533	5,05287	2480,35	140,505	69,99	0,079277
0,01243	8,34766	1489,05	175,635	69,99	0,079313
0,013455	13,9558	964,098	210,919	70	0,079434
0,011366	22,7658	499,277	246,073	70	0,079931
0,010081	36,6953	274,714	281,196	70,01	0,079739
0,00946	59,1999	159,8	316,244	70	0,080051
0,011562	95,8448	120,637	351,482	70	0,080054
0,011395	161,178	70,6977	386,677	70	0,079303

table 14: Test results for one water variant, where the viscosity is inaccurate after 10 shear rate

The material was in the gummy state when it was loaded in the rheometer. This seemed like a problem at first, but the 70 degrees and the compression caused the material to be completely fluid. This is a very insightful observation, because this gives more insight in how the material can be reprocessed and how the material behaves.

To ensure that the viscosity that is measured is correct, some variants need to be measured as well. These variants can have a similar effect, or even totally different, based on some small changes.

It is a good idea to measure the viscosity of 60 ml, 120 ml and 180 ml water.

Three samples were created with varying water variations. The hypothesis is that more water means a less viscous material.

During testing, the samples started drying up as the test progressed. This resulted in material to slip out from the device. The device then recorded inaccurate data.

The shear rates at 1,5, and 10 (1/s) were taken with their respective viscosities. Graphs were created. Table 15 shows the complete viscosity data.

Appendix D: Design

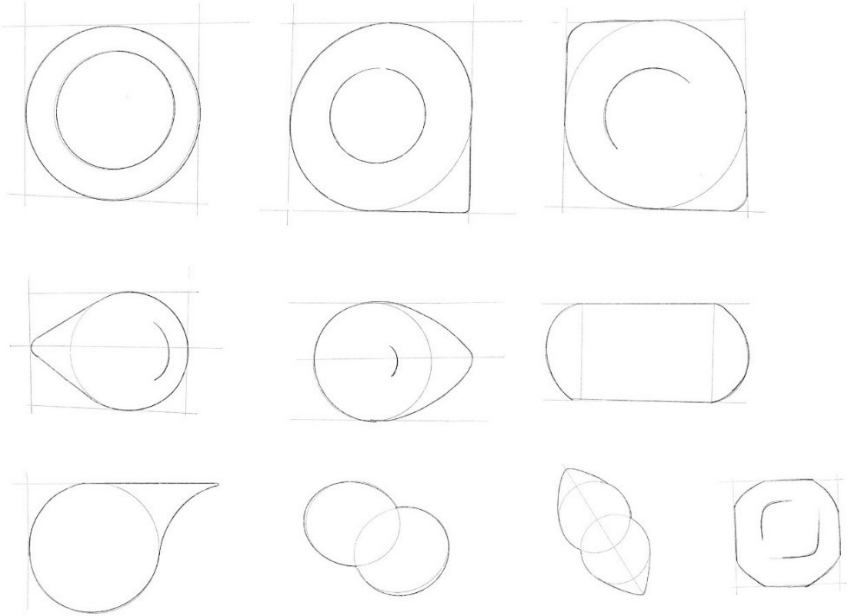
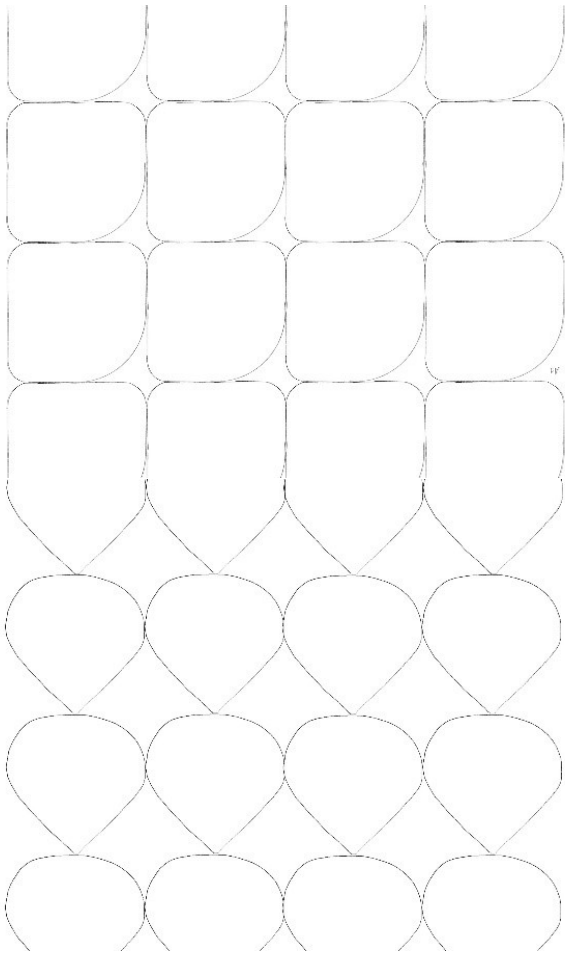

figure 82: Ideating on shapes for the game pieces.



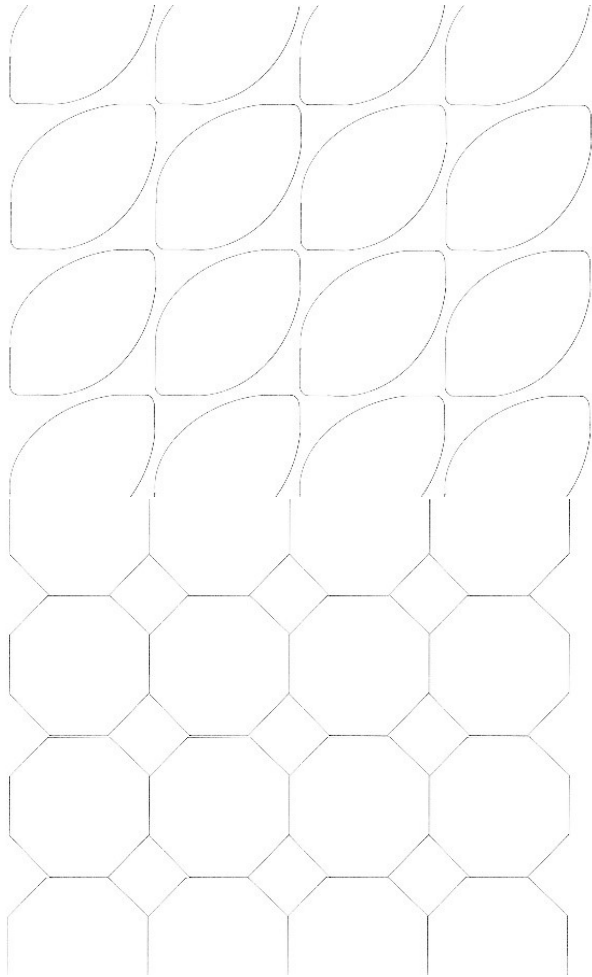

figure 83: Placing the shapes in a grid to determine whether there can be ambiguity.

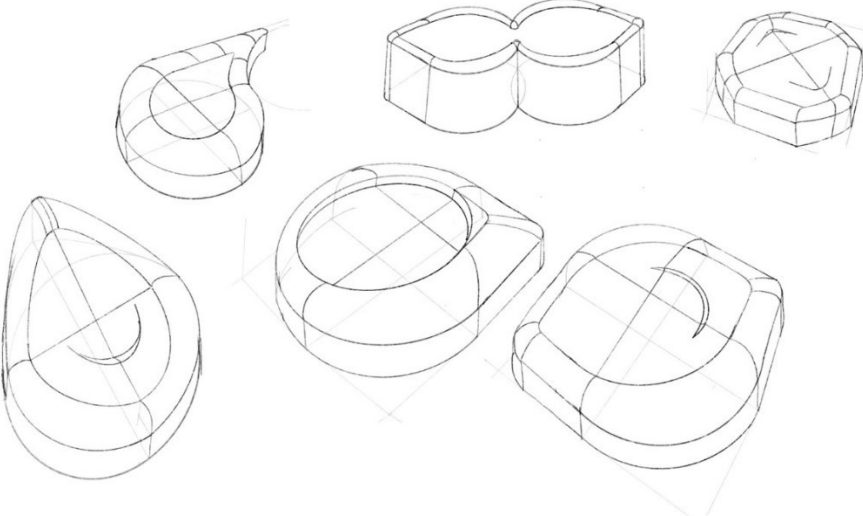

figure 84: 3D drawings of shapes.

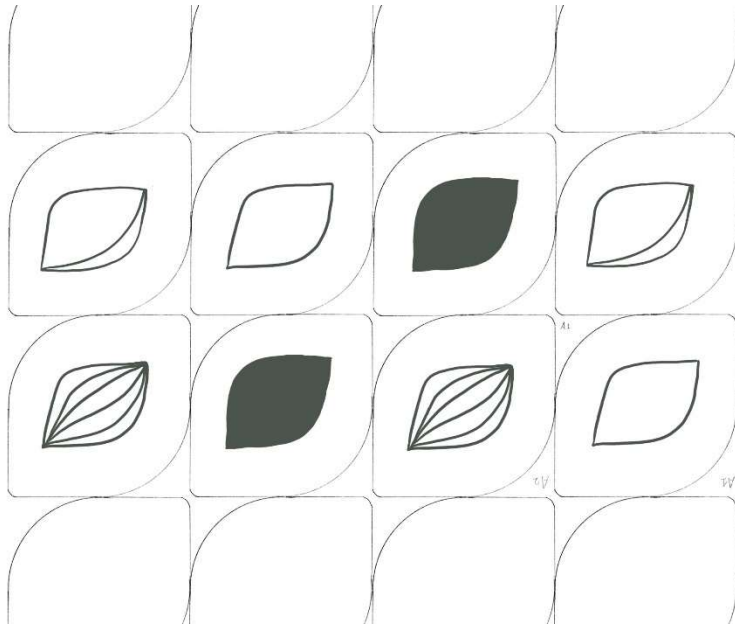

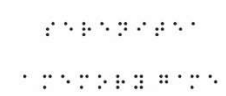



figure 85: Designing tactile patterns.



Serenitea  
a memory game





Serenitea is a memory game made from wasted tea leaves. These leaves come from drinking tea. Instead of throwing it away, they have been dried and made into a new game.



### Play with tactile

You can play memory based on touch. Each tile has a pattern on it. By playing with tactile, you need to find tiles with the same tactile pattern

Braille text describing a tactile pattern on a tile.



### Play with scent

You can play memory based on scent. If you flip the tiles, the hollow part has a smell. By playing with smell, you need to find tiles with the same smell

Braille text describing a scent pattern on a tile.

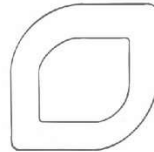

### Set up

Serenitea is played with 8 pairs (16 tiles). To choose which pairs you will play with, you both each grab 4 different pairs. Each player discards two pairs. You will not play with these tiles. The remaining tiles all go on the board.

Braille text describing the set up process for the game.

### Game play

pick 2 tiles  
are they a match?  
put them in the  
compartment  
and look for another pair

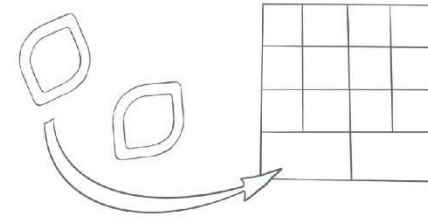

Braille text describing the game play rules.