

A vertical architectural model is shown on the left side of the slide. It features several stylized trees made of copper wire, standing on a light-colored base. The background of the model is a blurred view of a building's interior with a wooden ceiling and dark columns. The entire image is overlaid with a geometric pattern of white lines and semi-transparent teal and grey shapes.

ANNE KAMP | P5 PRESENTTATION | 26-06-2018

Mentors: Robert Nottrot, Hubert van der Meel,
Peter Koorstra and Daan Vitner

“Speaking architecture

*a semiotic study toward understanding visual
communication in architecture*

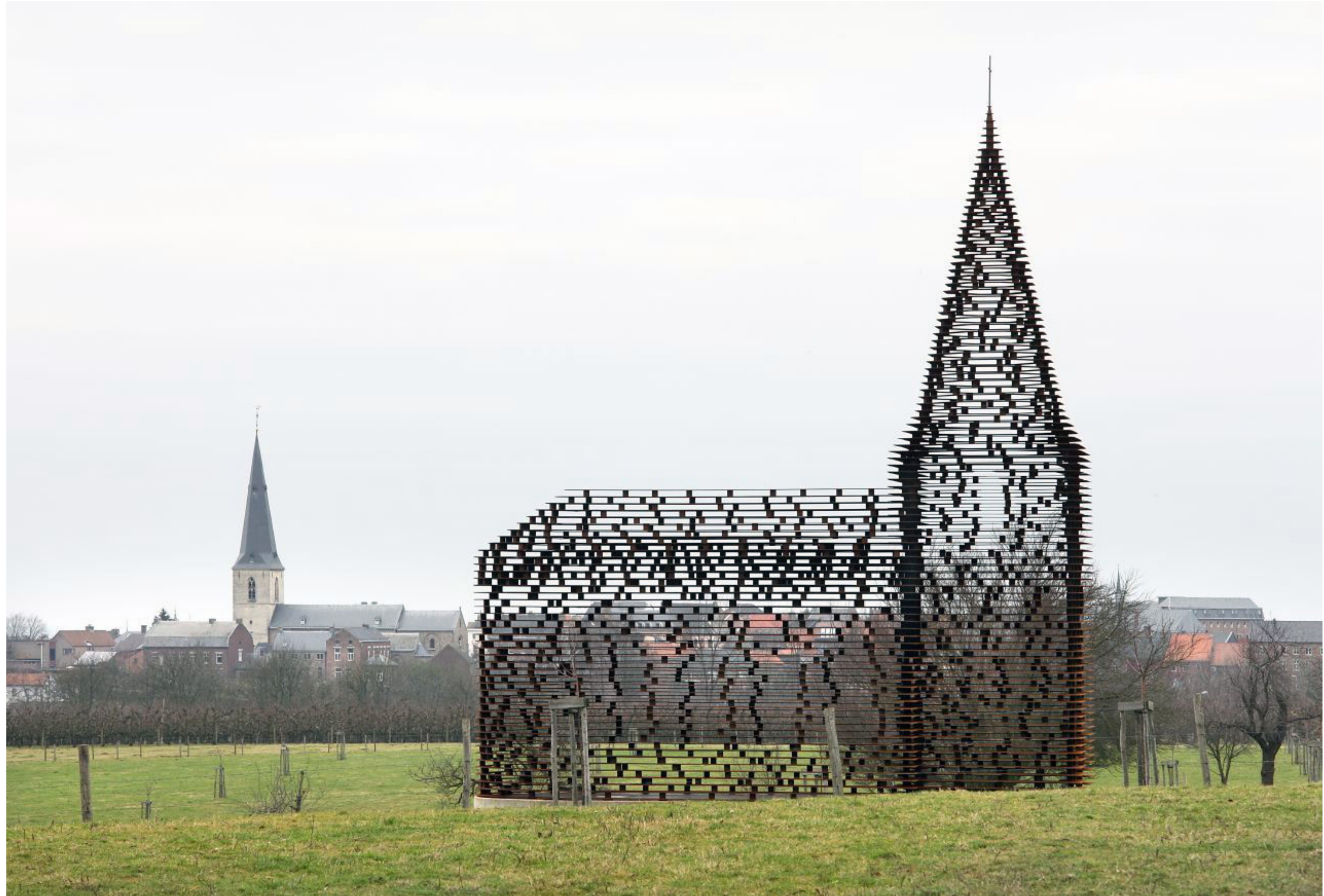





Architecture "speaks"

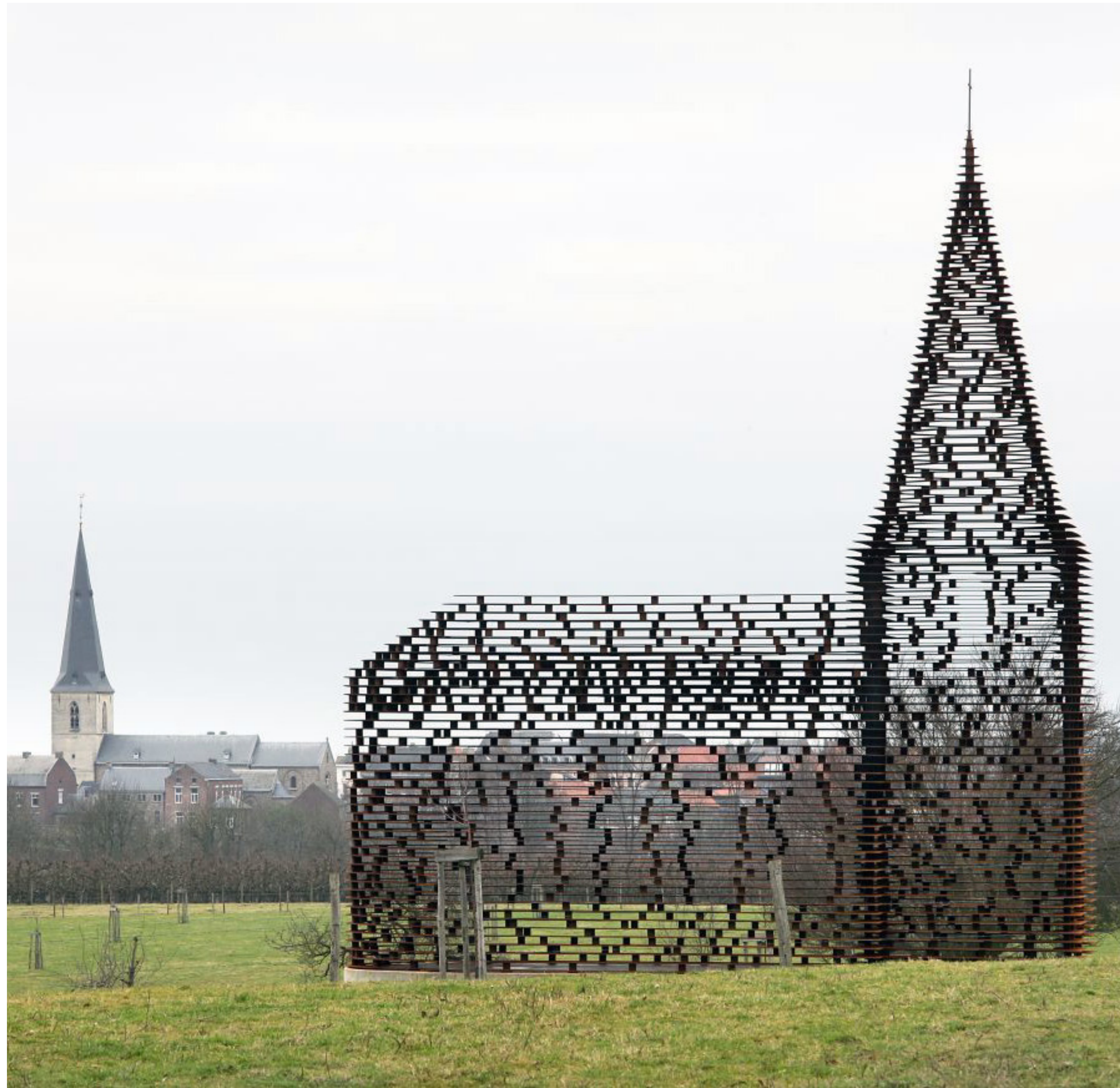

Architecture "speaks"

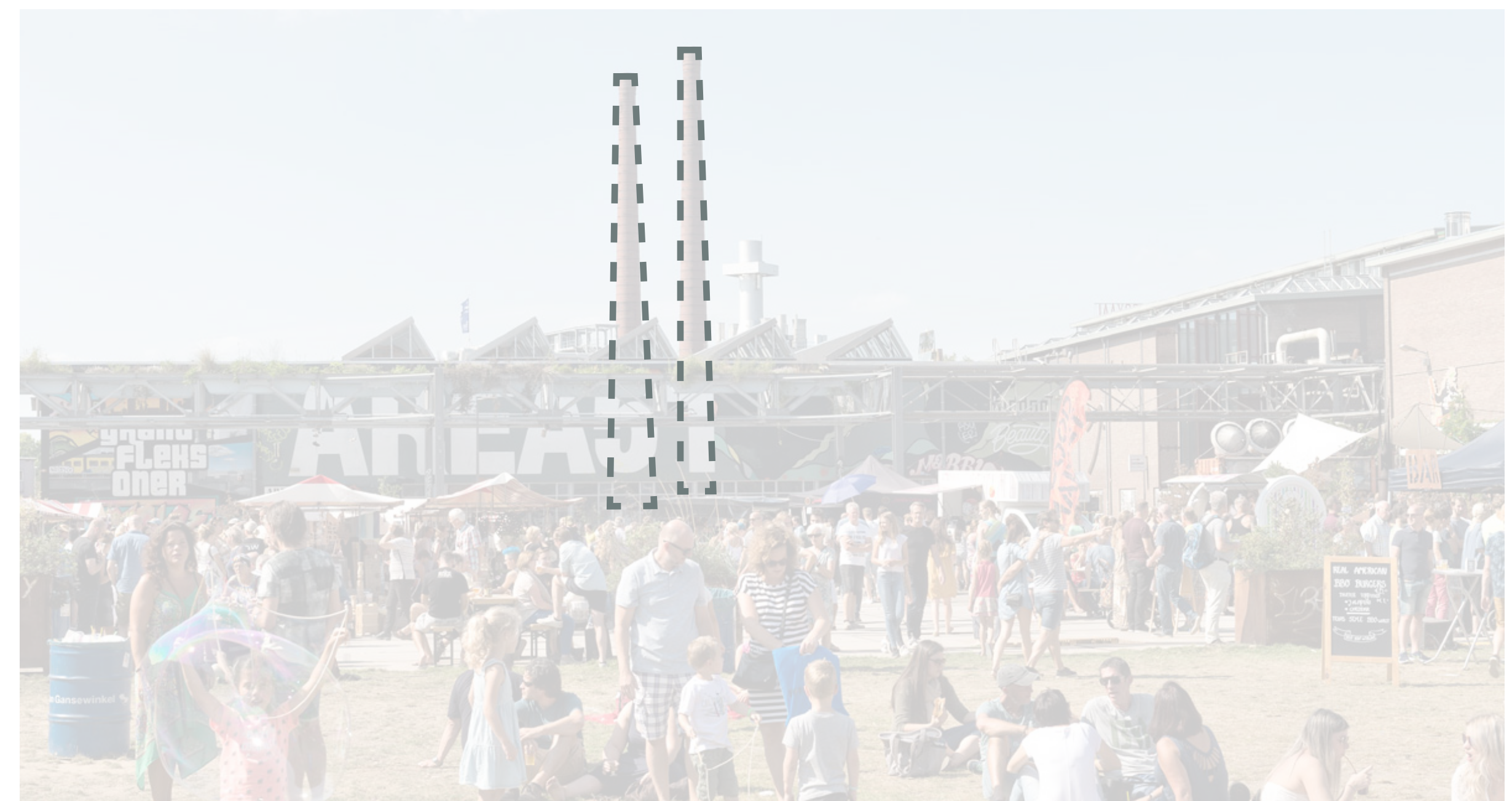
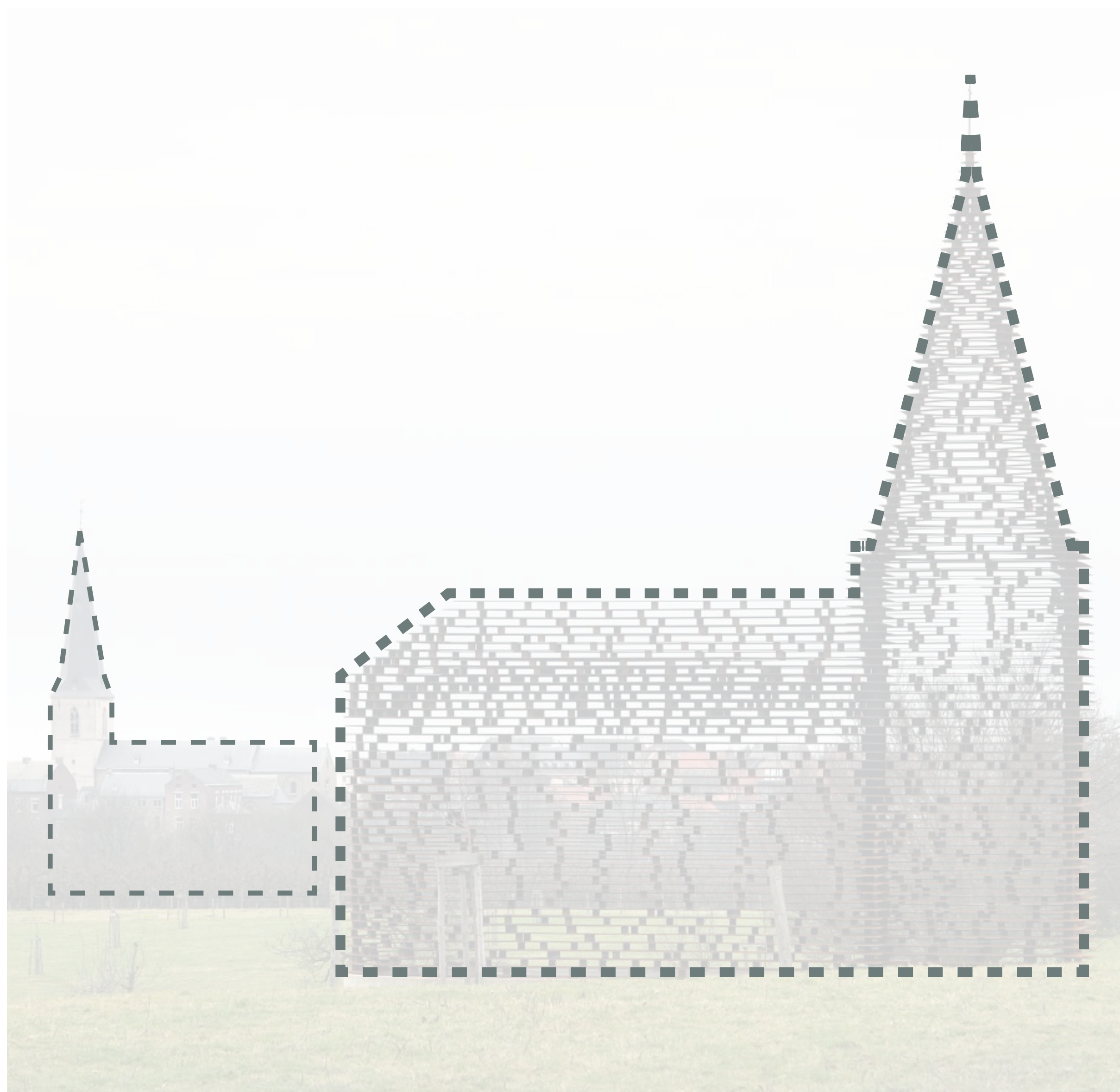

“Vormentaal”

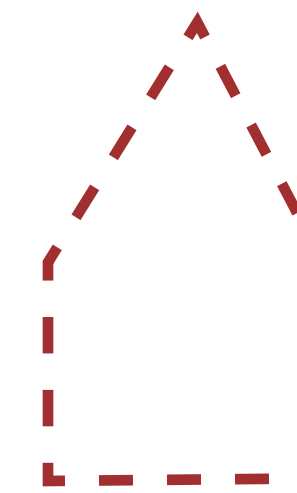
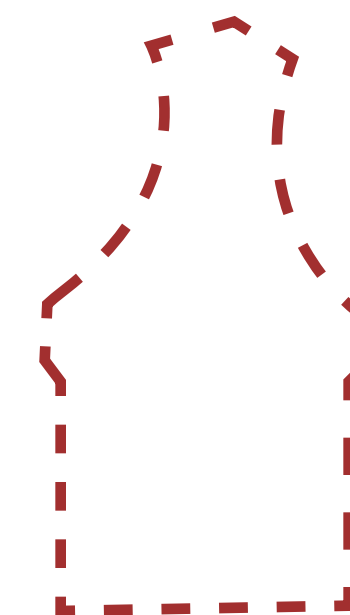
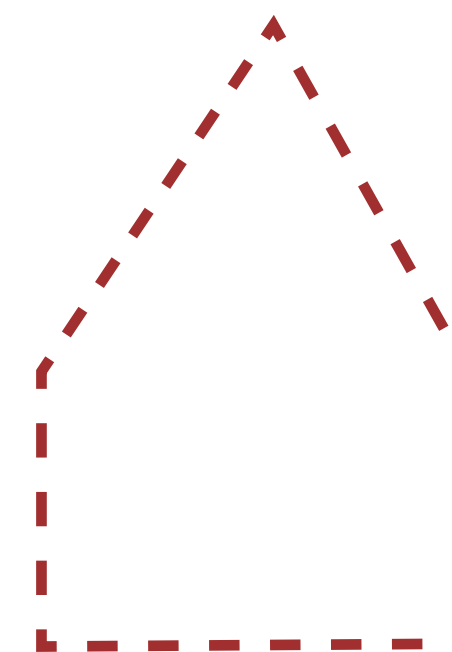
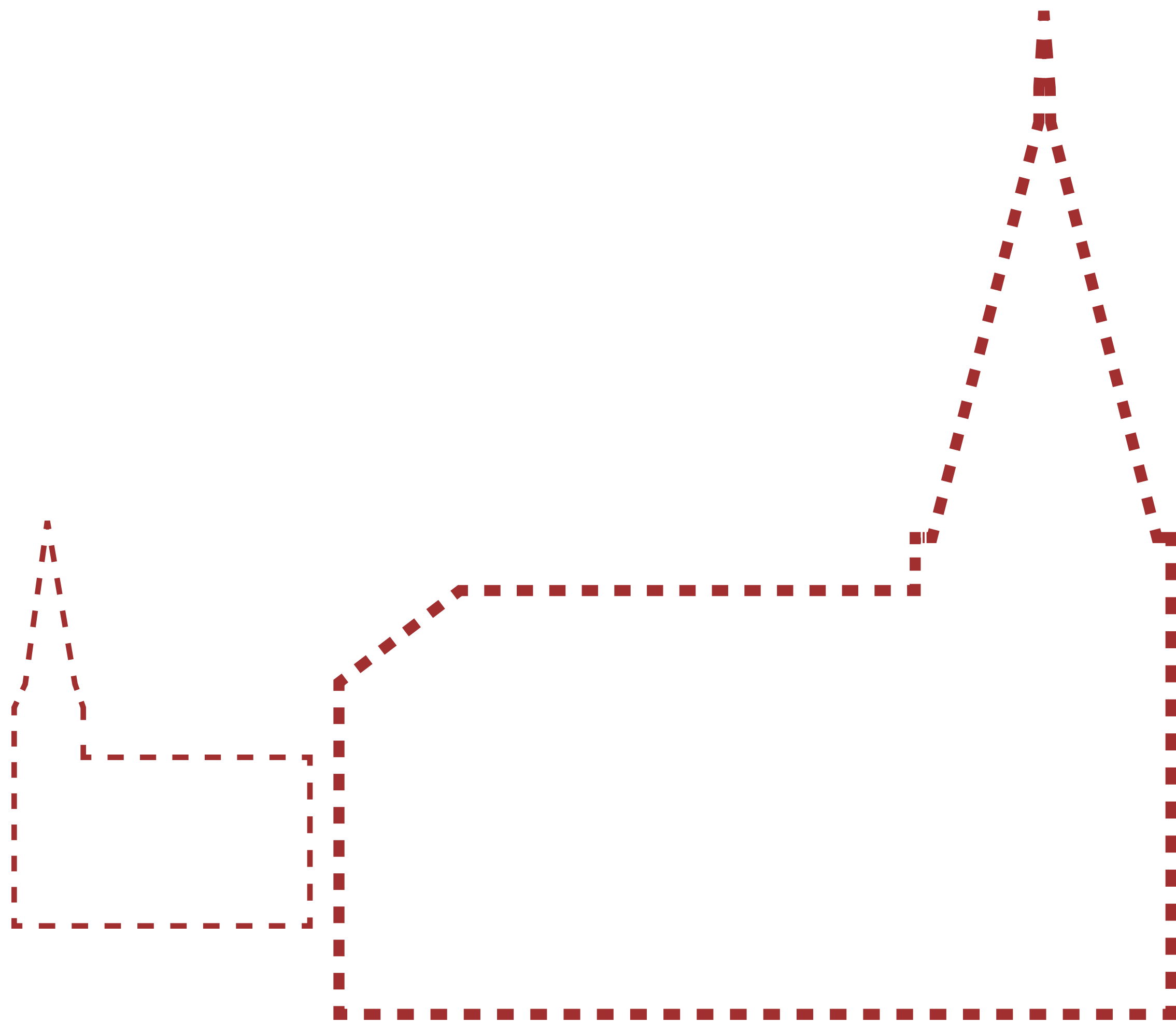

Presentatieopzet



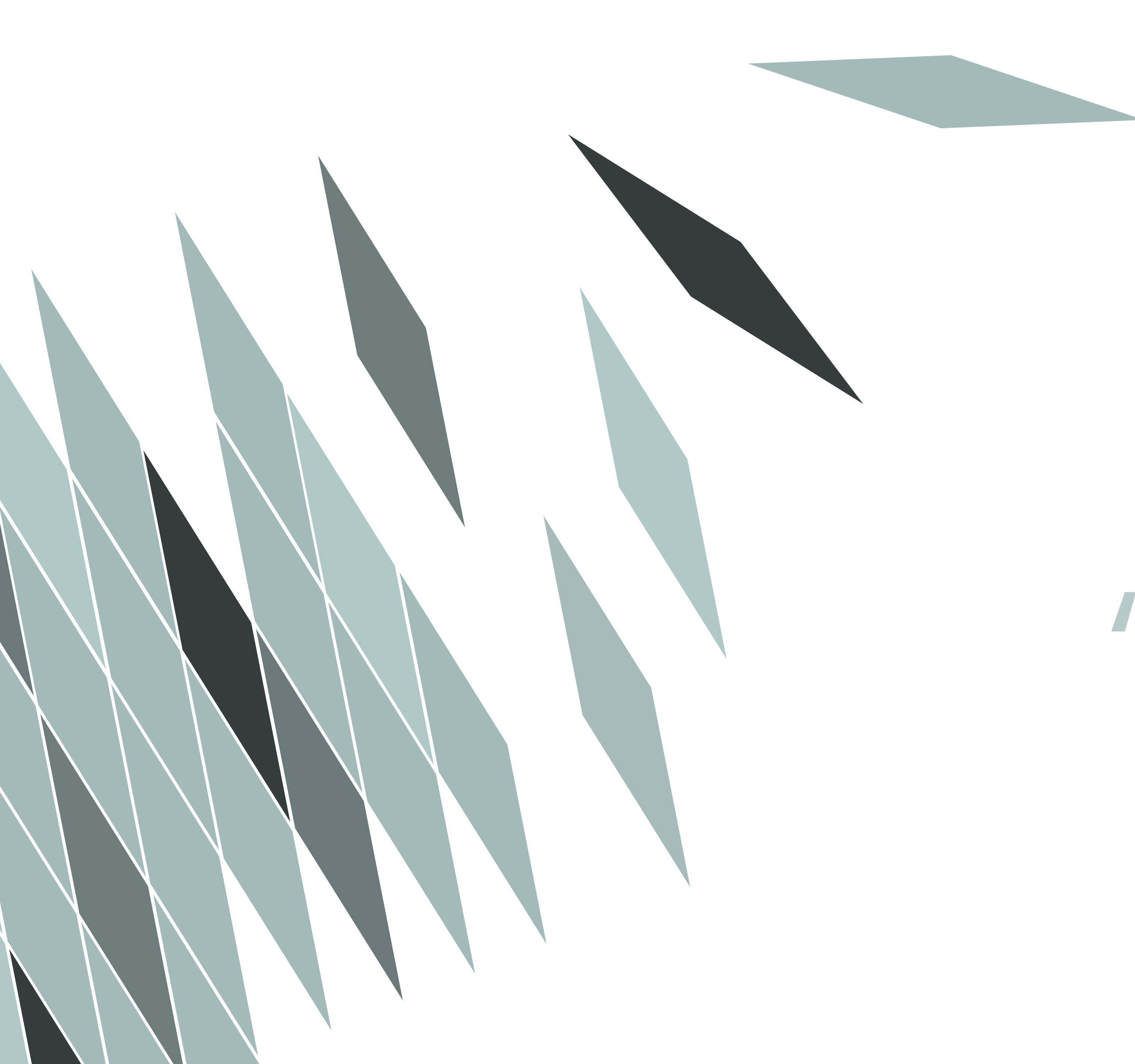

//Onderzoek

Speaking architecture



Architecture is not mute. It's an art of communication. It tells a story.

- *Libeskind (2009)*



What architectural principles play a role in architectural communication and in what way?



Onderzoeksvraag

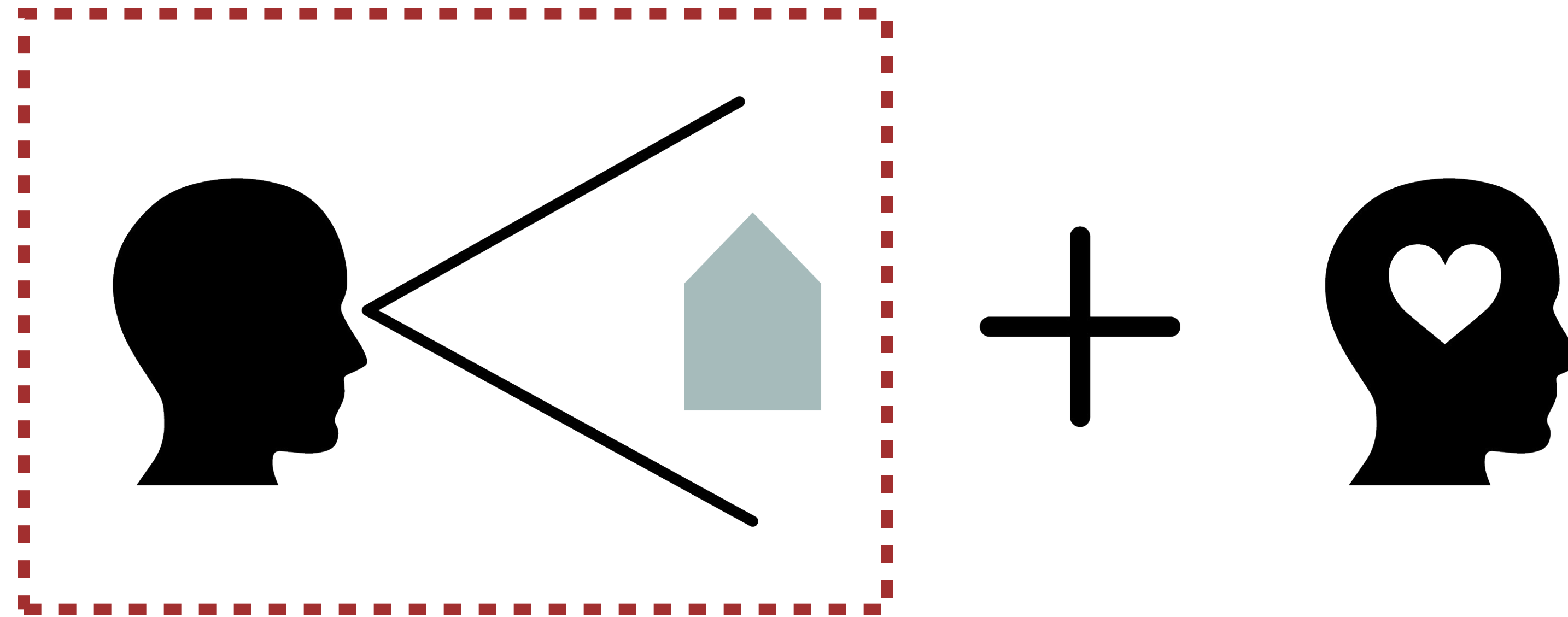

What architectural principles play a role in architectural communication and in what way?

Onderzoeksvraag

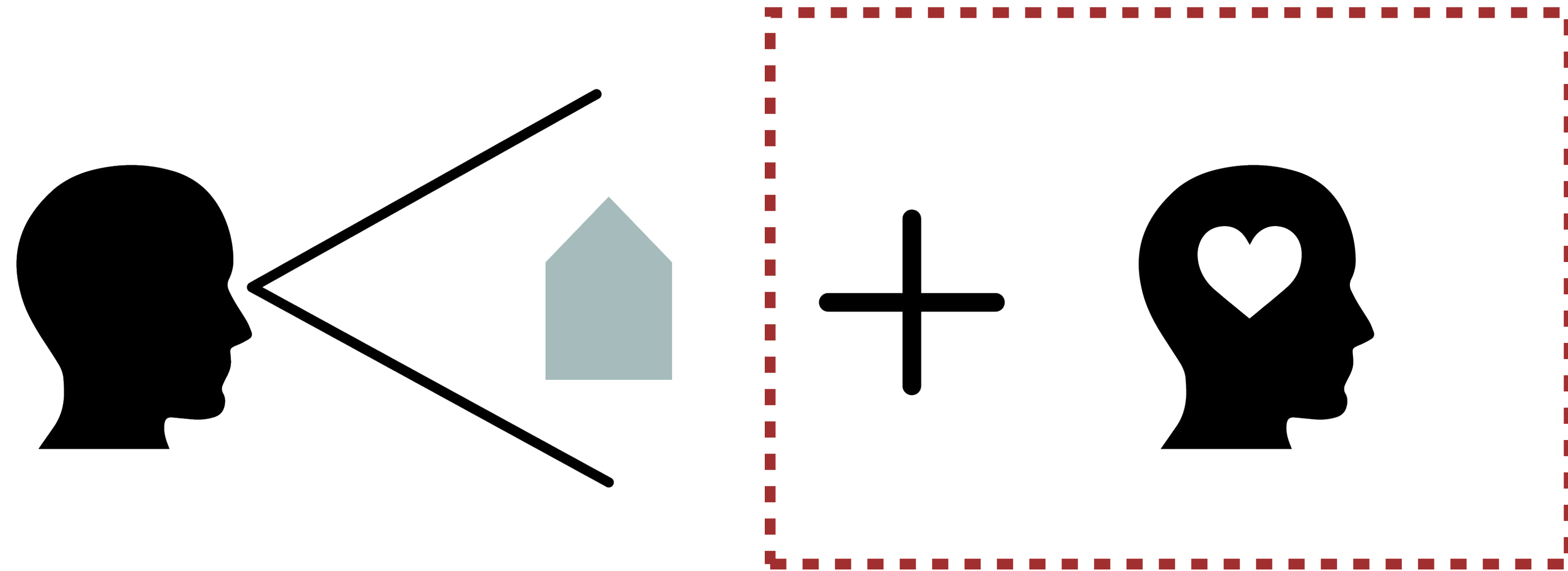

What architectural principles play a role in architectural communication and
in what way?

Onderzoeksmethode

What architectural principles play a role in architectural communication and in what way?

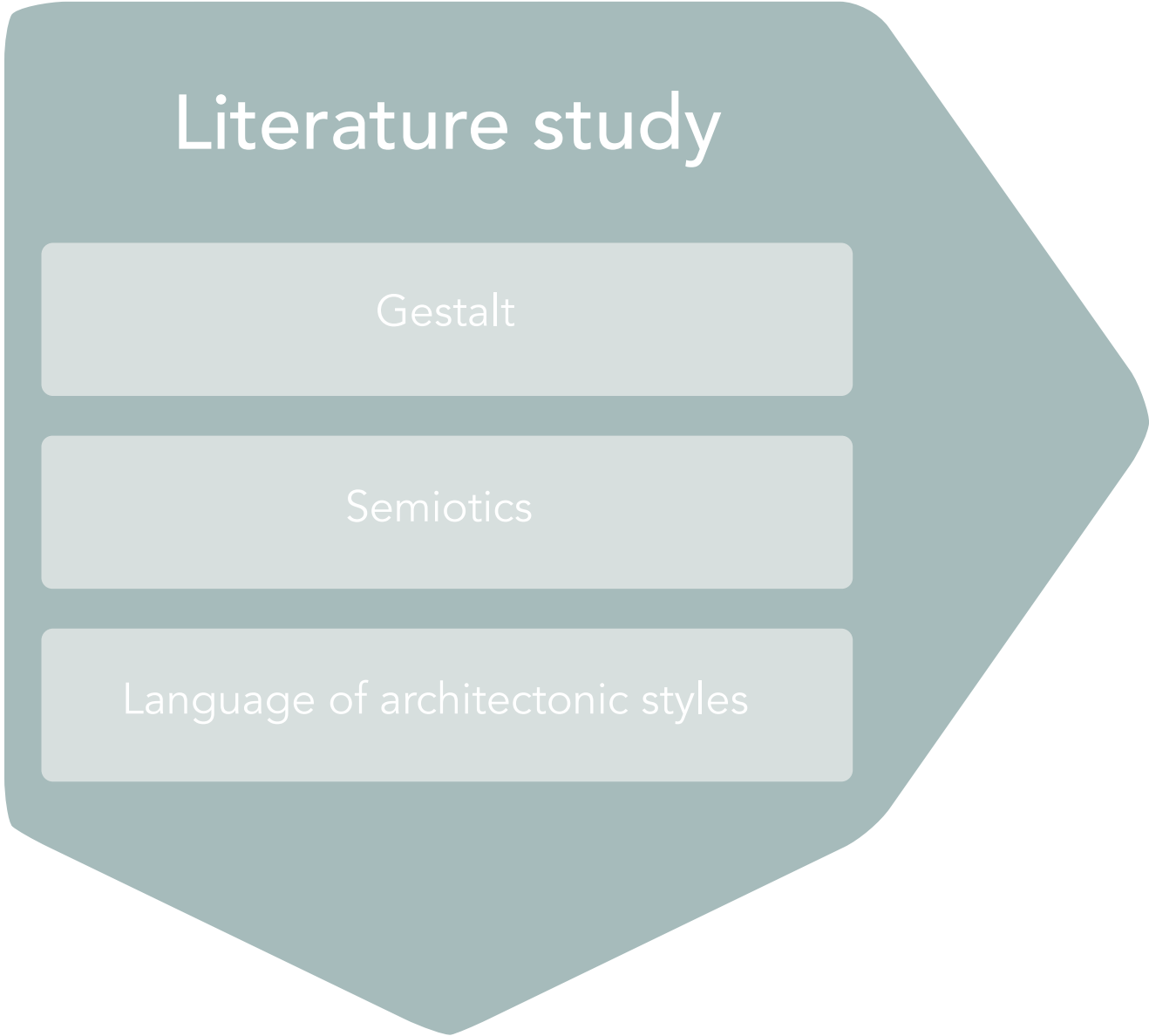

Conclusion

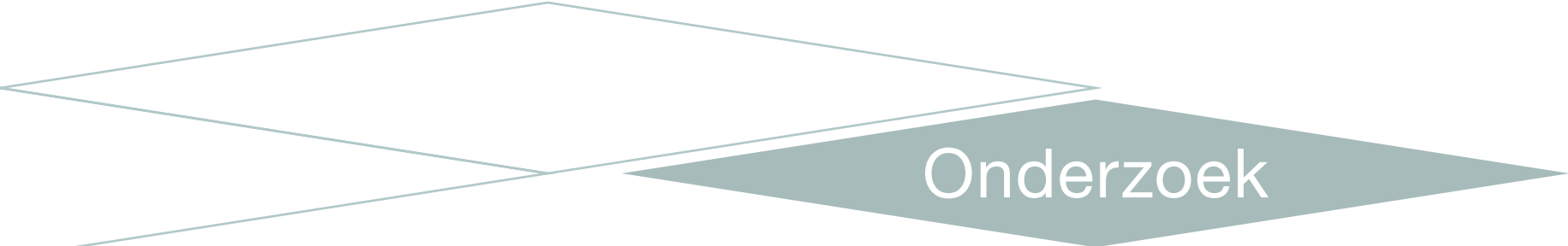

Language of architectural style

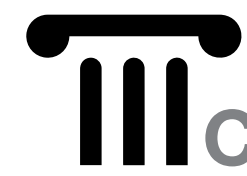

Classical language of architecture

John Summerson

VS.

Modern language of architecture

Bruno Zevi

<i>Order</i>	<i>Function</i>
<i>Symmetry & harmony</i>	<i>Asymmetry & dissonance</i>
<i>2D</i>	<i>3D</i>
<i>Composition</i>	<i>Decomposition</i>
<i>Aesthetics</i>	<i>True structure</i>
<i>Stagnation</i>	<i>Movement</i>

Gestalt theory

*Based on Prak (1977)

Law of proximity:

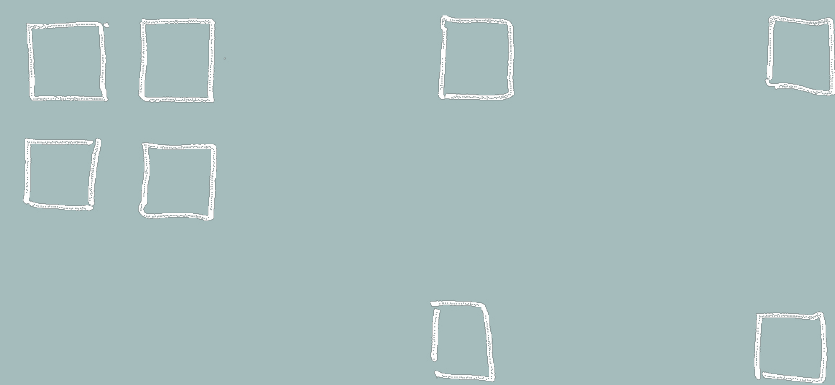

Law of simplest and largest figure:

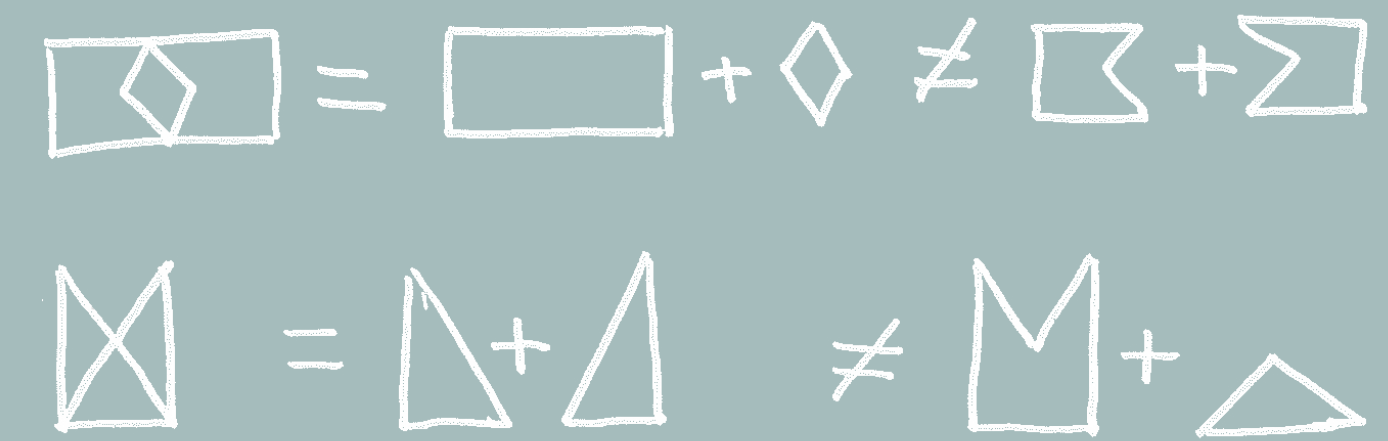

Law of similarity:

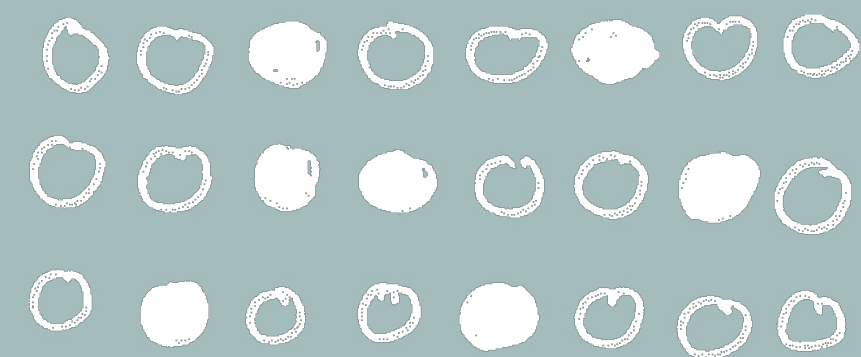

Law of continuity and closure:

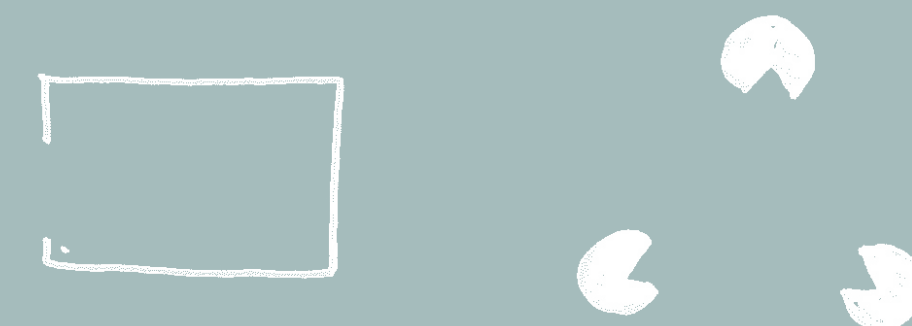

Semiotics

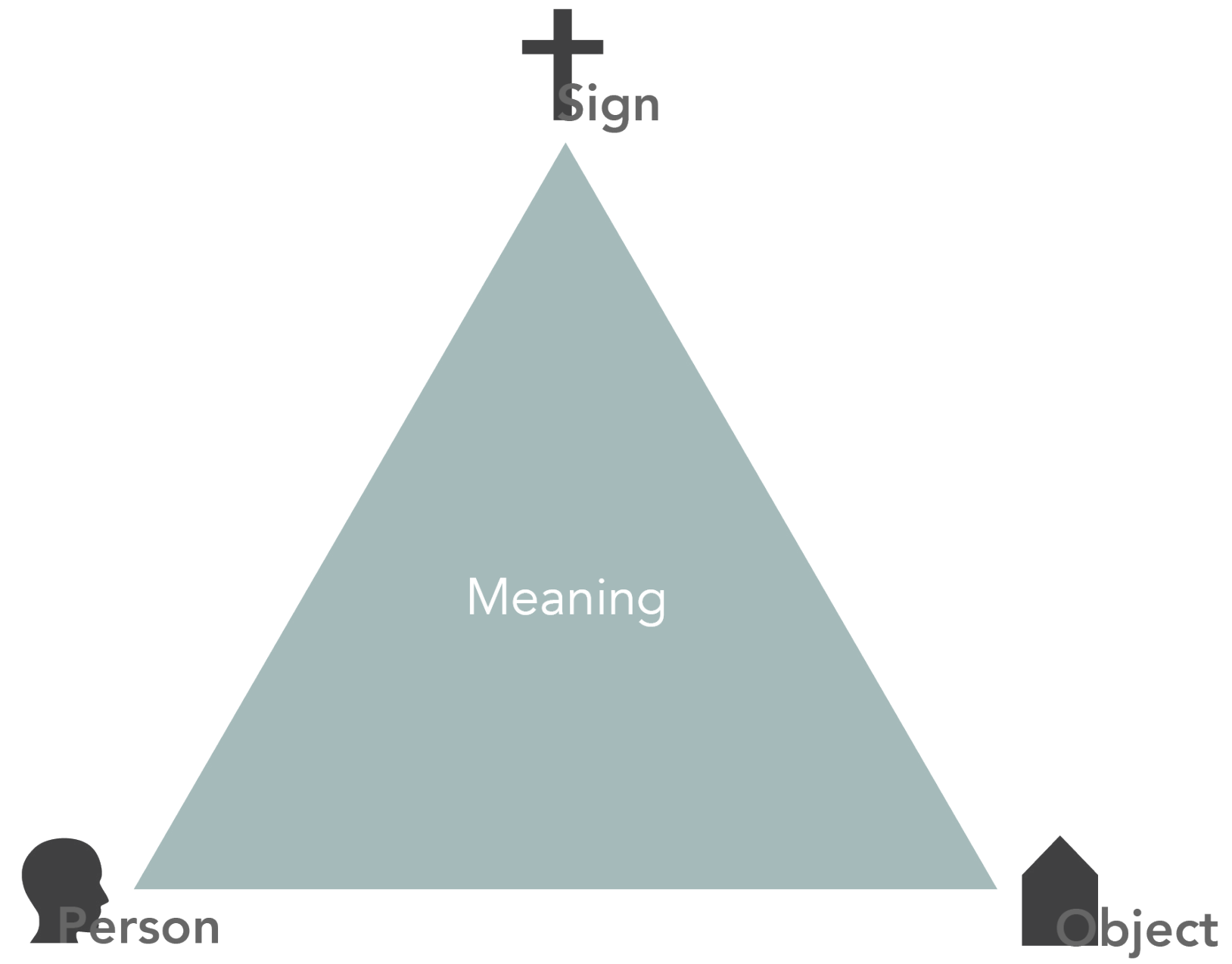

Triad of meaning

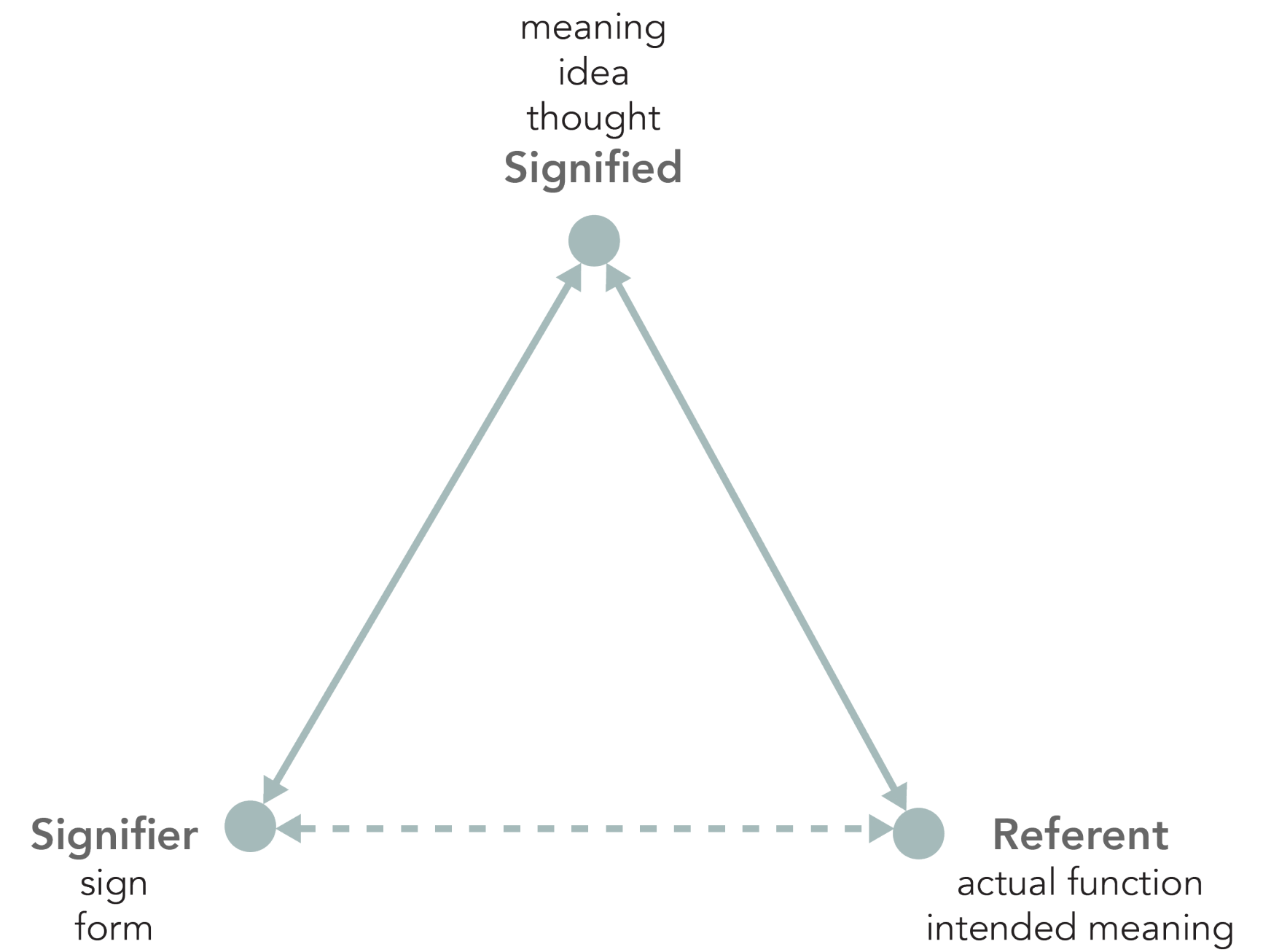

Jencks' semiotic triangle

**based on Jencks (1980)*

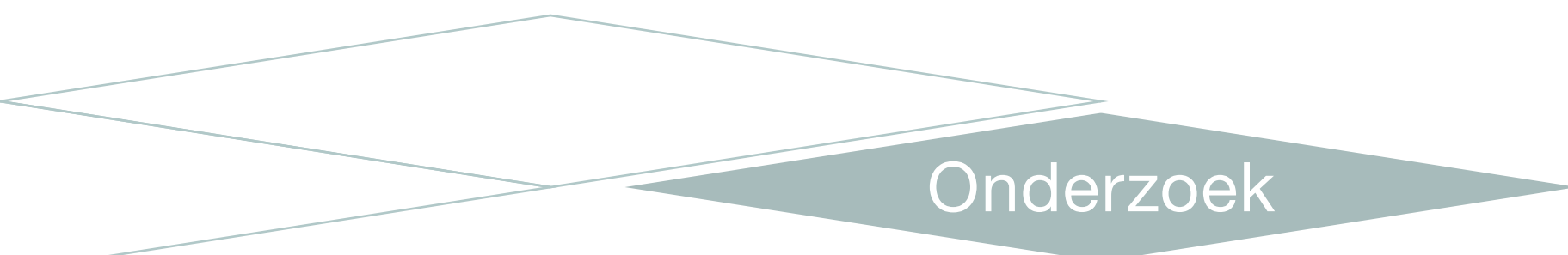

Semiotics

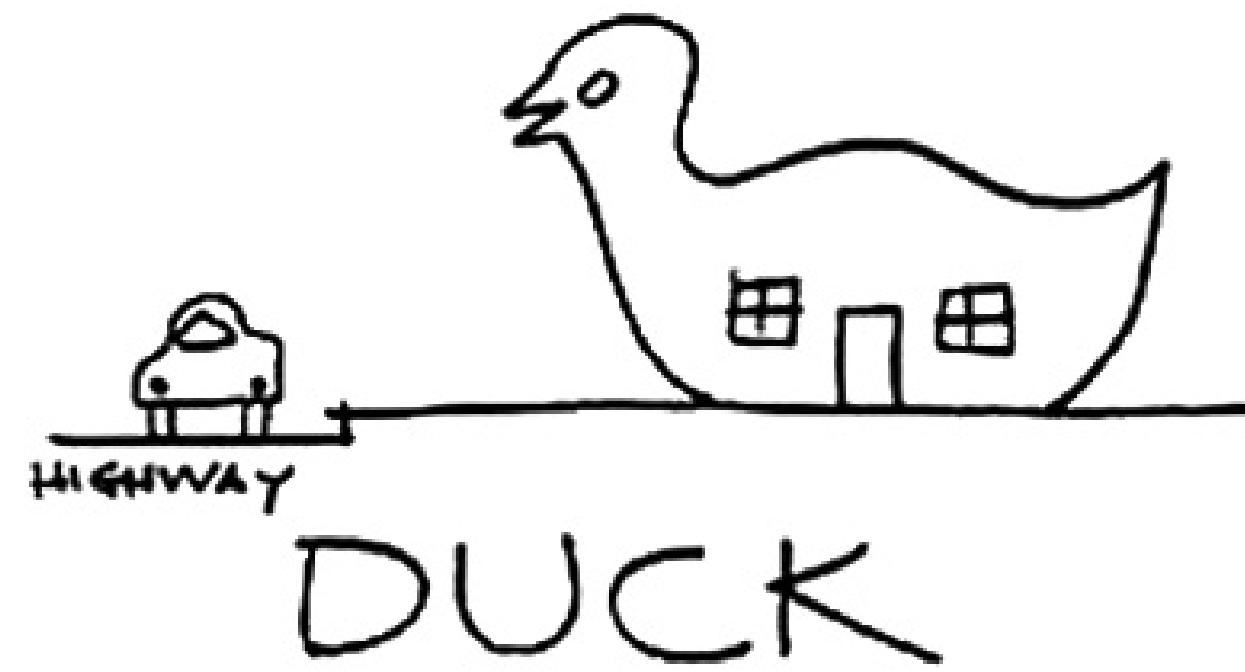

The 'duck' and the 'decorated shed'

*Venturi (1977)

Case studies

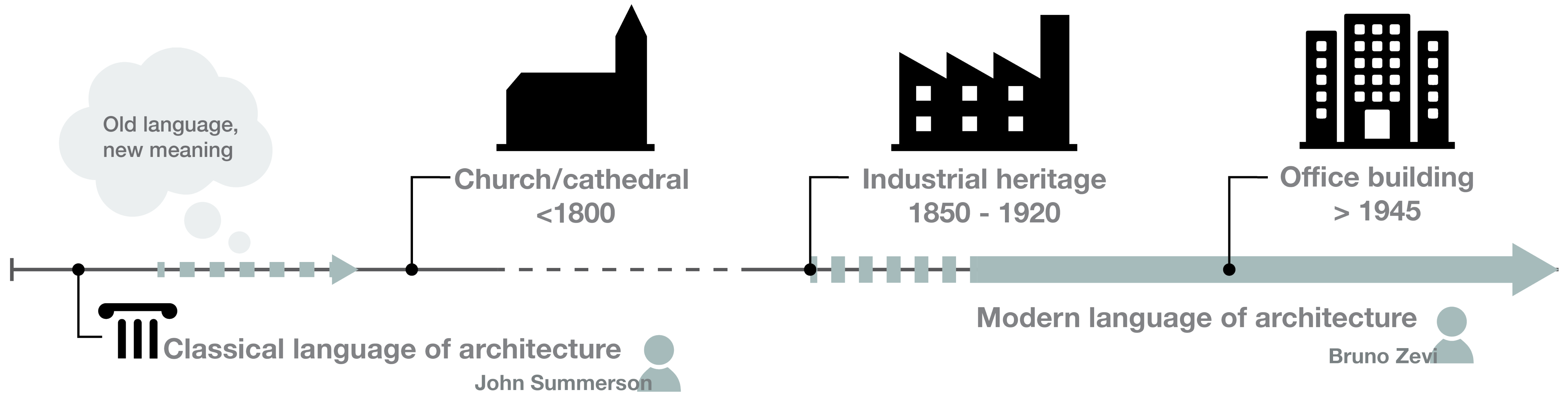

Case studies

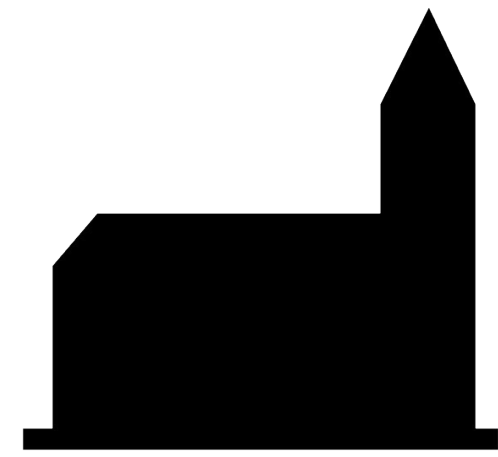

**Grote- of Sint
Bavokerk (1370-1520)**

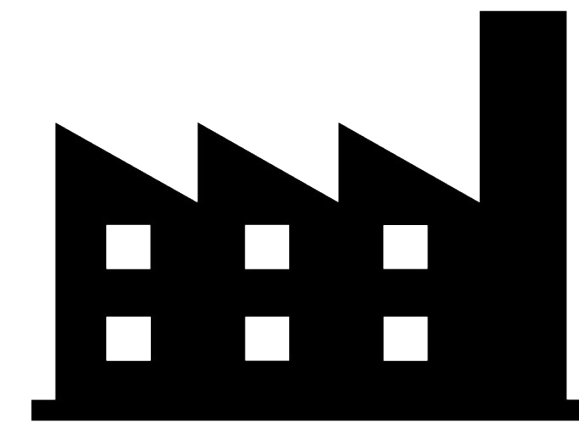

**AEG Turbine Hal
(1909)**

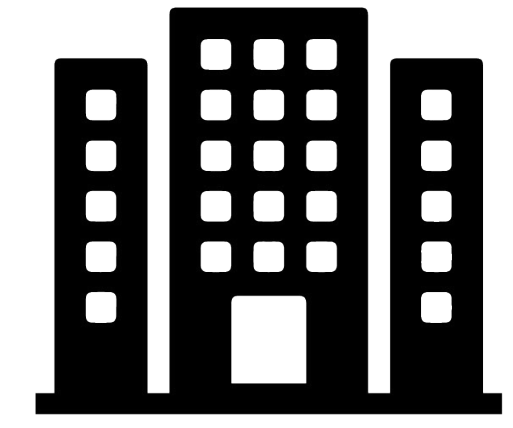

**Seagram Building
(1958)**



Conceptuele ruimtes

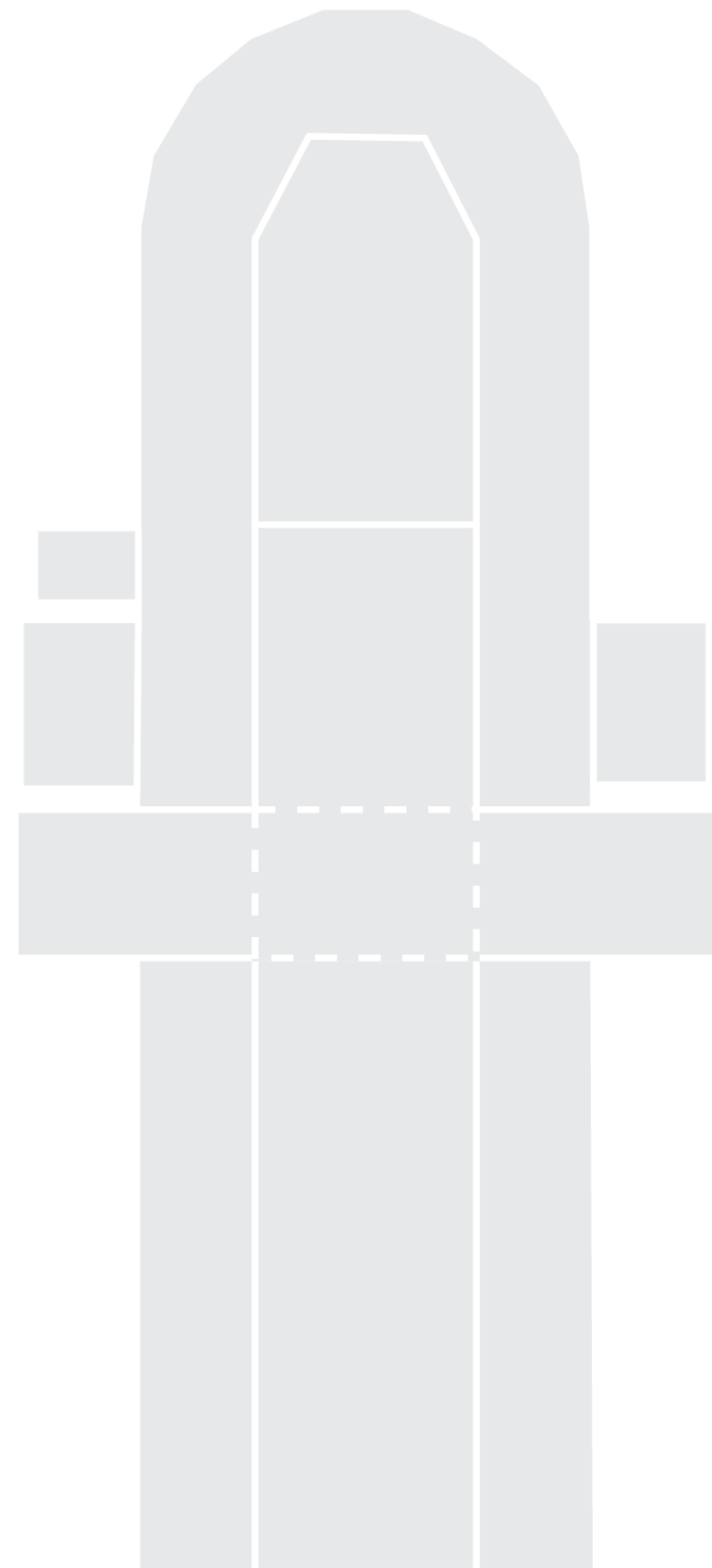

Bavo

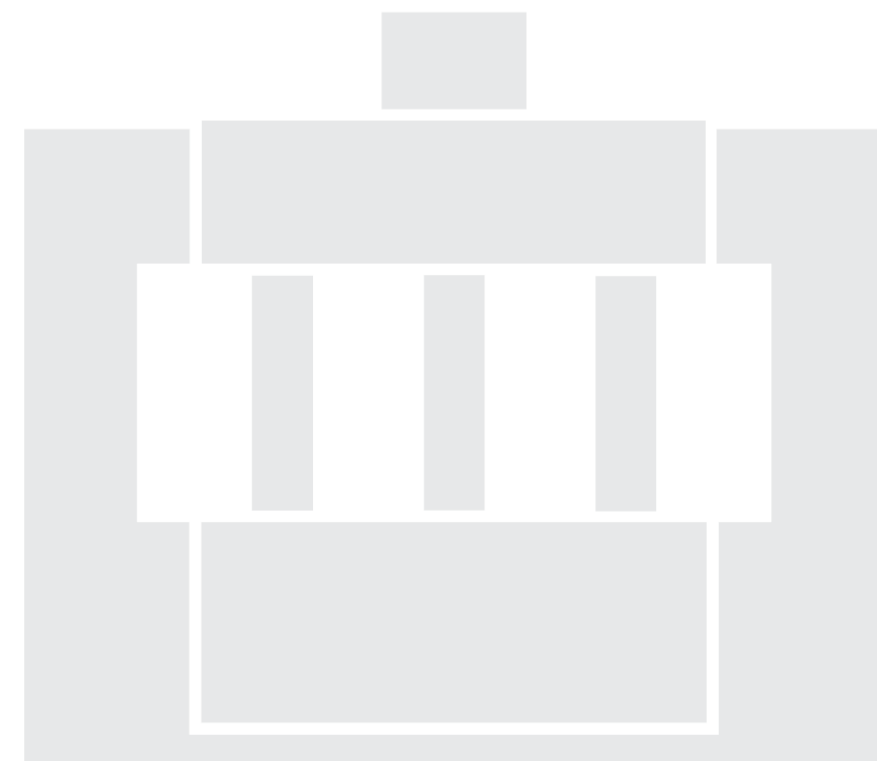

Seagram

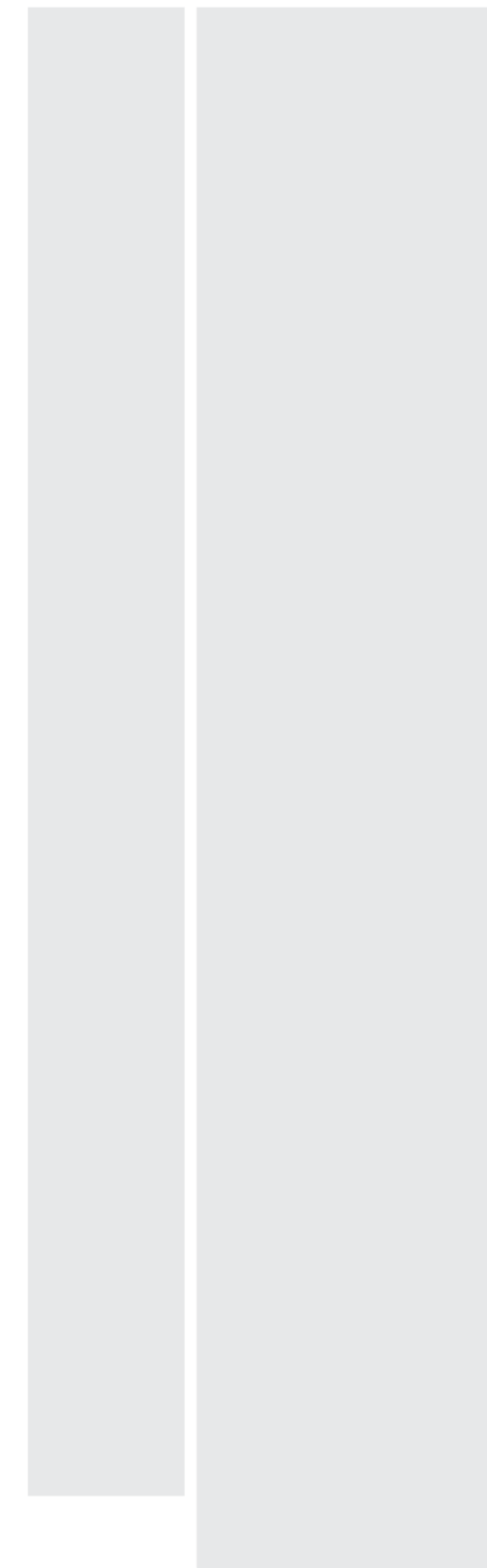

AEG

Ritme

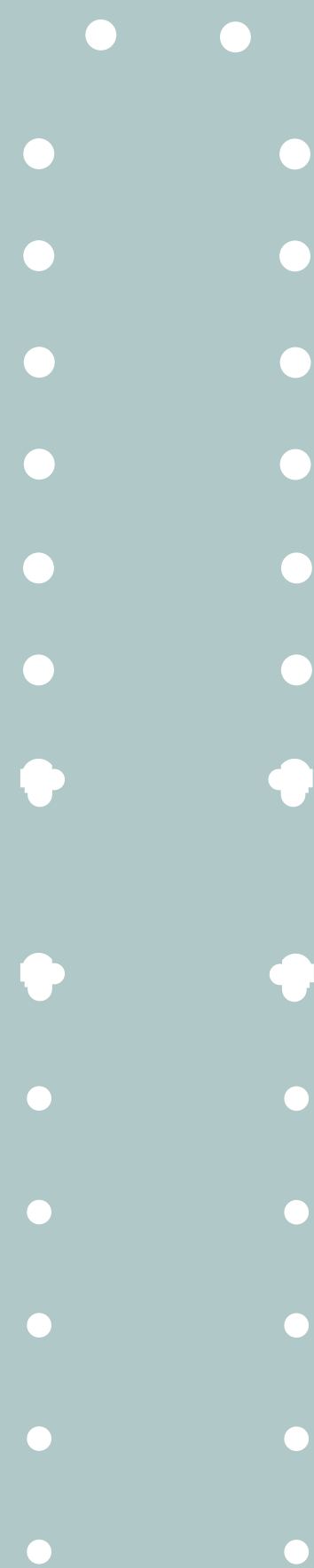

Bavo

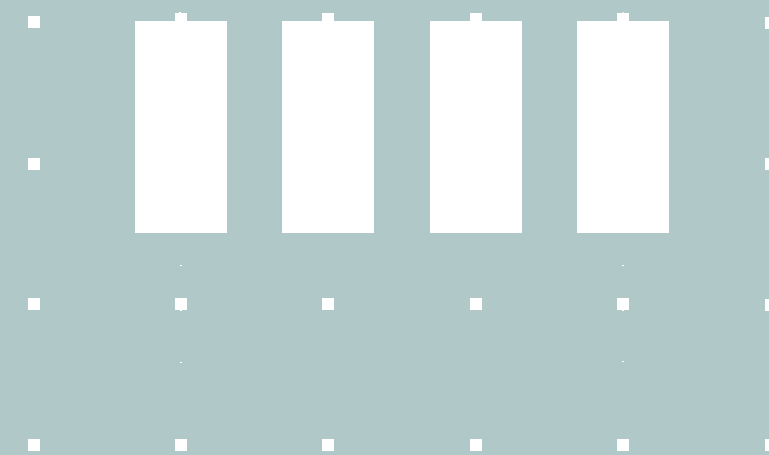

Seagram

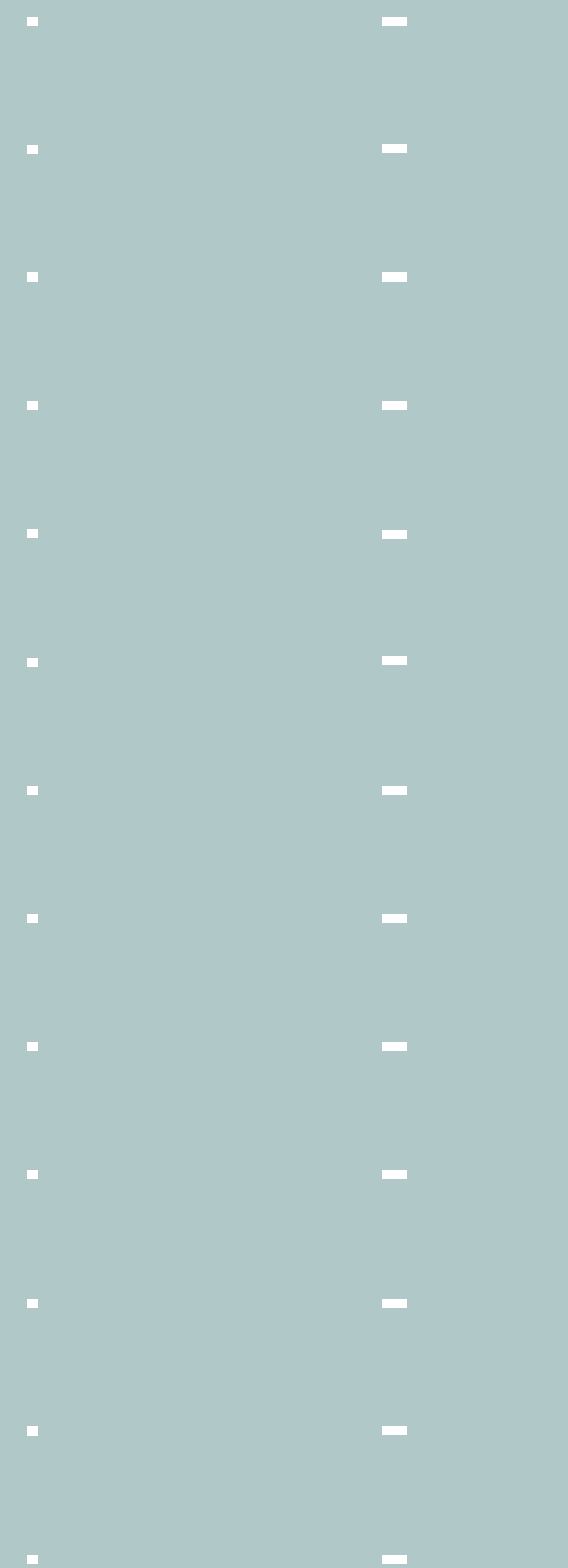

AEG

Organisatie van ruimtes

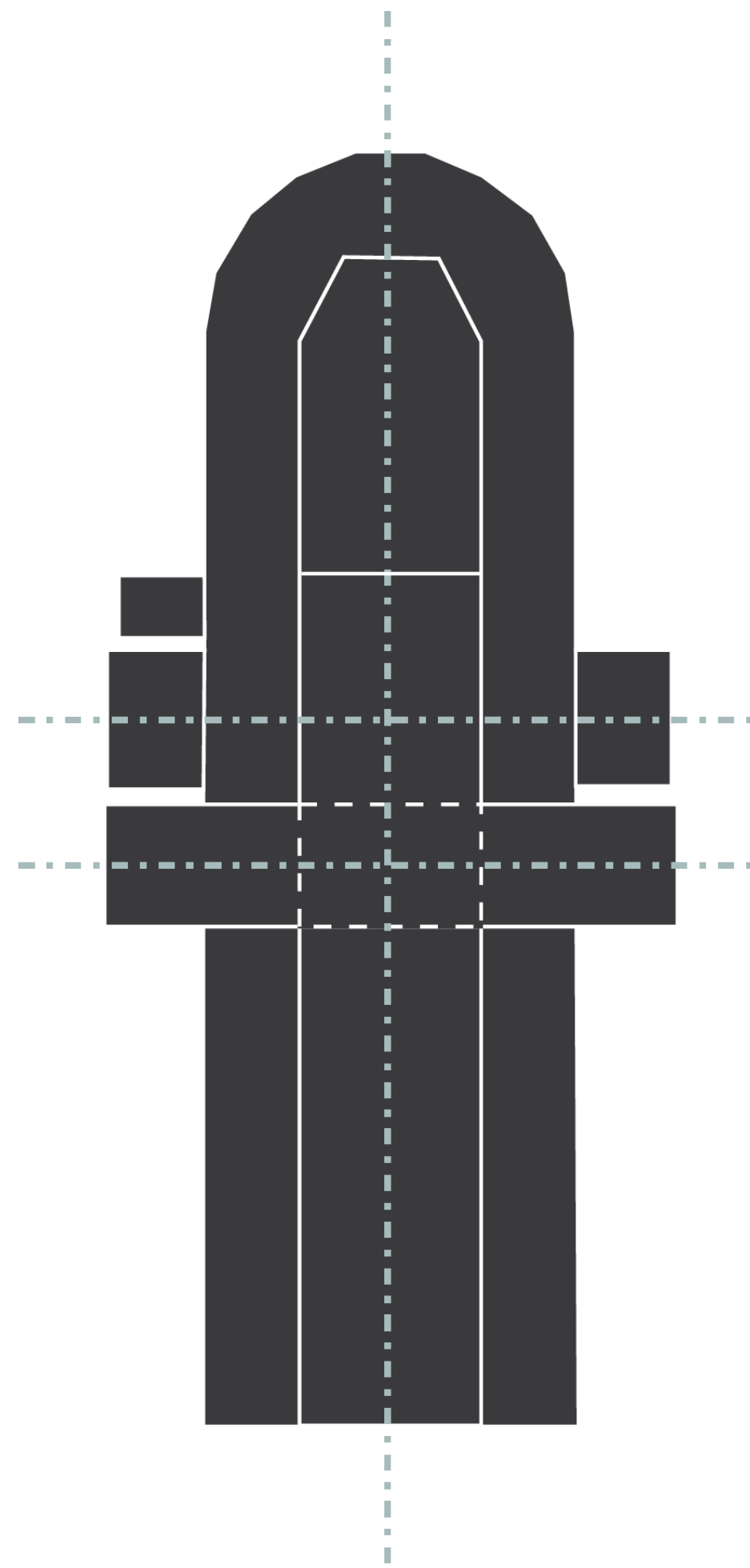

Bavo

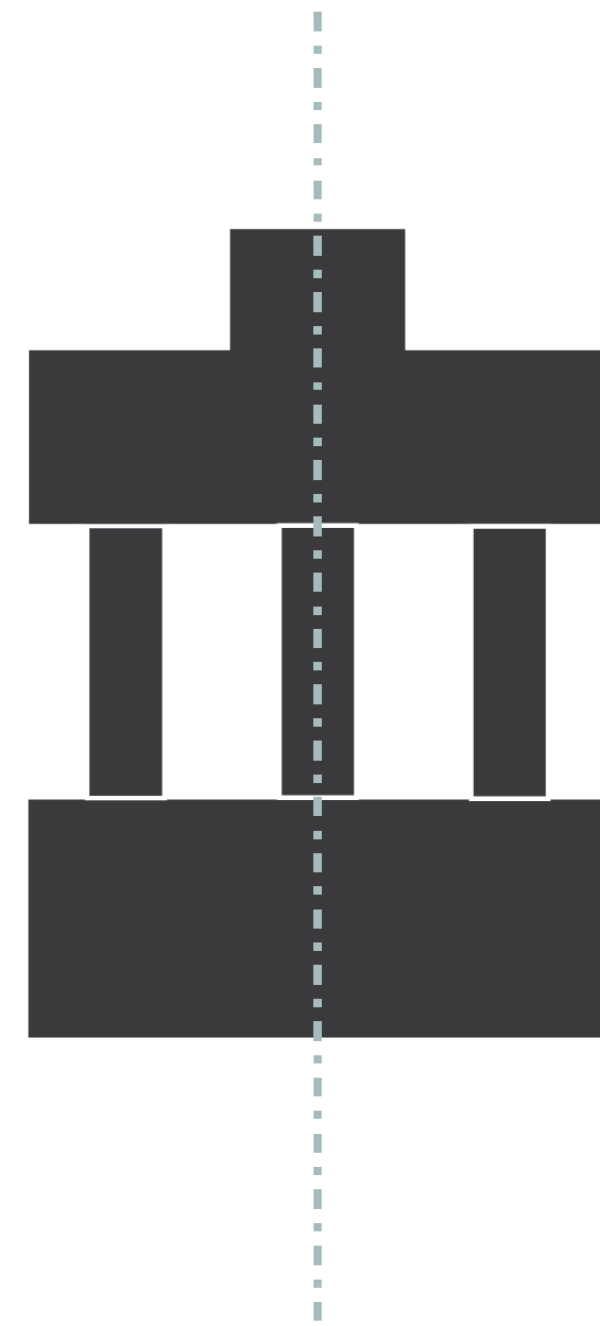

Seagram

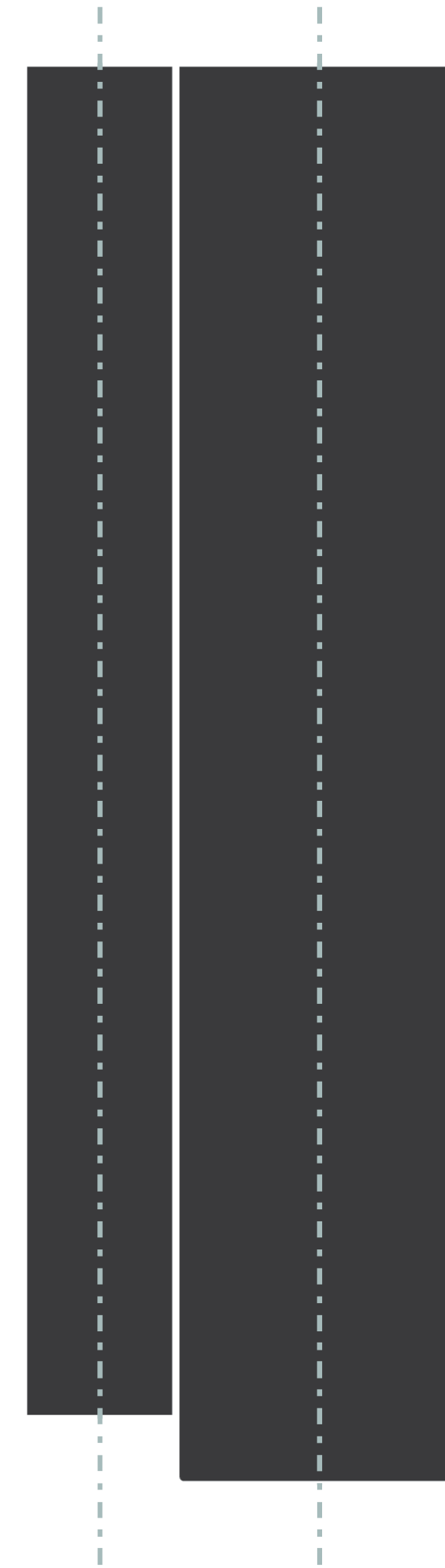

AEG

Symmetrie

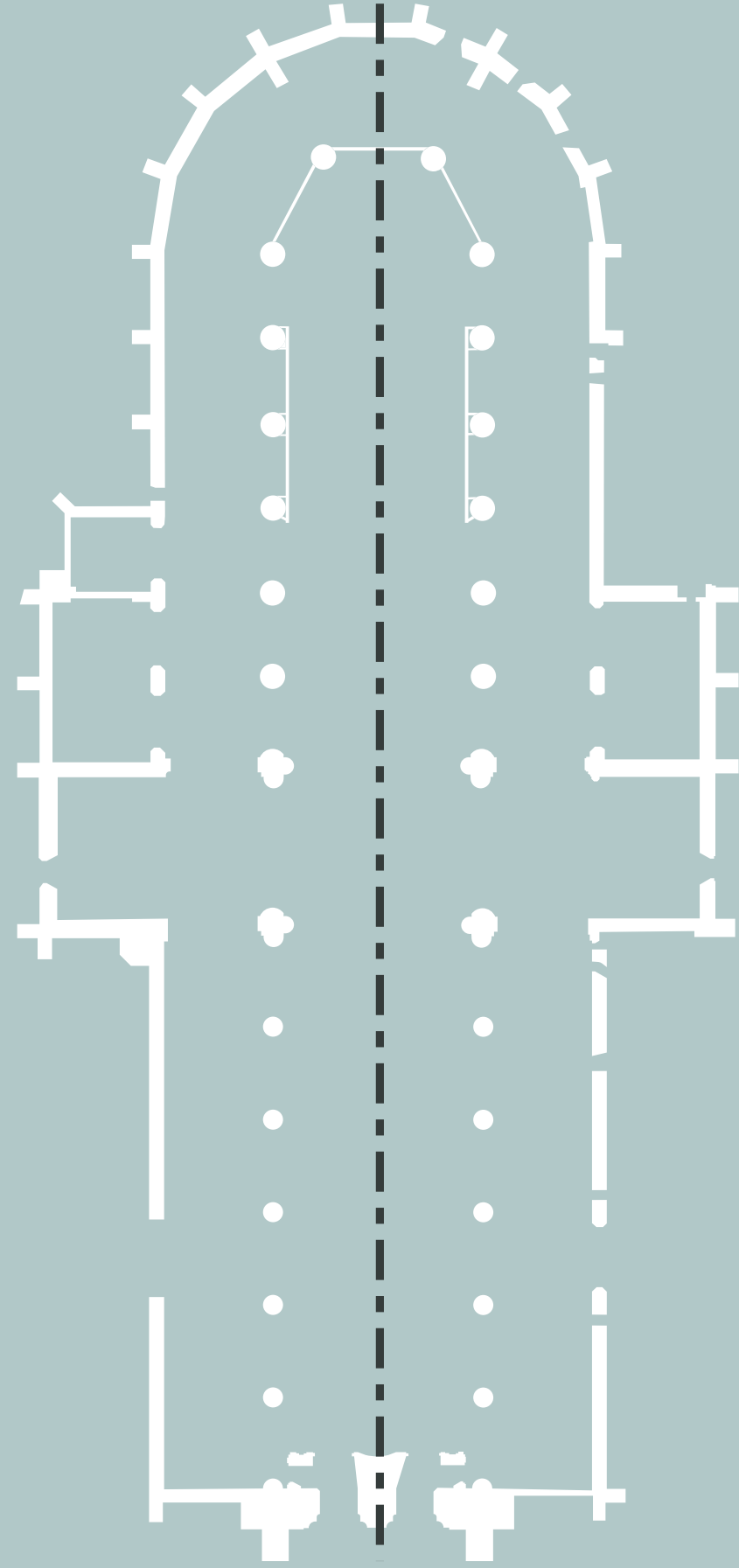

Bavo

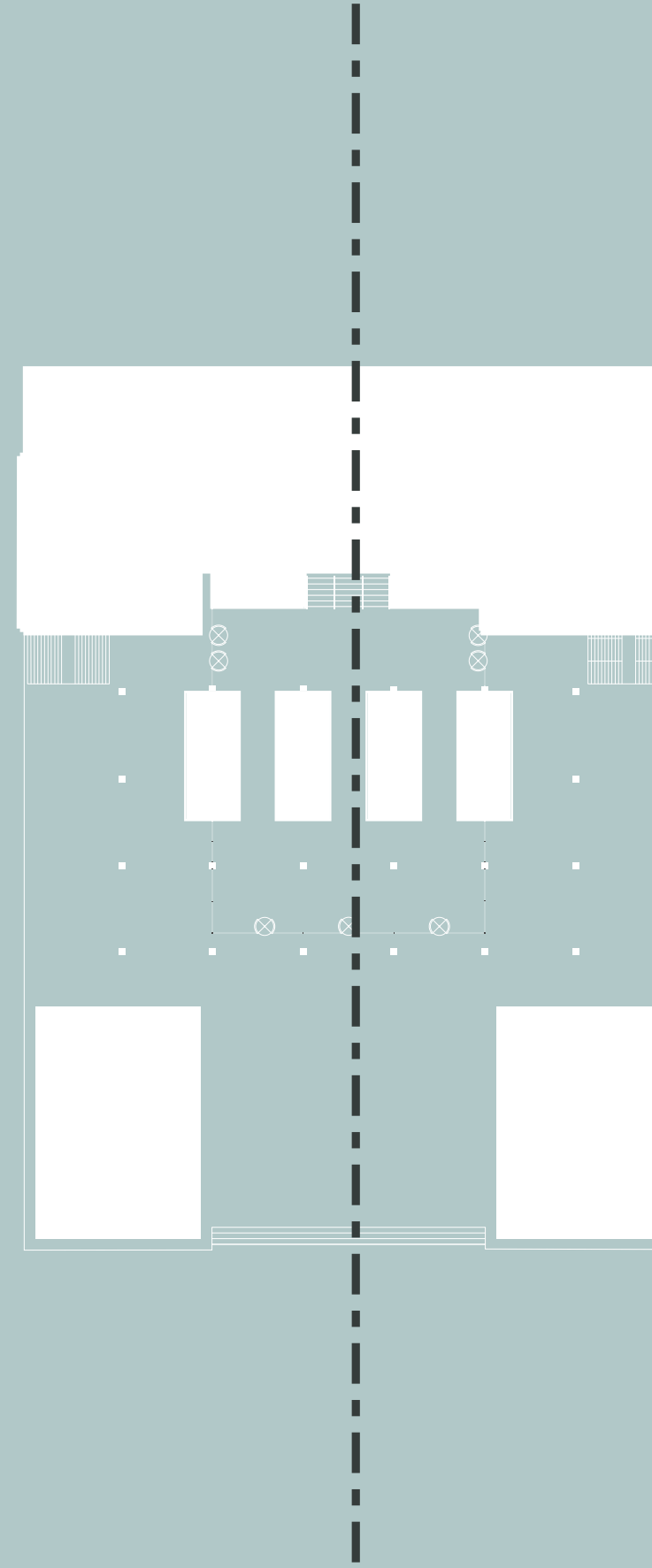

Seagram



AEG

Conclusie

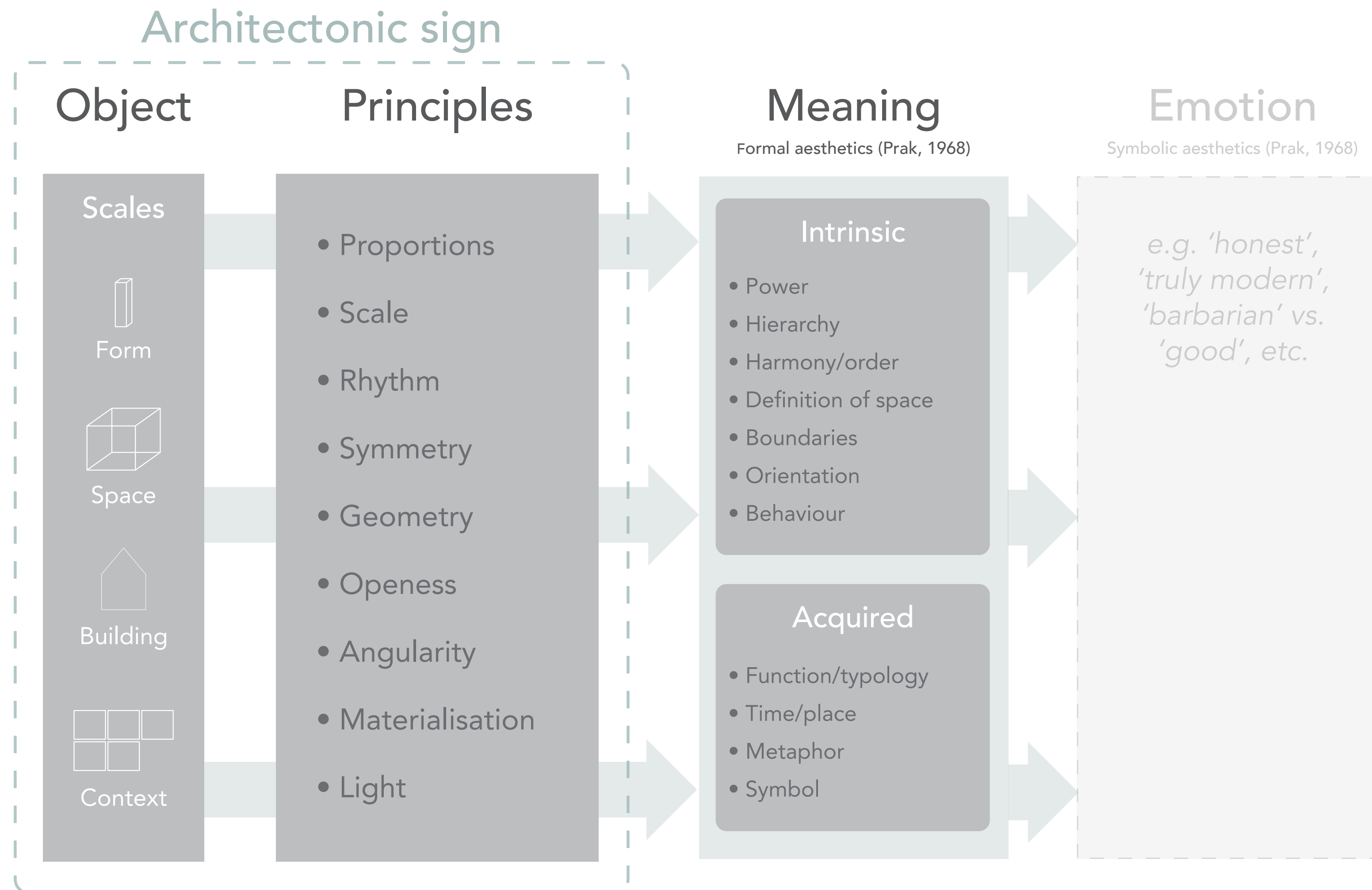



// De opdracht

Locatie, doelgroep en programma van het ontwerp

Haarlem

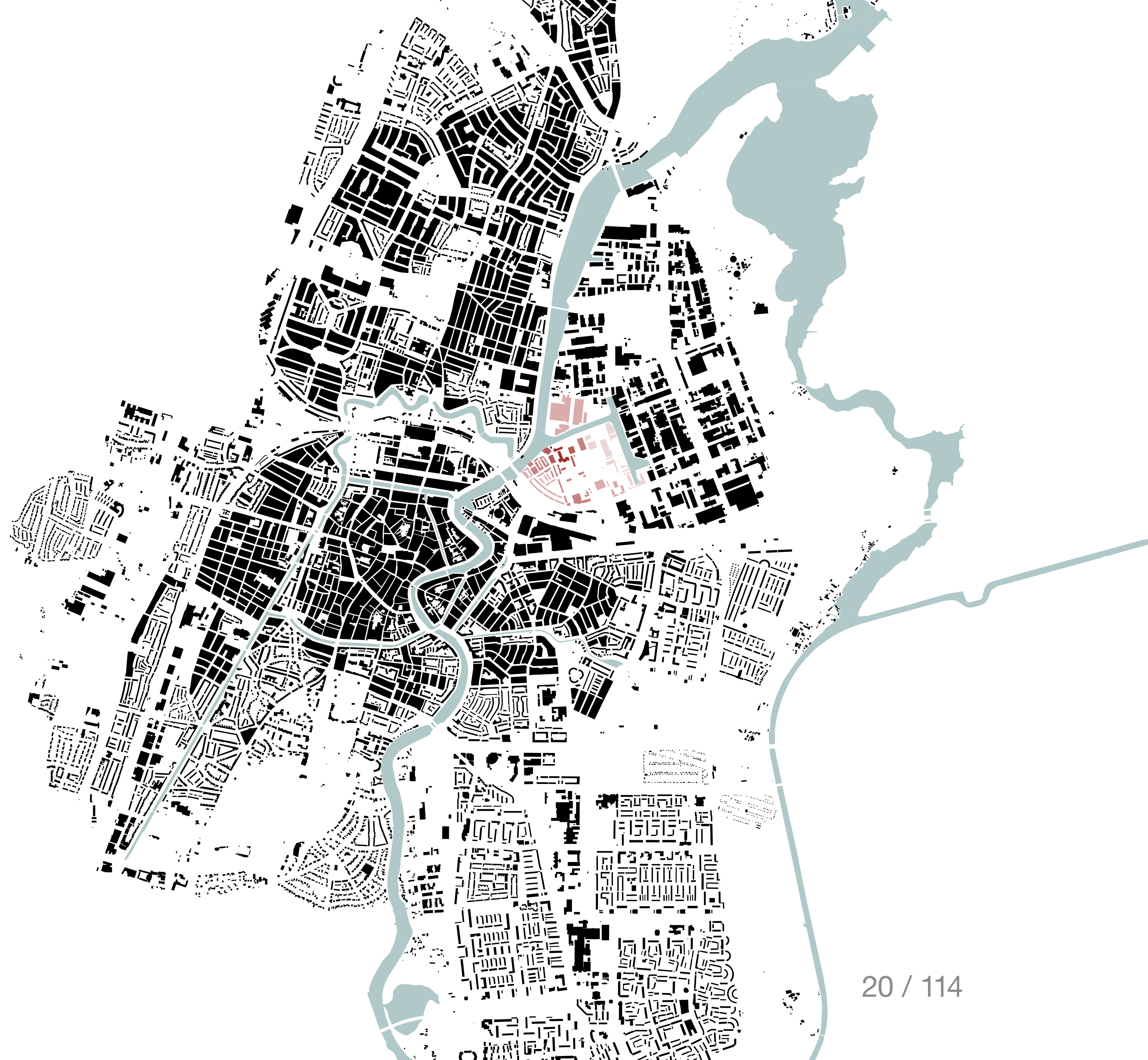

Waarderpolder



“De Nieuwe Energie”







Uitgangspunten programma

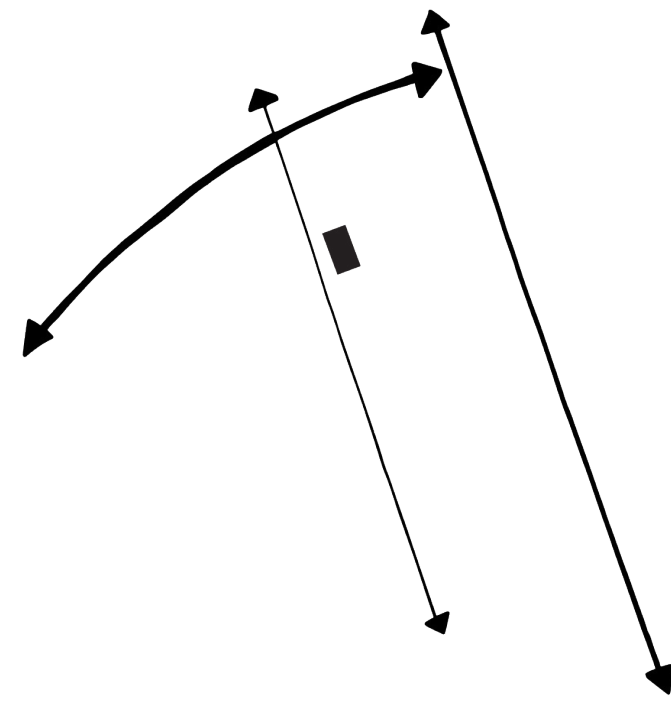

Drie richtingen

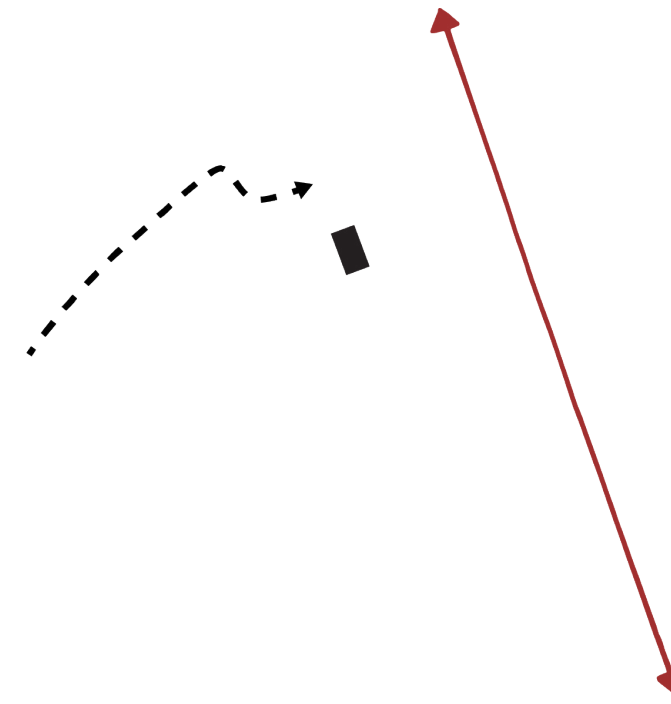

Hoofdontsluiting

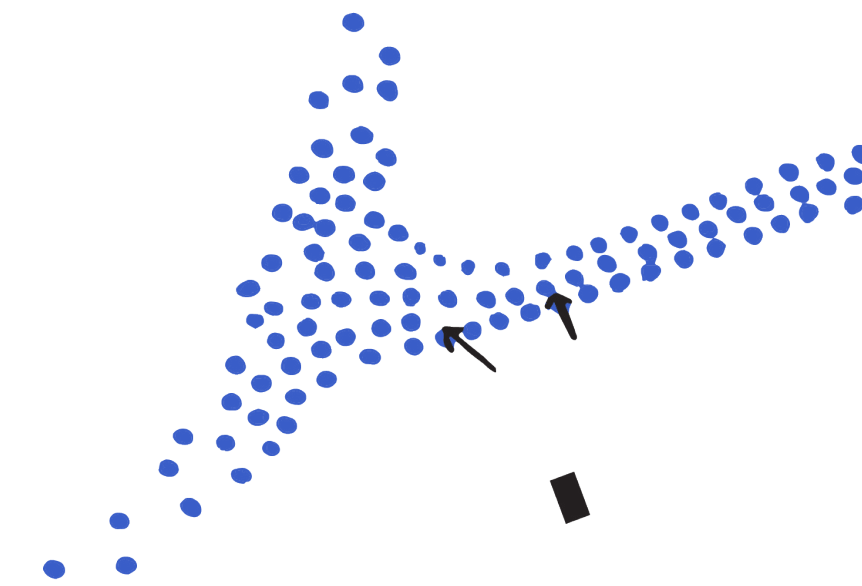

Het Spaarne

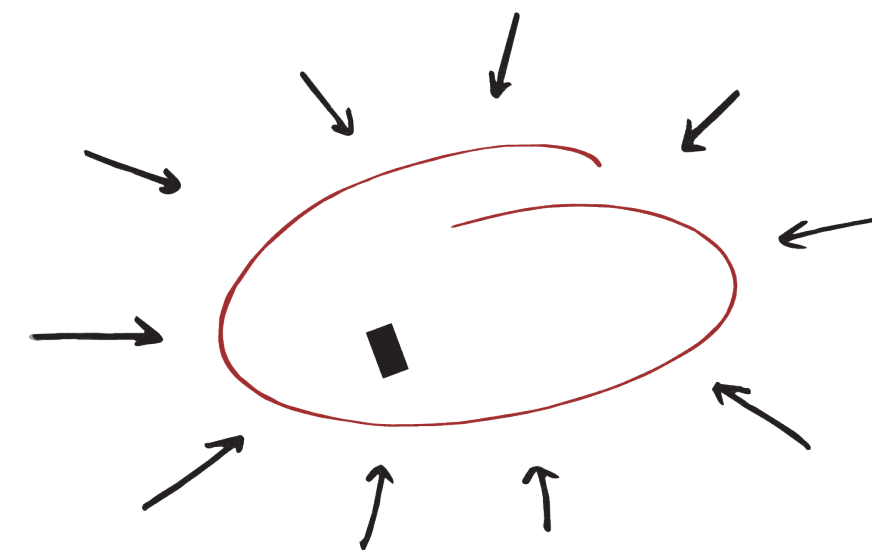

Centrum Waarderpolder

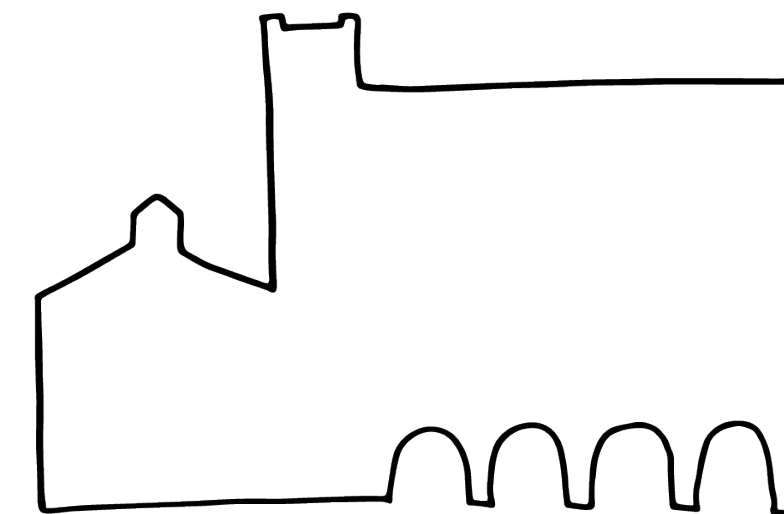

Industriële context

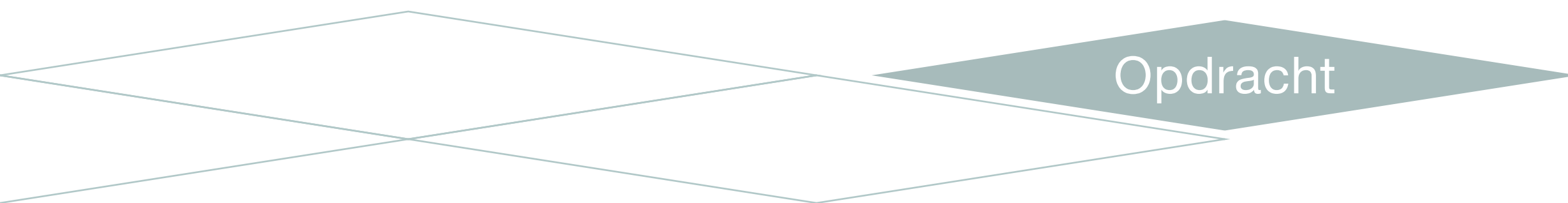

Doelgroepen



- *Woont/werkt in de Waarderpolder*
- *Wekelijks/tweewekelijks*
- *Wil ontmoeten*



- *Woont/werkt in de Haarlem*
- *Eens per maand*
- *Wil ontspannen*



- *Komt uit regio Haarlem of is toerist*
- *Incidenteel*
- *Wil bezoeken*

Uitgangspunten doelgroepen

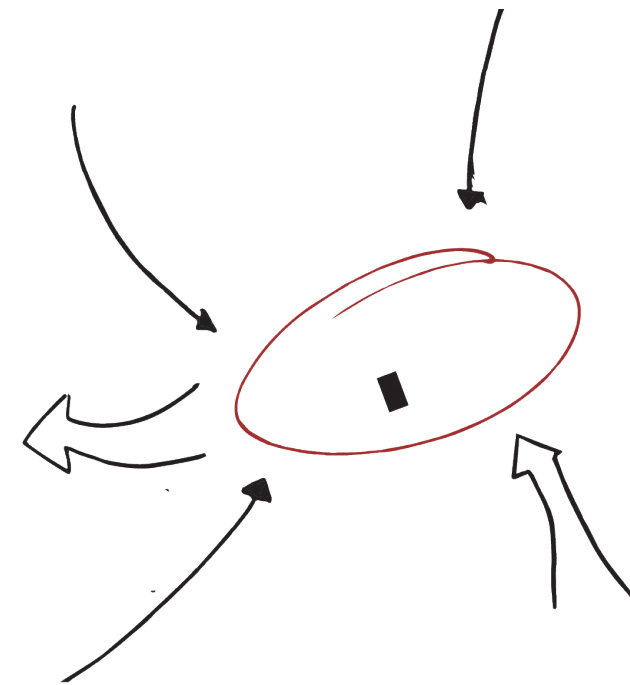

Thuishaven en startpunt



Culturele route

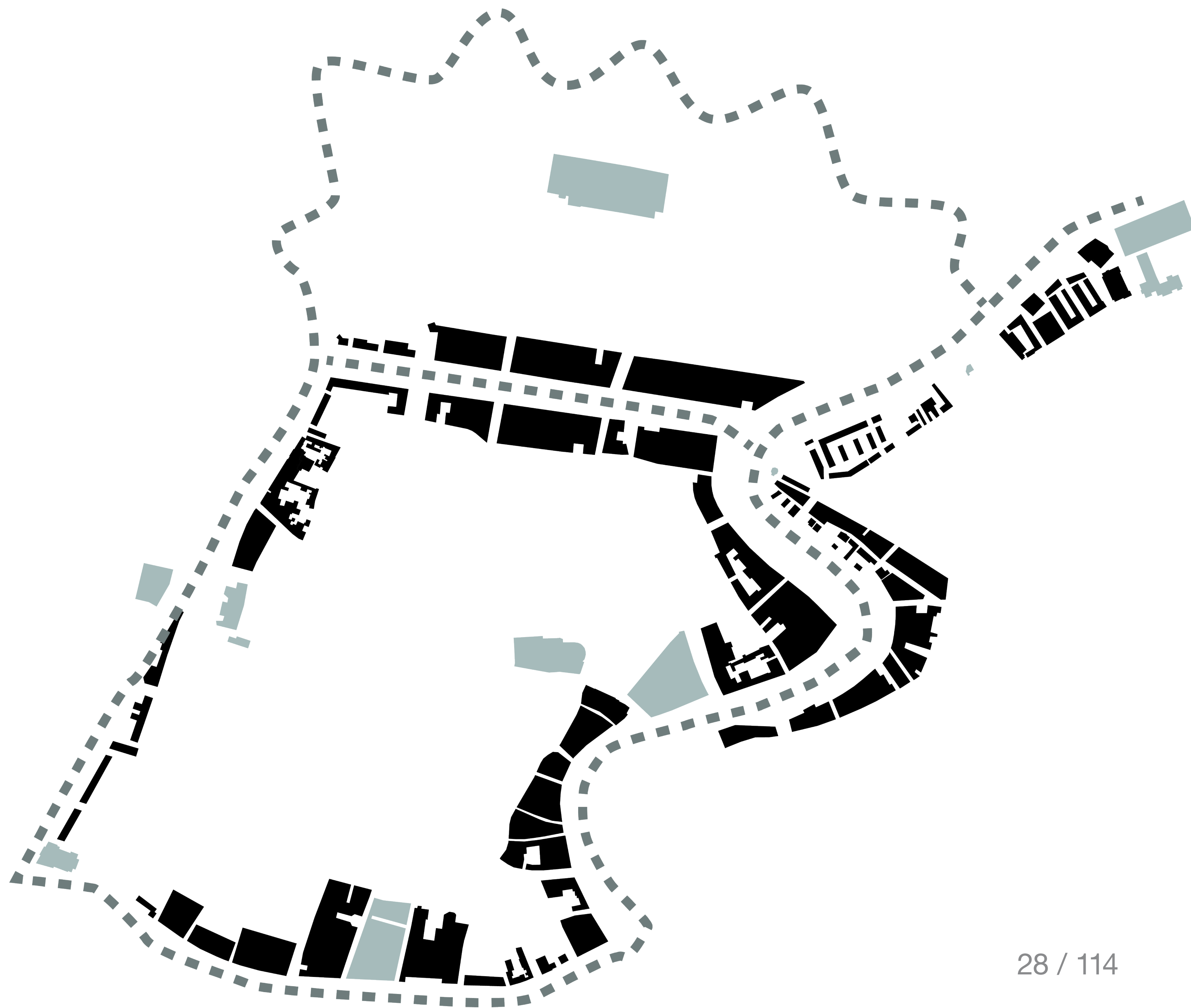

Programma

Vast programma

Pop-up programma

Festival/event

Weekmarkt



Opdracht

Programma

Vast programma

Pop-up programma

Festival/event

Weekmarkt



vast programma

veel eisen

minder flexibel

"binnen"

tijdelijk programma

weinig eisen

flexibel

"buiten"

Opdracht

30 / 114

Uitgangspunten programma

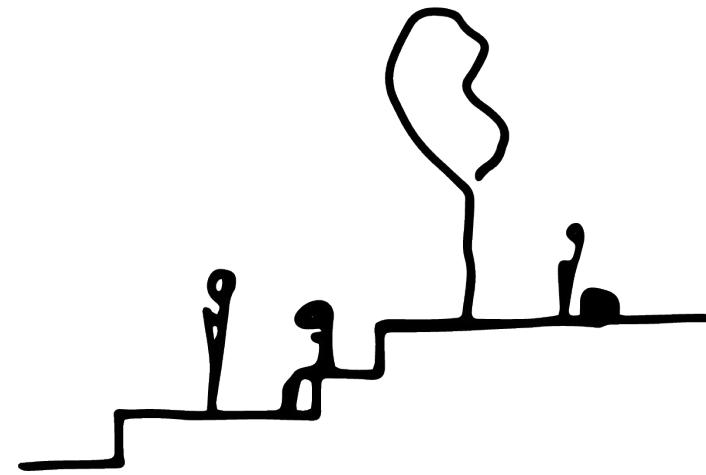

Prettige verblijfplaats

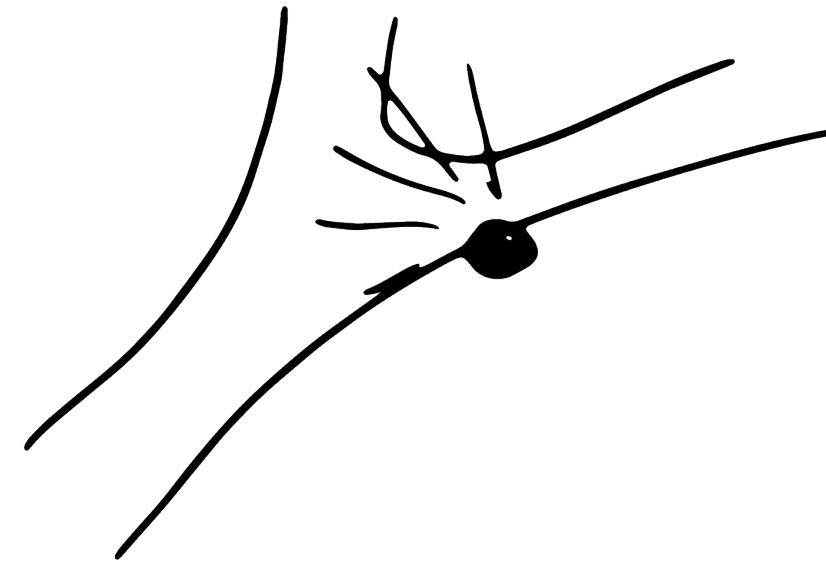

Zichtbaar aan het water

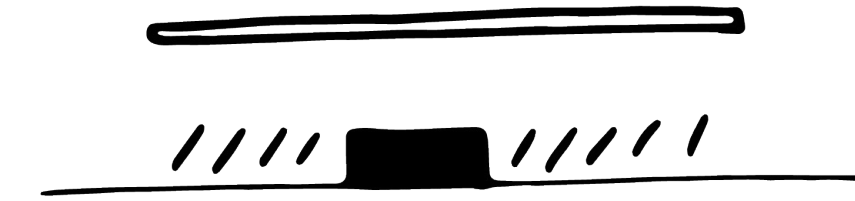

Dak verbindt

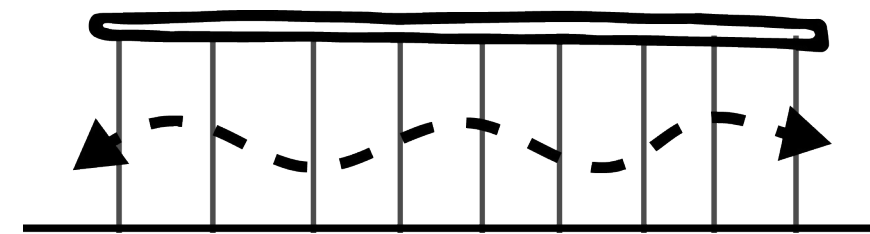

Structuur & programma

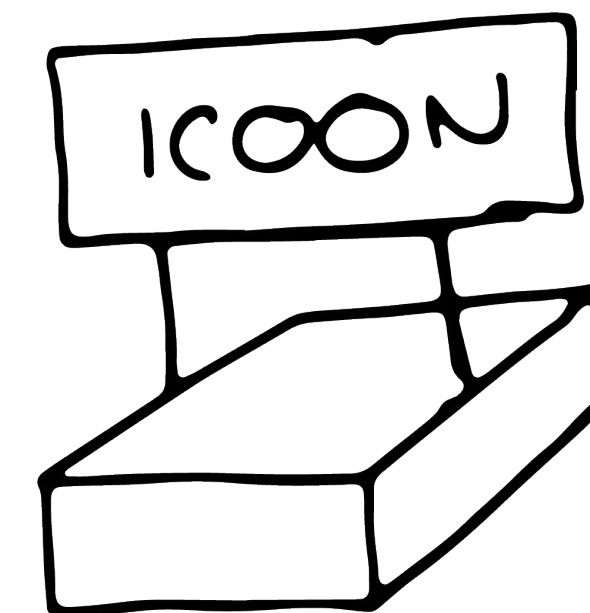

Iconisch gebouw

Opdracht



// Het ontwerp

*Multi interpretabele markt- en
evenmentenlocatie in Haarlem*

Situatie

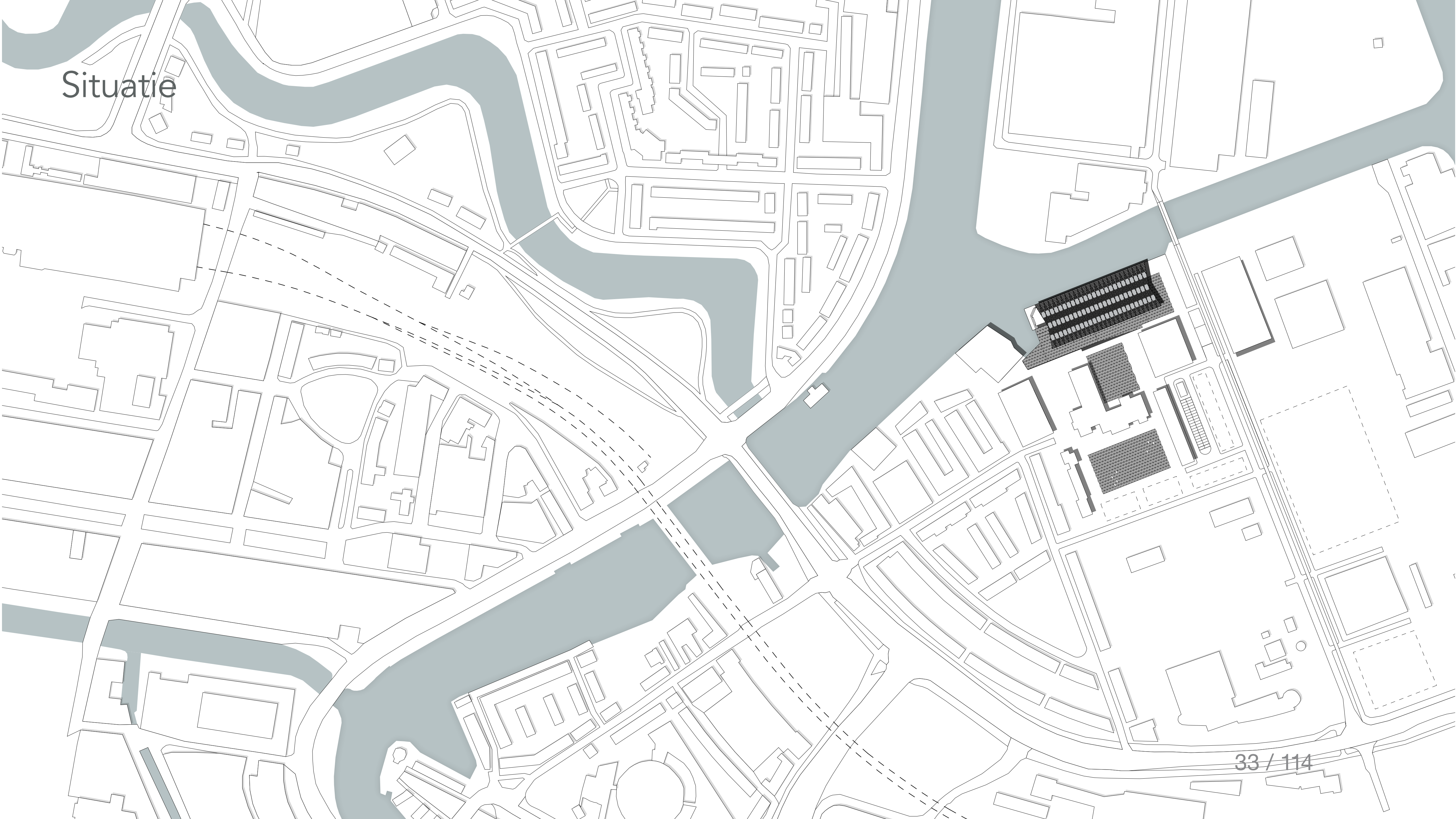

Directe context

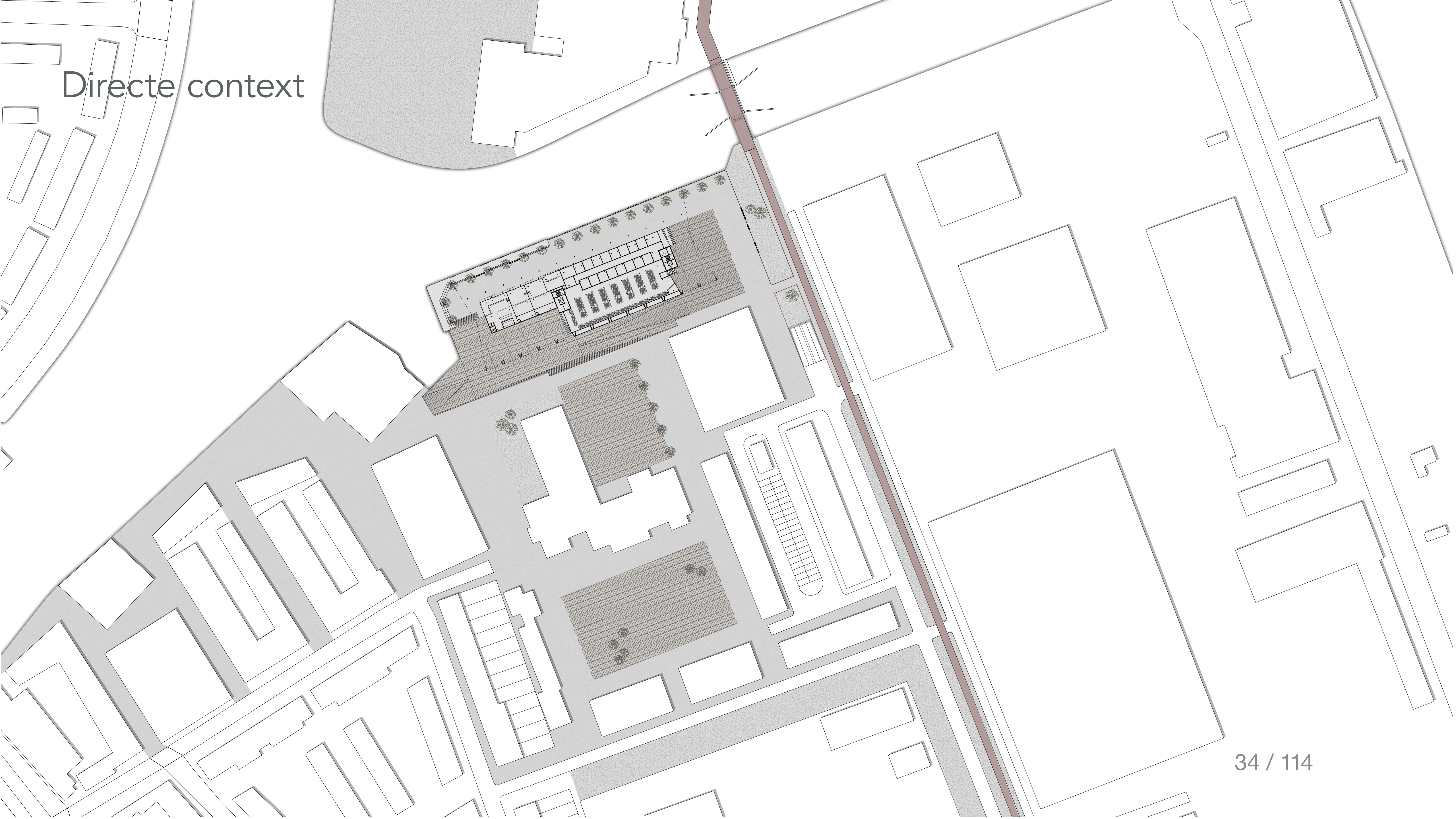

Ontwerp



Concept



"Dak", "bak" & "landschap"

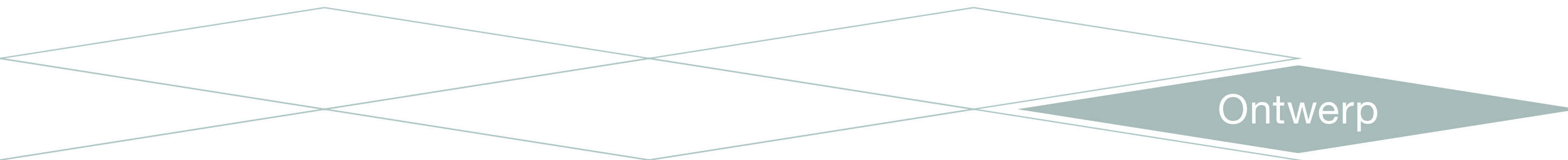

Concept



"Dak", "bak" & "landschap"

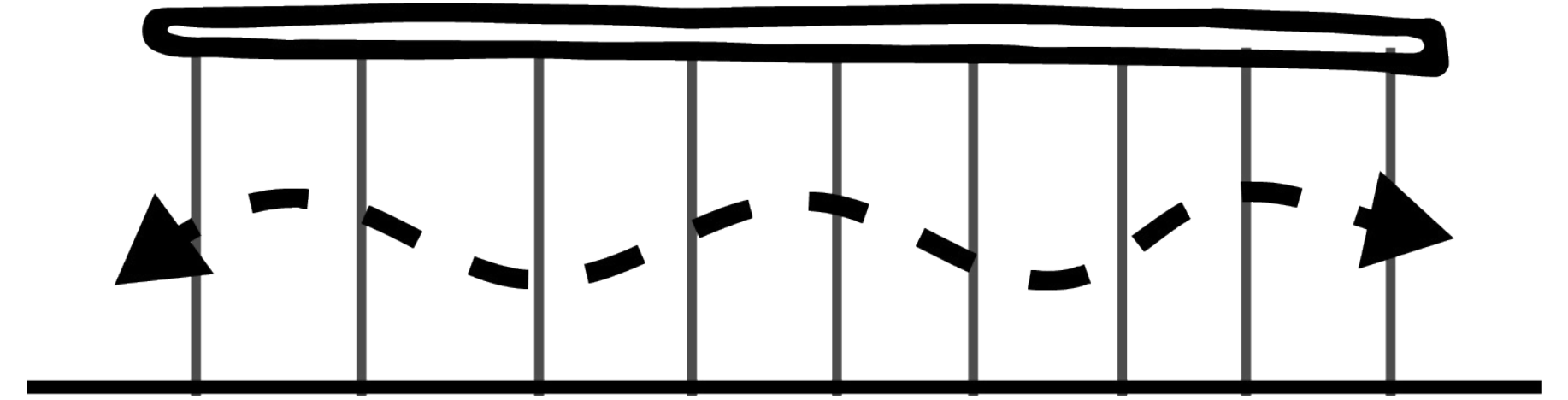

Structuur en programma

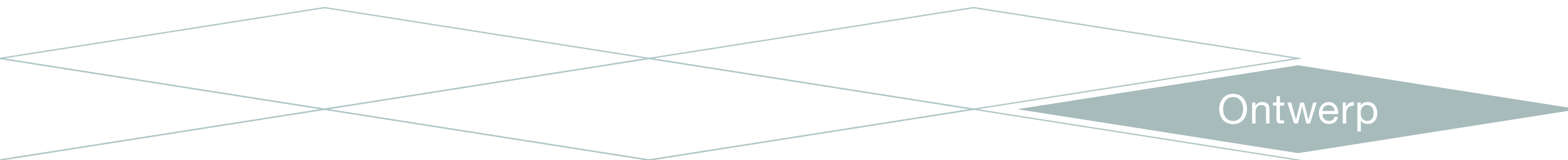

Ontwerp

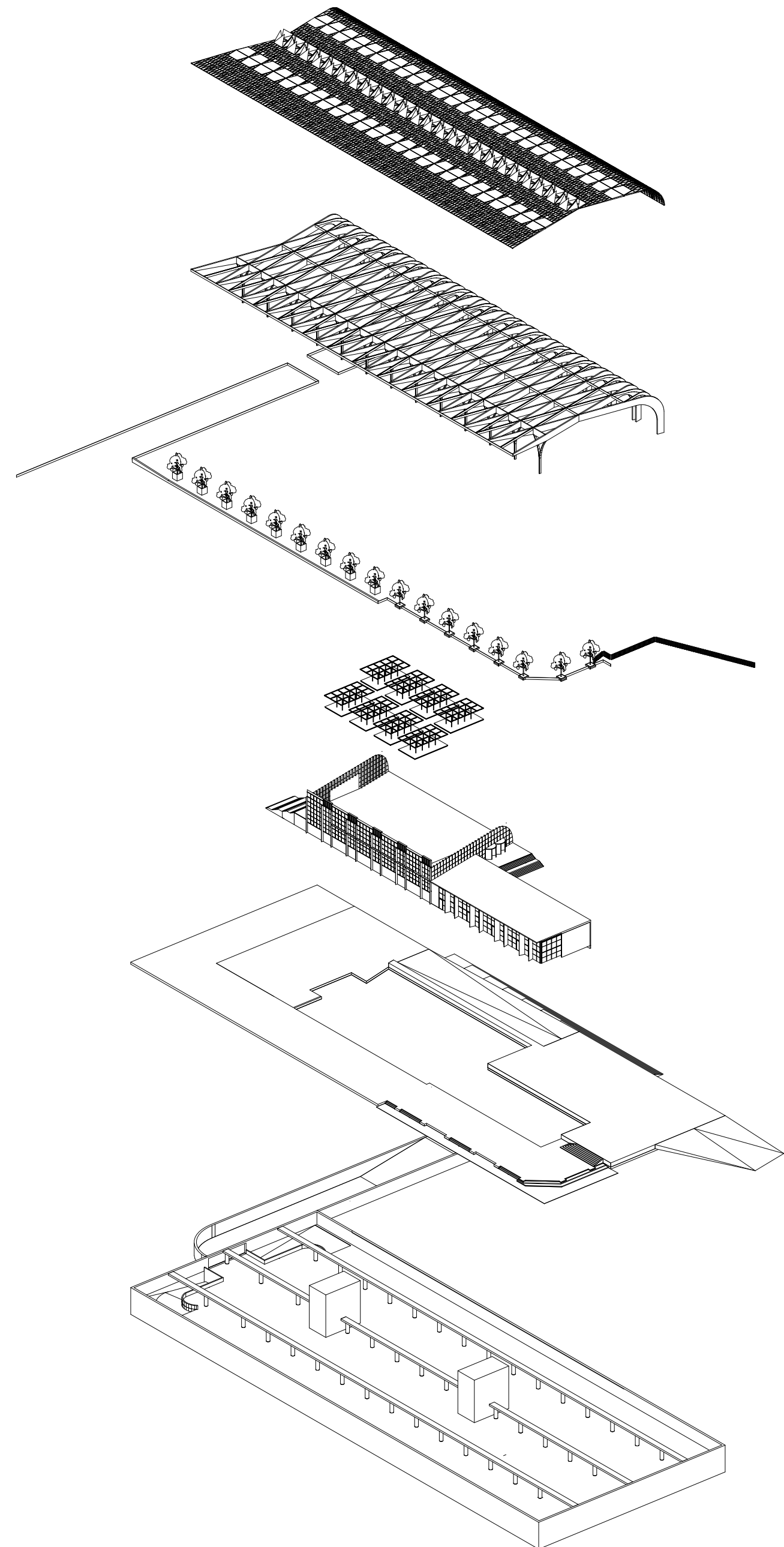

Niveau's van tijdelijkheid

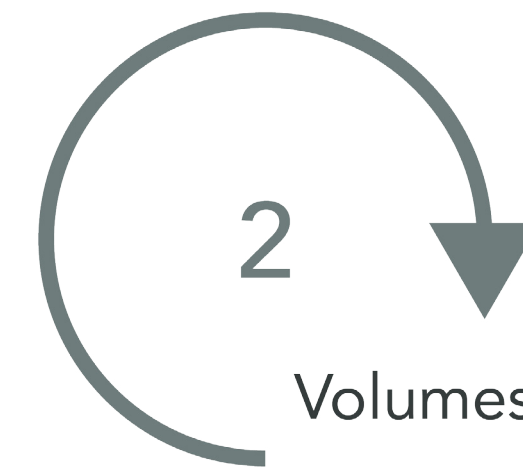
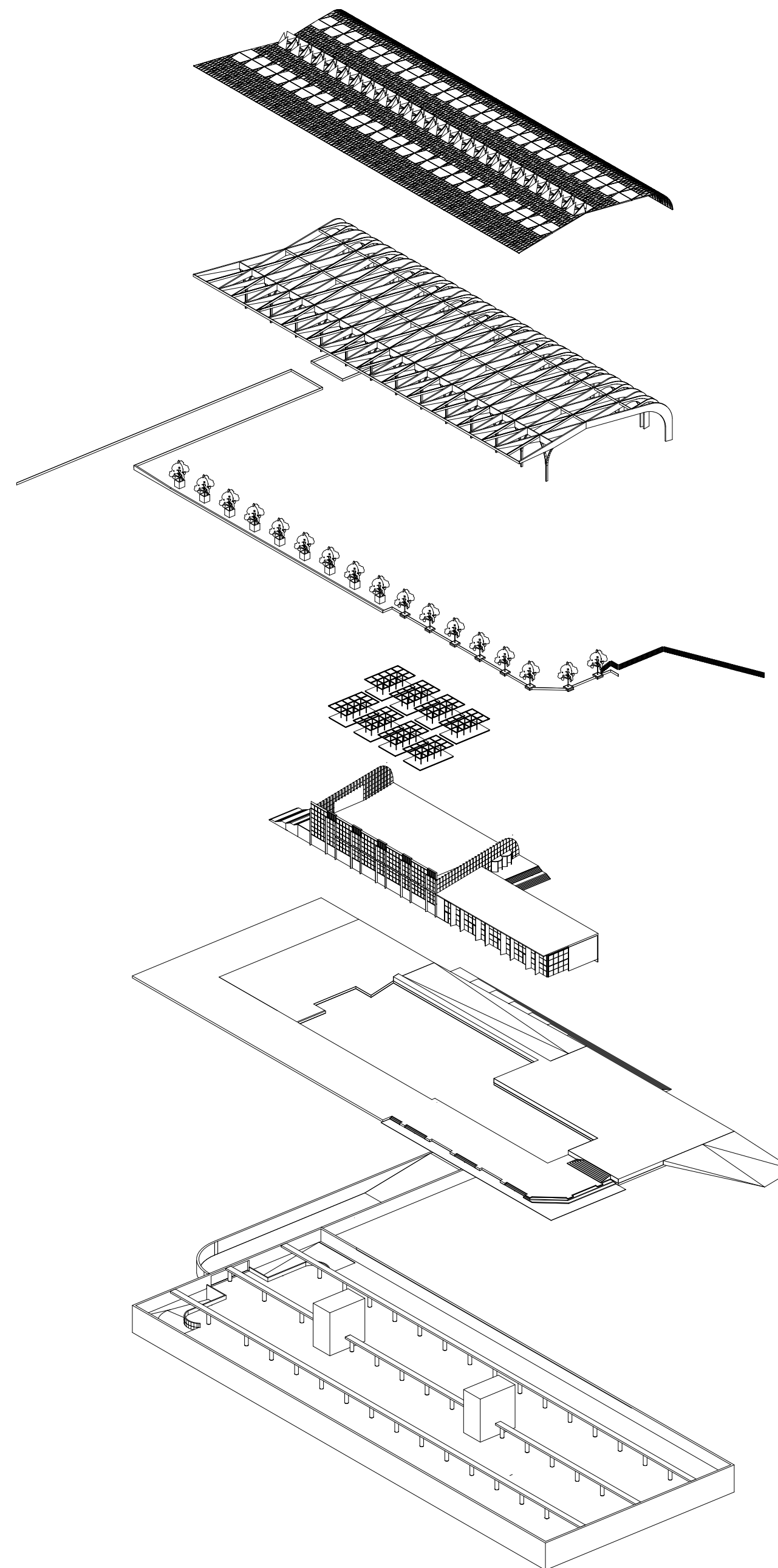

Niveau 1: dak & parkeergarage

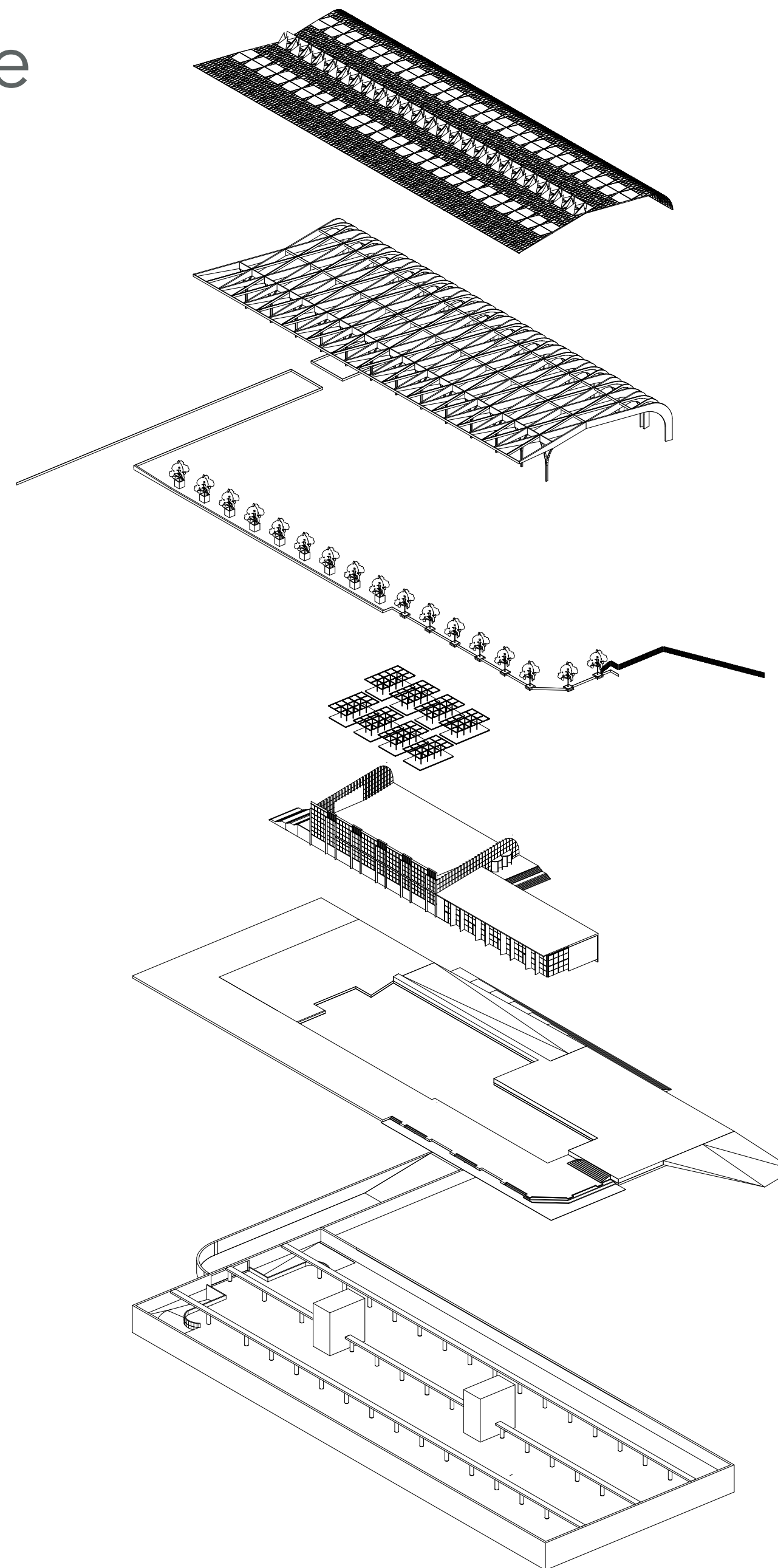





Dak

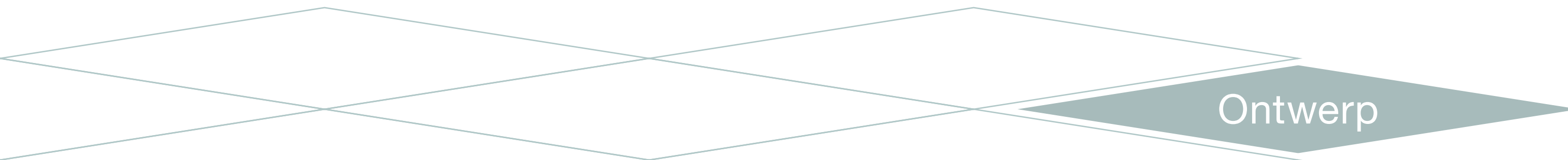
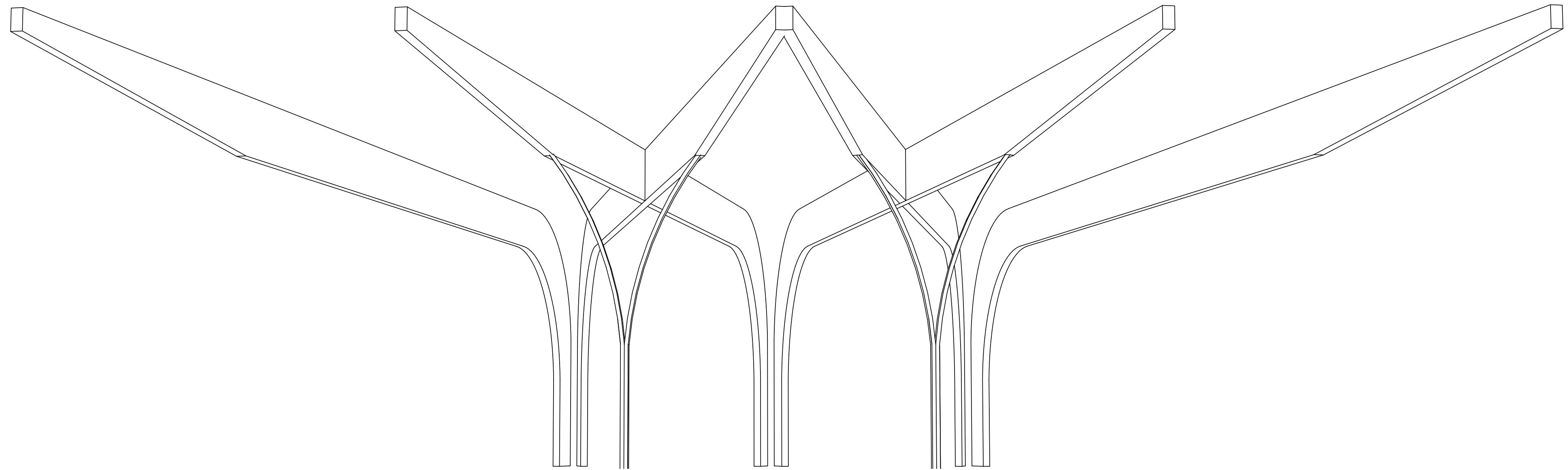



Dakbedekking

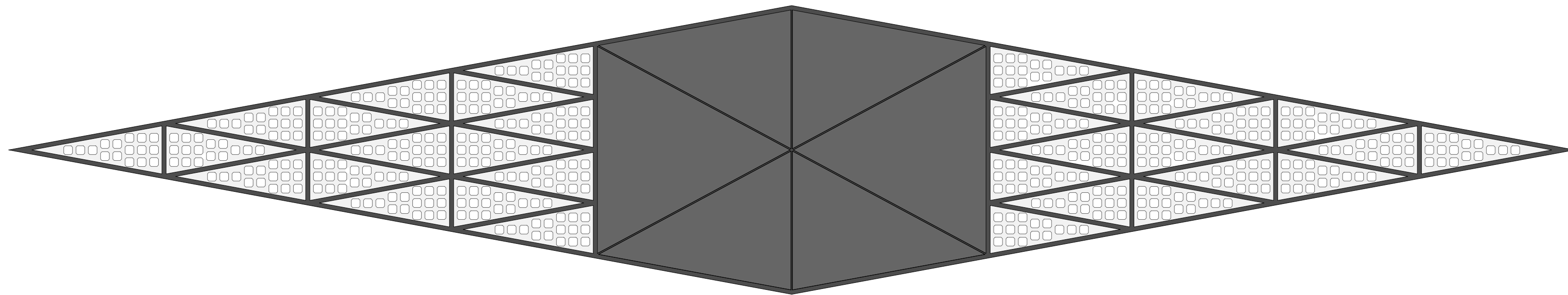
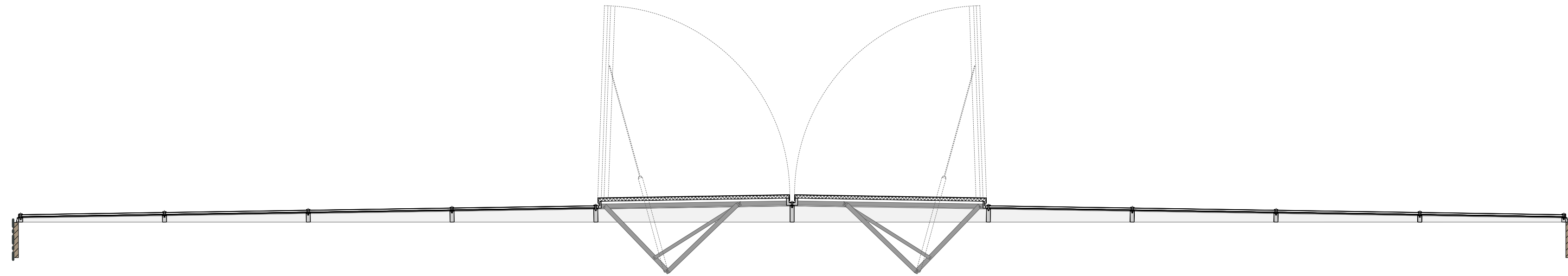



Dakbedekking

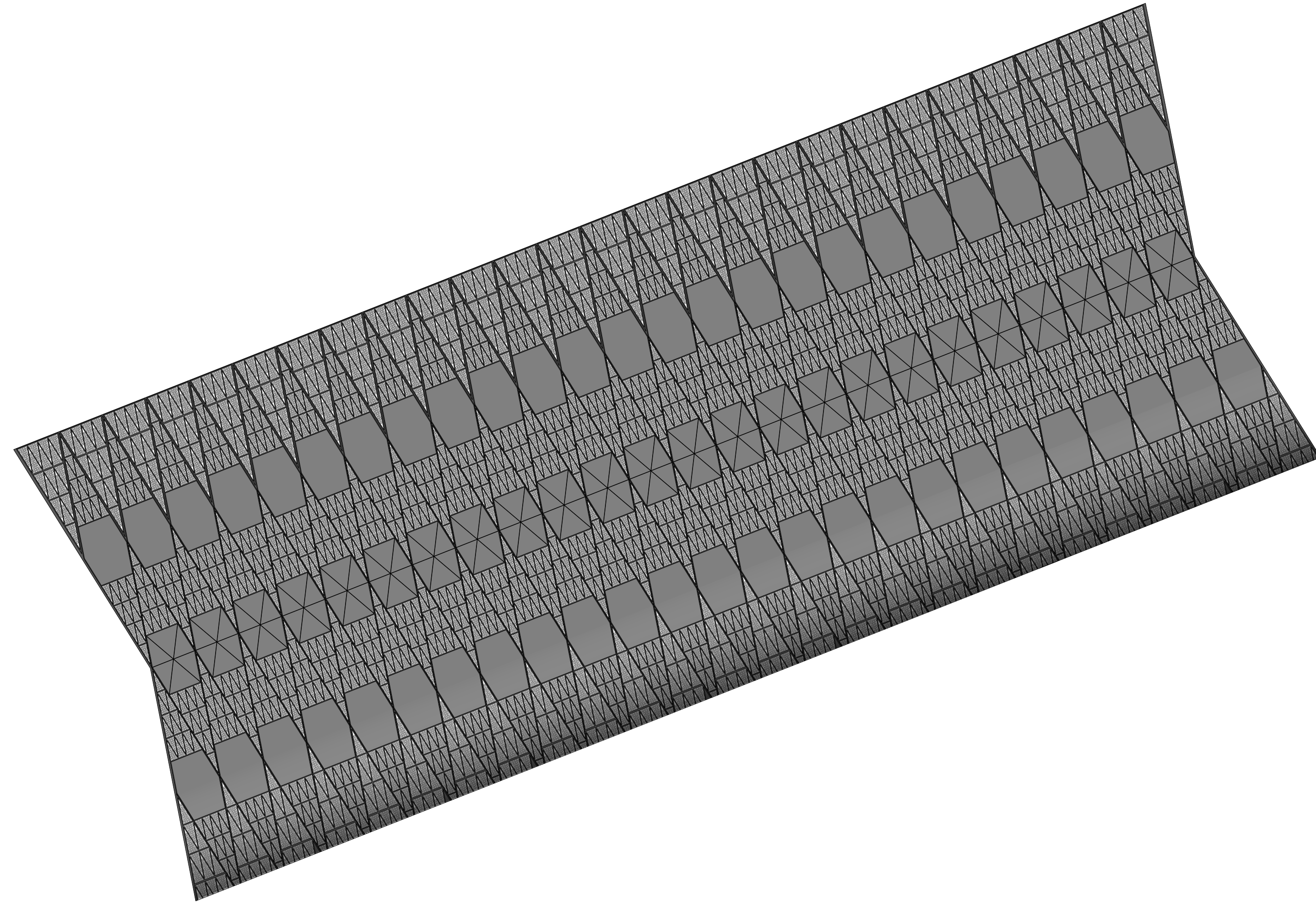



Parkeergarage - doorsnede

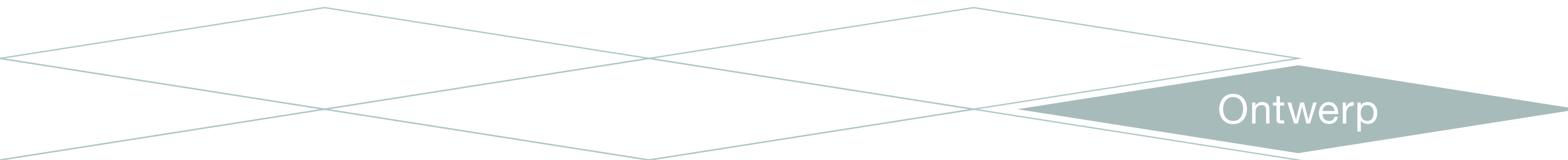
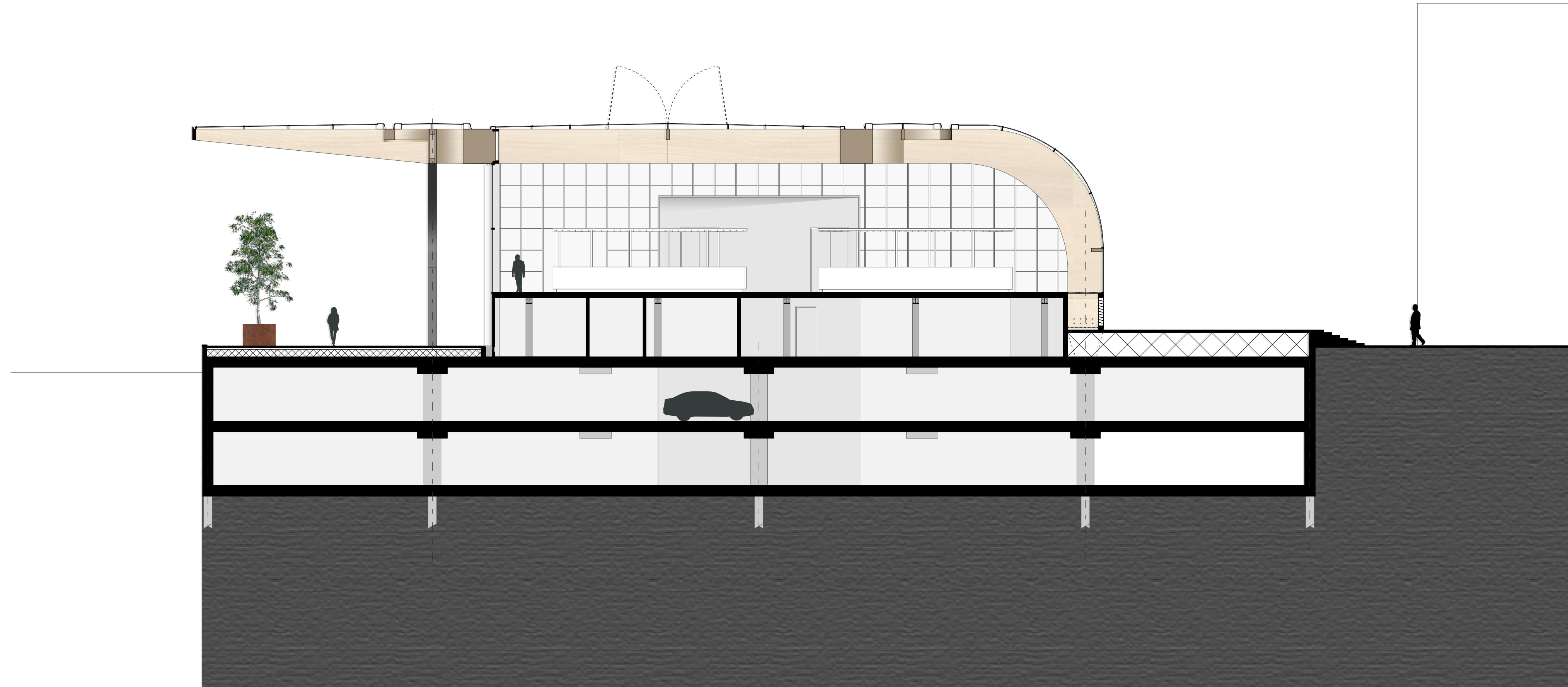
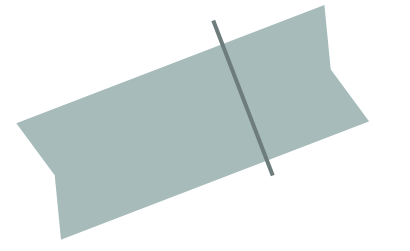



Constructie

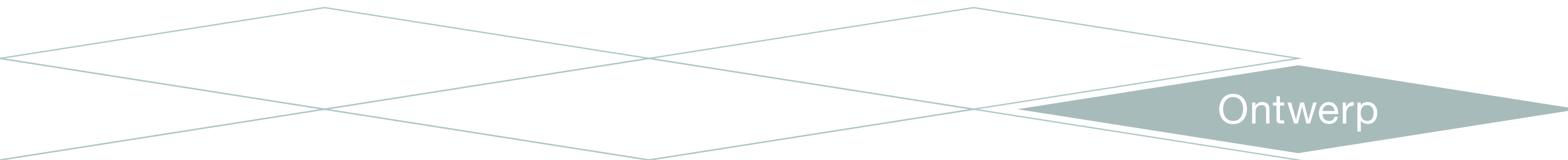
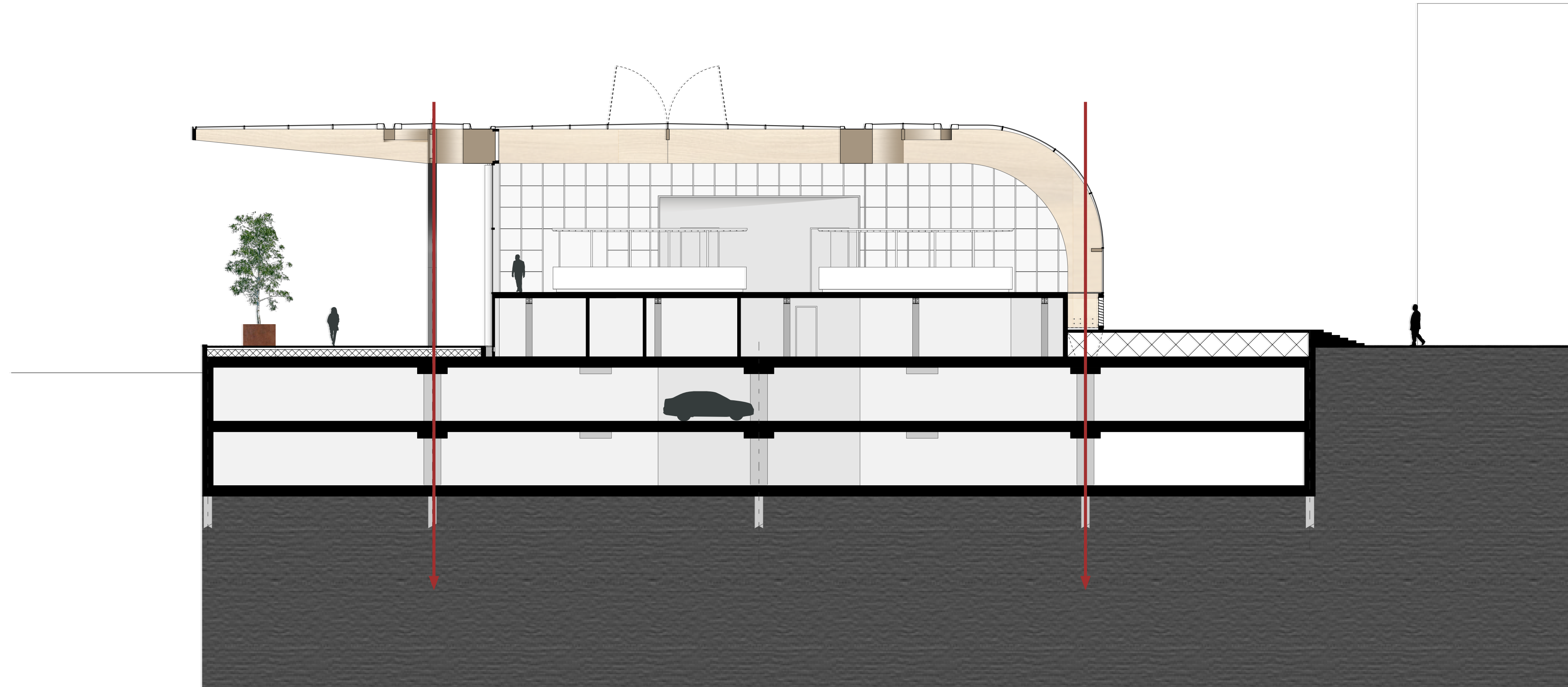
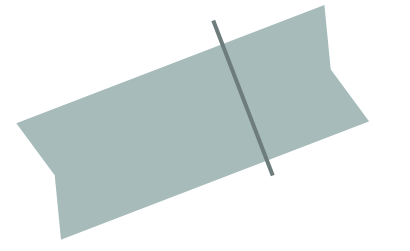



Parkeergarage - plattegrond L-1

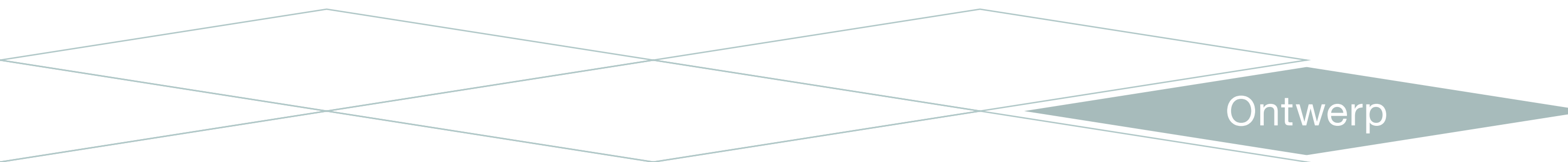
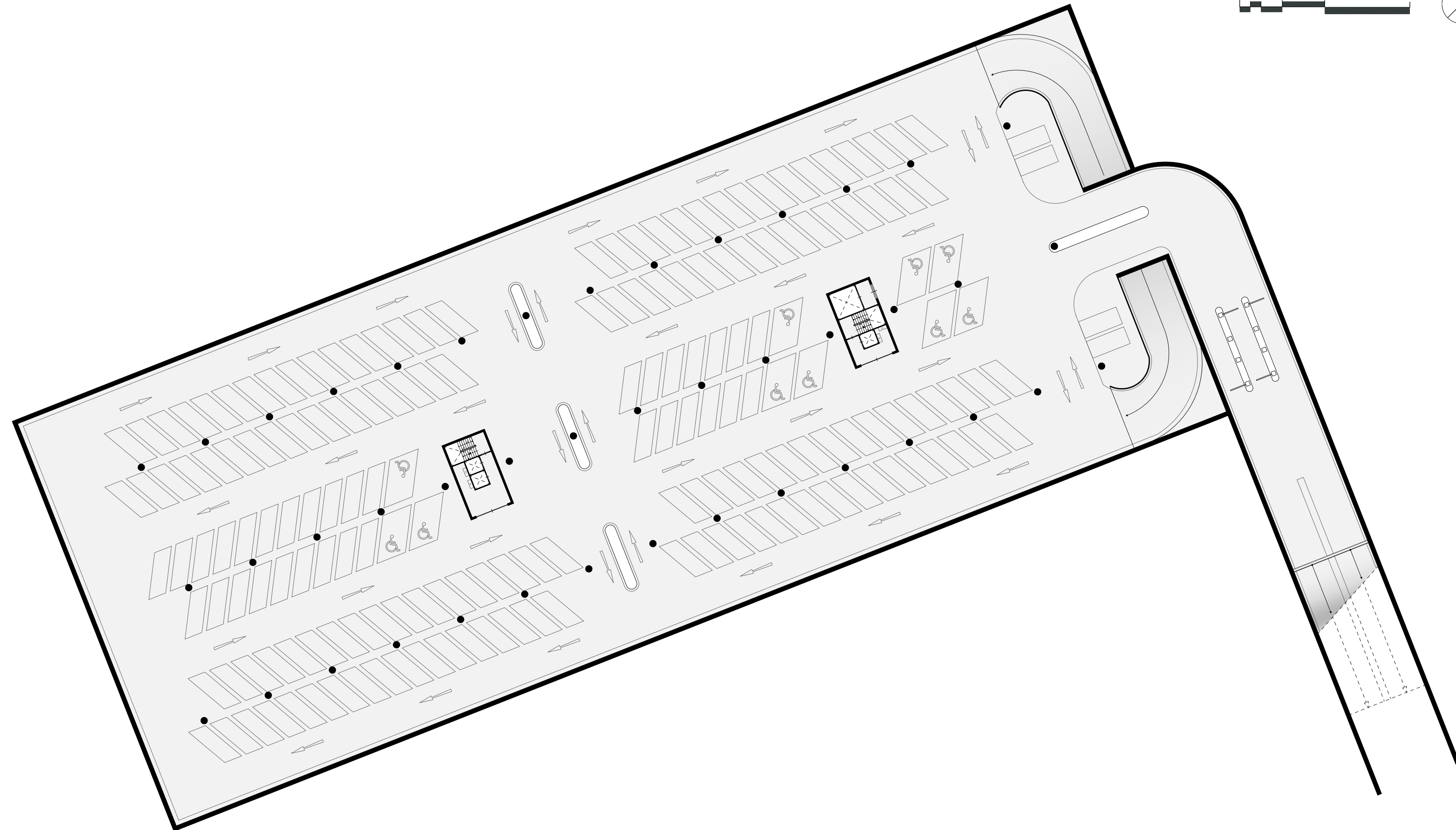
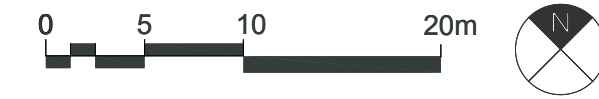



Stijgkernen

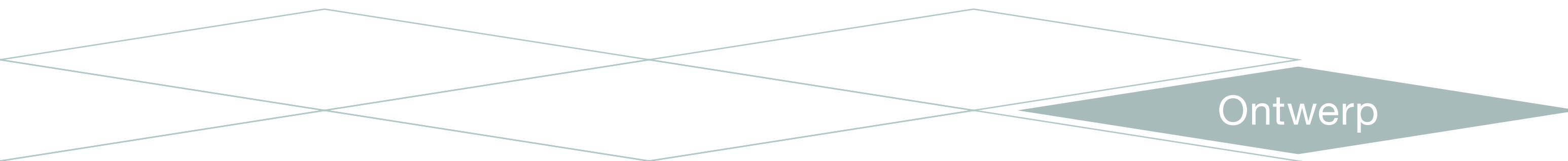
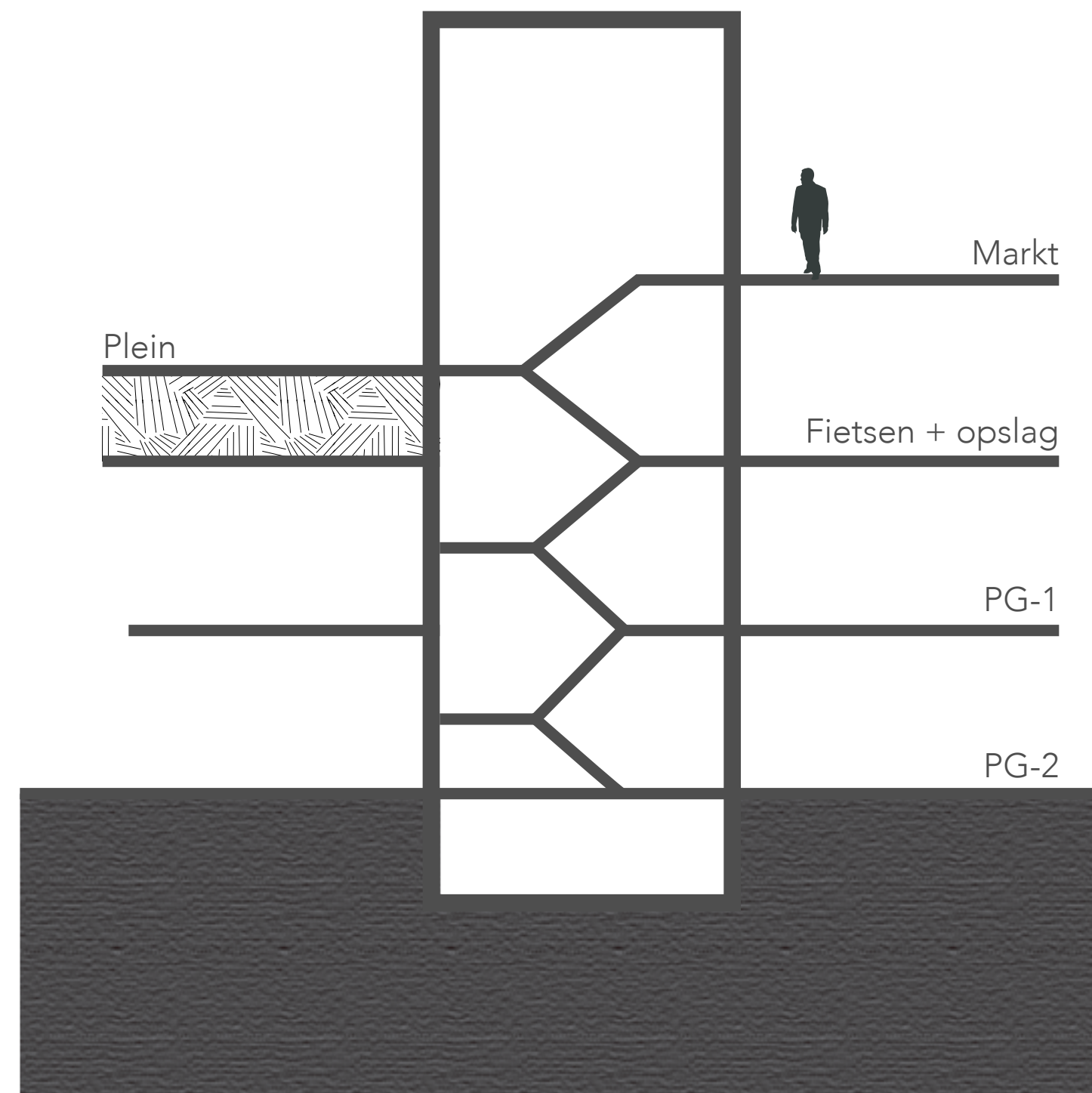

Niveau 2: volumes

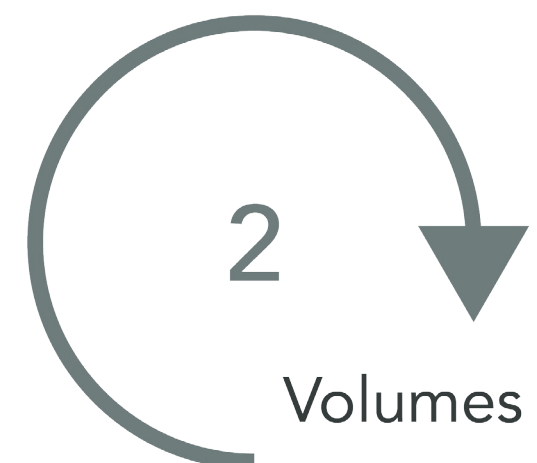
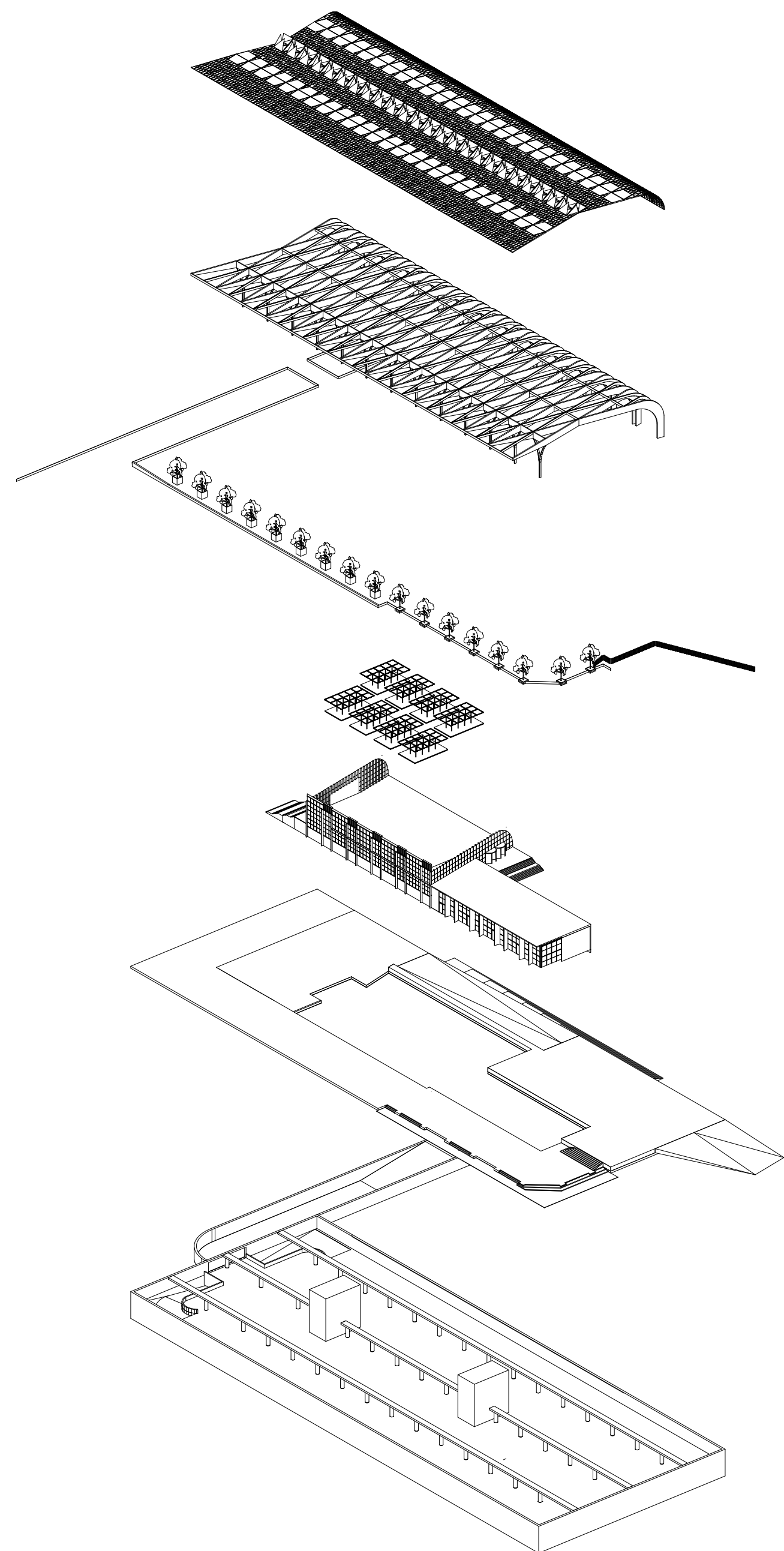

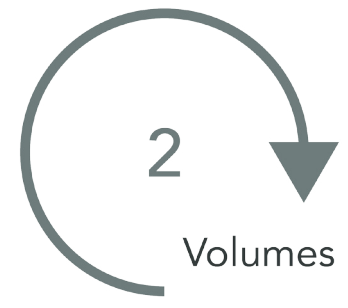

Lofts - doorsnede

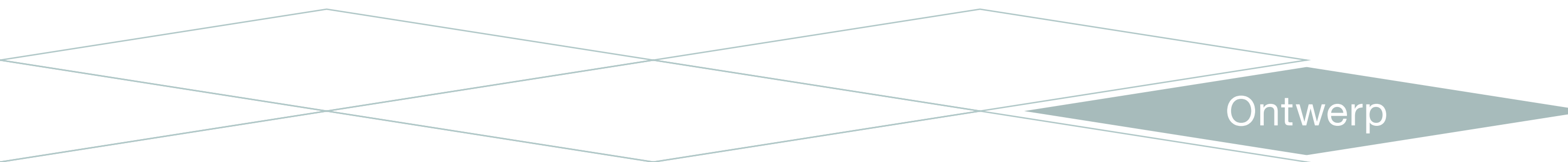
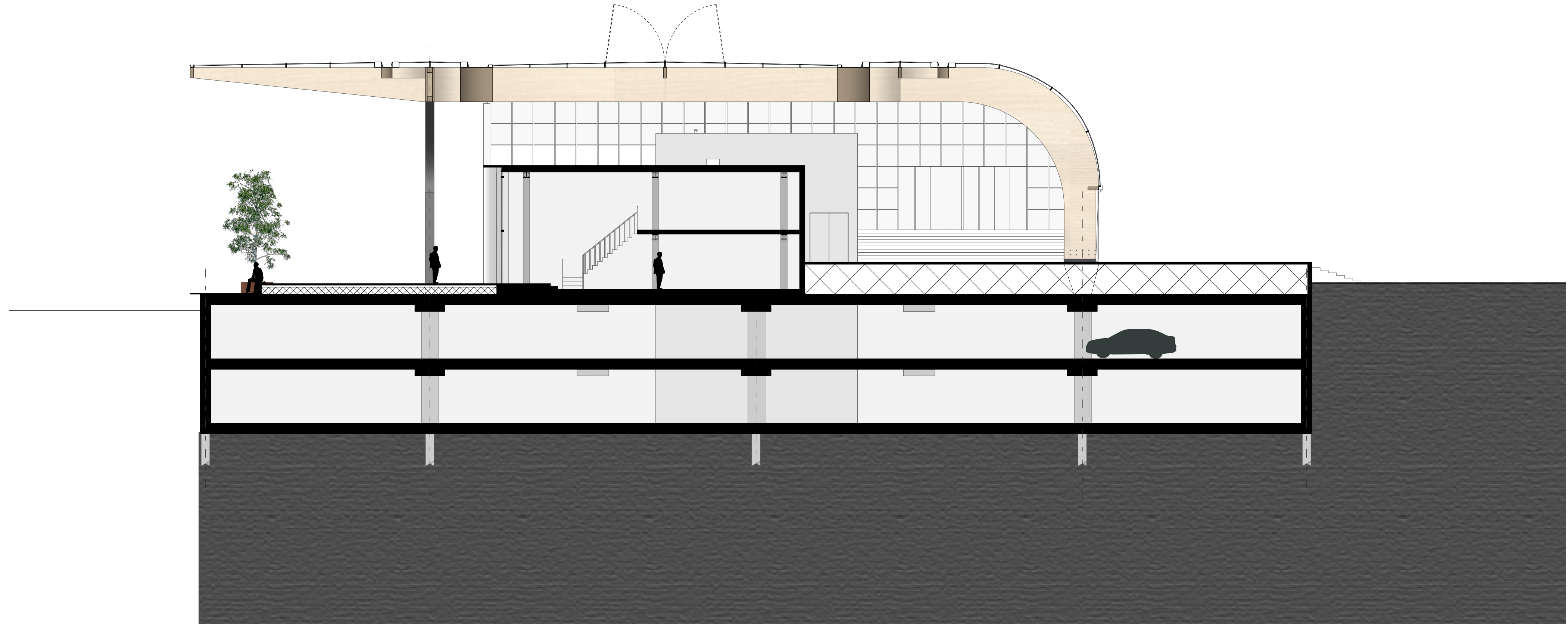

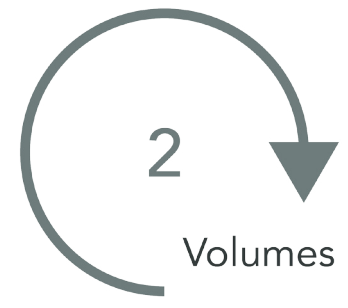

Lofts - plattegrond L0

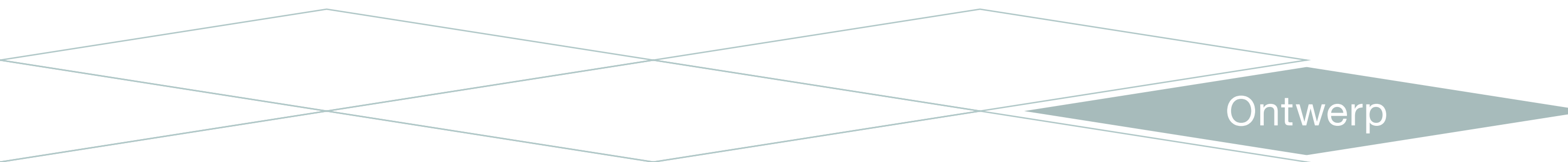
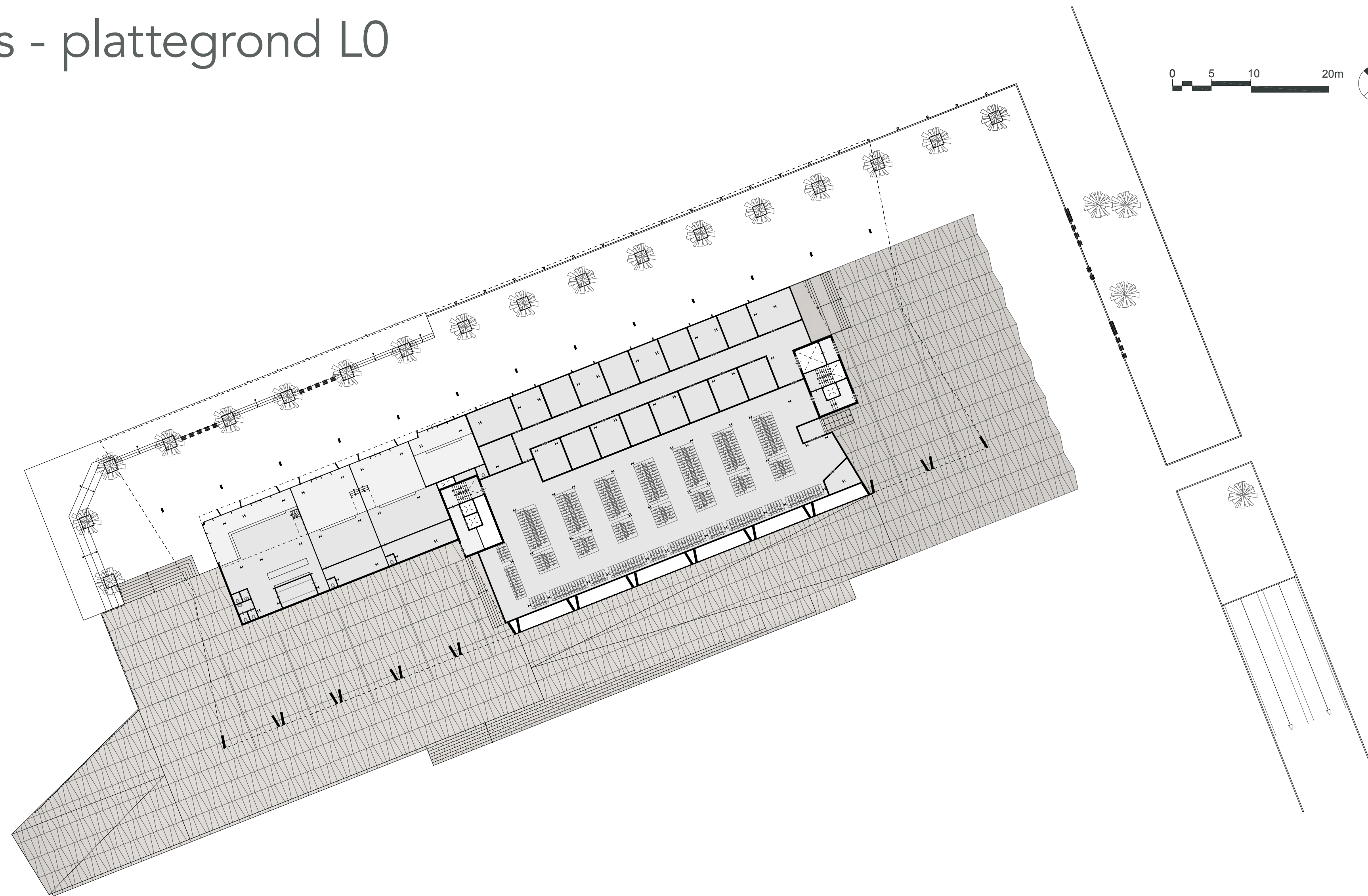

Lofts - klimaat

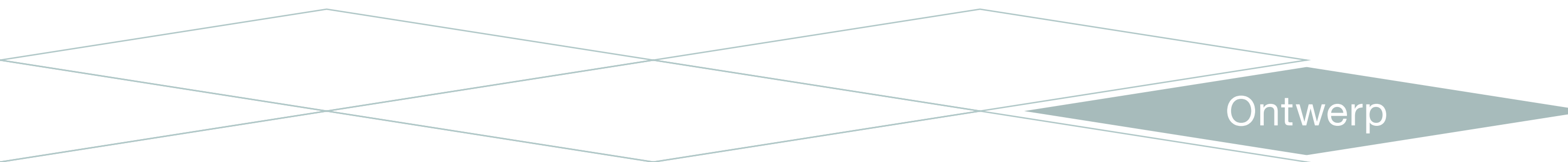
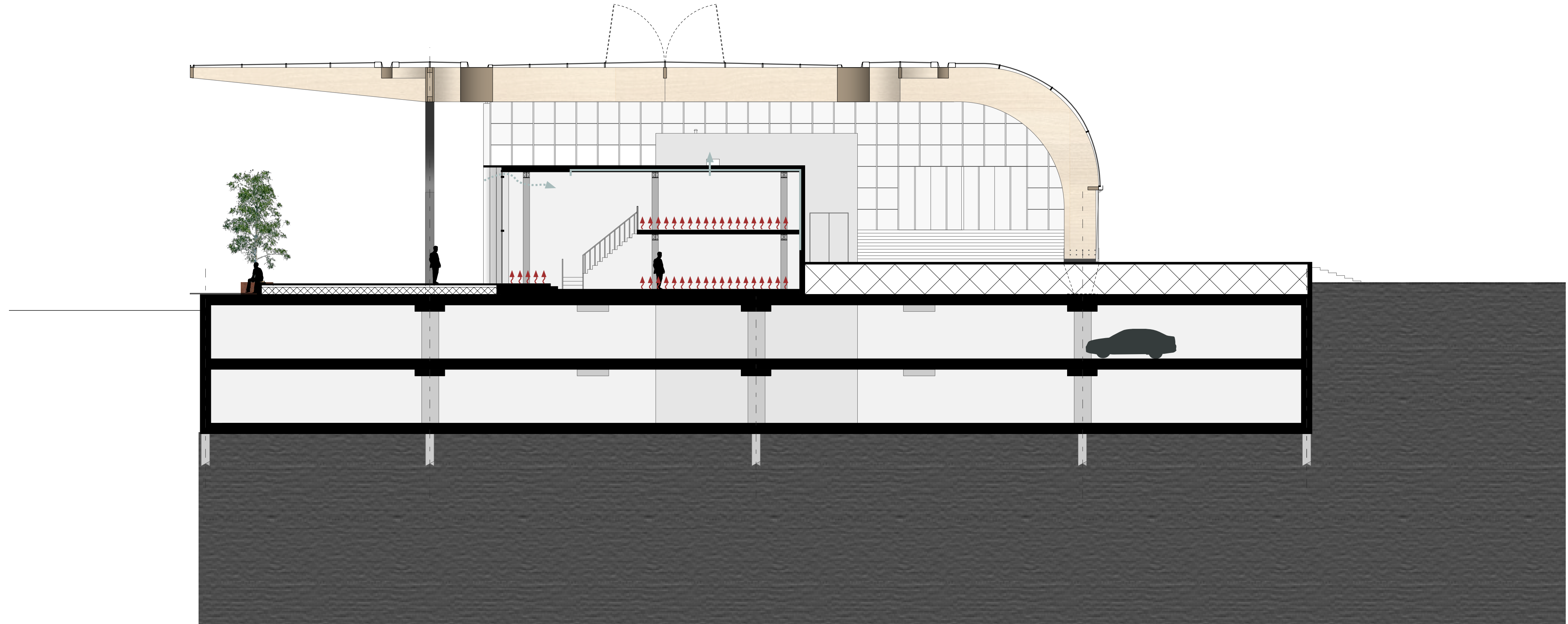
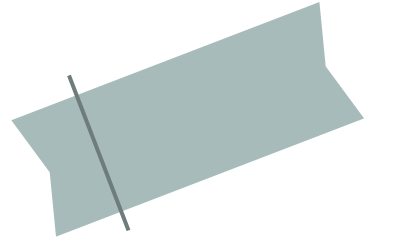

Markthal - doorsnede

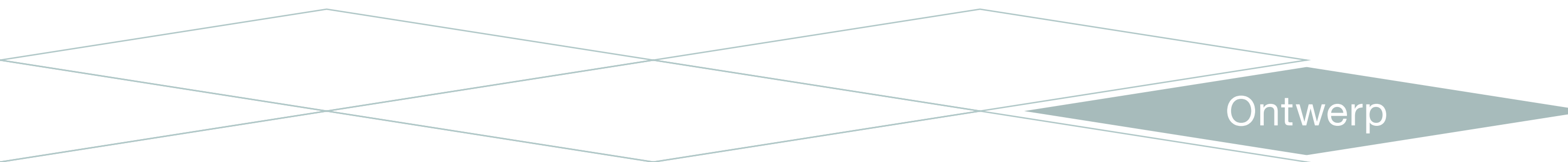
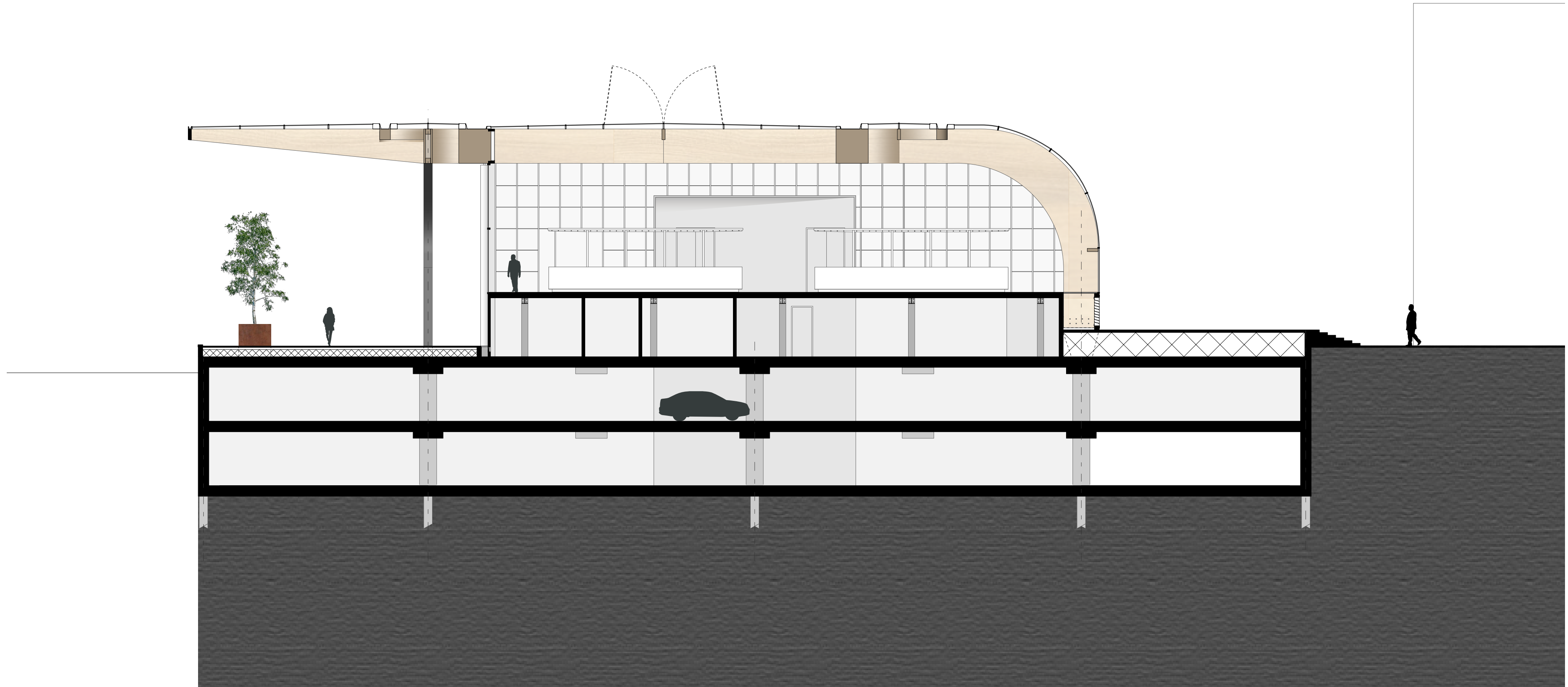
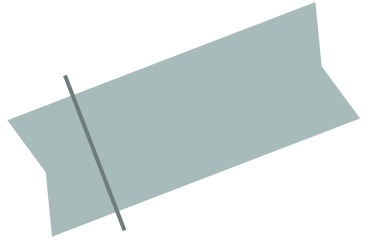

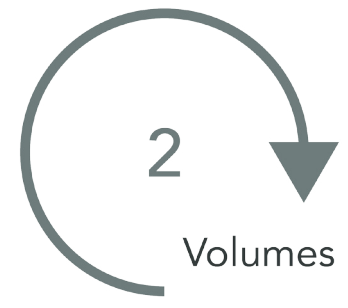

Markthal - plattegrond L1

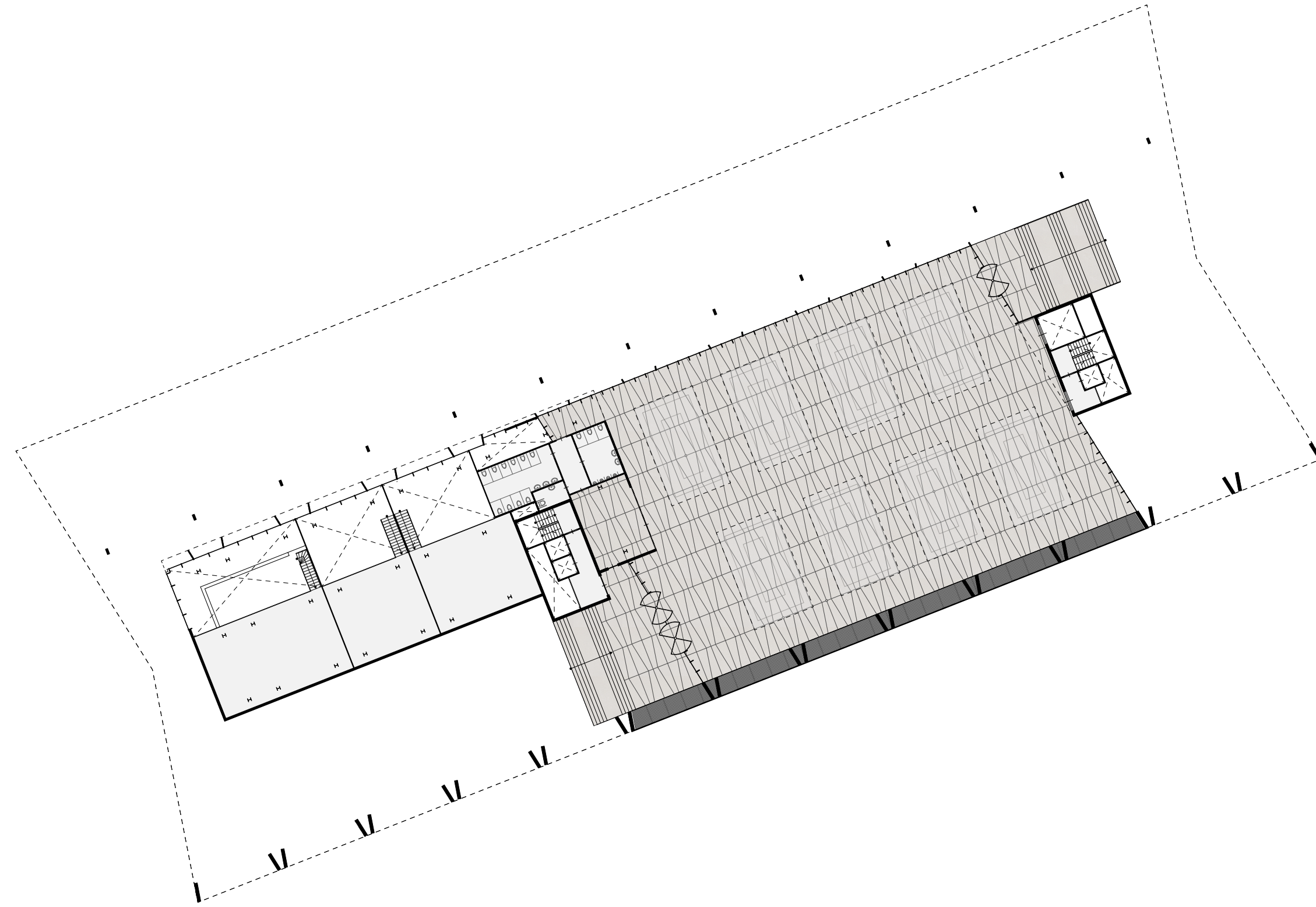
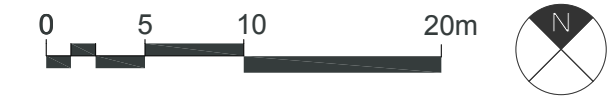

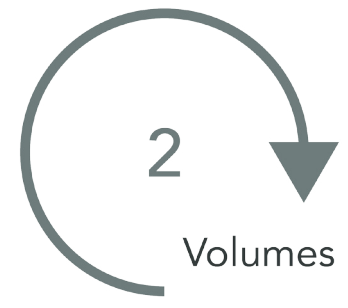

Markthal - plattegrond L0

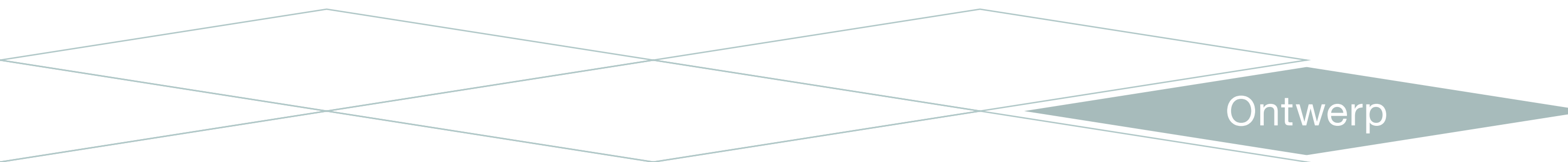
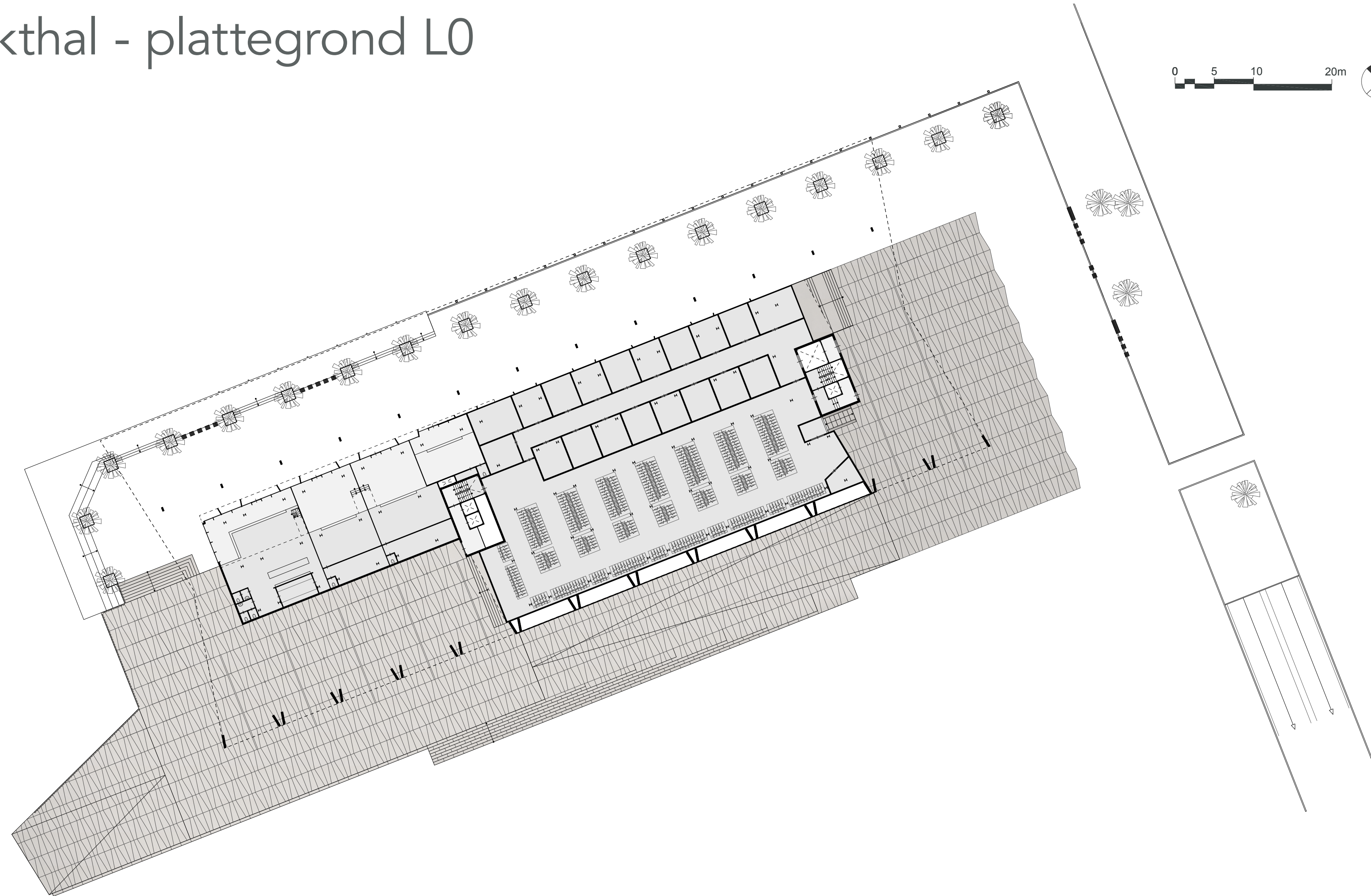
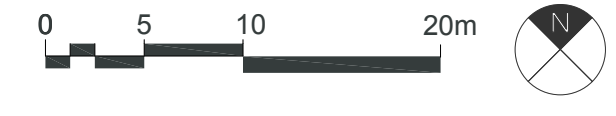

Markthal - klimaat

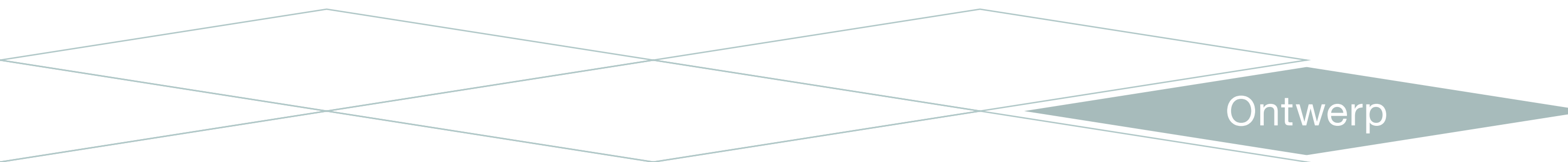
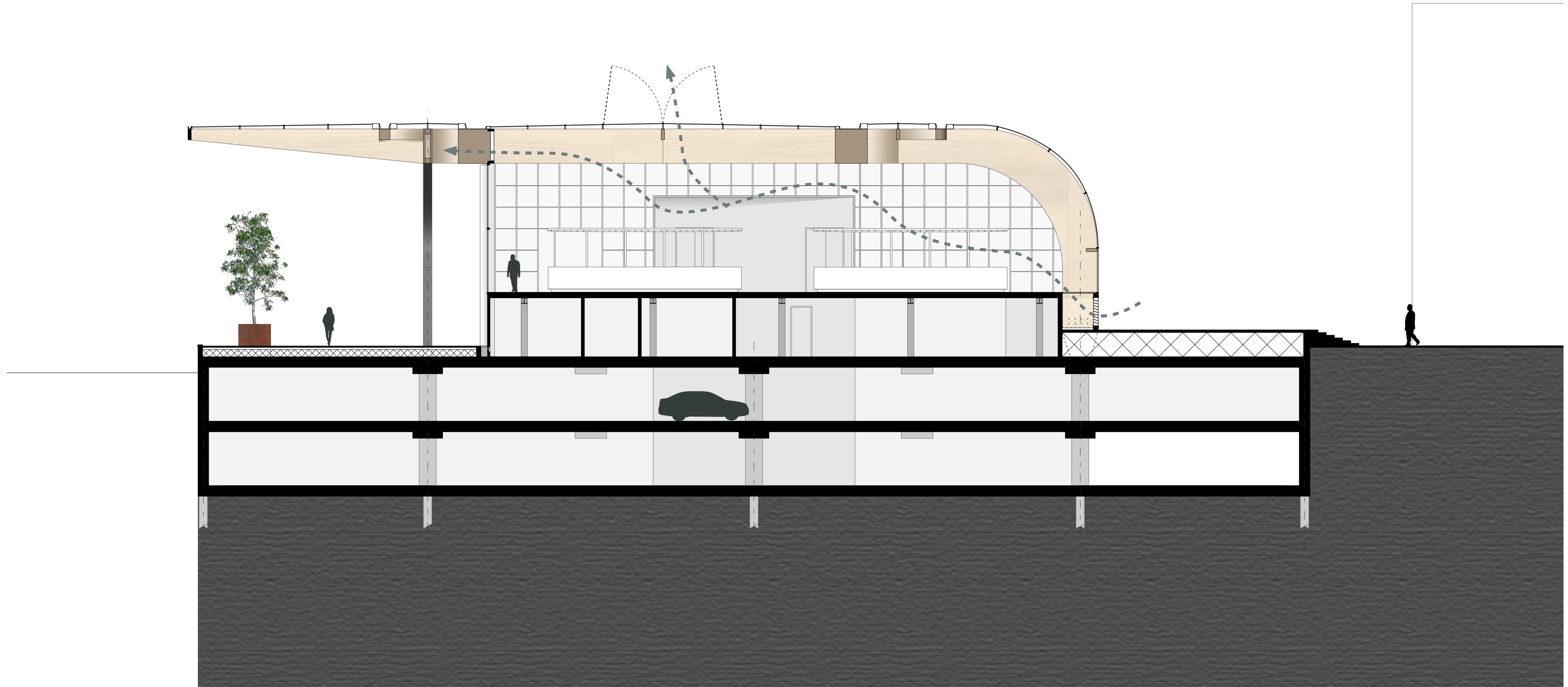
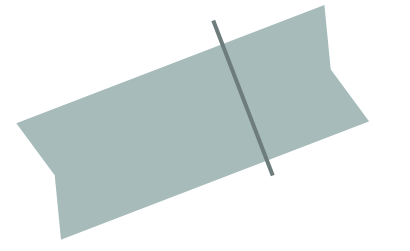

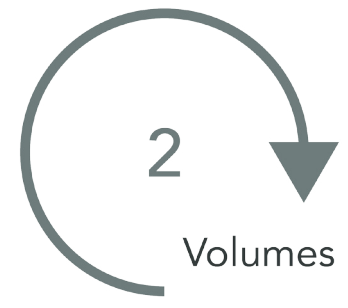

Gevel lichtplein

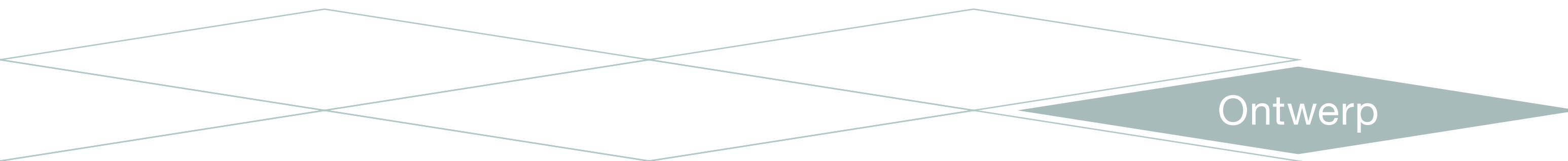
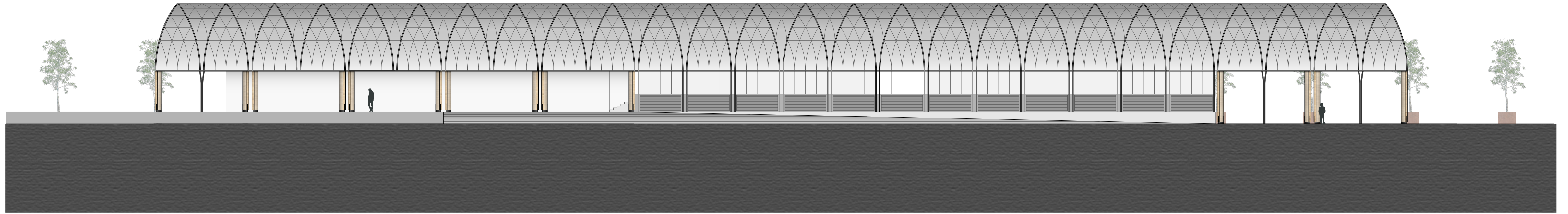



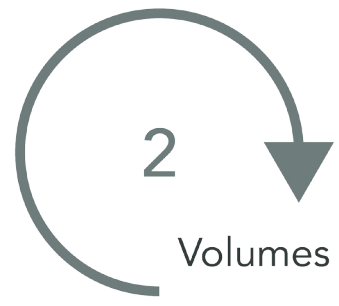

Constructie

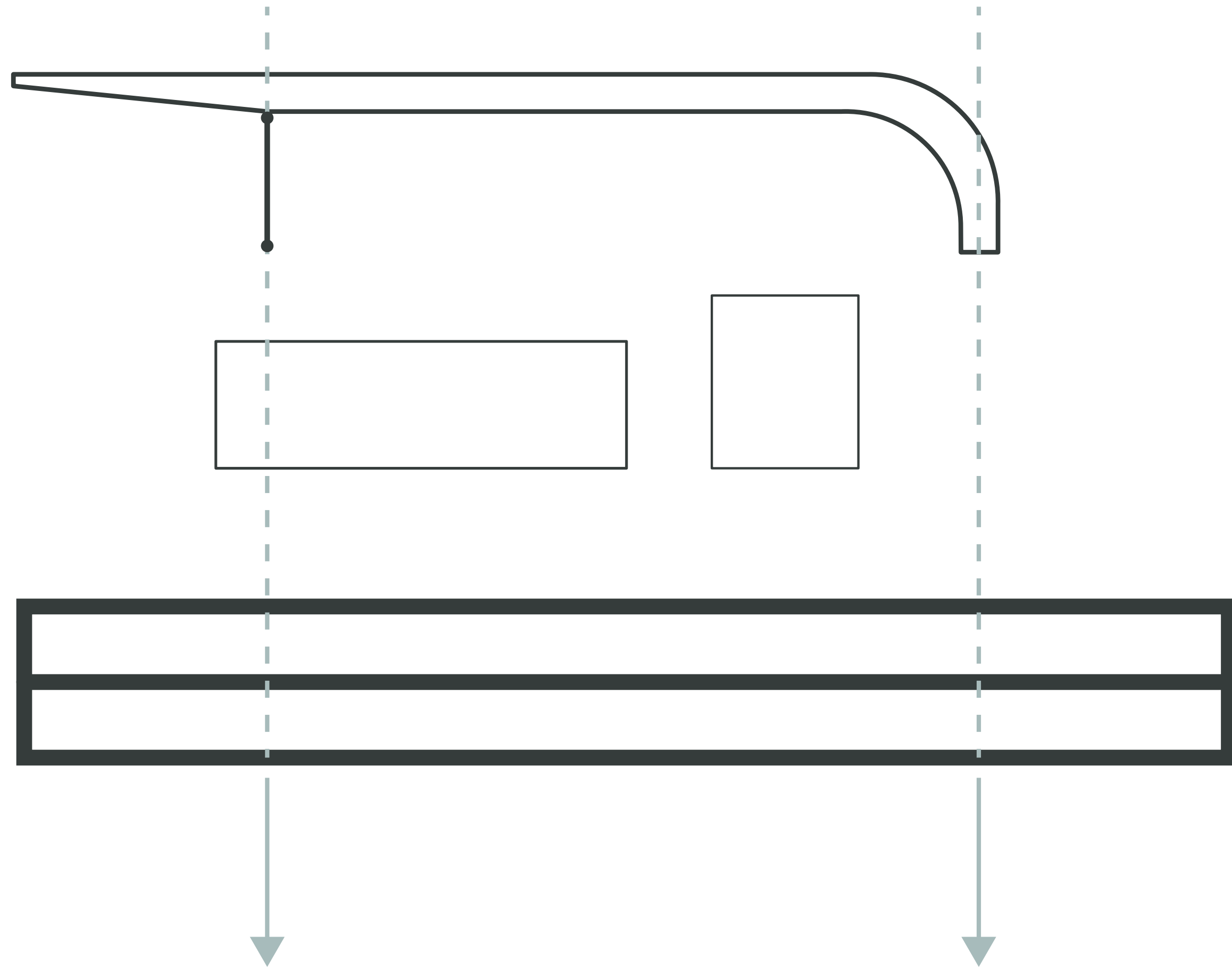

Dakconstructie

Lichte topconstructie

Fundering

Trekpalen

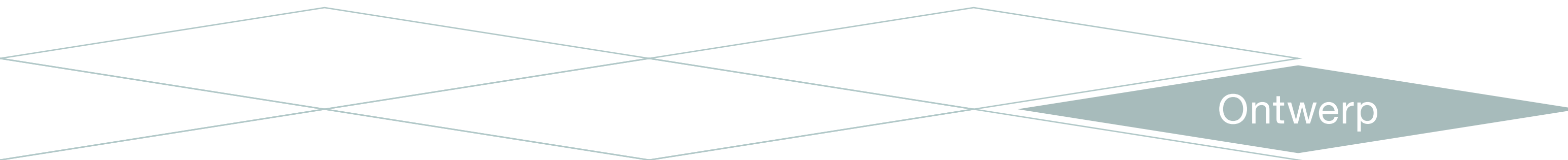

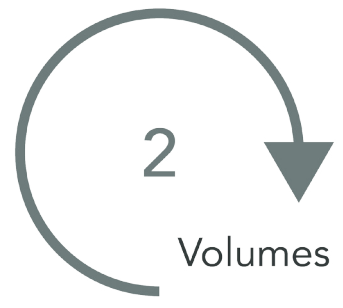

Constructie

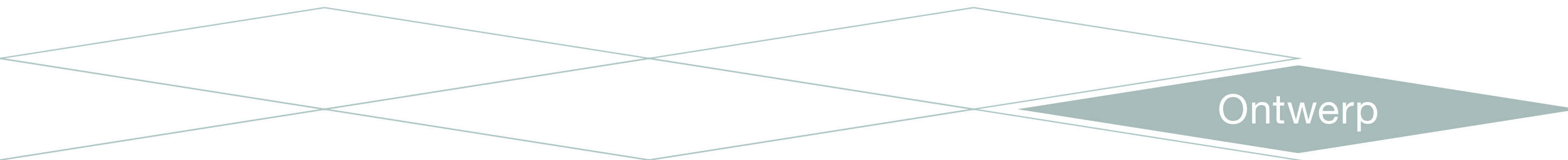
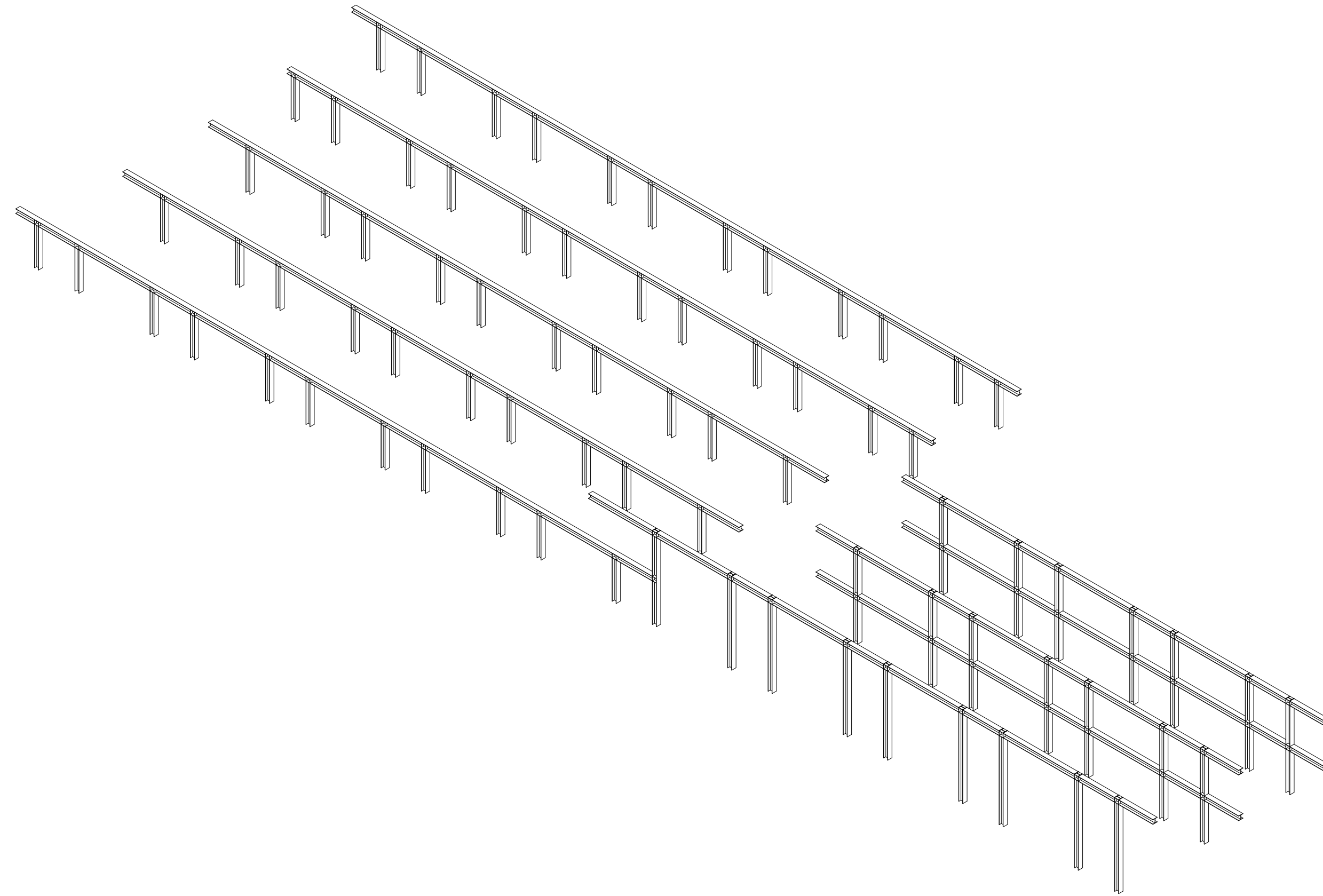

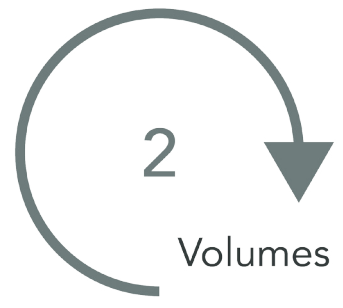

Gevel

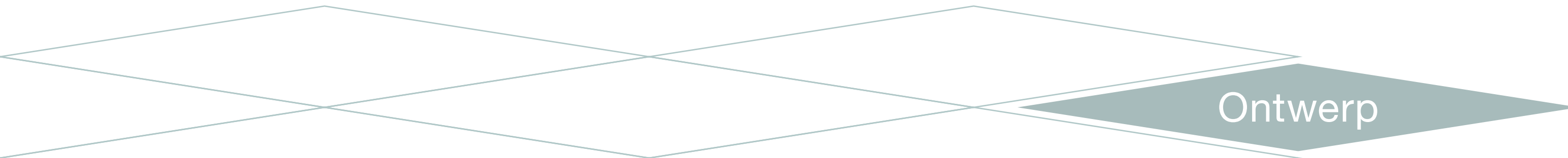
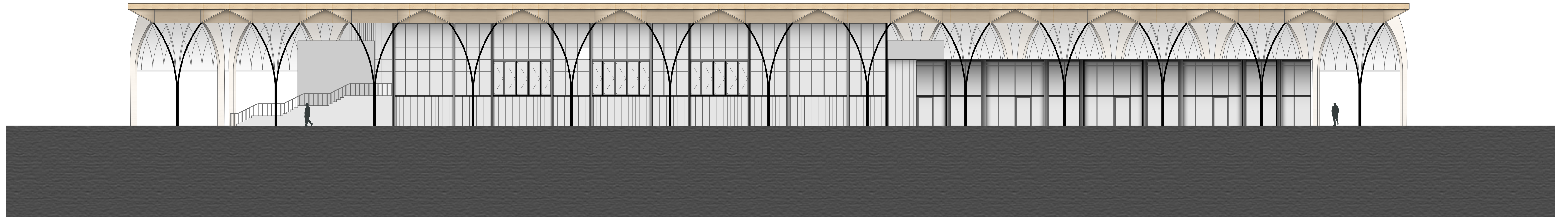

Gevel markthal

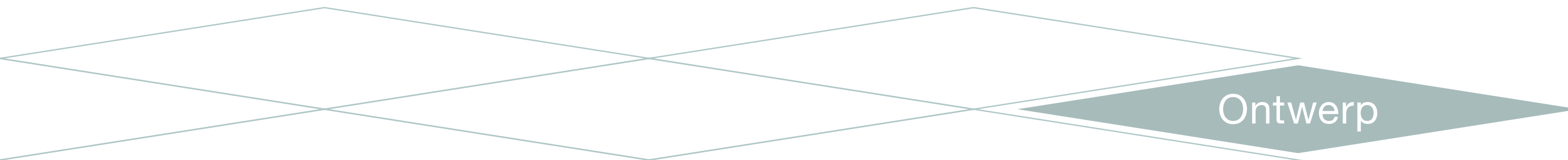
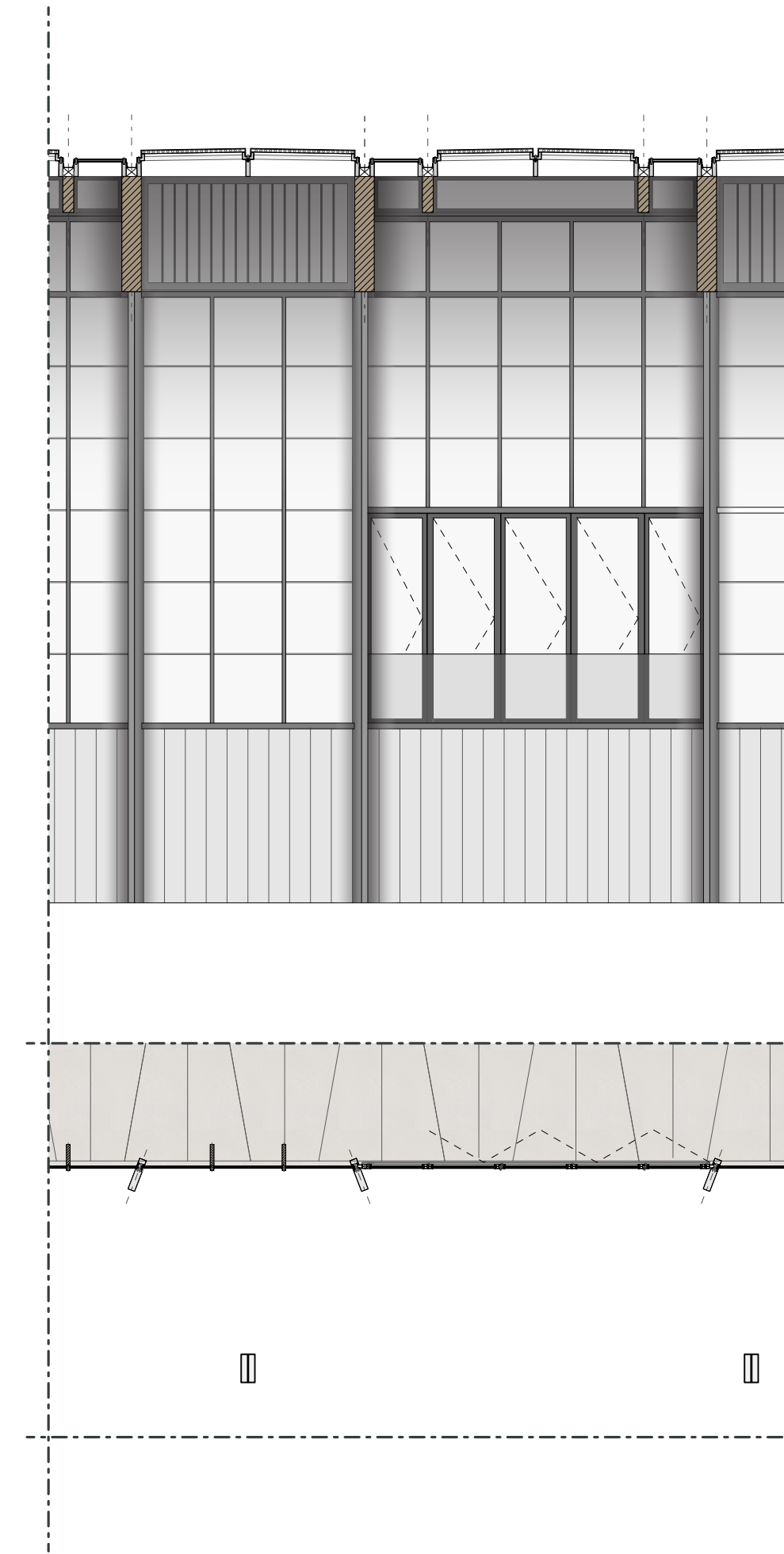
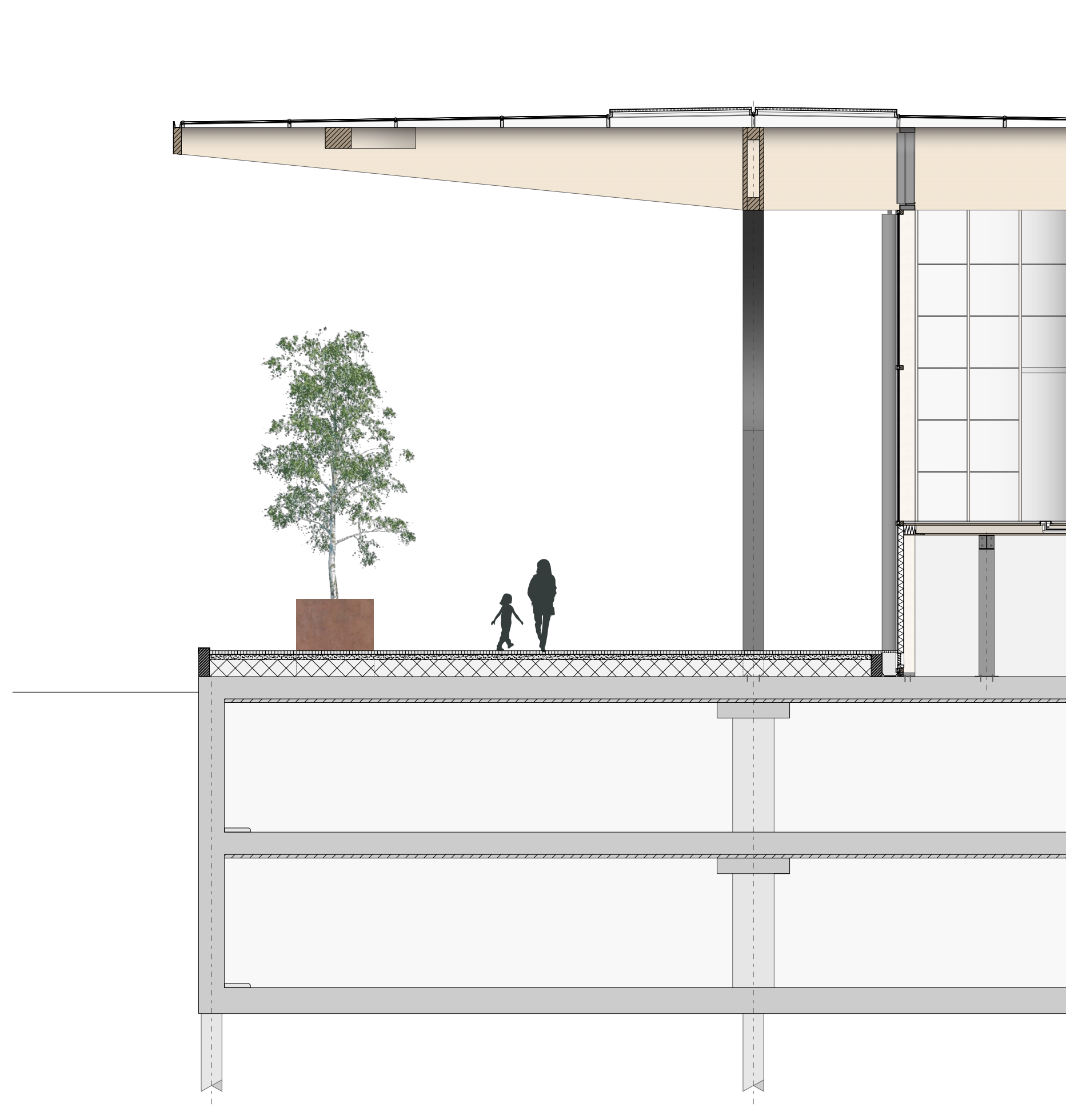
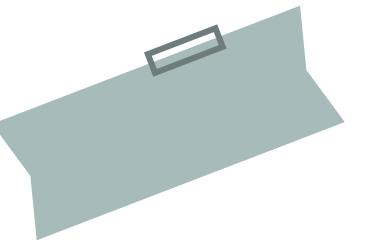

Gevel lofts

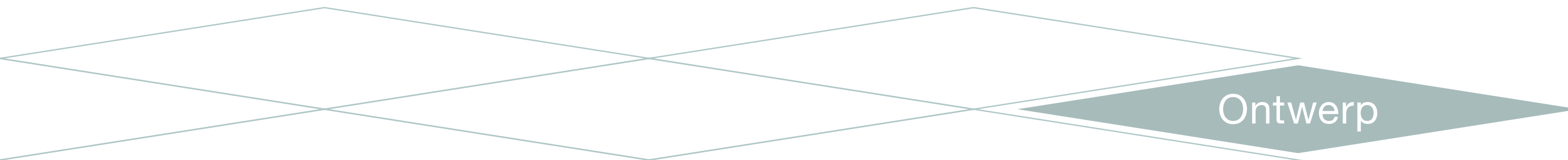
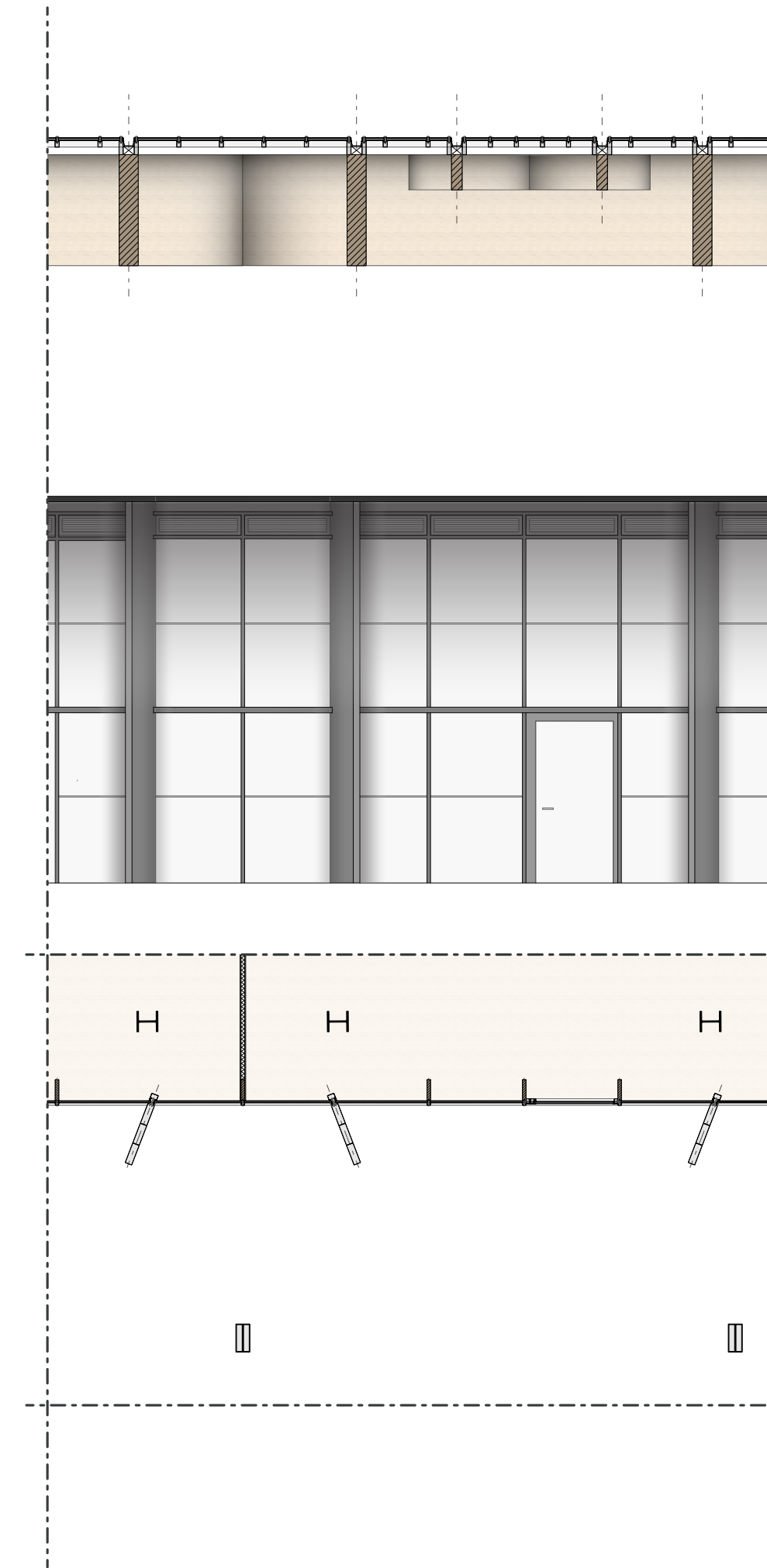
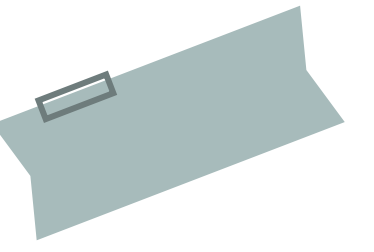



Niveau 3: marktkramen

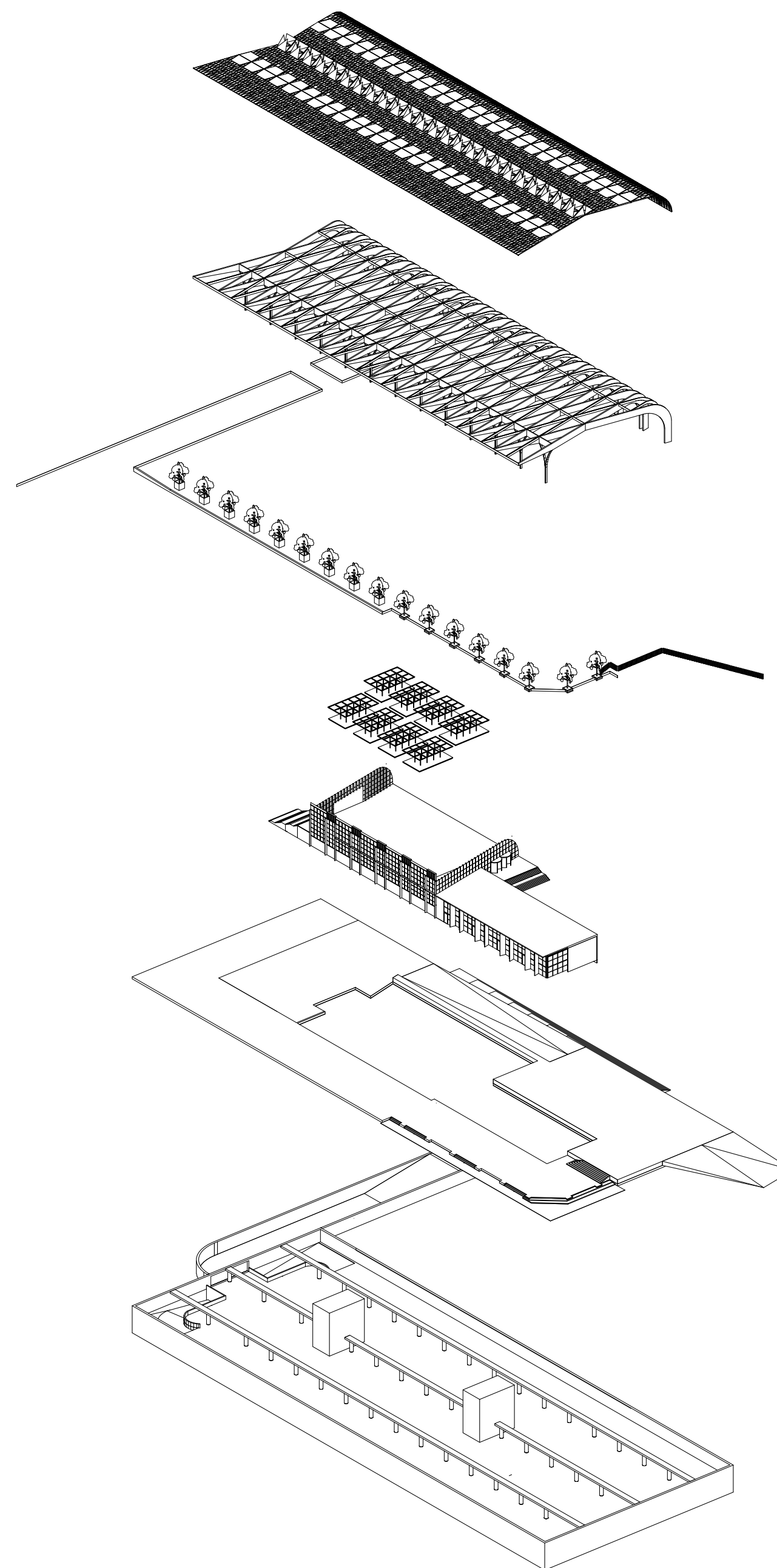



Marktkraam

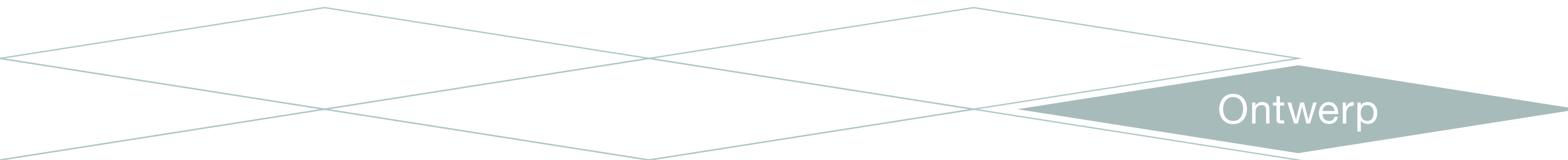
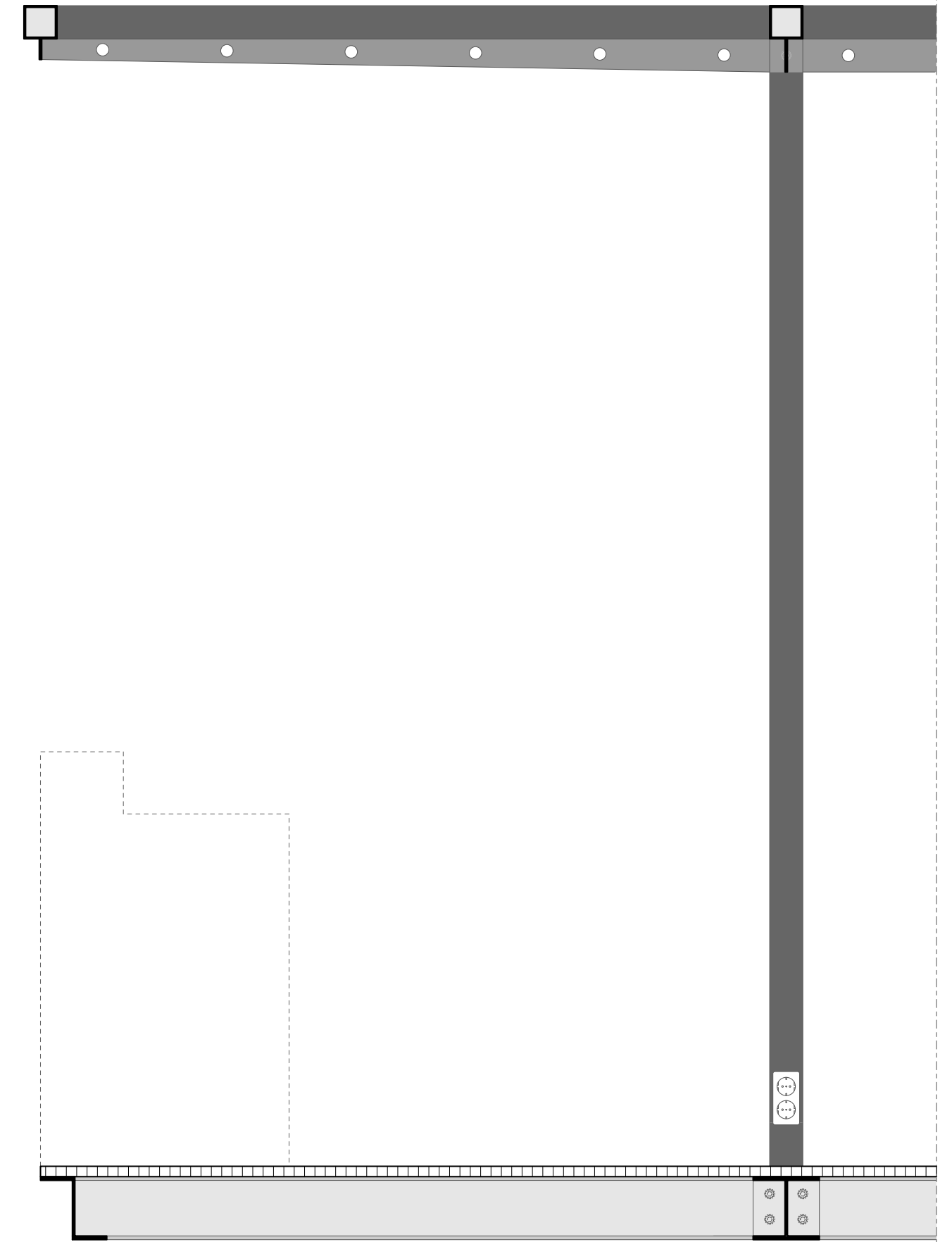
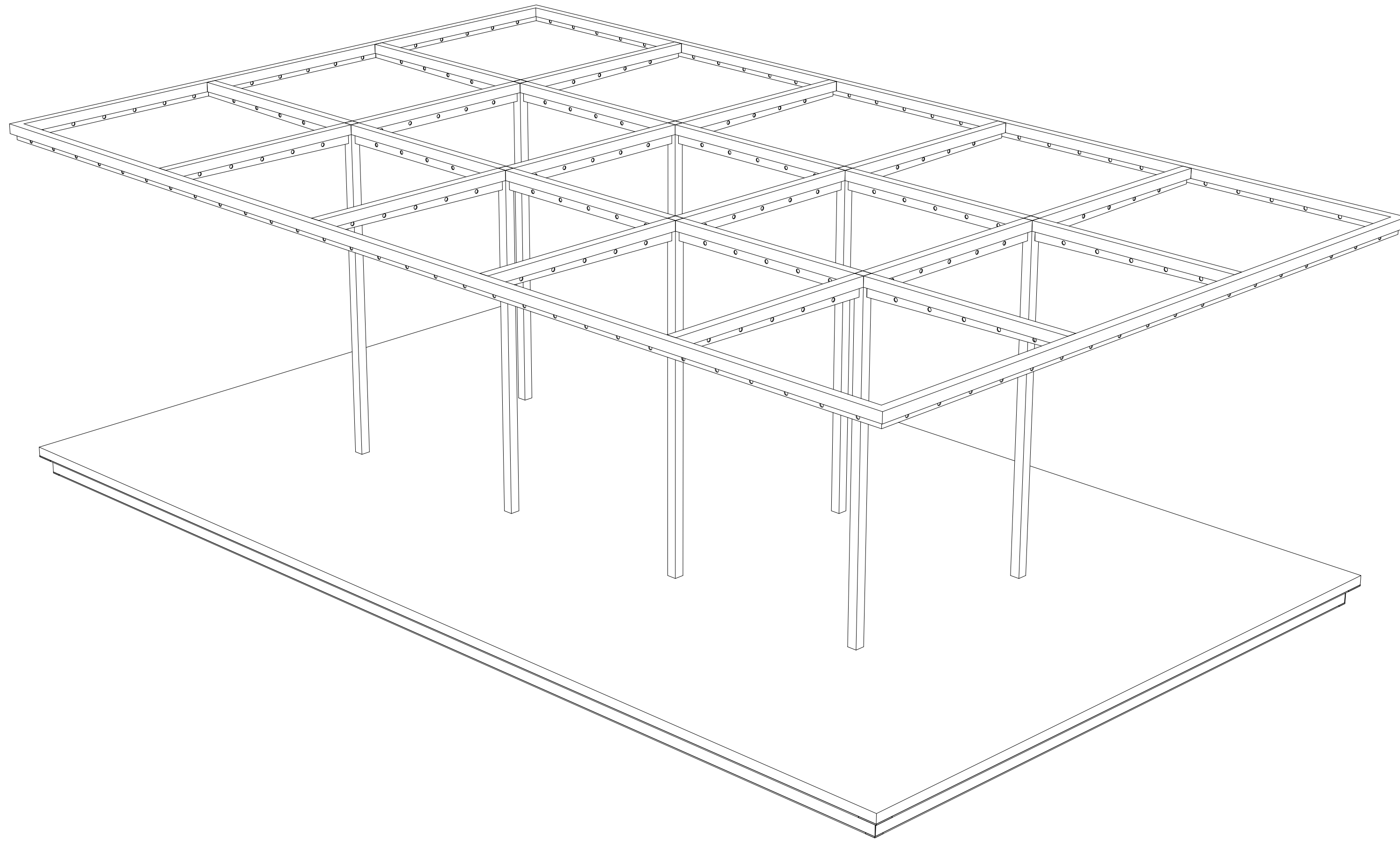

Niveau 4: openbare ruimte

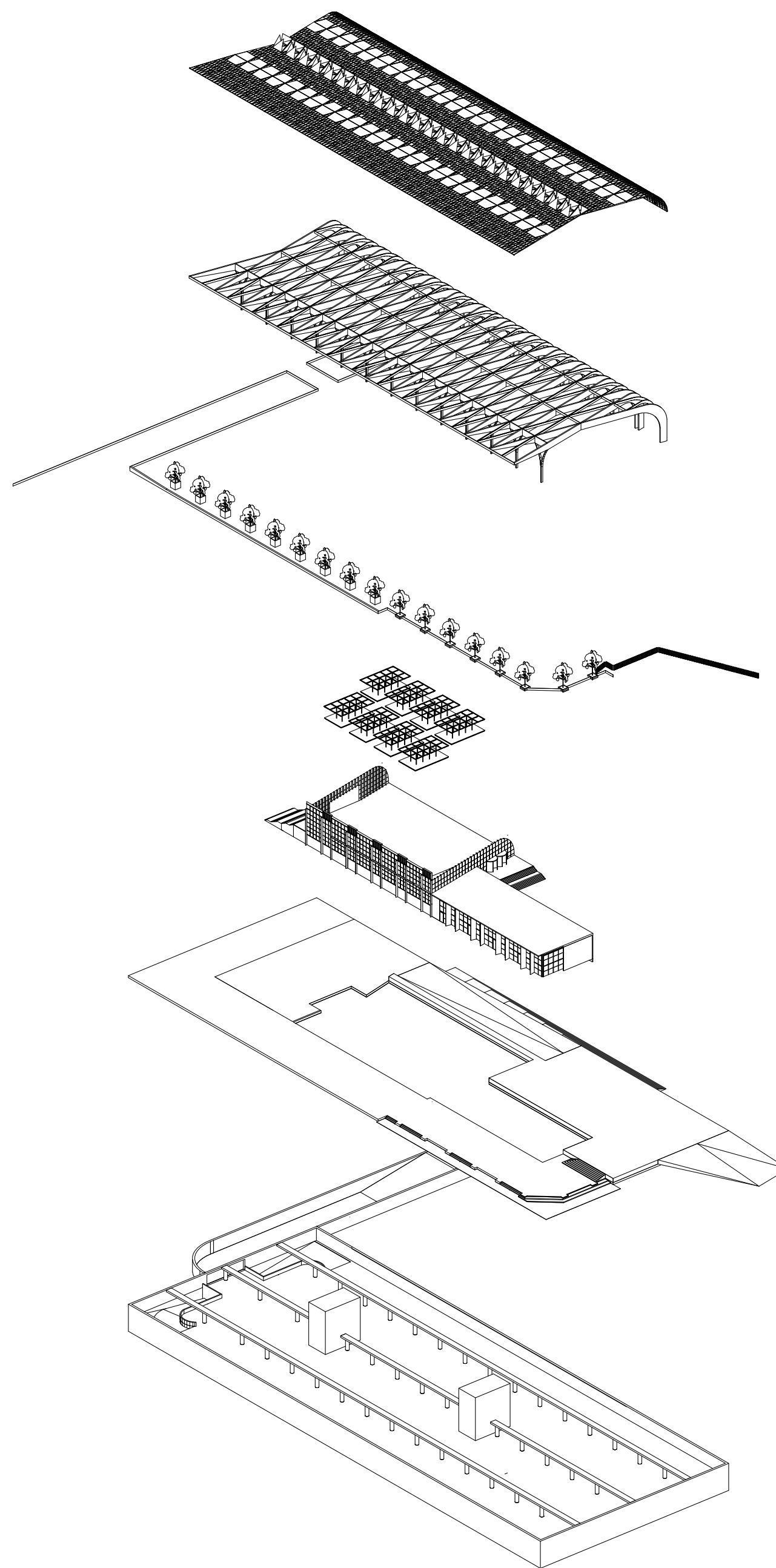

Pleinen

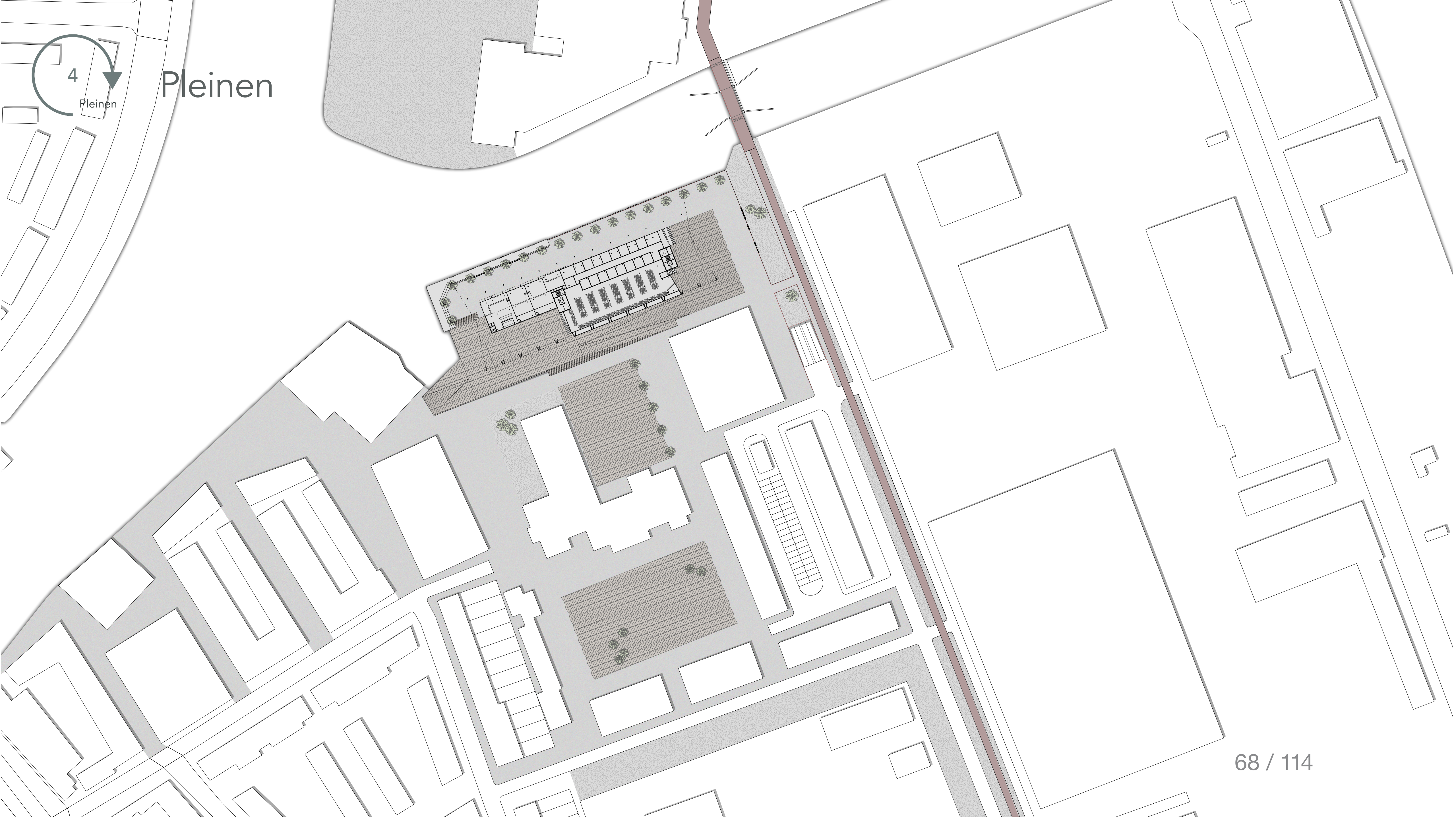
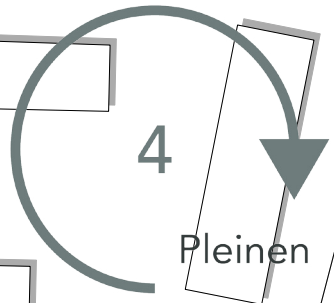



Pleinen - plattegrond

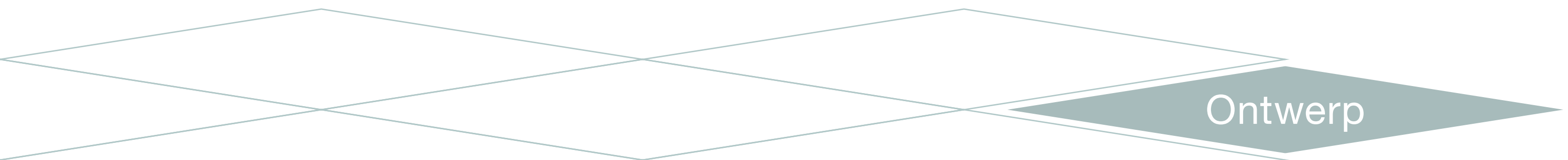
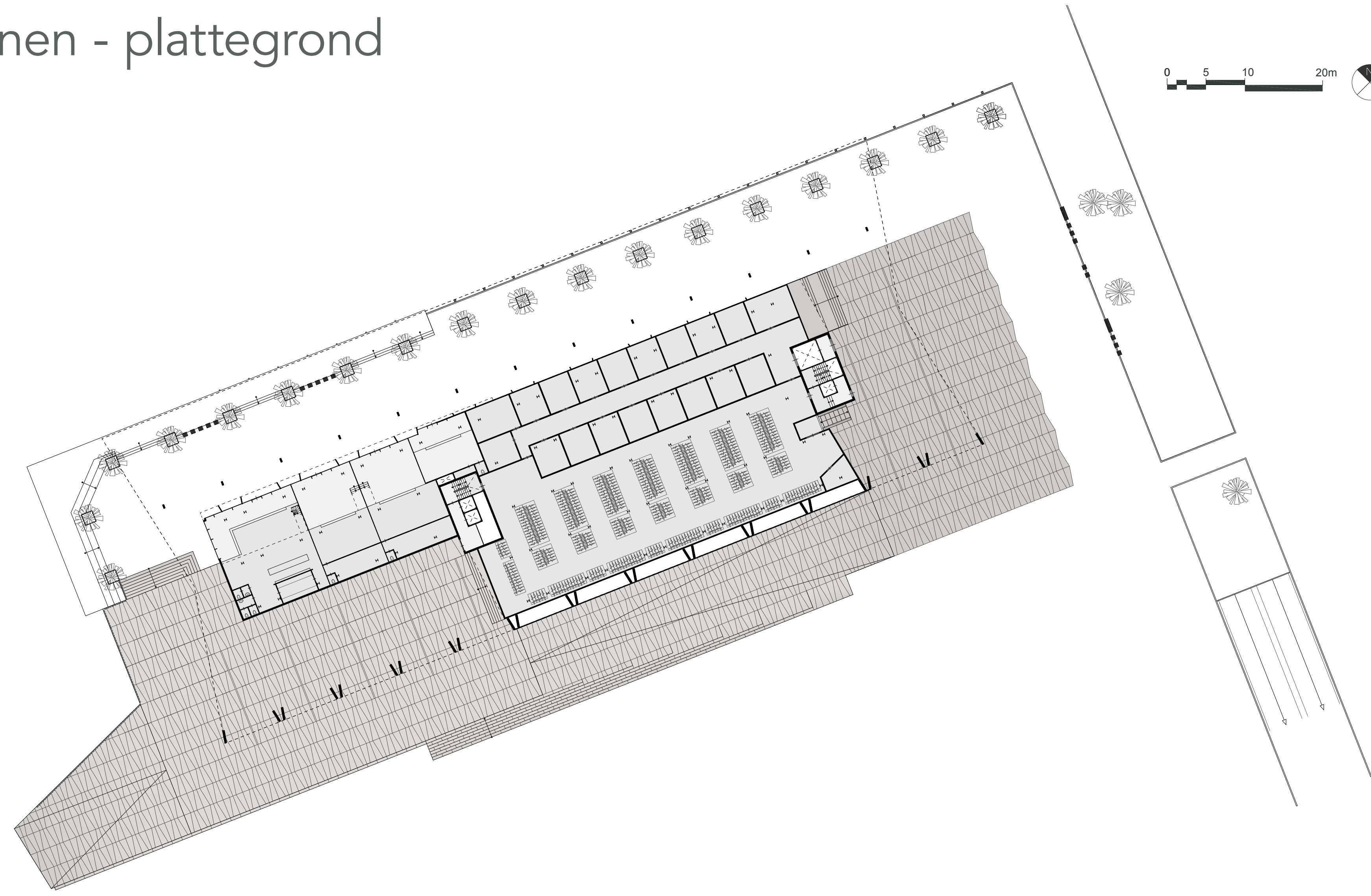



Pleinen - doorsnede

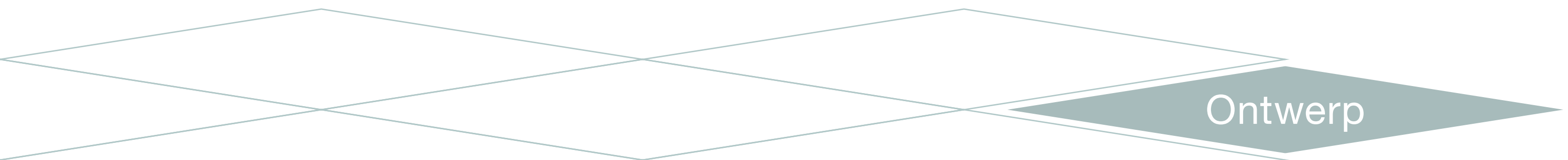
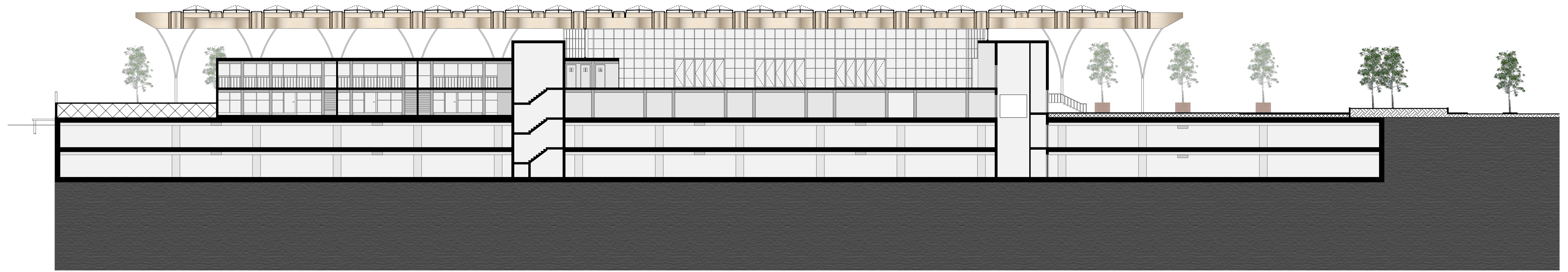
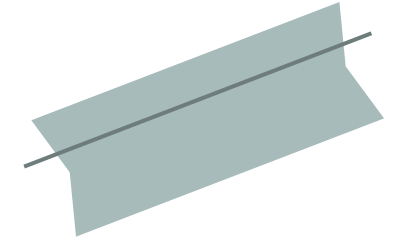



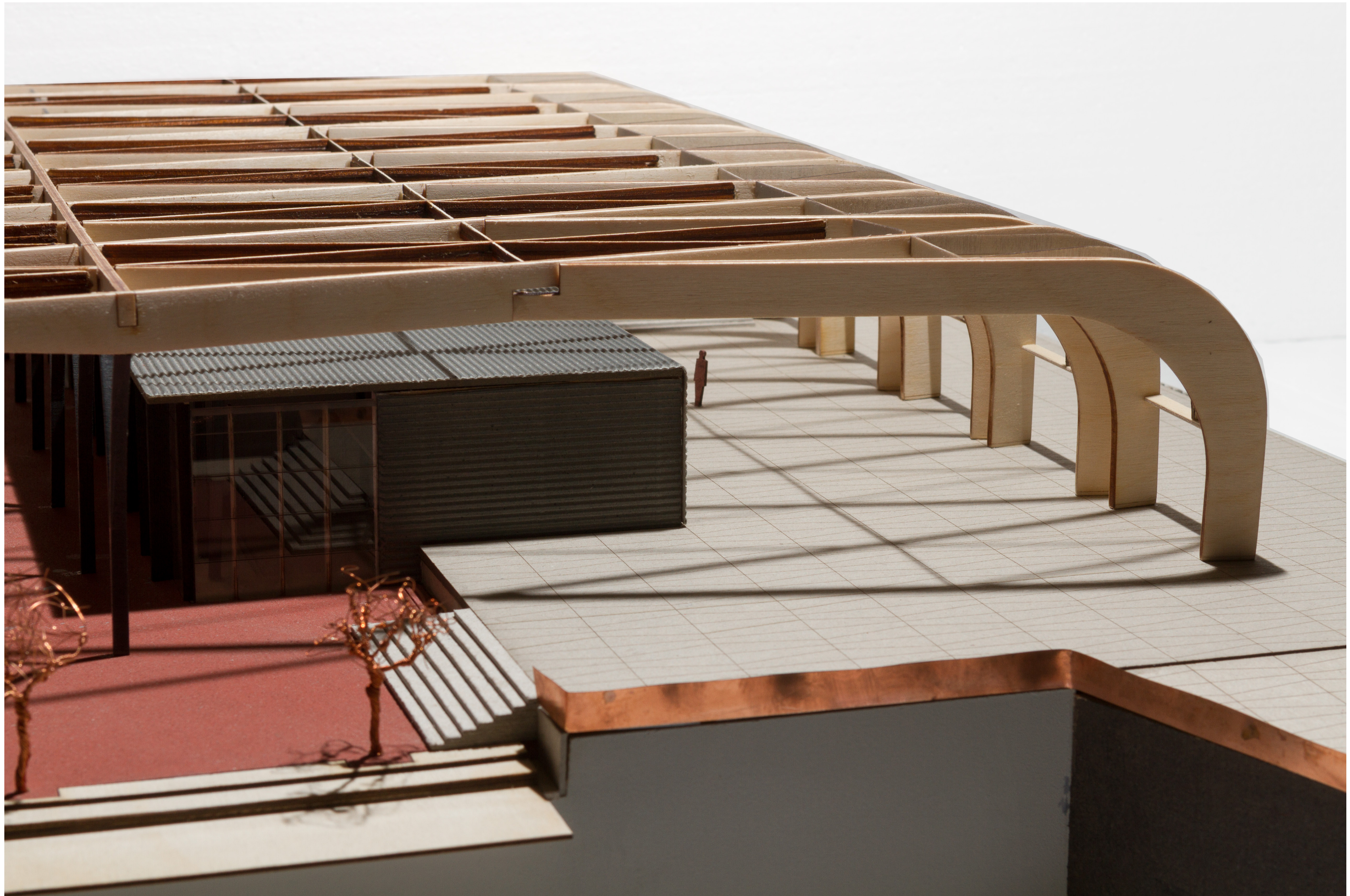



Pleinen - doorsnede

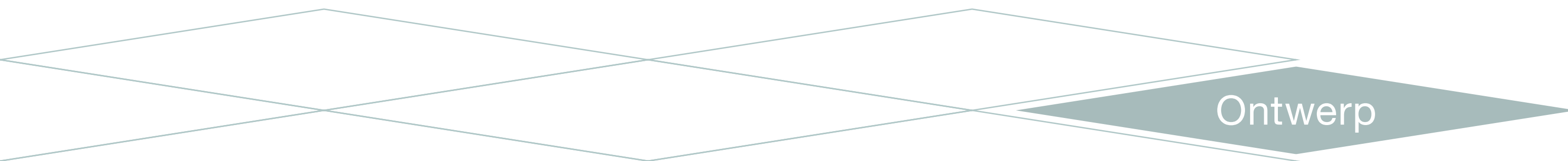
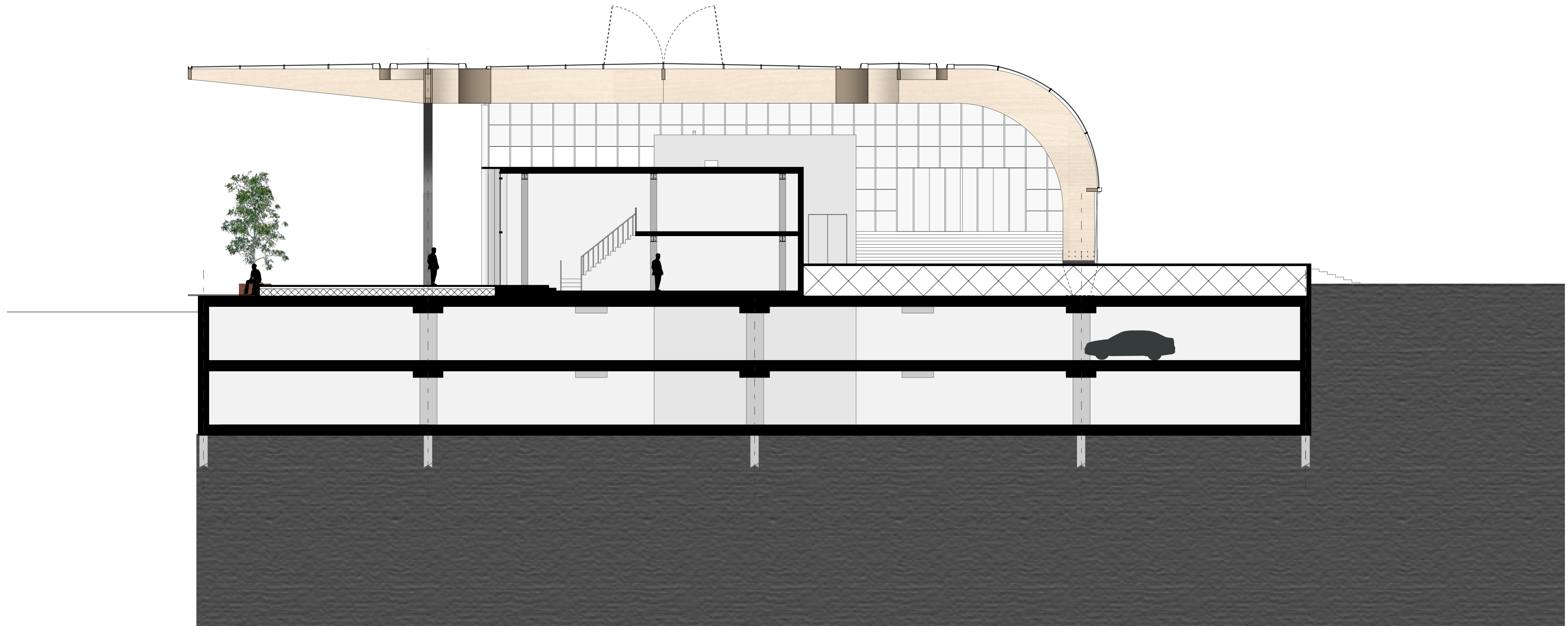
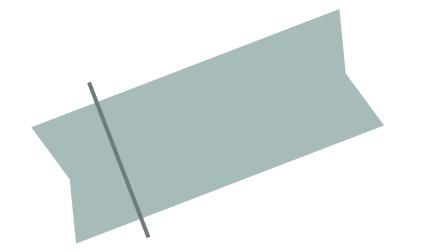



Pleinen - klimaat

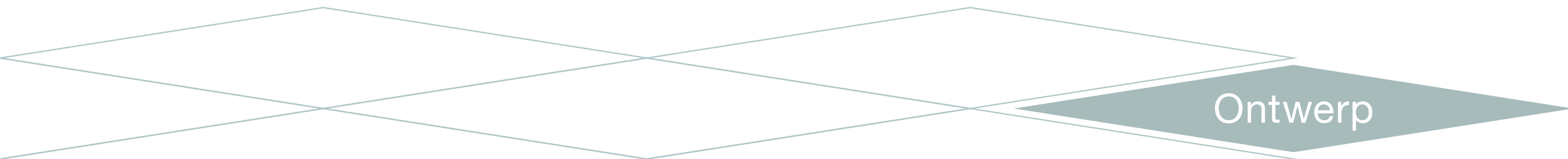
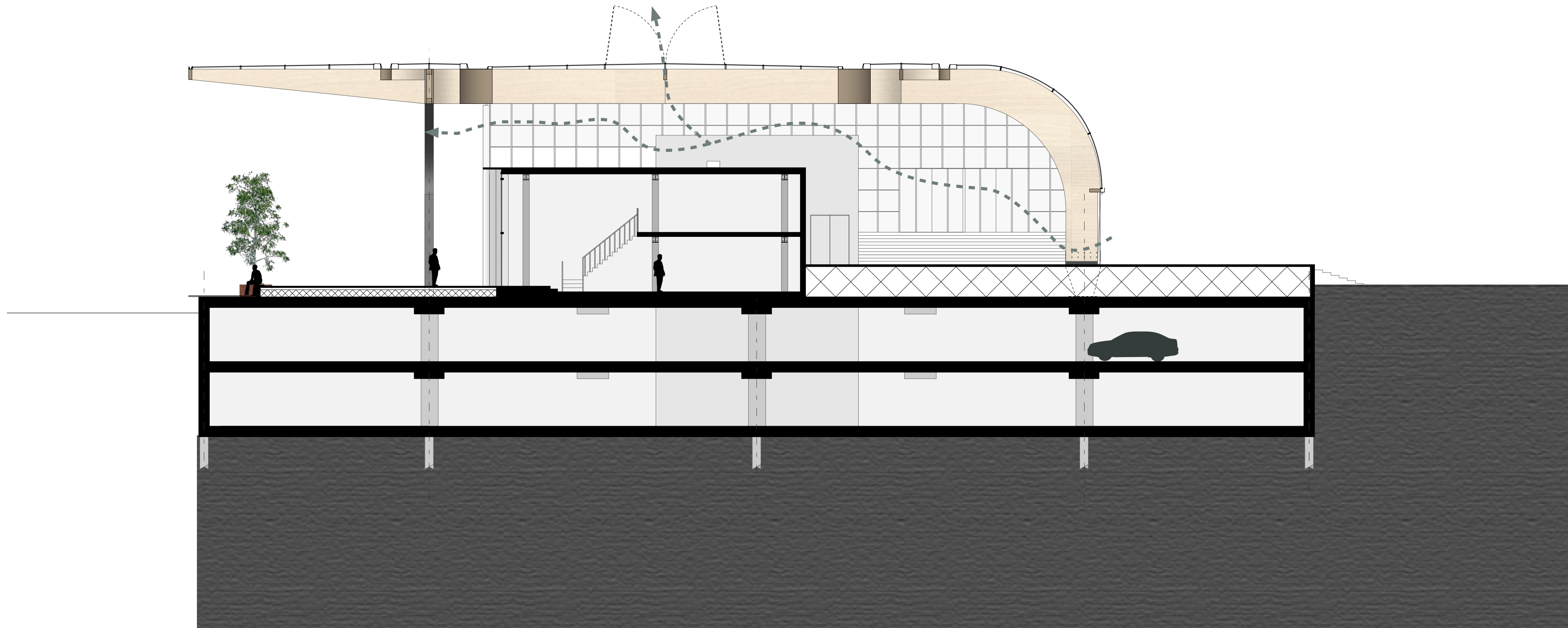
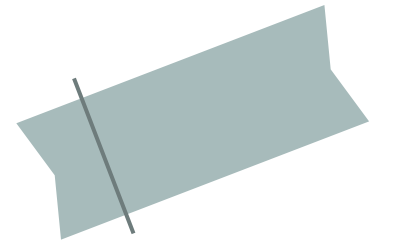

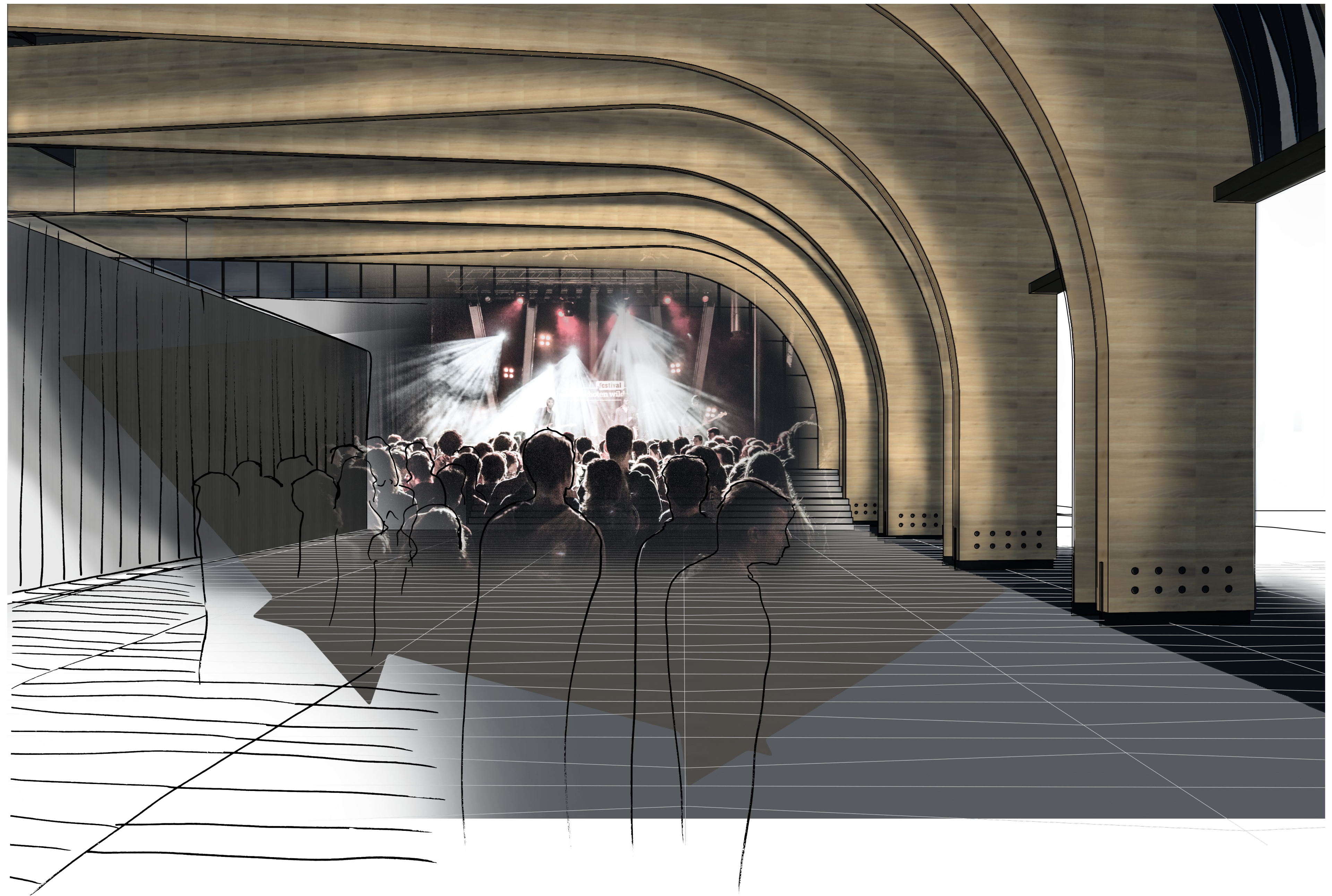

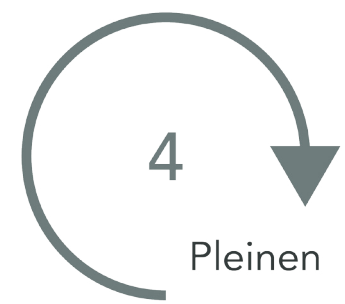

Kade

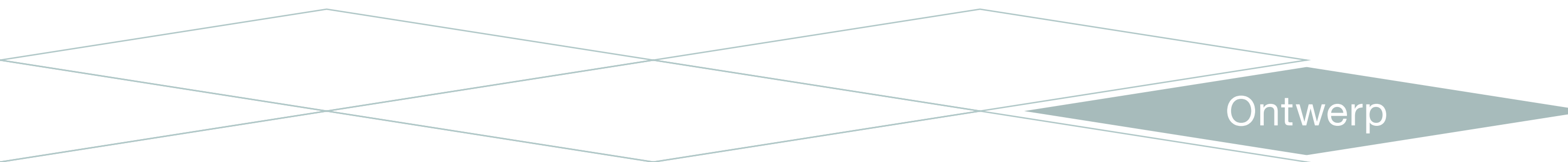
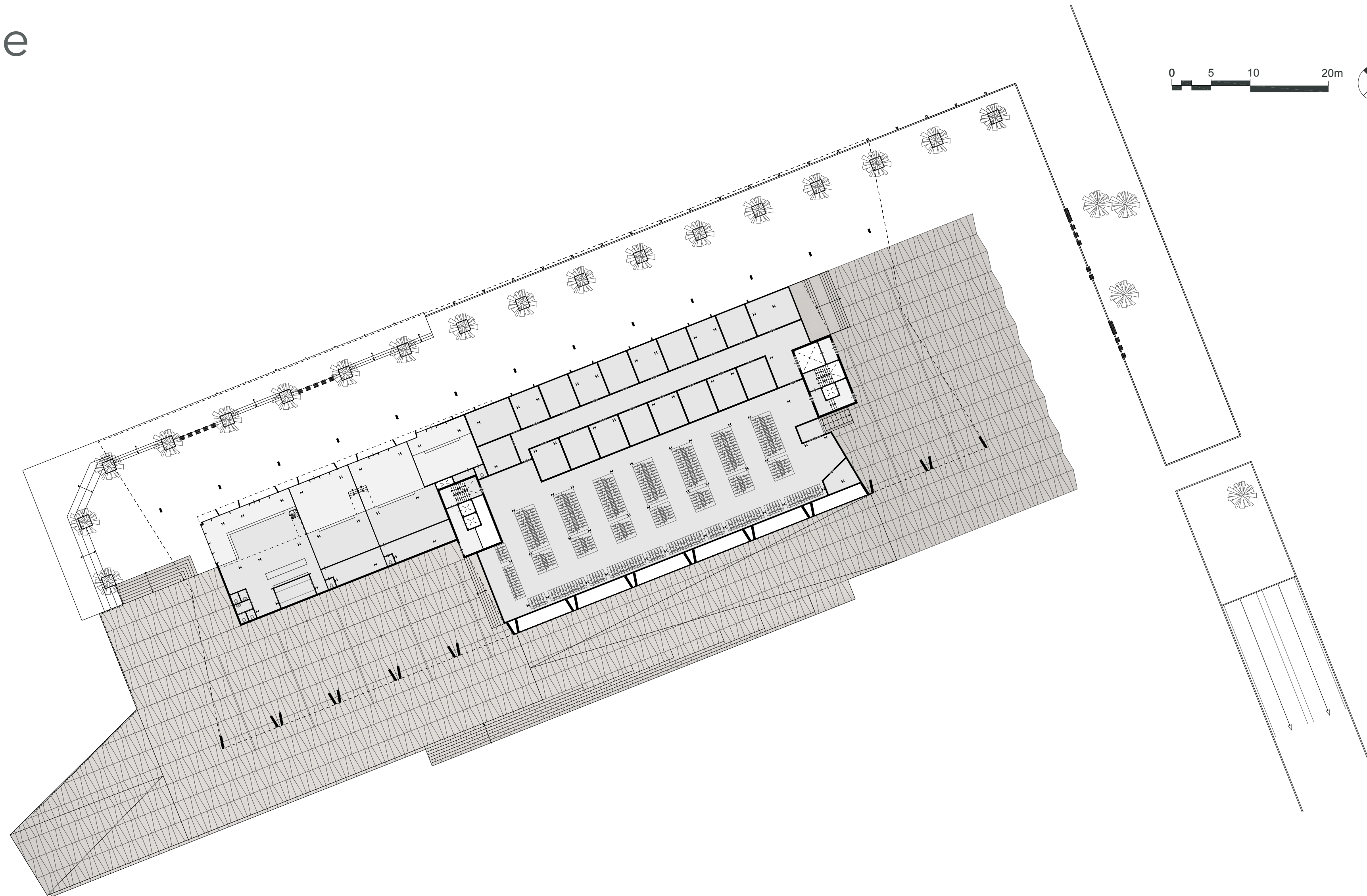
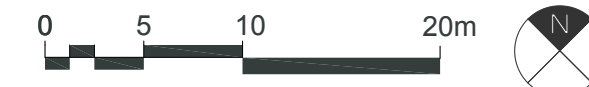









Cortenlijn

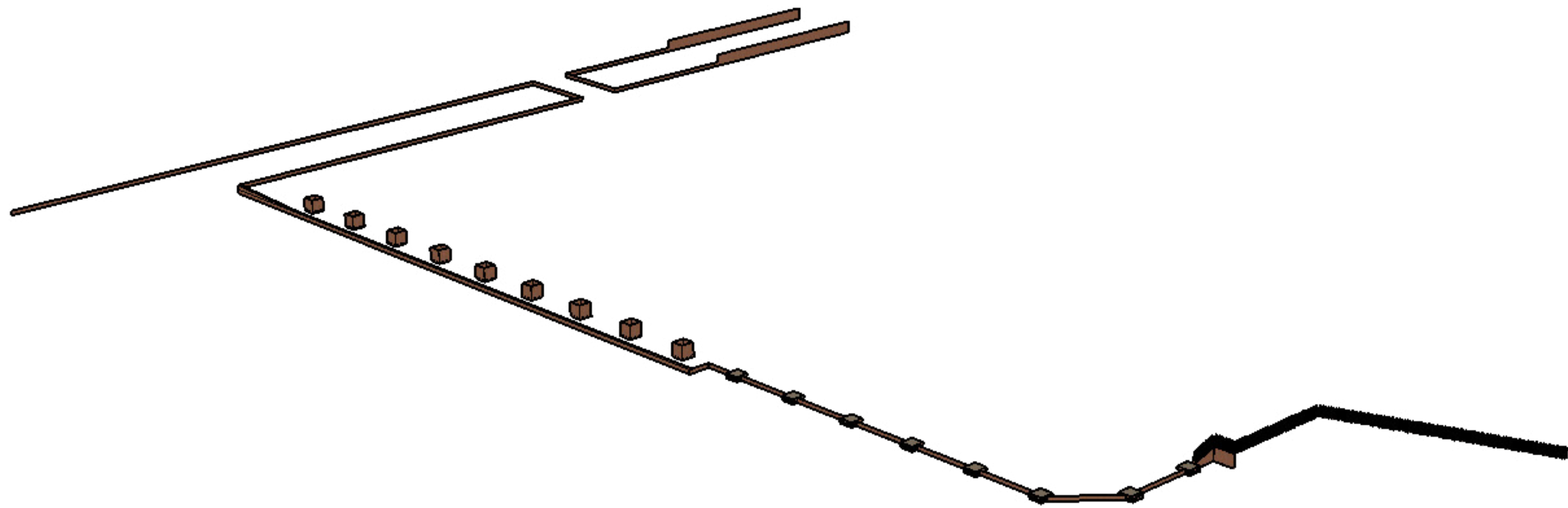

Materialisatie niveau 4



Culturele route

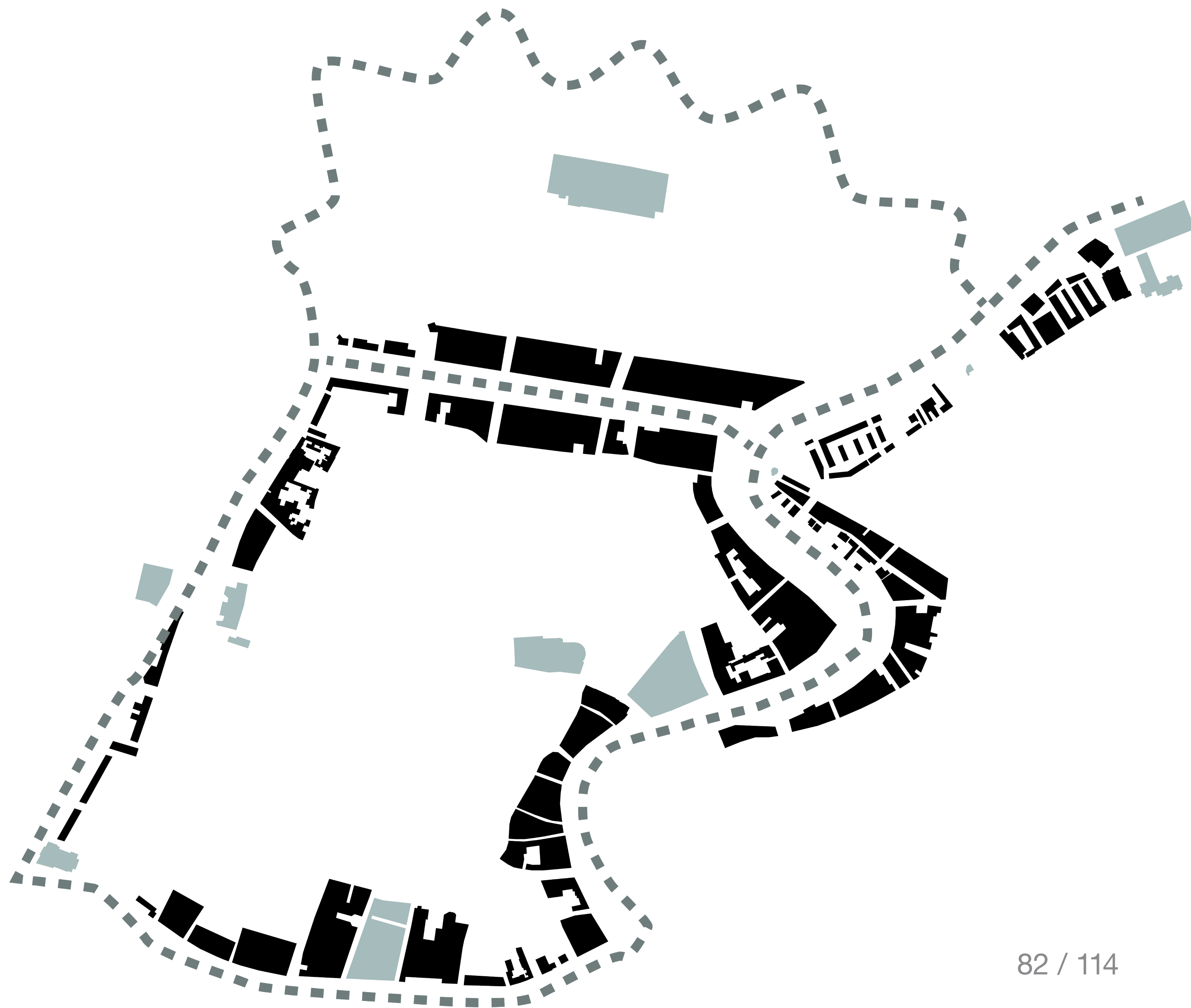



// Reflectie

Relatie onderzoek - ontwerp

Reflectie ontwerp

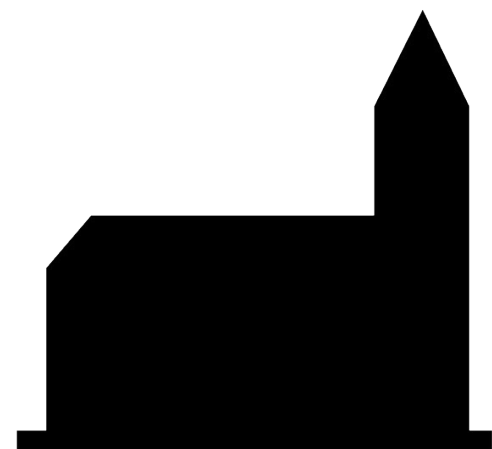

Markthal, Haarlem



Grote- of Sint
Bavokerk (1370-1520)

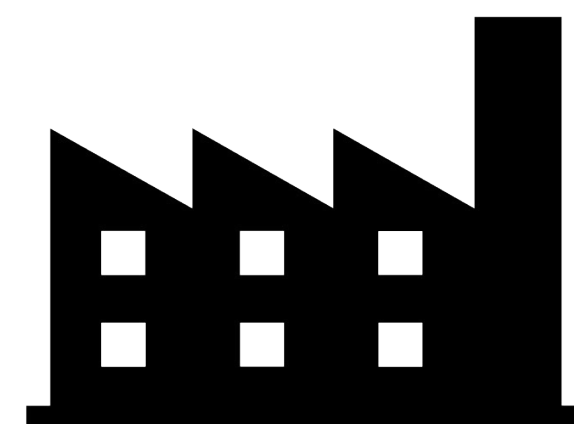

AEG Turbine Hal
(1909)

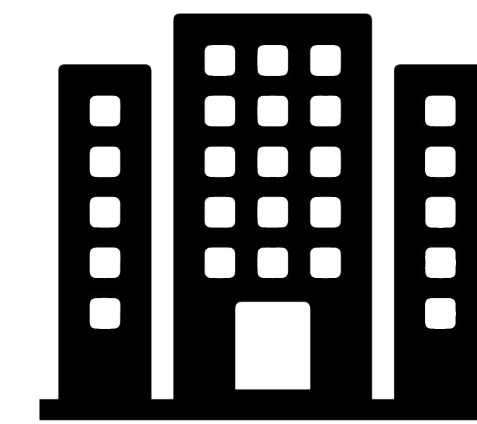

Seagram Building
(1958)



Conceptuele ruimtes

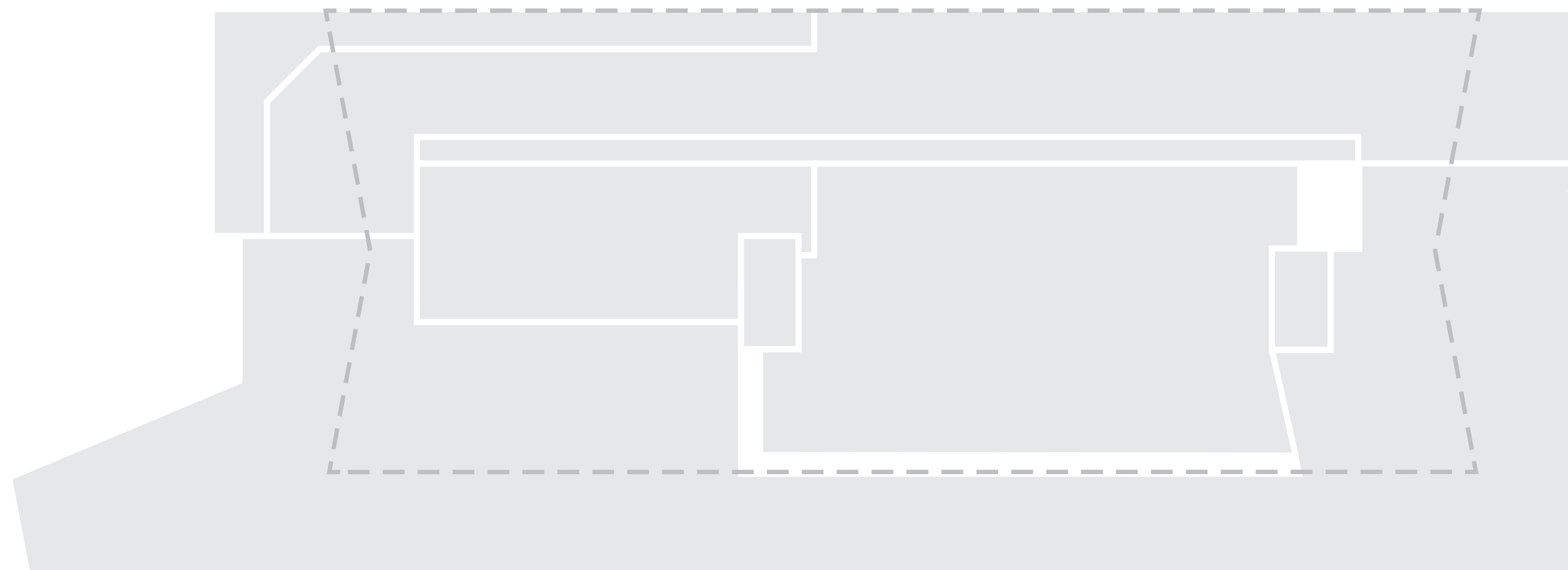

Seagram

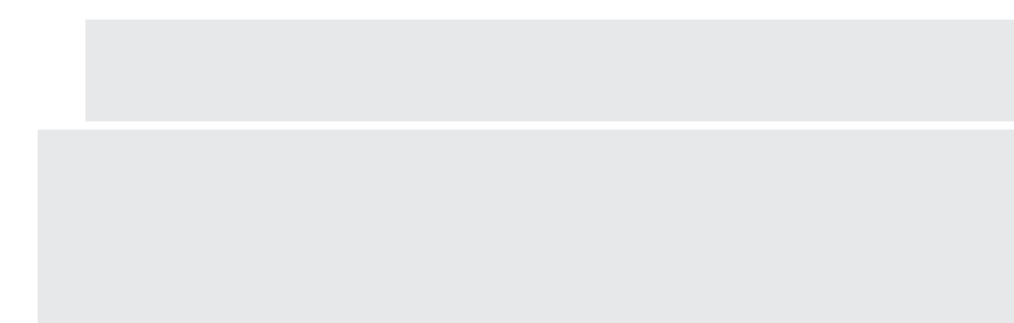

AEG

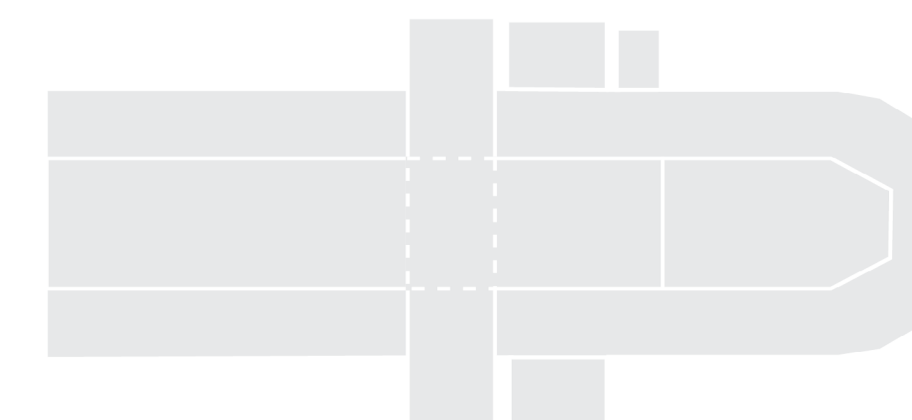

Bavo

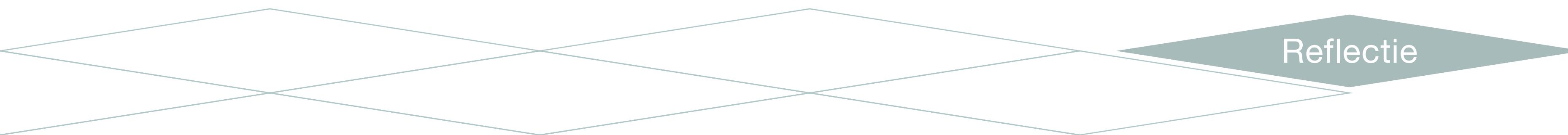

Reflectie

Organisatie van ruimtes

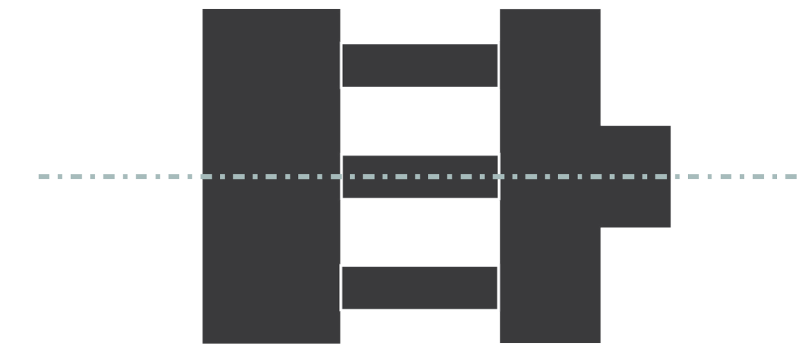
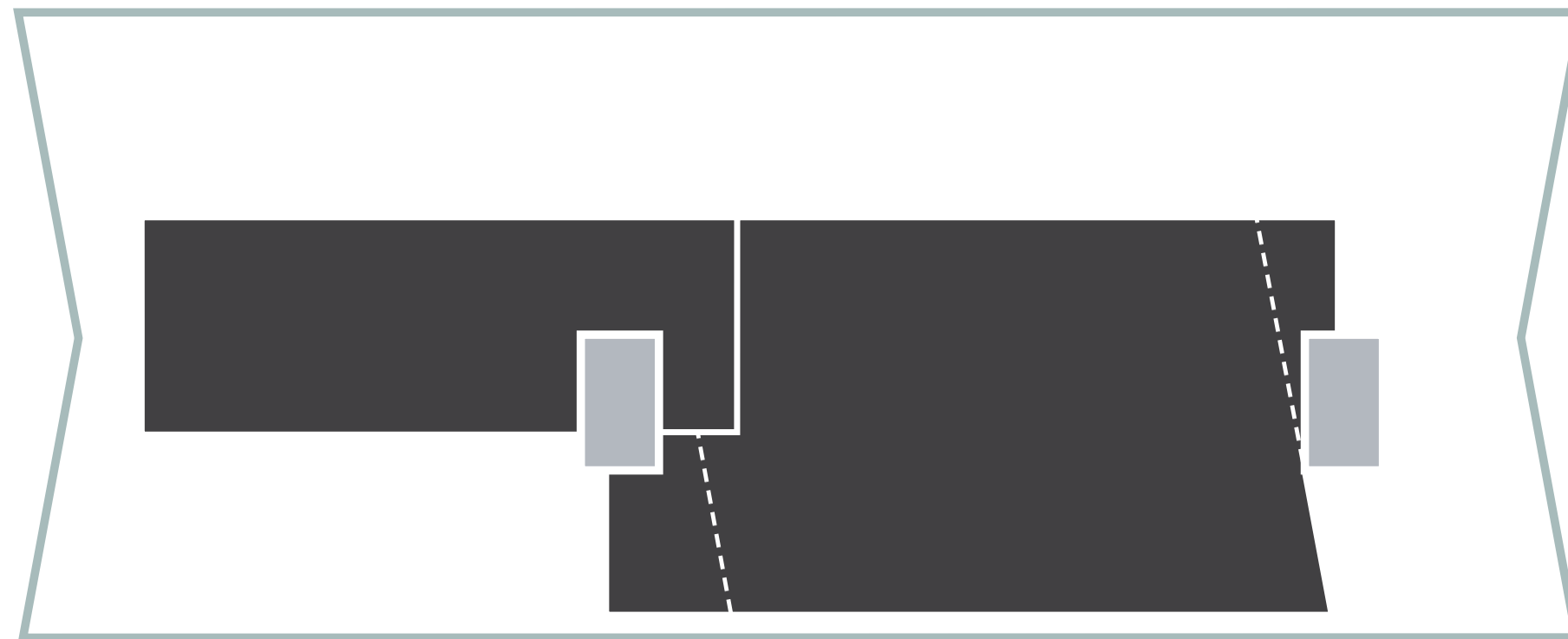

Seagram



AEG

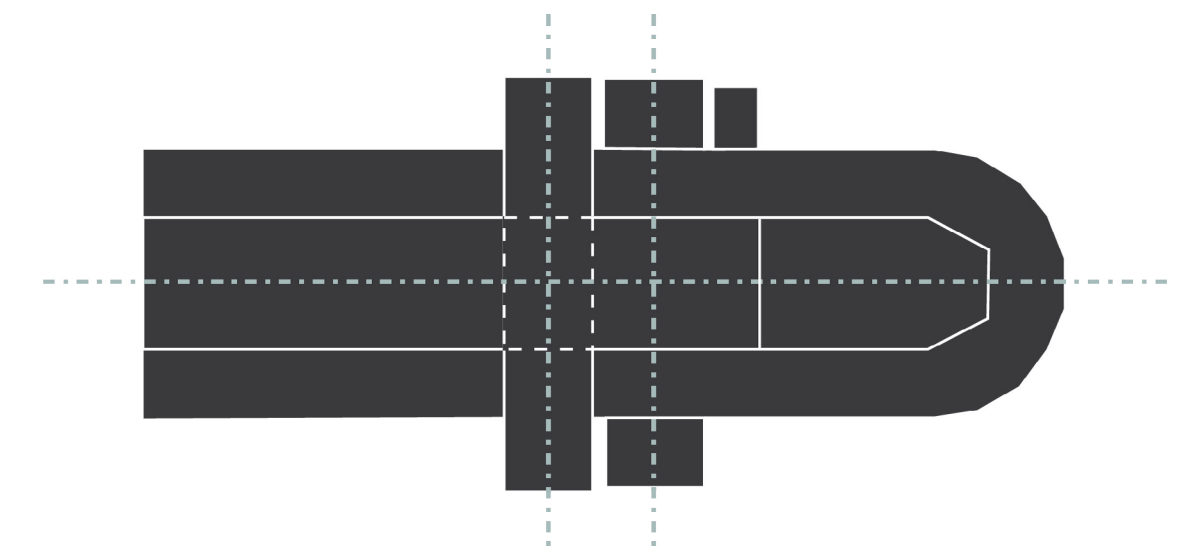

Bavo

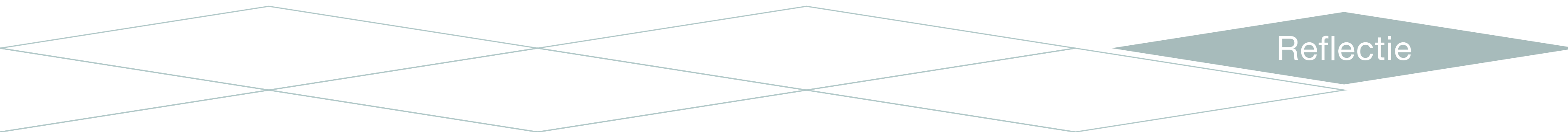

Relatie tussen route en ruimte

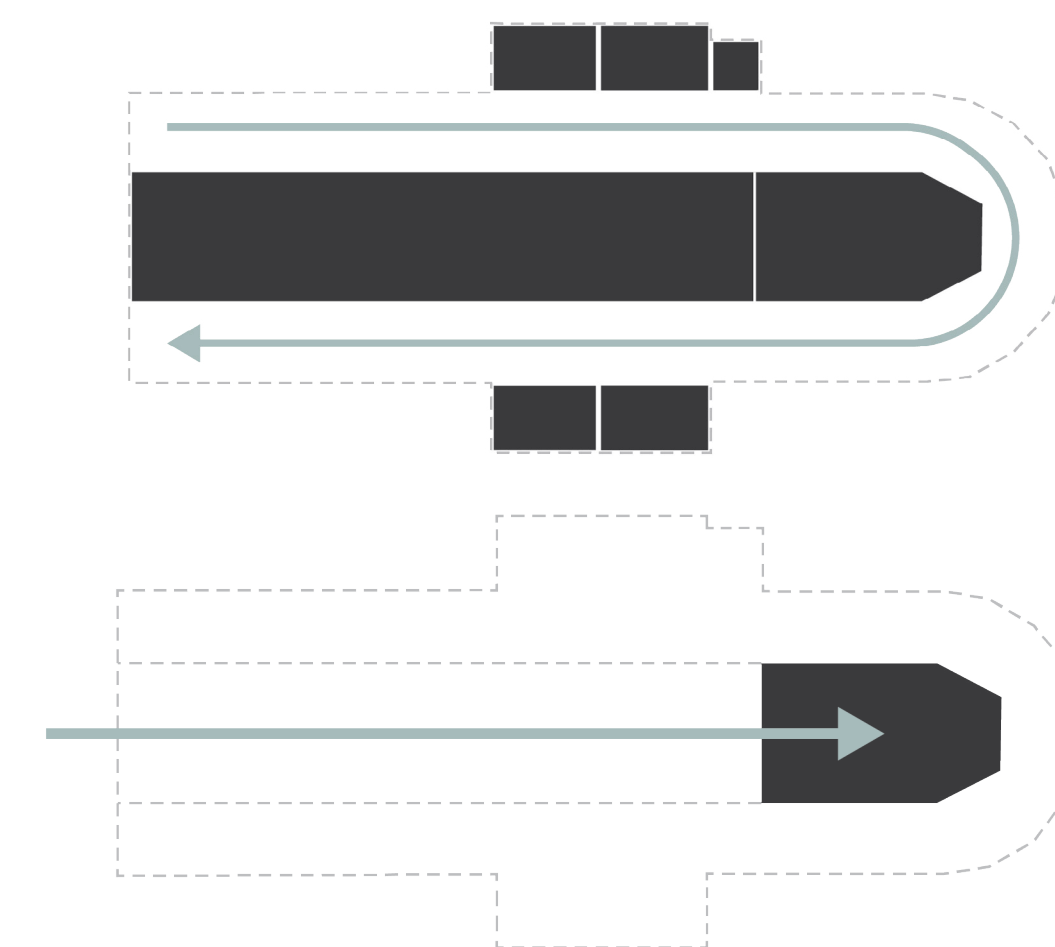
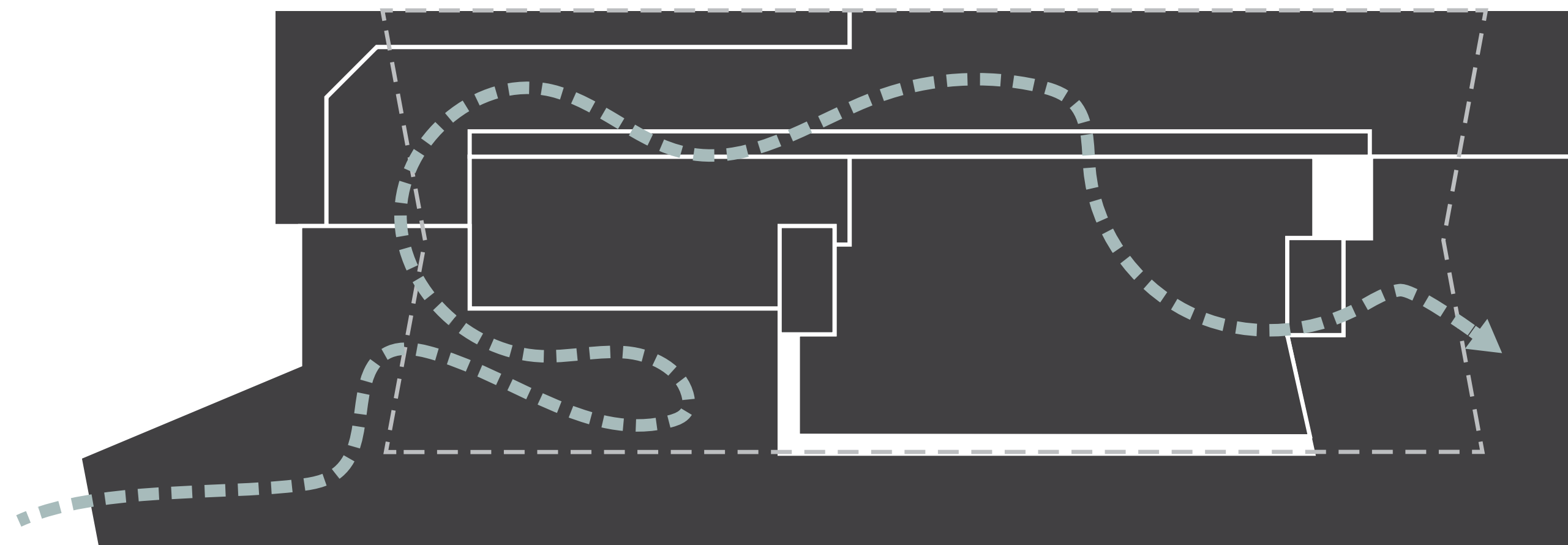

Bavo

Reflectie

Symmetrie

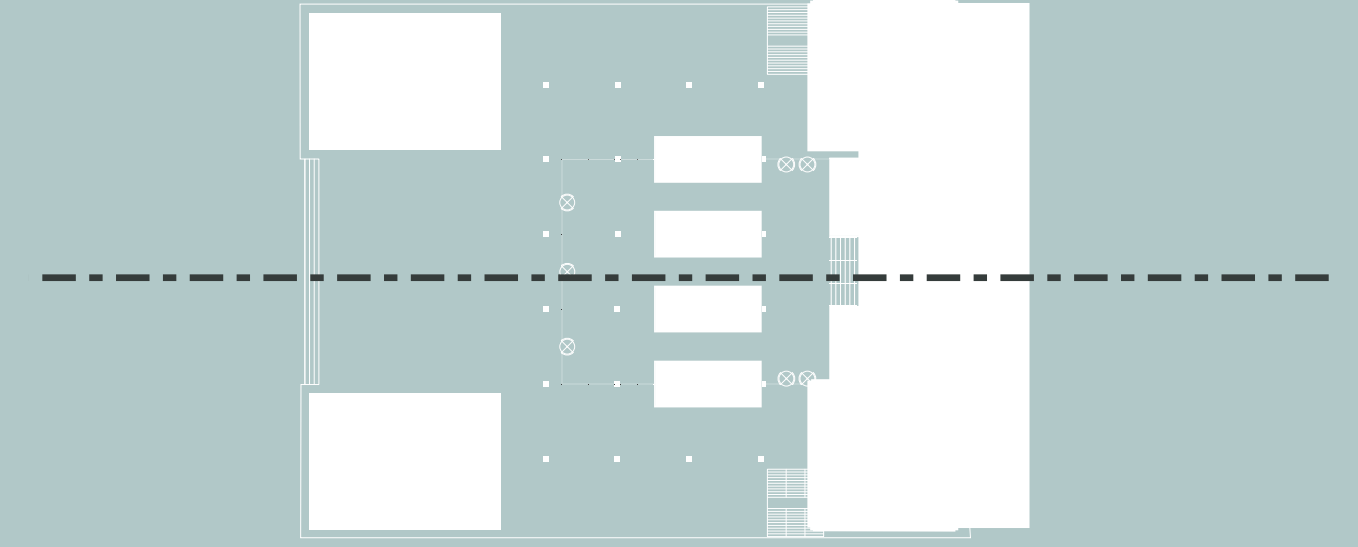
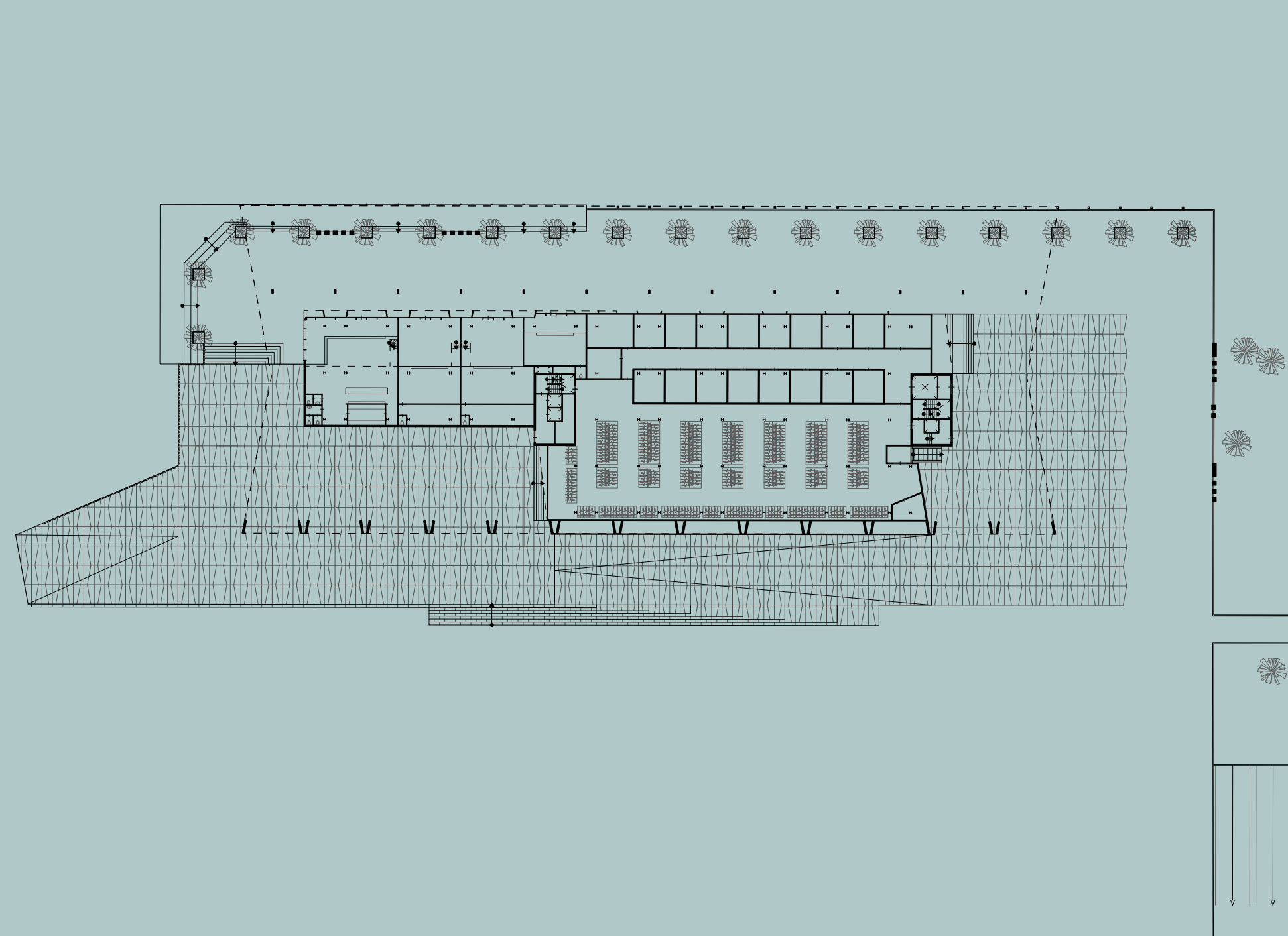

Seagram

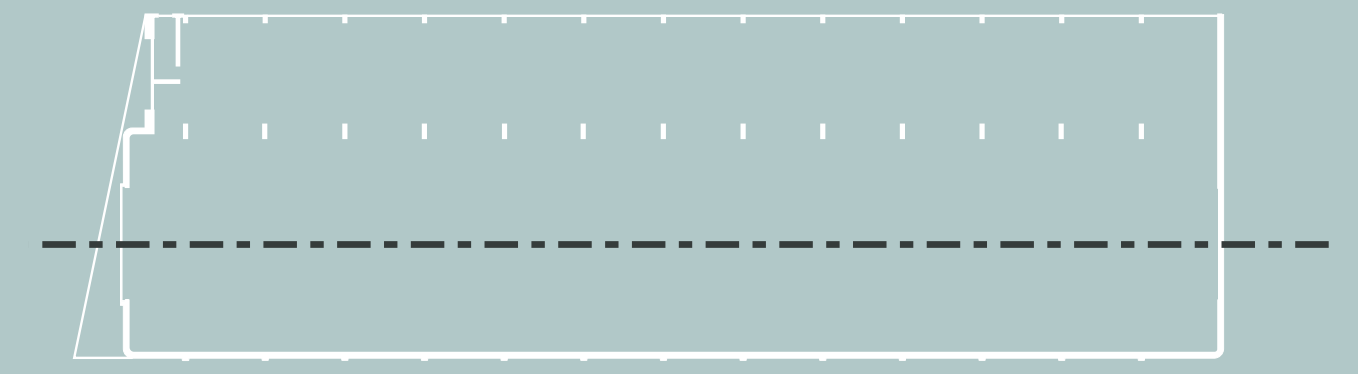

AEG

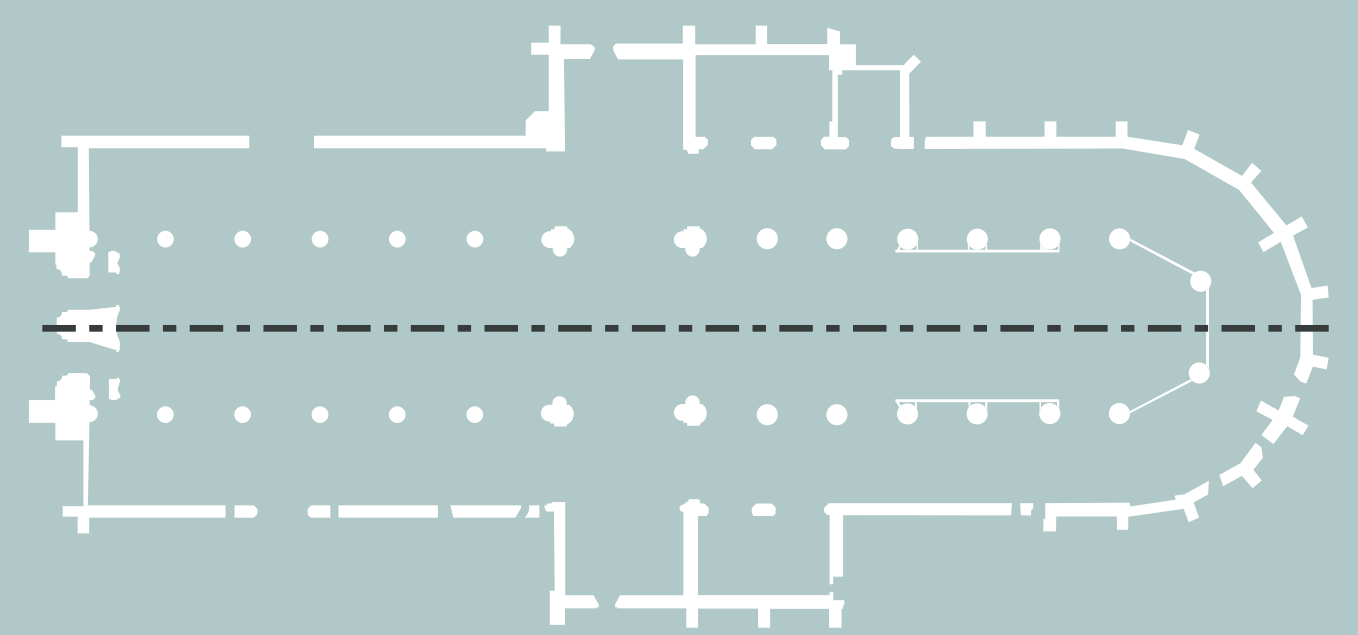

Bavo

Conclusie

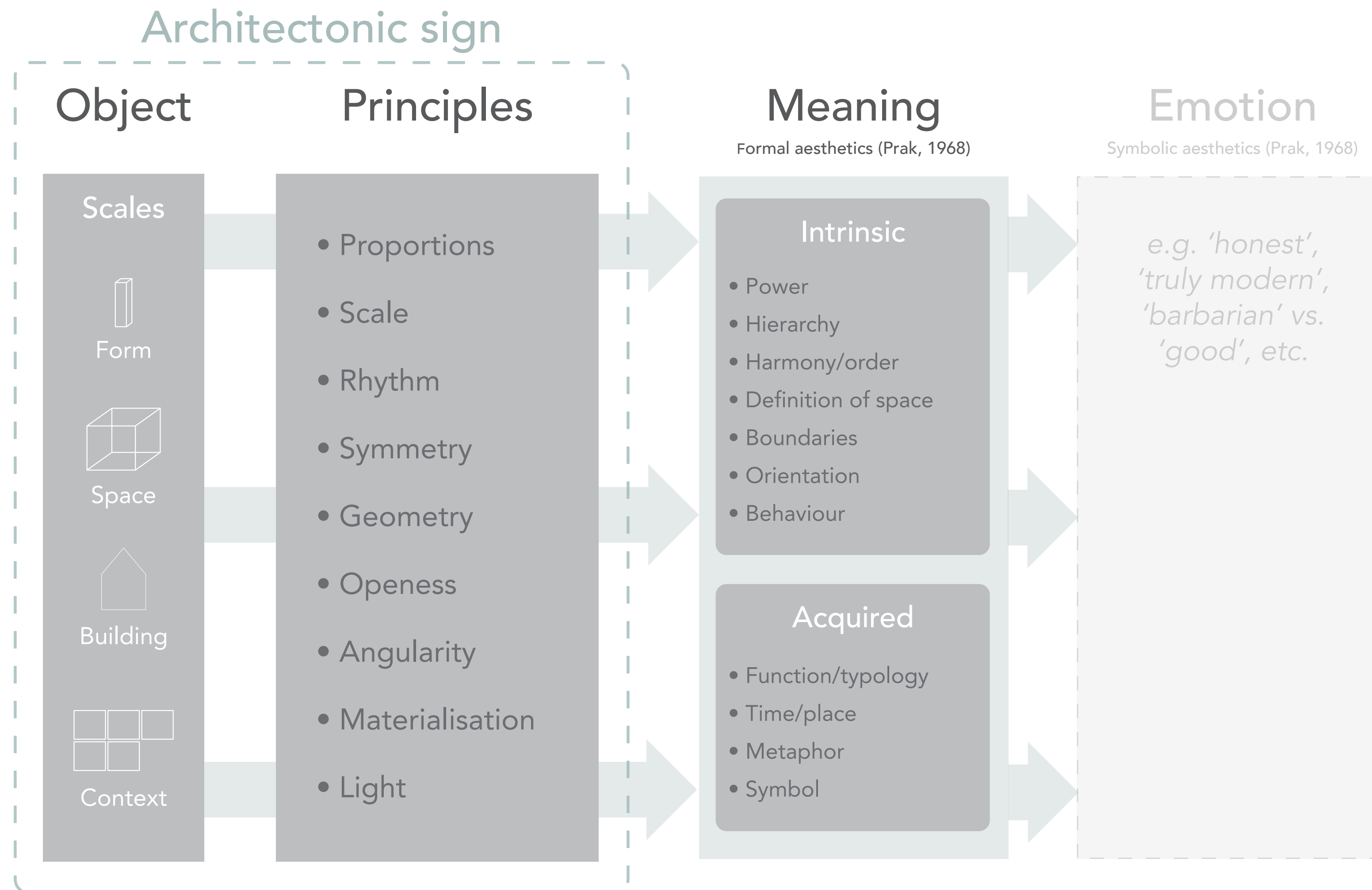



Met dank aan...

ExploreLab 23 (bezemwagen) en 24

Marloes Bier (voor de koffiepauzes en de oneindige hulp!)

Bram Peerlings (voor de mooie foto's)

Ronald en Marin (voor het aanhoren van al m'n gezocht)

Allessandra Moro (voor de tekeningen van de Turbinenfabrik)

Teo Cherici (voor het vertalen van de teksten van Allessandra)

Maquettebouwers: Marloes, Geert, Joost, Alex, Teddy, Karin, Louk, Rene, Ingrid en Jaïke

Conclusies onderzoek

- *Architectuur is een vorm van visuele communicatie d.m.v vorm, contravorm en hun eigenschappen;*
- *Architectonische communicatie vind plaats op verschillende schalen*
- *Architectuur kan complexiteit begrijpbaar maken;*
- *Architectuur kan zowel intrinsiek als aangeleerd communiceren;*
- *Architectonische communicatie is vierdimensionaal.*



0D A point



1D A line



2D A plane: in architecture, a two-dimensional drawing can be a floorplan, section or elevation.



2^{1/2}D A 2D projection of a three-dimensional object: in architecture, this resembles a perspective drawing or render.

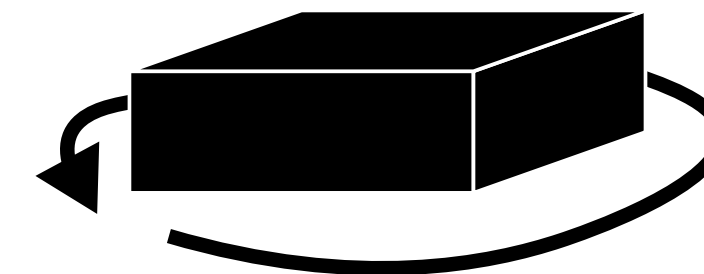

3D A form/space: in architecture, this can be a scaled model or computer model. You can move the model itself.

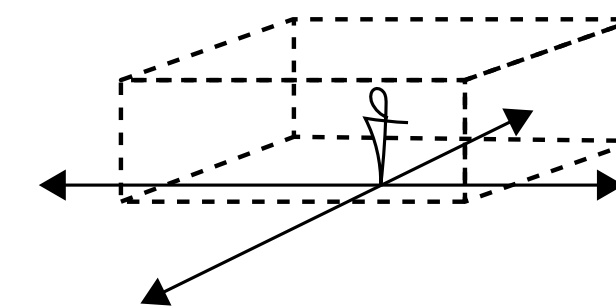

4D A building: architecture can be seen as a four-dimensional form of communication. The fourth dimension being *movement*. You can move through space at different moments in time.

Situatie

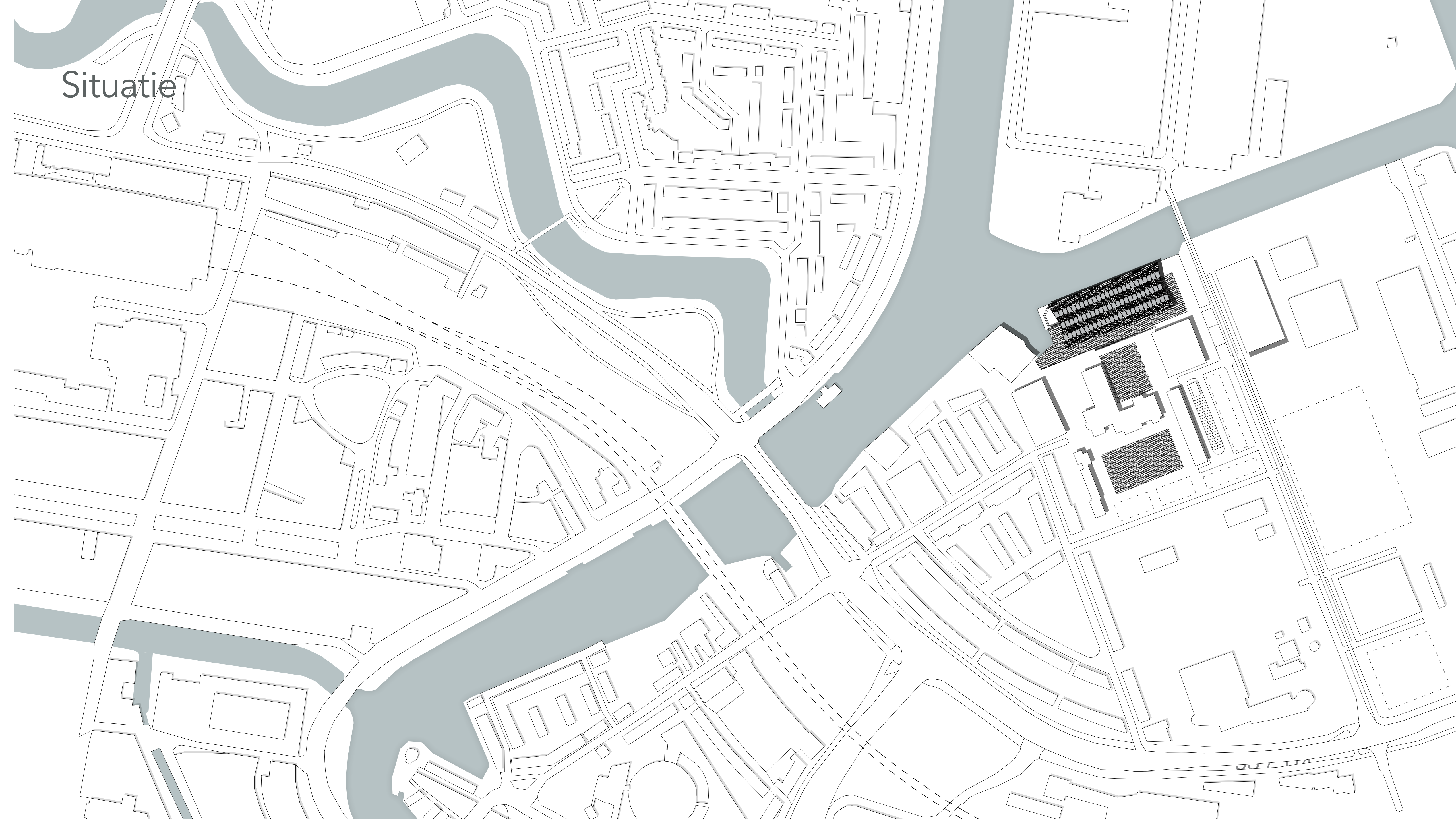

Context

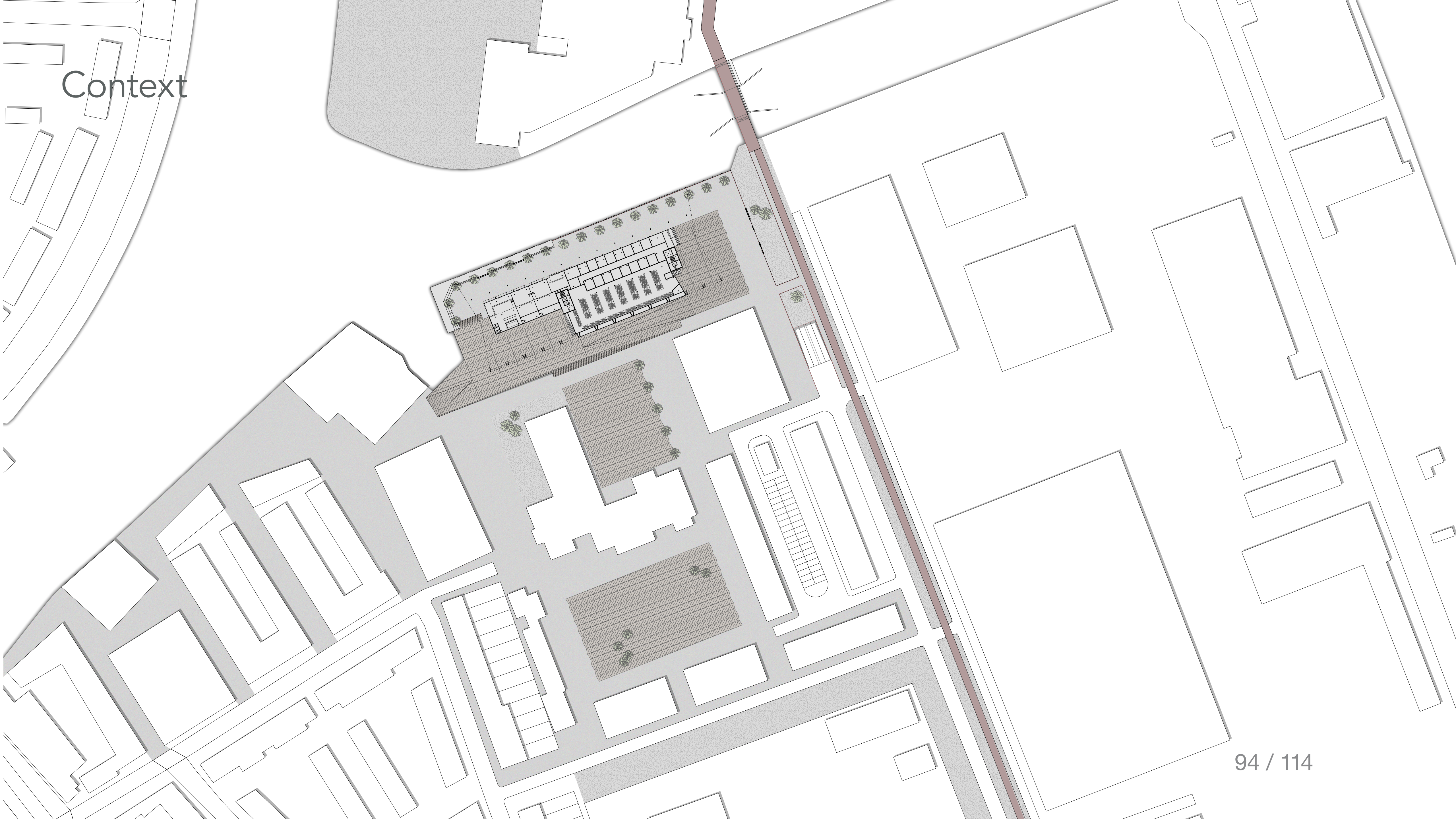

Plattegrond L-2

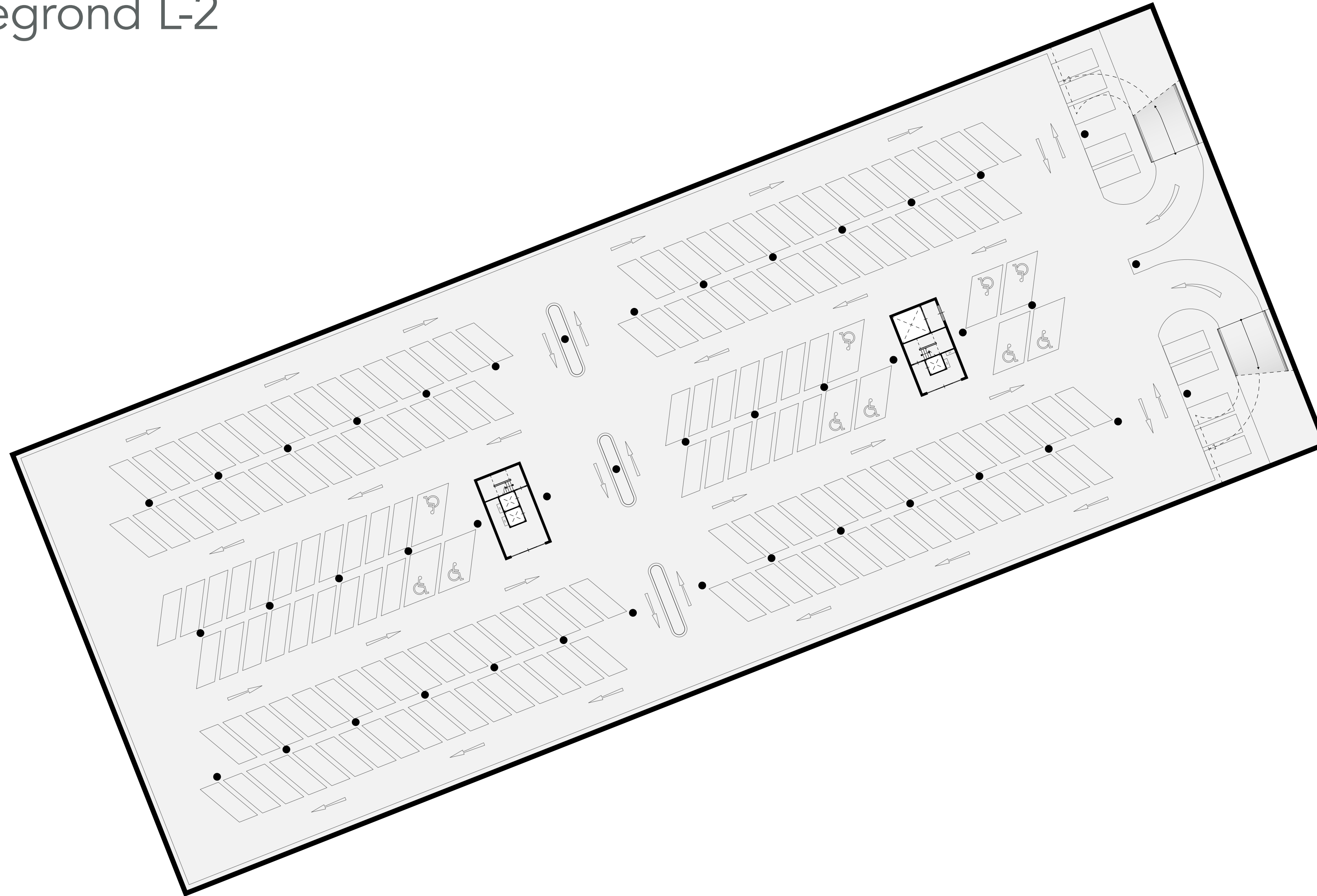

Plattegrond L-1

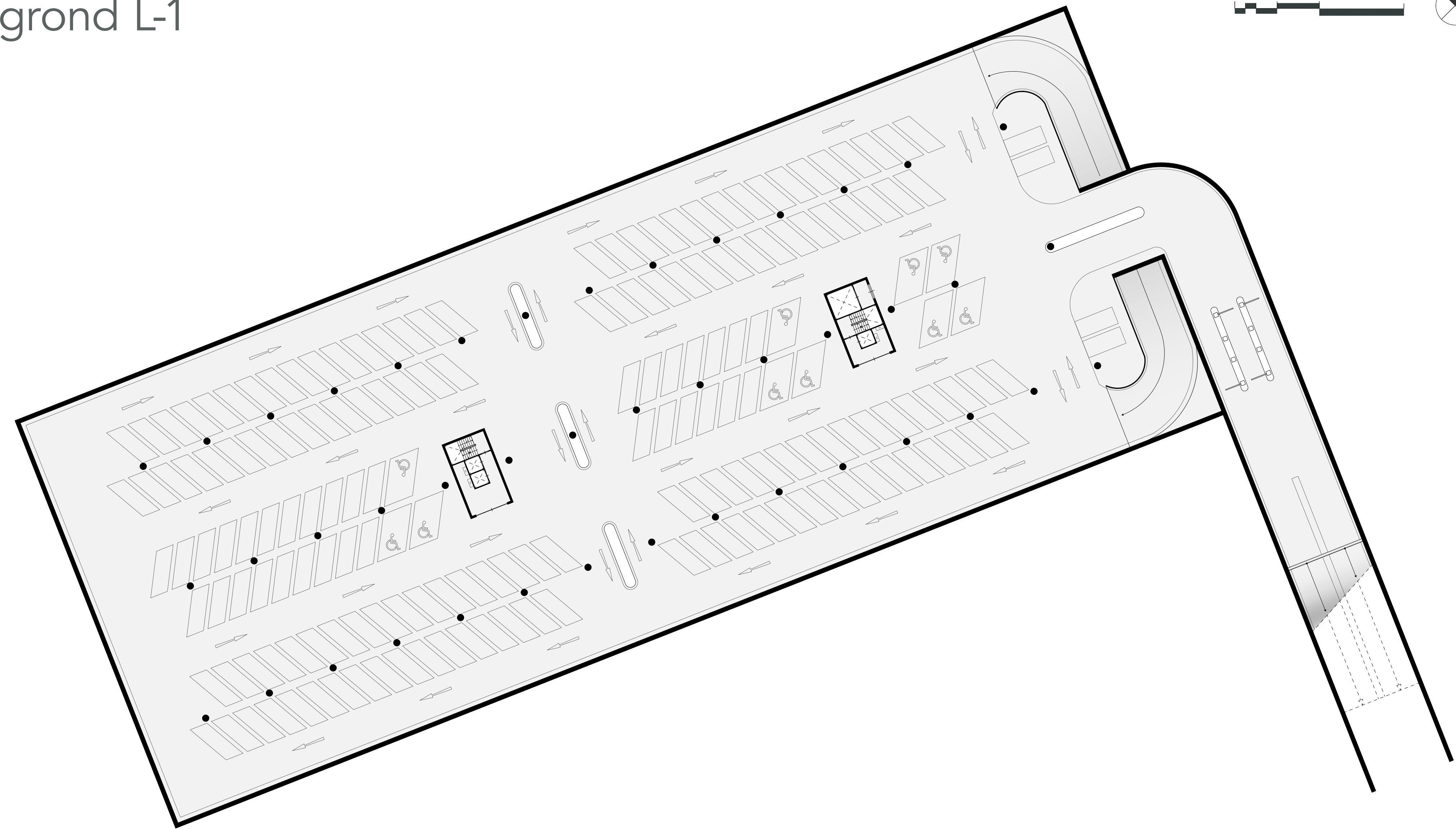

Plattegrond L0

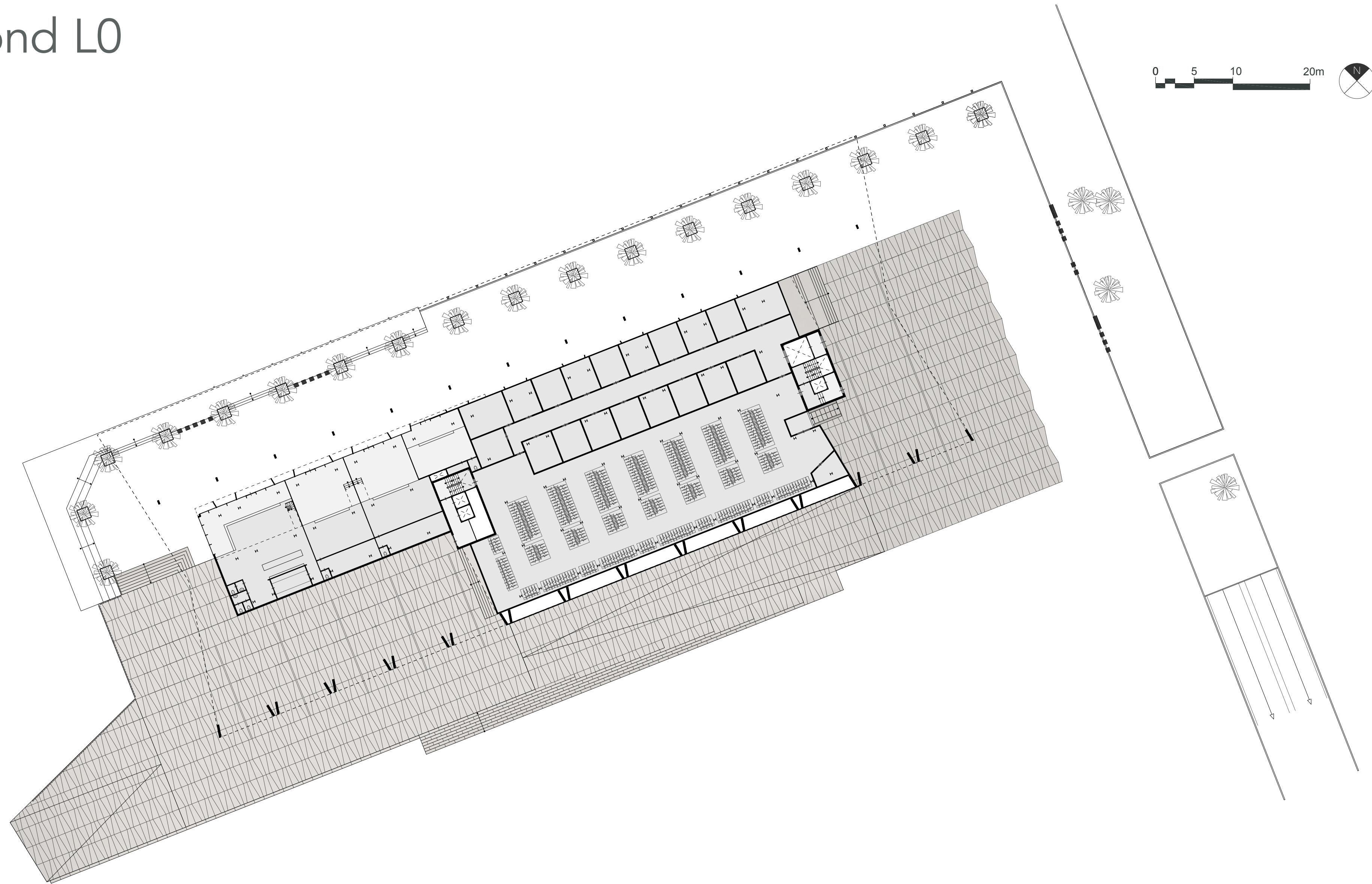

Plattegrond L1

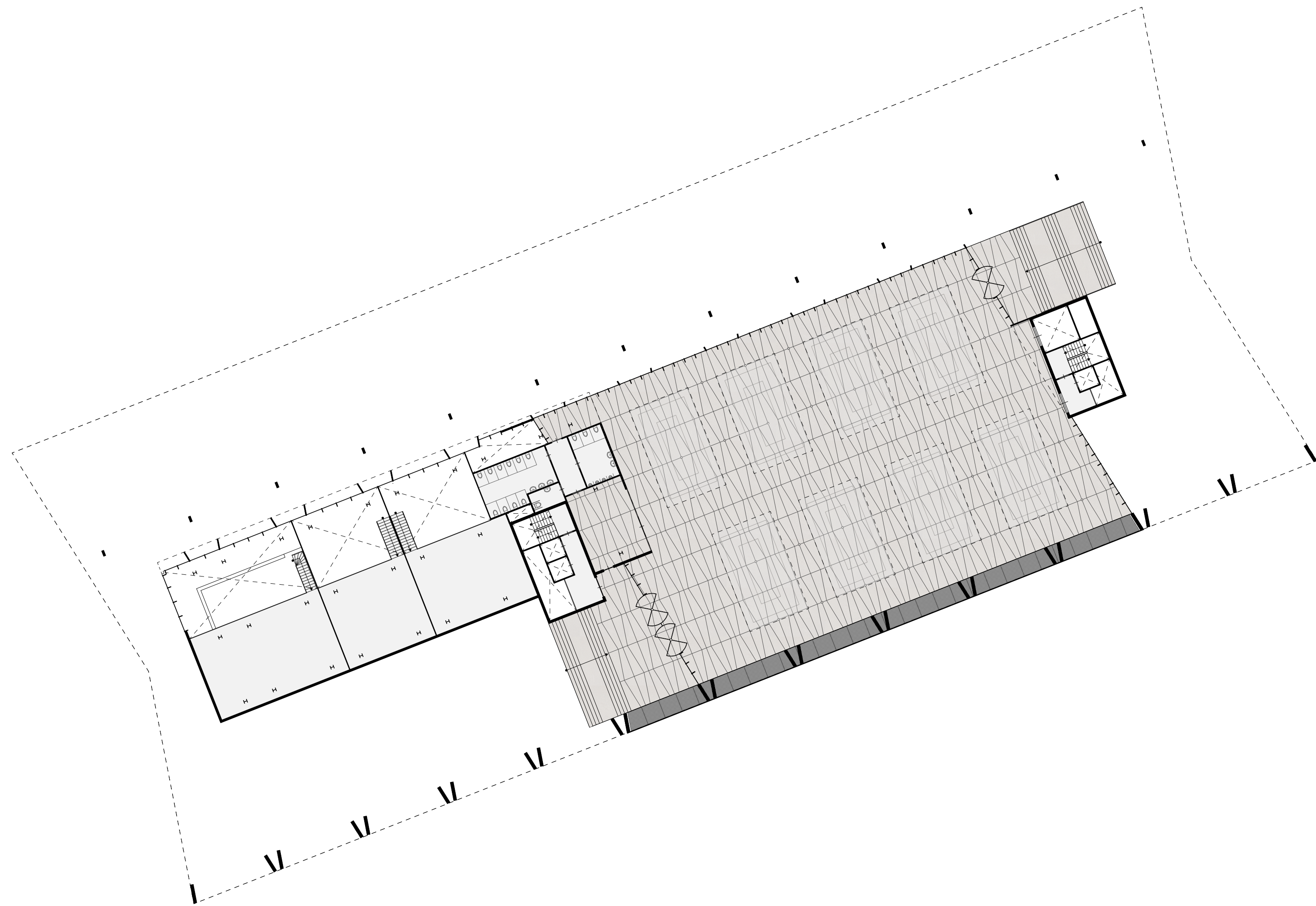
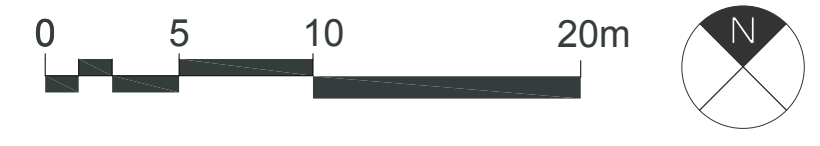

Dakaanzicht constructie

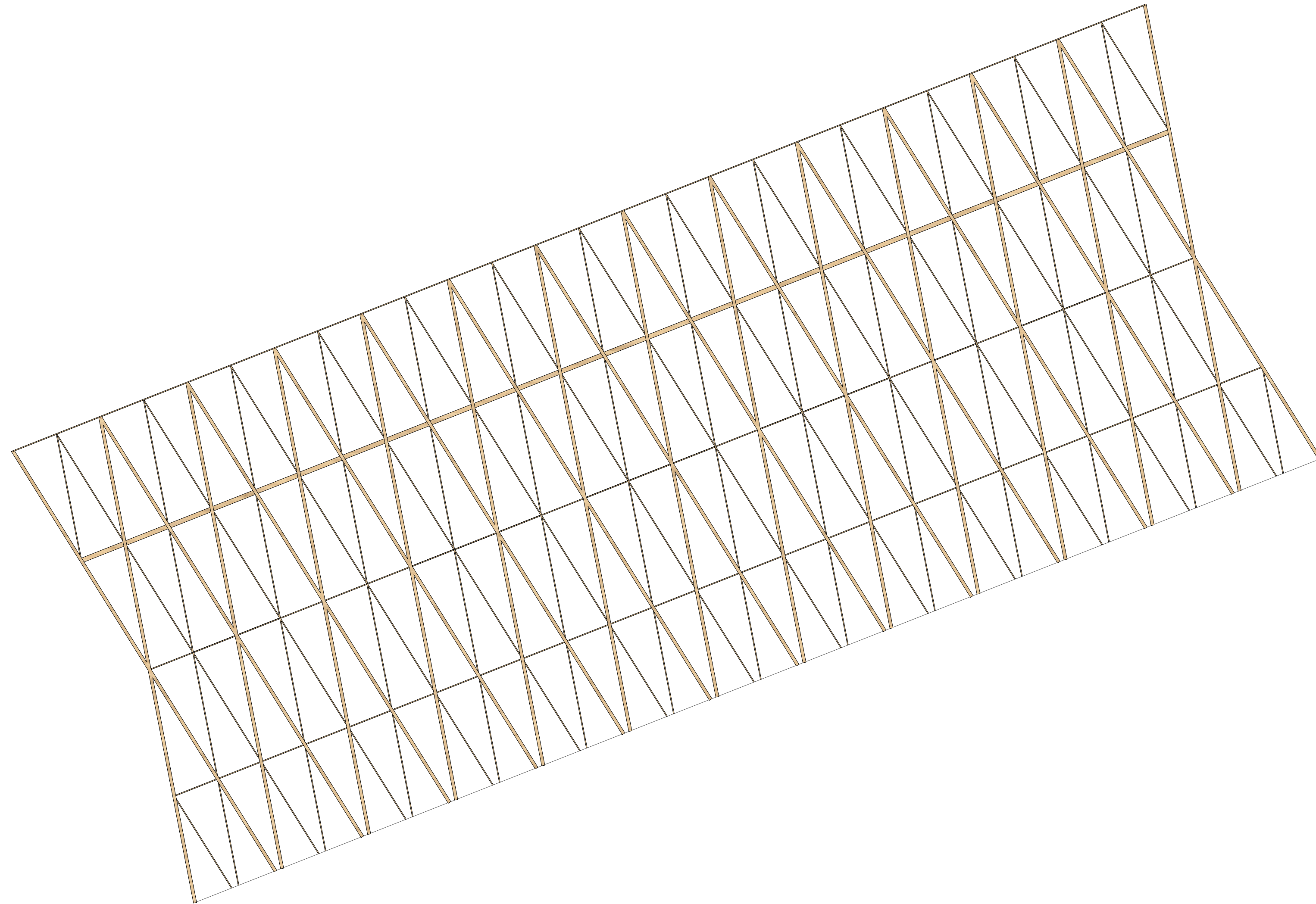

Dakaanzicht

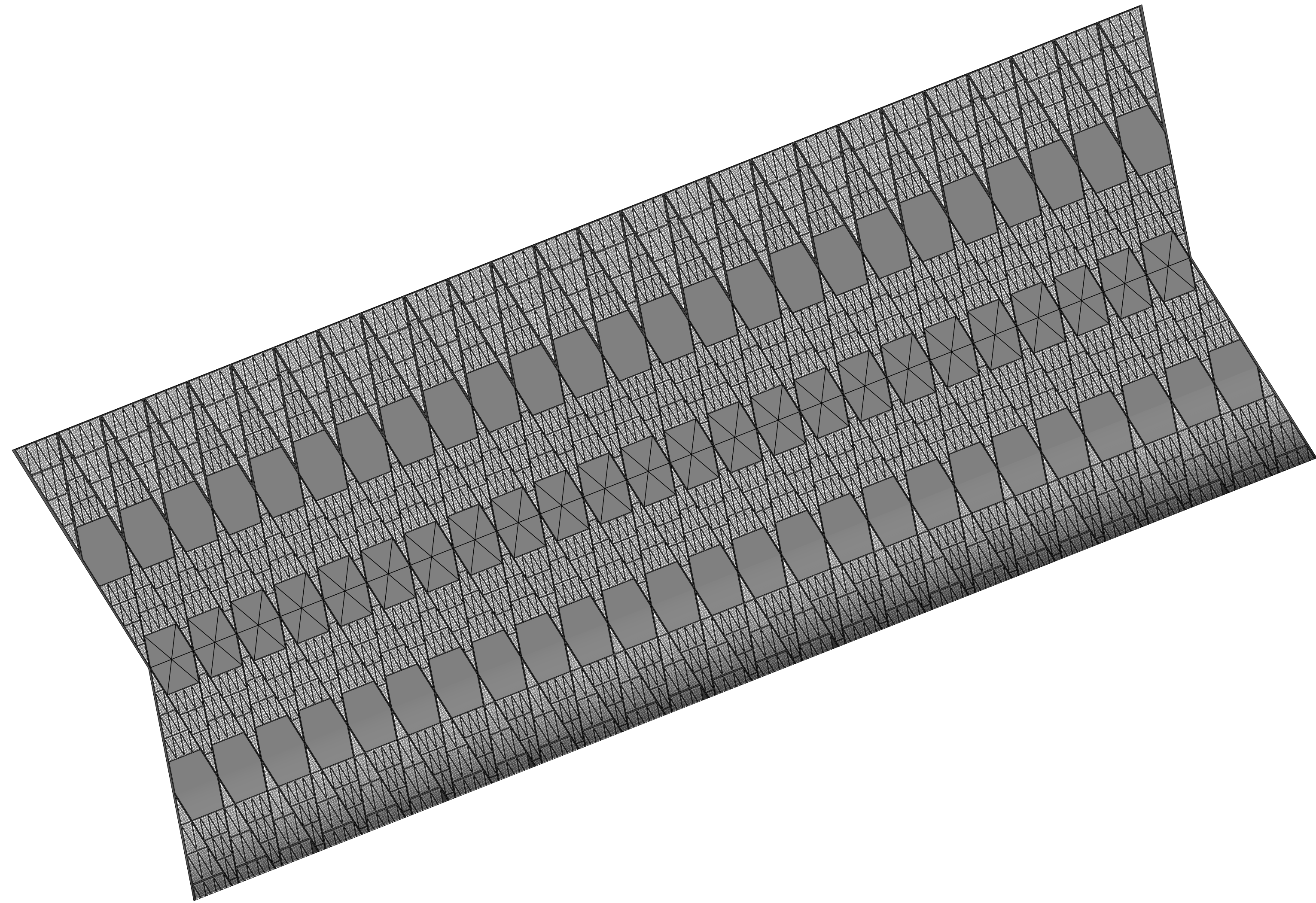
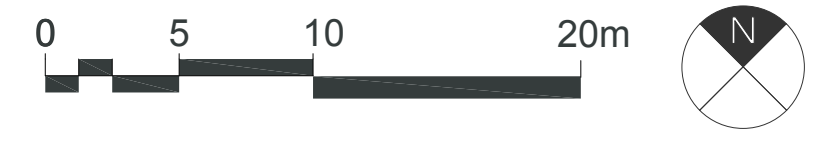

Doorsnede AA

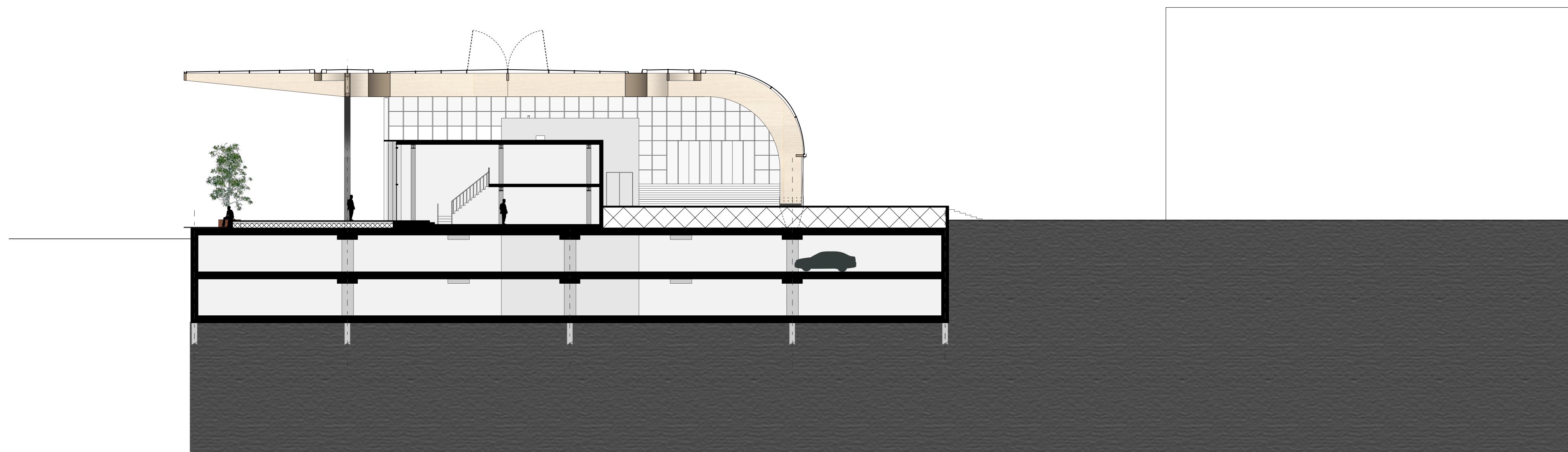

Doorsnede BB

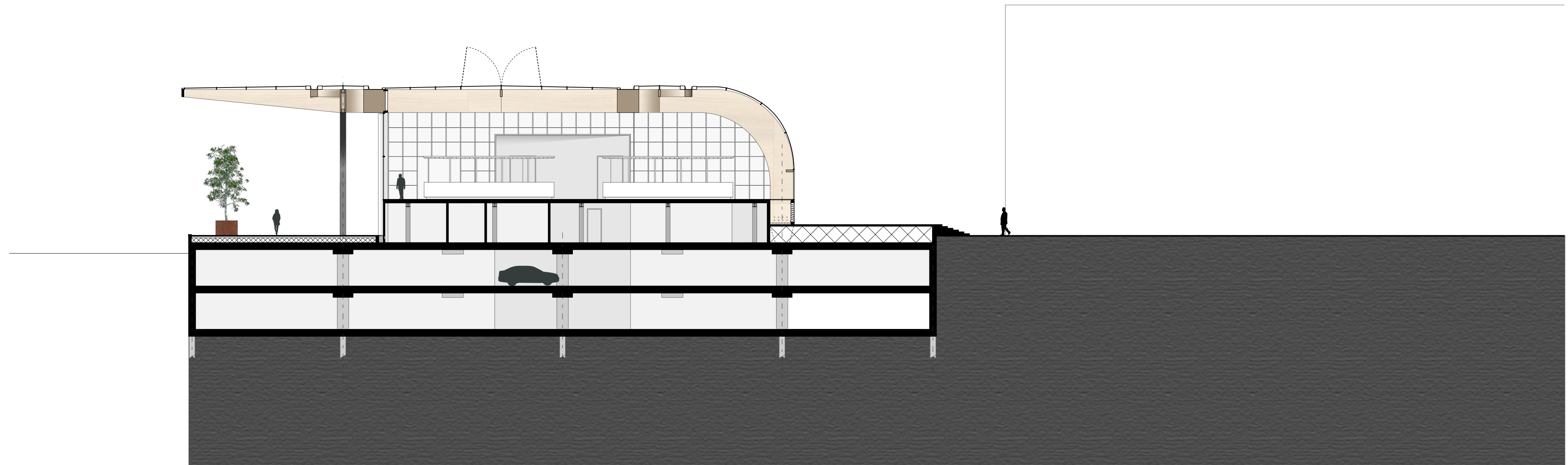

Doorsnede CC

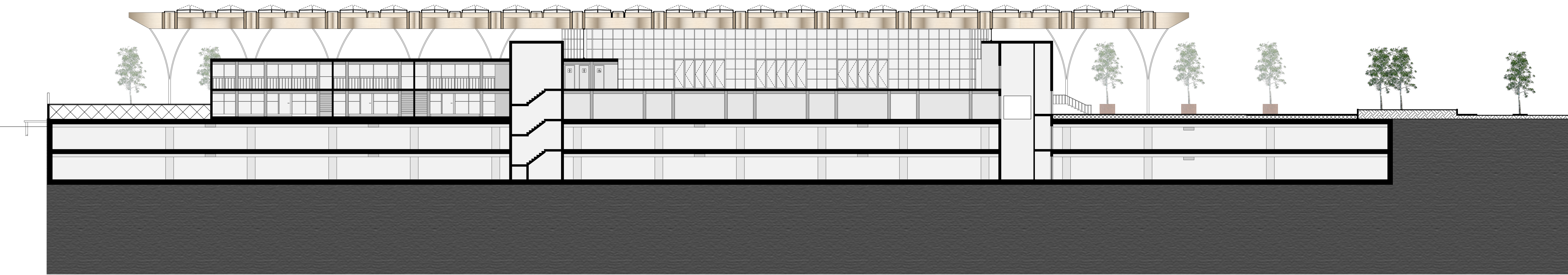

Gevelaanzicht kade

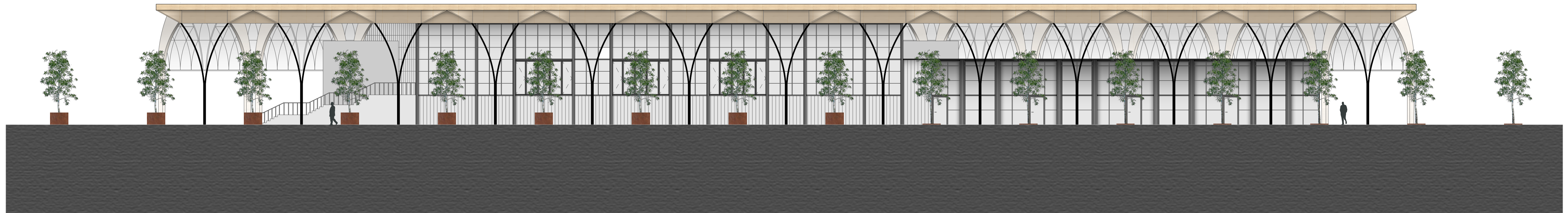

Gevelaanzich lichtplein

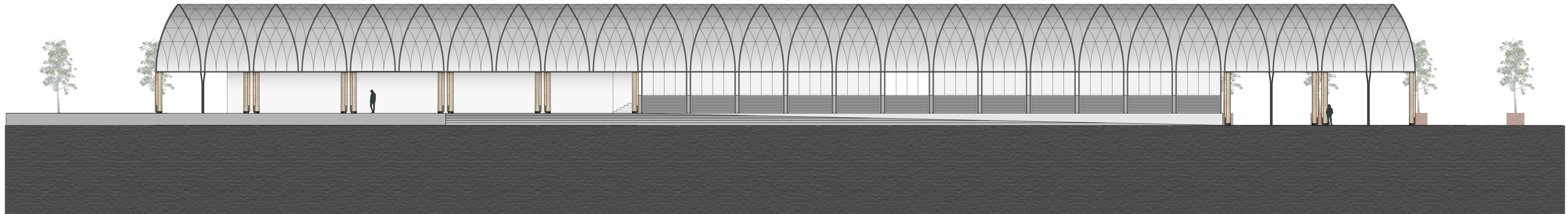

Marktkraam

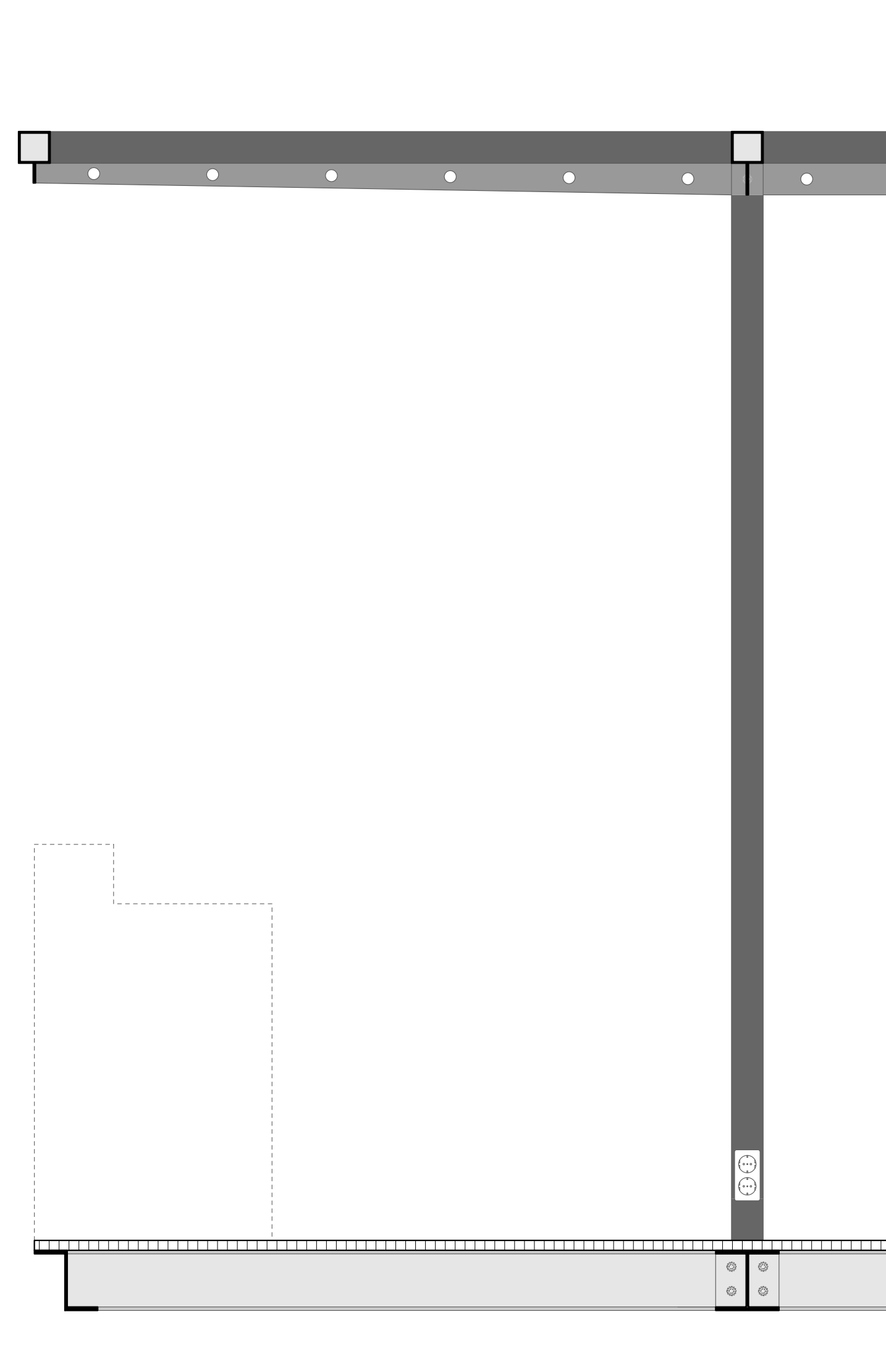
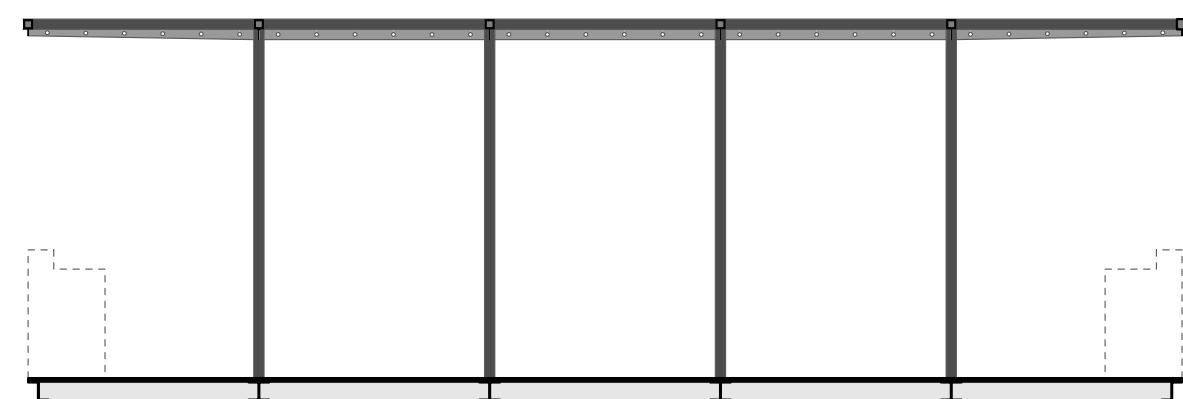
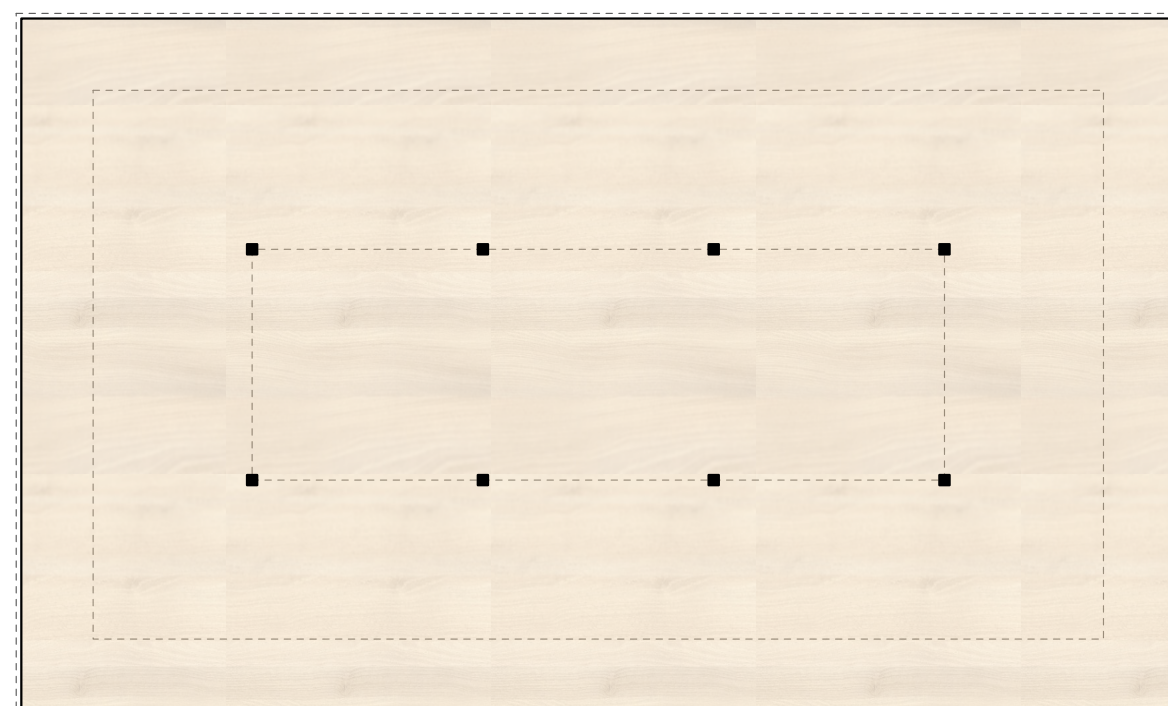
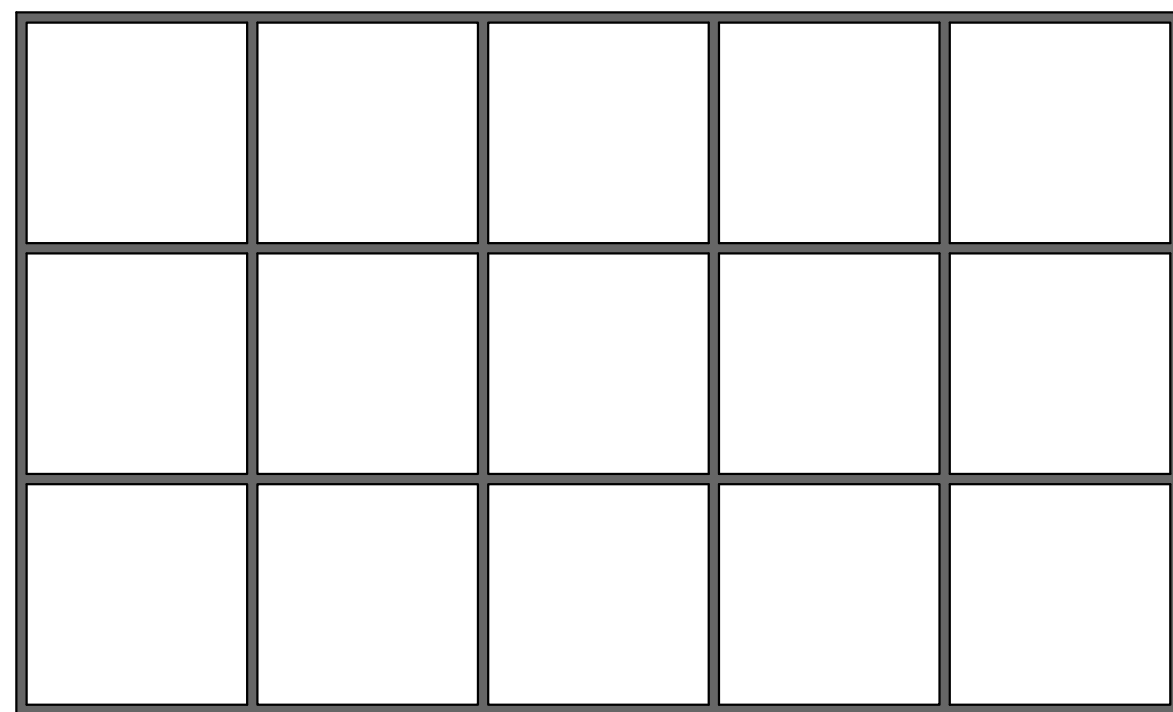

Gevelfragment markthal

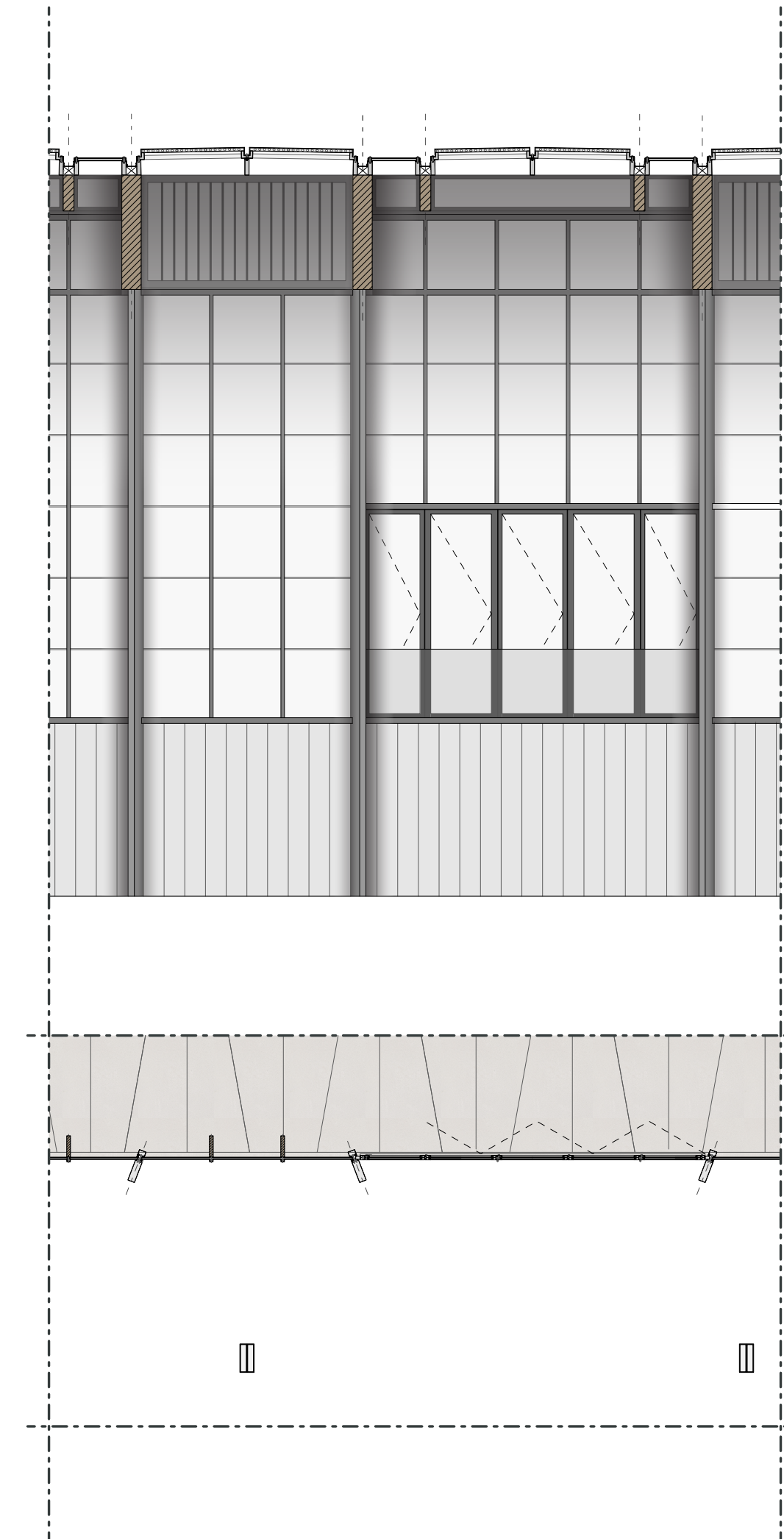
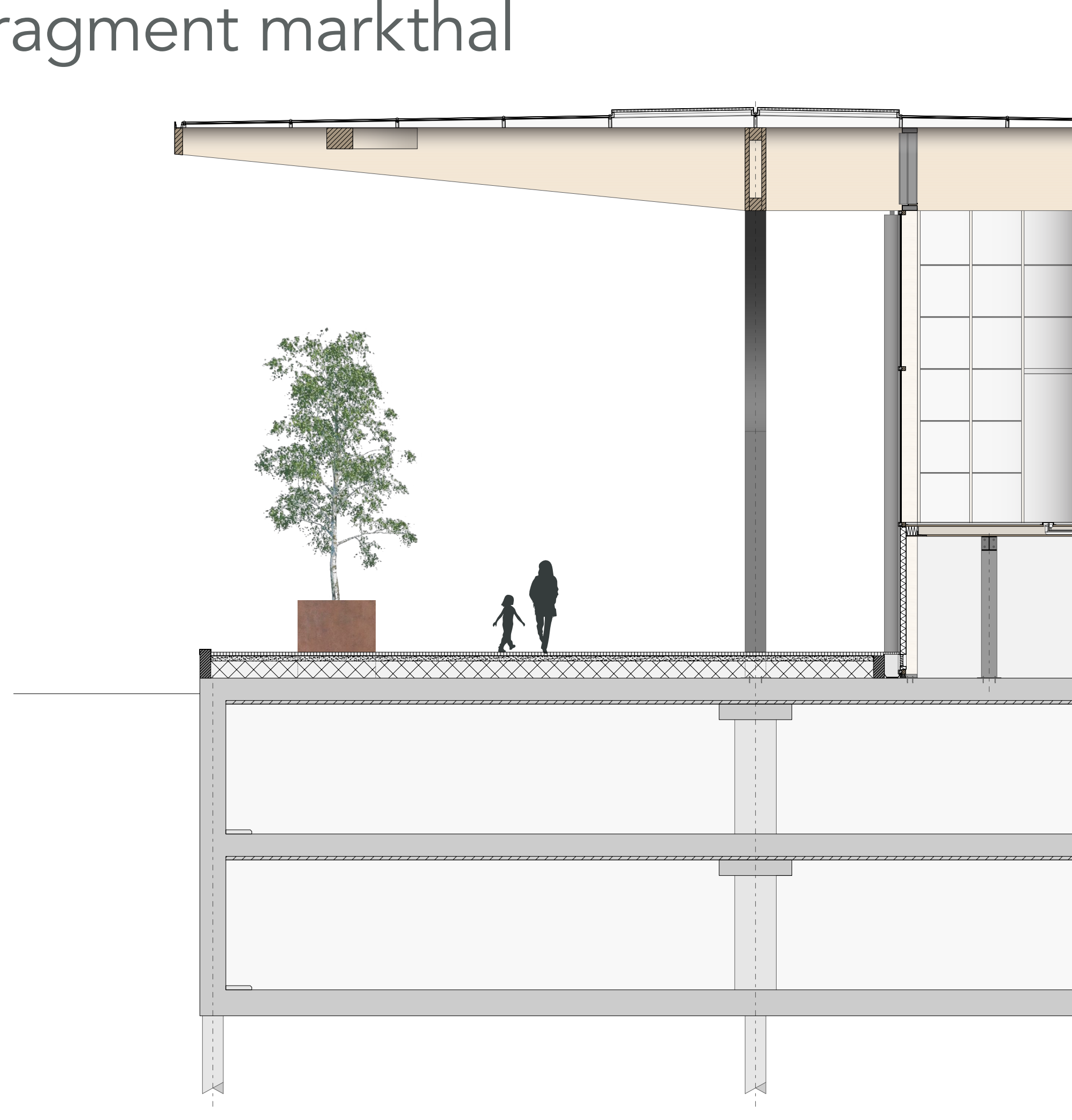

Gevelfragment lofts

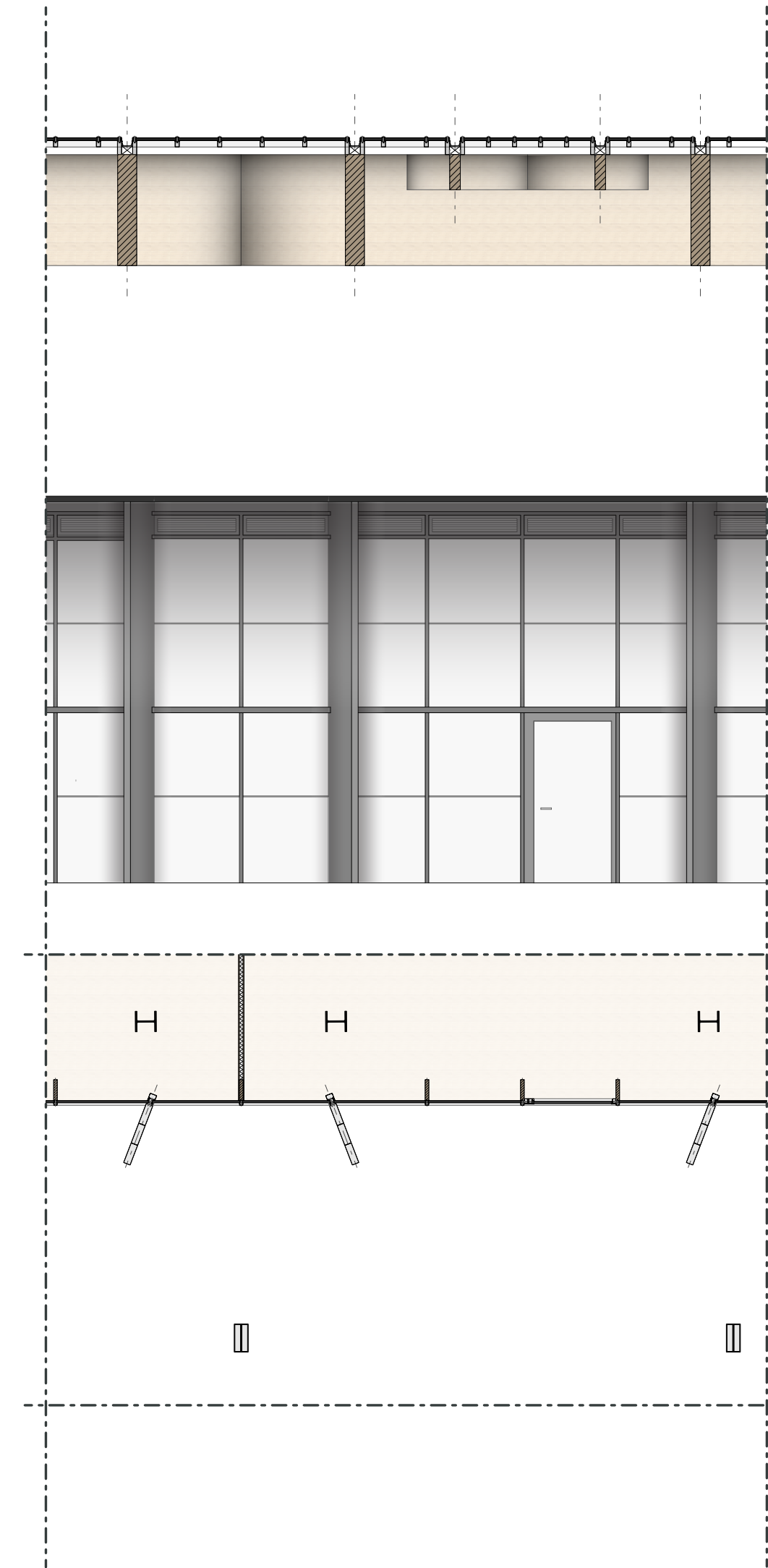
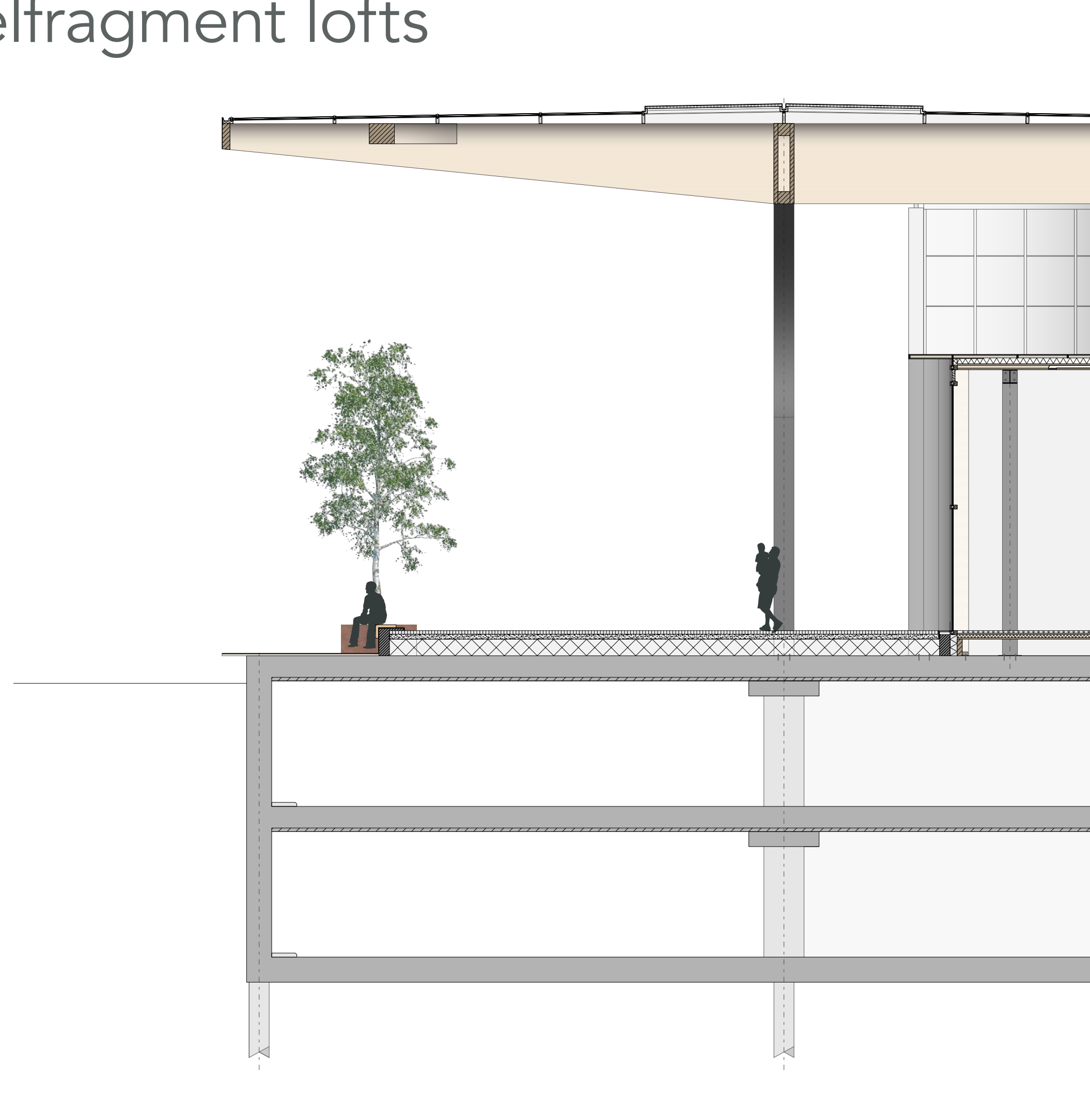

Dakfragment

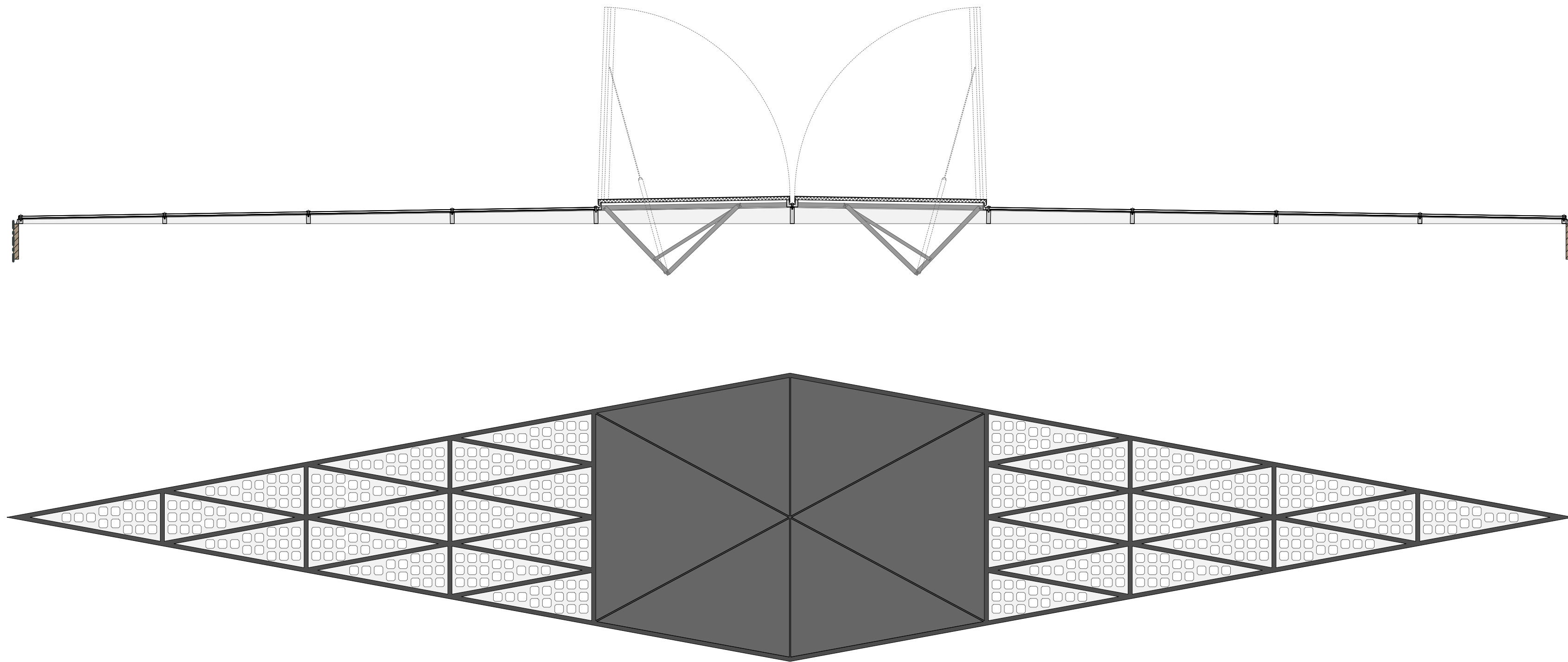

Detail portaal - grond

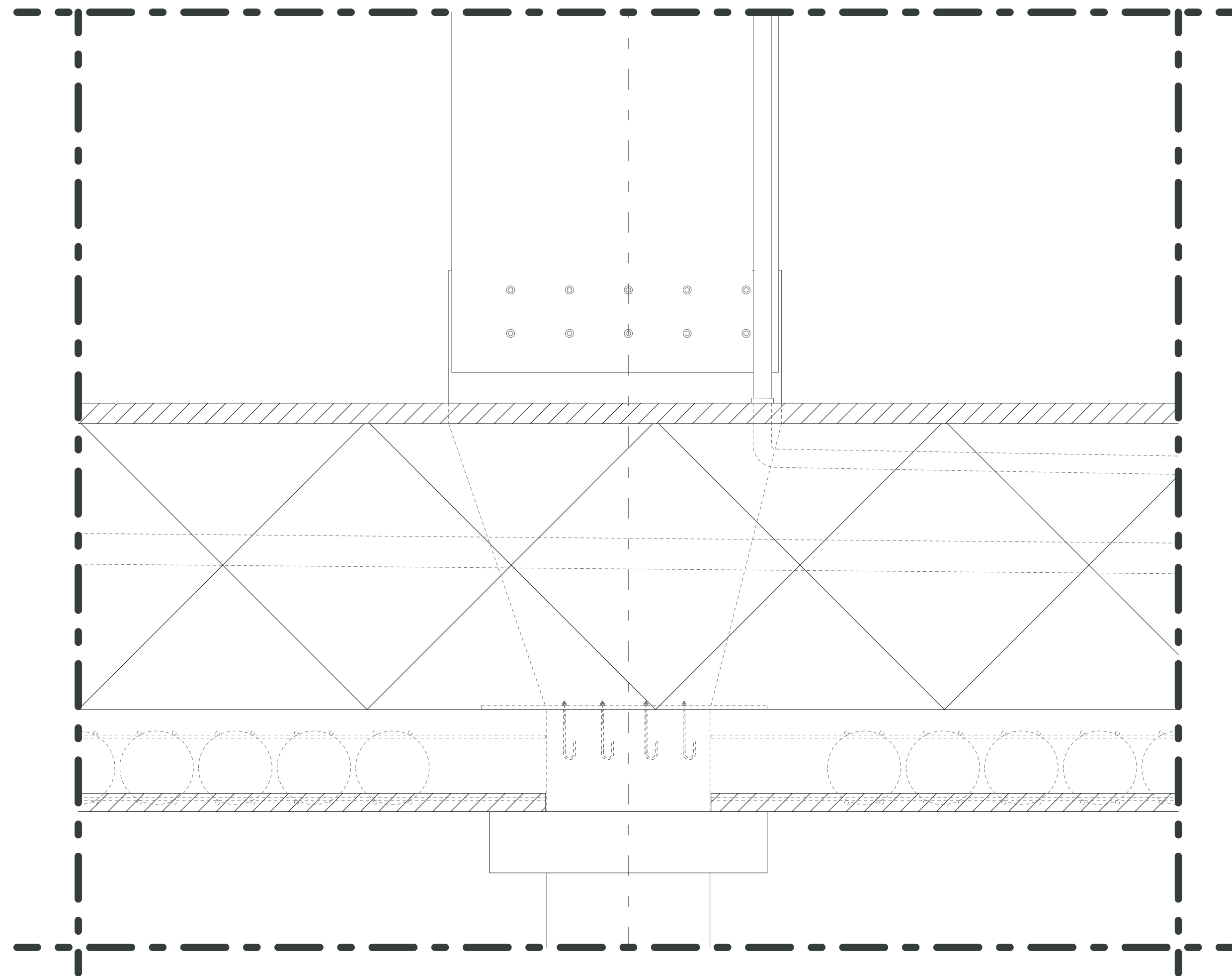

Detail gevel loft - grond

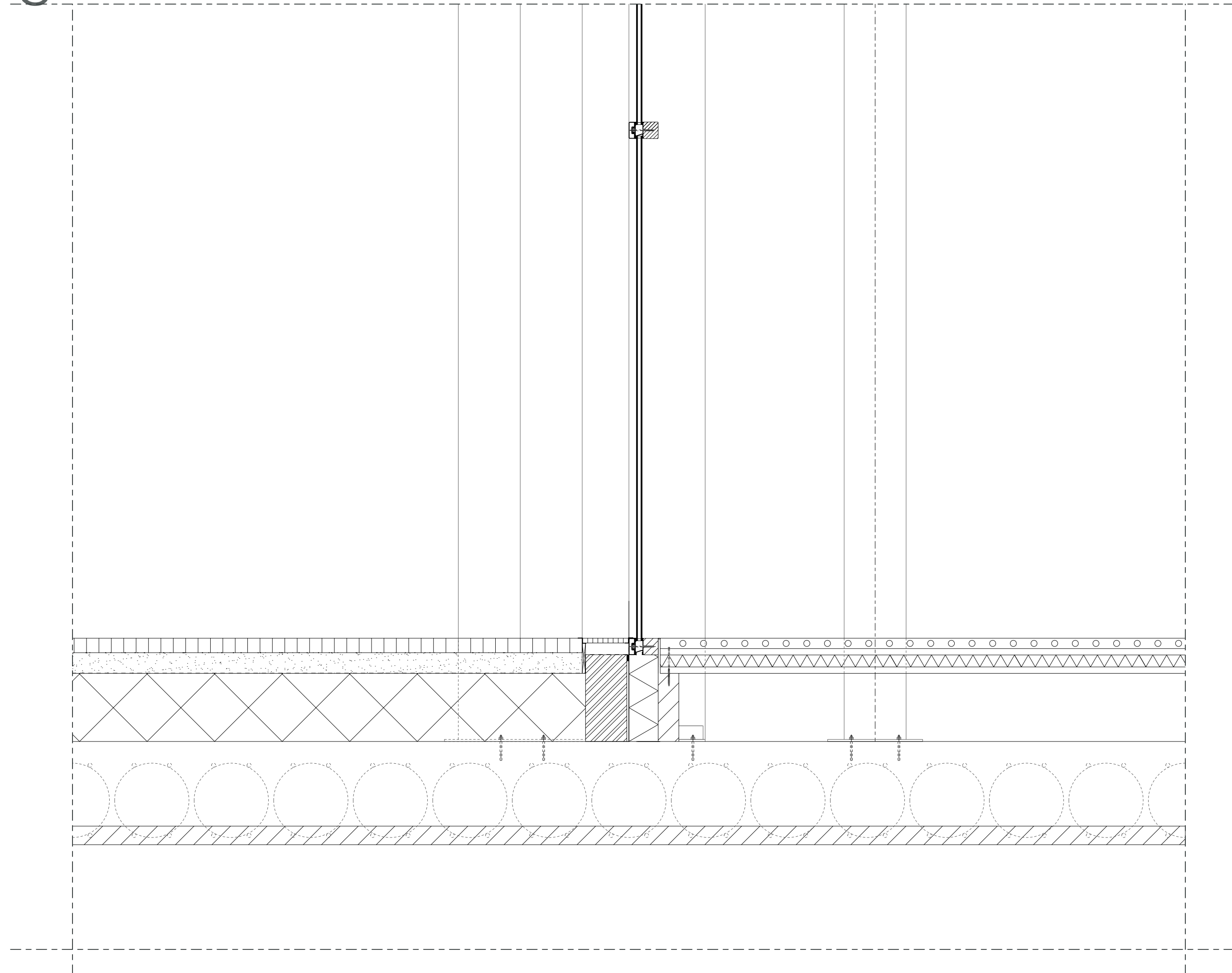

Hoekdetail gevel

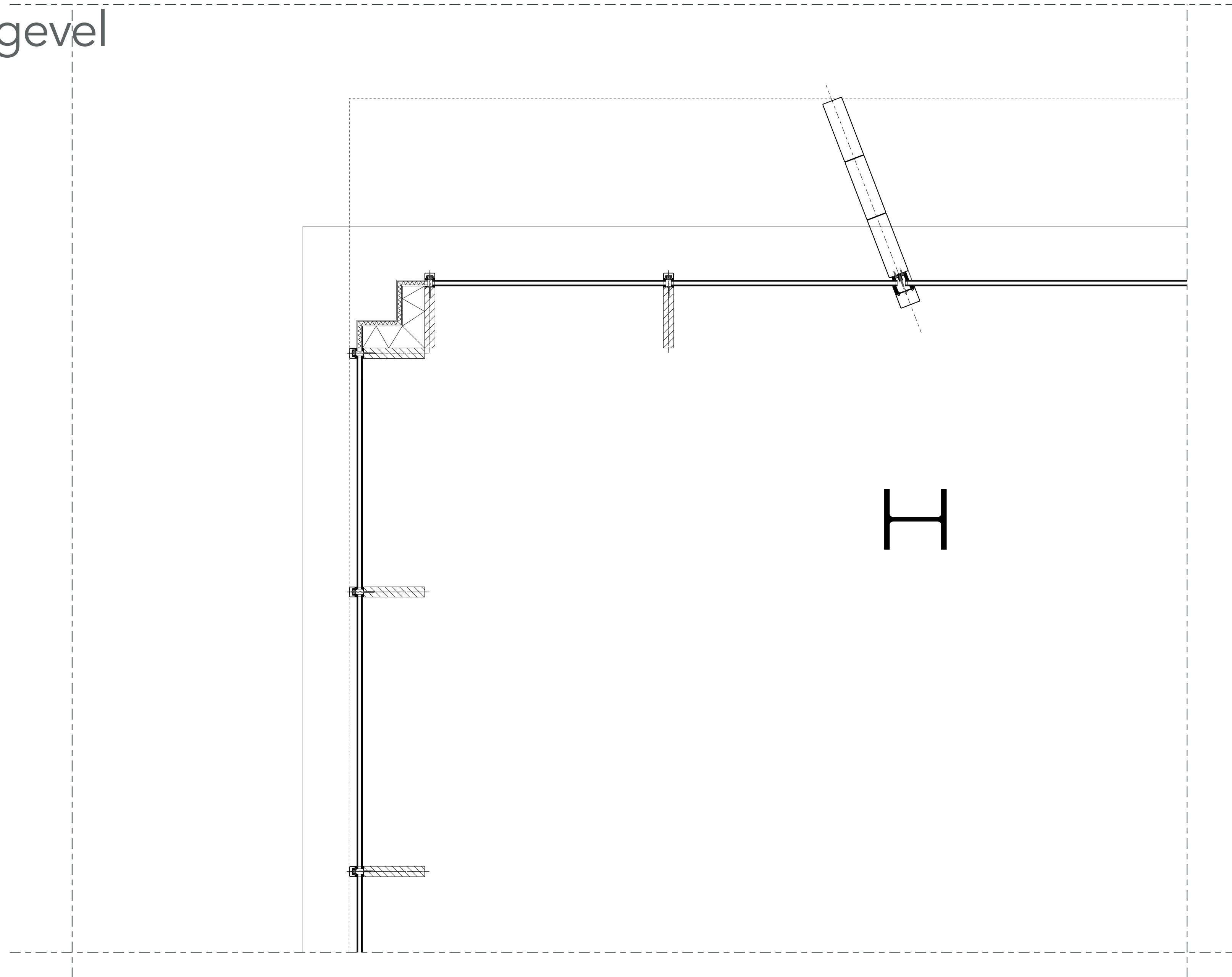

Wärmepump winter

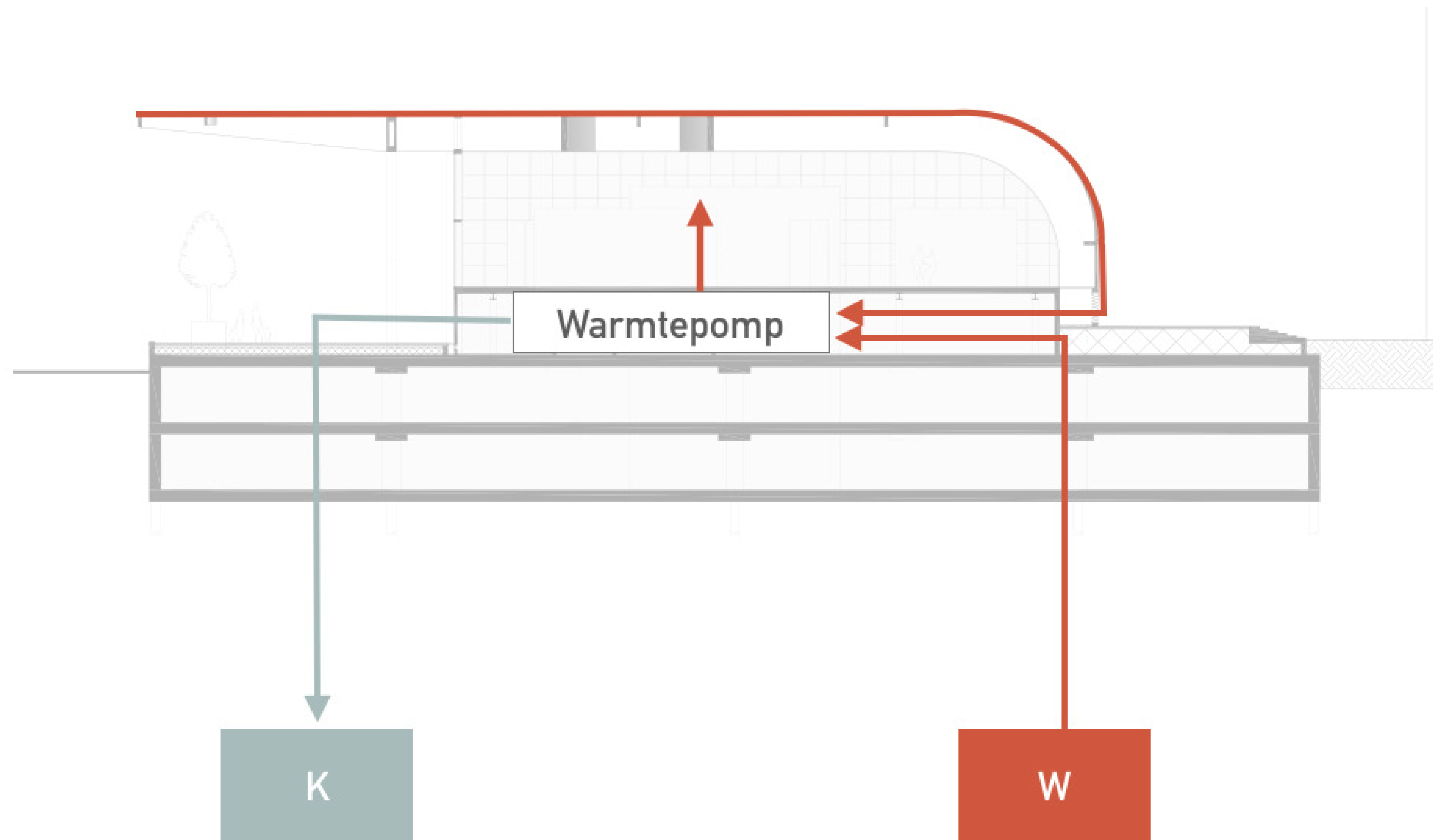

Warmtepomp zomer

