



# Panorama

The effectiveness of thermal buffering systems in the monumental Panorama Mesdag museum

Elke Mulders  
4615212  
Building Technology  
Graduation

Zara Huijbregts,  
Climate Design  
**Wido Quist**,  
Heritage & Technology





Sources: own



(Braaksma & Roos, 2022).



## The Panorama Mesdag Museum

Year	1880, expanded in 1910 & 2015
Architect(s)	Gerard Klomp (original design), Braaksma & Roos (renovation)
Location	Zeestraat 65, the Hague in the Netherlands
Function(s)	Museum, depot, restaurant, offices, educational spaces
Total area	2.680 m <sup>2</sup>
Rotonde	1.200 m <sup>2</sup>

Exhibition	Shop	Services	Museum route
Rotonde	Depot	Hallways	
Cafe	Educational space		

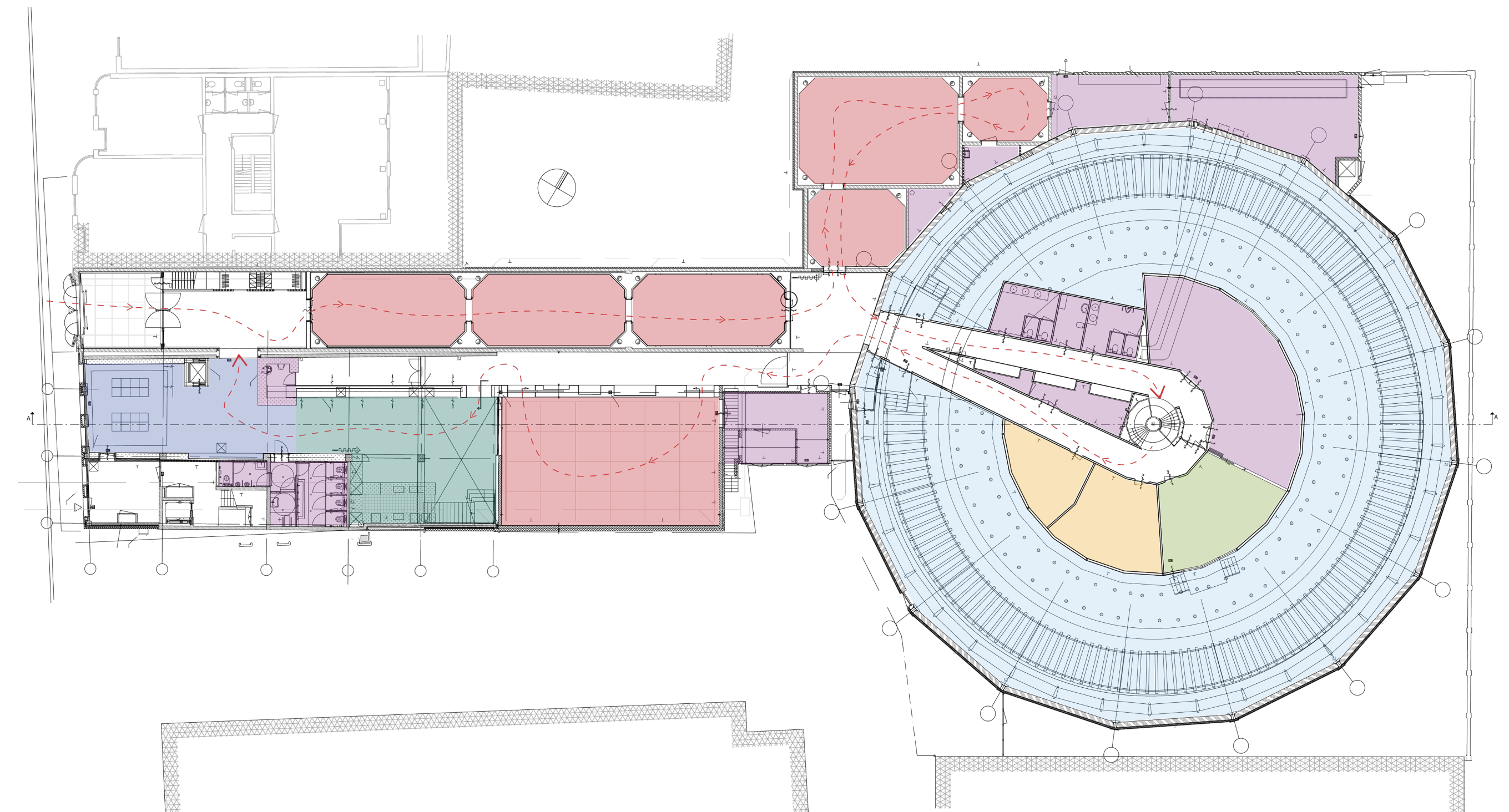



(Wikipedia, 2021).

Dimensions	14,5 x 114,5 m
Area	1660 m <sup>2</sup>
Weight	4500 kg



(Max Vandaag, 2021).



Panorama Mesdag

# Illusional panorama exhibition

- 1793 first exhibition in London, Robert Baker
- '19<sup>th</sup> century cinema'

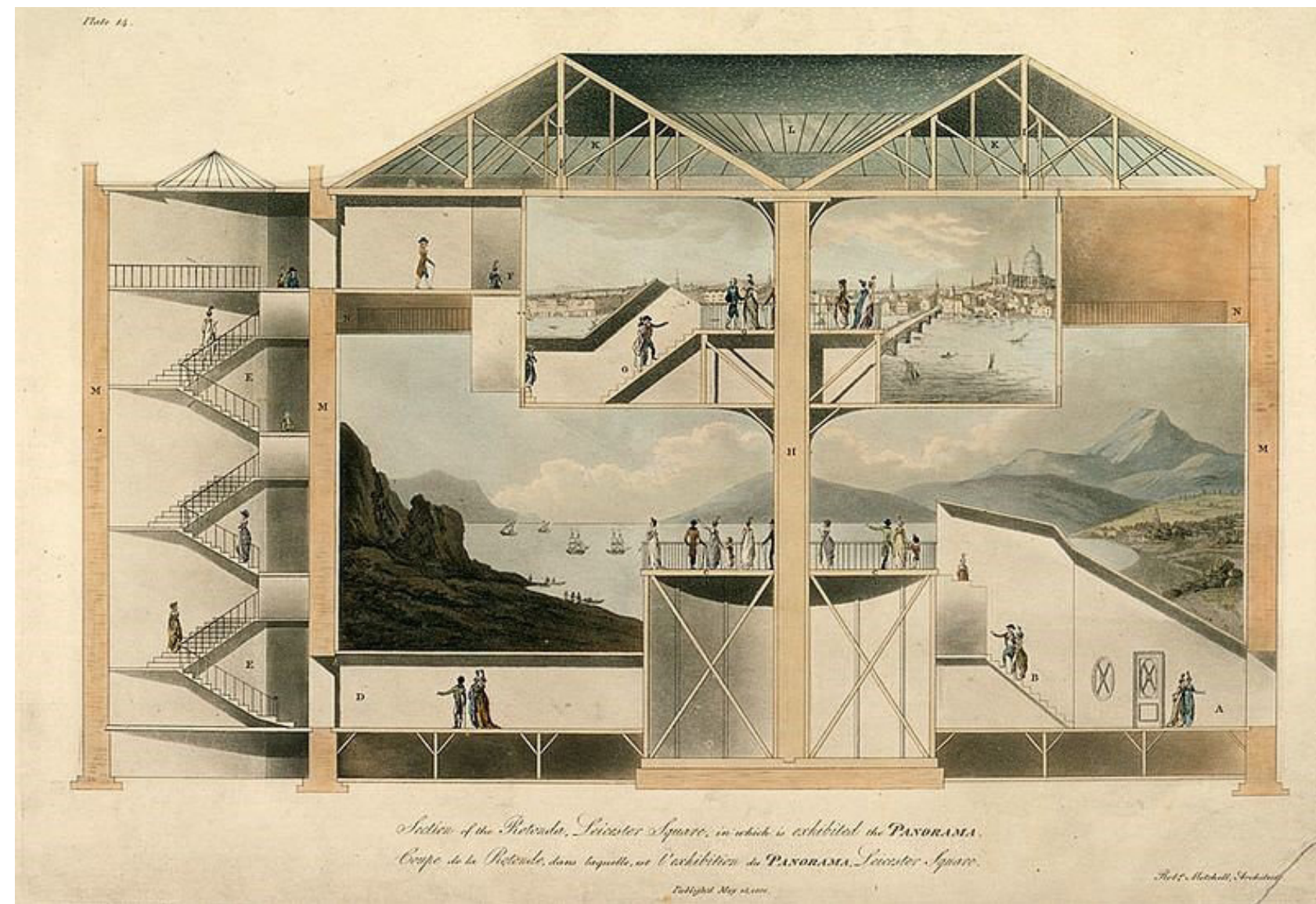

## Existing panorama exhibitions

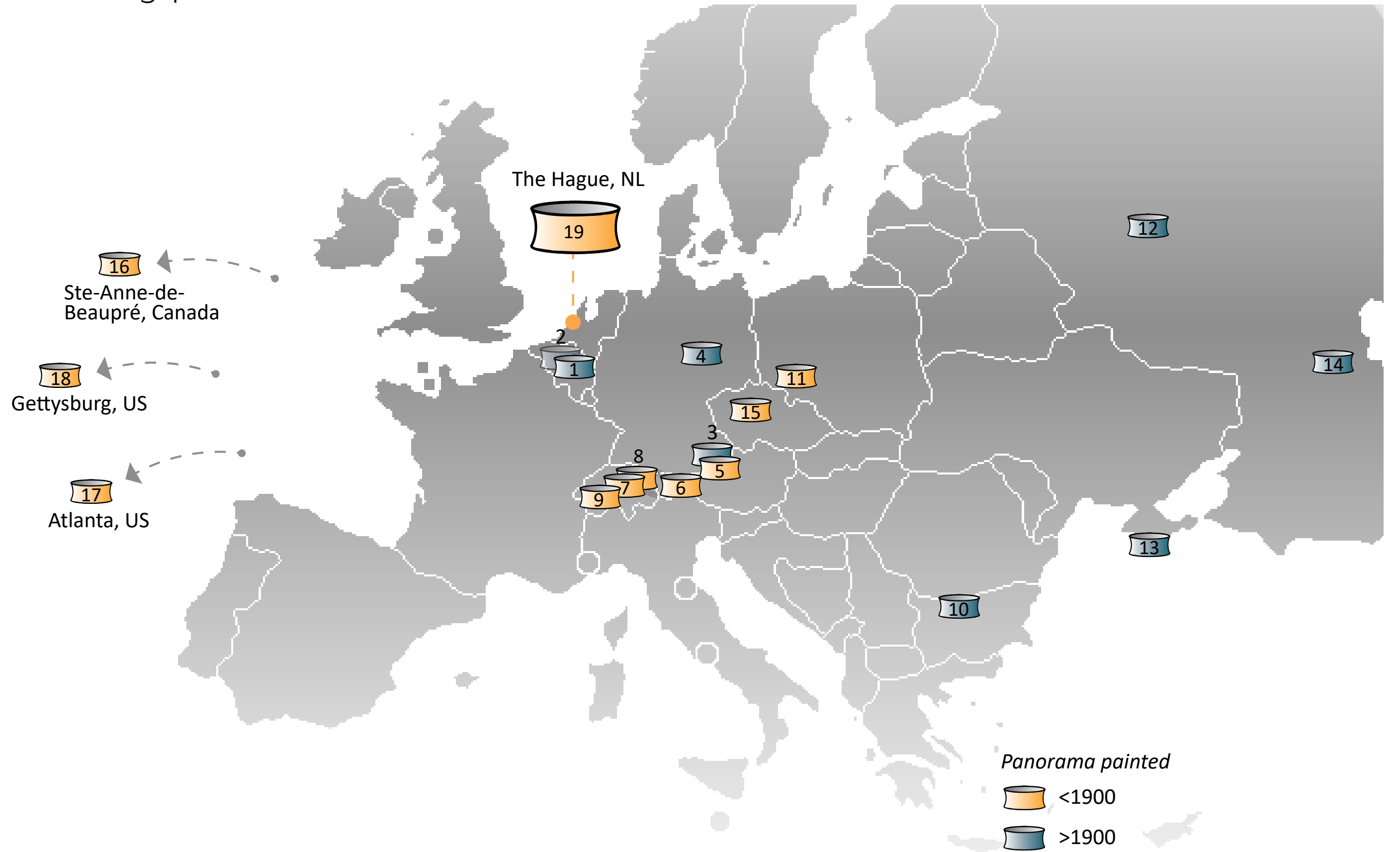

# Sustainability goals of the Panorama Mesdag Museum

Decrease carbon  
footprint



Decrease building  
energy consumption

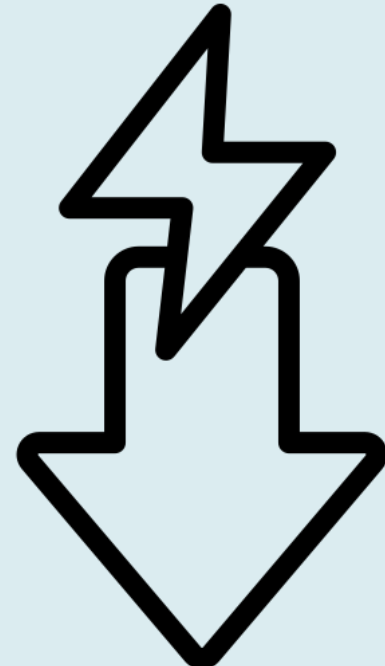

Monumental  
limitations



Art preservation

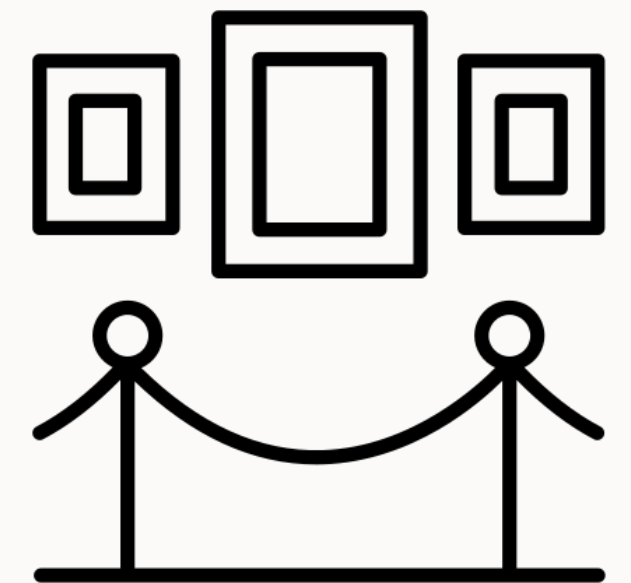

Decrease building energy consumption

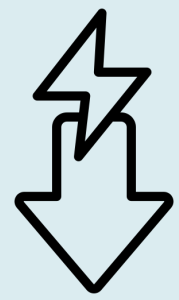

# Thermal buffering

**System** that stores and releases heat, **heat battery**



## Effect in buildings

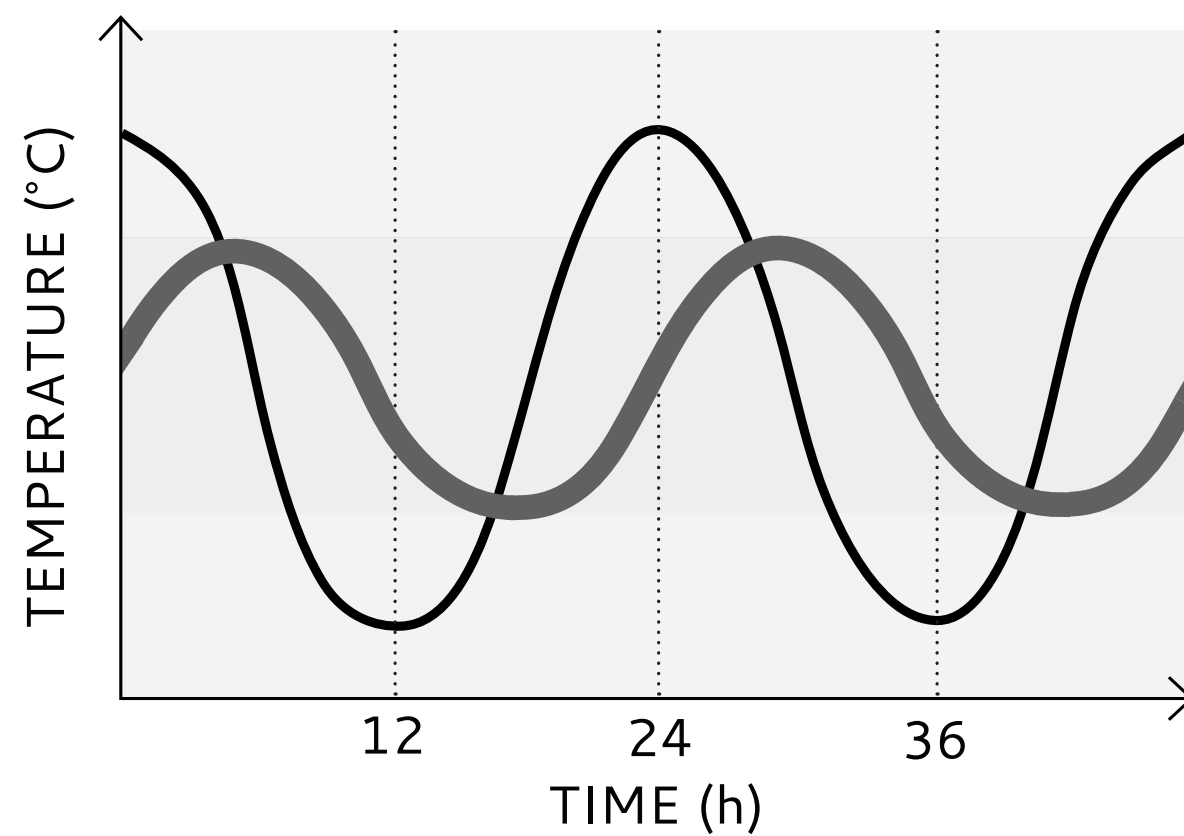

✗ without

✓ with thermal buffer

(Solarino, 2018)

## Advantages during winter

Store heat during the day

Release heat during the night

Lower energy consumption

## Advantages during summer

Store heat during the day

Release heat during the night

Constant temperature

Conservation panorama canvas

How can the **Rotonde** of the Panorama Mesdag Museum be **adapted** to **increase the thermal buffering capacity** of the building while not interfering with the monumentality of the exhibition building and the experience of the permanent Panorama Mesdag exhibition?

## Define current state

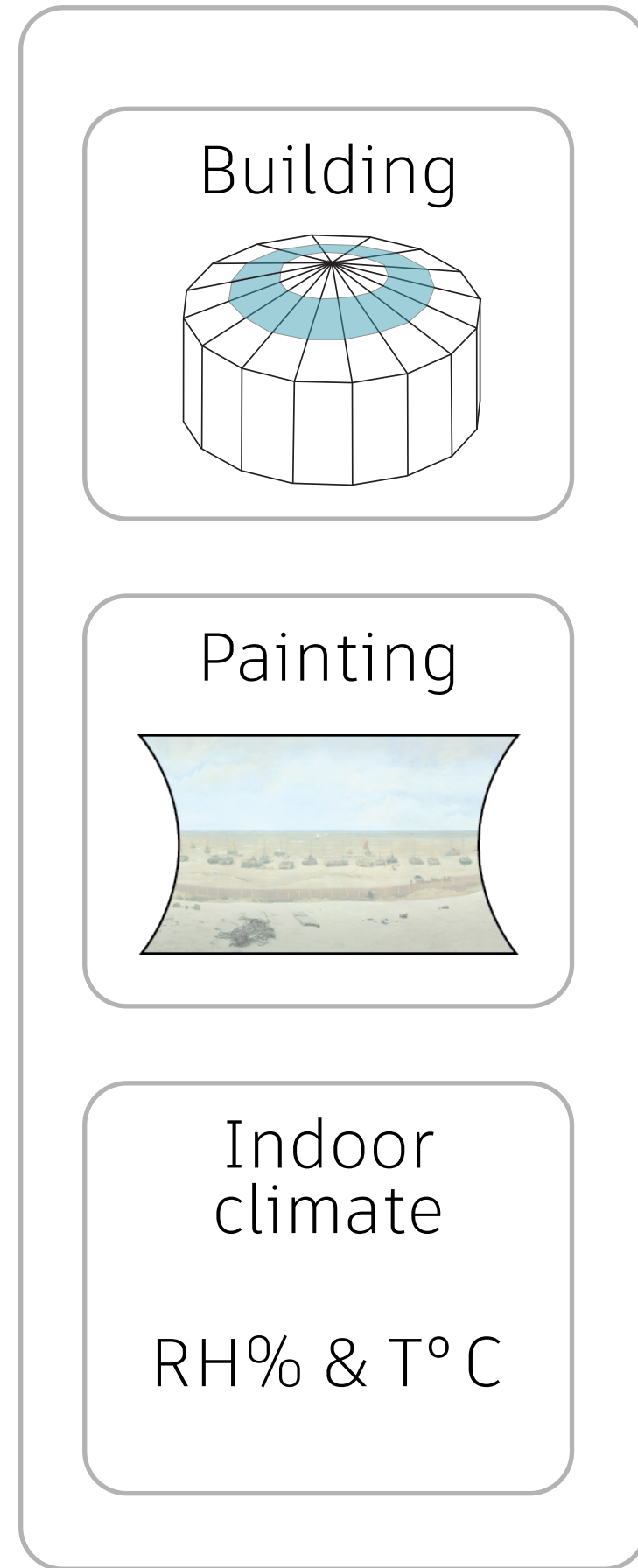

- Literature research
- Site visits
- Measurements

## Thermal buffering system

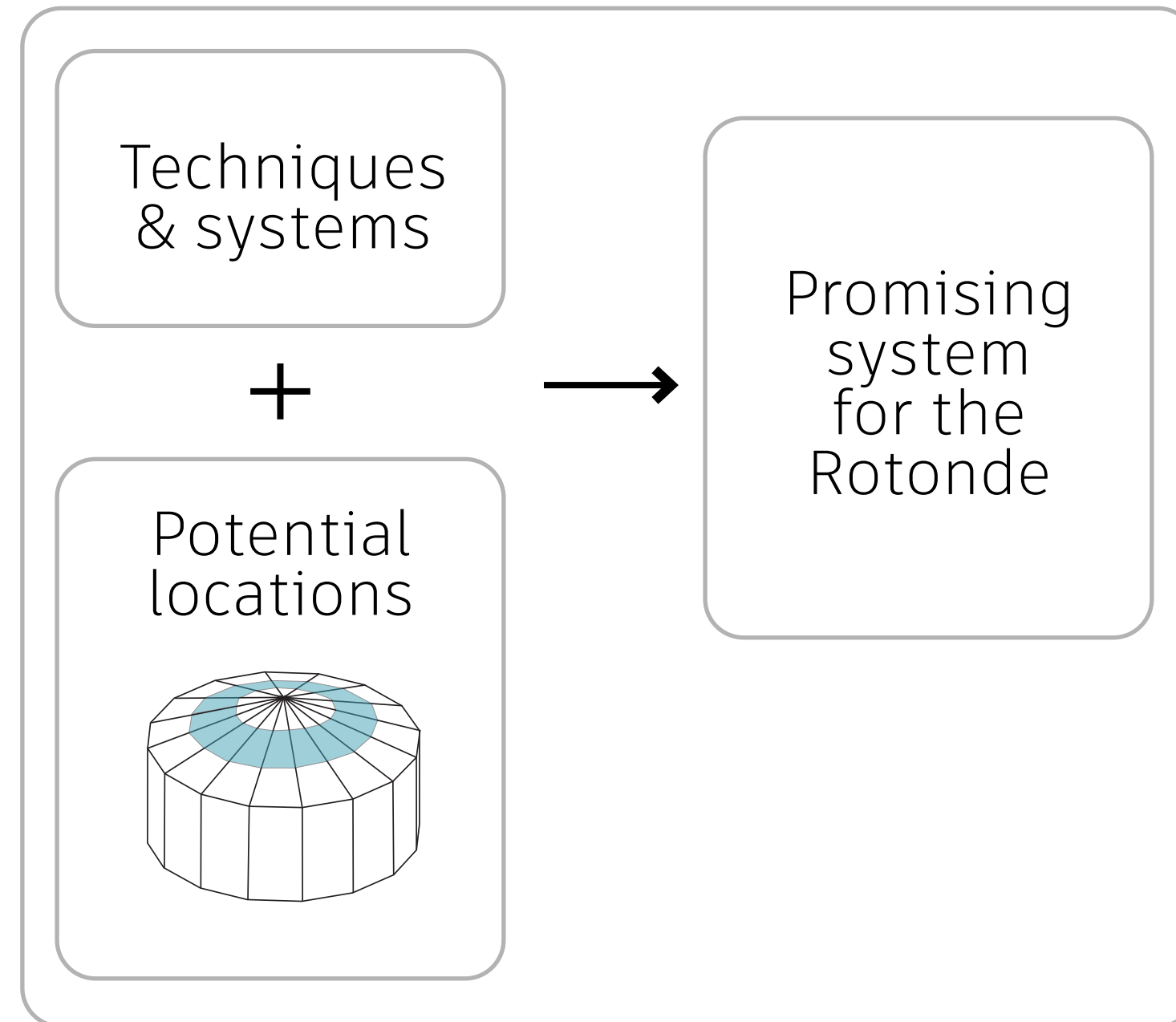

- Literature research

## Testing effect of proposed system - Simulations



- Testing through simulations

## Advise on suitable climate system



What is the **current state** of the monumental **Rotonde**  
where the Panorama Mesdag is exhibited?

# Original vs. New elements

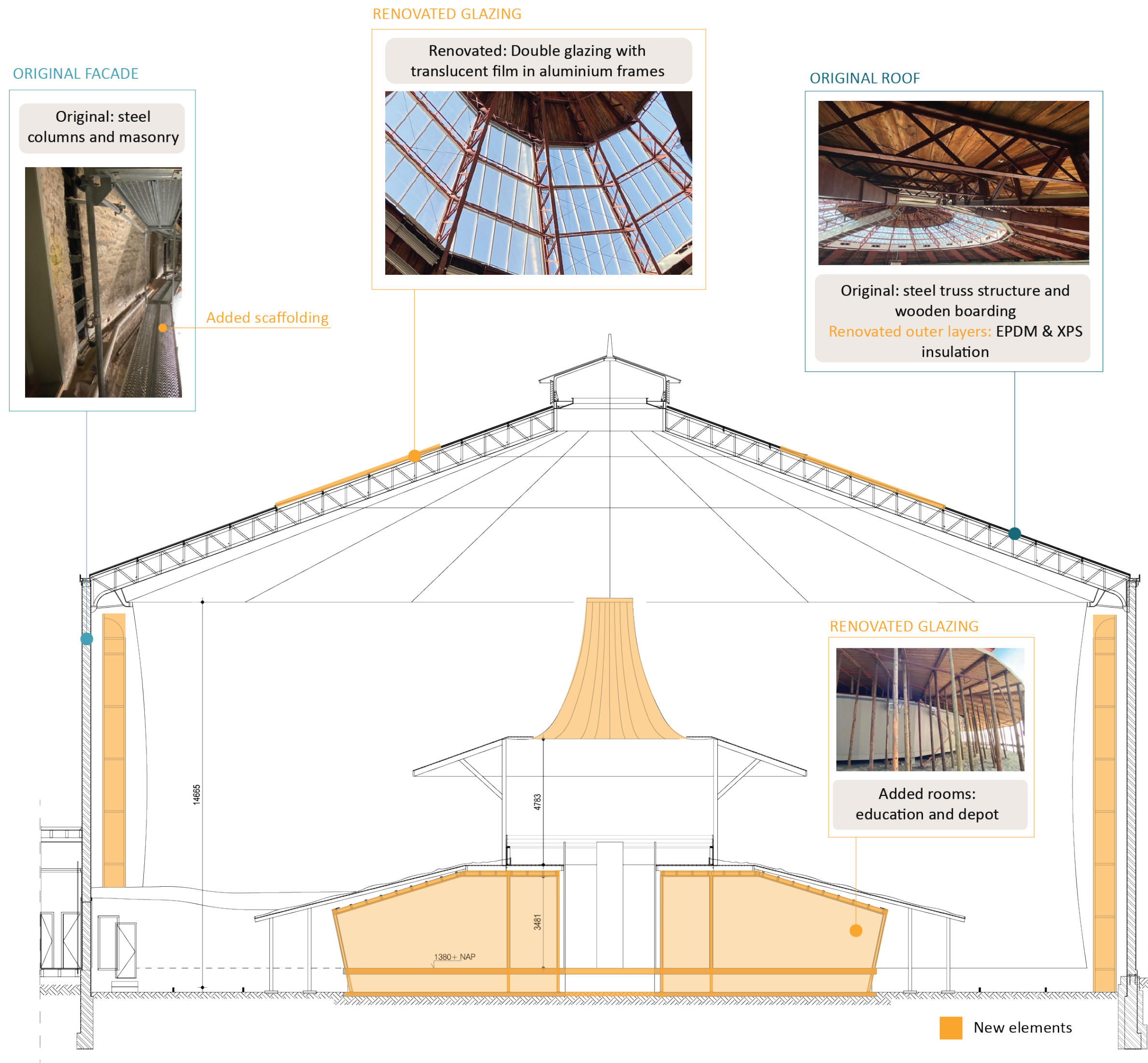

## Construction details

Layers	Floor	Facade	Roof	Skylight
<b>Exterior</b>				
1.	200-250 mm peat soil	Cement plaster	EPDM roofing with fine aggregate	5 mm float glass
2.	1500 mm sand	400 mm steel columns	40 mm XPS insulation	15 mm air cavity
3.		350 mm brickwork	Vapour barrier	6,76 mm safety glass: <ul style="list-style-type: none"> <li>3 mm float glass</li> <li>2 x 0,38 mm window safety foil</li> <li>3 mm float glass (translucent)</li> </ul>
4.		cement plaster	Wooden boarding	Aluminium frame
5.			Steel trusses	
<b>Interior</b>				
U-value [W/m <sup>2</sup> K]	n.a.	1,0- 2,0	0,714	2,975
Visual light transmittance [%]	n.a.	n.a.	n.a.	79,8
Solar heat gain [%]	n.a.	n.a.	n.a.	74,5

**State of the Rotonde**

**Good**, but minimal insulation & large solar heat gain

What is the **current state** of the Panorama Mesdag painting?

## Characteristics

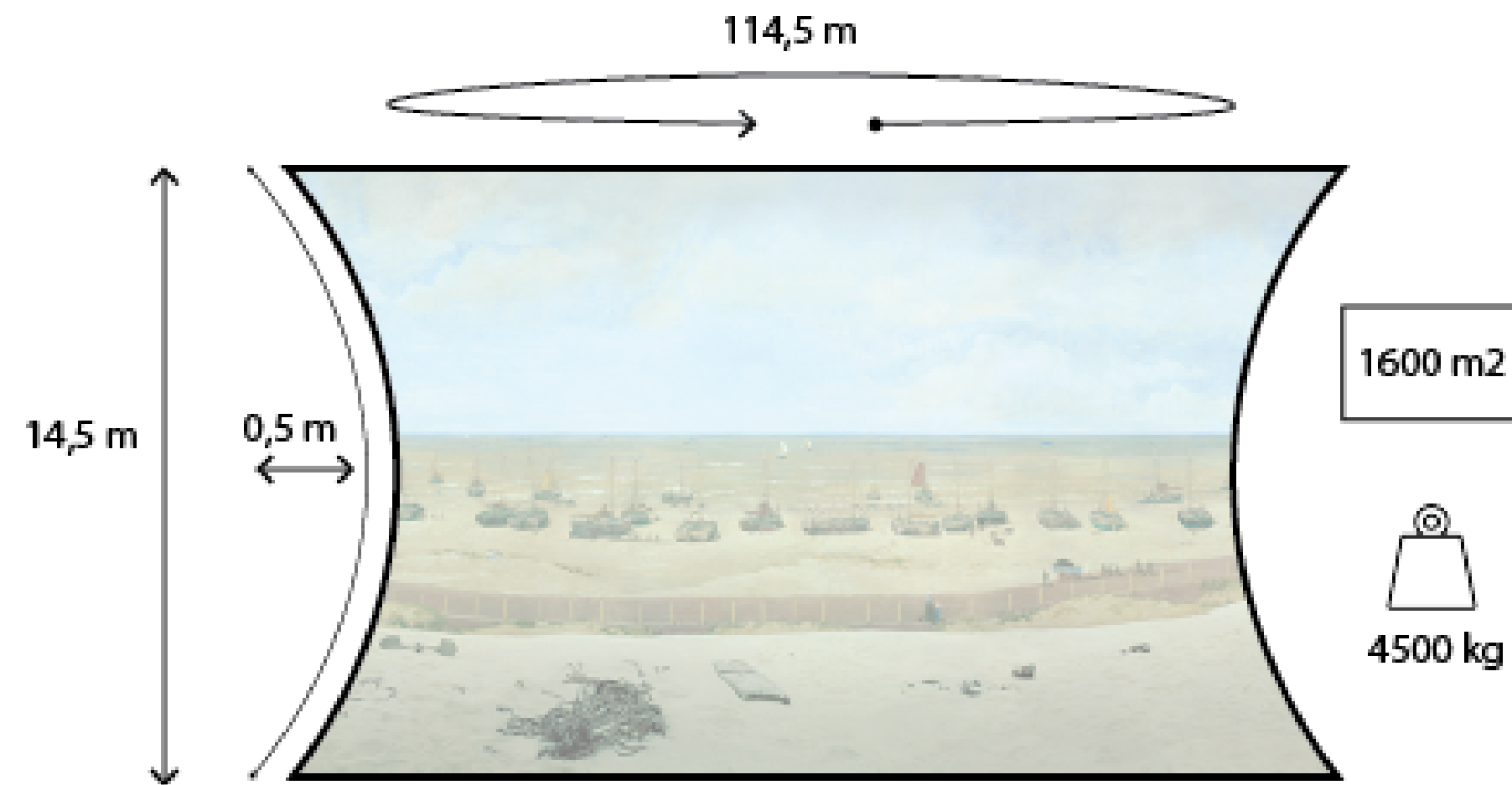

Source: Speldekamp, 2017.

## Damage and repairs overview

	Damage	Year of repairment	Repairment technique	Repairment material(s)	Current state
Canvas	Holes	1988-1996	<ul style="list-style-type: none"> <li>Remove previous repairs</li> <li>Fill holes</li> </ul>	Linen patches	Good
	Fractures	1988-1996	Relining canvas	<ul style="list-style-type: none"> <li>Nylon canvas</li> <li>Thermoplastic glue</li> </ul>	Good
	Stretched areas	n.a.	-	-	Stable
	Glue residu	1988-1996	Removing residu	n.a.	Good
	Air pockets	n.a.	-	-	Declining
Paint	Detaching paint	2017	<ul style="list-style-type: none"> <li>Confining paint with a resin</li> <li>Removing excess resin</li> </ul>	<ul style="list-style-type: none"> <li>Aquazol 200 (synthetic resin)</li> <li>Isopropanol</li> </ul>	Good, if done regularly
	Deposits	<ul style="list-style-type: none"> <li>1910</li> <li>1988-1996</li> <li>2017</li> </ul>	Removing deposits with a brush, vacuum cleaner and/or sponge	n.a.	Good, if done regularly
	Pulverised and faded paint	<ul style="list-style-type: none"> <li>1910</li> <li>1988-1996</li> <li>2017</li> </ul>	Retouches	Pencils	Good, if done regularly

### State Description

Good = Repaired and no risk to art object.  
 Stable = Not repaired, but not getting worse.  
 Declining = Damage is getting worse.  
 Bad = Severe damage with risk to art object.

## State of the Panorama Mesdag

**Good**, since adding a second canvas & repairs

What is the **current state** of the indoor climate of the Rotonde?

## Allowed range

indoor temperature and relative humidity

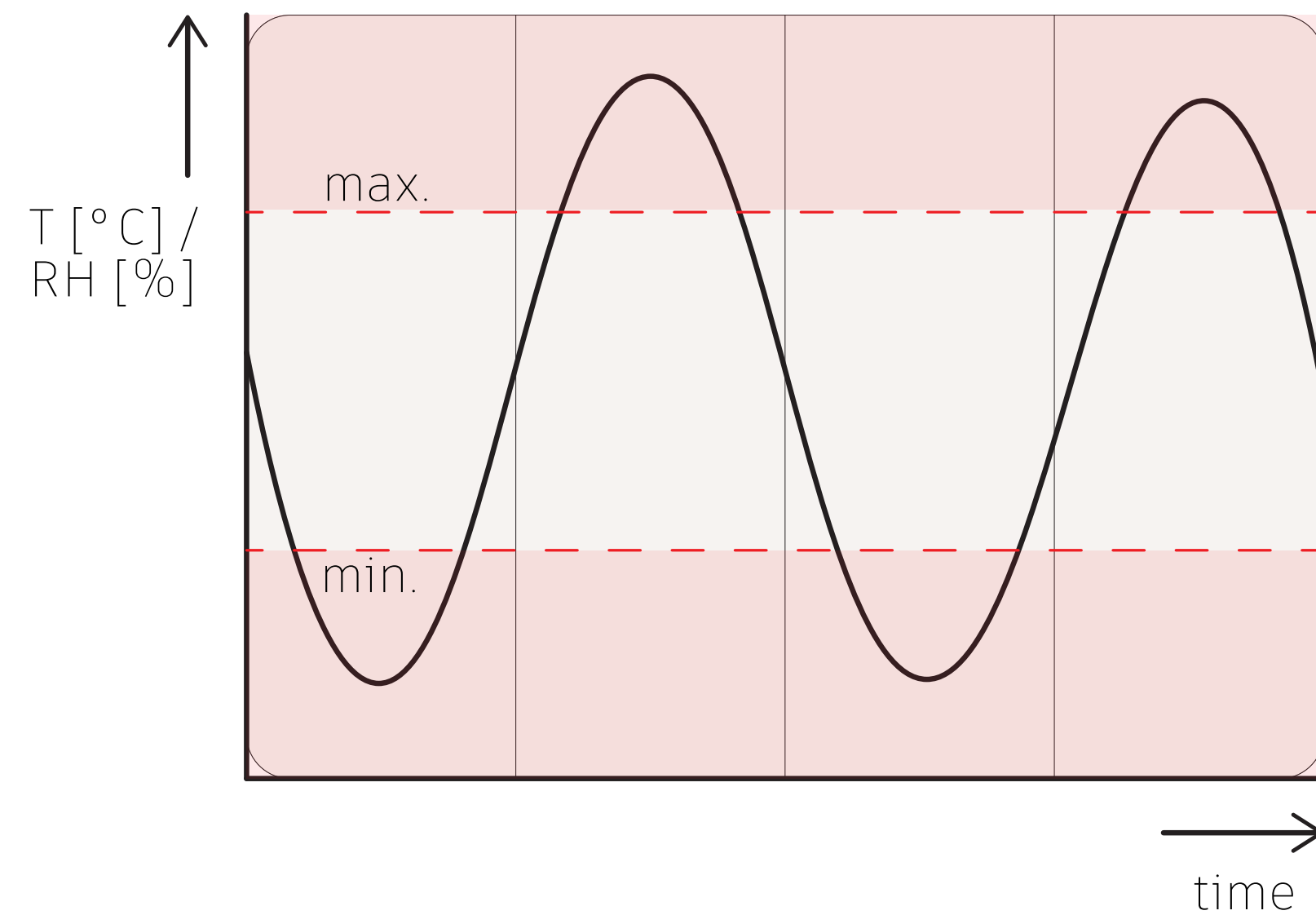

## Risks of damage

Stresses on the canvas

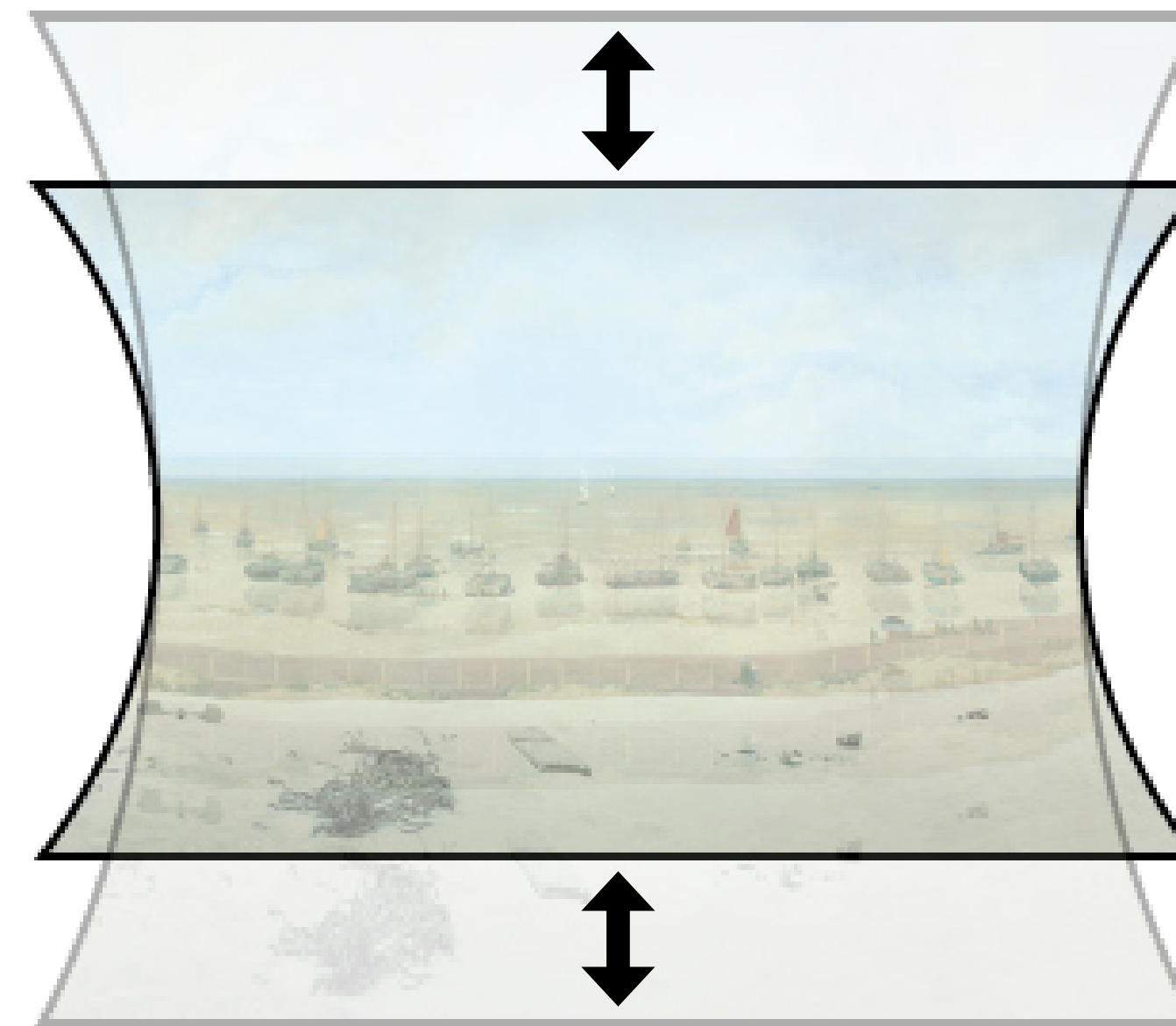

Mechanical damage to the canvas:  
fractures, holes, deformation

### Other risks

- mold growth
- paint damage
- chemical deterioration

# ASHRAE Climate classes in museums

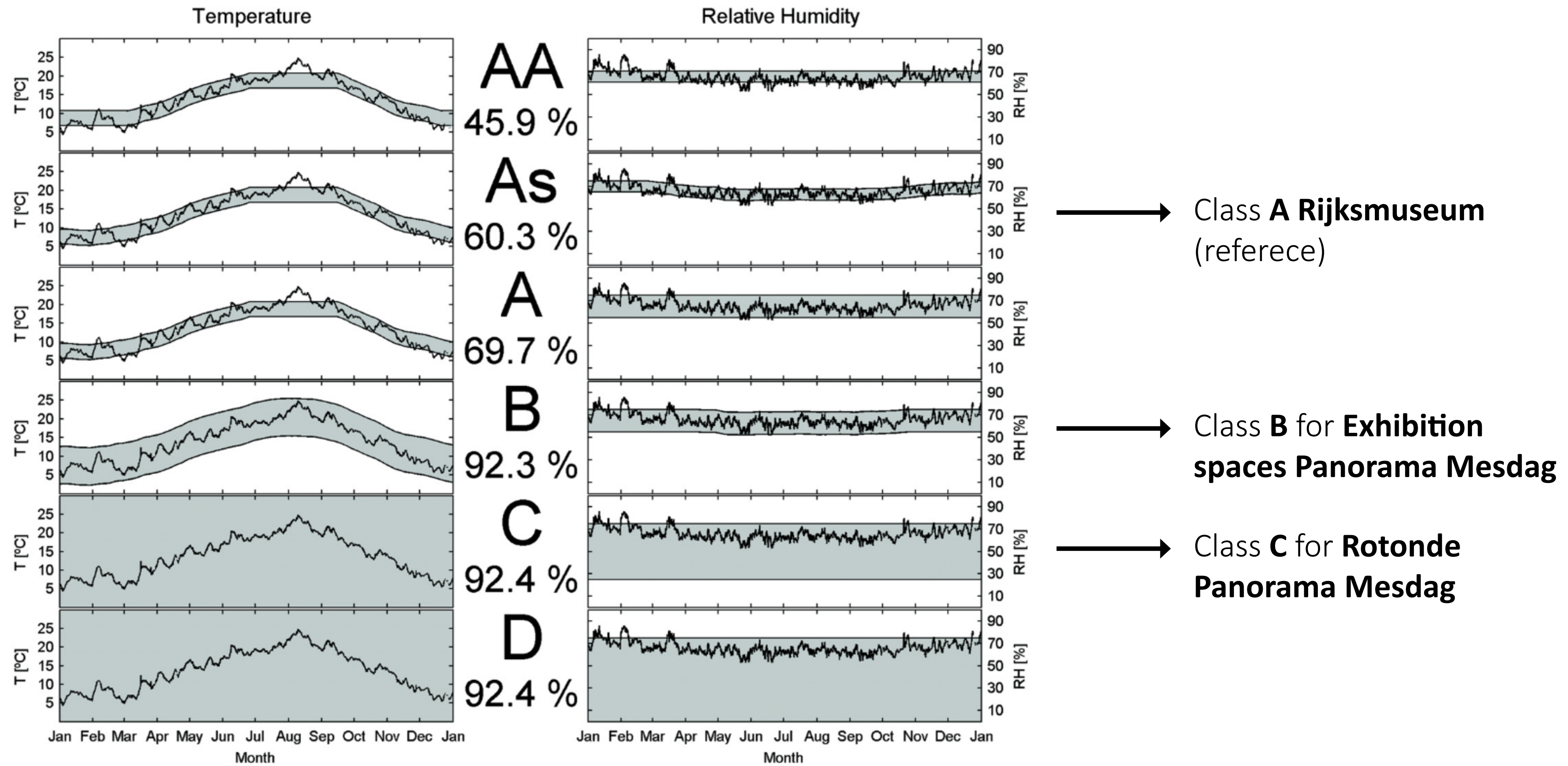

Current state: indoor climate

# Measurements



Temperature and relative humidity logger



Data receiver

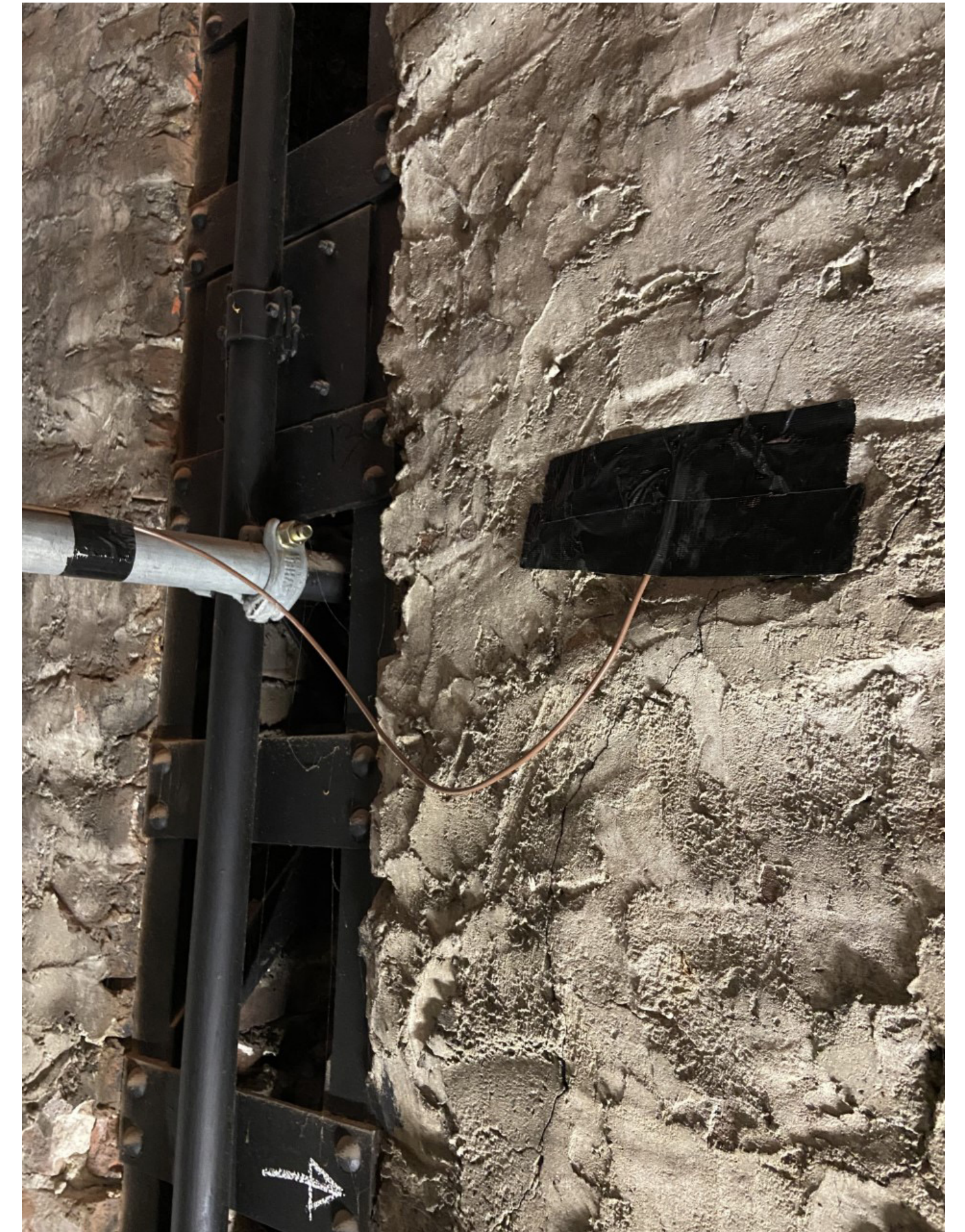

Surface temperature logger

# Measured operative temperature

Average behind the canvas between september '21-'22

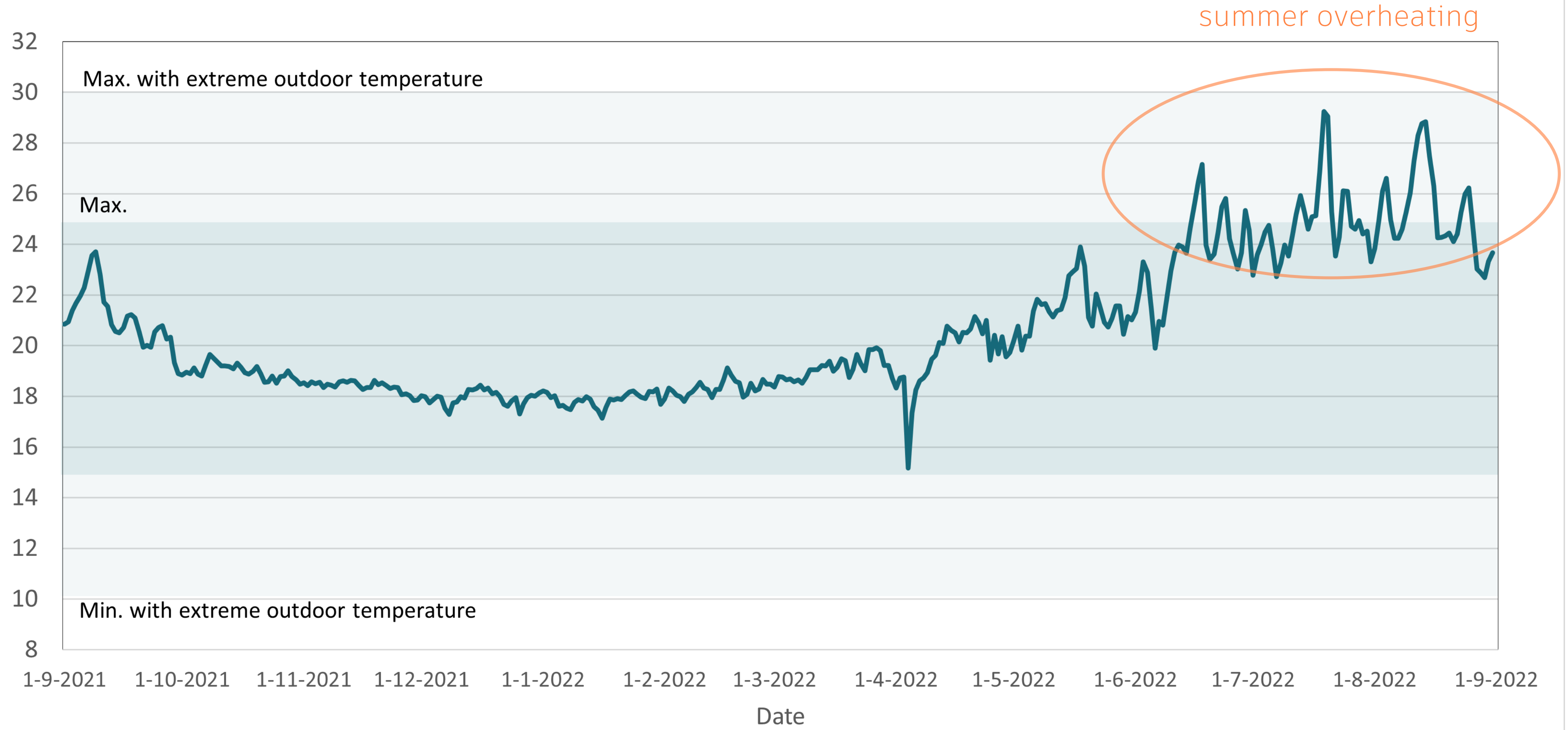

# Measured relative humidity

Average behind the canvas between september '21-'22

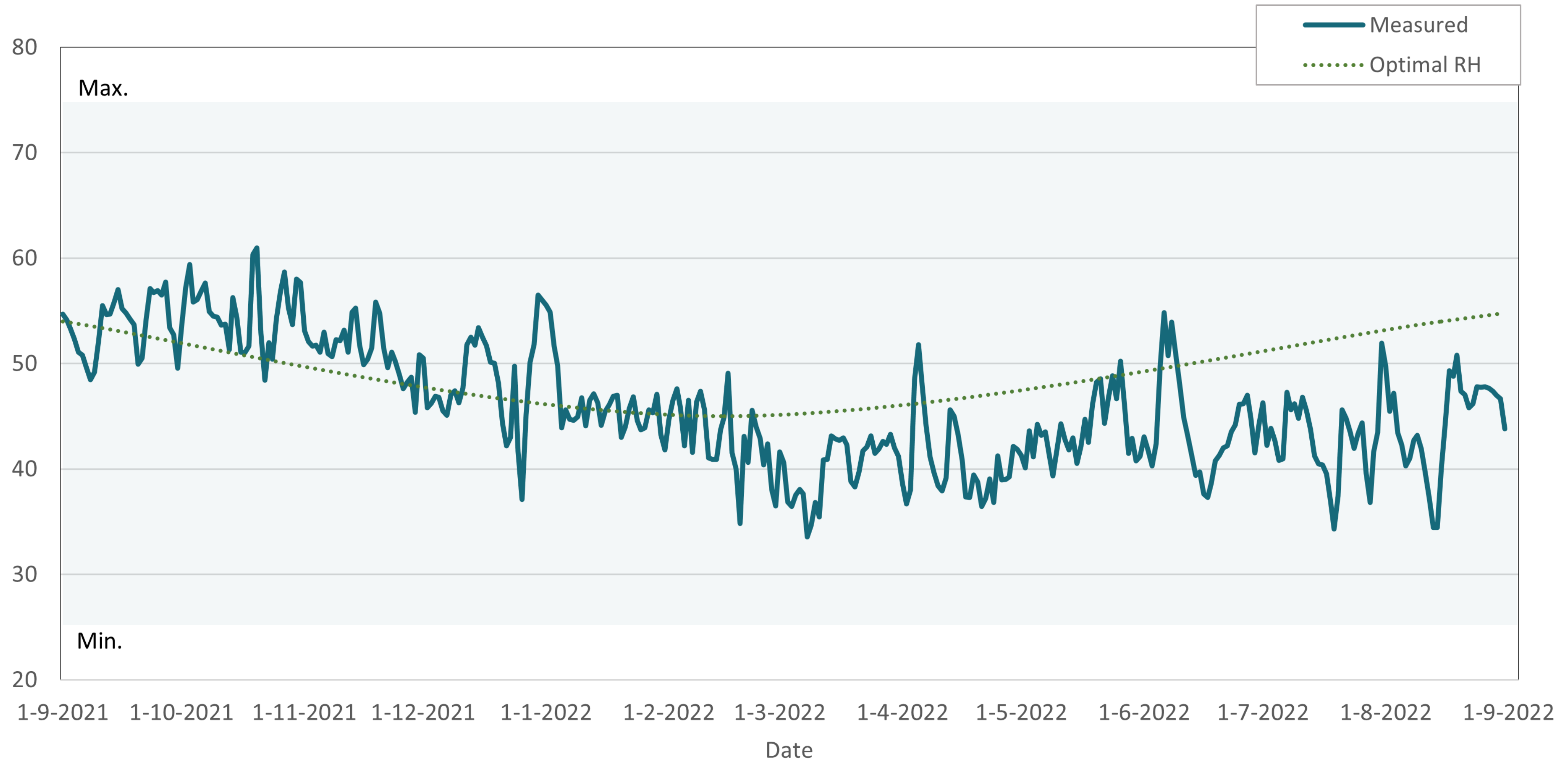

Current state: indoor climate

### Allowed range

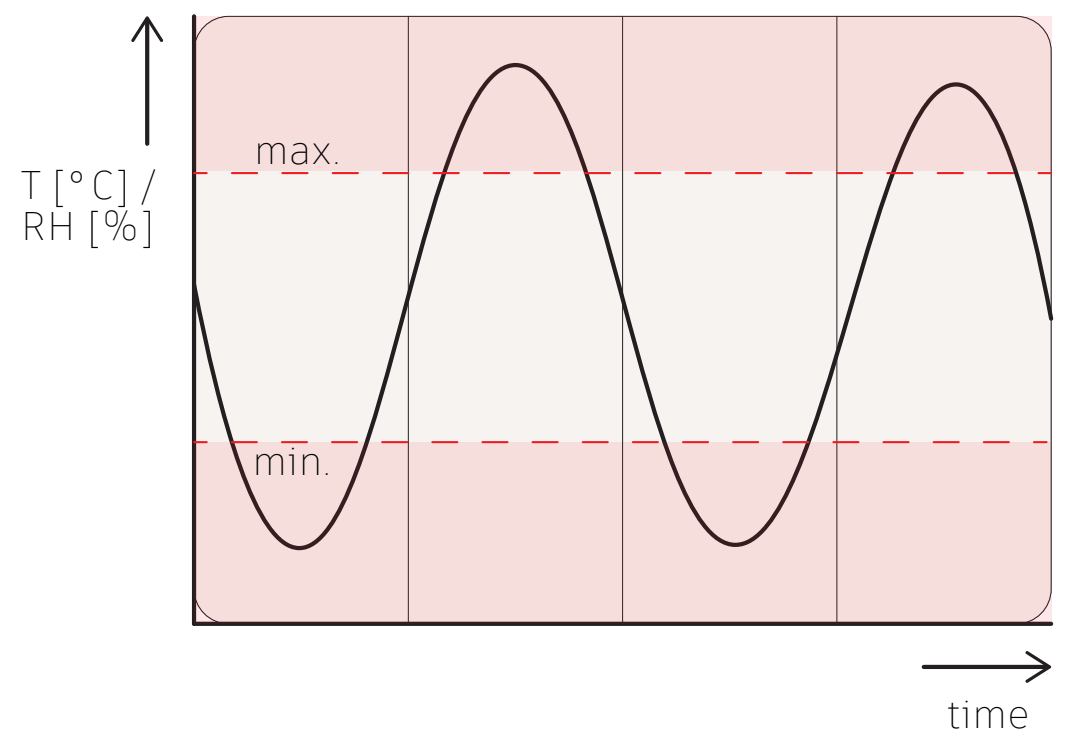

+

### Daily fluctuations

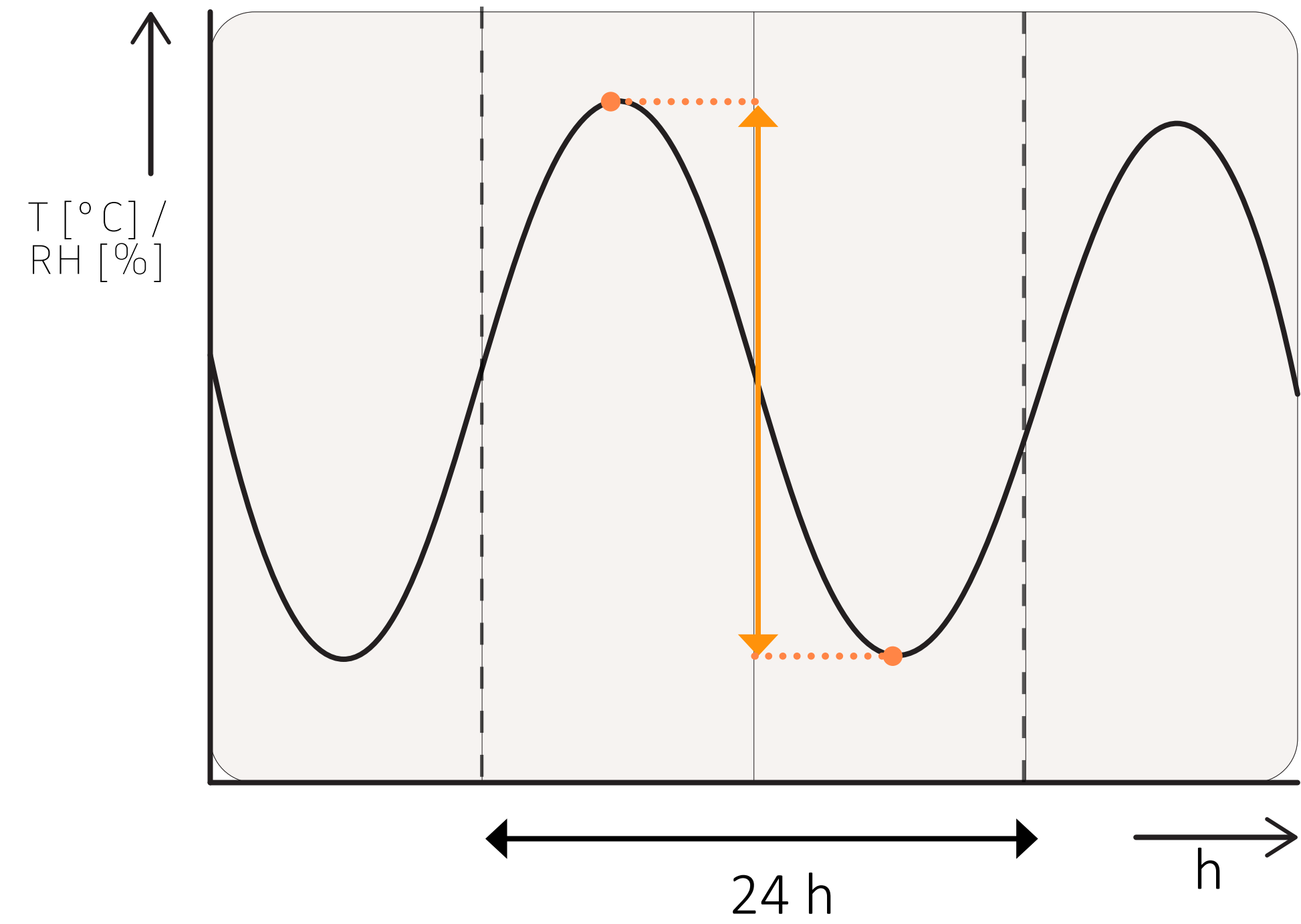

- Temperature < 5 °C
- Relative humidity < 10%

# Summer Temperature & relative humidity

Daily fluctuations

Average temperature in July 2022

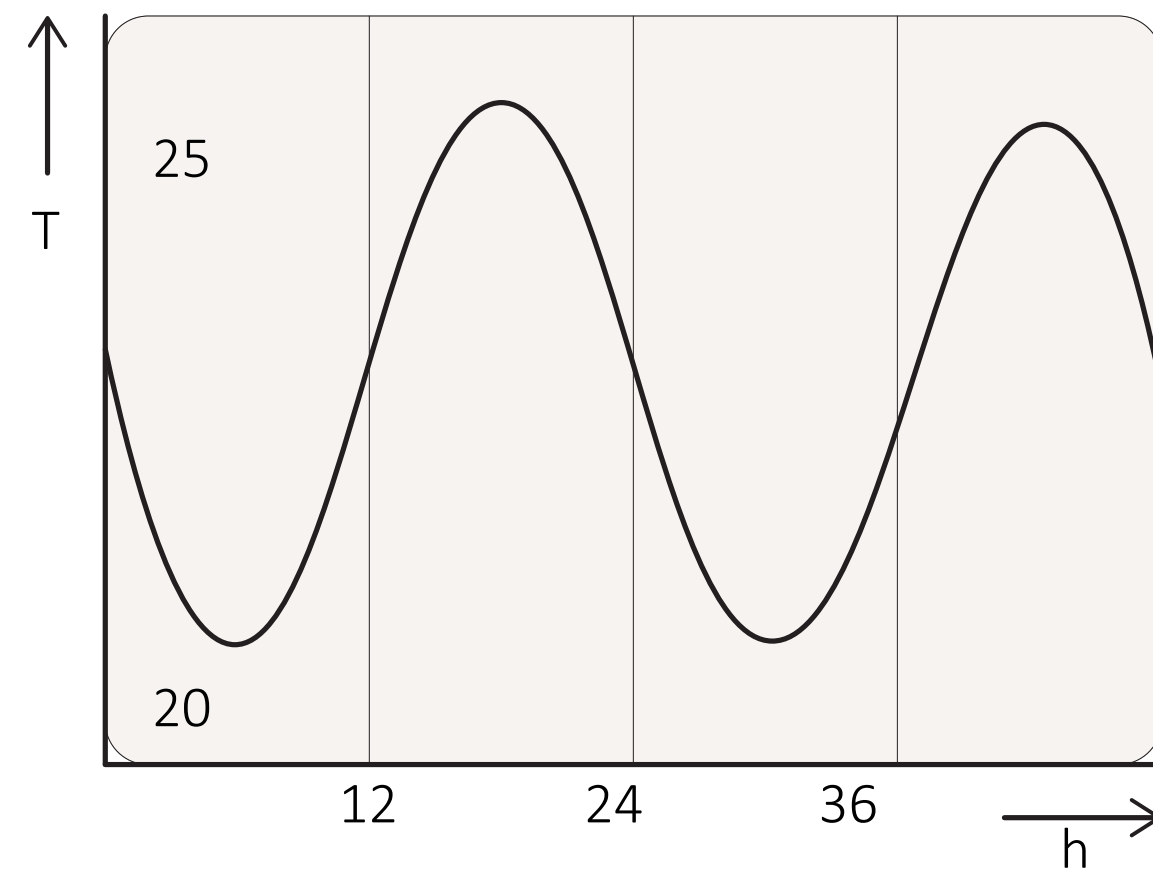

- T: 3,9°C fluctuation per 24u
- RH: 8,7% fluctuation per 24u

Variations over canvas

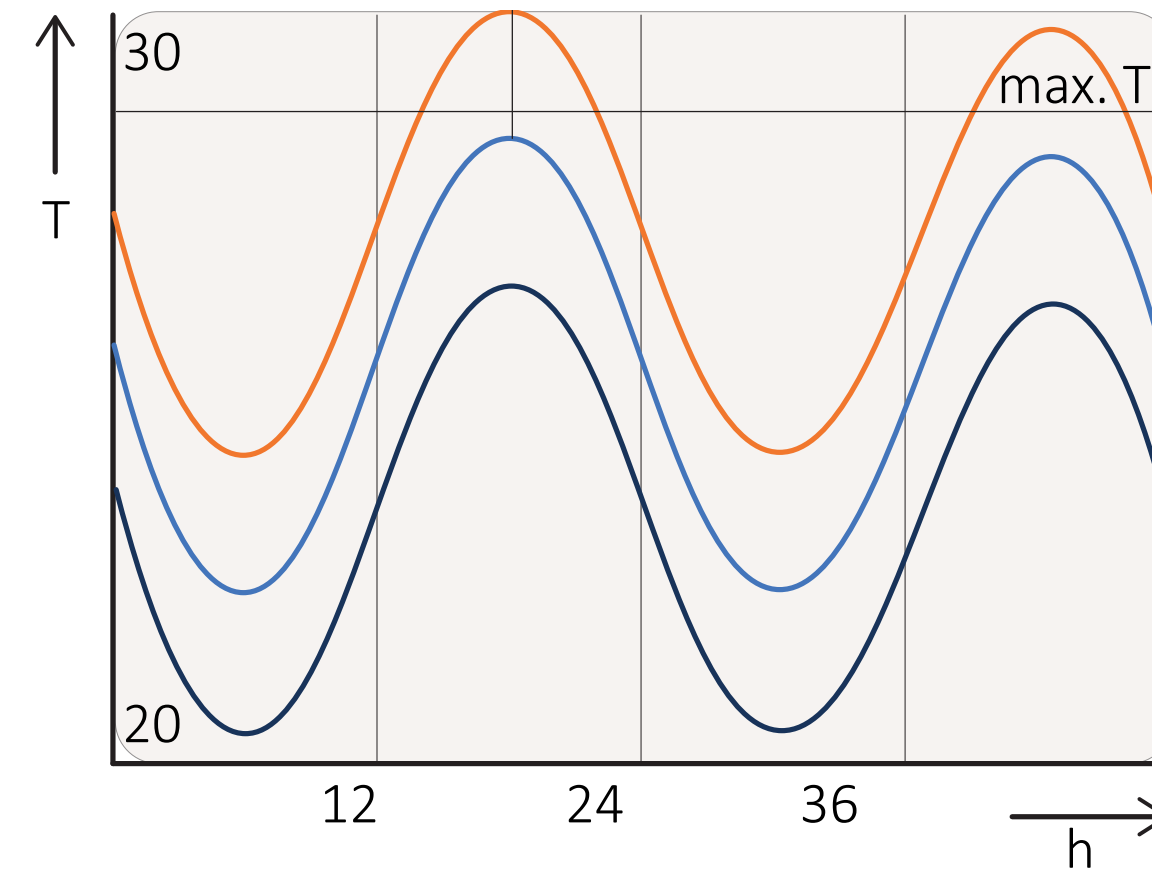

- T: Incidental > 5°C variation over canvas
- RH: Incidental >10% variation over canvas

Stresses on the canvas

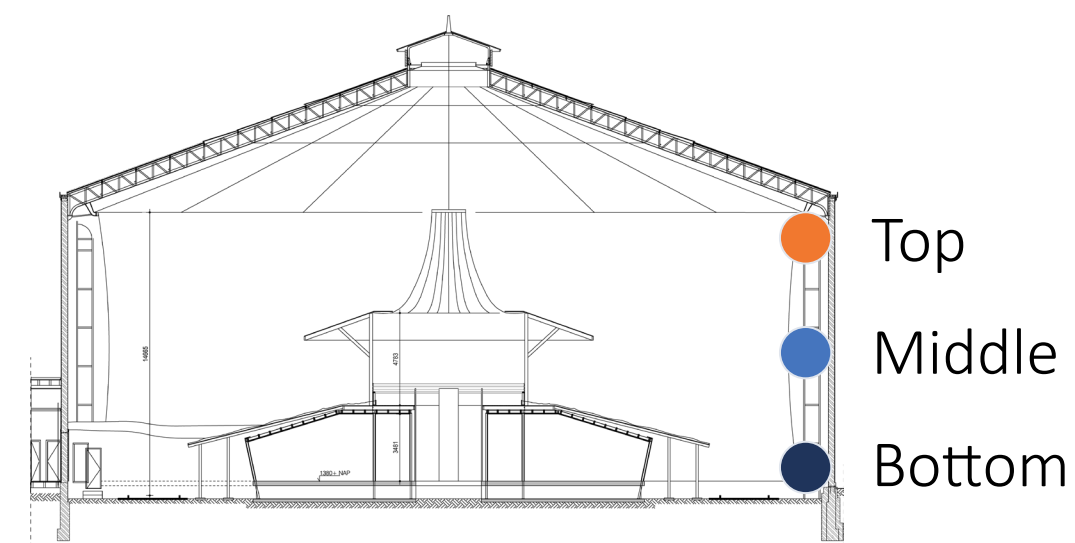
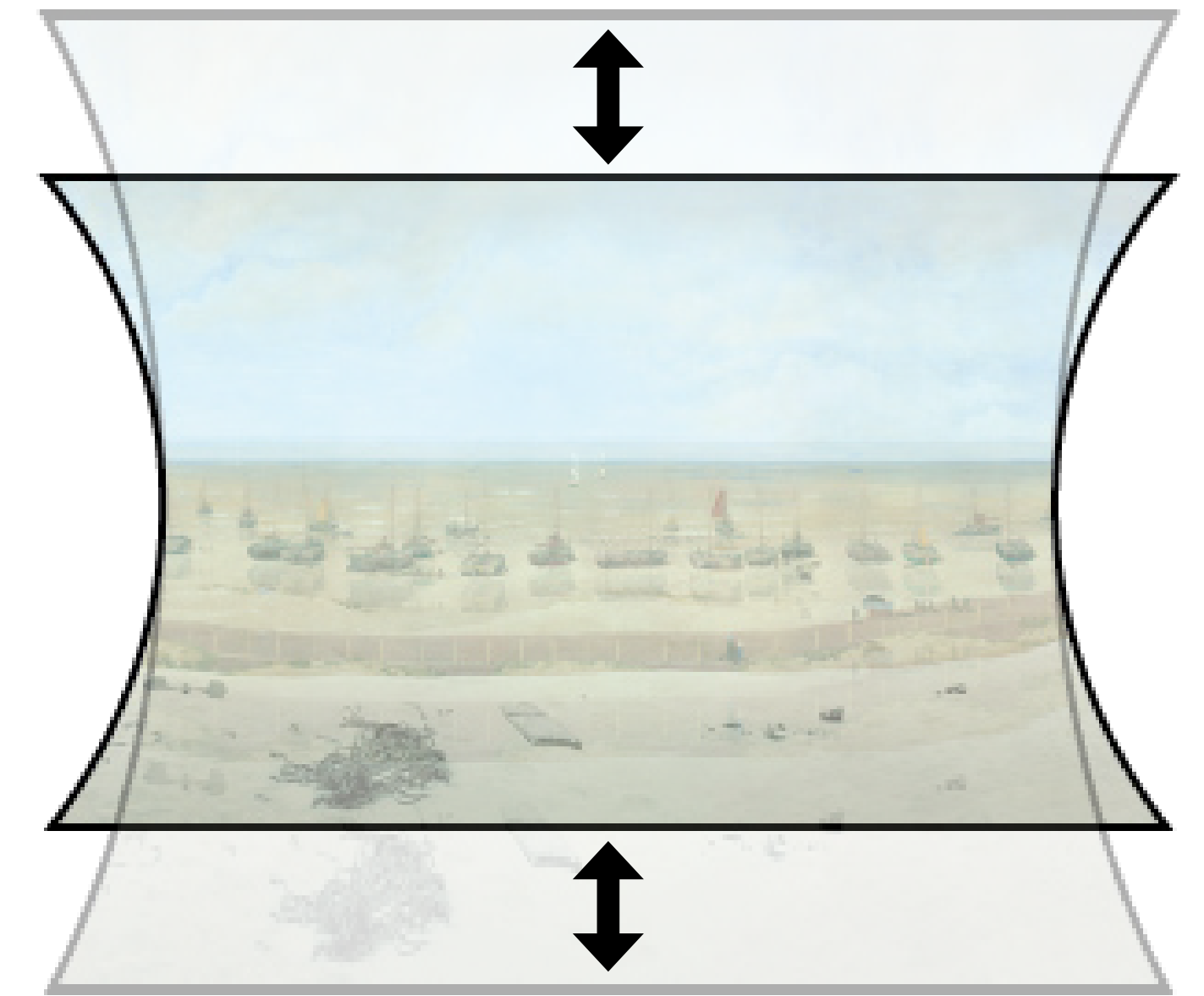

# Winter

## Temperature & relative humidity

### Daily fluctuations

Average temperature in January 2022

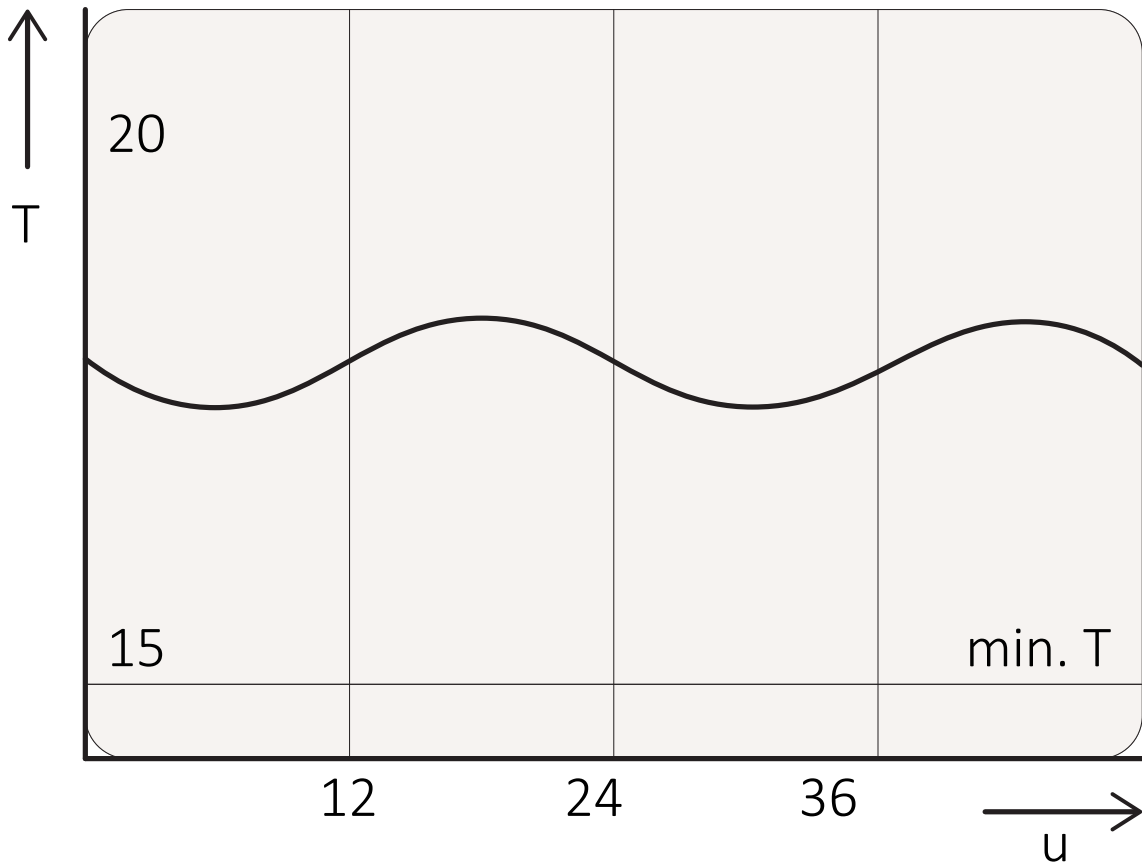

- T: 0,7° C fluctuation per 24u
- RH: 3,1% fluctuation per 24u

### Variations over canvas

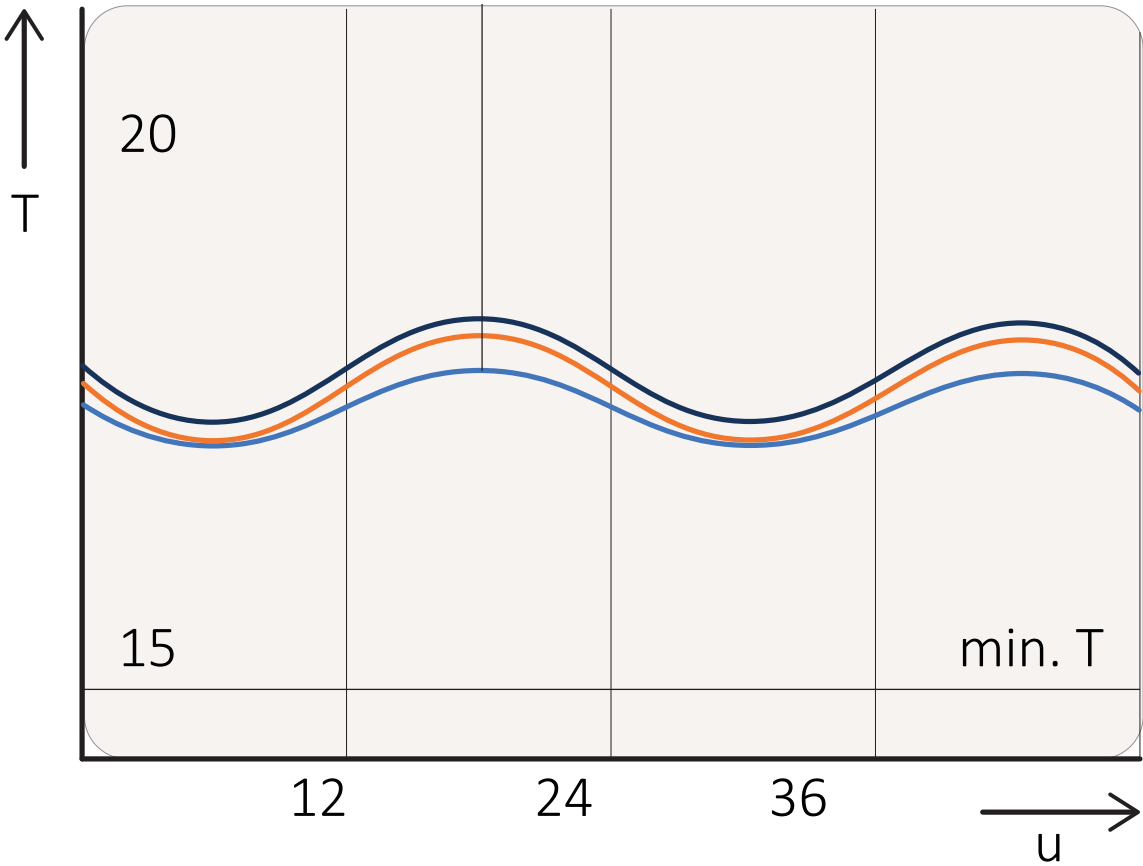

- T: Always <2° C variation over canvas
- RH: Always <10% variation over canvas

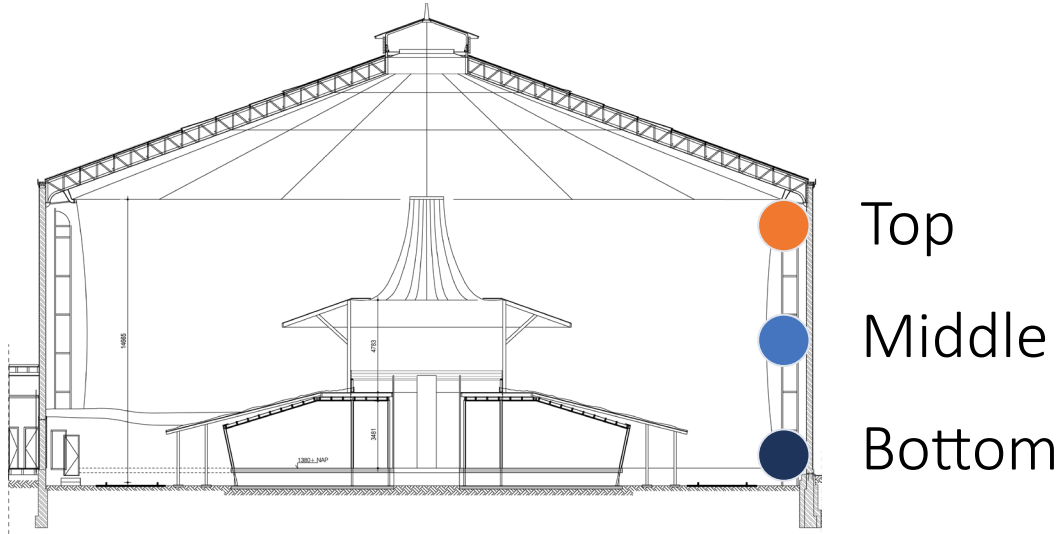

### Heating installation

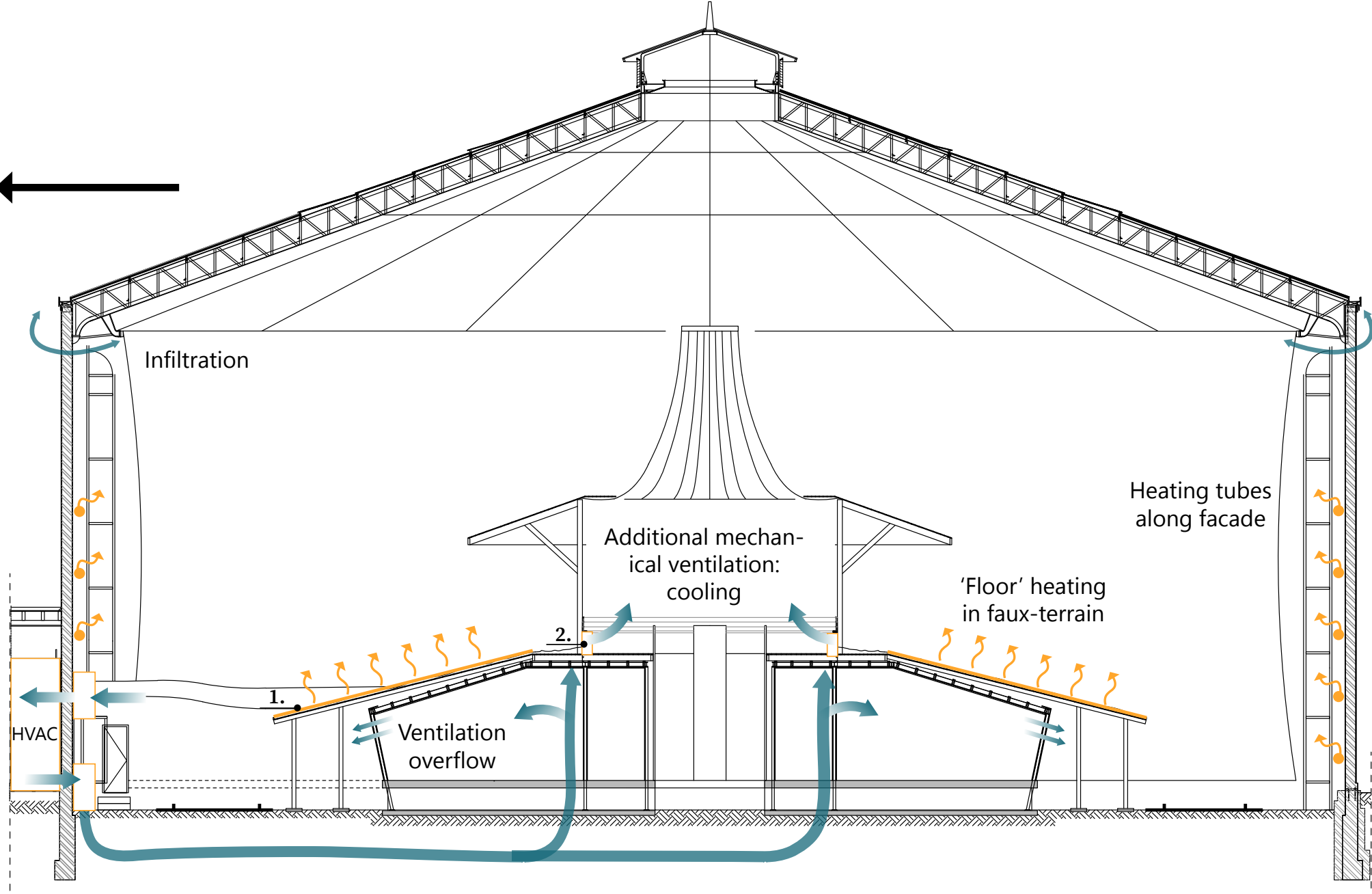

# Replacement of heating installation

- Risk on water leakages
- High energy consumption

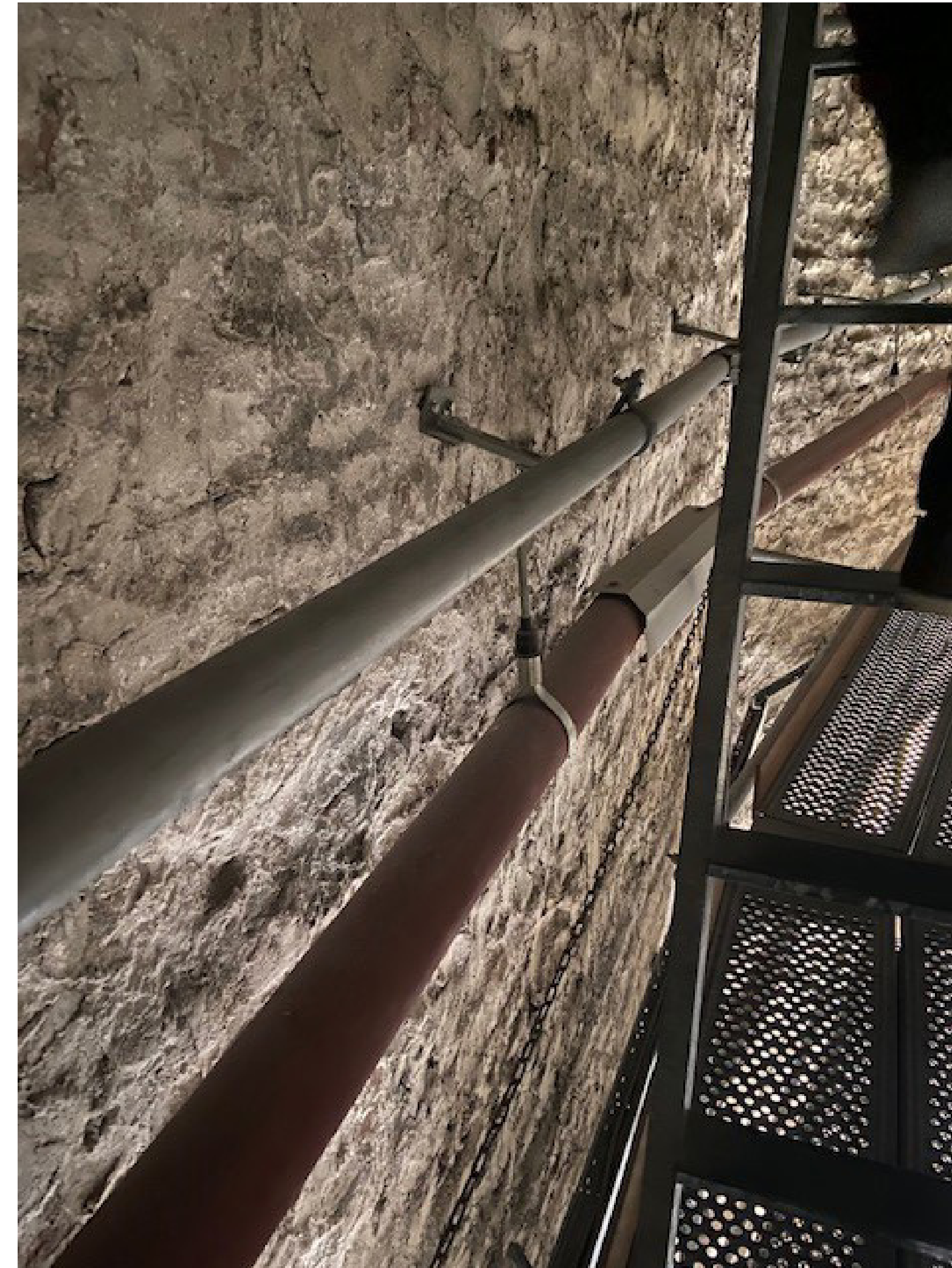
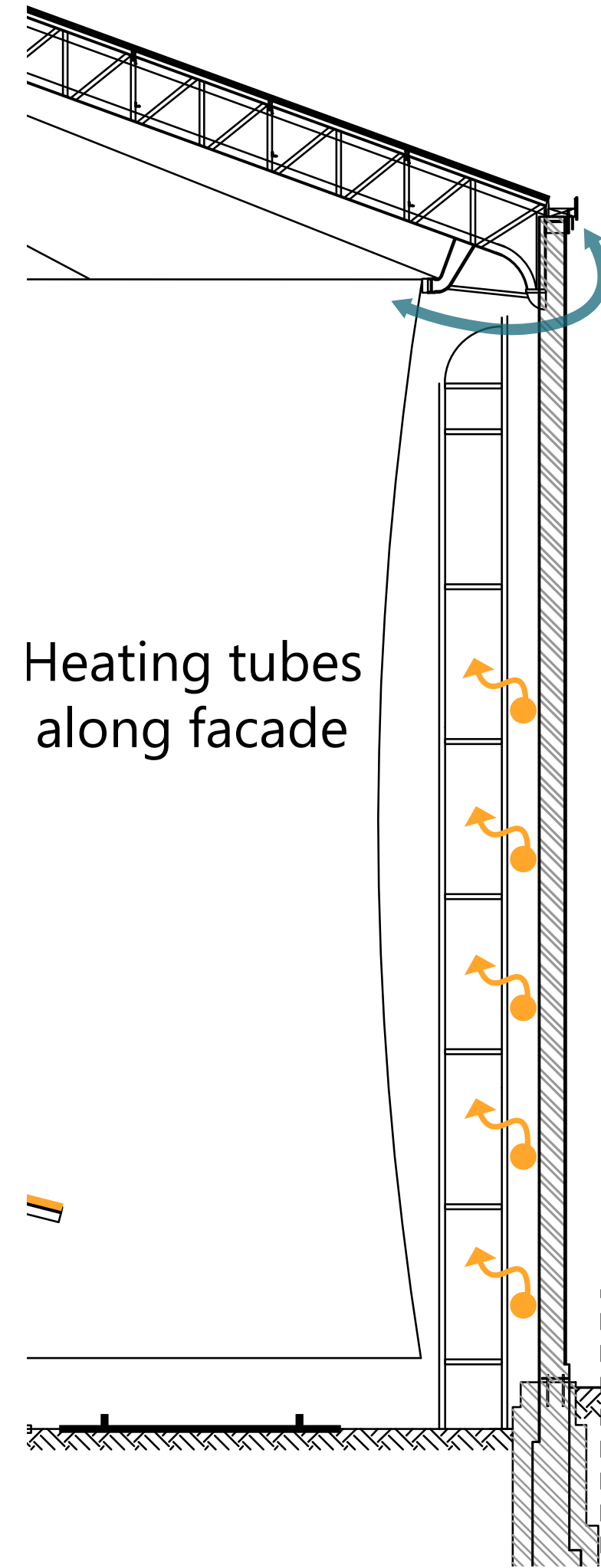

## Approach summer

Decrease fluctuations  
temperature and relative humidity

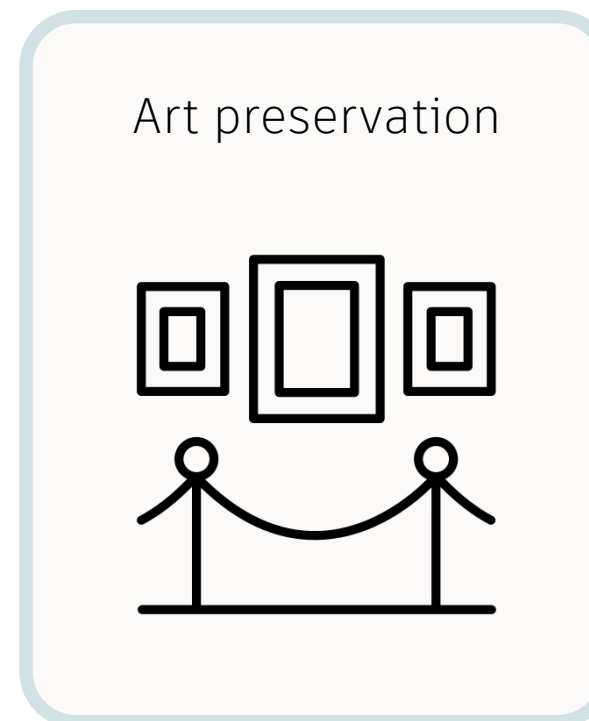
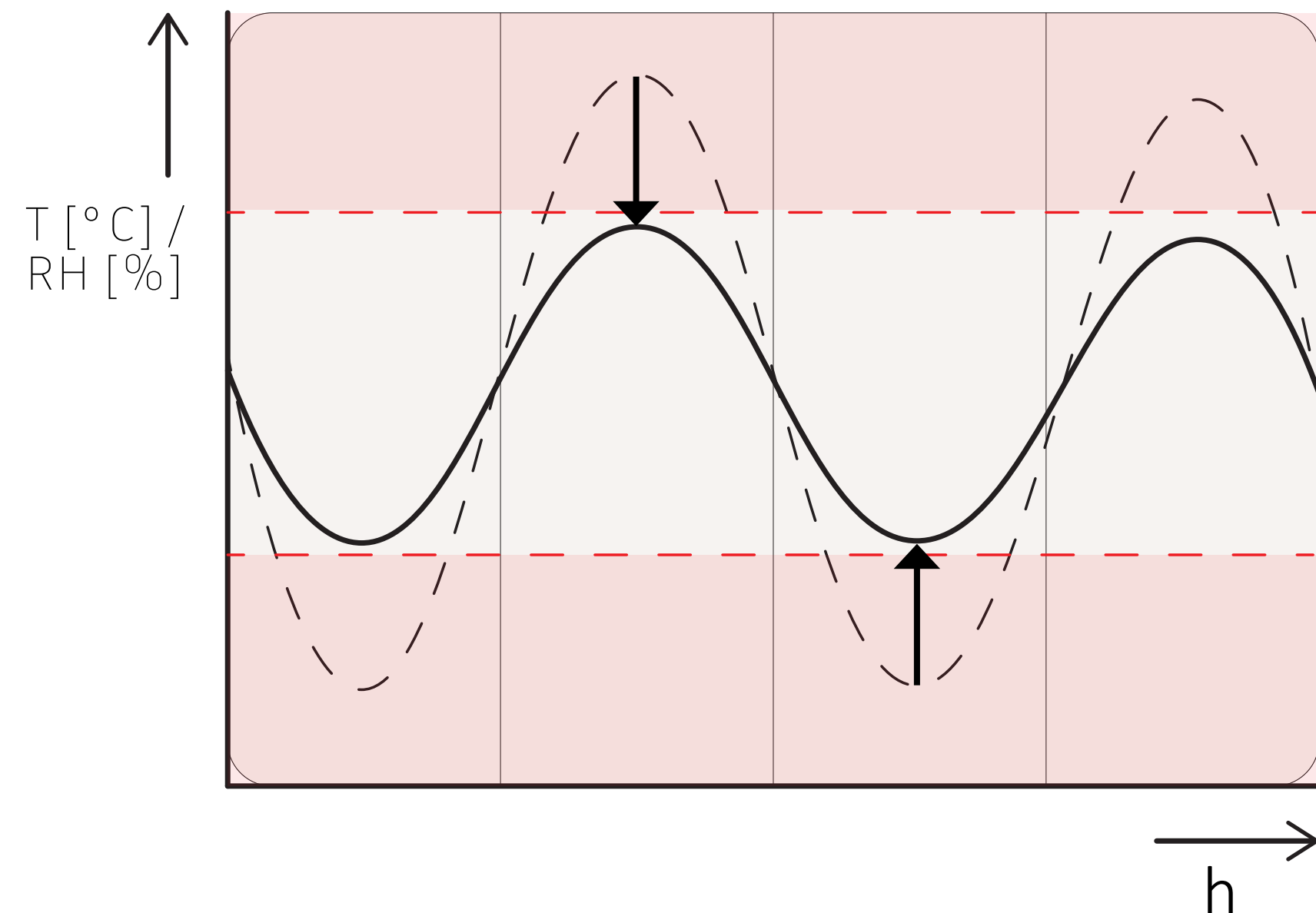

## Approach winter

Decrease heating demand / energy  
consumption

Decrease building  
energy consumption

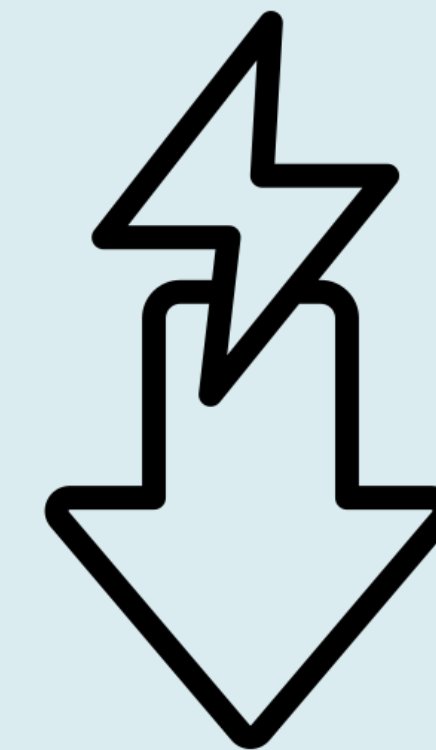

# Boundary conditions

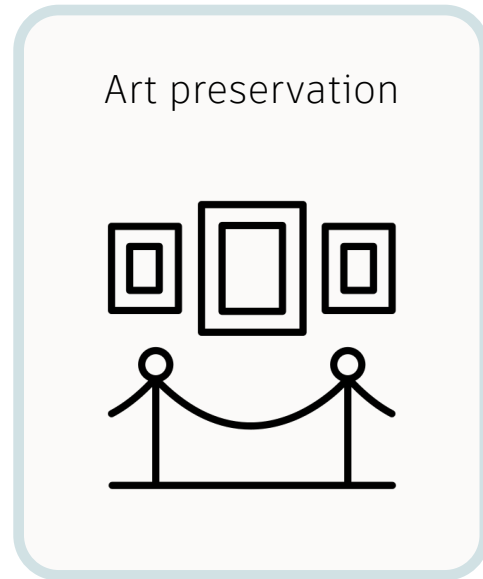

Art preservation

Stay within measured climate

Monitoring indicators

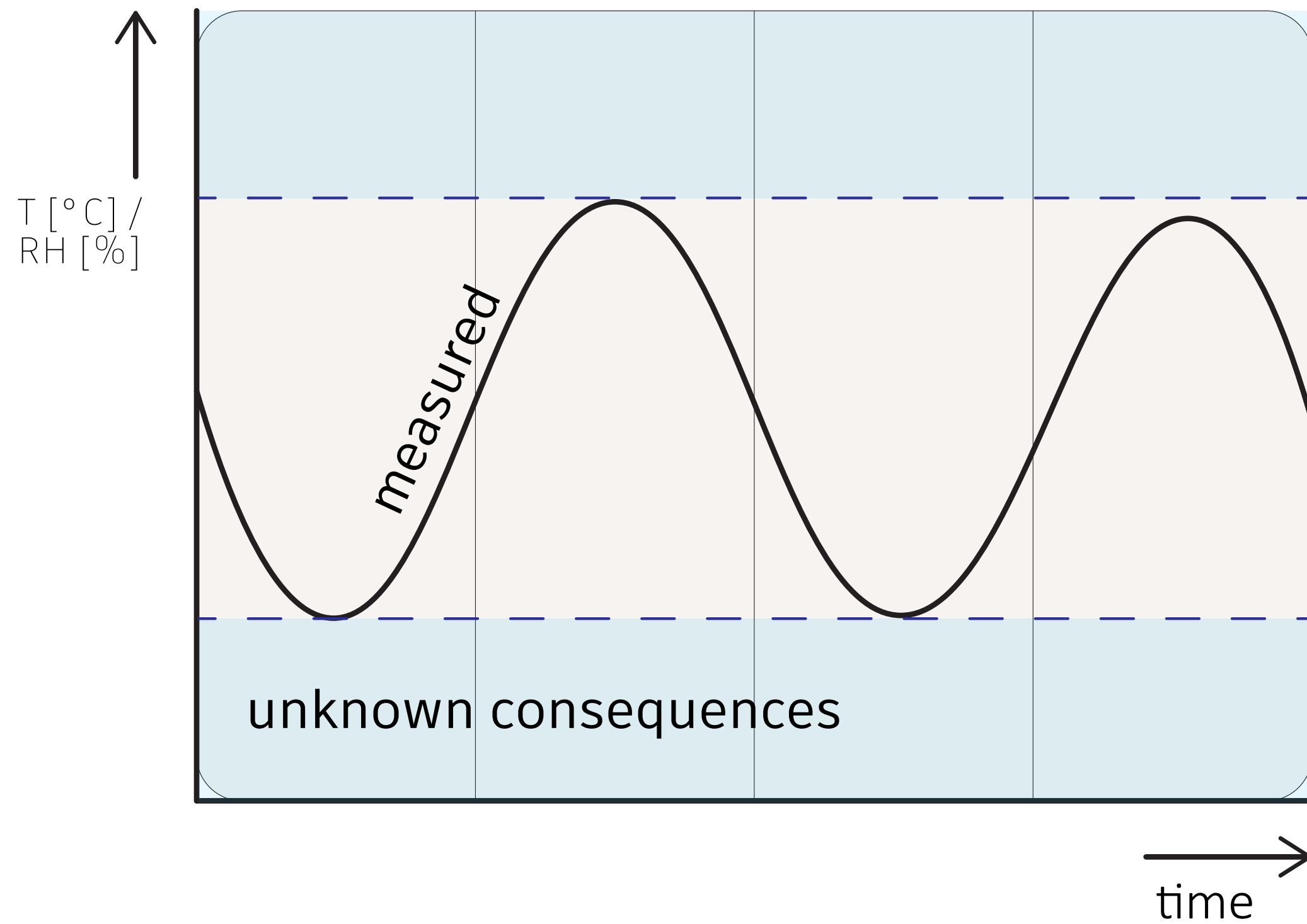

Yearly indoor climate fluctation indicators: average behind the canvas	Measured (2021-2022)	Requirements indoor climate
Minimum RH [%]	29.0	25
Maximum RH [%]	63.7	75
Minimum T [°C]	14.3	10
Maximum T [°C]	32.2	30
Days per year of RH fluctuation > 10 %/24hr	36	Not allowed
Maximum RH fluctuation [%/24hr]	16.6	10
Days per year of T fluctuation > 5 °C/24hr	16	Not allowed
Maximum T fluctuation [°C/24hr]	6.2	5
Days per year of T fluctuation > 3 °C/24hr	116	Not allowed

Complies with requirement indoor climate	
No	Yes

What are **possible techniques** for increasing the thermal buffering capacity of a building?

# Spatial requirements by the museum

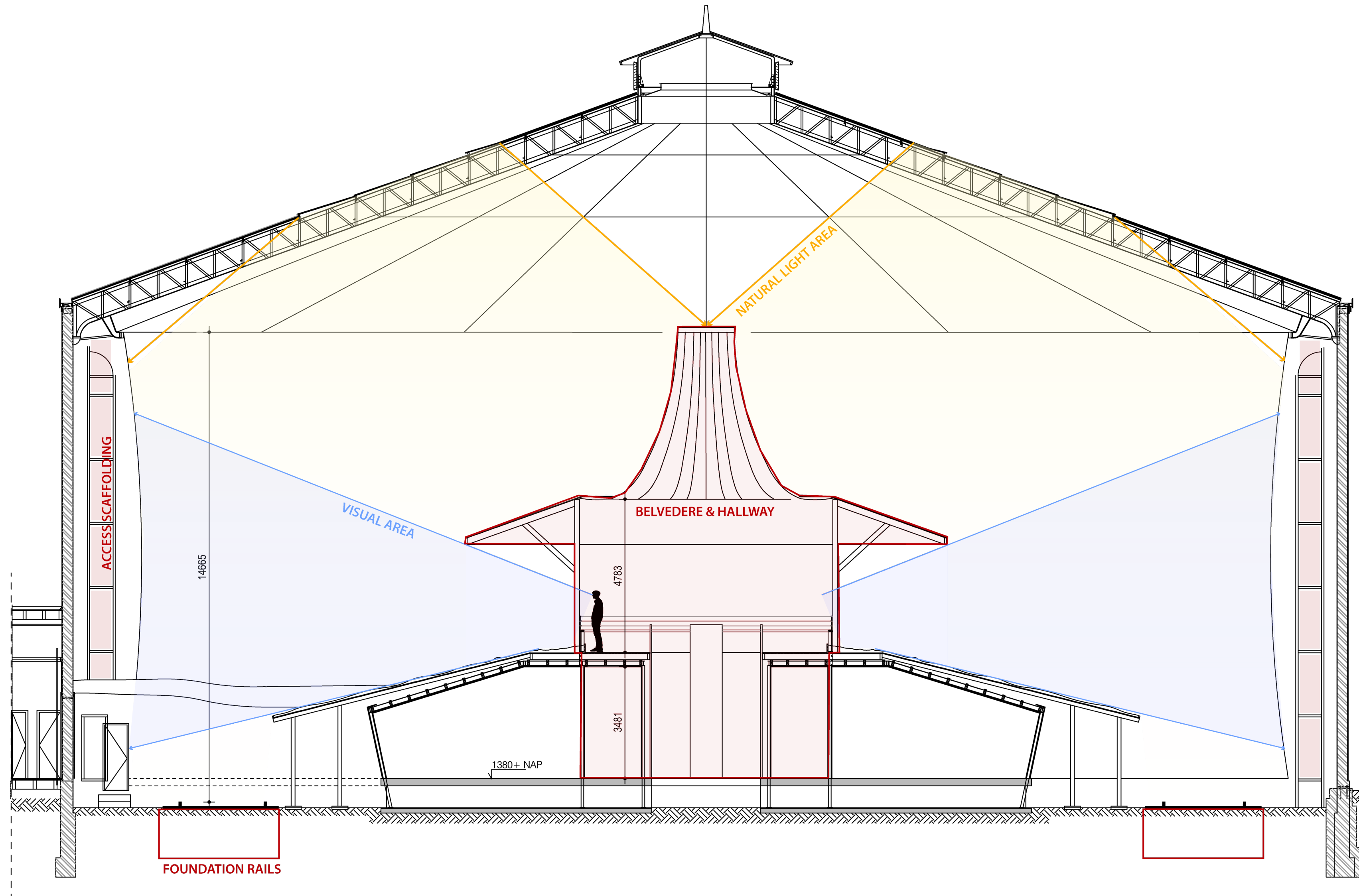

Passive climate installation

# Potential locations

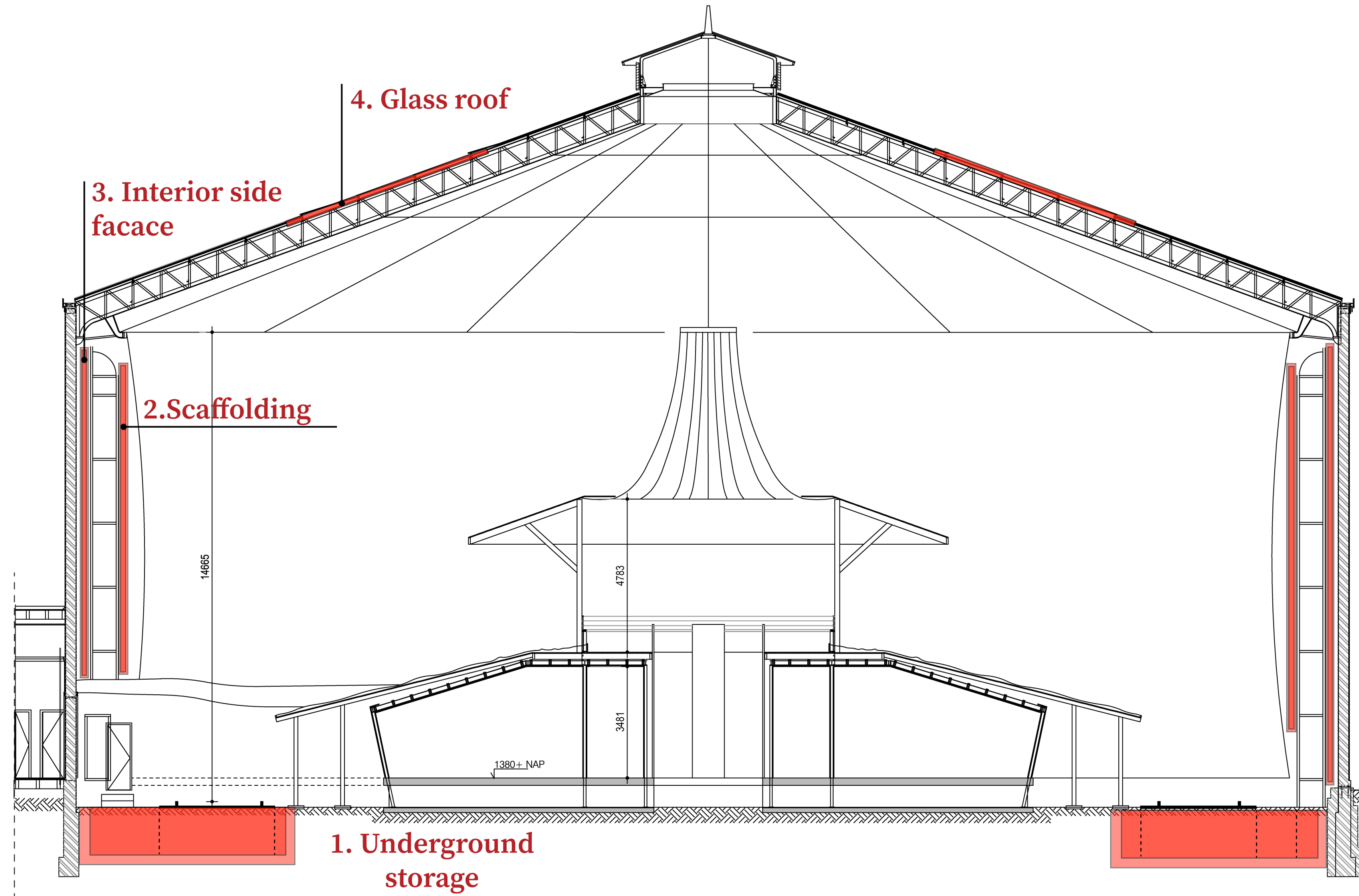

# Overview thermal buffering processes

## SENSIBLE HEAT

### Materials

Brick  
Water  
Basalt

### Climate systems

Water tank  
Underground storage  
Packed bed



(Klinkerkultur.de, 2022)

## PHASE CHANGE

### Materials

Salt hydrates  
Paraffin waxes  
Metallics

### Climate systems

Wall panels  
Packed bed  
Microcontainment in  
concrete construction



(Bol.com, 2022)

## THERMOCHEMICAL

### Materials

Carbonates  
Metal hydrides  
Silica gel

### Climate systems

Heat battery



(DiscoverMagazine.com, 2021)

# Potential thermal buffering system in Rotonde

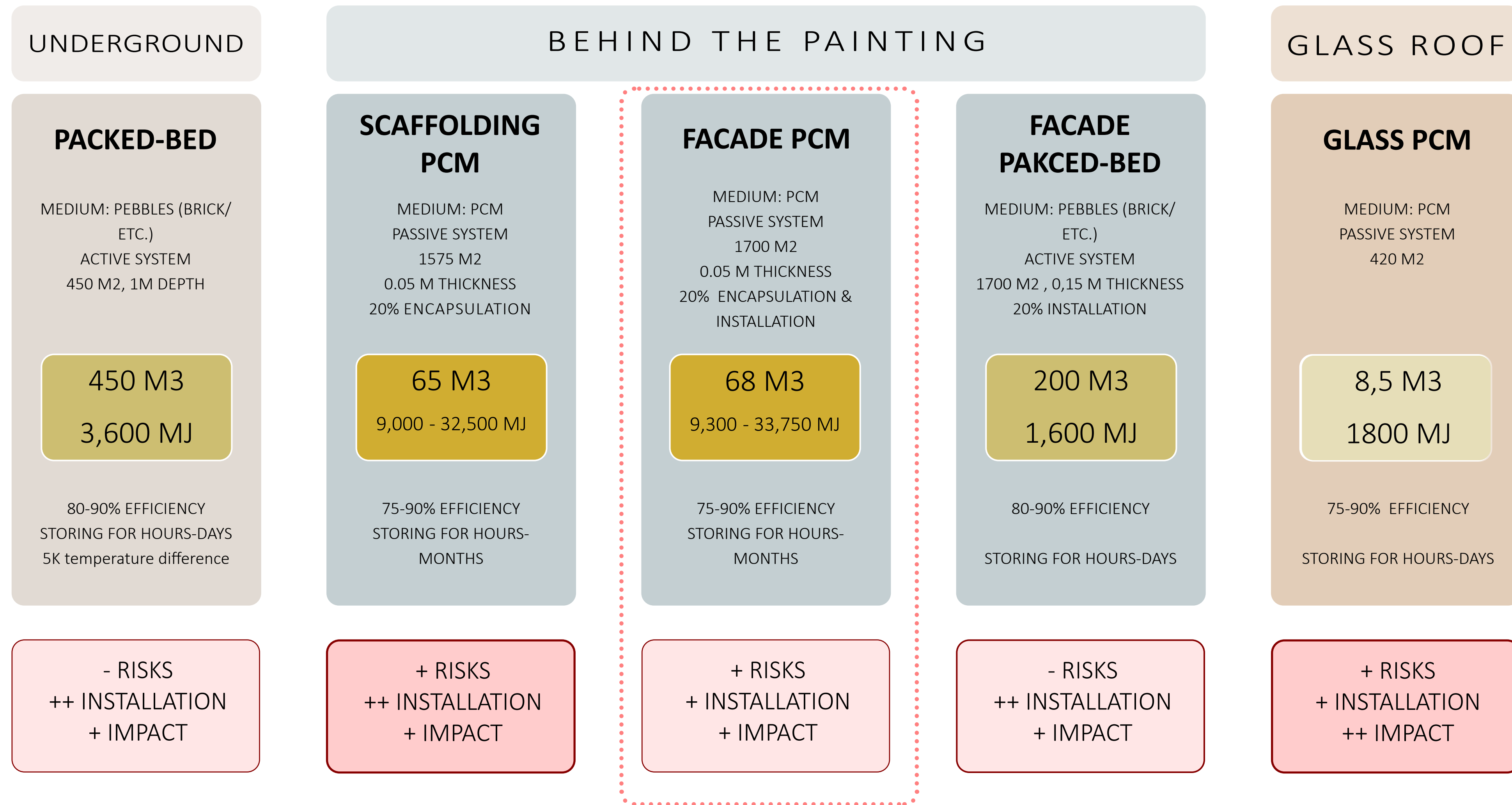

# Potential thermal buffering system in Rotonde

## BEHIND THE PAINTING

### FACADE PCM

MEDIUM: PCM  
PASSIVE SYSTEM  
1700 M<sup>2</sup>  
0.05 M THICKNESS  
20% ENCAPSULATION &  
INSTALLATION

68 M<sup>3</sup>

9,300 - 33,750 MJ

75-90% EFFICIENCY  
STORING FOR HOURS-  
MONTHS

+ RISKS  
+ INSTALLATION  
+ IMPACT

Solid = heat released



Liquid = heat stored



Temperature dependent -  
specific per PCM type

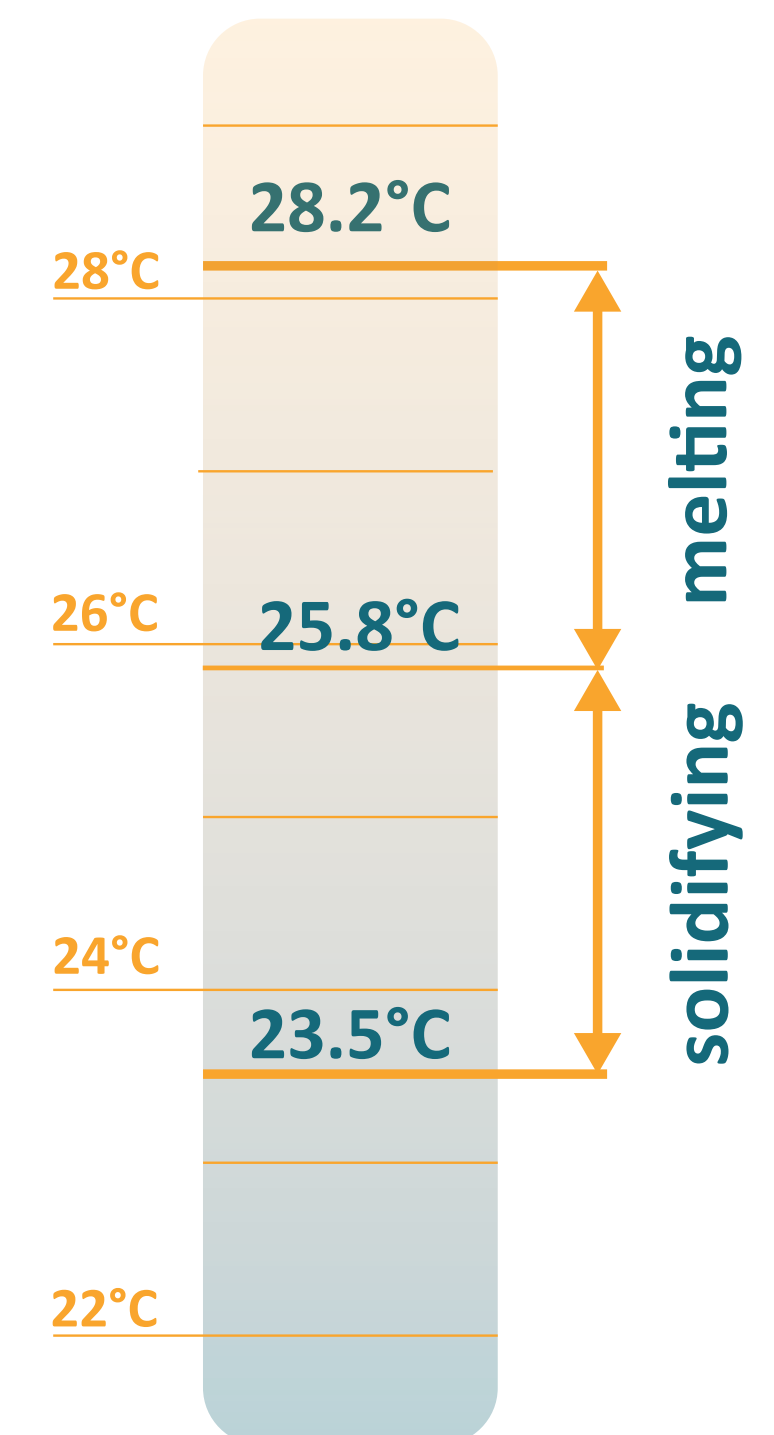

How can the most **suitable thermal buffering technique** for the **Rotonde be applied** without interfering with the monumentality of the building and the experience of the permanent panorama exhibition?

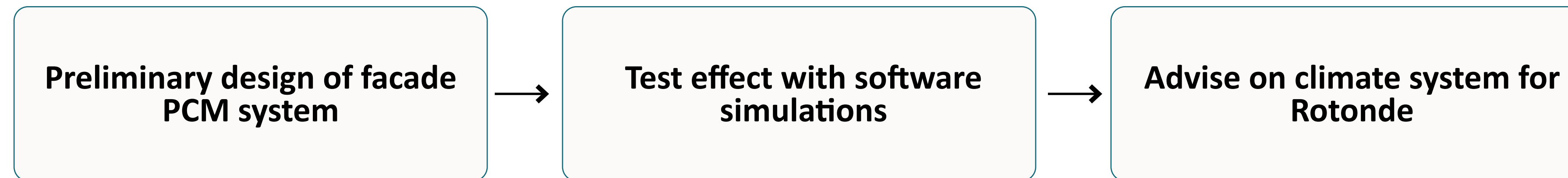

# Preliminary design

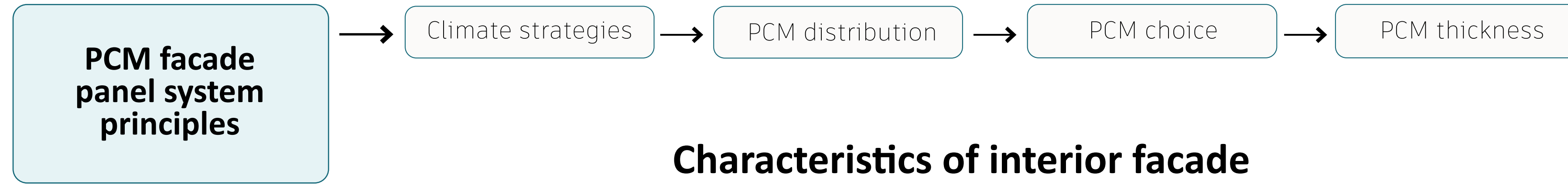

## Characteristics of interior facade

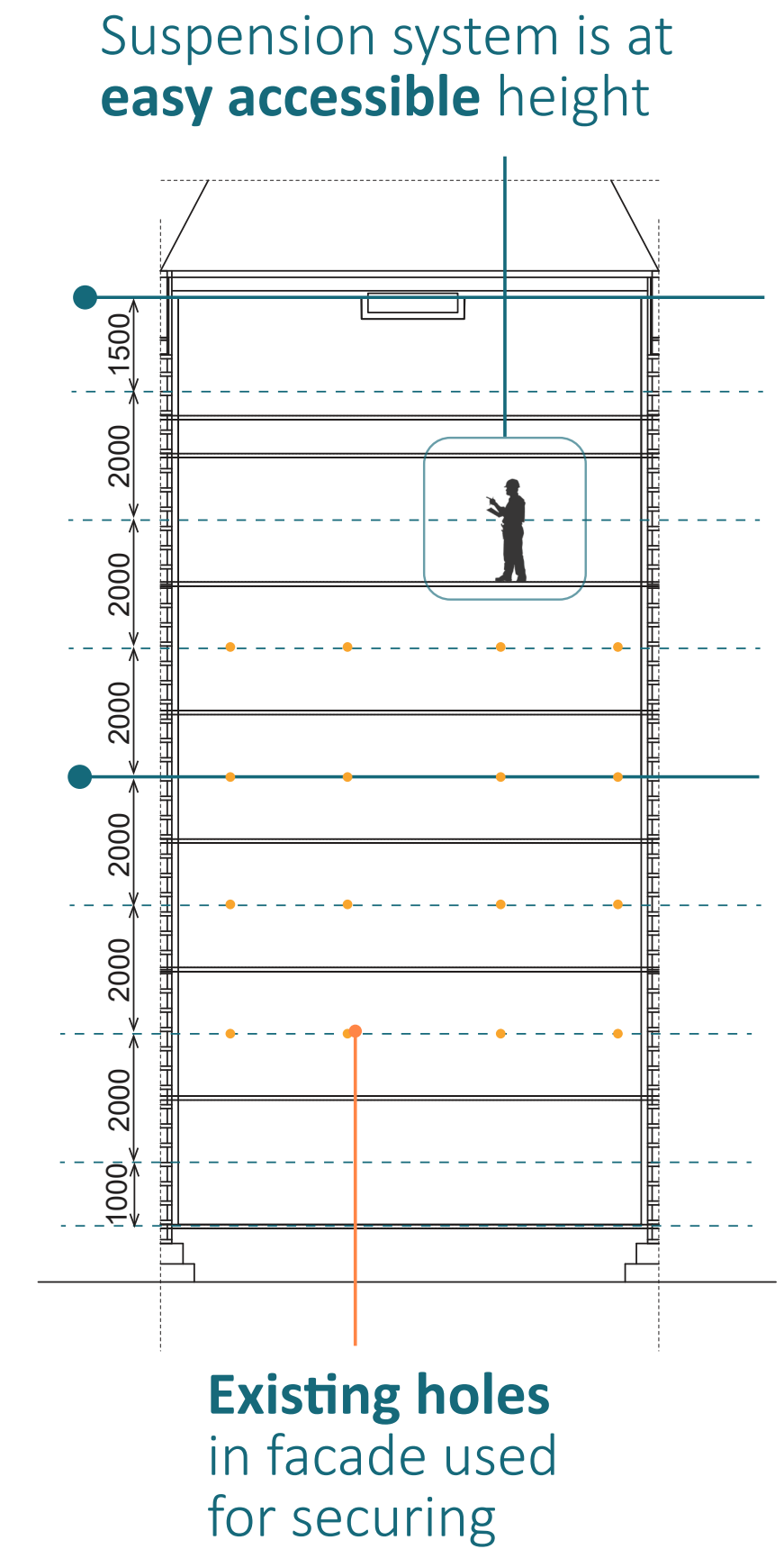
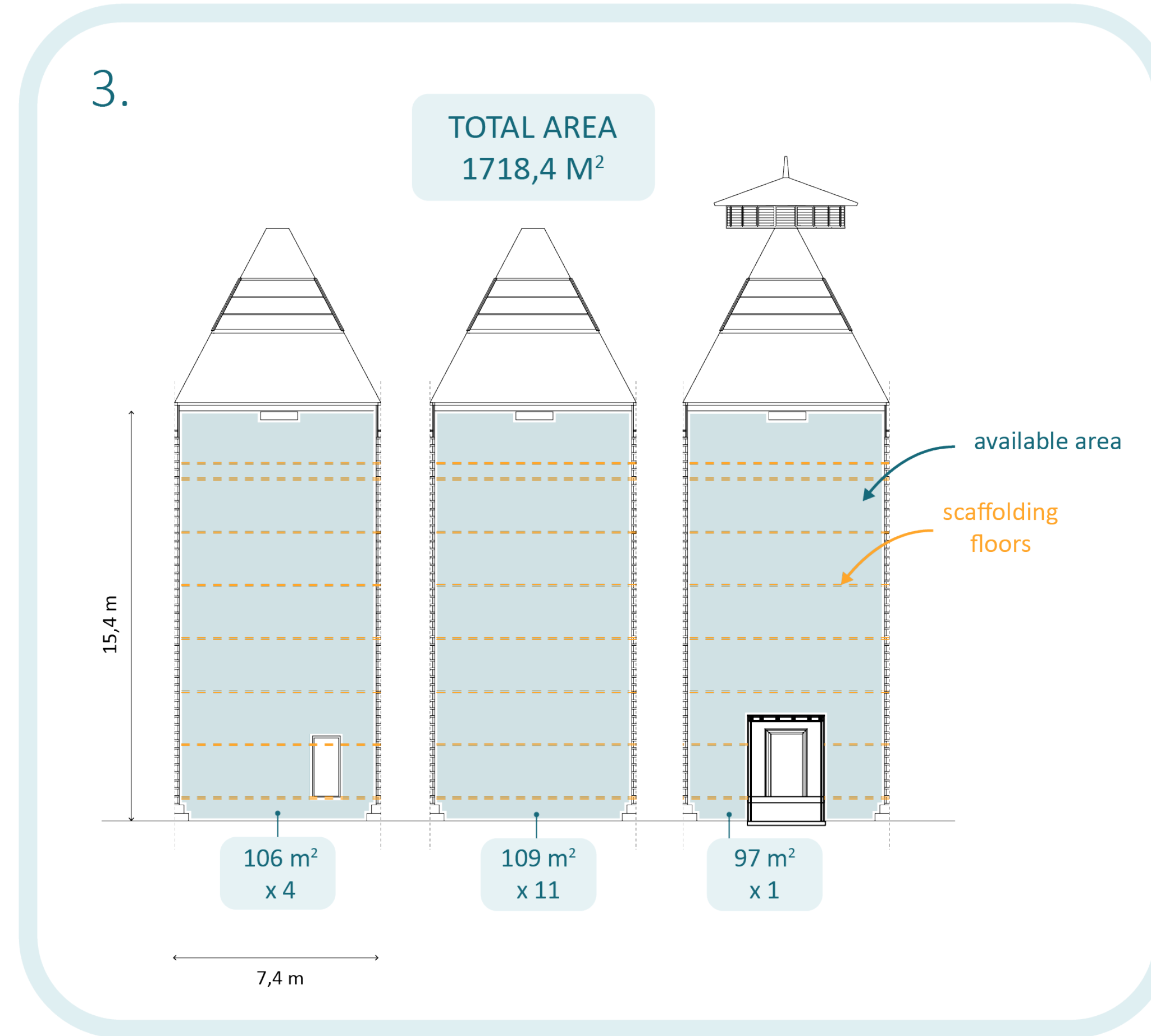
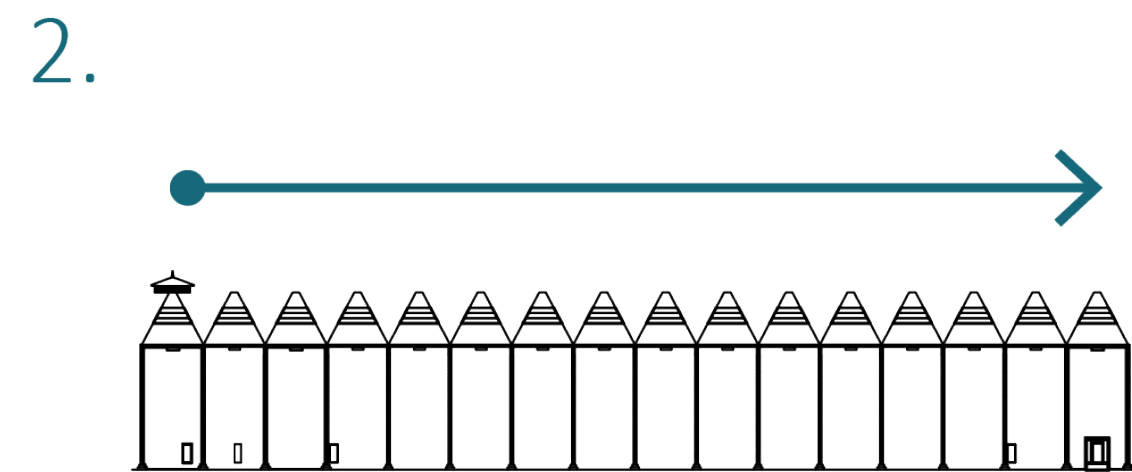
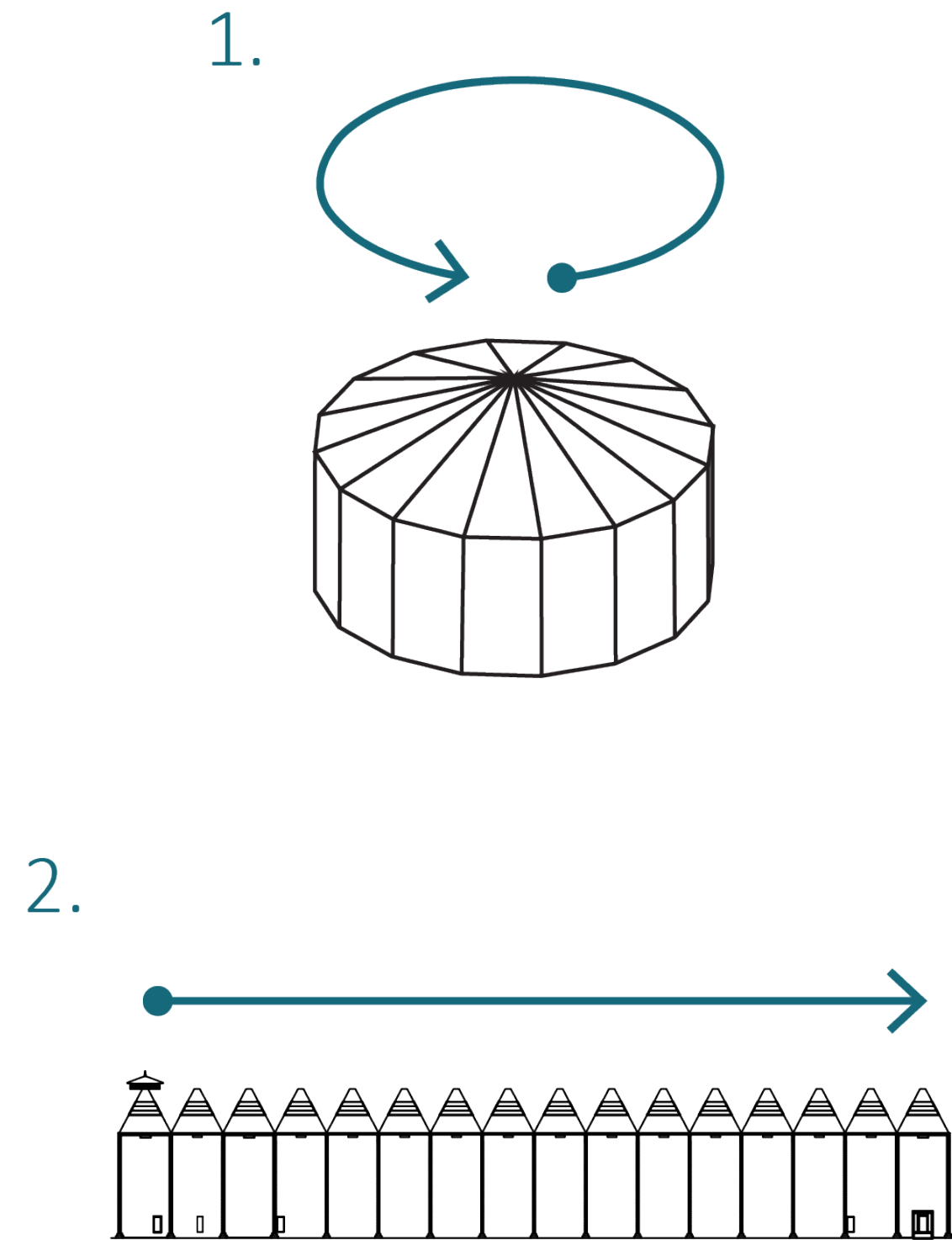

## Preliminary design

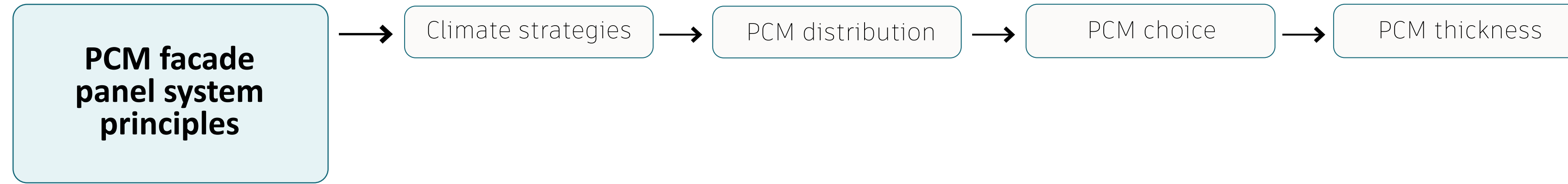

**Air flow around  
PCM panels**

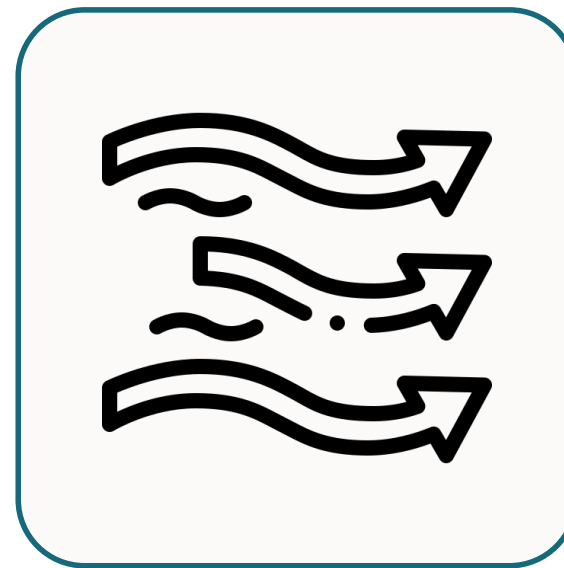

**Allows PCM  
expansion**

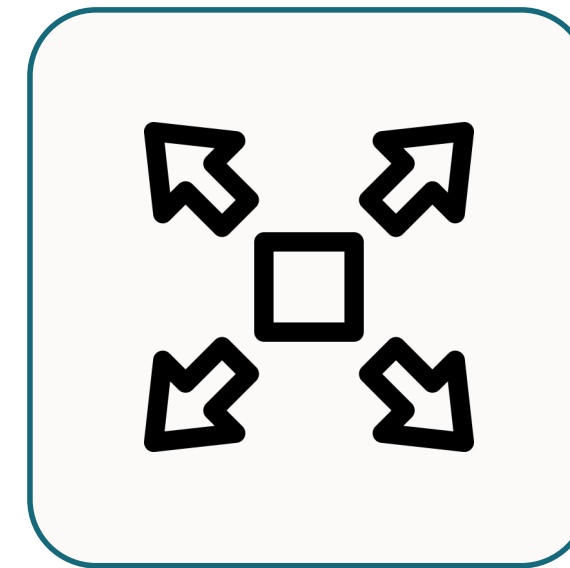

**(Re)placement  
by 1 person**

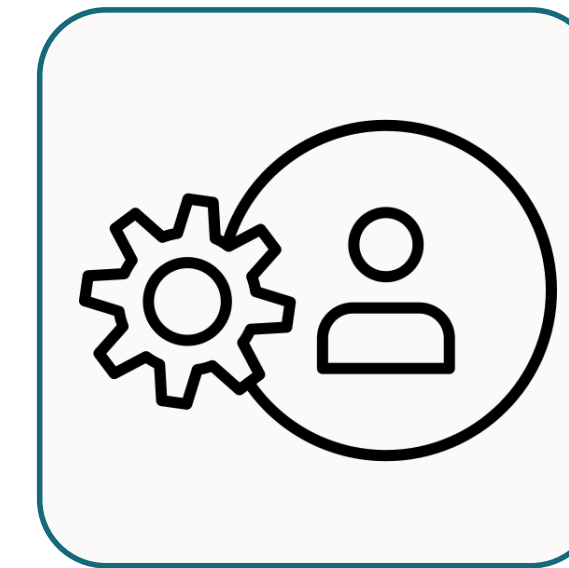

# Preliminary design

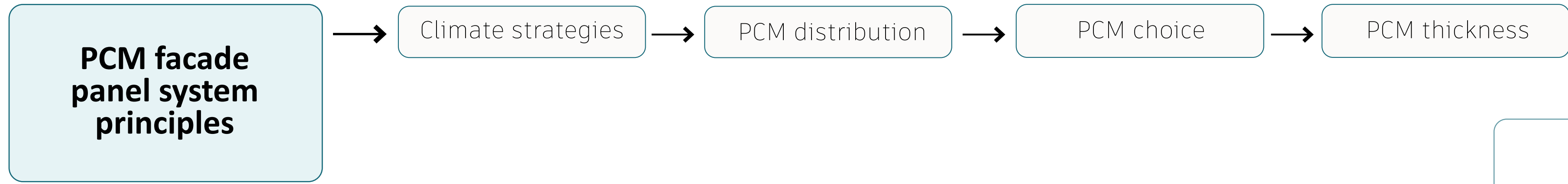

Masonry facade 350 mm  
Steel columns 400 mm  
PCM panels 4-22,7 mm  
Scaffolding (not included in Design-Builder) 640 mm

Canvas  
(location varies)

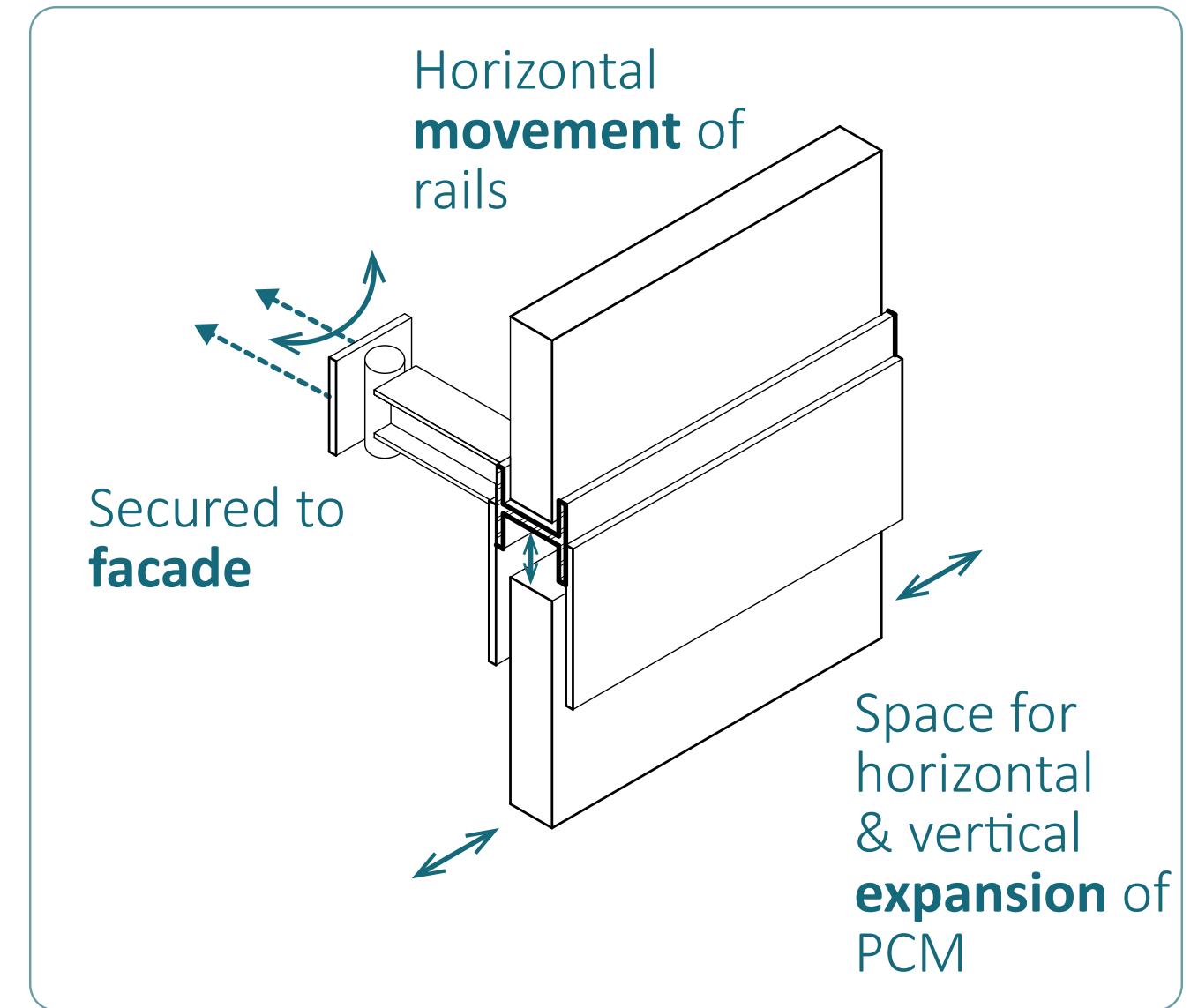
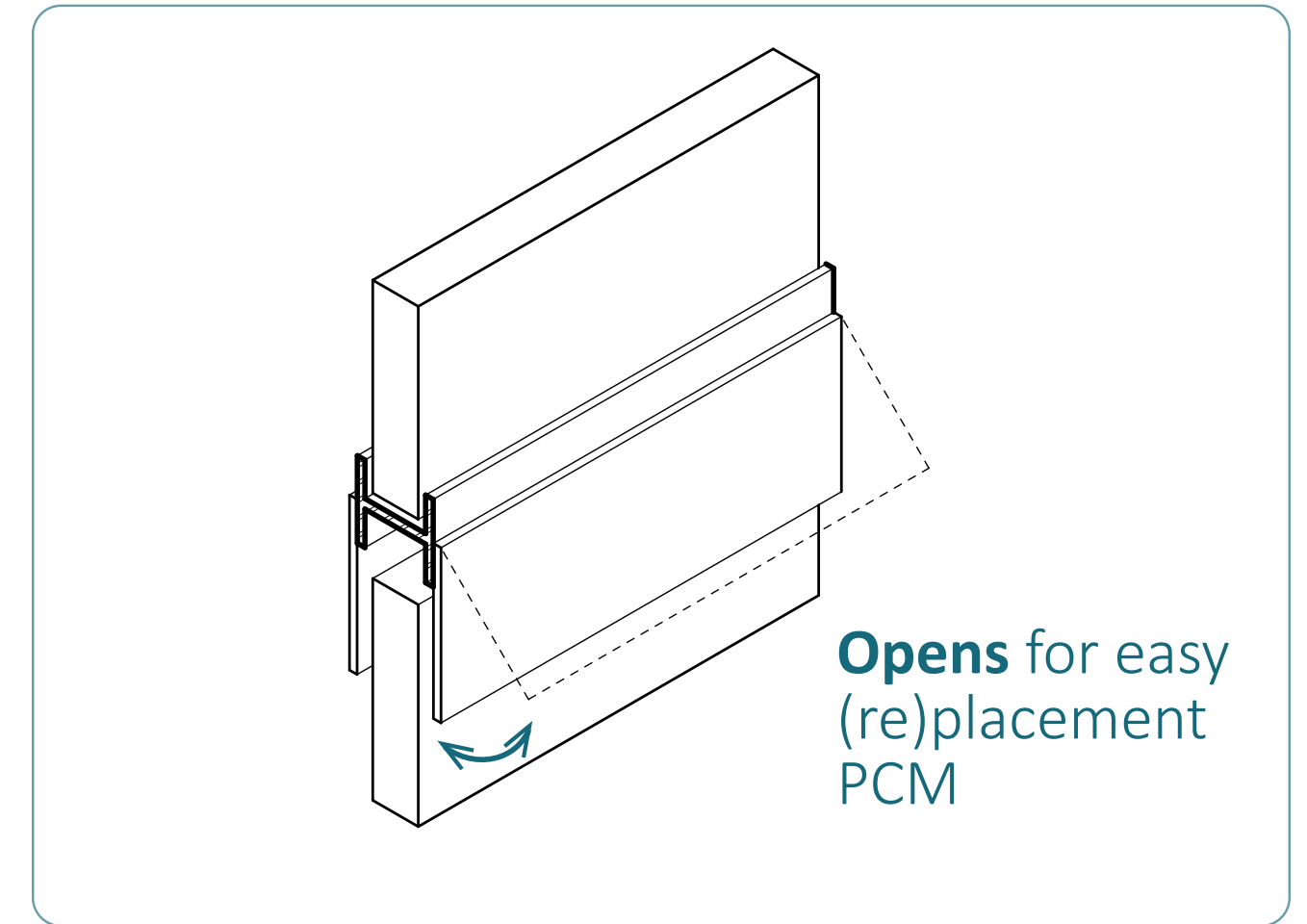
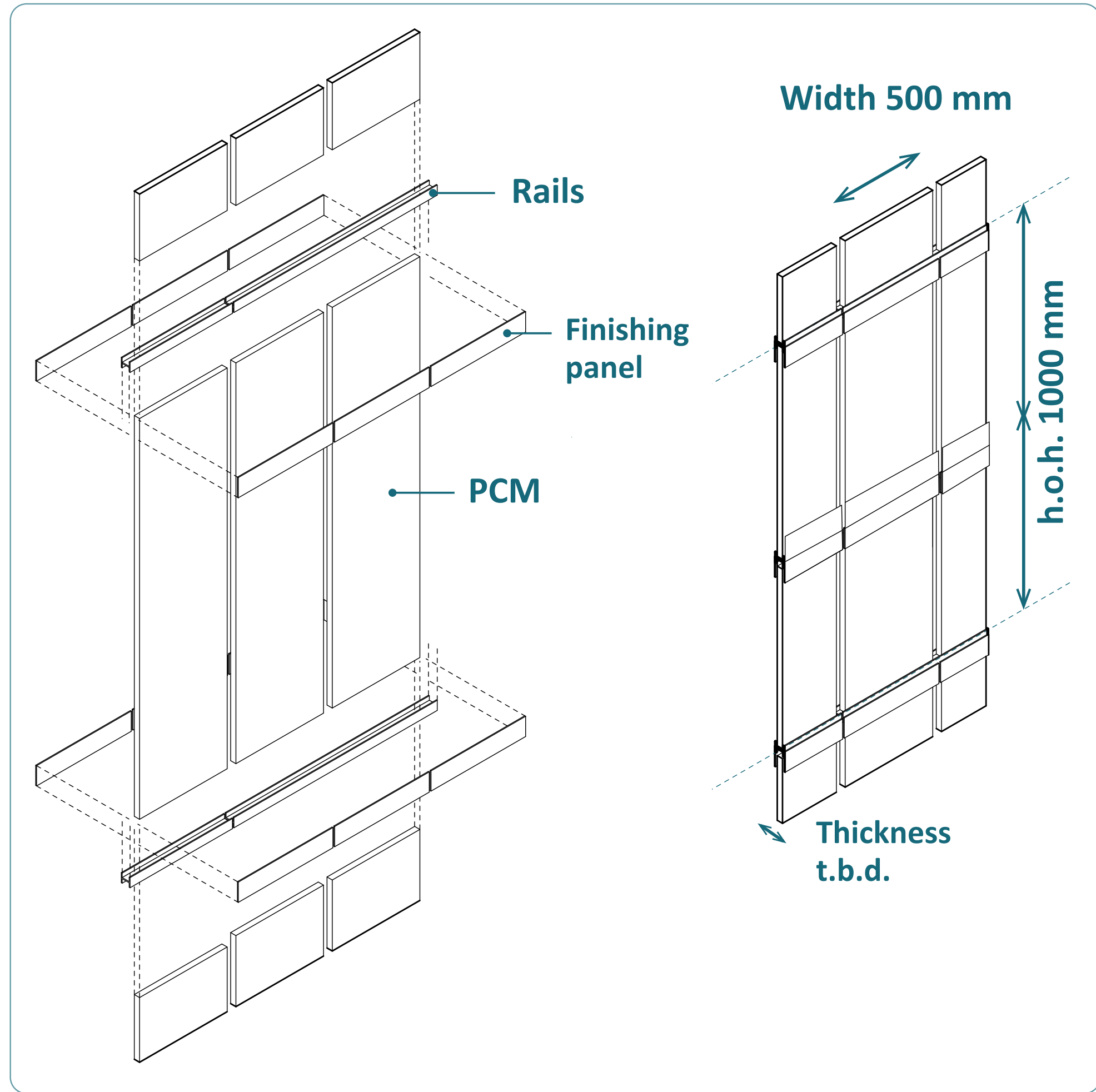
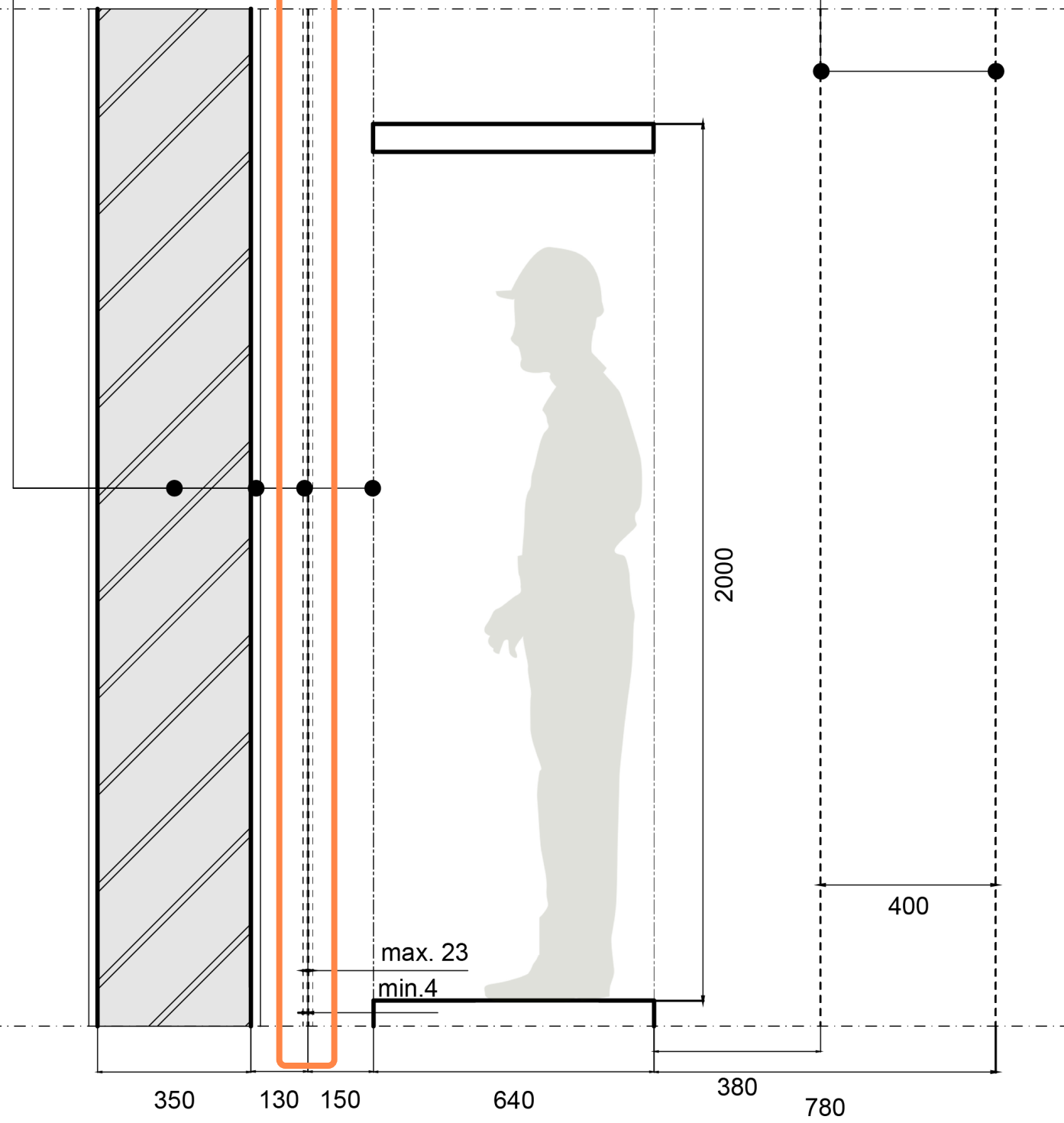

# Preliminary design

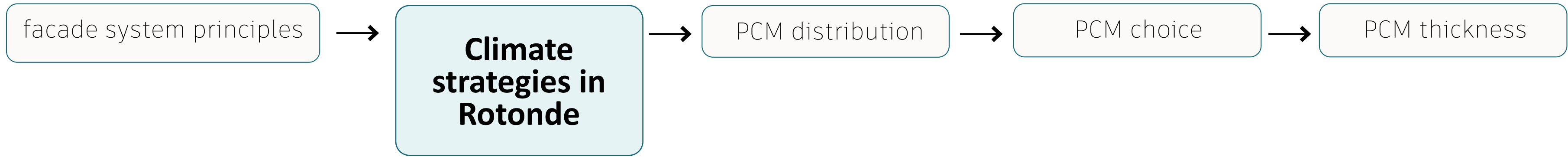

DESIGN OPTION 1.

Cooling PCM

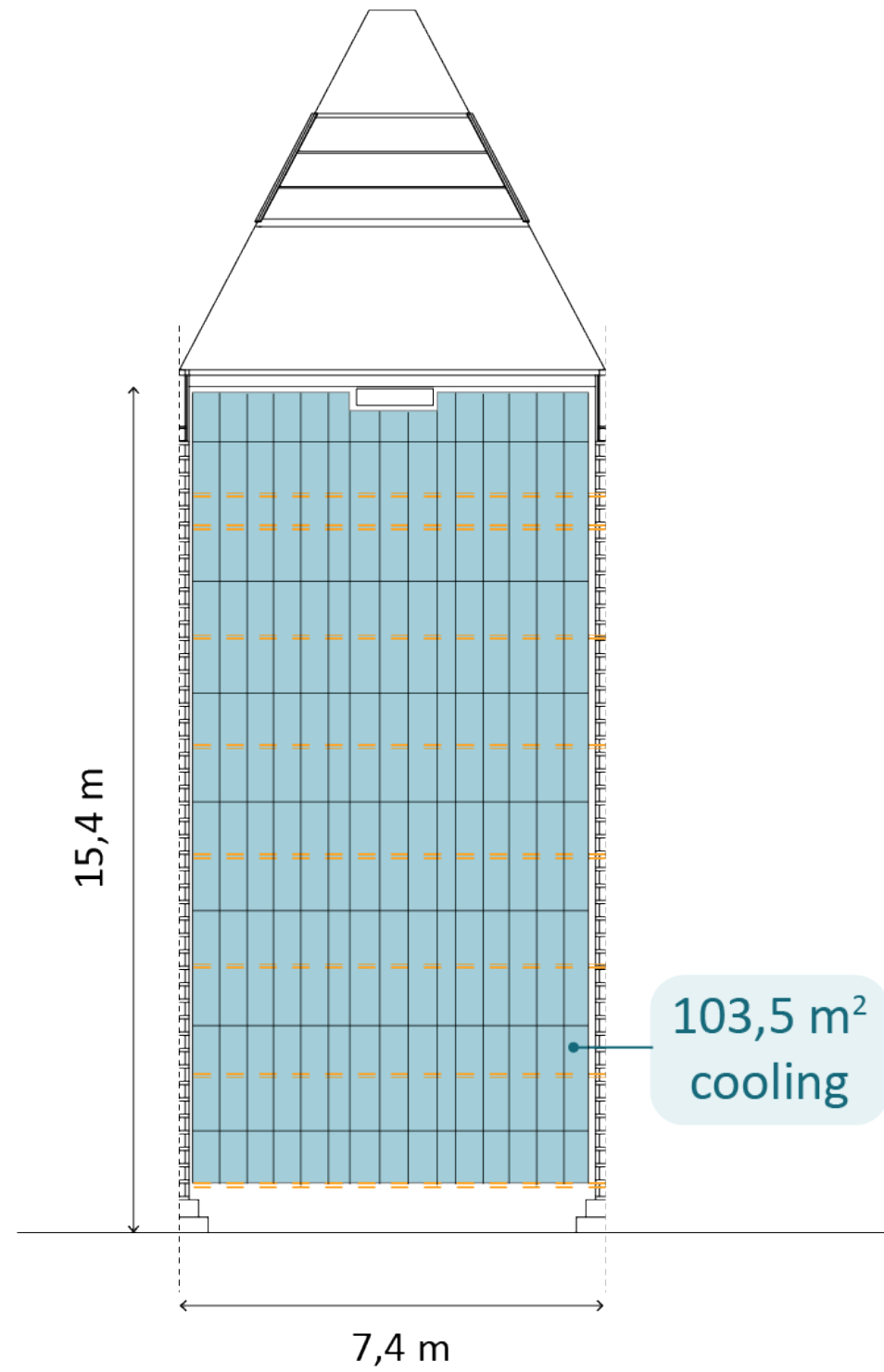

DESIGN OPTION 2.

Heating PCM

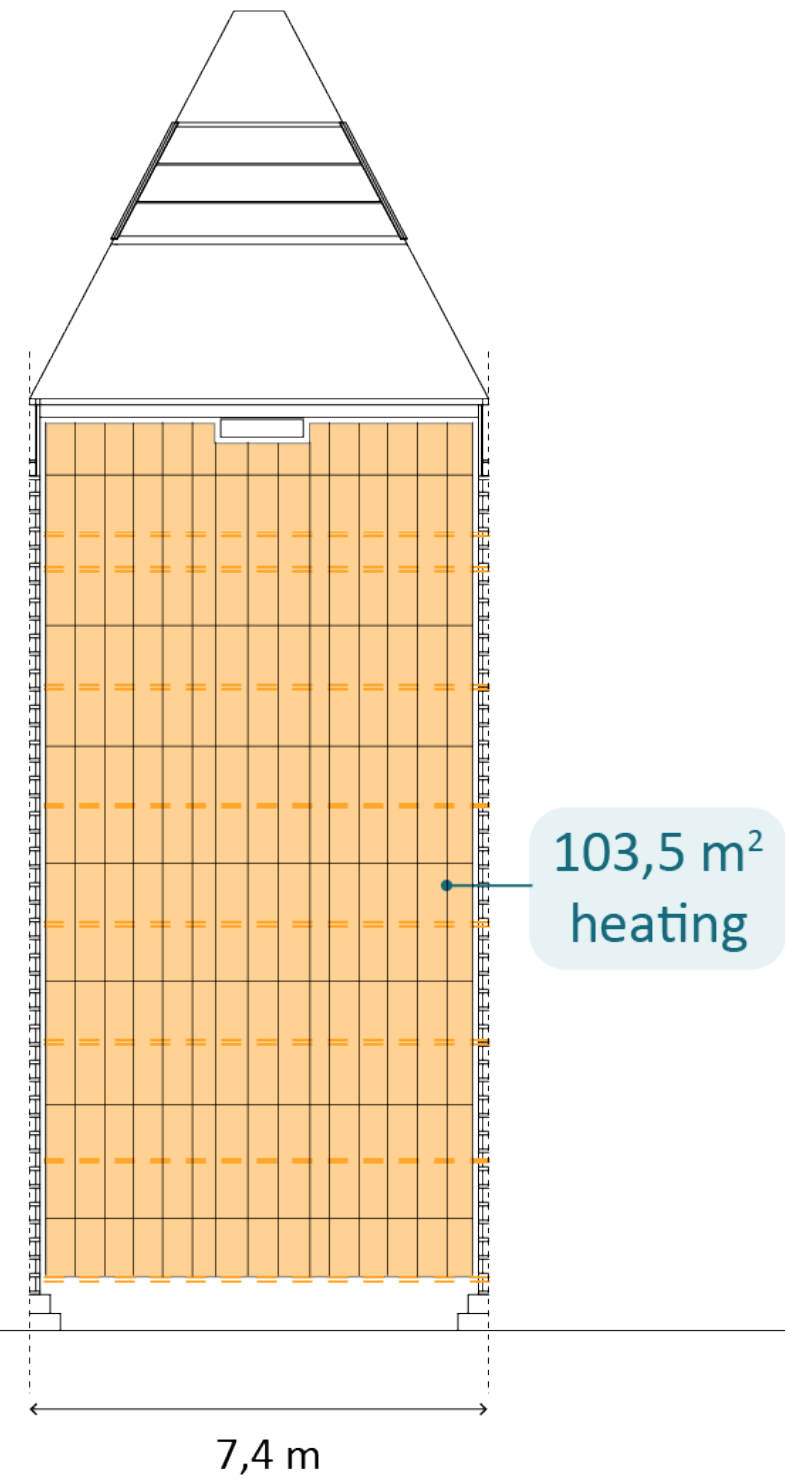

DESIGN OPTION 3.

Cooling & heating PCM combination

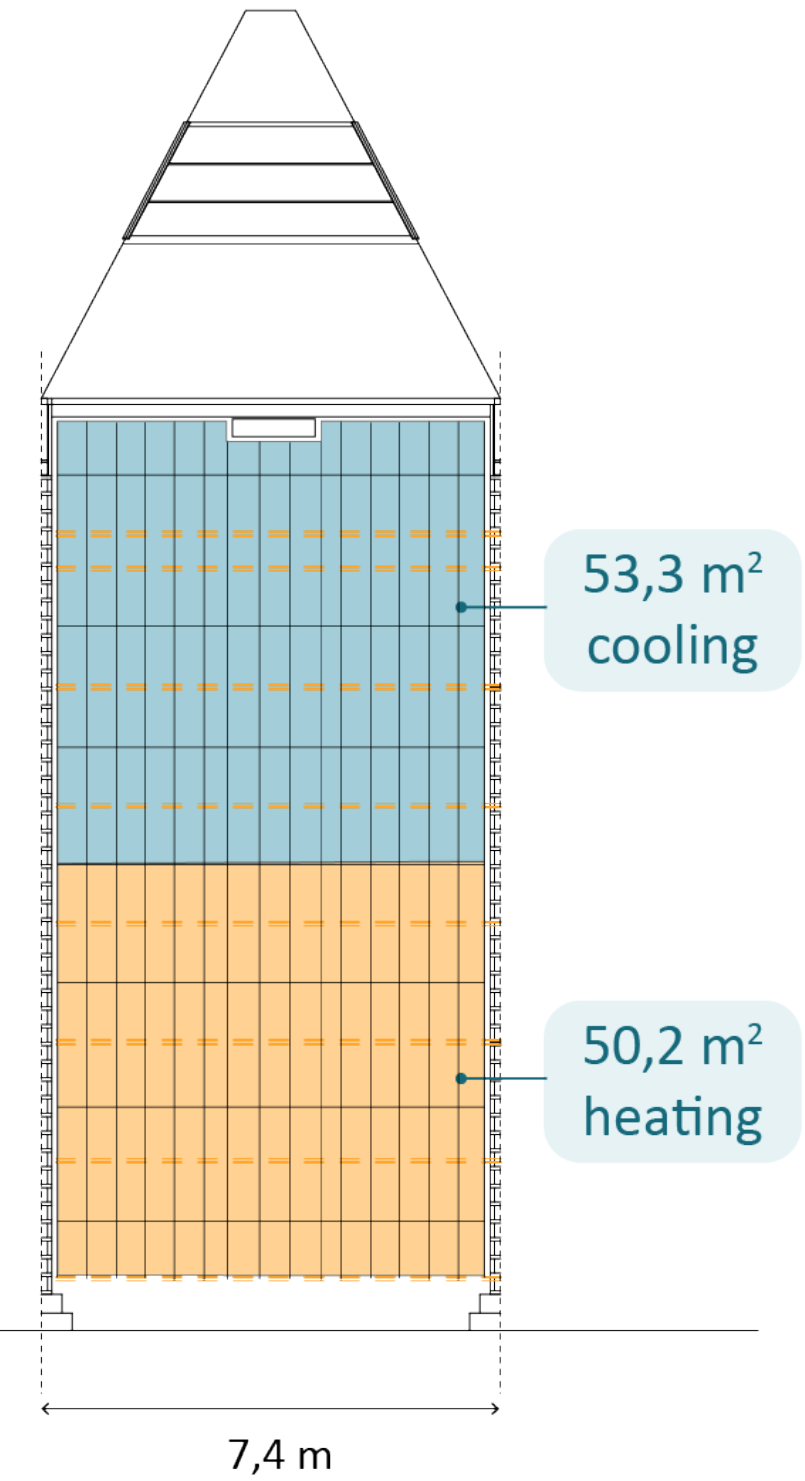

# Preliminary design

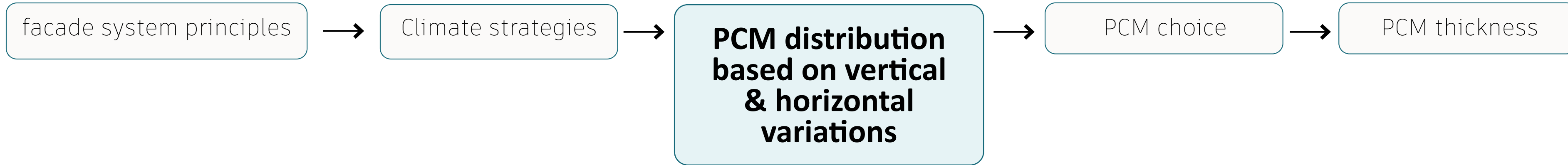

## horizontal differences

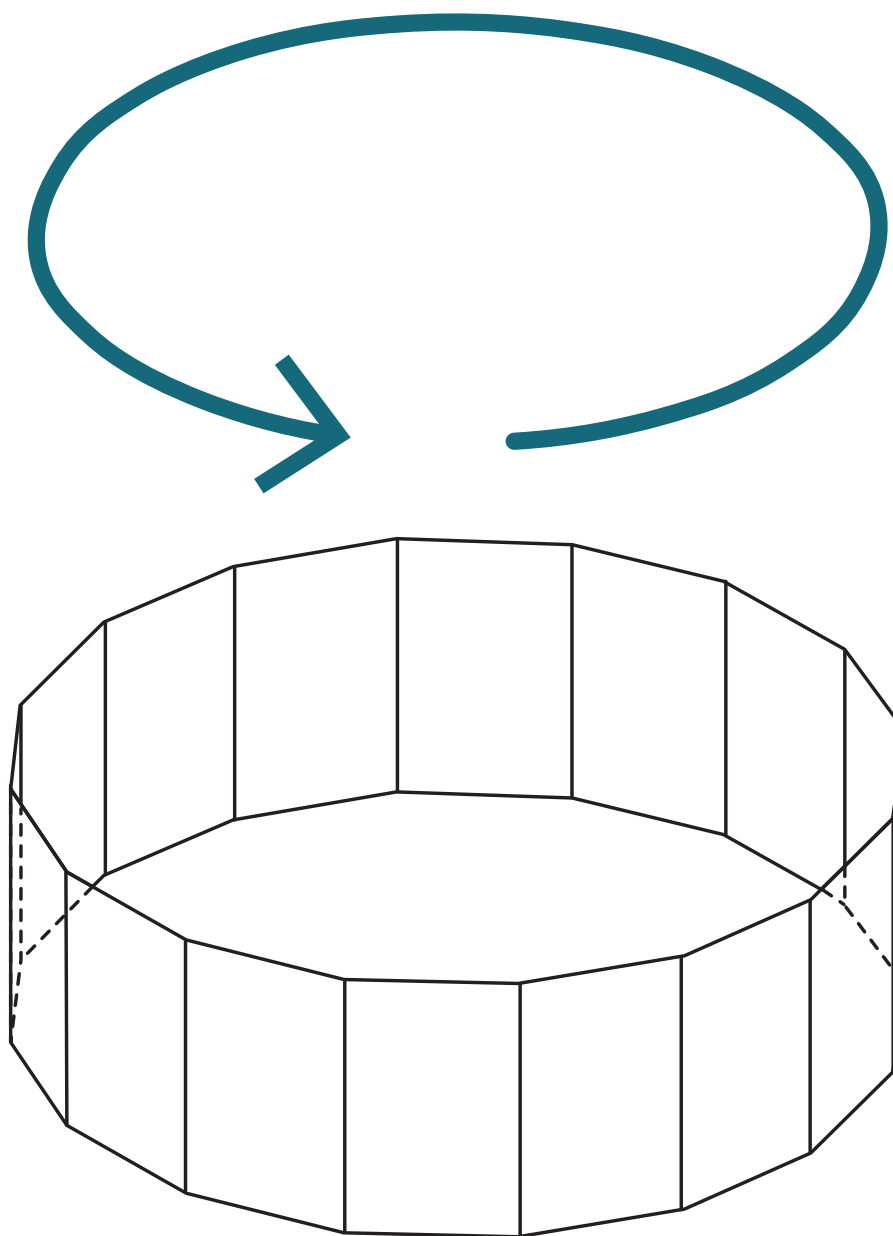

vertical differences

**No horizontal Variations**  
All variations are  $\leq 1\text{ }^\circ\text{C}$ ,  
so no impact on suitable PCM  
(melting & freezing temperatures)

Are given within a range of **1-2 °C**

**Vertical Variations**  
Winter:  $< 1\text{ }^\circ\text{C}$   
Summer: **2.6 °C**

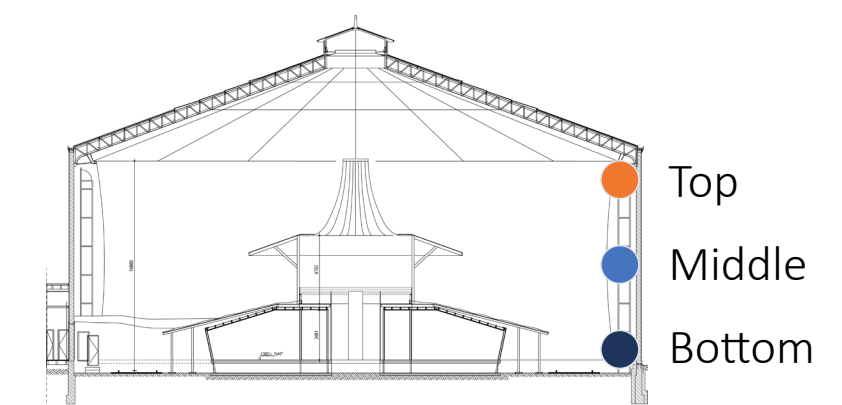
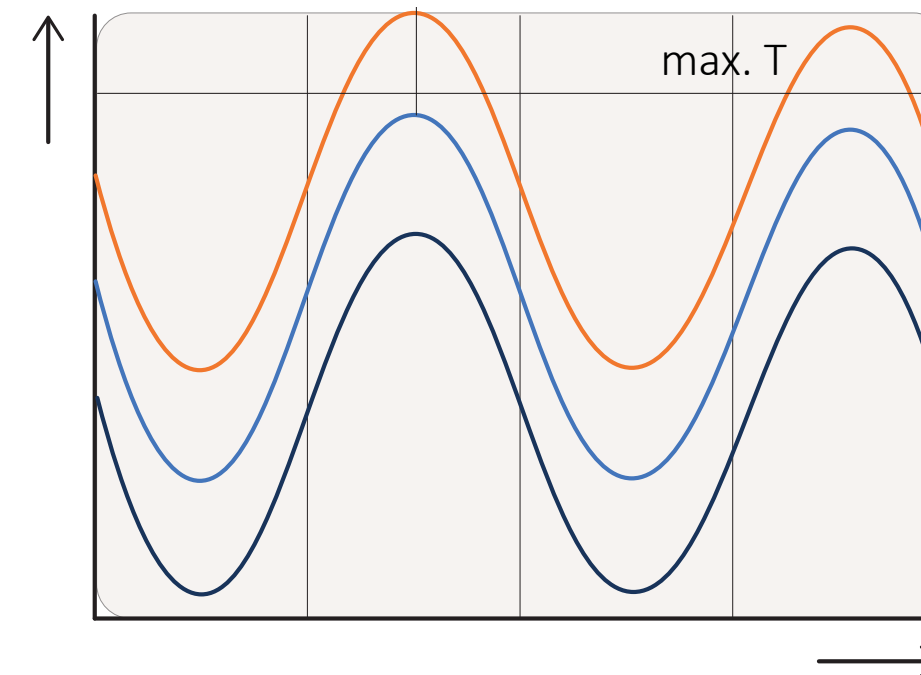

# Preliminary design

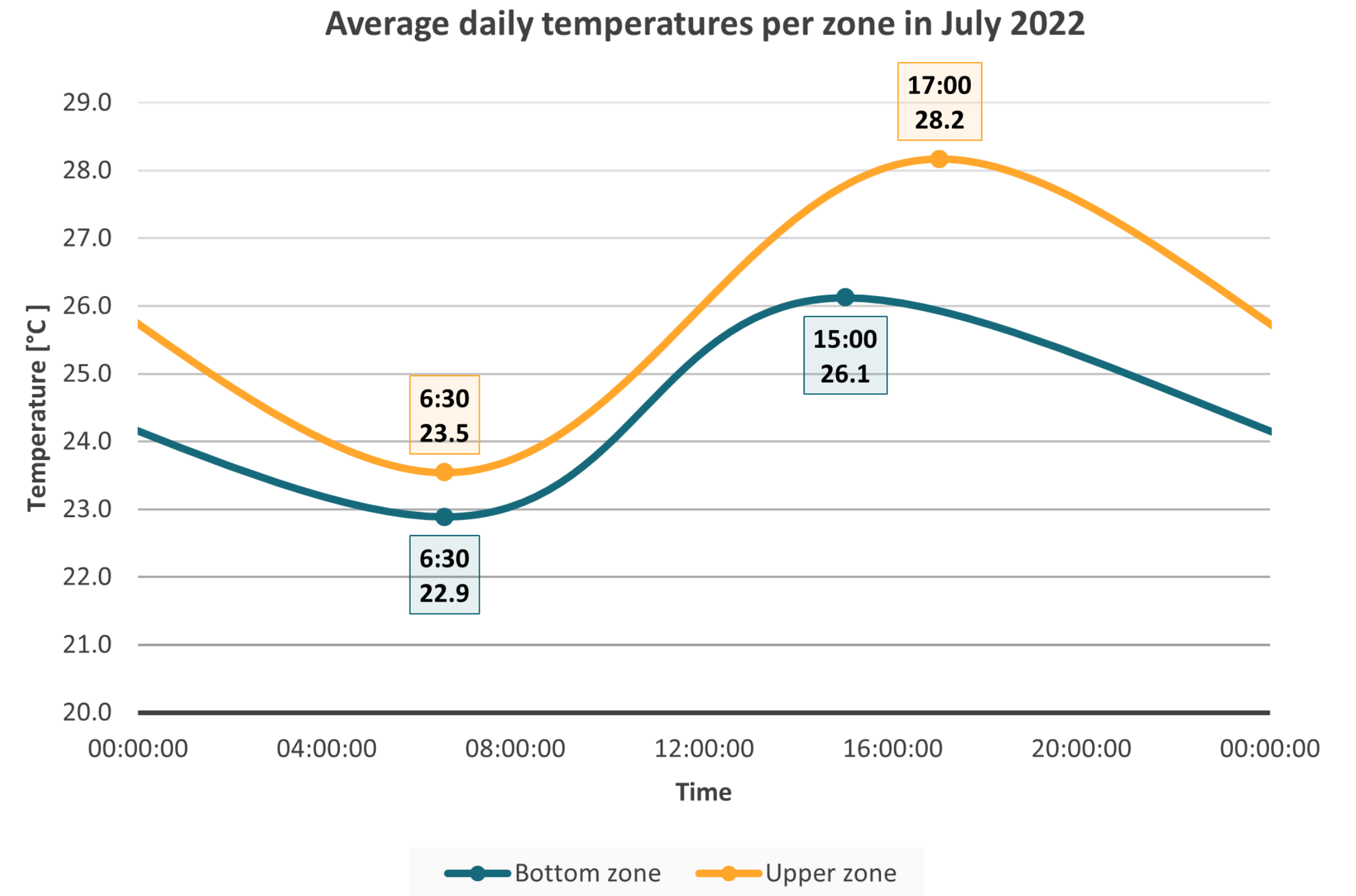
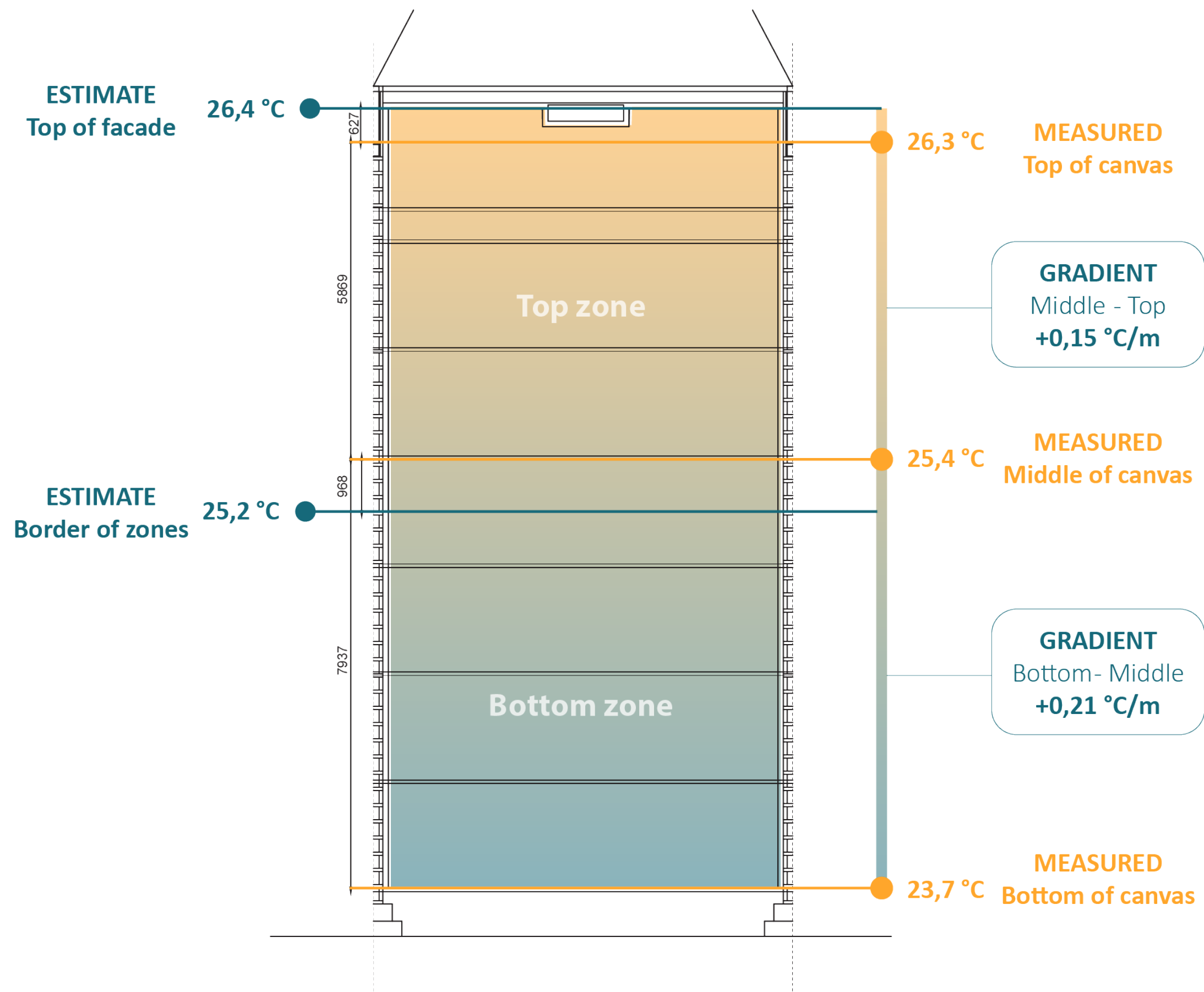
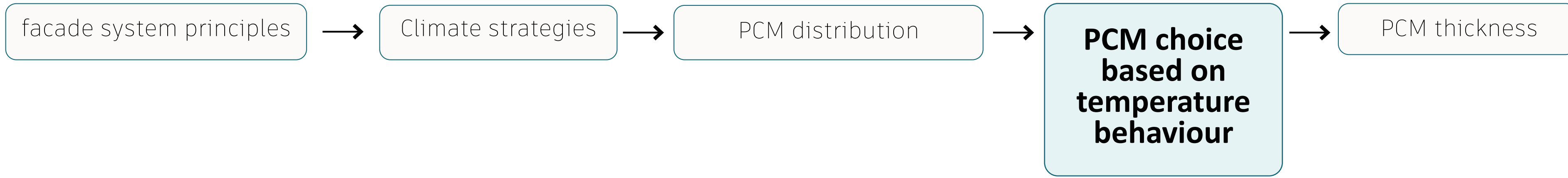

# Preliminary design

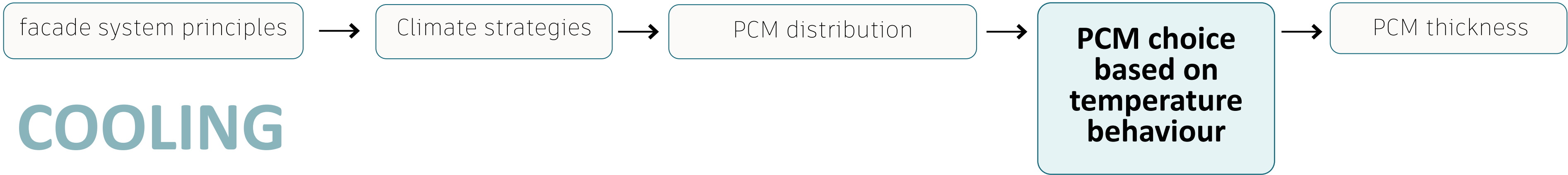

## COOLING Bottom zone

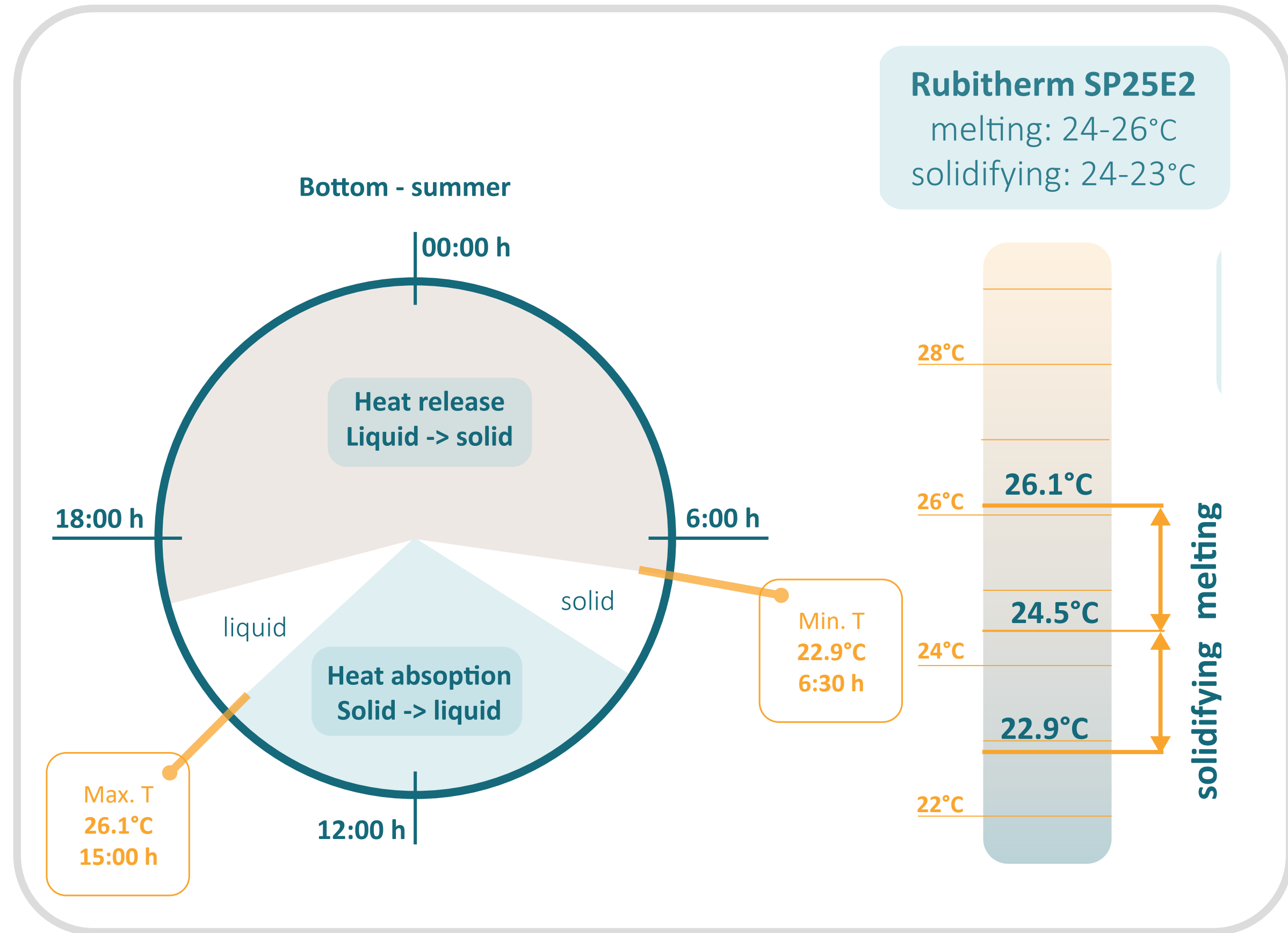

## Top zone

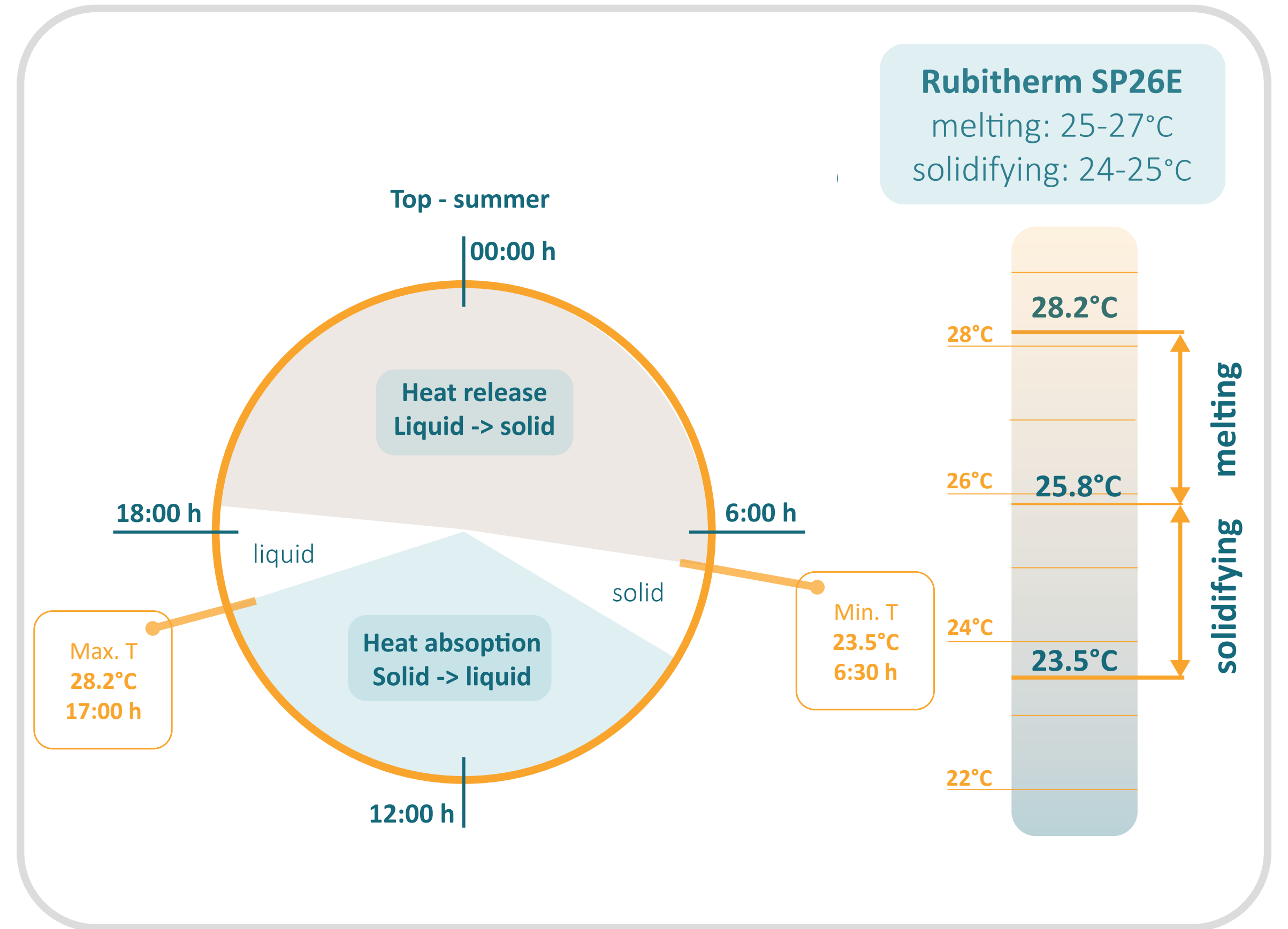

# Preliminary design

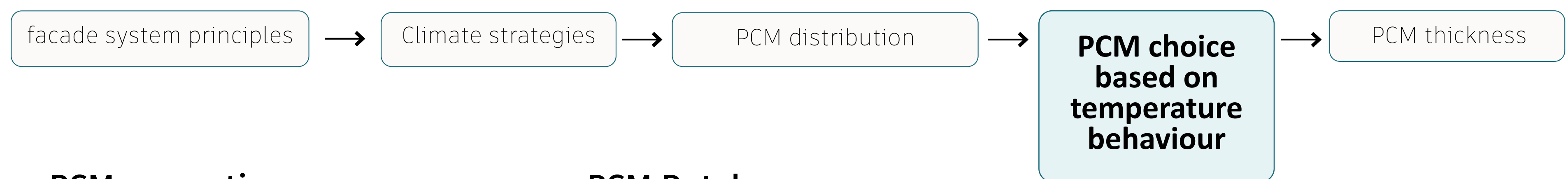

## PCM properties

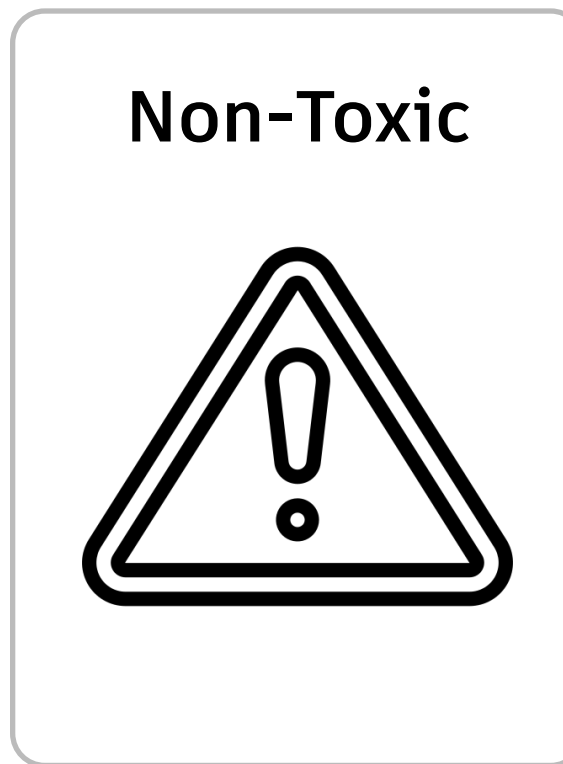
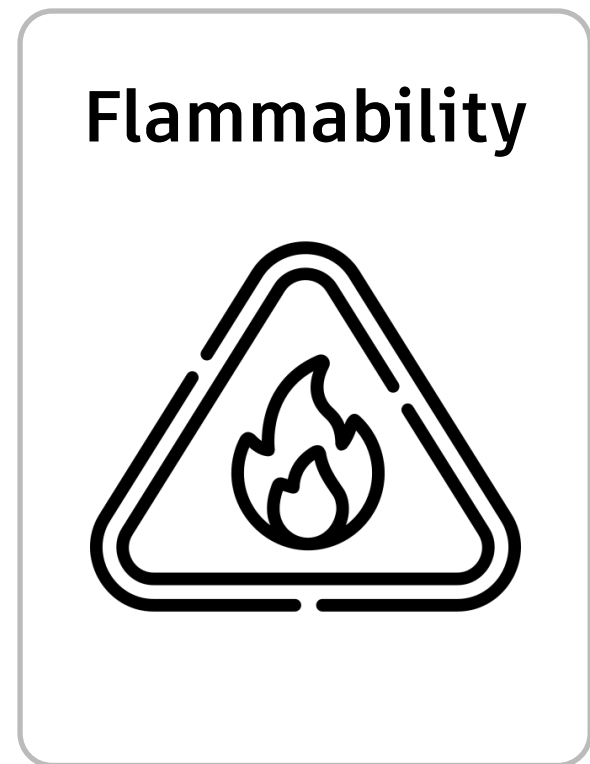
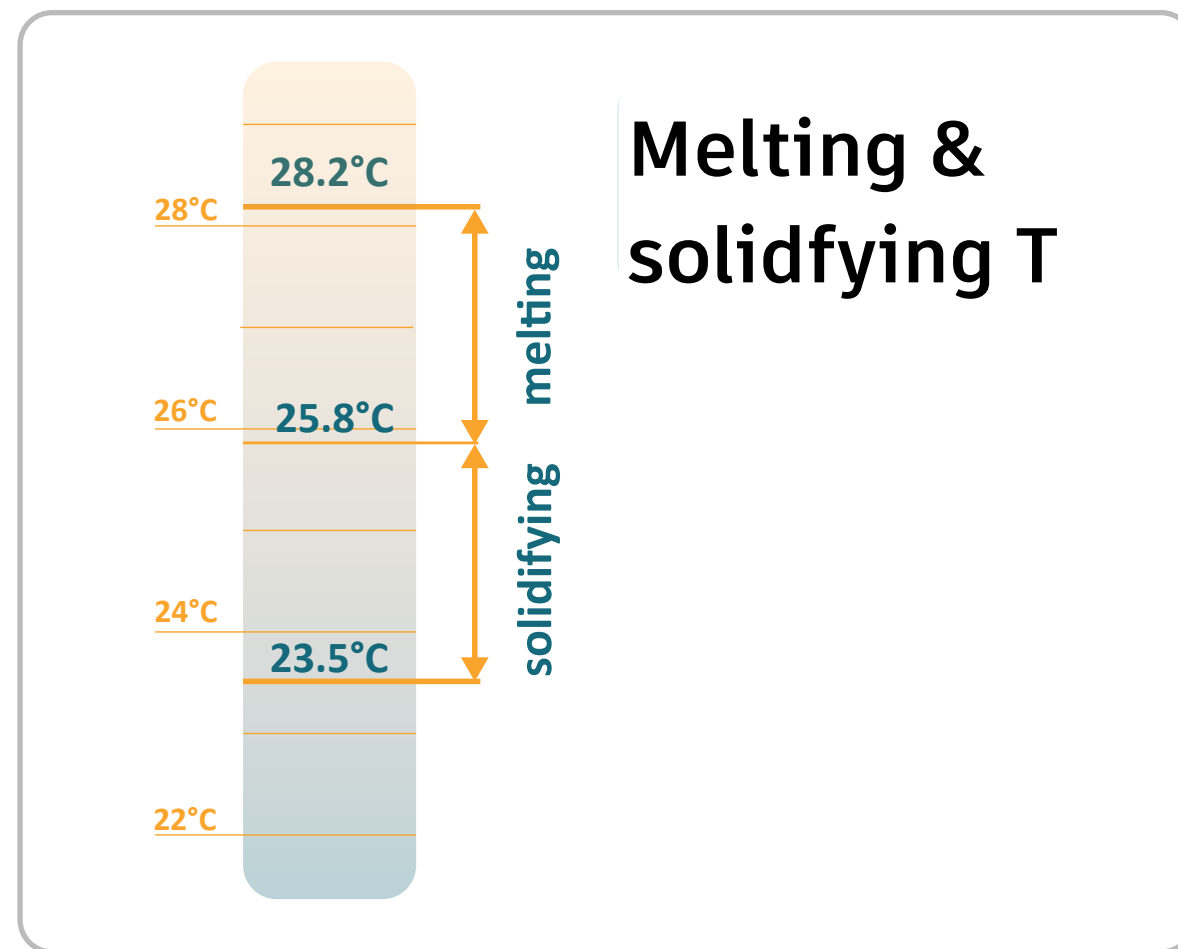

## PCM Database

PCMs	description	Heat storage temperature range	PC / Melting Temp (°C)	crystallisation Temp	Max Temp (°C)	Storage Capacity	(Latent) Heat (of fusion) ( kJ / kg )	Specific Heat ( kJ / kg*K )	Desnsity solid kg/l	Desnsity liquid kg/l	Thermal Conductivity ( W / m*K )	appearance	source	Flammability
ClimSel C7	Sodium Sulphate, Water and Additives		7		35	69 Wh/Litre for 0-15C	49 Wh/Litre	1 Wh/kg/°C			0,5-0,7 W/m/°C		Climator	
ClimSel C10	Sodium Sulphate, Water and Additives		10,5°C	5,5°C	35°C	70 Wh/Litre for 0-15C	49 Wh/Litre	1Wh/kg/°C			0,5-0,7W/m/°C		Climator	
ClimSel C-18	sodium nitrate, water and additives		-18.00		35°C	120 Wh/Litre	104 Wh/Litre	1Wh/kg/°C			0,5-0,7W/m/°C		Climator	
ClimSel C21	Sodium Sulphate, Water and Additives		21°C		35°C	60 Wh/Litre	43 Wh/Litre	1Wh/kg/°C		1,5	0,5-0,7W/m/°C		Climator	NO
ClimSel C-21	sodium chloride, water and additives		-21		35°C	117 Wh/Litre	104 Wh/Litre	1Wh/kg/°C			0,5-0,7W/m/°C		Climator	
ClimSel C24	Sodium Sulphate, Water and Additives		24°C		40°C	75 Wh/Litre	58 Wh/Litre	1 Wh/kg/°C		1,4	0,5-0,7W/m/°C		Climator	NO
ClimSel C28	Sodium Sulphate, Water and Additives		28°C		45°C	90 Wh/Litre	64 Wh/Litre	1Wh/kg/°C		1,5	0,5-0,7W/m/°C		Climator	NO
ClimSel C32	Sodiumsulphate, Water and Additives		32°C		45°C	90 Wh/Litre	64 Wh/Litre	1 Wh/kg/°C			0,5-0,7 W/m/°C		Climator	
ClimSel C48	Sodiumacetate, Water and Additives		48°C		65°C	95 Wh/Litre	68 Wh/Litre	1 Wh/kg/°C			0,5-0,7 W/m/°C		Climator	

**PCM Database**

- 112 PCM types
- 8 manufacturers

Source: Turin (2015). Additional information sources: Rubitherm (2022), Orange Climate - Autarkis (2022), ClimSel (2022).

## Preliminary design

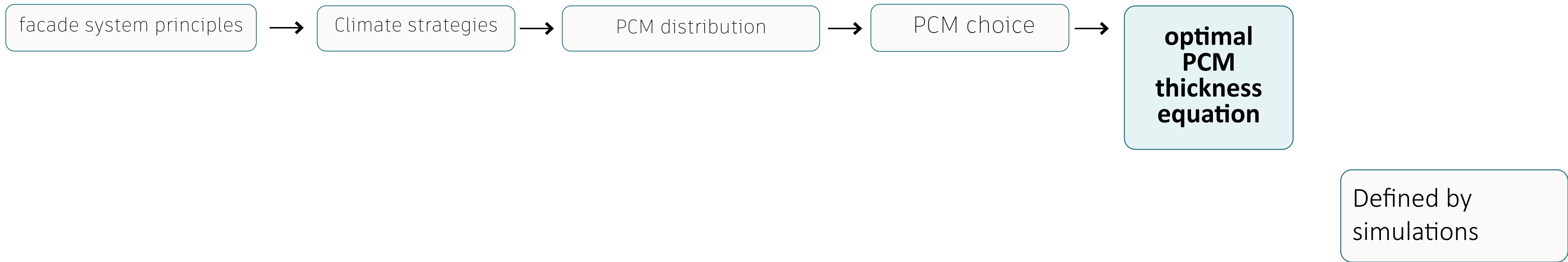

### PCM thickness definition

- Optimal thickness
- Maximum thickness: based on weight restriction facade

$$t_{\text{PCM,opt}} = \frac{Q}{C d}$$

**m**  
OPTIMUM PCM THICKNESS

**kJ/kg**  
LATENT HEAT  
PRODUCT SPECIFIC

**kJ/m<sup>2</sup>**  
HEAT GAIN  
LOCATION SPECIFIC

**kg/m<sup>3</sup>**  
PCM DENSITY  
PRODUCT SPECIFIC

Source: Solarino (2019)

facade system principles

Climate strategies

PCM distribution

PCM choice

PCM thickness

**Preliminary design options**

# COOLING

## Design Option 1.1

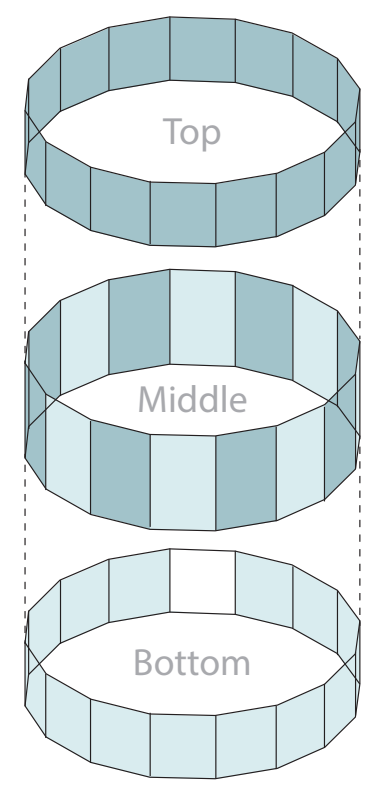

Cooling PCMs

- SP26E**  
5 mm  
910 m<sup>2</sup>
- SP25E2**  
12.5 mm  
765 m<sup>2</sup>

## Design Option 1.2

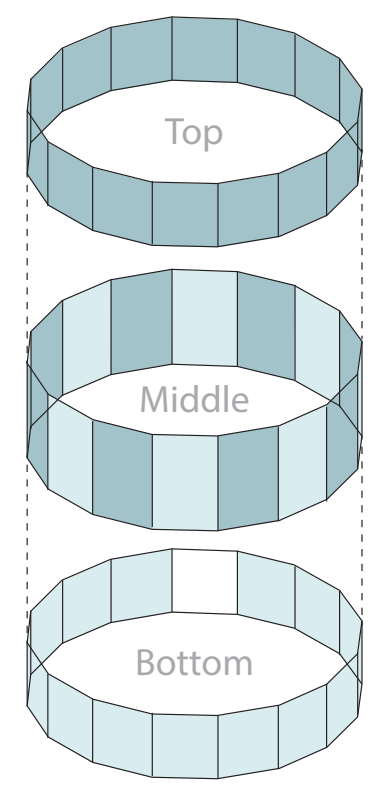

Cooling PCMs

- SP26E**  
12.5 mm  
910 m<sup>2</sup>
- SP25E2**  
12.5 mm  
765 m<sup>2</sup>

# HEATING

## Design Option 2.1

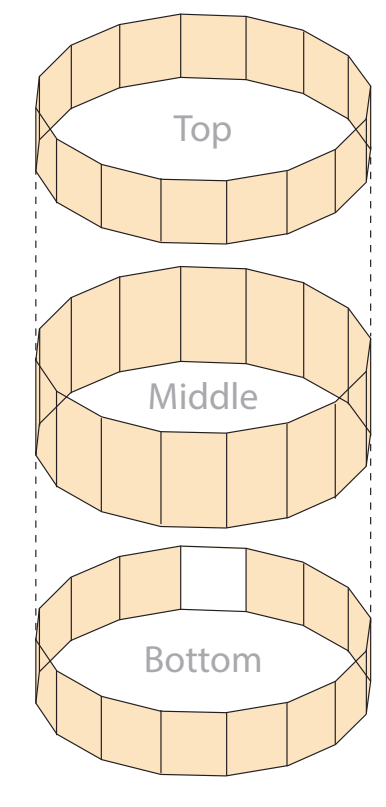

Heating PCM

- RT11HC**  
4 mm  
1675 m<sup>2</sup> PCM

## Design Option 2.2

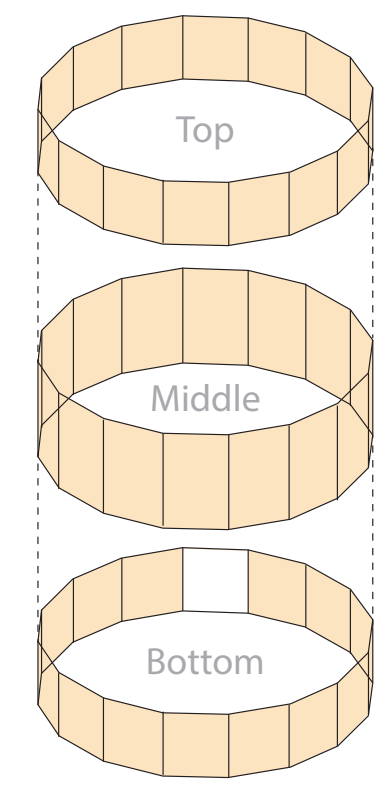

Heating PCM

- RT11HC**  
22.7 mm  
1675 m<sup>2</sup> PCM

# COMBINATION

## Design Option 3.1

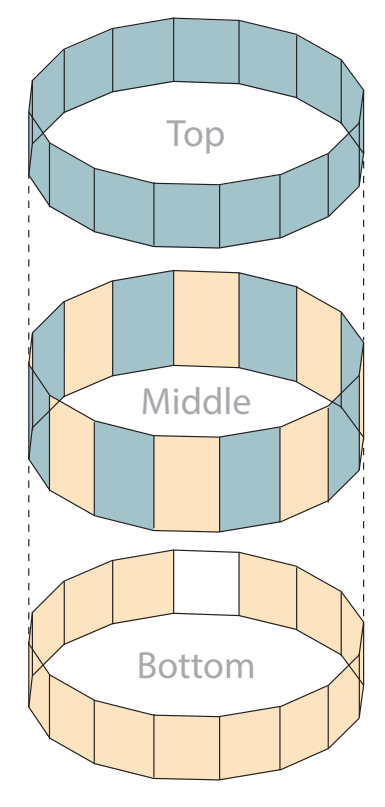

Cooling PCM

- SP26E**  
5 mm  
910 m<sup>2</sup>

Heating PCM

- RT11HC**  
4 mm  
765 m<sup>2</sup>

## Design Option 3.2

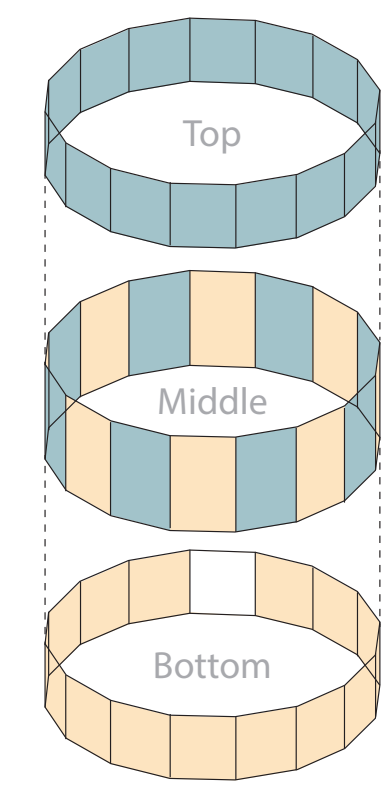

Cooling PCMs

- SP26E**  
12.5 mm  
910 m<sup>2</sup>

Heating PCM

- RT11HC**  
22.7 mm  
765 m<sup>2</sup>

## Software simulations

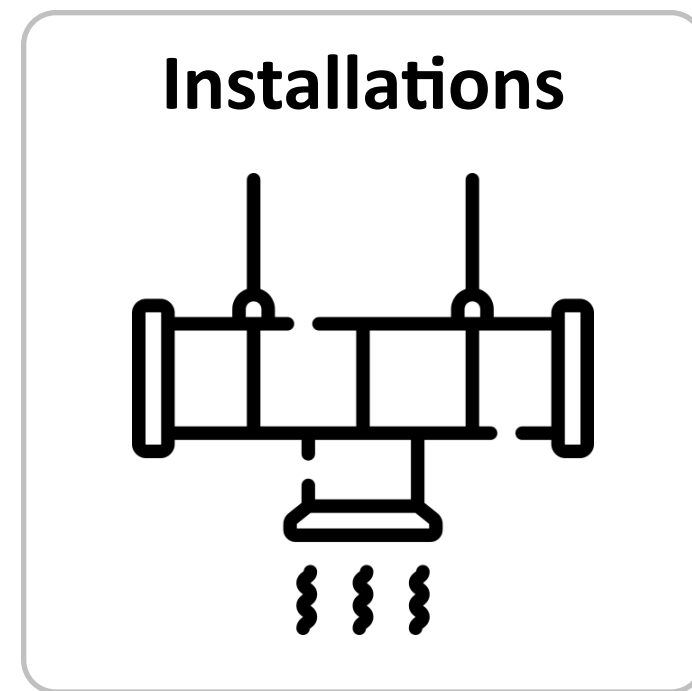
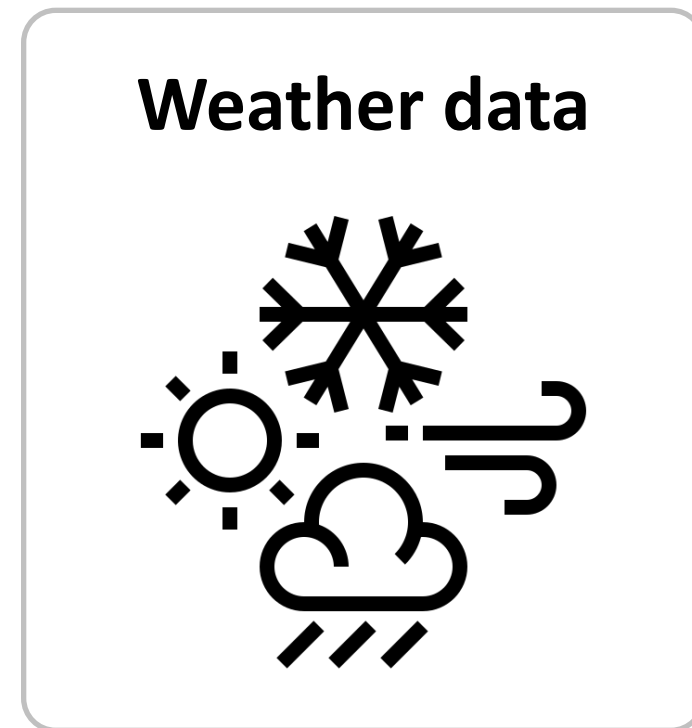
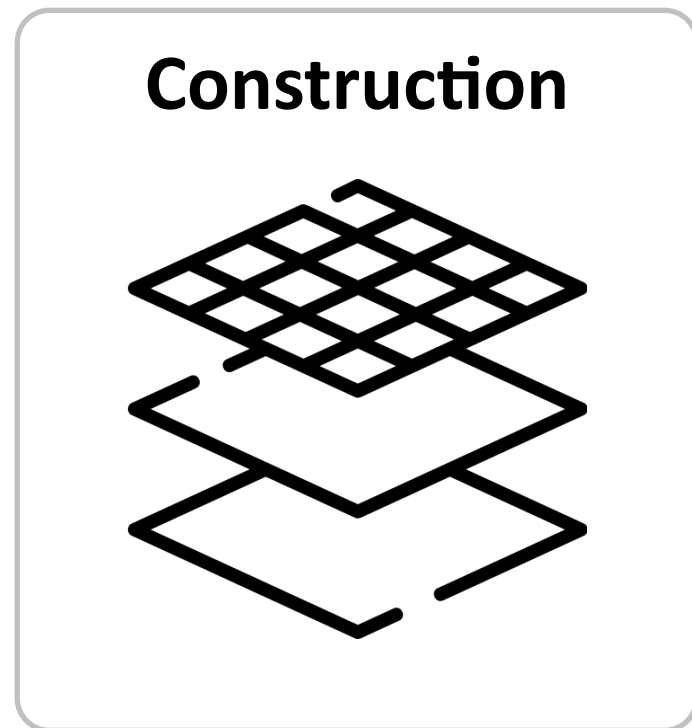
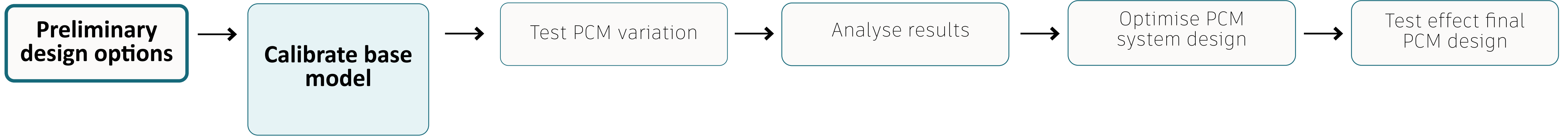

**Local data**  
surrounding buildings

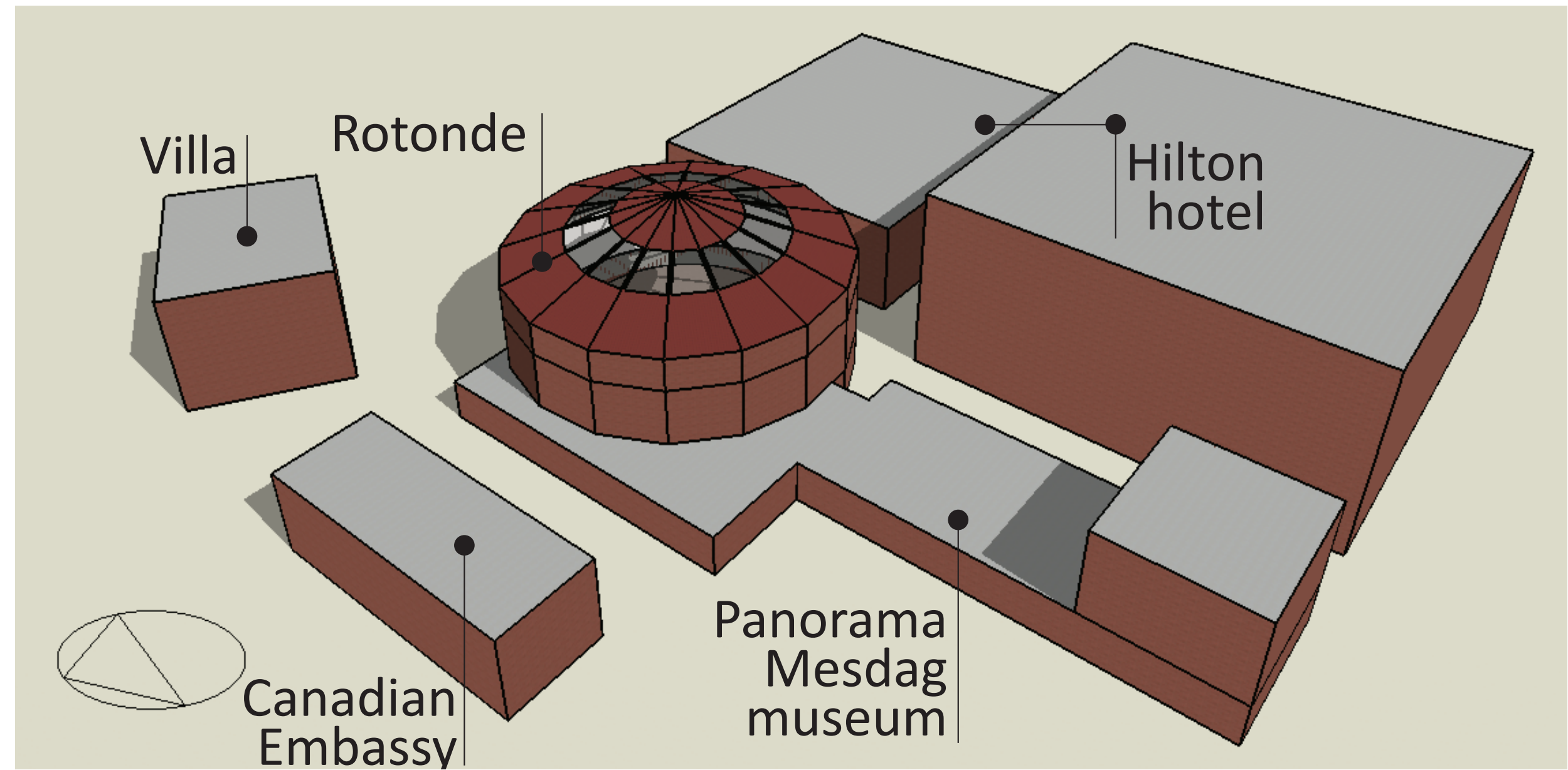

# Software simulations

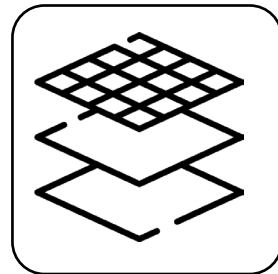
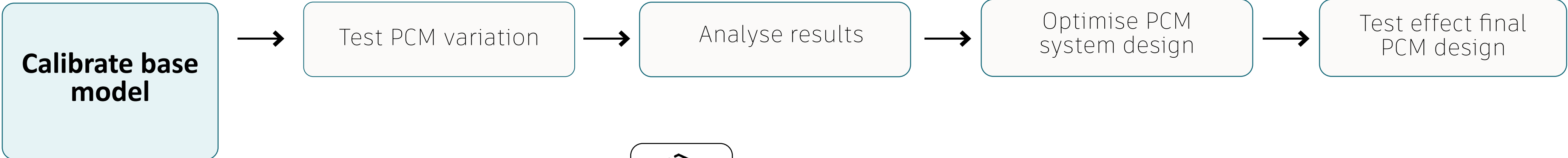

**Construction**  
Layout and material properties

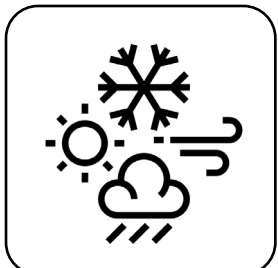

**Weather data**  
1 year hourly weather data

Weather data measured by  
**KNMI (Voorschoten)**  
+  
Outdoor temperature  
measured on roof museum

- 150mm concrete slab
- 25mm wooden floor blocks\_heating in sand
- Partition - 2 x 1 in. (2x25mm) gypsum plasterboard with 4 in. (100mm) cavity
- Earth, common (0.5m)
- Project internal floor
- RT11HC
- Lightweight 2 x 25mm gypsum plasterboard with 100mm cavity
- Solid brick wall, 350 mm, uninsulated Pre 1919
- Project partition
- Project unoccupied pitched roof
- 10mm wooden floor
- SP26E
- Flat roof U-value = 0.71W/m2K
- Dbl Clr 6mm/13mm Air

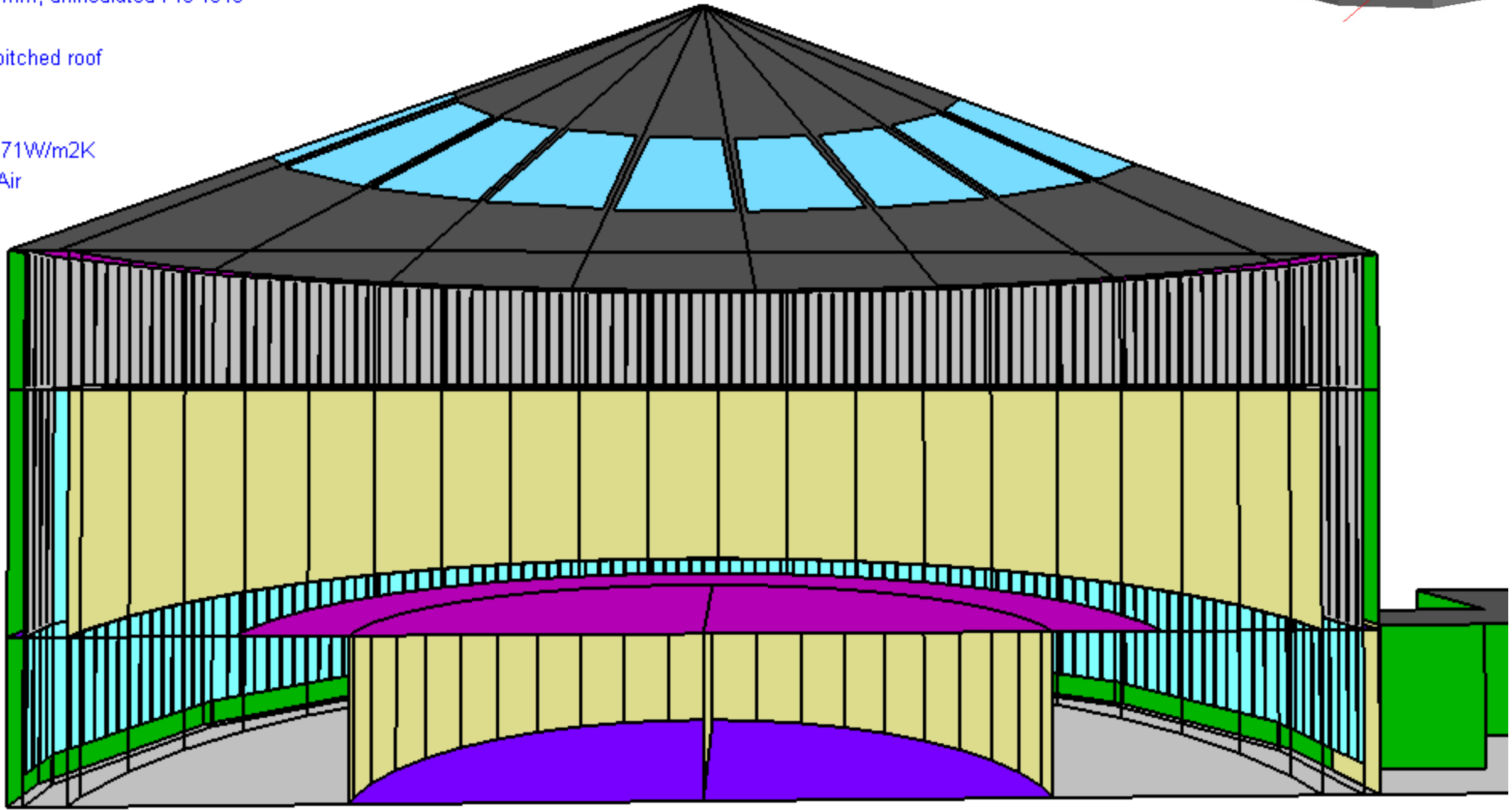
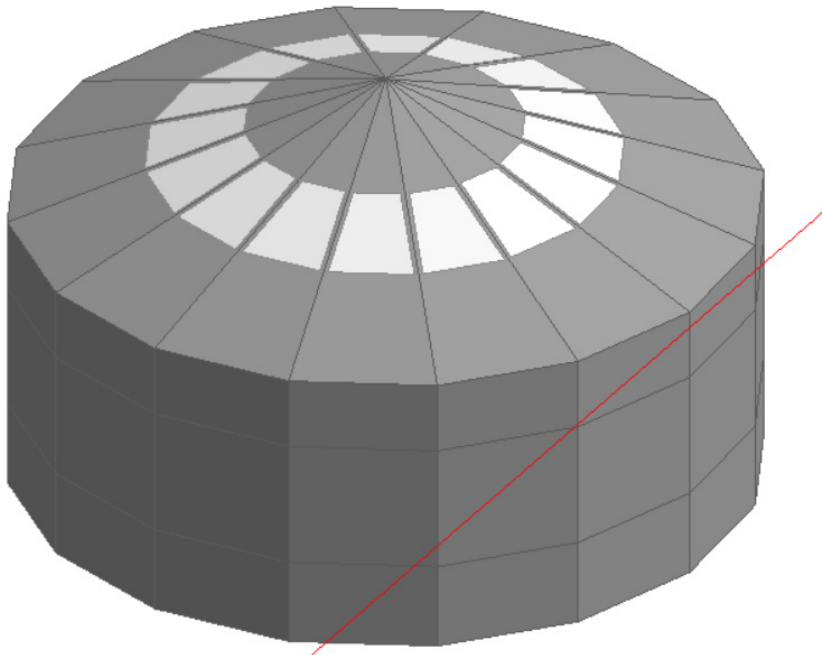

# Software simulations

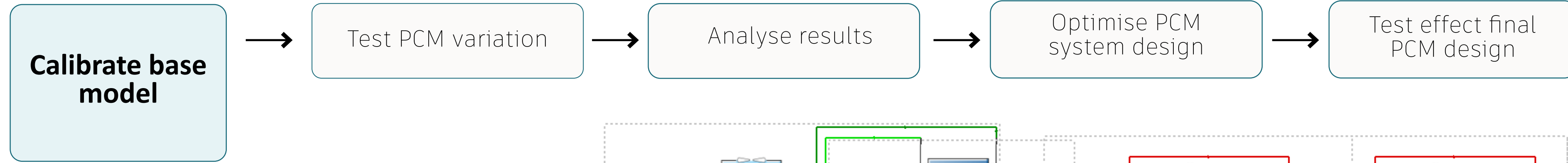

 **Climate installations**  
System properties and settings

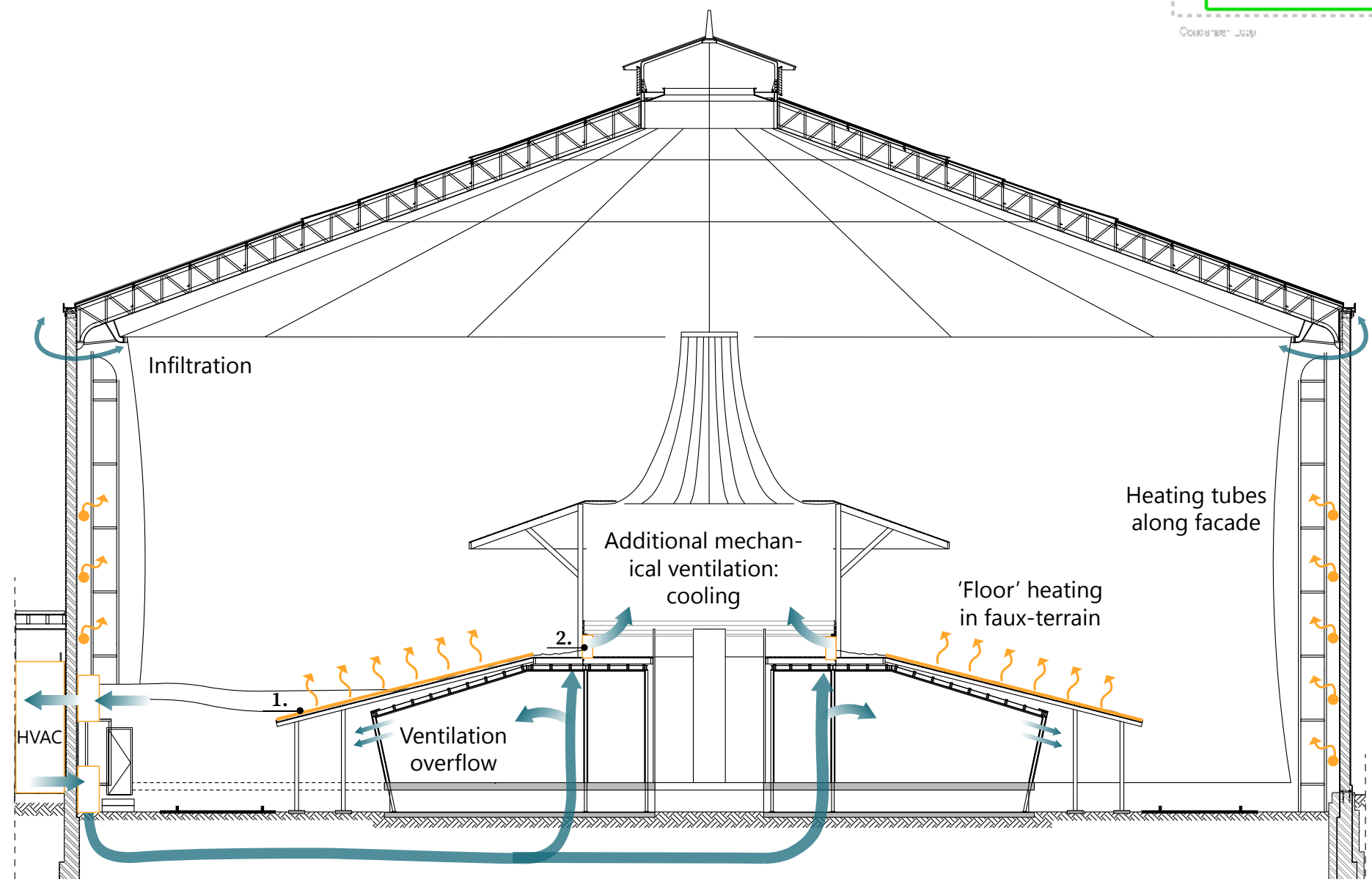
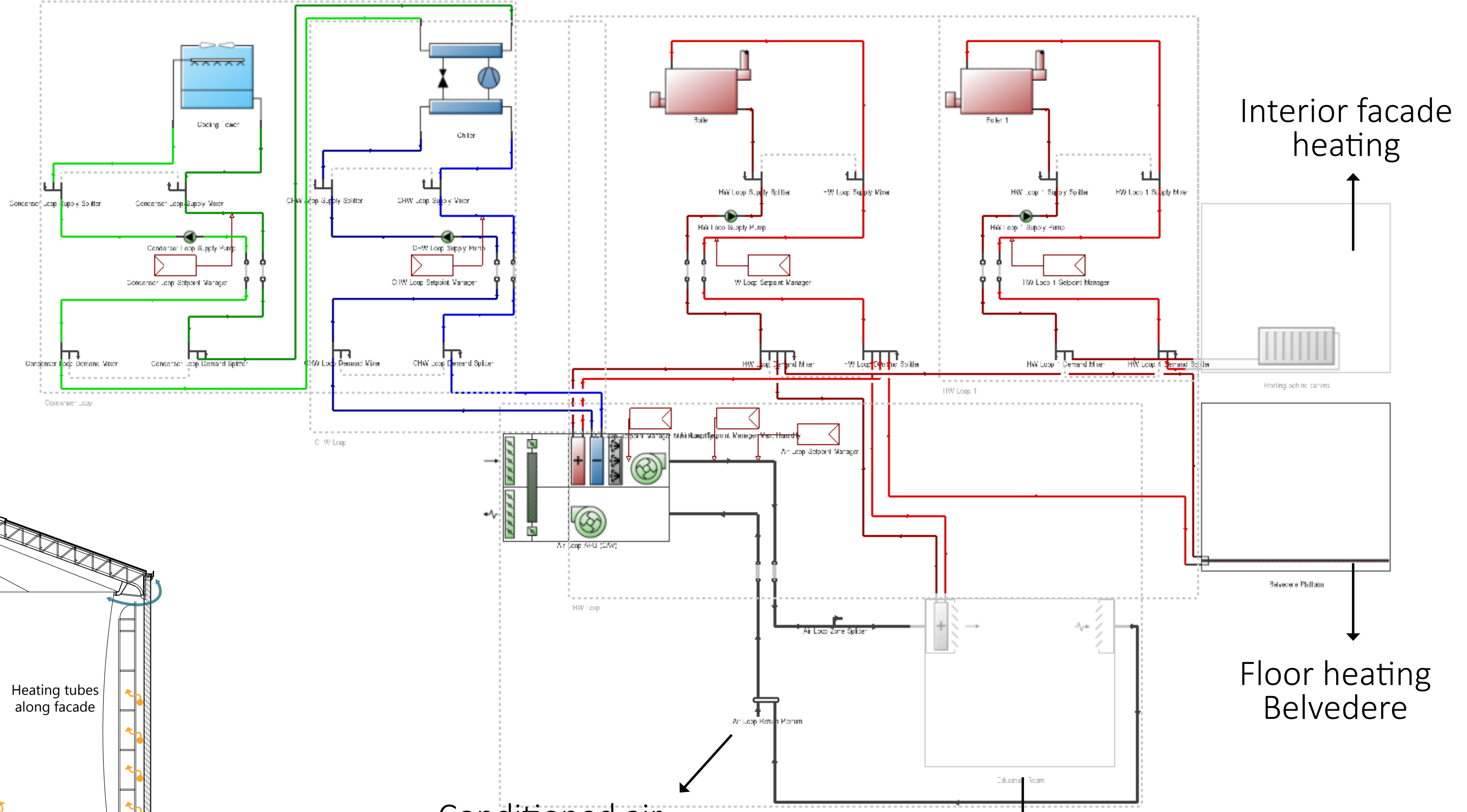

# Software simulations

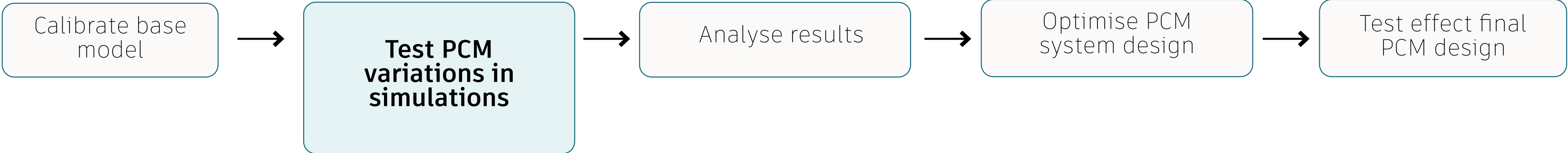

## PCM panels in DesignBuilder

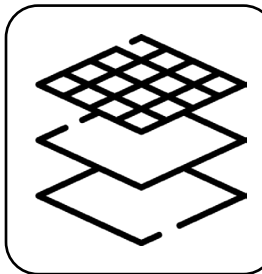
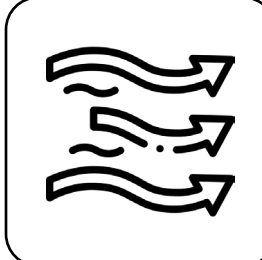
-  **PCM properties**
-  **Air flow around PCM panels**

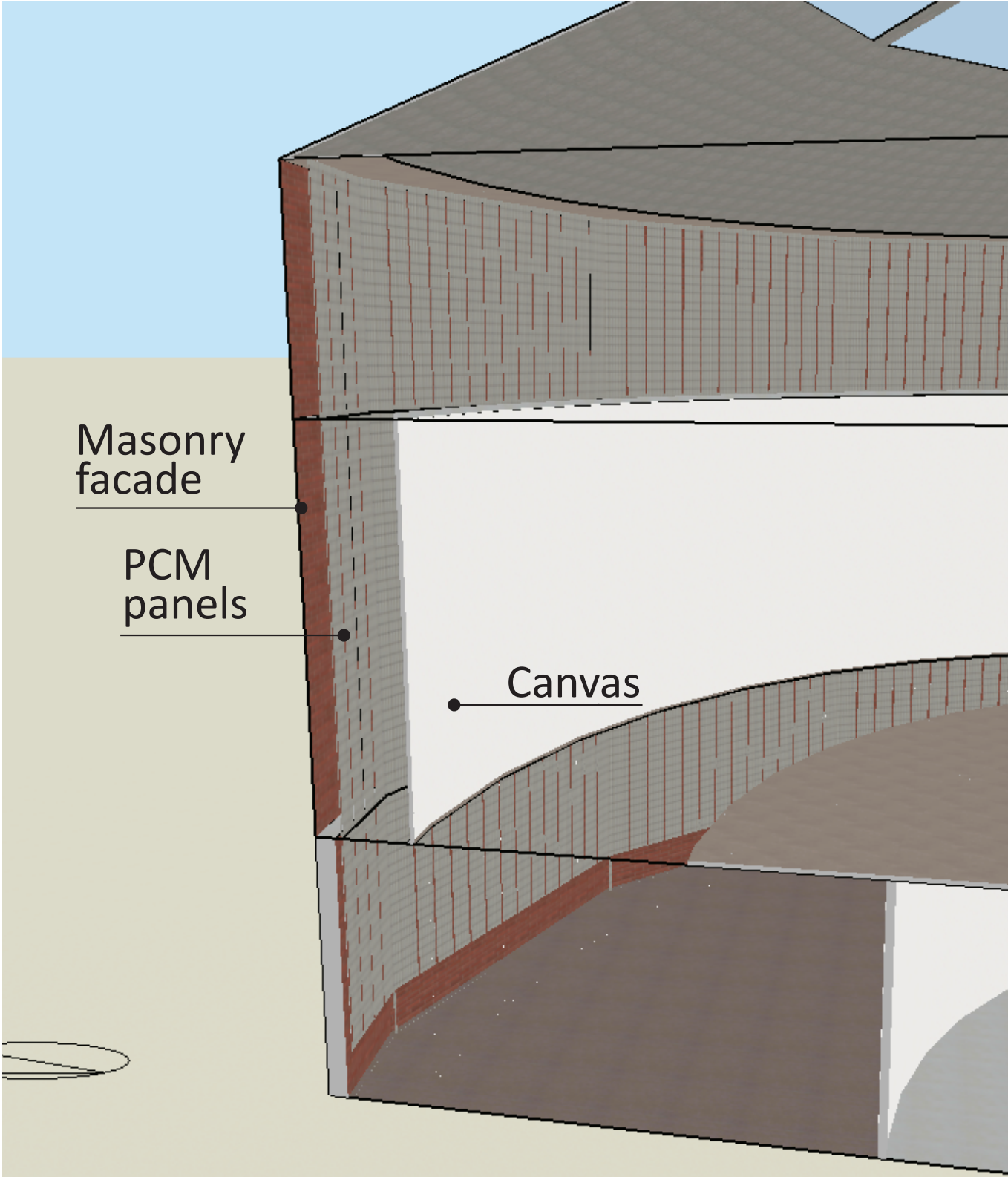

## Section PCM panels 1:10

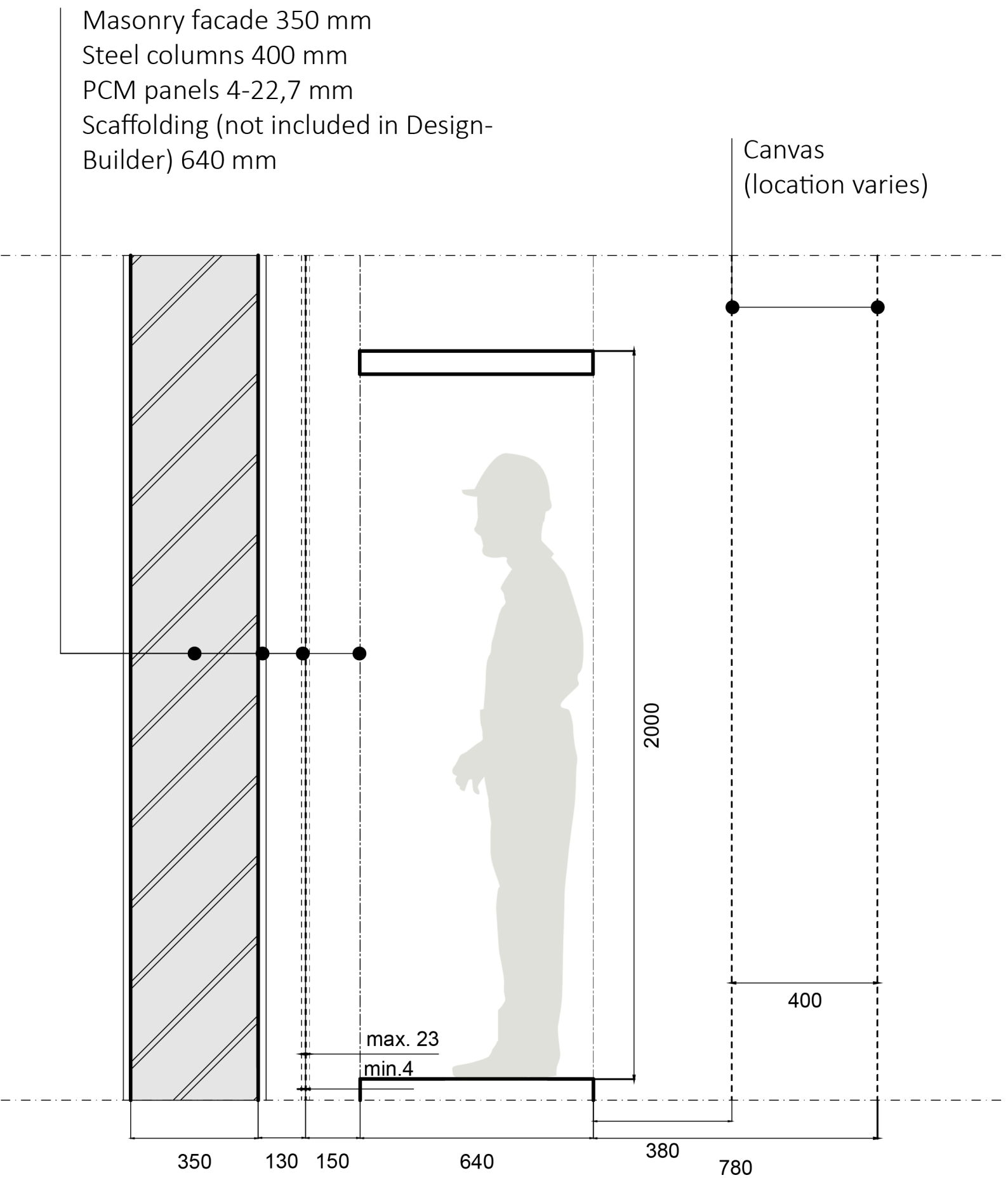

## Software simulations

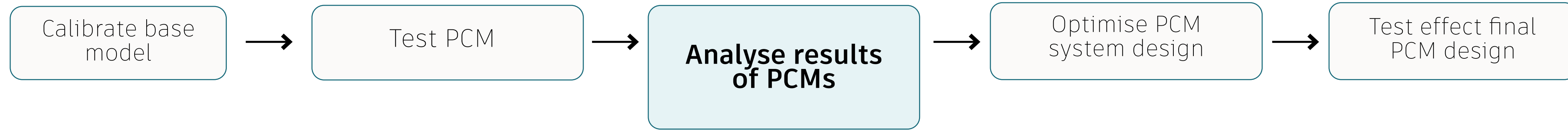

### Results winter

Minimal difference between cooling and heating PCMs



### Conclusion

PCM have no effect in winter, so not advised.

## Simulation results winter - PCMs

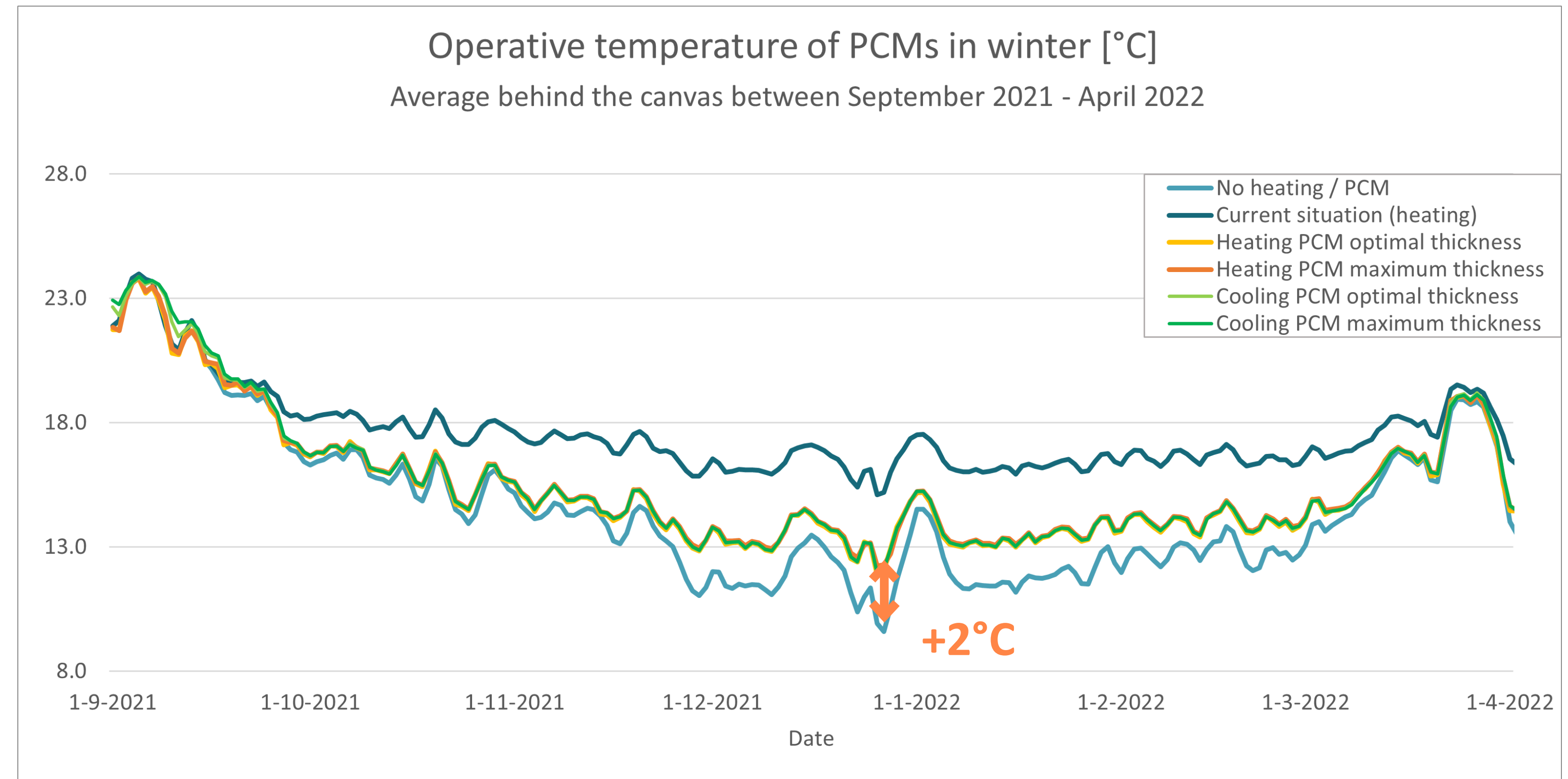
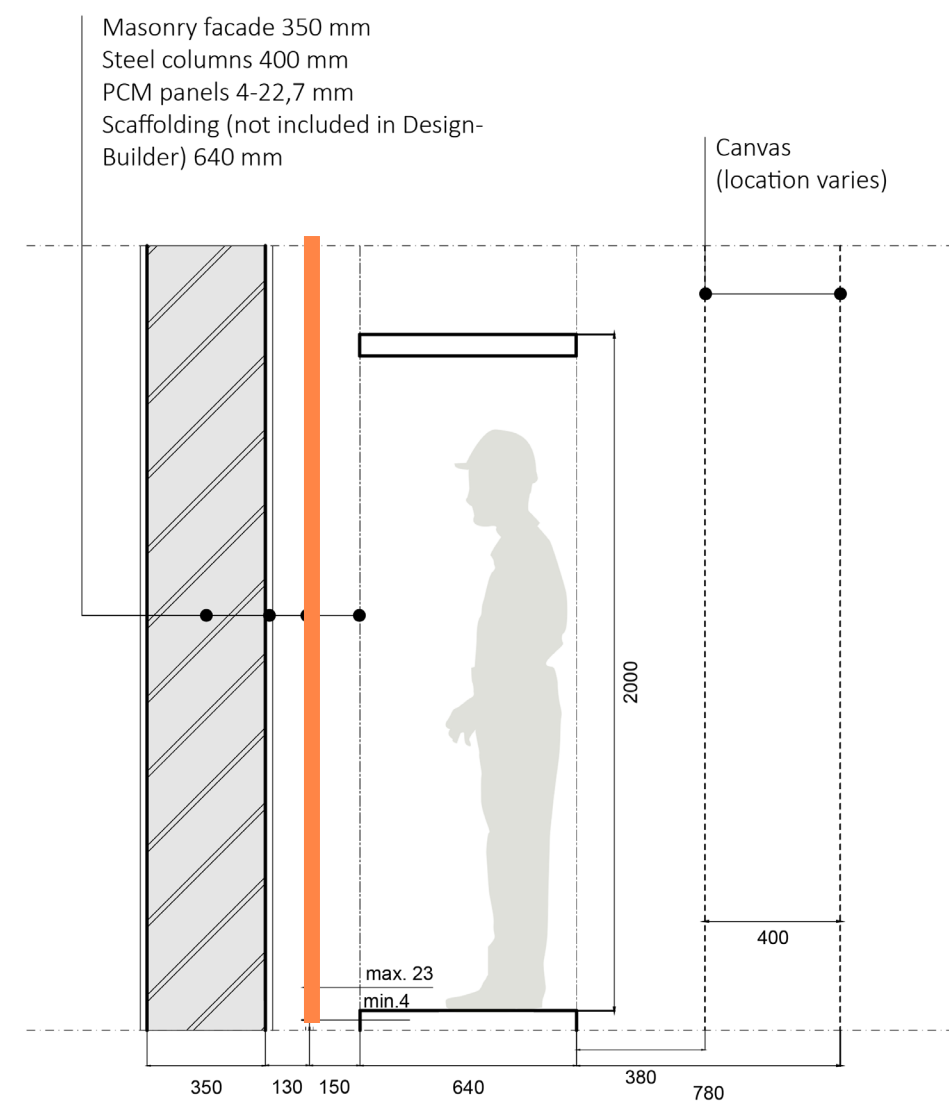

## Software simulations

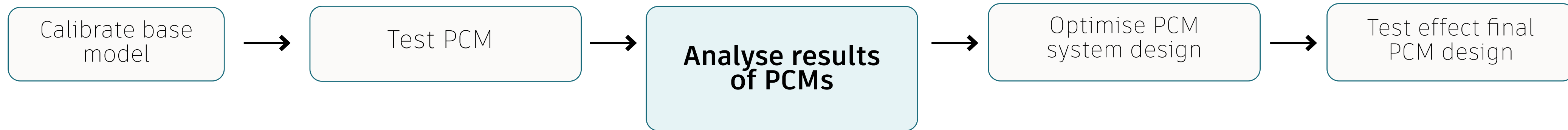

## Simulation results summer - Cooling PCMs

### Results summer

- Sufficient cooling effect when in T range.
- Outside T range negative heating effect.



### Conclusion

Cooling PCMs should be active on more days per year.

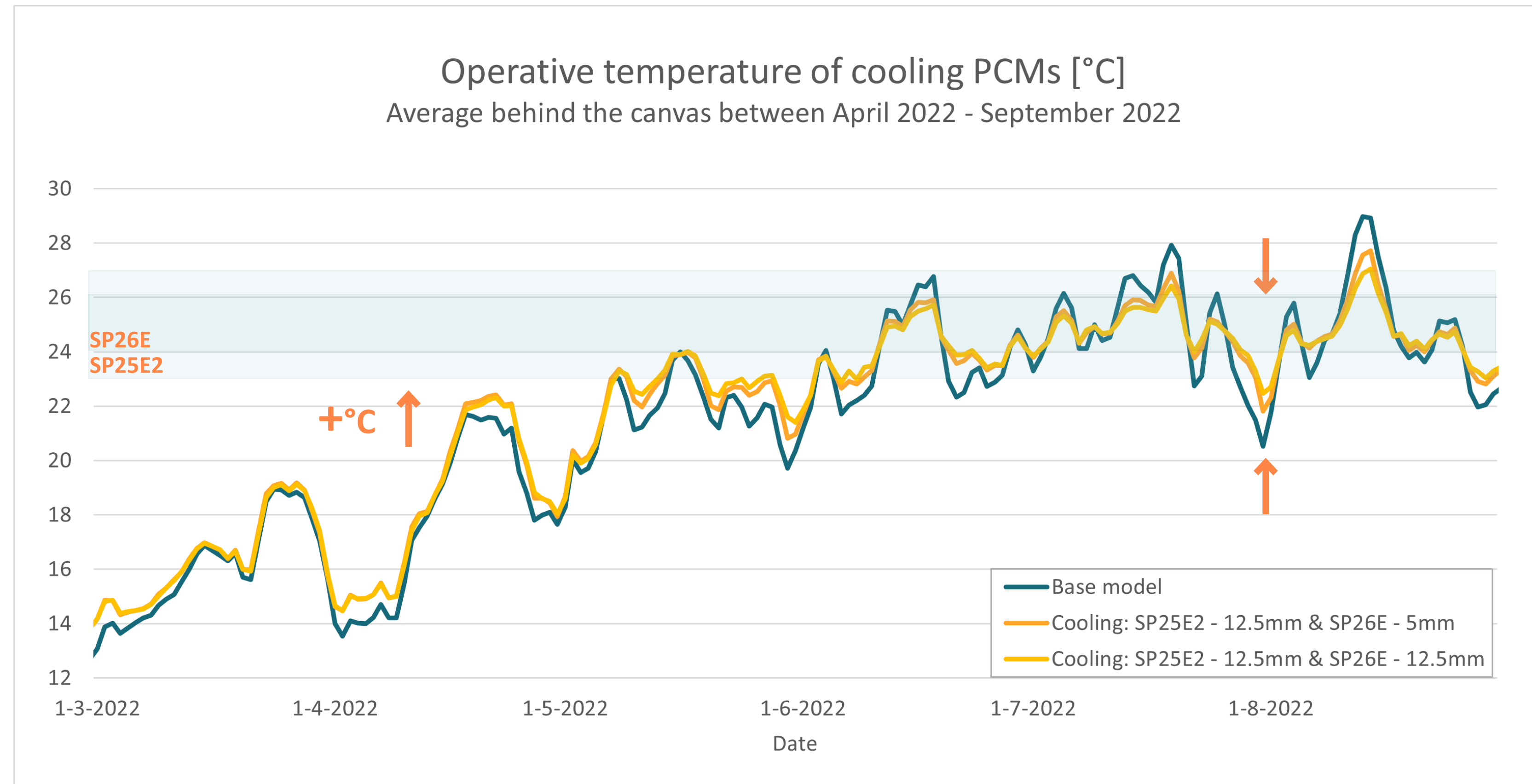

## Software simulations

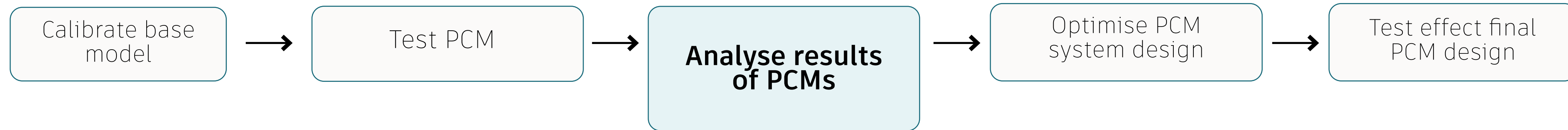

## Yearly fluctuation indicators - Cooling PCMs

### Conclusion

Cooling **PCMs should** be **active** on **more days per year**.

Differences of yearly indoor climate indicators: current situation vs PCM design options: average behind the canvas	Behind the canvas				
	Current situation (sim)	Cooling 1 optimal thickness	Cooling 2 maximum thickness	Combi 1 maximum thickness	Combi 2 optimal thickness
Minimum RH [%]	<b>37.4</b>	-0.8	0.8	0.0	0.0
Maximum RH [%]	<b>78.3</b>	9.9	6.7	0.1	0.1
Minimum T [°C]	<b>12.6</b>	-2.0	-1.9	-0.1	-0.1
Maximum T [°C]	<b>30.5</b>	-0.3	-1.8	0.0	0.0
Days per year of RH fluctuation > 10 %/24hr	<b>257</b>	-114	-131	-1	0
Maximum RH fluctuation [%/24hr]	<b>18.8</b>	3.9	2.9	0.2	0.4
Days per year of T fluctuation > 5 °C/24hr	<b>0</b>	2	0	0	11
Maximum T fluctuation [°C/24hr]	<b>4.9</b>	0.2	-0.2	0.0	0.2
Days per year of T fluctuation > 3 °C/24hr	<b>197</b>	-105	-136	-1	0

Not all indicators  
same / improved



=

Negative effect for  
preservation painting

# Software simulations

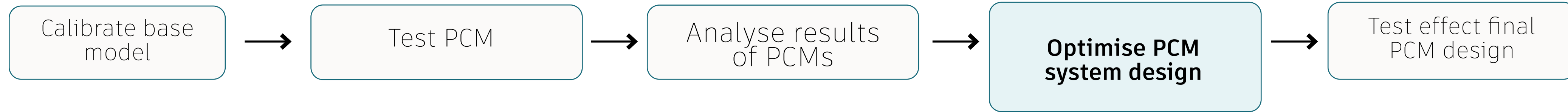

## PCM with larger T range

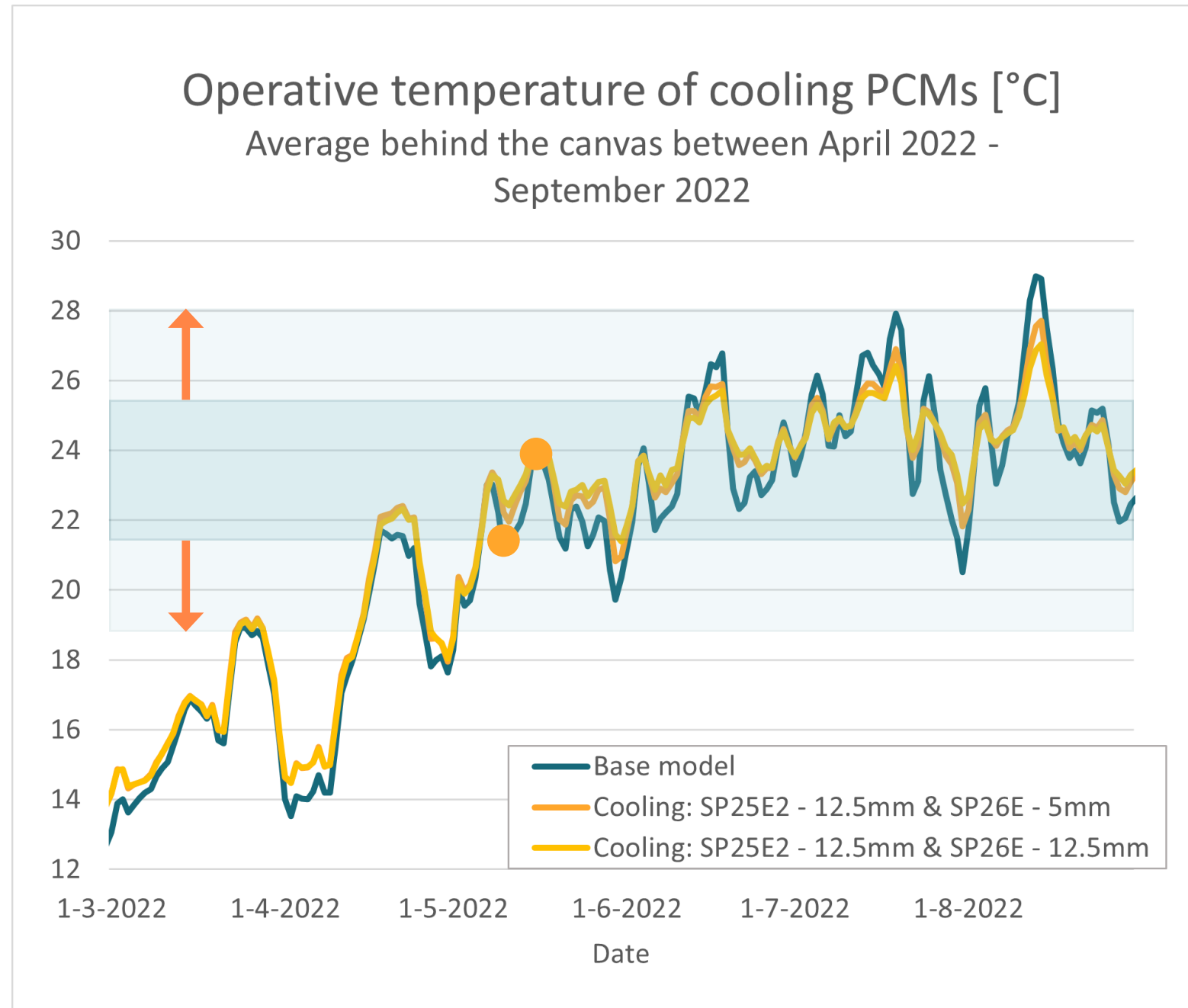

### Conclusion

PCM does not fully charge & discharge

## Multiple PCMs with different T range

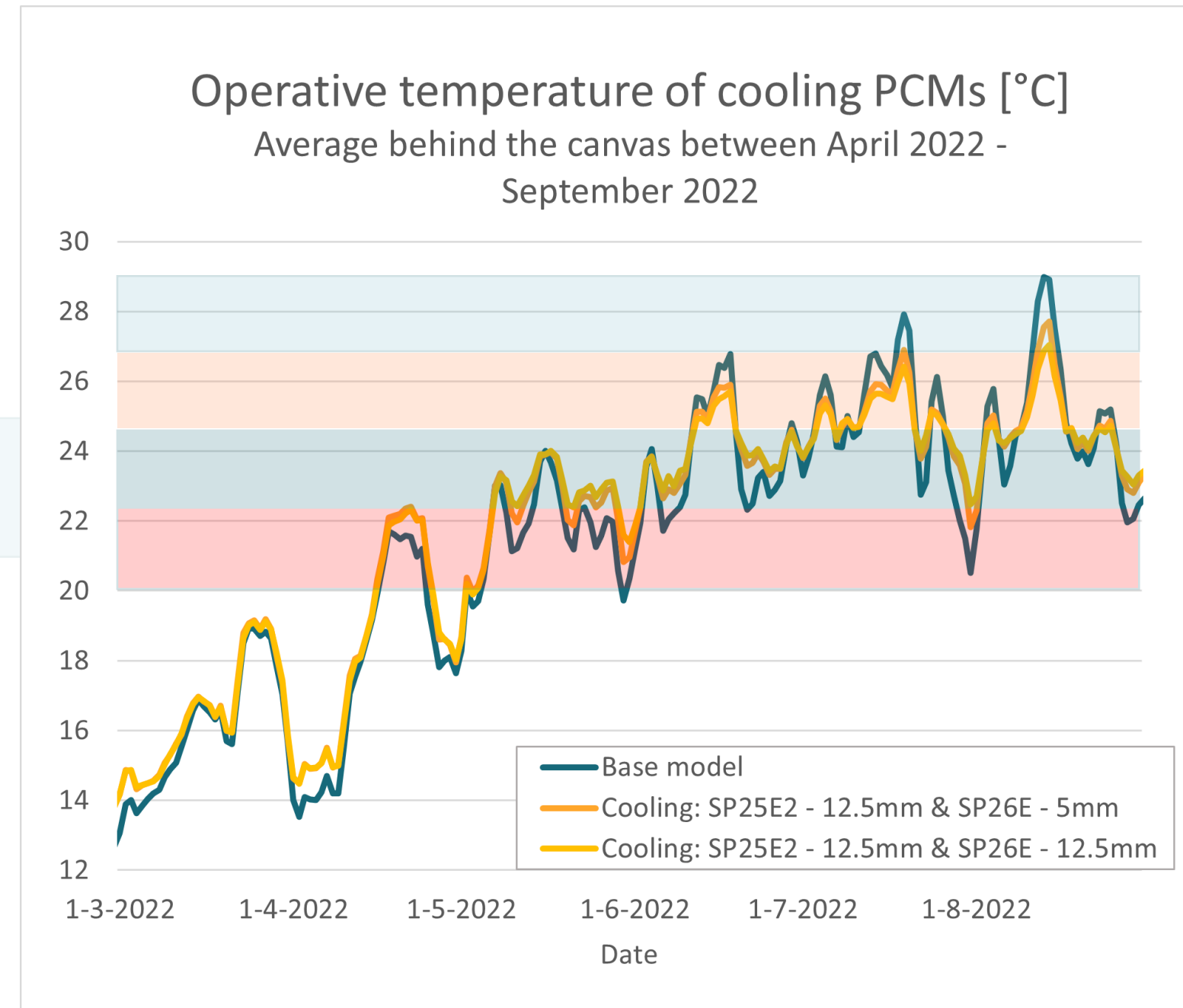

### Conclusion

Decrease in capacity and effect on indoor climate

## Increase consistency of daily fluctuations

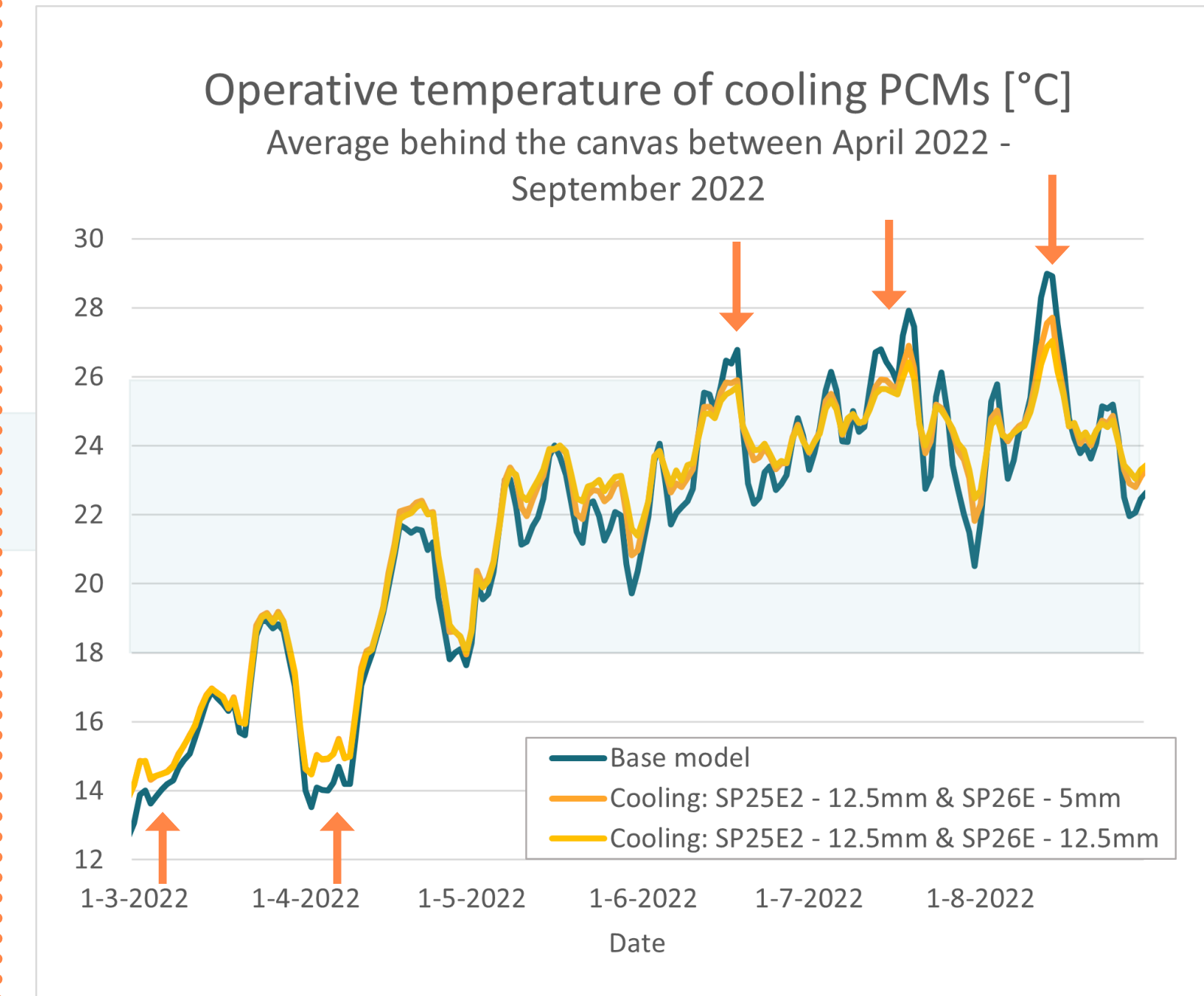

### Conclusion

PCM active on more days per year -> increase of effect on indoor climate

## Software simulations

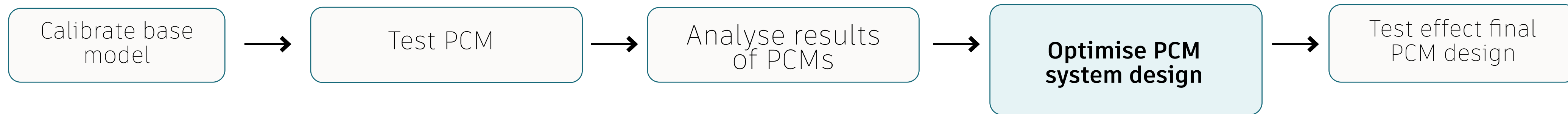

### Alternative situation

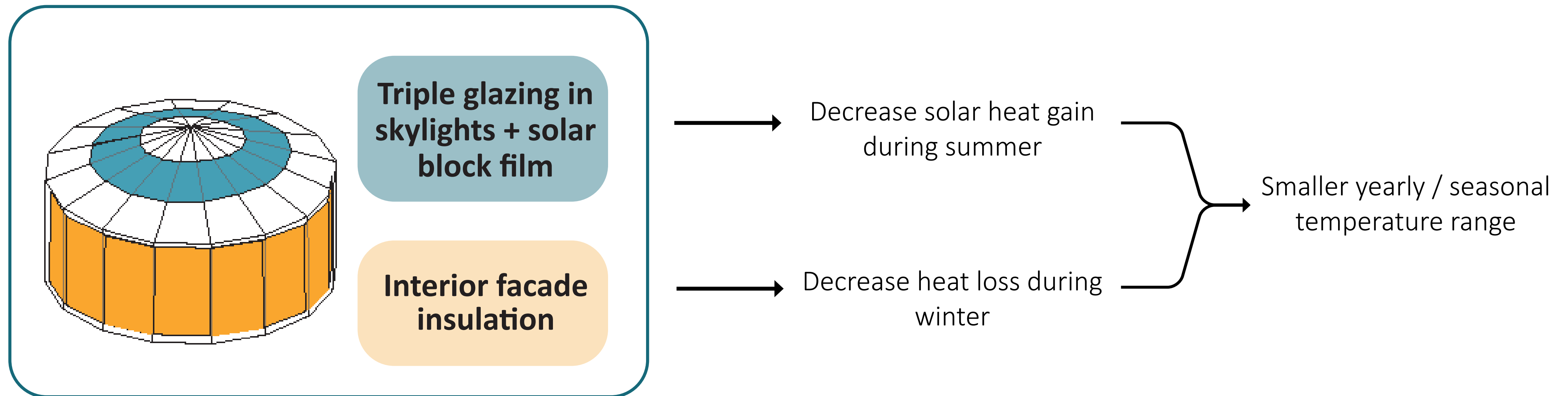

# Software simulations

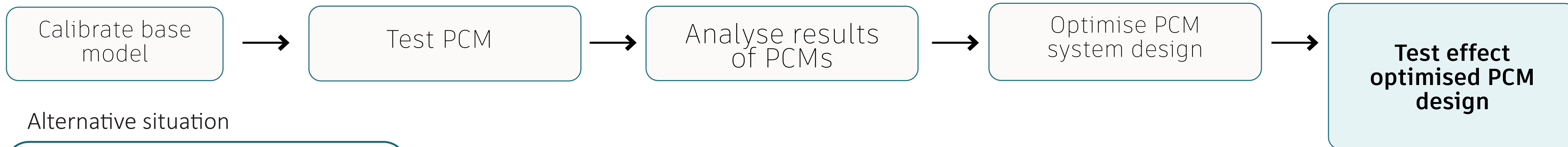

Alternative situation

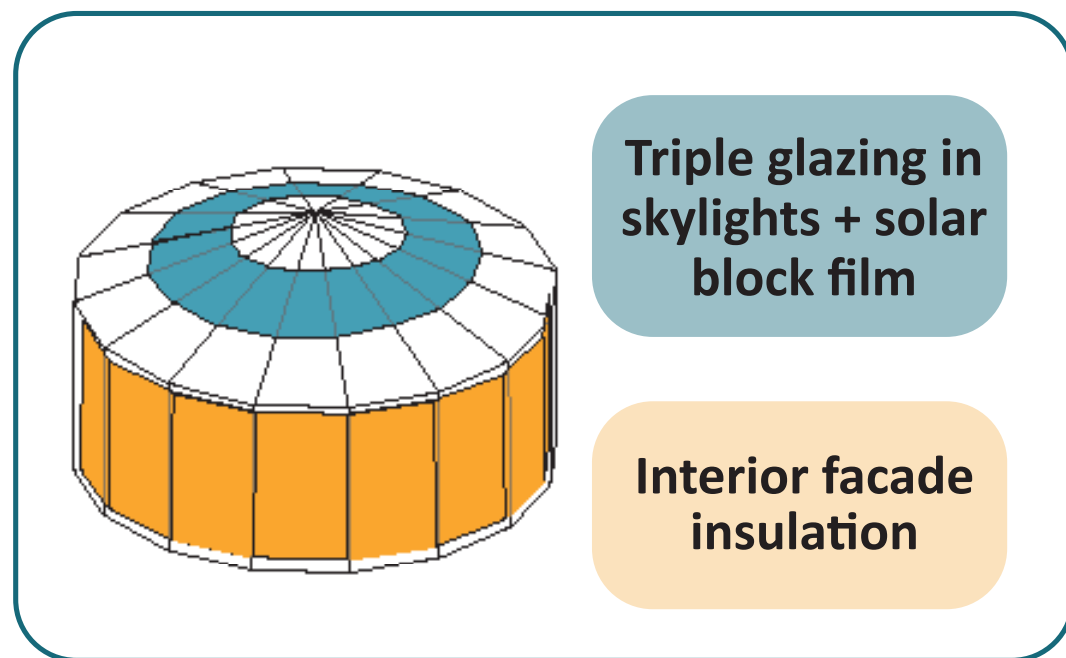

**PCM SP24E Rubitherm 12.5 mm**

- Melting: 24-25
- Solidifying: 21-23

**Results summer**

- Temperature - 4 to 5 °C on **peak summer days**
- **Average temperature -1.5 °C**

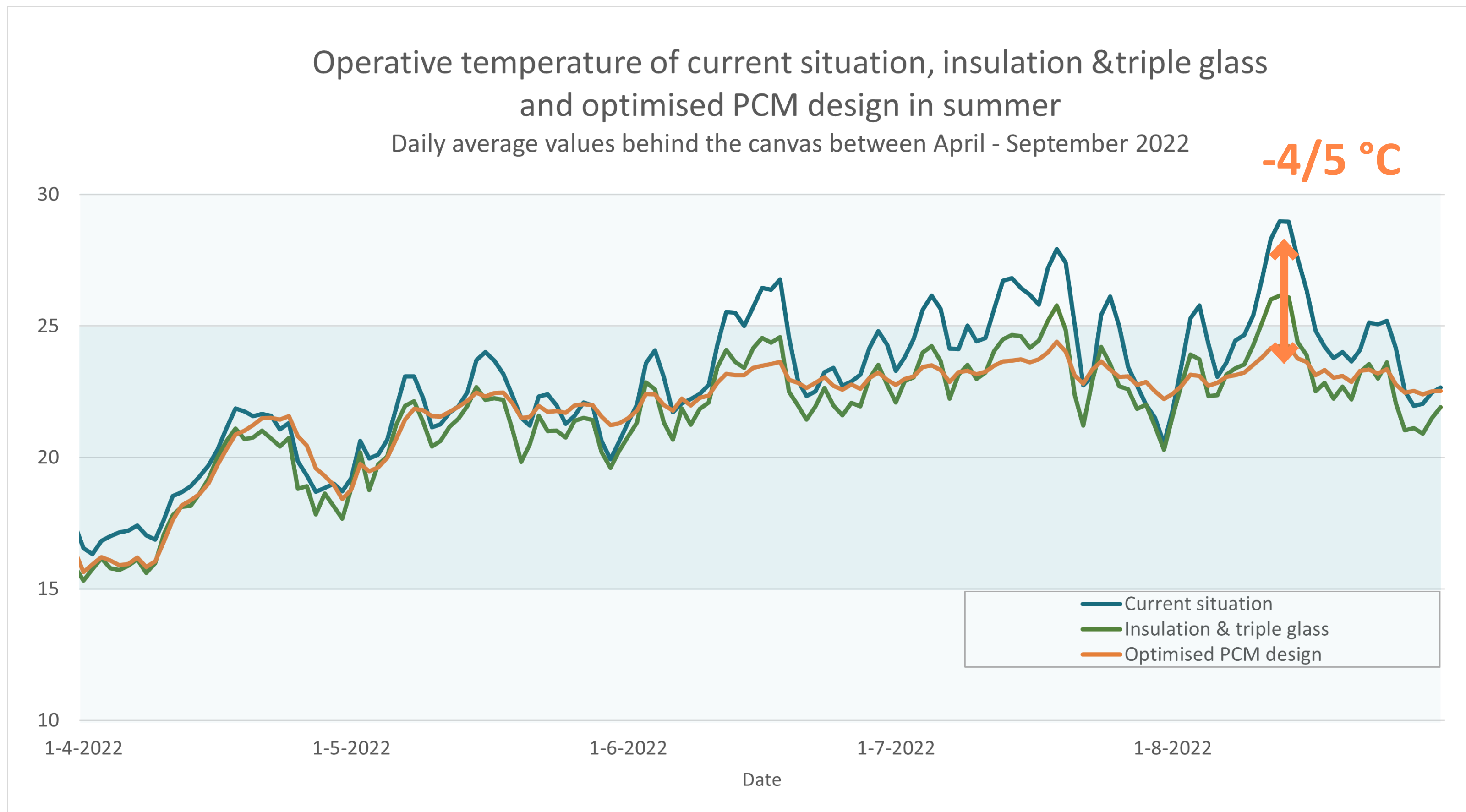

**Software simulations**

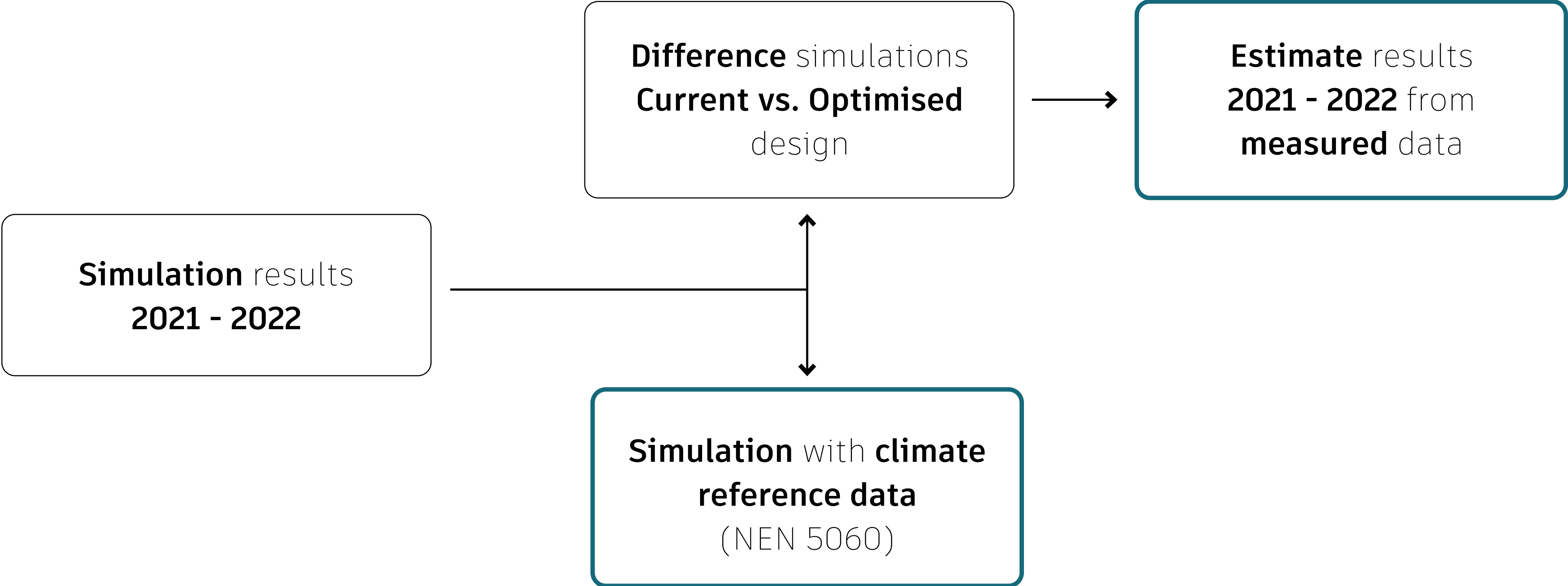

# Software simulations

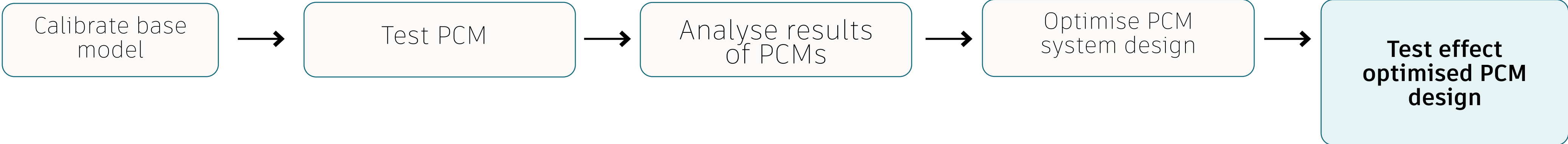

**-50% heating demand if current T winter is setpoint**

**Conclusion**

- Sufficient **cooling**
- **No heating** required (+15 °C)

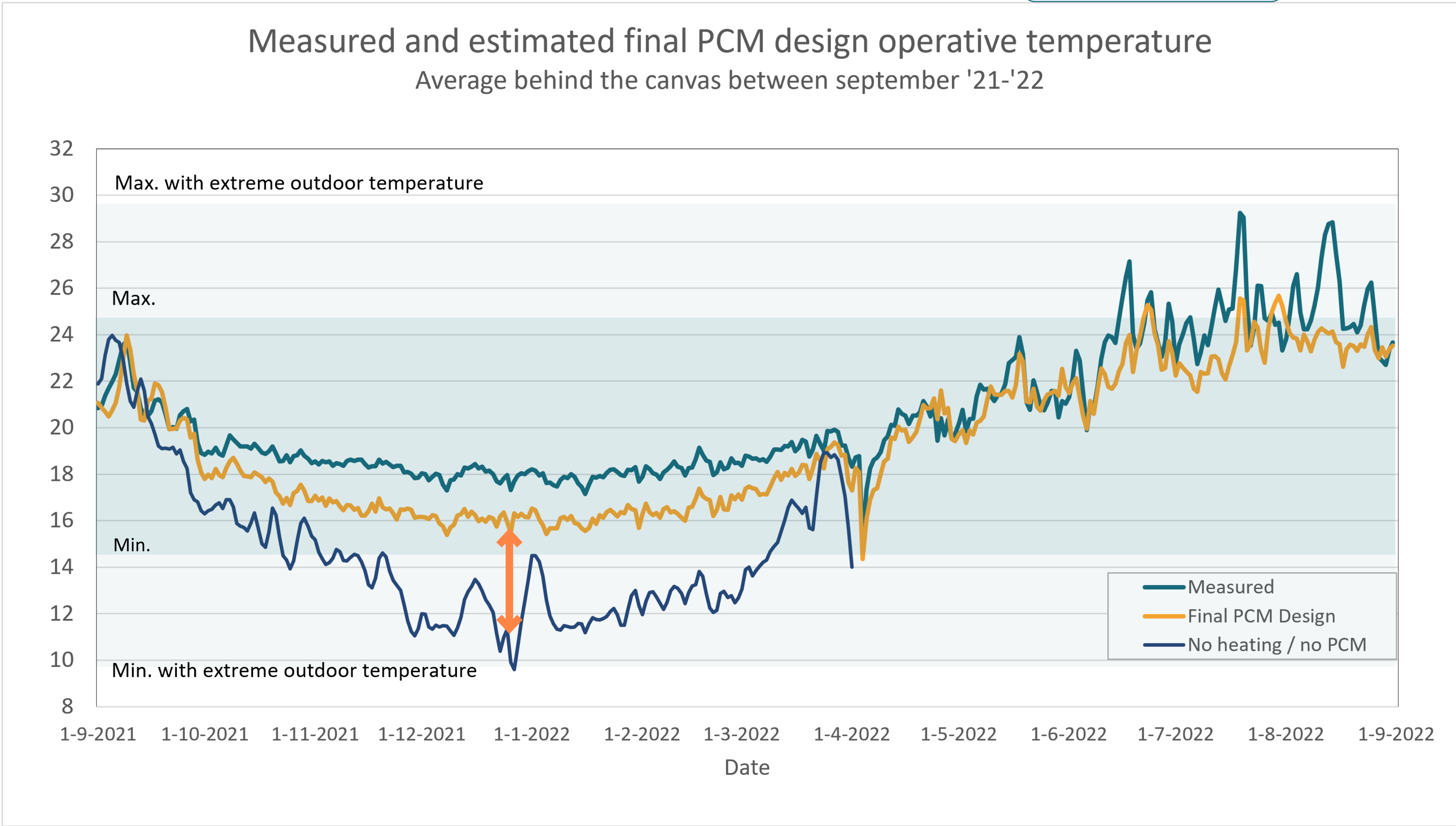

## Software simulations

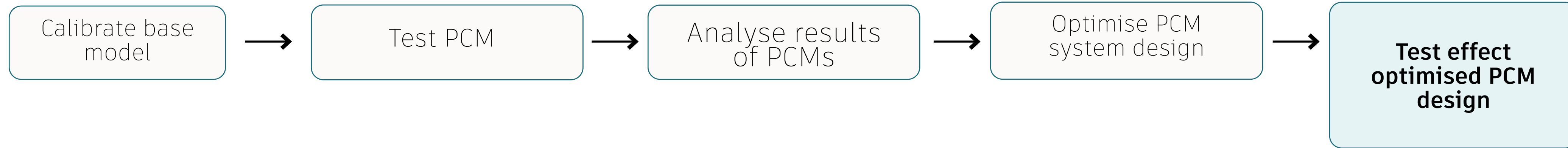

### Measured and estimated final PCM design relative humidity

Average behind the canvas between september '21-'22

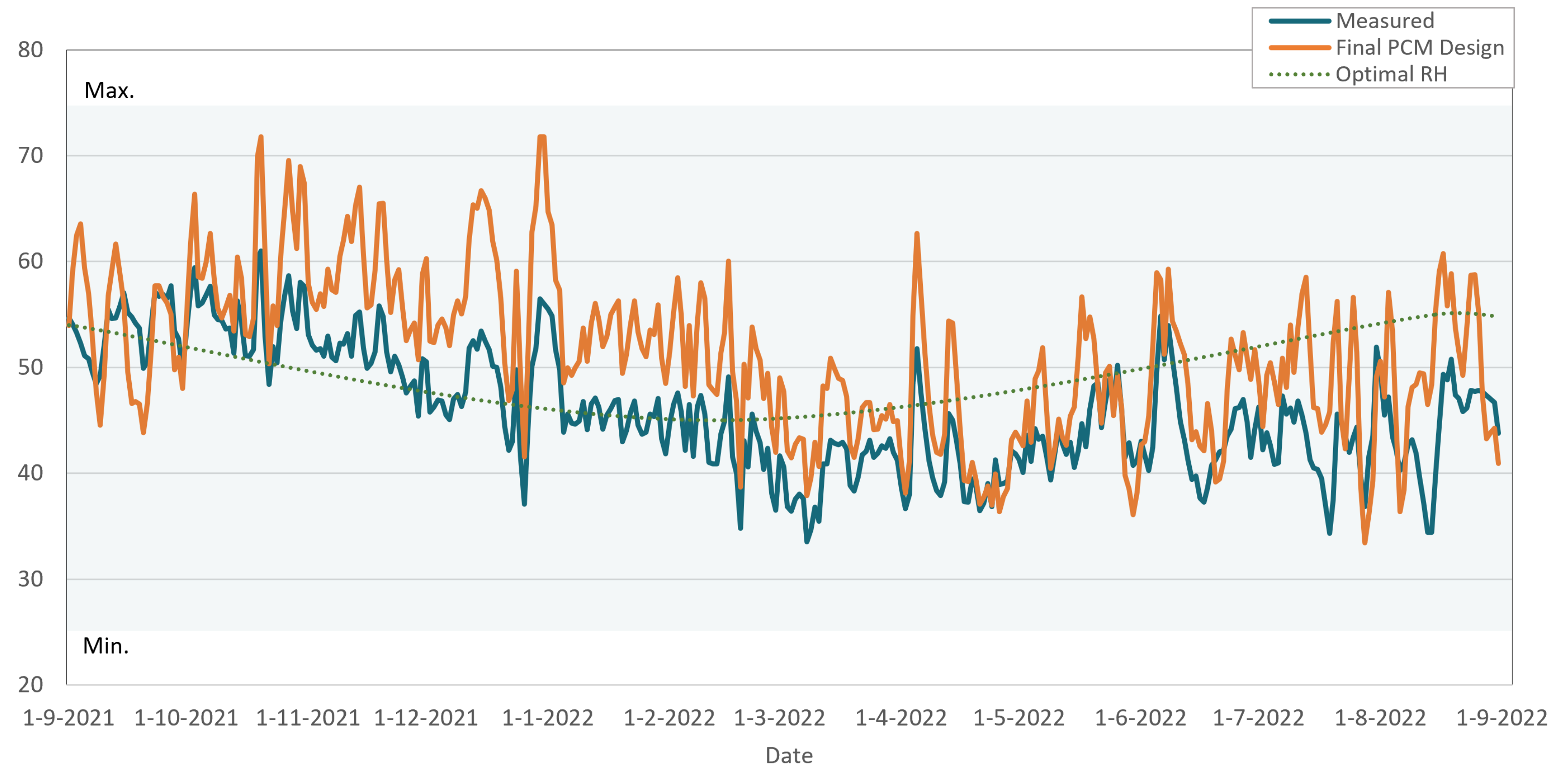

### Conclusion RH

- winter **dehumidification** advised

# Software simulations

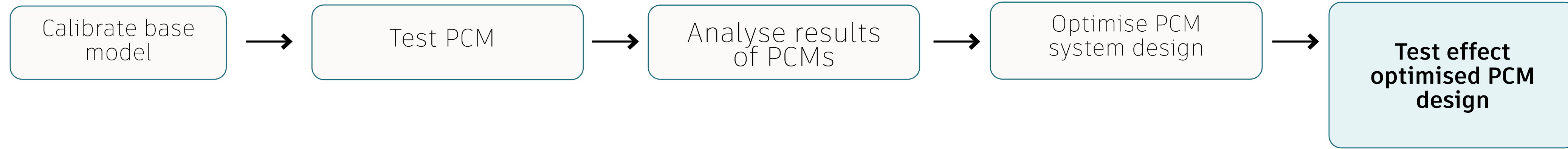

Yearly indoor climate fluctation indicators: average behind the canvas	Behind the canvas		
	Measured	Estimate of final PCM Design	Required indoor climate
Minimum RH [%]	29.0	32.7	25
Maximum RH [%]	63.7	71.8	75
Minimum T [°C]	14.3	14.1	10
Maximum T [°C]	32.2	27.1	30
Days per year of RH fluctuation > 10 %/24hr	36	14.6	0
Maximum RH fluctuation [%/24hr]	16.6	16.6	10
Days per year of T fluctuation > 5 °C/24hr	16	0	0
Maximum T fluctuation [°C/24hr]	6.2	4.6	5
Days per year of T fluctuation > 3 °C/24hr	116	7.7	n.a.

Complies with intended indoor climate		
No, but improved	No	Yes

## Fluctuations Optimised PCM Design

**Daily RH fluctuations**

- occur **-50%/year**

**daily T fluctuations**

- large: occur **-100%/year**
- small: occur **-90%/year**

Indoor climate of **optimised design is safe** for preservation of the painting

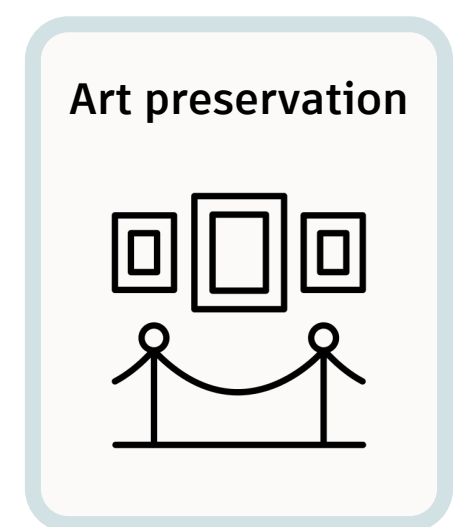

# Software simulations

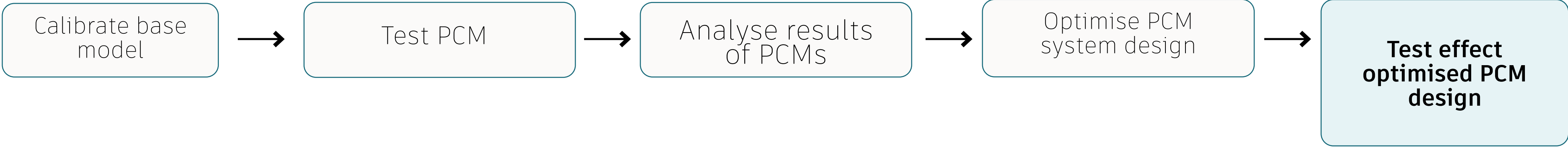

## Climate reference data

**Results**

- sufficient cooling
- minimal heat loss winter



**Conclusion**  
**Comparable** effect to 2021-2022 simulations

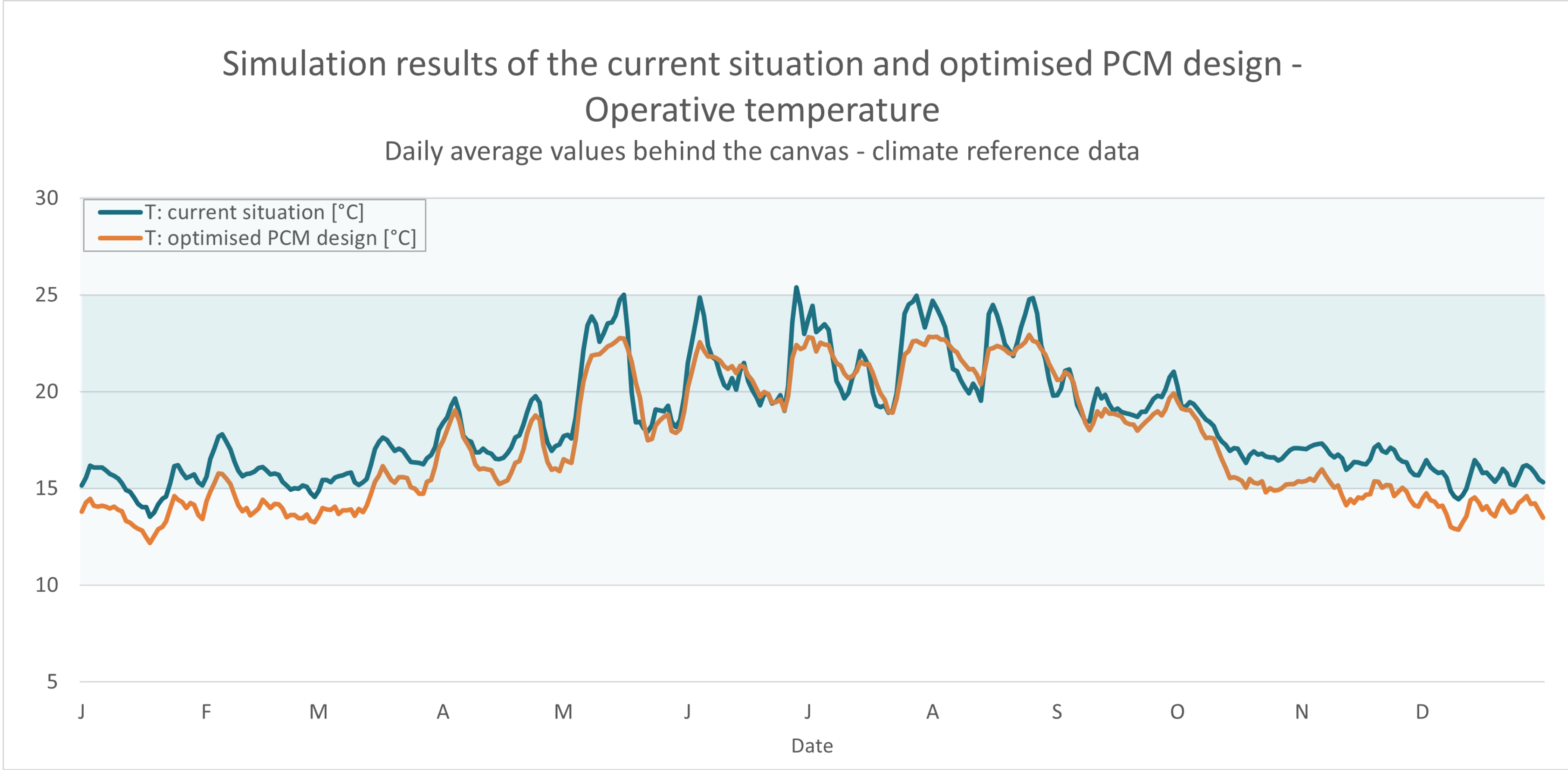

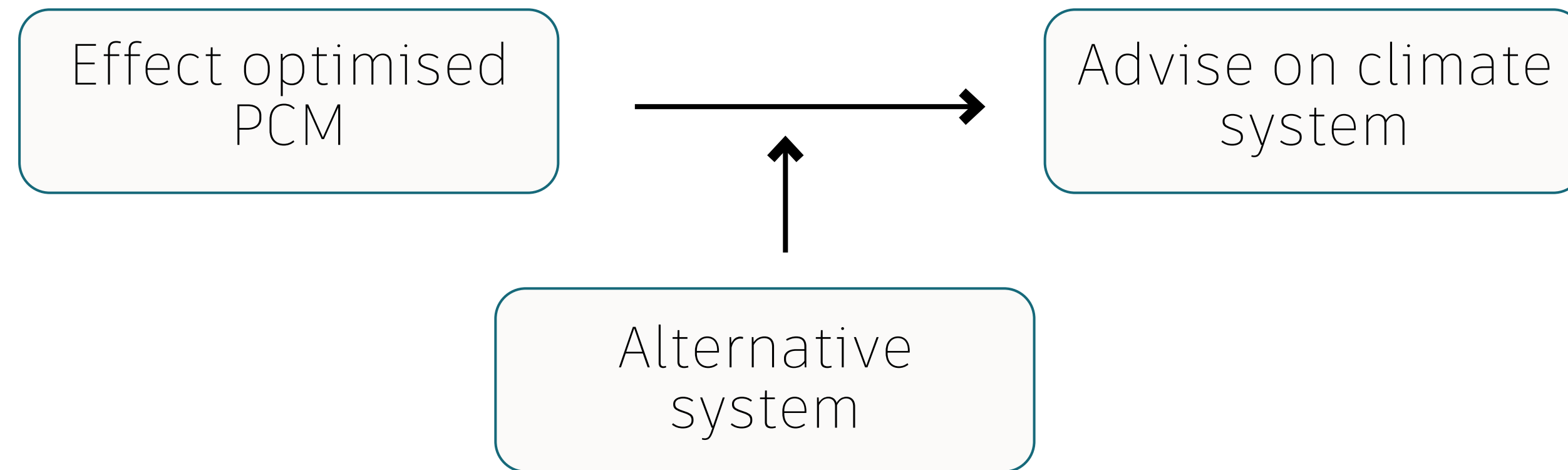

Effect optimised  
PCM

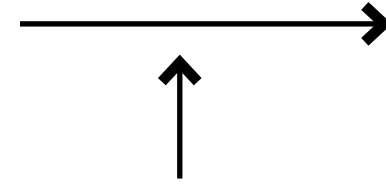

Advise on climate  
system

Alternative  
system

UNDERGROUND

**PACKED-BED**

MEDIUM: PEBBLES (BRICK/  
ETC.)  
ACTIVE SYSTEM  
450 M2, 1M DEPTH

450 M3  
3,600 MJ

80-90% EFFICIENCY  
STORING FOR HOURS-DAYS  
5K temperature difference

- RISKS  
++ INSTALLATION  
+ IMPACT

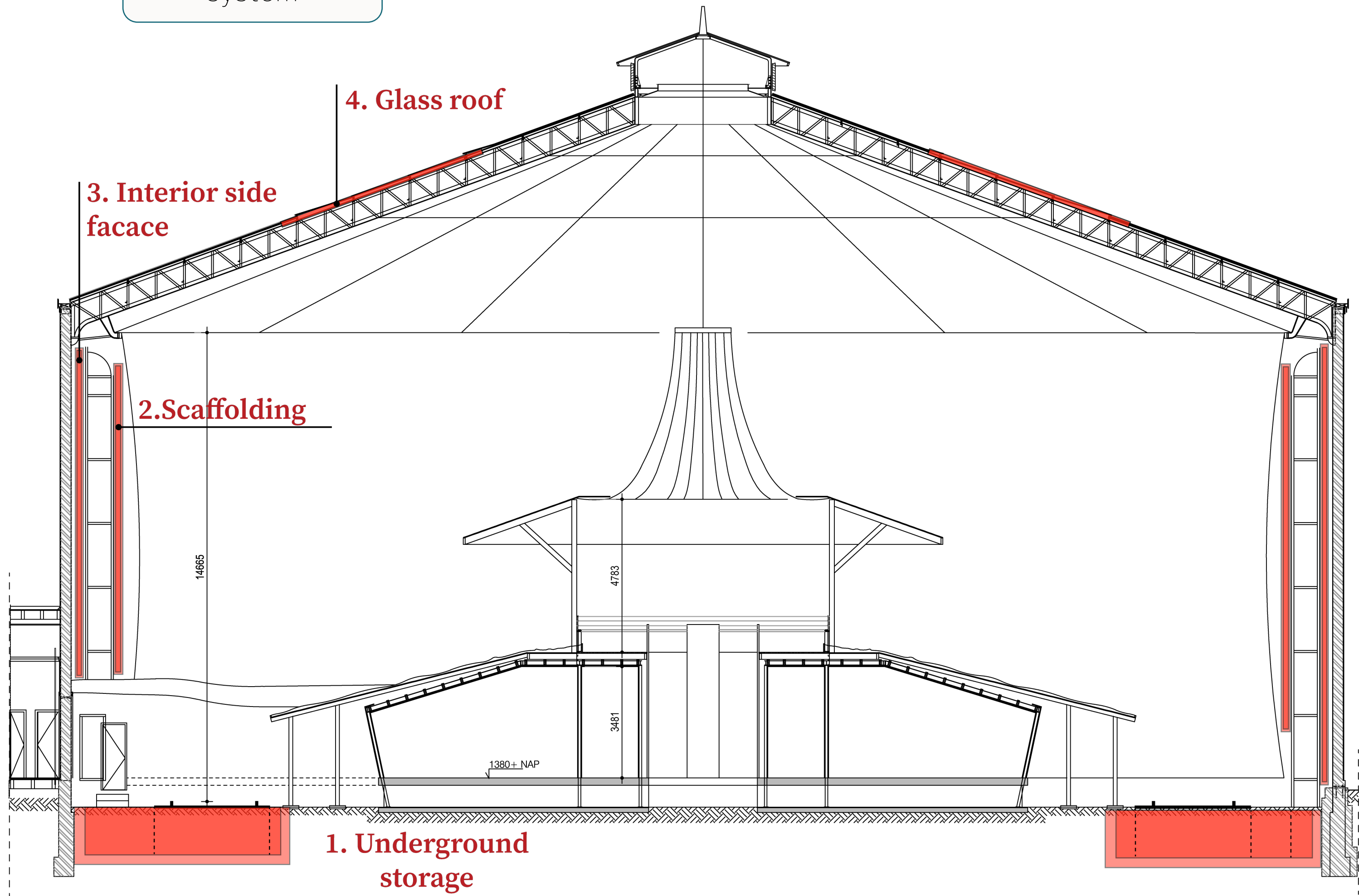

Alternative system

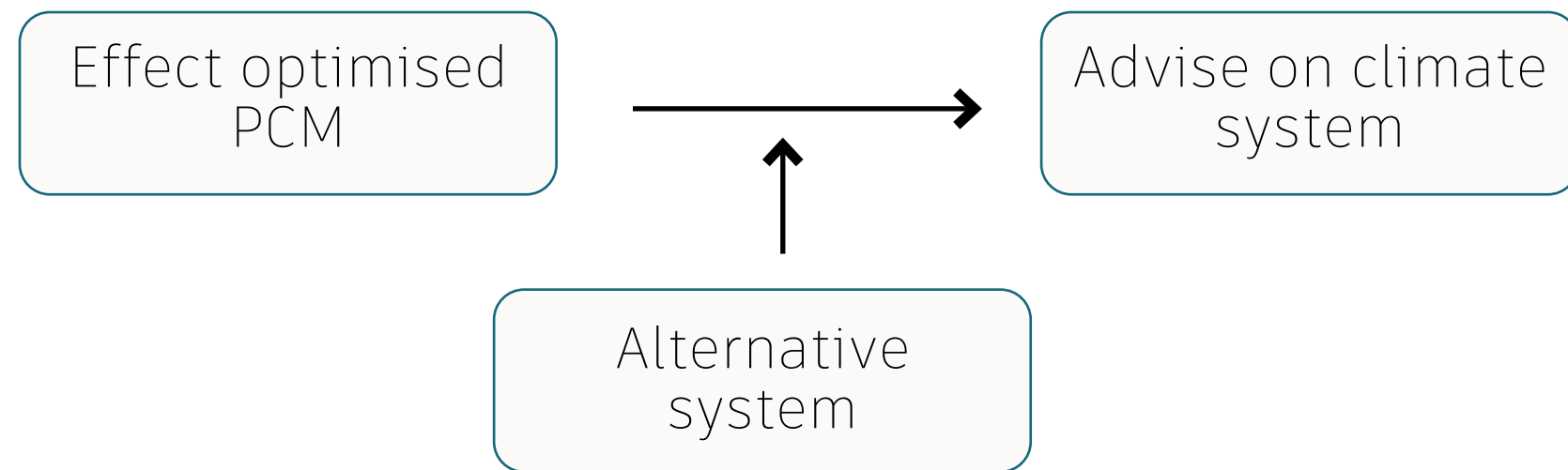

**Results**

- minimal cooling
- minimal heating effect



**Conclusion**

- **Not advised** for implementation **by itself**
- Further research needed: **insulation & triple glazing**

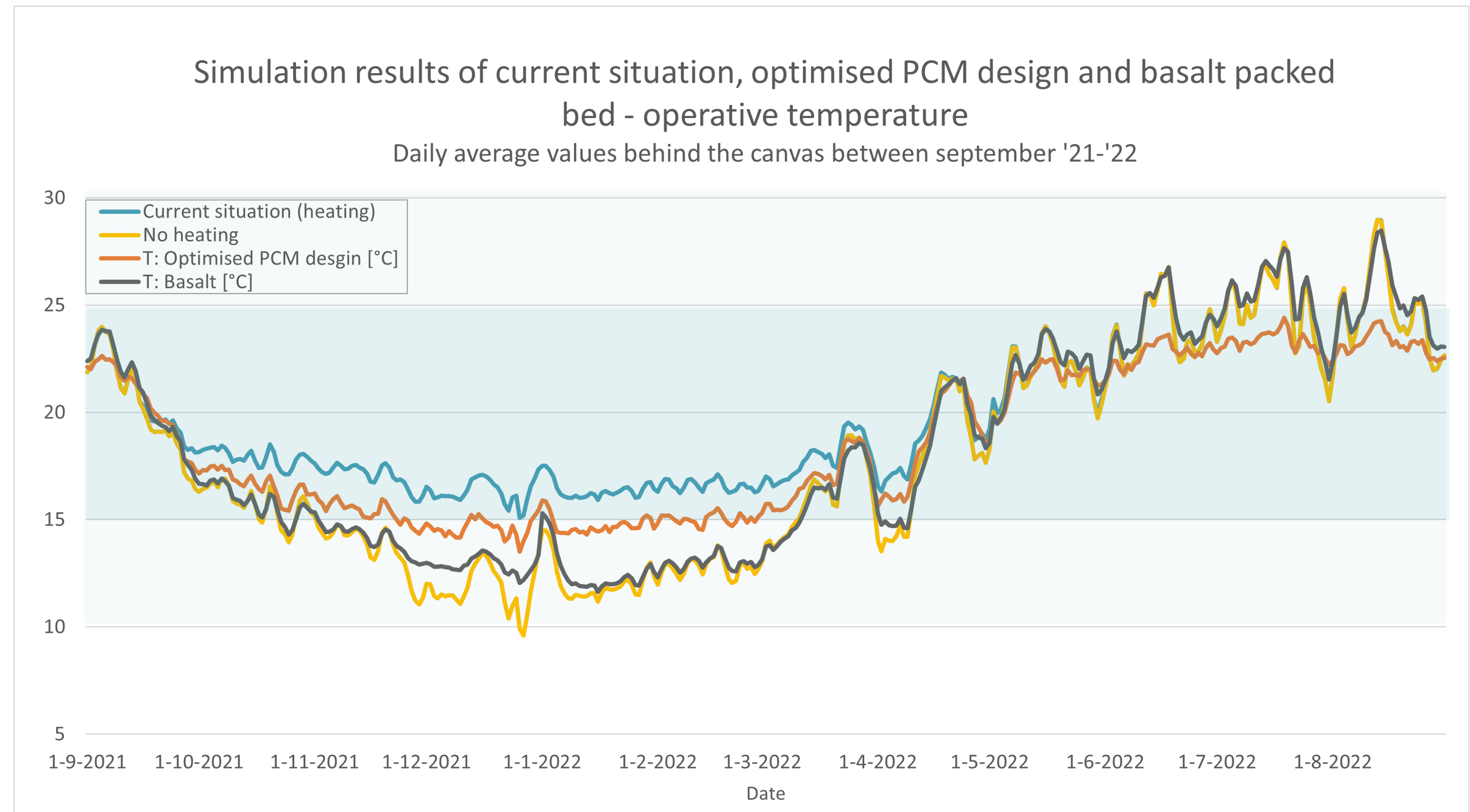

How can the **Rotonde** of the Panorama Mesdag Museum be **adapted** to **increase the thermal buffering capacity** of the building while not interfering with the monumentality of the exhibition building and the experience of the permanent Panorama Mesdag exhibition?

### Decrease heating demand

#### **Improve building envelope**

- Facade insulation
- Triple glazing + solar block film

### Improve indoor climate

#### **Cooling & decrease fluctuations**

- PCM facade panels

**Additional ventilation / dehumidification** advised to improve relative humidity

**Step 1.**

Improve quality  
building envelope  
for cooling effect



Evaluate  
indoor climate



**Step 2.**

Facade insulation

PCM / Basalt packed  
bed

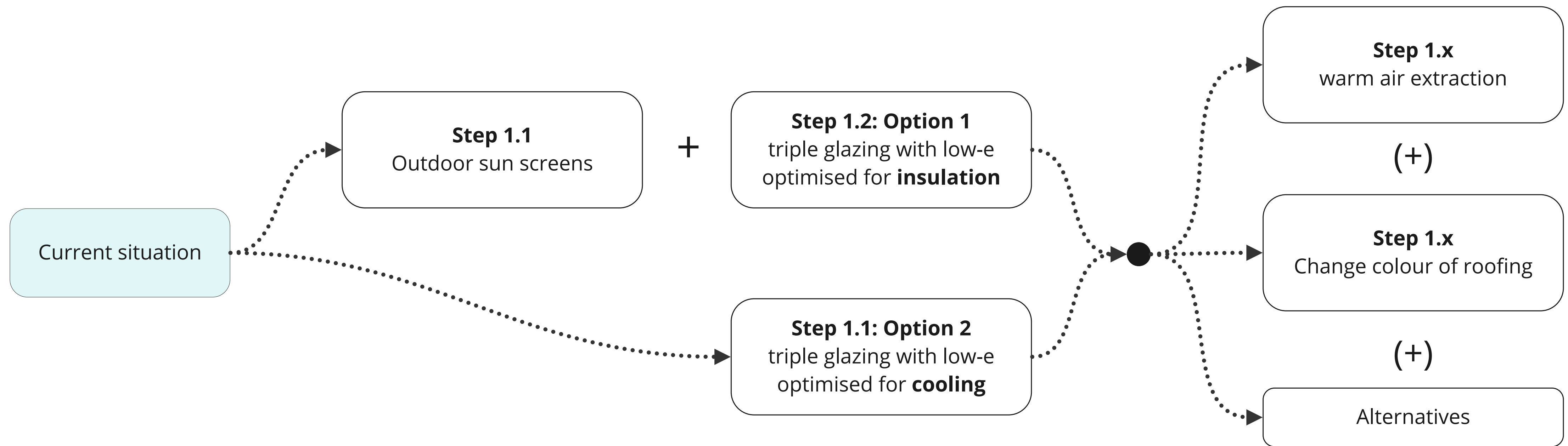

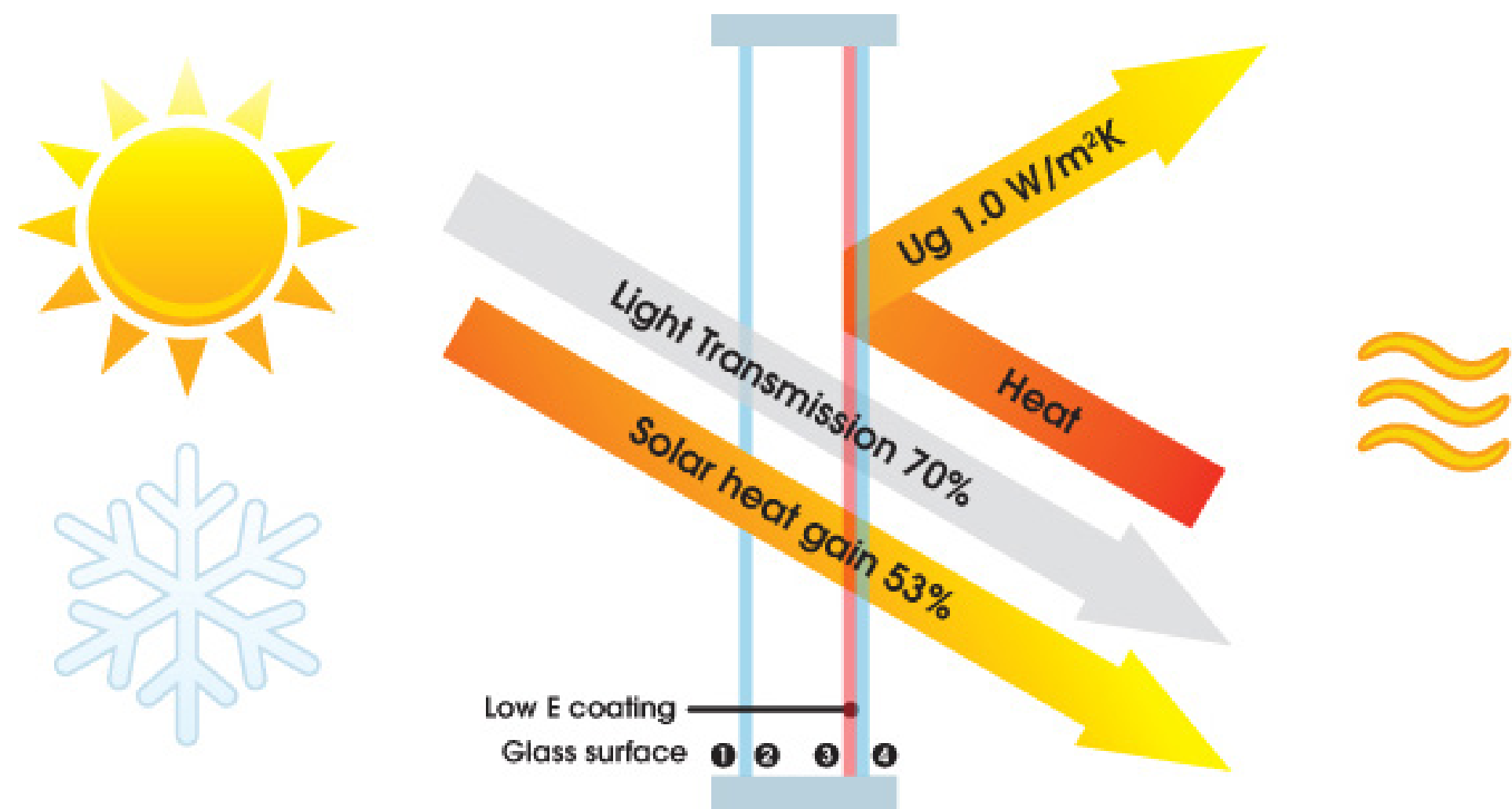

(Sligoglass, 2015).

**Insulated glazing with low e coating**  
Cooling & insulating effect



(Helioscreen, 2021).

**Exterior sunshading**  
Further research needed to define feasibility.

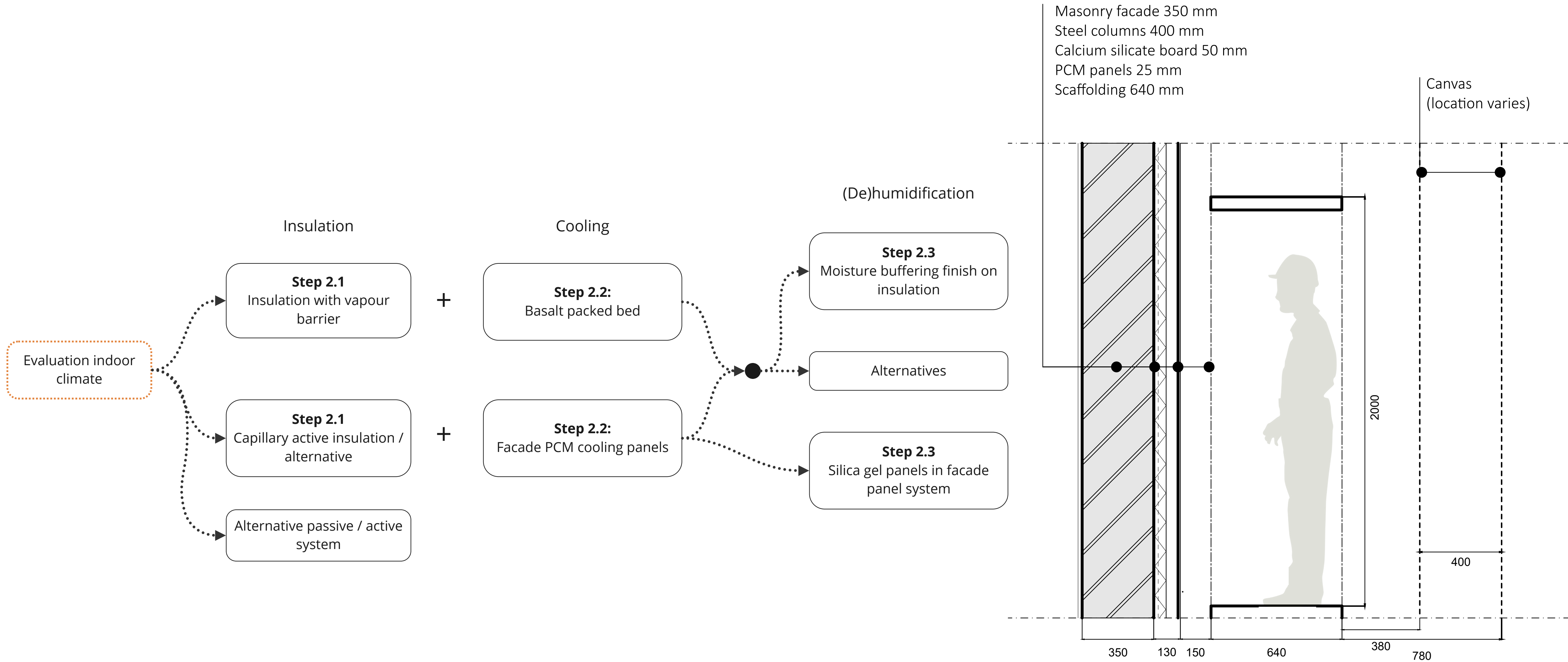

Advise on climate system

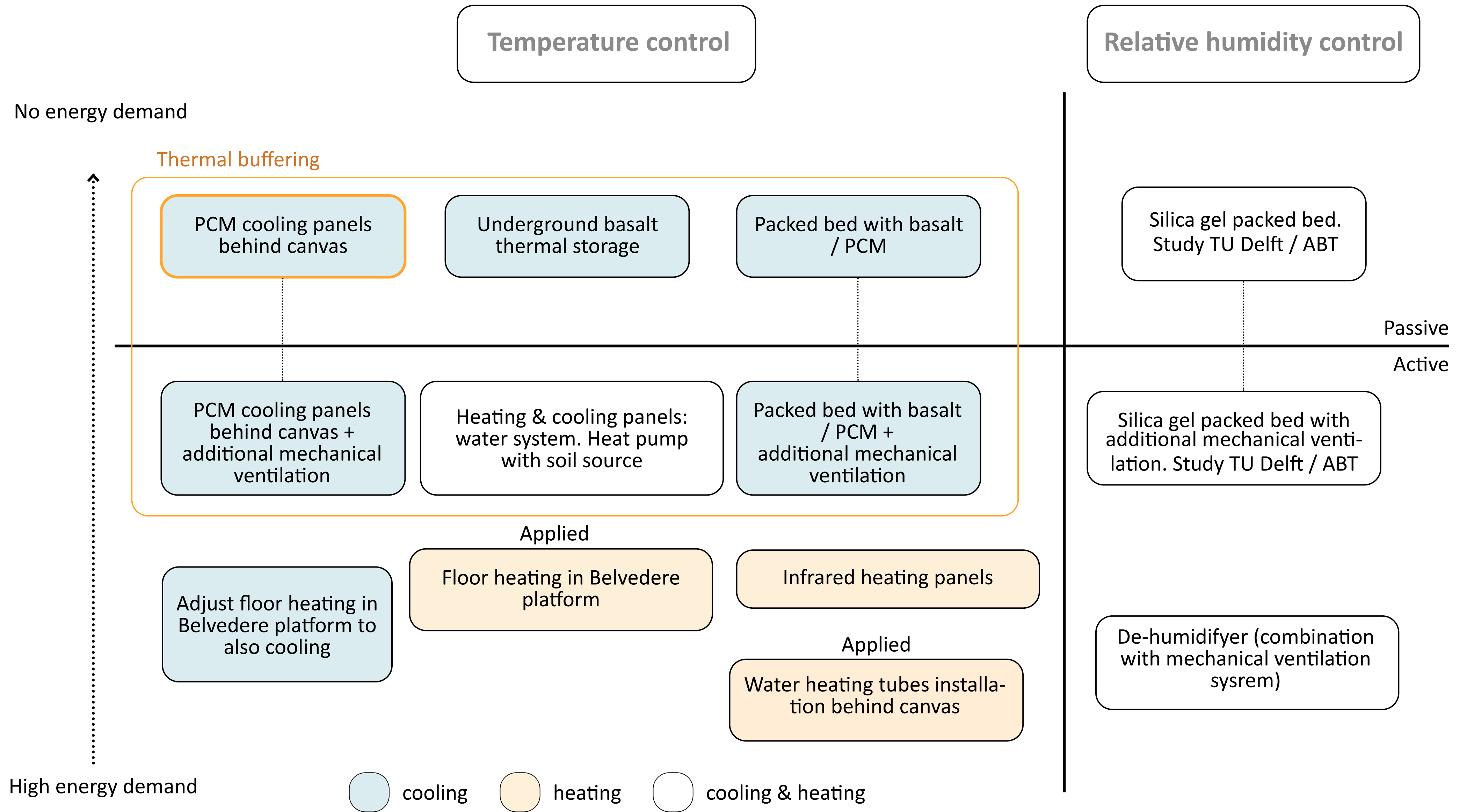

Advise on climate system

Can the application of the thermal buffering solution for the Rotonde be **relevant for other monumental panorama buildings** or any monumental building with a similar building envelope?



ORIGINAL FACADE

Original: steel H-columns and concrete walls



ORIGINAL ROOF

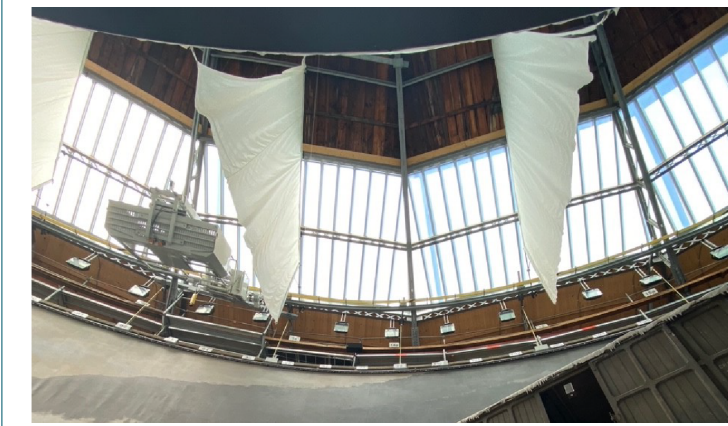

Original: steel truss structure and wooden panels

RENOVATED GLAZING

Renovated: single glazing with uv-protective layers in aluminium frames

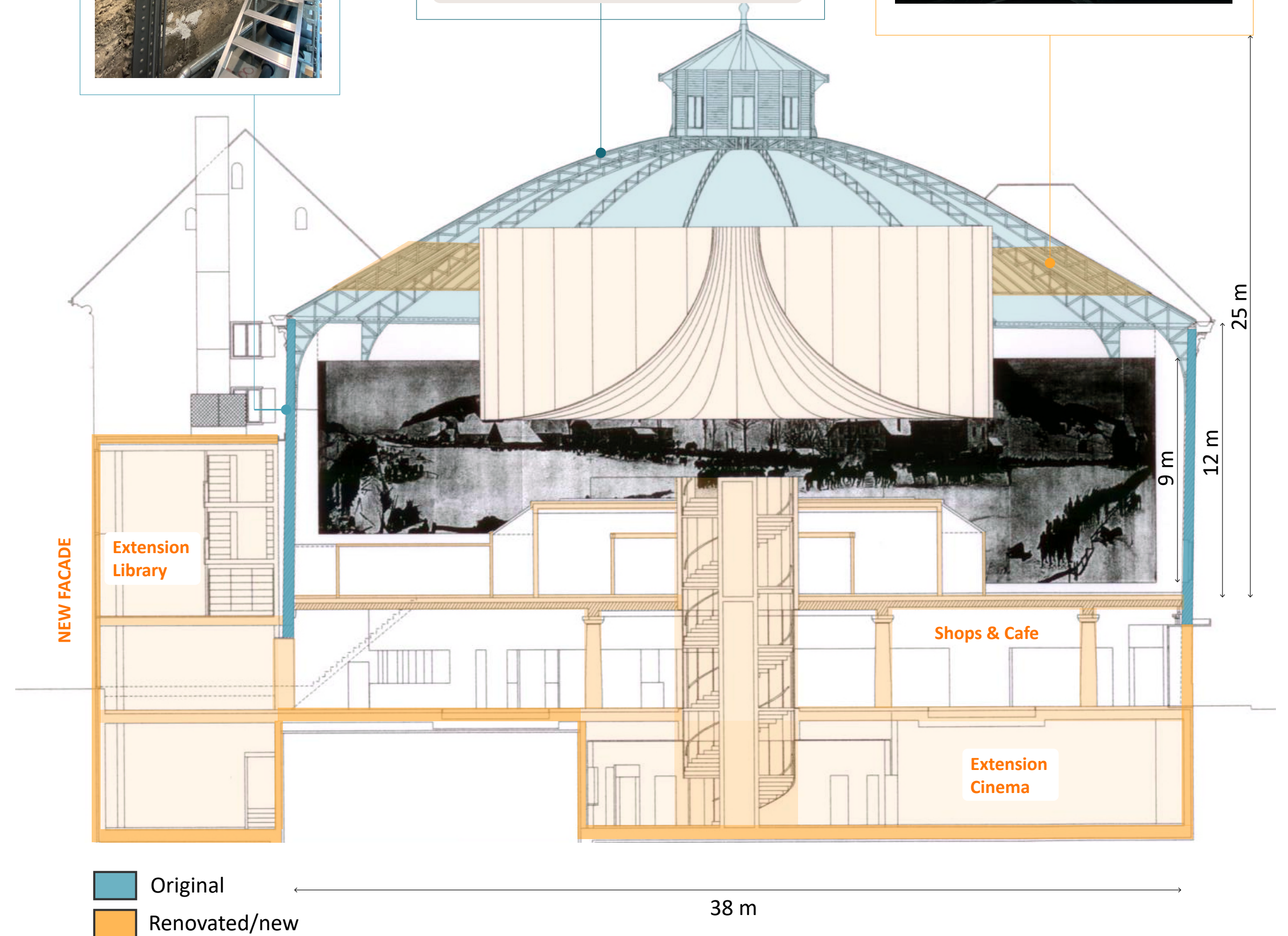

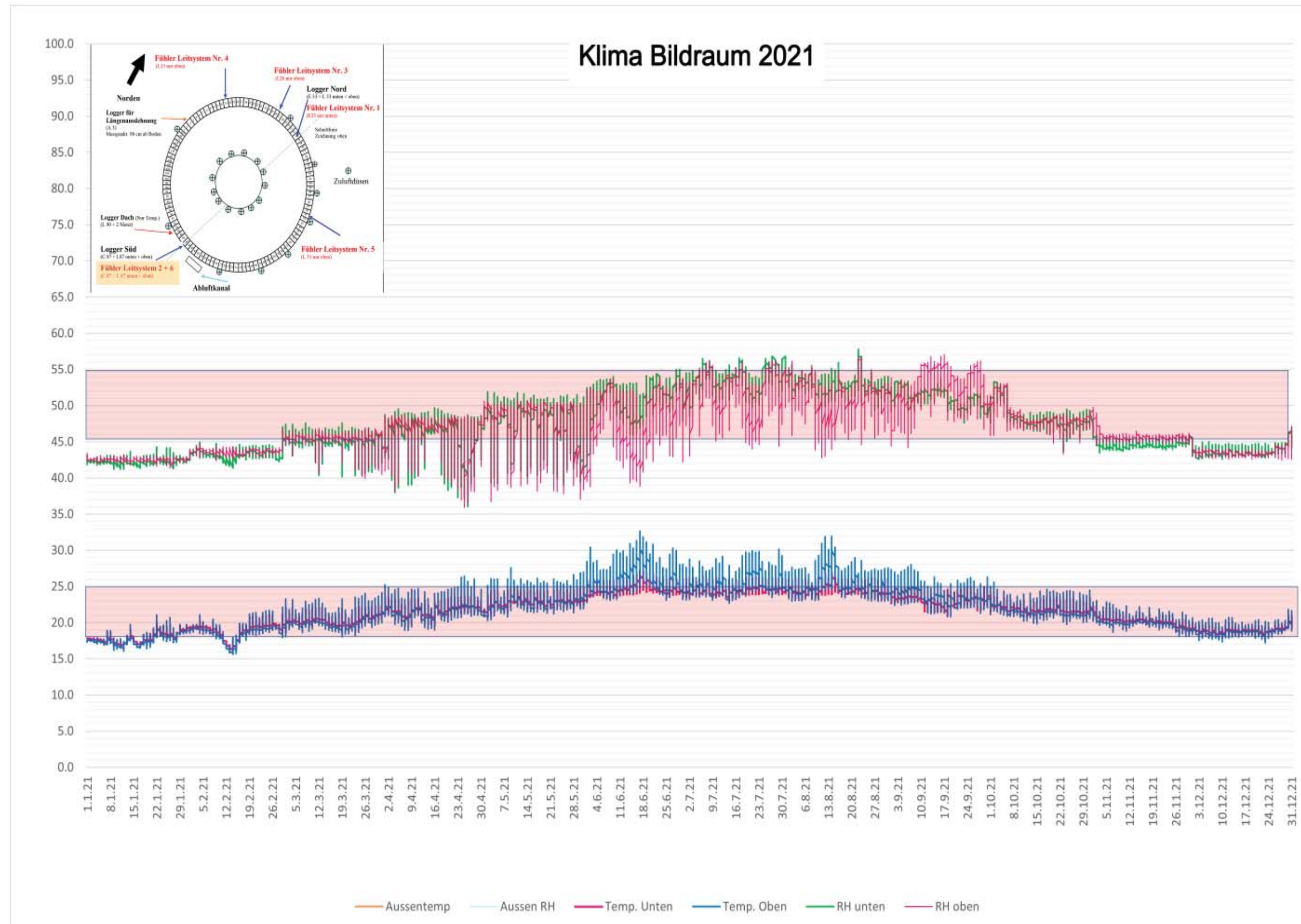

Source: Frei Wüest Expert Ingenieurbüro (2021)

Yearly climate indicators of the Rotonde of Panorama Mesdag and Bourbaki Panorama	Rotonde	Bourbaki
Minimum RH [%/per day, month, season or year]	29.0	36.4
Maximum RH [%/per day, month, season or year]	63.7	61.3
Minimum T [°C/per day, month, season or year]	14.3	15.9
Maximum T [°C/per day, month, season or year]	32.2	30.8
Days per year of RH fluctuation > 6 %/24hr	172	144
Maximum RH fluctuation [%/24hr]	16.6	15.8
Maximum T fluctuation [°C/24hr]	6.2	6.1
Days per year of T fluctuation > 3 °C/24hr	116	171

### Conclusion

- Indoor climate of Bourbaki Panorama similar to Rotonde in fluctuations of RH & T
    - Spatial possibilities similar
- => **PCM cooling panel suitable for increase quality of indoor climate**

Adds to **knowlegde** about application of **sustainable systems** to control **indoor climate**, specifically for **museums** in **monumental buildings**

This research shows the **importance** of a **well functioning building envelope** before the application of **additional climate control systems**

Helps **decrease stigma** around **PCM** as **expensive and not feasible** option - Effective systems of **62,5 Eu/m<sup>2</sup>** (PCM price)

