



Reclaiming the Power of Energy

Reclaiming Energy through the Community,
Ecology, and Landscape of Friesland

Colophon

Reclaiming the Power of Energy: Reclaiming energy through the community, ecology, and landscape of Friesland

R and D Studio: Spatial Strategies for the Global Metropolis (AR2U086)
Research and Design Methodology for Urbanism (AR2U088)

Master of Science, Architecture, Urbanism, and Building Sciences - Urbanism Track
Quarter Three, 2026 Q3
Delft University of Technolgy
Delft, the Netherlands

Authors:

Maran Bensink	5569729	M.Bensink@student.tudelft.nl
Ruby Kabuiku	6563775	R.P.M.Kabuiku@student.tudelft.nl
Cole von Feldt	6391834	N.J.B.VonFeldt@student.tudelft.nl
Aylin Yavuz	6285678	A.H.Yavuz@student.tudelft.nl

R and D Studio Tutors:

Irene Luque Martin
Caroline Newton

Studio Coordinators:

Verena Balz
Nikos Katsikis

Methodology for Urbanism Tutors:

Roberto Rocco
Juliana Goncalves

Introduction to the Course

The Q3 R&D Studio assesses spatial qualities at the regional scale. In the sequence of mandatory design studios as part of the MSc Urbanism program, the scale of Q3 is the largest to date. Students therefore work in small teams to manage research and design proposal deliverables. While analyzing the proposed design's effect on multiple administrative boundaries, students must consider the spatial considerations of existing and proposed policies.

The studio considered the theme of energy transition within the Netherlands as a guiding lens for design proposals. Through collaborative efforts, a spatial vision and development strategy have been created to address solution(s) for the further implementation of renewable energy within various regions of the Netherlands.

The R&D Studio was paired with the complementary Research and Design Methodology course.

Abstract

Globally, climate change has a significant influence on human well-being ad interaction. Current societal reliance on fossil fuels must be reduced through a transition to renewable energy. The Netherlands is poised to be a global leader in this transition. Local communities in the northern province of Friesland - residents, farmers, fishermen, and local energy companies - are often forgotten in this discussion. The proposed project seeks to provide benefits for both the residents and municipal governments of Friesland towards regional electric self-sufficiency.

The proposed project views the province in three different areas, the North Sea, Wadden Sea, and mainland Friesland, based upon unique ecological characteristics. These areas are accordingly assessed through three themes: energy production, ecological stewardship, and local engagement. Adherence to theoretical research of ecological stewardship, self-sufficiency from energy production, local engagement spurred through urbanization, and multilevel governance throughout

the energy transition helped to facilitate discourse and direction throughout the proposed project. When contextualized through the conceptual framework, each theoretical component is given spatial gravity: energy production and self-sufficiency in the North Sea, ecological stewardship of the ever-important Wadden Sea, local engagement through urbanization of five Frisian cities that couples with a multilevel governance framework that values bottom-up approaches.

While Friesland is one of the most energy-poor provinces in the country, it also has many geographical advantages that can play host to renewable energy transition including vast areas for wind, solar, and tidal energies production potential. The proposed project seeks to provide regional self-sufficiency, to the benefit of the province's residents and municipal governments. Various stakeholder identities have shaped the project to incorporate needs for a multitude of communities at all scales. The proposed project culminates in a unified vision with a plethora of action cards that are implemented in various contexts in different phases.

Keywords

Renewable Energy | Wind Energy | Connectivity | Ecological Stewardship | Friesland

Disclaimers:

Unless otherwise stated, all material in this report is product of the authors. An extensive list of images and illustrations can be found in the references.

Table of Contents

Chapter 1: Introduction	006	Chapter 7: Design Strategy	092
1.1 Energy Transition	008	7.1 Overall Strategy	094
1.2 Location	010	7.2 Individual Stakeholder Engagement	096
1.3 Site Visit	012	7.2.1 Stakeholder Forum	104
1.4 Current Issues	014	7.2.2 Stakeholder Profiling	106
1.5 Community Introduction and Input	016	7.2.3 Stakeholder Power Interest Matrix	108
1.6 Aim of the Project	018	7.2.4 New Governance Framework	110
Chapter 2: Theoretical Framework	020	7.3 Action Cards	112
2.1 Ecological Stewardship	022	7.3.1 Relationships of Actions	120
2.2 Energy Production	023	7.4 Timeline	122
2.3 Local Engagement	024	7.5 Phasing Information	124
2.4 Governance	025	7.6 Zoom In's	128
Chapter 3: Approach	026	7.6.1 Zoom In - North Sea	130
3.1 Probelem Statement	028	7.6.2 Zoom In - Wadden Sea	132
3.2 Research Question	030	7.6.3 Zoom In - Land	136
3.3 Methodology Framework	032	7.7 Combined Image	138
3.4 Conceptual Framework	034	Chapter 8: Conclusion and Reflections	140
Chapter 4: Analysis	036	8.1 Conclusion	142
4.1 Analysis Maps	038	8.2 Group Reflection	144
4.2 Alignment with current policie	046	8.3 Bibliography	146
4.3 Existing Energy Typologies	050	Chapter 9: Appendix	154
4.4 New and Experimental Energy Typologies	052	9.1 Individual Position Papers	156
4.5 Existing Energy Flow	054	9.2 Image Directory	164
4.6 Synthesis Map	056	9.3 Supporting Imagery	170
Chaper 5: Scenario Exploration	058		
5.1 Areas and Themes	060		
5.2 What If Scenarios	064		
5.3 What If Conclusions	076		
Chapter 6: Vision	078		
6.1 Vision Statement	080		
6.2 Possibilities and Potentials	082		
6.3 Vision Map	086		
6.4 Abstracted Vision Maps	088		
6.5 Proposed Energy Flow	090		



Figure 01: Frysland Wind Park in Friesland as seen from the Afsluitdijk

1

Introduction

- 1.1 Energy Transition
- 1.2 Location
- 1.3 Site Visit
- 1.4 Current Issues
- 1.5 Community Introduction and Input
- 1.6 Aim of the Project



Figure 1.1: Energy distribution (cables supported above roadway) in the foreground and energy production (Fryslan Wind Park) in the background is visible from the Afsluitdijk

1.1 Energy Transition

Why is energy transition needed?

It is undeniable that the Earth is undergoing a dramatic shift, both geophysical and climatologically. Climate change and global warming are introduced in primary school, but it seems that no matter how many times we recycle or turn off the tap while brushing our teeth, the situation only worsens.

Effects of Climate Change, Globally and Locally
Climate change is reshaping landscapes and ecosystems. Over the past century, global temperatures have risen by approximately 1.1 °C since 1800 (United Nations University, 2026), resulting in more frequent extreme weather events, scorching droughts, and more intense rainstorms. These changes have significant geophysical impacts on the makeup of our planet; for example, the cryosphere is undergoing rapid, accelerating ice loss. Arctic sea ice is shrinking not only in summer but also failing to recover in winter, reaching record-low levels (global climate risk). In the Netherlands, rising temperatures and changing precipitation patterns challenge agriculture (National Delta Programme, 2025), while projected sea level rises of two to five meters threaten low-lying areas by making the land boggy and forcing saline groundwater to the surface, endangering

freshwater supplies for residents and farmers (Utrecht University, 2022). Furthermore, while higher CO2 levels and temperatures can extend growing seasons for some crops, such as grassland, these benefits are often offset by summer water shortages and salt damage (STOWA, n.d.).

In addition to the negative geophysical and climatological changes, there are significant multifaceted effects on people, ranging from immediate health crises and economic instability to long-term threats to food and water security. Global warming has increased heatwave deaths, which affect the elderly, infants and the medically vulnerable the most (Lancet Countdown). For example, the August 2003 heatwave was responsible for 965 excess deaths in the Netherlands (Robine et al., 2008). Socioeconomic and racial disparities often determine susceptibility, otherwise described as environmental racism. In low-income regions, housing is often poorly insulated, and residents frequently lack access to heating or cannot afford the energy costs to run it. Similarly, while urban areas face the "urban heat island effect," residents in rural provinces like to

long-term Friesland often have less infrastructure to cope with extreme heat, such as fewer cooling centers and emergency services (Fastl et al., 2024).

Looking Forward
Effectively changing the current course of climate change necessitates transitioning energy systems away from fossil fuels toward sustainable, renewable alternatives. Numerous international, national, and local policies are already in place to support this shift, including the legally binding Paris Agreement, which aims to limit global warming. Shifting to cleaner energy and more sustainable systems could save over ten million lives annually by reducing air pollution and improving diets (World Health Organization, 2025) move the world from a dependence on oil to a dependence on critical minerals like lithium, cobalt, and rare earth elements (Dugoua & Noailly, 2025). While the northern Netherlands has significant potential for renewable energy generation, approximately one in twelve residents live in poverty (The Northern Times, 2020), highlighting the need for an inclusive energy transition accessible to all, regardless of economic status.



Figure 1.2: Flooding evacuations (Watersnoodmuseum, 2023)

Limburg Flood, 2021

In July 2021, Limburg experienced a devastating flood that caused the evacuation of over 12,000 people. In an infographic by the Watersnoodmuseum, they state that due to climate change, there is up to 19% more rainfall than a century ago. Over the flood period there was thirty times more water than usual flowing in the region. It was named a natural disaster.



Figure 1.3: Structural damage to residential buildings (Amin, 2015)

Gas drilling causes earthquakes in Groningen

The Netherlands has been Europe's largest gas producer for the last 60 years until it had to close in 2023 due to causing sinkholes and frequent earthquakes, leading to over 250,000 damage claims by 2023. For many of the people affected, the authorities' indifference had severe consequences - financial as well as emotional.



Figure 1.4: Galanthus nivalis (Plantlife, 2023)

Ecological effects of climate change

The increase in global temperatures is starting to change ecological cycles. In western Europe, thermophilic plant species have become more abundant compared to 30 years ago. In the new version of the Dutch flora, 41 new plants species have been added this year (Vliet and Leemans, 2004).

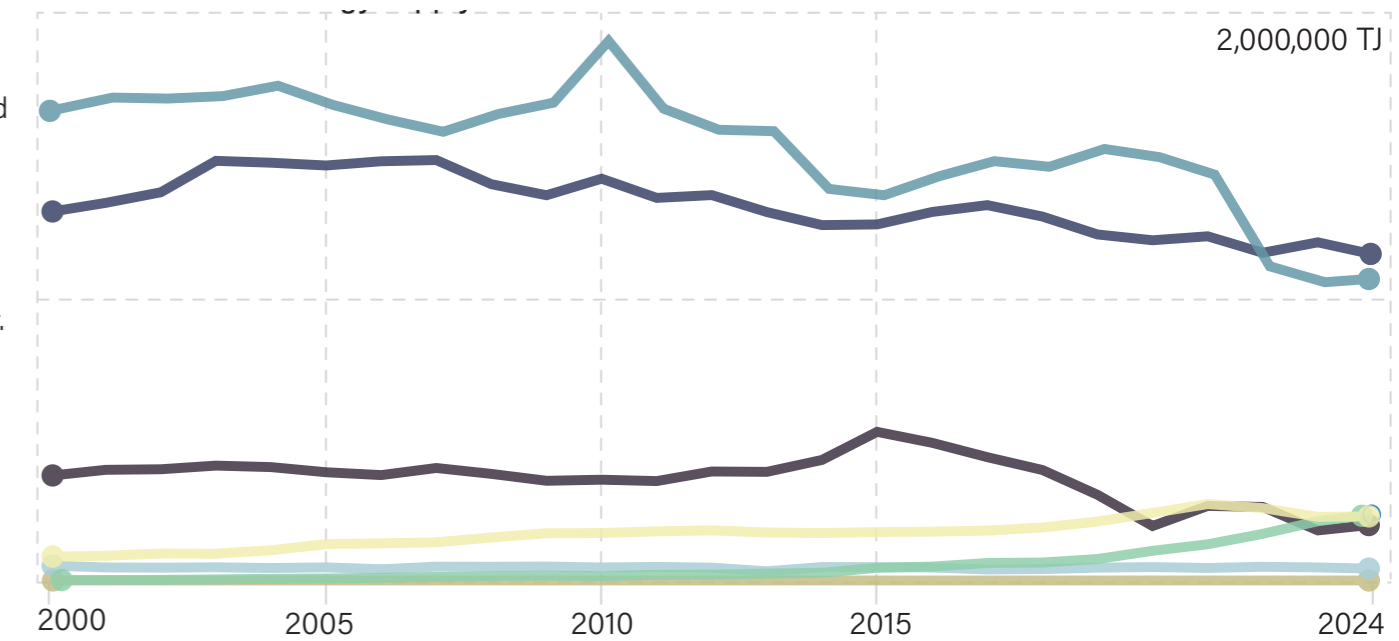

Figure 1.5: Evolution of total energy supply in The Netherlands since 2000



Figure 1.6: Total energy supply in The Netherlands (%)

1.2 Location

Introduction and History of Friesland

The history of Friesland traces back to its year 600 when the Frisian Kingdom stretched far into Belgium and Germany. The Frisian identity – one characterized as self-sufficient – remains to this day through not only the history of the former Kingdom, but its own recognized language that is different from Dutch (International Welcome Center North, 2024).

Located in the northern part of the country, Friesland lies outside the economic powerhouse region of the Randstad, which includes Amsterdam, Rotterdam, Utrecht, and The Hague. This therefore means that Friesland is at an economic and energy disadvantage from other provinces. In fact, Friesland is one of the most economically poor provinces in the country and has the second lowest GDP per capita (TNO, 2025, Statistics Netherlands, 2024).

Agrofood and biobased economies are most prevalent throughout Friesland, as most of the land area is occupied by farms. Other industries including sustainable energy, water technology, and life sciences are becoming more popular (International Welcome Center North, 2024).

Friesland's largest city, Leeuwarden, has a population of approximately 130,000 which ranks 20th in the country's most populous cities (Data Commons, n.d.). Leeuwarden serves as the main transit connection point to the rest of the country. Friesland is also known for the marveled ecology on its four islands: (from southwest to northeast) Vlieland, Terschelling, Ameland, and Schiermonnikoog. In between the mainland and the islands is the Wadden Sea which reaches northwards to the western Danish coast. UNESCO has placed protection over the Sea since 2009.

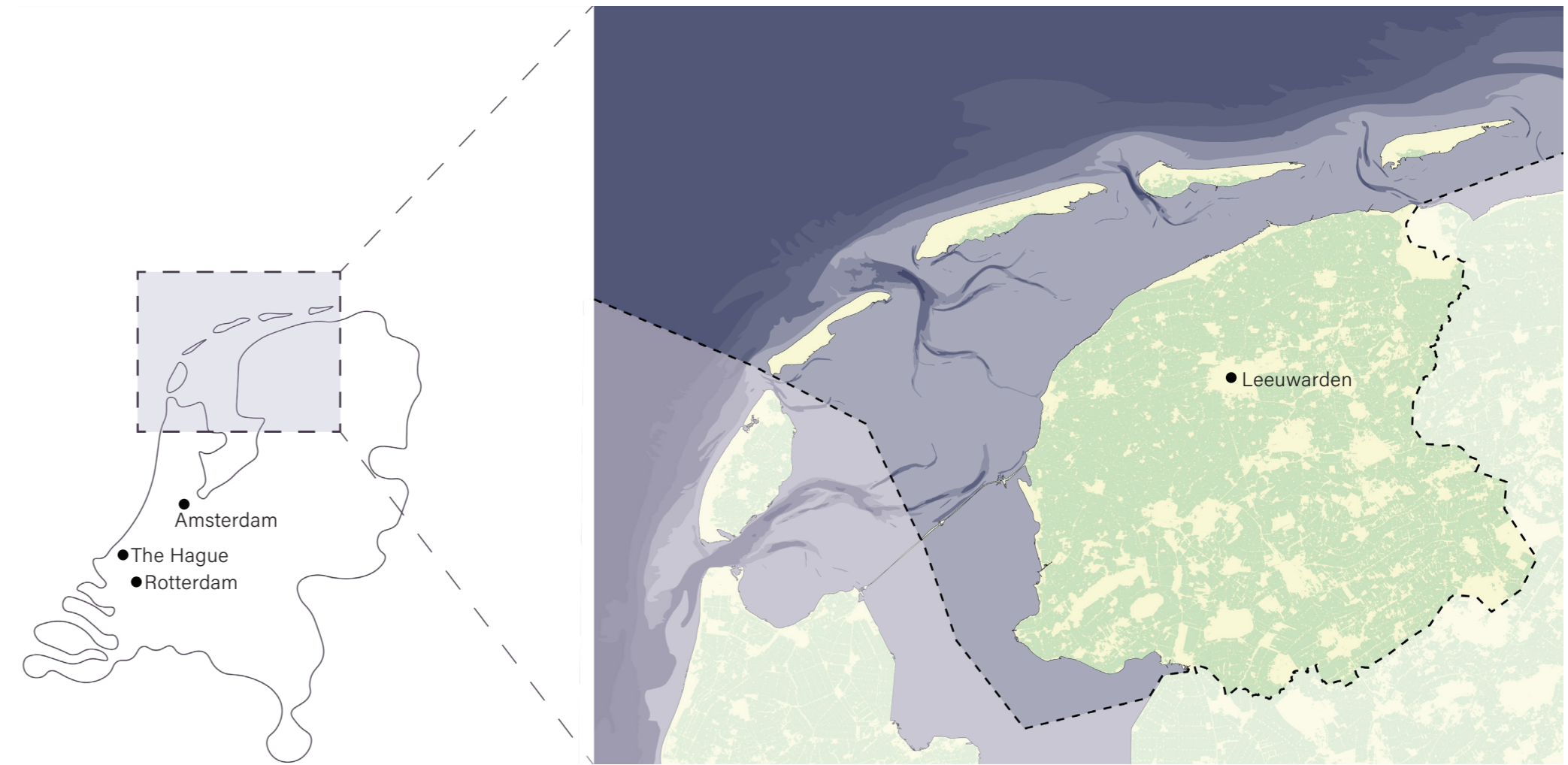

Figure 17: Location of Friesland compared to the rest of the Netherlands

Figure 18: Location of Leeuwarden within Friesland along with the defined scale and boundaries of the proposed project.

1.3 Site Visit

Traveling Northbound

The round-trip site visit to Friesland and its islands required over 330 kilometers traveled via train, 210 kilometers by car, 80 kilometers by ferry, and over 12.2 kilometers (16,000 steps) traversed on foot. In total, the exploration of Friesland took over 16 hours.

The agricultural prevalence of the province was immediately noticeable in the landscape, as the flat croplands spread for kilometers at a time. Small villages were dotted along the map with considerable distance between each other. The Friesland Wind Park in the Wadden Sea was incredibly educational to understand the size and complexities of a wind park, while the islands helped ground the importance of the environmental beauty that exists within the province.

Throughout the report, each chapter will include an additional photo from the site visit.

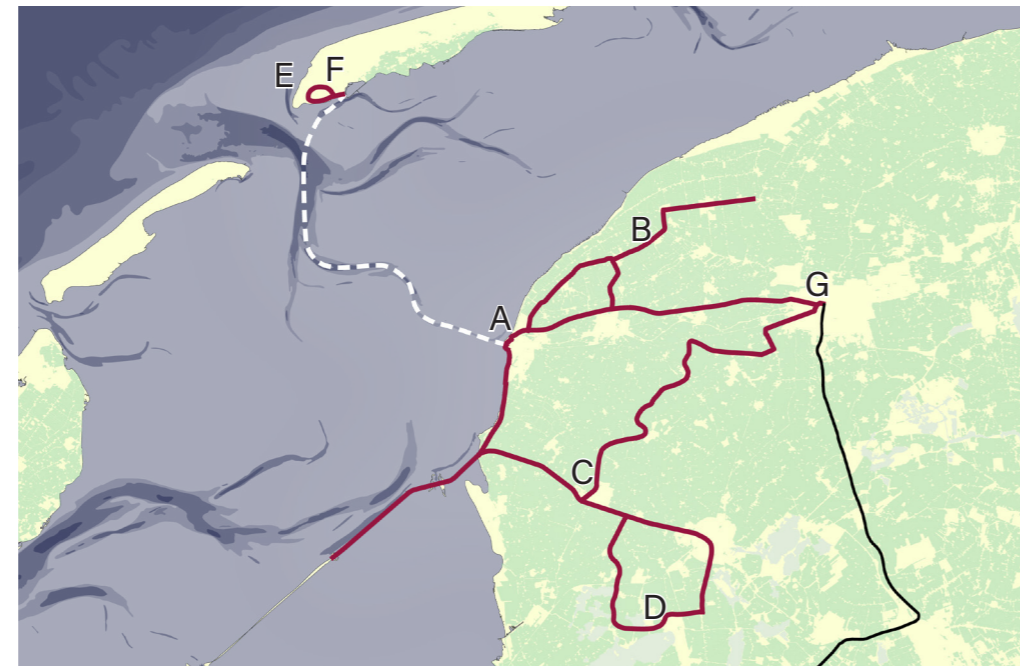

Figure 1.9: Map of travel during site visit excursion to Friesland on Monday, February 16, 2026

- NS Train
- Personal automobile and foot
- Ferry



Figures 1.10 - 1.16: Images from Site Visit. Locations shown on map

1.4 Current Issues

What issues are effecting Friesland and the world?

Frisian citizens involvement (figure 1.17)

This article argues that citizens in Friesland are not sufficiently involved in the energy transition. Decisions about renewable energy projects, such as wind parks, are often made in a top-down manner by governments and large institutions. As a result, local communities feel excluded from decision-making processes. The article states that the “Frisian citizens are insufficiently involved” (De Vries, 2026), highlighting a lack of participation. This can lead to resistance and reduced public support for sustainable projects.

The article emphasizes that energy transition is not only a technical issue but also a social one. Greater citizen involvement is necessary to improve trust and ensure that projects better reflect to the local needs and values. By integrating local knowledge and perspectives, policies can become more effective and legitimate (De Vries, 2026). Overall, the article stresses that participation is key to a successful and socially accepted energy transition.

Energy gap in the north (figure 1.18)

There is an increasing energy inequality between households inside and outside of the Randstad. People living in regions such as Friesland or Groningen often face higher energy costs due to larger and less energy-efficient homes. At the same time, their incomes are generally lower, making it harder to invest in sustainable solutions. The study, done by consultancy Berenschot, shows a clear North-South pattern in energy prices. Residents of Groningen (8.0%), Drenthe (7.8%), Friesland (7.5%), and Limburg (7.5%) spend the most of their income on energy, while those in Utrecht (5.0%) and Noord-Holland (5.8%) spend the least. (NL TIMES, 2025). It suggests that this inequality may increase as the energy transition continues, since many sustainable measures require upfront investments.

By 2035, a significant share of households may struggle to keep up with these changes. The article highlights that current policies do not sufficiently address these regional differences. It argues for more inclusive policies, such as targeted subsidies and financial support for vulnerable groups. Without such measures, the energy transition risks increasing the existing social and economic inequalities.

Iran war for energy action (figure 1.19)

The war in Iran has caused a rise of oil and gas prices and the world might deal with a shortage. Disruptions in key oil transport routes, such as the Strait of Hormuz, have caused energy prices to rise. The article explains that this situation “could both accelerate and delay the energy transition” (Chandrasekhar et al., 2026). On one hand, countries may invest more in renewable energy to reduce dependence on unstable fossil fuel markets. On the other hand, governments may rely more on fossil fuels in the short term to secure energy supply and stabilize prices. This creates a tension between immediate energy security and long-term climate goals.

The article shows that geopolitical conflicts play a significant role in shaping energy policy. It concludes that energy security is becoming an important driver of the transition, alongside environmental concerns, but that the transition to renewable energy might need to speed up.

Shortage of sustainable energy (figure 1.20)

This article explains that the Netherlands may face high financial costs if it fails to meet European renewable energy targets. Under EU regulations, countries must produce a certain share of energy from renewable sources. If they do not meet these targets, they may need to purchase renewable energy credits from other countries. Estimates suggest that costs could rise to billions of euros in the coming years (Koster, 2026). Progress in renewable energy production has slowed due to rising costs and investment uncertainties.

At the same time, EU targets are becoming more ambitious. The article emphasizes that additional investments in renewable energy and energy efficiency are necessary, some might say even a fully self-sufficient energy source could be considered. Without stronger action, the Netherlands risks both financial losses and missed climate goals, limiting its economic and environmental progress.



Figure 1.17: Friesch Dagblad article



Figure 1.18: NL Times article



Figure 1.19: CARBONBRIEF article

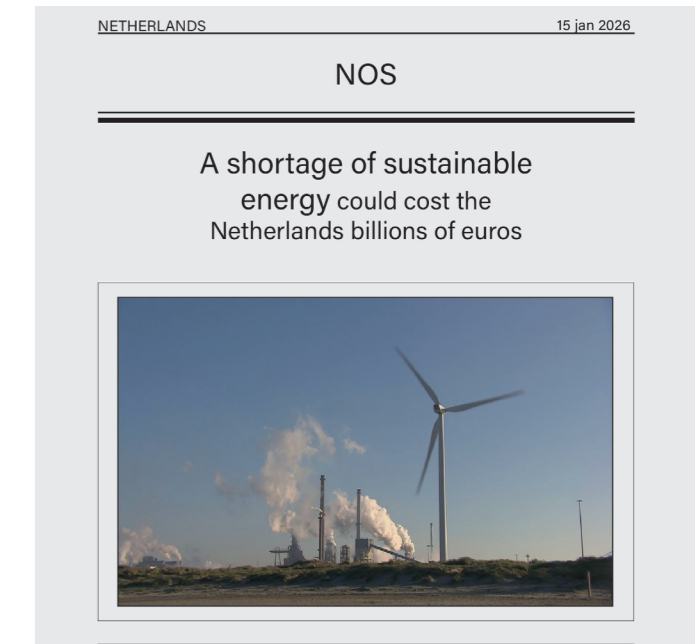

Figure 1.20: NOS article

1.5 Community Introduction and Input

How do Frisians feel?

The Netherlands has ambitions to achieve a sustainable society, and, by 2050, the energy supply must be almost entirely sustainable (Het Friese Burgerperspectief, 2020). To achieve this within Friesland, the "Friese burgerperspectief" has mapped out the wishes and concerns of citizens via a survey. This quantitatively displays the local citizens' opinions regarding the energy transition process. Most citizens support the energy transition, but only when it does not come at the expense of the landscape; most respondents feel a deep connection to the land and consider it part of the Friesland identity.

Therefore, landscape interventions are only acceptable if, for example, they are appropriately sited within the landscape and minimize disruption to locals. Other citizen worries include lack of clarity in the transition process, ignored participation from their side, and the lack of viable alternatives.

DUTCH CLIMATE AGREEMENT (KLIMAATAKKOORD)

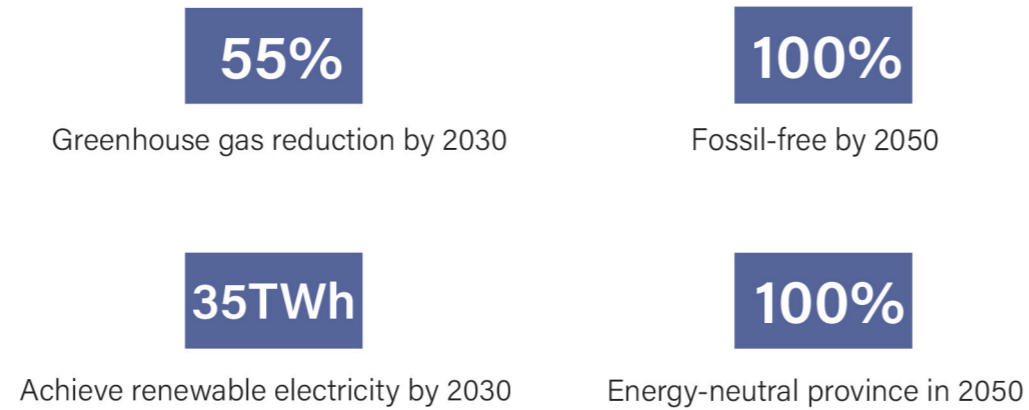
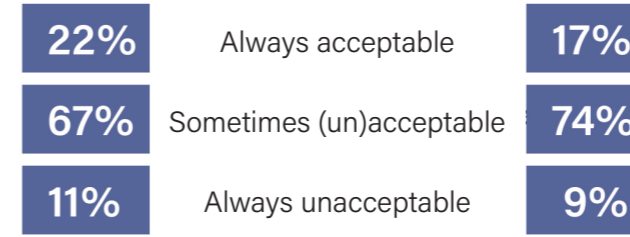
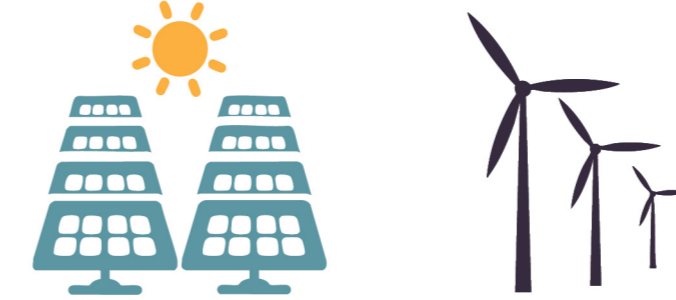

Figure 1.21: Dutch Climate Agreement metrics. Based off these metrics, the Dutch government has serious ambitions about investing in renewable energy.

SUPPORT FOR LANDSCAPE INTERVENTION



ACCEPTABLE IF...

- ...the disruption to local residents is limited
- ...they are located in remote areas
- ...they fit well into the landscape
- ...local residents can make use of the generated energy
- ...local residents are involved in a timely manner in the planning and decision-making process

WORRIES OF FRIESLANDERS

- Government's plans too ambitious
- Clarity
- (Financial) support
- Participation in discussions and decision-making
- Fairness
- Lack of viable alternatives

Figure 1.22: Compilation of community input. Frisians are committed to the renewable energy transition, as long as there are no adverse consequences.

ENERGY IN THE LANDSCAPE

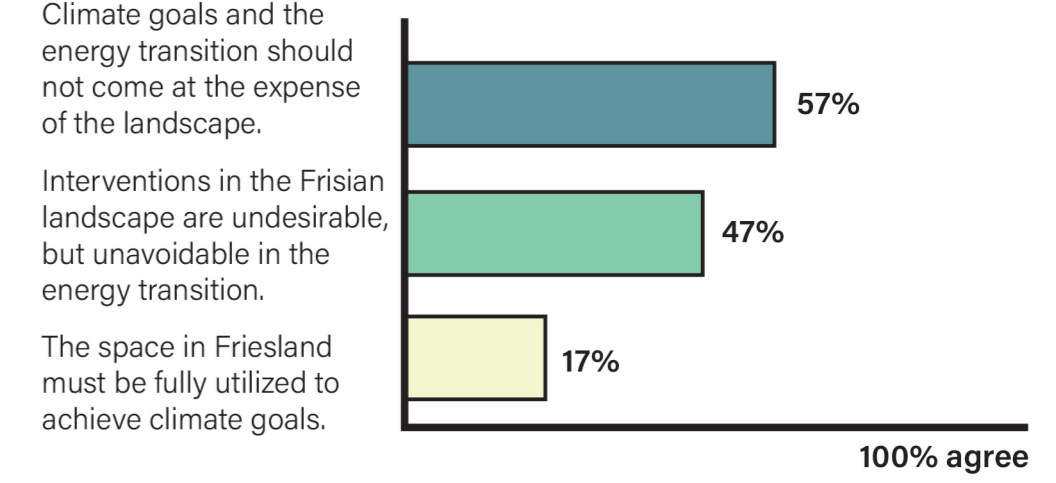

78%

Consider climate change important to tackle



57%

Climate goals and the energy transition should not come at the cost of the landscape



88%

Feel connected to the Frisian landscape



82%

Wants to make own choices about heating my home

44%

Are willing to invest in making own home natural gas-free

80%

The government must also contribute financially

1.6 Aim of the Project

What are we trying to accomplish?

The aim of the project is to provide options and approaches that facilitate the renewable energy transition in Friesland without degrading the existing landscape. While Friesland is an energy-poor province, Frisians have their own unique culture that is tied to their landscape. It is therefore paramount to ensure that renewable energy infrastructure is not constructed or operated at the expense of the land.

The proposed project was guided by the Sustainable Development Goals from the United Nations. The chosen combination of eight goals (of the seventeen) was used to steer the project in what seemed most appropriate when considering energy production within Friesland. The aim became centered around ensuring the Frisians were an active community, and therefore beneficiary, of the renewable energy transition that is to take place in their province. Amongst the eight goals, four were chosen as most important to the project: Affordable and Clean Energy, Sustainable Cities and Communities, Climate Action, and Life Below Water.

At the center of the proposed project, and Q3 studio brief, is the spatial vision of a future Netherlands that relies on renewable energy. As such, UNSDG Goal #7, Affordable and Clean Energy, is paramount to the proposed project. Prioritizing this goal creates equity amongst Frisians in a province that is not wealthy, by Dutch standards. An emphasis on Goal #7 has direct consequences for Goal #11, Sustainable Cities and Communities. Through clean and affordable energy, the cities and communities of Friesland will prosper, especially through the contextual mindsets of localized energy production.

Goal #13, Climate Action, serves as the larger umbrella that the previous two goals must be adhere to. By prioritizing climate action, it ensures that no renewable energy infrastructure will come at the expense of the fragile, unique, and culturally significant ecology of Friesland, as the residents demand. Lastly, given the geographic borders of Friesland, Goal #14, Life Below Water, must be frequently considered when dealing with aquatic regions, particularly the North and Wadden Seas.

Goal 3: Ensure healthy lives and promote well-being for all at all ages

Goal 7: Ensure access to affordable, reliable, sustainable, and modern energy for all

Goal 8: Promote sustained, inclusive, and sustainable economic growth, full and productive employment, and decent work for all

Goal 11: Make cities and human settlements inclusive, safe, resilient, and sustainable

Goal 12: Ensure sustainable consumption and production patters

Goal 13: Take urgent action to combat climate change and its impacts

Goal 14: Conserve and sustainably use the oceans, seas, and marine resources

Goal 15: Protect, restore, and promote sustainable use of terrestrial ecosystems, forest, and biodiversity

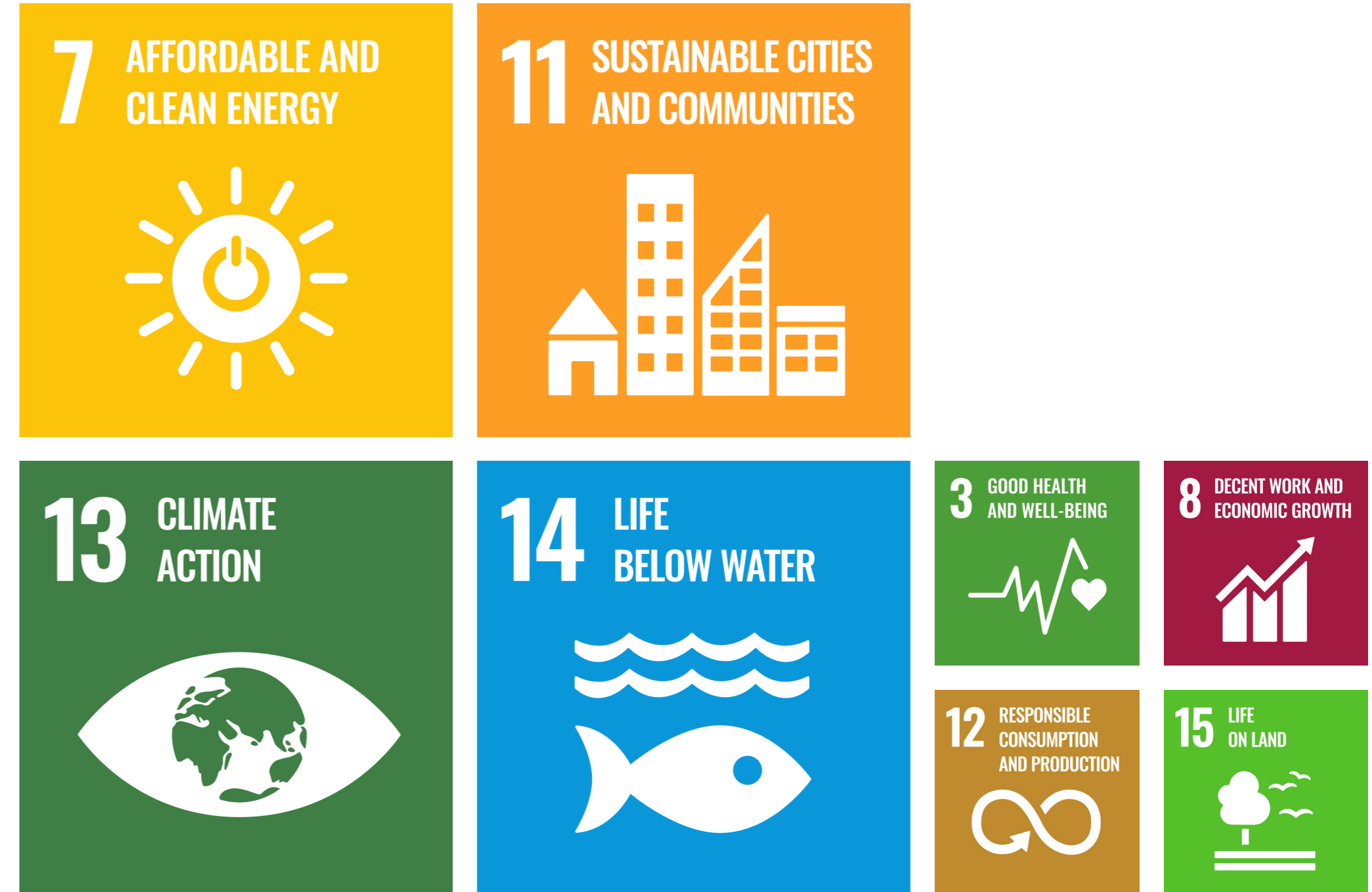

Figures 1.23 - 1.30: United Nations Sustainable Development Goals Squares (UNSDGs)

2 Theoretical Framework

- 2.1 Ecological Stewardship
- 2.2 Energy Production
- 2.3 Local Engagement
- 2.4 Governance



Figure 2.1: Coastal marsh landscape on Terschelling reveals the fragility and importance of the landscape to Friesland.

2.1 Ecological Stewardship

Stewarding one's local ecology

Nathan J. Bennett's *Environmental Stewardship: A Conceptual Review and Analytical Framework* (2017) was studied and referenced throughout Q3. Bennett's definition of local environmental stewardship is:

"Local environmental stewardship is the actions taken by individuals, groups or networks of actors, with various motivations and levels of capacity, to protect, care for or responsibly use the environment in pursuit of environmental and/or social outcomes in diverse social-ecological contexts" (Bennett et al. 2017).

Bennett emphasizes that there are three central elements of stewardship – actors, motivations, and capacity – which are a consequence of socio-ecological context(s) (ibid). The scale and complexity of a problem, in many cases, determines which actors are involved. Oftentimes, multistakeholder partnerships and hybrid networks are created to assemble multiple actors. These can be comprised of civil society and local organizations, public agencies, and NGOs, among others (Connolly et al. 2014; Finkbeiner and Basurto 2015; Romolini et al. 2016).

The 'Categories of assets that provide capacity to enable local environmental stewardship' table (*reference figure 9.1*) is a guiding tool Bennett uses to assess actors. The table lists six types of asset capital: social, cultural, financial, physical, human, and institutional. The final two assets, Human and Institutional Capital, were chosen as the most applicable for the Q3 study. Bennett's descriptions read:

Human: "The individual and group attributes, such as education, knowledge, leadership, past experiences, awareness, skills, and demographic factors (e.g., age and health of population) that enable stewardship"

Institutional: "The empowerment, agency, and options available to local communities to steward resources that results from broader governance, including systems of institutions (i.e., laws and policies, formal and informal organizations and decision-making processes) and structural processes related to power and politics (i.e., economic inequality, discrimination, levels of exclusion)" (Bennett et al. 2017).

Bennet considers capacity to be a fundamental concern of stewardship in relation to the potential for communities to successfully steward their environment. Bennett suggests that "there are two central factors that influence, positively or negatively, the capabilities of would-be stewards to take action: (1) local community assets and (2) broader governance factors." While these two have different components, their interaction is through policy as national laws and frameworks can support local stewardship efforts (ibid).

In regard to motivation, Bennett has again separated this element into two categories: intrinsic and extrinsic. The analysis of intrinsic motivation reveals that, as supported by texts from Rachel Carson and Dorinda Dallmeyer, an ethic of care towards the environment and non-humans will act as the primary motivation for individuals to pursue stewardship (ibid).

Lastly, Bennett also points out that local stewardship is just as valuable as stewardship efforts on the global scale, noting the importance of community-based conservation, management, and natural resource management (ibid).

2.2 Energy Production

Self-sufficiency within energy production

Jan Wiesenthal's *Self-consumption and self-sufficiency in energy sharing communities in Germany: What is the impact of wind energy?* was studied and referenced throughout Q3. Wiesenthal found that including wind electricity generated from wind turbines in the energy production mix offers several benefits and serves as a promising alternative within existing energy sharing communities (Wiesenthal, 2025).

Wind power has been found to offer, on average, lower electricity generation costs compared to the rooftop photovoltaic sources (Kost C, Muller P, Schweiger JS, et al., 2024). Furthermore, when wind energy is added to the production mix, it provides benefits for the rate of self-sufficiency (Jafari-Marandi, et al., 2016).

Previous research in Nordic contexts concluded that self-sufficiency, at minimal cost, are achievable through wind turbines and storage systems (Rehmann et al., 2019 and Latinen 2021). In a similar research, three Swedish locations proved that when energy from wind and photovoltaics are used together, there is better energy sharing performance compared to only rely on one technology (Huang et al. 2022)

Wiesenthal's own research found that "with only wind production in the electricity generation mix, the self-sufficiency rate is higher than with only PV production" proving that wind power is "...better suited to cover electricity demand than [photovoltaics]. However, the highest self-sufficiency rates are visible with 75% wind and 25% PV production" (Wiesenthal, 2025). Finally, Wiesenthal's "...results provide ample evidence that wind is a promising technology for self-consumption and self-sufficiency in energy sharing communities" (ibid).

Branchetti Petrovich's *Parametrization of self-consumption and self-sufficiency in Renewable Energy Communities: a case study application* argued that citizen engagement is at the heart of collective energy self-sufficiency.

Petrovich acknowledged key characteristics within energy communities that can lead to self-sufficiency. First is through empowering citizens where energy communities "...increased awareness and capacity among citizens to produce the energy they consume, fostering greater involvement of electrical consumers in renewable energy generation." Next, is fostering community development where energy communities promote social cohesion in the understanding that citizens are likely to support local investment than national authorities (Koltunov et al. 2023)

Through his highly scientific research, Petrovich concludes that "the cornerstone of legislation concerning [energy communities] is the empowerment of citizens (Petrovich et al. 2025)

2.3 Local Engagement

Local engagement is spurred through public transit access and environmental education

Rebecca Johns' article, *Evaluating an experiential education program for raising awareness and affective engagement with climate resilience in local leaders* was studied and referenced throughout Q3 to assess local engagement in relation to the threat of climate change. Johns' aim was to recognize the urgency of increasing awareness and empowerment amongst communities towards climate resilience (Johns, 2015). Johns led experiential tours around Tampa Bay, USA since, within environmental education, an individual emotional affinity with nature is shown to facilitate protective behaviors towards nature environments (Hinds & Sparks, 2008). Because of this, nature-based curriculum is best taught through outdoor experiential learning (Dale et al., 2020).

The locality of the education, and subsequent emotional investment, was tested, too, since the propensity of citizen engagement and action is more effective from localized climate messages as opposed to global ones (Scannell and Gifford, 2013). Furthermore, the localized education and engagement is likely to overcome demographic barriers often associated with climate issues (Degeling and Koolen 2022).

In Johns' research, the participants most noted that education is the solution to the climate crisis, especially when it is aimed at local leaders and youth populations (Johns, 2015). In conclusion, the results of the research found that experiential education enhances an emotional connection with the environment and a refreshed perspective for participants to take local action themselves (ibid).

Also considered throughout Q3 is Harald Schuster's *Incidental, everyday social and spatial experiences in urban mobility as a driver of local social cohesion: towards social streets*. Schuster's study found that, "...incidental, everyday, and unplanned interactions between residents and their social and physical environment contribute to local social cohesion. Active mobility in neighborhoods creates opportunities for these interactions" (Schuster, 2025).

Schuster's psychological perspective analyzes how everyday experiences and interactions of neighborhood mobility can contribute to a localized sense of belonging and social cohesion (ibid). In this research, three dimensions of social cohesion are assessed, the third, and of most interest to the proposed project, is the orientation

to the common good – this creates a sense of responsibility and commitment to the community" (Dragolov et al. 2016, Schiefer and Van der Noll 2016, Delhey et al. 2018).

Through the use of public transit, passengers experience intergroup contact through daily exposure to broader urban diversity (Schuster, 2025). The participants within the study noted that "...spontaneous, incidental encounters with neighbors or with familiar faces they knew only from mundane 'nodding'-like interactions, such as waiting at a traffic light, made them feel recognized and provided them with a feeling of belonging" (ibid). This all resulted in an understanding that a renewed and entrenched sense of social cohesion amongst a population is, in part, due to the usage of public transit and interaction with a variety of other citizens (ibid).

2.4 Governance Theories

European multilevel governance in energy transitions

Jorg Radtke's *Multilevel governance of energy transitions in Europe: Addressing wicked problems of coordination, justice, and power in energy policy* was studied and referenced throughout Q3 as the governance theory framework to question policy creation and multilevel governance structures.

Radtke points out that there are likely to be pitfalls and difficulties when implementing participatory arrangements within energy policy (Radtke, 2023).

Recently, energy transitions have been significantly by bottom-up engagement through social movements, local initiatives, and niche actors (Radtke et al. 2020). These activities are generally based on a different logic than the top-down governance strategies and goal-oriented policies created by state institutions and coordinated with organized interests such as associations, unions, and large corporations (Radtke, 2023). The interaction of these two can create complexity, but within a democratic framework energy justice and inclusive participation must be considered and

included to ensure diversity in preferences (Jenkins et al. 2016; van Veelen and van der Horst 2018). As such, conflicting wishes will likely arise among local, regional, and national stakeholders.

"Forming (new) governance arrangements and using policy instruments at local, subnational, national, and supra-national levels are essential and constitutive preconditions for far-reaching energy transitions (Radtke, 2023). Even though previously amended energy, technology, and environmental policies are already existing components of international policies, the energy transition has surely created a new policy field (Radtke and Canzler 2019). There are indications that the 'new' governance created through the energy transition will require "open, flexible, cooperative, and participatory (and thus "soft") policy instruments than on top-down decision-making instruments" (Wurster 2013a).

It is then pointed out that energy justice is based on three pillars of justice: distributive, procedural, and recognition (Jenkins et al. 2016, 2017; Sovacool et al. 2017; Carley and Konisky 2020). Distributive is noticeable at the spatial level since due to the uneven distribution in expansion of renewable energies, mainly due to favorable natural conditions: wind power or photovoltaic expansion might thrive more in certain locations than others. This can impact how gains and losses are distributed. The other two dimensions, procedural and recognition, are related. It is argued that the gains should be distributed to the most affected communities to meet their needs, preferences, and identities (Devine-Wright and Batel 2017; van Veelen and Hagggett 2017; Manzo and Devine-Wright 2020).

3 Approach

- 3.1 Problem Statement
- 3.2 Research Question
- 3.3 Methodological Framework
- 3.4 Conceptual Framework



Figure 3.1: Major electrical station serving part of Friesland. Industrially sized sandbags litter the foreground, deployed as protection against flood encroachment.

3.1 Problem Statement

What is the problem?

Friesland is poised to be a major player in the renewable energy transition of the Netherlands. Situated on the North Sea, there is significant room for wind energy production (reference 2.2) that can provide immense benefit to the province and its residents.

Through the lengthy transition from fossil fuels to renewable energy sources, there must be many societal components taken into account – who is affected, how are they affected, within what timeline do certain implementations take place, and what role will current and future generations take in the transition, amongst others.

Most Frisian residents will likely be concerned about how the energy transition will affect their daily lives. They also want to ensure that their opinions are considered throughout the process, since their livelihood – especially as a province that has a

proportionally large agroeconomic industry – might be at stake. Others are certain to complain that the government's plans are too ambitious, out of concern for a drastic change in the status quo.

A local fisherman asks, "Will this transition be fair?" as he attempts to forecast what impacts renewable energy infrastructure might have on local fishing populations. "My farm needs financial support" claims a farmer, who is weary of how the government intends to use the abundant farmland within Friesland. Lastly, schoolchildren, perhaps not fully grasping the gravity of energy transition, simply want to know if and when it is safe for them to resume their childhood.

All these opinions, people, and communities must be considered throughout the energy transition process, and the proposed project.



Figure 3.2: Problem Statement Image depicting various local communities and their concerns and comments towards the renewable energy transition

How can the *residents of Friesland and its municipal governments benefit* from the energy transition process in which the *existing landscape identity guides* the establishment of *regional self-sufficiency*?

What is the existing landscape identity and how does this disrupt the energy transition?

What are the spatial implications of the energy transition process?

What are the policies that establish the regional self-sufficiency?

3.3 Methodological Framework

Step by step process

The method of our project has five main steps: The start, analysis, visioning, strategy and reflection.

Start

Firstly, we had to discuss our interest and potential location to come up with a project to study the energy transition. After discussing different interests, Friesland was chosen with a focus on communities that are often less heard in this process. After initial explorations and quick literature reading, a field trip was planned to visit this relatively unknown region. This provided a first impression and understanding of the region.

Through further reading of articles, media analysis, identifying local communities, analysing a survey, a problem statement was formulated. Based on this, the research questions were developed together with different frameworks to help answer the research question.

Analysis

Further we went into GIS mapping, research of energy typologies, current policies and existing energy flow led to an analysis summary in which key challenges were identified, such as spatial pressure, landscape identity, ecological sensitivity, and the imbalance between powerful actors and

local communities. Based on this, three areas were defined. Also, important main themes were defined to keep assessing our project in line with the analysis: Energy Production, Ecological Stewardship, and Local Engagement. To test these three main themes, a method using sliders was introduced to explore different possible futures. Extreme scenarios were created by setting each theme to its maximum level. This helped to test the limits of the system and to better understand conflicts and opportunities within the region.

Visioning

With the knowledge of our analysis, we came up with a vision statement. To create the vision map, spatial possibilities and potentials were mapped and further defined into the three themes to see the connections between them in the whole region. This way the vision map was completed.

Strategy

After defining the vision, a strategy was developed. Stakeholder roles were further defined, and policies were adapted or newly proposed. Action cards were created to describe spatial strategies and

interventions. These were then translated into a timeline, in spatial phasing sections, detailed zoom-in locations with and visual collages. The three themes were again used to guide these decisions.

Reflection

In the final phase, the results were evaluated and the research questions were answered. The limitations of the project were discussed, as well as possible future developments.

This reflection helped to better understand the impact of the design choices and the relevance of the project for a fair and balanced energy transition in Friesland.

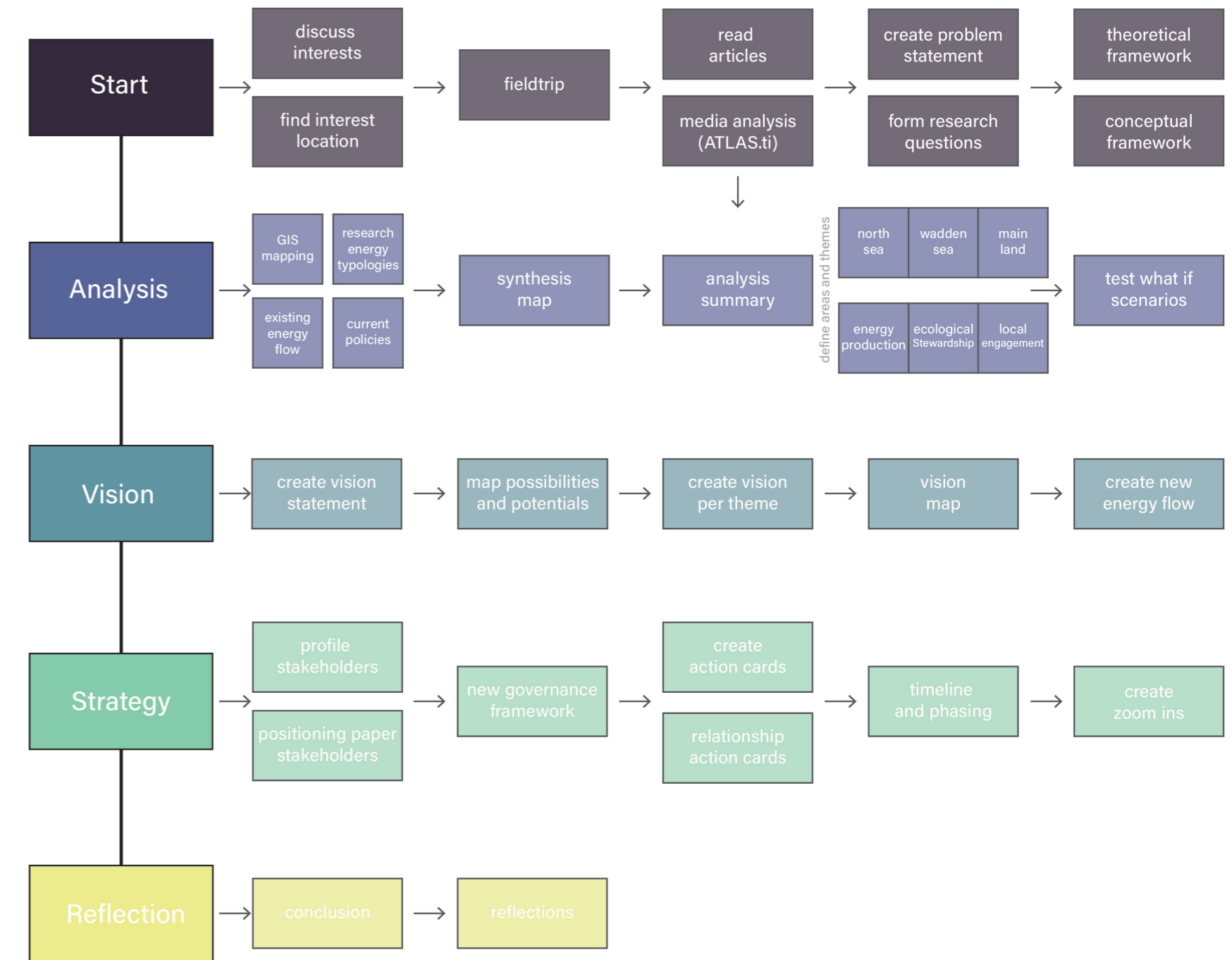

Figure 3.3: Methodology Framework graphically shows the overall project workflow

3.4 Conceptual Framework

A Concept of a Project

Our conceptual framework is built around the idea that the energy transition in Friesland should create clear benefits for the region itself and its communities. We chose the three main pillars; energy production, ecological stewardship, and local engagement, because they represent the key challenges and opportunities in this region. Friesland has strong potential for renewable energy, a highly valuable ecological system in the Wadden Sea, and local communities that are directly affected by spatial changes. By combining these three concepts, we aim to create a balanced and future-oriented approach.

These pillars are strongly interconnected. Energy production provides economic opportunities and energy security within the region, but it must be developed in a way that respects ecological systems. Ecological stewardship ensures that natural landscapes are protected and even strengthened, which also improves the quality of life for residents and their thoughts about keeping the landscape identity. Local engagement supports

these two by focusing on how people contribute to the energy transition and in this way benefit from these changes. The relationships between the pillars; such as coexistence, quality of life, and participation and costs, show how each theme influences others and creates a dynamic system.

Our perspective is focused on creating regional self-sufficiency and keeping the landscape identity. The way governance works is important here. This means that we see the energy transition not only as a technical challenge, but as a spatial and social opportunity for Friesland. This perspective shapes the framework by emphasizing local value creation, landscape identity, and a fair distribution of benefits.

The framework guides our research by helping us evaluate design choices and strategies. It allows us to test whether interventions contribute to all three pillars and whether they strengthen the region as a whole. In this way, the framework acts as a tool to make more integrated, balanced, and place-specific decisions throughout the project.

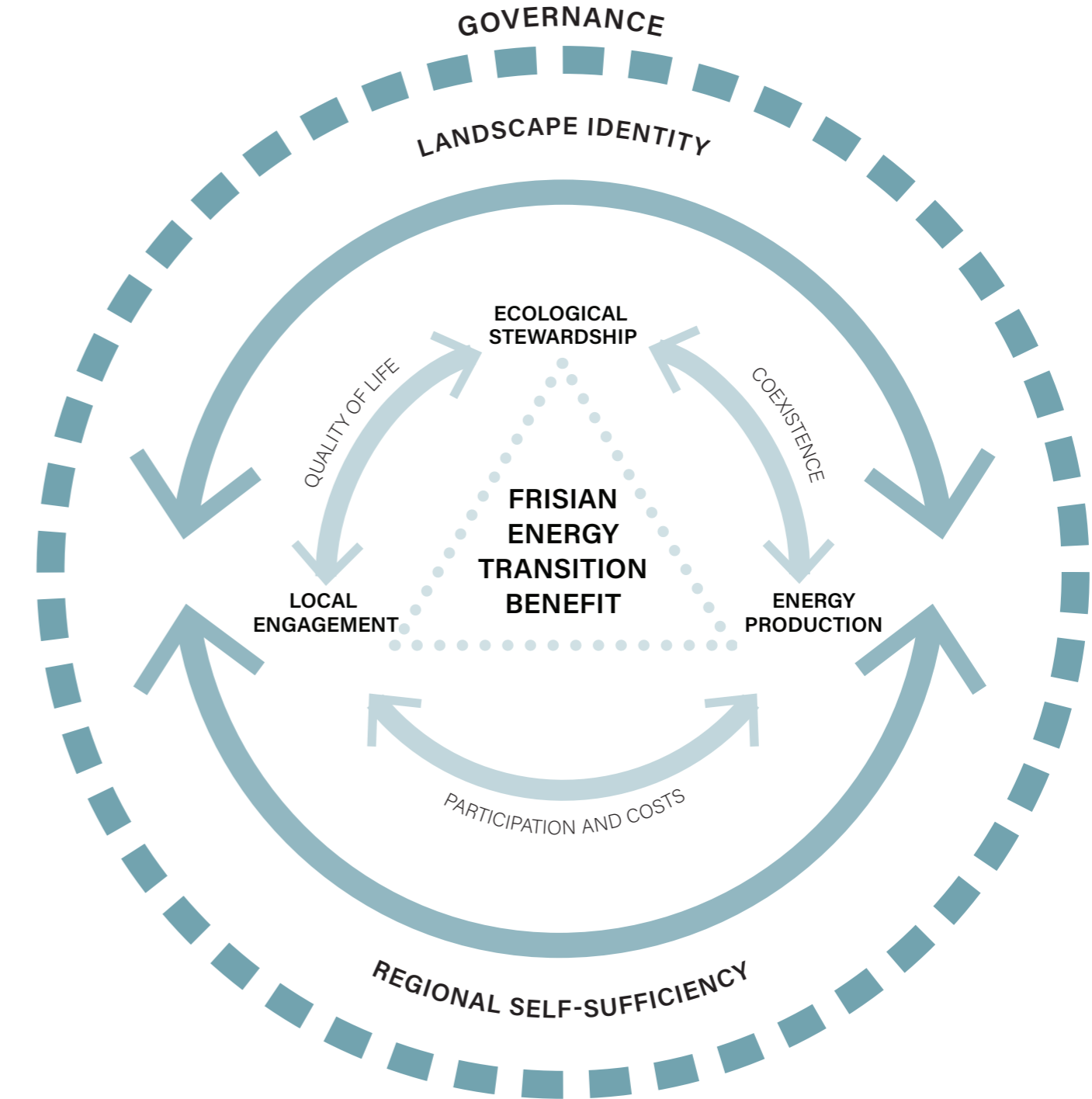

Figure 3.4: Conceptual Framework visualization

4 Analysis

- 4.1 Analysis Maps
- 4.2 Alignment with current policies
- 4.3 Existing Energy Typologies
- 4.4 Existing Energy Flow
- 4.5 Synthesis Map



Figure 4.1: Local farmhouse on mainland Friesland makes use of existing energy framework and codes to supply energy at an individual scale

4.1 Analysis Maps

All things energy

The map on the right shows the existing energy structures in Friesland. These are electricity lines (25 kV, 52 kV, 220 kV and 310 kV) that connect the production sites with the urban areas. The main source of renewable energy in Friesland is wind energy (Friese energietafel, 2024). Offshore park 'Windpark fryslân' on the IJsselmeer is an important source providing energy for roughly 500,000 households (Provincie Friesland, n.d.). The wind turbines are arranged in a hexagonal cluster, ensuring minimal horizon pollution, enhancing the landscape identity. It can be deduced from the map that the largest part of onshore wind energy production is located in the northwest.

Solar energy also plays a role in the energy production as the second most important pillar in the regional energy strategy (Regionale Energiestrategie (RES)) (Regiegroep Regionale Energie Strategie RES Fryslân, n.d.).

The Province of Friesland has a series of solar parks, and new ones are regularly planned, which are mainly located on or near the edges of residential areas and infrastructure.

All of these energy measures are being implemented to meet the goals of the climate agreement. As shown in figure 4.2, the EU goal for the share of renewable energy is to reach 39% by 2030 and 100% by 2050 (PBL, 2024 & Hub, 2024). According to current figures, we are expected to generate about 29–36% renewable energy by 2030, which means we will not meet the targets. To meet the targets, more renewable energy must be generated, and consumption will also have to be drastically reduced. The Frisian target for 2050 is shown in figure 4.3. This indicates that after accounting for reduced consumption, the RES 1.0 targets, and energy potential from biogas and renewable heat, there remains a residual production target that must be met (Friesland, n.d.).

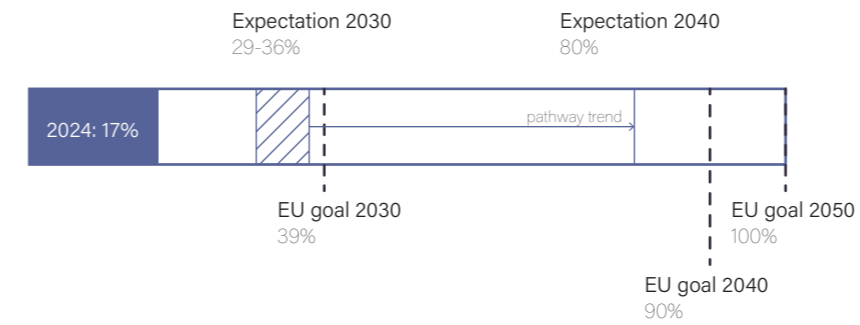

Figure 4.2: Percentage of renewable energy of total gross final consumption in The Netherlands

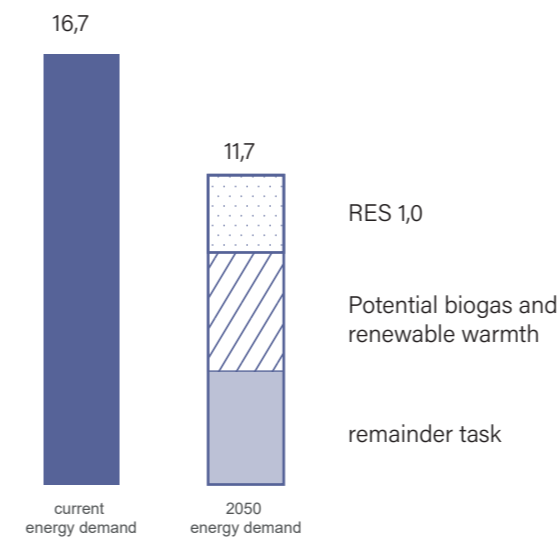

Figure 4.3: Frisian task 2050, TWh

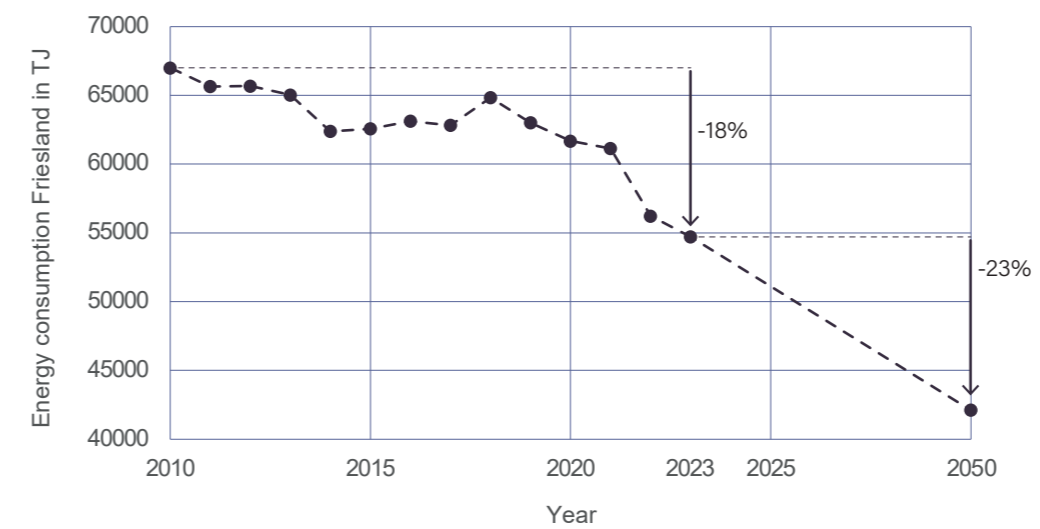

Figure 4.4: Total energy consumption, Friesland (TJ)

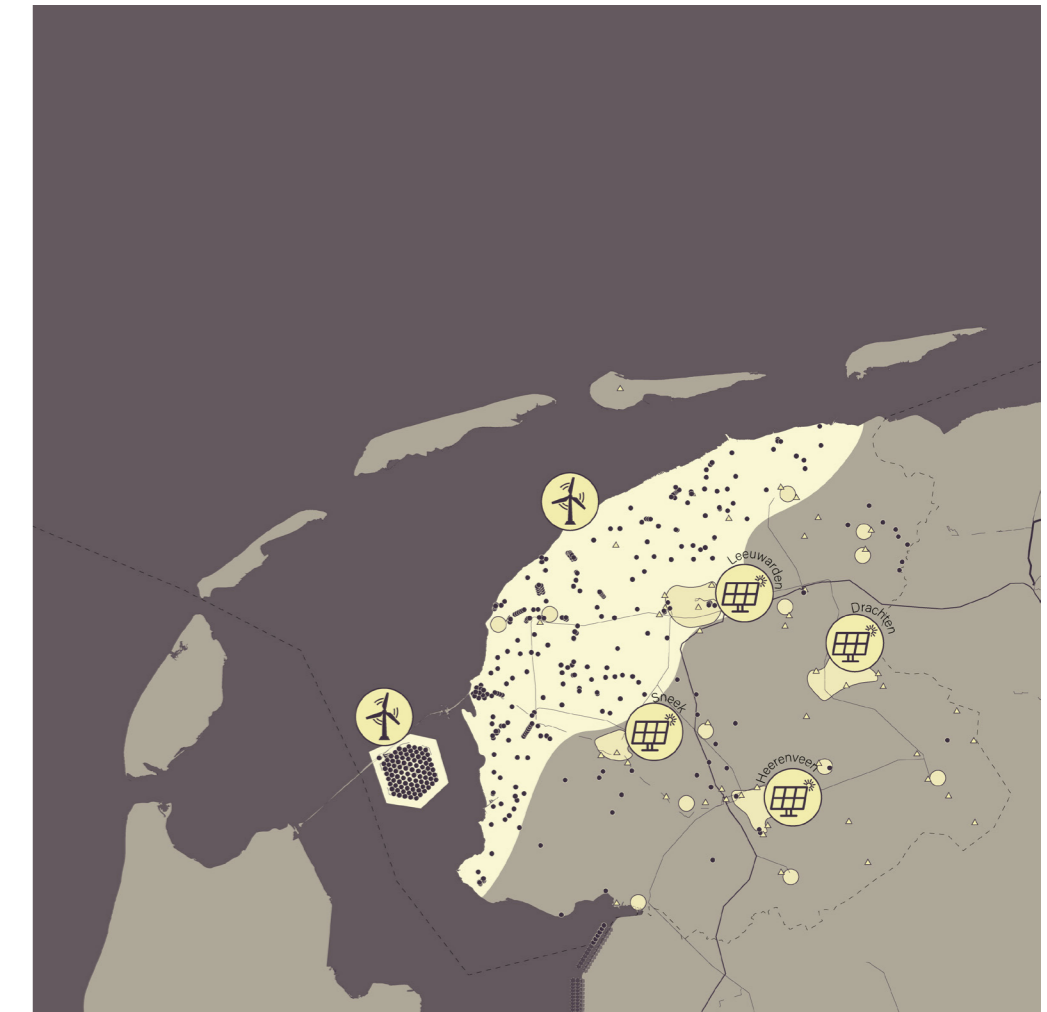

Figure 4.5: Existing energy infrastructure

- Wind turbine
- Wind turbine outside area
- ▲ Solar park
- ⊕ Dense area with wind energy production
- ⊞ Urban area with solar parks nearby

Water composition

Multiple water characteristics exist: deep waters in the North Sea, tidal differences in the Wadden Sea, and lakes and rivers in the mainland.

The Wadden Sea, together with the North Sea coastal zone and the Wadden Sea region of Germany and Denmark, is the largest contiguous intertidal area in the world (Rijkswaterstaat, 2021). Over a period of 12 hours and 25 minutes, the ebb and flow of the tides moves seawater into the North Sea through channels (reference figure 9.2), while high and low tide alternate every six hours. Wind speed and direction play a decisive role; northwesterly winds push water into the Wadden Sea, while easterly and southerly winds push water out of the sea. The tidal current causes sediment exchange, resulting in erosion and sedimentation. (Rijkswaterstaat, 2021). The water depth between the seas differs roughly from -30m to 0m.

Areas north of the islands are closed to fishing due to the Wadden Sea's protected status (reference figure 4.8). The same protected status exists for part of the North Sea, which is also closed to fishing.

Large interntional vessels use shipping lanes in the North Sea, while limited ship traffic occurs in the Wadden Sea's few deep canals. Rivers and small lakes connect mainlind cities.

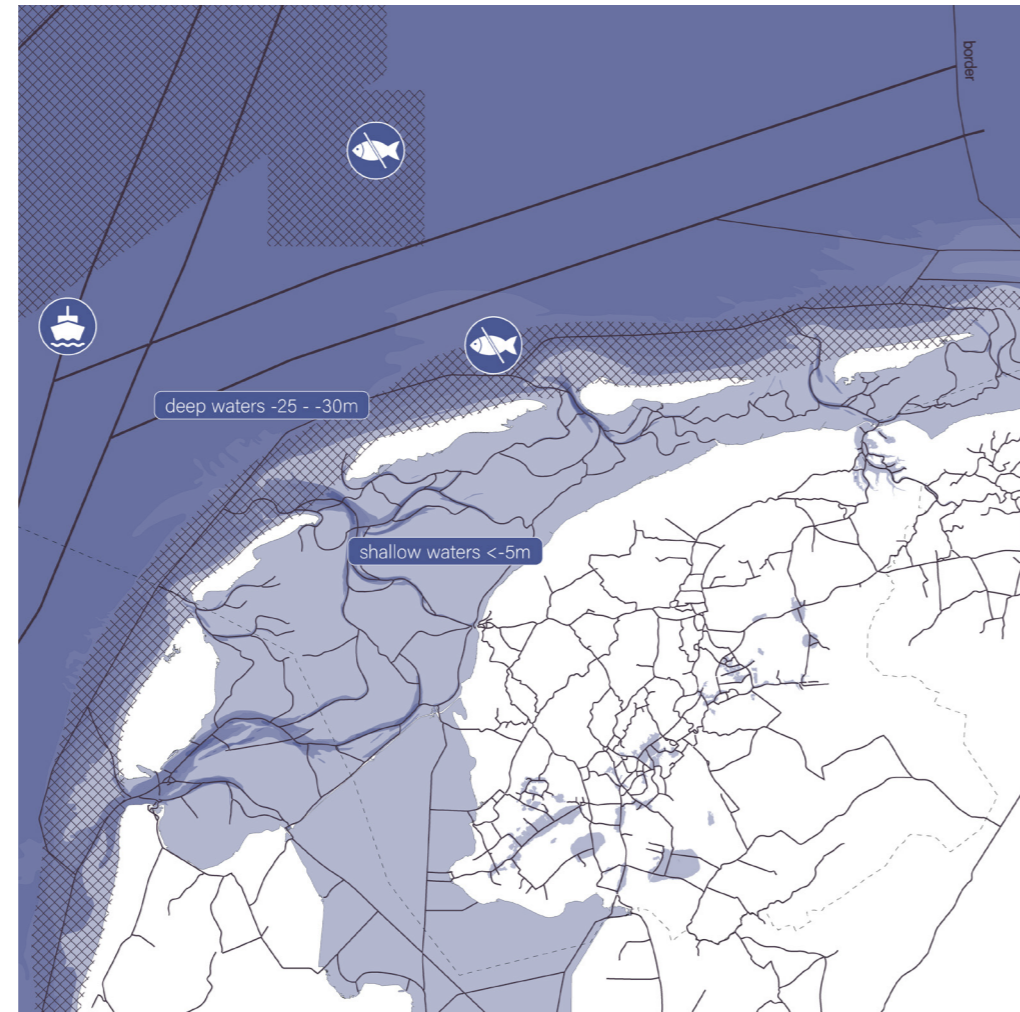
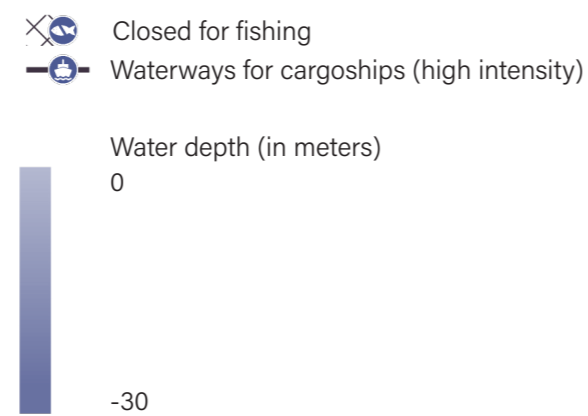

Figure 4.6: Existing water composition



The windiest of places

As is visible in photos from the site visit (reference 1.3), there are many wind turbines in Friesland - both on land and offshore (in the IJsselmeer). This was reflected in the problem statement image (reference 3.7) and is therefore a primary form of energy production that must be considered.

Given the vast farmland within the province and expansive North Sea immediately adjacent, the potential for wind energy is a key metric in the analysis. Unsurprisingly, the open waters lend themselves to the highest potential for wind energy production, followed closely by open farmland that already has existing localized production. Residential and passenger infrastructure exhibit the least potential.

Since wind power has, on average, lower electricity generation costs compared to solar power, and add significant benefits towards the potential of self-sufficiency (reference 2.2), it is necessary to explore its potential in Frieslan, (Kost C, Muller P, Schweiger JS, et al., 2024 and Jafari-Marandi, et al., 2016).

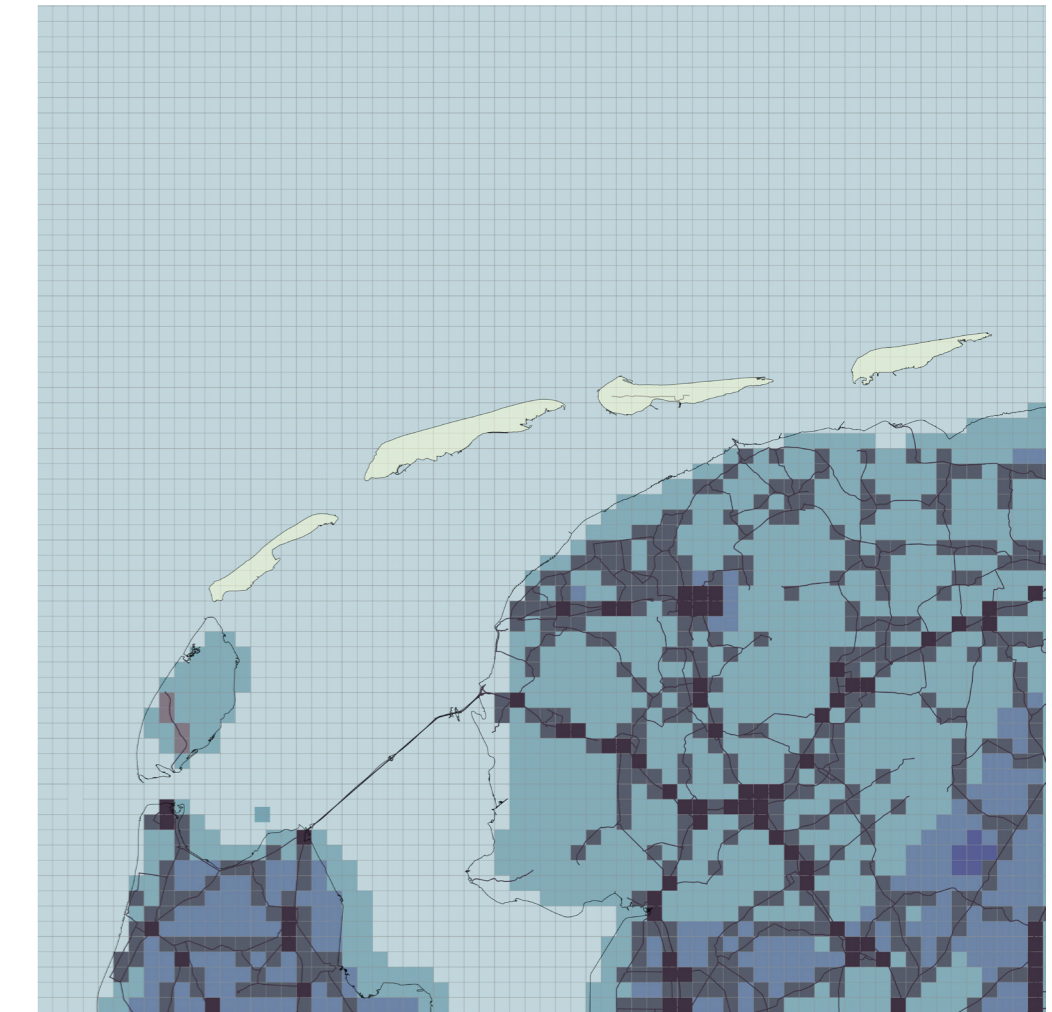
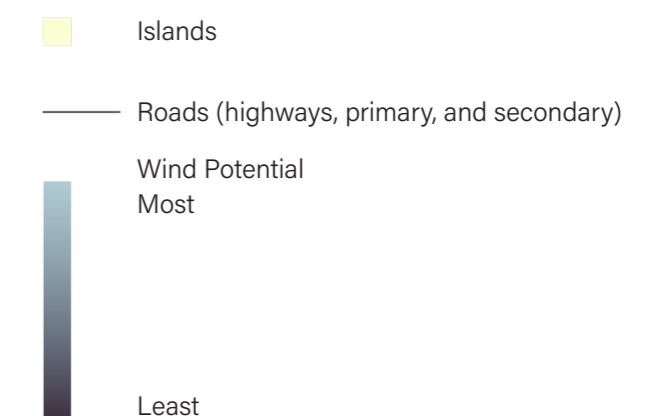

Figure 4.7: Wind infrastructure potential



Ecological considerations

The region has many areas protected by Natura 2000, national regulations, and KRM-areas.

In the North Sea, nature conservation consists of protected areas, species, and habitats, which are within the framework of Natura 2000, KRM (Kaderrichtlijn Mariene Strategie) (Marine Strategy Framework Directive), and the application of the 'Wet Natuurbescherming' (Nature Conservation Act). This protection is based on three (European) frameworks: Habitats Directive (safeguarding biological diversity through the conservation of habitats, flora, and fauna), Birds Directive (conservation of wild bird species), and MSFD areas (good environmental status) (Rijkswaterstaat, n.d.). Species protection covers the entire Dutch North Sea and ensures species protection through specific measures (for example, porpoises and sharks) (ibid).

Per UNESCO (n.d.), the Wadden Sea's key ecological features include "tidal channels, seagrass beds, mussel beds, sandbanks, mudflats, salt marshes, beaches, and dunes." Many plant and animal species are present, and altogether, it is a highly valuable ecological area.

Many smaller ecological areas on land are also protected, including near the lakes (reference figure 4.6) and National Park Alde Feanen.

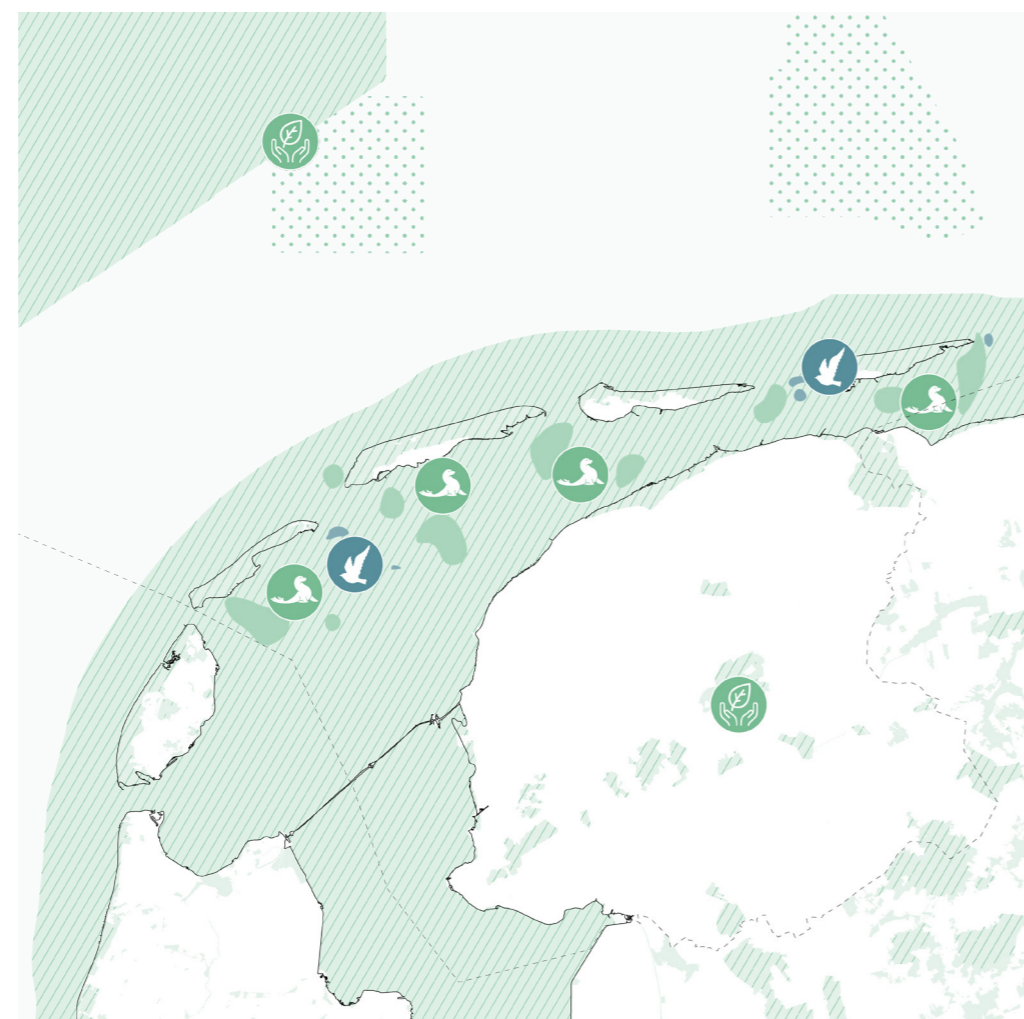





Figure 4.8: Existing ecological composition

-  Protected areas
-  Area with seal moorings
-  Bird breeding locations (sand plates)

Watch out for birds!



The proposed location for the offshore wind park will be in the middle of an intercontinental migration path. Figure 4.9 shows the East Atlantic Flyway - an annual migration of millions of birds from their breeding ground in the arctic to their wintering sites in western and southern Africa (source).

A 2022 report on the East Atlantic Flyway, as part of multiple Wadden Sea Quality Status Reports, found that wind parks are classified as 'high prevalence pressure' for migrating birds less than 10% of the time. Nearly 80% of the time there is no pressure on the migration routes from wind parks. As seen in the Graph of Human Pressures (reference figure 9.3), wind parks rank comparatively much safer for migrating birds than many other human interventions (van Roomen, 2022).

Wind park operators will be required to cease nighttime production during migration season to provide maximized safety for the birds. It is also helpful to paint a single wind turbine blade black can significantly reduce bird mortality by up to 70%, (May et al. 2020). This will help protect the millions of birds that migrate each year.



Figure 4.9: Path of East Atlantic Flyway from the Arctic breeding region southwards to the western and southern non-nesting coasts of Africa

-  Wadden Sea Location
-  East Atlantic Flyway route

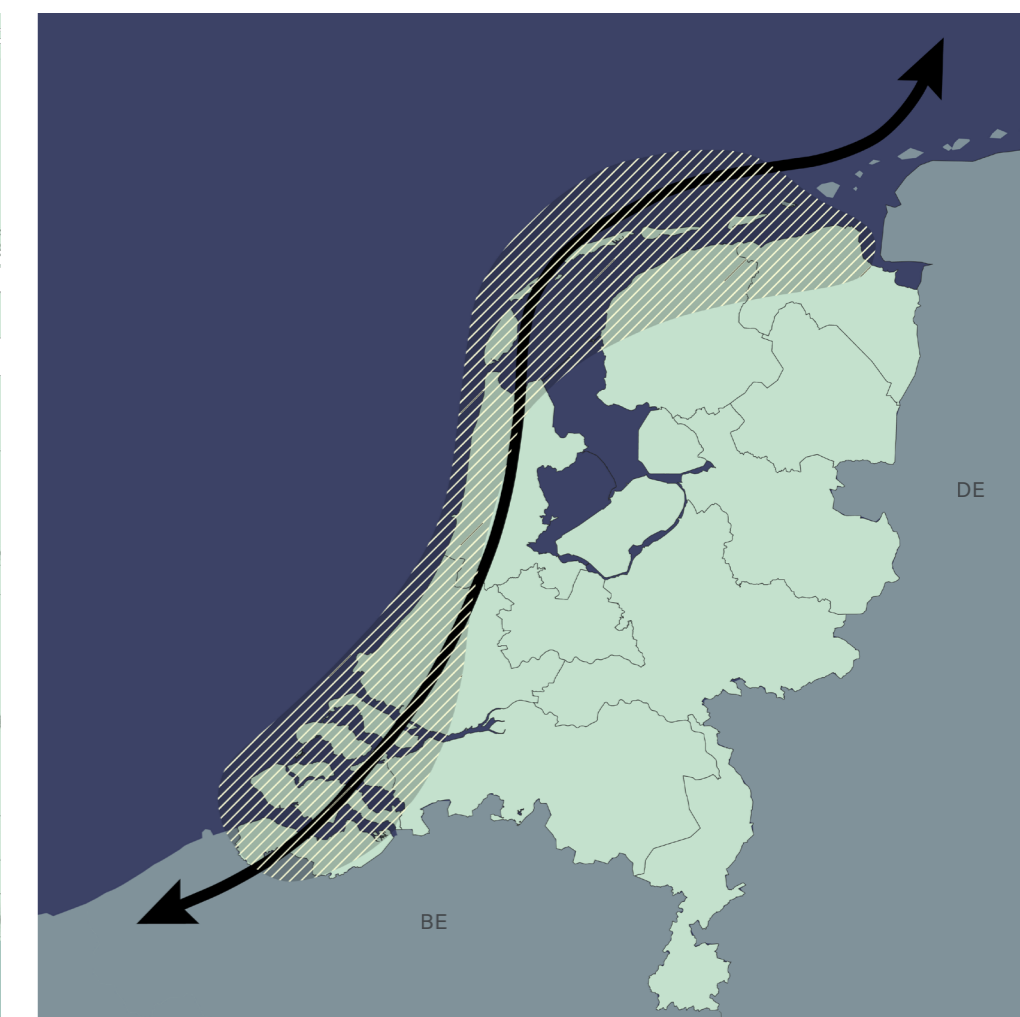



Figure 4.10: The entire western coast of the Netherlands is part of the East Atlantic Flyway. The Wadden Sea, in particular, plays an important role in the nourishment of thousands of bird species along the migratory path.

-  Abstracted East Atlantic Flyway route
-  East Atlantic Flyway Zone

What is the land used for?

A large majority of Friesland's 3,340 sq km landmass is used for agriculture and farming (*reference 1.2*). As only the eighth most populous province, with a population of roughly 665,000, its population density is 199 people / sq km, (Data Commons, n.d.). This means that people do not live closely together, which is reflected in expansive farm landscape (*reference 1.3*).

In contrast to the never-ending farms on mainland, Friesland's four islands contain little to no farming landscape. Instead, they are characterized by expansive beaches that encompass most of each island and are popular tourist destinations, particularly in the summer.

This difference in land use, and composition, make Friesland an ecologically unique province within the country.

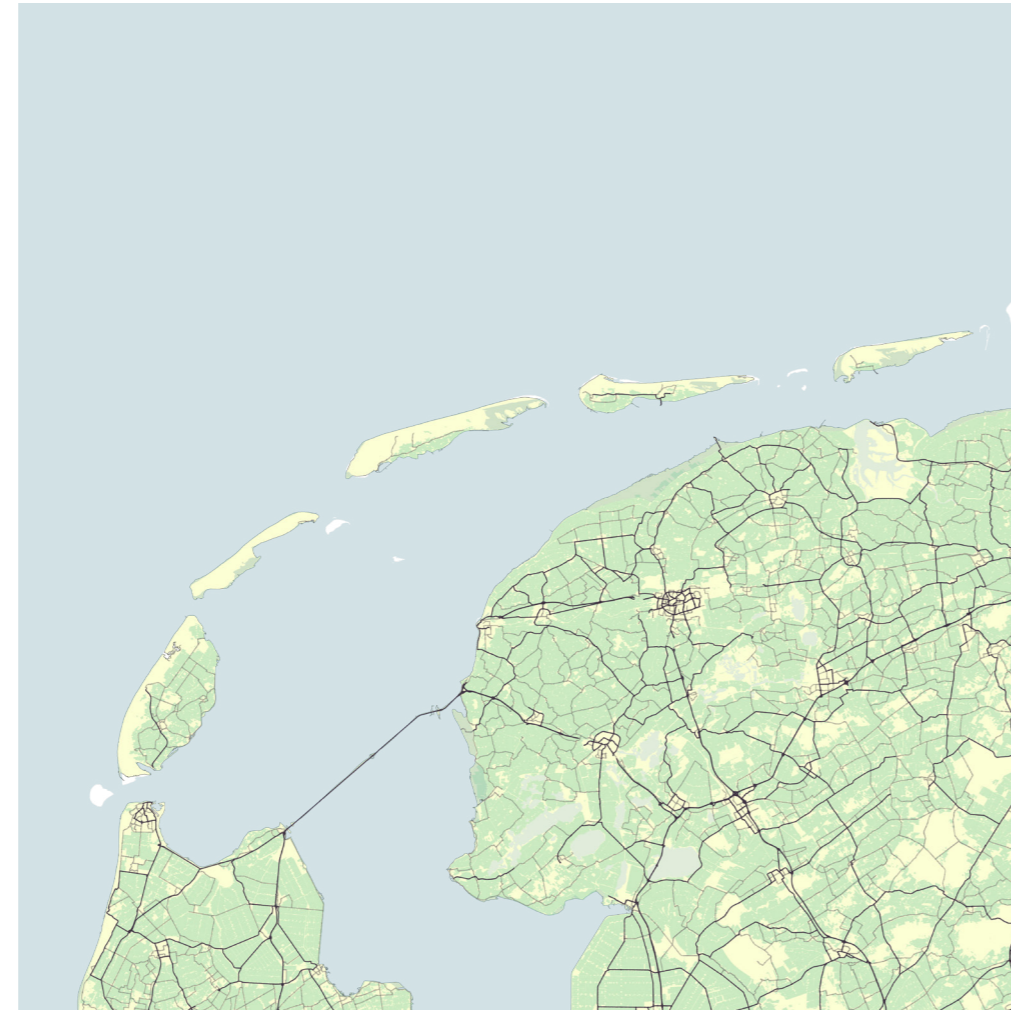

Figure 4.11: Existing land use distribution

- Agricultural land
- Non-agricultural land
- Road (highways, primary, and secondary)

Plant here, not there

The soil of mainland Friesland is mostly built up from sea clay, sand and peat. This can be explained by the land reclamation projects in Friesland. Between the 13th and 20th centuries, the marine clay area—which was then covered in salt marshes and formed part of the Wadden Sea—was reclaimed from the sea and cultivated for agricultural purposes. This allows us to determine the boundary of the marine clay. The islands were formed by deposited sediment consisting mainly of calcareous soil and sand, (Rijkswaterstaat, 2021).

Within Friesland, Silvis and Voskuilen (2020) identify three regions with varying agricultural land prices. The most expensive land is found in the north, while the least expensive land is in the east. This agricultural land price is directly related to the soil type; agricultural suitability, and thus land price, is strongly linked to soil quality. For example, clay soil and loam are fertile, heavy soils that retain water well, allowing high-yield crops to grow well, which increases the soil's value. In contrast, sandy soils are susceptible to drought and have moderate bearing capacity, making them generally suitable only for grassland and thus having a lower value.

With this knowledge in mind, land in the south-east of Friesland with a lower value can be used more efficiently as areas of energy production.

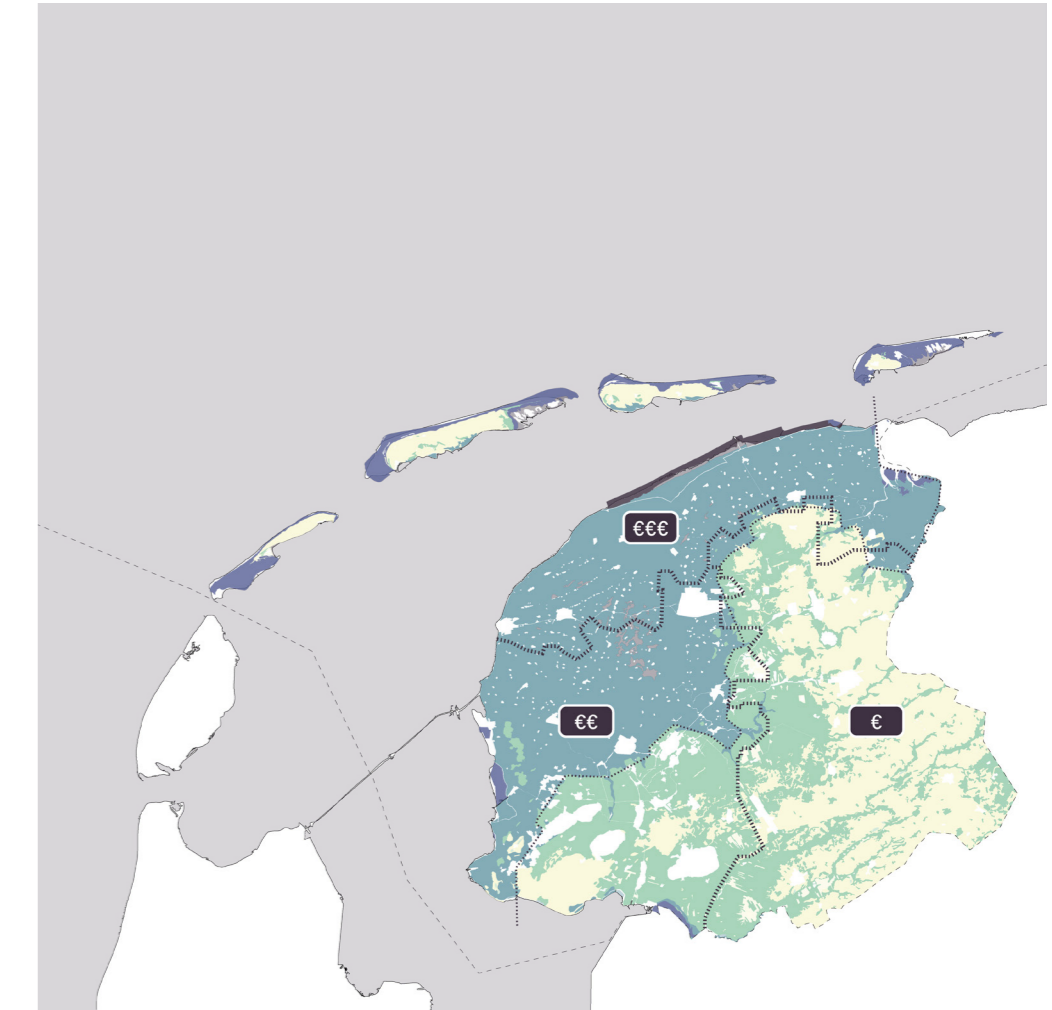

Figure 4.12: Existing soil type corresponding financial implication

- €€€ High agricultural land price
- €€ Low agricultural land price
- Agricultural area border
- Seacaly border

4.2 Alignment with Current Policies

The Dutch Approach to Energy Transition





Global Context and National Targets

The negative effects of over-reliance on fossil fuels on the Earth have gotten exponentially worse since the Industrial Revolution. The energy transition is an international effort to shift from fossil fuels to sustainable green energy. A global transition is necessary to maintain, preserve, and enhance myriad qualities. To address the issues of climate change, the Netherlands has to intervene with different forms of governance. Currently, the Dutch have a multi-level structure in which the legally responsible body at the different levels is given jurisdiction over different areas of land, each body has its own set of governance functions and competences, and they are in constant processes of negotiation (Clancy et al., 2024). Since the Netherlands is a member of the European Union (EU), this adds a further layer of governance at the supranational level which has an influence on national policies to meet international commitments, such as covenants and European legislation (Clancy et al., 2024). In terms of energy governance, a third layer, the Regional Energy Strategy (RES) is added at the regional level. The measures set out in the Climate Agreement, public authorities, residents, businesses, grid operators, energy collectives and social organisations need each other. The energy transition does not end at the council boundary.

This is why these parties are working together on a Regional Energy Strategy: the RES. This is happening in 30 energy regions in the Netherlands (Nationaal Programma Regionale Energiestrategie, n.d.).

Legislative Framework and Policy Strategy

The genesis of this process began with the Climate Law passed in 2019, which set goals and targets to achieve carbon neutrality. To meet the targets, the government has implemented a policy strategy called 'over-programming,' which aims to set higher targets than required to ensure the country meets the legally binding targets. Therefore, instead of a 55% reduction in GHG emissions, the Dutch government would aim for a 60% (Ministry of Economic Affairs and Climate Policy, 2024). The Climate Law must go through consultation and development to align with the European National Energy and Climate Plans. The Dutch government must design a 10-year climate plan every 5 years (Erbach & Dewulf, 2024).

-  International scale
-  National scale
-  Provincial scale
-  Municipality scale



Paris Agreement

- A **legally binding** international treaty on climate change.
- The goal is to hold “**the increase in the global average temperature to well below 2°C above pre-industrial levels**” and pursue efforts “to limit the temperature increase to 1.5°C above pre-industrial levels.



World Heritage Convention

- The Convention sets out the duties of States Parties in **identifying potential sites** and their role in **protecting and preserving them**.
- Each country pledges to **conserve** the World Heritage sites situated on its territory and to **protect** its national heritage.



Aarhus Convention:

- Centered on three main pillars of **access to information, public participation, and access to justice**.
- It requires Member States to engage in multi-level public participation when preparing integrated National Energy and Climate Plans.



EU Directives

- A legislative act that sets a **specific goal** that all EU Member States must achieve.
- It defines the result to be achieved while giving national authorities the **flexibility** to choose the **form and methods** of implementation.



Energy Efficiency Directive

- Reduce overall **energy consumption** and is therefore central to achieving the EU's climate ambition, while enhancing present and **future energy security** and affordability.



Habitats Directive

- Protect over a **thousand fauna and flora species** and 230 characteristic habitat types.
- Ensure habitat types are **maintained, or restored**, to a favourable conservation status within the EU.
- Halting the further decline or disappearance.



Birds Directive

- Protect all naturally occurring wild bird species present in the EU and their most important habitats. In addition to **halting the decline or disappearance** of bird species, the Directive aims to allow bird species to recover and thrive over the long-term.

Figure 4.13: Graphic cards depicting current Dutch climate policies

Dutch Approach cont.

Governance Model and Stakeholder Engagement

The Dutch approach consists of the 'Polder system', which facilitates consensus, pragmatic decision-making, and the recognition of differences (Voinea & Van Kranenburg, 2024). Rather than acting alone, the government works with over 100 social parties, including national and local governments, businesses, labor unions, and environmental organizations, to jointly negotiate and sign the Climate Agreement. This agreement defines the specific measures and targets each sector must meet to ensure broad societal support and practical decision-making. To ensure public participation, the Climate Law requires the government to incorporate input from various levels of government, including provinces, city councils, water authorities, and other relevant stakeholders (Erbach & Dewulf, 2024).



Climate Law

- A legislative framework that sets legally binding greenhouse gas emissions reduction targets to meet international obligations like the Paris Agreement.
- Reduce emissions by 49% by 2030 and 95% by 2050. Achieve carbon neutrality in the electricity sector by 2050



Mining Act

- Regulates the *use of subsistence sources* in the deep underground, such as the detection, extraction and storage of minerals and geothermal energy.
- Modulate the *provision of information* on the use of resources in the deep underground.



The Environment and Planning Act

- A comprehensive statute governing spatial *planning* and the *protection* and *utilization* of the physical environment.
- A framework law that consolidates multiple *binding policy domains*, environmental protection, spatial planning, climate adaptation, and public participation.



General Administrative Measure

- A government decision in which *legal rules* are further developed. Under the Environment Act, there are **4 AMvBs**: the Habitat Quality Decree (Bkl), the Decree on buildings for the living environment (Bbl), the Decree on activities environment (Bal) and the Environmental Decree.



Environmental Decree (Ob)

- Governs the "how" and "when" of the application process for an environmental permit.
- Goal is to simplify the interaction between citizens and the various levels of government, municipal, provincial, and national



Environmental Activities Decree (Bal)

- Regulation for citizens and businesses regarding *specific activities* that have an impact on the physical living environment.
- Rules and requirements for various environmental activities, such as *industrial operations, activities affecting the soil, and discharge of wastewater*



Environment Buildings Decree (Bbl)

- Central repository for *technical rules* on construction, safety, and health of building works.
- Designates which technical building activities *require a permit*.
- New EU-mandated obligations for *solar-ready buildings* and mandatory PV installations.



Environmental Quality Decree (Bkl)

- Sets *standards* and environmental values for the physical environment that *public authorities* must maintain to ensure safety and health

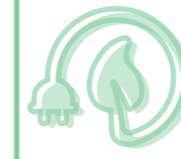

Ordinances of the Province of Fryslân

- To achieve safeguarding *safety*, protecting *health* and the environment, preserving Friesland's unique *landscape identity*.
- Wind Energy: *restrictions* on new wind turbines.
- Solar energy: *prioritizes rooftops* and urban areas.
- Water management: sets mandatory environmental values for *flood protection* and water quantity.
- Nature and Landscape: It strictly protects the *National Nature Network (NNN)*.
- Infrastructure: provincial roads and waterways, focusing on *safe operation*.



Environmental Vision of Terschelling

- A long-term, integral strategic plan currently being developed by the municipality to guide the future of the island's physical living environment.
- Livability and Housing: primary focus to address the *housing shortage*.
- Sustainability and Energy: It outlines the island's path toward *climate neutrality* and the *energy transition*.
- Nature and Landscape: It prioritizes the *preservation* of the island's unique ecological qualities.

Figure 4.13 continued

4.3 Existing Energy Typologies

Wind, Wind, Wind!

Offshore

Wind is one of the most reliable sources of renewable energy (*reference 2.2*) Offshore wind energy utilizes gigantic wind turbines anchored in the ocean or floating on the water. The wind sets the blades in motion, after which a generator converts this mechanical energy into electricity that is transported to the mainland via underwater cables. The major advantage is that the wind at sea blows stronger and more regularly, resulting in an energy field that is two to three times higher than on land. Effects include the potential disruption of marine ecosystems due to noise and altered currents, as well as higher installation and maintenance costs (Benkort et al., 2024).

On Land

Onshore wind turbines convert the kinetic energy of wind directly into electricity at locations where power is often needed immediately. Generating the energy is relatively simple and therefore inexpensive, reliable, and efficient. Advantages include lower transport costs and reduced dependence on foreign energy sources. However, the turbines often have a visual impact on the landscape and potential noise pollution for local residents, making careful integration into the environment necessary (Ministerie van Economische Zaken en Klimaat, 2025).

Make Use of Solar

On Land

Solar parks are large-scale installations of thousands of solar panels on the ground. These parks convert sunlight into electricity and can supply thousands of households with green power. The advantage is the enormous generation capacity and the opportunity for local residents to participate financially in the projects. The main disadvantage is the large land use that this production needs, although experiments are being conducted with the dual use of locations such as former landfills or greenhouses (GroenLeven, 2023).

On Roofs

Rooftop solar panels are a form of energy generation that utilizes existing surfaces of homes and commercial buildings to convert sunlight into electricity. Innovations even make it possible to integrate solar cells into roof tiles, facades, or windows. Advantages include direct CO₂ reduction without additional land use and the possibilities for aesthetic integration into the built environment. Disadvantages include the limited load-bearing capacity of some roofs or aesthetic concerns regarding historic buildings (TNO, n.d.).

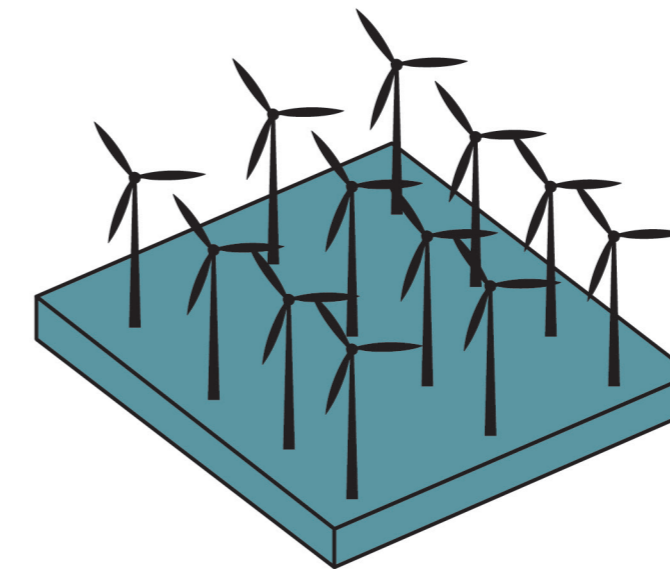

Wind offshore

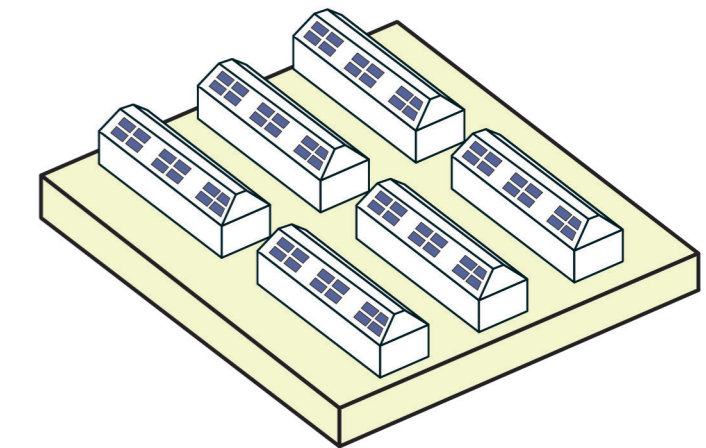

Solar on roof

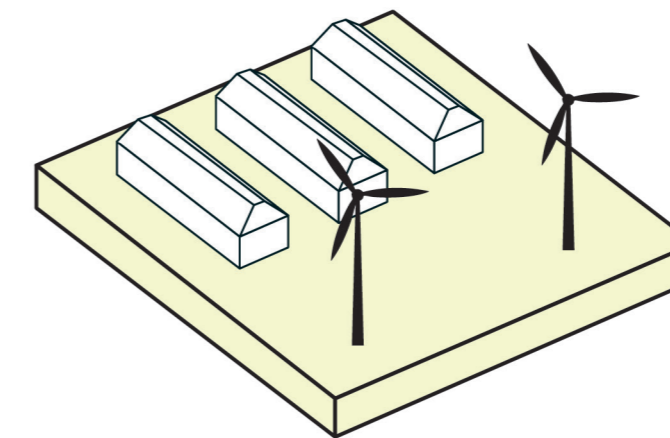

Wind on land

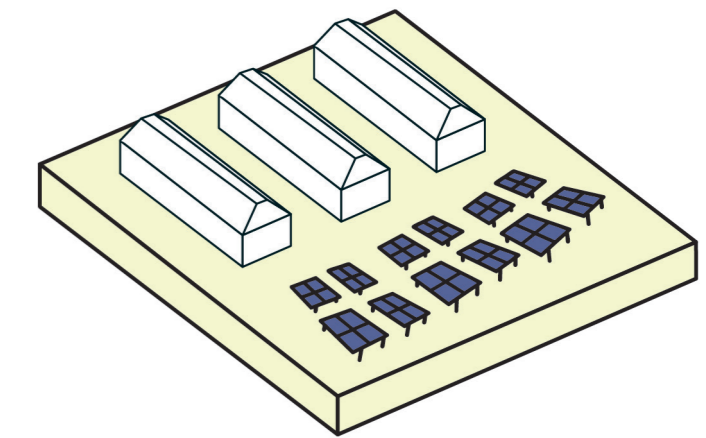

Solar on land

Figure 4.14: Diagrammatic representations of existing energy typologies throughout Friesland

4.4 New and Experimental Energy Typologies

Bio, tidal, wave, 'oh my!'

Bio-energy

Bio-energy can be extracted from organic materials such as manure, crop residues, wood, or biogenic waste. This biomass can replace fossil fuels for the production of heat, electricity, or transport fuels. The major advantage is that this source is storable and always available, which increases the resilience of the energy system. Despite that, strict monitoring is necessary to prevent competition with food supply and negative environmental impacts (FAO, n.d.).

Tidal energy

Tidal energy is generated by using the hydrokinetic energy from tidal and ocean currents. The TidalKite from SeaCurrent is an underwater kite anchored to the seabed that generates energy from tidal currents. The kite moves in a figure-eight pattern, with the pulling force driving a generator that supplies electricity continuously. The biggest advantage of this energy source is the supply of 100% clean "baseload" energy that is predictably available 24/7. A disadvantage is the need for extensive ecological monitoring, as tests often take place in vulnerable nature reserves such as the Wadden Sea (SeaCurrent, 2025).

Wave energy

Wave energy uses the constant movement of ocean waves to generate electricity via turbines or hydraulic systems. Symphony Wave Power is an example of the technology that directly converts water waves into sustainable electricity. The installation is located approximately six meters below the water surface, where a moving hull forces fluid through a turbine driven by changing wave pressure to power a generator. It is efficient, invisible, and has a low-maintenance. Although, the minimum water depth of 20 meters is required for installation. (Technology – Symphony Wave Power, n.d.).

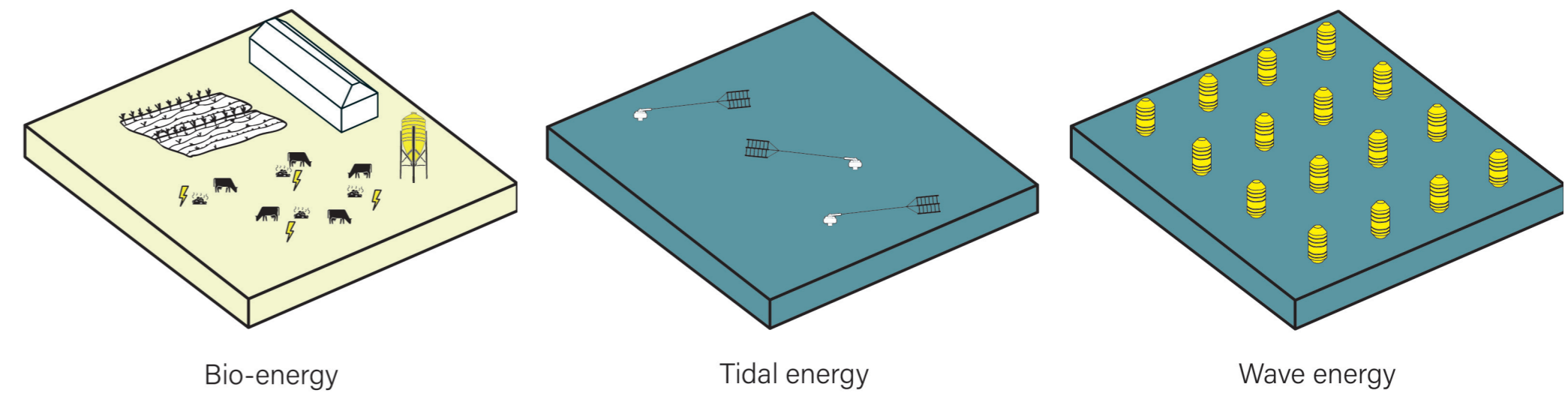

Figure 4.15: Diagrammatic representations of possible energy typologies to implement throughout Friesland

4.5 Existing Energy Flow

What are we dealing with?

The Netherlands is undergoing an accelerated energy transition with the goal of achieving climate neutrality by 2050. Despite this shift, the national energy system remains heavily dependent on fossil fuels, which account for approximately 76% of total energy consumption, with oil products (39%) and natural gas (37%) representing the largest shares. Renewable energy is expanding rapidly but currently constitutes only around 20% of the energy mix (International Energy Agency).

The rapid integration of renewable sources has highlighted structural limitations in the country's existing energy infrastructure. In particular, the ageing electricity grid is under significant strain, leading to congestion, capacity bottlenecks, and delays in connecting new consumers and producers (Taylor Wessing). Energy flow illustrates both the points of production and consumption, and with the region's growing population, demand continues to rise. While the Netherlands is advancing toward a climate-neutral future, the pace of infrastructure development is lagging behind the expansion of renewable energy, creating challenges for reliable and efficient energy delivery.

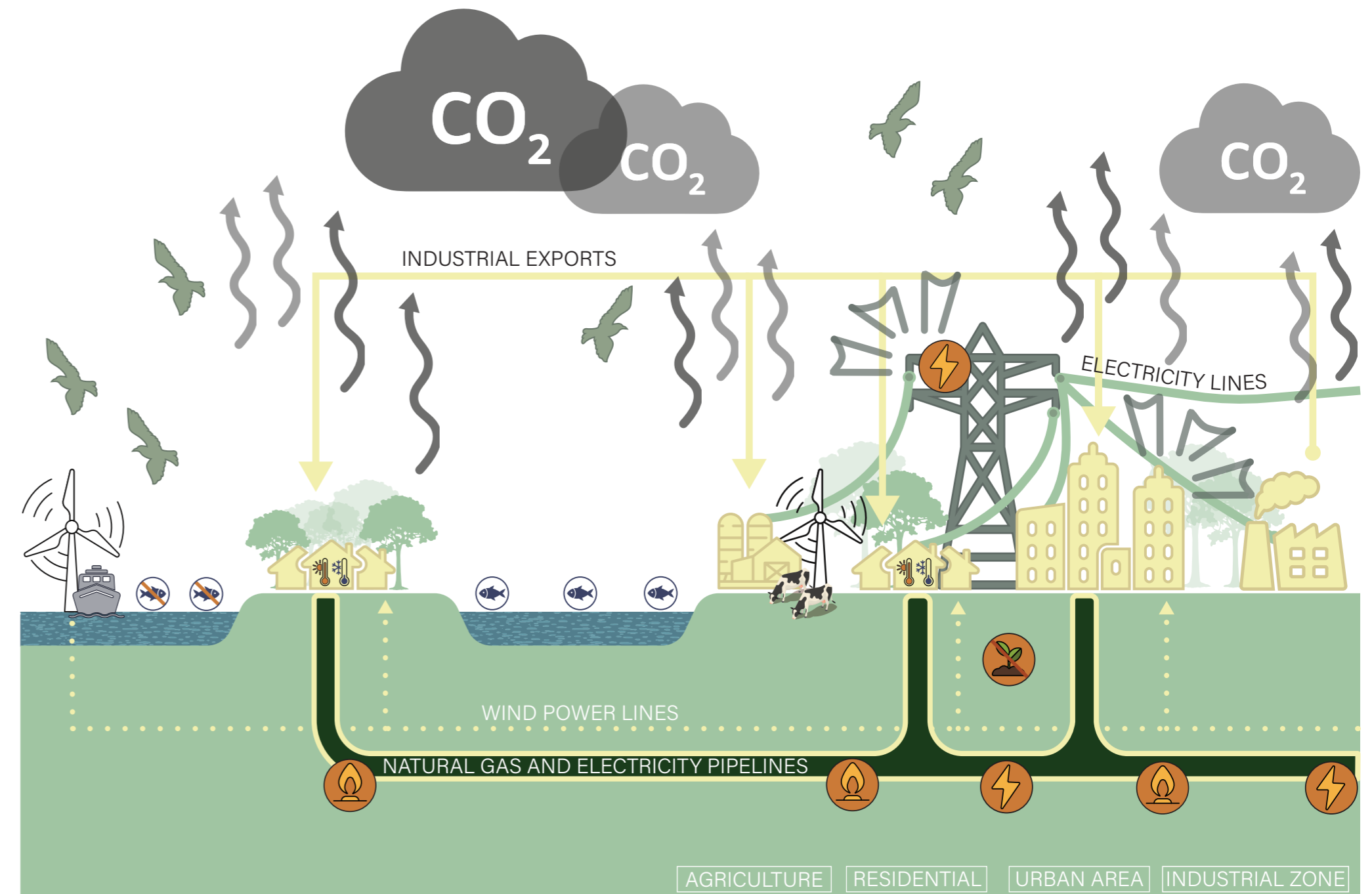
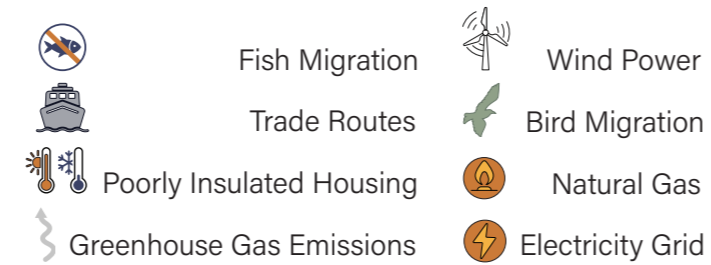

Figure 4.16: Current existing energy framework, shown in section from North Sea to land.

4.6 Synthesis Map

Synthesize, synthesize, synthesize

The synthesis map shows the most important layers from the analysis maps and their relation to each other.

It is worth noting that current energy production is concentrated primarily along the coast and on the IJsselmeer, areas where land is most expensive and ecology is protected. While this location is not ideal for ecological and financial considerations, these areas have the highest wind potential and are relatively close to consumers, making them logical locations. Energy is oftentimes produced at a local, and occasionally individual, scale.

The region's diverse landscape is also striking. The area has a low level of urbanization (*reference 1.2*), with large distances between cities, a high percentage of agricultural land, a unique (protected) tidal zone used by many animals for shelter, migration, and breeding. Four islands are characterized by expansive beaches and nature-centric tourism. Together, these characteristics make Friesland an ecologically unique province with a diverse landscape identity that must be protected.

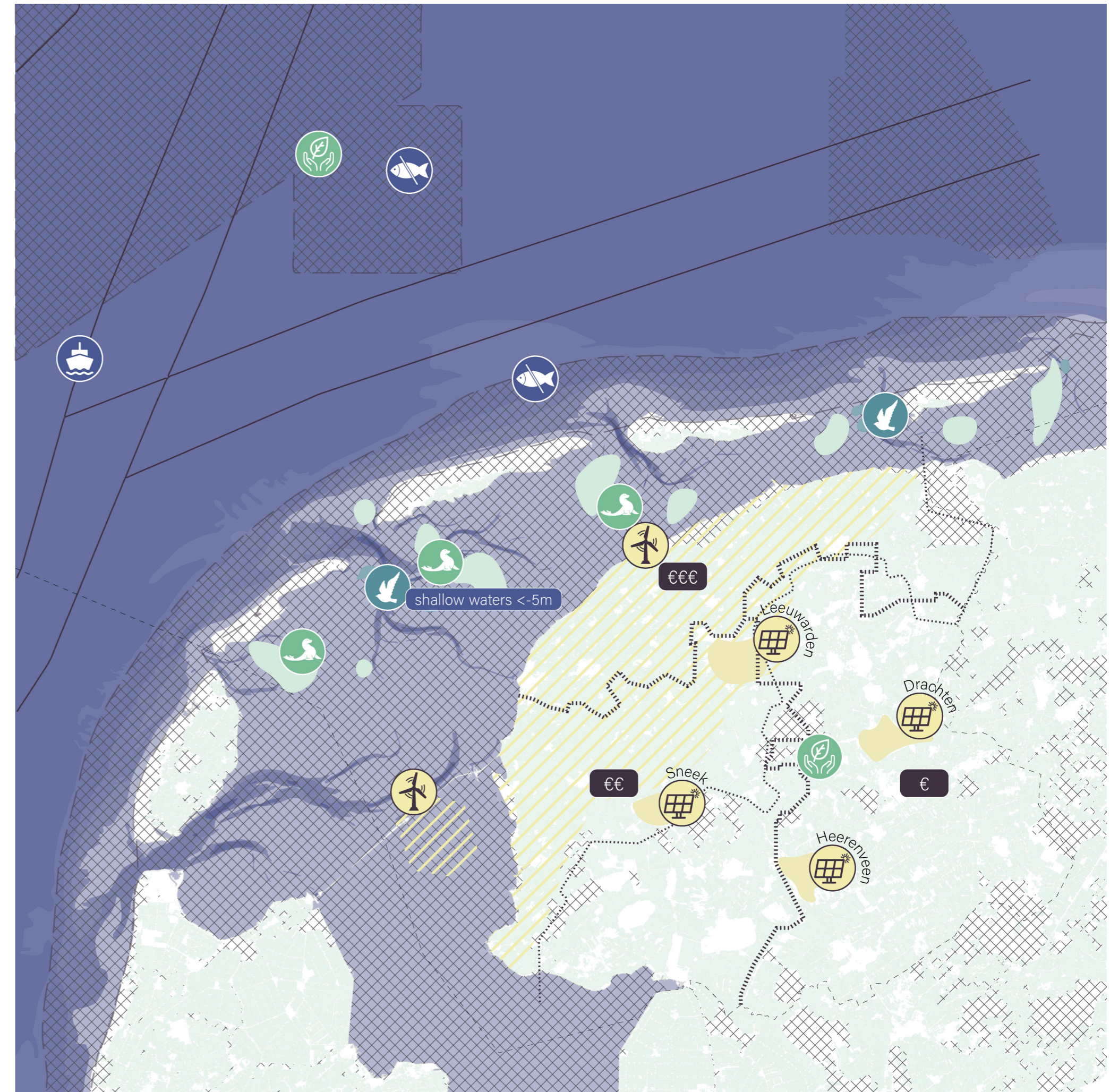
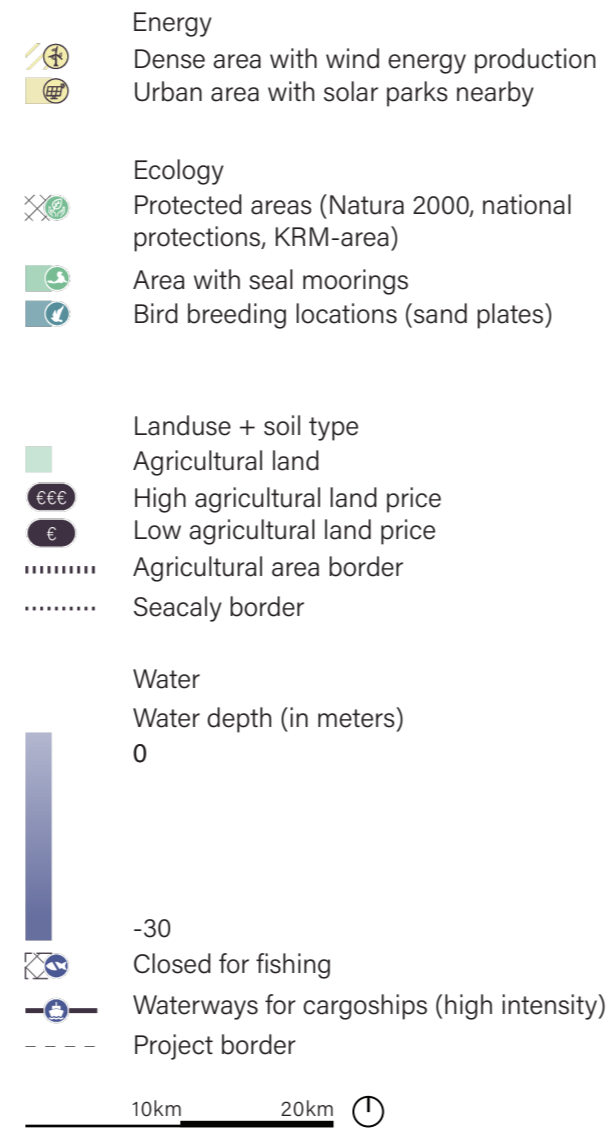

Figure 4.17: Synthesis map compiling all relevant information from the analysis phase

5 Scenario Exploration

- 5.1 Areas and Themes
- 5.2 What If Scenarios
- 5.3 What If Conclusions



Figure 5.1: A coastal home on the island of Terschelling has retrofitted their roof to implement photovoltaic panels for energy production

5.1 Areas and Themes

Three Unique Areas

Through the analysis (*reference 4.1*) and the synthesis map (*reference 4.5*), there is a clear distribution of space between three areas: North Sea, Wadden Sea, and mainland Friesland - each of which exhibit unique ecological characteristics.

Each site provides different contextual parameters and therefore warrants separate interventions. The North Sea requires consideration of international happenings, such as shipping routes. The Wadden Sea is protected by UNESCO due to its significance as the world's largest unbroken chain of intertidal sand flats and therefore requires special attention. Mainland Friesland exhibits a flat landscape with mainly agricultural activities, villages, and small cities (*reference 1.3*). Since the interaction of water is less significant in this area compared to the other two, it is considered through a different lens.

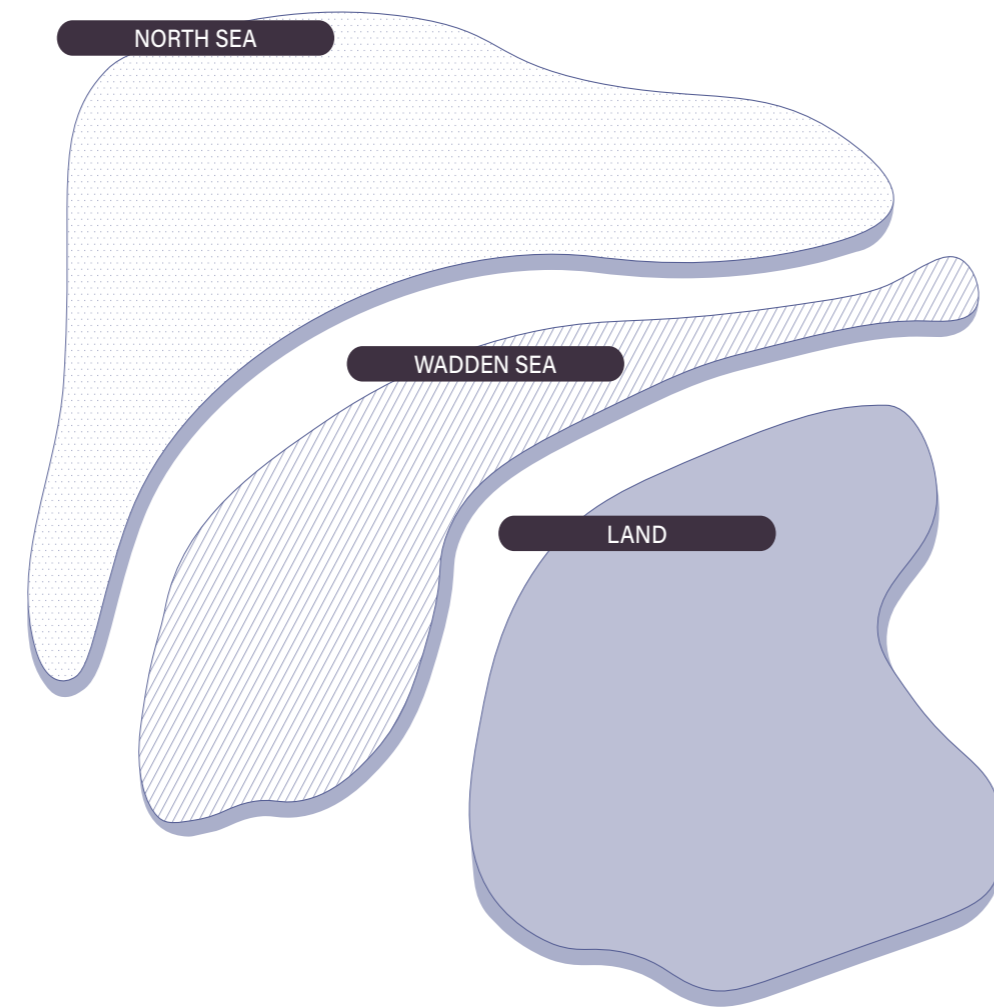

Figure 5.2: Diagrammatic representation of the three chosen areas of focus within Friesland



Figure 5.3: North Sea



Figure 5.4: Wadden Sea



Figure 5.5: Land

5.1 Areas and Themes

Three Separate Themes

Energy Production

This theme focuses on producing large amounts of renewable energy to support the regional and national energy transition. The North Sea has strong and stable wind conditions and large open space, which makes it suitable for efficient offshore energy production (reference 2.2). By concentrating energy production at sea, pressure on land and ecological areas can be reduced (reference 3.4)

Ecological Stewardship

This theme focuses on protecting and strengthening natural ecosystems. The Wadden Sea is one of the most important tidal landscapes in the world and supports many species of birds, fish and marine life. The goal is to maintain ecological balance here while carefully managing human activities and energy possibilities. Residents of Friesland can play an active role in the stewardship through personal responsibility toward the landscape (reference 2.1 and 3.4)

Local Engagement

This theme focuses on improving the local engagement of Frisians to be more active members in the energy transition process. Through local engagement residents of Friesland will play an important role in determining their province's renewable energy infrastructure and policies. By relying on cities and residents through an interconnected landscape, engagement and participation will increase (reference 2.3 and 3.4).



Energy Production
Producing large amounts of renewable energy to support the regional and national energy transition



Ecological Stewardship
Protecting and strengthening the natural ecosystems



Local Engagement
Improving the participatory processes for communities in Friesland during the energy transition

Figure 5.6: Three themes graphically represented

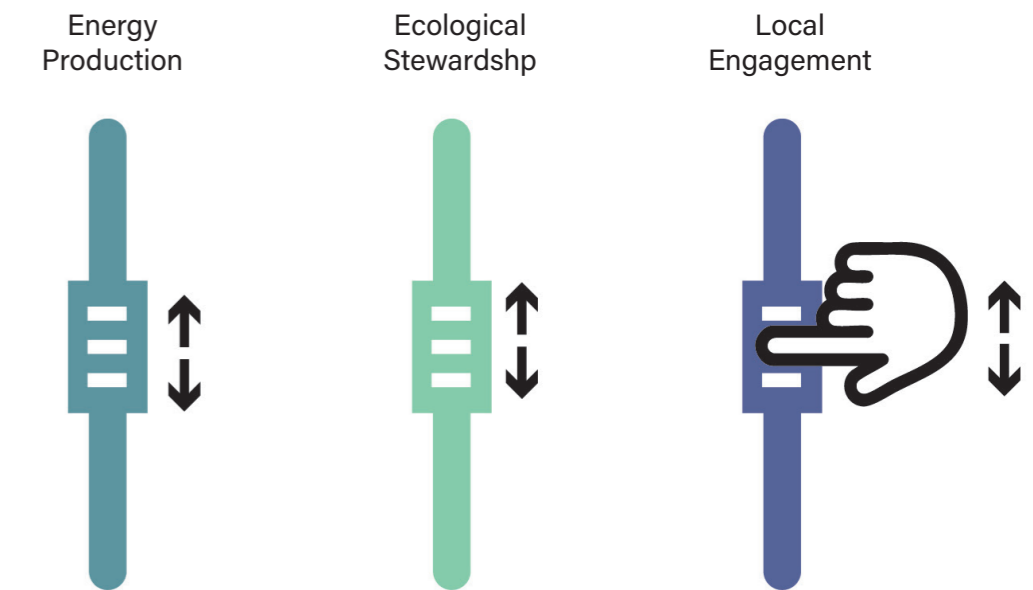

Figure 5.7: Sliders that relate to the three themes and can be adjusted per output per location

5.2 What If Scenarios

Scenario 1. What if there was 100% energy production across all three areas?

This scenario explores a future where energy production is maximized across the North Sea, the Wadden Sea, and on the land. Offshore wind parks in the North Sea provide large-scale energy due to strong and consistent wind conditions, while the Wadden Sea is used for predictable tidal energy systems. On land, renewable energies are integrated with existing land uses such as agriculture and settlements.

The main advantage of this scenario is the high energy output nearby, which could make Friesland energy self-sufficient and even allow for regional energy export (reference 2.2). It also creates opportunities for local investment and economic growth. However, the disadvantages are significant. Large-scale infrastructure can negatively impact biodiversity, especially in the sensitive Wadden Sea. It may also disrupt shipping routes and fisheries. In addition, overproduction can create pressure on the energy grid, and the landscape identity may be affected by visual pollution.

While this scenario is highly efficient in energy production, it creates strong ecological and spatial conflicts, especially in the Wadden sea and on land.

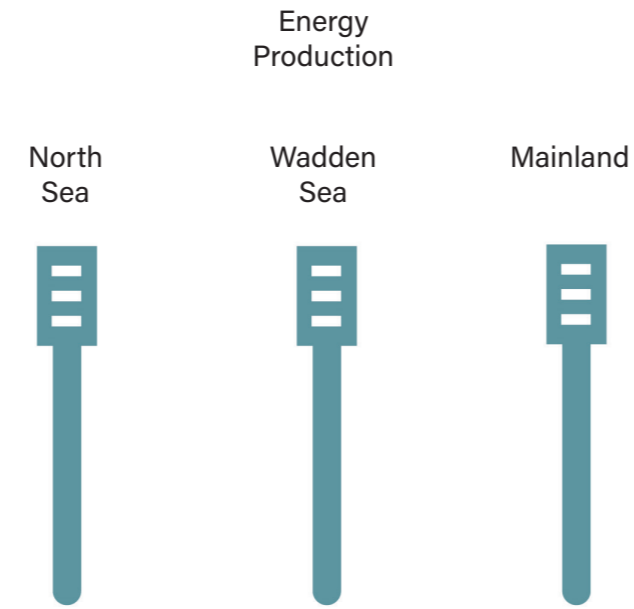

Figure 5.8: Full energy production is exhibited across all three areas

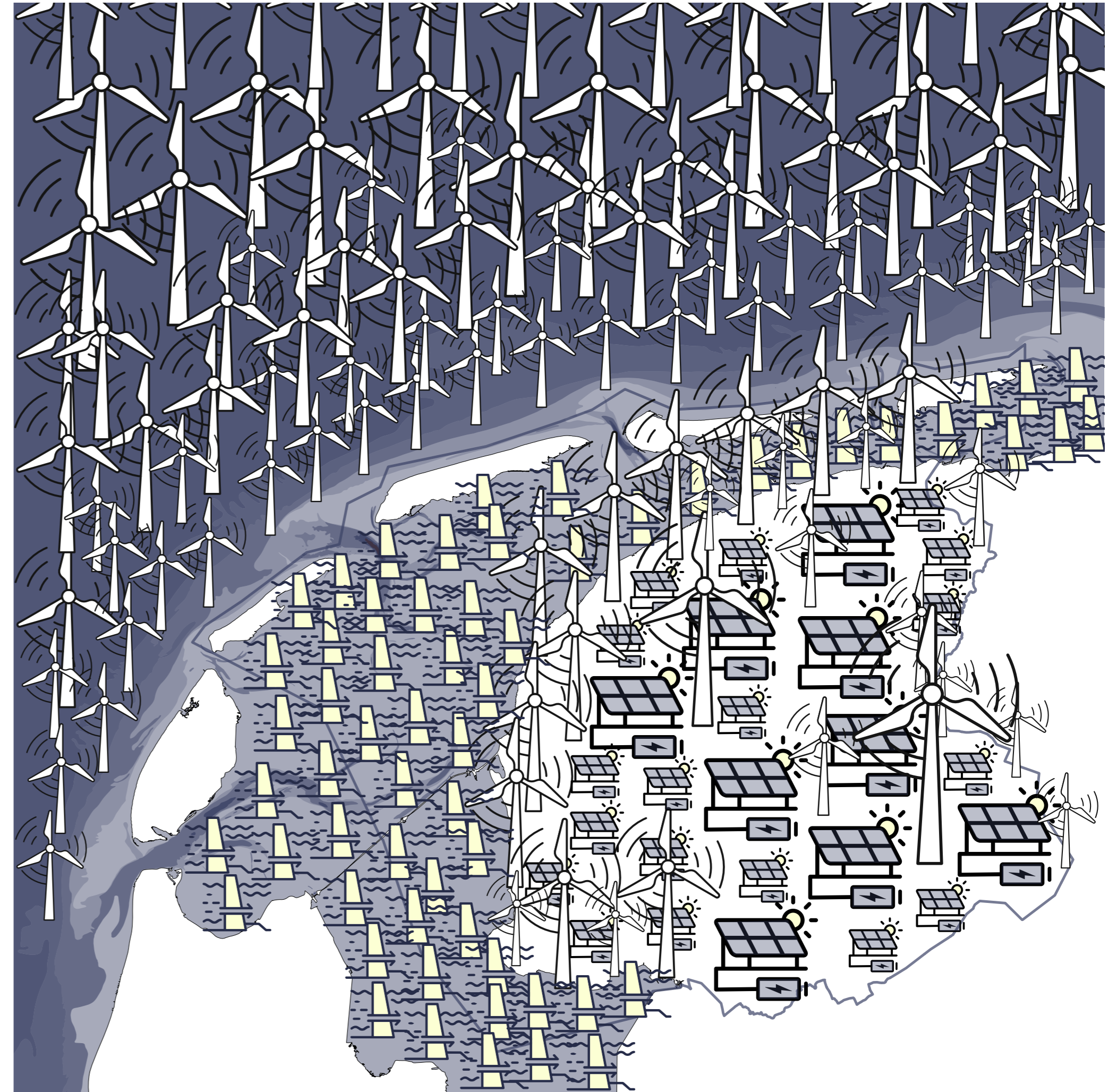
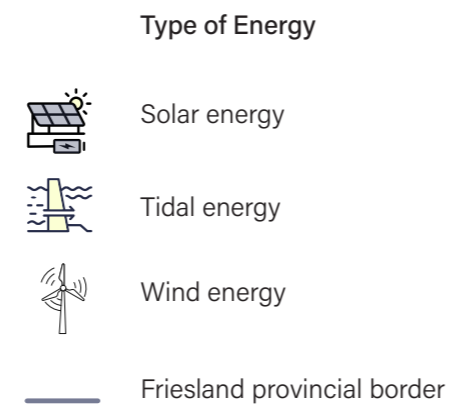

Figure 5.9: Explorative visualization of what 100% energy production might look like

5.2 What If Scenarios

Scenario 1 Reactions

The stakeholder responses to this scenario show a clear tension between ambition and caution. On the one hand, there is strong support for large-scale offshore energy development, especially in the North Sea, where it is seen as necessary and efficient. At the same time, stakeholders emphasize that energy production should be diversified, combining large and small-scale technologies to create a balanced system.

On the other hand, there is significant concern about the spatial and ecological impact, particularly in sensitive areas such as the Wadden Sea. Environmental organizations highlight the risks to biodiversity and argue that alternative locations should be prioritized. These responses indicate that while large-scale energy production is widely recognized as important, its spatial distribution remains highly contested. Overall, stakeholders support energy development, but only under conditions that carefully consider ecological limits and spatial quality.

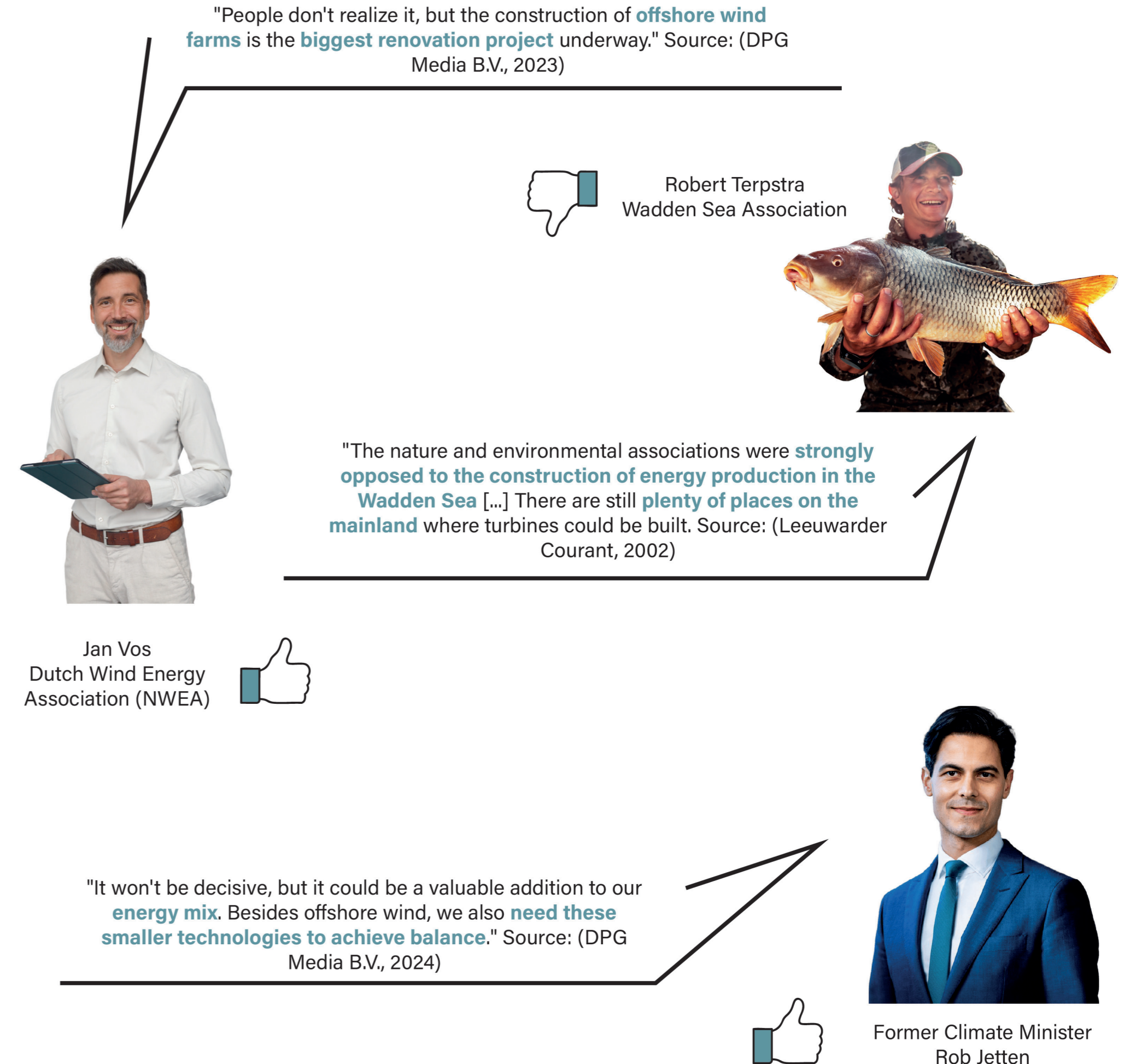

Figure 5.10: Reactions of Frisians based on What If Scenario #1

5.2 What If Scenarios

Scenario 2. What if we further existing ecological protections to steward biodiversity?

This scenario prioritizes ecological protection and biodiversity across the entire region. The North Sea, Wadden Sea, and inland areas are primarily managed as natural systems, with strict limitations on human interventions such as energy production. Sensitive ecosystems are restored and protected, supporting bird migration, marine life, and natural landscapes.

The main advantage of this approach is the preservation and strengthening of ecological systems (*reference 2.1*). Fisheries can benefit from healthier ecosystems, and the region maintains its unique natural identity. It also aligns with environmental goals and long-term sustainability.

However, this scenario has clear disadvantages. The lack of energy production limits the region's contribution to the energy transition and increases dependency on external energy sources. This may also lead to economic challenges and reduce opportunities for local development and innovation.

In conclusion, while this scenario strongly supports ecological values, it does not provide a realistic solution for the energy needs of the future.

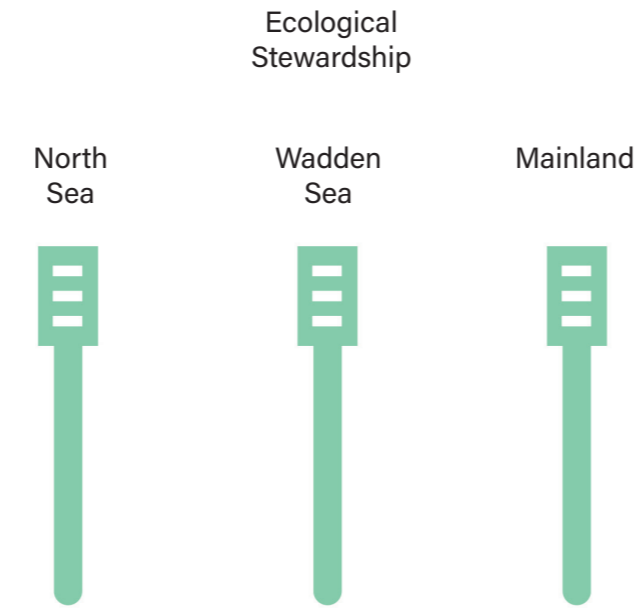

Figure 5.11: Full ecological stewardship is exhibited across all three areas

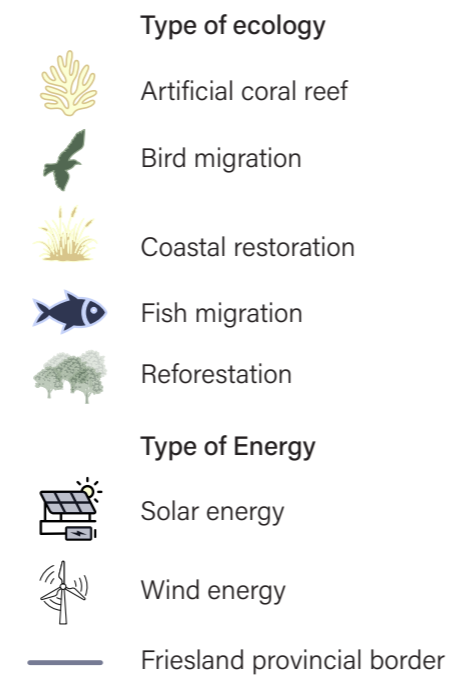
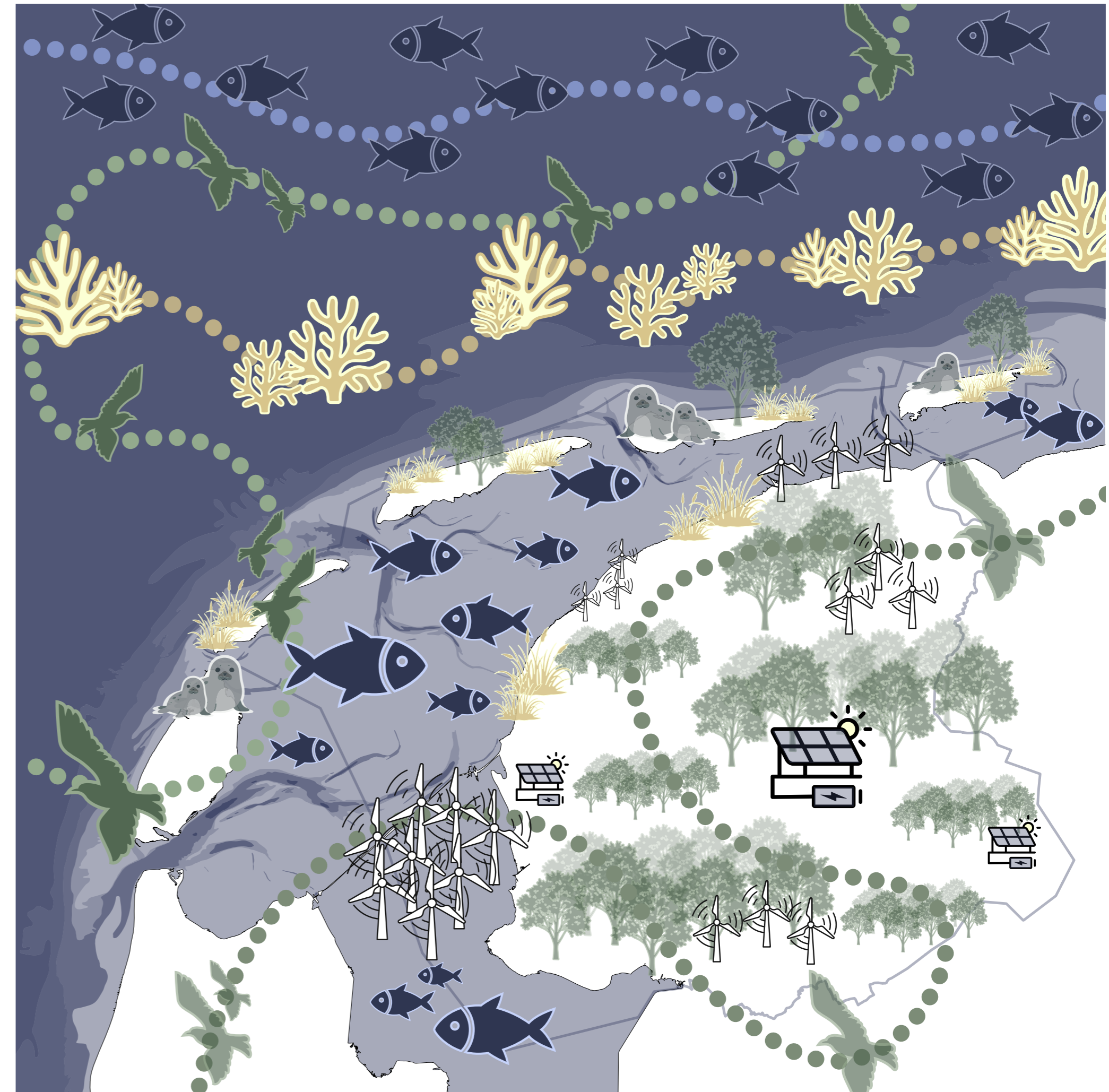

Figure 5.12: Explorative visualization of what full ecological protection might look like



5.2 What If Scenarios

Scenario 2 Reactions

The responses to this scenario reflect a strong divide between ecological priorities and socio-economic realities. Some stakeholders emphasize the need for long-term investment in the Wadden Sea region, suggesting that ecological protection can also create economic and social value if properly supported. However, others argue that a strict focus on ecology is unrealistic, as it ignores competing spatial and energy demands. This highlights the complexity of spatial planning in Friesland, where multiple functions must coexist within limited space.

Additionally, some local actors point out that renewable energy can provide financial benefits for communities, suggesting that excluding energy production may reduce local support. This shows that while ecological protection is widely valued, a fully preservation-based approach lacks feasibility. A balance between ecological and economic interests is therefore necessary.

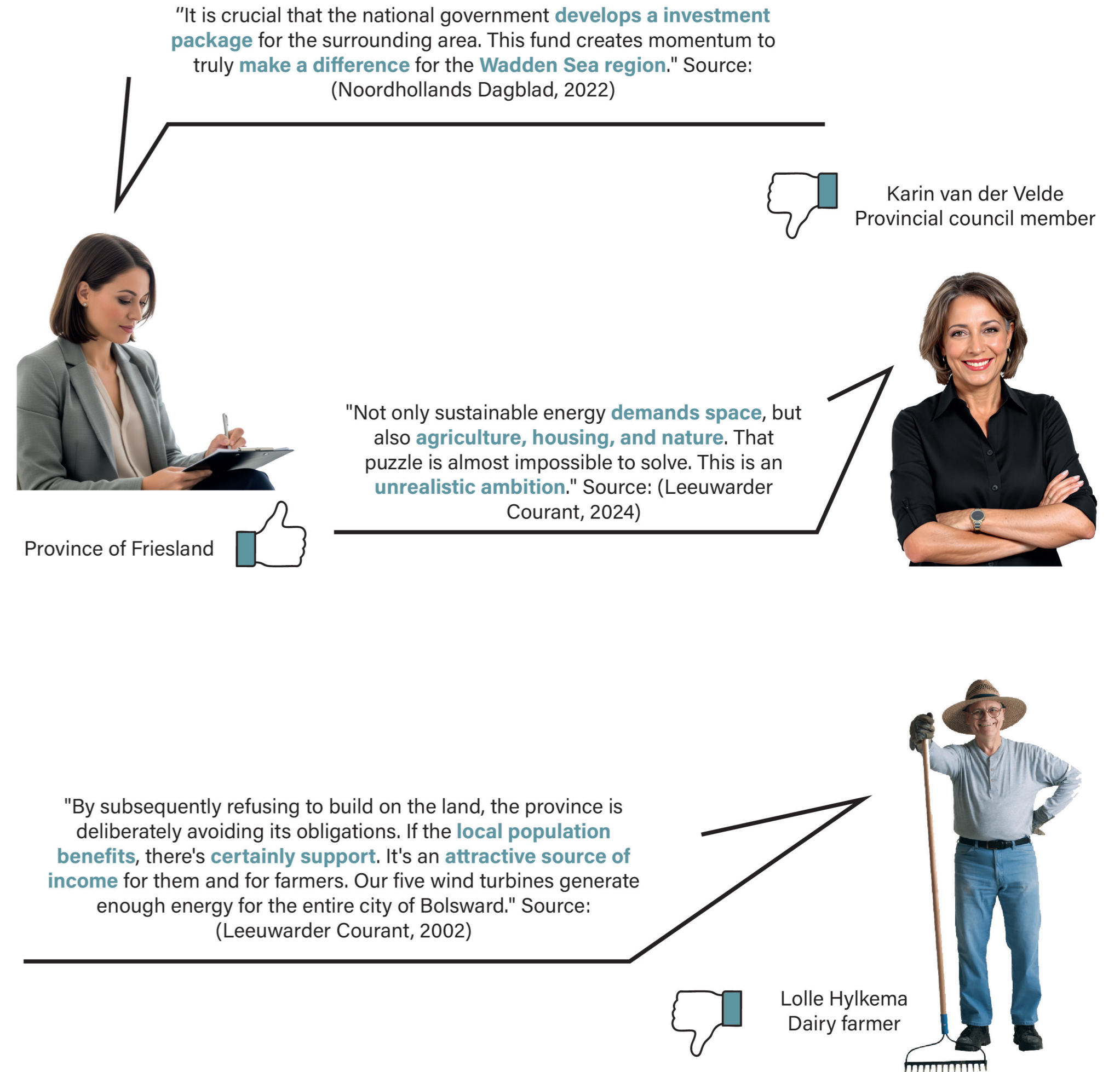

Figure 5.13: Reactions of Frisians based on What If Scenario #2

5.2 What If Scenarios

Scenario 3. What if Friesland cities are dependent on offshore energy and villages rely on localized production?

This scenario proposes a spatial division of the energy system, where cities depend on large-scale offshore energy production, while villages and rural areas rely on localized energy systems such as small wind turbines, solar panels, and bio-energy. This creates a decentralized energy network with strong local involvement.

The advantages of this approach include increased local ownership and participation, especially for farmers and residents. It reduces energy losses through local production and can relieve pressure on large-scale infrastructure. It also creates new economic opportunities and localized engagement, which, in turn, strengthens regional resilience (reference 2.3).

However, there are also challenges. Smaller communities may lack technical knowledge or resources, and coordination between local and large-scale systems can be complex. There may also be conflicts with other regions or countries over shared offshore resources. This scenario offers a balanced and socially inclusive approach but requires strong coordination and support to function effectively.

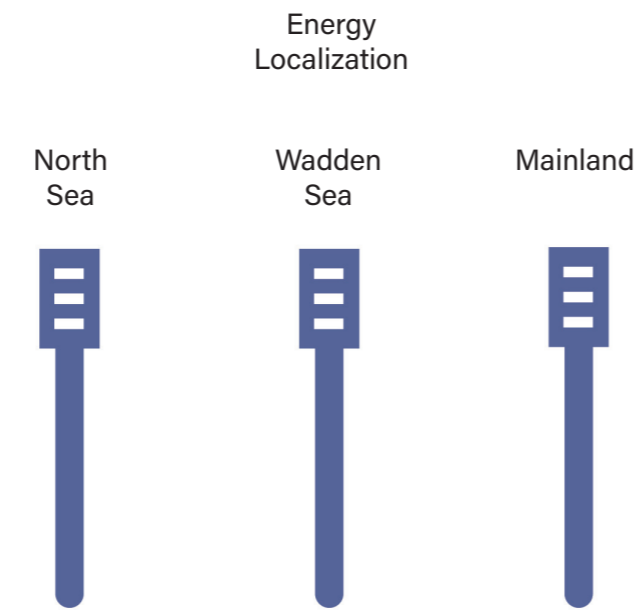

Figure 5.14: Full ecological stewardship is exhibited across all three areas

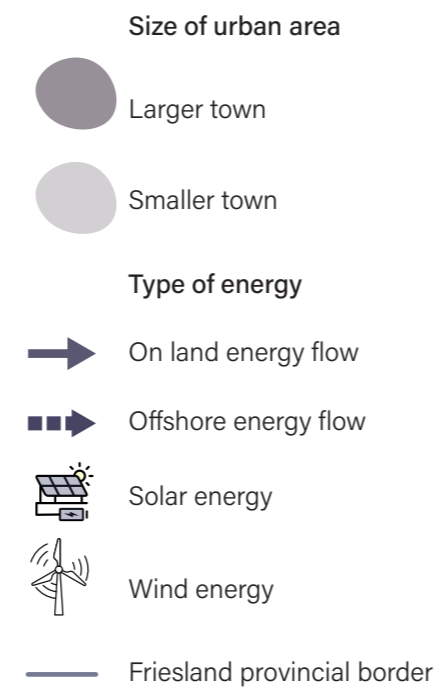
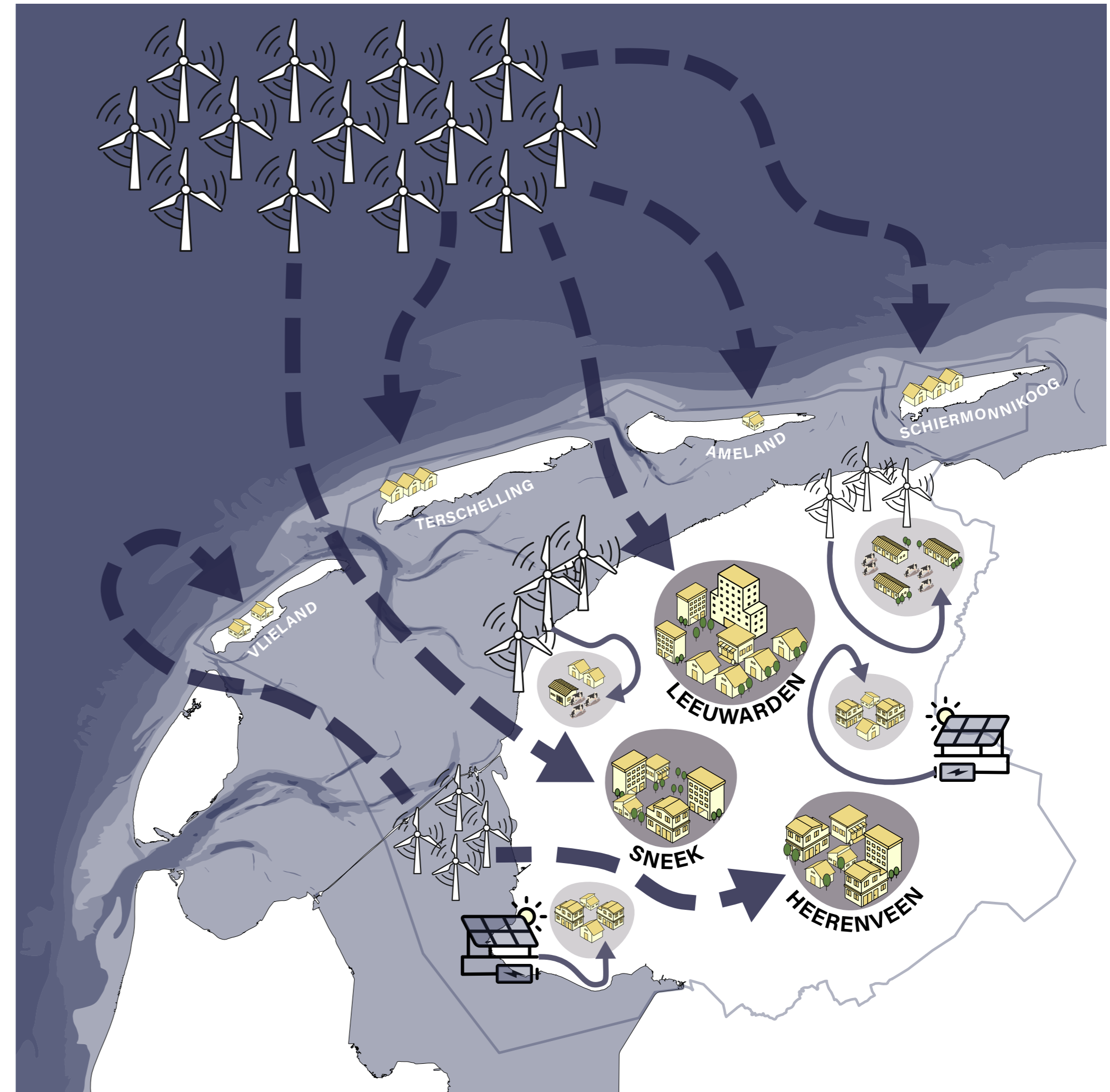

Figure 5.15: Explorative visualization of what varied energy distribution might look like



5.2 What If Scenarios

Scenario 3 Reactions

Stakeholder responses to this scenario are generally more positive and aligned with regional identity. Many actors highlight the importance of local ownership and control, emphasizing that energy production should benefit the region economically. This shows an idea to reduce dependence on external actors and have financial value within Friesland.

At the same time, there is recognition of the opportunities for local initiatives, particularly in villages, where smaller-scale energy systems can be more easily implemented and accepted. However, some stakeholders also express caution, warning against overdevelopment or forcing self-sufficiency at all costs. They repeat the importance of maintaining landscape quality and considering alternative energy sources outside the region. These responses suggest that this scenario is seen as promising but only if it remains balanced.



Figure 5.16: Reactions of Frisians based on What If Scenario #3

5.3 What If Conclusions

So, what? What if these all occur? How are they spatialized?

The exploration of the three “what-if” scenarios provides important insights into the spatial and strategic direction of the energy transition in Friesland. The North Sea clearly emerges as the area with the largest potential for energy production. Due to its strong and consistent wind conditions, it offers the opportunity to generate large amounts of renewable energy, which could contribute to making Friesland energy self-sufficient and even enable regional energy export (*reference 2.2*).

In contrast, the Wadden Sea is identified as a highly sensitive ecological system where energy production should remain present, but limited because of the possibilities of tidal energy. This area plays a crucial role in maintaining ecological balance and supporting biodiversity. Therefore, a focus on ecological stewardship is essential, including the protection of tidal landscapes and careful management of human activities (*reference 2.1*).

On land, the focus shifts towards supporting local communities, economies, and patterns of urbanization. Small-scale and locally integrated energy systems can strengthen community involvement and provide direct benefits to residents. In this way, the energy transition not only transforms energy systems but also reinforces the relationship between people and place (*reference 2.4*).

Together, these insights form the basis for the project’s vision, aiming to balance energy production, ecological protection, and local engagement within a coherent regional strategy (*reference 3.4*).

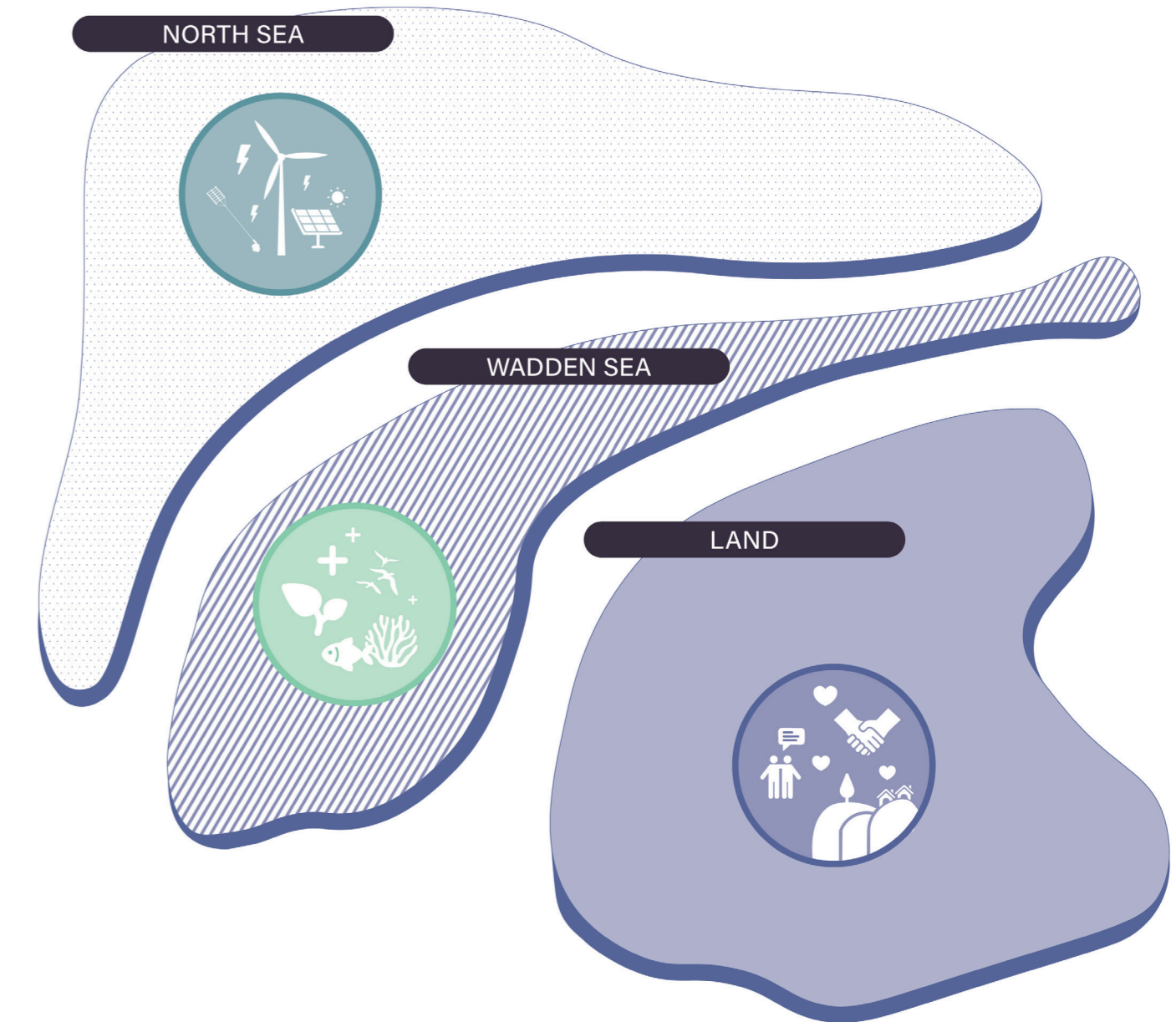

Figure 5.17: Concluded image of the distribution of themes amongst area: energy production in the North Sea, ecological stewardship in the Wadden Sea, and local engagement on land

6 Visions

- 6.1 Vision Statement
- 6.2 Possibilities and Potentials
- 6.3 Vision Map
- 6.4 Abstracted Vision Maps
- 6.5 Energy Flow Section



Figure 6.1: The intersection of the North and Wadden Seas hosts a fragile ecology that requires much consideration

By 2100, *Friesland will be the first self-sufficient province of The Netherlands* to the *benefit of its residents* and broader province. Public participation and frequent dialogue between the community and government will enable *vast renewable energy production, preservation of the landscape identity*, and will *enhance the ecological uniqueness* of the region.

6.2 Possibilities and Potentials

Where will wind energy be best suited?

After conducting an analysis of the province and considering multiple potential scenarios, locations of possible implementations became visible. Due to multi-layered regulations (shipping routes, Natura 2000, etc.) in the North Sea, there are prescribed zones in which the proposed energy production can exist.

Considering all the regulations at sea, it can be estimated that roughly 90% of the surface area is covered. Taking this into account, there remain three areas with a substantial surface area that can be utilized for energy production.

On land, in addition to ecological regulations, soil quality and price have also been taken into account. As concluded in report section 4.2 (*reference figure 4.12*), poor soil quality exists in the southeast of the province, and is therefore lower in value. Additionally, populated areas and coastal regions, where a significant amount of energy generation already takes place, are less suitable for new energy production. The combination of these factors means that an area in the southeast can be designated for energy generation, with the important caveat that this must be done with the landscape's identity and size in mind (*reference 3.4*).

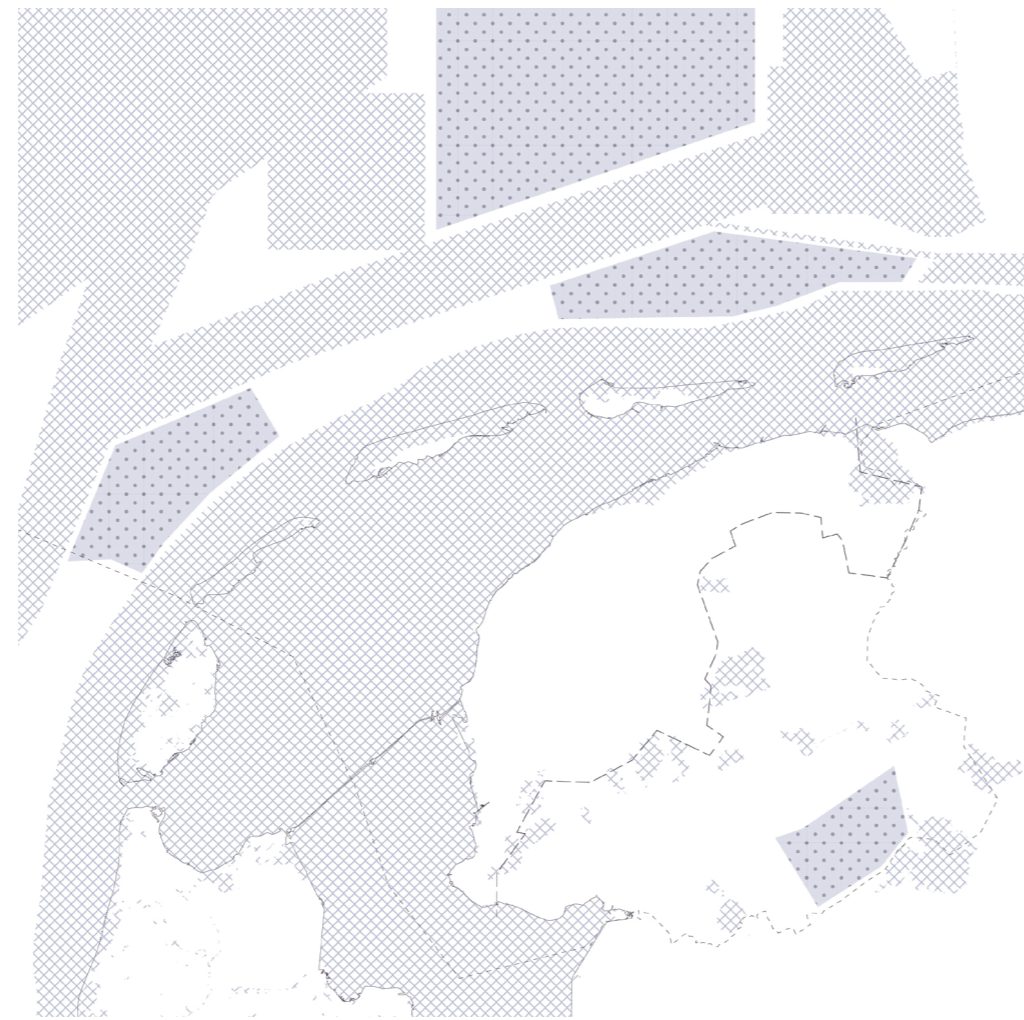







Figure 6.2: Potential locations for wind energy production

-  Restricted areas (Natura 2000, national protections, KRM-area)
-  Areas of possibility
-  Tidal water flow
-  Seaclay border
-  Project border

Islands for Education!

In the Wadden Sea, man-made islands can be constructed in the shallow areas between waterways.

The Marker Wadden serves as an example project for this possibility. In this project, sand, clay, and silt were extracted from the Markermeer to create islands with the goal of restoring nature. On a large scale, spawning grounds, islands, and natural shorelines have been created that benefit (endangered) animals and plants. A robust nature reserve has been created to restore nature in the area and at the national level. The development of new nature, both above and below water, provides new habitats for animals. (Natuurmonumenten, n.d.). Thanks to careful management, 170 plant species are now growing there six years after construction, and the area is used by a wide variety of animals (Havermans, 2022). It is also possible to visit part of the area (Natuurmonumenten, n.d.).

The areas of potential for new island construction are between the existing islands and the mainland. They will therefore be built at shallow points in the water and will remain distant from already existing sand plates and animal habitats to minimize their disturbance.

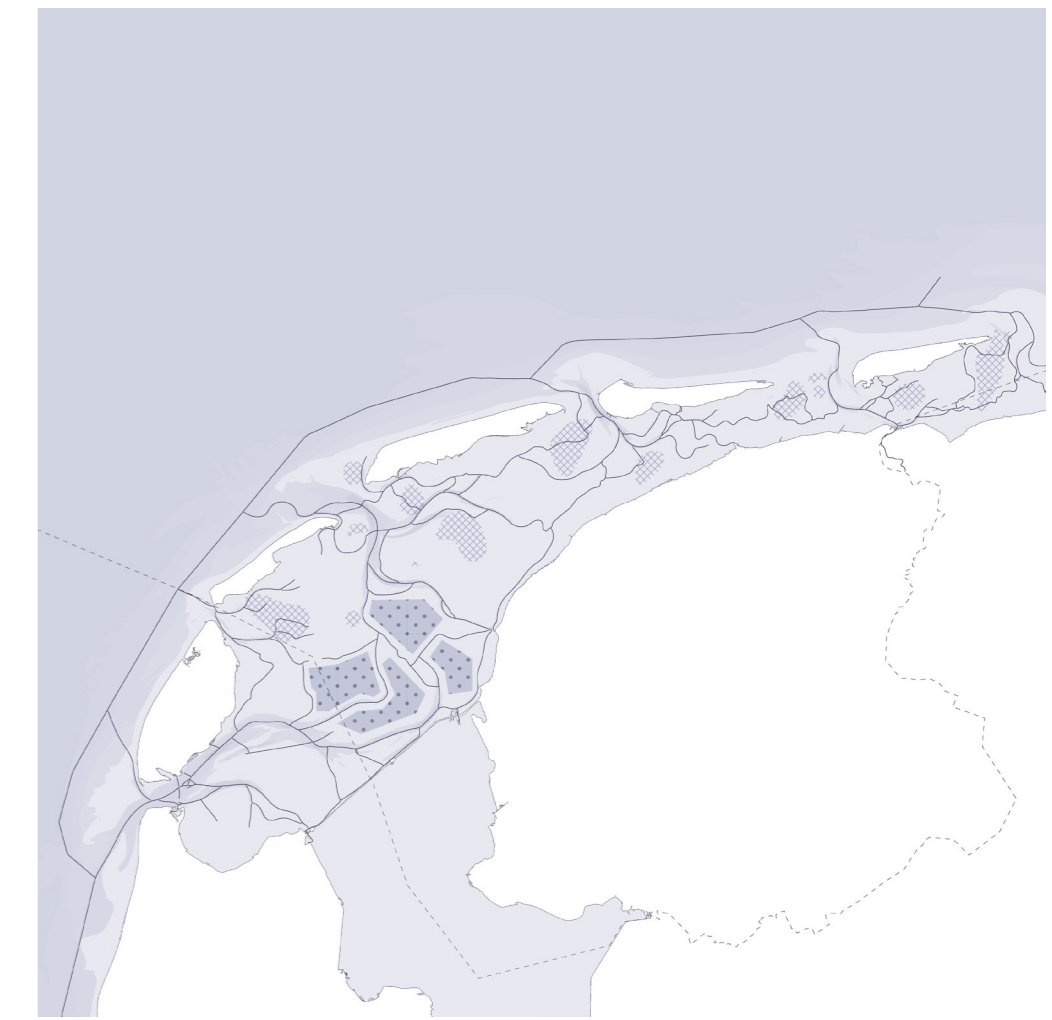







Figure 6.3: Possible locations for artificial land

-  Restricted areas (Natura 2000, national protections, KRM-area)
-  Areas of possibility
-  Tidal water flow
-  Seaclay border
-  Project border

6.2 Possibilities and Potentials

Can the space in between islands be used for production?

The North and Wadden Seas provide great potential for hydropower; wave energy and tidal energy.

The intertidal zones between the transverse ends of each island provide potential tidal energy production. Tidal energy is generated by using the hydrokinetic energy from tidal and ocean currents (reference 4.4). Since the tidal changes every six hours, and the channels between the islands, where the seawater flows, are small, the possibility arises (reference 4.1, page 40).

The zone just distant of the islands in the North Sea provides potential for wave energy according to Lamboo et al. (2024, figure 1.1). This zone is just outside of the protected ecological zone so it does not directly interfere with regulations. The water has a depth of -20m or more, a requirement for the installation of the system (Technology – Symphony Wave Power, n.d.). Spatially, there is sufficient physical space, but the use of that space remains a point of concern. The proposed area also includes waterways for shipping, and this must be taken into account. It is also important to consider military training zones, sand extraction areas, and cables running from energy parks to land. (Lamboo, 2024).

For all projects, the ecological impact is also a key consideration due to the Natura 2000 area.

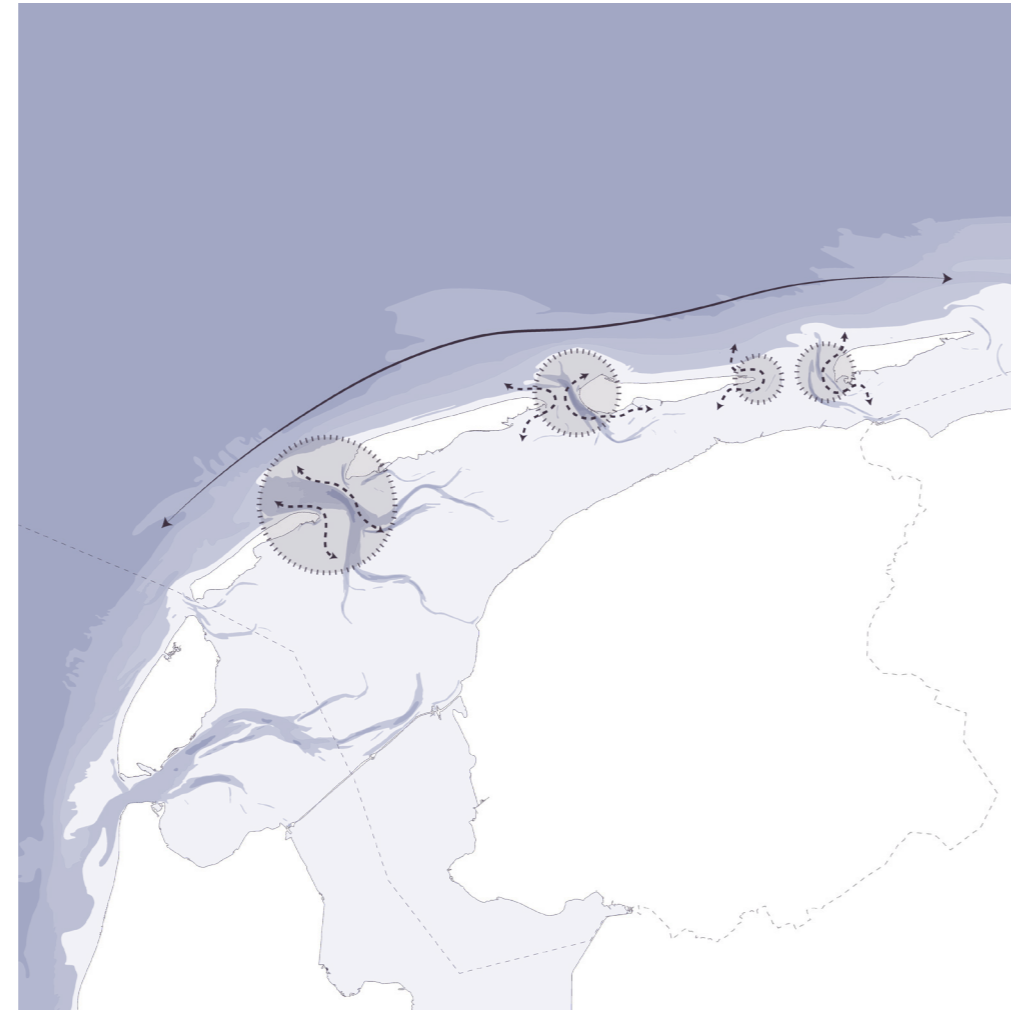







Figure 6.4: Potential locations for hydropower production

-  Areas of possibility
-  Tidal water flow
-  Hydropower potential
-  Seaclay border
-  Project border

How can local engagement and connectivity be increased?

Due to the energy transition and its implemented infrastructure, population growth is expected in Friesland in and around the current five largest cities; an urbanized area will be created inbetween them, too. To accommodate this growth, connectivity within the area, and to other provinces, must be improved as mobility currently relies on road connections for private automobiles.

A sustainably expanded public transit network is proposed to meet expected population needs and reduce car reliance. The enhanced network will bolster the accessibility of Frisian cities, and the larger province in general. This will also lead to a stronger connection with the region and the community through interactions during travel (reference 2.3), strengthening the local engagement. Reliance on public transportation will also have the beneficial effect of clean air since there will be less CO2 emitted by automobiles.

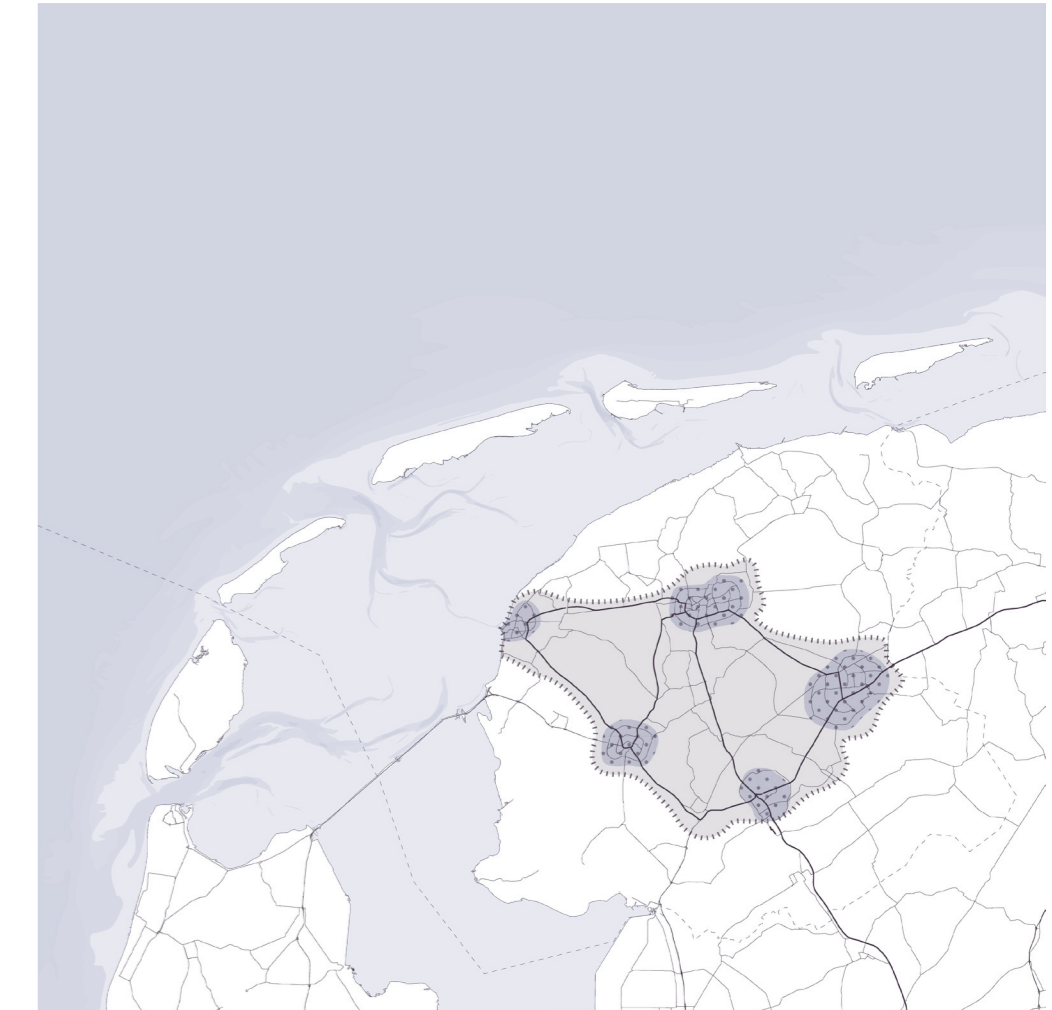





Figure 6.5: Potential locations for increased local engagement due to urbanization and greater connectivity

-  Areas of possibility
-  Transit connections
-  Seaclay border
-  Project border

6.3 Vision Map

So, what's the vision?

By 2100, Friesland will be the beacon of renewable energy in the Netherlands, where sustainable technological advancement, vibrant ecology, and enhanced local engagement – leading to an improved quality of life – coexist harmoniously (reference 3.4). As energy production begins to take up space in the region, ecological stewardship serves as a supporting measure to preserve the landscape's identity and advance ecological quality, which in turn promotes better living for citizens through increased local engagement.

Harnessing the region's distinctive resource density allows for maximized energy production, within stringent ecological thresholds. The North Sea is home to a 600 km² wind park, which would become the largest offshore wind park in the world (the feasibility of a park of this stature is from the Hornsea 2 Offshore Wind Park off the English coast in the North Sea) (ørsted). Assuming increased technological efficiency, the proposed wind park would supply 3.04 GW of power from 380 wind turbines (reference figure 9.7).











The southern and eastern portions of the province are two variations of wind parks. The first variation is similar to the large-scale wind park proposed in the North Sea for mass production. Both major wind parks produce energy for the urbanized Friesland,

with excess being sold to the remainder of the country. The second variant of on land wind production is at a smaller, more individual scale. In these locations, the villages produce their own energy that stays within their localized communities.

Multi-scalar ecological stewardship will preserve and elevate Friesland's landscape identity. This will establish spaces where locals and visitors can be immersed and educated on the uniqueness of the region's environmental network. The Wadden Sea retains its existing protections that prohibit large-scale interference and disruption. Tidal energy is captured between the existing islands (figure 6.4), and four new islands are created to provide ecological educational centers for the region (figure 6.3). The landscape near the northern and southwestern coasts of Friesland remains agricultural in accordance with the highest land value (reference figure xx in the Analysis chapter).

Strong relationships between residents and municipal governments enable comprehensive decisions (reference 2.4). Uplifting the public voice through engagement in governmental discussions,

which is facilitated by improved regional connectivity (figure 6.5), empowers civil society (reference 2.4). Five cities in Friesland – (clockwise from top in figure 6.6) Leeuwarden, Drachten, Heerenveen, Sneek, and Harlingen – experience urbanization as population and economic activity grow due to the renewable energy transition within Friesland. Greater connectivity throughout the five cities – impacting civic engagement – spurs urbanization. This is prioritized through public transit, as existing bus service between certain cities can be unreliable. Figure 6.6 also considered the individual vision maps each team member created (reference figures 9.3 - 9.6).

- | | | | |
|---|-------------------|---|---------------------------------|
|  | Urbanized core |  | Offshore energy production zone |
|  | Urbanized area |  | On land energy production zone |
|  | Solar energy |  | Tidal energy production zone |
|  | Wind energy |  | Wave power |
|  | Artificial Island |  | Ecological protection |
|  | Sand bar | | |

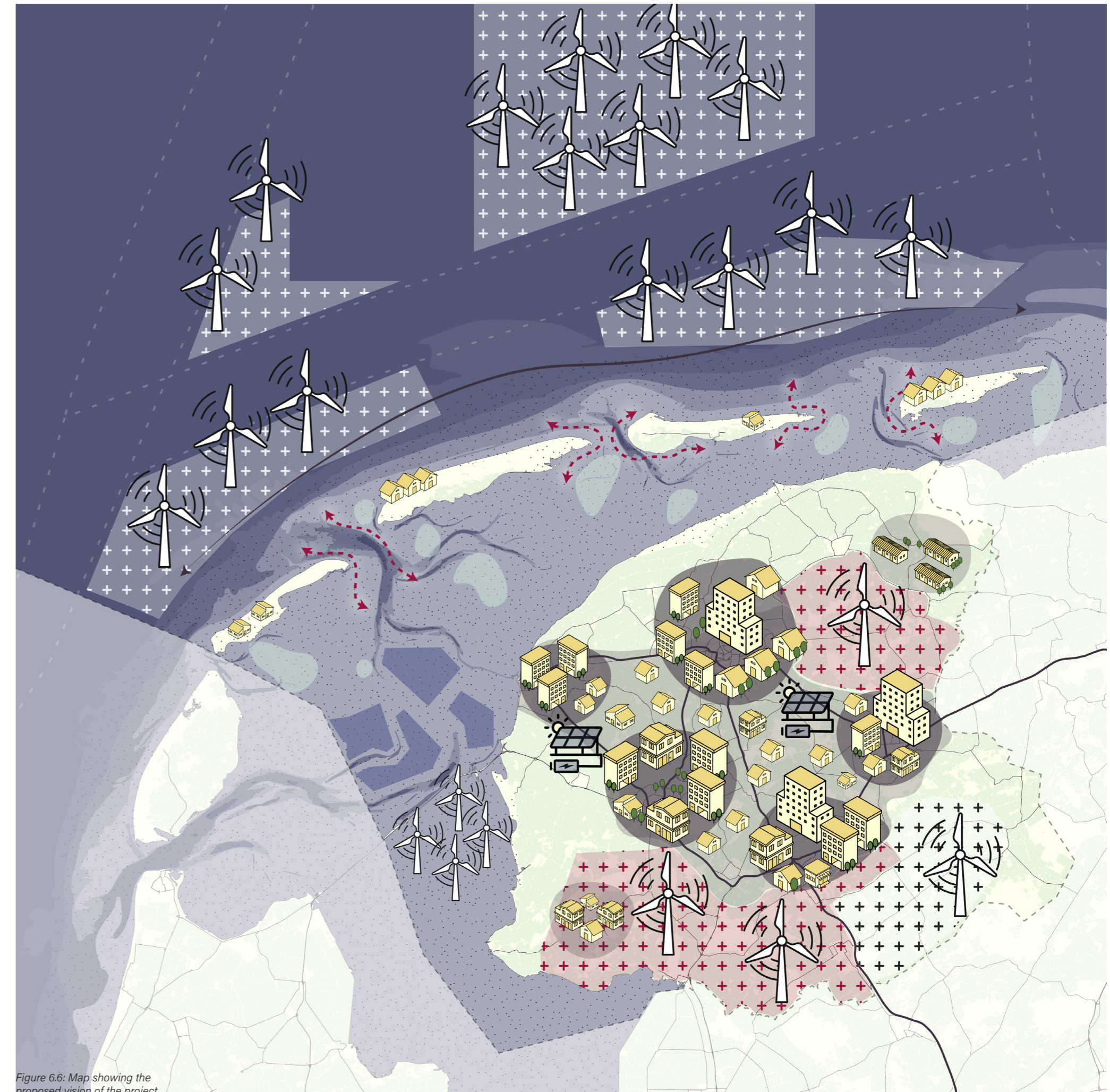

Figure 6.6: Map showing the proposed vision of the project

6.4 Abstracted Vision Maps

A Step by Step Comparison

Through the abstraction of layers, three different but simultaneous approaches that correspond with the research question (reference 3.2) and conceptual framework (reference 4.3), are revealed.

Energy production is visible in all three areas of the project (reference 5.1), but to differing degrees: the North Sea houses most of the energy production, with significant contributions coming from solar and wind energy on land. The existing Frysland Wind Park remains.

Natural sand bars and artificial islands help steward the ecological fragility and uniqueness of the Wadden Sea. Bird migration routes (reference 4.7) flourish and serve as a visible educational component.

Local engagement between Frisians and their municipal governments is enabled through urbanization. The vast public transit routes greatly improve connectivity of five primary cities and increase mobility. This also improves each of the city's connectivity to the rest of the country.

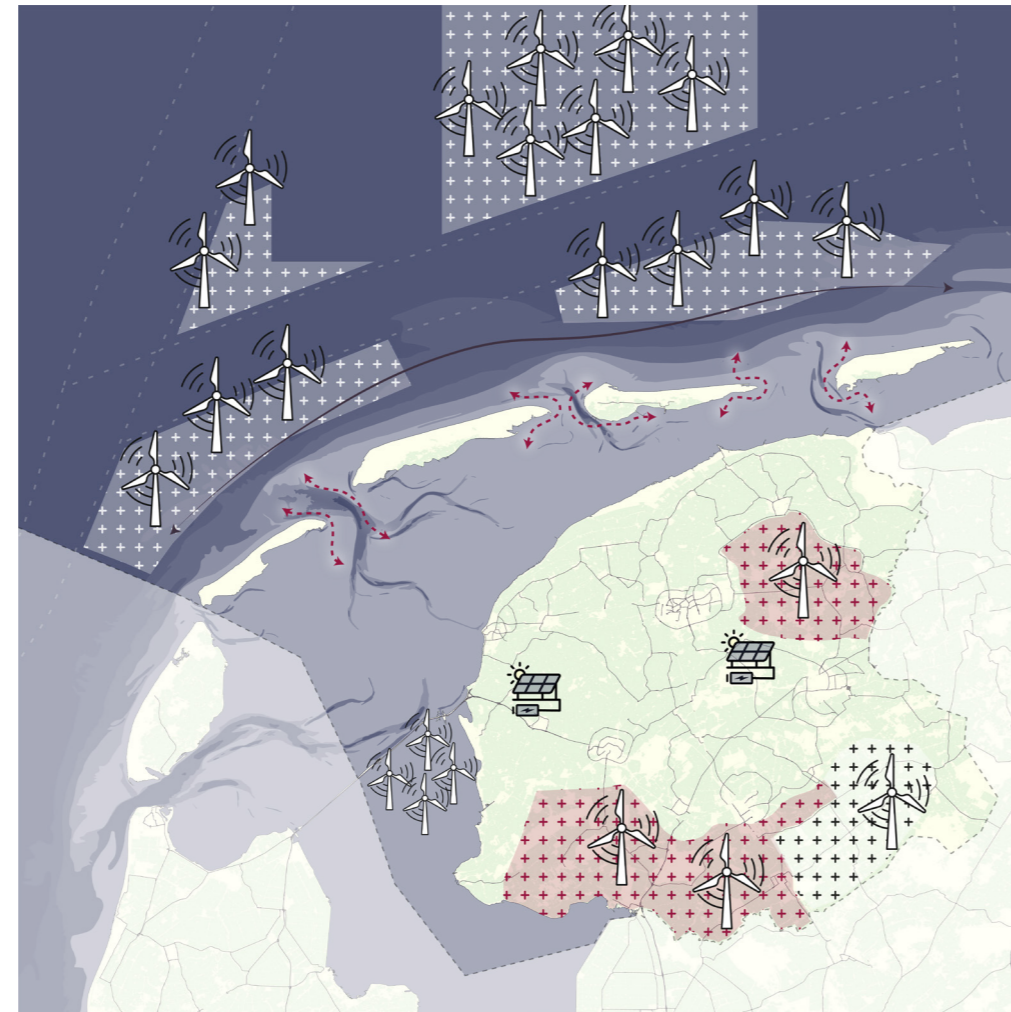







Figure 6.7: Abstracted energy production

10km 20km

-  Solar energy
-  Wind energy
-  Offshore energy production zone
-  On land energy production zone
-  Tidal energy production zone
-  Wave power

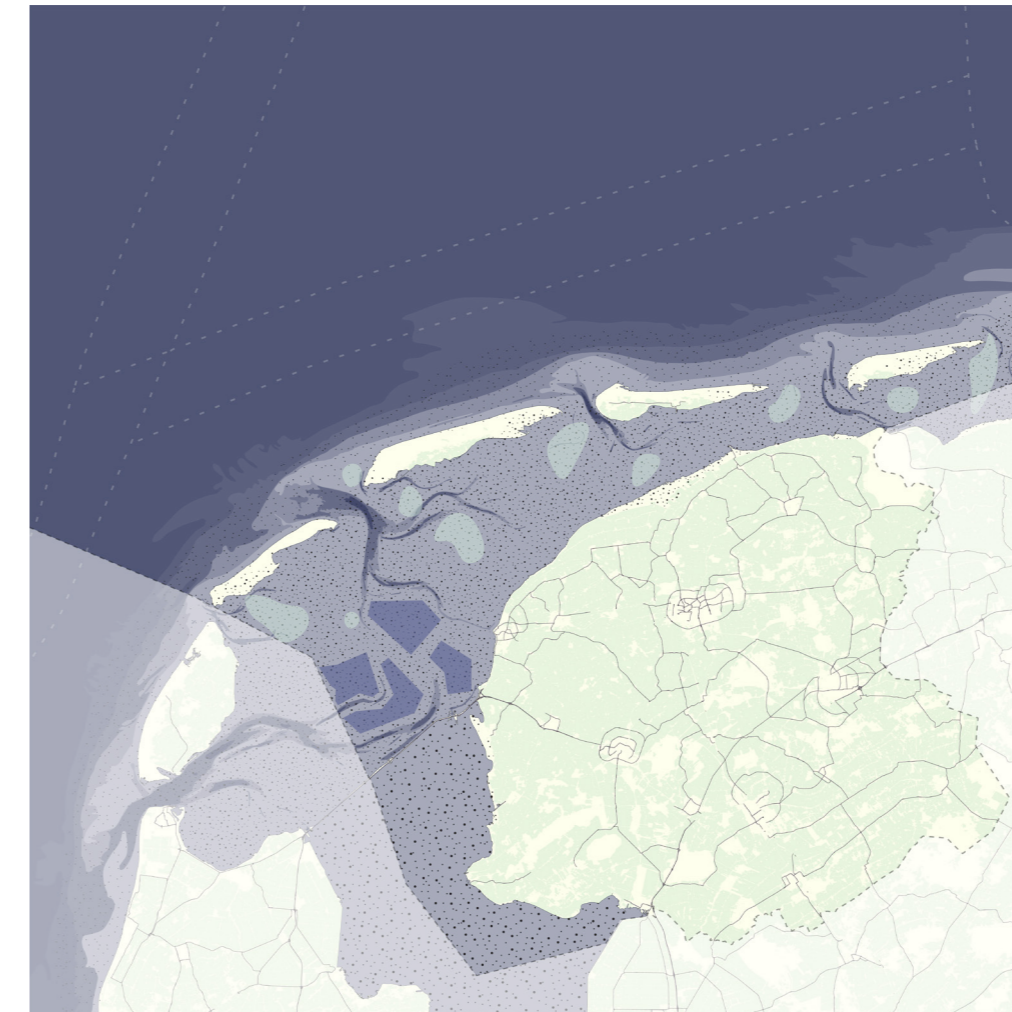

Figure 6.8: Abstracted ecological stewardship

-  Artificial Island
-  Sand bar
-  Ecological protection

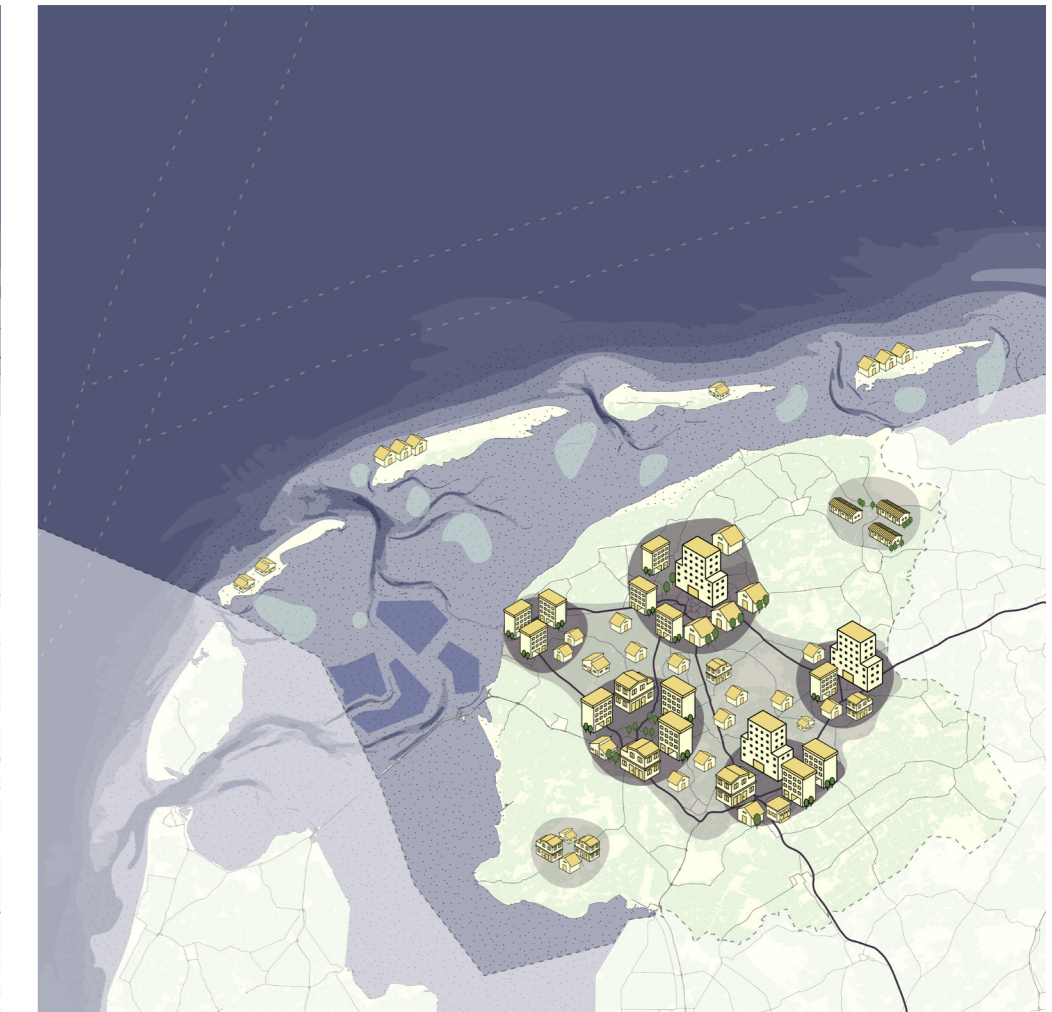



Figure 6.9: Abstracted local engagement through urbanization

-  Urbanized core
- Urbanized area

6.5 Proposed Energy Flow

Now this is how it works

The updated Energy Flow illustrates emerging locations and methods of energy production. The proposed vision emphasizes large-scale wind and tidal energy generation in the North Sea, with limited wave energy development in the Wadden Sea. Figure 6.11 highlights that the substantial energy output from the North Sea will supply major urban centers, while local energy production will support smaller villages, agricultural areas, and the islands. This intervention is a call to the vision of regional self-sufficiency in energy production. A notable addition is the man-made island (reference figure 6.3), designed for energy storage and community engagement through public education initiatives. It is also important to note that our vision does not aim to eradicate greenhouse gases but to gradually decrease emissions to a state that is healthy for residents and the environment, for that reason greenhouse emissions are still present but not accentuated. Ultimately, this energy flow demonstrates how the vision, energy production, ecological stewardship, and local engagement are expressed in the section.

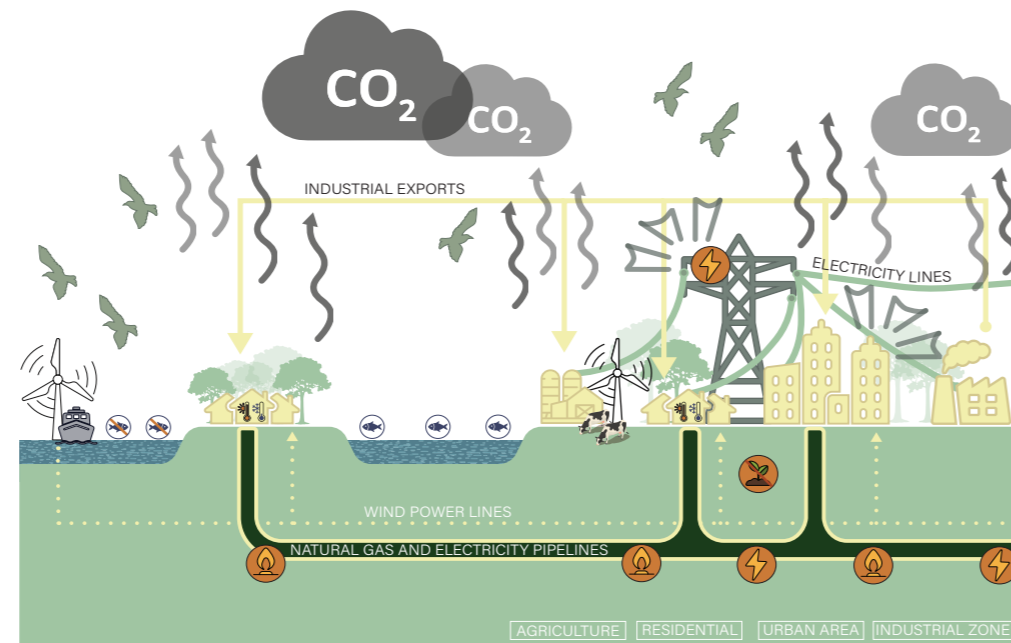

Figure 6.10: Current existing energy framework (reference 4.4)











-  Tidal Power
-  Wind Power
-  Coral Reef Support
-  Solar Power
-  Ecological Restoration
-  Trade Routes
-  Renewable Electricity Grid
-  Fish Migration
-  Greenhouse Gas Emissions
-  Bird Migration

Figure 6.11: Proposed energy framework that relies on renewable energy across all three areas



7 Design Strategy

- 7.1 Overall Strategy
- 7.2 Individual Stakeholder Engagement
 - 7.2.1 Stakeholder Forum
 - 7.2.2 Stakeholder Profiling
 - 7.2.3 Stakeholder Power Interest Matrix
 - 7.2.4 New Governance Framework
- 7.3 Action Cards
 - 7.3.1 Relationships of Actions
- 7.4 Timeline
- 7.5 Phasing Information
- 7.6 Phasing Details
- 7.7 Zoom In's
 - 7.7.1 Zoom In - North Sea
 - 7.7.2 Zoom In - Wadden Sea
 - 7.7.3 Zoom In - Land
- 7.8 Combined Image



Figure 7.1: Breezanddijk Transformer Station at the Friesland (Fryslân) Wind Park

7.1 Overall Strategy

Where do we go from here?

To translate the vision into a strategy, different approaches were done. Different stakeholders and policies were profiled to create a coherent strategy. To achieve this coherency, multiple actions need to be made and defined in so-called action cards. To achieve the goal in 2100, a timeline needs to be produced that is subdivided in different phasing for an optimal strategy. The action cards can be framed in the timeline to achieve self-sufficiency in Friesland by 2100.

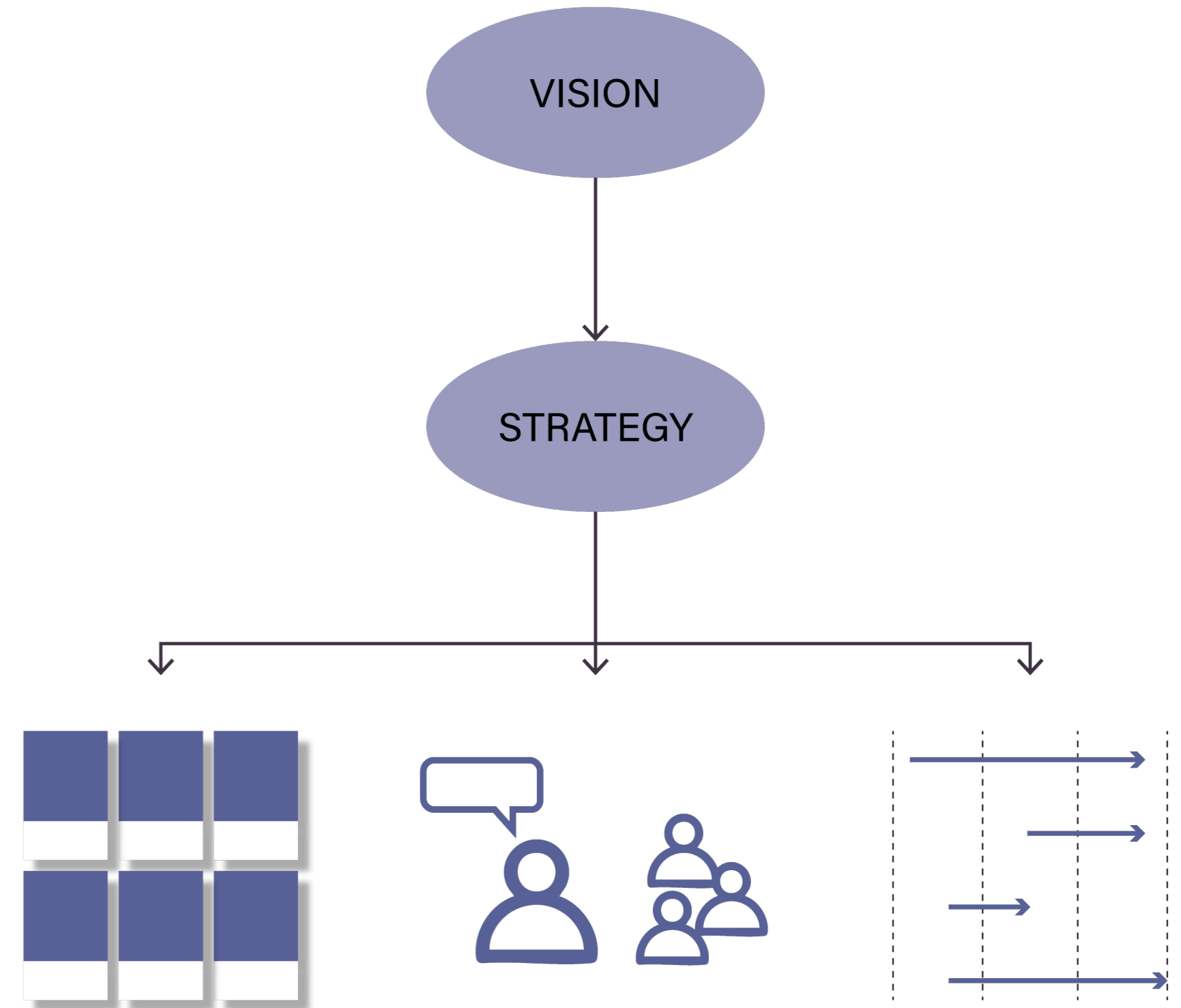

Figure 7.2: xxxx

7.2 Individual Stakeholder Engagement

North Seas Energy Cooperation

The North Seas Energy Cooperation (NSEC) is part of the European Commission and exists as a “regional non-binding cooperation framework, which aims to advance development of offshore renewable energy in the geographical area of the North Seas” (The North Seas Energy Cooperation). The NSEC represents Belgium, Denmark, France, Germany, Ireland, Luxembourg, Netherlands, Norway (non-EU member) and Sweden to create offshore renewable energy across the North Seas.

Europe must increase its offshore wind energy production by 25-fold to meet Paris Climate Change Agreement goals, which is one of the NSCE’s main focus amongst its nine member countries (Netherlands Enterprise Agency). The NSCE is a non-binding agreement and creates no national or international laws but wields major influence in the North Sea.

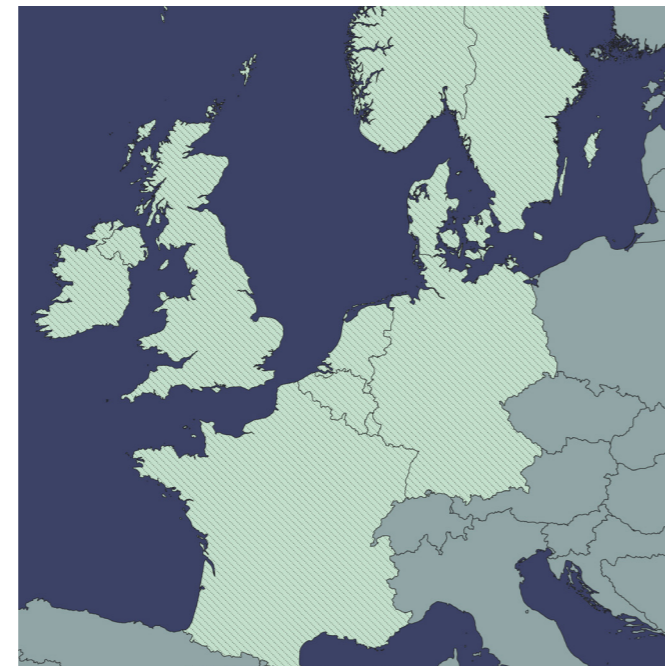

Figure 7.3: Map of NSCE member countries

250km 500km



“Continent-wide, Europe’s investment in clean energy is ten times that of fossil fuels (Holman, et al, 2025). Particularly, within the Netherlands, there is immense potential for increased offshore renewable energy production (figure 01). According to the 2022 Dutch Offshore Wind Guide, provided by the Dutch Ministry of Foreign Affairs, “offshore wind has a higher capacity and more consistent output than any other variable renewable energy source” (Netherlands Enterprise Agency).

The proposed project’s inclusion of 600 km² dedicated offshore wind farm has the potential to deepen the EU’s renewable energy capacity and accelerate its timeline.

In conclusion, the NSEC supports the proposed Reclaiming the Power of Energy project and looks forward to working with other stakeholders in their offshore renewable energy pursuit.”

- NSEC excerpt from von Feldt Position Paper



Figure 7.4 Envisioned stakeholder of North Seas Energy Cooperation

UNESCO

The United Nations Educational, Scientific and Cultural Organization (UNESCO) promotes cooperation in education, science, culture and communication to foster peace worldwide (UNESCO, 2025). It leads the world in protecting and advocating for the preservation and enhancement of ecological and heritage sites by establishing international standards and legal texts. UNESCO is governed by the Secretariat, the Executive Board, and the General conference where representatives from all Member States determine UNESCO's main lines of work.

As a specialized agency of the United Nations, UNESCO is well aware of the importance

of climate change, mitigation, and adaptation. In the context of the Wadden Sea, the goal is no different. Given the current state of climate change, if the status quo continues, sea-level rise may seriously impact the structure, functions, and characteristic biodiversity of the Wadden Sea ecosystem. Within this region, these objectives translate into the ambition to achieve carbon neutrality, a goal already articulated in the Sylt Declaration (2010).

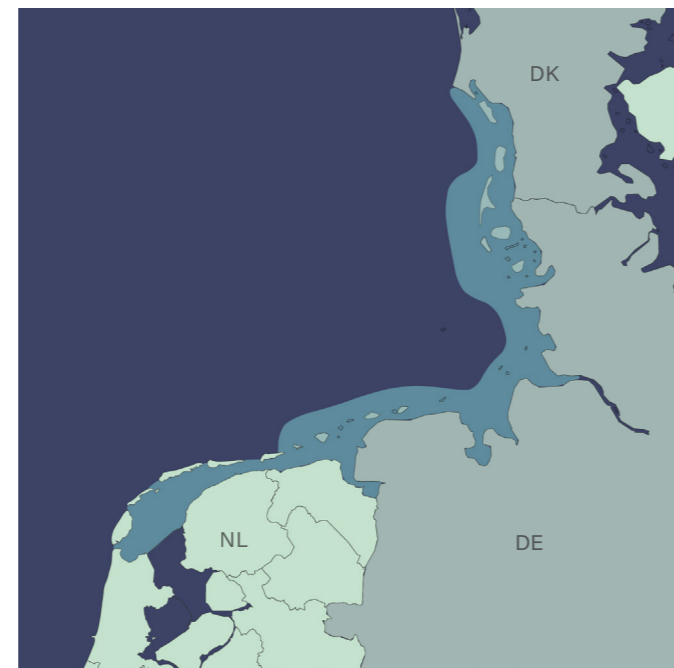

Figure 75: Map of UNESCO Wadden Sea territory

50km 100km

“While UNESCO advocates for the protection and enhancement of the unique ecological system of the Wadden Sea, it also recognises the urgency of reducing greenhouse gas emissions and transitioning toward more sustainable modes of living. The organisation is cautious that the application of new forms of energy production poses risks to the world heritage site. For example, the impairment of existing and future habitats, the disruption of natural processes such as bird and marine fauna migration, and unknown risks. Implementation of nature-based solutions to mitigate climate change, as well as preservation of the migratory processes. There is a call for nature-based solutions in the Wadden Sea, such as restoring salt marshes and seagrass. These habitats have been identified as critical for “Blue Carbon” sequestration, serving as natural carbon sinks (State of Conservation Report “The Wadden Sea (N1314)” 2025, p. 29).”

- NSEC excerpt from *Kabuiku Position Paper*



Figure 76: Envisioned stakeholder of UNESCO

Province of Friesland

The Province of Friesland, located in the north of the Netherlands, is one of the country's twelve provincial administrative bodies. As a subnational level of governance, the province occupies an intermediate position between the national government and the 18 municipalities. The provincial governance is organized through a Provincial Council (decision-making body) and the Provincial Executive (implementing policy and administrative affairs). The King's Commissioner, appointed by the national government, chairs both and plays a coordinating and supervisory role. In this way, Friesland is an example of the Dutch decentralized unitary system, in which provinces retain autonomous powers but simultaneously operate within a national framework of shared governance (The Association of Netherlands Municipalities, 2015).

The governance of Friesland is thereby distinctive from others because of the strong interaction between the province and its municipalities; not only playing a role in the administrative territory but also in local implementation of policies (Ministerie van Binnenlandse Zaken en Koninkrijksrelaties, 2016).



Figure 7.7: Map of Friesland in relation to The Netherlands

40km 80km



"Friesland aims to have fully transitioned to clean energy by 2050, generating as much energy as it consumes (Friese Energietafel, 2024). [...] While there is support for the proposed ambition, clear conditions and critical comments are in place.

[...] Friesland wants to prevent the occurrence of new spatial, ecological or social risks resulting from the energy-driven vision. [...] Energy infrastructure, generation, and storage must be integrated seamlessly into the current energy landscape and the surrounding area. This is a key guiding principle of the energy vision. New interventions should not only protect the landscape but also add value. [...] Particular emphasis is placed on engaging the younger generation to involve young people with knowledge and skills in the energy transition.

[...] Participation is seen as the answer to the transition, but the recognition that managing expectations and making far-reaching spatial decisions is an ongoing challenge for maintaining trust is inevitable (Friese Energietafel, 2024, Poepjes, S. n.d., Provincie Friesland, 2023)

[...] To argue that the energy transition process entails drastic changes to the landscape and difficult choices in spatial planning may seem unnecessary given the complexity of the process, but it remains an important end note."

- Province of Friesland excerpt from Bensink Position Paper



Figure 7.8: Envisioned stakeholder of the Province of Friesland

Municipality of Terschelling

The municipality of Terschelling is an island municipality that belongs to the province of Friesland and is part of the Wadden islands. It contains almost 5,000 residents and a multitude of recreational stays for the many tourists that visit the island. In terms of energy, out of all the Wadden islands, Terschelling has the greatest demand for electricity. The island has its uniqueness which has created three important pillars for the island: the sea, tourism, and nature (Gemeente Terschelling, 2026).



Figure 7.9: Map of Terschelling island in relation to Friesland

10km 20km



"[...] Terschelling is known for its open landscapes, starry sky, and unobstructed horizons. These qualities are not only important for nature but also for tourism, which is a key pillar of our local economy. The introduction of visible energy infrastructure; like offshore wind farms, artificial islands or solar fields, could significantly change the character of the landscape and reduce its attractiveness to visitors. We recommend following the "Solar Ladder" (Wassink et al., 2021), prioritizing rooftop solar first, followed by city locations and multiple land use. [...]"

"[...] The local energy cooperative "Terschelling Energie" is a very important local partner in achieving our sustainability goals (Gemeente Terschelling, 2023). Therefore, the aim is to achieve at least 50% local ownership in projects, so that the benefits of the transition attend to the local community. Additional preconditions have been included for the generation of solar energy on agricultural land, including a minimum of 60% local ownership (Knol et al., 2025). Please take this into account in your vision."

In conclusion, the Municipality of Terschelling supports the transition towards sustainable energy, but we remain concerned about how this vision is applied in our region."

- Province of Friesland excerpt from Yavuz Position Paper



Figure 7.10: Envisioned stakeholder of the Municipality of Terschelling

7.2.1 Stakeholder Forum

All Four Stakeholders Together

Overlapping Interests and Negotiated Transition

As the four profiled stakeholders meet, their interests overlap and contradict. Through this dialogue, their mixed concerns of the proposed project facilitate a more negotiated and adaptive approach to the energy transition one that balances the urgency of large-scale renewable energy deployment with the protection of ecological systems, regional identity, and local livelihoods.

Supranational Drivers: Energy Expansion vs. Ecological Protection

The NSEC underscores the strategic necessity of rapidly expanding offshore wind capacity to meet European climate targets, positioning initiatives such as the proposed project as critical contributions to a decarbonized energy system. At the same time, UNESCO emphasizes the global responsibility to safeguard the fragile ecosystems of the Wadden Sea, advocating precautionary approaches and integrating nature-based solutions to ensure that climate mitigation efforts do not compromise biodiversity and heritage.

Overlapping Interests and Negotiated Transition

As the four profiled stakeholders meet, their interests overlap and contradict. It is through this dialogue that their mixed concerns of the proposed project facilitate a more negotiated and adaptive

approach to the energy transition; urgency of large-scale renewable energy deployment with the protection of ecological systems, regional identity, and local livelihoods.

Regional and Local Priorities: Spatial Quality and Community Ownership

At the regional and local levels, the Province of Friesland and the Municipality of Terschelling highlight the importance of spatial quality, community engagement, and local ownership in shaping a just and context-sensitive transition. Their perspectives illustrate that the success of such projects depends not only on technical feasibility and policy alignment, but also on maintaining public trust, protecting landscape identity, and ensuring that benefits are equitably distributed.

Multi-Level Governance Structure

The hierarchy in this stakeholder forum is best understood as a multi-level governance structure, rather than a strict top-down chain of command. Authority, influence, and legitimacy are distributed across scales, but not equally. The hierarchy in this stakeholder forum is best understood as a multi-level governance structure, rather than a strict top-down chain of command. Authority, influence, and legitimacy are distributed across scales, but not equally.

At the top sits a supranational and normative layer, represented by actors such as the North Sea Energy Cooperation (NSEC) and UNESCO. NSEC exerts strategic and agenda-setting power—it shapes regional energy priorities and coordinates cross-border offshore development, even without binding authority. UNESCO, meanwhile, holds normative and regulatory influence through its World Heritage mandate, giving it significant leverage to constrain or condition projects in line with ecological protection standards. While neither directly implements projects, both strongly define what is considered acceptable or desirable. Below this is the national and regional governance layer, where the Province of Friesland operates. This level holds formal administrative authority over spatial planning, policy implementation, and regional coordination.

At the base is the local governance and community layer, represented by the Municipality of Terschelling and local actors such as energy cooperatives. This level has contextual and social legitimacy, grounded in direct exposure to the project's impacts. While it has less formal power compared to higher levels, it can exert influence through public support, participation processes, and conditions such as local ownership requirements. In practice, this gives local actors a form of soft power that can significantly affect project feasibility.



Figure 7.11: Stakeholders meet at a conference table to discuss their various interests

7.2.2 Stakeholder Profiling

Who has a voice in this process?

For Friesland's energy transition to be future proof, it is essential to identify and analyze the involved stakeholders. This ensures inclusivity, co-decision making and a better understanding of how different actors are affected by the energy transition (*reference 2.4*). By framing their interests and problem perceptions, it becomes clear which challenges exist, and by looking into their relation to the vision helps determine their needs and possible actions we need to make the process more efficient.

The stakeholders are subdivided in relation to the three themes. This structured approach also helps to compare stakeholders and to identify differences in their influence and involvement. Some actors have political or financial power, while others have local knowledge or ecological value. It also highlights existing imbalances, especially between actors with high decision-making power and those who are directly affected by the spatial interventions.

STAKEHOLDERS	INTEREST	PROBLEM PERCEPTION	THOUGHTS OF VISION	POWER	RESOURCES
NATIONAL GOVERNMENT NL	Achieving energy goals	Worries of decentralized transition	Hesitate	Control over plans and policies	Finances, policies, experience
EU	Achieving energy goals	Happy with energy transition	Positive	Say over international goals and policies	Finance, policies, collaborations
GRID OPERATORS	Profits and supply	Grid limits	Positive	Financial	Knowledge, resources
ENERGY COMPANIES	Production, sale of renewable energy	Only profit oriented, no issue with landscape pollution	Positive	Production power for Friesland	Finances, experience/knowledge
UNESCO	Nature protection	Ecological risk of transition	Neutral	Pressure on decisions	Land, experience
PROVINCE FRIESLAND	Achieving energy goals and independence	Balancing goals and decentralized transition	Positive	Control over plans and policies	Finances, policies, experience
NSEC (THE NORTH SEAS ENERGY COOPERATION)	Energy transition	Space competition	Neutral	Policy influence	Coordination
MUNICIPALITIES	Wants the best for own municipality and residents	Has own vision plans but needs more local residents participation	Positive	Control of local planning	Subsidies, policies, experience
PORT	Economic growth	Spatial pressure	Positive	Logistic control	Infrastructure
FOSSIL FUEL COMPANIES	Profits	Costs of transitioning to renewable energy	Hesitate	Current energy source	Finance
RESIDENTS	Green energy and co-decisioning	Concerned about being heard, finance and change of landscape	Positive	Voting power	Collaboration
FARMERS	Extra source of income, cheaper	Less agriculture	Neutral	Voting power, owners of land	Land, knowledge, resources
FISHERMEN	Green energy	Worried about job possibility	Hesitate	Voting power, food	Knowledge
NON-HUMAN	Nature	Habitat loss	Neutral	Indirect protection	Ecological value
HOUSING CORPORATIONS	Renewable energy	Wants cheapest and benefits for residents	Positive	Use of energy	Collaboration, financial
THE REST OF THE NETHERLANDS	Energy supply	Wants part of the renewable energy	Neutral	Political influence	Economy
VISITORS/TOURISTS	Visit (is)land	Worried about landscape and prices	Neutral	Profits/finance	Profits

Figure 7.12: Visualization of all considered stakeholders based off their interests, power, perceptions, and resources

7.2.3 Stakeholder Power Interest Matrix

How to the stakeholders relate to each other?

In this project, it is important to strategize who has influence in the energy transition and to make that shift more localized. Therefore, stakeholders are placed in a power-interest matrix to better understand their role in the energy transition in Friesland.

In the current situation, the energy transition is largely organized through a top-down approach. As figure 7.13 emphasizes, the (inter)national entities had the most power, where the province of Friesland takes the requirements made by the national and international entities and need to communicate this with their local communities. However, national governments and large energy companies possess most of the decision-making power, as they control investments, infrastructure, and planning processes. As a result, decisions are often made at a national level with limited input from the local communities.

At the same time, local stakeholders such as residents, farmers, fishermen, and municipalities have a high interest, as they are directly affected by the energy projects. However, they often have

less power in decision-making. This creates a gap between those who make decisions and those who experience the spatial, ecological, and social consequences.

The goal is to shift from this top-down approach towards a more balanced system with stronger local control (*reference 2.4 and 3.4*). By increasing local ownership, supporting energy cooperatives, and introducing small-scale energy systems, more decision-making power can be given to the people of Friesland. This shift allows local knowledge and values to play a more central role, leading to solutions that are better adapted to the region.

This approach also has several advantages. It can increase public support, reduce resistance to energy projects, and ensure a fairer distribution of costs and benefits. In addition, it strengthens the regional economy and helps communities to directly benefit from the energy they produce.

The shift is not about removing large-scale stakeholders, but about redefining their role. National governments and energy companies remain important for coordination, investment, and infrastructure, but their role becomes more supportive rather than dominant. Decision-making moves more towards the regional level, where municipalities and the province of Friesland have a stronger position while the residents and farmers help them to decide and achieve the energy transition. This way, they complement each other in a transition towards a more inclusive, fair, economically strong, and locally based energy system in which Friesland gains more control over its own energy system.

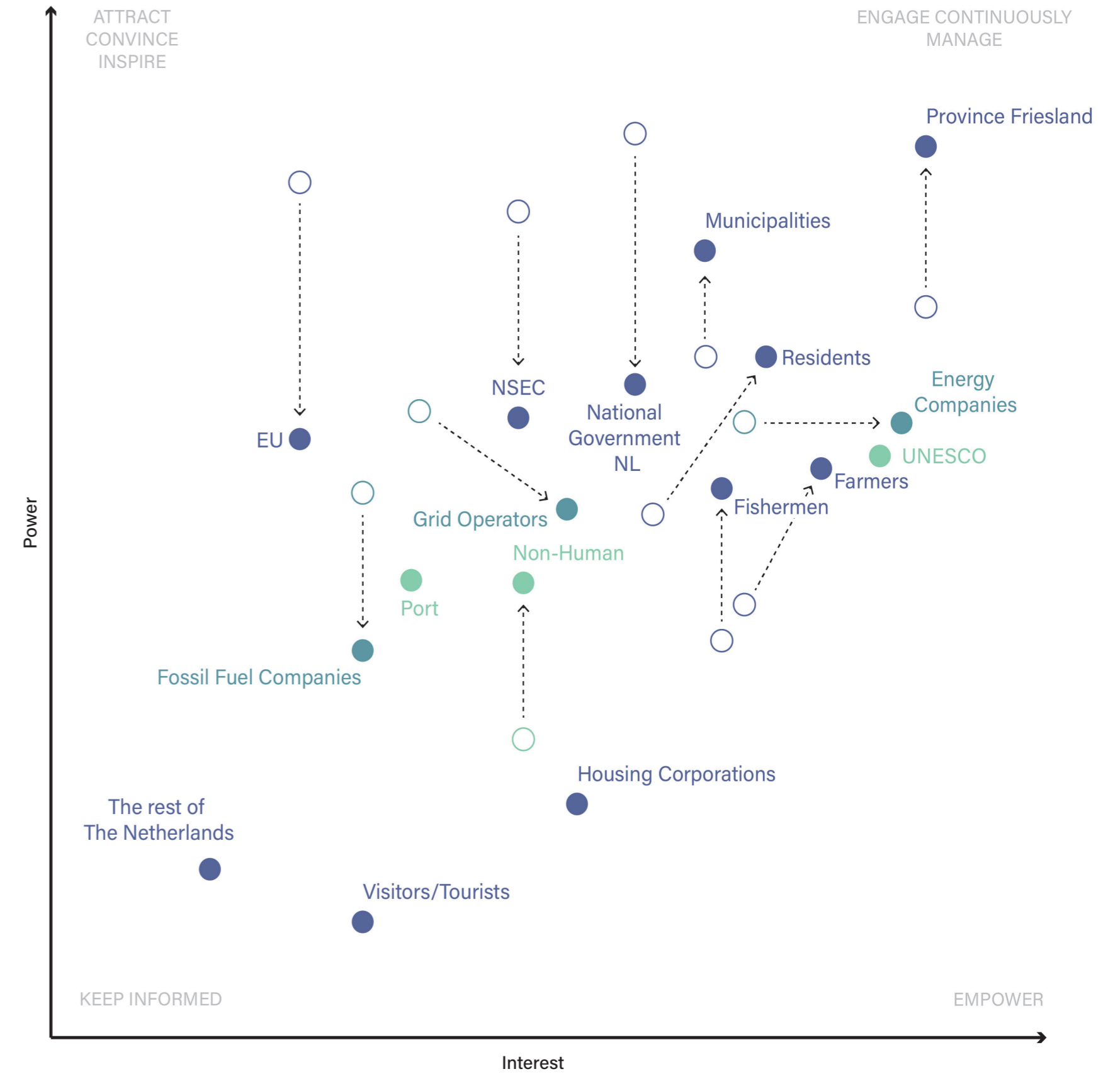

Figure 7.13: Power Interest Matrix of all stakeholders in figure 7.12. Dynamic movements indicate a change in power and/or interest from existing to proposed timelines

7.2.4 New Governance Framework

Introducing...the *NEW* Quality Control Board

The report of the Noordelijke Rekenkamer, which is an independent institution that investigates the efficiency, effectiveness, and legality of the policy of the province (De Noordelijke Rekenkamer, n.d.), gave an insight about the framework of the current decision-making process of the energy transition in Friesland (Jong et al., 2021). At the top are the EU and 'important' stakeholders that establish the rules and goals every country must achieve. Below them is the National Government of the Netherlands that assigns requirements for each province in order to achieve the EU goals.

Within the region are the elected representatives who hold political responsibility and final decision-making power. These actors include the Province Friesland, municipal councils, and Wetterskip Fryslân (water board of Friesland). They have the authority to define and approve the plans within the Regional Energy Strategy (RES).

The next layer focuses on the formulation and evaluation of plans. This consists of the Fryske Energy Alliance, representing multiple civil society organizations such as nature groups, agricultural actors and businesses, and technical partners such as Liander, who advise on technical feasibility and the impact on the electricity grid. Below this is the

project group, where analyses are conducted and plans are developed. This group mainly consists of civil servants, supported by external experts.

At the bottom of the framework is the Frisian society. Citizens are involved through consultations, working groups, and local initiatives. Although this layer is essential for local knowledge, its role remains limited. This framework shows that residents are involved, but mainly at the early stages of the process. Their influence decreases in the later layers of decision-making. After providing input, the process moves to institutional actors, and it is often unclear how this input is used. As a result, many citizens express the need to be more involved in the later phases.

Within the governance theories, it is stated that the interaction of bottom-up and top-down can create complexity, but within a democratic framework, energy justice and inclusive participation must be considered and included to ensure diversity in preferences (Jenkins et al. 2016; van Veelen and van der Horst 2018). All this supports the adjustment to create the Quality Control Board Friesland. It consists of nine people who are democratically appointed by the Frisian society. The board constantly has participation processes with the Frisian society to

ensure local engagement. Within the framework, the board constantly conducts a 'checks and balances' to the proposals and plans of the three layers where most decisions are made. They do this through quality assurance and quality control, where quality assurance relates to how a process is performed or how a product is made, and quality control deals with the inspection aspect of quality management (American Society for Quality (ASQ), 2024). This way, the inputs of Frisian society are better implemented in the decision making process and trust can be solidified.

This added board also comes in line with our policy to facilitate greater public participation in local infrastructure projects to ensure diverse voices and perspectives are included and to empower citizens through decentralized bottom-up government and local energy production. Overall, the governance framework formally shows the process of the decision-making within the energy transition. While the power-interest matrix before (reference figure 7.13) shows the altered power and/or interest within the region itself to achieve local participation of the regional self-sufficiency.

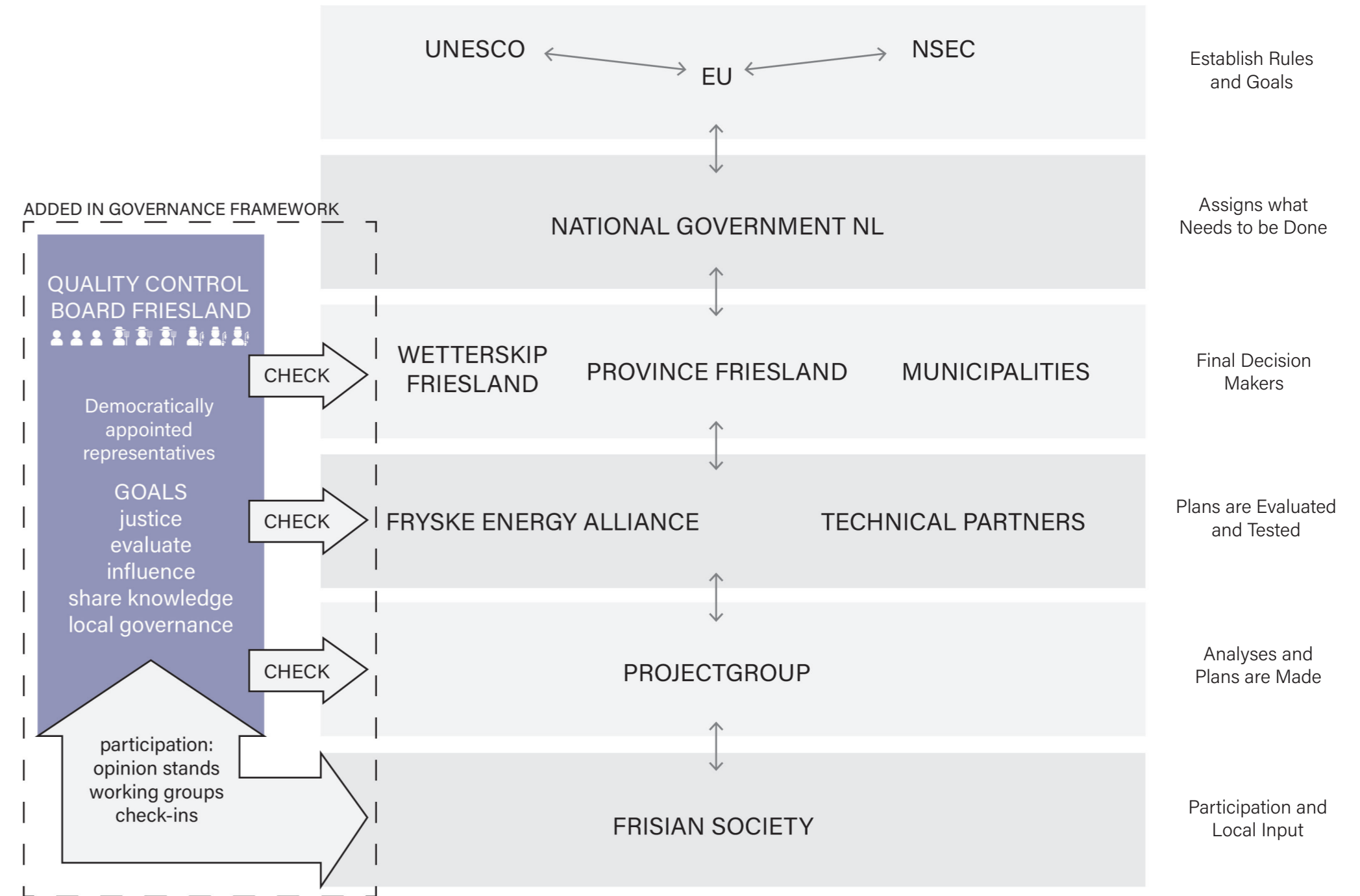

Figure 7.14: Formal structure of proposed governance with the Quality Control Board's various levels of overview implemented

7.3 Action Cards

A Pattern Language

To translate the vision into tangible actions, a pattern language of cards is introduced as a communication tool based on Bil (2025) (reference figure 7.15). The pattern language communicates a structured strategy that is directly connected to the vision. The cards are both spatially- and policy-based (reference 4.2) and organized by color within the familiar framework of three themes: ecological stewardship, energy production, and local engagement, introduced Chapter 5.

The cards have a title and description, along with a distinguishing code. Assessment terms are located underneath the diagram, which represents the action and its proficiency. The terms are based on the conceptual framework (reference 3.4). The actions are interrelated, meaning several actions complement each other and should be considered in tandem when implementing them (reference 7.3.1). This will ensure the themes are fully represented in every location to achieve the goals of resident and municipal government benefit on the path to regional self-sufficiency.

The cards can be implemented in the project's three areas based on their characteristics. This is illustrated in the zoom-in areas, where different themes are prominent, and the transitioned locations are illustrated spatially (reference 7.7).

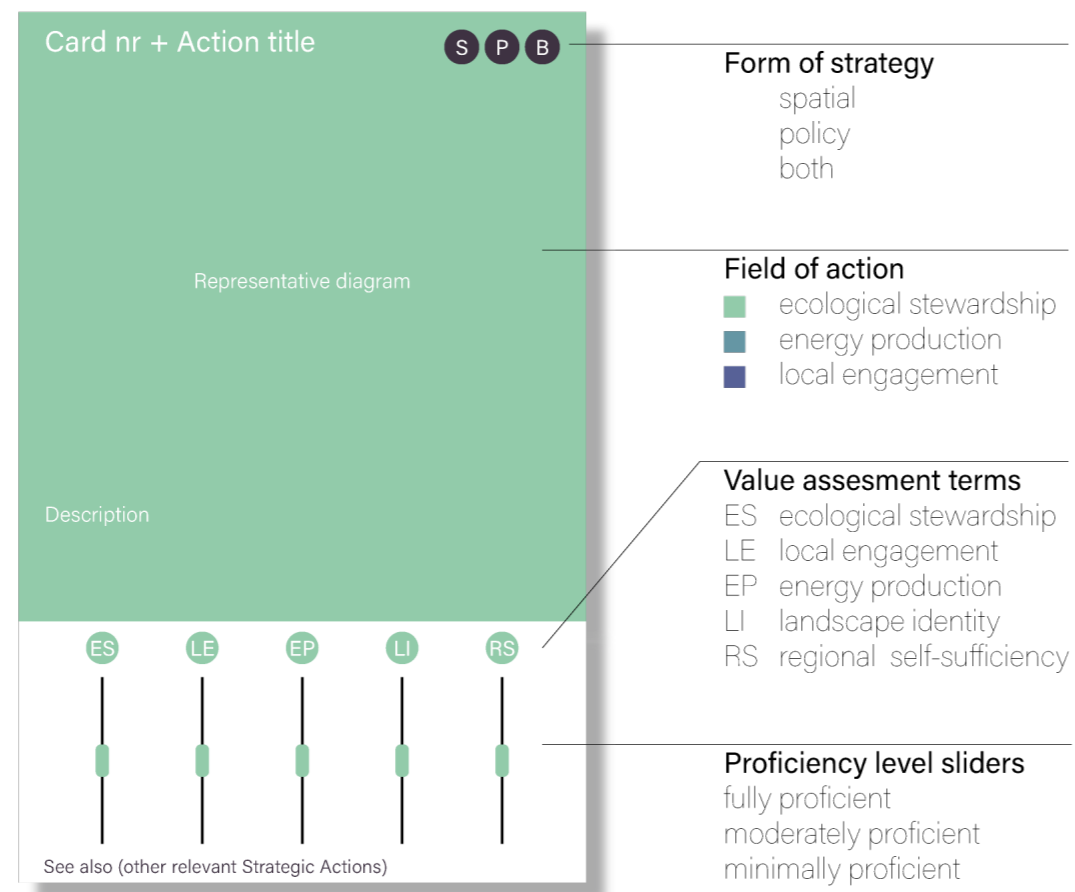
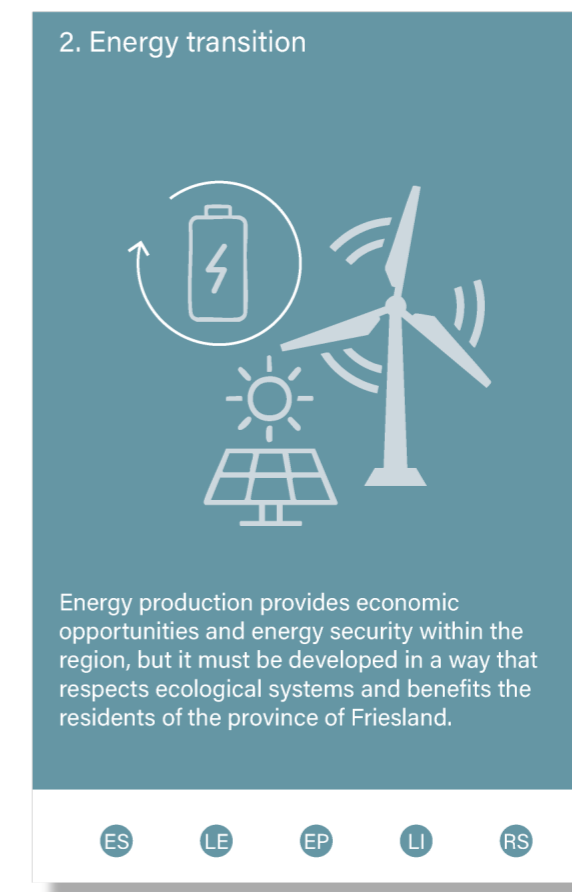
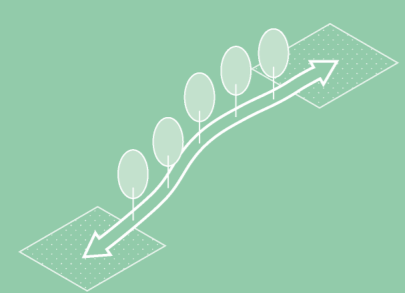

Figure 7.15: Action cards dictate the functions that can be deployed within the proposed vision



1.1 Green corridors S ○ ○



Establish corridors between existing and future ecological landscapes for improved biodiversity and promoting climate resilience.

ES	LE	EP	LI	RS
High	Low	Low	High	Low

See also 1.3, 1.6, 1.7, 1.10, 2.7, 2.8

1.2 Protected shorelines ○ ○ B

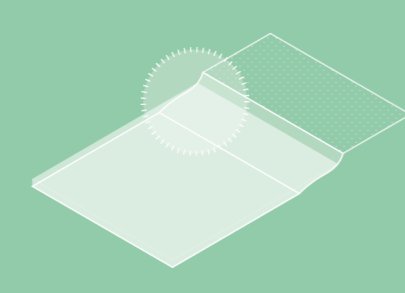

Protect and strengthen shorelines to lower flood risk, protect sealife and enhance ecological safety.

ES	LE	EP	LI	RS
High	Low	Low	High	Low

See also 1.3, 1.4, 1.5, 1.6

1.3 Protected animals zones ○ P ○



Protecting animal zones on land and in sea to strengthen the ecology.

ES	LE	EP	LI	RS
High	Low	Low	High	Low

See also 1.1, 1.2, 1.4, 1.5, 1.6, 1.8

1.7 Accomodating bird routes ○ P ○



Minimize infrastructural obstacles along bird migration routes to minimize interference and disturbtion.

ES	LE	EP	LI	RS
High	Low	Low	High	Low

See also 1.1, 1.6, 1.9

1.8 Protected sea migration routes ○ P ○



Minimize infrastructural obstacles along sealife migration routes to minimize interference and disturbtion in marine environments.

ES	LE	EP	LI	RS
High	Low	Low	High	Low

See also 1.3, 1.4, 1.6

1.9 Marking energy infrastructure ○ ○ B



Mark energy infrastructure, for example by painting wind turbine blades, to improve animal safety.

ES	LE	EP	LI	RS
High	Low	Low	High	Low

See also 1.7, 2.6, 2.7

1.4 Man-made islands S ○ ○



Adding islands in the Wadden Sea to enhance biodiversity, restore the natural environment, create new habitats, provide renewable energy and stimulate engagement through education.

ES	LE	EP	LI	RS
High	High	High	High	High

See also 1.2, 1.3, 1.5, 1.8, 2.1, 2.2, 3.1, 3.2

1.5 Aquatic vegetation S ○ ○

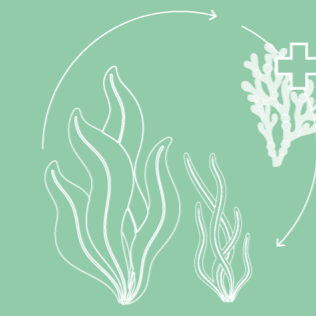

Protect and improve aquatic vegetation by introducing new species and strengthen the diversity.

ES	LE	EP	LI	RS
High	Low	Low	High	Low

See also 1.2, 1.3, 1.4, 1.6

1.6 Animal habitats ○ ○ B



Host new spots for animals habitats offshore and on land, for example artificial reefs along wind turbine poles, to improve local biodiversity.

ES	LE	EP	LI	RS
High	Low	Low	High	Low

See also 1.1, 1.2, 1.3, 1.4, 1.5, 1.7, 1.8, 1.10, 2.6, 2.7, 2.8

1.10 Mix-use landscape ○ ○ B

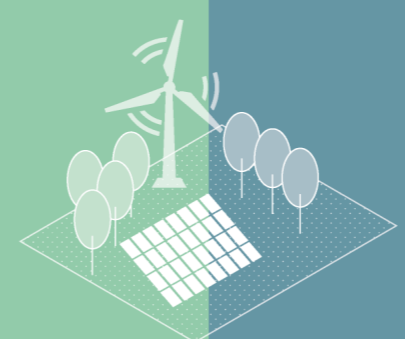

Stimulate multi-functional landscapes, where energy and biodiversity go hand-in hand, to avoid single-use zoning, improve biodiversity and maximize land efficiency.

ES	LE	EP	LI	RS
High	Low	Low	High	Low

See also 1.1, 1.6, 2.7, 2.8, 3.1

1.11 Scale-to-scale principle ○ P ○

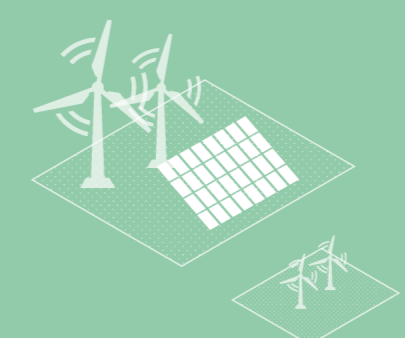

Safeguard the landscape identity by only implementing large-scale generation in large-scale landscapes.

ES	LE	EP	LI	RS
High	Low	Low	High	Low

See also 2.1, 2.2, 2.7, 2.8 3.1

2.1 Tidal energy S ○ ○

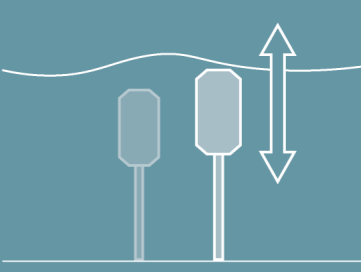

Use the natural ebb and flow of the ocean to generate electricity in the Wadden Sea with underwater turbines or dams.

ES	LE	EP	LI	RS
High	Low	Low	High	Low

See also 1.4, 1.11, 2.4, 2.9, 3.7, 3.8, 3.9

Figure 7.15 continued

2.2 Wave energy S ○ ○



Use wave energy to generate electricity from the movement of ocean waves with buoys and turbines.

ES
|
█

LE
|
█

EP
|
█

LI
|
█

RS
|
█

See also 1.4, 1.11, 2.4, 2.9, 3.7, 3.8, 3.9

2.3 Reuse existing energy infrastructure ○ ○ B

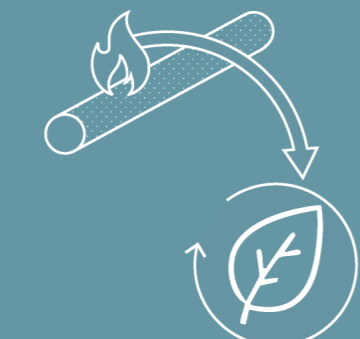

Repurpose existing energy infrastructure, for example gas pipelines, to support distribution of renewable energy resources.

ES
|
█

LE
|
█

EP
|
█

LI
|
█

RS
|
█

See also 2.9

2.4 Local storage ○ ○ B



Decentralize energy production and storage to accommodate local production and storage.

ES
|
█

LE
|
█

EP
|
█

LI
|
█

RS
|
█

See also 2.1, 2.2, 2.5, 2.7, 2.8, 3.7, 3.8, 3.9

2.8 Solar fields S ○ ○

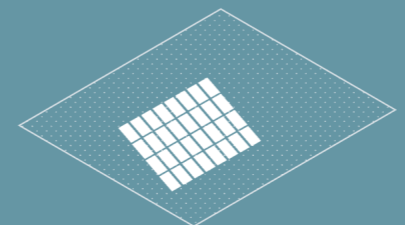

Assign designated places for solar fields to produce renewable energy.

ES
|
█

LE
|
█

EP
|
█

LI
|
█

RS
|
█

See also 1.1, 1.6, 1.10, 1.11, 2.4, 2.9, 3.7, 3.8, 3.9

2.9 Less reliance on natural gas ○ P ○



Removing subsidy on natural gas, while at the same time introducing more renewable energy sources, can help reduce reliance on it.

ES
|
█

LE
|
█

EP
|
█

LI
|
█

RS
|
█

See also 2.1, 2.2, 2.3, 2.5, 2.6, 2.7, 2.8, 2.10, 3.5

2.10 Fossil fuel taxes ○ P ○



Introduce fossil fuel taxes to reduce consumption and stimulate use of renewable energy.

ES
|
█

LE
|
█

EP
|
█

LI
|
█

RS
|
█

See also 2.9

2.5 Solar panels on roofs S ○ ○

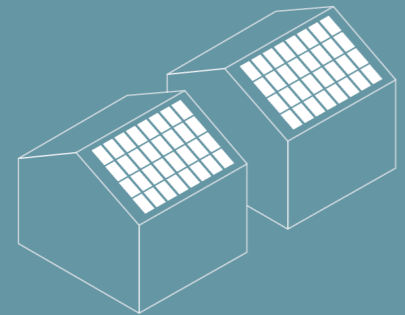

To enhance local self-sufficiency and decreasing reliance on a centralised grid.

ES
|
█

LE
|
█

EP
|
█

LI
|
█

RS
|
█

See also 2.4, 2.9, 3.7, 3.8, 3.9

2.6 Wind park offshore S ○ ○

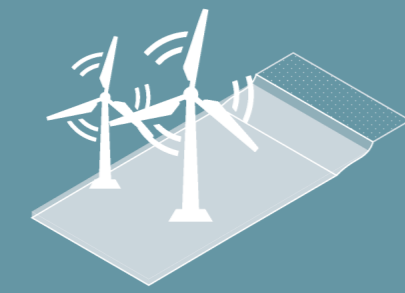

Wind energy offshore provides a sustainable cost-effective solution for renewable energy with a high potential.

ES
|
█

LE
|
█

EP
|
█

LI
|
█

RS
|
█

See also 1.6, 1.9, 2.9, 3.8, 3.9

2.7 Wind park on land S ○ ○

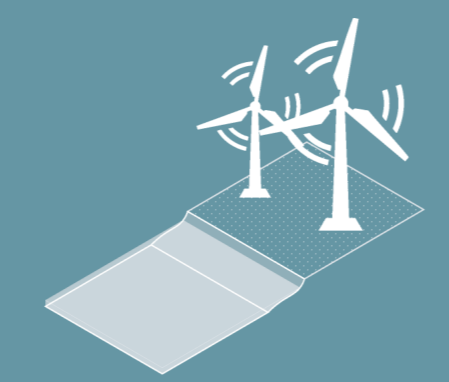

Wind energy on land provides a sustainable cost-effective solution for renewable energy with a high potential.

ES
|
█

LE
|
█

EP
|
█

LI
|
█

RS
|
█

See also 1.1, 1.6, 1.9, 1.10, 1.11, 2.4, 2.9, 3.7, 3.8, 3.9

3.1 Education centre ○ ○ B



Build education centres to educate on a careful and responsible approach to the landscape with particular emphasis on engaging the younger generation.

ES
|
█

LE
|
█

EP
|
█

LI
|
█

RS
|
█

See also 1.4, 1.10, 1.11, 3.2, 3.3

3.2 Workforce training ○ P ○



Prepare people for the future labor market by workforce training.

ES
|
█

LE
|
█

EP
|
█

LI
|
█

RS
|
█

See also 1.4, 3.1, 3.3

3.3 Curriculum alterations ○ P ○



Prepare people for the future labor market by workforce training and altering their current curriculum.

ES
|
█

LE
|
█

EP
|
█

LI
|
█

RS
|
█

See also 3.1, 3.2

Figure 7.15 continued

3.4 Expand public transit infrastructure ○ ○ **B**

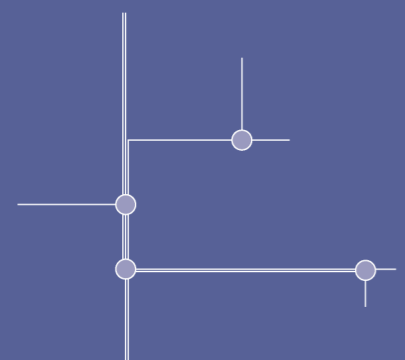

Expand and improve the public transit infrastructure at national, regional and local levels to strengthen its position as the main mobility form.

ES LE EP LI RS

See also 3.5, 3.6

3.5 Renewable based transit connections ○ **P** ○

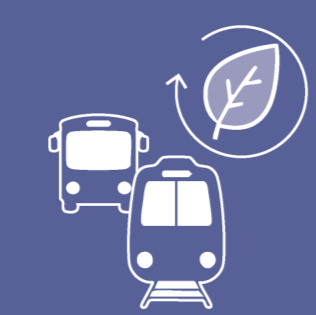

Prioritize renewable based transit options, for example hydrogen busses and green electricity trains, to increase sustainable connections.

ES LE EP LI RS

See also 2.9, 3.4, 3.6

3.6 More frequent public transit ○ ○ **B**



Increase frequency of public transit to improve their reliability and make it more attractive as a primary mode of travel.

ES LE EP LI RS

See also 3.4, 3.5

3.7 Participations processes in local energy processes ○ **P** ○



Facilitate greater public participation in local infrastructure project to ensure diverse voices and perspectives are included.

ES LE EP LI RS

See also 2.1, 2.2, 2.4, 2.5, 2.7, 2.8, 3.8, 3.9

3.8 Local energy sharing ○ **P** ○

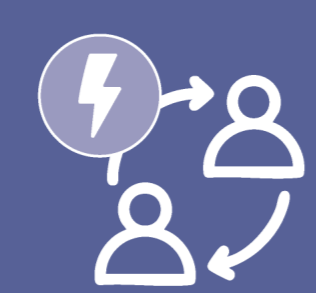

Sharing resources locally amongst residents promotes equitable access to essential resources and will boost their benefits from the production.

ES LE EP LI RS

See also 2.1, 2.2, 2.4, 2.5, 2.6, 2.7, 2.8, 3.7, 3.9

3.9 Citizen empowerment ○ **P** ○



Empower the citizens through decentralized bottom-up government and local energy production.

ES LE EP LI RS

See also 2.1, 2.2, 2.4, 2.5, 2.6, 2.7, 2.8, 3.1, 3.2, 3.3, 3.7, 3.8

Relation to current policy framework

The action cards are designed to support and enhance the existing multi-level governance framework. The current Dutch policy framework already reinforces and contributes to the global objective of climate change mitigation. Accordingly, these action cards can be implemented across different governance and spatial scales, reflecting the layered structure of the existing system. They address key domains; ecological stewardship, energy production, and local engagement to ensure that spatial interventions are carried out in a comprehensive and integrated manner. In this way, the proposed rules and regulations operate through a multi-layered approach, resulting in a well-rounded and coherent strategy.

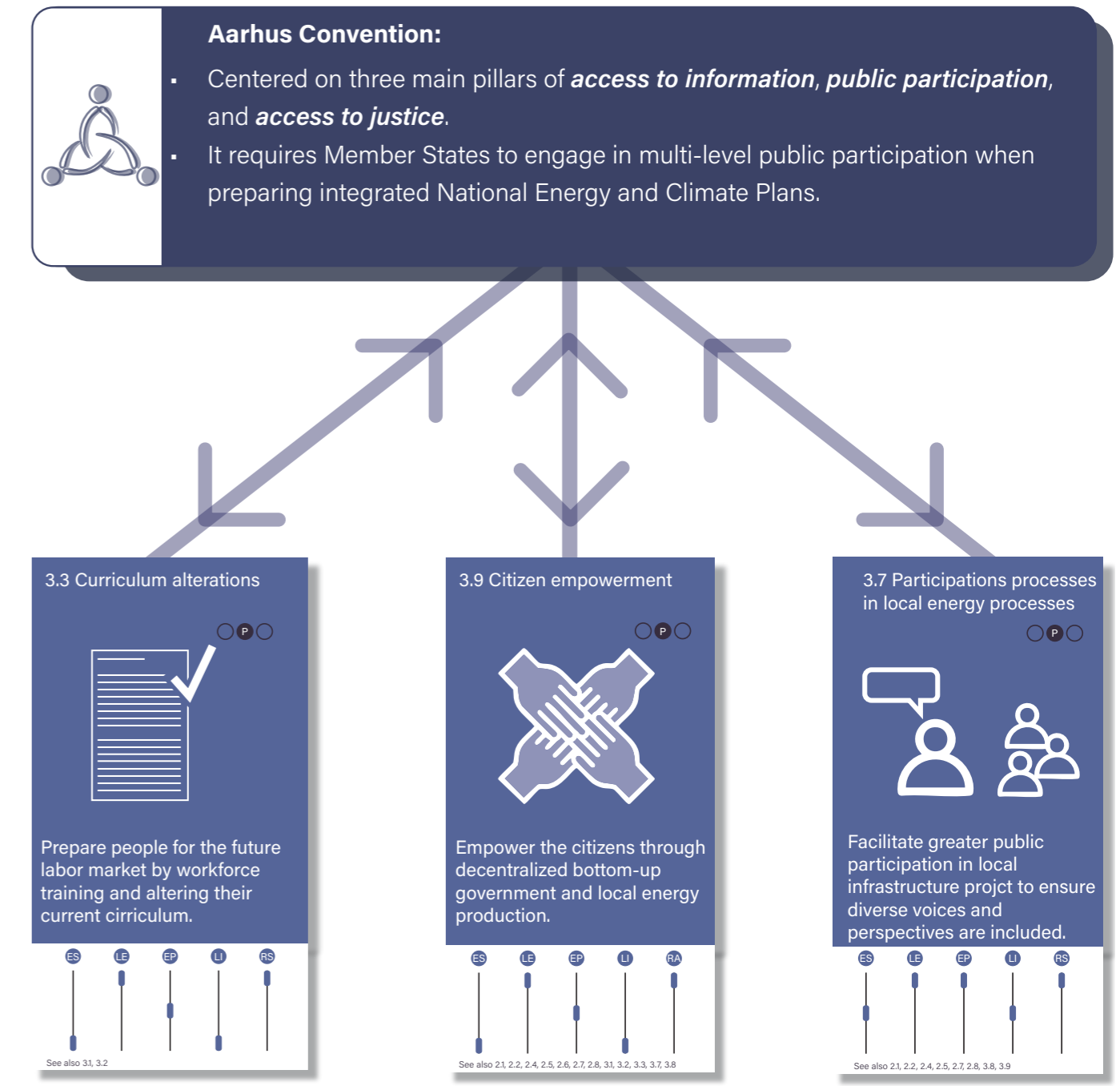

Figure 7.15.1 Relationship of policy and action cards

7.3.1 Relationship between Action Cards

A Pattern Field of Interrelationships

The pattern field (figure 7.16) establishes relationships between the several actions. The cards are organized on a landscape infrastructure graph with an x-axis that progresses from small to large scale interventions while the y-axis charts the level of technocracy; social ecologically driven non-technocratic interventions at the bottom and highly technocratic interventions at the top.

While many actions are evenly distributed across the field, some distinctions and patterns are visible; most of the energy production actions are grouped in the technocratic portion of the graph. This grouping is accurate since these actions are technology driven to facilitate the renewable energy transition. In an expected contrast, many local engagement actions are found in the non-technocratic half on the graph. These actions are based on behavioral change and/or are socially driven within the community of Friesland (or even nationally). Ecology stewardship actions are both technocratic and non-technocratic. In some instances, technology is required for ecological stewardship; for example, through the creation of new natural areas. In other cases, natural processes are allowed flourish, with minimal intervention from humans and a focus on observation of the process.

Within figure 7.16, relationships are identified between which actions support each other; this information is also written on the of the card (reference figure 7.15). Energy production actions, are able to interact with ecology stewardship cards, in turn strengthening each other. For example, solar fields (2.8) can positively contribute to biodiversity (Nationaal Consortium Zon in Landschap, 2021). In this case, an area is not intensively farmed or fertilized, and instead is planted with flowering plants which creates habitats for insects and small mammals (Nationaal Consortium Zon in Landschap, 2021). This change of land use has a positive effect on the ecology in the area and contributes to ecological corridors (1.1), animal habitats (1.6), and a mix-use landscape (1.10). Since the action of solar fields can be implemented at a small scale, self-sufficiency on a local level becomes possible through local energy sharing (3.8) and furthers citizen empowerment (3.9). The same principle can be applied to wind parks (2.7). Through the combination of multiple strategic actions cards within an area, optimal environments will be created.

The placement of the cards was made based on the community. If other stakeholders use the pattern field, their placement of actions might differ according to various perceptoins and interests, or through a different interpretation of the cards.

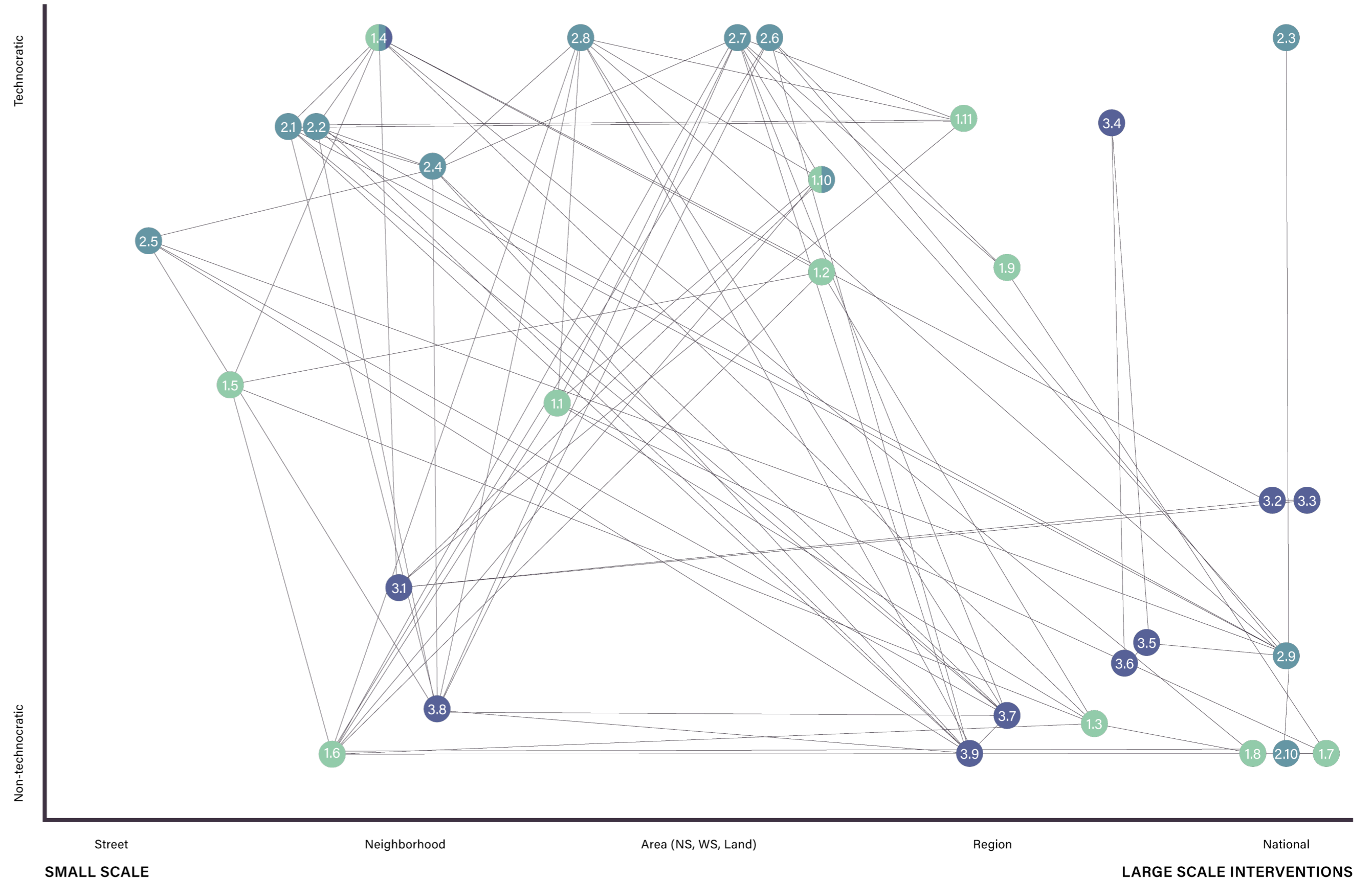

Figure 7.16: The pattern field quickly shows a graphic web of the relationships between each action card in regard to scale and level of technocracy

7.4 Timeline

How long will this process take?

The timeline presents a long-term strategy for the energy transition in Friesland, structured into four main phases: prepare, transition, self-sufficiency, and stabilize. It illustrates how governance, energy production, and ecological systems develop together over time. The first phase focuses on building awareness, knowledge, and participation among stakeholders, creating a strong foundation for the transition. At the same time, the ecology is being prepared for possible changes in the environment. In the transition phase, renewable energy systems are gradually implemented, while fossil fuel dependency decreases and ecological systems are protected and integrated into the design. The self-sufficiency phase represents a shift towards regional energy independence, where local communities and regional actors play a stronger role in co-producing and using local energy.

Finally, the stabilize phase focuses on maintaining and adapting the system, ensuring long-term resilience and balance between energy production, local engagement, and especially being aware that the ecology needs the time to adapt and to be stable.

The timeline also indicates 'key projects' that are imperative to the successfully implementation of the proposed project. These are large infrastructure initiatives that help spur real, tangible change towards renewable energy infrastructure and also enhance public buy-in and motivation.

The key projects are indicated by the vibrant circles and most of them occur before 2040. The creation of the Quality Control Board is the catalyst for motivating the other stakeholders and government(s) to move forward with the proposed project, while national curriculum alterations progress environmental mindedness within future generations. After that, offshore and on land wind parks begin construction to provide renewable energy Frisians and act as proof that real change is occurring. Prior to 2050, the public transit infrastructure is expanded to facilitate anticipated population growth and further connects the Frisian cities to boost local engagement and interest in the renewable transition. Finally, once many other components are in motion, the artificial island creation begins around 2065.

Overall, the timeline shows a gradual and integrated transformation towards a more sustainable and regionally controlled energy system.

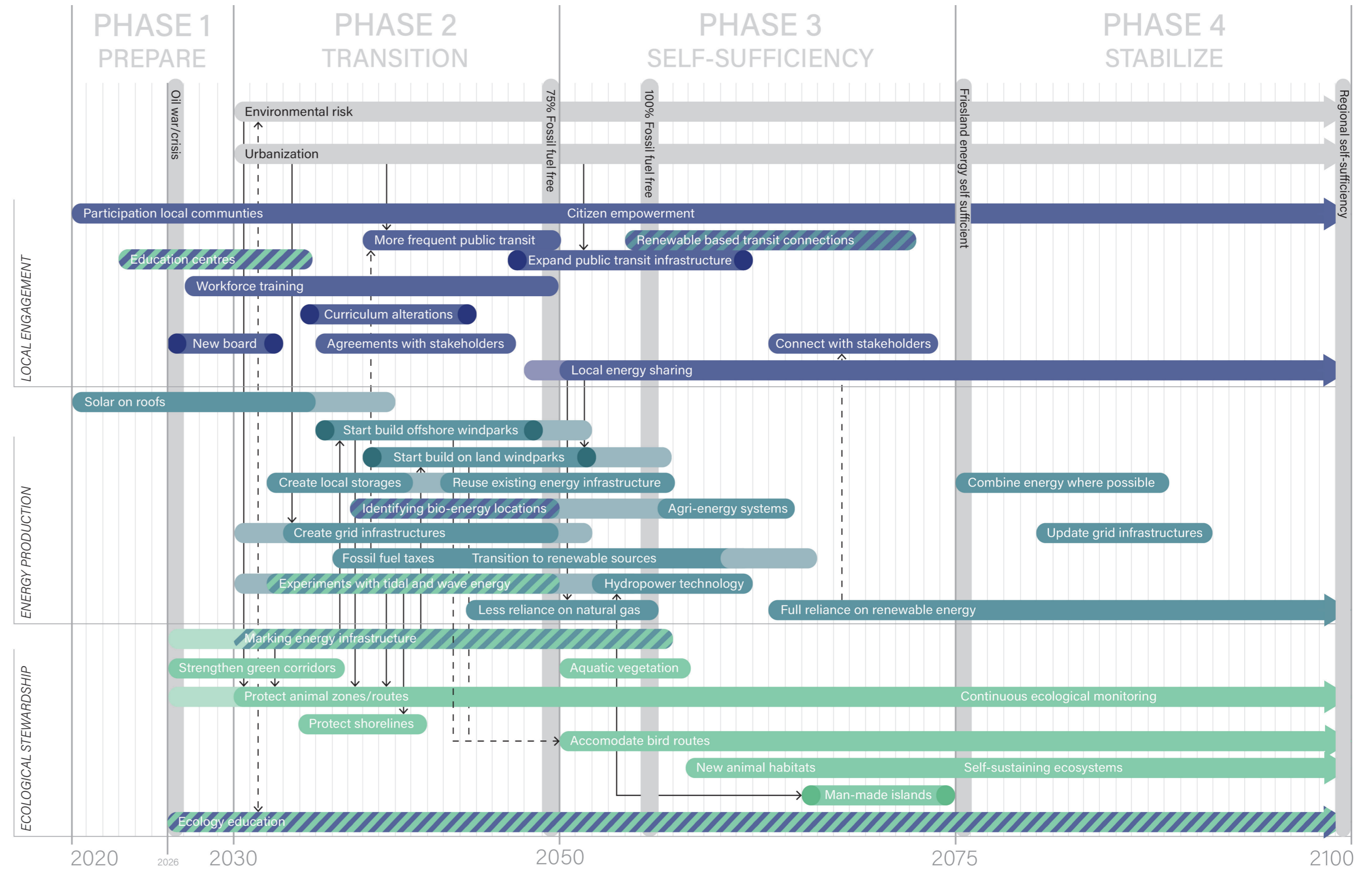

Figure 717: Timeline graphically shows the interactions and dependencies of actions with each other, separated into four phases. Key projects are denoted for their cruciality towards proposed project success.

- Key moments
- Local engagement
- Ecological stewardship
- Flexibility
- Indirect connection
- Important shifts
- Energy production
- Continuous
- Direct connection

7.5 Phasing in Sections

Preparation and Transition

The Prepare phase builds awareness, knowledge, and trust among all stakeholders. Local communities, governments, and others are informed about the energy transition through education, workshops, and participatory processes. The new board has begun talking with local communities and the province. Initial planning and small-scale pilot projects are also introduced, including solar panels on roofs and strengthening the ecology. By involving communities early, local support is strengthened and ensures that future interventions better reflect local needs and values, forming a strong and inclusive foundation for the transition.

The Transition phase focuses on large-scale implementation of renewable energy systems and spatial interventions that are decided with local participants and stakeholders. Fossil fuels are reduced while wind turbines, bio-energy, experiments with hydropower, and grid infrastructure expansion has begun. Ecological systems are protected and integrated into the design of the energy infrastructure. This phase enables a significant reduction in emissions while transforming the regional energy system. Public transit is expanded as a reaction to urbanization and curriculum alternations are implemented. Fast transitions are balanced with local involvement.

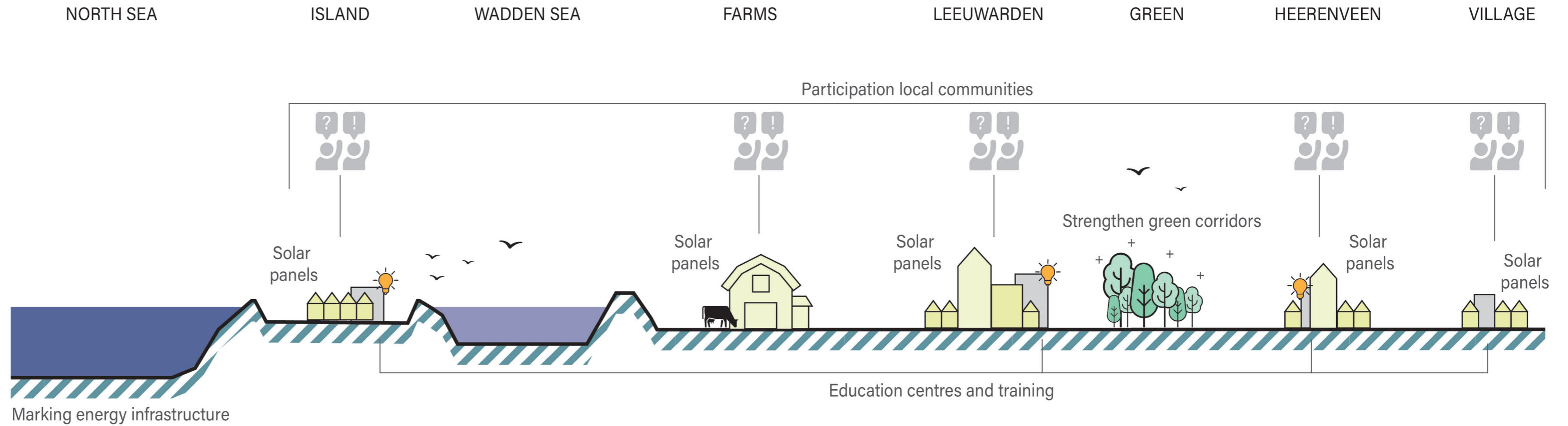

Figure 718: Section Phase 1

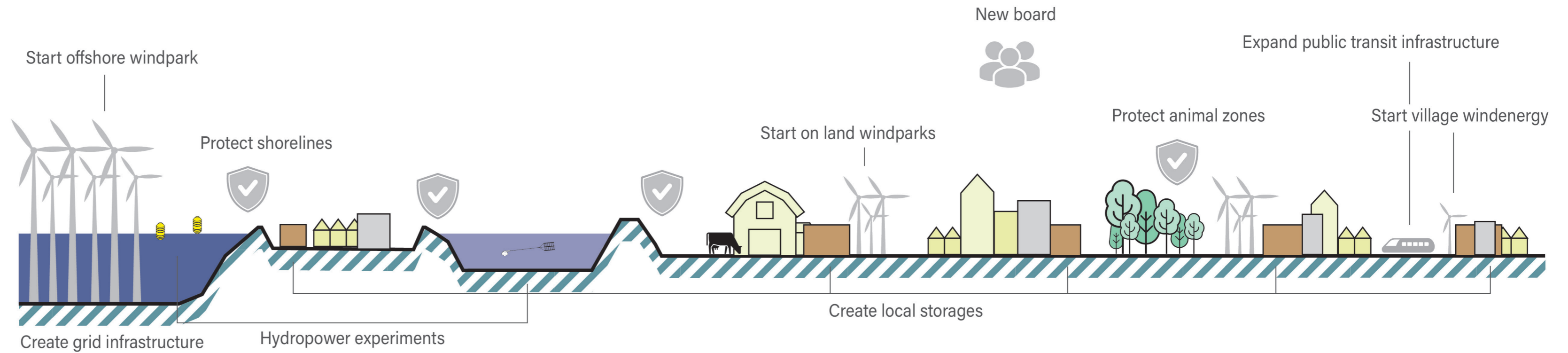

Figure 719: Section Phase 2

Self-Sufficient and Stabilize

In the Self-Sufficiency phase, regional self-sufficiency is achieved as energy is produced, managed, and partly owned by local communities. Governance acts in a decentralized system where there is full reliance on renewable energy within the region. Man-made islands are introduced to restore the natural environment and create hydropower. This phase is beneficial because it ensures that the economic and social benefits of the energy transition remain within Friesland. Public acceptance increases and strengthens the relationship between people, energy, and landscape.

The Stabilize phase focuses on maintaining and adapting the energy system over time. Renewable energy production is fully integrated, and ecological systems are continuously monitored and strengthened. Governance structures remain flexible and inclusive, allowing adjustments for new knowledge or conditions. Long-term resilience and balance between energy production, ecology, and local engagement is completed. Instead of constant expansion, the focus shifts towards optimization, maintenance, and sustainable coexistence, creating a stable and future-proof regional system where local engagement and energy self-sufficiency are achieved.

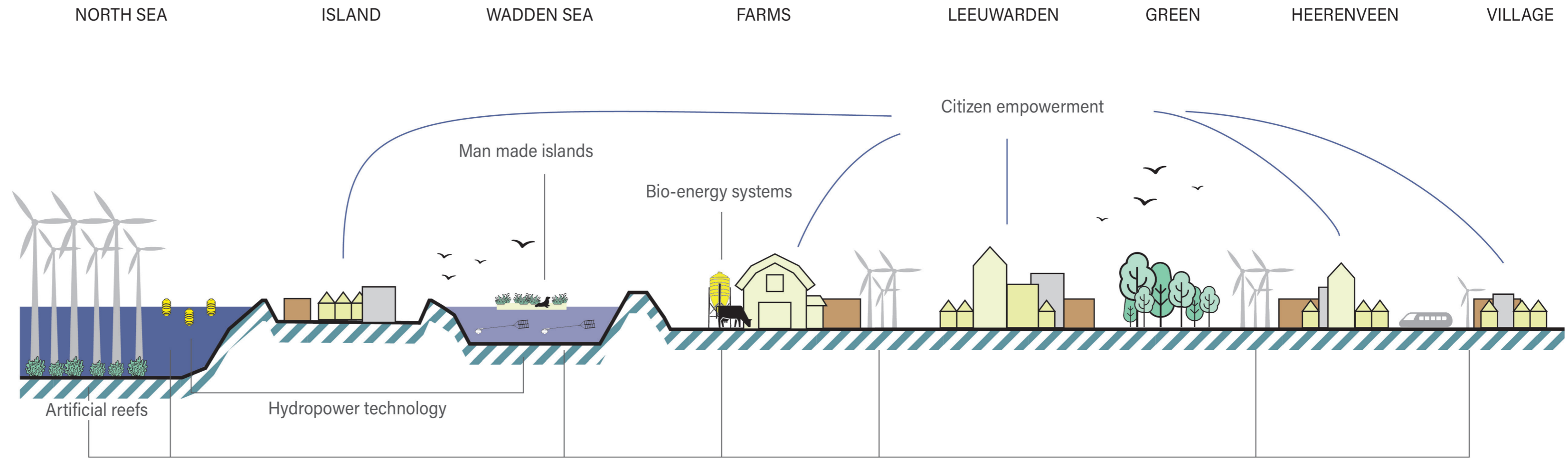

Figure 720: Section Phase 3

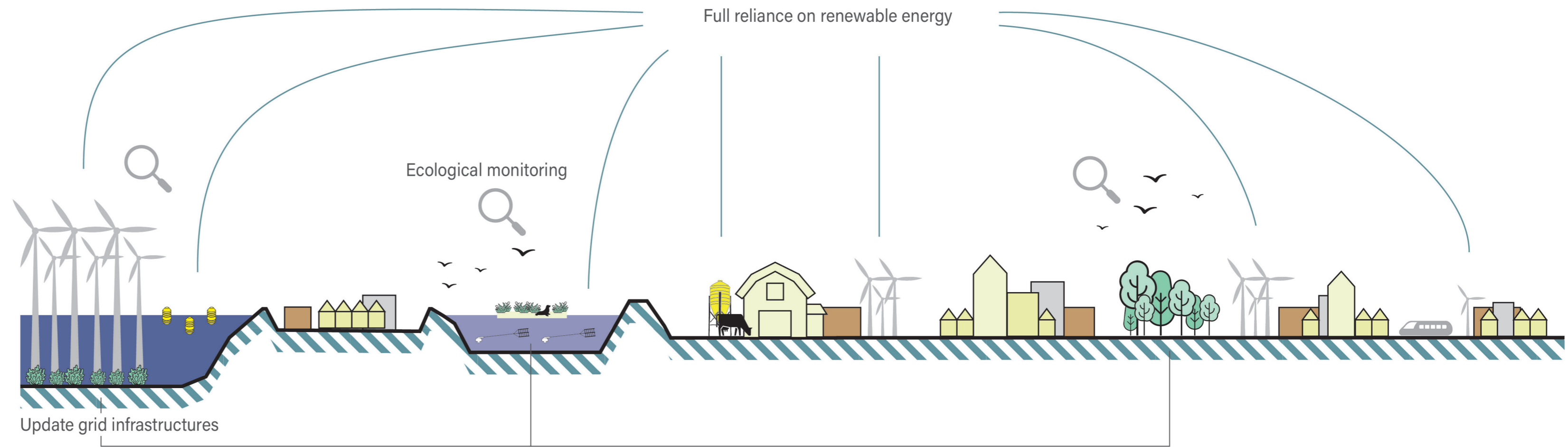

Figure 721: Section Phase 3

7.6 Zoom In's

Alignment of location interrelationships

To understand the strategy better, zoom-ins of different areas illustrate how policy and spatial actions are translated into design interventions. While the themes are reoccurring in every location and the actions in the different locations overlap, every location has a unique landscape identity where there is a balance between the traditional identity and the applied actions.

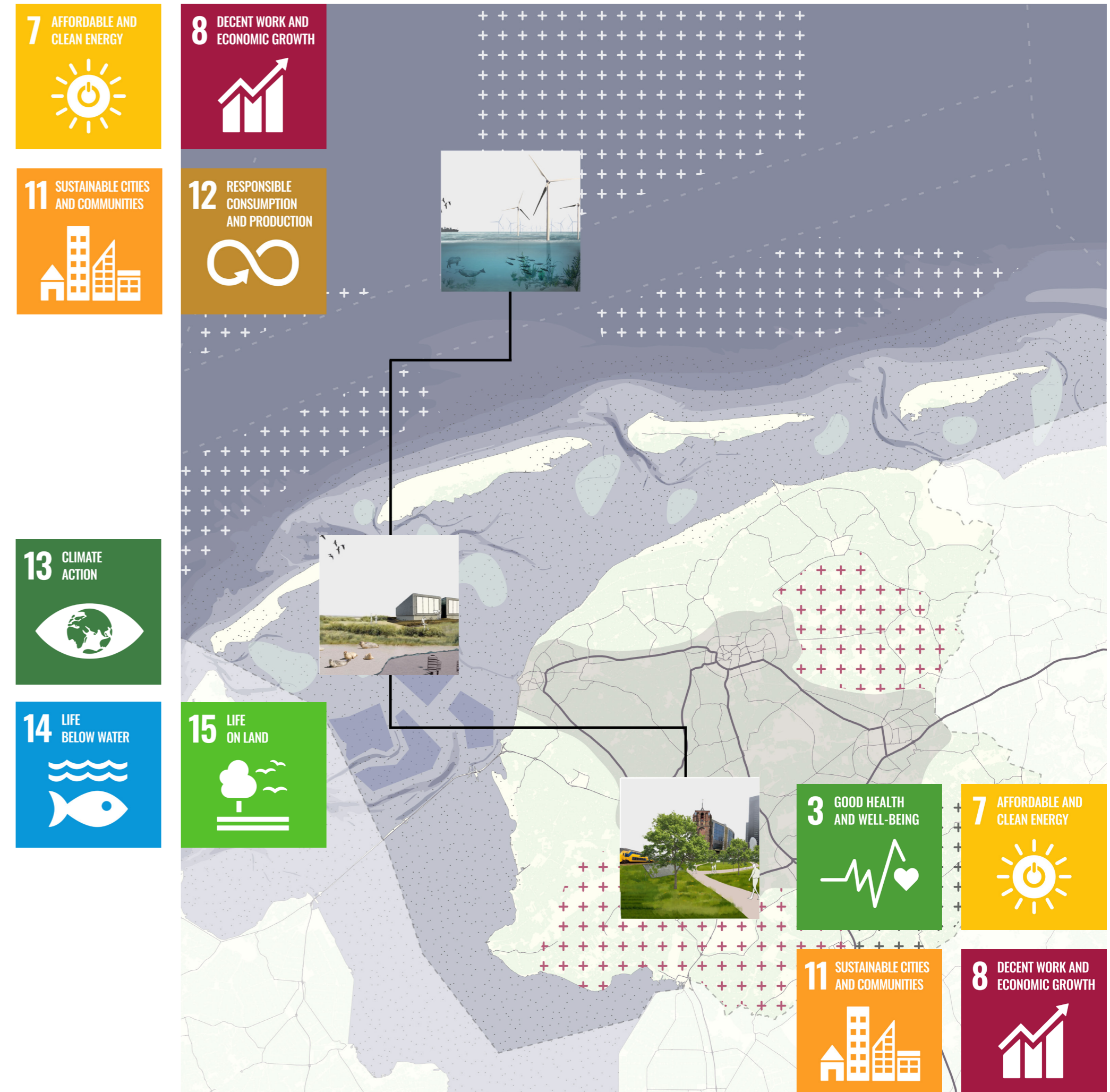

Figure 722: The overall zoom-in map denotes the chosen locations of the three zoom-ins to be further explored. The corresponding UNSDGs have been placed alongside the location which they are best represented.

7.6.1 Zoom In - North Sea

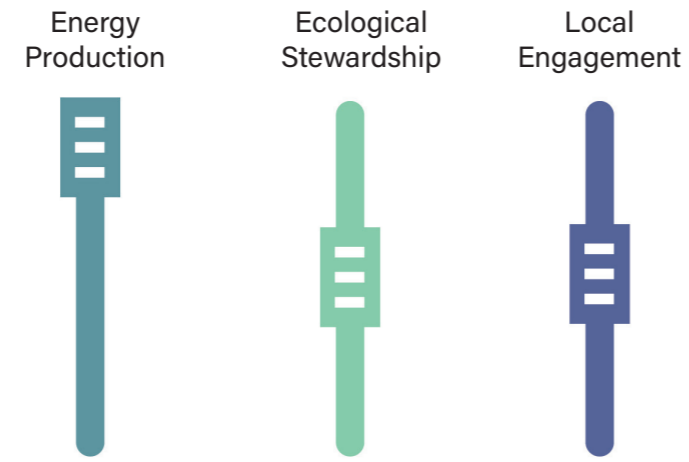

Figure 7.23: The North Sea makes full use of energy production while considered implementation of stewardship and engagement

Let's take a look at the North Sea

In the North Sea, the theme that stands out most is 'energy production'. The large-scale landscape makes a suitable place for large scale energy production (action card 1.11) with a wind park (2.6) (phase 2). In between ship routes and protected nature areas, large scale plots with high wind energy potential can be assigned to produce renewable energy.

The North Sea has become the primary energy source for wind energy for Friesland. The approx. 600 km² wind park will provide energy for the citizens and the new transit infrastructure of the Province of Friesland, empowering its citizens.

With the impactful implementation of a large-scale wind park, the protected areas as assigned already must remain untouched. Additionally, actions within the 'ecological stewardship' theme must further strengthen the ecology to minimize negative effects from the intervention. These include artificial reef creation near the base of individual wind turbines.

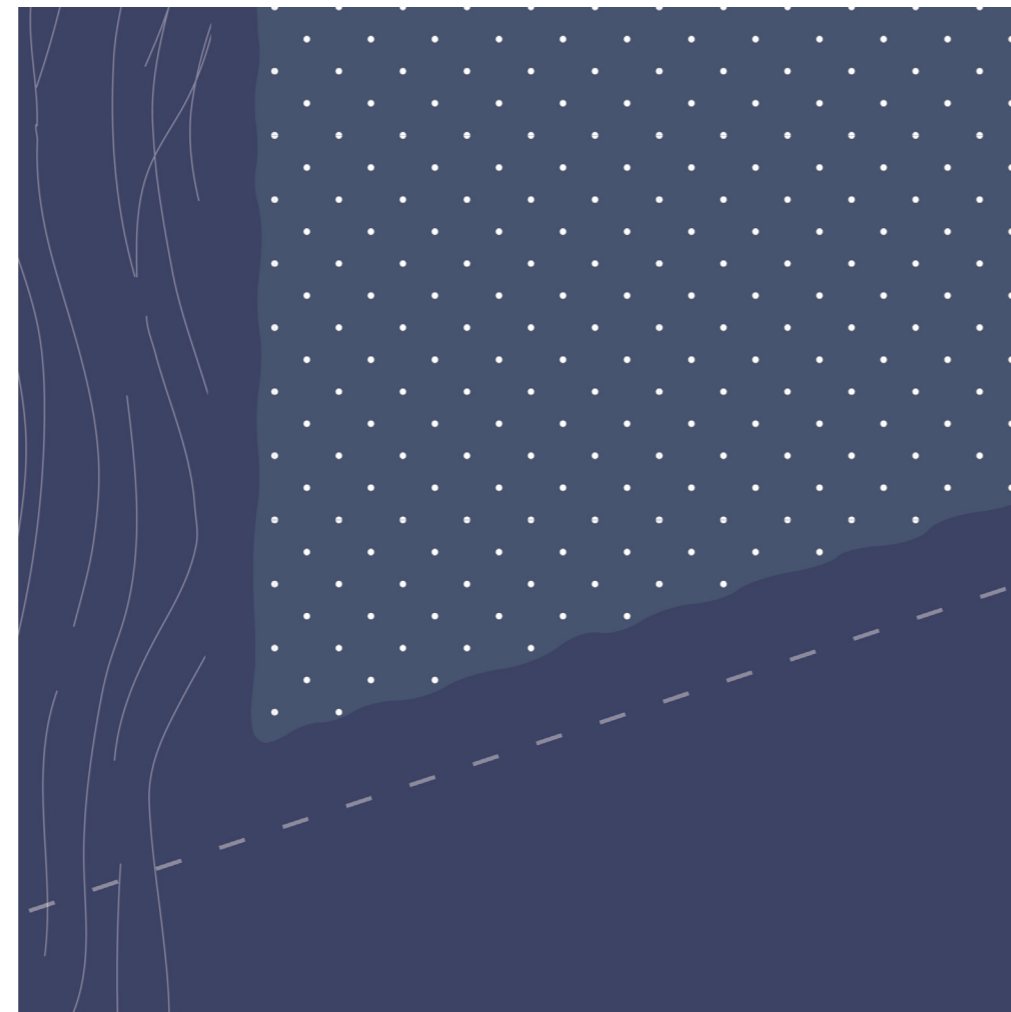
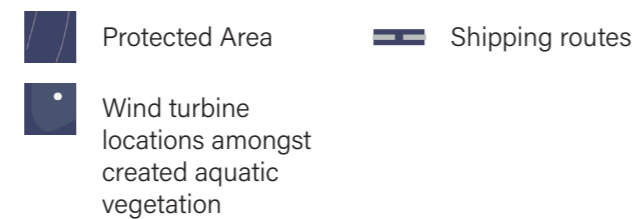

Figure 7.24: Map of North Sea intervention



2.5km 5km



Figure 7.25: Collage visualization of North Sea intervention. Aquatic biodiversity thrives as the vast wind park produces energy for Friesland.

7.6.2 Zoom In - Wadden Sea

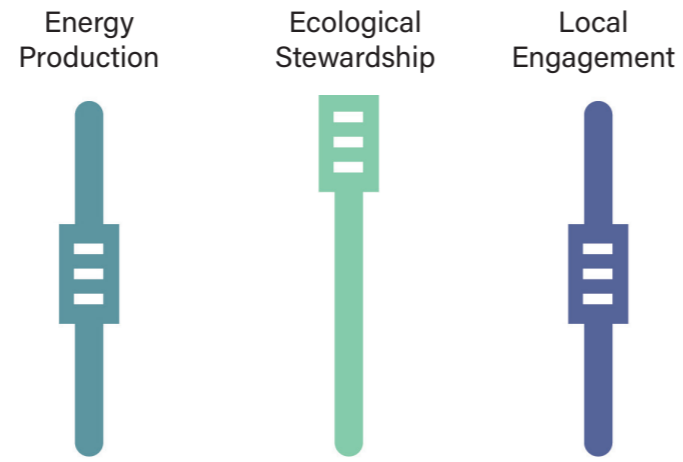

Figure 726: Ecological stewardship is the most prominent theme within the Wadden Sea area

Wadden Sea at 15km x 15km

In the Wadden Sea, 'ecological stewardship' plays the main role. The whole of the Wadden Sea is protected by UNESCO due to its unique characteristics. In the shallow water areas, man-made islands will be constructed (phase 3). The added artificial islands will enhance biodiversity, restore the natural environment, create new habitats, provide renewable energy, and stimulate engagement through education, and therefore serves multiple functions across all three themes.

On the islands an education center will be built to educate Frisians and visitors about a respectful and responsible approach towards the landscape. People will be prepared for the future labor market with a particular emphasis on the younger generation (3.1 & 3.2). During construction, sea migration routes must be taken into account to minimize disruption (1.8). During infrastructure construction, bird migration (1.7) and bird safety (1.9) will be protected, while island shorelines strengthened to enhance ecological safety (1.2).

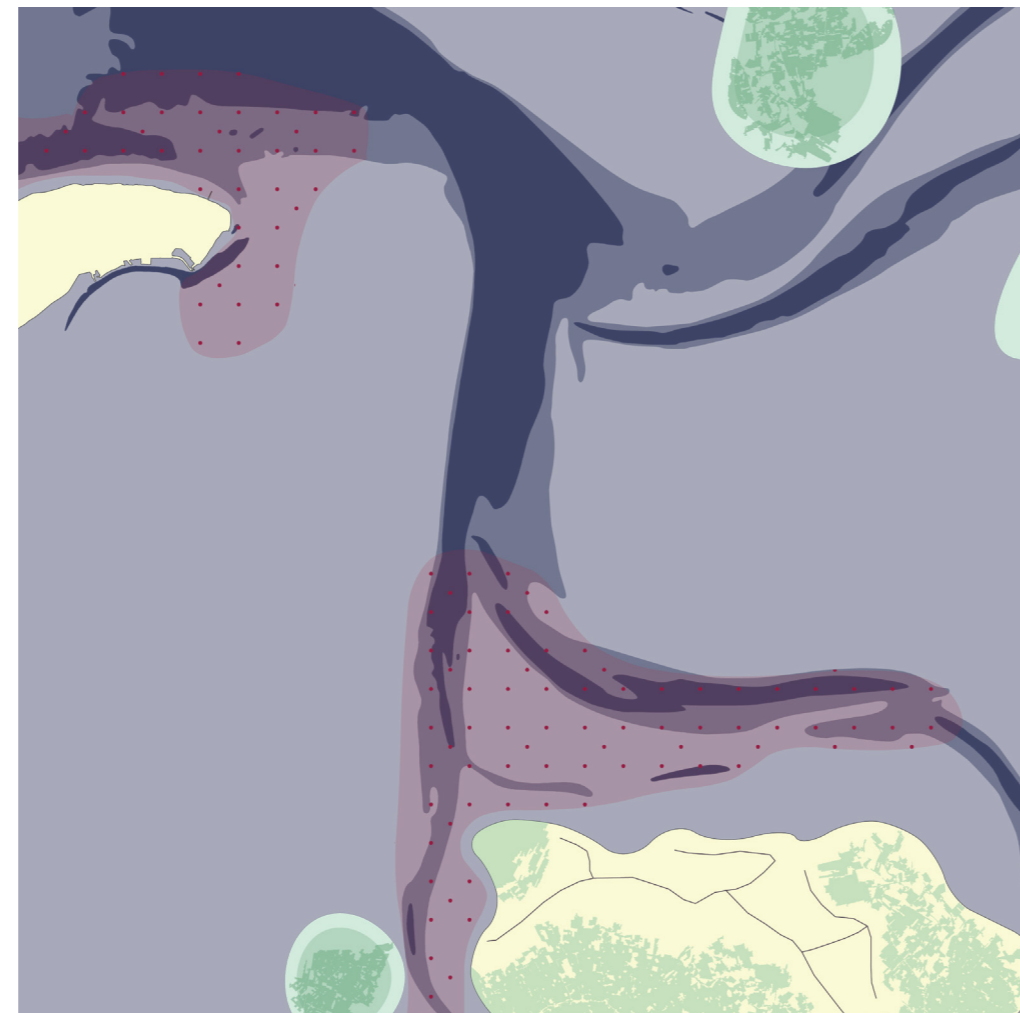

Figure 727: Map of Wadden Sea intervention

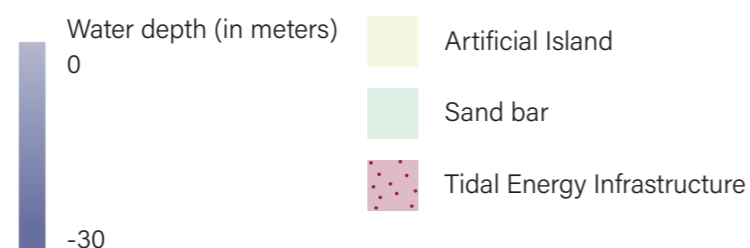

Figure 728: Tidal energy and marine sea life coexist on the artificial islands, while Frisians make use of the new education centers

Minimized disturbance of the existing islands

Ecology plays the most important role on the islands, with the protection of animal zones (action card 1.3), the preservation and creation of animal habitats (1.6), and aquatic vegetation (1.5) taking center stage (phases 2 and 3). Vegetation diversity will be increased by introducing new species, which will enhance biodiversity in the area. Due to the strategic placement along deeper waters, tidal energy (2.1) is also possible to generate energy from the tidal differences together with creating new habitats for marine life (1.6). Protecting migration routes (1.7, 1.8) and protecting the shoreline (1.2) are also necessary actions on these islands.

The sea is also well-suited for tidal energy due to its tidal differences (action card 2.1). In the navigation channels, technology will generate energy from the rising and falling water levels. These structures will create new habitats for marine life (1.6).

Few small-scale spatial interventions will be implemented on the islands to protect their landscape identity. A local energy storage facility (2.4) will serve as a pit-stop for energy from the North Sea before it continues to the mainland, while simultaneously supplying the island with that energy. Small-scale energy generation will ensure the island's self-sufficiency (1.11).

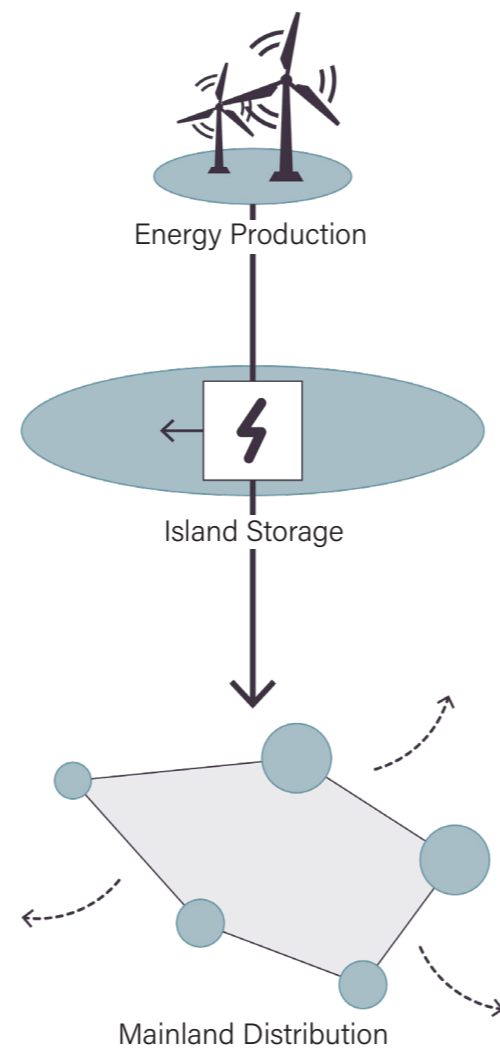

Figure 7.29: Abstracted diagram showing the route of energy circulation. Production occurs in the North Sea, storage is hosted at an island(s) in the Wadden Sea (with marginal energy distribution to the island), and transferred on land for consumption in the urban areas

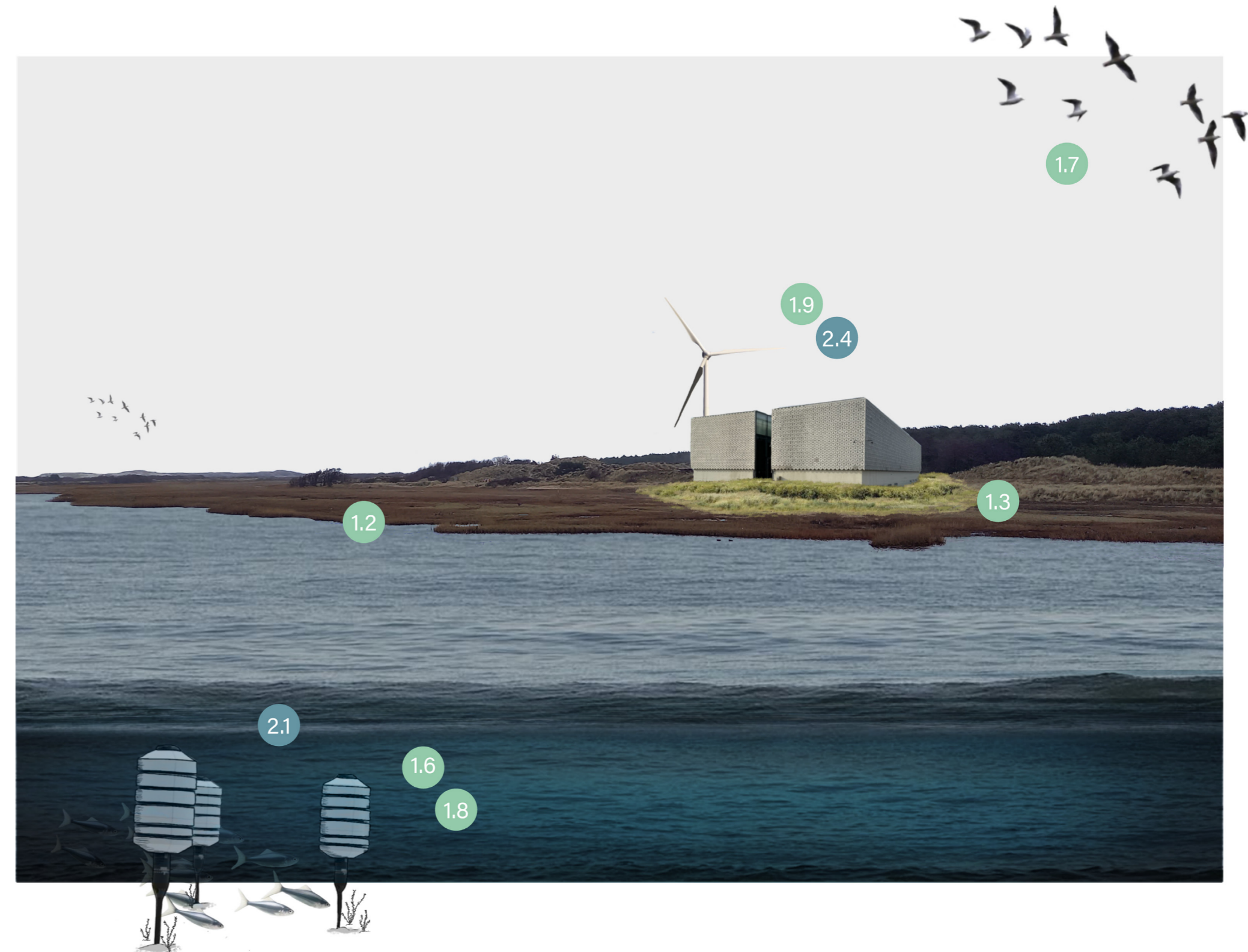

Figure 7.30: Artificial islands are created to strengthen ecological habitat and provide education centers for Frisians

7.6.3 Zoom In - Land

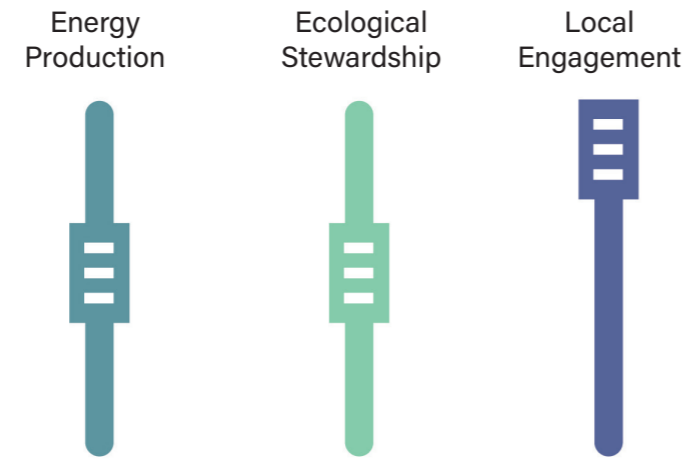

Figure 7.31: On land, local engagement is the functioning at the highest level

Rural to urban relationships are strengthened

The 'local engagement' theme on land, produces, stores, and shares energy locally to promote equitable access to essential resources and provides benefits for Frisians. Citizen empowerment is strengthened through a bottom-up approach.

Existing green corridors must be preserved, and future ones extended, to improve biodiversity and promote climate resilience. Corridors will connect rural and urban areas to maintain and add habitats.

The scale-to-scale principle is applied at areas of local production to achieve mix-use landscapes where the landscape identity is safeguarded, energy is produced, and ecology thrives. In rural areas, local energy production and storage (action card 2.4 & 3.8) are encouraged through participation (3.7) to achieve self-sufficiency via a decentralized approach. At the urban level, the focus is primarily on solar fields at the urban periphery and solar energy on rooftops in the denser city centers. Both follow the scale-to-scale principle (1.11) to protect the landscape's identity and create a mixed-use landscape (1.10).

The urban area becomes attractive through an expanded and more accessible public transportation network (3.4 & 3.6). This will be powered by renewable energy produced in the region (3.5).

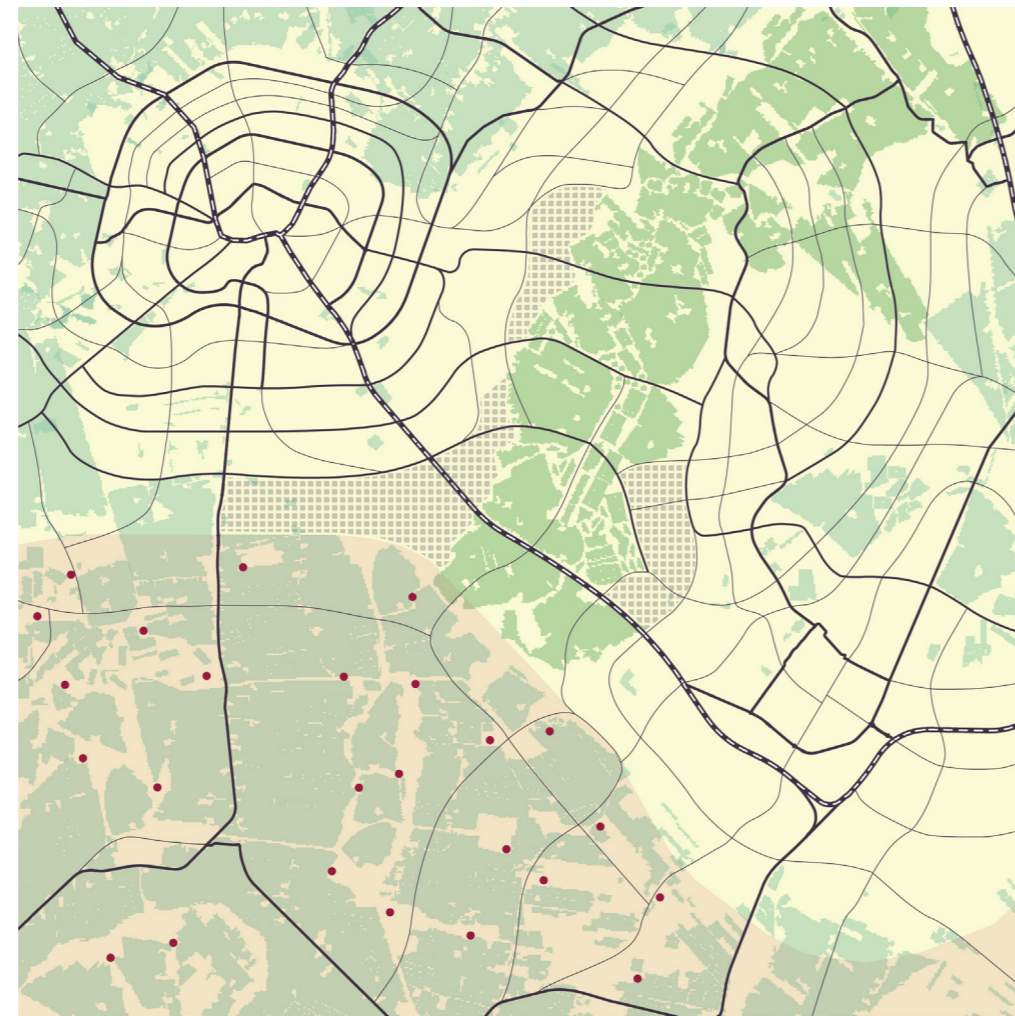

Figure 7.32: Map of mainland intervention

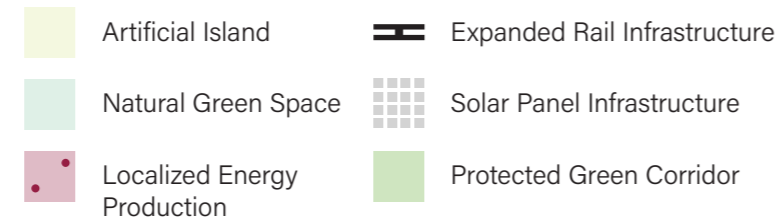

Figure 7.33: The rural and urban communities meet at the crossroads of public transit connectivity and biodiverse green corridors

By 2100, we can provide clean energy for all of Friesland while preserving landscape identity and promoting ecological abundance.



Figure 7.34: Triptych visualization highlighting the interconnectedness of all three locations: North Sea, Wadden Sea, and mainland Friesland

8 Conclusions and Reflections

- 8.1 Group Reflection
- 8.2 Individual Reflections
- 8.3 Bibliography



Figure 8.1: Terschelling's marshland coastal perimeter is a unique characteristic of the island but is vulnerable to impacts of climate change

By 2100, Friesland will be the first self-sufficient province of The Netherlands to the benefit of its residents and broader province. Public participation and frequent dialogue between the community and government will enable *vast renewable energy production, preservation of the landscape identity, and will enhance the ecological uniqueness* of the region.

SQ1: What is the existing landscape identity and how does this disrupt the energy transition?

The existing landscape identity of Friesland is characterized by open landscapes, strong water systems, agricultural fields, and a close relationship between people and nature. The region is known for its wide horizons, cultural heritage, and ecological value, particularly in areas such as the Wadden Sea. These qualities form an important part of the regional identity and are highly valued by residents.

However, this landscape identity can also disrupt the energy transition. Large-scale energy infrastructure, such as wind turbines and solar fields, can conflict with the open character of the landscape and lead to visual pollution. In ecologically sensitive areas, energy development may also threaten biodiversity and natural systems. As a result, there is often resistance from local communities and environmental organizations.

This tension creates a challenge, while energy production is necessary for a sustainable future, it must be carefully integrated into the landscape. Without this integration, the transition risks damaging the very qualities that define the region. Therefore, understanding and respecting landscape

identity is essential to reduce conflict and create more acceptable and context-sensitive energy solutions.

SQ2: What are the spatial implications of the energy transition process?

The energy transition has significant spatial implications, as it requires new forms of land and sea use. Renewable energy systems such as wind farms, solar fields, and energy storage facilities take up space and interact with existing functions like agriculture, housing, nature, and infrastructure. This creates increased spatial pressure, especially in a region like Friesland where land and ecological areas are already intensively used.

Energy production must be combined with other functions, such as agriculture or nature development, to reduce spatial conflicts. Offshore areas also become more intensively used, with wind energy, shipping routes, and ecological zones needing to coexist.

Another implication is the transformation of landscapes. Energy infrastructure changes the visual and physical character of the region, which can affect landscape identity and public perception. In addition, new infrastructure, such as cables and energy hubs, reshapes spatial connections between sea and land.

Overall, the energy transition is not only a technical process but also a spatial transformation that requires careful planning to balance energy needs with ecological and social values.

SQ3: What are the policies that establish the regional self-sufficiency?

Regional self-sufficiency in the energy transition is established through a combination of quality control governance, ownership, and spatial planning policies. One important policy is the promotion of local ownership, such as requiring a percentage of energy projects to be owned by local communities or cooperatives. This ensures that economic benefits remain within the region.

In addition, decentralized governance structures support regional developments. Municipalities and the Province Friesland play a stronger role in decision-making, while new governance models, such as the Quality Control Board Friesland, can increase local influence. Participation policies also ensure that residents are involved throughout the process, rather than only in early consultation stages.

Spatial policies further contribute by prioritizing local energy production and integrating energy systems into regional landscapes. This includes encouraging small-scale, community-based energy solutions near villages, alongside large-scale infrastructure for the urbanized cities.

Together, these policies shift the energy transition from a top-down system to a more balanced, regionally controlled approach. This strengthens local decision-making power, increases public support, and creates a more resilient and self-sufficient energy system in Friesland.

RSQ: How can the residents of Friesland and its municipal governments benefit from the energy transition process in which the existing landscape identity guides the establishment of regional self-sufficiency?

Residents and municipal governments in Friesland can benefit from the energy transition by aligning energy development with the existing landscape identity and strengthening regional self-sufficiency. By using the characteristics of the landscape, such as open views, water systems, and agricultural field, as a guiding principle, energy interventions can be better integrated into the environment. This reduces spatial conflict and preserves cultural and ecological values.

At the same time, regional self-sufficiency allows local actors to have more control over decision-making and energy systems. Through local ownership models, energy cooperatives, and community participation in a new form of a local board, residents can directly benefit economically and politically from energy production. The collaboration with the new Quality Control Board Friesland plays a key role in coordinating these processes and translating regional goals into local actions.

This approach also increases public acceptance, as communities feel more connected to the transition and see multiple benefits. In addition, it strengthens the regional economy by keeping financial flows within Friesland. Overall, combining landscape identity with regional governance creates a more balanced, inclusive, and sustainable energy transition that benefits both people and place. The proposed project successfully addressed the project brief and formulated research questions.

8.2 Group Reflection

Values and ethical considerations:

The creation of our group began with our shared interest in energy production, which we each selected from four options – production, circulation, storage, and consumption – at the onset of the course. Our project has been successful in its scope to primarily focus on energy production, remaining consistent with our initial scope of work.

This project is strongly guided by values of fairness, inclusivity, and participation of people and nature within the energy transition. One of the key points of ethical considerations is the balance between energy production and ecology protection, especially in sensitive areas of the region such as the identical landscape and marine life. The project also addresses issues of spatial justice as the local communities are affected by the energy developments. By proposing the new Quality Control Board Friesland, we created a more justice system where the residents are ethically more considered within the energy transition. At the same time, ethical challenges remain, such as including the voices of all residents stays difficult.

Societal relevance and potential impact:

The real involvement of stakeholders or local engagement would be valuable, especially for the local community. During our field trip we did not have time or preparation to talk to the local community. This could have given us a better understanding of the needs of the local community, tilting the project to a higher level. It could also add to specializing the zoom-ins more, making them even more location specific and related to the community living there. Although, because it is also a current issue that the Frisians feel left out of the

energy process, we found a lot of helpful articles in relation to this, so the project was not fully based on assumptions.

Reflect on group work:

The group work considered actively working together and a lot of discussions which helped us go through a lot of topics and important decisions that were key elements for the project. Each member had their own contribution with their own knowledge and skills. At the start we already had a color palette which saved us a lot of time but also helped to make the project coherent and make connections to different elements of the report. At the end, everyone worked on a different topic to be an expert in this. This also helped us communicate together and understand each other's work or if something was missing, the others could add to that. We learned a lot from each other. The narrative mind mapping exercise (figure 9.8) played a crucial role in the understanding and structure of the report, along which constantly referenced interconnectedness that threads from chapter 1 to chapter 8.

Implications for democracy, governance, and implementation:

In our project, regional governance played an important role. The role and participation of the citizens of Friesland, our community, is very important within our project. We wanted to give our community a voice, one that would not only be heard but also put into practice. To achieve this goal, a more bottom-up approach to the energy transition proved to be essential. As we gained more insight on the functioning of the current governance framework, it became clearer there is

no straightforward solution. An approach where top-down, as well as bottom-up is used, to tackle the transition, is needed in order to prevent large-scale fragmentation but also enable location-specific interventions suitable for the community living there. A new organ who keeps track of this approach has been introduced: the "Quality Control Board Friesland" (reference 7.2.4 New Governance Framework).

This new body, with democratically appointed representatives, is responsible for constantly checking the ideas and plans of the layers where most decisions are conducted to ensure the participation and input of the Frisian society is used during the whole decision-making process.

This board is a key body for measuring and monitoring spatial justice. This is because the body addresses multiple dimensions of justice. Looking back at the spatial justice benchmarking tool of the Methodology course (*figure 9.9*), it can be stated that the overall score has increased with the addition of the board within the governance framework. Specifically, the framework focuses primarily on the procedural and recognition dimensions, with fair voice, fair processes, fair rights, and fair support for communities playing the most significant roles. These are actually the components we scored lowest on during the exercise lecture but have now significantly improved.

Of the initially selected UNSDGs (reference 1.6), all were successfully implemented. They were used to guide the project in what seemed the most relevant when considering the energy transition in Friesland.

Risk reflection

In the analysis section of this report, the existing policy framework for climate mitigation in the Netherlands was examined. While this framework is extensive, it represents only a portion of the broader array of policies and strategies driving the national energy transition. According to the Climate Change Performance Index, a standardized tool comparing the climate performance of 63 countries and the EU, the Netherlands remains aligned with its key targets: a 55% reduction in greenhouse gas emissions by 2030 and climate neutrality by 2050 (Climate Change Performance Index, 2025). Furthermore, the country ranks 8th globally in the 2025 Energy Transition Index, as reported by NedZero(NedZero, 2025). So why does the energy transition feel stagnant?

Grid congestion

A central constraint lies not in technological capability, but in systemic and infrastructural limitations. According to NedZero, the primary barriers to progress are related to grid infrastructure, permitting procedures, and labor capacity rather than technological readiness (NedZero, 2025). In particular, grid congestion and limited transmission capacity are pressing issues in the northern Netherlands. These constraints not only restrict the expansion and deployment of renewable energy but also delay or discourage electrification processes (Altaghlibi, 2023)

Dutch industries are accelerating electrification in anticipation of the phase-out of natural gas, placing increasing pressure on an already saturated electricity grid (Pató, 2024). As a result, the grid is becoming overloaded, unable to accommodate both new renewable inputs and rising demand. Upgrading and transforming the grid to support this shift requires significant time, investment, and coordination. Critically, as noted by Altaghlibi (2023), insufficient grid capacity directly limits renewable energy investments. Conversely, without access to affordable renewable energy, electrification efforts are delayed—creating a reinforcing bottleneck within the transition.

Application to the Vision

For the proposed vision to be realized, the Netherlands must urgently accelerate the development and adaptation of its electricity grid to accommodate renewable energy flows. The International Energy Agency emphasizes the need for both short- and long-term strategies to address grid congestion. In the short term, optimizing existing grid operations can improve efficiency and relieve pressure. In the long term, substantial infrastructure expansion is required to support increasing volumes of renewable energy (Mereu, 2025).

Two primary pathways emerge: first, accelerating grid expansion by streamlining permitting procedures and reducing administrative complexity; and second, increasing capacity within the existing network through reconstruction, voltage uprating, and the implementation of advanced grid management practices. Together, these measures are essential to overcoming current bottlenecks and enabling a more effective and timely energy transition.

8.3 Bibliography

Chapter 1: Introduction

Amin, L. (2015, October 10). Shell and Exxon's €5bn problem: Gas drilling that sets off earthquakes and wrecks homes. *The Guardian*. <https://www.theguardian.com/environment/2015/oct/10/shell-exxon-gas-drilling-sets-off-earthquakes-wrecks-homes>

Chandrasekhar, A. C., Tandon, A. T., Dunne, D. D., Gabbatiss, J. G., Dwyer, O. D., & Lempriere, M. L. (2026, March 13). Q&A: What does the Iran war mean for the energy transition and climate action? *Carbon Brief*. <https://www.carbonbrief.org/qa-what-does-the-iran-war-mean-for-the-energy-transition-and-climate-action/>

De Vries, P. A. (2026, February 19). Friese burger wordt te weinig betrokken bij overgang naar duurzame energie. *Friesch Dagblad*. <https://frieschdagblad.nl/samenleving/friese-burger-wordt-te-weinig-betrokken-bij-overgang-naar-duurzame-energie-48535698.html>

Dugoua, E., & Noailly, J. (2025). Critical minerals and the clean energy transition: The role of innovation across the supply chain (Working Paper No. 435). Grantham Research Institute on Climate Change and the Environment.

Fastl, C., Arnberger, A., Gallistl, V., Stein, V. K., & Dorner, T. E. (2024). Heat vulnerability: Health impacts of heat on older people in urban and rural areas in Europe. *Wiener Klinische Wochenschrift*, 136(17–18), 507–514.

Friesland. IWCN. (2024, March 18). <https://iwcn.nl/friesland/#:~:text=History,a%20province%20of%20the%20Netherlands>

Global Climate Risks. (2026, March 27). Arctic sea ice hits record low winter maximum.

Government of the Netherlands. (2023). National Delta Programme 2024: Now for the future. Ministry of Infrastructure and Water Management.

Het Friese Burgerperspectief (Ed.). (2020). FRIESE ENERGIE: HET FRIESE BURGERPERSPECTIEF OP ENERGIE, KLIMAATVERANDERING EN DE ENERGIETRANSITIE [Report]. <https://planbureau.frl/wp-content/uploads/2020/03/20200226~ENERGIE~Publieks~DEF.pdf?x80738>

Koster, R. (2026, January 15). Tekort aan duurzame energie kan Nederland miljarden euro's kosten. NOS. <https://nos.nl/collectie/13871/artikel/2598230-tekort-aan-duurzame-energie-kan-nederland-miljarden-euro-s-kosten>

Lancet Countdown. (n.d.). Lancet Countdown on health and climate change. <https://lancetcountdown.org>

NL TIMES (Ed.). (2025, September 3). Energy gap widening: Households outside Randstad spend much more on energy bills. *NL Times*. <https://nltimes.nl/2025/09/03/energy-gap-widening-households-outside-randstad-spend-much-energy-bills#:~:text=Share%20this:-,Energy%20gap%20widening:%20Households%20outside%20Randstad%20spend%20much%20more%20on,contrast%20is%20even%20more%20extreme.>

NL Times. (2021, July 16). Limburg flooding officially named disaster; Evacuations started in north of province. <https://nltimes.nl/2021/07/16/limburg-flooding-officially-named-disaster-evacuations-started-north-province>

The Northern Times. (2020, October 16). One in twelve households in Friesland live in poverty. <https://northerntimes.nl/one-in-twelve-households-in-friesland-live-in-poverty/>

Place rankings - data commons. Home - Data Commons. (n.d.). <https://datacommons.org/ranking/Count~Person/City/country/NLD>

Robine JM, Cheung SL, Le Roy S, Van Oyen H, Griffiths C, Michel JP, Herrmann FR. Death toll exceeded 70,000 in Europe during the summer of 2003. *C R Biol*. 2008 Feb;331(2):171-8. doi: 10.1016/j.crvl.2007.12.001. Epub 2007 Dec 31. PMID: 18241810.

Statistics Netherlands. (2024, December 9). Regional key figures; National Accounts, 1995-2022. <https://www.cbs.nl/en-gb/figures/detail/84432ENG>

STOWA. (n.d.). Effects of climate change on agriculture (Delta fact).

Tno. (2025, November 17). 1 in 12 children growing up in energy poverty: TNO. <https://www.tno.nl/en/newsroom/2025/11/children-energy-poverty/#:~:text=The%20average%20disposable%20income%20in,with%20explicit%20attention%20to%20children.>

United Nations. (n.d.). Communications Materials - United Nations Sustainable Development. United Nations. <https://www.un.org/sustainabledevelopment/news/communications-material/>

United Nations University. (2026, January 21). 5 things to watch in climate and environment in 2026.

Utrecht University. (2022, November 5). How will the Dutch lowlands respond when the sea level rises by two and by five metres?

Watersnoodmuseum. (n.d.). Limburg 2021: Floods now and in the future. <https://watersnoodmuseum.nl/en/stories/limburg-2021-floods-now-and-in-the-future>

World Health Organization. (2025, October 29). Climate inaction is claiming millions of lives every year, warns new Lancet Countdown report [News release]. <https://www.who.int/news/item/29-10-2025-climate-inaction-is-claiming-millions-of-lives-every-year--warns-new-lancet-countdown-report>

Chapter 2: Theoretical Framework

Bennett, N.J., Whitty, T.S., Finkbeiner, E. et al. Environmental Stewardship: A Conceptual Review and Analytical Framework. *Environmental Management* 61, 597–614 (2018). <https://doi-org.tudelft.idm.oclc.org/10.1007/s00267-017-0993-2>

Carley, Sanya, and David M. Konisky. 2020. The justice and equity implications of the clean energy transition. *Nature Energy* 5:569–577. <https://doi.org/10.1038/s41560-020-0641-6>.

Connolly JJT, Svendsen ES, Fisher DR, Campbell LK (2014) Networked governance and the management of ecosystem services: the case of urban environmental stewardship in New York city, *Ecosyst Serv* 10:187–194. <https://doi.org/10.1016/j.ecoser.2014.08.005>

Dale, R. D., Powell, R. B., Stern, M., & Garst, B. (2020). Influence of the natural setting on environmental education outcomes. *Environmental Education Research*, 26(5), 613–631.

Degeling, D., & Koolen, R. (2022). Communicating climate change to a local but diverse audience: On the positive impact of locality framing. *Environmental Communication*, 16(2), 243–261.

Delhey, J., et al., 2018. Social cohesion and its correlates: a comparison of Western and Asian societies. *Comparative sociology*, 17 (3–4), 426–455. doi:10.1163/15691330-12341468.

Devine-Wright, P., and S. Batel. 2017. My neighbourhood, my country or my planet? The influence of multiple place attachments and climate change concern on social acceptance of energy infrastructure. *Global Environmental Change* 47:110–120. <https://doi.org/10.1016/j.gloenvcha.2017.08.003>.

Dragolov, G., et al., 2016. Social cohesion in the Westernworld. Cham: Springer International Publishing. doi:10.1007/978-3-319-32464-7.

Finkbeiner EM, Basurto X (2015) Re-defining co-management to facilitate small-scale fisheries reform: an illustration from northwest Mexico. *Mar Policy* 51:433–441. <https://doi.org/10.1016/j.marpol.2014.10.010>

Huang P, Han M, Zhang X, et al. Characterization and optimization of energy sharing performances in energysaving communities in Sweden, Canada and Germany. *Applied Energy* 2022; 326: 120044.

Hinds, J., & Sparks, P. (2008). Engaging with the natural environment: The role of affective connection and identity. *Journal of Environmental Psychology*, 28(2), 109–120.

Jafari-Marandi R, Hu M, Ömitaomu ÖA. A distributed decision framework for building clusters with different heterogeneity settings. *Applied Energy* 2016; 165: 393–404

8.3

Jan Wiesenthal 2025 IOP Conf. Ser.: Earth Environ. Sci. 1532 012002
Laitinen A, Lindholm Ö, Hasan A, et al. A techno-economic analysis of an optimal self-sufficient district. *Energy Conversion and Management* 2021; 236: 114041.

Jenkins, Kirsten, Darren McCauley, Raphael Heffron, Hannes Stephan, and Robert Rehner. 2016. Energy justice: A conceptual review. *Energy Research & Social Science* 11:174–182. <https://doi.org/10.1016/j.erss.2015.10.004>.

Johns, R., Raines, S., Moore, A. et al. Evaluating an experiential education program for raising awareness and affective engagement with climate resilience in local leaders. *Journal of Outdoor and Environmental Education* (2025). <https://doi-org.tudelft.idm.oclc.org/10.1007/s42322-025-00208-5>

Koltunov M, Pezzutto S, Bisello A, Lettner G, Hiesl A, van Sark W, Louwen A, Wilczynski E (2023) Mapping of Energy communities in Europe: Status Quo and Review of existing classifications. *Sustainability* 15:10–8201. <https://doi.org/10.3390/su15108201>

Kost C, Muller P, Schweiger JS, et al. Stromgestehungskosten Erneuerbare Energien Juli 2024. Fraunhofer ISE.

Laitinen A, Lindholm Ö, Hasan A, et al. A techno-economic analysis of an optimal self-sufficient district. *Energy Conversion and Management* 2021; 236: 114041.

Leemans, R., & Van Vliet, A. (2004). Ecological impacts of climate change in the Netherlands: Observed responses of species and ecosystems to changes in climate and extreme weather events. *Wageningen University & Research / WWF*.

Manzo, Lynne C., and Patrick Devine-Wright. 2020. Place attachment: advances in theory, methods and applications. Routledge.

Petrovich, C., Branchetti, S. & D’Agosta, G. Parametrization of self-consumption and self-sufficiency in Renewable Energy Communities: a case study application. *Energ. Ecol. Environ.* 10, 324–351 (2025). <https://doi-org.tudelft.idm.oclc.org/10.1007/s40974-025-00353-z>

Radtke, Jörg, and Weert Canzler (eds.). 2019. *Energiewende: Eine sozialwissenschaftliche Einführung*. Wiesbaden: Springer VS. <https://doi.org/10.1007/978-3-658-26327-0>.

Radtke, Jörg, and Emily Drawing. 2020. Technokratie oder Gemeinschaftswerk? Expertengremien und Partizipation in der Energiewende. *TATuP – Zeitschrift für Technikfolgenabschätzung in Theorie und Praxis/Journal for Technology Assessment in Theory and Practice* 29:36–42. <https://doi.org/10.14512/tatup.29.3.36>

Radtke, J., Wurster, S. Multilevel governance of energy transitions in Europe: Addressing wicked problems of coordination, justice, and power in energy policy. *Z Politikwiss* 33, 139–155 (2023). <https://doi-org.tudelft.idm.oclc.org/10.1007/s41358-023-00353-7>

Rehman H ur, Reda F, Paiho S, et al. Towards positive energy communities at high latitudes. *Energy Conversion and Management* 2019; 196: 175–195.

Romolini M, Grove JM, Ventriss CL et al. (2016) Toward an Understanding of Citywide Urban Environmental Governance: An Examination of Stewardship Networks in Baltimore and Seattle. *Environ Manag* 58:254–267. <https://doi.org/10.1007/s00267-016-0704-4>

Scannell, L., & Gifford, R. (2013). Personally relevant climate change: The role of place attachment and local versus global message framing in engagement. *Environment and Behavior*, 45(1), 60–85.

Schiefer, D. and Van der Noll, J., 2016. The essentials of socialcohesion: a literature review. *Social indicators research*,132 (2), 579–603. doi:10.1007/s11205-016-1314-5.

Schuster, H., Duden, G. S., van der Noll, J., & Rohmann, A. (2025). Incidental, everyday social and spatial experiences in urban mobility as a driver of local social cohesion: towards social streets. *Cities & Health*, 1–18. <https://doi-org.tudelft.idm.oclc.org/10.1080/23748834.2025.2550872>

Sovacool, Benjamin K., Matthew Burke, Lucy Baker, Chaitanya Kumar Kotikalapudi, and Holle Wlokas. 2017. New frontiers and conceptual frameworks for energy justice. *Energy Policy* 105:677–691. <https://doi.org/10.1016/j.enpol.2017.03.005>

van Veelen, Bregje, and Claire Haggett. 2017. Uncommon ground: the role of different place attachments in explaining community renewable energy projects. *Sociologia Ruralis* 57:533–554. <https://doi.org/10.1111/soru.12128>.

van Veelen, Bregje, and Dan van der Horst. 2018. What is energy democracy? Connecting social science energy research and political theory. *Energy Research & Social Science* 46:19–28. <https://doi.org/10.1016/j.erss.2018.06.010>.

Wurster, Stefan. 2013a. Staatstätigkeit II: neue Formen politischer Steuerung. In *Studienbuch Politikwissenschaft*, ed. Manfred G. Schmidt, Frieder Wolf, and Stefan Wurster, 351–377. Wiesbaden: VS.

Chapter 3: Approach n/a

Chapter 4: Analysis

Beenakker, I. F., Carton, L., van Kranenburg, H. L., & Veenman, S. (2024). Navigating the phase out and phase in of the Dutch energy transition: Focusing events, framing contests, and policy instruments. In H. L. van Kranenburg & S. Witjes (Eds.), *Organizing the Dutch energy transition* (pp. 13–59). Routledge. <https://doi.org/10.4324/9781003360131-3>

Benkort, D., Christiansen, N., Ho-Hagemann, H. T. M., Daewel, U., & Gilles, A. (2024). How do offshore wind farms affect the ocean? *Frontiers for Young Minds*, 12. <https://doi.org/10.3389/frym.2024.1336535>

East Atlantic Flyway. Wadden Sea World Heritage Flyway Initiative. (n.d.). <https://flyway.waddensea-worldheritage.org/east-atlantic-flyway>

Erbach, G., & Dewulf, N. (2024, December). The Netherlands’ climate action strategy. *European Parliamentary Research Service*.

FAO (Ed.). (n.d.). Sustainable bioenergy from agriculture. [fao.org. https://www.fao.org/energy/areas-of-work/sustainable-bioenergy-from-agriculture/en](https://www.fao.org/energy/areas-of-work/sustainable-bioenergy-from-agriculture/en)

Friese Energietafel. (2024). Friese energieviesie. <https://frieseenergietafel.nl/files/energieviesie-nov.24.pdf>

Friese Energietafel. (2024). Friese energieviesie. <https://frieseenergietafel.nl/files/energieviesie-nov.24.pdf>

Friese Energietafel. (n.d.). Uw vragen over het toekomstige Friese energiesysteem beantwoord. Kennisdocument ten behoeve van de Friese Energieviesie. <https://frieseenergietafel.nl/files/fet-kennisdocument-tbv--friese-energieviesie.pdf>

General Administrative Measure : Dutch State Treasury Agency. (2023, September 8). State of the Netherlands Green Bond Framework. Ministry of Finance. <https://www.dsta.nl>.

GroenLeven. (2023, July 7). Zonnepark de Zwette - groenleven.nl. <https://groenleven.nl/projecten/zonnepark-de-zwette/#:~:text=E%C3%A9n%20van%20de%20grootste%20zonnebronnen,de%20aanleg%20van%20het%20zonnepark>.

Havermans,O. (2022). Marker Wadden blijken doorslaand succes als project voor natuurherstel. *Trouw*. <https://www.trouw.nl/duurzaamheid-economie/marker-wadden-blijken-doorslaand-succes-als-project-voor-natuurherstel-bd20657e/?referrer=https%3A%2F%2Fwww.google.com%2F>

Hub, B. I. (2024, 16 mei). “Technically it is feasible: Netherlands climate neutral by 2050”. *VSK*. <https://www.vsk.nl/en/artikelen/technisch-is-het-haalbaar-nederland-klimaatneutraal-in-2050>

International Energy Agency. (2024). The Netherlands. <https://www.iea.org/countries/the-netherlands>

Jafari-Marandi R, Hu M, Ömitaomu ÖA. A distributed decision framework for building clusters with different heterogeneity settings. *Applied Energy* 2016; 165: 393–404

Jonkman, A., Geraerts, M., & Soons, D. (2025, May 9). Grid capacity in the Dutch energy sector. *Taylor Wessing*. <https://www.taylorwessing.com/en/insights-and-events/insights/2025/05/grid-capacity-in-the-dutch-energy-sector>

8.3

Kost C, Muller P, Schweiger JS, et al. Stromgestehungskosten Erneuerbare Energien Juli 2024. Fraunhofer ISE.

Lamboo, S., Taminiau, F. L., Beurskens, L. W. M., & TNO. (2024). Het potentieel van energie uit water in en rondom het Waddengebied. In TNO Publiek (TNO 2023 P11784). TNO. <https://waddenfonds.nl/wp-content/uploads/2024/01/TNO-2023-P11784-Het-potentieel-van-energie-uit-water-in-en-random-het-Waddengebied.pdf>

May, R., Nygård, T., Falkdalen, U., Hamre, Ø., Stokke, B. G., & Rydell, J. (2020). Paint it black: Efficacy of increased wind turbine rotor blade visibility to reduce avian fatalities. *Ecology and Evolution*, 10(14), 6870–6880. <https://doi.org/10.1002/ece3.6424>

Ministerie van Economische Zaken en Klimaat. (2025, December 23). Windenergie op land. Duurzame Energie | Rijksoverheid.nl. <https://www.rijksoverheid.nl/onderwerpen/duurzame-energie/windenergie-op-land>

Ministry of Economic Affairs and Climate Policy. (2024, June). Update of the National Energy and Climate Plan 2021-2030 (Official Journal No. 19410647) Natuurmonumenten. (n.d.). Het project Marker Wadden. Natuurmonumenten. <https://www.natuurmonumenten.nl/projecten/marker-wadden/projectbeschrijving>

Nationaal Programma Regionale Energiestrategie. (n.d.). Dutch National Programme Regional Energy Strategies. <https://www.regionale-energiestrategie.nl/english/default.aspx>

Natuurmonumenten. (n.d.). Het project Marker Wadden. Natuurmonumenten. <https://www.natuurmonumenten.nl/projecten/marker-wadden/projectbeschrijving>

PBL. (2024). Climate and energy outlook 2024 (Publicatienummer 5491). PBL Netherlands Environmental Assessment Agency. <https://www.pbl.nl/kev>

Place rankings - data commons. Home - Data Commons. (n.d.). <https://datacommons.org/ranking/Count-Person/City/country/NLD>

Provincie Friesland. (n.d.). Windpark Fryslân. <https://www.fryslan.frl/windpark-fryslan>

Regiegroep Regionale Energie Strategie RES Fryslân, n.d.

Shutting down offshore wind turbines during Peak bird migration. Noordzeeloket UK. (n.d.). <https://noordzeeloket.nl/en/functions-use/offshore-wind-energy/start-stop/movie-start-stop/shutting-down-offshore-wind-turbines-during-peak/>

Rijkswaterstaat. (2021). Duurzame bescherming en ontwikkeling van dynamische waddenzee natuur Morfologische veranderingen [Brochure].

Rijkswaterstaat. (n.d.). Natuur. <https://noordzeeloket.nl/functies-gebruik/natuur/>

SeaCurrent. (2025, August 4). TidalKite System - SeaCurrent. SeaCurrent.com. <https://www.seacurrent.com/tidalkite-system/>

Silvis, H., & Voskuilen, M. (2020, 12 november). Hoge grondprijs hoeft verduurzaming landbouw niet in de weg te staan. ESB, 105(4791S), 91.

Technology – Symphony Wave Power. (n.d.). symphonywavepower.nl. <https://symphonywavepower.nl/technology/>

TNO (Ed.). (n.d.). Solar energy on buildings. tno.nl. <https://www.tno.nl/en/sustainable/energy-supply/solar-applications/solar-panels-windows-facades-roofs/>

UNESCO. (n.d.) Waddenzee. <https://unesco.nl/werelderfgoed/waddenzee?map-bounds=52.26826029273596%2C1.661336076168305%2C54.39984605616638%2C9.571492326168304>

van Roomen, M., Agblonon, G., Citegetse, G., Crowe, O., Langendoen, T., Nagy, S., Schekkerman, H., & van Winden, E. (2022). Wadden Sea Quality Status Report: East Atlantic Flyway. Common Wadden Sea Secretariat. <https://doi.org/10.5281/zenodo.15221331>

Waddeneilanden en Waddenzee dienen als zodanig te blijven bestaan. (z.d.). <https://www.stedentipsvoortrips.nl/flora/relaties-vier-wadden-functiesbb.htm>

Policy Cards from section 4.2

Aarhus convention: United Nations Economic Commission for Europe. (1998, June 25). Convention on Access to Information, Public Participation in Decision-making and Access to Justice in Environmental Matters.

CE Delft. (2021). Energy poverty in the Dutch heat transition: Policy options

Climate Agreement: Government of the Netherlands / Rijksdienst voor Ondernemend Nederland. (2019). National Climate Agreement – The Netherlands (English translation) (PDF). <https://english.rvo.nl/sites/default/files/2020/07/National%20Climate%20Agreement%20The%20Netherlands%20-%20English.pdf>

Climate Law: Rechtsorde Nederland. (2019). Klimaatwet (BWBR0042394) (versie geldig per 1 januari 2026). <https://wetten.overheid.nl/BWBR0042394/2026-01-01>

Environmental Activities: Ministry of the Interior and Kingdom Relations. (2020, December). The Environmental Activities Decree of the Netherlands (Consolidated version). <https://www.government.nl>

Environment Buildings Decree : Ministry of the Interior and Kingdom Relations. (2020, December). The Environment Buildings Decree of the Netherlands (Consolidated version). <https://www.rijksoverheid.nl>

EU Bird directive: European Commission. (n.d.). Birds Directive. <https://environment.ec.europa.eu/topics/nature-and-biodiversity/birds-directive-en>

EU Directives: Clancy, J., Feenstra, M., & Kreuger, H. (2024, March). Netherlands Case study: Users TCP Gender and Energy Task, Subtask 2. User-Centred Energy Systems Technology Collaboration Programme. <https://doi.org/10.47568/7XR139>

EU Habitat directive: European Commission. (n.d.). Habitats Directive. <https://environment.ec.europa.eu/topics/nature-and-biodiversity/habitats-directive-en>

Environmental Decree: Ministry of the Interior and Kingdom Relations. (2020, December). The Environment Decree of the Netherlands (Consolidated version). <https://www.rijksoverheid.nl>

General Administrative Measure : Dutch State Treasury Agency. (2023, September 8). State of the Netherlands Green Bond Framework. Ministry of Finance. <https://www.dsta.nl>.

Prvince of Frisland Environmental Policy: Province of Fryslân. (2025). Omgevingsverordening Fryslân 2022 (Decentralised regulation CVDR703647). <https://lokaleregelgeving.overheid.nl/CVDR703647>

Terschelling environment policy: Gemeente Terschelling (n.d.). Omgevingsvisie. <https://www.terschelling.nl/omgevingsvisie>

World heritage: United Nations Educational, Scientific and Cultural Organization. (1972). Convention concerning the protection of the world cultural and natural heritage. <https://whc.unesco.org/en/convention/>

Chaper 5: Scenario Exploration n/a

Chapter 6: Vision

Havermans,O. (2022). Marker Wadden blijken doorslaand succes als project voor natuurherstel. Trouw. <https://www.trouw.nl/duurzaamheid-economie/marker-wadden-blijken-doorslaand-succes-als-project-voor-natuurherstel-bd20657e/?referrer=https%3A%2F%2Fwww.google.com%2F>

Hornsea 2 Offshore Wind Farm | ørsted. (n.d.). <https://orsted.co.uk/energy-solutions/offshore-wind/our-wind-farms/hornsea2>

Natuurmonumenten. (n.d.). Het project Marker Wadden. Natuurmonumenten. <https://www.natuurmonumenten.nl/projecten/marker-wadden/projectbeschrijving>

Chapter 7: Design Strategy

American Society for Quality (ASQ) (Ed.). (2024, December). Quality Assurance vs Quality Control: QA vs QC. asq.org. <https://asq.org/quality-resources/quality-assurance-vs-control?srltid=AfmBOooGwiuWNLgnyRD2TeFEsNe9CaUzdRunC36rF~ThTwQbBXvMalP9>

The Association of Netherlands Municipalities, Palstra, R., Steenberg, R., Eijkelhof, M., Hiehle, B.-J., & Van Weede, M. (2015). Local Government in the Netherlands. In VNG & VNG International, Local Government in the Netherlands. VNG. <https://www.vng.nl>

Bil, D.L. (2025). Recognising the Informal. <https://resolver.tudelft.nl/uuid:a59c79e0-63b0-42e2-9e6a-77786958dcda>

De Noordelijke Rekenkamer. (n.d.). Over ons. <https://www.noordeljkerekenkamer.nl/over-ons>

Friese Energietafel. (2024). Friese energievisie. <https://frieseeenergietafel.nl/files/energievisie-nov.24.pdf>

Gemeente Terschelling. (2026, January 26). Algemene informatie Terschelling.

Gemeente Terschelling. (2023). Samen duurzaam UITVOERINGSPROGRAMMA TERSCHELLING DUURZAAM 2023-2026. <https://cuatro.sim-cdn.nl/terschelling/uploads/uitvoeringsprogramma~terschelling~samen~duurzaam~2023-2026.pdf?cb=~Q6-GKq1>

GROW. (2023). Advancing multi-use in offshore wind farms; a roadmap for the Dutch North Sea. In Advancing Multi-use in Offshore Wind Farms. <https://grow-offshorewind.nl/files/downloads/Road2SID2023.pdf>

Holman, Rachel, and Janel Siemplenski Lefort. "How the Energy Crisis Sped up Europe's Green Transition." European Investment Bank, European Investment Bank, 17 June 2025, www.eib.org/en/essays/europe-energy-transition-renewable

Jong, E., Heslinga, S., Dieters, T., & Mos, E. (2021). Regionale democratie vergt energie. In Anneke Beukers, Noordelijke Rekenkamer, & Binnenlands Bestuur, noordeljkerekenkamer.nl. Noordelijke rekenkamer. <https://www.noordeljkerekenkamer.nl/download/20211129-eindrapport-frysla%CC%82n.pdf/59a2f86500f922d58b75212dbfd2946a>

Knol, S., Stellingwerf, E., & Friese Energietafel. (2025). VOORTGANGSRAPPORTAGE RES FRYSLÂN 2025. <https://frieseeenergietafel.nl/files/voortgangsrapportage-res-fryslan-2025-def.pdf>

Ministerie van Binnenlandse Zaken en Koninkrijksrelaties. (2016, 14 juni). Provinces, municipalities and water authorities. Public Administration | Government.nl. <https://www.government.nl/topics/public-administration/provinces-municipalities-and-water-authorities>

Nationaal Consortium Zon in Landschap. (2021). Meetprotocol biodiversiteit zonnevelden [Brochure]. Zon in Landschap

Netherlands Enterprise Agency, Dutch Offshore Wind Guide (2022). <https://www.rvo.nl/sites/default/files/2021/10/Dutch%20Offshore%20Wind%20Guide%202022.pdf>

The North Seas Energy Cooperation. European Commission of Energy, Climate change, Environment. (n.d.). <https://energy.ec.europa.eu/topics/infrastructure/high-level-groups/north-seas-energy-cooperation-en#nsec-objective>

Poepjes, S., Wassink, B., & Regiegroep Regionale Energie Strategie RES Fryslân. (n.d.). Regionale Energie Strategie Fryslân. In RES 1.0 FRYSLÂN. <https://frieseeenergietafel.nl/files/res-1.0-res-fryslan-nl-def-digitaal.pdf>

Provincie Friesland, Wetterskip Fryslân & Royal HaskoningDHV. (2023). Fryslân klimaatbestendig 2050+. Water en bodem sturend in de ruimtelijke inrichting van Fryslân (Versie 5; Referentienummer BI7727-RHD-ZZ-XX-RP-Z-0004)

Rijksoverheid. (n.d.). Provinces, municipalities and water authorities.

Trilateral Wadden Sea Cooperation. (2025). Report on the state of conservation of the World Heritage property "The Wadden Sea (N1314)": Common Wadden Sea Secretariat.

Vattenfall. (n.d.). Research into the effect of black blade in wind turbine. Vattenfall. <https://group.vattenfall.com/press-and-media/newsroom/2022/black-turbine-blades-reduce-bird-collisions/>

Wassink, B., Poepjes, S., & Regiegroep Regionale Energie Strategie RES Fryslân. (2021). REGIONALE ENERGIE STRATEGIE FRYSLÂN. In RES 1.0 FRYSLÂN. <https://frieseeenergietafel.nl/files/res-1.0-res-fryslan-nl-def-digitaal.pdf>

Chapter 8: Conclusion and Reflections

Altaghlibi, M. (2023, November 29). What is hindering the energy transition? ABN AMRO. <https://www.abnamro.com/research/en/our-research/what-is-hindering-the-energy-transition>

Climate Change Performance Index. (2025). Netherlands – Climate performance ranking 2025. <https://ccpi.org/country/nld/>

Mereu, M. (2025, January 22). The Dutch energy transition: New goals, new obstacles to overcome. IO+. <https://ioplus.nl/en/posts/the-dutch-energy-transition-new-goals-new-obstacles-to-overcome>

NedZero. (2025, July 17). The Netherlands is a global leader in energy transition, but implementation is hampered by system boundaries. <https://nedzero.nl/en/news/the-netherlands-is-a-global-leader-in-energy-transition-but-implementation-is-hampered-by-system-boundaries>

Chapter 9: Appendix n/a

9 Appendix

- 9.1 Individual Position Papers
- 9.2 Image Directory
- 9.3 Supporting Imagery



Figure 9.1: Afsluitdijk in Friesland. Frysland Windpark visible in the background.

9.1 Individual Position Papers

Reclaiming the power of energy: support, conditions and critical comments from the Province of Friesland - Maran Bensink

Friesland aims to have fully transitioned to clean energy by 2050, generating as much energy as it consumes ¹. The proposed vision centres on the province's role as a leading region in the production of renewable energy, balancing technology, ecology, and quality of life, while acknowledging the increasingly share of the landscape occupancy. Several important aspects can be summarised in bullet points:

The expansion of energy production must go hand in hand with protecting and improving landscape identity and ecology;

Ecological stewardship together with educational institutions in the landscape should safeguard and showcase Friesland's unique environment;

Energy poverty and grid congestion show the need for reliable, affordable and locally based energy;

A multi-level governance approach in needed in which citizen participation and civil society are essential to resolve the declining trust in policy.

The proposed vision largely alligns with the ambitions of the Province of Friesland, which recognizes the urgency of a just energy transition in the context of climate change. While there is support for the proposed ambition, clear conditions and critical comments are in place. Friesland wants to prevent the occurrence of new spatial, ecological or social risks resulting from the energy-driven vision. This response explains the large share of vision, identify opportunities and suggests refinements to mitigate risks and safeguard the identity of Friesland.

1. The expansion of energy production must go hand in hand with protecting and improving landscape identity and ecology

Energy infrastructure, generation, and storage must be integrated seamlessly into the current energy landscape and the surrounding area (fig. 1). This is a key guiding principle of the energy vision. New interventions should not only protect the landscape but also add value. This presents opportunities for energy hubs, for example, which can revitalize an area and enable mixed-use development where energy is combined with ecology. To provide additional guidance in this regard, various tools have been developed that offer tailored solutions for each landscape type. In this context, the application of the "scale-to-scale" principle - where large-scale generation occurs only in large-scale landscapes - is crucial to safeguarding the landscape's identity ². Regardless of these measures, spatial pressure will be placed on the landscape, ecology, and cultural-historical qualities, making change inevitable. The spatial challenge is greater than what Friesland can handle, which means a trade-off between values maybe unavoidable, and situations will arise in which the "future value" outweighs the "experiential value" ³.

2. Ecological stewardship together with educational institutions in the landscape should safeguard and showcase Friesland's unique environment.

The Province of Friesland supports the integration of educational institutions; a careful and responsible approach to the landscape is essential. Particular emphasis is placed on engaging the

younger generation to involve young people with knowledge and skills in the energy transition. By involving them, the Frisian labor market is prepared for the future, and a connection to the unique living environment is fostered ³.

3. Energy poverty and grid congestion show the need for reliable, affordable and locally based energy

Friesland promotes energy "for and by the community" with the aim of keeping the revenue from energy production within the province and placing control in the hands of citizens. Through so-called "Mienskipenerzjy," energy communities strive for a fair distribution of benefits and burdens. Decentralization and a transition to a more flexible system that accommodates local production and storage are essential to this effort (figure 1) ¹. However, the current knowledge document states that grid congestion will remain a persistent risk until at least 2050. Investments have a long lead time of up to 10 years, which makes a quick solution difficult ¹. Local generation and storage also have a significant impact on the landscape in terms of land use (see 1). The fragmentation of production also poses major challenges for local grids ^{1, 2, 3}.

4. A multi-level governance approach where citizen participation and civil society are essential to resolve the declining trust in policy.

'Mei inoar, mei de mienskip,' a Frisian expression that translates to "Together for the community" - the core motto of RES 1.0, which is based on the premise that support from locals is essential for a

successful energy transition. Friesland leads the way in the number of local energy cooperatives, where volunteers work tirelessly to make their own communities more sustainable, which has led to many innovative projects ². As mentioned in point 3, there is a focus on community energy, which promotes energy generated for and by the community. Special tools have been developed to facilitate meaningful dialogue between residents, government agencies, and other stakeholders regarding the transition. Figure 4 showcases people make use of these tools. Although community participation is viewed as valuable, it also creates tension between coordination and autonomy. Government leadership is essential to ensure an integrated system. Sometimes, undesirable choices must be made on a small scale to achieve a desired outcome on a large scale. Participation is seen as the answer to the transition, but the recognition that managing expectations and making far-reaching spatial decisions is an ongoing challenge for maintaining trust is inevitable ^{1, 2, 3}.

In summary, the Province of Friesland broadly supports the vision which is mainly in line with their own. However, this support is subject to strict conditions and has been met with some critical comments. Clear guide lines based on numbers are necessary to minimize risk on occurrence of new spatial, ecological or social risks. To argue that the energy transition process entails drastic changes to the landscape and difficult choices in spatial planning may seem unnecessary given the complexity of the process, but it remains an important end note.

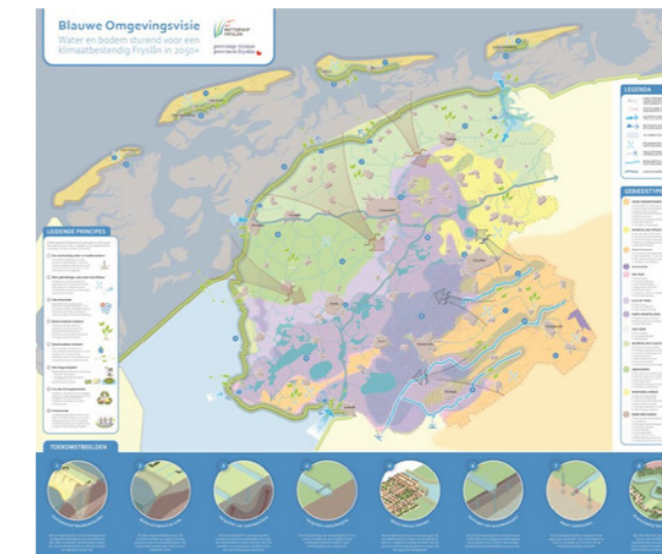

Water and soil management map (Provincie Friesland et al., 2023)



Executive board members with the youth council (Wetterskip Fryslan, n.d.)

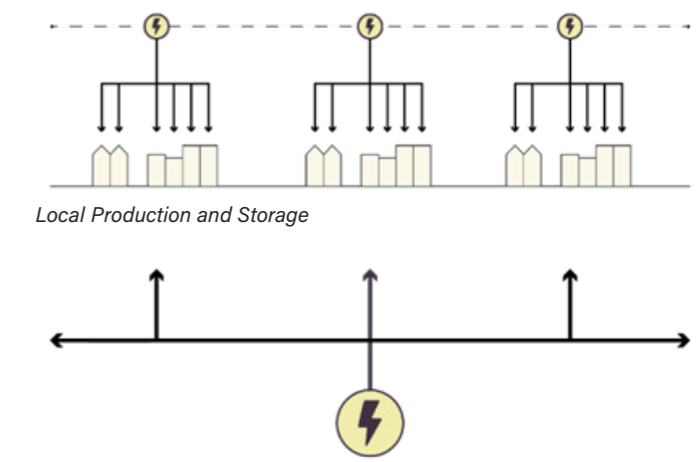

Local Production and Storage

Large Scale Production and Storage

Preferred decentralization of production and storage over large scale (own image)

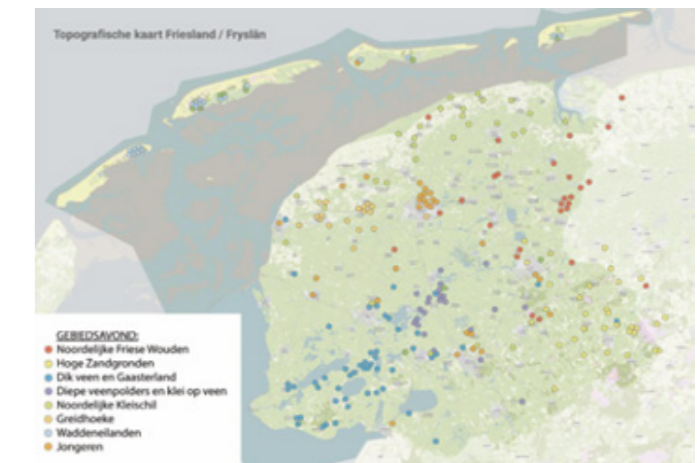

Map showing the attendance and origin of participants at the regional evenings (Provincie Friesland et al., 2023)

Letter from the North Seas Energy Cooperation to the Province of Friesland - Cole von Feldt

To the attention of the Municipal Government of the Province of Friesland,

This letter serves as the North Seas Energy Cooperation's (NSEC) response to the proposed Reclaiming the Power of Energy project from Group 4.2, particularly in its usage of the North Seas for immense renewable energy generation. The NSEC is part of the European Commission and exists as a "regional non-binding cooperation framework, which aims to advance development of offshore renewable energy in the geographical area of the North Seas" (The North Seas Energy Cooperation). The NSEC represents Belgium, Denmark, France, Germany, Ireland, Luxembourg, Netherlands, Norway (non-EU member) and Sweden to create offshore renewable energy across the North Seas. Since Reclaiming the Power of Energy actively pursues renewable energy that aligns with the missions of NSEC, we provide full support of its implementation.

In recent years, there has been a significant increase in offshore wind development in the North Seas region (Support Schemes for Offshore Wind). Continent-wide, Europe's investment in clean energy is ten times that of fossil fuels (Holman, et al, 2025). Particularly, within the Netherlands, there is immense potential for increased offshore renewable energy production (figure 01). According to the 2022 Dutch Offshore Wind Guide, provided by the Dutch Ministry of Foreign Affairs, "offshore wind has a higher capacity and more consistent output than any other variable renewable energy source" (Netherlands Enterprise Agency). Wind energy should therefore be the primary pursuit of NSEC countries as it is the most efficient and will become the future energy source for the continent.

The proposed project's inclusion of 600 km² dedicated offshore wind farm has the potential to deepen the EU's renewable energy capacity and accelerate its timeline. Since a 25-fold increase in offshore wind will be required within Europe to meet Paris Climate Change Agreement goals, the NSEC supports this bold proposal (Netherlands Enterprise Agency). While a wind farm of that size is monumental, it is not unprecedented. The Hornsea 2 Offshore Wind Farm, operational in August 2022, is currently the largest offshore windfarm in the world. Located in the North Sea off the coast of the United Kingdom, it provides energy to 1.4 million British homes each year (Ørsted). The Hornsea 2 therefore provides legitimacy to Reclaiming the Power of Energy's potential in the Dutch North Sea. Such a project would advance not only the interests of the NSEC, but will also benefit and impact Europe at a much broader scale. Reclaiming the Power of Energy also appropriately does not disturb the Wadden Sea ecology with its energy production proposal and therefore spares involvement and potential resistance from the Trilateral Wadden Sea Cooperation.

The Global Wind Energy Council recognizes that while Europe is currently the largest offshore wind market in the world, predictions indicate that the Asia-Pacific region will soon be the world leader (Netherlands Enterprise Agency). The NSEC believes that it is imperative for Europe to retain this standing for geopolitical power and to ensure energy independence from other countries. Remaining the largest offshore wind market will, at a global scale, assure the EU's competitiveness, but also, at a more localized scale, reduce energy prices for its citizens (Trans-European Networks for Energy).

The only reservations of the NSEC, in regard to the idealized outcomes of the project, is that the offshore wind park will not lead to energy independence for Friesland, but will be part of the larger European offshore renewable energy network as a whole. A 2022 report from the North Sea Wind Power Hub (NSWPH) – a consortium co-founded by the European Union – found that one well-planned hub-and-spoke network is the preferred design to achieve continental energy independence (Unlocking the North Sea as a Green Powerplant). Because of this approach, the NSWPH also points out that "no one country...can deliver the comprehensive and integrated solution [the EU] needs" (ibid). A 2030 model connects Germany and Denmark to the Netherlands (figure 02), while Belgium, Norway, and the United Kingdom are incorporated two decades later (figure 03). This scheme strengthens the energy corridors between each country. The NSEC, therefore, is uncertain that the proposed energy autonomy of Friesland will be realistic, since the 600 km² wind park will be part of the larger continental network.

In conclusion, the NSEC supports the proposed Reclaiming the Power of Energy project and looks forward to working with the Province of Friesland and other stakeholders in their offshore renewable energy pursuit. While the work of the NSEC is non-binding and creates no national or international laws, it is still recommended that this letter be considered in full as the NSEC remains the framework for facilitating coordination between member countries and offshore renewable ambitions.

Sincerely,
North Seas Energy Cooperation

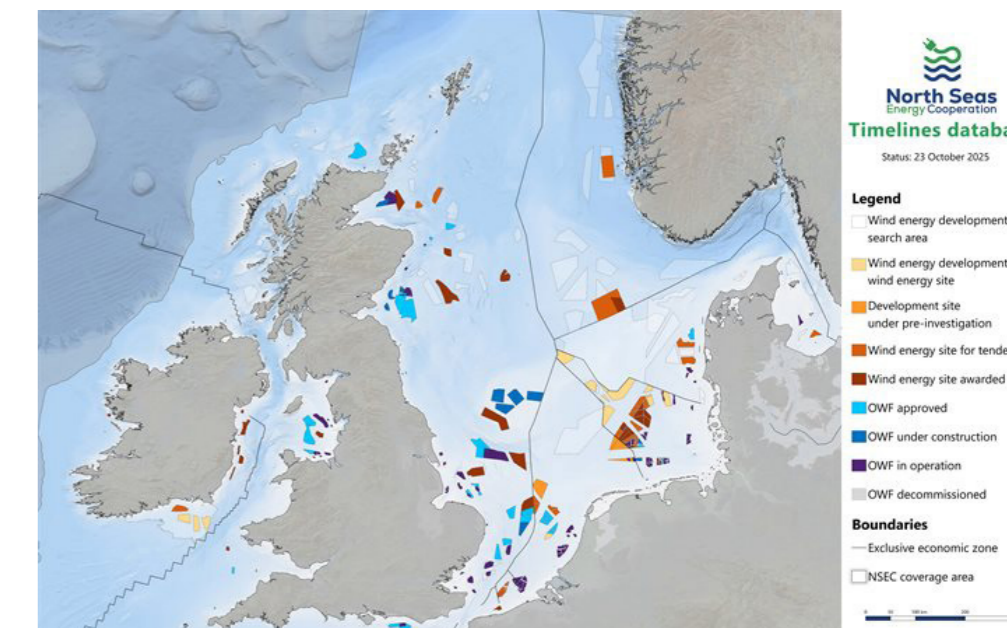

Map of North Sea's existing and planned wind farms, October, 2025. The Netherlands is not taking full advantage of its offshore capacity are compared to other countries (NCES).

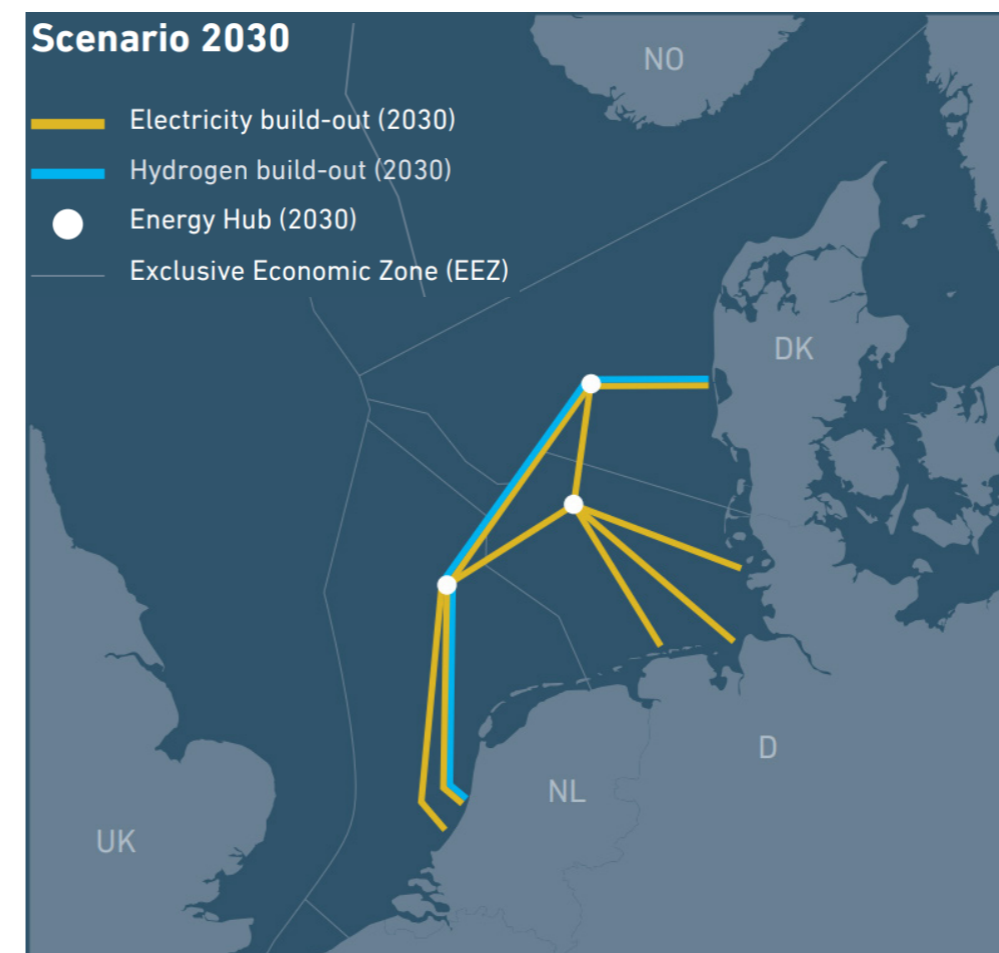

Offshore renewable energy infrastructure could be realized between Denmark, Germany, and the Netherlands by 2030. This puts the Netherlands at the forefront of the continent's offshore renewable efforts. (NSWPH).

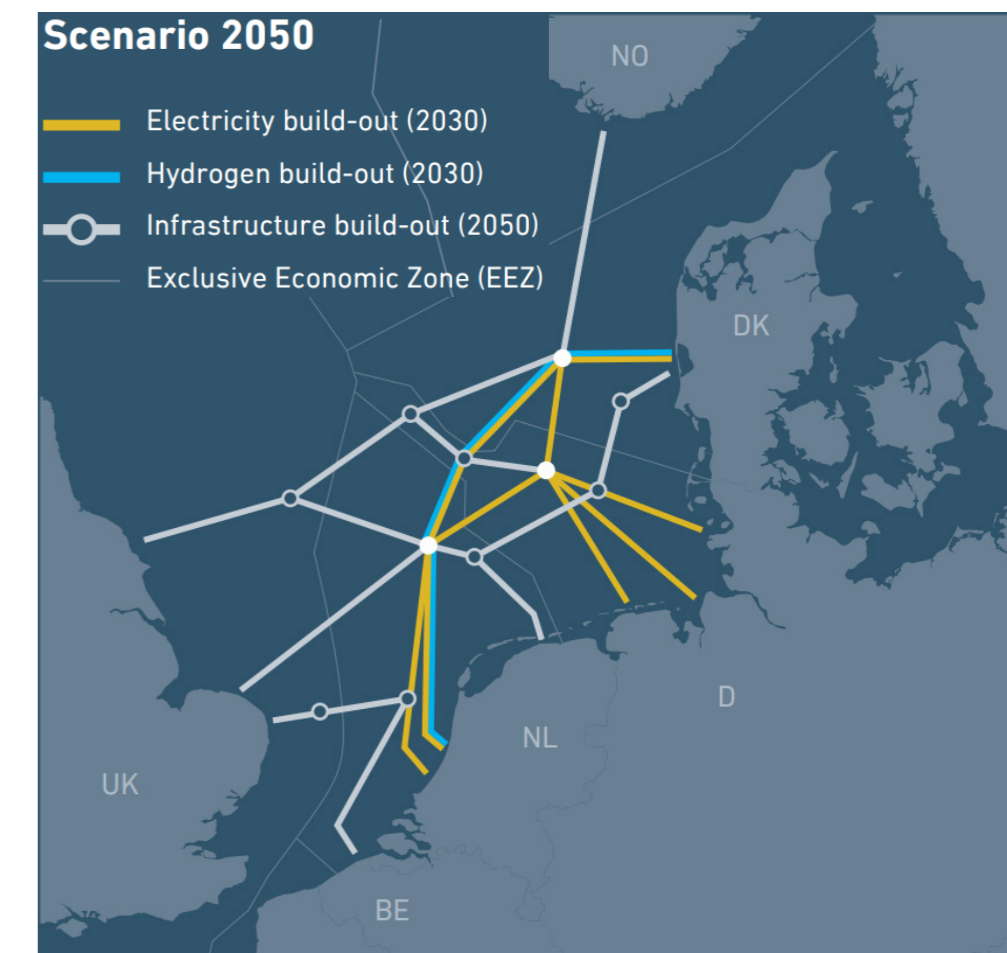

By 2025, three other countries potentially join the offshore renewable energy infrastructure network in the North Seas. This could pose troubles for the proposed energy independence of Friesland (NSWPH).

Municipality of Terschelling Position Paper - Aylin Yavuz

The Municipality of Terschelling recognizes the urgency of the energy transition and supports the goal of creating a more sustainable and climate-resilient future. However, we express serious concerns about the proposed regional vision, particularly regarding its spatial impact, ecological risks, and social consequences for our island. Terschelling is part of the Wadden Sea region, a highly valuable and sensitive natural area. Any large-scale intervention, especially related to energy production or storage, must be carefully considered in relation to these values. Your current vision, which includes offshore energy production, tidal energy systems, and local participation risks putting additional pressure on an already vulnerable environment. Therefore, we would like to highlight several concerns.

One of our primary concerns is the potential impact on ecology. The waters around Terschelling are essential for migratory birds, seals, and fish populations. The introduction of your energy technologies such as tidal kites or increased offshore infrastructure may disrupt these species. While some technologies are presented as low-impact, there is still limited long-term research on their growing ecological effects. Due to the Natura 2000 status, there are major questions regarding the possibility of large-scale renewable generation on the island itself, as the required space often conflict with protected nature reserves (Berenschot et al., 2022). We agree that offshore energy production is needed for a sustainable future, but from our perspective, the precautionary principle should apply: if impacts are uncertain, large-scale implementation should be avoided, which in this case are the tidal kites.

In addition to the ecological concerns, we are also worried about the visual and spatial impact of the proposed interventions. Terschelling is known for its open landscapes, starry sky, and unobstructed horizons. These qualities are not only important for nature but also for tourism, which is a key pillar of our local economy. The introduction of visible energy infrastructure; like offshore wind farms, artificial islands or solar fields, could significantly change the character of the landscape and reduce its attractiveness to visitors. We recommend following the "Solar Ladder" (Wassink et al., 2021), prioritizing rooftop solar first, followed by city locations and multiple land use. Only in the very last step agricultural land or nature spots come into play.

We also question whether the proposed level of community participation is realistic in practice. While the vision emphasizes bottom-up decision-making which we fully support, the scale and technical complexity of offshore energy systems often require top-down planning, national coordination, and large investments from external parties. There is a risk that local communities are involved only in a limited or symbolic way, without having real influence over key decisions. For Terschelling, meaningful participation means having the ability to say no, to set limits, and to protect our local values. The local energy cooperative "Terschelling Energie" is a very important local partner in achieving our sustainability goals (Gemeente Terschelling, 2023). Therefore, the aim is to achieve at least 50% local ownership in projects, so that the benefits of the transition attend to the local community.

Additional preconditions have been included for the generation of solar energy on agricultural land, including a minimum of 60% local ownership (Knol et al., 2025). Please take this into account in your vision.

Furthermore, the idea of using islands or nearby coastal areas as energy storage hubs raises practical and ethical concerns. The existing substations and control stations on the island will likely need to be improved or expanded, otherwise they will become overloaded in 2050 (Berenschot et al., 2022). Terschelling has limited space and infrastructure, and any additional functions would place pressure on land use, logistics, and local systems. It may also conflict with existing functions such as nature conservation, recreation, and housing. We believe that large-scale energy storage is better located outside of our sensitive island environments, for example further offshore or in designated industrial zones on the mainland of Friesland.

Finally, we emphasize the importance of long-term resilience and identity. Terschelling is not only a place for energy production or experimentation, but also a living community with its own culture, history, and relationship to the landscape. Any future development should strengthen, rather than undermine, this identity. A transition that is considered as forced or damaging will not gain our local support and may ultimately fail.

In conclusion, the Municipality of Terschelling supports the transition towards sustainable energy, but we remain concerned about how this vision is applied in our region. The Wadden Sea is a sensitive and valuable environment for our island. We believe that uncertain technologies should be approached with caution and that the unique qualities of the island must be protected. In addition, local participation should be meaningful, with real influence and fair distribution of benefits. Large-scale energy storage and infrastructure should not be placed on the island, but in the more suitable locations we mentioned. Only by respecting nature, landscape, and local communities, we believe this energy transition can become successful.



View on one of the main tidal channel systems in nature reserve Boschplaat on the Wadden isle Terschelling with the Wadden sea in the background (Kisjes, 2020)



Local ownership of a solar field only for households of Terschelling (Terschelling Energie, 2025)

Delegation of UNESCO Position Paper on the “Reclaiming the Power of Energy” Vision - Ruby Kabuiku

Introduction

The vision of ‘Reclaiming the Power of Energy’ aims to make Friesland a beacon of sustainable energy production, benefiting its residents and the broader province, whilst preserving landscape identity, enhancing its ecological uniqueness, and fostering a strong relationship between citizens and government through public participation by the year 2100. This proposal is comprised of three guiding themes: energy production, local engagement and ecological stewardship, which cover three locations: the inter-land, the Wadden Sea, and the North Sea. While the project’s intentions are good, it is important to recognize the significance of UNESCO’s role. The Wadden Sea is a UNESCO World Heritage Site, having been designated as such in 2009 and stretches across the Netherlands, Germany and Denmark. It is the largest unbroken system of intertidal sand and mud flats in the world (UNESCO). Such a location holds significant ecological value and must be managed with the utmost diligence. The structure of this vision aligns with UNESCO’s values by acknowledging the need for sustainable energy without compromising the region’s ecological and social values.

Role of UNESCO in the Wadden Sea

The Wadden Sea is designated as a UNESCO World Heritage site through the Outstanding Universal Value system, where three criteria stood out. Firstly, the region’s geomorphology comprises one of the world’s largest and most intact tidal-flat and barrier-island systems, shaped by uninterrupted natural processes amid rising sea levels, creating a highly dynamic and diverse coastal landscape. Secondly, ecological processes and productivity. It represents a rare, large-scale

intertidal ecosystem where natural dynamics remain largely undisturbed, supporting extremely high biological productivity and a rich network of transitional habitats between land, sea, and freshwater. Lastly, in terms of biodiversity and migratory importance, it sustains thousands of species. It serves as a critical hub for migratory birds, with millions relying on it annually for feeding, breeding, and resting.

As a specialised agency of the United Nations, UNESCO is well aware of the importance of climate change mitigation and adaptation. The organisation aims to advance peace and security through international cooperation in education, arts, sciences, and culture (United Nations). In the context of the Wadden Sea, the goal is no different. Given the current state of climate change, if the status quo continues, sea-level rise may seriously impact the structure, functions, and characteristic biodiversity of the Wadden Sea ecosystem. Within this region, these objectives translate into the ambition to achieve carbon neutrality, a goal already articulated in the Sylt Declaration (2010).

Vision Alignment

The ‘Reclaiming the Power of Energy’ vision covers three main principles which align with UNESCO’s goals. The vision recognizes that contemporary societies globally are facing an increasing frequency of extreme weather events, widely attributed to the intensifying effects of climate change, and Friesland is no exception. The scope of these challenges oscillates between immediate local impacts and systemic global implications, which include a multi-level approach to address them. The vision recognizes that a strong relationship between residents and the

municipal government enables comprehensive decision-making. Uplifting the public voice through engagement in governmental discussions, empowering civil society organizations to have a seat at the table. While the vision lacks a multi-national government approach, it recognizes the importance of dialogue among different stakeholders and governmental authorities. Furthermore, the strategy highlights the importance of harnessing the area’s distinctive resource density to maximize output within stringent ecological thresholds. It seeks to preserve and elevate the region’s landscape identity and protect its ecological importance through implementing various nature-based solutions. There is also a focus on establishing spaces where both locals and visitors can be immersed in and educated about the region’s unique environmental network, aligning with UNESCO’s values.

Conditions for full support

While UNESCO advocates for the protection and enhancement of the unique ecological system of the Wadden Sea, it also recognizes the urgency of reducing greenhouse gas emissions and transitioning toward more sustainable modes of living. In practice, this is reflected in national and regional policies that prioritize CO2 reduction by transitioning to renewable energy systems. UNESCO aims to strengthen support for initiatives that reduce carbon dioxide emissions, especially decarbonization of the energy sector (SIMP, p. 25). The organization agrees with the need for a sustainable energy transition; however, it emphasizes that this transition must be ecologically sound, with the safeguarding of natural processes in the Wadden Sea as a paramount priority. Implementation of

nature-based solutions to mitigate climate change, as well as preservation of the migratory processes. UNESCO also emphasizes the need for a trilateral dialogue between Denmark, Germany and the Netherlands and extending beyond national governments to include energy companies and other stakeholders with economic, spatial, and social impacts.

The organization is cautious that the application of new forms of energy production poses risks to the world heritage site. For example, the impairment of existing and future habitats, the disruption of natural processes such as bird and marine fauna migration, and unknown risks. The organisation is aware of and wary of the threats that the energy transition can pose to the Wadden Sea’s ecosystem and its Outstanding Universal Value. There is a call for nature-based solutions in the Wadden Sea, such as restoring salt marshes and seagrass. These habitats have been identified as critical for “Blue Carbon” sequestration, serving as natural carbon sinks (State of Conservation Report “The Wadden Sea (N1314)” 2025, p. 29). Additionally, TNO suggests Artificial Habitat Creation, in which energy infrastructure, including concrete anchors and hard foundations for “Energy from Water” (EuW) systems, can serve as temporary hard substrates on which marine ecosystems (such as shellfish and fish) can flourish, potentially enhancing local biodiversity during the project’s life. Similarly, UNESCO advocates for the systematic use of the “Guidance and Toolkit for Impact Assessments in a World Heritage Context”. For example, the Dutch PAWOZ-Eemshaven Programme, which involves traversing the World Heritage Site with electricity cables and hydrogen pipelines, is undergoing a Heritage

Impact Assessment to ensure these routes have the “least amount of impact possible” on the OUV.

Critical reflection

While UNESCO’s and the ‘Reclaiming the Power of Energy’ vision align, it is critical to note the potential risks in this project, starting with local engagement. UNESCO believes in direct dialogue, especially in the international area where the Wadden Sea exists. However, it is important to note that strengthening the relationship between such entities is difficult and takes time. The impacts of climate change are intensifying, and amid an increasingly volatile global geopolitical landscape, it is essential to maintain a clear focus on long-term objectives. Decisions in this domain must be approached with urgency, while remaining careful, comprehensive, and well-informed. While it is important to keep citizens educated and involved, participatory processes must be managed efficiently to avoid unnecessary delays.

Conclusion

In conclusion, the ‘Reclaiming the Power of Energy’ vision demonstrates a strong conceptual alignment with the principles of UNESCO, particularly in its commitment to integrating sustainable energy production with ecological stewardship and public engagement. Its recognition of the Wadden Sea’s value and the need to preserve its ecological integrity reflects an understanding of the site’s Outstanding Universal Value.

However, alignment in principle must be matched by precision in implementation. Ensuring that energy transition strategies remain within ecological limits, respect existing trilateral agreements, and incorporate effective

cross-border governance will be essential. Strengthening coordination between Denmark, Germany, and the Netherlands, alongside meaningful yet efficient stakeholder engagement, will determine the viability of this vision.

Ultimately, from a UNESCO perspective, the success of this strategy will depend on its ability to deliver a genuinely balanced transition—one that advances climate objectives while safeguarding the natural processes, biodiversity, and cultural significance of the Wadden Sea for future generations.



Bird Migration (UNESCO)



Wadden Sen (author)

9.2 Image Directory

Front page image

Terschelling picture: Authors' photo

Ameland picture: Natuur op Ameland | Mooi Ameland. (2022). <https://www.ameland-info.eu/natuur.php>

Schiermonnikoog picture: Nationaal Park Schiermonnikoog. (n.d.). Natuurmonumenten. <https://www.natuurmonumenten.nl/natuurgebieden/nationaal-park-schiermonnikoog/route/wandelroute-nationaal-park-schiermonnikoog-duin>

Friesland mainland picture: Vlieland picture: Plant mee in Friesland | Trees for All. (2024, October 1). Trees for All. <https://treesforall.nl/projecten/friesland/>

Icons and pictures: Adobe Stock

Figure 0.1: Authors photo

Chapter 1: Introduction

Figure 1.1: Authors' photo

Figure 1.2: Watersnoodmuseum. (n.d.). Limburg 2021 floods: Now and in the future. Retrieved April 8, 2026, from <https://watersnoodmuseum.nl/en/stories/limburg-2021-floods-now-and-in-the-future>

Figure 1.3: Amin, L. (2015, October 10). Shell and Exxon's €5bn problem: Gas drilling that sets off earthquakes and wrecks homes. The Guardian. <https://www.theguardian.com/environment/2015/oct/10/shell-exxon-gas-drilling-sets-off-earthquakes-wrecks-homes>

Figure 1.4: Plantlife. (n.d.). Snowdrop (*Galanthus nivalis*). Retrieved April 8, 2026, from <https://www.plantlife.org.uk/plants-and-fungi/snowdrop/>

Figure 1.5: International Energy Agency. (n.d.). The Netherlands. <https://www.iea.org/countries/the-netherlands>

Figure 1.6: International Energy Agency. (n.d.). The Netherlands. <https://www.iea.org/countries/the-netherlands>

Figure 1.7: Authors' drawing

Figure 1.8: Authors' drawing

Figure 1.9: Authors' drawing

Figures 1.10 – 1.16: Authors' photos

Figure 1.17: De Vries, P. A. (2026, February 19). Friese burger wordt te weinig betrokken bij overgang naar duurzame energie. Friesch Dagblad. <https://frieschdagblad.nl/samenleving/friese-burger-wordt-te-weinig-betrokken-bij-overgang-naar-duurzame-energie-48535698.html>

Figure 1.18: NL TIMES (Ed.). (2025, September 3). Energy gap widening: Households outside Randstad spend much more on energy bills. NL Times. <https://nltimes.nl/2025/09/03/energy-gap-widening-households-outside-randstad-spend-much-energy-bills#:~:text=Share%20this:-,Energy%20gap%20widening:%20Households%20outside%20Randstad%20spend%20much%20more%20on,contrast%20is%20even%20more%20extreme.>

Figure 1.19: Chandrasekhar, A. C., Tandon, A. T., Dunne, D. D., Gabbatiss, J. G., Dwyer, O. D., & Lempriere, M. L. (2026, March 13). Q&A: What does the Iran war mean for the energy transition and climate action? Carbon Brief. <https://www.carbonbrief.org/qa-what-does-the-iran-war-mean-for-the-energy-transition-and-climate-action/>

Figure 1.20: Koster, R. (2026, January 15). Tekort aan duurzame energie kan Nederland miljarden euro's kosten. NOS. <https://nos.nl/collectie/13871/artikel/2598230-tekort-aan-duurzame-energie-kan-nederland-miljarden-euro-s-kosten>

Figure 1.21: Authors' drawing, icons from <https://thenounproject.com/> (data sources needed?)

Figure 1.22: Authors' drawing, icons from <https://thenounproject.com/> (data sources needed?)

Figures 1.23 – 1.30: United Nations Sustainable Development Goals Squares (need proper citation)

Chapter 2

Figure 2.1: Authors' photo

Chapter 3

Figure 3.1: Authors' photo

Figure 3.2: Adobe Stock, Google. (n.d.). Google Earth. <https://earth.google.com>

Figure 3.3: Authors' drawing

Figure 3.4: Authors' drawing

Chapter 4

Figure 4.1: Authors' photo

Figure 4.2: Authors' drawing, data sources:

Friese Energietafel. (2024). Friese energievise. <https://frieseeenergietafel.nl/files/energievisie-nov.24.pdf>

Figure 4.3: Authors' drawing, data sources:

Hub, B. I. (2024, 16 mei). "Technically it is feasible: Netherlands climate neutral by 2050". VSK. <https://www.vsk.nl/en/artikelen/technisch-is-het-haalbaar-nederland-klimaatneutraal-in-2050>

Figure 4.4: Authors' drawing, data sources:

Friese Energietafel. (2024). Friese energievise. <https://frieseeenergietafel.nl/files/energievisie-nov.24.pdf>

Friese Energietafel. (n.d.). Uw vragen over het toekomstige Friese energiesysteem beantwoord. Kennisdocument ten behoeve van de Friese Energievise. <https://frieseeenergietafel.nl/files/fet-kennisdocument-tbv--friese-energievisie.pdf>

Figure 4.5: Authors' drawing, data sources:

Vittek, M. & Krijgsveld, K. (2025). Solar parks in the Netherlands. Zenodo. <https://zenodo.org/records/17349176>

TU Delft. (n.d.). OSM power points.

TU Delft. (n.d.). OSM power lines

Figure 4.6: Authors' drawing, data sources:

Top10NL. (n.d.). hoogte-lijn.

PDOK. (n.d.). Gebiedne gesloten voor visserij. <https://app.pdok.nl/>

PDOK. (n.d.). Vaarwegvakken. <https://app.pdok.nl/>

Figure 4.7: Authors' drawing (data resources: PDOK and Mijs.net)

Figure 4.8: Authors' drawing, data sources:

PDOK. (n.d.). Nationaal beschermd gebieden.

PDOK. (n.d.) Natura 2000.

Rijkswaterstaat. (n.d.). Natuurgebieden op de Noordzee – Kaart 2 Programma Noordzee 2022 – 2027. Rijkswaterstaat. <https://noordzeeloket.nl/functies-gebruik/natuur/>

Figure 4.9: Authors' drawing data sources: (East Atlantic Flyway | Flyways Initiative, n.d.)

Figure 4.10: Authors' drawing data sources: (East Atlantic Flyway | Flyways Initiative, n.d.)

Figure 4.11: Authors' drawing

Figure 4.12: Authors' drawing, data sources:

Baptist, M., van der Wal, J.T., Folmer, E., Gräwe, U. & Elschoot, K. (2021). An Ecotope map of the trilateral Wadden Sea. <https://data.mendeley.com/datasets/2rvtxpjtfjg/2>

Figure 4.13: Authors' drawing, icons from Adobe Stock

Figure 4.14: Authors' drawing, icons from <https://thenounproject.com/>

Figure 4.15: Authors' drawing, icons from <https://thenounproject.com/>

Figure 4.16: Authors' drawing, icons from Adobe Stock

Figure 4.17: Authors' drawing, data sources see figures 4.5, 4.6, 4.7, 4.8, 4.11 & 4.12

Chapter 5

Figure 5.1: Authors' photo

Figure 5.2: Authors' drawing, icon from <https://thenounproject.com/>

Figure 5.3: Authors' photo

Figure 5.4: Authors' photo

Figure 5.5: Authors' photo

Figure 5.6: Authors' drawing, icon from <https://thenounproject.com/>

Figure 5.7: Authors' drawing, icon from <https://thenounproject.com/>

Figure 5.8: Authors' drawing, icon from <https://thenounproject.com/>

Figure 5.9: Authors' drawing, icon from Adobe Stock

Figure 5.10: Authors' drawing, icon from <https://thenounproject.com/> pictures from Adobe Stock

Figure 5.11: Authors' drawing, icon from <https://thenounproject.com/>

Figure 5.12: Authors' drawing, icon from Adobe Stock

Figure 5.13: Authors' drawing, icon from <https://thenounproject.com/> pictures from Adobe Stock

Figure 5.14: Authors' drawing, icon from <https://thenounproject.com/>

Figure 5.15: Authors' drawing, icon from Adobe Stock

Figure 5.16: Authors' drawing, icon from <https://thenounproject.com/> pictures from Adobe Stock

Figure 5.17: Authors' drawing, icon from <https://thenounproject.com/>

Chapter 6

Figure 6.1: Authors' photo

Figure 6.2: Authors' drawing, data sources see figure 4.6 & 4.8

Figure 6.3: Authors' drawing, data sources see figure water

Figure 6.4: Authors' drawing, data sources see figure water &

Lamboos, S., Taminiau, F. L., Beurskens, L. W. M., & TNO. (2024). Het potentieel van energie uit water in en rondom het Waddengebied. In TNO Publiek (TNO 2023 P11784). TNO. <https://waddenfonds.nl/wp-content/uploads/2024/01/TNO-2023-P11784-Het-potentieel-van-energie-uit-water-in-en-rondom-het-Waddengebied.pdf>

Figure 6.5: Authors' drawing, data sources see figure water and PDOK

Figures 6.6 – 6.9: Authors' drawing (Adobe Stock source)

Figure 6.10: Authors' drawing, icon from Adobe Stock

Figure 6.11: Authors' drawing, icon from Adobe Stock

Chapter 7

Figure 7.1: Authors' photo

Figure 7.2: Author's drawing

Figure 7.3: Authors' drawing

Figure 7.4: Adobe Stock

Figure 7.5: Authors' drawing

Figure 7.6: Adobe Stock

Figure 7.7: Authors' drawing

Figure 7.8: Adobe Stock

Figure 7.9: Authors' drawing

Figure 7.10: Adobe Stock

Figure 7.11: Authors' drawing (image: Adobe Stock source)

Figure 7.12: Authors' drawing

Figure 7.13: Authors' drawing

Figure 7.14: Authors' drawing, icons from <https://thenounproject.com/>

Figure 7.15: Authors' drawing (Adobe Stock source)

Figure 7.15.1: Authors' drawing (Adobe Stock source)

Figure 7.16: Authors' drawing

Figure 7.17: Authors' drawing

Figures 7.18 – 7.21: Authors' drawing, icons from <https://thenounproject.com/>

Figure 7.22: Authors' drawing

Figure 7.23: Authors' drawing, icon from <https://thenounproject.com/>

Figure 7.24: Authors' drawing

Figure 7.25: Authors' drawing, data sources:

Dallas, D. (n.d.). [Photograph]. <https://nl.pinterest.com/pin/773634042282994543/>

Foca 2 [Photograph]. (n.d.). <https://nl.pinterest.com/pin/773634042283030708/>

The Standard. (n.d.). 'Super battery' schemes will store green power and... [Photograph]. <https://nl.pinterest.com/pin/773634042282994731/>

Leechan3240286. (n.d.). [Photograph]. <https://nl.pinterest.com/pin/773634042283030694/>

Mercado Livre. (n.d.). Planta Artificial P/ Aquários Decorativas C/ 40 Cm (altura) [Photograph]. <https://nl.pinterest.com/pin/773634042283028985/>

3D render.co.uk, "PLANT178~DIFFUSE" [Photograph]. (n.d.) <https://nl.pinterest.com/pin/773634042283028983/>

Panthera PL. (n.d.). Download premium png of PNG Backgrounds fish repetition about school of fish, school of fish png, tuna fish, real fish, and flock fish 12641319 [Photograph]. <https://nl.pinterest.com/pin/106397609940755221/>

βhæ~mā, Æ. (n.d.). [Photograph]. <https://nl.pinterest.com/pin/773634042282958940/>

Watkinds, L. (n.d.). [Photograph]. <https://nl.pinterest.com/pin/773634042283028871/>

Wind watch. (2013). National Wind Watch Picture Gallery [Photograph]. <https://www.wind-watch.org/pix/displayimage.php?pid=673>

[Photograph plants with rocks]. (n.d.). <https://nl.pinterest.com/pin/773634042283028980/>

Figure 7.26: Authors' drawing, icon from <https://thenounproject.com/>

Figure 7.27: Authors' drawing

Figure 7.28: Authors' drawing, data sources:

Camacho, C. (n.d.). [Photograph]. <https://nl.pinterest.com/pin/773634042282956525/>

Henri, J. (n.d.). [Photograph]. <https://nl.pinterest.com/pin/773634042282958948/>

Ktvstory. (n.d.). 3D Models | Over A Million Models For Download | TurboSquid [Photograph]. <https://nl.pinterest.com/pin/773634042282973099/>

Oradea, A. (n.d.). [Photograph]. <https://nl.pinterest.com/pin/773634042280772801/>

Panthera PL. (n.d.). Download premium png of PNG Backgrounds fish repetition about school of fish, school of fish png, tuna fish, real fish, and flock fish 12641319 [Photograph]. <https://nl.pinterest.com/pin/106397609940755221/>

Van der ploeg, M. (n.d.). [Photograph]. <https://nl.pinterest.com/pin/773634042282956500/>

Von Feldt, C. (2026). Afsluitdijk [Photograph].

βhæ~mā, Æ. (n.d.). [Photograph]. <https://nl.pinterest.com/pin/773634042282958940/>

Symphony Wave Power. (n.d.). Ocean eneergy mad simple [Photograph]. <https://symphonywavepower.nl/>

Figure 7.29: Authors' drawing

Figure 7.30: Authors' drawing, data sources:

Bensink, M. (2026). Terschelling [Photograph].

Camacho, C. (n.d.). [Photograph]. <https://nl.pinterest.com/pin/773634042282956525/>

Dallas, D. (n.d.). [Photograph]. <https://nl.pinterest.com/pin/773634042282994543/>

Panthera PL. (n.d.). Download premium png of PNG Backgrounds fish repetition about school of fish, school of fish png, tuna fish, real fish, and flock fish 12641319 [Photograph]. <https://nl.pinterest.com/pin/106397609940755221/>

Posyroids. (n.d.). Beach picture @posyroids on insta [Photograph]. <https://nl.pinterest.com/pin/773634042283031672/>

Von Feldt, C. (2026). Afsluitdijk [Photograph].

βhæ~mā, Æ. (n.d.). [Photograph]. <https://nl.pinterest.com/pin/773634042282958940/>

Symphony Wave Power. (n.d.). Ocean eneergy mad simple [Photograph]. <https://symphonywavepower.nl/>

Wind watch. (2013). National Wind Watch Picture Gallery [Photograph]. <https://www.wind-watch.org/pix/displayimage.php?pid=673>

Figure 7.31: Authors' drawing, icon from <https://thenounproject.com/>

Figure 7.32: Authors' drawing

Figure 7.33: Authors' drawing, data sources:

Bureau Toerisme Laag Holland. (n.d.). [Photograph]. <https://nl.pinterest.com/pin/773634042283044605/>

Catarina, A. (n.d.). Deco Alerta: Quero ter painéis fotovoltaicos na minha casa nova. O que tenho de fazer? [Photograph]. <https://nl.pinterest.com/pin/773634042283061779/>

Flevoland, Netherlands [Photograph]. (n.d.). <https://nl.pinterest.com/pin/773634042283060720/>

Oradea, A. (n.d.). [Photograph]. <https://nl.pinterest.com/pin/773634042280772801/>

Patel, J. (n.d.) [Photograph]. <https://nl.pinterest.com/pin/9922061674442407/>

Steintjes, B. (n.d.). [Photograph]. <https://nl.pinterest.com/pin/773634042283061129/>

Von Feldt, C. (2026). Leeuwarden [Photograph].

Wikipedia-bijdragers. (2025, 5 november). Oldehove (gebouw). Wikipedia. [https://nl.wikipedia.org/wiki/Oldehove~\(gebouw\)](https://nl.wikipedia.org/wiki/Oldehove~(gebouw))

Wind watch. (2013). National Wind Watch Picture Gallery [Photograph]. <https://www.wind-watch.org/pix/displayimage.php?pid=673>

Figure 7.34: Author's drawing, data sources see figures 7.25, 7.28, 7.30, 7.33 &

Ulla T. (n.d.). [Photograph]. <https://nl.pinterest.com/pin/773634042283078442/>

Chapter 8

Figure 8.1: Authors' photo

Chapter 9:

Figure 9.1: Authors' photo

9.3 Supporting Imagery

Table 1 Categories of assets that provide capacity to enable local environmental stewardship

Stewardship assets	Description
Social capital	The informal and formal relationships, including friendship, kinship and occupational networks, which facilitate trust and reciprocity to support stewardship
Cultural capital	The presence of and processes to maintain connections to place, traditions, knowledge, practices and artefacts that are central to a group's identity and that support stewardship
Financial capital	The financial resources (e.g., income, credit, debt, wealth, and poverty) that are available to individuals or collectives (groups or communities) and provide the ability and means to take stewardship actions
Physical capital	The technologies (both traditional and modern) and other infrastructure that enables individuals and groups to steward living and physical resources
Human capital	The individual and group attributes, such as education, knowledge, leadership, past experiences, awareness, skills, and demographic factors (e.g., age and health of population) that enable stewardship
Institutional capital	The empowerment, agency, and options available to local communities to steward resources that results from broader governance, including systems of institutions (i.e., laws and policies, formal and informal organizations and decision-making processes) and structural processes related to power and politics (i.e., economic inequality, discrimination, levels of exclusion)

Figure 9.1: 'Categories of assets that provide capacity to enable local environmental stewardship' table from Bennett et al. 2017. Table is used to assess the six actors at play.

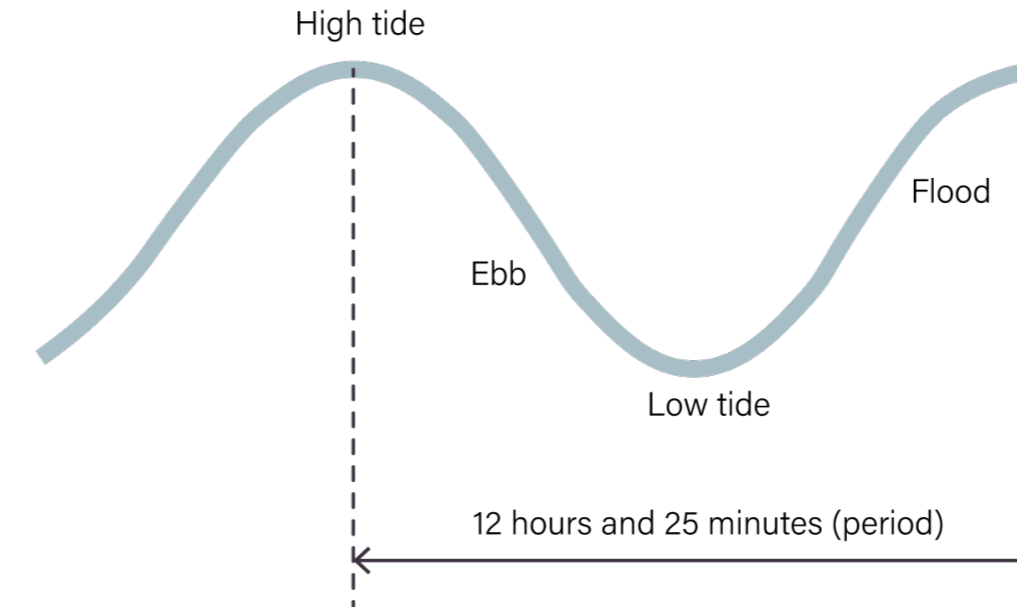

Figure 9.2: Ebb and flow of tides in the North Sea

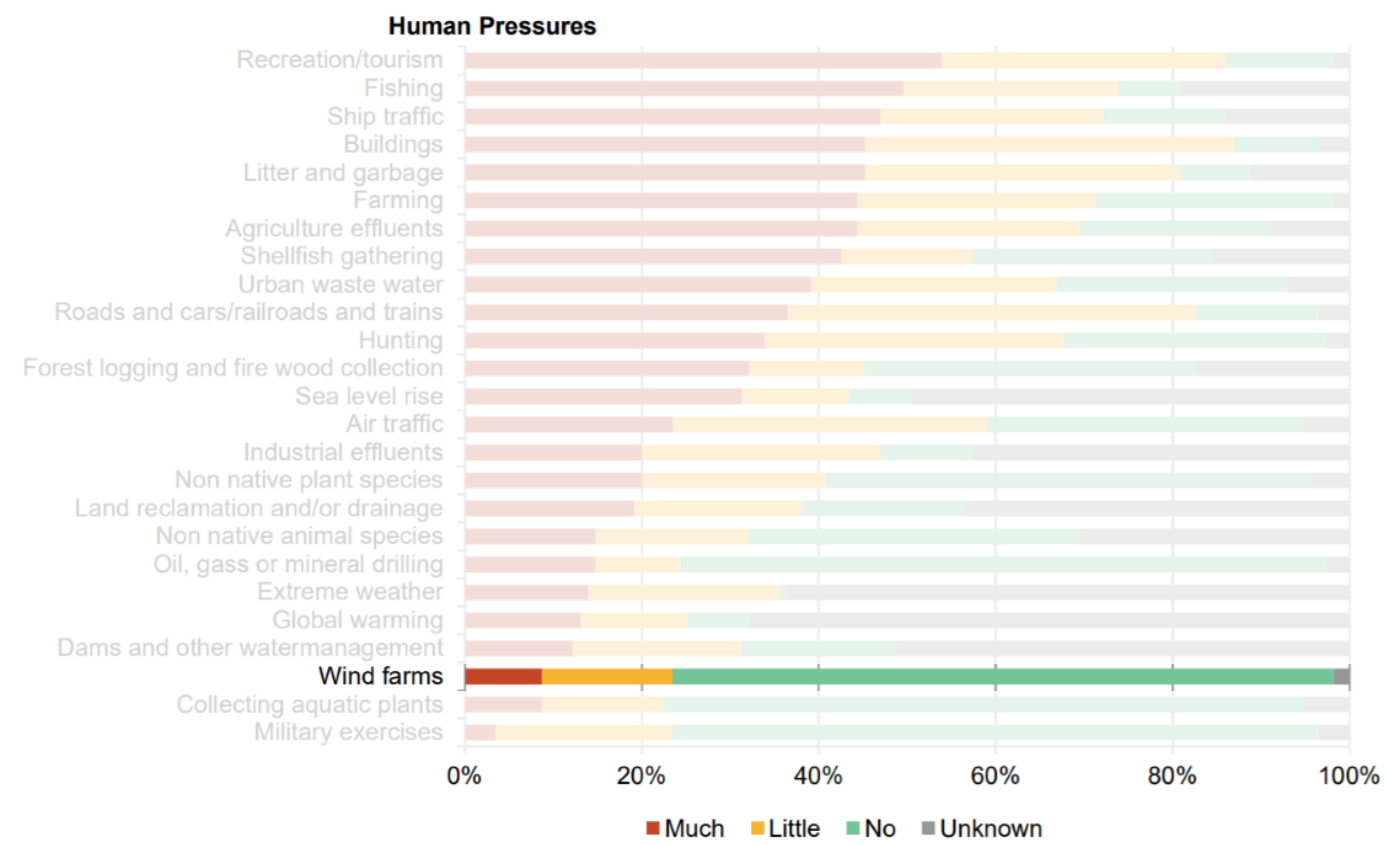

Figure 9.3: "Frequency distribution (%) of pressures indicated at 115 sites along the East Atlantic Flyway. Pressures are scored separately for timing, scope and severity, after which summed scores are summarized into four categories (high prevalence, low prevalence, absent or prevalence unknown)". (Wadden Sea Quality Status Report, n.d.)

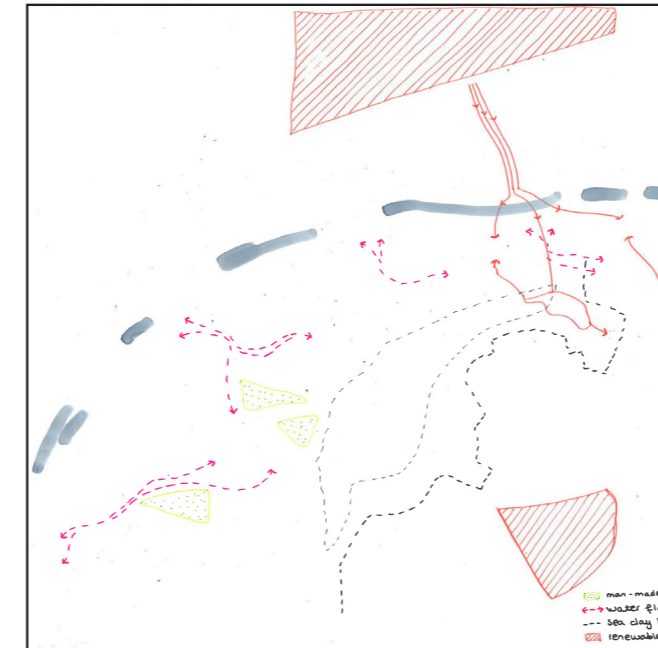

Figure 9.3: Bensink Individual Map

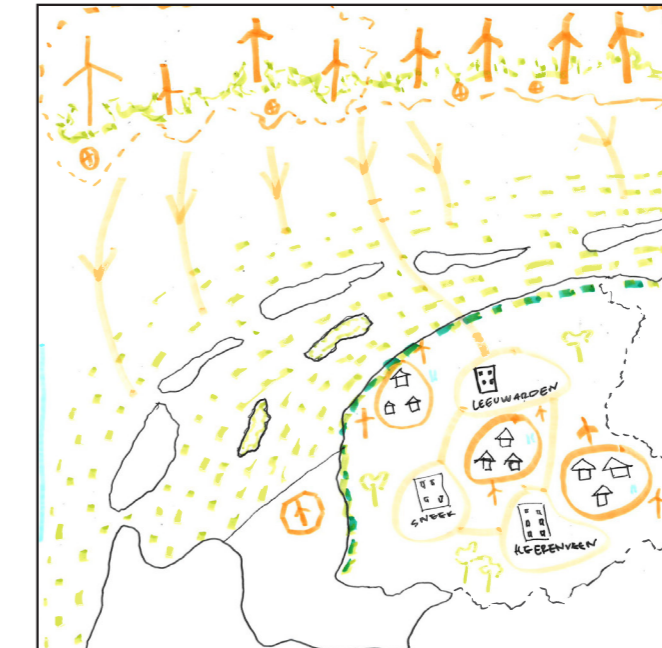

Figure 9.4: Kabuiku Individual Map

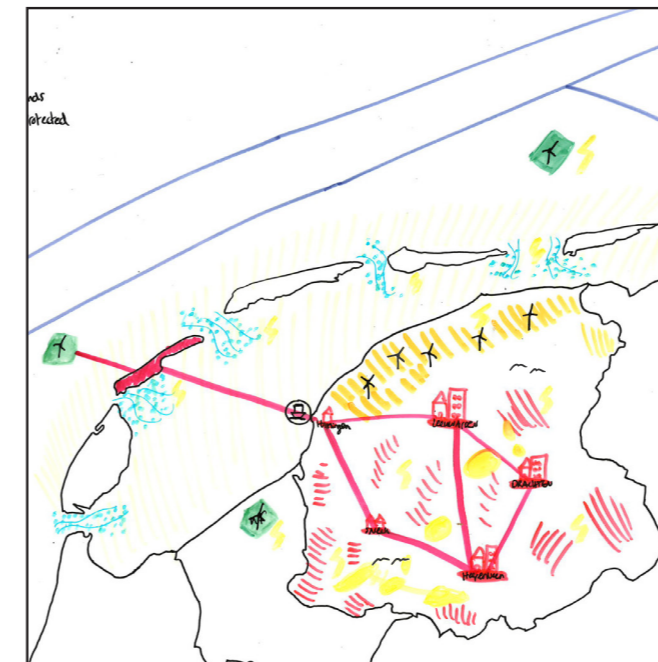

Figure 9.5: Yauz Individual Map

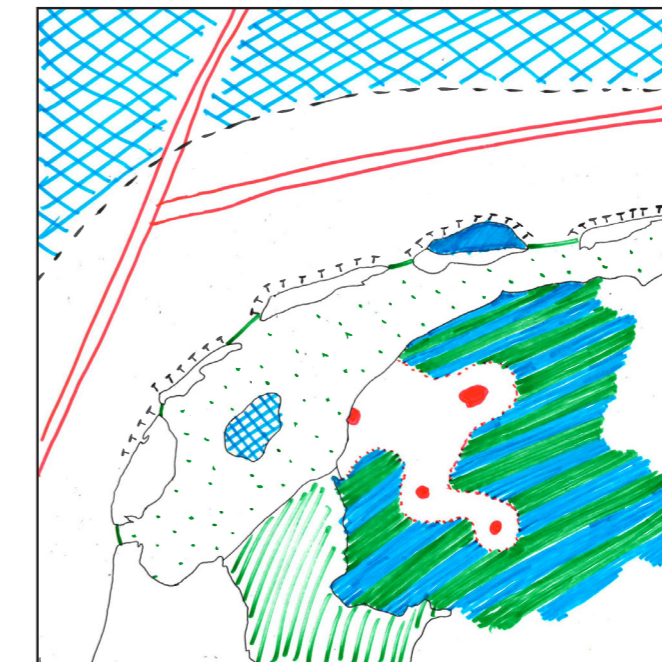

Figure 9.6: von Feldt Individual Map

HORNSEA 2 (ENGLAND)
 460 square kilometers
 165 turbines
 700 meter clearance radius
 8 mega watts/turbine
= 1.32 gigawatt capacity

PROPOSED DUTCH NORTH SEA WIND PARK
 600 square kilometers
 380 turbines
 700 meter clearance radius
 8 megawatts/turbine
= 3.04 gigawatt capacity

Figure 9.7: Proposed wind park mathematics compared to the precedent project of Hornsea 2 in the English North Sea

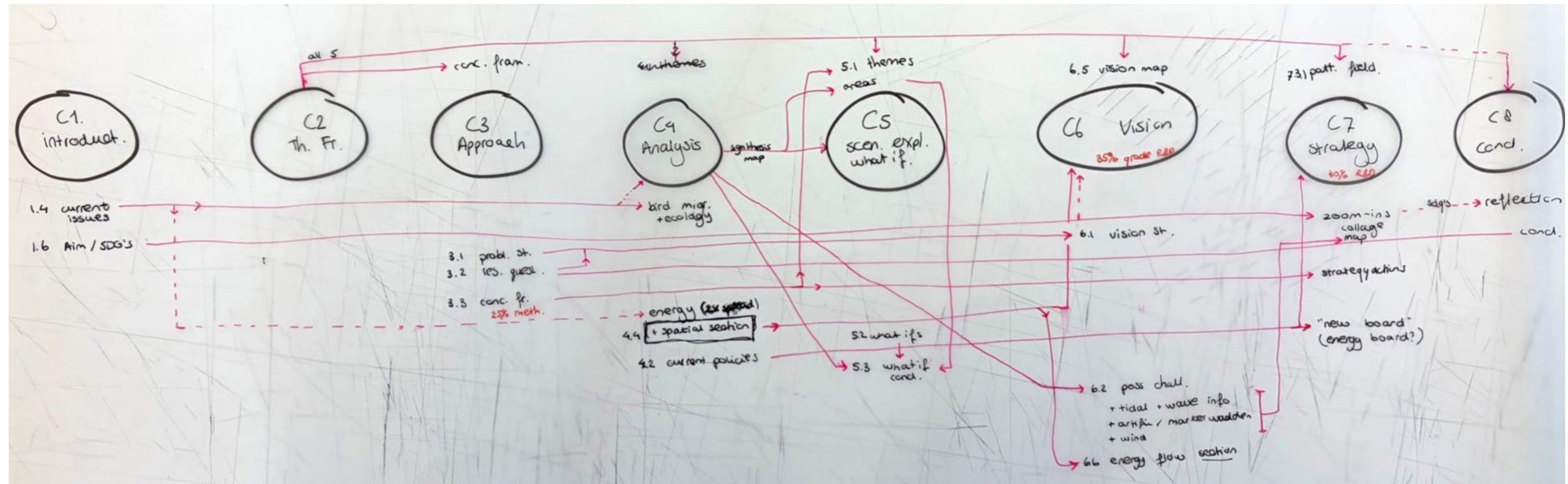

Figure 9.8: Mind mapping of project narrative and report interconnections

Spatial Justice Benchmarking Tool (Citizens)



About:
The Spatial Justice Benchmarking Tool (SJBT) is a qualitative evaluation tool designed to assess how dimensions of justice are addressed in urban governance and planning at the scale of a city or region. It supports evaluation and structured reflection. The tool defines levels of justice, ranging from Low to High, by assigning a score that reflects how well what is being assessed aligns with the three dimensions of Spatial Justice: distribution, procedure, and recognition.

The tool is intended to spark discussion and reflection based on these dimensions. Using this lens makes it possible to pay closer attention to how benefits and burdens are redistributed, how people are engaged and policy and decision-making processes become more responsive, and how the needs and aspirations of disadvantaged individuals, groups, and communities are recognised.

- How to use this tool:**
1. Start by clarifying what is being assessed, such as a plan, a vision, or a project.
 2. Review each column on the right. Each column represents a component of the Spatial Justice Conceptual Model (SJCM).
 3. Discuss how well the assessed material aligns with each component and assign it a rating from Low to High.
 4. Use post-it notes to record ideas or recommendations discussed by the group. Place these directly on the relevant component for reference.

Contact and further information:
Roberto Rocco (r.c.rocco@tudelft.nl)
Juliana Gonçalves (j.g.goncalves@tudelft.nl)
Hugo López (hlopez@sheffield.ac.uk)

Download the online version of the Spatial Justice Benchmarking Tool

Download the Spatial Justice Handbook

Download the Spatial Justice Conceptual Model



	DISTRIBUTIVE DIMENSION			PROCEDURAL DIMENSION			RECOGNITION DIMENSION		
FOUNDTIONAL TO THE VISION	The vision builds upon this component as a core principle. It shapes framing, priorities, beneficiaries, and governance, with strong clarity on who is included, how, and why.		Our vision values and policies are framed by the conditions that allows residents and communities to participate, organise, improve, and take ownership of what happens in their area. Also who is included where.						
	INTEGRATED INTO THE VISION	Considerations on this dimension are clear, specific, and connected across dimensions. The vision embeds it into its goals and strategies, signalling a coherent commitment.	The vision and policies are thought through with the aim of equity and affordability for all. This comes from the problem statements, goals, and strategies of the vision.						
RECOGNISED ACROSS DIMENSIONS	The vision addresses aspects of this dimension but unevenly. Elements of this dimension are present and coherent, yet not consistently connected or fully thought through.		The vision addresses aspects of a fair voice where participation becomes easier and meaningful. However, it could be better thought through where it gets meaningful or still becomes top-down approach for example.					The vision presents community led efforts for shared resources, however, this could be more connected to the public.	
PARTIALLY ACKNOWLEDGED	The vision identifies one or more concerns related to this component but vaguely. References appear, but without clarity, specificity, or coherence.		The vision identifies concerns of institutions, but this is less important in our vision, because the local committee of farmers, fishermen and residents are the ones that are specified in our vision.		The vision identifies that the government is becoming trustworthy, but this could be more specified with how this is applied in policies for example.				
NOT CONSIDERED	The vision does not address this component in any meaningful way. Any mentions are rhetorical, general, or disconnected from the rest of the text.						In our vision there is nothing considered with discrimination because this is not the problem of the region. The feeling of exclusion is present, but this is more related to having a fair voice.		The vision does not address different cultures or lifestyles.
COMPONENT 1	COMPONENT 2	COMPONENT 3	COMPONENT 1	COMPONENT 2	COMPONENT 3	COMPONENT 1	COMPONENT 2	COMPONENT 3	
FAIR SHARE Make sure basic opportunities, facilities and services, like jobs, parks, green streets, clean air, services, and public facilities are shared fairly across all neighbourhoods, not concentrated in a few lucky areas.	FAIR ACCESS Everyone should be able to reach jobs, schools, health care, public transport, and other opportunities easily and affordably, no matter where they live.	FAIR ABILITY TO SHAPE SERVICES & SPACES People should be able to use and shape the services and spaces around them. The city should create conditions that allow residents to participate, organise, improve, and take ownership of what happens in their area.	FAIR VOICE People must have real chances to take part in decisions about their neighbourhood. Participation should be easy, welcoming, and meaningful, not just a box-ticking exercise.	FAIR INSTITUTIONS City institutions should be able to learn, adapt, and change when something is not working. They must update rules, tools, and ways so they can respond better to people's needs.	FAIR PROCESSES Public institutions must treat residents fairly, act transparently, explain decisions clearly, and respond openly to concerns. People should feel that government is accountable and trustworthy.	FAIR RIGHTS The laws of the city should protect everyone equally and recognise the rights and dignity of groups who often face discrimination or exclusion.	FAIR SUPPORT FOR COMMUNITIES The city should support community-led efforts like mutual aid, neighbourhood groups, shared spaces, and collective projects that help people look after one another and manage common resources.	FAIR RESPECT FOR DIVERSITY & THE PLURIVERSE The city should value different cultures, lifestyles, and ways of being in and using space. No single group's way of life should dominate; diversity should be respected and included in planning decisions and created spaces.	

Group 4.2
This matrix helped us to evaluate our current vision and adapt this into a more accurate and spatial justice matter.

FOCUS COMPONENTS
LESS FOCUS COMPONENTS



Figure 9.9: Spatial Justice Benchmarking tool conducted in the methodology course

Figure 9.10: Team photo during excursion to Friesland

