

A circular approach to energy renovation

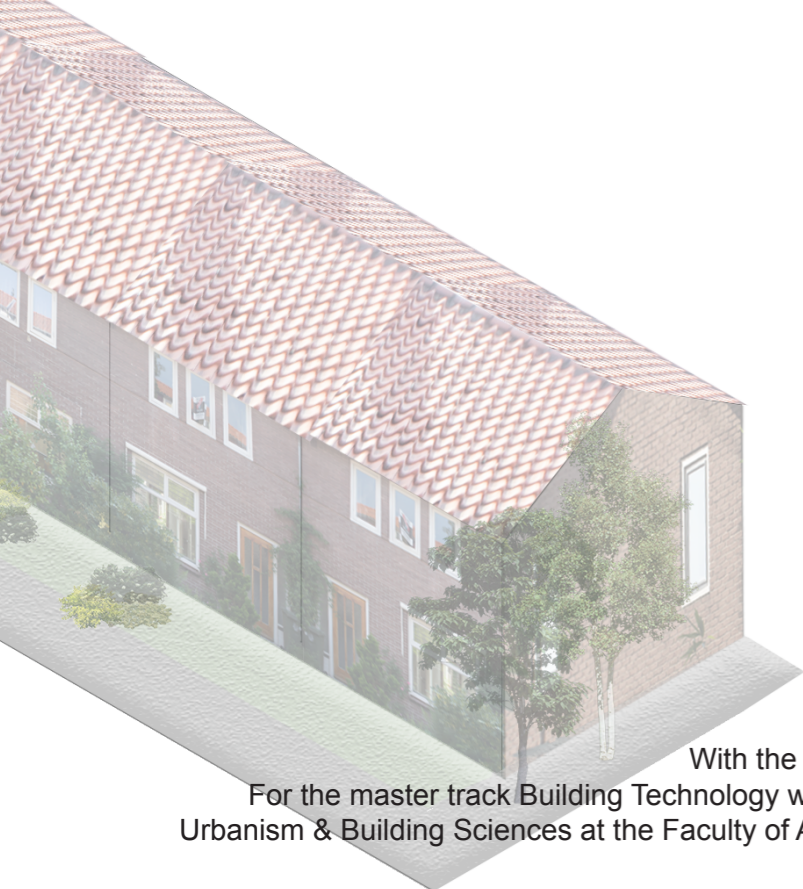

Dora Vancso
Technical University of Delft
MSc Building Technology Graduation | July 2018



Graduation thesis
With the title of *“A circular approach to energy renovation”*.
For the master track Building Technology which is part of the Master of Science Architecture,
Urbanism & Building Sciences at the Faculty of Architecture and the Built Environment at the Delft
University of Technology.

Author
Name: Dora Vancso
Student number: 4417461
Email: doravancso@outlook.com

Delft University of Technology
Faculty of Architecture
MSc Building Technology

Start date: 14 November 2017
Finish date: 3 July 2018



Members of graduation committee

First mentor: dr. ir. Sabine Jansen
Email: s.c.jansen@tudelft.nl
Faculty: Faculty of Architecture and the Built Environment
Department: Architectural Engineering + Technology | Building Services

Second mentor: ir. Arie Bergsma
Email: a.c.bergsma@tudelft.nl
Faculty: Faculty of Architecture and the Built Environment
Department: Architectural Engineering + Technology | Design of Construction

Third mentor: ir. Bob Geldermans
Email: r.j.geldermans@tudelft.nl
Faculty: Faculty of Architecture and the Built Environment
Department: Architectural Engineering + Technology | Climate Design & Sustainability

Delegate of board of examination: ir. Steven Steenbruggen
Email: s.steenbruggen@tudelft.nl
Faculty: Faculty of Architecture and the Built Environment
Department: Architecture | Complex Projects

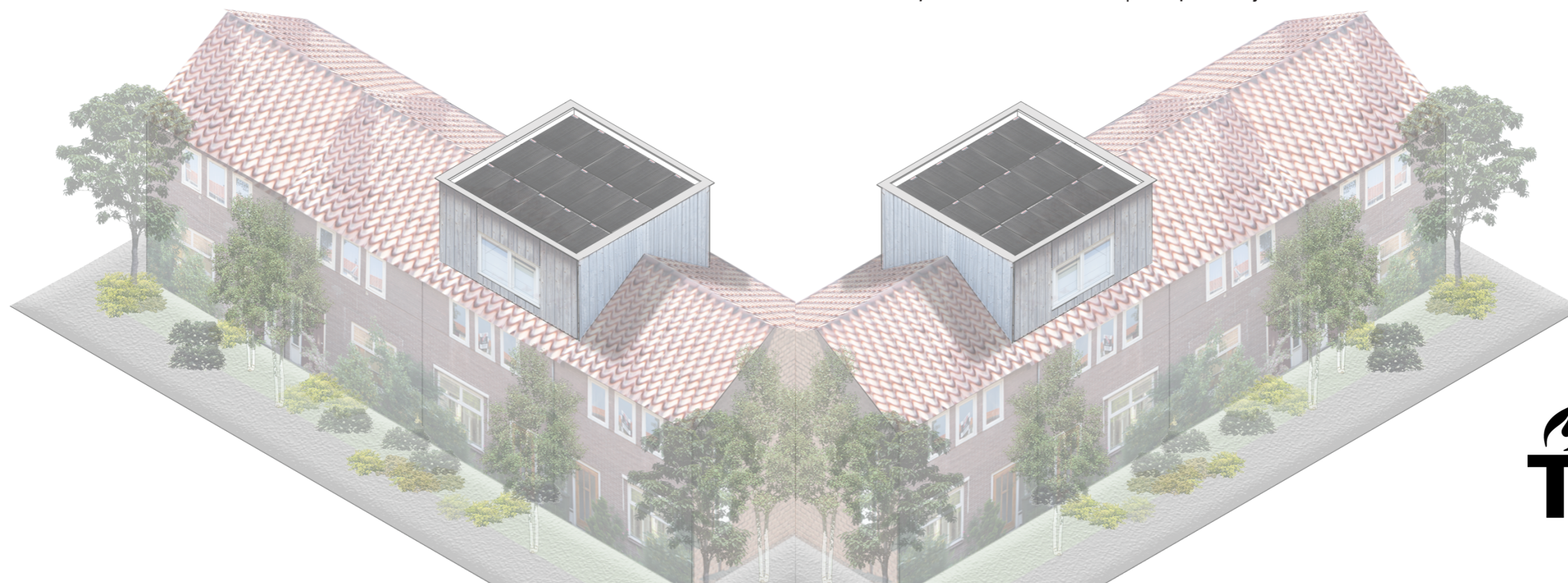

PREFACE

I have always had a love for nature. When I was much younger, this was apparent in my interest in animals. Not only did I love the furry and the cute, I was also fascinated by less huggable critters. I remember catching water snakes during the family vacations I spent at Lake Balaton and amusing myself for hours on end by watching the comings and goings of bugs and fish in the water. This love for animals soon turned my interest to the environment the animals lived in, in a broad sense. I noticed their struggle when man-made structures made their life difficult. Many years later I find this love for nature driving my passion for sustainable architecture.

I started studying interior architecture, more out of the feeling that I wanted to do something creative rather than because it was a truly fitting choice. After finishing my bachelor's degree I went to Delft, searching for what I felt I was missing before. It was in Delft that I started to understand the negative impact current human activities have on the planet and on nature and on how the built environment is a factor in this impact. The built environment is a sector which not only has a large resource consumption contributing to the corresponding pollution, but also a sector extensively contributing to global greenhouse gas emissions. Yet we need it, but in my opinion not in the way it has been utilized. By this point I knew that in my designs I wanted to make a contribution - no matter how small - to relieve the stress on nature from the pressure being put on it. Particularly when I started my master's in Building Technology I felt I was making steps to becoming that kind of a designer: I finally started to learn the tools and technologies to design truly sustainable architecture. My biggest frustration during my bachelor's years was that what we learned about sustainable architecture never went beyond plumping some PV panels on the building, adding a green roof and leaving the rest to the engineers. Esthetics were more important than pragmatism, appearance had higher priority than functionality and sustainable performance. The Building Technology track has given me a deeper technical understanding of sustainability in the built environment, how it manifests itself in different themes like (zero) energy building and building for the circular economy.

I felt I had finally started to answer the fundamental question I started asking myself a long time ago: How can I design buildings with a positive impact, respecting nature's boundaries and being comfortable for people at the same time? I am sure that answering this question will encompass a lifelong search. The thesis you're about to read is my first large leap towards finding an answer, diving into the themes of building for the circular economy and (zero) energy buildings. These are two key topics that are essential to minimizing the impact the built environment has on nature.

This graduation project would not have been the same without the many people who have supported me along the way.

First, I want to thank my supervisors, Sabine Jansen, Arie Bergsma and Bob Geldermans for their valuable comments and guidance throughout the entire process. Their commitment to the project has been a great help along the way. Sabine, always patiently answering my many questions about energy design and never failing to make time for me, even with a busy schedule. Arie, reminding me that ideas on paper can be inspiring but if they can't be built they will amount to nothing and showing me time after time how I could change my designs to be more realistic. And Bob, who has along the way turned into the voice in the back of my mind reminding me to never lose sight of the larger scale of the circular economy.

I want to thank my family for their unconditional love and support.

And finally, I want to thank Rick. Thank you for your patience and positivity.

ABSTRACT

Keywords: circular economy, circular building, energy renovation, design for disassembly, circularity assessment

Our world and environment is facing a multitude of complex and intertwined environmental problems. Man made climate change, caused by anthropogenic greenhouse gas emissions and causing an array of negative environmental effects. The raw material input and throughput currently necessary to sustain our human activities which create large quantities of waste. The built environment plays a large role in both: accounting to 50% of the raw materials used, 40% of the national waste stream, 40% of the total energy use in the Netherlands and 35% of the CO² emissions. A proposed solution for the waste problem is the shift from a linear economy to a circular economy. A proposed solution for the energy problem is transitioning to a (nearly) zero energy built environment. In this context, the depth of energy renovation of the existing building stock - which poses the biggest challenge for a (nearly) zero energy building stock - and building for the circular economy both needs to grow.

However, in the current policies in place, energy efficiency and high energy performance of buildings are prioritised over circularity. This can unintentionally result in building design and materials that do not lend themselves for circularity. It is not the high energy performance hindering the adoption of circular building design, but the choice of construction technique and materials. Furthermore, there is also a lack of consensus about how circularity in buildings can be assessed, while there are well known methods of assessing energy performance of buildings.

In this research, technical building design(s) for an energy renovation project are examined, implementing both circularity and energy performance ambitions. These building design(s) are assessed on their energy performance on the one hand, and on their circular performance on the other, by use of an assessment method partly based on existing circularity assessment methods and partly redefined and further developed for use in this thesis. The assessment method contains the following performance indicators: MAT1 intensity of material use, MAT2 environmental cost, MAT3 design for disassembly, MAT4 design for circular life cycles and E1 energy efficiency. This assessment is used to answer the main research question: "To what extent can circularity be implemented in the designs of energy renovation projects?"

The technical design(s) and the assessments of the design(s) thus support the scientific knowledge about the codevelopment of circularity and (nearly) zero energy ambitions in renovation projects, focusing on the meso scale of individual buildings. The research also supports the development of consensus about how the level of circularity in buildings can best be measured.

TABLE OF CONTENTS

Preface	4	7.8 Conclusion	113
Abstract	5	8. Research by design	114
Definitions	8	8.1 Highest level of circularity	115
1. Introduction	10	8.2 Boundary conditions	116
1.1 Background	11	8.3 Choice of parameters	117
1.2 Research framework	12	8.4 Design variants	118
2. Literature review of circular building & energy renovation	18	8.5 Conclusion	140
2.1 Essential concepts to understand circular building(s)	19	9. Validation & assessment	142
2.2 Boundary conditions for circular building	23	9.1 Assessment on intensity of material use over lifetime of building	143
2.3 Essential concepts to understand energy renovation	26	9.2 Assessment on environmental cost of materials	151
2.4 Boundary conditions for zero energy buildings	27	9.3 Assessment on design for disassembly	154
2.5 Current approaches to design circular buildings and energy renovations	29	9.4 Analysis on circular life cycles	161
2.6 Tools to support the development and assessment of circularity and energy performance	33	9.5 Assessment on energy efficiency	172
2.7 Conclusion	43	9.6 Conclusions circularity assessment	173
3. Reference projects for circular building & nZEB	46	9.7 Discussion circularity assessment and suggestions for future development assessment method	179
3.1 Fijn Wonen Circulair	47	10. Vision and suggestions	184
3.2 Circular redesign 2nd Skin project	50	10.1 Technology & systems	185
3.3 Conclusion	53	10.2 Business model and financial aspects	187
4. Development & refinement of assessment method	54	10.3 Legislation	188
4.1 Choice of assessment methodologies	55	11. Conclusions	190
4.2 Choice of indicators	55	11.1 Answers to research questions	191
4.3 MAT1 Intensity of material use over lifetime of building	60	11.2 Recommendations for future research	196
4.4 MAT2. Environmental cost of materials (MPG)	62	11.3 Personal reflection on graduation project and process	196
4.5 MAT3. Design for Disassembly	64	Bibliography	200
4.6 MAT4. Design for circular life cycles	70	Appendices	211
4.7 E1. Energy efficiency	73		
4.8 Conclusion	74		
5. Case study dwelling	76		
5.1 Spaargas project	77		
5.2 The Ramplaankwartier	78		
5.3 The case study dwelling	78		
6. Circularity assessment of existing roof structure	86		
6.1 Description of existing roof structure	87		
6.2 MAT1. Intensity of material use over lifetime of building	90		
6.3 MAT2. Environmental cost of materials (MPG)	91		
6.4 MAT3. Design for Disassembly	92		
6.5 E1. Energy efficiency	94		
6.6 Conclusion	95		
7. Energy & installations design	96		
7.1 Energy use of dwellings	97		
7.2 Energy design scope and ambitions	98		
7.3 Reducing the demand	99		
7.4 Heating and ventilation systems	101		
7.5 Dimensioning of the heating system	106		
7.6 Energy performance of the energy systems	109		
7.7 Roof design	112		

DEFINITIONS

This list contains the meaning of definitions used in this thesis.

Term	Definition
Circular economy	<p>The circular economy as defined by the Ellen MacArthur Foundation: “A circular economy is a global economic model that aims to decouple economic growth and development from the consumption of finite resources. It is restorative by design, and aims to keep products, components and materials at their highest utility and value, at all times.”</p> <p>The circular economy as defined by Metabolic (2017): “A circular economy is a new economic model for addressing human needs and fairly distributing resources without undermining the functioning of the biosphere or crossing any planetary boundaries.”</p> <p>Definition used in this thesis: “A circular economy is a global economic model that aims to decouple economic growth and development from the consumption of finite resources. It is restorative by design, and aims to keep products, components and materials at their highest utility and value, at all times. The larger goal is to address human needs and fairly distribute resources without undermining the functioning of the biosphere or crossing any planetary boundaries.”</p>
Circular building	Circular building as a noun is defined as follows by Pomponi and Moncaster (2017): “A circular building is a building that is designed, planned, built, operated, maintained and deconstructed in a manner consistent with Circular Economy principles.”
Circularity	The circularity of something (e.g. a product or building): to which extent something fits within the circular economy.
Resources	“From a human standpoint, a resource is anything that we can obtain from the environment to meet needs and wants. Resources vary in terms of how quickly we can use them up and how well nature can replenish them after we use them.” (Miller & Spoolman, 2012) They also differ across other scales: living and inanimate, availability, etc. An example of a renewable resource is solar energy. Other examples include forests, grasslands, fertile topsoil. Nonrenewable resources are resources existing in fixed quantities (stock) and can't be renewed on the short human timescale. Examples include energy resources (coal, oil), metallic mineral resources (copper), nonmetallic mineral resources (salt, sand) (Miller & Spoolman, 2012).
Components	A specific combination of different elements, which are made up of materials, which forms something with a specific function (e.g. a window).
Elements	The parts of components that can be viewed separately: e.g. a window is made up of multiple elements: glass panes, the frame, etc.
Zero energy building	A residential or commercial building with zero energy use, meaning the building related energy (BRE) on an annual basis can be compensated by on-site or nearby production of energy via renewable energy technologies (Marszal et al., 2011).

Nearly zero energy building	According to the EPBD (2010) which requires all Member States of the EU to ensure all new buildings should be nearly zero energy by 2020 and the existing building stock by 2050, a ‘nearly zero energy building’ is a building that has a very high energy performance. “The nearly zero or very low amount of energy required should be covered to a very significant extent by energy from renewable sources, including energy from renewable sources produced on-site or nearby.” For the EPBD Each member state can set the minimum energy performance requirements for buildings with a view to achieving cost-optimal levels.
Nul-op-de-meter	As defined by Stroomversnelling: a building in which the building related energy (BRE) and user related energy (URE) are both compensated by on site or nearby production of energy via renewable energy technologies.
Energy renovation	Renovating an existing building by making it more energy efficient and using renewable energy technologies for (a part of) the remaining energy demand. How much of either the BRE or the URE or both are compensated by on-site or nearby production of energy via renewable resources depends on the design possibilities and the ambition level.
Building related energy	The energy a building needs for heating, cooling, hot water and ventilation. Sometimes the energy needed for lighting is included as well. In the BENG this is included for utility buildings (Rijksdienst voor Ondernemend Nederland, n.d.).
User related energy	The energy demand for appliances.
Energy efficiency	The energy output of a function, divided by the energy input.
Energy performance of buildings	According to the EPBD (2010), the “energy performance of a building means the calculated or measured amount of energy needed to meet the energy demand associated with a typical use of the building, which includes, inter alia, energy used for heating, cooling, ventilation, hot water and lighting.”

1. INTRODUCTION

This chapter will introduce the background information and context necessary for understanding the problem addressed. After this the research framework is explained. The research framework contains the following themes: scope, problem statements, objectives, research questions, final products, approach and methodology and social and scientific relevance.

1.1 Background

Our world and environment is facing a multitude of complex and intertwined environmental problems. Naming any of these problems here shortly as the context in which this research is set doesn't do justice to their sheer scale and complexity, but it is necessary to do so, as it is the global context in which the problem statement is set. First, the complex problem of man made climate change. According to the IPCC summary for policymakers (2013), "it is extremely likely that human influence has been the dominant cause of the observed warming since the mid-20th century (...) caused by the anthropogenic increase in greenhouse gas concentrations and other anthropogenic forcings together." Second, the raw material input and throughput currently necessary to sustain our human activities which create large quantities of waste.

These human activities take place within a linear model, often referred to as a 'take, make, dispose' model (Ghisellini, Cialani, & Ulgiati, 2016). This linear economic model is damaging the environment as it creates chronically high levels of waste and can't sustain our economies in the long run, because a model based on continuous and infinite throughput of virgin resources can't be sustained on a finite planet (Ellen MacArthur Foundation & Granta Design, 2015). This current linear model affects every sector of the economy which uses physical resources: from consumer products like clothes, to the construction industry. The latter has a high resource intensity worldwide. In the Netherlands it accounts 50% of the raw materials used and 40% of the national waste stream (Government of the Netherlands, 2016). Because of the problems a linear economy entails, the need to change this is clear. Therefore in recent years attention is being paid to the circular economy as an alternative to the linear economy, which is restorative and regenerative, designing out waste (Ellen MacArthur Foundation & Granta Design, 2015).

The Dutch government agrees with the need to shift from a linear economy to a circular economy and has identified the construction industry as one of the main priorities (Government of the Netherlands, 2016).

The construction industry does not only have a high resource intensity, it also accounts for a large share of the total energy consumption and global greenhouse gas emissions. It is responsible for 40% of the total energy use in the Netherlands and 35% of the CO₂ emissions (Government of the Netherlands, 2016).

The existing building stock poses the greatest challenge here: it is mostly of poor energy performance and in need of renovation work, as opposed to new buildings which can easily be constructed with high energy performance levels (Konstantinou, Klein, Santin, Boess & Silvester, 2015). Within the building stock the housing stock is one of the biggest energy users (Eurostat, 2013, cited in Konstantinou, Klein, Santin, Boess & Silvester, 2015). Furthermore, the existing housing stock only grows by the addition of new houses with a very small percentage each year: in 2016 this was 0,7% (CBS, 2017).

In this context, both the depth of energy renovation, and circular building needs to grow. Even though the need for refurbishment is urgent, the rate of renovation and the resulting energy savings are relatively low (Konstantinou, Klein, Santin, Boess & Silvester, 2015).

The adoption of a circular building practice is also being hindered. This is due to several barriers, of which two are important to highlight here.

Even though there are policies in place for a circular economy in the Netherlands, energy efficiency and high energy performance of buildings are prioritised in the policies. This can unintentionally result in building design and materials that do not lend themselves for dismantling, refurbishment, reuse and high quality upcycling and thus for circularity. It's not the high energy performance per se that hinders the adoption of circular building design, but the choice of construction technique and materials (Henrotay, Debacker & Steinlage, 2017). This is illustrated in composite waste fractions such as coatings (fixed to glass fractions to improve energy performance) or thermal insulation (the inability

to separate it from walls, resulting in contaminated stony debris). Selective demolition and sorting of these upcoming waste fractions is in the majority of demolition cases seen as technically and/or financially unfeasible (Debacker & Manshoven, 2016).

The second barrier to highlight for the implementation of circular building is as follows. The technologies applied in circular buildings are still in their infancy: we lack a common understanding of what these technologies should look like and why some technologies might be preferred over others. This is due to the fact that we don't yet have a widely shared vision of what a circular built environment (and circular economy) is in its end state: all too often this is defined by specific activities associated with the circular economy, such as building with renewable materials or reducing the amount of materials needed. Measuring the progress towards the goal becomes difficult if the goal is not entirely clear. This also means there is a lack of consensus and understanding about methodologies and tools to objectively assess circularity, if the circular technologies really contribute to a circular economy (Metabolic, 2017).

To move towards a holistic sustainable building stock, an integral focus on energy performance and circular building is needed. And as illustrated by the second barrier, consensus & understanding about how to measure the progress towards a circular built environment (and the circular economy on a larger scale) is needed as well.

1.2 Research framework

1.2.1 Scope

The scope is limited to (1) the renovation of (2) existing residential Dutch rowhouses, with a case study house.

1. As mentioned, renovation of the existing building stock is key to reach energy and decarbonisation targets. Furthermore, designing a new building as opposed to a renovation is entirely different. Annual zero energy use can more easily be reached in new buildings, as opposed to existing buildings, where the design is largely influenced by existing conditions. This thesis therefore focuses on energy renovation.
2. This thesis uses a case study, which is a rowhouse built in 1934, a very common typology of housing in the Netherlands. Different types can be distinguished, built from before 1945 up until now. Because of the proliferation of rowhouses in the Netherlands, and on a larger scale in Europe, the case study is well suited with a view to the possible future scaling up of the design solution. The case study is the renovation of a rowhouse in the Ramplaankwartier in Haarlem within the Spaargas project, in which a new roof structure will be added to provide the residents with much needed extra space. This roof structure will function as an energy roof.

1.2.2 Problem statement

The main problem statement is as follows.

1. There is a lack of knowledge on how to design a circular building and how to integrate this with energy renovation.

The sub problem statements are then as follows.

2. Energy renovation can result in a building design which does not lend itself for circularity.
3. There is a lack of consensus and understanding about how circularity in buildings can best be assessed.

1.2.3 Objectives

The general objective is then:

1. Explore to what extent circularity can be implemented in the designs of energy renovation projects by designing a case study energy renovation project with roof extension in the Ramplaankwartier.

And the sub objectives are:

2. Define an assessment method that supports designing circular buildings and contributes to consensus and understanding about assessing circularity.
3. Design the case study energy renovation project so that the highest level of circularity possible is reached and validate the level of circularity and the energy performance.

1.2.4 Research questions

The main research question is:

1. To what extent can circularity be implemented in the designs of energy renovation projects?

The sub research questions are:

2. What are current design approaches and tools to reach circular buildings and buildings with high energy performance?
3. What assessment methodologies and tools exist to assess circularity and energy use?
4. Are there existing reference projects of buildings with high ambitions on circularity, possibly combined with a high energy performance?
5. How will the circularity and energy use be assessed in the case study energy renovation project so this assessment supports the design of circular buildings and contributes to consensus & understanding about assessing circularity?
6. How can the case study energy renovation project be designed so that the highest level of circularity possible is reached?
7. What is the circular and energy performance of the case study house without energy renovation?
8. What is the circular and energy performance of the case study energy renovation project?

1.2.5 Final products

To be able to answer the main research question, several final products are necessary.

1. A literature review about circular building and zero energy renovation, which will contain the following subjects:
 1. An explanation of essential concepts associated with circular building and zero energy renovation, which are necessary background knowledge.
 2. An overview of the existing design approaches utilized towards the design of circular buildings and towards the design of zero energy renovations. The approach can be viewed as a design strategy.
 3. An overview of current assessment methodologies & tools which exist to assess circularity and energy use in buildings.
 4. Reference projects of buildings with high ambitions on circularity, possibly combined with a high energy performance.
2. A method to assess circularity, based on the literature and validated by first assessing an existing roof structure in the Dickmansstraat and second by assessing the case study design(s).

3. (Technical) design(s) of the case study renovation. From a Building Technology perspective and in view of the main objective, the most interesting part of the renovation will be the energy roof structure. In the final technical design this structure will be detailed. At this point detailing the entire renovation seems not to be realistic given the time scale of the thesis, so a focus on the roof is chosen.

4. The validation and assessment of the circularity and energy use of the case study design. The method defined in 2. will be used.

1.2.6 Approach and methodology

The main methods used during this research are: literature study and research by design. The existing assessment methods researched in the literature study are the basis for the development of the assessment method. The design approaches studied in the literature study are starting points for the (technical) designs. The (technical) designs are validated during the design process regularly with the defined assessment method, changing the design where necessary. The validation of the assessment method itself is also done by testing it on the case study house without renovation, and by validating the (technical) designs. The final validation of the (technical) designs results in the conclusions drawn. Figure 1. shows an image of this methodology.

1.2.7 Social and scientific relevance

The research as described in this thesis is relevant in multiple aspects. It has scientific relevance, societal relevance, and is tightly embedded in ongoing research.

Social relevance

This thesis will contribute to the technological development of circularity in zero energy buildings. As understood from the Background research, the design of zero energy buildings, and mostly zero energy renovation will become increasingly important as the goal is to reach a fully zero energy building stock. Implementing circularity in this building stock has numerous social advantages:

- Less pressure on the environment because of building waste and mining of virgin resources.
- Circular strategies extend the lifecycle of a building, as it allows parts of the building to be replaced, providing a financial incentive. Another financial incentive applies to the materials themselves: circular models allow the value of materials to be exploited to the fullest.
- Circular strategies allow for greater flexibility in the use of the building, making it possible to update it over time as user demands change.

Scientific relevance

Most of the current research about circularity and circular precedents concern new buildings, the research applying circular principles to existing buildings is limited. Some research about circularity in existing buildings has been done, of which notable examples are Quirine Henry's graduation research 'Circular Façade Refurbishment' and Rebecca Leising's graduation research 'Steel curtain walls for reuse'. Both graduation projects focus on improving existing façade systems for the circular economy. Pomponi and Moncaster (2017) state that the built environment can be seen on three different levels: the meso-level (building), the macro-level (urban agglomerates) and the micro-level (building components), such as Leising's and Henry's graduation topics. Research into the macro-level in terms of CE is more advanced with the concept of eco-cities, and current research for the micro-level could suffice to bring circularity about. Both have one trait in common: the research focuses on improving the status quo by using new and high technologies, but when the focus switches to buildings, the high levels of existing building stock incorporate significant constraints in the design of new technologies. Pomponi and Moncaster (2017) go on to conclude the following: "the level of analysis which is currently lacking is the building as an entity per se. This is in stark contrast with the more standard practice of environmental impact assessment research, most often in terms of embodied energy and

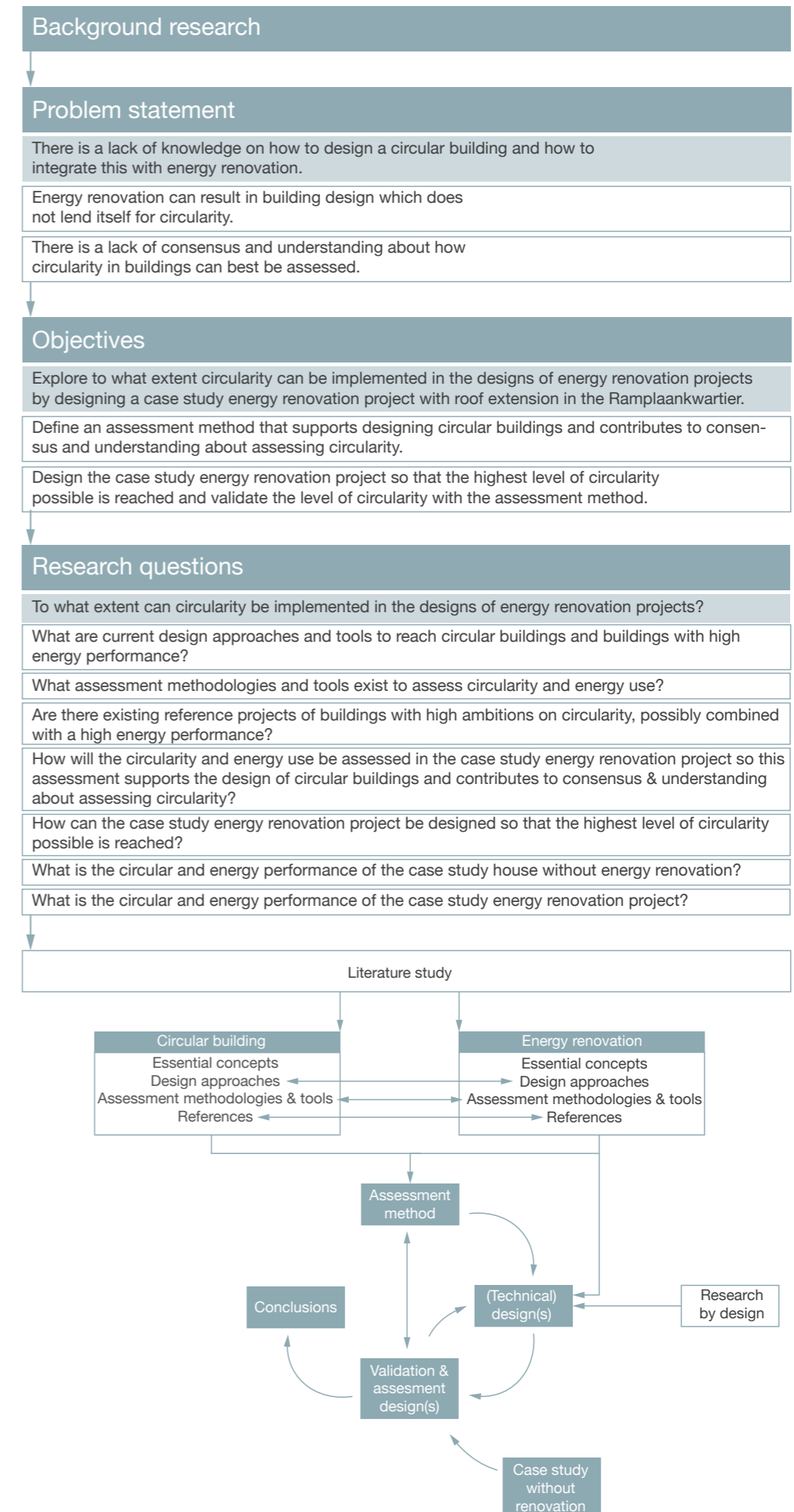

figure 1: methodology (source: own image)

carbon, for which buildings rather than cities or materials are the most common level of analysis in current literature.” This is where this research has scientific relevance: contributing to filling this gap of research about circularity on the individual building level.

2. LITERATURE REVIEW OF CIRCULAR BUILDING & ENERGY RENOVATION

This chapter provides the necessary context about circular building and energy renovation for the design assignment through literature review. The chapter explains some essential concepts about the circular economy, circular building and energy renovation which one must know before diving deeper into the material. The questions answered in this chapter are:

1. What are current design approaches and tools to reach circular buildings and buildings with high energy performance?
2. What assessment methodologies and tools exist to assess circularity and energy use?

2.1 Essential concepts to understand circular building(s)

2.1.1 Origins of the circular economy

The circular economy as a concept has deep-rooted origins. It can't be traced back to one point in time or to one school of thought. Multiple schools of thought have led up to the current concept of the circular economy. These are: Cradle to Cradle, Performance Economy, Biomimicry, Industrial Ecology, Natural Capitalism, Blue Economy and Regenerative Design. Of these schools of thought Cradle to Cradle (C2C) is perhaps the best known concept and has been influential for the definition of the circular economy by the Ellen MacArthur Foundation (Ellen MacArthur Foundation, n.d.). The Brundtland Commission, who coined one of the most cited definitions of sustainable development - "Development that meets the needs of the present without compromising the ability of future generations to meet their own needs" - in the well known report 'Our Common Future' (World Commission on Environment and Development, 1987), has also paved the way for the circular economy.

Michael Braungart and Bill McDonough invented the C2C concept. It is a design philosophy, which considers all materials to be nutrients. It divides industrial materials in two categories: technical and biological materials. The design philosophy wants to mimic nature's 'biological metabolism' as a model for the 'technical metabolism' flow of industrial materials. Components should be designed for continuous recovery and reuse. Three essential points are:

- Eliminate the concept of waste. Waste equals food: products and materials should be safe for human health and the environment, and they should be able to be reused continuously in biological or technical metabolisms.
- Power with renewable energy.
- Respect natural and human systems. Celebrate diversity: promote healthy ecosystems, respect local impacts. Stimulate social responsibility (Braungart & McDonough, 2002).

These ambitions make the C2C philosophy is a holistic one: it's philosophy is closely linked to the four natural resources, which are energy, water, top soil and materials (Luscuere, Geldermans, Tenpierik, & Jansen, n.d.)

2.1.2 The circular economy

With the growth in attention the circular economy has received recently, the number of ways in which it is defined has proliferated. Some consensus is developing in this field, but what a 'circular economy' means in practice is still often vague and undefined (Metabolic, 2017). This paragraph will explain two different views from two different parties on the circular economy, and arrive at a working definition to be used in this thesis. This working definition can also be found in Definitions.

The circular economy as explained by the Ellen MacArthur Foundation

The Ellen MacArthur Foundation is possibly the best known organisation in the field of the circular economy. Their working definition of the CE is:

"A circular economy is a global economic model that aims to decouple economic growth and development from the consumption of finite resources. It is restorative by design, and aims to keep products, components and materials at their highest utility and value, at all times." (Ellen MacArthur Foundation & Granta Design, 2015)."

To understand how this definition works in practice the Foundation set up three principles which form the backbone of a circular economy:

1. Enhance and preserve natural capital by:
 1. having control over finite stocks and

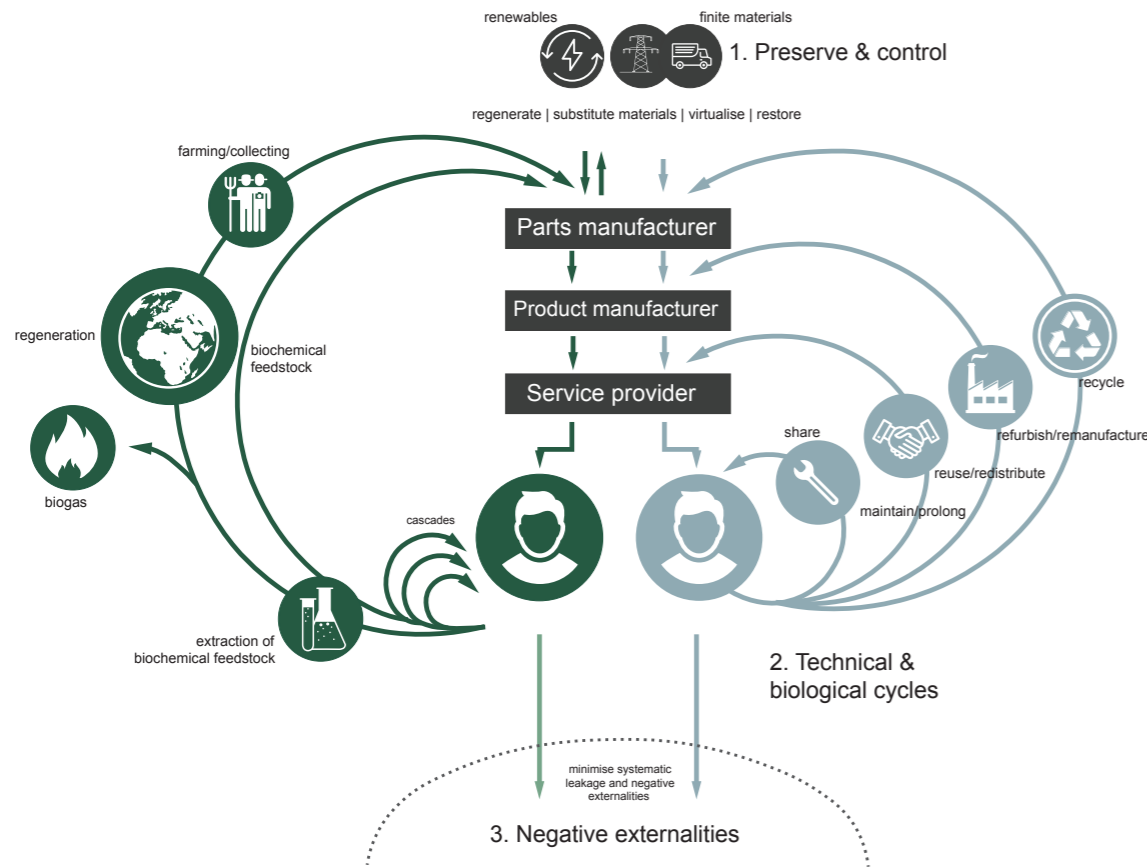

figure 2: the circular economy (adapted from Ellen MacArthur Foundation, 2017)

2. balancing renewable resource flows

- Products, components and materials must at all times be kept at the highest utility and value in both technical and biological cycles: this will optimise resource yields.
- Negative externalities must be tracked and designed out so that the system has maximum effectivity. Figure 2 shows how these principles work in technical (blue) and biological (green) cycles. The image shows several cyclic strategies different materials could go through. An unambiguous definition about what these terms used to describe the different cycles mean is essential, especially for the technical cycles as they are often used incorrectly (Kirchherr, Reike, & Hekkert, 2017). Figure 3 shows the definition of these different strategies.

Circular economy		Strategies	
Smarter product use and manufacture	R0 Refuse	Make product redundant by abandoning its function or by offering the same function with a radically different product	
	R1 Rethink	Make product use more intensive (e.g. by sharing product)	
	R2 Reduce	Increase efficiency in product manufacture or use by consuming fewer natural resources and materials	
Extend lifespan of product and it's parts	R3 Reuse	Reuse by another consumer of discarded product which is still in good condition and fulfils its original function	
	R4 Repair	Repair and maintenance of defective product so it can be used with its original function	
	R5 Refurbish	Restore an old product and bring it up to date	
	R6 Remanufacture	Use parts of discarded product in a new product with the same function	
	R7 Repurpose	Use discarded product or its parts in a new product with a different function	
Useful application of materials	R8 Recycle	Process materials to obtain the same (high grade) or lower (low grade) quality	
	R9 Recover	Incineration of material with energy recovery	
Linear economy			

figure 3: definition different cycles in the circular economy (adapted from Kirchherr, Reike, & Hekkert, 2017)

Biological materials can be cascaded, biochemically extracted, digested anaerobically or composted.

The diagram also shows which actor needs to be involved in the cycle. The following ambitions should also be followed:

- Cycling and using products for as long as possible through good maintenance and without changing them: this means less energy is needed to keep the product cycling, so the potential savings are higher. Ellen MacArthur calls this 'the power of the inner circle'.
- Maximising the number of cycles: the longer products are cycled, the less waste will be present. Ellen MacArthur calls this 'the power of circling longer.'
- Diversify the use of products across the value chain so there are many possibilities for use present and products can cycle for a longer time. Ellen MacArthur calls this 'the power of cascaded use.'
- Use uncontaminated material streams, making collection and redistribution easier. Ellen MacArthur calls this 'the power of pure circles.'

A final note: each cycle has a certain amount of energy associated with it to keep the product cycling: energy input is necessary to maintain, reuse, remanufacture and recycle materials. The power of the inner circle comes into play here: the tighter a circle, the less energy is needed to keep the product cycling. This shows why the life cycles of products are essential to consider and it is even more essential to focus on high quality reuse cycles as opposed to cycles where products are in fact downcycled.

Figure 4 shows how the input of energy facilitates a circular use scenario as compared to the linear scenario of take make waste.

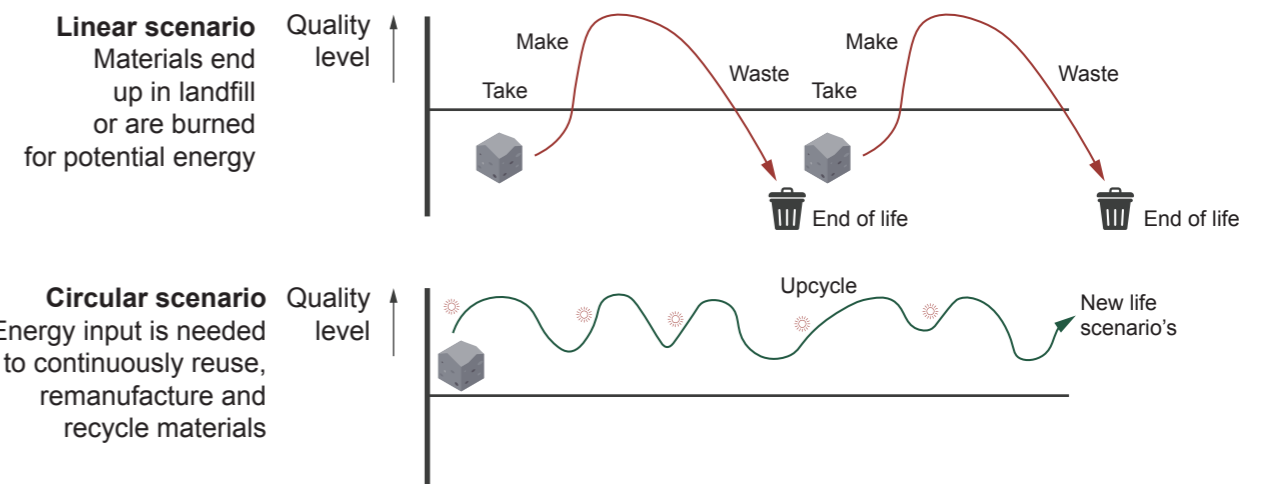

figure 4: input of energy for circular scenario, compared to linear scenario (adapted from Jansen, Luscuere, Tenpierik, & Geldermans, 2016)

Circular life cycles

Indeed, anticipating the life cycles of products and materials and making sure they fit in either the biological or technical cycles is the backbone of transforming linear material use to circular material use. This is illustrated by the formula in figure 5. In this formula M is the amount of material use (kg/year), P is the amount of products, W is the weight of the products and L is the life time of the products. The step to circular material use can be done by adding the regeneration factor of R. The component of 1-R stands for possible interventions the designer could take to delay or avert the step where the product turns into waste. Otherwise, making sure the product can cycle in the biological or technical cycles as defined by Ellen MacArthur. This global formula then has an outcome between 0 (perfectly circular) to 1 (linear). (Geldermans, Luscuere, Jansen, & Tenpierik, 2016).

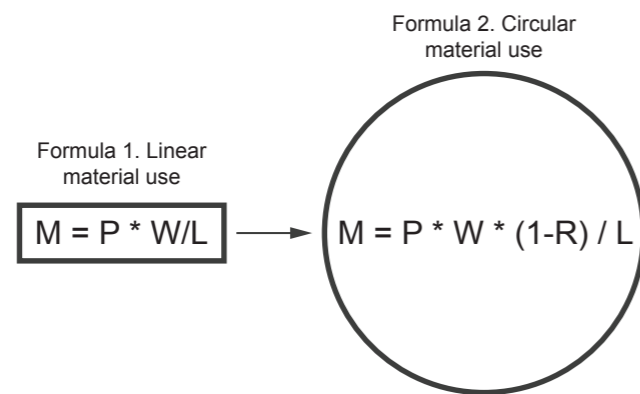

figure 5: from linear to circular material use (adapted from Geldermans, Luscuere, Jansen, & Tenpierik, 2016)

The circular economy as explained by Metabolic

Metabolic gives the following definition of a CE:

“The circular economy is a new economic model for addressing human needs and fairly distributing resources without undermining the functioning of the biosphere or crossing any planetary boundaries.”

They have also defined a set of seven characteristics of a CE, which are properties of this economy that describe the end state of the circular economy once it has been achieved.

The seven pillars which define a CE are as follows:

- Materials are incorporated in the economy in such a way that they can be cycled at continuous high value. This pillar is similar to the Ellen MacArthur Foundation’s definition about material use.
- All energy is based on renewable sources: energy is used intelligently and cascaded (taking into account exergy). The system strives for maximum energy efficiency.
- Biodiversity is structurally supported and enhanced through all human activities. Material and energetic losses are tolerated for the sake of preservation of biodiversity. The rule of preservation of complexity can also be applied here: the more preserved biodiversity, the more complex the ecosystem, the better.
- Human society and culture are preserved: as another form of complexity and diversity (and therefore resilience) human cultures and social cohesion are important to maintain.
- The health and wellbeing of humans and other species are structurally supported: toxic and hazardous substances should be eliminated. Economic activities should never threaten human health or well-being.
- Human activities generate value in measures beyond just financial: forms of value beyond financial include: aesthetic, emotional, ecological, etc. These often can’t be measured, so they should be recognized as value in their own right.
- The economic system is inherently adaptable and resilient: it should have governance systems, incentives and mechanisms in place so that it can respond adequately to shocks and crises.

Important to note is that not all of these characteristics are equally important at this moment. Considering the state of the global system, some areas are under more threat than others, such as the loss of biodiversity. The structural support of biodiversity is therefore a very high priority. Those that need to be prioritized over others include if there are long-term, irreversible impacts, impacts which undermine the ability of the earth to provide a safe operating space for humans, and impacts for which the outcomes for people or environment have a high degree of uncertainty.

Metabolic’s definition and seven pillars show a more holistic view of the circular economy, consistent with the C2C school of thought and sustainable development in general. Ellen MacArthur Foundation focuses more on material use.

In this thesis the goal is to explore to what extent circularity can be implemented in the designs of

energy renovation projects, with the help of a case study energy renovation project, focusing on the design of an energy roof. Two themes are obviously essential in view of the function of the roof: materials and energy. Other aspects matter as well: the health and wellbeing of the residents as they will have to use the design, possibly biodiversity/top soil (green roof), water use (capture of water on the roof), etc. The fact that this design assignment goes beyond materiality calls for a holistic definition and view of the circular economy. The used definition is therefore a combination between Ellen MacArthur’s inspiring view about material use and Metabolic’s more holistic definition:

“A circular economy is a global economic model that aims to decouple economic growth and development from the consumption of finite resources. It is restorative by design, and aims to keep products, components and materials at their highest utility and value, at all times. The larger goal is to address human needs and fairly distribute resources without undermining the functioning of the biosphere or crossing any planetary boundaries.”

2.1.3 Circular building

First, an explanation definitions for ‘circular building’. This thesis often talks about circular building as a verb as opposed to a circular building(s) as a noun. This is because circular building suggests a process - something to do - while circular buildings is a noun, suggesting static objects. These are the two ways one can view a building: as a static physical object, or a collection of functions and processes subject to change, from the production of materials, to the end of life phase. From the circular building viewpoint, it is essential we view a building by looking at all the phases associated with it, as decisions must be made in each phase to support circularity (Geldermans & Rosen Jacobson, 2015).

Furthermore, circular building as a noun is defined as follows by Pomponi and Moncaster (2017): “A circular building is a building that is designed, planned, built, operated, maintained and deconstructed in a manner consistent with Circular Economy principles.”

Both definitions are used in this thesis: circular building as a verb when mentioning the process of designing, building, etc and circular building as a noun when mentioning a specific building.

2.2 Boundary conditions for circular building

In this paragraph important boundary conditions are described for circular building. These have to do with how materials can be used and designed, but also other boundary conditions needed for implementation in the market, such as business model and legislation.

2.2.1 Intrinsic and relational properties of materials

To facilitate circularity, building materials and products need to meet a number of conditions. Two to mention here are the intrinsic and relational properties of materials and products.

The intrinsic properties are:

- The quality of the product or material and if it fits with the function it needs to fulfill.
- How sustainable the origins of the product or material are.
- The (non)toxicity of the material or product.
- If the material or product fits in technical or biological cycles of Ellen MacArthur. If the material or product can ‘reincarnate’ in a sustainable way.

There is not one optimal solution for the intrinsic properties the product or material needs, but it depends on the context: in one situation it might be better to have a complex composite product which is reused many times and in another situation it might be better to have a homogeneous product with a long lifetime in one cycle which can fully be recycled afterwards.

The relational properties are:

- The products need to be designed as fitting to the design and use of a building. This means that in the design process the designer needs to anticipate on different uses the building or product might go through in different life cycles. This has to do with dimensioning of materials or products, connections between them and technical life time of materials and products, which should fit with the function the material or product fulfills.

The relational properties are in the domain of adaptive buildings (Geldermans, Luscuere, Jansen, & Tenpierik, 2016), which will be discussed in the next paragraph.

Taking the intrinsic and relational properties into account is a learning process in which there is not one optimal solution: therefore, it is also important to register data about the intrinsic and relational properties. For buildings, the worth of the building product is in the interface between the intrinsic and relational properties. This worth is not true in absolute terms: it is always dependent on multiple parameters - for example how the user assesses the worth of the product also matters - and on the context of the design assignment for the building.

2.2.2 Demountability, flexibility, adaptability

Demountability in a circular building industry is an essential boundary condition for the following reasons:

- A building is a complex structure consisting of several components with different (technical) lifetimes. Components can only be cycled at continuous high quality or repaired/replaced at the end of their lifetime if they are demountable from the rest of the building.
- Buildings have long lifespans, so these changes will happen more often during it's entire lifetime (Pomponi & Moncaster, 2017).

Early research on this topic was done by Duffy & Brand in 1994. They defined a building in different layers, called shearing layers. In this theory a building has six layers: interior, space plan, services, structure, skin and site, and every layer has a different lifetime and lifecycle. In this theory a building has six layers: interior, space plan, services, structure, skin and site, and every layer has a different lifetime and lifecycle. The interior is changed often, site is infinite. Currently buildings are integrated in one single structure, and the layers with long-term cycles obstruct the layers with short-term cycles. This way if a product with a short lifetime needs to be replaced, it damages the layers with a long lifetime. The building should be redesigned into a structure which allows all the layers to change independently.

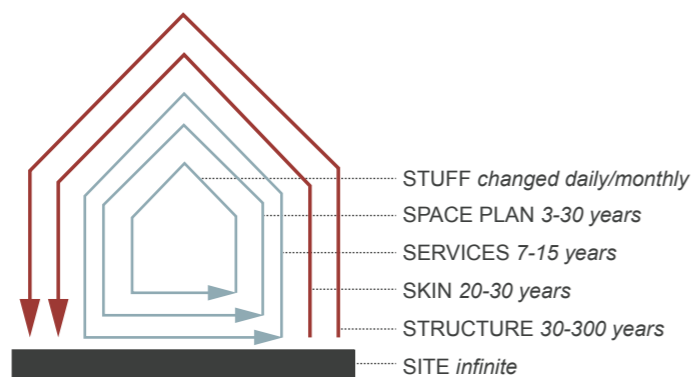

figure 6: Duffy & Brand shearing layers of change (adapted from Berge, 2009)

This conclusion is acknowledged by Berge, 2009, who builds upon the shearing layers and agrees that separation of buildings should be possible at three levels:

- separate building layers, interior, space plan, services, structure, skin and site

- separate building components: to allow disassembly
- separate materials: components must be made up of standardized use of materials instead of composite material

The 'Open Building' principle summarizes the shearing layers in two distinct parts: "carrier" (drager) and "encasing" (inbouw). Carrier parts call for a different view on circularity than encasing parts. This is summarized in figure 7.

	Carrier (drager)	Encasing (inbouw)
Properties	Long lifetime, fixed architecturally strong	Short lifetime, variable, demountable
Scope	Structure, bound on site, collective spaces	interior walls, kitchen, bathroom, installations (possibly facade elements)
Client	Investor	User
Sustainability/link to circularity	Long lifetime, keeping or adding worth	Fits with changes, less waste, facilitates circular reuse

figure 7: carrier and encasing (adapted from Geldermans, Luscuere, Jansen, & Tenpierik, 2016)

This focus on separation makes it clear that connections are a big challenge in designing circular buildings: the several products that make up a building must be connected in a way they can be taken out again, so that the products can be viewed separately and the circularity can be judged on the basis of the products themselves.

This ability to separate buildings in their constituent parts has been further worked out in design approaches towards disassembly and tools to measure disassembly. More on this later.

2.2.3 Business model

Current business models for buildings are finetuned to the linear model of make, use, dispose. Somebody buys a product from a supplier and disposes of it after use. In order for a product or building to be part of the circular economy, new types of business models that ensure the product is not turned into waste after the first life cycle. There is not one correct solution for shaping these business models; what they will look like will depend upon the project in question and the parties involved in the execution of the project. Usually circular business models involve a shift of ownership in which not a product is supplied, but a service. Service providing means that a supplier retains ownership rights over its products while clients pay for the delivered service (Bakker et al, 2014; Ellen MacArthur Foundation, 2012; Roos, 2014 cited in source 21). Implementing circular business models with service providing in the construction industry is difficult in practice. This is due to the multitude of suppliers and the long lifetime of buildings which add to the financial difficulty for the owners of a circular building to retain ownership rights through leasing solutions. A solution for this complexity and these barriers could be the entry of a new stakeholder in the process: a 'service provider', which can function as an intermediary between client and supplying parties. The service provider would offer a performance supported by a service, and is based on the product (the building (van den Brink, Prins, Straub & Ploeger, 2017)). In any case, partnerships will be essential, the entire current fragmented chain of design, construction and demolition needs to be transformed to a consortium of parties working together delivering services instead of products (Circle Economy, van Odijk, & van Bovene, 2014). One can imagine the complexity involved in changing this process.

Another aspect which needs mentioning for the business model driver is the fact that currently circular building in practice is not yet financially feasible. Virgin materials like concrete are cheap, and the reuse of building components, often not yet designed to be reused, more expensive (Circle Economy,

2.2.4 Legislation

Current legislation for building is not suited for circular building. Firstly, many of the existing policies and instruments have been developed from a linear viewpoint, which does not take into consideration a potential circular built environment. Current urban regulations and building permits are based on a linear and static vision of buildings that may impede changes and transformations supported by reversible design and materials recovery (Henrotay, Debacker, & Steinlage, 2017). Next to this, there is a fragmentation of policies over the different policy levels (from European level, like the Energy Performance of Buildings Directive, to national and regional level) which may lead to a lack of integration of the different policies, and could sometimes lead to contradictions (Henrotay, Debacker & Steinlage, 2017). Legal issues might also hinder the adoption of circular business models in the construction industry, as under Dutch property law the delegated ownership of individual components that are part of a larger construction is principally prevented (van den Brink, Prins, Straub & Ploeger, 2017).

There are some policies in place supporting circular building. The European Commission vocalized the need to transition to a Circular Economy in the EU Action Plan for the Circular Economy (European Commission, 2015). The EU states the following: “The transition to a more circular economy, where the value of products, materials and resources is maintained in the economy for as long as possible, and the generation of waste minimised, is an essential contribution to the EU’s efforts to develop a sustainable, low carbon, resource efficient and competitive economy. Such transition is the opportunity to transform our economy and generate new and sustainable competitive advantages for Europe.” The plan proposes legislature and an action plan, which includes long-term targets to reduce landfilling and to increase preparation for reuse and recycling of important waste streams. These targets can then lead Member States toward a circular economy.

In line with this action plan the Dutch government vocalized the need for a transition to a circular economy in the programme, “A circular economy in the Netherlands by 2050.” In this report the construction industry has been identified as one of the main priorities (Government of the Netherlands, 2016).

2.3 Essential concepts to understand energy renovation

2.3.1 The concept of (nearly) zero energy buildings

In existing literature the (nearly) zero energy building concept is described with a wide variety of terms. For example the definitions net zero energy (NZE) building, zero net energy (ZNE) building and zero energy building (ZEB) are all in wide use, and convey approximately the same meaning (DOE, 2015). This lack of commonly agreed definition is due to several aspects (Marszal et al., 2011):

- The metric: the unit applied for “zero” can be influenced by several aspects, which means more than one type of unit can be used in the definition and calculation methodology. These could for example be final, end-use, un-weighted energy, primary energy, CO2 equivalent emissions, exergy, the cost of energy or other parameters, depending on the definition. However, the most favoured metric, in line with the EPBD, is primary energy. What primary energy is is shown in figure 8.

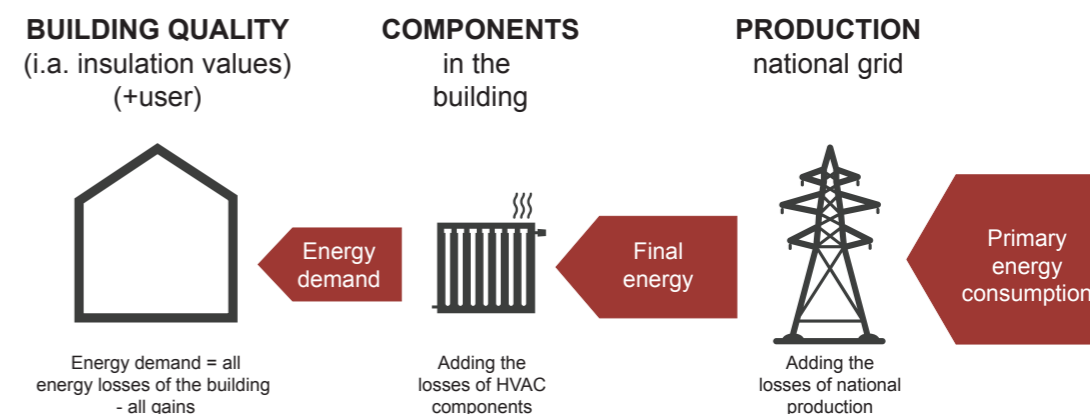

figure 8: primary energy (Jansen & Tenpierik, n.d.)

- Period of the balance: the period of time over which the building calculation towards zero energy is done can differ significantly. Commonly this balance is annual.
- Type of energy use included: different definitions exist here as well. The energy used by a building is generally split into two parts: building related energy (BRE), which is energy for heating, cooling, ventilation, lighting and domestic hot water. And user related energy (URE), which is for appliances such as computers, etc. Most definitions referring to ‘energy neutral’ take into account the BRE. There are more ambitious definitions, such as ‘nul-op-de-meter’, taking into account URE as well (Jansen & Tenpierik, n.d.). “Energy plus” buildings actually produce a surplus of energy.
- Other aspects to be considered have to do with: (1) the type of balance (often between energy use - renewable energy generation) (2) renewable energy supply options (off site or on site) (3) connection with energy infrastructure (4) requirements.

This thesis uses the definition by the EPBD for a (nearly) zero energy building (nZEB). According to the EPBD, a ‘nearly zero energy building’ is a building that has a very high energy performance. “The nearly zero or very low amount of energy required should be covered to a very significant extent by energy from renewable sources, including energy from renewable sources produced on-site or nearby.” The EPBD further specifies what is meant by energy performance: “The energy performance of a building shall be determined on the basis of the calculated or actual annual energy that is consumed in order to meet the different needs associated with its typical use and shall reflect the heating energy needs and cooling energy needs to maintain the envisaged temperature conditions of the building, and domestic hot water needs.” For the EPBD Each member state can set the minimum energy performance requirements for buildings with a view to achieving cost-optimal levels (EPBD, 2010).

Producing energy nearby could for example be by district heating and cooling or another technical system serving a group of buildings (Rabani, Madessa, & Nord, 2017). When upgrading a neighbourhood, as is the case in the case study area of the Ramplaankwartier, it might make more sense to choose for such a district system.

2.3.2 Energy renovation

When referring to energy renovation, the following is meant: renovating an existing building towards a (nearly) zero energy building by making it more energy efficient and using renewable energy technologies for the BRE demand.

2.4 Boundary conditions for zero energy buildings

In this paragraph important boundary conditions are described for energy renovation. These have to do with business models, legislation and market appreciation.

2.4.1 Business model

nZEB's need high initial investment costs to install the energy measures. After that, the energy consumption is reduced, resulting in lower monthly energy bills. This means the initial investments will have a certain payback time. This payback time is essential for a successful business model.

Concerning the business model, Tim Jonathan concludes in his thesis that the problem mainly lies in financing. An investment will be attractive for the owner-occupier if the investment is lower than the benefits generated by it. This means the target price of a renovation should be lower than the cost benefits one gains from energy savings. Currently it seems the relation between these are not in balance: the investment of zero energy renovation pilots are higher than the supposed benefits. The target price of 45.000 for a zero energy renovation of a rowhouse as proposed by Energiesprong¹ is hard to achieve (Jonathan, 2016). However, it is worth noting that the costs for zero energy buildings are decreasing, partly due to better technologies, and partly to upscaling of implementation.

2.4.2. Legislation

Legislation for energy renovation exists on several levels. First, the EU has promised compliance with the Kyoto Protocol. With this the EU has given a long term commitment to maintain global temperature rise below 2 °C and to reduce by 2020 overall greenhouse gas emissions by at least 20% before 1990 levels and 30% if an international agreement is reached. To reach these goals, binding emission reduction policies are necessary, of which one is the Energy Performance of Building Directive (EPBD, 2010). The EPBD requires all Member States of the EU to set minimum energy performance requirements for new buildings, and for the renovation of the building stock. These requirements are that all new buildings should be nearly zero energy by 2020, and that the existing building stock needs to be nearly zero energy by 2050. These requirements need to be implemented together with national financial measures to support the process.

The European Commission (European Commission, 2011, cited in Konstantinou, Klein, Santin, Boess & Silvester, 2015) confirms the need to focus on the existing residential building stock by stating refurbishment as the greatest challenge, suggesting that in the next decades the investments in energy-saving building components and equipment will need to increase by up to € 200 billion.

In line with the EPBD the Dutch government has implemented a mix of policy instruments to reach these goals for the national building stock, outlined in the 'Plan of Action Energy Saving in the Built Environment' (Government of the Netherlands, 2011). The goal of the plan is threefold:

- Contribute to the EU target of 20% CO2 reduction by 2020;
- Use energy saving in houses as a method to give people more control over the increase of their living expenses;
- Use energy saving to boost the construction sector

(Government of the Netherlands, 2011, cited in Vringer, van Middelkoop & Hoogvorst, 2016).

The EPBD has resulted in BENG for the Netherlands ("bijna energieneutrale gebouwen"). From 2020 on all newly built buildings will have to qualify with BENG, which is set to replace the currently often used EPC to calculate the energy performance of a building. BENG has three indicators:

- The maximum energy needed in kWh/m²/year .
- The maximum primary fossil energy use in kWh/m²/year.
- The minimum amount of energy which must be generated renewably in %. So the BENG indicators are energy demand, primary fossil energy use and percentage of renewable energy. The energy need is the building related energy.

Different government parties are working on policy to make energy saving more attractive (Vringer et al, 2016, cited in Jonathan, 2016).

¹ Energiesprong is an innovation programme, which ended in 2016 and of which the goal was to create large scale market supply and demand of zero energy buildings. It works on multiple levels: trying to create better financial possibilities, trying to change legislation to suit zero energy buildings better, trying to create a better demand and a different way of supplying buildings.

2.4.3. Market appreciation

Jonathan mentions that the market appreciation/demand is a complex aspect in the implementation of zero energy renovation projects. Addressing the homeowner is crucial: the emotional side of renovation projects needs to be addressed and emphasized for a successful renovation. Considering emotions and wishes of inhabitants is a crucial factor in the up-scaling and success (Jonathan, 2016). This is confirmed by (Mlecnik & Straub, 2015) who mention that currently the market appreciation for zero energy renovation is low because the supply side is fragmented - separate parties are responsible for a fraction of a renovation project, often it costs more and it takes longer to build, there's a lack of knowledge and the project management is also lacking. This is burdening to the client. To unburden the client and increase market appreciation, the renovation process needs to be reformulated and better collaboration between parties is necessary. Information and communication towards the supply and demand side actors is crucial.

2.5 Current approaches to design circular buildings and energy renovations

Designers can use several approaches to either design zero energy buildings, or circular buildings. Sometimes these approaches can be used to design a building with combined circular and energy renovation goals. The approaches (guidelines for design) focus on circularity, energy renovation or on a combination of both.

2.4.1 Approaches focusing on circularity

Designing for circularity can be concretised somewhat in the 10 R's, defined already in figure (3). These are strategies one could implement to design for circular life cycles. However, design approaches towards circularity can go further than these strategies. The best known school of thought and design approach towards circularity and worth exploring here is Cradle to Cradle.

Cradle to Cradle (C2C)

As explained before, the C2C concept considers all materials to be nutrients. The design philosophy is based on the idea of biomimicry: mimicing nature's biological metabolism as a model for the flow of technical materials in the circular economy. Components should be designed for continuous recovery and reuse. The model is achieved through 5 steps of redesign outlined in the famous book by Michael Braungart and Bill McDonough. These 5 steps are:

1. Produce without harmful contaminants.
2. Follow informed personal preference: Choose on available information and common sense, and ask suppliers to validate their product.
3. Create passive positive lists and bad lists: research all possible materials and chart all relevant information (waste in production, etc). Create a positive list of 'good' materials that could be used to phase out 'bad' ones and pick easy improvements first. The X list will contain materials that need to be phased out (toxic for example), the Gray List materials that are less urgent for phasing out and the P list (positive list) materials that are safe to use.
4. Activate the positive list
5. Rediscover/reinvent: redesign the former system, think out of the box. Don't only consider the biological and technical cycles, but also think of other benefits a product could bring (Braungart & McDonough, 2002).

These ambitions make the C2C philosophy a holistic one: it's philosophy is closely linked to the four natural resources, which are energy, water, top soil and materials (Luscuere, Geldermans, Tenpierik, & Jansen, n.d.)

The C2C approach can however be challenging for projects on a larger scale than products (Dobbelsteen, 2008), such as the individual building meso scale of the design assignment in this thesis.

2.4.2 Approaches focusing on energy renovations

Zero energy renovation can currently be achieved through several measures. These are roughly organised in the following categories:

- Actions regarding building envelope & building design aspects: insulation, air leakage reduction, improving doors and windows, control and exploitation of solar gain and daylight, etc.
- Actions regarding building systems and energy components: install the newest HVAC systems, improve electrical lighting systems, improve domestic appliances, install renewable energy systems, etc.
- Actions associated with building services and management tools, like monitoring and controlling the building during operation, utilization of metering services, clock controls, sensors, etc (Rabani, Madessa & Nord, 2017).

Technically it's possible to achieve a high level of renovation, as has been demonstrated by several European exemplary renovation projects (Attia, 2015, NeZeR, 2014) (Konstantinou, Klein, Santin, Boess & Silvester, 2015).

2.4.3 Approaches combining circularity and energy renovation

New Stepped Strategy (and origins)

The New Stepped Strategy was developed by van den Dobbelsteen (2008). It is a renewed version of the well known Trias Ecologica, which has been the commonly accepted guideline for sustainable building since 1980. The Trias Ecologica has a few versions, of which the best known is the Trias Energetica (Dobbelsteen, 2008). The Trias Energetica has the following steps: step (1) is reducing of the energy demand, step (2) is using energy from renewable sources and step (3) is only using fossil sources when necessary and doing this as efficiently as possible (Rijksdienst voor Ondernemend Nederland, 2013). Another version, more focused on materials, is the waste hierarchy (also called the 3R's). The general idea is that in several steps one must reduce the amount of waste generated. These steps are in an order of priority, and they are: reduce, reuse and recycling of waste (Van Ewijk & Stegemann, 2016) and (Kukreja, n.d.).

These strategies are outdated, and also have a 'less bad' approach, focused on limiting the damage in nearly zero energy buildings (Luscuere, Geldermans, Tenpierik & Jansen, 2016). Furthermore, the first and third step of the variants of the strategies are often mixed up in practice. And the strategies have also not brought the environment to the desired sustainable state, even after decades of use (Dobbelsteen, 2008). For that reason, Dobbelsteen developed a new version of the Trias Ecologica, called the New Steps Strategy.

The New Steps Strategy is a holistic, updated and superior version of abovementioned strategies. The Cradle to Cradle, or C2C theory has been a heavy influence for the New Steps Strategy. C2C's basic idea is that material cycles need to be closed and nothing but 'food' must be left at the final stage of a lifetime. A inspiring theory, but as mentioned before van den Dobbelsteen concludes that the C2C philosophy can be a challenging basis for projects on a larger scale than products, and for other aspects than just materials.

However, it can provide the starting point for an updated steps strategy for the built environment. The opportunity lies in the higher complexity of a large scale district or urban development as compared to products. Thanks to this complexity energy, water and material cycles can be closed through interconnected loops. Buildings use energy, water and materials, and produce different flows of waste:

waste water, waste material, waste heat. Usually these waste flows are dumped, or downcycled, which C2C sees as a 'less bad' approach. It is a mitigating step, but will still eventually result in waste. This problem can only be tackled by means of recycling, which is usually considered in the same cycle: waste heat towards energy, waste water towards water demand, etc. But this principle can also be applied to other cycles: waste heat to water, waste heat to materials, waste water to energy, etc. This enabling of recycling into another cycle and shifting of demands and resources where necessary through technical measures can mean efficiency: an even smaller demand for resources is necessary, and less waste is possible (van den Dobbelsteen, 2008).

The New Stepped Strategy is summarized as follows (figure 9):

1. Reduce the demand by smart design of the building (which is more than just insulation)
2. Recycle waste flows (internally and externally)
3. (a) Supply the remaining demand sustainable and (b) let only clean and nutritious waste go to nature/let waste be food.

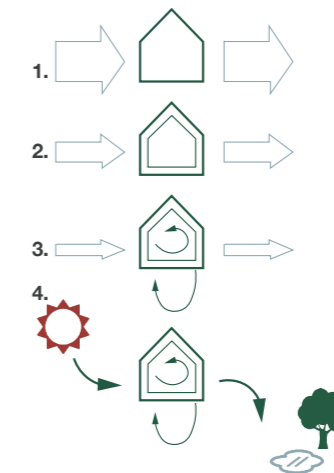

figure 9: New Stepped Strategy (adapted from van den Dobbelsteen, 2008)

1. Reducing the demand

This step relates to buildings and urban plans, and refers to passive design measures. Important is to use smart & bioclimatic design. It is defined as 'a design approach that deploys local characteristics intelligently into the sustainable design of buildings and urban plans'. The designer starts with a thorough analysis of the local context (climate, seasonal changes, weather, diurnal differences, geomorphology, landscape, cultural, historical and technical features, the built surroundings). This context leads to boundary conditions for the building site, which can then be translated into the design, to optimally site, orient and shape the building so the initial demand for resources is reduced to a minimum (van den Dobbelsteen, 2008).

Obviously the possibilities in the case of renovation as compared to new buildings are less, but nonetheless still present.

2. Reuse and recycle

Step 2 can be divided as follows:

1. Recycle internally
2. Collect waste water and waste material
3. Process waste water and waste material in a central treatment plant
4. Re-use the effluent of this in the building
5. Supply the resuming demand

As the NSS is a well known approach, further work has been done on adapting it to circular building approaches.

New Stepped Strategy adaptations

Notable work is done by Geldermans & Rosen Jacobson (2015), who have redefined some of the steps of the NSS for circular building. First, it's important to differentiate between building design and planning on the one hand, and materials and products on the other. Furthermore, the step 'reduce the demand' needs to be critically viewed in terms of circularity: from a circular point of view it's more about intelligent dimensioning linked to a certain lifespan. This stepwise approach is shown in figure 10 (Geldermans & Rosen Jacobson, 2015).

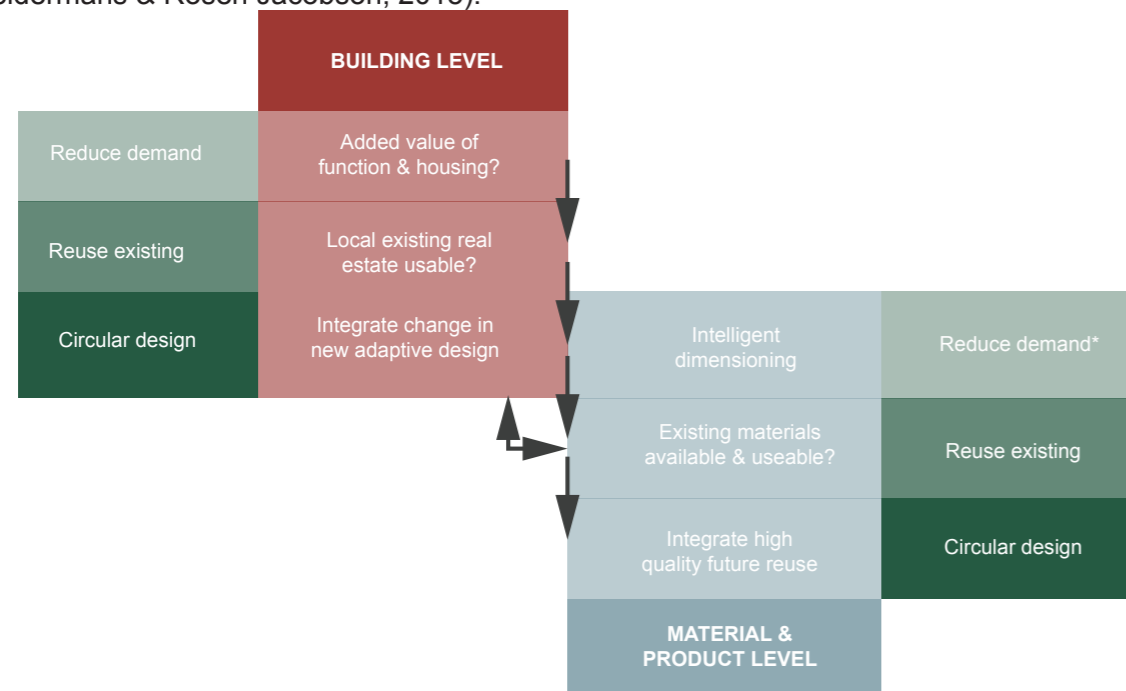

figure 10: stepwise approach circular building (adapted from Geldermans & Rosen Jacobson, 2015)

- integrate 'change' in a new adaptable design: distinguish generic elements with a long lifespan and high architectural or functional value from elements which can be changed, with a varying/short lifespan. Dimensions and connections are the leading principles in the design and construction of the building.
- use intelligent dimensioning: for products and materials, measures and capacities should be suited for the planned function, performance and lifespan. Overdimensioning might be an option to facilitate future changes in function or use, instead of reducing materials as much as possible. Reducing should be linked to lifespan: more material use might mean the product can be used more often.
- explore the usability and availability of existing materials: can materials close to the site be used in the design? Define a radius for the maximum distance for which it's relevant to collect materials. Use a 'harvest map'.
- integrate high quality future reuse: changeability must be a design principle, and anticipate biological and technical regeneration routes. Design for disassembly and flexibility. Use material and products that keep or increase in value.

Multi-criteria approach

The complexity of building renovation makes it into a non-linear multi-dimensional problem. Many factors during design need to be taken into account, related to energy performance, users' comfort, architectural aspects, economic aspects, etc. Multi-criteria approach is therefore an effective methodology for building renovation: it allows to keep into account many different parameters and using weighting to make the best choice possible. Several tools for multi-criteria approaches have been developed thus far, but Seghezzi & Masera (2017) mention that currently they show some limitations: as many parameters need to be taken into account complete optimality of all these parameters might not be achieved. The multi-criteria approach is a complex procedure.

Rabani et al. (2017) further mention that the main criteria assessed are often:

- (1) decreasing of energy use & improving energy performance
- (2) limiting impact on global greenhouse gas emissions
- (3) improvement of indoor environmental quality
- (4) upgrading of functionality and architectural quality
- (5) cost of the renovation

They mention that several of these criteria appear to be in conflict, like the improvement of energy use and architectural quality. Their conclusion is also that finding the optimum retrofit strategy is a complex task. In light of this complexity the multi-criteria approach, if used, needs to be viewed critically, and researched how it can best be applied to the case study. It does seem to be a good strategy, as in the design also criteria related to circularity need to be taken into account. Therefore a short explanation of what the method would look like

The method has to be followed in several steps:

- (1) define problem and formulate goal: the problem can be defined as finding the most suitable renovation solution in technological terms, considering installation issues.
- (2) identify the criteria and parameters: inspiration could be taken from Rabani et al's list above, but more criteria and parameters can be added, based on the design assignment. Circularity can be included here.
- (3) estimate weights: different approaches for weighting are available. The most used is the Analytic Hierarchy Process (AHP).
- (4) score determination
- (5) classify solutions
- (6) use feedback

Figure 11 shows how the different steps affect each other in the design process.

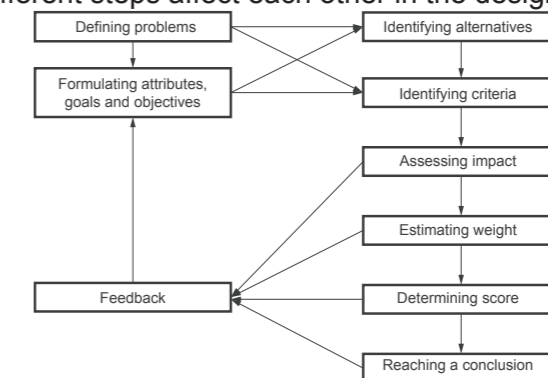

figure 11: multi-criteria approach (adapted from Seghezzi & Masera, 2017)

The attractiveness of the multi-criteria approach lies in its methodological and rational approach, ensuring the choice of design solution is based on a thorough validation and measurement (Seghezzi & Masera, 2017). Furthermore, it's very similar to using Key Performance Indicators for assessing circularity, as we will see later.

It can also be used as a method to assess circular or energy performance.

2.6 Tools to support the development and assessment of circularity and energy performance

2.5.1 Tools to support and assess circularity

Cradle to Cradle product certification

The C2C school of thought has also developed a product certification for designers and manufacturers. This certification process looks at a product within five quality categories, which are material health, material reutilization, renewable energy and carbon management, water stewardship and social fairness. The product receives a score in each category, ranging from basic to platinum. A product is assessed by a qualified independent organization trained by the C2C institute, and organization then licenses the certification if the product meets the demands. Every two years the manufacturer or designer must demonstrate efforts to improve their products in order to have it recertified (Cradle to Cradle Product Innovation Institute, n.d.).

Material Circularity Indicator (MCI)

The Circularity Indicators Project developed by the Ellen MacArthur Foundation provides a methodology and tools to assess how well a product functions in the context of a circular economy. These indicators can be used as a decision-making tool for architects and designers (Ellen MacArthur Foundation & Granta Design, 2015) It consists mainly of the Material Circularity Indicator. The Material Circularity Indicator measures how restorative the material flows of a product or company are and is part of this larger framework. The MCI measures the extent to which linear flow has been minimised and restorative flow maximised for a component. One that ends up in landfill after use and has been sourced from virgin materials is fully linear, and scores a 0. A product which is collected from reused elements and where the recycling efficiency is 100% can be considered a fully circular product and scores a 1.

The steps to follow are as follows:

1. First compute how much virgin feedstock is included in the product.
2. Calculate unrecoverable waste: how much of the material can be reused after end of life?
3. Calculate the linear flow index: measuring the proportion of material flowing in a linear fashion, i.e. how much is sourced from virgin materials and ends up as waste?
4. Calculate utility: exists of two components, one accounting for the lifetime and the other for intensity of use.
5. the Material Circularity Indicator can be calculated.

All these steps are based on formulas which can be found in the source (Ellen MacArthur Foundation & Granta Design, 2015).

BCI Assessment Model

In the validation of other fields like zero energy renovation, KPI's, or Key Performance Indicators are often used. Computable KPI's for the level of circularity are hardly known. In his graduation research, Jeroen Verberne has developed a BCI assessment model, made up of the Material Circularity Indicator (MCI) by the Ellen MacArthur Foundation explained before, a Product Circularity Indicator (PCI), System Circularity Indicator (SCI), and finally Building Circularity Indicator (BCI). The MCI is based on Ellen MacArthur Foundation's MCI project. The PCI incorporated the product disassembly possibilities. The SCI assesses the circularity of the products in a system together based on their weight and making a separation based on the shearing layers of Brand. The BCI assesses the separate systems as a whole with a factor for the level of importance for each system. Through a mathematical explanation partly based on Ellen MacArthur & Granta's Circularity Indicators, the BCI can be judged (Verberne, 2016).

Flex 4.0 Framework

A research project into the adaptive capacity of buildings has yielded several versions of instruments to assess this. The latest version is FLEX 4.0. The assessment is based on flexibility key performance indicators and weighting factors for each. The paper by Geraedts presents an instrument which can be used in practice to measure adaptability (Geraedts, 2016). This is not a measurement for the entire

circularity per se, but can be used to define a part of the measurement method.

Longevity Indicator

The Longevity indicator measures the time length for which a material is kept in a product system, to maximize the value during lifetime (Johnson, Figge & Canning, 2016, cited in Henry, 2018). This is not a measurement for the entire circularity per se, but can be used to define a part of the measurement method.

Disassembly Potential (Durmisevic, 2006)

To measure the extent to which a building structure can be transformed and disassembled, the Disassembly Potential by Durmisevic can be used. It assesses 8 different performance criteria, which measure the effect design decisions have on transformation. According to Durmisevic, "a structure can be transformed if its elements are defined as independent parts of a building structure, and if their interfaces are designed for exchangeability. One can define independence of building components and their exchangeability as two key performance criteria for transformable structures. Independence of parts is determined primarily by functional design domains, which deal with design of material levels and specification of clusters. Exchangeability of parts is defined predominantly by technical and physical design domains that deal with hierarchical order of elements within structures, and with connections between elements."

The performance indicators are summarized in figure 12. They are explained in more detail because they can also function as a design support in the design process.

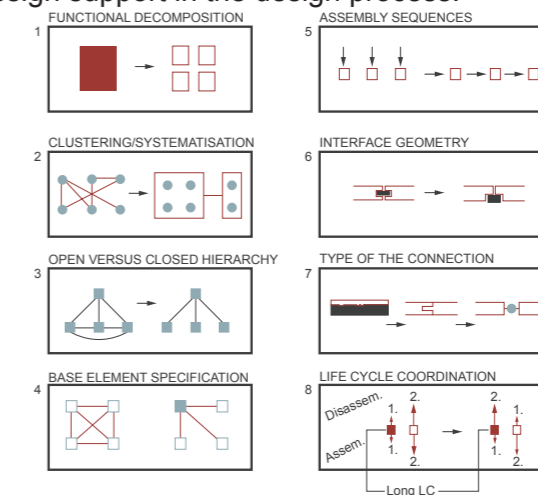

figure 12: summary performance indicators Disassembly Potential (adapted from Durmisevic, 2006)

1. Functional decomposition

This performance indicator is about if two or more functions are integrated into one building product or if each function has a separate product. Durmisevic defined three scenario's that determine the level of separation:

1. Integration
2. Incorporation
3. Separation: this option is favoured for design for disassembly.

So how can the designer design for separation? The first step is dividing the building into different parts with different functions and different life cycles. Durmisevic defines the main functions of a building as: supporting, enclosing, servicing and partitioning. Each can be further divided into subsections such as: foundation, frame, floor, facade, roof, ventilation, heating... etc. As an example of functional separation in walls, figure 13 illustrates three types of walls. Notice how Type 1 has all sub-functions integrated, type 2 has two sub functions integrated, and type 3 is completely separateable.

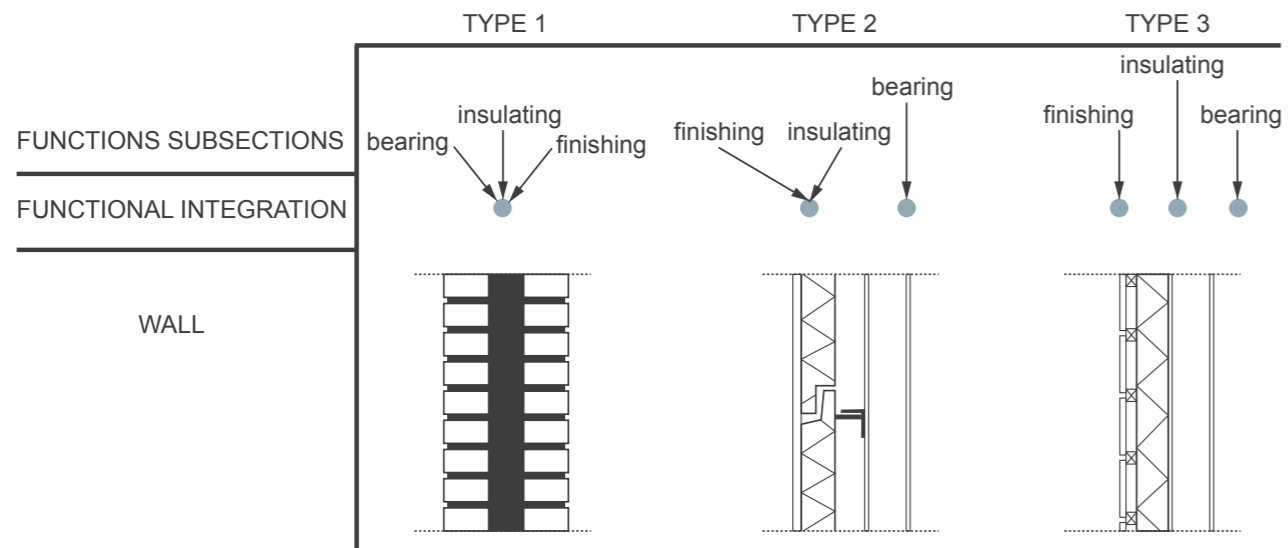

figure 13: types of walls (adapted from Durmisevic, 2006)

2. Clustering/systematisation

This performance indicator assesses how single building components are grouped together into sub-assemblies. A sub-assembly is a collection of parts that acts as an independent building section in production, exploitation and in assembly/disassembly. The more building parts are organised together in a sub-assembly, the less connections are needed on site, and the easier the assembly and disassembly there is. The assembly and disassembly process can then also occur in the factory where sub-assemblies are organised together. The designer can define the sub-assemblies based on their performance, the flexibility in production, the system design and geometrical or mechanical criteria. Durmisevic distinguishes four types of sub-assemblies:

1. Sub-assemblies on the subsystem level
2. Sub-assemblies on the component level
3. Sub-assemblies on system, component, element and material levels
4. No sub-assemblies present.

In these cases number 1 is the best option. To illustrate this by example: imagine a facade system as a subsystem, in which different functions such as enclosing, finishing, insulation, water protection and load bearing are organised separately from each other. These functions can be allocated through independent elements arranged into components. Components can then be replaced and interchanged with each other. Many modern facade systems have this type of modularity, figure 14 shows an example facade where the red squares indicate different components.

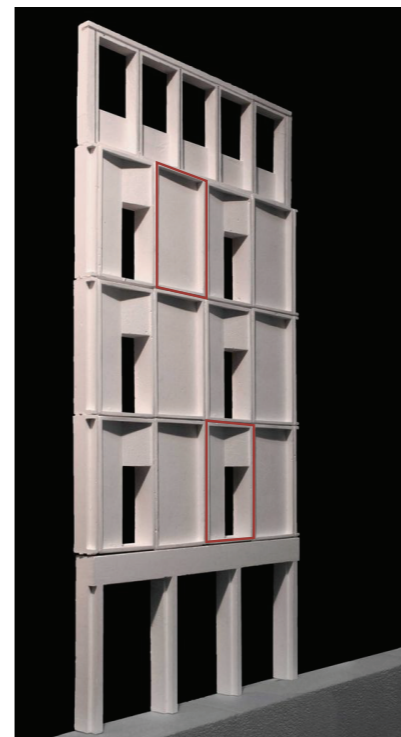
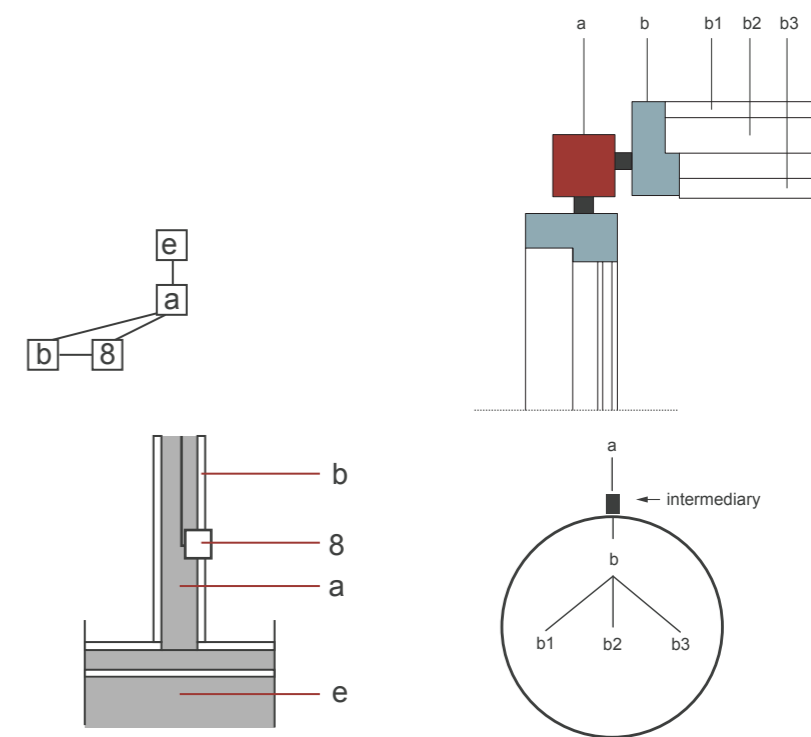

figure 14: clustering - figure 15: relational diagram figure (adapted from Durmisevic, 2006) - figure 16: base element functionality (adapted from Durmisevic, 2006)



3. Open versus closed hierarchy

This performance indicator assesses the relations in buildings. Traditional buildings were characterised by complex relational diagrams, which represented maximal integration of all building elements into one dependent structure. In such an environment, all the elements have relational dependencies with each other, and replacing one is not easy. There are six possible types of relational patterns that result in six types of assemblies:

1. Closed assembly
2. Layered assembly
3. Stuck assembly
4. Table assembly
5. Open assembly
6. Shared assembly

Furthermore, configurations can be horizontally oriented or vertically oriented, configurations which are vertically oriented can be seen as dynamic, while horizontal ones can be seen as static. Vertical relations represent relations within one functional group, while horizontal relations represent relations between different functional groups. The main rule is that sub-systems can only have relations with the load bearing system of the structure. That way components belonging to subsystems can easily be replaced. Figure 15 shows a simple relational diagram belonging to a wall where elements b, 8 and a can neither be replaced without damaging the other. This is a static system.

4. Base element specification

Each building product is a combination of several functions. And every building needs several sub-assemblies, as mentioned before. To provide independence from elements within one sub-assembly from elements within another, each cluster should have a base element which integrates all surrounding elements of that sub-assembly.

Figure 16 shows how this base element might function. A connection a has the function of intermediary between two independent assemblies.

5. Assembly sequences

The assembly sequence is influenced by the life cycle of assembled materials, the type, the geometry of the product edge and type of connections. It is essential that a structure can be taken apart with a minimum of destruction, waste and time. There are five types of assembly sequences:

1. Parallel assembly. Disassembly depends on the type of connections between elements.
2. Sequential assembly. Each element is fixed by a newly assembled element. There is a linear dependency.
3. Interlocking assembly.
4. Closed circle assembly.
5. Gravity assembly. This is the preferred type, where one element functions as the base element for all others. The key transformational aspect here is the type of connection between distinct elements.

6. Interface geometry

This performance indicator evaluates how the product edges are designed and if they can easily be taken apart. Open-linear geometries are preferable, with second best overlapping interfaces (so the element can be taken apart in one direction). Disassembly becomes impossible with interpenetrating geometries ('male' and female' connections).

7. Type of connection

This performance indicator evaluates the type of connections in the design. In general it's possible to define three main types of connections:

1. Direct (integral): The geometry of component edges form a complete connection here, like overlapping or interlocked geometry edges.
2. Indirect (accessory): Here additional parts are used to form the connections, such as internal screws or external accessory joints. These are preferred connections.
3. Filled: These are connections filled by a chemical adhesive/material, such as welding, or glue.

8. Life cycle coordination

This performance indicator deals with how materials are integrated with respect to their life cycle. Elements with a long life and the greatest dependencies in assembly, should be assembled first and disassembled last. Elements with shorter life cycles should be assembled last and disassembled first. By later assembly, less disassembly dependency is created as well.

This Disassembly Potential tool by Durmisevic can be used to guide the design through these design principles, and to assess the disassembly potential of the design.

Material passports & banks

BAMB, which stands for Buildings as Materials Banks, is an EU funded project started in 2015 and progressing for 3.5 years who "wants to enable a systemic shift in the building sector by creating circular solutions" ("About BAMB", n.d.). BAMB states that whether an industry goes circular depends on the value of materials - valuable materials will be reused or recycled. The aim is that materials in buildings maintain their value and will therefore function as banks of valuable materials, so materials and building components can be reused and thus decreasing the need for primary resource mining. Two strategies are essential to enable this shift: materials passports and reversible building design. For this end it's developing Materials Passports and a corresponding database & platform and developing reversible building design tools, and testing these in prototypes and pilot projects. The D1 Synthesis of the state-of-the-art report published outlines key barriers and opportunities for both of these tools in the current system (Debacker & Manshoven, 2016). They can be useful in defining the own design

strategy so a short introduction will be given here.

Debacker & Manshoven (2016) give the following definition for materials passports: "Materials Passports are (digital) sets of data describing defined characteristics of materials and components in products and systems that give them value for present use, recovery and reuse." The role of materials passports is threefold: first, it's for gathering data about materials and tracing materials and products in buildings, second, it has applications for organizing reverse logistics and third it's for accelerating innovation through information sharing. This last point is essential: currently information about materials used in buildings is barely available, which is a large cause of waste creation. By developing a materials passport together with a project materials can be tracked and opportunities for value are offered through recovery of materials. Furthermore a new value dimension can be added to the quality of the materials: by also tracking how suitable materials or products are for reuse as resources in other products and processes.

Several types of passports exist, like product passports, passports for products in buildings and building passports, as well as databases for tracking materials. (Mulhall et al., 2016, cited in Debacker & Manshoven, 2016, p. 54) identified at least 13 product passport initiatives. From these the Circularity Passports, developed by EPEA seem to be a good starting point for the development of BAMB Materials Passports and a related IT platform. The beta version can now be used.

When talking about materials passports, one must also mention the architect Thomas Rau. Together with Sabine Oberhuber, Rau has established Turntoo, a company specialised in circular economy principles. Turntoo has established the use of materials passports in the design of some well known buildings which were designed according to circular principles such as the Liander building. The goal is to provide materials with adequate information as to prevent waste and create value. Turntoo considers a building as a material bank, a depot of materials which have value at the different levels. ("Material passport", 2018). Rau mentions in his book 'Material Matters' that the material passport is simply a very precise inventory of all the materials, used resources and products in a building, where these are located, and how they are connected to the building. Turntoo has developed a 3D-BIM model for this. (Rau, Oberhuber, van Hennekeler & de Jong, 2016, p. 123-127)

Life Cycle Assessment (LCA)

Current LCA methodology is not really for circular product use, but it considers environmental impacts so worth to mention here. The Life Cycle Assessment is one of the more well-known methods for assessing environmental impacts, but faces some discussion in the scientific community, of which the foremost is that it's based on a linear model of building (Braungart et al, 2007, cited in Pomponi & Moncaster, 2017). In the same study this claim is contrasted by other studies claiming the LCA can and should be used as complementary tools for measuring circularity, such as authors mentioning that a framework such as Cradle to Cradle risks identifying solar technology as CO2 neutral or positive, while this might not be true. LCA is a tool to assess if a certain type of solar technology yields a net carbon reduction over its life cycle (Bakker et al, 2010, cited in Pomponi & Moncaster, 2017). Furthermore, the LCA method doesn't include the lifetime of products, while this is essential for the assessment of circularity (Franklin-Johnson, Figge, & Canning, 2016, cited in Henry, 2018). As it's such a well known method, many interpretations, variants and tools on the market exist. It has however been documented in an international standard: ISO 14040:2006. In light of the fact that disagreements about the LCA's suitability for circularity exist and the international standard documenting the process is from 2006, the application of LCA in this thesis must be viewed with a critical eye.

2.5.1 Tools to support and assess energy performance in energy renovation

Measuring zero energy use is easier than measuring circularity. After choosing the metric of the balance, balancing period and type of energy use included, it can be measured if zero energy consumption was achieved. The metric included is Primary Energy (figure 11 shows what primary energy is), the balancing period is a year and the type of energy included is building related energy.

Energie-index

An instrument which can voluntarily be used to calculate the energy performance of a building. Based on the Energie-Index, an energylabel can be determined. A certified energy advisor comes along and measures 150 predefined characteristics of the building, like the size, the insulation quality and the type of installations. Based on these characteristics, the Energie-Index number is calculated.

ENORM

A programme to calculate the EPC of buildings.

Uniec2

Uniec2 is an easy to use, online tool for assessing the energy performance of buildings and the calculation of other aspects like the EPC.

Energy simulation calculations

Energy simulation calculations are also useful to calculate the predicted energy use over a certain period of time. Programmes which can be used are for example: trnsys, honeybee, energieplus.

2.5.1 Tools to support and assess circularity and energy renovation

Roadmap Circular Land Allocation

The final strategy I would like to highlight here is the 'Roadmap Circulaire Gronduitgifte', developed by Metabolic, SGS and Search for the municipality of Amsterdam on 1st of June in 2017. It has a holistic view, taking into account the natural resources materials, energy, water, and the themes ecosystems, resilience and adaptivity. The roadmap gives a strategy, but also a framework with assessment criteria to measure the circularity of the design. The framework for measurement connects to others like BREEAM and GPR Gebouw. In designing circular building, four principles are leading, which describe the most effective sequence of decision making, and they form the basis of the assessment framework (Metabolic, 2017).

1. Reduce: design a system in which there is a low demand for energy and materials, but not at the expense of human comfort or quality of life.
 2. Synergy: principles of cascading and reusing wastestreams. Residual heat from for example cooling systems can be reused for heating.
 3. Production and purchase: when synergies are exhausted, further demand should use clean, renewable or otherwise ecologically favorable sources. Locally produced means are preferably. The impact and efficiency should be leading.
 4. Management: one needs feedback about how the system works for optimal functioning. This means creating transparant data and using information systems.
- These principles have been translated into Key Performance Indicators (KPI). The themes, principles and corresponding KPI's are summarized in figure 17.

Theme: materials
Principle: Reduce KPI 1. Material use over lifetime KPI 2. Environmental impact used materials
Principle: Synergy KPI 3. Design for disassembly KPI 4. Theoretical reuse of materials and components at same quality level KPI 5. Use secondary materials for building process KPI 6. Reuse materials during construction phase
Principle: Produce KPI 7. Policy about circular contracts KPI 8. Certification materials KPI 9. Use and documentation of critical and scarce materials KPI 10. Use renewable materials
Principle: Management KPI 11. Materials passport
Apex criteria KPI 12. Total score circular material use
Theme: adaptivity & resilience
Principle: Reduce KPI 1. Reduce dependency on external material- and energy flows KPI 2. Climate proof building
Principle: Synergy KPI 3. Fitness for urban plan KPI 4. Flexible, redundant and adaptive design
Principle: Management 5. Information management systems
Theme: water
Principle: reduce KPI 1: Reduce need for water
Principle: Synergy KPI 2: Cascade water flows KPI 3: Recovery of resource from waste water streams
Principle: Management KPI 4. Presence of water management system: monitoring and feedback KPI 5. Rainproof design
Theme: water
Principle: reduce KPI 1. Energy efficiency KPI 2. Embodied energy
Principle: Synergy KPI 3. Energy cascading
Principle: Produce KPI 4. Renewable energy KPI 5. Energy matching
Principle: Management KPI 6. Feedback about performance KPI 7. Contracts for energy systems based on performance
Theme: ecosystems & biodiversity
Principle: reduce KPI 1. Embedded impact on biodiversity
Principle: Synergy KPI 2. Ecosystem services
Principle: Management KPI 3. Promote local biodiversity

figure 17: Roadmap's themes, principles and corresponding KPI's (source: own image)

The criteria are well explained and can easily be adapted in the own design strategy. It is however, not finished yet. In a conversation with Gerard Roemers, the project manager of the Roadmap, he confirms the Roadmap needs more detailing and some aspects are not considered yet, such as Health & Wellbeing. Some indicators are still difficult to assess at this point, as it is not entirely clear what is the worst possible value and the best possible value. The plan for the future is pragmatic: as soon as the Roadmap starts being used by different parties, it becomes clearer what are good designs

and less good designs, and the score is compared to the design scoring best so far and worst so far. The more the Roadmap is used, the better this information becomes. The Roadmap is meant as a 'living' document, constantly being improved during use (G. Roemers, personal communication, April 3, 2018).

BREEAM/LEED

BREEAM is a holistic assessment methods: validating a building's environmental, social and economic sustainability performance. It can be used for masterplanning, new construction, in-use buildings and renovation & fit-out of homes and commercial buildings. It is a worldwide accepted tool (BREEAM, 2018).

BREEAM Domestic Refurbishment is an environmental certification scheme that is used to assess the sustainability of a refurbishment project and covers 33 issues within the following categories:

- Management: covers the management of the overall process
- Health and Wellbeing: covers measures to improve occupant health
- Energy: improvements to the homes energy efficiency
- Water: installation of fittings to reduce and monitor water use
- Materials: use of sustainable materials
- Waste: reducing, reuse and recycling of materials
- Pollution: avoidance of pollution
- Innovation: exemplary and innovative approaches followed

For each category one can score a number of credits that are awarded according to how many of the requirements (criteria - similar to multi criteria approach) are met. The credits are combined to give an overall rating for the project. Above 30% the project passed, and this percentage moves up towards outstanding, when the project reaches more than 85% (Wiseman & Summerson, n.d.).

The criteria are straightforward and explained to minute detail. An example within energy:

- Improvement in energy efficiency rating: one can obtain 6 credits for the improvement to the dwellings energy efficiency rating. This issue is assessed using the Energy calculator and SAP or RdSAP - credit allocation is based on exceeding EER improvement benchmarks, from the baseline EER (BREEAM, 2012).

This way each category has several of these criteria for which one can obtain credits. These criteria can then be fitted into a multi-criteria approach, as they are clear and already weighted (based on the amount of points to obtain) so this assessment method fits very well with the multi-criteria approach. (BREEAM, 2012).

GPR Gebouw

A holistic assessment tool, which measures 'sustainability' in five themes: Energy, Environment, Health, User value and Future value. Per theme one can earn a credit from 1 to 10. For existing buildings the advantage of using GPR is that you can see the improvement of quality for each intervention, so comparing interventions becomes easy - it can also be used during the design process ("GPR Gebouw maakt duurzaam bouwen meetbaar en bespreekbaar", 2018).

2.7 Conclusion

This chapter provided the necessary context about circular building and energy renovation for the design assignment. The questions addressed are:

1. What are current design approaches and tools to reach circular buildings and buildings with high energy performance?
2. What assessment methodologies and tools exist to assess circularity and energy use?

The working definition chosen for a circular economy is:

"A circular economy is a global economic model that aims to decouple economic growth and development from the consumption of finite resources. It is restorative by design, and aims to keep products, components and materials at their highest utility and value, at all times. The larger goal is to address human needs and fairly distribute resources without undermining the functioning of the biosphere or crossing any planetary boundaries.", based on a combination of the definition given by the Ellen MacArthur Foundation and Metabolic.

The approaches explained can be seen as design guidelines, design frameworks. The tools are can be seen as supporting instruments or assessment methodologies.

The approach identified aiming towards circular building (and only circular building) is cradle to cradle: a design philosophy based on the idea of biomimicry.

Design approaches towards zero energy use most often are simply a set of actions which can be taken. These are roughly organized in the following categories:

- Actions regarding building envelope & building design aspects: insulation, air leakage reduction, improving doors and windows, control and exploitation of solar gain and daylight, etc.
- Actions regarding building systems and energy components: install the newest HVAC systems, improve electrical lighting systems, improve domestic appliances, install renewable energy systems, etc.
- Actions associated with building services and management tools, like monitoring and controlling the building during operation, utilization of metering services, clock controls, sensors, etc (Rabani, Madessa & Nord, 2017).

There are some design approaches which can be used to combine both energy renovation and circularity, such as:

- the New Stepped Strategy
- a multi-criteria approach

The tools to assess circularity are:

- The cradle to cradle product certification: a certification method in which building products can receive a circularity score.
- Material Circularity Indicator (MCI) assessing the circularity of a product (considering recycled feedstock, virgin feedstock, how much of the material is recycled/reused after end of life and utility)
- The BCI assessment model: made up of the MCI, but also considering the building as a whole.
- Flex 4.0 framework: assessment method about the adaptive capacity of buildings.
- Longevity indicator: assessment method for the time length for which a material is kept in a product system.
- Disassembly potential: assessment method (but also design support) about the disassembly potential of buildings, containing a set of sub performance indicators.
- Life cycle analysis: not truly a circularity assessment tool, but mentioned because it does assess environmental impacts of materials.

Another tool, which is not an assessment method or an approach, but does support circularity, is a material passport. It is a digital set of data describing defined characteristics of materials and components in products and systems that give them value for present use, recovery and reuse.

The tools to assess energy performance in energy renovation are:

- Energie-Index: a tool to calculate the energy performance of buildings, determining an energy label.
- Programmes to calculate the EPC of buildings: ENORM, Uniec2.
- Programmes for energy simulations over a certain period of time: Tmsys, honeybee, energieplus

Some tools can be used to assess energy performance and circularity to some extent. These are:

- Roadmap Circular Land Allocation: it is an assessment methodology which considers energy use, material use, water use, adaptivity & resilience and ecosystems & biodiversity and is thus a holistic method.
- BREEAM/LEED: also holistic assessment and certification methods, considering management, health and wellbeing, energy, water, materials, waste, pollution, innovation.
- GPR Gebouw: another holistic assessment method considering multiple themes, energy, environment, health, user value and future value.

3. REFERENCE PROJECTS FOR CIRCULAR BUILDING & nZEB

The question addressed in this chapter is:

4. Are there existing reference projects of buildings with high ambitions on circularity, possibly combined with a high energy performance?

This chapter contains two reference projects for circular building and (nearly) zero energy building. These reference projects give a good indication of the implementation of both themes in housing in practice.

3.1 Fijn Wonen Circulair

Fijn Wonen Circulair is a new housing concept by Van Wijnen. The concept can be applied for renovation projects and for new buildings.

According to Van Wijnen, the housing concept scores 70% on the Building Circularity Index (assessed by Alba Concepts), which is based on Verberne's graduation research: Building circularity indicators: an approach for measuring circularity of a building, explained in chapter 2 (Verberne, 2016).

The focus of the circular housing concept is on demountability and remountability: the idea was to create a design which can easily be taken apart and its constituent components can then be reused. By making a remountable house, the owners (housing corporations or other investors) can easily respond to changing demographic or urban situations in the region where the house is located. In times of a shrinking population in certain parts of the Netherlands and growing flexibility in the needs of inhabitants, this facilitated remountability in the house becomes essential to be able to respond to these changing conditions. Furthermore, the houses have net zero energy use.

The house design is then based on the following key points:

- Demountability to facilitate relocatability.
- Net zero energy use house without gas connections.
- Affordable: for housing corporations and for residents.
- The functional lifetime is the same as the technical lifetime because of the demountability, the modularity and the reuse of elements (Bouwwereld, 2017).

These key points already give a good idea about with circular building means to Van Wijnen. In a personal conversation with Marije Kamphuijs, the project partner, she further clarified how circularity was integrated in the housing concept. The most important outcomes of this conversation is described below.

Circular building concept

The housing concept is meant to be deployed on a large scale, around 200-300 houses per year. For that reason, Van Wijnen was searching for circular solutions which are suited to this large scale. This meant that some solutions which are seen as circular, such as the use of renewable materials, would give rise to significant risk if they would be deployed on this scale: for these solutions the performance hasn't been tested yet on a larger scale and over a longer period of time, so using them on this scale for the first time would be risky if the product for example would not behave as predicted. Van Wijnen was seeking circular solutions which would bring an acceptable risk with them. The solution they found was to focus on traditional building materials and elements which have been tested thoroughly, but redesign the house so it's completely modular, demountable and the traditional building elements can be reused later.

"The market isn't ready for many of the circular building solutions being hailed now. However, waiting with circularity wasn't an option for us, but which solutions are already possible with the materials we already have? How can we use them so they can be reused indefinitely in closed loops?"

Design principles

As mentioned, the housing concept focuses on demountability, and the use of traditional materials. Well known design principles such as not using wet connections but bolting everything together instead are deployed, as well as standard components so they can be reused on other houses. To give an example, the floor is the same in every house.

Van Wijnen did some small scale pilot tests with less traditional materials (such as biobased materials) in the bathrooms, but came across some serious barriers during execution.

Boundary conditions and barriers for implementation

When the construction phase was taking place and Van Wijnen wanted to test biobased materials in the bathrooms, they ran into problems with volume: the supplier was only willing to deliver the materials in large bulks, more than Van Wijnen needed and thus going completely against circular building principles. This goes to show that the attitude of suppliers and other parties towards circularity is essential to implement it successfully.

Another problem they ran into is certification: new and innovative materials often don't have certification yet, and certifying them is quite expensive. This is a barrier in the area of legislation: the degree to which it's difficult to get certification is defined often by legislation.

The business model was also heavily influential in design decisions. The idea was to agree upon a lease contract: Van Wijnen would stay the owner of the house, and the housing corporation would lease it for a certain amount of years. After those years passed, the corporation could either buy the house, or give it back and pay for the use of the house. It was not possible to agree upon such a lease contract at this point in time, again because of scale problems. Implementing these lease contracts for 200 to 300 houses a year would heavily influence the money flows in the company, so more deliberation about how to shape new contracts is necessary. The contract they have implemented is as follows: the corporation or buyer is the owner of the house and together with partners Van Wijnen gives the buyer a performance assurance about the performance of the house. This way the risk is shared among multiple parties. Furthermore, Van Wijnen supplies the buyer with something akin to a 'voucher', with which the buyer can come back after a certain period and use it to demount and move the house. Van Wijnen is constantly researching new possibilities for business models.

Van Wijnen also ran into technical problems during the design: they noticed that demountability aspects don't go well with for example airtightness. Creating an airtight building and thus a building which performs better on energy efficiency would be easier with wet connections (M. Kamphuijs, personal communication, March 7, 2018).

Assessment methodology

The assessment methodology chosen is the BCI, developed by Verberne, and deployed by Alba Concepts. According to Kamphuijs, the BCI is simply based on measuring the reuse of materials and the degree to which they can be demounted. All the other indicators such as the use of renewable materials, or materials with low environmental cost (or within the other themes which often touch upon the circular economy such as energy or biodiversity) are just boundary conditions: good to have, not necessary to facilitate circularity. Alba Concepts gave the Fijn Wonen houses a score of 70% on the BCI.

Concluding

Van Wijnen searched for 'safe' circular solutions for their houses, which is understandable considering the scale of the project. However, the big question remains: will the buyer come back after the functional lifetime of the house has ended to demount it, transform it, move it to another area? If not, then it doesn't matter that the elements can in theory be demounted: the impact of them on the environment is the same as a traditional house, as they are traditional building parts. An other critical point: Van Wijnen does not share technical details about their house because they want to remain the expert in this field and do not want their knowledge to be copied. Somewhat understandable, but without a broad support for the sharing of detailed knowledge in this field, marketwide implementation is being obstructed.

Positive points are the fact that elements with a shorter technical lifetime such as the installations can easily be replaced without damage to the rest of the house, and that the houses developed have net zero energy use, bringing the impact attributed to the use to zero.

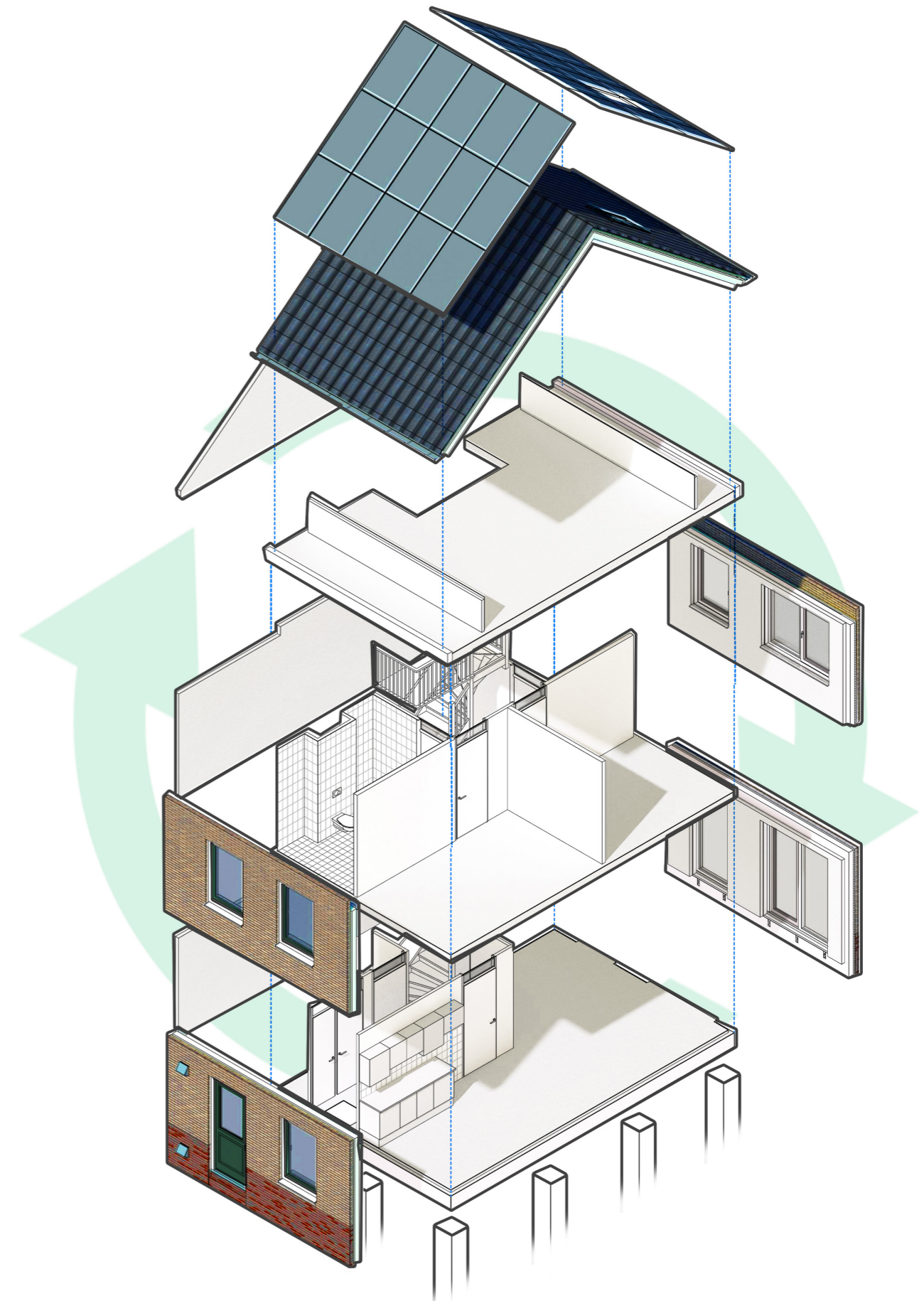

figure 18: Fijn Wonen Circulair concept (Bouwwereld, 2017)

3.2 Circular redesign 2nd Skin project

The 2ndSkin project is an integrated and prefabricated façade module which allows residents of multi-family post-war residential apartment buildings to upgrade their house to zero energy performance, with minimal disturbance during the renovation. The objective is not only to provide zero energy use, but at the same time provide possibilities for upscaling and a broad adaptability for multiple houses. The design can therefore be considered more like an approach than an one off solution. Furthermore, the goal is also to learn the framework and criteria in which the solution might be adjusted to other buildings or upscaled.

To meet the requirement of zero energy use, the entire system has three distinct parts:

1. Increase the thermal resistance of the facade by applying either the prefabricated module or exterior insulation variant.
2. with installed heat recovery in the facade component.
3. Use PV panels to generate electricity.

Two variants of the 2nd Skin Facade Refurbishment system have been designed:

- Prefabricated: prefab facade modules are connected to the existing facade through a substructure. This version has been tested in a mock-up. Systems for heating, ventilation and energy generation are integrated in the panels.
- Exterior insulation: the application of an exterior insulation system that is glued to the facade of the residential building. This variant is being applied to the case study building located in Rotterdam. (Konstantinou, Klein, Santin, Boess & Silvester, 2015).

What is interesting about the 2ndSkin project is that Quirine Henry has redesigned it into a circular variant. It is therefore a perfect example of circularity and zero energy use coming together in the built environment. Henry has concluded in her research that the prefabricated variant has most potential to be upgraded in a circular way. Therefore some more explanation of the prefab variant.

The prefab variant is independent from the structure. It exists of prefab floor-height elements, which contain new windows and building systems for ventilation, heating and energy generation. The prefab elements themselves are attached to the existing facade of the building through a substructure of wooden posts. This means the system can easily be accessed from the outside, so maintenance becomes easy. This system also provides the opportunity to replace the services when they become outdated. Ventilation pipes are embedded in insulation board and attached to the facade elements: fresh air is inlet through the facade, the outlet through existing ventilation shafts of the building. PV panels and installations for heat recovery are placed on the roof. The steps for assembling the project are as follows (image x):

- (1) installing the substructure of the 2nd Skin Facade - wooden posts are attached to the building with steel U-profiles and bolts.
 - (2) Placing the prefab facade element with integrated ventilation pipes on the substructure.
 - (3) Placing the prefab elements with windows and shading devices on the substructure.
 - (4) Installing the internal lining of the windows and placing airtight sealing between the prefab modules.
 - (5) Placing cladding on the modules, which can be made from various materials.
 - (6) Extra insulation is added on the roof.
 - (7) Finish the insulation on the roof with a cladding material.
 - (8) Install PV panels on the roof.
- (Konstantinou, Klein, Santin, Boess & Silvester, 2015)
(Konstantinou, Guerra-Santin, Azcarate-Aguerre, Klein, & Silvester, 2017)

Figure 19 shows an image of the sequence of how the prefabricated elements are connected to the facade.

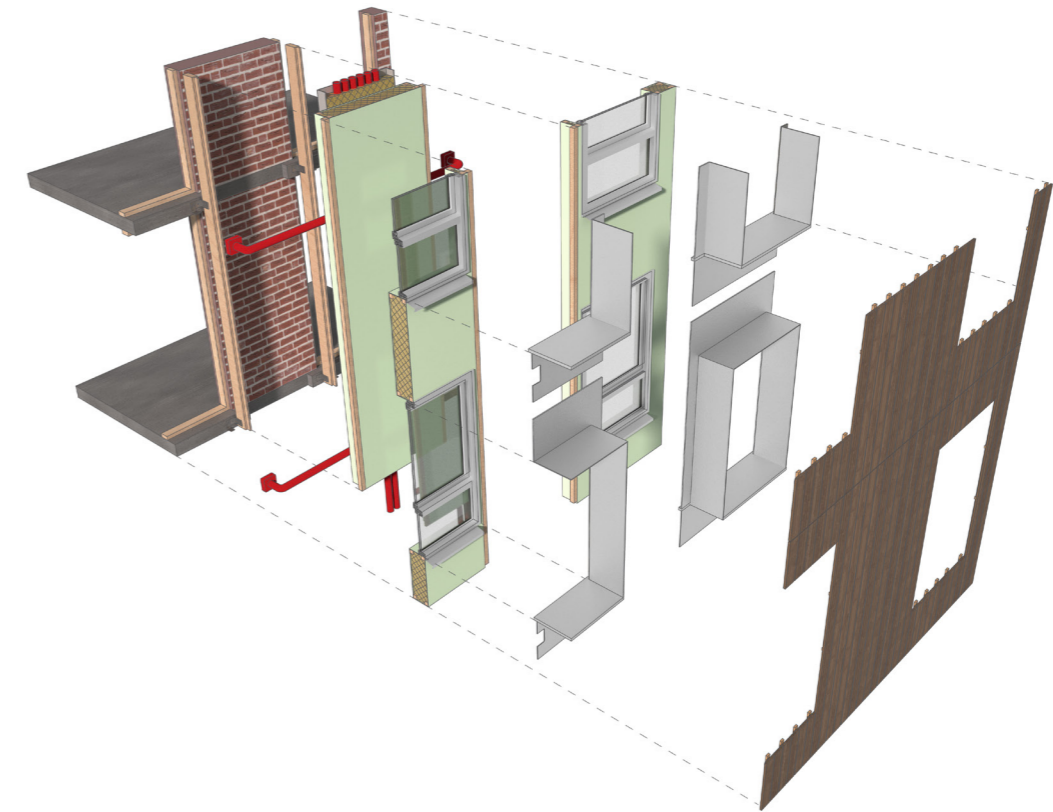

figure 19: 2nd Skin project - prefabricated variant (T. Konstantinou, personal correspondence, January 8, 2018)

Henry concludes that the system still has room for improvement when looking at reuse- and recyclability of the materials. The Disassembly Potential of the system can also still be improved. The different components themselves have very different scores in MCI-value, ranging from 0,42 (windows) to 0,80 (substructure). The structural insulated panels are considered to be the weakest link. Connections between elements within those panels are based on glue, and the integration of functions such as insulation and ventilation pipes are also a problem, as ventilation pipes have the shortest lifecycle, so at a certain point they need to be taken out. Henry's redesign therefore focused on the optimisation of the structural insulated panels in terms of reuse- and recyclability of materials and reversibility of connections.

The basic concept of the redesign as follows. The contractor wanted to find a solution which could be upscaled effectively, as the Netherlands has a large stock of post-war residential buildings. The idea arose to design a universal facade refurbishment system which could be applied to any residential building. The new system consists of standardised elements, stored in a factory. If the need arises for a building to be renovated with this concept, the dimensions of the building are used to define the exact dimensions of the modules needed, based on a standard grid. These can then be assembled off site, and transported to the building. At the end of life, the prefab modules can be brought back to storage, taken apart and reused. The reusability is reinforced through a simple concept: the connections have changed from wet to dry, and can be attached based on the size of the building to be renovated through using a predefined grid based on slits. The modules can thus be rearranged by pulling them loose and sliding them in another slit (Henry, 2018) (figure 20).

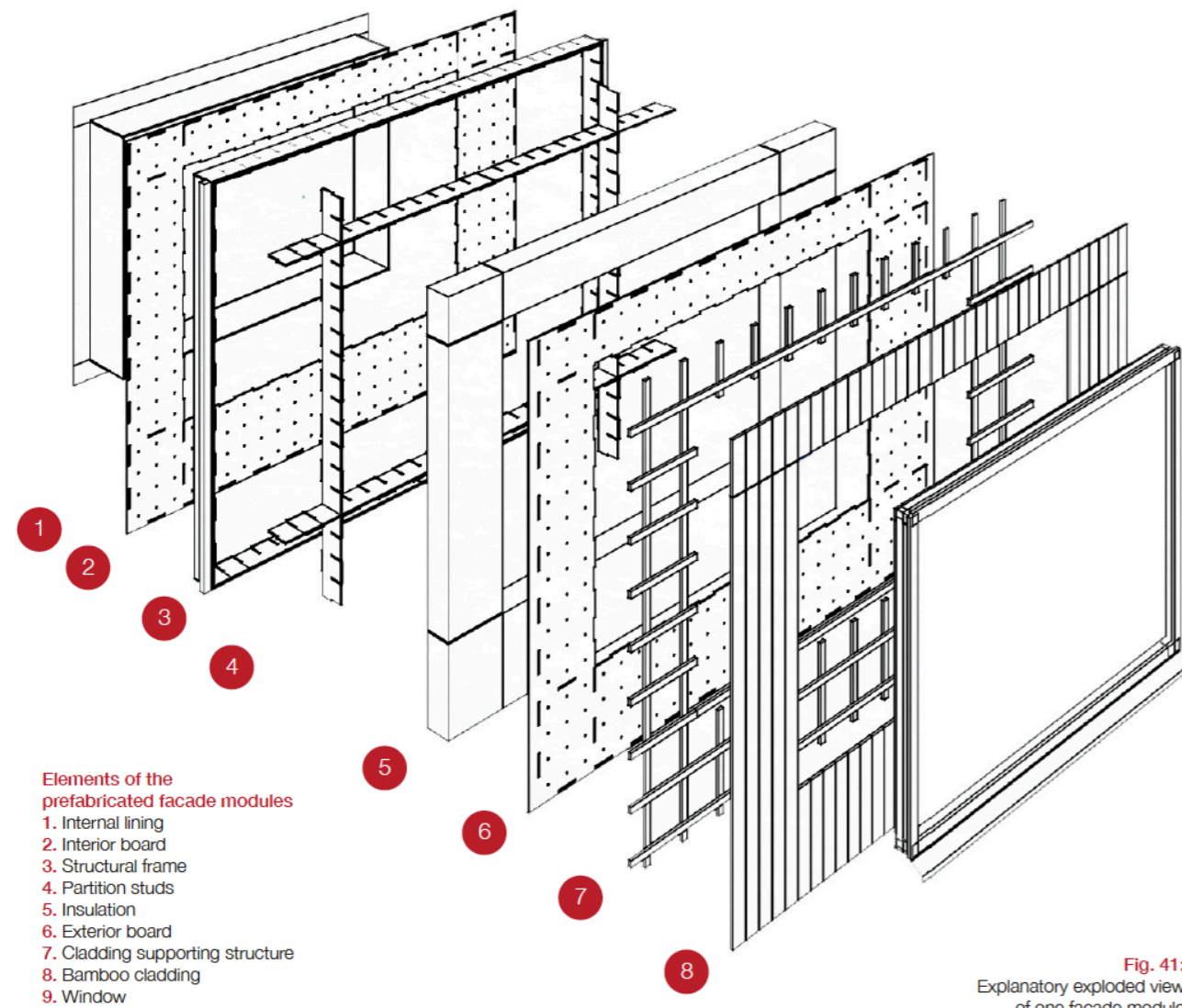
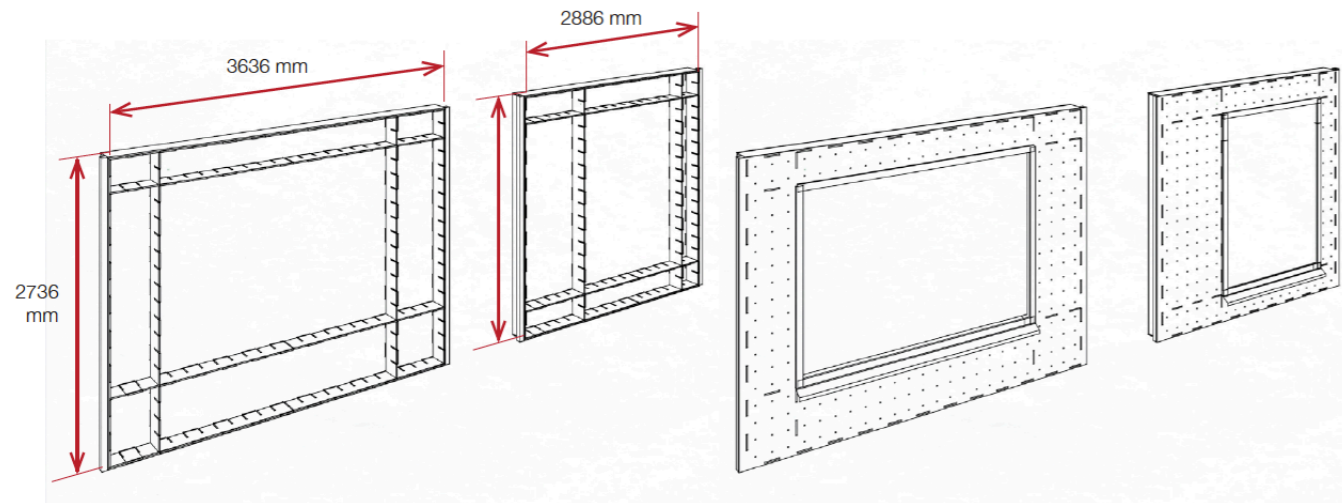

Fig. 41:
Explanatory exploded view
of one facade module

figure 20: circular redesign 2nd skin project (Henry, 2018)

3.3 Conclusion

The question answered in this chapter is:

4. Are there existing reference projects of buildings with high ambitions on circularity, possibly combined with a high energy performance?

There are. The two reference projects detailed in this chapter were chosen because they show a holistic vision towards circularity and towards energy use. However, neither has been built (yet). Fijn Wonen Circulair is being developed further, and so is the 2nd Skin project (both the original project and the circular redesign).

In the case of Fijn Wonen, the barriers present for implementation discussed during the interview are interesting to note. Marije Kamphuijs explained how in spite of their initial high ambitions some things were simply not possible at this moment, due to external influences like the attitude of suppliers or legislation, like certification for certain innovative materials which does not exist yet. Furthermore, some ideas were simply too risky to take on for a corporation like Van Wijnen: like implementing lease contracts. And as a final note: it became evident that Van Wijnen could not focus on multiple principles of circular building as detailed in chapter 2. Their focus was completely on demountability. Concluding: Fijn Wonen circulair is an existing reference project of a building with initial high ambitions on circularity, that were hindered by several barriers in practice. The ambitions for energy performance are high: net zero energy use without a gas connection.

The 2nd skin project and circular redesign of it is an interesting reference project: initially focused on high energy performance, it has been redesigned into being both circular and having high energy performance. However, it is not built yet, and possibly might never be: currently the 2nd skin project variant which is being built is the exterior insulation variant, which is not circular at all.

4. DEVELOPMENT & REFINEMENT OF ASSESSMENT METHOD

This chapter answers the following research question:

5. How will the circularity and energy use be assessed in the case study energy renovation project so this assessment supports the design of circular buildings and contributes to consensus & understanding about assessing circularity?

In Chapter 2 several assessment methodologies for circularity and energy use are considered, and this chapter describes the choice for the assessment methodology. The assessment methodology is tested on the old roof design currently present (described in the next chapter). During this process it became clear that the assessment methodology needs further development & refinement, which is also described in this chapter.

4.1 Choice of assessment methodologies

The assessment methodology chosen for circularity is Metabolic's Roadmap. This methodology has been described in Chapter 2. The reason for this choice is firstly because of the Roadmap's holistic approach towards circular building. Secondly, it's a fairly straightforward manual which can easily be followed during the design process. Thirdly, it is still under development, as confirmed in a conversation with Gerard Roemers, the project leader of the Roadmap. It is therefore interesting to further refine it in this thesis.

The assessment method chosen for the energy use is Uniec2. This is an easy to use online programme to calculate the EPC of a building and to assess its energy performance.

4.2 Choice of indicators

As explained before, the Roadmap has 32 different performance indicators, organised in the themes Materials (12 indicators), Energy (7 indicators), Water (5 indicators), Ecosystems & Biodiversity (3 indicators) and Adaptivity & Resilience (5 indicators). The Roadmap states it's not necessary or even desirable to take each indicator into account when assessing the circularity of a building. The designer must choose a combination of indicators which will yield an integral and balanced end result. Indicators might either:

- Have a degree of overlap between them, possibly resulting in scoring double points for the same part. This is to be avoided in the choice of indicators.
- Or be mutually exclusive to some extent. In the choice of indicators this is to be encouraged. That will result in the most integral end result, taking into account many different factors. If the designer would choose indicators which are only supportive of each other, that might mean that problems are simply shifted elsewhere in the design.

Figure 21 shows an overview of all the possible indicators and the possible causal relationships between them.

There are three possible causal relationships between the indicators.

- First, between indicators for which if the designer tries to influence the point outcome of one indicator, the point outcome of the other will be influenced in the same manner. These are indicated in red in figure 21. A combination of these indicators doesn't necessarily have to be avoided at all costs, but it is preferable to not have too many of them in the indicator set.
- Second, between indicators for which if the designer tries to influence the outcome of one indicator, it is probable that it influences the underlying goal of the other indicator, but this doesn't influence the points significantly. These are shown in orange in figure 21. Taking these indicators into account in the set is not a problem.
- Third, indicators which are mutually exclusive to some extent: this is actually a good thing, because taking them into account means the designer doesn't focus on one aspect, so problems aren't simply shifted to another area of the design. These are shown in green in figure 21.

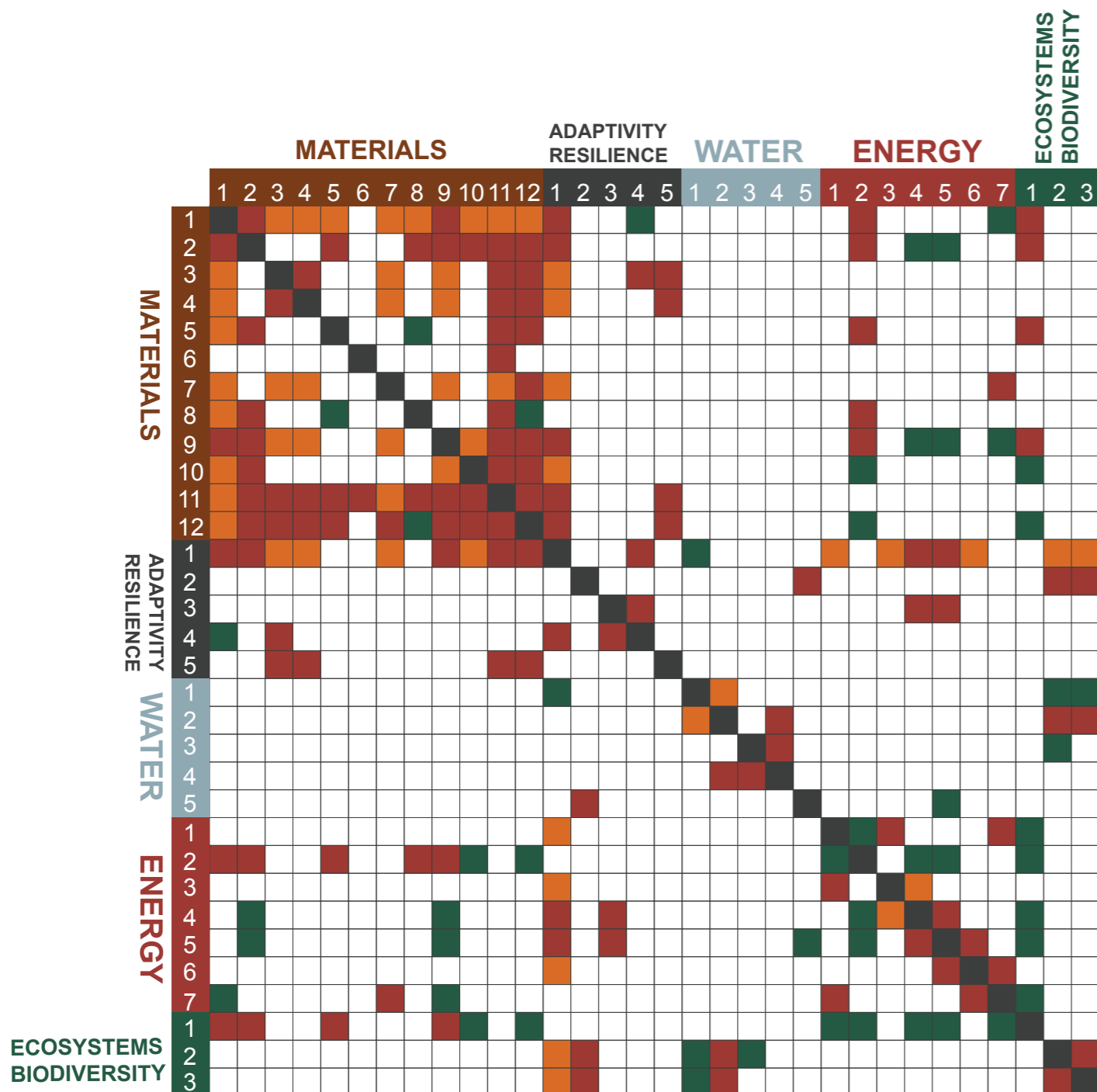

figure 21a: relationship between indicators (adapted from Metabolic, 2017)

1	Intensity of material use over lifetime of building
2	Environmental cost of materials
3	Design for Disassembly
4	Theoretical reusability of materials or components at similar quality level
5	Use of secondary materials for the build
6	Reuse of areas at the site and waste streams during construction phase
7	Policy on the matter of circular contracting suppliers
8	Buying materials in a sustainable way: certification
9	Use and monitoring of rare and critical materials
10	Use of renewable/biobased materials
11	Materials passport
12	Total circular material score
1	Reduce dependency on external material- and energy streams
2	Climate-resilient building
3	Fitting in urban plan
4	Flexible, redundant and adaptive design
5	Information management systems
1	Water use
2	Cascading of water streams: useful use of gray and rainwater
3	Recycling of nutrients from waste water
4	Monitoring and feedback water management systems
5	Rainproof design
1	Energy efficiency
2	Embodied energy
3	Energy cascading
4	Renewable energy
5	Energy matching
6	Feedback about performance of energy systems
7	Contracts based on performance of energy systems
1	Embedded ecosystems impact
2	Ecosystemservices
3	Fostering local biodiversity

figure 21b: set of indicators organized in themes materials, adaptivity & resilience, water, energy and ecosystems & biodiversity (adapted from Metabolic, 2017)

Based on the causal relationships between indicators and the function the roof structure has to fulfill, I think the following indicators need to be taken into account.

- **MAT 1. Intensity of material use over lifetime of building.** This especially matters because it's a secondary roof structure added to a structure below, so low weight design with intense use of materials is needed to unburden the underlying structure.
- **MAT 2. Environmental cost of materials.** This does have overlap with MAT 1 (red). If less material is used, the environmental cost calculation (MPG) will have a better end result. However, the MPG takes much more things into account besides weight of used materials, like embodied energy. This indicator matters because according to C2C philosophy, materials with bad environmental impacts like toxicity should be banned. The MPG calculation takes environmental impacts such as these into account.
- **MAT 3. Design for Disassembly.** This is essential: if the building can't be disassembled, circularity is not possible.
- **E1: Energy efficiency.** Assessing how much energy is needed during the user phase of the building. An essential indicator if the goal is to make an energy renovation.

Indicators not taken into account are:

- **MAT 4:** Theoretical reusability of materials or components at similar quality level. This indicator assesses how probable it is that components and materials can be reused at the end of their lifetime on a similar quality level. This indicator has serious overlap with MAT3. Design for Disassembly.
- **MAT 5: Use of secondary materials for the build.** Has overlap with MAT 2. Environmental cost of materials. The MPG calculation will give a lower value if secondary materials are used. This indicator is therefore left out, but must be kept in mind as a possible way of scoring better on MAT 2.
- **MAT 6: Reuse of areas at the site and waste streams during construction phase.** This is not unimportant, but outside the scope of this design process.
- **MAT 7: Policy on the matter of circular contracting suppliers.** This indicator is a boundary condition: good contracts are essential for functioning circular buildings. However, it is outside the scope of the design process.
- **MAT 8: Sustainable sourcing of materials: certification of bought renewable materials and metals.** Has overlap with MAT 2, so will be taken into account in MAT 2.
- **MAT 9: Use and recording of rare and critical materials.** Has several overlaps, so will be taken into account in the other indicators.
- **MAT 10: Use of renewable materials.** Has overlap with MAT 2, renewable materials have lower environmental cost. This indicator will therefore be graded in MAT 2.
- **MAT 11: Use of materials passport.** This indicator is also a boundary condition. A materials passport is an essential tool to facilitate circularity, and is needed for grading many of the other indicators. It will therefore be made, but not separately be graded.
- **MAT 12: Total material score.** This is not an indicator on itself, it is an extra check done by Metabolic itself, to see if there are no double points.
- **E3: Energy cascading:** Has overlap with E1 Energy efficiency, as cascading can be used to reach higher energy efficiency. Possible energy cascading design will therefore be taken into account in E1.
- **E4: Renewable energy.** Strangely enough Metabolic itself does not show a red relationship between this indicator and E1, Energy Efficiency, even though E1 is graded based on the EPC score of a design. The EPC calculation itself takes into account how much energy is needed for building related energy and lighting, and how this energy is generated (renewable, on site, or not). So taking into account renewable energy generated separately is not necessary.
- **E5: Energy matching.**
- **E6: Feedback about performance of energy systems.** a boundary condition. Outside the scope.
- **E7: Contracts based on performance of energy systems.** also a boundary condition, designing this is outside the scope of this thesis.
- **W1. WU: Water use.** This indicator is not taking into account because it depends on toilet, tap, shower design. These will probably not be present in the roof structure but in the rest of the house.

- **W2: Cascading of water streams:** useful use of gray and rainwater. This indicator is important for roofs because the roof structure is the first line of defence against rain: it can be used to collect and store rainwater to reuse it in the building. However, the assessment method is built on indicators such as installing a rainwater tank, avoiding using drinking water for irrigating greenery and proposing solutions like using waste of washing machines to flush toilets. All of these aspects can be assessed on the larger scale of the house, which is outside the scope of this thesis as it focuses only on the roof structure.
- **W3: Recycling of nutrients from waste water.** Metabolic states that the assumption is this goes through the municipal sewage treatment plants, so outside the scope of this design.
- **W4: Monitoring and feedback water management systems.** A boundary condition for responsible water use, outside the scope.
- **W5: Rainproof design.** Many of the parts of a building which have to be made rainproof such as basements and thresholds are not present in the roof structure.
- **EC2: Ecosystem services.** Evaluating the added value of the biodiversity in the design on several aspects like rainwater buffering, sequestration of CO2 and fine dust, reduction of urban heat island effect, etc. Greenery and biodiversity in the built environment on a large and small scale is essential for liveable cities and an easy way to improve some of the problems urban living poses for people. Furthermore, a roof might fulfill a function as a green roof. However, as this function can also be fulfilled in the garden on site where it also adds to the comfort of the residents, this indicator is left out of consideration.
- **EC3: Fostering local biodiversity.** Has overlap with EC2.
- **A&R1: Reduce dependency on external material- and energy streams.** Indicator is based on combination of E5 and MAT9, which are both not taken into account.
- **A&R2: Climate-resilient building.** Based on indicator W5 and how much the design contributes to urban heat island mitigation. As the house is placed in a neighbourhood with much greenery, urban heat island mitigation doesn't play a large role.
- **A&R3: Fitting in urban plan.** The design is not a large, iconic structure for which it would matter that it fits in the urban plan. Furthermore, Metabolic states this indicator is not graded but is taken into account on municipality level when handing in a design.
- **A&R4: Flexible, redundant and adaptive design.** This indicator assesses if a building can be adapted to future different use. However, we are assessing a roof structure on a house here; chances are small it will have different future use.
- **A&R5: Information management systems.** A boundary condition. It assesses if information about the design is organised so in the future it can be easily found. This indicator is not taken into account separately.
- **E2: Embodied energy.** This indicator is part of another indicator.
- **EC1: Embedded ecosystems impact.** This indicator is part of another indicator.

4.3 MAT1 Intensity of material use over lifetime of building

4.3.1 Metabolic methodology

Indicator one to be assessed is the intensity of material use of the building over its lifetime. According to the Roadmap it's relevant for circular building because the use of materials (and especially if these materials are not renewable) needs to be prevented and minimised. The indicator is not yet finished; the Roadmap contains one version, but Metabolic has given a suggestion for how to update this version in the future. Figure 22 shows the scoring methodology now and in the future as proposed by Metabolic. Currently it's dependent on handing in information, and in the future Metabolic wants to make this further dependent on a benchmark value, if the Roadmap has been used more often and the average material use for tenderers becomes clear (G. Roemers, personal correspondence, April 3, 2018).

The difficulty in assessing the intensity of material use currently with a comparison to a benchmark value is understandable: information about the benchmark is simply not yet present. The proposed future benchmark (material use per square meter for Amsterdam houses) seems an arbitrary value for the design researched in this thesis. Different buildings and houses might not be comparable in that manner in different cities, or even neighbourhoods and streets. A large city such as Amsterdam might have mainly apartment buildings, while the case study building here is a typical Dutch rowhouse. Each design might need a different minimum amount of materials. By comparing each design to one average benchmark, these nuances between different typologies in different cities are lost. Nuances between different types of materials with different weights (wood compared to steel) are also lost. In a conversation with Gerard Roemers, the project leader of Metabolic's Roadmap, he confirms this: in the future Metabolic would like to make it dependent on typologies of different buildings (G. Roemers, personal correspondence, April 3, 2018).

The second part of the assessment, an analysis in which the designer actively shows that different building elements have been researched with the goal to reduce the amount of materials needed during the build and during the lifetime of the building is logical. Handing in this analysis gives 25 points. Showing that design choices are made based on the analysis gives 25 points as well. One suggestion for the future is to change the amount of points which can be received to reflect the quality of the analysis, instead of receiving points for handing in information.

4.3.2 'New' methodology

The proposed (future) methodology by Metabolic, where the score is determined based on a benchmark can be adapted to the situation in this thesis, because there is an existing roof structure present which can function as a benchmark. The evaluation is twofold:

1. First, the weight of the materials in the existing roof is used to compare the weight of materials in the new design to. The intensity of material use can be calculated with formula $IM = M / L * B$. However, in this thesis only the weight of materials is calculated to compare. Firstly, the lifetime of the existing and new roof structures are most likely the same, so no difference in outcome there. Secondly, an argument can be made for excluding the occupancy rate and square meters in the formula: the formula can positively be influenced by a higher occupancy rate, but a higher occupancy rate will not benefit the residents wellbeing positively. The formula can also be positively influenced if the house in question is larger, but this then has a negative effect on energy performance, etc.
2. Second, as a support to the quantitative assessment in step 1, the material use for different building elements during build and during lifetime of the building is described. This means:
 1. Researching in the design process how to avoid material use for main functions : structure, roofs, closed and open facades, interior walls, installations, finishing of floor, wall and ceiling. Developing variants.
 2. Ensuring the elements used are of high quality (long technical lifetimes), so less replacements of elements during lifetime of building is needed.

3. Taking into account the manufacturing processes of separate elements: minimising material use per functional unit.
4. Minimising waste on building site during build.

This description is essential because the hypothesis is that the new design will use more materials per square meter than the old design, for example due to extra installations such as PVT panels on the roof. If this addition of materials can be justified and serves an extra function, than that doesn't necessarily mean that the new design is 'worse' than the old.

Assessment now	
Action	Points
Hand in an overview of the amount of materials in kg or tons	25
Hand in LCA in which designer shows that he/she researched how the necessary material use can be reduced for the following building elements during the build and during the lifetime of the building (replacements): structure, roofs, closed and open facades, interior walls, installations, finishing of floor, wall and ceiling. The designer should show the lifetime of the building and of the elements.	25
Show that design choices are made based on the LCA analysis.	25
Calculate intensity of material use by either formula: $IM = \frac{M}{L * B}$ $IM = \frac{M}{L * m^2}$ L = Technical lifetime B = Occupancy rate M = Material use in tons	25
Assessment future method	
Calculate intensity of material use & compare benchmark (Amsterdam house): $IM = \frac{M}{L * B}$ $IM = \frac{M}{L * m^2}$ $\frac{IM}{IM \text{ benchmark}}$?

'New' methodology	
Quantitative	
Step 1. Measure weight in kg of new roof structure	
Step 2. Measure weight in kg of existing roof structure	
Step 3. Compare weight new to weight old in chart: conclude how much kg better or worse	
Qualitative	
Step 1. Description of how unnecessary material use is avoided during design process for: structure, roofs, closed and open facades, interior walls, installations, finishing of floor, wall and ceiling.	
Step 2. Describe technical lifetimes of elements and replacements necessary.	
Step 3. Describe manufacturing process of elements and if the material used per functional unit is efficient or not.	
Step 4. Describe building on site and if waste is present.	

figure 22: Metabolic methodology (top), methodology used in this thesis (bottom) (source: own image)

4.4 MAT2. Environmental cost of materials (MPG)

4.4.1 Metabolic methodology

Indicator two to be assessed is the environmental cost of materials. This indicator evaluates the environmental cost (shadow costs) of materials on several area's. This is important for circular building because it's important to reduce the impact of the materials on the environment. Several tools for an MPG-calculation are available, the tool used for this is MRPI-MPG Software. The MPG stands for 'Milieuprestatie Gebouwen' and indicates the environmental impact of materials used in a building. The environmental impact is based on a life cycle analysis of a product or material. LCA's already done for products are collected in the 'Nationale Milieudatabase', so often it is not necessary to do ones own LCA, because the material or product or something similar will already be in the database.

The outcome of the LCA is then dependent on at least the following 11 sub-indicators:

- Exhaustion of abiotic raw materials (excluding fossil fuels)
- Exhaustion of fossil fuels
- Climate change over 100 years
- Ozone layer depletion
- Photochemical oxidation (smog)
- Acidification
- Eutrophication
- Toxicity for humans
- Aquatic toxicity fresh water
- Aquatic toxicity maritime environments
- Terrestrial toxicity

These environmental effects are measured in equivalents (for example CO2 equivalents for global warming) and multiplied with so called environmental costs or shadow prices. This shadow price is the cost of preventive measures which need to be taken to prevent a certain environmental effect. The costs give an indication of how much money society is willing to invest to prevent a certain environmental effect. The outcomes of these costs for sub indicators are then summarized in one final number: shadow costs of the material or product per bvom2 per year (NIBE, 2018).

An important point to mention is that measures which can positively influence the EPC might negatively influence the MPG and the other way around. Solar panels or thicker insulation yields a better EPC, a worse MPG. Because the EPC of buildings becomes lower each year the MPG calculation is becoming more important every year for the sustainability of buildings (Rijksdienst voor Ondernemend Nederland, n.d.). A second important critical point to mention is that the MPG-calculation is in fact a tool based on a linear system: the LCA analyses behind it analyze environmental impacts from cradle-to-grave. It does give a good first indication of the environmental cost of materials, but it does not take into account possible circular life cycles - if it did, the outcome might be different. Imagine a material which has a high environmental cost if it's analyzed from cradle-to-grave, but might be very suited for reuse. If the analysis would then take into account multiple life cycles, the environmental impact might be entirely different. This is essential information to keep in mind when working with the MPG and LCA. Figure 23 shows how the MPG calculation is currently valued in Metabolic's Roadmap. What is striking here that the designer has the choice from two different scales: one up to 100 points, which is not a linear scale (from 10 points to 25, then 40 - 60 - etc) and one up to 6 which is a linear scale. The reason for this is not known, and Metabolic was not available for further questioning about the reason for this scale.

4.4.2 'New' methodology

This indicator is not heavily adapted for this research. The suggestion is to use a linear scale for the points from 0 to 100, shown in figure 24.

Assessment now	
MPG calculation outcome	Points
10% under reference value (< € 0,63/bvom2/year)	10 OR 1
20% under reference value (< € 0,56/bvom2/year)	25 OR 2
30% under reference value (< € 0,49/bvom2/year)	40 OR 3
40% under reference value (< € 0,42/bvom2/year)	60 OR 4
50% under reference value (< € 0,35/bvom2/year)	80 OR 5
> 50 % under reference value (< € 0,35/bvom2/year)	100 OR 6

figure 23: current quantitative assessment method for environmental cost materials (adapted from Metabolic, 2017)

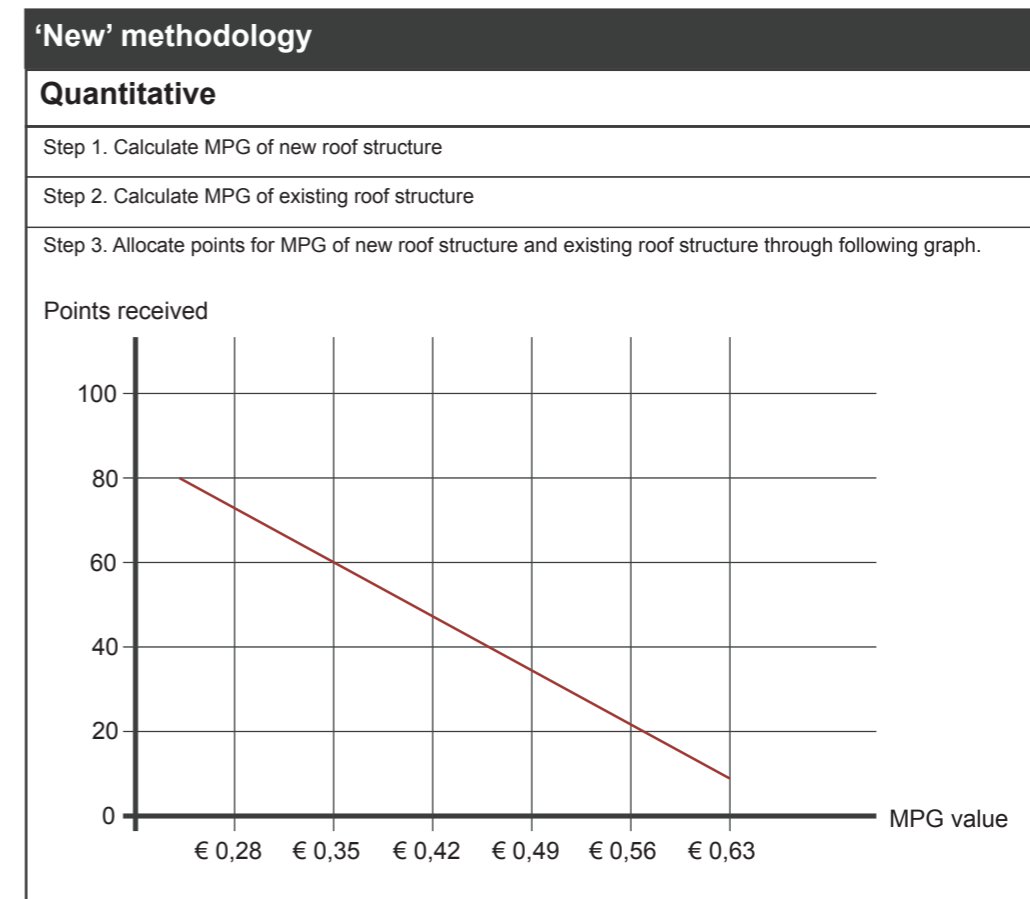

figure 24: Methodology used in this thesis (source: own image)

4.5 MAT3. Design for Disassembly

4.5.1 Metabolic methodology

This indicator evaluates the extent to which in the design disassembly is facilitated (with the goal to repair, replace or reuse components). This is important for circular building because in a circular economy materials need to be reused at high quality after their first function has ended. A building needs to facilitate the ability for this reuse without damaging the elements in such a way that they can only be reused as materials (downcycling). In the Metabolic method the design is assessed based on 10 design principles.

These design principles are:

- Document materials and methods for disassembly: building drawings, labeling of connections and materials and a 'demountability plan' contribute to efficient disassembly and demountability.
- Select materials based on precautionary principles: materials chosen with attention to the future impact and high quality so they're profitable to reuse.
- Make accessible connections: visually, physically and ergonomically accessible connections.
- Eliminate chemical connections.
- Use bolted, screwed and nailed connections - standard use and limited amount of connections so demountability doesn't need a lot of people.
- Separate mechanical, electrical and sanitary systems.
- Take into account how much labour and people are needed when designing connections: minimise.
- Simplicity in structure and shape.
- Interchangeability: use materials and systems which are modular, independent and standardised.
- Safe deconstruction: make sure workers can easily and safely move around, have access to equipment and the location in a safe way.

Metabolic states there are two possibilities for grading the implementation of these principles in the design:

1. The designer receives 100 points for each principle which has been implemented in the design according to the assessor.
2. Some of the principles have been translated in specific design starting points, for which points can be scored. These design starting points and corresponding points are shown in figure 25.

The second scoring methodology poses some potential problems:

- Not every principle is present in the grading. Metabolic states: the principles which are about connections between elements are translated in the grading methodology.
- Some indicators, like 2.1 Differentiation between 'drager' and 'inbouw' have no linear scale: if the designer has 'waarden in % inbouw' of 31 instead of 30 percent, this is a sudden addition of 5 extra points.
- Furthermore, based on literature study in chapter 2, other methods which measure disassembly seem more elaborate. For example Durmisevic' Disassembly Potential not only focuses on connections, but also on functional decomposition, base element, etc.

In this thesis therefore a different methodology is designed for this indicator, taking inspiration from the Disassembly Potential Tool and Metabolic's method. First, the Disassembly Potential Tool by Durmisevic is compared to Metabolic's design principles. Figure 26 shows an overview of this comparison: on the left (column 1) the design principles in the Metabolic assessment, on the right (column 4) the performance indicators in the Disassembly Potential Tool. Column 2 shows if design principles by Metabolic have overlap with Durmisevic' performance indicators, while column 3 shows if Durmisevic' performance indicators have overlap with Metabolic's design principles. Note how several of Durmisevic' performance indicators might all have overlap with one of Metabolic's design principles:

Assessment now	
Design principle	Points
Differentiation between carrier and encasing	
<i>Clarification: carriers are building parts with a long lifetime, such as the structure. The encasings are building parts which can be replaced without damaging the carrier. If more building parts are encasings, the building can more easily be transformed.</i>	
<10% of the building belongs to 'encasing' instead of 'carrier'	0
between 10% - 30% of the building belongs to 'encasing' instead of 'carrier'	5
between 30% - 50% of the building belongs to 'encasing' instead of 'carrier'	10
>50% of the building belongs to 'encasing' instead of 'carrier'	15

Movable interior walls	
<i>Clarification: if interior walls are easily movable, the building is more transformable.</i>	
Not movable without far-reaching/expensive architectural interventions	0
Not movable, can be demolished	5
Movable by demolition and building it up again	10
Easily movable without interventions	15

Demountable facade	
Facade elements can't be demounted and need to be demolished	0
Between 20 and 50% of the facade elements can be demounted	5
Between 50 and 90% of the facade elements can be demounted	10
All facade elements are demountable (<90%)	15

Connection details interior walls	
'Indringende' connections	0
Wet connections	3
Unique connectors for the project	7
Demountable not-unique connectors project	11

Interchangeability of "inbouw" components	
Encasing parts (walls, floors, ceilings) can't be interchanged	0
<50% is interchangeable	3
50-80% is interchangeable	7
All floors, ceilings and walls are interchangeable	11

Connection details "kopgevel" elements	
'Indringende' connections	0
Wet connections	3
Unique connectors for the project	7
Demountable not-unique connectors project	11

figure 25: quantitative assessment method for disassembly (adapted from Metabolic, 2017)

this goes to show how Durmisevic' indicators might be more detailed, influencing a more general design principle which is the Metabolic principle. Some design principles such as number 1, 2, 8 and 10 are not present in Durmisevic' performance indicators, while some performance indicators such as UCL, TCL, LCS and MJ are not present in the design principles. This gives a good indication of where both assessment methodologies might be refined further.

Another point of attention: Durmisevic' method is only focused on disassembly, while the first Metabolic principle (design with attention to future use) does also give an indication about what happens with building components after the first life cycle. Semantically speaking attention to future use should also not actually be a part of 'design for disassembly' as this only implies how well a building can be taken apart. It is however an essential part of a circular building, as explained in chapter 2. For that reason, an extra performance indicator is added: design for circular life cycles. This performance indicator is detailed in paragraph 4.6.

The new method of assessment for design for disassembly is then detailed in figure 27. It contains most of Durmisevic' weighted performance indicators, with the addition of two extra indicators:

- Deconstruction plan (adapted from Metabolic)
- Prefabrication: the amount of prefabrication heavily influences building and disassembly time.

Some of Metabolic's indicators are left out:

- 2. Attention for future use is left out as this is a part of the new performance indicator design for circular life cycles.
- 8. Simplicity in structure and shape is left out as this is very difficult to quantify and measure. Furthermore a simple structure is not necessary easy to deconstruct - it doesn't directly need to influence the disassembly potential but it can be an indication that the building is easy to deconstruct.
- 10. Make deconstruction safe for laborers is left out as this is will always need to be the case: giving points for safe deconstruction is like giving points for making a building that doesn't collapse.

Figure 27 then shows the new assessment methodology for Design for Disassembly. Each indicator is weighted, partly based on Durmisevic' weights, some weights added based on own interpretation of how important indicators are. The assessment methodology is organised in several themes, to make selection between indicators easier. It might be thinkable that not every indicator can be taken into account or matters for the design assignment. The final score is the weighted average of all the seperate grades.

Column 1	Column 2	Column 3	Column 3
DfD aspects Metabolic	Overlap with Durmisevic?	Overlap with Metabolic?	DfD aspects Durmisevic
1. Document materials and methods for deconstruction- make a deconstruction plan	N.A.	5.	FS (Functional separation) ↕ 0.9
2. Choose materials/components with attention to future use - high quality/profitably reusable	N.A.	5.	FDP (Functional dependence) ↕ 0.7
3. Make visual, physical and ergonomically accessible connections	GP T AF	8.	SF (Structure of material levels) ↕ 0.9
4. Eliminate chemical connections	TC	8.	C (Type of clustering) ↕ 0.9
5. Use bolted, screwed, nailed connections	TC	N.A.	UCL (Use life cycle coordination) ↕ 0.9
6. Seperate mechanical, electrical, sanitary	FS FDP	N.A.	TCL (Technical life cycle coordination) ↕ 0.9
7. Take into account amount of labor and people in designing connection points. Minimize	GP AF SPE T	N.A.	LCS (Coordination of life cycle & size) ↕ 0.3
8. Simplicity in structure and shape	N.A.	8.	R (Type of relational pattern) ↕ 1
9. Design interchangeable, modular, independent, standardized components	FS FDP SF C R B AD AS	8.	B (Type of base element) ↕ 1
10. Make deconstruction safe for laborers	N.A.	8.	AD (Assembly direction) ↕ 0.9
		8.	AS (Assembly sequences) ↕ 0.7
		6.	GP (Geometry of product edge) ↕ 0.9
		6.	SPE (Standardisation product edge) ↕ 0.5
		4.	TC (Type of connection) ↕ 0.9
		6.	AF (Accessibility to fixings) ↕ 0.9
		3.	T (Tolerance) ↕ 0.5
		N.A.	MJ (Morphology of joints) ↕ 0.7

figure 26: comparison Disassembly Potential & Metabolic (source: own image)

'New' methodology			
Indicator	Weight		Grading

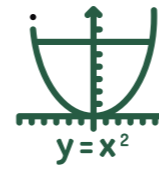

Theme: Possibility to separate different functional groups and replace functions

6. Type of base element (B)	1	BE - intermediary systems/components	1
		BE - on two levels	0.6
		With 2 functions (BE & 1 building function)	0.4
		No base element	0.1
7. Type of relational pattern (R)	1	Vertical	1
		Horizontal in lower zone of diagram	0.6
		Horizontal between upper/lower zone diagram	0.4
		Horizontal in upper zone	0.1
8. Functional separation (FS)	0.9	Separation of functions	1
		Integration functions same lc in 1 element	0.6
		Integration functions different lc in 1 element	0.1
9. Type of clustering (C)	0.9	Clustering according to the functionality	1
		Clustering according to the material life cycle	0.5
		Clustering for fast assembly	0.3
		No clustering	0.1
10. Use life cycle coordination (UCL)	0.9	long LC (1) / long LC (2) or short LC (1)/short LC (2)	1
		(1) assembled first (2) assembled second	
		Long LC (1)/short LC (2)	0.8
		Medium LC (1)/long LC (2)	0.6
		Short LC (1)/medium LC (2)	0.3
		Short LC (1)/long LC (2)	0.1
11. Technical life cycle coordination (TCL)	0.9	long LC (1) / long LC (2) or short LC (1)/short LC (2) or long (1)/short (2)	1
		(1) assembled first (2) assembled second	
		Medium LC (1)/long LC (2)	0.5
		Short LC (1)/medium LC (2)	0.3
		Short LC (1)/long LC (2)	0.1



Theme: Information

1. Deconstruction plan (DP)	1	Does the DP state how separate components should be disassembled for replacement?	add 0.2
		Does the DP state how elements within components can be disassembled?	add 0.2
		Does the DP state the most efficient method to disassemble the entire design?	add 0.1
		Does the DP give information about possible future uses for components?	add 0.2
		Does the DP give information about possible future uses for elements?	add 0.2
		Are connections & materials labeled?	add 0.1



Theme: Speed and comfort of assembly & disassembly

Speed and comfort of assembly & disassembly			
2. Assembly direction (AD)	0.9	Parallel - open assembly/shared assembly	1
		Stuck assembly	0.6
		Base element in stuck assembly	0.4
		Sequential, seq. base element	0.1
3. Accessibility to fixings (AF)	0.9	Accessible	1
		Accessible + operation (no damage)	0.8
		Accessible + operation (reparable damage)	0.6
		Accessible + operation (partly reparable damage)	0.4
		Not accessible - total damage	0.1
4. Assembly sequences (AS)	0.7	Component -> component	1
		<i>Regarding material levels</i>	
		Component -> element	0.8
		Element -> component	0.6
		Element -> element	0.5
		Material -> component	0.3
		Component -> material	0.2
		Material -> material	0.1
5. Prefabrication (PF)	0.7	Main functional groups divided in functional prefab component(s) (facade part 1 + part 2)	*1 OR 0,8
		Main functional groups divided in components/sub functions (facade prefab + finishing prefab)	0,8
		Prefabricated components + elements on site	0,6
		Mostly sub functions connected on site, some prefabrication for (sub)functions	0,4
		No prefabrication	0,1

** Depends on size of building:
1 point is earned if the prefab components are the largest size possible (transportation), 0,8 if the prefab components could've been larger*



Theme: Connections & interfaces

12. Geometry of product edge (GP)	0.9	Open linear	1
		Symmetrical overlapping	0.8
		Overlapping on one side	0.7
		Unsymmetrical overlapping	0.4
		Insert on one sides	0.2
		Insert on two sides	0.1
13. Type of connection (TC)	0.9	Accessory external connection or system	1
		Direct connection + fixing devices	0.8
		Direct integral connection + inserts (pin)	0.6
		Direct integral connection	0.5
		Accessory internal connection	0.4
		Filled soft chemical connection	0.2
		Filled hard chemical connection	0.1
		Direct chemical connection	0.1
14. Morphology of joint (MJ)	0.7	Knot (3D connection)	1
		Point	0.8
		Linear (1D connection)	0.6
		Service (2D connection)	0.1
15. Standardisation product edge (SPE)	0.5	Pre-made geometry	1
		Half standardised geometry	0.5
		Geometry made on the construction site	0.1
16. Tolerance (T)	0.5	High tolerance	1
		Minimum tolerance	0.5
		No tolerance	0.1

figure 27: new assessment method Disassembly Potential (source: own image)

4.6 MAT4. Design for circular life cycles

This indicator is in fact the backbone of circular building: building materials need circular life cycles instead of linear ones, otherwise a circular use of building parts, keeping them at their highest utility and value at all times and designing out waste, is not possible. The importance of circular life cycles for the CE has been discussed in chapter 2. A quick summary of the most important points discussed there:

- In a circular economy building parts can cycle in either biological or technical cycles to create closed loops. Four “power’s” should be considered: the power of the inner circle (cycle products for as long as possible through good maintenance and minimise energy needed for each cycle), the power of circling longer (maximising the number of cycles and the time spent in cycles), the power of cascaded use (diversify use of products among the chain to there are more possibilities for cycles and the power of pure circles (use uncontaminated materials).
- Depending on the context the optimal path of life cycles needs to be sought. This means that complex products which can have multiple short reuse life cycles are not necessarily better than homogeneous products which can be recycled without quality loss. The fitting cycles depend on the function of the building part (quality of performance), the exact composition and the performance life time (defined by the shearing layers of Brand).
- Building parts and their cycles need to be designed as such that they fit with the function they need to fulfill in the building. This also means designing as such that possible future other uses of the building and the building part is anticipated on by the designer.

We can translate these points (which are essentially design principles) into a qualitative assessment, assessing the fitness of the building part in question to cycle in circular life cycles. This method should then assess if the building part in question can cycle in biological or technical cycles, but it should also consider which path of cycling from the possible scenario’s of cycling is most suited for the building part. In a best case situation, the building part will then follow the optimal path of cycling, but could also follow other possibilities, diversifying the use among the chain.

To explain what I mean by this further, let’s take a look at the example of a generic solar panels. Solar panels will degrade during their lifetime, resulting in lower efficiencies. The general rule of thumb is that a PV module degrades with 1% each year (Jordan & Kurtz, 2012). Usually PV modules come with a warranty of 20 years, meaning that in 20 years the efficiency will be 80% of what it was in the beginning. This warranty can be taken to mean that the quality of performance of the solar panel can’t be guaranteed anymore after 20 years (the panel performs worse) so at some point it will need replacement. Which scenario’s of cycling are possible? We know the panel’s exact composition, it’s is a composite technical product, often having laminated parts which are difficult to separate. We also know that the separate materials, such as steel, silicium and glazing in the panel can be recycled without quality loss (Ten Brinck, 2016). The optimal path of cycling then seems recycling of the materials in the panel. Reuse of the entire panel is not possible because of the degraded efficiency. Remanufacture is difficult because the discarded parts are probably damaged due to disassembly. Repurpose is difficult because of the composition and sizes of the parts: which other function will need parts of these exact sizes? With recycling we can ensure all the materials get a second life at the same high quality as the panel was in the beginning of it’s first life. We have identified the optimal path. We also know that because of good European infrastructure (central PV panel recycling organisation PV Cycle), about 96% of the materials in solar panels are already recycled (Ten Brinck, 2016). So, a current solar panel performs “well” in terms of following the optimal path of cycling (recycling), but it has little other cycling possibilities.

The qualitative assessment is shaped in the form of different questions the designer needs to ask, before being able to judge if the building part performs well in terms of circular life cycles or not. These questions are:

1. *Is the building part to be assessed a component, element or material (and if a component, can it be taken apart in it’s constituent elements/materials)?*

This question determines the composition of the building part. A component is for example a window, a element the window frame and a material the glazing in the window. This is important information because it determines re-use possibilities: for example, a window might be reused in it’s entirety in a new project and thus less energy is needed for it to enter a second life cycle, while it’s separate materials can be taken apart and can be recycled.

2. *Does the building part contain biological, technical materials or both?*

Which type of materials are contained in the building part determines if the material fits within the biological cycles or within the technical cycles (or both).

3. *What is the performance/technical lifetime of the building part?*

4. *Does this performance/technical lifetime fit with the function the part has to fulfill?*

The technical lifetime of a building part must fit with the function it has to fulfill and can also influence the life cycles.

5. *Can the building part cycle in one or more of the biological or technical cycles?*

6. *What is the most suited path of cycling for the building part?*

Question 5 first determines in which cycles the part could cycle (the more the better, diversify use), and 6 then determines what is the best possibility: so for example a building part could be reused and recycled, but the best possible path is that the part is reused as many times as possible and only then recycled.

7. *How likely is it that the part will follow this path of cycling at this point in time?*

8. *How likely is it that the part will follow this path of cycling in the future (include boundary conditions?)*

Question 7 then determines if the best scenario of cycling can be followed now: this would be the optimal situation and the best outcome for this qualitative assessment. However, it is possible that currently the infrastructure is not present for this cycle, but it might be in the future. This should also be considered, and question 8 then considers future scenario’s.

The assessment methodology is summarized in figure 28.

1. Is the building part to be assessed a component, element or material? (and if component, can it be taken apart in its constituent elements/materials?)



Information questions: needed for assessment
Assessment questions

2. Does the building part contain biological, technical materials or both?



3. What is the performance/technical lifetime of the building part?



4. Does this technical lifetime fit with the function (building layer) of the part?



5. Can the building part cycle in one or more of the biological or technical cycles? If not, then what happens to the building part after end of life time?

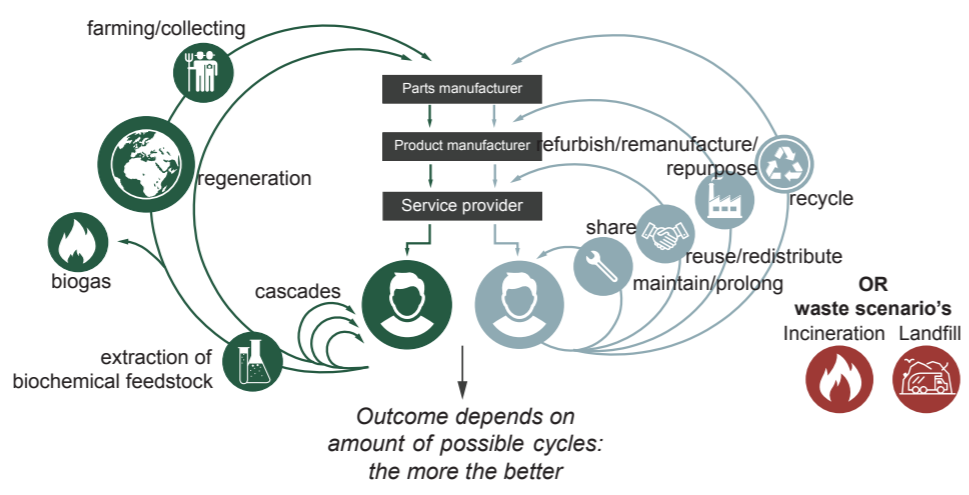

6. What is the most suited path of cycling for the building part? Explain why.

7. How likely is it that the part will follow this path of cycling at this point in time? Explain why.

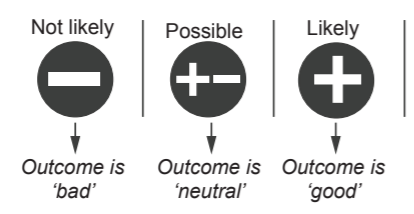

8. How likely is it that the part will follow this path of cycling in the future? Explain why.

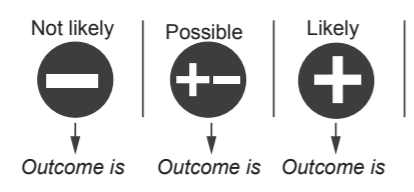

figure 28: qualitative assessment design for circular life cycles (source: own image)

4.7 E1. Energy efficiency

This indicator assesses the energy demand during the user phase of the building. The points for energy efficiency are calculated by comparing the EPC value to the reference value, which is the current demand for the EPC set in the 'Bouwbesluit'. From 2015 on this is for housing 0,4. If the design receives the 0,4 currently set in regulations, the points received are 0, and if the design is 'energy neutral' the points received are 100. This methodology is used in this thesis as well.

Figure 29 shows how points are awarded.

EPC calculation outcome	Points
EPC calculation 20% under reference value (<EPC of 0,32)	0
EPC calculation 40% under reference value (<EPC of 0,24)	25
EPC calculation 60% under reference value (<EPC of 0,16)	50
EPC calculation 80% under reference value (<EPC of 0,08)	75
EPC calculation 100% under reference value (=EPC of 0)	100

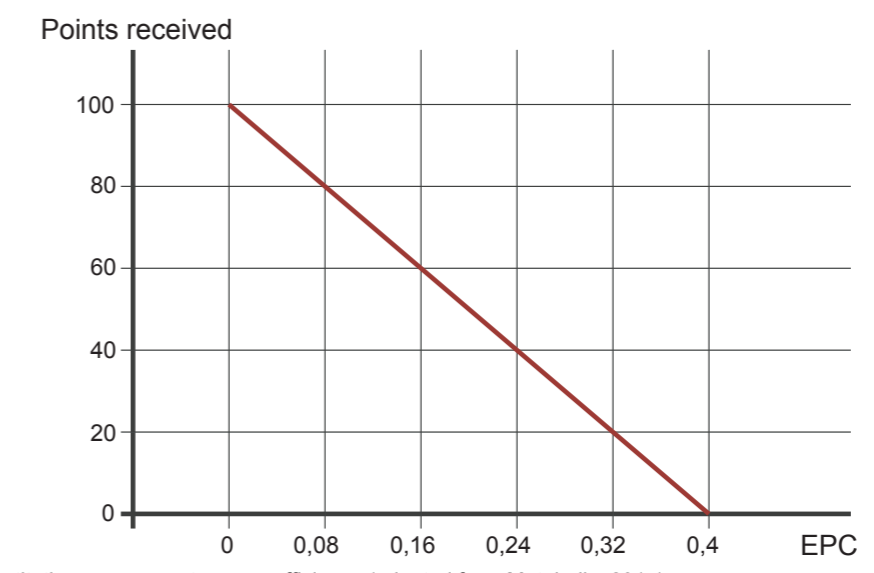

figure 29: quantitative assessment energy efficiency (adapted from Metabolic, 2017)

Some points to consider: The EPC is the current measure for energy efficiency often used, but will be replaced with the BENG by 2020, so then the assessment methodology also needs updating.

An EPC value of 0 only means that the BRE (building related energy) is compensated with renewable energy generation. It however does not take into account the user related energy (Bewust Nieuwbouw, 2016). The value of 0 is somewhat misleading: it does not mean zero impact. Furthermore, the assessment methodology maximum points (100) are for an EPC value of 0 and it doesn't consider energy positive buildings - such a building should be rewarded with higher points. If the designs turn out to be energy positive, this could be rewarded by giving 100+ points.

The programme Uniec2 will be used to calculate the EPC. Uniec2 also shows the BENG outcomes.

4.8 Conclusion

This chapter answers the following research question:

5. How will the circularity and energy use be assessed in the case study energy renovation project so this assessment supports the design of circular buildings and contributes to consensus & understanding about assessing circularity?

The starting point for the assessment methodology is Metabolic's Roadmap. From the possible indicators to assess the following are chosen:

- MAT1: Intensity of material use over lifetime of building
- MAT2: Environmental cost of materials
- MAT3: Design for Disassembly
- E1: Energy efficiency

MAT1 will be quantitatively assessed by comparing the weight of design variants with the benchmark value weight of the existing roof structure. As a support to the quantitative assessment, the material use for different building elements during use and during lifetime of building is described. This description is necessary because the hypothesis is that the new design will use more materials than the old design, for example due to extra installations such as PV/T panels on the roof. If the addition of materials can be justified and serves an extra function, this doesn't necessarily mean that the new design is 'worse' than the old.

MAT2 will be quantitatively assessed by calculating the environmental costs of materials in an MPG calculation, using the MRPI-MPG software. The points received are based on the outcome of the calculation, which is a value in shadow costs of the design per bvom^2 per year. This outcome for the new design is compared to the old design, so it can be stated if the design scores better or worse.

MAT3 will be quantitatively assessed by a methodology based partly on Metabolic's principles and partly on the Disassembly Potential Tool. A set of 16 different sub-indicators is organized in three themes (Information | Speed, comfort and safety of assembly & disassembly | Possibility to separate different functional groups and replace functions). Each indicator can receive a score between 0 and 1, and each indicator has a weight to distinguish between their relative importance. The total score is then the weighted average of the indicators taken into account - it is not unthinkable that not each indicator can be assessed in every design.

During development of MAT3 it became clear that a new indicator needed to be added: design for circular life cycles. This indicator is in fact the backbone of circular building and determines the fitness of building parts to cycle in circular life cycles. It is a qualitative assessment, in which a set of questions is used to determine the amount of possible cycles the building part can undertake in either biological or technical cycles (the more the better) and is used to determine how likely it is that the part will follow the optimal path of cycling at this point in time and in the future. If it's not likely in either scenario, that's a negative 'bad' outcome, if it's likely, that's a positive, 'good' outcome for this indicator.

E1 will be quantitatively assessed by an EPC calculation. The points received are based on how much the EPC calculation is above or below the reference value of 0,4, which is the current requirement in the 'Bouwbesluit' for housing.

5. CASE STUDY DWELLING

This chapter describes some necessary background information about the case study dwelling, located in the Ramplaankwartier.

5.1 Spaargas project

This thesis is set within the context of the Spaargas project. Spaargas is a multi-annual project by foundation De Ramplaan. The main goal of the project is to transform the Ramplaankwartier neighbourhood in Haarlem to a sustainable one, in which the use of natural gas for heating is eliminated and replaced by locally produced renewable energy. This is achieved by proposing energy renovation solutions for the dwellings in the area, fitting with the wishes of the residents. Residents can sign up for participation in the project online. They can then either anonymously hand in information about their dwelling, or they can actively think along with the Spaargas team. The TU Delft's role in the whole is to develop different sustainable options for energy for the dwellings in the neighbourhood, either on the level of individual dwellings or on the level of the entire neighbourhood. The residents can then give feedback about which options for the dwellings they prefer. From this collaboration the municipality of Haarlem and the TU Delft then develop a thought through package of sustainable measures. Spaargas then searches for external funding and adequate business model(s) ("Wat is SpaarGas?" n.d.).

5.1.1 TU Delft research for Spaargas

The current state of the art of the TU Delft's research is described here: this is still under development and might change in the future (S. Jansen, personal communication, November 27, 2017).

The TU Delft research for Spaargas is done within the framework of the European project "Smart Urban Isles". The research takes place in several steps.

1. The potential for energy saving in the different dwellings is researched.
2. The potential for renewable energy generation for heating in the neighbourhood, on individual building level and on district neighbourhood level is researched.
3. Different scenarios for supplying heat to the dwellings are developed.
4. Cross scenarios between individual dwelling level and district neighbourhood level are also researched.

At this point the TU Delft has developed three scenarios for potential energy saving in the dwellings.

1. **'Easy' renovation:** insulating the cavity walls of the facades, applying double glazing in the windows and insulating the floor and roof. Insulating the facades and floor is not possible in every dwelling, as some typologies in the Ramplaankwartier have too little space in the cavity and/or the crawl space in the floor is not high enough. The crawl spaces could be dug out, but this would cost about 2000 euros.
2. **Energy renovation:** using high performance insulation material, possibly using low temperature radiators for heating and adding a ventilation system with demand-driven exhaust.
3. **Ambitious renovation and remodelling** of the dwelling: using high performance insulation material, possibly replacing the outer wall of the cavity wall with extra insulation and stone strips. Adding an extra roof structure or other house extension, using floor heating and adding a new (concrete) floor, and adding a ventilation system with heat recovery.

The TU Delft has developed several scenarios for renewable energy generation for heating, scenarios for individual dwellings but also on neighbourhood level. The possible individual scenarios are as follows:

1. **Individual air to water heatpump in combination with gas boiler.** A hybrid heatpump (for heating of the home) is placed next to the gas boiler. The heatpump has the outdoor air as its source. Under about 5 degrees °C the heatpump doesn't work anymore, and the gas boiler starts working. Domestic hot water is delivered by the boiler. About 4 PV panels deliver 1100 kWh/year in terms of electricity needed for the heatpump. This energy system is suitable for the 'easy' renovation scenario. However, if the dwelling has better insulation, the heatpump will be able to deliver more heat and less gas is necessary. The hybrid heatpump will cost about € 4500,- and the PV panels about € 1600,-. This is an existing system that can already be implemented. Figure (x) shows a scheme of this system.
2. **All electric system with individual heatpump based on PV/T panels.** A water to water

heatpump is placed in each dwelling and about 12 to 15 PV/T panels supply the heatpump with water and electricity. From these PV/T panels about 10-12 are needed for the electricity for the heatpump (2500-3000 kWh/year), while about 3 panels can thus be used for electricity for appliances. The heatpump also supplies the domestic hot water, next to the heating need. If the home is not insulated sufficiently and it's a very cold day, then it's possible that extra heating power might be needed. The type of PV/T panels researched for this are Triple Solar panels. The heatpump has a peak power of 6 kW for heat. The entire system will cost about € 22500,-. This is an existing system that can already be implemented. Figure 29 shows a scheme of this system.

3. System with individual heatpump in combination with PV/T panels and a ground source.
 This is similar to system 2, but it uses less electricity because of the ground source and it needs less PV/T panels. Each dwelling receives a water to water heatpump and about 6 to 8 PV/T panels (2500-3000 kWh/year). The heatpump also supplies the domestic hot water. This system includes an external storage tank of about 200-300 liters. Extra heating power might be needed on very cold days. The heatpump has a peak power of 6 kW for heat. The entire system will cost about €21000,- for the heatpump and PV/T panels and about €4000,- for the ground source. Figure 30 shows a scheme of this system.

The possible collective scenario's for renewable energy generation for heating are:

1. Individual heatpump with a collective ground source ('warmte-koude opslag').
2. Individual heatpump with a collective ground source and collective booster heatpumps.
3. Collective ground source and only delivery in dwellings.

The energy design in this thesis is based on the individual scenario 2: all electric system with individual heatpump based on PV/T panels.

5.2 The Ramplaankwartier

The Ramplaankwartier is one of the neighbourhoods in Haarlem. It is a neighbourhood consisting largely of dwellings: 2720 people live there in 1105 households. Most of the dwellings are rowhouses built in the period between 1925 and 1936, and have low energy performance. This low energy performance is illustrated in the energy labels of the dwellings (figure 31). The Ramplaankwartier is a typical Dutch neighbourhood in the sense that it consists largely of rowhouses and that the houses are pre-war houses. A study showed that this typology of housing is about 7,7% of the entire Dutch housing stock (Agentschap NL, 2011).

5.3 The case study dwelling

The case study dwelling in question is located in the Dickmansstraat. This street is chosen for several reasons:

- A large part of the street (and parts of surrounding streets as well) were developed simultaneously in 1934, so many of the dwellings located there are the same and are of poor energy performance. Some houses have had some renovations during the years. The design can therefore be scaled up.
- During the TU Delft research it became clear that this typology of house is too small for current standards: this is illustrated in the fact that many residents in the Dickmansstraat and surrounding streets chose to add a roof structure for extra space to their dwelling.
- The combination between poor energy performance and too little living space inspired the scope of the design assignment explained in chapter 2: the addition of a roof structure, providing residents with extra space and functioning as an energy roof.

The fact that there are already roof structures present has the big advantage that one such existing roof structure can be used as a benchmark value to compare the new roof structure design, developed in chapter 7, to. This comparison gives a good indication of the performance of the new roof structure design. The case study dwelling to be renovated is number 46, and the dwelling with existing roof structure which is analyzed in chapter 6 is number 40. Pictures of the street and the case study dwelling can be found in figures 31a to 31f.

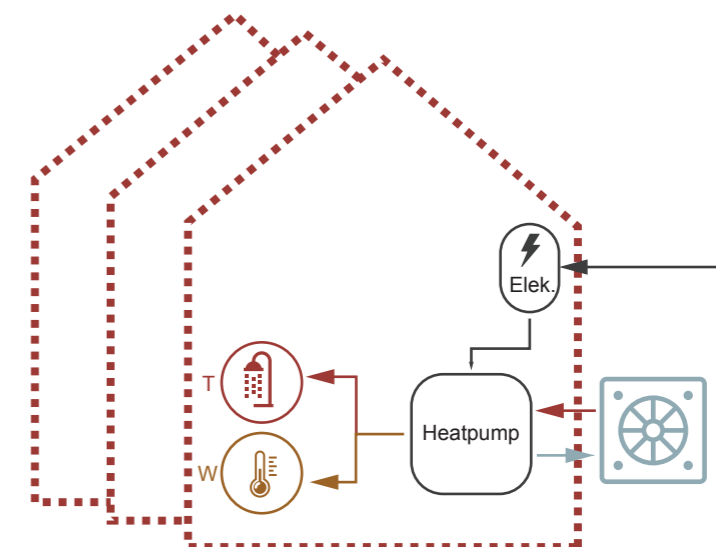

scenario 1: individual air to water heatpump in combination with gas boiler

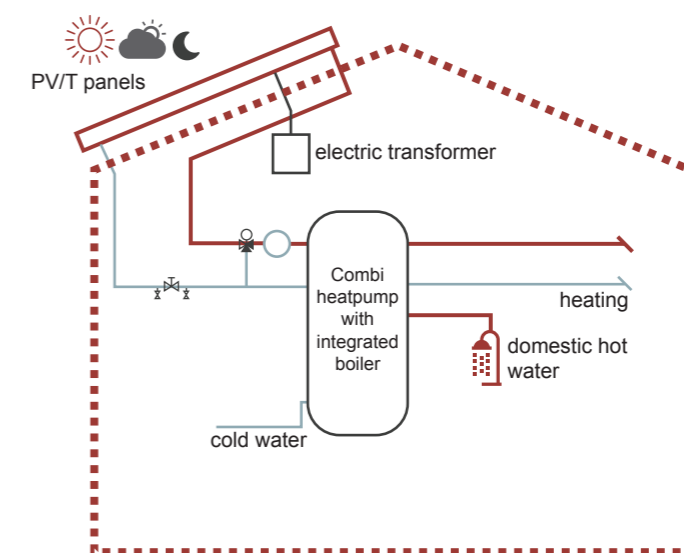

scenario 2: all electric with individual heatpump based on PV/T panels

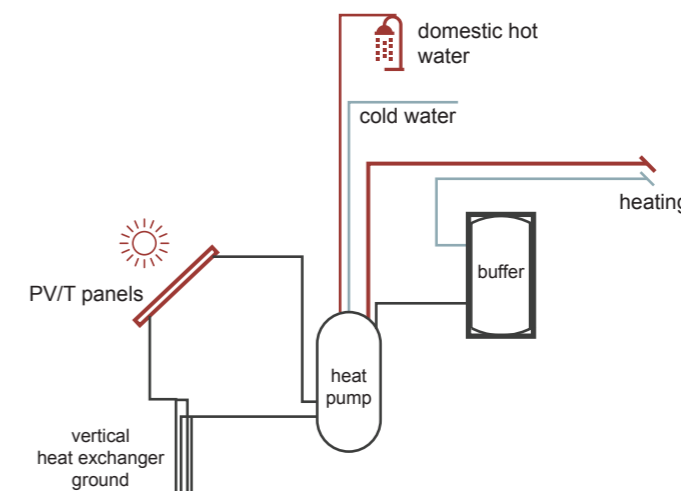

scenario 3: individual heatpump with PV/T and ground source

figure 30: individual scenario's of renewable energy generation proposed by TU Delft (under development) (source: adapted from S. Jansen, personal communication, November 27, 2017)



figure 31: energy labels of dwellings in the Ramplaankwartier (source: own image)



figure (32a) front view of case study dwelling block (source: own image)



figure (32b) view of dwellings typology: 4 rowhouses in a block (source: own image)



figure (32c) front view of case study dwelling (source: own image)



figure (32d) view of Dickmansstraat (source: own image)



figure (32e) back view of variety of roof structures built on top of dwellings (source: own image)



figure (32f) front view of typical existing added roof structure (source: own image)

6. CIRCULARITY ASSESSMENT OF EXISTING ROOF STRUCTURE

In this chapter, the level of circularity for an existing roof structure will be assessed. Most of the houses in the Dickmansstraat have added extra roof structures to increase the living area. This assessment is done for Dickmansstraat 40, which added the roof structure in 2006.

The research question answered in this chapter is:

7. What is the circular and energy performance of the case study house without energy renovation?

The assessment method used is described in chapter 4, minus MAT4. Design for circular life cycles. This indicator was developed late in the process and because of time limitations couldn't be assessed for the existing roof structure.

6.1 Description of existing roof structure

The roof structure is located at the Dickmansstraat 40. The planning application for the roof structure was handed in in 2006, and the drawings used for this application are the basis of this circular assessment. The typology of the roof structure is 'roof structure increased cam', see figure 33. This typology is most common in the Dickmansstraat, as it creates an extra living area, and the houses built in 1934 are too small for current standards.



figure 33: typologies of roof structures, from left to right: roof dormer - extended roof dormer - roof structure elevated cam - roof structure elevated cam flat roof (source: own image)

Figure 34 shows the different parts of the roof structure which will be assessed in this chapter. The elements which will be accounted for in the assessment are drawn in orange.

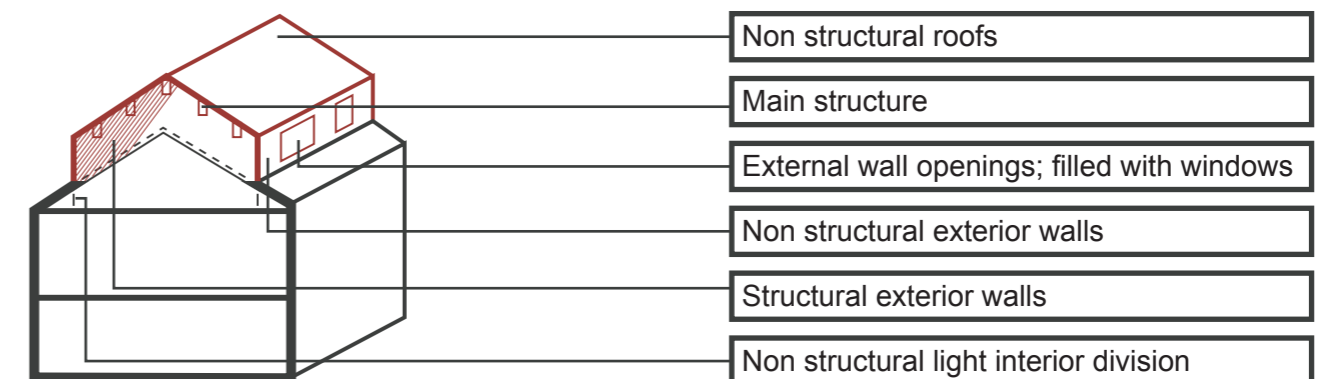

figure 34: detailing different parts of existing roof structure (source: own image)

An ISOBOUW roof lies on top of purlins, which carry the roof. Two types of facades can be identified: two structural exterior walls which transfer the roof loads to the dividing wall, and a light panel on the front facade and back facade which is non structural. The front and back facade have external wall openings; filled with windows. Figure 35 shows a picture of this roof structure from the front facade.



figure 35: front facade roof structure

The next pages contain drawings of the house and of the existing roof structure. One detail which is essential for the assessment is missing from the original drawings, namely the detail of the non structural exterior wall. This is assumed based on standard roof structures.

figure 36: facades and sections of Dickmansstraat 40 (source: building permit application)

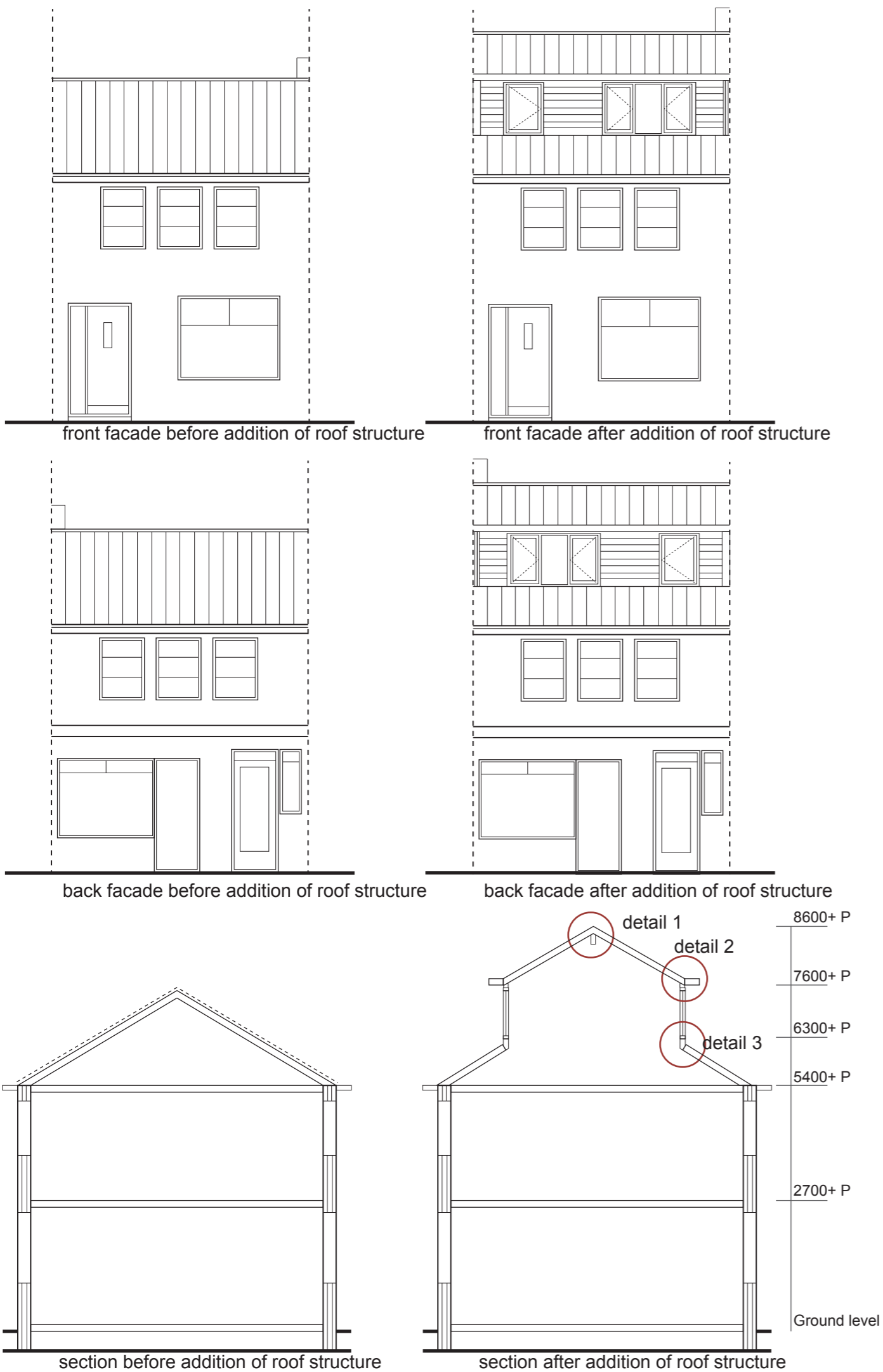
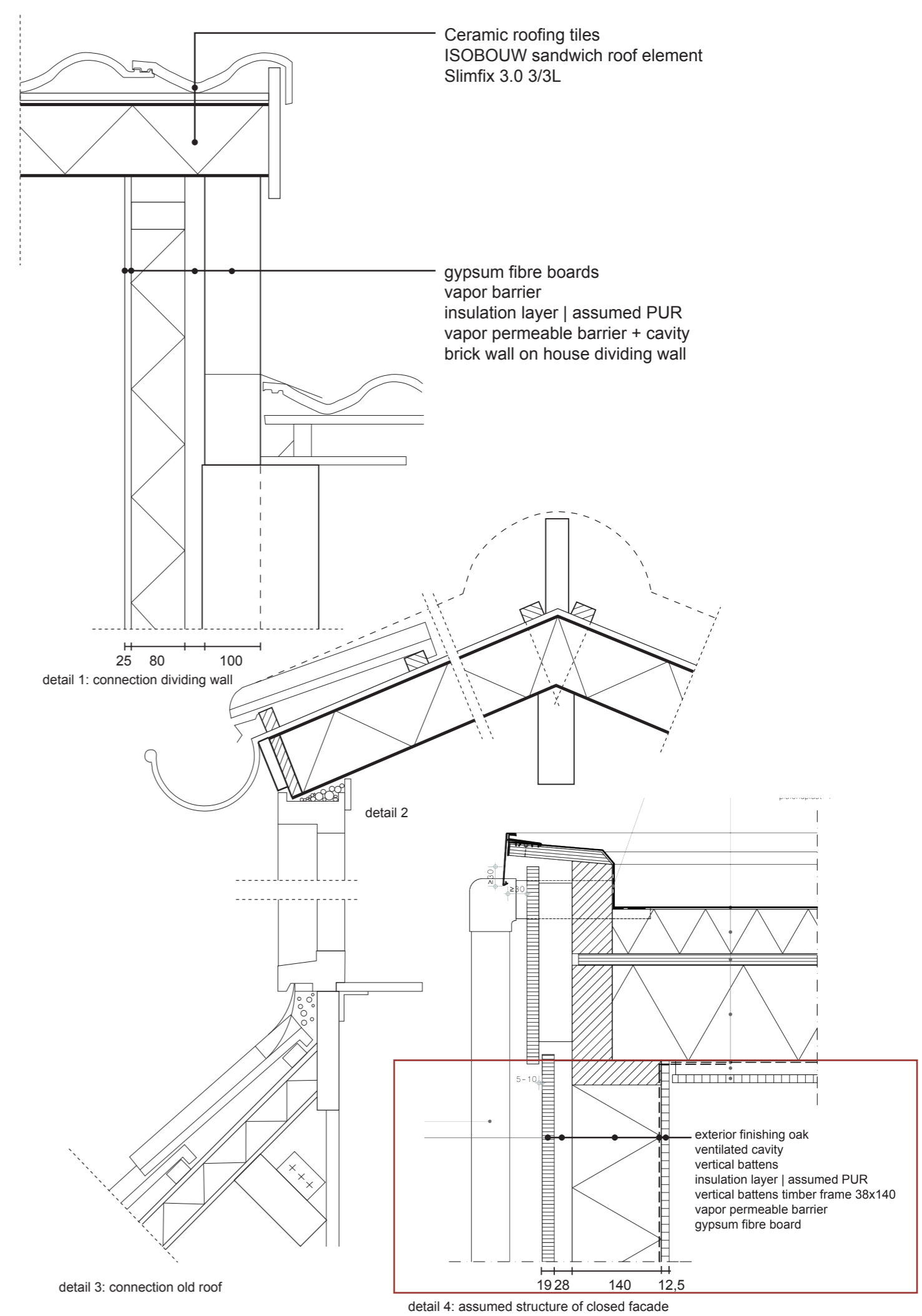

figure 37: details of Dickmansstraat 40 (source: building permit application)



6.2 MAT1. Intensity of material use over lifetime of building

As explained in paragraph 4.3, the assessment for this indicator is based on two points:

1. Comparing the weight in the materials of the design to a benchmark, in this case comparing the old roof structure with the new roof structure.
2. Showing how in the design it was attempted to reduce the material use for different building elements during build and during lifetime of building.

The total weight of the roof structure is **4560 kg**. A detailed description of this calculation can be found in Appendix 1. Calculation weight old roof structure.

Figure 38 shows the weight of the existing roof structure compared to the other newly developed design variants, which are explained in chapter 8.

Variant	Total weight design variants (kg)
SIP structure	± 3150 kg
Solid wood	± 3380 kg
Steel frame	± 4940 kg
Existing roof structure	± 4560 kg

figure 38: weights of existing roof structure and design variants developed (source: own image)

For point 2 we do not have enough information about the old roof structure to assess this with certainty, but the assumption is that no special attention was paid to reduce material use for different building elements during build and during lifetime of building outside of standard economic reasons. This roof structure has a much lower R_c value and thus lower energetic performance than the new variants proposed, but it almost weighs the same as the heaviest variant. This gives an indication that the weight per functional unit (in this case per m^2 with an $R_c = 1 \text{ W/mK}$) could've been reduced further.

Concluding, In comparison with the new variants the old roof structure performs worse than the SIP structure variant and the solid wood variant, and better than the steel frame variant in terms of weight. The assumption is that no attempt was made during design to reduce weight of materials.

6.3 MAT2. Environmental cost of materials (MPG)

As we've seen in paragraph 4.4, the evaluation of this indicator is based on an MPG-calculation. Several tools for an MPG-calculation are available, the tool used for this is MRPI-MPG Software.

Figure 39 shows how points can be received: the MPG calculation yields a result under or over the reference value, which is € 0,70/bvom2/year.

An elaborate description of how the elements were added in the software is available in Appendix 2. Calculation MPG old roof structure. The calculation gives a result of **€ 0,61/bvom2/year**, so the points received based on figure 29 are **15**.

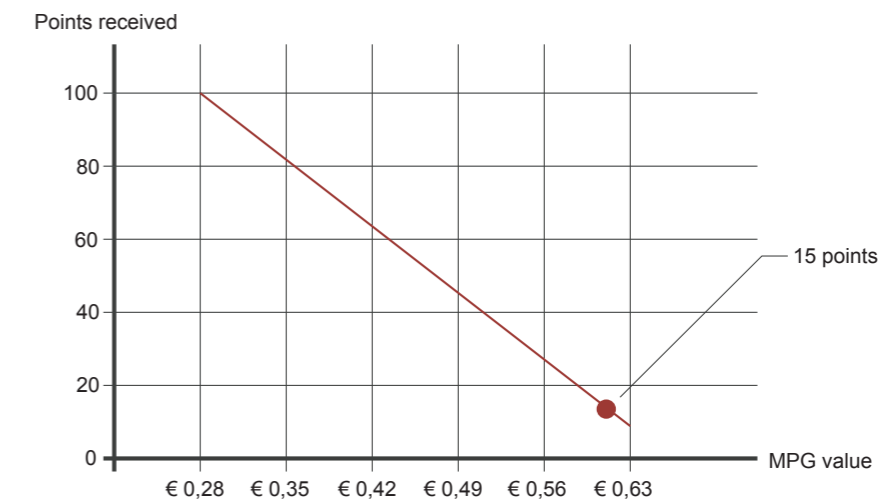

figure 39: grading system MPG calculation (source: own image)

6.4 MAT3. Design for Disassembly

Figure 40 shows the points received per sub-indicator taken into account and the total points scored. Figure 41 to the right shows the relational diagram for the design, used to determine sub indicator 7.

Indicator	Weight	Outcome	Grading
2. Assembly direction (AD)	0.9	Sequential assembly 0.1 points	0.09

It is a sequential assembly. In the case of the side walls, first the brick wall is placed after which the front wall is placed. The timber frame structure in the front and back facade is sequential traditional build, after which windows are placed. The roof is then placed on top.

Indicator	Weight	Outcome	Grading
3. Accessibility to fixings (AF)	0.9	Accessible 1 point	0.54
		Accessible + operation (no damage) 0.8 point	
		Accessible + operation (total damage) 0.1	

The fixings which fix the ISOBOUW element to the purlins are accessible of the ceramic roof tiles are taken off. Other fixings are not shown directly on the detail drawings, but the assumption is that the external cladding is nailed to the understructure of the timber frame construction, the interior gypsum fibre boards are also nailed or screwed to the understructure. These are accessible. Other fixings are chemical and thus not accessible. The score is the average

Indicator	Weight	Outcome	Grading
4. Assembly sequences (AS)	0.7	material -> material 0.1 points	0.07

The structure is assembled from material to material.

Indicator	Weight	Outcome	Grading
5. Prefabrication (PF)	0.7	Mostly sub functions connected on site, some prefabrication for (sub)functions	0.21

The ISOBOUW element is prefabricated, other elements are built up on site.

Indicator	Weight	Outcome	Grading
6. Type of base element (B)	1	No base element 0.1	0.1

No base element is present.

Indicator	Weight	Outcome	Grading
7. Type of relational pattern (R)	1	Horizontal between upper/lower zone diagram 0.4	0.4

In the relational pattern we can see that there are horizontal connections between the upper and lower zone of the diagram.

Indicator	Weight	Outcome	Grading
8. Functional separation (FS)	0.9	Integration functions different in 1 element 0.1 point	0.09

There is integration of sub-functions. Insulation is integrated with the structure, the roof is made up of an integrated insulated structural component and ceramic tiles, windows are integrated with the facade. However, the insulation layer placed before the brick side wall is probably a front wall such as a Metalstud wall, meaning it could be removed without damaging the brick. In the side wall the sub functions are not (entirely) integrated, in the front and back facade they are, and in the roof they are as well. External cladding of oak is in durability class II, meaning that without treatment the lifetime is around 15-25 years. However, the external cladding is painted in this case, so the durability will be increased somewhat. For the wood applied in the interior and for the timber frame structure this 25 years does not count, as the method of testing the durability of wood tests the durability for fungi, which is not a concern for the interior. For wood applied in the interior it is difficult to estimate the lifetime as it's more dependent on wear resistance, resistance to damage and resistance to fire. This is different in every case. (Stichting Probos, 2009). It is safe to assume the wood applied in the interior, in the timber frame and the roof will be used for as long as the insulation. The assumed insulation, PUR, has a higher lifetime: around 75-100 years (Milieucentraal, n.d.). The ceramic tiles on the roof have a long lifetime, more than 100 years. (Bouwinformatie, n.d.) They will probably have a longer lifetime than the ISOBOUW element underneath. The average lifetime of a brick wall is estimated at 100 years ("10 belangrijke redenen waarom baksteen duurzaam is," 2015). The meranti window frames are in durability class 2-4, meaning the lifetime can differ from 5-25 years without treatment. However, the window frames are also treated, and this increases the lifetime. The lifetime of the HR+ glazing in the window frames is around 20 years (Dubbelglasprizen, n.d.). It is assumed that the entire window will be replaced at once after the performance starts to drop. Concluding, the external cladding with a shorter lifetime is probably nailed to the understructure with a longer lifetime - meaning integration. The windows with shorter lifetime are integrated with the timber frame with longer lifetime. The roof element probably has the same lifetime as the timber frame, and is screwed, so not integrated. There is integration of functions with different lifecycles in 1 element.

Indicator	Weight	Outcome	Grading
9. Type of clustering (C)	0.9	No clustering 0.1 point	0.09

The only clustering is the ISOBOUW prefabricated element. Otherwise there is no clustering.

Indicator	Weight	Outcome	Grading
10. Use life cycle coordination (UCL)	0.9	Long LC (1)/short LC (2) 0.8	0.72

The windows will probably be replaced during the lifetime of the roof structure. The exterior and interior cladding's might also be replaced. Even though the ceramic roof tiles have a longer (technical) lifetime than the ISOBOUW elements, it's not probable the ISOBOUW element will be replaced, so their use life cycles are the same. Elements with long use life cycles are placed first.

Indicator	Weight	Outcome	Grading
11. Technical life cycle coordination (TCL)	0.9	Long LC (1)/short LC (2) 0.8 points	0.63
		Medium LC (1)/long LC (2) 0.6 points	

Mostly elements with longer technical life cycles are placed first. The only exception is the roof, where the ceramic tiles placed later have a longer technical life cycle. The score is the average between long(1)/short (2) and medium LC (1)/long LC(2).

Indicator	Weight	Outcome	Grading
12. Geometry of product edge (GP)	0.9	Open linear 1 point	0.9

The geometry of the product edge is open linear.

Indicator	Weight	Outcome	Grading
13. Type of connection (TC)	0.9	Direct integral connection 0.5 point	0.27
		Filled hard chemical connection 0.1	

Some direct integral connections, some chemical connections. Score becomes the average between direct integral connection = 0,5 and filled hard chemical connection = 0,1.

Indicator	Weight	Outcome	Grading
14. Morphology of joint (MJ)	0.7	Point 0,8	0.32
		Service (2D connection) 0.1	

The morphology of the joint is a combination between point (screw) and 2D/service (glued surfaces). The score is the weighted average.

Indicator	Weight	Outcome	Grading
15. Standardisation product edge (SPE)	0.5	Geometry made on the construction site 0.1	0.05

The geometry is mostly made on the site.

Indicator	Weight	Outcome	Grading
16. Tolerance (T)	0.5	High tolerance 1 point	0.5

There is tolerance between all main functional groups.

Total score | 0,33 or 33 points

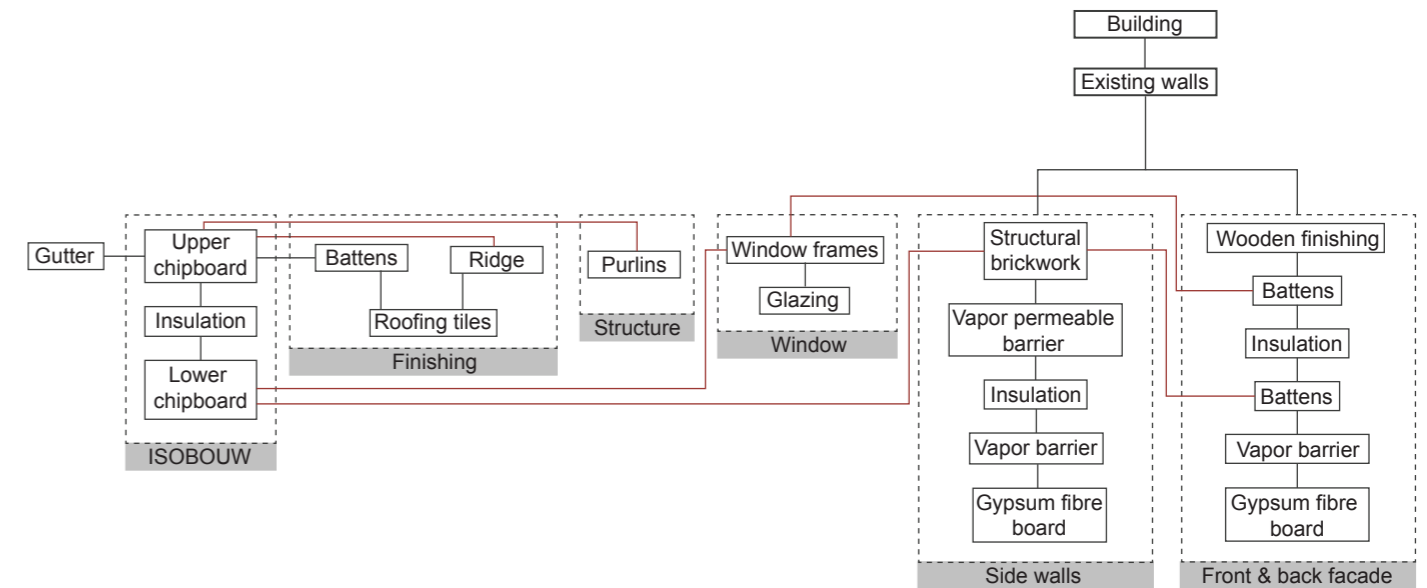

figure 41: relational pattern existing roof structure (source: own image)

6.5 E1. Energy efficiency

This assessment is focused on the roof structure, but the EPC calculation, which is used in this assessment, has been done for the entire building. The points for the roof structure will then be assessed as part of the entire building. The house scores well above the value of 0,4 for the EPC. It has an EPC of **1,9**. Figure 42 shows the corresponding points for EPC results. The roof structure scores 0 points. A summary of these results, calculated in the programme Uniec2, can be found in Appendix 3. Calculation Uniec2 old roof structure

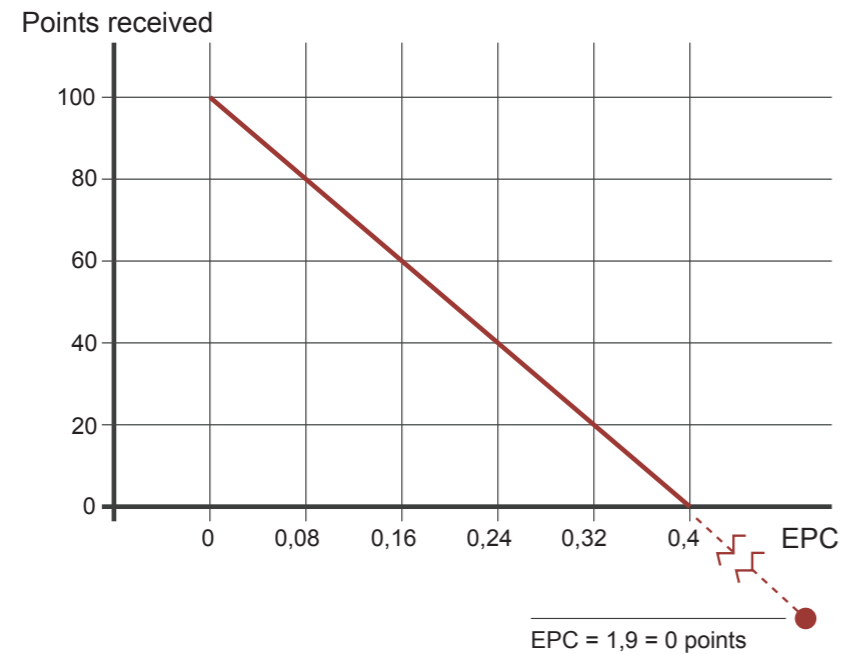

figure 42: grading system EPC calculation (source: own image)

From this we can conclude that the roof structure receives 0 points for this indicator.

6.6 Conclusion

In this chapter, the level of circularity for the existing roof structure at the Dickmansstraat 40, built in 2006, is assessed based on the assessment methodology developed in chapter 4. The indicator of design for circular life cycles could not be taken into account due to time limitations. The other indicators are taken into account. The question answered here is:

7. What is the circular and energy performance of the case study house without energy renovation?

For indicator MAT1: intensity of material use over lifetime of building, the weight of the roof structure is measured to be 4557 kg. Compared with the new design variants developed, it scores worse than design variant 1 and 2 and better than design variant 3. The assumption is that no special attention was paid to reduce material use for different building elements during build and during lifetime of building outside of standard economic reasons. This can't be stated for sure because the information needed is not present, but the fact that the roof structure has much worse energy performance than the new variants but is heavy compared to them shows how the weight of materials per functional unit is quite high and could probably have been reduced further.

For indicator MAT2: the environmental cost of materials, the roof structure's environmental cost is € 0,61/bvom2/year, meaning it receives 15 points from the 100.

For indicator MAT3: design for disassembly, the roof structure receives a score of 0,33 or 33 points from the 100.

For indicator E1: Energy efficiency, the roof structure is calculated to have an EPC of 1,9 and receives no corresponding points.

7. ENERGY & INSTALLATIONS DESIGN

This chapter presents the designs of energy & installations in the case study house. These designs presented here are part of the total design assignment, resulting in several variants which are assessed in chapter 8 Validation and assessment.

The first step in any energy renovation is to reduce the energy demand, by smart & bioclimatic design (following the New Stepped Strategy presented in chapter 2). A second step is to choose installations systems based on the design assignment. In this case the systems to decide on are those for heating and for ventilation. The goal of the total design assignment is not only to find the best possible solution for the installations in the case study, but to answer the following research question: 'How can the case study energy renovation project be designed so that the highest level of circularity is reached?' For that reason, two types of PV/T panels are chosen, one with higher efficiency but lower potential for circularity, and one with lower efficiency but higher potential for circularity. These will be assessed on their performance in chapter 8.

7.1 Energy use of dwellings

Before explaining the energy design of the dwelling, it is important to understand the energy use of dwellings. For that purpose important concepts and definitions are explained.

First it's important to remember the concept **primary energy**, explained in chapter 2.

The primary energy includes the transport and conversion losses of an energy carrier before entering the meter of the dwelling. The definition is as follows: "Primary energy is an energy form found in nature that has not been subjected to any conversion or transformation process." (Keyes, 2007, cited in Hoekstra, 2016). This means the energy consumption of the dwelling is not the total energy consumption needed - this depends on the efficiency of the energy carrier in question. Different energy carriers have different efficiencies, expressed in a factor or in a percentage. In the case of electricity, in the Netherlands we count an efficiency of 39% according to the NEN7120 norm or a factor of 2.56. This means 2.56 units of energy consumption is needed for 1 unit of energy demand in the dwelling. For gas we count a factor of 1, or an efficiency of 100%. Figure 43 shows how primary energy works. In this scheme we can see that the primary energy consumption depends upon the energy demands in a building (the energy needed in the building) the efficiency of the energy system in the building (taking into account losses in system components) and the efficiency of the national production of energy carriers, such as electricity.

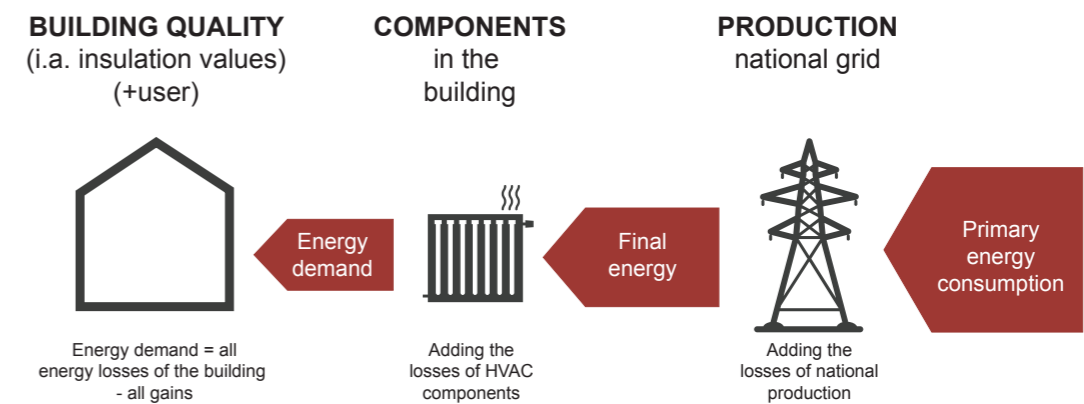

figure 43: primary energy (adapted from Jansen & Tenpierik, n.d.)

7.1.1 Energy demands

A dwelling has different **energy demands**. These are categorized in building related energy (BRE) and user related energy (URE). The BRE flows are the energy demands for heating, cooling, domestic hot water (DHW), ventilation and lighting. The URE demand is that for appliances. The **energy performance** of the building then is "the calculated or measured amount of energy needed to meet the energy demand associated with a typical use of the building, which includes, inter alia, energy used for heating, cooling, ventilation, hot water and lighting." (EPBD, 2010). Different definitions of (nearly) zero energy buildings take into account different energy flows. The energy design presented in this thesis takes into account only the BRE.

7.1.2 Energy power and need

An important distinction has to be made between **energy power** and **energy use** when discussing the energy system. To explain this we take the example of heating.

- Energy use for heating is measured according to a certain time period, usually a year: how much energy is needed (or used) by heating in the dwelling over an entire year. This is measured in kWh/year.
- Energy power is the maximum power needed at a certain moment to supply the required heat in

Watt at that moment. In the case of heating - the maximum power needed at the coldest moment in winter to supply the required heat, measured in Watt.

The size of all components is based on the maximum power required. It should be able to provide the heating at the coldest outdoor temperature. As mentioned before, the overall energy performance is based on the annual energy use for the different demands and the efficiency of the system for supplying this.

7.1.3 Energy carriers

There are different types of **energy carriers**. An energy carrier is defined as a product containing energy in the form of fuel, heat or power (CBS, n.d.). Energy carriers can be subdivided into primary energy carriers and secondary energy carriers. Primary energy carriers are energy carriers found in nature, such as the fossil fuels and the wind and the sun (CBS, n.d.). Secondary energy carriers are energy carriers originating from the conversion of primary energy carriers, such as electricity generated in a power plant (CBS, n.d.). Different energy carriers are utilized for different energy demands. Dutch dwellings are usually connected to the grid for electricity and natural gas. Natural gas is used for heating, cooking, DHW and electricity is used for ventilation, lighting and appliances. The natural gas and electricity enter the house at the meter, where annual final consumption of energy is measured. Gas is measured in m³ and electricity in kWh (Hoekstra, 2016).

To be able to compare the energy used by different energy flows, we can express the energy use in Joules.

- 1 Joule is the work required to produce one Watt of power for one second - or watt-second (Ws). A Joule is therefore a unit of energy, expressed in a unit of power (watt) and a unit of time (second).
- Electricity is expressed in kilowatt hours (kWh), which is also a unit of power and a unit of time.
- 1 kWh electricity = 3,6 megajoules (MJ), because one kW is 1000 J/S and an hour has 3600 seconds.
- The specified energy (calorific value) of natural gas is 31,56 MJ per cubic meter.

7.2 Energy design scope and ambitions

The goal of the design presented here is to renovate the dwelling into (nearly) energy neutral, meaning the BRE demand is compensated by renewable resources. To reach this, the energy demand of the building first needs to be minimised, it will however never become zero. So then renewable energy must be produced to compensate the remaining demand (Jansen & Tenpierik, n.d.). Another source states that research shows that without using renewable energy generation (such as solar power or wind power) it is not possible to build energy neutral buildings (Dulk, 2012). The introduction of renewable energy generation changes the scheme for primary energy presented in figure 44. This figure shows how renewable energy production can either directly be supplied to the building, or a part is exported (or temporarily stored) as in the case of renewable energy generation sometimes energy is produced when it is not directly needed.

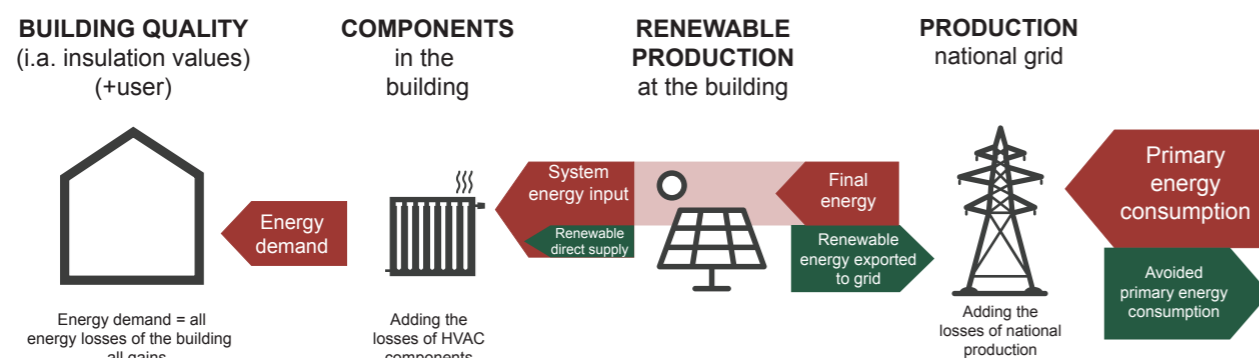

figure 44: primary energy (adapted from Jansen & Tenpierik, n.d.)

The scope of the (energy) design has been defined in chapter 1. Important points are:

- The case study dwelling will be extended with an extra roof structure to provide the residents with much needed extra space, and this roof structure will function as an energy roof.
- Only the roof structure itself will be detailed and assessed, the ground floor and first floor will not be worked out in detail.

Chapter 5 explained some background information about the case study dwelling, the Spaargas project which is the context of the design assignment, and studies for the project and Ramplaankwartier neighbourhood already undertaken by the TU Delft to develop different design scenario's for the renovation of dwellings in the Ramplaankwartier. The energy design presented in this chapter builds upon this information. A quick summary of the most important points in chapter 5:

- The case study dwelling to be renovated is Dickmansstraat 46.
- The ambition of the Spaargas project is to eliminate the use of natural gas for heating in the dwellings in the Ramplaankwartier, the neighbourhood where Dickmansstraat 46 is located.
- The energy design is based on one of the scenario's studied by the TU Delft for the project: scenario 2 for renewable energy generation - an all electric system with an individual heatpump in the dwelling, PV/T panels as a heat and electricity source and low temperature heating in the dwelling (hence the scope of the energy roof).

Some other practical points to take into account are:

- The roof can be built up until the first purlin according to current regulations (H. Sombroek, personal communication, February 20, 2018). This partly defines the space available for PV/T panels on the roof.
- The roof structure should fit in with the rest of the street view.
- The roof should transfer forces to the dividing walls between houses.

The (nearly) energy neutral ambition for the case study dwelling is therefore to eliminate the gas connection in the dwelling and change the energy system into an all electric one, in which an energy roof with PV/T panels supplies electricity and heat for the dwelling and the emission system is a low temperature one. produce electricity and by salderen give energy back to supplier, supplier subtracts that energy from annual use - less money paid for electricity.

Now that we have defined the ambitions for the energy design, the next step is to design the system, following the New Stepped Strategy.

7.3 Reducing the demand

The scope of the energy design imposes some limitations to what's possible in terms of reducing energy need for the dwelling. The scope has consequences for the shape of the roof structure, meaning well known passive measures such as optimal orientation towards the sun aren't possible. There are two possibilities for the main shape in which the addition of floor space is as large as possible, and these are shown in figure 45. Option 1 is chosen as the shape to continue with in the design process.

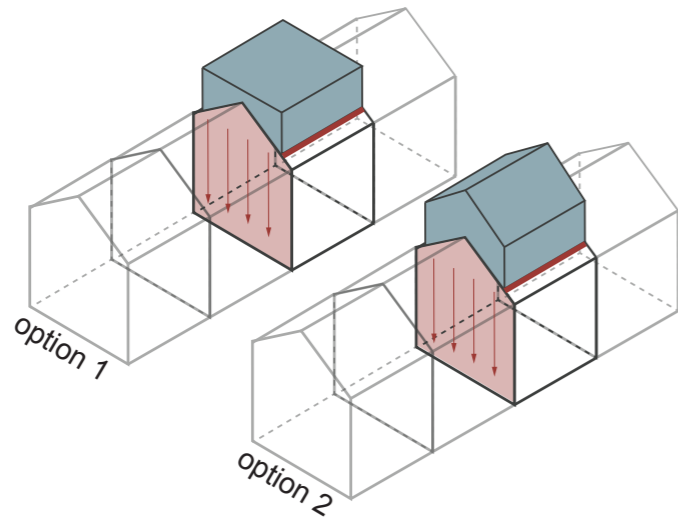

figure 45: possible shapes of roof structure (source: own image)

Other passive measures to be taken which will influence the energy use are the following (Yanovshtchinsky, Huijbers, & Dobbelsteen, 2012):

- Post insulation of the facades on the ground floor and high Rc value in facades for new roof structure.
- Replacement of old windows with better performing ones in terms of U-value.
- Avoiding thermal bridges in the new roof structure.
- Sealing all openings: making an airtight building.

Designing the renovation of the lower part of the house is outside the scope of this thesis, as the focus is on the roof structure. Instead, an Rc value ($\text{m}^2\text{K/W}$) is determined which can be used in energy calculations and new types of windows.

The options for insulating the lower part of the building are as follows (figure 46):

- The cavity can be filled with insulation.
- The cavity can be filled + an extra layer of insulation can be placed on the inner wall.
- The outside of the cavity wall can be replaced with a thicker layer of insulation and a finishing with brick slips.

Insulation on the interior wall might be preferable because it would mean higher energy efficiency, but it has a drawback: it changes the hygrothermal performance of the facade and might therefore cause durability and performance problems (Zhou, Carmeliet, & Derome, 2018). This would also take away from the floor space in the dwelling, while the roof structure is added in the first case to add floor space. Replacing the outer cavity wall might also be a preferable option for the higher energy efficiency, but this would be quite an undertaking in terms of costs and renovation time: the dwellings are organized by four in one block and they have one continuous front and back facade over the entire length of the block. This means that for this option all the dwellings in the block should be renovated simultaneously, as one can imagine the difficulty in removing only part of the outside of the cavity wall. Even if all the dwellings are renovated simultaneously, it would still be a large undertaking. Furthermore, removing the outside of the cavity wall would cause quite an amount of unusable waste, going against circular ambitions in this thesis. For these reasons, option 2 and 3 are dismissed and option 1 is chosen as the option to continue with. Choosing a commonly used material for this, EPS pearls, would then mean an Rc value of $2 \text{ m}^2\text{K/W}$ for the front and back facade of the lower part of the dwelling.¹

¹ λ value of EPS pearls = $0,0337 \text{ W/mK}$. λ value of brick 2000, interior = $0,955 \text{ W/mK}$, exterior = $1,289 \text{ W/mK}$ (Kort, 2009).

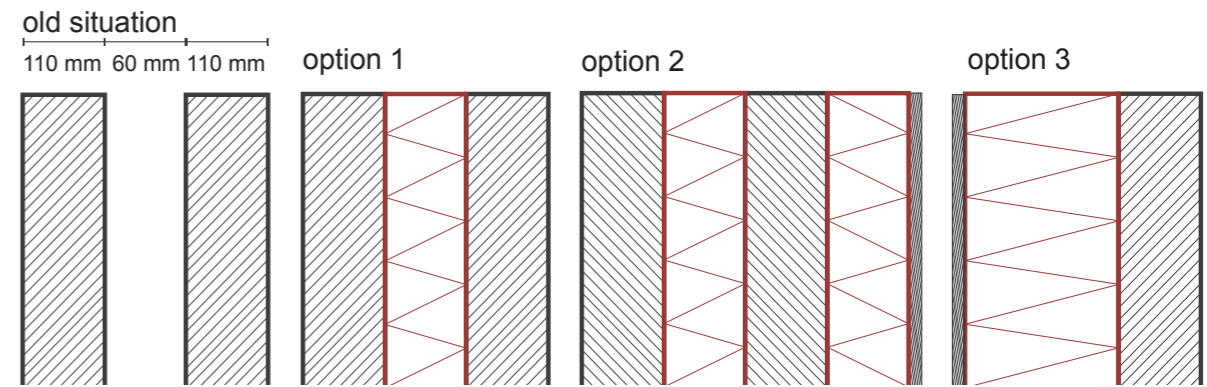

figure 46: options of insulating the east and west facades (source: own image)

For the replacement of the windows the same type is chosen as in the new roof structure. To be precise, these are aluminium windows by with triple glass: the RT 72 Reflex from Kawneer (see chapter 8).

Furthermore, an Rc value of $5 \text{ m}^2\text{K/W}$ is chosen as the reference value to calculate the facades of the roof structure with, and an Rc value of $7 \text{ m}^2\text{K/W}$ is chosen to calculate the new roof with. These values are used in the design phase to design several variants to test the other indicators, keeping the energy performance the same. The values are chosen beforehand because then during the design process of the roof structure it's easier to ensure same energy performance for different design variants.

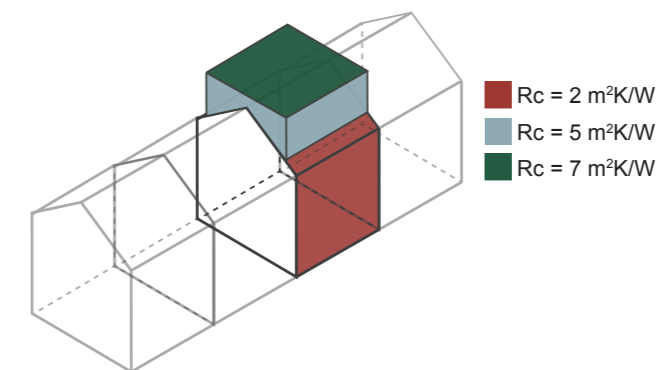

figure 47: Rc values of case study dwelling after reduce measures (source: own image)

7.4 Heating and ventilation systems

We've already defined that the energy system chosen is based on studies for the area and is an individual all electric system based on PV/T panels, a heatpump and low temperature heating. This paragraph provides more context for each part of the heating system. It will also explain the ventilation design.

7.4.1 PV/T panels for heating, electricity and DHW

For the PV/T panels, the primary energy source is solar energy from the sun. This solar energy can be utilized for two distinct purposes: firstly light can be directly converted into electricity by solar panels (Knier, n.d.) and secondly, infra-red radiation can be used to heat fluids, generating thermal energy using solar collectors (Yanovshtchinsky, Huijbers, & Dobbelsteen, 2012). The combination between both, which can be utilized for heating, electricity and DHW needs, is called PV/T panels.

In it's most basic form, a PV/T panel is a solar collector with a plate surface equipped with PV cells (Al-Waeli, Sopian, Kazem, & Chaichan, 2017). The fluid in the collector extracts heat generated by the PV module, cooling it down. As the efficiency of PV modules decreases as the temperature increases, this is beneficial for the PV module. The extracted heat in the heat exchanger can then be used for heating purposes in the home (Tripanagnostopoulos, Souliotis, Battisti, & Corrado, 2003). Many

different types of these systems exist. They can differ on PV laminate used (crystalline silicon, CIGS, CdTe, etc) on type of collector (flat plate liquid, flat plate air, concentrator, vacuum tube), on type of heat transfer medium (air, water or water-glycol mixture), on type of absorber, type of insulation, whether or not they're building integrated and the method of attaching the PV module to the absorber (Keizer, Bottse, & Jong, 2017). Figure 48 shows this characterization.

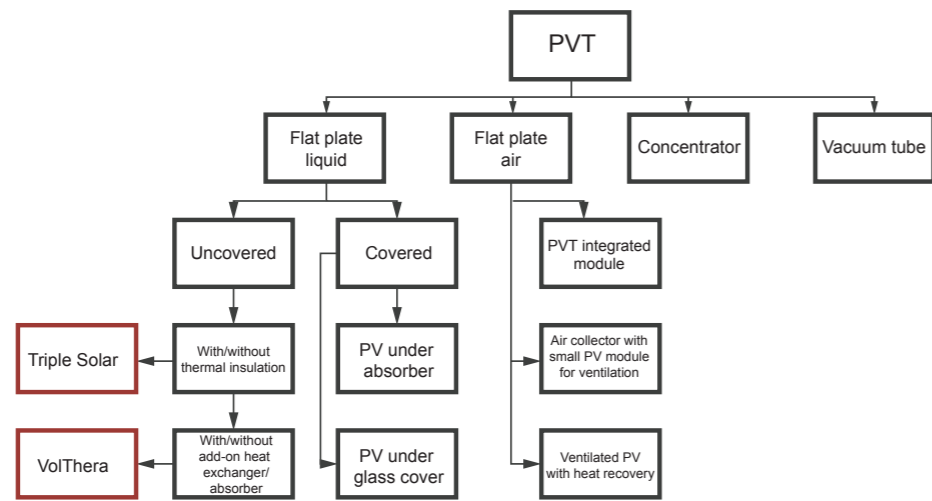

figure 48: types of PV/T panels (adapted from Keizer, Bottse, & Jong, 2017).

This thesis will research uncovered flat plate liquid PVT panels. PVT systems using air instead of water have several disadvantages, like having a low heat transfer, needing large volumes for transferring heat and losses through leakage (Timmerman, 2009). Liquid flat plate PVT systems are therefore the first choice. Uncovered or covered systems both have their advantages and disadvantages. Covered PVT collectors produce more thermal energy but less electricity, while uncovered PVT collectors produce less thermal energy but higher electrical performance (Kim & Kim, 2012). Uncovered PVT panels are chosen for this design assignment. Within this category two products are chosen to compare: Triple Solar and VolThera. Triple Solar is a PV module laminated on a heat exchanger without insulation, which has the advantage that also ambient heat can be harvested on cloudy days or nights. In the Triple Solar PV/T panel, a meandering tube containing monopropylene glycol or ethylene glycol runs through a flat plate heat exchanger (convection fins). VolThera is a type of PVT panel with a separate solar collector adjusted to fit behind different types of PV panels. VolThera states their PV/T panel can easily be taken apart at the end of the lifetime, so separate elements and materials can be recycled. The VolThera panels are built up as follows. Monocrystalline cells are laminated together and covered with glazing, put in a frame. The collectors are made of polypropylene, with galvanized steel profiles they are wedged in the frame. The fluid used is propylene glycol, because this is non toxic, in contrast with ethylene glycol which is toxic. In the galvanized steel profiles poron strips improve the connection between collector and frame. Glue is used to connect the poron strips and galvanized steel profiles (A. Meesen, personal communication, May 16, 2018). Figure 49 shows the Triple Solar panel and figure 50 the VolThera panel. The advantage of Triple Solar's convection PV fins is the enhancement of the thermal transmittance of the PV/T panel. According to the laws of thermodynamics the heat generated by the PV modules can be transported by conduction, convection and radiation. The convection fins on Triple Solar enhance the thermal transmittance because the area is increased and thus this increases the convective heat transfer. This increased capacity is useful in winter when a high capacity is needed. However in other seasons the convection is also increased, which increases the losses. For a study comparing the efficiencies an entire year needs to be calculated. In addition in the Triple Solar system the PV modules are in direct contact with the heat exchanger, so heat transfer can take place through conduction, adding to the thermal efficiency of the system. In the VolThera system the collector is not fully in contact with the PV module and the area of the collector is less large, so heat transfer through conduction and convection is less, and will partly take place through radiation. Concluding, Triple Solar is more interesting in terms of higher thermal transmittance and VolThera is interesting in terms of circularity and demountability.

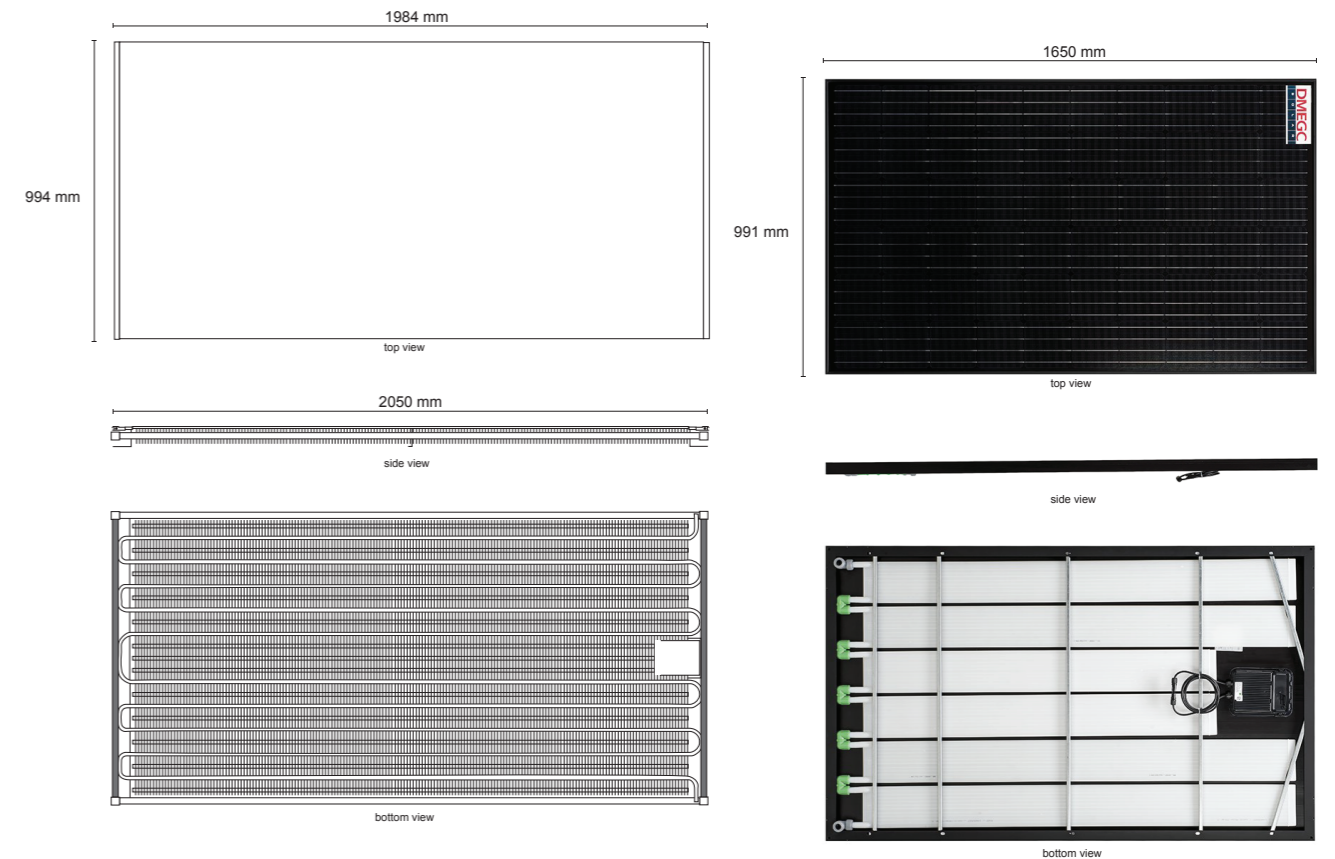

figure 49 (left): types of Triple Solar panels (adapted from Triple Solar BV, n.d.)

figure 50 (right): VolThera panel (A. Meesen, personal communication, May 16, 2018)

7.4.2 Heat pump

Using solar energy for heating purposes has some limitations, due to several reasons: how much solar energy is available changes over the course of a day and over the course of a year, and most solar energy is available when there is less space heating demand (summer). Secondly, the temperature generated by the system is not enough for heating needs in cold countries such as the Netherlands. The most well known solution to solve these problems is to couple the solar energy generating system with a heat pump (Chwieduk, 2012). The heat pump lifts the heat from the heat source at a lower temperature level to a higher temperature, suitable for heating purposes. Furthermore, a heat pump system requires a storage tank to provide enough capacity (Hoekstra, 2016). Concluding, the total energy generating system in this design assignment are PV/T panels on the roof combined with a heat pump and (integrated) buffer. And finally, as the heat pump will also provide the DHW, a separate boiler for this hot water is also included in the system.

7.4.3 Low temperature heating

The emission system for thermal energy must be a low temperature system, as the heat pump supplies energy on lower temperatures than traditional (gas-fired) systems would. The lower the temperature is of the heat delivery, the higher the efficiency of the heating generation system will be. Within the low temperature (LT) systems several choices are possible: LT radiators or convectors, floor- wall, or ceiling-heating systems. Between LT radiators and convectors, radiators are the best choice as convectors are less comfortable for the residents (BOOM-SI, Israels, & Stofberg, 2017). Integrated heating in the floor, wall or ceiling has some advantages over radiators, but it is more expensive, and from the circularity viewpoint less interesting, as it is fully integrated into wall/floor/ceiling and can't be replaced or repaired when damaged. For those reasons LT radiators are chosen as the thermal energy distribution system. 'Low temperature' radiators can mean different things. The Energievademecum counts a radiator as 'low temperature if the temperature of the water entering the

LT radiator is a maximum of 55 °C (BOOM-SI, Israels, & Stofberg, 2017). In the NEN 7120 norm a system is low temperature if the average temperature between water entering the radiator and leaving the radiator is < 50 °C . Uniec2, the programme used to calculate the performance of the energy design, follows this value. Furthermore, when calculating the Triple Solar system in Uniec2, one must choose a temperature between 30 °C and 35 °C in Uniec2 (very low temperature emission system) These values are determined as the heating temperature of the emission system. More about this in paragraph 6.5.2.

The scheme of the heating and DHW system can be found in figure 51.

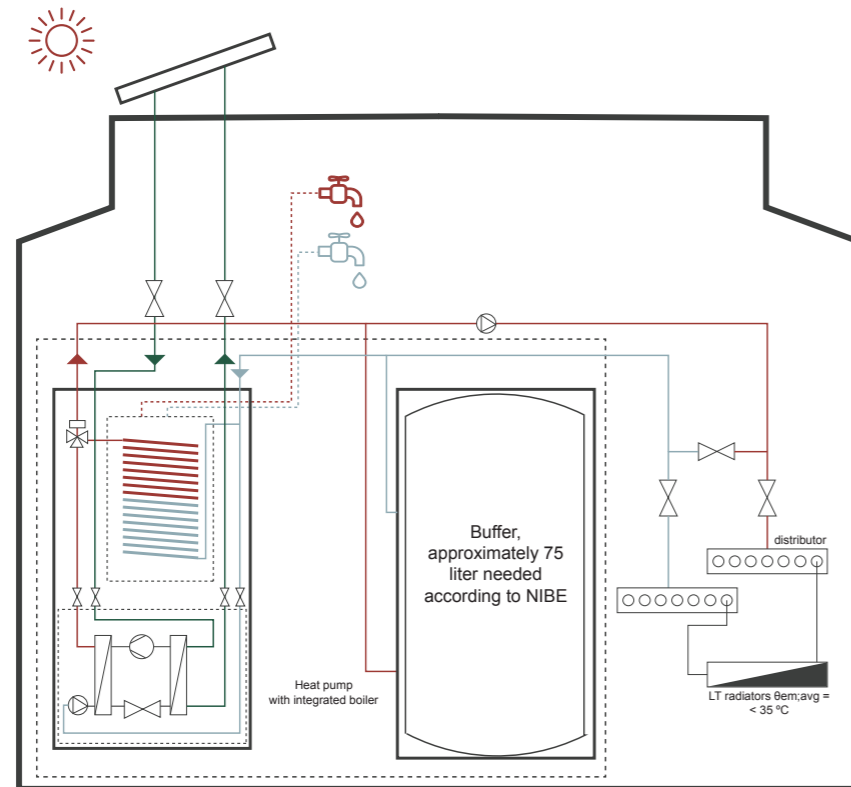

figure 51: heating and DHW system, heat pump with integrated boiler and buffer (source: own image)

7.4.4 Ventilation system

In energy renovations such as the design assignment it is a desirable measure to add a balanced ventilation system with heat recovery, because this adds to the energy efficiency of the home (BOOM-SI, Israels, & Stofberg, 2017). Balanced ventilation can be distinguished into two types of systems: central systems and decentral systems. In decentral systems a ventilation unit is installed in the facade which mechanically ensures the airflow in and out of the room. A heat exchanger integrated in the unit heats up the incoming air to some extent, thereby heating up the room so less thermal energy needs to be supplied. A central system also works with a heat exchanger, but instead the heat exchanger is placed in a central location in the building, and every room has an inlet connected by tubes to the central unit. The exhausts are placed in strategic rooms such as the toilets (Yanovshtchinsky, Huijbers, & Dobbelsteen, 2012). The decentral system has a limited capacity due to size restrictions, but it has the major advantage that it's easily placed without major interventions in the home. Placing such a system allows the inhabitants to be minimally disturbed during the renovation. Furthermore, the components can easily be replaced when they are damaged, adding to the circularity of the ventilation system. For the renovation of the case study, a combination between decentralised balanced ventilation and ventilation system C is selected. Ventilation system C is a traditional system with natural supply and mechanical exhaust (BOOM-SI, Israels, & Stofberg, 2017). Currently the dwelling has system A: a system with natural supply and exhaust. Even though this system is negative in terms of energy efficiency, it does have advantages for residents, as it is comfortable: they can control the ventilation

themselves.

An innovative system currently on the market is the Fresh-R, a unit which can be mounted on the wall or in the window pane. CO2 sensors with smart control make sure the unit only works when needed. The ventilation scheme can be found in figure 52. The house will be divided in three zones: ground floor, first floor and roof structure. The Fresh-R window panes are only placed on the ground floor and roof structure, as these are more general living areas in which heat recovery and thus incoming warm air positively influences the comfort. The toilet on the first floor should also receive a mechanical outlet, as the decentral Fresh-R units only ventilate one space. The first floor only has bedrooms and a wet cell: here no heat recovery is present, but an exhaust in the wet cell, ventilation vents in the bedrooms and overflows between the rooms ventilate the zone.

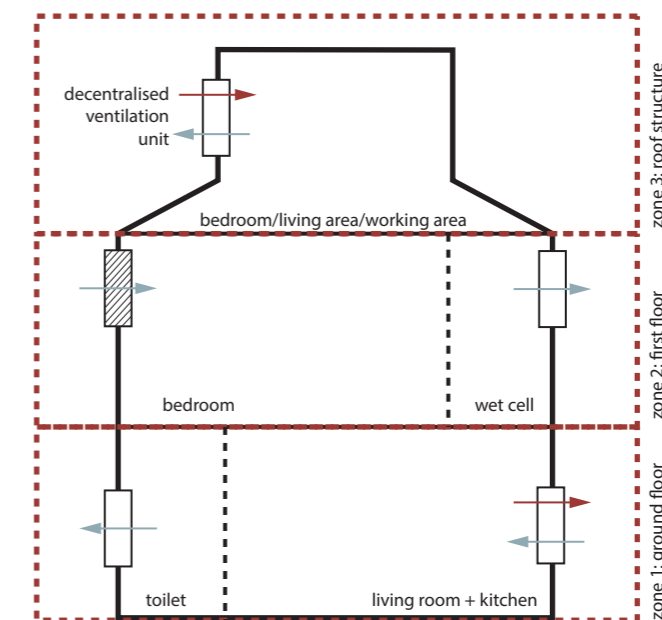

figure 52: proposed ventilation scheme for the dwelling (source: own image)

In this scheme two Fresh-R window panes are placed: one in the roof structure and one in the living room on the ground floor. A general value for how much fresh air the house needs to receive is 0,7 dm³/s/m² (Bouwbesluit, 2012). The interior floor space in the roof structure is 25,8 m², so the total air refreshment of the roof structure needs to be 65 m³/h. A value the Fresh-R can easily provide, see the specifications in figure 53.

Specifications	
Heat recovery	87% efficiency
Power consumption	5,3 W at 25 m ³ /hr 41.2 W at 120 m ³ /hr
Sound db(A)	25 dB(A) at 35 m ³ /hr 45 dB(A) at 120 m ³ /hr
Capacity	Automatic regulation up to 120 m ³ /hr
Full automatic operation	Self regulating flow control based on CO ²
Continues heat recovery at sub zero temperatures	Yes - automatic defrost mode

figure 53: specifications Fresh-R (adapted from Fresh-R, n.d.)

7.5 Dimensioning of the heating system

The dimensioning of the heating system is based on the energy power and the energy need, as explained in paragraph 6.1.3, in which the power needed determines the size of all components (heat pump, PV/T and emission system).

7.5.1 Heat balance

The first step is therefore determining the power needed of the heat pump. This is done by setting up a heat balance for the dwelling in question. The heat balance is made up by all of the heat flows (Q) going in and out of the space. These are:

- Transmission (Q_{trans}): heat transfer through the building envelope in J/s or W.
- Ventilation (Q_{vent}): heat transfer by air refreshing in the space in J/s or W.
- Infiltration (Q_{inf}): heat transfer by air flow through cracks and seams in J/s or W.
- Solar radiation (Q_{solar}): radiation of the sun entering through glazed surfaces in J/s or W.
- Internal heat load (Q_{intern}): production of heat inside the space, by people, appliances or lighting in J/s or W.
- Heating need (Q_{heat}): heat added or discharged from the space by actively heating or cooling the space in J/s or W.

Furthermore, the assumed outside and inside temperature influence these heat flows. Usually an outside temperature of -10 °C and 20 °C is assumed. A situation in which all the heat flows are constant is assumed (stationary situation). In that case we can say that :

$$(1.) Q_{in} = Q_{out} \text{ (J/s or W)}$$

The heat balance is then defined by the following formula:

$$(2.) Q_{trans} + Q_{vent} + Q_{inf} + Q_{solar} + Q_{intern} + Q_{heat} = 0$$

In which:

$$(3.) Q_{trans} \text{ (W)} = U \cdot A \cdot (T_e - T_i)$$

$$(4.) Q_{vent} \text{ (W)} = V_{vent} \cdot \rho \cdot C_p \cdot (T_e - T_i)$$

$$(5.) Q_{inf} = V_{inf} \cdot \rho \cdot C_p \cdot (T_e - T_i)$$

$$(6.) Q_{solar} = A_{glass} \cdot q_{sun} \cdot ZTA = \text{not taken into account as the heating need is calculated when there's no sun (winter/cloudy/night).}$$

$$(7.) Q_{intern} = \text{not taken into account as this is negligible.}$$

The exact calculation for the different formulas can be found in Appendix 4. The summary of the outcomes:

$$Q_{transmission} = -2192 \text{ W}$$

$$Q_{vent, wtw} = -1965,6 \text{ W}$$

$$Q_{infiltration} = -792 \text{ W}$$

The Q heat is then calculated as follows:

$$- 2191,5 \text{ W} - 1966 \text{ W} - 792 \text{ W} + Q_{heating need} = 0 \text{ W}$$

This means that the Q_{heating need} = 4949,5 W. Figure 54 visualizes this heating need.

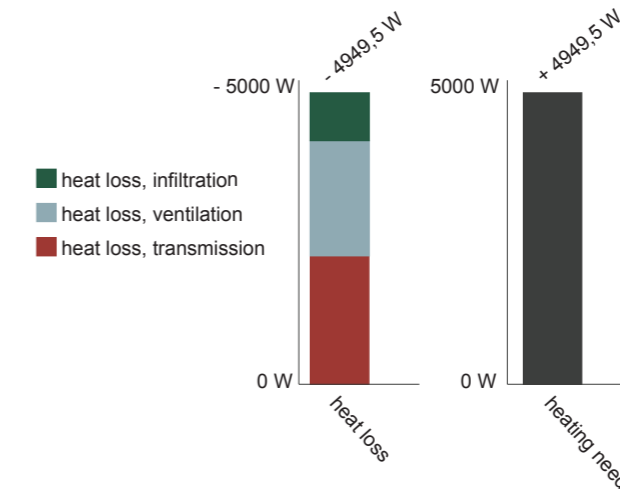

figure 54: heating need offset to heat loss (source: own image)

This is the capacity the heat pump will need. The heat pump chosen is the NIBE F1245 with a power of 5 kW.

The PV/T system supplies to types of power: heating power and electrical power. The heating power for the dwelling needs to come from the PV/T systems, and the electrical power can come from the PV/T panels and from the grid, to which the dwelling remains connected.

7.5.2 Dimensioning PV/T panels

The next step is therefore determining the amount of power the PV/T system can supply. As mentioned before, two types of PV/T panels are researched: VolThera and Triple Solar. Triple Solar panels have a higher yield, while VolThera panels have more potential in terms of circularity.

To calculate the amount of PV/T panels we need for heating, we can use either the COP (coefficient of performance) or the SCOP (seasonal coefficient of performance) of the heating system. The COP is determined by the ratio between energy usage of the compressor in the heatpump and the useful heat extracted from the condensor. A high COP means high efficiency (Industrial Heat Pumps, n.d.). However, the COP is highly dependent on operating conditions, so the SCOP is a more precise number: it is a realistic indication of energy efficiency over a year, the average COP during a certain period of time (Heat pumping technologies, n.d.). The COP for a heat pump is calculated by the energy supplied to the heating system divided by the electrical energy used by the compressor in the heat pump.

$$(7.) COP = \frac{Q_{useful heat}}{Q_{electric}}$$

The SCOP and COP are determined by several factors. The temperature difference between the heat source and the emission system plays a large role. These determine the condensation and evaporation temperature in the heat pump. The smaller the temperature difference, the higher the COP. This relation is described by the Carnot cycle (Industrial Heat Pumps, n.d.):

$$(8.) COP_{h,Carnot} = \frac{T_{cond}(K)}{T_{cond} - T_{evap}}$$

However, the compression cycle is not going to be ideal: the system has losses. For that reason the real COP_h is determined by the Carnot efficiency and the system efficiency (Industrial Heat Pumps, n.d.):

$$(9.) COP_h = \eta \cdot COP_{h,Carnot}$$

Triple Solar

Triple Solar has supplied a 'declaration of equivalence' ('gelijkwaardigheidsverklaring') stating the SCOP values of a Triple Solar PV/T system. This declaration of equivalence is included in Uniec2, the programme which is used to calculate the energy performance of the systems over a year. In this declaration of equivalence a system with 16 m² of PV/T panels and a very low temperature emission system < 30 °C or < 35 °C is described. The interior temperature of the dwelling is 20 °C. The used SCOP in Uniec2 for Triple Solar is then:

- 5,35 for heating
- 3,55 for domestic hot water

Obviously the case study dwelling presented here might have different actual SCOPs for the heating and domestic hot water supply systems. The SCOP will depend on several parameters which might differ in the case study dwelling as compared to the system described by Triple Solar in Uniec2. These parameters which might differ are:

- Most importantly, the temperature difference between heat source and emission system (Hoekstra, 2016).
- Actual losses in the system such as compressor efficiency (Hoekstra, 2016)
- The heat pump itself: the Triple Solar PV/T system in Uniec2 uses the NIBE F1255-6 kW output heat pump. The case study dwelling presented doesn't require this power for the heatpump, so the efficiency for the heat pump chosen can differ from the efficiency of the heat pump calculated in Uniec2. "The sizing of the heatpump and it's components in relation to the heat demand will affect energy coverage and part-load operation." (Heat pumping technologies, n.d.)
- The amount of PV/T panels. The SCOP is calculated based on 16 m² of PV/T panels, but this will differ in the case study building.

To calculate the actual SCOP precisely, the system should be simulated over a year. This is interesting for future research, in the design presented here the SCOP values for Triple Solar in Uniec2 are used to (roughly) calculate the energy performance of the design.

The heating need has been defined on 4949,5 W = 4950 W. Using formula (7.) we can then calculate that the electricity power needed is:

- $4950 \text{ W} / 5,5 = 900 \text{ W}$.

The power to be supplied by the PV/T panels is then:

- $4950 - 900 = 4050 \text{ W}$.

The amount of PV/T panels needed depends on the panel's ability to transfer heat to the absorber underneath and the temperature difference between outside temperature and the temperature of the fluid source.

According to Triple Solar, their PV/T panels have a heat transfer of 60 W/m²K. Assuming a temperature difference of 5 K (worst case scenario), this means the panels can supply:

- $60 * 5 = 300 \text{ W/m}^2$.

This then means that to supply the demand of 4050 W on a cold day or at night, we need $4050 / 300 = 13,5 \text{ m}^2$ of panels. Triple Solar states in their general calculation that the square meters of PV/T needed is 3 times the heat pump power, so that in this case that would mean $3 * 5 \text{ kW} = 15 \text{ m}^2$. This is quite similar to the hand calculation. Using the PVT 340, which is about 2 m² per panel, we then need $13,5/2 = 6,75 = 7 \text{ PV/T}$ panels.

VolThera

How many VolThera panels are needed is more difficult to tell as the exact specifications are not known, and the VolThera system is not yet in the Uniec2 programme. VolThera is currently working on having it included in the programme (A. Meesen, personal communication, June 14, 2018). Also, they are testing the systems now and these test setups show a first indication for the SCOP of their system,

if the emission system has a temperature of < 35 °C:

- 4,5 for heating (shown in the test setups)
- 3,5 for domestic hot water (a first educated guess by Anouk Meesen)

Just as for the Triple Solar system, the case study dwelling prestend might have different actual SCOPs for the heating and domestic hot water supply.

Using formula (7.) we calculate that the electricity power needed with abovementioned SCOP is:

- $4950 \text{ W} / 4,5 = 1100 \text{ W}$.

The power to be supplied by the PV/T panels is then:

- $4950 - 1100 = 3850 \text{ W}$.

According to a presentation given by Anouk Meesen from Alius Energy, on a sunny cold winter day the panels can supply 190 W thermal energy. At night or on a grey day they can supply 175 W of thermal energy, and on a sunny summer day 375 W of energy. Using the value of 190 W to calculate the total amount of panels needed, we find that we need $3850 / 190 = 20,3 = 21 \text{ PV/T}$ panels to supply the heating demand. This number might differ slightly, but in any case the current roof does not have the space: it has space for about 15 VolThera panels. This problem can be solved by integrating an extra electrical heating element, which will supply the remaining power needed.

This means more VolThera panels are placed on the roof than Triple Solar panels: they supply the same heat, but not the same electricity: more electricity is supplied in the VolThera variant. However, the goal is to keep the EPC the same of both variants so they can be compared fairly, so extra solar panels will need to be added in the Triple Solar variant. This is explained in the next paragraph.

7.6 Energy performance of the energy systems

In the previous paragraph the hand calculation for the dimensioning of the systems is explained. The second step is to calculate the annual energy performance. This is (partly) done in the programme Uniec2, which can be used to calculate the EPC of buildings. This outcome for the EPC is then used in chapter 9 to assess the design.

Uniec2 is not yet fully equipped to calculate energy systems with PV/T panels as a source. However, Triple Solar is included in the system, albeit in a slightly cryptic way. VolThera is not yet included, but if the EPC of the Triple Solar system is calculated in Uniec2, the EPC of the VolThera system can be approximated with hand calculations based on the COP of 4,5 for heating, 3,5 for DHW and the yearly energy needed for heating and hot water calculated by Uniec2 for the Triple Solar system. This calculation is explained in the following text.

The results of the Uniec2 calculation of the Triple Solar system (with the addition of 4 JA-Solar JAM6(K)(BK)(SE)-60-300/PR panels to reach the same EPC as VolThera) can be seen in figure 56. These results mean the following:

- Verwarming (excl. hulpenergie) $E_{h;p} = 6541 \text{ MJ}$: the amount of electrical primary energy needed for heating in the dwelling. This is calculated by using the SCOP of 5,5. Uniec2 calculated the yearly heating need of the dwelling at **13614 MJ**. This means that $13614 \text{ MJ} / \text{COP } 5,35 = 2544,67 \text{ MJ electrical energy}$ is needed (supplied by the grid and by the PV part of the PV/T panels) and $13614 \text{ MJ} - 2544,67 \text{ MJ} = 11069 \text{ MJ thermal energy}$ is supplied by the source. So the 2544,67 MJ electrical energy can then be calculated to primary electrical energy by multiplying with the primary energy factor of 2,56 for electricity, which is $2544,67 * 2,56 = 6514 \text{ MJ}$.

- Warmtapwater (excl. hulpenergie) $E_{w;p} = 6217 \text{ MJ}$: the amount of electrical primary energy needed for domestic hot water in the dwelling. This is calculated by using a SCOP of 3,55. Uniec2 calculated the heating need for domestic hot water at **8621 MJ**. The calculation then is $8621 \text{ MJ} / 3,55 = 2428,45 \text{ MJ of electrical energy}$ needed. This is $2428,45 \text{ MJ} * 2,56 = 6217 \text{ MJ}$ of primary electrical energy needed.

- Zomercomfort **Esc;p = 3.502 MJ**: the amount of electrical primary energy needed for summer comfort in the dwelling.
- Ventilatoren **Ev;p = 1411 MJ**: the amount of electrical primary energy needed for ventilators in the dwelling.
- Lighting **EL;p = 3978 MJ**: the amount of electrical primary energy needed for lighting in the dwelling.
- Op eigen perceel opgewekte & verbruikte elektriciteit **Ep;pr,us;el = 27007 MJ**: the amount of avoided electrical primary energy generated by the PV/T panels on the dwelling.
- Karakteristiek energiegebruik Eptot = -5386 MJ: this is the primary electricity demand minus the avoided primary electricity, so in this case: Eptot = Eh;p + Ew;p + Esc;p + Ev;p + EL;p - Ep;pr,us;el
- The Eptot is used to calculate the EPC, according to NEN 7120. Figure 55 shows the formula for the EPC calculation, which Uniec2 uses as well. In this formula we can see that the EPC depends on the Eptot, divided by several other values such as the several standard factors (the F values), the user surface (Ag), a correction factor (CEPC;woon), the amount of housing units in the calculation (Nw) and the loss surface of the dwelling (Als).

$$EPC_{woon} = \frac{E_{PTot}}{(f_{g;adm;nb} \times A_g + f_{ls;adm;nb} \times A_{ls} + f_{start;W;adm;nb} \times N_W) \times C_{EPC;woon}}$$

figure 55: formula for calculating EPC of dwelling (Source: NEN 7120)

This information summarized above can be used to approximate the energy performance and the EPC of the VolThera system by hand calculations. In the formula for the EPC calculation, we can see that the numbers below the dividing line are the same for the Triple Solar and VolThera systems, as these numbers are not dependent on the energy system but rather on the dwelling. The Eptot is the only value dependent on the energy system. Furthermore, both energy systems should have the same EPC outcome - otherwise they can't fairly be compared on their performance. This means that to calculate the EPC of the VolThera system, we only need to make sure the Eptot is the same as the Triple Solar system, as the EPC will then be the same as the Triple Solar system. For the VolThera system the values determining the Eptot are then calculated as follows:

- Eh;p: Uniec2 calculated the heating need of the dwelling at 13614 MJ. This means that 13.614 / COP 4,5 = 3025 MJ of electrical energy is needed. Converting this to primary electrical energy is: 3025 MJ * 2,56 = 7744 MJ. **Eh;p = 7744 MJ.**
- Ew;p = Uniec2 calculated the heating need for domestic hot water of the dwelling at 8621 MJ. This means that 8621 / COP 3,5 = 2463 MJ of electrical energy is needed. Converting this to primary electrical energy is: 2463 MJ * 2,56 = 6305 MJ. **Ew;p = 6305 MJ.**
- Esc;p = same as Triple Solar = **3502 MJ.**
- Ev;p = same as Triple Solar = **1411 MJ.**
- EL;p = same as Triple Solar = **3978 MJ.**
- Ep;pr,us;el = depends on two values. Firstly, the maximum electrical yield of the solar panel at optimum circumstances, which is measured in Watt peak (Wp). One source states a VolThera panel has a value between 260 - 275 Wp (Keizer, Bottse, & Jong, 2017). As the Wp is measured in optimum circumstances, this electrical yield will not be achieved over the entire year, so this value is measured

by a factor (Tentensolar, n.d.). The multiplication of the Wp of the panel with the factor is then the yield of the panel in kWh per year, which can be calculated to MJ (the unit of Ep;pr,us;el in Uniec2). The Triple Solar 'gelijkwaardigheidsverklaring' shows a factor of 0,8 for their panels. This latter is used to calculate the yield of the VolThera system in avoided primary electrical energy². **Ep;pr,us;el = 28.754 MJ.**

- Eptot = Eh;p + Ew;p + Esc;p + Ev;p + EL;p - Ep;pr,us;el = **- 5812 MJ.**

As we can see, the value of - 5.812 MJ for the Eptot of the VolThera system is very similar to the value calculated by Uniec2 for Triple Solar, which is -5.386 MJ. To reach this value for the Triple Solar system, it was necessary to add extra solar panels: 4 JA-Solar JAM6(K)(BK)(SE)-60-300/PR panels.

From this we can conclude that the EPC of both systems will be approximately the same, which is -0,09. The entire Uniec2 calculation is included in Appendix 5.

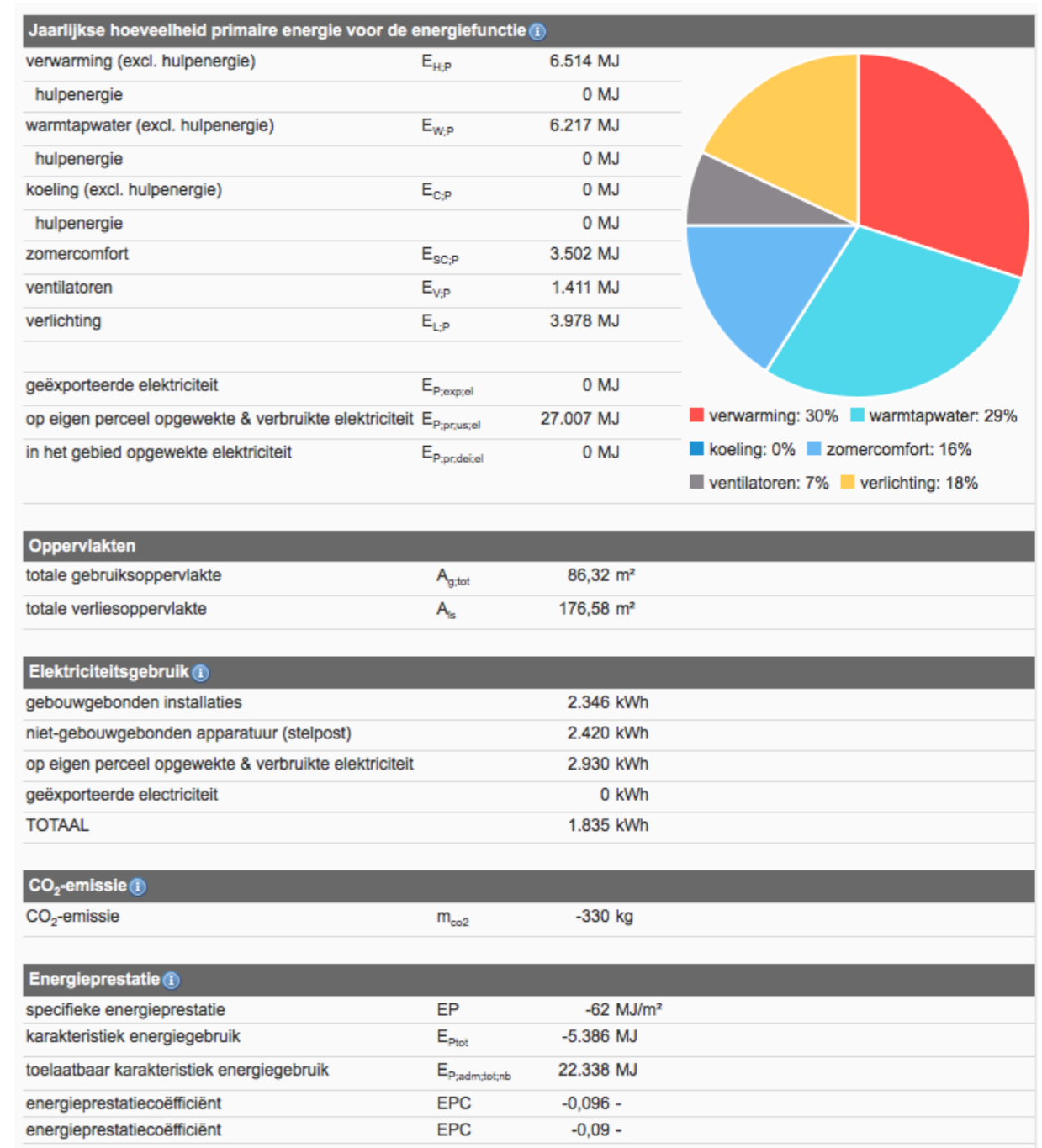

figure 56: results Uniec2 calculation Triple Solar system (source: own image)

² 260 Wp * 0,8 = 208 kWh/year/panel. With 15 panels this means 208 kWh * 3,6 * 15 * factor 2,56 = 28.754 MJ

7.7 Roof design

The Triple Solar variant needs 7 Triple Solar panels, 4 JA-Solar JAM6(k)-60/280-300/PR PV panels and the VolThera variant needs 15 VolThera panels and a supplemental electrical element for the remaining heat demand. For this the roof space present needs to be used to an absolute maximum: the panels need to be built up to the edges of the roof. This poses a problem: usually when placing PV(T) panels on the roof, an area needs to be left empty at the edge, because of strong winds there (about a factor of 3 higher than elsewhere on the roof (Zonnepanelen.net, n.d.)). These strong winds on flat roofs are known as corner vortices, and these vortices might uplift the panel placed at the edge if it's not anchored to the roof with enough ballast (Banks, 2013). This problem can be solved in two ways: either the ballast traditionally placed to keep the panels fixed needs to be heavier at the edges (Zonnepanelen.net, n.d.), or the panels can be integrated in the roof (BIPV/T - building integrated PV/T). This latter is the better choice: with smart design we can ensure no extra ballast (or even ballast at all) is needed. One study investigated several classes of BIPV/T panels integrated in or attached to roofs and their respective wind loading formula's. This study found that there are two possibilities if one does not want to place the panels in the traditional ballast-weighted method on the roof: either the panels are integrated in the outer layer of the roof, or they form an integral part of the roof. In the first case the connections are essential (between panel-roof covering, between panel-roof), in the latter the roof should behave as a single skin product (Geurts & Bentum, 2007). Fully detailing the roof design is outside the scope of this thesis, but the assumption is that the PV/T panels form an integral part of the roof. The possible roof layouts of the systems can be found in figure 57.

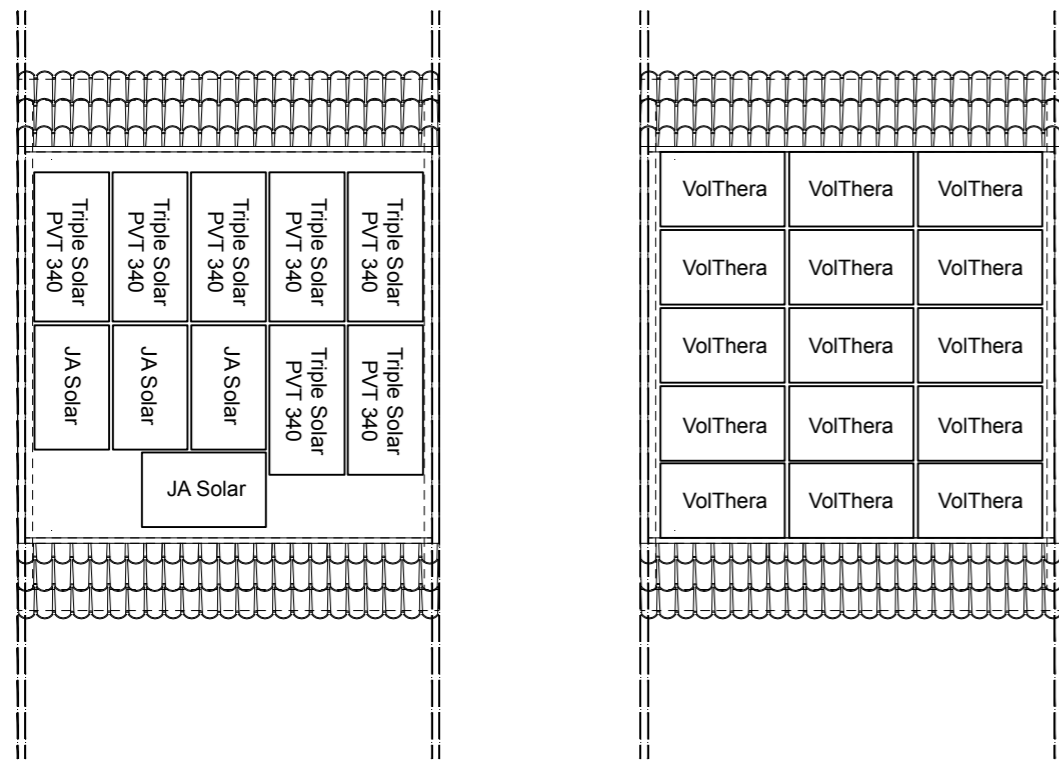

figure 57 to the left layout Triple Solar system, to the right layout VolThera system (scale: 1:100) (source: own image)

7.8 Conclusion

This chapter describes system choices for heating, DHW and ventilation. Two types of PV/T systems are chosen to research and assess on their circularity performance: Triple Solar, a system with higher thermal transmittance but less flexibility and less options for demountability and VolThera, a system with lower thermal transmittance and more flexibility. The dimensioning of the systems is approximated firstly on power use for a cold day to calculate the maximum dimensions of the systems, and then approximated on yearly energy performance. From the first approximation we see that we need around 7 Triple Solar PV/T panels and 21 VolThera panels. However, the roof fits about 15 VolThera panels, so this means an extra electrical element will need to supply the remaining power for the VolThera system. The EPC of both designs need to be the same to be able to compare them in the next chapter - for this the Triple Solar has 4 extra JA-Solar PV panels. Summarizing, the Triple Solar variant has 7 Triple Solar panels, 4 JA-Solar JAM6(k)-60/280-300/PR PV panels and the VolThera variant has 15 VolThera panels and a supplemental electrical element for the remaining heat demand. The yearly energy performance is approximated partly in Uniec2 and partly by hand calculations: the Triple Solar system is included in the Uniec2 database, but the VolThera system not - this latter is calculated by hand. These calculations show that the systems have an approximate EPC of about -0,09. The NIBE F1245 (5kW) heatpump is the power source, providing for heating and for DHW. The heat is distributed by < 35 °C LT radiators.

The ventilation system is divided in three zones: on the ground floor and on the second floor (new roof structure) decentral Fresh-R units with heat recovery provide ventilation. On the first floor, where only bedrooms are present, the ventilation is provided by natural supply and mechanical suction from the wet cell.

The next step is assessing the two types of PV/T panels chosen on their performance in terms of energy and circularity in chapter 9.

8. RESEARCH BY DESIGN

This chapter presents the research by design process undergone and several design variants developed to answer the following research question, which is:

How can the case study energy renovation project be designed so that the highest level of circularity possible is reached?

Answering this research question through a design process will directly influence the answer found for the main research question, namely 'to what extent can circularity be implemented in the designs of energy renovation projects?'

8.1 Highest level of circularity

Highest level of circularity is defined as scoring as high as possible on all of the performance indicators. Previous chapters detail the performance indicators taken into account, which are summarized in figure 58.

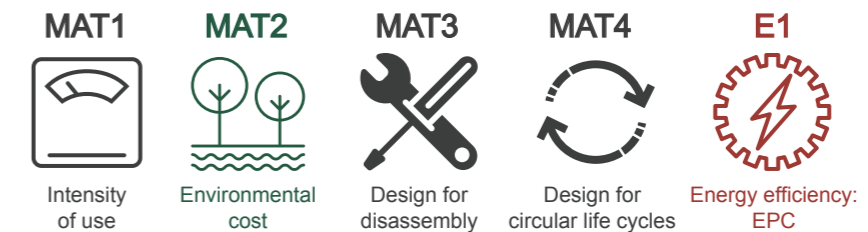

figure 58: performance indicators taken into account (source: own image)

However, indicators might have a negative mutual influence on each other, meaning scoring high on one indicator might mean another indicator receives a lower score. This means the development of variants is necessary to understand where performance indicators influence other indicators, so that we can arrive to an underpinned understanding about how different design decisions can be made to score as high as possible on the indicators.

The hypotheses are that between indicators, the following influences exist:

- If the intensity of material use over the lifetime of a building (MAT1) is decreased and thus the score for this indicator becomes better, the score for E1 becomes worse: less material use (less insulation, less energy services) will probably mean a worse EPC. If MAT1 is decreased, this will probably mean a better score for MAT2 as well: light materials such as wood score best on their environmental cost in the NIBE index, and less and lighter materials means less materials with environmental cost associated with them. However, this last point can't be taken as a general rule, but might differ across different materials somewhat.
- If the score for design for disassembly increases, this might mean a worse score for MAT1 and MAT2. Environmental cost of materials. This is because designing for disassembly will almost automatically entail using more materials: more connectors and fittings.

Furthermore, these indicators are not the only thing that matters: others aspects influence the design as well, such as the owners' wishes and comfort, the boundary conditions of the house, and more.

Developing design variants by changing design parameters can help in understanding how all these aspects influence each other in the design. Several variants have therefore been developed, in which design parameters vary. Each variant focuses on a different performance indicator.

8.2 Boundary conditions

There are some boundary conditions influencing the design of the roof structure which are worth mentioning here. These boundary conditions can be seen as practical necessities for the design, which need implementation no matter what happens to the other performance indicators.

8.2.1 Prefabrication and speed of building

It is essential that the roof structure needs to be built very quickly. When such roof structures or similar ones like dormers are added, the procedure of building is usually done within a day or two, while the structure itself is largely prefabricated. For the resident's comfort this is important as it means that they won't have to leave their home during construction. Following this practice for this design assignment is important so it can be a competitive product for standard roof structures/dormers. For this a prefabrication strategy is defined, which all the variants should follow. Figure 59 shows the prefabrication strategy of the structure. Each facade is made up of three main components: structure, exterior finishing(s) and interior finishing(s). The structural components are prefabricated in the factory, including windows. After the structural prefab panels are connected on site, the roof is placed. The finishings are placed afterwards on site and or not prefabricated. The roof itself is divided in six components, as the area is too large to transport in a standard sized truck (2,55 m x 4 m x 12 m (Evofenedex, n.d.)). These components are also divided in the sub functions structural panel - exterior finishing - interior finishing. This division should allow the structure to be built within two days. Each variant largely follows this strategy, and further detailing about prefabrication is explained per variant.

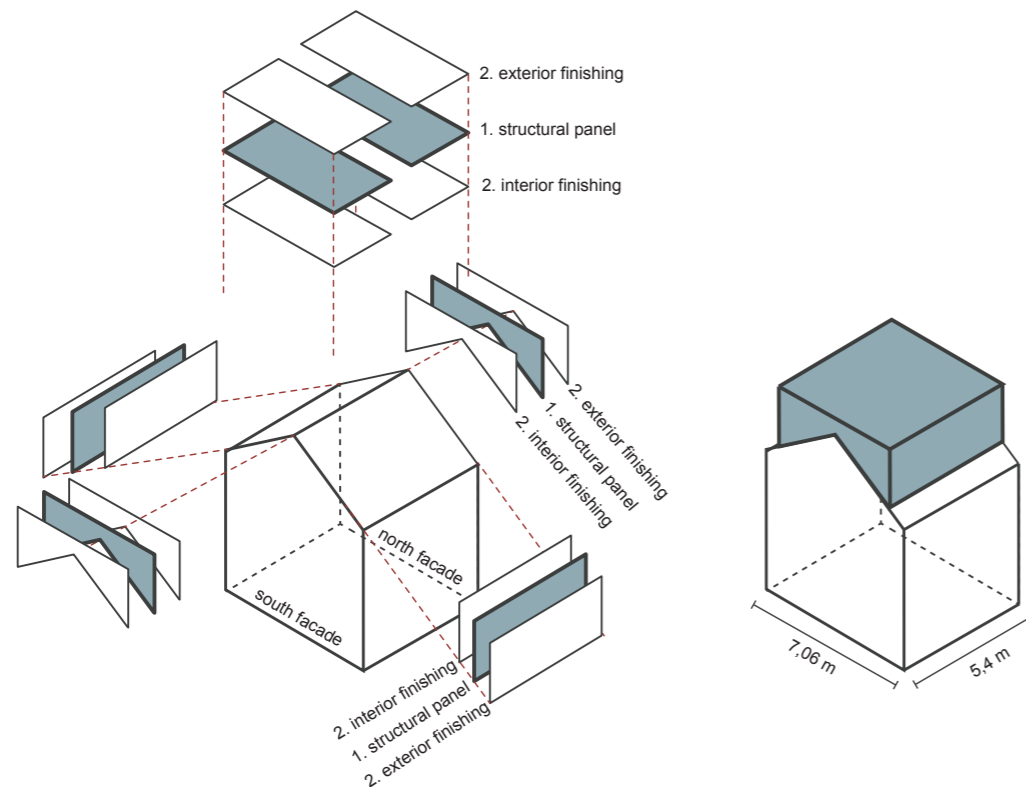

figure 59: prefabrication strategy (source: own image)

8.2.2 Other practical necessities

1. As mentioned in chapter 5 it is not possible to build beyond the first purlin.
2. The structure needs to transfer forces to the dividing walls.
3. A flat roof is chosen as the typology to continue with.
4. The two design variants for the energy design have already been defined in chapter 7.

8.3 Choice of parameters

The design variants are developed by changing design parameters to influence the outcomes of the performance indicators. Many different design parameters on a variety of levels could be considered during building design. Because of time limitations, it is obvious not all can be considered in the development of the variants. This paragraph details which parameters were taken into account and why.

The design can be influenced by on several levels. To explain these levels, we refer to the shearing layers of Brand, see figure 6 (explained in chapter 2).

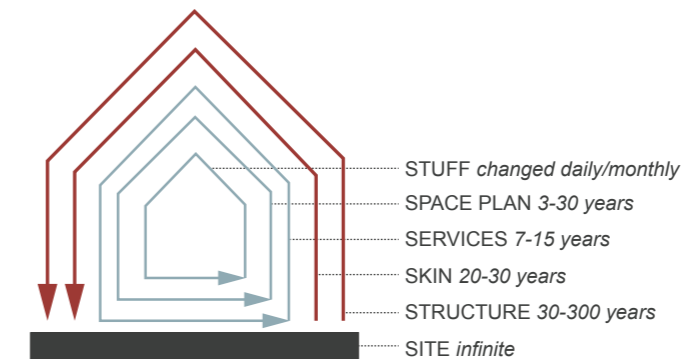

figure 6: Duffy & Brand shearing layers of change (adapted from Berge, 2009)

The layer of the skin can further be subdivided on several levels.

1. It can first be subdivided into facade, floor and roof.
2. The facade can be subdivided into open and closed facade. The open facade can be subdivided in glazing and framing and the closed facade in interior finishing, core (containing insulation) and exterior finishing.
3. The floor can be subdivided into floor finishing, ceiling finishing and core (possibly containing insulation).
4. The roof can be subdivided into exterior finishing, ceiling finishing and core (possibly containing insulation).

8.3.1 Structure

The first layer in which design variants are developed by changing parameters is the layer of the structure. The structure is an essential part of the design: it will most likely heavily influence the outcome of each performance indicator, and it also influences other aspects like building time. The three main structures researched are: a structure based on SIP panels, a structure based on solid wood construction and a structure based on steel frame construction.

8.3.2 Insulation

The design variants are also different in the insulation material used in the skin. Changing the material used for insulation is interesting to research, because the insulation material will heavily influence the outcome of the energy efficiency, but on the other hand during literature research it became clear there is a difference between the environmental cost of different insulation materials. There are many types of insulation materials: biological materials such as cork, flax, hemp and wool, EPS, PUR or PIR, wood fibre, cellular glass, repurposed materials such as repurposed jeans, high performing materials such as rigid foams (polyurethane, phenolic foams), etc. An example of how the environmental cost can differ between insulation materials: the PU foam insulation is generally known as being very high performing, with a low R_c value. It is therefore a popular insulating material, especially for renovation

projects like this, where there is little space available. But the high insulating value of polyurethane comes with a price: compared to some other classes of insulating materials it has higher embodied energy associated per functional unit (1m² with R=1m²K/W) and higher global warming potential per functional unit (GWP in kg CO₂ eq), as can be seen in figure 60. This figure shows a range between different products of the insulating material, but as can be seen the best scoring value for PU is always higher than the best scoring values for glasswool, mineral wool, EPS, and cellulose (Hill, Norton, & Dibdiakova, 2018). Both parameters (embodied energy and global warming potential) are taken into account in the life cycle analyses which form the basis of the environmental cost calculation. This gives an indication that the high performance associated with polyurethane might actually not perform well in terms of the environmental cost. Furthermore, the different insulating materials in figure 58 show a wide range between best and worst values.

Researching different insulating materials is therefore interesting, because at this point it's not clear if the possible negative environmental impact of the individual material weighs up to the positive impact of the total material use in the system, when the indicator of energy efficiency matters as well. And because different insulation materials show a wide range of environmental impact. Each design variant uses a different insulation material. The type of insulation material is also based on how thick the facades of the variants can be.

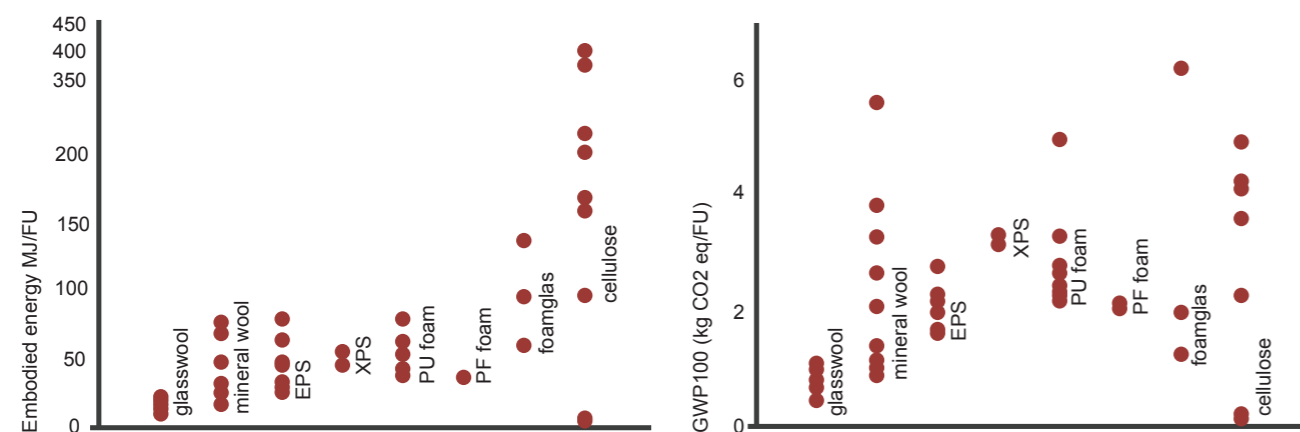

figure 60: embodied energy and GWP of different classes of insulation materials (adapted from Hill, Norton, & Dibdiakova, 2018)

8.4 Design variants

The design variants developed have quite some overlap. Figure 61 shows the general floor plan for each developed variant, the east and north facades and the places where separate details of the variants have been developed. Figure 62 shows a before and after of the case study house. Each variant has the same exterior finishing (thermal modified spruce), the same windows and window sizes (Alcoa RT 72 Reflex aluminium windowframe) and the same height of the walls. They differ in the thicknesses of the walls and the roof, meaning the interior floor plan has some minor deviations per variant, but these deviations are negligible. The major differences between the variants can therefore best be seen on the details. Keeping the other parts the same size ensures they can be compared to each other effectively.

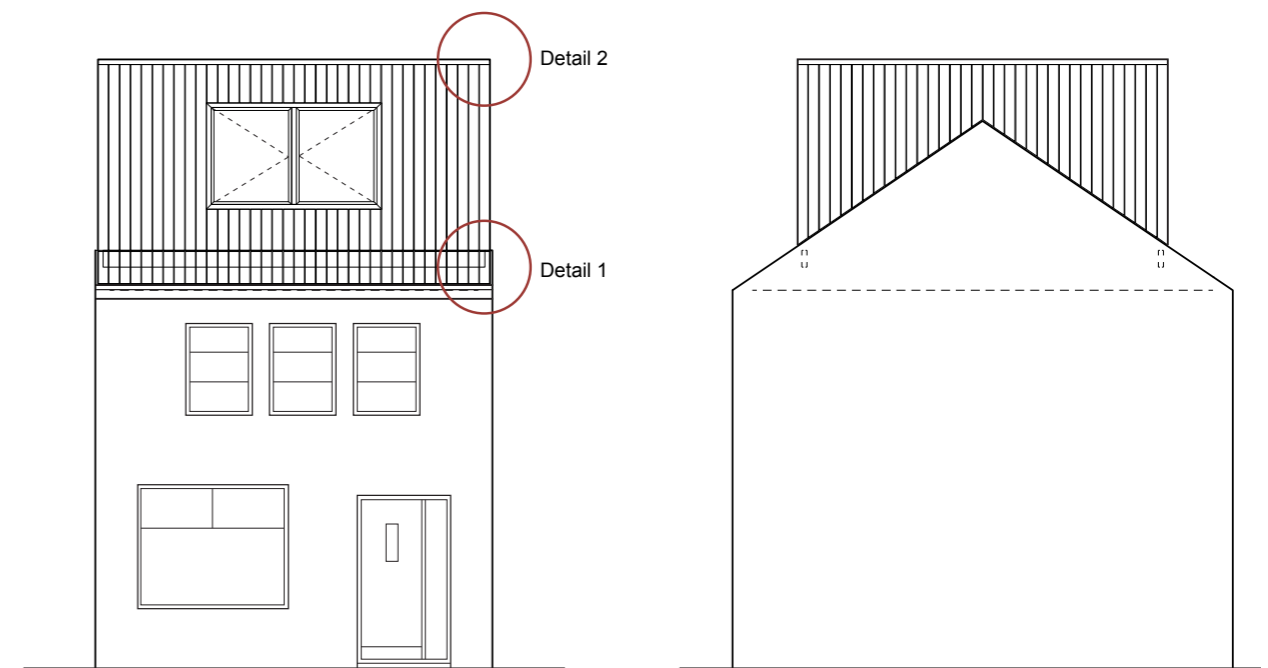

figure 61a: east facade and location of details developed. Scale: 1:100

figure 61b: north facade Scale: 1:100

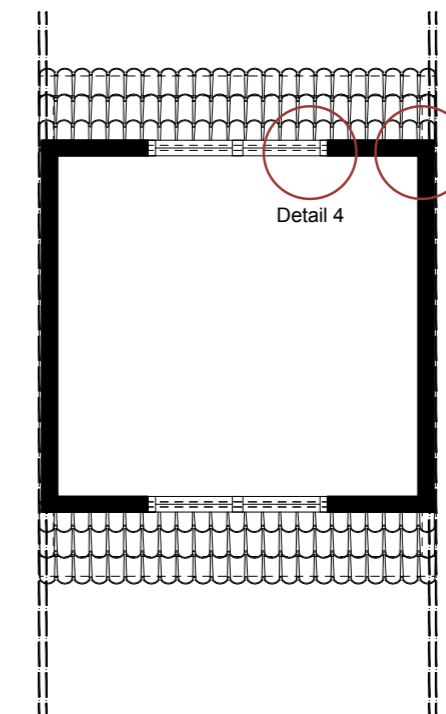

figure 61c: floor plan and location of details developed. Scale: 1:100



figure 62a: before view of case study dwelling



figure 62b: after view of case study dwelling

8.4.1 SIP structure variant

General description variant

The first variant developed is aimed towards being lightweight, with the main structural panels being SIP panels. SIP panels are sandwich panels: two construction plates are glued together with a core of a highly insulating material. Because of the high R_c value of the insulating core and the fact that the panels have loadbearing capacity without the need for additional structure, they are known for being a lightweight method of construction (Hopkin, Lennon, El-Rimawi, & Silberschmidt, 2011). Next to this lightweightness, the SIP system has the advantage of easy prefabrication, simple and fast construction on site, easy to make an airtight envelope, avoidance of thermal bridging and freedom in shape. It has the following disadvantages: firstly, it's a sandwich panel: glues are necessary to use for it to gain its loadbearing capacity, but this makes separation and reuse of the elements difficult. The construction plates are engineered wood products: wood glued together, creating a stronger panel. Additives are generally to be avoided when designing for circularity, but the use of large amounts of additives is unavoidable in SIP construction. Furthermore, finishing is needed on the interior and exterior is often needed. The SIP panels in the design are from the Kingspan TEK system. Two OSB plates are glued with a core of a highly insulating material, in this case polyurethane. This particular variant of SIP panels is the lightest to be found currently on the market: Kingspan has also developed a system with EPS insulation, but EPS has lower insulating values so the wall becomes thicker to reach the same R_c value.

Construction variant

The construction order of the system can be found in figure 63. Part of the structure is prefabricated and part of it is built on site. The core of the facades and roof are prefabricated up to the point that they are waterproof: this means the SIP panel, waterproof layer and first layer of the understructure (vertical battens) are built in the factory. These can be combined on site, after which the exterior finishing and energy system can be placed. In this way the construction should be quite quick: step 3 and in any case ensure that the building is water- and windproof quickly.

Material use variant

The material use of the variant is summarized in figure 64, showing the main materials used in different components and some general information about the material itself.

figure 63: general construction of SIP system in steps (source: own image)

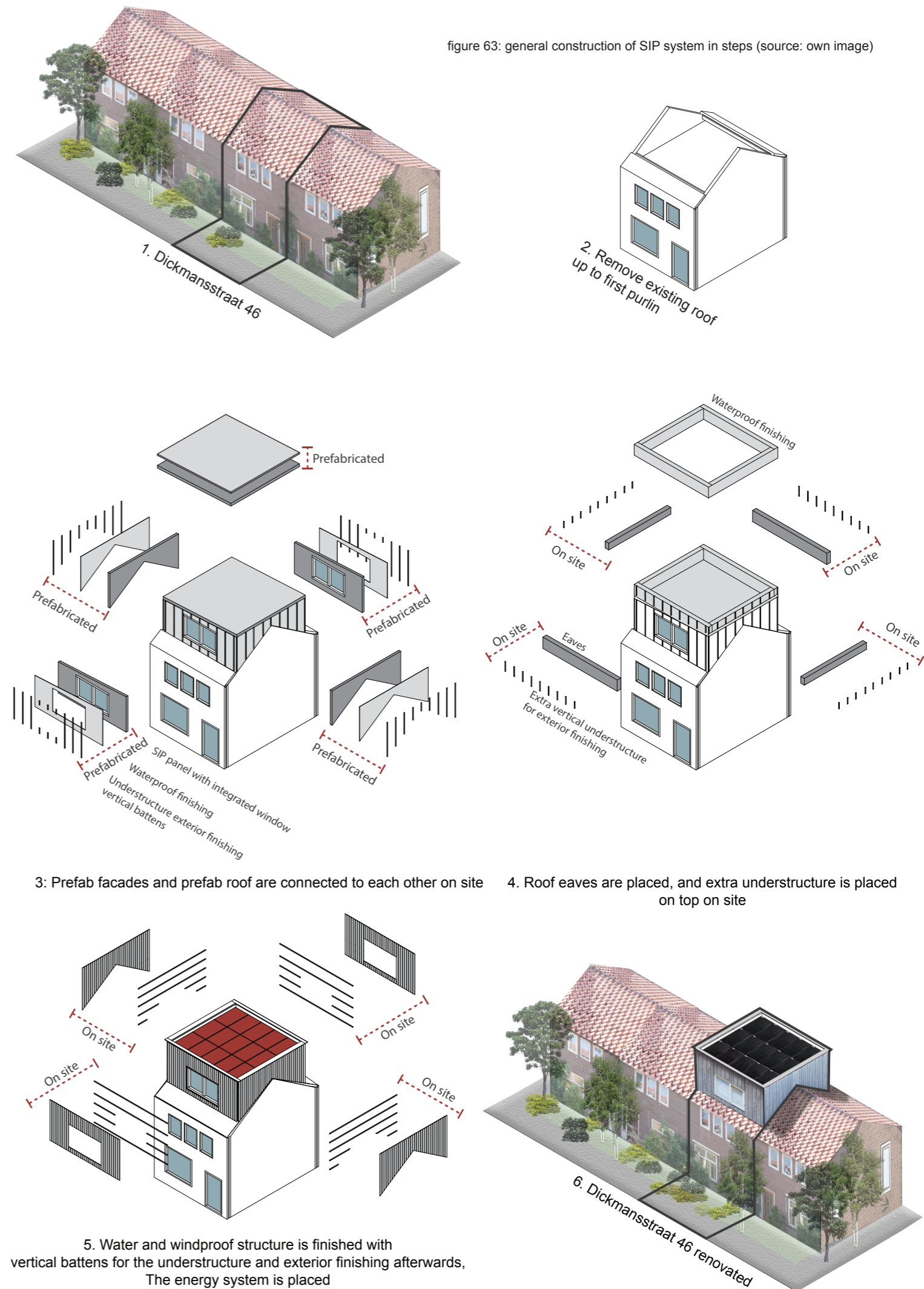

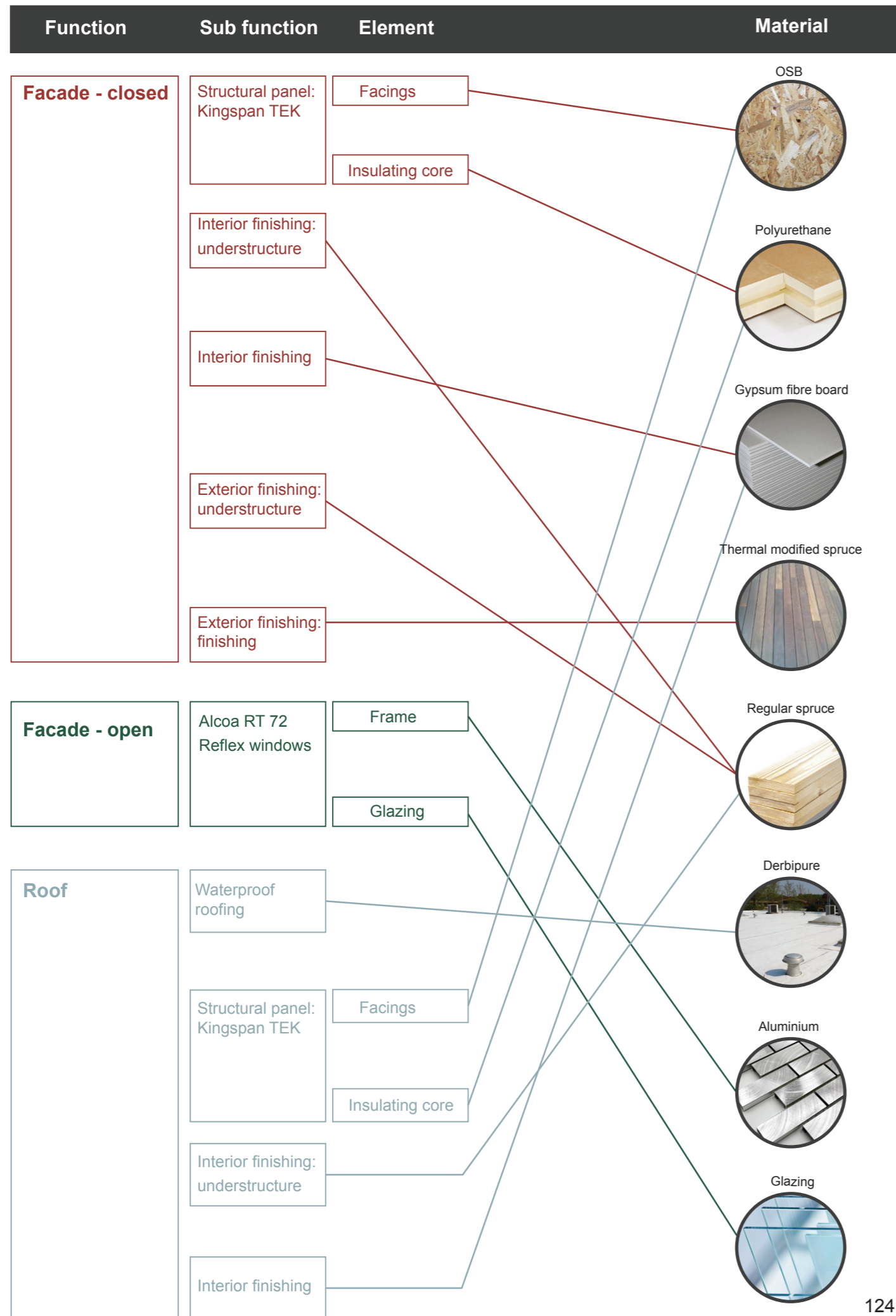

Material description
<p>OSB Engineered wood product: (waste) wood chips mixed with adhesives and pressed into plates. It is structurally strong but often seen as unsightly (Nishimura, 2015).</p>
<p>Polyurethane A high performance rigid insulation thermoset insulation foam (Kapps & Buschkamp, 2004). Possibly high environmental cost compared to other classes of insulation materials.</p>
<p>Gypsum fibre board Circular choice: recyclable without quality loss, supplier (Fermacell) takes back used boards (Fermacell, n.d.). Composition is gypsum, recycled paper fibres, water. It's pressed into boards under high pressure. Coating needed to finish it off: still little additives present.</p>
<p>Thermal modified spruce A wood finishing is chosen because of the low environmental impact associated with wood and it is thermal modified to increase the technical lifetime without the need for additives. Spruce is a wood type often used in buildings, and can be sourced sustainably.</p>
<p>Regular spruce Construction spruce wood used as understructure: thermal modification is not necessary as it is covered with other materials to protect it from the elements.</p>
<p>Derbipure First roofing material to receive Cradle to Cradle certificate. The bitum/rubber is replaced by biological components, like vegetal oils and pine-resins. It is reinforced with a composite glass/polyester weaving which is impregnated with acrylic coating. Derbigum states it's 100% recyclable (Derbigum, n.d.). This is a big step forward for roofing materials: rubber roofing is problematic in terms of circularity. Rubber roofing contains butyl rubber, among others such as different inorganic additives. "After production, the product can't be reprocessed due to the formation of chemically cross-linked molecular networks in the product. Burning for energy production is not a good option as volatile products and inorganic fillers become released, which must be removed from the gaseous decomposition product. Rubber can't be truly recycled" (Prof. G. J. Vancso, personal communication, May 20, 2018). Bitumen is an oil product: it is made by refining crude oil. Since bitumen production is directly linked to oil production, it has large environmental shadow costs associated with it. It has a negative effect on human health and many other negative effects (Morsali, 2018).</p>
<p>Aluminium and glazing The type of window frame chosen is the Kawneer RT 72 Reflex aluminium window frame with triple glass. Aluminium is chosen because it has the highest estimated service life time compared to other materials such as PVC or wood (Asif, Davidson, & Muneer, n.d.) and because of high rates of recycling in the industry (Blomberg & Söderholm, 2009). Kawneer is quite innovative in terms of circularity of their products. Their profiles can be produced by recycled aluminium such as AR100 or AR90 if the customer wishes this, they are researching possibilities to take back frames after end of first user phase with the specific goal of keeping the value for as long as possible as high as possible (so reusing frames before recycling is necessary). Together with the TU Delft and with VMRG they are involved in the 'facade identification system' research, researching how through advanced sensing techniques the state of the frame and thus minor damage can be identified early to extend the lifetime of the frame. And finally, possibilities for leasing windows are also investigated in the 'facade as a service' project at the TU Delft. The future vision is that the supplier will remain the owner of the product and will invoice the user for the performance during use (A. Smit, personal communication, May 16, 2018). With this Alcoa is showing a true vision towards circularity in their products, going beyond simply offering opportunities for recycling materials. Glass can always be remelted and poured into new shapes.</p>

Details variant

The details of the variant are shown in figures 65a to 65d.

Figure 65a: SIP: windowframe connection detail. Scale: 1:5 (source: own image)

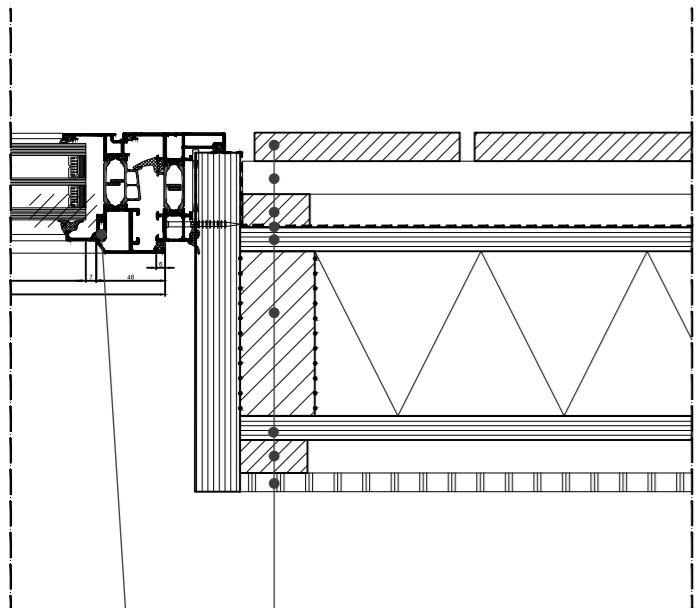

Spacer
Seam seal

Figure 65b: SIP: horizontal section wall detail. Scale: 1:5 (source: own image).

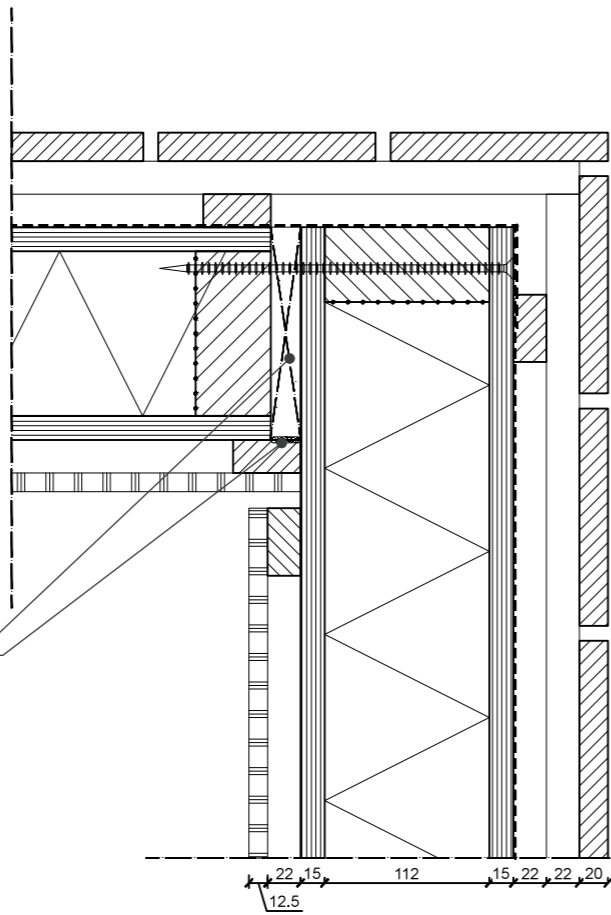

Exterior finishing: thermal modified European whitewood
Horizontal battens
Vertical battens
Vapor permeable waterproof layer
OSB
Wooden beam
OSB
Vertical battens
Gypsum fibre board (Fermacell)

Alcoa RT Reflex 72

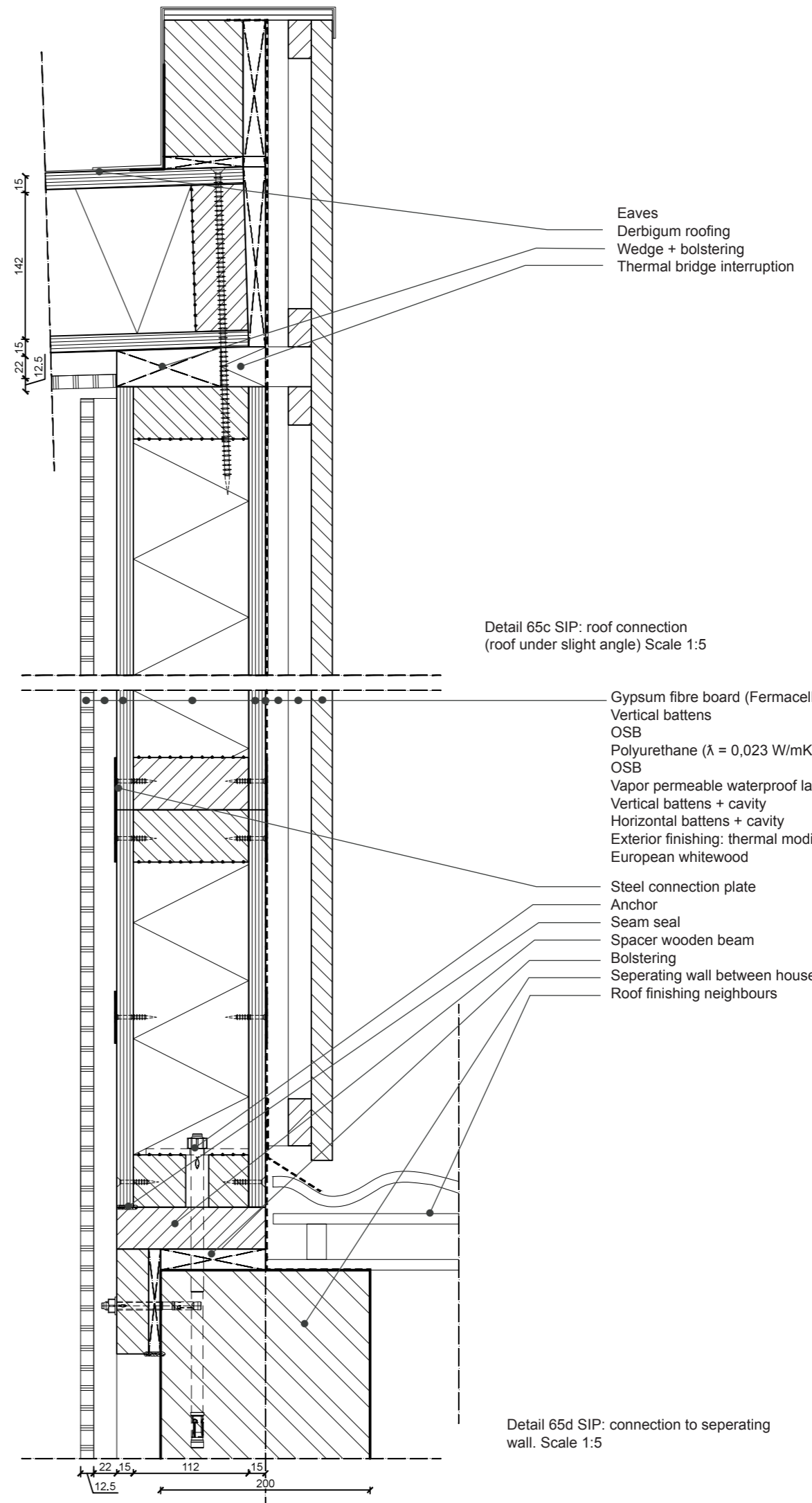

Detail 65c SIP: roof connection (roof under slight angle) Scale 1:5

Gypsum fibre board (Fermacell)
Vertical battens
OSB
Polyurethane ($\lambda = 0,023 \text{ W/mK}$)
OSB
Vapor permeable waterproof layer
Vertical battens + cavity
Horizontal battens + cavity
Exterior finishing: thermal modified European whitewood

Steel connection plate
Anchor
Seam seal
Spacer wooden beam
Bolstering
Separating wall between houses
Roof finishing neighbours

Detail 65d SIP: connection to separating wall. Scale 1:5

8.4.2 Solid wood variant

General description variant

Another variant is also aimed towards being lightweight and having little environmental cost, with the main structure being a solid wood building system. The system chosen as a basis is the Novatop system. Solid wood building systems are based on cross lamination: timber elements are stacked and glued perpendicularly into panels. The panels can be cut to the desirable size and have loadbearing capacity without the need for additional structure (Jones, Stegemann, Sykes, & Winslow, 2016). Constructions from wood as a general rule often have little environmental cost and are lightweight, as they are based on a renewable material with low densities as compared to other building materials such as concrete or brick. A solid wood building system has the further advantages of easy prefabrication, simple and fast construction on site, easy to make an airtight envelope, avoidance of thermal bridging, freedom in shape and esthetical qualities in the interior, so no need for interior finishing. It does need exterior finishing. It has the disadvantage that to reach the desirable R_c value of 5 for the walls and 7 for the roof, thick walls and roofs are needed as the solid wood panels themselves have low λ values, but do need a certain thickness to reach their loadbearing capacity. Furthermore, the use of additives in cross-lamination is unavoidable. However, it has better demountability possibilities than the SIP structure (functions of insulation and structure are separated), and more freedom to choose certain materials with lower environmental cost, such as perhaps a different insulation material than PU. For those reasons it's interesting to investigate as a variant and compare to the SIP panels.

Construction variant

The construction order of the system can be found in figure 66. Part of the structure is prefabricated and part of it is built on site. The prefabricated facade components are made up of the NOVATOP solid elements, insulation between vertical battens, a waterproof finishing and the first layer of the understructure for exterior finishing - the vertical battens. The prefabricated roof is made up of the NOVATOP element, which can be filled with insulation, and a waterproof layer. These prefab components are then combined on site. The eaves are placed on site, and the exterior finishing is also done on site.

Material use variant

The material use of the variant is summarized in figure 67, showing the main materials used in different components and some general information about the material itself.

figure 66: general construction of solid wood variant in steps
(source: own image)

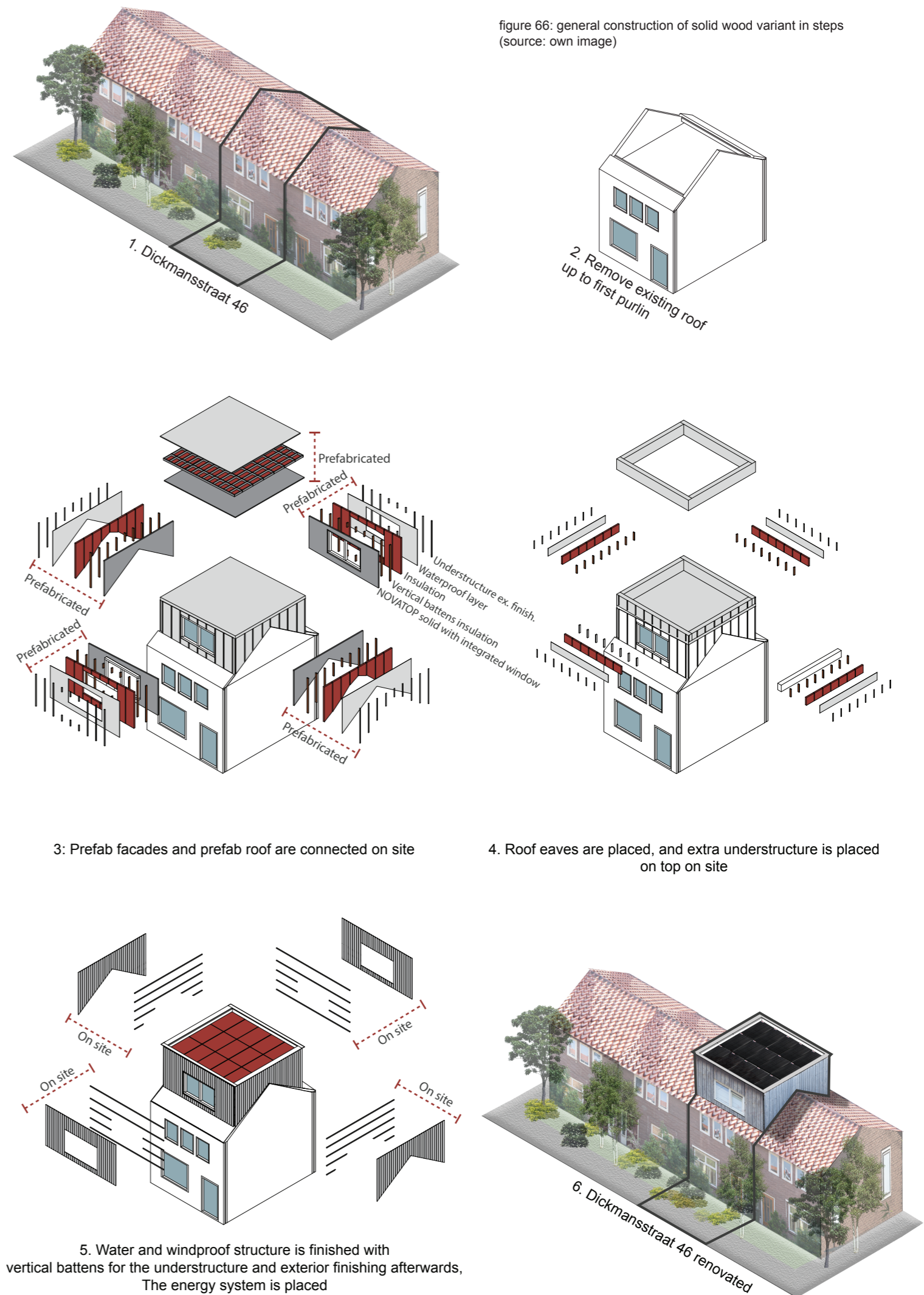
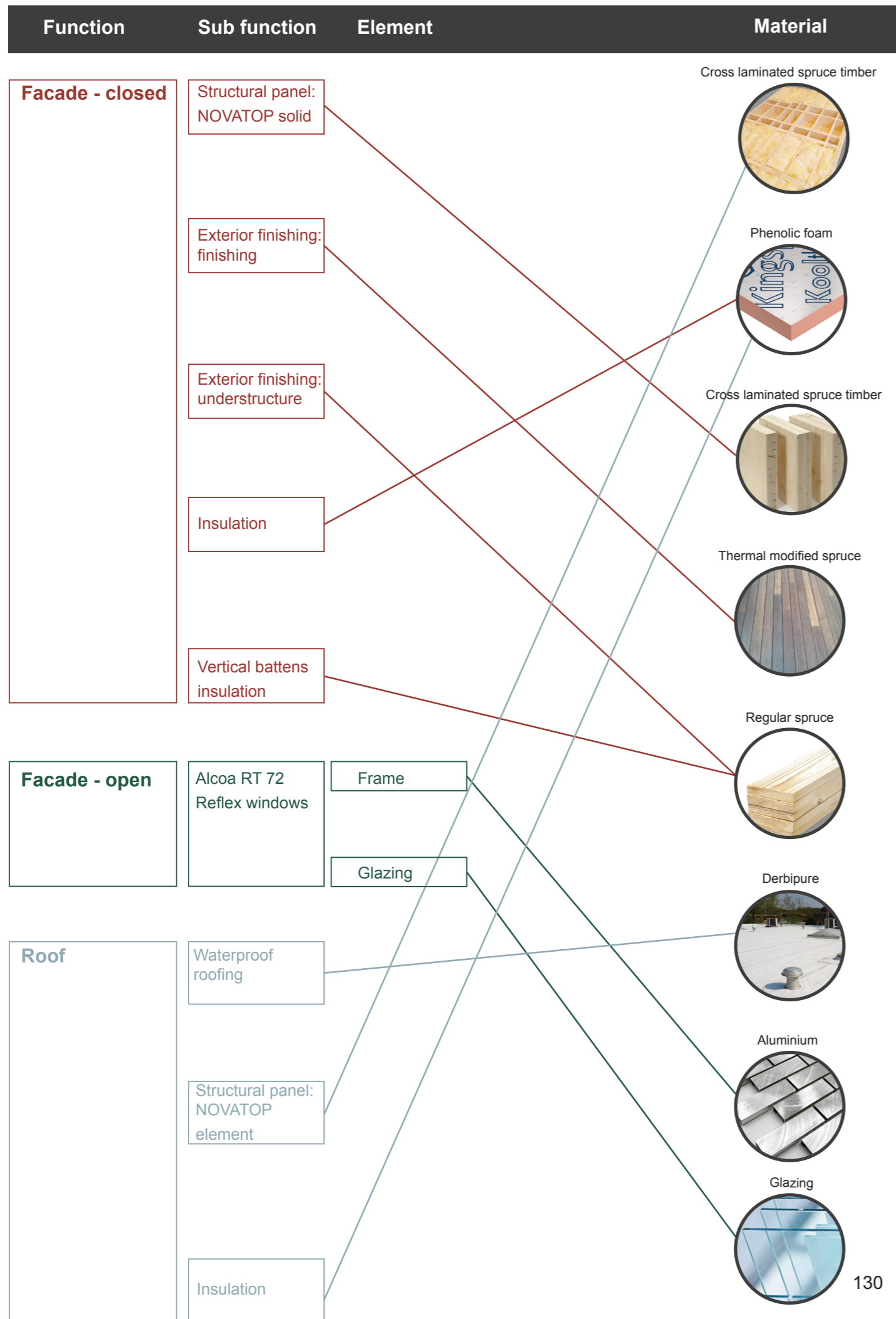

figure 67: material use solid wood variant (source: own image)



Material description
<p>Cross laminated spruce timber (CLT)</p> <p>The panels are manufactured from dried spruce slats assembled in layers; the grain orientation of each layer is always perpendicular to the adjacent layers. The number of layers can differ and determines the final thickness of the panel. The slats are bonded together on all faces so the final component has excellent dimensional stability (NOVATOP, n.d.).</p>
<p>Phenolic foam</p> <p>Kingspan's Kooltherm phenolic foam. The phenolic foam is quite similar to the polyurethane foam in their manufacturing process, the fact that they are thermosets and their energy performance (Fangareggi & Bertucelli, 2012). It is different from the polyurethane foam in that it has a DUBO-keurmerk by NIBE, showing that it is 'the most environmentally friendly choice in the category.' However, this DUBO-keurmerk is based on traditional life cycle analyses, considering only a cradle-to-grave scenario.</p>
<p>For the description of the other materials, see SIP variant.</p>

Details variant

The details of the variant are shown in figures 68a to 68d.

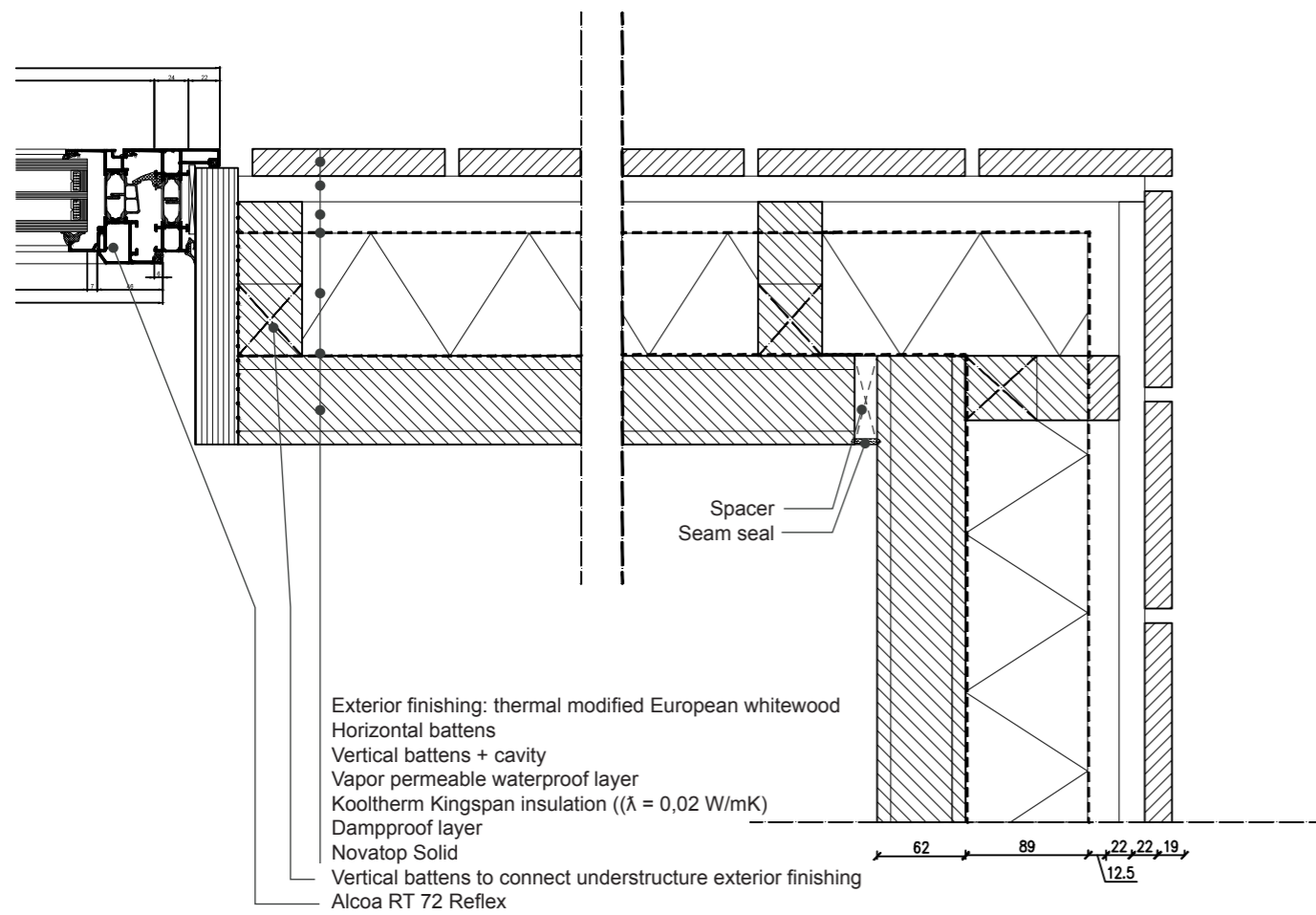

Figure 68a: Solid wood: windowframe connection detail. Scale: 1:5 (source: own image)

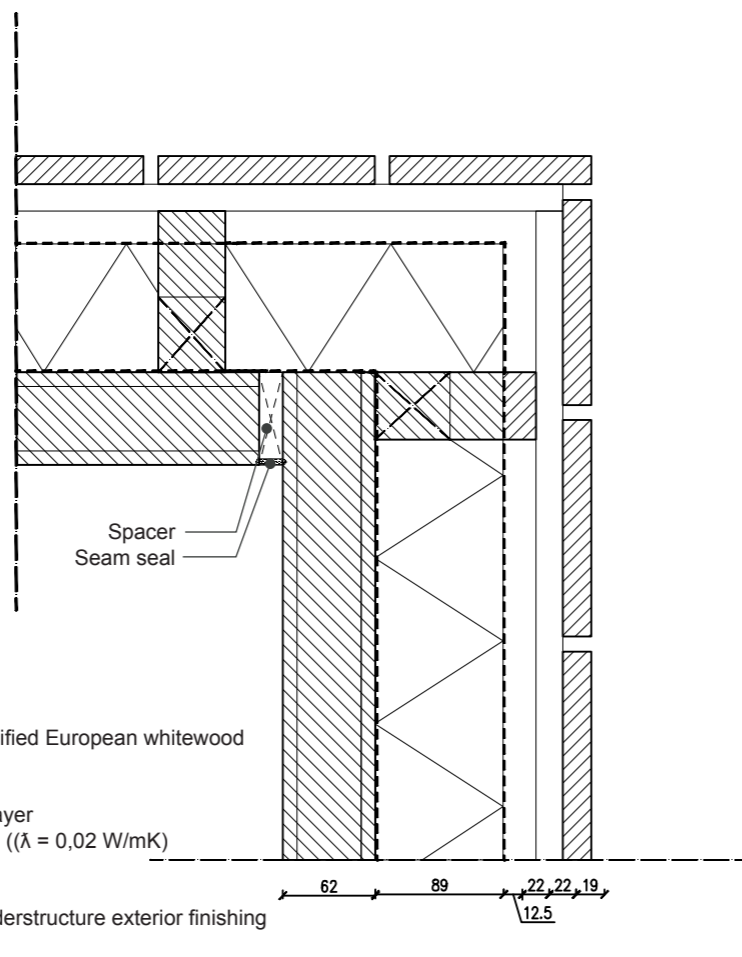

Figure 68b: Solid wood: horizontal section wall detail. Scale: 1:5 (source: own image)

Figure 68c: Solid wood: roof connection (roof under slight angle) Scale: 1:5 (source: own image)

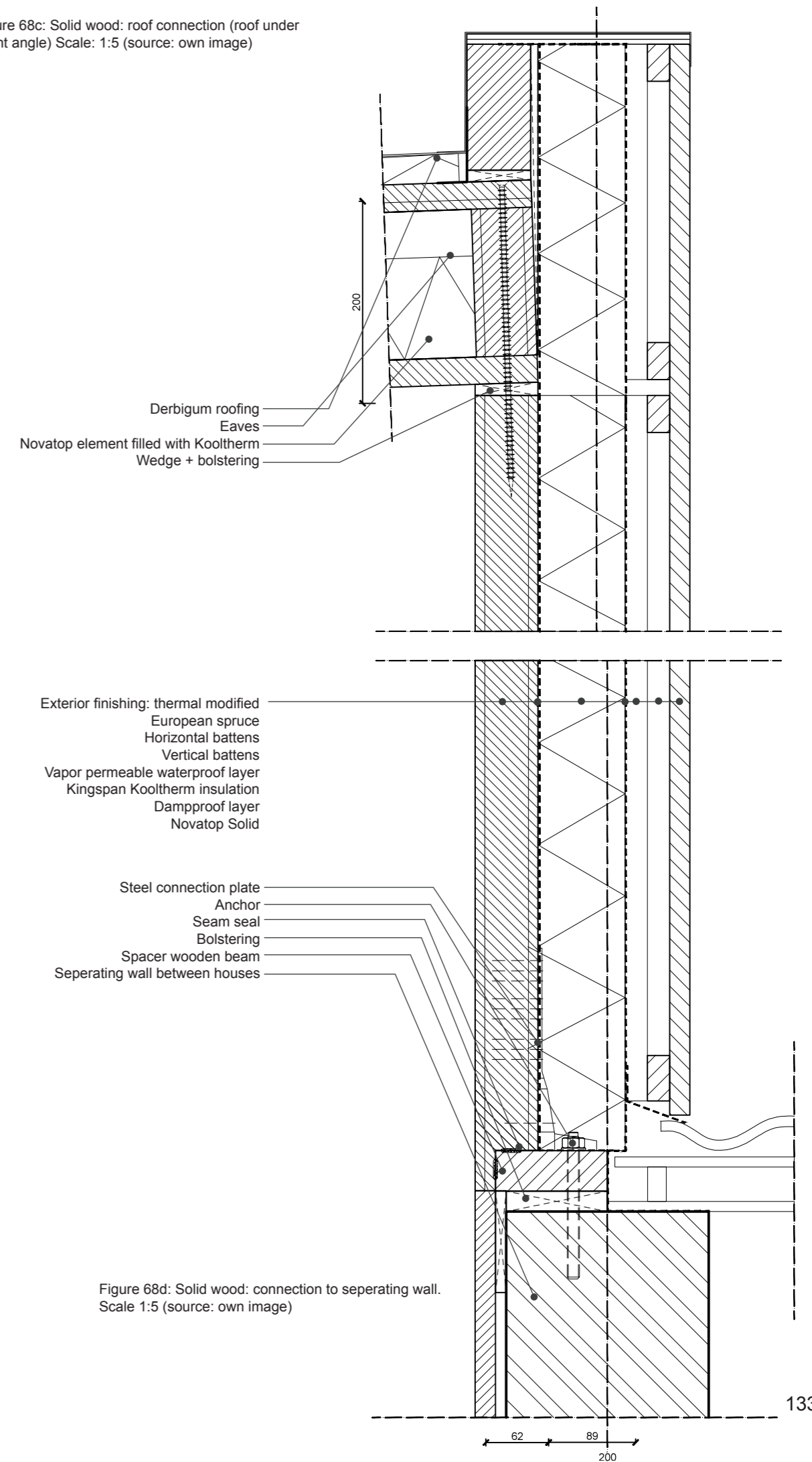

Figure 68d: Solid wood: connection to separating wall. Scale 1:5 (source: own image)

8.4.3 Steel frame variant

General description variant

The final variant is aimed towards demountability, with the main structure being a steel frame construction. Steel frame is very similar to the more traditional timber frame construction systems, but it can have better overall performance as it compares the advantages of timber frame construction with the advantages of using steel: it's a light construction method, the construction on site is simple and fast and the structure is resistant to molds and insects and overall has a longer lifetime than wood constructions (Bouwen met staal, 2004). Furthermore, this system has the highest potential for demountability, as no additives are involved. The downsides of the system are the fact that it needs an extra layer of insulation on the outside of the steelframe to avoid thermal bridging, it needs finishing on the interior and exterior and finally, even though prefabrication is possible, the time spent on prefabricating the components will take some time as there are more separate elements than in the SIP and massive wood construction. For those reasons it's interesting to investigate as a variant probably scoring higher on demountability than the SIP and massive wood variants.

Construction variant

The construction order of the system can be found in figure 69. Part of the structure is prefabricated and part of it is built on site. The prefabricated facade components are made up of the steel frame filled with insulation material, the outer gypsum fibre board, an extra layer of insulation and the waterproof finishing and first layer of the understructure. On site the interior gypsum fibre board is placed, and so are the eaves and the rest of the exterior finishing.

Material use variant

The material use of the variant is summarized in figure 70, showing the main materials used in different components and some general information about the material itself.

figure 69: general construction of steel frame variant in steps (source: own image)

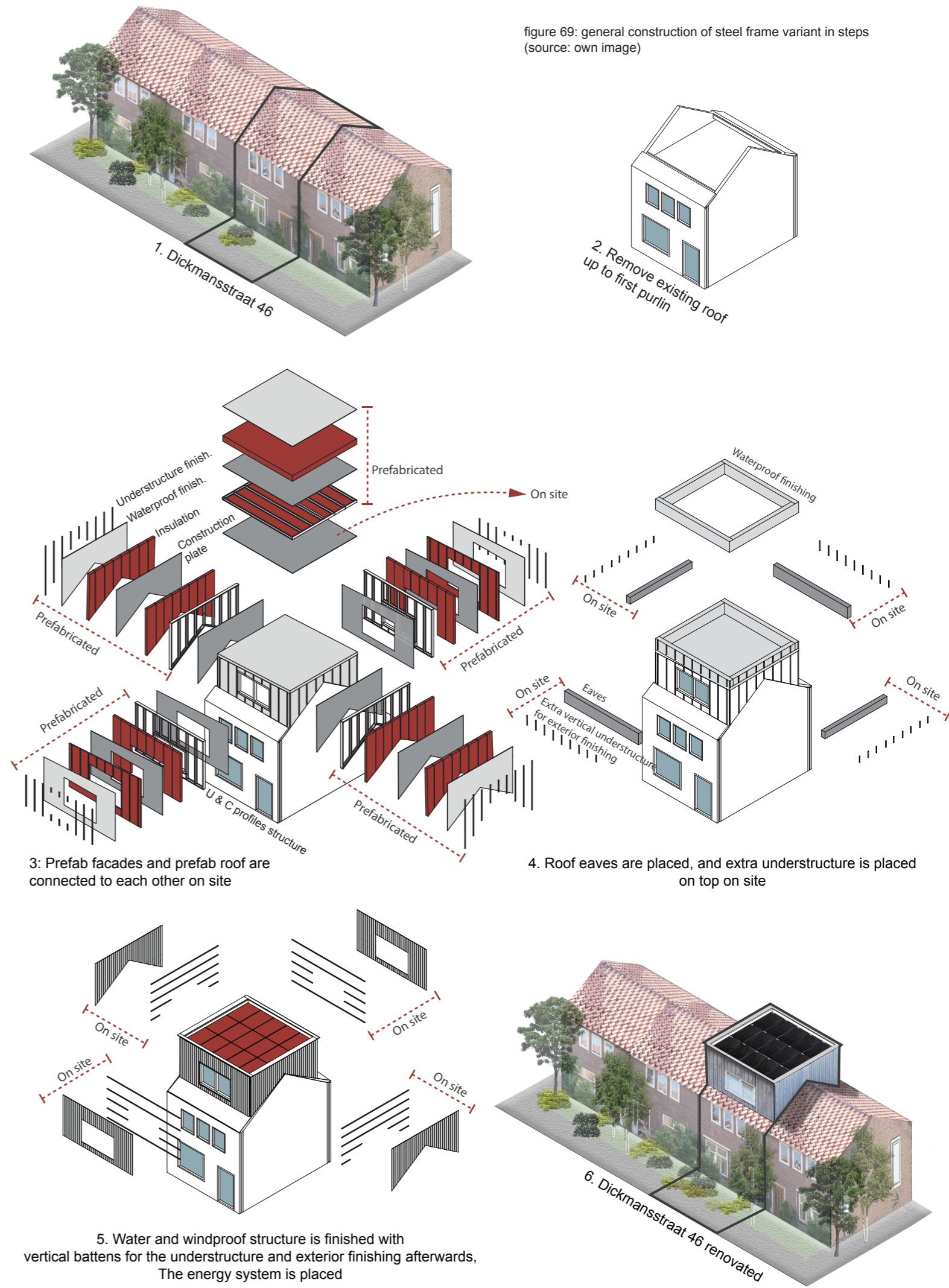
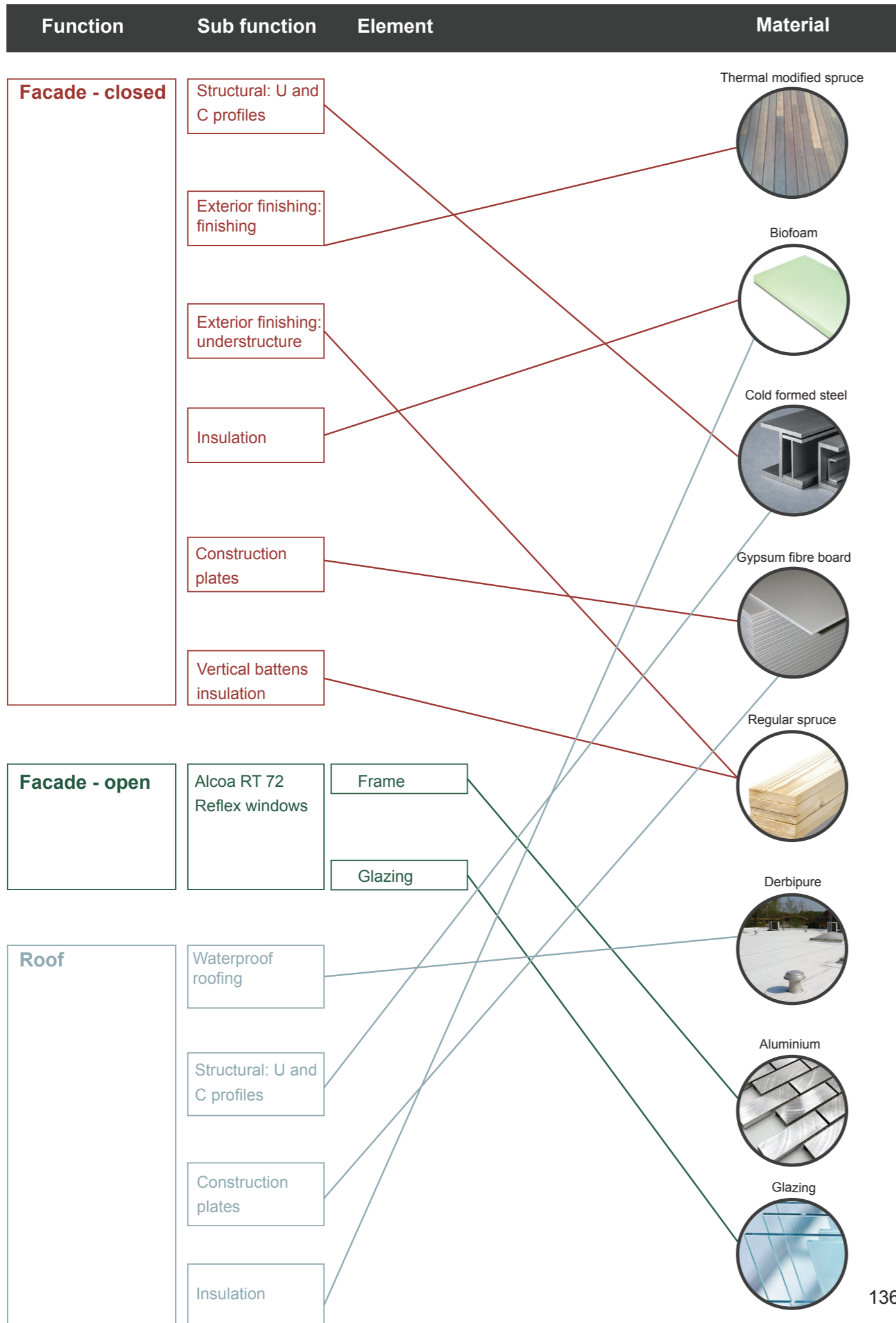

figure 70: material use steel frame variant (source: own image)



Material description
<p>Biofoam</p> <p>A cradle to cradle certified insulation material made from plant-based PLA thermoplastic. It has multiple end of life possibilities: it can be composted, remelted because of the thermoplastic properties and thus fully remanufactured into something else without significant loss in quality ("BioFoam," n.d.). However, this does mean it has lower energy performance than the other insulation materials</p>
<p>Cold formed steel</p> <p>"Cold-formed steel (CFS) members are made from structural quality sheet steel that are formed into C-sections and other shapes by roll forming the steel through a series of dies. No heat is required to form the shapes (unlike hot-rolled steel), hence the name cold-formed steel. A variety of steel thicknesses are available to meet a wide range of structural and non-structural applications." (BuildSteel, n.d.)</p>
<p>For the description of the other materials, see SIP variant.</p>

Details variant

The details of the variant are shown in figures 71a to 71d

Figure 71a: Steel frame: windowframe connection detail. Scale: 1:5 (source: own image)

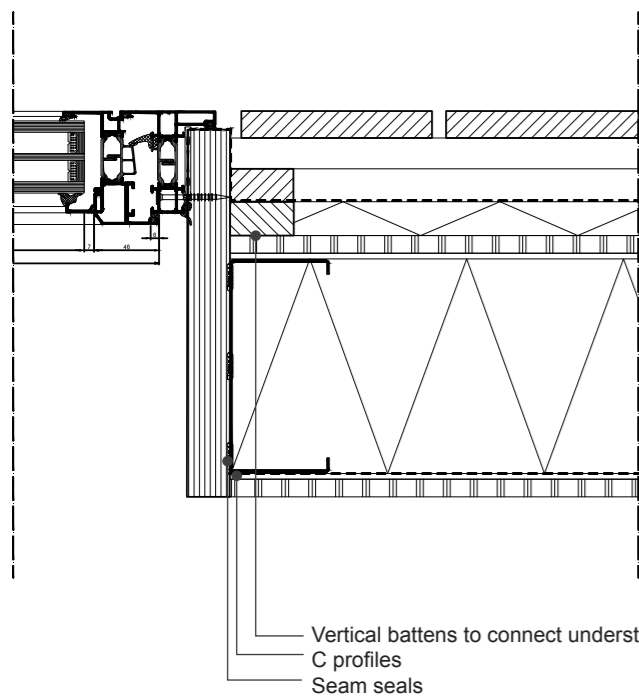

- Vertical battens to connect understructure exterior finishing
- C profiles
- Seam seals
- Exterior finishing: thermal modified European whitewood
- Horizontal battens
- Vertical battens
- Vapor permeable waterproof layer
- Biofoam insulation ($\lambda = 0,034 \text{ W/mK}$)
- Gypsum fibre board
- Biofoam insulation
- Gypsum fibre board

Figure 71b: Steel frame: horizontal section wall detail. Scale: 1:5 (source: own image)

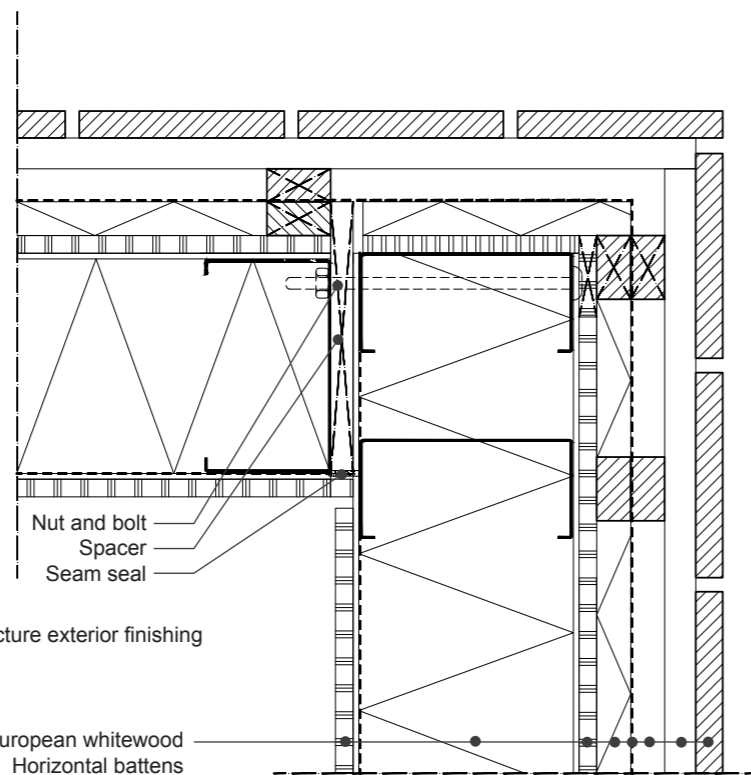

- Nut and bolt
- Spacer
- Seam seal

Figure 71c: Steel frame: roof connection (roof under slight angle) Scale: 1:5 (source: own image)

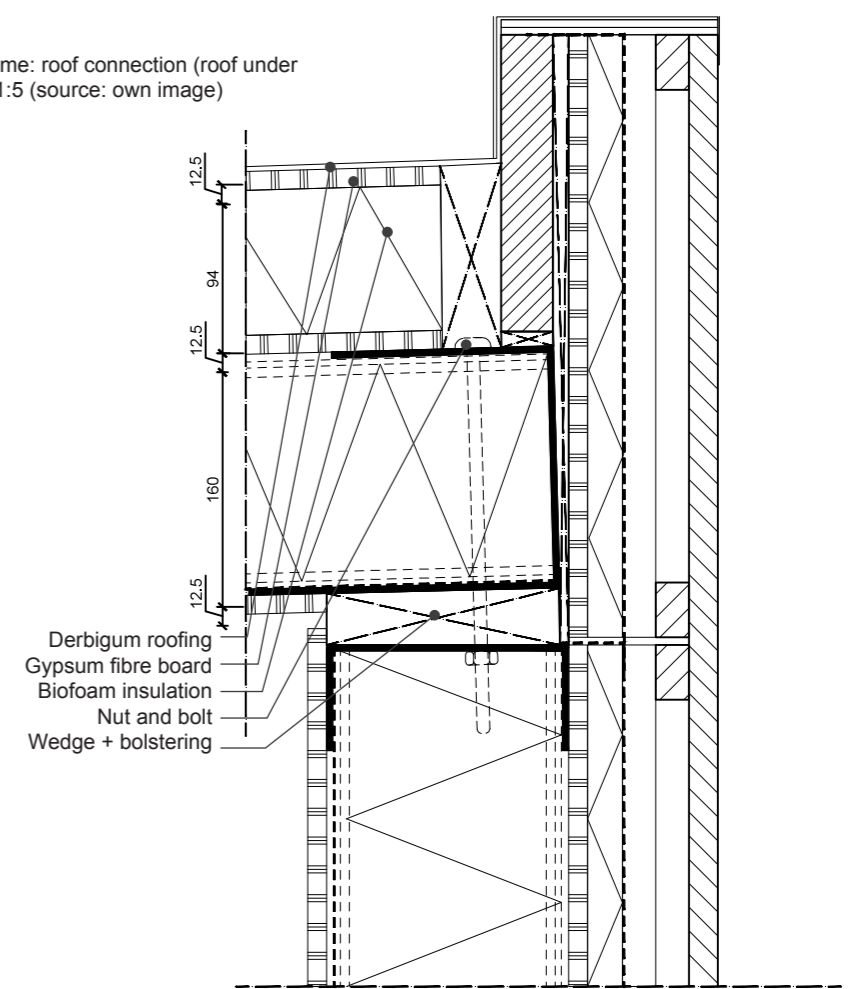

- Derbigum roofing
- Gypsum fibre board
- Biofoam insulation
- Nut and bolt
- Wedge + bolstering

- Exterior finishing: thermal modified European whitewood
- Horizontal battens
- Vertical battens
- Vapor permeable waterproof layer
- Biofoam insulation ($\lambda = 0,034 \text{ W/mK}$)
- Gypsum fibre board
- Biofoam insulation
- Dampproof layer
- Gypsum fibre board
- C profiles (vertical)
- U profiles (horizontal)
- Spacer wooden beam
- Bolstering
- Seam seal
- Anchor
- Separating wall between houses

Figure 71d: Steel frame: connection to separating wall. Scale 1:5 (source: own image)

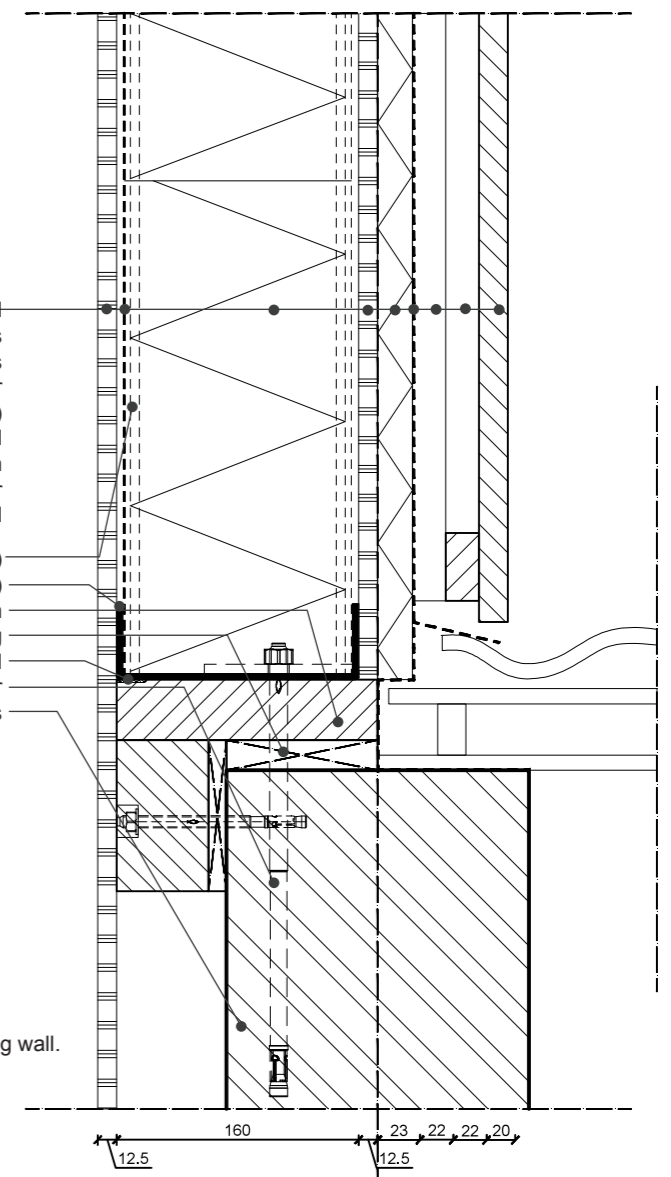

8.5 Conclusion

The question posed in this chapter is: ‘How can the case study energy renovation project be designed so that the highest level of circularity possible is reached?’ Highest level of circularity is defined as the optimal combination between the indicators MAT1 (intensity of material use), MAT 2 (environmental cost), MAT 3 (design for disassembly), MAT 4 (design for circular life cycles) and E1 (energy efficiency). However, it is possible that the indicators have mutual exclusivity to some extent, so to find the optimal combination between these indicators three design variants are developed in which the parameters of the structure and insulation are changed between variants. The design variants are developed for prefabrication in the first place. In the second place, each variant has different strengths and weaknesses. The first variant, SIP structure, is lightweight and has potentially low environmental cost, but it is probably not very demountable. The second variant, solid wood, is lightweight - but heavier than SIP, has potentially low environmental cost and is probably slightly better in demountability. The third variant, steel frame, is heaviest, but also probably most demountable. Furthermore, in chapter 5. two different energy designs are presented: a Triple Solar variant and a VolThera variant. Combining these with the three design variants, we end up with six possible case study energy renovation designs. These designs all attempt to reach the highest level of circularity possible and are therefore all potentially an answer to the research question posed. However, to answer the question fully, the designs need to be assessed on their circularity performance, which is done in the next chapter.

Figure 72 shows the summary of the design variants developed and the hypotheses about the outcomes of the different assessments. In the following chapter, the different design variants are assessed, and so are the two energy variants.

TYPE & HYPOTHESES ABOUT ASSESSMENT	Triple Solar High efficiency Less suited for circularity EPC = -0,09	VolThera Low efficiency More suited for circularity EPC = -0,09
SIP structure variant Lightweight Potentially low environmental cost Not very demountable		
Solid wood variant Lightweight, heavier than SIP Potentially low environmental cost More demountable than SIP, less demountable than steelframe		
Steel frame variant Heaviest Environmental cost might be low or high Most demountable		

figure 72: summary design variants developed (source: own image)

9. VALIDATION & ASSESSMENT

Chapter 5 presented the circularity assessment to be used in this chapter. Chapter 6 presented the two energy designs to be assessed and chapter 7 presented the roof structure designs to be assessed. This chapter brings the two together, describing the circularity assessment outcomes of the different design variants. The research question answered for each variant here is:

8. What is the circular and energy performance of the case study energy renovation project?

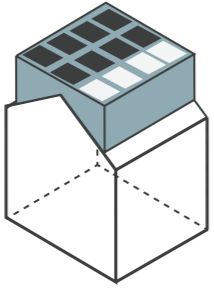
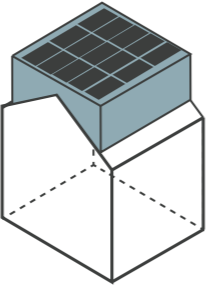
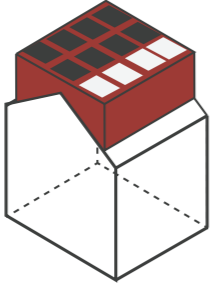
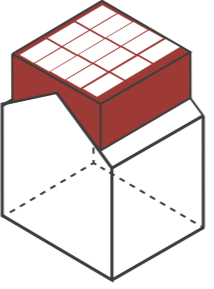
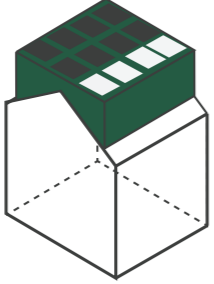
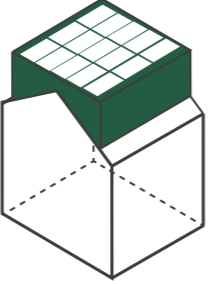
For simplicity every part is assessed separately: the SIP structure variant, the solid wood variant, the steel frame variant, the Triple Solar PV/T system and the VolThera PV/T system. The energy variants only take into account the PV/T panels themselves and no other extra installation parts such as the inverter or connections, as these are the same for both variants.

First each variant is assessed on performance indicator MAT1: Intensity of material use over lifetime of building.

Second each variant is assessed on performance indicator MAT 2: Environmental cost.

Third each variant is assessed on performance indicator MAT3: Design for disassembly

Fourth each variant is assessed on performance indicator Design for circular life cycles.

The final assessment on energy efficiency is the grading of the EPC in the designs - in previous chapters an EPC of -0,09 is found for both the Triple Solar and the VolThera variants.

9.1 Assessment on intensity of material use over lifetime of building

The intensity of material use over lifetime of building is assessed as described in paragraph 4.3. The first part of this assessment is a calculation of the weights of the roof structures. The second part is a qualitative description of material usage during build and during lifetime of building to give the reader context about the quantitative assessment.

9.1.1 Quantitative assessment: comparison weights materials

Figure 73 shows the total weight of the design variants, the weight of the design variants per m² facade, the total weight of the energy variants and the weight of the existing roof structure. A detailed description of how these weights are calculated are added in Appendix 6.

Variant	Total weight design variants (kg)
SIP structure	± 3150 kg
Solid wood	± 3380 kg
Steel frame	± 4940 kg
Existing roof structure	± 4560 kg
Triple Solar	± 377 kg
VolThera	± 600 kg

figure 73: weights design and energy variants, separately (source: own image)

Combining the weights of the design variants and the energy variants yields 6 variants in total: the total weights of these variants are summarized in figure 74, compared to the weight of the existing roof structure.

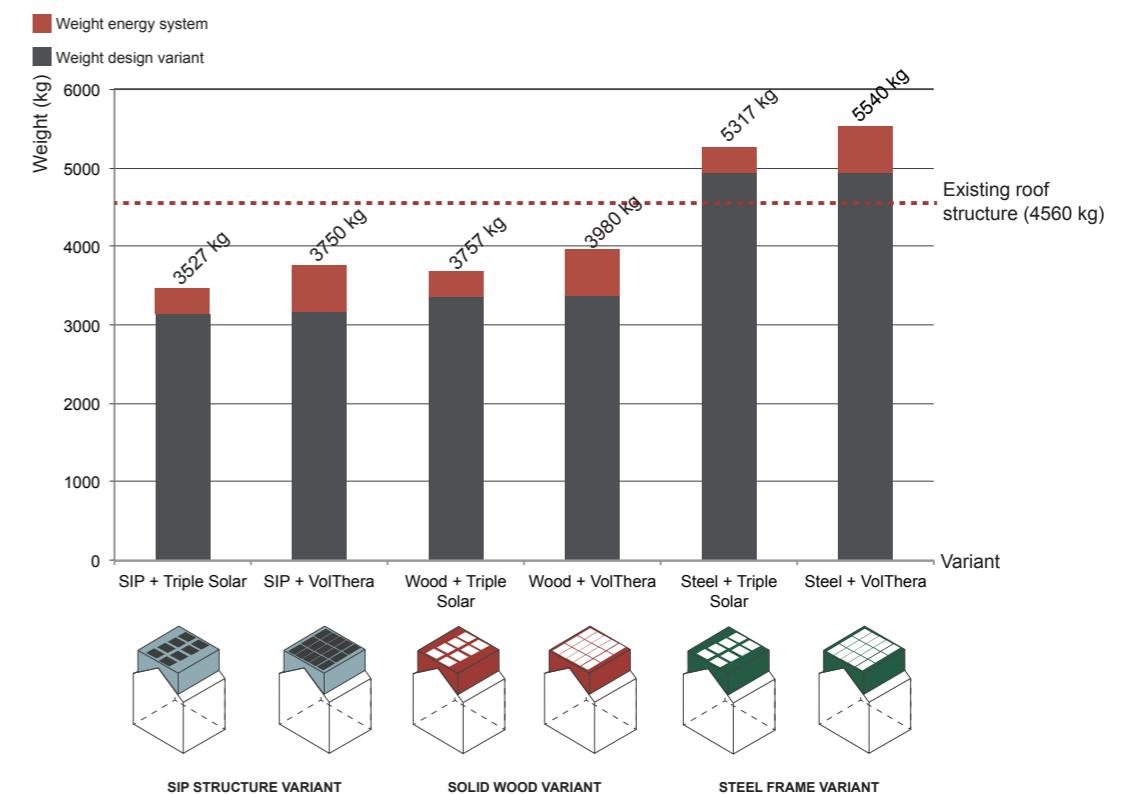

figure 74: weights final variants (source: own image)

9.1.2 Reducing material usage during build and during lifetime of building

Structure 1: SIP structure variant

From the variants the SIP structure variant uses the absolute minimum total material usage to secure the desirable energy performance. The facade thickness is dimensioned precisely to have an Rc value of 5 m²K/W and the roof thickness is dimensioned to have an Rc value of 7 m²K/W. The exterior finishing has the minimum recommended thickness for open exterior spruce finishing (Centrum Hout, 2012). It is positioned as an open cladding, leaving space between the boards instead of overlapping, minimising wood usage. One gypsum fibre board plate with the minimum thickness of 12,5mm is used to finish off the SIP panel on the interior: this is necessary to create an even wall and because OSB needs finishing for esthetic reasons. The roof is finished with Derbipure - this is necessary for the roof to be waterproof. The windows in the design are dimensioned to reach the desired energy performance, and use minimum materials as the aluminium profiles are hollow and only have material where necessary. This is visible on the detailing.

Technical lifetimes

It is difficult to estimate the functional lifetime of the renovated case study dwelling. If building parts reach the end of their technical lifetime, it is preferable that these are replaced before demolition. If the dwelling is considered to be not suitable anymore to live in, the final step is demolition. There are several reasons why the building might be demolished instead of refurbished again. One of these reasons is that the possible modifications during the refurbishment are limited by the inflexibility of the existing building: if the desired modifications in the future are too complex or simply not possible, the building could be torn down to be replaced by a new one. It could also be possible that the core of the building - the structure - has problems which are non-repairable. Furthermore, it could be that the function of the dwelling (living) becomes obsolete in the area, (Konstantinou, 2014, cited in Henry, 2018), but this is very unlikely to happen for this particular location in Haarlem. As it is very difficult to tell how long the case study dwelling will stand after it's renovated, an arbitrary value of 75 years is assumed here.

- **SIP structural panels:** Kingspan takes into account a technical lifetime of 75 years for the SIP TEK panels (Henry, 2018). The panels themselves are made up of two separate elements: OSB board (chipboard) and polyurethane insulation.
- **Interior finishing: gypsum fibre board:** MRPI takes into account a technical lifetime of 75 years for gypsum fibre boards.
- **Exterior finishing: thermal modified spruce:** Spruce is naturally placed in durability class 4. However, by thermally modifying the whitewood (heating it with high temperatures) the durability class is increased to class 2. This upgrades the technical lifetime from between 5-10 years to between 15-25 years (Eppinga, n.d.).
- **Understructures interior and exterior finishing:** This technical lifetime of the spruce found by Eppinga, n.d. only counts for wood exposed to outdoor conditions, as the durability tests are based on the wood's durability towards molds, etc. The wood in the exterior understructure is less exposed to the environment and will probably have a longer technical lifetime, although it's hard to say how long exactly. This spruce is not thermal modified. The assumption is that as soon as the exterior finishing needs replacement the understructure will need replacement too. This is also because the understructure will at that point be damaged by the connections between exterior finishing and understructure. The spruce in the understructure of the interior finishing is not exposed to the environment and will probably not be affected by molds. The assumption is if the interior finishing is replaced, so is this understructure.

- **Derbipure roofing:** The technical lifetime of the Derbipure roofing material is unclear. The bitumen roofing materials produced by Derbigum, the company producing Derbipure, have a technical lifetime of 40 years. The Derbipure roofing material might have a shorter lifetime due to the fact that it's made up of biological materials, but the 40 years is used as a reference value (Derbigum, 2016).

- **Alcoa aluminium window frame and glazing:** The estimated service lifetime of aluminium window frames, and thus the entire window, is 43,6 years (Asif, Davidson, & Muneer, n.d.).

Manufacturing process

- **SIP structural panels:** The panels are made up of two separate elements: OSB board (chipboard) and polyurethane insulation, glued together resulting in a strong sandwich panel. The panels are sawn to the exact specifications of the architect: this means some waste must be present in the manufacturing process of the SIP panels in the form of saw residues. However, according to the supplier, waste within the production process is reused (Pennings, 2017, cited in Henry, 2018).

- **Interior finishing gypsum fibre board:** It's made from gypsum and recycled paper fibres, mixed with water and then pressed in boards under high pressure. The boards are dried and coated with a water repellent and cut to desired sizes (Fermacell, n.d.). Using virgin materials as the raw gypsum material means the raw material needs to be extracted either by open-pit quarrying or by mining. Gypsum fibre boards can be recycled quite easily, so the raw material might also be based on recycled gypsum powder (Lushnikova & Dvorkin, 2016). On average, for every 92,9 square meters of gypsum board product manufactured, about 0,4% of the material input ends up as a lesser quality product, deemed "waste". Of this 0,4% about 0,04% is hazardous and needs to be incinerated, but the majority of the waste is recycled, used in agriculture or returned to the quarry site (Bushii & Meil, 2011). A very small percentage ends up in landfill. Fermacell uses 25% of recycled gypsum powder in their products (Fermacell, n.d.). From this information we can conclude some waste is present during the manufacturing process of the gypsum fibre boards, but overall this is a very small percentage, and the production of the boards is quite efficient.

- **OSB panels:** The manufacturing process of chipboard can be seen in figure 75. Chips are made with a ring flaker, which cuts the raw material up into the chips, after which they are organised in different categories by size and used for the corresponding type of board. The board itself usually has a structure of three layers: large chips are placed in the core layer and the surface layers are comprised of smaller chips and thus have a smoother surface. The chips are blended with adhesives (urea formaldehyde, melamine formaldehyde, phenol formaldehyde and isocyanate resins) by putting the chips in a drum and spraying them with the resin mist. This method ensures that the resin used is minimised, as it's deposited on the surface of the chips as small dots. As a final step the chips can be pressed together, the board cut to standard sizes to minimise waste and sanded. The raw material used for the chips often includes waste wood from factories producing wood for applications in which larger pieces of wood are needed, dismantled wood in construction, annual grasses etc. Sometimes small-diameter wood is used as the raw material, but the use of virgin trees is decreasing more and more as the use of waste wood for the raw material is becoming more popular (Nishimura, 2015). We can conclude the following about the manufacture of chipboard:

- As the chips are often made from waste wood and different sizes of chips can be used for different boards, the process of manufacturing the chips is highly efficient in terms of material usage. A small amount of chips not fitting into a size category are waste.
- The resins used are utilized very efficiently: the minimum amount of resin is used to be able to bond the chips together.
- Little waste is present in the form of sawdust.

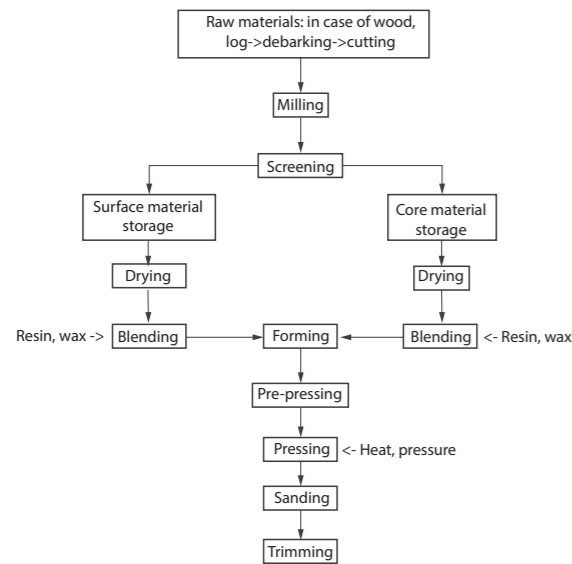

Figure 75: Manufacturing process wood (adapted from Nishimura, 2015)

•Polyurethane insulation: The manufacturing process of rigid polyurethane insulation is quite efficient. Rigid polyurethane thermoset insulation is formed by two liquid components - a polyol and a polyisocyanate. When these two liquids are mixed together, a polyaddition reaction takes place, resulting in the polyurethane molecules. The foaming process itself needs a blowing agent to shape the foam cells. The foaming process for rigid polyurethane insulation takes place between facings arranged parallel, in which the cavity is the thickness required for the foam. As the liquid components are measured precisely and the foam shaping is done according to the thickness and size required, virtually no waste is produced (Kapps & Buschkamp, 2004).

• Spruce elements (thermal modified exterior finishing, understructures: The production process of the spruce. After the wood is harvested from the forest (sustainably managed forests in Europe), it is transported to the sawmill for further processing. During this processing, about 50% is turned into board or plank products. The remaining 50% is either used up for the fibers in the engineered wood market, or as veneers, or used as biomass for energy. A small amount ends up as waste. As there are many different products a log can yield, the production process is efficient in terms of waste - even the smallest parts can be used (Ramage et al., 2017). Figure 76 shows the variety of usages for wood. The thermal modification is simply the heating up of the wood to a high temperature so the chemical structure changes. A process in which no extra materials are involved. The planks for the exterior finishing and understructure come in standard dimensions and the supplier needs to saw this to the dimensions asked by the architect. In this dimensioning process some saw residues will most likely be present.

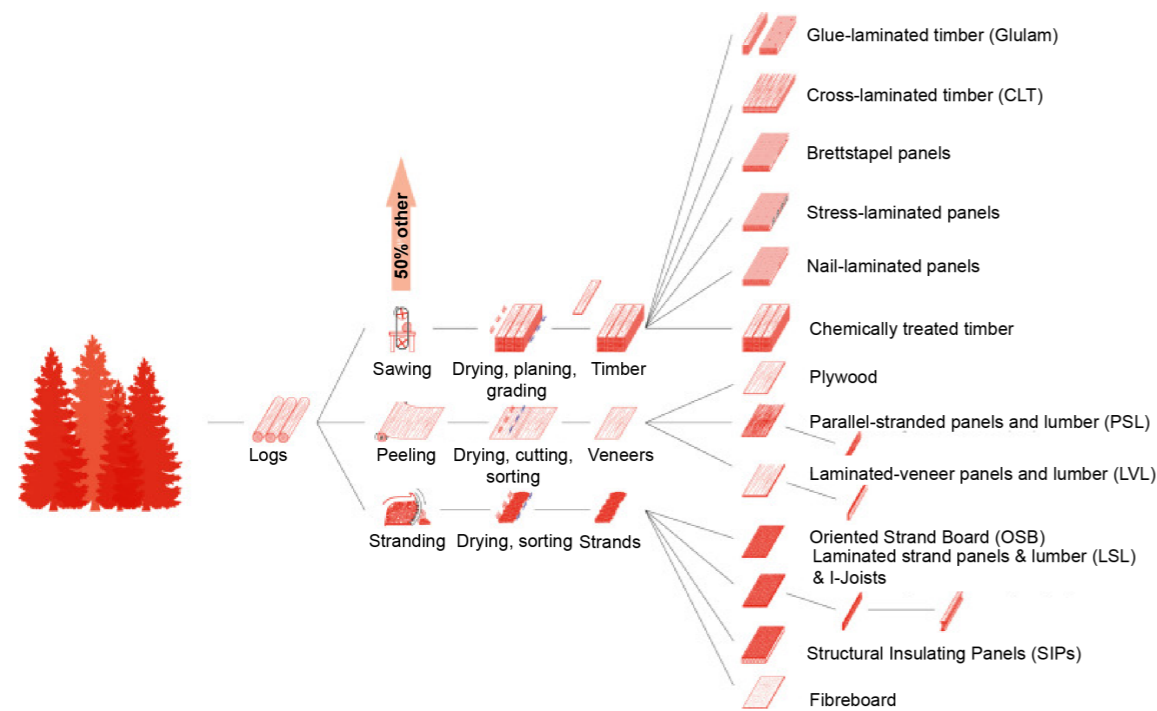

Figure 76: Variety of wood products (Ramage et al, 2017)

• Derbipure roofing: The production process is not detailed by Derbigum and they could not be reached for comments, so the waste generated during production can't be answered at this point.

• Kawneer RT 72 Reflex aluminium windows with triple glass: Aluminium and glass can both be recycled repeatedly without loss in quality, and this is standard practice in the industries. Scraps are collected, sorted and again included in the production process. However, when aluminium is made from virgin raw materials (bauxite), the production process does involve some unusable waste (Hall, n.d.), but a large amount of the aluminium circulating today is actually recycled aluminium - secondary aluminium production amounts for about 60% of primary aluminium production (Blomberg & Söderholm, 2009).

Building process on site

The amount of prefabrication reduces material use on the construction site: the components are delivered in correct sizes. According to Kingspan, their panels are delivered according to the correct specifications so waste on the building site is not present for the SIP panels (Kingspan, 2015). Waste on the building site might be present in the following area's:

- Tolerances - wooden planks and adjusters are used to place the components correctly together. Cutting these to size might entail some minor waste.
- The placement of the roofing and waterproof foils: these are delivered in rolls to the site. When they are cut up to the size desirable, some material might be left over.
- Interior finishing of gypsum fibre board: residual saw pieces left when sawing to exact size. However, these can be returned to Fermacell and will be recycled.
- Understructure of exterior and interior finishing and finishing: the understructure and exterior finishing planks are dimensioned according to the specifications. However, as these are built on site it could happen that some edges need to be resized.

The conclusion of the qualitative description is as follows. The amount of materials used is at the absolute minimum to deliver a certain energy performance and waterproofness. Some materials are present for esthetic reasons: without the interior finishing the interior would be unsightly. If the roof structure is used for the technical lifetime of the main structural elements (75 years), the exterior finishing of spruce needs to be replaced three times. The roofing will also need a replacement or upgrade during the lifetime. The aluminium windows will probably also need a replacement during the 75 years. The exterior finishing could've been chosen more efficiently: there are types of wood available such as oak in a higher durability class, so the lifetime of the exterior finishing + understructure can be higher with a different type of wood, so less replacement is necessary. The production processes for all the elements are quite efficient in terms of material usage per functional unit.

Structure 2: Solid wood variant

The solid wood variant is the second best in terms of total material usage, but coming very close to the SIP variant. The two elements/components which are different from the SIP variant are the Novatop laminated spruce used as the structural component and the Kooltherm insulation in stead of polyurethane.

The structure (solid wood) is an existing product and the thickness is the thinnest variant the supplier delivers. According to Novatop's specifications, the load imposed in this case should be able to be carried by the thinnest variant (taking into account a characteristic wind load of 0,5 kN/m) (NOVATOP, n.d.) However, a structural optimization should be done to calculate if it needs to be thicker or could be even thinner, minimising the material usage further. The insulation is dimensioned precisely to reach the Rc value of 5 m²K/W for the facades and 7 m²K/W for the roof. No interior finishing is needed in this case as the interior is quite esthetic and the exterior finishing is the same as in the SIP variant: dimensioned to be minimal for the spruce material.

Technical lifetimes

- **Novatop cross laminated spruce:** In the case of wood as a structural material, such as the cross-laminated structure present here, it's hard to tell the exact technical lifetime. The data published addressing the lifetime of construction materials is limited in general. However, studies published show that buildings are rarely demolished because the main structure is degraded, no matter the type of material used in the structure. A survey of 227 demolished buildings in which 27 buildings had a wooden structure and were over a 100 years old, none of the wooden buildings were demolished because of technical failure of the wooden structure (Ramage et al., 2017). From this we can assume the cross laminated solid elements will have no problem to stand for the 75 years assumed for the roof structure.

- **Kooltherm insulation:** The lifetime of the Kooltherm plates is not entirely clear, one source states that with good processing, the lifetime of the Kooltherm plates can be longer than the service life of the building. Another source states: 'Under standard conditions of use, the construction material does not display any material change during the period of use.' (Kingspan, 2014). From this the conclusion is the insulation should be fine for the 75 years counted for the roof structure and can function longer than that.

- The other materials, **exterior finishing, understructure exterior finishing and roofing** are described before.

Manufacturing process

- **Novatop laminated spruce:** The manufacturing process of CLT laminated wood is shown in figure 77. In this process some waste is present in the form of saw residues (Harris, 2015). NOVATOP has standard dimensions for their Solid elements, and these need to be sawn into the specifications of the case study dwelling. Waste must be present in this area, as the panels with standard dimensions need to be sawn to shape for the design assignment. It is unclear if NOVATOP reuses residues in the process.

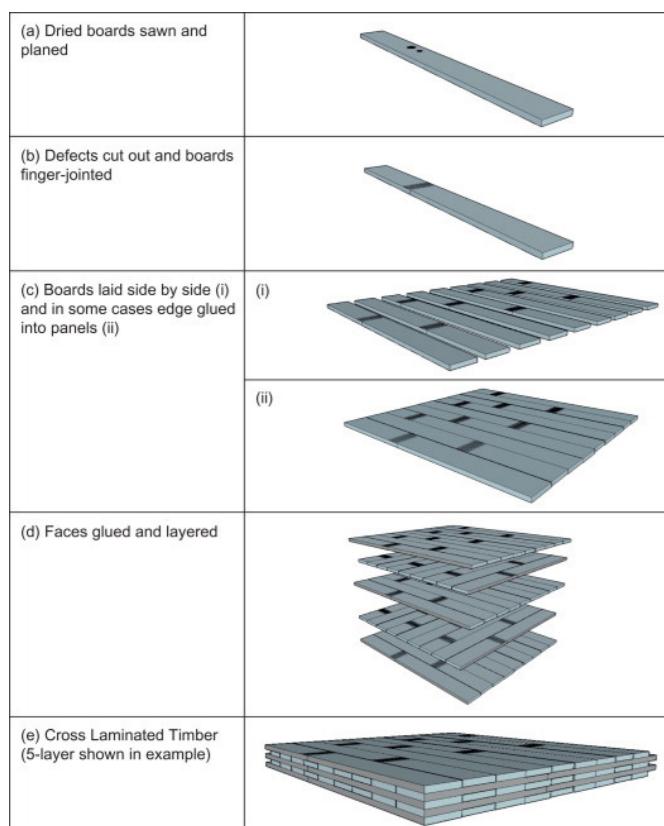

Figure 77: manufacturing process CLT (Harris, 2015)

- **Kooltherm insulation:** The Kooltherm insulation is a resol (phenolic) rigid foam insulation plate. The foaming process is quite similar to the process of foaming polyurethane (Fangareggi & Bertucelli, 2018), so virtually no waste is present during the manufacturing process.

Building process on site

In this design the amount of prefabrication is also high. The NOVATOP solid elements are delivered according to site (even though waste is present to saw them to size) and so is the insulation. Waste on the building site can be present in the following area's:

- Tolerances.
- The placement of roofing and waterproof foils.
- Understructure of exterior and interior finishing and finishing.

The conclusion of this qualitative assessment is as follows. The material usage in the design is minimal to reach the desired performance:

a structural analysis should show out if the structural solid wall can be dimensioned thinner, or needs to be thicker. The exterior finishing of spruce needs to be replaced three times during the 75 years counted for the roof structure. A better type of wood could've been chosen. The roofing and aluminium windows will both need approximately one replacement. A better type with longer technical lifetime could not have been chosen. Some material waste will be present on the building site, but the high amount of prefabrication reduces this. The production processes for all the elements are quite efficient in terms of material usage per functional unit. However, the hypothesis is that they are less efficient than the SIP structure variant.

Structure 3: Steel frame variant

The steel frame variant is heaviest in terms of total material usage. This is also because of the amount of gypsum fibre boards in the design: these are however necessary on both sides of the steel frame to create structural stability. Here also a structural analysis and optimization could show out if the steel structure frame could be dimensioned with less material. The exterior finishing is the same as the other variants. The elements or components which are different from the other two variants are detailed below in terms of material usage per functional unit.

Technical lifetimes

- **Cold formed U and C steel profiles:** The service life of a steel structure depends on several factors, but generally speaking steel can have a very long technical lifetime. Especially in this case, where the steel is not exposed to the outdoors, the 75 years counted for this roof structure should not be a problem.

- **Biofoam insulation:** The technical lifetime of the Biofoam insulation used in this design is not entirely clear. The producer states it is durable, rot free, fungal proof and resistant to UV radiation, so the assumption is it should be able to be used for the 75 years determined, as it is not exposed to outdoor conditions (Synbra Technology, n.d.).

Manufacturing process

- **Cold formed U and C steel profiles:** Steel is well known for being a material with a well functioning secondary scrap market, in which scrap steels are collected and inserted back into the production process, also during production of new steel. About 40% of the steel produced is recycled material (Björkman & Samuelsson, 2014). Waste is present when virgin raw materials for the production of new steel are used.

- **Biofoam insulation:** As it is produced from PLA, a thermoplastic, left over materials can be added back into the production processes, something the Biofoam manufacturer stimulates - it is thus cradle to cradle certified, as no chemical waste is produced when this product is produced (Synbra Technology, n.d.).

Building process on site

Building with steel means building with small tolerances, as the steel profiles can be produced with very precise dimensions. Furthermore the prefabrication strategy reduces waste on the building site. However, as explained in chapter 7, this design entails more work on site than the other variants, so waste from cutting elements to size will probably be most in this design. This is especially true for the large amount of gypsum fibre board used in this design.

The conclusion of the qualitative assessment is as follows. As is true for the other two designs, the exterior finishing of spruce needs to be replaced three times, and a better type of wood could've been chosen. The roofing and aluminium windows will both need approximately one replacement. The production processes for all the elements are quite efficient in terms of material usage per functional

unit. The waste during building on site is probably most for this design variant.

Energy design 1: with Triple Solar panels and 4 JA-Solar PV panels

The Triple Solar panels have higher heat transfer than the VolThera panels, so they are from the two variants most efficient: less Triple Solar panels are needed. To reach the same EPC as the VolThera variant, 4 JA Solar PV panels are added.

Technical lifetime

The technical lifetime of the Triple Solar panels is not exactly known. The PV modules will degrade over time, resulting in lower efficiencies. How much the PV cell will have to degrade to be deemed as end of technical lifetime depends on the efficiency: modules with high efficiency and highly degraded might still have a higher efficiency than modules which are not degraded but have low efficiency (Jordan & Kurtz, 2012). Usually PV modules come with a warranty of 20 years. This is based on a general rule of thumb that a PV module degrades with 1% each year, so after 20 years of use the PV will produce at least 80% of the power it produced in the beginning. However, a study found this 1% is not entirely accurate. For monocrystalline modules, the one used in the Triple Solar PV/T, the degradation rate is less than 0,4% for panels made after 2000 (Lombardo, 2014). To be on the safe side, let's assume the panel needs replaced when it's degraded to 80% of the starting functionality. If it degrades at a rate of 0,4% per year, the PV modules will have a technical lifetime of 50 years. The panel is built up as follows: the PV panels are made up of monocrystalline cells which are laminated together, covered with glazing and placed in a frame. This frame is then laminated to the heat exchanger. The heat exchanger is made up two elements: copper tubes which contain either monopropylene glycol or ethylene glycol as the fluid and aluminium slats. Figure 54 shows a picture of the Triple Solar panels in array. Figure 55 shows technical drawings of the PV/T panels.

The technical lifetime of the other elements is not entirely clear. It is assumed the copper and aluminium heat exchangers will have no problem to function for the 50 years the PV modules do.

The big drawback is that the elements of the Triple Solar panel are integrated together: if either one breaks, replacement of the entire panel is needed. However, as the general technical lifetime, 50 years is assumed for the Triple Solar panels.

Manufacturing process

Concluding: A replacement of the system once during the lifetime of the roof structure is probably needed. In terms of material use: less material is used in the Triple Solar system to provide the energy need of the house, as compared to the VolThera system.

Energy design 2: with VolThera panels

Technical lifetime

The warranty for the PV modules is stated: the company gives 25 years warranty of 80% power output. However, the warranty is not necessarily the technical lifetime, so for these PV modules also a technical lifetime of 50 years is counted. The technical lifetime of the polypropylene collectors is not clear. Predicting the lifetime of plastic parts depends on many factors: stress level, temperature, type of loading, environmental conditions, etc. Absolute lifetime prediction is almost impossible. One method to make an educated guess is using experience with a similar part and material (Graman, Cruz, & Jansen, 2013). One source states that polypropylene pipe systems designed for hot & cold application in domestic buildings are designed for a life expectancy of 50 years (Spirinckx, Pieper, & Peeters, 2013). It is assumed the polypropylene collectors will have the same technical lifetime of 50 years as the PV modules.

So as the general technical lifetime, 50 years is assumed for the VolThera panels.

Manufacturing process

Concluding: A replacement of the system once during the lifetime of the roof structure is probably needed. In terms of material use the VolThera panels score worse than the Triple Solar panels: more total material is needed to provide the heating need, but the panels themselves use less material in terms of kilograms.

9.2 Assessment on environmental cost of materials

Figure 78 shows the environmental cost of the different design variants. Each design variant and energy variant is first calculated separately, and the combination between them and points received for the total result is shown in the figure 79. For the design variants the BVO floor area of the roof structure is taken, and for the energy variants the entire floor space of the house is taken as the energy system supplies the entire house with energy. Only the PV/T panels are calculated: the heatpump and other installations which are the same for both variants are not taken into account - the total energy system will thus have a higher environmental cost in reality. The relative differences between the two energy systems however will stay the same.

Assessing the energy variants is difficult: the exact products themselves have not yet been assessed on LCA and therefore not been added to the 'Nationale Milieudatabase' the MPG-calculation is based on. What has been added in the database is an individual solar collector system + storage, based on square meters, and a PV panel system based on crystalline silicon of 135 Wp/m². In the MPG-calculation, these are used as reference values for the Triple Solar and VolThera systems. As the energy systems calculated are based on the reference value currently in the database, a description of how the variants might differ in reality:

- The fluids in the variants: the Triple Solar variant uses monopropylene glycol or ethylene glycol (Triple Solar BV, 2018). The VolThera variant uses propylene glycol (A. Meesen, personal communication, May 16, 2018). Which fluid MRPI calculates with is not stated: it seems most likely that this will be water as water can be considered the most common type of fluid used for solar collectors (Al-Waeli, Sopian, Kazem, & Chaichan, 2017). The VolThera variant uses propylene glycol as opposed to ethylene glycol because it's non-toxic, and the company believes a sustainable product shouldn't use a toxic fluid (A. Meesen, personal communication, May 16, 2018). Propylene glycol is a water-soluble fluid and is considered to be safe for use in food, drugs and cosmetics (according to the US Food and Drug administration). Because it's low level of toxicity (for animals and humans) and it's properties as a solvent, antifreeze or humectant it has widespread use in many industries. It's environmental consequences are also limited due to rapid biodegradation (McMartin, 2014). Ethylene glycol on the other hand, is shown to be toxic for humans and rodents according to a review paper (Fowles, Banton, Klapacz, & Shen, 2017). In the environmental cost calculation toxicity for humans, for fresh water, maritime and terrestrial ecosystems is considered (paragraph 4.4). From this we can conclude that PV/T systems using propylene glycol will score lower on these indicators than PV/T systems using ethylene glycol. So if the Triple Solar panels use ethylene glycol, then the VolThera panel will have lower environmental cost.
- The collectors: the VolThera variant uses a polypropylene collector, while the Triple Solar variant uses a combination between copper tubes and aluminium heat exchanger. Polypropylene is a thermoplastic polymer used in many applications (Ceresana, 2017). The Environmental Working Group classifies polypropylene as low environmental hazard (scoring 1 on a scale from 1 to 10 with 10 high environmental hazard). It is not suspected to be an environmental toxin (Environmental Working Group, 2018). In this case however, it's difficult to tell which material has lowest environmental impact without a life cycle analysis: both of them will probably also have an effect on some of the sub-indicators considered in the environmental cost calculation, such as exhaustion of fossil fuels and exhaustion of abiotic raw material. So it is important to keep in mind the variants differ from the material used in the collectors, but no conclusion can at this point be drawn from this information.

An elaborate description of how the variants are calculated in the MRPI software is available in

Appendix 7.

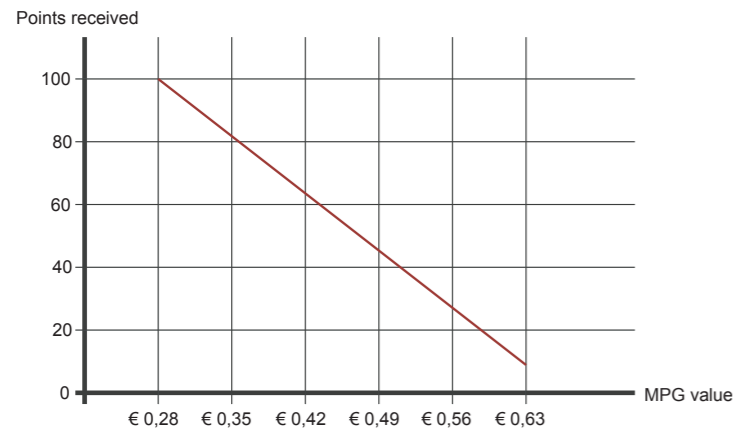

Variant	Total environmental cost (€/m² BVO)
SIP structure	0,39
Solid wood	0,54
Steel frame	0,36
Existing roof structure	0,61
Triple Solar	0,43
VolThera	0,59

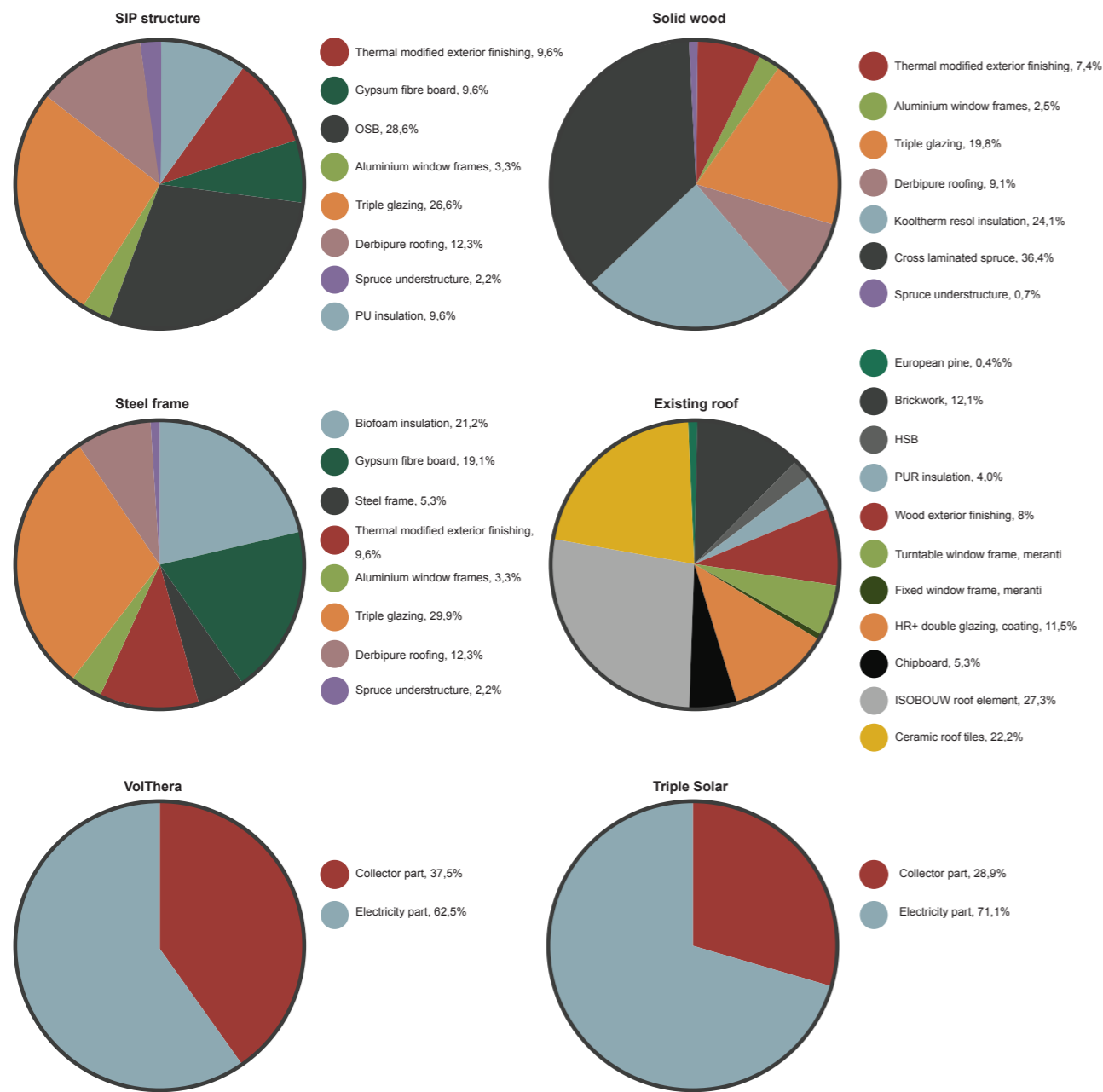

Figure 78: environmental cost design and energy variants separately, broken down in material use (source: own image)

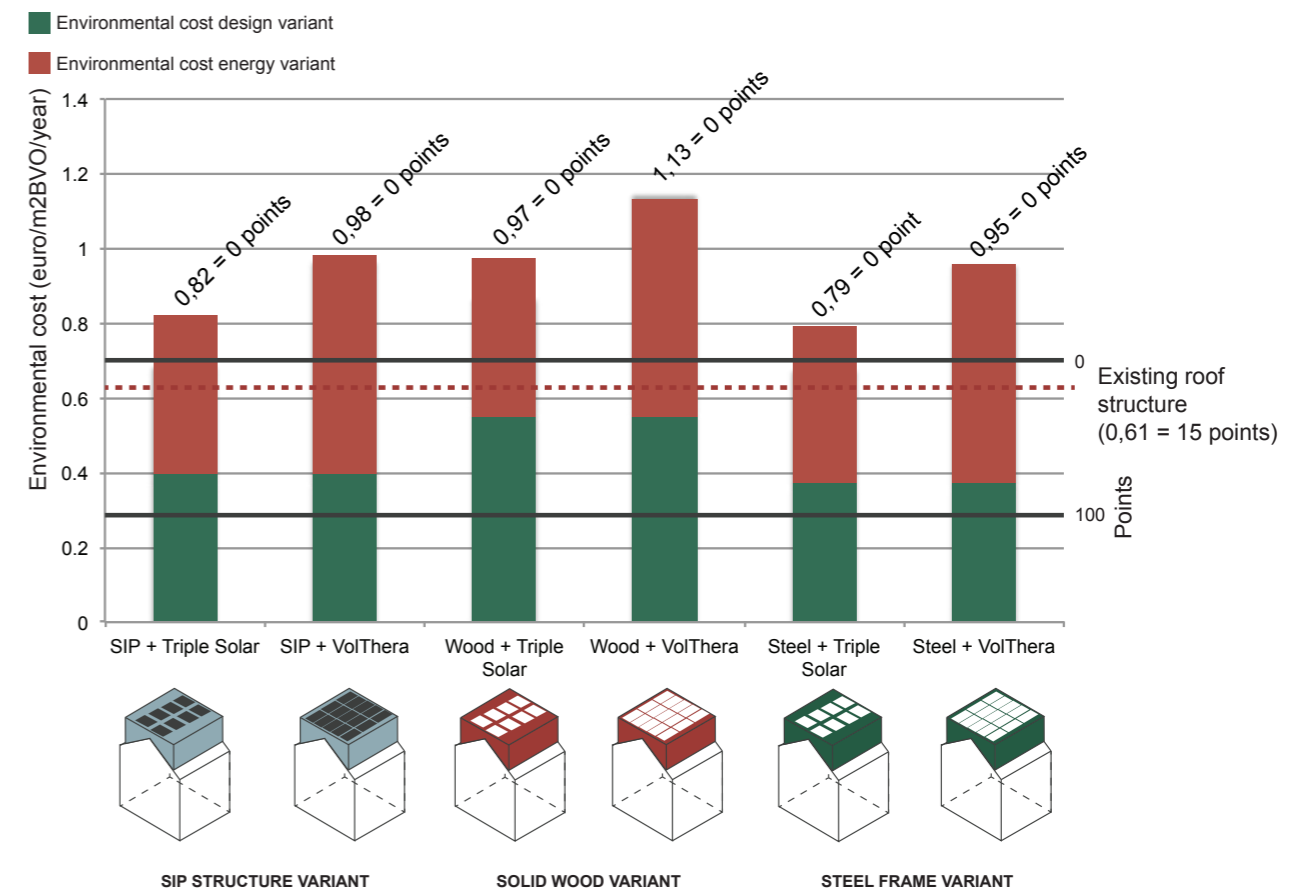

Figure 79: environmental cost final variants (source: own image)

9.3 Assessment on design for disassembly

The design variants and energy variants are assessed by the methodology outlined in paragraph 4.5. Each design and energy variant is first assessed separately and the outcomes of the sub-indicators are described. Later the variants are combined.

9.3.1. Sip structure variant

The figure below contains the points scored for each separate sub indicator and explanation. The relational pattern for the SIP structure and the division between functions for the relational pattern, which is needed to assess sub indicator 7, can be found in figures 81 and 82. The structure scores a total of 0,58 or 58 points.

Indicator	Weight	Outcome	Grading
2. Assembly direction (AD)	0.9	Stuck assembly 0,6 points	0,54

There is a logic to the assembly direction: some elements need to be assembled before others: it counts as a stuck assembly.

3. Accessibility to fixings (AF)	0.9	Accessible 1 point Accessible + operation (no damage) 0,8 point	0,81
----------------------------------	-----	--	------

The fixings of the finishings are accessible, but main fixings (between the structural components need an additional operation be accessed. This additional operation can be done without damage. The score is the average.

4. Assembly sequences (AS)	0.7	Component -> element 0,8 points	0,56
----------------------------	-----	-----------------------------------	------

The assembly sequence is first components (sip panels) after which they are finished with elements (exterior and interior finishings). The sequence is component -> element.

5. Prefabrication (PF)	0.7	Prefabricated components + elements on site 0,6 points	0,42
------------------------	-----	--	------

There is some prefabrication for components, some elements are connected on site.

6. Type of base element (B)	1	With 2 functions (BE & 1 building function) 0,4 points	0,4
-----------------------------	---	--	-----

The base element are the SIP panels: everything is connected to them. They have a double function.

7. Type of relational pattern (R)	1	Vertical 1 point	1
-----------------------------------	---	--------------------	---

The rule for the relational pattern is that vertical connections are between parts in the same functional group and horizontal connections are between parts in different functional groups. Horizontal connections to the base element are allowed. In this case the SIP panels have a double function: they function as base element and as structure/thermal insulation. The horizontal connections are between SIP structure and other functions. The other connections are vertical.

8. Functional separation (FS)	0.9	Integration functions same lc in 1 element 0,6 points	0,54
-------------------------------	-----	---	------

There is heavy integration of some sub functions: the thermal insulation is fully integrated with the structure and base element in the SIP panel. Other sub functions are separated, but the integration of functions in the SIP panels plays a large role.

Figure 80: assessment DfD for SIP variant (source: own image)

Indicator	Weight	Outcome	Grading
9. Type of clustering (C)	0.9	Clustering for fast assembly 0,3	0,27

Clustering happened mostly according to fast assembly.

10. Use life cycle coordination (UCL)	0.9	Long LC (1)/short LC (2) 0,8	0,72
---------------------------------------	-----	--------------------------------	------

As the SIP panels also function as base elements, they probably have the longest use lifetime of all the elements. The technical lifetime of wood will in all cases be shorter than the 75 years Kingspan calculates for the SIP panels, so it is safe to assume the use lifetime of the exterior finishing will also be shorter. The interior gypsum fibre panels might have a shorter use lifetime if the residents want to replace them. The roofing will need replacement. Components with long life cycles are placed first, components with shorter ones second.

11. Technical life cycle coordination (TCL)	0.9	long LC (1) / long LC (2) or short LC (1)/short LC (2) or long (1)/short (2) 1 point	0,9
---	-----	--	-----

As stated above, the SIPs with a long lifetime are made first, and after this elements with shorter technical life cycles are added. The use life cycle is dependent heavily on the technical life cycle in this case.

12. Geometry of product edge (GP)	0.9	Open linear 1 point	0,9
-----------------------------------	-----	-----------------------	-----

The geometry of the product edge is open linear.

13. Type of connection (TC)	0.9	Direct integral connection + inserts (pin) 0,6 Filled hard chemical connection 0,1	0,32
-----------------------------	-----	---	------

A combination between direct integral connection + fixing device and filled hard chemical connection. The direct connections (screws) are used to combine the main functions together, while the chemical connection is in the SIP panels. The score is the weighted average.

14. Morphology of joint (MJ)	0.7	Point 0,8 Service (2D connection) 0,1	0,32
------------------------------	-----	--	------

The morphology of the joint is a combination between point (screw) and 2D/service (glued surfaces). The score is the weighted average.

15. Standardisation product edge (SPE)	0.5	Pre-made geometry 1 point	0,5
--	-----	-----------------------------	-----

The geometry is pre-made.

16. Tolerance (T)	0.5	High tolerance 1 point	0,5
-------------------	-----	--------------------------	-----

There is tolerance between all main functional groups.

Total score | 0,58 or 58 points

Functional division

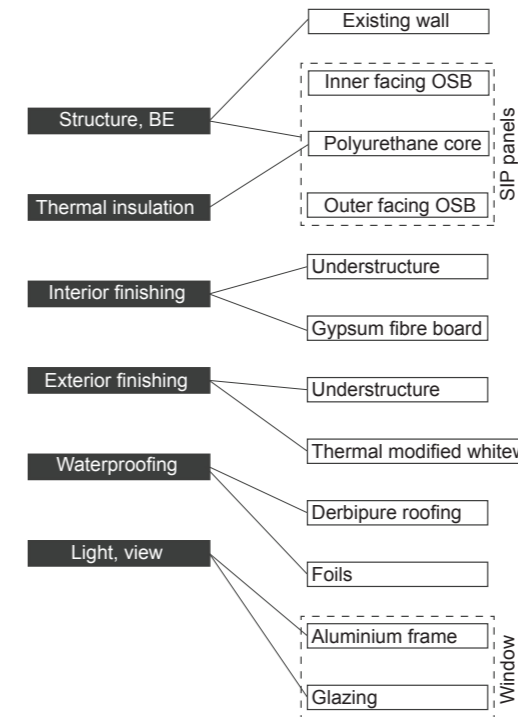

Figure 81: functional division for SIP variant (source: own image)

Relational pattern

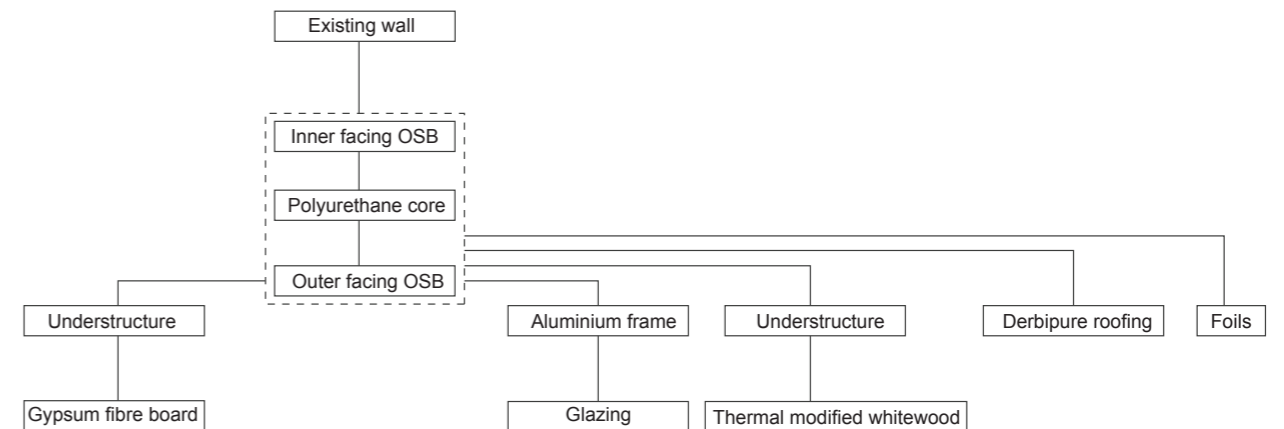

Figure 82: relational diagram SIP variant (source: own image)

9.3.2. Solid wood variant

The figure below (figure 83) contains the points scored for each separate sub indicator and explanation. The relational pattern for the SIP structure and the division between functions for the relational pattern, which is needed to assess sub indicator 7, can be found in figures 84 and 85. The structure scores a total of 0,62 or 62 points.

Indicator	Weight	Outcome	Grading
2. Assembly direction (AD)	0.9	Stuck assembly 0,6 points	0,54

The massive wood structure has the same assembly direction as the SIP structure. It is a stuck assembly.

3. Accessibility to fixings (AF)	0.9	Accessible 1 point	0,81
		Accessible + operation (no damage) 0,8 point	

Some fixings are accessible, others need extra operation to be accessed. The score is the average.

4. Assembly sequences (AS)	0.7	Component -> element 0,8 points	0,56
----------------------------	-----	-----------------------------------	------

Mostly components are connected to each other. There are some elements: the exterior finishing are elements connected on site. The sequence is component -> element.

5. Prefabrication (PF)	0.7	Prefabricated components + elements on site 0,6 points	0,42
------------------------	-----	--	------

There is some prefabrication for components, some elements are connected on site. The structure, first part of insulation and cladding is prefab, the exterior finishing are elements on site.

6. Type of base element (B)	1	With 2 functions (BE & 1 building function) 0,4 points	0,4
-----------------------------	---	--	-----

The base element are the solid wood panels: everything is connected to them. This means they have an extra function.

7. Type of relational pattern (R)	1	Vertical 1 point	1
-----------------------------------	---	--------------------	---

In the relational pattern we can see that the NOVATOP solid and element function as the base element. The horizontal connections are between the BE's and the other functions.

8. Functional separation (FS)	0.9	Separation of functions 1 point	0,9
-------------------------------	-----	-----------------------------------	-----

There is separation of functions. Each function can be taken apart without damaging the others.

Indicator	Weight	Outcome	Grading
9. Type of clustering (C)	0.9	Clustering for fast assembly 0,3	0,27

Clustering happened mostly according to fast assembly.

10. Use life cycle coordination (UCL)	0.9	Long LC (1)/short LC (2) 0,8	0,72
---------------------------------------	-----	--------------------------------	------

Components with long use life cycles are placed first, components with shorter ones second. The structure is placed first and is finished with exterior and interior finishing which might be replaced during lifetime of structure.

11. Technical life cycle coordination (TCL)	0.9	long LC (1) / long LC (2) or short LC (1)/short LC (2) or long (1)/short (2) 1 point	0,9
---	-----	--	-----

The use life cycle is dependent heavily on the technical life cycle in this case. And components with long technical lifetimes are placed first.

12. Geometry of product edge (GP)	0.9	Open linear 1 point	0,9
-----------------------------------	-----	-----------------------	-----

The geometry of the product edge is open linear.

13. Type of connection (TC)	0.9	Direct integral connection + inserts (pin) 0,6	0,32
		Filled hard chemical connection 0,1	

A combination between direct integral connection + fixing device for the exterior finishings. The main connections between structural elements are direct integral connections + fixing devices and accessory external connection for connecting SOLID to wall. There is heavy use of adhesives in the CLT: this means the solid walls can't be disassembled in their separate wooden elements. The score is the average.

14. Morphology of joint (MJ)	0.7	Point 0,8	0,56
------------------------------	-----	-------------	------

The morphology of the joint is mostly point (screw) for the large part of the connections.

15. Standardisation product edge (SPE)	0.5	Pre-made geometry 1 point	0,5
--	-----	-----------------------------	-----

The geometry is pre-made.

16. Tolerance (T)	0.5	High tolerance 1 point	0,5
-------------------	-----	--------------------------	-----

There is tolerance between all main functional groups.

Total score | 0,62 or 62 points

Figure 83: assessment DfD for solid wood variant (source: own image)

Functional division

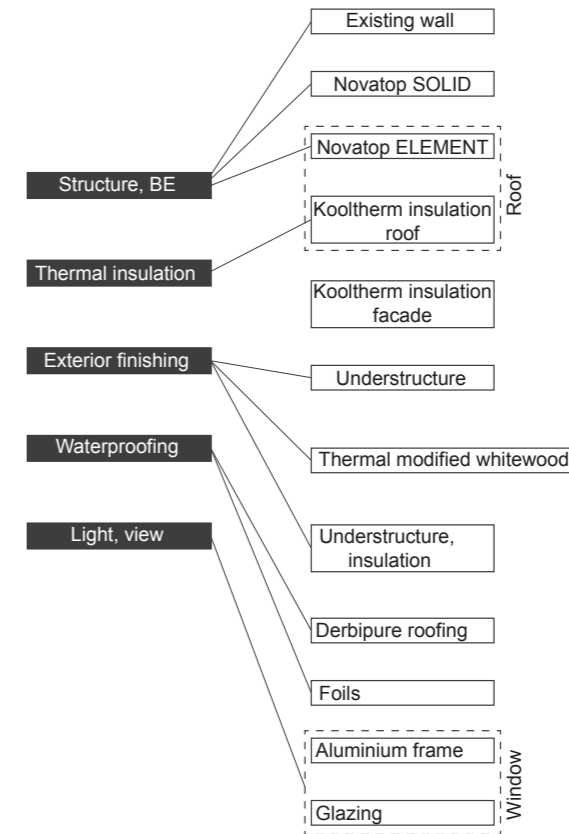

Figure 84: functional division for solid wood variant (source: own image)

Relational pattern

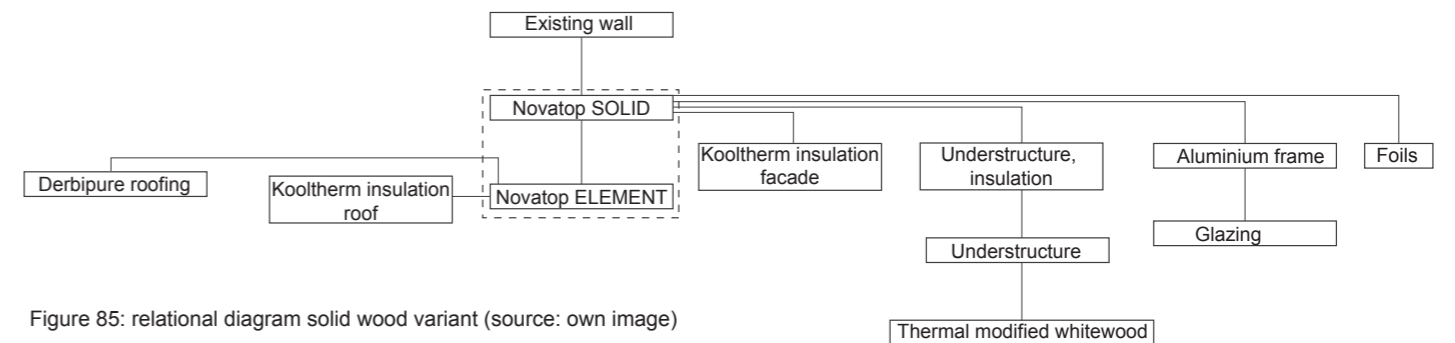

Figure 85: relational diagram solid wood variant (source: own image)

9.3.3. Steel frame structure variant

The figure below (figure 86) contains the points scored for each separate sub indicator and explanation. The variant scores a total of 0,64 or 64 points.

Indicator	Weight	Outcome	Grading
2. Assembly direction (AD)	0.9	Stuck assembly 0,6 points	0,54

The steel frame variant has the same assembly direction as the SIP and solid wood structures. It is a stuck assembly.

3. Accessibility to fixings (AF)	0.9	Accessible 1 point	0,81
		Accessible + operation (no damage) 0,8 point	

Some fixings are accessible, others need extra operation to be accessed. The score is the average.

4. Assembly sequences (AS)	0.7	Component -> element 0,8 points	0,56
----------------------------	-----	-----------------------------------	------

Mostly components are connected to each other. There are some elements: the exterior finishing are elements connected on site. The sequence is component -> element.

5. Prefabrication (PF)	0.7	Prefabricated components + elements on site 0,6 points	0,42
------------------------	-----	--	------

There is some prefabrication for components, some elements are connected on site. The structure, first part of insulation and cladding is prefab, the exterior finishing are elements on site.

6. Type of base element (B)	1	With 2 functions (BE & 1 building function) 0,4 points	0,4
-----------------------------	---	--	-----

The base element is the steel frame: everything is connected to them. This means they have an extra function.

7. Type of relational pattern (R)	1	Vertical 1 point	1
-----------------------------------	---	--------------------	---

The connections are between BE (steel frame) and other functions. This means the relational pattern is a vertical pattern.

8. Functional separation (FS)	0.9	Separation of functions 1 point	0,9
-------------------------------	-----	-----------------------------------	-----

There is full separation of functions.

Figure 86: assessment DfD for steel frame variant (source: own image)

Indicator	Weight	Outcome	Grading
9. Type of clustering (C)	0.9	Clustering for fast assembly 0,3	0,27

Clustering happened mostly according to fast assembly.

10. Use life cycle coordination (UCL)	0.9	Long LC (1)/short LC (2) 0,8	0,72
---------------------------------------	-----	--------------------------------	------

Components with long use life cycles are placed first, components with shorter ones second. The structure is placed first and is finished with exterior and interior finishing which might be replaced during lifetime of structure.

11. Technical life cycle coordination (TCL)	0.9	long LC (1) / long LC (2) or short LC (1)/short LC (2) or long (1)/short (2) 1 point	0,9
---	-----	--	-----

The use life cycle is dependent heavily on the technical life cycle in this case. And components with long technical lifetimes are placed first.

12. Geometry of product edge (GP)	0.9	Open linear 1 point	0,9
-----------------------------------	-----	-----------------------	-----

The geometry of the product edge is open linear.

13. Type of connection (TC)	0.9	Direct integral connection + inserts (pin) 0,6	0,63
		Direct connection + fixing devices 0,8	

A combination between direct integral connection (screws) but also direct connections with fixing devices such as bolts and nuts. The score is the average.

14. Morphology of joint (MJ)	0.7	Point 0,8	0,56
------------------------------	-----	-------------	------

The morphology of the joint is mostly point for the large part of the connections.

15. Standardisation product edge (SPE)	0.5	Pre-made geometry 1 point	0,5
--	-----	-----------------------------	-----

The geometry is pre-made.

16. Tolerance (T)	0.5	High tolerance 1 point	0,5
-------------------	-----	--------------------------	-----

There is tolerance between all main functional groups.

Total score | 0,64 or 64 points

9.3.4. Energy systems

Assessing the PV/T systems with the methodology outlined is not possible for every indicator. The indicators which matter and which can be assessed for the PV/T panels are: accessibility to fixings, functional separation, technical life cycle coordination, type of connection and tolerance. The assessment for the Triple Solar variant is shown in figure 87 and the assessment for the VolThera variant shown in figure 88.

Indicator	Weight	Outcome	Grading
-----------	--------	---------	---------

3. Accessibility to fixings (AF)	0.9	Not accessible - total damage 0.1 points	0.1
----------------------------------	-----	--	-----

The PV panel is laminated onto the heat exchanger, and the fixings are therefore not easily accessible

8. Functional separation (FS)	0.9	Integration functions different lc in 1 element 0.1 point	0.1
-------------------------------	-----	---	-----

The two distinct functions of the PV/T panel, the PV module and the heat exchanger are laminated together. There is no functional separation. The technical life cycles of these two functions are different. The use life cycle is probably the same.

11. Technical life cycle coordination (TCL)	0.9	long LC (1) / long LC (2) or short LC (1)/short LC (2) or long (1)/short (2) 1 point	0.9
---	-----	--	-----

The element with shorter technical life cycle (PV module) is laminated onto the element with longer technical lifecycle (heat exchanger).

13. Type of connection (TC)	0.9	Direct chemical connection 0.1 point	0.1
-----------------------------	-----	--	-----

Laminated connections, direct chemical connection.

16. Tolerance (T)	0.5	No tolerance 0.1 point	0.1
-------------------	-----	--------------------------	-----

There is no tolerance.

Total score | 0,26 or 26 points

Figure 87: assessment DfD for Triple Solar variant (source: own image)

Indicator	Weight	Outcome	Grading
-----------	--------	---------	---------

3. Accessibility to fixings (AF)	0.9	Accessible 1 point	0.9
----------------------------------	-----	----------------------	-----

The fixings between the PV panel and the collector are galvanized steel and are easily accessible.

8. Functional separation (FS)	0.9	Separation of functions 1 point	0.9
-------------------------------	-----	-----------------------------------	-----

There is full separation of the two main functions (PV and collector)

11. Technical life cycle coordination (TCL)	0.9	long LC (1) / long LC (2) or short LC (1)/short LC (2) or long (1)/short (2) 1 point	0.9
---	-----	--	-----

The element with the long technical life cycle (collector) is placed under the element with the shorter technical life cycle (PV module)

13. Type of connection (TC)	0.9	Accessory external connection or system 1	0.9
-----------------------------	-----	---	-----

The connection between PV and collector is an accessory external connection (galvanized steel rods).

16. Tolerance (T)	0.5	High tolerance 1 point	0.5
-------------------	-----	--------------------------	-----

There is tolerance visible on the drawing between PV and collector.

Total score | 0,82 or 82 points

Figure 88: assessment DfD for VolThera variant (source: own image)

Figure 89: summary DfD assessment design and energy variants separately, compared to existing roof structure (source: own image)

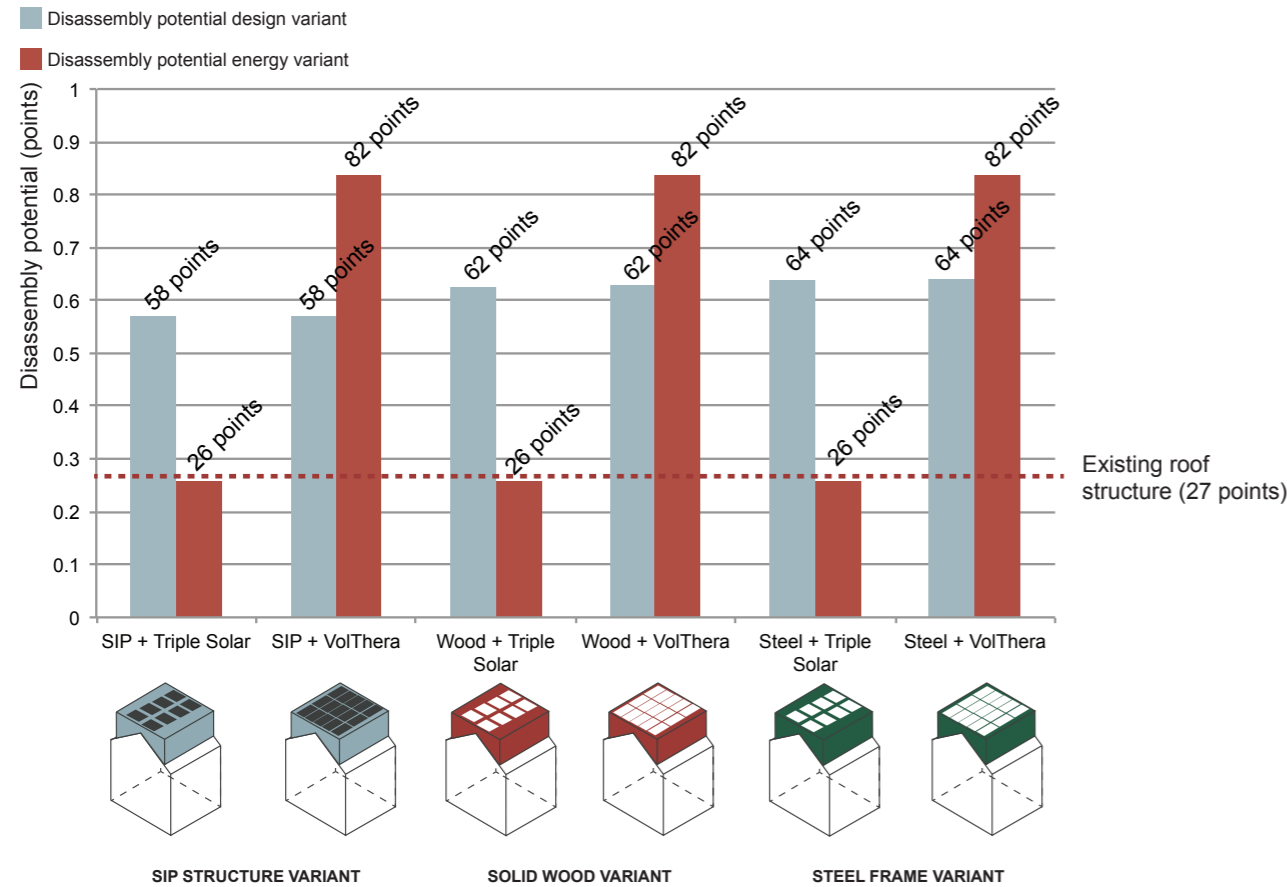
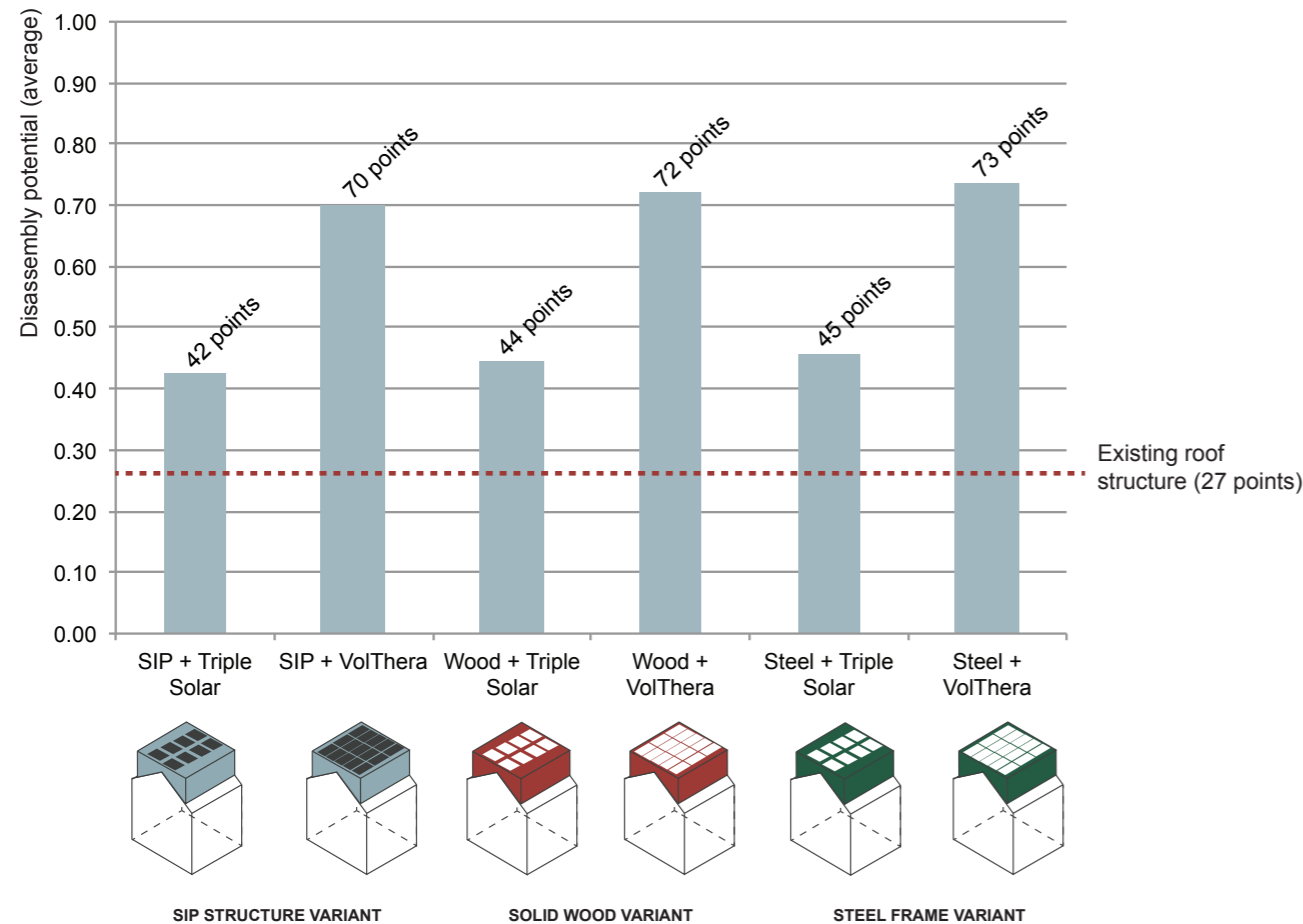

Figure 90: average between design and energy variant for the six variants, compared to existing roof structure (source: own image)



9.4 Analysis on circular life cycles

The method described in 4.6 is used to analyze the fitness for circular life cycles of the most important building parts in the variants. Each variant is described separately.

9.4.1 SIP structure variant

The assessment is done for the Kingspan TEK SIP panels, the window frame + triple glazing, the Derbipure roofing material, the thermal modified spruce exterior finishing and the gypsum fibre board interior finishing. Figure 91 contains a summary of the outcome of this qualitative assessment for the building parts. Some more explanation about the outcomes is given below.

Kingspan TEK SIP panel

The Kingspan SIP panels are components in which OSB facings are glued to a polyurethane core. The elements can't be taken apart from each other. It contains technical and biological materials (wood chippings in OSB). The technical lifetime is 75 years according to Kingspan, this fits with its function of structure. It can't cycle in any of the possible cycles and will very likely be incinerated at the end of its lifetime. This is because of the following reasons:

- Reuse is difficult because (1) firstly it's sawn in personalized shapes (triangular where it fits on the dividing walls between houses for example). (2) Secondly, the walls are quite small and there were little possibilities in designing the SIP panel for overdimensioning so it could be sawn up and reused. And (3) thirdly, part of the simple functionality of SIPs is that connections can directly be drilled in the panels: for reuse purposes this can be seen as damage.
- It can't be remanufactured into something else as the elements can't be taken apart without significant damage to the elements. Currently Kingspan takes into account a take back period of 30 years, after which the facings could be removed with burning iron wire. However, this significantly damages the elements and there is no need for this quality element or material, so they are burned.
- Recycling without quality loss of the materials is also very difficult for both polyurethane (thermoset) (Simón, Borreguero, de Lucas, & Rodríguez, 2018) or OSB (Woodguide, n.d.).
- The SIP panels are worthless after first life cycle, and in their current form the only end of life possibility is incineration.

In the future there might be other possibilities as Kingspan is working on a recycling process on the one hand and a demountable SIP panel on the other (Pennings, 2017 cited in Henry, 2018). The product however, as it is now, does not have possibilities for circular life cycles.

Alcoa window frame + triple glazing

Aluminium window frames have a service lifetime of about 43,6 years. After this period of time they will most likely be replaced, for example because better window systems become available, or because the entire window fails (for example, the air tightness can't be guaranteed by the flexible strips in the frame anymore) However, the aluminium frame's technical performance is shown to be unaffected in accelerated aging tests (Salazar, 2014). This lifetime of the entire window fits with the function: better and more energy efficient window systems are constantly in development (Salazar, 2014), so replacements of window systems will probably happen. Furthermore, in the shearing layers we see that the skin of a building has a cycle between 20-30 years. As mentioned before, the supplier Kawneer is quite innovative in their view towards circularity. Andre Smit, product manager at Kawneer, mentions the following circular measures Kawneer is taking:

- Kawneer is affiliated with the foundation Alueco. Alueco's goal is to recycle aluminium within Europe as much as possible, so that the high quality of the material doesn't get lost and to avoid unnecessary transport costs. Kawneer takes back old window products and recycles materials.
- Kawneer gives the client the option to choose aluminium window frames with recycled aluminium:

AR100 or AR90.

- Next to recycling, Kawneer also focuses on reuse: together with Alueco, reuse of products is researched with the specific goal to keep the product high quality as long as possible and reuse products before they're recycled. Kawneer is developing a company infrastructure in which windows are taken back from the customer, so the window (parts) can either be reused by another customer, or the materials can be recycled in the production process.
- Keeping the products at high quality also means considering maintenance: together with the TU Delft and VMRG they are involved in the 'facade identification system' project to identify the state of a facade.
- Kawneer is involved in the 'facade as a service' project at the TU Delft. The project researches the possibilities to grant a facade flexible functionality during its life cycle, and how the supplier can remain the owner of the product and sells a performance instead of the product (A. Smit, personal communication, May 16, 2018).
- From these facts we can conclude the possible circular scenario's are reuse of product, remanufacture (replace damaged parts after first life cycle and bring window up to required energy performance), recycling of materials.

The most suited path of cycling for the building parts would then be, considering the power of the inner circle, to first reuse the window in another design or in the case that the window needs to be updated remanufacture it, and if these cycles are not possible anymore recycle the materials in the window. Because of Kawneer's innovativeness, at this point it's possible the windows (either as a component or as elements) might already be reused/remanufactured after first life cycle, and if Kawneer continues building up this infrastructure in the future it will be likely that the windows will follow this path of cycling.

Derbipure

Derbipure is a composite material, made up of partly plant based materials and partly technical materials. It's difficult to tell the exact performance/technical lifetime, a reference value of 40 years is used in this thesis. This fits with the building layer (skin) according to the shearing layers.

Reusing or repurposing the material will be difficult: the roofing is exposed to the elements and will be degraded and damaged over time. Recycling seems the best option: according to Derbigum, their material is 100% recyclable in their Macalusor recycling process and it can be recycled as new raw material in the production of new Derbipure, without loss in quality. More specifically, the Macalusor process is a recycling system: roofers can deposit roofing clippings at selected dealers for free, where the roofing clippings are collected by Derbigum and recycled in the production process. High quality recycling of the roofing is therefore possible. However, at this point 30% of the roof clippings are inserted into their own production process, the other 70% is recycled in other processes (although it's not further explained where). (Derbigum, n.d.). The best scenario would be that 100% of the material is recycled in Derbigum's production process. As at this point that's 30%, the process could be better. But Derbigum is making progress, so in the future it's very likely that the material can fully be recycled without quality loss.

Thermal modified spruce

The technical lifetime of between 0-25 years fits with the function (skin) of the thermal modified spruce. As the thermal modified spruce is a wood without additives, it can cycle in biological and technical cycles. The best possibility is for it to be cascaded. This is because of a few reasons: firstly, the shape it's sawn into is a personalized shape. Adding this to the fact that after its first life cycle it will be weathered because it's exposed to the environment, it's unlikely it can be reused as an entire element in a new design. It could however go through cascaded cycles, for example be repurposed in cross laminated timber. The goal for the cascades is to keep the wood as a high quality product as long as possible, so that the CO₂ in the wood product is bound for as long as possible (as this will be exhausted when the wood is burnt) (BTG, 2014). Another option is that the wood is shredded and used as a secondary base material for construction plates like OSB plates. This product is however of lower quality than CLT for example and should therefore be the last cascade (the product can't

be lifted to a higher quality wood after this step anymore). At this point it's unlikely that the wood will be cascaded into a high quality product: suppliers don't have the infrastructure present, and instead wood "waste" from the timber and construction sector is collected by waste management companies and sorted in the quality categories of A (unpainted, untreated), B (painted, lacquered, glued) and C (impregnated wood). A-wood is seen as biomass, while B and C types are not. A is often shedded and repurposed (Sortiva, n.d.) or used to generate biogas. There are laws (LAP3) to determine what needs to happen with each type of wood after end of lifetime: A and B types need to be applied 'usefully', aiming towards recycling, C types need to be burnt for fuel. Currently however, there is not enough capacity to recycle all A and B types of wood, and they are often still used for the generation of biogas (LAP3, 2017). If contaminated wood types are burnt, strict emission laws determine the standard of the power plants (Bio energie cluster Oost Nederland, 2013).

Research is underway to see how the timber and construction sector could implement cascading of wood products. One study researched possibilities for 'cascading in time' in which the functional use of wood in time is maximised. The study evaluated and selected the best cascading options by value optimisation, for the different wood sectors. The study researched the timber and construction sector's infrastructure, and concluded that there are currently no programmes available to explicitly encourage wood cascading in this sector. However, the study also indicated current policy targets (waste management plans), which could be used as a tool to design cascades in the wood sector. The waste management plan's detailed sector plans can be used to ban certain applications, and if effectively enforced they could also be used as a policy tool to stimulate further cascading in the different wood sectors. Furthermore, there is increasing awareness and interest in the Netherlands about how biobased materials can best be utilised in different life cycles, as shown in the biobased pyramid, the Rutte 2 coalition agreement and motions, such as the Motion of Dik-Faber in 2013 which formulated that given biomass should be used in the best possible way (cascaded) and reuse should have priority over co-combustion. Furthermore, the issue is also partly addressed in fiscal instruments like MIA and VAMIL, which is a fiscal stimulation system, supply tax deductions for environmental-friendly investments. The study then concludes that this growing awareness shows how development is underway to support cascading in the wood sector, and that the next step is concrete policy measures which should be implemented (Vis, Reumerman, & Gartner, 2014). From this information we can conclude that the movement for cascading is somewhat underway, and if this movement continues, in the future it's possible that wood products will go through cascaded cycles before being downcycled or burnt for biogas.

Gypsum fibre board

The gypsum fibre board has a long technical lifetime, which doesn't entirely fit with its function of interior finishing (skin). However, this does give it good possibilities for reuse. Furthermore gypsum fibre board plates are rectangular, and not painted or otherwise finished. They are also protected as they are located on the interior. This means that if the gypsum fibre board are removed after a certain period of time and they are not damaged, they could be reused as entire elements, possibly cut up to other sizes. If reuse is not possible, they could be remanufactured into another product, as gypsum fibre board has many functionalities (Fermacell, n.d.). If the panels can't be reused or remanufactured anymore, they could be recycled. Taking into account the power of the inner circle, this would be the best possibility for new life cycles. Fermacell, the supplier of the gypsum fibre boards, accepts returns of their products and of sawed residues from the construction site, if they are not contaminated. They then recycle these products. 25% of Fermacell products have recycled material in them, without causing quality loss (Fermacell, n.d.). In general the infrastructure to recycle gypsum fibre board without quality loss is being built up: the European GtoG project (gypsum to gypsum) promotes the increase in the culture of recycling gypsum fibre boards and to close the loop for gypsum products and systems, together with relevant stakeholders in the construction chain. Gypsum can eternally be recycled without loss in quality (Marlet, 2014). Because of the current recycling infrastructure present and Fermacell's (and Europe's) policy to recycle and not reuse, it's unlikely that the panels will be reused at this point in time. In the future it's possible that reuse of entire panels will become more normalized, but it's difficult to say at this point in which direction the sector will develop.

Is the building part to be assessed a component, element or material (and if component, can it be taken apart?)

Does the building part contain biological, technical materials or both?

What is the performance/technical lifetime of the building part?

Does this performance/technical lifetime fit with the function (building layer) of the part?

Can the building part cycle in one or more of the biological or technical cycles?

What is the most suited path of cycling for the building part?

How likely is it that the part will follow this path of cycling at this point in time?

How likely is it that the part will follow this path of cycling in the future?

Kingspan TEK SIP panels

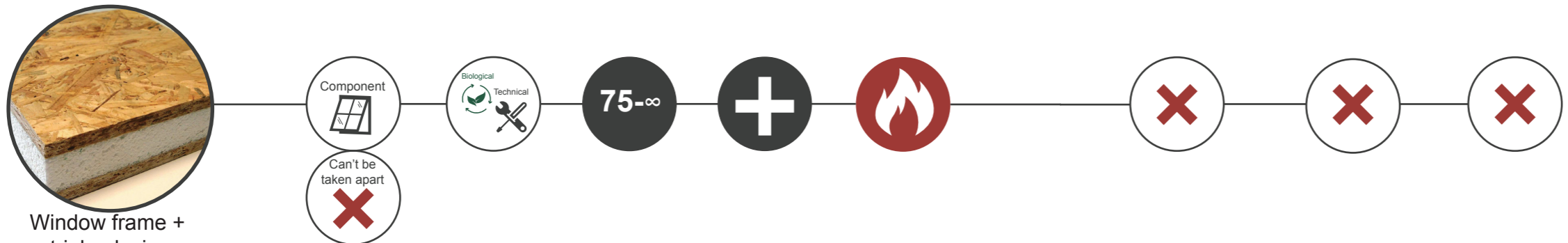

Window frame + triple glazing

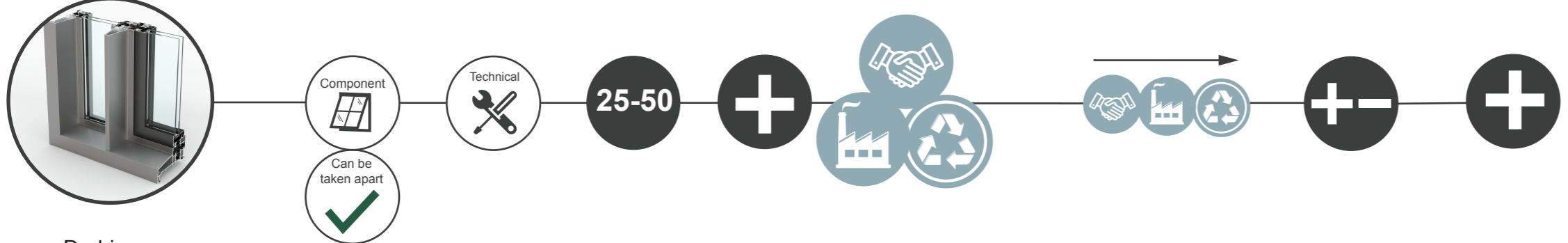

Derbipure

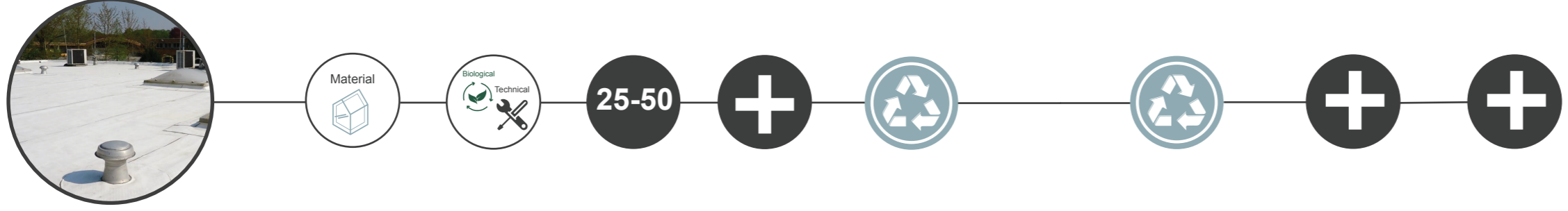

Thermal modified spruce

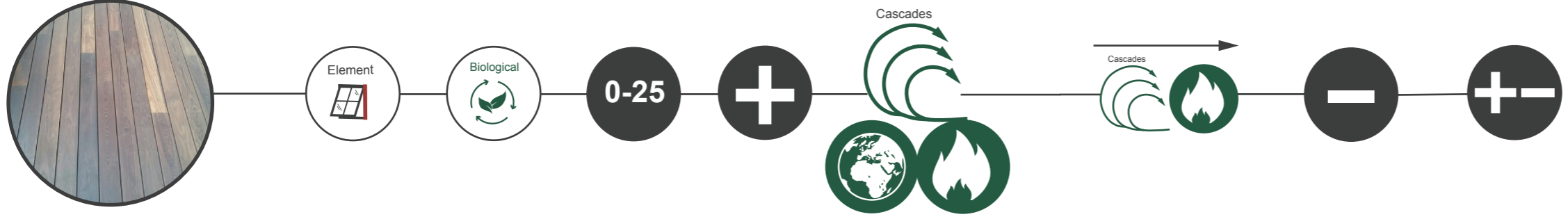

Gypsum fibre board

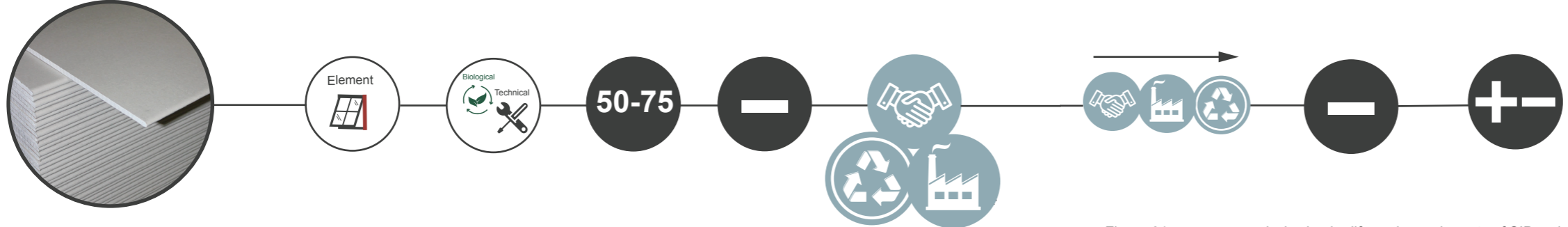

Figure 91: summary analysis circular life cycles main parts of SIP variant (source: own image)

9.4.2 Solid wood variant

The assessment here has two parts that the SIP structure doesn't: the Novatop Solid/Element CLT building parts and the Kooltherm phenolic foam insulation. These are discussed separately below.

NOVATOP Solid/Element: laminated spruce

Just as is the case for the thermal modified spruce, explained in 9.4.1, it would be best if the laminated spruce is cascaded: but it could also be reused first if it's cut up in suitable sizes (contrary to the exterior finishing) because it's protected from the environment and will thus not degrade or be damaged over time. It should be taken into account that the CLT has heavy use of additives for the possible cascades.

Kooltherm insulation

The Kooltherm insulation has a long technical lifetime, it does not degrade over time and is protected from the environment. It can be removed from the design assignment without damage and could be cut up into other sizes to be reused in other project. Kingspan states that they invest in suitable and responsible solutions for when the products become available at the end of the life cycle of a building. They take back the products, and if it's clean and undamaged it might be reused (Kingspan, 2014). However, just as in the case of thermoset polyurethane insulation, recycling is very difficult, especially without quality loss. The only circular scenario would then be that it's reshaped and placed in another project. If this is no longer possible, the material will become waste.

This is actually a problem for thermoset plastics in general, that they are very difficult to recycle without quality loss. This is because of their molecular structure, in which molecular chains are chemically bonded into strong cross-linked networks. These prevent the material from melting as a thermoplastic could (Guo, 2014). The possibilities which are available for processing of the materials are mechanical, thermal or chemical. The material can be pulverized to be reused as fillers in new components (mechanical), but this is a form of downcycling so doesn't fit in a circular model. The materials could be combusted for energy, but this will release toxic compounds and in doesn't fit in a circular model as it destroys the value of the material. There are some other methods to decompose (rupture the chemical bonds in the polymers which cause their thermoset properties) the thermosets so the monomers can

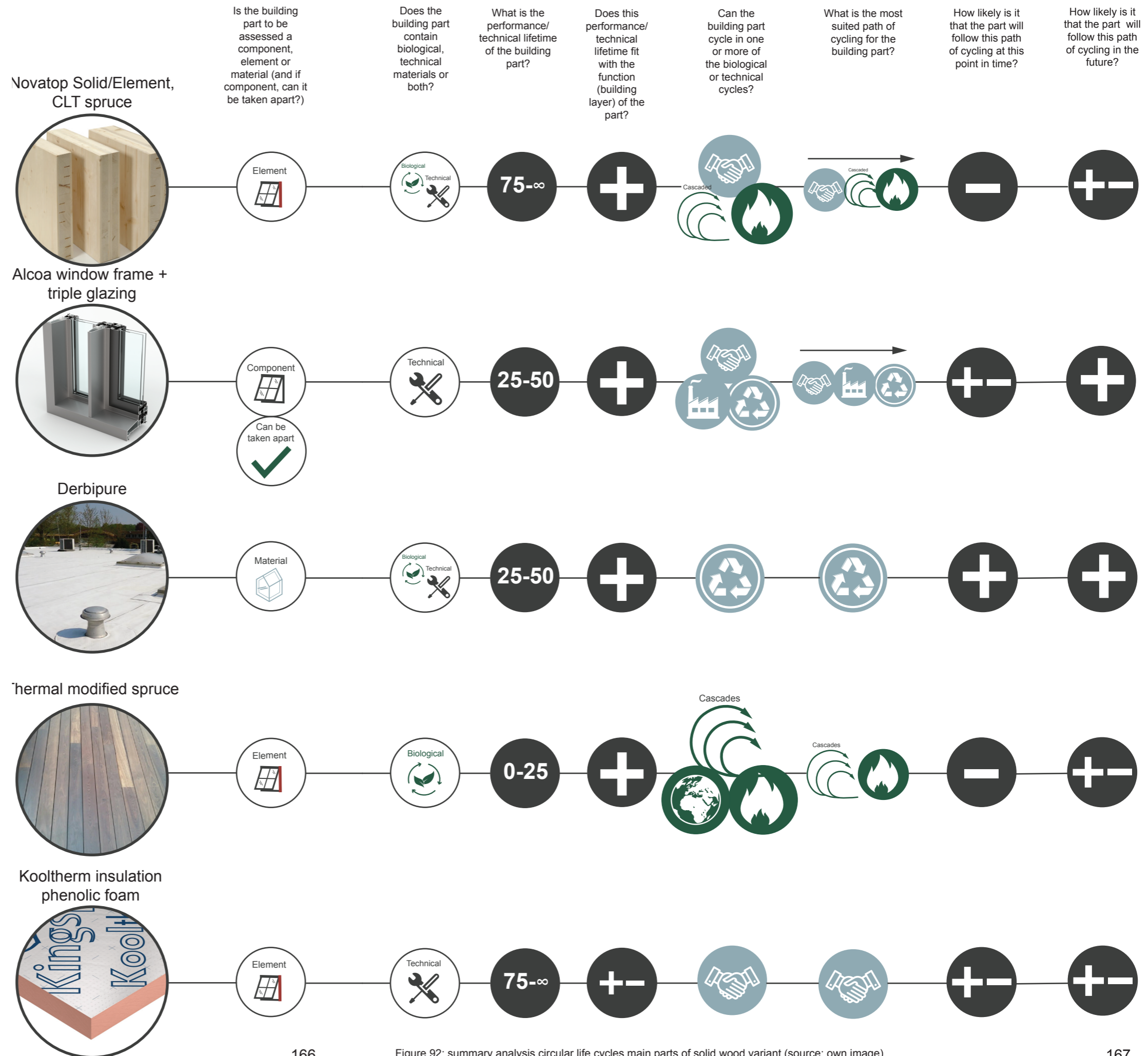

be reused in another thermoset but these are energy intensive, will still constitute some waste and some processes release toxic compounds (Morales Ibarra, 2018). In my view they can be seen more as end of the pipe waste management solutions instead of a circular recycling scenario. However, they are still preferable over waste scenario's such as landfill (Morales Ibarra, 2018).

9.4.3 Steel frame variant

The assessment here has two parts different from the SIP and solid wood variants: the steel frame (C and U cold formed steel profiles) and Biofoam insulation. These are described below.

Cold formed steel profiles

It is a well known fact that steel is a much recycled material. Large companies like Tata Steel have a well functioning business model for the recycling of steel, as it is economically favourable for them to do so. It should be noted that this recycling comes without quality loss: recycled steel has the same properties as new steel (Tata Steel, n.d.) Furthermore, in most parts of the world the infrastructure for steel “scrap” collecting, processing and re-utilizing is already present. However, the recycling process itself obviously uses energy: the scrap is smelted and combined together with new steel. Electricity is used as energy source for the smelting (Björkman & Samuelsson, 2014). The remelted steel can be used for multiple functions. However, the reuse of steel profiles is most preferable. Reusing steel profiles is quite easy because they can be disconnected without damaging them, and the profiles have standardized sizes. By resizing the length (cutting off edges) the steel profile can be reused in another construction (Bouwen met staal, n.d.). This is also already often done: currently in the Netherlands 49% of the steel profiles is reused. The steel construction companies take back the profiles and then it can be used in another project (Bouwen met staal, n.d.). The most suited life cycle path would then be that the steel is reused in other projects, and if this is no longer possible it's recycled.

Biofoam

Biofoam is a biobased insulation material made from the thermoplastic PLA. It has multiple end of life cycle scenario's: it can be reused, recycled (remelted) into multiple types of products, composted and biodegraded (“BioFoam,” n.d.). ISOBOUW, the supplier, also takes back insulation materials to recycle them in their production process. However, it would be best if the

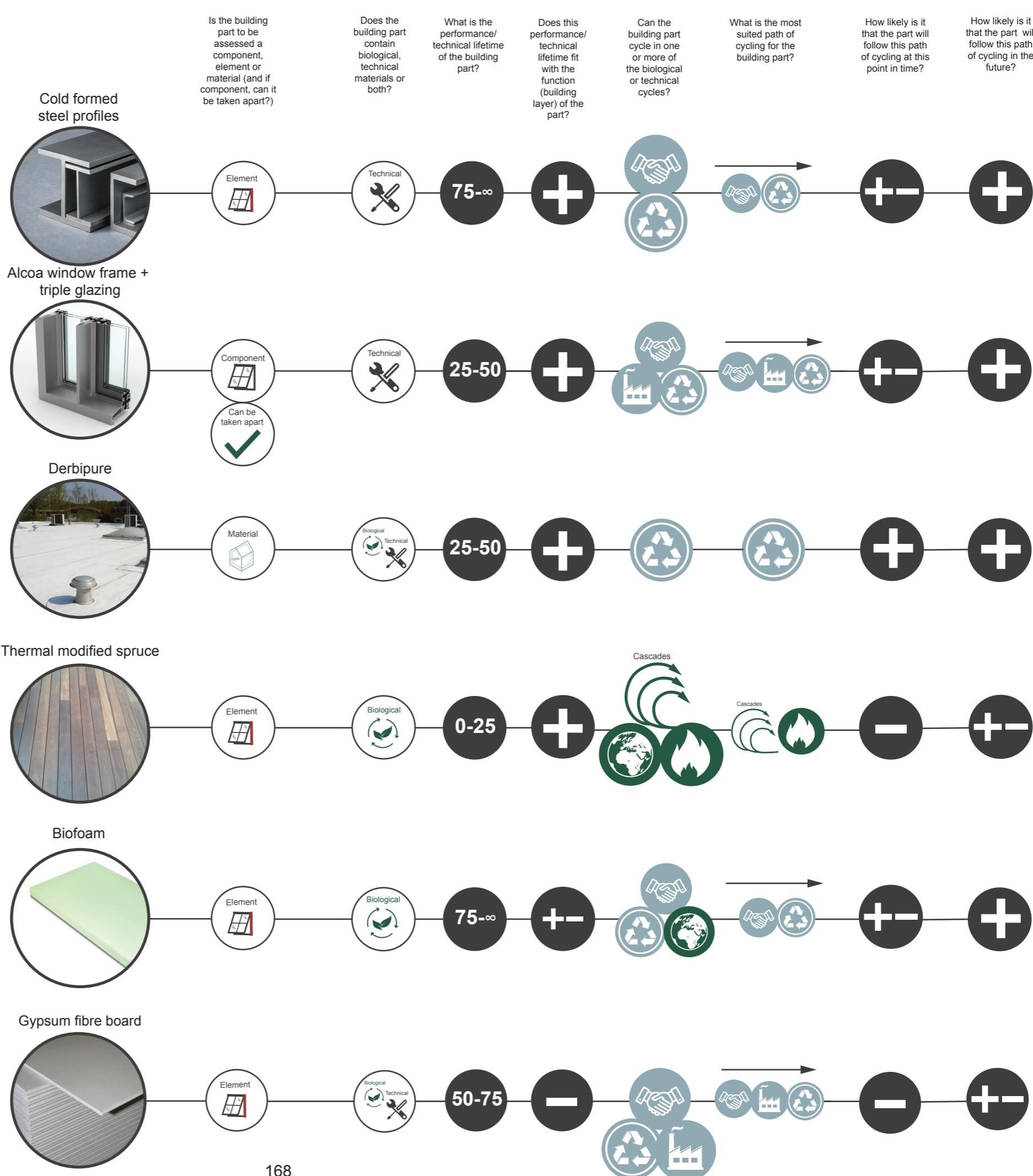

Figure 93: summary analysis circular life cycles main parts of solid wood variant (source: own image)

Biofoam would be reused first before it enters other life cycles, as this would cost the least amount of energy. This is also possible as the foam has a long technical lifetime, and is protected from the environment in the design and can be removed. It could be cut up in new insulation plates in a second life cycle. As ISOBOUW at this point focuses on recycling, it's unlikely that the Biofoam will be reused in a first phase- but ISOBOUW has shown to be considerate of C2C philosophy, so as awareness increases in the future this could be possible (ISOBOUW, n.d.)

9.4.4 Energy systems

Triple Solar

In the case of the Triple Solar panels, recycling is the best scenario. Scenario's of refurbishment, remanufacture or repurpose are difficult as the panel is laminated together and the elements can't be removed without damage. Furthermore, because the PV cells will degrade, to obtain a similar high quality product after first life cycle it's necessary to recycle the silicium in the cells. The copper and aluminium and glazing in the panel can also be recycled without quality loss. Europe has a well functioning organisation for the recycling of PV panels: PV Cycle. There are collection points for old PV panels across Europe, where people can hand in their old solar panels/PV/T panels hassle free. According to European law, all the sellers of solar panels in the EU need to pay a disposal fee to PV Cycle when they sell solar panels (Duiker, 2014). Not every part can be recycled and some waste is present, but high quality recycling is generally possible. About 96% of all the materials are recycled without quality loss (Brinck, 2016). Because of the good European infrastructure present it's thus very likely that after it's first life cycle, the elements will be recycled.

VolThera

The VolThera panel does have options for refurbishment, remanufacture or repurpose as the different elements from the panel can be removed without damage to the panel. One scenario could be that after the panel has reached a point where the PV cells are degraded as such that they need replacement, the collector is fitted as a whole behind another PV module. This would be the best first case scenario, and if remanufacture is no longer possible, the seperate materials can be recycled, just as in the case of the Triple Solar panel. As VolThera has shown to be engaged with circularity, it's possible that this could scenario could happen at this point, and in the future it's likely if they keep developing their circular view.

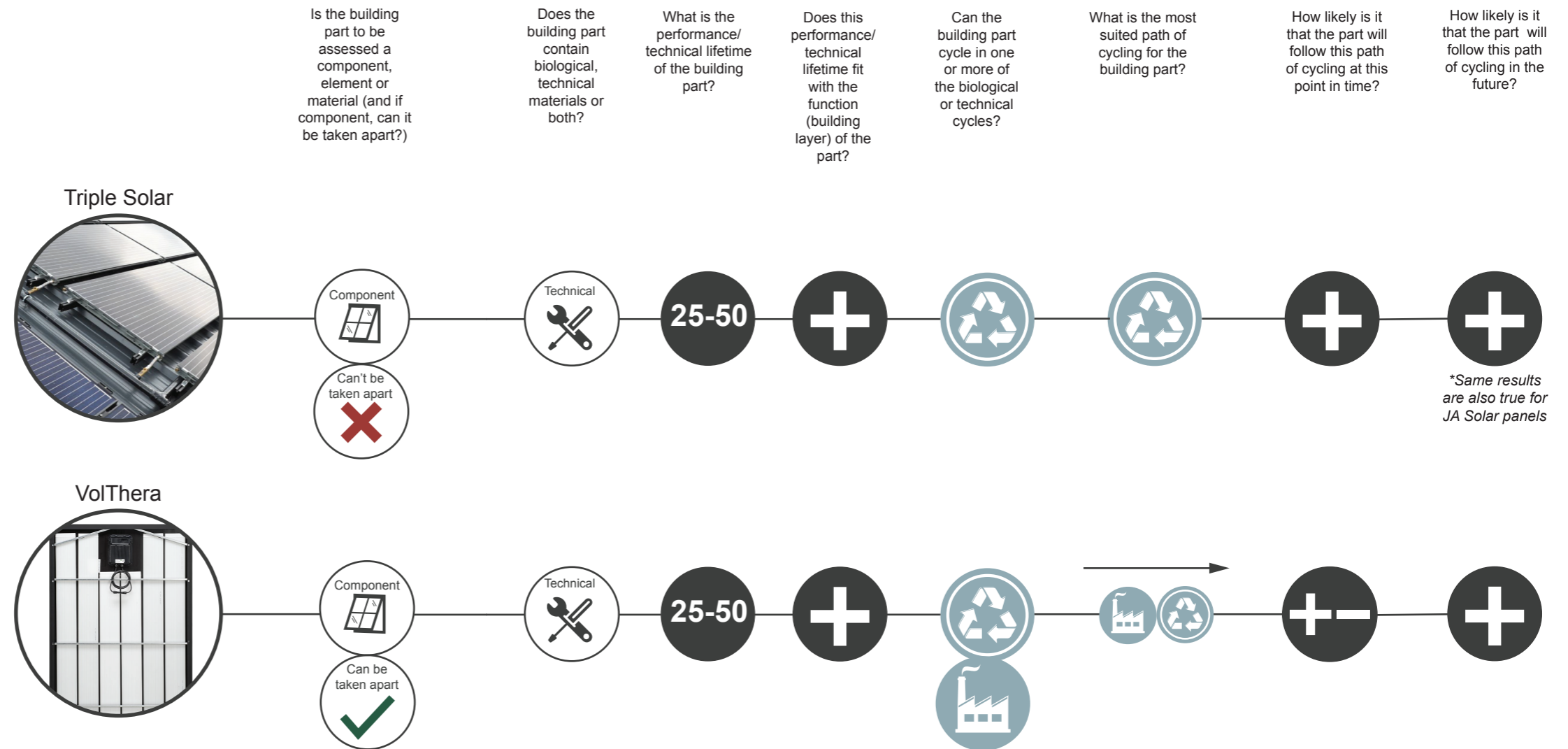
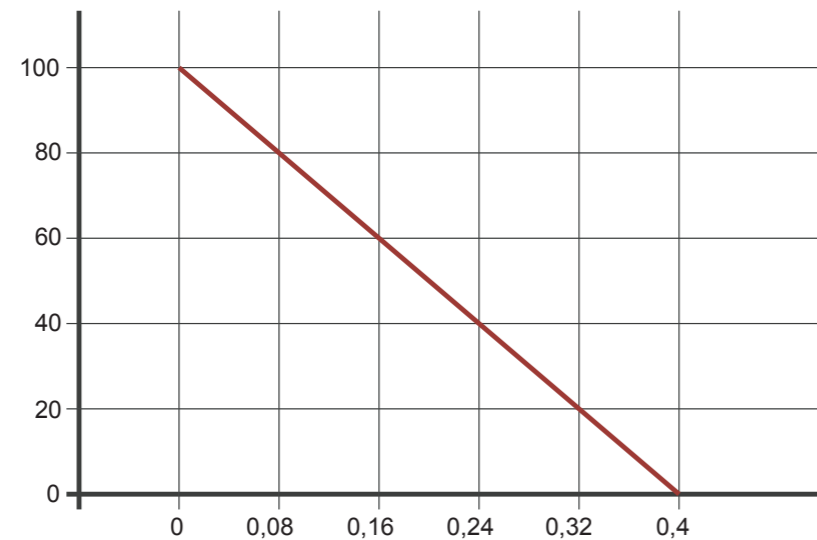

Figure 94: summary analysis circular life cycles energy variants (source: own image)

9.5 Assessment on energy efficiency

The assessment on energy efficiency is an EPC calculation, for which the designs can receive points. All design variants have the same EPC, defined in chapter 7, namely -0,09. Figure 95 shows the results of the assessment. As the value of -0,09 for the EPC is above the maximum 0, which in the assessment method outlined is the highest outcome, the designs receive more than 100 points - namely 118 points.



Variants	EPC outcome	Points
Triple Solar + design variant	-0,09	+120 points
VolThera + design variant	-0,09	+120 points

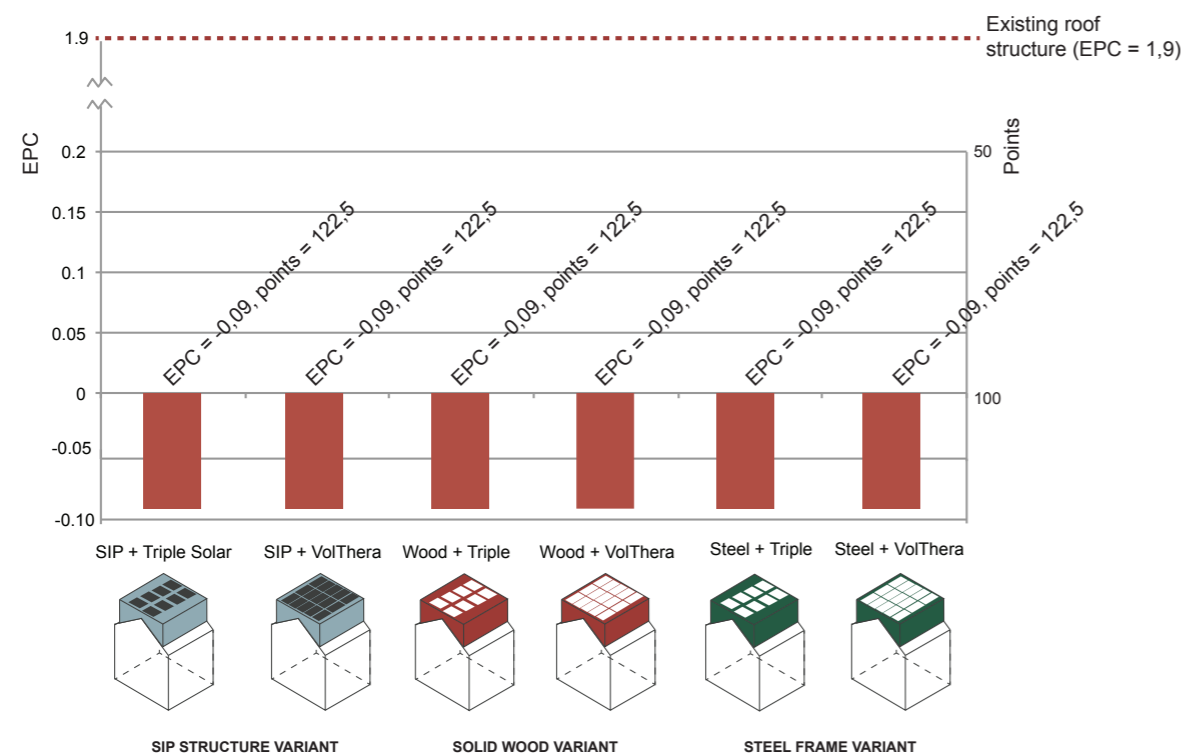

Figure 95: EPC of both energy variants with points scored (top) and design + energy variants combined in final variants and outcome (bottom)

9.6 Conclusions circularity assessment

The question asked in this chapter is:

8. What is the circular and energy performance of the case study energy renovation project?

This question is answered by assessing the variants developed in chapters 7 and 8 on the performance indicators in the assessment methodology, developed in chapter 4. The methodology contains the performance indicators MAT1 Intensity of material use, MAT2 Environmental cost of materials, MAT3 Design for disassembly, MAT4 Design for circular life cycles and E1 Energy efficiency. MAT 1, MAT2, MAT3 and E1 are also assessed for the existing roof structure and are quantitative performance indicators, while MAT4 is a qualitative analysis and is only assessed for the new variants developed. The variants are both design variants (roof structure) and energy variants (PV/T panel system). They are first assessed separately, and afterwards combined into six final variants (SIP + Triple Solar, SIP + VolThera, Solid wood + Triple Solar, Solid wood + VolThera, etc.)

For MAT1 Intensity of material use we see that the SIP structure, combined with Triple Solar energy system is the lightest and thus performs better in terms of intensity of material use and the steel frame structure combined with VolThera panels the heaviest and performs worst in terms of intensity of material use. This was the expected outcome. The SIP variants, solid wood variants are both lighter than the existing roof structure, while the steel frame variants are slightly heavier. Figure 96 summarizes the outcomes of the quantitative part of the assessment for intensity of material use.

For MAT2 Environmental cost of materials we see that neither of the final variants scores any points: this is largely due to the energy systems, which have high environmental cost. The best scoring design is the steel frame variant with Triple Solar energy system, while the worst is the solid wood variant with VolThera energy system. Assessing the energy systems is however still difficult at this point, as the MRPI database only contains a few types of standard products for solar collectors and PV panels. The two main differences between VolThera and Triple Solar in terms of environmental cost is that VolThera uses a non-toxic collector fluid, while Triple Solar will possibly use a toxic fluid, and the material usage for the collector: VolThera uses polypropylene, while Triple Solar uses a copper and aluminium. The non toxic fluid in VolThera will positively influence its environmental cost, but it's difficult to estimate how the collector materials will influence the outcome of the environmental cost.

Furthermore, the environmental cost of each variant is broken down in terms of the relative influence different building parts cause on the environmental cost. Some striking results are as follows. For the three different design variants we see that the triple glazing have a relatively high influence on the result (between 19,8% and 29,9% depending on the variant). What is interesting is that in the SIP variant the OSB material has an influence of 28,6% on the environmental cost, which is high. In the solid wood variant, the cross laminated spruce has the largest influence with 36,4%, but the Kooltherm resol insulation is also significant with 24,1%. The Biofoam insulatin in the steel frame variant has an influence of 21,2%, which is also quite significant, while in the SIP variant the polyurethane insulation only has an influence of 9,6%. This last result is surprising: the hypothesis as explained before (figure 58) was that the polyurethane would have a more significant effect on the environmental cost in the SIP variant. These separate design and energy results are shown in figure 78, and the results of the final variants (which is the average between design variant and energy variant) are summarized in figure 97.

For MAT3 Design for Disassembly we see that the different variants are quite similar in their outcome: the SIP variant scores worse with 58 points of the 100, and the steel frame variant scores best with 64 points of the 100. This is mainly because of the fact that in the SIP structure the sandwich panels can't be demounted because they are glued together, while in the steel frame structure no additives are used. We also see that the Triple Solar energy variant scores 26 points of the 100, and the VolThera variant scores 64 points of the 100. These separate design and energy results are shown in figure 98, and the results of the final variants (which is the average between design variant and energy variant)

are summarized in figure 99.

MAT4 Design for circular life cycles is different from the other performance indicators in that it is a qualitative analysis, analyzing the fitness of the design variants for circular life cycles. The most important building parts present in each design are analyzed with the methodology outlined in chapter 4. The main questions to analyze the fitness for circular life cycles are as follows:

- What are the possible scenario's of cycling?
- What is the optimal path of cycling for the building part?
- How likely is it that the building part will follow this path of cycling at this point in time?
- How likely is it that the building part will follow this path of cycling in the future?

The best case scenario is that the building part has many possible scenario's for cycling (diversify use), it's very likely that it will follow the optimal path of cycling in this point in time, and in the future. The worst case scenario is that it has no possible scenario's for cycling, and thus it also can't follow a path of cycling in this point in time or in the future. There are possibilities in between, where a building part has for example only one possible scenario of cycling but it is likely that it will follow this scenario now and in the future.

The summary of the analysis is shown in figure 101. In my view the design performing best on circular life cycles is the steel frame variant, while the SIP panel is the worst. The solid wood variant is in between. The difference between these design variants is the structure (SIP panels for SIP, CLT spruce for solid wood, steelframe for steel frame), the insulation (polyurethane in SIP, Kooltherm in solid wood, biofoam in steel frame).

- The SIP variant's main structure SIP panels has no possibilities for circular life cycles: it will most probably be incinerated at end of lifetime. This means the structure and insulation are both not suited for circular life cycles.
- The CLT spruce has three possibilities for circular life cycles, but at this point will likely be incinerated for biogas - in the future it might follow the optimal path (reuse - cascades - incineration biogas).
- The steelframe has two possibilities for circular life cycles and it's possible that it follows the optimal life cycle at this point - in the future this is likely.
- The Biofoam insulation used in the steelframe variant has 3 different possibilities for cycling and even though at this point it's not likely that it will follow the optimal path (be reused first) it's likely to be recycled, and for this material the loops can be entirely closed.
- The Kooltherm insulation can possibly be reused, but this is the only option: high quality recycling is not yet feasible and loops can't entirely be closed for this material.

So the SIP variant's main structure + insulation is not fitted for circular life cycles, the solid wood variant's structure is partly fitted for circular life cycles, but it's insulation is not really fitted, and the steel frame variant's structure and insulation are fitted for circular life cycles.

From the energy variant's the VolThera variant has best possibilities for circular life cycles: as it can also be easily remanufactured partly, and the Triple Solar variant can only be recycled. From this we can conclude that the steel frame variant + VolThera has most potential for circular life cycles.

For E1 energy efficiency, each final variant scores the same: with an EPC of -0,09 they score above the 100 points, scoring 122,5 points.

The EPC of each variant and the points scored for assessment on energy efficiency is shown in figure 100.

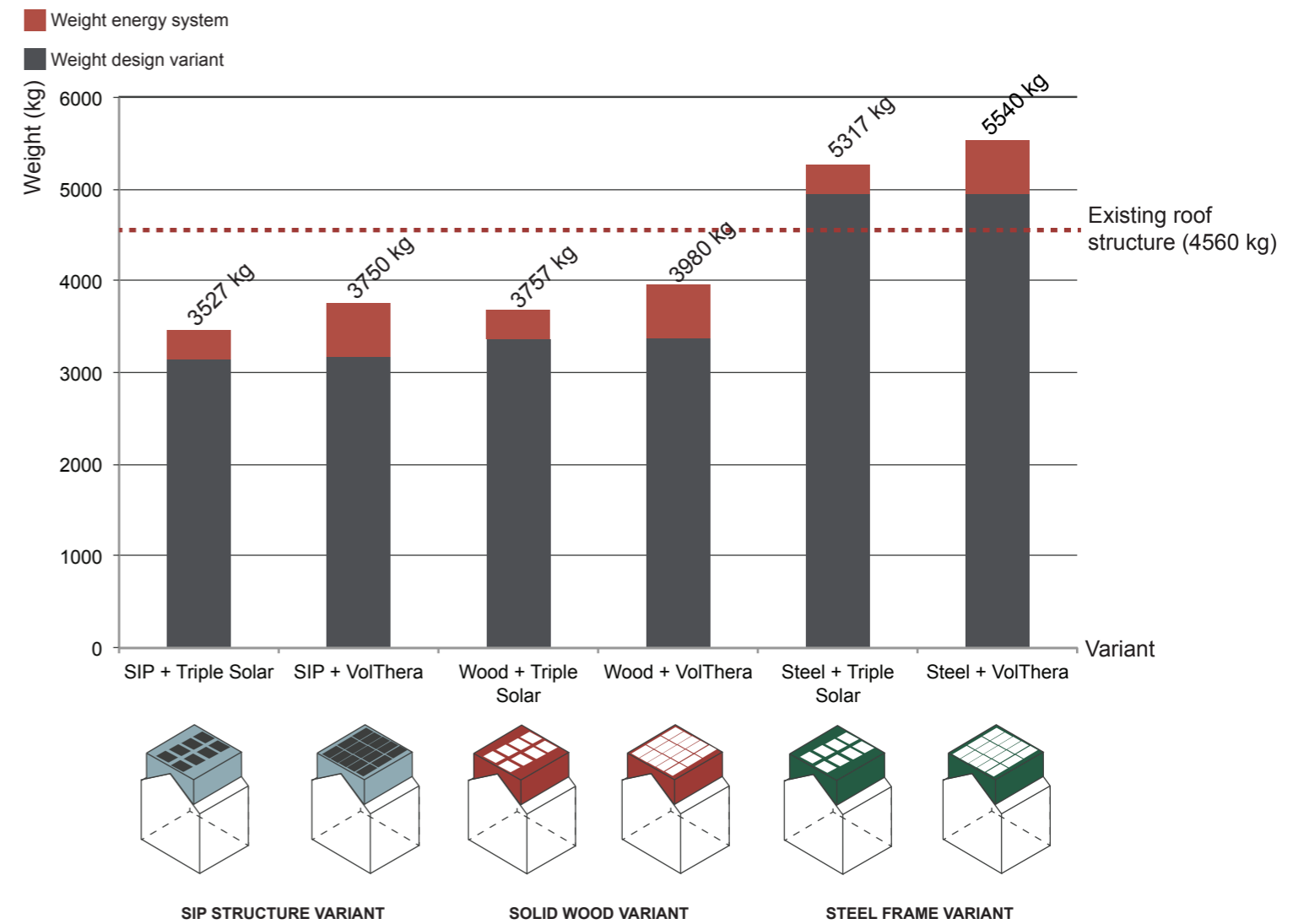

Figure 96: results quantitative assessment MAT1 intensity of material use (source: own image)

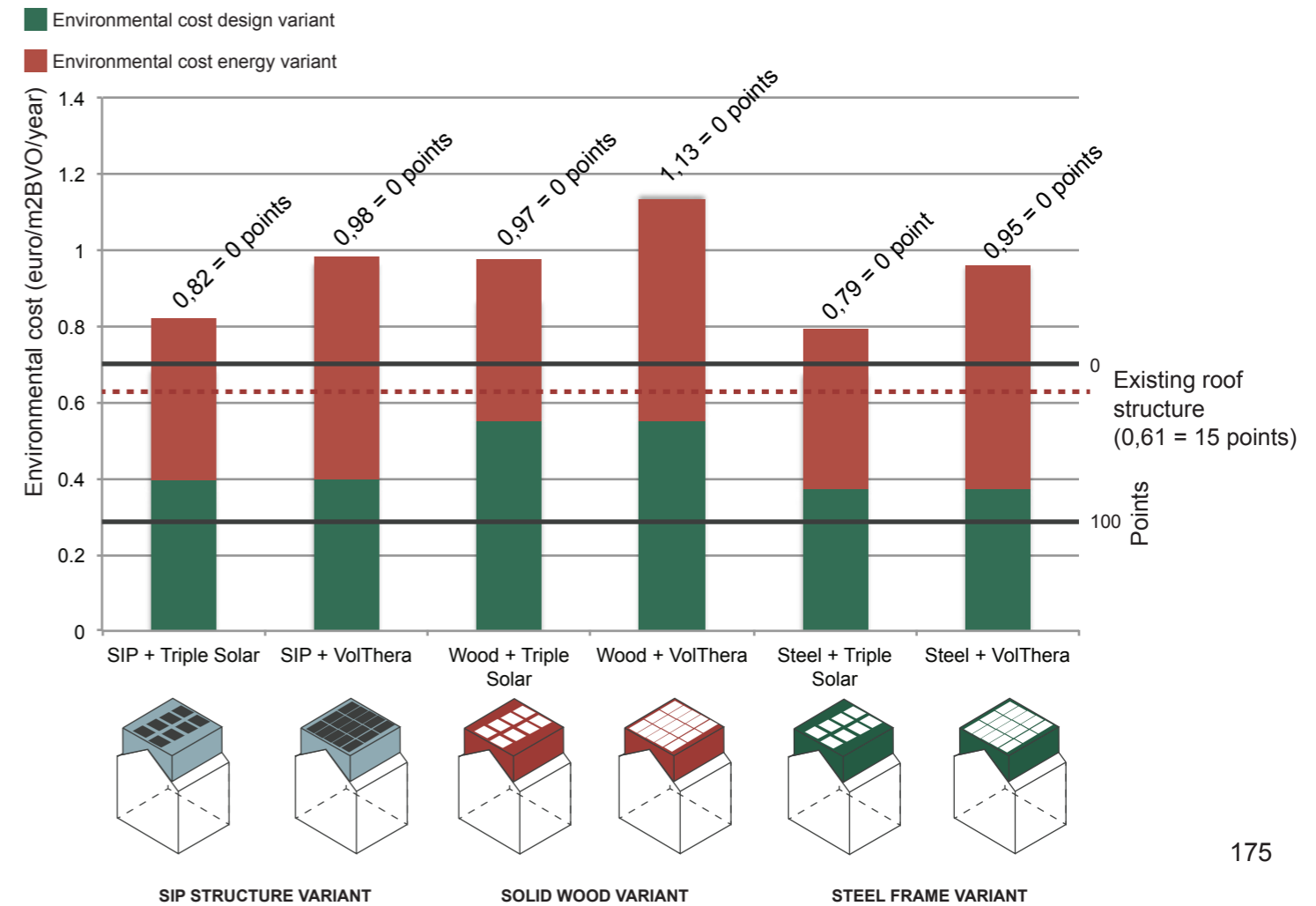

Figure 97: results assessment MAT2 Environmental cost (source: own image)

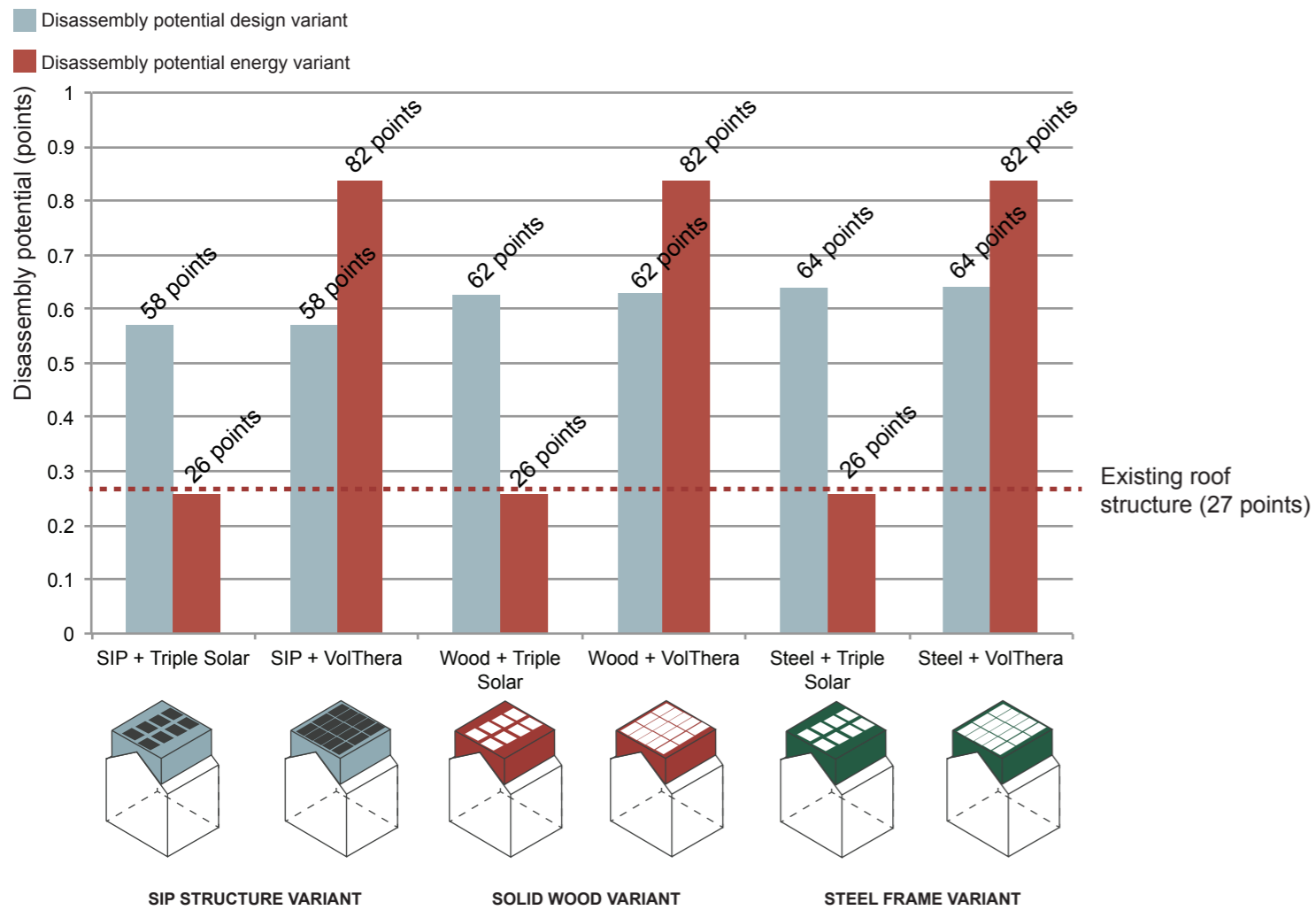

Figure 98: separate results assessment MAT2 Design for disassembly (source: own image)

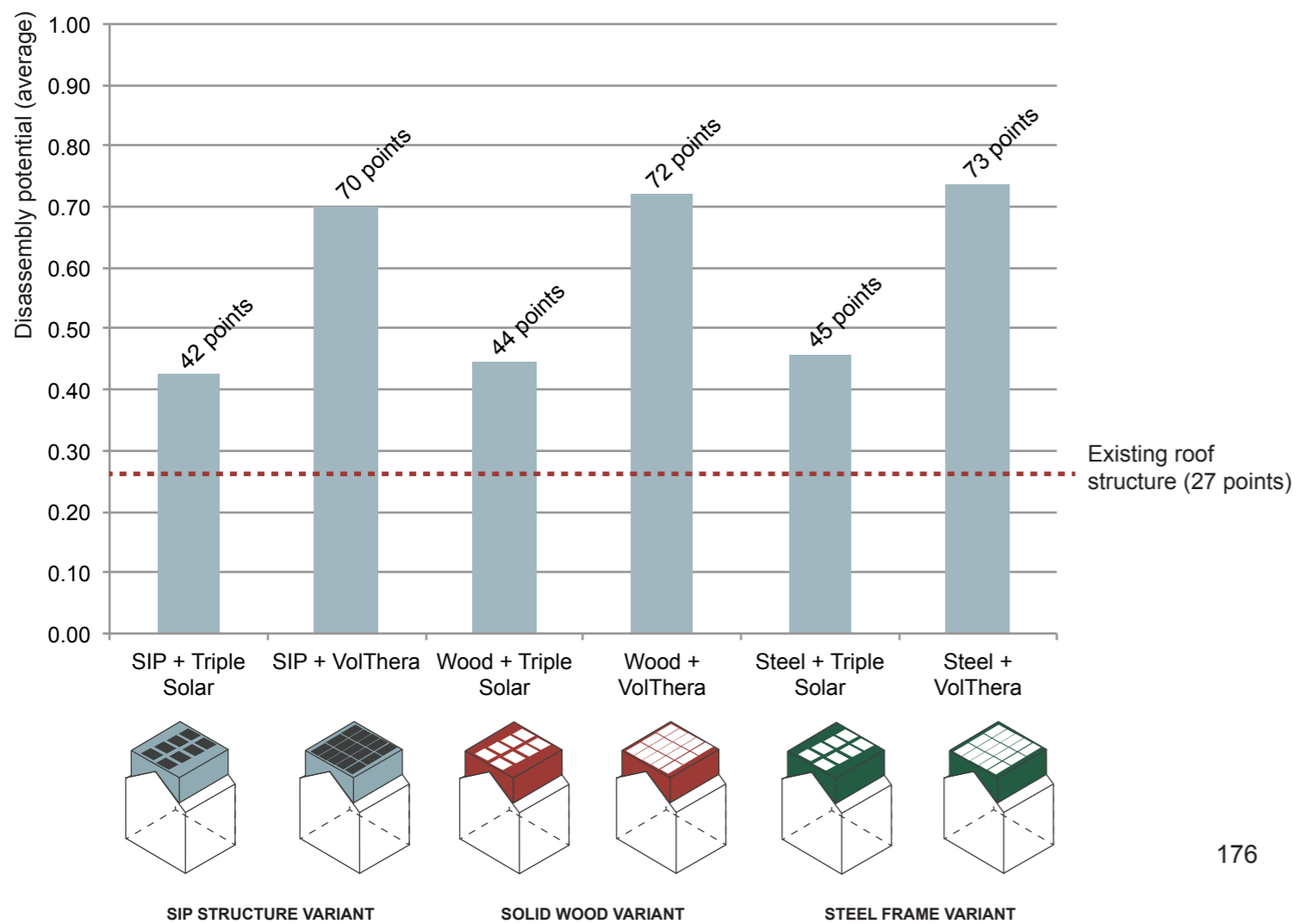

Figure 99: average results assessment MAT2 Design for disassembly (source: own image)

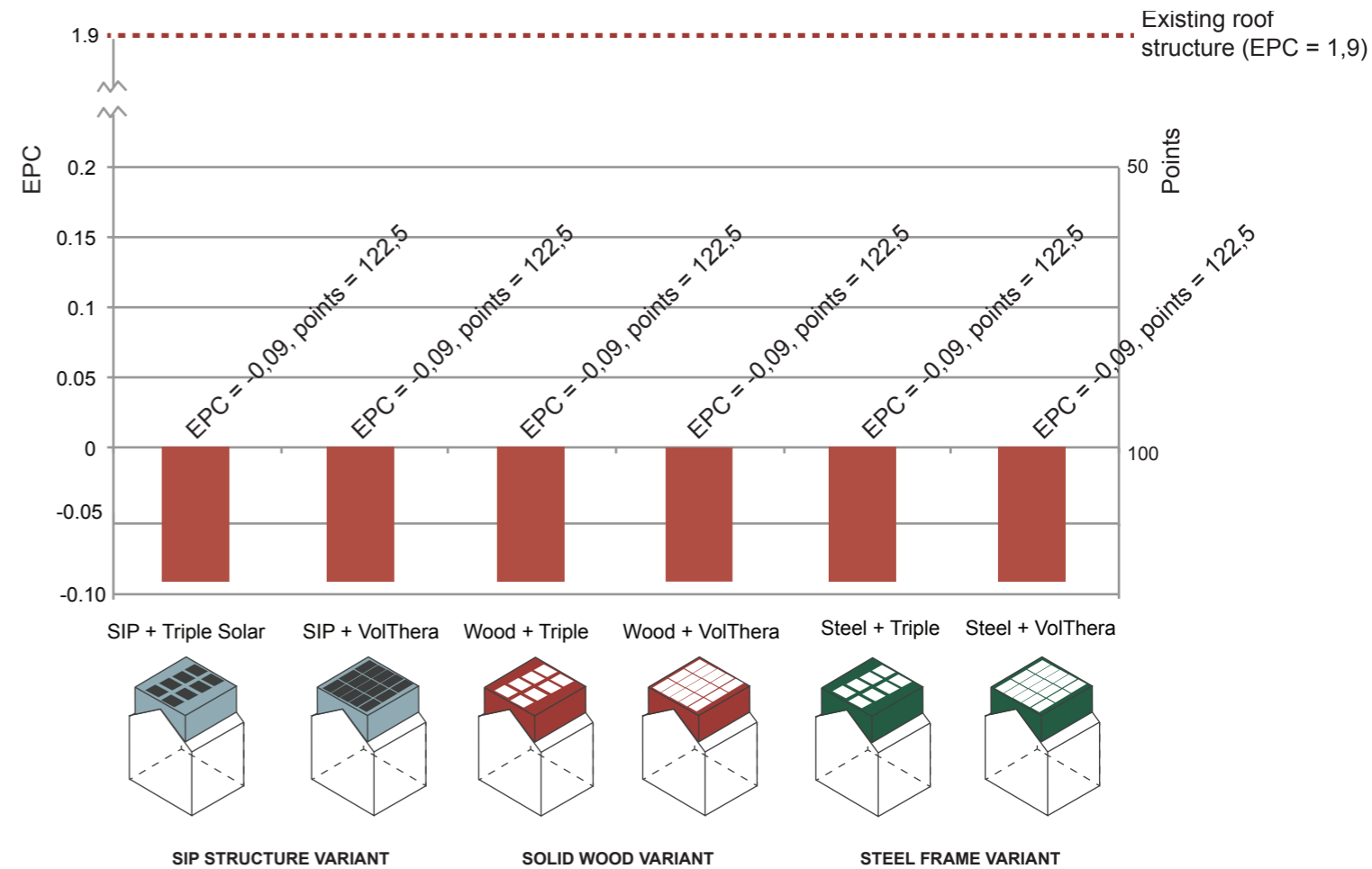
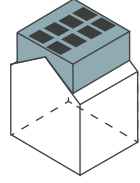

Figure 100: results assessment E1 energy efficiency (source: own image)

Summarizing,

- For **MAT1 intensity of material use** the SIP variants scores best, the solid wood variants in between, the steel frame variants worst. This latter is also the only one heavier than the existing roof structure.
- For **MAT2 environmental cost** no variants are good enough to score any points. This high environmental cost is because of the energy systems. In terms of design variants, the steel frame variant is best, followed very closely by the SIP variant and then the solid wood variant. The best overall final variant is steel frame + Triple Solar, and the worst overall final variant is solid wood + VolThera. However, the energy variants assessment is not entirely fair: only standard products are in the MRPI database, so in reality the energy variants might differ (VolThera doesn't use a toxic fluid, fore example)
- For **MAT3 design for disassembly** the variants are quite similar, in the design variants the SIP variant scores worst and the steel frame variant best. In the average result between design variant + energy variant, the steel frame + VolThera scores best, and the SIP + Triple Solar scores worst.
- For **MAT4 design for circular life cycles** I believe the steel frame variant + VolThera has most potential for circular life cycles, while the SIP variant + Triple Solar has least potential for circular life cycles.
- For **E1 energy efficiency**, each variant scores the same: EPC of -0,09 and 122,5 points.

SIP + Triple Solar



SIP + VolThera

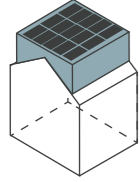

Wood + Triple Solar

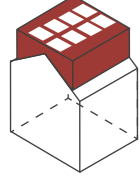

Wood + VolThera

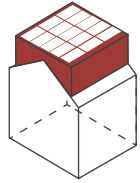

Steel + Triple Solar

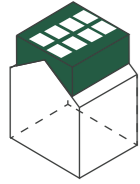

Steel + VolThera

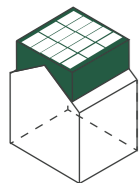

Building part	What is the part?	Amount of possible cycles?	Likelihood following optimal path of cycling now?	Likelihood following optimal path of cycling future?
Building Part 1	SIP panels	0	0	0
Building Part 2	Window frame triple glazing	3	+ -	+
Building Part 3	Derbipure roofing	1	+	+
Building Part 4	Exterior finishing thermal modified spruce	3	-	+ -
Building Part 5	Gypsum fibre board	3	-	+ -
Building Part 6	Triple Solar system	1	+	+
Building Part 1	SIP panels	0	0	0
Building Part 2	Window frame triple glazing	3	+ -	+
Building Part 3	Derbipure roofing	1	+	+
Building Part 4	Exterior finishing thermal modified spruce	3	-	+ -
Building Part 5	Gypsum fibre board	3	+ -	+ -
Building Part 6	VolThera system	2	+ -	+
Building Part 1	CLT spruce	3	-	+ -
Building Part 2	Window frame triple glazing	3	+ -	+
Building Part 3	Derbipure roofing	1	+	+
Building Part 4	Exterior finishing thermal modified spruce	3	-	+ -
Building Part 5	Kooltherm insulation	1	+ -	+ -
Building Part 6	Triple Solar system	1	+	+
Building Part 1	CLT spruce	3	-	+ -
Building Part 2	Window frame triple glazing	3	+ -	+
Building Part 3	Derbipure roofing	1	+	+
Building Part 4	Exterior finishing thermal modified spruce	3	-	+ -
Building Part 5	Kooltherm insulation	1	+ -	+ -
Building Part 6	VolThera system	2	+ -	+
Building Part 1	Cold formed steel profiles	2	+ -	+
Building Part 2	Window frame triple glazing	3	+ -	+
Building Part 3	Derbipure roofing	1	+	+
Building Part 4	Exterior finishing thermal modified spruce	3	-	+ -
Building Part 5	Biofoam insulation	3	+ -	+
Building Part 6	Gypsum fibre board	3	-	+ -
Building Part 7	Triple Solar system	1	+	+
Building Part 1	Cold formed steel profiles	2	+ -	+
Building Part 2	Window frame triple glazing	3	+ -	+
Building Part 3	Derbipure roofing	1	+	+
Building Part 4	Exterior finishing thermal modified spruce	3	-	+ -
Building Part 5	Biofoam insulation	3	+ -	+
Building Part 6	Gypsum fibre board	3	-	+ -
Building Part 6	VolThera system	2	+ -	+

Figure 101: results analysis Design for circular life cycles (source: own image)

9.7 Discussion circularity assessment and suggestions for future development assessment method

Now that the assessment method has been tested in practice, it's interesting to discuss the indicators, possible weaknesses found and how these might be further developed and refined. The performance indicators will be discussed separately.

9.7.1. Intensity of material use

In the Metabolic method this indicator is not yet finished: the future vision is that the intensity of material use will be calculated by the following formula:

- Intensity of material use = mass materials / lifetime building * (occupancy rate OR area building)
- Then the outcome for the calculation is compared to a benchmark value and this determines the score.

Metabolic hopes that if the Roadmap is used more often, they can gather a database which contains the outcomes for the calculation of different typologies of housing: the benchmark to which a new design is compared is then the best scoring design within that typology (so a rowhouse is compared to a rowhouse with a good score).

I partly adopted this future method for this thesis, but instead of calculating the entire formula only calculated the weight of materials and compared this to the existing roof design as a benchmark.

For the future development of this indicator, I believe the calculation should not be dependent on either the occupancy rate or the area of the building. By including them in the calculation, the risk is that one tries to influence the score for the formula by either making a smaller space for more people (negatively influencing the wellbeing of users) or by making a bigger building (worse energy performance, taking up rare space, etc). Furthermore, both parameters are often already set in the programme of requirements for a building design.

I do however agree with Metabolic's future ambition to fill a database with typologies of buildings, and use these as benchmarks to compare the material use of the design to. The intensity of material use can then be calculated by the following formula:

- Intensity of material use = mass materials / lifetime building

Developing this database will in time give a clear idea about how far material use can be reduced for different types of buildings. This quantitative assessment needs to be supported by a description of material usage in the design for different components during build and during lifetime of building, as more material use can be justified if it serves a positive function (solar panels adding to higher energy performance). I believe new software can play an important role in reducing material usage: parametric tools such as Grasshopper can be used to prove that the material usage is at an absolute minimum for the function the component has to fulfill (material usage per functional unit). As an example: a steel structure can be optimized in Karamba to use as little material as possible for it to reach structural integrity.

9.7.2 Environmental cost of materials

As already mentioned in chapter 4, the problem with this performance indicator is that the tool is based on a linear model: the LCA analyses behind it analyze environmental impacts from cradle-to-grave, not taking into account possible circular scenarios. "The conventional cradle-to-grave approach, even when it includes credits for substituted materials, is not fully suitable for meaningful interpretation within a circular economy setting." (Dieterle, Schäfer, & Viere, 2018)

However, the strength of this indicator lies in the infrastructure behind it: the open source 'Nationale

Milieudatabase' contains the life cycle analyses of a wide array of building products, so the designer does not have to do their own LCA, which is very time consuming but can easily check the database. The goal should therefore be to keep this infrastructure, as it is very valuable and adapt it to a circular economy mindset.

There is a body of research about how LCA methodology could be adapted to a circular mindset. One study proposes adjusting the functional unit within the goal and scope definition of the LCA. In this study a life cycle assessment of aluminium cans (taking into account different scrap sources) was performed. In the study they introduced the idea of multiple co-functions in the functional unit definition to be able to move from one life cycle to multiple life cycle modelling, so they could take into account 30 recycling loops for the cans (Niero & Olsen, 2016). There are other possibilities for adapting LCA methodology to a somewhat circular mindset: substitution methods, recycled content method and equal share method (van der Harst, Potting, & Kroeze, 2016).

Another study suggests a life cycle gap analysis (LCG-A) to complement the results of a traditional LCA. This complementary result of the life cycle gap analysis could then also be added to the database, to help in interpreting the LCA results with a circular economy mindset. How does this LCGA-A work? This analysis identifies and evaluates theoretical circularity gaps in the fourth phase of an LCA, interpretation (after goal and scope definition, inventory analysis and impact assessment). It introduces the LCG coefficient, which is in simple terms the environmental impact (LCA) of the initial product's life cycle minus the environmental benefits obtained from a second life. It can thus be used to identify how a second life can result in a lower LCG coefficient. As the LCG-A is introduced in the interpretation phase, it can actually be combined with other LCA adjustment methods (Dieterle et al., 2018).

These examples show that there is a multitude of methods and guidelines for how to adapt LCA methodology to a circular mindset, but there is still no consensus on which is the best approach. There is a need for new and unambiguous ISO guidelines (van der Harst et al., 2016), which can then in the future replace the current LCA methodology which is the basis of the environmental cost calculation. I believe multiple life cycle modelling has most potential, as this method could consider different circular scenario's (recycling, remanufacture) and would thus best fit in a circular economy mindset. It could also be adapted to the life cycles best fitting with the product analyzed. This LCA methodology could then replace the now linear LCA methodology in the Nationale Milieudatabase. Before we reach that point, the LCG-A can be the perfect transition tool: it can be added to the traditional life cycle analyses in the 'Nationale Milieudatabase', so that the database can be used with a circular mindset as well.

Another point to mention which needs consideration: the environmental cost calculation considers different environmental effects, from material health effects like toxicity material for humans to exhaustion of fossil fuels (and thus embodied energy) needed to produce materials. It could make sense to only include environmental effects in the new LCA methodology which directly relate to material health, and not include environmental effects having to do with energy needed to produce materials. That is because then the indicator starts to overlap with the indicator design for circular life cycles.

9.7.3 Design for disassembly

The method used in the end leans heavily on Durmisevic' Disassembly Potential tool, with the addition of the sub-indicators Prefabrication and Deconstruction plan and the removal of the sub-indicators Functional dependence, Structure of material levels and Coordination of life cycle & size. The first two are removed because they are quite similar to other sub indicators, and the latter is removed because it is not relevant on the scale of the case study dwelling. This final remark is important: during use of the method, I noticed how important the scale of a building is for which sub indicators matter or can even be taken into account. As an example, let's take the sub indicator of assembly sequences. Each design variant has a combination between components assembled first and elements connected to components. The main components are for example the SIP panels with waterproofing and first layer of understructure for exterior finishing, and the elements are then the exterior finishing connected on site.

According to the presented methodology, it is best if entire components are connected to components, but one can imagine this is much more important for for example a large office building which might be transformed into a different function into it's lifetime and in which all facade components are uniform. In such a building it's possible that a new layout of facade will be necessary in the future, in which facade components can then be replaced and interchanged. In the case study dwelling, it is unlikely the main components will be replaced during lifetime of building, and more likely that the exterior or interior finishing will be replaced.

These scale and typology differences should be reflected in the (future) methodology, weighting different performance indicators as more important and perhaps changing how points can be received for different indicators for different typologies and scales of buildings. Concluding, the design for disassembly method should consider the function and scale of the building more.

9.7.4 Design for circular life cycles

The analysis of this performance indicator is a first step towards analyzing the fitness of a building part for circular life cycles. The result of the analysis firstly describes the possible cycles the building part could go through (reuse, recycling, etc). It then describes the optimal path of cycling the part could take. It concludes if the part will now follow likely follow this path of cycling, and if not, if this is likely in the future based on current trends.

This analysis has some overlap with the MCI indicator from the Ellen MacArthur foundation. This indicator is also on the scale of individual products and considers the following things:

- How much input is coming from virgin and recycled materials and reused components?
- How long and intensely is the product used compared to an average?
- How much material goes into landfill (or energy recovery), how much is collected for recycling, which components are collected for reuse?
- How efficient are recycling processes used to produce recycled input and to recycle material after use?

I purposefully didn't use the MCI, because the MCI only considers technical material cycles (not the biological cycles) in current time and doesn't consider the development of the sector: perhaps a product can't be circular at this point, but it might in the future. It does have some strong points: it is quantified (measuring the products circularity between a range of 0 and 1), considers if the product uses recycled feedstock (not considered in this thesis) and considers utility.

I think a methodology which considers design for circular life cycles should have the following points:

- Taking inspiration from the MCI: considering the input of recycled, reused or remanufactured feedstock.
- Considering the optimal life path for the product in question, in which a heterogeneous product with many short life cycles but which can often be reused is not necessarily better than a homogeneous product which can only be recycled but has a long lifetime. In the method in this thesis this is more a descriptive analysis, but it could be quantified. In general reusing or remanufacturing components is better than recycling them, as the first two processes will use less energy. But if the recycled product is then used for longer, this energy use is offset.

In the MCI the quantification is as follows: imagine a product of 1 kilo. Of this product 0,3 kilo's is virgin feedstock, 0,4 kilo's is recycled feedstock and 0,3 kilo's is reused feedstock. From the product 0,3 kilo's is recycled after the lifetime with 100% efficiency, 0,4 is reused with 100% efficiency. This means 0,3 kilo's is waste. The product then has a linear flow index of 0,3. The product is used for 50 years while the industry average is 25: the utility function is 1,8. The MCI is then $MCI = 1 - LFI \times Utility = 0,46$. This means the product is not fully circular (1) but also not linear (0). So the MCI does not consider the different energy uses for recycling, reuse, remanufacture, but does consider lifetime.

I believe the method should also account for the energy use in the cycles and the cycles possible.

In its simplest form this could be done as follows. Take a component. Imagine the component can be recycled and remanufactured - and in both cases 50% of the component can be either recycled or remanufactured. Based on the qualitative analysis, we would say that it's best if the component is remanufactured - and perhaps in a later stage recycled if remanufacture is no longer possible. Imagine the recycling process costs 100 units of energy, while the remanufacturing process costs 50 units of energy. In both cases the lifetime of the product is the industry average: 50 years. Based on this we determine the MCI of the component, which hypothetically is 0,5 (if either 50% is recycled or remanufactured). Up to this point we have not differentiated between the type of life cycle. We could then say that if the product is remanufactured, in terms of energy that would be two times better than if it's recycled.

So then we could say: the component is recycled, has a lifetime of 50 years and thus an MCI of 0.5. This could be better in terms of energy use for the cycle: a factor of 2 better if the component was reused. MCI offset to energy use recycling scenario compared to possibility of other scenario's: $0,5/2 = 0,25$.

Perhaps then 'likeliness' factors, considering how likely it is that the product will follow this path, now and in the future, could also be introduced.

This is a first idea: introduce some kind of factoring method to consider energy use of the cycles if there are multiple cycles possible and considering this in accordance with the lifetime. It's obviously not foolproof yet: how could multiple cycles be considered for example, so if a building product goes through two remanufacturing cycles first and then 4 recycling cycles?

9.7.5 Energy efficiency

The performance indicator for energy efficiency is based on giving a score for the EPC of the design. This performance indicator follows the Metabolic method, and in the future the goal is to make the score outcome dependent on the BENG, which is set to replace the EPC in 2020 to assess energy performance of buildings. The BENG depends on three sub indicators: the energy need of a building, the primary fossil energy use of a building and renewable energy generated by the building or on the site.

Future vision assessment method

The separate performance indicators have been reflected upon. Also interesting to consider, is the integration between indicators and which indicators I believe to be most important

In my vision the most important indicators for circularity are design for disassembly, design for circular life cycles and environmental cost. This should not be taken to mean that the other indicators don't matter, but here I would like to reflect on these indicators and the combination between them further. I see these indicators as affecting different scales, from the micro scale of separate building parts to the meso scale of the building, to the macro scale of the planet. The environmental cost assessment, as mentioned before, could in fact be translated to an assessment of the material's health: if materials are for example toxic for ecosystems, this is reflected in the result of this indicator. In the C2C vision we've seen that the first step is to produce without harmful contaminants and to phase out all materials which are toxic. The environmental cost calculation can be used to do this. It should then be considered as the first step: phasing out harmful materials to be able to choose 'good' materials. This will affect the micro scale of the product itself, but also the larger scale of the planet: it's important we choose materials to use which won't cause negative environmental effects. The next step, after we have chosen healthy materials, is also on the micro scale: determine if the material has good options for circular life cycles. And then if a product uses multiple materials, make sure that either the entire product can cycle, or the product can be taken apart so the separate elements can cycle. This should be reflected in the indicator design for circular life cycles. The third level is on the scale of the building: we've chosen healthy materials, chosen how to design them in building parts, and now the building

parts need to be combined. Then we need to be able to take apart the building parts, and we arrive to design for disassembly indicator.

My final vision for the future would be that the eventual set of indicators - after they have been further developed - could be included in a generally accepted method. One example I thought of is including them in BREEAM or LEED, as they are broad sustainability assessment methods tested many times and generally well known. Other options might also be possible. BREEAM and LEED already include themes for materials and energy performance, albeit not (yet) with a circular mindset. The performance indicators are organised in the themes management, health, energy, transport, water, materials, waste, land use and ecology and pollution. The performance indicator set for circularity could fit into either materials or waste or could be included as a new theme. The performance indicator for energy efficiency then fits into the theme of energy. To solve the environmental problems the built environment contributes to, it is essential we move towards an integral and holistic approach for sustainability, where there is space for circularity, energy performance and other themes such as biodiversity which were not included in the scope of this thesis. Where we don't simply shift problems to another area, because our focus is on another theme. In reality these themes are intertwined and don't exist on their own islands. For example, in this thesis high energy performance of the building caused high environmental cost. This is an example of where different sustainability themes overlap and lines are blurred: a holistic and integral assessment method will ensure we keep sight on the entire system. And why develop an entirely new method which will take years before it is widely in use, if the indicators themselves might be included in and adapted to an existing well known method which already has the infrastructure, knowledge and reputation present for marketwide implementation? Obviously, the will to cooperate between different parties will be essential for the success of such an overlapping, integral assessment method.

10. VISION AND SUGGESTIONS

In previous chapters several design variants have been developed to research to which extent circularity can be implemented in the designs of energy renovation projects. These variants have all been assessed on the performance indicators of intensity of material use, environmental cost, design for disassembly, energy efficiency and design for circular life cycles. The designs and assessment methodology presented are therefore mainly technical research: focusing on technical aspects of circularity in the built environment. However, developing technology is only a part of what is needed for a circular built environment.

This chapter will therefore first reflect on the technology & systems developed in this thesis. Afterwards, other themes which determine whether the technology can successfully be implemented are discussed. These themes are business models, financial aspects and legislation.

10.1 Technology & systems

The technical research developed in this thesis is twofold: on the one hand it was a design process to design a circular (nearly) zero energy dwelling, on the other hand a process to develop an assessment methodology for circularity. Both are essential parts of the technology & systems of circular (nearly) zero energy buildings. In the conclusions of chapter 9 already suggestions have been given for how to further develop the assessment methodology, so here I will reflect on the developed designs.

10.1.1 Design

During the design process it became clear for me that the technical design challenge for circular (nearly) zero energy buildings lies mainly in combining circularity with other practical boundary conditions and not so much in combining circularity with high energy performance. I want to illustrate this by an example.

One practical boundary condition is the construction time of variants. The steel frame variant I have aimed to design as demountable as possible: indeed, it has the highest score for disassembly potential of the variants (even though it's quite a close call). The cost of this high score is complexity: comparing the scheme for construction method of the steel frame variant (figure 67) with the scheme for construction method of the SIP variant (figure 61), we see how the steel frame variant has more layers, more unique elements and thus needs more manpower and time to be built. The simplest SIP design variant which can be built quickest and will therefore probably be cheapest, is least demountable (and scores worst on design for circular life cycles), as it is made up of glued sandwich panels.

My first suggestion for future development is in improving building products such as SIP panels, to still have all their simple and cheap functionality, but to be able to disassemble them as well, albeit perhaps not on the building site, but rather in the factory by the supplier. Kingspan is working on creating industrial processes which allow for the separation of the SIP panels in such a way that the materials are fully recyclable without quality loss, so a demountable sandwich panel (Pennings, 2017, cited in Henry, 2018). However, for sandwich panel technology at this point it's necessary to use adhesives to guarantee the strength and airtightness of the panels. At this point a demountable connection method which ensures the same airtightness and strength is not yet developed by Kingspan. But this product development can be an interesting shift of focus to explore: not the designer creates full demountability of the design on the building site, but the supplier creates it in the factory after taking back their (composite) product. This could create an efficient chain of building: the designer can choose composite products to use which have great functionality in other areas such as building time and simplicity, and the supplier can design an industrial separation process in the factory which is quicker, easier and cheaper than the separation process on the building site would be: there it is inevitable that separation is done by manual labor. In this way the responsibility for a circular strategy is shifted from the designer in the design phase to the supplier in the material and component production phase. According to Nussholz & Milios (2017) to one source, circular strategies can be adapted in three different phases of a building: (1) the material and component production phase (2) the design phase and (3) the end-of-life phase. Figure 102 shows an overview of these phases and circular strategies which can be adapted in the different phases. If very tight construction time or other practical boundary conditions make it difficult to adapt the circular strategies in the design phase, solutions in the other phases need more attention. Obviously the best solution will consider all phases and search for an optimum solution.

Lifecycle phases	(1) Material and component production	2) Design	(3) End-of-life
Circular strategies	<ul style="list-style-type: none"> - Use fewer hazardous materials - Design for recycling - Prolonged lifespan - Design for product disassembly - Design for product standardisation - Use of secondary materials - Take-back schemes 	<ul style="list-style-type: none"> - Design for disassembly - Design for adaptability and flexibility - Design for standardisation - Design out waste - Design for modularity - Specify recyclable materials - Design to reintegrate secondary production 	<ul style="list-style-type: none"> - Disassembly - Selective demolition - Enable reuse of products and components - Closed-loop recycling - Open-loop recycling

Figure 102: circular strategies in different building phases (source: Nussholz & Milios, 2017)

This is how I believe the SIP variant should be further improved: on product level. However, the other designs could also be further improved.

One interesting possibility to explore would be designing the solid wood variant as such that it only contains biological, biodegradable materials which can cycle optimally in biological cycles. It would then first be necessary that the building components can cascade, but they should also be able to be used as biomass for the generation of biogas without harmful emissions in a later phase in the life path. Two measures which immediately come to mind for the solid wood variant are: using a type of adhesive in the cross laminated timber which is biodegradable and replacing the insulation with a biodegradable insulation type such as Biofoam. The development of biological adhesives is under development taking inspiration from adhesives found in nature. It is a complex field of study due to several reasons, but the diversity of biological attachment devices found in nature is huge, and offers inspiration for a variety of functions (Flammang & Santos, 2015). Significant advances have been made in past years to develop biological adhesives which are biodegradable as well: biodegradable polymers are already being used as low-cost alternatives to regular adhesives (Petrie, 2007). One notable example is the 'mussel glue' pioneered by Columbia Forest Products, used in plywood (McKeag, 2014).

For the steel frame variant, it would be interesting to explore how the building time of the variant can be speeded up while keeping the potential for demountability the same. This is a design challenge more than a technical challenge. The goal would be that the components of the steel frame variant are fully demountable, and can cycle optimally in the technical cycles.

Concluding, there are three options for future development of the designs presented here.

- The first option is assure demountability by supplier: improving products such as the SIP panels which have great functionality in other areas but are not demountable and don't fit in circular life cycles.
- The second option is focusing on the biological cycles: designing a building of which the components can fully cycle in the biological cycles: first considering cascades, then considering if the components can biodegrade or be used as biomass for the generation of biogas? This would also mean that the components need to be demounted.
- The third option is focusing on the technical cycles: designing a building which is fully demountable, but also has quick building and demountability time, and of which the components can fully cycle in the technical cycles.

In my view the latter might deserve most attention, as "evidence indicates that more economic value can often be captured in the end-of-use strategies corresponding to the inner, shorter, technical cycles." It is also better understood how the technical cycles can function in circular business models and how they could be capitalized upon (Ellen MacArthur Foundation & Granta Design, 2015).

10.2 Business model and financial aspects

Circularity is about the technical side of building as much as about the building process. In a circular economy, we believe that after the first cycle of use, a building or building part still has value. As buildings can stand for decades, circular business models will inevitably mean a long commitment and partnership between the owner(s) of the building and building parts. The concept of a circular business model still lacks a commonly accepted definition, but they generally share the idea that companies can capitalize on a circular offer (Nussholz & Milios, 2017). Many different types are possible (Carra & Magdani, 2017).

The possible business model I would like to explore for the design variants here is 'product as a service'. These type of business models exist on multiple levels. For example, in Henry's research (2018) she explains two possibilities for the 2nd Skin Facade Refurbishment system: one more basic variant in which the product and service provider retains ownership rights of the asset and the client leases the asset. The second option is to take this one step further, and the client leases the service of 'having an energy neutral home'. This option puts responsibility at the service provider to deliver the best possible performance because the client pays for the performance and not the product. The service provider will want to decrease costs to increase profit: and as a result the service provider will strive for efficient resource usage (Henry, 2018).

The design variants presented here are unique one off solutions, in which separate building components and have different end of first life cycle scenario's, different lifetimes and different performances.

This is where the service provider as extra stakeholder in the building process comes in: the service provider can take the role of intermediary between suppliers of these components and elements and user. The service provider can offer the residents in the Ramplaankwartier a leasing contract, in which the SP leases the service of having an energy neutral home. The residents would pay a monthly fee for this. It would be best if this monthly fee can be the same as the usual monthly energy costs of the dwelling before renovation, following Stroomversnelling's¹ idea - in this way nothing changes in terms of finances for the residents, they only get a better home and pay the monthly fee to the service provider. The service provider delivers the products which will shape the building and deliver the desired energy performance in collaboration with the suppliers behind the products, and maintains management over the overall performance of the building. The service provider could then, in collaboration with the building component's suppliers, decide how to use the separate building components. For example, installations in the building might be leased from the suppliers. Installations are suitable for this, as they have short life cycles, value can be recovered from them at the end of their first life cycle and they need to deliver a certain performance. Other building parts might receive a more traditional treatment. For example, wooden parts could still simply be bought from suppliers, as these parts have less value left at the end of their first life cycle. Circularity for these parts can then be ensured by legislation (a top down approach): this is not yet perfect for wood, but the LAP3 legislation requires A and B types of wood to have 'useful' end of lifecycle scenario and aims towards implementing cascading in the wood sector over time. There are multiple scenario's possible for the building parts, depending on the value they retain over lifetime, the lifetime itself, and other parameters. Per building part the service provider should consider which strategy is best to ensure circularity, but also for economical reasons.

For this kind of model to work, some requirements are needed: (Brink, Prins, Straub, & Ploeger, 2017).

- The client asks for a performance instead of physically defined products, so the service provider can search for the optimal solution.
- The client's demand for the performance should not define the performance too much, as this impedes the ability of the service provider to deliver a competitive service.
- A tight organization on the supply side with trust and transparency between different parties is needed because of the increased complexity of this type of business model.

¹ Stroomversnelling is a collaboration between different parties which aims to renovate houses to 'nul-op-de-meter' (compensating BRE and URE need). Suppliers of the renovation deliver a performance guarantee for 30 years on the interior climate and energy performance of the dwelling. The costs of the renovation should be divided over a certain period of time and should be the same as the previous monthly energy bills, so that nothing changes for the financial situation of the residents.

- Demountability of the building parts is necessary.

Another advantage of this business model is that it can give the renovation of houses in the Ramplaankwartier in the Spaargas project a boost. Firstly, the residents of the houses don't have to make a big initial investment, but instead can pay a monthly fee to the service provider. The service provider in turn can renovate multiple dwellings in the Ramplaankwartier, using similar designs or products (in which for example the resident can personalize the design by choosing a different type of exterior finishing), so decreasing development costs but increasing monthly revenue by maintaining multiple dwellings.

10.3 Legislation

The business model can only be successful if legislation is in place to facilitate this. Chapter 2 has already discussed some of the current barriers in legislation for circular buildings, including current regulations and building permits which are based on a linear and static vision of buildings, impeding changes and fragmentation of policies over the different policy levels. Furthermore, under Dutch property law, the delegated ownership as described in the business model of individual components that are part of a larger construction is principally prevented.

However, incentives are in place to solve these issues. In the national programme Nederland Circulair in 2050, the following strategic ambitions have been set:

- Resources in existing chains are used as efficiently as possible.
- New raw materials should be renewable and generally available.
- New production methods should be developed and new methods of consumption should be stimulated.

Furthermore, some other ambitions by the government which are interesting to mention:

- One of the main action points is the development of a measurement methodology to determine the level of circularity in a building (Van Santem & Pelgrim, 2018)
- The ambition is synergy between the circular transition and the energy transition.
- The government wants the building sector to take its own responsibility, while stimulating pilot projects (Rijksoverheid, 2016).

The government wants to reach these ambitions by dissolving obstructive rules and laws such as mentioned before, and by mainly taking a stimulating role: smart financial incentives, knowledge and innovation, international collaboration and stimulating circular behavior. These ambitions are currently being translated into 'Transition Agenda's' for different sectors: biomass and food, plastics, maker industry, building industry and consumption goods. In these agenda's the agreements are made about:

- Development directions for 2021, 2025 and 2030 (concrete, ambitious and achievable)
- 'Action agenda' in which innovative projects are selected.
- 'Knowledge agenda' in which new knowledge and research questions are formulated and the right indicators are developed which can monitor the progress (assessment method)
- 'Social agenda' in which the effects of the circular transition on the job market are described and development of circular business models is initiated
- 'Investment agenda' which aims to take away financial obstructions and wants to develop financially circular business cases (Rijksoverheid, n.d.).

As mentioned in chapter 2, the legislation in place for energy renovation is more complete, and more compelling: the binding emission reduction goals set by the EU require all member states, and also the Netherlands, to set minimum energy performance requirements for new buildings and for the renovation of the existing building stock. As these agreements are binding, the Dutch government has implemented a mix of policy instruments to reach these goals.

To truly reach synergy between the circular transition and the energy transition, I believe the circularity

goals should be as binding as the energy goals defined by the government (such as all new buildings should be nearly zero energy in 2020). As the 'Transition Agenda' for the built environment is not yet available, at this point it can't really be said if this Agenda is concrete enough: the future will have to show if a top-down approach can take away current barriers present. The research developed in this thesis is in any case interesting knowledge for this Agenda: addressing both the assessment method and synergy between circularity and energy performance.

11. CONCLUSIONS

This chapter contains a summary of answers to the research questions asked in chapter one, recommendations for future research and a personal reflection on the graduation process.

11.1 Answers to research questions

1. What are current design approaches and tools to reach circular buildings and buildings with high energy performance?

The approach identified aiming towards circular building (and only circular building) is cradle to cradle: a design philosophy based on the idea of biomimicry.

Design approaches towards zero energy use most often are simply a set of actions which can be taken. These are roughly organized in the following categories:

- Actions regarding building envelope & building design aspects: insulation, air leakage reduction, improving doors and windows, control and exploitation of solar gain and daylight, etc.
- Actions regarding building systems and energy components: install the newest HVAC systems, improve electrical lighting systems, improve domestic appliances, install renewable energy systems, etc.
- Actions associated with building services and management tools, like monitoring and controlling the building during operation, utilization of metering services, clock controls, sensors, etc (Rabani, Madessa & Nord, 2017).

There are some design approaches which can be used to combine both energy renovation and circularity, such as:

- the New Stepped Strategy
- a multi-criteria approach

2. What assessment methodologies and tools exist to assess circularity and energy use?

The tools to assess circularity are:

- The cradle to cradle product certification: a certification method in which building products can receive a circularity score.
- Material Circularity Indicator (MCI) assessing the circularity of a product (considering recycled feedstock, virgin feedstock, how much of the material is recycled/reused after end of life and utility)
- The BCI assessment model: made up of the MCI, but also considering the building as a whole.
- Flex 4.0 framework: assessment method about the adaptive capacity of buildings.
- Longevity indicator: assessment method for the time length for which a material is kept in a product system.
- Disassembly potential: assessment method (but also design support) about the disassembly potential of buildings, containing a set of sub performance indicators.
- Life cycle analysis: not truly a circularity assessment tool, but mentioned because it does assess environmental impacts of materials.

Another tool, which is not an assessment method or an approach, but does support circularity, is a material passport. It is a digital set of data describing defined characteristics of materials and components in products and systems that give them value for present use, recovery and reuse.

The tools to assess energy performance in energy renovation are:

- Energie-Index: a tool to calculate the energy performance of buildings, determining an energy label.
- Programmes to calculate the EPC of buildings: ENORM, Uniec2.
- Programmes for energy simulations over a certain period of time: Tmsys, honeybee, energieplus

Some tools can be used to assess energy performance and circularity to some extent. These are:

- Roadmap Circular Land Allocation: it is an assessment methodology which considers energy use, material use, water use, adaptivity & resilience and ecosystems & biodiversity and is thus a holistic method.
- BREEAM/LEED: also holistic assessment and certification methods, considering management,

health and wellbeing, energy, water, materials, waste, pollution, innovation.

- GPR Gebouw: another holistic assessment method considering multiple themes, energy, environment, health, user value and future value.

3. Are there existing reference projects of buildings with high ambitions on circularity, possibly combined with a high energy performance?

Yes. Two notable examples of reference projects which have not been built yet, but are under development are: Fijn Wonen Circulair and the 2nd Skin project with 2nd Skin circular redesign by Quirine Henry. Fijn Wonen Circulair is a new housing concept by Van Wijnen, which can be applied to renovation projects and for new buildings. According to Van Wijnen, the concept scores 70% on the Building Circularity Index and the focus is on demountability and remountability. The house has the following key points:

- Demountability to facilitate relocatability
- Net zero energy use house without gas connections
- Affordability: for housing corporations and for residents
- The functional lifetime is the same as the technical lifetime because of the demountability, the modularity and reuse of elements.

The materials used are traditional: it has been taken into consideration to use materials with low environmental impact such as biobased materials, but in practice it was not possible for Van Wijnen to use such materials. This is also the negative point of this reference project: the big question is if the house will be demounted and used somewhere else. If not, then it doesn't matter that the materials are demountable: they will have the same impact on the environment as that of a traditional house.

Henry's project is interesting because of the project's focus on high energy performance which has been redesigned into a circular project. Henry assessed the existing 2nd skin design on its Disassembly Potential and MCI. She also assessed her circular redesign on the Disassembly Potential and MCI, and found her new design approached an MCI of 1, and had much better disassembly potential.

4. How will the circularity and energy use be assessed in the case study energy renovation project so this assessment supports the design of circular buildings and contributes to consensus & understanding about assessing circularity?

The starting point for the assessment methodology is Metabolic's Roadmap. From the possible indicators to assess the following are chosen:

- MAT1: Intensity of material use over lifetime of building
- MAT2: Environmental cost of materials
- MAT3: Design for Disassembly
- E1: Energy efficiency
- E2: Embodied energy
- EC2: Embedded ecosystems impact

MAT1 will be quantitatively assessed by comparing the weight of design variants with the benchmark value weight of the existing roof structure. As a support to the quantitative assessment, the material use for different building elements during use and during lifetime of building is described. This description is necessary because the hypothesis is that the new design will use more materials than the old design, for example due to extra installations such as PV/T panels on the roof. If the addition of materials can be justified and serves an extra function, this doesn't necessarily mean that the new design is 'worse' than the old.

MAT2 will be quantitatively assessed by calculating the environmental costs of materials in an MPG calculation, using the MRPI-MPG software. The points received are based on the outcome of the calculation, which is a value in shadow costs of the design per bvom2 per year. This outcome for the new design is compared to the old design, so it can be stated if the design scores better or worse.

MAT3 will be quantitatively assessed by a methodology based partly on Metabolic's principles and partly on the Disassembly Potential Tool. A set of 16 different sub-indicators is organized in three themes (Information | Speed, comfort and safety of assembly & disassembly | Possibility to separate different functional groups and replace functions). Each indicator can receive a score between 0 and 1, and each indicator has a weight to distinguish between their relative importance. The total score is then the weighted average of the indicators taken into account - it is not unthinkable that not each indicator can be assessed in every design.

During development of MAT3 it became clear that a new indicator needed to be added: design for circular life cycles. This indicator is in fact the backbone of circular building and determines the fitness of building parts to cycle in circular life cycles. It is a qualitative assessment, in which a set of questions is used to determine the amount of possible cycles the building part can undertake in either biological or technical cycles (the more the better) and is used to determine how likely it is that the part will follow the optimal path of cycling at this point in time and in the future. If it's not likely in either scenario, that's a negative 'bad' outcome, if it's likely, that's a positive, 'good' outcome for this indicator.

E1 will be quantitatively assessed by an EPC calculation. The points received are based on how much the EPC calculation is above or below the reference value of 0,4, which is the current requirement in the 'Bouwbesluit' for housing.

E2 is not assessed separately: it is part of the MPG-calculation in MAT2.

EC2 is not assessed separately: it is part of the MPG-calculation in MAT2.

5. How can the case study energy renovation project be designed so that the highest level of circularity possible is reached?

The question posed in this chapter is: 'How can the case study energy renovation project be designed so that the highest level of circularity possible is reached?' Highest level of circularity is defined as the optimal combination between the indicators MAT1 (intensity of material use), MAT 2 (environmental cost), MAT 3 (design for disassembly), MAT 4 (design for circular life cycles) and E1 (energy efficiency). However, it is possible that the indicators have mutual exclusivity to some extent, so to find the optimal combination between these indicators three design variants are developed in which the parameters of the structure and insulation are changed between variants. The design variants are developed for prefabrication in the first place. In the second place, each variant has different strengths and weaknesses. The first variant, SIP structure, is lightweight and has potentially low environmental cost, but it is probably not very demountable. The second variant, solid wood, is lightweight - but heavier than SIP, has potentially low environmental cost and is probably slightly better in demountability. The third variant, steel frame, is heaviest, but also probably most demountable. Furthermore, in chapter 5. two different energy designs are presented: a Triple Solar variant and a VolThera variant. Combining these with the three design variants, we end up with six possible case study energy renovation designs. These designs all attempt to reach the highest level of circularity possible and are therefore all potentially an answer to the research question posed. The variants are summarized in the next figure.

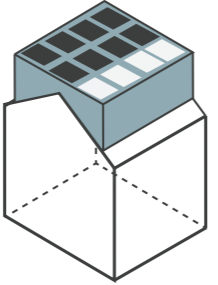
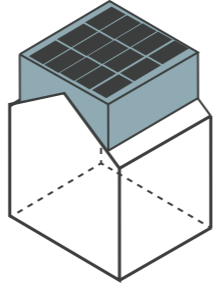
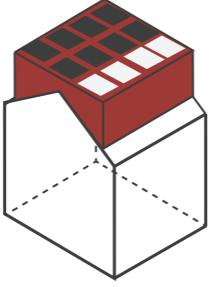
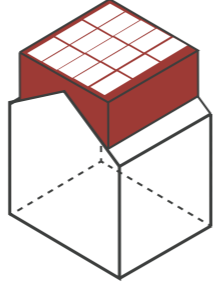
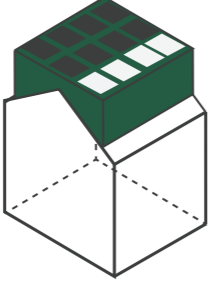
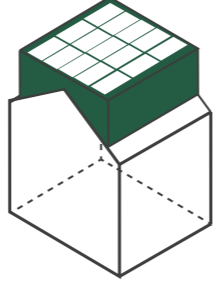
TYPE & HYPOTHESES ABOUT ASSESSMENT	Triple Solar High efficiency Less suited for circularity EPC = -0,09	VolThera Low efficiency More suited for circularity EPC = -0,09
SIP structure variant Lightweight Potentially low environmental cost Not very demountable		
Solid wood variant Lightweight, heavier than SIP Potentially low environmental cost More demountable than SIP, less demountable than steelframe		
Steel frame variant Heaviest Environmental cost might be low or high Most demountable		

6. What is the circular and energy performance of the case study house without energy renovation?

The indicators MAT1 intensity of material use, MAT2 environmental cost of materials, MAT3 design for disassembly and E1 efficiency are taken into account, according to the assessment methodology developed. MAT4 design for circular life cycles could not be assessed due to time limitations.

For indicator MAT1: intensity of material use over lifetime of building, the weight of the roof structure is measured to be 4557 kg. Compared with the new design variants developed, it scores worse than design variant 1 and 2 and better than design variant 3. The assumption is that no special attention was paid to reduce material use for different building elements during build and during lifetime of building outside of standard economic reasons. This can't be stated for sure because the information needed is not present, but the fact that the roof structure has much worse energy performance than the new variants but is heavy compared to them shows how the weight of materials per functional unit is quite high and could probably have been reduced further.

For indicator MAT2: the environmental cost of materials, the roof structure's environmental cost is € 0,61/bvom2/year, meaning it receives 15 points from the 100.

For indicator MAT3: design for disassembly, the roof structure receives a score of 0,33 or 33 points from the 100.

For indicator E1: Energy efficiency, the roof structure is calculated to have an EPC of 1,9 and receives no corresponding points.

7. What is the circular and energy performance of the case study energy renovation project?

The six design variants are assessed by the methodology developed. The methodology contains the performance indicators MAT1 Intensity of material use, MAT2 Environmental cost of materials, MAT3 Design for disassembly, MAT4 Design for circular life cycles and E1 Energy efficiency. MAT 1, MAT2, MAT3 and E1 are also assessed for the existing roof structure and are quantitative performance indicators, while MAT4 is a qualitative analysis and is only assessed for the new variants developed. The variants are both design variants (roof structure) and energy variants (PV/T panel system). They are first assessed separately, and afterwards combined into six final variants (SIP + Triple Solar, SIP + VolThera, Solid wood + Triple Solar, Solid wood + VolThera, etc.)

The outcome of the assessment is detailed in 9.6 Here only the most important results are summarized.

- For **MAT1 intensity of material use** the SIP variants scores best, the solid wood variants in between, the steel frame variants worst. This latter is also the only one heavier than the existing roof structure.
- For **MAT2 environmental cost** no variants are good enough to score any points. This high environmental cost is because of the energy systems. In terms of design variants, the steel frame variant is best, followed very closely by the SIP variant and then the solid wood variant. The best overall final variant is steel frame + Triple Solar, and the worst overall final variant is solid wood + VolThera. However, the energy variants assessment is not entirely fair: only standard products are in the MRPI database, so in reality the energy variants might differ (VolThera doesn't use a toxic fluid, fore example)
- For **MAT3 design for disassembly** the variants are quite similar, in the design variants the SIP variant scores worst and the steel frame variant best. In the average result between design variant + energy variant, the steel frame + VolThera scores best, and the SIP + Triple Solar scores worst.
- For **MAT4 design for circular life cycles** I believe the steel frame variant + VolThera has most potential for circular life cycles, while the SIP variant + Triple Solar has least potential for circular life cycles.
- For **E1 energy efficiency**, each variant scores the same: EPC of -0,09 and 122,5 points.

1. To what extent can circularity be implemented in the designs of energy renovation projects?

Circularity is defined by the performance indicators chosen in this thesis (intensity of material use, environmental cost of materials, design for disassembly, design for circular life cycles). The performance indicator 'energy efficiency' is then the indicator assessing the energy performance of the energy renovation. A successful implementation of circularity means scoring as high as possible on the circularity indicators and on the energy efficiency indicator. The indicators are not yet perfect, and in the elaborate conclusions of chapter 9 I have described how I believe they could be further developed. Here I will answer this research question based on how the indicators are now and will not consider further developed indicators.

All of the design variants score 0 points for the environmental cost assessment. This is because of the huge environmental cost the energy systems have. High environmental cost is the price of energy renovation. Both high energy performance and low environmental cost can't be achieved.

In the energy systems a high score for design for disassembly and better options for circular life cycles negatively influence the energy performance: the VolThera panel system has better options for disassembly and thus also better options for circular life cycles, but performs less efficiently in terms of energy than the Triple Solar panel system, which has worse disassembly potential and worse options for circular life cycles but performs more efficiently in terms of energy. Here we see how for the energy systems, high energy performance negatively influences design for disassembly and circular

life cycles. However, for the design variants, the high EPC does not negatively influence the outcome.

In the results we also see that not surprisingly design for disassembly and design for circular life cycles have some overlap/positive influence on each other. The SIP panels can't be demounted, and also don't have options for circular life cycles. The fact that they can't be demounted also influences the outcome of the disassembly potential.

Another interesting result is that the high EPC of the new design does not necessarily mean high weight: four of the six variants are lighter than the existing roof structure which has an EPC of 1,9.

Concluding, if we define successful implementation of circularity by implementing the performance indicators fully, then this means circularity can't fully be implemented in the designs of energy renovation projects, but we have to make some choices between which indicators to consider more than others.

- Either we choose high score on energy efficiency (=low score on environmental cost), or we choose high score on environmental cost (=low score on energy efficiency).
- Either we choose energy efficient energy systems (=low score energy systems on design for disassembly and design for circular life cycles) or we choose less efficient energy systems (=higher score energy systems on design for disassembly and design for circular life cycles).

11.2 Recommendations for future research

Recommendations for future research are suggested in several themes:

- A technical research, researching the effect of other design parameters on the outcomes of the circularity assessment. The designs presented here vary in the parameter of structure typology, the insulation material and the used PV/T panel in the energy system. The outcome of other parameters on the assessment can be interesting to research, such as different types of window frames (steel, wood, plastic) or different types of exterior finishing (wood, tiles, ceramic products...), different types of interior finishing, there are many different design possibilities for parametric research into how the performance indicators can be influenced positively or negatively in the design process.
- A technical structural research focusing on the first performance indicator intensity of material use: what is the minimum amount of materials needed in the different design variants to reach structural integrity of the designs, and how can the material use in the non-structural functions be minimised to a minimum? This can be an optimization and formfinding process in a parametric design programme such as Grasshopper.
- A technical design research into how the integration between roof + PV/T system can be done, taking into account the performance indicators such as design for disassembly, etc.
- A technical research, further developing the performance indicators presented in the assessment method: for example, how can the performance indicator design for circular life cycles be quantified?
- A technical research into how the assessment method or performance indicators can be integrated into a current generally accepted method, with the goal to reach one overlapping integral methodology which is well known and already has a good reputation in the sector. First the generally accepted methods already present can be analyzed, afterwards one could be chosen which would be most suitable, and then this method could be adapted to integrate the performance indicators in this thesis.
- A research into how the business model suggested in chapter 10 can be developed and a financial case can be made for circular (nearly) zero energy dwelling renovation in the Ramplaankwartier.

11.3 Personal reflection on graduation project and process

Design process

First, I would like to reflect on the design process undertaken during this graduation process. At the beginning of the design process the view I took towards the circular economy and towards circular building was quite holistic. I was encaptured by some schools of thought which view the circular

economy as a way to change an entire global system, incorporating themes of equality, nature preservation, etc. For that reason I started off not only wanting to take into account materials and energy, but also water use and biodiversity.

However, the more I dove into the material, the more my focus started to be towards material use and energy use. I realized that in this case the roof's function as an energy roof is more important than the potential for greenery or water capture, because of the limited space on site to implement energy production measures, while the garden attached to the house can fulfill an important role towards biodiversity and sustainable water use and is not suited for energy production. I did ponder about implementing these energy production measures somewhere else so roof space became available for other functions: perhaps a ground source for the heat pump? However I always came back to the initial idea of the energy roof, also because for the residents this would be the least radical renovation in terms of time: the entire renovation could be finished within two or three days, disturbing the inhabitants as little as possible.

I realized at some point that I did actually take into account effects of the design on biodiversity and nature, but within the environmental cost calculation: and with this calculation I actually stepped back into my holistic view, as the calculation takes into account impacts on a much larger (global) scale than only on the scale of the site. If materials are unhealthy, have severe embedded ecosystems impact, are toxic to humans or animals, then that is reflected in the environmental cost. When I added the indicator "design for circular life cycles" much later, after my P4, that's where I felt the entire indicator set was coming more together and my view was shifting to a larger scale. Now I was also considering impacts years in the future. I was also analyzing legislation, company policies and other practical boundary conditions needed for the circular built environment, and not only looking at the technical side of things.

In hindsight, I should've added this indicator much sooner: it proved to be an essential part for me to understand circularity in the built environment better and I believe it lifted my final results to a higher level. However, I do regret that because I added this indicator after the P4, I had little time to develop it to its full potential and to be able to reflect on the implications of it more.

This is something I have struggled with throughout the entire process: define my scope tightly from the beginning and follow this through. I have gone back many times in the process, changed parts and changed them again when I started to doubt the first elaboration and/or new information became available. This is also because this topic of circular economy is enormous and it's very easy to get lost in the amount of information. It's easy to spend hours on tiny details, losing sight of the bigger picture. If I would start this thesis again, I would think my scope through better and make sure I could stick to it - rather defining a smaller scope and possibly adding to it later.

However, when I chose to develop several variants to test the impact of the different performance indicators on each other (I did not consider this from the beginning, I first thought about developing 1 variant) this methodology worked out quite well. The variants developed gave me the ability to visualize the performance indicators' mutual influence very clearly, giving me clear results to reflect upon.

Relationship between research and design

The design process is essential for the research presented here. It is a research by design process, where different variations of the design give information about how different performance indicators for circularity can be combined and how they mutually influence each other negatively or positively. The direct answer to the research question is answered through the research by design process. I was looking for the optimal solution between performance indicators, and the challenge was to make visible during the design process how decisions influence indicators, so that an informed decision about the design can be made. The results of the assessment of different design variants clearly show how performance indicators influence each other, but also have some unexpected results which are very

interesting to take into account when designing circular buildings.

Applicability in practice

During the design process I constantly had to watch to make sure I was still taking into account the practical applicability of the designs developed. It's easy to lose sight of this. I remember one early design variant which was aimed towards demountability, but the fact that it was demountable also meant it had serious thermal bridging, was very difficult to build and would be expensive. In the end I managed to consider practical applicability as well. The designs have different levels of practical applicability: the SIP variant is easiest to build and will most likely be cheapest as well, while the steel frame variant is least practically applicable for the residents. However, before any of the variants could be chosen, they need further development. I have given some suggestions in chapter 10 about how they could be developed. Other boundary conditions which are necessary for applications of the results in practice and which need to be worked out are financial aspects (a solid financial case/circular business model), and how current legislation will influence the applicability. Furthermore, I can imagine it would be beneficial to brainstorm with the residents: esthetics haven't really been considered in the design process, but the final design should also be comfortable for the residents to live in.

Bibliography

- Agentschap NL. (2011). *Voorbeeldwoningen 2011 - bestaande bouw*. Sittard.
- Al-Waeli, A. H. A., Sopian, K., Kazem, H. A., & Chaichan, M. T. (2017). Photovoltaic/Thermal (PV/T) systems: Status and future prospects. *Renewable and Sustainable Energy Reviews*, 77, 109–130. <https://doi.org/https://doi.org/10.1016/j.rser.2017.03.126>
- AliusEnergy BV. (n.d.). VolThera: combineert eenvoud met elektrisch en thermisch rendement. Retrieved from www.aliusenergy.nl
- Alternative Energy Tutorials. (n.d.). Heat Exchanger Design. Retrieved June 14, 2018, from <http://www.alternative-energy-tutorials.com/energy-articles/heat-exchanger-design.html>
- Asif, M., Davidson, A., & Muneer, T. (n.d.). *Life cycle of window materials - a comparative assessment*. Edinburgh.
- Azcarate-Aguerre, J. (2018). Facade leasing pilot project at TU Delft. Retrieved June 16, 2018, from <https://www.tudelft.nl/en/architecture-and-the-built-environment/research/projects/green-building-innovation/facade-leasing/facade-leasing-pilot-project-at-tu-delft/>
- Banks, D. (2013). The role of corner vortices in dictating peak wind loads on tilted flat solar panels mounted on large, flat roofs. *Journal of Wind Engineering and Industrial Aerodynamics*, 123, 192–201. <https://doi.org/https://doi.org/10.1016/j.jweia.2013.08.015>
- Berge, B. (2009). *The Ecology of Building Materials*. Oxford, UK: Architectural Press.
- Bewust Nieuwbouw. (2016). Wat betekent EPC, BENG, A-label en nul-op-de-meter? Retrieved May 17, 2018, from <https://www.bewustnieuwbouw.nl/epc-energielabel-en-nul-op-de-meter/>
- Bio energie cluster Oost Nederland. (2013). Energie uit biomassa - houtverbranding. Retrieved May 26, 2018, from <http://www.bioenergieclusteroostnederland.nl/bio-energie/biomassa/22-informatie/energie-uit-biomassa.html>
- Björkman, B., & Samuelsson, C. (2014). Chapter 6 - Recycling of Steel BT - Handbook of Recycling (pp. 65–83). Boston: Elsevier. <https://doi.org/https://doi.org/10.1016/B978-0-12-396459-5.00006-4>
- Blomberg, J., & Söderholm, P. (2009). The economics of secondary aluminium supply: An econometric analysis based on European data. *Resources, Conservation and Recycling*, 53(8), 455–463. <https://doi.org/https://doi.org/10.1016/j.resconrec.2009.03.001>
- BOOM-SI, Israels, E., & Stofberg, F. (2017). *EnergieVademecum: Energiebewust ontwerpen van nieuwbouwwoningen*.
- Bouwen met staal. (2004). *Handboek staalframebouw*. Zoetermeer: Bouwen met staal.
- Bouwen met staal. (n.d.). Recycling en hergebruik. Retrieved June 25, 2018, from <https://www.bouwenmetstaal.nl/themas/duurzaam/recycling-en-hergebruik/>
- Bouwen met staal. (n.d.). Duurzaamheid + staal. Retrieved June 25, 2018, from https://www.bouwenmetstaal.nl/uploads/editor/BmS_Duurzaamheid_en_Staal_A4_lowres.pdf
- Bouwinformatie. (n.d.). Dakpannen. Retrieved April 8, 2018, from <https://www.livios.be/nl/bouwinformatie/ruwbouw/dak/zadeldak/dakpannen/>
- Bouwwereld. (2017). Fijn Wonen: 70 procent circulair. Retrieved May 21, 2018, from <https://www.bouwwereld.nl/nieuws/fijn-wonen-70-procent-circulair/>
- Braungart, M., & McDonough, W. (2002). *Cradle to Cradle: remaking the way we make things* (1st ed.). New York: New York: North Point Press.
- BREEAM. (2012). *BREEAM Refurbishment Domestic Buildings*.
- Brinck, T. ten. (2016). Zonnepaneel nu voor 96% recyclebaar. Retrieved June 25, 2018, from <https://www.duurzaambedrijfsleven.nl/recycling/12957/zonnepaneel-nu-voor-96-procent-recyclebaar>
- Brink, R. van den, Prins, M., Straub, A., & Ploeger, H. (2017). Finding the right incentives; circular business models for the construction industry. In *International Research Conference 2017 Shaping Tomorrow's Built Environment* (pp. 189–200). Manchester: University of Salford.
- BTG. (2014). BTG toont aan dat cascaderen in de houtsector loont, ook voor duurzame energie. Retrieved June 25, 2018, from <https://www.biobasedeconomy.nl/2014/03/27/btg-toont-aan-dat-cascaderen-in-de-houtsector-loont-ook-voor-duurzame-energie/>
- BuildSteel. (n.d.). What is Cold-Formed Steel Framing and How Can I Use It?
- Bushi, D. L., & Meil, M. J. (2011). *A Cradle-to-Gate Life Cycle Assessment of 1/2" Regular and 5/8" Type X Gypsum Wallboard*.
- Carra, G., & Magdani, N. (2017). *Circular business models for the built environment*.
- CBS. (n.d.). Begrippen - primaire energiedrager. Retrieved June 4, 2018, from <https://www.cbs.nl/nl-nl/onze-diensten/methoden/begrippen?tab=p#id=primaire-energiedrager>
- CBS. (n.d.). Begrippen - secundaire energiedrager. Retrieved June 4, 2018, from <https://www.cbs.nl/nl-nl/onze-diensten/methoden/begrippen?tab=s#id=secundaire-energiedrager>
- CBS. (n.d.). Begrippen - energiedrager. Retrieved June 4, 2018, from <https://www.cbs.nl/nl-nl/onze-diensten/methoden/begrippen?tab=e#id=energiedrager>
- CBS. (2017). 2016: hoogste aantal nieuwbouwwoningen in vijf jaar. Retrieved May 8, 2018, from <https://www.cbs.nl/nl-nl/nieuws/2017/04/2016-hoogste-aantal-nieuwbouwwoningen-in-vijf-jaar>
- Centrum Hout. (2012). *Opbouw, detaillering en tips: gevelbekleding van massief hout*. Almere.
- Ceresana. (2017). Market Study: Polypropylene (4th Edition). Retrieved May 8, 2018, from <https://www.ceresana.com/en/market-studies/plastics/polypropylene/>
- Chow, T. T. (2010). A review on photovoltaic/thermal hybrid solar technology. *Applied Energy*, 87(2), 365–379. <https://doi.org/https://doi.org/10.1016/j.apenergy.2009.06.037>
- Chwieduk, D. A. (2012). 3.15 - Solar-Assisted Heat Pumps A2 - Sayigh, Ali BT - Comprehensive Renewable Energy (pp. 495–528). Oxford: Elsevier. <https://doi.org/https://doi.org/10.1016/B978-0-08-087872-0.00321-8>

- Circle Economy, van Odijk, S., & van Bovene, F. (2014). *Circulair bouwen: het fundament onder een vernieuwde sector*. Retrieved from <https://insights.abnamro.nl/2014/12/circulair-bouwen-het-fundament-onder-een-vernieuwde-sector/>
- Cradle to Cradle Product Innovation Institute. (n.d.). Get Cradle to Cradle Certified™. Retrieved June 24, 2018, from <https://www.c2ccertified.org/get-certified/product-certification>
- De Ramplaan. (n.d.). Wat is Spaargas. Retrieved June 4, 2018, from <https://deramplaan.nl>
- De Ramplaan. (n.d.). Wat is SpaarGas? Retrieved from <https://deramplaan.nl/spaargas/>
- Debacker, W., & Manshoven, S. (2016). *D1 Synthesis of the state-of-the-art: Key barriers and opportunities for Materials Passports and Reversible Building Design in the current system*.
- Derbigum. (2016). Vraag en antwoord: hoe lang gaat een dak mee? Retrieved April 8, 2018, from <https://derbigum.be/blog/nl/hoe-lang-gaat-een-dak-mee/>
- Derbigum. (n.d.). Plantaardige/ecologische dakbedekking. Retrieved June 25, 2018, from <https://www.derbigum.nl/oplossingen/plantaardige-ecologische-dakbedekking>
- Dieterle, M., Schäfer, P., & Viere, T. (2018). Life Cycle Gaps: Interpreting LCA Results with a Circular Economy Mindset. *Procedia CIRP*, 69, 764–768. <https://doi.org/https://doi.org/10.1016/j.procir.2017.11.058>
- Dobbelsteen, A. van den. (2008). Towards closed cycles - New strategy steps inspired by the Cradle-to-Cradle approach. In *25th Conference on Passive and Low Energy Architecture*. Dublin.
- Dobbelsteen, A. Van Den, Jonathan, T., & Kruizinga, J. (2015). Prêt-à-Loger : Zero-Energy Home with Maximum Living Quality Increase. Delft: Delft University of Technology.
- DOE. (2015). A common definition for zero energy buildings. Washington: Office of Energy Efficiency and Renewable Energy.
- Dubbelglasrijzen. (n.d.). Levensduur dubbel glas. Retrieved April 8, 2018, from https://www.dubbelglasrijzen.net/levensduur-dubbel-glas/#Gemiddelde_levensduur_van_20_jaar
- Duiker, H. (2014). Recycling zonnepanelen. Retrieved April 8, 2018, from <http://www.allesoverzonnepanelen.nl/recycling-zonnepanelen/>
- Dulk, F. W. den. (2012). *Op weg naar minimum energie woningen met EPC ≤ 0: 2012-09*. Amersfoort.
- Durmisevic, E. (2006). *Transformable Building Structures: Design for disassembly as a way to introduce sustainable engineering to building design & construction*. Delft University of Technology.
- Durmisevic, E., Berg, M. C., & Atteya, U. (2017). Design Support for revisable buildings with focus on visualizing and simulating transformation capacity during initial design phase. In *International HISER Conference on Advances in Recycling and Management of Construction and Demolition Waste* (pp. 263–269). Delft.
- Ellen MacArthur Foundation. (n.d.). Schools of Thought. Retrieved May 21, 2018, from <https://www.ellenmacarthurfoundation.org/circular-economy/schools-of-thought/cradle2cradle>
- Ellen MacArthur Foundation, & Granta Design. (2015). *Circularity Indicators: an Approach to Measuring Circularity Methodology*.
- Ellen MacArthur Foundation, & Granta Design. (2015). *Circularity Indicators: an Approach to Measuring Circularity Project Overview*. Retrieved from https://www.ellenmacarthurfoundation.org/assets/downloads/insight/Circularity-Indicators_Project-Overview_May2015.pdf
- Environmental Working Group. (2018). Polypropylene. Retrieved June 22, 2018, from <http://www.ewg.org/skindeep/ingredient.php?ingred06=705094>
- EPBD. (2010). Directive 2010/31/EU of the European Parliament and of the Council of 19 May 2010 on the Energy Performance of Buildings (recast. Official Journal of the European Union.
- Eppinga. (n.d.). Gemodificeerd hout: duurzaam en betaalbaar. Retrieved April 8, 2018, from <https://eppinga.nl/gemodificeerd-hout/>
- European Commission. (2015). Communication from the Commission to the European Parliament, The Council, The European Economic and Social Committee and the Committee of the Regions: Closing the Loop - an EU action plan for the Circular Economy. Official Journal of the European Union.
- Evofenedex. (n.d.). Afmetingen vrachtauto's en combinaties EU. Retrieved April 8, 2018, from <https://www.evofenedex.nl/kennis/vervoer/maten-en-gewichten-vrachtwagens/afmetingen-vrachtautos-en-combinaties-eu>
- Fangareggi, A., & Bertucelli, L. (2018). Chapter 12 - Thermoset insulation systems A2 - Guo, Qipeng BT - Thermosets (Second Edition) (pp. 401–438). Elsevier. <https://doi.org/https://doi.org/10.1016/B978-0-08-101021-1.00012-5>
- Fangareggi, A., & Bertucelli, L. (2012). 9 - Thermoset insulation materials in appliances, buildings and other applications A2 - Guo, Qipeng BT - Thermosets (pp. 254–288). Woodhead Publishing. <https://doi.org/https://doi.org/10.1533/9780857097637.2.254>
- Fermacell. (n.d.). *Gipsrecycling bij fermacell*.
- Fermacell. (n.d.). fermacell Gypsum Fibreboard. Retrieved April 8, 2018, from https://www.fermacell.com/fermacell_gypsum_fibreboard_1236.php
- Flammang, P., & Santos, R. (2015). Biological adhesives: from biology to biomimetics. *Interface Focus*, 5(1), 20140086. <https://doi.org/10.1098/rsfs.2014.0086>
- Fowles, J., Banton, M., Klapacz, J., & Shen, H. (2017). A toxicological review of the ethylene glycol series: Commonalities and differences in toxicity and modes of action. *Toxicology Letters*, 278, 66–83. <https://doi.org/https://doi.org/10.1016/j.toxlet.2017.06.009>
- Fresh-R. (n.d.). Fresh-R Window Pane. Retrieved April 8, 2018, from <http://fresh-r.eu/fresh-r-window-pane>
- Geldermans, B., & Jacobson, L. R. (2015). Circular material & product flows in buildings. Delft: Delft University of Technology.

- Geldermans, B., Luscuere, P., Jansen, S., & Tenpierik, M. (2016). Beyond Cities: Materialen, producten & circulair bouwen. *TVVL Magazine*, 45(1), 22–25.
- Geldermans, R. J. (2016). Design for Change and Circularity – Accommodating Circular Material & Product Flows in Construction. *Energy Procedia*, 96, 301–311. <https://doi.org/https://doi.org/10.1016/j.egypro.2016.09.153>
- Geraedts, R. (2016). FLEX 4.0, A Practical Instrument to Assess the Adaptive Capacity of Buildings. *Energy Procedia*, 96, 568–579. <https://doi.org/https://doi.org/10.1016/j.egypro.2016.09.102>
- Geurts, C. P. W., & Bentum, C. A. van. (2007). *Wind loads on solar energy roofs*. Delft.
- Ghisellini, P., Cialani, C., & Ulgiati, S. (2016). A review on circular economy: the expected transition to a balanced interplay of environmental and economic systems. *Journal of Cleaner Production*, 114, 11–32. <https://doi.org/https://doi.org/10.1016/j.jclepro.2015.09.007>
- Gladek, E. (2018). The seven pillars of the circular economy. Retrieved from <https://www.metabolic.nl/the-seven-pillars-of-the-circular-economy/>
- Government of the Netherlands. (2011). Plan of Action Energy Saving in the Built Environment. the Hague: Ministry of the Interior and Kingdom Relations.
- Government of the Netherlands. (2016). *A Circular Economy in the Netherlands by 2050*. Retrieved from <https://www.government.nl/documents/policy-notes/2016/09/14/a-circular-economy-in-the-netherlands-by-2050>
- GPR. (2018). GPR Gebouw maakt duurzaam bouwen meetbaar en bespreekbaar. Retrieved July 2, 2018, from <http://www.gprsoftware.nl/gpr-gebouw/>
- Graman, P. J., Cruz, J., & Jansen, J. A. (2013). *Lifetime Prediction of Plastic Parts*.
- Guo, Q. (2014). Recycling the “unrecyclable”: a new class of thermoset plastics. Retrieved June 26, 2018, from <http://theconversation.com/recycling-the-unrecyclable-a-new-class-of-thermoset-plastics-26594>
- Hall, L. (n.d.). Aluminum. Retrieved April 8, 2018, from <http://www.madehow.com/Volume-5/Aluminum.html>
- Harris, R. (2015). 8 - Cross laminated timber A2 - Ansell, Martin P. BT - Wood Composites (pp. 141–167). Woodhead Publishing. <https://doi.org/https://doi.org/10.1016/B978-1-78242-454-3.00008-1>
- Heat pumping technologies. (n.d.). Efficiency and heat pumping application.
- Henrotay, C., Debacker, W., & Steinlage, M. (2017). How do current policies support a transition towards a circular economy in the built environment? In *HISER International Conference 2017: Advances in Recycling and Management of Construction and Demolition Waste* (pp. 226–229). Delft.
- Henry, Q. (2018). *Circular Façade Refurbishment*. Delft University of Technology.
- Hill, C., Norton, A., & Dibdiakova, J. (2018). A comparison of the environmental impacts of different categories of insulation materials. *Energy and Buildings*, 162, 12–20. <https://doi.org/https://doi.org/10.1016/j.enbuild.2017.12.009>
- Hoekstra, S. (2016). *The ENergy Roof: integrated with photovoltaic-thermal, heat pump, storage, ventilation and heat recovery for a “nul-op-de-meter” renovation*. Delft University of Technology.
- Hopkin, D. J., Lennon, T., El-Rimawi, J., & Silberschmidt, V. (2011). Full-scale natural fire tests on gypsum lined structural insulated panel (SIP) and engineered floor joist assemblies. *Fire Safety Journal*, 46(8), 528–542. <https://doi.org/https://doi.org/10.1016/j.firesaf.2011.07.009>
- Industrial Heat Pumps. (n.d.). Coefficient of Performance. Retrieved April 8, 2018, from http://industrialheatpumps.nl/en/how_it_works/cop_heat_pump/
- ISOBOUW. (n.d.). BioFoam 's werelds eerste biologische schuimisolatie. Retrieved June 25, 2018, from https://www.isobouw.nl/media/10170/162099_biofoam_brochure_-lr.pdf
- Jansen, S., Luscuere, P., Tenpierik, M., & Geldermans, B. (2016). Energie(-plus) en circulariteit. *TVVL Magazine*, 1, 18–21.
- Jansen, S., Luscuere, P., Tenpierik, M., & Geldermans, B. (2016). Energie(-plus) en circulariteit. *TVVL Magazine*, 1, 18–21.
- Jansen, S., & Tenpierik, M. (n.d.). *Memo EU definitions on NZEB*.
- Jonathan, T. (2016). *The value of Net Zero Energy Renovations*. Delft University of Technology.
- Jones, K., Stegemann, J., Sykes, J., & Winslow, P. (2016). Adoption of unconventional approaches in construction: The case of cross-laminated timber. *Construction and Building Materials*, 125, 690–702. <https://doi.org/https://doi.org/10.1016/j.conbuildmat.2016.08.088>
- Jordan, D. C., & Kurtz, S. R. (2012). *Photovoltaic Degradation Rates - An Analytical Review. Progress in Photovoltaics: Research and Applications*.
- Kapps, D. M., & Buschkamp, S. (2004). *The production of rigid polyurethane foam*. Leverkusen.
- Keizer, C. de, Bottse, J., & Jong, M. de. (2017). PVT Benchmark.
- Kim, J.-H., & Kim, J.-T. (2012). Comparison of electrical and thermal performances of glazed and unglazed PVT collectors. *International Journal of Photoenergy*, 2012, 7. <https://doi.org/http://dx.doi.org/10.1155/2012/957847>
- Kingspan. (2015). *Kingspan TEK Bouwstelsel*. Gemert.
- Kingspan. (n.d.). *Kooltherm product safety information*.
- Kingspan. (2014). *Environmental product declaration Kooltherm K5 Kingspan Insulation*.
- Kirchherr, J., Reike, D., & Hekkert, M. (2017). Conceptualizing the circular economy: An analysis of 114 definitions. *Resources, Conservation and Recycling*, 127, 221–232. <https://doi.org/https://doi.org/10.1016/j.resconrec.2017.09.005>
- Knier, G. (n.d.). How do photovoltaics work? Retrieved May 20, 2018, from <https://science.nasa.gov/science-news/science-at-nasa/2002/solarcells>

- Konstantinou, T., Guerra-Santin, O., Azcarate-Aguerre, J., Klein, T., & Silvester, S. (2017). A zero-energy refurbishment solution for residential apartment buildings by applying an integrated, prefabricated façade module. In *Powerskin Conference* (pp. 231–240). Munich: TU Delft Open.
- Konstantinou, T., Klein, T., Santin, O. G., Boess, S., & Silvester, S. (2015). An integrated design process for a zero-energy refurbishment prototype for post-war residential buildings in the Netherlands. In *5th CIB International Conference on Smart and Sustainable Built Environments* (pp. 261–270). Pretoria: CIB (International Council for Research and Innovation in Building and Construction).
- Kort, E. (2009). Lambda waarde materialen. Retrieved from <http://www.ekbouwadvies.nl/tabellen/lambdamaterialen.asp#baksteen>
- Kukreja, R. (n.d.). The “Reduce, Reuse, Recycle” Waste Hierarchy. Retrieved from <https://www.conserve-energy-future.com/reduce-reuse-recycle.php>
- Lombardo, T. (2014). What is the lifespan of a solar panel? Retrieved May 20, 2018, from <https://www.engineering.com/DesignerEdge/DesignerEdgeArticles/ArticleID/7475/What-Is-the-Lifespan-of-a-Solar-Panel.aspx>
- Luscuere, P., Geldermans, B., Tenpierik, M., & Jansen, S. (n.d.). De duurzaamheid voorbij: beyond cities. *TVVL Magazine*, 45(1), 2–6.
- Lushnikova, N., & Dvorkin, L. (2016). 25 - Sustainability of gypsum products as a construction material A2 - Khatib, Jamal M. BT - Sustainability of Construction Materials (Second Edition). In *Woodhead Publishing Series in Civil and Structural Engineering* (pp. 643–681). Woodhead Publishing. <https://doi.org/https://doi.org/10.1016/B978-0-08-100370-1.00025-1>
- Ma, Z., Cooper, P., Daly, D., & Ledo, L. (2012). Existing building retrofits: Methodology and state-of-the-art. *Energy and Buildings*, 55, 889–902. <https://doi.org/https://doi.org/10.1016/j.enbuild.2012.08.018>
- Marlet, C. (2014). GtoG Life + Project: First step towards gypsum circular economy.
- Marszal, A. J., Heiselberg, P., Bourrelle, J. S., Musall, E., Voss, K., Sartori, I., & Napolitano, A. (2011). Zero Energy Building – A review of definitions and calculation methodologies. *Energy and Buildings*, 43(4), 971–979. <https://doi.org/https://doi.org/10.1016/j.enbuild.2010.12.022>
- Mauro, G. M., Hamdy, M., Vanoli, G. P., Bianco, N., & Hensen, J. L. M. (2015). A new methodology for investigating the cost-optimality of energy retrofitting a building category. *Energy and Buildings*, 107, 456–478. <https://doi.org/https://doi.org/10.1016/j.enbuild.2015.08.044>
- McKeag, T. (2014). How to make a better adhesive without the nasty chemicals. Retrieved June 19, 2018, from <https://www.greenbiz.com/blog/2014/10/07/how-make-better-adhesive-without-nasty-chemicals>
- McMartin, K. (2014). Propylene Glycol A2 - Wexler, Philip BT - Encyclopedia of Toxicology (Third Edition) (pp. 1113–1116). Oxford: Academic Press. <https://doi.org/https://doi.org/10.1016/B978-0-12-386454-3.01029-0>
- Metabolic. (2017). *Roadmap Circulaire Gronduitgifte: een introductie in circulaire bouwprojecten*. Amsterdam. Retrieved from <https://www.metabolic.nl/publications/roadmap-circulaire-gronduitgifte/>
- Milieucentraal. (n.d.). Isolatiematerialen vergeleken. Retrieved from <https://www.milieucentraal.nl/energie-besparen/energiezuinig-huis/isoleren-en-besparen/isolatiematerialen-vergeleken/>
- Miller, J. G. T., & Spoolman, S. (2012). *Living in the environment*. Belmont: Yolanda Cossio.
- Mlecnik, E., & Straub, A. (2015). Experiences of homeowners regarding nearly zero-energy renovations and consequences for business models. In *PLEA 2015: 31th International PLEA Conference “Architecture in (R)evolution.”* Bologna.
- Morales Ibarra, R. (2018). Chapter 20 - Recycling of thermosets and their composites A2 - Guo, Qipeng BT - Thermosets (Second Edition) (pp. 639–666). Elsevier. <https://doi.org/https://doi.org/10.1016/B978-0-08-101021-1.00020-4>
- Morsali, S. (2018). A novel perspective to bitumen refineries life cycle assessment and processes emissions. *Acta Ecologica Sinica*. <https://doi.org/https://doi.org/10.1016/j.chnaes.2017.08.005>
- NeZeR. (2015). *Success cases of Near Zero Energy Building Rehabilitation (NZEBR)*.
- NIBE. (2018). Omschrijving methode milieuclassificaties bouwproducten. Retrieved May 17, 2018, from <http://www.nibe.info/nl/methode>
- NIBE. (n.d.). F1245-5. Retrieved April 8, 2018, from <https://www.nibenl.eu/nibedocuments/16091/F1245-5.pdf>
- Niero, M., & Olsen, S. I. (2016). Circular economy: To be or not to be in a closed product loop? A Life Cycle Assessment of aluminium cans with inclusion of alloying elements. *Resources, Conservation and Recycling*, 114, 18–31. <https://doi.org/https://doi.org/10.1016/j.resconrec.2016.06.023>
- Nishimura, T. (2015). 6 - Chipboard, oriented strand board (OSB) and structural composite lumber A2 - Ansell, Martin P. BT - Wood Composites (pp. 103–121). Woodhead Publishing. <https://doi.org/https://doi.org/10.1016/B978-1-78242-454-3.00006-8>
- NOVATOP. (n.d.). SOLID FOR WALLS AND PARTITIONS. Retrieved June 14, 2018, from <https://www.novatop-system.cz/en/products-2/15168-2/>
- NOVATOP. (n.d.). *NOVATOP SOLID: Technical documentation*.
- Nussholz, J., & Milios, L. (2017). *Applying circular economy principles to building materials: front running companies business model innovation in the value chain for buildings*. Berlin.
- Oosting, M., & Kamphuijs, M. (n.d.). Fijn Wonen Circulair. Retrieved April 8, 2018, from <http://www.platform31.nl/wat-we-doen/programmas/wonen-en-wijken/circulaire-woningbouw/praktijkvoorbeelden-circulaire-woningbouw/fijn-wonen-circulair>
- Petrie, M. (2007). Biodegradable Polymers in Adhesive Systems. Retrieved June 19, 2018, from <https://www.adhesivesmag.com/articles/88268-biodegradable-polymers-in-adhesive-systems>
- Pomponi, F., & Moncaster, A. (2017). Circular economy for the built environment: A research framework. *Journal of Cleaner Production*, 143, 710–718. <https://doi.org/https://doi.org/10.1016/j.jclepro.2016.12.055>

- Rabani, M., Madessa, H. B., & Nord, N. (2017). A state-of-art review of retrofit interventions in buildings towards nearly zero energy level. *Energy Procedia*, 134, 317–326. <https://doi.org/https://doi.org/10.1016/j.egypro.2017.09.534>
- Ramage, M. H., Burrige, H., Busse-Wicher, M., Fereday, G., Reynolds, T., Shah, D. U., ... Scherman, O. (2017). The wood from the trees: The use of timber in construction. *Renewable and Sustainable Energy Reviews*, 68, 333–359. <https://doi.org/https://doi.org/10.1016/j.rser.2016.09.107>
- Rau, T., Oberhuber, S., Hennekeler, R. van, & Jong, J. de. (2016). *Material matters: een alternatief voor onze roofofbouwmaatschappij*. Amsterdam: Bertram + de Leeuw Uitgevers.
- Rijksdienst voor Ondernemend Nederland. (n.d.). MilieuPrestatie Gebouwen - MPG. Retrieved May 17, 2018, from <https://www.rvo.nl/onderwerpen/duurzaam-ondernemen/gebouwen/wetten-en-regels-gebouwen/nieuwbouw/milieuprestatie-gebouwen>
- Rijksdienst voor Ondernemend Nederland. (n.d.). Wettelijke eisen - BENG. Retrieved May 16, 2018, from <https://www.rvo.nl/onderwerpen/duurzaam-ondernemen/gebouwen/wetten-en-regels-gebouwen/nieuwbouw/energieprestatie-beng/wettelijke-eisen-beng>
- Rijksdienst voor Ondernemend Nederland. (2013). *Infoblad Trias Energetica en energieneutraal bouwen*. Utrecht.
- Rogers, T. (2015). Everything you need to know about Polylactic Acid (PLA). Retrieved from <https://www.creativemechanisms.com/blog/learn-about-polylactic-acid-pla-prototypes>
- Salazar, J. (2014). 21 - Life cycle assessment (LCA) of windows and window materials BT - Eco-efficient Construction and Building Materials (pp. 502–527). Woodhead Publishing. <https://doi.org/https://doi.org/10.1533/9780857097729.3.502>
- Seghezzi, E., & Masera, G. (2017). Identification of Technological and Installation-related Parameters for a Multi-criteria Approach to Building Retrofit. *Procedia Engineering*, 180, 1056–1064. <https://doi.org/https://doi.org/10.1016/j.proeng.2017.04.265>
- Simón, D., Borreguero, A. M., de Lucas, A., & Rodríguez, J. F. (2018). Recycling of polyurethanes from laboratory to industry, a journey towards the sustainability. *Waste Management*, 76, 147–171. <https://doi.org/https://doi.org/10.1016/j.wasman.2018.03.041>
- Sortiva. (n.d.). Houtrecycling. Retrieved June 25, 2018, from <http://www.sortiva.nl/onze-activiteiten/activiteiten/houtrecycling>
- Spirinckx, C., Pieper, H., & Peeters, K. (2013). *Life cycle assessment of a polypropylene random copolymer (PP-R) pipe system for hot and cold water distribution in the building (according to EN ISO 15874)*.
- Stichting Probos. (2009). Infoblad houtsoortenkeuze en toepassingen. Stichting Probos.
- Stocker, T. F., Qin, D., Plattner, G.-K., Tignor, M., Allen, S. K., Doschung, J., ... Midgley, P. M. (2013). IPCC, 2013: Summary for policymakers. In *Climate Change 2013: The Physical Science Basis. Contribution of Working Group I to the Fifth Assessment Report of the Intergovernmental Panel on Climate Change*. Cambridge and New York: Cambridge University Press.
- Synbra Technology. (n.d.). BioFoam. Retrieved April 8, 2018, from <https://www.synbratechnology.com/biofoam/>
- Tata Steel. (n.d.). Recyclable and recycled. Retrieved April 6, 2018, from <https://www.tatasteeleurope.com/en/sustainability/steel-for-a-sustainable-future/the-life-cycle-of-steel/recyclable-or-recycled>
- Ten Brinck, T. (2016). Zonnepaneel nu voor 96 procent recyclebaar. Retrieved May 22, 2018, from <https://www.duurzaambedrijfsleven.nl/recycling/12957/zonnepaneel-nu-voor-96-procent-recyclebaar>
- Tentensolar. (n.d.). Zonnepanelen: van Wp naar kWh. Retrieved June 25, 2018, from <https://www.tentensolar.nl/semi-overheid/dossiers/item/zonnepanelen-van-wp-naar-kwh.html>
- Timmerman, M. B. (2009). *Ontwerp van fotovoltaïsch-thermische zonnepanelen / Design of a PV-Thermal panel*. Universiteit Twente.
- Tripanagnostopoulos, Y., Souliotis, M., Battisti, R., & Corrado, A. (2003). Application aspects of hybrid PV/T solar systems. *Physics Department, University of Patras, Patras, 26500*.
- Triple Solar. (n.d.). Opbrengsten triple solar. Retrieved April 6, 2018, from <http://www.triplesolar.eu/wp-content/uploads/2016/05/Triple-Solar-opbrengsten-2016.pdf>
- Triple Solar BV. (2018). Triple Solar warmtepomppaneel: bronsysteem voor water/water warmtepomp.
- Triple Solar BV. (n.d.). *Specificaties PVT warmtepomppaneel*.
- UNFCCC. (n.d.). Kyoto Protocol.
- Urgenda. (n.d.). *Ons huis energieneutraal: praktijkvoorbeelden van bestaande woningen*.
- van der Harst, E., Potting, J., & Kroeze, C. (2016). Comparison of different methods to include recycling in LCAs of aluminium cans and disposable polystyrene cups. *Waste Management*, 48, 565–583. <https://doi.org/https://doi.org/10.1016/j.wasman.2015.09.027>
- Van der Sanden Groep. (2015). 10 belangrijke redenen waarom baksteen duurzaam is. *De Architect*. Retrieved from <http://www.dearchitect.nl/productnieuws/artikel/2015/11/10-belangrijke-redenen-waarom-baksteen-duurzaam-is-101132869>
- Van Ewijk, S., & Stegemann, J. A. (2016). Limitations of the waste hierarchy for achieving absolute reductions in material throughput. *Journal of Cleaner Production*, 132, 122–128. <https://doi.org/https://doi.org/10.1016/j.jclepro.2014.11.051>
- Van Wijnen. (2018). Fijn Wonen. Retrieved April 6, 2018, from <https://www.vanwijnen.nl/projecten/fijnwonen/>
- Verberne, J. J. H. (2016). *Building circularity indicators an approach to measuring circularity of a building*. Eindhoven University of Technology.
- Vis, M. W., Reumerman, P., & Gartner, S. (2014). *Cascading in the wood sector*. Enschede.
- Vringer, K., van Middelkoop, M., & Hoogervorst, N. (2016). Saving energy is not easy: An impact assessment of Dutch policy to reduce the energy requirements of buildings. *Energy Policy*, 93, 23–32. <https://doi.org/https://doi.org/10.1016/j.enpol.2016.02.047>

- Warmtepomp-weetjes. (2018). Bereken benodigd warmtepomp-vermogen. Retrieved May 20, 2018, from <https://warmtepomp-weetjes.nl/warmtepomp/warmtepomp-vermogen/>
- Wiseman, T., & Summerson, G. (n.d.). *Sustainable refurbishment of domestic buildings using BREEAM*.
- Woodguide. (n.d.). OSB. Retrieved June 26, 2018, from <http://www.woodguide.org/guide/osb/>
- World Commission on Environment and Development. (1987). *Our common future*. Oxford; New York: Oxford University Press.
- Yanovshchinsky, V., Huijbers, K., & Dobbelsteen, A. van den. (2012). *Architectuur als klimaatmachine*. Amsterdam: Uitgeverij Sun.
- Zeiler, W., Gvozdenović, K., de Bont, K., & Maassen, W. (2016). Toward cost-effective nearly zero energy buildings: The Dutch Situation. *Science and Technology for the Built Environment*, 22(7), 911–927. <https://doi.org/10.1080/23744731.2016.1187552>
- Zhou, X., Carmeliet, J., & Derome, D. (2018). Influence of envelope properties on interior insulation solutions for masonry walls. *Building and Environment*, 135, 246–256. <https://doi.org/https://doi.org/10.1016/j.buildenv.2018.02.047>
- Zonnepanelen.net. (n.d.). Legplan zonnepanelen, bepaal de layout op uw dak. Retrieved from <https://www.zonnepanelen.net/legplan/>

Appendix 1. Calculation weight old roof structure

The parts to measure are: the closed facade of the front and back which is a light structure, the closed facade on the side walls which is a brick structure and the windows, and the weight of the roof.

Weight, closed facade, front and back

Structure

- 19 mm oak (specific weight = 700 kg/m³) - 140 mm PUR (specific weight = 45 kg/m³) - 12,5 mm plasterboard (specific weight = 1100 kg/m³)
- Vertical and horizontal battens whitewood between insulation (specific weight = 580 kg/m³).
- Vertical battens whitewood to carry external cladding (specific weight = 580 kg/m³).

Weight battens - between insulation

- Length = 12,1 m
- Profile = 38 x 140 mm = 0,0053 m³
- Total weight = 12,1 x 0,0053 x 580 = **37,33576 kg**.

Weight battens - external cladding

- Length = 7,8 m
- Profile = 28 x 50 = 0,0014 m³
- Total weight = 7,8 x 0,0014 x 580 = **6,3336 kg**.

Weight oak, PUR, plasterboard/m²

- Weight oak = 0,019 x 700 = 13,3 kg/m²
- Weight PUR = 0,140 x 45 = 6,3 kg/m²
- Weight plasterboard/m² = 0,0125 x 1100 = 13,75 kg/m²
- Total = **33,35 kg/m²**

Total weight closed facade, front and back

- (Weight battens x 2) + (weight oak, PUR, plasterboard x 2,795 x 2) = 273,76522 kg

Weight, closed facade, side walls

Structure

- 100 mm brick (specific weight = 2000 kg/m³) - 80 mm PUR (specific weight = 45 kg/m³) - 25 mm plasterboard (specific weight = 1100 kg/m³).
- Brick wall on dividing wall. Area = 5 m².
- Front wall from PUR and plasterboard is larger than brick wall: goes down until the floor. Area = 10,89 m².

Weight brick wall

- Weight brick/m² = 0,100 x 2000 = 200 kg/m².

Weight front wall PUR/plasterboard

- Weight PUR/m² = 0,08 x 45 = 3,6 kg/m².
- Weight plasterboard/m² = 0,025 x 1100 = 27,5 kg/m².
- Total = 31,1 kg/m²

Total weight closed facade, side

- (Weight brick x 5 x 2) + (Weight front wall x 10,89 x 2) = 2677,358 kg.

Weight, windows



Rapportage Freetool MRPI Milieuprestatie Gebouw

- Two types of windows: turn-tilt windows (6 times in total roof structure) and fixed windows (2 times in total roof structure).
- As a reference for the turn-tilt windows: HEBO system 90 - turn tilt
- As a reference for the fixed windows: HEBO system 90 - fixed
- Glazing = HR+, so two glazing panes of 4 mm.

Turn-tilt windows weight

- Volume frame (meranti) = 0,03176 m³
- Specific weight meranti = 640 kg/m³
- Weight frame = 640 x 0,03176 = 20,3264 kg
- Volume of glass in window = 0,0043 m³
- Specific weight glass = 2500 kg/m³
- Weight glass = 2500 x 0,0043 = 10,75 kg
- Total = 20,3264 + 10,75 = 31,0764 kg

Fixed windows weight

- Volume frame (meranti) = 0,022 m³
- Volume of glass in window = 0,0053 m³.
- Weight frame = 640 x 0,022 = 14,08 kg
- Weight glass = 2500 x 0,0053 = 13,25 kg
- Total = 14,08 + 13,25 = 27,33 kg

Total weight all windows

- (turn-tilt weight x 6) + (fixed weight x 2) = 241,1184 kg.

Weight, roof

- ISOBOUW roof element and ceramic roof tiles.
- Total area of roof is approximately 24,5916 m².

ISOBOUW weight

- The thickness of the ISOBOUW element shown in the drawings is approximately 106 mm thick. This matches with ISOBOUW Slimfix 3.0 3/3 L.
- Weight ISOBOUW Slimfix 3.0 3/3 L = 9 kg/m²
- Total weight = 24,5916 x 9 = 221,3244 kg

Ceramic roof tiles weight

- The assumption is that the roof tiles are traditional ceramic roof tiles, as they've been reused from the old roof. According to bh-keramiek.com, 1 weighs 3,1 kg and there are 15/m².
- Total weight = 15 x 3,1 x 24,5916 = 1143,5094 kg.

Total weight roof

- 221,3244 + 1143,5094 = 1364,8338 kg.

Total weight roof structure

- **total weight closed facade, front and back + total weight closed facade, side + total weight windows + total weight roof = 4557 kg.**

In deze rapportage zijn de resultaten en de invoer opgenomen van de milieuprestatieberekening gebouw van Circulaire analyse dakopbouw Dickmansstraat 40. De resultaten zijn verdeeld naar de verplichte milieuprestatieberekening voor het bouwbesluit op basis van artikel 5.2 en naar de MPG score. Tot slot is een verantwoording voor de berekening opgenomen.

Algemene gegevens

Naam project:	Circulaire analyse dakopbouw Dickmansstraat 40
Organisatie:	TU Delft
Gebruiksfunctie:	Woongebouw
Bvo:	18,72 m ²
Levensduur:	25 jaar
Datum rapportage:	14-05-2018

Resultaat bouwbesluit

In bijlage I is een overzicht opgenomen van de geselecteerde producten inclusief hoeveelheden en eventuele dimensies van het product. In de onderstaande tabel zijn de relevante resultaten opgenomen.

Milieu-impact	berekende waarde	eenheid
Uitputting abiotische grondstoffen (excl. fossiel)	0	kg Sb eq./ m ² BVO*jaar
Uitputting fossiele energiedragers	0,03	kg Sb eq./ m ² BVO*jaar
Klimaatverandering (100 jaar)	5,07	kg CO ₂ eq./ m ² BVO*jaar

De berekende resultaten zijn direct gekoppeld aan de in bijlage I opgenomen producten, een afwijkende materialisatie of productkeuze heeft invloed op de berekening. Indien in het verdere ontwerp- en bouwproces andere materiaalkeuzes worden gemaakt dient de milieuprestatie opnieuw berekend te worden.

Resultaat MPG-score

In bijlage I is een overzicht opgenomen van de geselecteerde producten inclusief hoeveelheden en eventuele dimensies van het product. De MPG-score van Circulaire analyse dakopbouw Dickmansstraat 40 is 0,61 € / m² BVO. In de onderstaande tabel is dit resultaat weergegeven naar de verschillende bouwdeelen.

Bouwdeel	Resultaat
Fundering	0%
Vloeren	0%
Draagconstructie	0,4%
Gevels	50%
Daken	49,6%
Installaties	0%
Inbouw	0%

Bijlage I, invoer berekening

- ongetoetst
- getoetst

Fundering		
Vloeren		
Draagconstructie		
Hoofdraagconstructies		
Liggers	<input checked="" type="checkbox"/> Europees Naaldhout, gedroogd, geschaafd, duurzame bosbouw [250,75]	27 m1
Gevels		
Gevels, dicht		
Spouwwallen, buitenblad	<input checked="" type="checkbox"/> Baksteenmetselwerk [90]	5,9 m2
Spouwwallen, binnenblad, systeem	<input checked="" type="checkbox"/> Houten buitenwandelement, HSB prefab; incl. isolatie; duurz.bosbeheer; NBvT	5,6 m2
Isolatielagen	<input checked="" type="checkbox"/> PUR/PIRschuim platen (pentaan geblazen) [4.5]	5,6 m2
Bekledingen	<input checked="" type="checkbox"/> Gevelbekleding van Europees naaldhout, verduurzaamd, geschilderd [18]	5,6 m2
Gevels, open		
Kozijnen	<input checked="" type="checkbox"/> Az.loofh. (Meranti), kozijn+draaivalraam; geschilderd, h&s, duurz.bosb;NBvT	5,5 m2
Kozijnen	<input checked="" type="checkbox"/> Aziatisch loofhout (Meranti), kozijn vast; geschilderd, duurz. bosb.; NBvT	1,8 m2
Beglazing	<input checked="" type="checkbox"/> HR+ (dubbel) glas; coating, 4/15/4 mm	4,5 m2
Vensterbanken	<input checked="" type="checkbox"/> Spaanplaat; plaat [14]	9,9 m1
Daken		
Daken, hellend		
Daken	<input checked="" type="checkbox"/> Renovatie dakelement, massief PIR, spaanplaat en OSB, duurzame bosbouw [3.5]	23,7 m2
Bedekkingen	<input checked="" type="checkbox"/> Keramische pan - ongeglazuurd	23,7 m2

Appendix 3. Calculation Uniec2 old roof structure

Jaarlijkse hoeveelheid primaire energie voor de energiefunctie ¹		
verwarming (excl. hulpenergie)	$E_{H,P}$	66.204 MJ
hulpenergie		2.720 MJ
warmtapwater (excl. hulpenergie)	$E_{W,P}$	25.730 MJ
hulpenergie		0 MJ
koeling (excl. hulpenergie)	$E_{C,P}$	0 MJ
hulpenergie		0 MJ
zomercomfort	$E_{SC,P}$	6.088 MJ
ventilatoren	$E_{V,P}$	0 MJ
verlichting	$E_{L,P}$	3.978 MJ
geëxporteerde elektriciteit $E_{P,exp,el}$ 0 MJ		
op eigen perceel opgewekte & verbruikte elektriciteit $E_{P,pr,us,el}$ 0 MJ		
in het gebied opgewekte elektriciteit $E_{P,pr,de,el}$ 0 MJ		



- verwarming: 66%
- warmtapwater: 25%
- koeling: 0%
- zomercomfort: 6%
- ventilatoren: 0%
- verlichting: 4%

Oppervlakten		
totale gebruiksoppervlakte	$A_{g,tot}$	86,32 m ²
totale verliesoppervlakte	A_{vs}	163,36 m ²

Aardgasgebruik (exclusief koken) ¹	
gebouwweggebonden installaties	2.614 m ³ aeq

Elektriciteitsgebruik ¹	
gebouwweggebonden installaties	1.387 kWh
niet-gebouwweggebonden apparatuur (stelpost)	2.420 kWh
op eigen perceel opgewekte & verbruikte elektriciteit	0 kWh
geëxporteerde electriciteit	0 kWh
TOTAAL	3.807 kWh

CO ₂ -emissie ¹	
CO ₂ -emissie	m_{co2} 5.435 kg

Energieprestatie ¹		
specifieke energieprestatie	EP	1.213 MJ/m ²
karakteristiek energiegebruik	$E_{p,tot}$	104.718 MJ
toelaatbaar karakteristiek energiegebruik	$E_{p,adm,tot,nb}$	21.844 MJ
energieprestatiecoëfficiënt	EPC	1,918 -
energieprestatiecoëfficiënt	EPC	1,92 -

BENG indicatoren ¹		
energiebehoefte	174,8 kWh/m ²	✗
primaire energiegebruik	324,2 kWh/m ²	✗
aandeel hernieuwbare energie	0 %	✗

Alle bovenstaande energiegebruiken zijn genormeerde energiegebruiken gebaseerd op een standaard klimaatjaar en een standaard gebruikersgedrag. Het werkelijke energiegebruik zal afwijken van het genormeerde energiegebruik. Aan de berekende energiegebruiken kunnen geen rechten ontleend worden.

Algemene gegevens

projectomschrijving	Versie 1 Dickmansstraat 46
variant	oud
straat / huisnummer / toevoeging	Dickmansstraat 46
postcode / plaats	2015JD Haarlem
eigendom	Koop
bouwjaar	1934
renovatiejaar	
categorie	Energieprestatie Woningbouw
woningtype	tussenwoning
aantal woningbouw-eenheden in berekening	1
gebruiksfunctie	woonfunctie
datum	14-05-2018
opmerkingen	

Indeling gebouw

Eigenschappen rekenzones			
type rekenzone	omschrijving	interne warmtecapaciteit	Ag [m ²]
verwarmde zone	Huis	aditioneel, gemengd zwaar	86,32

Interne warmtecapaciteit volgens bijlage H *nee*

Infiltratie

meetwaarde voor infiltratie $q_{v,10;spec}$	<i>nee</i>
lengte van het gebouw	5,40 m
breedte van het gebouw	7,06 m
hoogte van het gebouw	8,60 m

Eigenschappen infiltratie			
rekenzone	positie	dak en/of geveltype	$q_{v,10;spec}$ [dm ³ /s per m ²]
Huis	nv	hellend dak	0,70 (forfaitair)

Open verbrandingsstoestellen

Open verbrandingstoestellen		
type verbrandingstoestel	B [kW]	toestel in rekenzone
kachel, overige vaste brandstof	25	Huis

Bouwkundige transmissiegegevens

Transmissiegegevens rekenzone Huis	
------------------------------------	--

constructie	A [m ²]	R _c [m ² K/W]	U [W/m ² K]	g _{gl} [-]	zonwering	beschaduwng	toelichting
ground floor - vloer op/boven mv; boven kruipruimte - 34,5 m²							
ground floor	34,45	0,15					
F - East - 1 - buitenlucht, O - 27,0 m² - 90°							
cavity wall front and back	16,20	0,28					minimale belem.
window, old	8,74		5,10	0,80	nee		minimale belem.
deur	2,06		2,22	0,00	nee		minimale belem.
F - West - 1 - buitenlucht, W - 27,0 m² - 90°							
cavity wall front and back	13,78	0,28					minimale belem.
window, old	11,94		5,10	0,80	nee		minimale belem.
deur	1,28		2,22	0,00	nee		minimale belem.
R - East - 1 - buitenlucht, O - 21,1 m² - 31°							
roof, old	21,06	1,00					minimale belem.
R - West - 1 - buitenlucht, W - 21,1 m² - 31°							
roof, old	21,06	1,00					minimale belem.
F - East - 2 - buitenlucht, Z - 6,8 m² - 90°							
front and backfaca...	3,12	3,00					minimale belem.
window, roof structure	3,64		3,00	0,80	nee		minimale belem.
F - West - 2 - buitenlucht, Z - 6,8 m² - 90°							
front and backfaca...	3,12	3,00					minimale belem.
window, roof structure	3,64		3,00	0,80	nee		minimale belem.
N - brick wall - buitenlucht, N - 5,0 m² - 90°							
side wall	5,00	3,00					minimale belem.
R - 2 - buitenlucht, O - 12,3 m² - 31°							
roof, ISOBOUW	12,30	3,00					minimale belem.
R - 1 - buitenlucht, W - 12,3 m² - 31°							
roof, ISOBOUW	12,30	3,00					minimale belem.

De lineaire warmteverliezen zijn berekend volgens de forfaitaire methode uit hoofdstuk 13 van NEN 1068.

Overige kenmerken vloerconstructies (inclusief evt. kruipruimten en onverwarmde kelders)

ground floor - vloer op/boven mv; boven kruipruimte

hoogte bovenkant vloer boven slaaveld (h)	0,23 m
omtrek van het vloeropperveld	10,80 m
grootste dikte v.d. gevels/wanden ter hoogte v.d. bk vloer ($d_{bw,v}$)	0,34 m
gem. vert. afstand tussen MV en bk kelder-, kruipruimtevloer (z_0)	0,34 m
kruipruimteventilatie (ϵ)	0,0012 m ² /m ¹
warmteweerstand v.d. kelder-, kruipruimtevanden boven mv (R_{xw})	1,24 m ² K/W
warmteweerstand v.d. kelder-, kruipruimtevanden onder mv ($R_{bw,o}$)	1,24 m ² K/W
warmteweerstand v.d. kelder-, kruipruimtevloer (R_{bf})	0,00 m ² K/W
grootste dikte v.d. wand t.h.v. de bk kelder-, kruipruimtevloer ($d_{bw,o}$)	0,34 m

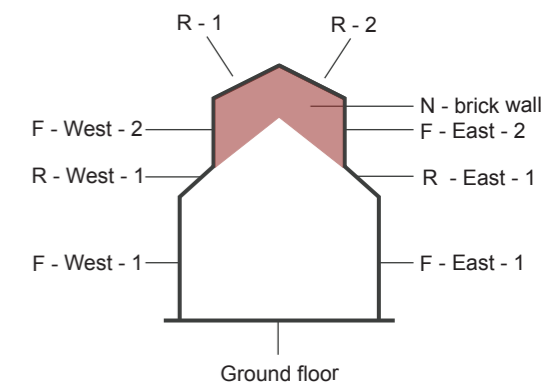

Verwarming- en warmtapwatersystemen

verwarming/warmtapwater 1

Opwekking

type opwekker	individueel cv-toestel, binnen EP-omgrenzing
indeling LT/HT voor opwekker	hoge temperatuur
toepassingsklasse (CW-klasse)	4 (CW 4, 5 en 6)
type CV-ketel - verwarming	conventionele ketel
type CV-ketel - warmtapwater	gasgestookt warmwatertoestel C.V (40%)
aantal opwekkers	1
transmissieverlies verwarmingssysteem - januari (H_T)	266 W/K
warmtebehoefte verwarmingssysteem ($Q_{H,nd;an}$)	47.170 MJ
hoeveelheid energie t.b.v. verwarming per toestel ($Q_{H,dis;nren;an}$)	49.653 MJ
hoeveelheid energie t.b.v. warmtapwater per toestel ($Q_{W,dis;nren;an}$)	8.894 MJ
opwekkingsrendement verwarming - CV ketel ($\eta_{H,gen}$)	0,750
opwekkingsrendement warmtapwater - CV ketel ($\eta_{W,gen}$)	0,340

Kenmerken afgiftesysteem verwarming

Type warmteafgifte (in woonkamer)					
type warmteafgifte	positie	hoogte	R_c	$\theta_{em,avg}$	$\eta_{H,em}$
radiator- en/of convectiverwarming	buitenwaa	< 8 m	$\geq 2,5 \text{ m}^2\text{K/W}$	> 50 °	0,95

regeling warmteafgifte aanwezig	ja
afgifterendement ($\eta_{H,em}$)	0,950

Kenmerken distributiesysteem verwarming

ongeïsoleerde verdeler / verzamelaar aanwezig	nee
buffervat buiten verwarmde ruimte aanwezig	nee
verwarmingsleidingen in onverwarmde ruimte en/ of kruipruimte	nee
distributierendement ($\eta_{H,dis}$)	1,000

Kenmerken tapwatersysteem

aantal woningbouw-eenheden aangesloten op systeem	1
warmtapwatersysteem ten behoeve van	keuken en badruimte
gemiddelde leidinglengte naar badruimte	forfaitair
gemiddelde leidinglengte naar aanrecht	forfaitair
inwendige diameter leiding naar aanrecht	$\leq 10 \text{ mm}$
afgifterendement warmtapwater ($\eta_{W,em}$)	0,742

Douchewarmteterugwinning

douchewarmteterugwinning	nee
--------------------------	-----

Zonneboiler

zonneboiler	nee
-------------	-----

Hulpenergie verwarming

hoofdcirculatiepomp aanwezig	ja
------------------------------	----

hoofdcirculatiepomp voorzien van pompregeling	ja
werkelijk vermogen hoofdcirculatiepomp bekend	nee
aanvullende circulatiepomp aanwezig	nee
ondergrens van de modulatie van de brander (m_{min})	0,4
aantal toestellen met waakvlam	0

Aangesloten rekenzones

Huis

Ventilatie

ventilatie 1

Ventilatiesysteem

ventilatiesysteem	A. natuurlijk toe- en afvoer
systeemvariant	A1 standaard
luchtvolumestroomfactor voor warmte- en koudebehoefte (f_{sys})	1,24
correctiefactor regelsysteem voor warmte- en koudebehoefte (f_{reg})	1,00

Kenmerken ventilatiesysteem

werkelijk geïnstalleerde ventilatiecapaciteit bekend	nee
luchtdichtheidsklasse ventilatiekanalen	onbekend

Passieve koeling

max. benutting geïnstal. ventilatiecapaciteit voor koudebehoefte	ja
max. benutting geïnstal. spuicapaciteit voor koudebehoefte	ja

Aangesloten rekenzones

Huis

Resultaten

Jaarlijkse hoeveelheid primaire energie voor de energiefunctie		
verwarming (excl. hulpenergie)	$E_{H,P}$	66.204 MJ
hulpenergie		2.720 MJ
warmtapwater (excl. hulpenergie)	$E_{W,P}$	25.730 MJ
hulpenergie		0 MJ
koeling (excl. hulpenergie)	$E_{C,P}$	0 MJ
hulpenergie		0 MJ
zomercomfort	$E_{SC,P}$	6.000 MJ
ventilatoren	$E_{V,P}$	0 MJ
verlichting	$E_{L,P}$	3.970 MJ
geëxporteerde elektriciteit	$E_{P,exp,el}$	0 MJ
op eigen perceel opgewekte & verbruikte elektriciteit	$E_{P,pr,us,el}$	0 MJ
in het gebied opgewekte elektriciteit	$E_{P,pr,dei,el}$	0 MJ
Oppervlakten		
totale gebruiksoppervlakte	$A_{g,tot}$	86,32 m ²
totale verliesoppervlakte	A_{ls}	163,36 m ²
Aardgasgebruik (exclusief koken)		
gebouwbonden installaties		2.614 m ³ aeq
Elektriciteitsgebruik		
gebouwbonden installaties		1.387 kWh
niet-gebouwbonden apparatuur (stelpost)		2.420 kWh
op eigen perceel opgewekte & verbruikte elektriciteit		0 kWh
geëxporteerde electriciteit		0 kWh
TOTAAL		3.807 kWh
CO ₂ -emissie		
CO ₂ -emissie	m_{co2}	5.435 kg
Energieprestatie		
specifieke energieprestatie	EP	1.213 MJ/m ²
karakteristiek energieverbruik	$E_{P,tot}$	104.718 MJ
toelaatbaar karakteristiek energieverbruik	$E_{P,adm,tot,nb}$	21.844 MJ
energieprestatiecoëfficiënt	EPC	1,918 -
energieprestatiecoëfficiënt	EPC	1,92 -
BENG indicatoren		
energiebehoefte		174,8 kWh/m ²
primair energieverbruik		324,2 kWh/m ²
aandeel hernieuwbare energie		0 %

Uniec 2.2 is gebaseerd op NEN7120;2011 "Energieprestatie van gebouwen" (inclusief het Nader Voorschrift) en NEN 8088-1 "Ventilatie en luchtdoorlatendheid van gebouwen" inclusief alle wettelijk van kracht zijnde correctiebladen.

Alle bovenstaande energiegebruiken zijn genormeerde energiegebruiken gebaseerd op een standaard klimaatjaar en een standaard gebruikersgedrag. Het werkelijke energiegebruik zal afwijken van het genormeerde energiegebruik. Aan de berekende energiegebruiken kunnen geen rechten ontleend worden.

Studentenlicentie

Appendix 4. Calculation of heating need

To calculate the necessary capacity of a heat pump, the first step is calculating the heating need on a cold day. This is calculated with an exterior temperature of -10 °C and an interior temperature of 20 °C. The heating need is defined by the following formula's:

$$Q_{\text{transmission}} = U \cdot A \cdot (T_e - T_i)$$

$$Q_{\text{transmission}} = U \cdot A \cdot (T_e - T_i) \text{ for all facades/windows} = -2191,5 \text{ W}$$

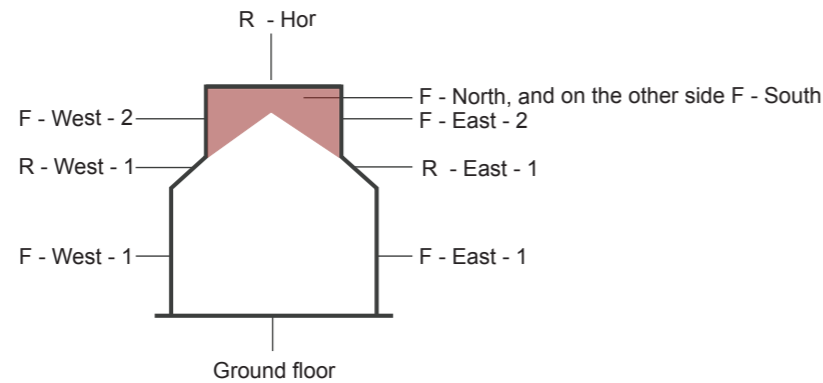

skin part	surface	% of glass	surface closed parts	surface window	% frame	surface glass
F-East-1	29,16	35	19	10,2	26	7,6
F-West-1	29,16	43	17	12,5	26	9,3
F-East-2	13,5	53	6	7,2	26	5,3
F-West-2	13,5	53	6	7,2	26	5,3
R-East-1	9,45	0	9	0,0	26	0,0
R-West-1	9,45	0	9	0,0	26	0,0
R-Hor	29,5	0	29,5	0,0	26	0,0
Ground floor	33,5	0	33,5	0,0	26	0,0
F-North	7,5	0	7,50	0,0		
F-South	5,7	0	5,7	0,0		

closed facades	surface	Rc-value	U-waarde	Qtransmission
		m ² K/W	W/m ² K	W
F-East-1	19	2	0,46	-262,0
F-West-1	17	2	0,46	-229,8
F-East-2	6	5	0,19	-36,8
F-West-2	6	5	0,19	-36,8
R-East-1	9	2	0,46	-130,6
R-West-1	9	2	0,46	-130,6
R-Hor	29,5	7	0,14	-123,4
Ground floor	33,5	3,8	0,25	-253,1
F-North	7,5	5	0,19	-43,5
F-South	5,7	5	0,19	-33,1

windows and doors	surface	Rc-value	U-waarde	Qtransmission
		m ² K/W	W/m ² K	W
F-East-1	10,2		0,82	-251,1
F-West-1	12,5		0,82	-308,5
F-East-2	7,2		0,82	-176,0
F-West-2	7,2		0,82	-176,0

Total Qtransmission	-2191,5
----------------------------	----------------

$$Q_{\text{vent,wtw}} = (1 - N_{\text{WTW}}) \cdot Q_{\text{vent}} \cdot \rho \cdot c_p \cdot (T_e - T_i)$$

$$V_{\text{vent}} = 0,06 \text{ m}^3/\text{s}$$

A general value for calculation is 0,7 dm³/s/m². For this house that means a value of 0,06 m³/s.

$$\rho = 1,2 \text{ kg/m}^3$$

$$C_p = 1000 \text{ J/kg.K}$$

$$N_{\text{wtw}} = T_{\text{air,in}} - T_e / T_i - T_e = 0,91$$

The FreshR has an efficiency of 87%. In that case the $T_{\text{air,in}}$ is 17,4 °C.

$$Q_{\text{vent}} = V_{\text{vent}} \cdot \rho \cdot c_p \cdot (T_e - T_i) = -1008 \text{ W}$$

$$Q_{\text{vent,wtw}} = (1 - N_{\text{WTW}}) \cdot V_{\text{vent}} \cdot \rho \cdot c_p \cdot (T_e - T_i) = -1965,6 \text{ W}$$

$$Q_{\text{infiltration}} = V_{\text{inf}} \cdot \rho \cdot c_p \cdot (T_e - T_i)$$

$$V_{\text{inf}} = C_0 \cdot n \cdot V / 3600 = 0,022 \text{ m}^3/\text{s}$$

A N of 0,2 can be taken for a house in which the seals are reasonably closed off. As only the roof structure has the seals closed off very well and the bottom part probably not so much, this value is chosen. C_0 is a value of 1,5 and the volume of the home is 260 m³.

$$Q_{\text{infiltration}} = V_{\text{inf}} \cdot \rho \cdot c_p \cdot (T_e - T_i) = -792 \text{ W}$$

$$Q_{\text{transmission}} + Q_{\text{ventilation}} + Q_{\text{infiltration}} + Q_{\text{heating need}} = 0$$

$$-2191,5 \text{ W} - 1966 \text{ W} - 792 \text{ W} + Q_{\text{heating need}} = 0 \text{ W}$$

$$Q_{\text{heating need}} = 4949,5 \text{ W}$$

Appendix 5. Uniec2 energy performance calculation Triple Solar variant

Jaarlijkse hoeveelheid primaire energie voor de energiefunctie ⁱ		
verwarming (excl. hulpenergie)	$E_{H,P}$	6.514 MJ
hulpenergie		0 MJ
warmtapwater (excl. hulpenergie)	$E_{W,P}$	6.217 MJ
hulpenergie		0 MJ
koeling (excl. hulpenergie)	$E_{C,P}$	0 MJ
hulpenergie		0 MJ
zomercomfort	$E_{SC,P}$	3.502 MJ
ventilatoren	$E_{V,P}$	1.411 MJ
verlichting	$E_{L,P}$	3.978 MJ
geëxporteerde elektriciteit	$E_{P,exp,el}$	0 MJ
op eigen perceel opgewekte & verbruikte elektriciteit	$E_{P,prus,el}$	27.007 MJ
in het gebied opgewekte elektriciteit	$E_{P,prde,el}$	0 MJ

■ verwarming: 30% ■ warmtapwater: 29%
■ koeling: 0% ■ zomercomfort: 16%
■ ventilatoren: 7% ■ verlichting: 18%

Oppervlakten		
totale gebruiksoppervlakte	$A_{g,tot}$	86,32 m ²
totale verliesoppervlakte	A_{ls}	176,58 m ²

Elektricitetsgebruik ⁱ	
gebouwwgebonden installaties	2.346 kWh
niet-gebouwwgebonden apparatuur (stelpost)	2.420 kWh
op eigen perceel opgewekte & verbruikte elektriciteit	2.930 kWh
geëxporteerde electriciteit	0 kWh
TOTAAL	1.835 kWh

CO ₂ -emissie ⁱ		
CO ₂ -emissie	m_{co2}	-330 kg

Energieprestatie ⁱ		
specifieke energieprestatie	EP	-62 MJ/m ²
kenmerkend energiegebruik	$E_{p,tot}$	-5.386 MJ
toelaatbaar kenmerkend energiegebruik	$E_{p,adm,tot,nb}$	22.338 MJ
energieprestatiecoëfficiënt	EPC	-0,096 -
energieprestatiecoëfficiënt	EPC	-0,09 -

Uniec^{2.2}

- Huis - P5
Triple Solar PV/T

-0,09

Algemene gegevens

projectomschrijving	Huis - P5
variant	Triple Solar PV/T
straat / huisnummer / toevoeging	Dickmansstraat 46
postcode / plaats	2015JD Haarlem
eigendom	Koop
bouwjaar	1934
renovatiejaar	2018
categorie	Energieprestatie Woningbouw
woningtype	tussenwoning
aantal woningbouw-eenheden in berekening	1
gebruiksfunctie	woonfunctie
datum	25-06-2018
opmerkingen	

Indeling gebouw

Eigenschappen rekenzones			
type rekenzone	omschrijving	interne warmtecapaciteit	Ag [m ²]
verwarmde zone	huis	aditioneel, gemengd zwaar	86,32

Interne warmtecapaciteit volgens bijlage H: *nee*

Infiltratie

meetwaarde voor infiltratie $q_{v,10,spec}$	<i>ja</i>
lengte van het gebouw	5,40 m
breedte van het gebouw	7,06 m
hoogte van het gebouw	8,50 m

Eigenschappen infiltratie			
rekenzone	positie	dak en/of geveltype	$q_{v,10,spec}$ [dm ³ /s per m ²]
huis	inval	plat of geen dak	0,25 (meetwaarde)

Open verbrandingstoestellen

Het gebouw bevat geen open verbrandingstoestellen.

Bouwkundige transmissiegegevens

Transmissiegegevens rekenzone huis	
------------------------------------	--

constructie	A [m ²]	R _c [m ² K/W]	U [W/m ² K]	g _{gl} [-]	zonwering	beschaduwing	toelichting
F - East - 1 - buitenlucht, O - 29,2 m² - 90°							
voor + achtergevel	18,93	2,00					minimale belem.
raam 1,17 (3 stuks)	3,51		0,82	0,50	nee		minimale belem.
voordeur (1 stuks)	3,12		0,86	0,00	nee		minimale belem.
raam 3,6 (1 stuks)	3,60		0,82	0,50	nee		minimale belem.
F - West - 1 - buitenlucht, W - 29,2 m² - 90°							
voor + achtergevel	16,37	2,00					minimale belem.
raam 1,17 (3 stuks)	3,51		0,82	0,50	nee		minimale belem.
raam 3,3 (1 stuks)	3,30		0,82	0,50	nee		minimale belem.
achterdeur 2,87 (1 stuks)	2,87		1,15	0,05	nee		minimale belem.
achterdeur 2,6 (1 stuks)	2,60		1,15	0,05	nee		minimale belem.
raam 0,52 (1 stuks)	0,52		0,82	0,50	nee		minimale belem.
Ground floor - vloer op/boven mv; boven kruipruimte - 33,5 m²							
begane grondvloer	33,50	3,80					
R - East - 1 - buitenlucht, O - 9,5 m² - 30°							
dak oud	9,45	1,00					minimale belem.
R - West - 1 - buitenlucht, Z - 9,5 m² - 90°							
dak oud	9,45	1,00					minimale belem.
F - East - 2 - buitenlucht, N - 13,5 m² - 90°							
voor + achtergevel nieuw	9,80	5,00					minimale belem.
raam nieuw dakopbo...	3,70		0,82	0,50	nee		minimale belem.
F - West - 2 - buitenlucht, W - 13,5 m² - 30°							
voor + achtergevel nieuw	9,80	5,00					minimale belem.
raam nieuw dakopbo...	3,70		0,82	0,50	nee		minimale belem.
R - hor - buitenlucht, HOR, dak - 29,5 m² - 0°							
dak	29,50	7,00					minimale belem.
F - North - buitenlucht, N - 9,7 m² - 90°							
voor + achtergevel nieuw	9,70	5,00					minimale belem.
F - South - buitenlucht, Z - 9,7 m² - 90°							
voor + achtergevel nieuw	9,70	5,00					minimale belem.

De lineaire warmteverliezen zijn berekend volgens de forfaitaire methode uit hoofdstuk 13 van NEN 1068.

Overige kenmerken overconstructies (inclusief evt. kruipruimten en onverwarmde kelders)

Ground floor - vloer op/boven mv; boven kruipruimte

hoogte bovenkant vloer boven maaiveld (h)	0,20 m
omtrek van het vloerveld (P)	10,40 m
grootste dikte v.d. gevels/wanden ter hoogte v.d. bk vloer (d _{bw,v})	0,28 m
gem. vert. afstand tussen MV en bk kelder-, kruipruimtevloer (z _o)	0,45 m
kruipruimteventilatie (ε)	0,0012 m ² /m ¹
warmteweerstand v.d. kelder-, kruipruimtwanden boven mv (R _{xw})	2,12 m ² K/W
warmteweerstand v.d. kelder-, kruipruimtwanden onder mv (R _{bw,o})	2,12 m ² K/W
warmteweerstand v.d. kelder-, kruipruimtevloer (R _{bf})	0,00 m ² K/W

grootste dikte v.d. wand t.h.v. de bk kelder-, kruipruimtevloer (d_{bw,o}) 0,28 m

Verwarming- en warmtapwatersystemen

Triple Solar

Opwekking

type opwekker	combi-warmtepomp
bron warmtepomp	bodem
toestel - warmtepomp	Nibe F1255-6 (PC) met bron van 16 m ² Triple Solar - ook bij PV invullen (geen zonnepanelen invullen)
ontwerpaanvoertemperatuur	30 < θ _{sup} ≤ 35°
energiefractie warmtepomp	1,000
aantal warmtepompen	1
type bijverwarming	elektrisch element
bijstooktoestel geïntegreerd	ja
transmissieverlies verwarmingssysteem - januari (H _T)	96 W
warmtebehoefte verwarmingssysteem (Q _{H,nd;an})	13.644 MJ
hoeveelheid energie t.b.v. verwarming per toestel (Q _{H,dis;nren;an})	13.614 MJ
hoeveelheid energie t.b.v. warmtapwater per toestel (Q _{W,dis;nren;an})	8.624 MJ
opwekkingsrendement verwarming - warmtepomp (η _{H,gen})	0,950
opwekkingsrendement warmtapwater - warmtepomp (η _{W,gen})	0,350
opwekkingsrendement - bijverwarming (η _{H,gen})	0,000

Regeneratie

zonne-energiesysteem voor regeneratie nee

Kenmerken afgiftesysteem verwarming

Type warmteafgifte (in woonkamer)					
type warmteafgifte	positie	hoogte	R _c	θ _{em;avg}	η _{H;em}
radiator- en/of convectiverwarming	buitenwand	< 8 m	≥ 2,5 m ² K/W	≤ 50 °	1,00

regeling warmteafgifte aanwezig ja
 afgifterendement (η_{H;em}) 1,000

Kenmerken distributiesysteem verwarming

buffervat buiten verwarmde ruimten aanwezig nee
 verwarmingsleidingen in verwarmde ruimten en/of kruipruimte nee
 distributierendement (η_{H;em}) 1,000

Kenmerken tapwatersysteem

aantal woningbouw-eenheden aangesloten op systeem 1
 warmtapwatersysteem ten behoeve van keuken en badruimte
 gemiddelde leidinglengte naar badruimte 4-6 m
 gemiddelde leidinglengte naar aanrecht 8-10 m
 inwendige diameter leiding naar aanrecht ≤ 10 mm
 afgifterendement warmtapwater (η_{W;em}) 0,766

Douchewarmteterugwinningdouchewarmteterugwinning *nee***Zonneboiler**zonneboiler *nee***Hulpenergie verwarming**hoofdcirculatiepomp aanwezig *ja*hoofdcirculatiepomp voorzien van pompregeling *ja*aanvullende circulatiepomp aanwezig *nee***Aangesloten rekenzones**

huis

Ventilatie**ventilatie 1**

ventilatiesysteem *mechanische toe- en afvoer - decentraal*
 systeemvariant *Vaven, Fresh-r Nearly Zero (Fresh-r + Fresh-r Forward)*
 luchtvolumestroomfactor voor warmte- en koudebehoefte (f_{sys}) *1,0 (forfaitair conform systeemvariant D.5b NEN 8088-1)*
 correctiefactor regelsysteem voor warmte- en koudebehoefte (f_{reg}) *0,70 (forfaitair conform systeemvariant D.5b NEN 8088-1)*

Kenmerken ventilatiesysteem

werkelijk geïnstalleerde ventilatiecapaciteit bekend *nee*
 luchtdichtheidsklasse ventilatiekanalen *geen ventilatiekanalen*

Passieve koeling

max. benutting geïnstal. ventilatiecapaciteit voor koudebehoefte *ja*
 max. benutting geïnstal. spuicapaciteit voor koudebehoefte *ja*

Kenmerken warmteterugwinning

toevoerkanaal tussen buiten en WTW toestel *geïsoleerd kanaal*
 type isolatie toevoerkanaal tussen buiten en WTW toestel bekend *nee*
 lengte toevoerkanaal tussen buiten en WTW toestel (L_{bu}) *4,0 m*
 rendement warmteterugwinning vlg. NEN 5138 *0,80*
 rendement warmteterugwinning inclusief dissipatie *ja*
 fractie lucht via bypass *0*

Kenmerken ventilatie

totaal nominaal vermogen (P_{nom}) centrale ventilatie-units *30,00 W (1 units)*
 totaal nominaal vermogen (P_{nom}) decentrale ventilatie-units *18,00 W (3 units)*
 reductiefactor luchtvolumestroomregeling centrale ventilatie-units (f_{regfan}) *0,364*
 reductiefactor luchtvolumestroomregeling decentr. ventilatie-units (f_{regfan}) *0,364*
 totaal effectief vermogen (P_{eff}) van alle ventilatie-units *17,472 W*

Aangesloten rekenzones

huis

Zonnestroom**PVT Triple solar**type zonnestroompaneel *Triple Solar PVT340 - Apv=2,00m2 - ook bij verwarming invullen*

Zonnestroom eigenschappen				
ventilatie	A_{PV} [m ²]	oriëntatie	helling [°]	beschaduwng
sterk geventileerd - vrijstaand	14,00	HOR	0	minimale belemmering

Extra PV paneeltype zonnestroompaneel *JA-Solar JAM6(K/BK) (L) 30-300/PR - Apv=1,63m2*

Zonnestroom eigenschappen				
ventilatie	$n_{panelen}$	oriëntatie	helling [°]	beschaduwng
niet geventileerd - op dak/gevel, geen spouw	4	Z	45	minimale belemmering

Resultaten

Jaarlijkse hoeveelheid primaire energie voor de energiefunctie		
verwarming (excl. hulpenergie)	$E_{H,P}$	6.514 MJ
hulpenergie		0 MJ
warmtapwater (excl. hulpenergie)	$E_{W,P}$	6.217 MJ
hulpenergie		0 MJ
koeling (excl. hulpenergie)	$E_{C,P}$	0 MJ
hulpenergie		0 MJ
zomercomfort	$E_{SC,P}$	3.500 MJ
ventilatoren	$E_{V,P}$	1.411 MJ
verlichting	$E_{L,P}$	3.970 MJ
geëxporteerde elektriciteit	$E_{P,exp;el}$	0 MJ
op eigen perceel opgewekte & verbruikte elektriciteit	$E_{P;pr;us;el}$	27.037 MJ
in het gebied opgewekte elektriciteit	$E_{P;pr;dei;el}$	0 MJ
Oppervlakten		
totale gebruiksoppervlakte	$A_{g,tot}$	86,32 m ²
totale verliesoppervlakte	A_{ls}	176,58 m ²
Elektriciteitsgebruik		
gebouwbonden installaties		2.346 kWh
niet-gebouwbonden apparatuur (stelpost)		2.420 kWh
op eigen perceel opgewekte & verbruikte elektriciteit		2.930 kWh
geëxporteerde electriciteit		0 kWh
TOTAAL		1.835 kWh
CO ₂ -emissie		
CO ₂ -emissie	m_{co2}	-330 kg
Energieprestatie		
specifieke energieprestatie	EP	-62 MJ/m ²
karakteristiek energiegebruik	$E_{P,tot}$	-5.386 MJ
toelaatbaar karakteristiek energiegebruik	$E_{P;adm;tot;nb}$	22.338 MJ
energieprestatiecoëfficiënt	EPC	-0,096 -
energieprestatiecoëfficiënt	EPC	-0,09 -
BENG indicatoren		
energiebehoefte		57,0 kWh/m ²
primair energiegebruik		-11,8 kWh/m ²
aandeel hernieuwbare energie		115 %

Het gebouw voldoet aan de eisen inzake energieprestatie uit het Bouwbesluit 2012.

Uniec 2.2 is gebaseerd op NEN7120;2011 "Energieprestatie van gebouwen" (inclusief het Nader Voorschrift) en NEN 8088-1 "Ventilatie en luchtdoorlatendheid van gebouwen" inclusief alle wettelijk van kracht zijnde correctiebladen.

Alle bovenstaande energiegebruiken zijn genormeerde energiegebruiken gebaseerd op een standaard klimaatjaar en een standaard gebruikersgedrag. Het werkelijke energiegebruik zal afwijken van het genormeerde energiegebruik. Aan de berekende energiegebruiken kunnen geen rechten ontleend worden.

Studentenlicentie

Verklaringen

OMGEVINGSCOLLECTOR/ WARMTEPOMPSYSTEEM VAN TRIPLE-SOLAR

Deze gelijkwaardigheidverklaring is opgesteld conform NEN 7120 (EPG), inclusief aanvullingenblad juni 2017, voor een individueel verwarmingstoestel, niet behorend tot warmtelevering door derden, volgens onderstaand installatieschema:

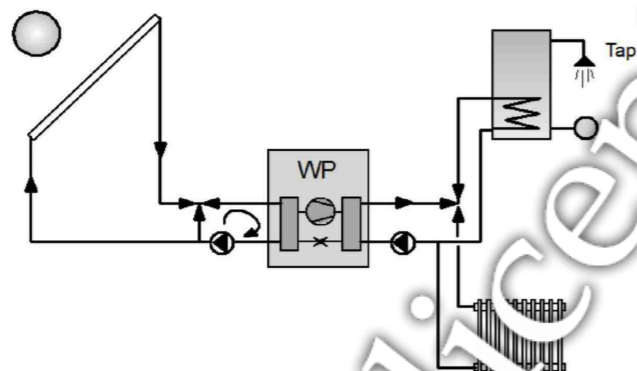

1. Met een omgevingscollector:
 - a. Met een oppervlak van 16 m².
 - b. Thermische prestatiegegevens (IAM, η_{th} en verliescoëfficiënten $c1$ t/m $c6$) volgens metingen van TNO (Oversloot, 2017).
 - c. Met PV-prestatiegegevens: Rendement η_{pv} van 17,5 % en temperatuurcoëfficiënt voor vermogen van -0,39 %/K
 - d. Georiënteerd tussen 90- en 270° (van ZuidWest) en een helling tussen 30- en 45°.
 - e. Met weergegevens (meteo) volgens NEN5060A2 (De Bilt).
 - f. Zonder beschaduwing.
2. Voor één warmtepomp:
 - a. NIBE F1255 6 kW, met prestatiegegevens (COP en P_{th}) volgens EN14511 en EN14825 testen, uitgevoerd door Austrian Institute of Technology en NIBE.
 - b. Met maximale temperatuur van de verdamper 30 °C.
 - c. Met afsnakefficiëntie η_{c} (te) lage verdamper- en (te) hoge condensortemperatuur.
3. En een tapwatervat met een inhoud van 180 liter, met thermische gelaagdheid en een vatverlies gelijk aan 1,37 W/K.
4. Voor levering van ruimteverwarming met een (Z)LTV CV-warmte afgiftesysteem:
 - a. Bruto warmtebehoefte $Q_{H;dis;nren}$ van de woning: 2,5-5-10-20-40-60 GJ/jaar.
 - b. Met ontwerp aanvoertemperatuur van < 30 °C en < 35 °C, bij een ΔT van respectievelijk 3- en 5 K. Voetpunt van de stooklijn/behoefte ligt op 12 °C (≤ 150 MJ/m²) en 16 °C (> 150 MJ/m²).
 - c. Voor een binnentemperatuur van 20 °C, zonder nachtverlaging.
5. En voor levering van warm tapwater met een tapwaterbelasting $Q_{W;dis;nren}$ conform vergelijking 19.11 van NEN7120, voor 6,5- 9,0- 11,5- en 14,0 GJ/jaar, met een tappatroon geschaald met tapklasse 4.
6. Waarbij de energieprestatie (benodigde aandrijfenergie voor levering van ruimteverwarming en warm tapwater is berekend met de methodiek beschreven in [Berkel, 2016] en een daarbij behorende rekentool:
 - a. Waarbij voor elk uur sequentieel, voor een geheel jaar (8760 uur), in Excel de systeemtoestand wordt berekend.
 - b. Met een expliciete tijdsintegratie, van een uur op het volgende uur.

ENTRY

triple solar
verder zonder gas

NIBE

- c. Waarbij rekening is gehouden met de thermische capaciteiten van de collector en het opslagvat.
 - d. Met als input voor weergegevens NEN5060 en uurlijkse waarden voor warmtebelasting voor ruimteverwarming en tapwater.
 - e. Met als output de opwekkingrendementen op ruimteverwarming en tapwater.
 - f. Waarbij het programma is gecontroleerd en gevalideerd aan een simulatie met het commercieel systeem-softwareprogramma PolySun (www.velasolaris.com) en de NEN7120-rekentool voor Lucht/Water-warmtepompen.
7. De tabellen geven het opwekkingsrendement voor ruimteverwarming en warm tapwater, afhankelijk van warmtebehoefte voor ruimteverwarming en warm tapwater, evenals de elektrische opbrengst van de PVT-collector bij onbeschaduwde toepassing.

Ruimteverwarming, $\Theta_{supp} < 30$ °C						
	Bruto warmtebehoefte $Q_{H;dis;nren}$ [GJ]					
	2,5	5	10	20	40	60
$\eta_{H;opw}$ [-] @ $Q_{H;dis} / Ag;tot \leq 150$ MJ/m ²	4,16	4,91	5,39	5,76	5,45	4,54
$\eta_{H;opw}$ [-] @ $Q_{H;dis} / Ag;tot > 150$ MJ/m ²	3,84	4,76	5,39	5,76	5,92	5,73

Ruimteverwarming, $\Theta_{supp} < 35$ °C						
	Bruto warmtebehoefte $Q_{H;dis;nren}$ [GJ]					
	2,5	5	10	20	40	60
$\eta_{H;opw}$ [-] @ $Q_{H;dis} / Ag;tot \leq 150$ MJ/m ²	4,07	4,76	5,25	5,45	5,24	4,37
$\eta_{H;opw}$ [-] @ $Q_{H;dis} / Ag;tot > 150$ MJ/m ²	3,78	4,66	5,27	5,61	5,76	5,55

Tapwater				
	Tapwateraangifte $Q_{W;dis;nren}$ [GJ]			
	6,5	9	11,5	14
$\eta_{W;opw}$ [-] @ $Q_{H;dis} / Ag;tot \leq 150$ MJ/m ²	3,46	3,61	3,68	3,77
$\eta_{W;opw}$ [-] @ $Q_{H;dis} / Ag;tot > 150$ MJ/m ²	3,46	3,61	3,68	3,77

Elektrische opbrengst			
8 stuks PV panelen	Paneelafmeting [m ²]	PV-opbrengst [Wp/m ²]	Opbrengstfactor [-]
PVT340	2	170	0,8

De opwekkingrendementen zijn inclusief elektrische bijstook en alle hulpenergie. Voor tussenliggende waarden mag lineair worden geïnterpoleerd.

8. Deze verklaring betreft het gebruik van het collectoroppervlak t.b.v. PV en warmtepomp. Het collectoroppervlak en de thermische opbrengst mag niet aanvullend als zonneboiler, zonneverwarmingssysteem, worden meegenomen in de EPC-berekening.

Referenties:

Berkel, van J., Aantekendrapportage Gelijkwaardigheid van Zonthermische Warmtepompen conform NEN7120, Entry Technology Support BV, in opdracht van RVO, augustus 2016.

Berkel, van J., Van de rekentool voor Triple Solar Omgevingscollector-Warmtepomp, Entry Technology Support BV, in opdracht van Triple Solar, januari 2017.

Oversloot, H., Meetresultaten Triple Solar collector, rapport TNO 2017 R10903, 28 juni 2017.

Rhemen, dinsdag 13 maart 2018

Dr. ir. J. van Berkel,
Entry Technology Support BV

ENTRY

triple solar
verder zonder gas

NIBE



Codering:	2015-0737GK-PV-WB
Betreft:	Gecontroleerde Kwaliteitsverklaring
Toepassing:	NEN 7120, ISSO 82.1 en ISSO 75.1
Fabrikant:	JA-Solar
Type:	PV-panelen diverse typen
Ingangsdatum verklaring	30-09-2015 (2 juni 2016, 16-09-2016, 16-01-2017 en 7-11-2017 uitgebreid met aantal PV-panelen)
Geldigheidsduur verklaring	

PV-paneel	Afmeting 1 paneel (lxb)	Piekvermogen per m ² paneel [Wp/m ²]	Toegevoegd op
PV-paneel JAM6(R)(BK) 60-265		160	30-09-2015
PV-paneel JAM6(R)(BK) 60-270		165	30-09-2015
PV-paneel JAM6(K)-60-290/PR		175	02-06-2016
PV-paneel JAM6(K)(SE)-60-285/PR		170	02-06-2016
PV-paneel JAM6(K)(SE)-60-290/PR		175	02-06-2016
PV-paneel JAM6(K)(BK)-60-280/PR		170	02-06-2016
PV-paneel JAM6(K)(BK)-60-285/PR		170	02-06-2016
PV-paneel JAM6(K)(BK)(SE)-60-265/4BB		160	02-06-2016
PV-paneel JAM6(K)(BK)(SE)-60-270/4BB		165	02-06-2016
PV-paneel JAM6(K)(BK)(SE)-60-280/4BB	1650x991 mm	170	02-06-2016
PV-paneel JAM6(K)(BK)(SE)-60-285/PR	Oppervlakte 1,63 m ²	170	02-06-2016
PV-paneel JAP6(SE)-60-265/4BB		160	02-06-2016
PV-paneel JAP6(SE)-60-270/4BB		165	02-06-2016
PV-paneel JAM6(K)(BK)-60-265/4BB		160	16-09-2016
PV-paneel JAM6(K)(BK)-60-270/4BB		165	16-09-2016
PV-paneel JAM6(K)-60-290/PR		180	16-01-2017
PV-paneel JAM6(K)-60-300/PR		180	16-01-2017
PV-paneel JAM6(K)(BK)-60-290/PR		175	16-01-2017
PV-paneel JAM6(K)(BK)-60-295/PR		180	16-01-2017
PV-paneel JAM6(K)(BK)-275/4BB		165	16-01-2017
PV-paneel JAM6(K)(BK)-280/4BB		170	16-01-2017
PV-paneel JAP6-60-265/4BB		160	16-01-2017

Vervolg zie volgende bladzijde



PV-paneel	Afmeting 1 paneel (lxb)	Piekvermogen per m ² paneel [Wp/m ²]	Toegevoegd op
PV-paneel JAP6-60-270/4BB	1650x991 mm	165	16-01-2017
PV-paneel JAP6(K)-60-270/4BB	Oppervlakte 1,63 m ²	165	16-09-2016
PV-paneel JAP6(K)-60-275/4BB		165	16-01-2017
PV-paneel JAP6(SE)-72-315/4BB	1956x991 mm	160	02-06-2016
PV-paneel JAP6(SE)-72-320/4BB	Oppervlakte 1,94 m ²	165	02-06-2016
PV-paneel JAP6(K)-72-325/4BB		165	16-01-2017
PV-paneel JAM6S01-300/PR		180	7-11-2017
PV-paneel JAM6S05-295/PR		180	7-11-2017
PV-paneel JAM6S05-300/PR		180	7-11-2017
PV-paneel JAM6S02-280/SC		170	7-11-2017
PV-paneel JAM6S02-285/SC		170	7-11-2017
PV-paneel JAM6S02-295/PR		180	7-11-2017
PV-paneel JAM6S02-300/PR		180	7-11-2017
PV-paneel JAM6(K)(BK)-60-300/PR	1650x991 mm	180	7-11-2017
PV-paneel JAM6S07-275/SC	Oppervlakte 1,67 m ²	165	7-11-2017
PV-paneel JAM6S07-280/SC		170	7-11-2017
PV-paneel JAM6S07-295/PR		180	7-11-2017
PV-paneel JAM6(K)(BK)(SE)-60-295/PR		180	7-11-2017
PV-paneel JAM6(K)(BK)(SE)-60-300/PR		180	7-11-2017
PV-paneel JAP6-60-270/4BB		165	7-11-2017
PV-paneel JAP6S07-275/SC		165	7-11-2017

De piekvermogens uit de bovenstaande tabel mogen alleen worden gebruikt als aangetoond kan worden dat het betreffende paneel van JA-Solar is toegepast.

Appendix 6: Weight calculations variants

SIP variant

Component	Amount	Elements	Material	Densities (kg/m ³)	Amount	Length (m)	Thickness (m)	Weight/m	Weight/m ²	Area element (m ²)	Total weight element		
E-W facade Windows, Alcoa RT 72 Reflex	2	Interior finishing	Gypsum fibre board	1150			0,0125		14,375	8,2	117,875		
		Interior plate	OSB	600			0,015		9	8,2	73,8		
		Insulation	Polyurethane	35			0,112		3,92	8,2	32,144		
		Exterior plate	OSB	600			0,015		9	8,2	73,8		
		Vertical battens	Spruce	580		9	2,7			0,0009	12,6846		
		Horizontal battens	Spruce	580		5	5,5			0,0008	12,76		
		Exterior finishing	Spruce	580				0,02		11,6	11,5	133,4	
		Aluminium frame				1	9,42		1,5			14,13	
		Glass panes				2500	2		0,021		1,35	141,75	
		Horizontal beam	Spruce	580		4	5				0,0055	63,8	
		Total weight, component(s)											1352,2872
		N-facade	1	Interior finishing	Gypsum fibre board	1150			0,0125		14,375	16,4	235,75
Interior plate	OSB			600			0,015		9	7,5	67,5		
Insulation	Polyurethane			35			0,112		3,92	7,5	29,4		
Exterior plate	OSB			600			0,015		9	7,5	67,5		
Vertical battens	Spruce			580			19,3			0,0009	10,0746		
Horizontal battens	Spruce			580		4	5,2			0,0008	9,6512		
Exterior finishing	Spruce			580				0,02		11,6	9,76	113,216	
Horizontal beam	Spruce			580							0,0055	35,4728	
Total weight, component(s)												568,5646	
S-facade	1			Interior finishing	Gypsum fibre board	1150			0,0125		14,375	13,6	195,5
				Interior plate	OSB	600			0,015		9	5,7	51,3
				Insulation	Polyurethane	35			0,112		3,92	5,7	22,344
		Exterior plate	OSB	600			0,015		9	5,7	51,3		
		Vertical battens	Spruce	580			19,3			0,0009	10,0746		
		Horizontal battens	Spruce	580		4	5,2			0,0008	9,6512		
		Exterior finishing	Spruce	580				0,02		11,6	9,76	113,216	
		Horizontal beam	Spruce	580							0,0055	35,4728	
		Total weight, component(s)										488,8586	
		Roof	2	Interior finishing	Gypsum fibre board	1150			0,0125		14,375	12,2	175,375
				Interior plate	OSB	600			0,015		9	14,5	130,5
				Insulation	Polyurethane	35			0,142		4,97	14,5	72,065
Exterior plate	OSB			600			0,015		9	14,5	130,5		
Derbipure roofing	Composite pine resin/vegetable oils/glass&polyester reinforcement/acrylic coating			1222				0,003		3,666	14,5	53,157	
Horizontal beam	Spruce			580			16				0,0055	51,04	
Total weight, component(s)												1225,274	
Total weight, roof structure													3146,1258

Massive wood variant

Component	Amount	Elements	Material	Densities (kg/m ³)	Amount	Length (m)	Thickness (m)	Weight/m	Weight/m ²	Area element (m ²)	Total weight element		
E-W facade Windows, Alcoa RT 72 Reflex	2	Novatop Solid	Spruce + additives	490			0,062		30,38	8,2	249,116		
		Insulation	Kooltherm resol	35			0,089		3,115	11,5	35,8225		
		Construction plate	Gypsum fibre board	1150				0		0	0		
		Vertical battens	Spruce	580		9	2,7			0,0009	12,6846		
		Vertical battens	Spruce	580		9	2,7			0,0016	22,5504		
		Horizontal battens	Spruce	580		5	5,5			0,0008	12,76		
		Exterior finishing	Spruce	580				0,02		11,6	11,5	133,4	
		Aluminium frame				1	9,42		1,5			14,13	
		Glass panes				2500	2		0,021		1,35	141,75	
		Total weight, component(s)										1244,427	
		N-facade	1	Novatop Solid	Spruce + additives	490			0,062		30,38	7,5	227,85
				Insulation	Kooltherm resol	35			0,089		3,115	9,76	30,4024
Construction plate	Gypsum fibre board			1150				0		0	0		
Vertical battens	Spruce			580			19,3			0,0009	10,0746		
Vertical battens	Spruce			580			19,3			0,0016	17,9104		
Horizontal battens	Spruce			580		4	5,2			0,0008	9,6512		
Exterior finishing	Spruce			580				0,02		11,6	9,76	113,216	
Total weight, component(s)												409,1046	
S-facade	1			Novatop Solid	Spruce + additives	490			0,062		30,38	5,7	173,166
				Insulation	Kooltherm resol	35			0,089		3,115	9,76	30,4024
				Construction plate	Gypsum fibre board	1150				0		0	0
				Vertical battens	Spruce	580			19,3			0,0009	10,0746
		Vertical battens	Spruce	580			19,3			0,0016	17,9104		
		Horizontal battens	Spruce	580		4	5,2			0,0008	9,6512		
		Exterior finishing	Spruce	580				0,02		11,6	9,76	113,216	
		Total weight, component(s)										354,4206	
		Roof	2	Novatop Element	Spruce + additives						37,7	14,5	546,65
				Insulation chambers	Kooltherm resol	35			0,146		5,11	14,5	74,095
				Exterior insulation	Kooltherm resol	35			0,027		0,945	14,5	13,7025
				Derbipure roofing	Composite pine resin/vegetable oils/glass&polyester reinforcement/acrylic coating	1222				0,003		3,666	14,5
Total weight, component(s)												1375,209	
Total weight, roof structure												3383,1612	

Steel variant

Component	Amount	Elements	Material	Densities (kg/m3)	Amount	Length (m)	Thickness (m)	Weight/m	Weight/m2	Area element (m2)	Total weight element		
E-W facade	2	Interior plate	Gypsum fibre board	1150			0.0125		14,375	8.2	117,875		
		U profiles	Steel	7800	2	5				0.001	78		
		C profiles	Steel	7800	8	2.3				0.0004	57,408		
		Insulation	Biofoam	35			0.142		4,97	8.2	407,54		
		Exterior plate, 1	Gypsum fibre board	1150			0.0125		14,375	11.5	165,312.5		
		Insulation	Biofoam	35			0.028		0,98	11.5	11,27		
		Exterior plate, 2	Gypsum fibre board	1150			0		0	0	0		
		Vertical battens	Spruce	580	9	2.7				0.0009	12,684.6		
		Horizontal battens	Spruce	580	5	2.7				0.0008	15,221.52		
		Exterior finishing	Spruce	580	5	5.5				0.0008	12,76		
		Aluminium frame			1	9.42				11.6	11.5	133.4	
		Glass panes			2	0.021				1.5		14.13	
		Total weight, component(s)			2500						1.35	141.75	
		Total weight, component(s)											1601,13124
		N-facade	1	Interior plate	Gypsum fibre board	1150			0.0125		14,375	16.4	235,75
U profiles	Steel			7800		11.12				0.001	86,736		
C profiles	Steel			7800	9	1.75				0.0004	49,14		
Insulation	Biofoam			35			0.142		4,97	7.5	37,275		
Exterior plate, 1	Gypsum fibre board			1150	4	5.2	0.0125		14,375	9.76	140.3		
Insulation	Biofoam			35			0.028		0,98	9.76	9,564.8		
Exterior plate, 2	Gypsum fibre board			1150			0		0	0	0		
Vertical battens	Spruce			580		19.3				0.0009	10,074.6		
Horizontal battens	Spruce			580		19.3				0.00108	12,089.52		
Exterior finishing	Spruce			580	4	5.2				0.0008	9,651.2		
Total weight, component(s)					580					11.6	9.76	113,216	
Total weight, component(s)													703,79712
S-facade	1			Interior plate	Gypsum fibre board	1150			0.0125		14,375	13.6	195.5
				U profiles	Steel	7800		11.12				0.001	86,736
				C profiles	Steel	7800	9	1.4				0.0004	39,312
		Insulation	Biofoam	35			0.142		4,97	5.7	28,329		
		Exterior plate, 1	Gypsum fibre board	1150	4	5.2	0.0125		14,375	9.76	140.3		
		Insulation	Biofoam	35			0.028		0,98	9.76	9,564.8		
		Exterior plate, 2	Gypsum fibre board	1150			0		0	0	0		
		Vertical battens	Spruce	580		19.3				0.0009	10,074.6		
		Horizontal battens	Spruce	580		19.3				0.00108	12,089.52		
		Exterior finishing	Spruce	580	4	5.2				0.0008	9,651.2		
		Total weight, component(s)			580					11.6	9.76	113,216	
		Total weight, component(s)											644,77312
		Roof	2	Interior plate	Gypsum fibre board	1150			0.0125		14,375	12.2	175,375
				U profiles	Steel	7800	2	5.2				0.001	81.2
				C profiles	Steel	7800	9	5.3				0.0004	148,824
Insulation	Biofoam			35			0.142		4,97	14.5	72,065		
Exterior plate, x2	Gypsum fibre board			1150			0.0125		14,375	14.5	416,875		
Insulation	Biofoam			35			0.095		3,325	14.5	48,212.5		
Derbipure roofing	Composite pine resin/vegetable oils/glass&polyester reinforcement/acryloating			1222			0.003		3,666	14.5	53,157		
Total weight, component(s)												1991,257	
Total weight, roof structure												4940,95848	

Energy variant

Triple Solar JA Solar VolThera	Weight of panel (kg),		
	Type of panel (with liquid)	Amount of panels	Total weight (kg)
	PVT 280	43	7
Standard	19	4	76
	40	15	600

Appendix 7: MPG calculations design variants

SIP structure variant



Rapportage Freetool MRPI Milieuprestatie Gebouw

In deze rapportage zijn de resultaten en de invoer opgenomen van de milieuprestatieberekening gebouw van Assessment SIP structure variant. De resultaten zijn verdeeld naar de verplichte milieuprestatieberekening voor het bouwbesluit op basis van artikel 5.2 en naar de MPG score. Tot slot is een verantwoording voor de berekening opgenomen.

Algemene gegevens

Naam project:	Assessment SIP structure variant
Organisatie:	TU Delft
Gebruiksfunctie:	Woongebouw
Bvo:	24,5 m2
Levensduur:	75 jaar
Datum rapportage:	22-06-2018

Resultaat bouwbesluit

In bijlage I is een overzicht opgenomen van de geselecteerde producten inclusief hoeveelheden en eventuele dimensies van het product. In de onderstaande tabel zijn de relevante resultaten opgenomen.

Milieu-impact	berekende waarde	eenheid
Uitputting abiotische grondstoffen (excl. fossiel)	0,001	kg Sb eq./ m2 BVO*jaar
Uitputting fossiele energiedragers	0,013	kg Sb eq./ m2 BVO*jaar
Klimaatverandering (100 jaar)	2,09	kg CO2 eq./ m2 BVO*jaar

De berekende resultaten zijn direct gekoppeld aan de in bijlage I opgenomen producten, een afwijkende materialisatie of productkeuze heeft invloed op de berekening. Indien in het verdere ontwerp- en bouwproces andere materiaalkeuzes worden gemaakt dient de milieuprestatie opnieuw berekend te worden.

Resultaat MPG-score

In bijlage I is een overzicht opgenomen van de geselecteerde producten inclusief hoeveelheden en eventuele dimensies van het product. De MPG-score van Assessment SIP structure variant is 0,39 € / m2 BVO. In de onderstaande tabel is dit resultaat weergegeven naar de verschillende bouwdeelen.

Bouwdeel	Resultaat
Fundering	0%
Vloeren	0%
Draagconstructie	0%
Gevels	52,2%
Daken	12,8%
Installaties	0%
Inbouw	34,9%



Rapportage Freetool MRPI Milieuprestatie Gebouw

Bijlage I, invoer berekening

ongetoetst

getoetst

Fundering		
Vloeren		
Draagconstructie		
Gevels		
Gevels, dicht		
Isolatielagen	<input checked="" type="checkbox"/> NVPU; PU plaat; gecacheerd, alulaminaat [5.2]	44,1 m2
Bekledingen	<input checked="" type="checkbox"/> Vuren delen, thermisch behandeld; duurzame bosbouw [1000]	0,85 m2
Gevels, open		
Kozijnen	<input checked="" type="checkbox"/> Aluminium vast en/of draaiend, geanodiseerd	7,4 m2
Beglazing	<input checked="" type="checkbox"/> Drievoudig glas; droog beglaasd [21]	5,4 m2
Daken		
Daken, plat		
Bedekkingen	<input checked="" type="checkbox"/> Plantaardig membraan; enkel laags (3,0 mm); mechanisch bevestigd [3]	29 m2
Installaties		
Inbouw		
Binnenwanden		
Niet dragende wanden, systeem, bekledingen	<input checked="" type="checkbox"/> Gipskartonplaat [12.5]	70,8 m2
Niet dragende wanden, systeem, bekledingen	<input checked="" type="checkbox"/> OSB [1000]	1,76 m2
Niet dragende wanden, systeem, bevestigingsprofielen	<input checked="" type="checkbox"/> Europees naaldhout profiel [46,71]	206 m1

In deze rapportage zijn de resultaten en de invoer opgenomen van de milieuprestatieberekening gebouw van Assessment massive wood variant. De resultaten zijn verdeeld naar de verplichte milieuprestatieberekening voor het bouwbesluit op basis van artikel 5.2 en naar de MPG score. Tot slot is een verantwoording voor de berekening opgenomen.

Algemene gegevens

Naam project:	Assessment massive wood variant
Organisatie:	TU Delft
Gebruiksfunctie:	Woongebouw
Bvo:	24,5 m2
Levensduur:	75 jaar
Datum rapportage:	21-06-2018

Resultaat bouwbesluit

In bijlage I is een overzicht opgenomen van de geselecteerde producten inclusief hoeveelheden en eventuele dimensies van het product. In de onderstaande tabel zijn de relevante resultaten opgenomen.

Milieu-impact	berekende waarde	eenheid
Uitputting abiotische grondstoffen (excl. fossiel)	0	kg Sb eq./ m2 BVO*jaar
Uitputting fossiele energiedragers	0,024	kg Sb eq./ m2 BVO*jaar
Klimaatverandering (100 jaar)	3,64	kg CO2 eq./ m2 BVO*jaar

De berekende resultaten zijn direct gekoppeld aan de in bijlage I opgenomen producten, een afwijkende materialisatie of productkeuze heeft invloed op de berekening. Indien in het verdere ontwerp- en bouwproces andere materiaalkeuzes worden gemaakt dient de milieuprestatie opnieuw berekend te worden.

Resultaat MPG-score

In bijlage I is een overzicht opgenomen van de geselecteerde producten inclusief hoeveelheden en eventuele dimensies van het product. De MPG-score van Assessment massive wood variant is 0,54 € / m2 BVO. In de onderstaande tabel is dit resultaat weergegeven naar de verschillende bouwdeelen.

Bouwdeel	Resultaat
Fundering	0%
Vloeren	0%
Draagconstructie	36,4%
Gevels	53,8%
Daken	9,1%
Installaties	0%
Inbouw	0,7%

Bijlage I, invoer berekening

ongetoetst

getoetst

Fundering		
Vloeren		
Draagconstructie		
Hoofddraagconstructies		
Constructies (kg)	<input checked="" type="checkbox"/> Gelamineerd naaldhout voor constructieve toepassingen, duurzame bosbouw	1992 kg
Gevels		
Gevels, dicht		
Isolatielagen	<input checked="" type="checkbox"/> Fenolschuim [4.3]	100,52 m2
Bekledingen	<input checked="" type="checkbox"/> Vuren delen, thermisch behandeld; duurzame bosbouw [1000]	0,85 m2
Gevels, open		
Kozijnen	<input checked="" type="checkbox"/> Aluminium vast en/of draaiend, geanodiseerd	7,4 m2
Beglazing	<input checked="" type="checkbox"/> Drievoudig glas; droog beglaasd [21]	5,4 m2
Daken		
Daken, plat		
Bedekkingen	<input checked="" type="checkbox"/> Plantaardig membraan; enkel laags (3,0 mm); mechanisch bevestigd [3]	29 m2
Installaties		
Inbouw		
Binnenwanden		
Niet dragende wanden, systeem, bevestigingsprofielen	<input checked="" type="checkbox"/> Europees naaldhout profiel [46,71]	90,41 m1

Rapportage Freetool MRPI Milieuprestatie Gebouw

In deze rapportage zijn de resultaten en de invoer opgenomen van de milieuprestatieberekening gebouw van Assessment staalframebouw. De resultaten zijn verdeeld naar de verplichte milieuprestatieberekening voor het bouwbesluit op basis van artikel 5.2 en naar de MPG score. Tot slot is een verantwoording voor de berekening opgenomen.

Algemene gegevens

Naam project:	Assessment staalframebouw
Organisatie:	TU Delft
Gebruiksfunctie:	Woongebouw
Bvo:	24,5 m2
Levensduur:	75 jaar
Datum rapportage:	22-06-2018

Resultaat bouwbesluit

In bijlage I is een overzicht opgenomen van de geselecteerde producten inclusief hoeveelheden en eventuele dimensies van het product. In de onderstaande tabel zijn de relevante resultaten opgenomen.

Milieu-impact	berekende waarde	eenheid
Uitputting abiotische grondstoffen (excl. fossiel)	0	kg Sb eq./ m2 BVO*jaar
Uitputting fossiele energiedragers	0,015	kg Sb eq./ m2 BVO*jaar
Klimaatverandering (100 jaar)	3,11	kg CO2 eq./ m2 BVO*jaar

De berekende resultaten zijn direct gekoppeld aan de in bijlage I opgenomen producten, een afwijkende materialisatie of productkeuze heeft invloed op de berekening. Indien in het verdere ontwerp- en bouwproces andere materiaalkeuzes worden gemaakt dient de milieuprestatie opnieuw berekend te worden.

Resultaat MPG-score

In bijlage I is een overzicht opgenomen van de geselecteerde producten inclusief hoeveelheden en eventuele dimensies van het product. De MPG-score van Assessment staalframebouw is 0,36 € / m2 BVO. In de onderstaande tabel is dit resultaat weergegeven naar de verschillende bouwdeelen.

Bouwdeel	Resultaat
Fundering	0%
Vloeren	0%
Draagconstructie	5,3%
Gevels	66%
Daken	8,6%
Installaties	0%
Inbouw	20,1%

Bijlage I, invoer berekening

ongetoetst

getoetst

Fundering

Vloeren

Draagconstructie

Hoofddraagconstructies

Constructies (kg)	<input checked="" type="checkbox"/> Staal zwaar constructiestaal o.a. balken, profielen en liggers	992 kg
-------------------	--	--------

Gevels

Gevels, dicht

Isolatielagen	<input checked="" type="checkbox"/> Schuimisolatie van biopolymeren (BIO-EPS) [4]	130 m2
Bekledingen	<input checked="" type="checkbox"/> Vuren delen, thermisch behandeld; duurzame bosbouw [1000]	0,85 m2

Gevels, open

Kozijnen	<input checked="" type="checkbox"/> Aluminium vast en/of draaiend, geanodiseerd	7,4 m2
Beglazing	<input checked="" type="checkbox"/> Drievoudig glas; droog beglaasd [21]	5,4 m2

Daken

Daken, plat

Bedekkingen	<input checked="" type="checkbox"/> Plantaardige membraan; 3,0 mm boven laag en 2,5 mm onder laag; koud verlijmd	29 m2
-------------	--	-------

Installaties

Inbouw

Binnenwanden

Niet dragende wanden, systeem, bekledingen	<input checked="" type="checkbox"/> Gipskartonplaat [12.5]	171 m2
Niet dragende wanden, systeem, bevestigingsprofielen	<input checked="" type="checkbox"/> Europees naaldhout profiel [46,71]	76,54 m1

Rapportage Freetool MRPI Milieuprestatie Gebouw

In deze rapportage zijn de resultaten en de invoer opgenomen van de milieuprestatieberekening gebouw van Triple Solar. De resultaten zijn verdeeld naar de verplichte milieuprestatieberekening voor het bouwbesluit op basis van artikel 5.2 en naar de MPG score. Tot slot is een verantwoording voor de berekening opgenomen.

Algemene gegevens

Naam project:	Triple Solar
Organisatie:	TU Delft
Gebruiksfunctie:	Woongebouw
Bvo:	92,1 m2
Levensduur:	75 jaar
Datum rapportage:	22-06-2018

Resultaat bouwbesluit

In bijlage I is een overzicht opgenomen van de geselecteerde producten inclusief hoeveelheden en eventuele dimensies van het product. In de onderstaande tabel zijn de relevante resultaten opgenomen.

Milieu-impact	berekende waarde	eenheid
Uitputting abiotische grondstoffen (excl. fossiel)	0,001	kg Sb eq./ m2 BVO*jaar
Uitputting fossiele energiedragers	0,011	kg Sb eq./ m2 BVO*jaar
Klimaatverandering (100 jaar)	1,6	kg CO2 eq./ m2 BVO*jaar

De berekende resultaten zijn direct gekoppeld aan de in bijlage I opgenomen producten, een afwijkende materialisatie of productkeuze heeft invloed op de berekening. Indien in het verdere ontwerp- en bouwproces andere materiaalkeuzes worden gemaakt dient de milieuprestatie opnieuw berekend te worden.

Resultaat MPG-score

In bijlage I is een overzicht opgenomen van de geselecteerde producten inclusief hoeveelheden en eventuele dimensies van het product. De MPG-score van Triple Solar is 0,32 € / m2 BVO. In de onderstaande tabel is dit resultaat weergegeven naar de verschillende bouwdelen.

Bouwdeel	Resultaat
Fundering	0%
Vloeren	0%
Draagconstructie	0%
Gevels	0%
Daken	0%
Installaties	100%
Inbouw	0%

Bijlage I, invoer berekening

ongetoetst

getoetst

Fundering		
Vloeren		
Draagconstructie		
Gevels		
Daken		
Installaties		
Warmtelevering		
Zonneverwarminginstallaties	<input checked="" type="radio"/> Individuele zvi; collector+opslagvat (bij 4m2 collector)	13,79 m2
Elektrische installatie		
Elektriciteitsopwekkingsystemen	<input checked="" type="radio"/> Kristallijn silicium, paneel (135 Wp/m2); paneel+inverter+bekabeling+steun	13 m2
Inbouw		



Rapportage Freetool MRPI Milieuprestatie Gebouw



Rapportage Freetool MRPI Milieuprestatie Gebouw

In deze rapportage zijn de resultaten en de invoer opgenomen van de milieuprestatieberekening gebouw van Triple Solar. De resultaten zijn verdeeld naar de verplichte milieuprestatieberekening voor het bouwbesluit op basis van artikel 5.2 en naar de MPG score. Tot slot is een verantwoording voor de berekening opgenomen.

Algemene gegevens

Naam project:	Triple Solar
Organisatie:	TU Delft
Gebruiksfunctie:	Woongebouw
Bvo:	92,1 m2
Levensduur:	75 jaar
Datum rapportage:	22-06-2018

Resultaat bouwbesluit

In bijlage I is een overzicht opgenomen van de geselecteerde producten inclusief hoeveelheden en eventuele dimensies van het product. In de onderstaande tabel zijn de relevante resultaten opgenomen.

Milieu-impact	berekende waarde	eenheid
Uitputting abiotische grondstoffen (excl. fossiel)	0,001	kg Sb eq./ m2 BVO*jaar
Uitputting fossiele energiedragers	0,013	kg Sb eq./ m2 BVO*jaar
Klimaatverandering (100 jaar)	1,9	kg CO2 eq./ m2 BVO*jaar

De berekende resultaten zijn direct gekoppeld aan de in bijlage I opgenomen producten, een afwijkende materialisatie of productkeuze heeft invloed op de berekening. Indien in het verdere ontwerp- en bouwproces andere materiaalkeuzes worden gemaakt dient de milieuprestatie opnieuw berekend te worden.

Resultaat MPG-score

In bijlage I is een overzicht opgenomen van de geselecteerde producten inclusief hoeveelheden en eventuele dimensies van het product. De MPG-score van Triple Solar is 0,41 € / m2 BVO. In de onderstaande tabel is dit resultaat weergegeven naar de verschillende bouwdelen.

Bouwdeel	Resultaat
Fundering	0%
Vloeren	0%
Draagconstructie	0%
Gevels	0%
Daken	0%
Installaties	100%
Inbouw	0%

Bijlage I, invoer berekening

- ongetoetst
 getoetst

Fundering		
Vloeren		
Draagconstructie		
Gevels		
Daken		
Installaties		
Warmtelevering		
Zonneverwarminginstallaties	<input checked="" type="radio"/> Individuele zvi; collector+opslagvat (bij 4m2 collector)	24,5 m2
Elektrische installatie		
Elektriciteitsopwekkingsystemen	<input checked="" type="radio"/> Kristallijn silicium, paneel (135 Wp/m2); paneel+inverter+bekabeling+steun	13 m2
Inbouw		