

# P5 PRESENTATIE

19-12-2014

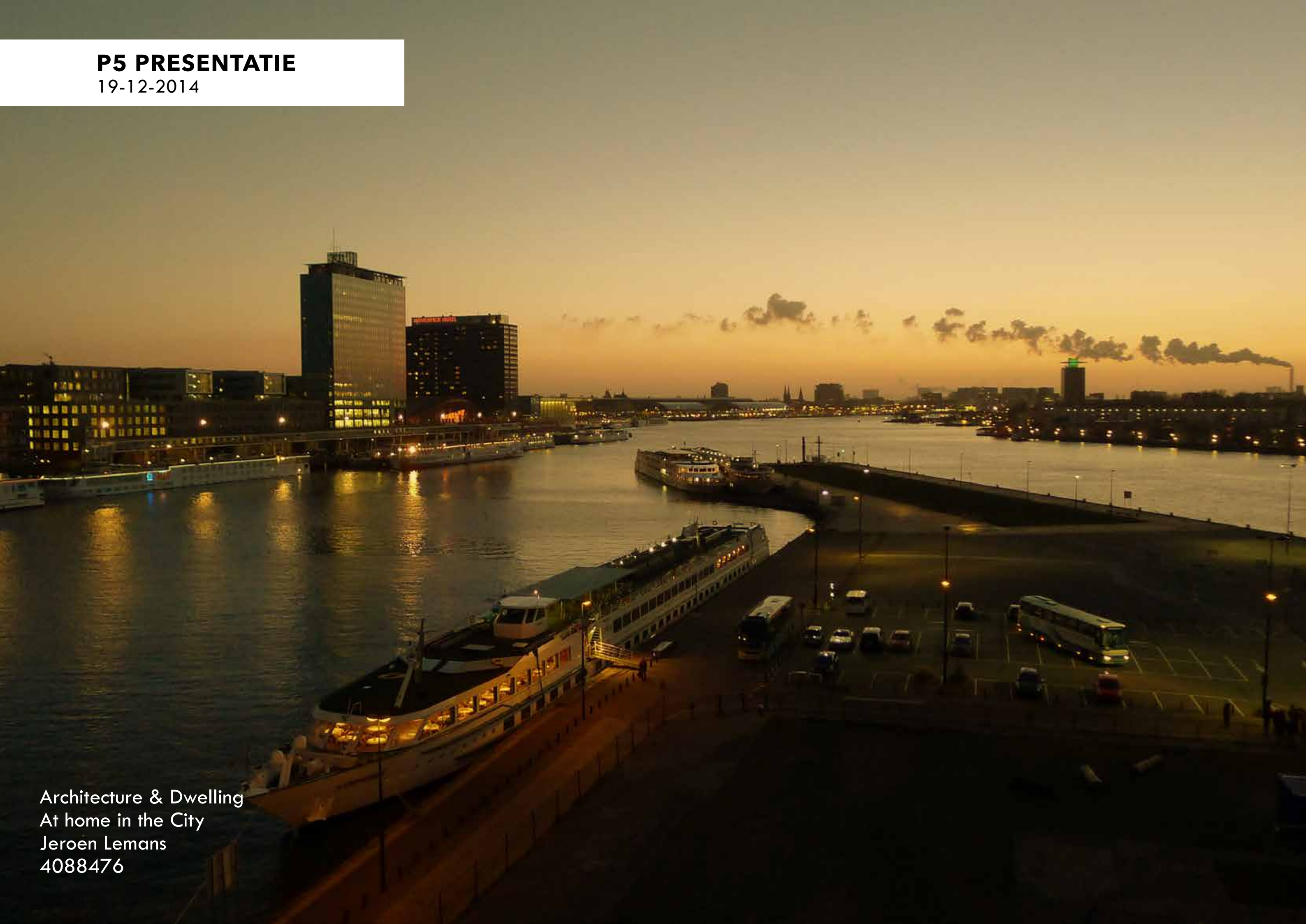

Architecture & Dwelling  
At home in the City  
Jeroen Lemans  
4088476

# 1 INHOUDSOPGAVE

ONTWERPOPGAVE

AANPAK

PLAN

WOONCONCEPT

TECHNIEK

IMPRESSIE

WONINGEN

KLIMAAT



## 2 ONTWERPOPGAVE

Hoe kan één van de meest levendige evenementlocatie's van Amsterdam, de Kop van Java Eiland een woongebouw huisvesten zonder de capaciteit van het evenement te verliezen?



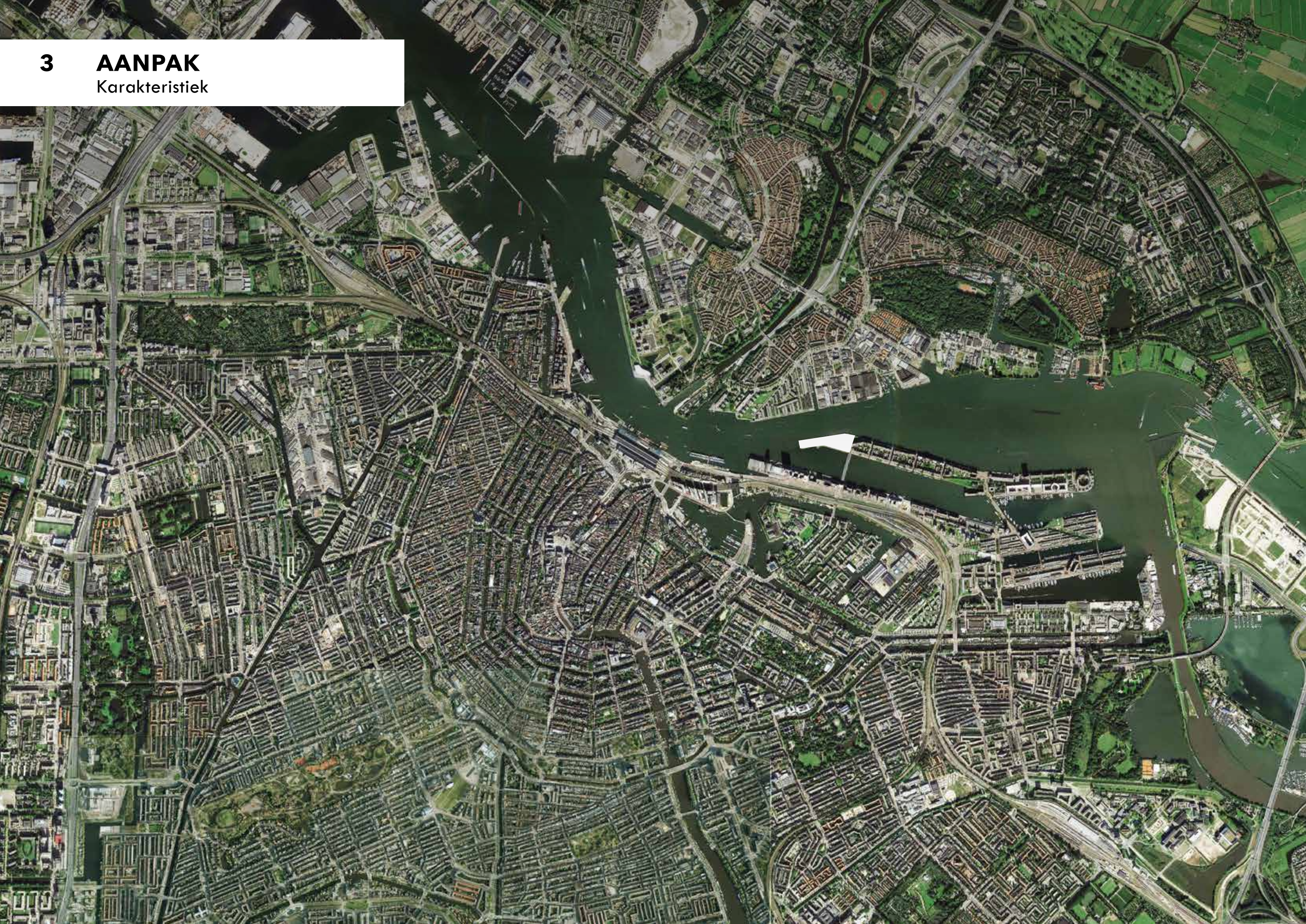



4

# AANPAK

Karakteristiek





5

# AANPAK

Karakteristiek





**6**

## **AANPAK**

Karakteristiek

**THE EYE**

**SHELL TOREN**

**AMSTERDAM CS**

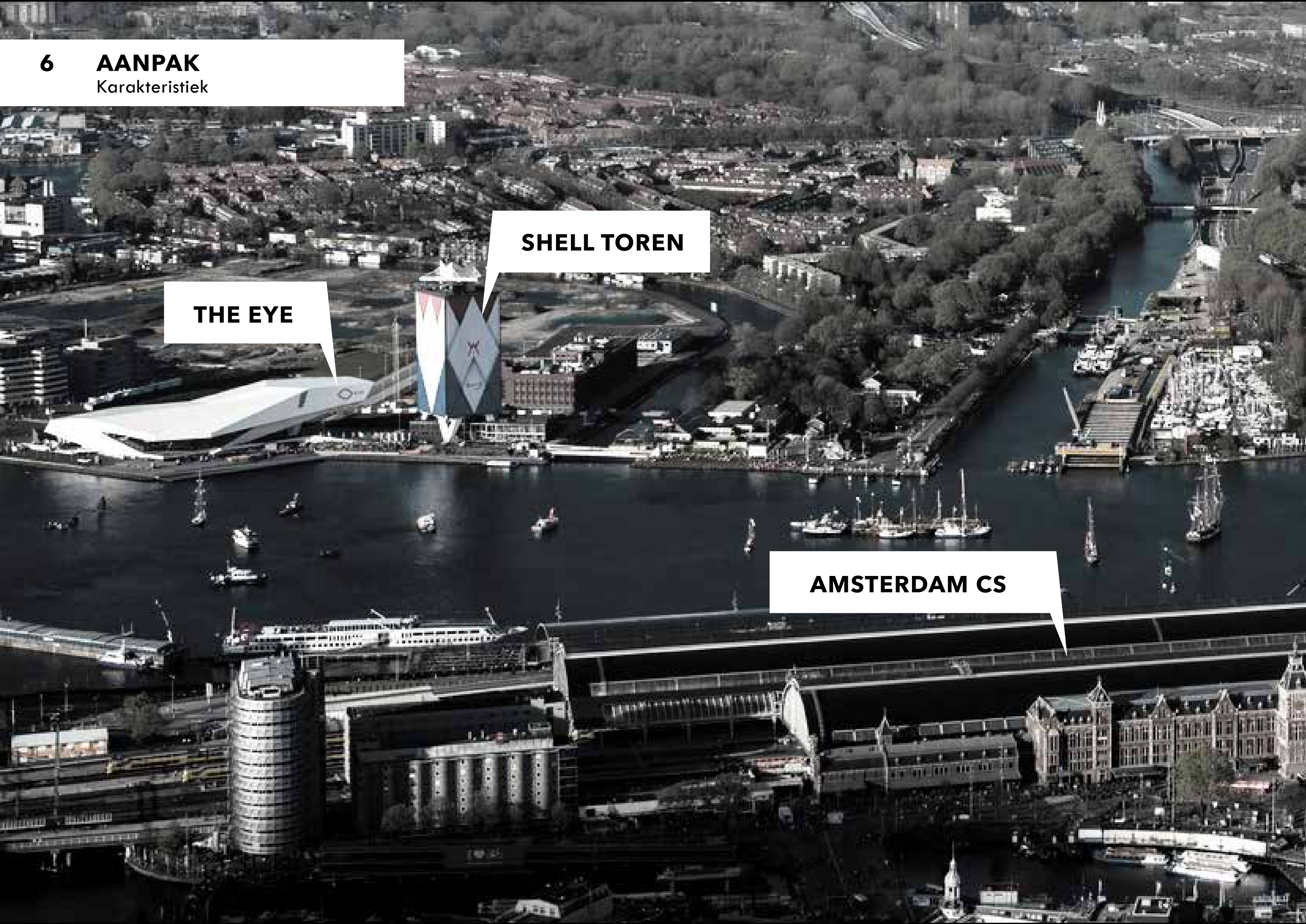

7

**AANPAK**  
Karakteristiek



**AMSTERDAM CS**



An aerial photograph of a city harbor, likely Amsterdam, showing a dense cluster of buildings along the waterfront and numerous sailboats in the water. A white callout box points to a modern building on the right side of the image.

**MUZIEKGEBOUW  
AAN HET IJ**





**10 AANPAK**  
Voorgaande functie





# 11 AANPAK

Leeftijd





13 AANPAK  
Inkomen





**14 AANPAK**  
Woningwaarde



**15 AANPAK**  
Huidig gebruik

**HOND UITLATEN**

**HARDLOPEN**

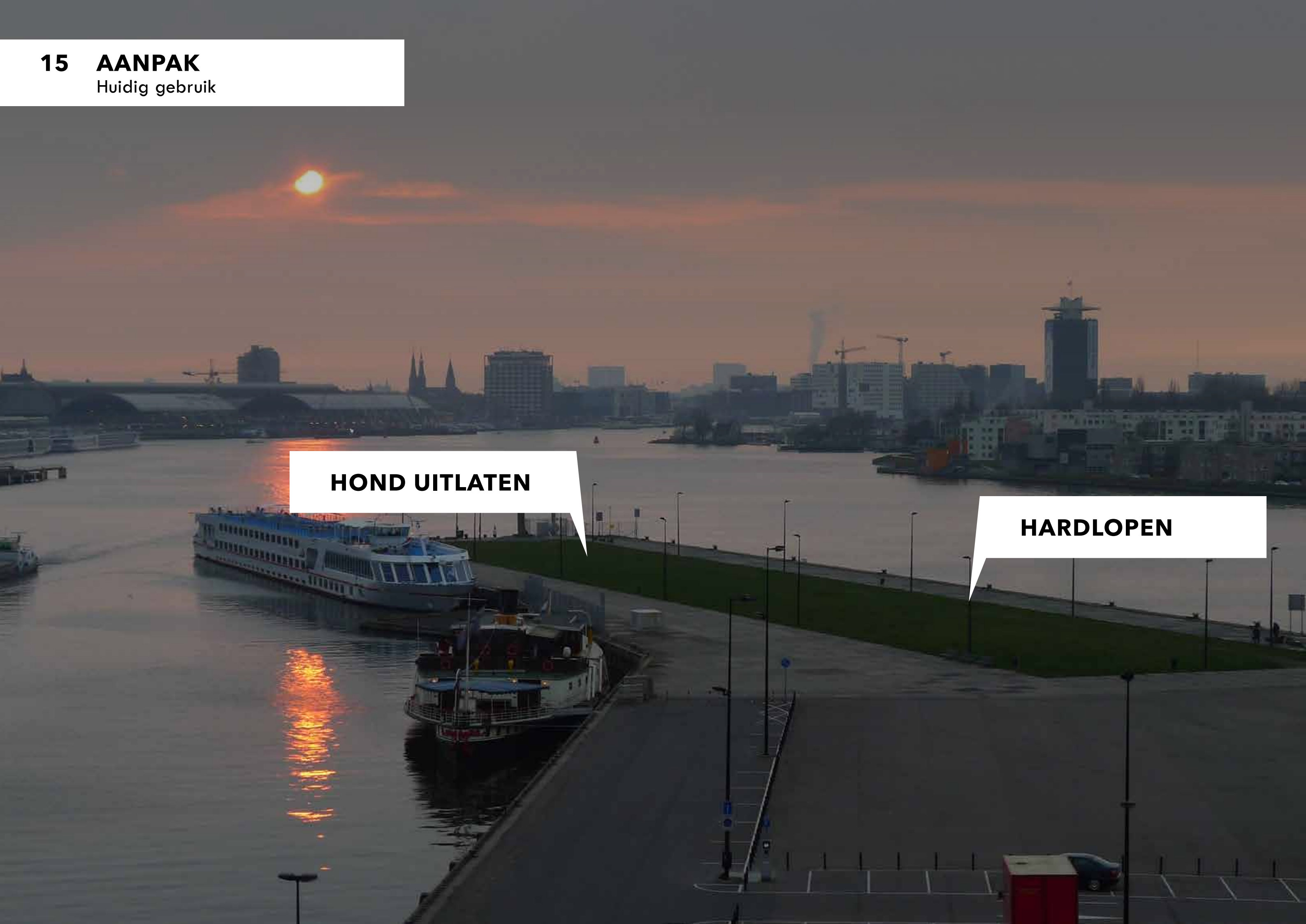



**16 AANPAK**  
Huidig gebruik

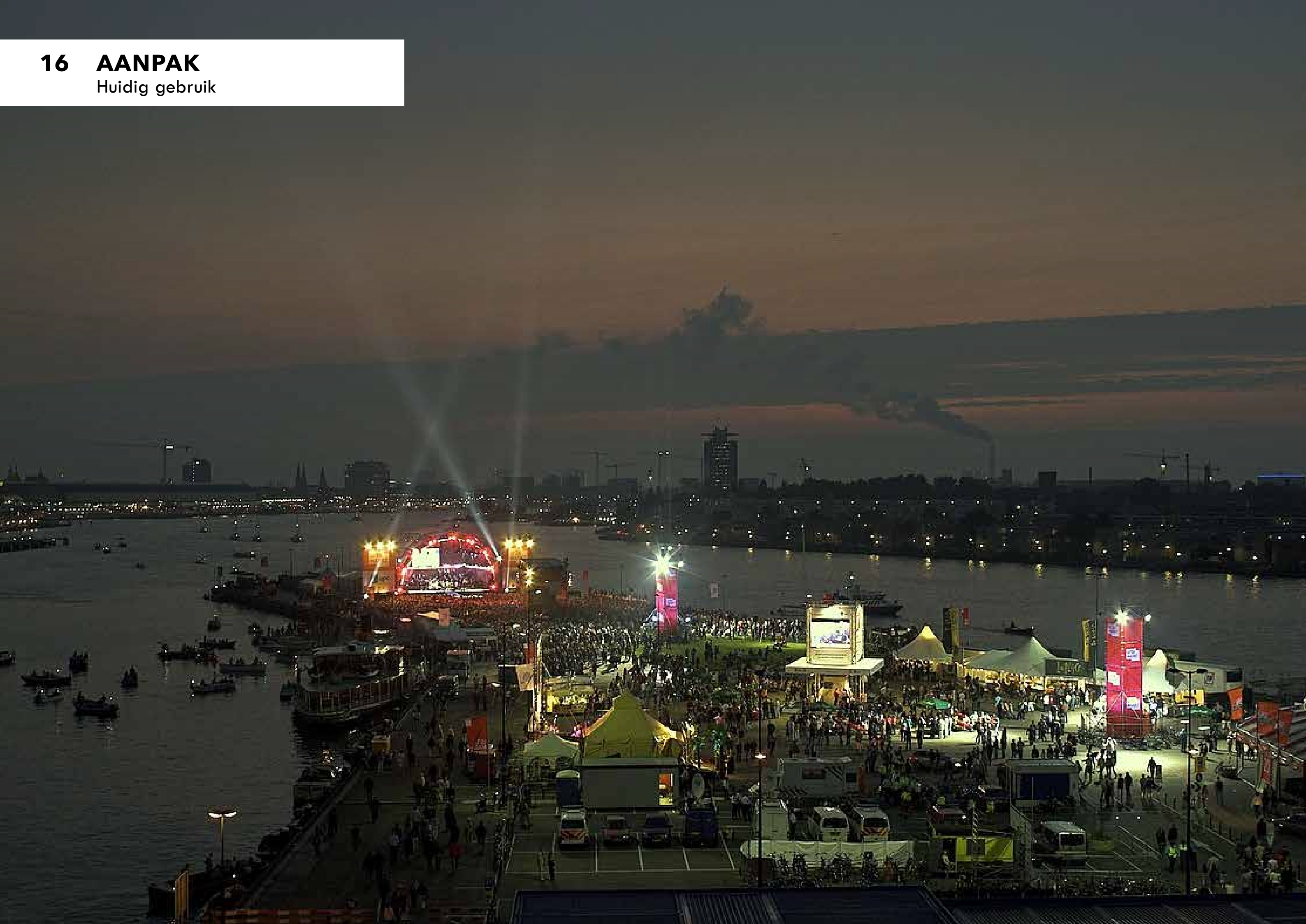



**17 AANPAK**  
Huidig gebruik

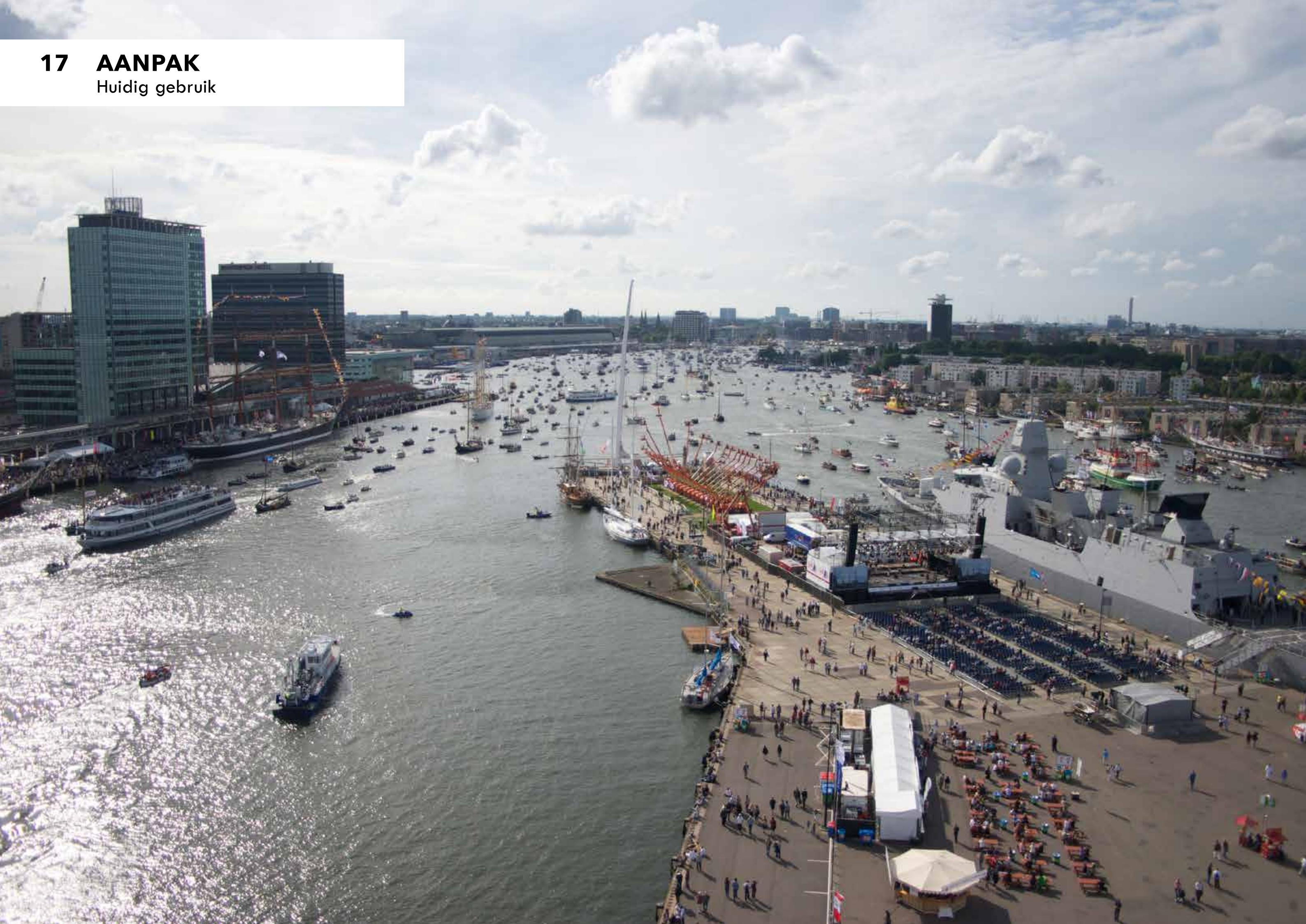



**18 AANPAK**  
Evenementen configuraties

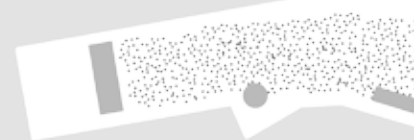
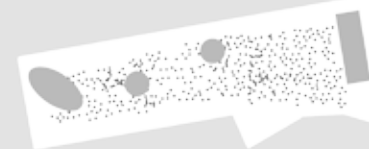

# 19 AANPAK

Evenementen categorieën

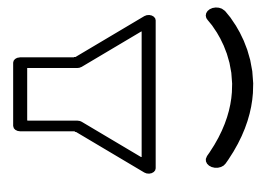

Categorie A  
Laag risico

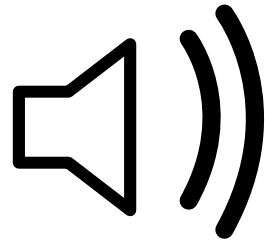

Categorie B  
Gemiddeld risico

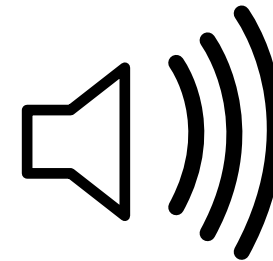

Categorie C  
Hoog risico



**20 AANPAK**  
Evenement & overlast

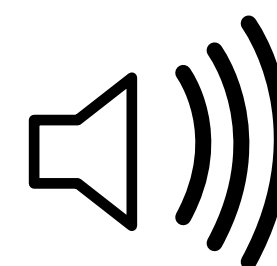
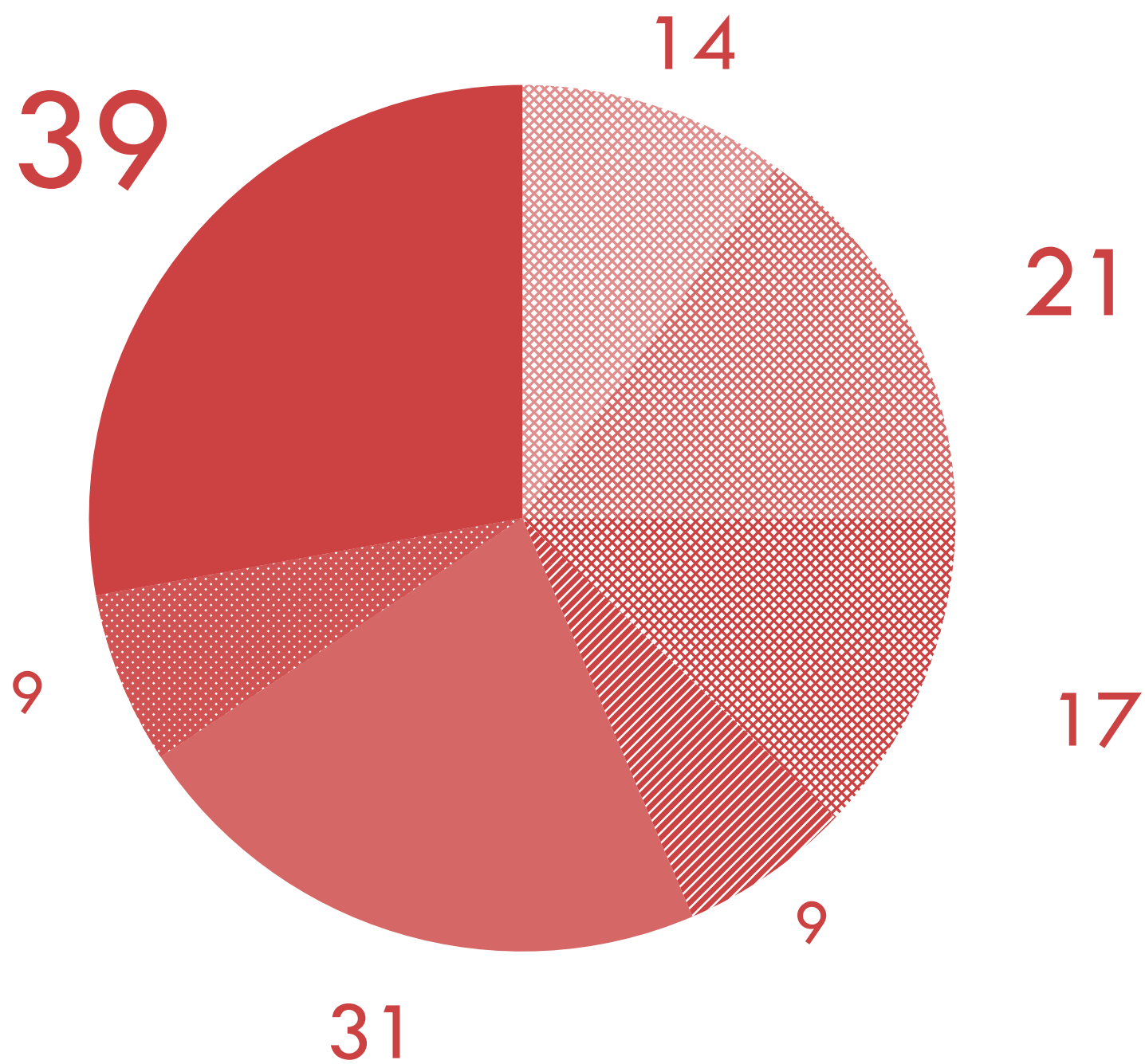

Categorie C  
Hoog risico





**21 AANPAK**  
Overlast & organisatorisch aspect

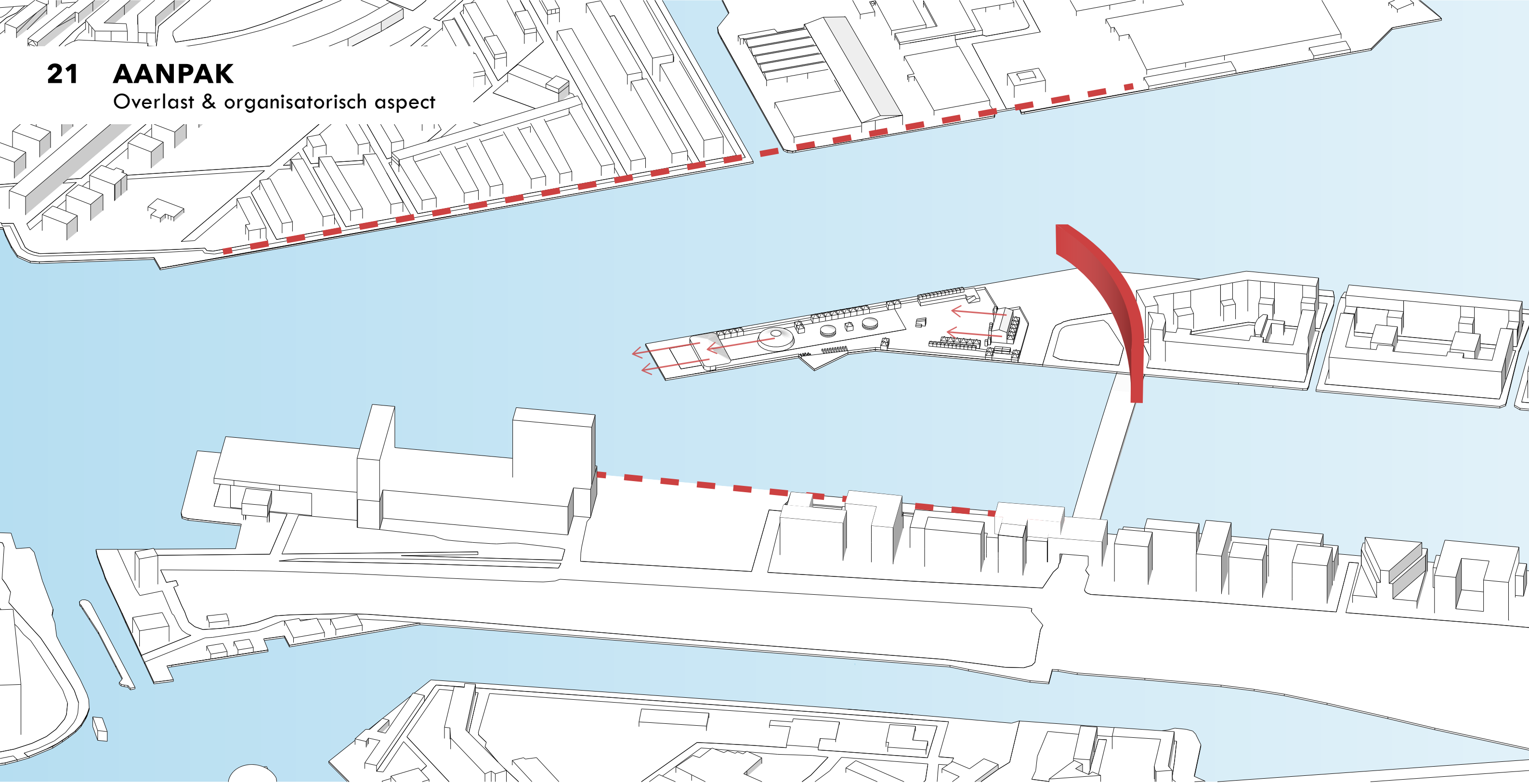

Configuratie van het evenement

Buurtparticipatie

**22 AANPAK**  
Overlast & omgevings aspect

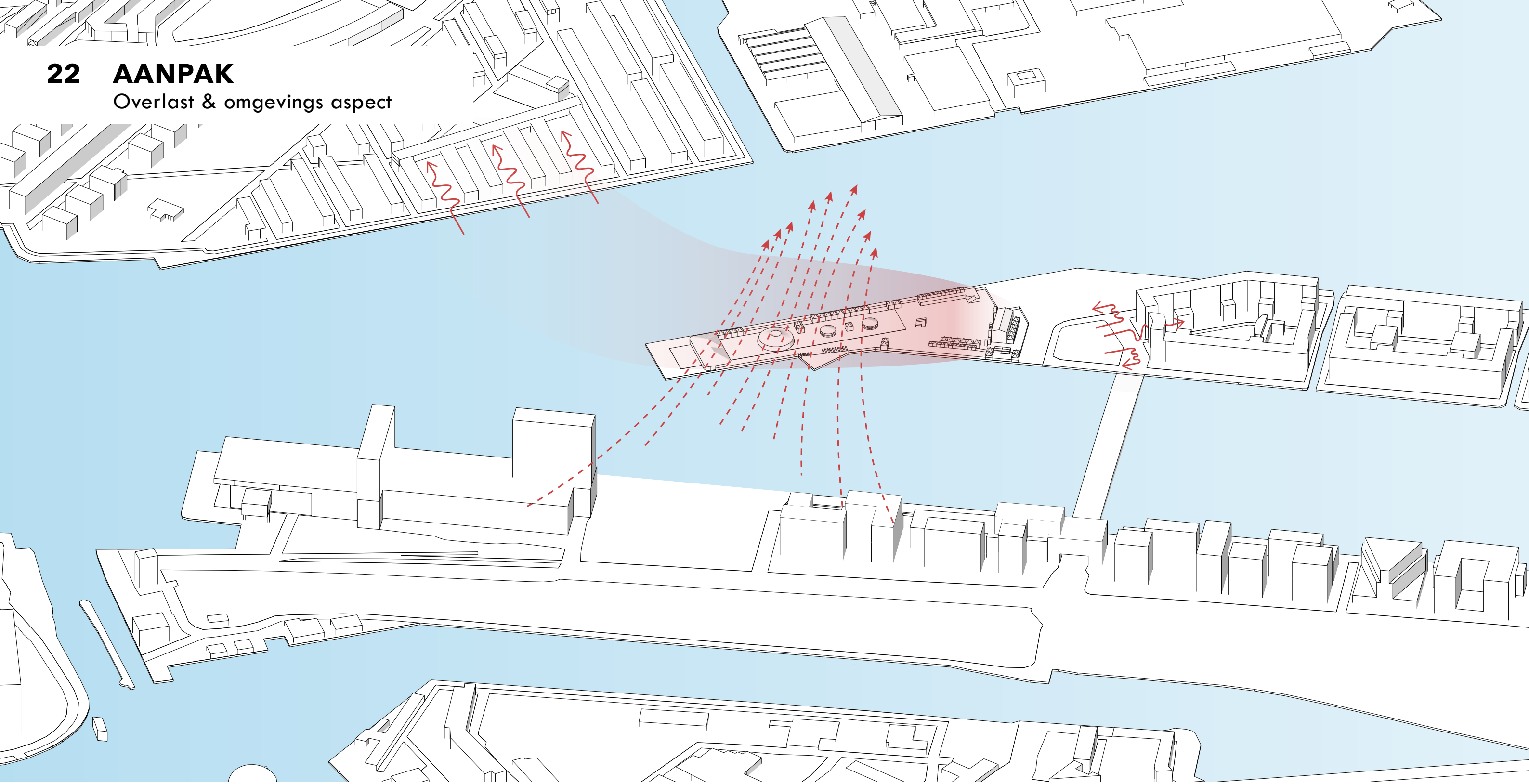

Wind verspreid geluidsoverlast en versterkt de resonantie tussen woningen



**23 AANPAK**  
Overlast & technisch aspect

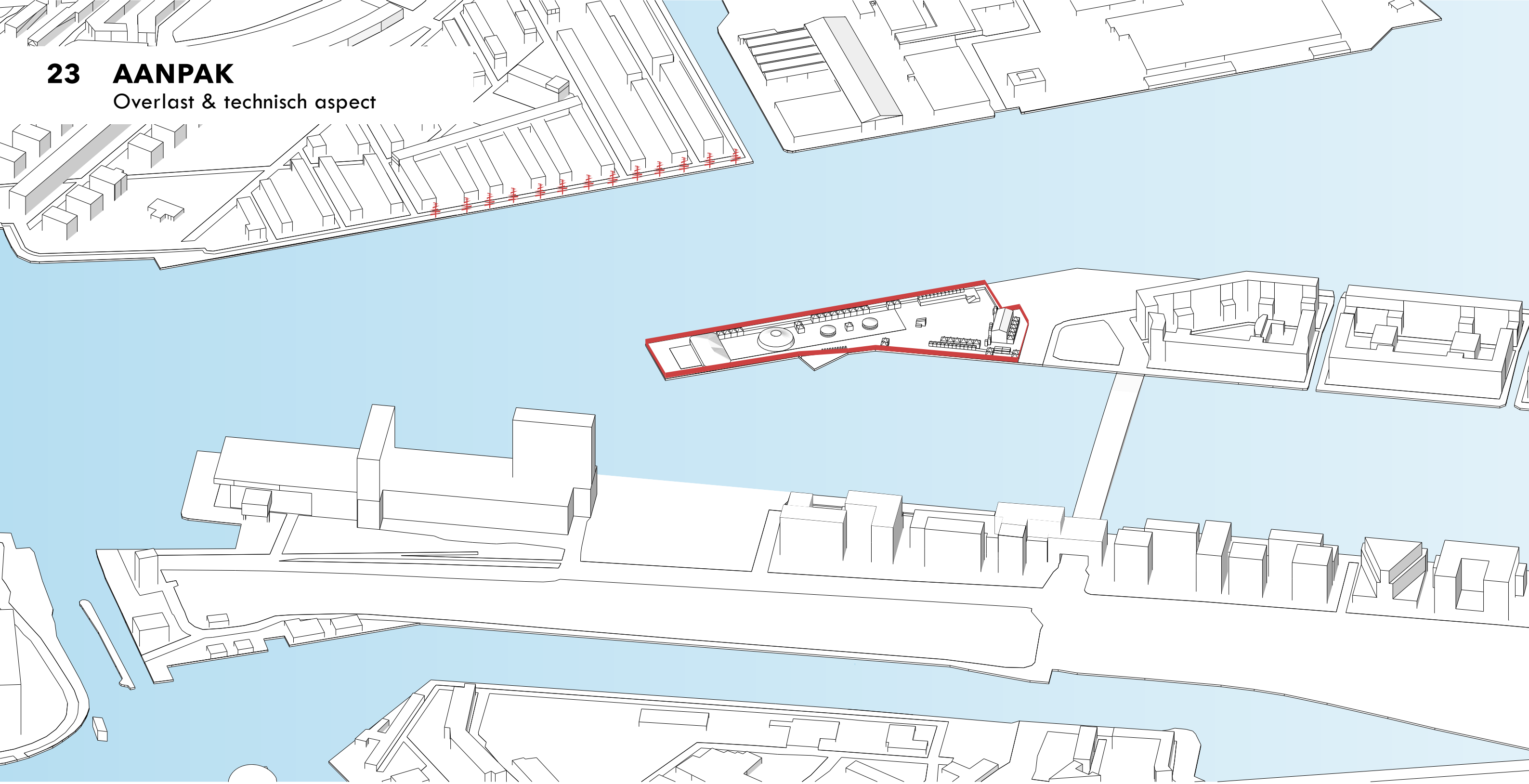

Optimalisatie van akoestiek van het evenement

Verhoog de geluidsisolatie van de woningen of omgeving

**24 AANPAK**  
Overlast & sociaal aspect

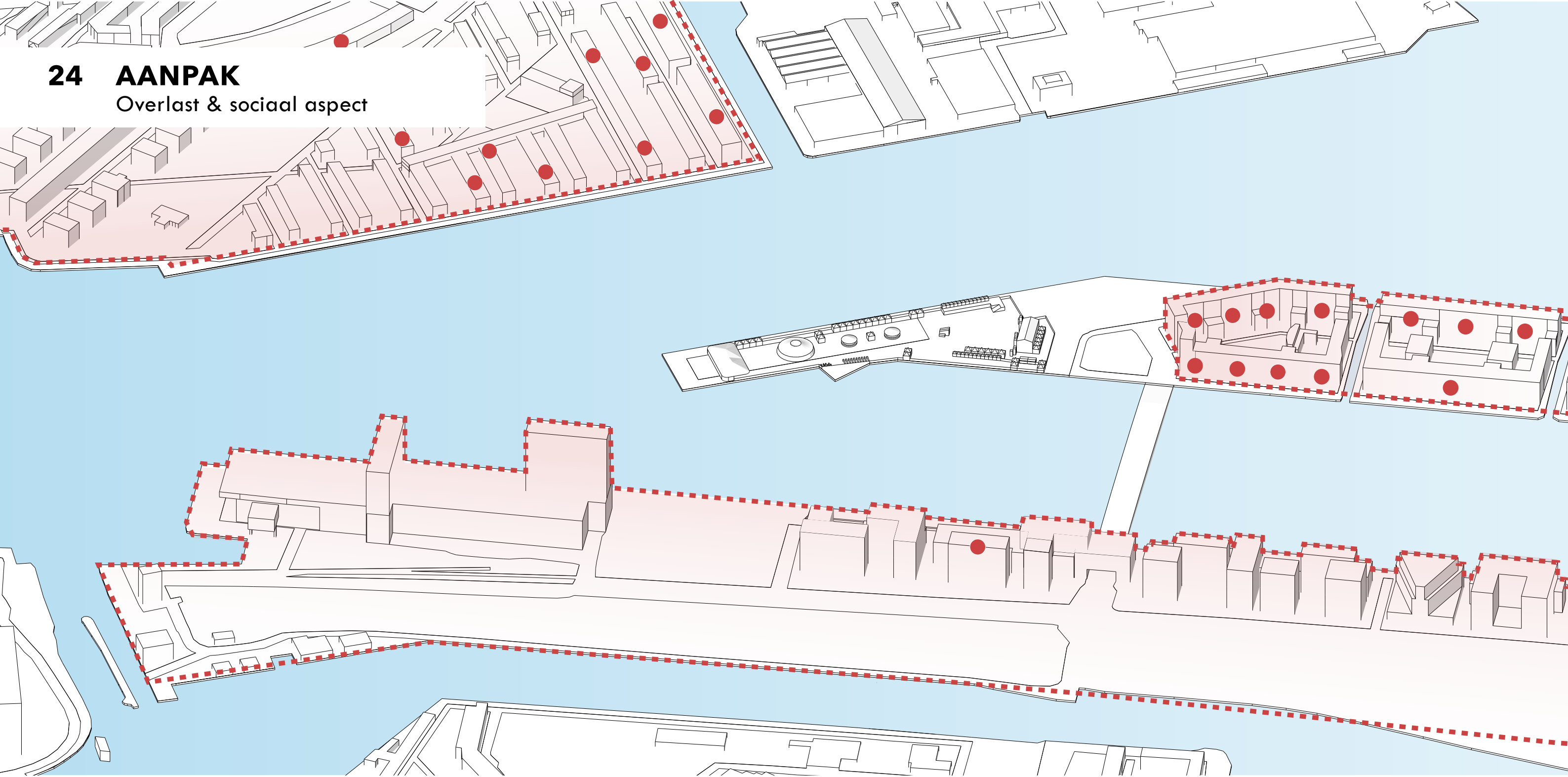

Totale beleving van het evenement kan overlast beperken

Stressfactor is hoger bij mensen met maatschappelijke problemen



## 25 AANPAK

Overlast evenementen

..evenement is controleerbaar, maar de bezoekers niet..





**27 AANPAK**  
Overlast evenementen





..een conflict in relatie met toegankelijkheid en territoriale aanspraak.



## 29 AANPAK

### Territoriale aanspraak

“Wanneer je je bij het ontwerpen van iedere ruimte en ieder onderdeel bewust bent van de mate van territoriale aanspraak en de daarbij passende vormen van ‘toegankelijkheid’ ten opzichte van hetgeen ernaast ligt, dan kun je deze verschillen tot uitdrukking brengen in geleding van vorm, materiaal, licht en kleur en daarmee een ordening introduceren.

Dit zal weer tot grotere duidelijkheid en meer begrip kunnen leiden bij bewoners en bezoekers over hoe het bouwwerk ten aanzien van toegankelijkheid in verschillende ‘sferen’ in elkaar zit.

De mate waarin plekken en ruimten toegankelijk zijn, biedt maatstaven voor het ontwerpen. De keuze van architectonische elementen, hun geleding, vorm en materiaal laten zich mede hierdoor bepalen.”

- *Herman Hertzberger*

## 30 AANPAK

### Territoriale aanspraak

“Wanneer je je bij het ontwerpen van iedere ruimte en ieder onderdeel bewust bent van de mate van territoriale aanspraak en de daarbij passende vormen van ‘toegankelijkheid’ ten opzichte van hetgeen ernaast ligt, dan kun je deze verschillen tot uitdrukking brengen in geleding van vorm, materiaal, licht en kleur en daarmee een ordening introduceren

Dit zal weer tot grotere duidelijkheid en meer begrip kunnen leiden bij bewoners en bezoekers over hoe het bouwwerk ten aanzien van toegankelijkheid in verschillende ‘sferen’ in elkaar zit.

De mate waarin plekken en ruimten toegankelijk zijn, biedt maatstaven voor het ontwerpen. De keuze van architectonische elementen, hun geleding, vorm en materiaal laten zich mede hierdoor bepalen.”

- Herman Hertzberger



**31 AANPAK**  
Toegankelijkheid





**32 AANPAK**  
Toegankelijkheid | Vorm









**34 AANPAK**  
Toegankelijkheid | Licht









**36 AANPAK**  
Toegankelijkheid | Zonering





**37 AANPAK**  
Architectonische elementen





**38 AANPAK**  
Architectonische elementen

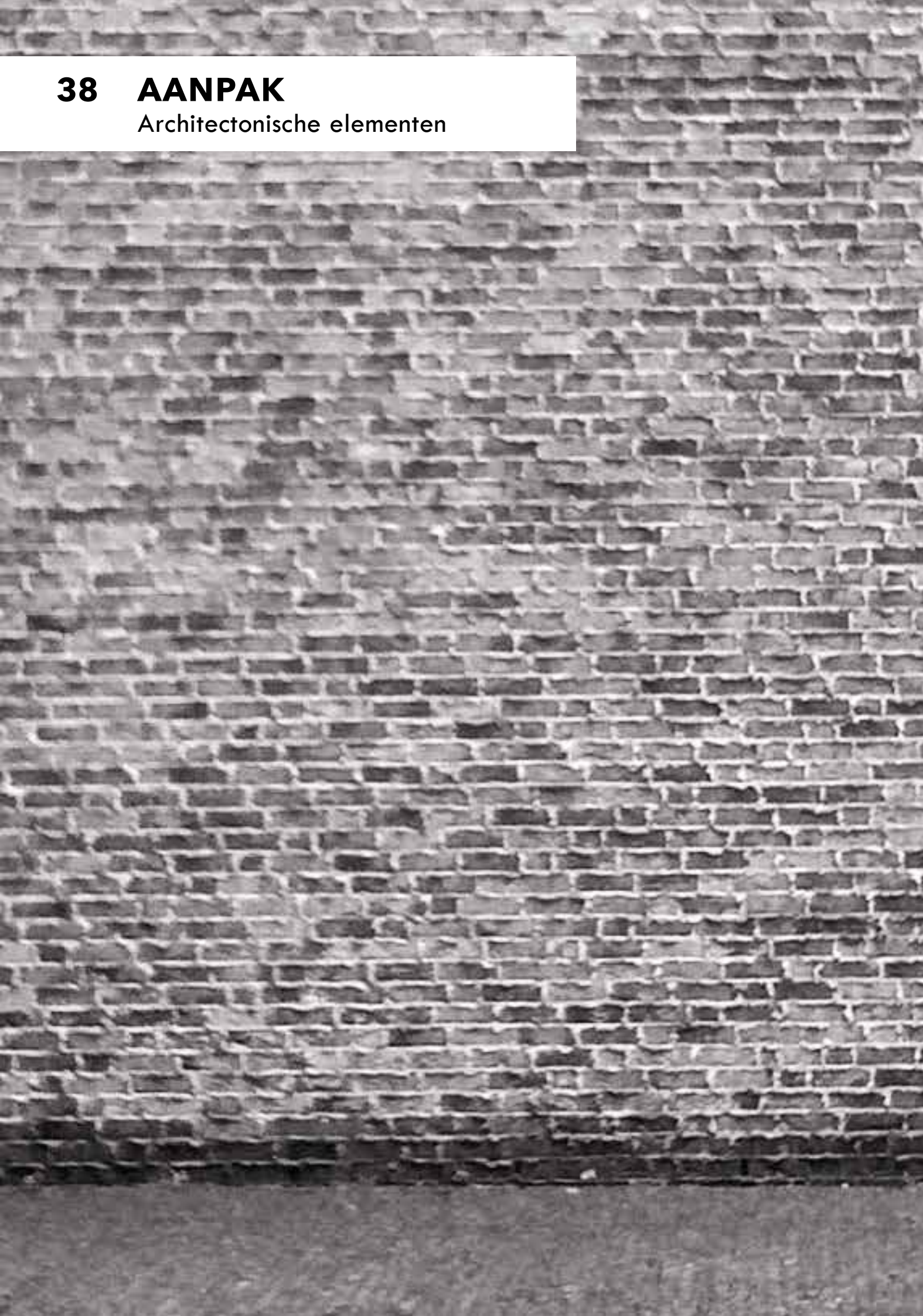



**39 AANPAK**  
Architectonische elementen

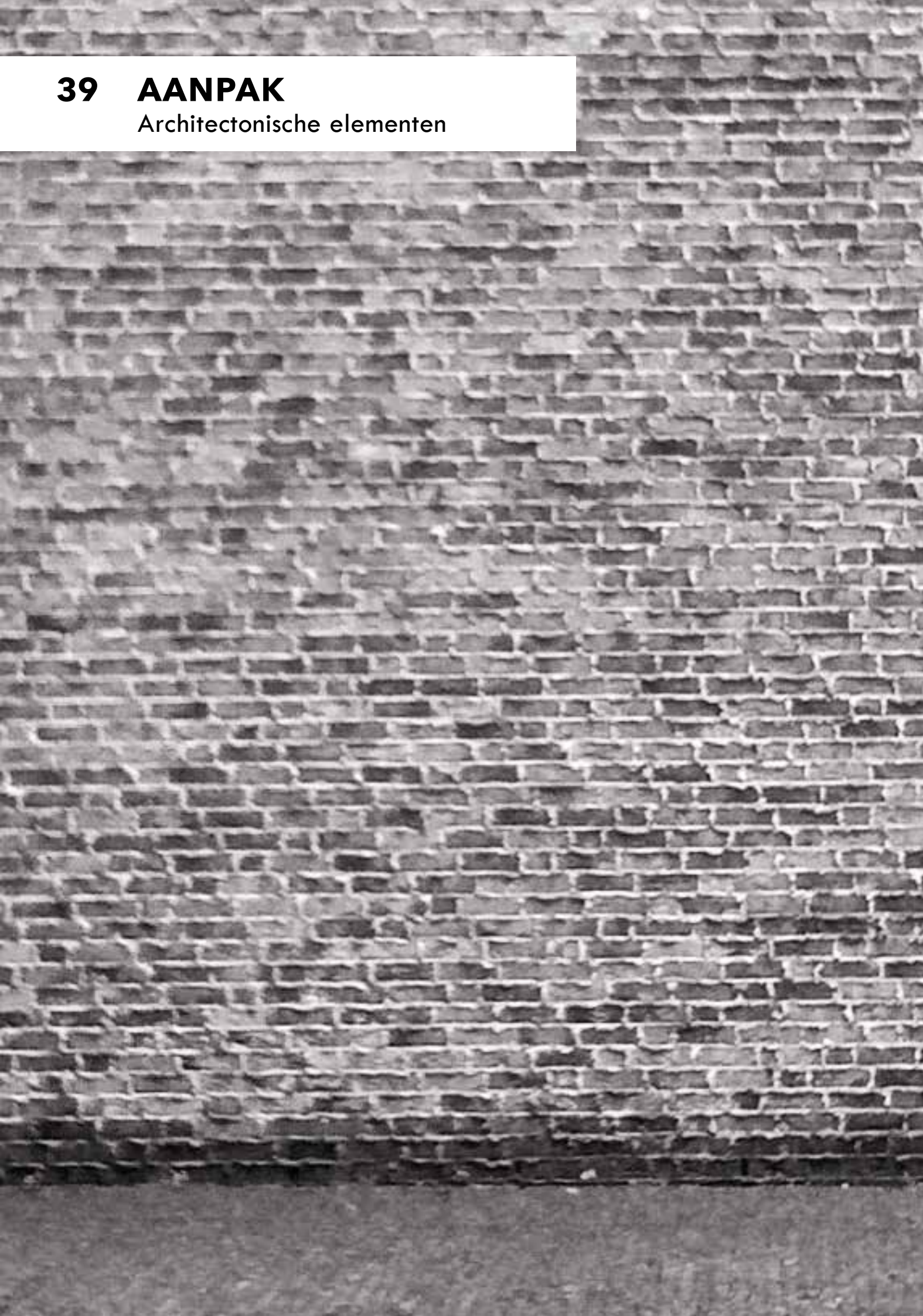



**40 AANPAK**  
Architectonische elementen





**41 AANPAK**  
Architectonische elementen



**42 AANPAK**  
Architectonische elementen





**43 AANPAK**  
Architectonische elementen



**44 AANPAK**  
Architectonische elementen





**45 AANPAK**  
Architectonische elementen





**46 AANPAK**  
Architectonische elementen





**47 AANPAK**  
Architectonische elementen



**48 PLAN**  
Stedenbouwkundig ontwerp

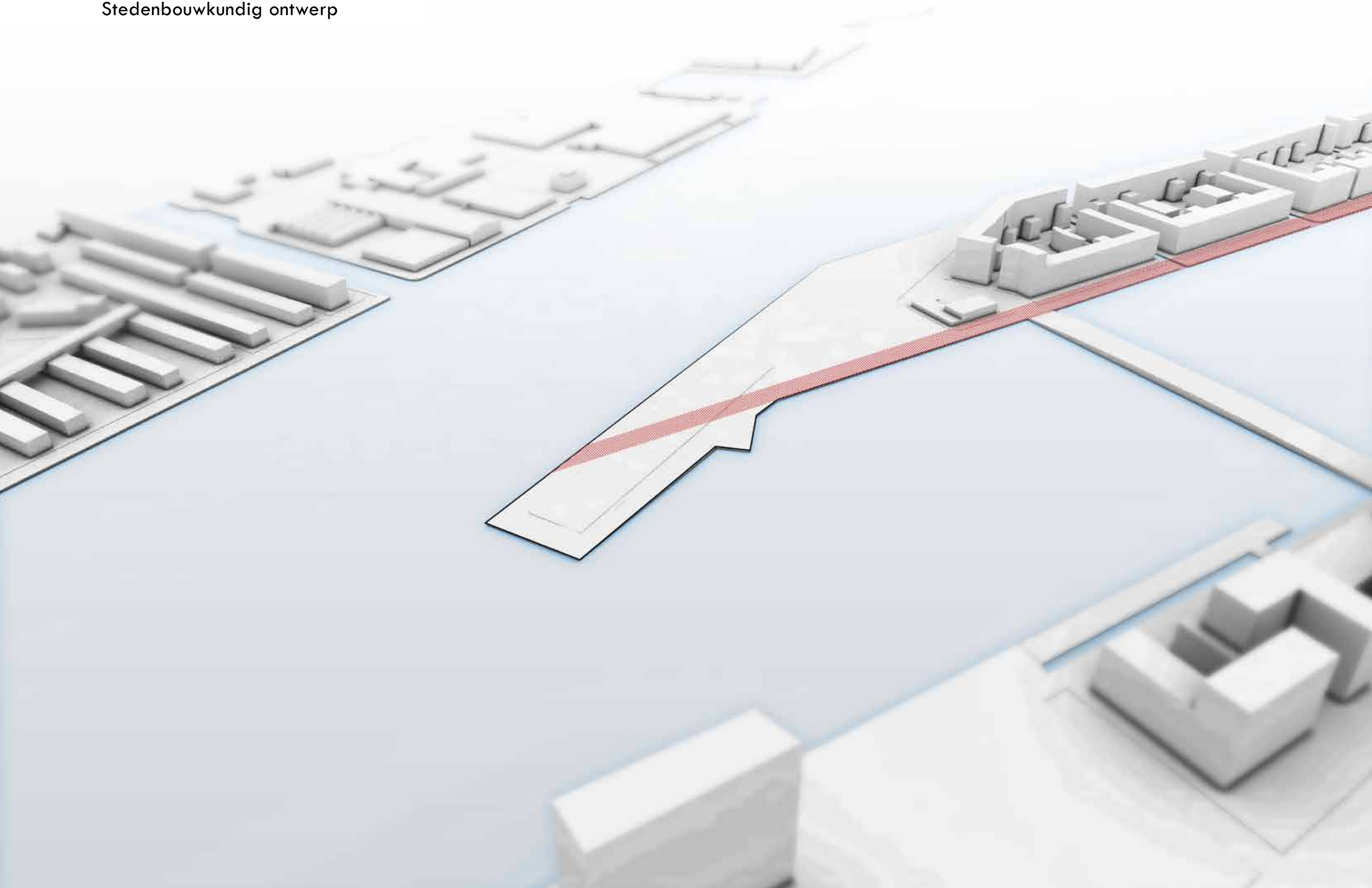



**49 PLAN**  
Stedenbouwkundig ontwerp

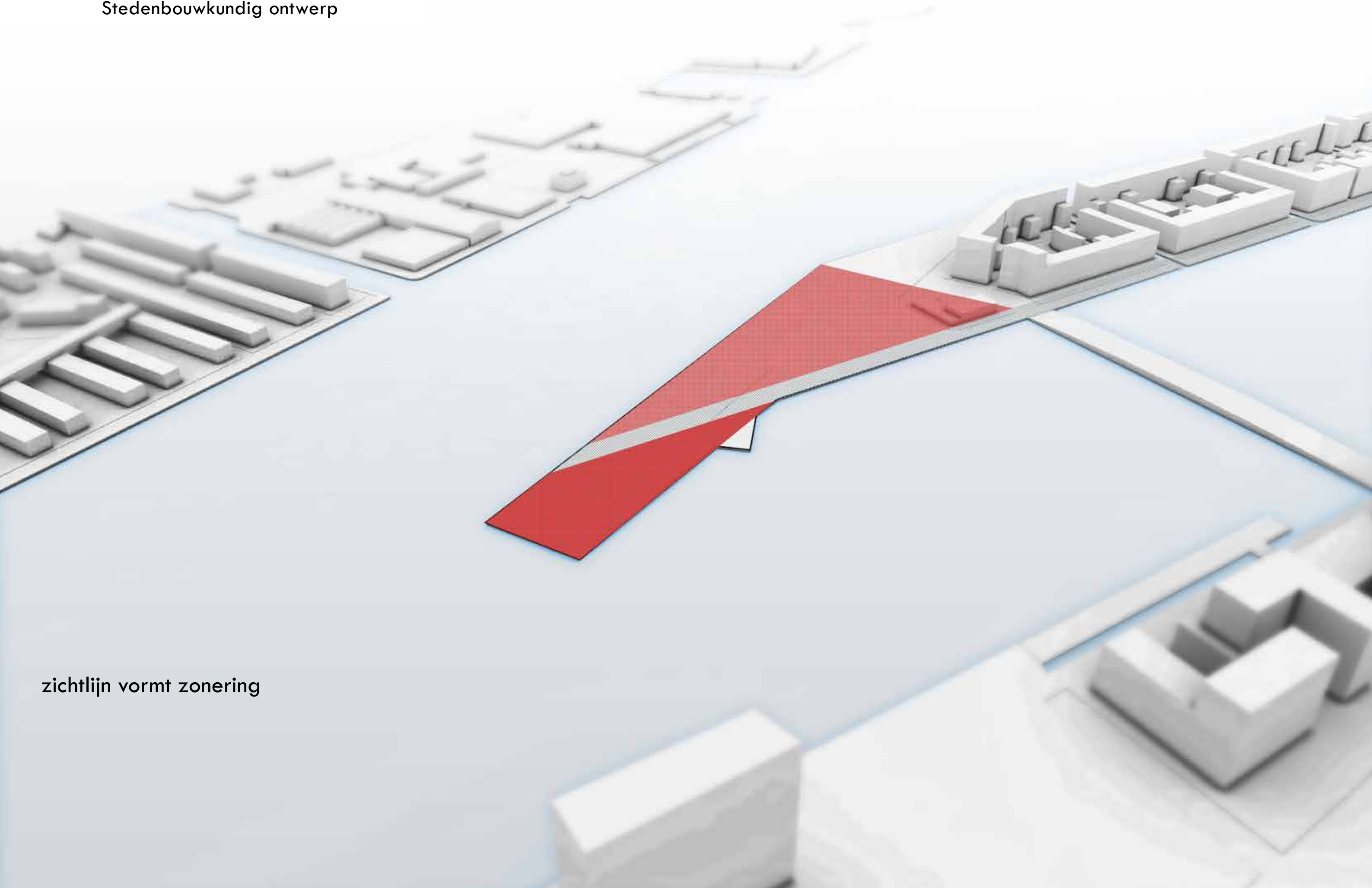

zichtlijn vormt zonering

**50 PLAN**  
Stedenbouwkundig ontwerp

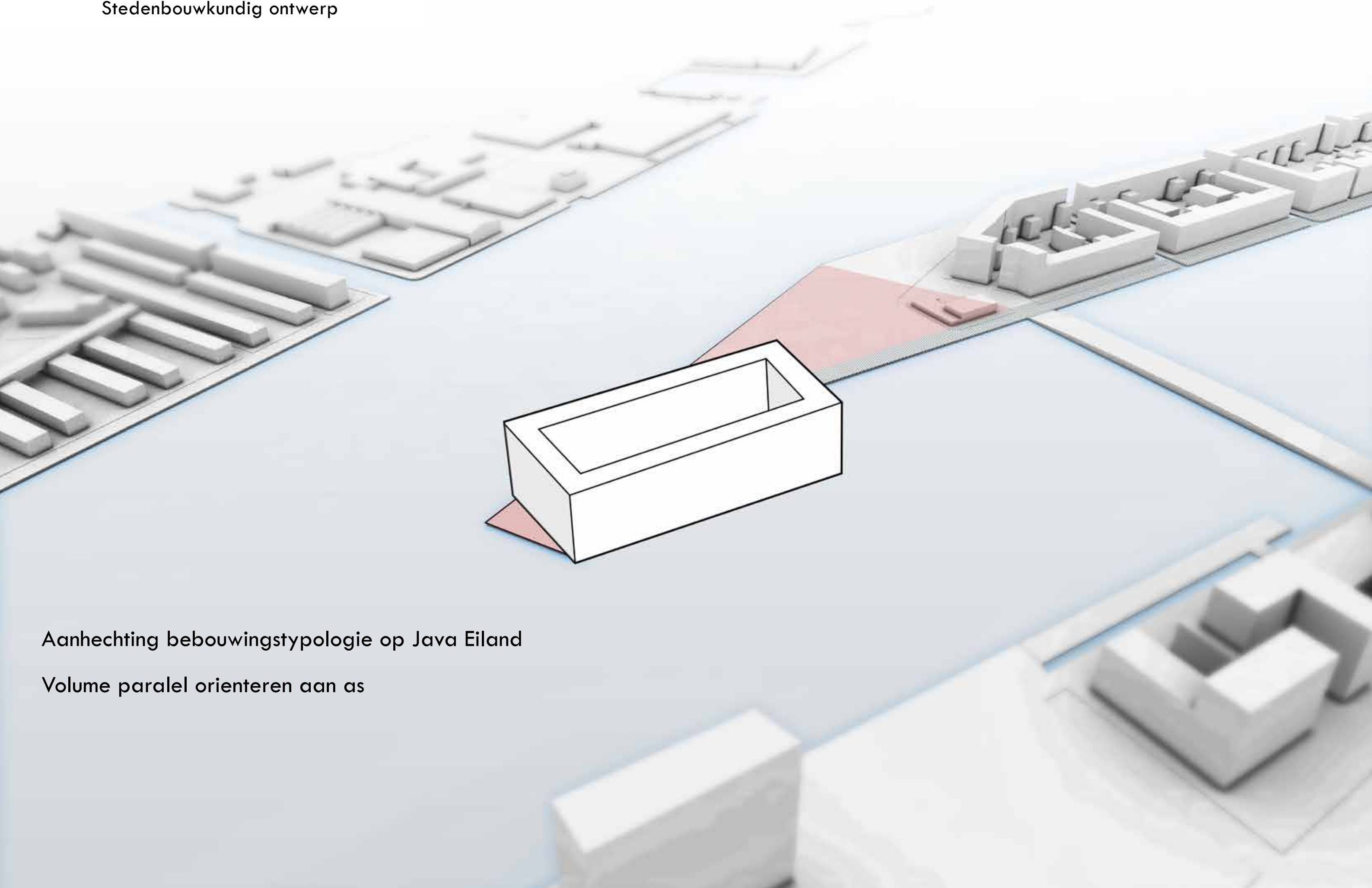

Aanhechting bebouwingstypologie op Java Eiland

Volume parallel oriënteren aan as



**51 PLAN**  
Stedenbouwkundig ontwerp

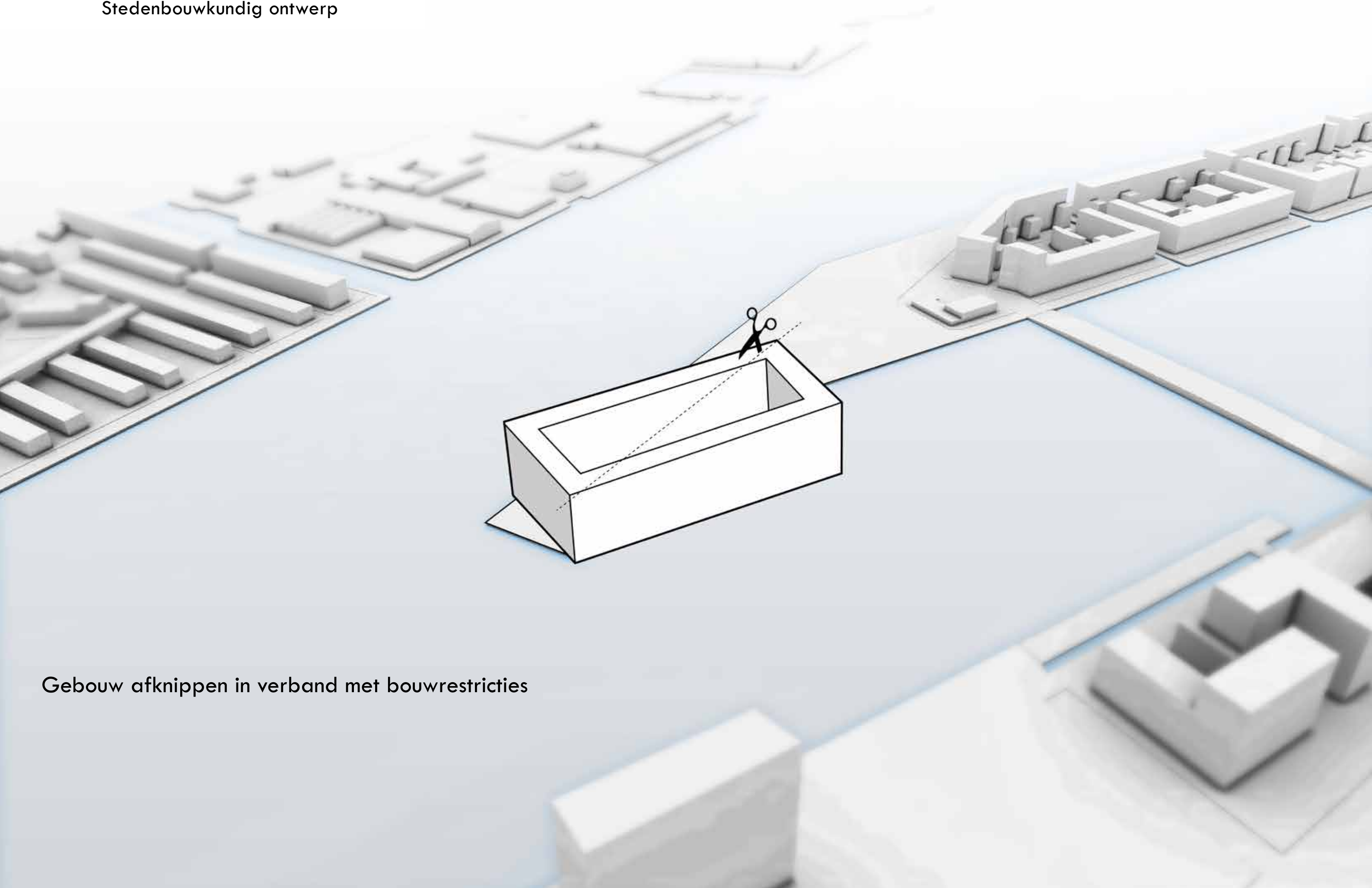

Gebouw afknippen in verband met bouwrestricties

**52 PLAN**  
Stedenbouwkundig ontwerp

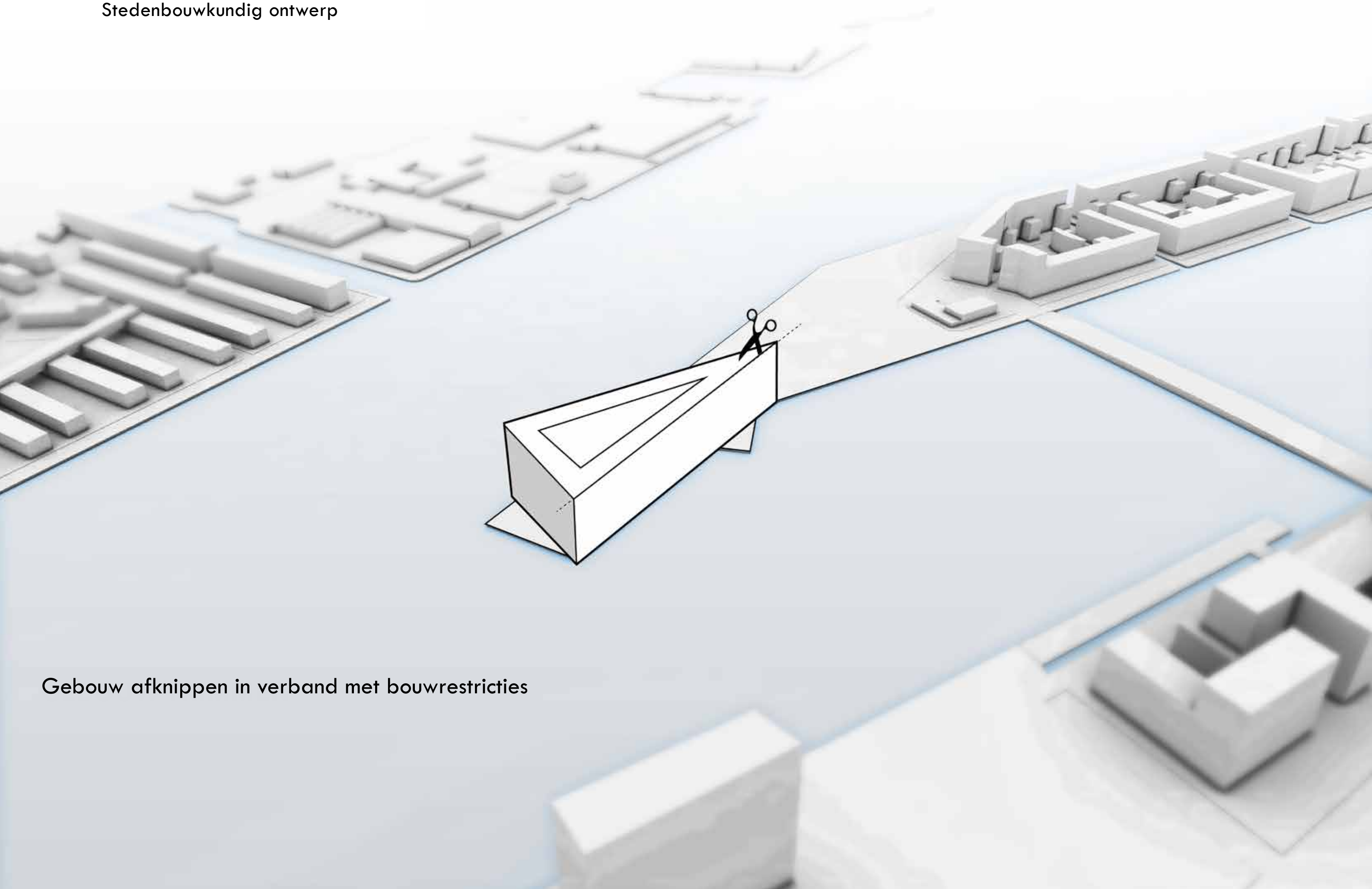

Gebouw afknippen in verband met bouwrestricties



**53 PLAN**  
Stedenbouwkundig ontwerp

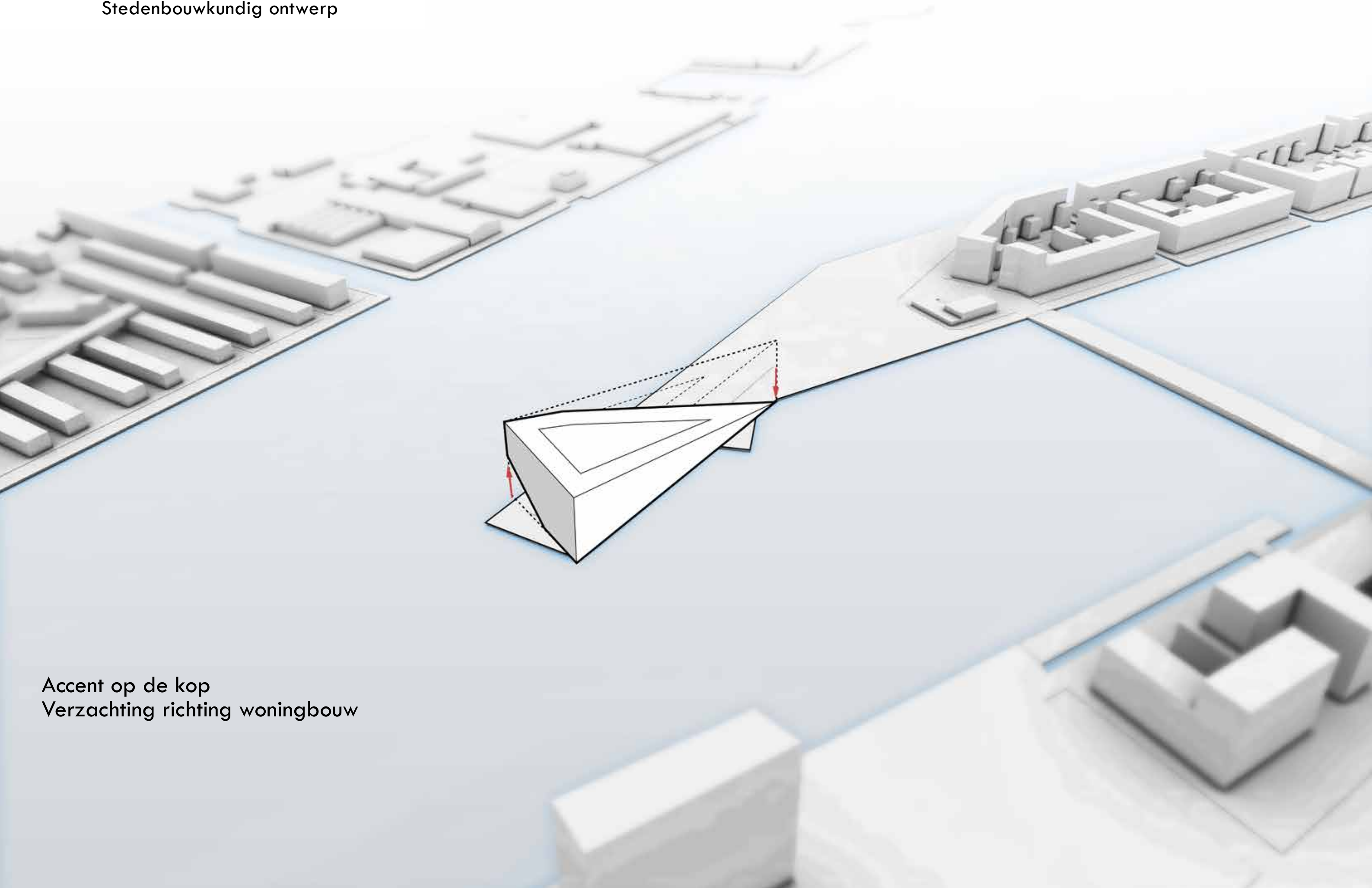

Accent op de kop  
Verzachting richting woningbouw

**54 PLAN**  
Stedenbouwkundig ontwerp

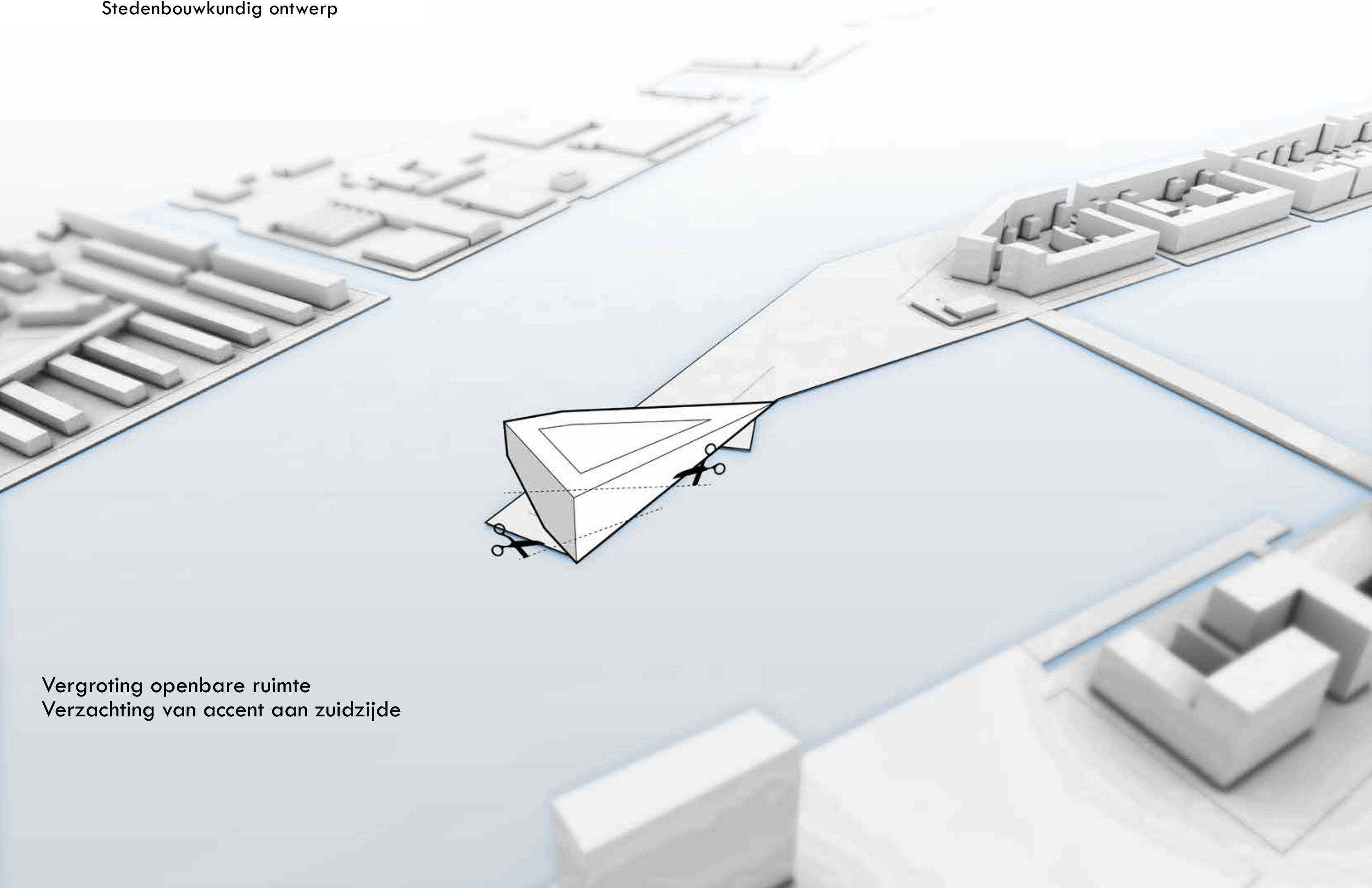

Vergroting openbare ruimte  
Verzachting van accent aan zuidzijde



**55 PLAN**  
Stedenbouwkundig ontwerp

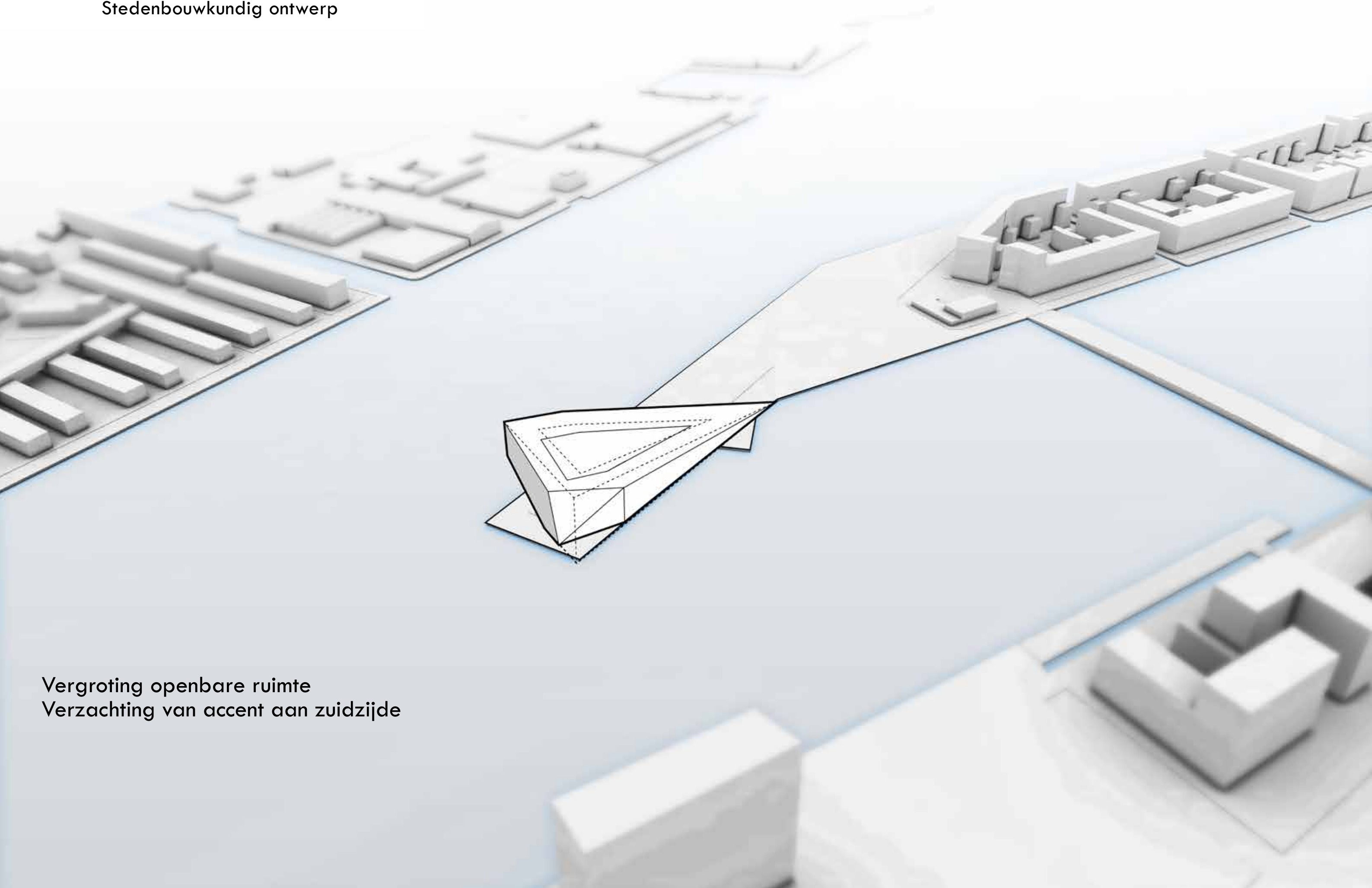

Vergroting openbare ruimte  
Verzachting van accent aan zuidzijde

**56 PLAN**  
Stedenbouwkundig ontwerp

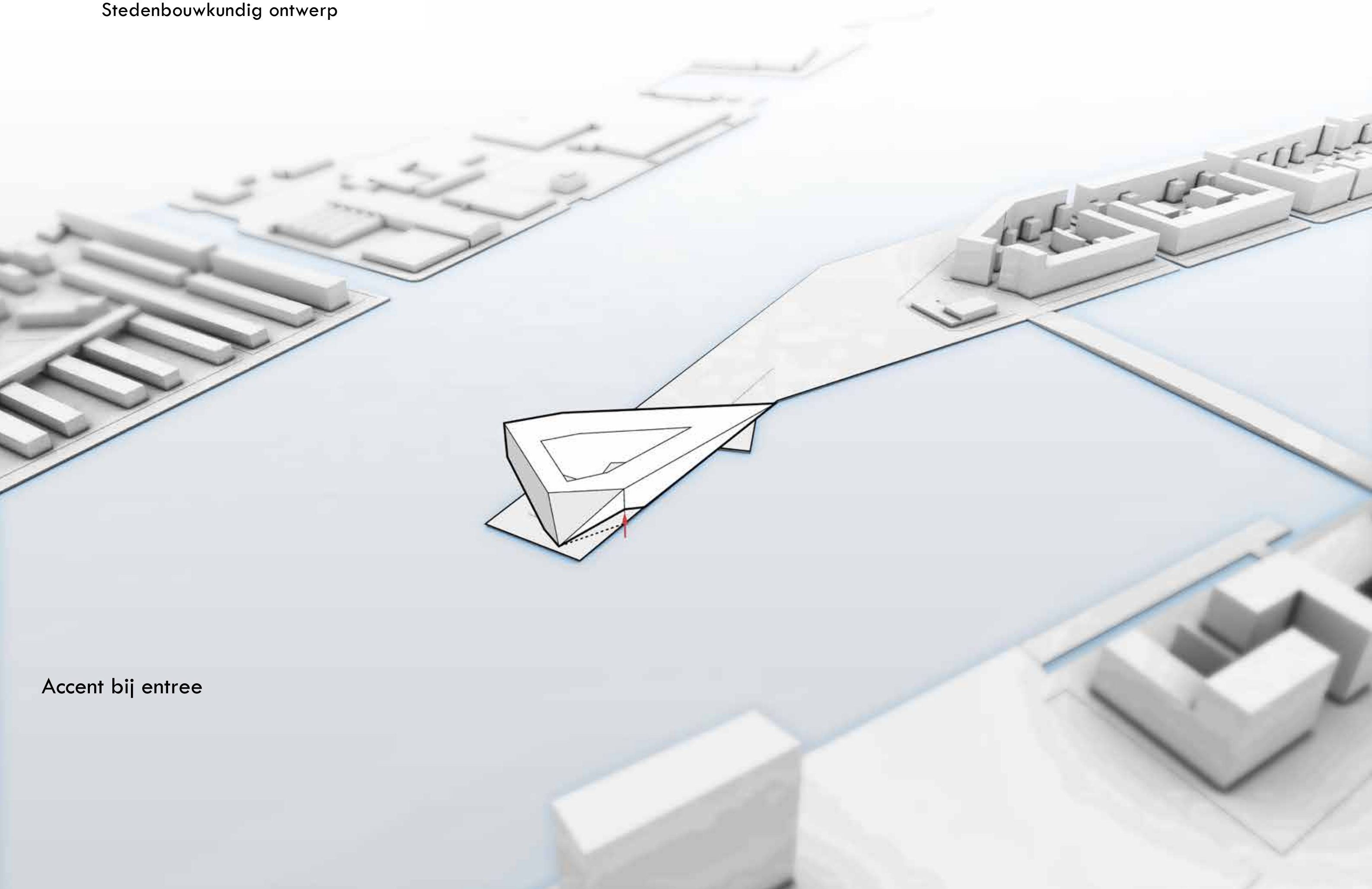

Accent bij entree



**57 PLAN**  
Stedenbouwkundig ontwerp

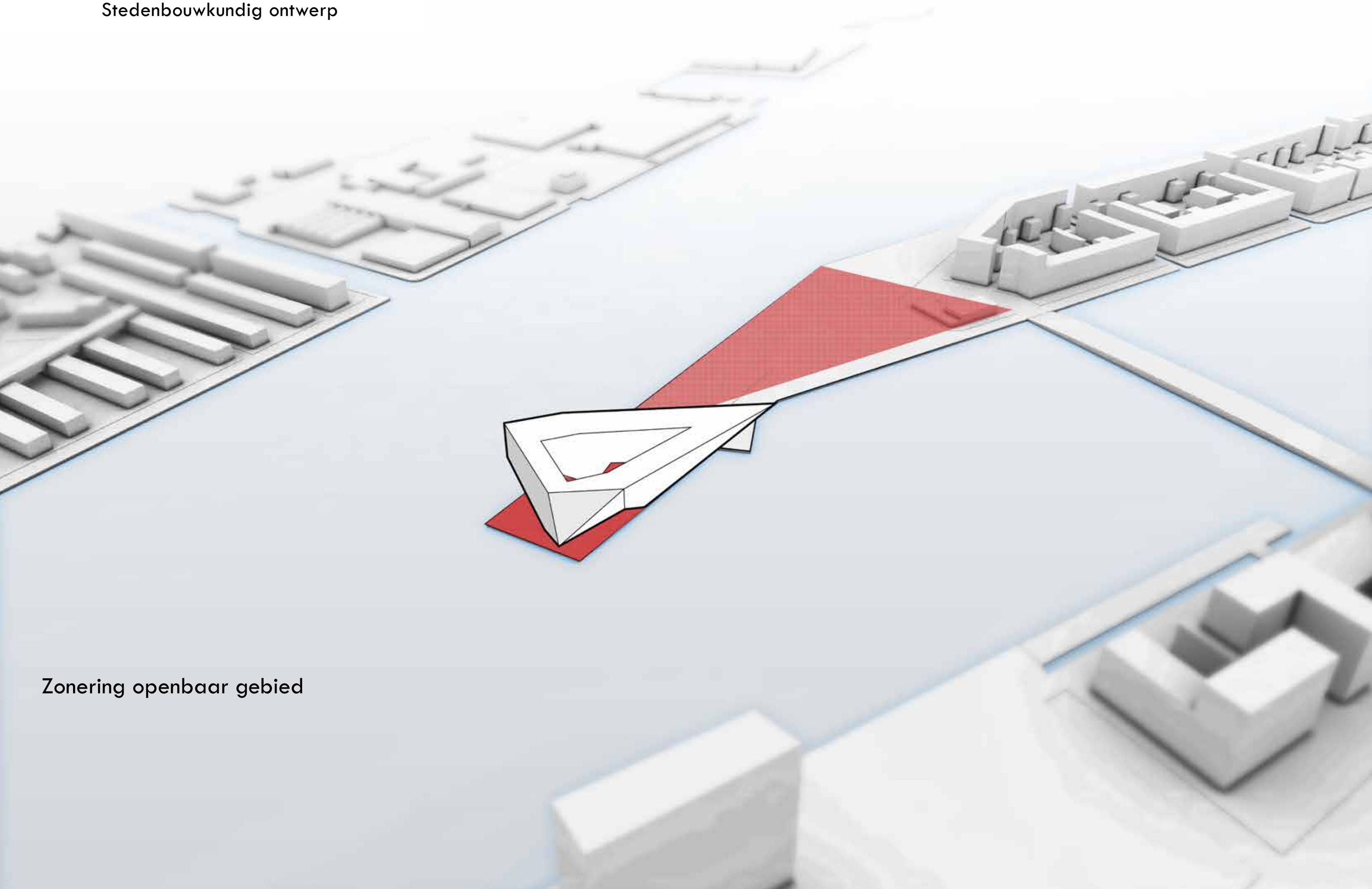

Zonering openbaar gebied

**58 PLAN**  
Vorm & constructie





**59 PLAN**  
Vorm & constructie

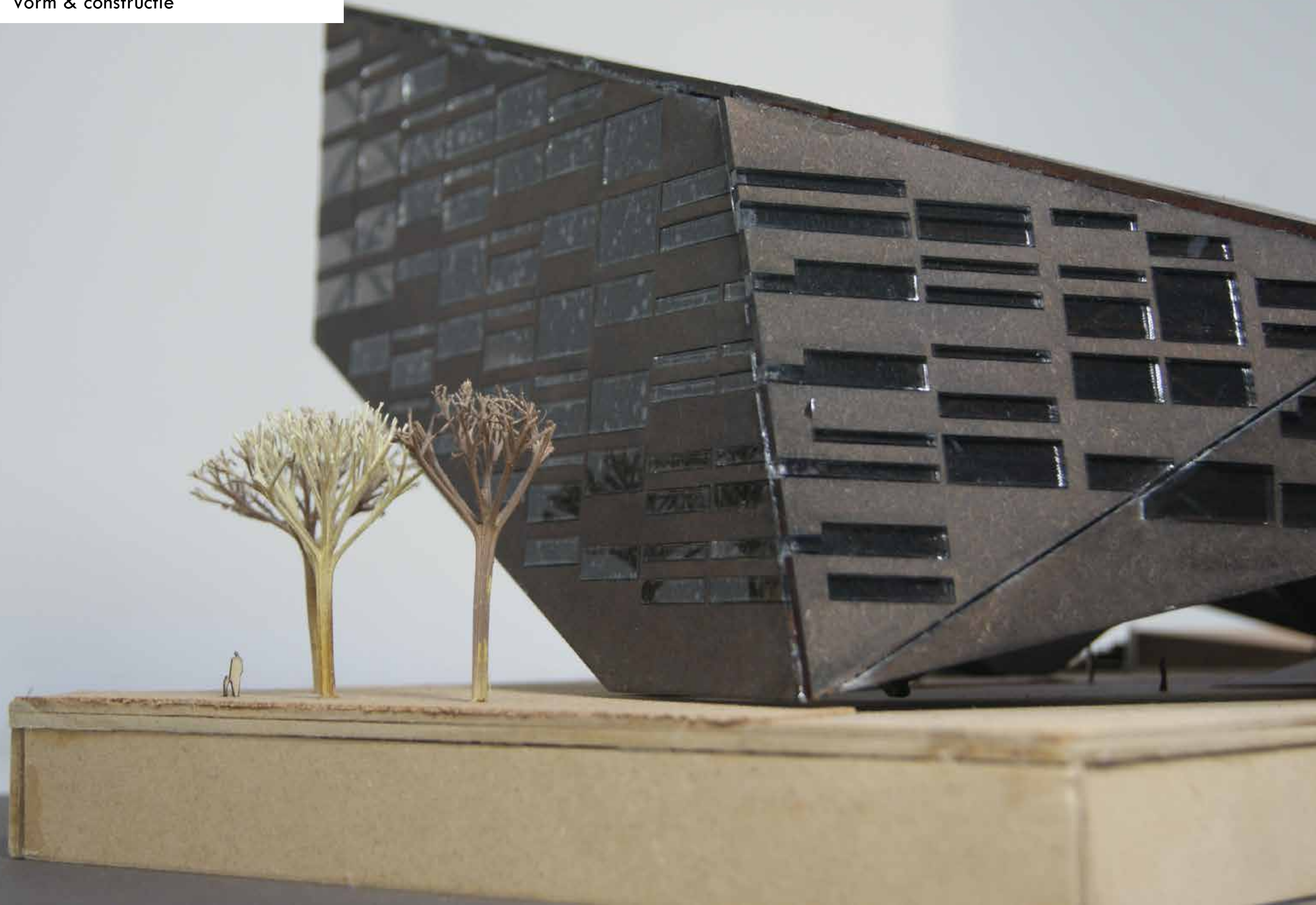



**60 PLAN**  
Vorm & constructie





**61 PLAN**  
Vorm & constructie

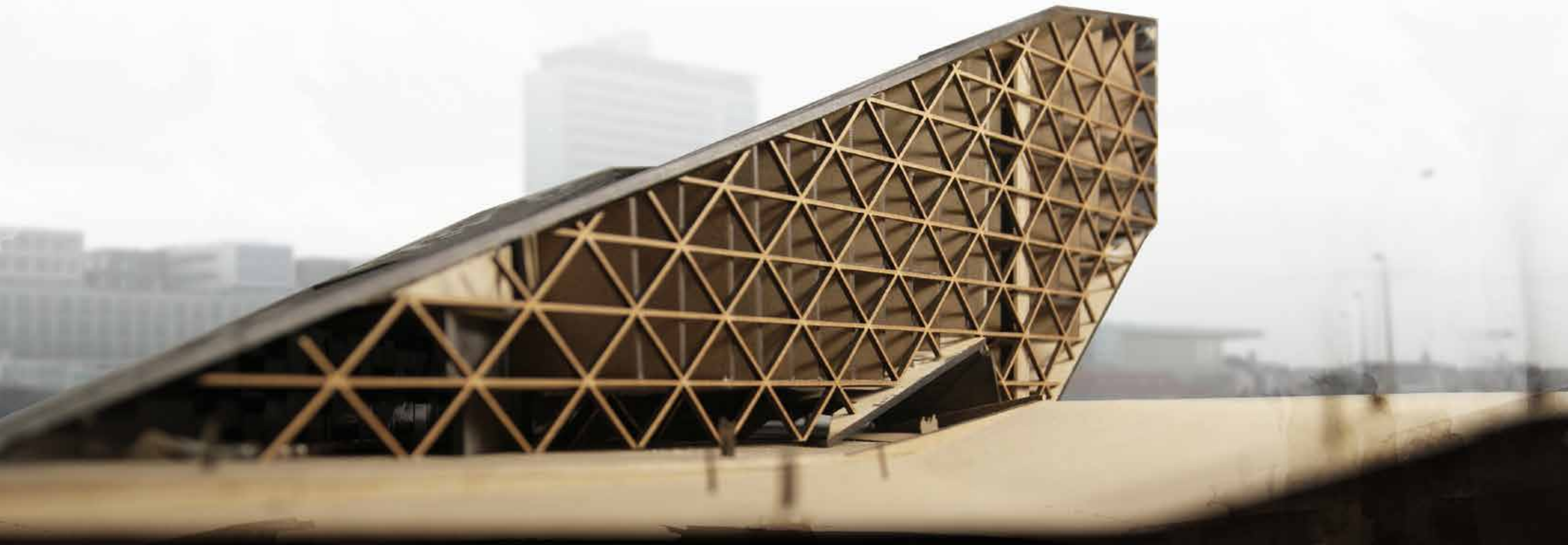
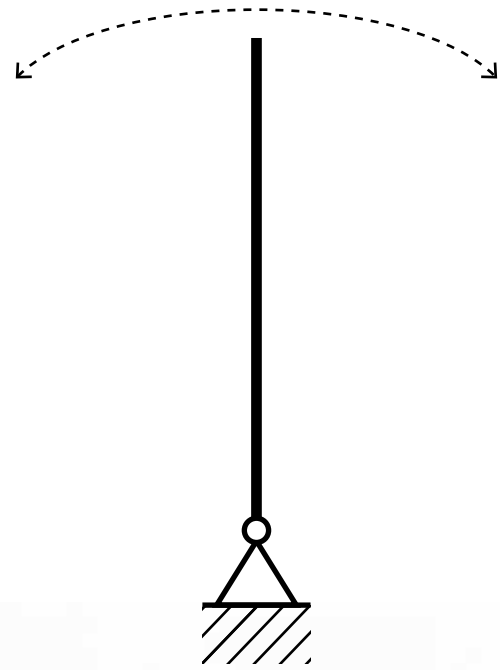

**62 PLAN**  
Vorm & constructie

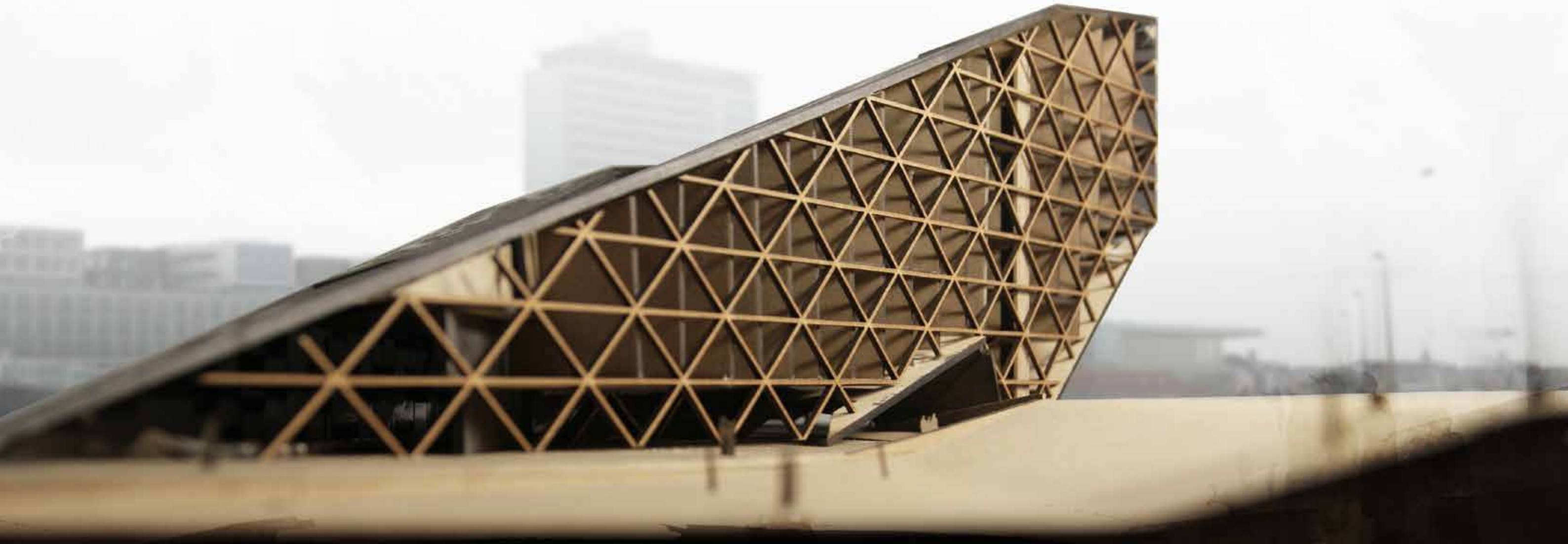
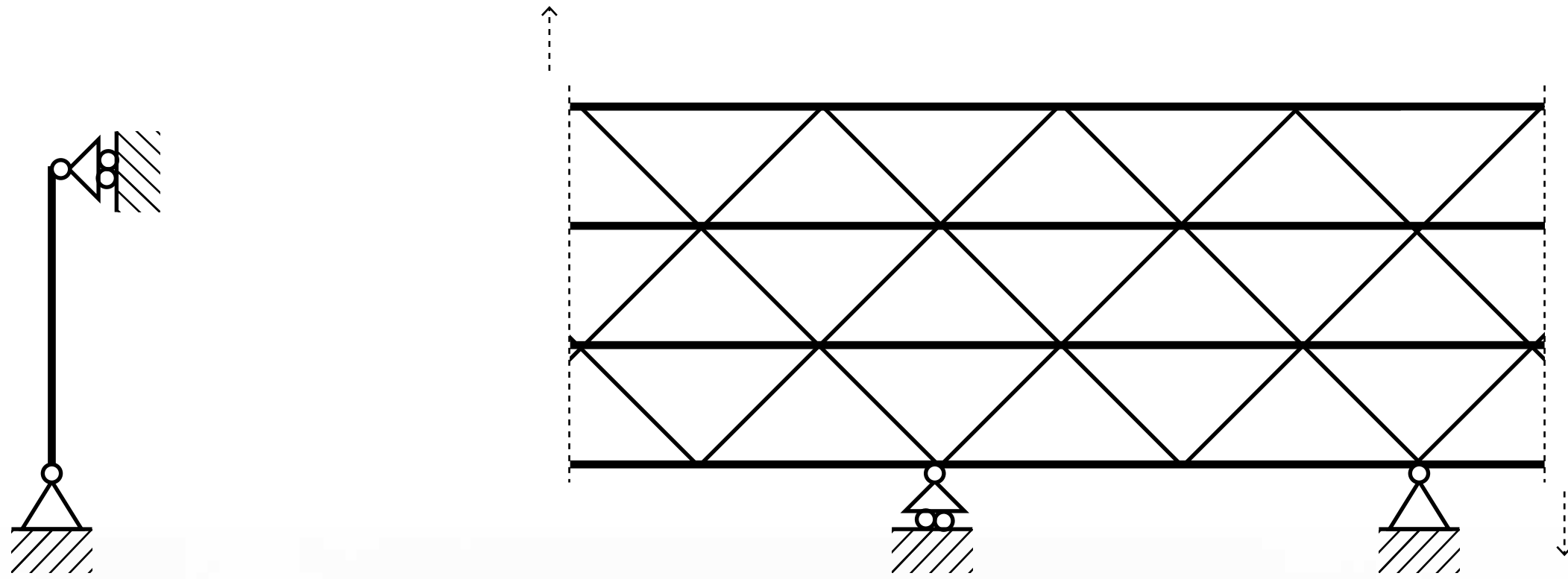



**63 PLAN**  
Vorm & constructie

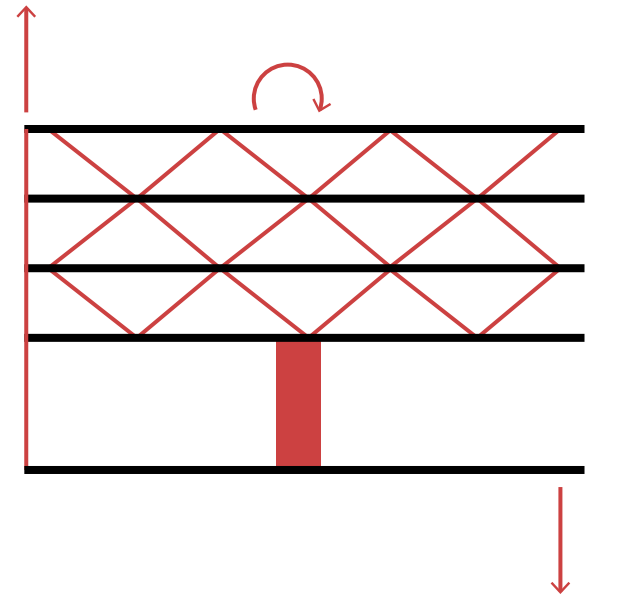

“Balans” en mogelijkheid overspanning

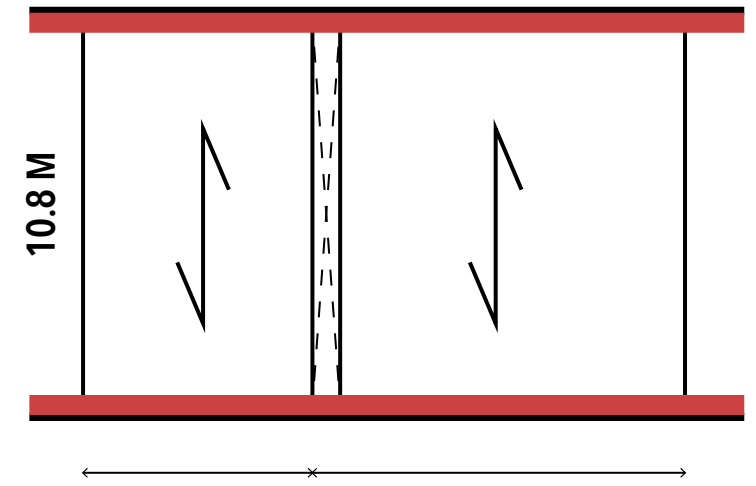

Flexibiliteit in beukmaat (breedte woning)

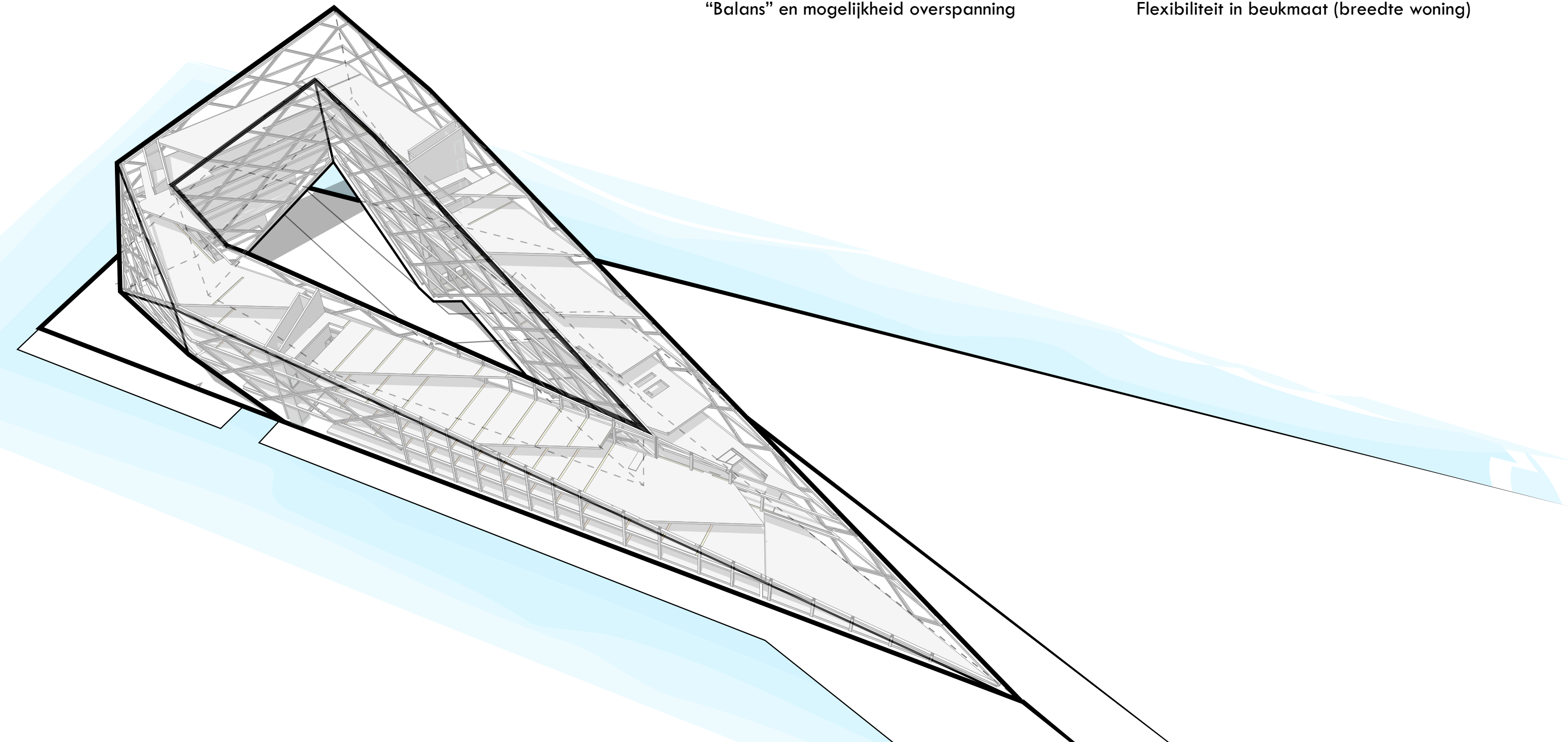

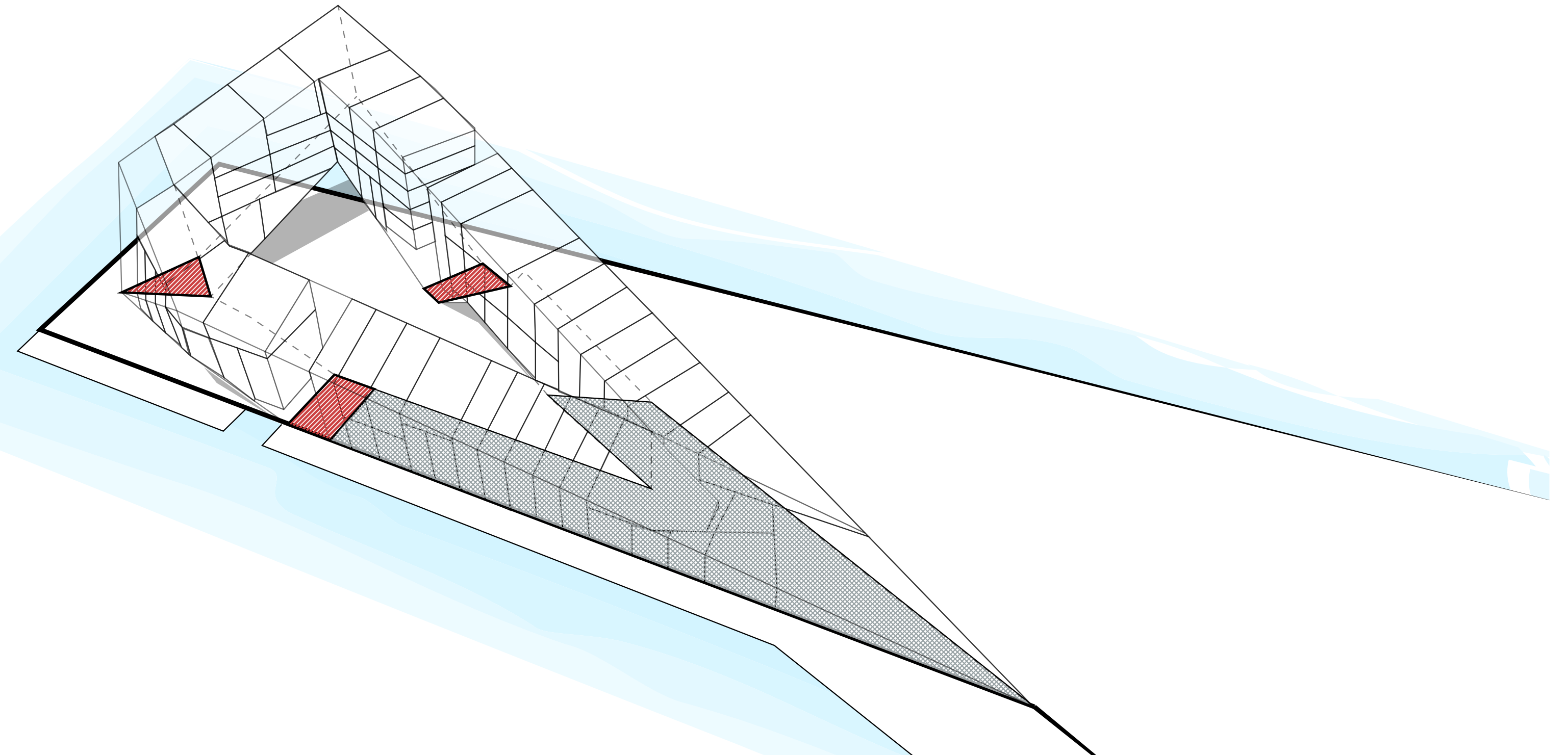



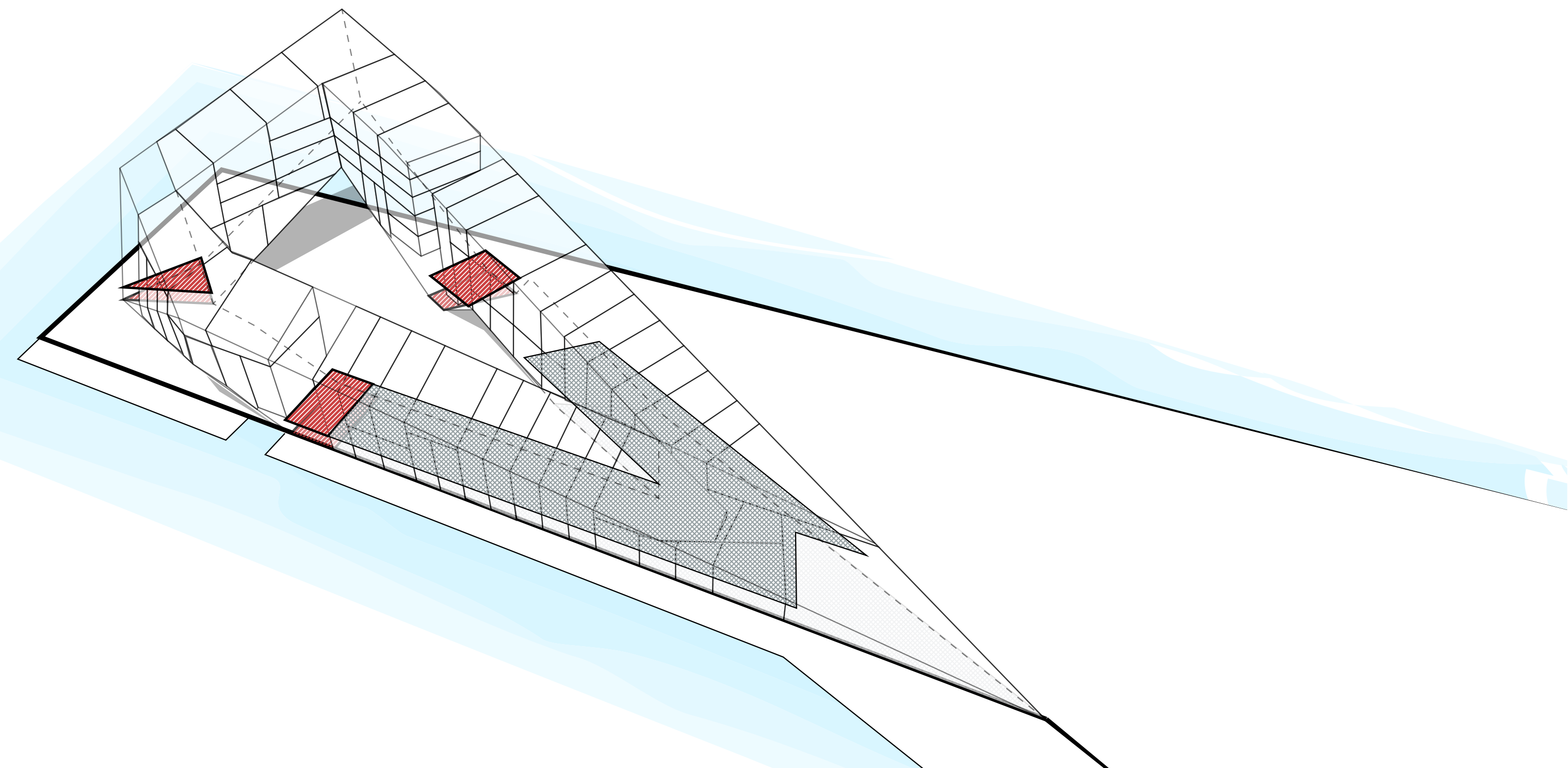

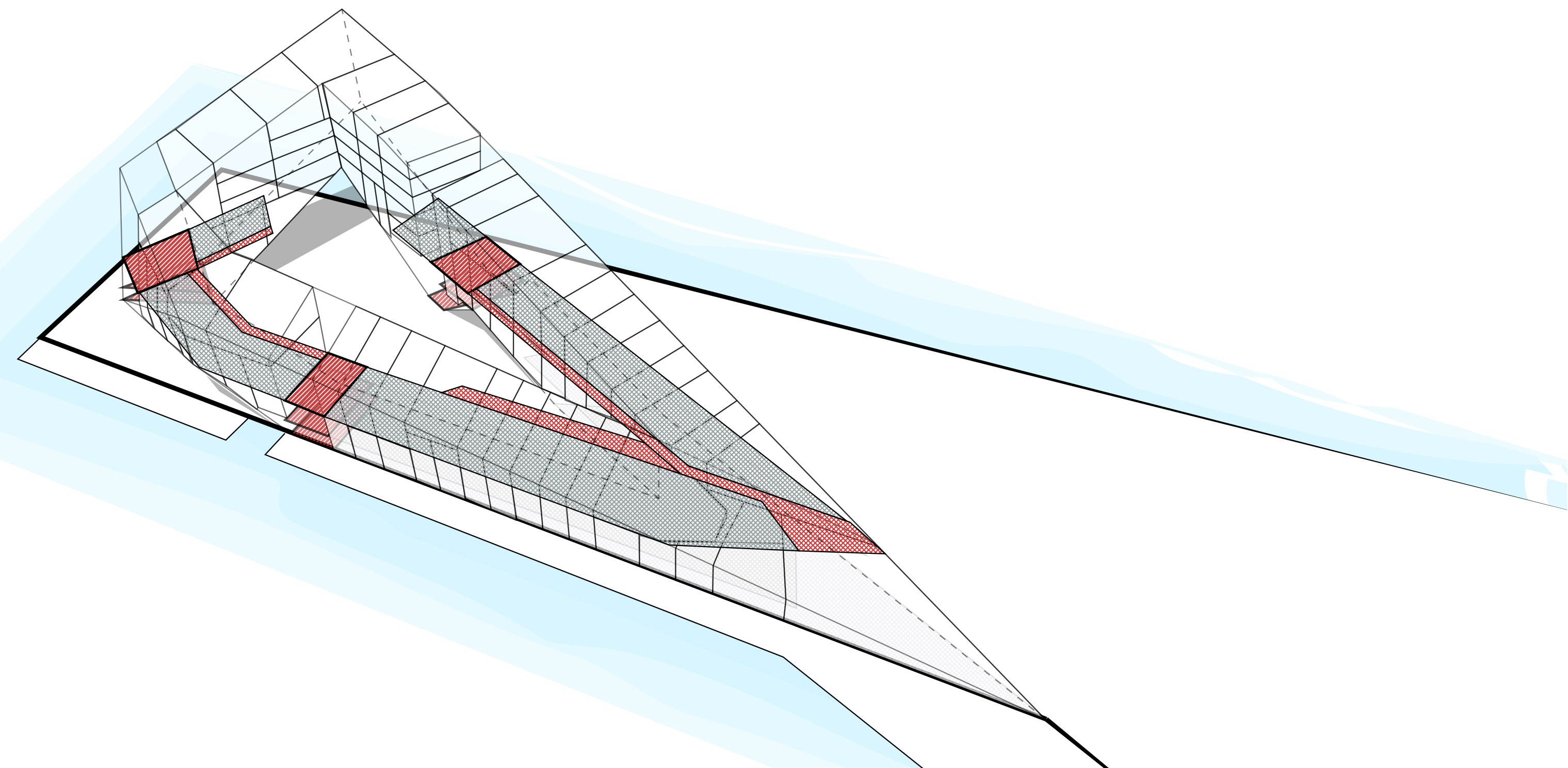



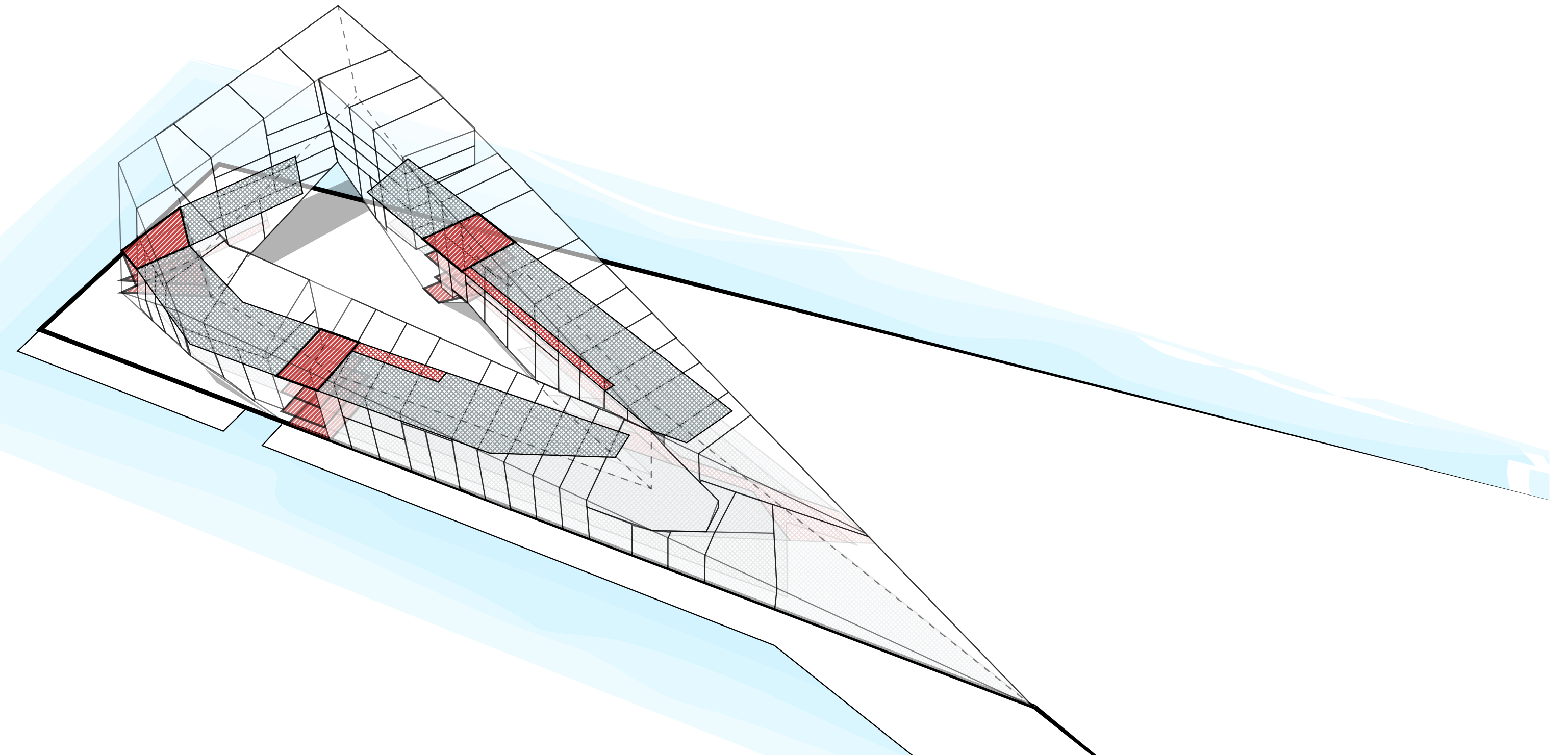

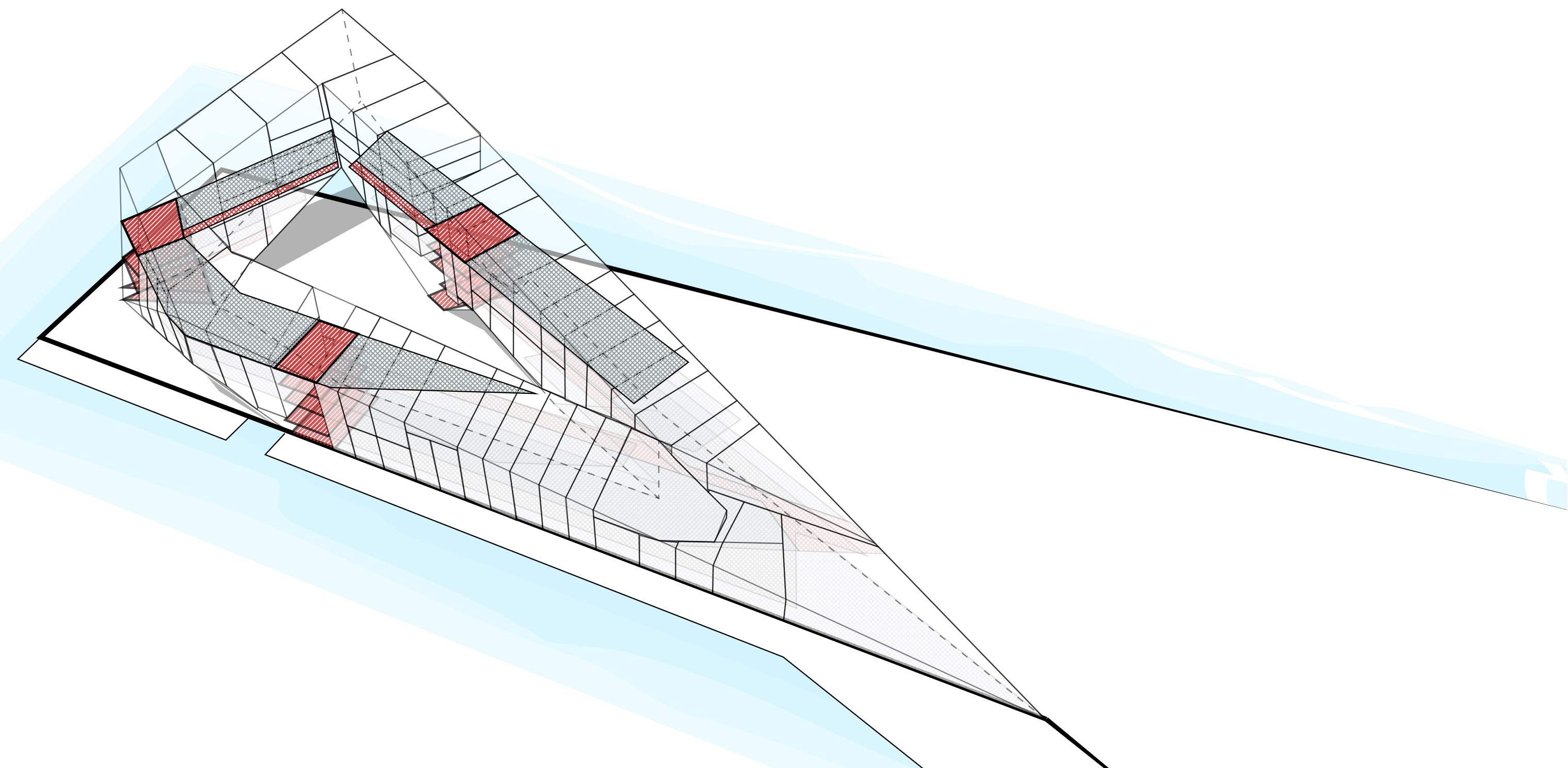



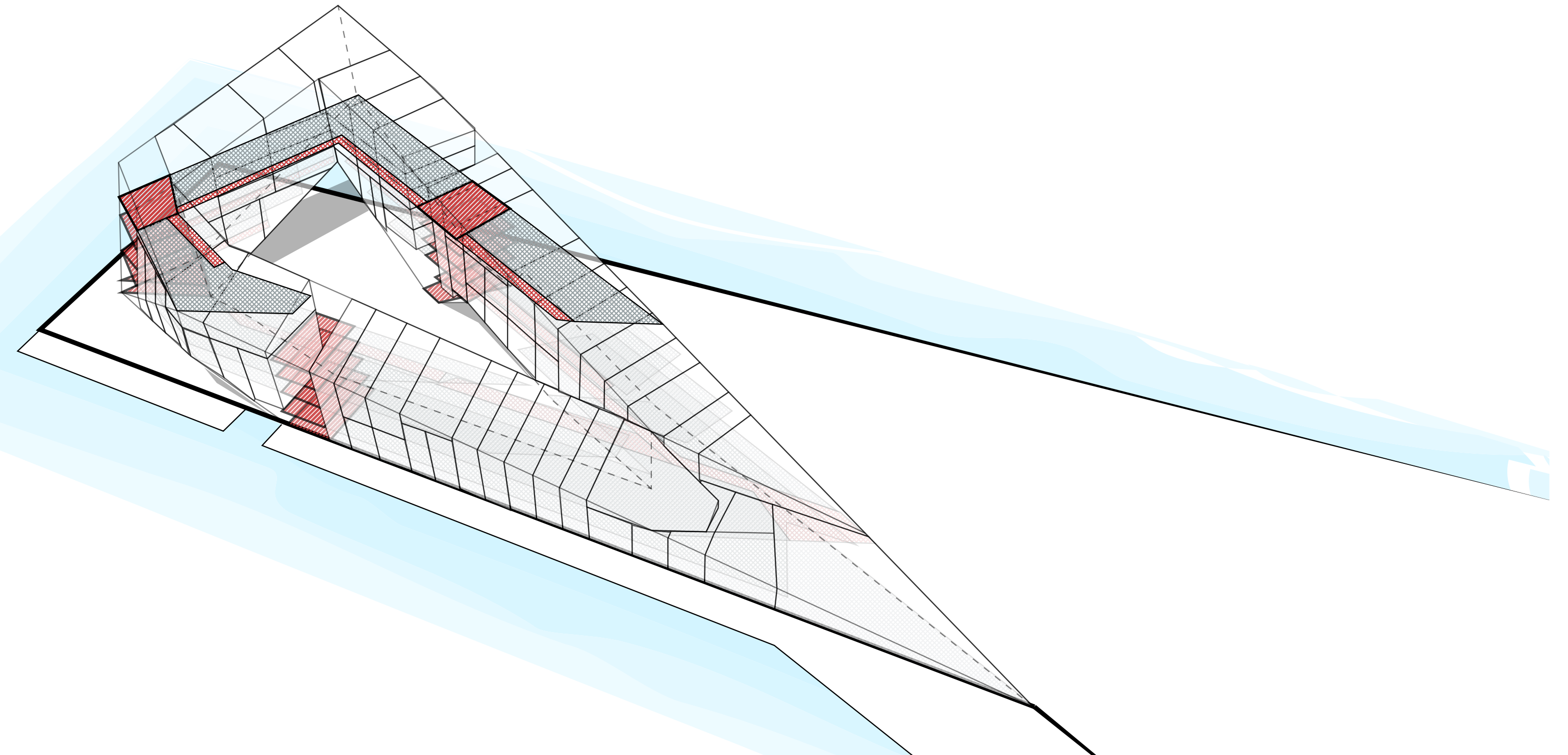

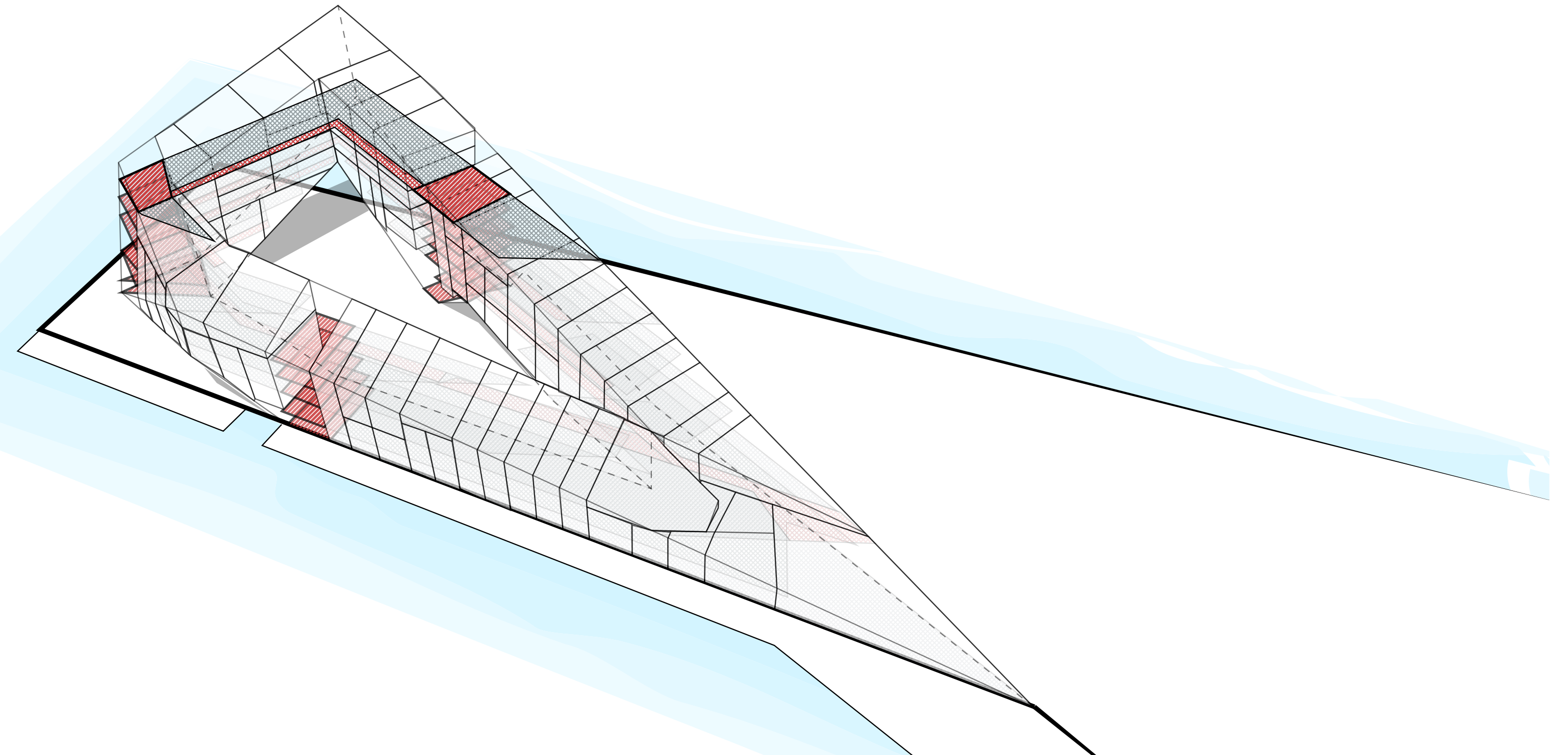



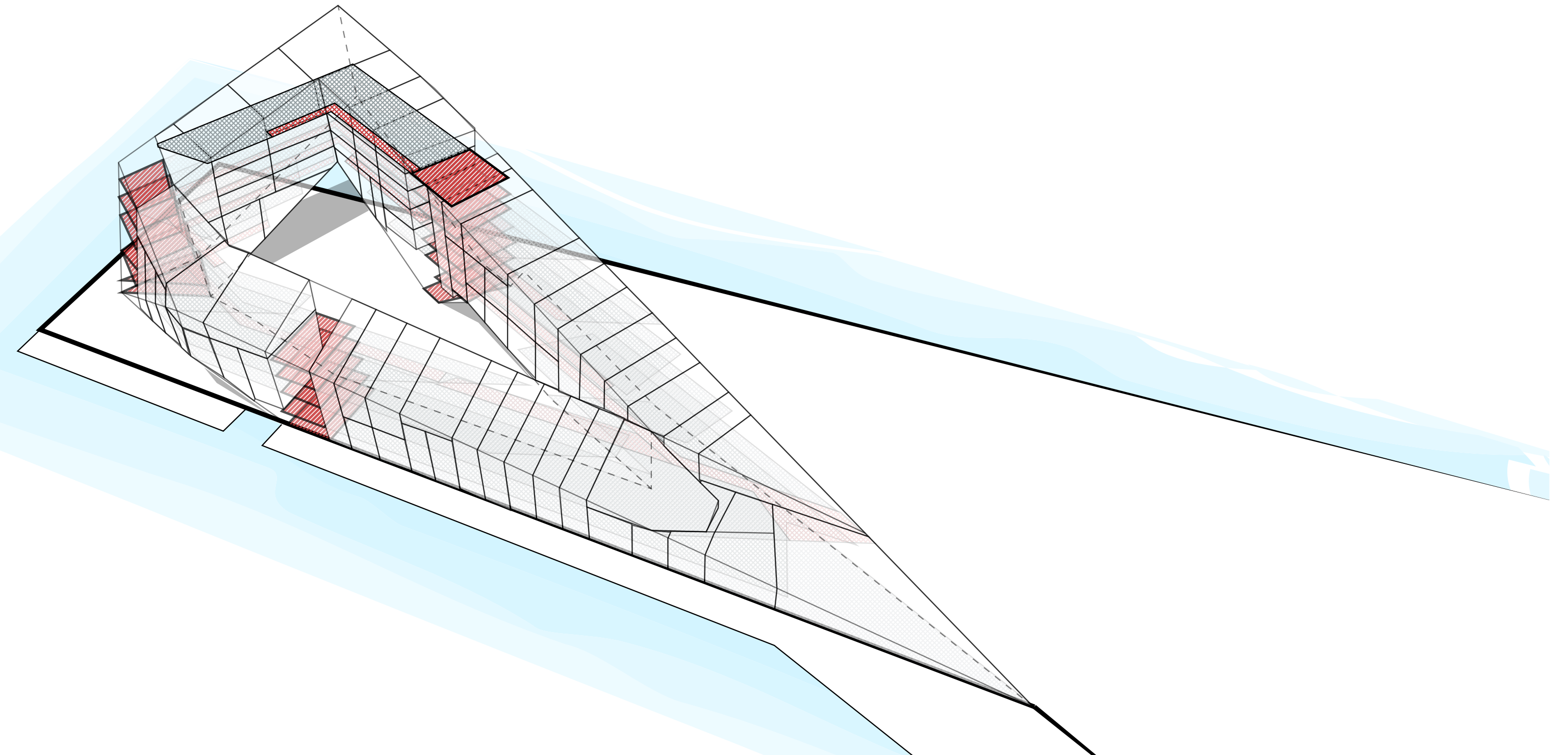

# 72 PLAN

70 Woningen | 5 Typologieën

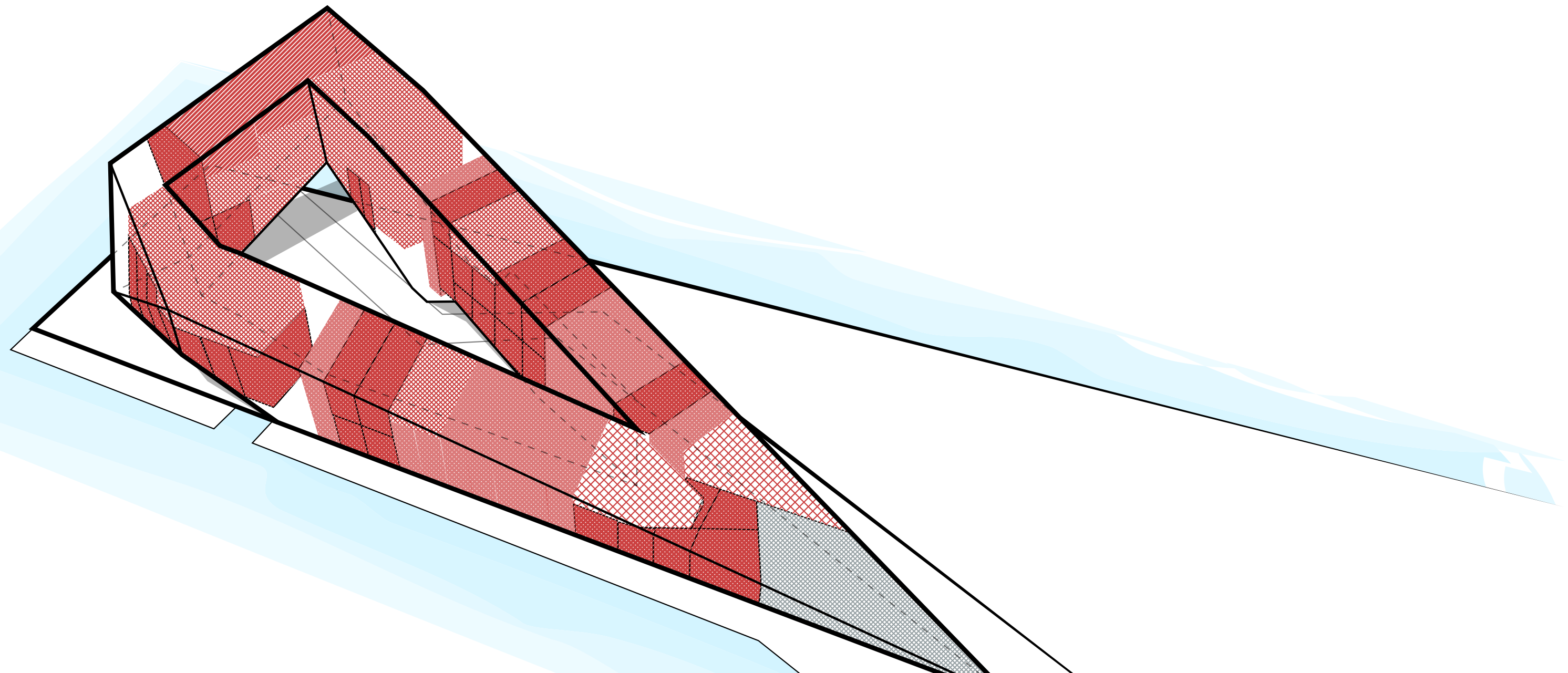



**73 WOONCONCEPT**  
Hokjescultuur



**74 WOONCONCEPT**  
Hokjescultuur





**75 WOONCONCEPT**  
Hokjescultuur







**77 WOONCONCEPT**  
Non-verbale communicatie













**81 WOONCONCEPT**  
Non-verbale communicatie



**82 WOONCONCEPT**  
Atmosfeer





**83 WOONCONCEPT**  
Atmosfeer



**84 WOONCONCEPT**  
Onderzoek atmosfeer





# 85 WOONCONCEPT

Onderzoek atmosfeer | Abstractie

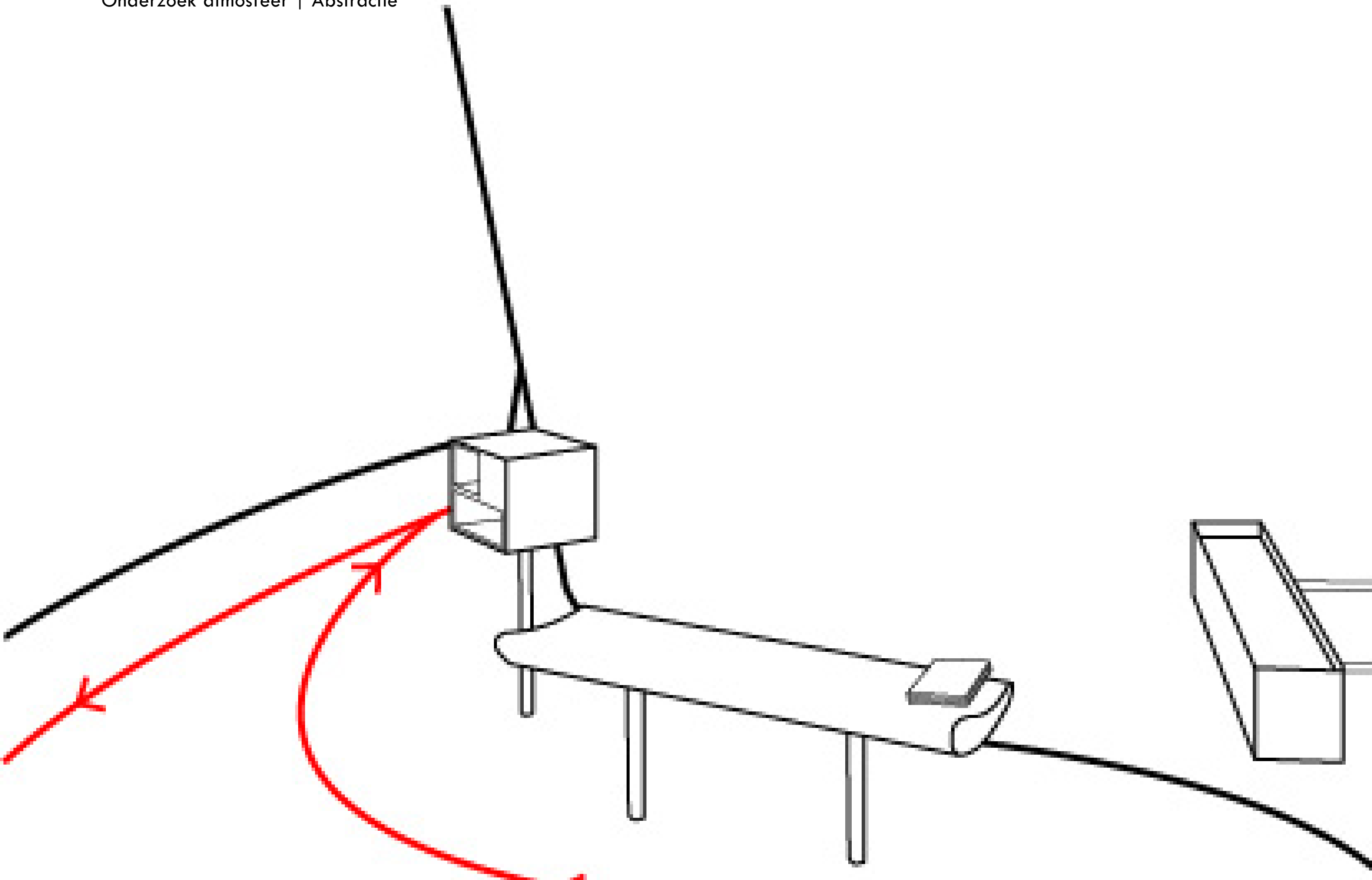

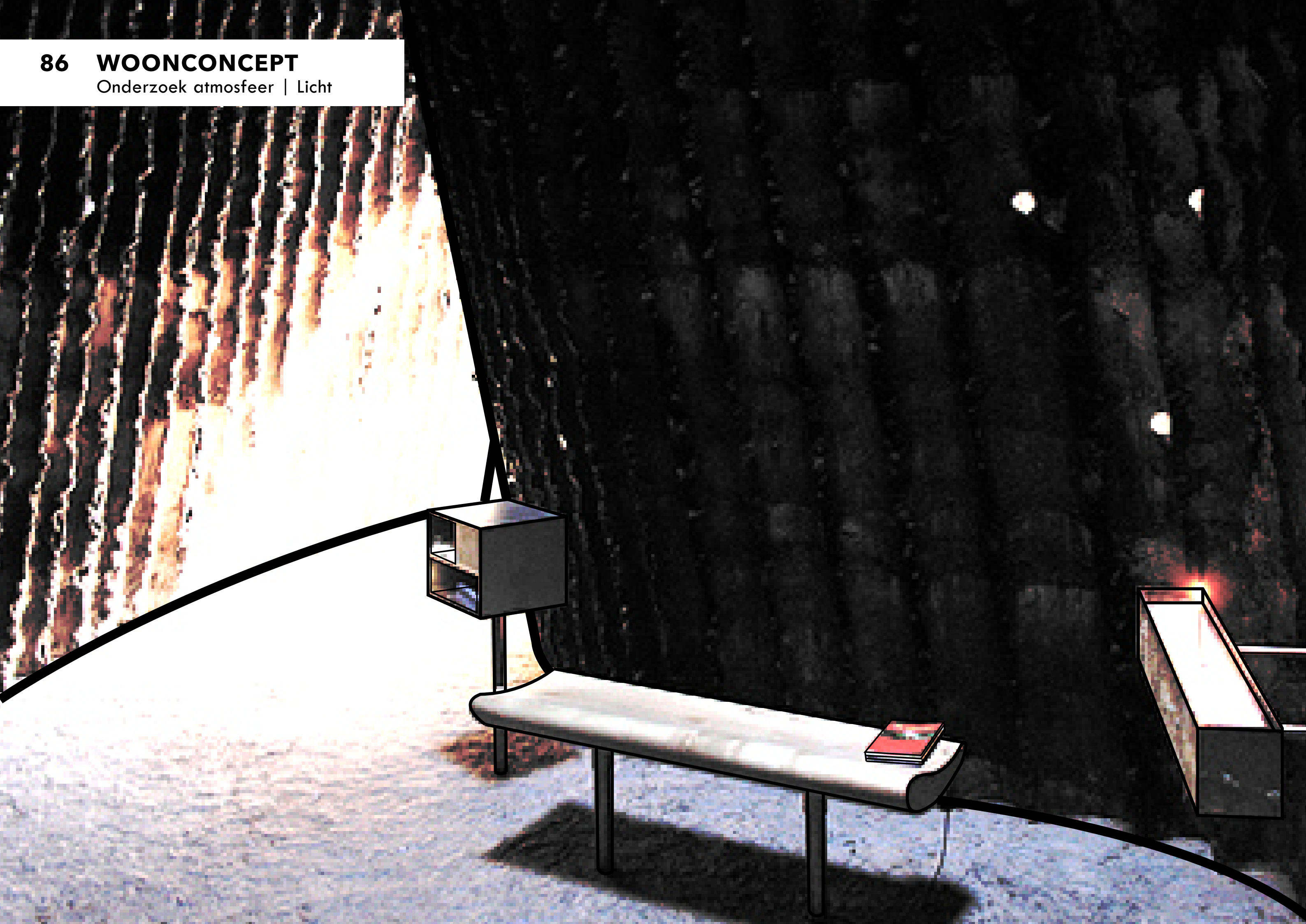



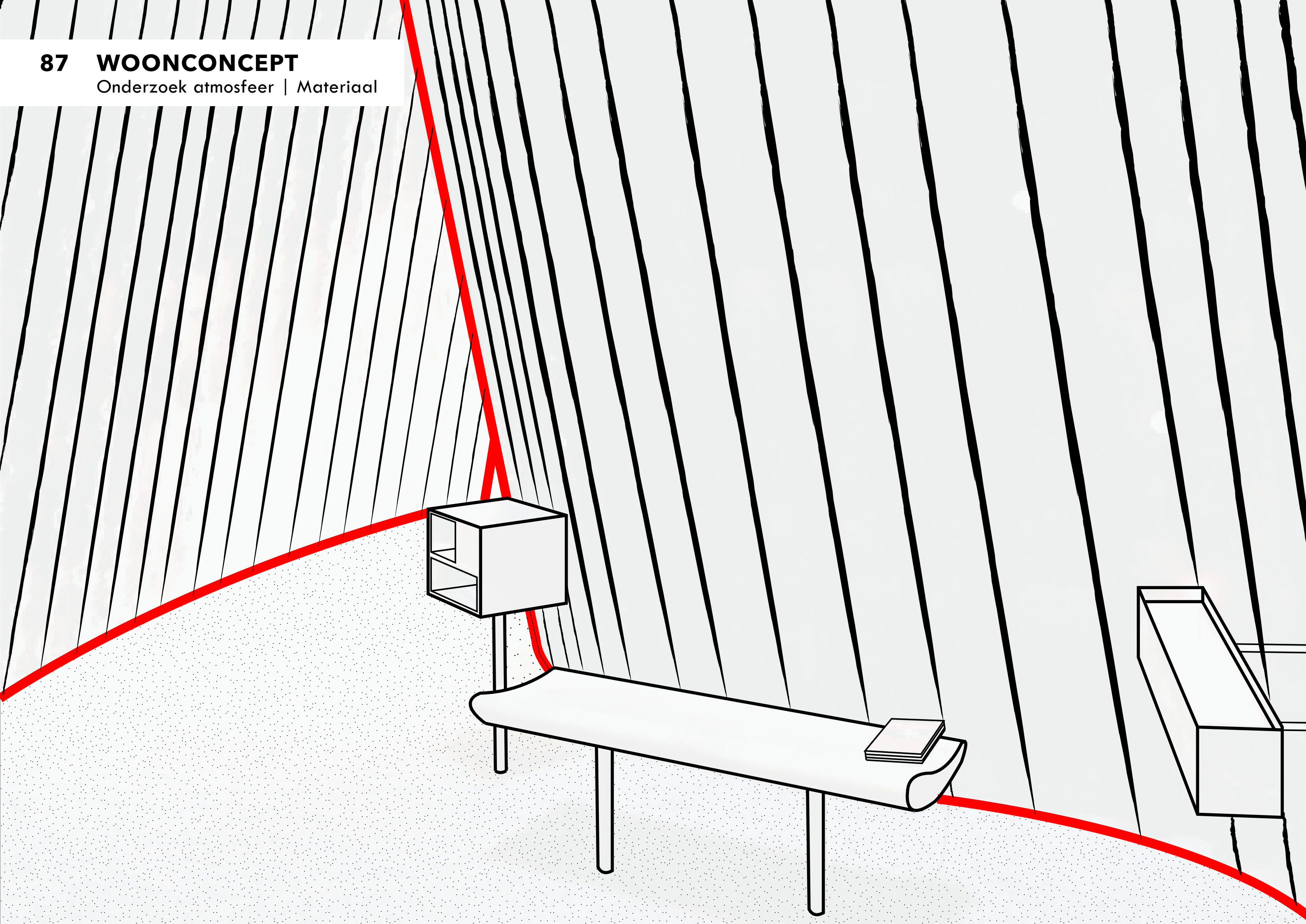

**88 WOONCONCEPT**  
Onderzoek atmosfeer | Proporties

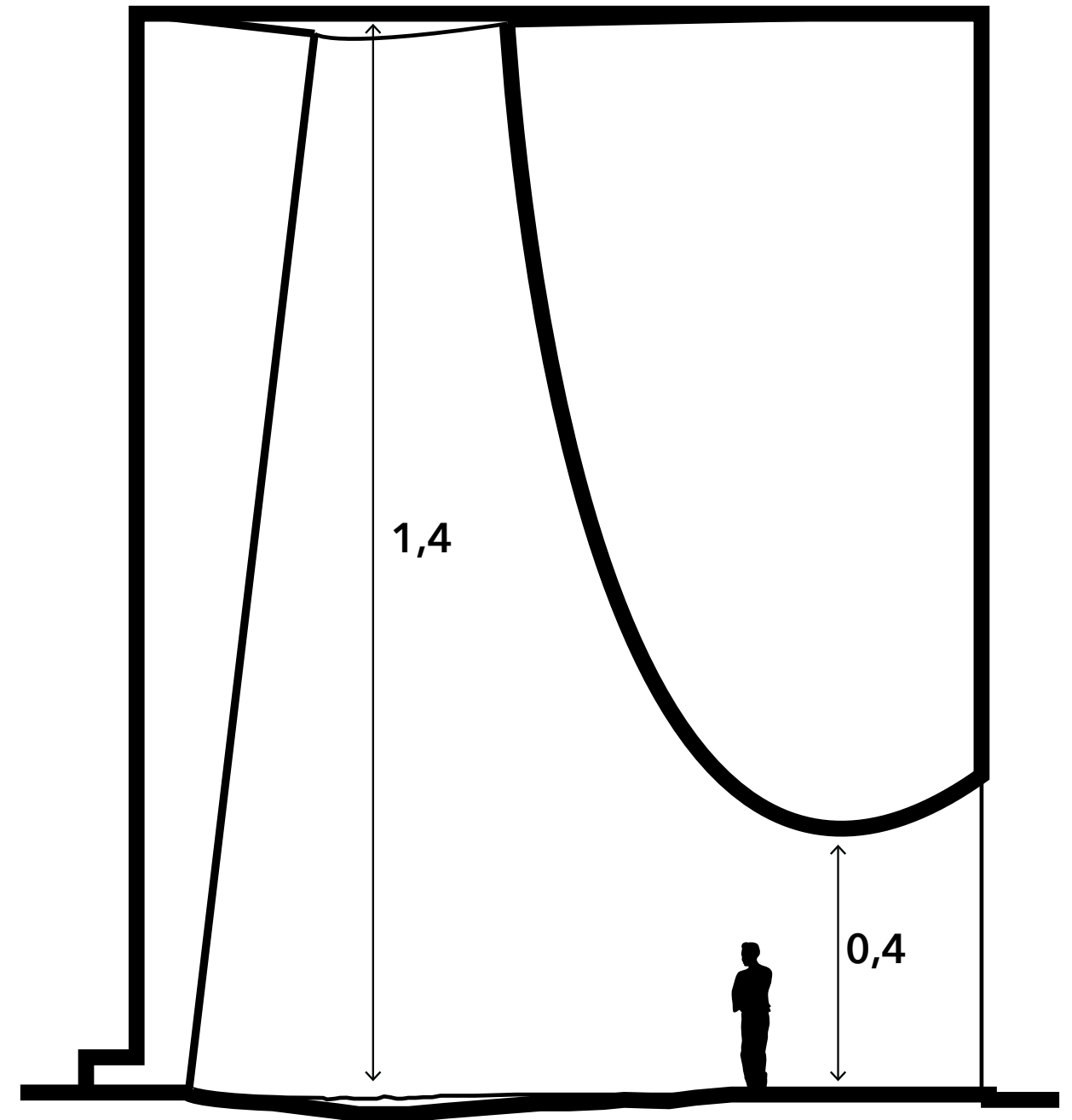
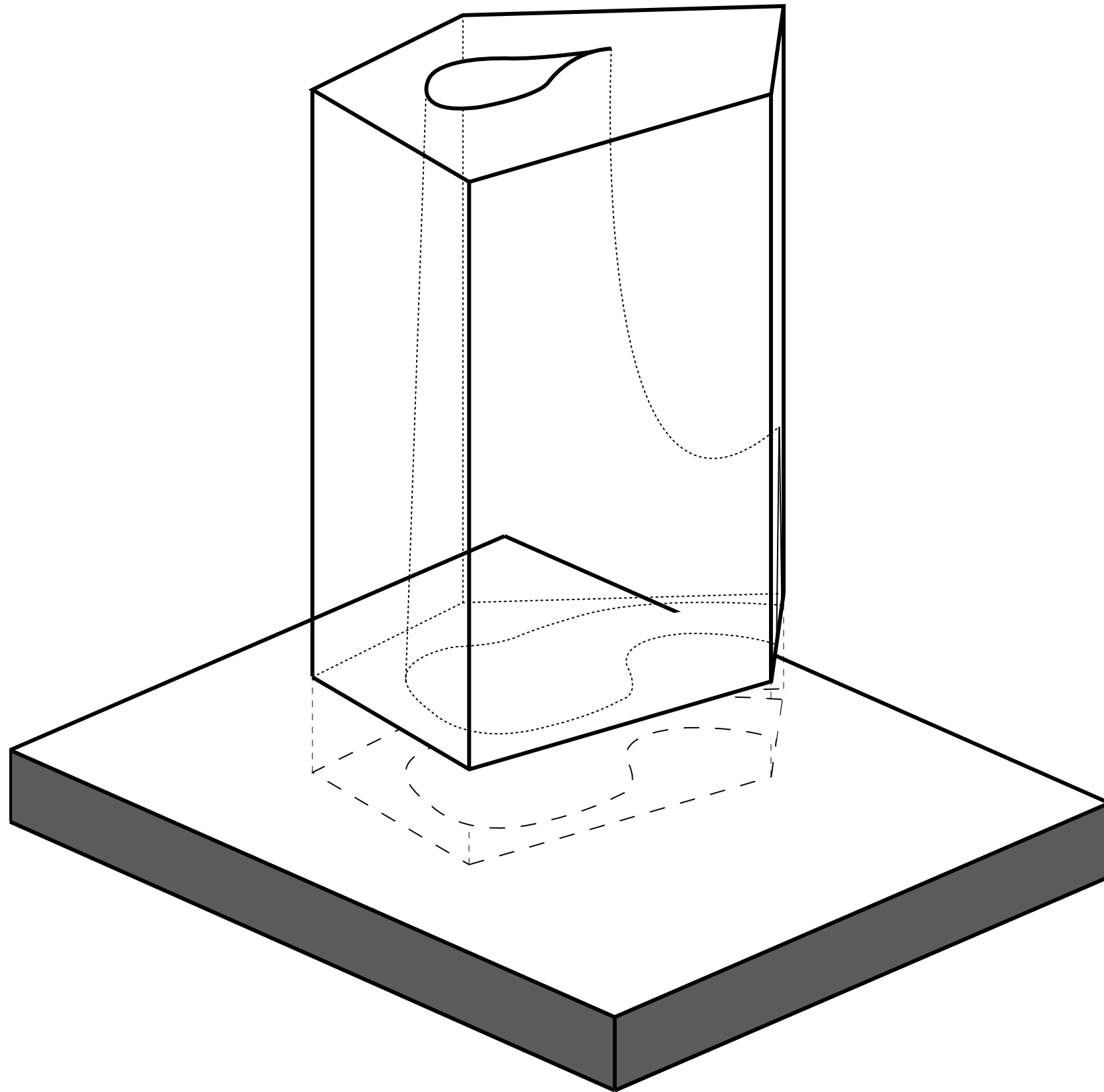



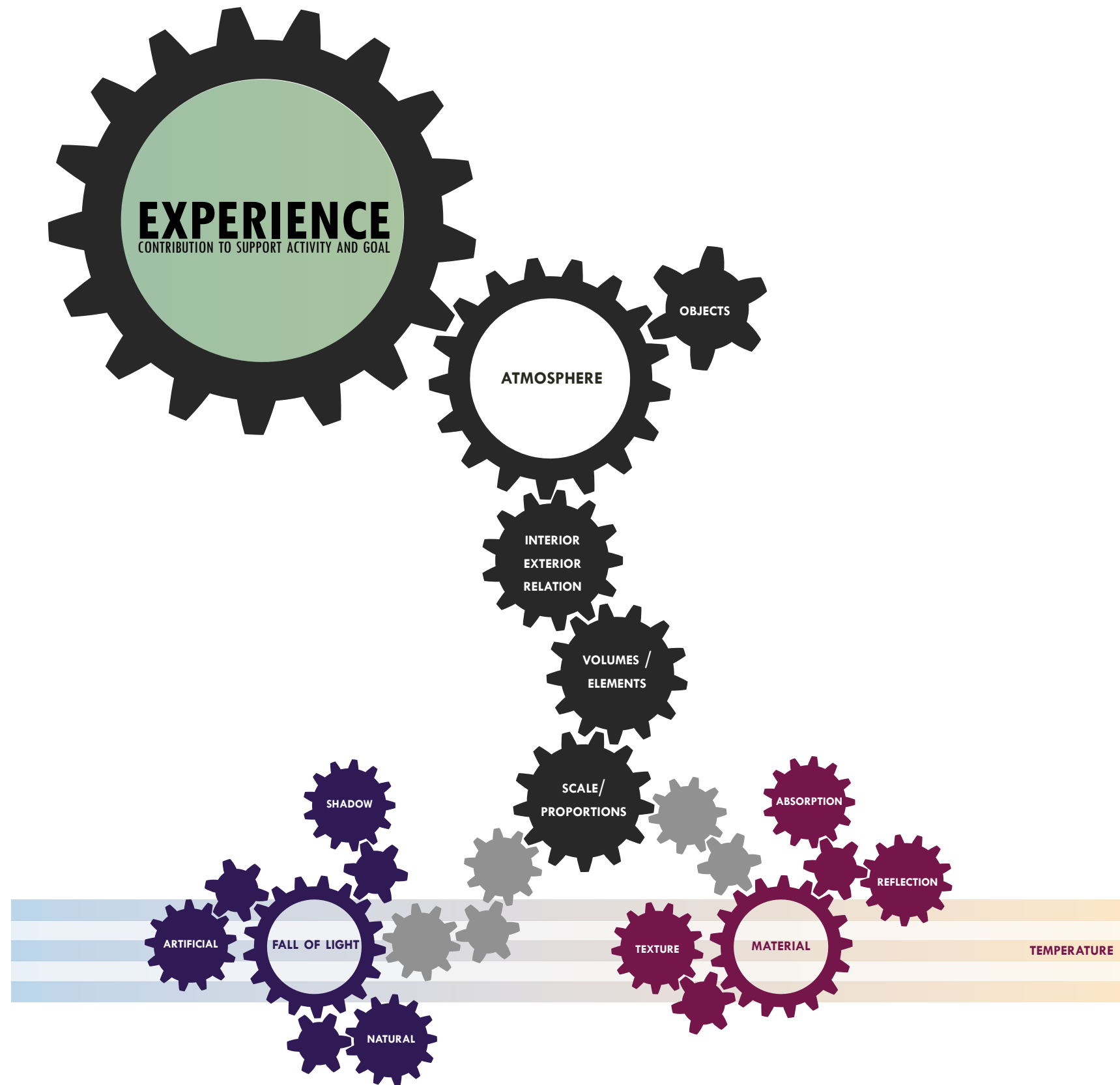

**90 WOONCONCEPT**  
Onderzoek atmosfeer | Licht

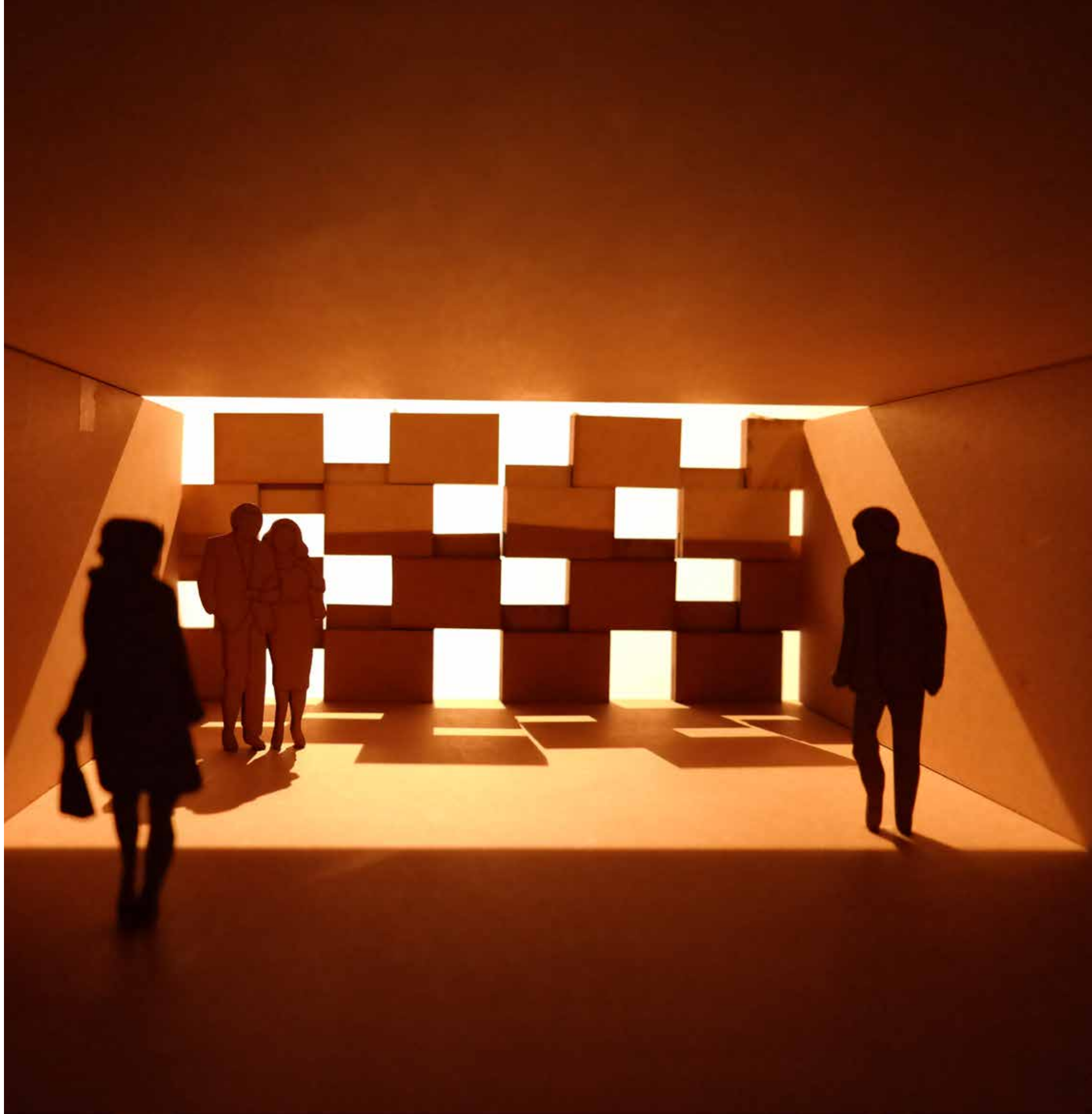



**91 WOONCONCEPT**  
Onderzoek atmosfeer | Licht



**92 WOONCONCEPT**  
Onderzoek atmosfeer | Licht

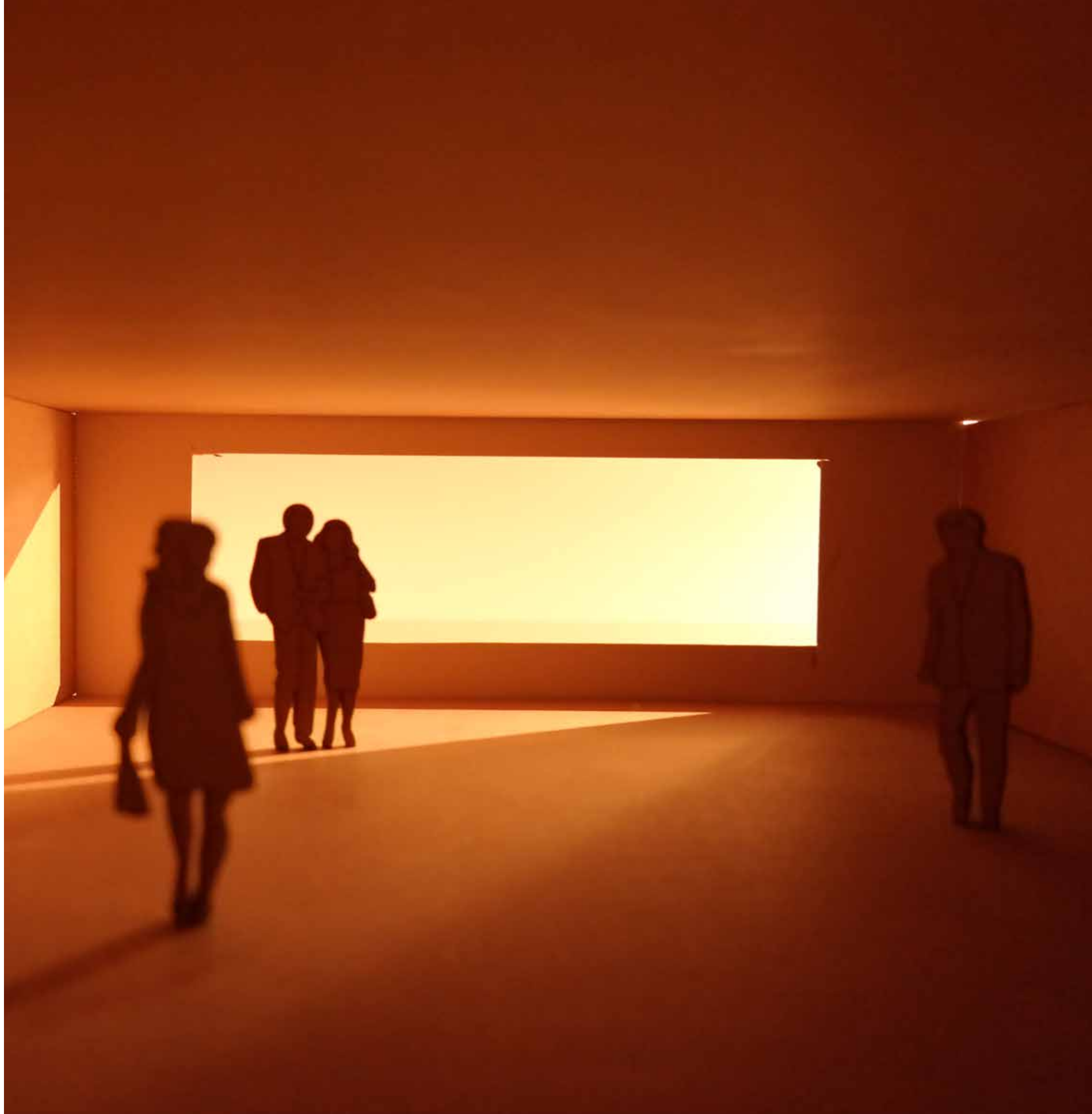



**93 WOONCONCEPT**  
Onderzoek atmosfeer | Licht

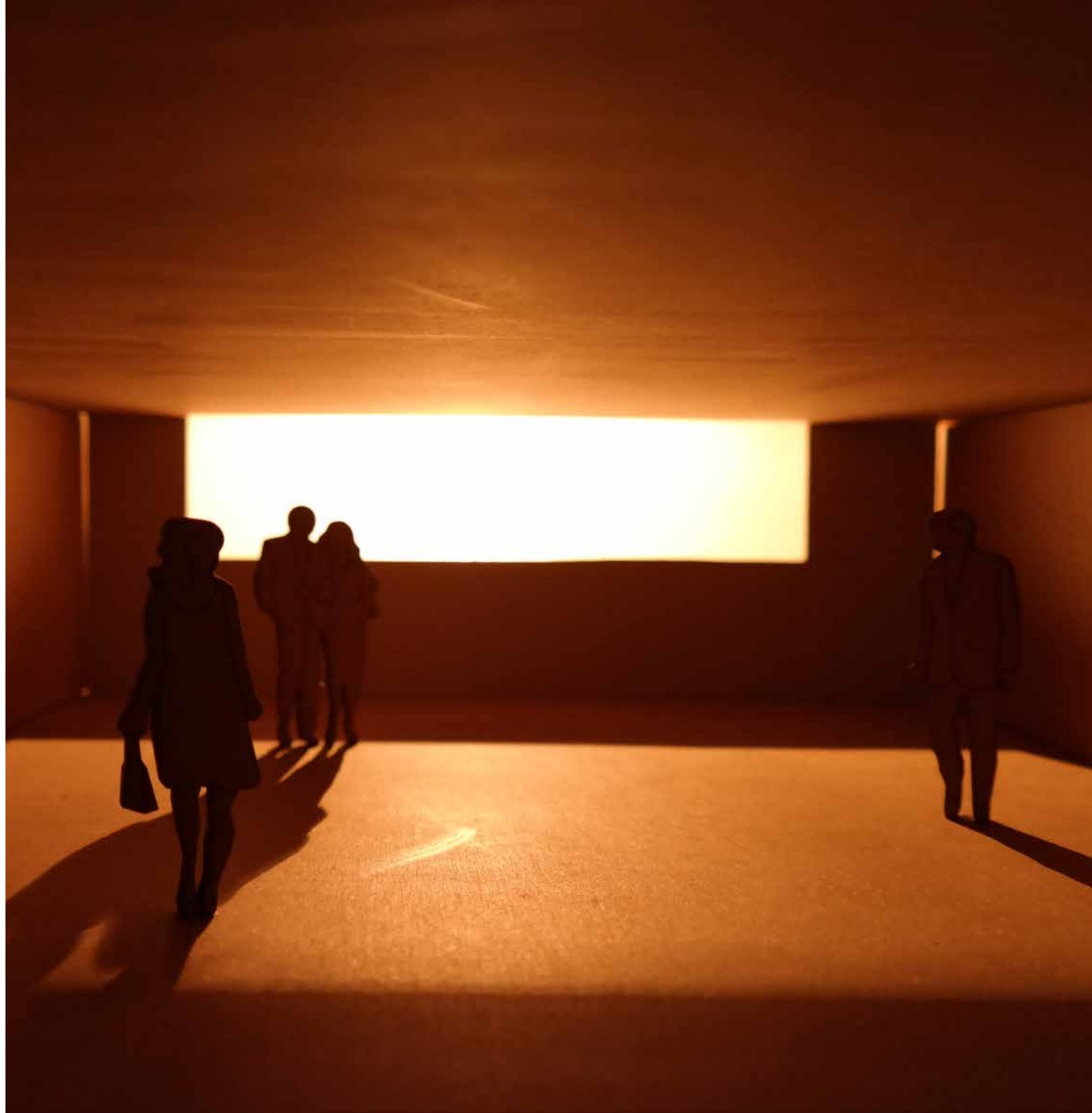

**94 WOONCONCEPT**  
Onderzoek atmosfeer | Licht

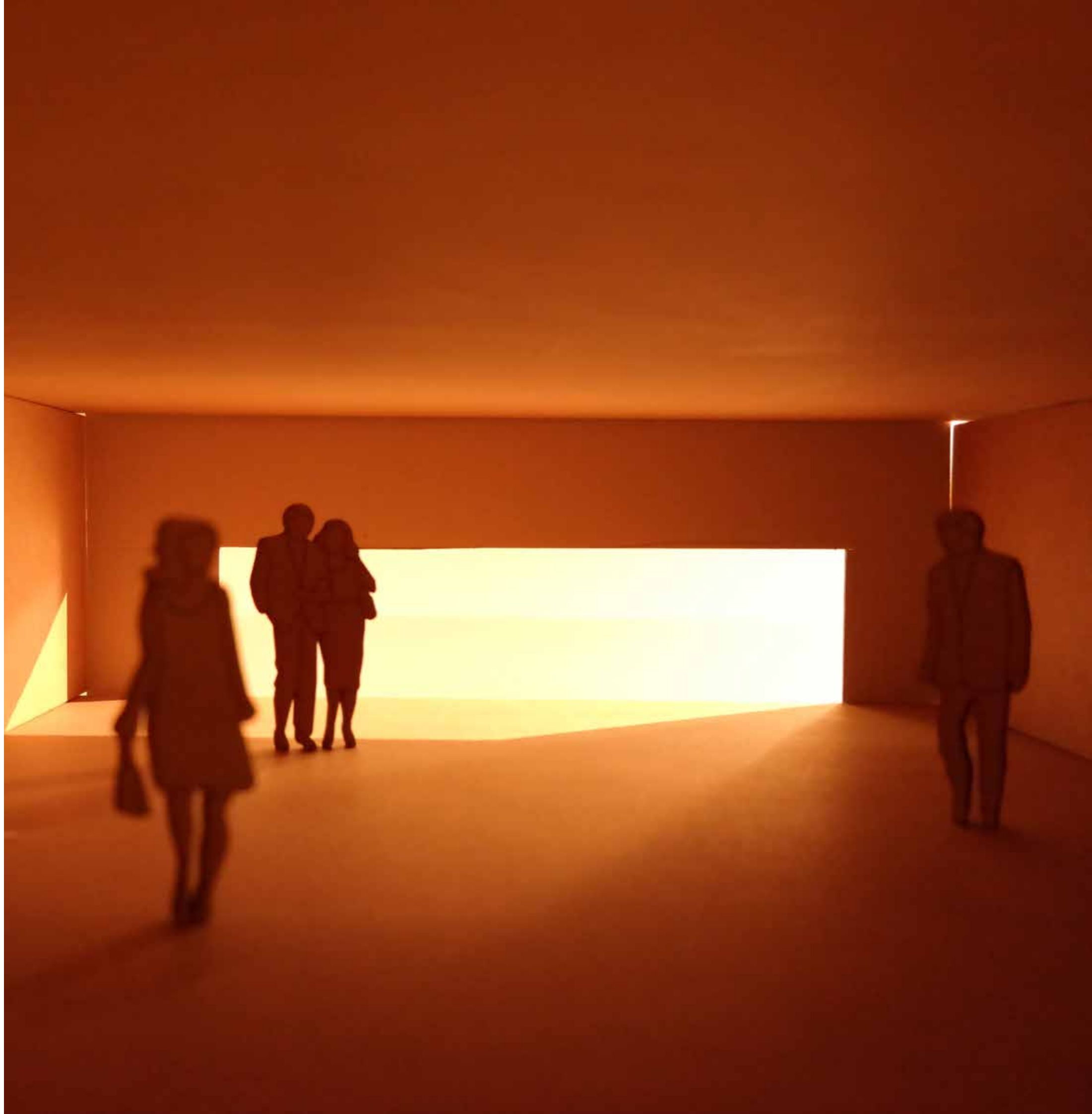



**95 WOONCONCEPT**  
Onderzoek atmosfeer | Licht

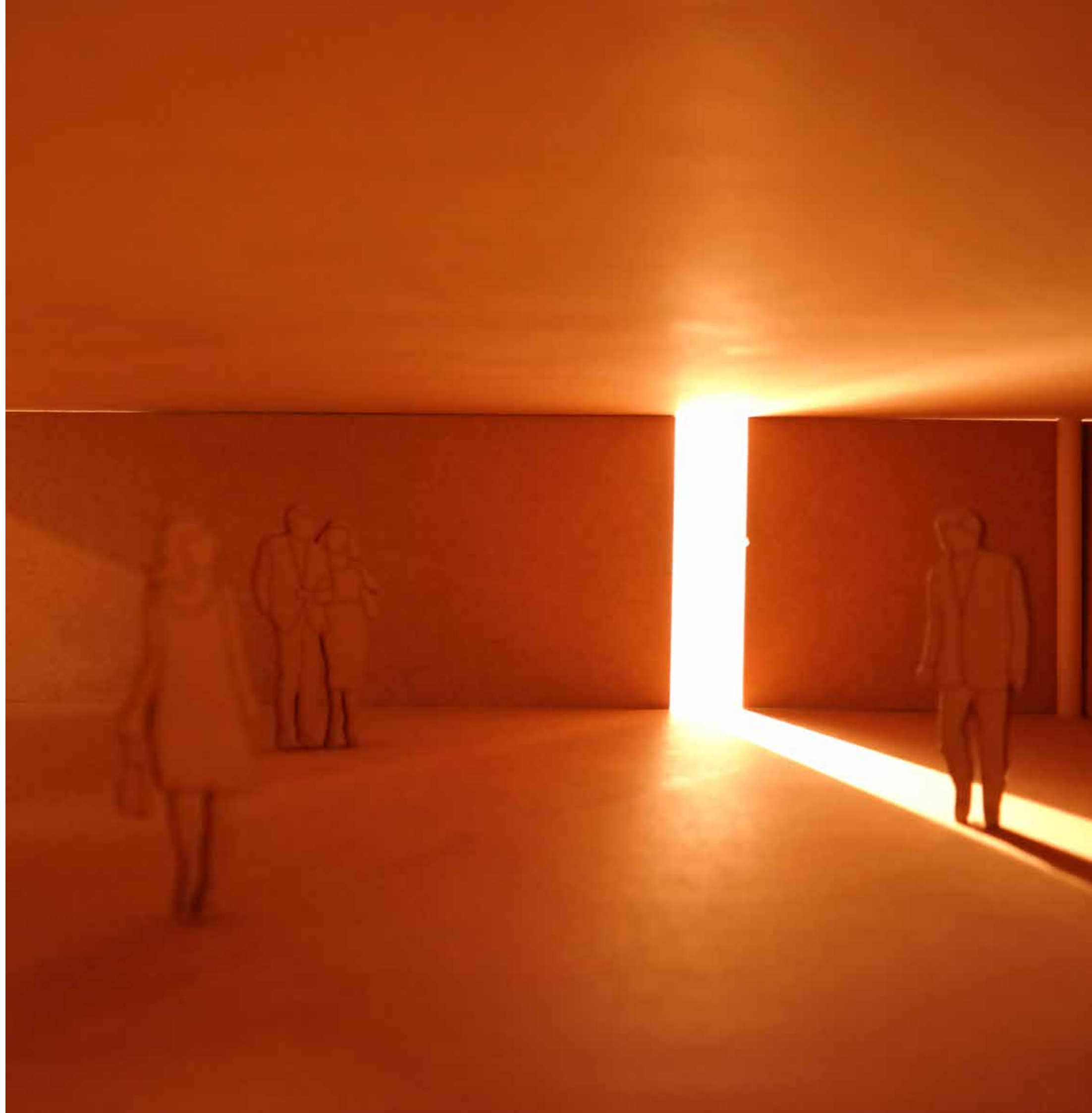

**96 WOONCONCEPT**  
Onderzoek atmosfeer | Licht

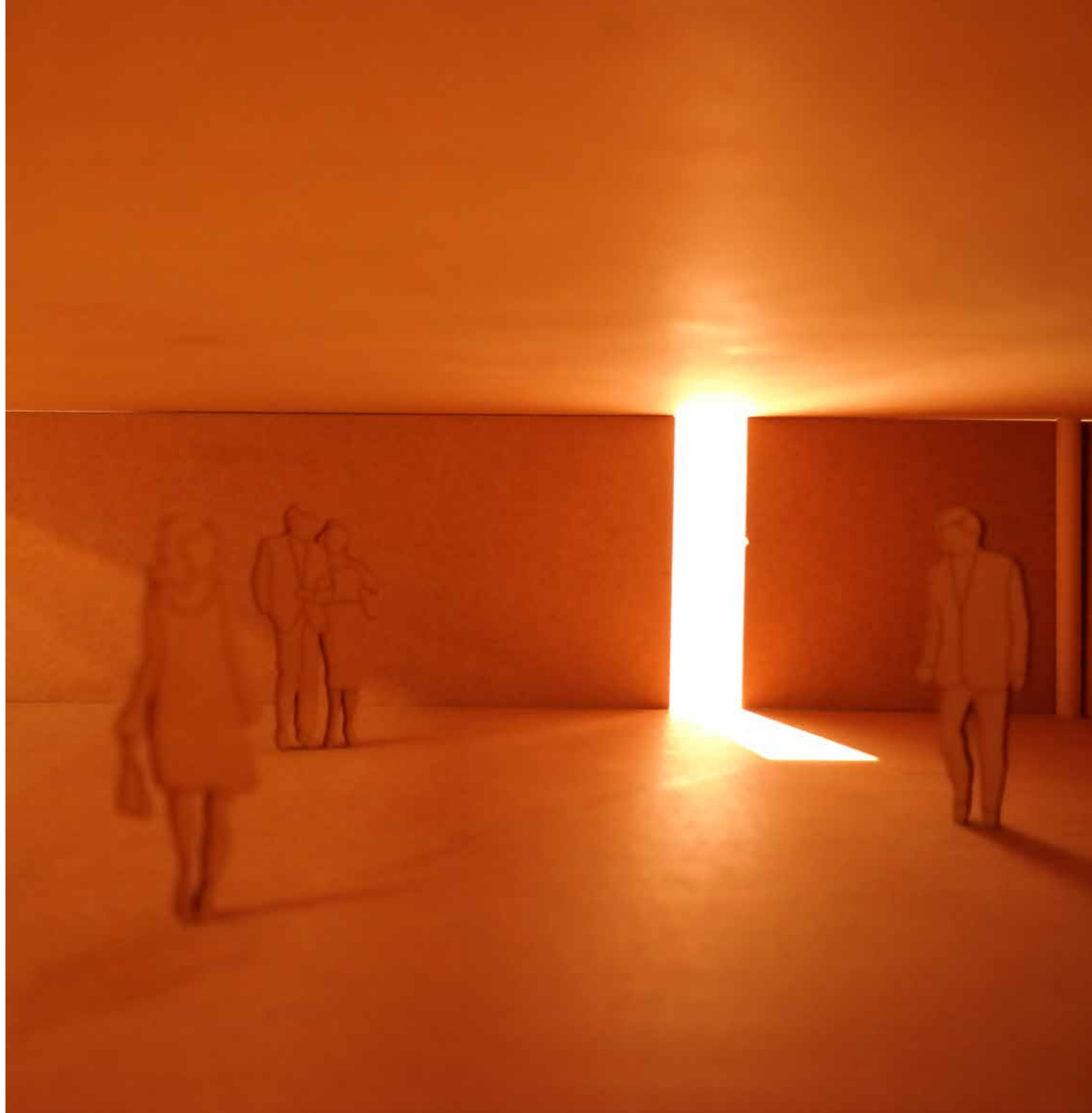



**97** **TECHNIEK**  
Gevelopeningen

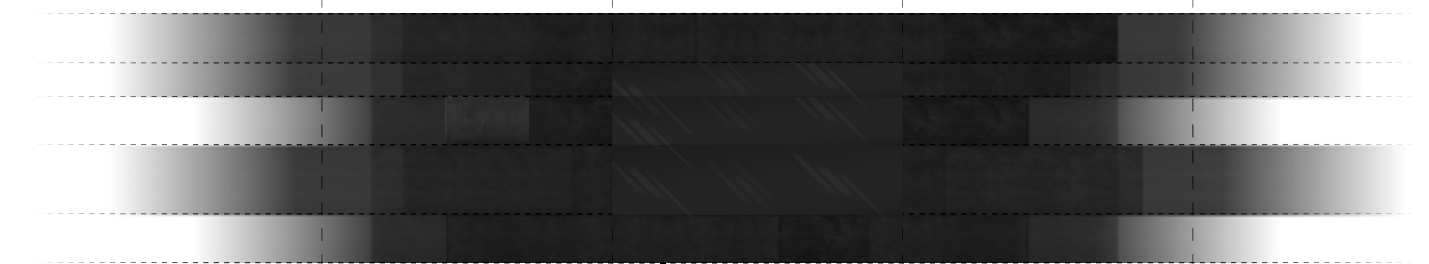
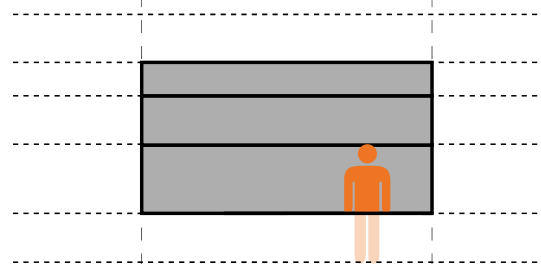
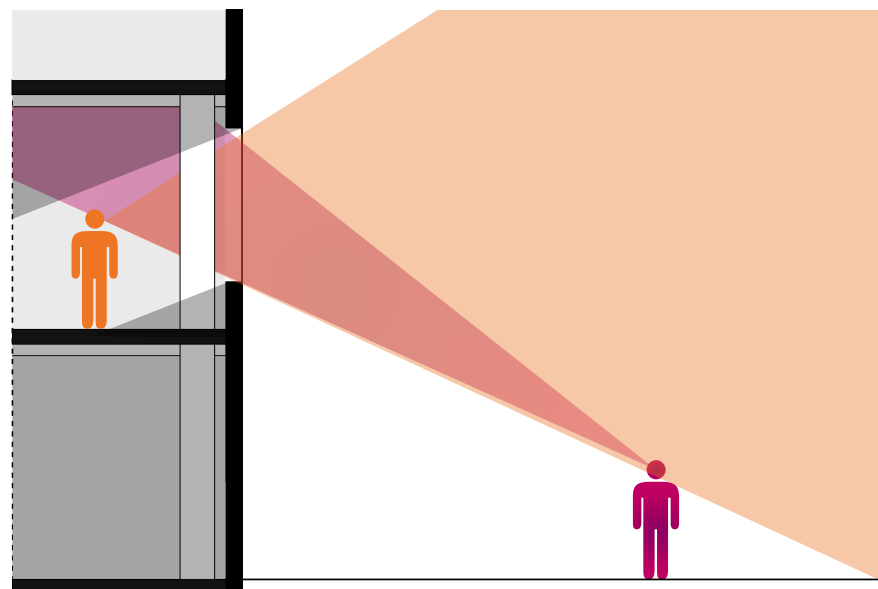
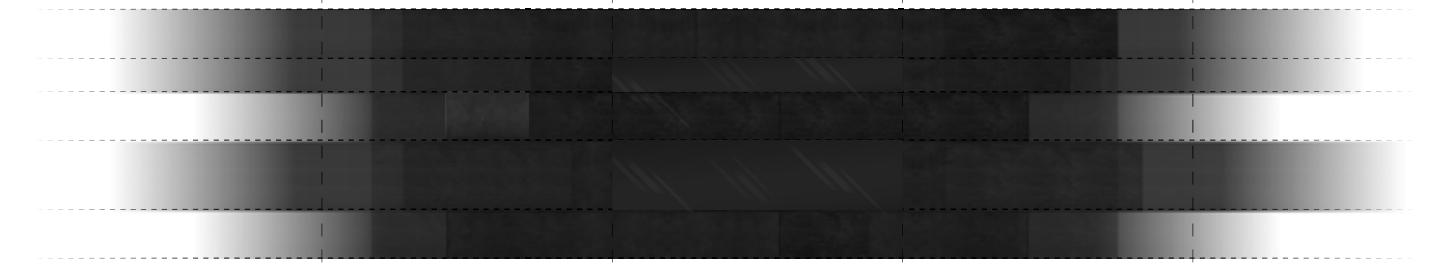
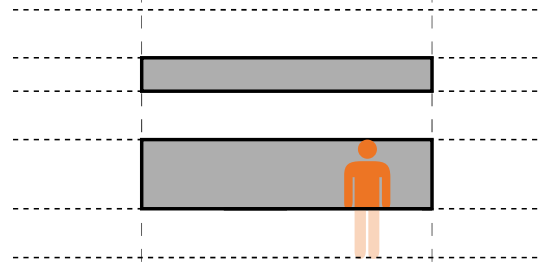
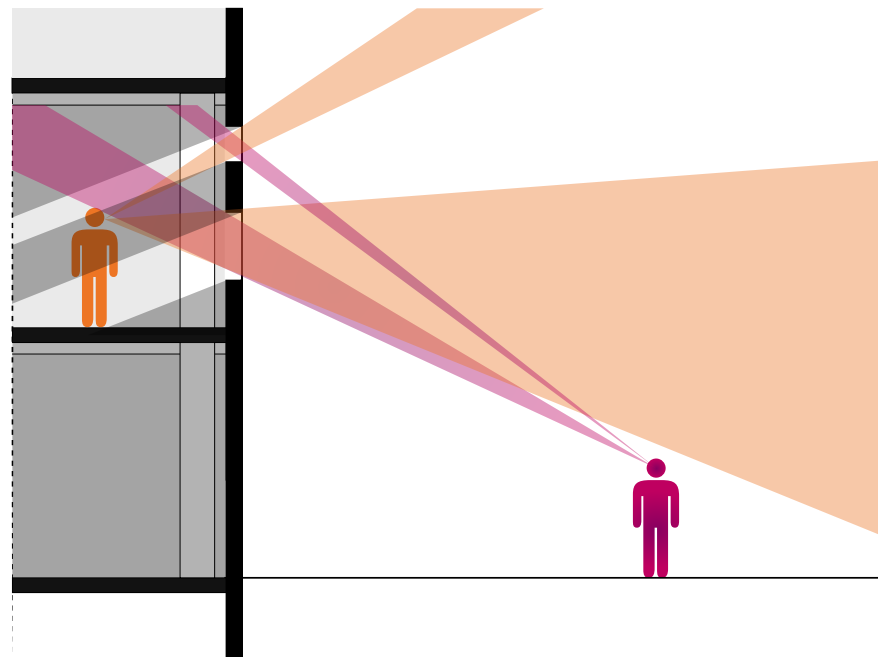
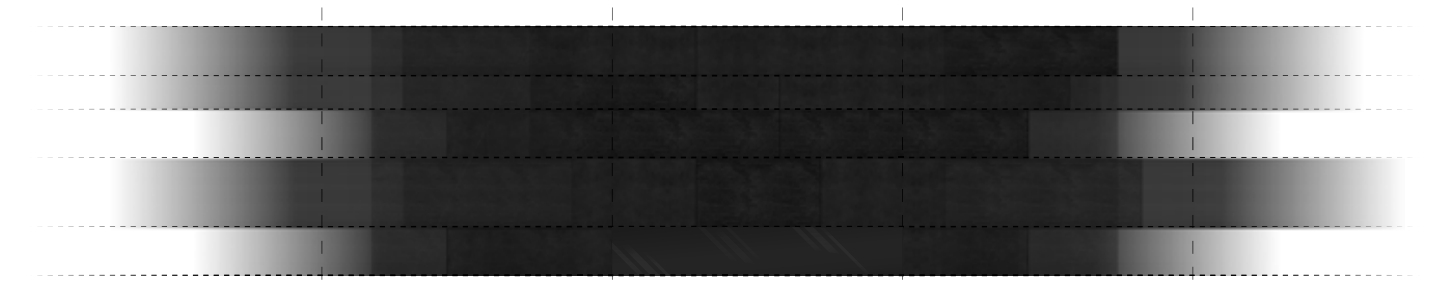
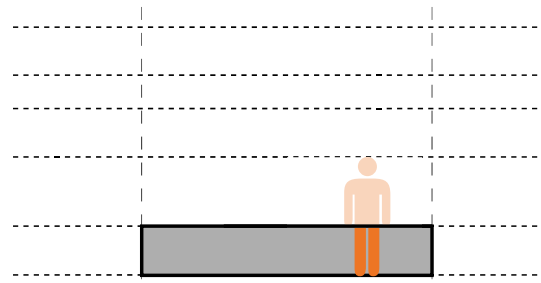
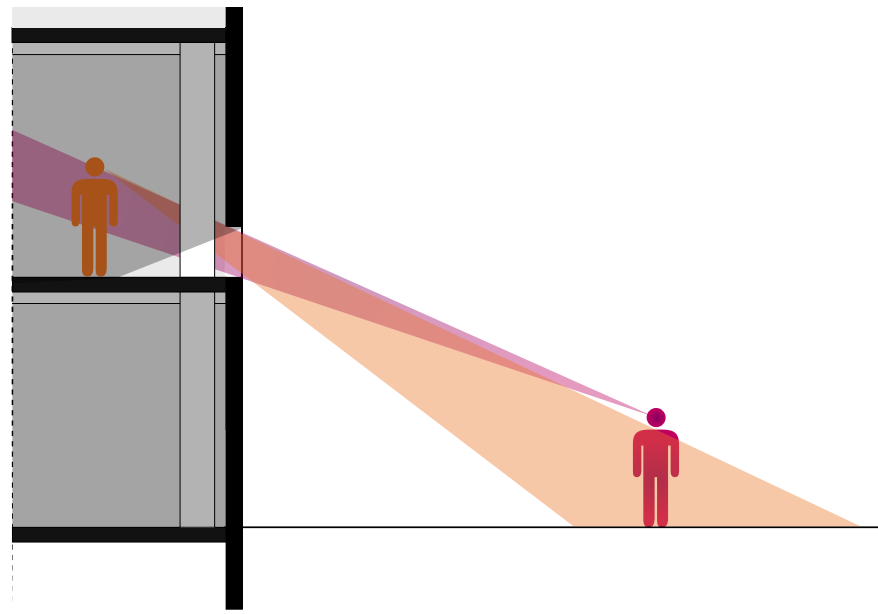

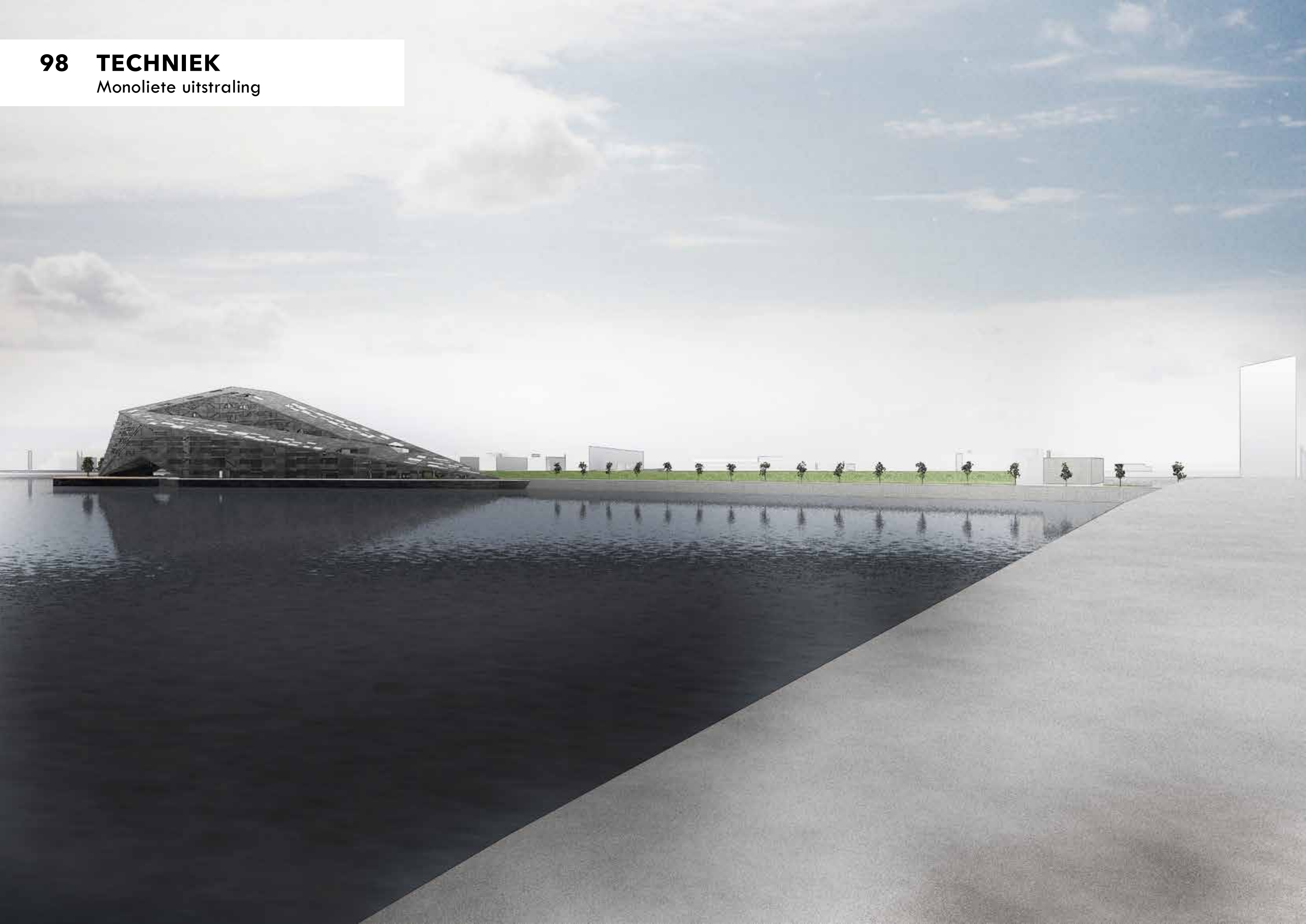



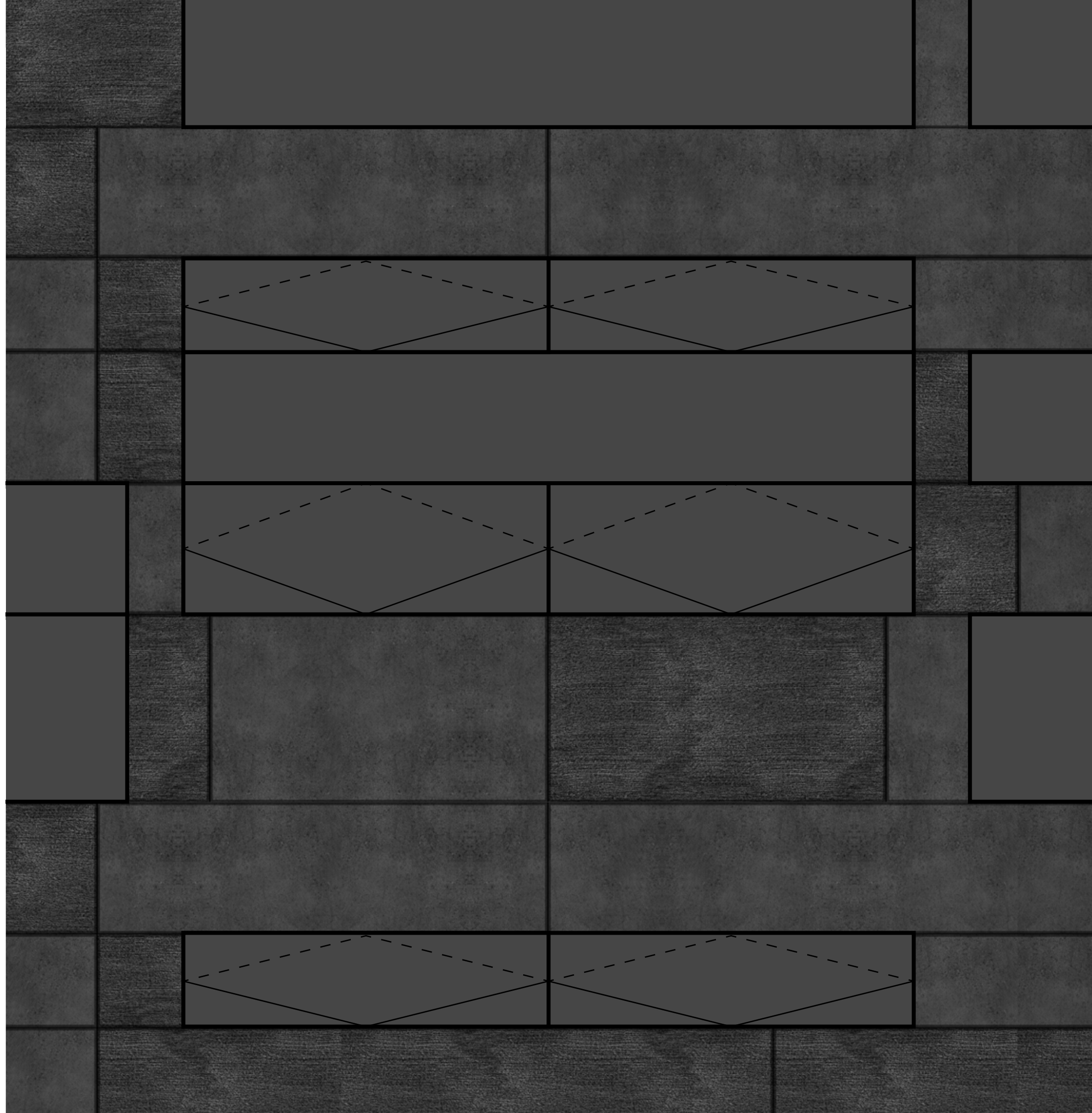



**100 TECHNIEK**  
Detailering

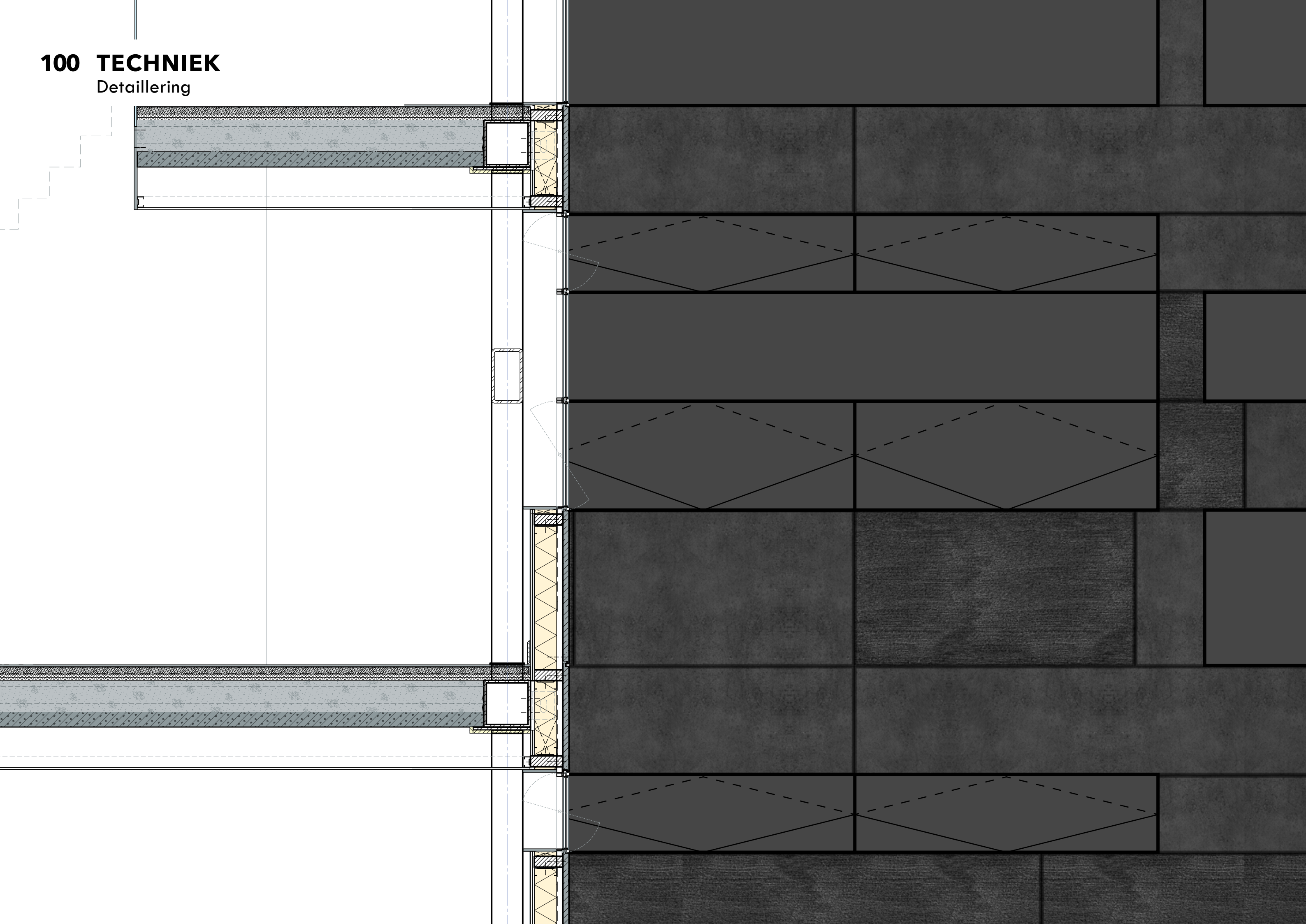



# 101 TECHNIK

## Detailing

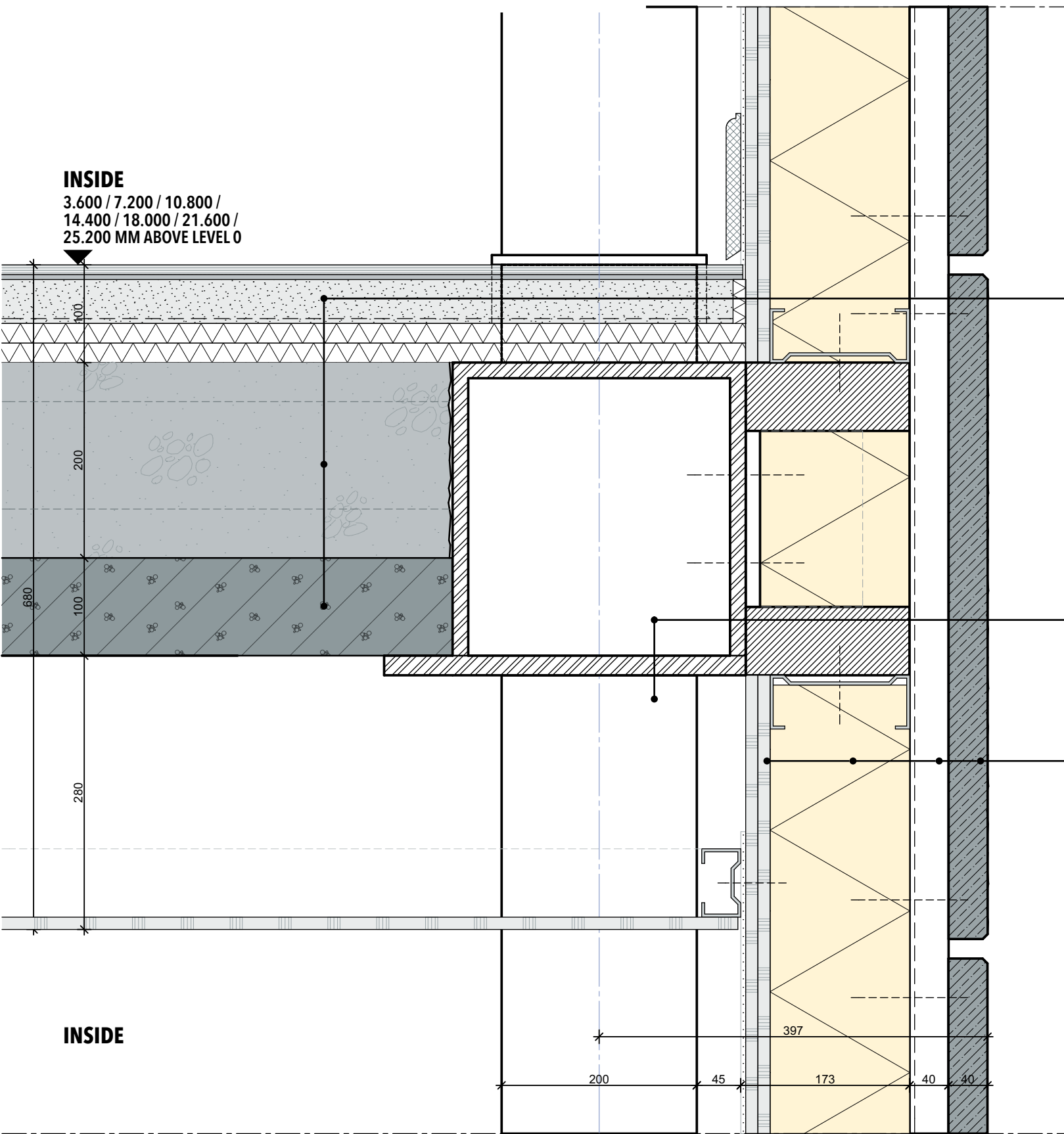

**FLOOR**  
FLOOR FINISH  
70 MM FLOATING SCREED WITH FLOOR HEATING  
300 MM WINGFLOOR

**STEEL STRUCTURE**  
STEEL TRUSS  
WITH RECTANGULAR HAT BEAM  
BEAMS AND DIAGONALS RECTANGULAR PROFILE

**FACADE**  
40 MM NATURAL STONE (ROUGH OR SMOOTH)  
40 MM CAVITY  
WATER RETAINING FOIL (WATERKERENDE LAAG)  
TIMBER FRAME STRUCTURE  
UNDERLAY FOIL (DAMPOPEN LAAG)  
DOUBLE PLASTERBOARD  
STUCCO

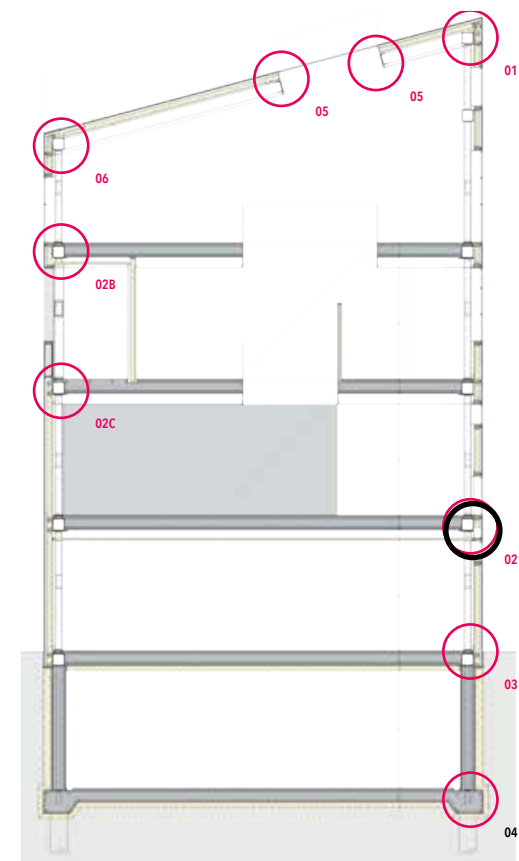

# 102 TECHNIK

## Detailing

**INSIDE**  
 3.600 / 7.200 / 10.800 /  
 14.400 / 18.000 / 21.600 /  
 25.200 MM ABOVE LEVEL 0

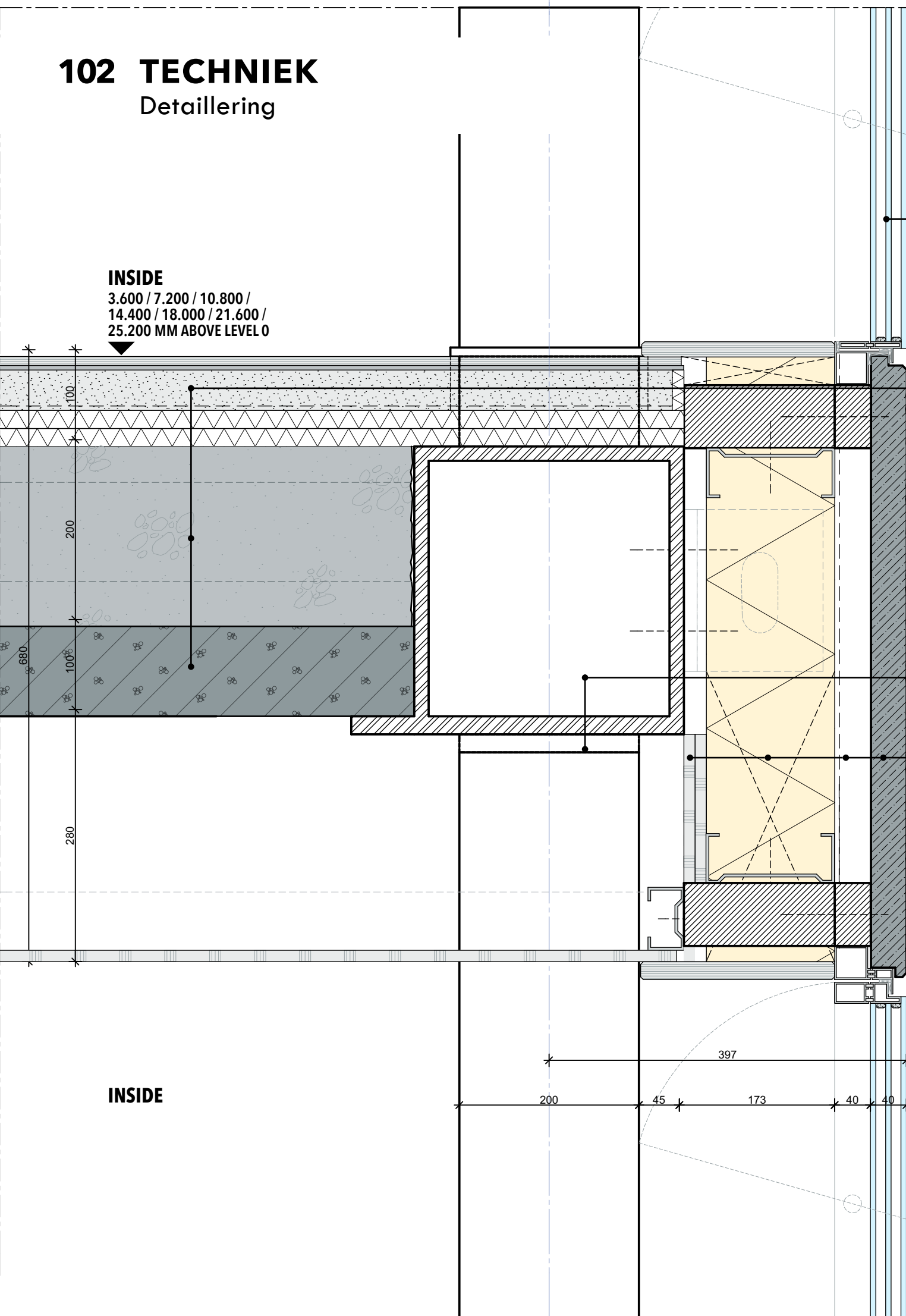

**PIVOT WINDOW**  
 40 MM FRAME  
 TRIPLE GLAZED  
 SMART GLASS ON INNER GLASLAYER  
 OUTER LINE OF GLASS = OUTER LINE FACADE

**FLOOR**  
 FLOOR FINISH  
 70 MM FLOATING SCREED WITH FLOOR HEATING  
 300 MM WINGFLOOR

**STEEL STRUCTURE**  
 STEEL TRUSS  
 WITH RECTANGULAR HAT BEAM  
 BEAMS AND DIAGONALS RECTANGULAR PROFILE

**FACADE**  
 40 MM NATURAL STONE (ROUGH OR SMOOTH)  
 40 MM CAVITY  
 WATER RETAINING FOIL (WATERKERENDE LAAG)  
 TIMBER FRAME STRUCTURE  
 UNDERLAY FOIL (DAMPOPEN LAAG)  
 DOUBLE PLASTERBOARD  
 STUCCO

**INSIDE**

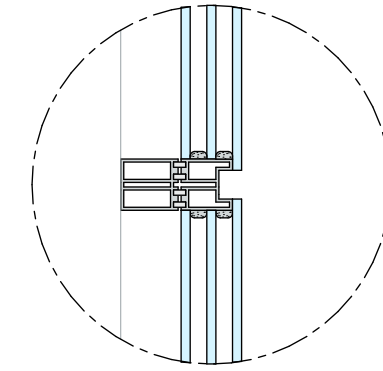

**WINDOW FRAME**  
 FIXED TOP WINDOW  
 FIXED BOTTOM WINDOW

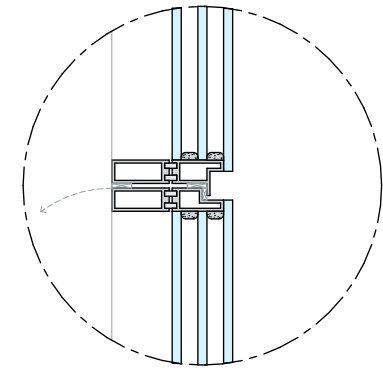

**WINDOW FRAME**  
 FIXED TOP WINDOW  
 PIVOTTING BOTTOM WINDOW

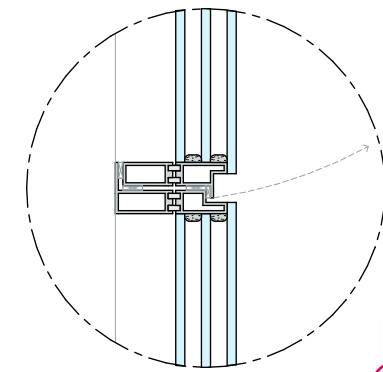

**WINDOW FRAME**  
 PIVOTTING TOP WINDOW  
 FIXED BOTTOM WINDOW

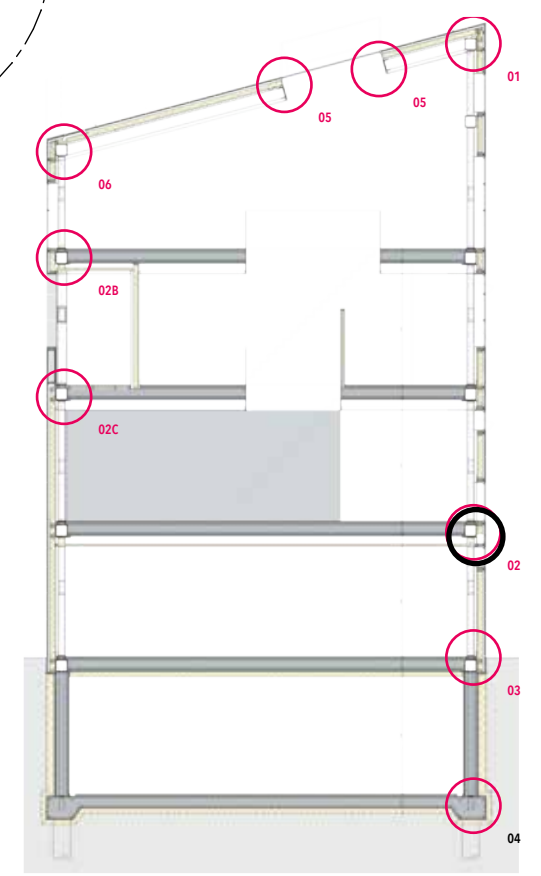



# 103 TECHNIK

## Detailing

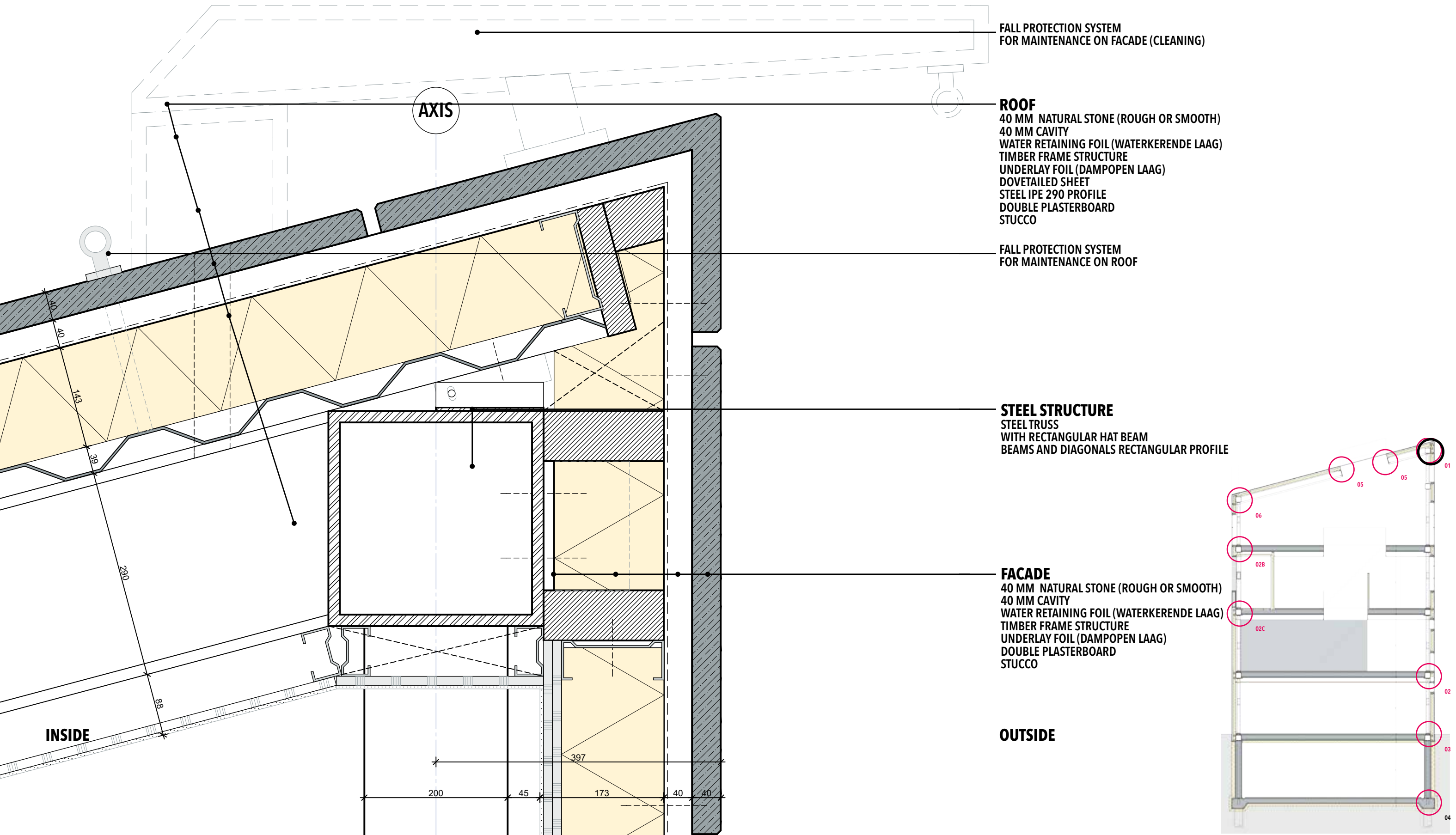

# 104 TECHNIEK

## Detailling

### ROOF

40 MM NATURAL STONE (ROUGH OR SMOOTH)  
40 MM CAVITY  
WATER RETAINING FOIL (WATERKERENDE LAAG)  
TIMBER FRAME STRUCTURE  
UNDERLAY FOIL (DAMPOPEN LAAG)  
DOVETAILED SHEET  
STEEL IPE 290 PROFILE  
DOUBLE PLASTERBOARD  
STUCCO

GUTTER FOR DRAINAGE  
REMOVABLE STONE PLATE FOR MAINTENANCE

### FACADE

40 MM NATURAL STONE (ROUGH OR SMOOTH)  
40 MM CAVITY  
WATER RETAINING FOIL (WATERKERENDE LAAG)  
TIMBER FRAME STRUCTURE  
UNDERLAY FOIL (DAMPOPEN LAAG)  
DOUBLE PLASTERBOARD  
STUCCO

### STEEL STRUCTURE

STEEL TRUSS  
WITH RECTANGULAR HAT BEAM  
BEAMS AND DIAGONALS RECTANGULAR PROFILE

OUTSIDE

INSIDE

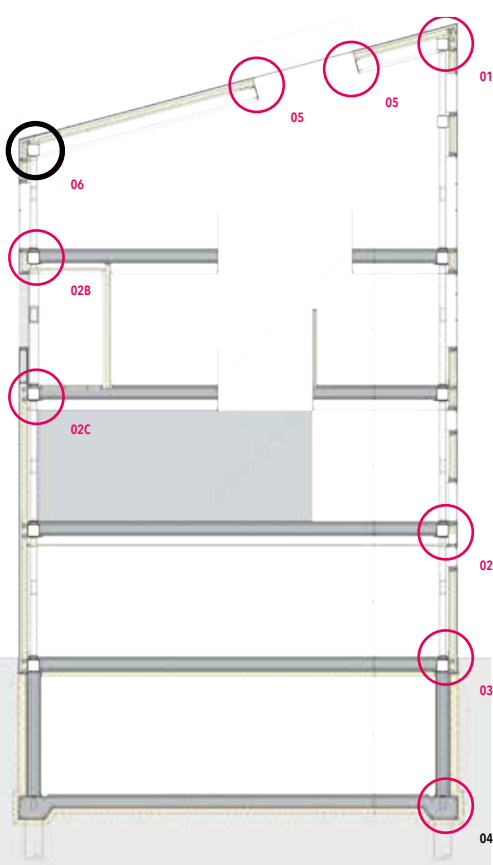
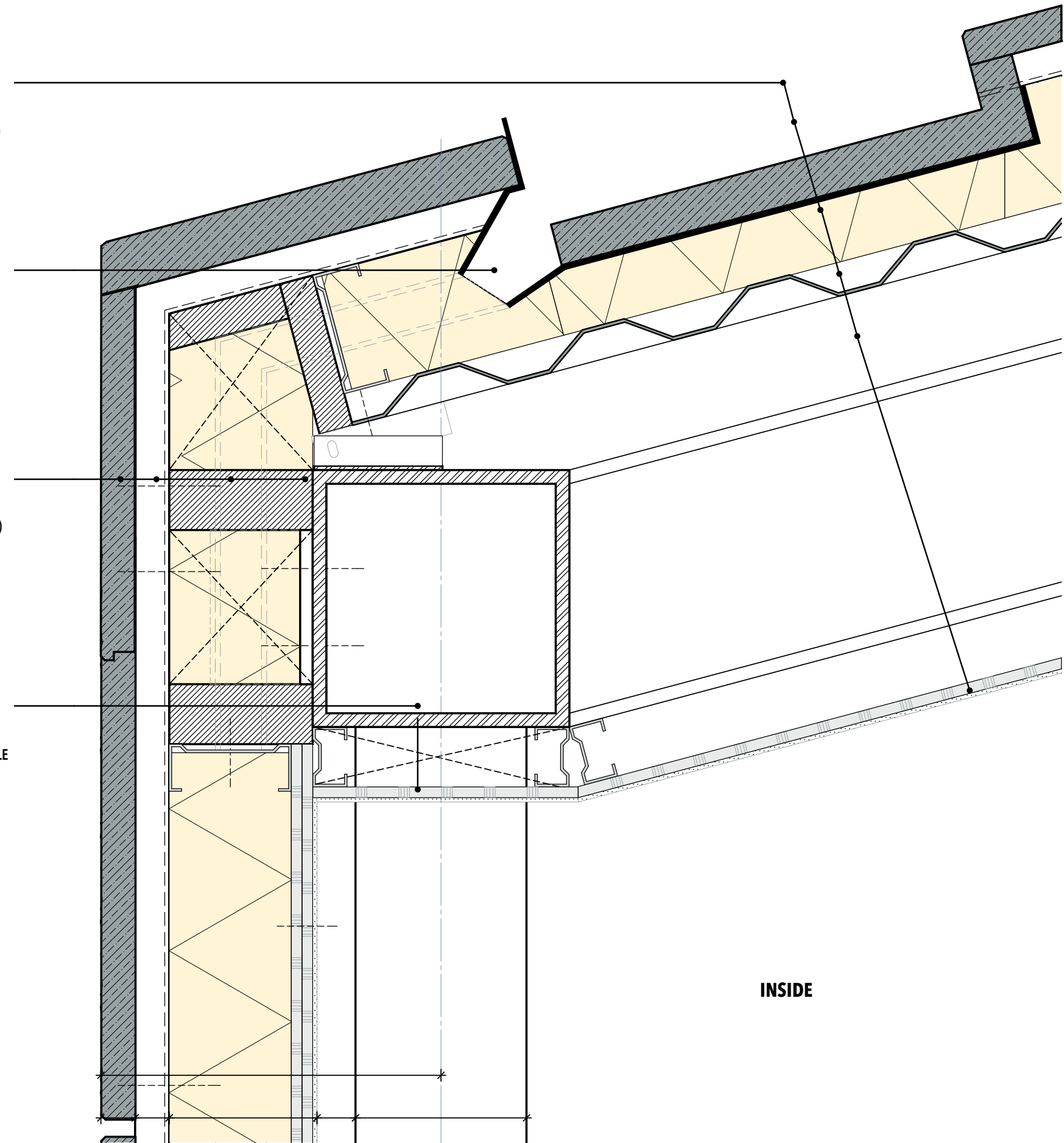



# 105 TECHNIK

## Detailing

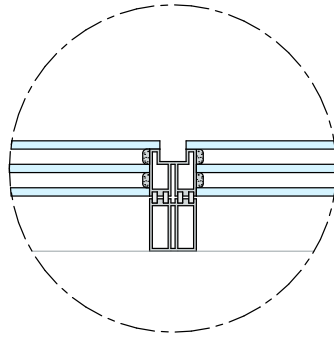

**VERTICAL WINDOW FRAME**  
FIXED LEFT WINDOW  
FIXED RIGHT WINDOW

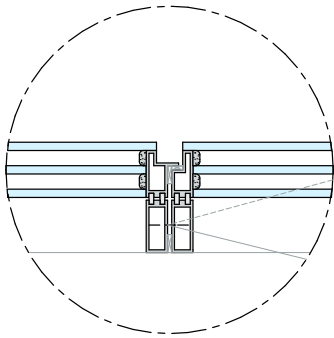

**VERTICAL WINDOW FRAME**  
FIXED LEFT WINDOW  
PIVOTTING RIGHT WINDOW  
(SECTION BOTTOM PART)

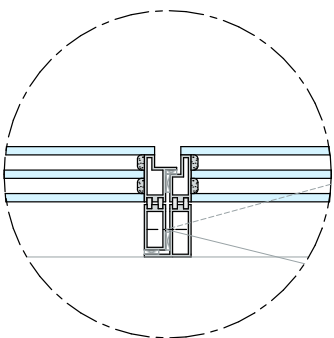

**VERTICAL WINDOW FRAME**  
FIXED LEFT WINDOW  
PIVOTTING RIGHT WINDOW  
(SECTION TOP PART)

**FACADE**  
40 MM NATURAL STONE (ROUGH OR SMOOTH)  
40 MM CAVITY  
WATER RETAINING FOIL (WATERKERENDE LAAG)  
TIMBER FRAME STRUCTURE  
UNDERLAY FOIL (DAMPOPEN LAAG)  
DOUBLE PLASTERBOARD  
STUCCO

**SEPERATION WALL**  
140 MM CAVITY FOR PIPING  
100 MM METAL STUD FRAME  
100 MM INSULATION  
DOUBLE PLASTERBOARD  
STUCCO

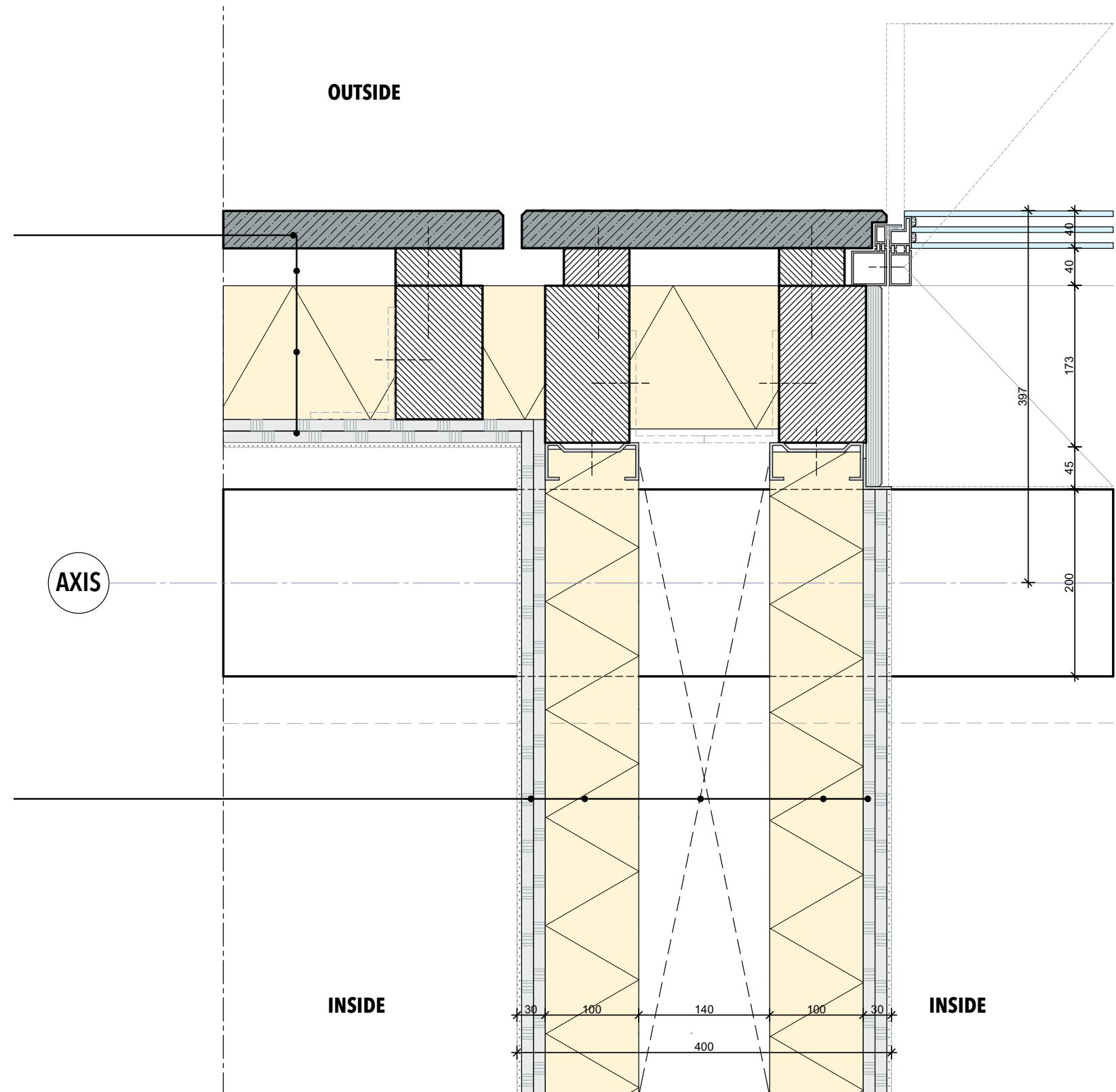
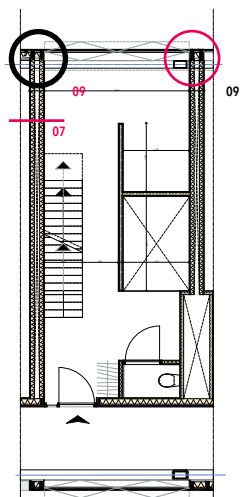

# 106 IMPRESSIE

Stedenbouwkundige situatie

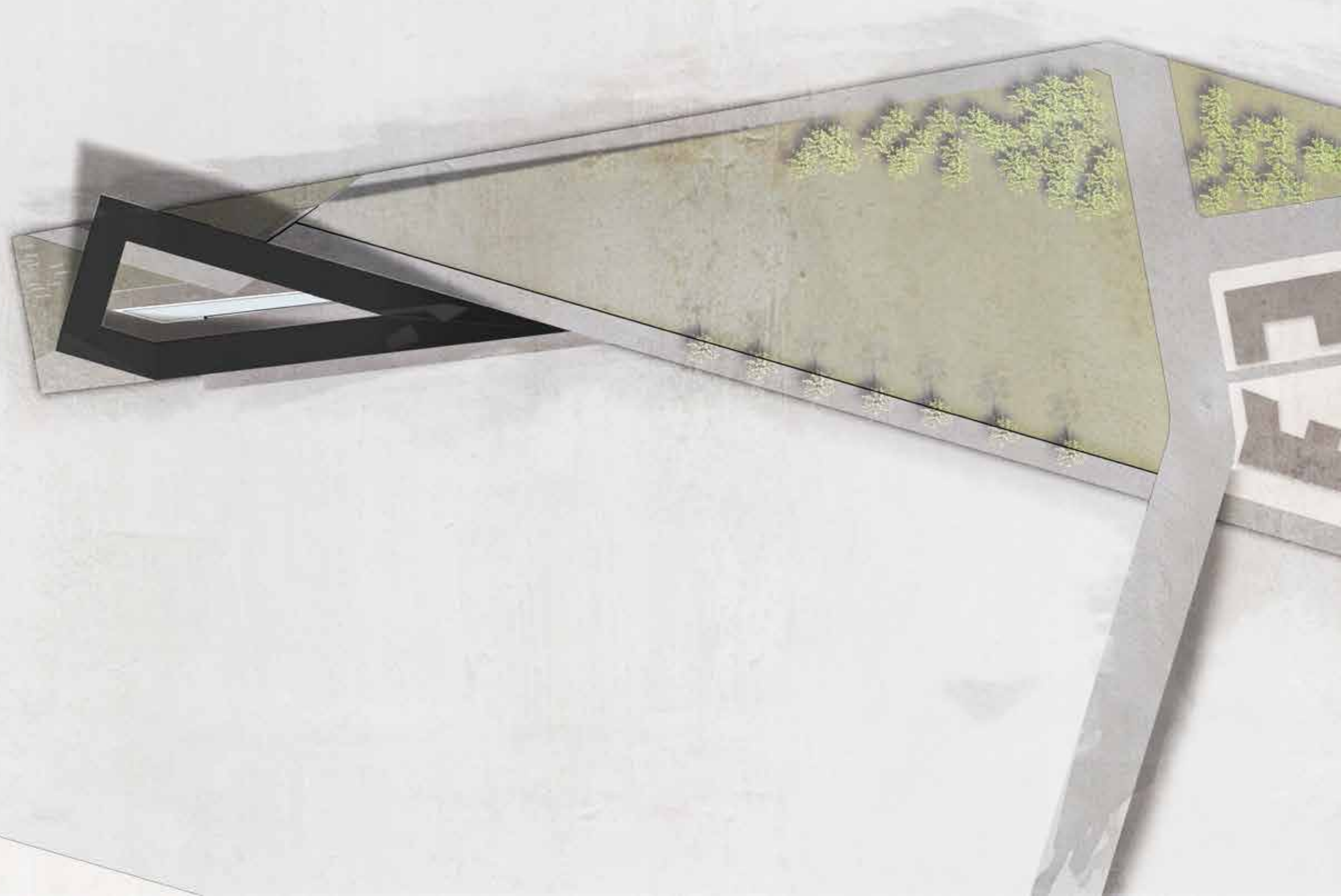



**107 IMPRESSIE**  
Benadering boulevard

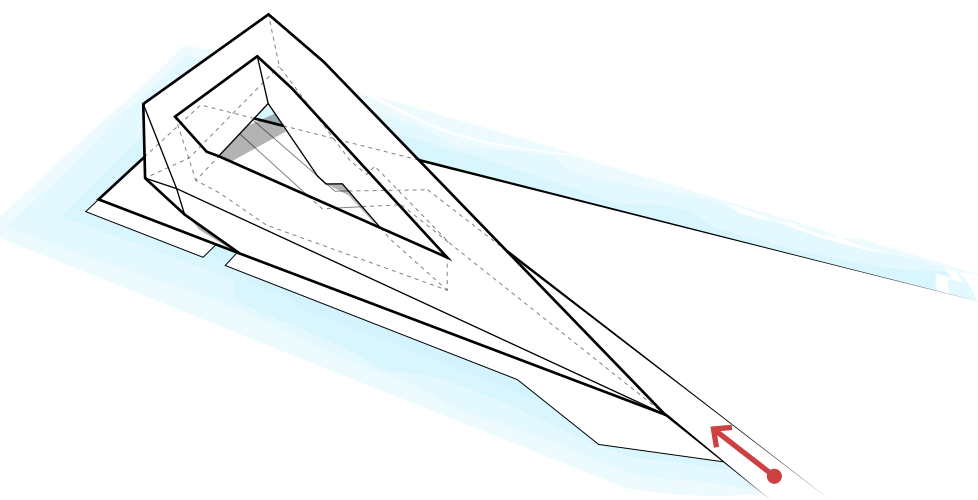

**108 IMPRESSIE**  
Benadering boulevard

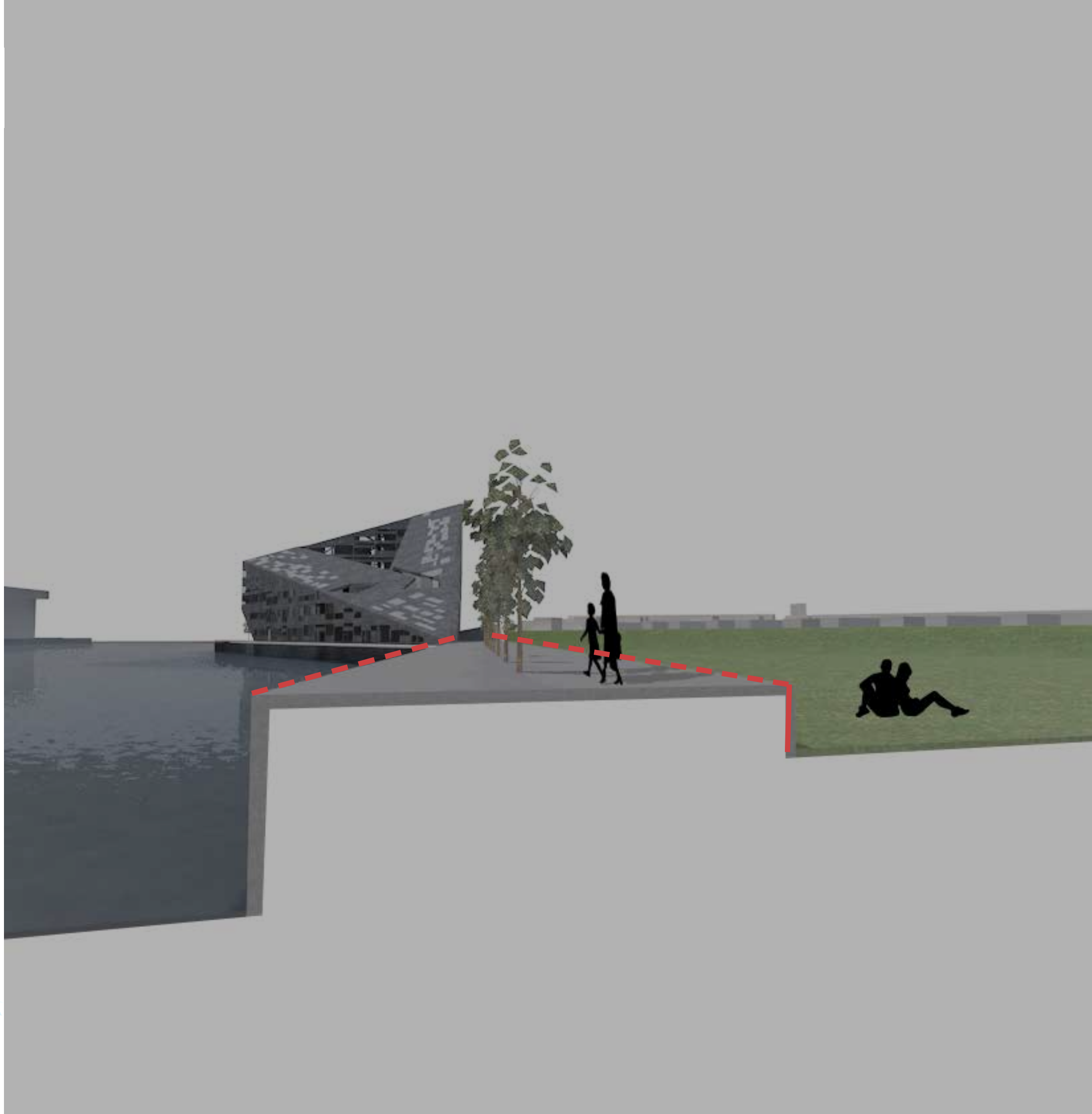
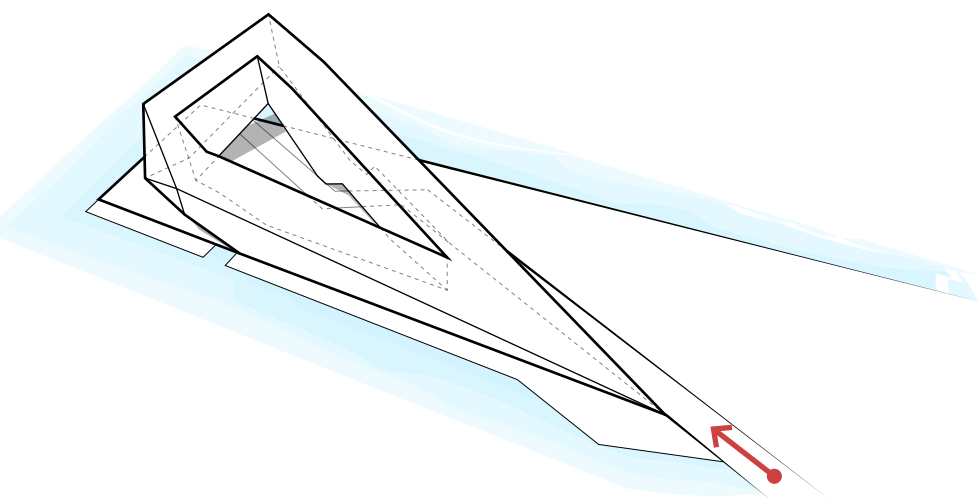



**109 IMPRESSIE**  
Benadering boulevard

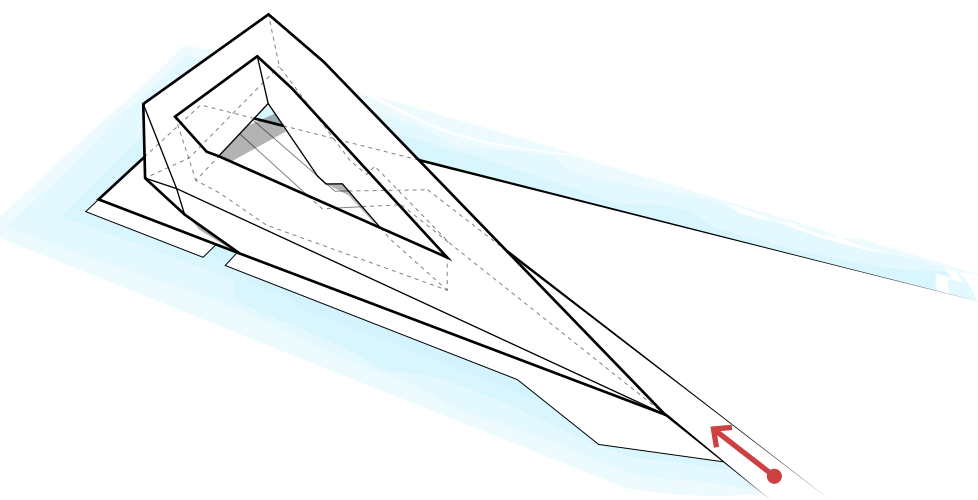
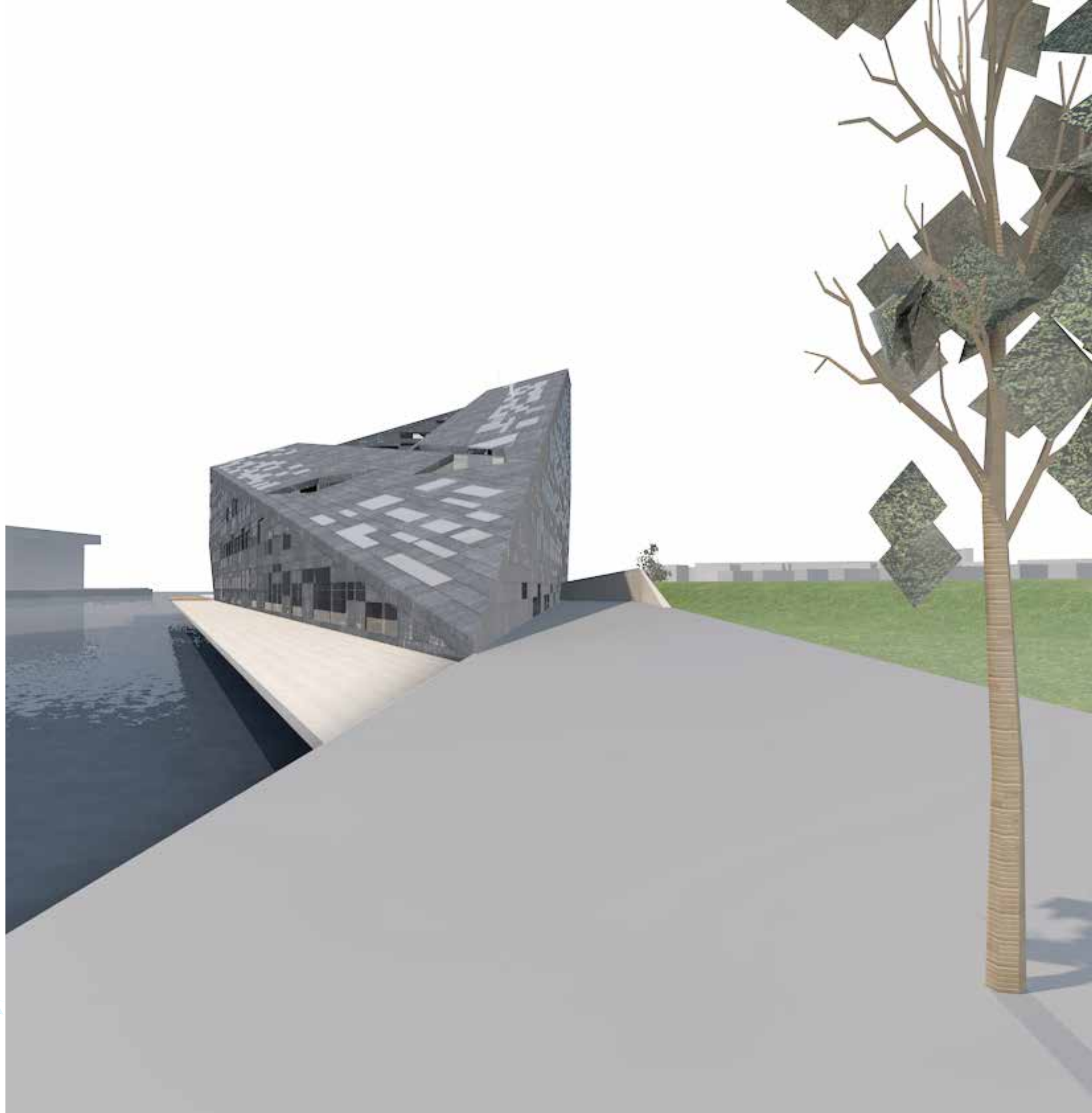

**110 IMPRESSIE**  
Benadering boulevard

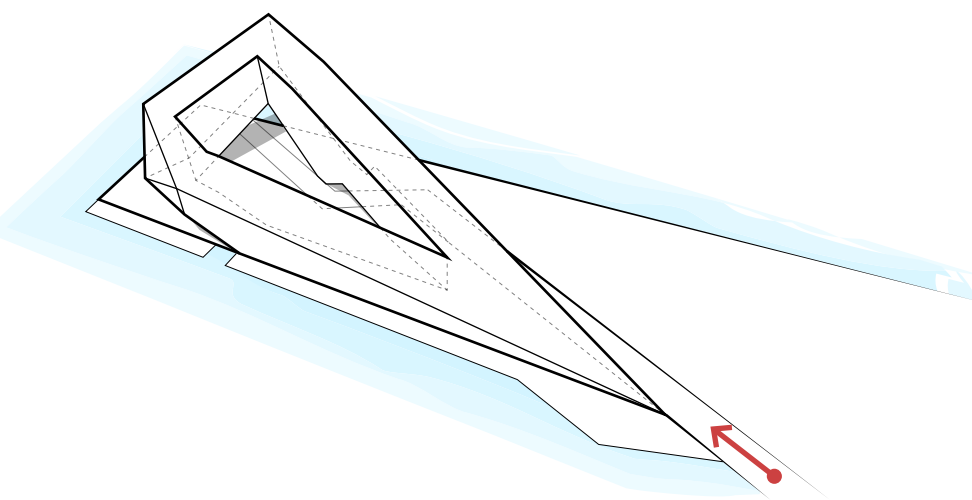
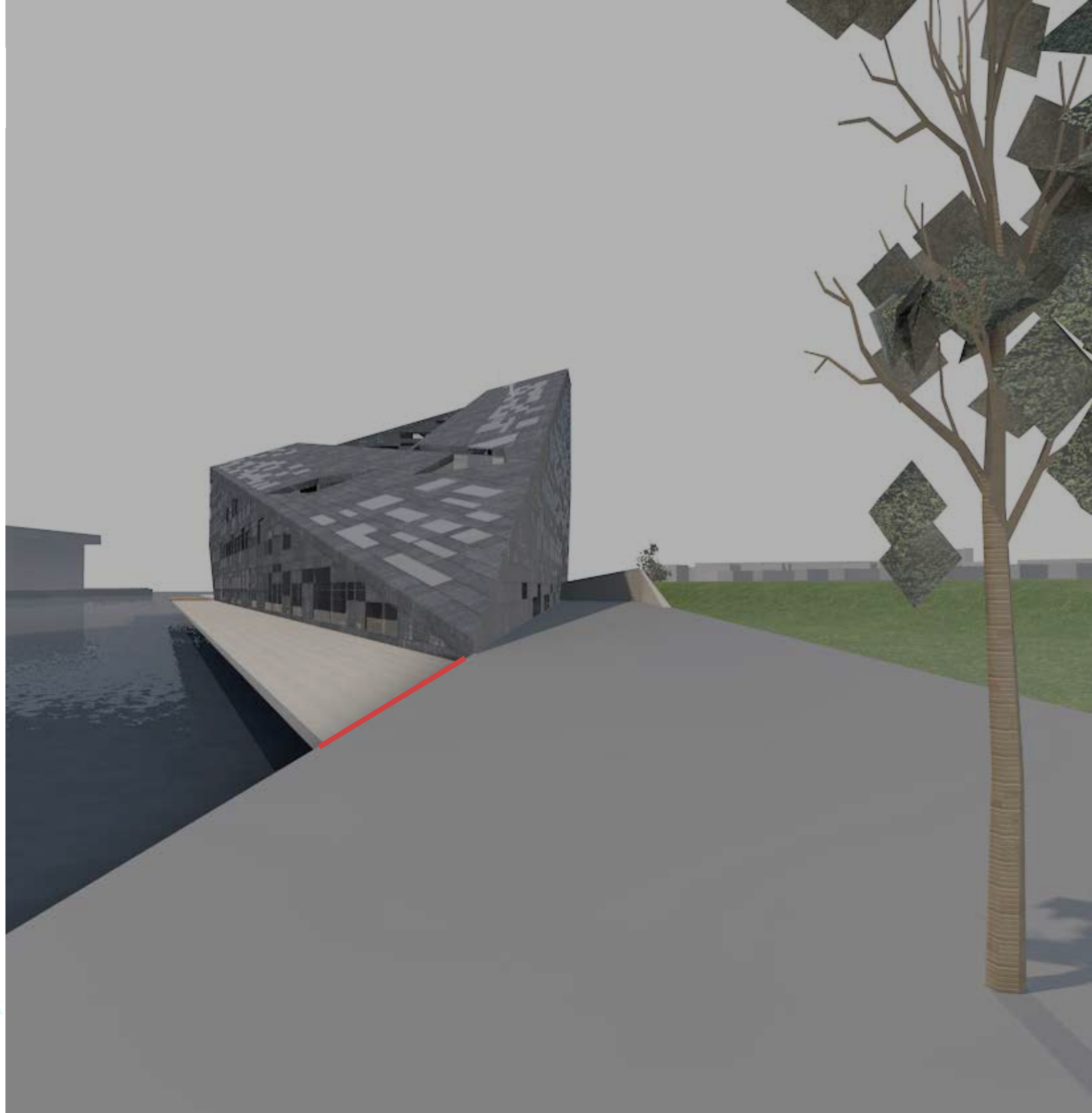



**111 IMPRESSIE**  
Benadering courtyard

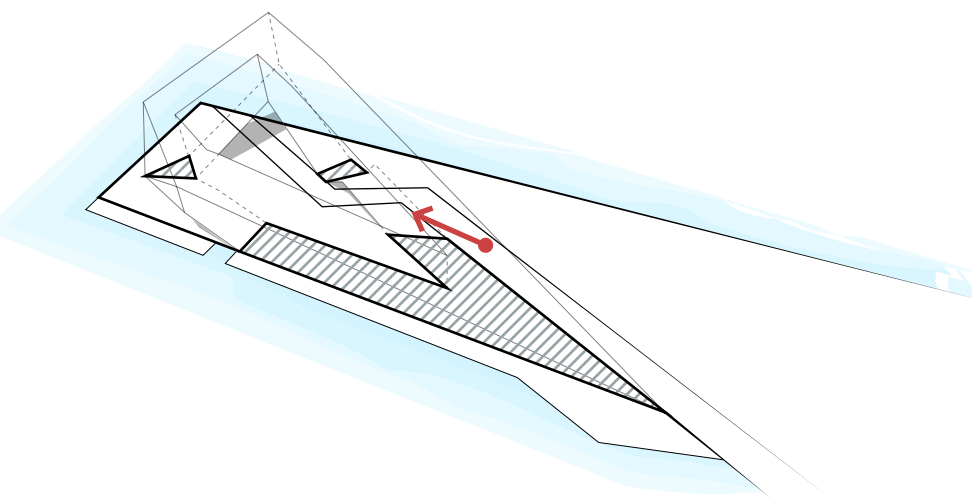

**112 IMPRESSIE**  
Benadering courtyard

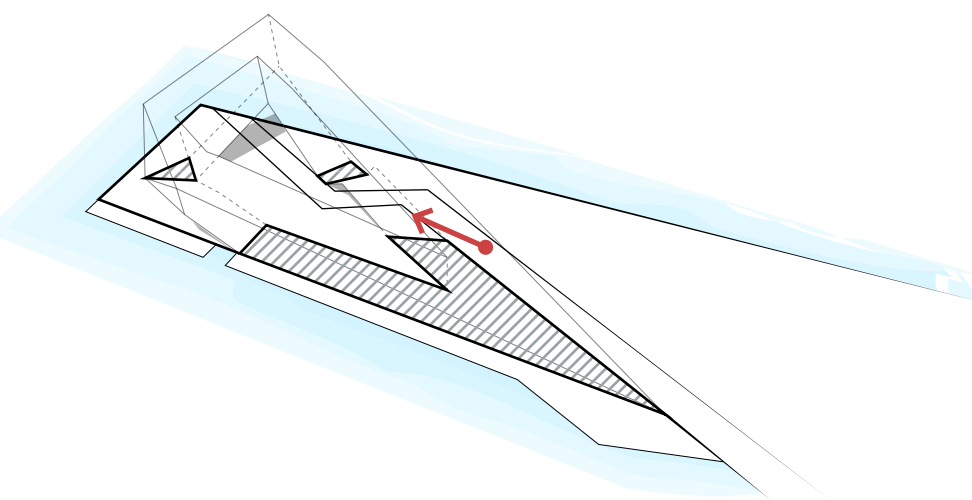
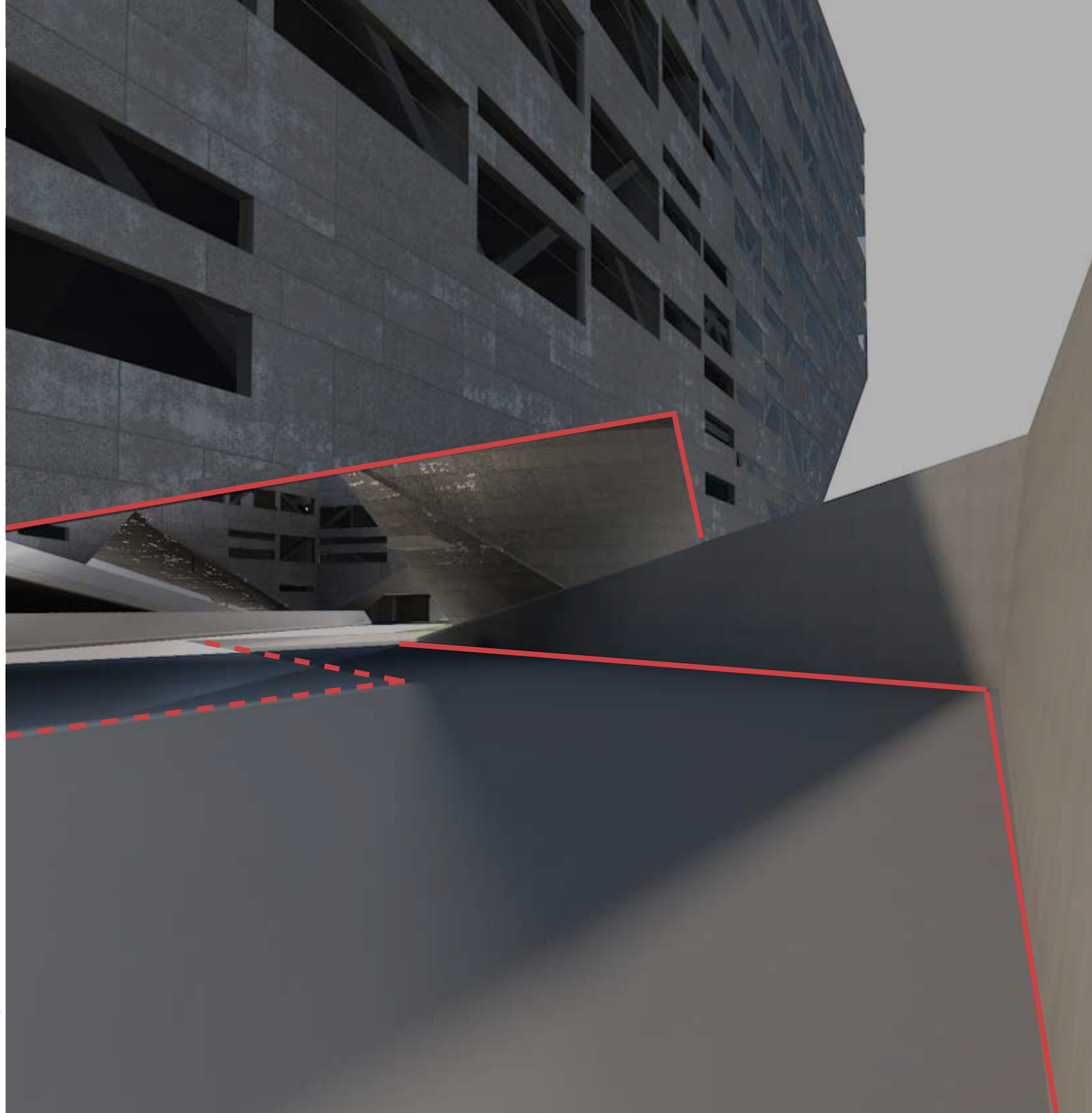



**113 IMPRESSIE**  
Courtyard

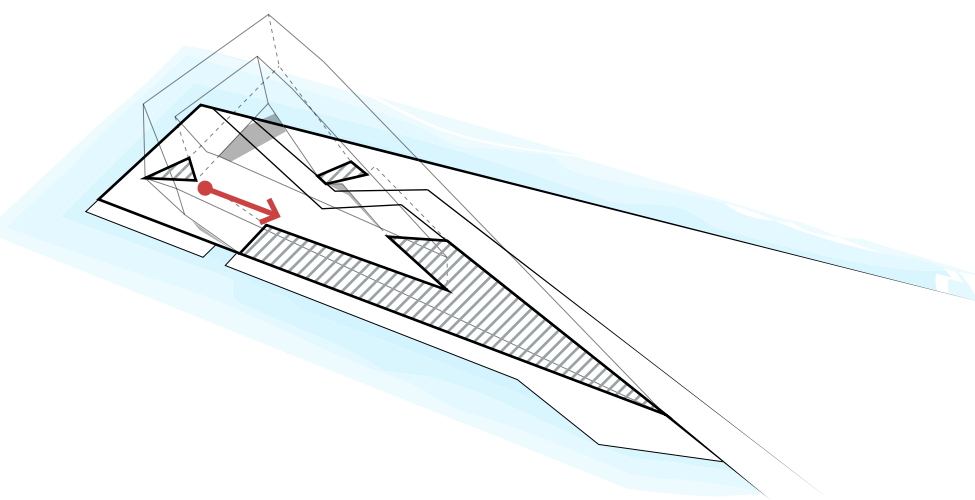
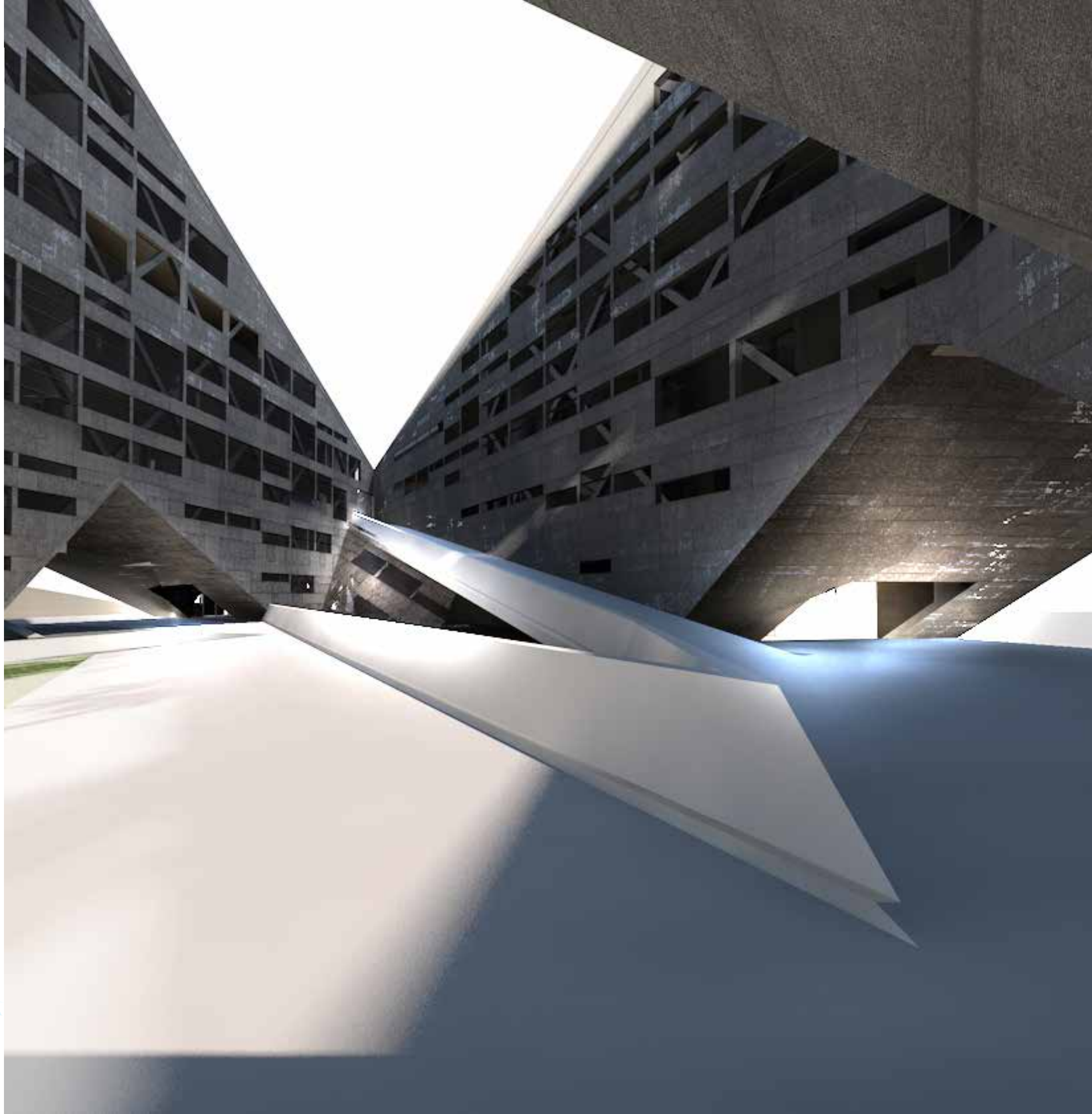

**114 IMPRESSIE**  
Courtyard

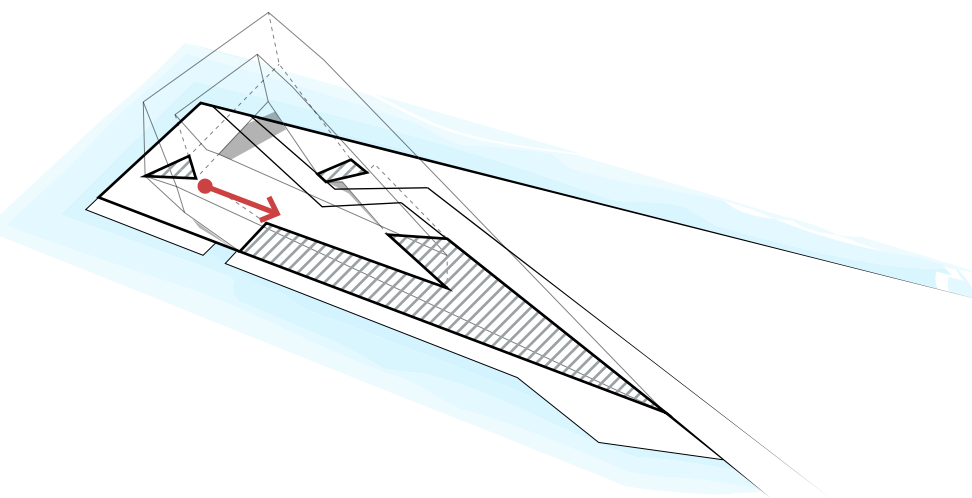
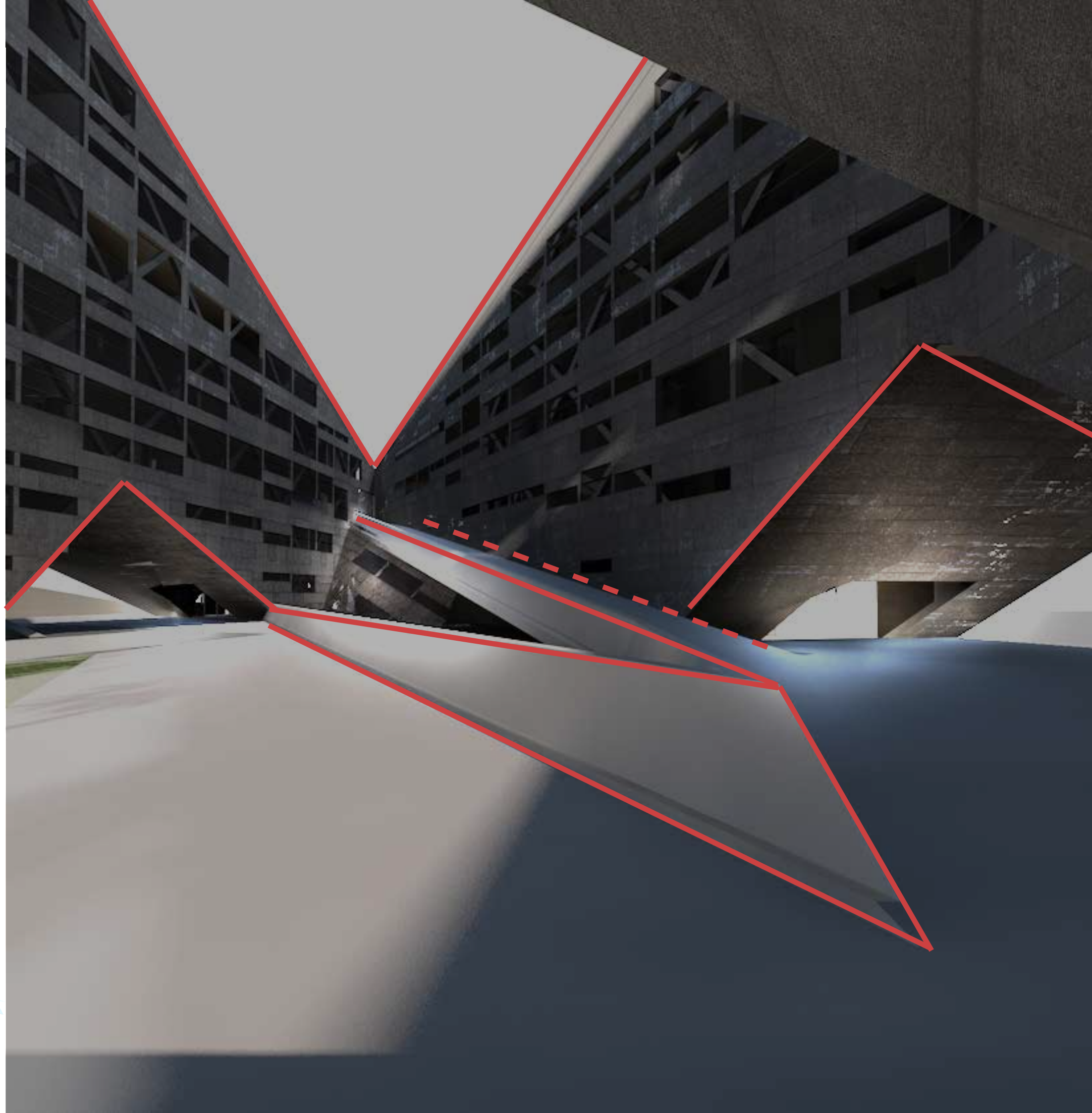



**115 IMPRESSIE**  
Courtyard

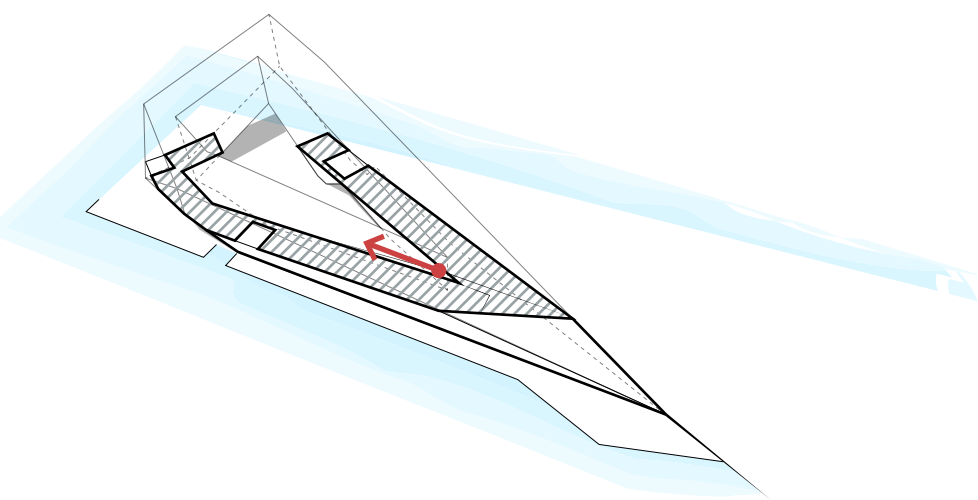

**116 IMPRESSIE**  
Courtyard

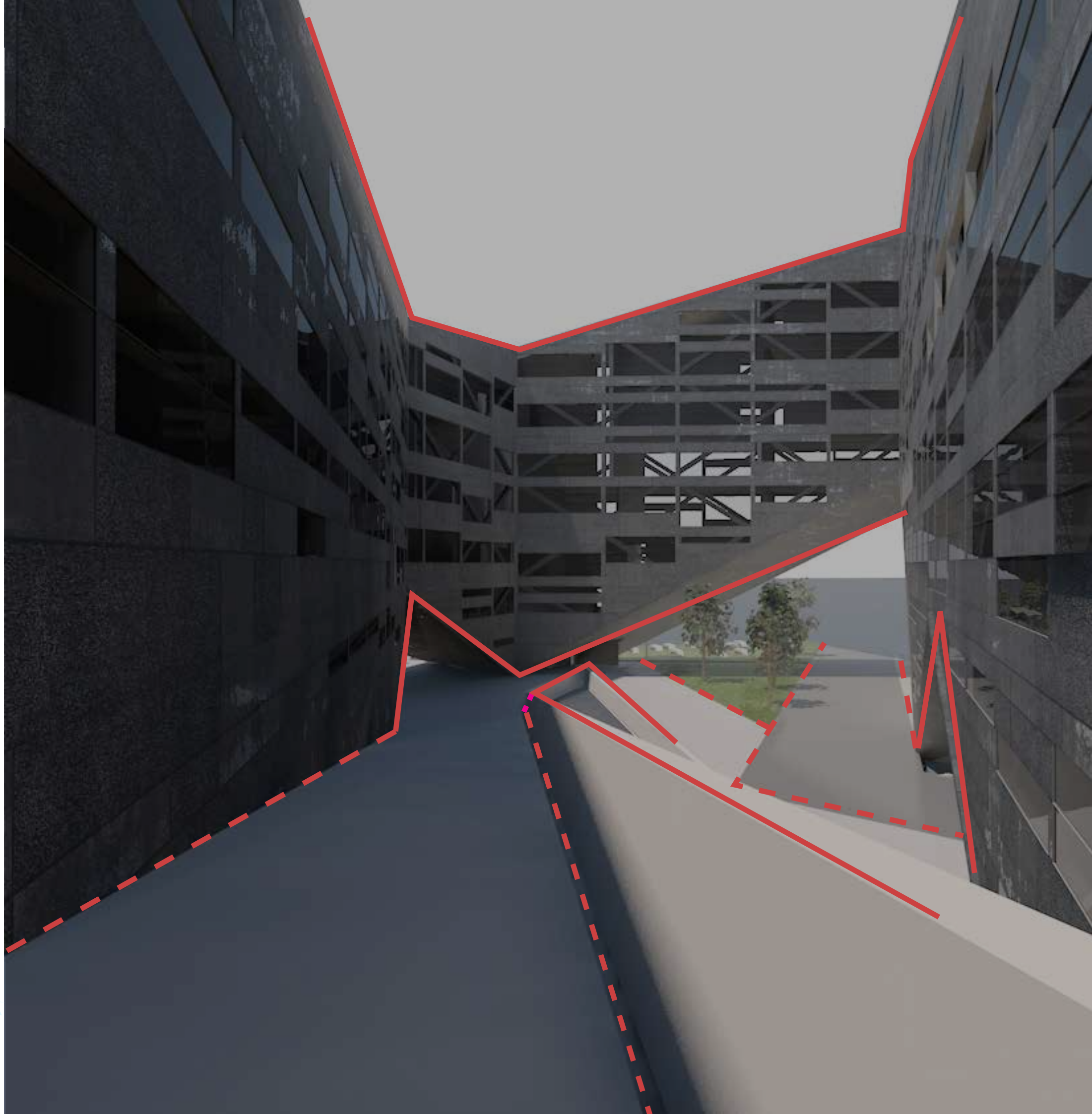
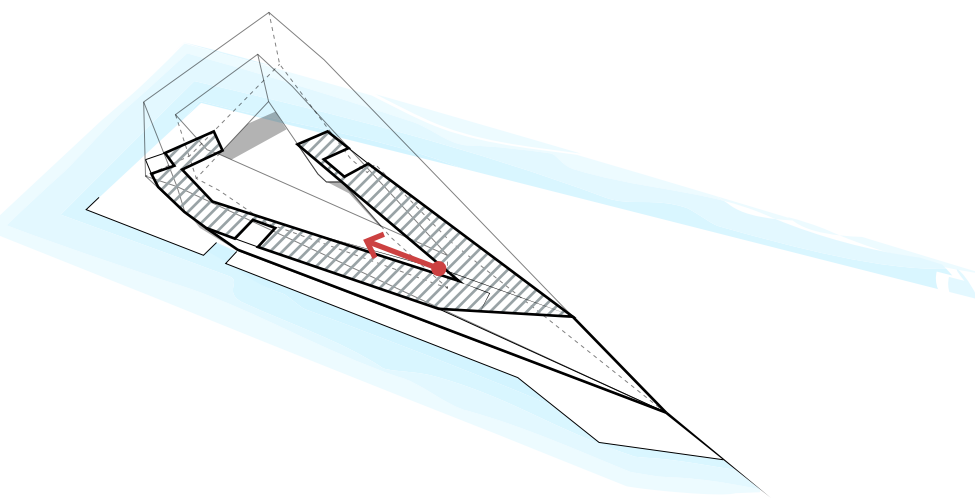



**117 IMPRESSIE**  
Openbaar uitzicht

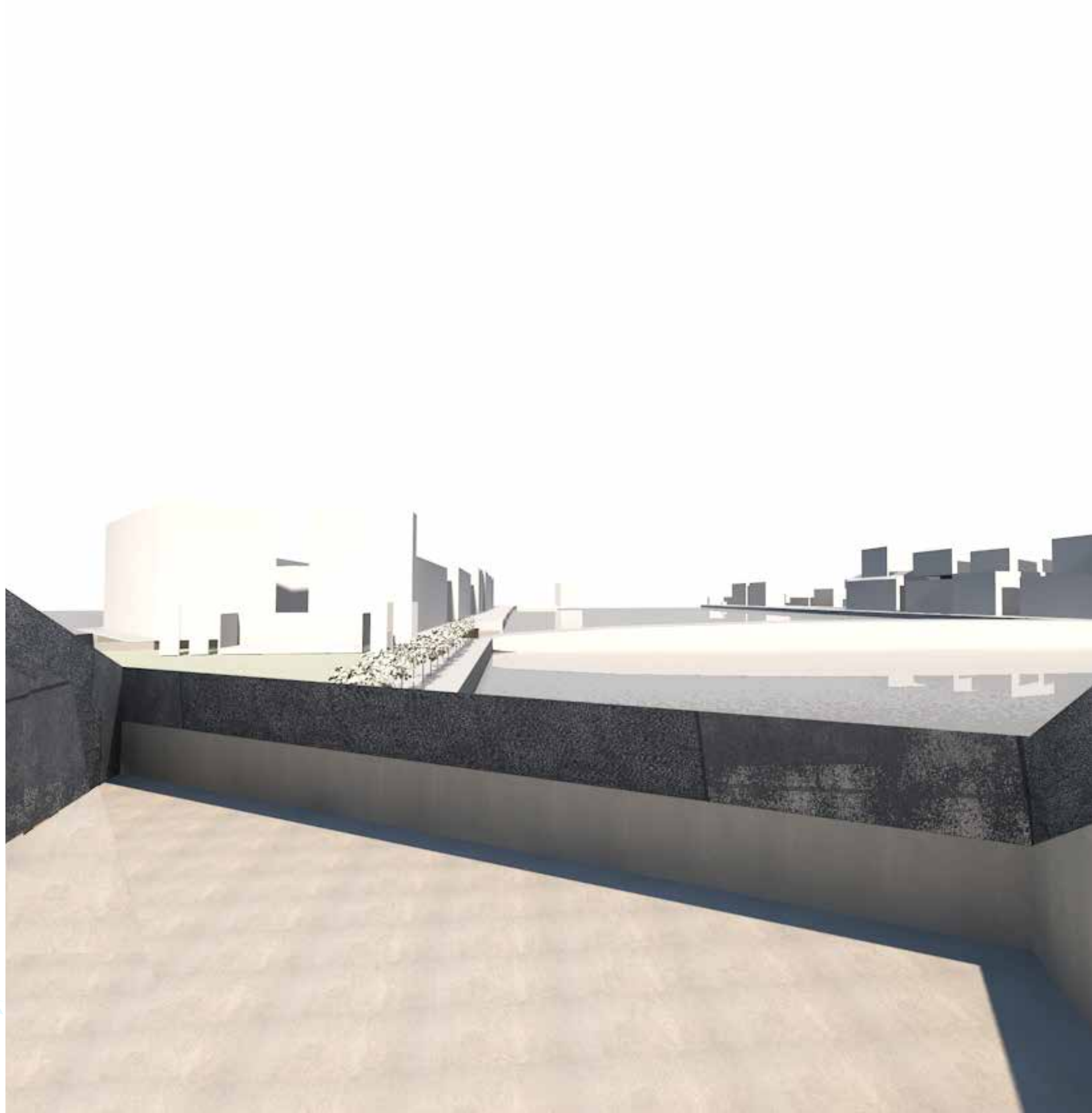
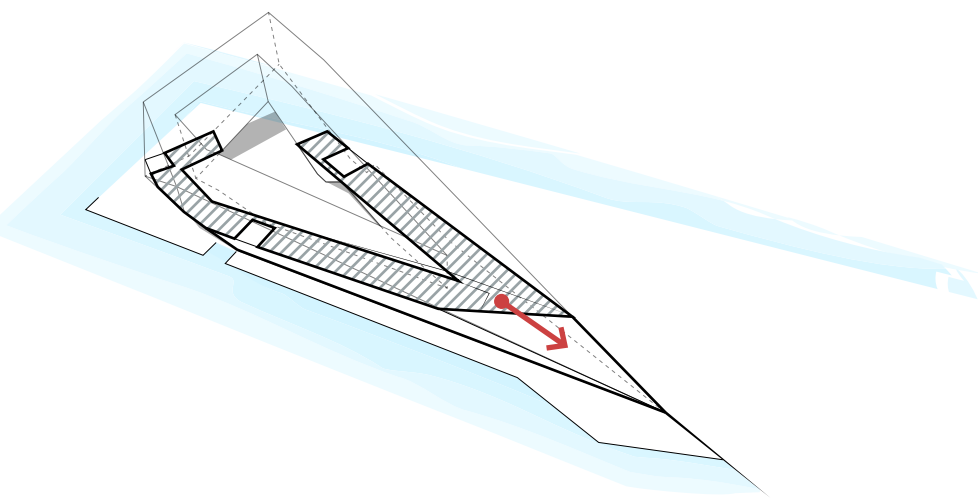

# 118 IMPRESSIE

Benadering entree gebouw

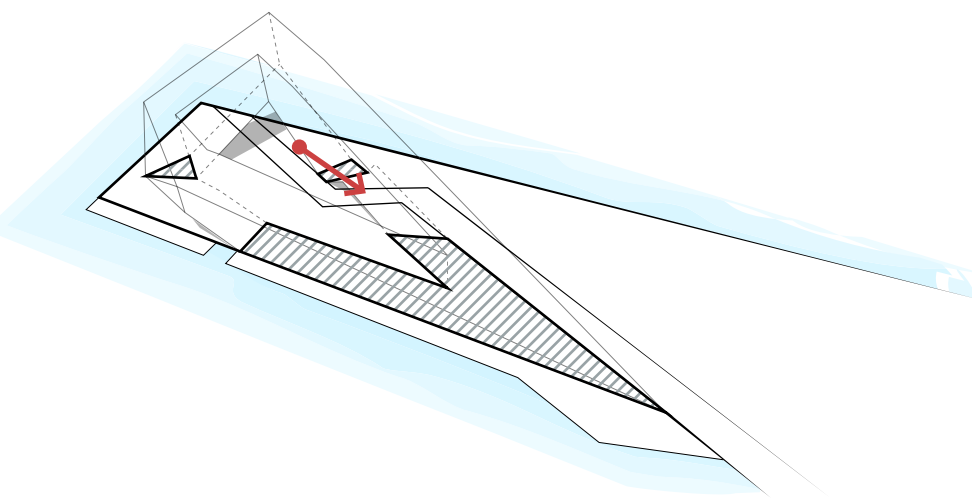



# 119 IMPRESSIE

Benadering entree gebouw

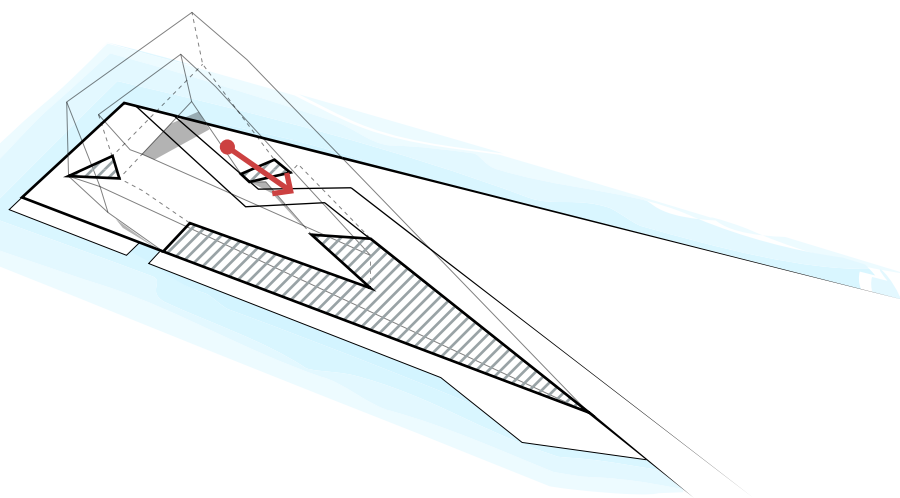
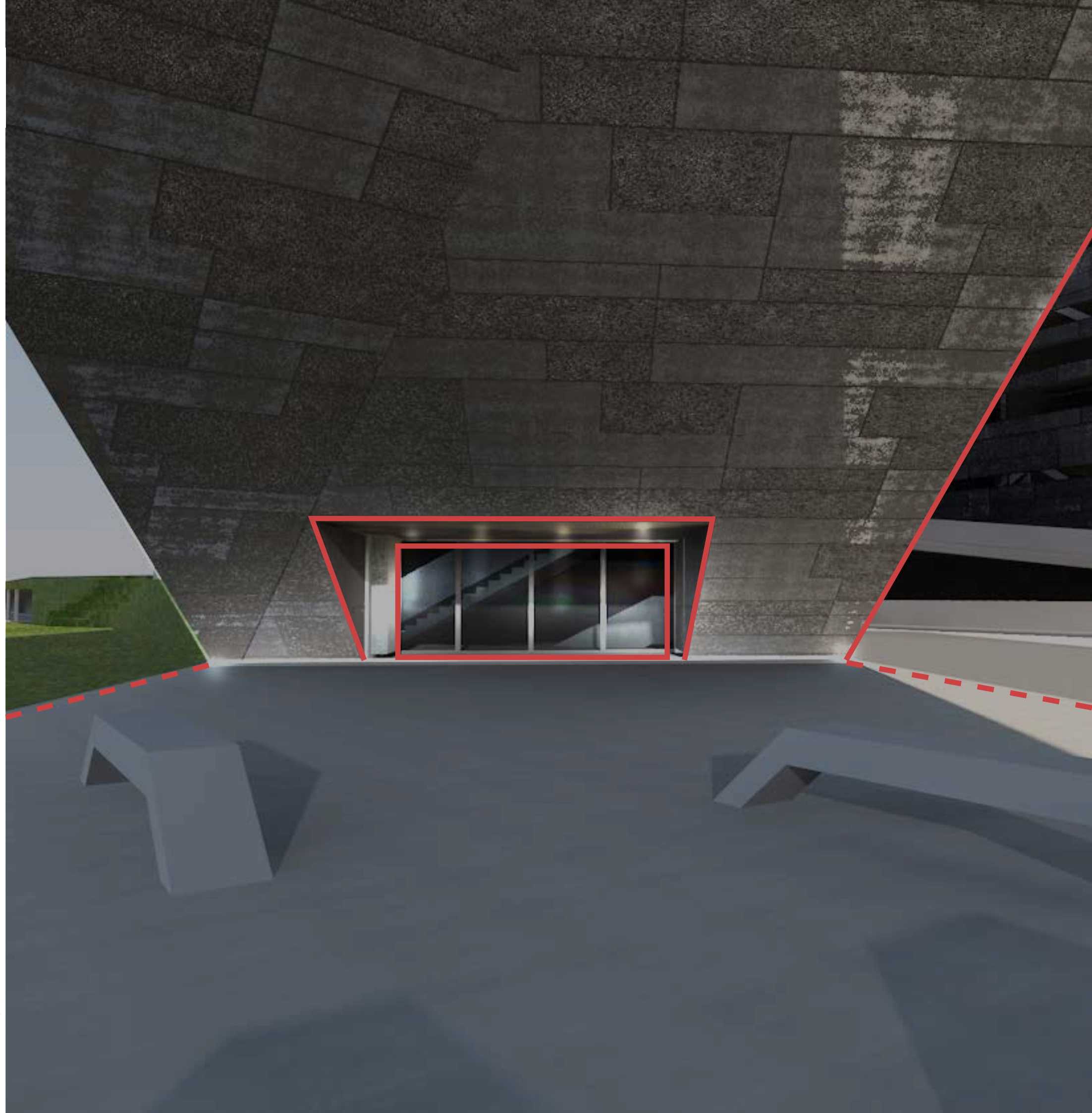

**120 IMPRESSIE**  
Trappenhuis

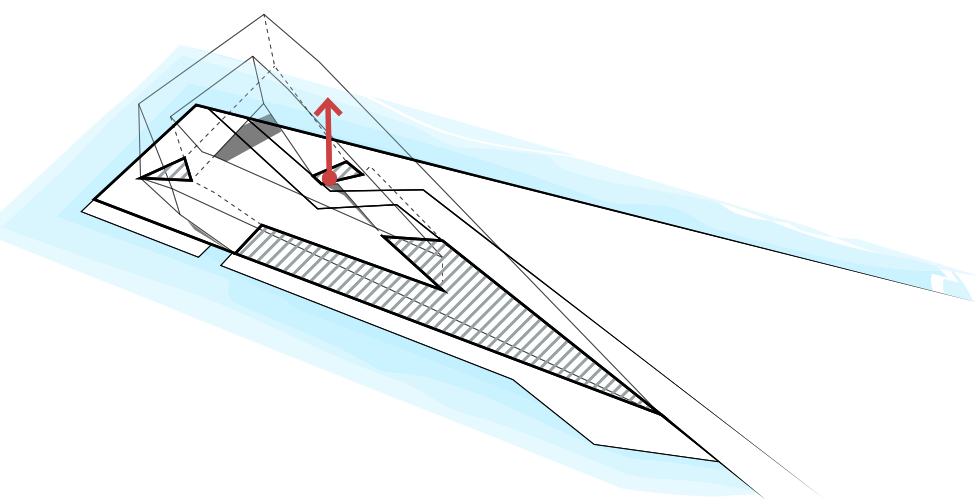



**121 IMPRESSIE**  
Trappenhuis

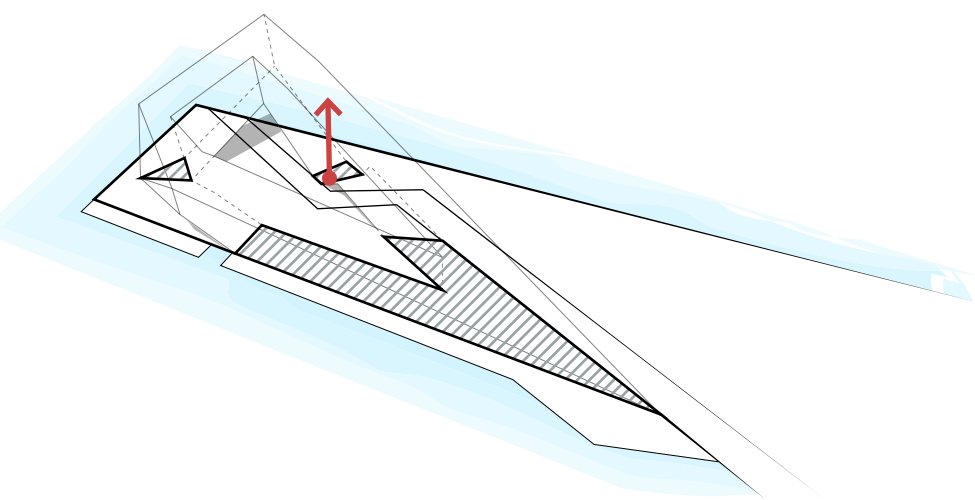

## 122 IMPRESSIE

Benadering entree woningen

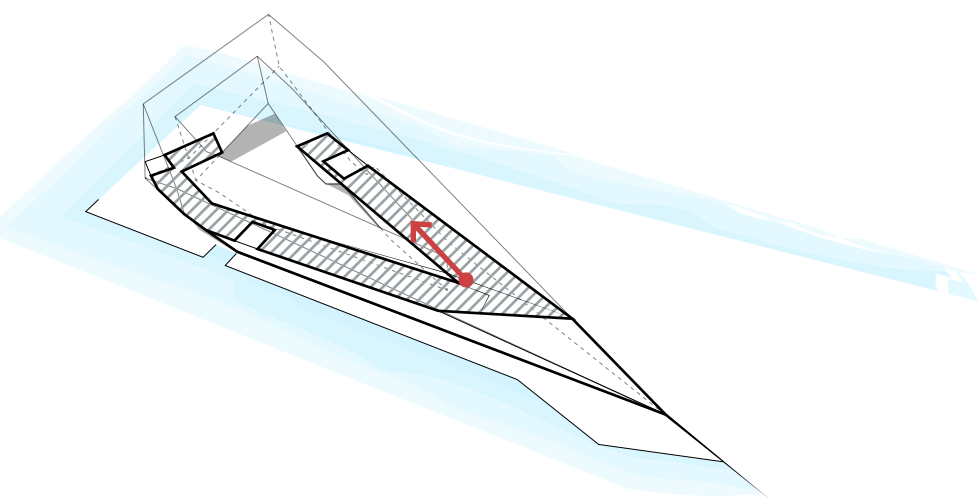



# 123 IMPRESSIE

Benadering entree woningen

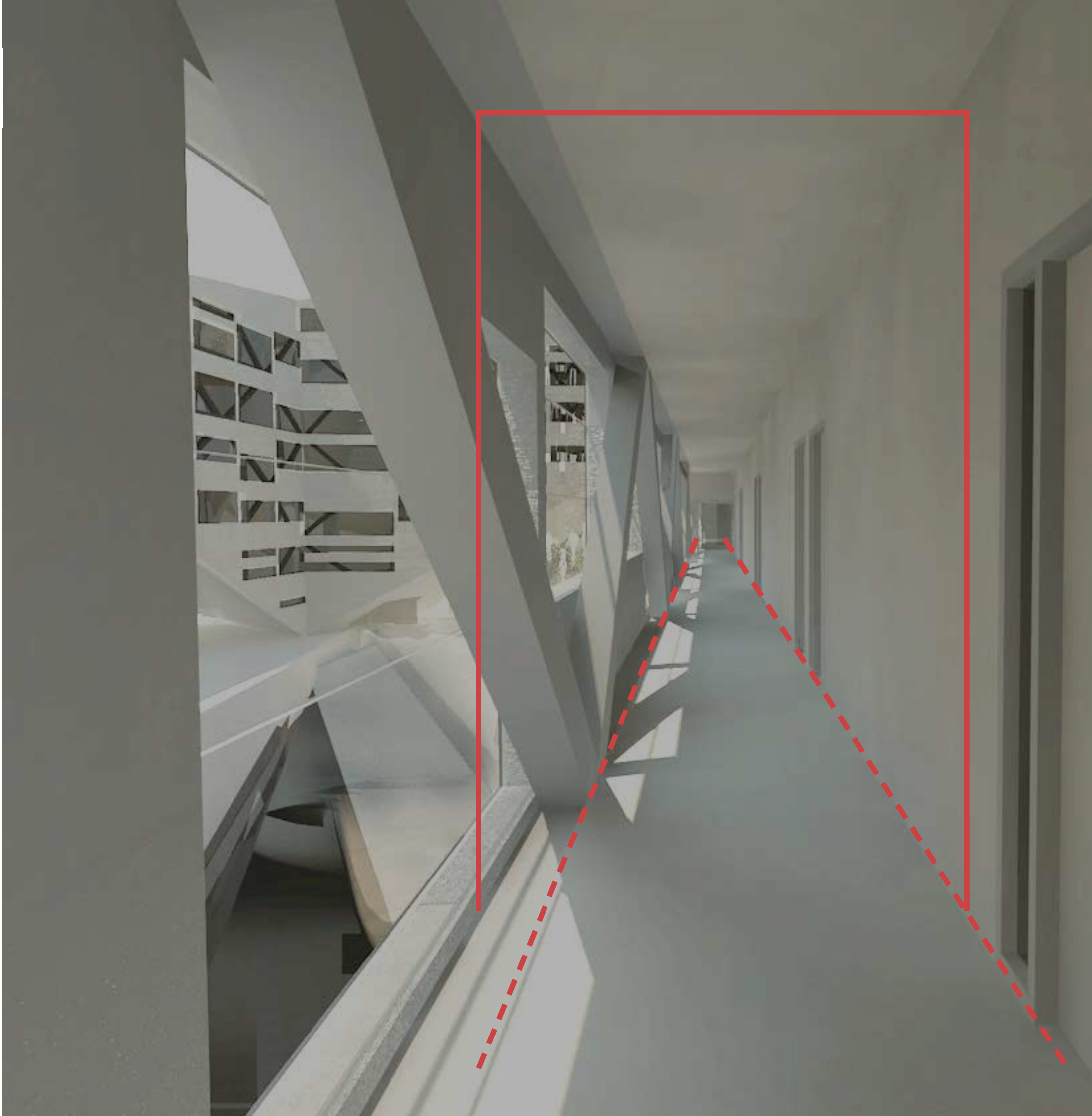
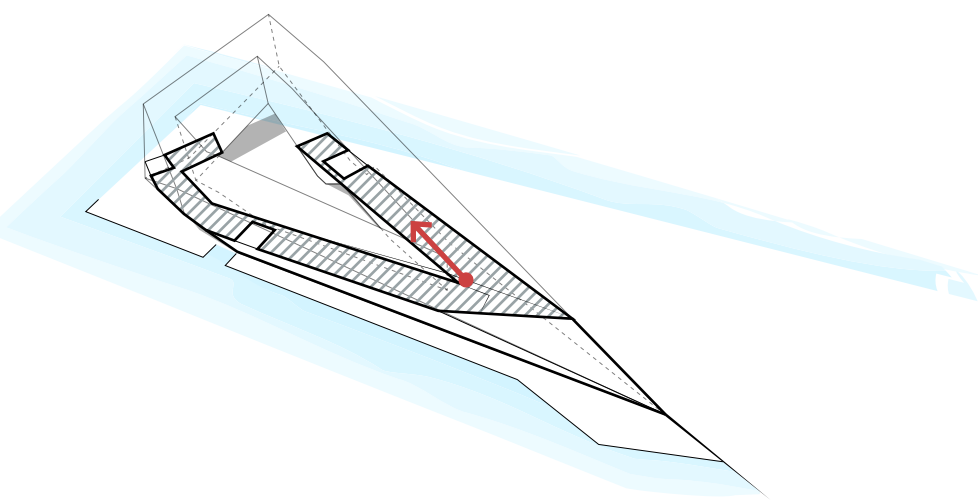

**124 IMPRESSIE**  
Langsdoorsnede

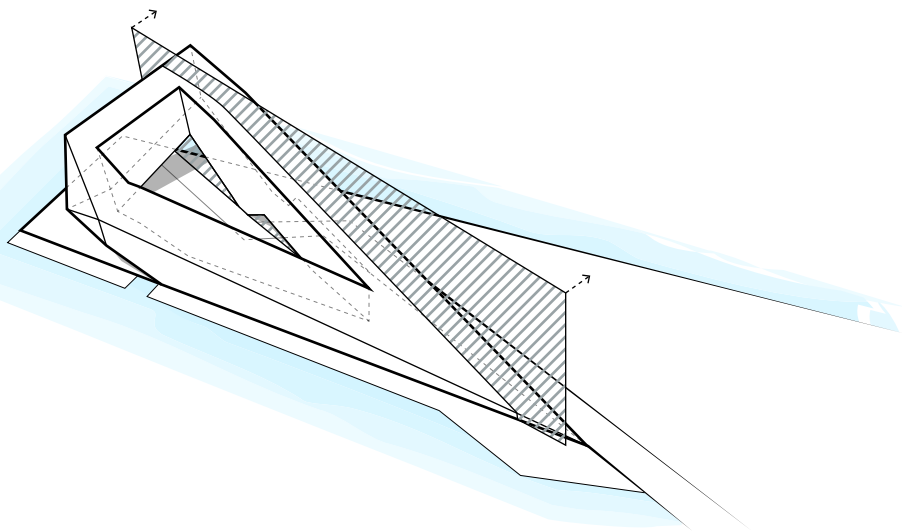
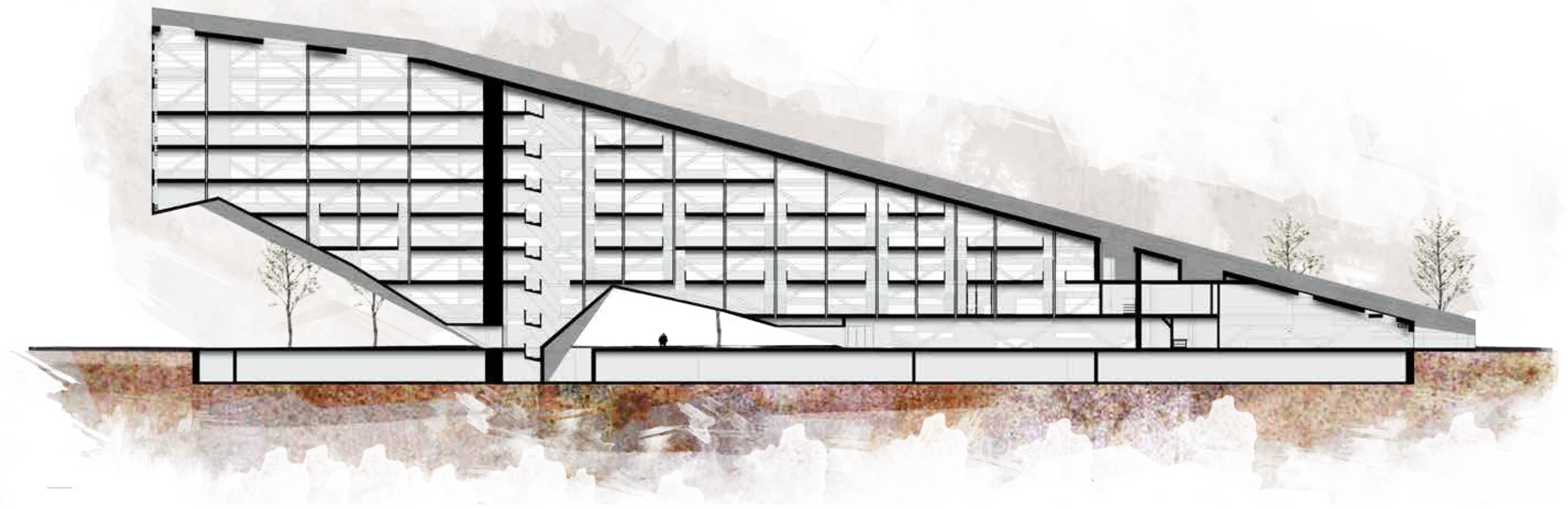



**125 WONING A**  
Locatie & aantal

# TYPE A

5.4 METER BREED  
2 LAAGS  
110 M<sup>2</sup>

30x

13x

23x

2x

3x

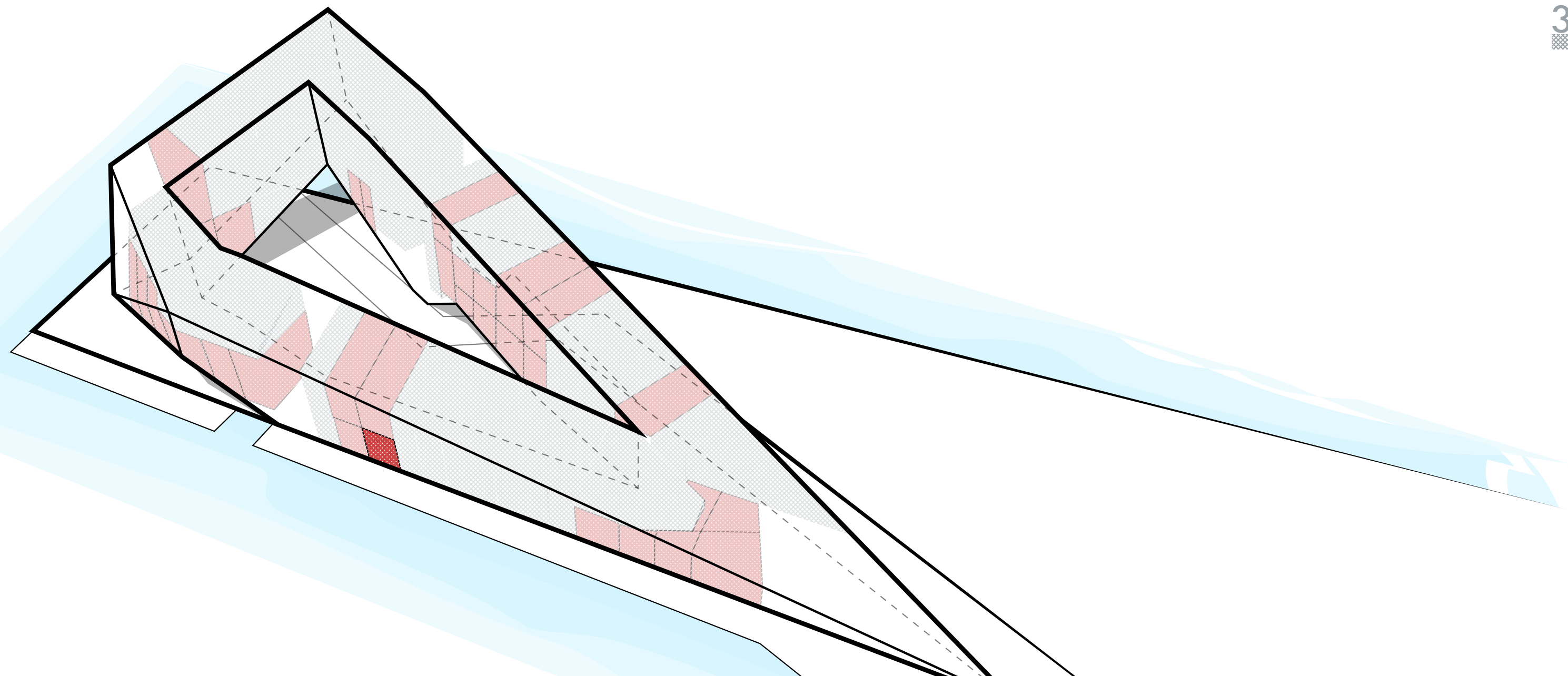

**126 WONING A**  
Doorsneden

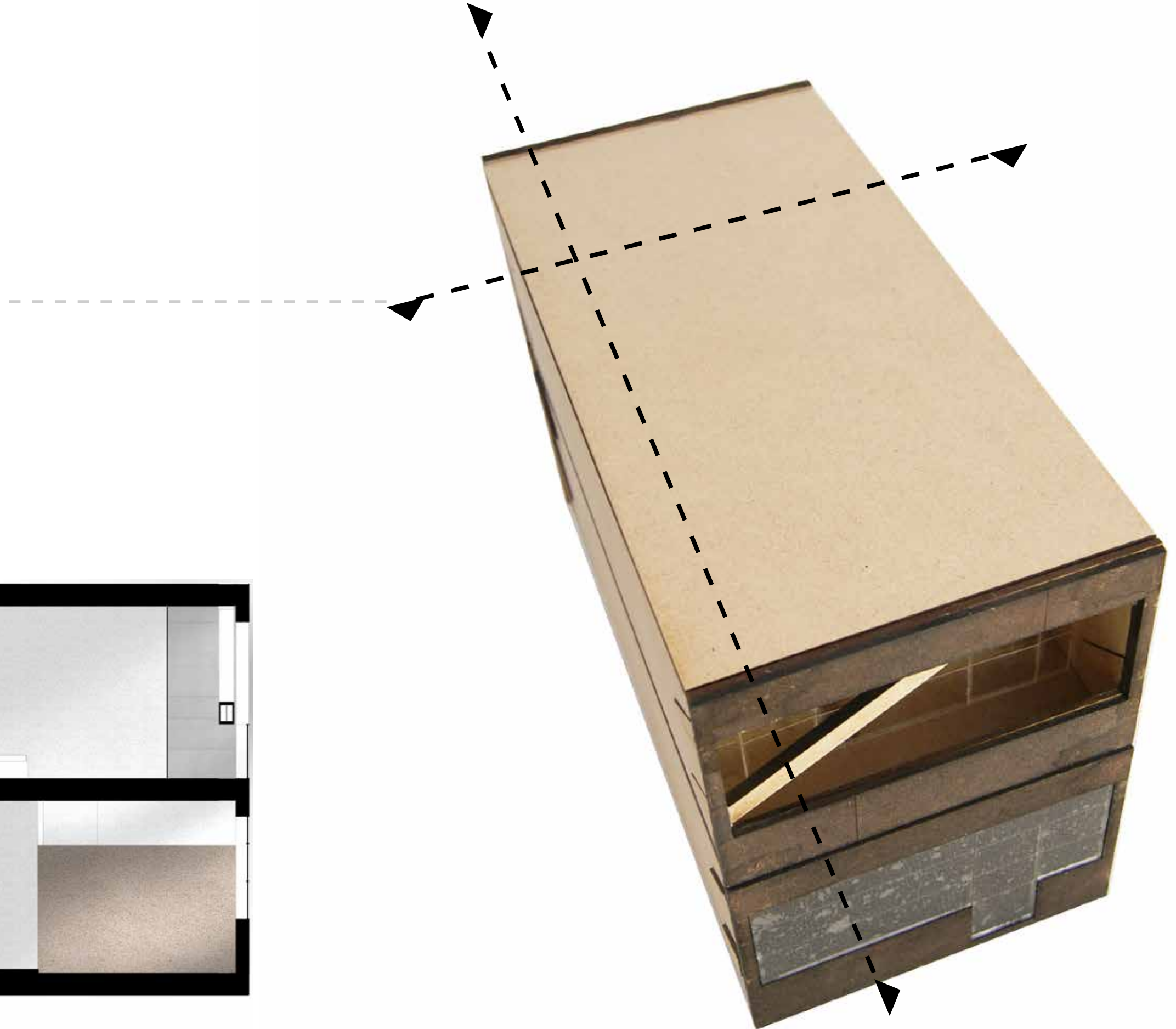
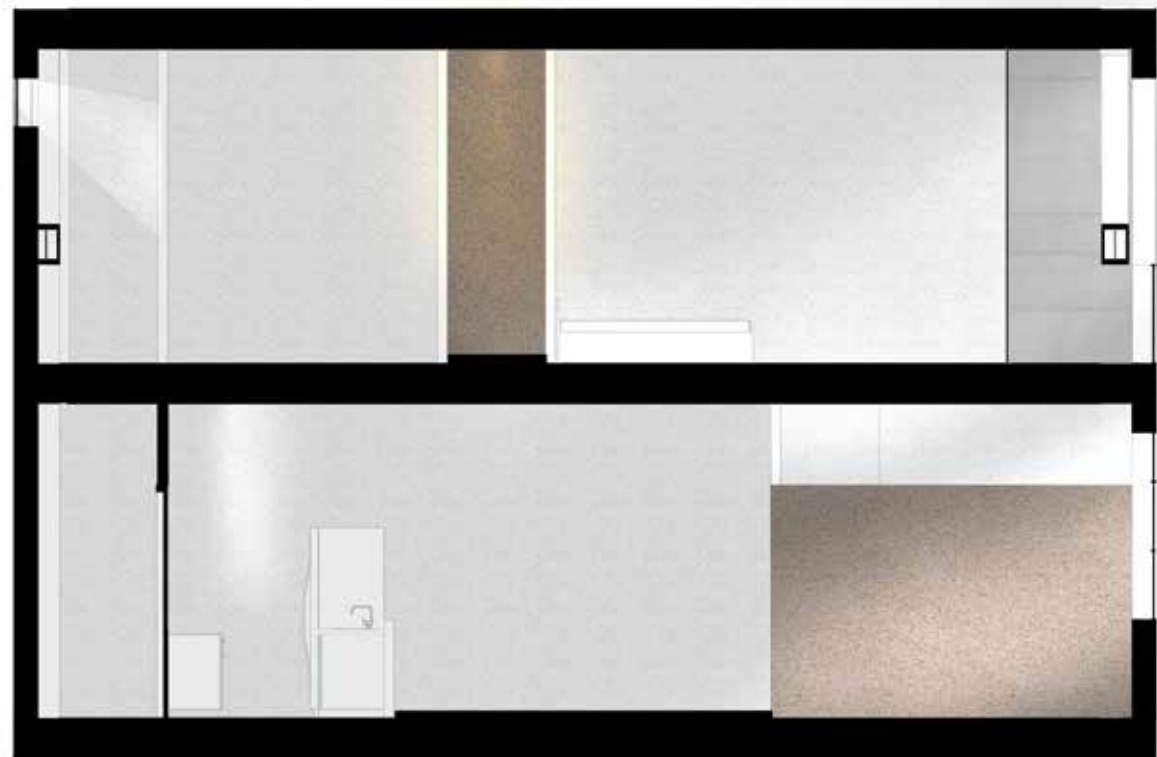
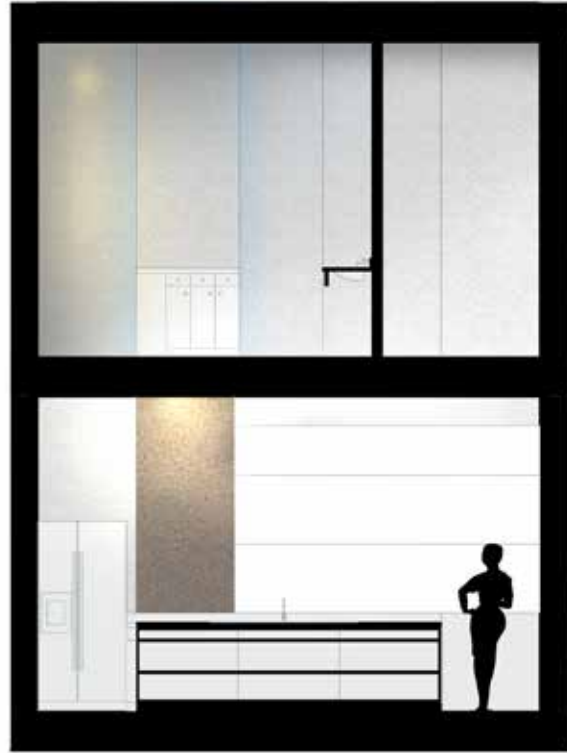



# 127 WONING A

Plattegrond begane grond



**128 WONING A**  
Plattegrond 1e verdieping





**129 WONING A**  
Leefruimte

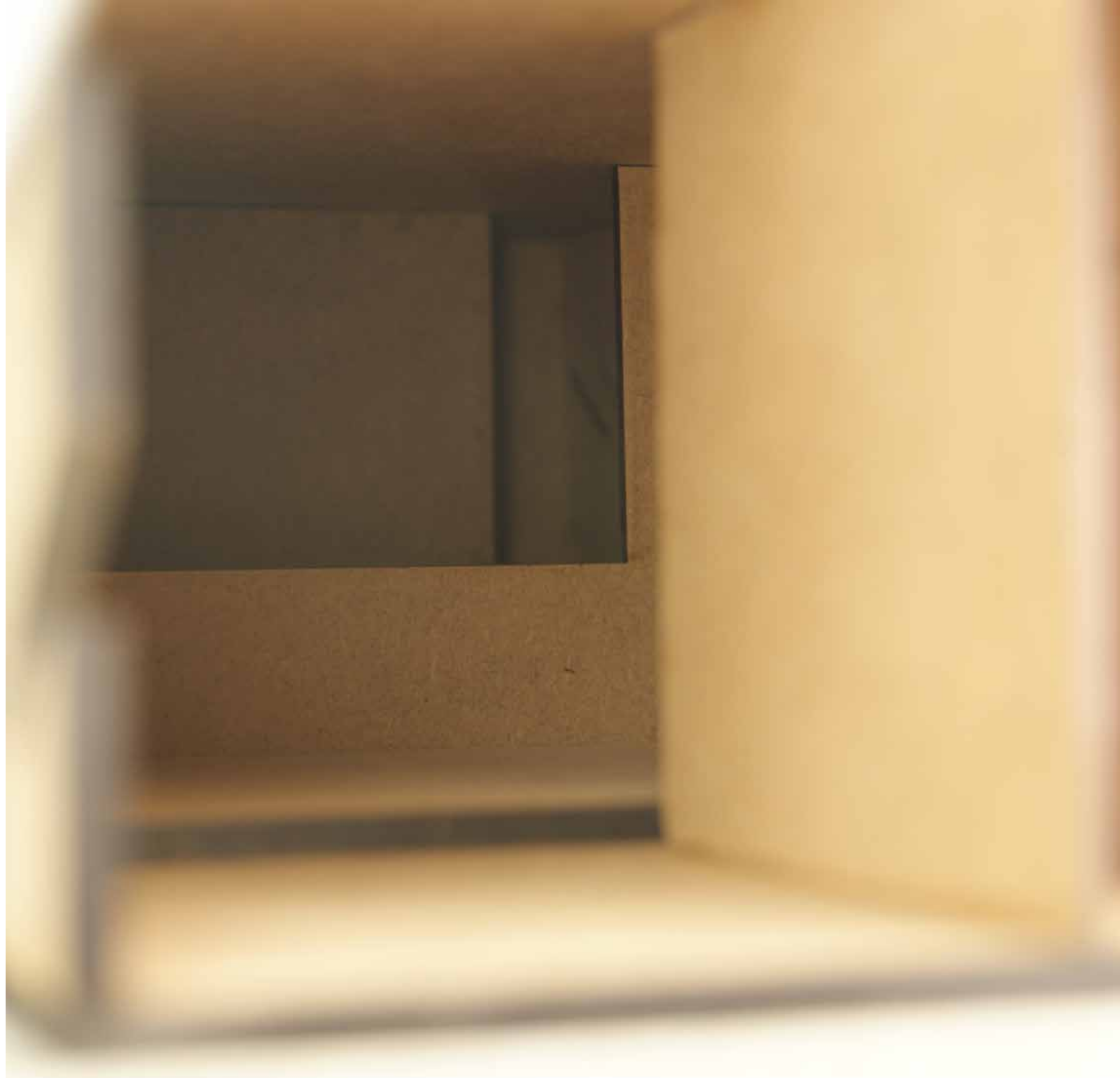

**130 Woning A**  
Buitenruimte bij privezone





**131 WONING B**  
Locatie & aantal

**TYPE B**  
4.2 METER BREED  
2+ LAAGS  
100 M<sup>2</sup>

30x

13x

23x

2x

3x

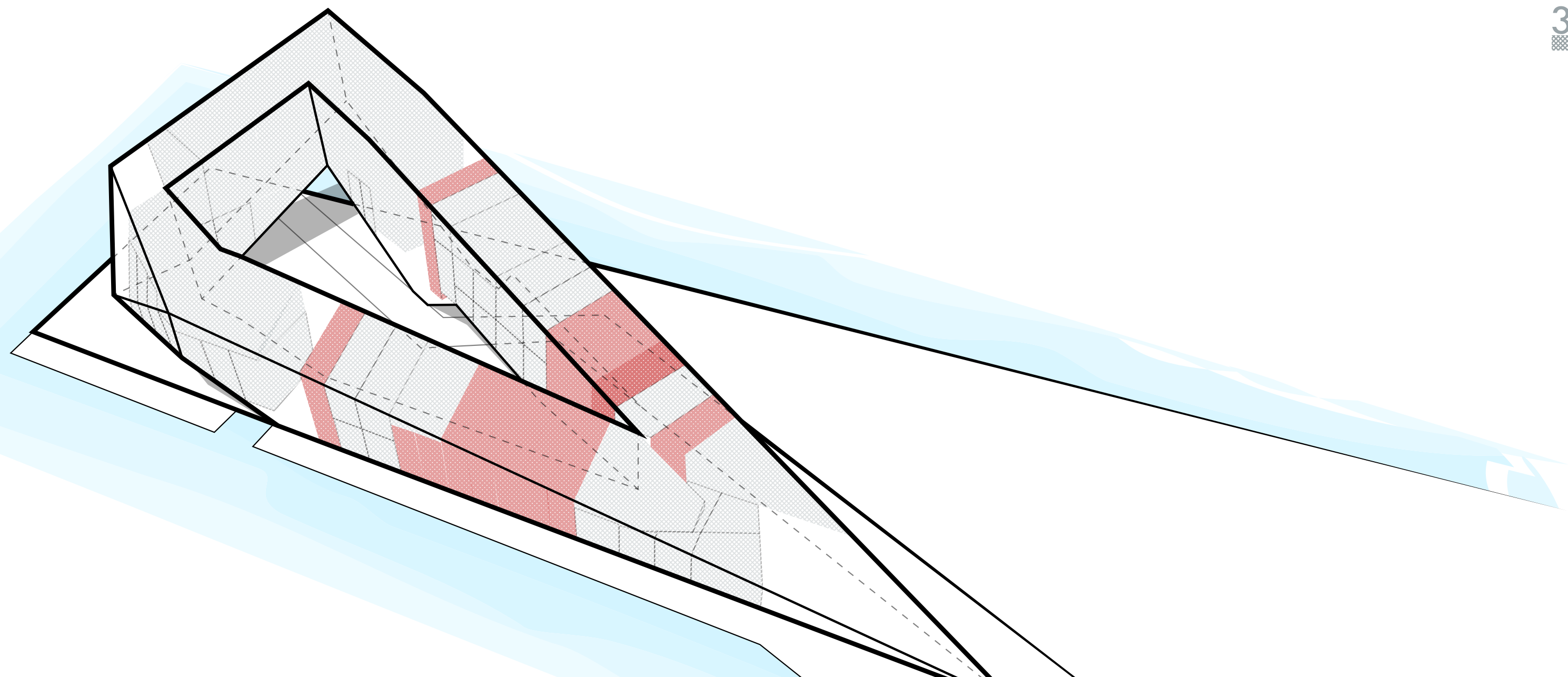

**132 WONING B**  
Doorsnede

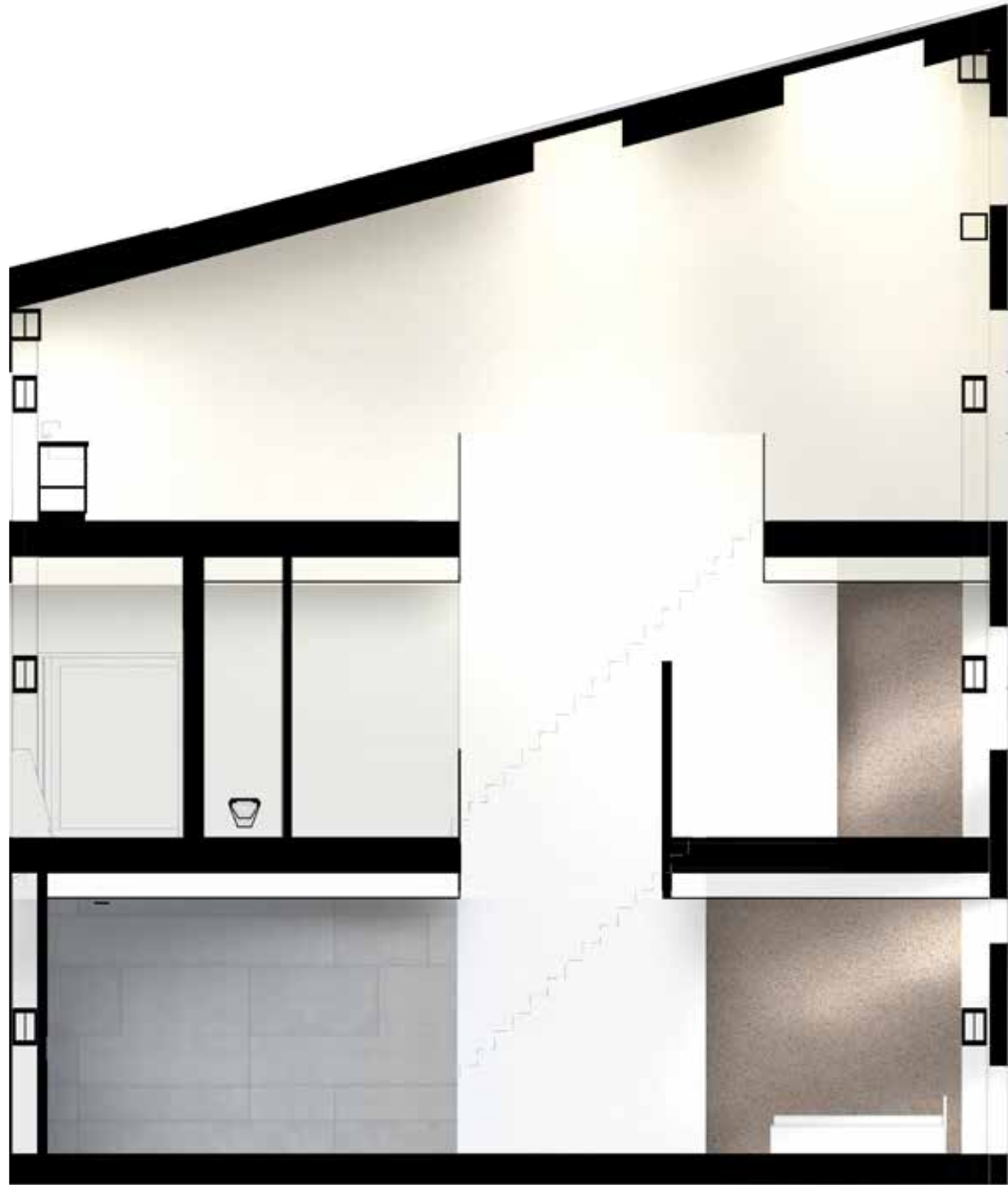



**133 WONING B**  
Plattegrond 3e verdieping

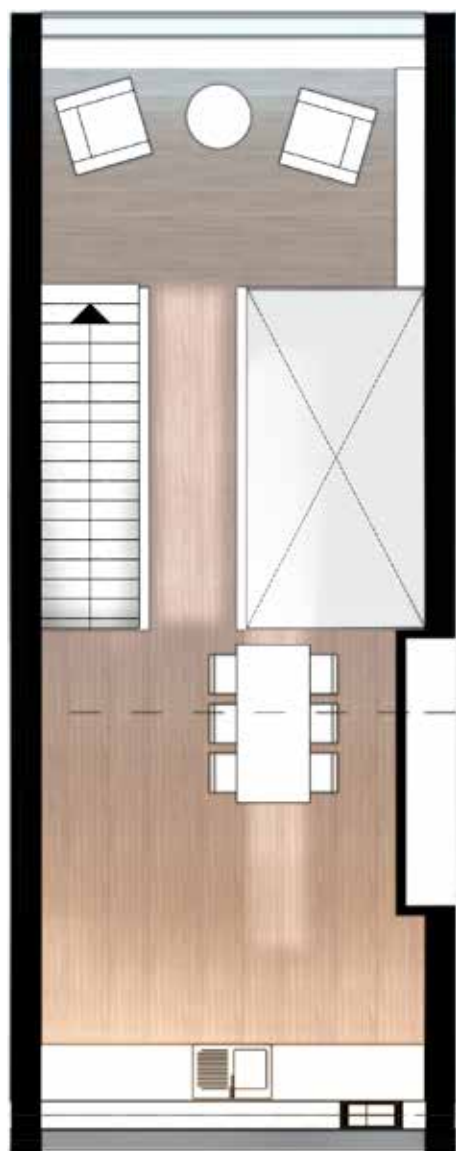

**134 WONING B**  
Plattegrond 2e verdieping

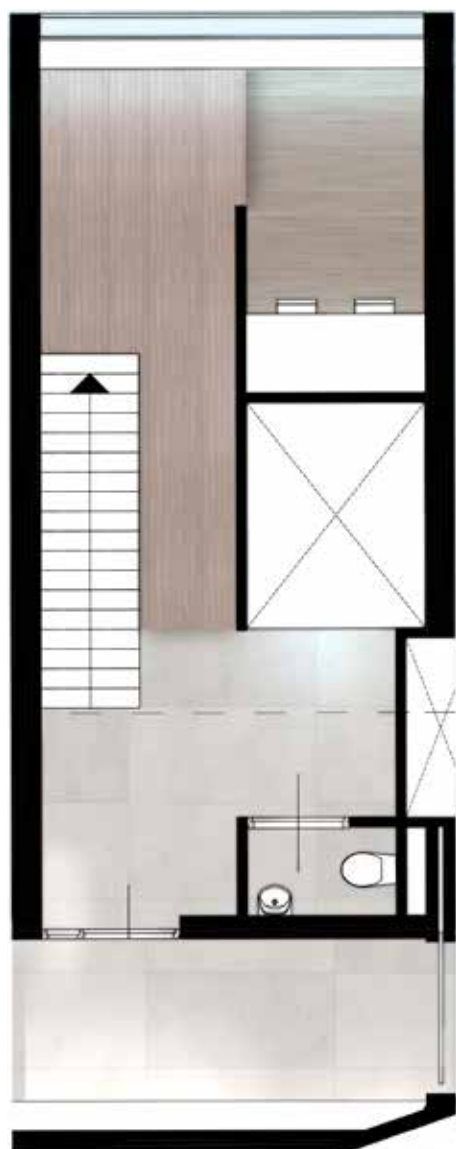



**135 WONING B**  
Plattegrond 1e verdieping

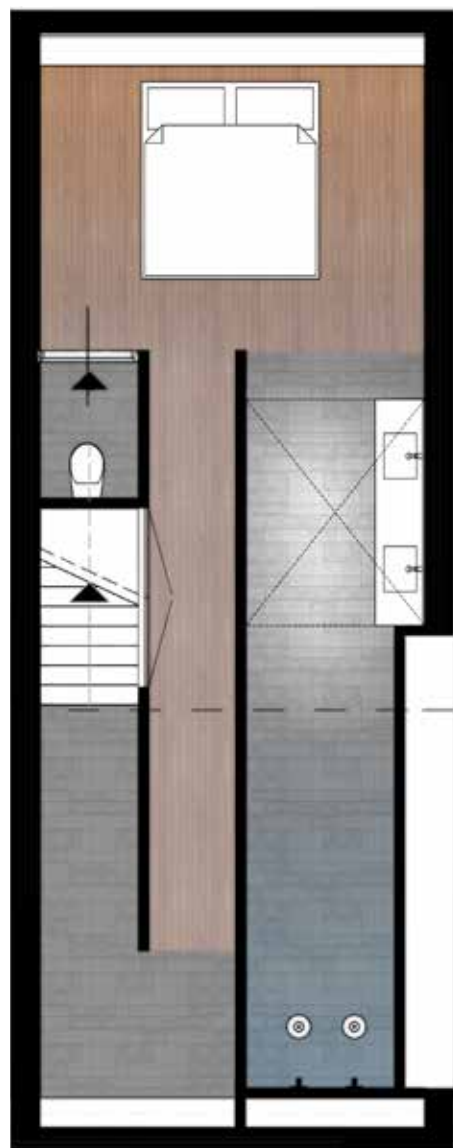

**136 WONING B**  
Impressie leefruimte

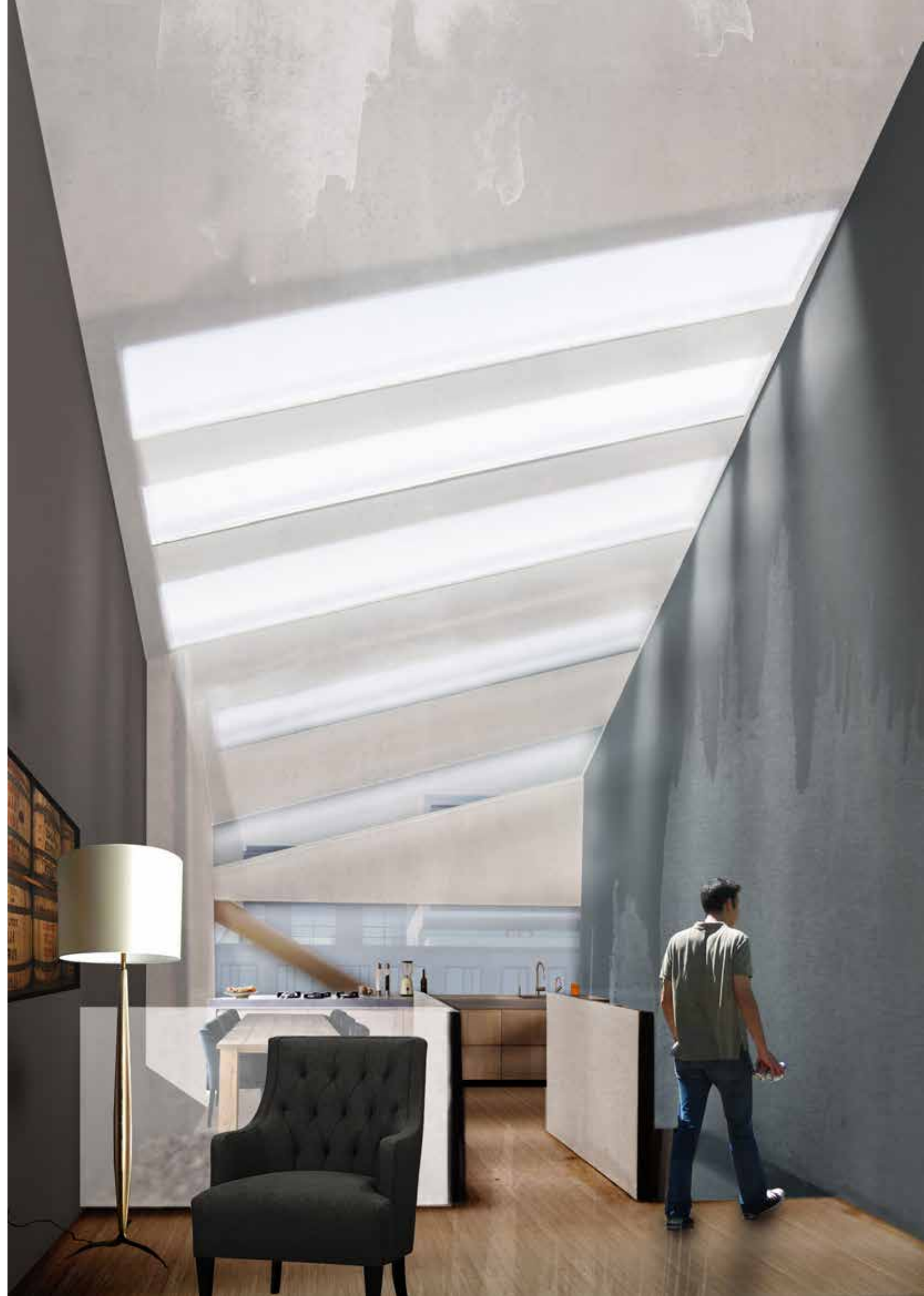



**137 WONING B**  
Impressie ontvangst

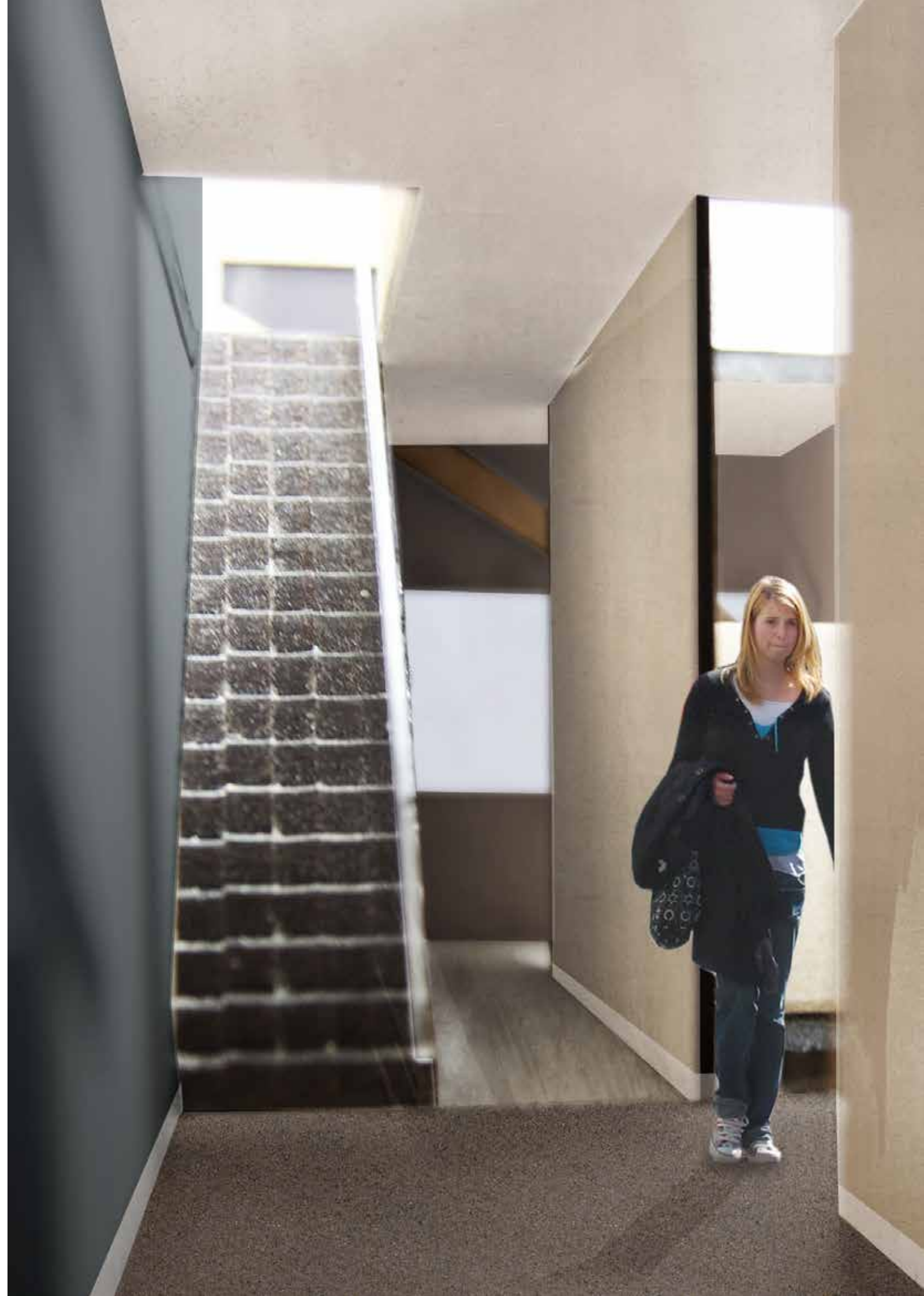
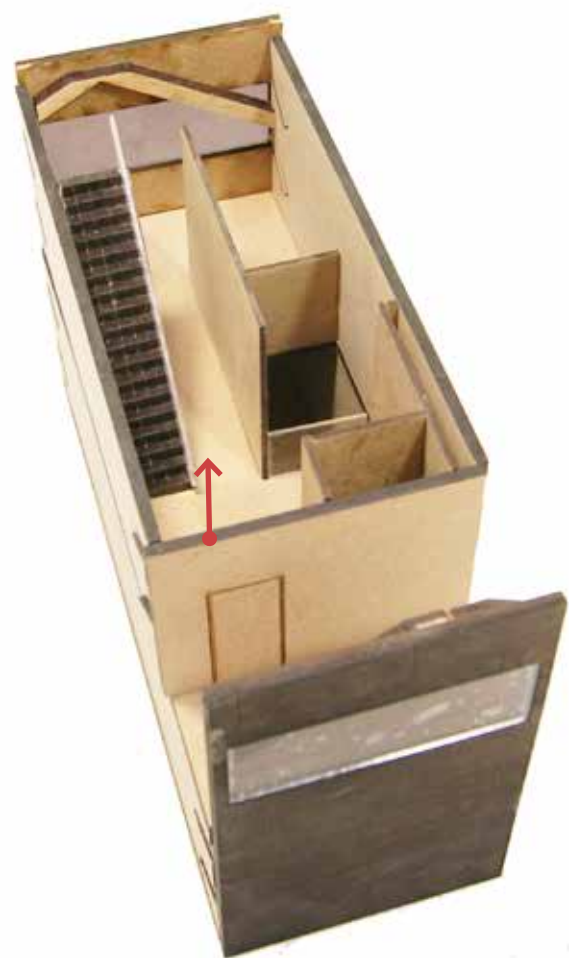

**138 WONING B**  
Impressie privezone





# 139 KLIMAAT

Primaire verwarming

lokaal geregeld

natuurlijk opwarmen door glasoppervlak bij leefruimte

opstijgen van warme lucht voor variatie van temperatuur in ruimtes.

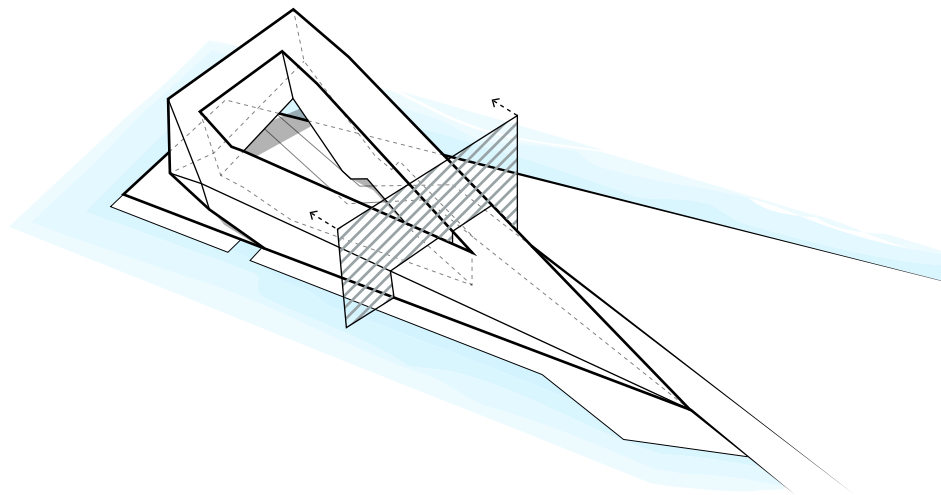
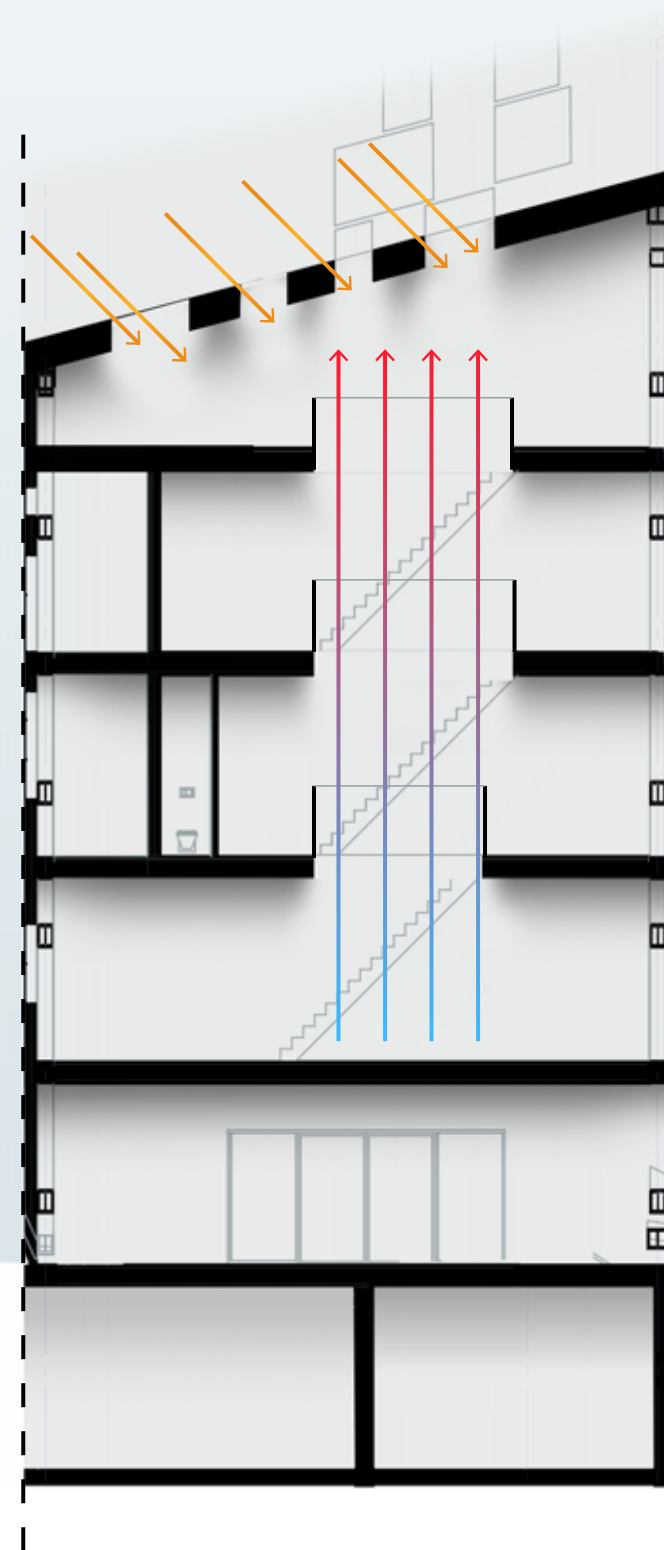
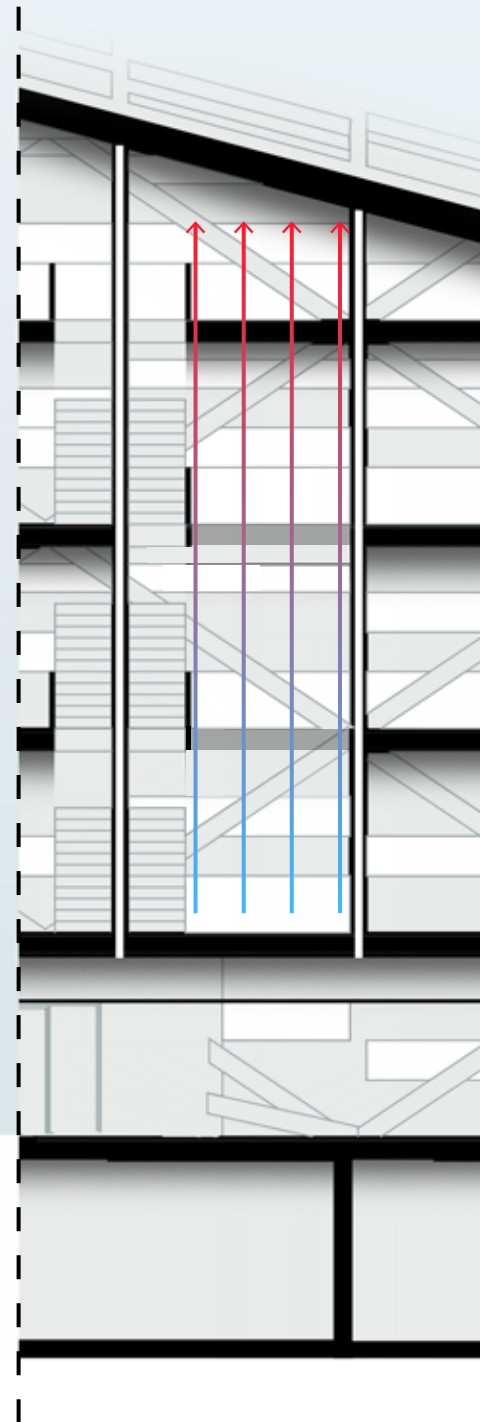

# 140 KLIMAAT

Secundair verwarmingsysteem

geclusterde bronopwekking  
individueel geregeld door distributiesysteem

LAGE Temperatuurverwarming in vloerpakket  
Warmtepomp met distributiesysteem  
aangesloten op IJwater

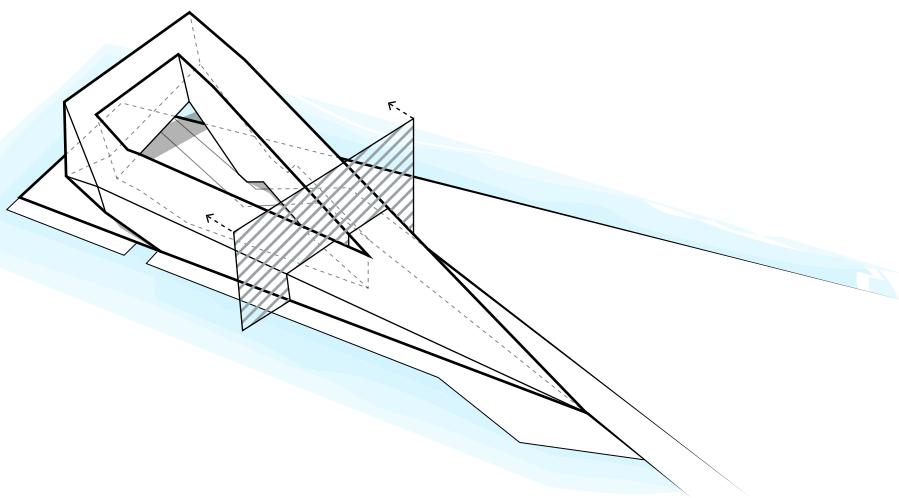



# 141 KLIMAAT

Secundaire afkoeling

geclusterde bronopwekking  
individueel geregeld door distributiesysteem

LAGE Temperatuurverwarming in vloerpakket  
Warmtepomp met distributiesysteem  
aangesloten op IJwater

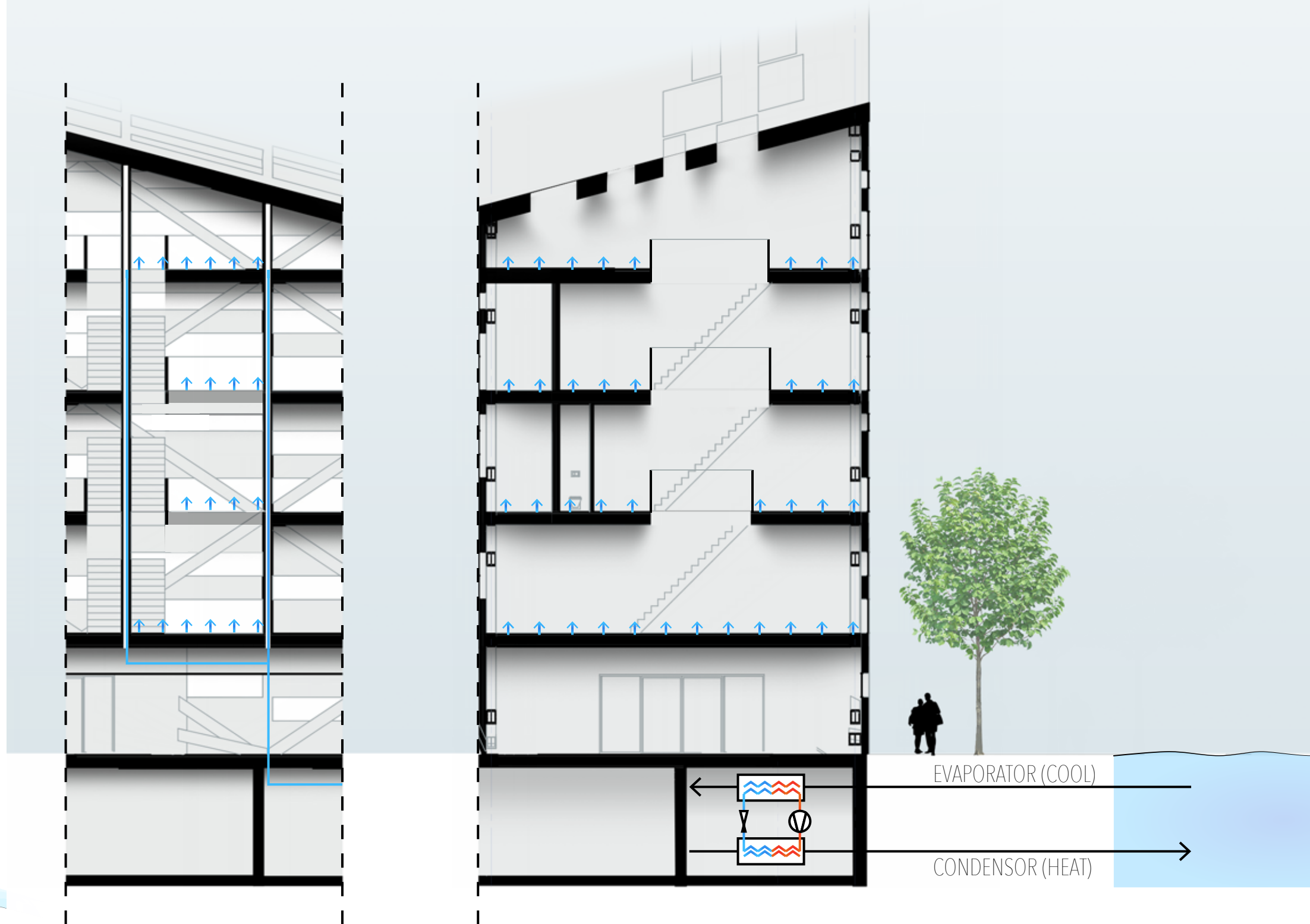
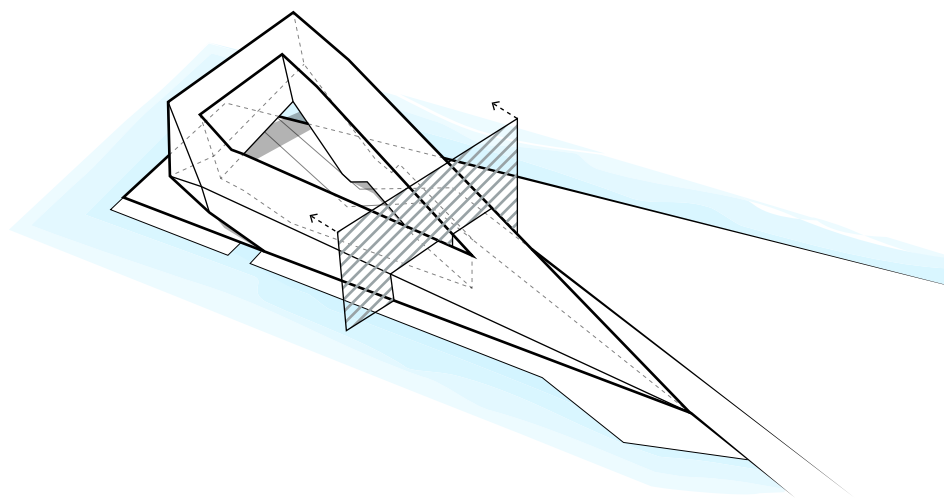

# 142 KLIMAAT

## Ventilatie

lokaal geregeld (individueel)

Natuurlijke toevoer door middel van een suskast in het gevelpakket

mechanische afvoer in badkamer, toilet en keuken

\*badkamer voorzien van warmtepompboiler

suskasT: ventilatierooster met hoge geluidwering

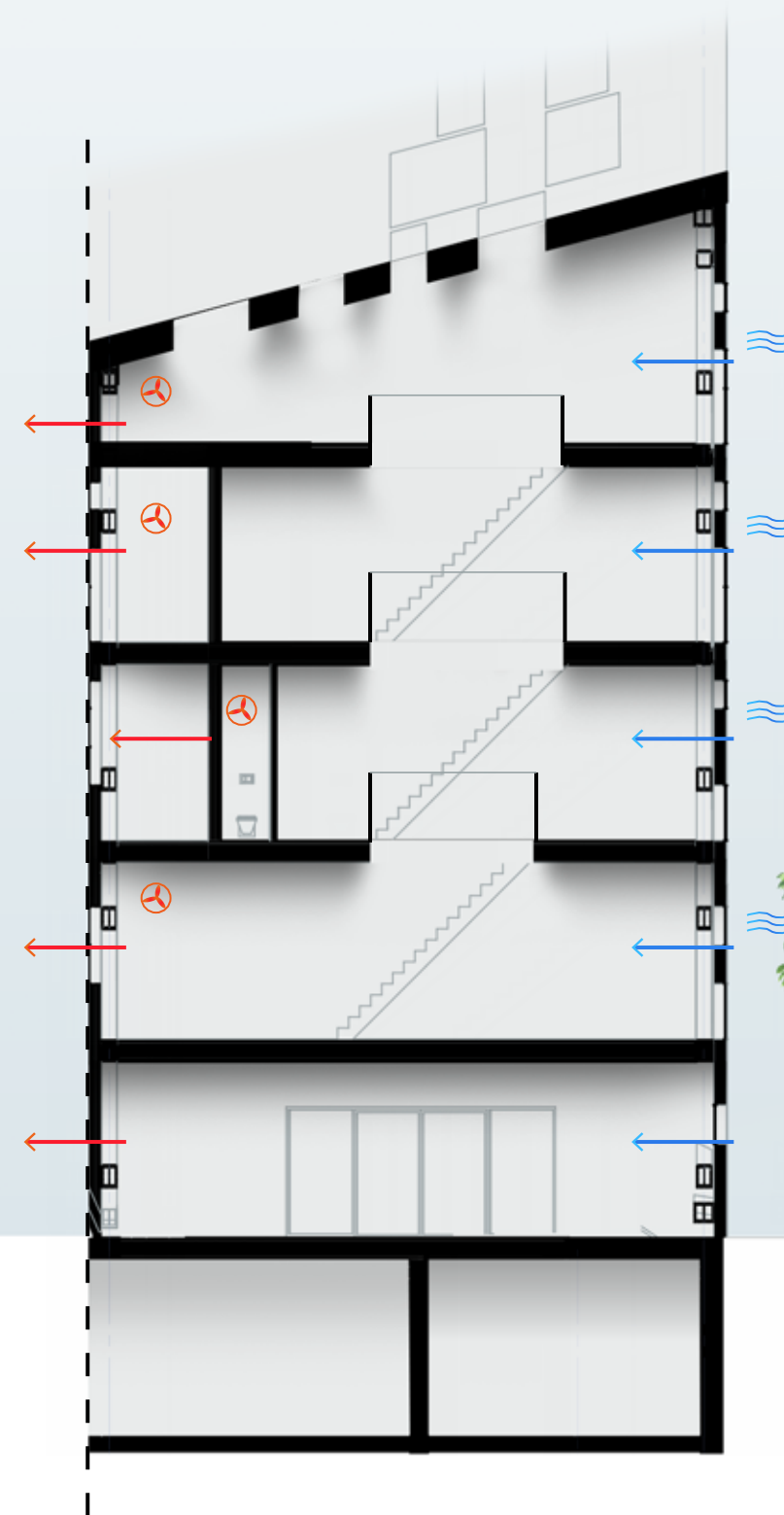
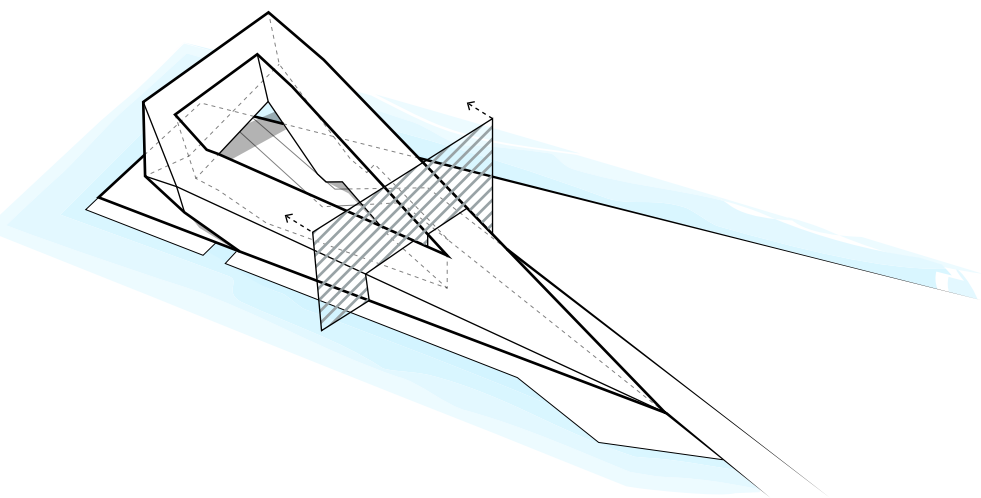



# 143 KLIMAAT

Warm tapwater

geclusterde opwekking met behulp van  
warmtepomp  
lokaal geregeld door warmtepompboiler

Warme ventilatielucht in warmtepompboiler  
warm tapwater verdeeld naar keuken en  
badruimte

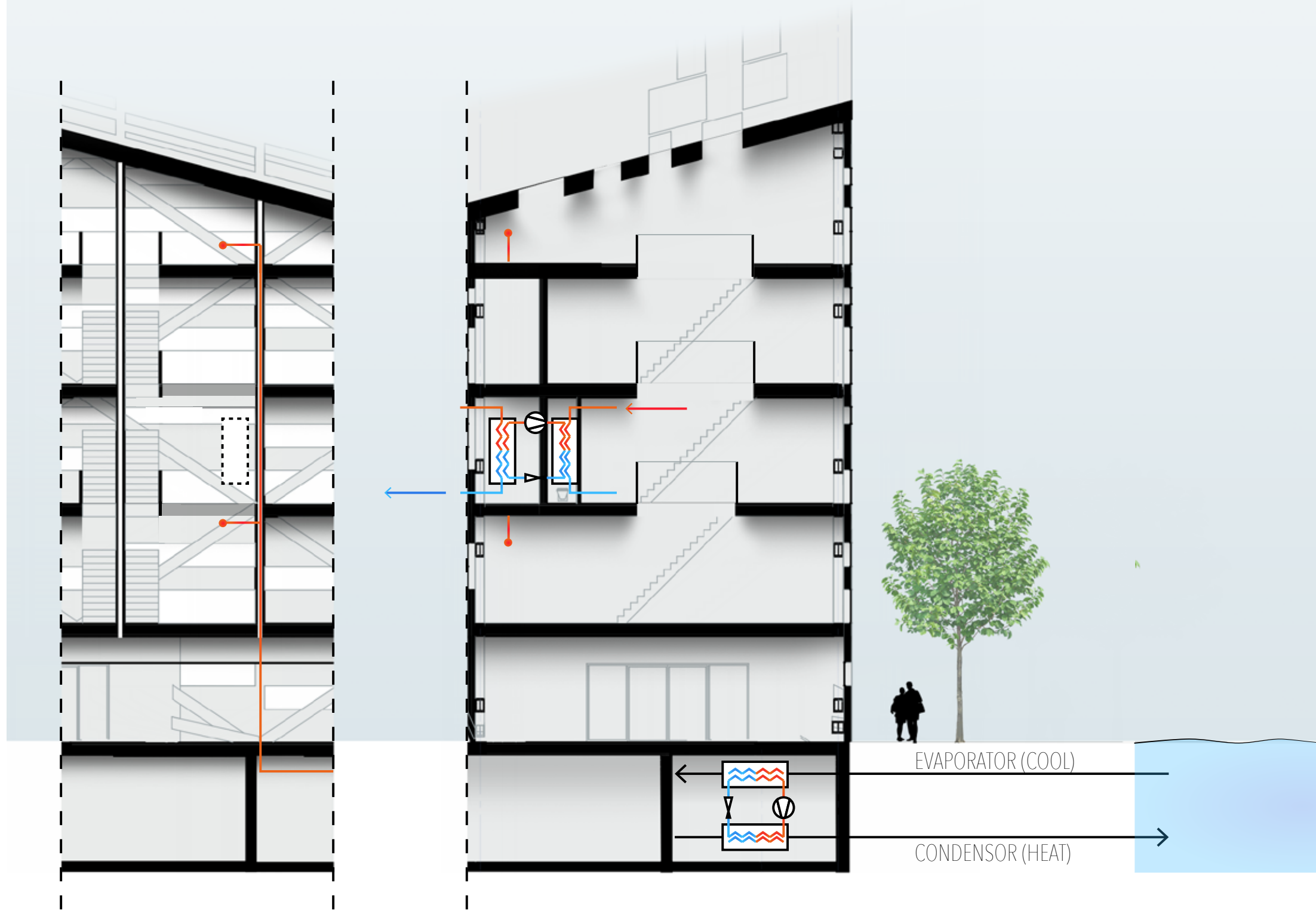
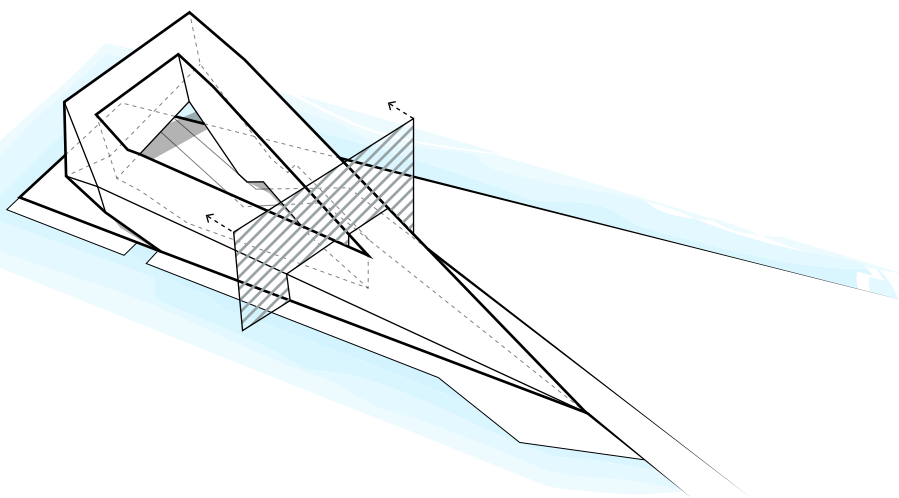

# 144 KLIMAAT

Electriciteit

aansluiting op regionale groene  
energievoorziening

Windmolenpark

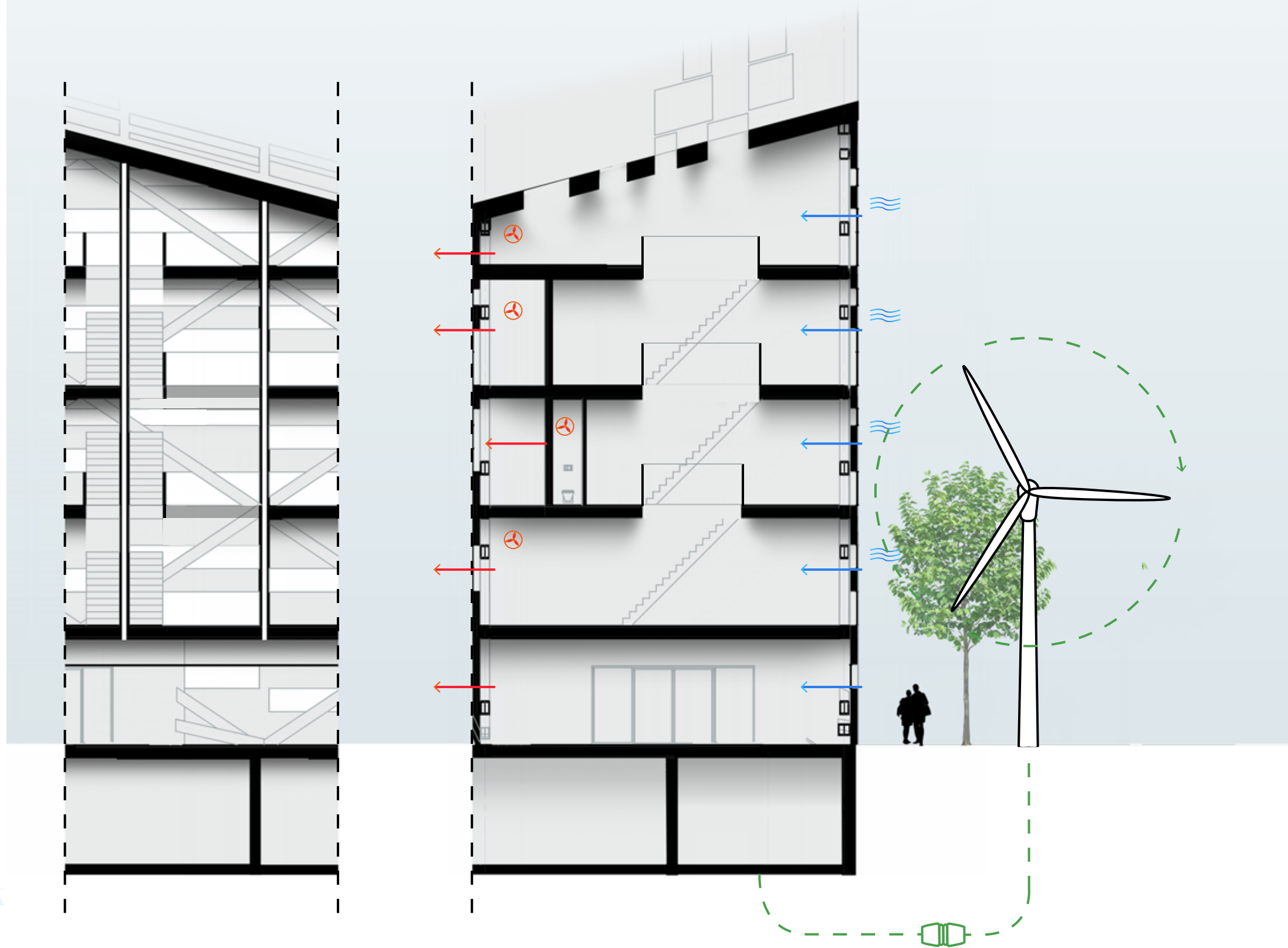
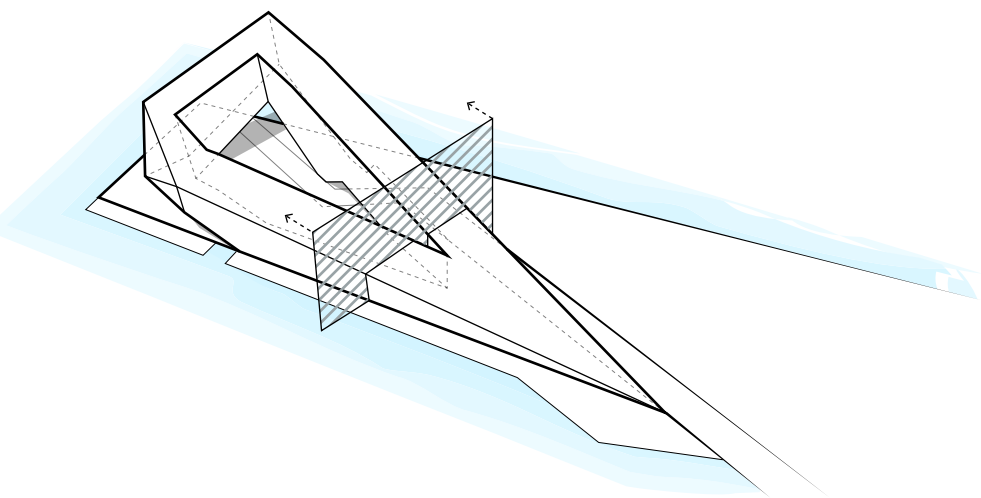

**145 WONING C**  
Locatie & aantal

**TYPE C**  
10.8 METER BREED  
1 LAAG  
100 M<sup>2</sup>

30x

13x

23x

2x

3x

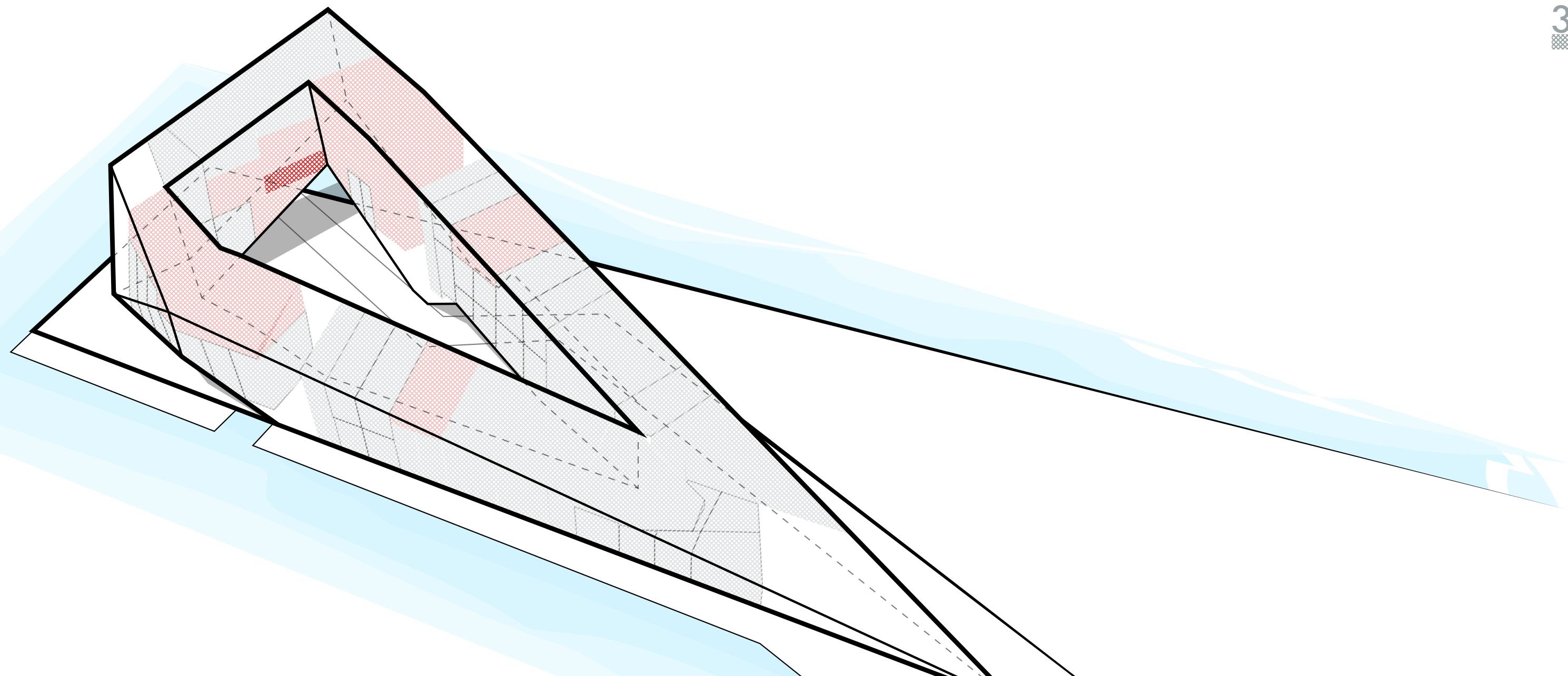



**146 WONING C**  
Doorsneden

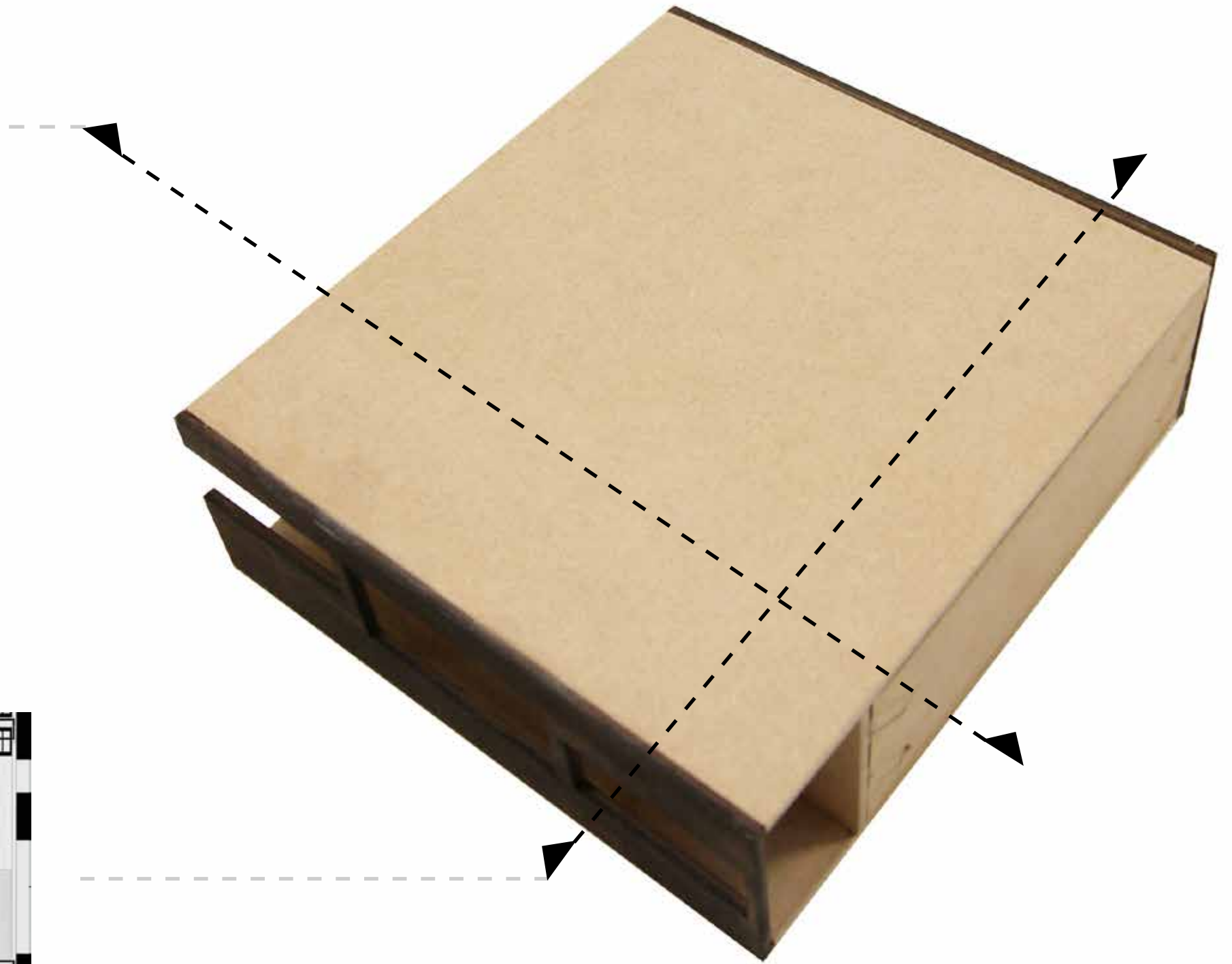
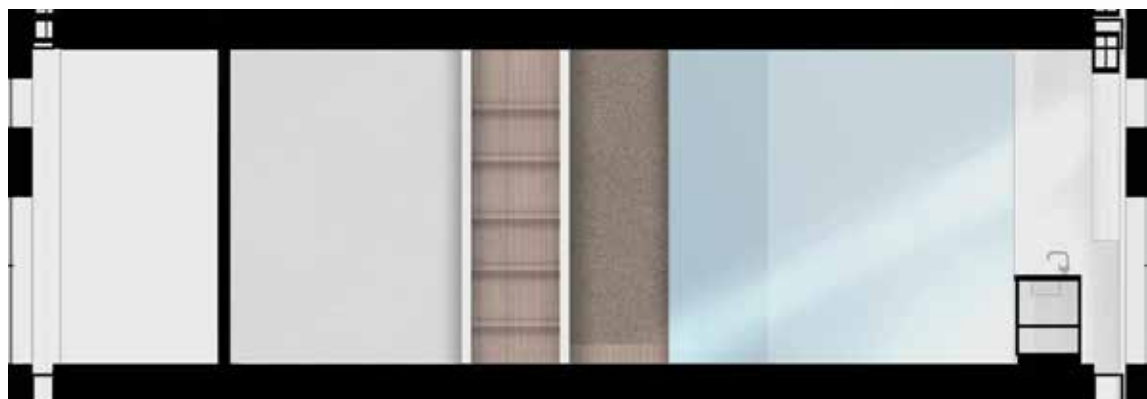

# 147 WONING C

Plattegrond 4e verdieping

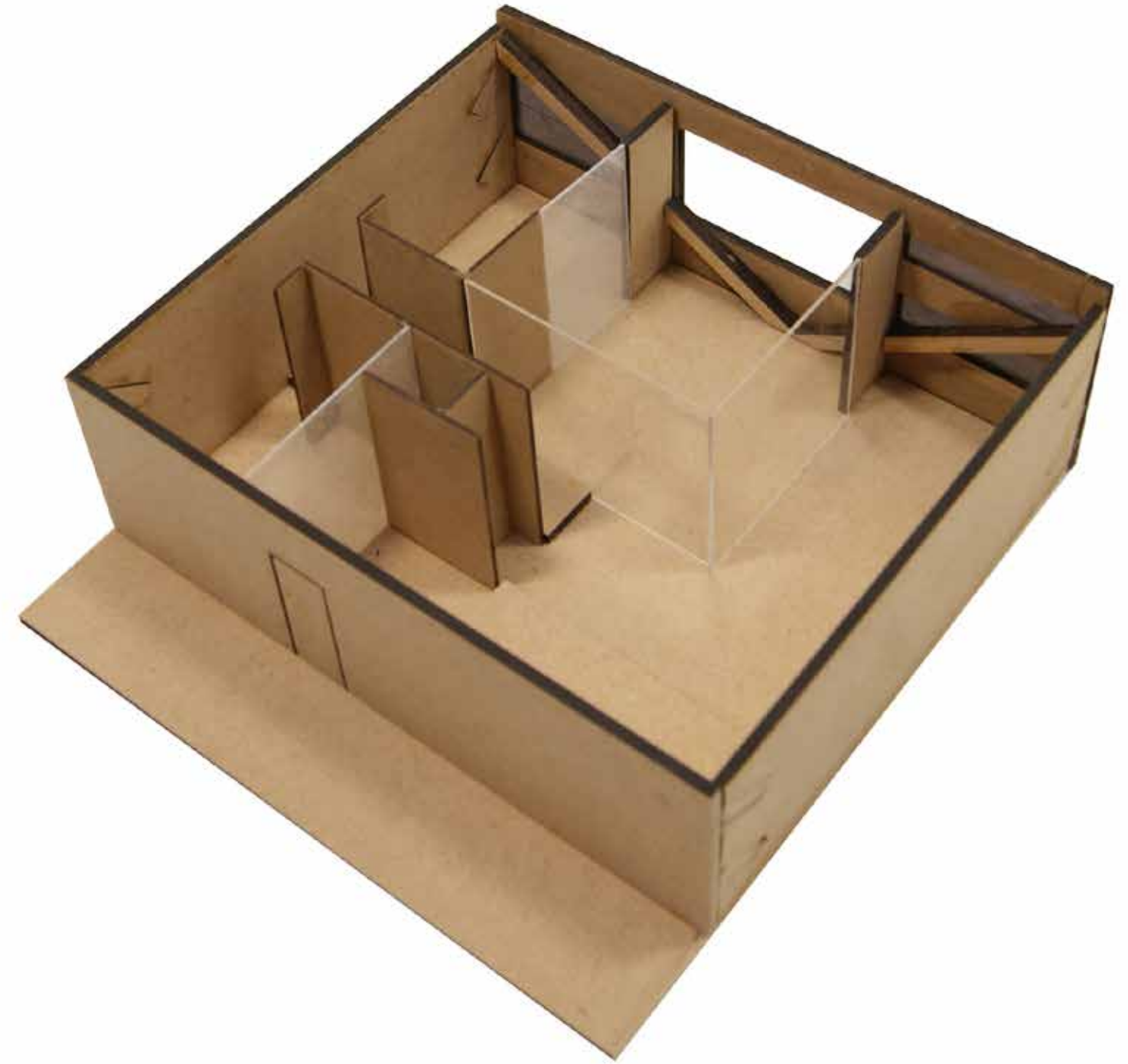

**148 WONING C**  
Impressie leefruimte

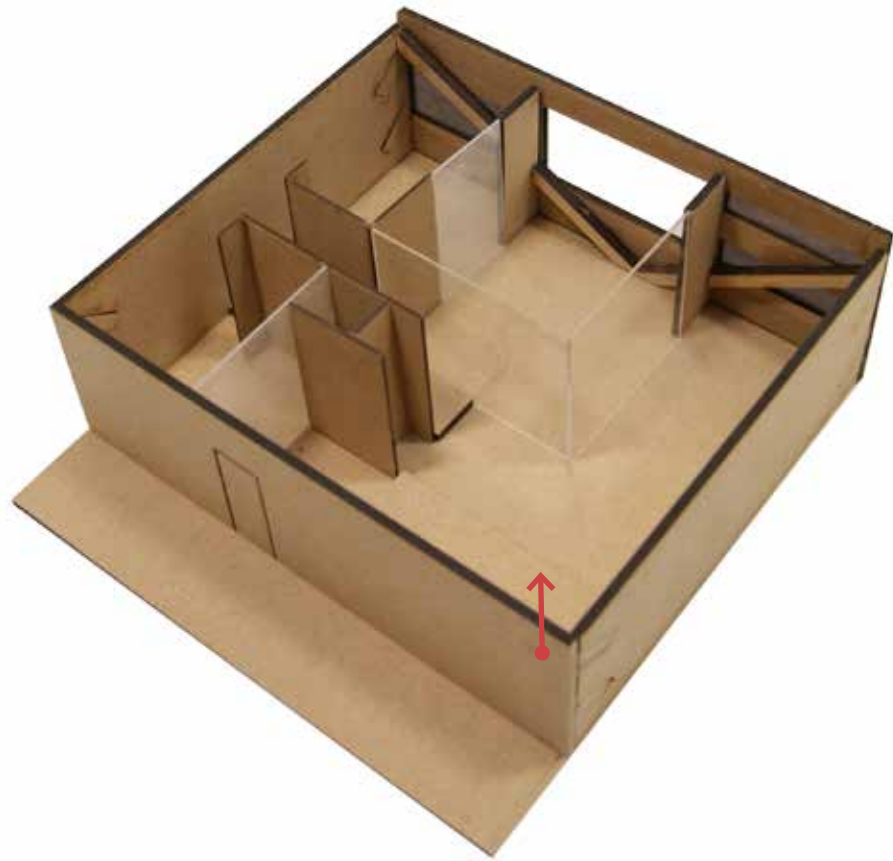



**149 WONING C**  
Impressie leefruimte

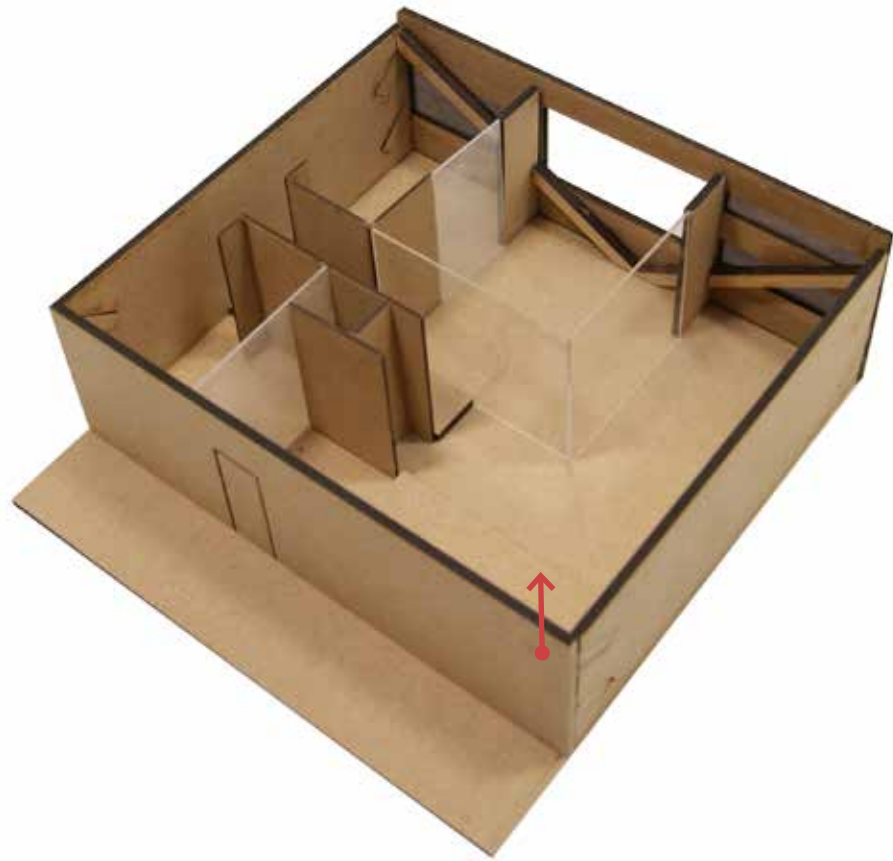

**150 WONING C**  
Impressie badruimte

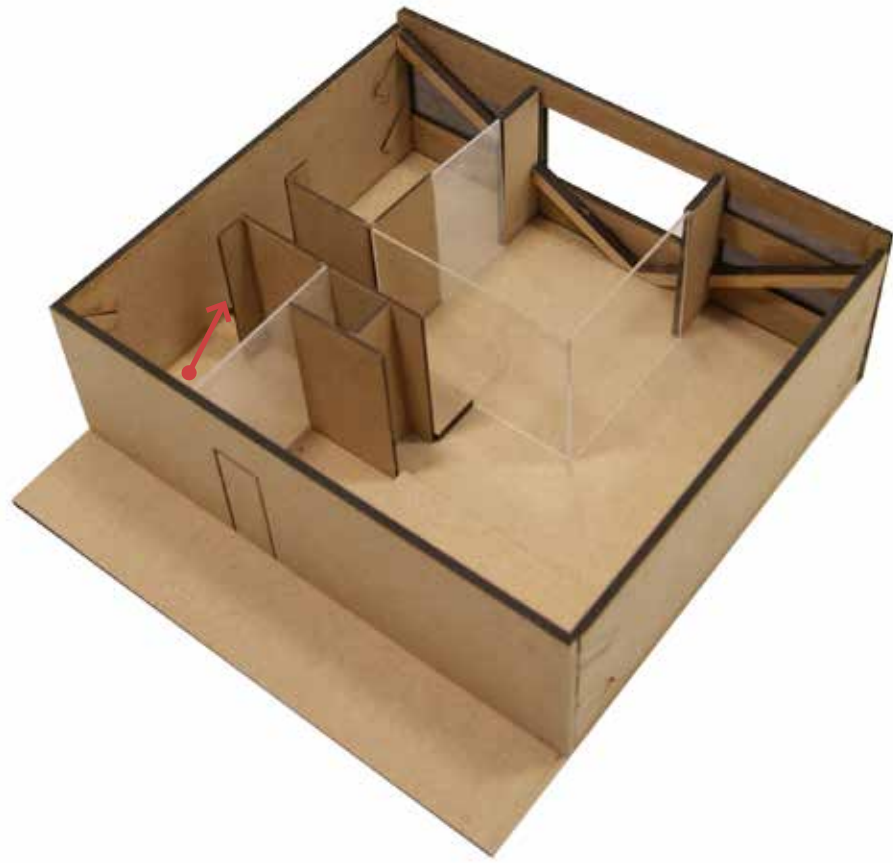



# 151 WONING D1 & D2

Locatie & aantal

# TYPE D

PUNTWONING

1 / 2 LAAGS

100 M<sup>2</sup> / 110 M<sup>2</sup>

30x

13x

23x

2x

3x

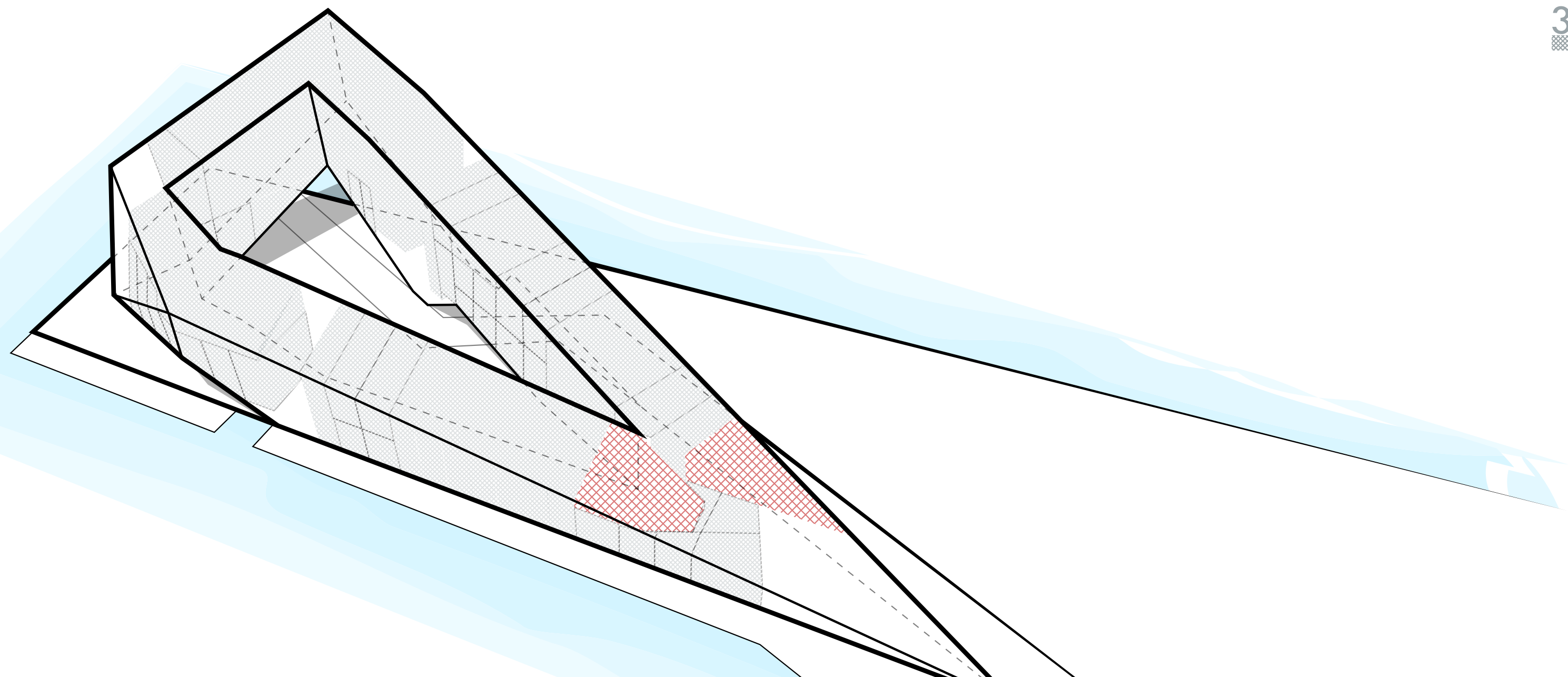



**152 WONING D1**  
Doorsneden

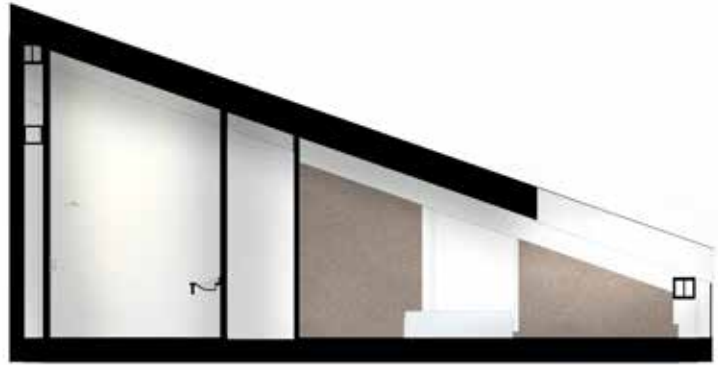
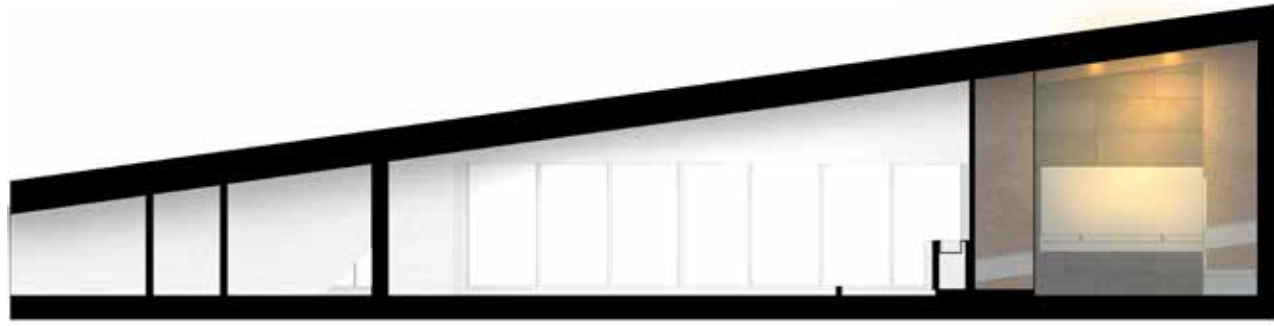

**153 WONING D1**  
Plattegrond 2e verdieping

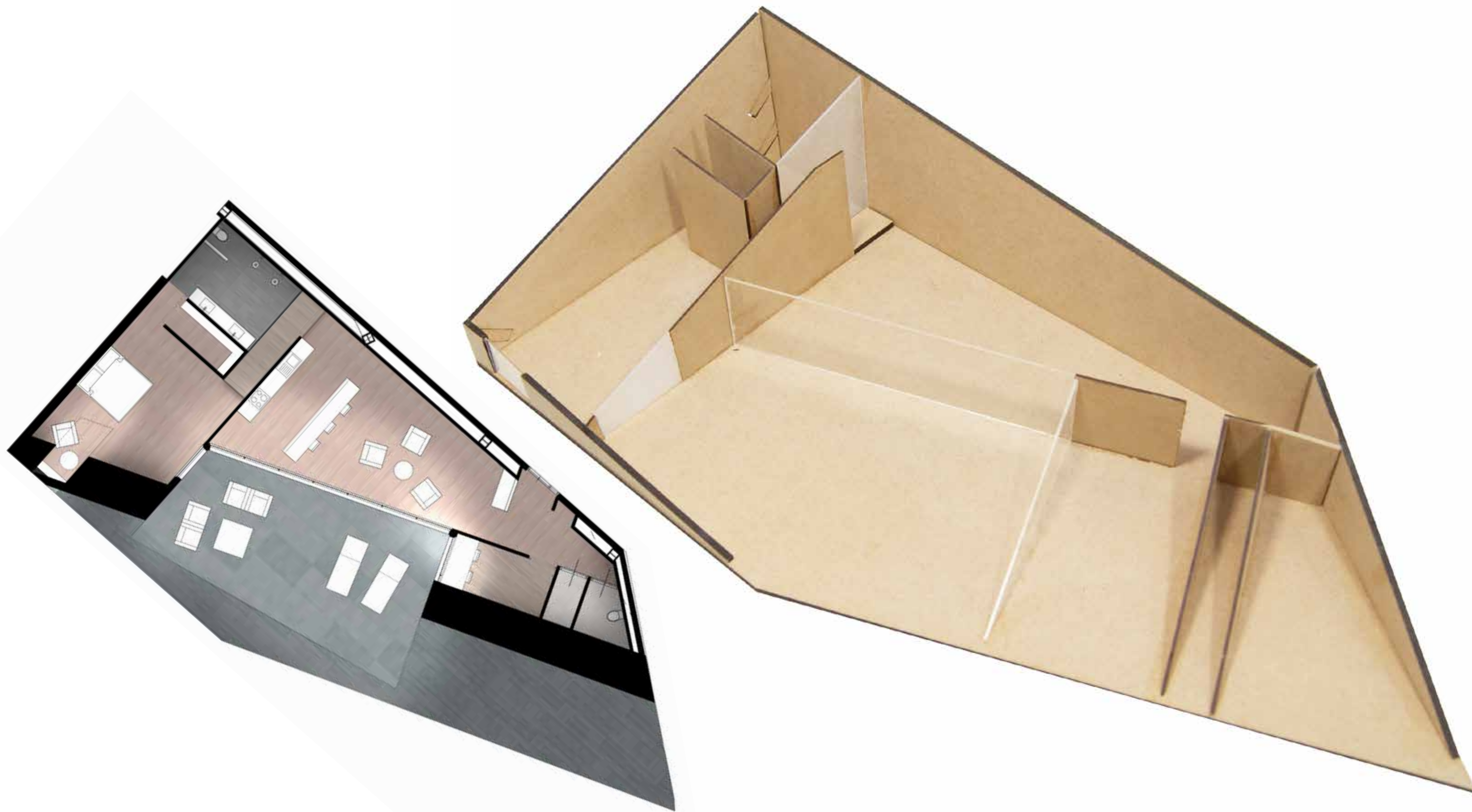



**154 WONING D1**  
Impressie leefruimte

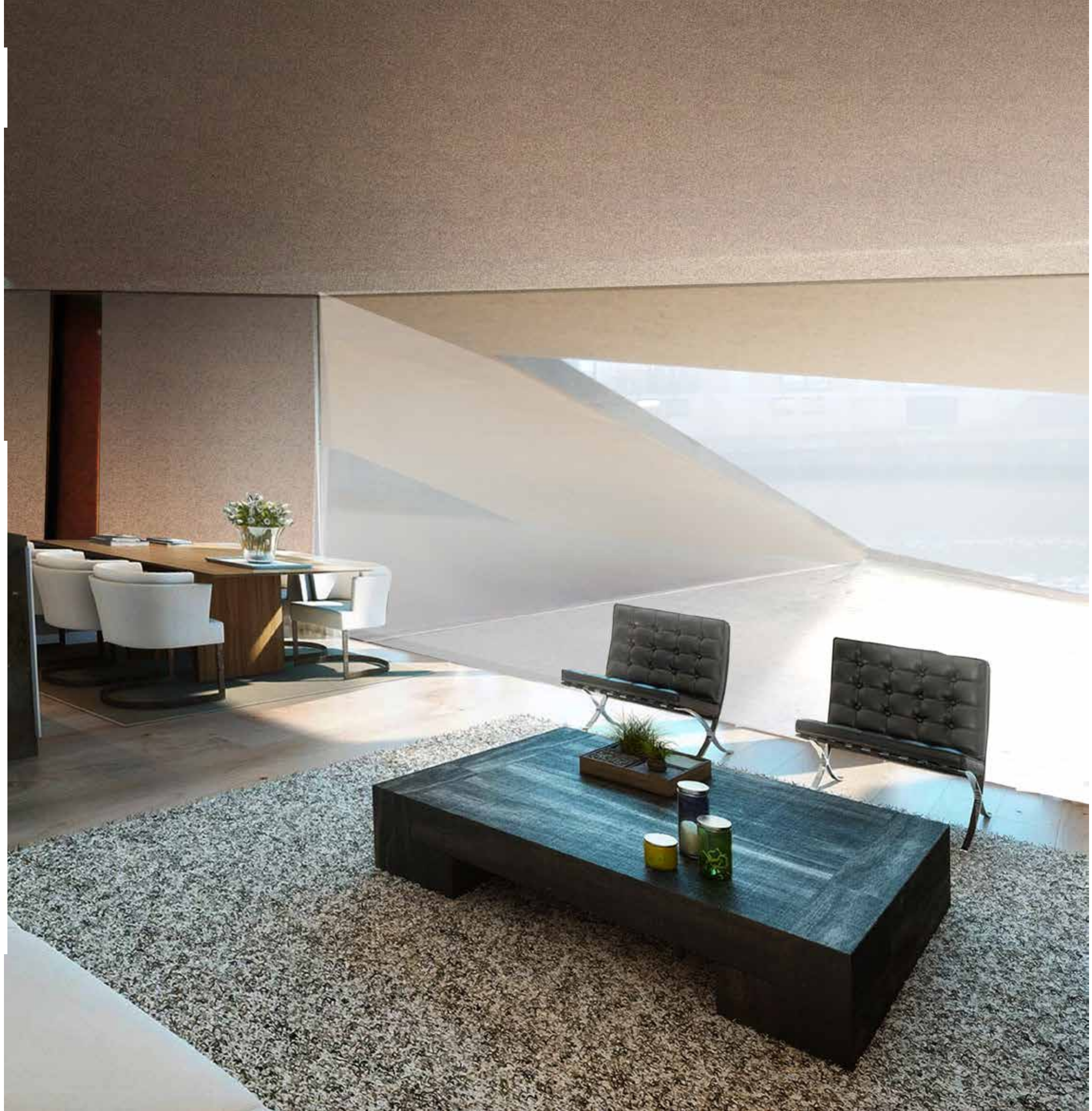
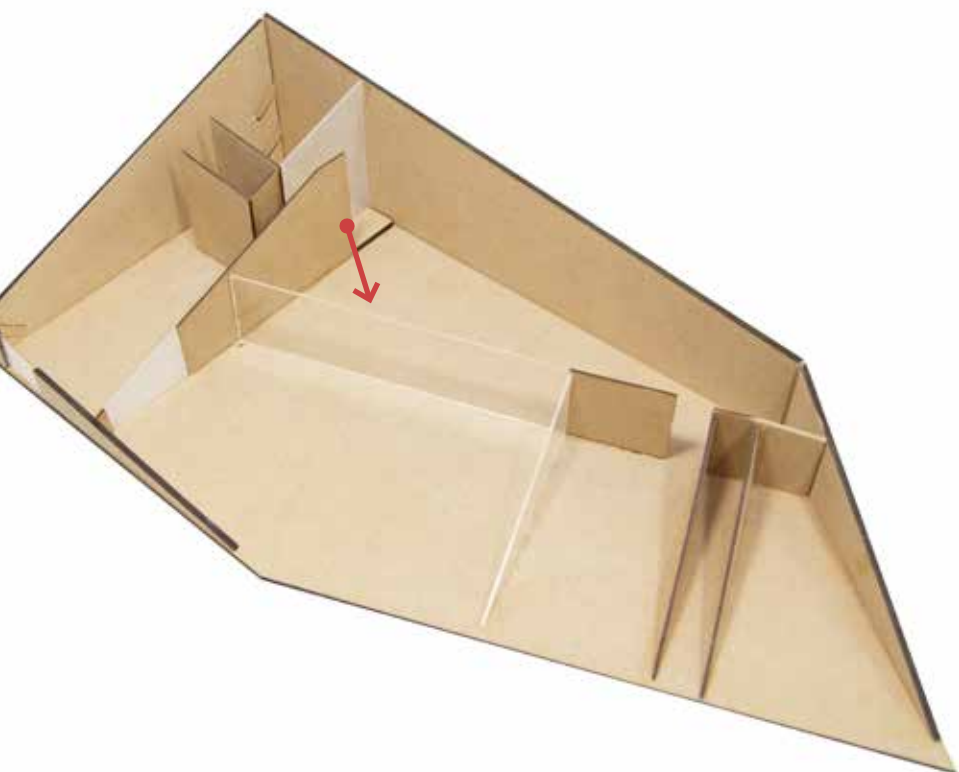



**155 WONING D1**  
Impressie privezone



# 156 WONING D2

Doorsneden

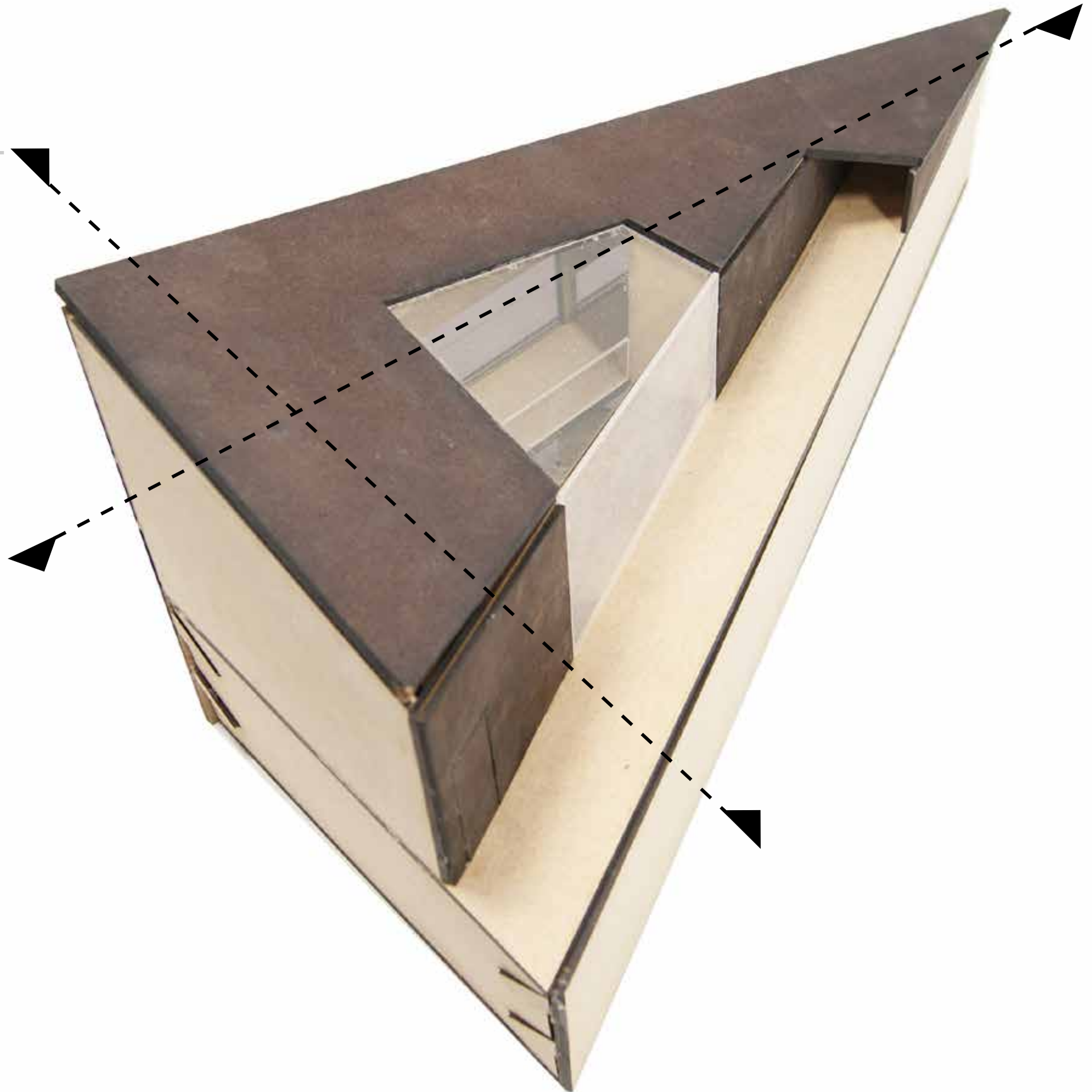
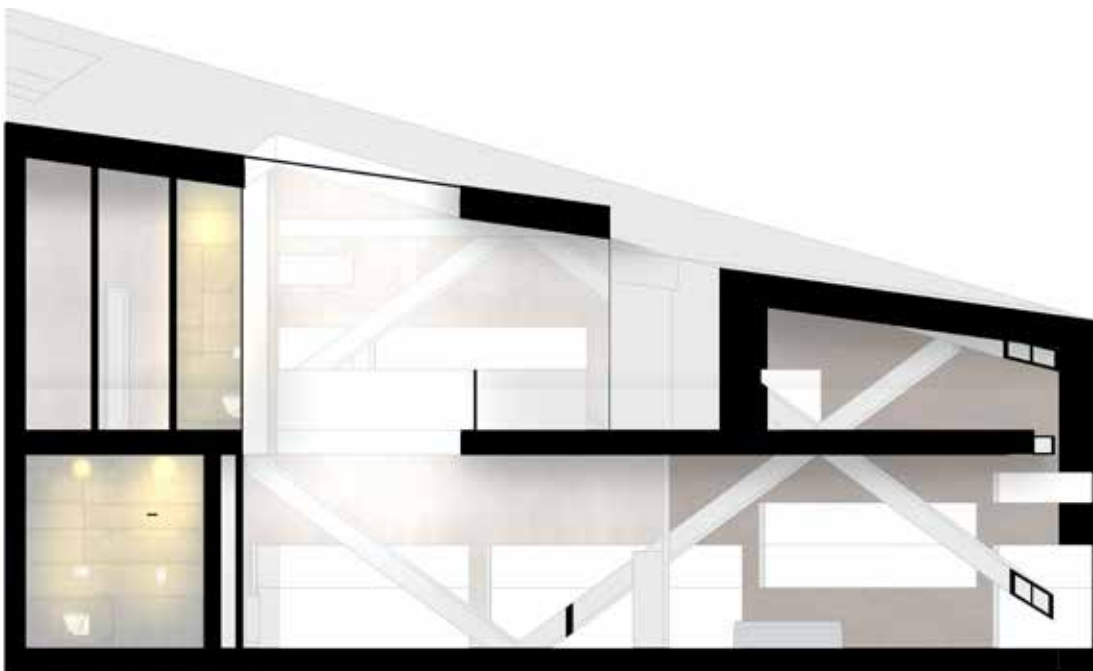
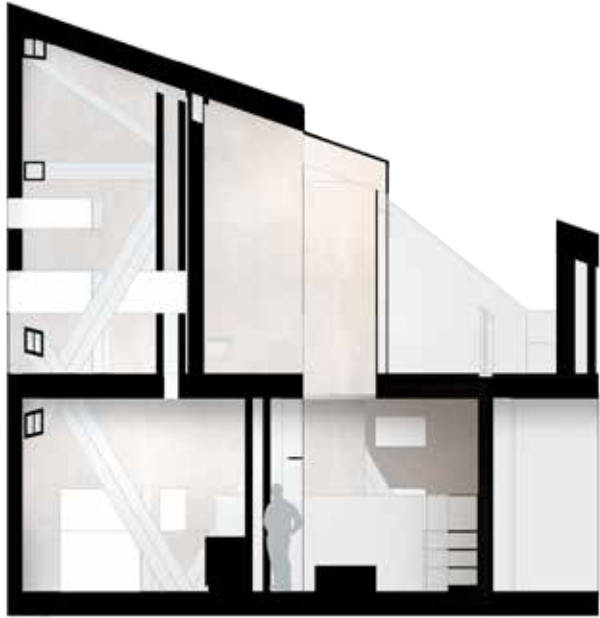



**157 WONING D2**  
Plattegrond 2e verdieping

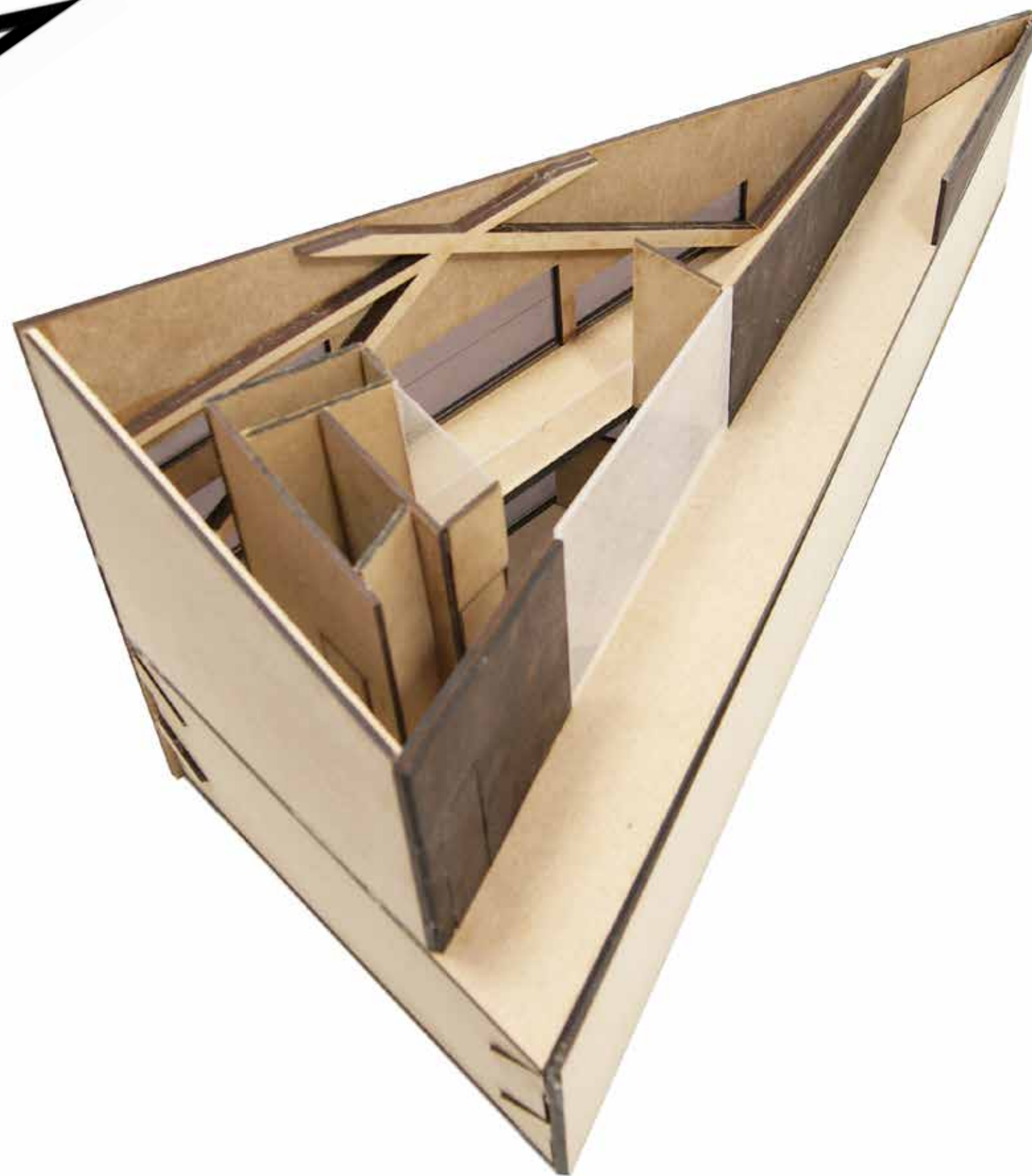
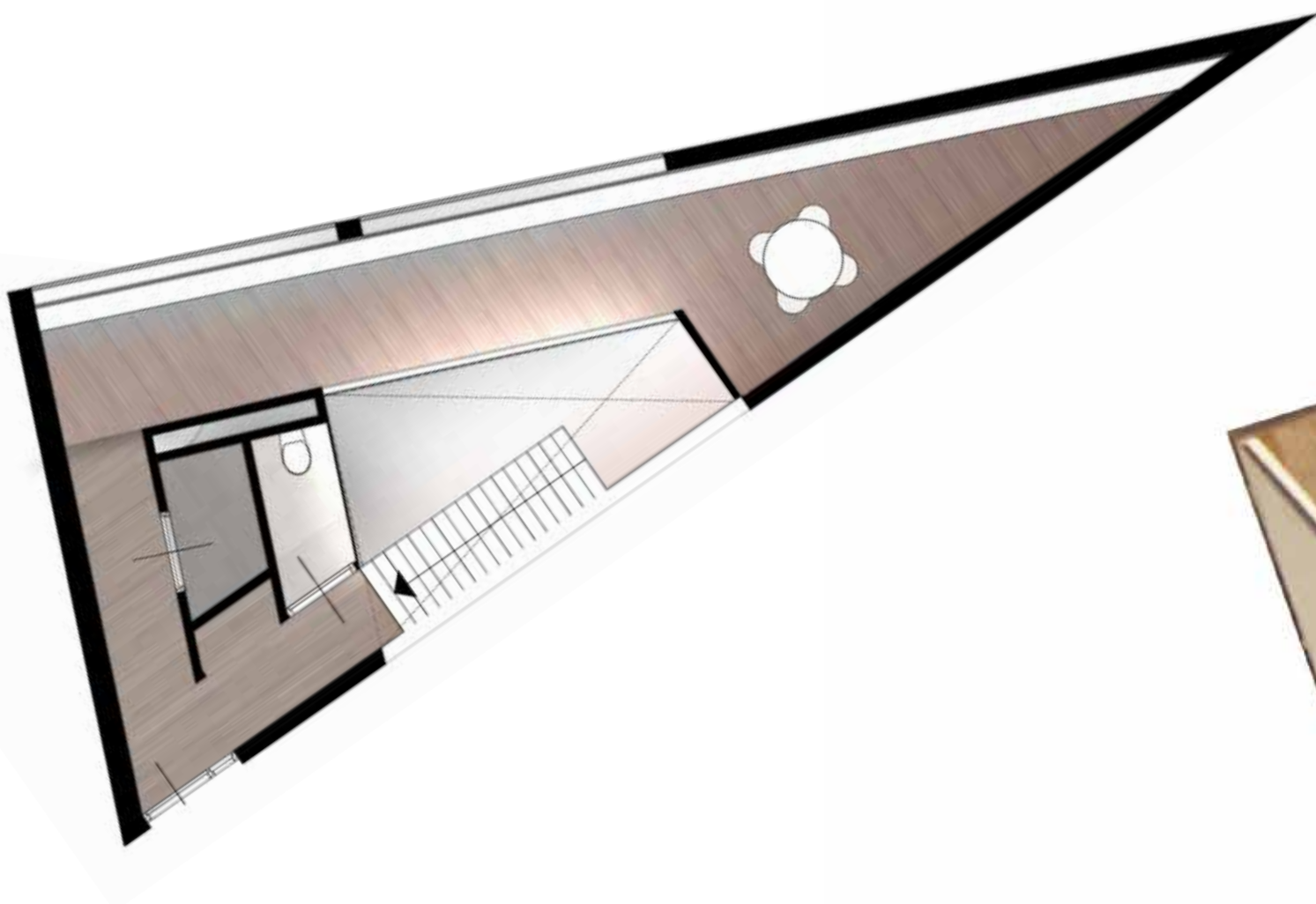

**158 WONING D2**  
Plattegrond 1e verdieping

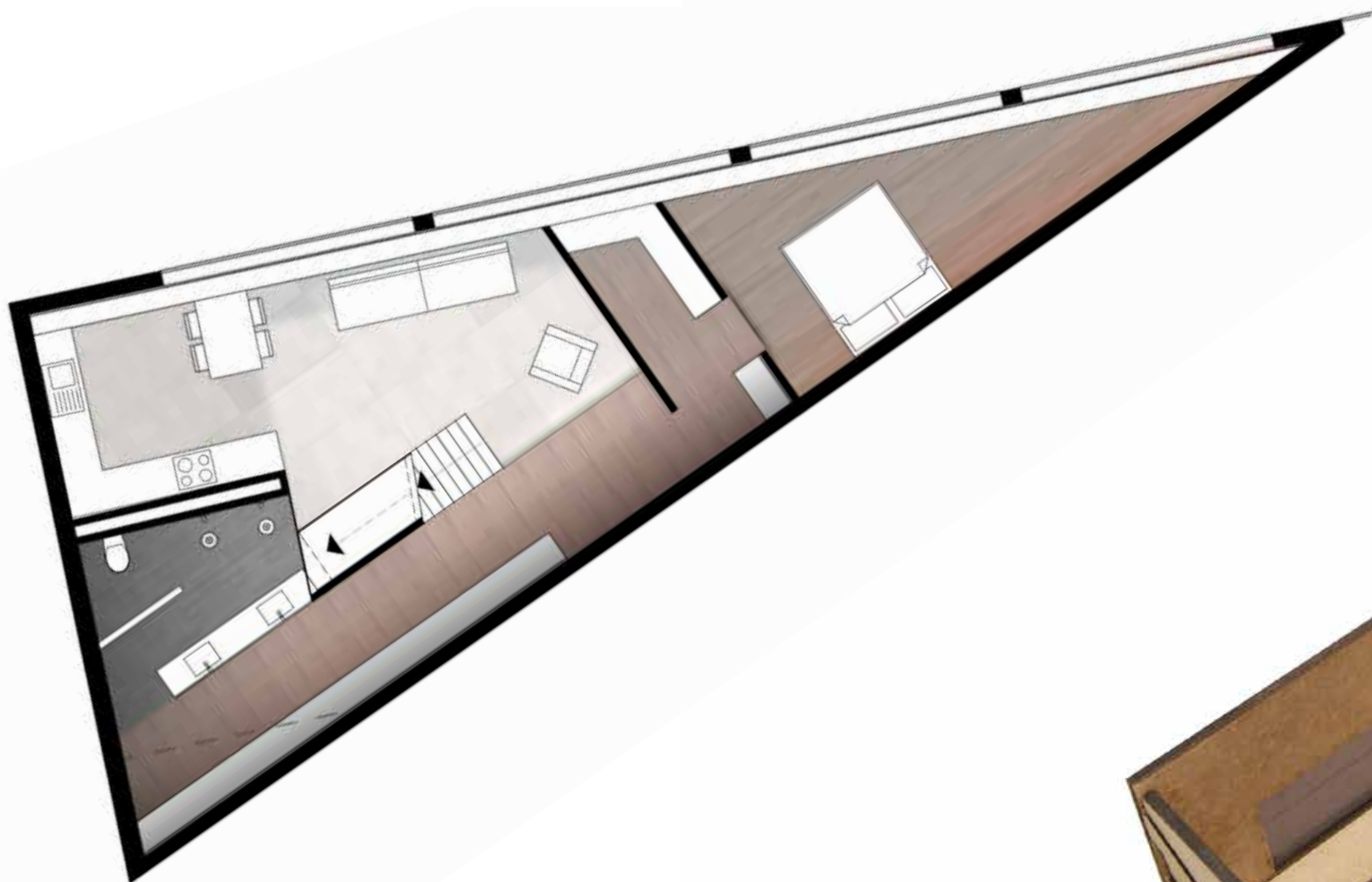



**159 WONING D2**  
Impressie leefruimte

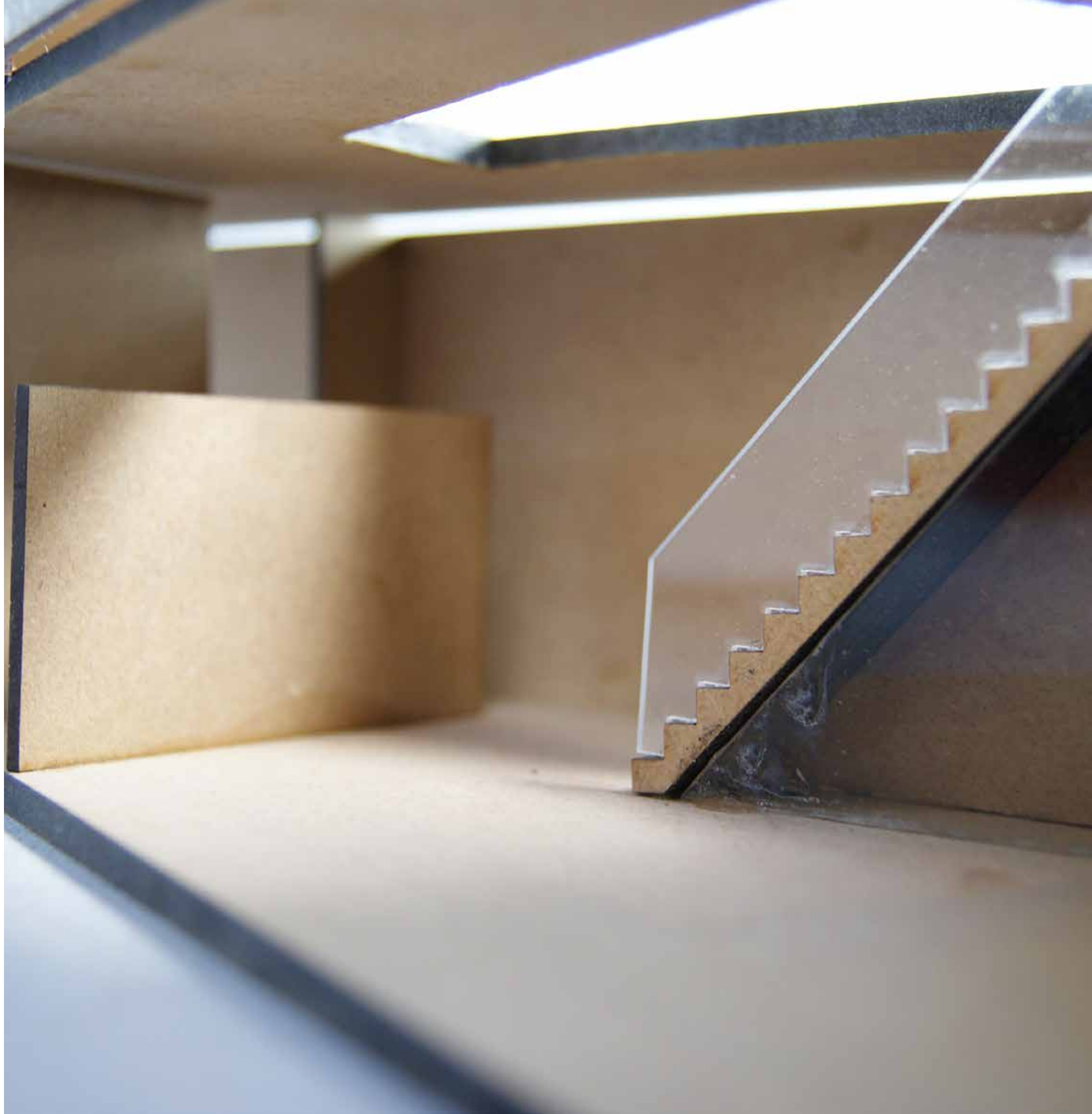
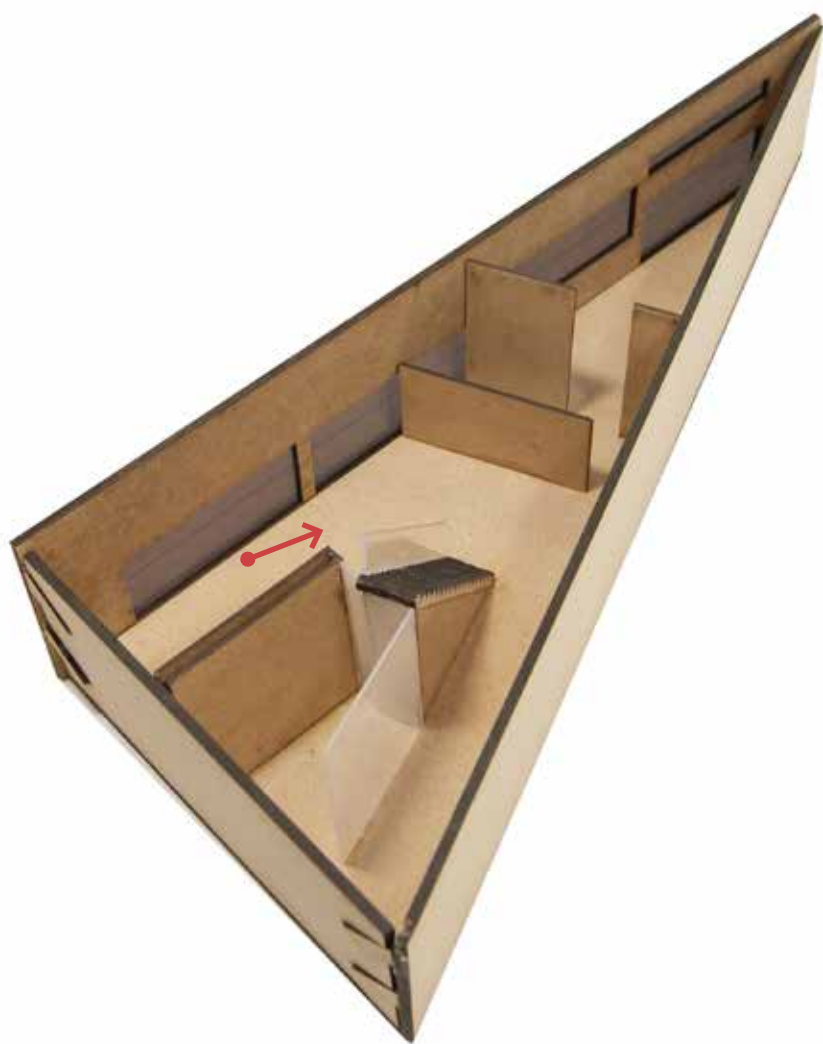



**160 WONING D2**  
Impressie leefruimte





**161 WONING D2**  
Impressie hal



**162 WONING E**  
Locatie & aantal

**TYPE E**  
10.8 METER BREED  
1 LAAG  
210 M<sup>2</sup>

30x

13x

23x

2x

3x

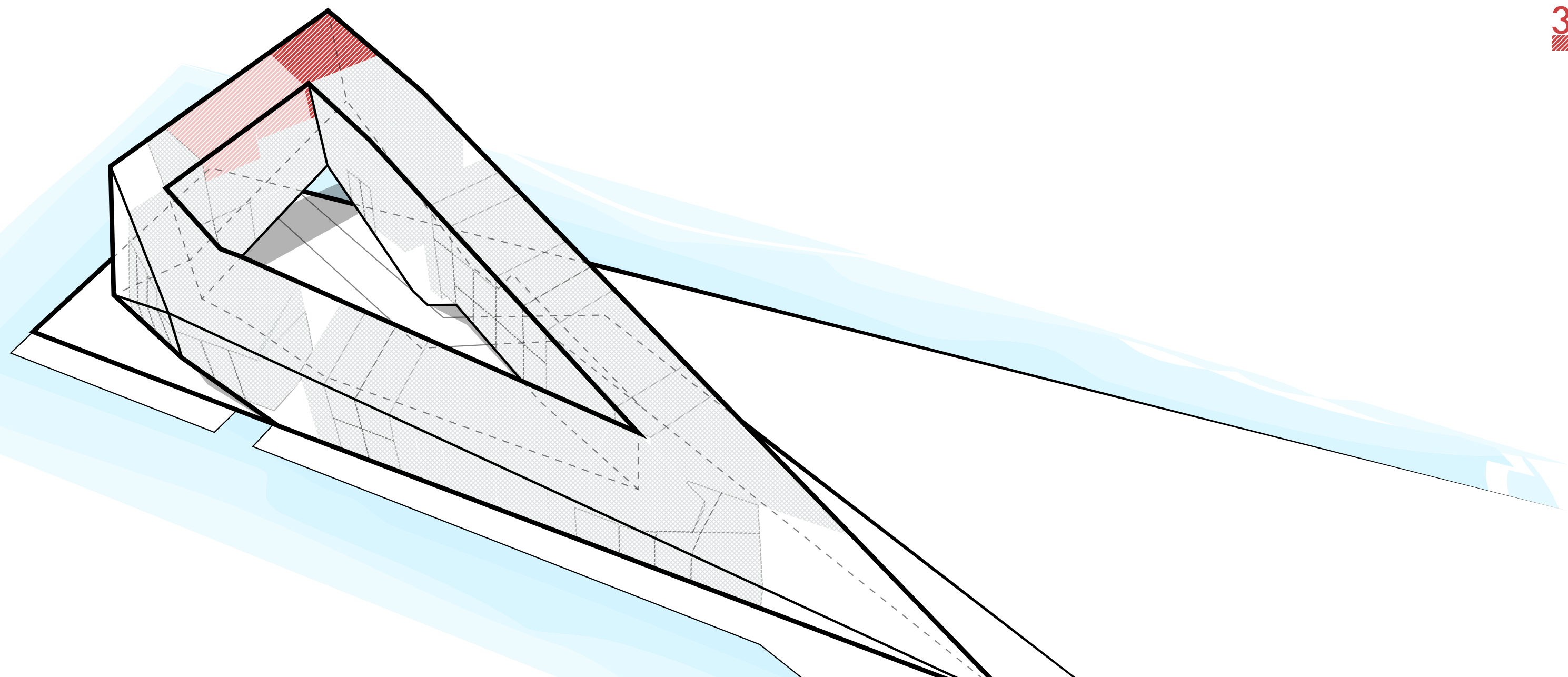





**164 WONING E**  
Plattegrond 5e verdieping

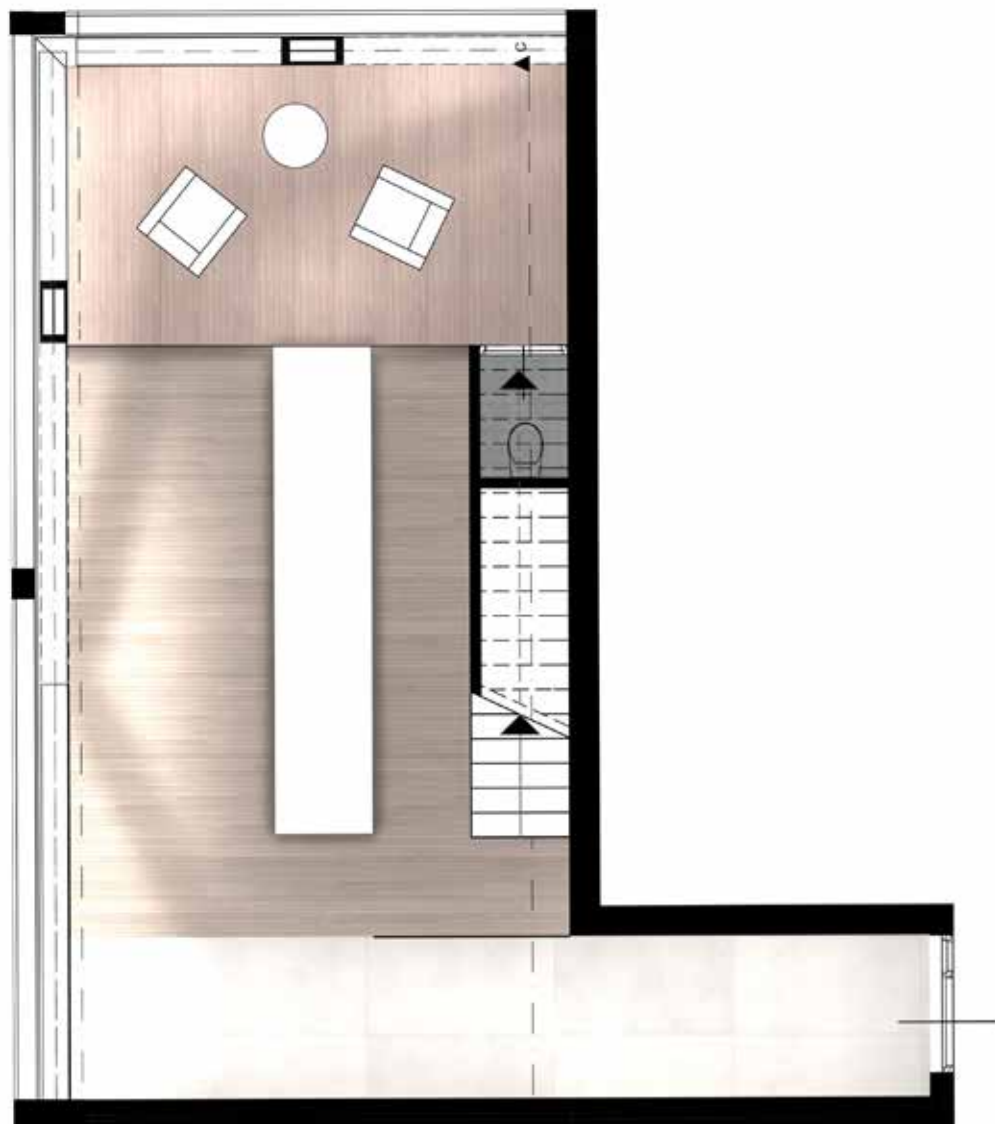



**165 WONING E**  
Plattegrond 6e verdieping



**166 WONING E**  
Plattegrond 7e verdieping

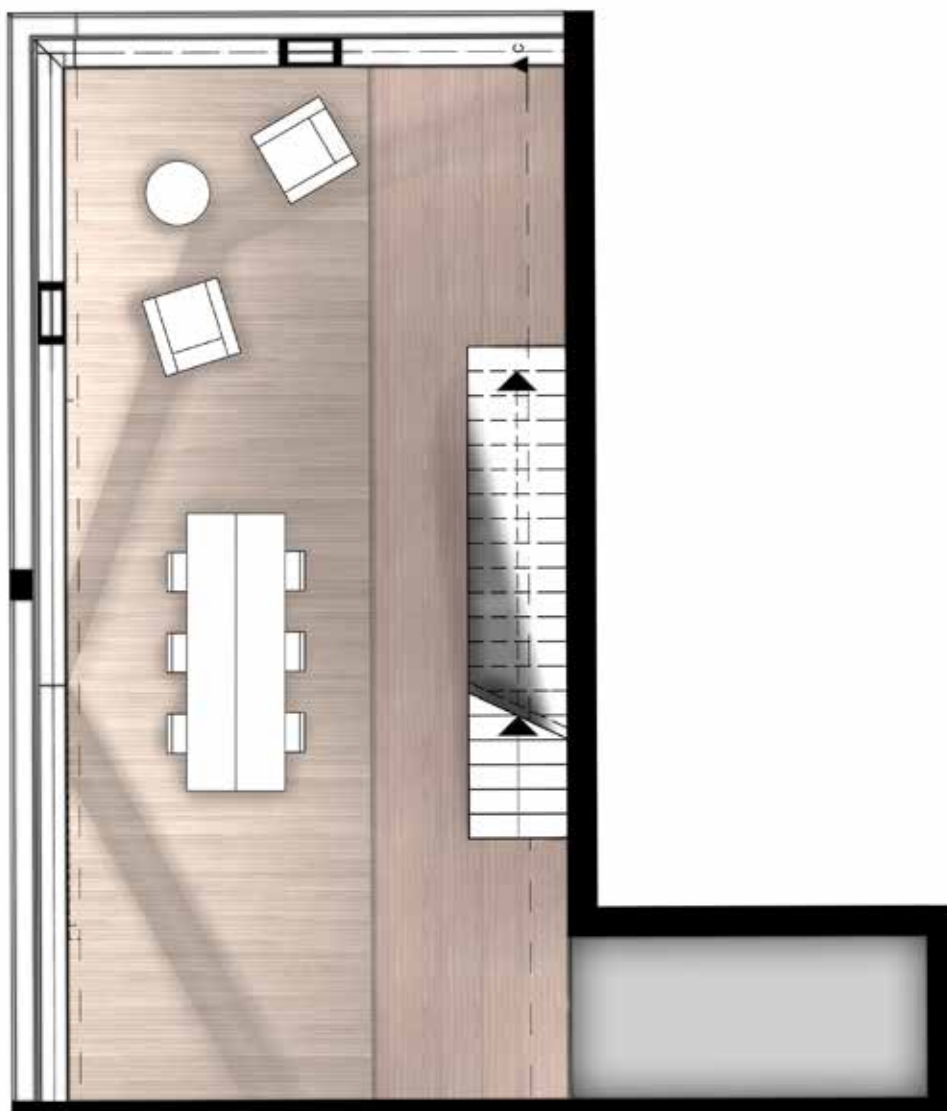



**167 WONING E**  
Plattegrond 8e verdieping

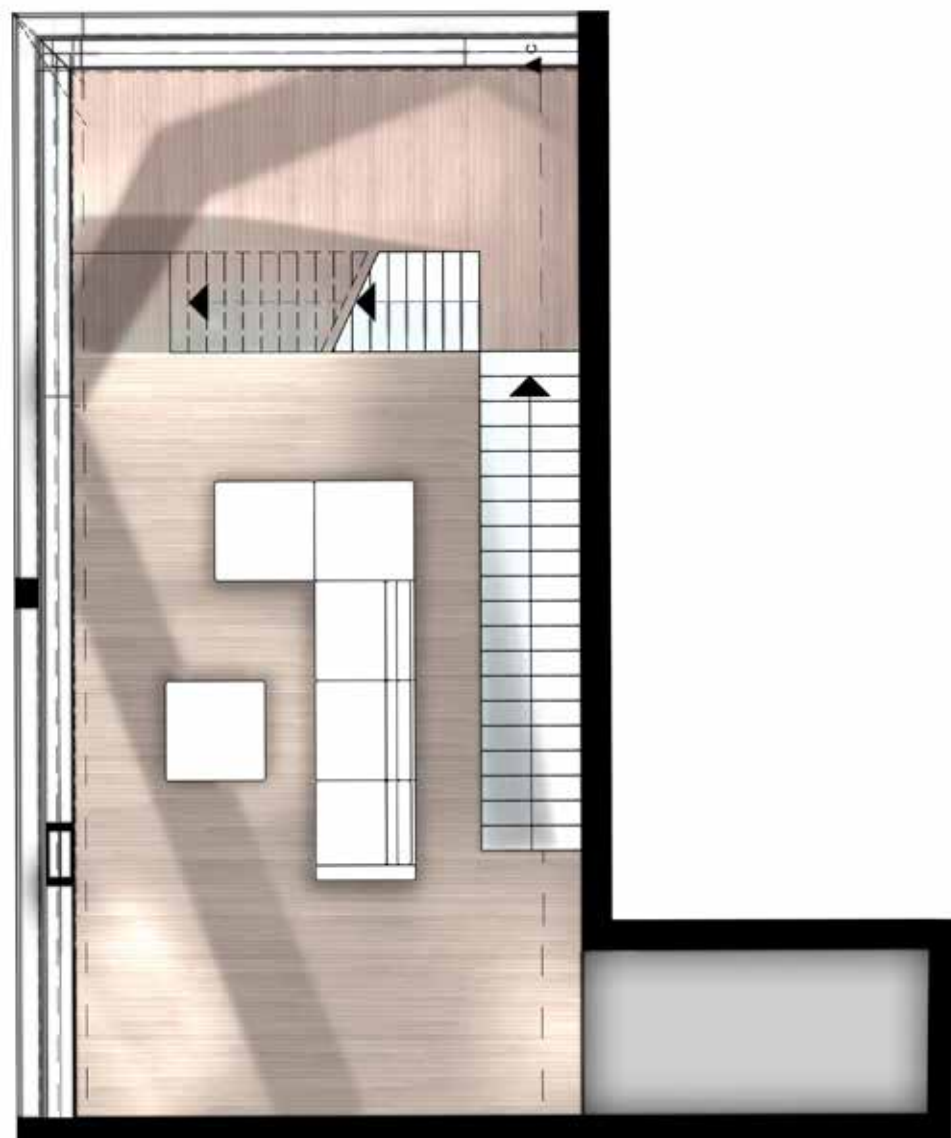

**168 WONING E**  
Impressie ontvangst zone

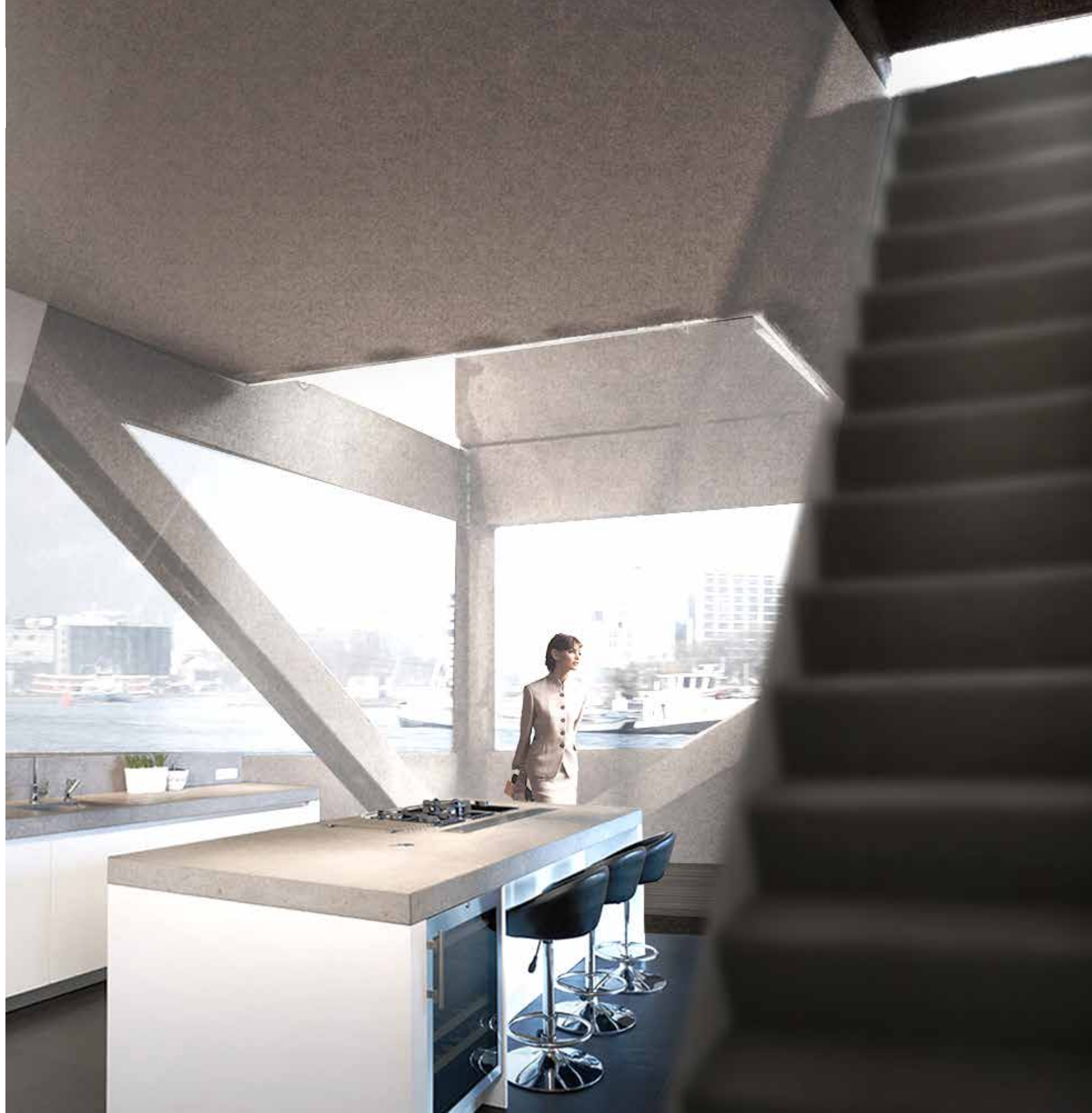



**169 WONING E**  
Impressie ontvangst zone





**170 WONING E**  
Impressie ontvangst zone

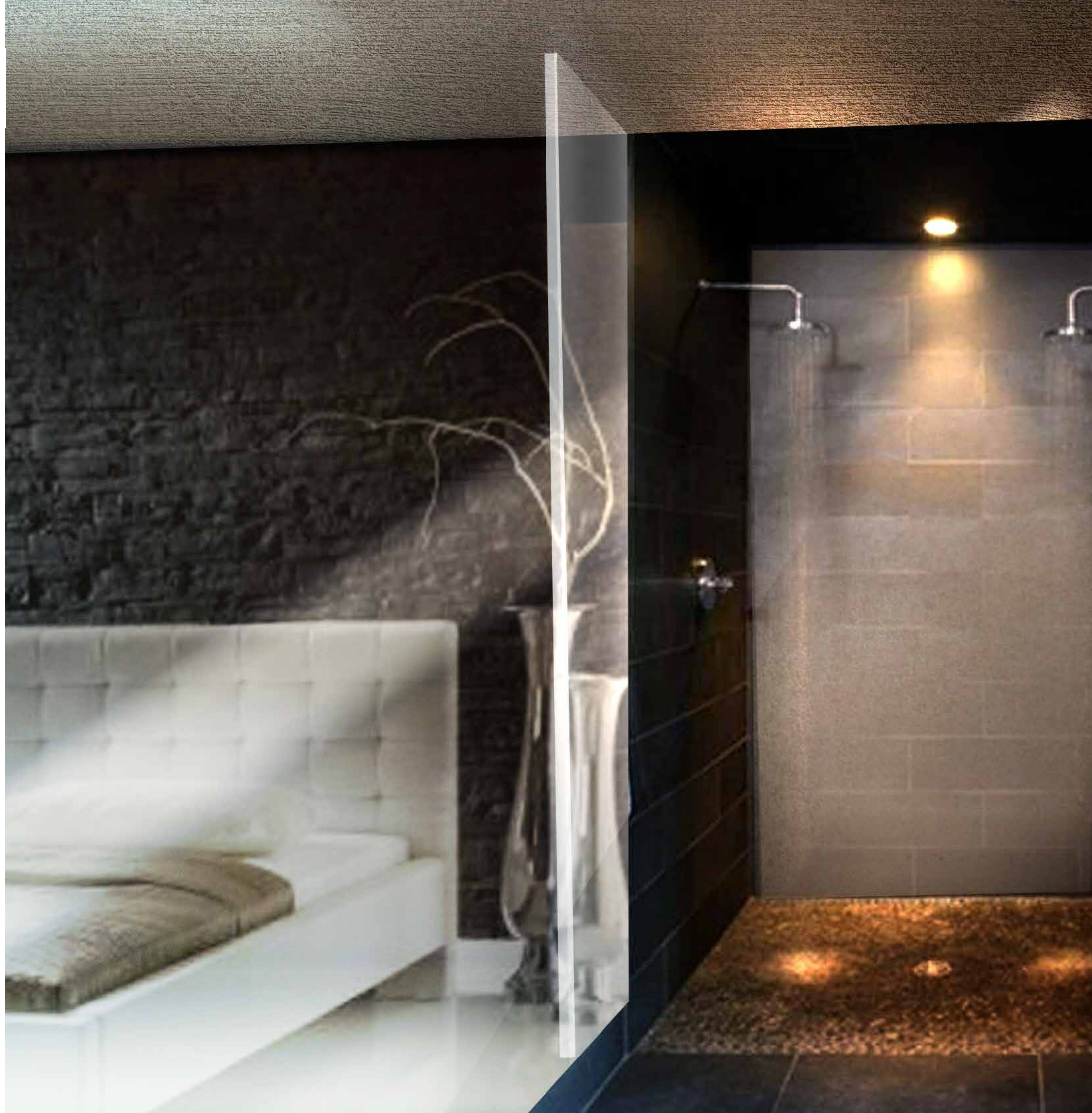



**171 WONING E**  
Impressie ontvangst zone

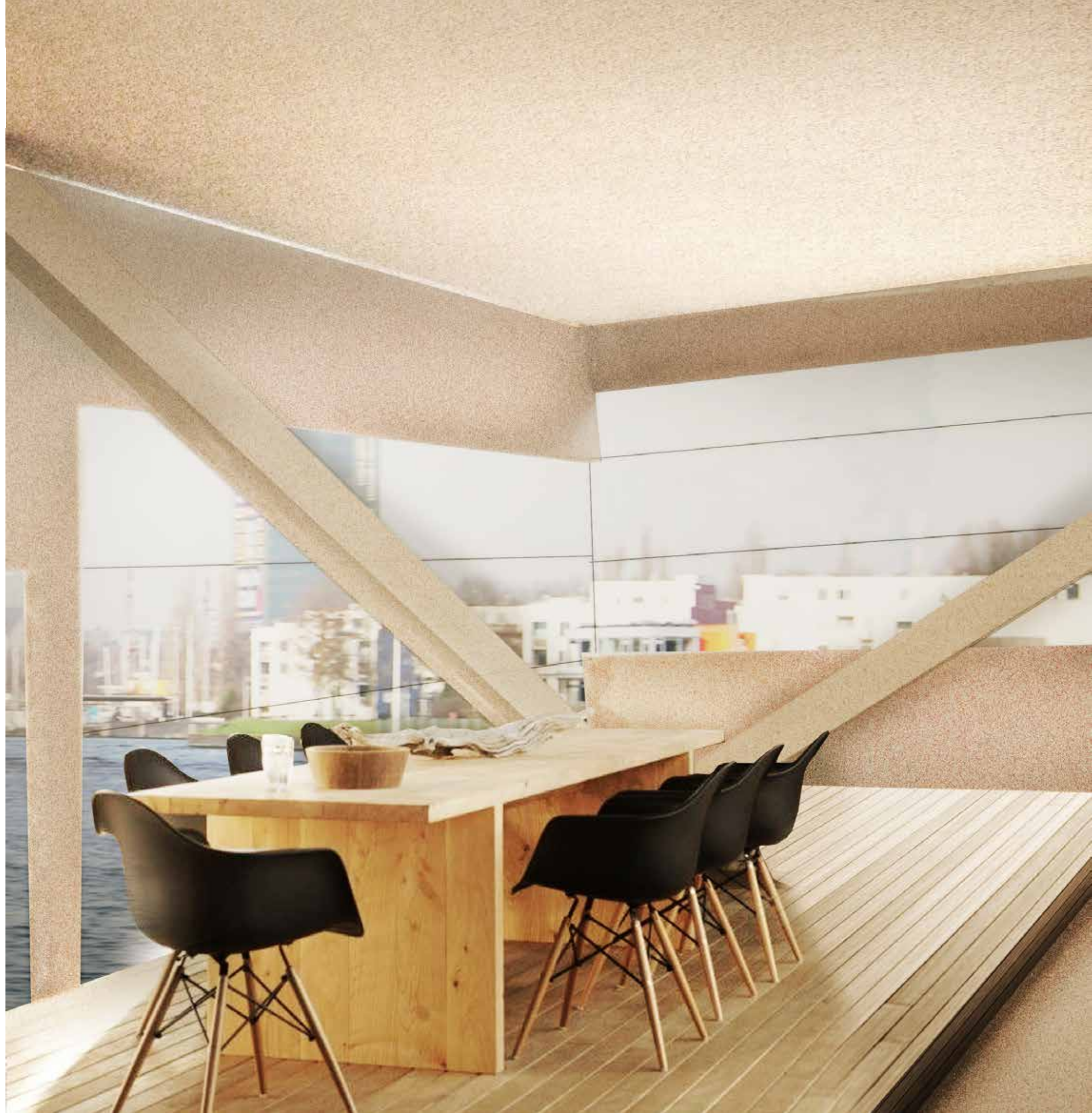



**172 WONING E**  
Impressie ontvangst zone

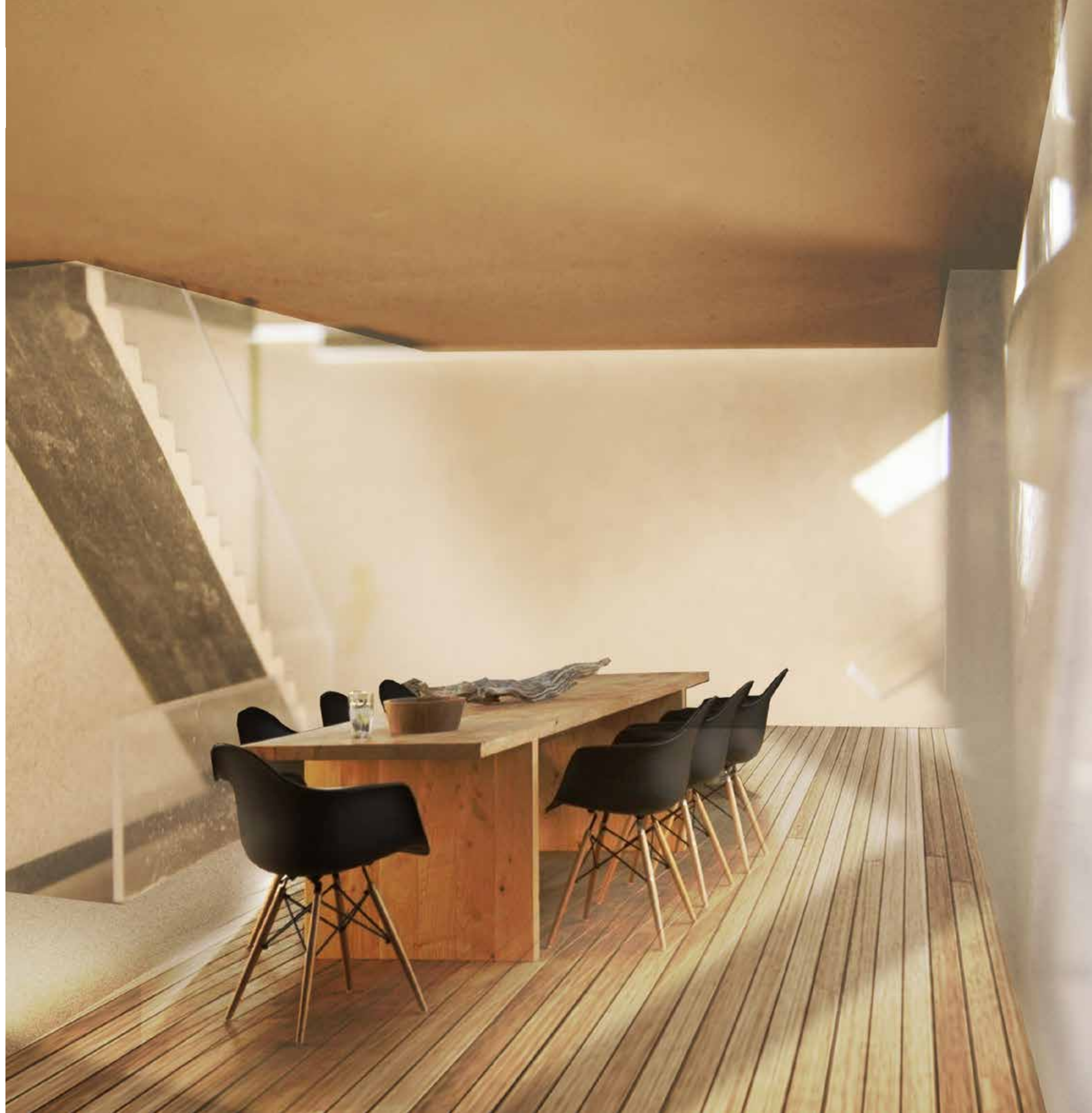



Hoe kan één van de meest levendige evenementlocatie's van Amsterdam, de Kop van Java Eiland een woongebouw huisvesten zonder de capaciteit van het evenement te verliezen?



**174 NIEUW ICOON**  
VAN HET IJ

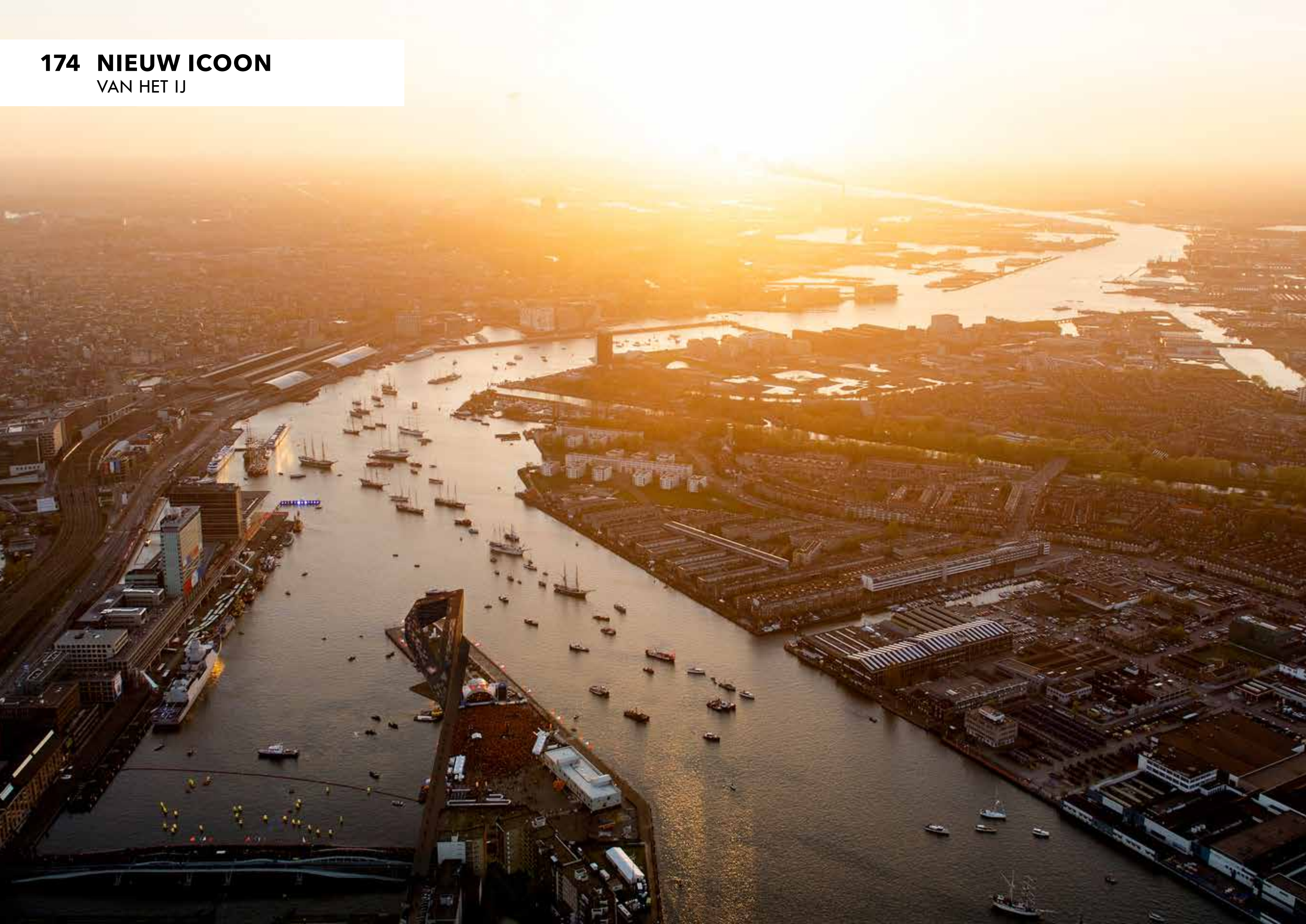



# 175 NIEUW ICOON

Van het IJ





# 176 NIEUW ICOON

Van het IJ

