





PILOT PAVILION

**for multifunctional public use
in East-Africa.**





FOREWORD

Rural areas in the Lake Victoria Region often lack regular water and energy supply and the inhabitants generally live in poor constructed houses in difficult climate conditions. Focussing on finding sustainable and locally available alternatives, by reinterpreting and introducing natural and sustainable resources in a new way.

Building a PAVILION, *-reacting on the sustainable and climate conditions of the Lake Victoria Region, while modifying it to the cultural and individual needs of the specific context-* step by step in accordance with the community.

In the form of this easy-to-read handbook, the local people will be empowered to understand the potentials of the Pavilion by means of explaining the single structural elements, and their requirements in the sequence of construction.

Simple drawings and schemes illustrate the building steps to be taken on site in order to build the Pavilion in collaboration with the community.^{*} The drawings not only serve as a communication tool, but also as an inspiration for other communities and as guidance for maintenance activities after the building phase in order to keep the building in good condition.

^{*}This manual will be developed into detail further on and can be changed after experiences on the construction phase / units will be changed.



CONTENT

Foreword	3
Content	4
Introduction	6
CONSTRUCTION SITE	
Team	7
Tools	8
CONSTRUCTION PROCESS: PAVILION	
<u>1 Pavilion</u>	9
<u>Foundation</u>	
1. Preparation construction site	10
2. Pile foundation	11
3. Foundation watertank	12
4. Strip foundation	13
<u>Primary bamboo structure</u>	
5. Bamboo columns	14
6. Horizontal bamboo poles	15
7. Reciprocal frame	18
<u>Secondary structure</u>	
8. Bamboo construction	20
9. Papyrus ceiling	21
10. Wood battens	22
11. Counter battens long	23
12. Counter battens short	24
<u>Roof</u>	
13. Roof edge capping	26
14. Rain pipe, watertank	27
15. Damp proof layer	28
16. Jute fabric	29
17. Ferrocement roof	30



CONTENT

Floor

18. Well compacted hardcore.	31
19. Bituminous felt paper	32
20. Compressed clay soil	33
21. Rammed earth floor	34

Optional: Walls

22. Exterior and Interior walls - closed, permeable, open	35
23. Windows, doors, plaster.	36

Optional: Water system

24. Drainage system, cover mat	37
--	----

Optional: Electricity

25. Electricity, solar panels	38
---	----

CONSTRUCTION PROCESS: MODIFICATION

<u>2 Pavilions</u>	39
------------------------------	----



INTRODUCTION

The PILOT PAVILION is designed to be reproducible and both simply and sustainably constructed by local people reinterpreting the use of local materials in the Lake Victoria region and fulfills several goals:

- * The pilot can be implemented into several areas around Lake Victoria
- Solutions and building techniques incorporated into the design should be communicated to the community, accepted, adopted and further developed by them
- The region deals with the tropical rainforest climate with heavy rainfalls during the rainy season, followed by a dry season with many sun hours. The building should create awareness of rainwater and solar energy collection, free sources that are available
- * People use eucalyptus for construction of their buildings. Eucalyptus is locally produced and a fast-growing wood, but it demonstrably harms the soil around as it consumes a high demand of water. For this reason bamboo is introduced as construction material, growing in different forests in the region but not used as construction material. Bamboo is growing rapidly and is a sustainable, natural and endless resource. The material is pretty lightweight, has a tensile strength comparable to steel and a compressive strength even higher than concrete.
- The building system will show how to incorporate sustainable cycles into architecture.
- * The multifunctional building is supposed to fulfil a social function therewith reacting on socio-cultural and economic problems of the region.
- Workers have knowledge of the building system and facilities in order to maintain it.
- * The pavilions can be featured, clustered and copied in many ways according to the individual context.



Lake Victoria and surrounding countries



CONSTRUCTION SITE

TEAM

The construction team building the PAVILION consists of skilled and unskilled workers. The amount of workers depends on the time schedule, the weather conditions and the number of pavilions that will be built.

Common experts needed on the construction site:

* A local contractor has to be responsible for the different construction steps and guide the individual employees. The contractor knows the availability of materials and suppliers in the area.

* If the local circumstances allow it, an electrician is needed to connect the building to the electricity grid.

For the installation of solar panels an solar panel expert is needed, to install the panels on the roof and the connection to the inverter and battery.

* To guide and store the rain water that will be collected from the roof a water system has to be installed. The rain water should be filtered and be led to the waterstorage tank, from which it can be pumped to the water source. A constant water quality and temperature have to be assured.

Less common experts needed on the construction site:

* The bamboo expert is responsible for the selection procedure, the supply of well-treated bamboo and the processing of the material. The 'Kenya Bamboo Centre' is located in Nairobi, from where employees have the willingness to join the construction site.

* The ferrocement expert has to guide the mixing procedure of the different ferrocement layers and the water resistant additions.

It is important that the experts involved in the construction phase transfer their knowledge to the local people/workers, which offers the local people the possibility to resolve the small problems themselves.



Contractor



Electrician / Solar panels



Water system



Bamboo expert



Ferrocement expert



CONSTRUCTION SITE

TOOLS

Different tools are needed for the construction phase, especially for the further processing of bamboo and ferrocement special tools are required.



- 1 generator
- 2 work bench
- 3 horizontal + rope
- 4 shovel
- 5 cement mixer

- 6 wood saw
- 7 metal saw
- 8 drill
- 9 drill bit (length > 3 bambo poles)
- 10 drill bit, grater

- 11 sander
- 12 pliers
- 13 wrench
- 14 trowel
- 15 hammer



CONSTRUCTION PROCESS

1 PAVILION

The following pages illustrate and explain the 25 consecutive building steps leading to the construction of one Pavilion. Steps 22 to 25 are optional and therefore variable according to the circumstances and desired requirements.

The sequence of the steps serves as a guideline for the activities on the construction site.

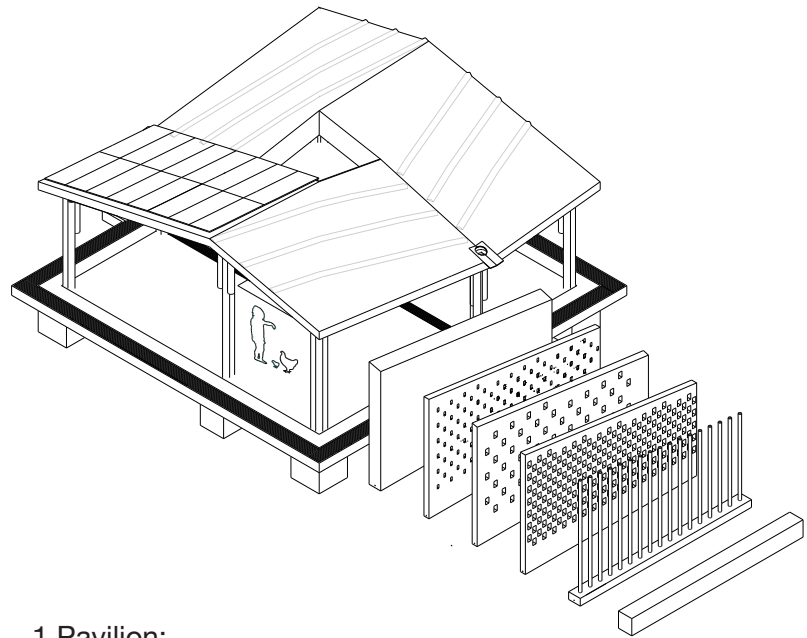

1 Pavilion:

Ground surface: 71,40 m²

Roof surface: 67,90 m²

Lowest point roof: 2.56 m

Highest point roof: 3,99 m



1 FOUNDATION / Preparation construction site

Preparation construction site

- Preparing the construction tools
- Determine the orientation of the building
- Measuring the site
- Marking the building plot and the height of the building. (outdoor area, gradient of 2% away from the building)

Element

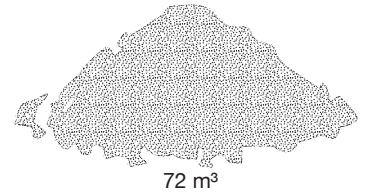

Material

Excavation of the vegetation and ground.

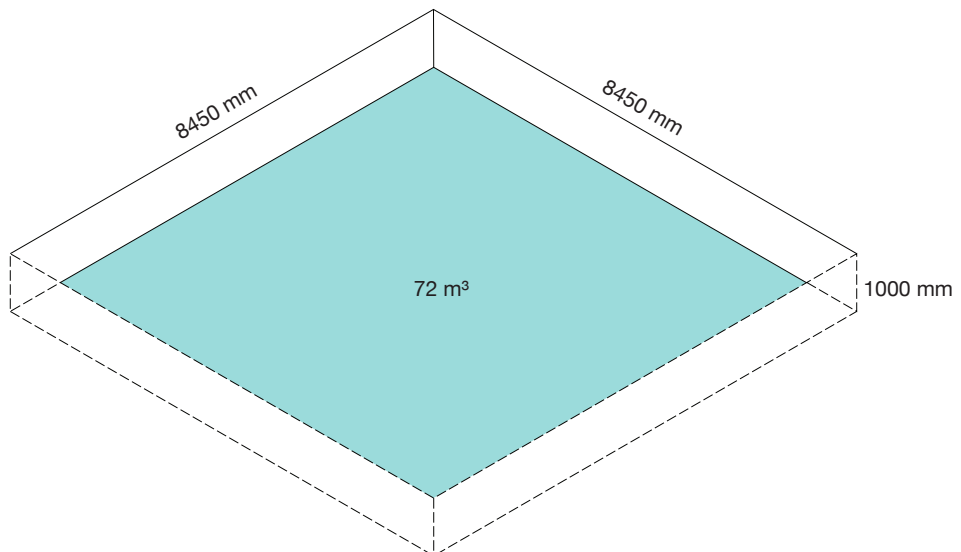



FOUNDATION / Pile foundation 2

Element

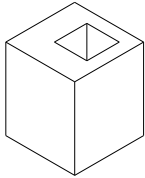

corner: 850 x 850 x 1000 mm
4x

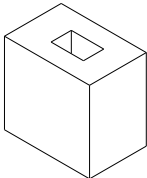

middle: 700 x 1050 x 1000 mm
4x

Pile foundation

Connects the structure to the ground and transfers loads to the ground

- Mix the cement
- Pour the footing

Material

Concrete proportion:

Cement	Sand	Ballast
(50 kg)	(wheelbarrow)	(wheelbarrow)
1	: 2	: 4

Addition: Water

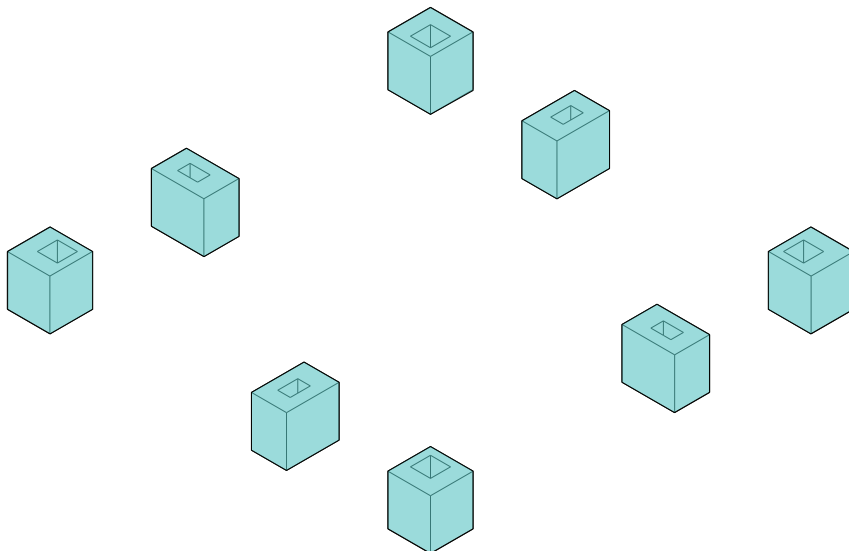



3 FOUNDATION / Foundation water tank

Foundation watertank

Collected water will be led to the water storage underneath ground level in the middle of the building

-Water or a standard water storage tank of 5000L fits in the foundation

Material

Concrete proportion:

Cement (50 kg)	Sand (wheelbarrow)	Ballast (wheelbarrow)
1	: 2	: 4

Addition: Water

Element

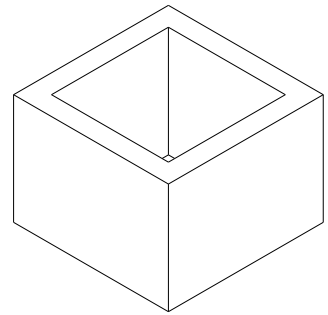

2450 x 2450 x 1750 mm

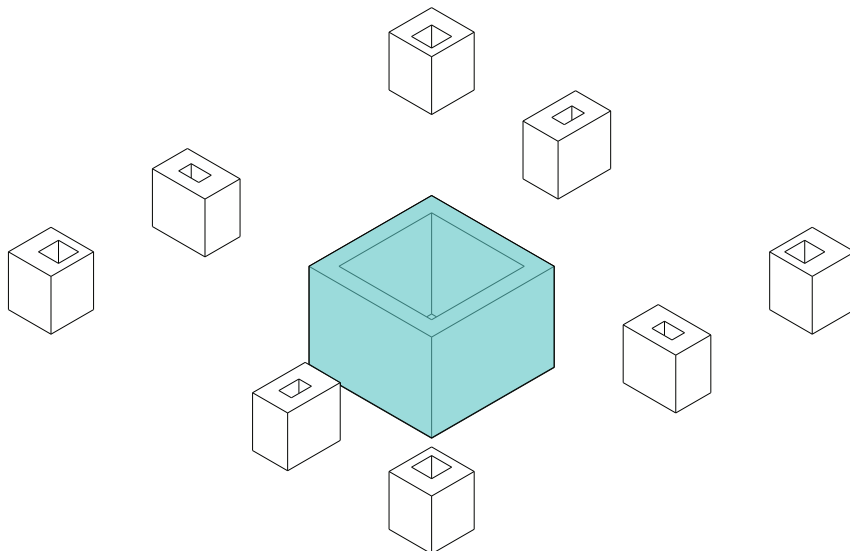



FOUNDATION / Strip foundation 4

Element

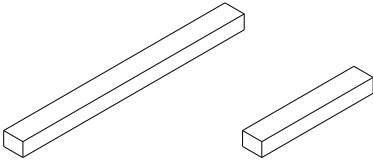

outside long: 350 x 250 x 4025 mm

4x

outside short: 350 x 250 x 2025 mm

4x

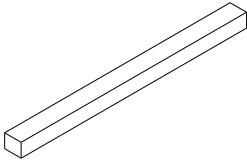

middle: 300 x 250 x 4100 mm

4x

Fabrication strip foundation

The strip foundation provides the base for (possible) interior and exterior walls and allows future changes

Material

Concrete proportion:

Cement (50 kg)	Sand (wheelbarrow)	Ballast (wheelbarrow)
1	:	2
	:	4

Addition: Water

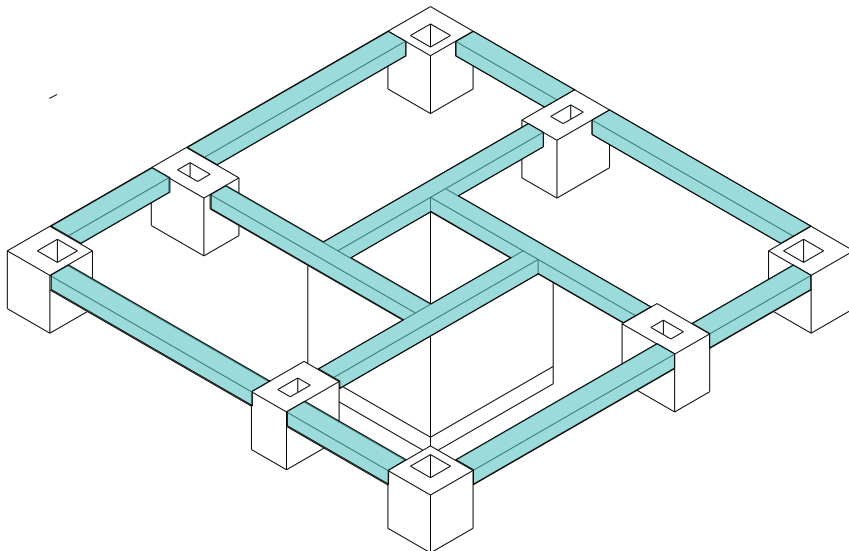



5 PRIMARY BAMBOO STRUCTURE / Bamboo columns

Bamboo columns

- Indigenous Yushania alpina specie
- Bamboo poles \varnothing 150 mm
- Selecting straight bamboo poles without cracks
- Bamboo has to be treated 3 months before with chemicals, e.g. borax and boric
- Holes should be drilled around the nodes

Material

Securing bamboo: Bolts M10, washer, nuts

Element (assembling page 16+17)

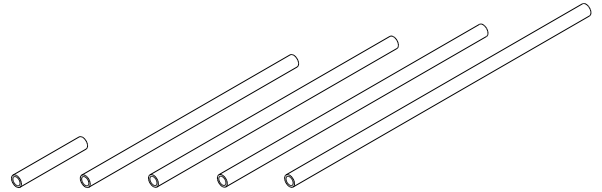

\varnothing 150 mm	
L = 1030 mm	12x
L = 3250 mm	4x
L = 3515 mm	6x
L = 3875 mm	6x
L = 4575 mm	4x

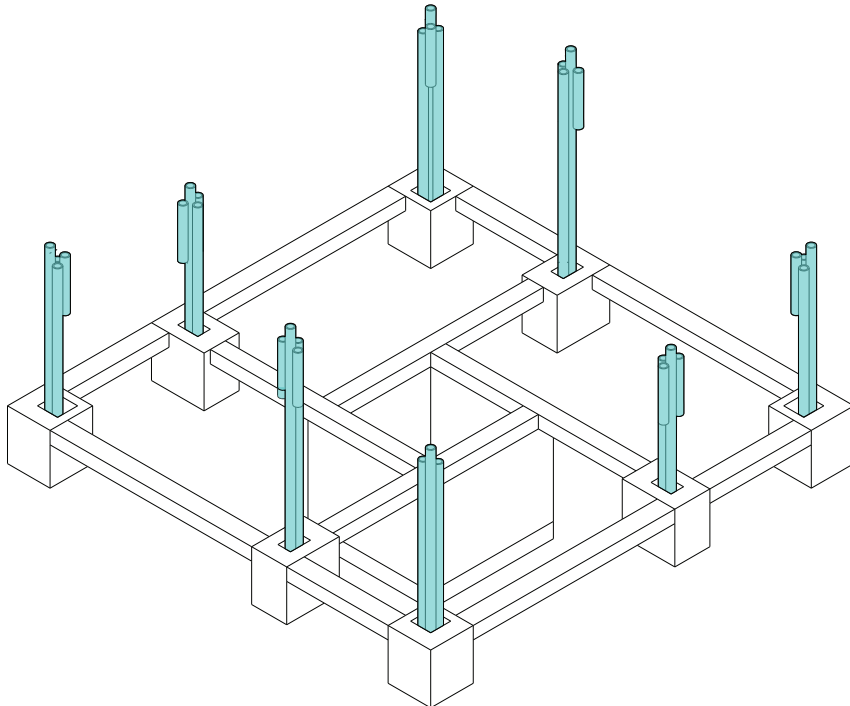



PRIMARY BAMBOO STRUCTURE / Horizontal bamboo poles

6

Element (assembling page 16+17)

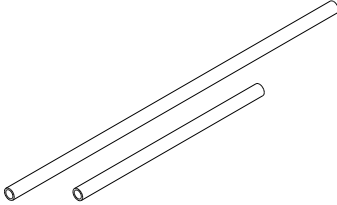

Ø 150 mm

L = 2800 mm

8x

L = 4800 mm

8x

Horizontal bamboo poles

- Indigenous *Yushania alpina* specie
- Bamboo poles Ø 150 mm
- Selecting straight bamboo poles without cracks
- Bamboo has to be treated 3 months before with chemicals, e.g. borax and boric
- Holes should be drilled around the nodes

Material

Securing bamboo: Bolts M10, eye bolts, washer, nuts

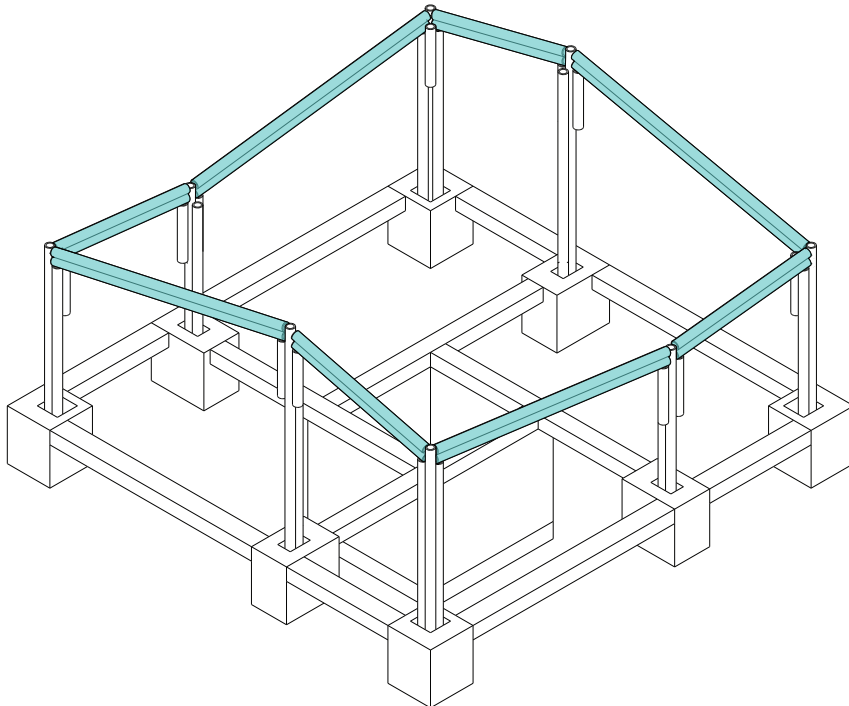



ASSEMBLING BAMBOO FRAME A

2X Frame A

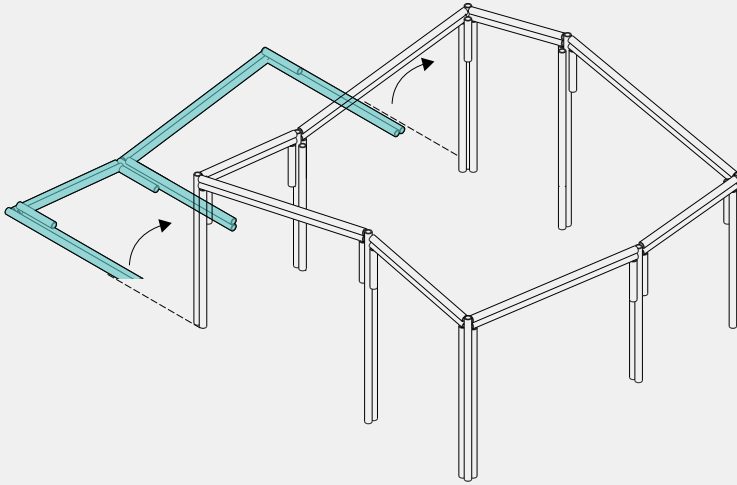

All underlined bamboo measurements have a fish-mouth, which guarantees an actuated/frictional connection.

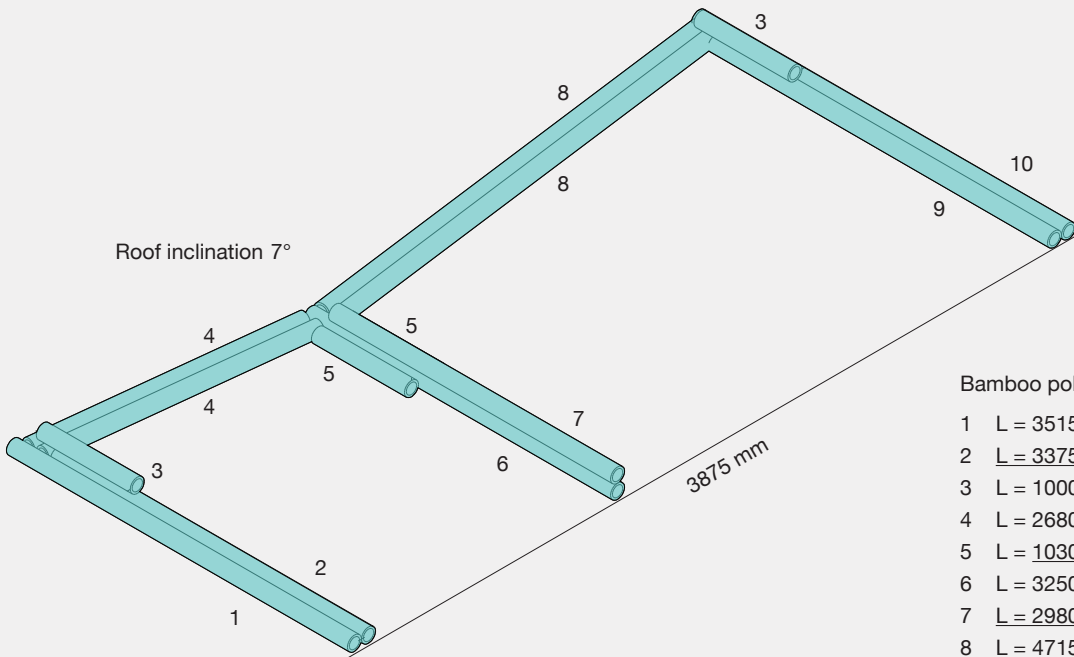
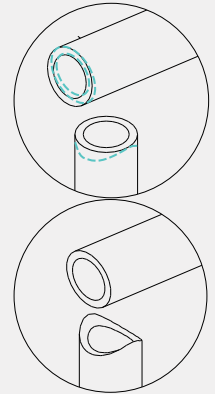

Bamboo poles

1	L = 3515 mm	1x
2	<u>L = 3375 mm</u>	1x
3	L = 1000 mm	2x
4	L = 2680 mm	2x
5	L = <u>1030 mm</u>	2x
6	L = 3250 mm	1x
7	<u>L = 2980 mm</u>	1x
8	L = 4715 mm	2x
9	<u>L = 3730 mm</u>	1x
10	L = 3875 mm	1x



ASSEMBLING BAMBOO FRAME B

2X Frame B

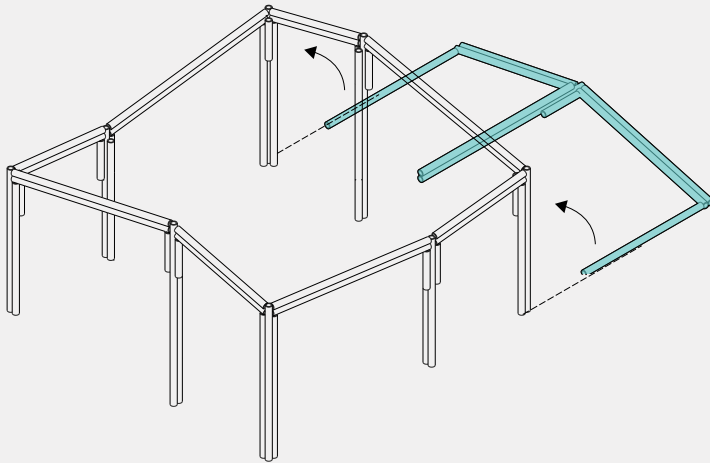

All underlined bamboo measurements have a fish-mouth, which guarantees an actuated/frictional connection.

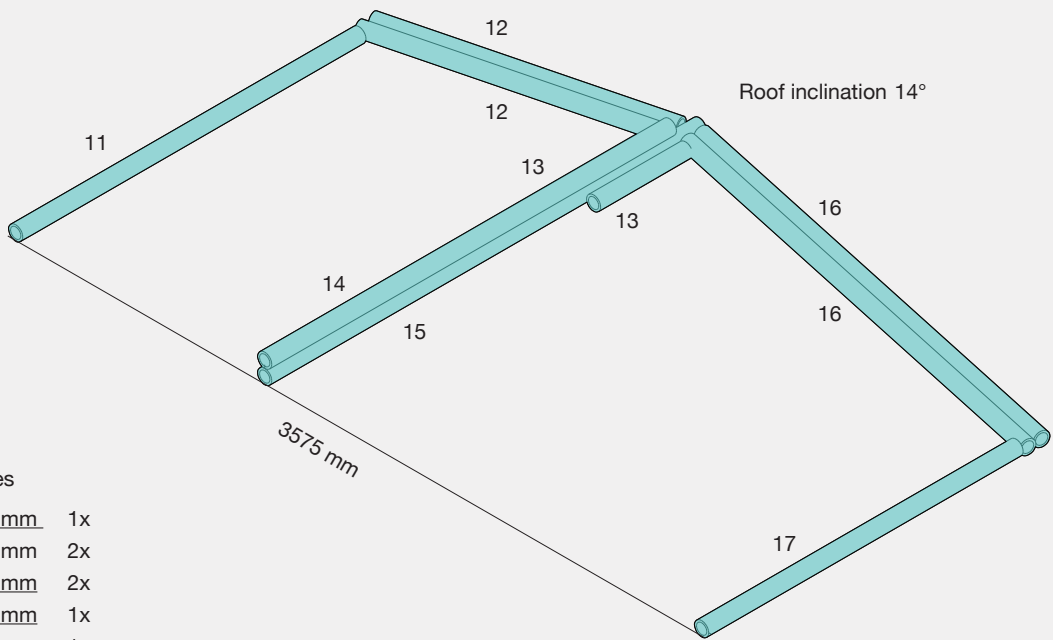
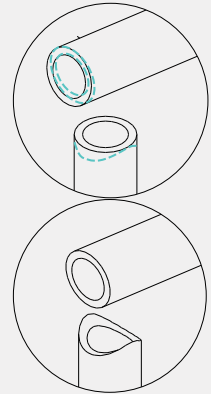

Bamboo poles

11	<u>L = 3795 mm</u>	1x
12	L = 2770 mm	2x
13	<u>L = 1030 mm</u>	2x
14	<u>L = 4285 mm</u>	1x
15	L = 4575 mm	1x
16	L = 4805 mm	2x
17	<u>L = 3425 mm</u>	1x



7 PRIMARY BAMBOO STRUCTURE / Reciprocal frame

Reciprocal frame

- Indigenous Yushania alpina specie
- Bamboo poles \varnothing 150 mm
- Selecting straight bamboo poles without cracks
- Bamboo has to be treated 3 months before with chemicals, e.g. borax and boric
- Holes should be drilled around the nodes

Material

Securing bamboo side: Bolts M10, washer, nuts

Securing bamboo middle: steel wire \varnothing 2 mm + rubber ring

Securing bamboo pair: Bamboo sticks \varnothing 10 mm

Element (assembling page 19)

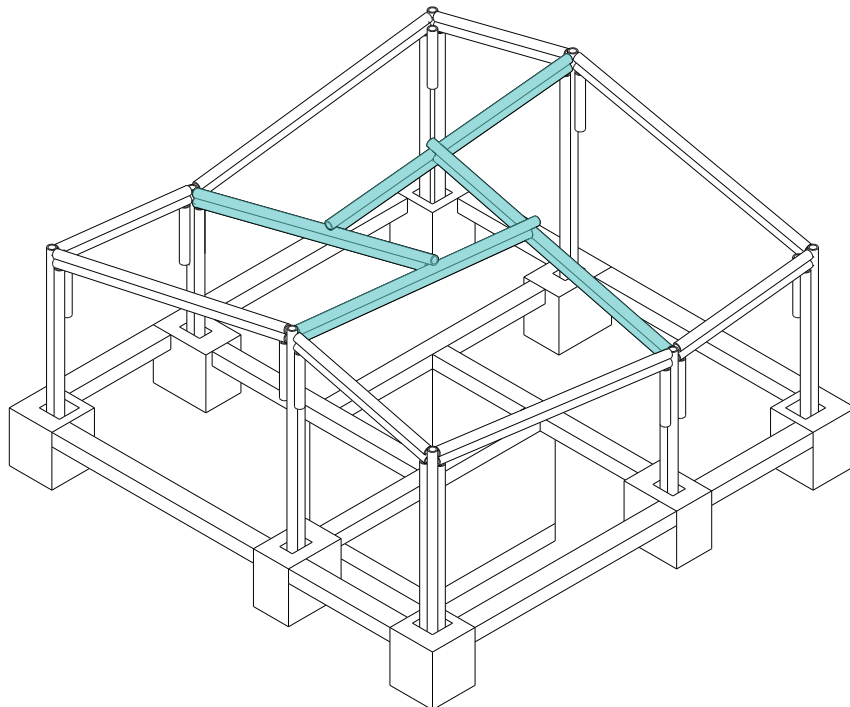
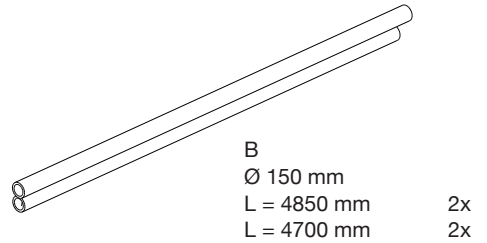
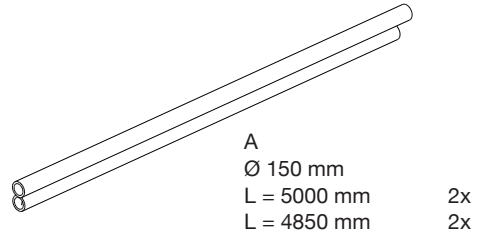



ASSEMBLING RECIPROCAL FRAME

Reciprocal frame

In order to assemble the reciprocal frame, two support columns are needed to position the pairs of bamboo and can be removed after the last pair of bamboo. A rubber ring is placed in between the bamboo pairs in order to avoid shifts and steel wire is wrapped around to reinforce the connection.

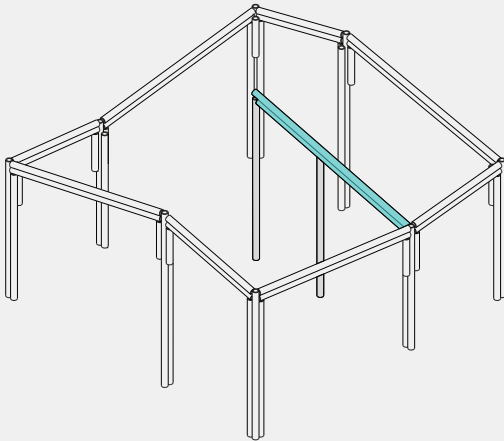

Step 1, A - roof inclination 14°

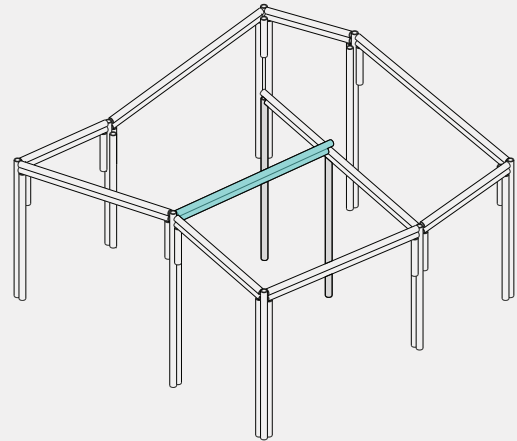

Step 2, B - roof inclination 6°

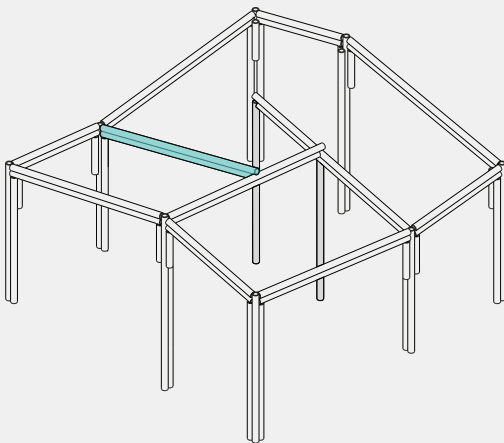

Step 3, A - roof inclination 14°

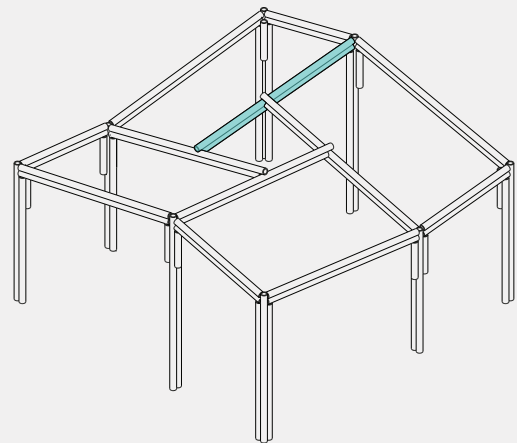

Step 4, B - roof inclination 6°



8 SECONDARY STRUCTURE / Bamboo construction

Bamboo construction

- Indigenous Yushania alpina specie
- Bamboo poles \varnothing 75 mm
- Selecting straight bamboo poles without cracks
- Bamboo has to be treated 3 months before with chemicals, e.g. borax and boric
- Holes should be drilled around the nodes

Element

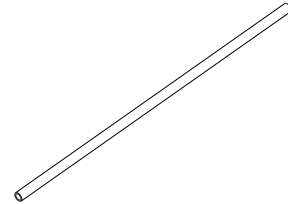

\varnothing 75 mm
L = 2850 mm

44x

Material

Securing bamboo side: Bolts M10, washer, nuts

Securing bamboo middle: steel wire \varnothing 2 mm

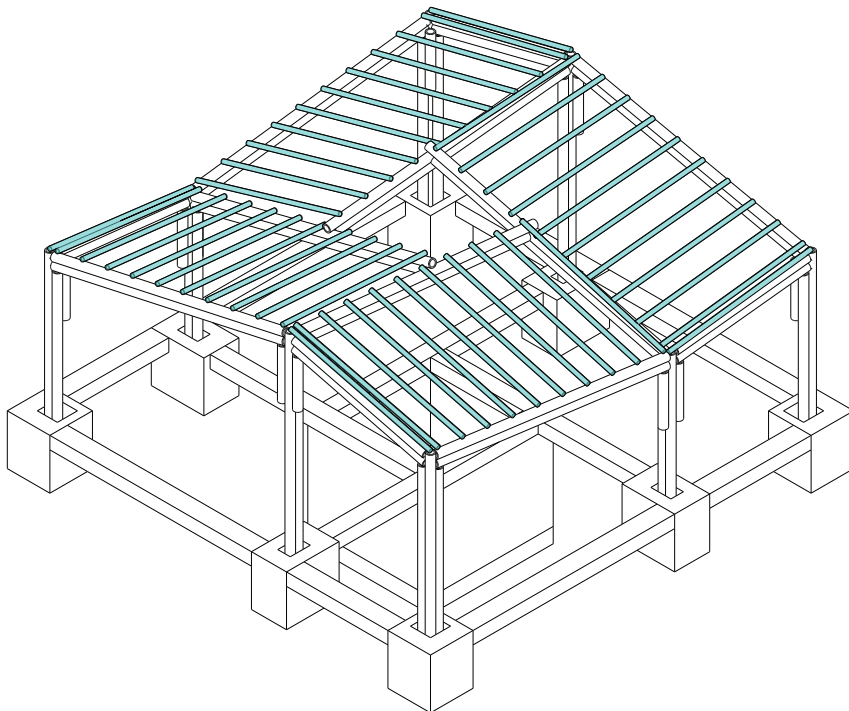



SECONDARY STRUCTURE / Papyrus ceiling

9

Element

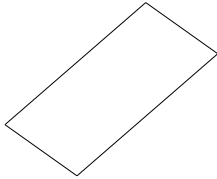

Available in different sizes
68 m²

Papyrus ceiling

- Papyrus mat is commonly used for ceilings
- Protects against mosquitoes and other insects

Material

Securing papyrus ceiling: nailed

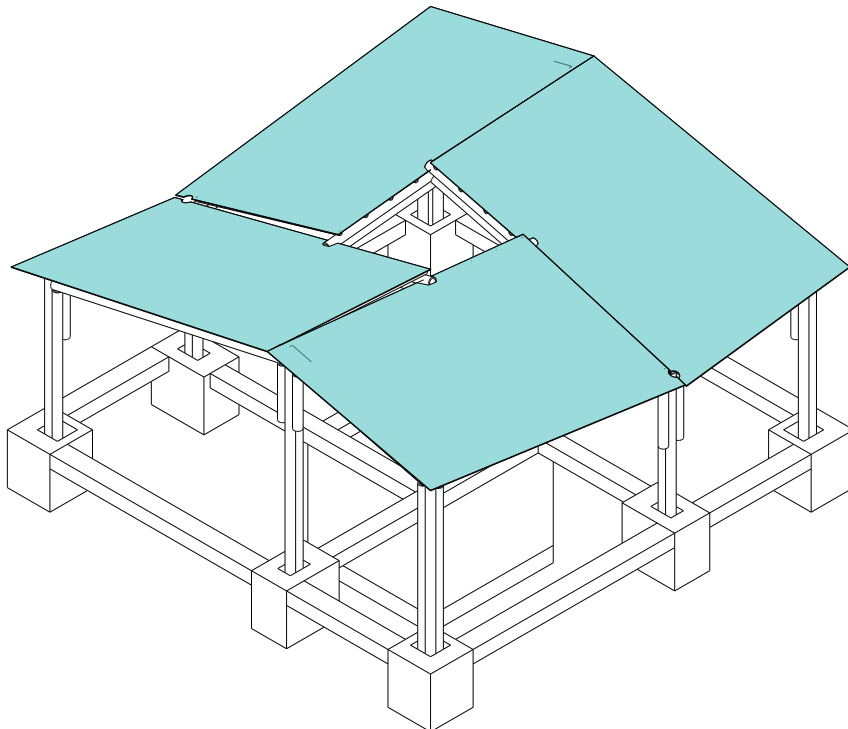



10 SECONDARY STRUCTURE / Wood battens

Wood battens

- Important to use dry wood
- Forms the underlayer for the balancing layer on top

Element

Material

Securing: nailed

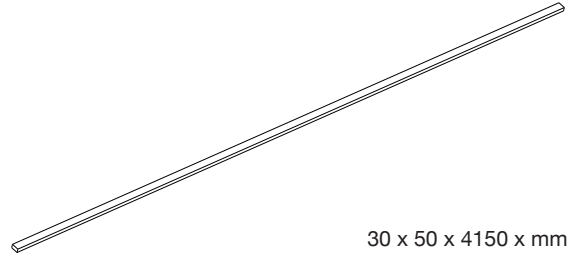

30 x 50 x 4150 x mm
24x

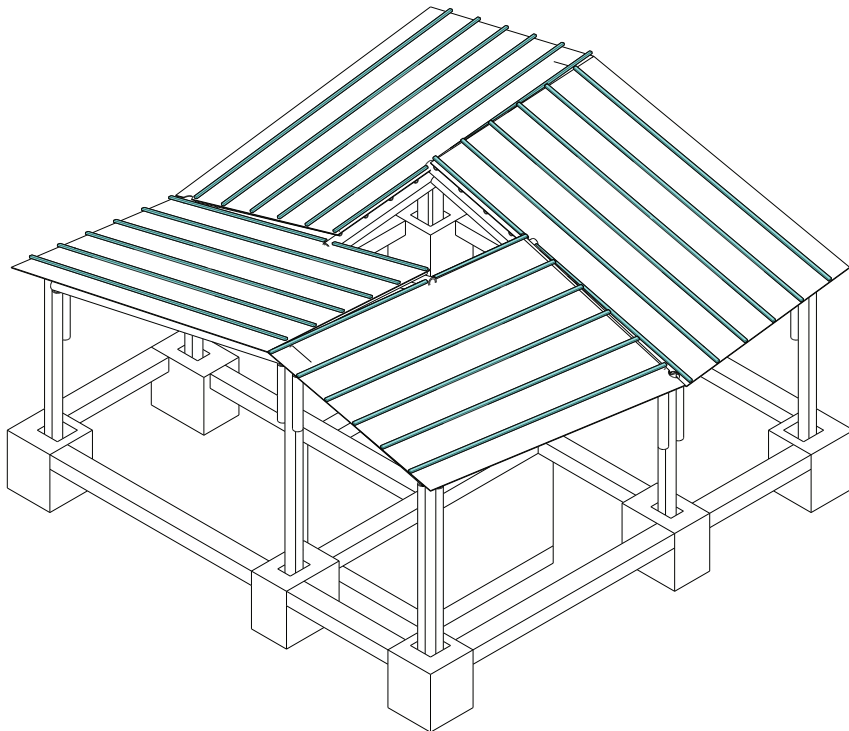



SECONDARY STRUCTURE / Counter battens long 11

Element (assembling page 25)

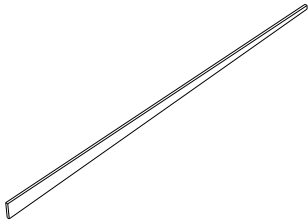

Long: min 30 (max 170) x 20 x 3370 mm
44x

Counter battens long

- Important to use dry wood
- Forms the balancing layer between the main bamboo construction and the finishing ferroce-ment roof in order to protect the bamboo
- The counter battens decline height to a min of 30 mm

Material

Securing: nailed

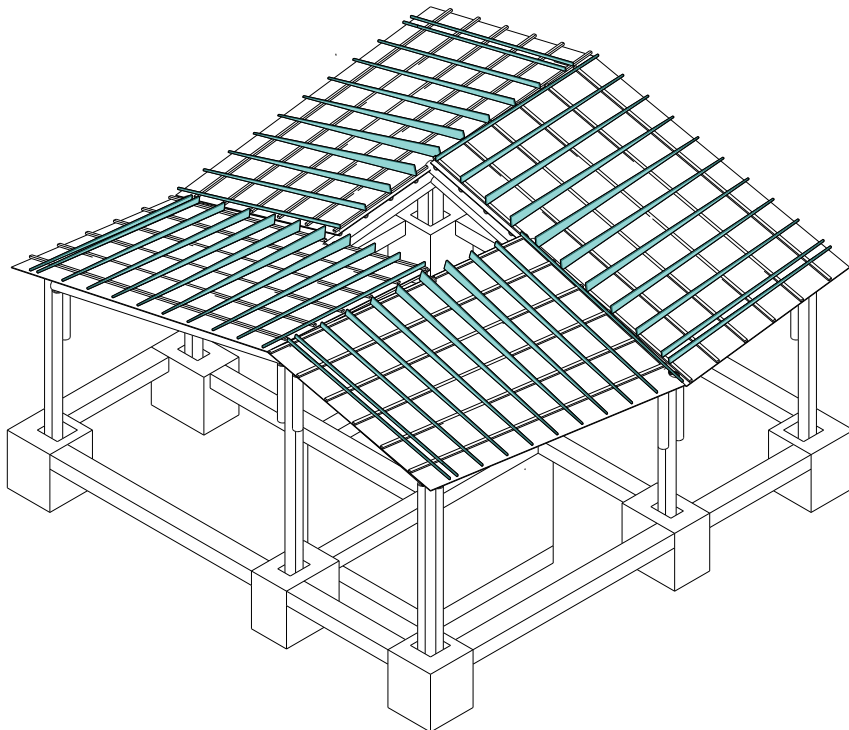



5 12 SECONDARY STRUCTURE / Counter battens short

Counter battens long

- Important to use dry wood
- Forms the balancing layer between the main bamboo construction and the finishing ferroce-ment roof in order to protect the bamboo
- The counter battens decline height to a min of 30 mm

Element

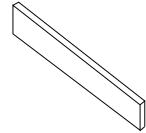

Short: min 30 (max 170) x 20 x 500 mm
240x

Material

Securing: nailed

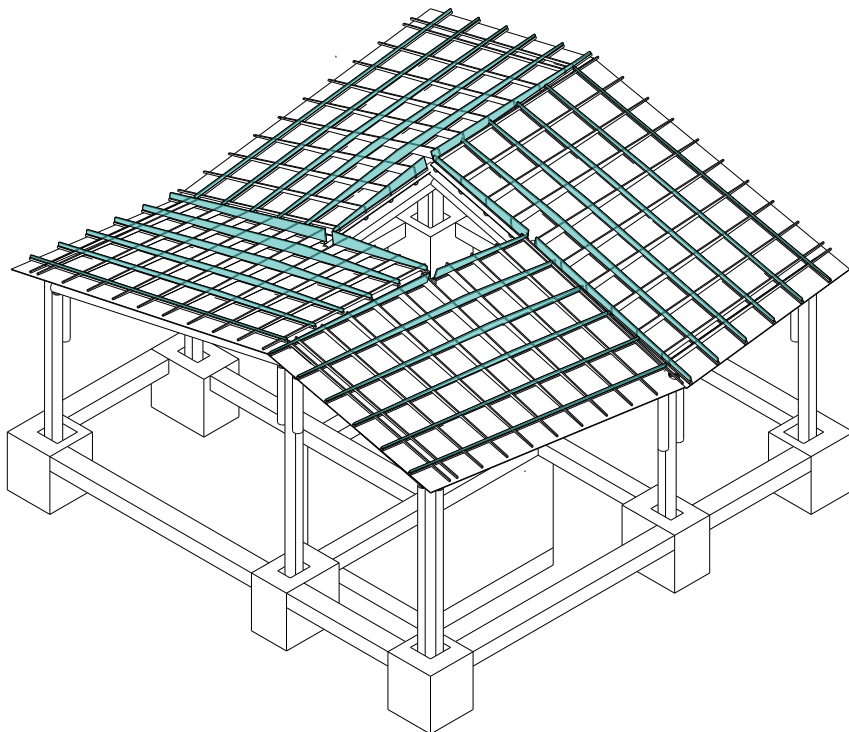



COUNTER BATTENS

- Every counter batten appears two times
The wooden board can be cut half with the right dimensions.

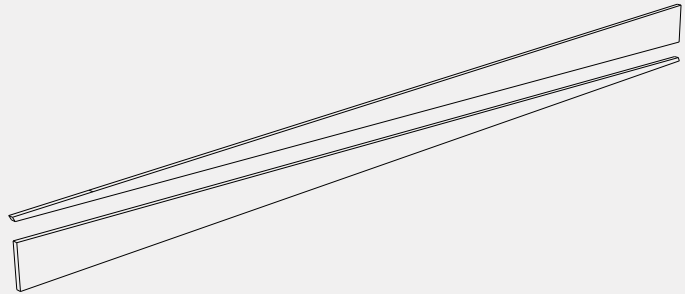

- The marked points where the roof surfaces connect have to be positioned in the same layer. The counter battens should balance these height differences creating a smooth surface.

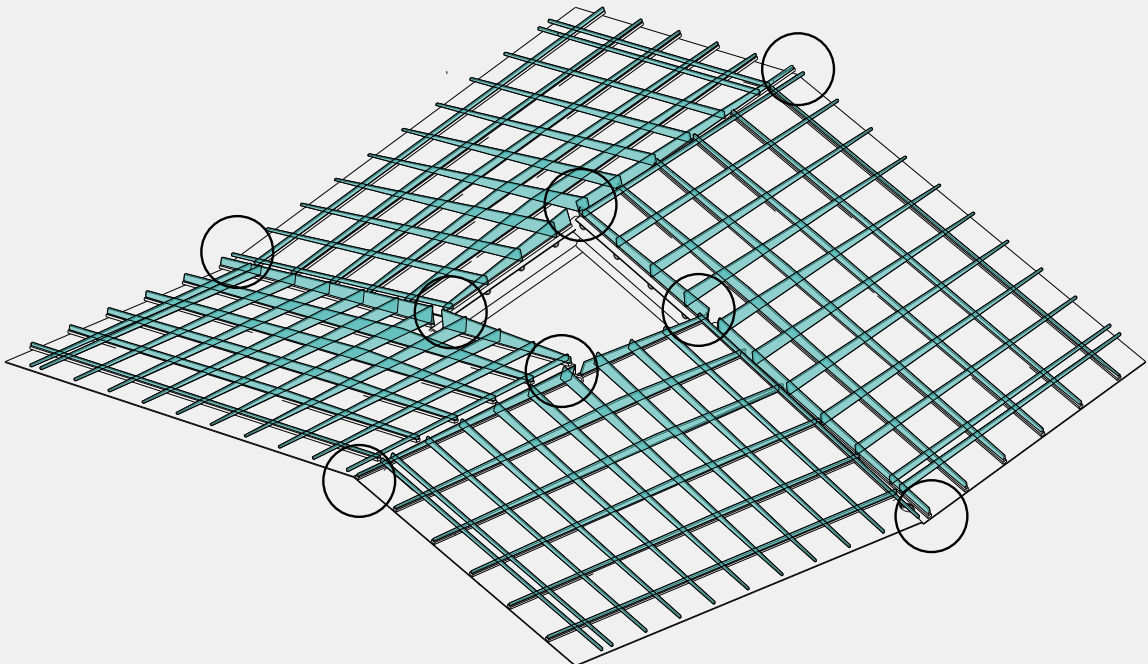



13 ROOF / Roof edge capping

Roof edge capping

- Protects the main bamboo construction and wall against rain
- Metal plate leads the water from the lowest roof-point to the ground

Material

Securing: screws

Element

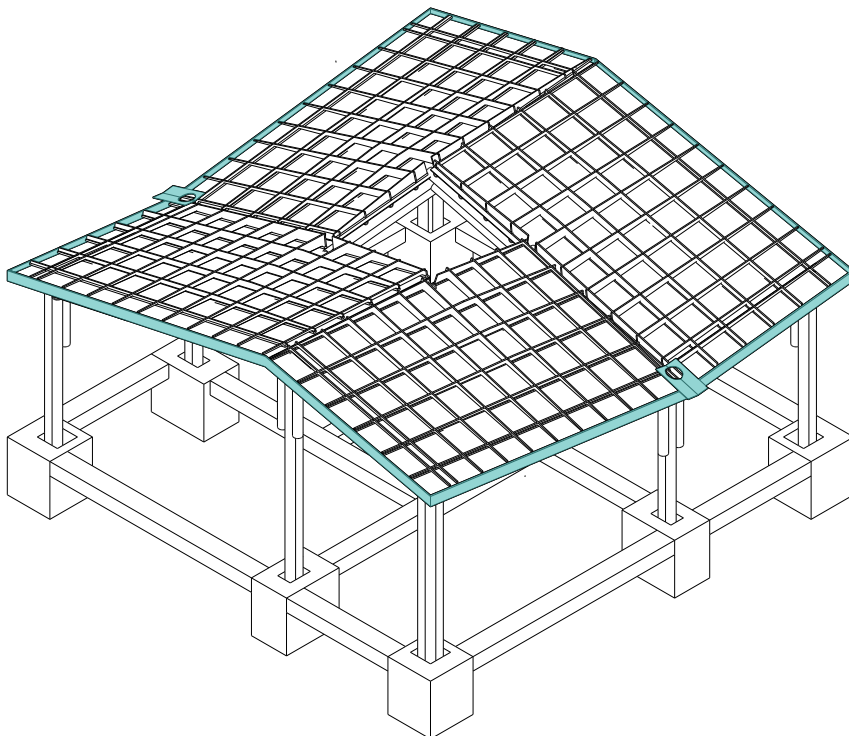
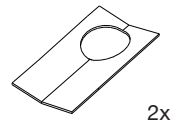
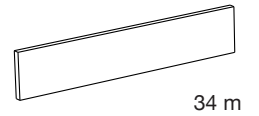



ROOF / Rain pipe, watertank 14

Element

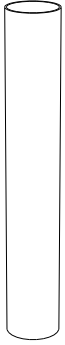

Ø 160 mm

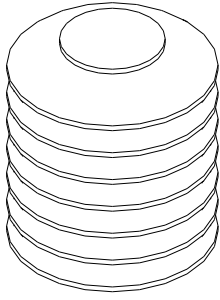

5000 L

Rain pipe, watertank

- Rain pipe leads the collected rain water from the roof to the storage tank, located underneath the building

Material

Securing: clamps

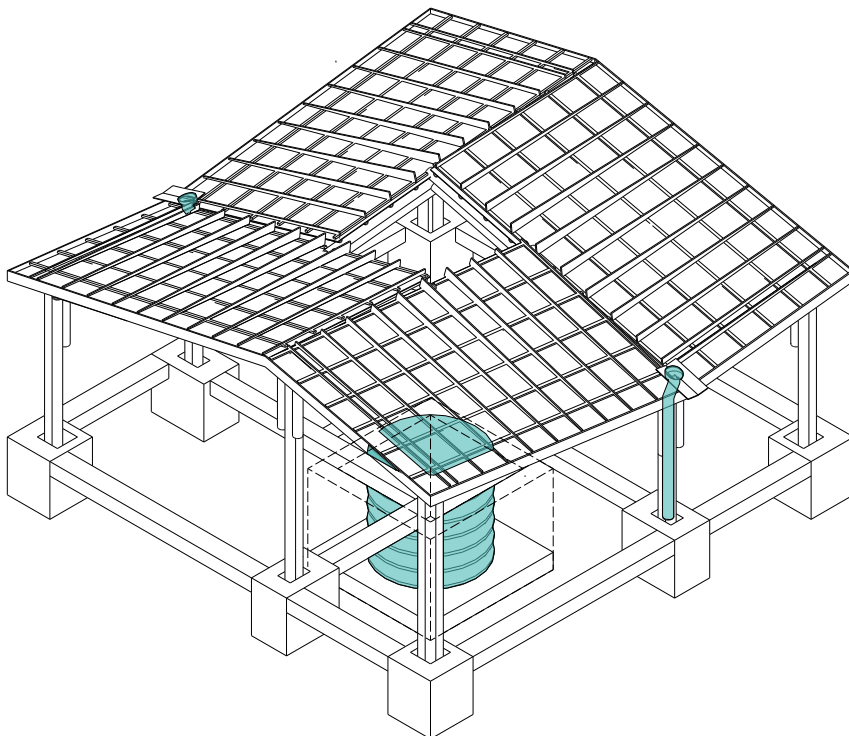



15 ROOF / Damp proof layer

Damp proof layer

- Moisture control, prevents moisture to pass into the construction and interior

Material

Securing: nails

Element

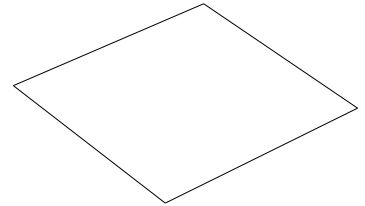

72 m²

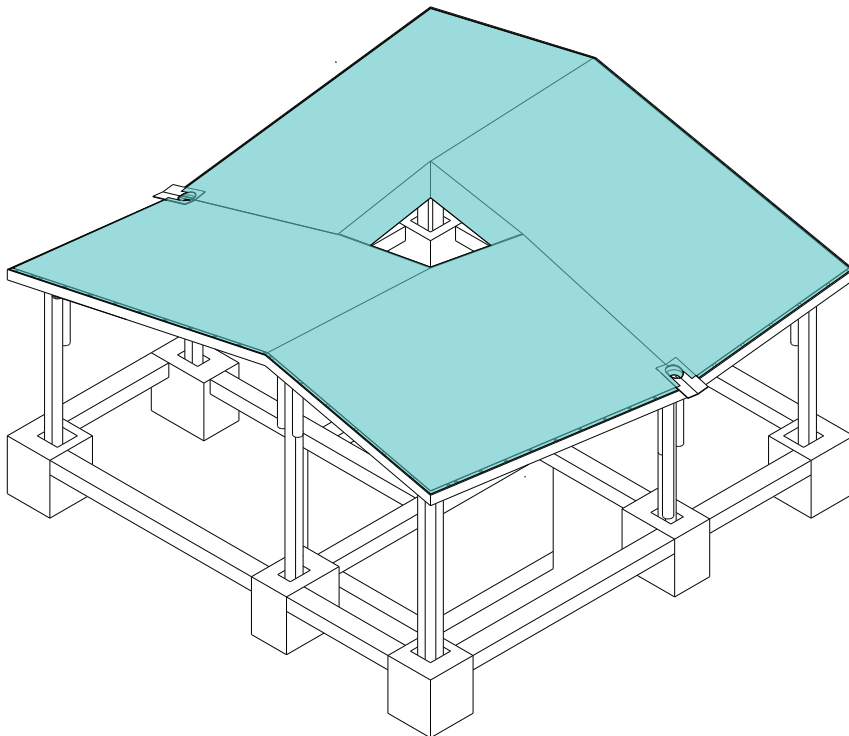



Element

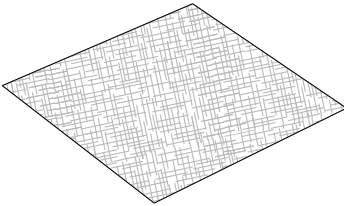

5 mm thickness, 72 m²

Jute fabric

- The jute fabric has to be stretched over the wooden counter battens and serves as underlayer for the ferrocement to stick on

Material

Securing: nails

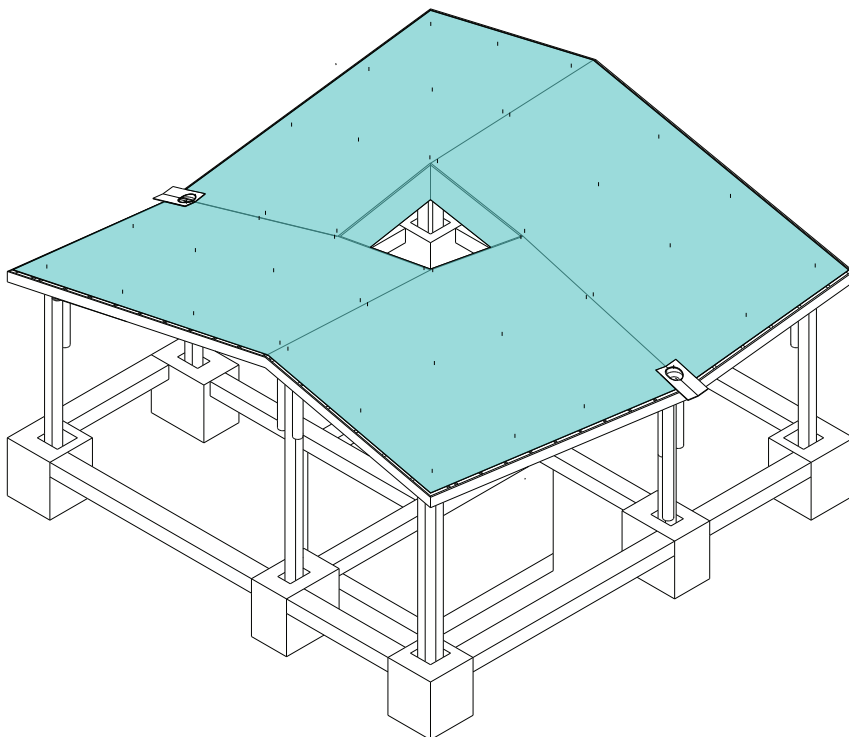



17 ROOF / Ferrocement roof

Ferrocement roof

- The ferrocement roof consists of one layer of welding mesh/chicken wire and 3 layers of ferrocement
- To make the roof water resistant, the last layer has to be mixed with latex/acrylic
- The roofshape follows the underlying structure, which also marks the drainage direction
- It is important that the welding mesh/chicken wire is covered by ferrocement to prevent corrosion

Element

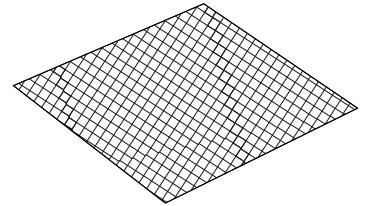

chicken wire, 72 m²
ferrocement 30 mm, 72 m²

Material

Securing: staples

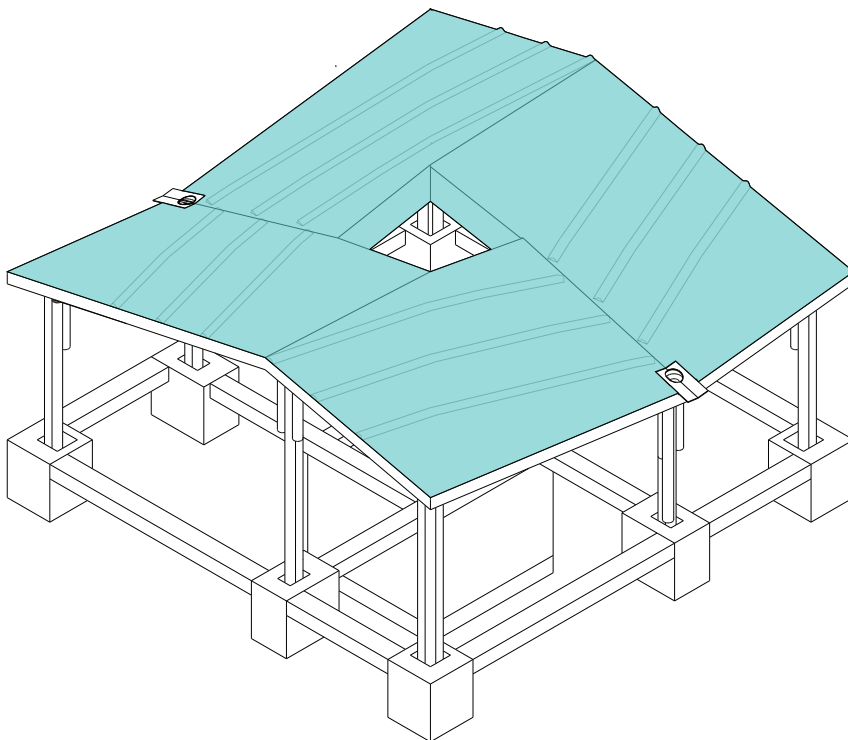



FLOOR / Well compacted hardcore 18

Element

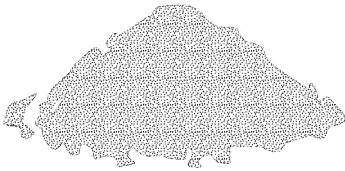

7,5 m³

Well compacted hardcore

- Well compacted hardcore has to be placed between the strip foundation
- Hardcore layer interrupts capillary action
- Thickness 150 mm

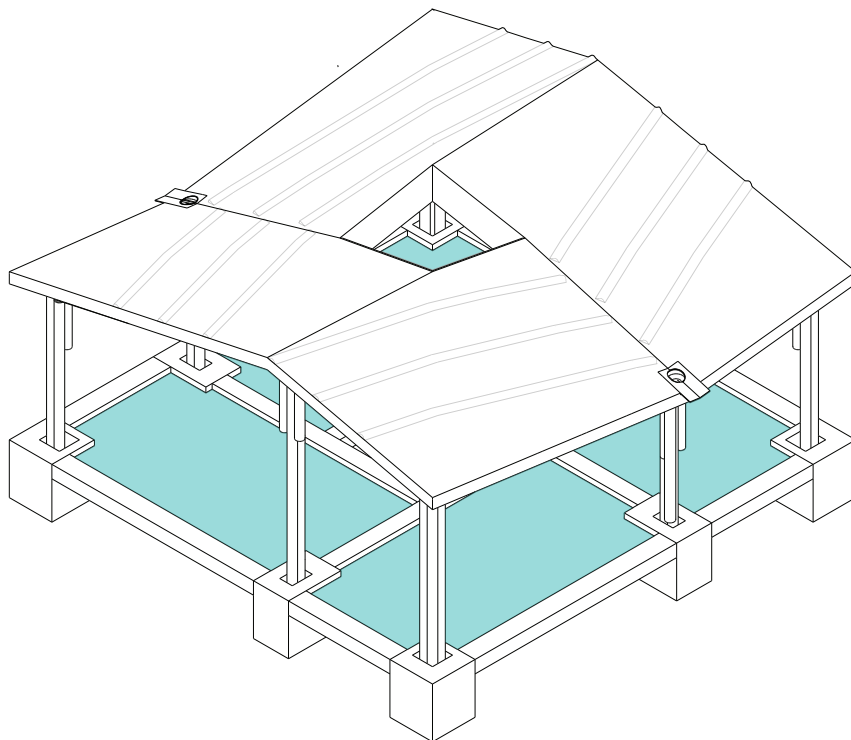



19 FLOOR / Bituminous felt paper

Drainage system, bituminous felt paper

- Masonry layer 200 mm, protection against water and serves as frame for the rammed earth floor
- Bituminous felt paper prevents moisture to pass into the construction and interior

Element

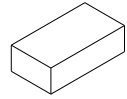

brick

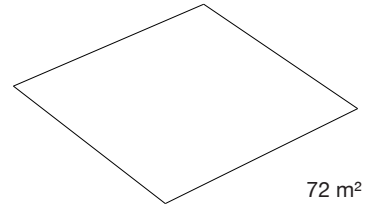

72 m²

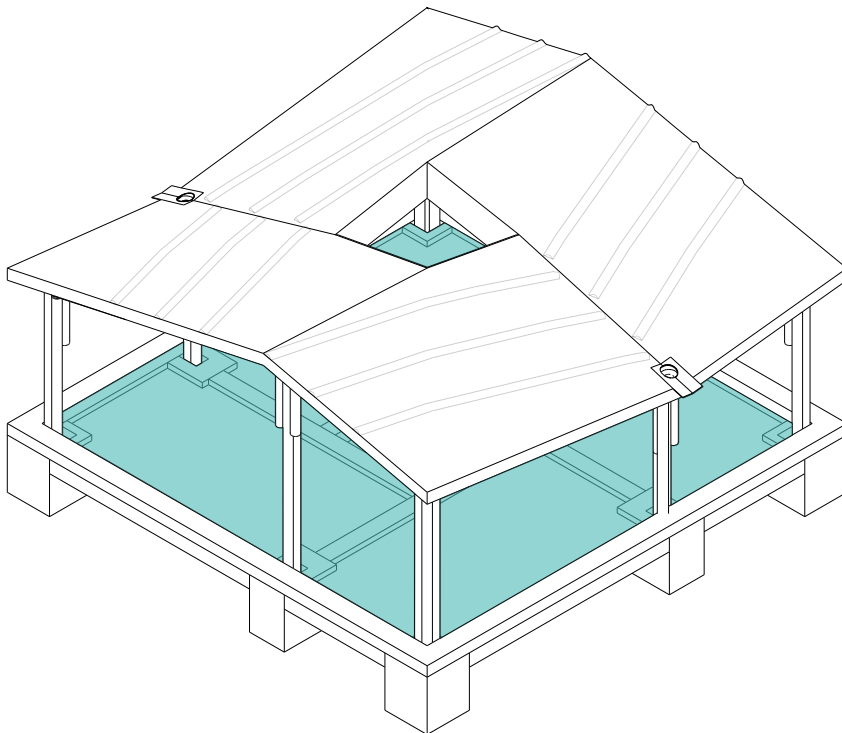



Element

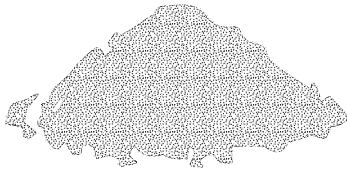

5 m³

Compressed clay soil

- The compressed clay soil has be placed on top of the bituminous felt paper.
- Acts as thermal insulation.
- Thickness 100 mm.

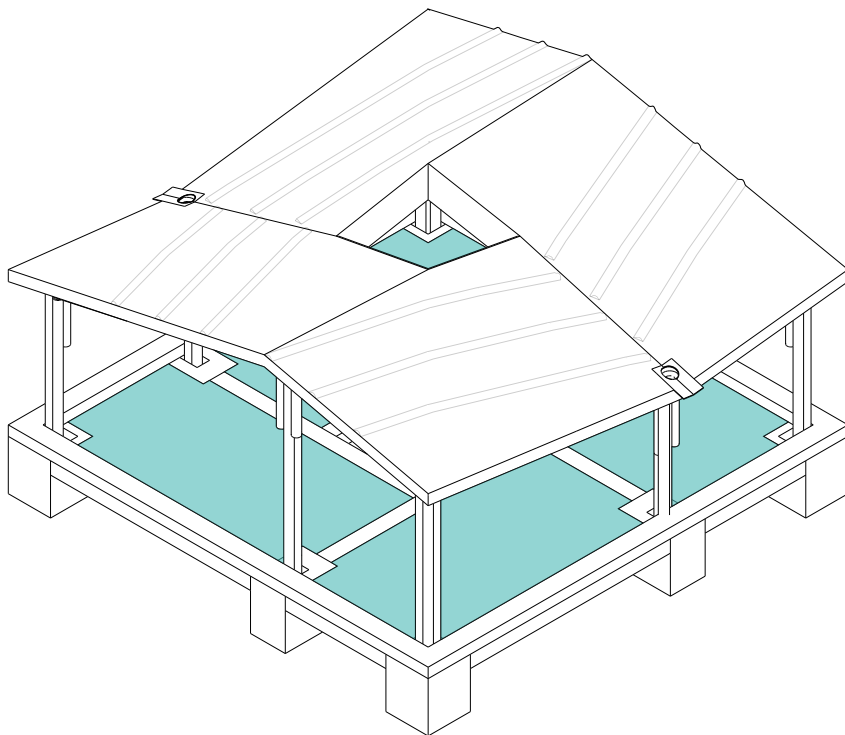



21 FLOOR / Rammed earth floor

Rammed earth floor

- The rammed earth floor consist of three layers rammed earth 60 mm - 60 mm - 80 mm
- Thickness 200 mm
- Top coat: 2mm hard wax layer

Material

After the rammed earth is completely dry, the surface has to be waxed (2mm) which increases the durability and lustre

Element

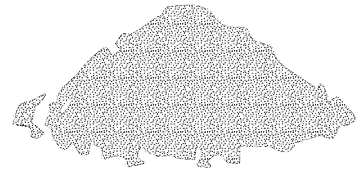

10 m³

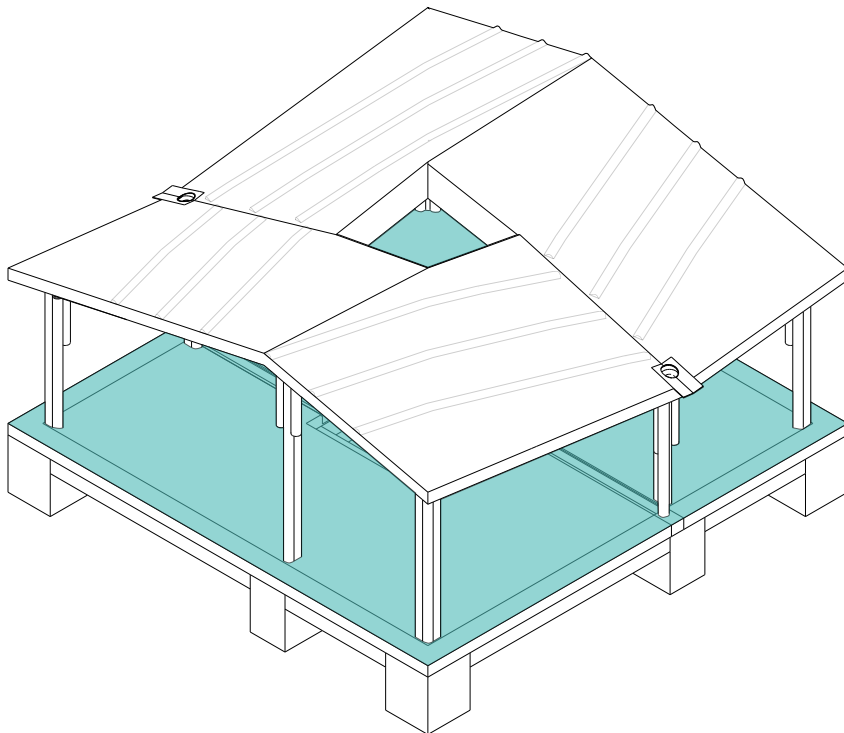



OPTIONAL: WALLS / Exterior and Interior walls 22

Element

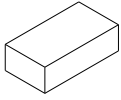

brick

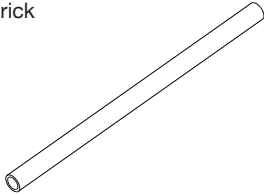

bamboo

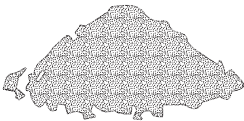

rammed earth

Exterior and Interior walls

- The exterior and interior walls are not load-bearing and can therefore be chosen according to individual needs
- The wall can be either completely closed, different levels of permeability or completely open

Material

Mortar proportion:

Cement	:	Sand	Water
(50 kg)		(wheelbarrow)	
1		3	

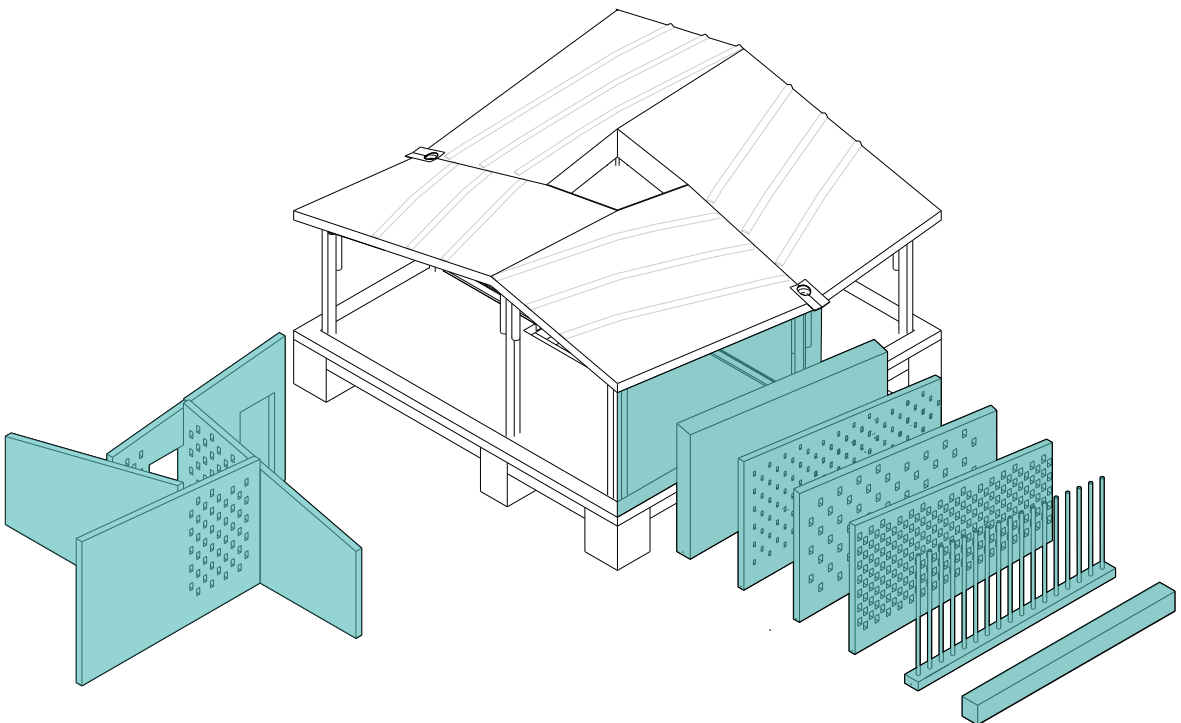



23 OPTIONAL: WALLS / Windows, doors, plaster

Water system cover, windows, doors, plaster

Element

- Removable bamboo mat to cover the drainage system
- Dependent on the function, steel or wooden doors and windows can be placed

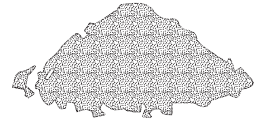

Material

Plaster proportion:

Cement	Sand	Water
(50 kg)	(wheelbarrow)	
1	: 3	

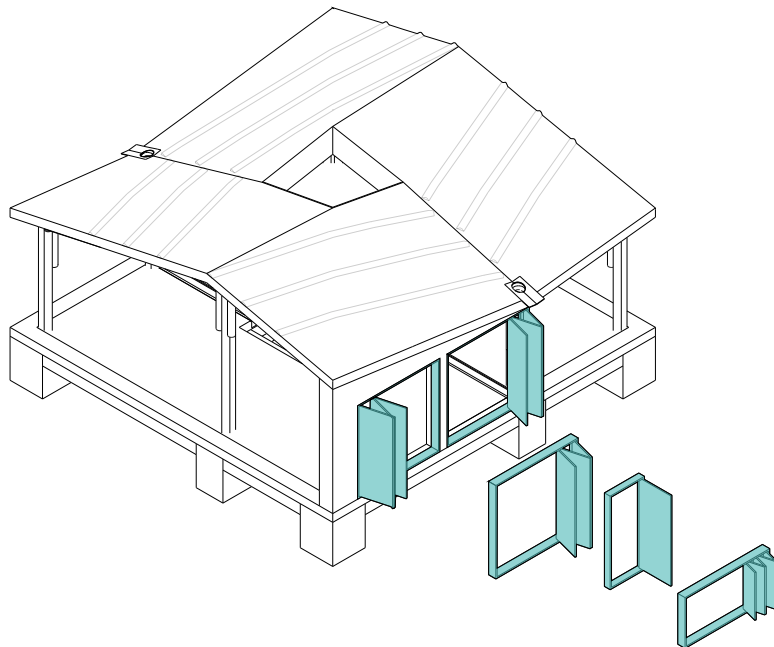



OPTIONAL: WATER SYSTEM / Drainage system, cover mat 24

Element

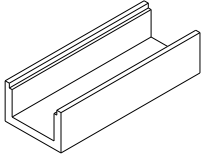

300 x 250 mm
L = 34m

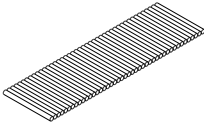

bamboo mat
Ø 20 mm

Water system cover, windows, doors, plaster

- Drainage system collects the water from the surrounding to avoid water in the building
- Removable bamboo mat to cover the drainage system

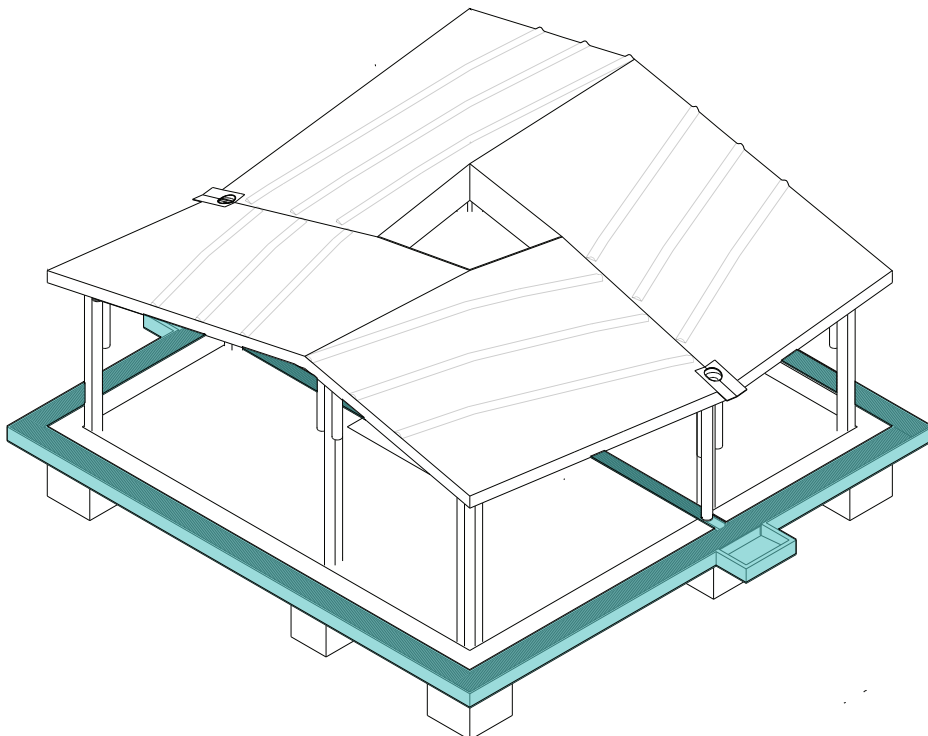



25 OPTIONAL: ELECTRICITY / Electricity, solar panels

Electricity, solar panels

- Electricity can be installed on the assigned spots, taking safety into account with rainwater
- Installation of solar panels on the roof - inverter
- battery

Material

Frame solar panels

Element

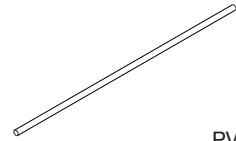

PVC pipes

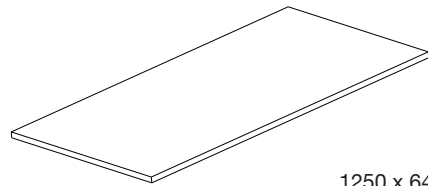

1250 x 640 mm

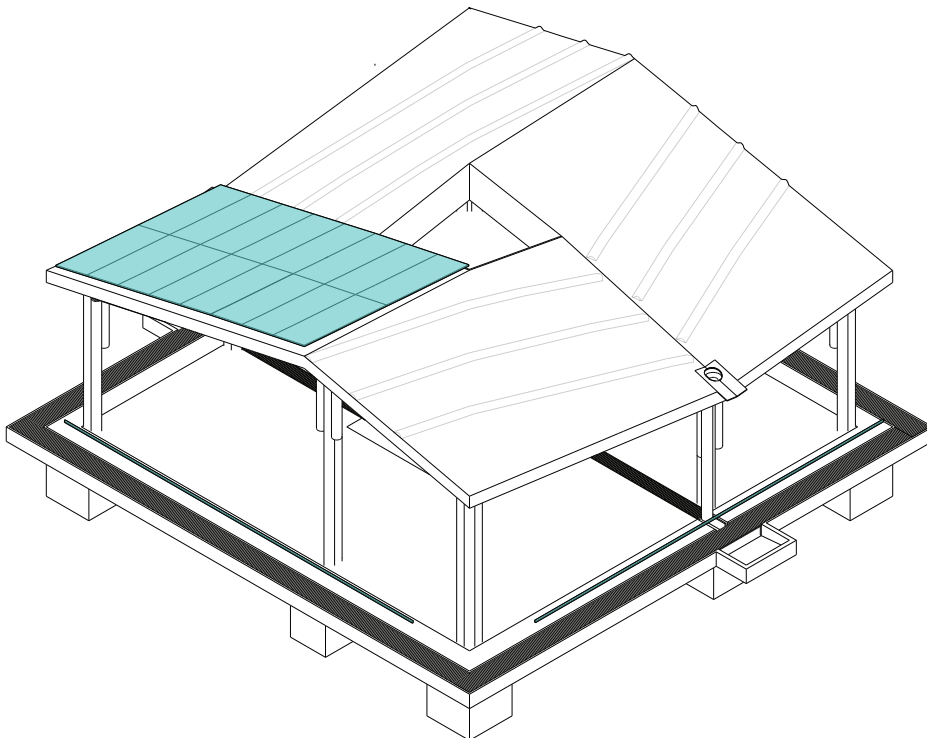



CONSTRUCTION PROCESS

2 PAVILIONS

2 Pavilions

The modular system of the pavilions has the capacities to be clustered and featured in many different ways.

Two pavilions can be easily connected, but some remarks have to be taken into account for the construction steps of the two connecting facades:

- Pile and strip foundation have to be combined (step 2,4)
- Wooden battens and counter battens have to be 150 mm shorter. (step 10,11,12)
- Roof edge capping has to follow the outer facade (step 13)
- Floor drainage system has to follow the outer facade (step 19)

