

everyday life as an open project

THE GOOD BANALITY
&
THE PLEASURE OF
BOREDOM

P4

Aleksandra Gordowy | explorelab 23
• Armina Pilav • Robert Nottrot •
• Tom Avermaete • Jan van de Voort

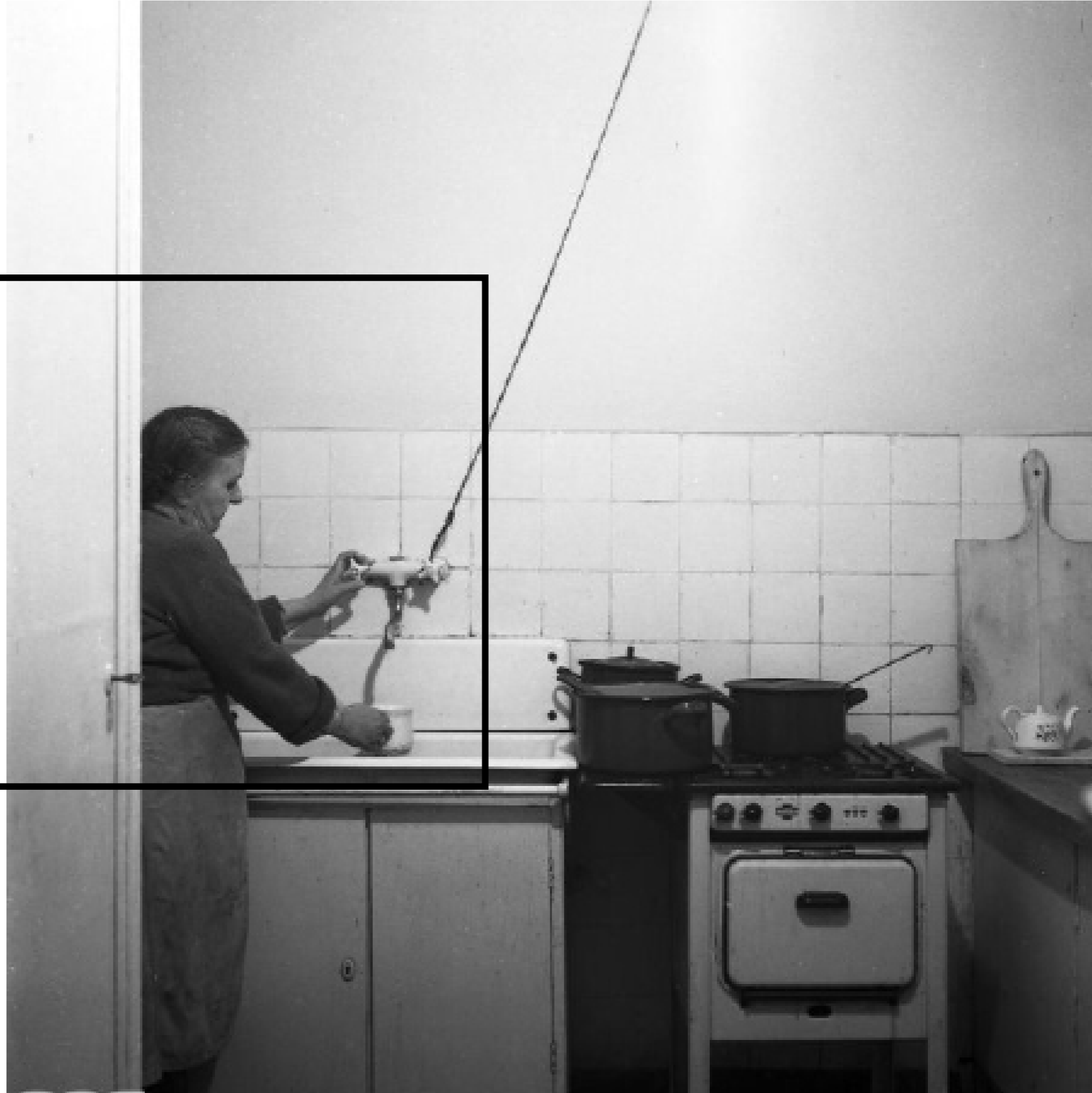

content of the presentation



Elin Danielson-Gambogi, After breakfast, 1890, oil on canvas

I. RESEARCH

II. DESIGN

?	I	PROBLEM FORMULATION	1.1 Why does boredom matter? 1.2 Boredom: spatial, political, economic, social and cultural lens for the post-industrial city of Łódź
◯	II	OPEN TOOLBOX	2.1 The (new) lexicon 2.2 Why does banal matter?
⊗	III	CONTEXT	3.1 contemporary Łódź 3.2 Void 3.3 The project environment: home as a productive and non-productive space 3.4 The tenement as the basic matter of the public space of a city: the typology 3.5 working plane & 4 scales of intervention
∞	IV	RESEARCH CONCLUSION	4.1 3 lines of problem statement
◯	V	OPEN PROJECT WITHIN ENCLOSED SPACE	5.1 Working within the existing - particularity of Łódź tenements
	VI	DESIGN	6.1 Strategy and implementation 6.2 Structure and instalations
⊙	VII	USER PROFILE	7.1 Who? 7.2 How to communicate inside community?
◯	VIII	CONCLUSIONS	home as a productive and non-productive space



Elin Danielson-Gambogi, After breakfast, 1890, oil on canvas

I. RESEARCH

II. DESIGN

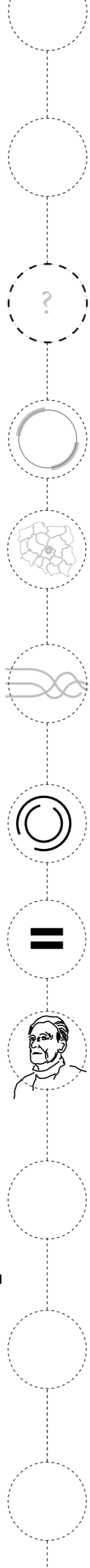

V OPEN PROJECT WITHIN ENCLOSED SPACE

VI DESIGN

VII USER PROFILE

VIII CONCLUSIONS

- 1.1 Why does boredom matter?
- 1.2 Boredom: spatial, political, economic, social and cultural lense for the post-industrial city of Łódź

- 2.1 The (new) lexicon
- 2.2 Why does banal matter?

- 3.1 contemporary Łódź
- 3.2 Void
- 3.3 The project environment: home as a productive and non-productive space
- 3.4 The tenement as the basic matter of the public space of a city: the typology
- 3.5 working plane & 4 scales of intervention

- 4.1 3 lines of problem statement

- 5.1 Working within the existing - particularity of Łódź tenements

- 6.1 Strategy and implementation
- 6.2 Structure and instalations

- 7.1 Who?
- 7.2 How to communicate inside community?

home as a productive and non-productive space



Elin Danielson-Gambogi, After breakfast, 1890, oil on canvas

RESEARCH

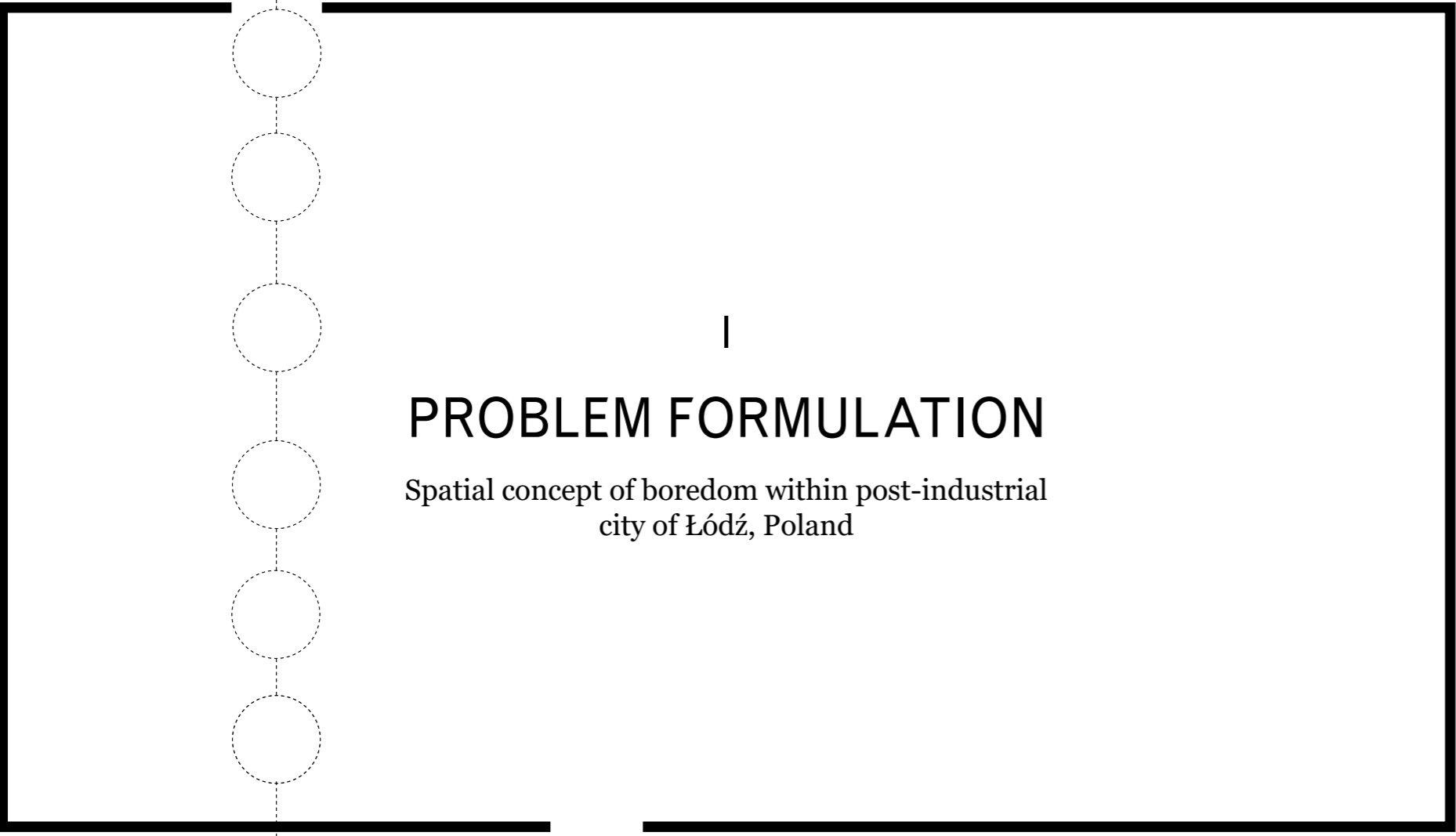
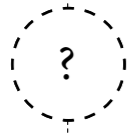
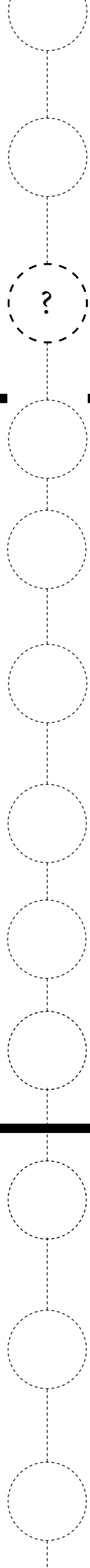

I

PROBLEM FORMULATION

Spatial concept of boredom within post-industrial
city of Łódź, Poland

***Boredom** is a disability of expecting something new, it is a feeling of existing in a world (even if temporary), where nothing can happen, where either it's going to be always the same, or, if something will happen, the observer doesn't care: even if something happens it is like it never happened.*

Leszek Kołakowski

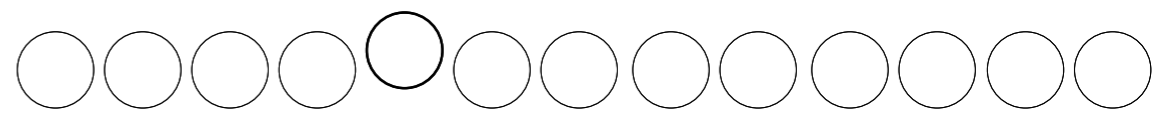

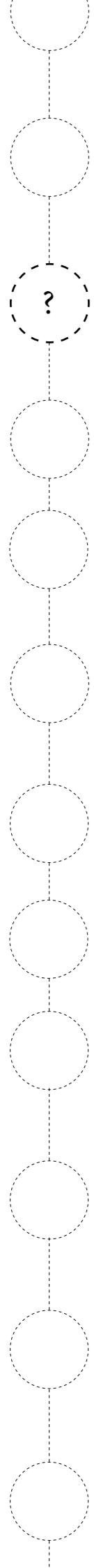

1.1 Why does **boredom matter**?

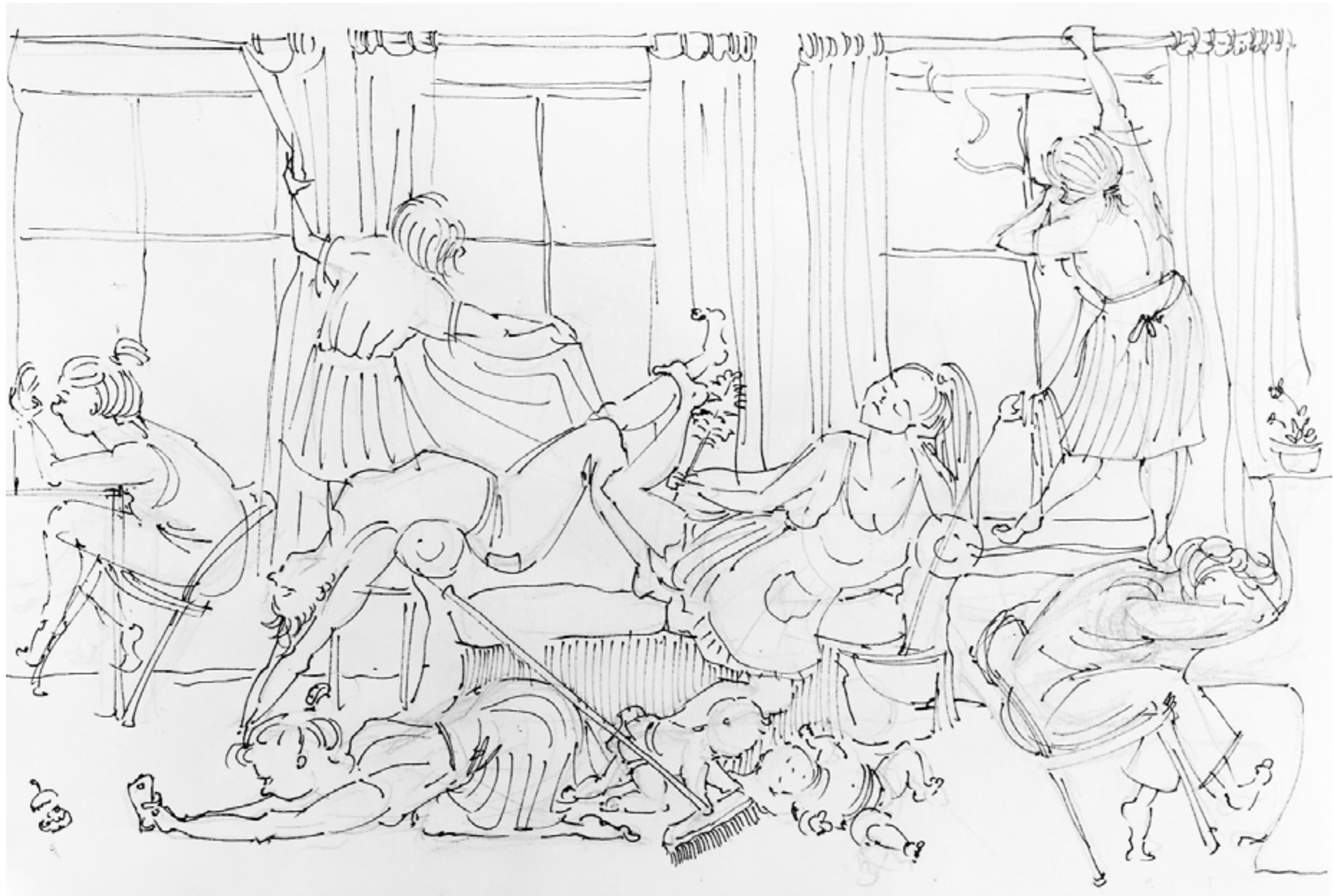

On average our **attention spans** are now thought to be less than that of a goldfish – **eight seconds.**

As soon as a new stimulus is noticed, however, it is no longer new, and after a while it bores us.

Dr Sandi Mann, The guardian

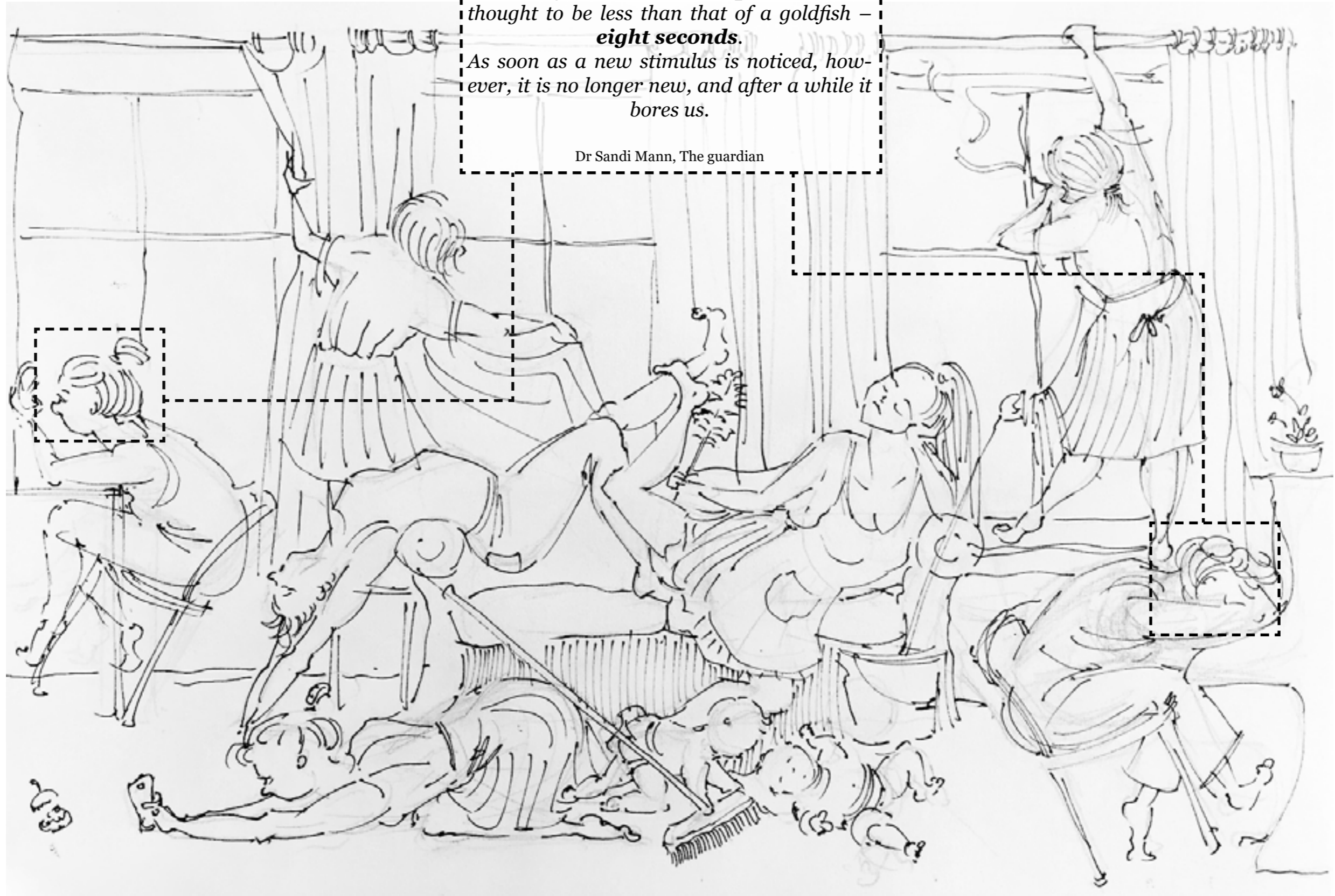

(...), the most compelling attributes of [boredom] are precisely those that give it such a **democratizing affect**, to which every individual is susceptible, and inevitably experiences it as a consistent and often unavoidable part of life in the modern world.

Julia Jason Haladyn, Boredom and Art, essay 2005

On average our **attention spans** are now thought to be less than that of a goldfish – **eight seconds.**

As soon as a new stimulus is noticed, however, it is no longer new, and after a while it bores us.

Dr Sandi Mann, The guardian

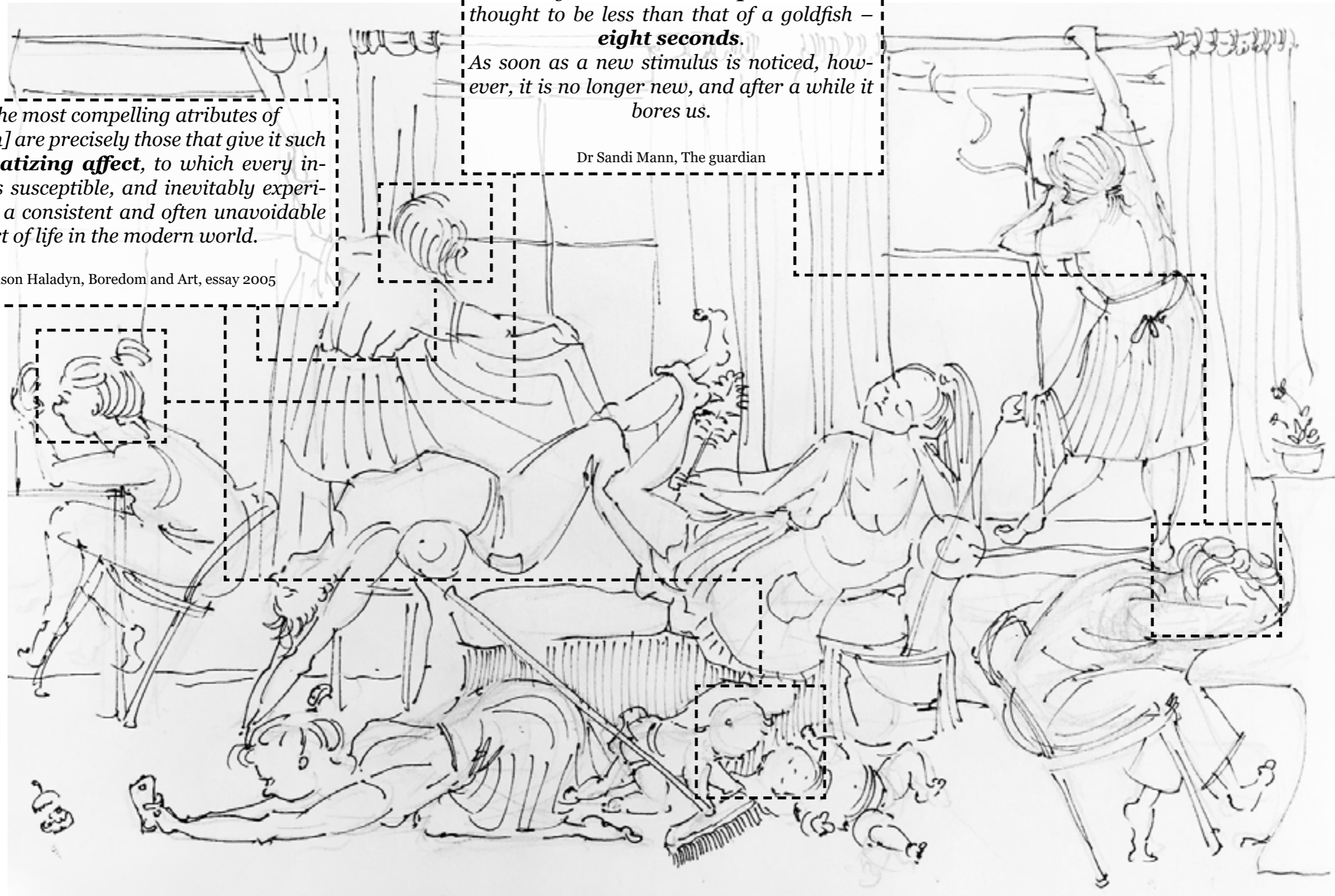

(...), the most compelling attributes of [boredom] are precisely those that give it such a democratizing affect, to which every individual is susceptible, and inevitably experiences it as a consistent and often unavoidable part of life in the modern world.

Julia Jason Haladyn, Boredom and Art, essay 2005

*On average our **attention spans** are now thought to be less than that of a goldfish – **eight seconds.***

As soon as a new stimulus is noticed, however, it is no longer new, and after a while it bores us.

Dr Sandi Mann, The guardian

*Most of us think of **being bored** at work as a negative experience, but a new study suggests it can have positive results including an increase in creativity because it gives us time to daydream.*

January 9, 2013, Dr Sandi Mann & Rebekah Cadman, University of Central Lancashire at the Annual Conference of the British Psychological Society Division of Occupational Psychology

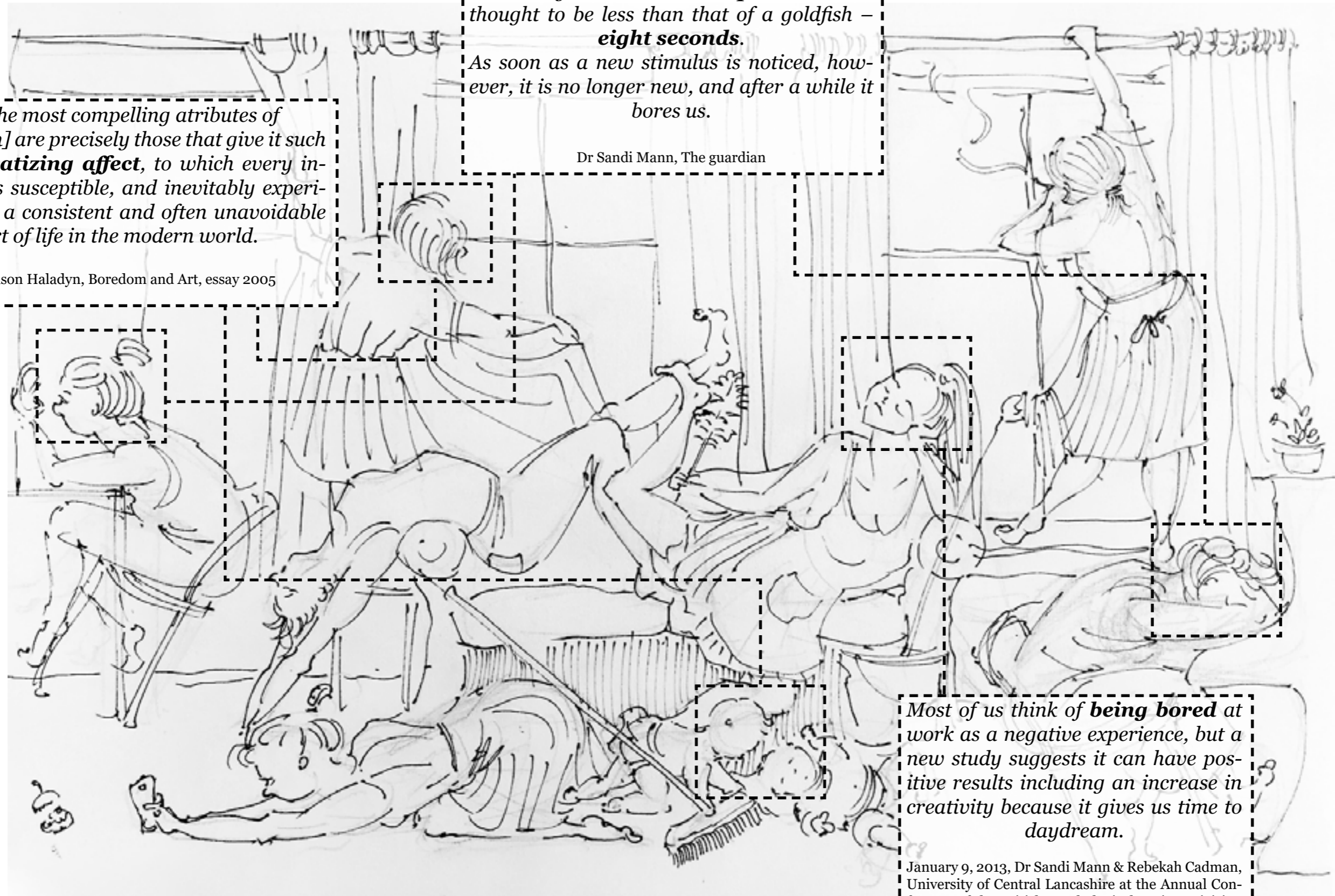

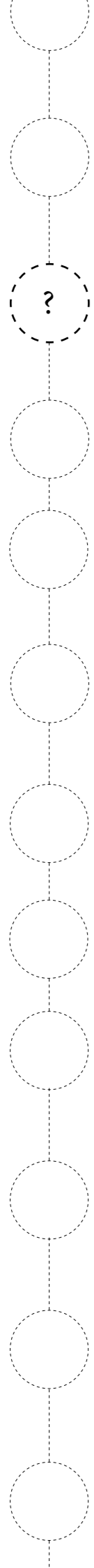

1.2 **Boredom:** spatial, political, economic, social and cultural lense for the history of post-industrial **city of Łódź**

WORLD

c. 1435,
Jan van Eyck,
St. Jerome in His Study,



c. 1500-1505
Giovanni di Pietro
The Agony in the Garden



1884,
Jules Breton
Song of the Lark;
Edgar Degas
Two Ironing Women



'Realism carries a hint of poetic allegory, as the lark is traditionally a symbol for daybreak'



1882, Eduard Manet,
A bar at Folies- Bergere



"her look - public, outward, blase fails to register only identity..."

beg. XX
Frankfurt School
Walter Benjamin

dialectical relation of the upper-class boredom with the tedium of modern labour

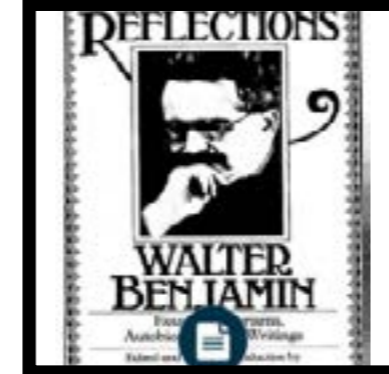

1950-60
Ivan Chtcheglov,
Henry Lefebvre
New Urbanism
Situacionism
Paris

critique of boredom



1965
Barbara Rose
'If, on seeing some of the new paintings, sculpture, dances or films, you are bored, probably you were intended to be; Boring the public is one of the ways of testing its commitment'

Andy Warhol
pop art
'making the audience bored...'



1963
Betty Friedan
'Feminine Mystique'



1957
Jeanne Dielman
Chantal Akerman,

Wirginia Woolf, Room on One's Own



1985, film
Der Frühstückclub

"Research suggests that chronic boredom is responsible for a profusion of negative outcomes such as overeating, gambling, truancy, antisocial behaviour, drug use, accidents, risk taking and much more. We need less, not more, stimulation and novelty"

Dr Sandi Mann
'Why boredom is good'



ŁÓDŹ

XV

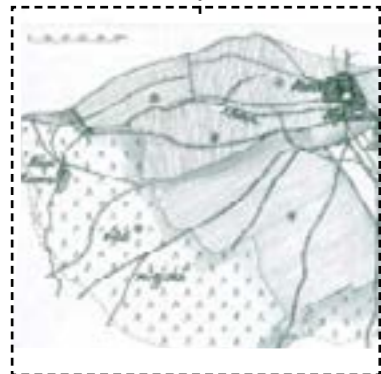

agricultural settlement

XVI



weaving settlement

XVIII



industrial revolution

1823

1884

1882

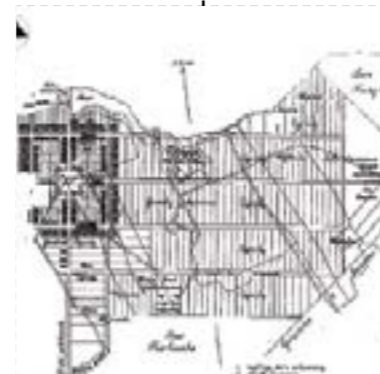

1923

1950 - 60

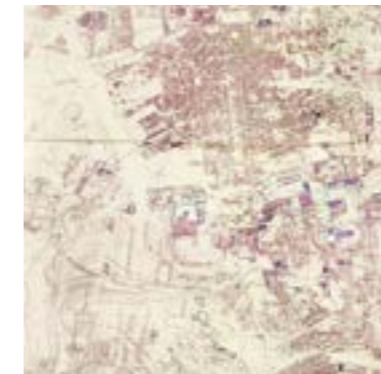

densification of industry

1950

1963

1963

1957

2017



new identity searching



Marek Okrassa, Notations of Boredom, oil on canvas, 2004 - 2016



film presented on exhibition 'Workers leaving the workplace' in Contemporary Art Museum, Łódź

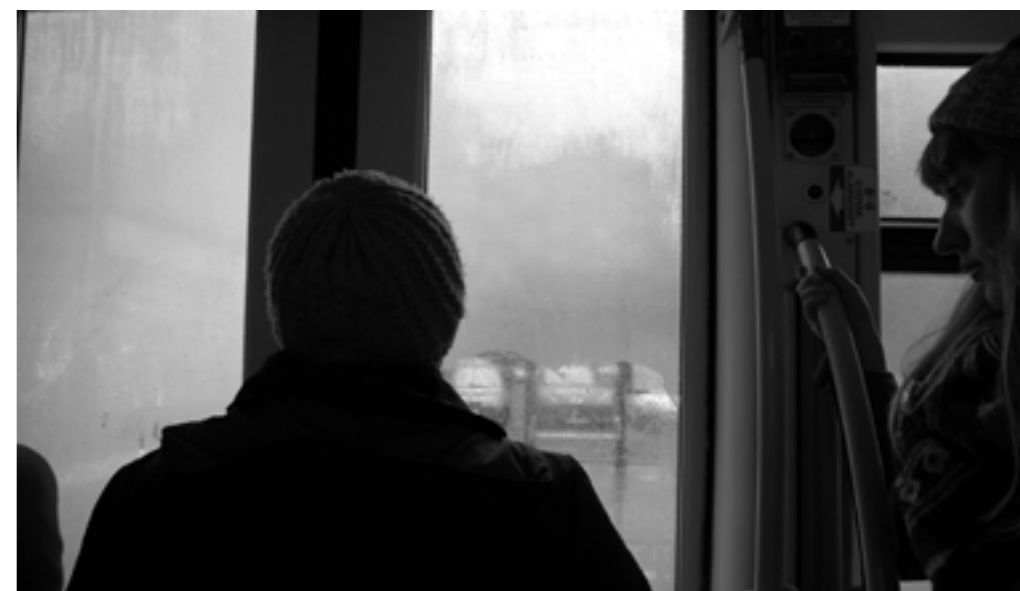



Chantal Akerman, La Chambre, 1972

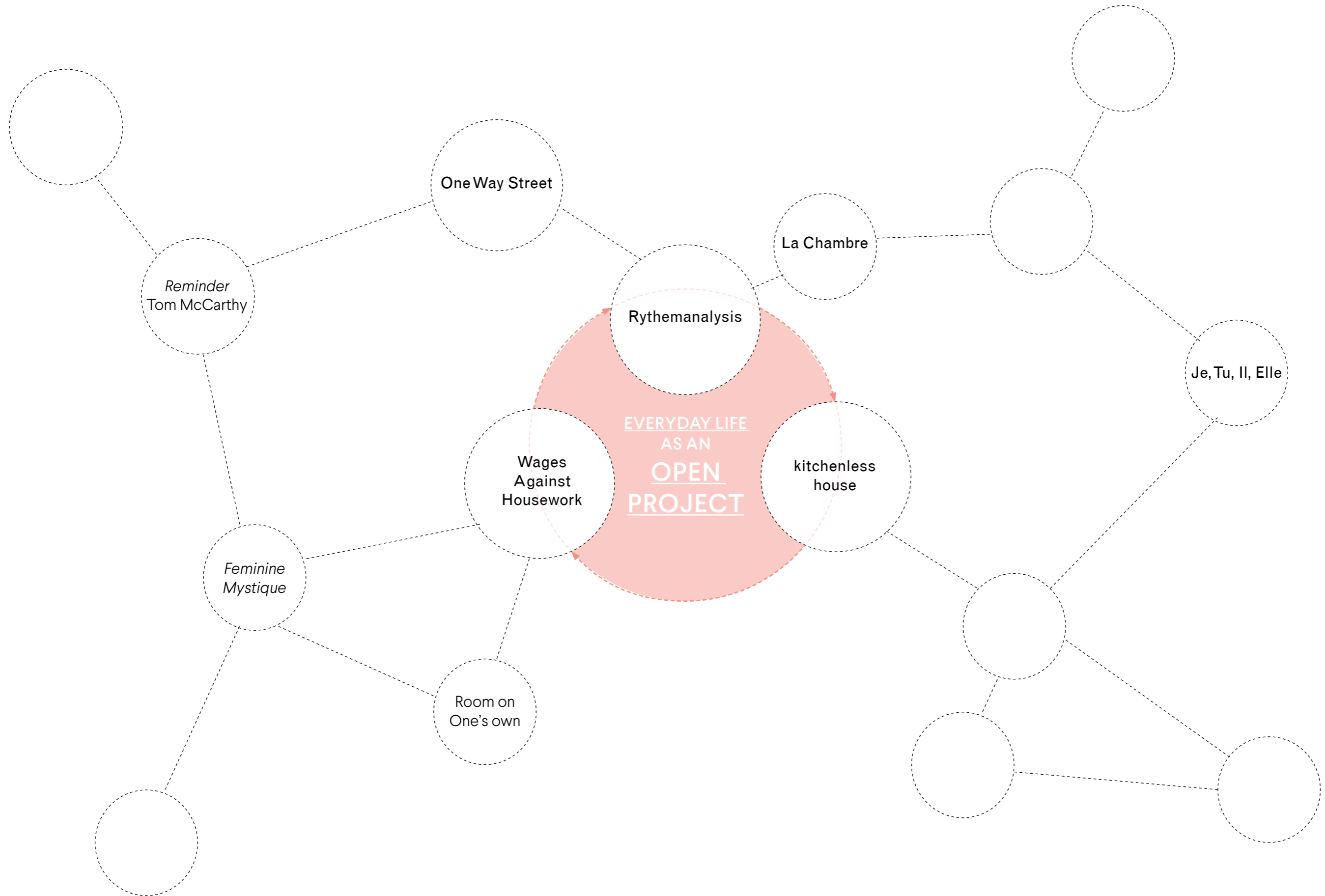

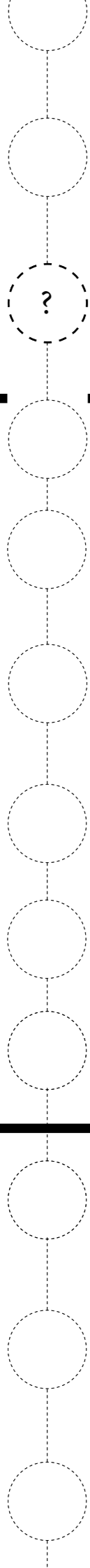

?

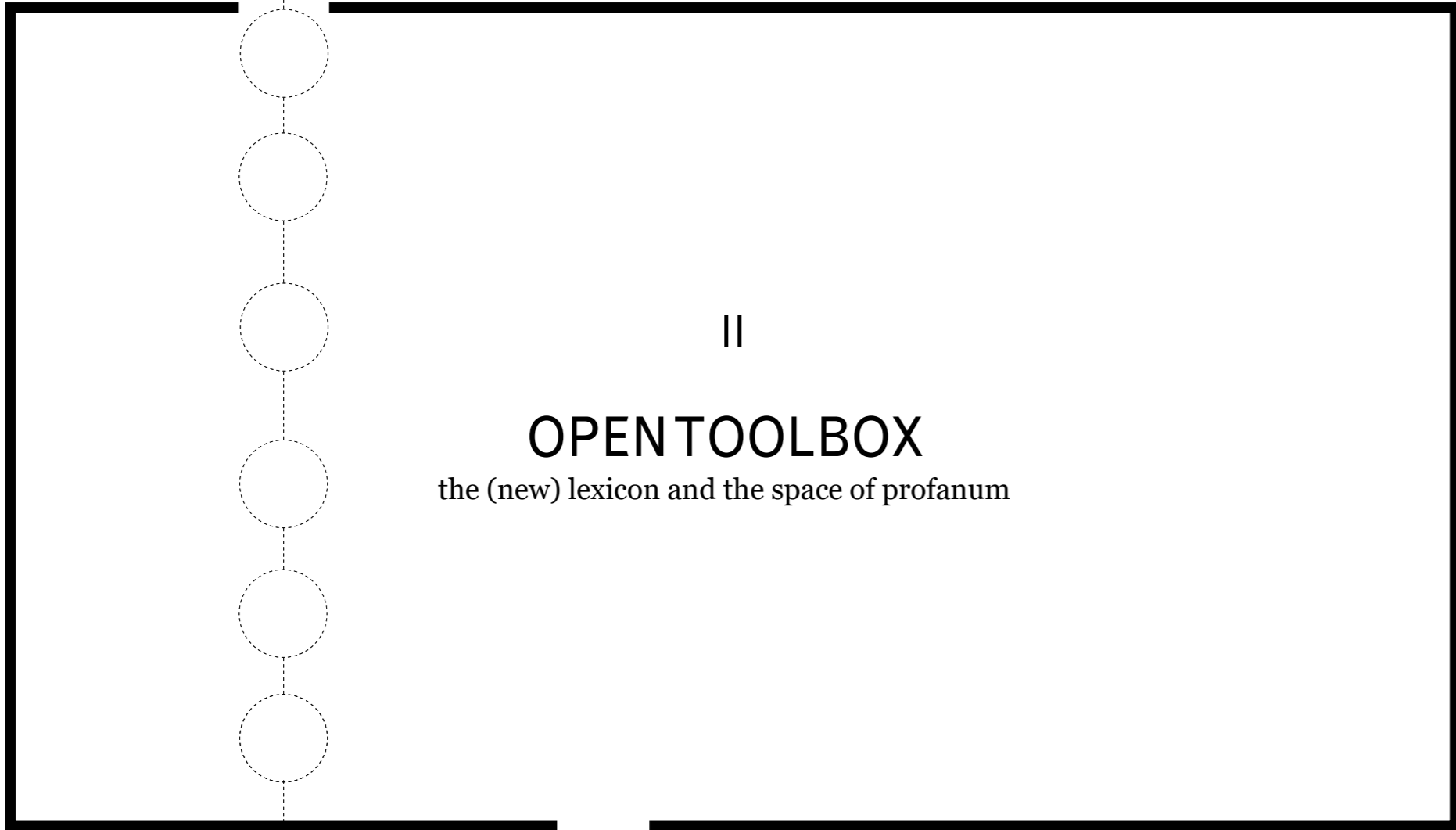

II

OPENTOOLBOX

the (new) lexicon and the space of profanum

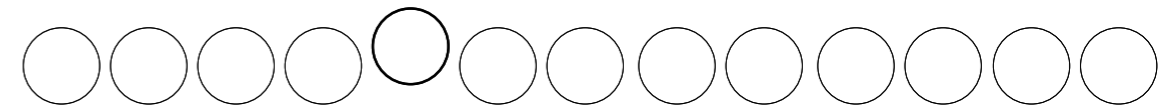
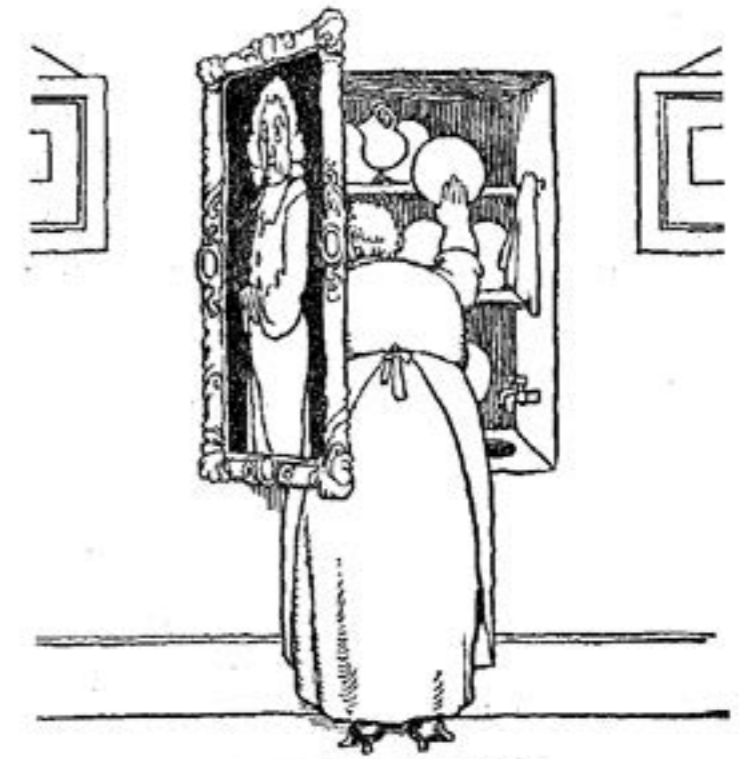

ASSEMBLY LINE

[Empty dashed rectangular box]

HOW CAN THE NOTION OF ASSEMBLY LINE
SPATIALLY CONTRIBUTE TO THE CON-
STRUCTION OF OUR EVERYDAY?

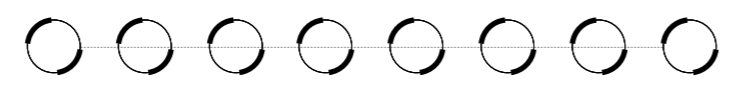

[Empty dashed rectangular box]

[Empty dashed rectangular box]

ASSEMBLY LINE

HOW CAN THE NOTION OF ASSEMBLY LINE
SPATIALLY CONTRIBUTE TO THE CON-
STRUCTION OF OUR EVERYDAY?

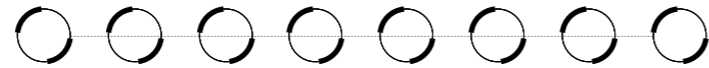

OTIUM - NEGOTIUM

DOES OUR DAILY SPACE CONTRIBUTE TO LIKE-
WISE UNDERSTOOD DIVISION:
OTIUM - NEGOTIUM?

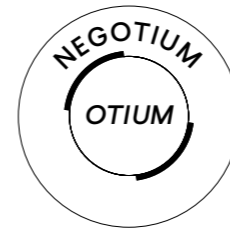

ASSEMBLY LINE

**HOW CAN THE NOTION OF ASSEMBLY LINE
SPATIALLY CONTRIBUTE TO THE CON-
STRUCTION OF OUR EVERYDAY?**

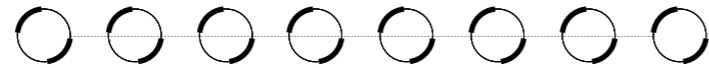

IDLE IDYLL

THE BLESSING OF DOING NOTHING



OTIUM - NEGOTIUM

**DOES OUR DAILY SPACE CONTRIBUTE TO LIKE-
WISE UNDERSTOOD DIVISION:
OTIUM - NEGOTIUM?**

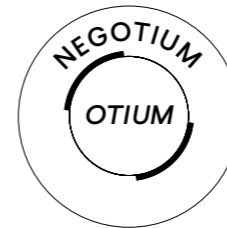

ASSEMBLY LINE

HOW CAN THE NOTION OF ASSEMBLY LINE
SPATIALLY CONTRIBUTE TO THE CON-
STRUCTION OF OUR EVERYDAY?

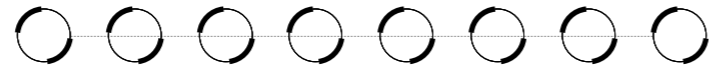

IDLE IDYLL

THE BLESSING OF DOING NOTHING



OTIUM - NEGOTIUM

DOES OUR DAILY SPACE CONTRIBUTE TO LIKE-
WISE UNDERSTOOD DIVISION:
OTIUM - NEGOTIUM?

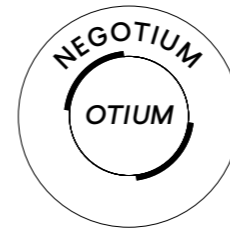

GOOD BANALITY

THE ARCHITECTURE OF EVERYDAY



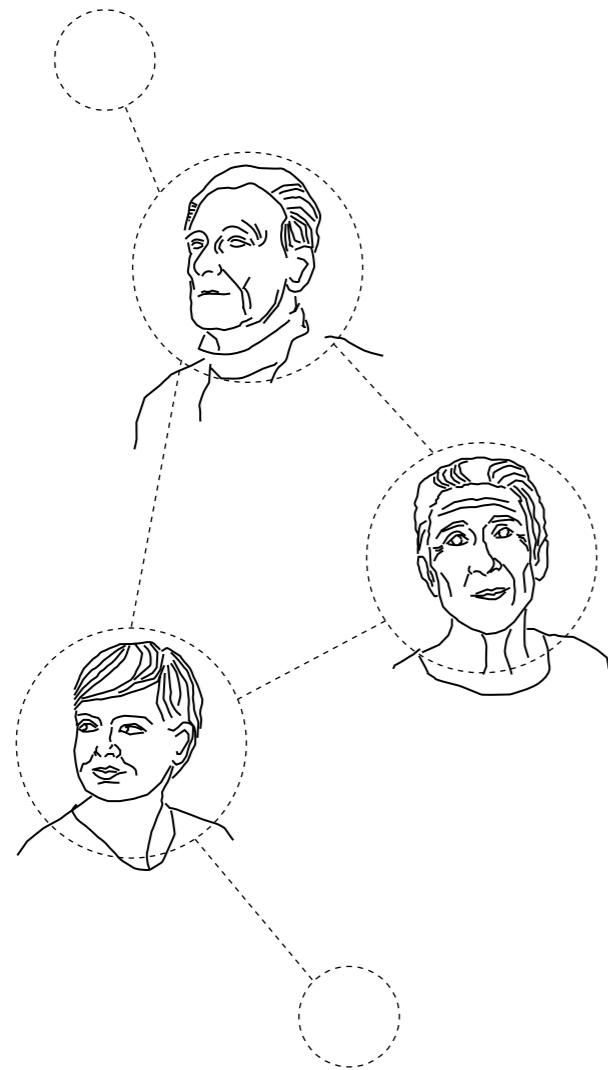

The city constitutes of spaces of high representative importance - churches, museums, authorities buildings - this may be called a sphere of sacrum,
and **spaces of profanum** – those of the everyday use, inhabiting, work. The latter, as contributing to the banal, the mediocrity and the everyday, paradoxically, very often stay unnoticed, therefore non-celebrated. In order to improve the quality of their performance, **prioritize the commonness over the exceptional**, we need to aim towards shifting our attention on everyday life, on slowness and boredom, on habits and repetitions, on essentials and obviousness. Only then, we may proudly contribute to the **making-of a good life**, or else, a **good banality**.



SHORPY

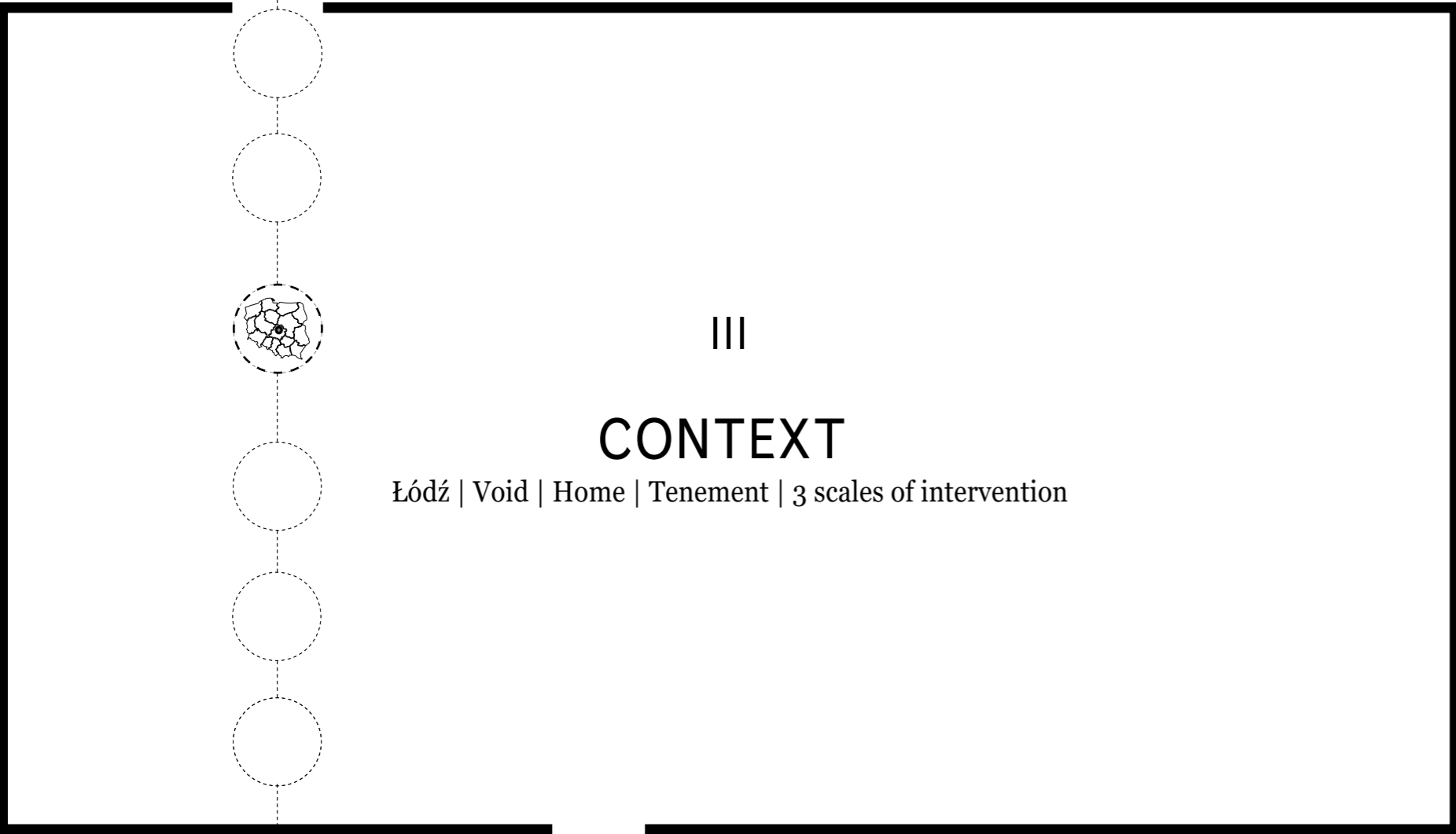
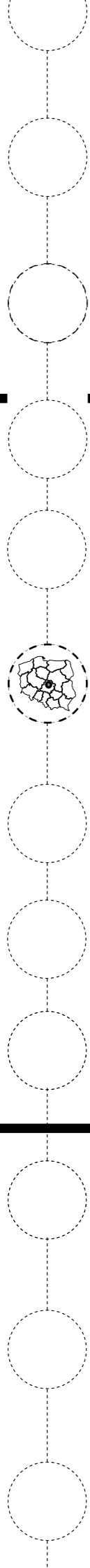

III

CONTEXT

Łódź | Void | Home | Tenement | 3 scales of intervention

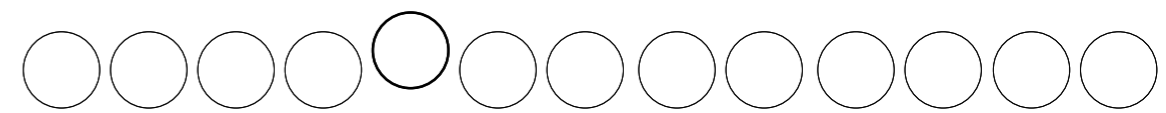
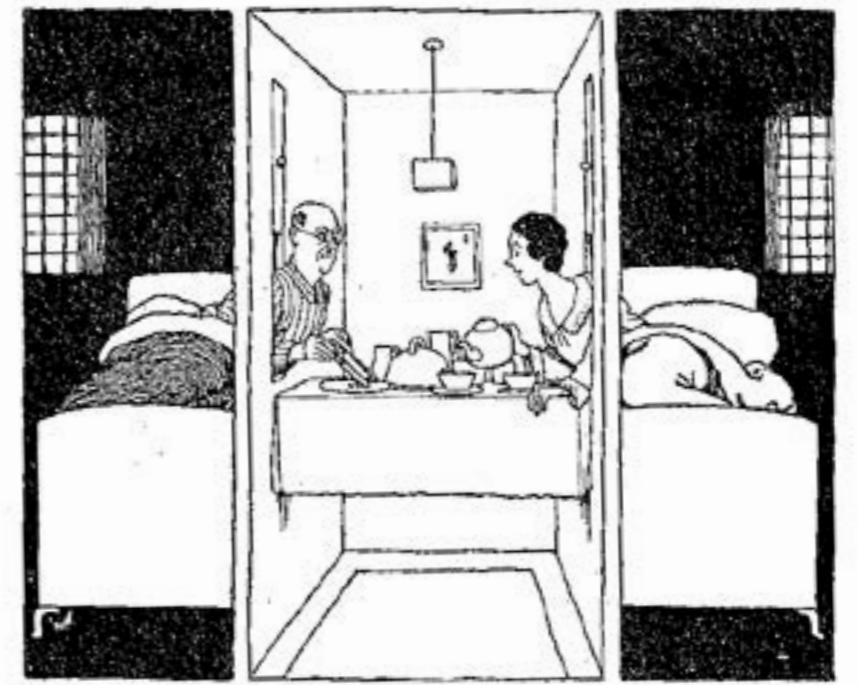



1.2 City of **Łódź**: a view into **Modernity**

*'To be modern is to find ourselves
in an environment that promises us adventure, power, joy, growth,
transformation of ourselves and the world—and, at the same time,
that threatens to destroy everything we have, everything we know,
everything we are.'*

Marshall Berman

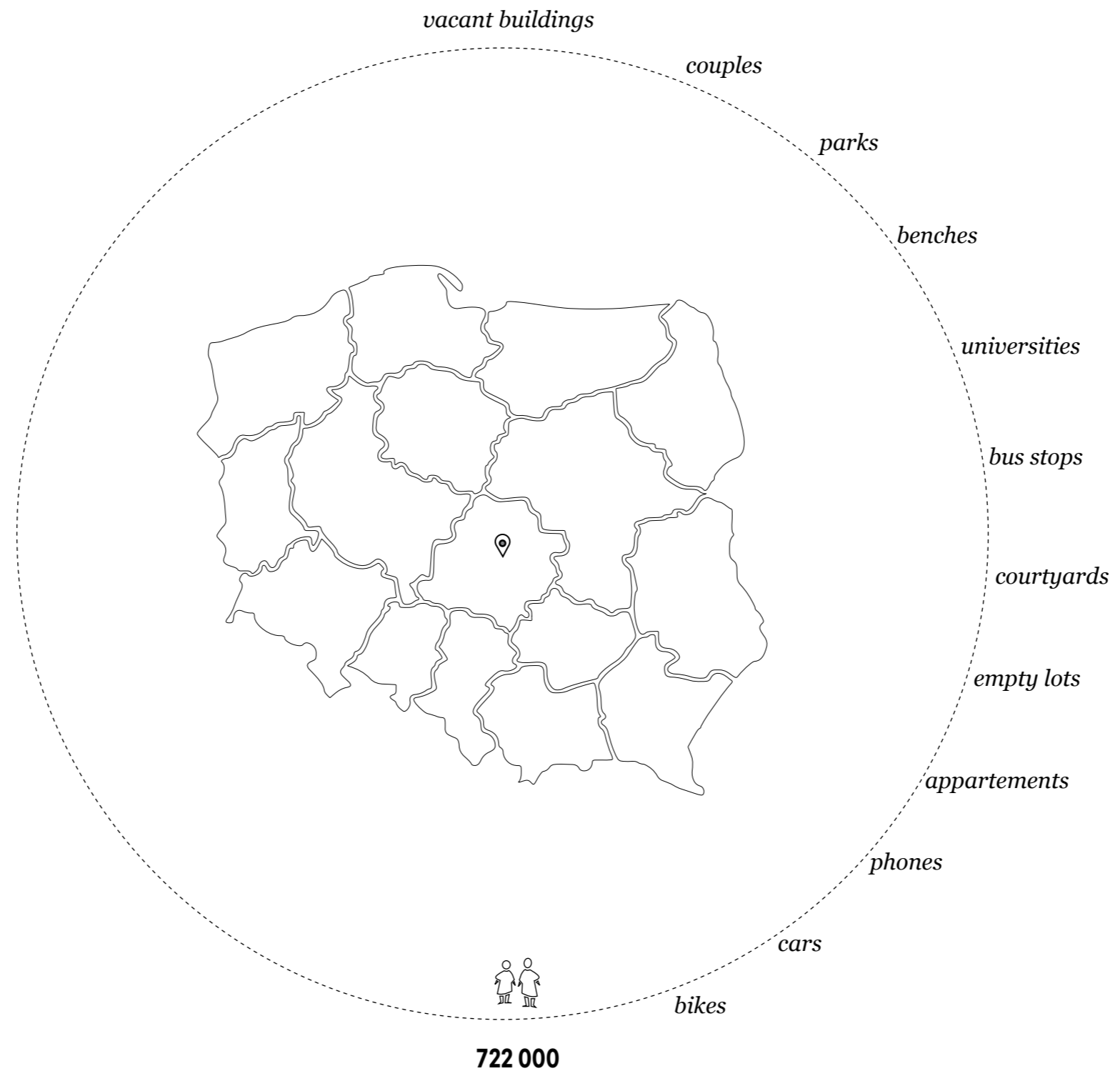

RURAL

XIV

URBAN

2017

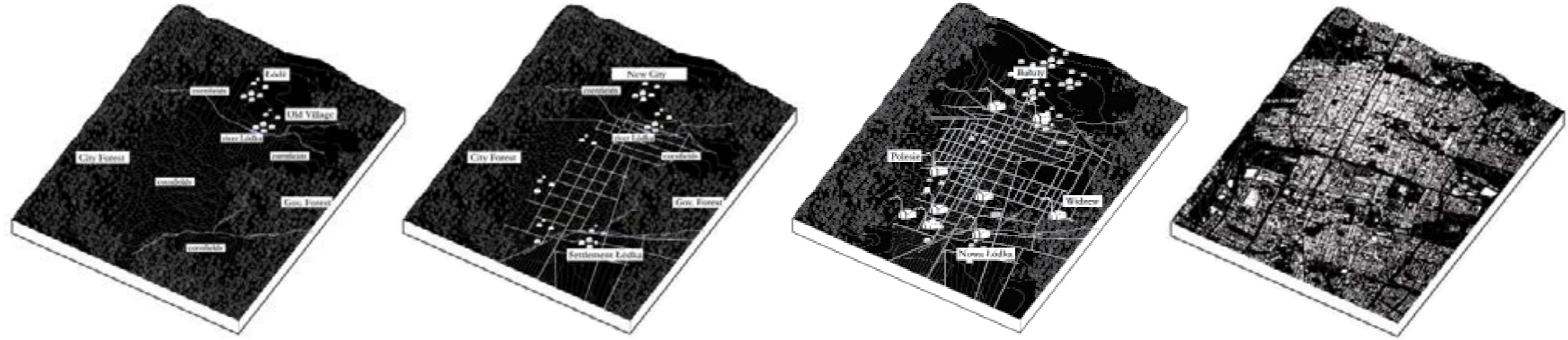



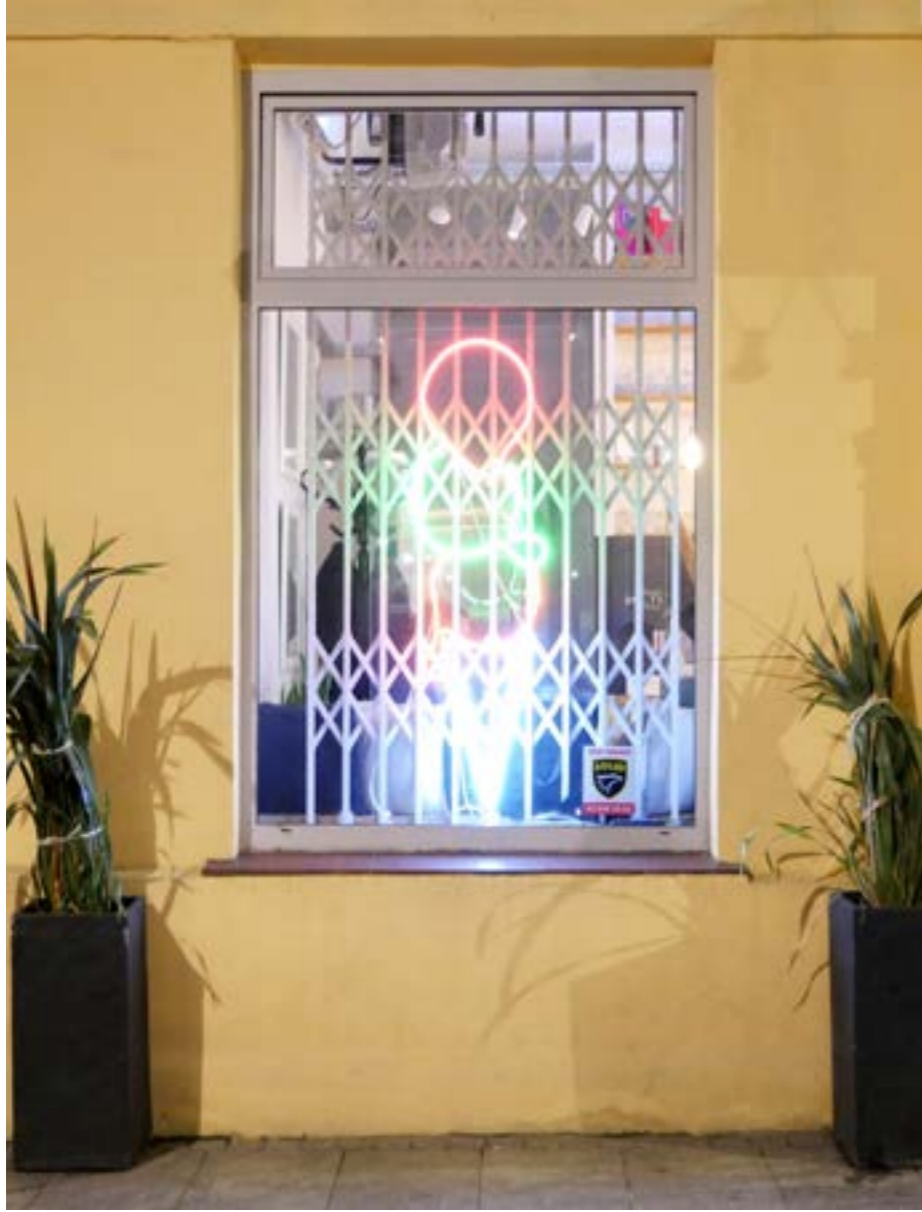

[THE MASS CULTURE THAT PROLIFERATES WITH THE URBAN FABRIC GENERALLY OFFERS THE PROMISE OF A NEGATION OF BOREDOM WITHOUT UNDERSTANDING IT]

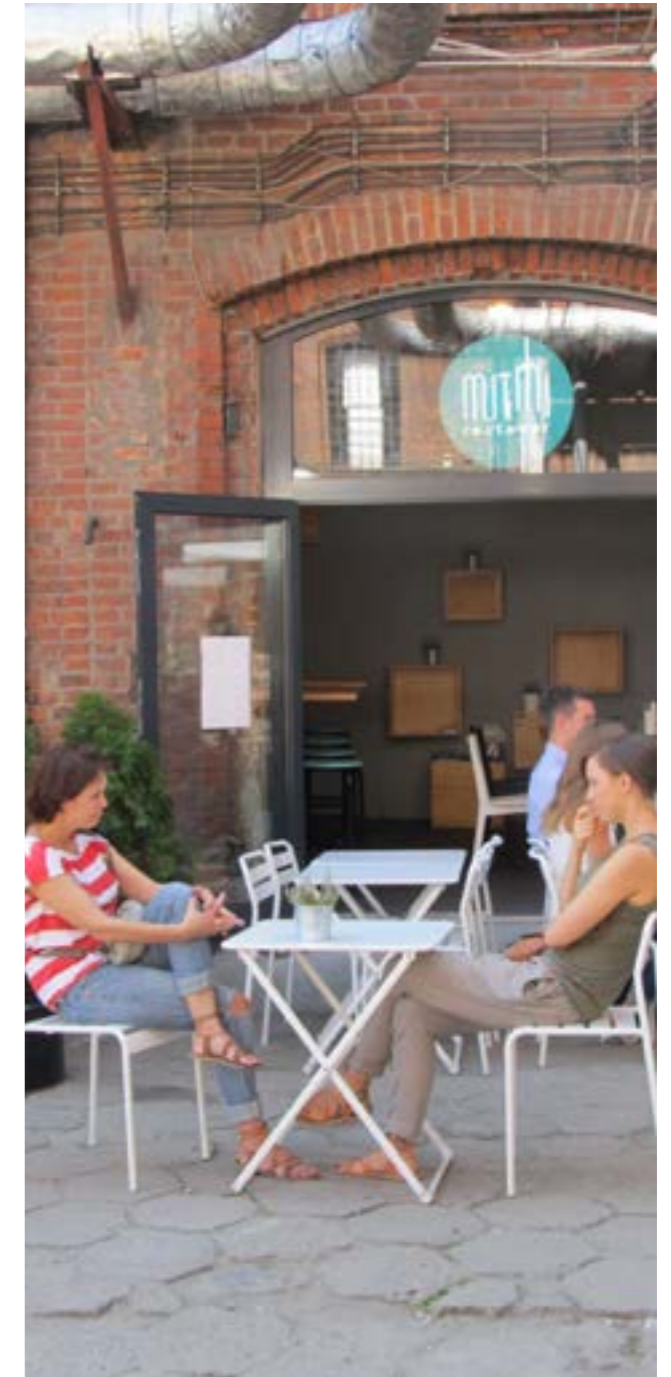

BOREDOM WITHIN MODERNITY, VIEWED AS AN OVERLOAD OF STIMULUS / SIGMUND KRACAUER, 1920













INABILITY TO TOLERATE EMPTY SPACE LIMITS THE AMOUNT OF SPACE AVAILABLE

[WILFRED BION]

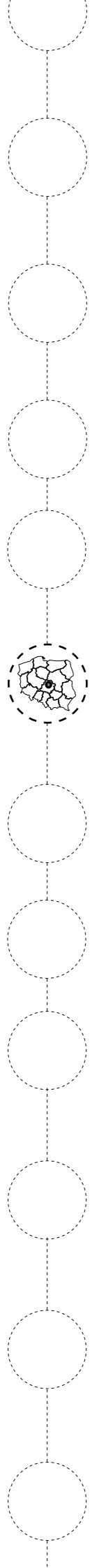

2.2

Void: the context and the tool

VOID

FULL

courtyards

- residential
- commercial
- private
- non residential parking

open

- unused
- greenscape
- itches

- education
- bars & restaurants
- culture
- sacral
- hotels & hostels
- services
- public services
- retail
- wedding dresses
- backeries
- flower shops
- banks
- nightclubs

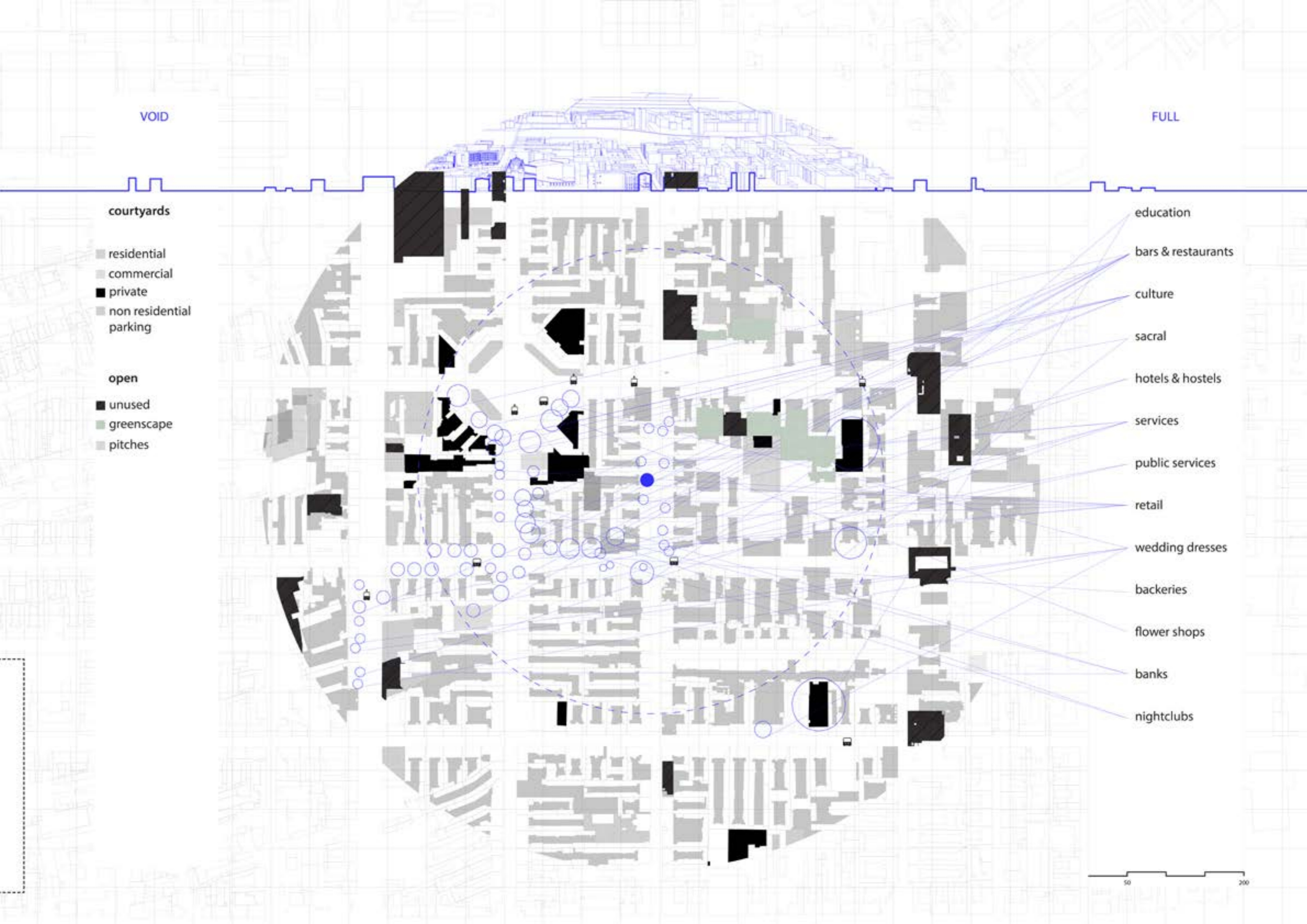

VOID

FULL



- open
- unused
- greenscape
- pitches

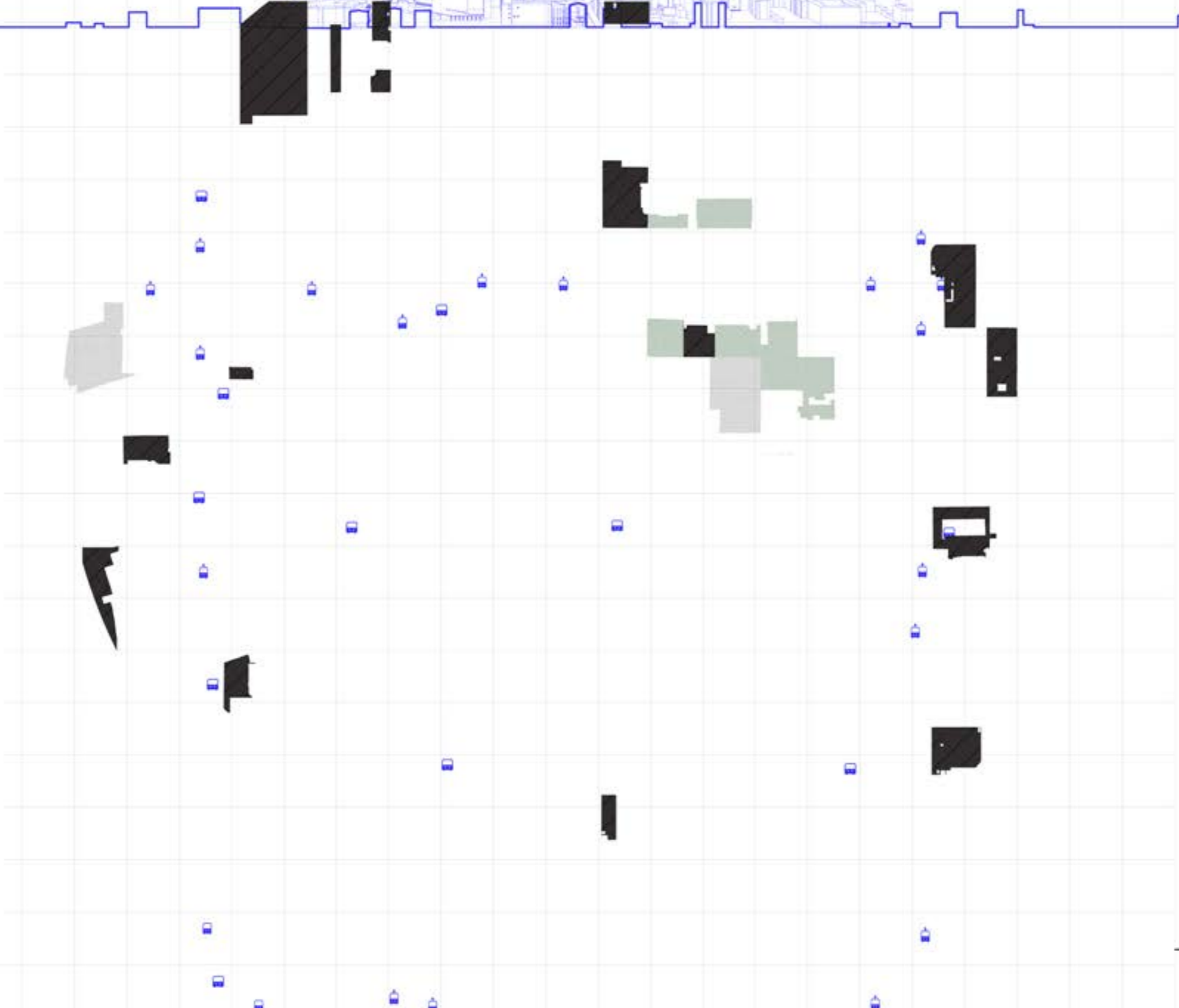



VOID

FULL



courtyard & open
■ non residential
parking





VOID

FULL



courtyards

residential



VOID

FULL

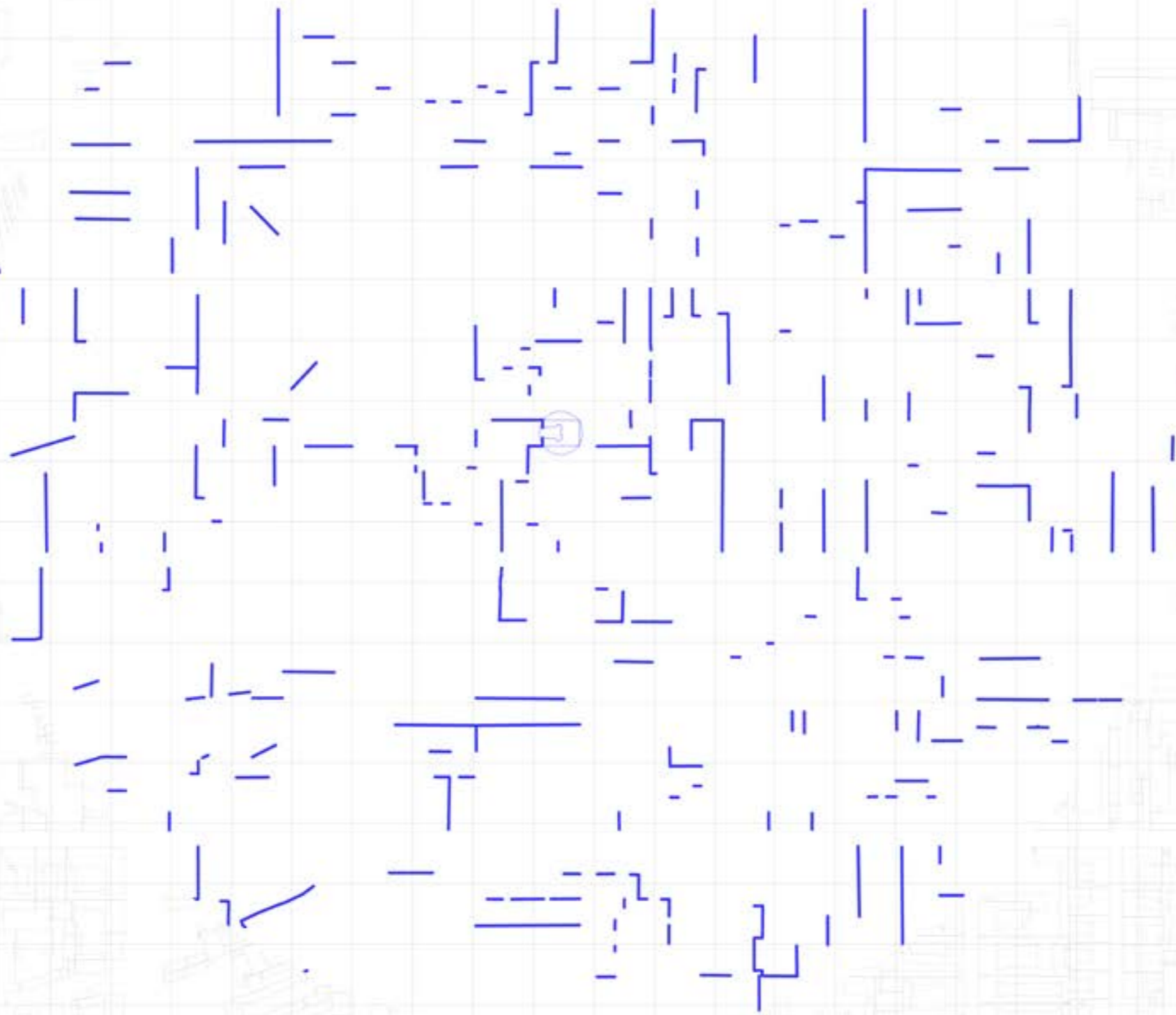

VOID

FULL

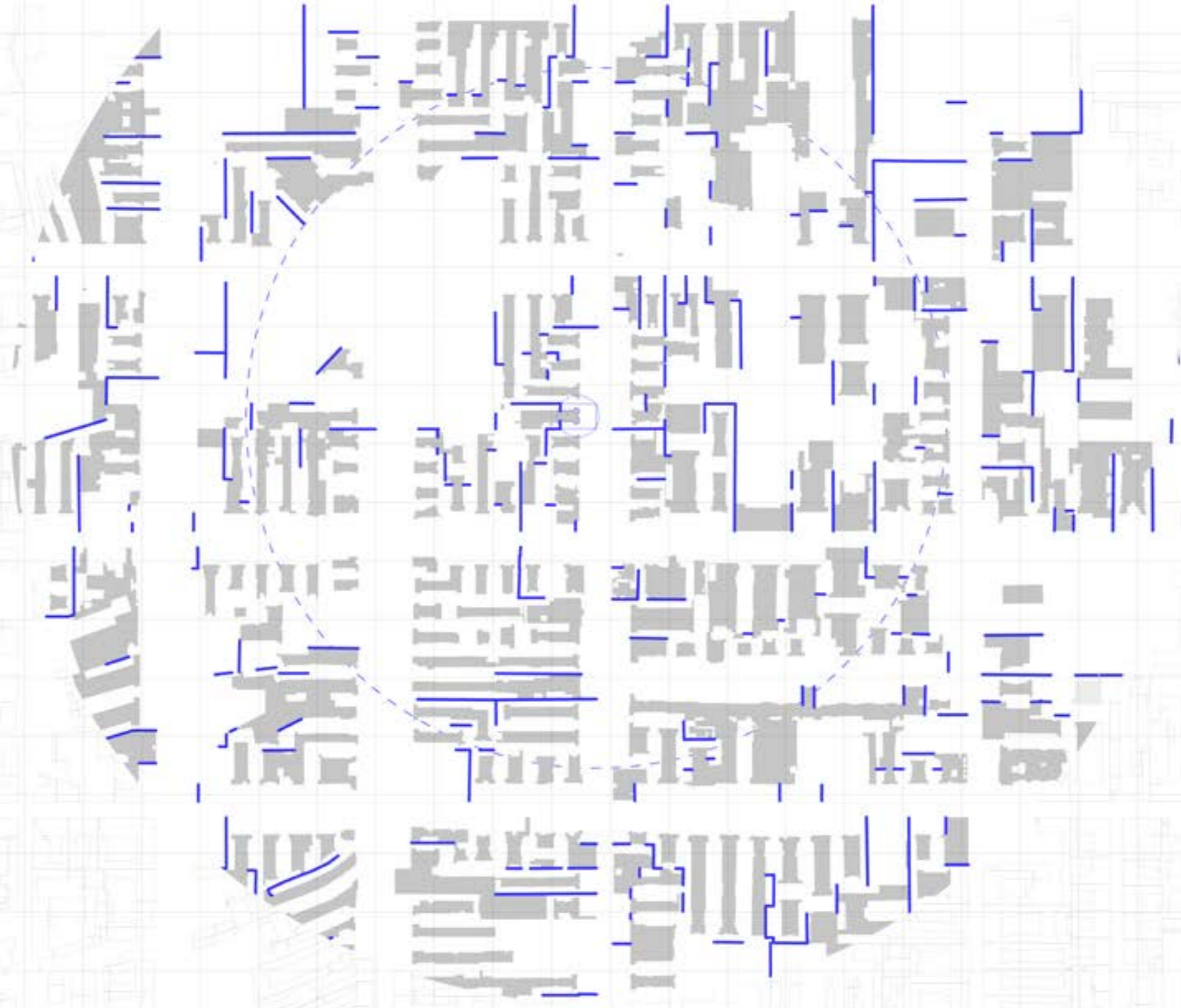
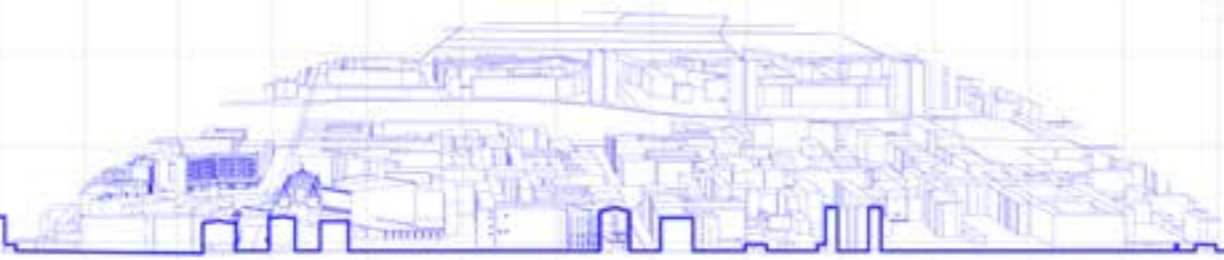



m² / 

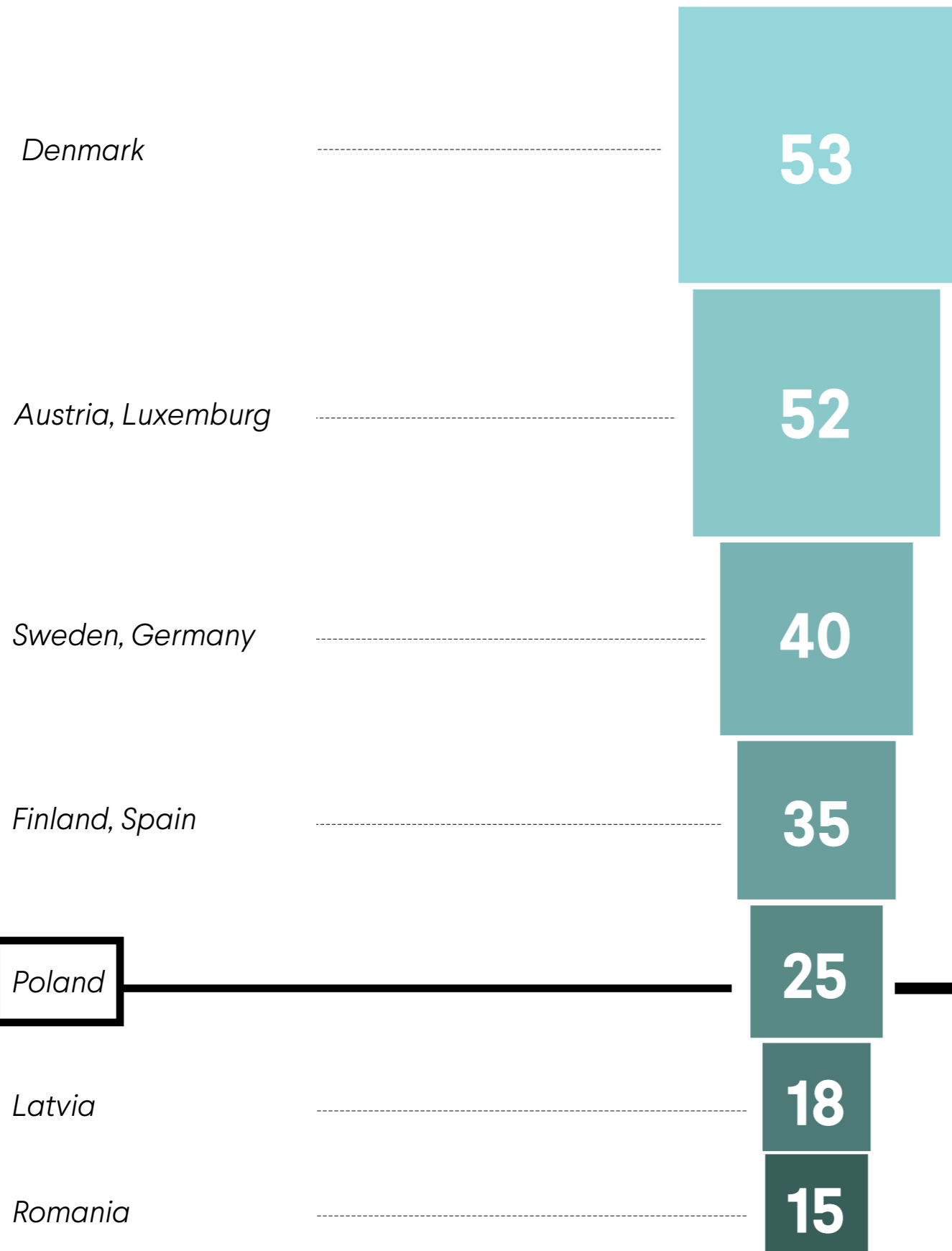

average 50m² appartement

oversized houses on the countryside

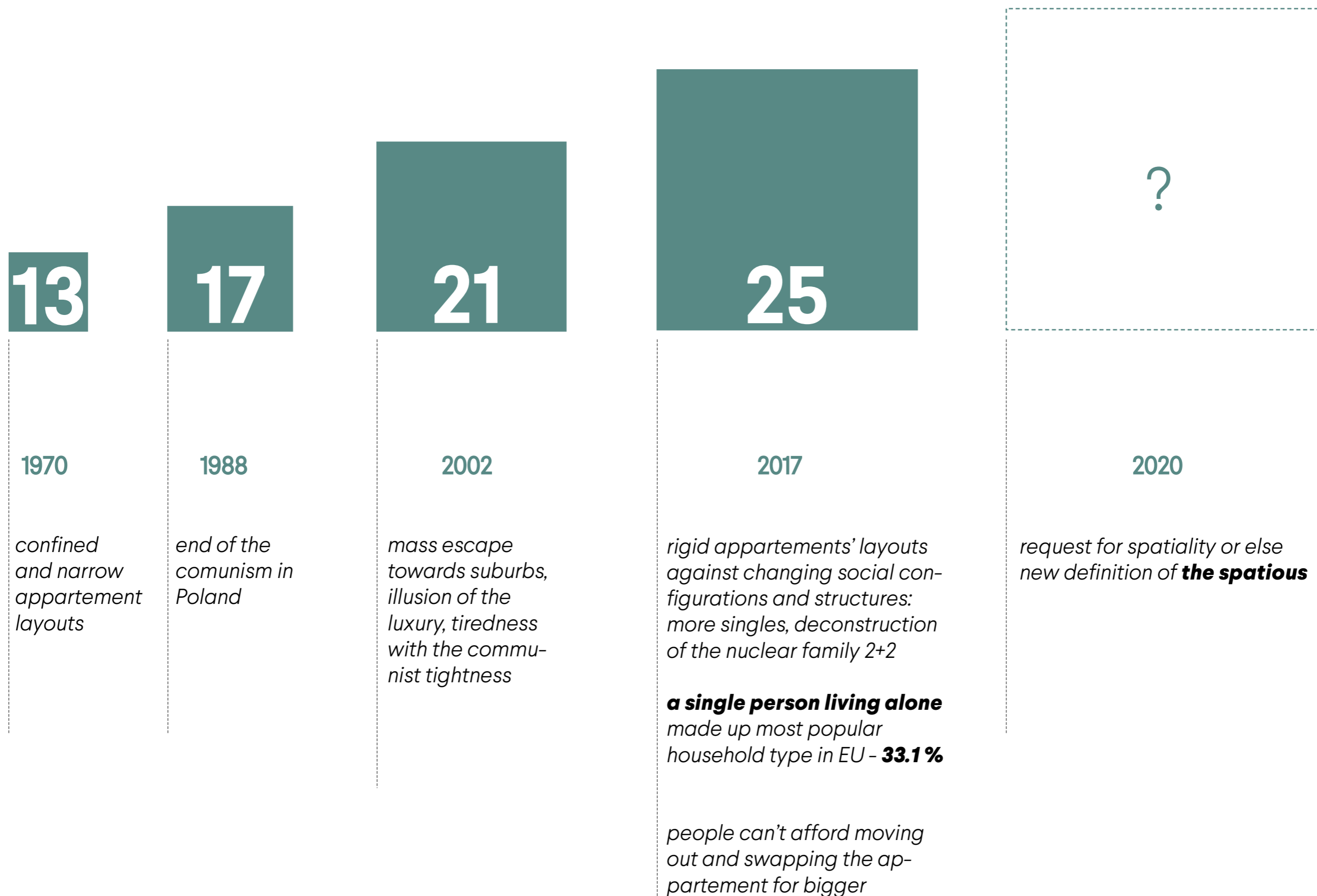

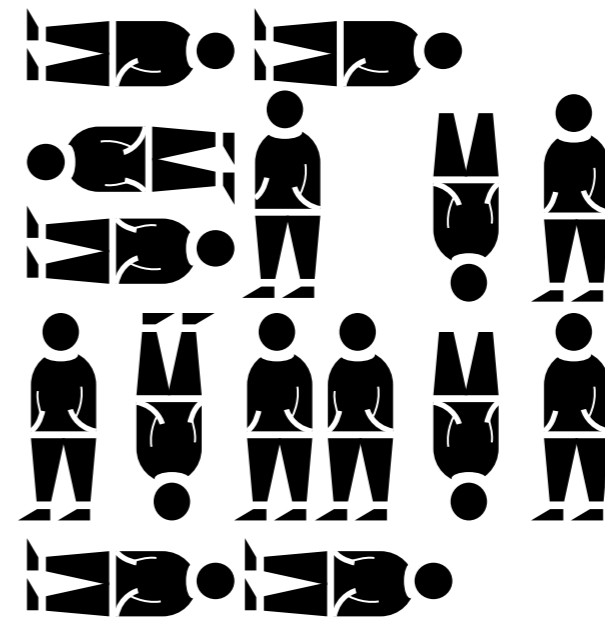
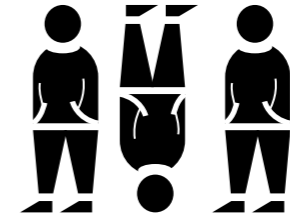
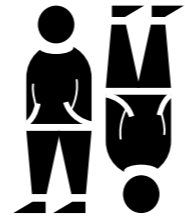
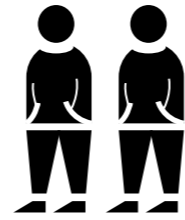

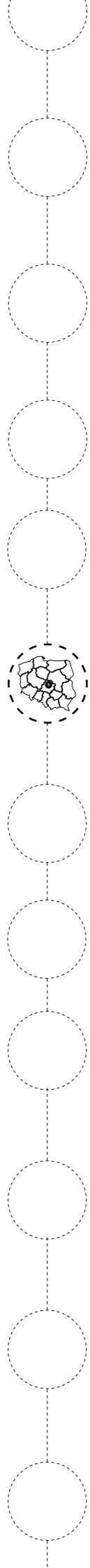

2.2

The project environment:

**home as a productive
&
non-productive space**



THE BUNGALOW KITCHENETTE



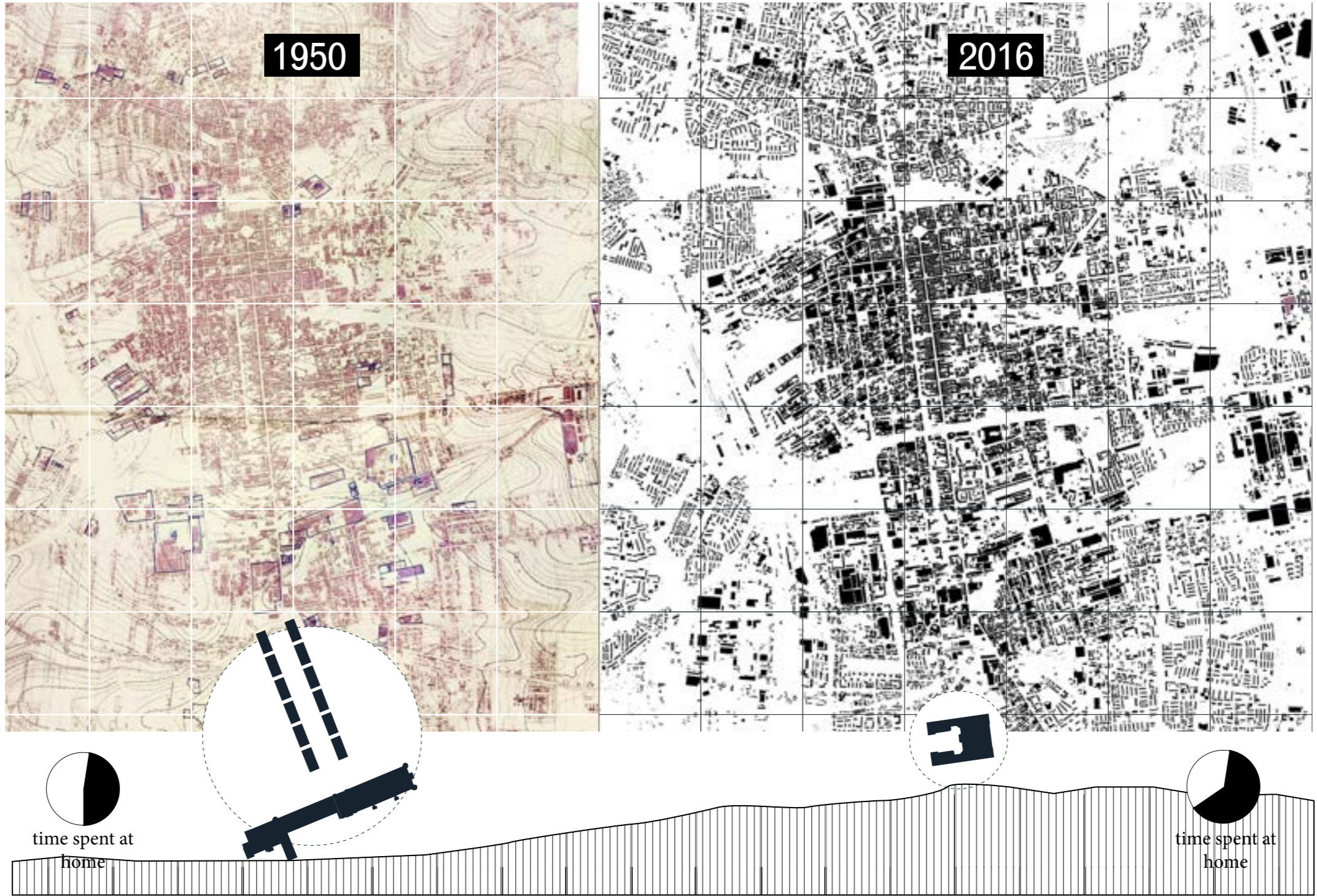

1950

2016

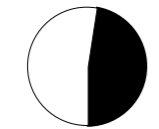

time spent at home

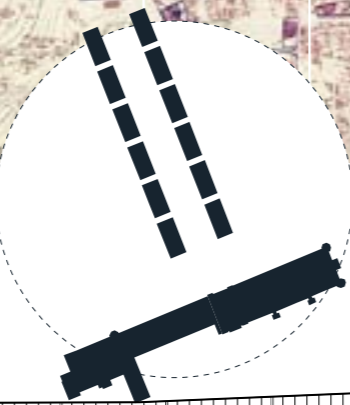

time spent at home

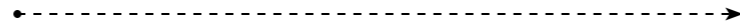
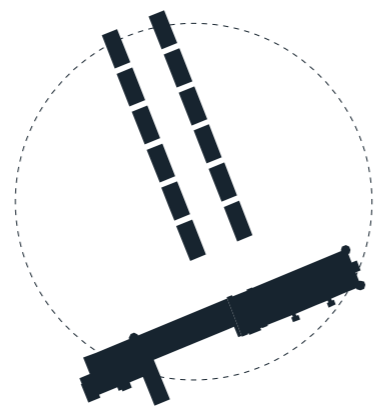

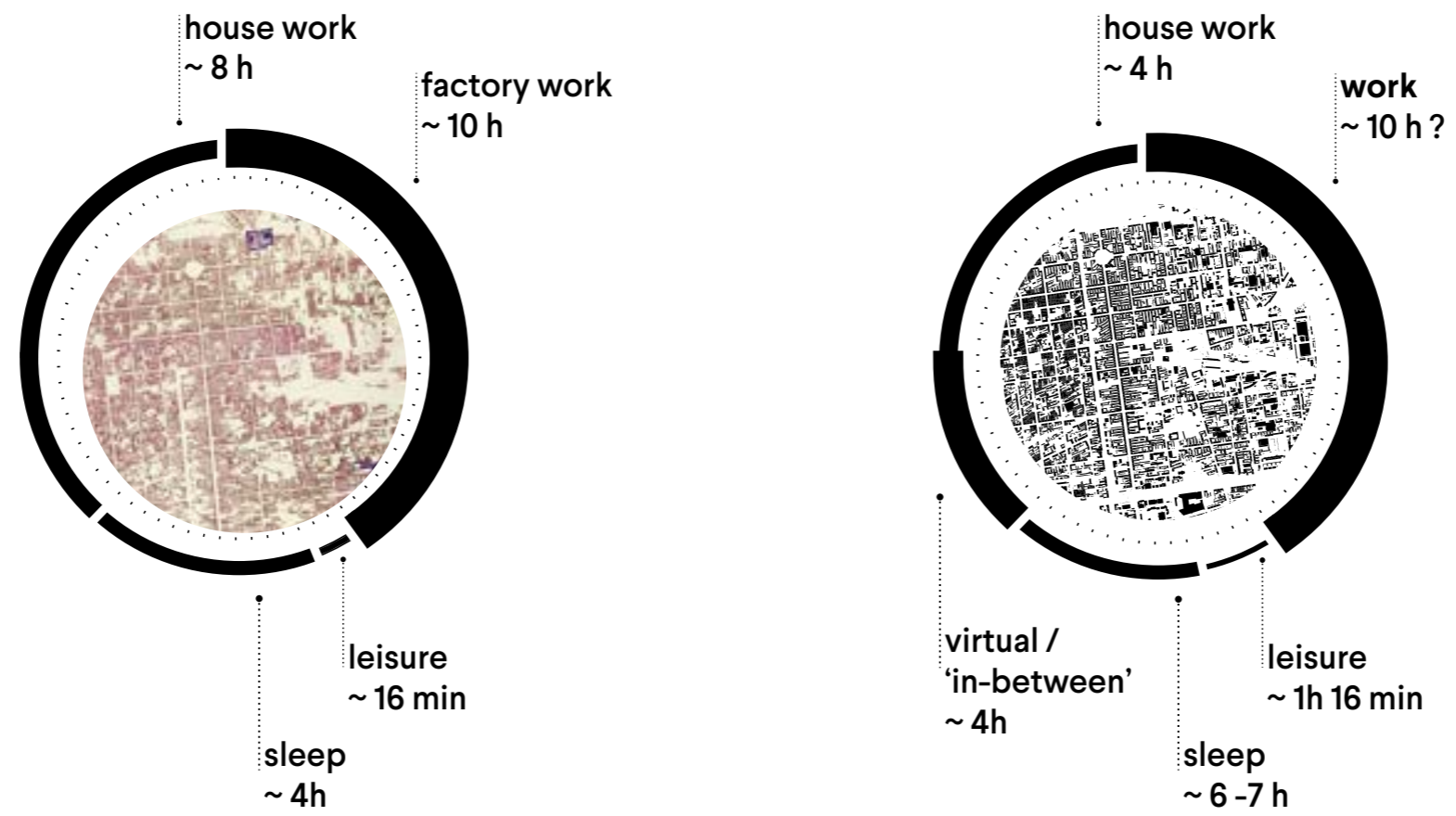

16 minutes - that was left for leisure for the polish female factory workers after completing a day of two working shifts

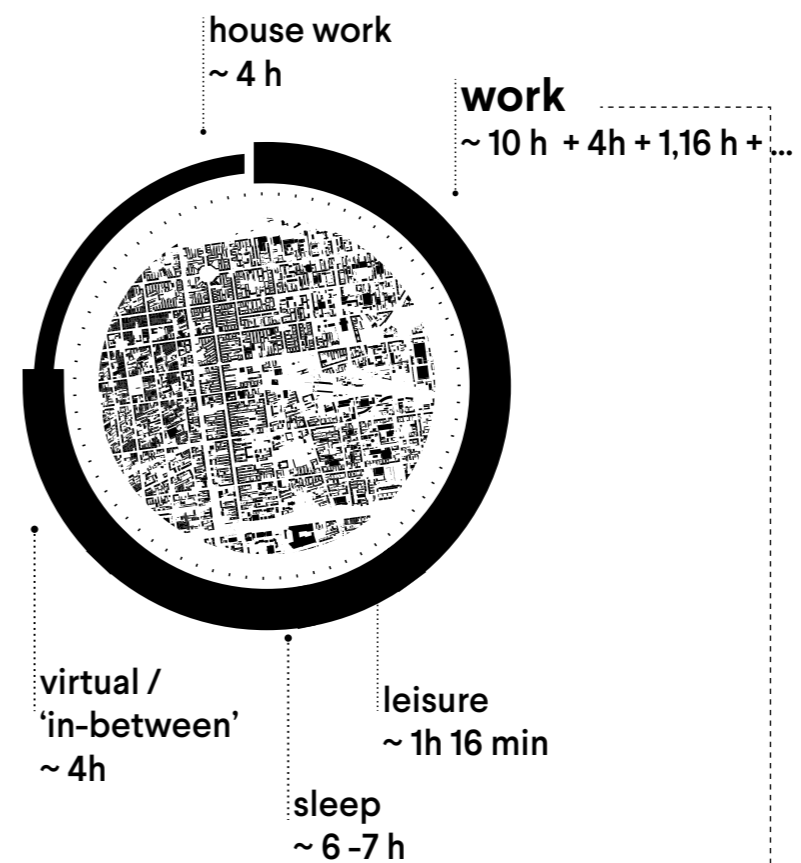
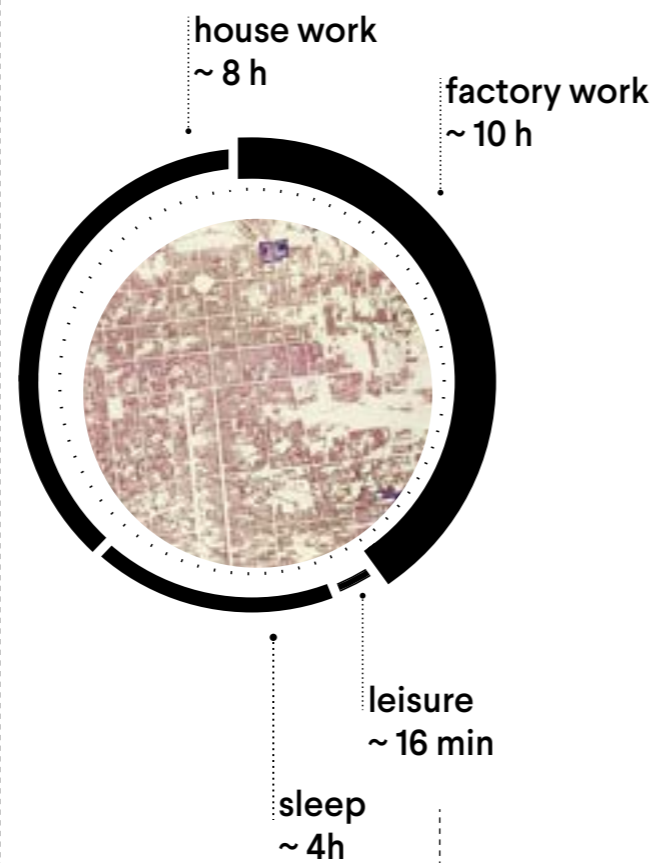

20% time - this is the free time of a Google Inc employee that the company offered to pay for, taking advantage of the employees' creativity while doing nothing

ABSTRACTING
THE HOME
PRACTICES OF
WORK AND LEISURE

DECONSTRUCTING
THE MYTHS OF THE
CULTURAL CONSTRUCT
OF CONTEMPORARY DWELLING

DOMESTICATING
THE NON-PRODUCTIVE
WITHIN
THE ARCHITECTURAL PROJECT OF BOREDOM



photos source: National Digital Archive of Poland

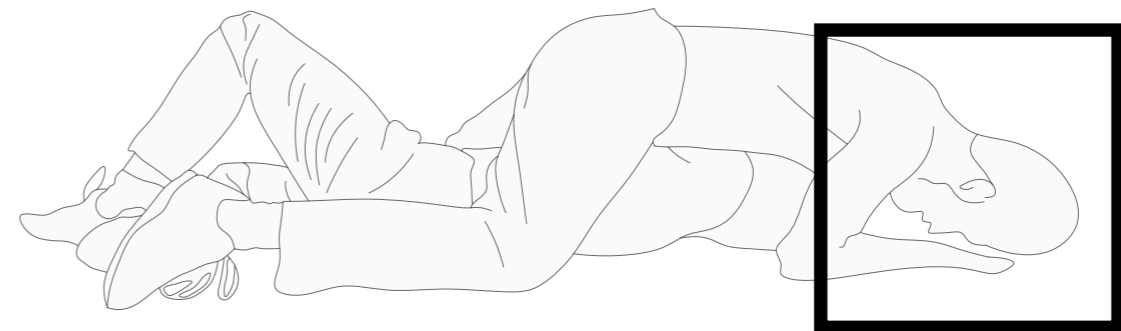

ABSTRACTING
THE HOME
PRACTICES OF
WORK AND LEISURE

DECONSTRUCTING
THE MYTHS OF THE
CULTURAL CONSTRUCT
OF CONTEMPORARY DWELLING

DOMESTICATING
THE NON-PRODUCTIVE
WITHIN
THE ARCHITECTURAL PROJECT OF BOREDOM

There have been considerable changes in the household composition and living arrangements of Europeans: this is particularly true in relation to patterns of family formation, with traditional boundaries becoming increasingly blurred and different types of family nuclei becoming more common. The average age at which people get married has risen, as **an increasing proportion of young people begin their adult lives by living alone or cohabiting**, rather than leaving the parental home when they are ready to marry.

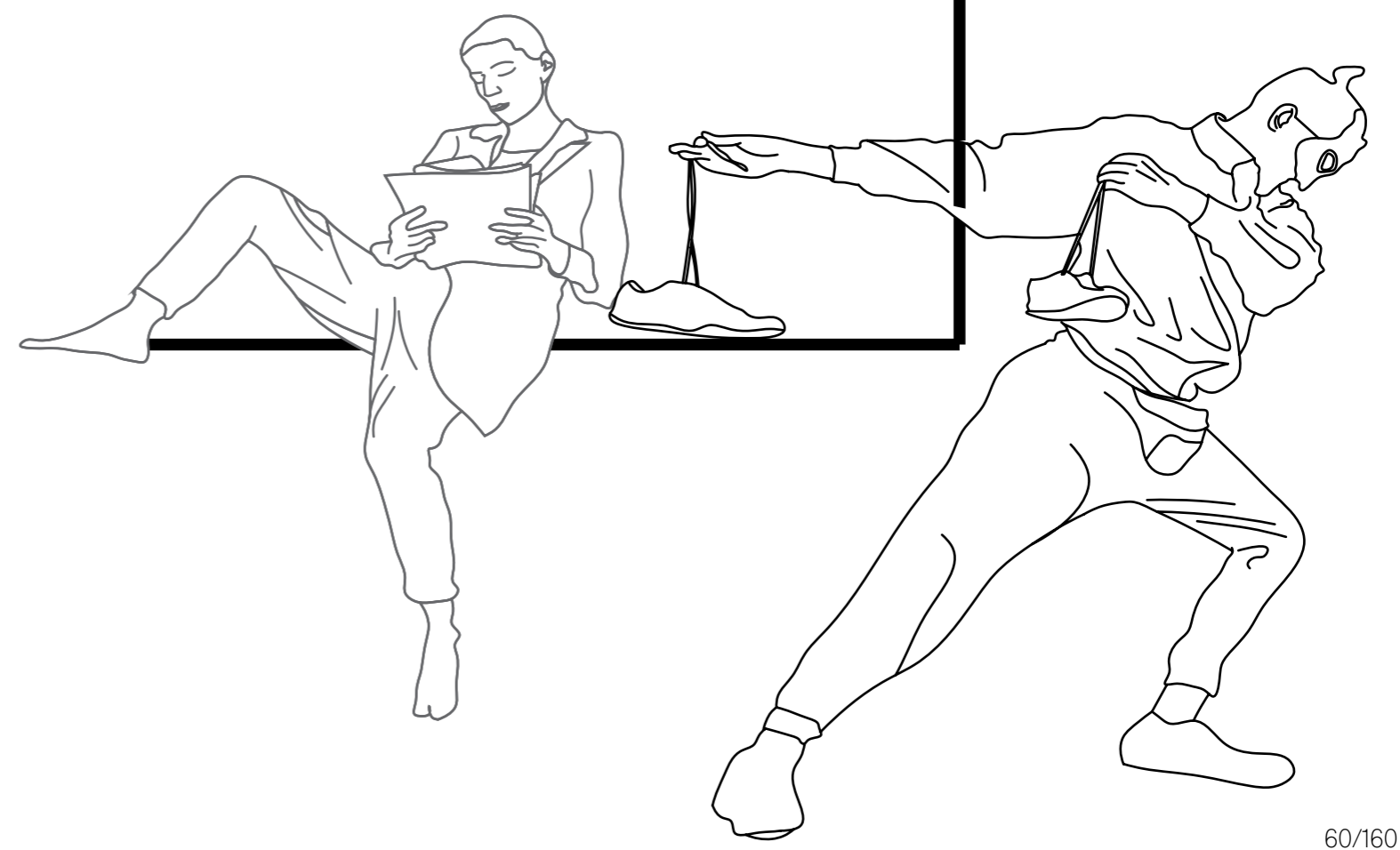
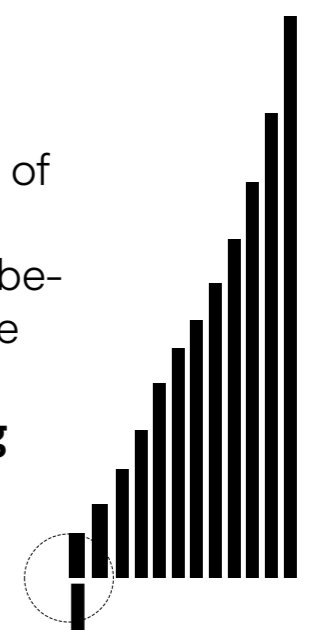

ABSTRACTING
THE HOME
PRACTICES OF
WORK AND LEISURE

DECONSTRUCTING
THE MYTHS OF THE
CULTURAL CONSTRUCT
OF CONTEMPORARY DWELLING

DOMESTICATING
THE NON-PRODUCTIVE
WITHIN
THE ARCHITECTURAL PROJECT OF BOREDOM

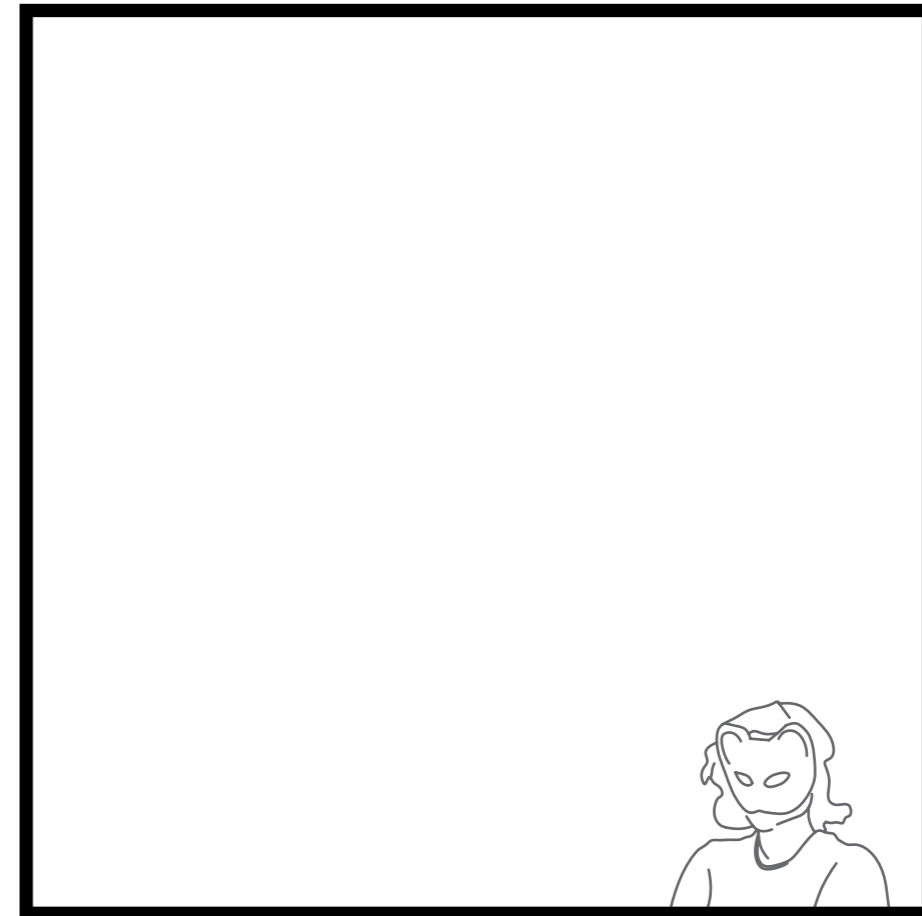

s Bureau had expanded its analysis c
 he term "unrelated individuals" to d
 en the percentage of persons living
 nt of all people during the last 40 ye



A New Way of Living.

WeLive is a new way of living built upon community, flexibility, and a fundamental belief that we are only as good as the people we surround ourselves with. From mailrooms and laundry rooms that double as bars and event spaces to communal kitchens, roof decks, and hot tubs, WeLive challenges traditional apartment living through physical spaces that foster meaningful relationships. Life is better when we are part of something greater than ourselves. Whether for a day, a week, a month, or a year, by joining WeLive - you'll be psyched to be alive.



Communal Living Is Alleviating Millennial Ennui

With six adults per apartment, a new approach to building community in Brooklyn focuses on

JAMES HANLIN | JUL 29, 2015

Share Tweet

Let's talk

Tell us a bit about yourself and we will be in touch.

Name
 Aleksandra Gordowy
 Email
 ola.gordowy@gmail.com
 Phone number
 795469735

Preferred move-in date

Required

- Over \$3,000
- \$2,500 to \$3,000
- \$2,000 to \$2,500
- \$1,500 to \$2,000
- \$1,200 to \$1,500
- Less than \$1,200

Submit

BUSINESS INSIDER

INTERNATIONAL

Millennials are paying thousands of dollars a month for maid service and instant friends in modern 'hacker houses'

Mike Robinson

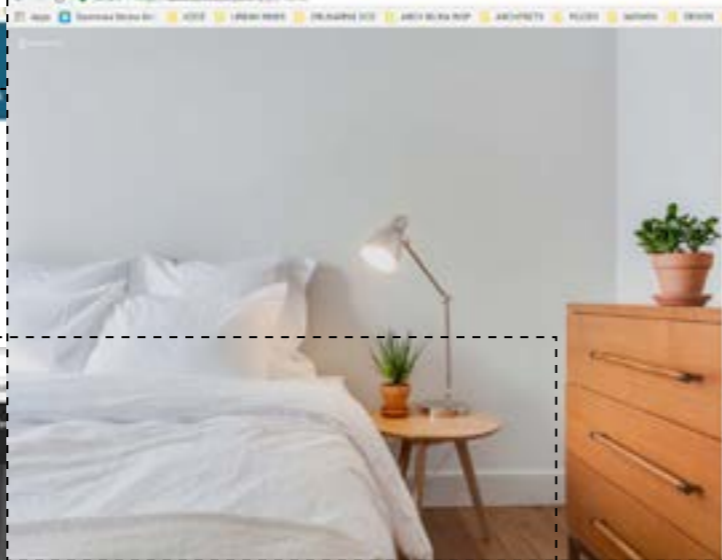

clipster

Welcome to the first in Poland live-in business incubator

Be a part of our fast like a rocket pre-acceleration program and join us for the next 3 crazy months

APPLY

Deadline for applications - 17.05.2017



Home. Made.

Shared housing for those who live life in common.

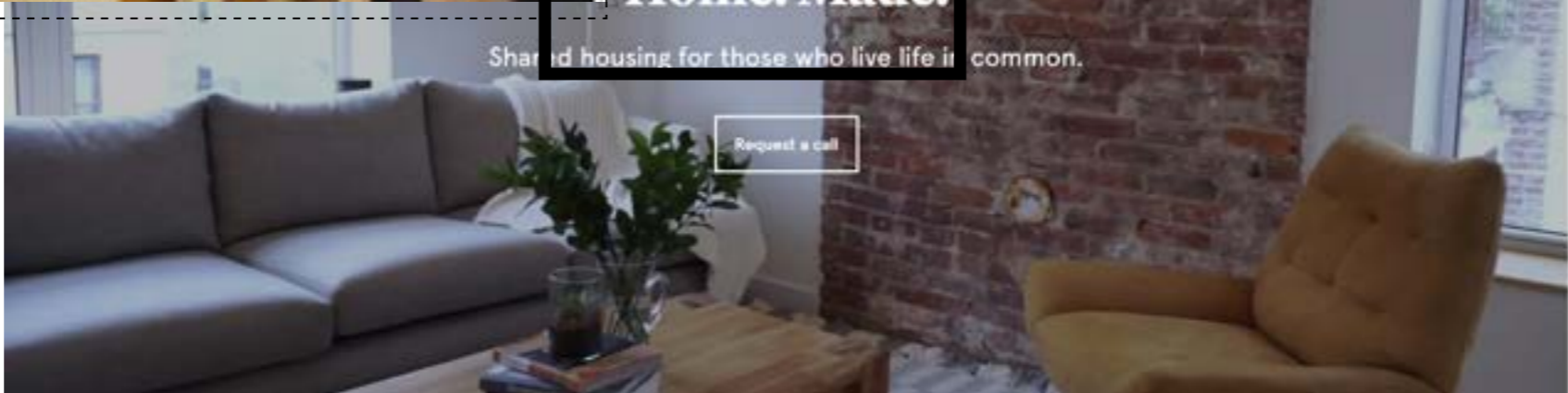

Request a call

ABSTRACTING



DECONSTRUCTING



DOMESTICATING

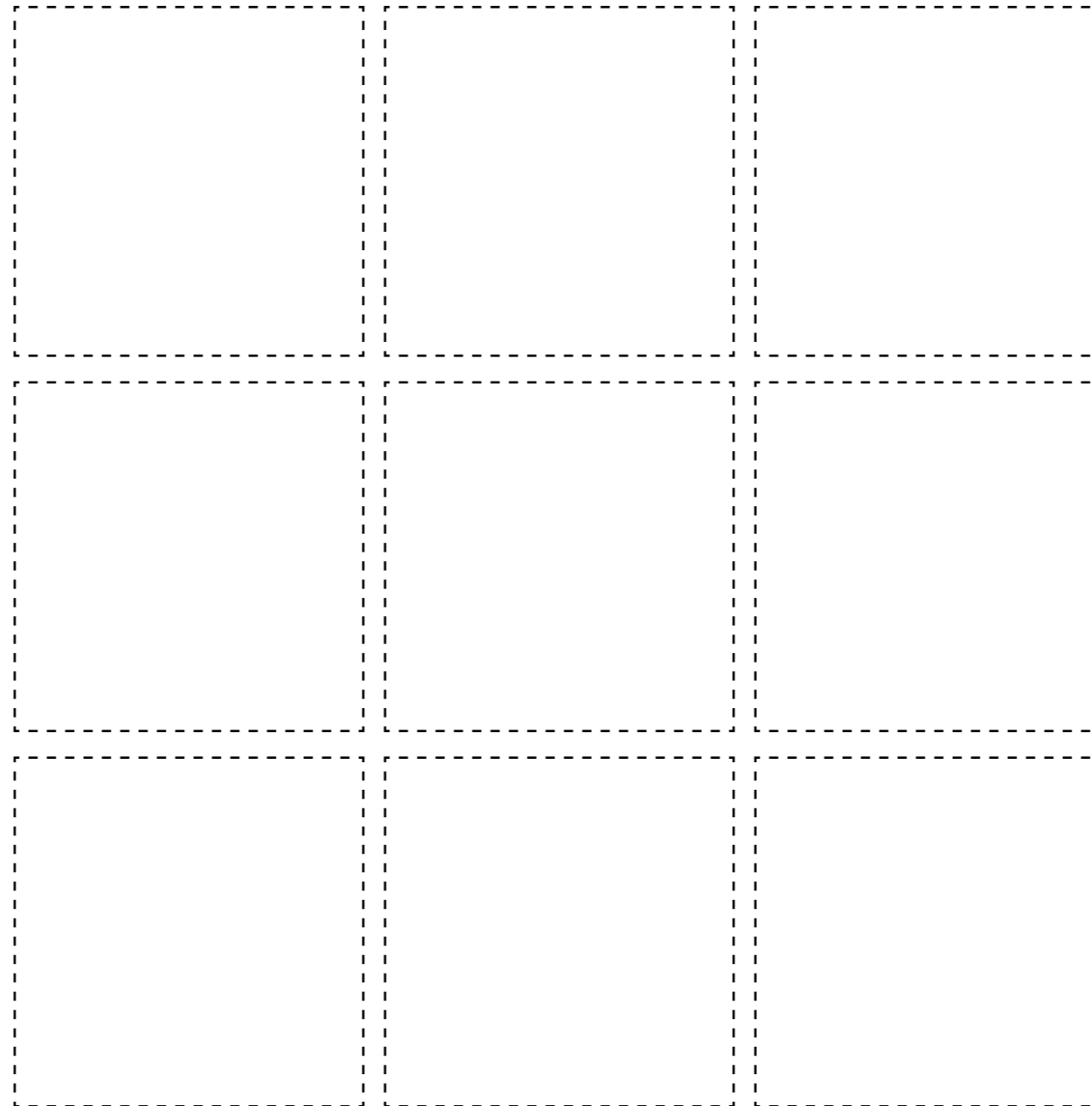

ABSTRACTING



DECONSTRUCTING



DOMESTICATING

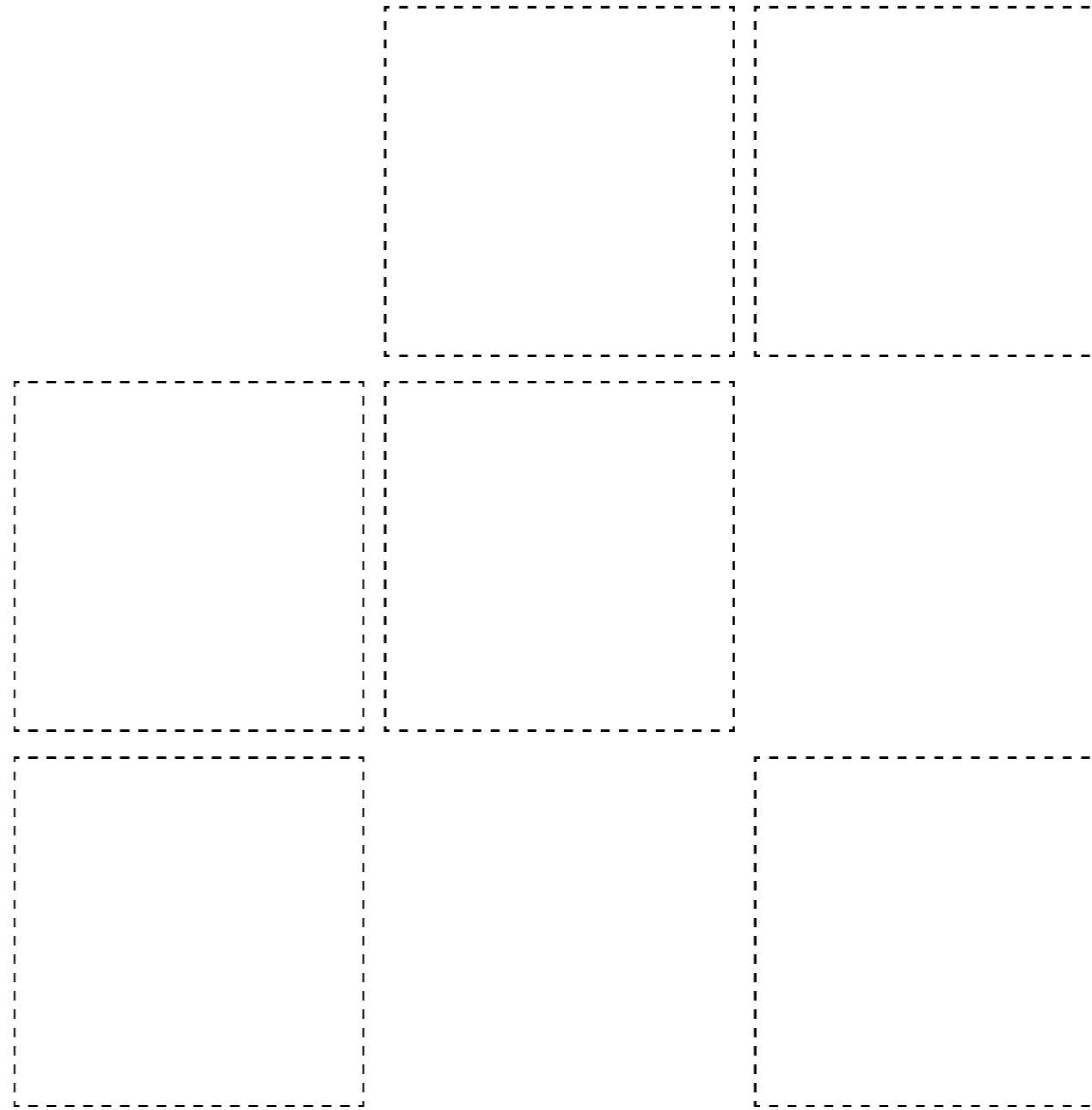

ABSTRACTING



WORK

DECONSTRUCTING



LEISURE

DOMESTICATING

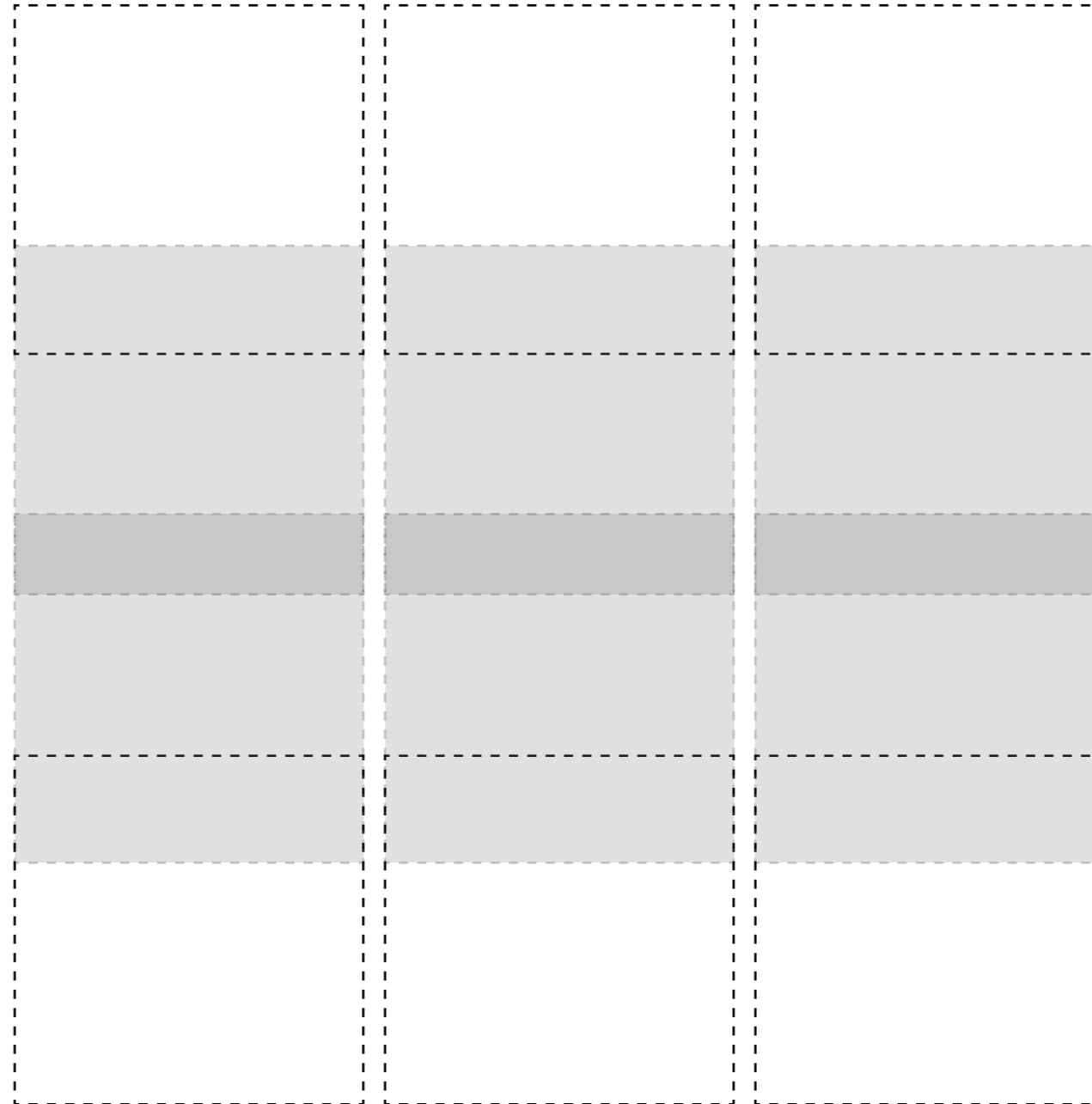

WORK

ROUTINE

BOREDOM

LEISURE

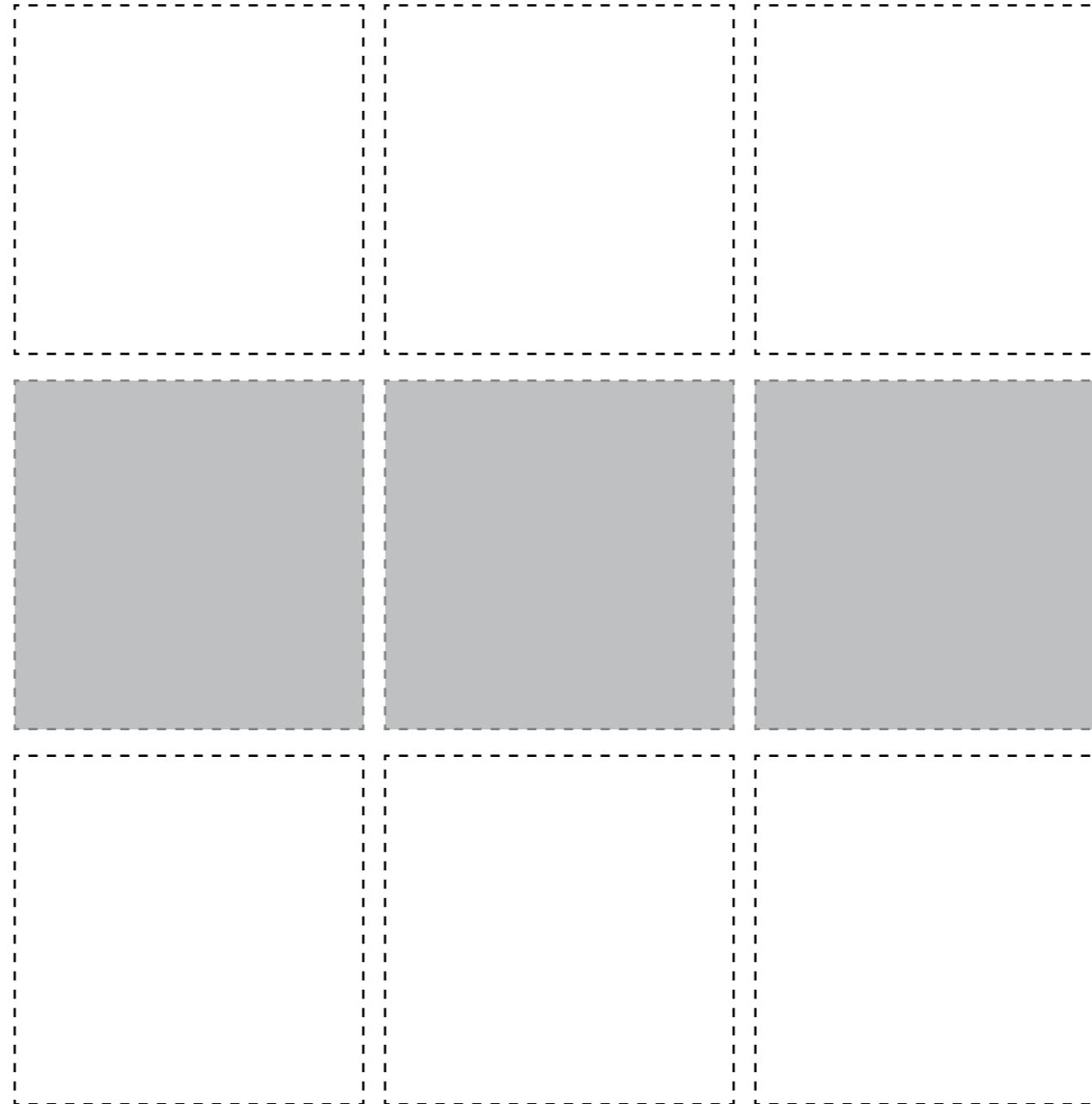

WORK

ROUTINE

LIVING

BOREDOM

LEISURE

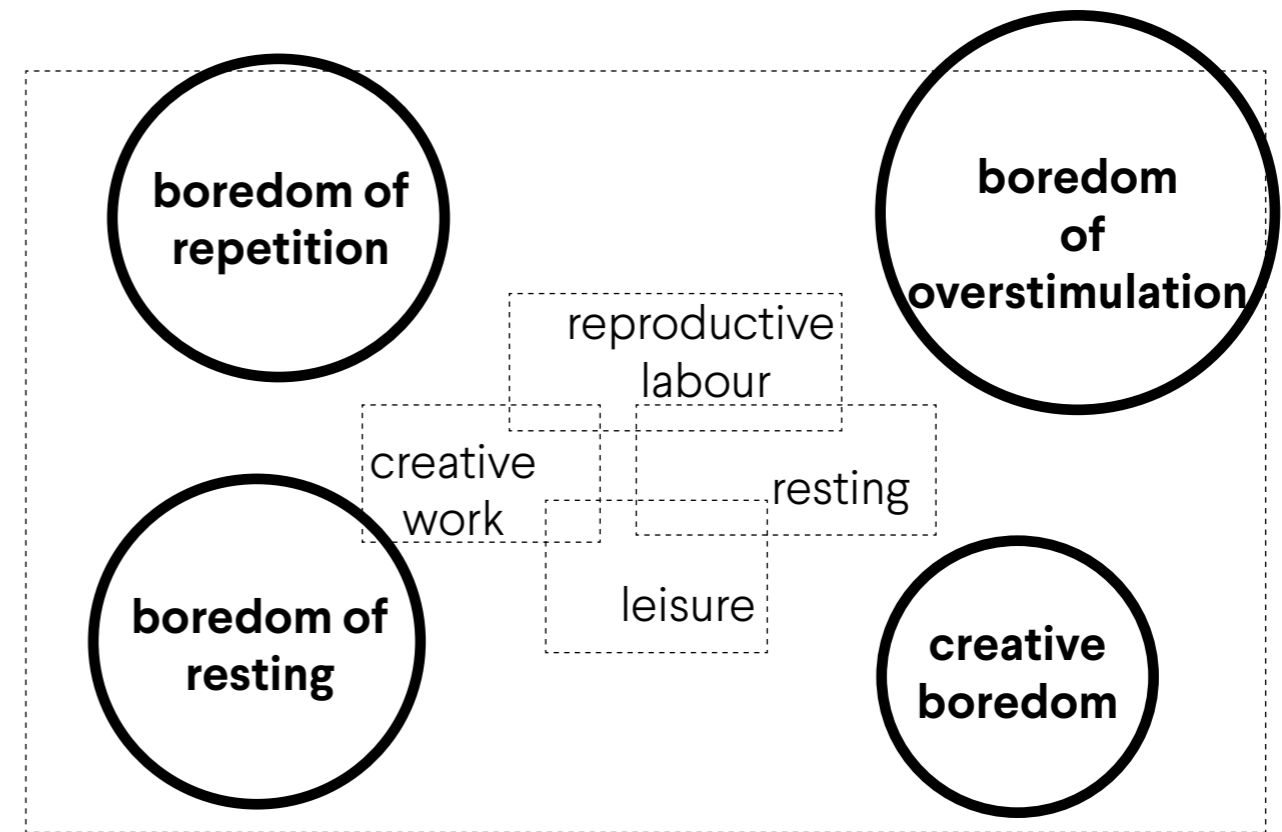
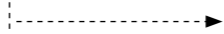
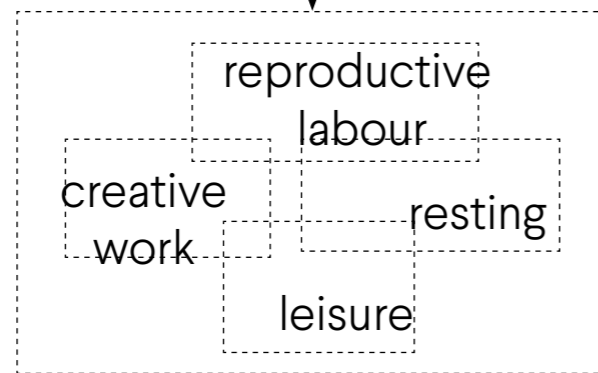
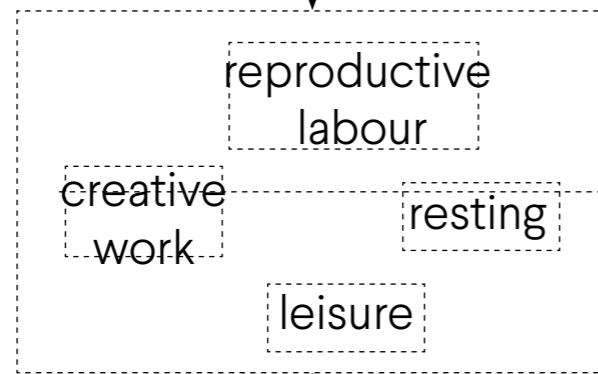
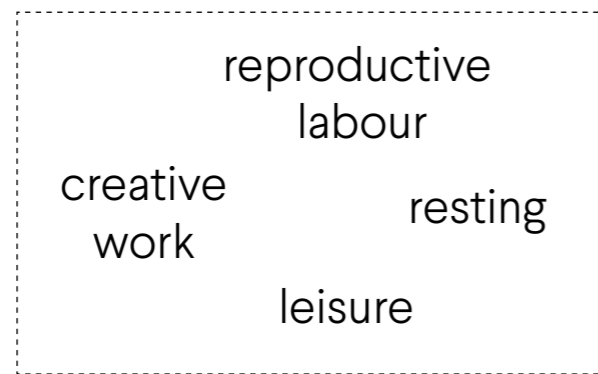

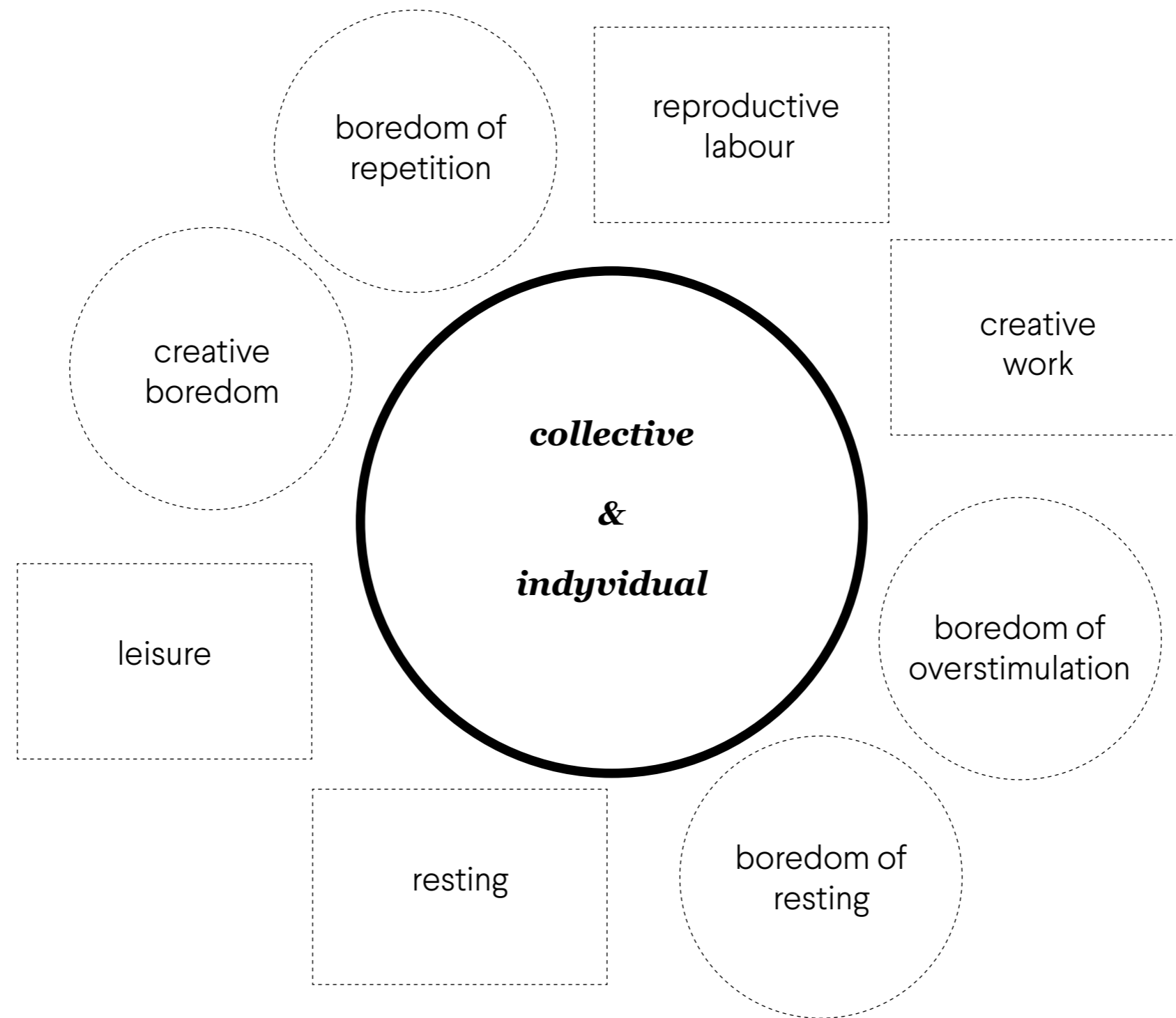

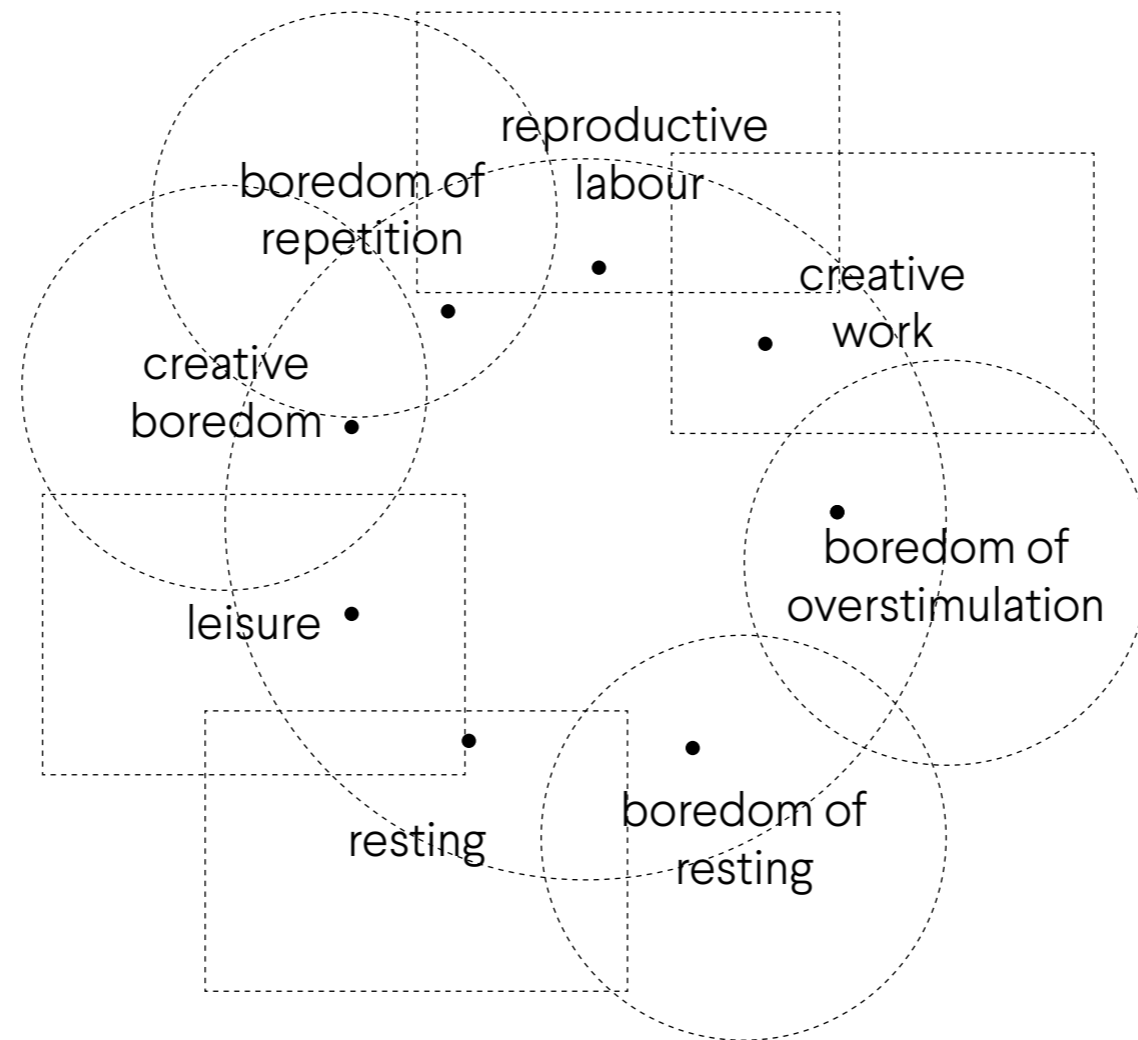

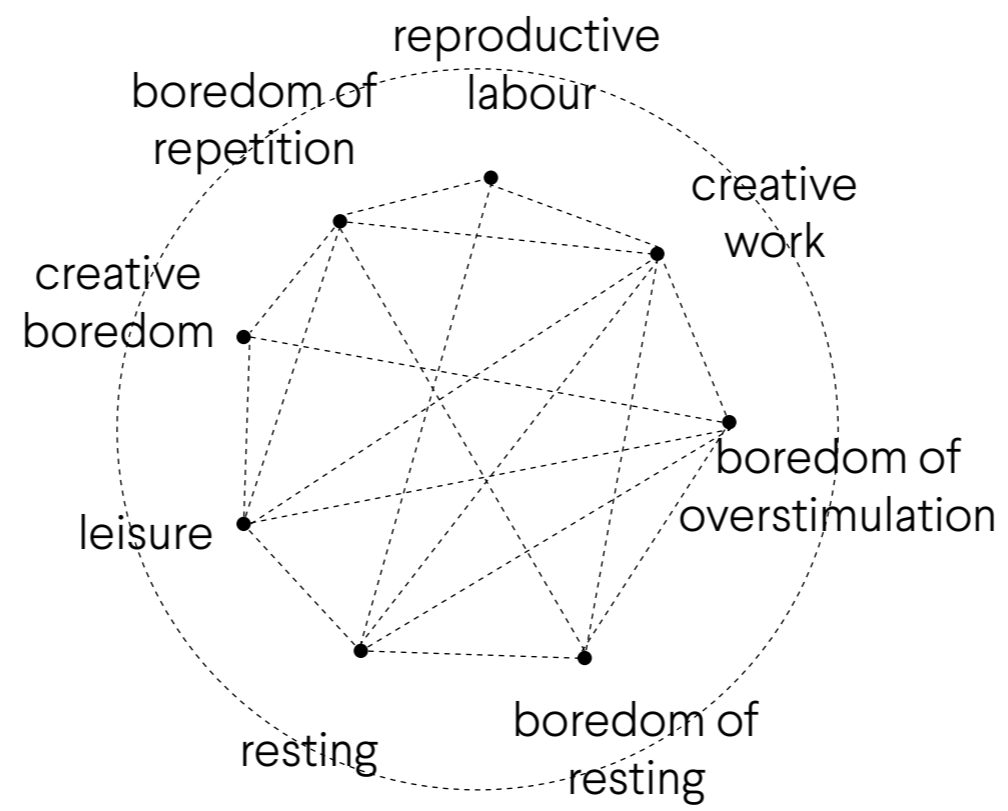

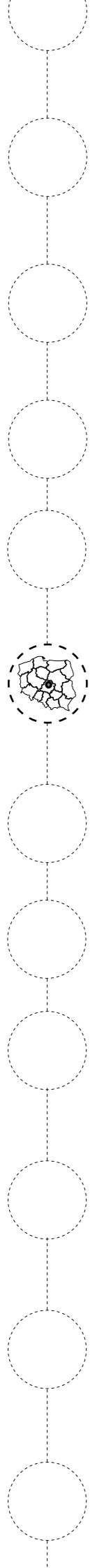

3.4

Tenement

typology

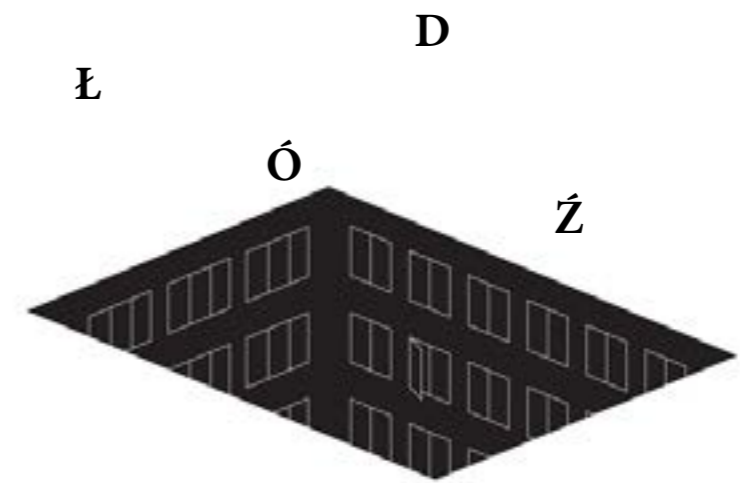

FROM SINGLE TO MULTIFAMILY

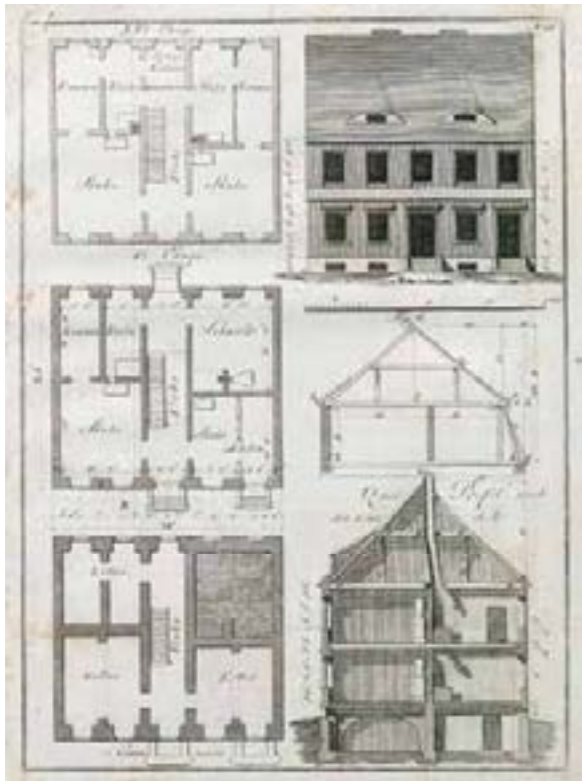

model two-families city house, 1799

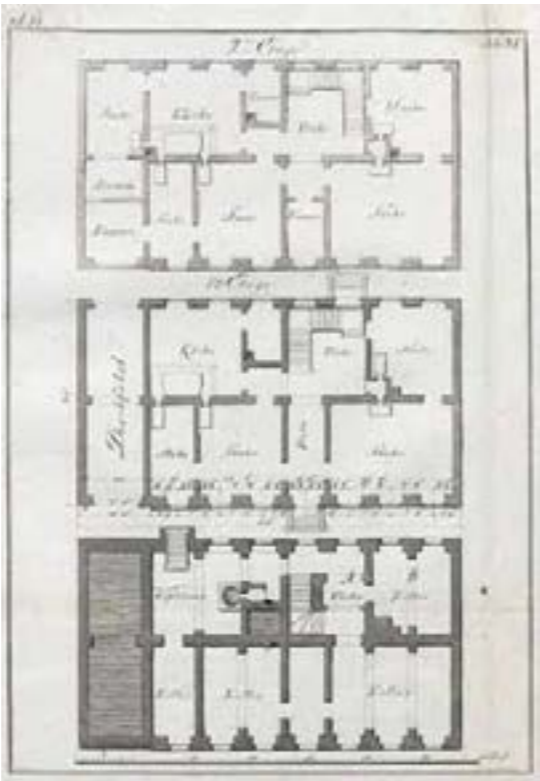

model tenement with the drive-through gate, 1799

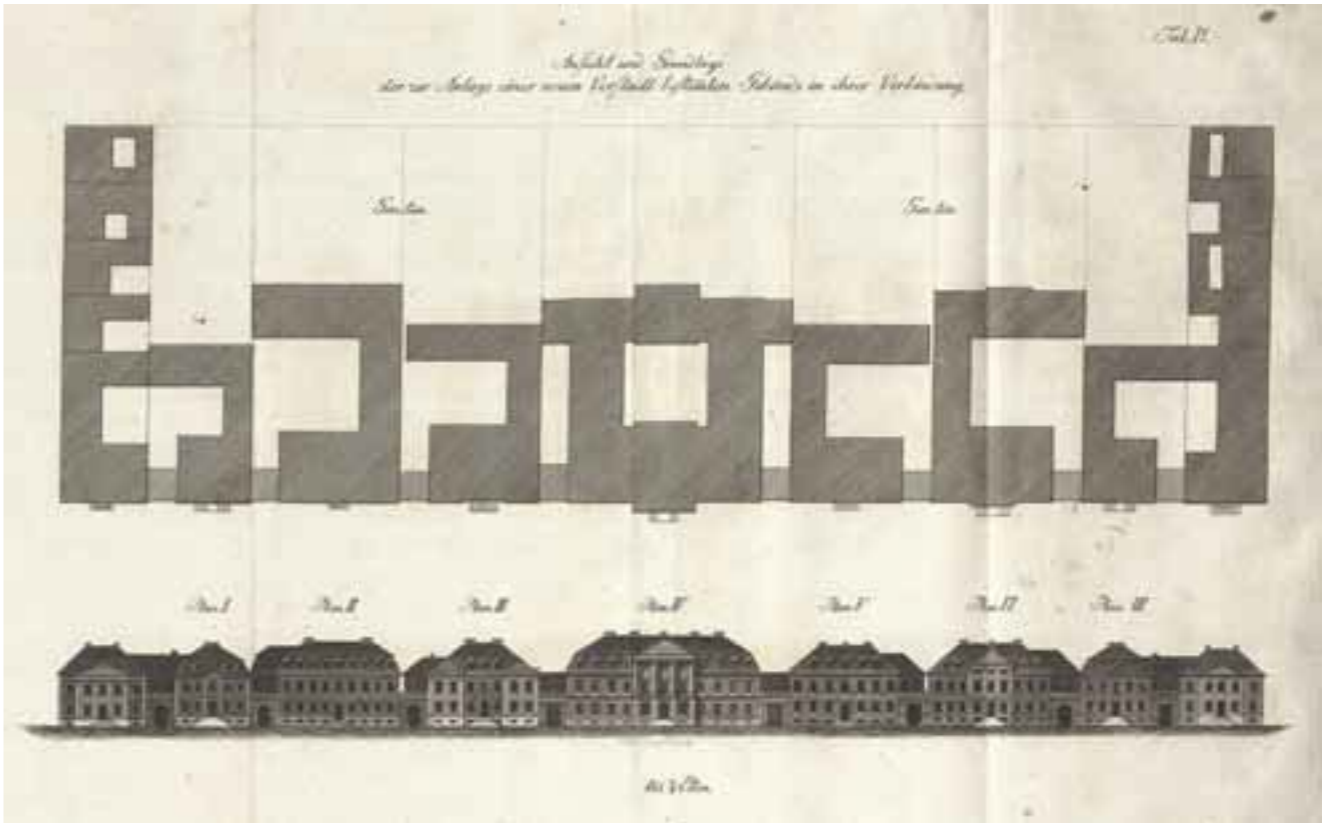

parataxis - architectural composition made out of single elements - facades in this case, 1799

THE ALEGORY OF SOCIAL STRUCTURES

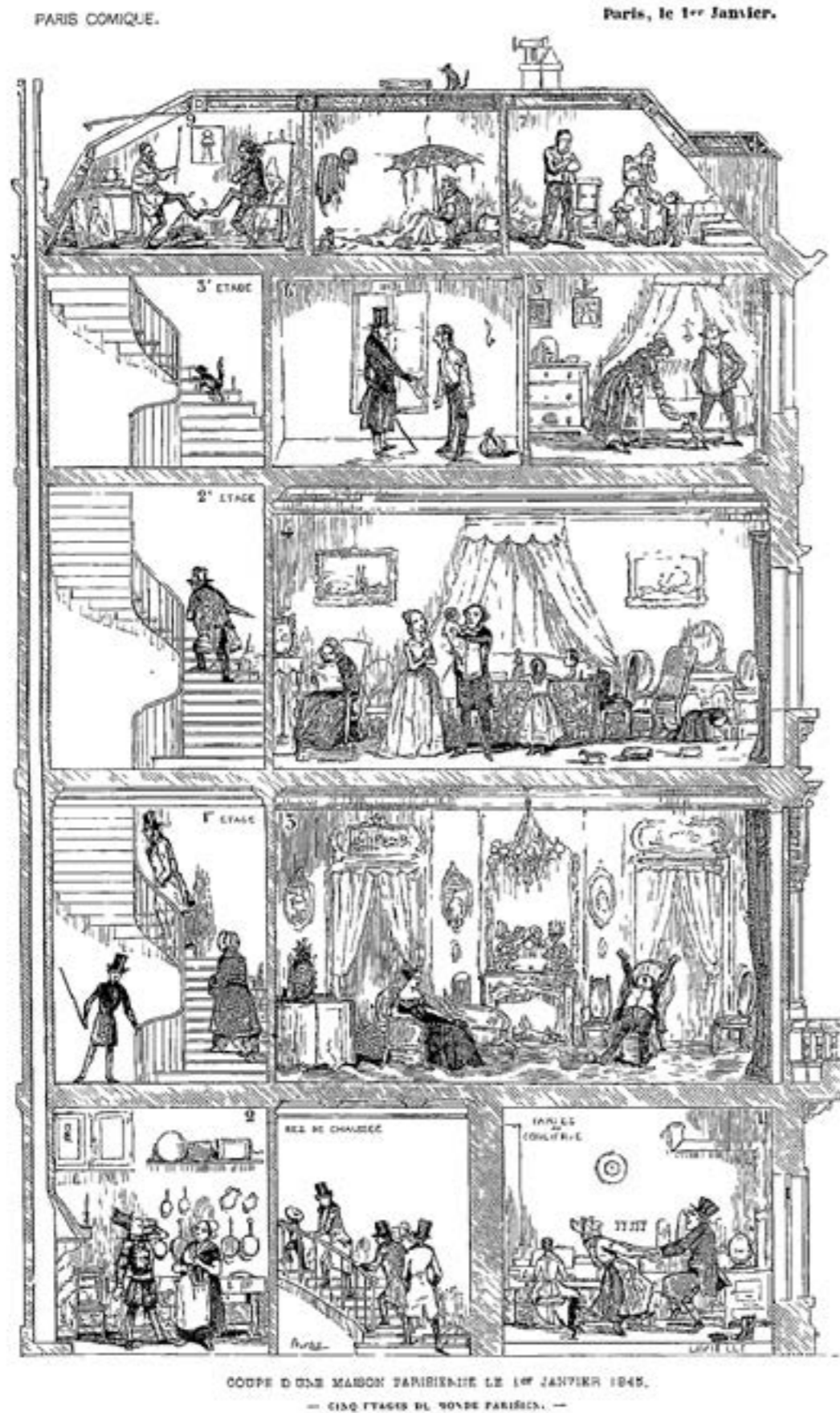

Tenement is not a building in the literally meaning. It is rather a binary, dual set, comprising of the facade and functional-constructional structure. The entire thing is sort of a cell making off the urban tissue of the city...

Michał Domińczak, Artur Zaguła, *Typologia Łódzkiej Kamienicy*





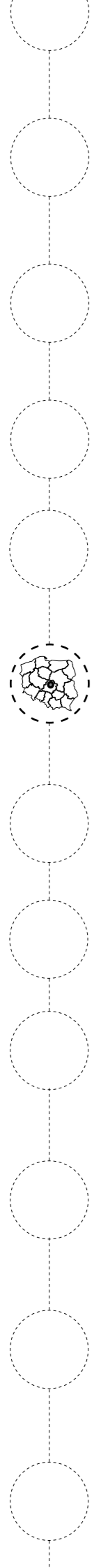

3.4

4 scales of intervention

working plane

SCALE

URBAN

city

ARCH

building

FURN

furniture

TIME

city

ACTION

transformations within the
culturally, historically and ar-
chitecturally constructed city
block;

setting up a **strategy**

transformations within existing tenements and be-
tween them;
changing the relationship between the two neigh-
bouring buildings;
optimazing the quality by filling in the missig parts
setting up a **new typology of an appartement**
within existing structure

changing the constelations
of furniture and by installing
mobile walls **playing with the
disappearance and reap-
pearance** of the objects/fur-
niture;
zoning activities by isolating
single pieces of furniture

RESULT

**WELL PRESERVED HIS-
TORICAL CITY FABRIC,
INTENSIFICATION OF
ITS PRIMARY FUNCTION -
HOUSING,
NEW TYPOLOGY WITHIN
OLD STRUCTURES**

**UPGRADED SOCIAL
STRUCTURES, LIVING
AND WORKING CON-
DITIONS,
POSSIBILITY OF DIS-
CUSSION UPON A
HEALTHIER PHILOSO-
PHY OF LIVING**

**INTRODUCING A NEW WAY OF THINKING
ABOUT THE INTERIOR;
TAKING ADVANTAGE OF THE SPACE OPEN
FOR CONSTANT
RE-INTERPRETATION;
DECONSTRUCTING CULTURAL AND POLIT-
ICAL BURDEN ATTACHED TO OBJECTS OF
EVERYDAY USE**

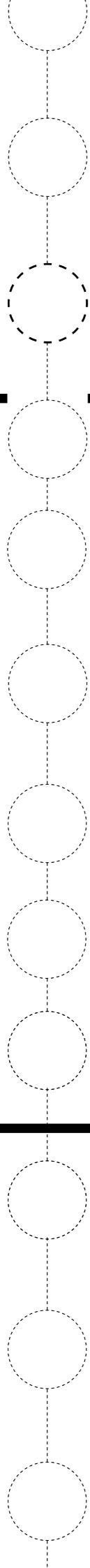

IV

RESEARCH CONCLUSION

3 lines of problem statement

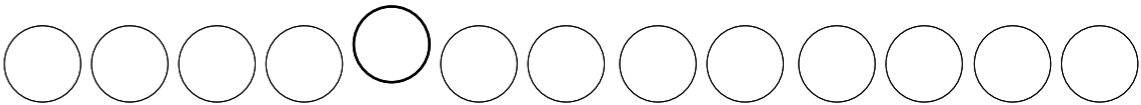

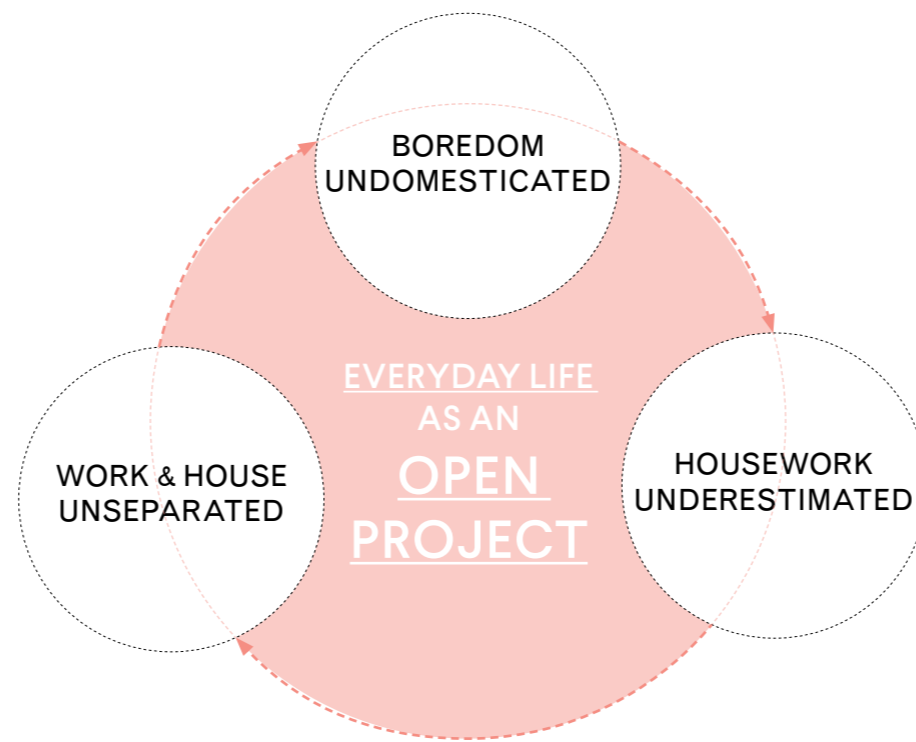

DESIGN

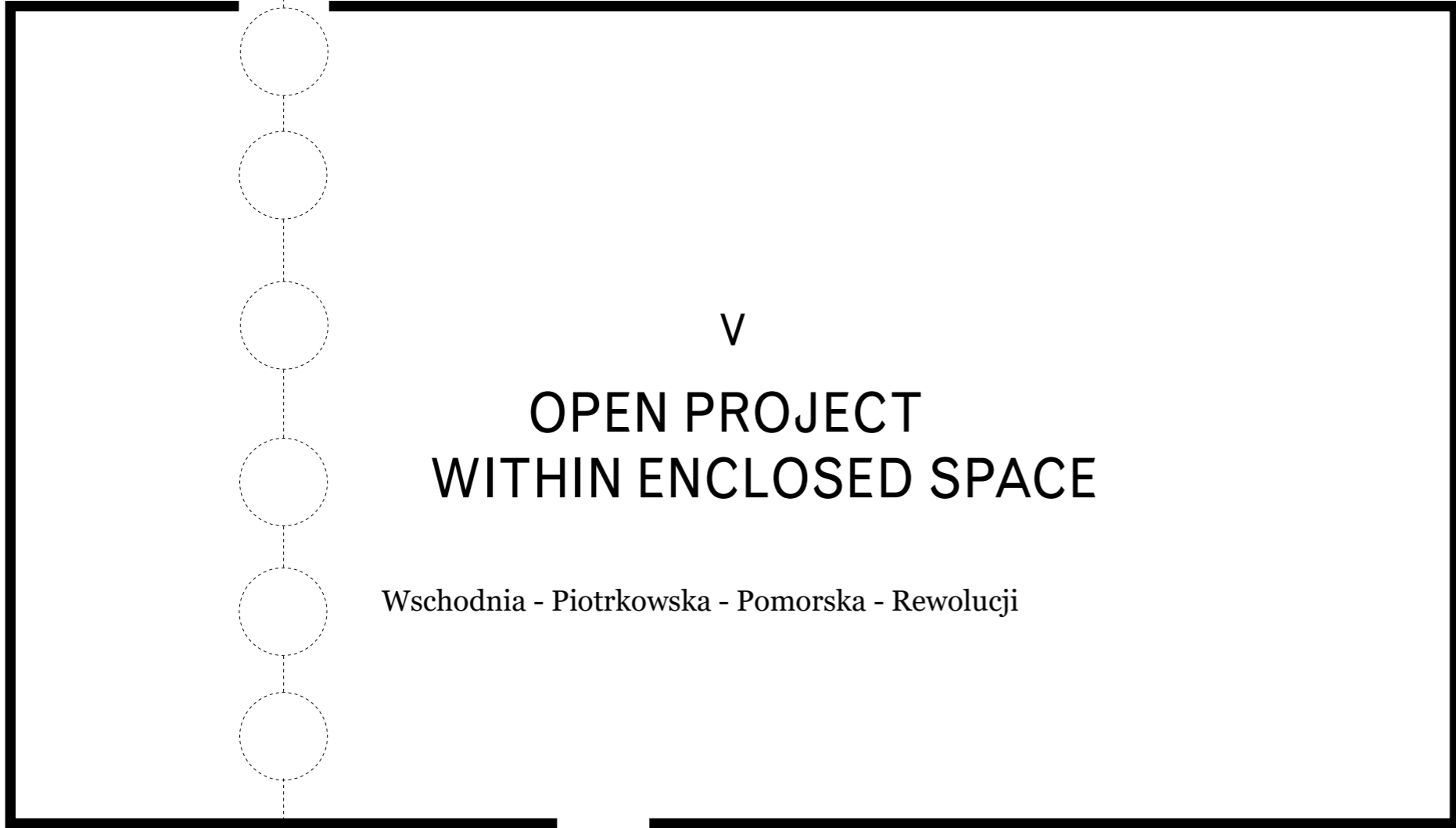
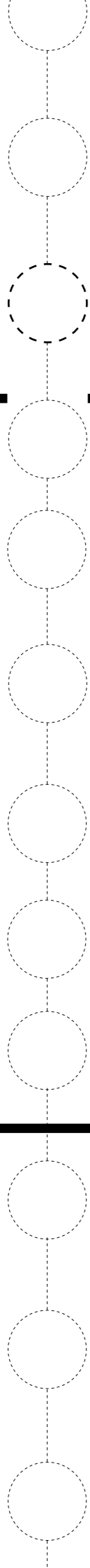

V
OPEN PROJECT
WITHIN ENCLOSED SPACE

Wschodnia - Piotrkowska - Pomorska - Rewolucji

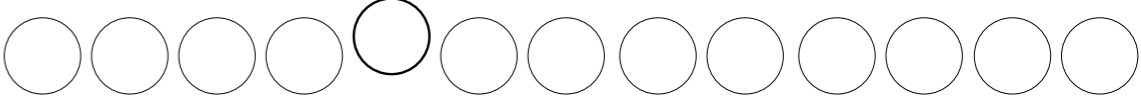



IN - BETWEEN

URBAN

city

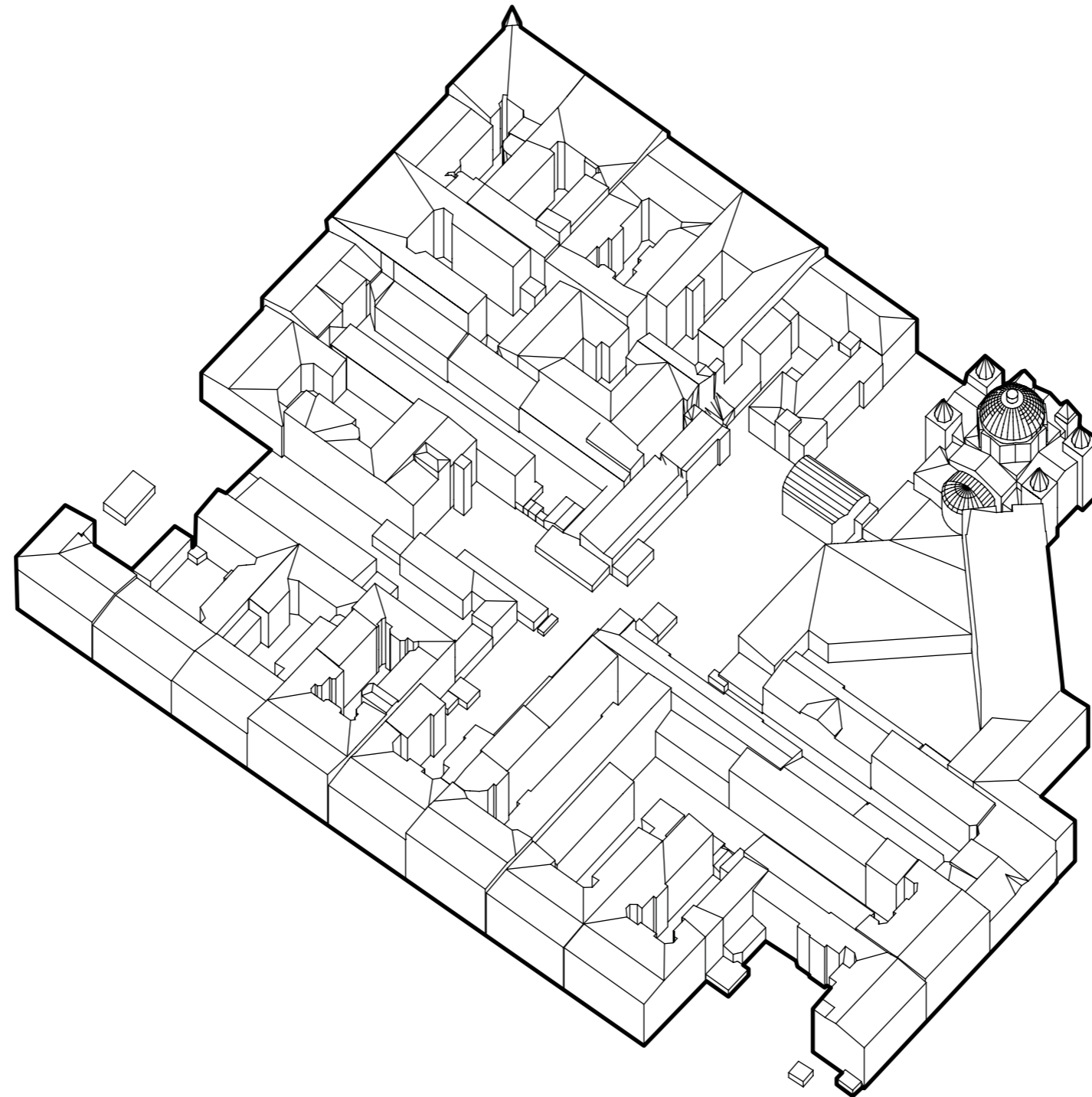

4

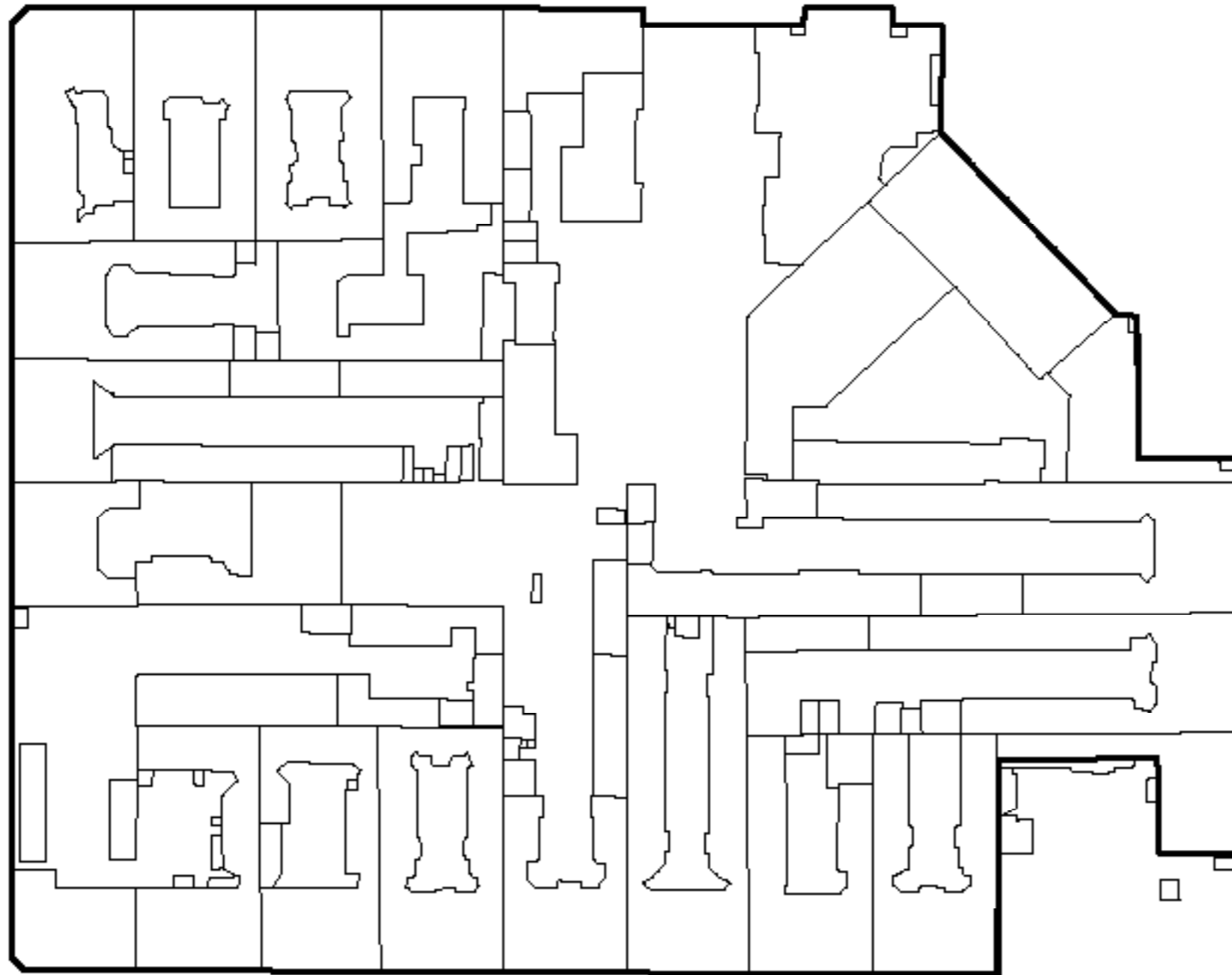

4

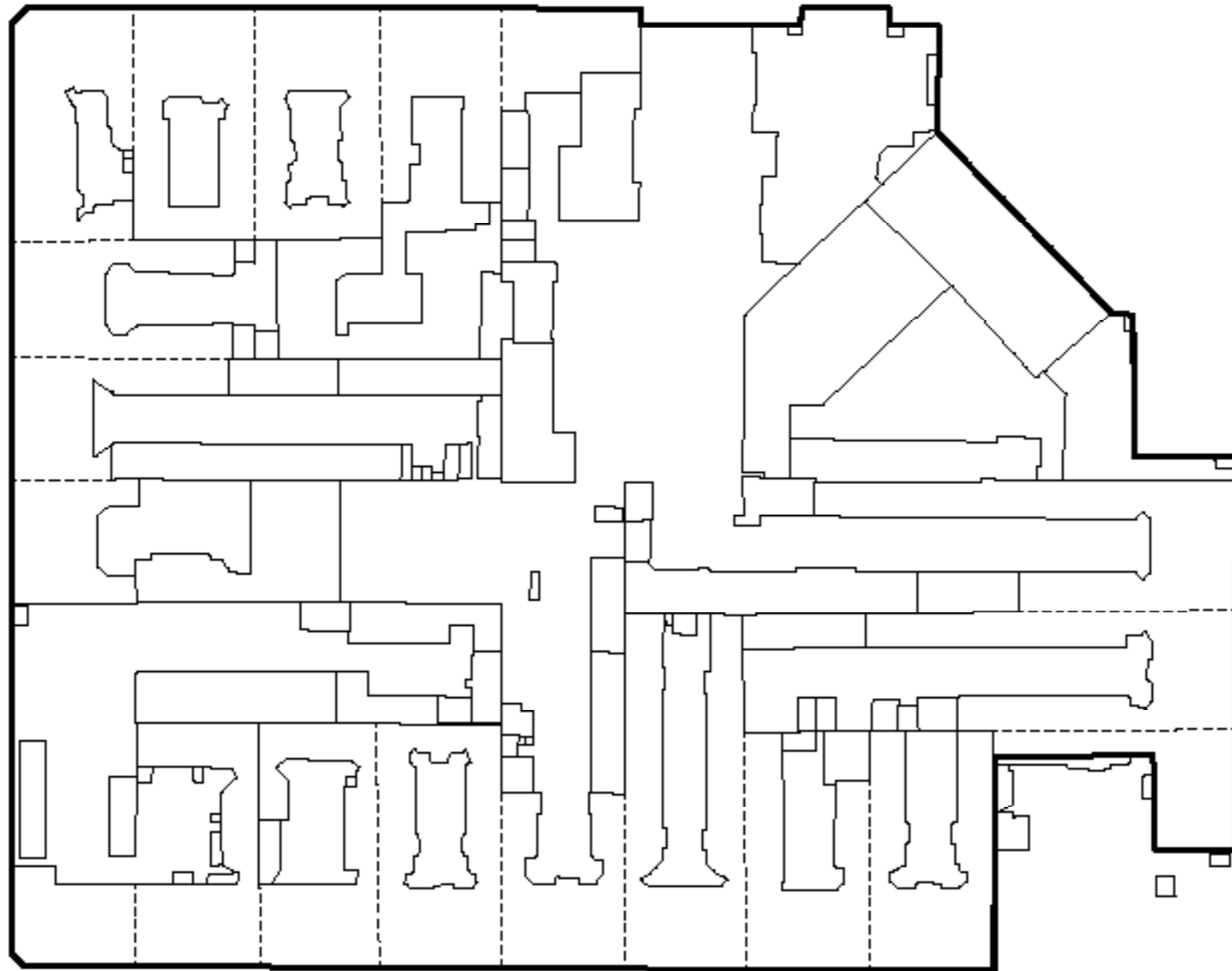

4

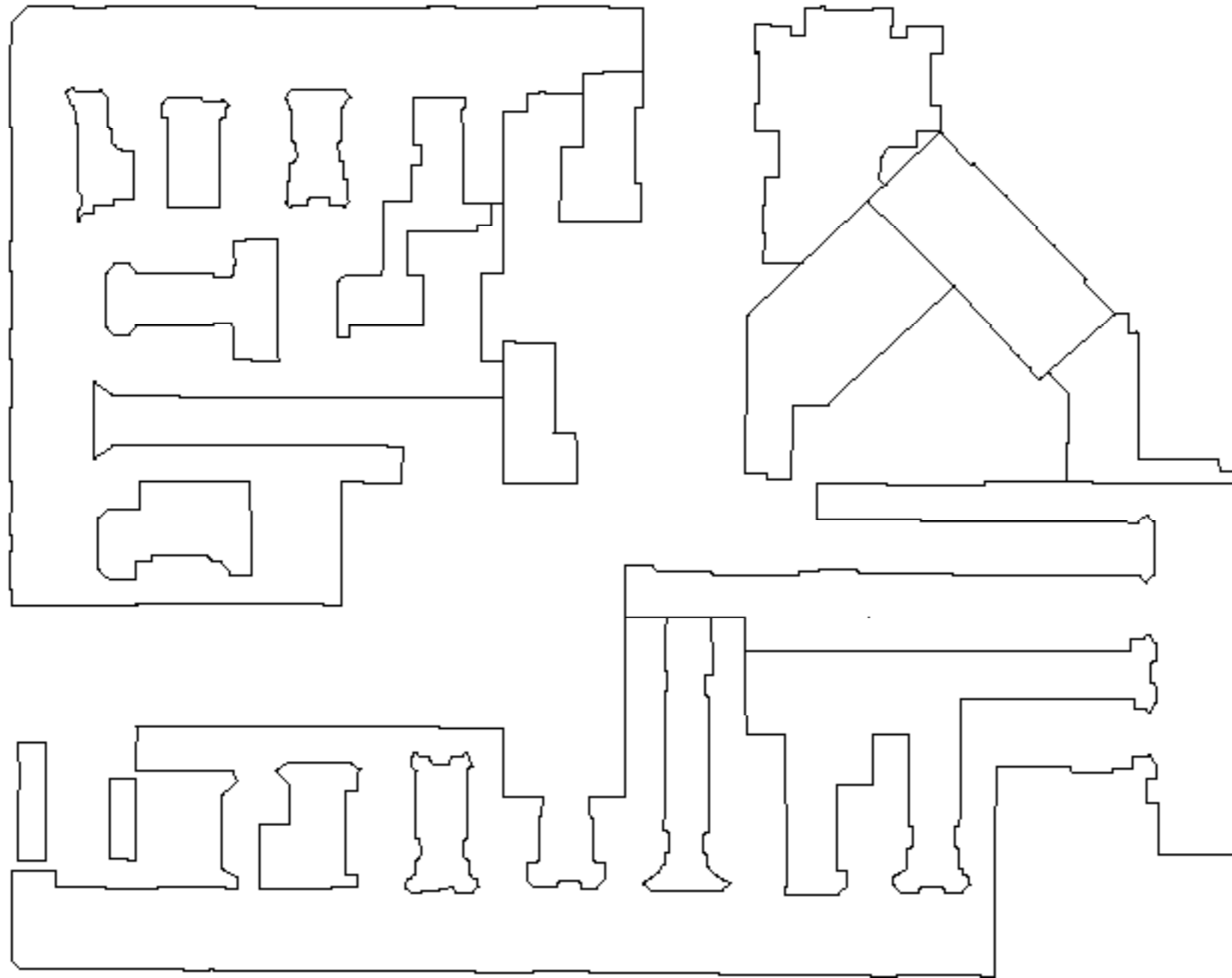

4

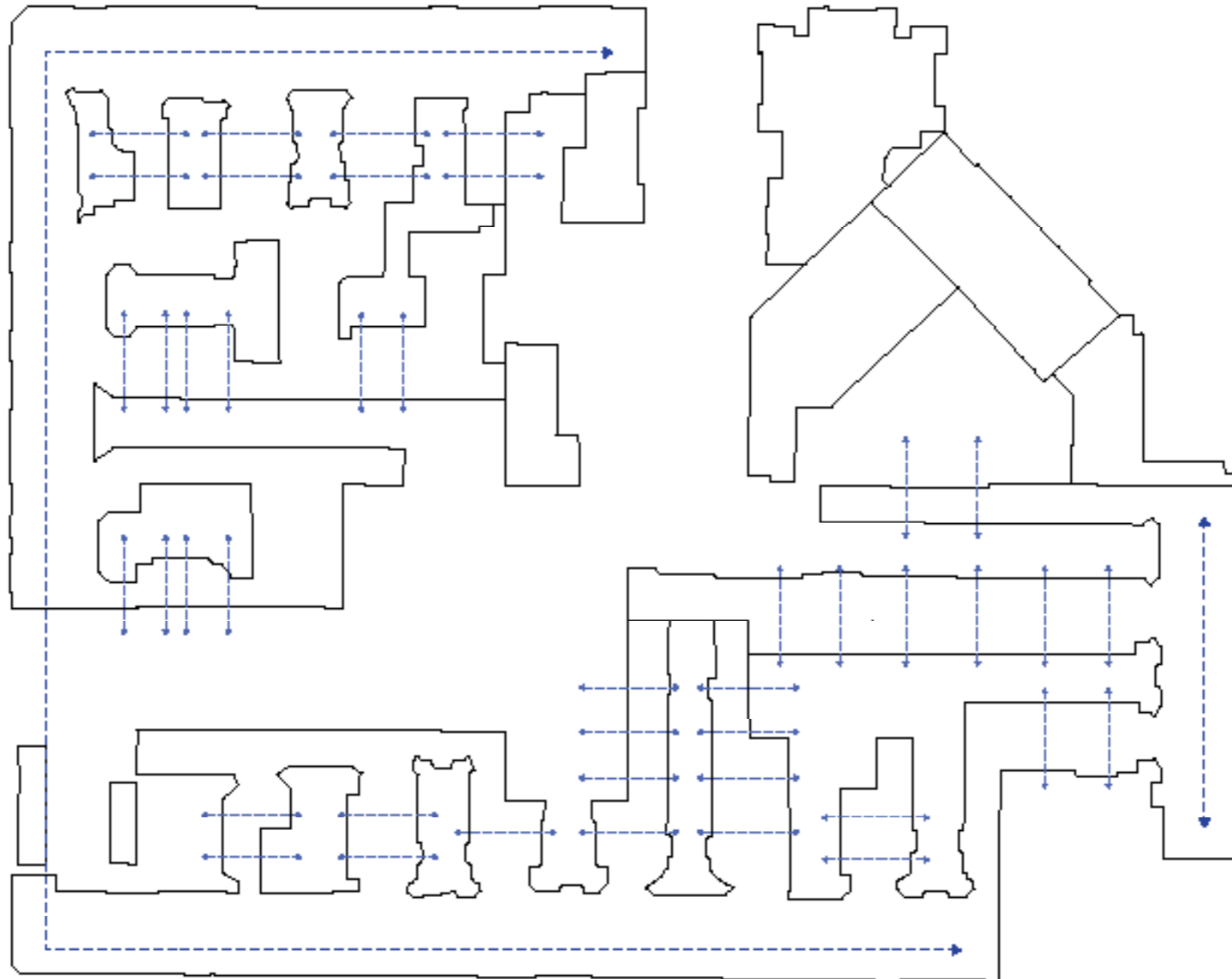

ARCH
building

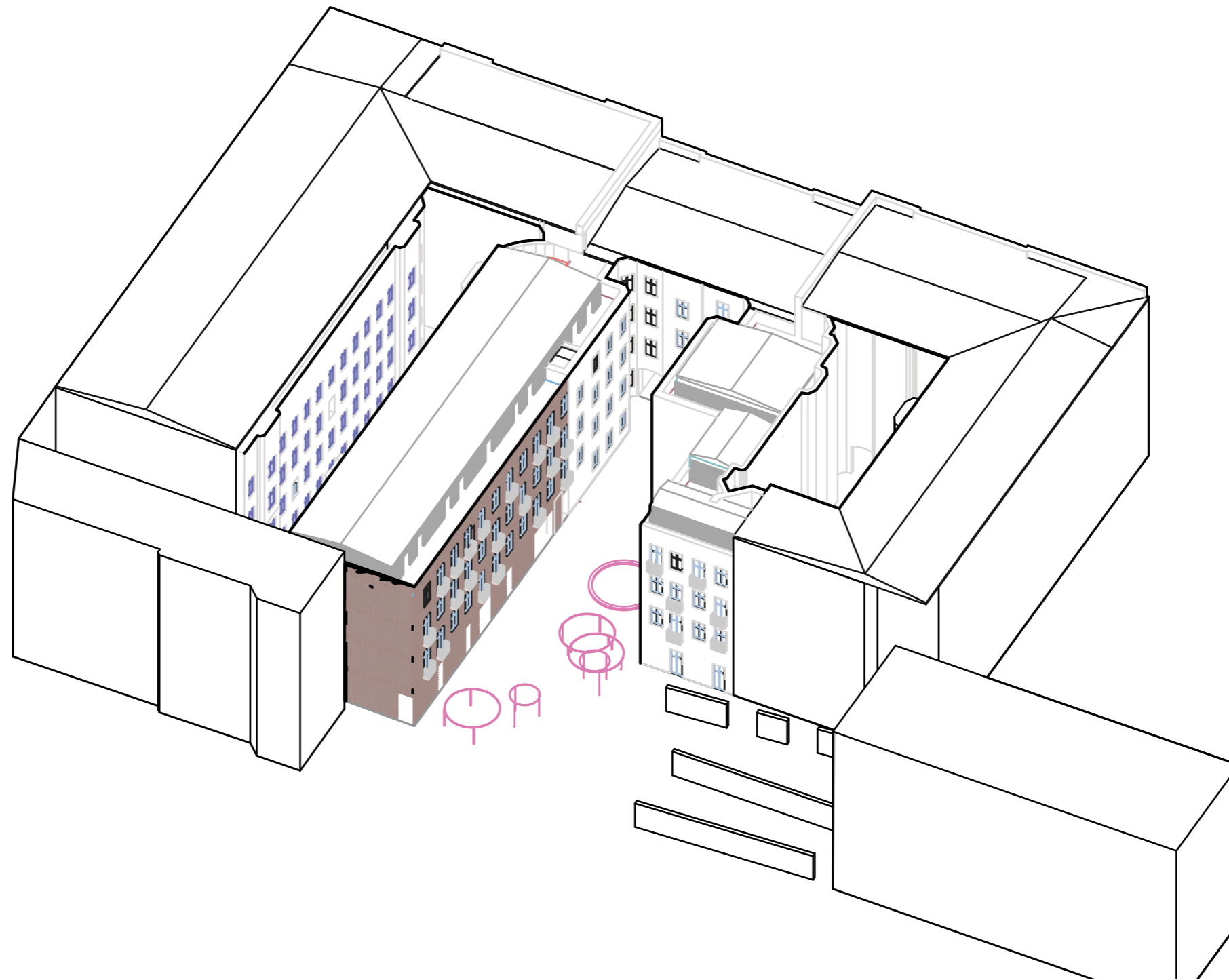

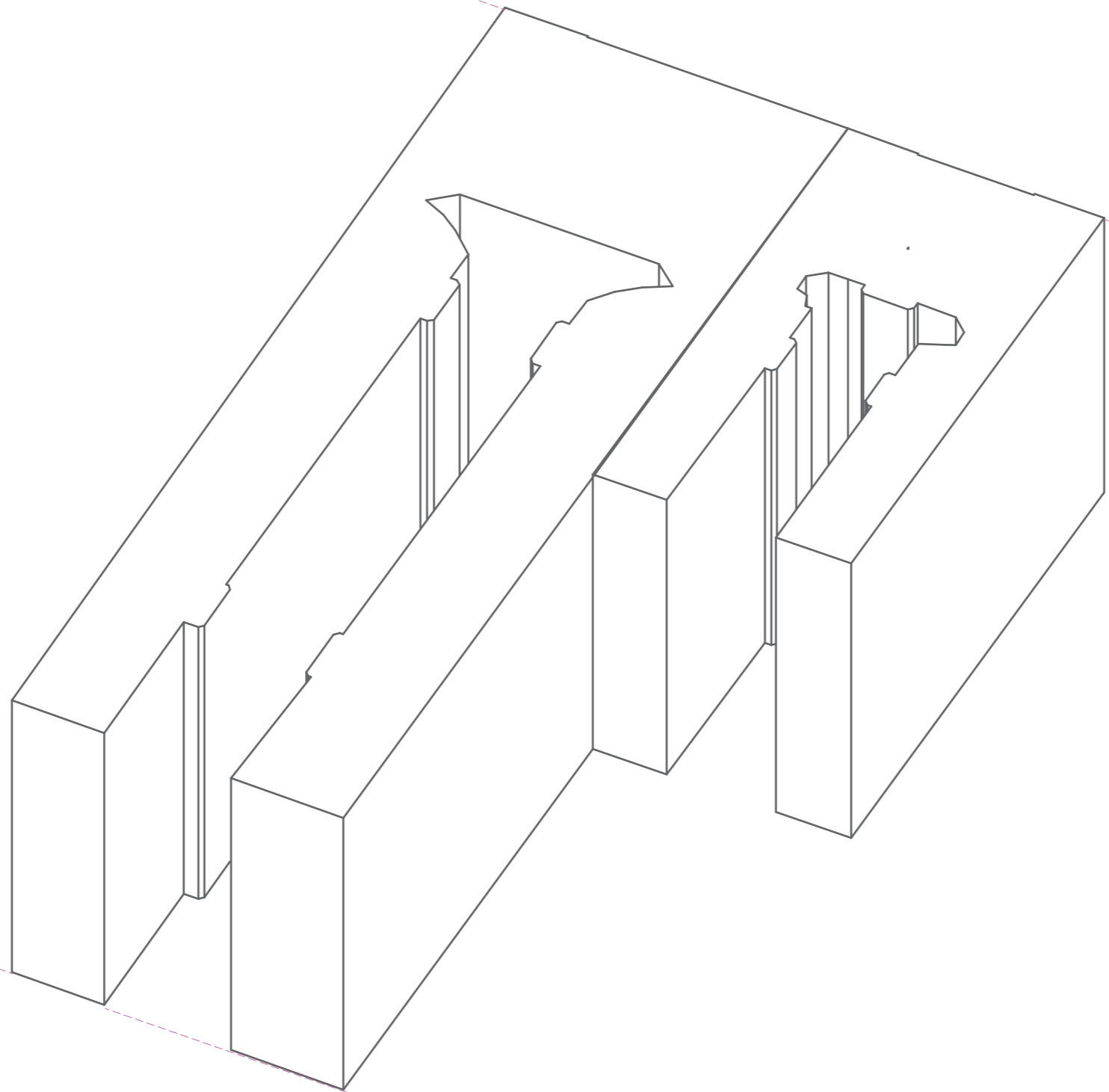

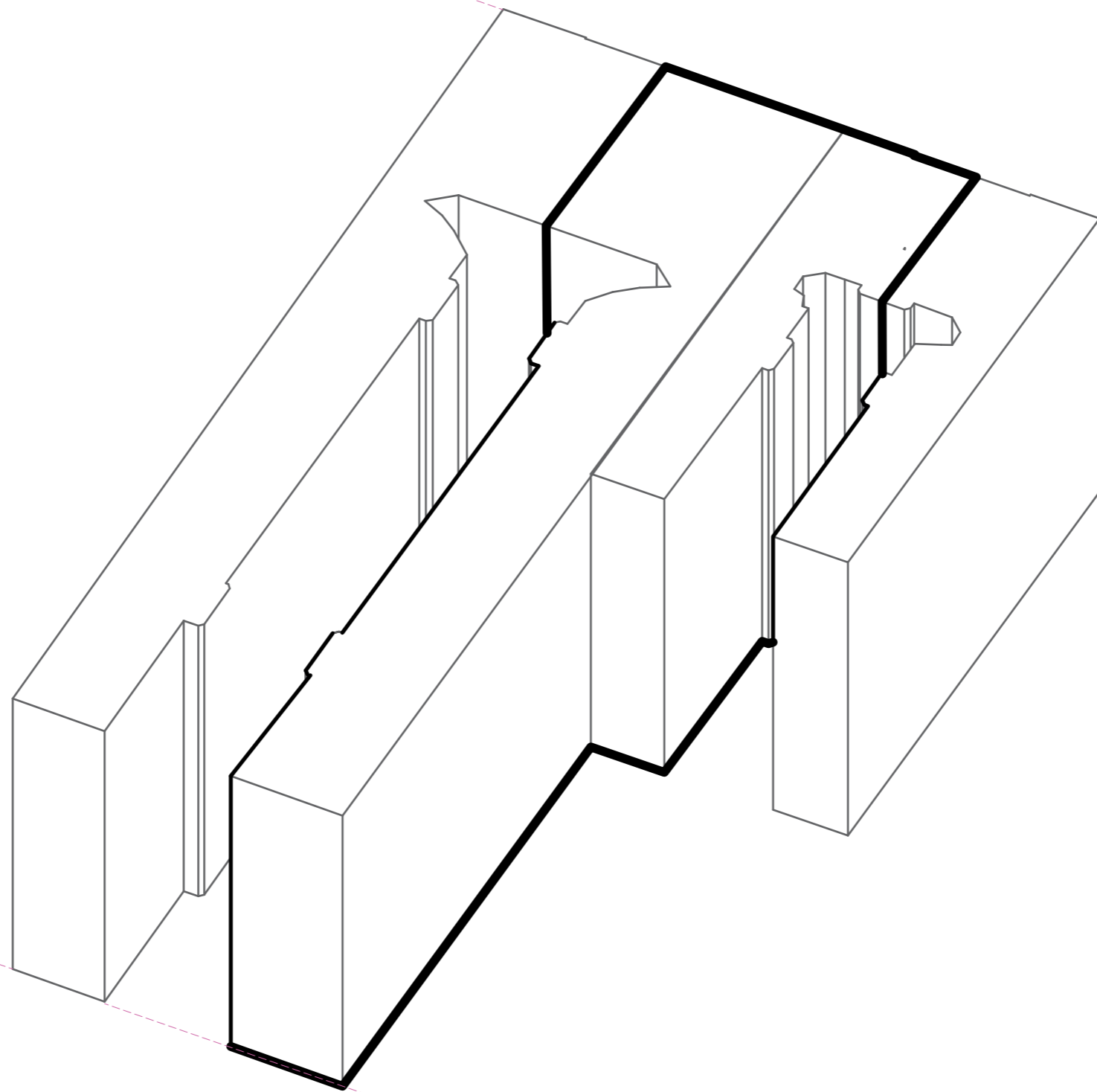

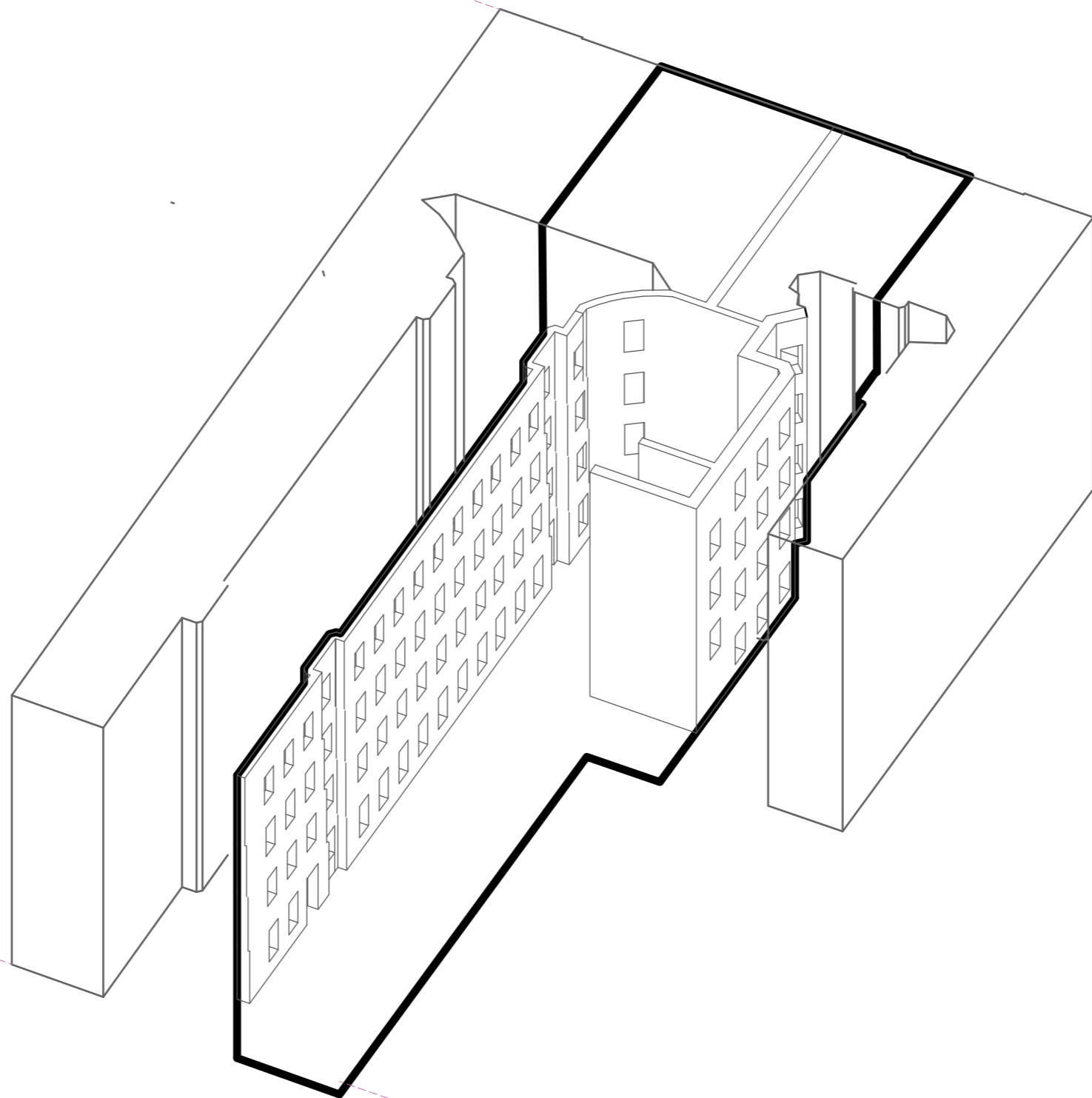

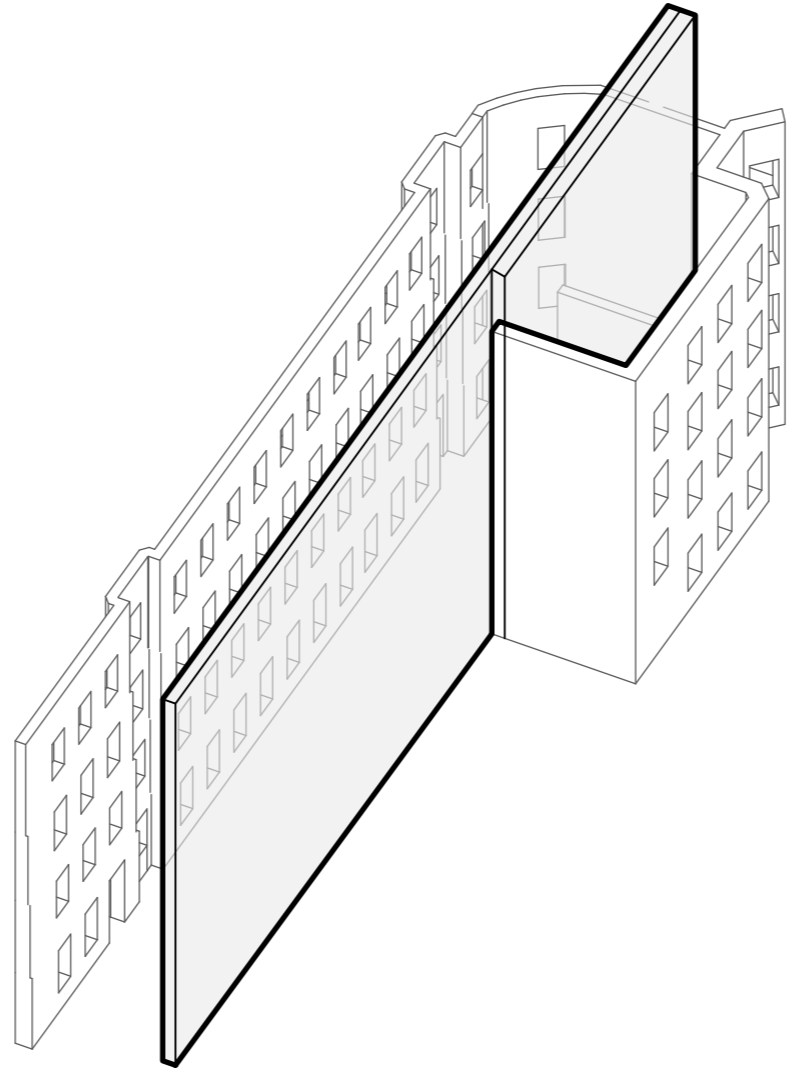

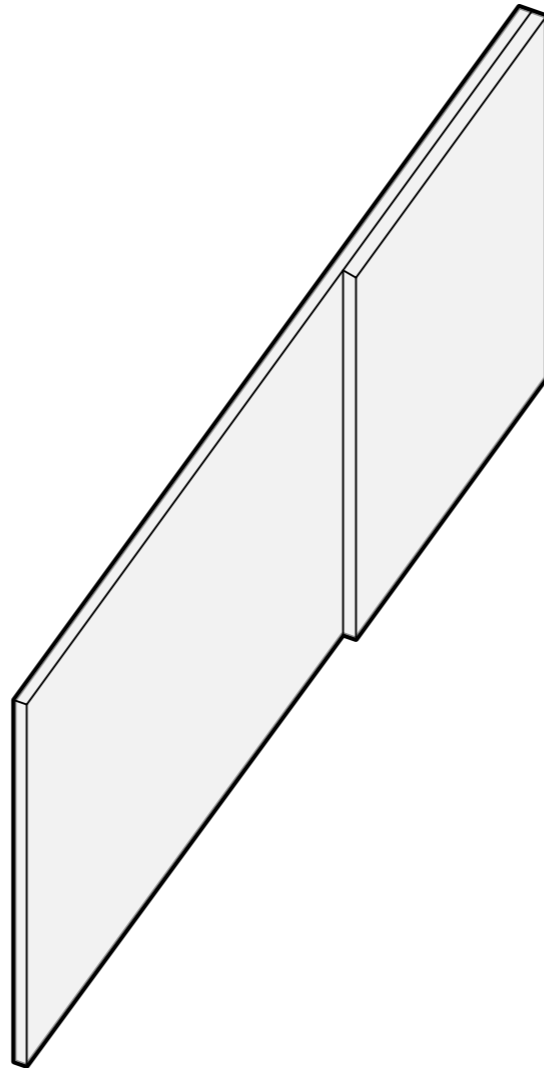

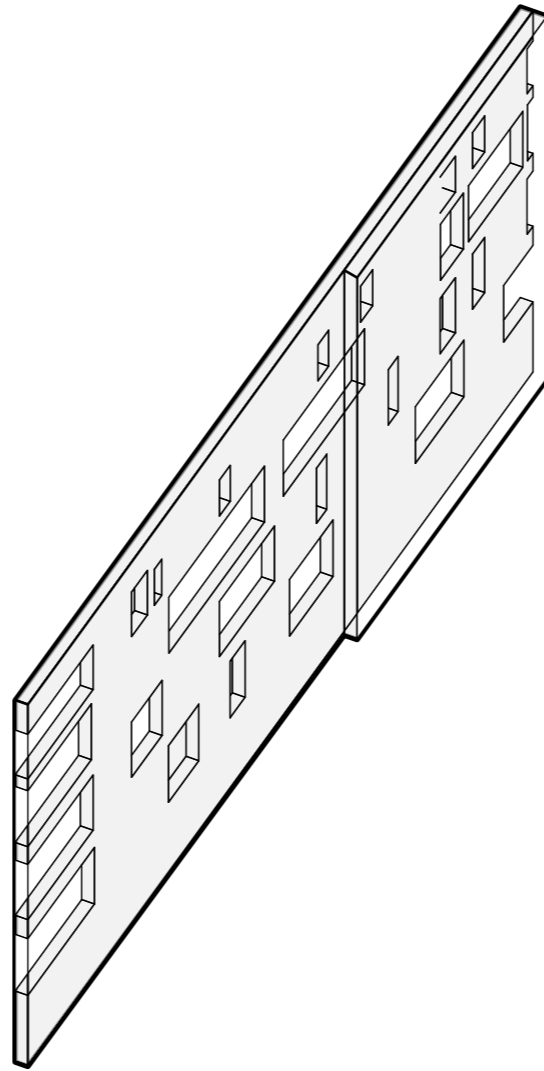

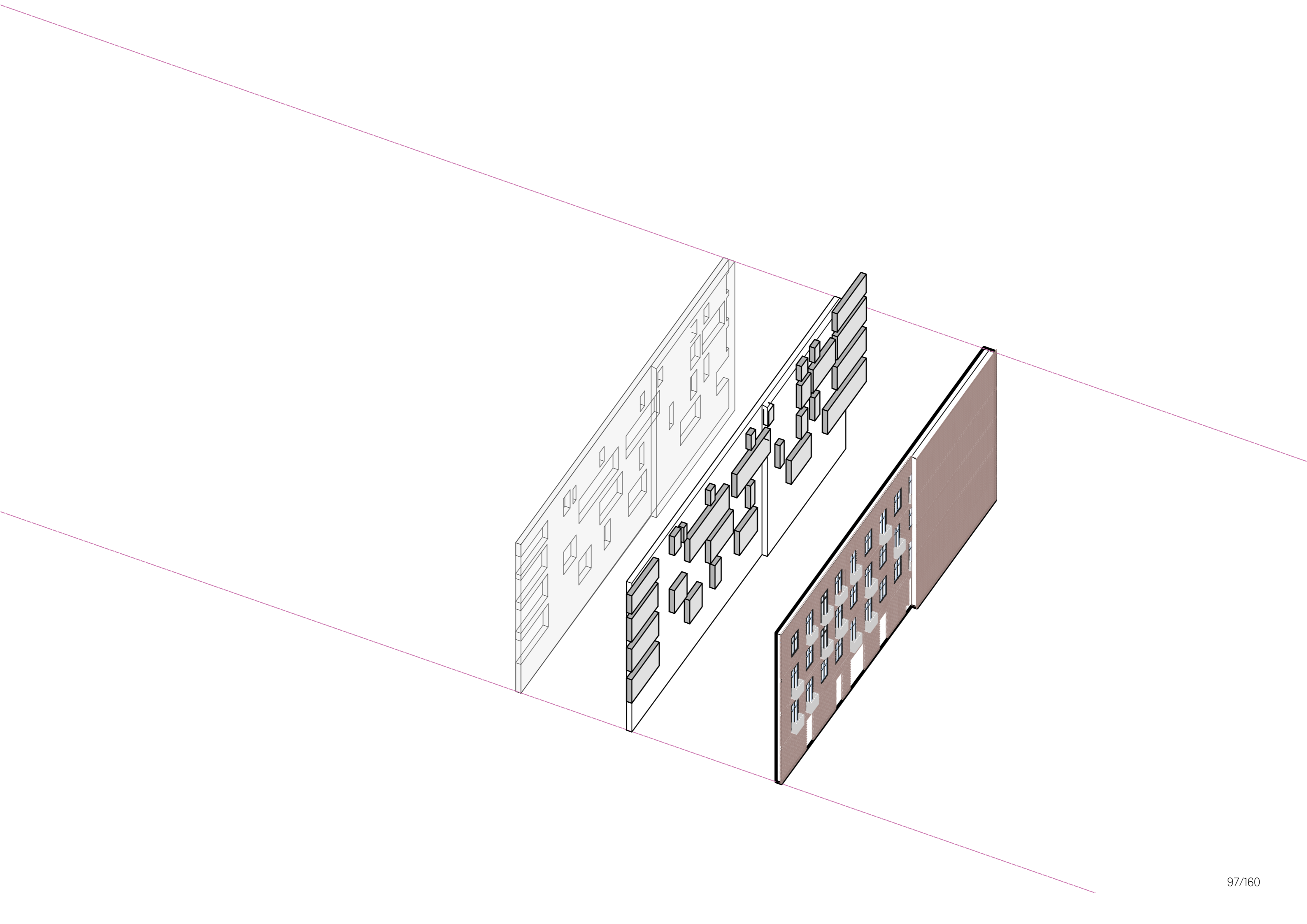

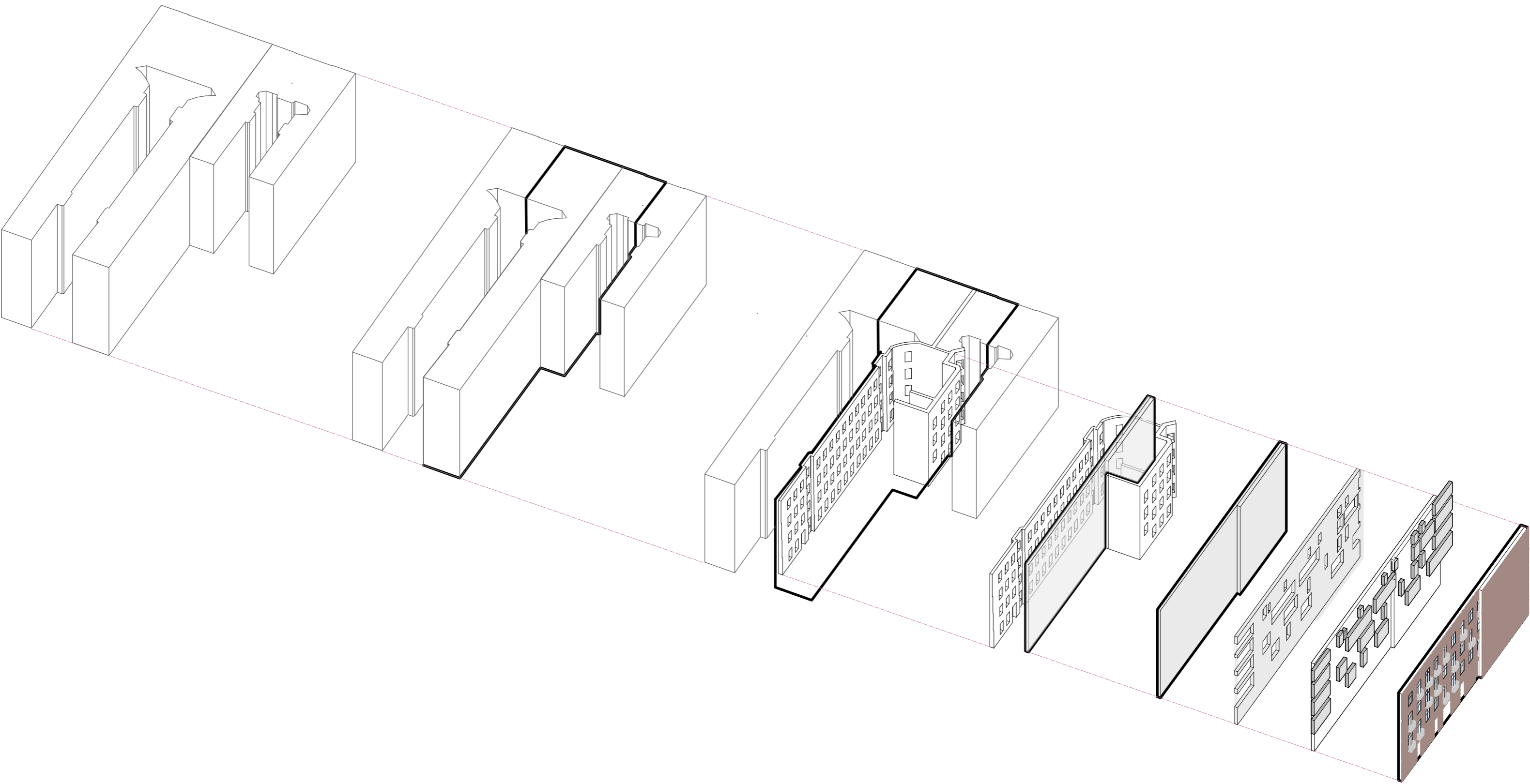



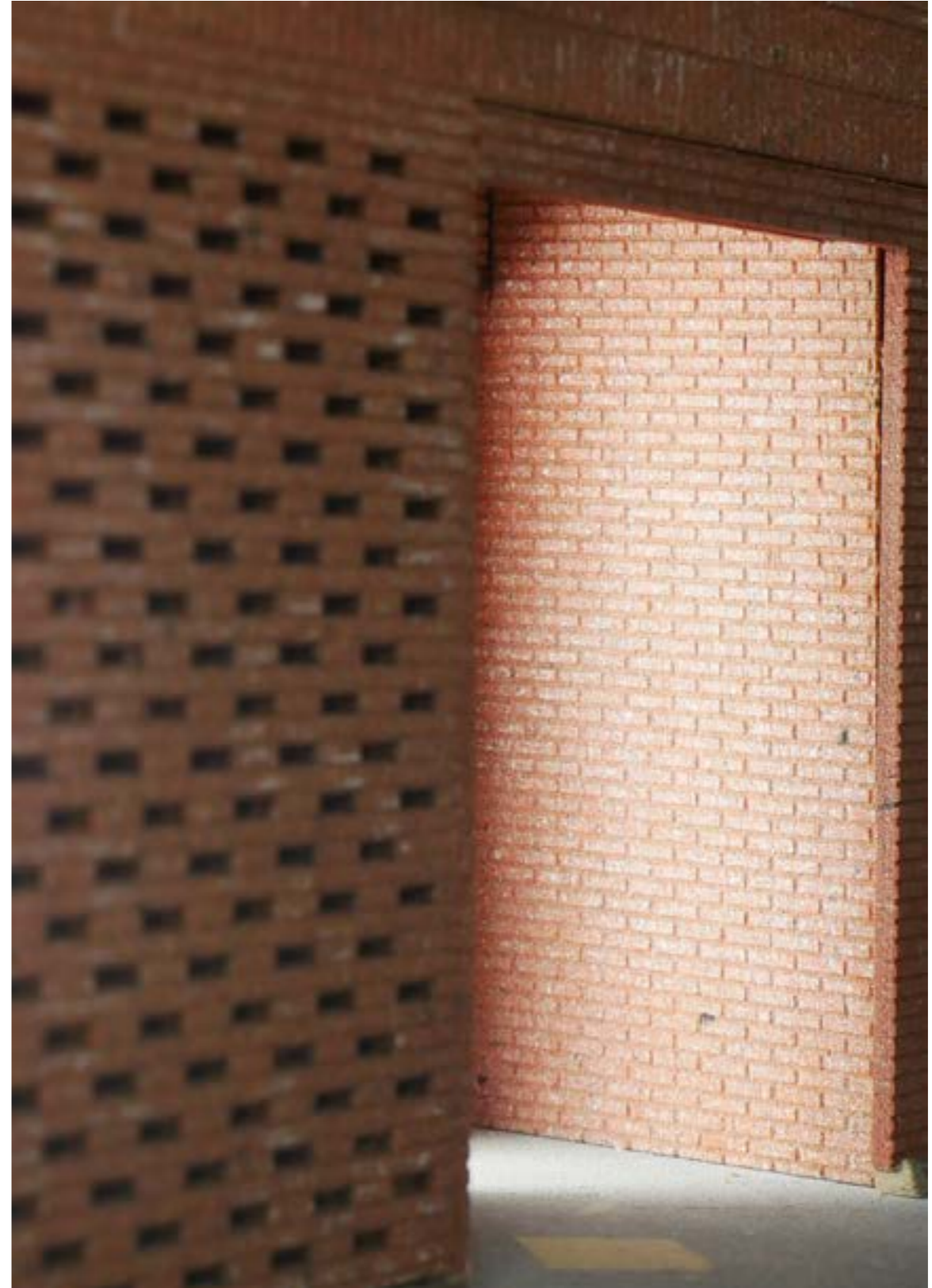

FURN

furniture

furniture - fr. *mobilier*, it. *mobilia*

movables, something easy to move around. Comes from Medieval times, when one of the main requirements for the furniture was to be easily transportable so that the magnates who possessed many residences in different places could travel between them easily and efficiently.













sliding



folding



pivot

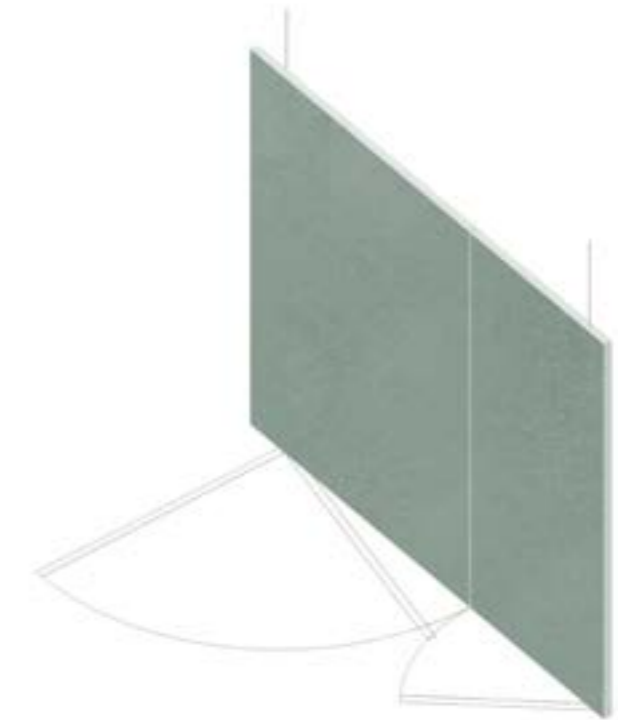

**curtain
line**

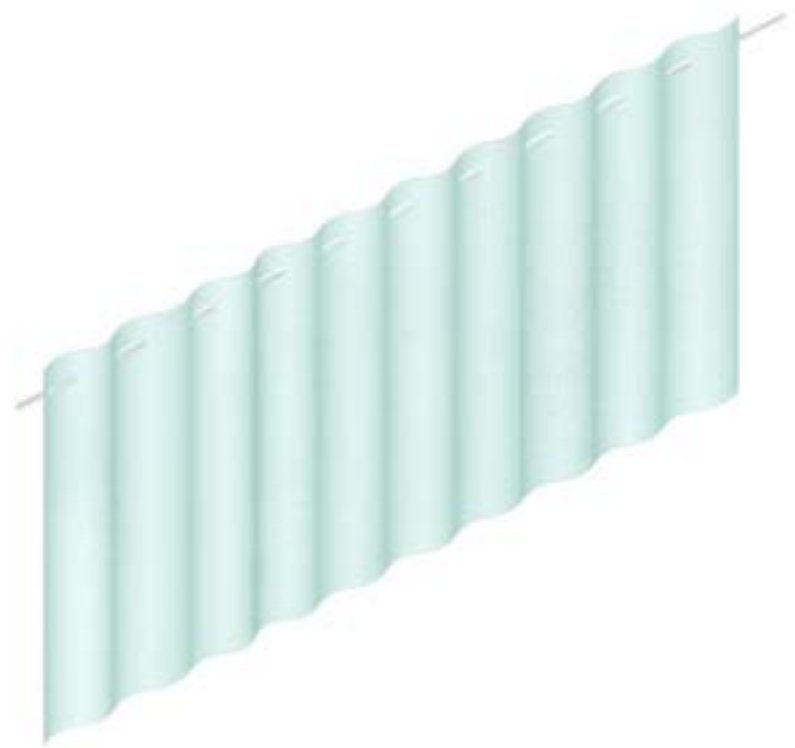
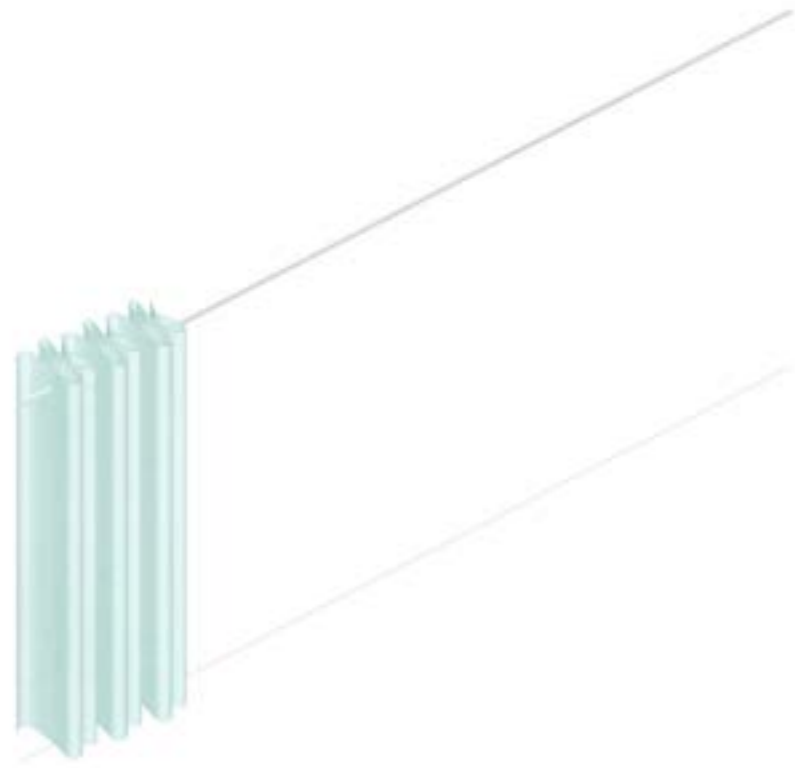

**curtain
round**

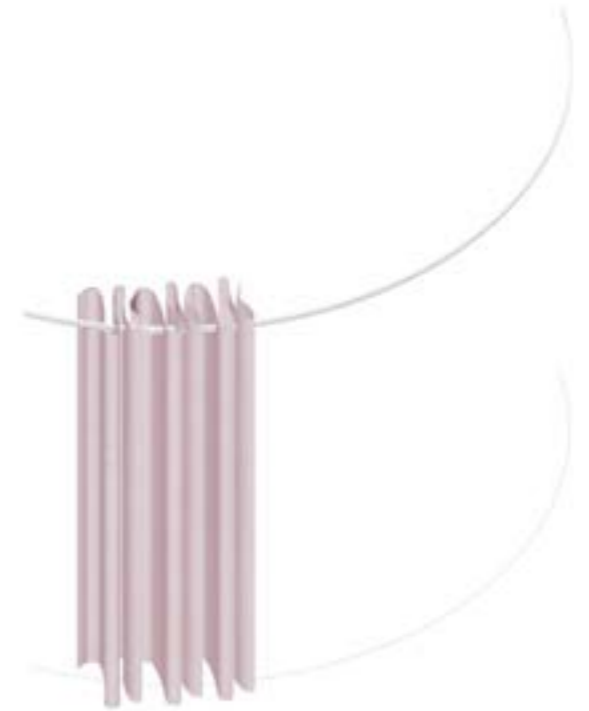

TIME

THE ORGANISM AND THE USER PROFILE

functions & who



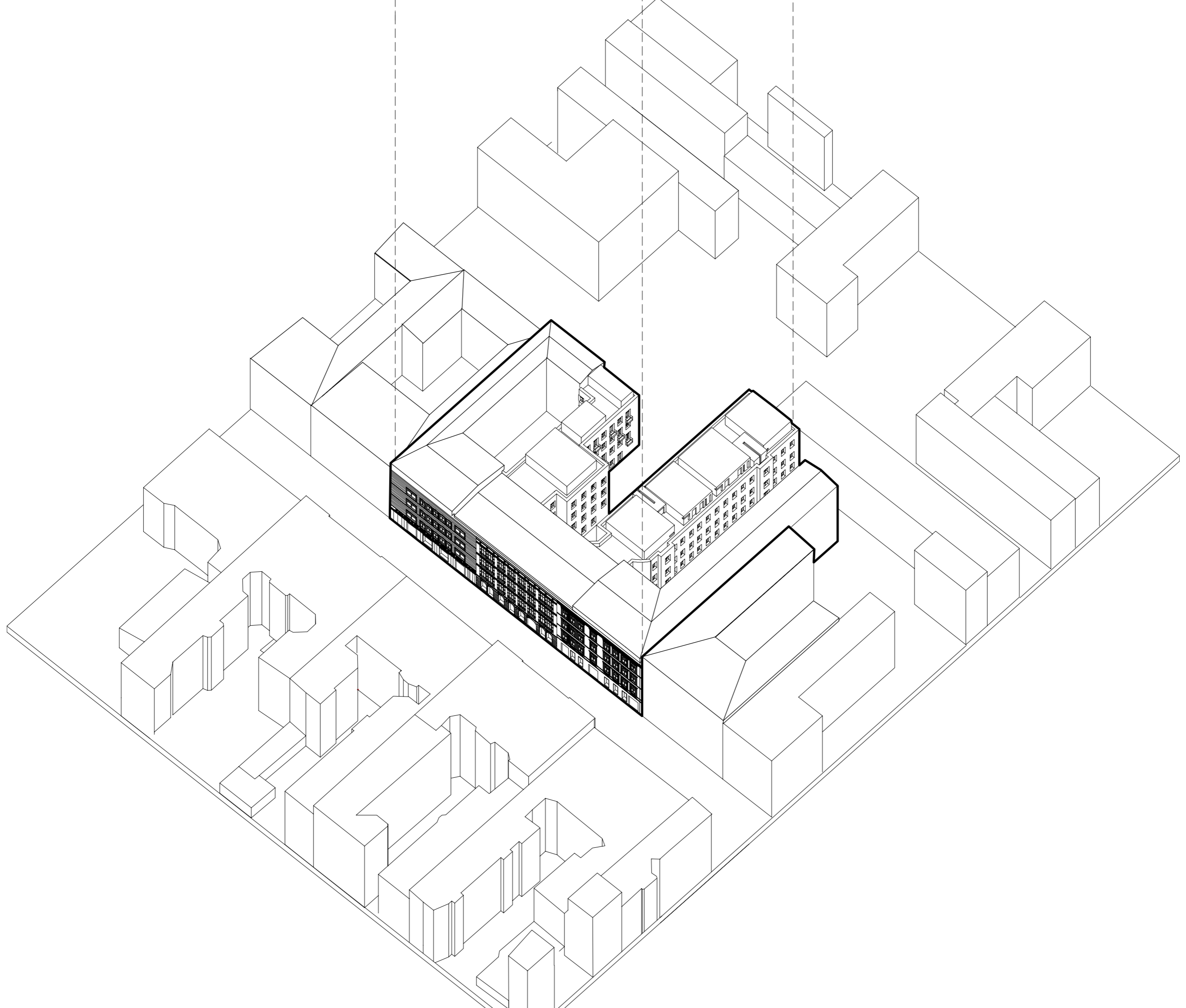

groundfloor

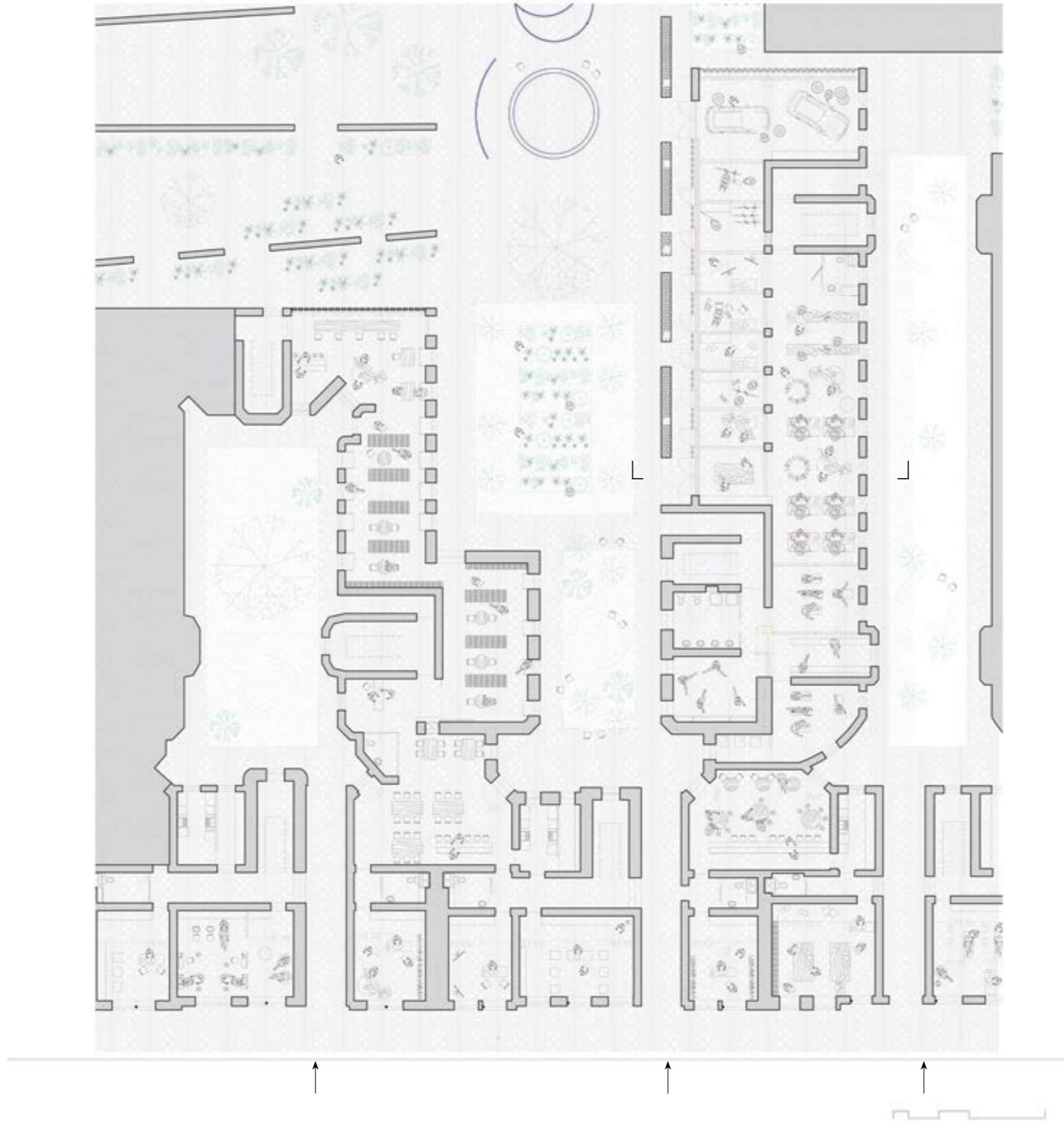

0

workshops, sheds
/ flexible rooms /

cafe & bar

existing shops

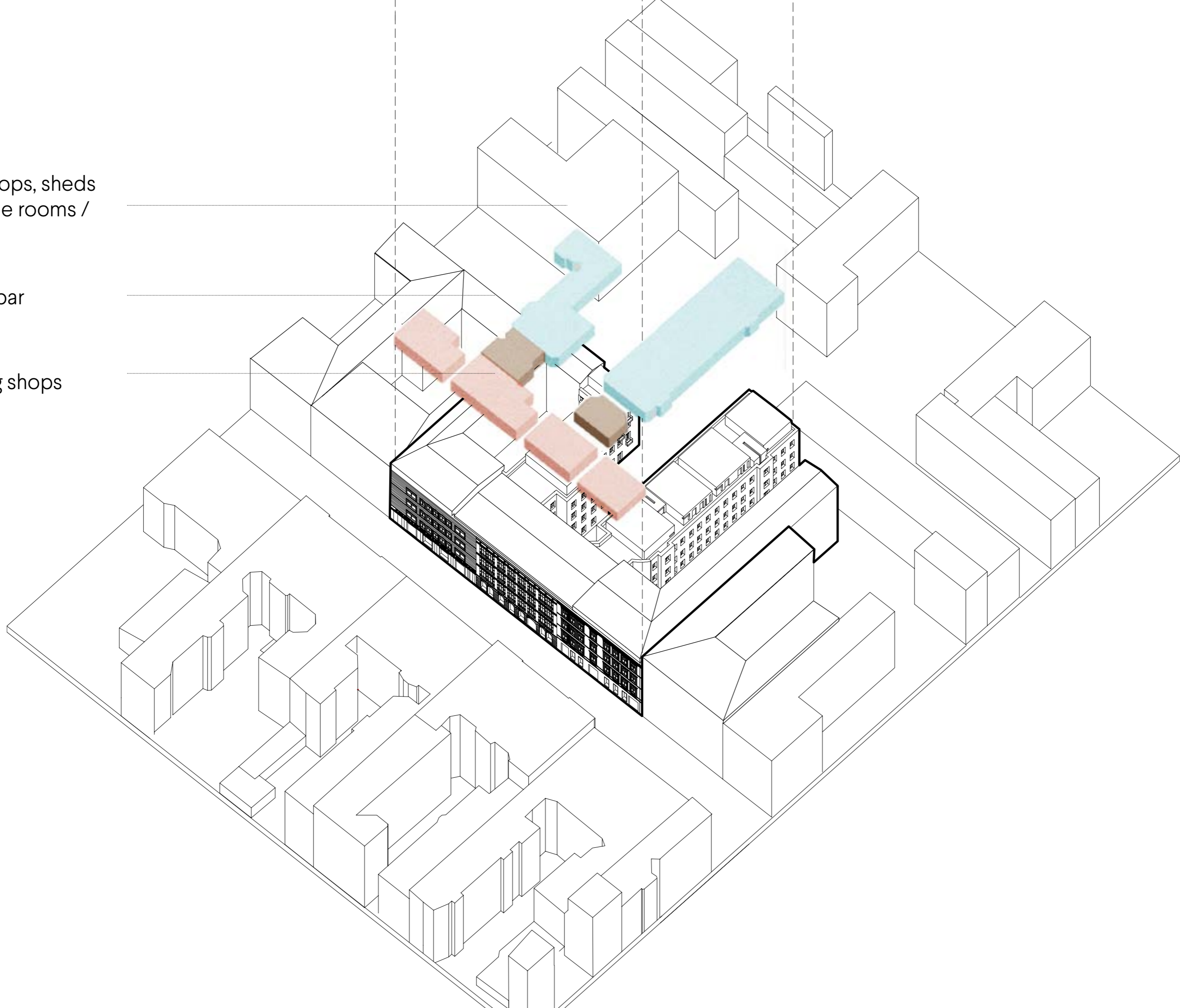

SHOPS
GROUND FLOOR

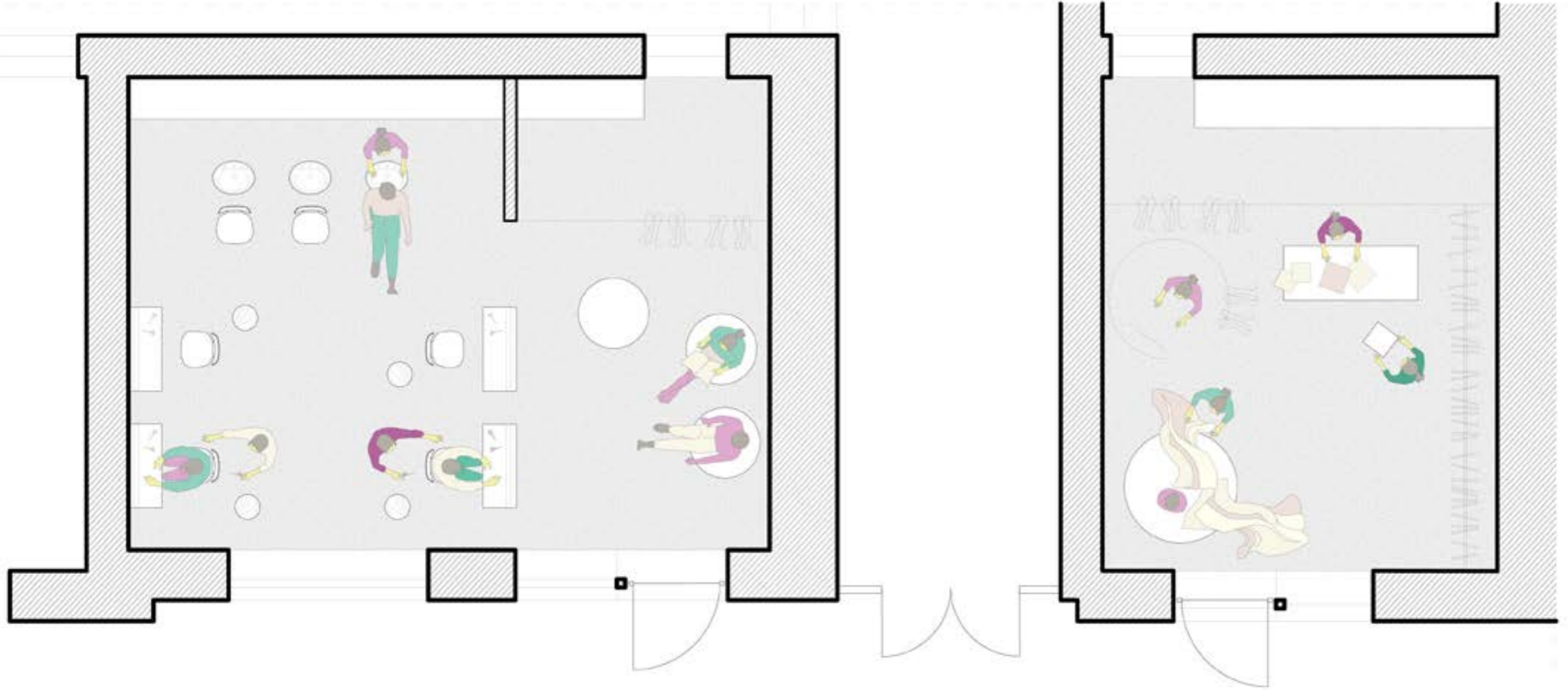

COMMON SPACE

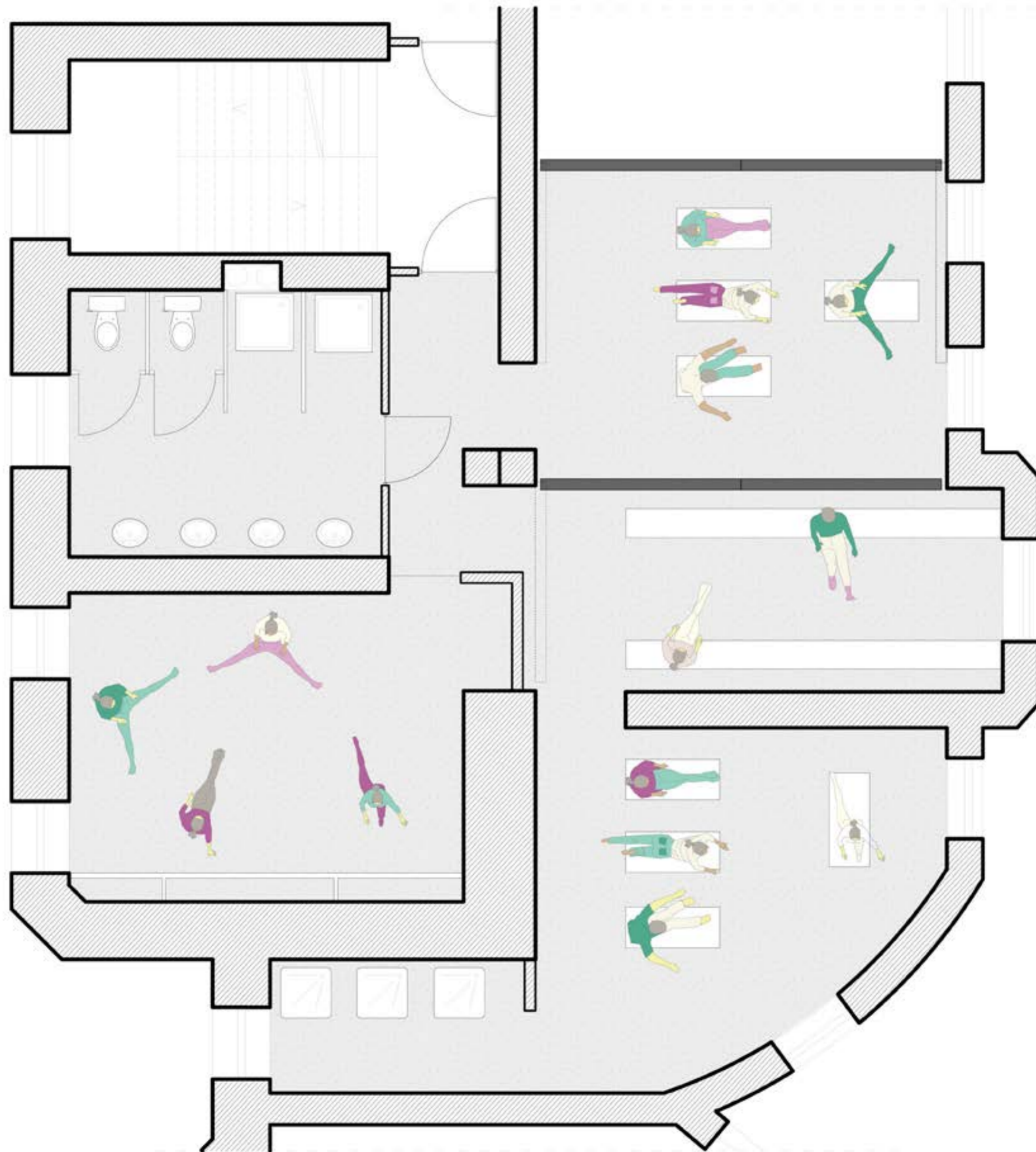



1st

shared
household spaces

living

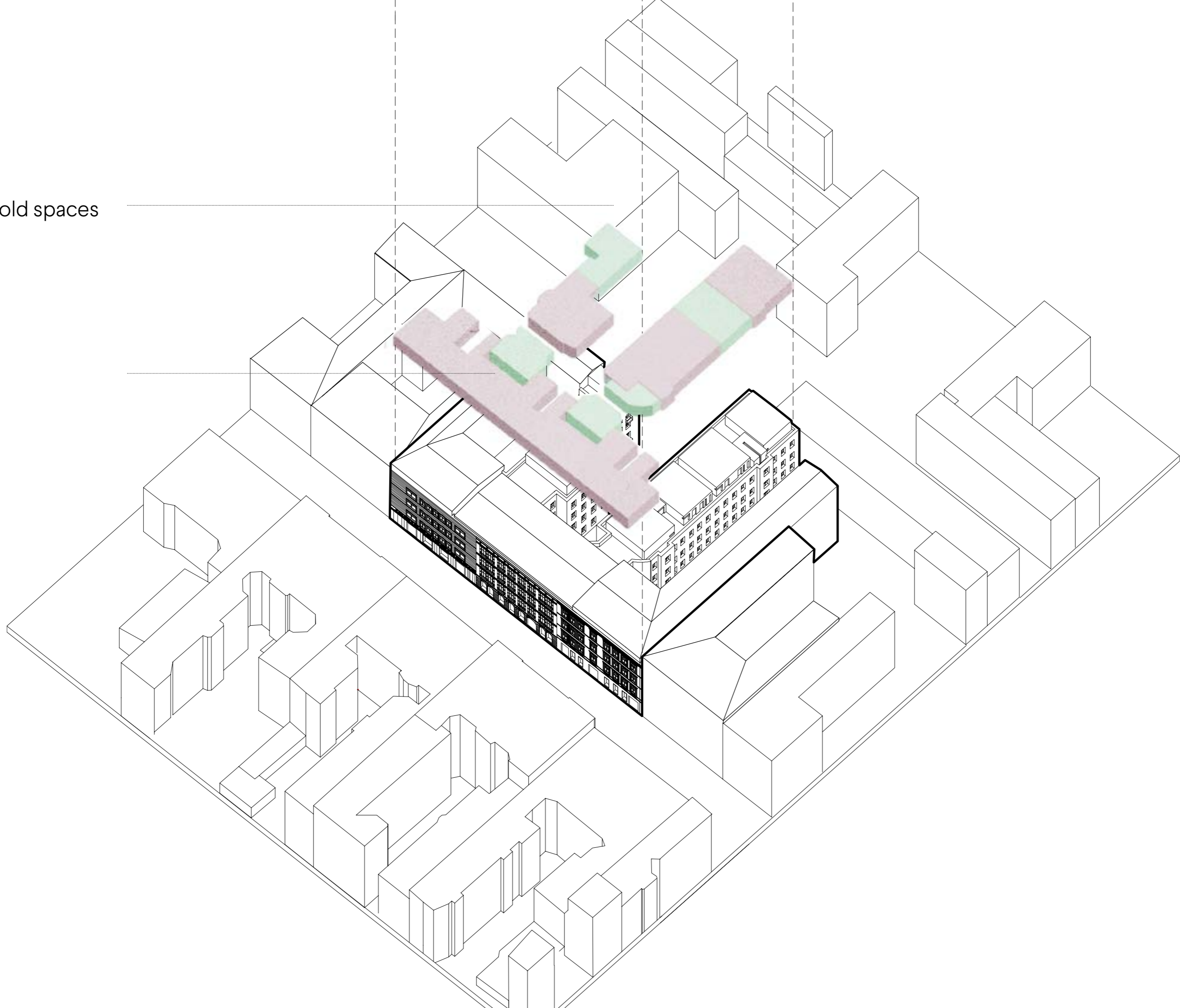

COMMON HOUSEHOLD
SPACE

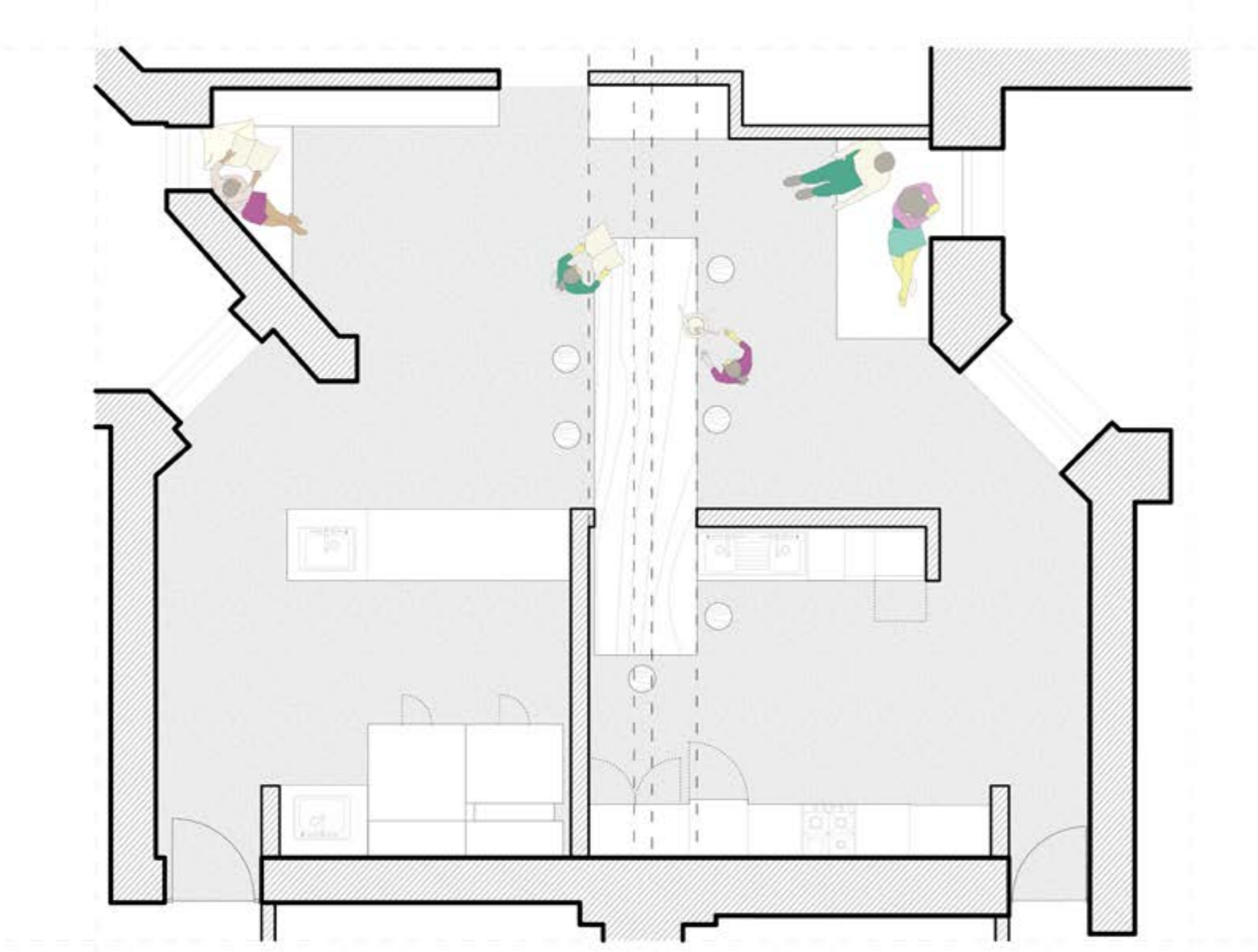

2nd

living

common
rooms

working
spaces

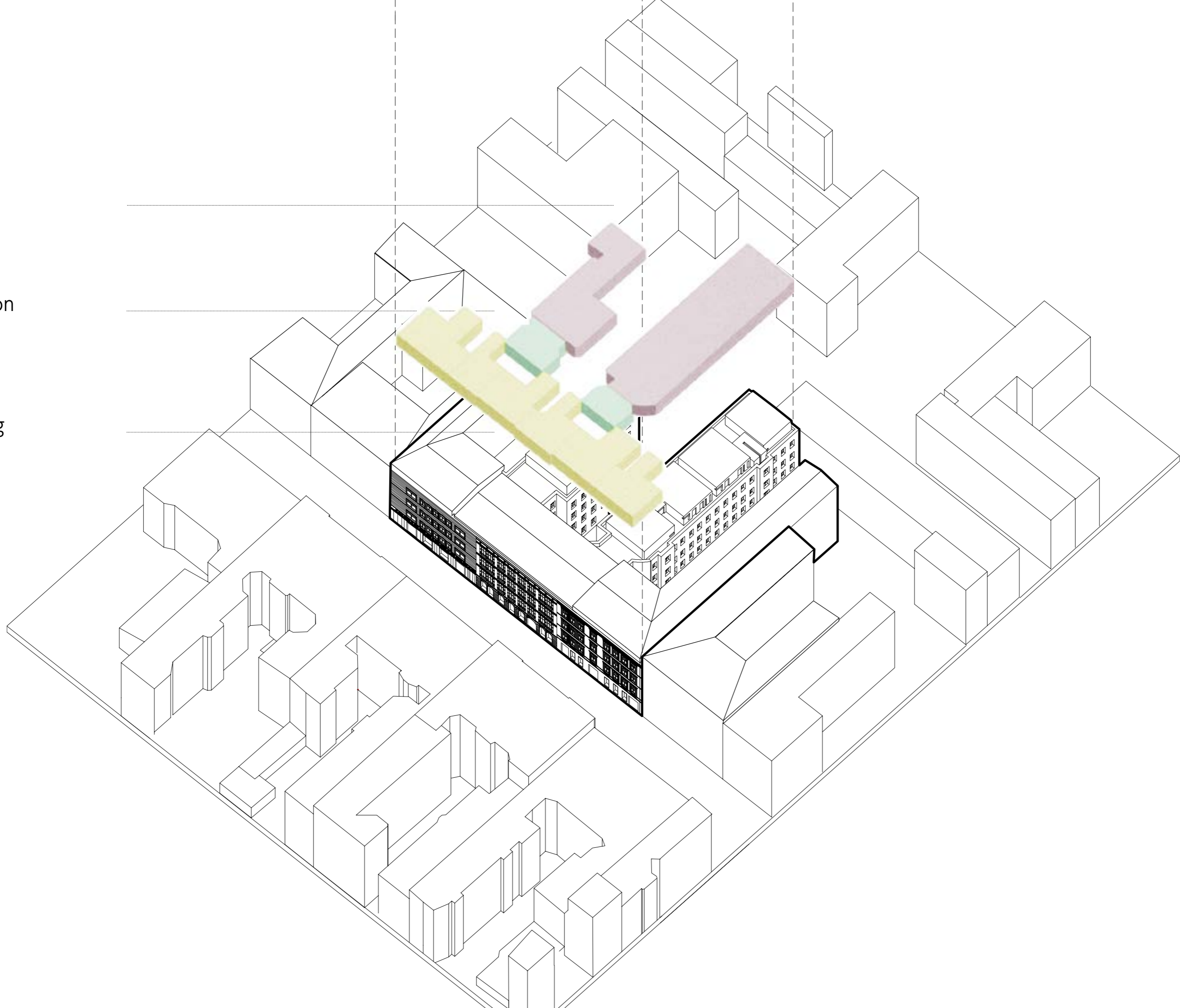

OFFICE &
COMMON SPACE

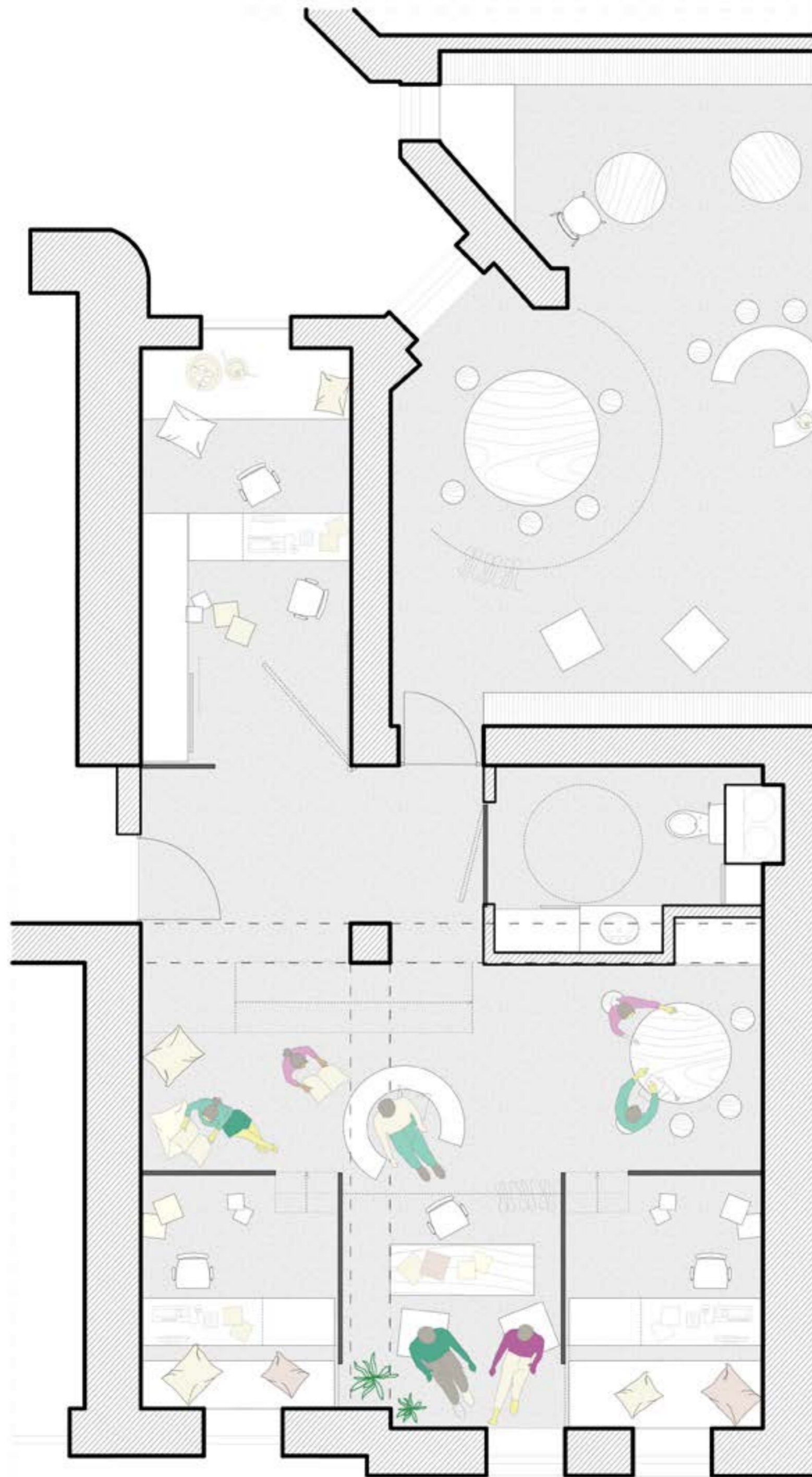

3rd

shared household
spaces

living

kindergardens

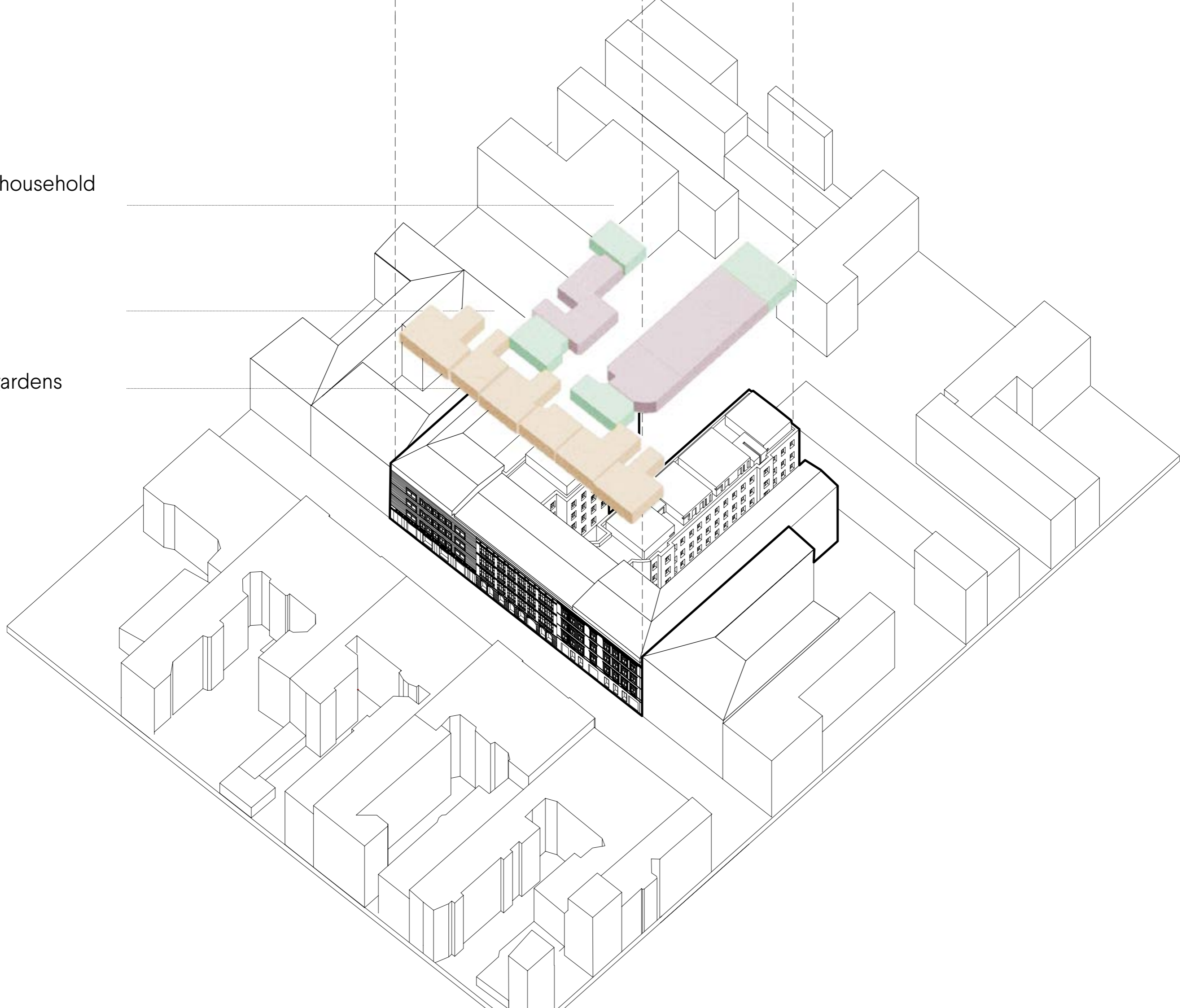

KINDER GARDEN

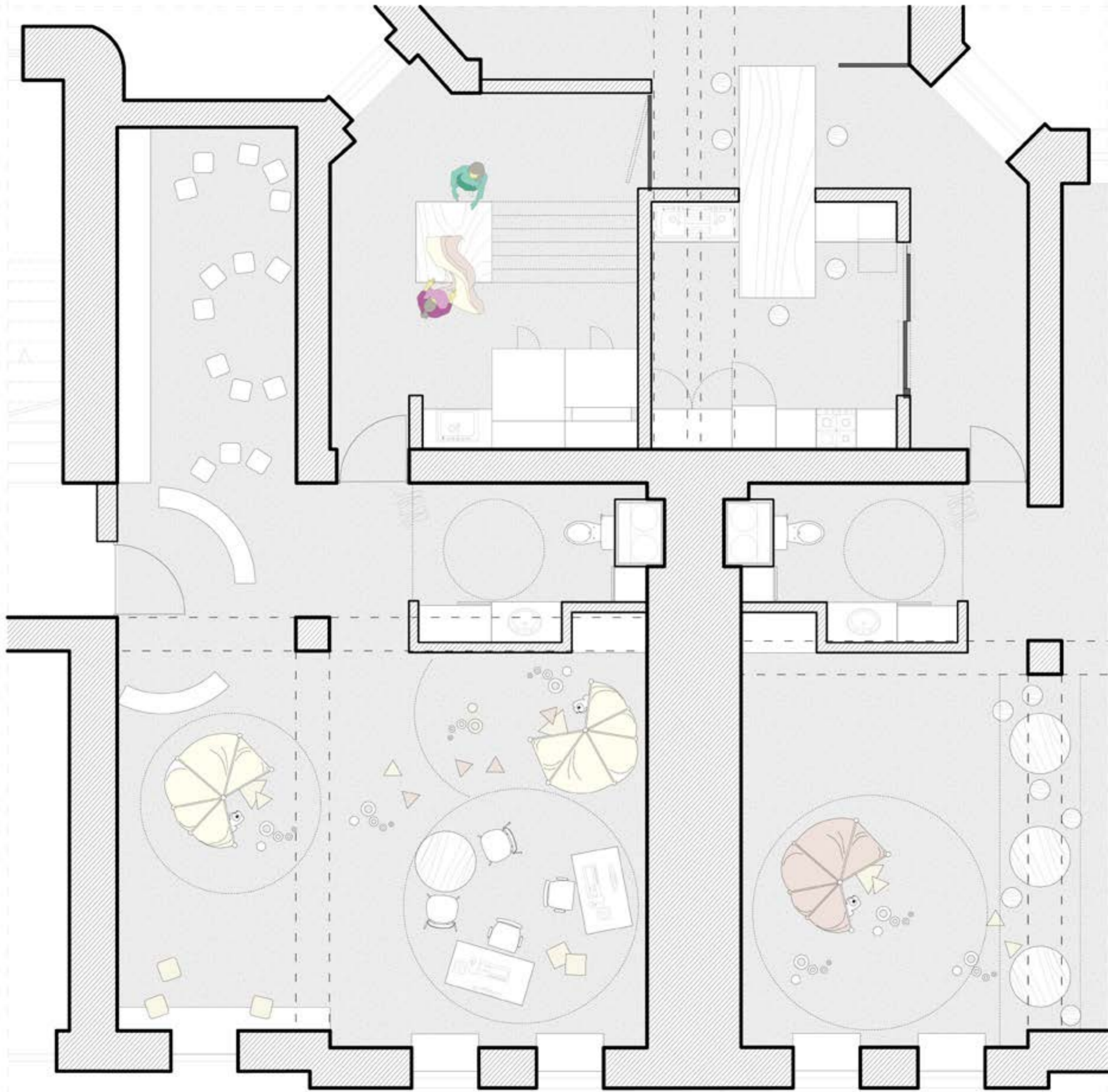

4th

working spaces

living

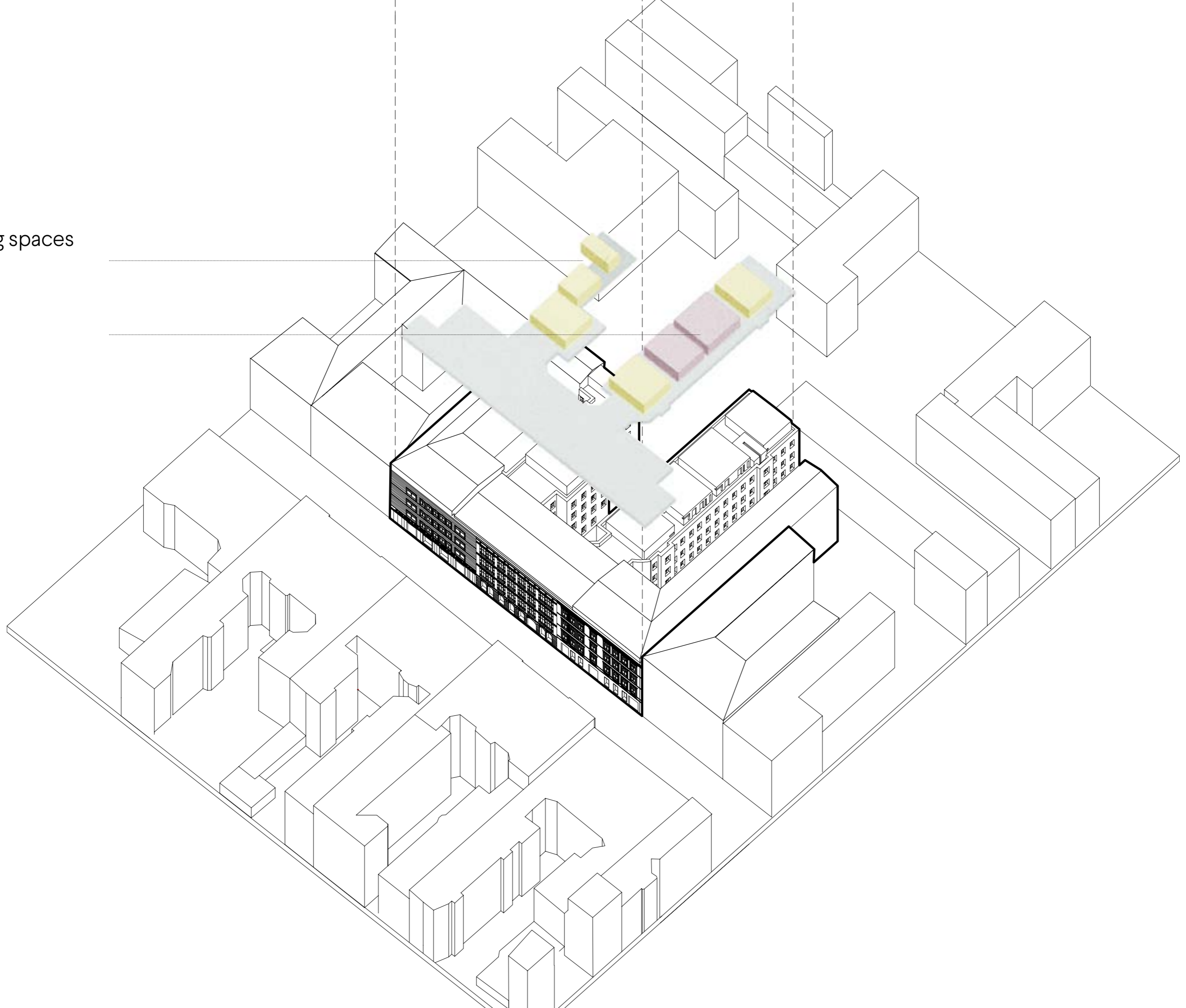

WORKING SPACES

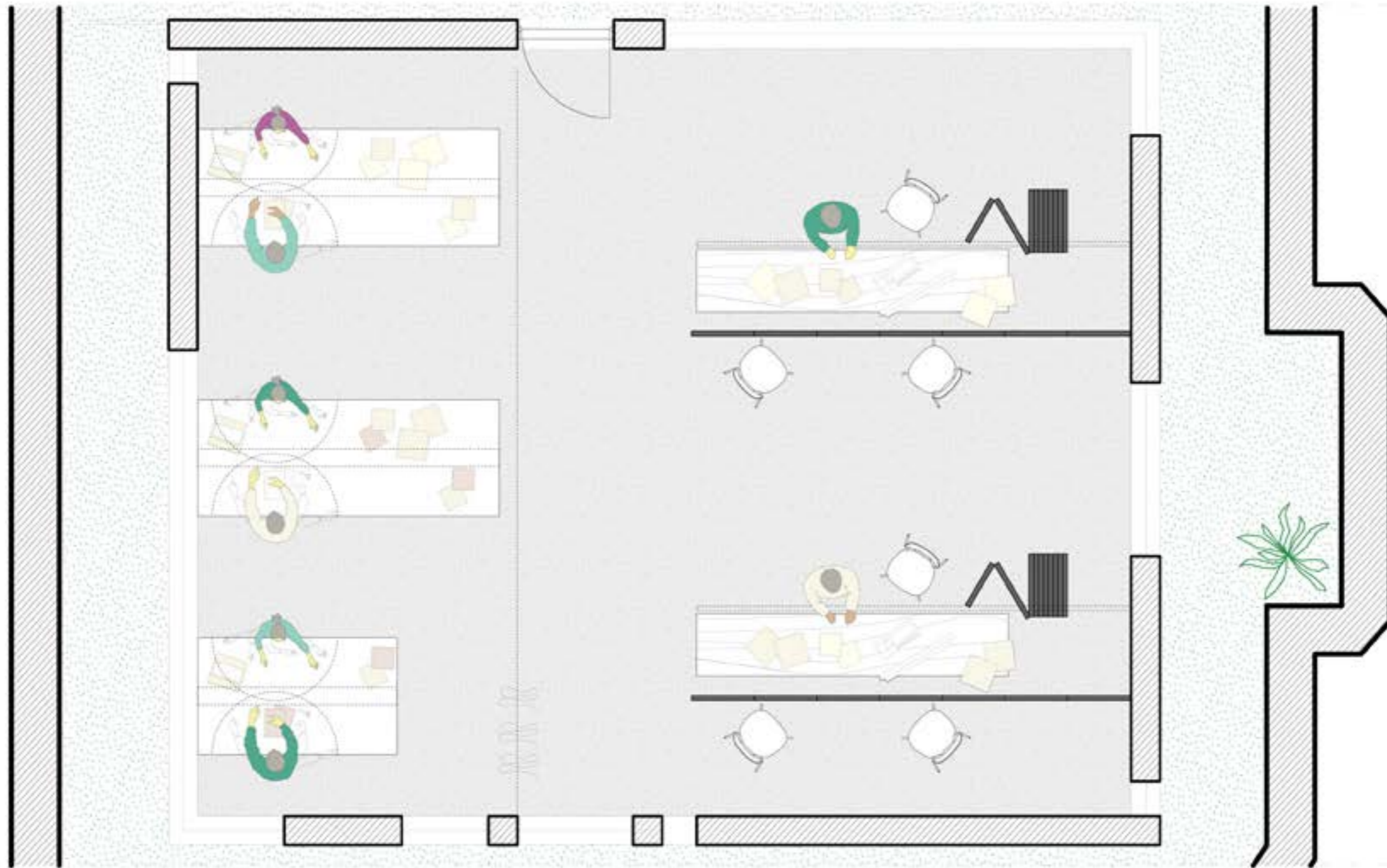



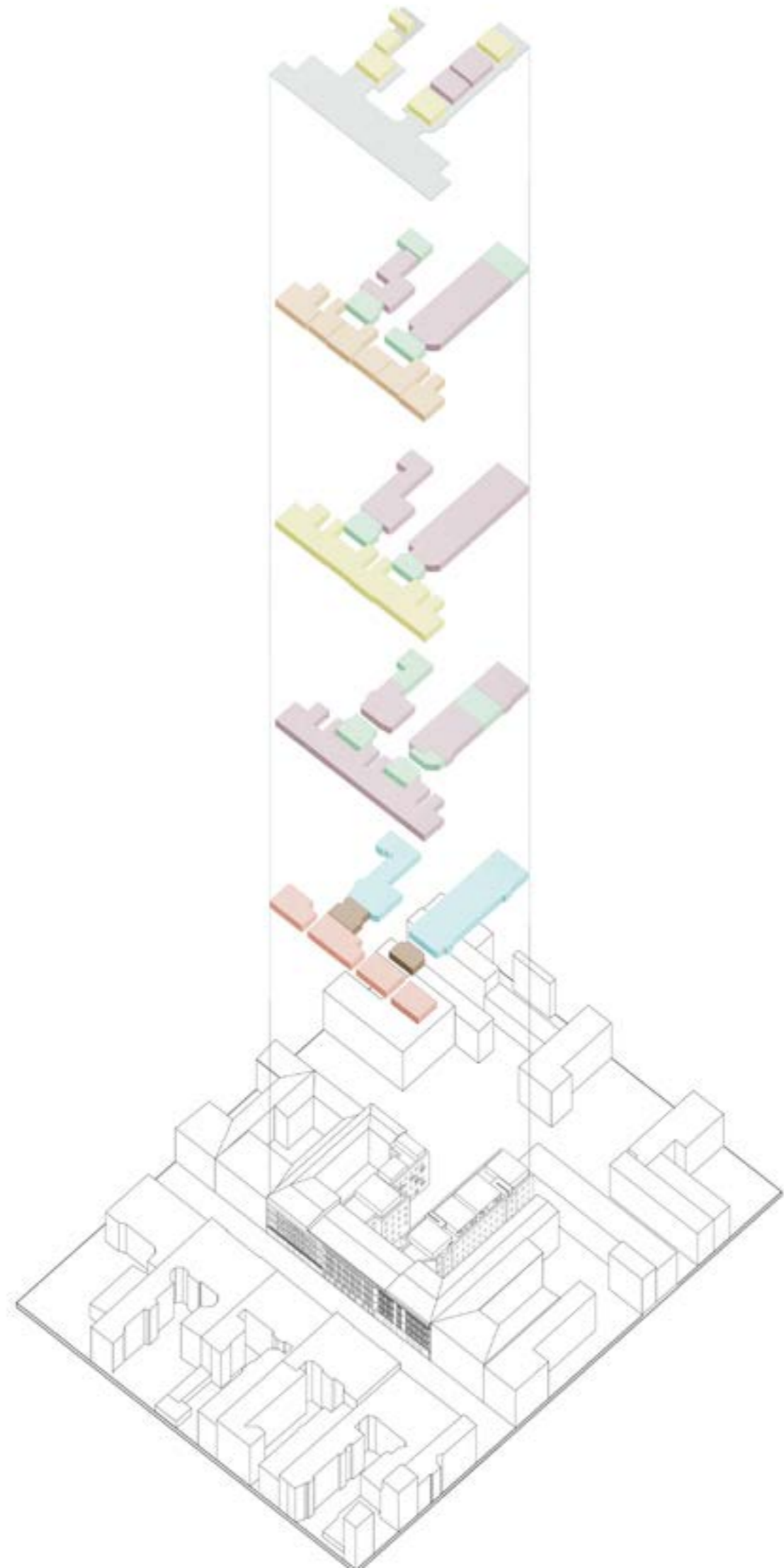

**TYPE OF
APARTEMENT**

**SMALL
APARTEMENT**

**MIDDLE SIZE
APARTEMENT**

**LARGE SIZE
APARTEMENT**

**TYPE
OF USER**

**SINGLE
NO KIDS**

**SINGLE +
KID(S)**

**COUPLE
NO KIDS**

**COUPLE +
KID(S)**

**FRIENDS /
STUDENTS**

**FAMILY
MORE
THAN 1 KID**

**FRIENDS /
STUDENTS**

**USE OF
COMMON
SPACES**

**SHARE OFFICE
SHARE LEISURE
SHARE SMALL
PART OF HOUSE-
HOLD DUTIES**

**MIGHT SHARE OFFICE
SHARE LEISURE
SHARE HOUSEHOLD DU-
TIES SPACE
SHARE KINDERGARDEN**

**MIGHT SHARE
OFFICE
SHARE HH DUTIES
MIGHT SHARE
LEISURE**

**MIGHT SHARE
OFFICE
SHARE HH DUTIES
MIGHT SHARE
LEISURE
SHARE KINDER-
GARDEN**

**MIGHT SHARE
OFFICE
SHARE HH DUTIES
MIGHT SHARE LEI-
SURE**

**SHARE HH DUTIES
SHARE KINDER-
GARDEN
MIGHT SHARE
OFFICCE
SHARE LEISURE**

**SHARE HH DUTIES
SHARE LEISURE
MIGHT SHARE
OFFICE
MIGHT SHARE KIN-
DERGARDEN**

**SMALL
APARTEMENT**

**SINGLE
NO KIDS**

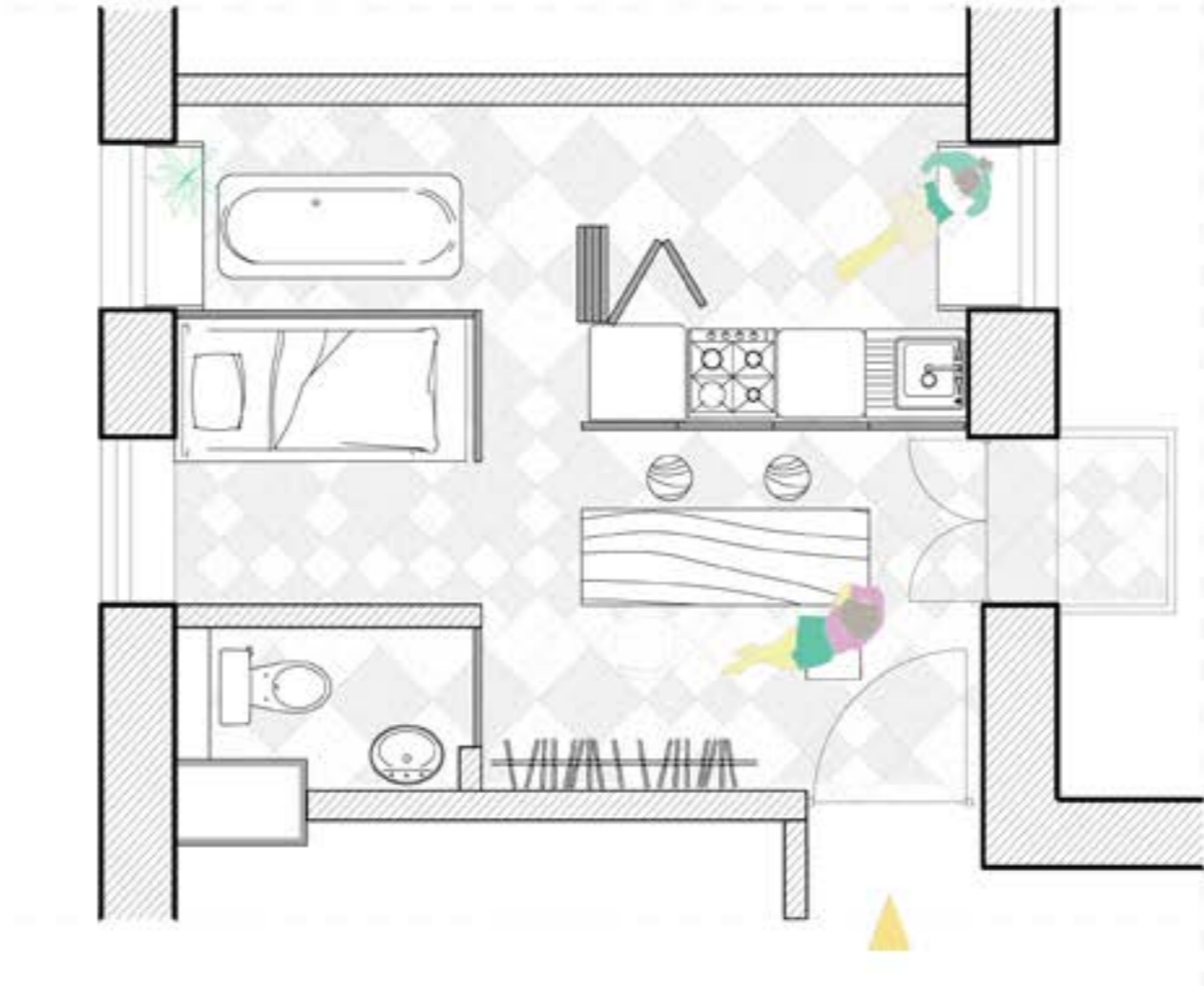

**SMALL
APARTEMENT**

**SINGLE
NO KIDS**



**SMALL
APARTEMENT**

**SINGLE
NO KIDS**



**SMALL
APARTEMENT**

**SINGLE
+ KIDS**

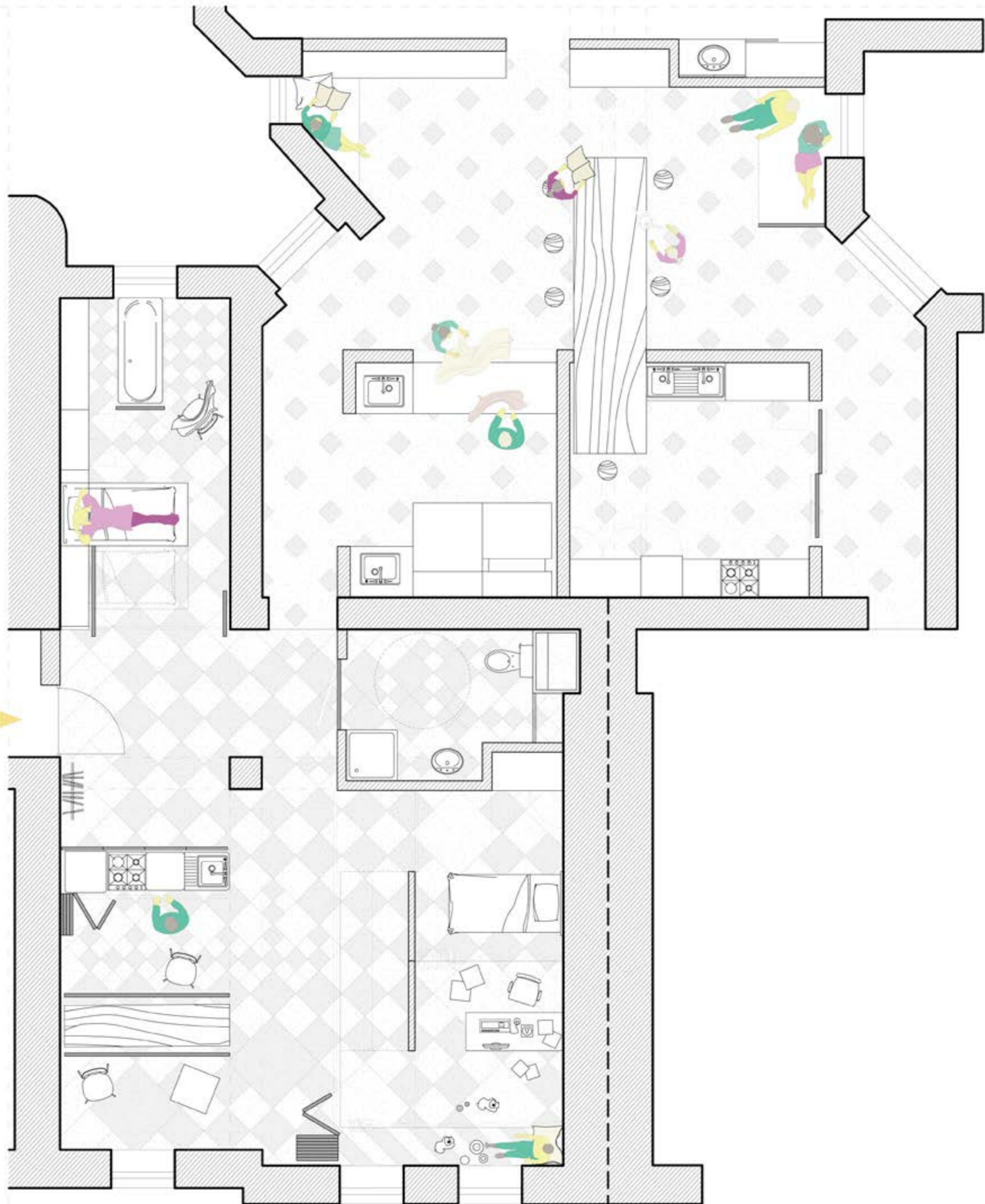

**SMALL
APARTEMENT**

**SINGLE
+ KIDS**

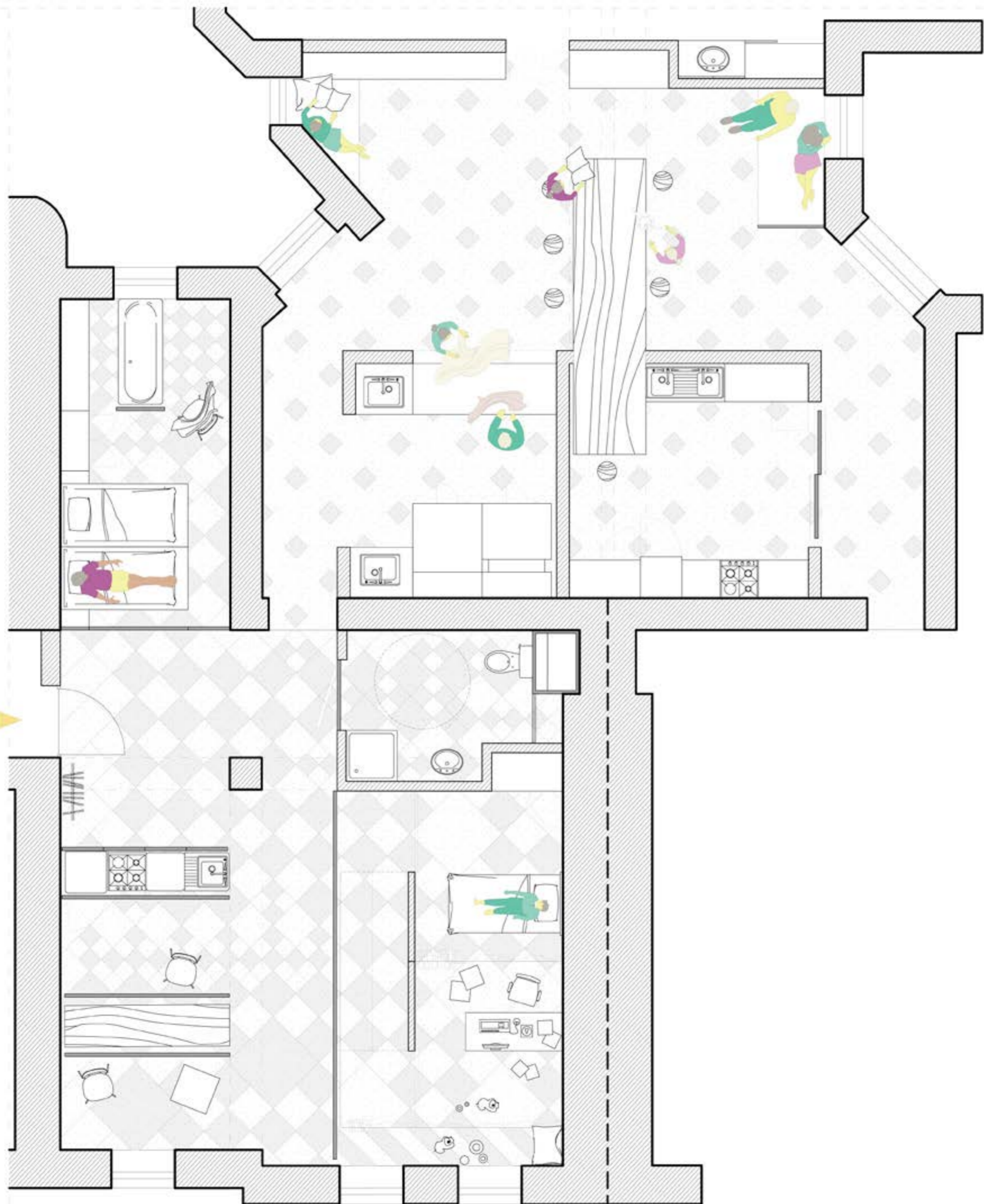

**SMALL
APARTEMENT**

**SINGLE
+ KIDS**

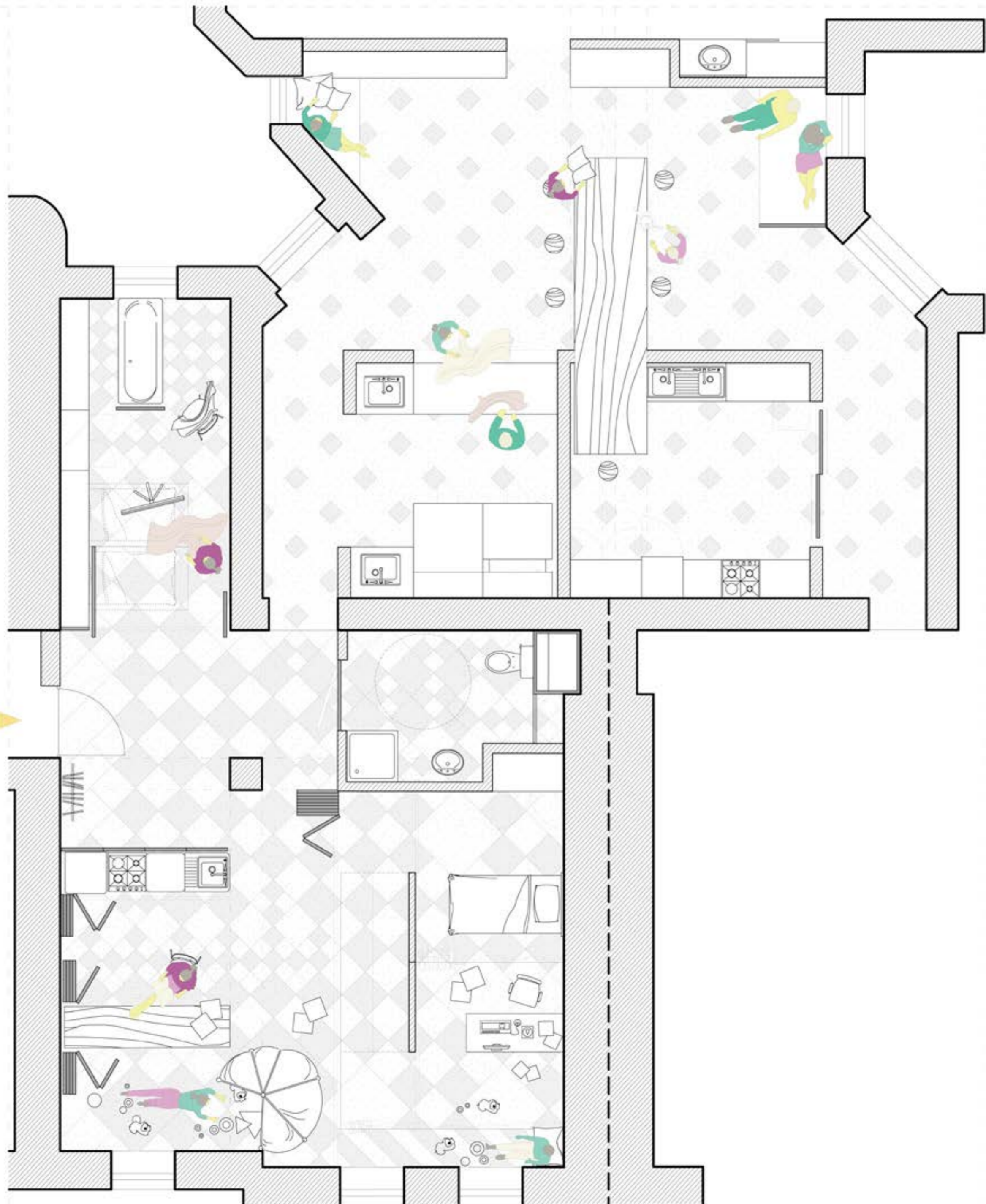

MIDDLE
APARTEMENT

COUPLE
NO KIDS

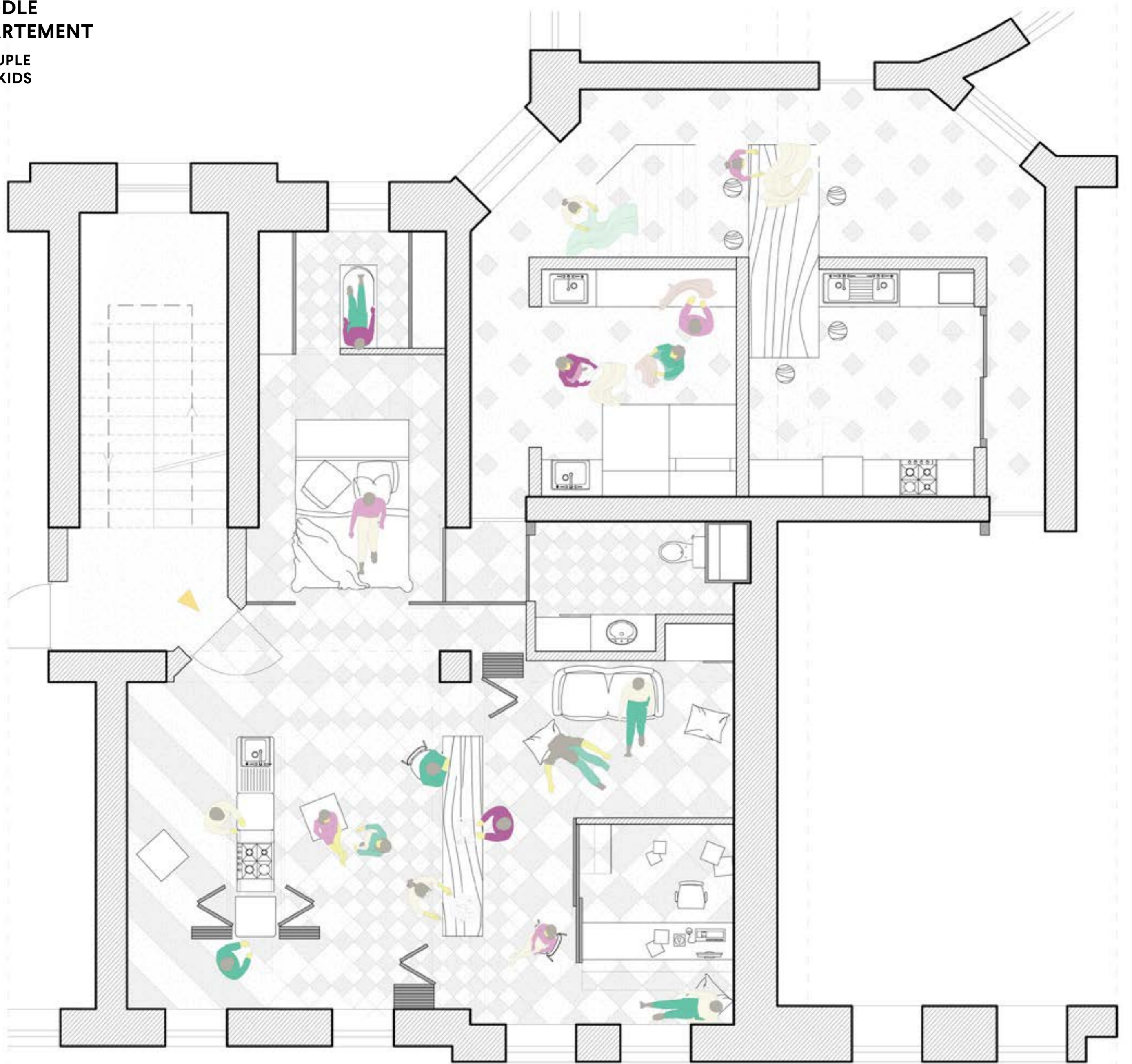

MIDDLE
APARTEMENT

COUPLE
NO KIDS



MIDDLE APARTEMENT

STUDENTS
/ FRIENDS

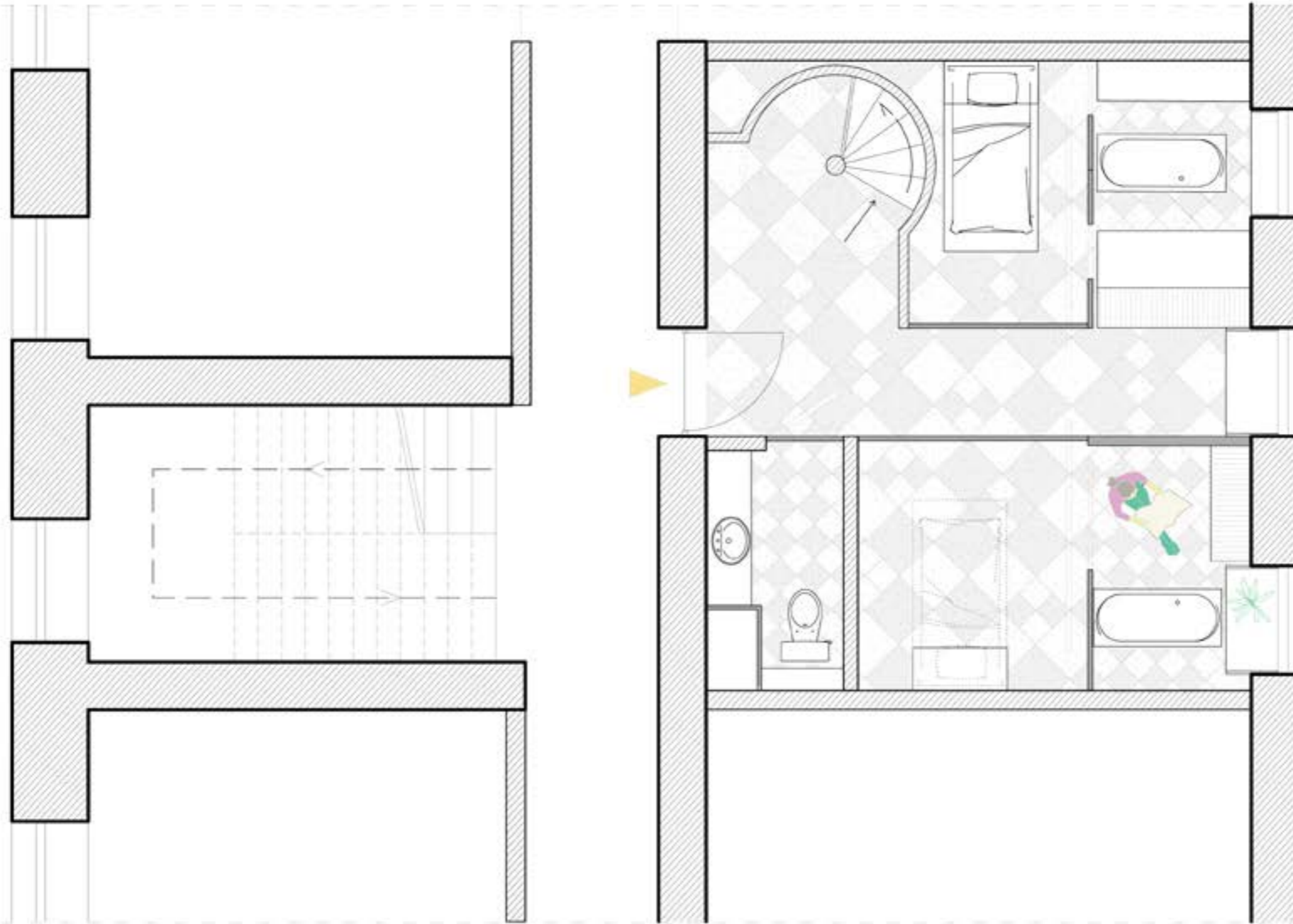

MIDDLE APARTEMENT

STUDENTS
/ FRIENDS

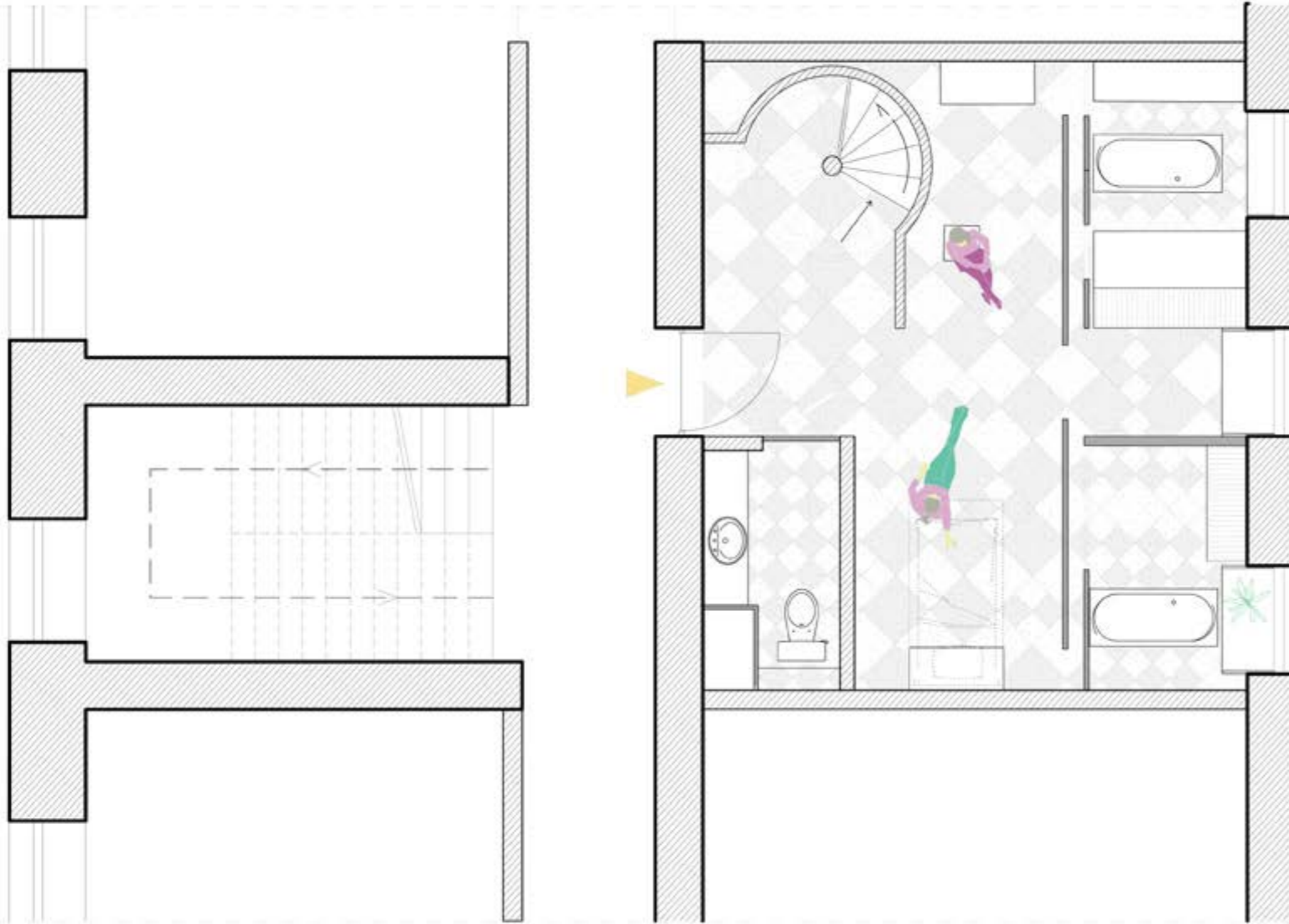

MIDDLE APARTEMENT

STUDENTS
/ FRIENDS



MIDDLE APARTEMENT

STUDENTS
/ FRIENDS



LARGE
APARTEMENT
FAMILY



















① wall:

refurbished brickwork skin
130 x 60 x 270

stainless steel ties

cavity 25 mm

barrier against
moisture condensation

wood fiber pavatex thermal insulation
140 mm

refurbished brick loadbearing wall

wallheating 18 mm board

plasterboard 18 mm

② air inlet

③ triple glazed window
installed from outside,
opening towards inside;
wooden frame

④ oak window seat 400 mm wide

⑤ foam glass loadbearing
and insulating block

⑥ reinforced concrete lintel cast in situ

⑦ oak board outside ceiling skin 20 mm
fixed on stainless
steel profiles to brickwork

⑧ folding and sliding wall with hidden rails
system: *l'invisible*

⑨ linen curtain

⑩ shadow gap corresponding
with folding wall shadow gap

⑪ oak table with steel bottom structure

⑫ floor:

wooden panels 20 mm

floorheating 25 mm board

contact sound insulation fiberwood
pavatex 50 mm

prefabricated concrete slab 200 mm,
spanning 6m

sound (mass) and thermal insulation
200 mm pavatex

plasterboard 18 mm x 2
fixed on steel profiles

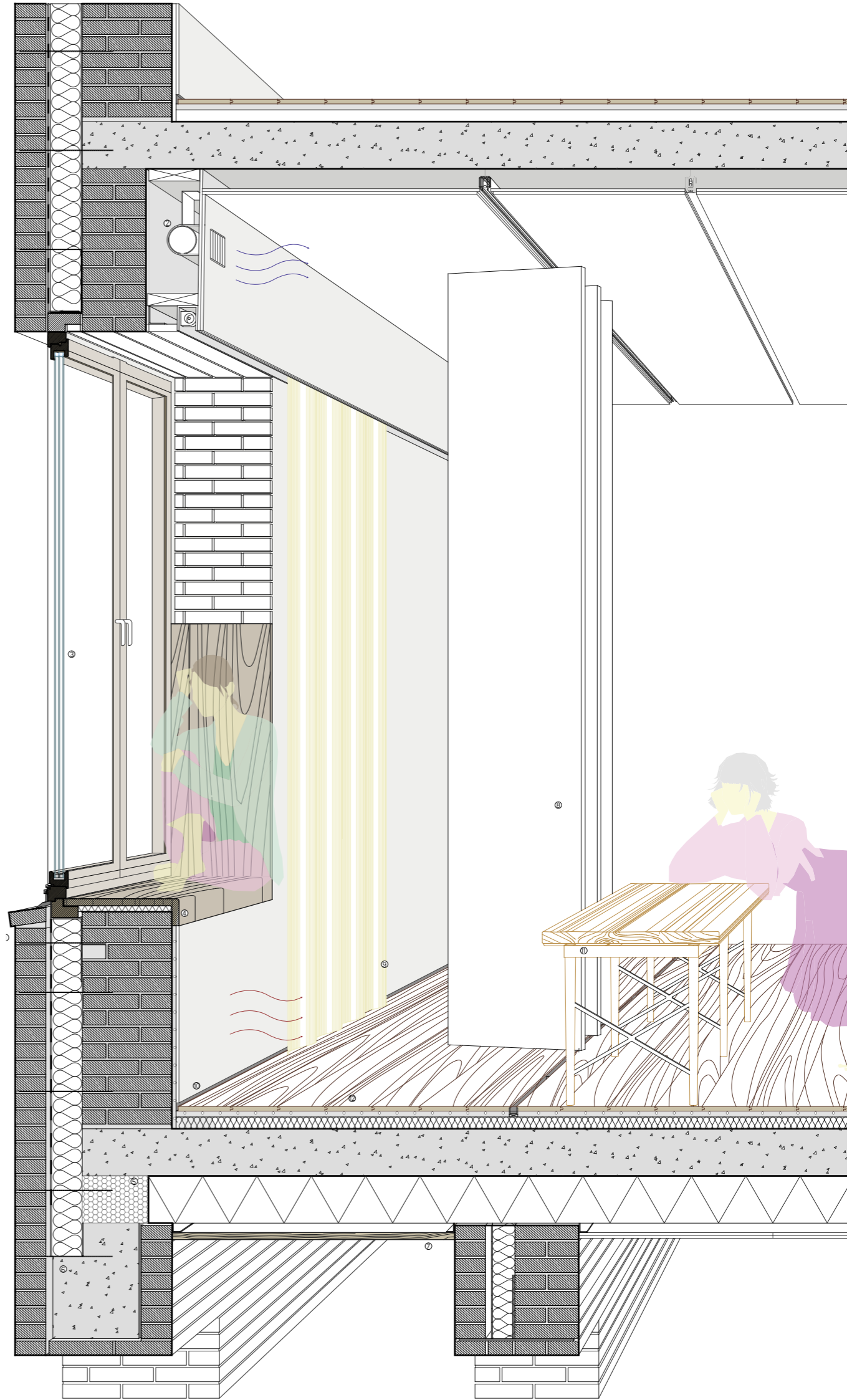

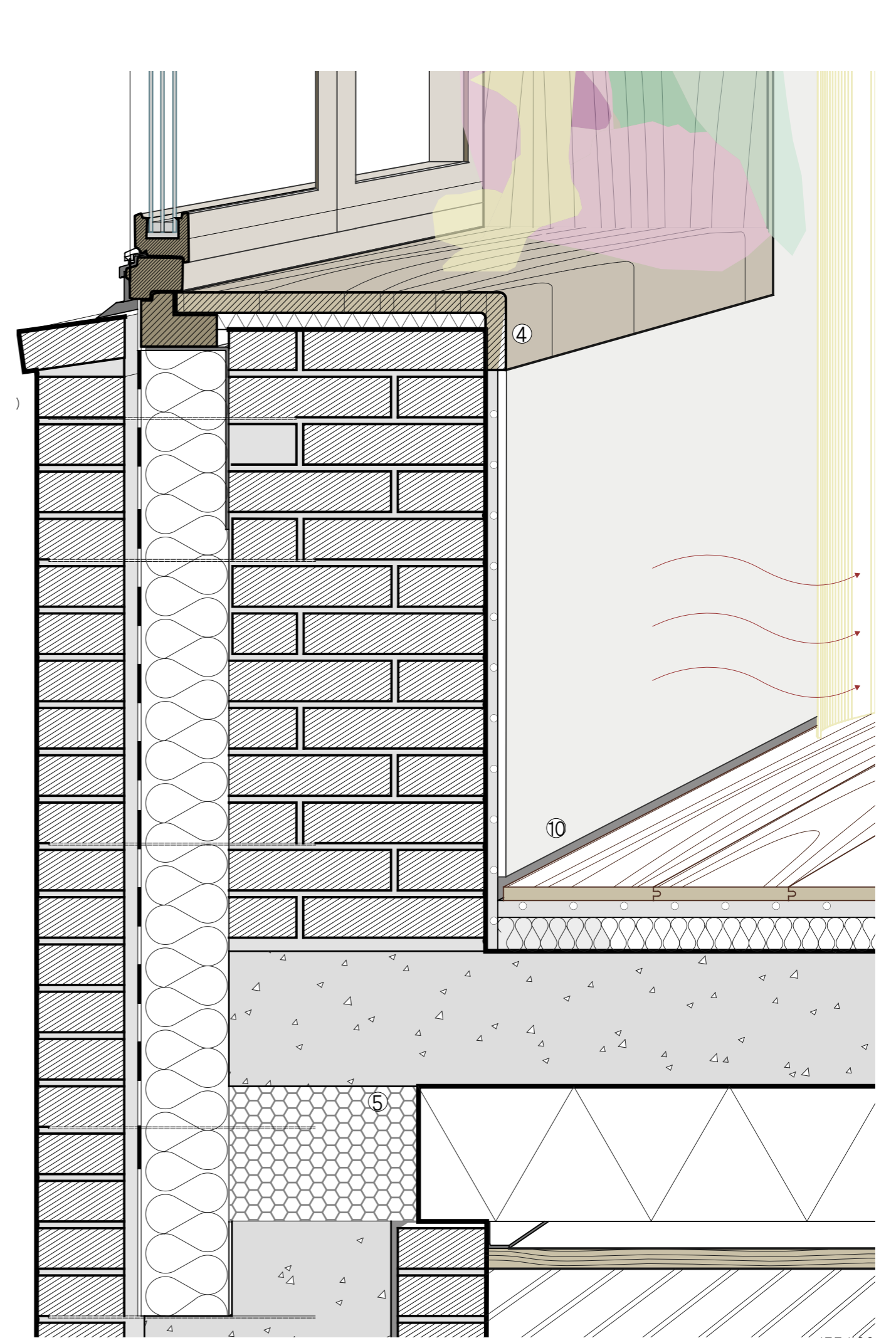
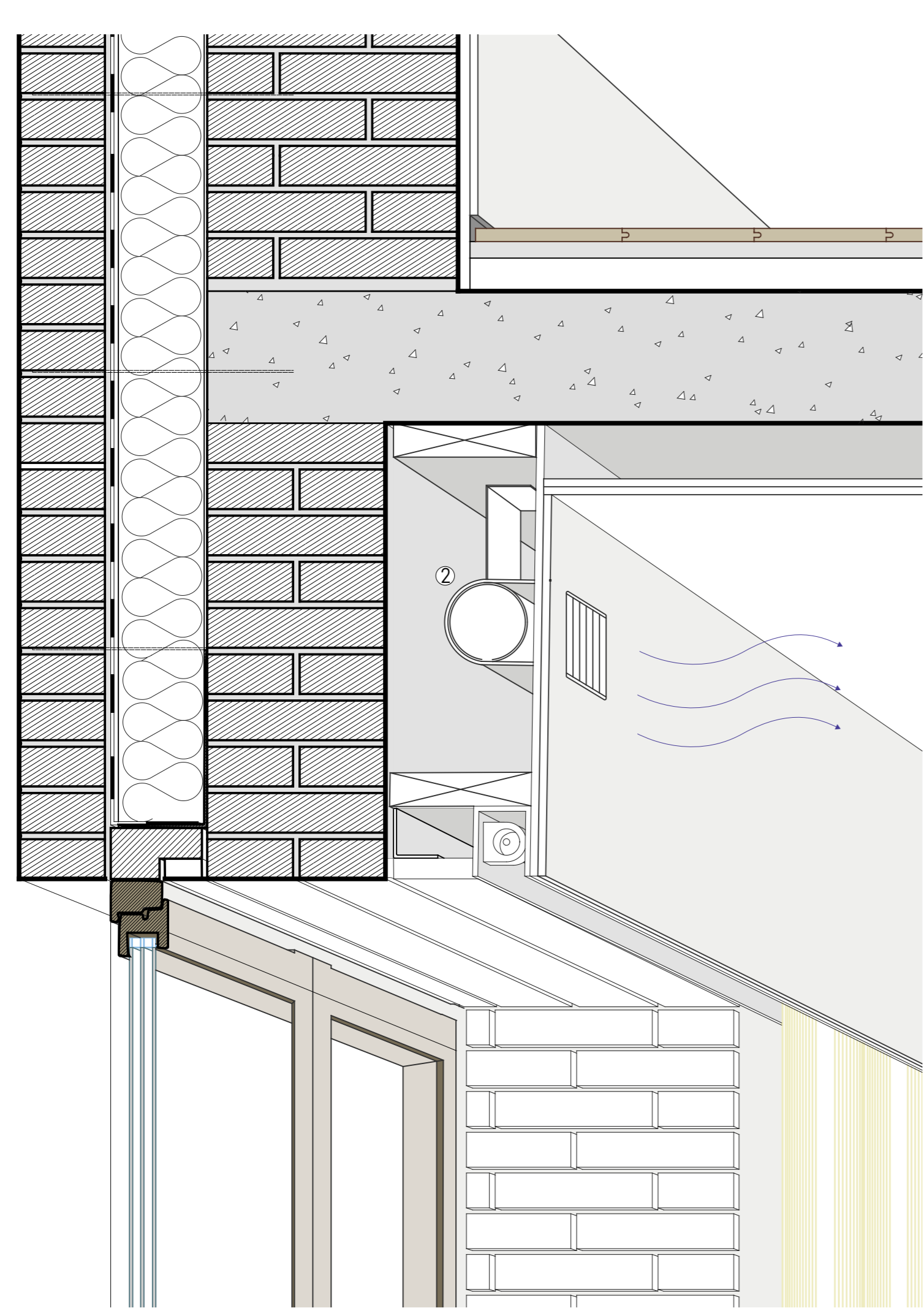

ADDED VOLUMES

**INNER VERTICAL CO-
MUNICATION**

**LEVELING OF OLD AND
NEW FLOORS**

**GARDEN & PLAY-
GROUND IN THE COUR-
YARD**

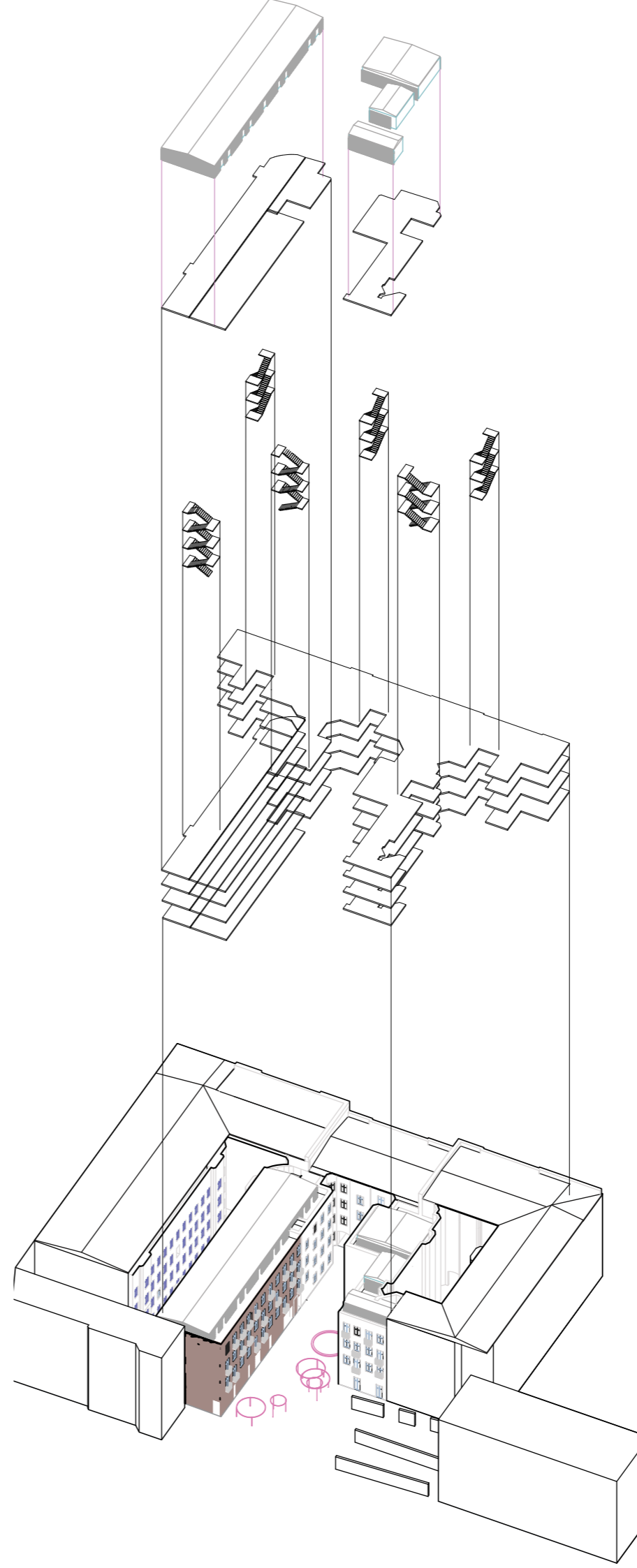



thank you

Special thanks to my Mum, Dad, Myrto, Carolina, Gosia, Chen,
Benjamin, Agata, Fransesco, Francesca, Aidan, Bob, Rina,
Ghert and all my friends who supported and influenced this
project and me throughout the entire process in an immense
way