



# Den City

Rotterdam, Central District

# Ontwerp opdracht

The development and architecture of Tall buildings are at the center of attention in the architectural discourse. It responds to major concerns of our society; the land scarcity in metropolitan areas and its high value, the need of intensifying land use in order to contribute to sustainable development. And the need and ambition of densifying urban centres in order to revitalise and prepare them for the century to come. Tall buildings are a reality, also in the Netherlands and in particular Rotterdam.

**The assignment will be a design for a Tall building in the Station area in Rotterdam.** The challenge is to design 270.000 m<sup>2</sup>, a complete district of mixed functions, on a 16.000 m<sup>2</sup> plot and embed it into the urban pattern.

Den Haag / Amsterdam

Gouda

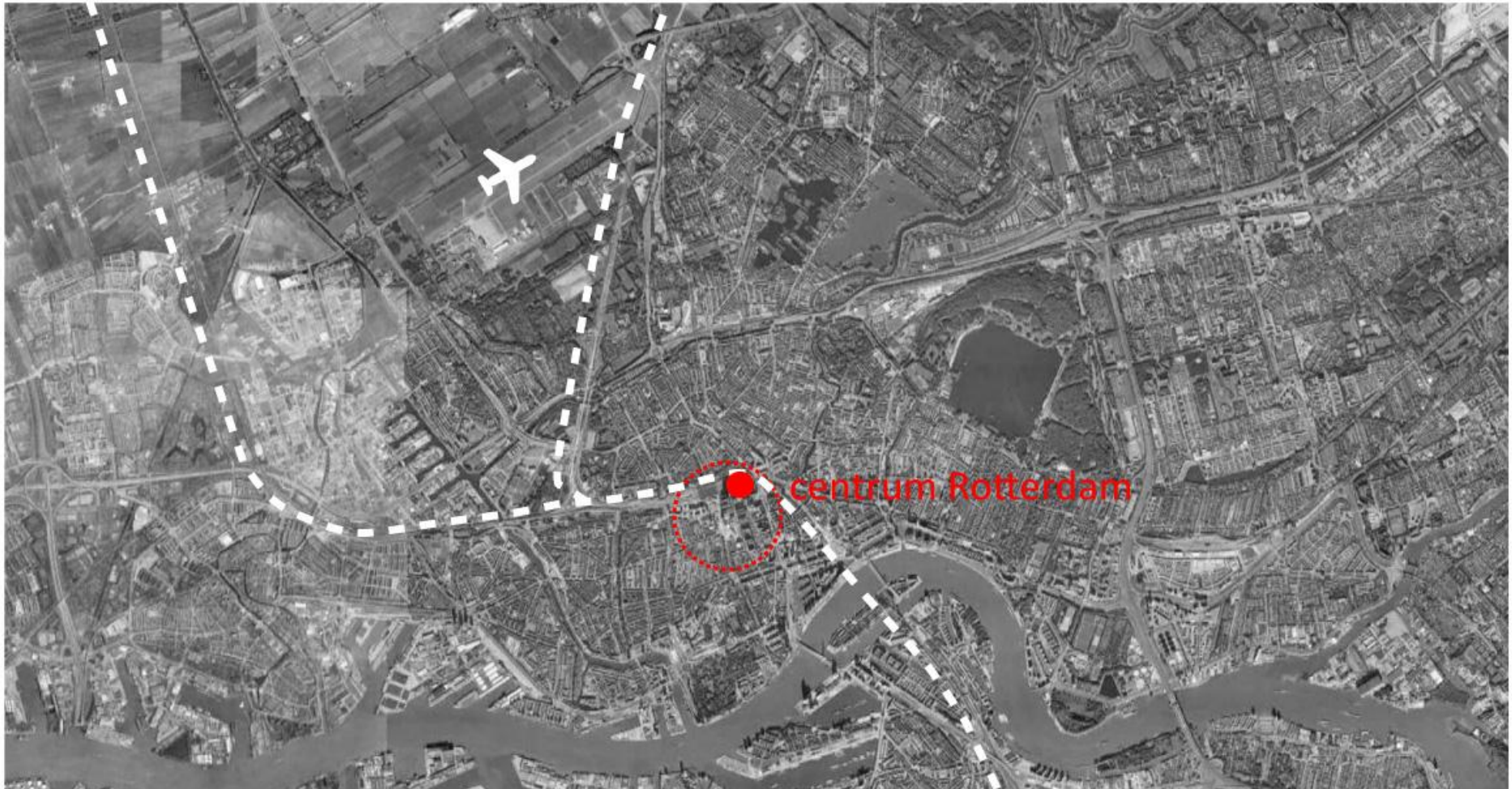

Dordrecht / Antwerpen



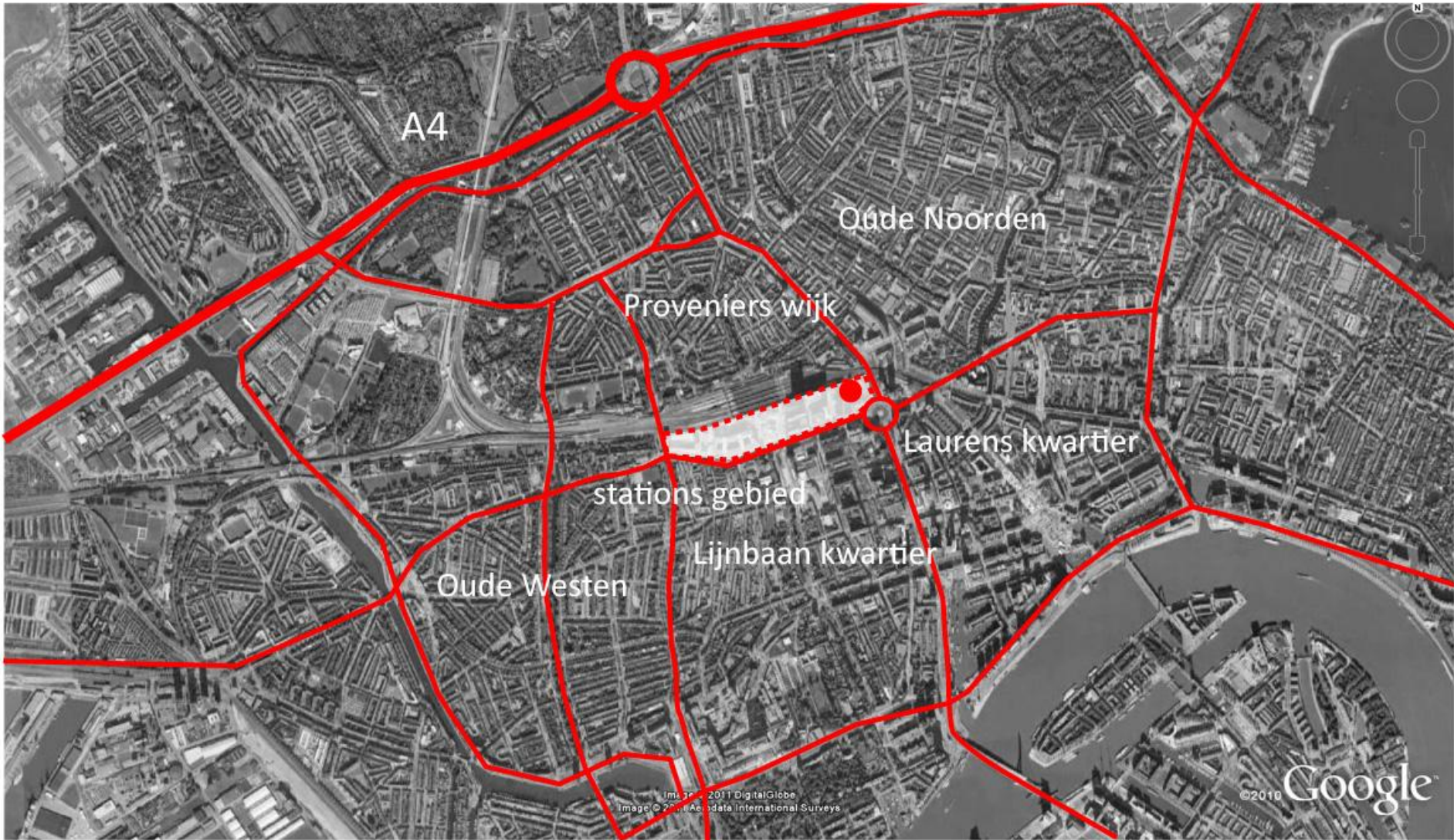

A4

Oude Noorden

Proveniers wijk

Laurens kwartier

stations gebied

Lijnbaan kwartier

Oude Westen

©2010 Google

Imagery © 2011 DigitalGlobe  
Image © 2011 Aerialdata International Surveys



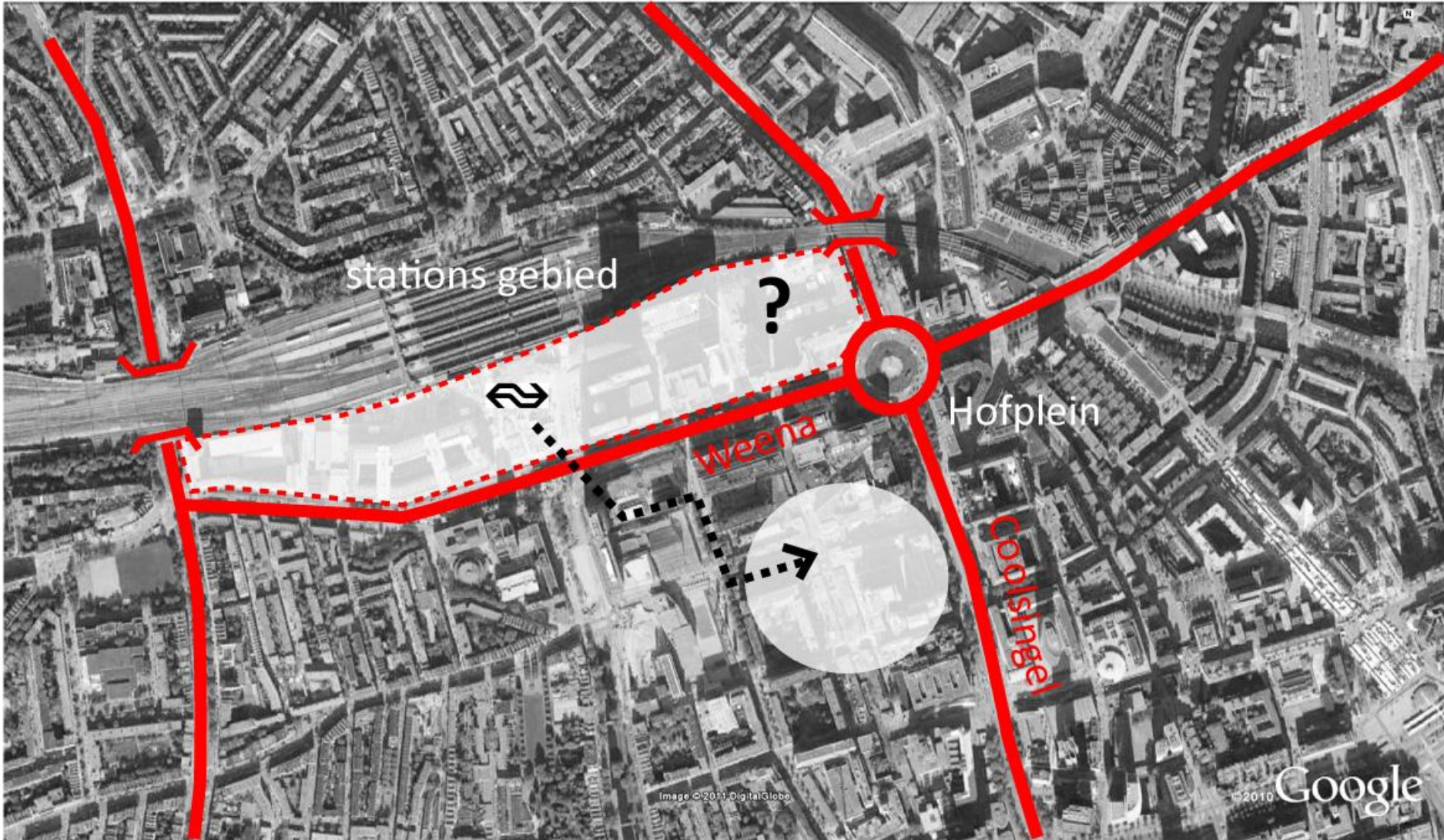

stations gebied

?

Hofplein

Weena

Coolisnigel

©2010 Google

Image ©2011 DigitalGlobe



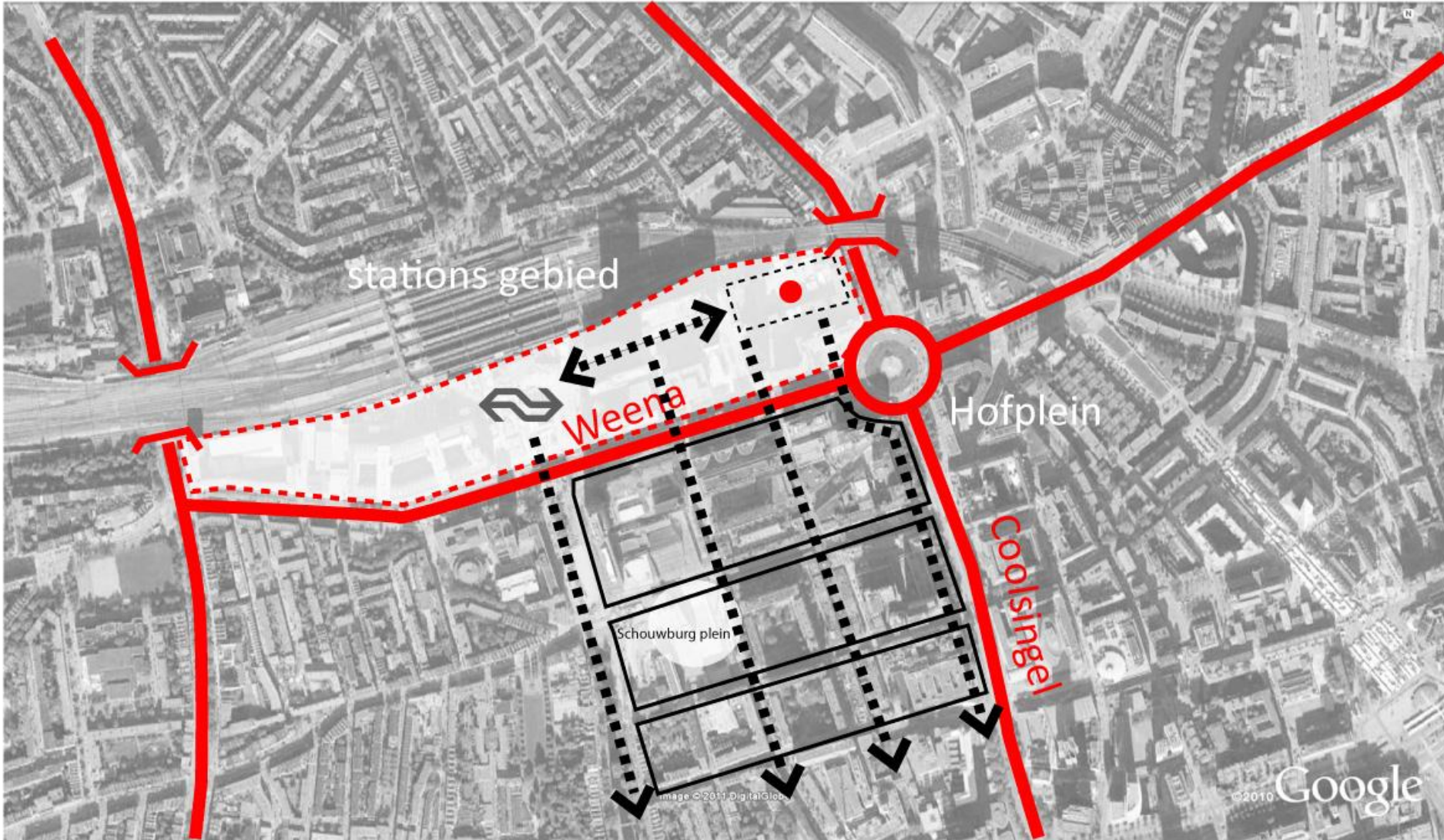

Stations gebied

Weena

Hofplein

Schouwburg plein

Coolingsingel

©2010 Google



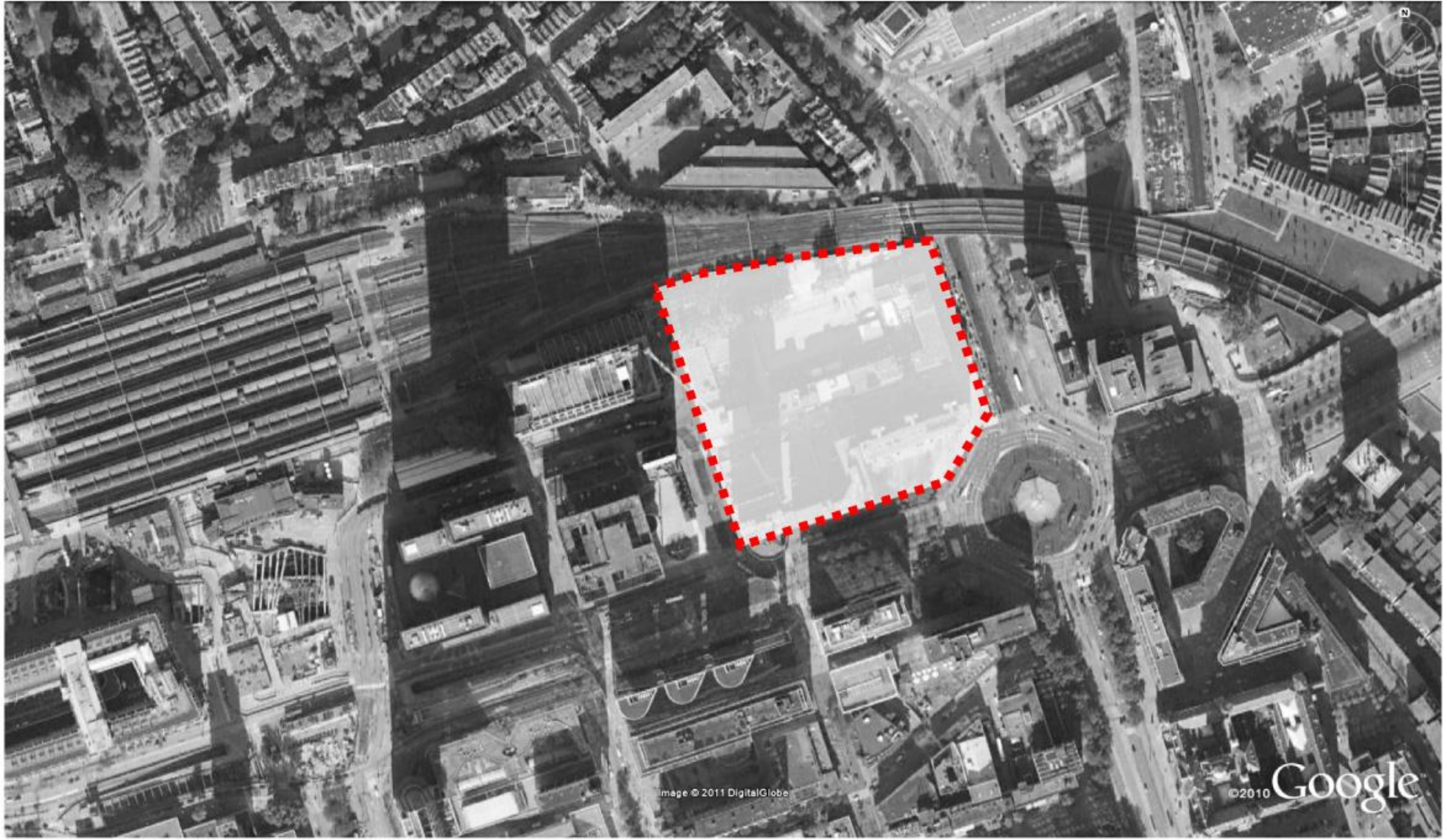
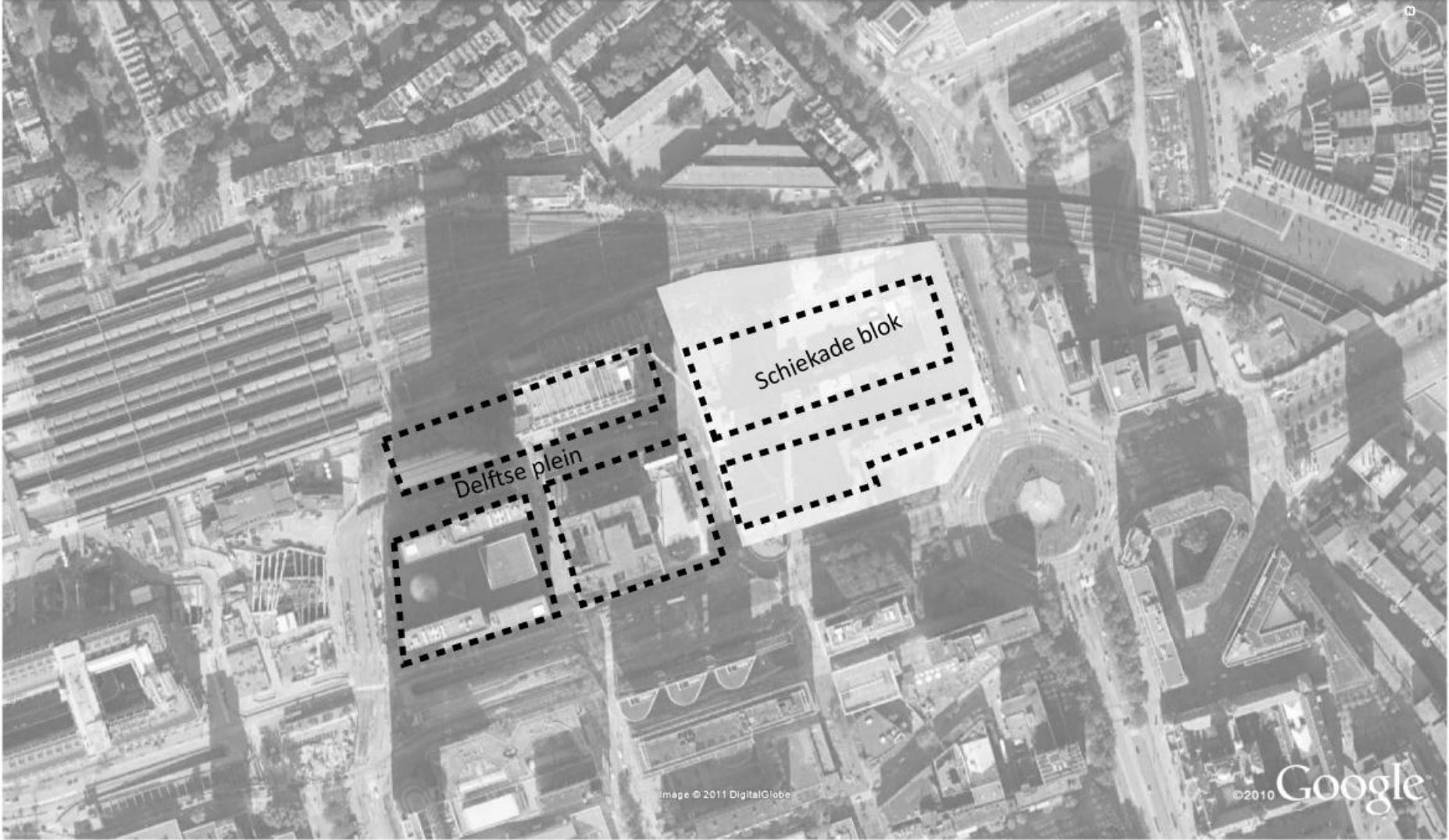

Image © 2011 DigitalGlobe

©2010 Google



Delftse plein

Schiekade blok



# Concept design

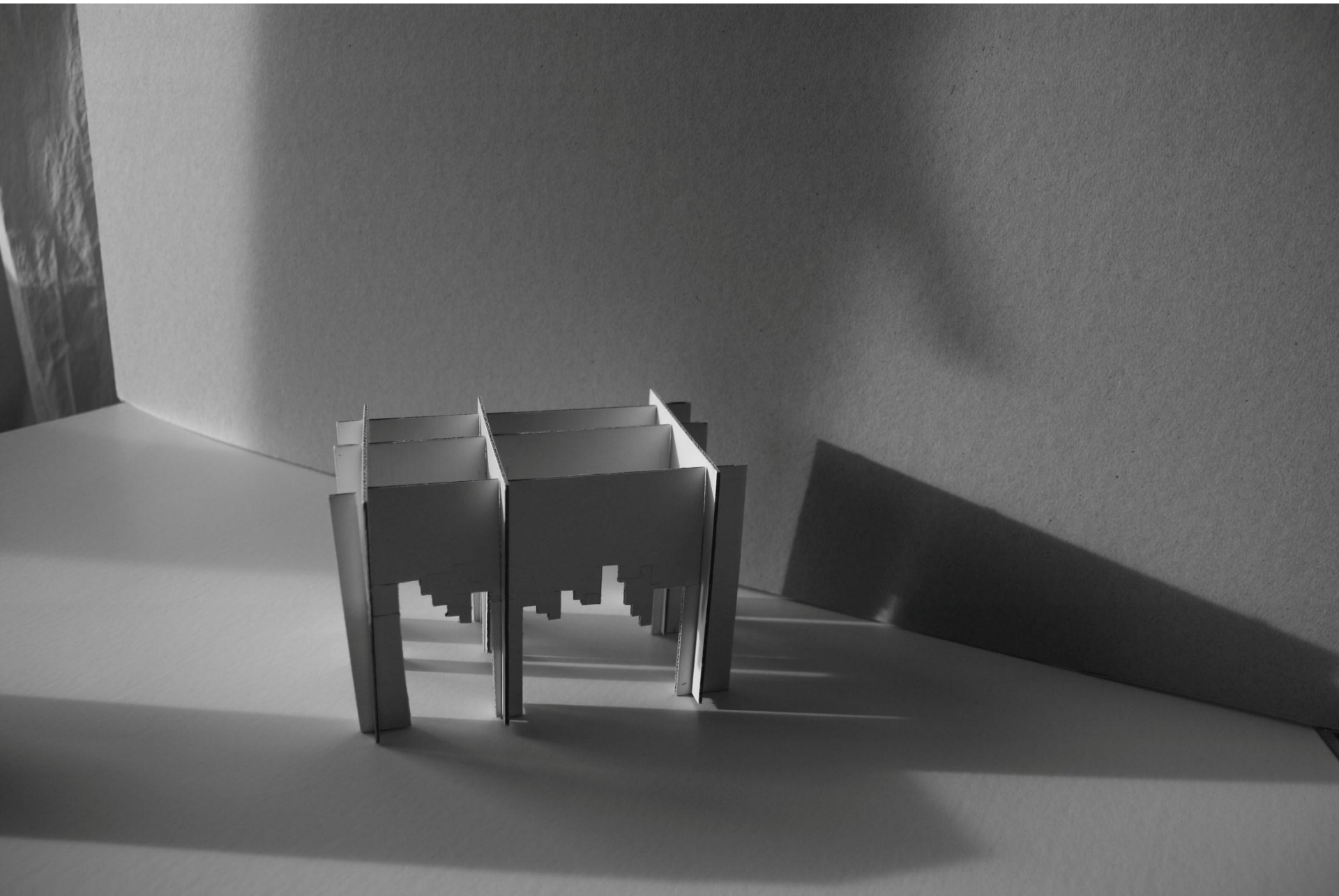





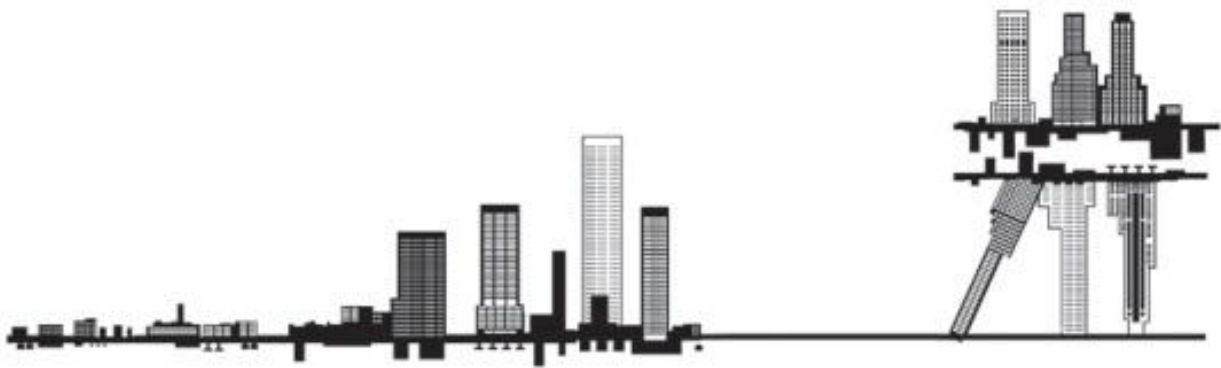
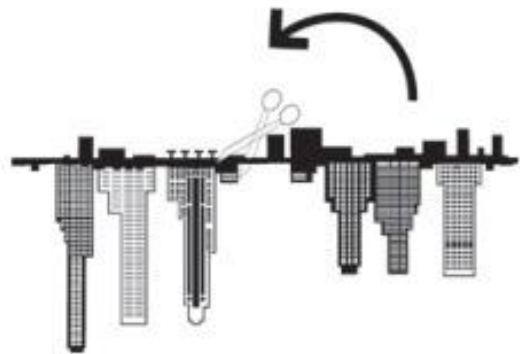



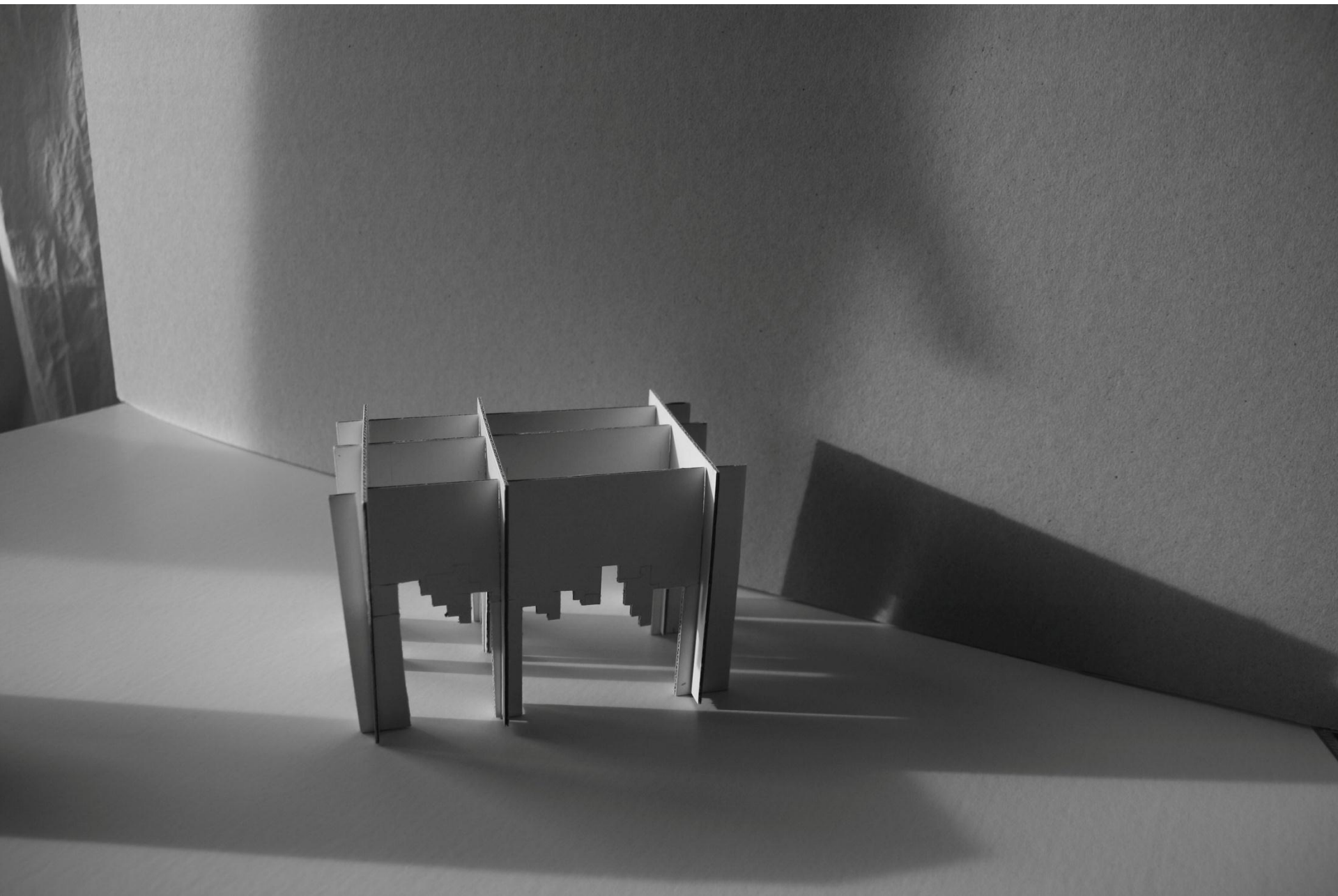

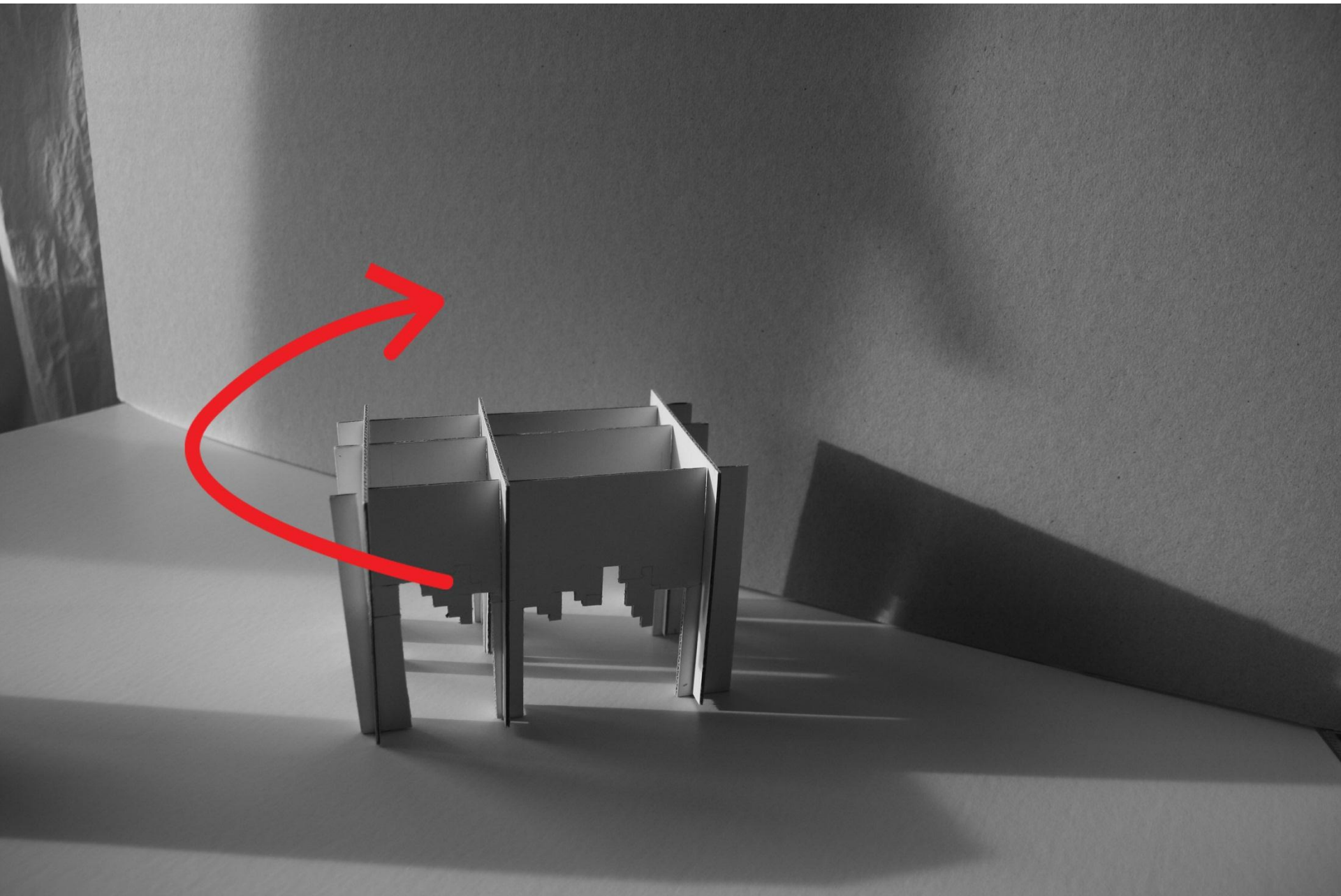



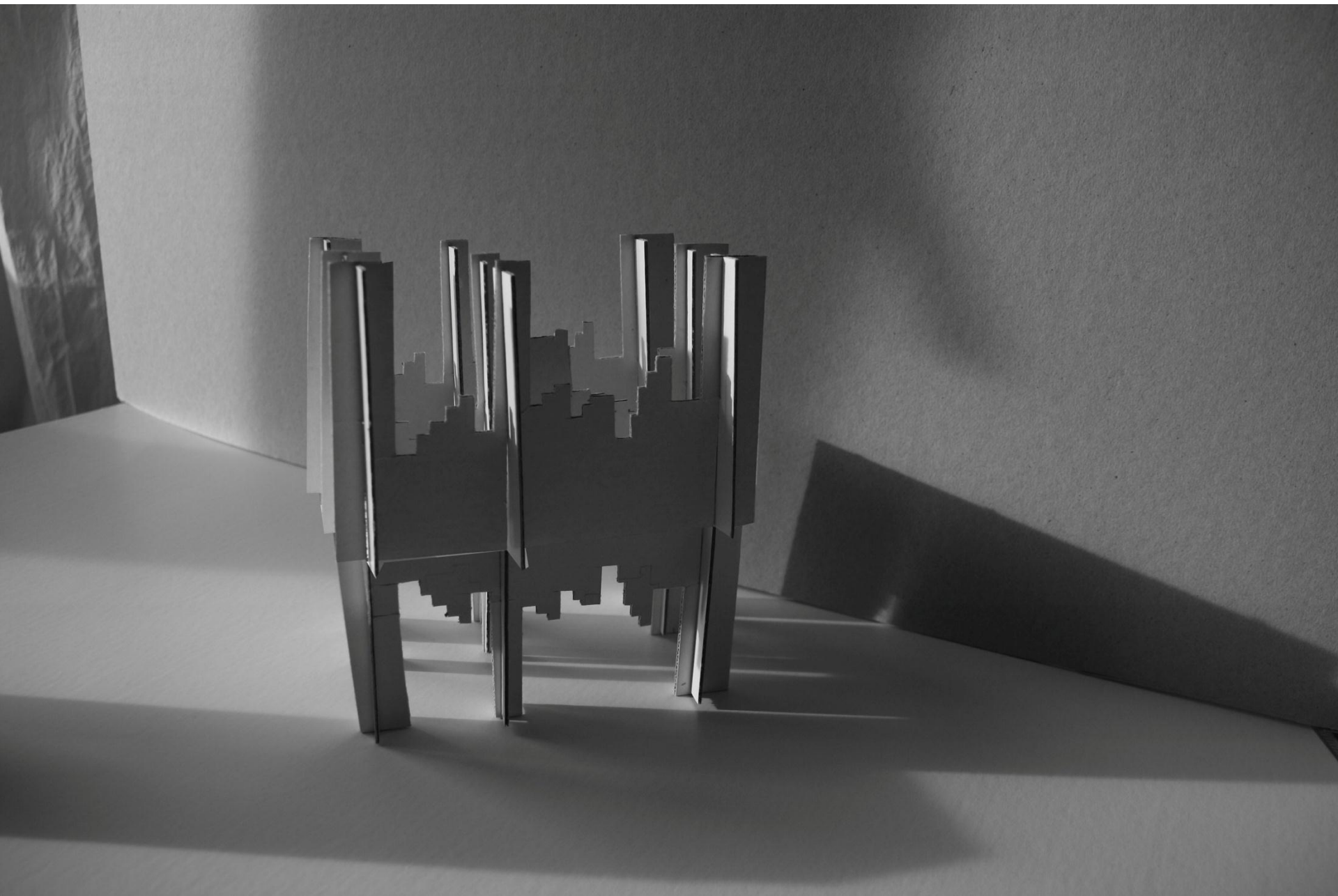

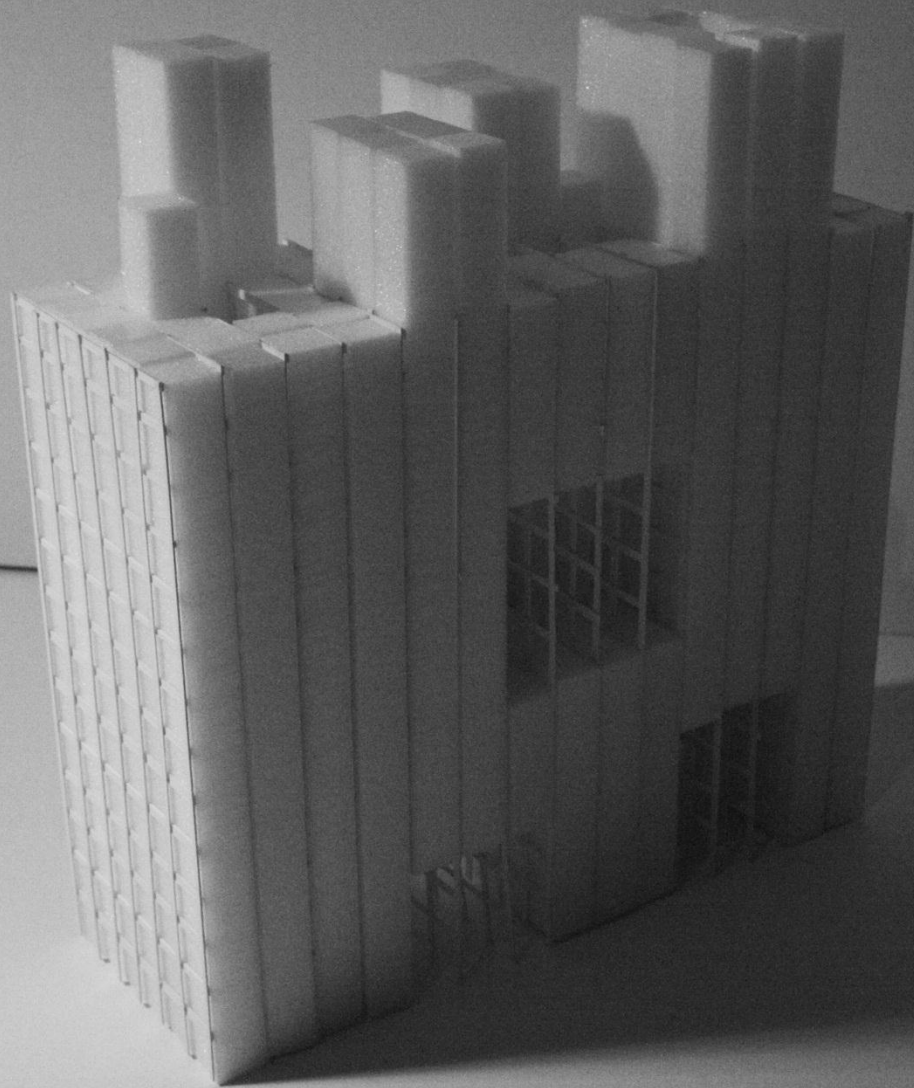





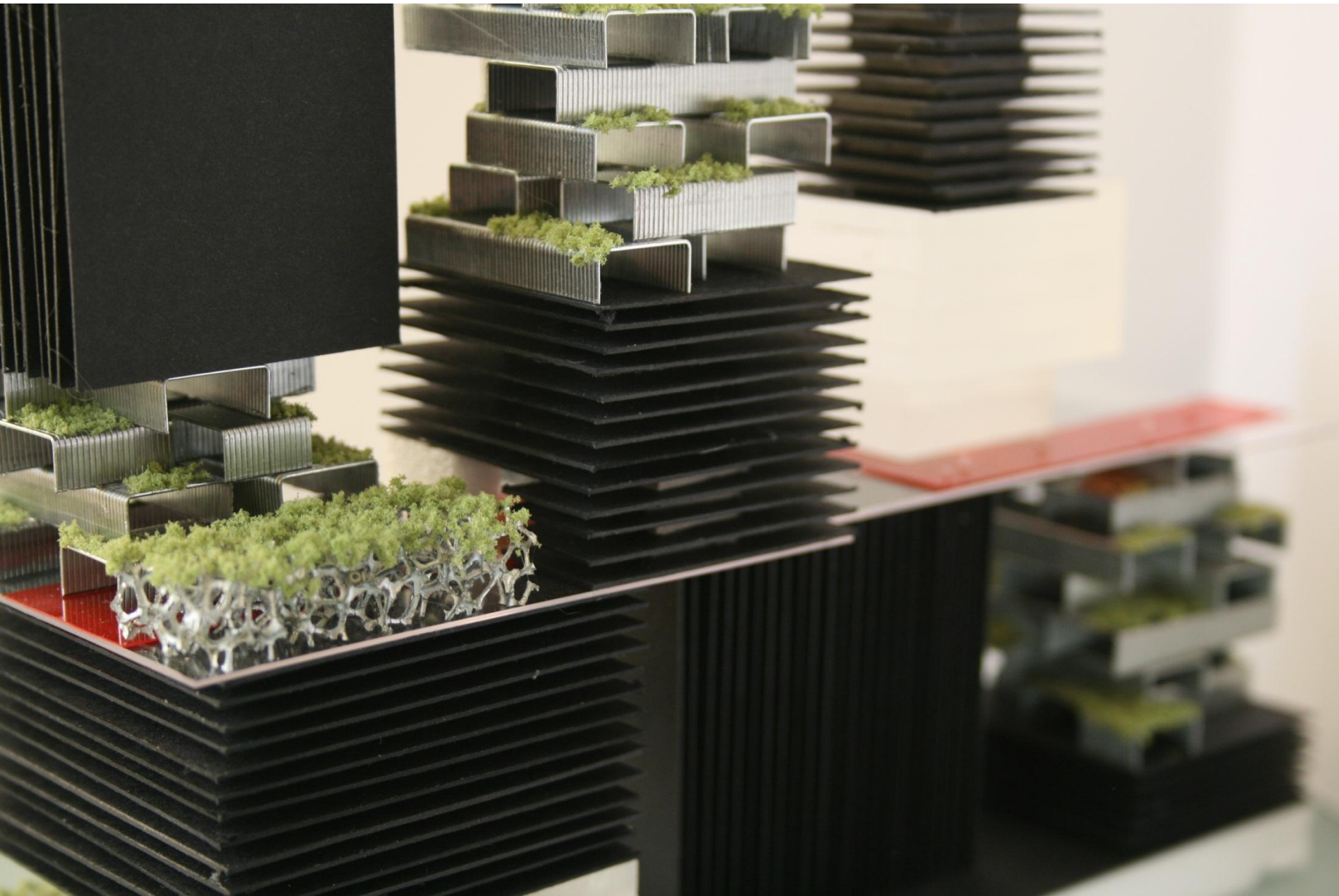





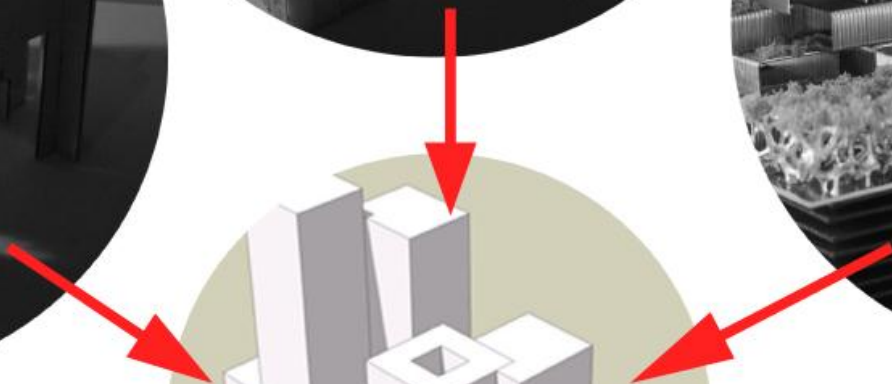
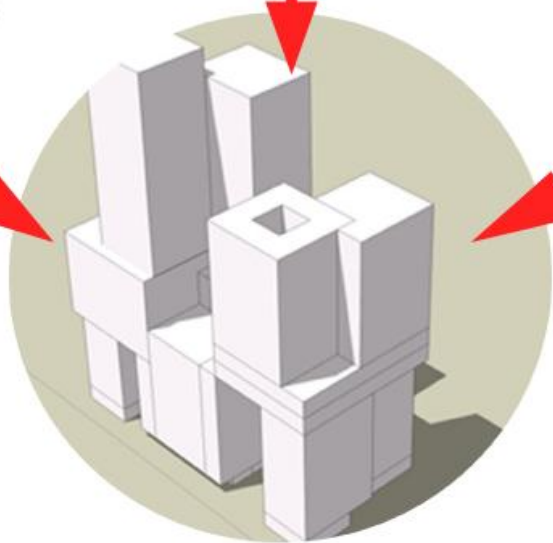
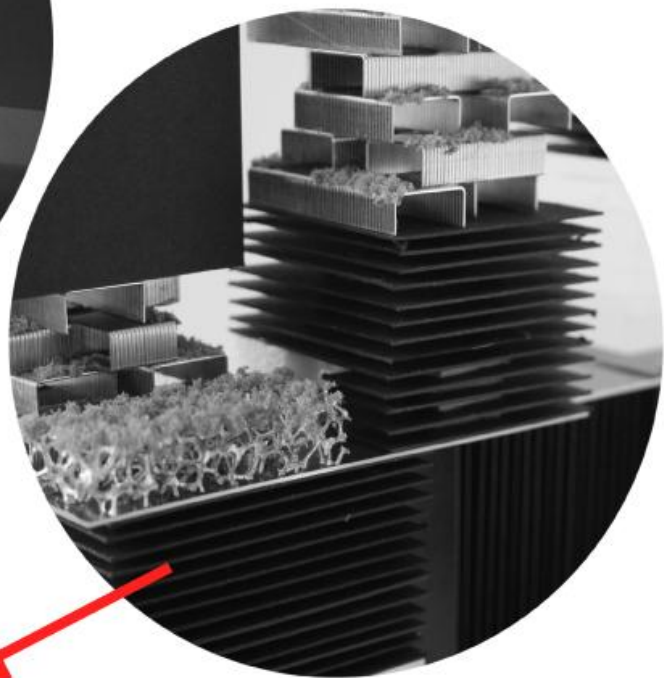
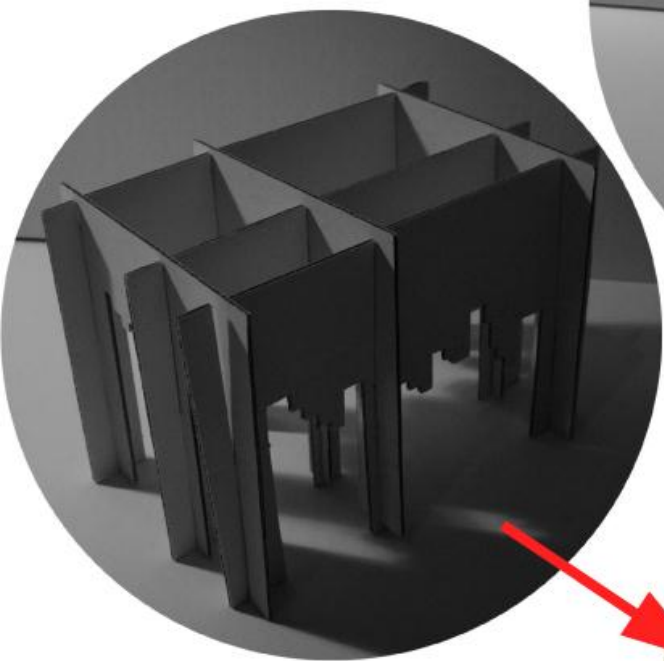



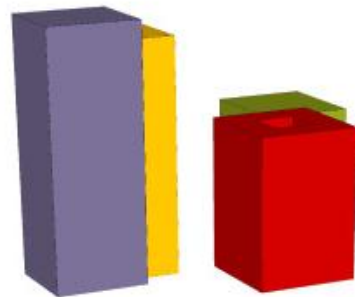

Appartementen  
Casino  
Hotel  
Congres



Retail  
Casino lobby  
Hotel lobby  
Expositie

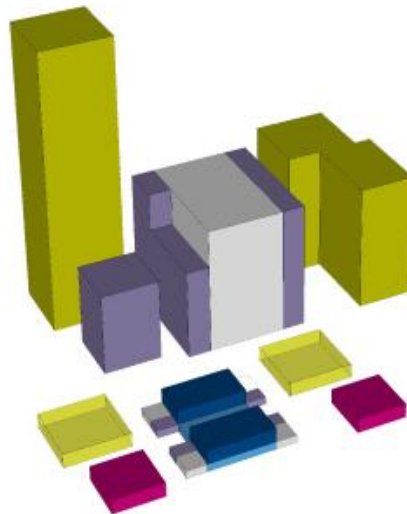

Kantoor  
Appartementen  
Parkeergarage

Kantoor lobby  
Schowcase  
Winkels  
Supermarkt  
Lobby appartementen  
Entree parkeergarage

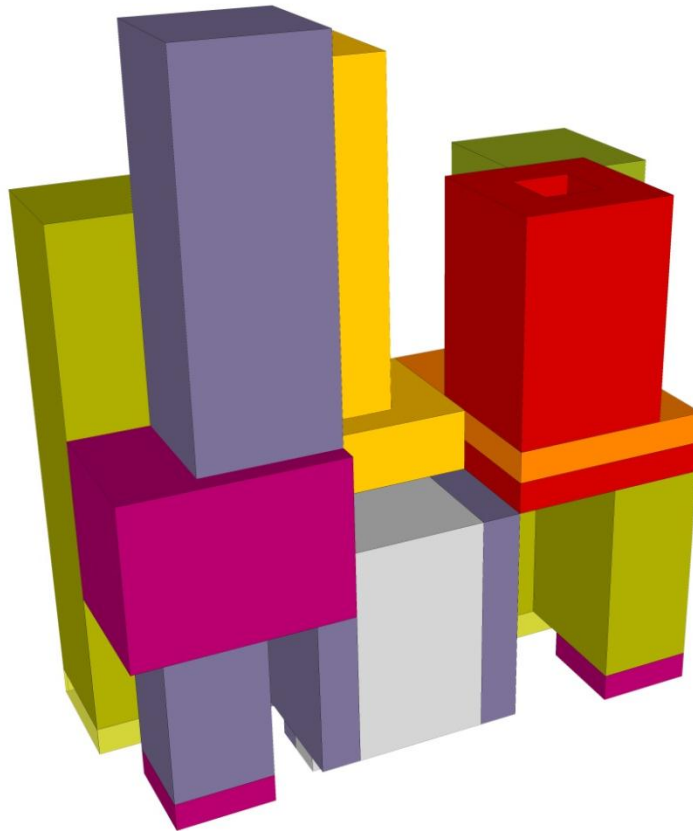

Appartementen

Casino

Hotel

Congres

Retail

Casino lobby

Hotel lobby

Expositie

Kantoor

Appartementen

Parkeergarage

Kantoor lobby

Schowcase

Winkels

Supermarkt

Lobby appartementen

Entree parkeergarage

programma



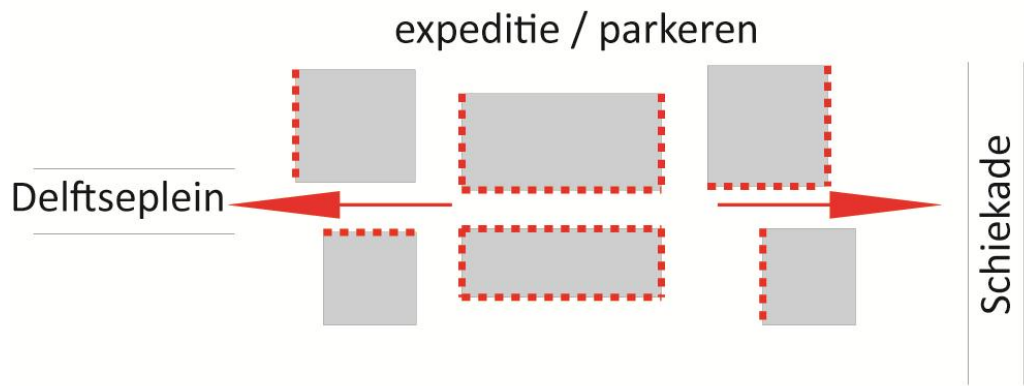
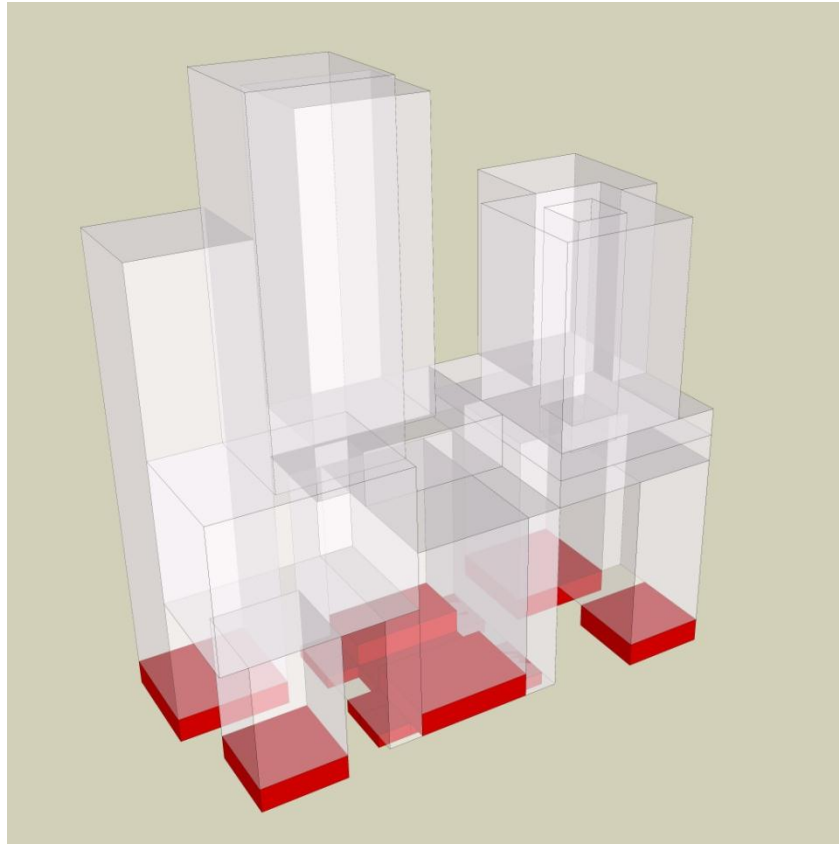

orientatie

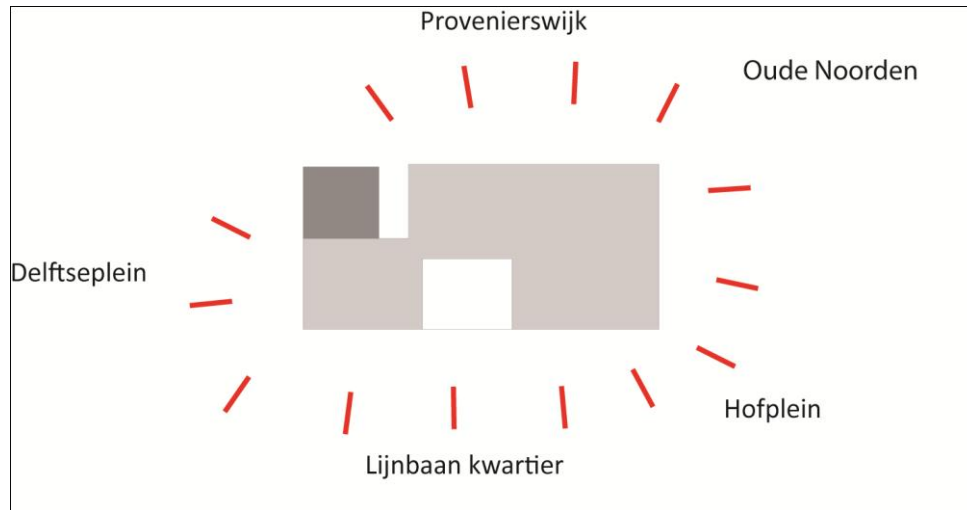
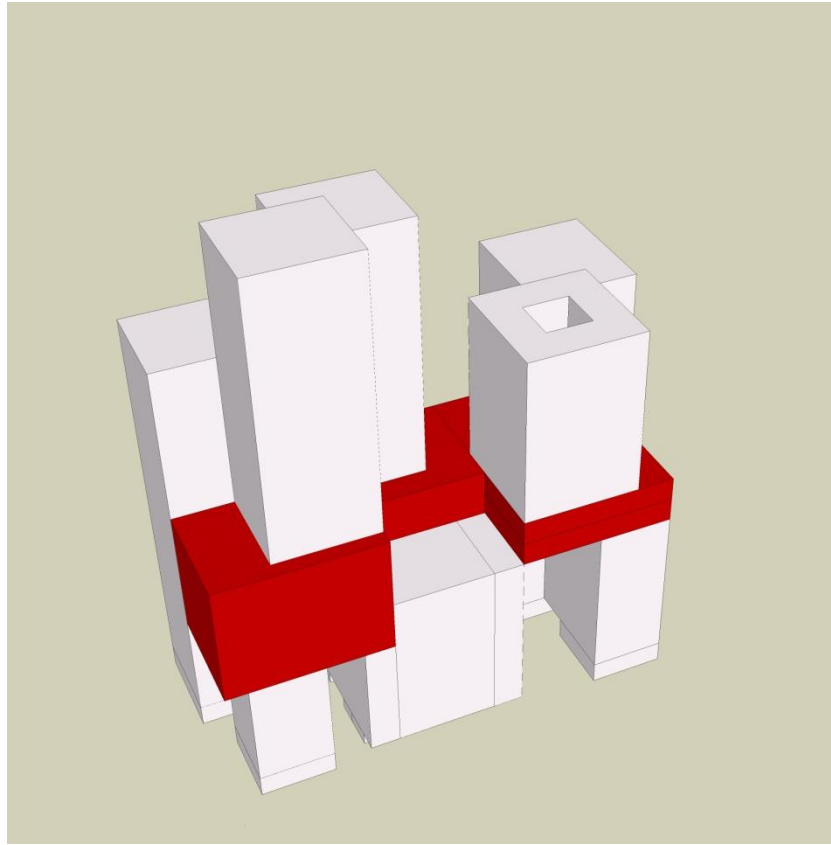

orientatie



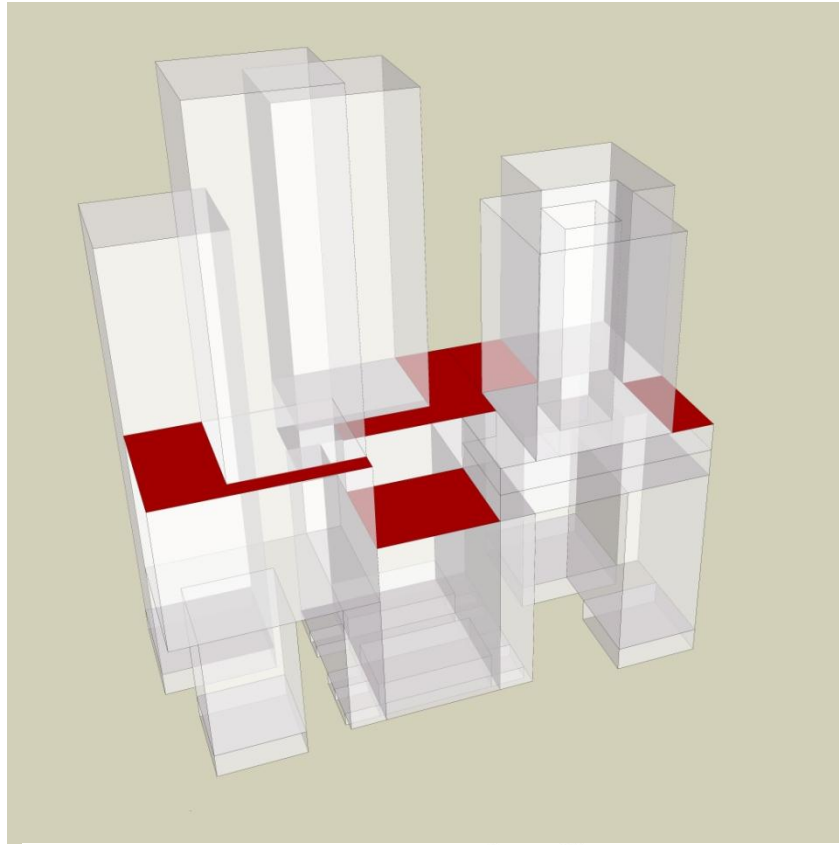

Provenierswijk

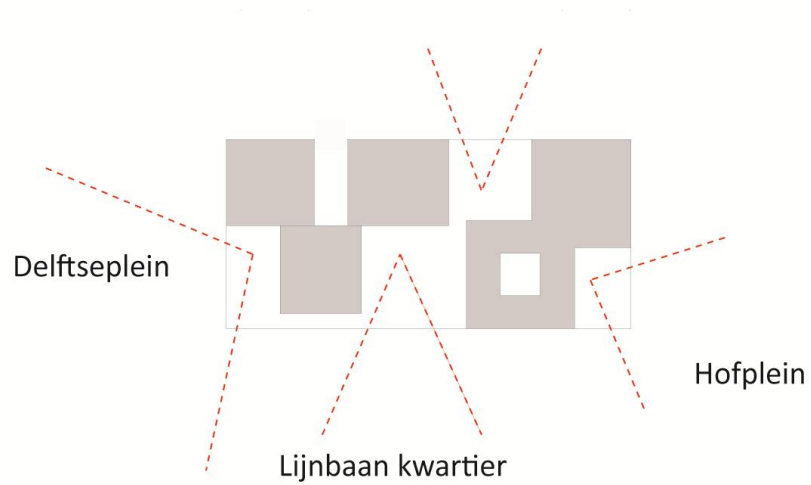

orientatie

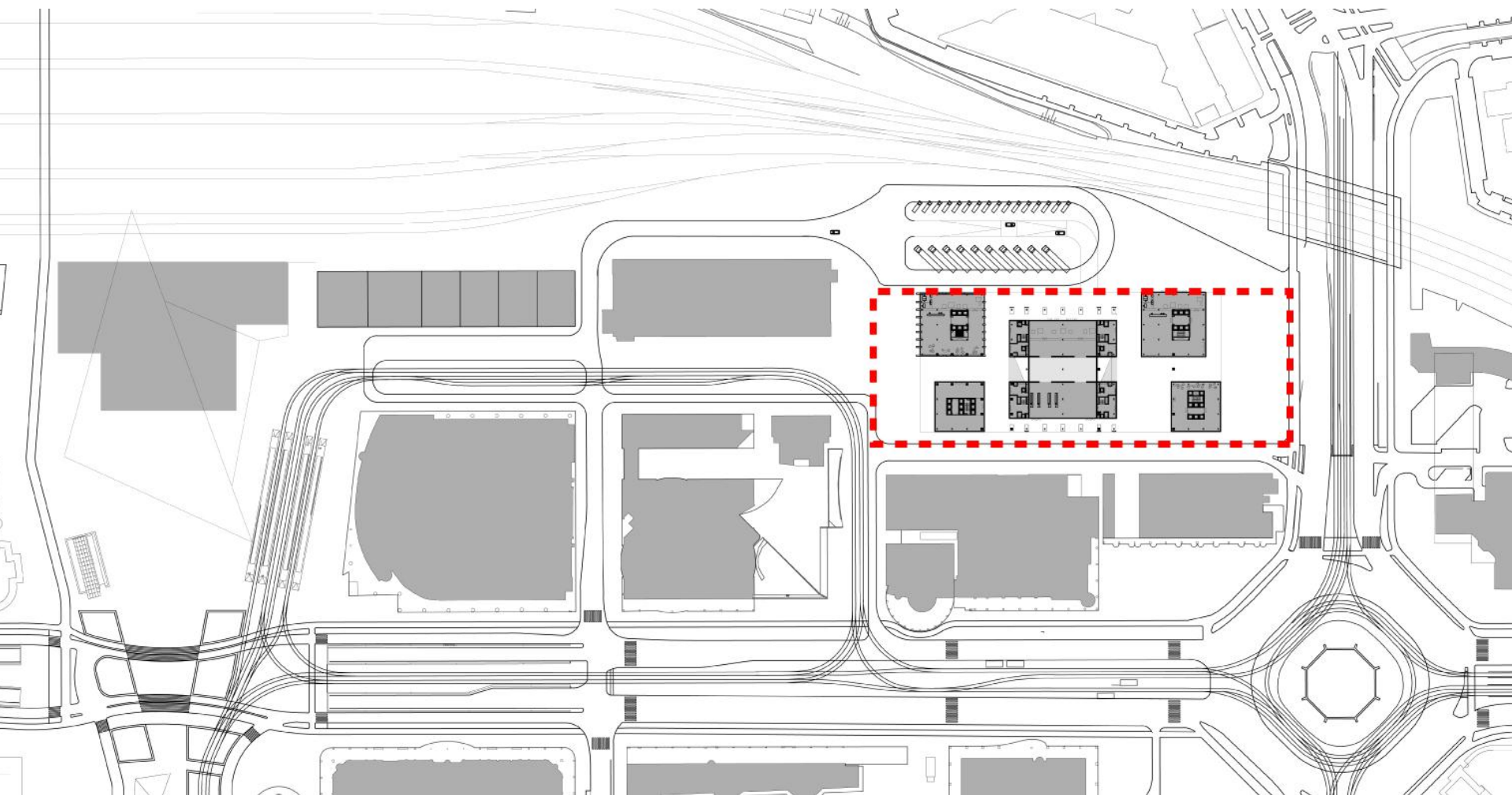

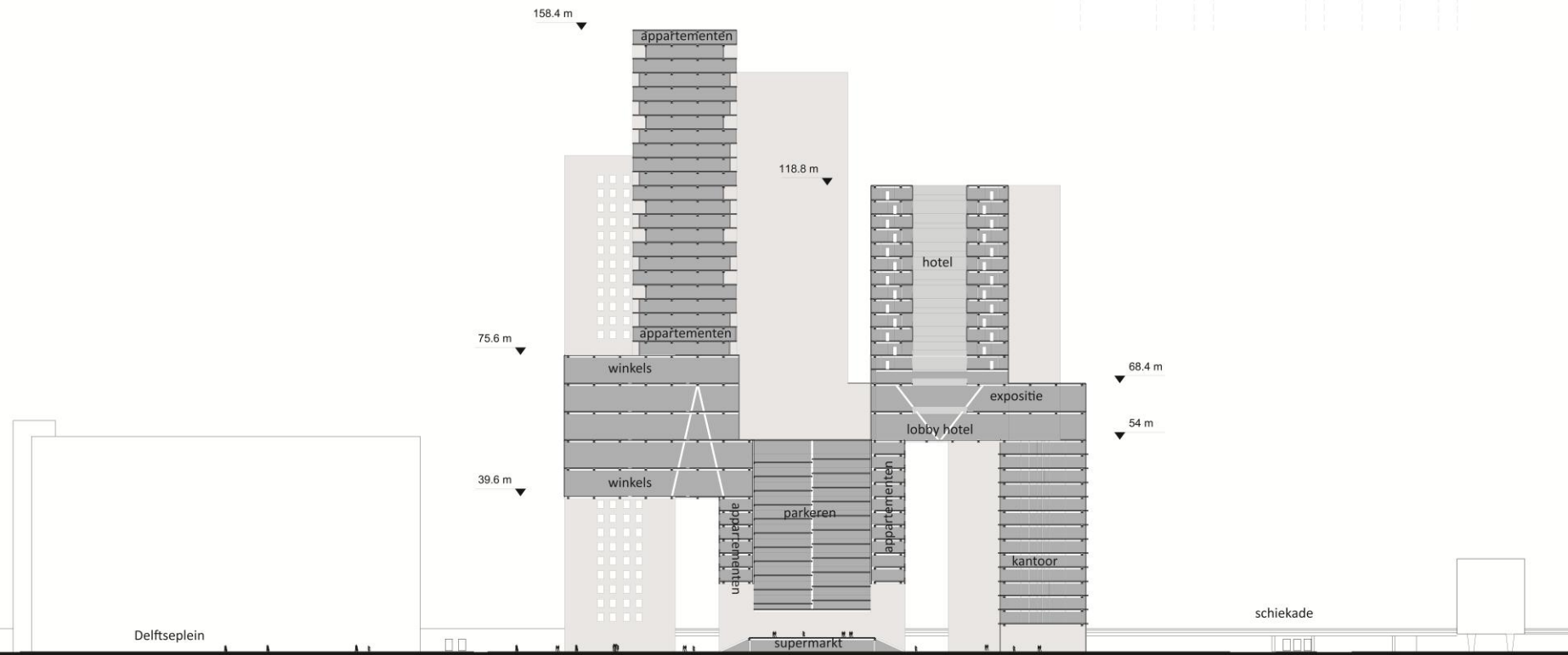
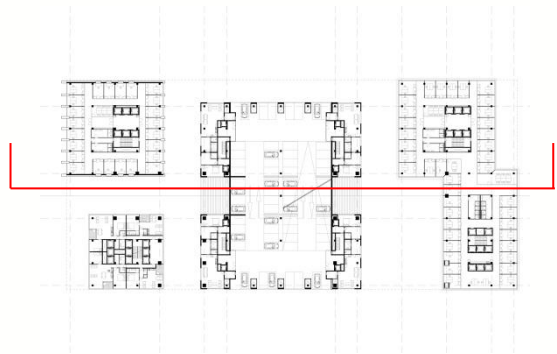

Delftseplein

158.4 m

75.6 m

39.6 m

appartementen

118.8 m

appartementen

winkels

winkels

appartementen

parkeren

appartementen

hotel

lobby hotel

expositie

kantoor

68.4 m

54 m

supermarkt

schiekade



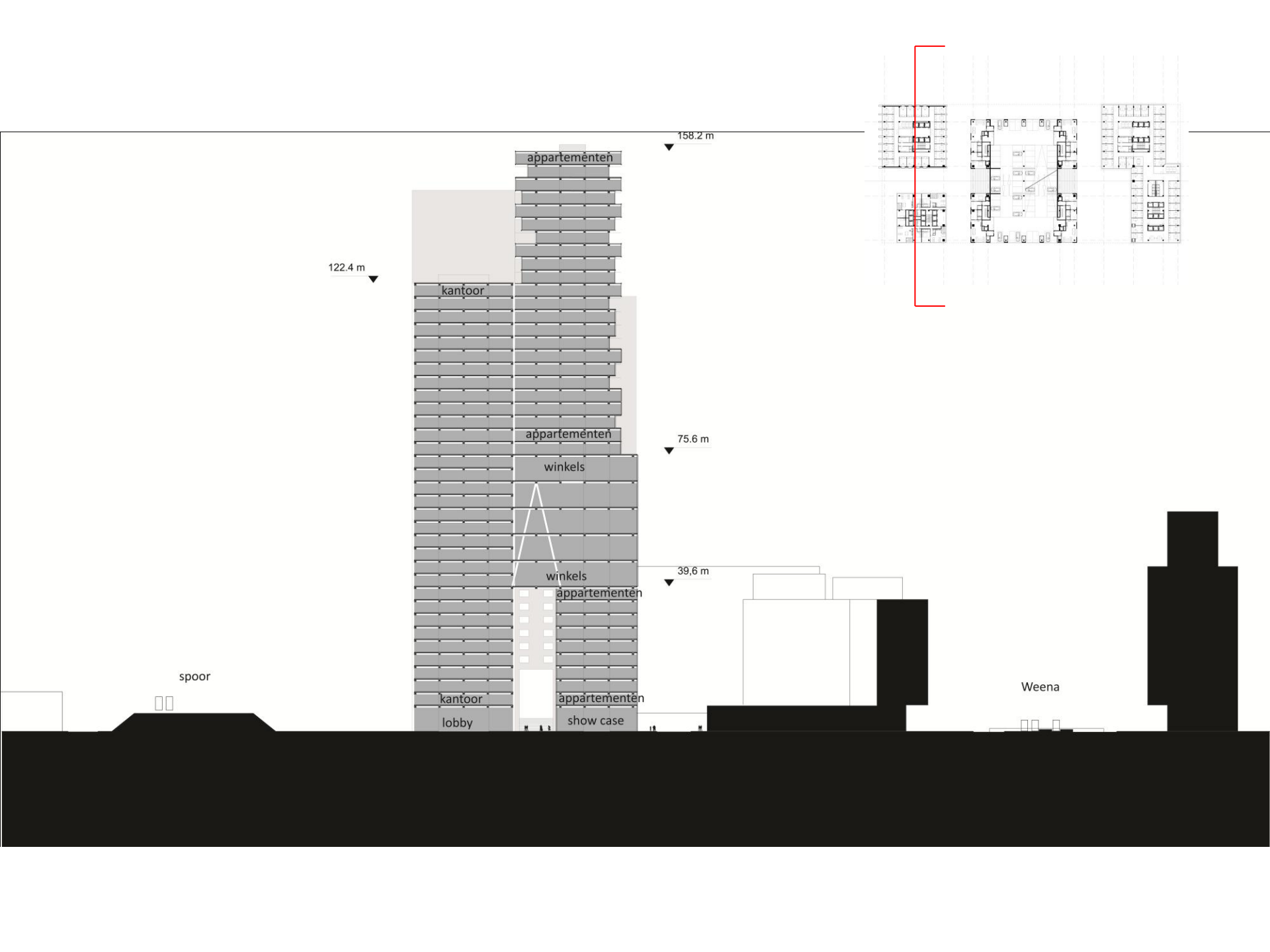

appartementen

158.2 m

122.4 m

kantoor

appartementen

75.6 m

winkels

winkels

39.6 m

appartementen

spoor

kantoor

lobby

appartementen

show case

Weena







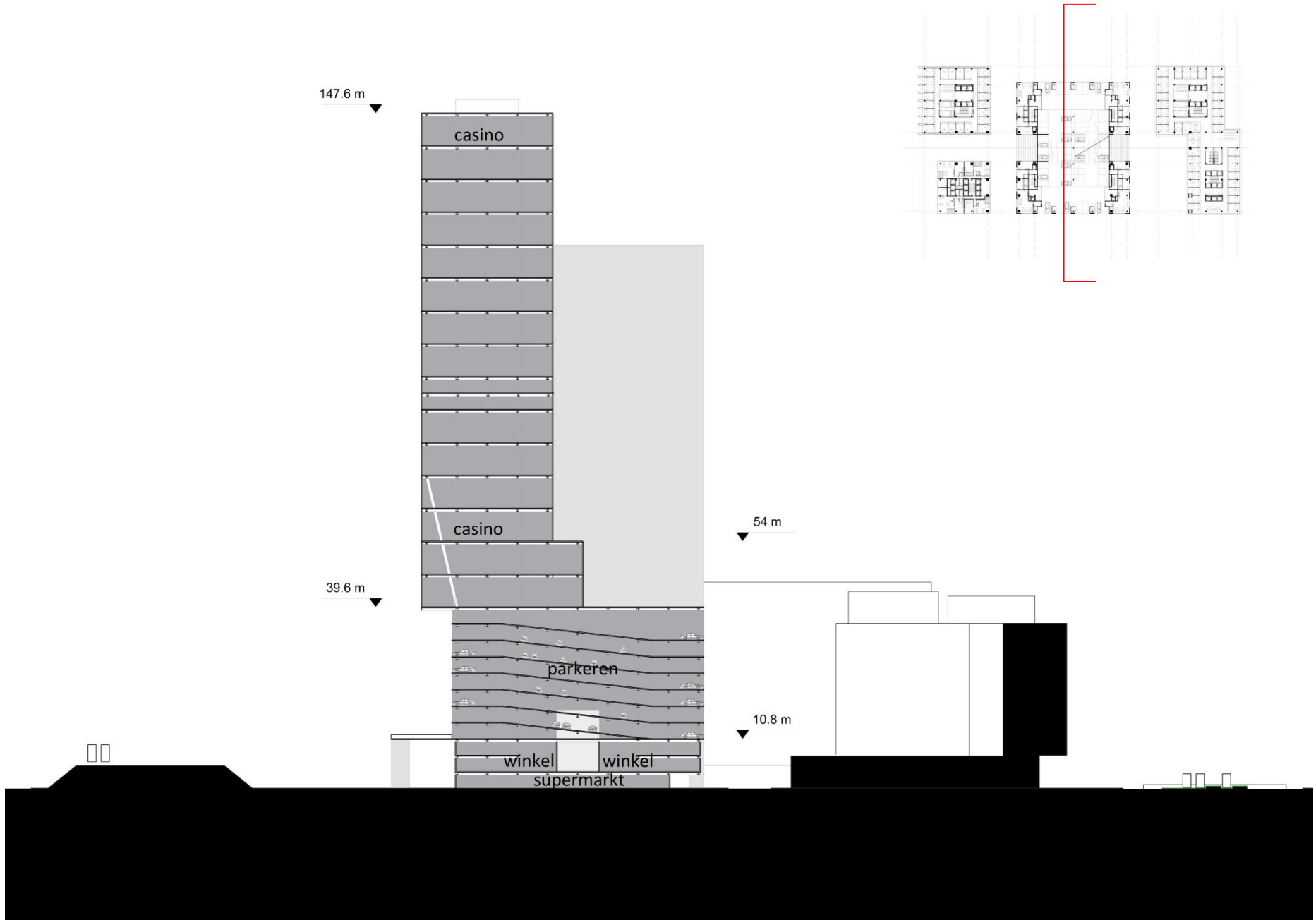

147.6 m

casino

casino

39.6 m

54 m

parkeren

winkel

winkel

supermarkt

10.8 m

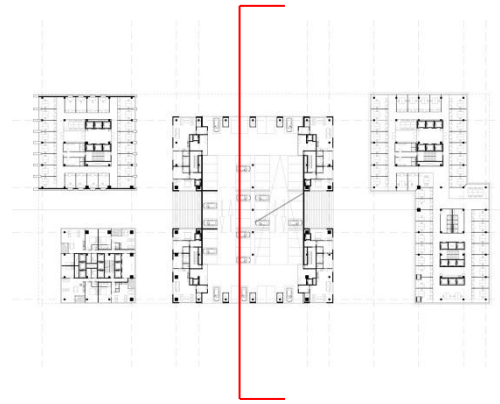



Voorzicht  
1:500

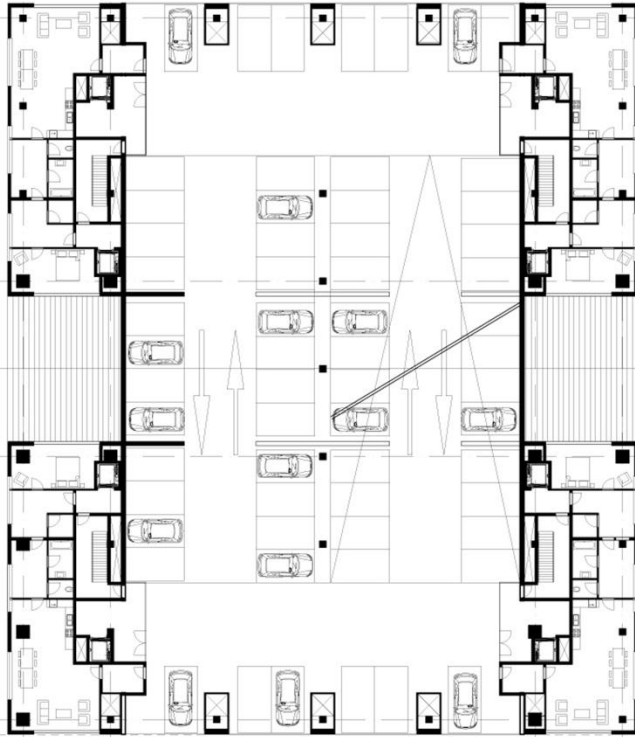
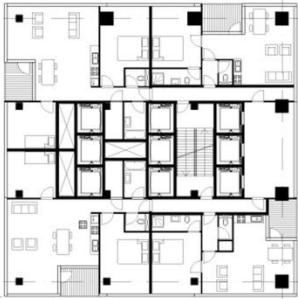

Low rise



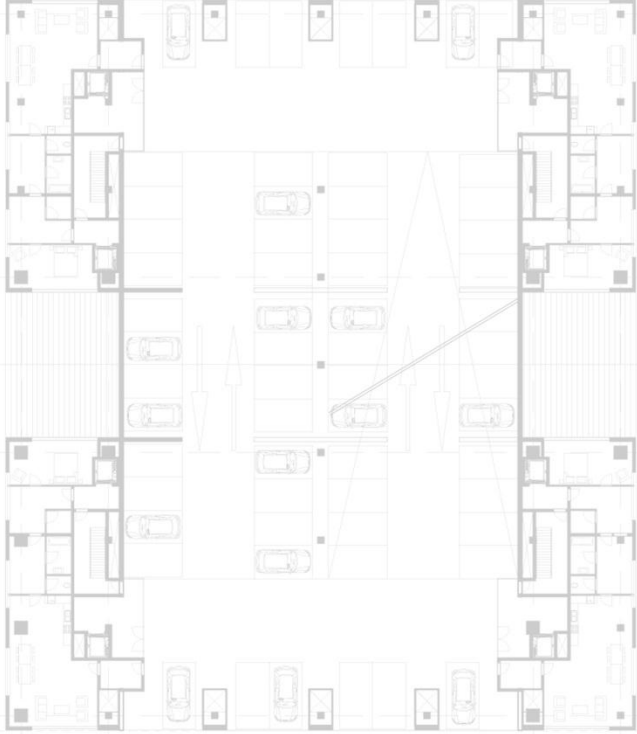
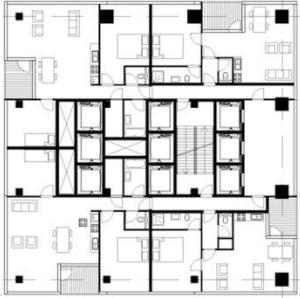

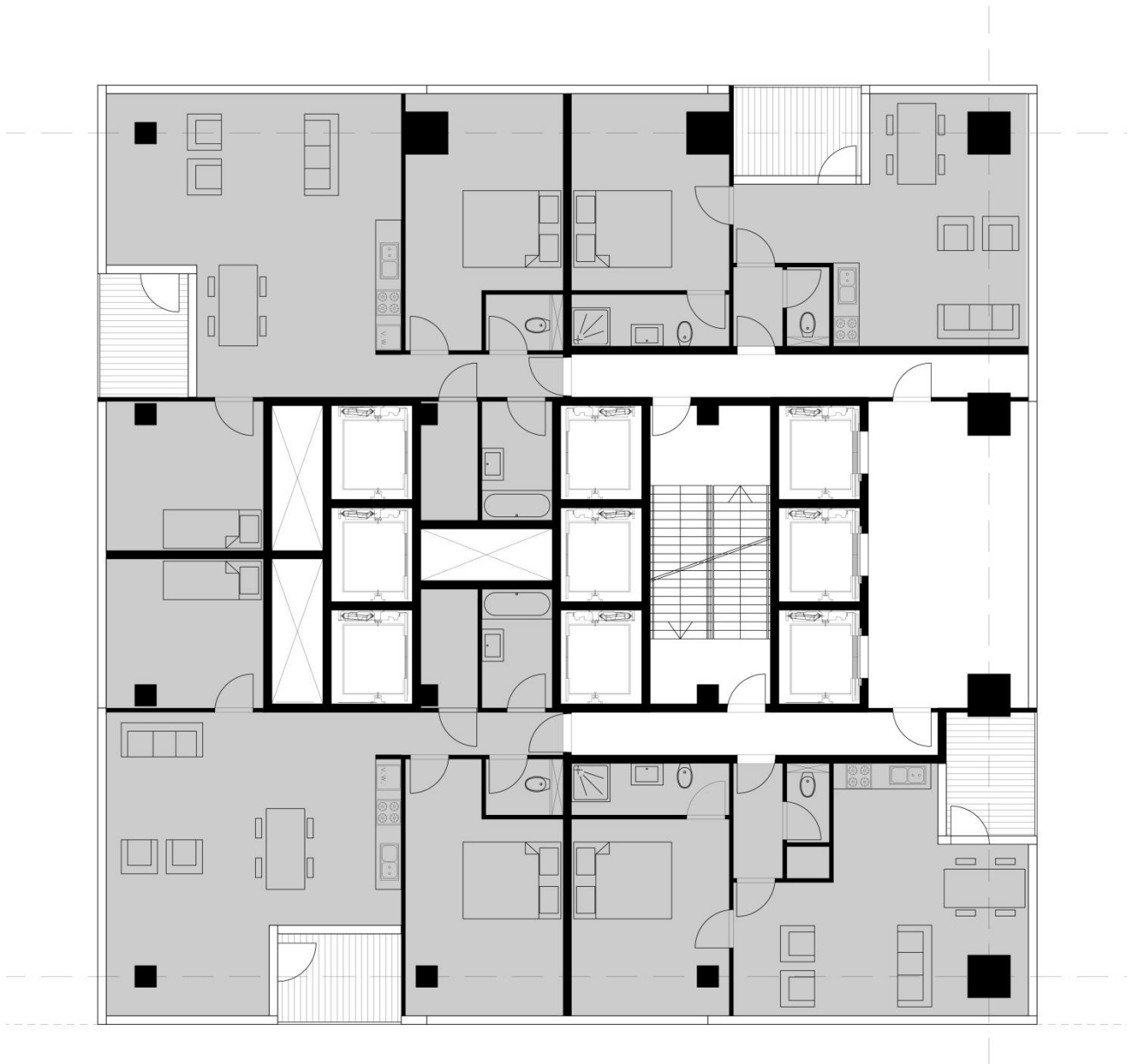

appartements

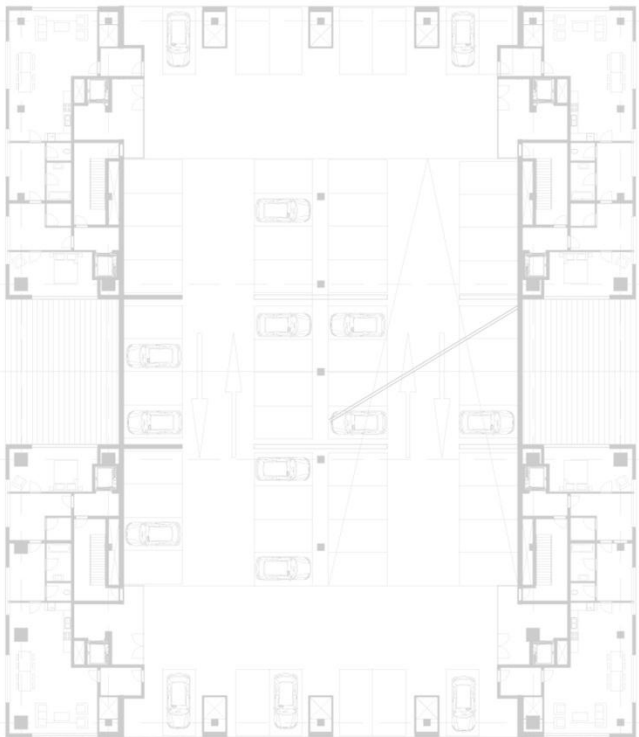
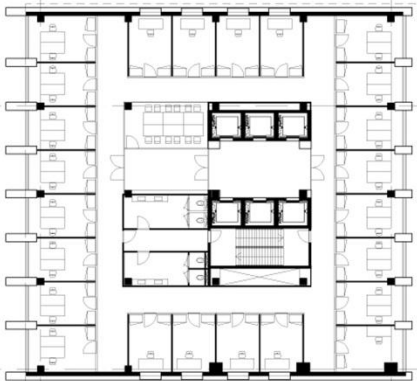



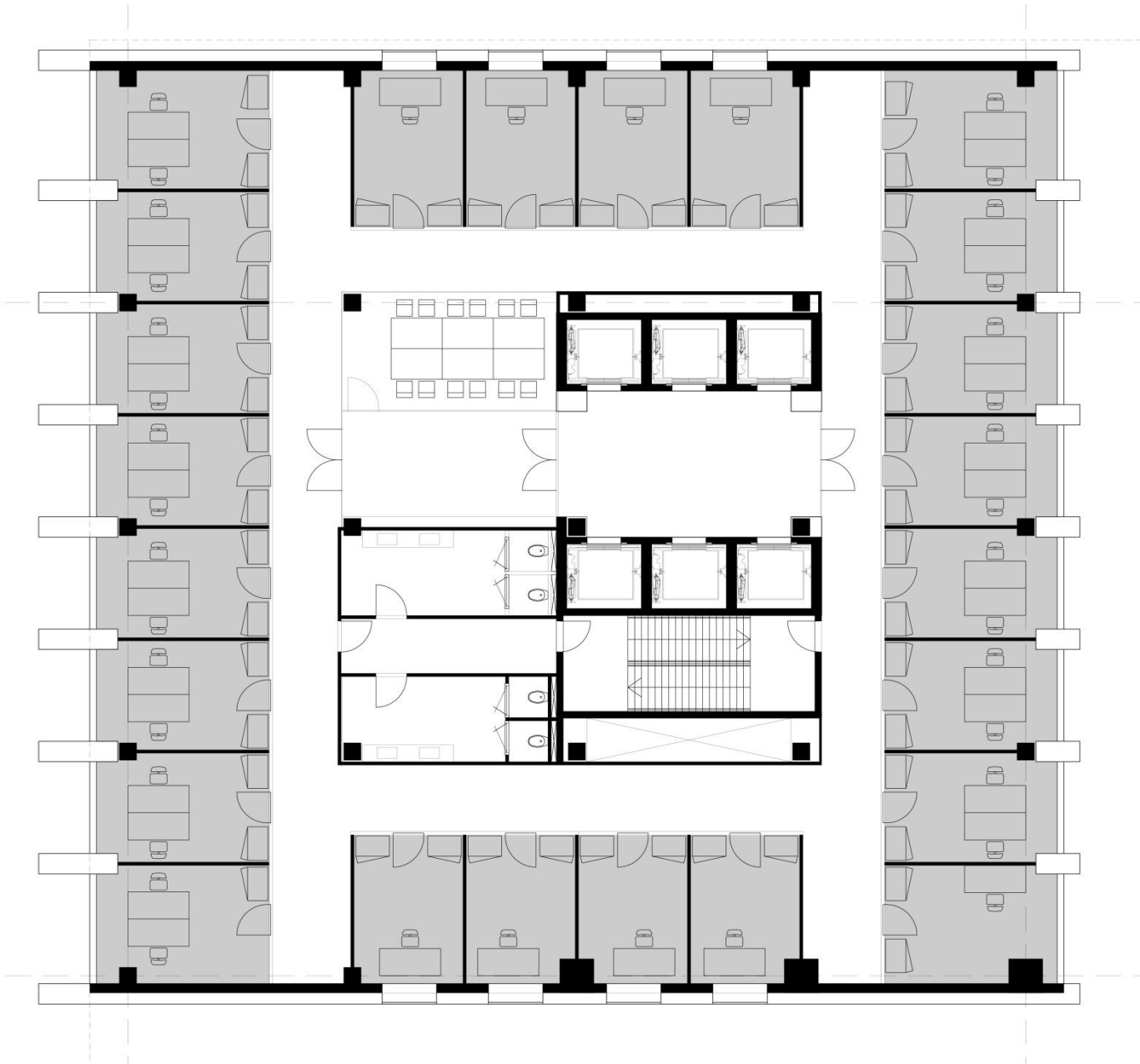

kantoor



kantoor

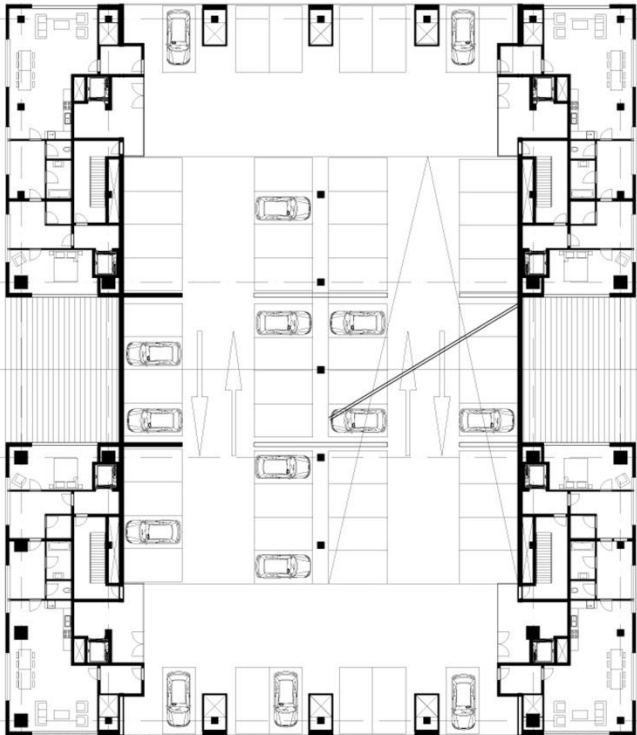

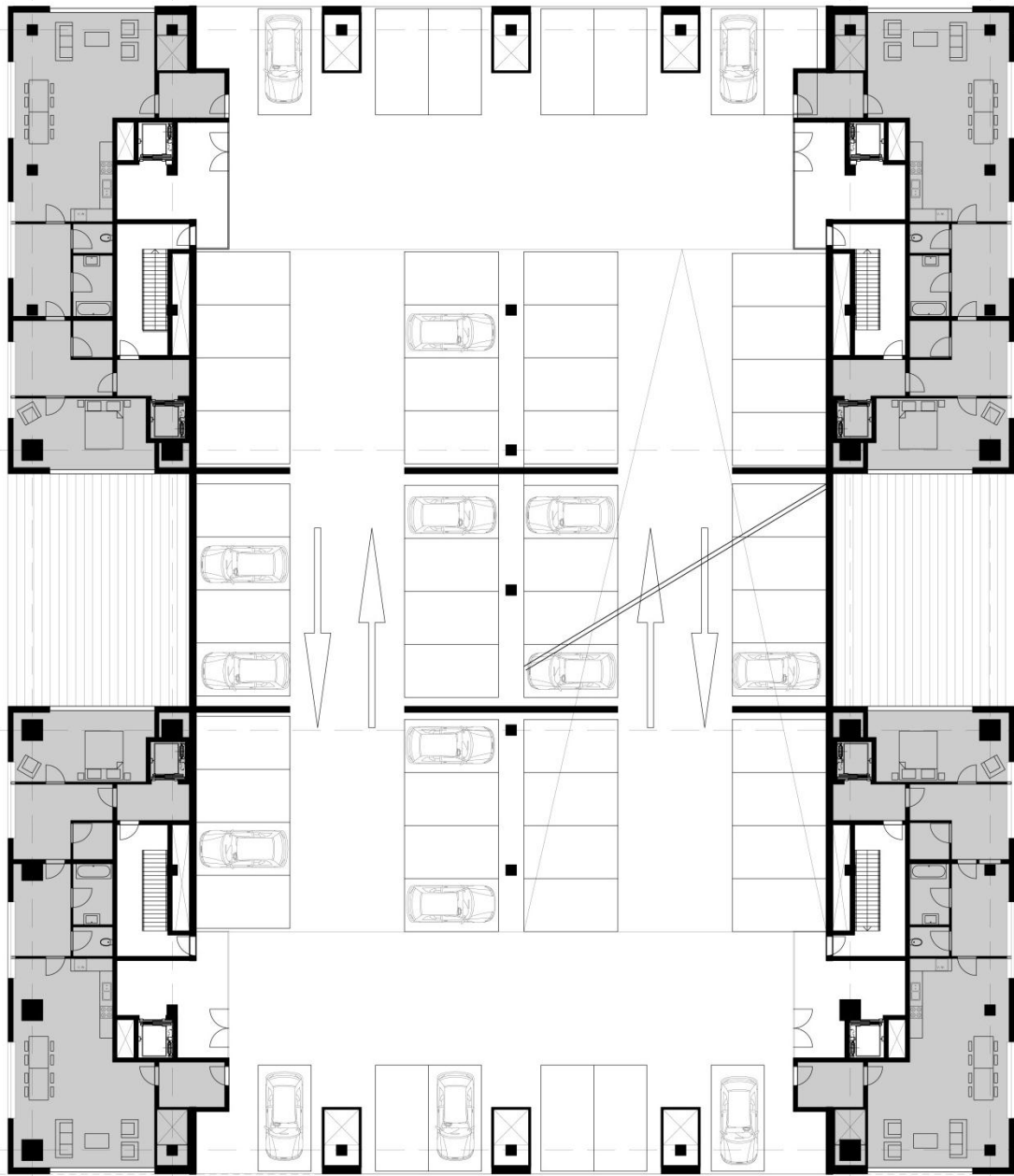

Parkeren



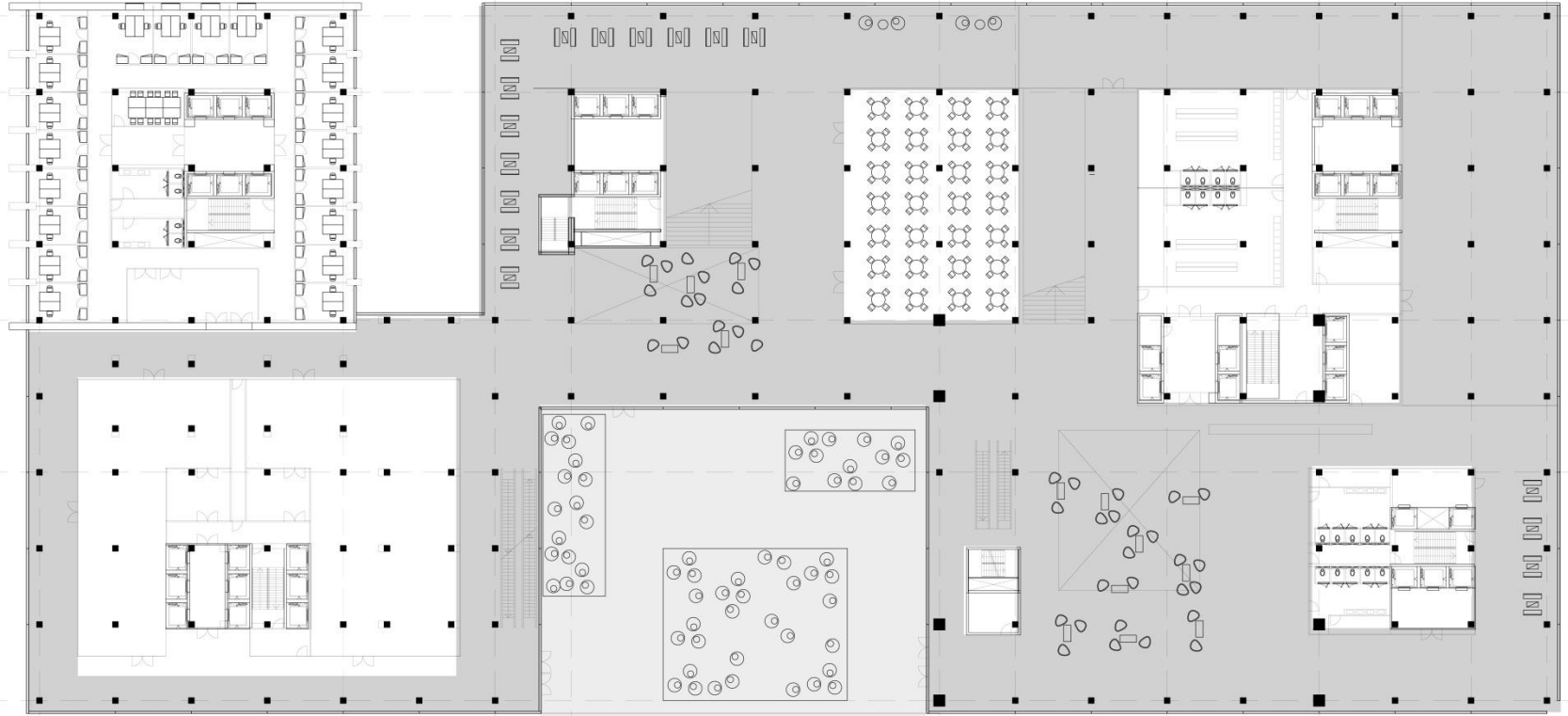

Mid rise

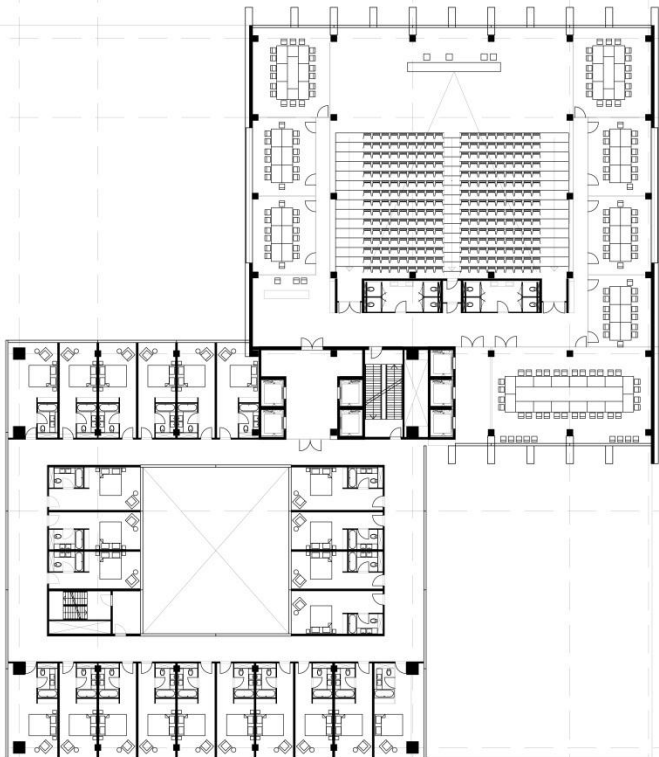



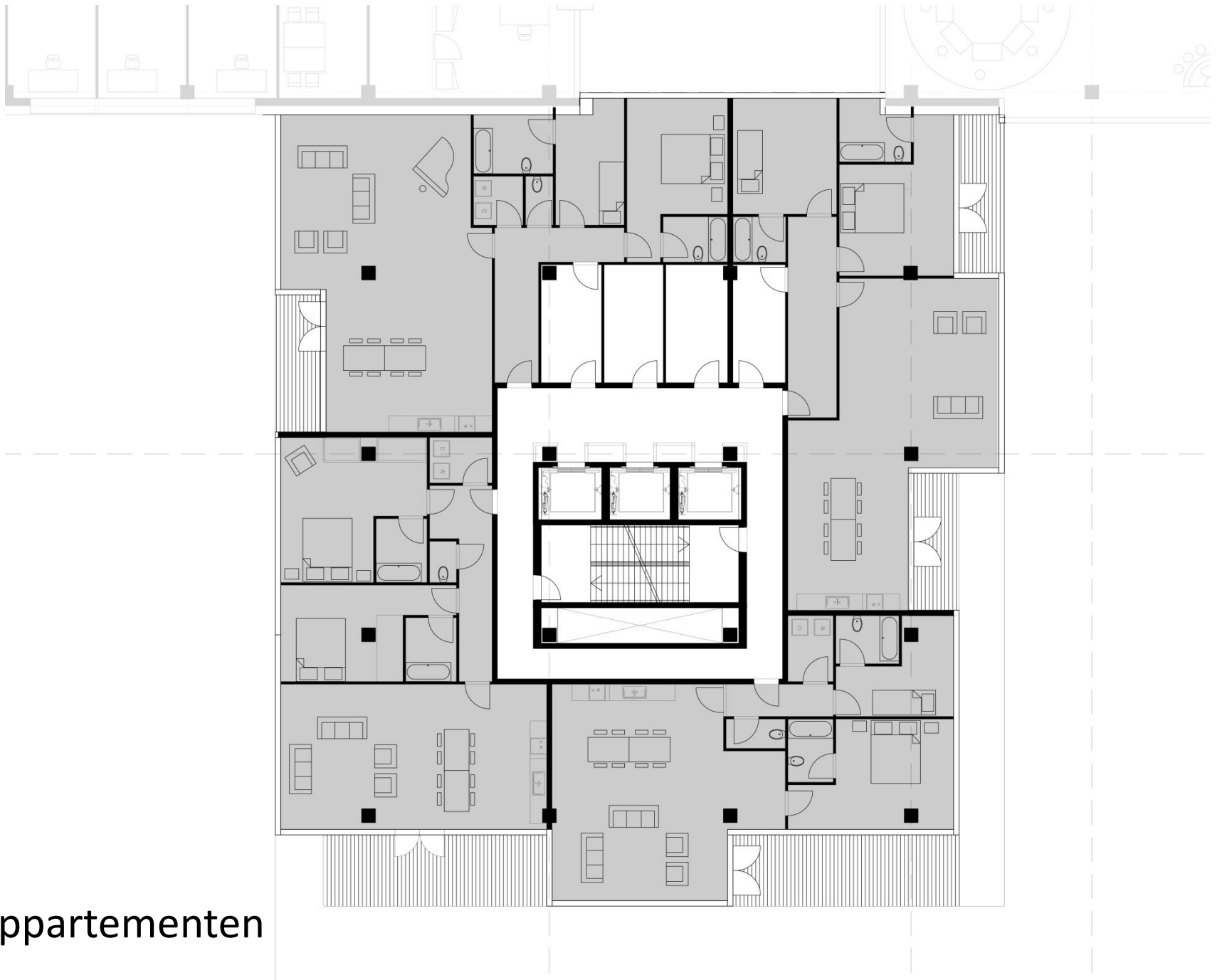

appartements



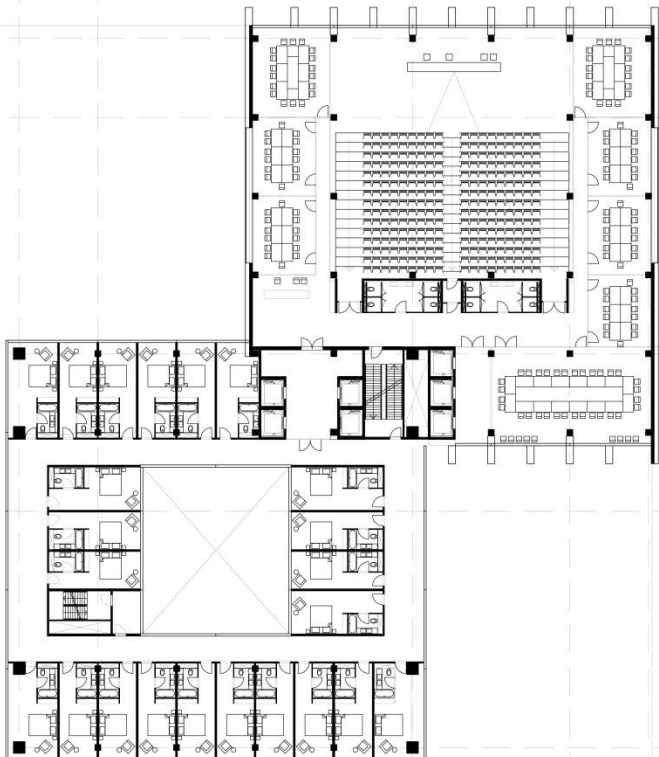



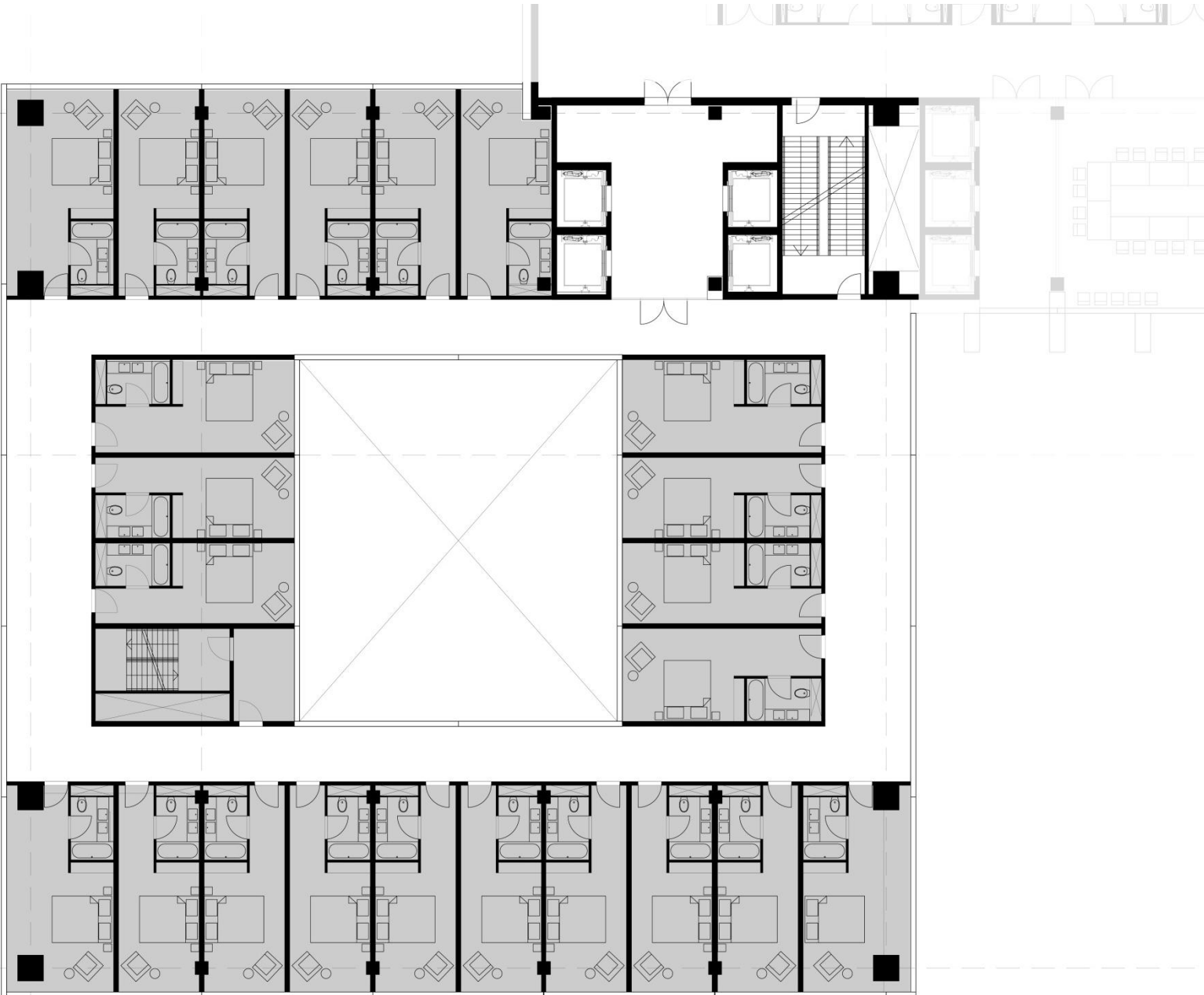

hotel

# Gevel design



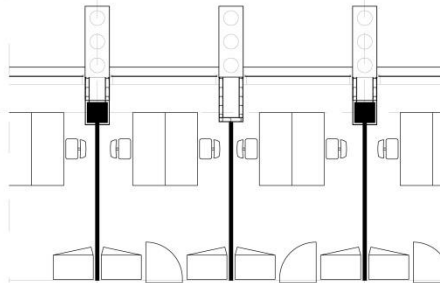
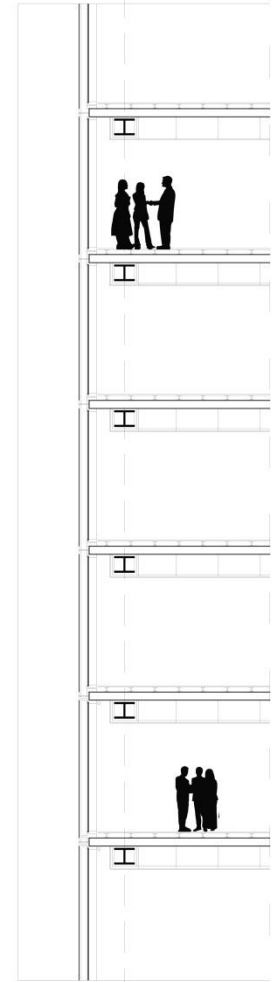
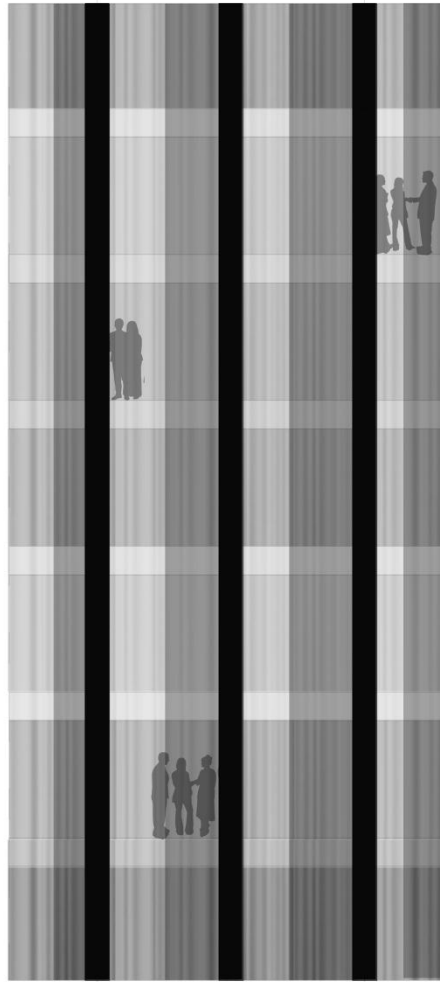
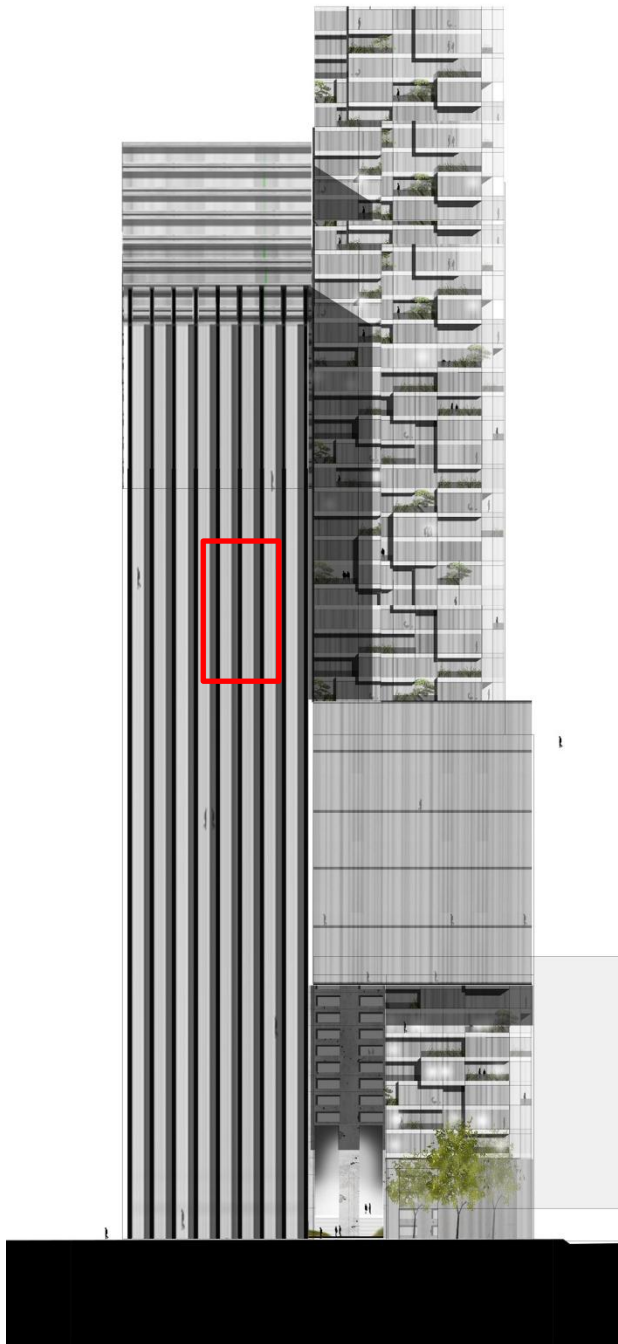

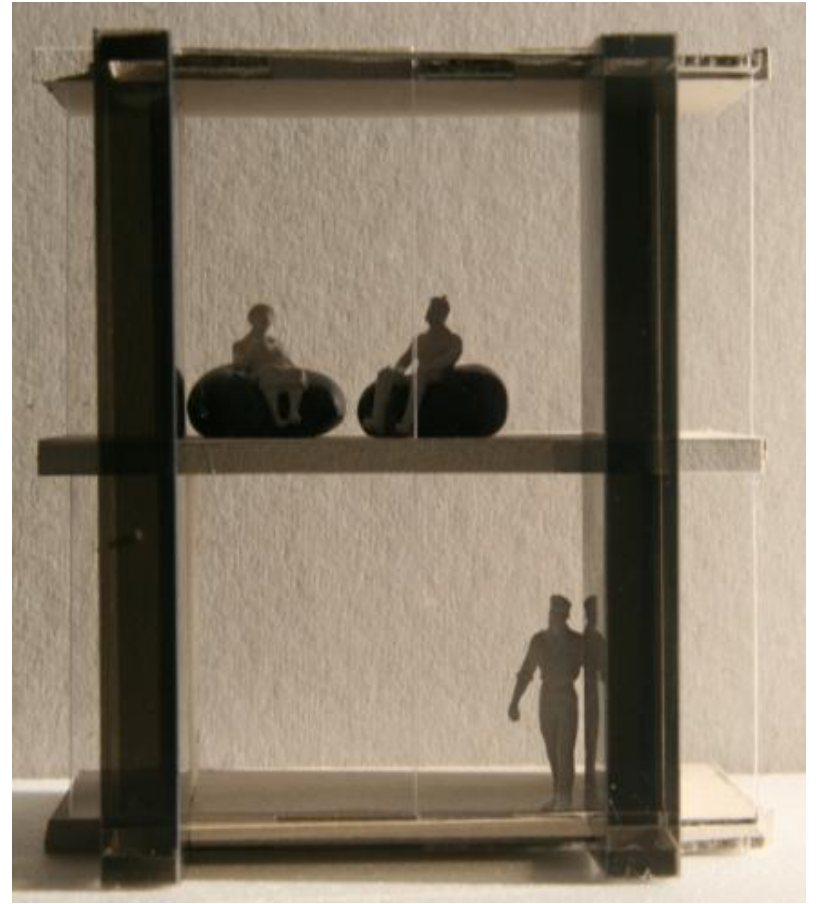
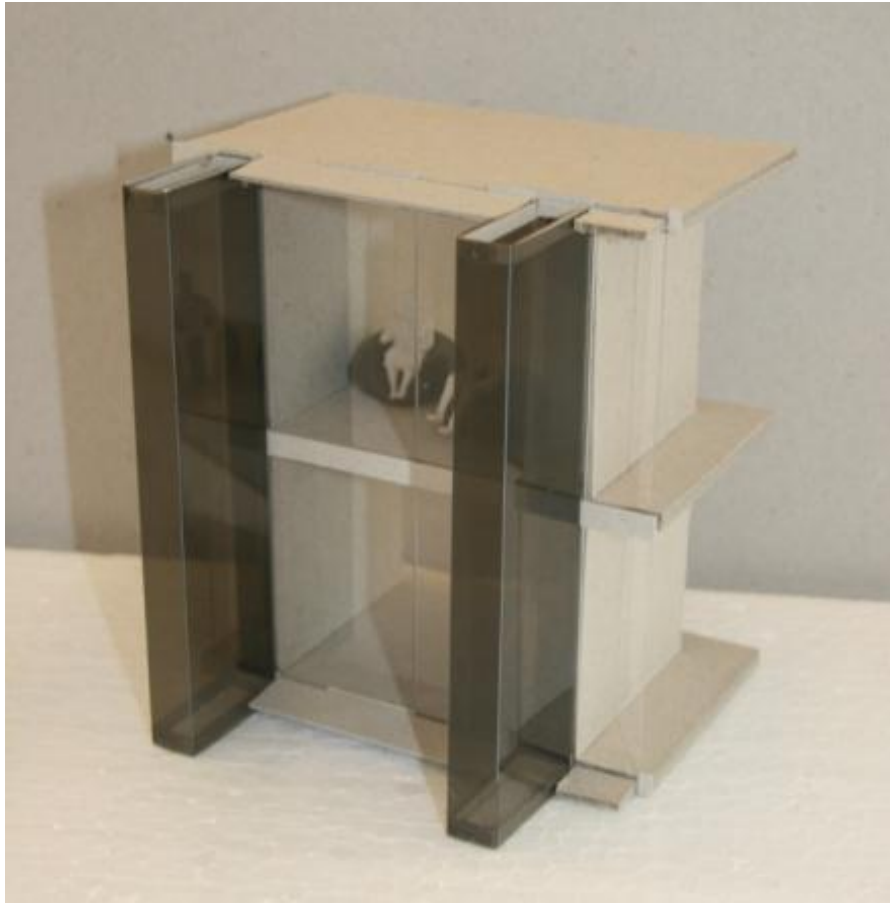



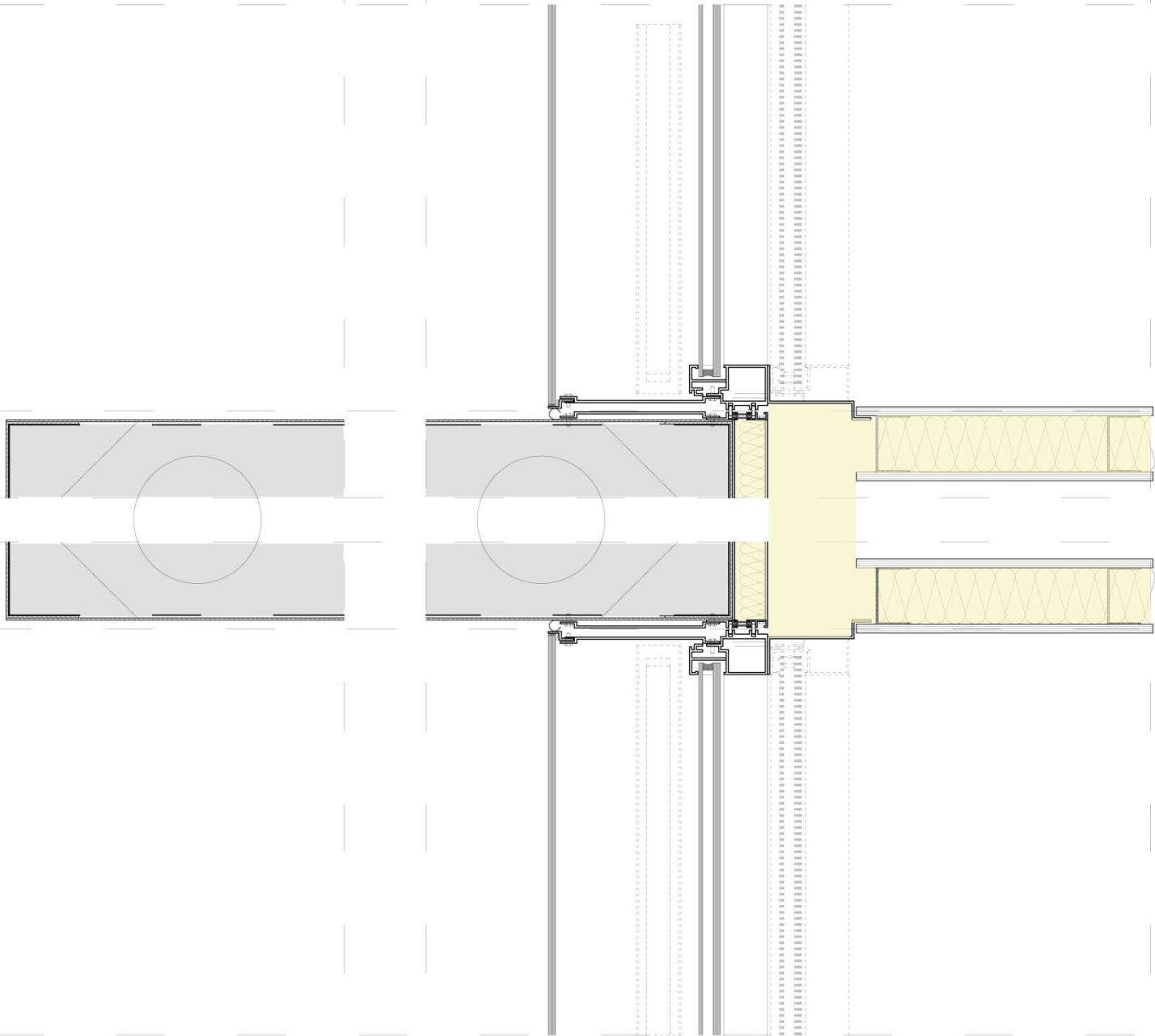



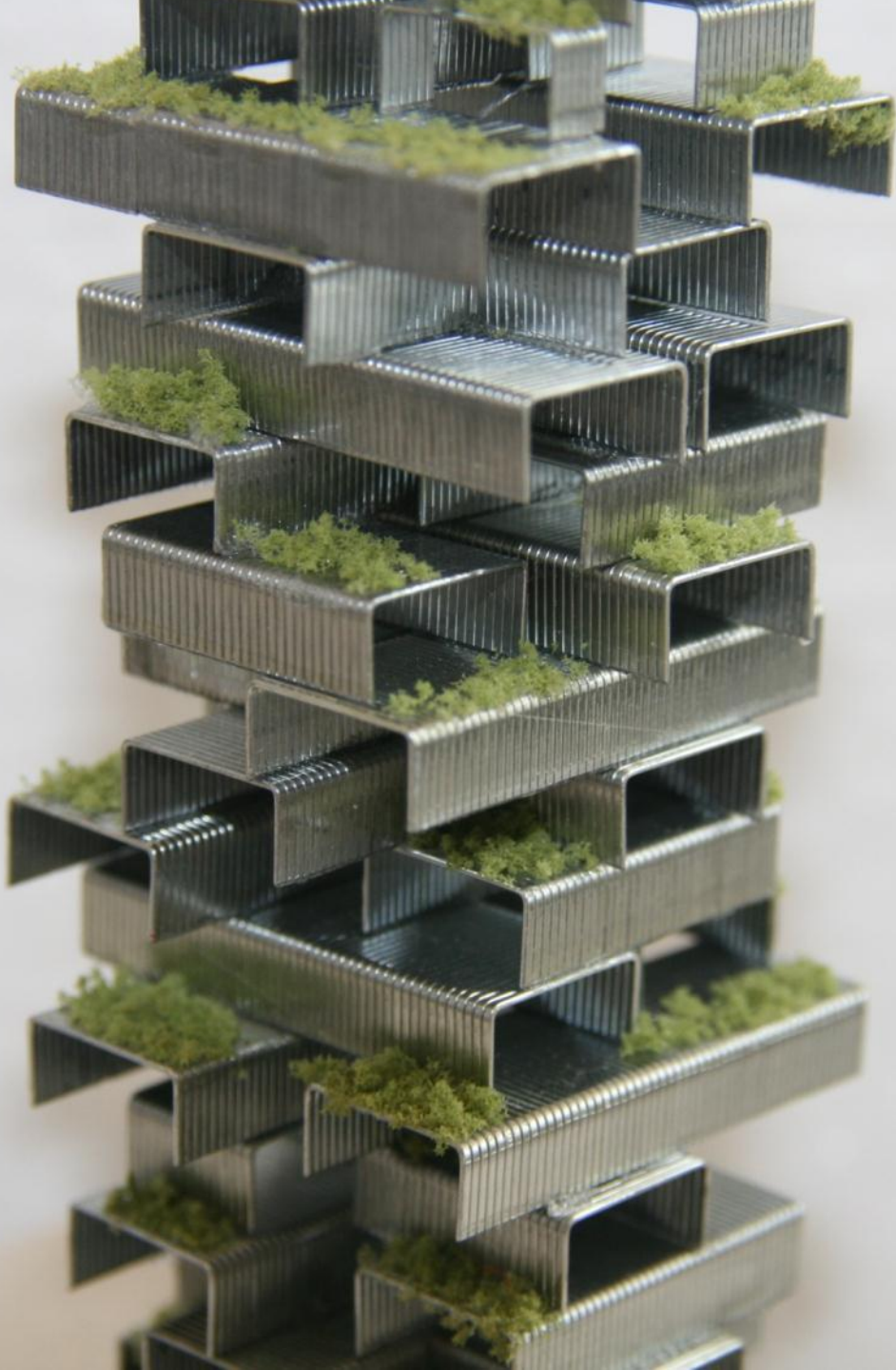

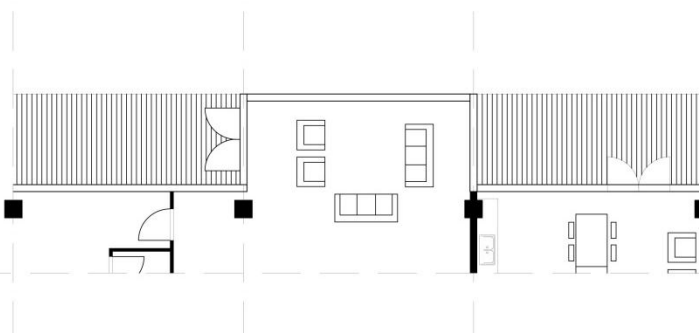
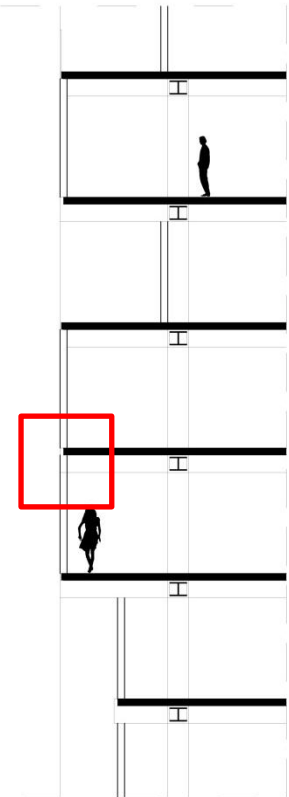
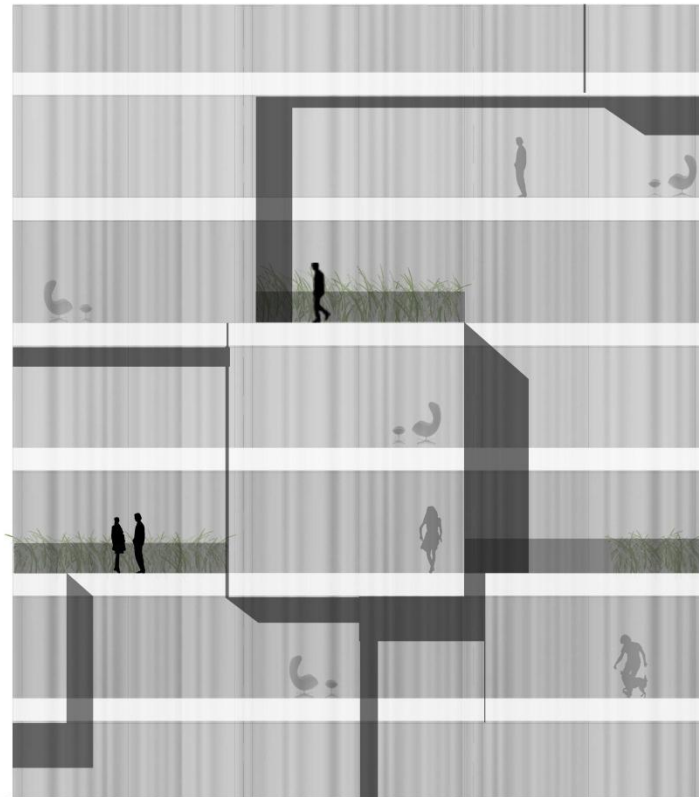
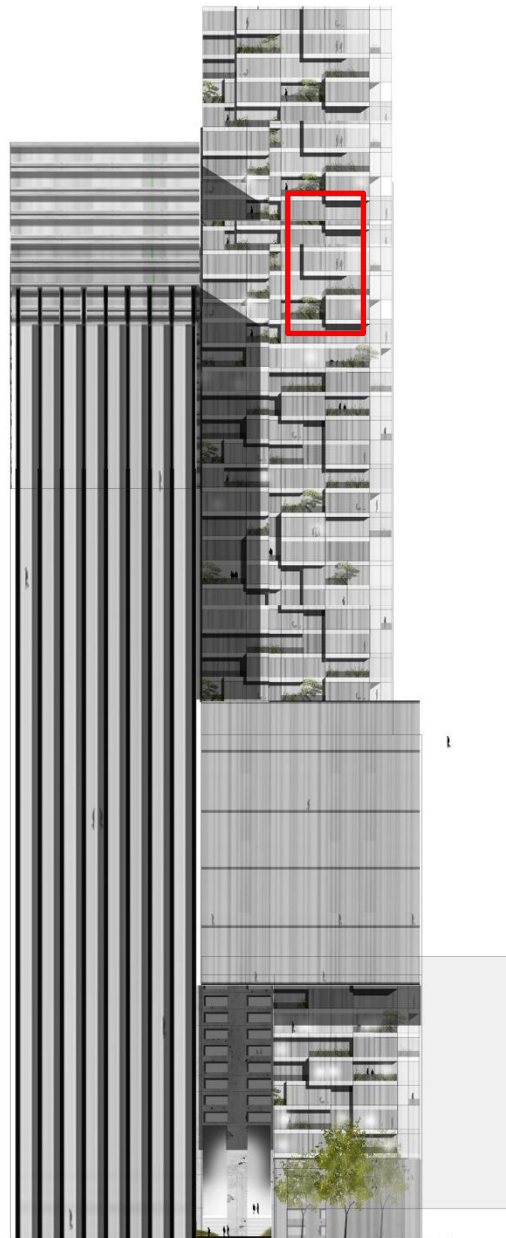

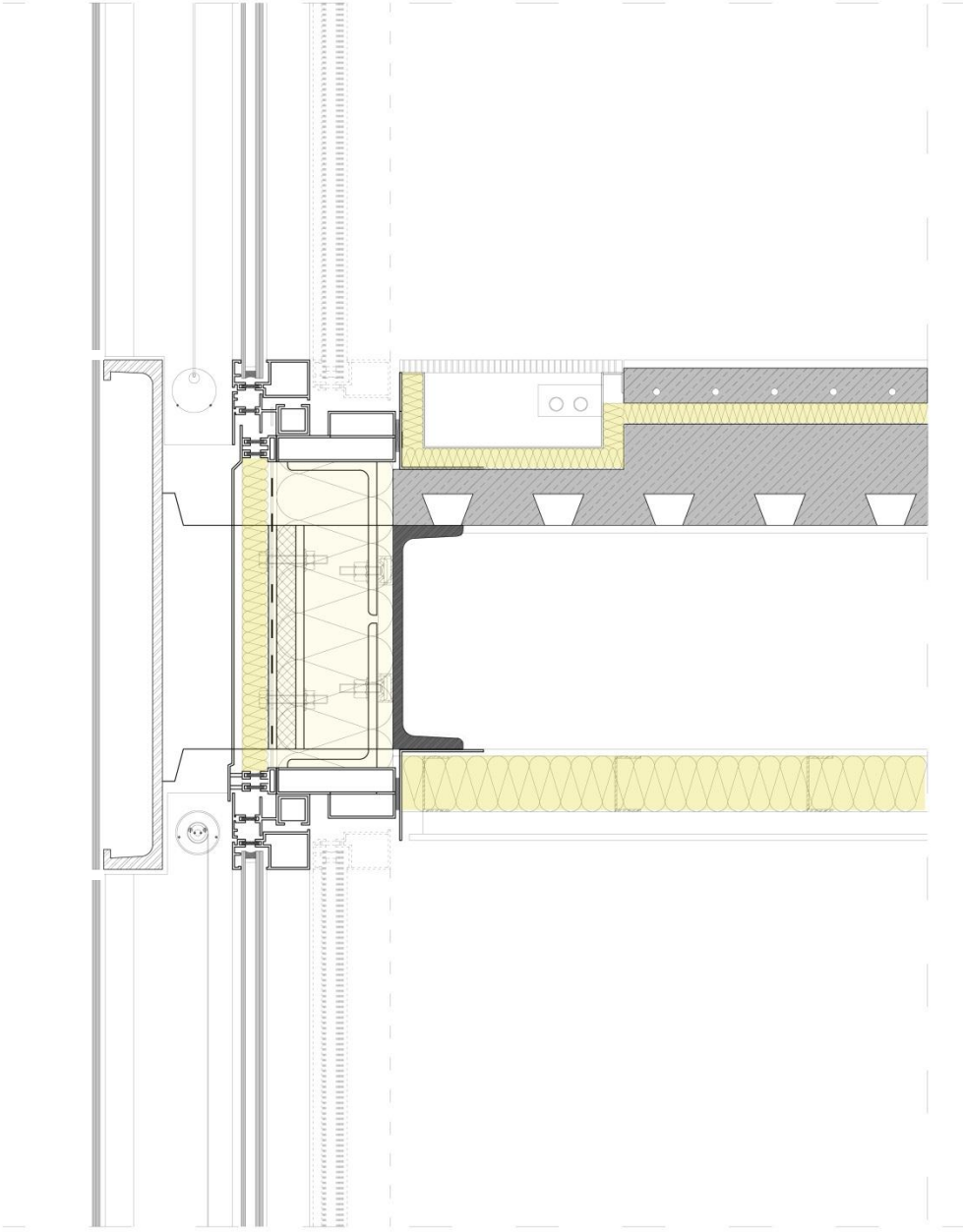

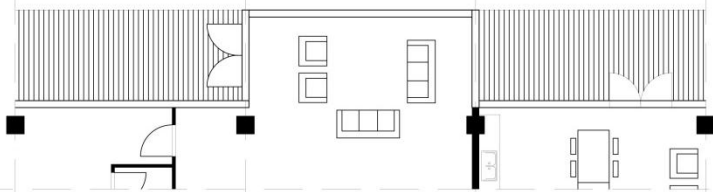
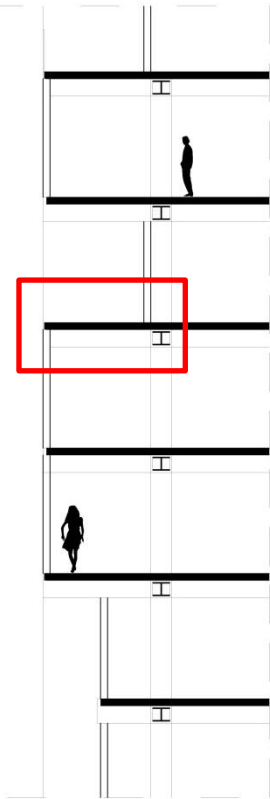
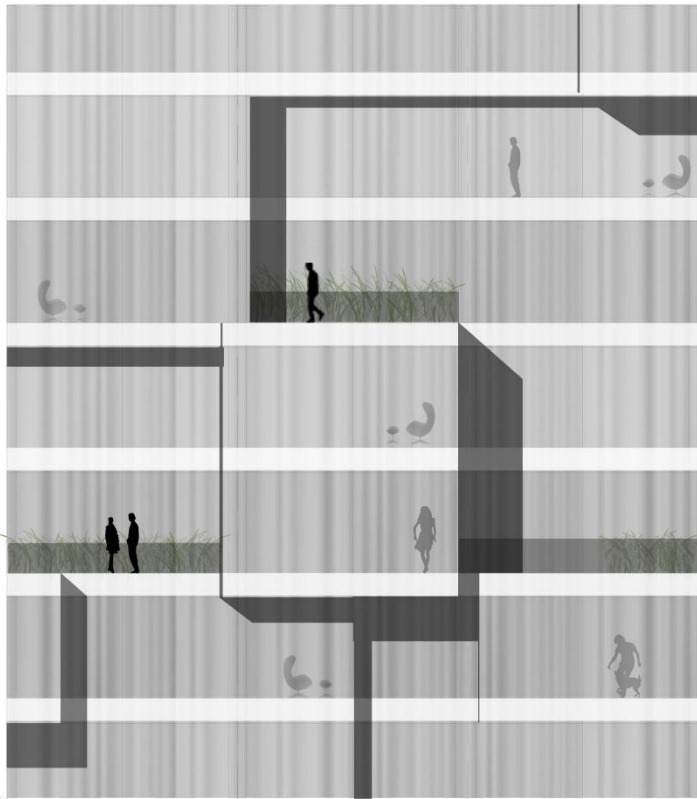

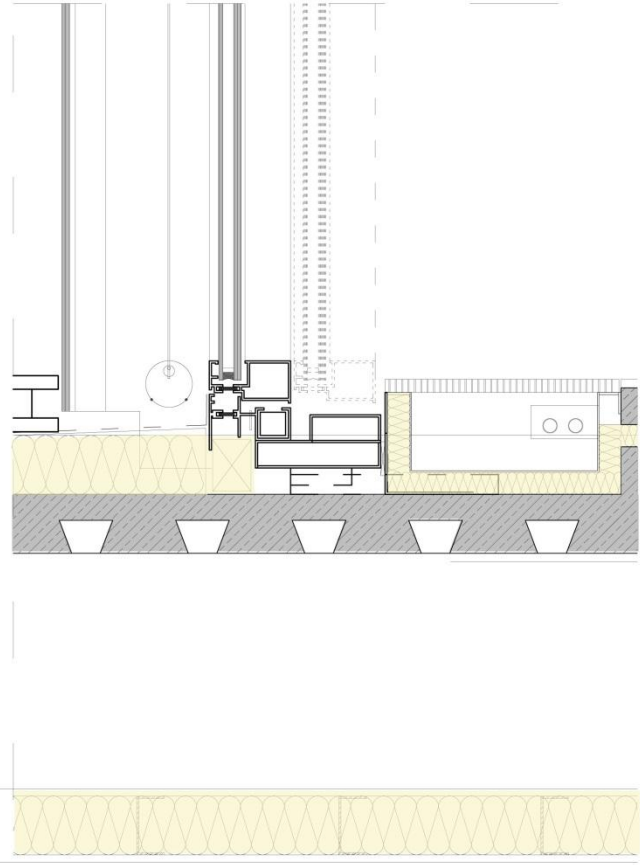
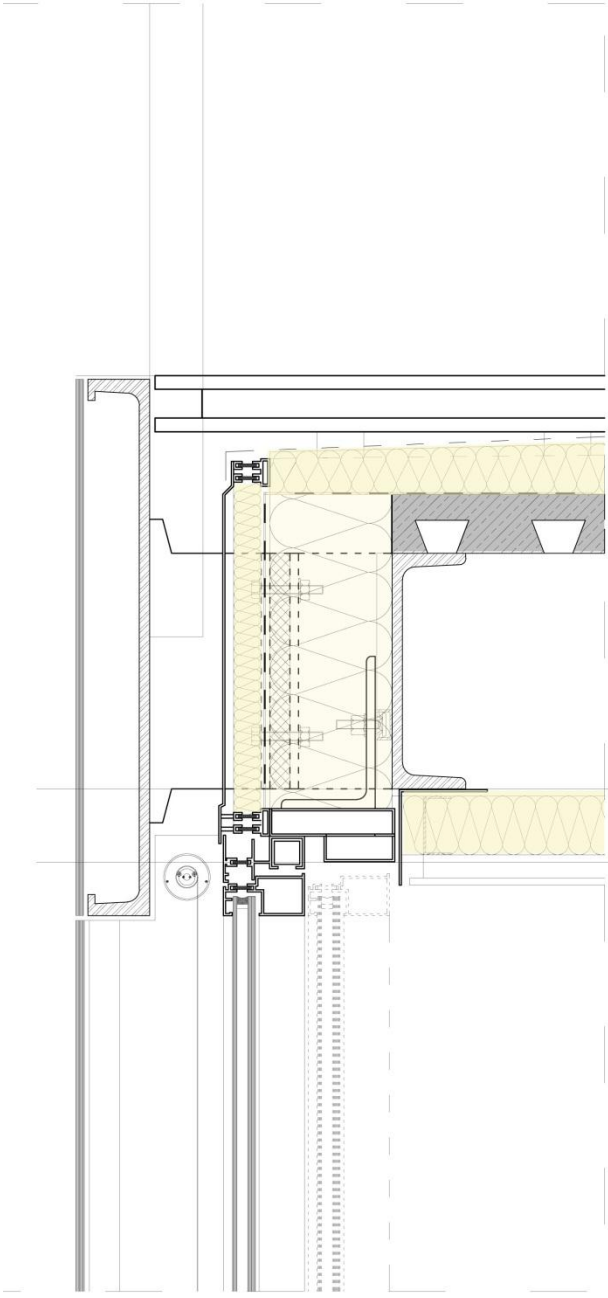



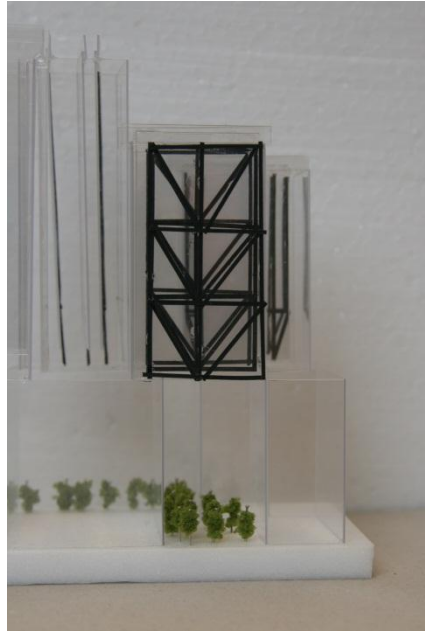
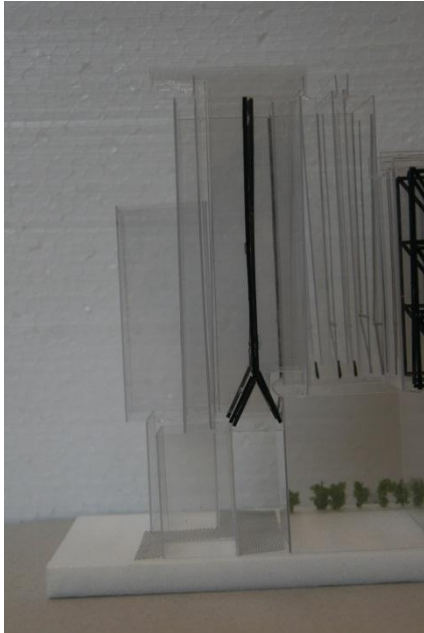
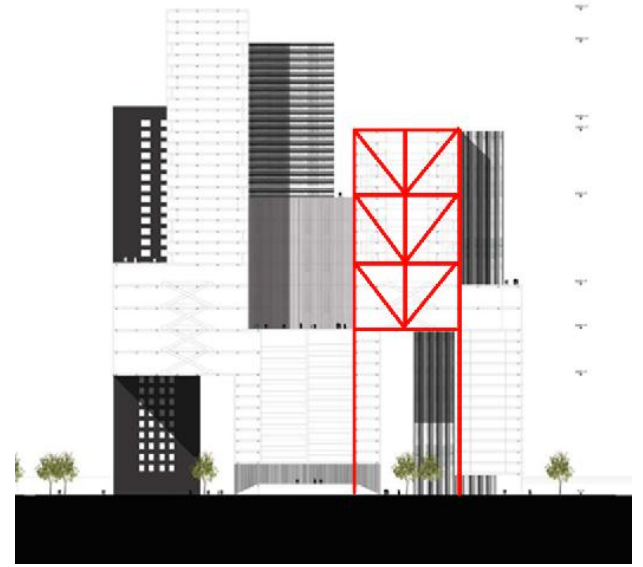
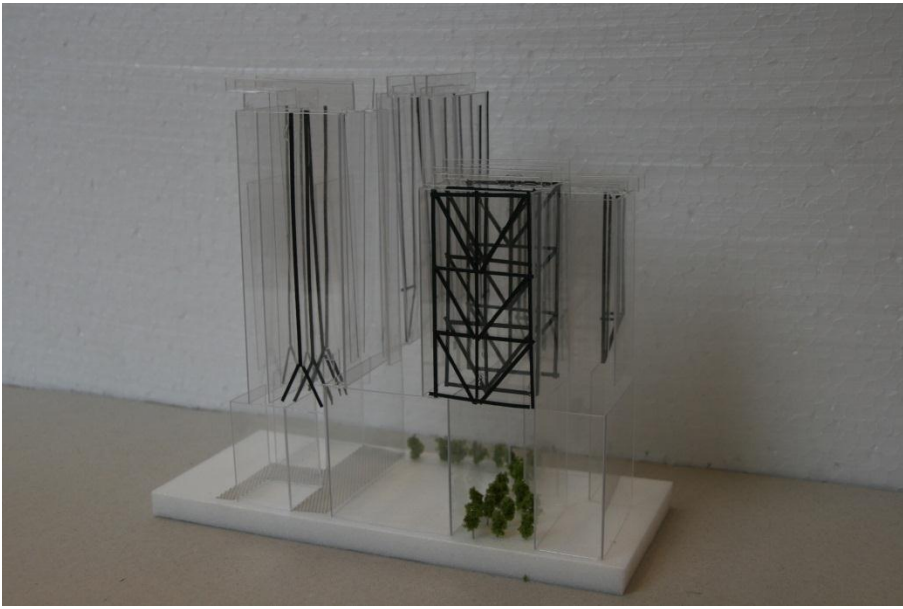

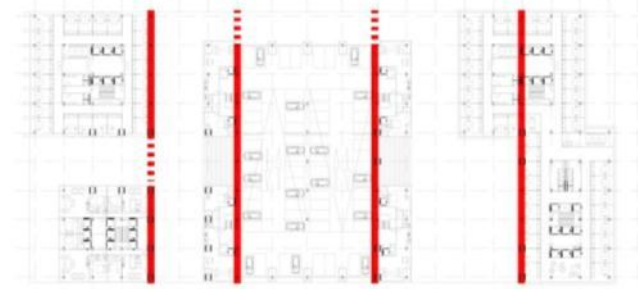
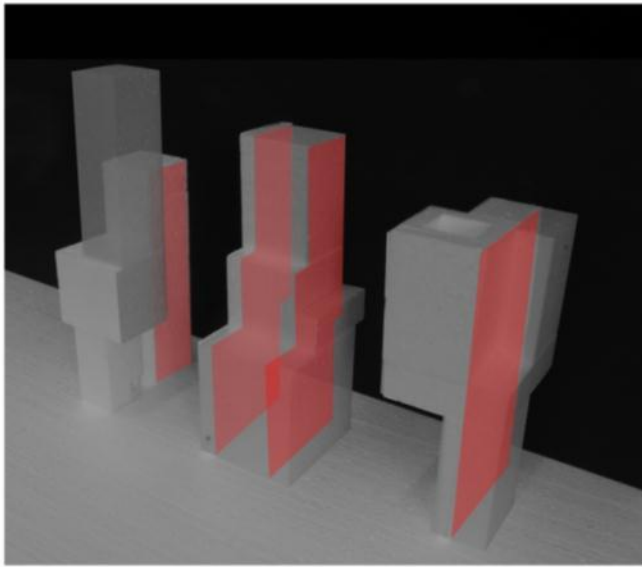

Low rise

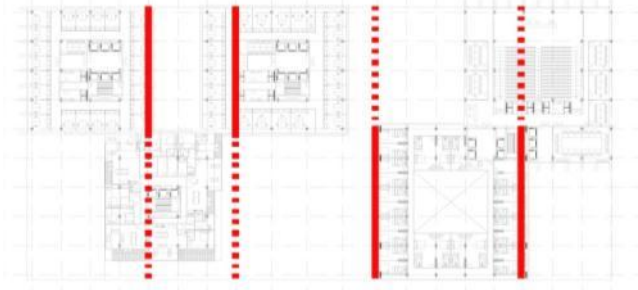

High rise

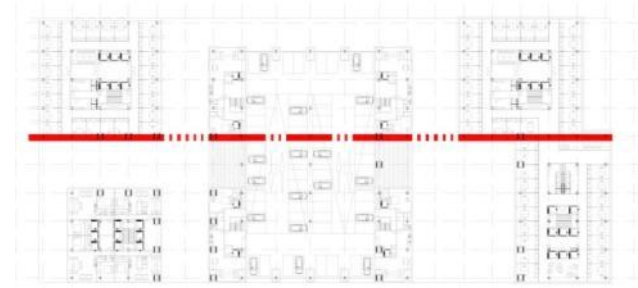
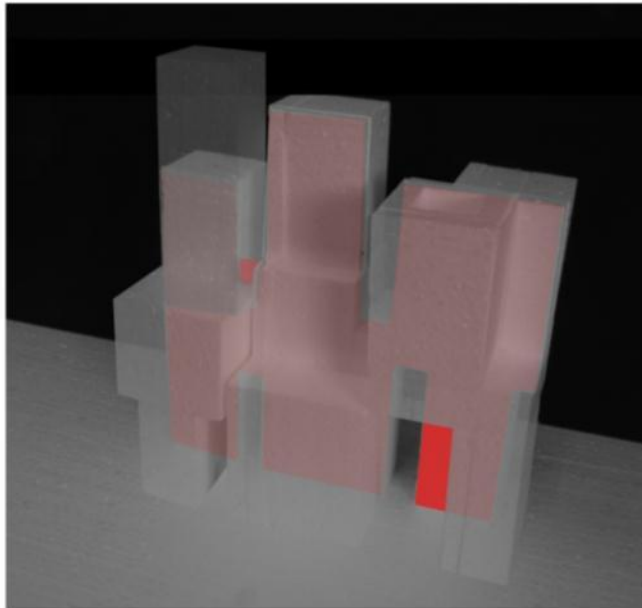

Low rise



High rise





Vragen?

