

# Additive Manufactured Glass Connection



Willem Sebastiaan Koenen



# Additive Manufactured Glass Connection

**Master (MSc) thesis**

Additive Manufactured Glass Connection - The polyester glass connection

Version - 2nd of July 2017

**Author**

Willem Sebastiaan Koenen  
Student number: 4321596  
wskoenen@hotmail.com

**Mentors**

Prof. Dr.-Ing. Ulrich Knaack  
Dr. Ir. Christian Louter

AE+T - Design of Construction  
AE+T - Structural Design

**External committee member**

Ing Peter de Jong

MBE - Design & Construction Management



Delft University of Technology  
Faculty of Architecture and the Build Environment  
Department of Building Technology

01.West.110  
Julianalaan 134  
2628BL Delft  
The Netherlands



# Acknowledgement

This master thesis has been written to obtain the title of engineer(ir) at the TU Delft. This achievement represents the end of a study journey through seven and a half years of Dutch higher education, of which the last three and a half were in Delft. I want to use this moment to thank everyone that has supported me during this whole journey, and to thank those who supported me with the final parts of my graduation.

First of all, this project would not have been possible without both of my mentors, Ulrich Knaack and Christian Louter. Where one pushed me to challenge my thoughts and go beyond my comfort zone, the other was the voice of reason who helped me make these bold ideas possible. This valuable combination of opinions made it possible for me to create something truly fascinating, with this graduation project. Furthermore, this project would not have been possible without the help of Mark van Erk and Tudor Cosmatu, from the additive manufacturing lab, who were always willing to give advice and help out with the AM. For the structural tests I want to thank Fred Veer and Kees Baardolf, who made them possible. I also want to thank all the other researchers who were willing to sit down with me and provide valuable input.

Finally I want to thank my family, who supported me in every way imaginable. I also want to thank my friends from Arnhem and Delft, who helped me through these fun and sometimes stressful times. They were always willing to facilitate a sparring session and give valuable feedback on all of my projects. It was a hell of a ride.

Willem Koenen



# Abstract

For this thesis an additively manufactured (AM) glass connection was researched. The aim was to see if it was possible to use plastic based AM for end use parts in the façade. This was done in three parts, which are presented in this thesis. The first part consists of research in all currently available technology that could be used to create such a connection. The following section is about the design process of the AM connection and its engineering. The final part of the research further validates the design by means of structural tests and a rough price comparison to already existing glass connections.

The first part of this research focused on glass connections, additive manufacturing and topology optimization. This was primarily literature research that gave insight into which existing bases could be used to build on further in this project. The research showed that the spider profile has the most potential for further development and become a new sort of connection. The research also provided insight in the different AM technology's that could make the new connection. That research was necessary to selected the final production method and used materials. In the final part of the literature study insight in topology optimization was obtained to design the connection with the help of topology optimization.

The findings from the first part of the research provided the basis for the design and engineering processes of this new AM glass connection. The connection was designed with the help of topology optimization. The idea behind the optimization was to reduce the stresses in the glass and to attach the connection to the glass without drilling. The result of the optimization was a connection that has the shape of a line and that would be bonded to the glass with Transparant Silicone Structural Adhesive better known as TSSA. This connection consists of a number of different elements. The first is a separate AM piece that would be laminated to the glass and could be inserted into the remainder of the joint that connects four corners of four different glass plates. The second element is adapted to allow for the free movement of the glass panels by locally removing material so it would be weaker in one direction. Alternatively, it is given a power joint, which is a rubber joint that allows for movement in all directions. This connection was calculated multiple times to see how the connection would perform.

In the final part of this thesis the joint itself was researched to further validate the connection. This was done by making a prototype of the connection to see how everything could work and if it was actually suitable for production. For this validation, process a number of tests were done on smaller specimens to show how strong the material is and to give validation to the calculations. Finally, a small study was done in to the market potential of custom glass connections like this one by making price comparisnos to currently existing spider profiles.

The details are not the details.  
They make the design

*Charles Eames*

# Table of content

1		13
	INTRODUCTION	13
	1.1 Problem statement	13
	1.2 Research objective	13
	1.3 Research question	13
	1.4 Relevance	14
	1.5 Research methodology	14
	1.6 References	16
2		20
	GLASS CONNECTION	20
	2.1 Time line	20
	2.2 Rebate glazing	22
	2.3 Leaded glazing	23
	2.4 Rebate with glazing bead	24
	2.5 T-profile	25
	2.6 Patent glazing	26
	2.7 Curtain wall	27
	2.8 Sealant glazing	28
	2.9 Suspended glazing and patch fittings	29
	2.10 Planar glazing	30
	2.11 Spider glazing	31
	2.12 Cable-Lattice façades	32
	2.13 Laminated bridle joints	33
	2.14 Laminated metal inserts	34
	2.15 References	35
3		41
	ADDITIVE MANUFACTURING	41
	3.1 Generic AM procedure	42
	3.2 AM for plastics	44
	3.3 Materials	49
	3.4 Alternatives for Plastics	51
	3.5 Benefits of AM for the built environment	52
	3.6 References	53
4		59
	TOPOLOGY OPTIMIZATION	59
	4.1 The mathematics for structural optimization problems	60
	4.2 Types of structural optimization	61
	4.3 Methods of topology optimization	62
	4.4 Topology optimization software	66
	4.5 References	
5		71
	DESIGN RESEARCH: THE ADDITIVE MANUFACTURED GLASS CONNECTION	71
	5.1 Schematic design and boundary conditions	71
	5.2 Design strategy	72
	5.3 Design development	76
	5.4 Engineering and validation	84
	5.5 Construction of prototypes	90
	5.7 References	96



6		101
	DESIGN VALIDATION	101
6.1	Testing	101
6.2	Price comparison	110
7	CONCLUSION	115
7.1	The glass connection	115
7.2	The production process	116
7.3	A new glass connection	116
7.4	Additive manufacturing for façades	116
7.5	Polyesters for façades	117
7.6	the solution for everything that is topology optimization	117
7.7	Further research suggestions	118
	IMAGE CREDITS	120
	BIBLIOGRAPHY	122
	APPENDIX	124





# Intro duction



# 1

## Introduction

### 1.1 Problem statement

In the façade there is a constant development towards more transparency, with metal inserts in the façade as the current state of the art for structural façades. The issue with these façades is that the tectonics of the glass façade are dictated by those of the steel construction (Wurm, 2007). How can additive manufacturing with polymers shape the next big glass connection that is more transparent and works better with the glass? Can a relatively new technique/technology for the building industry, like additive manufacturing be used to make a fully glazed façade in which steel no longer dictates the shape of the final geometry? Where the façade can become truly free-form and the glass can be used as a planar element in this system.

### 1.2 Research objective

The objective of this research is to design a new glass connection for a free-form façade that works with the glass. This should be done by utilizing the potential of additive manufacturing with polymers to further develop the current state of the glass connection.

### 1.3 Research question

*What kind of additively manufactured connection can be the next big innovation in the field of glass connections?*

Sub questions

- What kind of glass connections already exist?
- What kind of glass connections are relevant for this research?
- How does additive manufacturing work?
- What kind of additive manufacturing processes and materials are relevant for this research?
- What are the benefits of additive manufacturing for the built environment?

## 1.4 Relevance

The current perception of the building industry is that additive manufacturing is a very expensive production technique compared to the current way of building. It is only in the building industry that people think this way, because the price of additive manufacturing is going down every year and there are constant improvements in printing technology, new materials that are suitable for printing are constantly developed and improved. At the same time additive manufacturing has one benefit that makes it unique. Because it gives the designer 'complexity for free'. What creates the opportunity for the designer to focus more on design performance and innovation than on the way it has to be produced (Langelaar & Keulen, 2015). In architecture this free complexity is not used at this moment. Additive manufacturing is only used to make small scale models but it has the power to actually realize the free form designs that are now constantly generated with the help of Grasshopper®, Rhino® and other complex CAD tools. At the same time additive manufacturing allows for the integration of smarter software in its digital design process that can make the parts better by only using materials where needed to reduce the weight and the amount of used materials for the analysed part.

This research will show the potential of additive manufacturing with polymers in the built environment. Especially in the façade industry it can open the road toward the next step in glass connection technology.

## 1.5 Research methodology

The methodology of this thesis is based on research by design. The research is divided in three research phases from P1 until P2, P2 until P3 and finally P3 until P4. The final phase being from P4 until P5 will be used to reflect on the data and finalize the research.

The first part of this research will be used to understand additive manufacturing and the relevant applications. At the same time a historical research will be done towards the development of the glass connection from the year 70 AD up till modern day. The objective of this phase of the thesis is to get a better understanding of these two tracks and get an idea how they could be combined in a relevant way. A number of sketch designs will be made so they can be developed further in the following phases.

The result of the first phase should be a comprehensive understanding of the development of the glass connection. An overview of the current and relevant applications of additive manufacturing.

The second phase will be focused on the development of the connection and a structure for its application. Several of these designs should be produced as prototypes and should be tested at the TU Delft. The progress of the design and prototypes will be analysed in FEM models to better understand the structural behaviour of the tested prototypes.

The third phase of the research will focus on further development of the chosen connections. These will be improved, analysed and tested like the prototypes in phase two.

The final phase of this thesis will be mainly focused on reflection and analysis of all the different output results that this research provided. Like the production of the final mock-up.

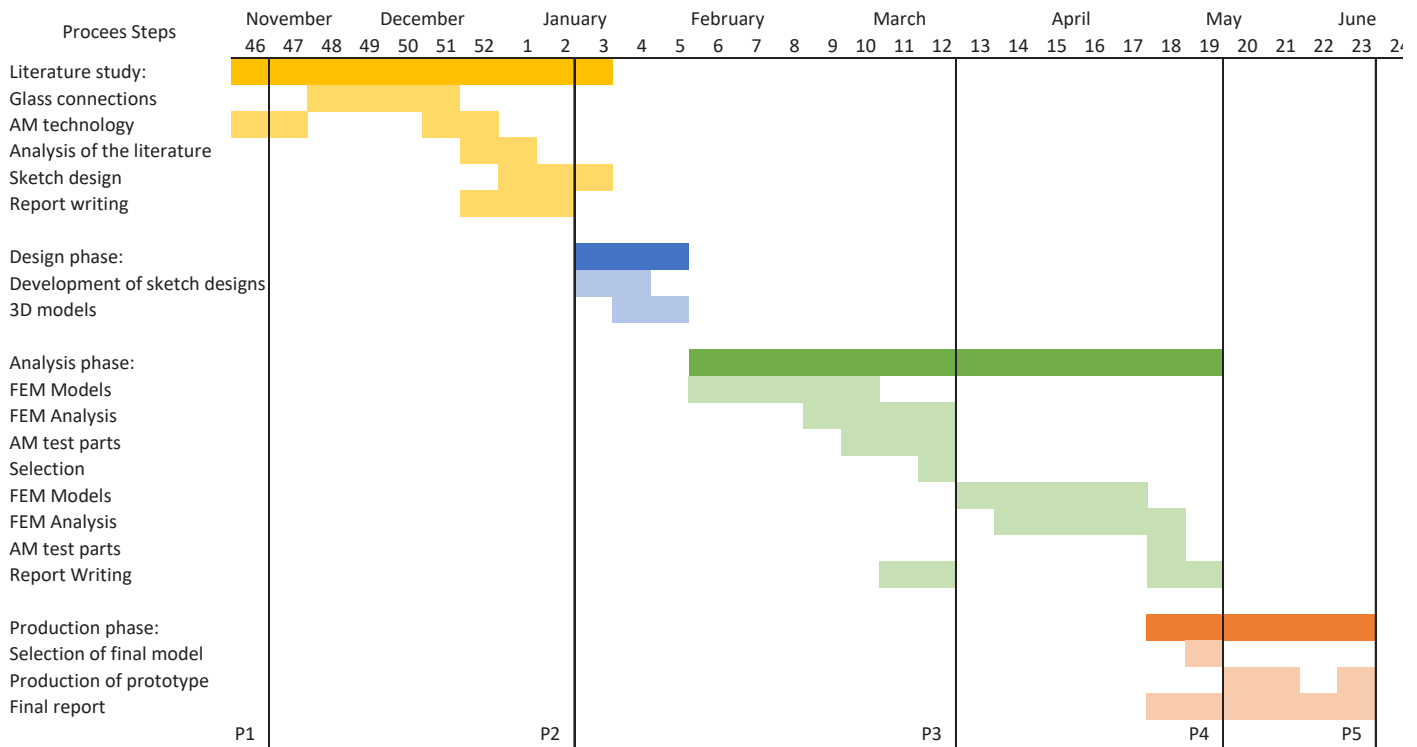

Figure 1.1.-Weekly time frame for graduation project

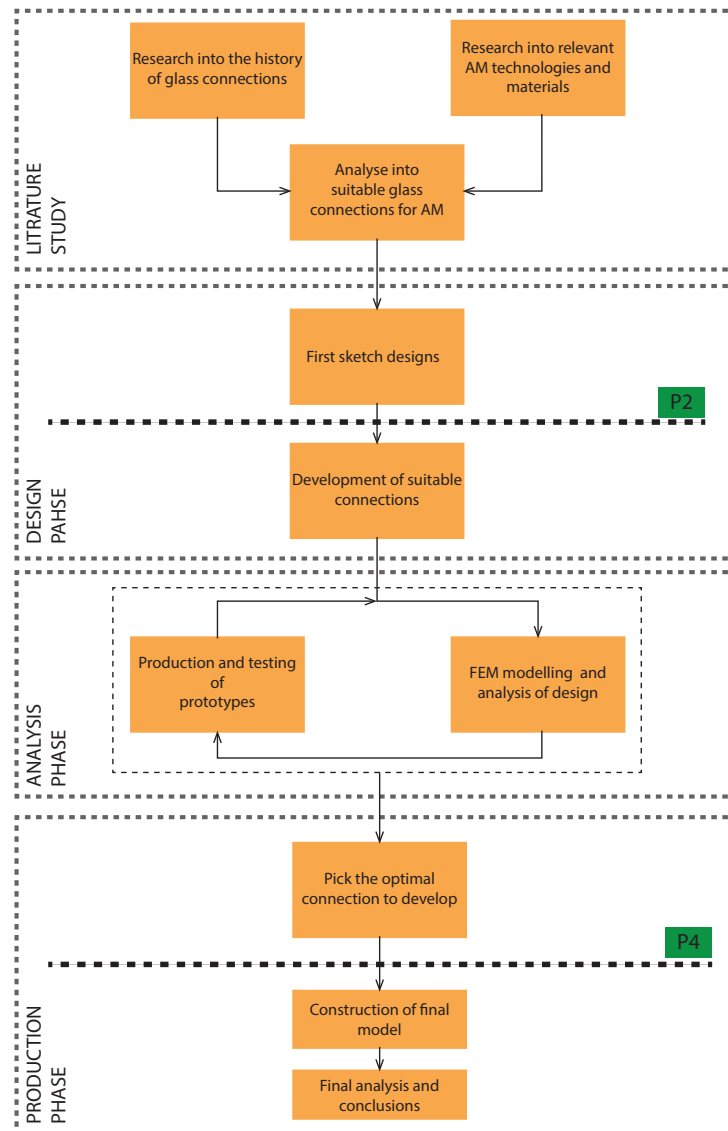

Figure 1.2.-Research framework

## 1.6 Reference

Langelaar, M., & Keulen, F. (2015). Topology optimization. A natural counterpart of additive manufacturing. TU Delft Lecture Notes.

Wurm, J (2007). *Glass structures: Design and construction of self-supporting skins*. Berlin: Birkhäuser



## SUMMARY

AM is a very advanced technology that is changing industries all over except for one. That industry is our own, the building industry. A technology like AM can change and improve the way that buildings are made. To reduce the amount of materials used and use them in a smarter way. This thesis will try to show the potential of AM for a façade application what can make AM more attractive for the building industry.



Façade of the Breganz art Gallery  
(source ; Rory Hyde)



# Glass connection

# 2

## Glass connection

The glass connection for the purpose of this research is the way that glass is connected to other glass plates but also the way it is connected to the rest of the building. For the purpose of this research the history of all these connections methods will be mapped with the purpose of seeing where additive manufacturing might be feasible and can expand on the current range of connections. This will be done with a timeline of all the major innovations surrounding the glass connections. These connections will then be discussed in the remainder of the chapter. The aim of this chapter is to provide an idea what was the driving force behind these innovations. While at the same time mapping what kind of connections there are.

This chapter will answer the following questions:

- What kind of glass connections do already exist?
- What kind of glass connections are relevant for this research?

### 2.1 Time line

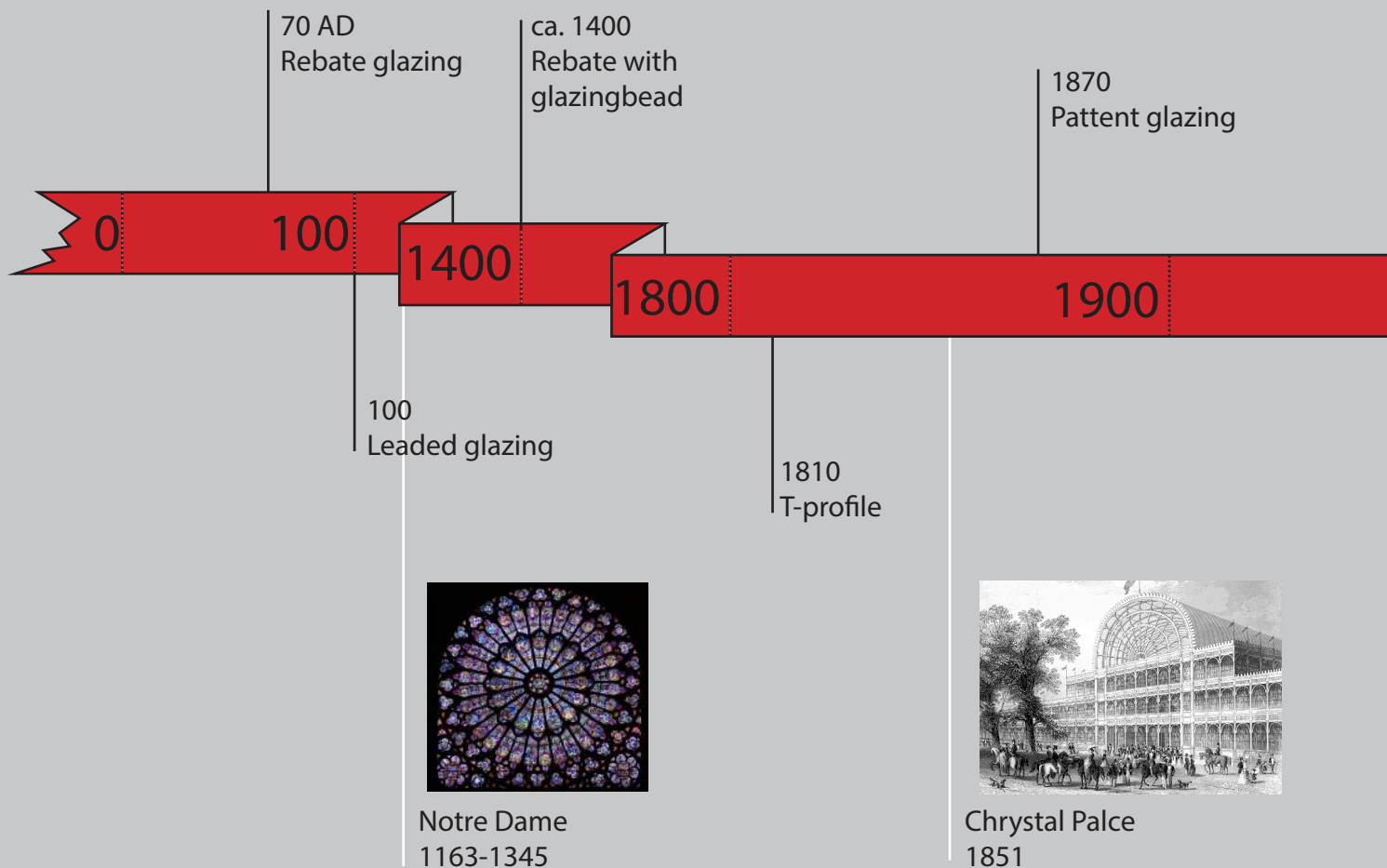

For the clarification of a number of four icon will be used. These icons make it easier to identify the different functions of the different components. The following icons are used to explain the details:



= the glazing units



= the fixing element that transfers the different loads



= the load bearing structure



= the joint that forms the seal for water-tightness

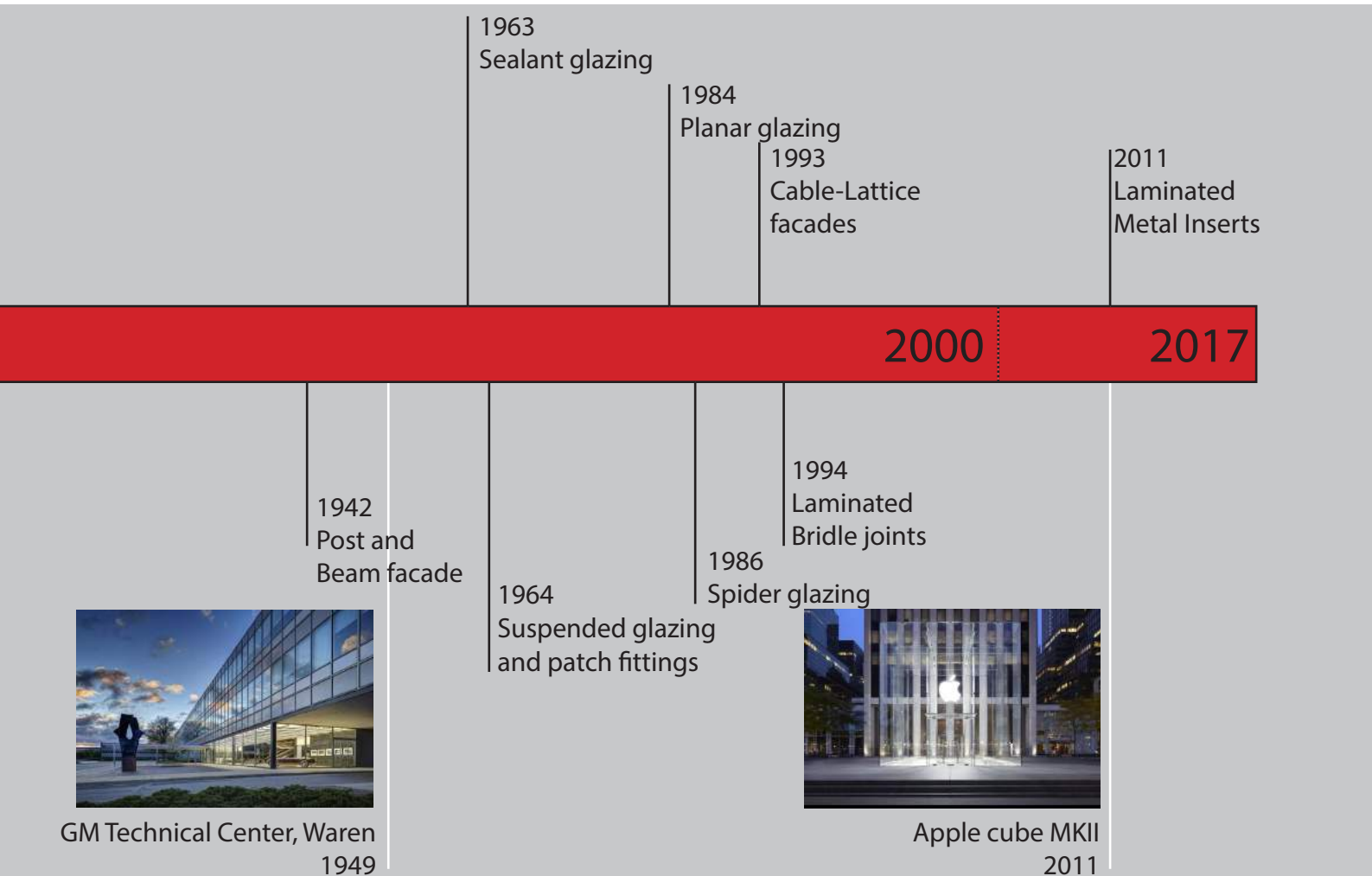

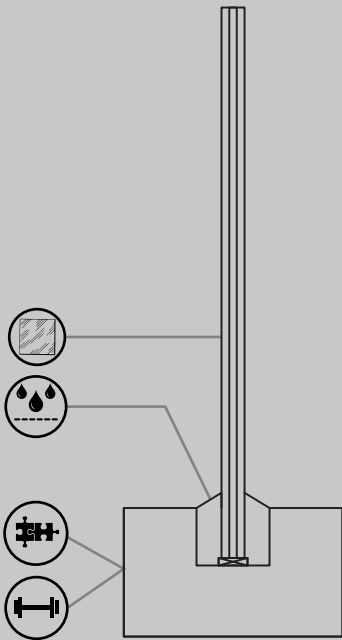

Figure 2.1-Schematic rebate glazing



Figure 2.2-Traditional window

## 2.2 Rebate glazing

60AD - Wet connection - Stone/Wood/Metal - Infill

The first glass connections that were made were glazing bead systems. These connection consisted of a frame with a cut out that would hold the glass this was then fixed with a putty. There is evidence of this connection being used in excavated villas in Pompei (Schittich, Staib, Balkow, Schuler, & Sobek, 2007) with the connection being executed in bronze and wood with a dimension of 300x500mm. This connection was the default standard for a long time because of the way buildings were made. With the window and its infill being a infill for a hole in a solid wall (Knaack, Klein, Bilow, & Auer, 2007). Later when the dimensions of the holes in the wall became bigger, because of the use of wooden lintels and arches. The dimensions of the holes in the wall became bigger as well, but for the glass making industry it wasn't possible to keep up with these innovations

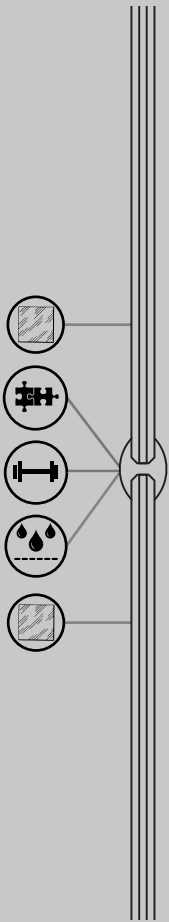

Figure 2.3-Schematic leaded glazing

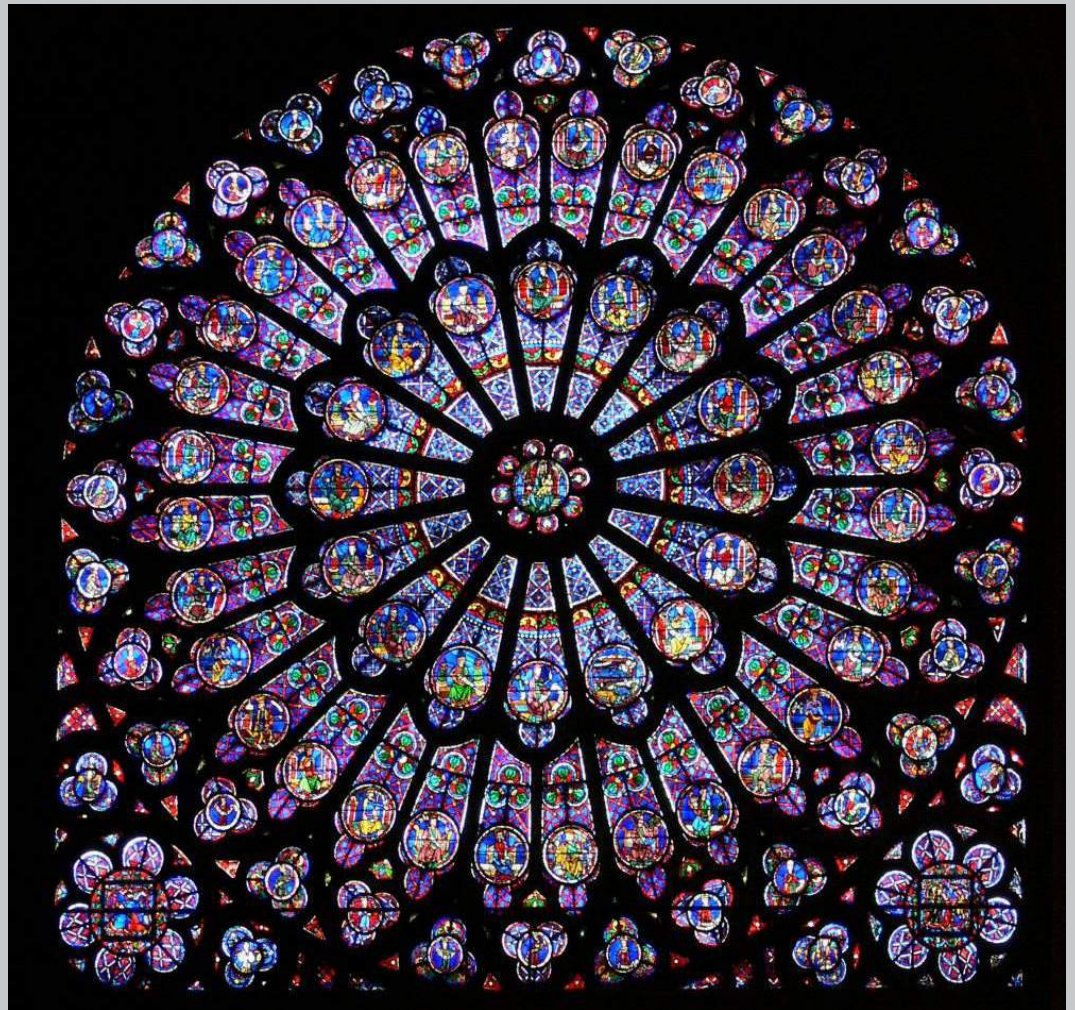

Figure 2.4-Notre Dame, Paris

## 2.3 Leaded glazing

100AD - Wet Connection - Lead - Infill

The solution for working with these smaller parts in the bigger holes was to connect these smaller pieces with Lead elements. These elements were H-shaped and could so accommodate two glass pieces and connect them with each other. The most famous example is the medieval churches build in Gothic style which uses a lot of big openings and arches to accommodate them see figure 2.4.

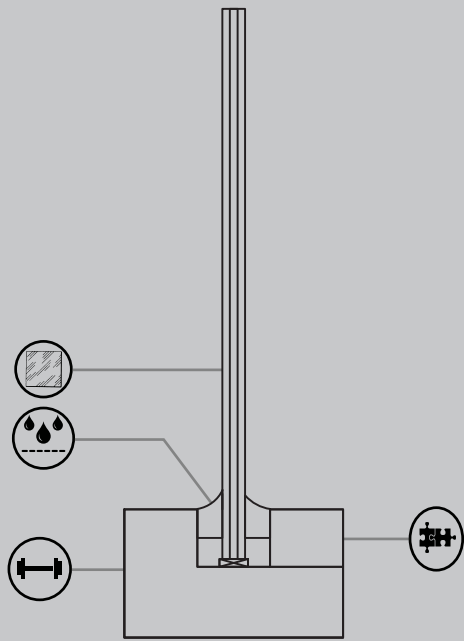

Figure 2.5-Schematic rebate with glazing bead



Figure 2.6-Window Porto Covo

## 2.4 Rebate with glazing bead

ca. 1400 - Wet connection - Stone/Wood/Metal - In-fill

The addition of a glazing bead was one of the major innovations in the 17th century when glass became more available because of improvements in the production process of glass. This glazing bead was a major innovation that separated the fixing and sealing parts of the connection. This change in the rebate glazing made it easier to fix the glazing within the frame. This also improved the connection in such a way that the glass plates were fixed better against wind suction. The addition of the glazing bead also created a difference within the sealing system with different sealing surfaces for the internal and external parts. What in turn changed the aesthetics of the than covered rebate (Schittich et al, 2007).

This connection hasn't changed in its functionality since it was first used. Only the range of materials that are used to make the different profiles for the connection has been greatly expanded. That in combination with the relative ease that the different parts can be produced with all different dimensions, made this connection the standard connection system for most glazing situations.



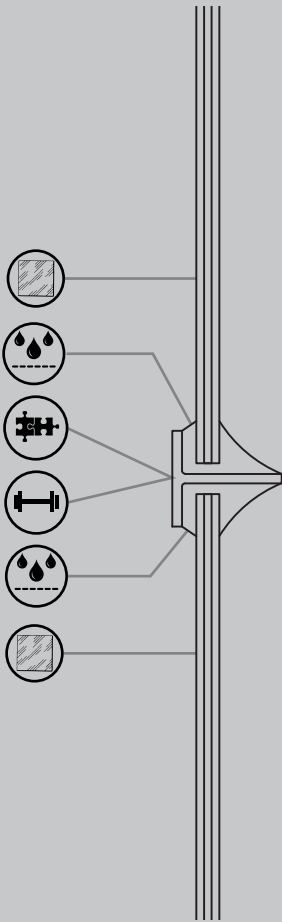

Figure 2.7-Schematic T-profile glazing



Figure 2.8-Bicton Gardens Palm House

## 2.5 T-profile

1810 - Wet connection - Metal - Infill/Stabalizing

In the beginning of the industrial revolution when it became feasible to build with cast iron this was done immediately. The most known example is the Victorian greenhouses where the improvements in the production cast iron made it possible to make slender iron skeletal constructions instead of massive walls with holes in them (Schittich et al., 2007). The connection they used for these structures was a rebate glazing system that was fixed with putty. It is interesting to see how these greenhouses were built because the glass was used to stabilize the skeletal structure and was only fixed with putty (Wurm, 2007). This wet connection was so successful that it was used in everything from train station covers to dwellings in that time period.

The most interesting part of this connection, is the fact that it was the first time that glass was used as more than just material to fill a hole in the wall. Instead it also had the function to stabilize the metal skeletal structure that usually formed the greenhouse.

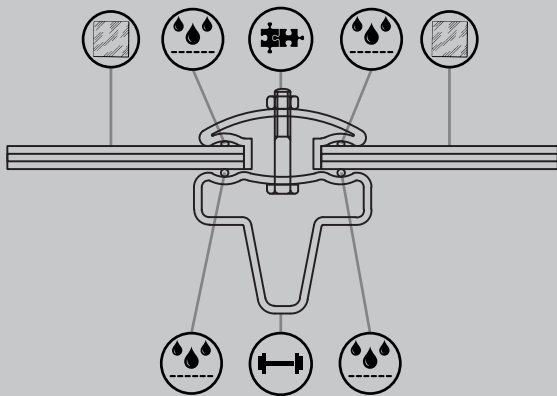

Figure 2.9-Schematic metal patent glazing



Figure 2.10-skylight with patent glazing

## 2.6 Patent glazing

1870 - Dry connection - Wood/Metal - Infill

Patent glazing is the name for a collection of different glazing connections that were first introduced in the nineteenth century (Brookes, & Meijes, 2008). They were first developed when the glasshouse became more popular and people wanted to move the green houses from garden to garden. Different systems were developed that worked with dry connections because the system uses a clamping bar that made it possible to disassemble them, so that the owner could move it to another garden (Hix, 1996).

At the time a lot of different systems were developed and patented all with the intention to make the production as efficient as possible. For example the Crystal Palace was first made with wooden glazing bars but manufacture improved the system so it was rebuilt with metal glazing bars when it was moved to Sydenham (Hix, 1996 & Brookes & Meijes, 2008). These prefabricated cast iron connections were capable of facilitating light weight roof constructions. This connection made it possible to let a lot of natural light enter the factories of the time. The development of these connections was going on way past the nineteenth century. Although the system is not so popular anymore, because of problems with thermal bridging (Brookes, 2008).

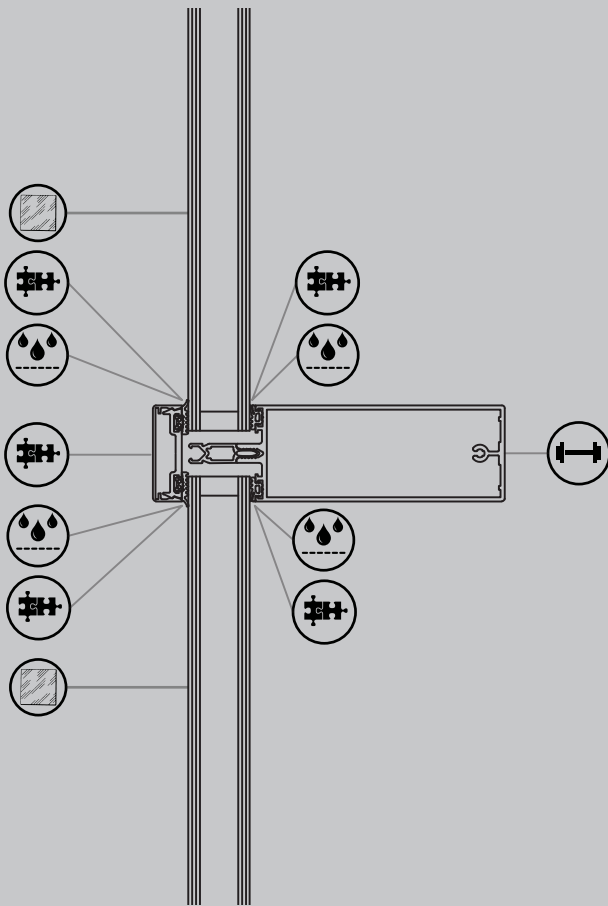

Figure 2.11-Schematic curtain wall profile



Figure 2.12-Fred Olsen Amenity Centre, London

## 2.7 Post and beam façade

1942 - dry connection - Metal - Infill

In the beginning of the twentieth century the spiritual successor of patent glazing was developed in the United States of America namely the post and beam façade. Over the years there have been many different interpretations of this façade but they all work with the same kind of clamping connection. What is characteristic for this façade connection type is its build-up of different posts and beams. The fact that most of these façades are suspended from one floor to the other like a curtain is why these façades are also known as curtain walls. The glazing connection that is used, uses a vertical and horizontal frame in a rectangular grid and is mostly commonly used for high rise buildings. The connection works with an extruded aluminium profile, a spacer and a glazing bar that holds the glass. This connection system was developed with one major factor in mind and that was the economics of the façade. Because the curtain wall systems allowed for a great deal of prefabrication which greatly reduced the cost of the façade (Schittich et al, 2007). Later on the system was further developed to provide more transparency and options for prefabrication.

The first generation of these façades still used putty to fix and seal the glazing an example of this is the Lever Building from SOM in New York. The first time that this idea of prefabrication was used on the whole façade was after the introduction of sealing gaskets made of synthetic rubber what was for the General Motors Technical Centre in Warren, Michigan by Eero Saarinen (Schittich et al, 2007). This development of integrating functions to optimize the prefabrication reached its current state with the introduction of the integral gasket which sealed and fixed the glazing to the frame construction what can be seen in the Fred Olsen Amenity Centre in London by Norman Foster. These integral gaskets would later also develop into the thermal breakers that make it possible for this glazing system to be used today.

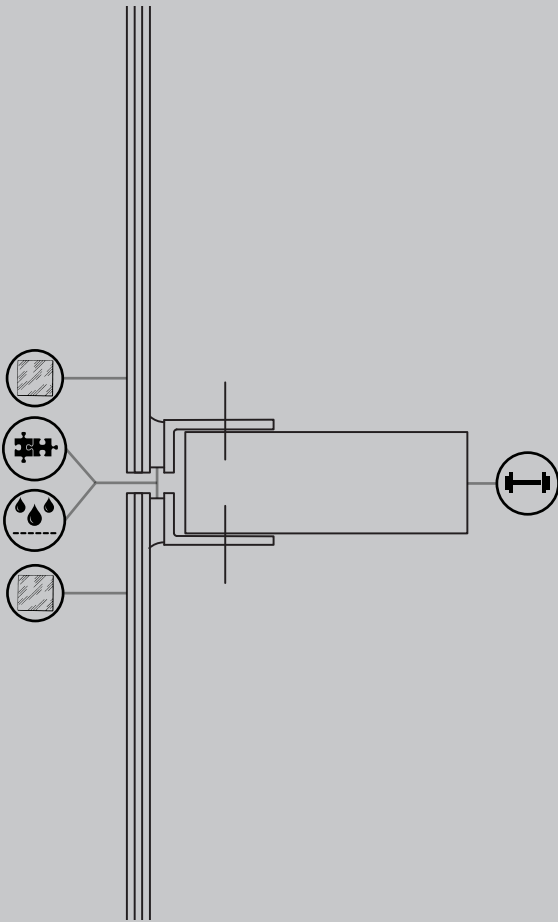

Figure 2.13-Schematic sealant glazing



Figure 2.14-Suspended sealant glazing

## 2.8 Sealant glazing

1963 - Wet connection - Metal/Silicone - Infill

The introduction of the synthetic seals in the mid 1960's led to experimenting with adhesives which could glue the glass to the frame. Because this made it possible to clad buildings in completely uniform and smooth skin. For this connection the adhesives would not just function as a seal to create water tightness but also carry the self-weight of the glass pane and transfer the wind loads to the supporting structure. A very famous example of this where the whole building is clad in the same uniform glazing is the Pacific Design Center in Los Angeles by Cesar Pelli and Victor Grun. This connection quickly became famous under the name 'structural glazing' and made its mark on American architecture where in some cases these buildings worked well (Schittich et al, 2007). The connection and its uniformity and lack of scale gained a lot of criticism. That combined with the fact that energy efficiency in the areas of cooling and artificial lighting meant that these façades and connection never became as popular outside of the United States of America.

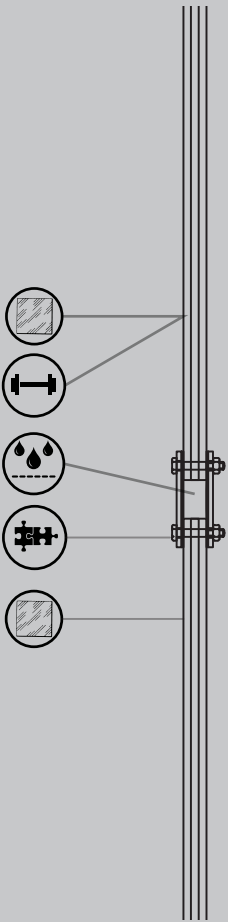

Figure 2.15-Schematic patch fitting



Figure 2.16-Willis, Faber & Dumas headquarters, Ipswich

## 2.9 Suspended glazing and patch fittings

1964 - Dry connection - Metal - Structural

After the introduction of the structural sealant glazing. The idea of suspending the panes from above to reduce the risk of deflection was formed and executed. The first examples of this can be found in Wilhelm Lembrück Museum(1964) in Duisburg from Manfred Lehbruck and the entrance foyer of Maison de la Radio(1960-63) in Paris from Henri Bernard. In both of these cases the panes were stiffened with glass fins that were glued to the panes. The actual connection was done with clamps fitted on the top of the panes in articulated bearings to evenly distributed the loads. The benefit of this connection method was the increased transparency but at the time only feasible for one-storey(Schittich et al, 2007).

A big step forward was made with the office building of Willis, Faber & Dumas(1973) in Ipswich from Norman Foster. It was done for this three-storey office building. Were the façade had the following build-up of six panes with a two meter width per line of the planning grid. The first plate of glass is suspended from the top floor with a clamping connection and every following plate is connected with a corner patch fitting to all the adjacent panes with a small suspended glass fin per floor providing stiffness for the wind load(Schittich et al, 2007, Brookes & Meijes, 2008 & Foster, 2016 ).

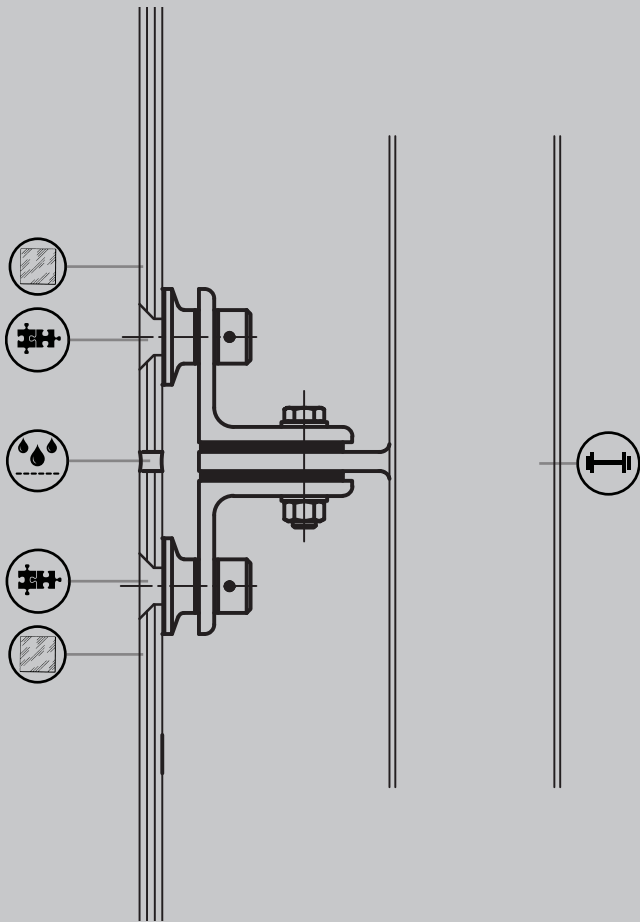

Figure 2.17-Schematic Planar glazing on steel structure



Figure 2.18-Renault Centre, Swindon

## 2.10 Planar glazing

1982 - Dry connection - Metal - Structural

The next step toward the all glass façade was to remove the outside patch fitting, because in Ipswich they still extended beyond the glass pane. The solution for this was again found by the collaboration of Foster and Pilkington. This following step brought the connections into the pane of the glass hence the name planar glazing. The first building that made use of this connection the Renault Centre (1982) in Swindon did not suspend its glazing but screwed it to a steel support structure. This made it possible to have a completely flush façade again (Schittich et al, 2007).

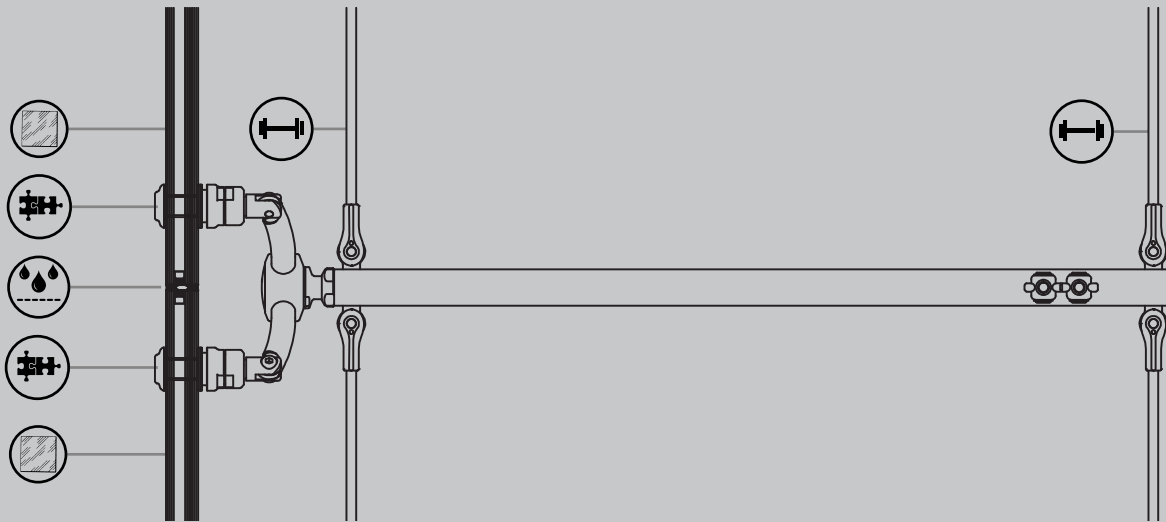

Figure 2.19-Schematic suspended spider glazing



Figure 2.20-Parc-de-La Villette, Paris

## 2.11 Spider glazing

1986 - Dry connection - Metal - Structural

Soon after the Renault Centre this technology was pushed further. This was done first in France with the construction of the Parc-de-La Villette(1986) in Paris by Adrien Fainsilber and Rice Francis Ritchie later known as RFR engineers. Because they were capable of making the first planar connected façade that was suspended in 8 x 8 meter bay's with steel cable trusses. This dematerialized the supporting steel structure again what improved the transparency of the façade (Schittich et al, 2007).

The engineering firm RFR has developed these spider connections ever since with the aim the dematerialize these connections even further. A number of notable projects that were important for this were; the Louvre Piramide(1989) in Paris by Leoh Ming Pei and a office building on the Avenue Montaigne(1993) in Paris by Epstein, Glainmann et Vidal. The other major innovation that was driven by RFR was the usage of insulating glazing in combination with spider glazing. This was done for a bank in Montgermont(1990) (Schittich et al, 2007).

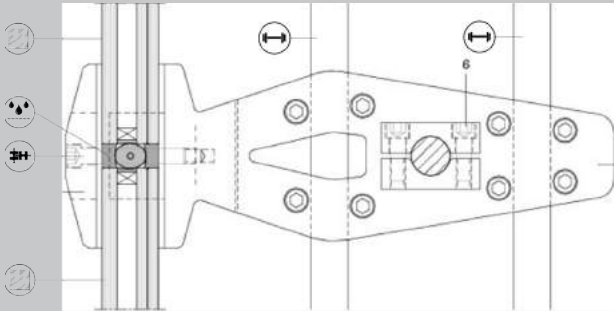

Figure 2.21-Detail of cable lattice façade



Figure 2.22-ThyssenKrupp Quarter façades

## 2.12 Cable-Lattice façades

1993 - Dry connection - Metal - Structural

After the introduction of the planar spider glazing the developments of further de-materialisation went fast. Because in eight years after Parc-de-La Villette there was the introduction of the first cable-lattice façade for the Hotel Kempinski(1993) from Helmut Jahn in Munich. This façade was engineered by Jörg Schlaich(Schittich et al, 2007). He made this façade possible by spanning cables in the atrium in a horizontal direction which are pre stressed. On these cables there are clamping plates located that would hold the glass plates. This creates the aesthetic of light-weight glass wall that floats in the air (Schittich et al, 2007).



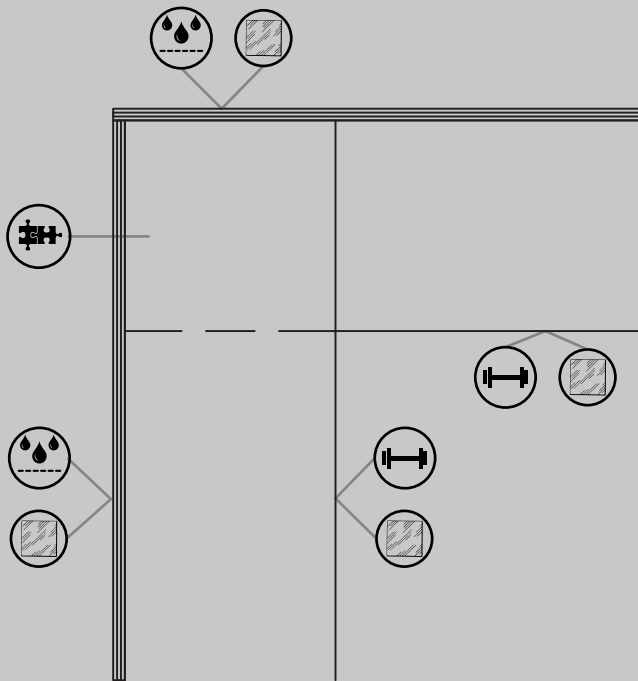

Figure 2.23-Schematic laminated bridle joint



Figure 2.24-Broadfield House Glass Museum, Broadfield

## 2.13 Laminated bridle joints

1994 - Wet connection - Glass - Structural

At the same time as the Cable-Lattice glazing a different development was being made to move to a zero percent metal content. This was done for Rick Mather for the extension of a house and later for Design Antenna with Tim Macfarlane for the extension of a museum. The real innovation was done by two British engineers Laurence Dewhurst and Tim Macfarlane. They used carpentry techniques as the bridle joint to laminate beams and structural fins together which made it possible to make glass extensions to existing buildings. The down side of this technology is that the size of the structures is rather limited and the structures can not shake there experimental character(Schittich et al, 2007).

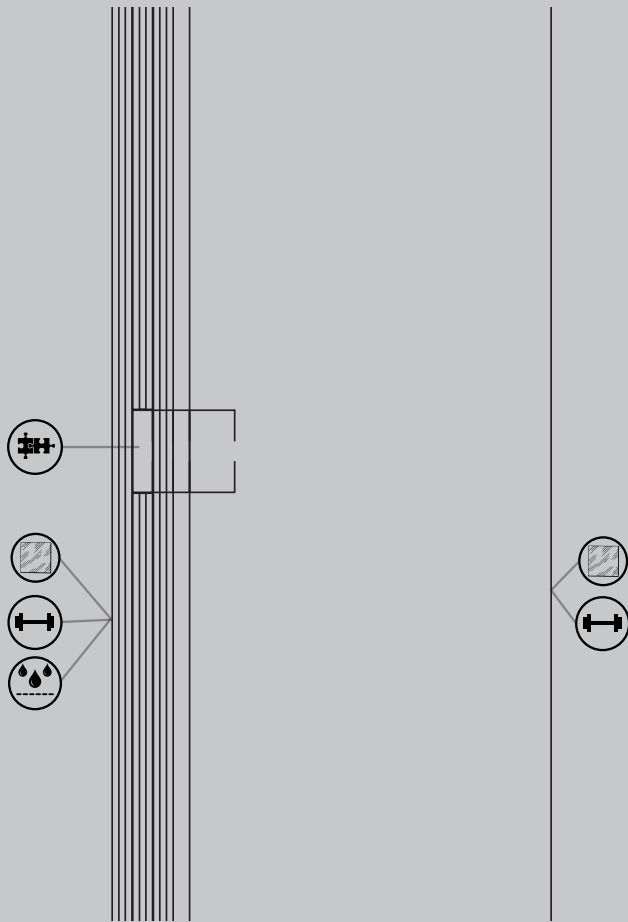

Figure 2.25-Schematic metal insert

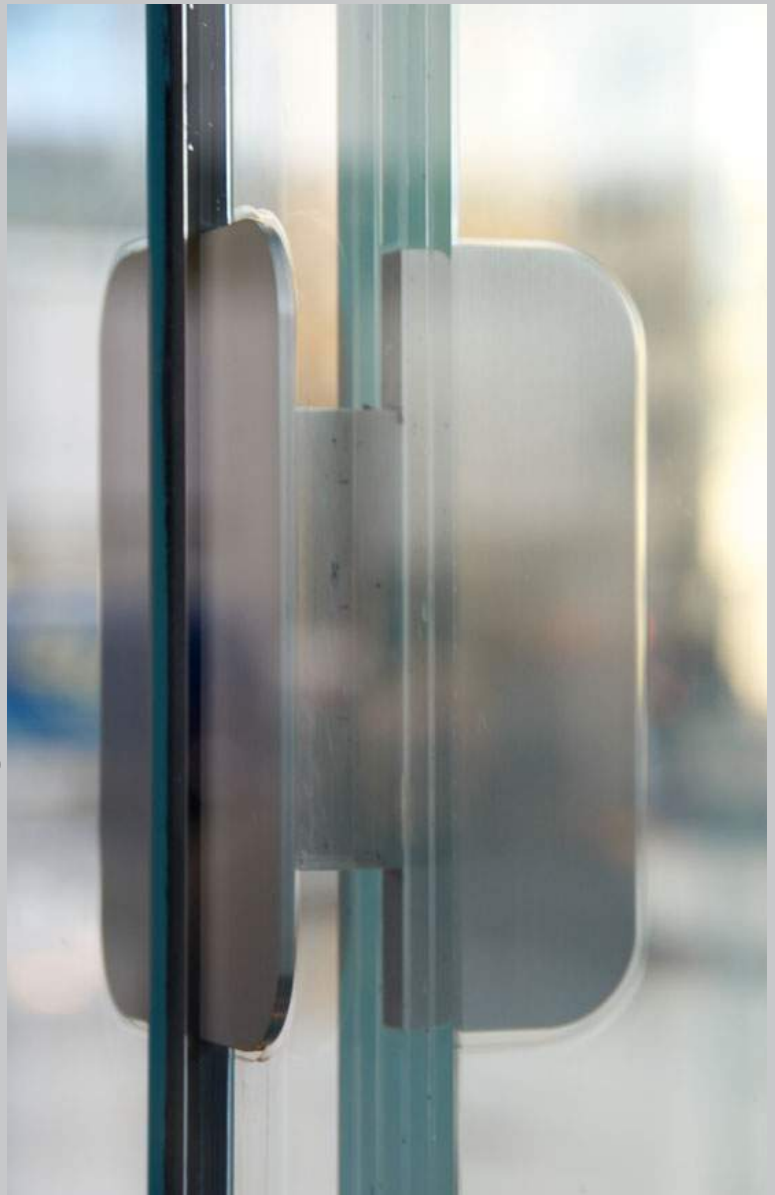

Figure 2.26-Apple Cube MK2, New York

## 2.14 Laminated metal inserts

2011 - Wet connection - Metal/Glas/Interlayer - Structural

The current state of the art of structural glazing is the work of former engineer of Dewhurst and Macfarlane namely Jamse O'Callaghan. To facilitate bigger and stronger structures he laminated metal parts in to the glass laminate what would connected the different plates to each other. At the same time the metal would be bonded to the intermediate layer of the laminate and this layer would then carry the load. The most famous examples of this can be found in the different Apple stores of which the New York one is the most famous. This is right now the way to make a glazed façade that can be up to 15 meters.

## 2.15 References

Brookes, J., Meijes, M. (2008) *Cladding of Buildings(fourth edition)*.  
Abingdon: Taylor & Francis

Foster, N. (n.d.) willis faber dumas headquarters. Retrived 15th of December 2016, from <http://www.fosterandpartners.com/projects/willis-faber-dumas-headquarters/>

Hix, J. (1996) *The Glasshouse*  
London: Pahadion

Knaack, U., Klein, T., Bilow, M. & Auer, T. (2007). *Façades: Principals of construction*  
Berlin: Birkhäuser

Schittich, C., Staib, G., Balkow, D., Shuler, M. & Sobek, W. (2007). *Glass Construction Manual(second edition)*  
Berlin: Birkhäuser

Wurm, J. (2007). *Glass structures: Design and construction of self-supporting skins*.  
Berlin: Birkhäuser

## SUMMARY

The glass connection has a long history this can be seen in the timeline. During this time there was a very broad application of the various connections. The development of the connections has been in line with the evolution of the window itself. Because, it developed from the infill of a hole in the wall to wards fully glazed buildings for which the connection had to be adapted. One of the driving factors for this is the search for more transparency for the façade which leads to connections with fewer visible materials. The latest developments are also focusing more on localised connections which have been developed in the last 30 years. These localised connections are probably also the most interesting to develop in the next stage of this research.



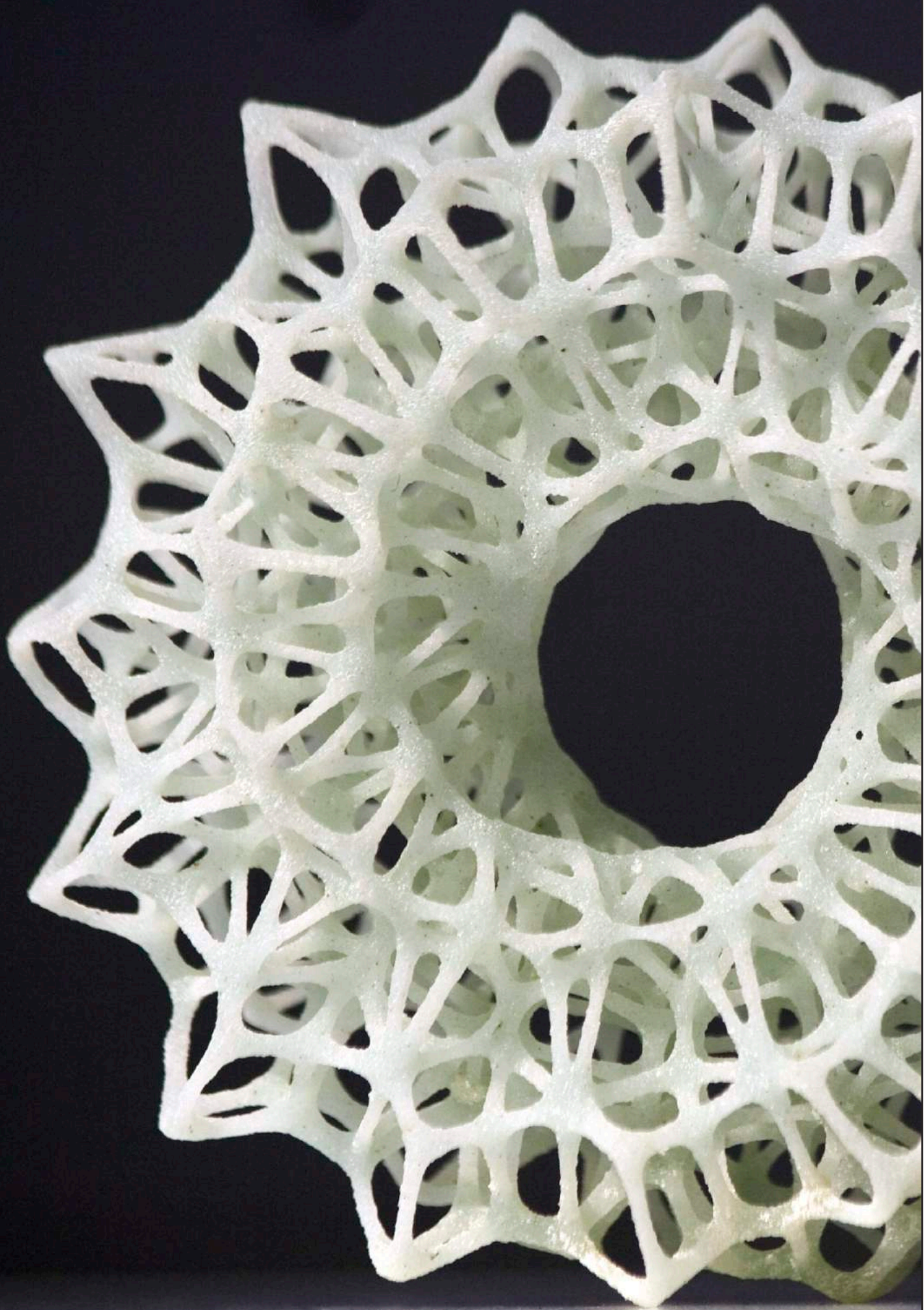

Möbius Net by Bathsheba Sculpture  
(Source: 3dprinting.com)



# Additive manufacturing





# 3

## Additive manufacturing

Additive manufacturing(AM) is a fabrication technology that is being used to directly fabricate a three-dimensional model that has been made with the help of Computer Aided Design. This is why this technology that was first developed in the 1960's was known as Rapid Prototyping(RP) (Gibson, I., Rosen, D. & Stucker, B., 2015). In recent years this technology has been developed way beyond that. AM now has a broad field of application in a lot of industries except for the built environment there AM can not shake its RP roots.

This chapter will show how AM works. What are important factors to take in consideration when the decision has been made to produce a AM end product. Because AM sounds very easy but it is a more complex than most people think it is. In this chapter that issue will be addressed but it will also show what the benefits of AM are to show that AM is ready to become part of the built environment.

This chapter will answer the following questions:

- How does AM work?
- What kind of AM processes and material are relevant for this research?
- What are the benefits of AM for the built environment?



Figure 3.1-Urban Cabin by DUS Architecten

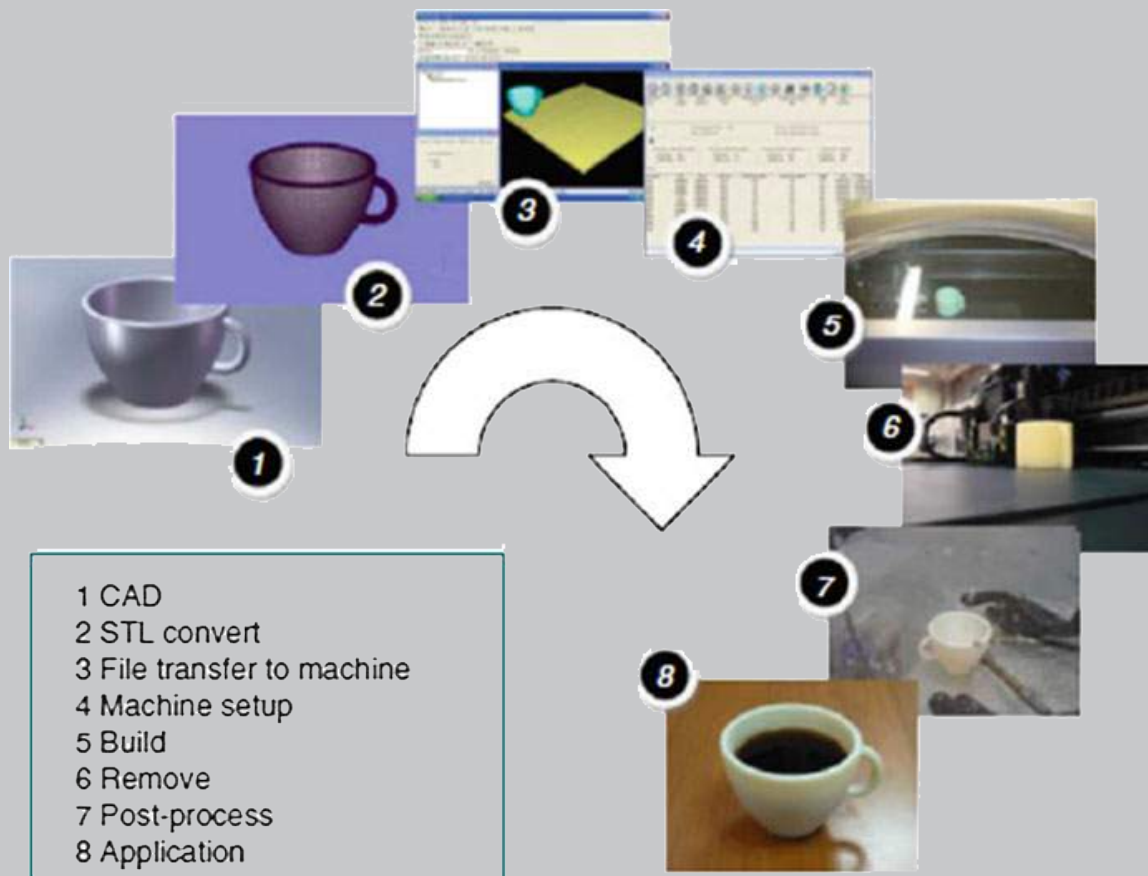

Figure 3.2- The generic 8-steps AM process

## 3.1 Generic AM procedure

AM is a relatively fast way to make finished products or prototypes that uses the digital environment in the most complete way possible. To go from a digital design in CAD towards a finished product, it needs a number of generic steps. Although these steps can vary from model to model. For example, a simple visualization model requires less work than a complex engineered product. The next eight steps that are going to be discussed are those generic steps (Gibson, I., Rosen, D. & Stucker, B., 2015);

### 1 CAD

The model for AM has to be made in the digital environment of Computer Aided Design (CAD). The data has to describe the outside geometry, which can be done with most CAD-solid modelling software. This can even be done with reverse engineering equipment like laser scanners as long as it describes the outside surface.

### 2 Conversion to AM Recognizable format

The CAD data has to be exported to a file format that the AM machine can handle. At this moment the standard format for this is the STL format. This format works by describing the object as a triangular mesh geometry. This format was developed in 1993 by 3D systems and has been developed ever since (Burns, 1993). Recently a consortium of companies has been developing a new file format for AM with the name 3D Manufacturing Format (3MF). The benefit of this format is that it contains all the model information and not just the outside geometry. Which makes it possible to make more complex geometries with multiple materials and/or colors (3MF, 2016).

### 3 File transfer to machine

The STL file will then be transferred to the AM machine. If necessary, the file should be manipulated so that it is the right size, the orientation is correct, and if necessary, supports are added to the geometry.

## 4 Machine setup

When the file has been send to the machine the machine has to be setup as well. This relates mostly to different building parameters like material constraints, sufficient power supply, layer thickness, speed and etc.

## 5 Build

The building step is a computer controlled phase that can be carried out without a lot of supervision. The printing should only be monitored in the beginning of the process to see if everything starts off alright. Further on in the building process only superficial monitoring is required to make sure nothing goes wrong with the production of the part like running out of material or power.

## 6 Removal and clean up

Once the building of the parts is finished the part can be removed from the machine. The part isn't ready for use straight away because it usually still needs to be cleaned up by hand. The material that has to be removed is usually support material or other excess print material but a skilled operator can do this without damaging the part.

## 7 Post-processing

If necessary additional post processing to part can be done. If done this is done to improve the surface quality or improve the strength of the part. Examples of this are polishing, sandpapering, and the application of coatings.

## 8 Application

Then the parts is finished and finally ready for use. It is very important to note that the AM parts have different properties than when they would have been made with a other production process with the same materials. This should be taken in consideration by the designer before he starts with an AM design. What is also an issue is that there a currently no standards for AM. Although they are currently being developed by the ASTM F42 Technical Committee on Additive Manufacturing Technologies, which is addressing this problem and trying to great a global set of standards for AM(ASTM, 2016)



Figure 3.3-Selection of different filaments

## 3.2 AM for plastics

At this moment AM for plastics is the most common way of using AM. This is because the technology was first developed for the use of plastics in the 1987. This was then made with the purpose of making fast prototypes that is why they named it 'rapid prototyping' (Strauss, H., 2013). There are a number of points why polymers are selected for this research:

### 1 The variation in materials.

Currently there is already a broad range of polymers that can be used for AM. With different forms of feeding the material to the printer for all the different production methods examples are; filaments, pellets or substrates. With this range of materials it is easier to choose the right production method for your project. The constant innovation of these polymers is also beneficial for printing with plastics because the range of properties becomes broader and broader.

### 2 Energy

Because of the relative low melting point of most plastics the energy consumption is relatively low. This also has a positive effect on the machines because they require less heat shielding, insulation and temperature control.

### 3 Weight

The weight of the plastics makes printing in plastics very attractive because the machine can be lighter and uses less energy compared to other AM technologies.

### 4 Speed

With the lighter materials the printers are also capable of having a higher build speed. Which makes it possible to produce more parts in the same time

### 5 Cost

Because of a number of the previous mentioned arguments(Energy, Weight and Materials). Printing with plastics is relatively cheap. That combined with the fact that the most important patents are already expired. What makes it possible to have a lot of open source systems what greatly reduces the price

The AM process for the use of polymers can be divided in roughly five principles:

## 1 Stereolithography

Stereolithography(SLA) means the curing thin layers of liquid photopolymers with a light source being a laser or a halogen lamp. This works as follows the parts are generated in bath of epoxy or acrylic resin. A light source traces the layers and the material is cured locally. When a layer is finished the work platform is lowered and the next layer is added to the model. For SLA it is necessary to add support structures for overhangs and undercuts which have to be removed after the product has been cured with UV light (Stauss, H., 2013 & Gibons, I. et al., 2015). This method is known for its high accuracy and high quality surface finishes. The only drawback at the moment is the material that remains sensitive to UV light and humidity. So further research in to the resins is required to make this method ready for AM (Strauss, H., 2013).

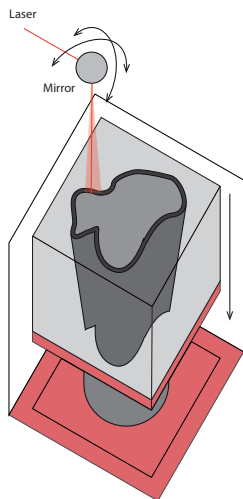

Figure 3.4-Schematic SLA printing

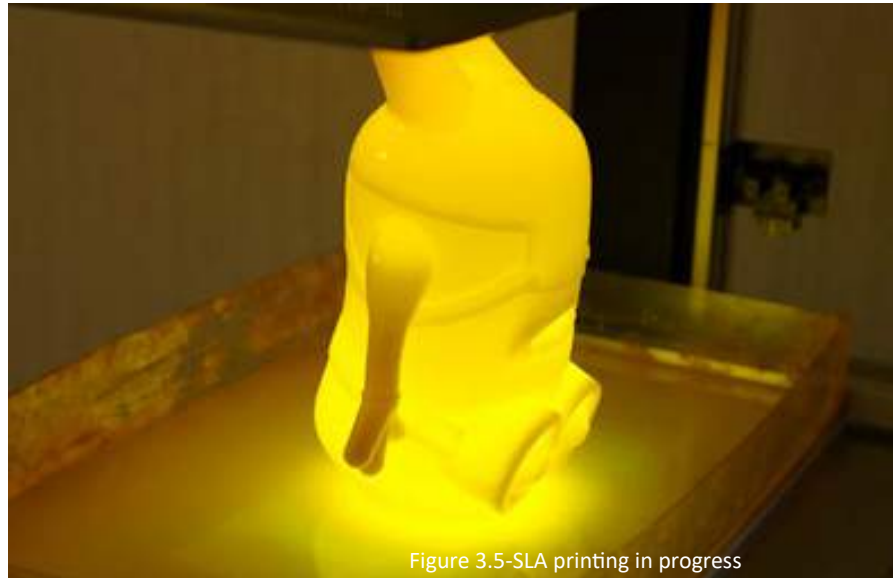

Figure 3.5-SLA printing in progress

## 2 Selective Laser Sintering

Selective Laser Sintering(SLS) is also know under the name Powder Bed Fusion(PBF) and is very similar to SLA in the way it produces the parts. Because instead of a fluid it uses a powder mix that is melted to gether. The sintering works with melting powder that has been heated to a few degrees below its melting temperature to reduce the energy demand of the laser. The preheating of the powder will also reduce the change of warpage and improve the fusion with previous layer. This process does not require any supports because the additional powder material can work as a support material. In the design this should be taken in account so that the powder can be removed from the inside of the print if it is a hollow object. The powder that is not used can be put back in to the storage container and be used again. This method is also available for broad range of other materials like metals and ceramics (Strauss, H., 2013).

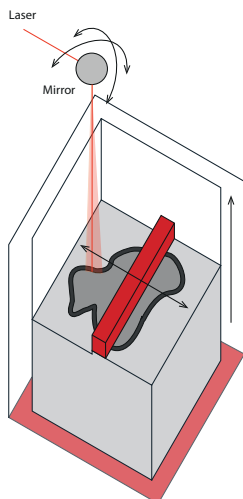

Figure 3.6-Schematic SLS printing

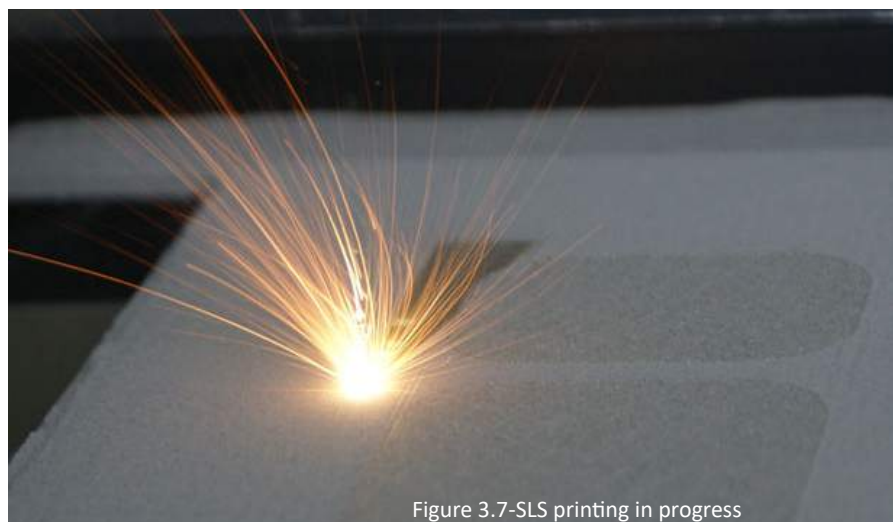

Figure 3.7-SLS printing in progress

### 3 Fused Deposition Modeling

Fused Deposition Modeling(FDM) or Fused Filament Fabrication(FFF) is an additive manufacturing method that actually adds material and does not just bond it together with gluing, sintering or curing. This material is then deposited on a work platform where the extrusion head or the work platform can change in height.

FDM works with depositing lines of materials in a 2D pane this is done by heating up the polymers to their melting point and then depositing the material from the heated extruder head much like a hot-glue gun. The material will then cure directly onto the previous layer. To make sure the layers bond properly it is important to keep the temperature of the last layer close to its melting point so that the next layer can bond properly to it. For this technique it is necessary to work with support structures if the design asks for it because the walls are not self-supporting when they are not cured yet. These structures are generated by software so they do not need to be modelled by hand and can be deposited by a secondary nozzle what improves the changes of removing the supports without damaging the product.

This systems first makes the contour lines and then fills them in with one of the selected grid patterns this is done to improve the printing speed reduce the material consumption and the weight of the part. This combined with the wire output and the dimensions of the nozzle head the surface and edges have a stepped contour. This determines the limitations in accuracy and surface finish. Then the biggest down side of this technology is the anisotropic build-up of the structure because of the material distribution. This anisotropic properties are mostly a result of the layered build up and the adhesion between the layers in the Z-direction. What means that the strength of the parts greatly reduced in the Z-direction. This is something that always should be taken into account when making parts that have to endure stresses in multiple directions or have to endure long-term stresses (Strauss, H., 2013).

A benefit of this printing technology is that is currently the AM technology that offers the most freedom. Because the extruder's can be mounted on to everything. This opens up the way to combine FDM extruder's with robotic arms. What would mean that 3D printing can finally step away from the layer by layer process and become truly 3D.

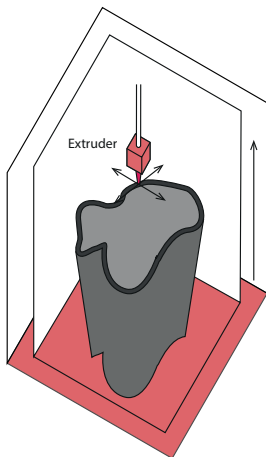

Figure 3.8-Schematic FDM printing

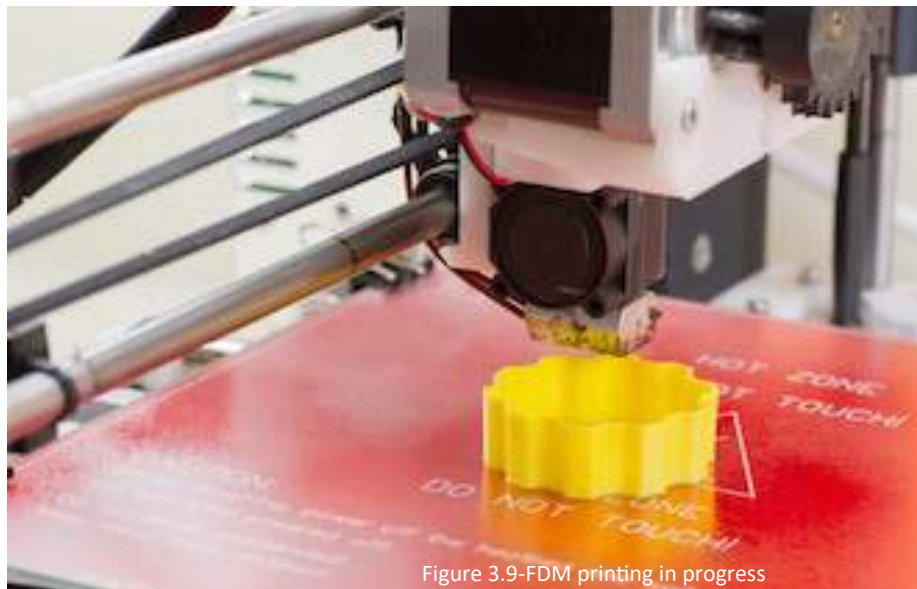

Figure 3.9-FDM printing in progress

## 4 3D-Printing

3D-printing(3DP) is the most comparable to conventional inkjet printing but is also very similar to SLA and SLS. Because it deposits little drops of glue onto a bed of powder and in that way joins the materials in question to gather to form the end product. For the way it works with the powder it is the same as for the SLS. So there are no supports needed but cavity should be accessible to remove excess material what can be removed with compressed air. The benefit of this method is that the prints can be infiltrated with epoxy resins or additional glues to make the final product stronger. With 3DP it is also possible to add colour cartridges to the glue so it can be used to collar the print while printing. This can be done to show a FEM-analysis on the model to make the forces more visible. Currently this technique is used a lot for investment casting to make complex moulds (Strauss, H., 2013).

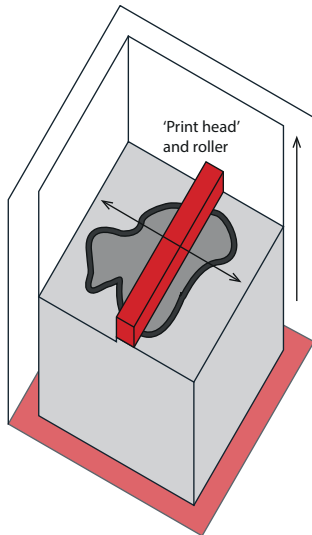

Figure 3.10-Schematic 3DP printing

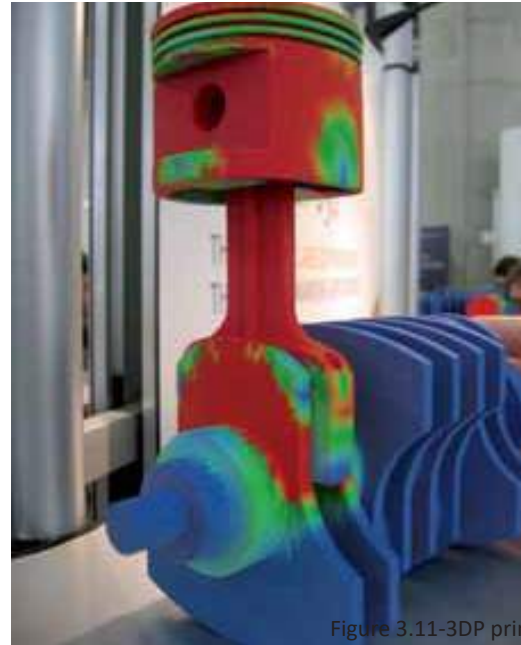

Figure 3.11-3DP printed part

## 5 Ink Jetting

Ink jetting works with placing individual drops of highly viscous plastics on a work platform that can be lowered to build up the different layers. These droplets are printed and the immediately cured with a UV lamp that is placed behind the nozzle. When the layer is cured it is smoothed out with a roller the platform is lowered and the next layer is added. This method uses a support structure what can be easily removed with the help of a water jet. Because the material is placed as loose particles the prints are very precise and incredibly smooth. Ink Jetting also opens up the possibility to print with multiple materials in the same print to make soft and hard parts in one print (Strauss, H., 2013).

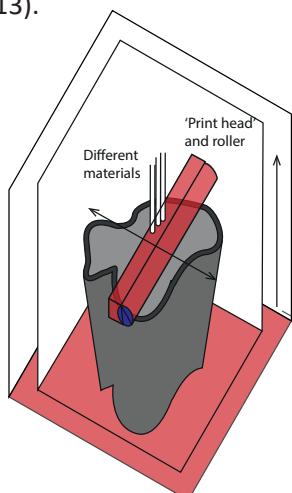

Figure 3.12-Schematic Ink Jettig printing

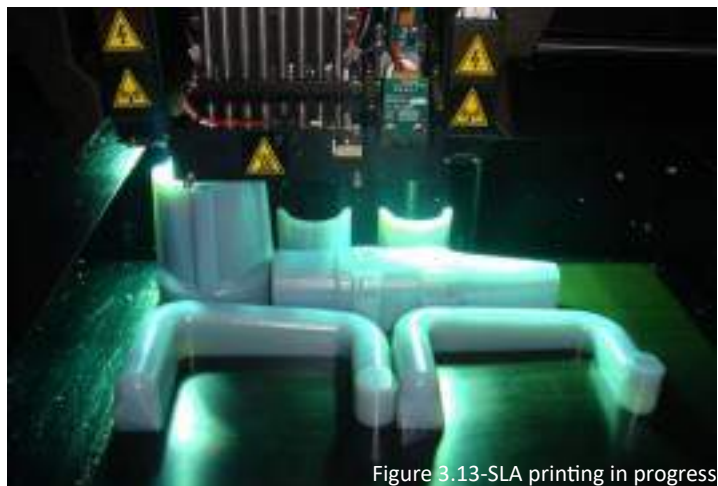

Figure 3.13-SLA printing in progress

## 6 Overview

In recent times AM has had a big development in quality of the finished prints and the size of the available build volumes. The biggest development has been taking place with the FDM printers, because these printers can very easily be built by the user them self. The store bought machines can be easily adapted and upgraded to fit the need of every individual user. As AM is going to develop the price of the other systems is going to drop and the machines will become even bigger and more advanced. A big influence for this could be the maker movement that could open source this whole development to make bigger and better machines.

Also the development of new and better software that gives designers more freedom over the internal workings of the print will make AM more attractive. Software like MIT's Foundry software that makes it possible to design the internal parts of the print by working with multiple materials in the same print(Vidimce, K., Kaspar, A., Wang, Y. & Matusik, W. 2017). What creates a lot of opportunities on how to fabricate the different components because the designer will have even more control over the final design.



## 3.3 Materials

### 1 Polymers

Special material mixes are available and constantly developed by the different producers because these new materials are key to making AM more attractive for more and broader applications. These AM materials differ in their performances from their more traditional counterparts. The biggest factor for this is the anisotropic nature of AM what means that the strength in the Z-direction is less than that in the X- and Y-direction. This is the result of the layered fabrication process that is characteristic for AM.

For this research a number of materials that are suited for engineering applications are presented these are different polymers than the PLA and ABS varieties that are usually used. For example a more engineered material like PEEK what has better mechanical properties than PLA. This can be seen in table 3.1 in which the first material is a PLA an example.

Manufacturer		Material name	Material	Process	UTS MPa		Yield S MPa		E modulus GPa	
					x-y	z	x-y	z	x-y	Z
Ultimaker	USA	PLA	PLA	FDM	36		38		2.4	
Markforged	USA	Tough Nylon	PA	FDM	54		31		0.84	
		Onyx	PA	FDM	30		36		2.9	
Stratasys	GER	FDM Nylon 6	PA	FDM	67.6	36.5	49.3	28.9	2.2	1.8
		Ultem 1010	PEI	FDM	81	42	64	37	2.7	2.2
		Ultem 9085	PEI	FDM	69	42	47	33	2.2	2.1
Arevolabs	USA	Katevo	PEEK	FDM	95				4.4	
		Quantevo	PEAK	FDM	75				3	
Indmatec	GER	PEEK 450G	PEEK	FDM	97				3.7	
EOS	GER	PEEK HP3	PEEK	SLS	90		4250			

Tabel 3.1-Engineering polymers for AM



Figure 3.14-Part made out of PEEK

## 2 Composite

Lately a big development has been the introduction of additional fibres in the filaments to further enhance the properties of the polymers. This can be done with fibres with a random distribution in the material or with a continuous fibre which creates even stronger parts. Although these enhanced materials are very new they have great promise to rival their metal counterparts in mechanical properties. That is also the reason that different manufacturers keep making these materials and improving them.

The materials properties in both tables are not complete. Because most of these materials are so new that they have not yet been independently tested and the manufacturers are not willing to share their data. What probably has to do with the performance of the material because they can not guarantee the advertised strength in all directions.

Manufacturer		Material name	Material	Process	UTS MPa		Yield S MPa		E modulus GPa	
					x-y	z	x-y	z	x-y	Z
Markforged	USA	Carbon CFF	PA-CF	FDM	700				51	
		Kevlar CFF	PA-KV	FDM	610				26	
		Fiberglass CFF	PA-FG	FDM	590				22	
		HSHT Glass CFFF	PA-FG	FDM	600				21	
Windform	IT	XT 2.0	PA-CF	SLS	83				8.9	
		LX 2.0	PA-FG	SLS	59				6.2	
Arevolabs	USA	Katevo -CF	PEEK-CF	FDM	145				20	
		Quantevo -CF	PEAK-CF	FDM	105				8	
EOS	GER	CarbonMide	PA12-CF	SLS	72/56	25	6100	2200		
3Dxtech	USA	End of JAN	-	FDM	-	-	-	-	-	
Colarfabb	NL	XT-CF20	PET-CF	FDM	76				6,2	

Tabel 3.2-Composites for AM s



Figure 3.15-Battle robot made out of Markforged Carbon CFF

## 3.4 Alternatives for Plastics

Plastics are not the only material that can be used for AM. Recently a lot of development has been taking place in the field of metals for AM. An overview of the available materials can be seen in tabel 3.3. This the overview of the available materials from EOS Germany. Currently there are roughly two techniques that are being used for metal AM the first is powder bed process which is SLS but with higher temperatures. The second is the powder feed process what is easiest described as build up welding and can be used for spot repairs.

### EOS Materials Metal

Product class	Product name	Material type*	Typical applications
Maraging steel	EOS MaragingSteel MS1	18 Mar 300 / 1.2709	Series injection molding tools; mechanical parts
Stainless steel	EOS StainlessSteel GP1	Stainless steel 17-4 / 1.4542	Functional prototypes and series-production parts; mechanical engineering and medical technology
	EOS StainlessSteel PH1	Hardenable stainless steel 15-5 / 1.4540	Functional prototypes and series-production parts; mechanical engineering and medical technology
	EOS stainlessSteel 316L	1.4404 / UNS S31673	Lifestyle: jewellery, functional elements in yachts, spectacle frames, etc. Aerospace: supports, brackets, etc. Medical: functional prototypes and series-production parts in e.g. endoscopy and orthopedics
	EOS StainlessSteel CX	Tooling grade steel	Manufacturing of injection moulding tools for medical products or products from corrosive plastics
	EOS StainlessSteel 17-4PH	Stainless steel 17-4PH / 1.4542 / X5CrNiCuNb17-4 ASTM F899-12b	Medical instruments (surgical tools, orthopedic instrumentation) Acid- and corrosion resistant parts.
	Nickel alloy	EOS NickelAlloy IN718	Inconel™ 718, UNS N07718, AMS 5662, mat. # 2.4668
EOS NickelAlloy IN625		Inconel™ 625, UNS N06625, AMS 5666F, mat. # 2.4856 etc.	Functional prototypes and series-production parts; high-temperature turbine components
EOS NickelAlloy HX		UNS N06002	Components with severe thermal conditions and high risk of oxidation, e.g. combustion chambers, burner components, fans, roller hearths and support members in industrial furnaces
Cobalt chrome	EOS CobaltChrome MP1	CoCrMo super alloy, UNS R31538, ASTM F75	Functional prototypes, series-production parts, mechanical engineering, medical technology, dental
	EOS CobaltChrome SP2	CoCrMo super alloy	Dental restorations (series-production)
	EOS CobaltChrome RPD	CoCrMo super alloy	Removable partial dentures
Titanium	EOS Titanium Ti64	Ti6Al4V light metal	Functional prototypes and series-production parts; aerospace, motorsports etc.
	EOS Titanium Ti64ELI	Ti6Al4V ELI	Functional prototypes and series-production parts in medical technology
	EOS Titanium TiCP**	TiCP Grade 2, 3.7035, ASTM F67 (UNS R50400), ISO5832-2)	Medical implants (trauma plates, CMF Implants, spinal cages, dental implants)
Aluminium	EOS Aluminium AISi10Mg	AISi10Mg light metal	Functional prototypes and series-production parts; mechanical engineering, motorsports etc.

Tabel 3.3-Metelas suited for AM(source: eos)

## 3.5 Benefits of AM for the built environment

In the previous parts of this chapter AM was described how AM works and what kind of materials are currently suitable for AM. There still remains one question what are the benefits of AM for the built environment. This part will show why AM is ready to be utilized to its full potential and should be used to make finished products for the built environment.

The first and most relevant benefit of AM should be the design freedom that is created with AM. Because AM is one of the few technologies that makes it possible to directly manufacture the building components straight from the 3D-CAD design. This offers a lot of freedom for the designer and creates the opportunity to generate a lot of complexity that otherwise was not possible. Because it makes it possible to use Topology Optimization(TO) software that uses Finite Element Modelling(FEM). It is possible to use these programs because the fabrication method is completely free in the way it produces the part. With the right software it is even possible to use thicker walls or a more solid infill where the stresses are higher. This will also mean that the parts are used in a more structural efficient matter(Hopkinson, N., Hague, R. & Dickens, P. 2006). These more optimised parts with FEM will also lead to a reduction in weight and materials usage. What then could lead to a lighter and more flexible structure so that the total material footprint of the building can become smaller.

The freedom in the manufacturing of the part that you have with AM is, because AM is a tool less process. This makes it so that it is more feasible to produce the complex parts that have been described before. This is possible because AM does not require any moulds to generate its products and these mould usually come with a high investment. The fact that AM is this tool less process means that the designer no longer has to design for fabrication but now can design for manufacturing(Strauss H., 2013, Hopkinson, N. et al. 2006), Knaack, U., Klein, T., Bilow, M. & Auer, T. 2007).

The fact that AM is a tool less process does mean that it does not require major investments if a product is changed is one other benefit. Because it means that a batch size of one is enough to start production. The effect of this is that it becomes more feasible to make a structure like the Kunsthauz in Graz with it 6000 individually shaped point fixers(Strauss H., 2013). This relates to the first point as well because the parts that are made for a free form building will fit better in the building because they are also free from. What means that the realised buildings that employed AM is closer to the original design. (Hopkinson, N. et al. 2006)

The last major benefit is the opportunity of part consolidation because AM has to capabilities to manufacture the whole part at one so that the final product is one thing and is no longer made up out of severable smaller components. What is important for the Built Environment is the possibility to make AM parts with multiple materials at the same time. Because one part usually has to fulfil multiple functions. This means that it can open up the possibility of fully integrated hinges or even power conduits. These applications are still the furthest away of real life applications but will also bring us closest to the Polyvalent Wall and show the biggest potential and benefit of AM for the Build Environment. (Strauss H., 2013, Hopkinson, N. et al. 2006), Knaack, U. et al. 2007).

These four topics are the biggest benefits of AM for the Build Environment. To summarise the benefits they are;

- Freedom of geometry and complexity of the geometry
- A tool less process
- The batch size of one
- The integrating of different functions in one part.

All these benefits have in common that they give more freedom to the designer and allow for engineering that is completely in line with the architectural languages that has been used in the design.

## 3.6 References

3MF. (n.d.). 3MF | Supporting innovation in 3D printing. Retrived 15th of December 2016, from <http://3mf.io/>

ASTM. (n.d.) ASTM F42 Technical Committee on Additive Manufacturing Technologies. Retrived 15th of December 2016, from <http://astm.org>

Gibons, I., Rosen, D. & Stucker, B., (2015) *Additive Manufacturing Technologies: 3D printing, Rapid Prototyping and Direct digital Manufacturing* (second edition)  
New York:Springer

Hopkinson, N., Hague, R. & Dickens, P. (2006) *Rapid Manufacturing: An industrial revolution fr the digital age*  
Chichester: Wiley

Knaack, U., Klein, T., Bilow, M. & Auer, T. (2007). *Façades: Principals of construction*  
Berlin: Birkhäuser

Strauss H. (2013) *AM Envelope: The potential of Additive Manufacturing for façade construction*  
TU Delft. <http://repository.tudelft.nl/islandora/object/uuid:3a69355a-51d7-4207-943f-57a03f855d04?collection=research>

Vidimce, K., Kaspar, A., Wang, Y. & Matusik, W. (2017) *Foundry: Hierarchical Material Design for Multi-Material Fabrication*  
Massachuttes Institute of Technology

## SUMMARY

AM is a production process that fully embraces the digital environment in which its models are being made. The technology has a lot of potential and makes designs accessible that were before out of reach for most applications. Mostly because of the 'free' complexity that requires more knowledge from the designer but can vastly improve the products. The only thing is that AM is not fully accepted in the built environment. The small localised application that is the aim of the research is perfectly suited for the current capabilities of AM and use it in such a way that the parts become better and smarter. This can in time make AM more acceptable for the building industry. Especially combined with the constant development of the available polymers for AM.



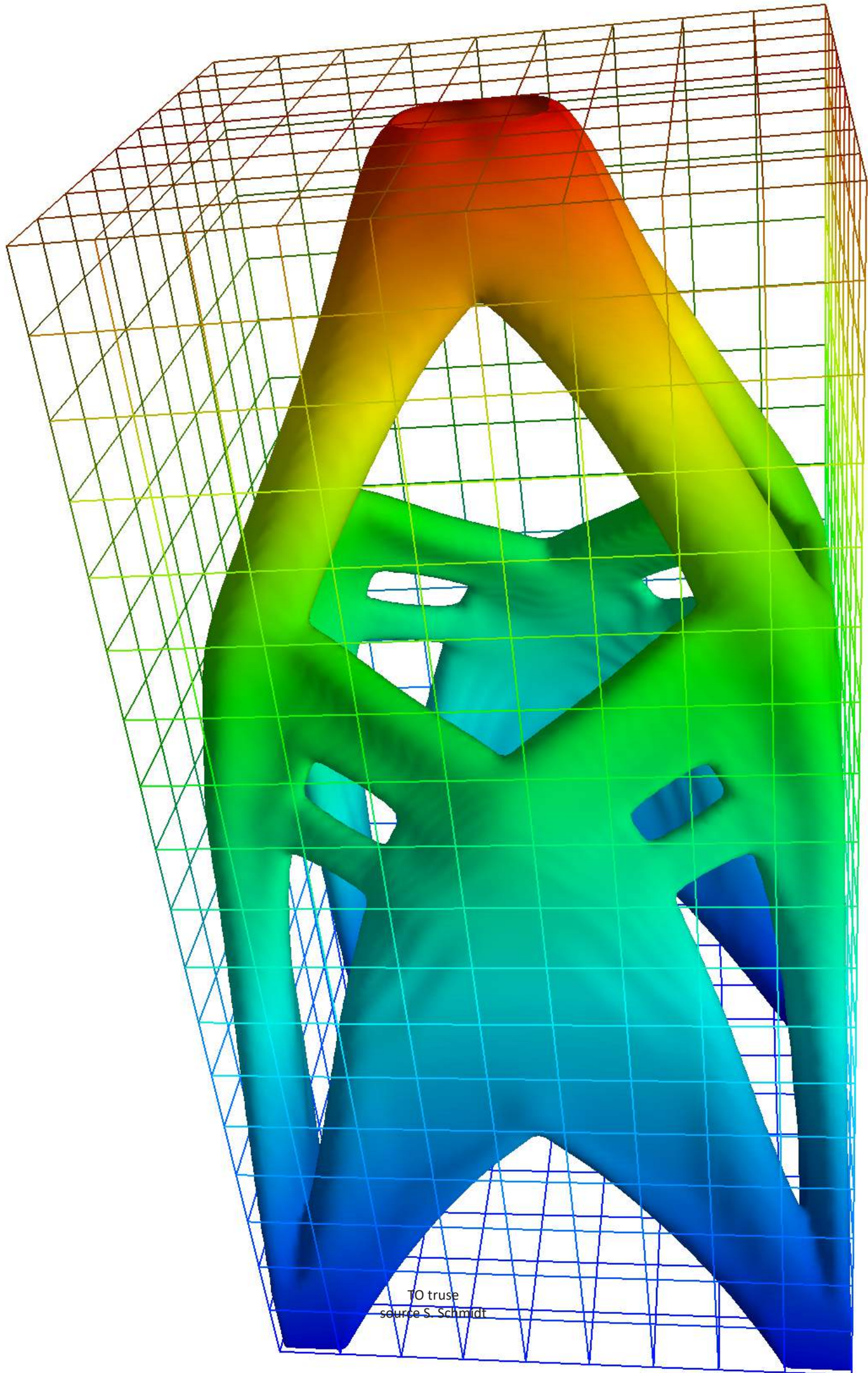

TO truse  
source S. Schmidt





# Topology Optimization



# 4

## Topology Optimization

Topology optimization(TO) is the most commonly used way of structural optimization. This method uses computer aided design to find the most optimal shape for a structure to sustain the loads that are working on it(Christensen, P. & Klarbring, A. 2009). This optimal shape can be influenced by the designer when the parameters are changed. These parameters can be defined as a design for maximum stiffness or minimum weight. The input can also be a variable in that case the parameters are the material properties or different load cases. All these parameters will determine what the optimal result is and what boundary condition should be maximised or minimised. This should then result in the 'best' result with the parameters and boundary conditions because it meets the set criteria.

What makes this method special is that it doesn't take in account how the product will look like and what it might cost because TO is limited to the structural aspects. The effect of this is that you will get a mathematically driven designs that can look very organic and are ideally suited for additive manufacturing(Keulen, F., Langelaar, M. & Baars, G. 2015). A example of this design process can be seen in the design for a chair in figure 4.1.

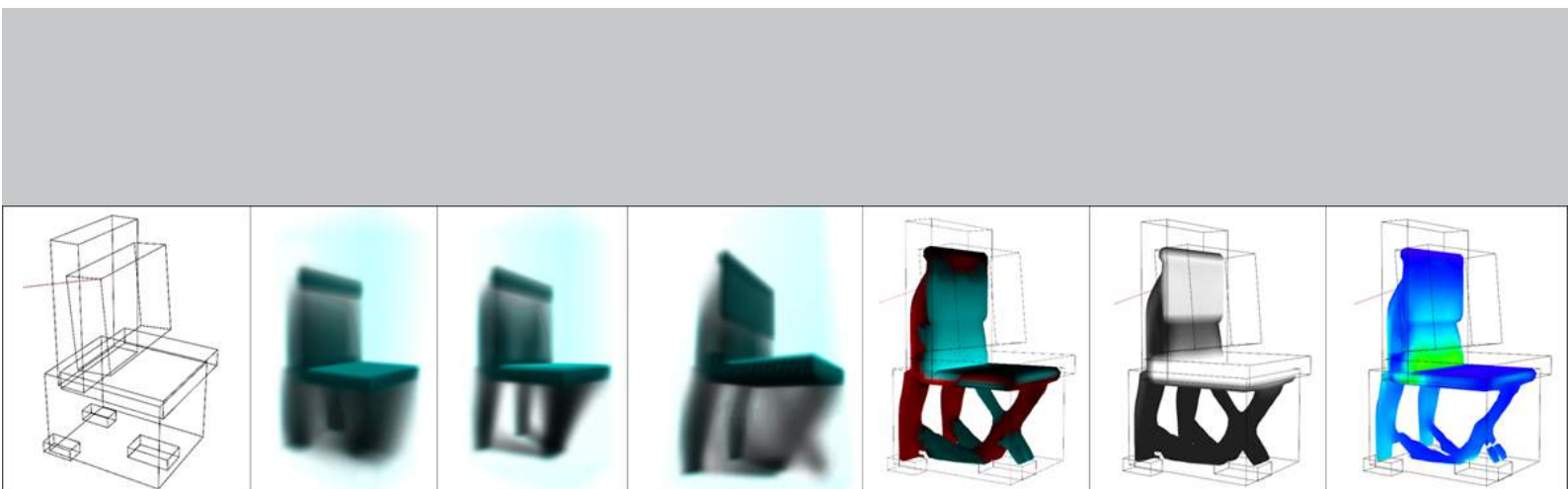

Figure 4.1 - Images of a topology optimization process for a chair.

# 4.1 The mathematics for structural optimization problems

A structural optimization problem usually consist out of three parts, one function and two variables. These elements are always present in these problems(Christensen, P. & Klarbring, A. 2009). These elements are then defined as follows.

Objective function(f):

This is the function that is used to classify or rate the design, because for every version of the design it creates a value that says something about the quality of the design. For example if you want to minimize the weight the value for f should be as low as possible

Design variable(x):

This is a function or vector that describes the design, which can be changed during the optimization process. This can represent the geometry or choice of material. When it is used to describe the geometry it can relate to a sophisticated interpolation of shape, or it can be as simple as the area of a bar, or the thickness of a sheet.

State variable(y):

For the given question x, y is a function the represents the response of the structure. This may represent the displacements, stress, strain or force

$$(SO) = \begin{cases} \text{minimize } f(x, y) \text{ with respect to } x \text{ and } y \\ \text{subject to } \begin{cases} \text{behaviorial constraints on } y \\ \text{design constraints on } x \\ \text{equilibrium constraint} \end{cases} \end{cases}$$

A structural optimization problem can have multiple objective function's, that would then look like as follows:

$$\text{Minimize } (f_1(x,y), f_2(x,y), \dots, f_\infty(x,y)),$$

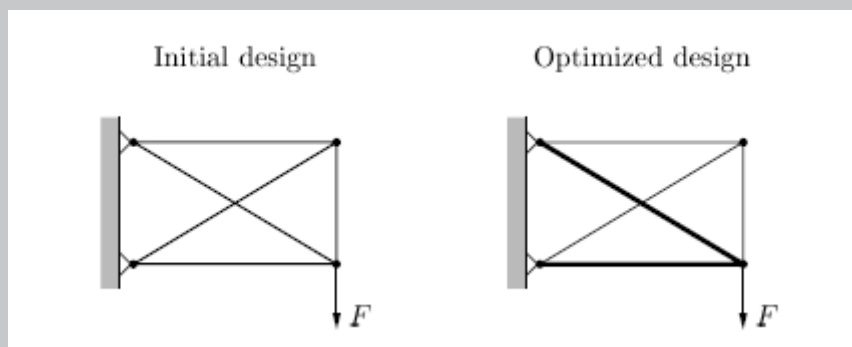

Figure 4.2 - sizing optimalization

For equations like these the number of objective functions, the constraints are the same as for (SO). The problem is that not all objectives can be satisfied so typically one would try to achieve a so-called Pareto optimality; this is a design where there is no other design that satisfies all the objectives better.

## 4.2 Types of structural optimization

There are three main types of structural optimization and these types are defined as followed by Christensen & Klarbring;

### **Sizing optimization:**

This optimization approach uses the variable of structural thickness and the dimensions as a design variable, this can be the cross-sectional dimensions of truss members or the thickness of different parts of a plate

### **Shape optimization:**

For this method the variable is the shape of the boundary of the structural domain, while keeping the same shape and maintaining the same connectivity of the structure.

### **Topology optimization:**

This is the most commonly used form of structural optimization. In this case this is done by making the geometry a discretization of the design domain, and applying values of 0 to 1 into these elements and taking away elements with low value. In short, this means that topology optimization only places material where it is most useful to achieve the objective.

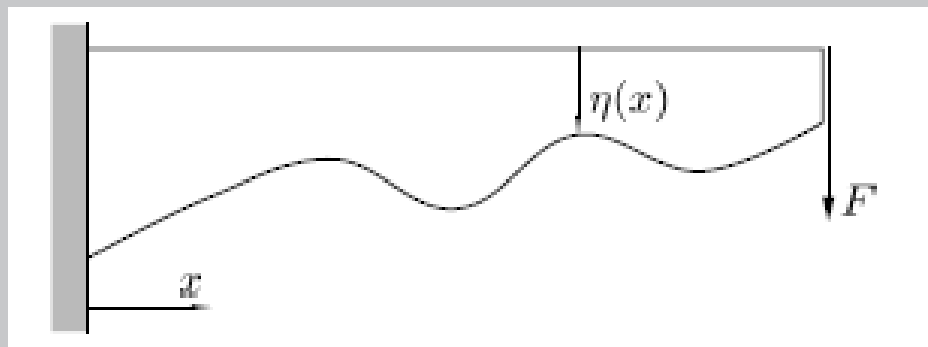

Figure 4.3 - Shape optimization

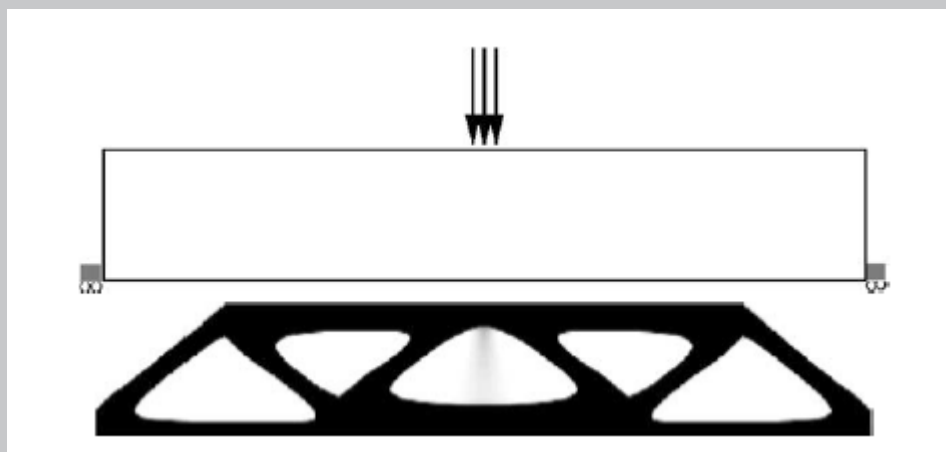

Figure 4.4 - Topology optimization

## 4.3 Method of topology optimization

Topology optimization is the most general and most used form of structural optimization, it studies the topology of structures. This method turns a given design domain into a finite element mesh with a state value, which describes if the part consists of material, void or an intermediate. This is done with taking in account predefined loads, boundary conditions and additional design restrictions as predefined areas for holes for connections.

TO is mostly used in the early phase of conceptual design. Because the optimized topology that can be found relatively quickly for a specific design problem. The results that can be found this way only need to be translated by the designers and engineers to the specific design context and manufacturability. Over the years there are several methods for the TO process developed by researchers (Pryudhi, B. 2016):

### 1 Homogenisation

This method is used for a more generalized topology and works by defining the optimal porosity of the elements. This then creates micro voids in the elements which in turn determine the porous elements which then creates a linear elastic structure. If part of the porous elements are only voids there will be no material placed in that location. If there is no porosity that part is defined as a solid material (Lundgren, J. & Palmqvist, C. 2012).

### 2 Solid Isotropic Microstructure with Penalisation

This method is based on the assumption that each element contains an isotropic material with a variable density. The elements are used in a way that the density of the material is the main design variable. Each element is visualized with a value between 0 to 1, or white, shades of grey and black. The elements with no density are represented as white what in turn implies the removal of the element. This process is then executed with a penalization with a power law interpolation to penalize the intermediate densities so that there will be one solution with only 0 and 1 in the material distribution. By varying the penalization parameter the amount of grey material can be influenced. This is done by creating a proper black and white solution which is the best from an engineering standpoint (Lundgren, J. & Palmqvist, C. 2012).

### 3 Evolutionary Structural Optimization

This is a very commonly used method that works with the assumption that a structure will develop towards an optimum if the stressed elements are removed in every iteration. This means that it should start with over dimensioned structure in which the least used elements can be removed. These underutilized elements are determined by comparing the local von Mises stress to the maximum von Mises stress in the structure as a whole. This process is repeated until it is no longer possible to remove any elements within the rejection ratio (Lundgren, J. & Palmqvist, C. 2012).

### 4 Level set

This is usually a method that is applied for shape optimisation but it can also be applied for topology optimisation if the boundary surfaces and lines are allowed to take new shapes. This method works by changing the boundaries of the domain. These boundaries are changed by adding or removing material in respectively areas with low or high stresses (Lundgren, J. & Palmqvist, C. 2012).

## 4.4 Topology optimization software

To actually apply TO a number of different software packages have been developed. These software packages all use one or more of the previously described methods of TO. This is just a brief summary of a few of the many programs that can be used for TO. With each their own up and down sides and requirements of other programs.

### 1 Millipede

This is a program is a structural analysis and optimization plug-in for the parametric modelling plug-in grasshopper for Rhino. The basis for this program are a couple of very fast structural analysis algorithms for linear elastic systems. The optimization algorithms in this program work with the homogenization method. With the speed that is built in this plug-in it works really well with Galapagos the evolutionary optimization algorithm tool in grasshopper. What is one of the major benefits is that the program is free for non-commercial usage.

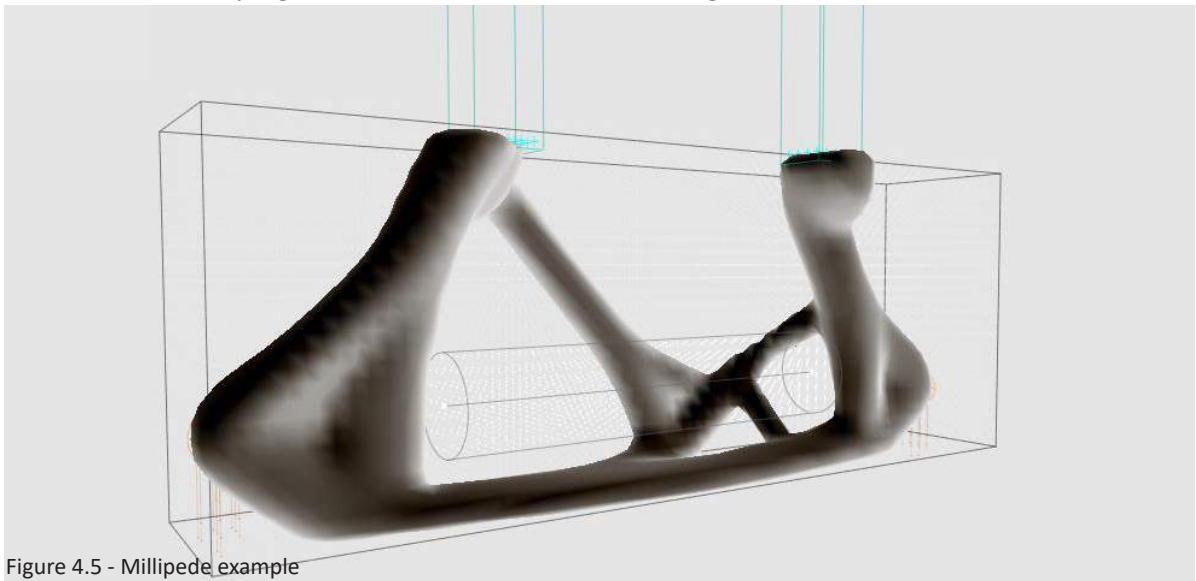

Figure 4.5 - Millipede example

### 2 Beso3D

Is a program based on the BESO method for topology optimization which has been developed by researchers of RMIT Australia. BESO3D can be used for 2D and 3D structures. Again the software is free for non-commercial usages and comes with a number of standalone programs and plugins for different software packages.

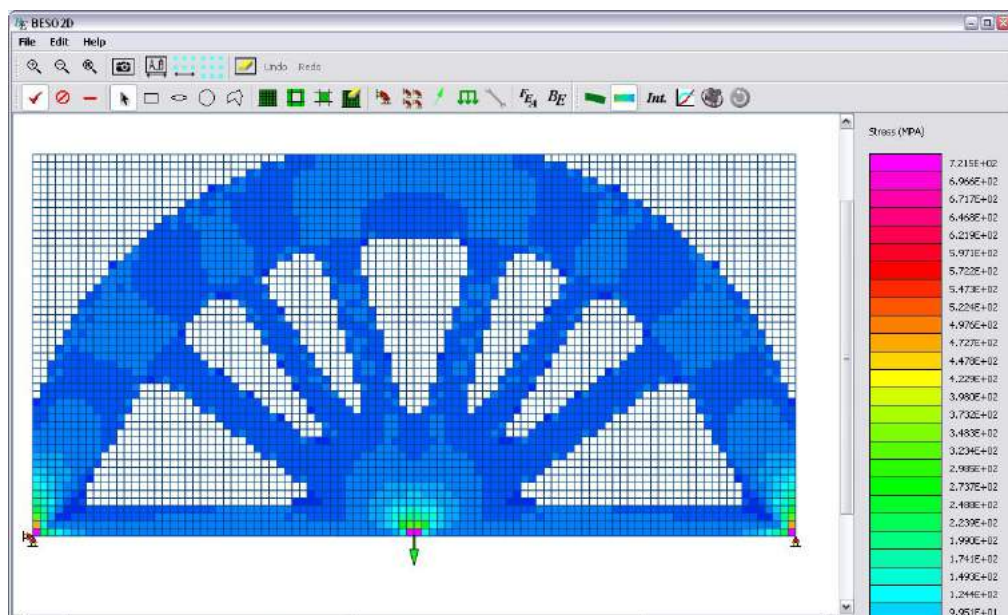

Figure 4.6 - Beso 3d example

### 3 ANSYS topology optimization

ANSYS is the maker of the world leading engineering simulation software which works with the help of Finite Element Models. In their latest update of their software package they now also included an additional option for topology optimization. This TO option works within the ANSYS 18 workbench. The great benefit of this is that within the same software all other calculations can be done as well like the verification of the design. The only downside for ANSYS is the steep price of the software package.

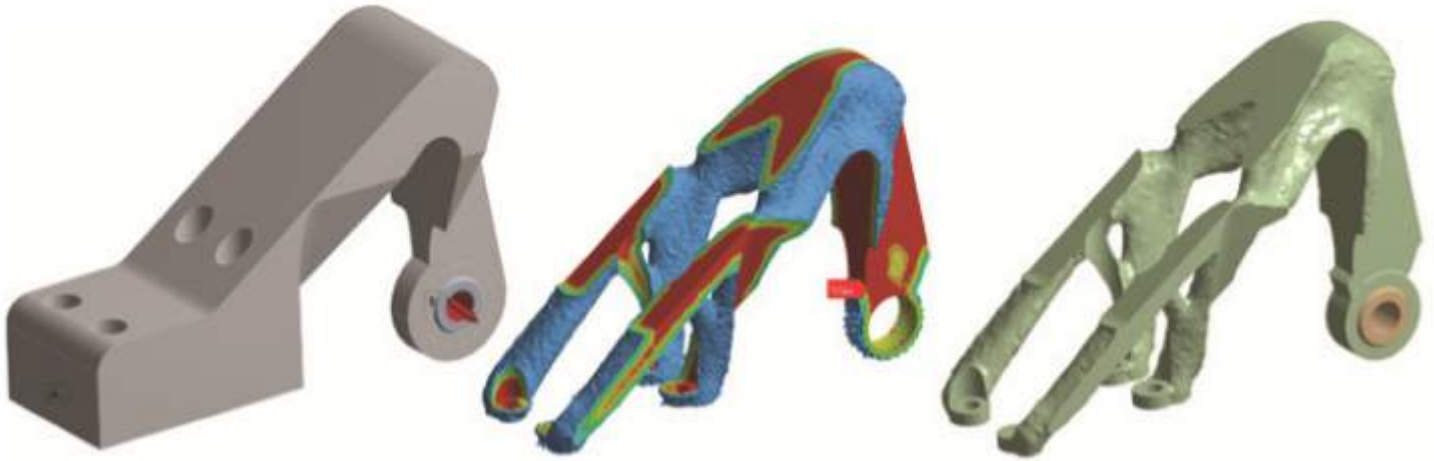

Figure 4.7 - ANSYS example

### 4 Altair Optistruct

This is a structural analysis solver for linear and non-linear design questions with dynamic and static load cases. The program works within the Altair Hyperworks environment which is also used as the mesh engine. Optistruct can use multiple optimization methods namely the SIMP and Level Set method for wide ranges of optimization questions. The software even allows the designer to work with manufacturing constraints like extrusion direction, pattern repetition and symmetry constraints what makes this a very complex but useful program.

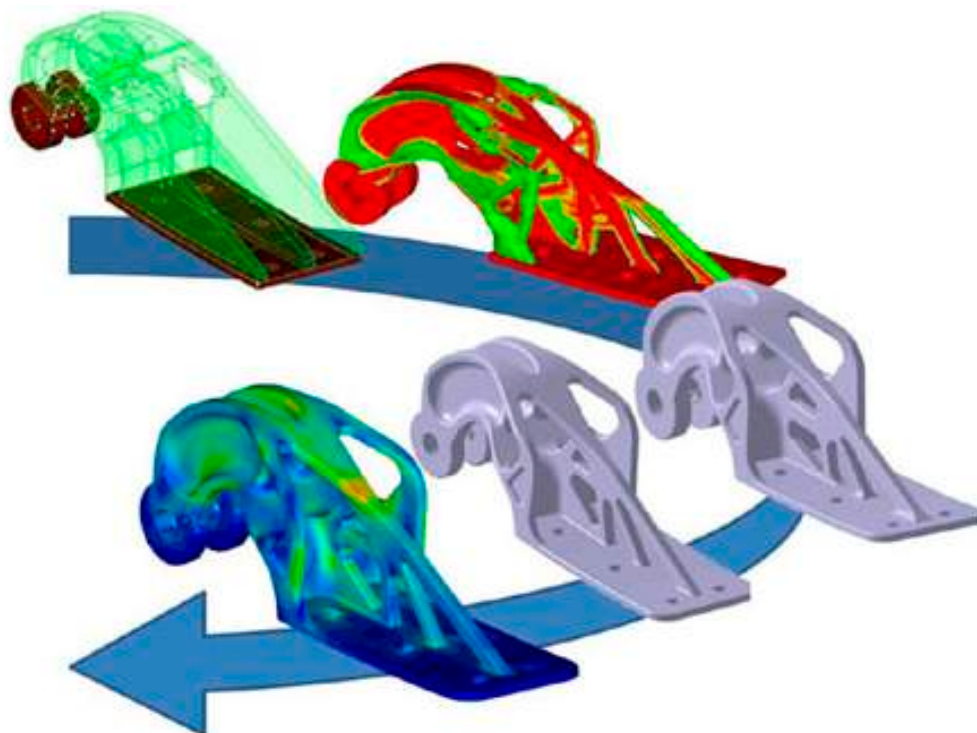

Figure 4.8 - Altair Optistruct example



## 5 SolidThinking Inspire

This piece of software is also developed Altair and uses similar algorithms as Optistruct. What makes Inspire different is its audience because it is developed for designers that are not very familiar with FEM analysis tools. Its goal is to find quick design solutions with topology optimization that can be checked by engineers in a later phase of the design process. Because the software is developed by Altair it has a lot of manufacturing constrains that Optistruct has as well.

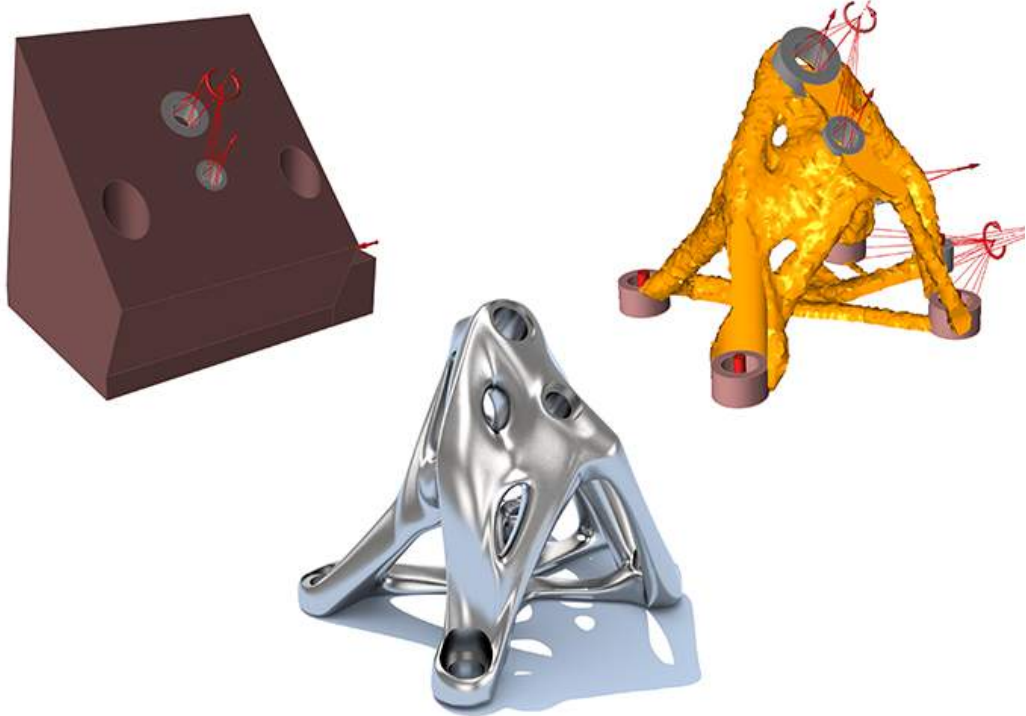

Figure 4.9 - SolidThinking Inspire example

## 4.5 References

Christensen, P. & Klarbring, A. (2009). *An introduction to structural optimization* (first edition) New York:Springer

Pryudhi, B. (2016). *3F3D: Form Follows Force with 3D printing* (Master's thesis, Technische Universiteit Delft, Delft, The Netherlands). Retrieved from <http://repository.tudelft.nl/islandora/object/uuid:b068f81c-1561-4733-a07d-05e60368184b?collection=education>

Langelaar, M., & Keulen, F. (2015). *Topology optimization. A natural counterpart of additive manufacturing*. TU Delft Lecture Notes.

Lundgren, J. & Palmqvist, C. (2012) *Structural Form Optimisation*. (Master's thesis, Chalmers University of Technology, Göteborg, Sweden). Retrieved from <http://publications.lib.chalmers.se/records/fulltext/162939.pdf>

## SUMMARY

Topology Optimisation is an ideal way to make more efficient shapes that are optimized for one or more specific parameters. This technique is now more interesting than ever. That is because of the combination with additive manufacturing which makes it more feasible to manufacture these complex shapes.

Currently there are still a lot of different methods and programs that can be used for Topology Optimisation. And it is up to the designer to decide which one works best for their project.



Sketch design  
First 1:5 model



**Design  
Research:  
The additive  
manufactured  
glass connection**



# 5

## Design research The additive manufactured glass connection

Before the new glass connection can be realised it should first be designed and engineered. In this chapter the theoretical knowledge will be put to use to see if it is feasible to make this AM glass connection. This will be done in a couple of phases; First the boundary conditions will be defined, The first digital models will be selected and analysed on criteria as there dimensions and contact points, after that a scale model will be made to see how well the elements can be produced with AM Than the best model will be adapted for it intended purpose and calculated to show that it can be done and finally a prototype will be made. All the steps in this research are aimed to create the best possible glass connection with AM. While taking in to consideration aspects as cost, current and potential AM technology, material and the ease of building.

### 5.1 Schematic design and boundary conditions

The goal of this design is to make a new and improved glass connection based on the spider glass connection(As seen on page 31). This new profile should make optimal usage of the potential of AM. That potential will be used by making use of TO the find the optimal shape for the new connection.

The glass panel that will be used is 1,5 x 1,5 meters and consists of two laminated panes of 6 mm. The glass plate is situated on a height of 15 meters facing the dominated wind direction in Delft which is Southwest(<https://nl.windfinder.com/windstatistics/delft>). For the calculations a rectangular setup will be used which has supports on the corners and will be loaded perpendicular to the plain to the glass plate. The prototype that will be made for this project will be based on these calculations. For the final prototype the joint at the corner of four glass plates will be made, because it show cases the potential for free form façades. Which could become cheaper when AM is used for the joints.

#### 1 Connection type

The decision was made to start from the spider profile. That is because this connections has the potential to be optimized in another material, because the connection has stayed the same since its introduction in the late 80's. A other factor for selecting this connection was the high cost and complexity of making the spider free form(Straus, H. 2013). While at the same time reducing the amount of material that is used for the connection.

#### 2 Additive manufacturing strategy

For the additive manufacturing the choice was made to work with FDM printers (As seen on page 46). These kind of printers are the most broadly adapted AM technique what makes them very interesting. Because they are so widely used there is a very broad range of available materials. These materials have then the most potential for a application like the AM joint.

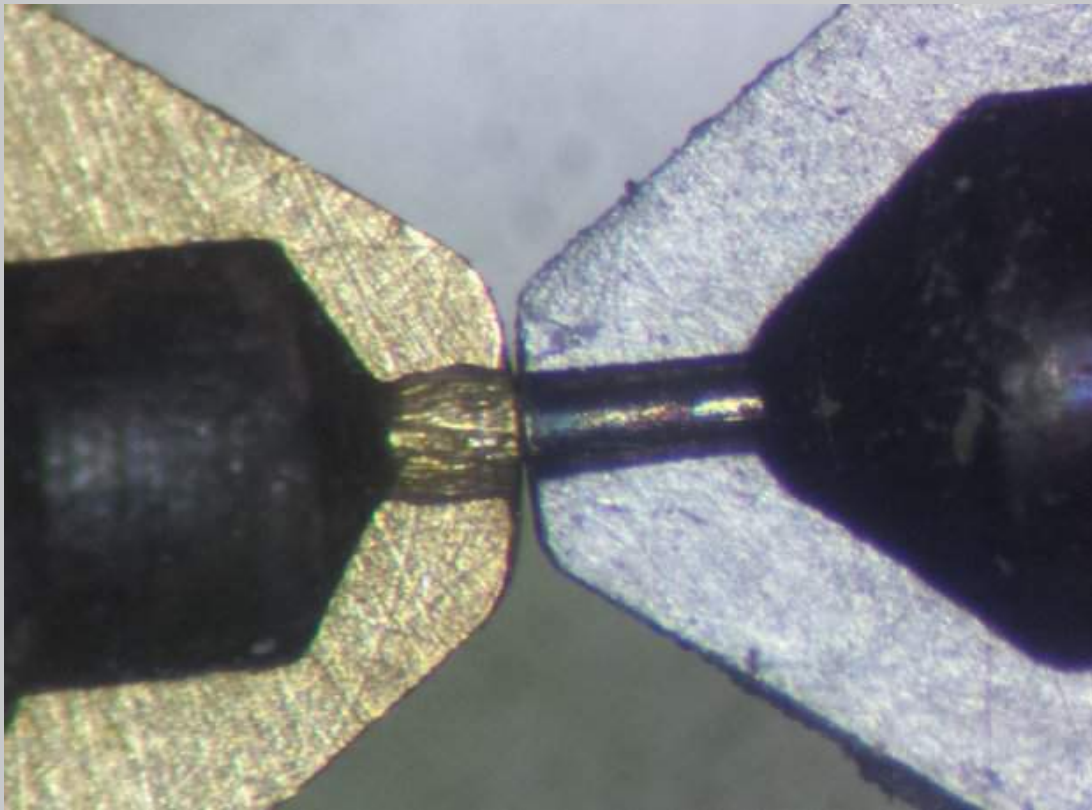

Figure 5.1 - On the left a brass nozzle and on the right a steel nozzle after printing carbon fibre

## 5.2 Design strategy

### 1 Material

The material that has been selected for this prototype is a co-polyester based on Polyethylene terephthalate (PET) with 20% short strain carbon fibre with a random distribution. This material is from ColorFabb and is called XT-CF20. Because of the earlier mentioned weakness in connection layers (Page 49) the strength in the Y-direction is assumed to be 1/3 less than that of the X-Y-direction. The used material properties are retrieved from the manufacturer's data sheet and CES Eductack are as follows:

Density		1.35	g/cm <sup>3</sup>
Max tensile strength		76	MPa
Elongation at break		7,5	%
Flexural strength	X	110	MPa
	Y	110	MPa
	Z	73	MPa
Flexural modulus	X	6,2	GPa
	Y	6,2	GPa
	Z	4,1	GPa
Poison ratio	xy	0,33	%
	Yz	0,33	%
	Xz	0,33	%
Shear Modulus	xy	2,4	GPa
	Yz	1,6	GPa
	Xz	1,6	GPa





Figure 5.2 - Example of a spool of XT-CF20 and a part made with the same material

The second material that is used is also a co-polyester from Colorfabb, but this material has flexible properties. It will be used to create the hinges to accommodate expansion of the glass plate. The used material properties are retrieved from the manufactures data sheet and CES Edupack are as follows:

Density		1.13	g/cm <sup>3</sup>
Max tensile strength		22	MPa
Elongation at break		400	%
Flexural Modulus	X	150	Mpa
	Y	150	MPa
	Z	100	MPa
Poison ratio	xy	0,33	%
	Yz	0,33	%
	Xz	0,33	%
Shear Modulus	xy	50	GPa
	Yz	33	GPa
	Xz	33	GPa

The material properties of the carbon fiber filament have been tested before and proven to be correct (Bayu 2016). Although in practice the material properties of material depend highly on the AM machine that has been used and the settings of the AM software that controls AM machine.

The new connections will be laminated to the glass with Dow Corning® Transparent Silicone Structural Adhesive (TSSA). The only downside for this way of connecting the components is that TSSA has not been approved to be used in Dutch buildings because the life expectancy of the connection has not been guaranteed up to 50 years. The glass panel with its connecting elements will be connected to the building with a M10 nut and bolt. This connection will than be fixed with a bolt and a washer to protect the plastic to divide the pressure of the connection better.

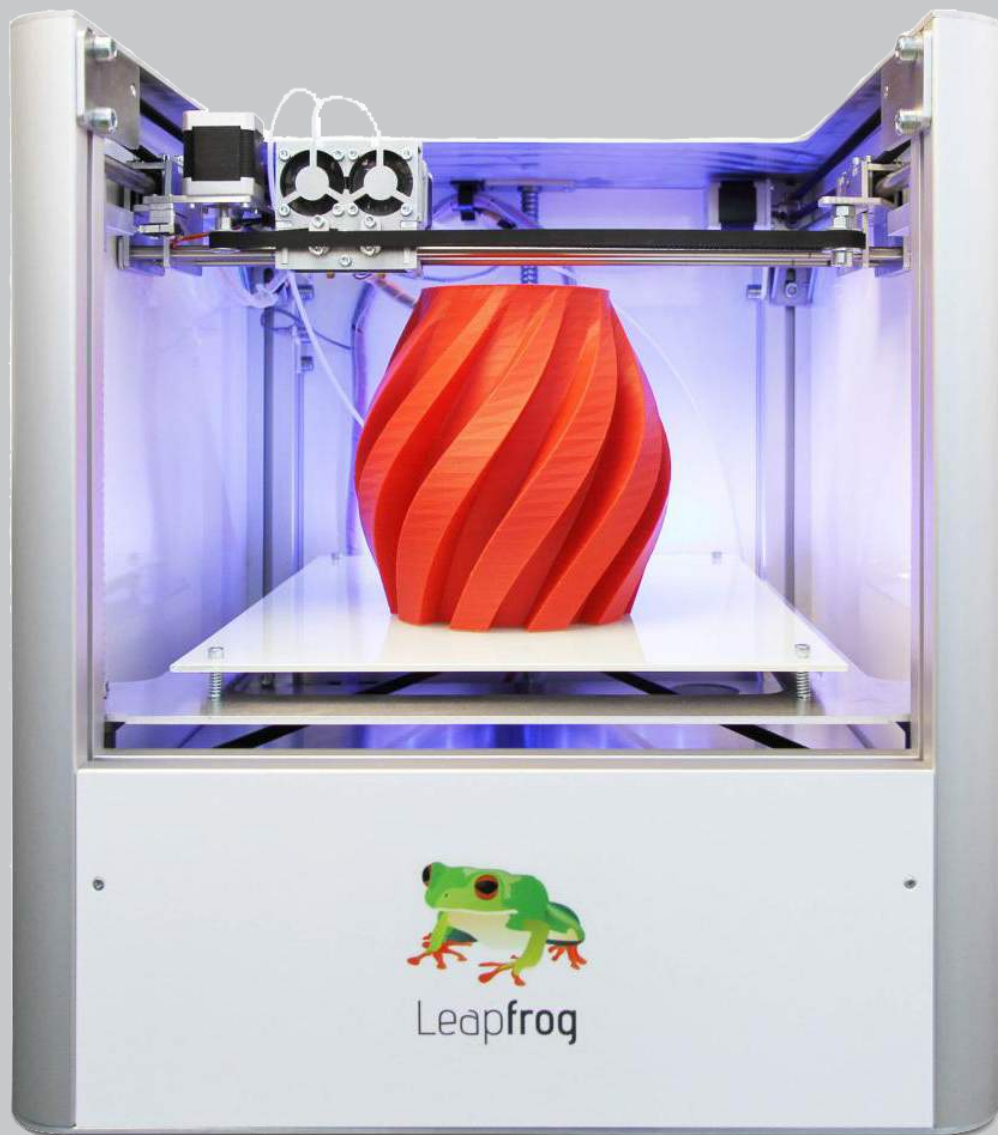

Figure 5.3 - one of the used AM-machines(Leapfrog Creator HS)

## 2 Printer

For the prototyping two different AM machines have been used. The first 3D printer that has been selected for this project is an Leapfrog Creator HS 3D printer. This machine has a build volume of 280x270x180 mm and will be used for the smaller parts. The second machine is a Lockess reptile with a build volume of 365x397x325 mm on this machine the bigger parts were printed. Both of these machines were adapted to print the reinforced PET with carbon fiber. This is necessary because of the higher temperatures that are needed to properly print PET with carbon fiber compared to normal PLA. These printers have also been fitted with stainless steel printer head, this is necessary because of the wear on the nozzle from the carbon fibre reinforcement what is highly abrasive on the normally used brass extruder nozzles.

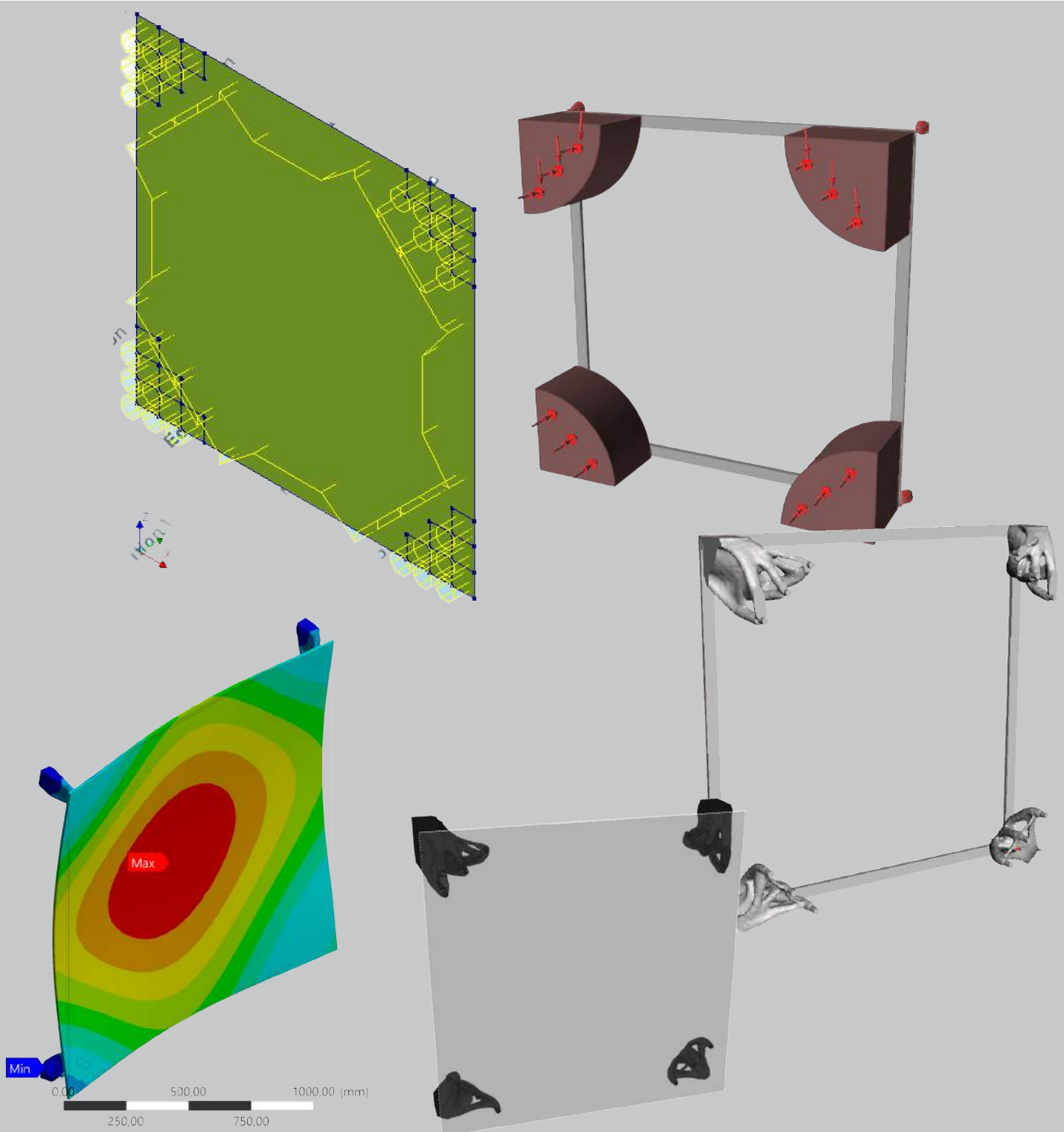

Figure 5.4 - Overview of the different steps in the design process

### 3 Topology strategy and validation

For the design of the connections TO will be used. This will be done with Inspire this very user friendly TO program will need a couple of things before it can work. It will need its input data like the different loads, design space, its constraints for the connections so it can deal with the loads, and the points that will function as the glass connections on which the loads will be placed. This first calculation to determine the loads per contact point will be done with Diana. Then the shape will be determined in Inspire as mentioned before. Finally the whole system with all connections and parts will be calculated in Ansys to check if the façade can function as a whole. The final calculations are done with Ansys because Ansys has the option to calculate composite materials which are usually anisotropic what means that they have different strengths in different directions. When these calculations are done a prototype will be manufactured and assembled to showcase the functionality of the connection. This process will be described in more detail the next part of this chapter.

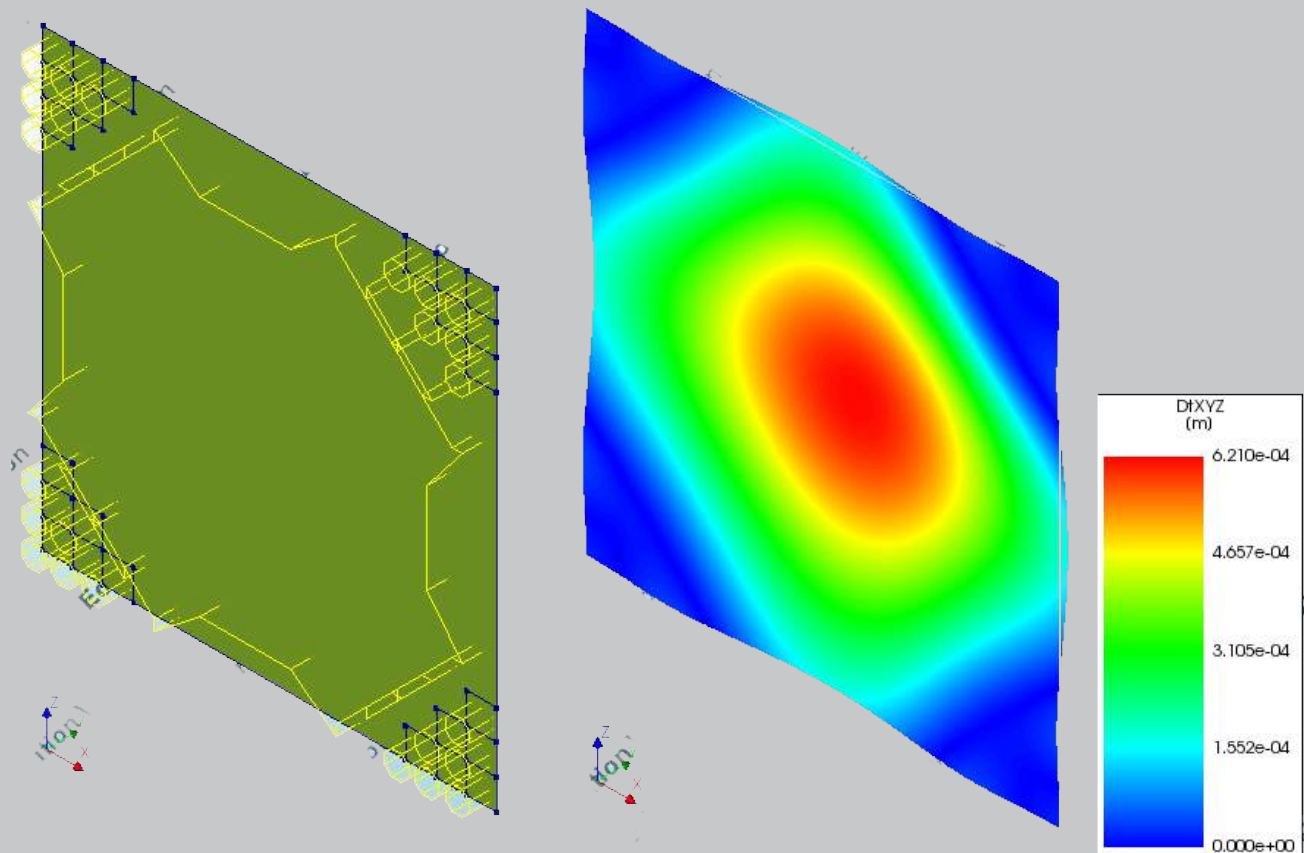

Figure 5.5 - Set up of Diana model and deflection output of Diana model.

## 5.3 Design development

The dimensions of the glass plate and location constraints where the given design input. For the design space and glass connection points were generated by the designer. These manual steps were necessary to create a model that could be used for topological optimization. The results from the topological optimization could then be used for FEM calculations and finally 3D printing.

### 1 Creating mechanical input

To create the mechanical input for the topological optimization a number of assumptions were made about the dimensions of the design space, the glass contact points, and the shape of the design space. This was done by making models of the glass plate which was supported where the glass should be connected to the profile. One of these models can be seen in Figure 5.5. This resulted in a number of load cases for the topological optimization model. These results and models can be seen in paragraph 5.3.3 Validation of possible designs.

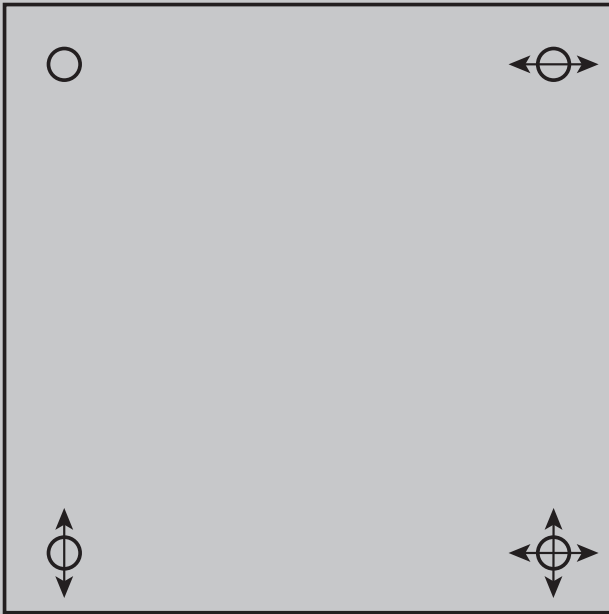

Figure 5.6 - Freedom of movement in for the glass plate

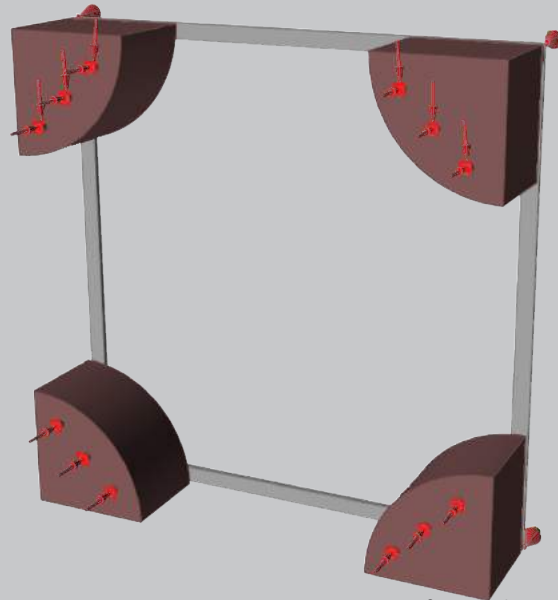

Figure 5.7 - Set up for topology optimization

## 2 Set up of topology model

The topological model that was used consisted out of a frame on which the design space would be placed. In the design space a number of cylinders were placed to simulate the actual connection to the glass. This frame was supported as a real façade panel would be. The top left corner is fixed, the top right corner can move horizontally, the bottom left corner can move vertically and the bottom right connection is free to move in all directions this can be seen in Figure 5.6. The set ups that was used for the actual topology optimization in Inspire can be seen in Figure 5.7. The dark red areas are the design space where inspire will remove the material. The arrows that are being placed on these dark red areas represent the forces that are working on the spiders.

### 3 Validation of possible designs

To find the most suitable connection for the final design a great number of possible shapes and dimensions for the joints were researched. The data of these connections is presented here. The names for the models are build up as follows. The first number is the radius of the design space. The next part is the number points that connect the joint to the glazing panel. Where the last part describes how the points are related to each other. For these panels the maximum deflection can be  $l/200$  what for the span of 1.5 meters results in maximum deflection of 7.5 millimetres. These computer models were used to get a better understanding of the forces that would work on the connection if it would have multiple contact points. The deflection values are only a indication.

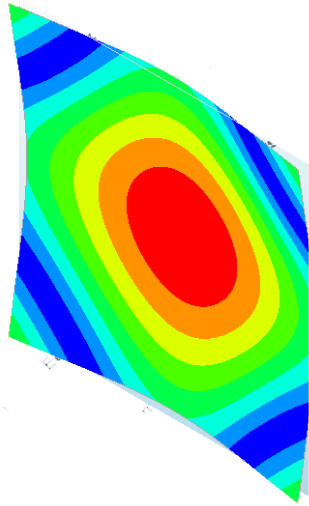
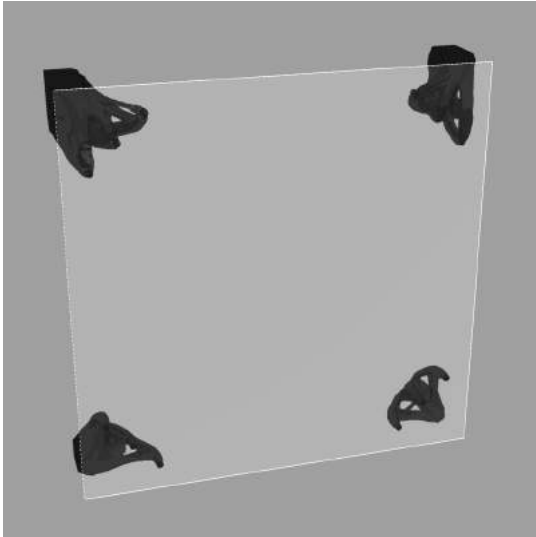

375 3p straight  
Reaction forces:  
119N, 72N, 119N

Maximum deflection:  
0.0001631 mm

Minimum deflection  
0 mm

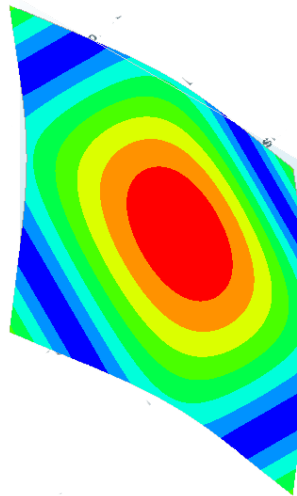
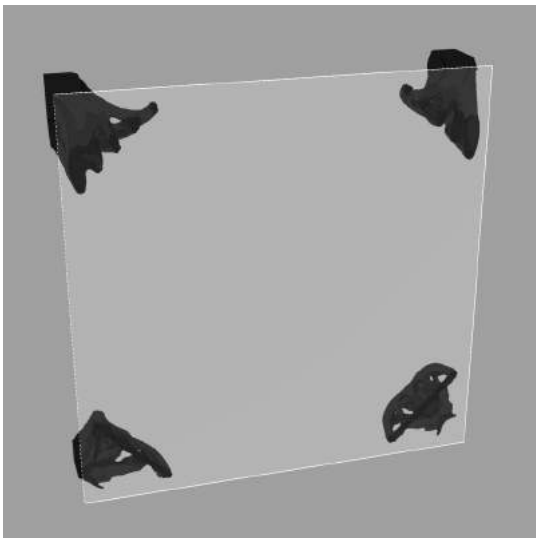

375 5p straight

Reaction forces:  
111N, 28N, 75N, 28N, 111N

Maximum deflection:  
1.5 mm

Minimum deflection  
0 mm

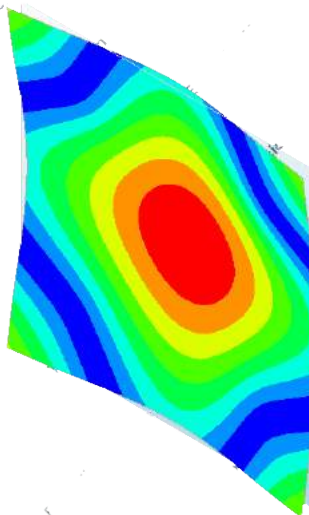
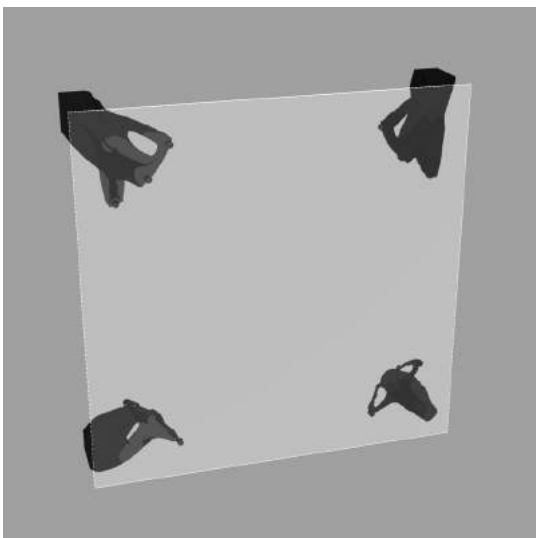

375 3p concave

Reaction forces:  
13N, 340N, 13N

Maximum deflection:  
0.6 mm

Minimum deflection  
0 mm

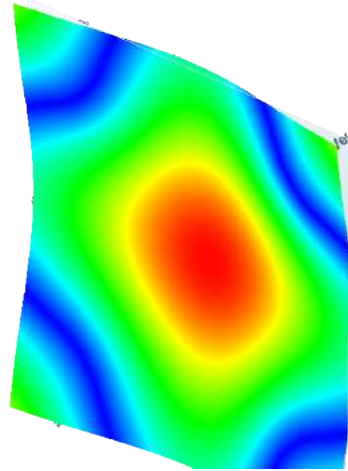
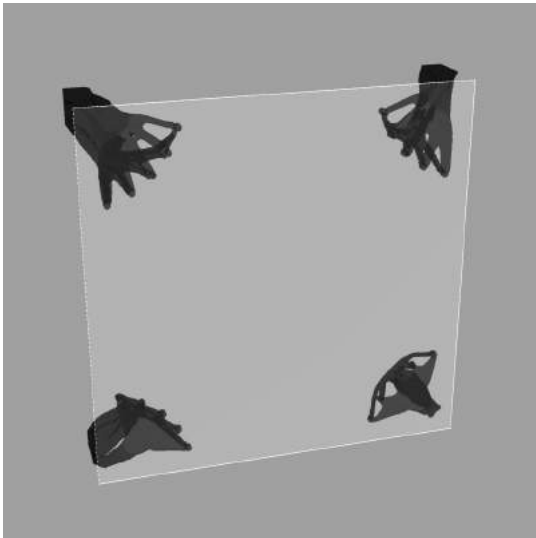

375 5p concave

Reaction forces:  
-107N, 214N, 89N 214N, -107N

Maximum deflection:  
0.6 mm

Minimum deflection  
0 mm

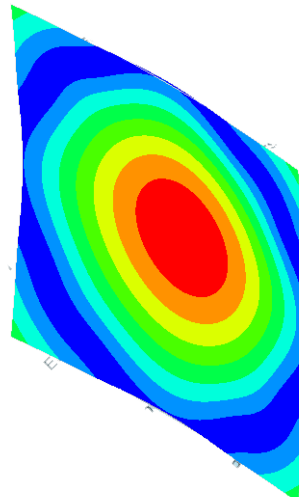
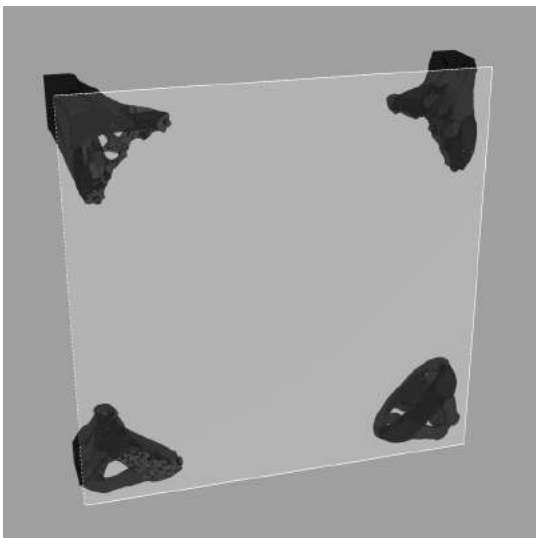

375 5p convex

Reaction forces:  
342N, -218N, 52N, -218N, 342N

Maximum deflection:  
0.8 mm

Minimum deflection  
0 mm

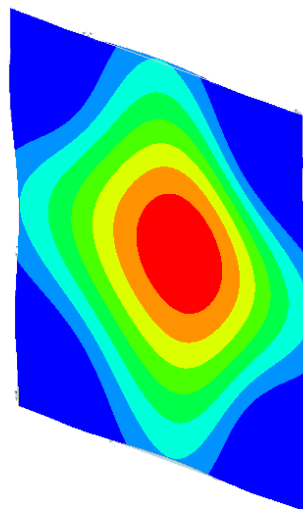
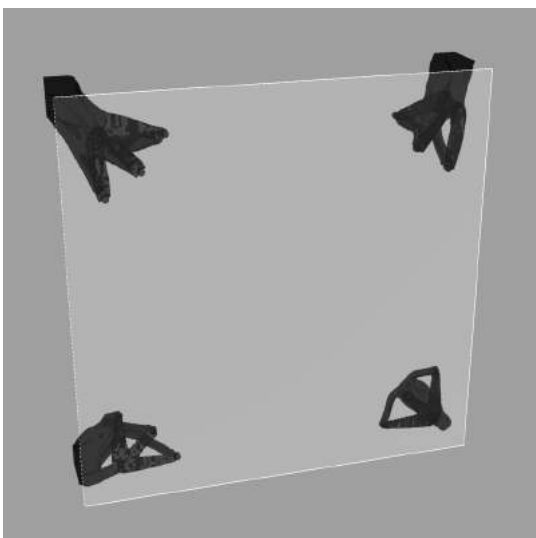

375 4p concave with center

Reaction forces:  
135N, 201N, 135N, centraal -154N

Maximum deflection:  
0.37 mm

Minimum deflection  
0 mm

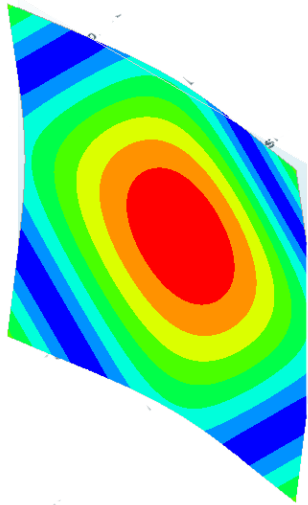
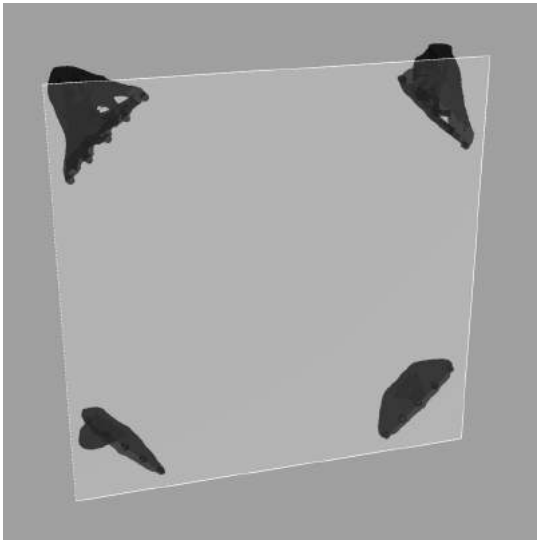

375 5p straight straight

Reaction forces:  
111N, 28N, 75N, 28N, 111N

Maximum deflection:  
1.5 mm

Minimum deflection  
0 mm

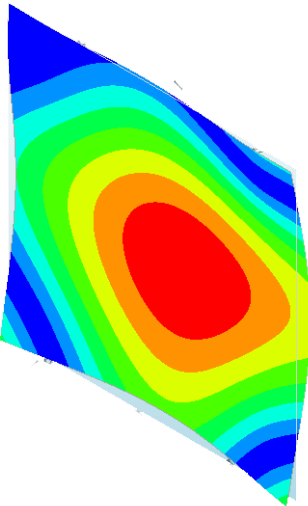
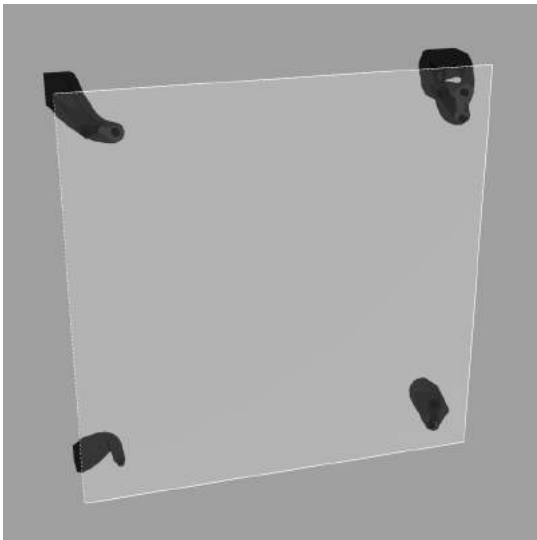

375 1p-3p variabel

Reaction forces:  
960N, -700N, -778N  
-700N, 353N  
353N, 700N  
353N

Maximum deflection:  
1.7 mm

Minimum deflection  
0 mm

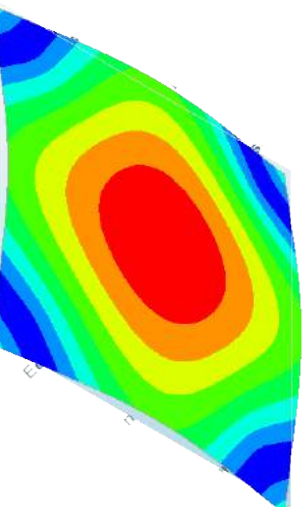
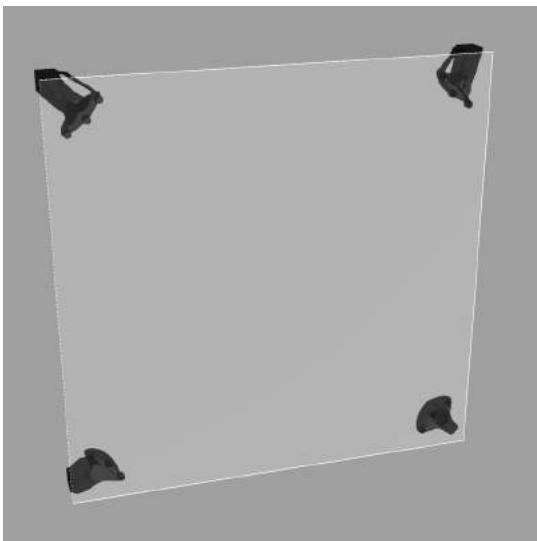

190 3p concave

Reaction forces:  
605N, -1547N, 605N

Maximum deflection:  
2 mm

Minimum deflection  
0



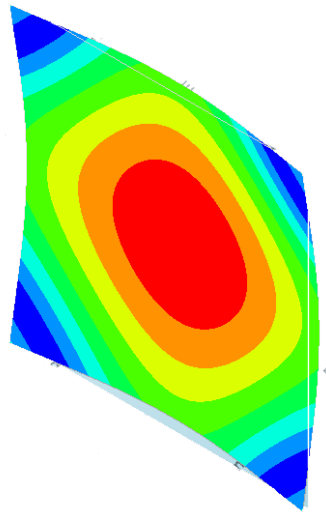
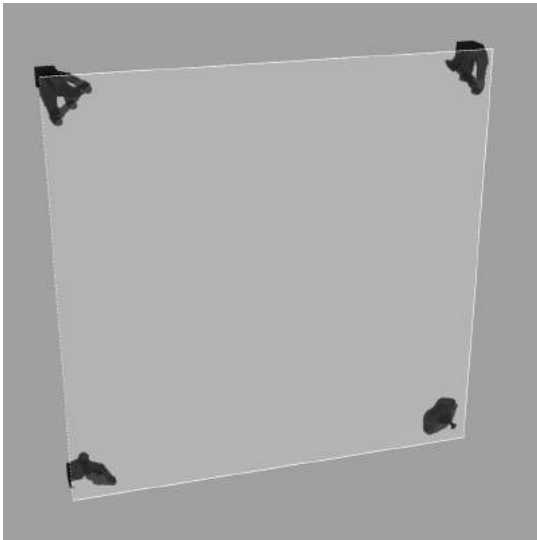

190 3p straight

Reaction forces:  
-280N, 255N, -280N

Maximum deflection:  
3.3 mm

Minimum deflection  
0

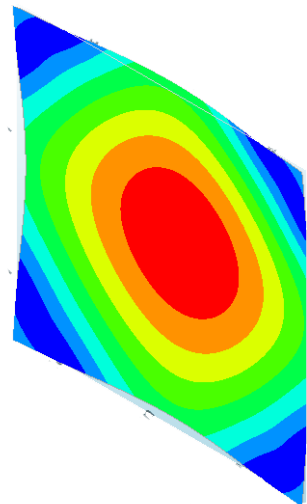
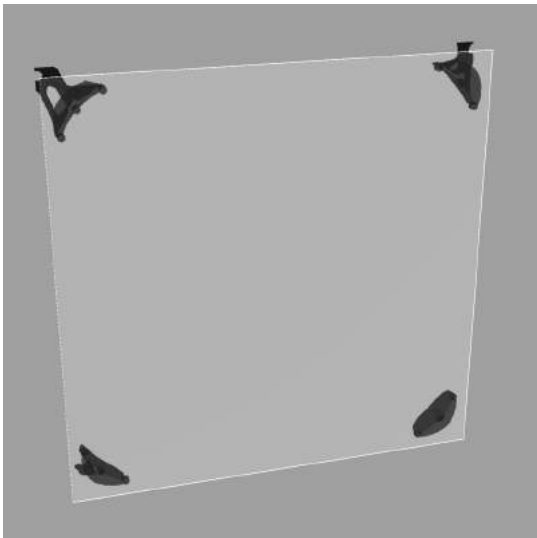

190 3p convex

Reaction forces:  
-680N, 1071N, -680N

Maximum deflection:  
2 mm

Minimum deflection  
0 mm

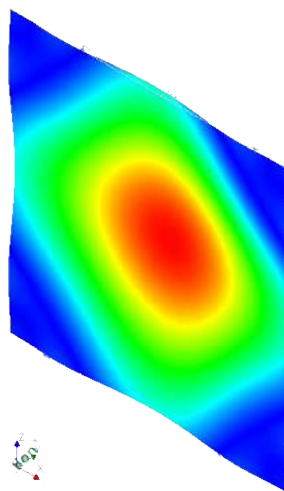
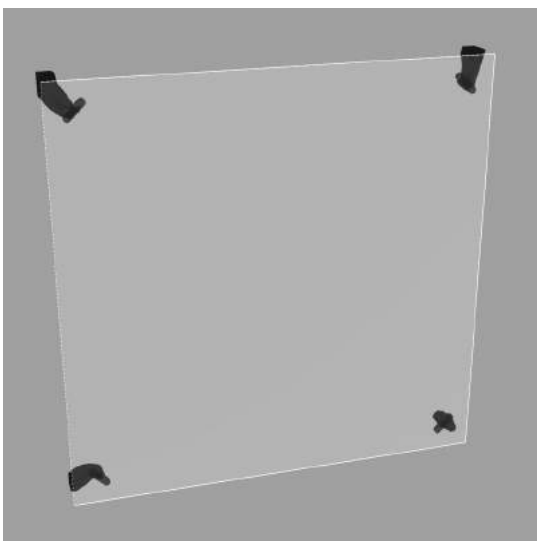

190 1p line

Reaction forces:  
309N

Maximum deflection:  
0.6 mm

Minimum deflection  
0 mm

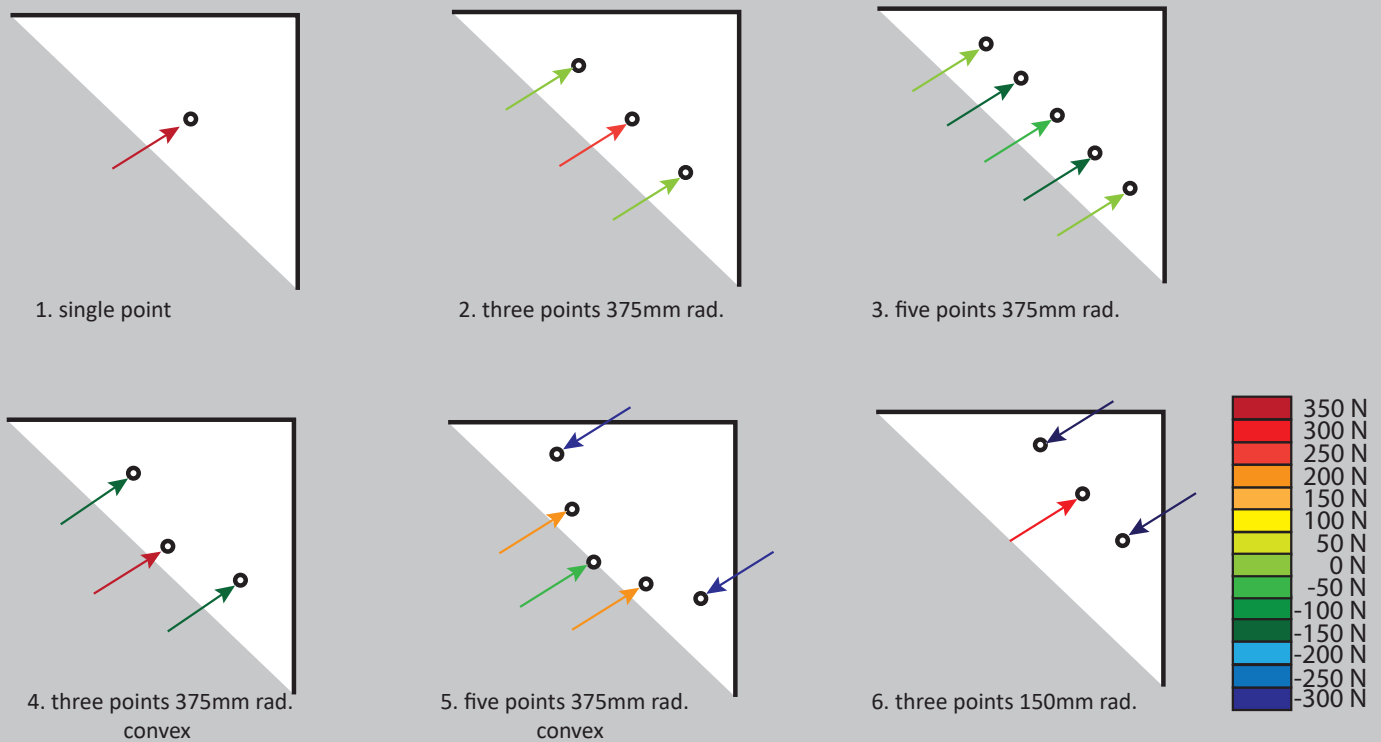

Figure 5.8 - Schematic representation of the contact points where additional forces are generated in the profile from drawing 3 to 6.

During the analysis of the designs some thing interesting became clear. That was that the introduction of multiple contact points to glass plate did not result in reduced stress in the connecting parts. Instead the points are so close together that additional moments between the contact points were created. This is most noticeable when the contact points do not form a straight line. Examples of this can configuration been seen in Figure 5.8.

This analysis had a substantial impact in the selection of the designs that would be developed further. Because the original strategy of having more contact points that would better spread the forces from the glass to the profile would not work.

Two connections with potential were selected were the forces in the connection were the first selection criteria. The second selection criteria for these connections was the dimension of the joint which needed to fit in the available 3d printers. As the final criteria the weight of the connection was selected because that greatly influences aspects as price and print time for 3d printed parts.

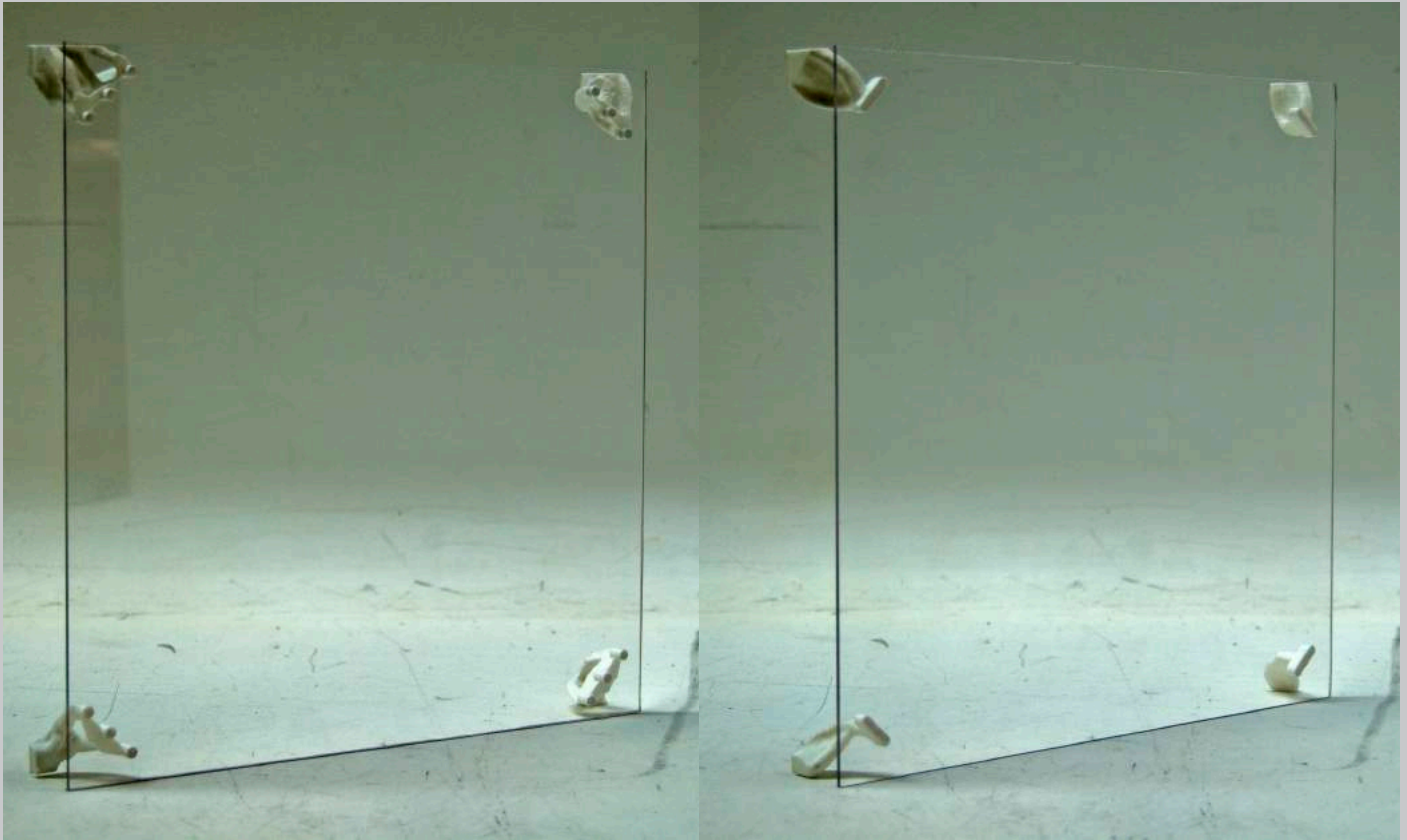

Figure 5.9 - 1:5 models of the selected connections

### 3 Validation of possible designs

The first prototypes were made on a 1:5 scale. This was done to see how well the connections could be manufactured on a smaller scale. A secondary benefit of these scale models was that the elements could be connected to a plexiglass plate. That made it possible to notice some of the complications that could arise during the build process.

The scale models are made from one sheet of Vivak® of 300x300 mm. The profiles are made out of 3D printed white PLA plastic and have dimension of roughly 30x26x26mm. The elements were joined together with transparent Uhu® glue.

From these two the second model was easier and better to manufacture than the first one. That is why that model was selected to be developed further.

## 5.4 Engineering and calculating

When the most optimal shape was defined the given design should be adapted to become a suitable connection that could be used. To do that a number of problems needed to be solved like; the connection to the glass, how is the element connected to the structure, how the system should be assembled, and what could be done to accommodate the thermal expansion of the glass plate. All of these solutions have to be integrated into the designed joint for the system to function properly as a whole. These topics also need to be answered to make an accurate model that can be calculated with ANSYS to see what the deformation of this system is and how that deformation can be minimized.

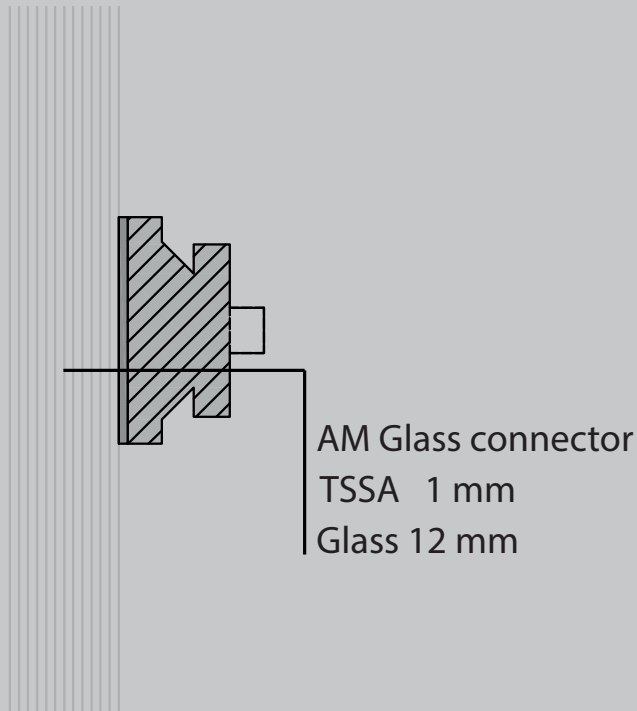

Figure 5.10 - Detailing of the glass connection

Figure 5.11 - Example of a TSSA bond

## 1 Glass connection

For this design the decision was made to go for a laminated connection to the glass. This connection would be made with Dow Corning® Transparent Silicone Structural Adhesive (TSSA). This is a high strength transparent silicone film of 1 mm. This material has to be cured off-site under heat and pressure in side of a autoclave to bond to the glass and the AM part. This material has a number of advantages compared to traditional ways of fixing glass to its support. One of the most interesting is that if the stress in the adhesive film exceeds its design values it will turn white until it fails. This is a good indicator if the connection is about to fail because normally the film is transparent.

Another benefit of this material is that has to be laminated so it is no longer necessary to drill the glass to create point fixings. This has as effect that glass plate won't be weakened by micro fractures caused by drilling the glass. This connection will make the system stronger and more durable. This way of connecting the glass has also the benefit that if it would be use with insulate glassing units the performance of these units is better because they are no longer penetrated by metal elements which create thermal bridges.

Laminating the glass has also a number of down sides. The biggest one is that the parts can only be bonded off-site. This means that the have to transported to the building site in there totality what influences the kind of connections that can be made to attach the façade to the building. The solution for this will be discussed later. The second down side is that if is very hard to separate the different elements when the façade is no longer needed. What makes it harder to properly recycle the different elements. This is especially true for the AM parts which will be hard to separate from the silicone. Which could otherwise be recycled to make new filament.

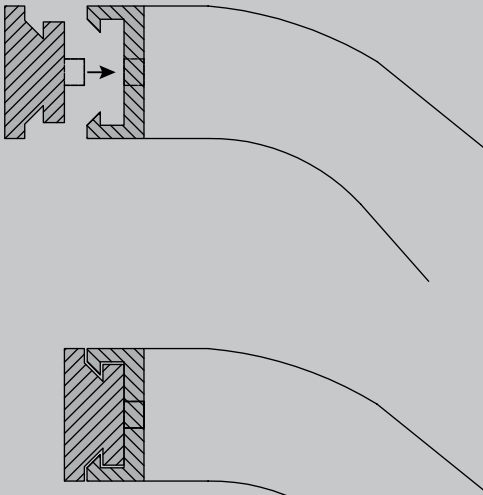

Figure 5.12 - Detailing of the structural connection



Figure 5.13 - prototypes of the structural connection

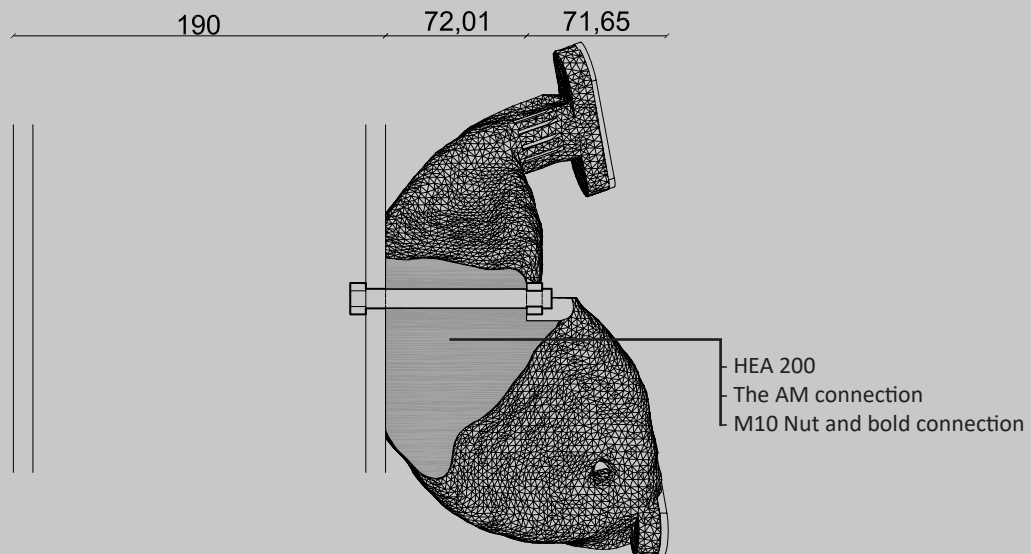

Figure 5.14 - Detailing of the connection to the structure

## 2 Structural connection

In the end the façade has to be connected to a structure to have any sort of function. For this first in co-polyester manufactured prototype the design decision was made to make individual profiles for the corners of the glass and these parts would be connected to the glass by lamination. This works for the prototype that consists out of one pane of glass. For a whole façade this was not a real solution. To solve this problem a 'snap-lock' connection was introduced. For which the first part would be bonded to the glass plate. The socket for this connection would be located in the main part of the AM connection. Now the connection can be connected to the building and in later stage of the building process the façade can be glaze relatively easily. This 'snap-lock' connection can be found in Figure 5.12 and 5.13 in which they are detailed and prototyped. A additional benefit of this connection is that the connection allows for relatively easy disassembly in case of breakage of one of the glass plates which can than be replaced.

The connection needs to have a connection to the supporting structure as well. That is the why the decision was made to integrate a hole in the AM part which can fit a threaded M10 rot or a M10 bolt. In this way the loads will be distributed evenly over al the connections and stress concentrations are avoided. This connection can been seen in Figure 5.14. The great benefit of this connection is that the AM connection will only need one bolt to be secured and that the glazing can be applied in a later phase of the project.

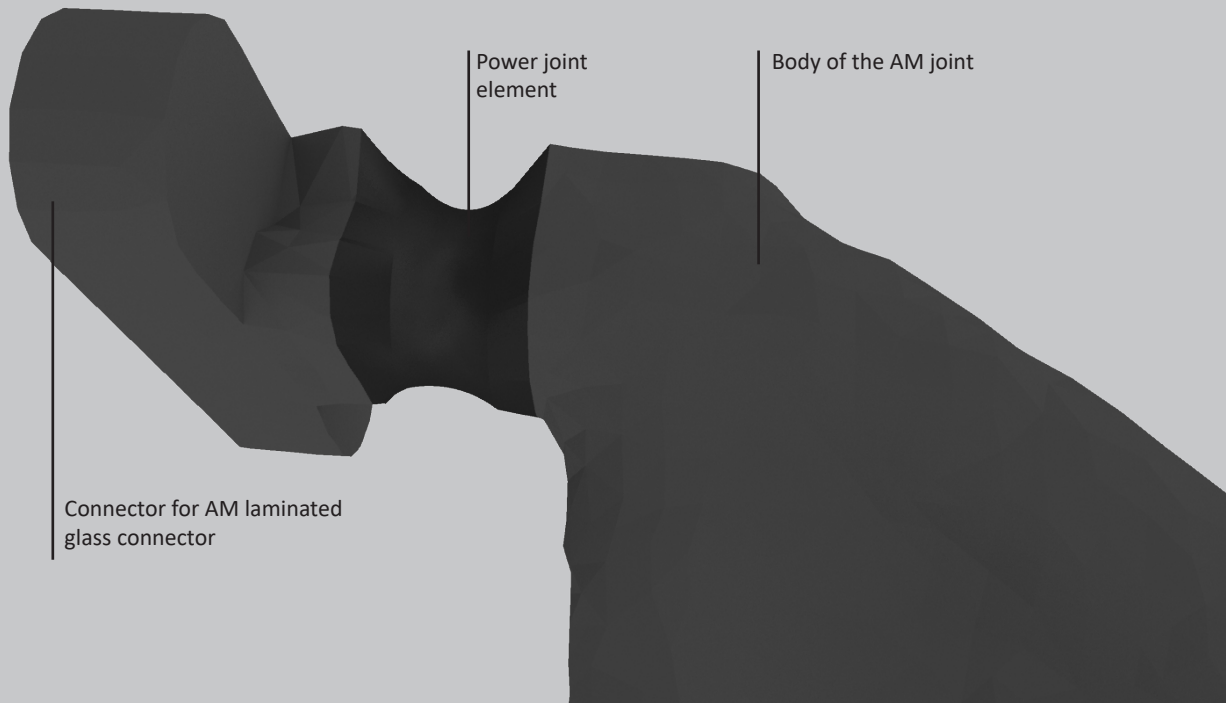

Figure 5.15 - Render of the power joint

### 3 Expansion of the glass panel

The glass panels that will be used are located in the façade so they are exposed to a broad range of temperatures. The glass panels respond to this by expanding in size at a linear rate of  $9,1 \mu\text{strain}/^\circ\text{C}$  (CES EduPack 2017) for example for steel this is around  $12 \mu\text{strain}/^\circ\text{C}$  (CES EduPack 2017). The expansion has to be facilitated, in current spider profiles this was done with oversized holes which allow for movement of the rotules. By using additive manufacturing you get the possibility to integrate this movement in the parts themselves. That is why three different options were calculated to see which gives the minimal amount of deflection. The first model was completely solid, the second model had a number of slots that allow for movement in different directions the third option has these slots filled with a flexible filament what should allow for the movement. The fourth option is a hybrid solution because some of the hinges work with slots which allow for movement in one direction the free moving joint has become a modern interpretation of what is called a “power joint”. The “power joint” has been used before in the Olympia park in Munich by Frei Otto (Otto, F., Nerdinger, W., Meissner, I., Barthel, R. and Bensing, C. 2015) but has not seen a lot of usage since then. All these options will be calculated to see the effects of using these different solutions for the problem of the deflection and expansion of the glass panel.

The “power joint” that has been designed for this AM connection should be printed at the same time on a dual extruder AM machine. This joint would be made with a flexible filament named nGen\_Flex that can be printed on all FDM printers according to the producer. This filament is rubber like material and by adapting the infill and number of outer shells the stiffness of the power joint can be determined. The proposed joint can be seen in Figure 5.15.

## 4 Calculating

For the validation four different models were calculated with the boundary conditions as earlier described. This is done with the help of ANSYS because this program lets you calculate anisotropic materials and composites like the materials that were used in this design. The results of these calculations will be presented here;

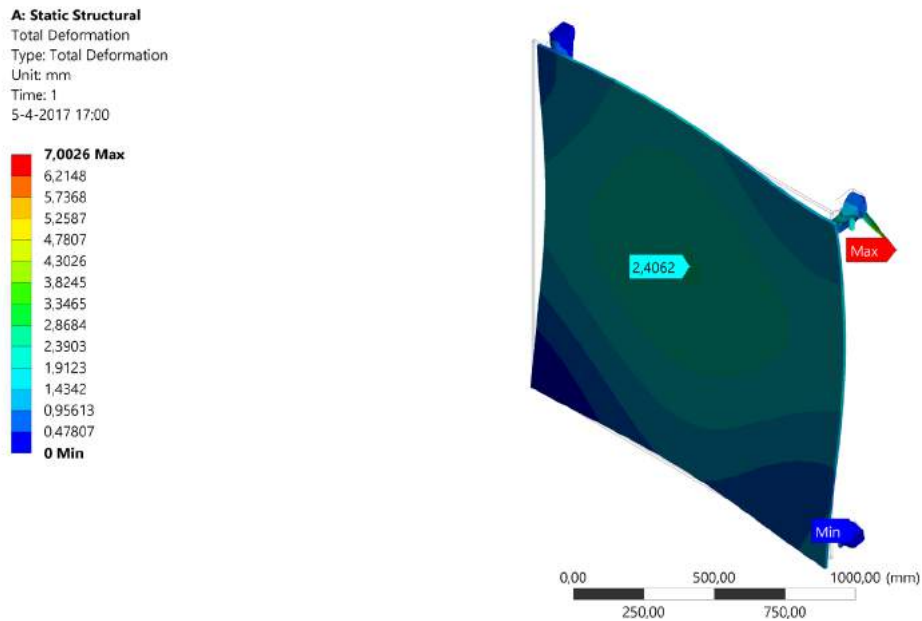

### Solid

The basis idea for this model was that the profile consisted out of one solid geometry. In theory this could work if the material was already flexible enough from its self. This turned out not to be true with only a very reasonable amount of deformation in the centre of the glass plate. The problem with this solution is that the steel rod that connects to the structure would have a deformation of more than 7mm. What is very problematic because this would destroy the profiles. This deformation occurs because the elements can not accommodate for the movement of the parts.

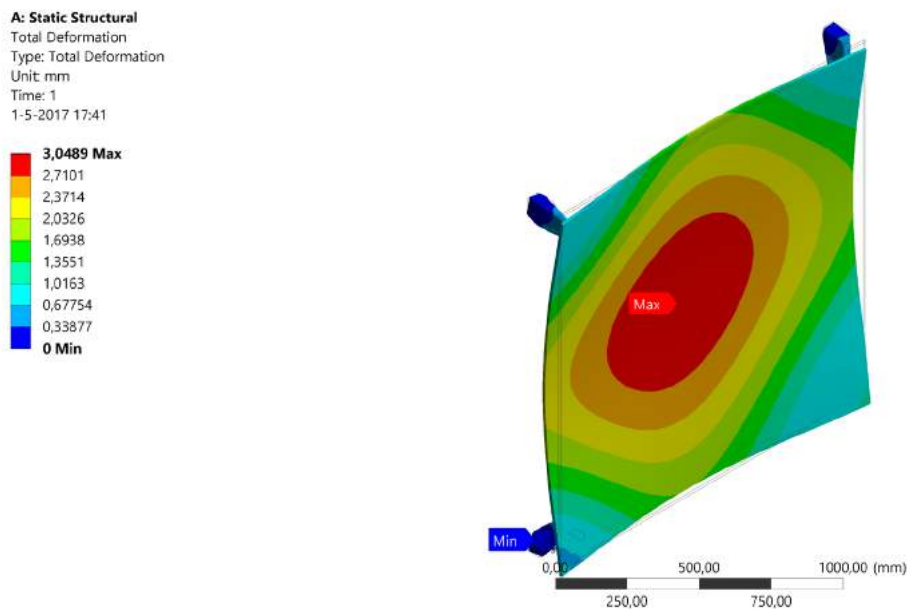

### Filled slots

In this model the connections have a number of slots with a width of 2 mm. That space is filled with the previously disused nGen\_Flex and should create a sort of hinges with in the structure. This system works but it results in bigger deformation of the glass plate although the deformation is still with in bounds with its 3.05 millimetres



**A: Static Structural**  
 Total Deformation  
 Type: Total Deformation  
 Unit: mm  
 Time: 1  
 13-4-2017 14:33

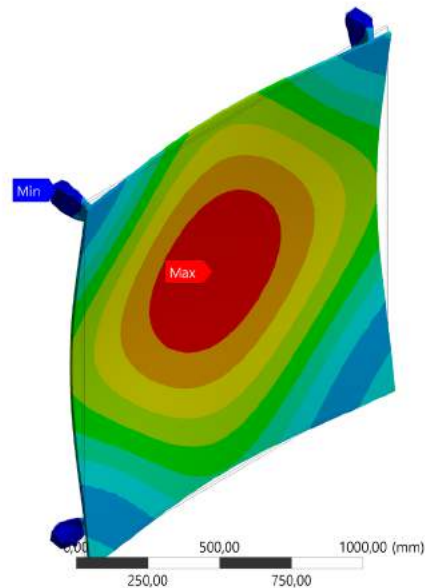
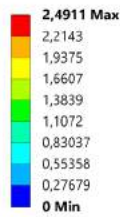

### Slots

This model unlike the previous model it does not have the slots in the spider filled with a flexible material. Because of this the joint can facilitate the movement better so the deflection of the glass plate as a whole is less in this case only 2.49 millimetres.

**A: Static Structural**  
 Total Deformation  
 Type: Total Deformation  
 Unit: mm  
 Time: 1  
 14-4-2017 12:12

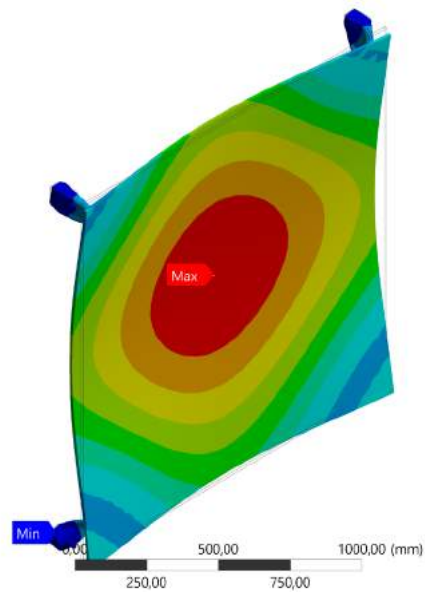
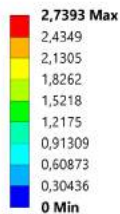

### Hybrid

The final model uses both the slots and the earlier mentioned power-joint. This was done to give the movement a more optimal way out that is more predictable. This can be seen in the slightly higher deformation of 2.74 millimetres. This is a good result and could be expected because it uses both design strategies.

## 5 Selection of design

From this comparison the conclusion could be drawn that the solution with the slots performed the best. Because it had the least amount of deformation in the glass plate. Not the least for this research and to test and showcase the full potential of additive manufacturing the hybrid solution is more interesting to be developed further. For both solutions the difference in maximal deflection is minimal with for the deflection being 2.49 millimetres and respectively 2.74 millimetres in the weaker model. What then results in deflection that is just 0.25 millimetres more.

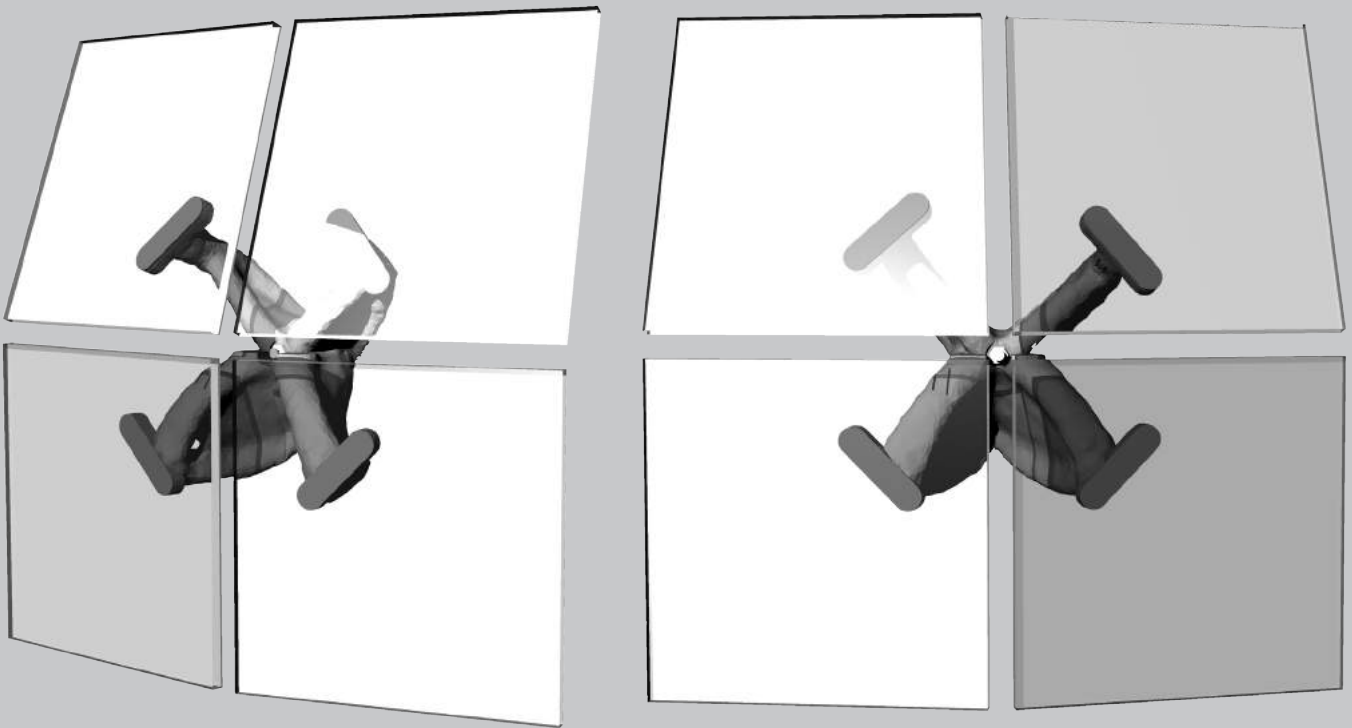

Figure 5.16 - Render of the first prototype

## 5.5 Construction of the prototype

For this research the previously describe system will be made in to a prototype. That prototype will be the spider profile on to which later the different glass plates can be fixed. A rendering of this prototype can be seen in Figure 5.16. The manufactured design will be a variation on the designed solution. Because of limitations of the available AM machines and materials.

### 1 Non AM-parts

The only Non AM-parts in this prototype are the glass plates and the silicone seal. The glass plates that are being used are 300x300 millimetres with a thickness of 5 millimetres. These plates have to be cut to size to properly fit on the AM profile. The other part the prototype that will be done during this process is the bonding of the AM parts to the glass. This was supposed to be done by laminating with TSSA but due circumstances the TSSA was no longer available. To solve this problem the decision was made that the parts would be glued with 3M Scotchweld 490 black. What is a two component epoxy glue that has been classified as a tough glue that can handle static and dynamic loads. The work that has been done in this phase of the production can be seen on page 91.

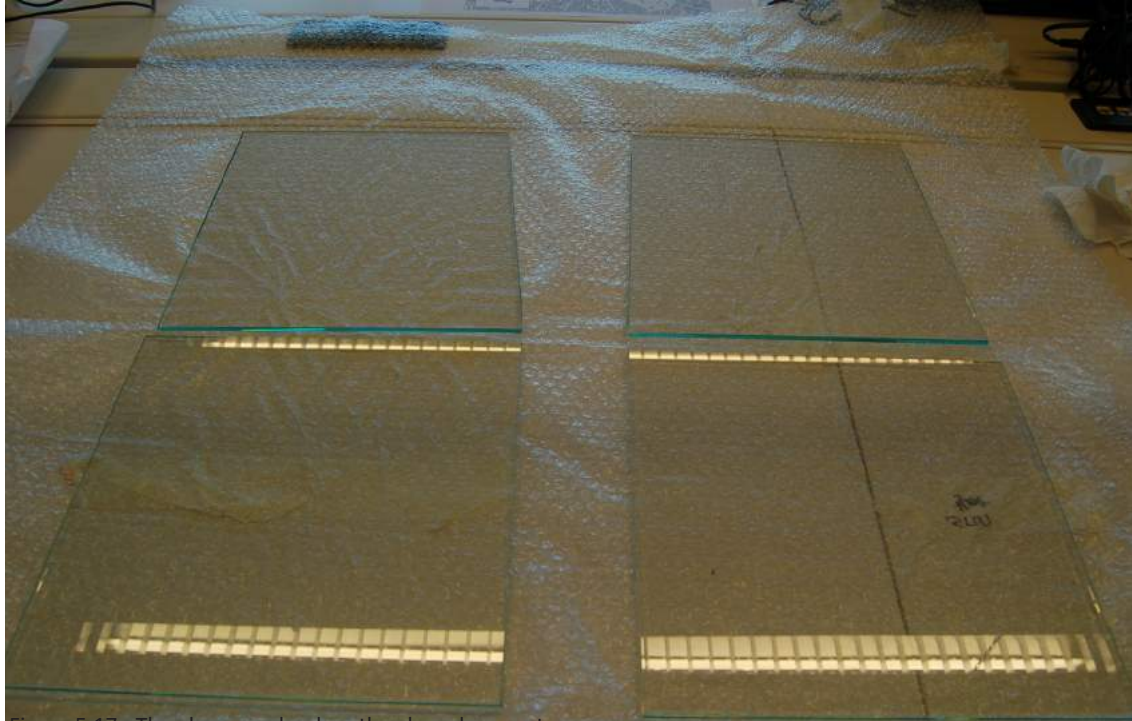

Figure 5.17 - The glass panels when they have been cut



Figure 5.18 - Glueing the AM parts to the glass

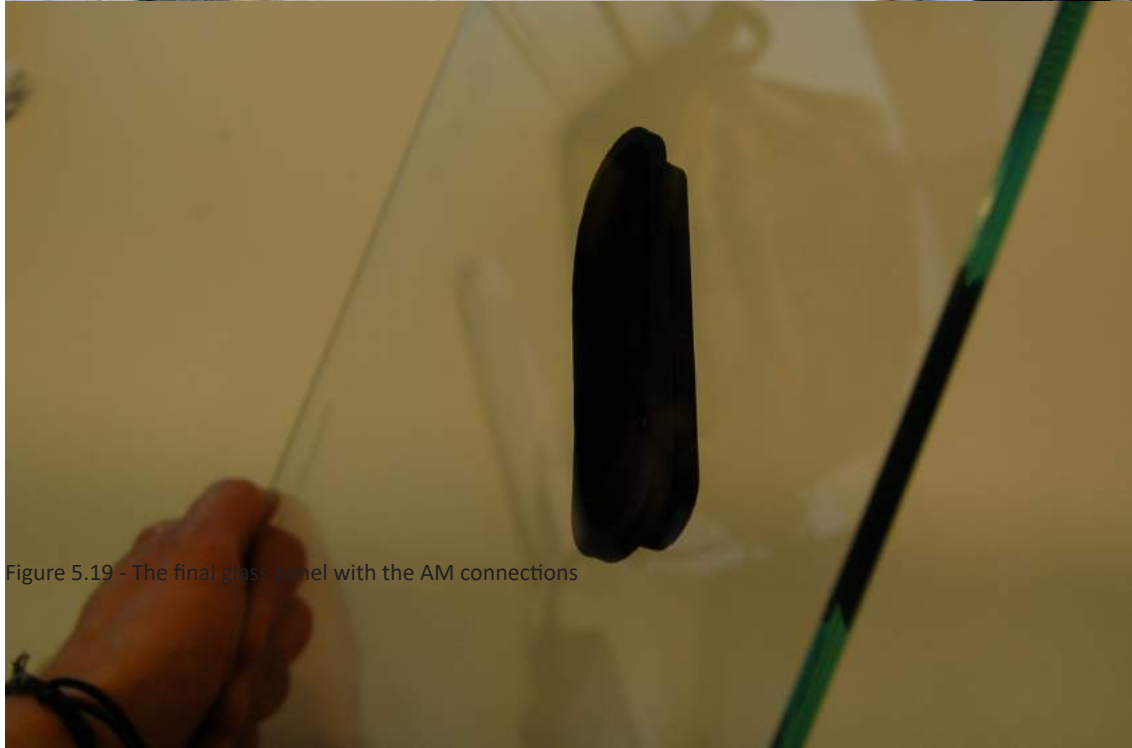

Figure 5.19 - The final glass panel with the AM connections

## 2 The AM connection

The models of the spider were first given supports for the overhangs in the model with Autodesk Meshmixer. The connection and it's support were then sliced with Simplefy3D special program that turns the model into model that the 3d printer can understand. For the actual print job the following settings were used for the carbon reinforced material.

Nozzle diameter	: 1.20 mm (stainless steel nozzle)
Temperature	: 260 degree Celsius
Printing speed	: 50 mm/s
Layer height	: 0.6 mm
Perimeter shells	: 2
Infill	: 80%
Extrusion multiplier	: 0.88
Extrusion width	: 1.44
Retraction distance	: 3 mm
Retraction speed	: 60 mm/s

The following settings were used for the flexible material.

Nozzle diameter	: 0.80 mm (stainless steel nozzle)
Temperature	: 250 degree Celsius
Printing speed	: 40 mm/s
Layer height	: 0.4 mm
Perimeter shells	: 2
Infill	: 20%
Extrusion multiplier	: 0.88
Extrusion width	: 0.90
Retraction distance	: 0 mm
Retraction speed	: 0 mm/s

The estimated printing time for the prototype was seventeen hours. Do to some unpredicted events and despite the previous tests there where a number of problems with the printer. What resulted in a printer that needed to be recalibrated. This resulted in a total printing time of more than 21 hours and a lot of down time for calibrating the printer. The final product was split in two different parts that where glued with 2 component acrylic glue due some printing errors.

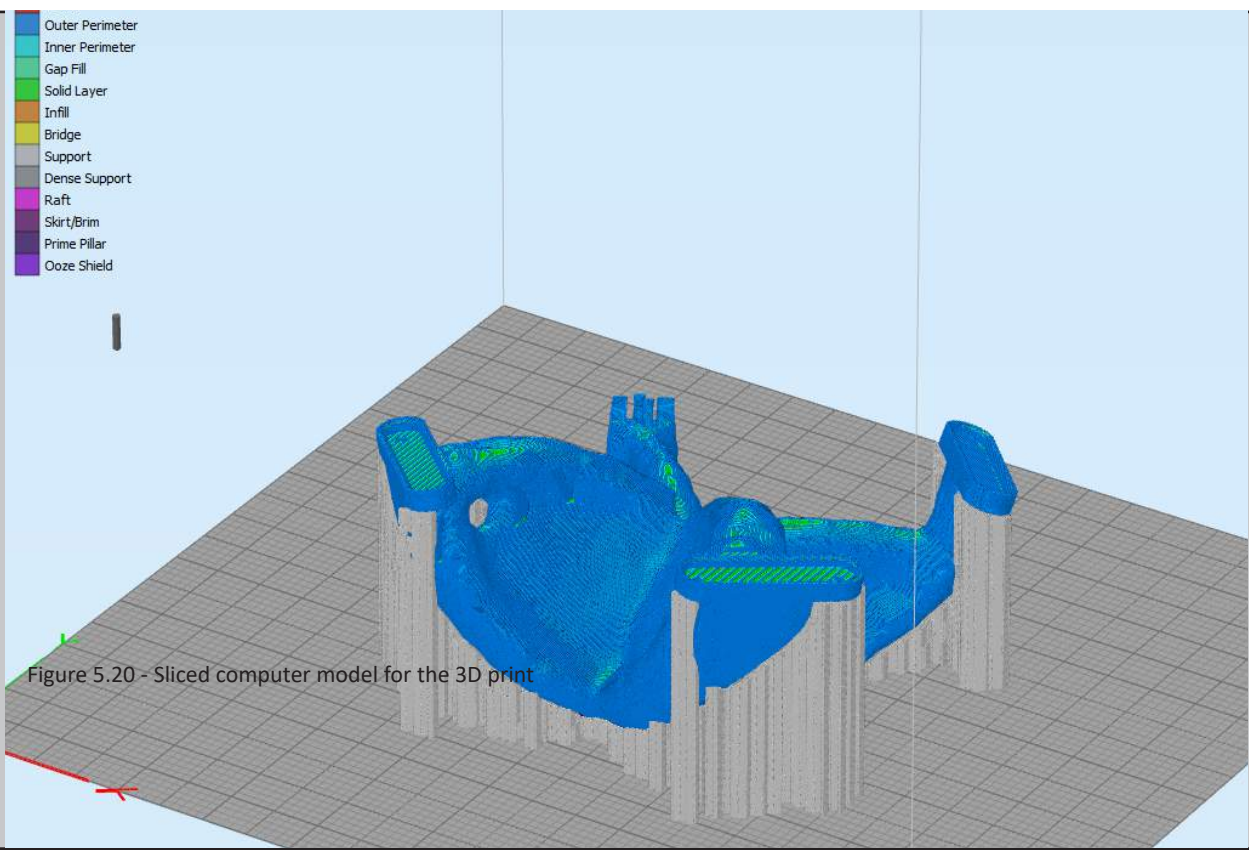

To manufacture the final prototype a number of changes have been made here as well. The most notable one is the “power joint” that could not be printed on the same printer. Because the size of the dual extruder printer was limited and could not fit the designed AM connection. There for the final “power joint” had to be adapted so it could be inserted in to the remainder of the joint. The effect of this was that it got more angels which made the part stiffer than its original design.

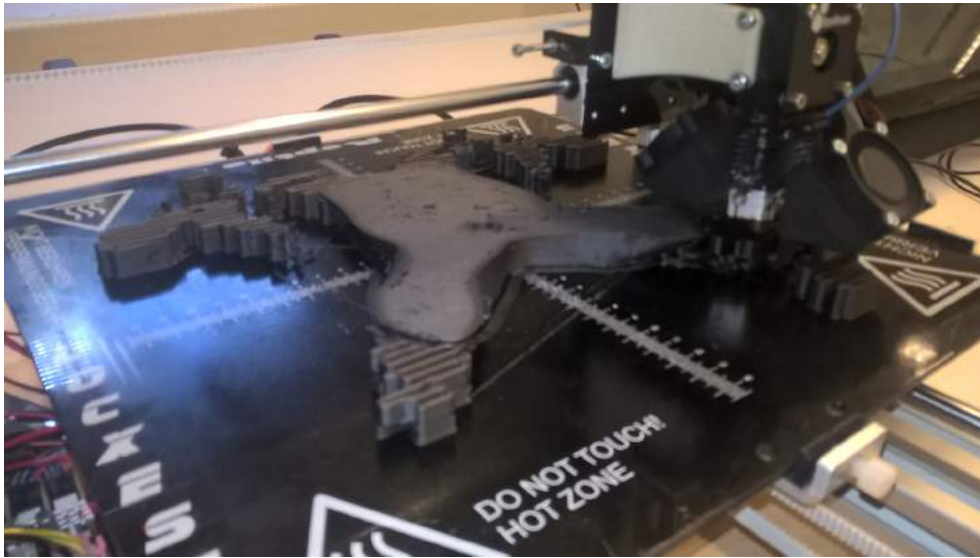

Figure 5.21 - AM in process for a couple of hours.

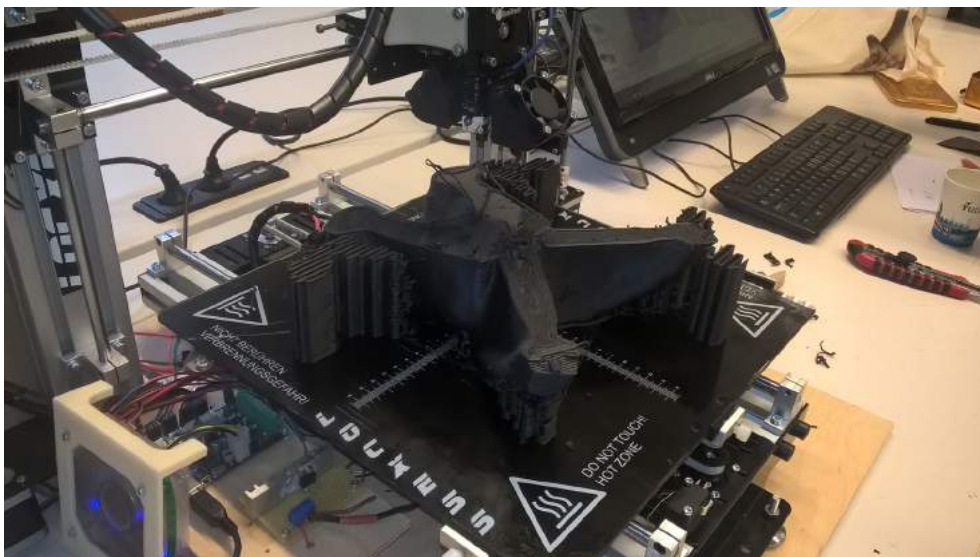

Figure 5.22 - The failed bottom have after the pause.



Figure 5.23 - The Finished AM part



Figure 5.20 - Attaching the glass plates to the connection



Figure 5.21 - The halve finished prototype



Figure 5.22 - The final glass panel with the AM connections

### 3 Final Build

The final prototype was built over the timespan of a month. The final element showcases the adaptability of the AM connection. The connection should be capable of handling a total dead load of 70 kilograms and wind load of 120 kilograms. The results can be viewed here.



## 5.6 References

*Frei Otto, complete works : lightweight construction, natural design* Basel [etc] : Birkhäuser, 2005.  
Otto, F., Nerdinger, W., Meissner, I., Barthel, R. and Brensing, C. 2015

Strauss H. (2013) *AM Envelope: The potential of Additive Manufacturing for façade construction*  
TU Delft. <http://repository.tudelft.nl/islandora/object/uuid:3a69355a-51d7-4207-943f-57a03f855d04?collection=research>



## SUMMARY

This chapter showed that it is possible to design and construct a fully functional AM glass joint. At the same time it showed that the current design is not perfect. Because a number of things in the AM part could be increased to further increase the make ability and functionality of the designed joint. It is only that a lot of these aspects that could be improved are in the field of AM it self what makes it very hard to have impact on those aspects as a building engineer.



Set up for structural testing

A detailed wireframe mesh of a mechanical component, possibly a bracket or a support structure, rendered in a light gray color against a darker gray background. The mesh is composed of numerous small triangles, providing a clear view of the object's geometry and internal structure. The component has a complex shape with several curved surfaces and a central opening.

# Design Validation



# 6

## Design validation

To validate the current design and the design process. A number of structural test will be done to see how well the performance of the AM joint matches the values that resulted from the calculations. These tests will also be done to see how stiff the joint is and what its weak spots are testing the joined until failure. At the same time the market potential of a joined like the one designed will be researched. By comparing this joint with a off the self joint from SADEV. This would give a indication of the price and show by extension the market potential for free from point connections that is made with the help op polymers.

### 6.1 Testing

To verify the designed AM connection the decision was made to structurally test the new AM connection. This was done to see how the connection would behave under the design loads where the focus was on the deflection within the part. The second part of the test was focused on the strength of the final part so the they would be tested until absolute failure. Both of the tests would be done by loading the test pieces under compression. In these test the load cases that were used in the previous calculations would be separated in there respective load cases; the wind load in the Z-direction of the printed part and the dead load in the Y-direction. All of these test will be done at the mechanical lab of the faculty of 3ME under the super vision of Christian Louter and Fred Veer.

#### 1 Set-up

For the test two specimens where used to test the different loads so one was used for the Z-direction and one for the Y-direction relative to the print direction. In this test only one quarter of the joint will be tested, because of size limitations of the machine where the specimens had to be placed for the test. Otherwise it could not have been loaded properly. There was a limitation in the available amount of filament which allowed only for the production of two quarters. To test these pieces in the different directions a intermediate element had to be used to properly position the pieces for the test. This intermediate element was a rectangular steel element that was fitted with slotted holes. The element could then be bolted to the table of the Zwick testing machine. The specimens would be bolted to the top or side of the steel rectangle depending on the direction that needed to be loaded. This setup can be seen Figure 6.1. This then only meant that the loading of test specimens would be off-centre and without a load to balance the forces in the AM connection.

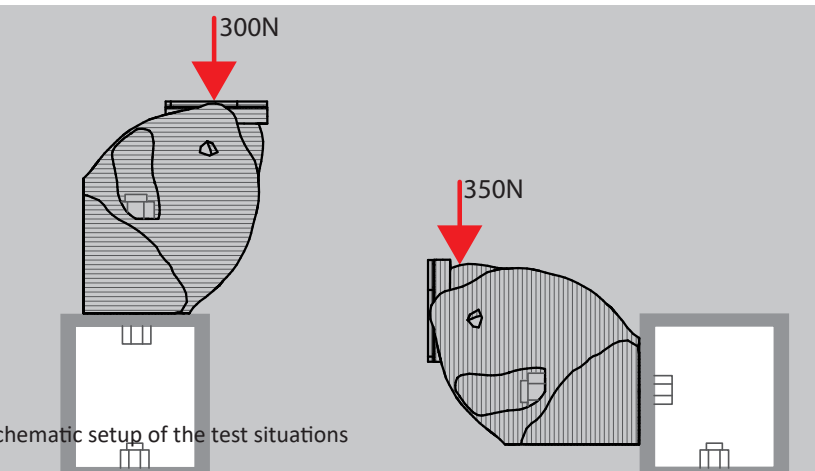

Figure 6.1 - Schematic setup of the test situations

## 2 Test results

### Specimen 1 - Y-direction (dead load)

The first three tests that were done with the first specimen involved giving the specimen a pre load of 50N and then load it up to 350N the designed dead load. That was done with a speed of 0.5mm/sec.

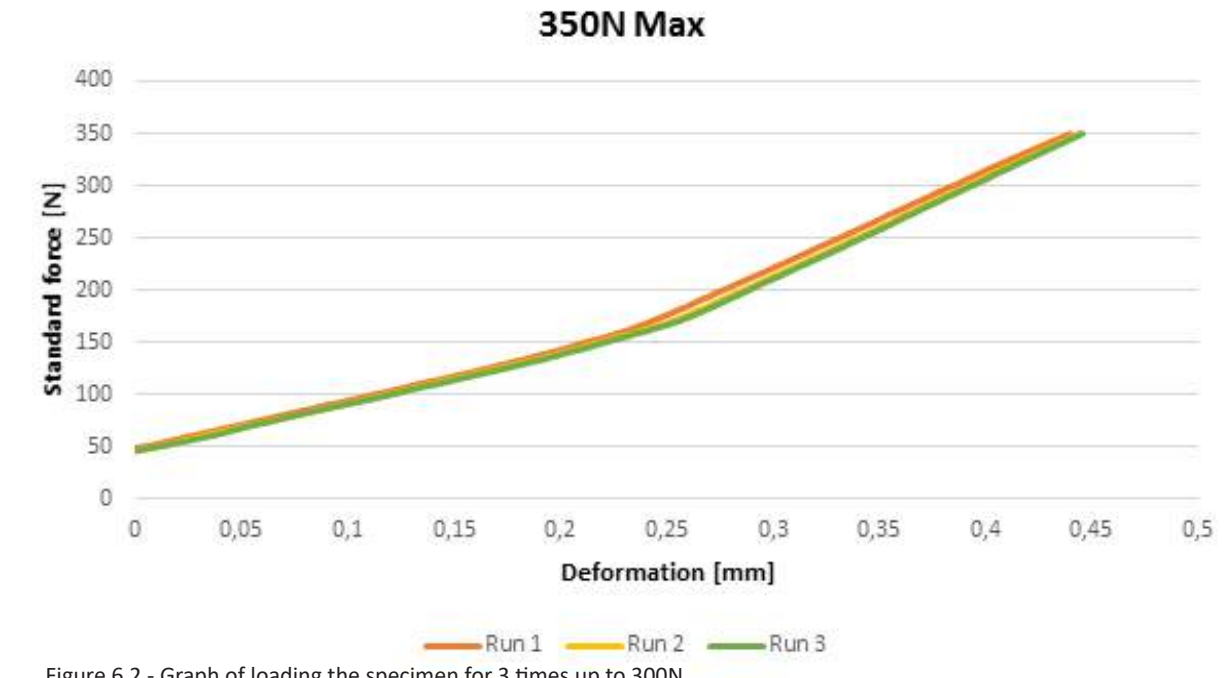

Figure 6.2 - Graph of loading the specimen for 3 times up to 300N

In the graph can be seen that with all 3 runs the differences in deformation are minimal. Still the deformation at the design load of 350N keeps giving a higher value. Because it started in the first run at 0,4398mm but at the third run it was already increased to 0,4454mm. This is only an increase of 1,27% but it is an indicator that some damage was being accumulated inside the joint.

The second test was executed under the same conditions as the first but this time the maximum load was doubled until 700N

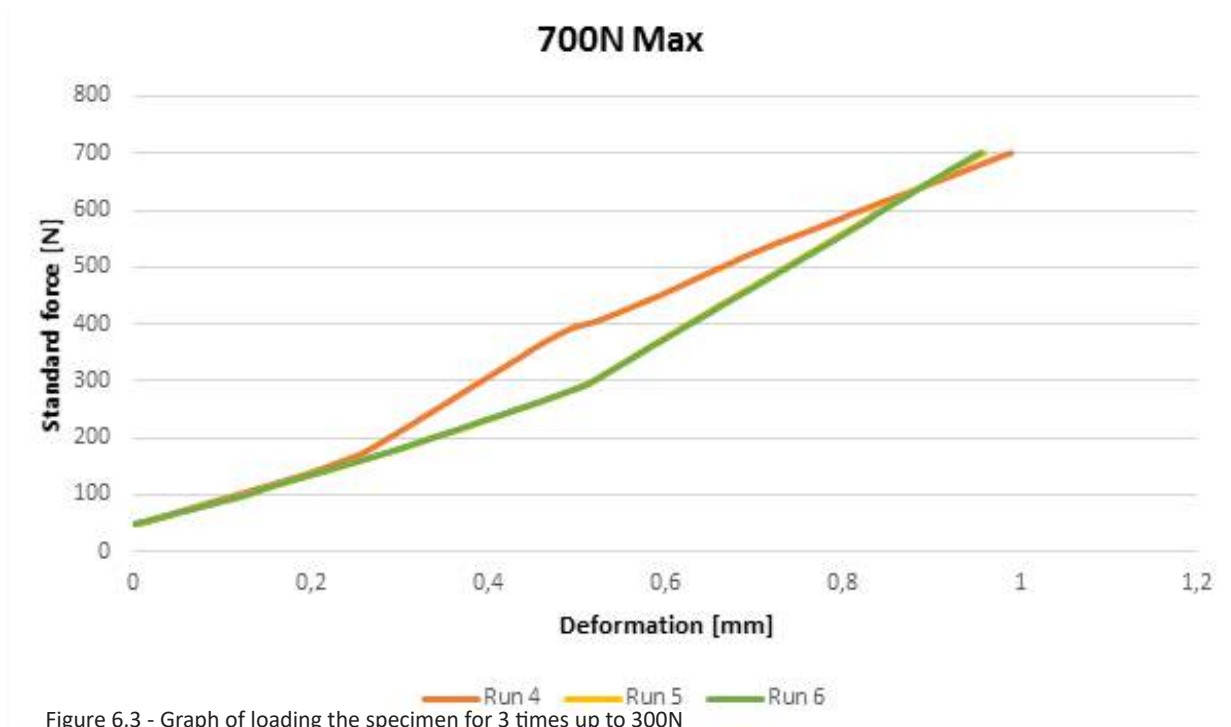

Figure 6.3 - Graph of loading the specimen for 3 times up to 300N

The results of the double load are more interesting because the first run up to 700N follows the trajectory of Run 3 in Figure 6.2. Which resulted in a deformation of 0,9908mm but the other two runs have deformation of 0,9569mm. This would mean that the deflection is decreased 3,4% what would imply that the joint has become stronger under a higher load while it was being damaged in the first test. This might have occurred because of the carbon fibre that is in the filament was activated during Run 4.

The last test that was done with this specimen was until failure and for this the speed of the testing machine was increased to 2.5mm/sec.

## Until Failure

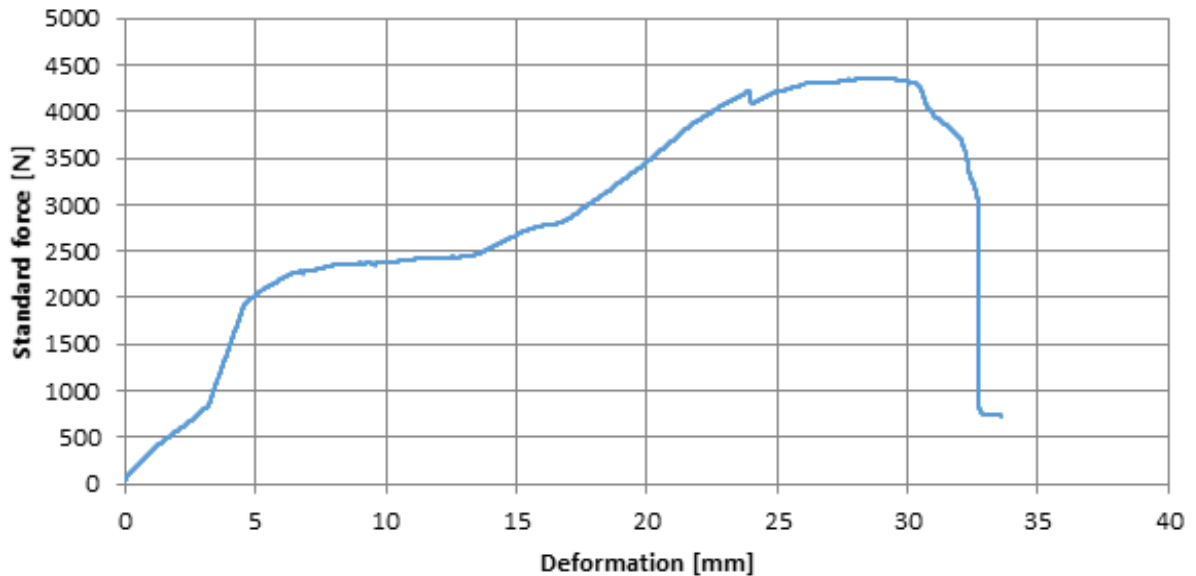

Figure 6.4 - Graph of the test until failure

What can be seen in the data from the final test is that probably due to the increased speed the deflection at the previous upper limits has been doubled. Then after the deflection has become around 6mm the stiffness reaches a moment where part of the joint was failing because the deformation doubles even further with an increase of only 200N. After that first sign of failure the specimen regains part of its stiffness and reaches its peak strength at 4309N with a deflection of 26,38mm. The part completely fails at 30000N when the strength drops to 860N this failure of delamination can be seen in Figure 6.5.

What can be seen after the part has failed is that the specimen mainly failed by delamination. Because the layers are completely separated with the crack originating from the area where it was bolted. That is not very surprising because the machine was pushing on one side of the specimen so a moment was introduced into the part and then the connection between the layers was the weakest connection. So one part of the connection tried to rotate away from the part that was bolted with cracking as a result. This result can be seen in Figure 6.6.



Figure 6.5 - Delamination at the point of failure

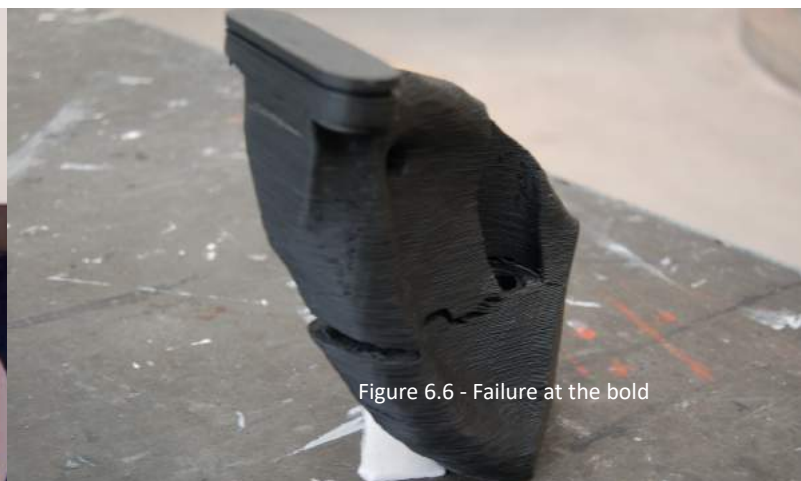

Figure 6.6 - Failure at the bolt

## Specimen 2 – Z direction (wind load)

With the second specimen the same tests were done with different loads. Instead of just repeating the same test three times the element what put true a cycle test to see how it would behave under continues loading and unloading.

The first test was a test cycle of loading to 300N and unloading until 50N to see how the test specimen would behave under the constant load changes and how that would affect the deflection within the part. This loading was done with a speed of 0,5mm/sec to get the most accurate results. When the load would hit its maximum it would be kept there for 30 seconds.

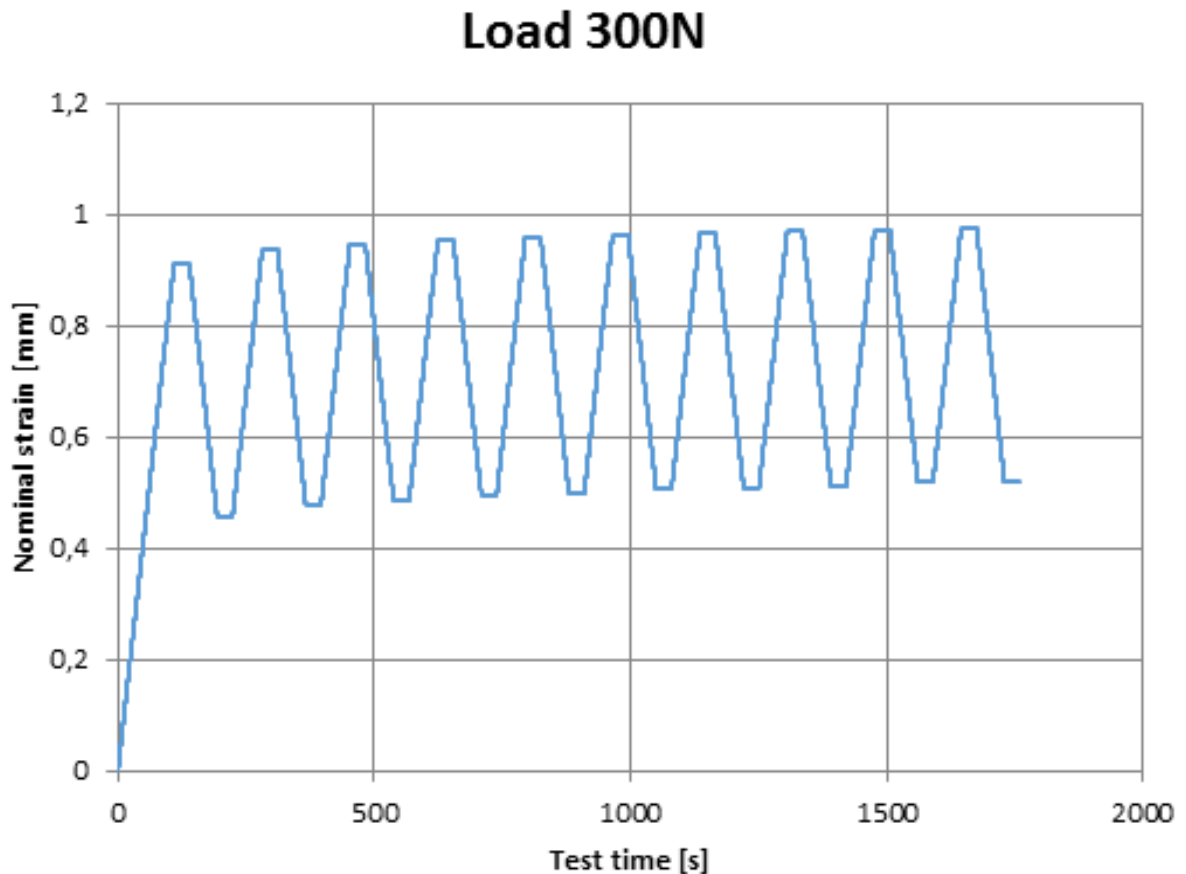

Figure 6.7 - Graph of cyclic loading up to 300N

As can be seen in the graph the deflection in the specimen is constantly increasing by a small amount but none the less. Examples of the high and low load for the fist, fifth and tenth cycle can be seen in the table below. This shows that the maximum deflection has increased by 7,3% what can mean that with all the loading and unloading a certain amount of damage is accumulating within the specimen. Or it was the deflection of the AM insert that would be bonded to the glass that was pushed further in to the remainder of the profile.

<i>Cycle</i>	<i>Deflection [mm]</i>
1 <sup>st</sup> high	0.9106
1 <sup>st</sup> low	0.4787
5 <sup>th</sup> high	0.9443
5 <sup>th</sup> low	0.5009
10 <sup>th</sup> high	0.9756
10 <sup>th</sup> low	0.5215

Figure 6.8 - Tabel of the load cycle up to 300N at the 1<sup>st</sup>, 5<sup>th</sup> and 10<sup>th</sup> cycle



The second test that was done with the second specimen was again cycle test but the upper limit was raised to 600N the speed of the machine was also raised to 2,5mm/sec and the resting time with the full load was increased to 60 seconds.

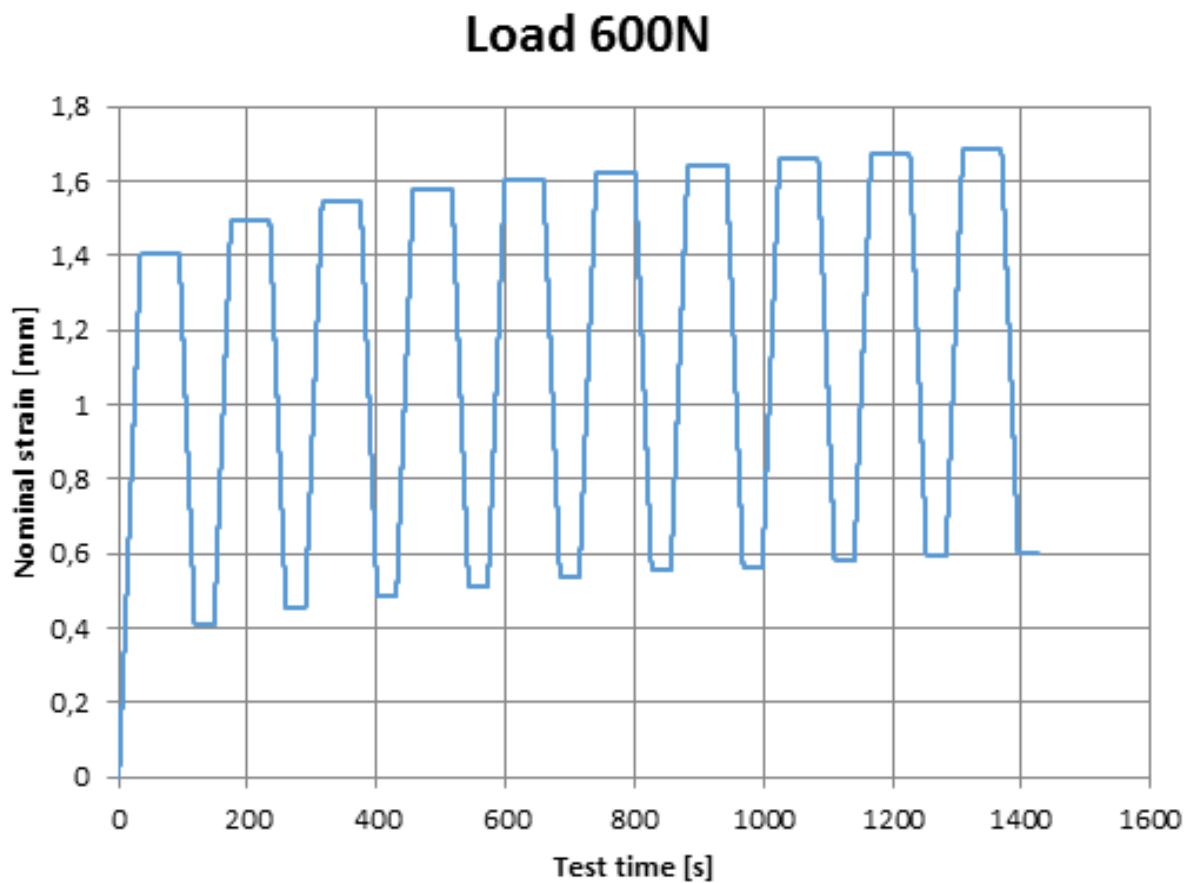

Figure 6.9 - Graph of cyclic loading test up to 600N

As with the lower cycle load the deflection constantly increases with every new cycle. It is only that the increase is more that with the previous test because the difference from the deflection in the first cycle to that of the tenth cycle is a increase of 19,8% what is an effective increase of 0,28milimeters. This is most likely again an accumulation of defects within the specimen that keep on weakening the tested specimen.

<i>Cycle</i>	<i>Deflection [mm]</i>
1 <sup>st</sup> high	1.4053
1 <sup>st</sup> low	0.4098
5 <sup>th</sup> high	1.6025
5 <sup>th</sup> low	0.5351
10 <sup>th</sup> high	1.6840
10 <sup>th</sup> low	0.6000

Figure 6.10 - Table of the load cycle up to 300N at the 1<sup>st</sup>, 5<sup>th</sup> and 10<sup>th</sup> cycle

The final test that was done in the Z direction that was done was a test until the part would fail. This was again done with a speed of 2,5mm/sec.

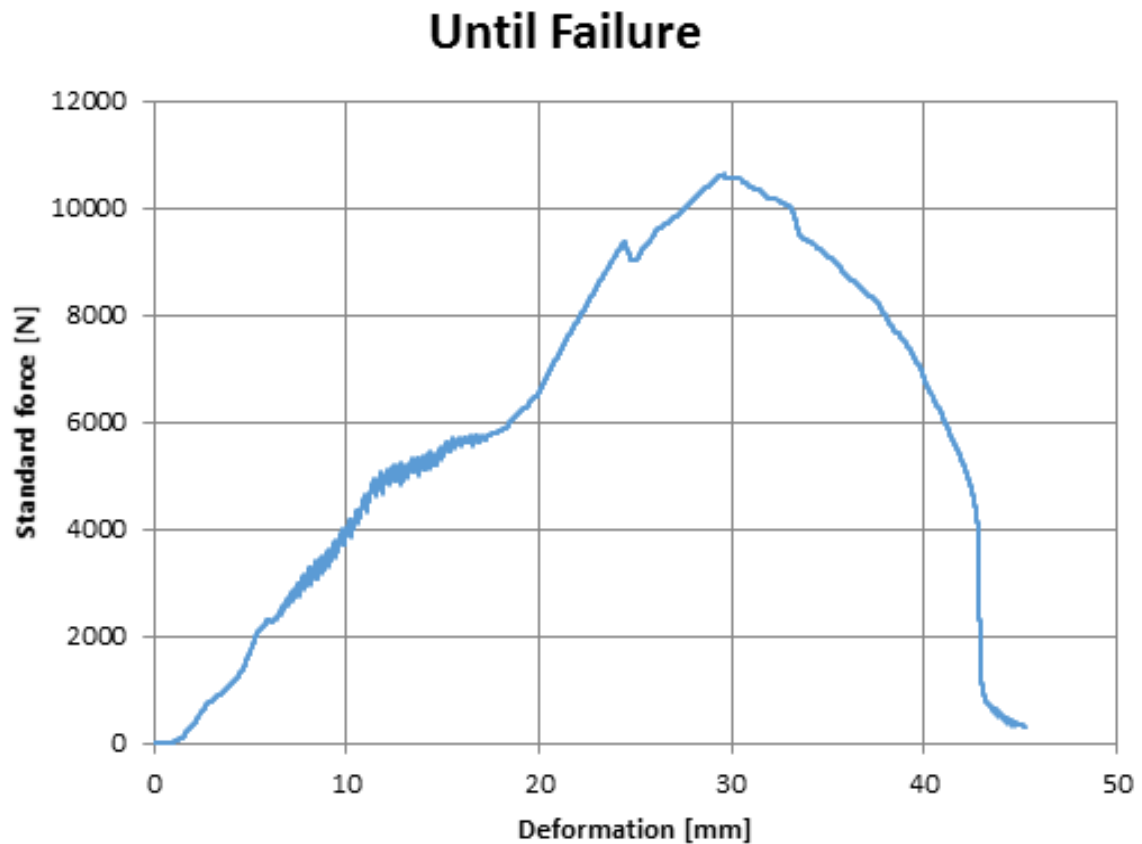

Figure 6.11 - Graph of the test until failure

What can be seen in the graph is that there was a steady increase in the strength of the part until the 2000N what was when the securely bolted specimen started to buckle on the steel block and this zig zagging pattern is probably that the press was finding a new stable hold on the specimen. When the press had found its stable hold it started digging in to the AM material but it still had a steady increase in strength until it reached its maximum strength of 10624N. Then the specimen started to fail from the bolted connection on with delamination in multiple layers which then formed diagonal cracks between these failed parts. This failure looks like that the loaded part wanted to rotate away from the fixed part. Just as could be observed in the first specimen that was tested.



Figure 6.12 - Delamination and rotation at the point of failure



Figure 6.13 - Failure at the hold

### 3 Calculations for validation

To compare the test additional FEM calculations were made of the tested specimens to properly compare the generated results from the test to the digital models. In these models the different loads will be separated to see how the specimens would behave under the test conditions.

#### Y - direction (dead load)

As can be seen is the deflection for the model that represents the dead load just 0,14474mm What is significantly less than the observed 0,4398mm at the location where the pressure is applied. The maximum stress of the parts was calculated as well. That stress could be found around the bolt what matches the results from the tests because the cracks started to form around the bolt and then expanded outward along the layers of the print. The maximum calculated stress was 362,4MPa what is more than the indicated flexural strength of 110MPa. What implies that the part was stronger then calculated.

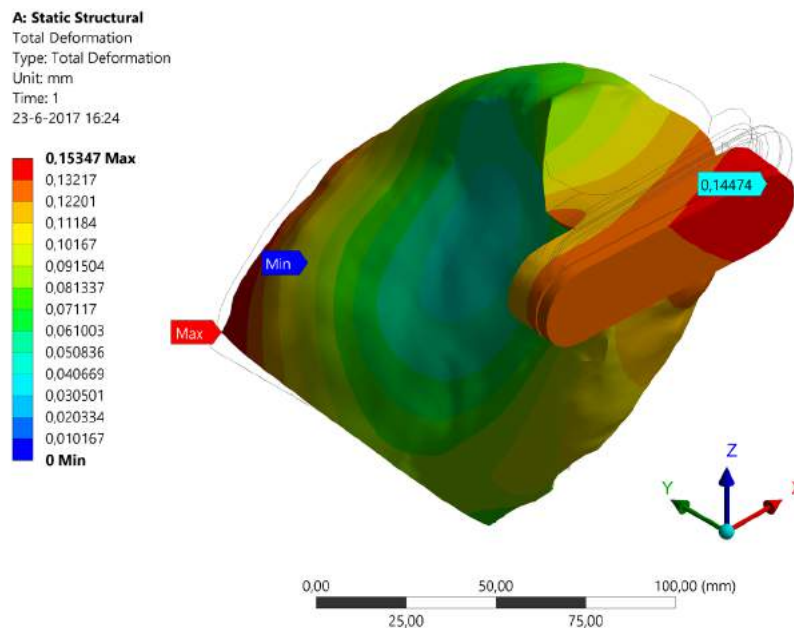

Figure 6.14 - FEM model of the deflection of the tested part under a load of 350N

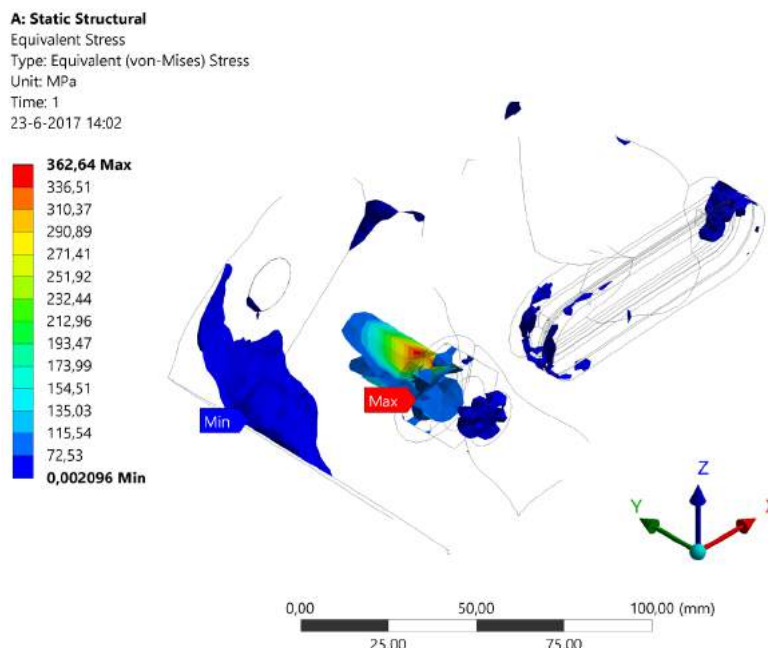

Figure 6.15 - FEM model of the von-mises stress at the moment of failure.

## Z - direction (wind load)

As can be seen in figure 6.16 is the deflection from the wind load in the computer model 0,19582mm. That is again less than the observed value 1,4053mm but this can be explained by the fit of the snap connection that might have been looser in the real life test than in the computer model due to the inaccuracy of the AM parts.

For this element the principal stresses have been calculated as well to see if the failure pattern of the tested elements corresponds with the observed failure pattern of the tested specimen. In the calculation the maximum is 93,8 MPa while the material should be capable of handling at least 110 MPa. The calculation did not show the same of displacement in the part what might have lead to greater forces around the bolt which then resulted in the failure of the tested specimen.

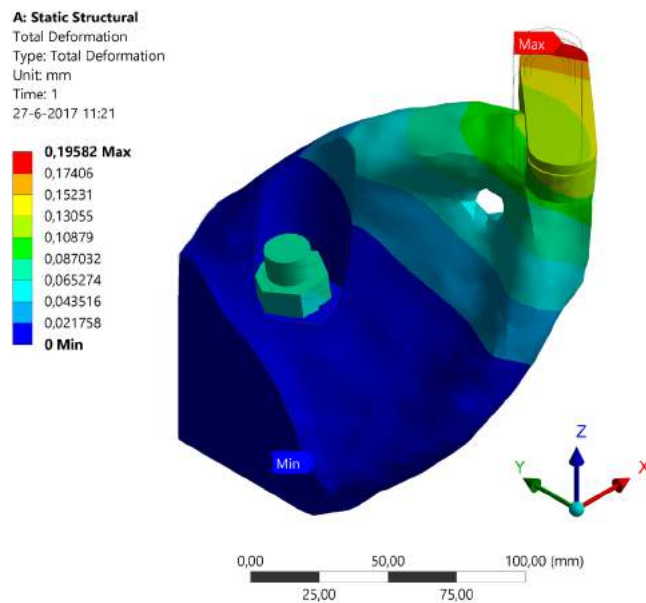

Figure 6.16 - FEM model of the deflection of the tested part under a load of 300N

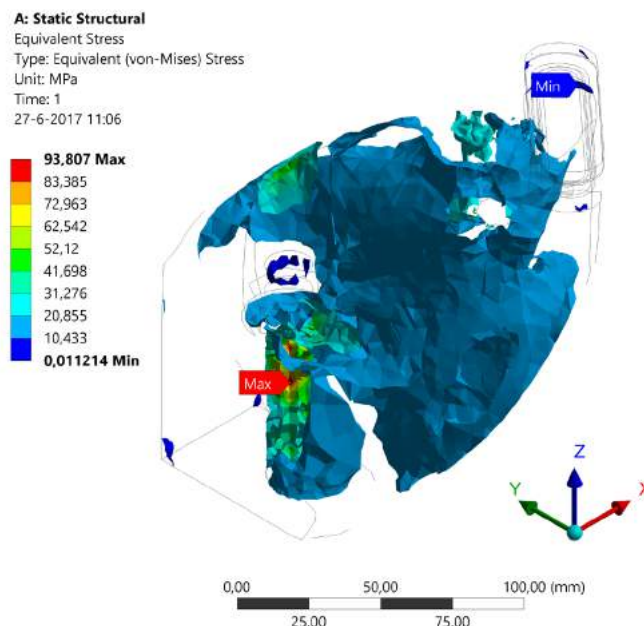

Figure 6.17 - FEM model of the von-mises stress at the moment of failure.

## 4 Conclusions of the tests

The conclusions that are drawn from these test are rather limited. Because of the limited sample size of just one specimen for the test and the fact that all the test have been done with the same specimens. To further increase the value of these test additional test should be done. At the same time the way of calculating should be improved because the differences in results from the calculations and test are rather large. This deviation in the calculations is probably due to the layered nature of the AM material what could not be properly simulated in the time frame of this research. If more test were done there would have been a base to adjust the calculations accordingly. Do the small sample size this relevance was not there so the calculation have not been changed.

### Deflection

After comparing the test results with the calculations that were made for this occasion. It has to be concluded that the material did not perform as the calculations predicted. Because both specimen were much weaker than the calculations implied. There are a number of reasons why this might be. The first is that the nature of the AM material with its layered build up is not modelled properly in FEM calculations why it appears stronger than it is. Then there is also the process of AM that is not as consistent as other manufacturing processes. The last reason why the values differ can be that the date from the manufacture is not correct so the input for the calculation was of.

### Failure of the connection

The failure conditions of both specimens where surprising because they were both a lot stronger than there designed values gave them credit for. Because they failed at respectively 4309N and 10624N what was a lot more than expected. A other interesting aspect was that they both failed from the bolted connection outward. Where the parts failed in a similar way because one part of the connection was moving away from the bolted part. Were the layers were the weak spot and delamination followed. The only difference was in how fast they failed and that was because one was loaded in plane to the direction of the layers and the second specimen was loaded perpendicular to the layers what made the part a lot stronger. It is interesting to see that the calculations for the stresses are of for both specimen. But the are both of in a different way. One was way to high and the other to low. As mentioned before the failure was around the bolt and this was verified in the calculations. Where the highest stress concentrations where also the highest around the bolt. What combined with the big defelection that was observed resulted in the failure over the layers.

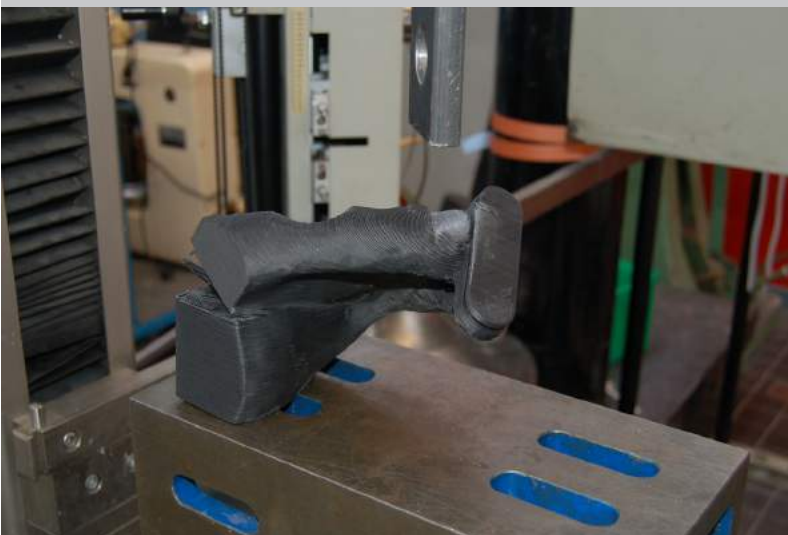

Figure 6.11 - Failed part loaded in the Z-direction



Figure 6.12 - Failed part loaded in Y-direction

## 6.2 Price comparison

To get a better understanding how the newly designed AM connection could perform in the market. A price comparison was made to an existing spider profile from SADEV. The profile in question is the S 3001 EVO with R1006 TSSA Rotules. This combination was selected because of its close resemblance to the AM connection.

This combination of the existing spider would have a combined weight of around 2 kg, which is slightly more than the AM joint that only weighs 1,8 kg. That makes the AM joint easier to handle on the construction side during the assembly of the building.

Then there is the more interesting comparison of the prices of the different joints. The standard spider has the following price build-up. The spider is 111 Euro's, the rotules are 50 Euro per rotul, for the spider four are needed so that would be 200 Euro's for the rotules. That would then bring the total price of the spider up to 311 Euro excluding taxes.

The AM connection weighs 1,8 kg and with a filament price of 0,045 Euro per gram the AM joint would be 81,1 Euro's for pure material cost and an additional 13,50 for the support material. The print time cost are around 24 Euro's. The other problem is the cost for the engineering; these are set for this comparison on 100 Euro's an hour with for a competitive product 3 hours of engineering time, because the AM joint is different for every height and orientation. The joint needs to be engineered for every iteration and that brings a lot of uncertainty to the price point of the AM connection.

That engineering process should be simplified if the joint wants to be competitive. Should the AM joint ever be brought to market. Because the wages of the engineer can ruin the price point of the AM connection. This is especially important because the AM joint has the advantage of the variation of the polyester. Because the polyesters make it possible to integrate a lot of functionality into the joint. These functions normally have to be added in the form of a rotul, which is very expensive and a complex connection.

SADEV S 3001 EVO	€	111	Material	€	81,1 +13,5
R1006 TSSA Rotules	€	50 x 4	Print time cost	€	24
			Engineering	€	100*3
Total	€	311	Total	€	418,60

Figure 6.20 - Rough estimation for the price comparison.

## SUMMARY

In this chapter an attempt was made to validate the design by validating the structural calculation to structural test. It turned out that the calculations were off by a very big margin. That was probably because of the layered nature of the AM material and the weak connection in between the layers. Additional test should be done to improve on these calculations. At the same time the design was validated on its price and on a first look it looks really good because of all its integrated functionality. When the engineering of each profile is taken in consideration the cost of the connection rises fast. What is something that should be taken into consideration when and if this joint would be brought to market.



The finished prototype



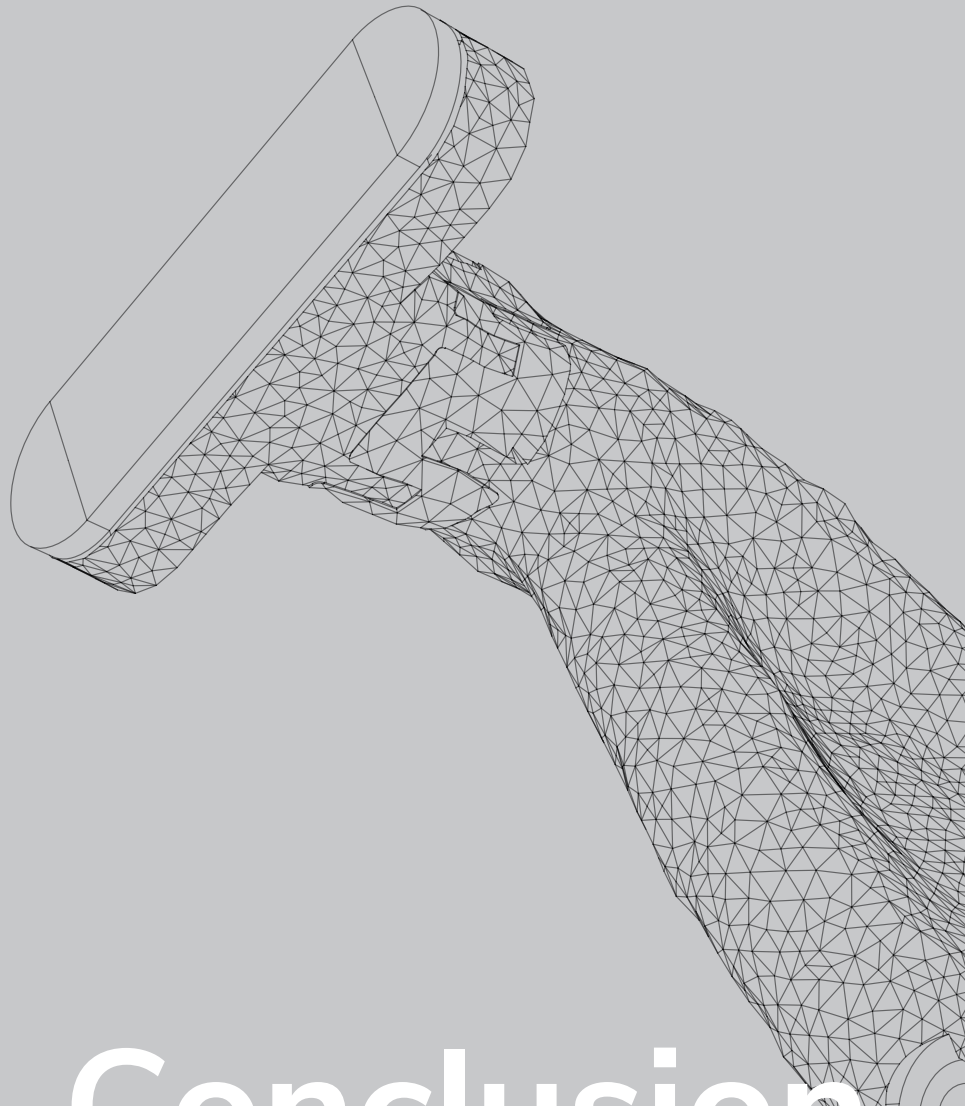

# Conclusion

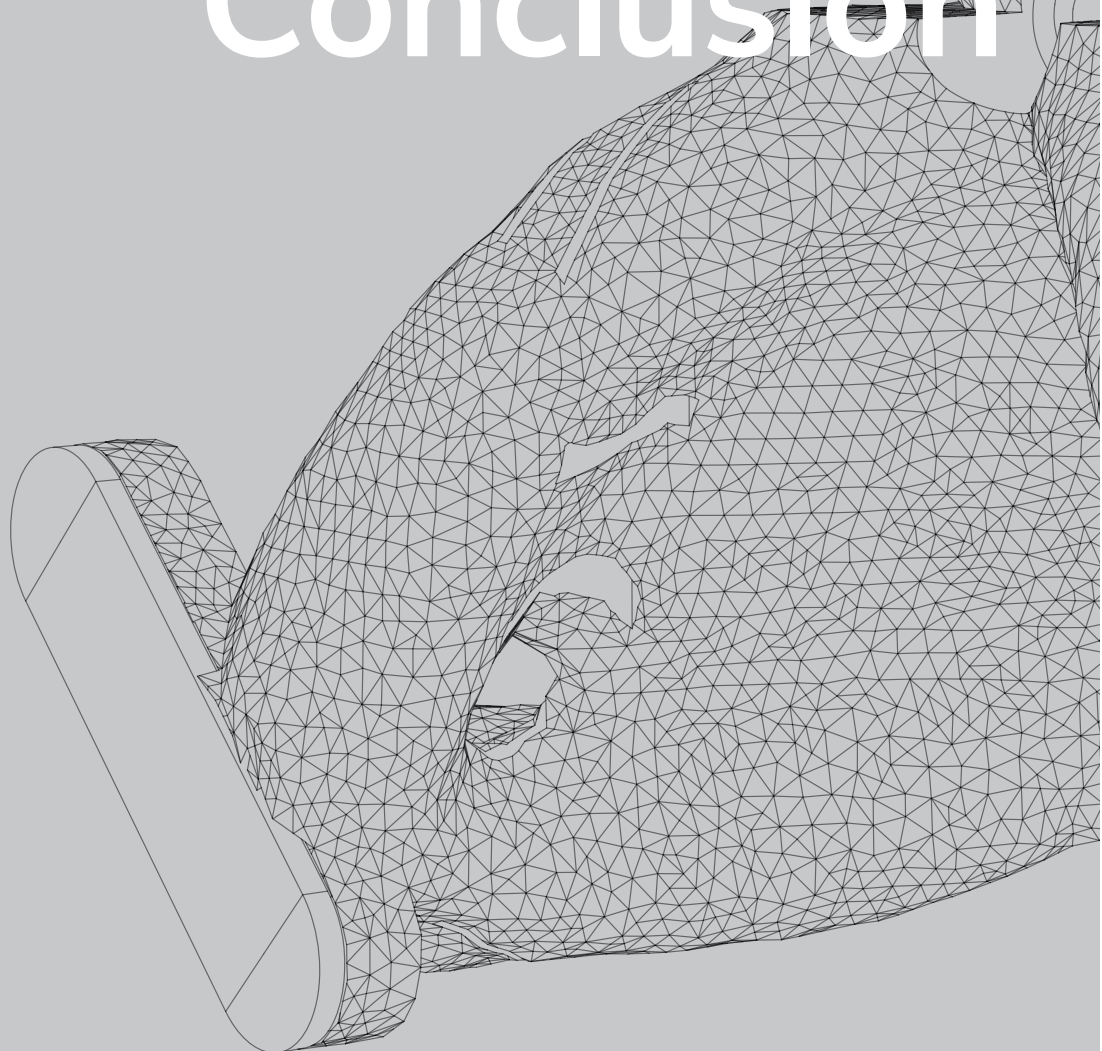



# 7

## Conclusion

This conclusion consists of two parts; the first part until 7.3 will have the answers and conclusions to the research questions which were the basis for this master thesis. The research questions were

- What kind of glass connections already exist?
- What kind of glass connections are relevant for this research?
- How does additive manufacturing work?
- What kind of additive manufacturing processes and materials are relevant for this research?
- What are the benefits of additive manufacturing for the built environment?

Whit the main research question being:

*What kind of additively manufactured connection can be the next big innovation in the field of glass connections?*

The themes of some of these questions overlap, and therefore have been combined in order to give a better and more integral answer. These themes are the glass connection and additive manufacturing. When the sub questions have been answered the main question of the research will be discussed.

Then in the second part from 7.4 on some other aspects that arose during the research process will be discussed. These are topics that had major impact on the research but were outside of the original scope of the research.

### 7.1 The glass connection

For this graduation research a comprehensive timeline was made with a description of the glass connections in question. From this timeline, the extrapolation was made that spider glazing had the most potential to be developed into a new sort of connection. This is because the current metal version of the spider profiles are all made with a cast or milled piece of metal. Therefore, the adoption of these profiles for a free form façade would be incredibly expensive with all the unique moulds that would be necessary or excess material that would be wasted if these spiders would be made out of metal. In addition the shape of the spider profile lends itself perfectly for further development towards a free form façade.

That is why the spider profile was selected to be the basis for this new AM glass connection. It also had potential for improving the way that the glass is connected to the profile. In the mean time the spider profile also has a lot of potential to change its shape so it would no longer have its generic aesthetic, but would have its shape formed by the forces that work on it.

## 7.2 The production process

The most interesting aspect of Additive Manufacturing (AM) for this research was to see if the connection could be made with a Fused Deposition Modelling (FDM) printer. This is because, FDM printing is currently the most used technique for AM. This means that the printers are relatively cheap and widespread in their usage, which makes them very interesting for broader applications. At the same time, these printers are still under development, for example bigger printers with more accuracy are expected in the near future. The other, more recent development in printing is the usage of multiple extruder heads which will allow for the usage of several materials in the same print. This has great potential for integrated parts.

The other major benefit of this way of printing is the amount of available material that is expanding every day. Some of the materials that are available now have only existed for a couple of months and new ones are developed every day, which are stronger and easier to print.

## 7.3 A new glass connection

The final product of this master thesis is a AM glass connection that has been shaped by the forces that work on it, which only was possible to manufacture with the help of Additive Manufacturing. It has shown that the material can withstand the forces that work on it. At the same time the goal of a more flexible glass connection has been realized. The result can be viewed on page 95.

## 7.4 Additive manufacturing for façades

This graduation has shown that it is possible to use additive manufacturing for more than just mock ups. It has shown that AM can be used for structural components with a dead load of 350N and a variable wind load of 310N. This is also immediately one of the critical points about the spider profile that has been developed for this project; the forces that work on it are still rather limited. The question therefore is: is additive manufacturing really the solution for structural problems within the field of architecture?

At the same time there is still the problem with additive manufacturing itself. It is still a rather slow process. The production of these prototypes alone already took more than seventeen hours. This is assuming that the whole printing process completes without any problems. This is especially a problem for bigger and more complex prints like the ones that have been made for this research. There were a lot of issues with the prints in question. The first conclusion of this research is that additive manufacturing can be used for façade components, but it is probably not the best solution to create a whole façade in this way. One other issue was the fact that for most prints you can only print with a fixed size for the extruder for FDM printing. Therefore, it is currently not possible to have parts in the print with more or less detail. If this would have been possible it could have greatly increased the accuracy of the print, without sacrificing the print speed. This addition to the printing technique would add a lot of additional benefits and could greatly improve the feasibility for AM parts in the façade.

## 7.5 Polyesters for façades

For this project a number of different polyesters have been used to create the prototype in question. Especially their broad range of properties were incredibly useful. For this project it was feasible to create an integrated joint with polyesters within the connection, which is something that otherwise could not have been achieved if normal rotules would have been used. The low conductivity of the polyester helps reducing the amount of cold bridges and heat leaks within the façade. Therefore, it is clear that there is a lot of potential for polyester components. It is just that the way that these components are made has to be developed further.

The polyesters that could be used for the façade have one benefit that gives them a competitive edge. This benefit is the possibility to get a lot of additional functionality from the whole range of available polyesters. This is because the smaller, more complex, elements add the most to the cost of current solutions. Polyester creates the opportunity to remove those smaller components to make more integrated parts possible what will reduce the price and complexity of competing components.

## 7.6 The solution for everything that is topology optimization

Topology optimization is a great tool that can be used in a very interesting and successful way, if it is applied properly. When it is applied properly, it can lead to a lot of improvements for the parts in question. At the same time, it comes with a trade off at this moment; most of the parts that are designed with the help of topology optimization can only be made with additive manufacturing. Topology optimization can lead to interesting designs that can look very organic, as can be seen in this report. However, to say that this was indeed the optimal solution for this type of connection remains uncertain. This is because in the end it is still a tool and the results of a tool are only as good as the person that wields that tool. This is one of the biggest problems that became clear within this research which is that topology optimization. Is often viewed as the solution for almost everything, but it is only the optimal solution for one very specific question. It is always hard to know if the right question was defined in the right way. Therefore, the conclusion has to be that; Topology optimization is not the solution for everything, but it can be a very handy tool.

## 7.7 Further research suggestions

### **Different AM materials and properties in multiple directions.**

To get a better understanding of AM materials, these materials should be tested. While collecting all the data about the material, the data should be stored in an open source database so that it is accessible to everyone. The research and accessibility of the AM materials and its properties in all directions will give a better overview of the strengths and weaknesses. This will in turn make AM more accessible because it will be easier to select the proper material for its function. This research should also take into account the different extrusion widths and shows what effects those have on the strength of the part. This will make AM a more feasible option for engineered parts.

### **Extensive advanced FEM calculations.**

During this research multiple numerical calculations have been done. However, when these calculations were compared with the test they appeared to be way off. Therefore, if AM should be used for structural end use parts, it's critical that a proper way of calculating these elements is developed. This could be done by better defining the weakness in the Z-direction of the AM parts where they are stacked. Moreover, tests can be performed so that a reduction factor for the layers can be defined. Because only if a standard for structural AM calculations is developed like a Eurocode for plastic AM so that they can be applied in a safe and consistent manner.

### **Different TO solutions for the question of the design for the spider design.**

The very first choice that you make for TO will define the remainder of the analyses. Therefore, the AM connection that has been developed during this research is only one solution that was generated from one of many starting points. That is why additional TO models should be run to see if a different approach could lead to a different and maybe better AM glass connections, because this research has shown that it is already possible to make one.

### **In-dept cost benefit analysis compared to existing solutions.**

Additional research should be done into the benefit of AM compared to more traditional manufacturing forms. AM can be beneficial for unique parts in a more complex shape. However, as soon as there is more repetition, it becomes more feasible to use more traditional methods. It would be very interesting to see in which aspects AM is more beneficial than casting for example.



## Image credits

- Figure 2.2: <https://www.flickr.com/photos/bremnerj/3701662918/>  
Figure 2.4: <http://www.therosewindow.com/pilot/Paris-N-Dame/table.htm>  
Figure 2.6: [https://en.wikipedia.org/wiki/Window#/media/File:Window\\_Porto\\_Covo\\_August\\_2013-2.jpg](https://en.wikipedia.org/wiki/Window#/media/File:Window_Porto_Covo_August_2013-2.jpg)  
Figure 2.8: <https://www.flickr.com/photos/lwr/17515603101>  
Figure 2.10: <http://www.patent-glazing.com/gallery08.html>  
Figure 2.12: <http://www.fosterandpartners.com/projects/ibm-pilot-head-office/>  
Figure 2.14: <http://www.mgsarchitecture.in/articles/façades-glazing/110-structural-glazing-the-demand-of-the-day>  
Figure 2.16: <https://www.architecture.com/Explore/Revealingthecollections/WillisFaberDumasHQ1992.aspx>  
Figure 2.18: <http://www.fosterandpartners.com/projects/renault-distribution-centre/>  
Figure 2.20: <http://www.ianritchiearchitects.co.uk/projects/lavillette/>  
Figure 2.21: <http://façadesconfidential.blogspot.nl/2010/12/thyssenkrupp-quarter-façades-giants.html>  
Figure 2.22: <http://façadesconfidential.blogspot.nl/2010/12/thyssenkrupp-quarter-façades-giants.html>  
Figure 2.24: [http://www.katsuhisakida.com/body\\_architect/uk/tim/body\\_tim\\_glassmuse04.html](http://www.katsuhisakida.com/body_architect/uk/tim/body_tim_glassmuse04.html)  
Figure 2.26: <http://www.eocengineers.com/project/apple-5th-avenue-mark-2-100>
- Figure 3.1: <http://houseofdus.com/work/#project-urban-cabin>  
Figure 3.2: Gibson, Rosen, & Stucker, 2015  
Figure 3.3: <https://cel-robox.com.au/filament/>  
Figure 3.4: Strauss, H., 2013  
Figure 3.5: <https://www.kudo3d.com/sla-3d-printing-difference-in-laser-and-dlp-light-generation/>  
Figure 3.6: Strauss, H., 2013  
Figure 3.7: <http://www.novomet-usa.com/eng/company/technologies-and-manufacturing/sls-selective-laser-sintering/>  
Figure 3.8: Strauss, H., 2013  
Figure 3.9: <https://www.3dsupplyguys.com/3d-printing-education-center/what-is-fdm-3d-printing/>  
Figure 3.10: Strauss, H., 2013  
Figure 3.11: Strauss, H., 2013  
Figure 3.12: Strauss, H., 2013  
Figure 3.13: <http://bme.ucdavis.edu/team/equipment/objet-3d-printer/>  
Figure 3.14: <http://www.prweb.com/releases/2013/4/prweb10494405.htm>  
Figure 3.15: <https://markforged.com/markforged-3d-printed-combat-robot/>
- Figure 4.1: <http://www.liftarchitects.com/blog/>  
Figure 4.2: Christensen, P. & Klarbring, A. 2009  
Figure 4.3: Christensen, P. & Klarbring, A. 2009  
Figure 4.4: Christensen, P. & Klarbring, A. 2009  
Figure 4.5: Millipede March2014 release notes  
Figure 4.6: BESO2D Manual – Getting started with BESO2D  
Figure 4.7: <http://www.esss.com.br/blog/es/2017/06/optimizacion-topologica-como-reducir-sus-costes-con-materia-prima-y-superar-mas-rapidamente-la-crisis/>  
Figure 4.8: <http://www.altairhyperworks.com/solution/Additive-Manufacturing>  
Figure 4.9: <http://www.solidthinking.com/ProductGallery.aspx?item=Inspire%20Gallery&category=Products>



Figure 5.1: <http://makezine.com/2015/09/11/carbon-fiber-filament-ruins-nozzles/>

Figure 5.2: <http://colorfabb.com/xt-cf20>

Figure 5.3: <https://www.lpfrg.com/en/creatr-hs/>

Figure 5.11: <https://www.glasinbeeld.nl/10450/nieuwe-kit-en-lijm-voor-glas-dow-corning/>

# Bibliography

3MF. (n.d.). 3MF | Supporting innovation in 3D printing. Retrived 15th of December 2016, from <http://3mf.io/>

ASTM. (n.d.) ASTM F42 Technical Committee on Additive Manufacturing Technologies. Retrived 15th of December 2016, from <http://astm.org>

Brookes, J., Meijes, M. (2008) *Cladding of Buildings(fourth edition)*. Abingdon: Taylor & Francis

Christensen, P. & Klarbring, A. (2009). *An introduction to structural optimization* (first edition) New York:Springer

De Witte, D. (2015) *Concrete in an AM process - Freeform concrete processing* (Master's thesis, Technische Universiteit Delft, Delft, The Netherlands). Retrieved from <https://repository.tudelft.nl/islandora/object/uuid:059aef3b-a2ad-4c16-8807-40c73823d77a?collection=education>

*Frei Otto, complete works : lightweight construction, natural design* Basel [etc] : Birkhäuser, 2005. Otto, F., Nerdinger, W., Meissner, I., Barthel, R. and Breusing, C. 2015

Foster, N. (n.d.) willis faber dumas headquarters. Retrived 15th of December 2016, from <http://www.fosterandpartners.com/projects/willis-faber-dumas-headquarters/>

Gibons, I., Rosen, D. & Stucker, B., (2015) *Additive Manufacturing Technologies: 3D printing, Rapid Prototyping and Direct digital Manufacturing* (second edition) New York:Springer

Hix, J. (1996) *The Glasshouse* London: Pahadion

Hopkinson, N., Hague, R. & Dickens, P. (2006) *Rapid Manufacturing: An industrial revolution fr the digital age* Chichester: Wiley

Knaack, U., Klein, T., Bilow, M. & Auer, T. (2007). *Façades: Principals of construction* Berlin: Birkhäuser

Langelaar, M., & Keulen, F. (2015). *Topology optimization. A natural counterpart of additive manufacturing*. TU Delft Lecture Notes.

Lundgren, J. & Palmqvist, C. (2012) *Structural Form Optimisation*. (Master's thesis, Chalmers University of Technology, Göteborg, Sweden). Retrieved from <http://publications.lib.chalmers.se/records/fulltext/162939.pdf>

Pryudhi, B. (2016). *3F3D: Form Follows Force with 3D printing* (Master's thesis, Technische Universiteit Delft, Delft, The Netherlands). Retrieved from <http://repository.tudelft.nl/islandora/object/uuid:b068f81c-1561-4733-a07d-05e60368184b?collection=education>

Schittich, C., Staib, G., Balkow, D., Shuler, M. & Sobek, W. (2007). *Glass Construction Manual(second edition)* Berlin: Birkhäuser

Strauss H. (2013) *AM Envelope: The potential of Additive Manufacturing for façade construction*  
TU Delft. <http://repository.tudelft.nl/islandora/object/uuid:3a69355a-51d7-4207-943f-57a03f855d04?collection=research>

Vidimce, K., Kaspar, A., Wang, Y. & Matusik, W. (2017) *Foundry: Hierarchical Material Design for Multi-Material Fabrication*  
Massachusetts Institute of Technology

Weller, B. (2009). *Glass in building : principles, applications, examples*  
München: Birkhäuser

Wurm, J. (2007). *Glass structures: Design and construction of self-supporting skins.*  
Berlin: Birkhäuser

# Appendices

## Product information



### Preliminary Data Sheet

20% milled carbon fibres  
Latest revision: Januari 2015

Properties	Test methods	Units	carbon fibres
<b>Physical properties</b>			
Specific gravity	ISO 1183	g/cm <sup>3</sup>	1,35
Water absorption at saturation, 23 °C	ISO 62	%	-
Humidity absorption, 23 °C/50 % r.h.	ISO 62	%	-
Mould shrinkage (flow direction, 3 mm)	ISO 2577	%	0,2 - 0,4
<b>Mechanical properties</b>			
Tensile strength (max.)	ISO 527	MPa	76
Elongation at break	ISO 527	%	7,5
Flexural strength	ISO 178	MPa	110
Flexural modulus	ISO 178	GPa	6,2
IZOD impact strength, notched	ISO 180/1eA	kJ/m <sup>2</sup>	6
IZOD impact strength, unnotched	ISO 180/1eU	kJ/m <sup>2</sup>	60
<b>Thermal properties</b>			
Heat distortion temperature (1,81 MPa)	ISO 75	°C	65
Relative temperature index, 3 mm, with impact	UL 746B	°C	-
Coefficient of linear thermal expansion	ISO 11359	K·10 <sup>-5</sup>	-
<b>Flammability</b>			
Burning behaviour	IEC 60695-11-10	-	HB @ 3,2 mm
UL recognition	UL94	-	-
<b>Electrical properties</b>			
Surface resistivity	ASTM D257	/sq	10 <sup>9</sup>
Comparative tracking index	IEC 60112	V	-
Glow wire rating, 1,6 mm	IEC 695-2-1	°C	-
<b>Processing conditions (injection moulding)</b>			
Drying conditions (dehumidifying drier)	: 3 - 5 Hours @ 65 °C		
Maximum allowable moisture content	: 0,02 %		
Melt temperature	: 235 - 255 °C		
Mould temperature	: 60 - 75 °C		
Screw speed	: 0,1 - 0,2 m/s		
Back pressure	: 0 - 1,0 MPa		
Injection pressure	: Keep to a minimum		
Injection speed	: Fast ram speed		
Hold pressure	: Keep to a minimum		
colorFabb	Tel:	+ 31 (0)77 - 398 09 09	
Noorderpoort 45	Fax:	+ 31 (0)77 - 397 14 14	
5916 PJ VENLO	Email:	sales@colorfabb.com	
The Netherlands	Website:	colorfabb.com	

This information is based on our experience to date and we believe it to be reliable. It is intended as a guide for use at your discretion and risk. We cannot guarantee favourable results and assume no liability in connection with the use of the product described. None of this information is to be taken as a license to operate under, or a recommendation to infringe, any patents.

# Technical Data Sheet

## Eastman Amphora™ Flex 3D Polymer FL6000

### Application/Uses

- Production of 3D Printing filaments

### Key Attributes

- Dimensional stability
- Enhanced aesthetics
- Excellent Temperature Resistance
- Excellent toughness
- Extended Processing Window
- Low odor
- Property retention in 3D applications
- Steam Sterilizable
- Styrene-free
- Workability

### Product Description

Eastman Amphora™ Flex 3D polymer FL6000, a flexible material uniquely engineered for extrusion-based additive manufacturing processes. Amphora Flex FL6000 is a polymer that can be used with standard 3D printers—eliminating the need to switch to specialized flex extruders. Thanks to exceptional layer-to-layer adhesion and melt strength, it prints at a faster speed than other elastomeric materials, saving you time. Amphora Flex FL6000 is an engineering-grade material that demonstrates superior durability and toughness, enabling designers to quickly create truly functional parts that can withstand the rigors of everyday use. Amphora Flex FL6000 is highly useful for applications that demand both the durability of an engineering-grade polymer and the comfort and utility of a flexible material. With a Shore A hardness level of 95, outstanding chemical resistance, and a temperature resistance that allows steam sterilization, users may find it to be the ideal polymer for additive manufacturing of prosthetics, orthotics, automotive parts, apparel, tooling, or a variety of consumer products.

### Typical Properties

Property <sup>a</sup>	Test <sup>b</sup> Method	Typical Value, Units <sup>c</sup>
<b>General Properties</b>		
Specific Gravity	D 792	1.13 g/cm <sup>3</sup>
<b>Mechanical Properties</b>		
Tensile Stress @ Yield	D 638	14 MPa (2030 psi)
Tensile Stress @ Break	D 638	22 MPa (3200 psi)
Elongation @ Yield	D 638	38%
Elongation @ Break	D 638	400%
Flexural Modulus	D 790	150 MPa (21750 psi)
Tear Strength	D 1004	350 N (79 lbf)
Durometer Hardness		
Shore D Scale	D 2240	55



# Dow Corning® TSSA Transparent Structural Silicone Adhesive

*Crystal Clear Bonding EXTERIOR*

### Aesthetics

- Crystal clear adhesive
- Almost invisible bonding
- Sleek and flush facade aesthetics
- Uninterrupted– no glass drilling
- Small point fixing connections\*

### Energy Efficiency & Durability

- Point-fixed gas-filled insulating glass without breaching IG cavity
- No glass drilling – no risk of gas loss
- For high performance double and triple glazed IG units

### Features

- High UV and temperature resistance
- Performance tested according to ETAG 002-1 requirements
- >9 times higher dynamic design load\*
- >50 times higher permanent design load\*
- High movement capability
- Factory bonding - for Dow Corning® Quality Bond TSSA applicators

### Applications

#### Point fixed glass facades:

- With and without mechanical deadload support
- Curved glass
- Laminated glass with functional or decorative interlayers

Dow Corning® TSSA is an optically clear and high strength silicone film for EXTERIOR FACADE applications. It is applied in factory and cures under heat. The high quality of crystal clear bonding is ensured through the well established *Quality Bond™* Program.



**PRESSGLASS**  
Constructed in 2015

**When Technology meets Aesthetics:** 2000 point-fixed connection points were bonded with crystal clear high strength silicone film - Dow Corning TSSA.

\*compared to 2-part structural glazing silicones from Dow Corning



# Dow Corning® TSSA – Transparent Structural Silicone Adhesive

## FEATURES & BENEFITS

- Crystal clear, transparent, high strength silicone film adhesive for point fixed frameless glazing applications
- 1.3 MPa (190 psi) dynamic design stress, 9.5 times higher compared to conventional structural glazing silicones
- 0.6 MPa (90 psi) dead load design stress
- Silicone film adhesive – clean non-messy application
- Suitable for factory glazing with cure in an autoclave
- Precatalyzed, ready to cure
- No by-products during cure
- UV- and weather –resistant
- Excellent, wide range temperature stability suitable for exterior facades: -50°C (-58°F) to +150°C (+300°F)
- Ready to use 50 mm (2 inch) diameter circular buttons
- No glass drilling allows for uninterrupted glass interlayers
- Suitable for use with laminated glass
- Can be cured simultaneously with PVB and DuPont™'s SentryGlas® Plus interlayers
- Suitable for annealed, heat strengthened and tempered glass
- Suitable for single and double glazed units
- Suitable for use with 316 alloy stainless steel
- Slim point fixing – for filigree façade aesthetics

High strength structural glazing silicone film adhesive

## APPLICATIONS

- *Dow Corning®* TSSA - Transparent Structural Silicone Adhesive is 1mm thick, transparent silicone film adhesive tailor made for structural point fixed frameless interior and exterior glazing applications. *Dow Corning* TSSA is suitable for laminated glass with different functional interlayers as well as point fixed frameless systems with gas filled insulating glass units. *Dow Corning* TSSA provides a design strength for dynamic loads which is 9.5 times higher than a conventional structural glazing silicone.

## TYPICAL PROPERTIES

Specification Writers: These values are not intended for use in preparing specifications. Please contact your local Dow Corning sales office or your Global Dow Corning Connection before writing specifications on this product.

Test*	Property	Unit	Result
<b>As supplied – uncured state</b>			
	Color		Crystal clear
CTM 97B	Specific gravity	g/ml	1.01
	Film Thickness	mm	1
	Curing Time at 120°C to 130°C (250°F to 266°F)	min	30
	Autoclaving temperature range	°C (°F)	120 to 150 (250 to 300)
<b>As cured</b>			
	Service temperature range	°C (°F)	-50 to 150 (-58 to 300)
ASTM D2204	Durometer Hardness	A scale	75
ASTM D412	Maximum Tensile strength	MPa (psi)	8.5 (1230)
ASTM D412	Elongation at maximum tensile	%	250
ASTM D412	Modulus at origin	MPa (psi)	9 (1300)
ASTM D412	Tensile strength at 100% elongation	MPa (psi)	4.5 (650)
ASTM D3165	Shear strength in lap shear	MPa (psi)	5.7 (825)
ASTM D3165	Shear modulus in lap shear	MPa (psi)	2.5 (360)
<b>As cured on typical hardware</b>			
	Tensile strength 50 mm button	MPa (psi)	4.5 (650)
	Shear strength 50 mm button	MPa (psi)	5.0 (725)

\*CTM: Corporate Test Method, copies of CTM's are available on request.  
ASTM D: American Society for Testing and Materials.





## Mechanical performances

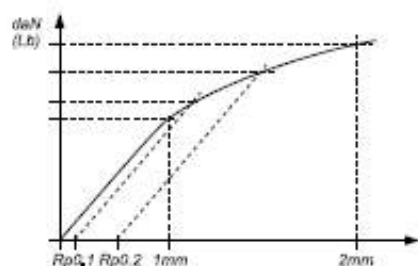

LOAD PARALLEL TO GLASS PER ARM	
1 mm (SLS*)	214 daN (481 lb)
2 mm	408 daN (912 lb)
Rp 0,1 (ULS**)	385 daN (820 lb)
Rp 0,2	427 daN (959 lb)

LOAD PERPENDICULAR TO GLASS PER ARM	
1 mm (SLS*)	110 daN (247 lb)
2 mm	199 daN (447 lb)
Rp 0,1 (ULS**)	153 daN (343 lb)
Rp 0,2	183 daN (411 lb)

\*SLS : Serviceability Limit State - load at 1 mm deformation \*\*ULS - Ultimate Limit State : load at the elastic limit (Rp0.1). Values are given without factor of safety - Tests available online : [www.sadev.com](http://www.sadev.com)

## Configuration

## GLASS SIDE VIEW

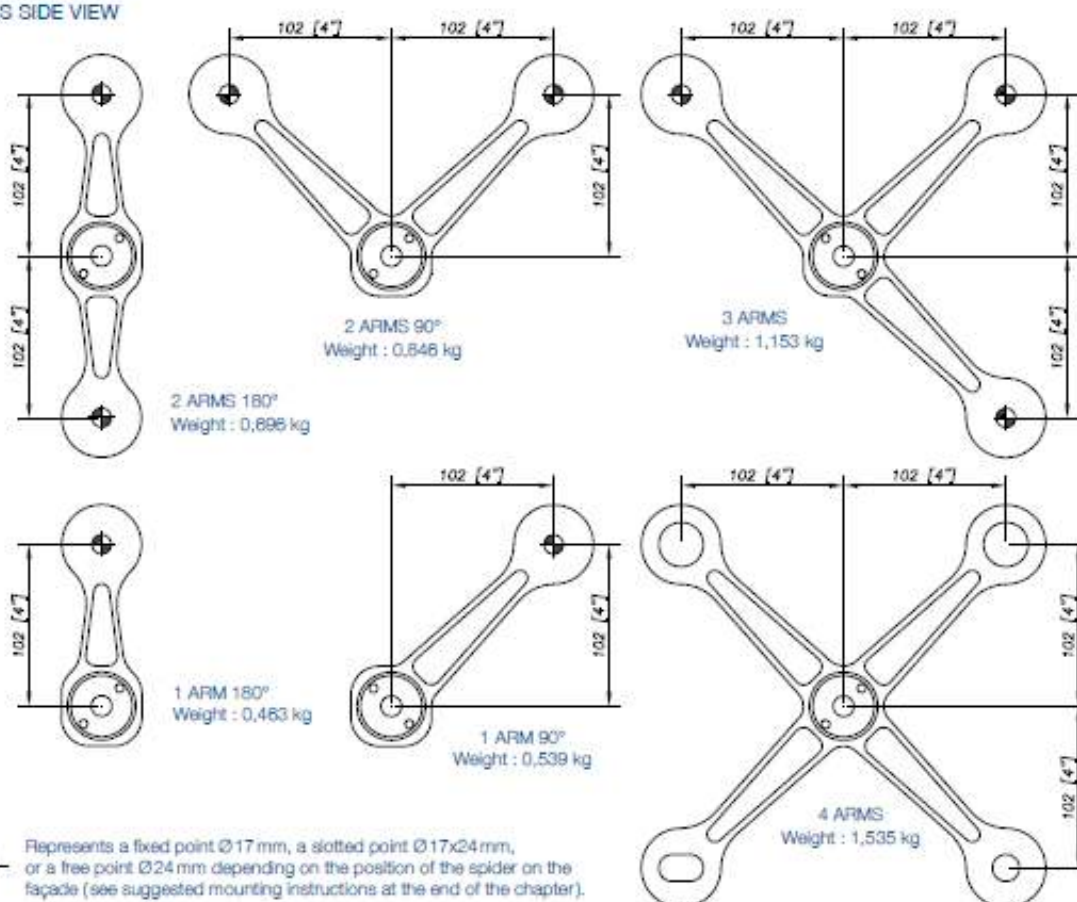

## Suggested mounting instruction

The drilling diameter for the pins is 6mm. Do not drill the holes for the pins in your structure before mounting the spiders. To fix the spider on your structure the "Omega" (see accessories) is highly recommended to adjust the spider's position. The fixing of the spider is done with a M16 or a M12 bolt (out of Sadev supply).

This bolt shall not be fitted into a vertical slotted holes due to the risk of slipping (under the weight), the pins are not designed to hold any permanent loads (cf. specification sheet). The spider has to be positioned on a flat support. The slotted holes Ø17x24mm and free holes Ø24mm in the spider are not to be used to adjust the spider! They are needed to absorb the manufacturing tolerances and the thermal deformation of the glass and of the structure. The spiders are standardized for M14 fittings (FXR, FXV); other diameters are available on request.

SADEV recommends using thread locking compound, except in case of specific mounting constraints.

# R 1006 TSSA

Designation: swivel fitting, Ø 60 mm,  
for UV bonding to glass.



REFERENCE TO ORDER			
GLASS THICKNESS	Ø AXIS	LENGTH AXIS (mm)	ARTICLE CODE
	M14	65	R1006TSSA-1465*
	SPECIAL	SPECIAL	R1006TSSA-SP

\* R1006TSSA-1465 : Model - type axis and length.

Patent N° : 9806556

Sealing strip between glazing available p.6.26

The swivel fitting R1006 TSSA has been specially designed for bonding type Dow Corning TSSA (Transparent Structural Silicone Adhesive).  
More information on [www.dowcorning.com](http://www.dowcorning.com).

## Dimensions

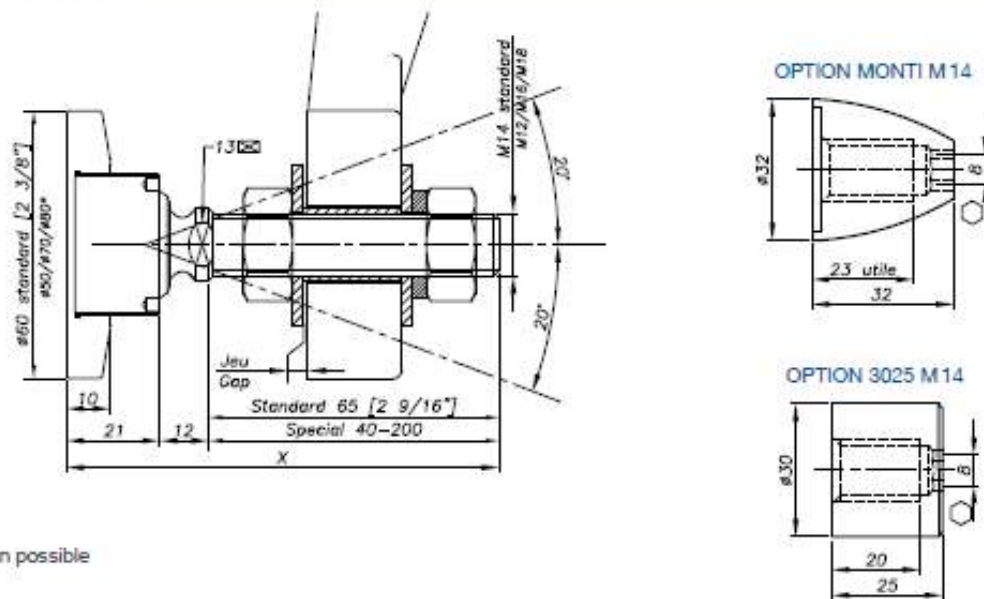

\* Option possible

## No glass drilling

SHEAR STRESS	MATERIAL
0.593 kN at 1mm deformation	1.191 kN at 1mm deformation
6.492 kN at failure	6.949 kN at failure
778 N/mm shear rigidity	
453 kNmm Bending Moment	
1191 kN tensile stress at 1mm deformation	
5949 kN tensile stress at failure	

It is important to provide the following information with each request: the glass composition (ex.: 10 mm monolithic, 6.6.4 laminated, 6.6.2-12-10 insulating) / the length and diameter of the threaded axle if not standard dimensions (M14, 65 mm) / the reference of the spider to be used as support, or the thickness of an existing support for the delivery of the spacer.

### Mechanical performance

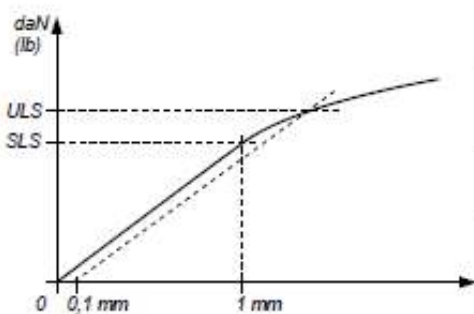

	BENDING CAPACITY			PULL OUT CAPACITY
	D	SLS*	ULS*	ULS*
M 14	45mm	344 daN (773 lb)	677 daN (1297 lb)	2000 daN (4496 lb)
	60mm	163 daN (343 lb)	364 daN (818 lb)	
M16	45mm	504 daN (1133 lb)	827 daN (1859 lb)	
	60mm	253 daN (568 lb)	525 daN (1180 lb)	

\*SLS - Serviceability Limit State: load at 1mm deformation  
 \*ULS = Ultimate Limit State: load at the elastic limit (Rp0.1).  
 Values are given without factor of safety.  
 Tests available online: [www.sadev.com](http://www.sadev.com)

### Components

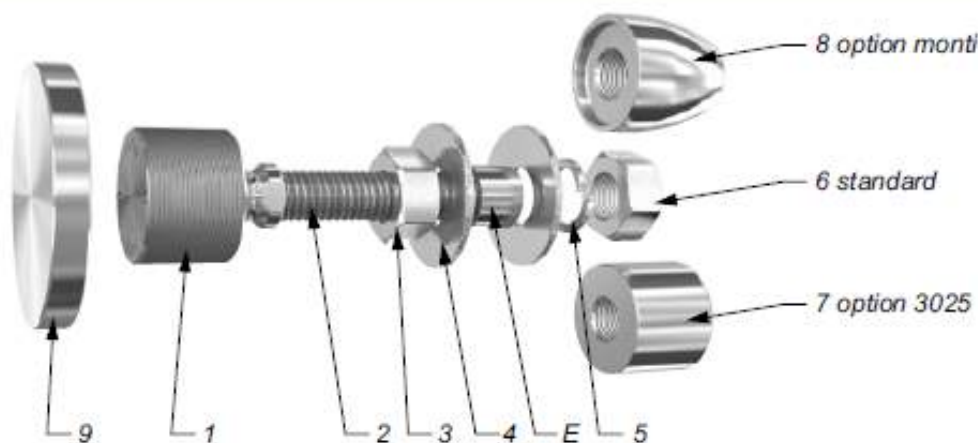

MARK	QUANTITY	DESIGNATION	MATERIAL
1	1	Swivel body	X2 Cr Ni Mo 17.12.2 as per EN 10088-3
2	1	Threaded Axle	X4 Cr Ni Mo 16.5.1 as per EN 10088-3
3	1	Nut DIN 934	A4
4	2	Washer	A4
5	1	Lock washer DIN127	A4
6	1	Nut DIN 934	A4
7	1	3025 Cap nut - Option	X2 Cr Ni Mo 17.12.2 as per EN 10088-3
8	1	Monti cap nut - Option	X2 Cr Ni Mo 17.12.2 as per EN 10088-3
9	1	Adhesion disk	X2 Cr Ni Mo 17.12.2 as per EN 10088-3

### Suggested mounting instruction

Attach adhesion disk N°9 onto the glass in accordance with technical specifications of UV glue manufacturer and glass fabricator (Can be adhered in the factory).

Mount parts N° 1/2 into part N°9. Thread on nut N°3 and apply washer N°4.

Insert the threaded axle into the support with spacer E (available on request), see technical page. Adjust the depth. Mount the second washer N°4, lock washer N°5, and nut N°6. Tighten to 60Nm (45 ft-lb) using a 22 mm wrench.

SADEV recommends using thread locking compound whenever possible.

