

**Document Version**

Final published version

**Citation (APA)**

Müller, S. C., Georg, H., Nutaro, J. J., Widl, E., Deng, Y., Palensky, P., Awais, M. U., Chenine, M., Küch, M., Stifter, M., Lin, H., & More Authors (2018). Interfacing Power System and ICT Simulators: Challenges, State-of-the-Art, and Case Studies. *IEEE Transactions on Smart Grid*, 9(1), 14-24. <https://doi.org/10.1109/TSG.2016.2542824>

**Important note**

To cite this publication, please use the final published version (if applicable).  
Please check the document version above.

**Copyright**

In case the licence states "Dutch Copyright Act (Article 25fa)", this publication was made available Green Open Access via the TU Delft Institutional Repository pursuant to Dutch Copyright Act (Article 25fa, the Taverne amendment). This provision does not affect copyright ownership.  
Unless copyright is transferred by contract or statute, it remains with the copyright holder.

**Sharing and reuse**

Other than for strictly personal use, it is not permitted to download, forward or distribute the text or part of it, without the consent of the author(s) and/or copyright holder(s), unless the work is under an open content license such as Creative Commons.

**Takedown policy**

Please contact us and provide details if you believe this document breaches copyrights.  
We will remove access to the work immediately and investigate your claim.

***Green Open Access added to TU Delft Institutional Repository***

***'You share, we take care!' - Taverne project***

**<https://www.openaccess.nl/en/you-share-we-take-care>**

Otherwise as indicated in the copyright section: the publisher is the copyright holder of this work and the author uses the Dutch legislation to make this work public.

# Interfacing Power System and ICT Simulators: Challenges, State-of-the-Art, and Case Studies

*IEEE Task Force on Interfacing Techniques for Simulation Tools*

Contributors: Sven Christian Müller, Hanno Georg, James J. Nutaro, Edmund Widl, Yi Deng, Peter Palensky, Muhammad U. Awais, Moustafa Chenine, Markus Küch, Matthias Stifter, Hua Lin, Sandeep K. Shukla, Christian Wietfeld, Christian Rehtanz, Christian Dufour, Xiaoyu Wang, Venkata Dinavahi, Md Omar Faruque, Wenchao Meng, Shichao Liu, Antonello Monti, Ming Ni, Ali Davoudi, and Ali Mehrizi-Sani

**Abstract**—With the transition toward a smart grid, the power system has become strongly intertwined with the information and communication technology (ICT) infrastructure. The interdependency of both domains requires a combined analysis of physical and ICT processes, but simulating these together is a major challenge due to the fundamentally different modeling and simulation concepts. After outlining these challenges, such as time synchronization and event handling, this paper presents an overview of state-of-the-art solutions to interface power system and ICT simulators. Due to their prominence in recent research, a special focus is set on co-simulation approaches and their challenges and

potentials. Further, two case studies analyzing the impact of ICT on applications in power system operation illustrate the necessity of a holistic approach and show the capabilities of state-of-the-art co-simulation platforms.

**Index Terms**—Co-simulation, communication systems, information technology, power system simulation, smart grids.

## I. INTRODUCTION

MODELING and simulation is a key method for solving engineering problems. Pioneered and perfected in avionics and defense, it is now used in virtually all technology domains. Engineering of the energy system traditionally meant sizing and placing infrastructures like centralized power plants or transmission lines. Loads were described with statistical models, and the focus was on the dynamics of the electrical equipment like transformers, generators or power lines. Planning and operating an electric power system is a complex task, but the computational tools made questions like optimal power flow or N-1 security easier to answer. The new millennium, however, introduced distributed and renewable generation, intelligent loads, and real-time markets, all enabled and empowered by information and communication technologies (ICT). These modern and future power systems can be described as cyber-physical systems [1] or even as heterogeneous systems, where physical/continuous parts, digital/discrete elements, people/agents/roles, markets, and the environment interact with each other in a close fashion. It is therefore necessary to model all these different domains and aspects in order to describe the entire behavior of the system. Because ICT is needed to make the power system more flexible and efficient, the complex interplay between digital world and physical infrastructure has to be understood. The ICT presents a solution and a problem at the same time: enabling complex controls in a smart grid while introducing additional complexity, new sources of failure, and security threats [2]. These developments also require a new level of detail in simulations of the power grid, because commonly ICT has only been considered very simplified, e.g., by guessing or only roughly estimating static communication latencies when

Manuscript received August 3, 2015; revised December 26, 2015; accepted February 15, 2016. Date of publication March 30, 2016; date of current version December 21, 2017. Paper no. TSG-00847-2015.

S. C. Müller, M. Küch, and C. Rehtanz are with the Institute of Energy Systems, Energy Efficiency, and Energy Economics, TU Dortmund University, Dortmund 44227, Germany (e-mail: svenchristian.mueller@tu-dortmund.de).

H. Georg and C. Wietfeld are with the Communication Networks Institute, TU Dortmund University, Dortmund 44227, Germany.

J. J. Nutaro is with the Department of Computational Sciences and Engineering, Oak Ridge National Laboratory, Oak Ridge, TN 37831-6085 USA.

E. Widl, M. U. Awais, and M. Stifter are with the Energy Department, Austrian Institute of Technology, Vienna 1090, Austria.

Y. Deng, H. Lin, and S. K. Shukla are with the Department of Electrical and Computer Engineering, Virginia Tech, Arlington, VA 22203 USA.

P. Palensky is with the Department of Electrical Sustainable Energy, Delft University of Technology, Delft 2600, The Netherlands.

M. Chenine is with the Department of Industrial Information and Control Systems, KTH Royal Institute of Technology, Stockholm 10044, Sweden.

C. Dufour is with Opal-RT Technologies, Montreal, QC H3K 1G6, Canada.

X. Wang and W. Meng are with the Department of Electronics, Carleton University, Ottawa, ON K1S 5B6, Canada.

V. Dinavahi is with the Department of Electrical and Computer Engineering, University of Alberta, Edmonton, AB T6G 2V4, Canada.

M. O. Faruque is with the Center for Advanced Power Systems, Florida State University, Tallahassee, FL 32310 USA.

S. Liu is with the Department of System and Computer Engineering, Carleton University, Ottawa, ON K1S 5B6, Canada.

A. Monti is with E.ON Energy Research Center, RWTH Aachen University, Aachen 52074, Germany.

M. Ni is with State Grid Electric Power Research Institute, Nanjing, China

A. Davoudi is with the Department of Electrical and Computer Engineering, University of Texas, Arlington, TX 76011 USA.

A. Mehrizi-Sani is with the School of Electrical Engineering and Computer Science, Washington State University, Pullman, WA 99164 USA.

Color versions of one or more of the figures in this paper are available online at <http://ieeexplore.ieee.org>.

Digital Object Identifier 10.1109/TSG.2016.2542824

simulating ICT-dependent control systems for the power grid. Some typical questions that require an in-depth consideration of the interdependencies of the both domains are:

- What is the effect of realistic (varying) latencies, packet loss or failures in the ICT system on the reliability and performance of novel monitoring, protection and control applications?
- What impact would cyber security threats have on the monitoring, protection and control of the power system?
- To what extent can a certain ICT infrastructure satisfy the requirements of novel monitoring, protection and control applications in the power system? Which ICT infrastructure would be needed?

Against this background, novel simulation frameworks have been developed in the recent past targeting the joint simulation of power and ICT systems. However, most leading solutions in this area are still subject to research and development. Therefore, quantitative benchmarks are not possible and solutions are hard to compare, and frequently similar problems arise in the conceptualization, development and application of the simulation frameworks. Therefore, this IEEE Task Force contribution has been elaborated in joint work of developers of several state-of-the-art power and ICT system simulators. The aim of this paper is to provide insights into the various challenges and solutions and to serve as a fast entry point into the problem of smart power system simulation, under consideration of the experience of the authors. For this, fundamental challenges in interfacing power system and ICT simulators are outlined (Section II) and an overview of the most advanced solutions to this problem is provided (Section III). Further, the importance and potential of a combined analysis of both domains is illustrated in two case studies investigating the impact of ICT on monitoring and control systems by use of state-of-the-art co-simulation approaches (Section IV). Finally, Section V concludes the paper.

## II. MODELING AND SIMULATION PRINCIPLES

The tools and methods available today for the modeling and simulation of power systems inevitably reflect the established engineering approaches of this field, and there is a broad spectrum of excellent simulation tools for electric transmission and distribution grids that cover the needs of traditional power system engineering. However, in the light of the possibilities offered and the challenges posed by modern smart grid solutions, the view of power systems has to become broader, including multiple (physical) domains and detailed ICT-based control schemes. Solutions from other industrial sectors that have faced a similar development in the past, e.g., the automotive industry, can only be adopted with care, as power systems are potentially very large and consist of components characterized by extremely different time scales. In the following, the governing principles regarding modeling and simulation of power systems and communication networks are discussed and compared, highlighting the challenges associated with coupling these two domains in a simulation environment.

It is noteworthy that the main difficulty in creating combined models of communication and power systems is not

a lack of appropriate mathematics and numerical methods. These fundamental problems have been addressed and resolved in several contexts that are suitable for modeling and simulating smart power systems [3]–[6]. Rather, it is the cost and difficulty of creating *new* models within *new* simulation frameworks for hybrid systems that makes a combined simulation difficult. There is a strong incentive to reuse existing simulation tools and the models within those tools, and the tradeoffs inherent in reuse of existing simulation software figures prominently, if only implicitly, in most work on the combined simulation of power and communication systems.

This tradeoff may be stylized as a choice between three options, of which we can pick only two. These are

1. Reuse, essentially as is, of communication and power system models that exist separately within well-established simulation packages.
2. Accurate simulation of the interactions between the power system and the communication system.
3. Rapid execution of the combined simulation.

The various solutions summarized in this article demonstrate the feasible combinations. Fast and accurate simulation of smart power systems requires building new models for the communication system or power system (but rarely both) within a simulation package designed for, or readily adapted to, a hybrid system simulation. On the other hand, simulations that exhibit a high degree of reuse rely on ad-hoc approaches to manage time and interactions between existing simulation packages and these computations can be accurate or rapidly executing, but not both.

Which combination is selected depends strongly on the perceived relative values of reuse, accuracy, and execution speed within the context of some particular simulation study. Thus, it is impossible to dictate a best solution, and even comparisons of solutions for co-simulation are difficult if we do not restrict ourselves to very narrow use cases. Therefore, we illustrate the range of solutions that are possible and indicate the benefits of each within the scope of its applications.

### A. Power Systems

Power systems comprise a complex arrangement of individual physical components that perform a multitude of different tasks associated with generation, transmission, distribution, storage, and consumption of energy. Despite their wide range of functionality and application, all these individual components are in general described by (sets of) *differential algebraic equations* (DAEs) that arise from fundamental physical laws such as energy conservation or Maxwell's equations [7], [8]. When a component has more than one operational mode, e.g., an on/off state or transformer tap position, then its set of DAEs are subject to change over time.

Due to their physical coupling, these individual components interact dynamically, i.e., their respective states are interdependent and their evolution with respect to time is linked. Within a model, these interdependencies appear as mathematical coupling of the components' DAEs. For instance, synchronous machines within the same network are coupled via the network frequency and thereby influence each other.

The actual model used in a simulation depends on the question at hand, and it is up to the model developer to choose the most appropriate model for a given problem. For instance, depending on the required level of detail, a distribution grid might be modeled in different ways, using either a sequence of quasi-static power flow calculations, an electro-mechanical Root Mean Square (RMS) simulation or an Electromagnetic Transient (EMT) simulation considering transient effects.

There is a large spectrum of tools dedicated to modeling and simulating the physical aspects of power systems. The methods employed by these tools can be categorized in two classes:

- *Steady-state calculations:* These methods (e.g., power flow computation) calculate a snapshot of a power system, i.e., the steady state according to a set of (step-wise) constant inputs and boundary conditions. In cases where the assumption of a quasi-static system evolution is adequate, a series of such snapshots is a sufficient simulation approach. However, such approaches fail to capture the transient dynamics of a power system. Typical time steps for these simulations are in seconds, minutes, or hours.
- *Continuous time calculations:* To take into account the dynamic effects within a power system, e.g., oscillations due to switching or faults, the underlying physical equations have to be solved with respect to time. In comparison to steady-state calculations this typically involves a much higher computational effort. *Numerical integration methods* are usually deployed for solving the DAE systems, and these methods control the step size of the time increment in the simulation to ensure stable and precise results. Thus, the models of physical continuous time processes are simulated using *discrete time steps*. The required step size depends on the dynamics of the system and can be, e.g., at the milli- or microsecond level.

Since the detailed consideration of ICT is of particular importance for short-term processes in the power system, the focus in the remainder of the paper is set on the combined analysis of ICT and dynamic power system simulation.

## B. Communication Networks

Communication networks are not usually modelled primarily on the basis of physical principles. Rather, the components of communication networks are modeled according to their functionality, which is governed by the range of capabilities offered by the respective hardware and software [9], [10].

Abstracting to the descriptive level of hardware and software allows simulation of communication processes as the sequential processing and transmission of (virtual) messages and signals. For this, communication networks are commonly simulated with the help of a *discrete sequence of events* in time, where each event marks a significant step of message processing or transmission. Between two consecutive events no relevant action is assumed to occur, hence the simulation can proceed in time from one event to the next. In this context, significant events refer to message processing at a single node or the transmission between (in most cases) two nodes. This means that the effects of these events are localized to the

respective nodes and only affect other nodes indirectly and after a delay, i.e., through causally related consecutive events.

As with power systems, the level of detail required for the modeling and simulation of a communication network depends on the problem at hand. Often the complex processes happening in the underlying software layers and the hardware are represented in a simplified manner by employing *statistical models*. These statistical models use random distributions to estimate delays due to transmission or waiting times due to message processing. Another possibility is the emulation of communication systems, where the functionalities of software and hardware processes are modeled in more detail, often using their actual implementation (e.g., by embedding networking software within a simulator).

## C. Challenges of an Integrated Analysis of Both Domains

The integrated analysis of power systems and communication networks is challenging for several reasons. First of all, the established tools for modeling power systems do not support detailed models of communication networks. Similarly, the established tools for simulating communication networks offer no support for modeling power systems. This leaves basically three feasible options for a combined analysis:

- *General purpose tools:* Some tools (e.g., MATLAB) allow simulation of hybrid models that combine both the power system domain and the communication network domain. Unfortunately, these tools often lack necessary modeling libraries and solvers, or they do not provide sufficiently validated models. Furthermore, they are not optimized for the task at hand and usually show an inferior performance in comparison to specialized tools.
- *Co-simulation approaches:* Here, dedicated tools are coupled to simulate each domain. The obvious advantage of co-simulation is the possibility of reusing the most adequate tools for each respective domain. However, this is accompanied by the need to find a way of synchronizing both simulation tools properly at runtime. In addition, this approach is often limited by the lack of adequate simulation Application Programming Interfaces (APIs) offered by the respective simulation tools.
- *Hardware-in-the-loop (HIL) approaches:* Coupling a real-world hardware setup for (part of) a domain with a simulation tool allows testing of hardware and software components under realistic conditions. Apart from the obvious advantage of replacing error-prone or incomplete models with real-world counterparts, HIL approaches deal with quite similar challenges as co-simulation approaches. In addition, they have to address the issue of guaranteeing the execution of the simulator in accordance to the real time constraint of the physical target.

In all three cases the combination of the fundamentally different simulation concepts behind power systems and communication networks has to be given special consideration. In general, the main methodical challenge is to detect, link, and handle related events in both domains.

For power system simulation, event detection is typically associated with values crossing certain thresholds. In contrast

to the discrete event-based approaches used for communication network simulations, the precise event detection by means of value threshold crossings is in general a computationally intensive operation, especially in the case of large systems.

Once an event has been detected, the information associated with that event has to be passed to the other domain where a reaction will take place. This is the most crucial point in interfacing the two domains. The responsible algorithms have to ensure the *synchronous* and *deterministic* execution of both domains simultaneously. For instance, a communication network simulator must not proceed to a future event while the power system simulator has not caught up in time and might still detect a preceding event.

### III. STATE-OF-THE-ART OF INTERFACING POWER AND ICT SYSTEMS SIMULATIONS

There exists a range of proposed solutions to the problem of proper time synchronization and event handling to link power system and communication network simulations. The actual methods depend strongly on the selected simulation approach, each coming with their own advantages and disadvantages.

As presented in the previous section, passing information from one domain to the other while assuring a synchronous and deterministic execution of both domains is the main challenge for connecting simulators using a co-simulation or HIL approach. This applies in particular to solutions using a continuous time power system simulation, on which we set the focus in the following section. In order to present related work in this context, the section first details simulation frameworks which are applied to interface simulators of both domains in Section III-A. Afterwards, existing co-simulation approaches are introduced in Section III-B and related work regarding HIL simulations is presented in Section III-C.

#### A. Simulation Frameworks

Recent trends in the field of computer simulation systems lead to the specification of simulations frameworks, which define standardized APIs to combine different simulators or to improve their efficiency. These approaches have been initially developed by the military and automation industries, and are exemplified by standards like the High Level Architecture (HLA) [11] and the Functional Mock-up Interface (FMI) [12]. While these standards have been applied in aforesaid fields for decades, their reuse in the course of developing co-simulation or HIL frameworks is anything but straight forward and has to take into account special requirements of power and ICT simulators. This section provides an overview of available frameworks and techniques, especially regarding their capability for simulating smart grids.

1) *IEEE 1516 High Level Architecture (HLA)*: Mainly driven by military research with the focus on enabling joint simulation training, different approaches to co-simulation have been developed since the mid-1990s. The first attempt to create a widely accepted standard resulted in the specification of the IEEE Standard 1278 – Distributed Interactive Simulation (DIS) in 1993 and its successor IEEE 1516-2000 – HLA resp., IEEE 1516-2010 – HLA evolved.

Following the standards terminology, a HLA-based simulation (also referred to as *federation*) consists of participating simulators (*federates*) and a centralized core component, the *Run-Time Infrastructure* (RTI). Based on a generic object-oriented model description – the so called *Object Model Template* (OMT) – the RTI provides an API to access system-wide and simulator-specific attributes and interactions, which must be implemented by the federates to enable bidirectional communication from and to the RTI. Challenges in applying HLA are license costs for advanced RTIs and considerable effort for implementing the standardized interfaces to the simulators. In terms of scalability, HLA based frameworks are providing the ability of highly parallelized simulations of large-scale systems, but – as a drawback - are introducing additional time-synchronization issues.

2) *Functional Mock-Up Interface (FMI)*: When extending a simulation by adding a shared library to the implementation, many difficulties have to be overcome including different header files and gaining knowledge about the functions the library exports. If there was a way that all libraries for one specific type of work exported the same functions and used the same header files, then implementation would become much easier and extensible. For example, a simulation module is generally expected to do a defined set of abstract tasks like getting the model inputs, advancing in time, and updating output values as the time progresses.

The FMI serves the purpose of providing a common interface by defining abstract functions to be implemented by every simulation component. It also defines how to export a simulation component as a shared library. Similarly, the rules for importing FMI components, called Functional Mock-up Units (FMUs), into a combined simulation are specified by the FMI standard. Currently, there are more than 50 different simulation packages that conform to the FMI standard [13]. Regarding the scalability, the FMI specification provides the flexibility to integrate simulation models in a distributed and parallel way. This potentially allows a speed-up over conventional single-threaded simulation approaches for large-scale network simulation [14], [15].

3) *Mosaik*: Mosaik [16] is a flexible Python-based open-source co-simulation framework dedicated to the analysis of smart grid applications. Apart from enabling the coupling of domain-specific simulators and control applications it provides a flexible mechanism for generating large-scale scenarios. This is done with the help of the Mosaik Specification Language (MoSL) that synthesizes simulation scenarios based on information provided by the individual simulation components. Mosaik adopts a discrete event-based simulation approach to execute models, and this approach also enables dynamic step size control at run time. Thereby, Mosaik provides a scalable solution for simulating even large-scale scenarios.

4) *Ad-Hoc Approaches*: Ad-hoc coupling of simulation tools is an alternative to the use of existing, standardized simulation frameworks. In an ad-hoc approach, the interfaces between simulators are implemented only within the simulators itself, possibly requiring far reaching adaptations of the simulators that are to be reused. One of the advantages of

using ad-hoc frameworks is its conciseness and efficiency. Most of the proprietary simulation tools do not provide direct interfaces for advanced simulation frameworks, and for this reason ad-hoc coupling is prominent in practice. As a result, tool developers have to tackle several challenges such as continuous and discrete-event integration, multi-platform time-synchronization, scalability, and usability, which are more easily solved with interoperability frameworks like the HLA and FMI.

### B. Co-Simulation Approaches

This section provides an overview of the state-of-the-art of co-simulation approaches for smart grids, which are summarized in Table I. Applying the simulation frameworks described in the previous subsection, these approaches can be assigned different strategies for realizing the interface between specialized simulators for both domains. Further, prominent examples for the corresponding strategies and their unique characteristics are outlined in the following.

1) *ADEVS: A Discrete Event System simulator (ADEVS)* is a simulation package for hybrid dynamic systems. The mathematical basis for ADEVS is Zeigler's Discrete Event System Specification (DEVS) [3], from which the simulation package derives its approach to managing time and interactions between simulated components. Within ADEVS, a power system model called the Toolkit for Hybrid Modeling of Electrical power systems (THYME) was developed to study control and communication problems in the context of wide area control. The THYME model includes electro-mechanical models of generators, the transmission network, and ZIP models of electrical loads, and these can be combined directly with discrete event models of control algorithms, communication networks, and other discrete event processes. This combination extends to the use of THYME as a module within communication network simulations, such as NS-2 and OMNET++, instance of which are described in [4] and [22]. The distinguishing feature of this approach to co-simulation is its precise handling of interactions between discrete event and continuous sub-systems, which emerges naturally from encapsulating the continuous time dynamics within a discrete event model.

2) *EPOCHS: The Electrical Power and Communication Synchronizing Simulator (EPOCHS)* is the first known co-simulator for realizing a combined simulation of power and communication systems. EPOCHS utilizes the concept of federated dynamic simulation integrating multiple components. It consists of three simulators: PSCAD/EMTDC for transient protection simulation with short term time domain responses (EMT), PSLF for large-scale power system stability simulations (RMS), and NS-2 for communication network modeling. An RTI is used to exchange shared data periodically by interfacing and synchronizing the individual simulators. The main purpose of EPOCHS has been to simulate agent-based protection systems. For time synchronization, EPOCHS applies a preprogrammed time-stepped synchronization with fixed synchronization points. This leads to a tradeoff between precision and efficiency.

3) *GECO: The Global Event-Driven Co-Simulation Framework (GECO)* is a co-simulation platform aimed at simulating communication-based power system monitoring,

protection, and control. It interfaces the power system simulator PSLF and the communication network simulator NS-2 using a global event-driven co-simulation framework where the co-simulation processes are rigorously synchronized. Because the dynamic power system simulation is necessarily solved in a time-discrete manner using a numerical integration method, GECO treats each of the iteration rounds of this numerical method as a time-tagged discrete event. These events are combined with the time-tagged discrete events created by the network simulator, and the entire simulation runs globally in a discrete event driven manner. To ensure the simulation's fidelity and accuracy, a global event scheduler maintains a global event queue to arrange the event sequence, thus providing a synchronization error free framework.

4) *INSPIRE: The Integrated co-Simulation of Power and ICT systems for Real-time Evaluation (INSPIRE)* co-simulation has been introduced in [19] and [20] and realizes a HLA 2010 based co-simulation of the commercial simulators DIgSILENT PowerFactory and OPNET Modeler using an IEC 61850 based OMT to model access to attributes and interactions across all domains. Time synchronization is realized using a time-stepped synchronization based on the HLA time management services. Compared to EPOCHS, INSPIRE is based on dynamic synchronization points, which are assigned according to the chosen step size of the power system simulator. INSPIRE includes highly detailed models and provides a generic architecture, which is extendable to various simulators and additional software tools to enhance the functionalities of the simulator. Up to now, INSPIRE has been applied for the evaluation of wide-area monitoring, protection, and control solutions, taking into account IEC 61850 and IEEE C37.118 for modeling the communication traffic and integrating application implementations realized in C++, Java, GNU R, and MATLAB.

5) *Comparison: EPOCHS* [21] utilizes a preprogrammed time-stepped synchronization with fixed synchronization points. In this scheme, the individual simulators halt at fixed synchronization points in order to exchange information. Hence, the EPOCHS is not suitable for applications which are time-critical and require numerous interfacing between the power system and communication network. Choosing the proper size of a synchronization step will lead to a trade-off between precision and efficiency. The main purpose of EPOCHS has been to simulate agent-based protection systems.

ADEVS [22] offers better synchronization than EPOCHS because it is based on discrete event system modeling. However, the ADEVS package is designed for general discrete event system and not for power system simulations specifically. As a consequence, the reliability of power system models and scalability of the hybrid simulation may be affected when the ADEVS is applied to power systems simulations. Up to now, it has been used in wide-area monitoring, protection, and control systems.

Compared to EPOCHS, INSPIRE [19], [20] is based on dynamic synchronization points, which are assigned according to the chosen step size of the power system simulator. INSPIRE includes highly detailed models and provides

TABLE I  
OVERVIEW OF STATE-OF-THE-ART CO-SIMULATION APPROACHES

	Recent Focus	Power System Simulator	Network Simulator	Simulation Frameworks	Time Strategy	Scalability	Execution Mode
GECO [17][18]	PMU-based WAMPAC, high voltage grid	PSLF	NS-2	Ad-hoc (TCL linking)	Global event-driven	Large systems	NA
INSPIRE [19][20]	WAMPAC, high voltage grid	DigSILENT PowerFactory	OPNET Modeler	IEEE 1516-2010 (HLA evolved)	Dynamic time stepped	Large systems	NA
EPOCHS [21]	Multi-agent protection and control systems	PSCAD/EMTDC, PSLF	NS-2	IEEE 1516-2000 (HLA)	Fixed time stepped	Large systems	NA
ADEVs [22]	WAMPAC	ADEVs	NS-2	Ad-hoc (integrated in NS-2)	DEVs	Large systems	NA
VPNET [23]	WAMPAC	VTB	OPNET Modeler	Ad-hoc (Sockets)	Time stepped	Small systems	NA
GridSim [24]	WAMPAC	Powertech TSAT	GridStat	Ad-hoc	Fixed time stepped	Components can be distributed	Real-time + HIL
PowerNet [25]	Controlling power devices	Modelica	NS-2	Ad-hoc (Unix named pipes)	Time stepped	Small systems	NA
Bergmann <i>et al.</i> [26]	Evaluation of DERs and VPPs	NETOMAC	NS-2	Ad-hoc (JNI)	Time stepped	Small systems	Close to real-time
Babazadeh <i>et al.</i> [27][28]	WAMC, HVDC, low voltage/mid voltage Grid	OPAL-RT	OPNET SITL	Ad-hoc, emulated, sockets	Real-time	Small (HIL), medium (emulated)	Real-time
Greenbench [29]	Cyber security, low voltage grid	PSCAD	OMNeT ++	Ad-hoc (IPC)	Global event-driven	Tested for small systems	NA

a generic architecture, which is extendable to various simulators and additional software tools to enhance the functionalities of the simulator. Up to now, INSPIRE has been applied for the evaluation of wide-area monitoring, protection, and control solutions.

By contrast, GECO [17], [18] uses a global event-driven co-simulation framework where the co-simulation processes are rigorously synchronized aimed at the modeling and simulation for the wide area power system monitoring, protection and control schemes. The fidelity of the emulation cannot be guaranteed if the system is scaled down.

6) *Other Solutions/Discussion*: Besides the co-simulations presented in Table I and described above, other approaches for combining power system and ICT simulation exist [31]–[35]. However, as some of them are focusing on modelling a steady state simulation for power system simulations (e.g., [33]–[35]), this manuscript neglects a detailed presentation of such approaches and instead refers to other overviews in [36]–[38].

With regard to scalability it should be noted that most co-simulation approaches have been developed in research projects and only applied in test systems but not in realistic network models with thousands of buses. The applicability of the approaches in larger systems as stated in Table I does not derive from the successful application in very large systems but from the characteristics of the concepts, i.e., whether the interfacing approach could in general handle large scale systems, e.g., due to a scalable and/or distributed execution. Also, as the co-simulation platforms listed in Table I integrate two individual simulators from both power system domain and ICT domain, the overall scalability of the co-simulation will

be largely determined by the scalability of the individual simulators themselves from both domains and how the integration interface is handled. More specifically, taking the GECO as an example, the power system simulator PSLF is able to simulate a system as large as 60 000 buses and the ICT simulator NS2 is able to simulate a network with at least 20 000 nodes and the simulation time is on the order of  $N \cdot \log(N)$ . Therefore, GECO has the capacity to model and simulate large national systems like WECC. However, it should be noted that the performance of dynamic simulations of very large power systems by itself is still subject of research and that the scalability of simulations of very large systems – as in the case of wide-area measurement systems (WAMS) – is an important and not yet solved research topic.

Notably, this subsection aims at providing an overview of the variety of existing co-simulation approaches, their capabilities as well as the applied simulators and interfacing strategies. Selecting the most appropriate co-simulation for a specific purpose is a difficult task. For a systematic guidance on selecting the most suitable co-simulation approach depending on specific user requests, the reader is hence referred to the co-simulation review and proposed decision tree in [39].

### C. Real-Time and HIL Approaches

Real-time (RT) and HIL approaches originate from the need to test, validate, and verify equipment before deployment in an operational setting. In such setups where a real world process or device (e.g., machines, controls, etc.) is directly or remotely connected via a communication system

to the simulation, the constraint of reacting fast enough to the external signals is imposed on the simulator. Therefore, RT simulators have to guarantee to finish the simulation timestep within a certain time constraint. Here, real time is often misinterpreted as the simulation time step or update rate of RT simulators and HIL setups (or the range of the frequency of the signal dynamics). Fundamentally, however, real time constraints are only determined by the dynamic of the interaction between the coupled simulation system and the hardware. Depending on the frequency response characteristic of the signal, this could be between several microseconds (e.g., a modular multilevel converter [40]) and up to seconds (e.g., a voltage controller [41]), which correspond to up to 1-10 kHz.

RT simulators – like OPAL-RT’s eMEGAsim [42] and RTDS [43] – usually support analog and digital extension interfaces for exchanging simulation outputs or inputs with external devices. Data acquisition and measurement conversion (sampling time) introduce delays which put a limit to the dynamic of the coupling and may also risk the stability of the coupling [44]. Not influencing the overall accuracy of the system, parts of the model could run in different time steps or multi-rate, if dynamics of sub-system are less than in other parts [45]. RT HIL approaches are used extensively by vendors and other academic institutions (e.g., [46] and [47], respectively).

A variant of RT HIL approaches, which is very similar to co-simulation, is interfacing with other simulation and emulation systems. e.g., the approach in [27] and extended in [28] and [48] utilizes, in addition to HIL, detailed simulation models of various power system monitoring and control devices that can co-exist both in the real time simulator as well as on separate platforms. These devices are executed in parallel with the RT simulator and appear as real world devices to subscribing applications. Reference [49] presents an example of C37.118 compliant simulation models of PMUs. The simulated models are also coupled with a communication systems emulator, allowing the extension of the overall simulation to include various network architectures, technologies, protocols, and conditions. As further RT examples related to the co-simulation approaches of Section III-B, [50] couples OPNET with a RT EMT simulation platform (similar to INSPiRE), and [51] interfaces RTDS with a communication emulator (as a second stage RT testing after offline co-simulations in VPNET).

Concluding, RT and HIL simulation approaches are very useful for testing applications (monitoring, control and protection) and real world hardware devices. The advantage of this approach is the simplification of the simulation time synchronization issues and relative ease of replicating real world conditions for studying and analyzing various smart grid application and control paradigms. The challenges here are related to the fact that the real time constraints on the various models and drivers make the system interfaces more difficult than in case of standard software. For a more comprehensive review on applications of RT and HIL simulation in smart grid research, the reader is referred to [52].

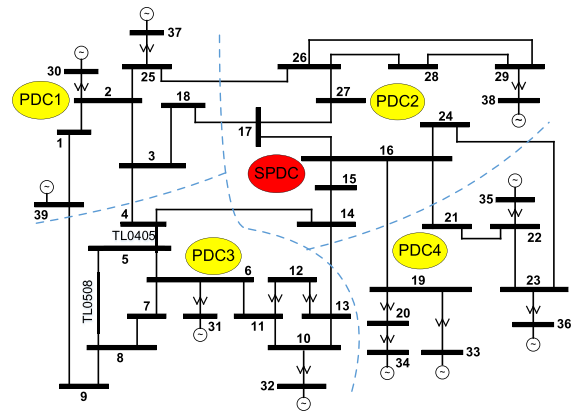

Fig. 1. IEEE 39-bus 10-machine system (New England Test System).

#### IV. CASE STUDIES

To illustrate the impact of ICT in power system operation and the necessity of a combined analysis, this section presents two case studies investigating the performance of a PMU-based state estimator and a wide-area power flow control application under consideration of different ICT scenarios. For this, two of the state-of-the-art approaches outlined in Section III-B (the GECO and the INSPiRE co-simulator) are used for simulations in the IEEE 39-bus, 10-machine system [53] visualized in Fig. 1. The application of the two co-simulations shall provide an insight into the capabilities of today’s state-of-the-art approaches, the relevance of a detailed consideration of ICT in power system simulations, and exemplary interesting use cases for end users of combined simulation frameworks. The frameworks also enable to analyze different scenario setups as well as different parameterizations, of course, which need to be defined by the user or developer of the smart grid application or infrastructure to be investigated.

##### A. GECO Co-Simulator

In this subsection, the impact of cyber-attacks on a linear all-PMU state estimator is investigated based on [18] by applying the co-simulation platform GECO. Each bus is assumed to have one PMU installed with a reporting rate of 30 Hz. The entire system is subdivided into four regions as shown in Fig. 1. Each region has one Phasor Data Concentrator (PDC) with 50 ms timer installed to collect measurements from all local PMUs in its region. The four PDCs are placed at buses 2, 6, 21, and 27. A Super PDC (SPDC) is deployed at bus 16 to collect data from the four PDCs and calculate the final state estimation. The measurement frequency is 30 Hz and the phasor packet size is 500 Bytes. Further, the communication links are placed in parallel with the transmission lines, have a data rate of 1 Gbps and each bus is a communication node that can send, receive, and route measurement data. More details of the system parameter setting can be found in Table II.

The following case study contains one normal operation scenario and three cyber-attack scenarios. These scenarios are

TABLE II  
GENERAL CO-SIMULATION SETTING

Communication Link Bandwidth	$BW$	1Gps
Communication Link Delay	$D$	5 ms
Measurement Rate	$\lambda$	30 times/sec
PDC Timer	$T_p$	50 ms
Super PDC Timer	$T_s$	50 ms
Phasor Packet Size	$S$	500 Bytes
PSLF Iteration Step	$\Delta$	10 ms
Measurement Error	$e$	1%

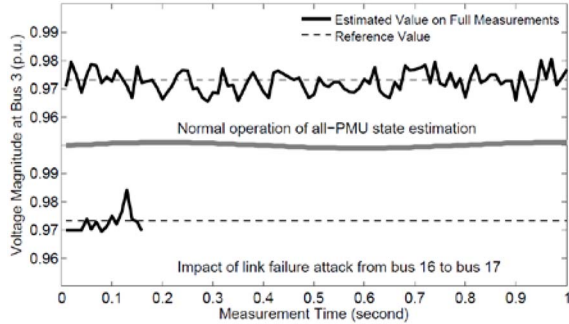

Fig. 2. All-PMU state estimation with normal operation and link failure attack.

simulated with GECO to show the impacts of the communication network on the all-PMU state estimator. Here, the estimated voltage magnitude at bus 3 is selected as the impact indicator by comparing the estimated results with the actual reference values, which are around 0.97 p.u.

1) *Normal Operation*: In Fig. 2, the all-PMU state estimation results at bus 3 shows the normal operation of the system. During the simulation, small random PMU measurement errors are introduced to make the simulation more realistic. There are no line fault attacks or network failure attacks in the system. It can be seen that the estimated voltage magnitude is close to the reference value.

2) *Link Failure Attack*: In this scenario, a communication link from bus 16 to bus 17 is blocked at  $t=0.2$  s. The state estimation results shown in Fig. 2 indicate the entire system state becomes unobservable after 0.2 s. The reason for no simulation output after this point in time is that the network connection from bus 16 to bus 17 is a critical path for operating the measurement system. When this link is cut off by attackers, the routing scheme has to find out an alternative but longer routing path for the measurements. After the new route is established, the communication delays for critical measurements increase such that they cannot arrive at the SPDC before its timer expires. Therefore, the system becomes unobservable.

3) *Link Saturation Attack*: Another common attack scenario is the communication network suffering from a link saturation attack. In this experiment, malicious traffic is injected into the link from bus 16 to bus 17 at  $t=0.2$  s. The results in Fig. 3 show that the malicious traffic does not affect the state estimator immediately. Instead, it gradually saturates the link and the impacts start to appear near 0.42 s.

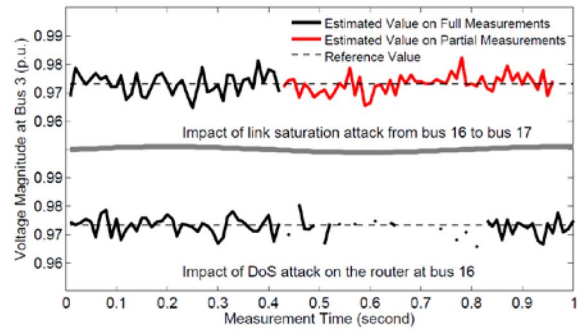

Fig. 3. Impact of link saturation attack and DoS attack.

After this time, the entire communication link is saturated and essential measurements have to compete with the malicious traffic for transmission through the network. Occasionally, some measurements will be discarded due to timer expiration. However, as can be seen from Fig. 3, the system state can still be recovered after 0.42 s because it can be estimated from other redundant measurements. From the results in Fig. 3, it can be concluded that the accuracy of the state estimation on partial measurements is still satisfactory. However, link congestions may also make the system unobservable. To resist this negative impact, advanced dynamic routing schemes could be implemented to auto-detect the saturation level of the communication link and proactively distribute the data flows.

4) *Denial of Service Attack*: A Denial of Service (DoS) attack depletes the available resources of the target by deliberately generating a large amount of redundant data or inquiries. In the all-PMU state estimator system, DoS attacks can use a large part of the computational resources at critical gateway routers, and this can lead to packets being dropped and long delays. In the DoS attack scenario, we assume that 10 compromised computers within the system start to send malicious data to the router located at bus 16 to deplete its resources at 0.2 s. The simulation results in Fig. 3 show that the behavior of the state estimator becomes intermittent starting at 0.4 s. The system state switches between unobservable and observable. Due to a large amount of malicious data in a short period of time, the router can be overloaded and packet dropping may occur. In the worst case, the system can be unobservable and non-recoverable. A prominent solution to prevent DoS attack is to setup backup routers in a dual-router structure. Other prevention schemes such as the malicious traffic detecting and filtering, and labeling the data packets with priorities, will also increase the robustness of the system.

#### B. INSPIRE Co-Simulator

In the following subsection, the impact of different ICT infrastructures on a power system control application are illustrated by use of the INSPIRE co-simulation. The setup is as follows: in a variant of the IEEE 39-bus system, a wide-area control application for overload relief is installed at the control center at bus 39 (Fig. 1). The application receives measurement data (currents, voltages) from all buses in the system and is eligible to send control commands to controllable loads. At  $t=20$  s, an outage of the line between node 5 and node 8

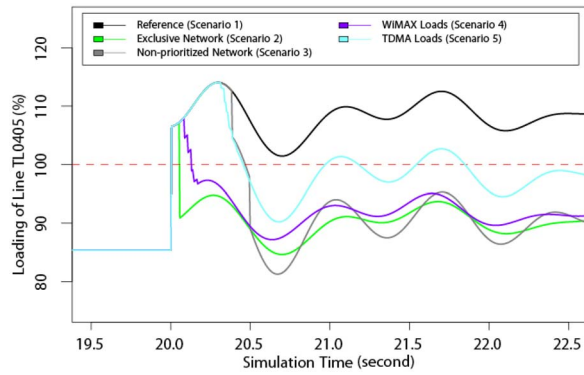

Fig. 4. Impact of ICT settings on performance of a control application.

occurs leading to an overload of line between node 4 and node 5. By control of the flexible loads at buses 4 and 5 the control application aims to relieve the overload. For details of the case study, please see [20], [55]. The performance of the control application is simulated for five different scenarios and the results are visualized in Fig. 4.

1) *Reference Scenario*: As a benchmark, this scenario shows the situation without power flow control. After  $t=20$  s, the line between node 4 and node 5 gets overloaded and remains above 100 % as no relieving action is initiated. For further information and detailed studies on the reference scenario, please refer to [20] and [55].

2) *Ideal Communication Network*: This scenario assumes ideal conditions for the control, in particular a fiber communication network based on optical ground wires is exclusively available for this application and the flexible loads respond immediately and to the full extent when the control command is received at the bus. Thus, only the inevitable delay of the idle communication network affects the performance. For this scenario, communication links have been assumed to be based on Digital Signal 1 (DS1) links with a bandwidth of 1.533 Mbit/s and cable lengths according to the corresponding transmission lines given by the power system. In this scenario both loads are adjusted simultaneously by 50 MW each and the overload is relieved within 52 ms.

3) *Network With Non-Prioritized Background Traffic*: Here, in contrast to scenario 2, background traffic interferes with the transmission, which has been modeled by a packet size of 1500 bytes to use 85 % of the available bandwidth (corresponding to 1.3124 Mbit/s). The interference of the background traffic with the messages sent as part of the control application cause a delay of the power flow control actions. In particular, the time until overload relief increases to approximately 470 ms and the loads respond asynchronously.

4) *Wireless WiMAX Infrastructure*: In this scenario, the change of the flexible loads no longer happens instantaneously when the control command is received at the bus of the electrical transmission network. Instead the loads are assumed to be distributed in an underlying distribution network. Therefore, the control commands are delivered by a wireless Worldwide Interoperability for Microwave Access (WiMAX) based infrastructure to separate controllable loads having 1 MW flexibility and being randomly distributed

in 7 hexagonal cells with a width of 2 km each. For connecting the wireless infrastructure to the reference network introduced before and to minimize additional latencies, each cell is assumed to be connected by a 100 Mbit/s Ethernet link to a central router connected to the substation network directly. To anticipate package losses, the extent of load shift is doubled, thus 100 control requests are sent from both bus 4 and 5. The results in Fig. 4 show the effect of the WiMAX communication. The overload is resolved within approx. 130 ms and only part of the load (34 MW at bus 4 and 60 MW at bus 5) contributes to the overload relief; the remaining control messages are not delivered successfully.

5) *Wireless TDMA Infrastructure*: Finally, the same setting as scenario 4 is simulated except for the use of a TDMA-based cellular mobile telecommunication infrastructure instead of WiMAX. TDMA provides lower bandwidth and causes higher delays. As a result, the overload is not relieved entirely as only 26 MW (bus 4) and 36 MW (bus 5) of the flexible loads are reached, and the delay until a response grows to 500 ms.

## V. CONCLUSION

Due to the increasing integration of power system and ICT processes in the evolution of smart grids, appropriate tools for simulating both domains together are required. Key challenges for interfacing discrete event based ICT simulators and continuous time based power system simulators are time synchronization and event handling. Various approaches have been described in this article for simulating both systems in one general purpose tool and for using specialized simulations of the distinct domains in a co-simulation or a HIL simulation. All of these approaches require a tradeoff between simulation accuracy, execution time, and ease of implementation.

Section III details how the state-of-the-art solutions developed in research address these challenges, e.g., by different time advance strategies and use of standardized simulation frameworks, and illustrates various ways of achieving a combined simulation successfully. Underlining the applicability and necessity of such an integrated analysis, the cases studies demonstrate two state-of-the-art co-simulation platforms for analyzing the impact of cyber-attacks, ICT failures, and ICT infrastructures on monitoring and control applications.

It can be concluded that the approaches available in present research already enable the interfacing of ICT and power system simulation. However, most approaches are still subject to research and are frequently tied to specific research projects as well as specific developers. For this reason, the development of the simulation frameworks is often not continued and detailed comparisons, e.g., with regard to their scalability and computational performance of the implementations, cannot be achieved. For developing the smart grid of the future, the available approaches need to be advanced, extended, and applied in much broader settings. To enable continuity, benchmarking as well as ongoing enhancements by the joint force of the research community, access to the implementations as Open Source would be of major importance. Beyond this, the industrial application of combined simulation solutions should be pushed and methods for comparative performance evaluations

should be developed to provide the engineer interested in applying these approaches with the necessary information to decide upon the right solution for his specific purpose. For comparative performance tests also the development of benchmark systems consisting of both power and ICT system models would be critical, which are not available in a suitable form as of now.

Summarizing, the mathematical fundamentals and advanced software approaches for a combined simulation of power and ICT domain already exist, but there are still major challenges to overcome with future research which include (i) improving the scalability of the combined simulations, (ii) improving the reuse of existing work, e.g., by Open Source access to the simulator implementations, and (iii) enabling comparative benchmarking, e.g., by publishing combined power and ICT benchmark systems.

## REFERENCES

- [1] M. D. Ilic, L. Xie, U. A. Khan, and J. M. F. Moura, "Modeling of future cyber-physical energy systems for distributed sensing and control," *IEEE Trans. Syst., Man, Cybern. A, Syst., Humans*, vol. 40, no. 4, pp. 825–838, Jul. 2010.
- [2] S. C. Müller, H. Georg, C. Rehtanz, and C. Wietfeld, "Hybrid simulation of power systems and ICT for real-time applications," in *Proc. IEEE PES Innov. Smart Grid Technol. Europe*, Berlin, Germany, Oct. 2012, pp. 1–7.
- [3] B. P. Zeigler, *Theory of Modeling and Simulation*, 1st ed. Hoboken, NJ, USA: Wiley, 1976.
- [4] J. Nutaro, *Building Software for Simulation: Theory and Algorithms With Applications in C++*. Hoboken, NJ, USA: Wiley, 2010.
- [5] N. Lynch, R. Segala, and F. Vaandrager, "Hybrid I/O automata," *Inf. Comput.*, vol. 185, no. 1, pp. 105–157, Aug. 2003.
- [6] E. A. Lee and H. Zheng, "Operational semantics of hybrid systems," in *Hybrid Systems: Computation and Control* (LNCS 3414). Heidelberg, Germany: Springer-Verlag, 2005, pp. 25–53.
- [7] J. Arrillaga and N. R. Watson, *Computer Modelling of Electrical Power Systems*, 2nd ed. Hoboken, NJ, USA: Wiley, 2001.
- [8] A. J. Wood, B. F. Wollenberg, and G. Sheble, *Power Generation, Operation, and Control*, 3rd ed. Hoboken, NJ, USA: Wiley, 2014.
- [9] R. M. Fujimoto, K. S. Perumalla, and G. F. Riley, *Network Simulation* (Synthesis Lectures on Communication Networks), J. Walrand, Ed. San Rafael, CA, USA: Morgan and Claypool, 2007.
- [10] A. S. Tanenbaum, *Computer Networks*, 3rd ed. Upper Saddle River, NJ, USA: Prentice Hall, 1996.
- [11] *IEEE Standard for Modeling and Simulation (M&S) High Level Architecture (HLA)—Framework and Rules*, IEEE Standard 1516-2000, 2000.
- [12] *Functional Mock-Up Interface for Model Exchange and Co-Simulation 2.0*. Accessed on Mar. 25, 2016. [Online]. Available: <https://www.fmi-standard.org/>
- [13] *FMI Consortium*. Accessed on Mar. 25, 2016. [Online]. Available: <https://www.fmi-standard.org/>
- [14] M. U. Awais, W. Gawlik, G. De-Cillia, and P. Palensky, "Hybrid simulation using SAHISim framework," in *Proc. 8th EAI Int. Conf. Simulat. Tools Tech.*, Athens, Greece, Aug. 2015, pp. 273–278.
- [15] V. Galtier *et al.*, "FMI-based distributed multi-simulation with DACCOSIM," in *Proc. Spring Simulat. Multi Conf.*, Alexandria, VA, USA, Apr. 2015, pp. 39–46.
- [16] S. Schütte, S. Scherfke, and T. Tröschel, "Mosaik: A framework for modular simulation of active components in smart grids," in *Proc. 1st Int. Workshop Smart Grid Model. Simulat.*, Brussels, Belgium, Oct. 2011, pp. 55–60.
- [17] H. Lin, S. Veda, S. Shukla, L. Mili, and J. Thorp, "GECO: Global event-DRIVEN co-simulation framework for interconnected power system and communication network," *IEEE Trans. Smart Grid*, vol. 3, no. 3, pp. 1444–1456, Sep. 2012.
- [18] H. Lin, Y. Deng, S. Shukla, J. Thorp, and L. Mili, "Cyber security impacts on all-PMU state estimator—A case study on co-simulation platform GECO," in *Proc. IEEE 3rd Int. Conf. Smart Grid Commun.*, Tainan City, Taiwan, Nov. 2012, pp. 587–592.
- [19] H. Georg, S. C. Müller, N. Dorsch, C. Rehtanz, and C. Wietfeld, "INSPIRE: Integrated co-simulation of power and ICT systems for real-time evaluation," in *Proc. 4th IEEE Int. Conf. Smart Grid Commun.*, Vancouver, BC, Canada, Oct. 2013, pp. 576–581.
- [20] H. Georg, S. C. Müller, C. Rehtanz, and C. Wietfeld, "Analyzing cyber-physical energy systems: The INSPIRE co-simulation of power and ICT systems using HLA," *IEEE Trans. Ind. Informat.*, vol. 10, no. 4, pp. 2364–2373, Nov. 2014.
- [21] K. Hopkinson *et al.*, "EPOCHS: A platform for agent-based electric power and communication simulation built from commercial off-the-shelf components," *IEEE Trans. Power Syst.*, vol. 21, no. 2, pp. 548–558, May 2006.
- [22] J. Nutaro, P. T. Kuruganti, L. Miller, S. Mullen, and M. Shankar, "Integrated hybrid-simulation of electric power and communications systems," in *Proc. IEEE Power Eng. Soc. Gen. Meeting*, Tampa, FL, USA, Jun. 2007, pp. 1–8.
- [23] W. Li, A. Monti, M. Luo, and R. A. Dougal, "VPNET: A co-simulation framework for analyzing communication channel effects on power systems," in *Proc. IEEE Elect. Ship Technol. Symp.*, Alexandria, VA, USA, Apr. 2011, pp. 143–149.
- [24] D. Anderson *et al.*, "A virtual smart grid-real-time simulation for smart grid control and communications design," *IEEE Power Energy Mag.*, vol. 10, no. 1, pp. 49–57, Feb. 2012.
- [25] V. Liberatore and A. Al-Hammouri, "Smart grid communication and co-simulation," in *Proc. IEEE Energytech*, Cleveland, OH, USA, 2011, pp. 1–5.
- [26] J. Bergmann *et al.*, "Scalability of smart grid protocols: Protocols and their simulative evaluation for massively distributed DERs," in *Proc. 1st IEEE Int. Conf. Smart Grid Commun.*, Gaithersburg, MD, USA, Oct. 2010, pp. 131–136.
- [27] D. Babazadeh, M. Chenine, K. Zhu, A. Al-Hammouri, and L. Nordström, "A platform for wide area monitoring and control system ICT analysis and development," in *Proc. IEEE PowerTech*, Grenoble, France, Jun. 2013, pp. 1–7.
- [28] D. Babazadeh and L. Nordström, "Agent-based control of VSC-HVDC transmission grid—A cyber physical system perspective," in *Proc. IEEE Workshop Model. Simulat. Cyber-Phys. Energy Syst.*, Berlin, Germany, 2014, pp. 1–6.
- [29] M. Wei and W. Wang, "Greenbench: A benchmark for observing power grid vulnerability under data-centric threats," in *Proc. 33rd IEEE Int. Conf. Comput. Commun.*, Toronto, ON, Canada, May 2014, pp. 2625–2633.
- [30] P. Oliveira, T. Pinto, H. Morais, and Z. Vale, "MASGriP—A multi-agent smart grid simulation platform," in *Proc. IEEE Power Energy Soc. Gen. Meeting*, San Diego, CA, USA, Jul. 2012, pp. 1–8.
- [31] F. Perkonigg, D. Brujic, and M. Ristic, "MAC-Sim: A multi-agent and communication network simulation platform for smart grid applications based on established technologies," in *Proc. 4th IEEE Int. Conf. Smart Grid Commun.*, Vancouver, BC, Canada, Oct. 2013, pp. 570–575.
- [32] G. Celli, P. A. Pegoraro, F. Pilo, G. Pisano, and S. Sulis, "DMS cyber-physical simulation for assessing the impact of state estimation and communication media in smart grid operation," *IEEE Trans. Power Syst.*, vol. 29, no. 5, pp. 2436–2446, Sep. 2014.
- [33] K. Anderson and A. Narayan, "Simulating integrated volt/var control and distributed demand response using GridSpice," in *Proc. 1st Int. Workshop Smart Grid Model. Simulat. 2nd IEEE Int. Conf. Smart Grid Commun.*, Brussels, Belgium, Oct. 2011, pp. 84–89.
- [34] D. P. Chassin, K. Schneider, and C. Gerkenmeyer, "GridLAB-D: An open-source power systems modeling and simulation environment," in *Proc. IEEE PES Transm. Distrib. Conf. Expo.*, Chicago, IL, USA, Apr. 2008, pp. 1–5.
- [35] M. Lévesque, D. Q. Xu, G. Joós, and M. Maier, "Co-simulation of PEV coordination schemes over a FiWi smart grid communications infrastructure," in *Proc. IEEE 38th Annu. Conf. Ind. Electron. Soc.*, Montreal, QC, Canada, Oct. 2012, pp. 2901–2906.
- [36] W. Li and X. Zhang, "Simulation of the smart grid communications: Challenges, techniques, and future trends," *Comput. Elect. Eng.*, vol. 40, no. 1, pp. 270–288, Jan. 2014.
- [37] W. Li, X. Zhang, and H. Li, "Co-simulation platforms for co-design of networked control systems: An overview," *Control Eng. Pract.*, vol. 23, pp. 44–56, Feb. 2014.
- [38] K. Mets, J. A. Ojea, and C. Develder, "Combining power and communication network simulation for cost-effective smart grid analysis," *IEEE Commun. Surveys Tutorials*, vol. 16, no. 3, pp. 1771–1796, Mar. 2014.
- [39] W. Li, M. Ferdowsi, M. Stevic, A. Monti, and F. Ponci, "Cosimulation for smart grid communications," *IEEE Trans. Ind. Informat.*, vol. 10, no. 4, pp. 2374–2384, Nov. 2014.

- [40] H. Saad *et al.*, "Real-time simulation of MMCs using CPU and FPGA," *IEEE Trans. Power Electron.*, vol. 30, no. 1, pp. 259–267, Jan. 2015.
- [41] F. Andr n, S. Henein, and M. Stifter, "Development and validation of a coordinated voltage controller using real-time simulation," in *Proc. 37th Annu. Conf. IEEE Ind. Electron. Soc.*, Melbourne, VIC, Australia, Nov. 2011, pp. 3713–3718.
- [42] *OPAL RT eMEGAsim PowerGrid Real-Time Digital Hardware in the Loop Simulator*. Accessed on Mar. 25, 2016. [Online]. Available: <http://www.opal-rt.com/>
- [43] *RTDS Technologies—RTDS Simulator*. Accessed on Mar. 25, 2016. [Online]. Available: <http://www.rtds.com>
- [44] A. Viehweider, F. Lehfuss, and G. Lauss, "Interface and stability issues for SISO and MIMO power hardware in the loop simulation of distribution networks with photovoltaic generation," *Int. J. Renew. Energy Res.*, vol. 2, no. 4, pp. 631–639, Dec. 2012.
- [45] F. Lehfu , G. Lauss, and T. Strasser, "Implementation of a multi-rating interface for power-hardware-in-the-loop simulations," in *Proc. 38th Annu. Conf. IEEE IES*, Montreal, QC, Canada, Oct. 2012, pp. 4777–4782.
- [46] P. Mitra, "ABB's HVDC grid simulation center: A powerful tool for real-time research of DC grids," in *Proc. Eur. Wind Energy Assoc. Annu. Event*, Barcelona, Spain, Mar. 2014.
- [47] L. Vanfretti *et al.*, "SmarTS Lab—A laboratory for developing applications for WAMPAC systems," in *Proc. IEEE PES Gen. Meeting*, San Diego, CA, USA, Jul. 2012, pp. 1–8.
- [48] M. Armendariz, M. Chenine, A. Al-Hammouri, and L. Nordstr m, "A co-simulation platform for medium/low voltage monitoring and control applications," in *Proc. IEEE Conf. Innov. Smart Grid Technol.*, Washington, DC, USA, Feb. 2014, pp. 1–5.
- [49] A. T. Al-Hammouri *et al.*, "Virtualization of synchronized phasor measurement units within real-time simulators for smart grid application," in *Proc. IEEE PES Gen. Meeting*, San Diego, CA, USA, Jul. 2012, pp. 1–7.
- [50] F. Guo *et al.*, "Comprehensive real-time simulation of the smart grid," *IEEE Trans. Ind. Appl.*, vol. 49, no. 2, pp. 899–908, Mar./Apr. 2013.
- [51] M. Stevic *et al.*, "A two-step simulation approach for joint analysis of power systems and communication infrastructures," in *Proc. IEEE PES Innov. Smart Grid Technol. Europe*, Lyngby, Denmark, Oct. 2013, pp. 1–5.
- [52] C. Dufour and J. B langer, "On the use of real-time simulation technology in smart grid research and development," *IEEE Trans. Ind. Appl.*, vol. 50, no. 6, pp. 3963–3970, Nov./Dec. 2014.
- [53] T. M. Athay, V. R. Sherkat, R. Podmore, S. Virmani, and C. Puech, "Transient energy stability analysis," in *Systems Engineering for Power: Emergency Operating State Control*, Washington, DC, USA: U.S. Dept. Energy, Sep. 1979, pp. 122–126.
- [54] H. Lin, "Communication infrastructure for the smart grid: A co-simulation based study on techniques to improve the power transmission system functions with efficient data networks," Ph.D. dissertation, Dept. Elect. Comp. Eng., Virginia Tech, Blacksburg, VA, USA, 2012.
- [55] K. H. Georg, "Co-simulation based performance evaluation of ICT-infrastructure for smart grids," Ph.D. dissertation, Dept. Elect. IT Eng., Tech. Univ. Dortmund, Dortmund, Germany, 2015.

Authors' photographs and biographies not available at the time of publication.