

PART II: METHODOLOGY

Chapter 3

OVERVIEW OF THE METHODOLOGY

3.1. INTRODUCTION

After identifying the sources of tactic cost estimates for PAWN, we will discuss a number of issues related to the costs and benefits of policies, such as determining which costs and benefits are relevant and treating time streams of costs and benefits where some components vary randomly with the weather. Then we present and discuss the PAWN System Diagram, which indicates the major parts of the problem and the relations among them, as well as the corresponding parts of our impact-assessment methodology. The chapter concludes by describing how the remainder of this part of the report is organized.

3.2. SOURCES OF TACTIC COST ESTIMATES

Tactic cost estimates were obtained from many different sources. Some were taken from relatively old Dutch reports, others from newer Dutch reports, and some from informal communication with people in the Netherlands who made estimates for PAWN. Available estimates differed widely with respect to level of detail, quality, and format. We put all of the estimates on a consistent basis with respect to content, price level, and underlying assumptions.

For many tactics, point estimates of costs were sufficient. In other instances, costs were developed as a function of tactic capacity. (Sensitivity analysis to investigate uncertainty was often done to select the best estimates.)

Every attempt was made to use Dutch sources for tactic cost estimates. In a number of instances, however, such estimates were not available and the PAWN staff had to make the cost estimates themselves. Frequently, this was done simply by choosing appropriate analogies and making slight adjustments to the estimated cost of the analogies, but in other instances cost-estimating relationships (CERs) and design models had to be developed.

For major technical tactics, the systematized Dutch estimates and the estimates by the PAWN team, including the substantive work on CERs and design models, are documented in Vol. XVI.¹ Included are methods for estimating the cost components for pumping stations, pipelines and syphons, and canals. At times we were able to formalize empirical relationships among cost and characteristics--i.e., develop CERs--using data on current and proposed infrastructure. This was the case for the pumping station investment CER. On the other hand, for estimating the cost of pipelines and canals, CERs and design models had to be built. The design models were required to obtain the design characteristics necessary for input into the CERs.

A number of these CERs were incorporated in the major tactic cost model that the water distribution model uses as a subroutine to calculate technical tactic costs as a function of both the tactic design characteristics and the varying water-flows during its operation. When a particular design for a tactic is being analyzed with the water distribution model, the appropriate cost parameters for the corresponding CERs must be specified.

For irrigation system cost, design, and operation, various detailed models were built, as summarized in Chap. 12 and detailed in Vol. XIII.

For various other tactic costs, the sources are mentioned in appropriate chapters.

We believe that our methods have provided tactic cost estimates that are sufficiently accurate (in a relative sense) for the kinds of analyses in which they have been used. However, they provide approximations to, rather than precise estimates of, cost. They have been tested and judged to be reasonable within the ranges considered in PAWN.

3.3. TREATMENT OF COSTS AND BENEFITS

From a particular policy, different user groups and interest groups will experience different impacts. As an example, suppose the Dutch government were to adopt a policy of increasing the availability of surface water for purposes of irrigation. Then the following could be among the impacts:

- Money must be spent to build the facilities (e.g., canals and pumping stations) necessary to implement this policy. This requires a rise in taxes, a reduction in other government services, or a rise in the national debt. This burden falls on the population as a whole.
- For a few years, until the needed facilities have been completed, jobs will be created, which may be desirable or not depending on whether people with suitable skills are unemployed.
- Once the facilities are complete, and farmers can begin to expand the area of land they irrigate, the farmers will benefit from greater crop yields. This benefit will be small in years with average or heavy rainfall, and large in exceptionally dry years.
- Not all of the benefit due to increased crop yields will accrue to the farmer. The government will receive some in increased taxes, and if food prices fall in response to the increased supply, consumers may benefit as well.
- Shipping may suffer because of the diversion of water from rivers. This will cause water levels to fall, which could restrict the passage of the larger ships. Goods may be delayed, or carried on smaller ships, or carried on partially loaded

large ships. The cost of the shipping delays, and the added operating cost of the ships, may come out of the carrier's pocket, or out of the shipper's pocket. As with farmers' benefits, these costs will be larger in dry years than in wet ones. In addition, some shippers and carriers using Dutch waterways are not Dutch; thus the impact is distributed between Dutch and foreign pockets.

- In some places that heretofore have been unpolluted, the environment may suffer because of the introduction of somewhat polluted surface water from other locations. In other places that heretofore have been heavily polluted, the environment may benefit.

3.3.1. Monetizable Versus Nonmonetizable Impacts

The impact on the environment is an example of a nonmonetizable impact. This means only that there is no accepted method for assigning a money value to the impact--in the example, no method for deciding how much it would be worth to reduce the salt or heavy metal content of a stream or pond by one concentration unit. Nonmonetizable impacts are generally ignored during the screening stage of analysis. Some nonmonetizable impacts are considered in the design of policies, and many are presented in impact assessment.

All the other impacts mentioned in the example above are monetizable, which means that we can estimate a money value for each of them. The money values of any two such impacts can be added together (if they have the same sign), or netted out (if they have opposite signs); in general, they can be compared on an equal footing. Thus, the cost to shipping may be compared with the benefit to farmers, to determine if the policy is profitable from a purely economic viewpoint. This does not mean that shippers should necessarily bear a cost in order that others may benefit, but the fact that we are dealing with monetizable impacts suggests that some mechanism (e.g., a law) may be created by which farmers may recompense shippers, and that both groups will subsequently feel better off than before.

3.3.2. Problems with Monetizing Impacts

Monetizing impacts is not straightforward, however. Consider, for example, only the costs associated with constructing and operating the facilities (canals, pumping stations, etc.) in our example. There will be an initial outlay (for construction) in, say, the first three years, followed by a fixed annual outlay (for maintenance and staff) for the life of the facilities. In other words, the costs associated with constructing the facilities are spread over time in a nonuniform fashion, and hence comparisons must be made between expenditures occurring at different times.

Moreover, it may not be clear which facilities' costs ought to be charged to the policy in question, and which costs ought to be

considered "sunk." For example, a policy to divert surface water to irrigation would rely on existing facilities (e.g., the weir at Driel) as well as on new ones. Is it appropriate to include at least part of the cost of the weir at Driel in the cost of the policy, even though the weir has already been built and paid for?

In addition, there may be variable costs, such as the cost of energy for pumping, which will vary randomly from day to day and from year to year. Monetizable benefits also occur randomly over time; as we noted in the example, irrigation will benefit farmers much more in dry years than in wet years, and which years will be wet is dictated by processes that appear random. We need some way to include such random costs and benefits in our comparisons.

Finally, one may ask from whose point of view should monetizable costs and benefits be presented? The farmer is most concerned with the effect of the policy on his after-tax profit. Ideally, the government is concerned with the overall effect on the nation (although it may have some passing interest in the effect on tax revenues). Thus, from the government's point of view, it may not be very important whether the overall national benefit accrues mostly to farmers or to consumers, since the total may be the same in either case. And neither point of view takes into account the cost imposed on foreign interests, such as foreign shippers and ship owners.

In the remainder of this section, we will discuss each of these issues, and describe how we have dealt with them in PAWN. We will also describe the sources of cost estimates for PAWN tactics.

3.3.3. Which Costs Are Relevant?

The question of which costs are relevant becomes difficult only when one fails to consider that the costs of two or more policies are to be compared. There is never any point in "comparing" the cost of a single policy. If in the above example it seems that there is only one policy, be advised that you have been hoodwinked! There are two policies: (1) the announced policy of increasing the surface water available for irrigation; and (2) the "silent" policy of not doing so--i.e., of continuing the current practice. What we wish to calculate is not the cost of either policy, but rather the difference in the costs of the two policies. Anything that contributes the same cost to both policies is irrelevant. It may be included or excluded from the cost calculation of both policies at the discretion of the analyst. In our example, because the weir at Driel exists in both policies, its cost would appear in any total cost accounting of both policies, and hence net to zero in the cost difference between the policies. It is therefore unnecessary to include the cost of the weir at Driel in our calculations.

In general, relevant costs are incremental costs, costs (or savings) that would be incurred if a policy were implemented, but not if the current practice were continued. This amounts to accepting the current

situation as a benchmark, and measuring cost differences from it. When we replace an existing pumping station with a new one that has a larger capacity, we assume that the incremental labor cost is zero because the same operators that ran the old pumping station would run the new one. But when we add a new pumping station, the labor is incremental--and relevant--because it reflects a required increase in operating personnel.

Of course, we could choose any other situation as a benchmark, and in some instances we have done so. For example, in the Southeast Highlands, we sometimes consider a scenario in which certain canals and locks have been improved to facilitate shipping. When we do, the improved situation is taken as the benchmark, and the cost of the improvements is not charged to tactics that further change the infrastructure; otherwise they would be.

As another example, we have estimated the least-cost means by which drinking-water companies can provide water to their customers. Among the options they have are: exploiting groundwater; using existing surface water reservoirs; and building new reservoirs. We have charged the cost of the existing reservoirs against the policy, because over the long term (we are evaluating a policy for the long term), if an existing reservoir were not used, it could be dismantled, its operating and maintenance cost saved, and the land sold. In other words, we are not comparing policies in all of which the currently existing facilities continue to exist, and hence it is proper to include the cost of these facilities in some of the policies and not in others. (Note that if a particular facility existed in all policies, its cost would "net out" when any two policies were compared.)

Fixed and variable costs may be distinguished in many different ways. In PAWN, variable costs are those that can vary in the short run and fixed costs are those that cannot. The short run is a day or ten days, while the long run is anything longer, often a year or years. The short run corresponds to the time it might take to implement some day-to-day action (e.g., a managerial tactic) and see its effect on the water management system; it also corresponds to the ten-day time-step that is usually the basis of our models. The long run reflects the fact that some tactics, such as the construction of new infrastructure, would take months or years to implement.

Another distinction is between investment and operating costs. Investment costs are those costs incurred to purchase facilities or equipment. Operating costs are those for the labor, energy, and materials (e.g., lubricants or replacement parts) that are necessary to operate a system or provide normal maintenance.

Pumping energy cost, an operating cost which can vary from minute to minute and certainly from day to day, is a short-run or variable cost. But the annual payment to cover the investment in a pumping station is a long-run or fixed cost because it will be constant for many years. Although an operating cost, the annual maintenance and labor cost for a pumping station or some other facility is also considered a

long-run or fixed cost because it generally involves a commitment to pay money for a relatively long period of time; it is rare to build a pumping station, shut it down soon after, and henceforth use it intermittently. In contrast, the labor cost for operating irrigation equipment is not considered a fixed cost because it varies with the operating policy for the equipment, which changes from day to day with the weather.

The relevance of costs depends on whether they are short-run or long-run, fixed or variable, and on the nature of the decision. In a decision about short-run alternatives, long-run costs are irrelevant. For example, in deciding how to operate a lock, the investment cost of the lock does not matter. Variable costs are not always relevant either. If we are deciding how much irrigation water to apply at a particular time, then both labor and energy costs are relevant. But if we are deciding how to distribute a fixed amount of irrigation water among different crops or times, then the energy cost for pumping is not relevant because it does not vary with the decision. Clearly, in deciding which variable costs are relevant to a decision, it is important to ask, "variable with respect to what?"

3.3.4. Time Streams of Costs

The costs of a policy must be compared with its benefits, but the costs and benefits will be distributed differently over time. In general, there will be a concentration of the costs in the early years of the policy, due to the required investment in facilities, whereas the benefits will flow in at a varying annual rate once the facilities have been completed. This sounds appropriate for a classical cost-benefit analysis. But we have used a somewhat different approach that is easier to apply yet gives equivalent results. We will explain our treatment of costs here and benefits immediately after. In order to collapse a time stream of costs into a single number for comparison with the annual benefits, we calculate an index known as the annual fixed cost. The annual fixed cost of any specified facility consists of two components, the annualized investment cost and the annual fixed operating and maintenance cost.

The annualized investment cost is obtained by applying a capital recovery factor to the total investment. (A capital recovery factor is merely a device for converting a lump-sum payment made now into an equivalent stream of equal annual payments, as summarized in Vols. XIII and XVI and described in any text on engineering economics.) An interpretation of the annualized investment cost is that the total investment is financed with borrowed funds, and the loan is paid off with equal annual payments, including principal and interest, over the useful life of the facility. To avoid a difficulty with different facilities having different lives, we assume that just at the time that the facility reaches the end of its life, when the loan will be fully paid off, another loan, equal to the initial investment, is negotiated to finance a replacement facility.

To the annualized investment cost must be added the annual fixed operating and maintenance costs. These costs are usually incurred for labor (e.g., an operator and helper at a pumping station) and maintenance material, and are relatively independent of the amount of use made of a facility. All other costs, including some labor costs, are variable, and moreover randomly variable, and are considered separately below, along with the benefits.

The procedure for annualizing the investment cost is closely related to a procedure known as discounting. As we have used it, however, annualization has a purely financial interpretation, while discounting has often been interpreted more widely. In discounting, for example, the discount rate (which corresponds to our interest rate) need not represent only the cost of borrowed money. It can also represent an individual's time-preference for money (if your individual discount rate is higher than the interest rate, you should borrow money, even though you have no particular need to do so--or so says the theory). Sometimes investments are discounted for risk (e.g., you demand a higher expected return from an investment that is more likely to lose money). And there are other, less common uses for discounting.

In PAWN, we have chosen to reflect only the cost of borrowing money in the interest rate. Thus, in all our calculations, either of costs or benefits, we have assumed the interest rate to be 10 percent, which we understand is about the rate at which the Dutch government was able to borrow funds in 1976; moreover, it is the rate proposed by the Commissie voor Beleidsanalyses (COBA, the Committee on Policy Analysis). We have not tried to factor in future inflation, or to infer the Dutch government's time-preference for money and incorporate it in our analysis. We chose to ignore future inflation not only because it is hard to forecast, but also because its effects on randomly occurring costs and benefits are extraordinarily difficult to calculate. (We express all costs and benefits in constant 1976 Dfl. Although this apparently ignores inflation, it can also be interpreted as taking future costs and benefits in inflated Dfl of their year of occurrence and deflating them appropriately to 1976.) We have dealt with risk by presenting the risky--i.e., randomly variable--costs and benefits separately from the relatively predictable investment and fixed operating costs. As explained below, both expected values and extreme values of these random impacts are presented, so that the decisionmakers can assign whatever weight they wish to the reduction of risk.

3.3.5. Random Costs and Benefits

Some elements of the cost of operating a facility will vary randomly from year to year. An example is the cost of energy used by a pumping station, which will be proportional to the amount of water pumped. The amount of water to be pumped in a year will depend on the amount of rainfall during the year; for example, it may depend on whether the pump delivers irrigation water or is used to drain low-lying areas in winter. Similarly, the benefits of a policy to agriculture, shipping,

and other groups will depend on the rainfall and river flow during the year. Since we cannot predict which years will be wet and which dry, these costs and benefits accrue to the various groups in randomly varying streams.

A widely accepted method for dealing with random costs and benefits is to consider only their expected values, which are merely the average values over many years of differing dryness. The expected annual net benefits (where "net" indicates random benefits minus random costs) are compared with the annual fixed cost, and the decision to accept or reject the policy is made on the basis of which is larger.²

3.3.6. Attitudes Toward Risk

The above approach has the disadvantage that it does not capture people's attitudes toward risk. Most people are risk-averse, especially when the risk involves large amounts of money. This means only that people are willing to pay an "insurance premium" in order to avoid the possibility of large costs, even though the amount of the premium exceeds the expected annual cost being avoided. There is a body of literature that recommends, in such situations, that the different possible values of random net benefits be replaced by some measure of the decisionmaker's "utilities" for those values. (For example, the decisionmaker may feel that a loss of one million Dfl is four times as bad as a loss of one-half million Dfl, so his utilities for those two outcomes would be in the ratio of four to one.) Then the expected annual utility can be calculated, instead of the expected annual net of all costs and benefits, and the decision to accept or reject the policy can be based on this figure.

We believe that this approach, too, has serious drawbacks. There is no single decisionmaker for the policies considered in this study. Instead, decisions will be arrived at by a consensus among many people. We have found no practical way to estimate a group utility function (it is hard enough to estimate an individual's utility function). Further, once the decision is made, it must be defended. Since a utility function is based on personal, internal feelings and attitudes, it is hard to argue that any particular utility function should be accepted as the proper one to use for an important governmental decision.

For PAWN, we were unwilling to rely on either of these approaches exclusively. We did use the first approach (comparison of expected costs with expected benefits) in the screening stage of the analysis, and during the design of policies. For impact assessment, however, we believed that some consideration must be paid to other attitudes toward risk. For the reasons given above, we rejected the use of utility functions. Instead, along with the expected benefits and costs, we also display the benefits and costs that would obtain in an extremely dry year (a very rare occurrence). Giving each decisionmaker an idea of the range of annual costs and benefits that might result from a policy will, we believe, allow him to factor into his decision any degree of risk aversion he feels comfortable with.

Thus, we display the monetizable costs and benefits in two components: the annual fixed cost and the annual net benefits. The former component consists of all costs that are relatively predictable for each policy, while the latter component consists of the random, unpredictable costs and benefits. We liken the annual fixed cost to an insurance premium that is paid to insure against the random net losses that result from not adopting the policy in question. (In the remainder of the report, we usually use the word losses when referring to a loss of benefits; the word "disbenefits" can be misleading when used for that purpose.)

3.3.7. Point of View

One's point of view affects the choice of which cost components to consider. What is a "real" cost to one may be a benefit to another and a transfer payment to yet another.

For example, taxes from a personal viewpoint are a real cost; from a government viewpoint, they are a benefit (revenue); and from the viewpoint of the nation as a whole, they are a transfer payment (i.e., they do not create real wealth, but merely transfer it from one group to another). And depreciation, investment credits, interest on loans, "profits," etc., may be counted differently depending on the viewpoint.

In determining whether a farmer would choose to buy new sprinkling equipment, for example, we calculated his expected net benefits from irrigation by including tax payments, deductions, and credits; furthermore, we assumed that farmers could deduct interest on the annualized investment cost from their income taxes (we assumed a marginal tax rate of 40 percent for this). By contrast, we did not include taxes and these other factors when calculating costs that would be paid directly by the national government, such as the cost of new facilities and other technical tactics. (Indeed, if the national government were to buy irrigation equipment for farmers, then we would calculate its costs the same way.)

For decisions about the overall water management policy, PAWN takes the perspective of the nation as a whole. For other decisions whose outcome we are trying to estimate--such as a farmer's decision about the purchase of irrigation equipment or a water consumer's decision about whether to use more or less water--we take the point of view of the relevant decisionmaker.

To ensure that cost and benefits were properly distributed, with none neglected and none double-counted, we spent considerable effort developing and applying a methodology to estimate their distribution among producers, consumers, and the government. This is described in a later chapter.

3.4. DIVIDING THE PROBLEM INTO PARTS: THE PAWN "SYSTEM DIAGRAM"

Figure 3.1 presents the PAWN system diagram, which shows the important parts of the problem and their interrelations. Each "box" in the diagram also represents a different model or substudy for assessing the impacts of policies, and the lines show different kinds of interrelations. The methodology is not one large model, however, but rather is a toolkit of models, along with other techniques and experience.

The "hub" of the methodology is the water distribution model, which simulates the distribution of water. The different parts of the problem/methodology, which we often call sectors, are arranged in two rings around the distribution model, depending on whether they primarily affect the supply of or the demand for water.

Three kinds of interrelations are shown in the figure. First, there is "net rain" (precipitation minus evaporation), which originates in the external supply of water to the Netherlands and goes directly to agriculture, to the natural environment, to groundwater storage, and to surface water storage in the IJssel lakes. Second, water-flows, with characteristics of quantity, quality, and salinity, are shown traveling in both directions between the water distribution model and the other sectors, with two exceptions: external supply, where the water only flows into the country, and shipping, where no flow is shown because it neither consumes the water nor alters its quality. Of course, the characteristics of the water flowing in one direction may be quite different from that flowing in the other.

Finally, various data flows are shown. Ship traffic goes to the lock sector from the shipping (industry) sector; the shipping sector in turn receives information on the ship delays at locks from the lock sector, as well as the water depths and velocities from the water distribution model. Note that several other data flows occur that could not conveniently be shown on the diagram. The environment sector receives information on new facilities being built (which might locally damage the environment) from the drinking-water companies sector (new reservoirs) and from the water distribution model (new canals, etc.).

Except for the data on new facilities, these flows take place every ten days (the time-step for our analysis) throughout the year being analyzed.

Consider an example of the interaction among sectors during one time-step: The external supply provides the amount of net rain being received by agriculture and various other sectors and the amount of river water entering the country. On the basis of the rain it receives, the agriculture sector determines how much irrigation water it needs to avoid damage to irrigated crops, and demands this amount from the distribution model. The distribution model balances this demand with similar demands from the other sectors and, on the basis of the specified managerial strategy, decides how, and to what extent, to meet the demands. It may respond to demands by withdrawing water

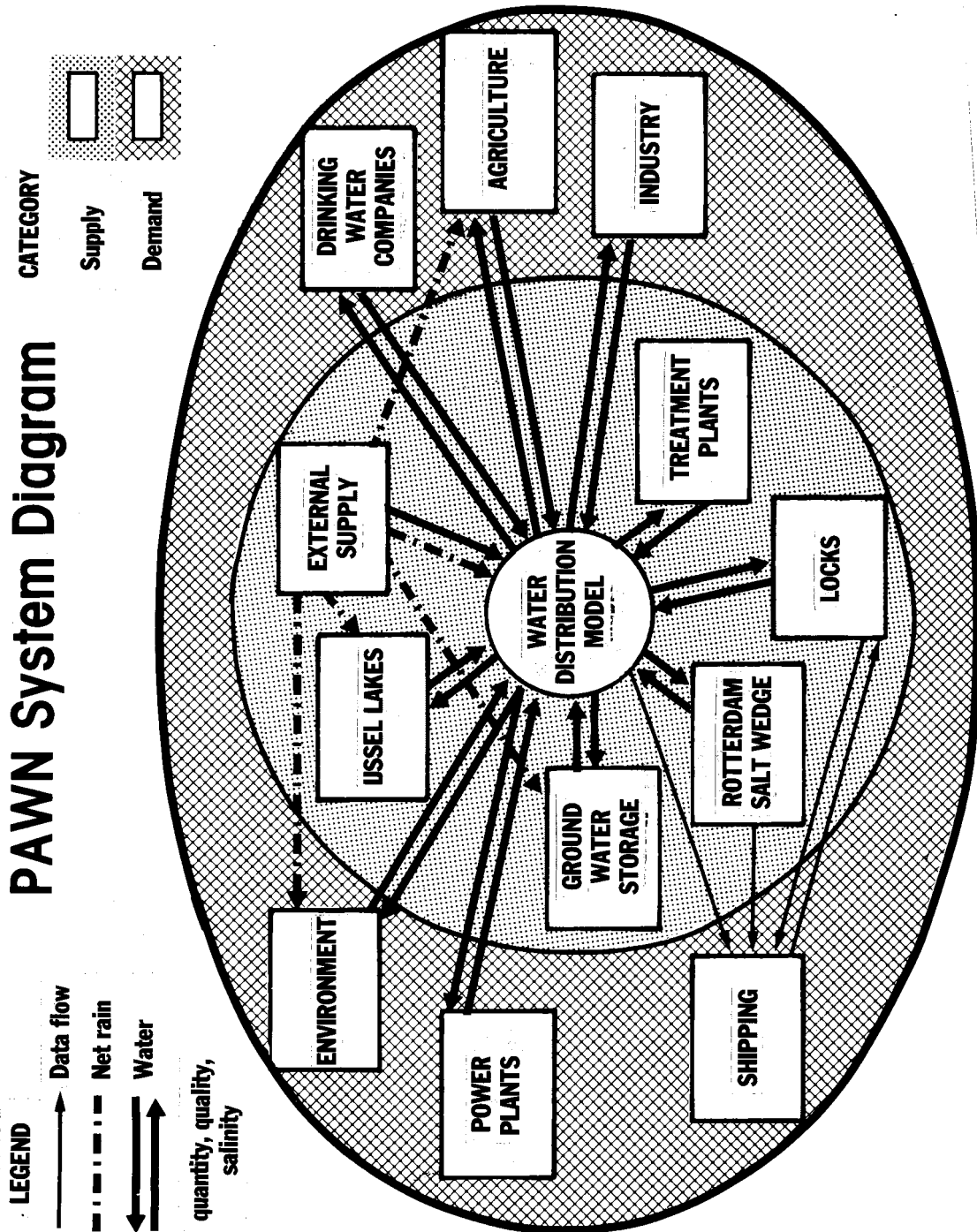

Fig. 3.1--PAWN system diagram

from storage and by using part or all of the external supply of river water in the time-step. It may also use some of this river water to replenish surface water storage in the IJssel lakes. If agriculture does not receive all the water it demanded, it suffers losses to crops with irrigation equipment as well as those without; models in the agriculture sector calculate these losses. Similarly, the reduced water levels in the rivers and canals caused by large extractions of water for agriculture lead to monetary losses by the shipping industry, which are calculated by appropriate models for that sector.

Although we will not discuss the other sectors in this example, we should point out that almost all contain models to estimate demands, costs, or losses.

3.5. ORGANIZATION OF THE REMAINDER OF THIS PART

The remainder of this part consists of 17 brief chapters that describe the methodology in more detail. Because the problem and the methodology are structured in terms of the system diagram, there is a chapter corresponding to each component of the diagram.³ However, agriculture is such an important and complex sector that its chapter is followed by separate chapters on sprinkling irrigation and on agricultural benefits. The remaining chapters deal with broader issues. One chapter describes certain national impact categories not shown on the system diagram (e.g., public health). Another describes the methodology for distributing monetary benefits and costs among producers, consumers, and the government. And the final chapter in the part describes our scenarios.

Note that certain chapters after this part discuss additional components of the PAWN methodology specific to particular stages of analysis. Chapter 21, Secs. 22.1-22.5, and Secs. 23.1-23.2 describe the details of the screening process, including a powerful technique for establishing bounds on the annual net benefits. Chapters 24 and 26 and Secs. 25.1-25.4 and 28.1 describe the strategy design and policy design process and present details of the response design model and managerial strategy design model. Finally, and perhaps most important, Chap. 29 presents and discusses a master flowchart that describes how all the components of the PAWN methodology fit together and are used for impact assessment. It also describes a few previously undiscussed components that either adjust input databases to reflect changes in policy or summarize model outputs to simplify comparison.

NOTES

1. The annualized fixed cost of a tactic was obtained by applying a capital recovery factor of 0.10 to the investment cost and adding the fixed annual operating cost. A capital recovery

factor of 0.10 reflects a useful life of approximately 50 years and a discount rate of 10 percent.

Investment costs include a contingency of 15 percent but do not include value-added tax. The annual maintenance cost was estimated to be 1.0 percent of the total investment cost (excluding contingencies) for pumping station and locks, and 0.5 percent of other facilities.

2. In classical cost-benefit analysis, the net present value of the time stream of costs would be compared with the net present value of the corresponding time stream of benefits.

Instead of using net present value for both costs and benefits, we have used a procedure that is easier to apply and gives equivalent results. We expressed nonrandom costs (investment and nonrandom fixed operating and maintenance costs) as an equivalent constant annual cost. The random net benefits are assumed to have identical statistical distributions for every year. Hence the expected annual net benefit, which is the mean of the distribution, is the same in every year and can be compared directly to the annual fixed cost.

In comparison to classical cost-benefit analysis, our approach groups costs and benefits differently and omits net present value calculations. Why then does our approach yield equivalent results in the decision to accept or reject a policy? First, the different grouping does not change the decision because exactly the same basic costs and benefits are included. Second, if classical cost-benefit analysis had used the same grouping of costs as we do, the net present value of the nonrandom costs and the time stream of net benefits would have been compared. But the ratios of the net present values to their equal annual equivalents are the same for both the nonrandom costs and the random net benefits.

The assertion about the ratios can be proven in the following way. Suppose

$$B_t = \text{random net benefits in year } t$$

$$i = \text{interest rate (discount rate)}$$

$$r = 1/(1+i)$$

Then the net present value of the net benefits, NPV_B , is

$$NPV_B = B_0 + rB_1 + r^2B_2 + \dots + r^tB_t + \dots + r^nB_n$$

When we take the expected value of this, assuming the net benefits have identical statistical distributions in every year, we find the following:

$$\text{Exp}(\text{NPV}_B) = \text{Exp}(\sum r^t B_t) = (\sum r^t) \text{Exp}(B)$$

When we replace the time stream of net benefits above with the time stream of annual fixed costs, our final result has the same form, with the expected value of the fixed cost stream being equal to the annual fixed cost as we have defined it. And the same ratio--the r term--applies.

3. The exception is the treatment plant sector, which is considered as part of the scenario.

Chapter 4

WATER DISTRIBUTION MODEL

4.1. INTRODUCTION

The surface water management system in the Netherlands is a large system of many components. The system infrastructure consists of the rivers and canals that transport water, the lakes and reservoirs that store water, and the weirs, locks and lock bypasses, sluices, and pumping stations that are used to control the transport of water to and within the various regions of the country. The water distribution model (DM) described in this chapter simulates the major components of this system in detail and contains aggregated representations of the other components. (Volume XI describes the model in detail.)

4.2. DESCRIPTION OF THE MODEL

For convenience, three categories of subsystems are distinguished in the overall water distribution system:

- The large rivers, canals, and lakes that comprise the national system (e.g., the Rijn River and its branches--the Waal, IJssel, and Neder-Rijn--the Maas River, the Amsterdam-Rijnkanaal, the Noordzeekanaal, the IJssel lakes, and the Zoommeer).
- The networks of waterways (small rivers, canals, boezems, and lakes) that transport water from the national system into the regions and comprise the regional systems.
- The networks of ditches that carry water from the regional systems to the individual farms and the inlet works and small waterways that connect the ditch network to the regional systems.

The major waterways of the surface water distribution system in the Netherlands are shown in Fig. 4.1. The national and regional systems are schematized in the DM as a single network--called the PAWN network--consisting of 92 nodes and 154 links. (See Fig. 4.2.)¹ In general, the links represent sections of these waterways, and the nodes locations where waterways join or places where water is stored. (Links joining storage nodes may represent an open connection between two bodies of water or the sluices, locks, and pumps that transport water between the two bodies.) For the purpose of modeling drainage, groundwater, and the water demands of agriculture, the entire country is divided into 77 districts, and the networks of ditches are treated in an aggregated way within the districts.

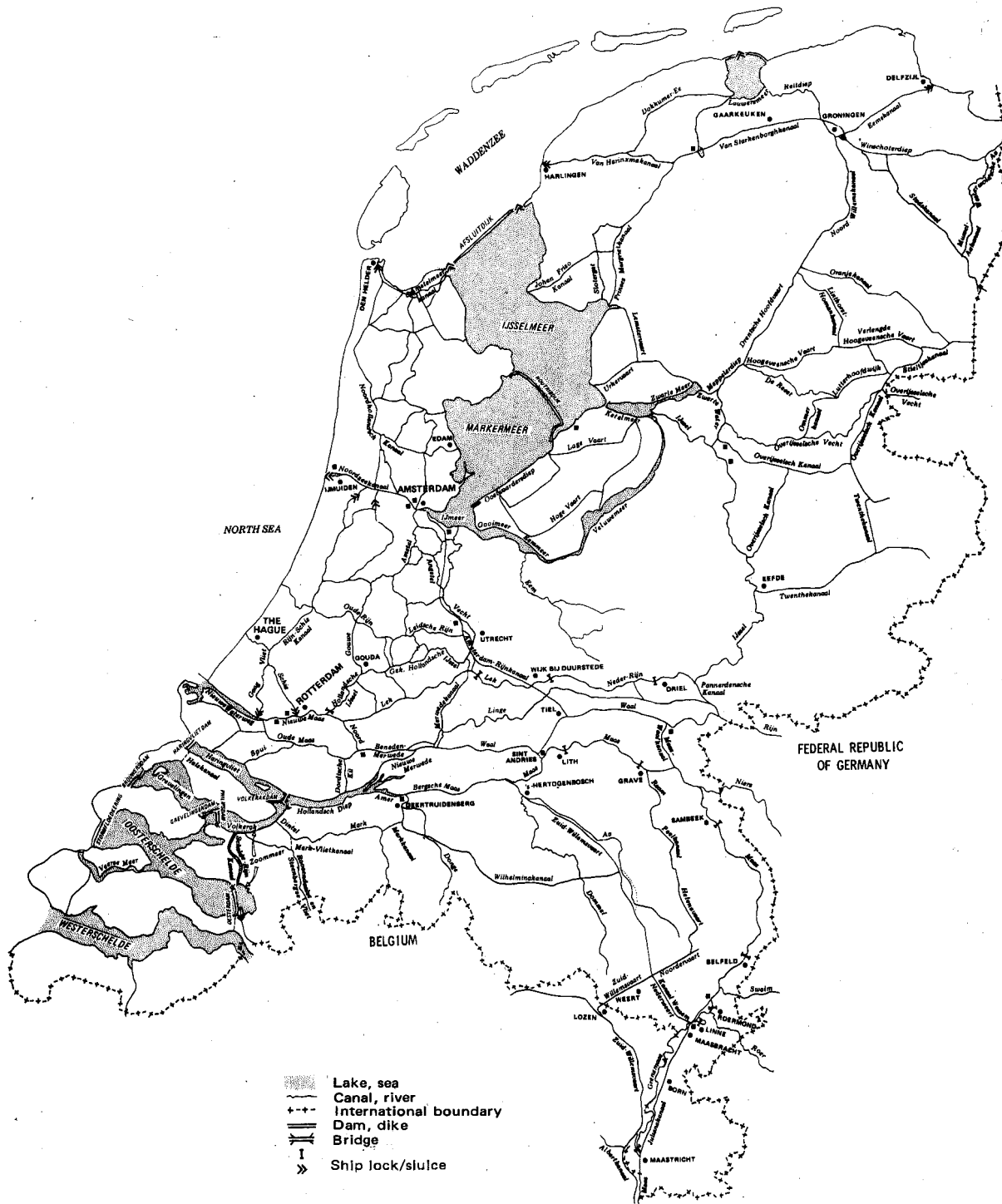

Fig. 4.1--Major waterways in the Netherlands

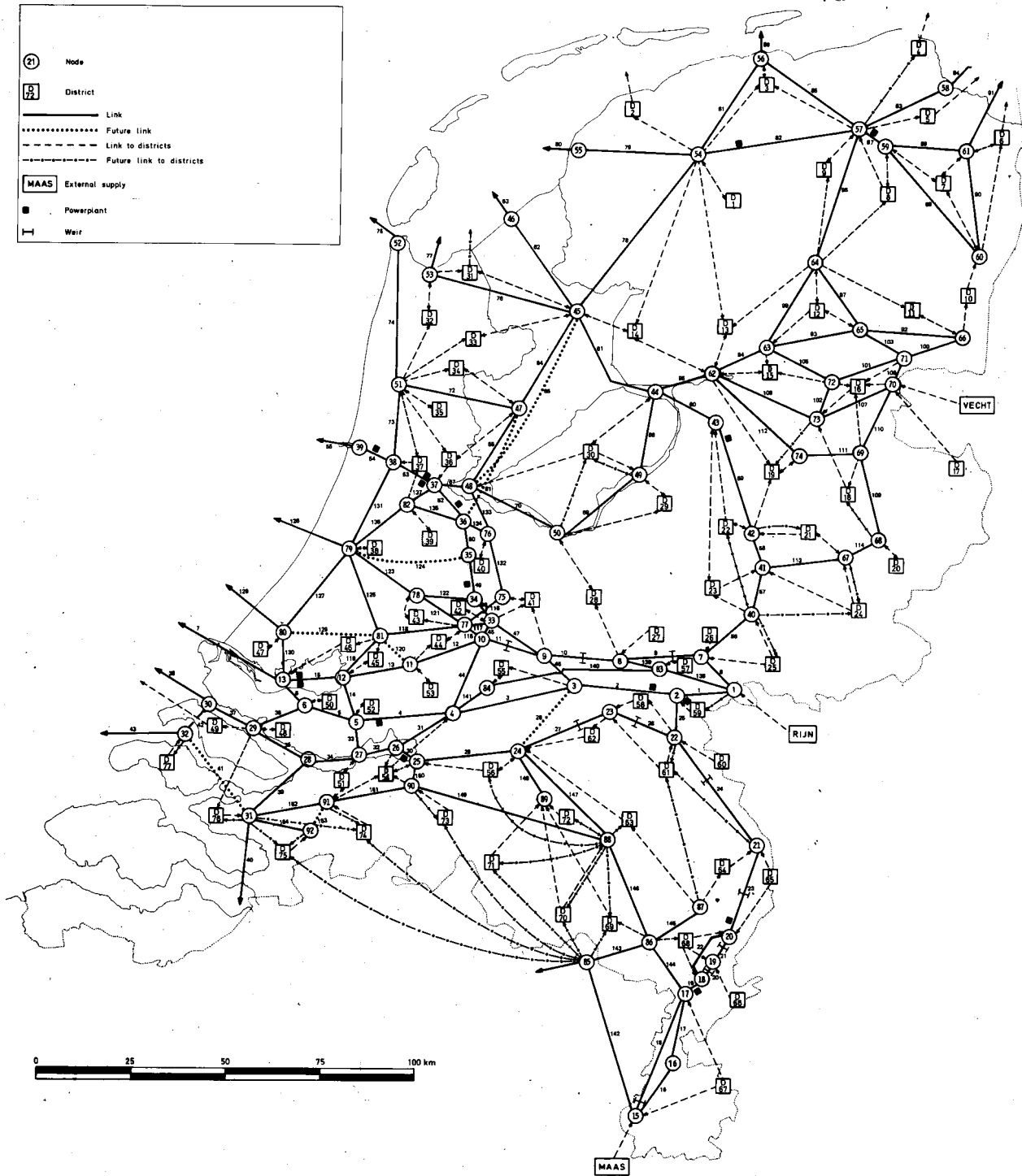

Fig. 4.2--The PAWN network

In Fig. 4.2 the circles (with enclosed numbers) represent the nodes, and the lines joining the circles are the links. The squares (with enclosed numbers) indicate the 77 districts into which the Netherlands has been divided for modeling agriculture and groundwater, and the dashed lines connecting the district squares to the nodes indicate the closest nodes on the waterways where the districts extract and discharge water. District discharges and extractions are apportioned among the nodes by means of district extraction and discharge distribution keys. These keys assign a fraction of the total district extraction (discharge) to one or more nodes. They also define the capacity of the district link to the node. (The process of modifying keys is summarized in Sec. 29.2.4 and is fully presented, along with the keys, in Vol. XIV.)

The links indicated by solid lines in Fig. 4.2 represent waterways in the current infrastructure. The links indicated by dotted lines represent waterways that do not currently exist; they are included in the network so that they may be evaluated as possible future additions. As part of the default parameters defining the network, these links are given flow capacities of zero and are not used unless nonzero capacities are supplied by the user as part of the DM inputs.

A complete account is kept of all the water that enters the country and all the water that leaves. (There are a few exceptions: The model does not include the southwestern corner of the country, the coastal dunes, and the islands in the North Sea--the first because a special analysis showed that it was not cost-beneficial to bring water there, and the others because they were separate systems. The drinking-water storage in the dunes is taken account of by other PAWN models.) Each point in the country is assigned to one of 14 weather stations, and a specified year's historical precipitation and evaporation patterns from these stations are used to determine precipitation on and evaporation from all bodies of water, and precipitation on and evapotranspiration from all croplands and nature preserves. The flows of the major rivers entering the country (the Rijn, Maas, Overijsselsche Vecht, Roer, Niers, and Swalm) in the specified year are entered as discharges at the nodes where these rivers enter the network. (The weather and river flow data, referred to as the external supply of water, are discussed in the next chapter.) Drainage from streams and small rivers and groundwater drainage into the large rivers, originating inside the country, are calculated as part of the discharges from the districts to the nodes of the network. At nodes on the upper Maas, additional discharges are entered that represent drainage from highlands areas in Belgium and Germany to the Maas that is not included as part of the discharges of the major rivers.

The water demands of each of the water-use categories is represented in detail in the DM. Agriculture is by far the largest user of water; croplands cover more than 60 percent of the country, and during a dry period, evapotranspiration from croplands may be over 1000 m³/s, most of which is provided by precipitation. (In contrast, the combined use of water by drinking-water companies and industry is about 30 m³/s.) Agricultural demands are calculated by a submodel of the DM called

the district hydrologic and agriculture model (DISTAG) that performs detailed water balance calculations within each of the districts (including groundwater) and determines the water extraction and discharge demands from the distribution system for each of the districts as a whole. DISTAG is described in Chap. 11.

Level control requires a large percentage of the water available during dry periods: Evaporation from open water and leakage from canals and ditches can amount to as much as 300 m³/s (approximately one-half of this is due to evaporation from the IJssel lakes). In the districts, constant water levels are maintained and water required for level control is part of the water demand of the district. For links in the network, evaporation creates a diminished flow in the link, or, for links representing canals, a demand at the upstream end of the link to replace the water lost by evaporation. At nodes representing bodies of water used for storage, e.g., the IJssel lakes, evaporation from the storage area is treated as an irreducible water demand on the storage of the lake.

Although shipping requirements for water are not represented as a direct demand, water shortages are reflected by increased shipping costs due to low flows in the major shipping arteries--the Rijn, Waal, IJssel, and Maas--and to shipping delays at locks when insufficient water is available for optimum locking operations. These costs are incorporated in the DM by special loss functions described in Chaps. 6 and 7.

Water demand for pollution control takes two forms: Higher quality water is used to dilute polluted water by flushing, and water-flows are used to push back salt intrusion from the North Sea or brackish bodies of water. These flushing water demands are represented as desired flushing flows through districts, desired minimum flows on specified links (for cooling water for electrical power plants, for combating salt intrusion at salt-fresh locks, for flushing the canals in cities, etc.), and by management policies that reduce lower priority demands for Rijn water during periods of low flows in order to increase the discharge in the Rotterdamse Waterweg and, thereby, decrease the inland penetration of the Rotterdam salt wedge. (The model for the Rotterdam salt wedge incorporated in the DM is described in Chap. 8.)

The water demands of drinking-water companies and industry are input as groundwater extractions in the districts and surface water extractions at the nodes of the network. These demands may come from the scenario or from models for these sectors described in subsequent chapters.

4.3. HOW THE MODEL OPERATES

A DM run simulates the water distribution for a calendar year (January 1 through December 31), using a decade as the computational time-step. A decade is nominally a ten-day interval, but for convenience in

aggregating results for monthly, seasonal, and yearly comparisons, the Dutch define a decade as a variable-length interval dividing the year into thirty-six decades. Each month is divided into three decades: two ten-day decades and a third decade comprising the rest of the month.

To analyze a water management policy with the DM, we must provide input describing the policy. The distribution system infrastructure, in the form of the complete PAWN network, is always input. But a set of technical tactics modifying that network is also input as the technical strategy to be analyzed. Its description includes relevant changes to the network capacities and keys.

Similarly, the current set of managerial rules for operating the infrastructure is also input. But a set of managerial tactics modifying some of these rules is also input as the managerial strategy to be analyzed. It is possible to invoke one of a limited set of predefined managerial strategies merely by specifying a keyword for the strategy.

Various cost files are also read into the DM. One file includes the cost parameters for each technical tactic described in Sec. 3.2 and a label identifying the tactic; the DM uses these parameters in the major tactic cost model, described in the same section, to estimate the cost of each technical tactic being analyzed as a function of its design characteristics and the varying water-flows (or levels) during its operation. Another file includes the annual fixed cost of sprinklers by district. (Chapter 12 describes how these costs and the corresponding variable cost factors are calculated. The variable cost factors are used by DISTAG.)

Finally, various data files describing the scenario are read into the DM. (As a further aid in the preparation of run inputs, a special computer program called PREPDM (preprocessor for the DM) was written that prepares input data files for a run as a function of keyword inputs that define certain scenario variables. That program is discussed further in Chaps. 13 and 29, and fully described in Vol. XIV.)

Given input and calculated data by decade on how much water is available across the country (from precipitation, river discharges, drainage of groundwater into the surface water system, and storage), and how much water is desired by the various water users, the DM determines the water-flows in the links (sections of the major rivers and canals) and the levels of the storage nodes (lakes). For each decade, the distribution of water-flows in the network is demand-driven and is determined in several steps. All desired extractions and discharges (by districts, industry, etc.) are entered at the nodes, desired and minimum flows are specified for certain links, and target and emergency levels specified for the special storage lakes (IJssel lakes, Zoommeer and Grevelingen when fresh, and the Maas weir ponds). A trial set of flows is obtained that meets the demands but may exceed flow capacities or the quantities of water available. When any of the constraints are violated, the DM invokes managerial rules that cut back

demands for cooling water, flushing, and surface water sprinkling that affect the violated constraints until the constraints are met (or until the demands are reduced to their minimum values). As such actions occur during a decade, the DM prints messages describing the action (e.g., the schedule selected for the weir at Driel, a reduction in flushing on links whose extractions come from the IJssel lakes, etc.). If any constraints are still violated, messages are printed notifying the user of the violations so that remedial action can be taken on subsequent runs (reducing the demands, changing management policy parameters, etc.).

After the water distribution has been determined for a decade, the DM determines pollutant concentrations at each node and in each district, for up to six pollutants: salt (chloride ion), heat, phosphate, BOD, nitrogen, and chromium. Salt concentrations are always calculated but calculations for the other pollutants are optional. Pollutant concentrations in the rivers when they enter the country are combined with pollutant discharges internal to the Netherlands, and changes in concentrations over time are modeled as exponential decay processes. The resulting concentrations are compared with water quality standards and the violations are reported. (The standards and the development and calibration of the submodels for each pollutant are described in Secs. 16.2 and 16.3, respectively, of Vol. XI.)

The DM then calculates the monetary losses to agriculture and shipping when compared with the ideal situation in which neither of these users suffers any losses due to water shortage or salinity, and provides water temperatures at nodes from which costs of meeting thermal standards can be determined for the electric power industry with the model described in Chap. 17.

The DM produces considerable output, both in printed reports and in datasets that other programs can use. It provides information on the water management system, including: flows, water levels, extractions, discharges, shipping depths, and pollutant concentrations. And it provides information on various costs, including: operating costs for irrigation and for tactics, shortage and salinity losses for agriculture, low-water shipping losses, and shipping delay losses. This information is produced decade by decade and in a summary giving totals or averages for the entire year, and is presented by district, node, link, region, etc.

By comparing the summary output of the DM for runs with different tactics or policies, we can determine the relative monetary benefits of the different tactics or policies to agriculture and shipping. We can also compare the effects of different tactics or different policies on pollutant concentrations throughout the distribution system. Various other effects can be determined by additional analysis of DM outputs. The DM facilitates this by producing several special datasets for subsequent analyses. These include a dataset showing the influence of electric power plant heat discharges on the temperature at nodes that is used by the electric power reallocation and cost model to calculate the costs of meeting thermal pollution standards; a dataset giving

shipping depths on the network that is used by the long-run fleet requirements model to calculate the necessary size and associated cost of a future inland shipping fleet; and a dataset of agricultural costs and losses (i.e., lost benefits) that is used by the benefit computation program to calculate agricultural net benefits by crop. Later chapters discuss the various models that use DM output, and Fig. 29.1 illustrates how various DM outputs are used in impact assessment.

4.4 VALIDATION

Flows and pollutant concentrations calculated by the DM were compared with measured values in 1976 as part of the validation process for the DM and its components. (The validation process for DISTAG is described in Chap. 11.) We chose 1976 as the validation year because it was the driest year for which we had data, and in PAWN we were most concerned with dry years; also, it was the most recent year of those for which we had data. (Validation details are given in Chap. 8 of Vol. XI. Ideally, had the data been available, validation would have been done with a different dry year than 1976, which was also used in calibration. The RWS is checking the model with recently available data for 1982, which was partly dry.)

The computed flows in the links of the network compared favorably with the measured flows, with several exceptions. We made several modifications that considerably improved the agreement for every exception.²

The calculated salinities were generally in agreement, particularly after some modifications to improve the agreement in a few locations where the computed concentrations were a bit low.

For BOD and phosphate, the computed values represent the average values of the measured concentrations over the year fairly well but tend to dampen seasonal variations. For chromium, the calculated values also represent the average measured concentrations fairly well but do not follow month-to-month variations well.

NOTES

1. In the DM, the PAWN network of nodes and links is divided into a national system and six regional systems. The national system represents the major rivers, canals, and lakes that transport water into and across the country: the Rijn branches (the IJssel, Neder-Rijn, and Waal rivers), the Rijn Delta, the Maas River, the Amsterdam-Rijnkanaal, the Noordzeekanaal, and the IJssel lakes. The links and nodes of the regional systems represent the portions of the water distribution system infrastructure that connect the national system to the different regions and transport water

within the regions. Each of the regional systems extracts and discharges water at a few nodes of the national system, but does not connect to any other regional system (with one minor exception). This factoring of the network into smaller networks simplifies the problem of determining the overall water distribution in the DM since the water distribution in the national system can be determined separately from that in the regional systems, knowing the regional system extractions at the nodes of the national system.

2. At the time the DM was documented, it appeared that there was still a significant discrepancy for the Noordzeekanaal discharges at IJmuiden, but the RWS subsequently concluded that this was specious.

Chapter 5

EXTERNAL SUPPLY

5.1. INTRODUCTION

The water budget for an average year in the Netherlands is shown below:

	Amount (million m ³)	Percent
<u>Inflow</u>		
Rijn	69,000	63
Rain	30,000	27
Maas	8,000	8
Other rivers	3,000	2
<u>Outflow</u>		
Discharge to sea	90,000	80
Evaporation	20,000	20

However, this aggregate picture obscures the fact that water-flows are not constant. They vary from year to year, and during a year they vary by season and by region. For example:

- In 1976 the river inflows were about half of the annual average, rain was considerably reduced, and evaporation was much higher than usual.
- Generally, river discharges are high in winter, when evaporation demands are low. It is not uncommon to experience winters with much rain, followed by hot, dry summers.
- In some years, some regions experience "mini-droughts" while other regions have adequate supplies of water.

Similarly, the inflow of salt (most of which comes from the Rijn) is not constant. In particular, the concentration of salt in the Rijn has steadily increased over the past fifty years or so. Much of this increase comes from industry and potash mining operations in the Rijn basin, which are essentially unaffected by weather conditions. Therefore, in dry years, the discharge of the Rijn decreases, but the amount of salt "dumped" into it remains about the same, thus increasing the salt concentration of the water.

The variation in rain, evaporation, river discharges, and salt means that changes to the water management system will have different effects in different years. Therefore, to study the effects in a particular year, we must make assumptions about rain, evaporation, river discharges, and salt. We embody such assumptions in what we call an external supply scenario.

Such scenarios can be synthetically generated, but we chose to use historical data in the PAWN analysis. In addition to being easy to compile, the historical scenarios have the advantage of being familiar to the decisionmakers and hence facilitate the understanding and interpretation of results.

To study the long-run impacts of any change to the water management system, we wish to consider the average impacts over a number of years (i.e., the expected impacts).¹ A straightforward way to compute average impacts would be to compute the impacts for many different years, and then take the average. We rejected this approach, primarily because the computational costs would have been too high, but also because data for many years were not available. Instead, we selected five scenarios (ranging from very wet to very dry), and assigned probabilities to these years. We could then calculate bounds on various impacts using appropriate weighted averages of the impacts computed for the five (or fewer) selected scenarios.

In this chapter, we describe the external supply scenarios used in PAWN, and explain how probabilities were assigned. We also conclude that the impacts calculated for a particular external supply scenario approximate the expected impacts, the average over many years of differing dryness.

5.2. SPECIFYING EXTERNAL SUPPLY SCENARIOS

To account for seasonal variation within a single year, each external supply scenario contains the following data for each of the 36 decades within a year:

- Rainfall and evaporation at 14 weather stations that provide national coverage and thus account for regional variation of rain and evaporation.
- Discharges of the Rijn, the Maas, the Overijsselsche Vecht, and several other small rivers.
- Salt concentrations of the Rijn.

5.2.1. Selecting Five External Supply Scenarios

We used three measures of dryness to select four of the supply scenarios. (The fifth supply scenario reflects a wet year.) We used historical data (by decade) for the years 1930 through 1976 to obtain the dryness measures. We then ranked the 47 years with respect to each measure, and examined the rankings in order to choose (subjectively) the four dry years to be used.

The three dryness measures used were:

- Average Rijn discharge at Lobith (just west of the German border).
- Average Maas discharge at Borgharen (just north of the Belgian border).

- Maximum cumulative net deficit at De Bilt. De Bilt is at the geographical center of the Netherlands. Meteorological data from this site are among the most extensive in the country. (Net deficit is potential evapotranspiration minus rainfall. The maximum cumulative net deficit is the largest value of the net deficit over all decades in the year.)

For each year, we calculated the values of each measure for each of the following three time intervals. Since we had found that agriculture losses dwarf those in any other sector, we gave greatest weight to criteria related to rainfall and evaporation over the growing season:

- Whole year (January-December)
- Entire growing season (March-September)
- Peak of growing season (May-August)

Combining the three dryness measures with the three time intervals produced nine dryness criteria. We also considered a tenth criterion--the critical capacity over the entire growing season. The critical capacity is the least amount of storage capacity that would be needed to compensate for a net deficit in any decade. Critical capacity takes into account the fact that water is stored in the root zone from one decade to the next, and is therefore a good indicator of crop damage.

Our rankings show that 1976 was an extremely dry year; it is also considered a particularly dry year by Dutch water management experts, who estimate its probability of occurrence at about 2 percent. The Rijn flow was particularly low in March-May, and during most of July; indeed, during the first two decades of July it was the lowest in recorded history. Only a substantial increase in Rijn discharges in late July, which continued through September, kept the drought from becoming more critical--especially in the area around the IJsselmeer.

To get a worst-case scenario for our analysis, albeit an artificially created one, we reduced some of the 1976 Rijn discharges still further by using, for each decade, the minimum of the discharges for that decade in 1934, 1949, and 1976. These were the top-ranked years on our three Rijn discharge criteria. We assigned the name DEX (for "extremely dry") to the supply scenario having these worst-case Rijn flows, in combination with the actual 1976 flows of the Maas and minor rivers, and actual 1976 rainfall and evaporation.

1959 was chosen as the "very dry" year. It ranked first on three of the criteria and was always among the top ten.

1943 was chosen as the "moderately dry" year, since it appeared to be the least dry among the years ranked as dry.

1967 was chosen as the "average" year. Its Rijn and Maas flows were about average, and it ranked 18th out of the 47 years on critical capacity.

1965 was chosen as an "extremely wet" year, based on actual measurements for that year. For example, of the 47 years we considered, 1965 had the largest Rijn discharge during the growing season.

5.3. FORECASTING RIJN SALT CONCENTRATIONS

In 1876 the average salt concentration in the Rijn at Lobith was less than 20 ppm. In 1976 the average was over 200 ppm. These figures suggest that as much as 90 percent of the total salt load in the Rijn now comes from waste salt dumped into the river by industrial firms, and the size of this salt dump appears to be steadily increasing. In 1976 the governments of five nations (the Netherlands, France, West Germany, Switzerland, and Luxembourg) agreed to clean up the Rijn. In particular, they agreed that the amount of salt dumped into the Rijn by France's Alsatian potash mines (the worst single source of salt on the river) should be reduced by 60 kg/s (about half of their current discharge). Although the treaty was approved by four of the nations, France has refused to ratify it.

In order to choose an appropriate average annual salt dump, and to specify how the amount dumped should be varied decade by decade over the year, we analyzed historical data on salt concentrations of the Rijn at Lobith. Data from 1970 through 1977 were used in a regression model to obtain a relationship for estimating the salt load in a decade, given the year's average salt load, the year's average Rijn discharge, and the Rijn discharges in that decade and the previous decade.² The results indicated that there is an important seasonal pattern in the salt load. (This pattern was subsequently incorporated into the distribution model (DM).)

These results allowed the salt dumped in any year to be estimated from the total salt load observed in that year. (Details are given in Sec. 6.2.1 of Vol. XI.) We estimated the salt dump for the years 1930 through 1977 (the years for which we had data on salt concentrations), and found that the trend in the amount dumped was fit rather well by the straight line:

$$D = 40 + 5.9(\text{year} - 1930),$$

where D is the amount dumped, in kg/s (see Fig. 5.1).

The salt in the Rijn comes from two sources. A "natural" or "background" salt concentration of about 25 ppm is always present. Much more important, a great deal of salt is "dumped" in the Rijn by industry and mining operations. We estimate that the amount dumped was only about 40 kg/s in 1930, and on average has increased by almost 6 kg/s each year since then. This trend suggests that 311 kg/s would be dumped in 1976. (In fact, somewhat less--284 kg/s--was actually observed. This was because of economic conditions and because the French held back some of the salt to dump in a later period with greater flows.)

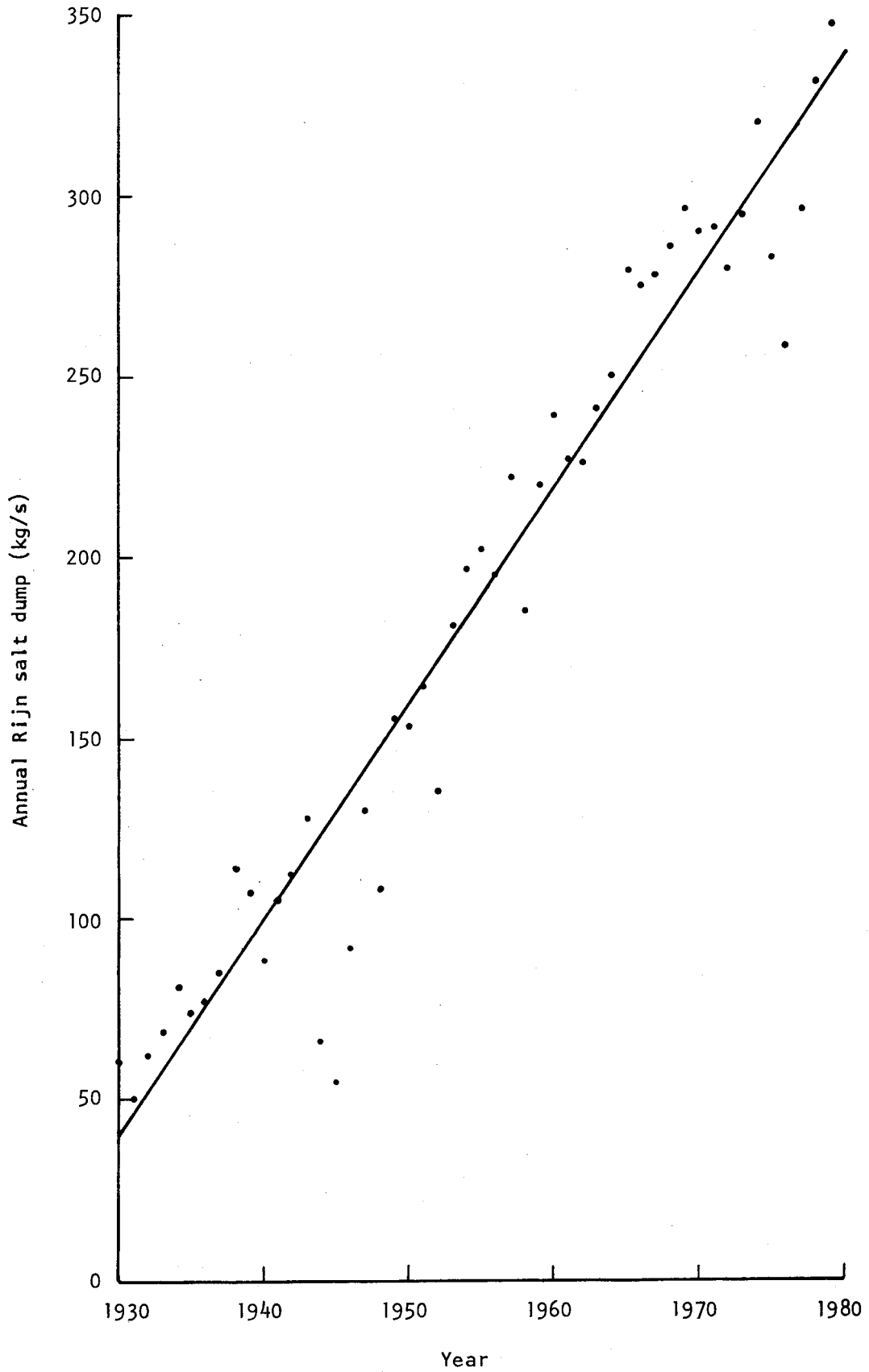

Fig. 5.1--Rijn salt dump

To complete the external supply scenario, we must make a scenario assumption about the Rijn salt dump, which means choosing the amount of increase from the trend and the decrease from some future treaty, if any. The reference and alternative assumptions, and the reasons for their choice, are given in Chap. 20. We combine the assumed Rijn salt dump with the natural salinity of the Rijn and the seasonal pattern of the salt dump to produce decade-by-decade salt loads for each of the five external supply scenarios. (The salinities for the other rivers are discussed in Sec. 20.5.6.)

5.4. ASSIGNING SCENARIO PROBABILITIES

To determine upper and lower bounds on the expected annual benefits of a tactic, we needed a weighted average of the benefits obtained using these four supply scenarios. For this purpose we first had to assign probabilities to each scenario. Two sets of probabilities were assigned to the years: one based on agriculture shortage losses, and one based on agriculture salinity losses.³ We estimated the probabilities using a simplified version of the DM to determine agriculture losses for the 47 years 1930 through 1976.

For estimating shortage losses, we ran a detailed simulation of only the water distribution system in the northern half of the country--all districts that extract and/or discharge water from the IJssel River or the IJssel lakes. Cost considerations made it impractical to simulate water distribution for the entire country, and the northern section is the more important for agriculture. More than two-thirds of the cultivated area in these districts is grassland. Since the hydrologic properties of grassland and land planted with other crops are virtually identical, we assumed that the entire cultivated area was planted with grass.

We made a run of the DM to simulate the period 1933 through 1976. (We could not simulate 1930-1932 because we lacked data on the IJsselmeer, which was created in 1933.) We then ranked these 44 years according to the total agriculture shortage loss over the year. The shortage losses in 1976 were the worst of all 44 years (more than 35 percent of the grass crop was lost). This suggests that the shortage losses associated with 1976 would be exceeded one year in 44; equivalently, the likelihood of these losses being exceeded is 2 percent ($1/44 = .02+$). Similar likelihoods can be calculated from the other scenario rankings:

For 1959,	7 percent	(3/44)
For 1943,	21 percent	(9/44)
For 1967,	63 percent	(28/44)
For 1965,	100 percent	(44/44)

For estimating salinity losses, we ran a detailed simulation only of the water distribution system in the Midwest and Utrecht, an area in which the majority of the valuable glasshouse crops are grown. We assumed the

existing distribution of crops, but we calculated losses only for the glasshouse crops (vegetables and flowers) in Delfland. These are the most valuable and most salt-sensitive crops grown in the Midwest. More than one-fifth (3600 ha) of the cultivated area of Delfland is devoted to glasshouse crops, which have a market value of more than 1000 Dflm.

We ran the DM for the 47 consecutive years, and computed the salinity losses for the glasshouse crops of Delfland for each year. Our implementation of the model, designed largely for estimating single-year impacts, carries forward salt left in the root zone at the end of one growing season to the beginning of the next, and salinity losses indicated a considerable carry-over effect. Exceptionally wet years were followed by years with less-than-usual salinity losses (even if they were dry years); exceptionally dry years were followed by years with greater-than-usual salinity losses. Since we were interested in the likelihood of salinity losses for independent years, we adjusted for this carry-over by using statistical techniques to explain as much of the annual salinity losses as possible by the initial salt concentration, and then used the residual salinity loss as a measure of "current-year" loss.

We ranked the 47 years according to their residual salinity losses. The losses in 1976 were the worst of all 47 years (more than 15 percent of the glasshouse crops). Thus the likelihood of the 1976 salinity losses being exceeded is 2 percent (1/47). The likelihoods for the other scenarios are:

For 1959, 9 percent (4/47)
For 1943, 13 percent (6/47)
For 1967, 57 percent (27/47)
For 1965, 100 percent (47/47)

The likelihoods described above are summarized in Table 5.1 as probabilities. Note that, although we have assigned a probability of occurrence of .02 to DEX, the actual probability that such a dry year will occur is probably less. The Dutch experts generally agree that 1976 has a 2 percent probability of occurrence, and DEX is drier than 1976. Therefore, we are likely to be overestimating the benefits to be derived from some of the tactics.

Table 5.1

PROBABILITIES OF ANNUAL LOSSES EXCEEDING
THOSE OF FIVE CHOSEN YEARS

	DEX	1959	1943	1967	1965
Shortage losses	.02	.07	.21	.63	1.00
Salinity losses(a)	.02	.09	.13	.57	1.00

(a) These probabilities are used only for estimating salinity losses in the Midwest and Utrecht region and, in certain circumstances, shortage losses in Delfland.

5.5. IMPACTS FOR THE 1943 SCENARIO TO APPROXIMATE AVERAGE IMPACTS

In most years, the Netherlands has enough water and experiences little damage for lack of it. During years of drought, however, the damage can be very high. Thus, the expected annual damage is the average of many low values, plus only a few high ones. Consequently, a year in which average damages are observed is hardly an average year--in fact, such a year must be somewhat drier than average. The same should be true for other impacts that vary with dryness, such as the concentration of various pollutants: The average value of an impact must occur in a year that is drier than average.

Of the five external supply scenarios, we would anticipate the impacts for 1943--a year of moderate dryness--to be closest to their average values. Indeed, when we examined the crop losses from the simulation of 44 years that we used to assign scenario probabilities, we found that the losses for the 1943 scenario were roughly comparable to the average losses for the 44 years. We have therefore concluded that impacts for the 1943 scenario can be used to approximate the average impacts.

NOTES

1. Merely because a policy produces large net benefits in an extremely dry year does not mean that it is worthwhile. For example, suppose that the policy provides benefits only in the driest year, and such a year can be expected to occur once every fifty years. Then the expected benefits from the policy (the average over a large number of years) would be 1/50, or 2 percent, of the benefits in the driest year.
2. Further details are provided in Vol. XI.
3. A set of probabilities based on low-water shipping losses was developed late in the study, after most of our analysis was completed (see Vol. IX). We used the probabilities based on agriculture salinity losses in our analysis to estimate the benefits from tactics that would reduce shipping losses. The probabilities based on low-water shipping losses place lower weights on the drier years. Thus, our analysis tends to overestimate the benefits from tactics that reduce low-water shipping losses.

Chapter 6

SHIPPING

6.1. INTRODUCTION

Although it consumes no water, inland shipping is a primary user group that could be significantly affected by water management policies. For the Netherlands, shipping is a major means of transporting domestic goods, particularly sand and gravel and agricultural products, and transport on the Rijn and Maas is a vital link between the inland industrial areas and the North Sea ports of Rotterdam, Amsterdam, and Antwerp.

Inland shipping is also important to Europe as a whole. It forms a vital transportation link between the major harbors of Rotterdam, Amsterdam, and Antwerp and the industrial areas of Germany. Ships of many nations carry raw materials and finished goods along the network of rivers and canals. The inland shipping routes carry more than 60 percent of the Dutch international transport. The international importance of these Dutch waterways is underscored by the Act of Mannheim, which guarantees free and unhindered navigation to all ships on the Rijn and its Dutch branches.¹

Water management policies can have important consequences for shipping operations. By modifying the navigational characteristics of the shipping network or its operation, policies affect travel times and distances, and, consequently, shipping costs. More specifically:

- Modifying water levels and flows in rivers and canals changes how much cargo ships can carry, and thus how many ships are needed to carry a given amount of cargo.
- Withdrawing water from rivers, particularly the Waal and IJssel, directly reduces shipping depths and can lead to future costs from either increased sedimentation or dredging.
- Changing the shipping network or infrastructure may force carriers to reroute or otherwise alter their behavior.
- Restricting lock operations on canals to reduce freshwater losses or salt intrusion through locks increases delays for ships using the locks. (Discussed in Chap. 7.)
- Changing withdrawals and water distribution may have long-run implications for the size of the shipping fleet needed to carry all cargo without added storage or delay.
- Modifying the shipping network or ship traffic can affect shipping safety and probability of accidents.

We have limited the shipping analysis to the effects of changes in the quantity of water available to shipping. Tactics which affect water

quality or salinity could also be important, but only so far as they change the quantity or distribution of water in the network.

6.2. GENERAL APPROACH

To determine how water management policies affect shipping costs, we must be able to characterize shipping operations in a reference situation. This involves describing the characteristics of the shipping network and fleet, commodities to be transported, cost coefficients, water availability, and ship traffic distribution, among other factors. Most of these elements depend on the time frame and are thus context variables. Water availability must be specified because it is primarily a function of river flow and precipitation. Finally, the distribution of ship traffic on the network will be a function of both the context and water availability; it therefore must be determined by the various models used in the study.

We used the following general approach to evaluate how the various tactics affect shipping operations:

- Define cases by specifying (1) context, (2) fraction of total shipping costs that applies to Dutch vessels, and (3) shipping scenario.
- Assign ship traffic to the network for each case.
- Assess impacts of tactics and calculate cost changes for all affected ship traffic.

In practice, the calculation of cost changes can be simplified by developing loss functions for low-water and lock-delay losses. These functions are used to determine the losses for any situation, given only the shipping depths on major waterways and the flows through various canals.

Certain impacts on shipping cannot be described by loss functions. These include the change in long-run fleet requirements and major network tactics, which will be discussed later. Price and regulation tactics can also be applied to the shipping industry, but we concluded that they were either unnecessary or not relevant to the basic problem. Finally, we looked at the shipping industry and markets, to determine how these might be directly affected by alternative water management policies.

6.3. SHIPPING COSTS

In general, shipping costs consist of fixed and variable components. Fixed costs include: (1) investment and financing expenses, (2) depreciation, and (3) a fraction of labor, maintenance, administration, and insurance costs that does not depend on the ship's activity level. Variable (operating) costs include (1) fuel and oil, (2) lock, harbor,

canal, and loading or unloading fees, and (3) the part of labor, maintenance, administration, and insurance costs that does depend on activity. Separation of these costs is necessary because of the distinction between short-run and long-run costs. In the short run, water management policies affect only variable costs; in the long run, they may affect investment decisions and thus change fixed costs. Except for the long-run fleet calculations,² we considered only the variable costs in the shipping analysis.

To calculate shipping costs, we first separated all transport into trips (by ships of different type, size, and load), then calculated the cost per trip for each vessel. Average cost per trip can be calculated using a standard formula developed by the EBW (Economisch Bureau voor het Weg- en Watervervoer), the Netherlands Economic Bureau for Road and Water Transport. This formula considers both sailing time and waiting time per trip, and multiplies each by standard coefficients that depend on the type and size of ship being considered. These cost calculations are discussed in more detail in Vol. IX.

6.4. LOW-WATER LOSS FUNCTIONS

Adequate water levels are vital to shipping. Otherwise, ships cannot carry their maximum loads, more trips become necessary, and operating costs increase for transporting a given amount of goods. Policies that change flows and water levels on the network will affect shipping depths for various waterways and routes. We developed low-water loss functions as a means of calculating the shipping costs of such changes.

To develop these loss functions, we had to describe domestic and international shipping operations in the Netherlands and in Western Europe for the 1976 and 1985 contexts. This description had to include:

- Description of goods to be transported between all origins and destinations.
- Description of the shipping fleet participating in domestic or international transport, including the change in mean load capacity (by type and size of vessel) as a function of the maximum draught.
- Specification of the shipping network in the Netherlands and areas of Western Europe, including relationships between depth and flow.
- Distribution of traffic by type and class of ship and type of commodity.
- Shipping costs by type and class of ship.

Our description of the 1985 fleet was based on the fleet specifications developed for a shipping cost study by the DVK (Dienst Verkeerskunde), the shipping branch of the Rijkswaterstaat; the NVK (Nederlands Vervoerswetenschappelijk Instituut), the Netherlands Institute of Transport; and the EBW. These organizations developed a description of

shipping and carrier behavior during normal and low-water periods. With computer models they determined ship traffic and shipping costs (in both contexts) for a range of water-level and flow conditions on the network. The analysis procedure and results of this study are presented in Ref. 6.1.

To use these results in developing the low-water loss functions, we devised a system of critical points. Every shipping route has a shallowest point that determines the maximum draught of ships using the route. We identified five major locations on the shipping network where depths are strongly affected by water management tactics. These critical points for shipping are:

- Lower Rijn near the mouth of the Ruhr.
- Upper Rijn between Keulen (Cologne) and Karlsruhe.
- Maas (minimum depth of all sections in the Netherlands).
- IJssel between Doesburg (Duisburg) and the Twenthekanaal.
- Waal between Weurt and Gorinchem, the minimum of the two sections: Weurt to St. Andries and St. Andries to Gorinchem.

We assigned routes to the ship traffic between each combination of origins and destinations, determined the critical points passed by each route, and grouped the shipping routes by the combination of critical points that they pass. This process gives seven major shipping routes and about 15 minor routes that can be combined to form a fixed shipping cost term. The major routes and their critical points are shown in Table 6.1.

Table 6.1

CRITICAL POINTS ASSOCIATED WITH THE MAJOR SHIPPING ROUTES

Route Name	Upper	Lower	Waal	Maas	IJssel
	Rijn	Rijn			
Upper Rijn-Waal	X	X	X	-	-
Lower Rijn-Waal	-	X	X	-	-
Maas-Waal	-	-	X	X	-
Lower Rijn-IJssel	-	X	-	-	X
Maas-IJssel	-	-	-	X	X
Upper Rijn-IJssel	X	X	-	-	X
Waal-IJssel	-	-	X	-	X

Using the shipping study results, we calculated and plotted the costs per route against the corresponding minimum critical point depth for the route to generate the seven low-water loss functions. The loss function in the 1976 context for the Upper Rijn-Waal route is shown in Fig. 6.1. The remaining loss functions can be found in App. B of Vol. IX.

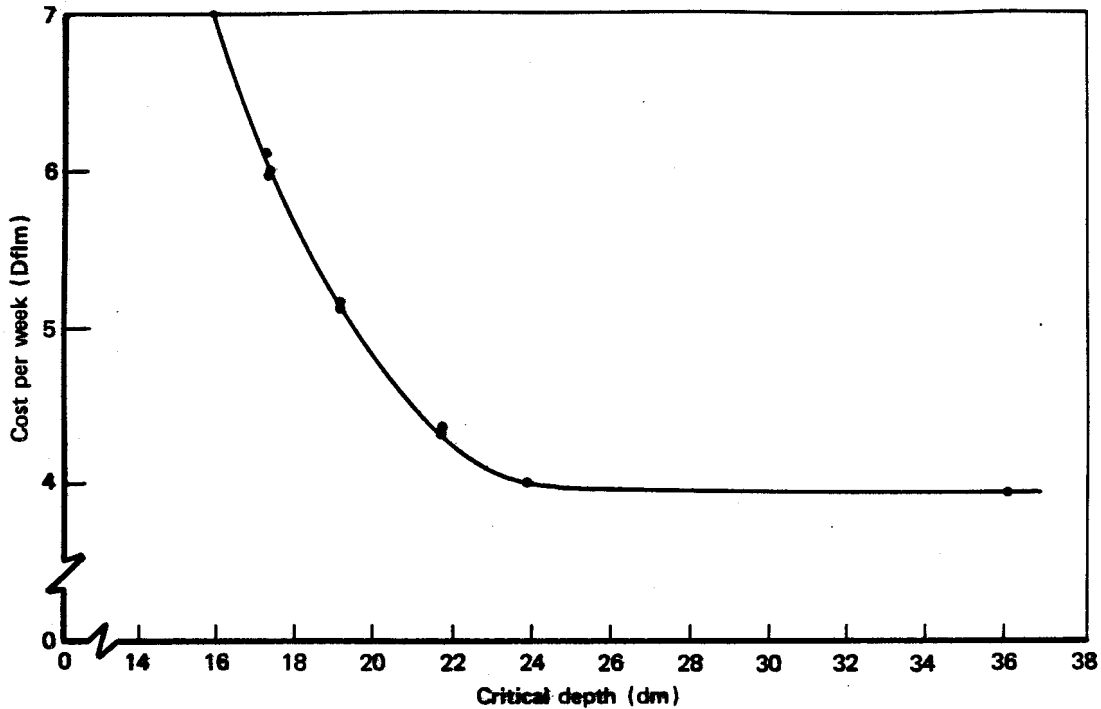

Fig. 6.1--Low-water loss function for Upper Rijn-Waal (1976)

These curves can be used to find shipping costs, provided that we know the shipping depths at the critical points. Using various data sources, we derived equations for these depths as a function of the appropriate flow rates. We also derived equations for the immediate depth reduction caused by withdrawals from the Waal and IJssel.

Low water levels can cause the fleet capacity to be inadequate to carry all available cargo. When this occurs, goods must be delayed and stored until water levels rise. Using storage costs from the shipping study, we developed storage cost functions based on the depths on the Waal and IJssel. These functions can be used like the low-water loss functions to calculate storage costs for any given situation.

6.5. SEDIMENTATION LOSS FUNCTION AND DREDGING COST MODELS

The Waal River in the Netherlands is heavily traveled by Dutch and other vessels of the Western European shipping fleet; these vessels often carry cargo to and from Rotterdam Harbor, which is Europe's busiest port. The upper reaches of the Waal include some shallow stretches. Two locations in particular--one downstream of Tiel and one downstream of St. Andries (Fig. 6.2)--are critical for inland shipping under low-water conditions. Some of the PAWN tactics involve

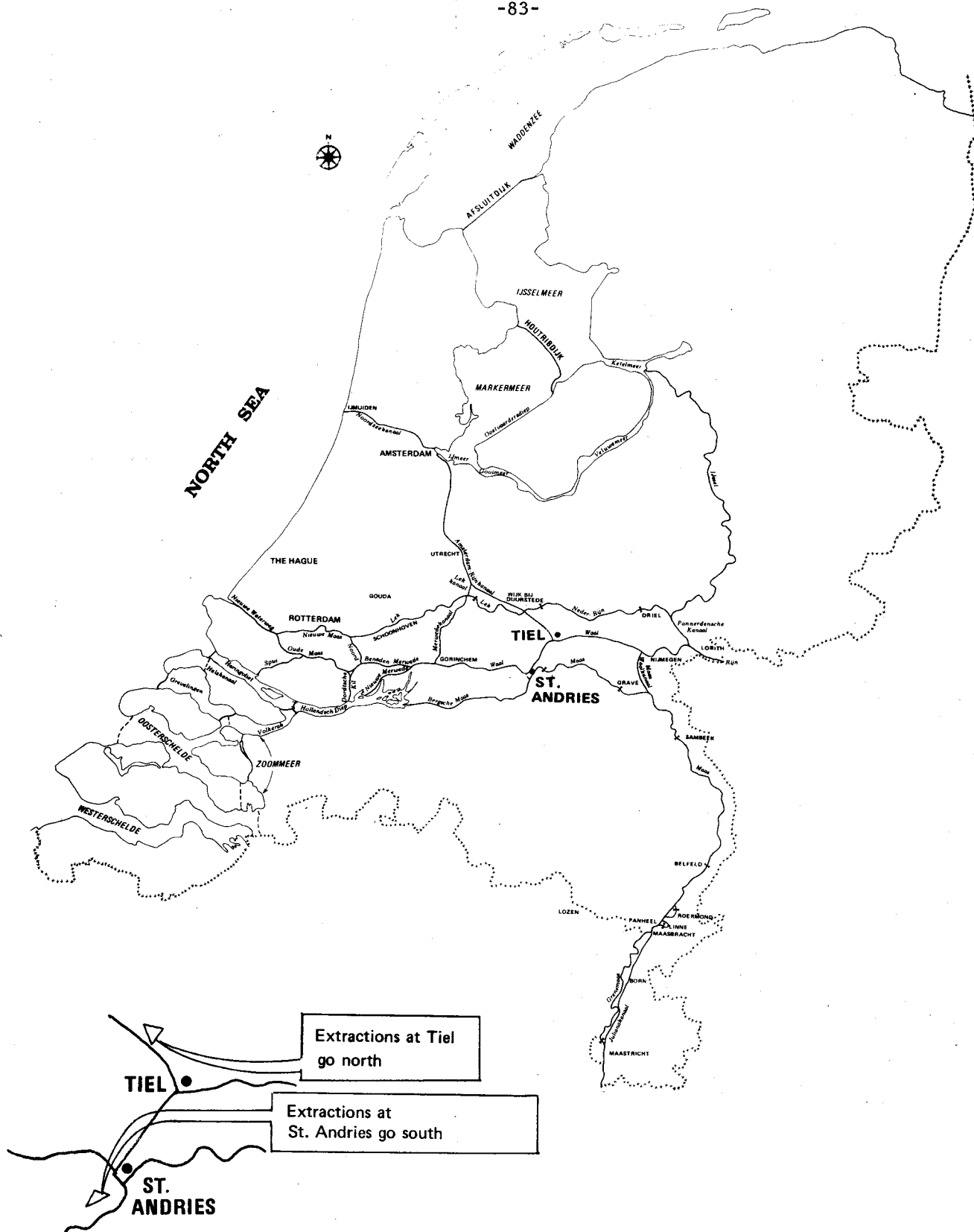

Fig. 6.2--Critical extraction locations leading to sedimentation build-up

extracting water from the Waal near these locations. When water is extracted, the reduced velocity of the flow increases the rate at which sand is deposited on the river bottom, and a sandbar will form. In this event, costs will be incurred either because ships must be operated with reduced cargoes, or because the sediment must be dredged from the river. We built the sedimentation model, the dredging cost model, and the sedimentation loss function model to estimate these costs for tactics which involve extractions from the Waal. (For a complete discussion, see Vol. XVIII.)

The sedimentation model estimates the depth and volume of sediment as a function of the extraction schedule. There are two versions of this model for use with the current river configuration: one for Tiel and one for St. Andries. A third version of the model is intended to investigate the effect of narrowing the Waal at Tiel by lengthening the groins³ along its bank.

The PAWN sedimentation model is a simplified model which reproduces results obtained from more complex physical models of sedimentation developed by the RWS. We wished to follow the effect of a tactic in decades through an entire year. Because the extraction rate might be different in each decade, however, a vast number of extraction schedules are possible; consequently, we could not run the RWS models for a few cases and fit the results with a simple function. Instead, we ran related cases with the RWS model to gain insight into the relation between extraction rates and schedules and the amount of sediment deposited, as predicted by the model. Knowing this relationship enabled us to design a simplified model which determines how much a prescribed extraction schedule will increase the depth and volume of sediment in each decade.

We found that sedimentation goes through two phases: a build-up phase, which starts when the extraction starts and lasts until the deepest part of the sandbar has reached the critical point, and the fully formed phase, which starts when the critical point has been reached and lasts until extraction stops. With a constant extraction rate in the fully formed phase, the depth of the sediment remains constant, but the length of the deposit increases as the current moves the sand downstream at the same rate it is deposited by the extraction. The build-up phase lasts about 12 decades at Tiel and 24 decades at St. Andries.

We compared the results of the PAWN sedimentation model with those obtained from the RWS models and found that there was good agreement in the build-up phase, but that agreement was not as good in the fully formed phase. Consequently, when cases involving fully formed sandbars are used in the PAWN analysis, the results obtained from the PAWN sedimentation model have been checked by running the appropriate RWS model.

We investigated the effect of narrowing the Waal downstream of Tiel by running the RWS model with a particular narrowed configuration the RWS provided. For this configuration, the results indicated that narrowing the Waal will result in an increase in depth of about 12 cm over the

present configuration when no extractions are made, and that there will be no significant deposits due to extractions.

The dredging cost model calculates the cost of dredging the sediment. In building it, we adopted a very conservative dredging policy, that is, one that results in an upper bound on dredging costs. Our policy is to dredge all the sediment that is deposited, even though in reality much of it would eventually be carried downstream without affecting shipping. We based our estimate on cost data for several types of dredges currently available in the Netherlands. RWS personnel are concerned about both short- and long-term morphological changes if the extensive dredging that we visualize is used; consequently, they feel that dredging should be done in small increments. This approach means that the dredges must be used inefficiently, possibly only a few hours a day. At the suggestion of RWS personnel, we increased our estimated dredging cost by a factor of 3 to allow for the additional cost due to this constraint. Our estimate for the cost of dredging then became 16.2 Dfl/m³.

The sedimentation loss function model is used to estimate the cost to shipping due to sedimentation when the sediment is not dredged away. The sedimentation resulting from an extraction will not be deposited at the critical point until months after the extraction, but will then persist for months. During the time it is present, there will be a variation in river water levels and, consequently, in river depths. This variation can be estimated statistically. We used a 50-year history of river flows as a statistical sample to estimate the expected loss to shipping due to a specified extraction. In doing this, we allowed for the possibility that locations other than Tiel may at times be critical for shipping. Since the loss to shipping is spread over several years while the sandbar is present, we estimate its present worth using a discount rate of 10 percent. We estimate that an extraction which results in a deposit having a maximum depth of 20 cm will cause a loss to shipping of between 9 and 15 Dflm, depending on the amount of traffic; one which results in a maximum depth of 40 cm will cause a loss of between 21 and 35 Dflm. (These are the present worth of the future losses.) For tactics that require continued extractions year after year, our method underestimates the long-term shipping loss due to sedimentation. However, none of the tactics considered in PAWN involved continued heavy extractions year after year, only in occasional years.

6.6. LONG-RUN FLEET REQUIREMENTS MODEL

Water management policies that change shipping depths will affect the capacity of vessels in the shipping fleet. If the effects persist, overall fleet capacity will have to adjust to maintain the relation between supply and demand for transport. These adjustments will change the number of ships and their size distribution, and thus the total fixed costs of the fleet.

One obvious approach to estimating long-run fleet changes is to define an optimal fleet for each situation, then compare the fleets required under each alternative policy. This is extremely difficult, because cargo and water conditions vary with time, seasonally and randomly. Fortunately, it is not necessary to specify an optimal fleet in order to investigate how water management policies will affect the required fleet size. Instead, we determined how the nominal 1985 fleet (projected by NVI/DVK/EBW) would have to be scaled to meet long-run changes. We defined a fleet proxy to represent the fleet required to carry an average amount of cargo a certain percentage of the time. The basic proxy we used was the 90 percent fleet, that is, the fleet sufficient to carry the cargo 90 percent of the time. We defined "percent of the time" in terms of Rijn flows at Lobith. The 90 percent fleet corresponds to a Rijn flow at Lobith (decade average) of 1098 m³/sec. By our definition, the flow at Lobith will be less than this value 10 percent of the time (over a number of years). We can compare alternative policies by considering the fleet required during all weeks that have Rijn flows greater than or equal to the criterion value.

Using the shipping study results as a basis, we developed a model to calculate the required fleet for any given situation, as defined by the five critical point depths. This model uses the critical point depths to select the most appropriate shipping study case. It adjusts the number of ships required on each major route in that case to account for differences in the critical point depths and load factors for all ships. To this result it adds the ships required for the remaining fixed-route shipping and calculates the annualized investment and annual fixed costs of the fleet.

Selecting the appropriate Rijn flow for a particular proxy criterion leaves two important questions. First, is the 90 percent proxy a reasonable and sensible choice? Second, does specifying the proxy criterion in terms of a Rijn discharge adequately characterize the water conditions? Or should other factors, such as net precipitation and the level of the IJsselmeer, be included in our definition?

We investigated how sensitive the results were to the proxy criterion, net precipitation, and lake levels, and found that:

- For criterion values less than 90 percent, precipitation and lake levels are unimportant.
- If net precipitation is positive, no difference exists for any criterion value or IJsselmeer level.
- Fleet requirements increase little until the criterion approaches 90 percent. Beyond this value the fleet increases more rapidly, especially under extremely dry conditions.

Fleet cost is moderately sensitive to an increase in the percentage of Rijn flows for which the fleet is to carry all the goods with no delay. But large variations in the net precipitation and IJsselmeer

level conditions have little influence on fleet cost, and managerial strategy has only slightly greater effect.

To apply the proxy to the analysis, we need only select an appropriate decade in one external supply scenario. This decade must have the proper Rijn flow and must occur during the growing season, to ensure that water management policies directed toward agriculture will affect the water distribution during the decade. Alternative policies can then be compared by determining the required fleet during this decade in each case.⁴

6.7. MAJOR NETWORK TACTICS

For some major technical and managerial tactics, shipping variable costs will not be limited to low-water and lock-delay losses. These tactics may require changes in ship routing or other aspects of carrier behavior. However, when carriers change their behavior, it must be to reduce costs. Our initial estimates of variable costs will thus represent an upper bound for the actual ones.

We calculated the variable costs for each technical and managerial tactic following the procedure outlined earlier in Sec. 6.2, estimating only those costs not included in the low-water and lock-delay loss functions. Many tactics did not need to be considered in detail because they had only negligible costs for shipping. Certain other tactics could not be studied completely because they were too complex. These latter tactics (closing the Oude Maas and Nieuwe Maas and canalizing the IJssel) could be eliminated during the screening analysis, however, because they did not provide sufficient benefits to justify even their investment costs. Among the tactics that were analyzed in more detail were:

- Closing the Spui (temporarily or permanently)
- IJsselmeer level changes
- IJmeer configuration
- Water transport through the locks at Wijk bij Duurstede
- Constructing the Krimpenerwaardkanaal
- Constructing the Kanaal Maarssen-Bodegraven
- Constructing a Zwarte Meer Dam

In all cases, the shipping variable costs were much less than investment and operating costs for the tactics.⁵

Tactics may also affect shipping safety. However, the preliminary analysis of accidents did not yield useful quantitative results. It indicated that insufficient data and problems inherent in accident prediction made it impossible to develop useful models. Moreover, the water management policies under consideration will not affect those variables which are most important in determining ship accident rates. As a result, safety considerations were not included in the final analysis.

6.8. MARKET ANALYSIS

We have not addressed the problem of how carriers and shippers will react to cost changes. To do so requires understanding the structure and operation of the shipping industry and transport markets, as well as the effects of government policies on industry behavior.

Unfortunately, the industry and market structures are complex, and information is limited. Both domestic and international shipping markets are characterized by large amounts of private transport, and by unregulated transport under contracts that include different rates and provisions for low-water rate increases. Consequently, we could obtain only a superficial knowledge of these markets, and could not answer the essential questions about real fleet capacity, ship ownership and operation, transport contracts, price structures, and low-water surcharges.

Without this information, we could not investigate how cost changes induced by water management policies will affect the behavior of carriers and shippers. Because the shipping fleet using Dutch waterways is international, however, shipping costs do not fall only on Dutch carriers. Therefore, if we determine the fraction of total costs that relate to Dutch carriers, we can consider the effects of cost changes on the Dutch shipping industry.

Using data from the low-water loss function study, we estimated the Dutch fraction to be about 62 percent for low-water losses and lock delays. This fraction did not vary significantly between shipping study runs or contexts.

NOTES

1. Although the Rijn has three branches in the Netherlands, the Waal, IJssel, and Neder-Rijn/Lek, the IJssel is not included under the treaty. It does not connect the Upper Rijn directly with the North Sea. Free navigation on the Rijn is also guaranteed by provisions of the Congress of Vienna (1815) and the Treaty of Versailles (1919).
2. Not all participants in the analysis agreed with this decision to separate variable and fixed costs and to use only variable costs in the short run. The DVK, NVI, and EBW argued that all shipping calculations should be made with total costs, representing the average price of ship transport, based on the normal number of productive hours per ship per year. These organizations felt that we could not adequately determine the fixed costs of additional ships when fleet capacity was insufficient. They argued that it would require far more time and effort than was available to consider properly the fleet requirements and

construction decision processes. As a consequence, the shipping cost study (discussed earlier) was performed with both variable and total shipping costs, although we used only the variable cost figures in our analysis. The study results indicate that variable costs are normally about one-third of total costs.

3. A groin is a damlike structure projecting from the river's bank for the purpose of trapping and holding sand, thus narrowing the river.
4. Any method of estimating the required changes in the long-run fleet will have its weaknesses and limitations. We believe that our proxy is a reasonable choice, given data and time constraints. A thorough analysis would require a long and comprehensive investigation of fleet characteristics, shipping markets, and the structure of the industry. After we had completed our analysis, however, the DVK, NVI, and EBW suggested another approach to the problem. Unfortunately, we do not know enough about this approach to be able to comment on either its theoretical validity or the difficulty in applying it to the problem.
5. In addition to variable costs, these tactics may also change the size of the long-run fleet and the associated fixed costs. We incorporate these fixed costs in impact assessment by means of the long-run fleet proxy. For tactics that are permanent facilities, we could have used the fixed cost part of the DVK total costs instead of our fleet proxy; indeed, in some instances it would have been easier.

REFERENCE

- 6.1. Nederlands Vervoerswetenschappelijk Instituut, Economisch Bureau voor het Weg- en Watervervoer, and Administratie Centrum voor het Beroepsvervoer, De Kosteneffecten voor de Binnenscheepvaart van Wateronttrekkingen aan Rivieren en Kanalen in Nederland (The Costs for Inland Shipping of Water Withdrawals from Rivers and Canals in the Netherlands), Report No. 901/654, Rijswijk, July 1980.

Chapter 7

LOCKS

7.1. INTRODUCTION

Locks on waterways benefit shipping operations by maintaining adequate depths without requiring large flow rates. They thus conserve water for other uses. In the Lowlands areas of the Netherlands, locks also isolate freshwater lakes and canals from the influence of tides in the North Sea and separate fresh from salt water.

Ships are delayed when passing through a lock. Unfortunately, water management tactics at locks generally increase ship delays. Because of this conflict between shipping and water management, we analyzed lock operations and developed lock-delay loss functions for Lowlands (salt/fresh) and Highlands (fresh/fresh) locks.¹ The loss functions specify the additional delay and energy costs from the use of various technical or managerial tactics at the locks.

7.2. SALT/FRESH LOCKS

When salt/fresh locks are used, an exchange of salt and fresh water takes place, and some salt passes through them to contaminate the fresh water, reducing its value for agriculture.² The amount of salt intrusion at a lock depends on many factors, including lock dimensions, saltwater concentration, relative water levels, and the number of lock cycles. At many locks the flow of fresh water out of the lock or nearby sluices may dilute the salt water sufficiently. At other locks, however, the resulting salt concentrations are objectionable, and additional measures are necessary to reduce salt intrusion.

These measures can be separated into technical and managerial tactics. Technical tactics change lock characteristics by adding anti-salt technology. Considering the cost and effectiveness of potential tactics, we selected only three: (1) pneumatic barriers, (2) excavation and selective withdrawal systems, and (3) Kreekrak systems. (These systems, which are difficult to explain concisely, are described in Vol. IX.)

Managerial tactics change lock operation policies. These tactics include (1) choosing whether or not to use existing anti-salt technology, (2) flushing the locks with fresh water, (3) reducing the number of lock cycles by restricting lock operations, and (4) reducing the salt intrusion per cycle. Flushing will be limited by water availability, so the most likely tactics to reduce salt intrusion will be to reduce the number of lock cycles--for example, by requiring a specific number of ships in the lock before cycling or by requiring them to wait a specified time before being passed through the lock, or by closing the lock at certain times such as high tide. These tactics increase delays and are least preferred by carriers.

Both technical and managerial tactics have costs that may limit their application. Technical tactics may have large initial investment costs and operating expenses. Managerial tactics, on the other hand, increase delay times for shipping and may cause unwanted freshwater losses through the locks.

7.3. FRESH/FRESH LOCKS

Ship locks in the Highlands may also have water management problems. Operating a lock transfers water from the high-water to the low-water side. Normally such water losses are not important. During dry periods, however, they become an undesirable loss of water needed to maintain shipping depths or meet the demands of other users.

As with Lowlands locks, technical and managerial tactics can be used. Technical tactics include plugging lock leaks and other methods of saving and reusing lock water. Managerial tactics include those that can be used at Lowlands locks, with the exception of flushing. At Highlands locks, however, because water loss is important only during dry periods, technical tactics may be less appealing because of their high investment costs. Thus, it is often desirable to restrict lock operating hours or lock cycles to reduce losses.

7.4. LOCK MODEL DESCRIPTION

Figure 7.1 shows the basic form of the Lowlands lock analysis model. It consists of a lock operation model and a lock salt model. Lock and ship traffic characteristics and technical tactics determine the model parameters. The lock operation model simulates the passage of ships over a period of one or more weeks, using operating policies based on input managerial tactics. The lock salt model calculates daily salt intrusion, water loss, and delay and energy costs using the simulation results. At the end of the simulation, the models calculate final statistics for the entire period.

The type of technical tactic considered determines the specific equations used in the model. The calculations are based on an equilibrium analysis of the entire lock complex, including sluices. The equations and the development and calibration of the entire lock model are described in Chap. 6 and App. E of Vol. IX.

In the Highlands analysis, because of time and data restrictions, we used a simplified version of the lock model. We replaced the computer simulation with an aggregated mathematical model of lock operation, and substituted a simple water-loss calculation for the salt model. The model is based on procedures described in Refs. 7.1 and 7.2. It uses a series of equations and empirical curves to calculate the delay and total passing times for ships at a lock, as a function of ship arrival rates and lock capacity. The freshwater loss calculation uses the leakage rates, lock volumes, and number of lock cycles to determine the total consumption rate at a lock complex.

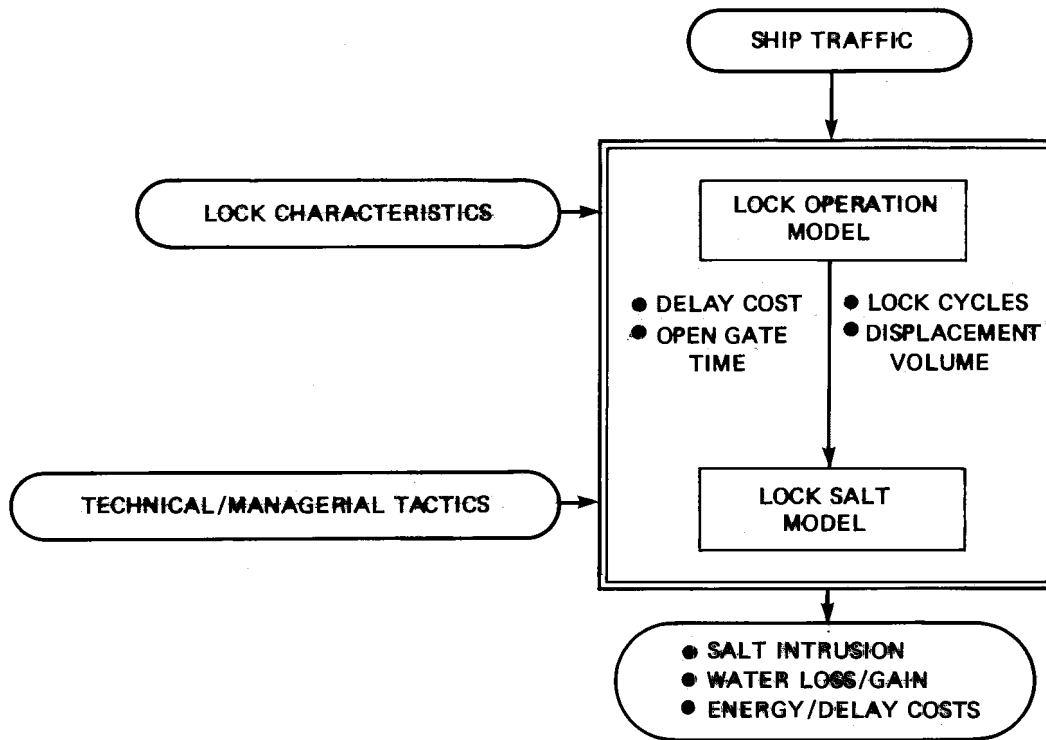

Fig. 7.1--Lock analysis model

7.1

7.5. ANALYSIS PROCEDURE AND RESULTS

We investigated eleven salt/fresh locks in the Netherlands, as shown in Fig. 7.2. The results for each lock complex were expressed as salt intrusion, water loss, and costs per day for each managerial tactic combined with all appropriate technical tactics. This information can be expressed in terms of the nominal salt intrusion (assuming no anti-salt technology use and normal managerial tactics) and the reduction in this salt intrusion that can be achieved for a corresponding increase in investment, delay, and energy costs. Because the reduction factors were found to be almost independent of the rate of flushing (freshwater loss) through the lock complex, we could use an average reduction fraction that depended only on the choice of managerial and technical tactics.

Figures 7.3 and 7.4 show typical loss functions derived from the Lowlands lock analysis for the Volkerak locks during late summer in 1976. Table 7.1 contains the nominal salt intrusions. Figure 7.3 shows the reduction in salt intrusion and the corresponding ship delay plus energy cost for one technical tactic (representing a particular level of investment in salt intrusion technology). Figure 7.4 shows

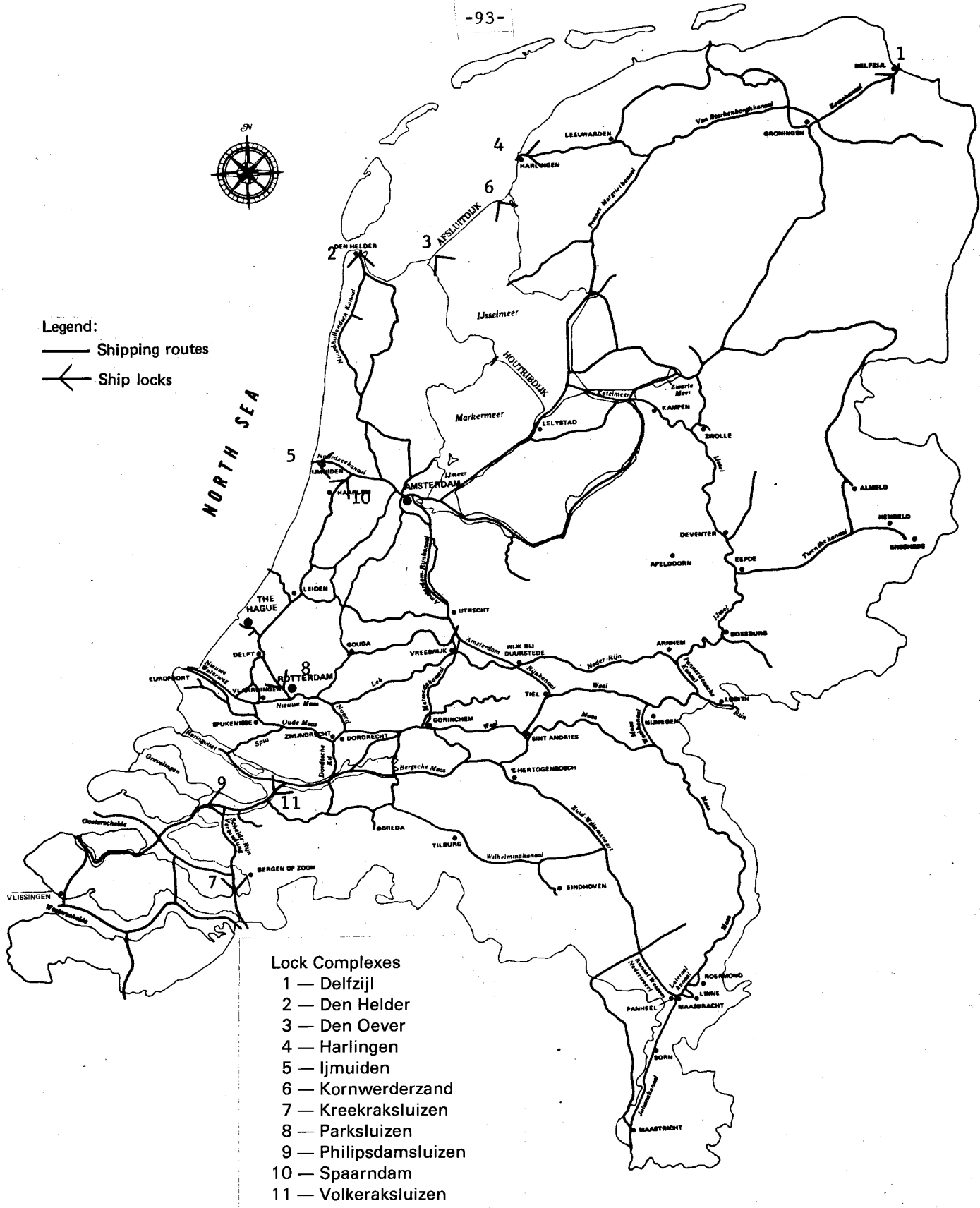

Fig. 7.2--Lowland salt-fresh locks

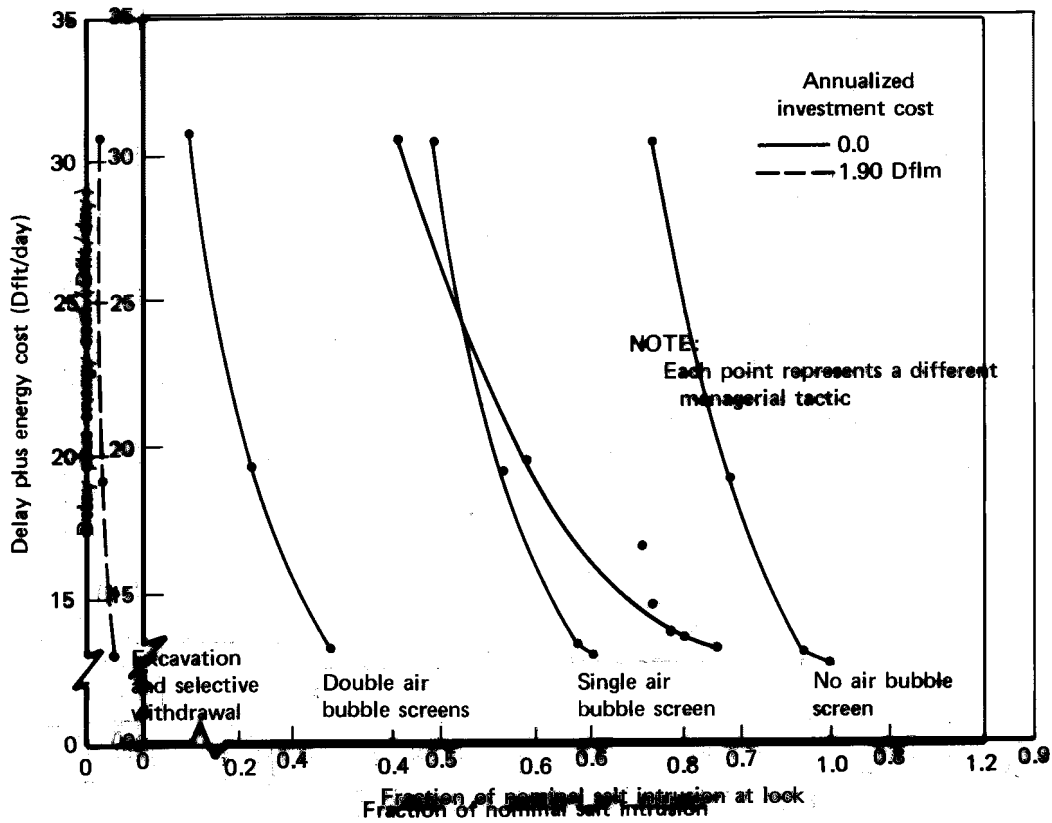

Fig. 7.3--Loss function for Volkerak locks: salt intrusion reduction with single air bubble screen

the corresponding curves for all technical tactics considered at the lock. For each technical tactic, we plotted the results for all managerial tactics, then drew an envelope curve to represent the most efficient set of managerial tactics of those considered. This can be seen in Fig. 7.3, which shows both the points and curve. Figure 7.4 shows only the curves. The curves for the other locks can be found in App. E of Vol. IX.

The curves representing all technical tactics at each salt/fresh lock are used in the managerial strategy design model (described in Chap. 26) to investigate managerial tactics at locks. In the DM, only the curves representing the actual technology at current locks or currently planned technology at locks to be constructed in the future are used, together with a specification of the minimum flushing rate for each. For this lock technology, these curves reflect the most efficient managerial tactics.³

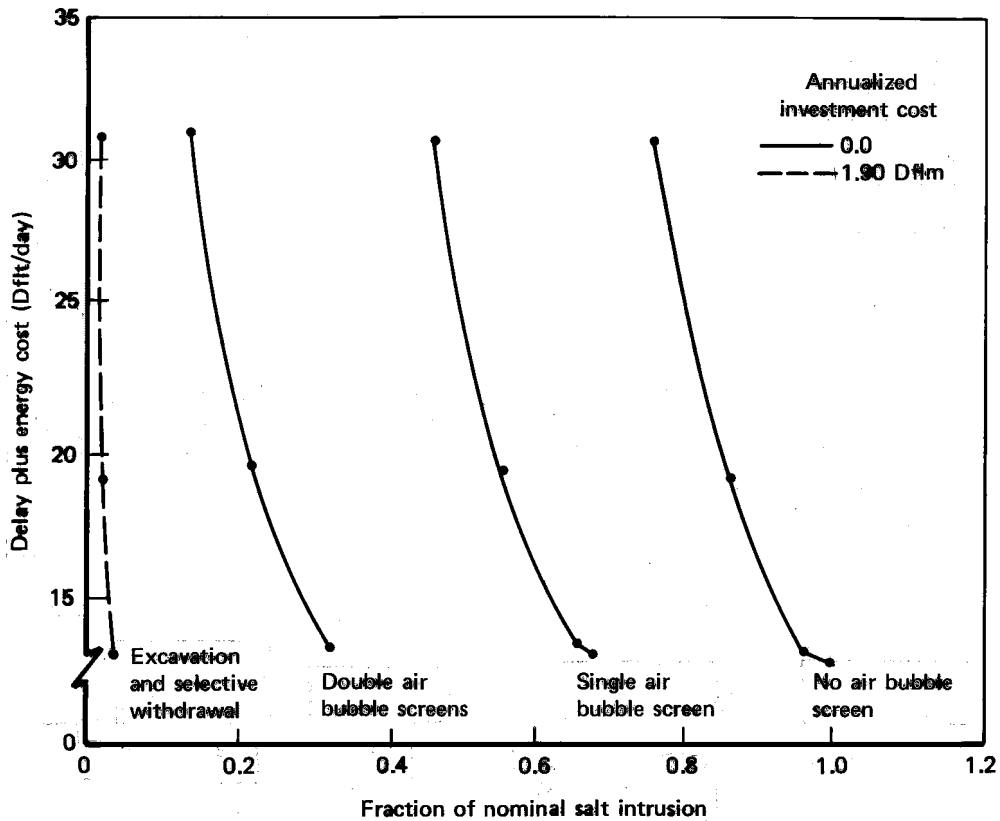

Fig. 7.4--Loss function for Volkerak locks: salt intrusion reduction with different tactics

The lock model as applied to Highlands locks does not allow using a variety of managerial tactics. Instead, tactics are limited to restricting operating hours at each lock. The RWS used this policy during low-flow periods in 1976 [7.3]. Restricting operating hours at a lock is equivalent to restricting the number of lock cycles. We calculated ship delay costs and water consumption for an appropriate range of lock cycles and plotted the results. The envelope curve for each graph represents the loss function for the lock complex.

The Highlands canals were divided into segments, as shown in Fig. 7.5, to facilitate incorporating the results into the water distribution calculations. Each segment consists of a series of lock complexes of varying configurations and dimensions. The locks on the segments were classified by type, based on their dimensions, characteristics, and ship traffic. We selected one lock of each type for detailed analysis, as described above, and generated a delay-cost versus water-loss curve for the lock. We estimated loss functions for each canal by

Table 7.1

NOMINAL SALT INTRUSION AT VOLKERAK LOCKS
(AUGUST-OCTOBER)

Flushing Rate (m ³ /s)	Salt Intrusion (million kg Cl /day)
5.0	6.11
10.0	5.25
15.0	4.51
20.0	3.88
25.0	3.30
30.0	2.87
35.0	2.46
40.0	2.12
45.0	1.82
50.0	1.56

adding the delay costs (at each flow rate) for the appropriate number of locks of each type on the canal.

The results of the analysis are shown as curves of ship-delay cost versus water consumption for each canal section or lock, whichever is appropriate. Figure 7.6 presents the loss functions for the locks at Maasbracht on the Julianakanaal for three different fractions of the average ship traffic through the lock during 1976. The curves for the other canal segments and locks can be found in App. F of Vol. IX.

The Lateraalkanaal and the Maas through Linne and Roermond form parallel paths for ships and water in the middle of Limburg. When water shortages occur on the Maas and it becomes necessary to limit lock operations, the Lateraalkanaal is affected first. The limited Maas flow can be used more efficiently through Linne and Roermond. As lock operations are restricted, delays increase at locks on both branches, and ship traffic will redistribute itself. The analysis procedure used at other locks is based on the assumption that ship traffic remains known and constant. When alternative routes are available, such as in this case, the problem requires optimization.

Using the procedure discussed earlier, we developed curves of the total delay on each branch as a function of ship traffic, for given water consumption on the branch. These curves were combined with flow and traffic constraints to form what mathematicians call a convex programming problem. This problem was solved for various total flows to give the flow division and total delay costs for shipping on the two routes.

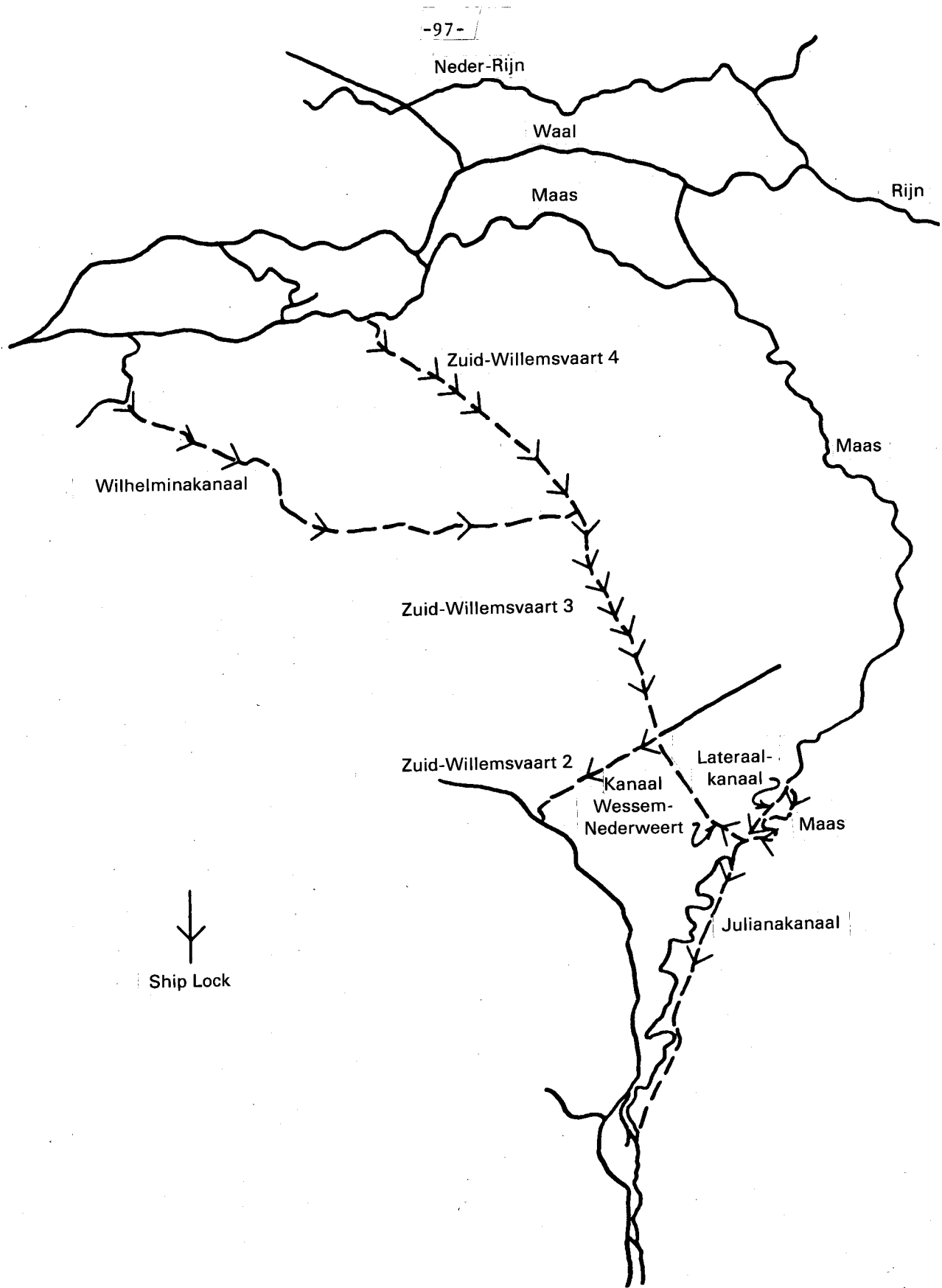

Fig. 7.5--Highlands canals and locks

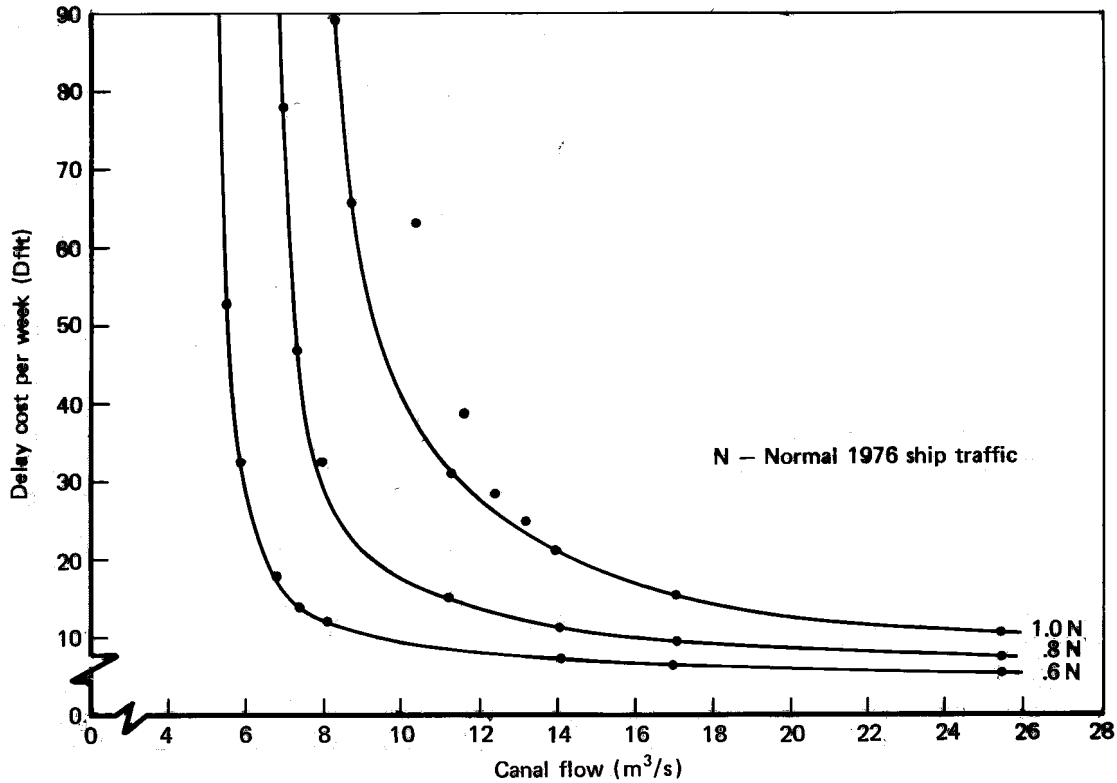

Fig. 7.6--Loss functions for Maasbracht at three traffic levels (1976)

NOTES

1. Throughout this chapter, for convenience we will consider Lowlands locks to be salt/fresh and Highlands locks to be fresh/fresh. Although fresh/fresh locks are also found in the Lowlands, our analysis did not consider them.
2. The corresponding loss of fresh water from the freshwater to the saltwater side of the lock can sometimes cause problems, e.g., for nature preserves surrounding the freshwater body.
3. There are several reasons for this treatment of locks in the DM. A preliminary analysis by PAWN concluded that changes in technology were not cost-effective at the current locks (while future locks included extensive technology in their designs). Moreover, at the time the PAWN analysis was done, it appeared that managerial tactics at salt/fresh locks did not matter much for the overall water management problem. However, the RWS now believes differently for the Zoommeer.

REFERENCES

- 7.1. Kooman, C., and P. A. de Bruijn, Lock Capacity and Traffic Resistance of Locks, Rijkswaterstaat Communications No. 22, Government Publishing Office, The Hague, 1975.
- 7.2. Rijkswaterstaat, Directie Limburg, Beleidsanalyse "Watervoorziening van het Julianakanaal," (Policy Analysis of Water Supply on the Julianakanaal), December 1979.
- 7.3. Zuiderveen-Borgesius, N. W., De Maas in de Droge Zomer van 1976 (The Maas in the Dry Summer of 1976), Rijkswaterstaat, Directie Waterhuishouding en Waterbeweging, District Zuidoost, Afdeling Maas, Nota 77.5, Maastricht, May 1977.

Chapter 8

ROTTERDAM SALT WEDGE

8.1. INTRODUCTION

The Rijn River's major outlet to the sea is the Nieuwe Waterweg, which is fed by the Oude Maas and the Nieuwe Maas (Fig. 8.1). As the ocean tide rises and falls, salt water ebbs and flows into these rivers and causes an increase in salt concentration, which, under some conditions, extends as far upstream as the mouth of the Hollandsche IJssel in the Nieuwe Maas and threatens to enter the mouth of the Spui in the Oude Maas. Salt intrusion into the mouth of the Hollandsche IJssel is of particular interest in PAWN, as water extracted from the Hollandsche IJssel at Gouda forms the main irrigation supply for the agriculturally rich Zuid-Holland area. Saltwater intrusion into the Spui is undesirable as it may then enter the fresh water of the Haringvliet. Early investigations, however, showed that the salt wedge would not enter the Spui even under conditions of extremely low river flows. (It could enter as a result of storms at sea, but this rarely occurs, and so was not considered to be of interest in PAWN.) Consequently, PAWN concentrated on salt intrusion into the Hollandsche IJssel.

The extent to which salt intrudes into the rivers is determined by a balance between the river flow and the inflow of salt water that occurs as the tide rises. Some of the water management tactics considered in PAWN (those involving large extractions for agricultural uses) will result in reduction in the river flows and a consequent increase in salt intrusion. To estimate how the choice of tactics affects salt intrusion, we developed the Rotterdam salt wedge model and the Gouda inlet salinity model.

8.2. ROTTERDAM SALT WEDGE MODEL

8.2.1. Description of the Model

The Rotterdam salt wedge model calculates the average salt concentration as a function of the distance upstream from the mouth of the Nieuwe Waterweg into both the Oude Maas and the Nieuwe Maas. "Average" salt concentration is that observed at a particular location averaged over the flow cross-section and over the tidal cycle. Our model finds the equilibrium value that would exist if many tide cycles had occurred while the river flow remained constant. PAWN uses this model to calculate the change in average salt concentration at the mouth of the Hollandsche IJssel caused by changes in river flows. The model will also handle two different river geometries; one is the present configuration, and the other represents a PAWN tactic in which the mouth of the Oude Maas is closed with a dam.

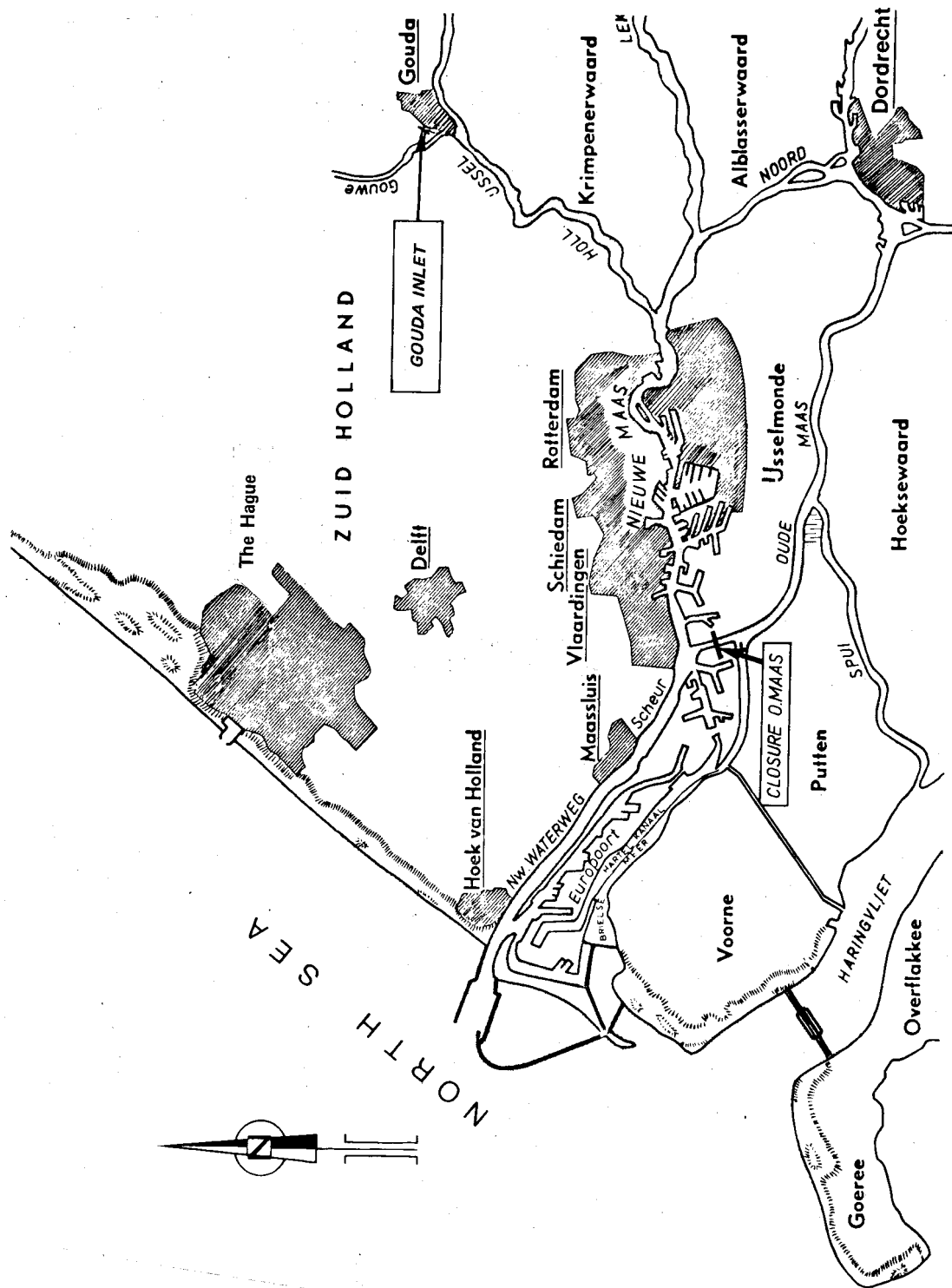

Fig. 8.1--The Rotterdamse Waterweg (Nieuwe Waterweg, Oude Maas, Nieuwe Maas, Hollandsche IJssel, etc.)

The model is based on physical principles, although it must be calibrated with measured data. We have chosen this type of model over a statistical model because the statistical data on salt intrusion are clouded by configuration changes made over the years, such as modifications to Rotterdam Harbor and the dredging and filling of the Nieuwe Waterweg and the Nieuwe Maas. We have used a modified version of a model first developed by Van der Burgh [8.1]. This model has the advantage of being simple and well known to the RWS. Its limitations are that it is a one-dimensional model, and that past experience has shown that it will not always predict the effects of changes in river geometry.

To best reproduce the available measured data, we modified the original Van der Burgh model in two ways. First, Van der Burgh related the salt concentration in the river mouth to the concentration in the sea using the flood number, which is determined by the river discharge and the flood volume (the volume of water that flows into and out of the river mouth because of the tide at sea). For the modified model, we found that the available data were better represented by using an expression that involved only the river discharge.

Second, Van der Burgh's model was developed for a single river branch and contained two empirically derived calibration constants for calculating salt dispersion. We modified the model by adding a third calibration constant and then determined the values of the three constants separately for the Nieuwe Waterweg, the Nieuwe Maas, and the Oude Maas. This modification not only improved the fit to the available data but made it possible to calculate salt concentration in all three branches.

8.2.2. Calibration of the Model

We used three sources of data to calibrate the model. The first dataset consists of a large number of data points obtained from measurements of salt concentration by instruments permanently installed on the river bottoms at a number of locations with different depths. These instruments were necessarily located near the bank of the rivers, so they do not provide information on the distribution of salt over the flow cross-section.¹

The second dataset consists of a series of measurements made to calibrate the Delft Hydraulics Laboratory's (DHL) scale model of the river system, as well as various computer models. Measurements were made for two years (1973 and 1974) when the configuration of the river channels was essentially the same as it is at present.²

The third dataset consists of a series of new experiments conducted by the staff of the DHL with their scale model of the Rotterdamse Waterweg system. Tests were made both with the existing configuration and with the Oude Maas closed (these tests provided the only data available with the Oude Maas closed). Since these were laboratory tests, it was possible to instrument them completely and to obtain truly simultaneous

measurements of flows and salt concentration at a number of locations. Unfortunately, the model was not large enough to allow reliable measurements to be made at the point of greatest interest, the mouth of the Hollandsche IJssel.

To calibrate the model, we calculated the variation of salt concentration along all of the three rivers, using an initial set of estimates for the three calibration constants to measure salt dispersion. This was done for flow conditions and tide heights appropriate for each set of observed data. We observed the agreement between the calculated and measured data and adjusted the calibration constants to improve it. Different constants were used in each river branch, and for cases with the Oude Maas open and closed, but we found that good agreement could be obtained when the constants were considered independent of river flows. This was important in PAWN, because it showed that our model could be used to calculate the effect of changes in river flow on salt intrusion. We found a single set of calibration constants that gave good agreement with all three datasets. A typical comparison between measured and calculated salt concentrations in the three rivers is shown in Fig. 8.2.

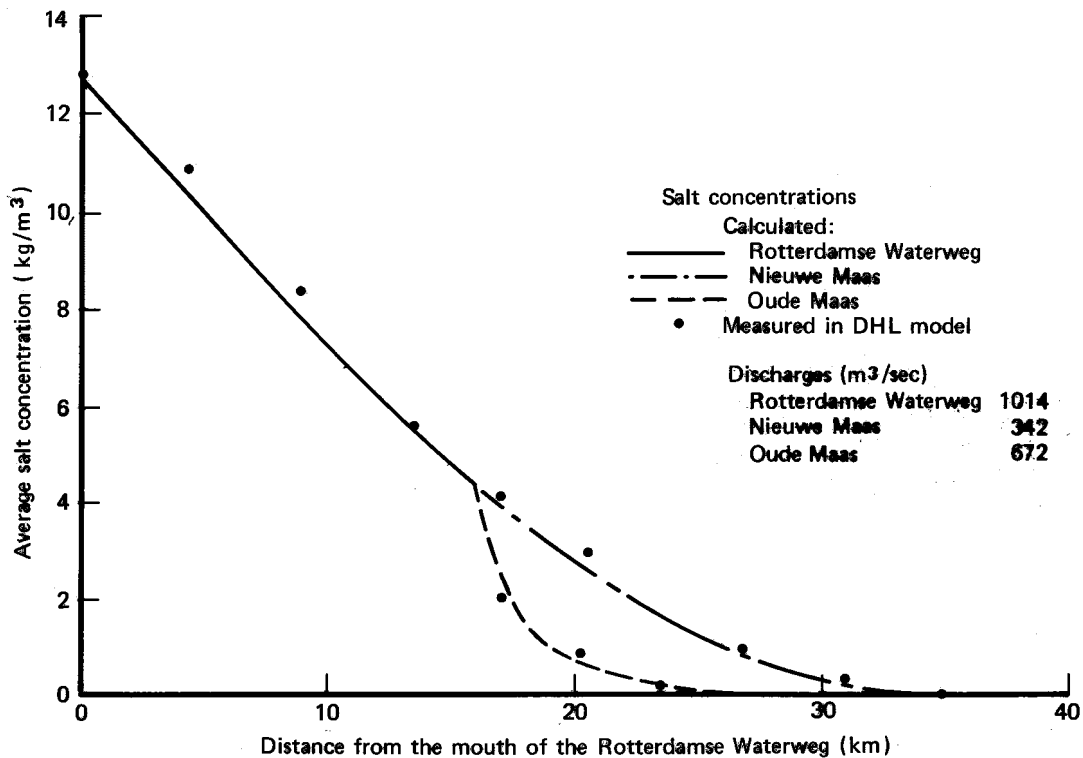

Fig. 8.2--Comparison between measured and calculated salt concentrations

8.2.3. Applying the Model

We used the calibrated Rotterdam salt wedge model to calculate the salt concentrations in the mouth of the Hollandsche IJssel for a series of flows in the Nieuwe and Oude Maas, both with the Oude Maas closed and with the present configuration (with it open). These relations were then fitted with simple equations for incorporation into the DM. Only those for the present configuration were actually built into the DM because the other configuration was ruled out early in the screening analysis.

8.3. GOUDA INLET SALINITY MODEL

8.3.1. Description of the Model

Water is extracted from the Hollandsche IJssel for agricultural use at Gouda, which is some 15 km upstream from the mouth of the Hollandsche IJssel. The Hollandsche IJssel ends near this point, so that, except for the tide, the only flow into it results from the extraction of water at Gouda. To estimate the salinity of the extracted water, we had to relate the salt concentration at the mouth of the Hollandsche IJssel to that at the Gouda extraction point.

A model was developed at the DHL that calculates the equilibrium salt concentration at the Gouda extraction point as a function of the salt concentration at the mouth of the Hollandsche IJssel and the rate of extraction at Gouda. The equilibrium concentration is the concentration that would exist after many tide cycles if the river discharges and the extraction rate remained constant. Thus, the equilibrium salt concentration is an upper bound on the actual concentration in situations in which the change in river flow results in an increase in salt concentrations at Gouda.

The average location of the salt wedge during a tide cycle is obtained from the Rotterdam salt wedge model. Using this average location and measured data on the tidal variation at the mouth of the Hollandsche IJssel, the Gouda inlet salinity model calculates the flow of water and salt in and out of the mouth of the Hollandsche IJssel during a tide cycle. When there is a net inflow of salt, the model calculates the movement of salt up the Hollandsche IJssel. This movement is caused by the diffusion of salt from the higher concentration at the mouth of the Hollandsche IJssel and by the transport of salt from the current caused by the extraction. We investigated the effects of different extraction rates at Gouda and found that (at least for the extraction rates of interest) salt concentrations at Gouda were insensitive to the extraction rate and depended only on the average salt concentration at the mouth of the IJssel. The extraction rate, however, does influence the time that elapses before the salt water reaches the inlet at Gouda.

The model is operated in a series of time-steps, and the calculation is carried through enough tide cycles that the equilibrium salt

concentration at Gouda is reached (the concentration that would exist if the river flows remained constant indefinitely).

In the real world, however, the river flows vary significantly in a period of ten days. This variation results not only from variations in Rijn flow, but also from the "Haringvliet effect." Over the two-week period from neap to spring tide, there is a variation in the mean sea level that causes a corresponding variation in the water level--and hence the amount of water stored--in the Haringvliet and the Hollandsch Diep. This in turn causes a periodic variation in the river flows. On the basis of available information, which is quite limited, we have represented the Haringvliet effect as a sinusoidal variation in river flow. The variation has a period of approximately two weeks and amounts to about 250 m³/s in the Nieuwe Maas in the present configuration. It is estimated that the variation will be about 150 m³/s if the Oude Maas is closed.

PAWN is interested in the salt concentration at the Gouda extraction point averaged over a decade (ten days). Consequently, the Gouda inlet salinity model was designed to average the equilibrium salt concentration at Gouda over a ten-day period, taking into account the ten-day variation in Rijn flow and the two-week variation in river flows caused by the Haringvliet effect.

Simple functions were then devised that allow the decade average salt concentration at Gouda to be calculated from the average river flows during that decade, both for the present configuration and for one with the Oude Maas closed. These functions were built into the DM.

8.3.2. Validation of the Model

There are limited data on salt intrusion into the Gouda extraction point to use in verifying the model. For July and August 1976, the model results are fairly close to the measured salt concentrations at Gouda. Other than this, the model's credibility rests on the fact that it is based on physical principles. The primary uncertainty in the model is the estimation of salt diffusion. However, there are theoretical and experimental data to help in this estimation, and a sensitivity analysis showed that the results of the model were insensitive to variations within the range of uncertainty which the RWS considered reasonable.

NOTES

1. Thus, estimation of the average salt concentration was approximate. In this set of data, river flows were not measured directly, but were calculated by IMPLIC (a detailed model developed by the RWS to calculate flows in the Netherlands river

system) for the days on which salinity measurements were taken. Thus, the variation of salt concentration with river flow obtained from these data was somewhat approximate; furthermore, since the data are limited to observations of salt concentrations which have actually occurred, they provide no information on flow conditions which would lead to extreme salt intrusion.

2. Measurements of salt concentration and flow velocity were taken on two successive days at six locations along the rivers. These measurements were obtained from instruments lowered into the water from boats, so that the distributions of both salt concentration and flow velocity over the river cross-section were obtained. Because it was not practical to make measurements in both the Nieuwe and Oude Maas on the same day, observations in each were made on successive days. Actual tide height was also measured on these two days. These data provided nearly simultaneous information on river flows, tide height, and salt concentration, but for only two days in each of two years. Because the river flows were not extreme on these days, however, the test provided no information on conditions that would lead to the highest salt concentrations.

REFERENCE

- 8.1. Burgh, P. van der, Ontwikkeling van een methode voor het voorspellen van zoutverdelingen in estuaria, kanalen en zeeën (Development of a Technique to Forecast Salt Distributions in Estuaries, Canals, and Seas), Rijkswaterstaat, Deltadienst, Afdeling Waterhuishouding, Report 01-72, January 1972 (in Dutch only).

Chapter 9

THE IJSSSEL LAKES

9.1. INTRODUCTION

A considerable amount of the water that enters the Netherlands in the Rijn is sent north in the IJssel River, where it flows into the only major water storage basin in the Netherlands, the IJssel lakes. The IJsselmeer is a large (1200 km²), shallow freshwater lake, closed off from the Waddenzee by the Afsluitdijk. Several smaller lakes connect to it. The largest of these, the Markermeer, is about one-half the surface area of the IJsselmeer; all of the rest are about 15 percent of the area of the IJsselmeer. Dikes around the shores of the lakes protect the adjacent land areas, which may lie as much as 5 m below lake level. These geographic features can be seen in Fig. 9.1.

The Dutch use sluices and locks to control flows between the lakes, and between the IJsselmeer and the Waddenzee. By discharging excess water to the Waddenzee through sluices in the Afsluitdijk, they control the water levels of the lakes. Currently, they try to keep the IJsselmeer and Markermeer at approximately the same level, but this target level is lower in winter (NAP - 0.4 m)¹ than in summer (NAP - 0.2 m). At present, the change from the winter target level to the summer target level is made around the first of April, and the change from the summer level back to the winter level is made around the first of October.

Because rain and river discharges into the lake are not fully predictable and because flows out the Afsluitdijk may be reduced by the presence of high winds or a storm surge in the Waddenzee, perfect control of the lake levels is impossible, and occasional overshoots of water level occur. In addition, because of their large size and shallow depth, the IJsselmeer and Markermeer are sensitive to wind setup--the piling up of water at one end of the lake by the wind--and to waves formed by wind. Combinations of wind effects and high water levels may, under extreme conditions, lead to the dikes being overtopped and the surrounding land flooded. Such combinations of high winds and large inflows of water are more likely in winter than in summer; that is why the levels are kept lower in the winter than in the summer.

One of the tactics proposed for making more fresh water available in the summer for sprinkling crops is to increase the summer water level in the IJsselmeer and Markermeer. It has also been suggested that to reach this higher level, the change from the lower winter level be made at an earlier date. Both of these actions pose potential safety hazards, because they increase the probability that under some rare circumstances of high inflows, rain, and winds, some of the dikes surrounding the lakes would be overtopped, and the adjacent land

flooded. The flood safety methodology discussed in this chapter estimates the increased risk associated with this tactic. (Later chapters cover other concerns associated with the IJssel lakes, such as the benefits from having additional water available, and various pollution issues.)

9.2. FLOOD SAFETY MODELS FOR THE IJSSEL LAKES

To assess the risks associated with increasing the summer target level, we developed two models.

The IJsselmeer filling model simulates water levels, given a time series of inflows, and a specified water-level control policy. We ran it using historical data on rain and river flows into the lake, to determine the probability of high lake levels, given that higher summer lake levels would be maintained.

The dike safety model uses the probability distribution of lake levels, and estimates obtained from the literature on frequency of winds at various velocities, to estimate the probability that dikes around the IJsselmeer or Markermeer would be overtopped because of combinations of high water levels and high winds.

9.3. HOW SAFE IS RAISING THE SUMMER IJSSELMEER AND MARKERMEER LEVELS?

We used our models to estimate the probability that the dikes at the southern end of the IJsselmeer would be overtopped. (In a preliminary analysis using our models, we had concluded that these dikes, which experienced the highest winds and the longest fetch, were the critical ones for IJsselmeer safety.) We found that two physical phenomena have a strong effect. First, the capacity of the sluices increases substantially as the water level in the lake rises, because the greater head difference increases the ability of the sluices to discharge water. Second, the setup resulting from a given wind is reduced when the water is deeper, so the water level on the dike face does not increase as fast as the average water level. Both of these effects work to reduce the hazard of increasing the summer target level. We reached the following conclusions, which are strongly affected by these phenomena.

First, as long as the summer target level is kept under NAP + 0.1 m, the probability of overtopping in the summer is lower than in the winter. Thus, summer water levels can be raised to around NAP + 0.1 m with no significant increase in overall danger.

Second, target levels as high as one meter above NAP significantly increase the probability of overtopping, especially if combined with an advance in the spring changeover date.

Third, moving the changeover date from the first of April to the first of March increases the probability of overtopping in summer by a

factor of 10 to 100. When lower summer target levels are used, however, safety is primarily determined by winter conditions; consequently, safety does not diminish significantly as long as the summer target level is NAP + 0.1 m or lower.

We also investigated the safety of the dikes protecting the island of Marken. (Our preliminary analysis had indicated that these dikes were the critical ones for the Markermeer.) This island is located against the west side of the Markermeer, and consequently only easterly and northerly winds have enough fetch to develop any setup or waves against it (in our analysis, we specifically examined easterly winds). These winds are substantially lower than the westerly winds which affect the IJsselmeer, and Marken is exposed to less fetch than the dikes at the southern end of the IJsselmeer. The island is protected with dikes which are much lower than those surrounding the IJsselmeer. Our results indicate that these dikes are too low to provide the same safety as those around the IJsselmeer. In spite of a lower overall level of safety, the conclusions we reached regarding the effects of changing the summer target levels or using an earlier changeover date are similar to those we found for the IJsselmeer.

9.4. QUALIFICATION ON RESULTS

Uncertainty pervades the attempt to estimate events as rare as these overtoppings with data covering only 40 years. Consequently, we cannot say whether our safety estimates are conservative or optimistic. Whenever we could, we chose assumptions that we believe to be conservative. Further, our analysis of the inaccuracies in the dike safety model indicated that our results probably overestimate the true likelihood of flooding. Because so few data are available, however, and because winds and water levels may be correlated to some extent (we have assumed them to be independent), we cannot be certain that our final results are conservative. Still, although the overtopping probabilities calculated here may have large uncertainties, we consider them to be satisfactory yardstick measures of safety for comparing various water management tactics.

We have one further reservation regarding the validity of our results. We have used the probability of waves overtopping the full height of the dike as a measure of safety. It is possible that if higher summer target levels are maintained over a long series of years, the dikes may be weakened and ultimately may slump, allowing flooding at water levels lower than we estimate. We could find no way of quantifying this possibility.

NOTE

1. The reference point from which water levels are commonly measured in the Netherlands. NAP is an abbreviation for "Normaal Amsterdams Peil," a term dating from about 1624, when it presumably indicated an average water level at Amsterdam. In that year, the harbor of Amsterdam was still connected directly to the North Sea.

Chapter 10

GROUNDWATER STORAGE MODEL

10.1. INTRODUCTION

Hydrologists distinguish two soil layers. The top layer, called the unsaturated zone, consists of soil particles, water, and air. The bottom layer, called the saturated zone, consists only of soil particles and water. In PAWN, we use the term groundwater to mean the water in the saturated zone. We call the boundary between the saturated and unsaturated zones the groundwater level.¹

The groundwater level rises and falls. Recharge, the flow of rainwater into the saturated zone, tends to raise the groundwater level. Basic drainage, the flow of water from the saturated zone into rivers and streams, and groundwater extractions tend to lower it.

In the Highlands,² farmers, industries, and drinking-water companies dig wells and extract groundwater. These activities lower the groundwater level and reduce basic drainage. As a result, two problems may arise:

- Many areas in the Highlands are covered with trees and other plants that depend on groundwater. Lowering the groundwater level may lead to the destruction of these environmentally valuable areas.
- Water entering the surface water system from basic drainage flows downstream where it can be extracted by other users (e.g., farmers). Reducing basic drainage may deprive other parts of the country of needed water.

Since the demand for groundwater is expected to rise, we needed to estimate the impacts of increased groundwater extractions. We developed the groundwater storage model, which determines basic drainage and groundwater levels due to recharge and groundwater extractions. It is built into the plot water model, which will be discussed in the next chapter. This chapter briefly discusses how the model works, how we derived the parameters it needs, and how well it works.

10.2. HOW THE GROUNDWATER STORAGE MODEL WORKS

The hydrologic principle called Darcy's Law implies that basic drainage is directly proportional to the height of the groundwater level measured from some particular datum. Since we have no idea what the datum or the constant of proportionality is, we write what we call the basic drainage equation:

$$D = a + bG ,$$

where D is the rate of basic drainage (m^3/sec), G is the groundwater level measured downward from the soil surface (m), and a and b are parameters whose values must be supplied.

The amount of water needed to bring the groundwater level up to the soil surface is directly related to the groundwater level, and the constant of proportionality is a known soil characteristic. Using this fact, the above basic drainage equation, and the principle of conservation of mass, we can write simultaneous equations whose solutions give the groundwater level at the end of any time interval, given rates of recharge and extraction, and the groundwater level at the beginning of the time interval. We describe the details of these calculations in Vol. XII.

To estimate the parameters of the basic drainage equation, we obtained data on actual groundwater levels for some 224 groundwater wells in the Highlands for the period 1953-1977, measured every two weeks. We assigned each of these wells to one of 29 drainage regions,³ defined on the basis of hydrologic considerations. We averaged the groundwater levels in each region to obtain an average groundwater level for the entire region. We created a special version of the groundwater storage model that used these average groundwater levels as data, and computed the basic drainage for many two-week time-steps. From this time series, we estimated the coefficients of the basic drainage equations for each of the 29 regions, using ordinary least squares regression.

We did not build a groundwater storage model for the Lowlands. Except in very dry years, the groundwater level is practically at the surface, so little additional groundwater can be stored. In dry years the level drops a bit, but there is no water to store.

10.3. VALIDATION

Since the groundwater storage model is a part of the plot water model, discussed in the next chapter, its validation depends in large part on the validation of that model, also discussed in the next chapter.

We also compared measured groundwater levels with levels computed by the model. Figure 10.1 gives such a comparison. The agreement between calculated and measured values is quite good, although, as is often the case in comparisons of this sort, there appears to be more variation in the measured data than in the calculations. The agreement is adequate for the purposes of PAWN.

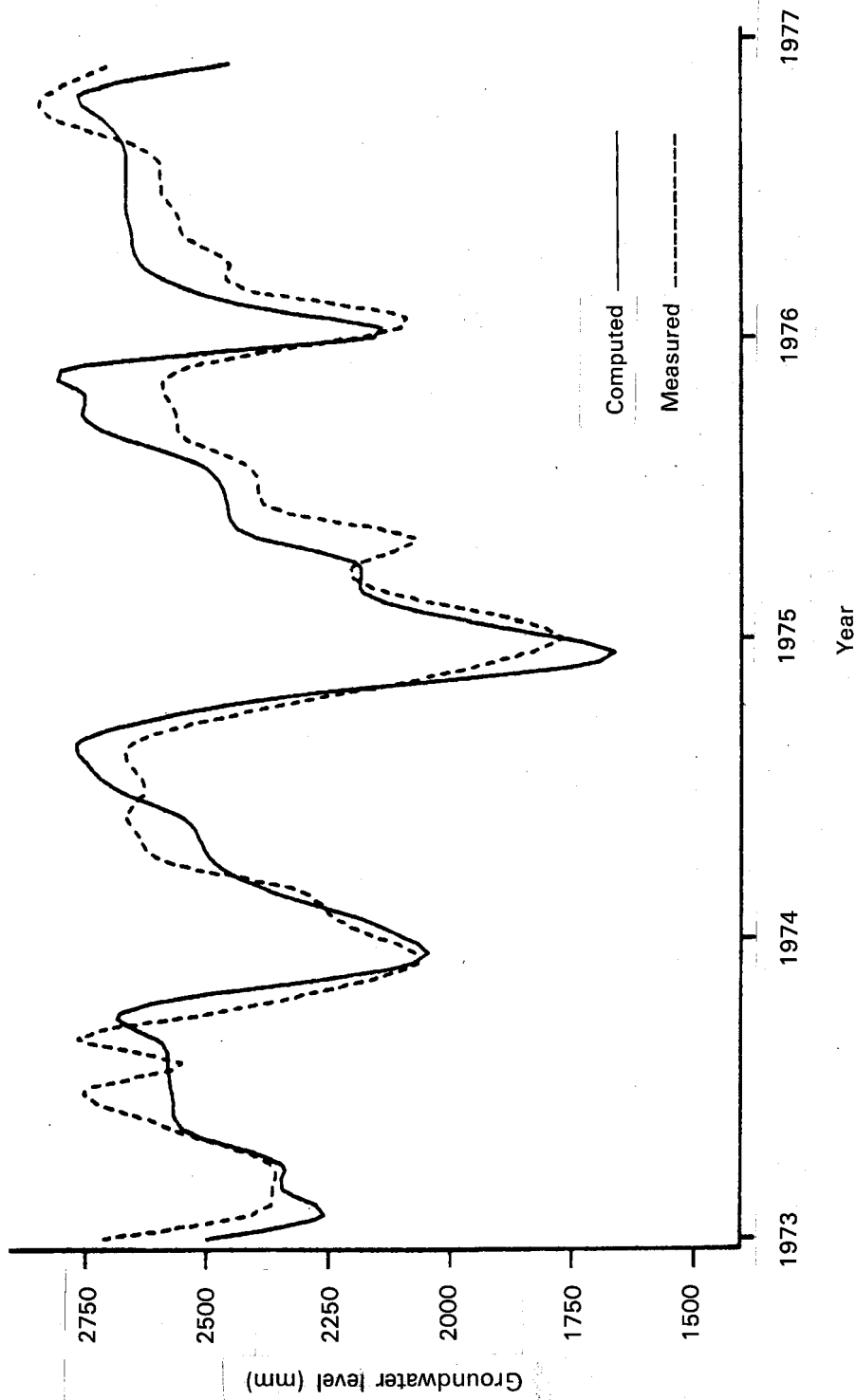

Fig. 10.1--Comparison of measured and computed groundwater levels for high Highlands part of drainage region 4

NOTES

1. Our discussion of hydrologic theory is considerably simplified, since we are concerned only with giving a general impression of our models. Details will be found in Vol. XII.
2. The region called the Highlands consists of that part of the country that lies more than 2 m above mean sea level.
3. Actually, we defined 17 groundwater regions, each of which was subdivided into a "low" part and a "high" part. Only 29 of the resulting 34 subregions were actually used.

Chapter 11

AGRICULTURE AND HYDROLOGY

11.1. INTRODUCTION

Because agriculture consumes more water than any other user in the Netherlands, it is a major factor in questions about present and future water management, such as:

- How do changes in water management policy affect the quantity and quality of water used by agriculture for sprinkling?
- What are the direct consequences of these changes on agriculture? How do they affect sprinkling costs, crop yield, farm income, etc.?

11.2. DISTRICT HYDROLOGIC AND AGRICULTURE MODEL

On the basis of geography and surface water hydrology, we divided the Netherlands into 77 regions called districts, the basic hydrologic entities of PAWN. (See Fig. 11.1.) Agricultural demands, and flows of water and salt between districts and the national system, are calculated by a submodel of the water distribution model (DM) called the district hydrologic and agriculture model (DISTAG). DISTAG computes

- The quantity and quality of water used for sprinkling
- Sprinkling costs, physical damage to crops, and loss of income due to lack of water and/or high salinity

DISTAG computes the above agricultural quantities by simulating that part of the hydrologic cycle that is connected to agriculture. It computes actual evapotranspiration from plants, and various flows of water and salt within the soil and between the soil and the surface water. It uses the groundwater storage model, described in the previous chapter, to compute groundwater levels. Moreover, each district also contains other elements of the land surface area (e.g., cities, industries, and vegetation-covered land that is not part of agriculture) that contribute to the hydrology of agriculture. For example, water running off the roads and roofs of cities may be extracted for sprinkling crops, and groundwater extractions by industries may lower the groundwater level, decreasing the groundwater supply for agriculture. DISTAG computes water and salt flows for these district elements, too.

Neither the kinds of crops nor the geographic, economic, and hydrologic factors that affect agriculture are uniform over the

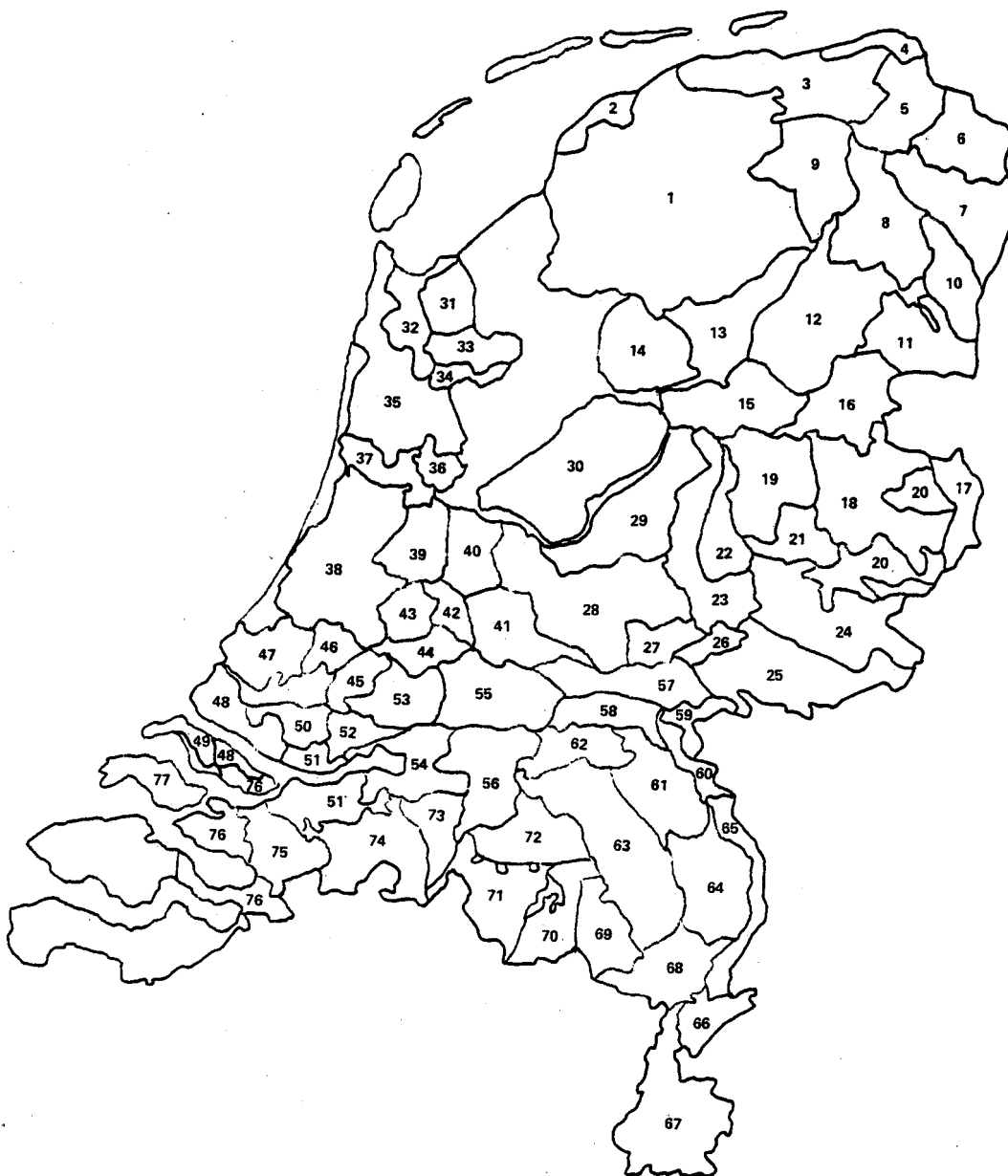

Fig. 11.1--PAWN districts

nation--or even within small areas such as districts. For example, we used 16 important soil types and 14 crop types (13 cash crops plus nature). Moreover, if sprinkling occurs at all, the water may be drawn either from the surface water or from groundwater--leading to entirely different demands and costs. On the basis of the soil and crop types, the type of sprinkling (if any), and other hydrologic properties, we divided the nation into 1259 areas called plots. They describe the agricultural situation in 1976. By adding new sprinkled plots, or increasing the areas of existing ones, we created sprinkler scenarios that reflected assumptions about how sprinkling might increase in the future. These scenarios are explained in Chap. 12.

Three subroutines in DISTAG simulate the agriculture and hydrology of plots:

- The plot water model computes water requirements by agriculture.
- The plot salt model computes salt concentrations of the soil.
- The plot damage model computes agricultural damage.

Because issues involving sprinkling are so important, we discuss them in greater detail in Chap. 12. Crop prices are discussed in Chap. 13. In this chapter, we first describe the major agriculture models and show how the DM uses them. We then discuss briefly how we validated the agricultural methodology.

11.3. DESCRIPTION OF THE MAJOR AGRICULTURE MODELS

This section explains DISTAG and the three plot models and shows how the DM uses them. We first outline how they work together, and then explain each individually.

We consider three levels of the water management system:

- The national system
- The districts
- Agriculture within districts (the plots)

The basic logic of the methodology resembles an arc. As illustrated in Fig. 11.2, it begins at the most detailed level (agriculture), rises to the most general (the nation), and then returns to the most detailed. First, agriculture formulates a "request" for water from the districts. This request is combined with other district requirements to obtain a request for water by districts from the national system. At the national level, the amount of water requested by all users is compared with the amount of water available from all

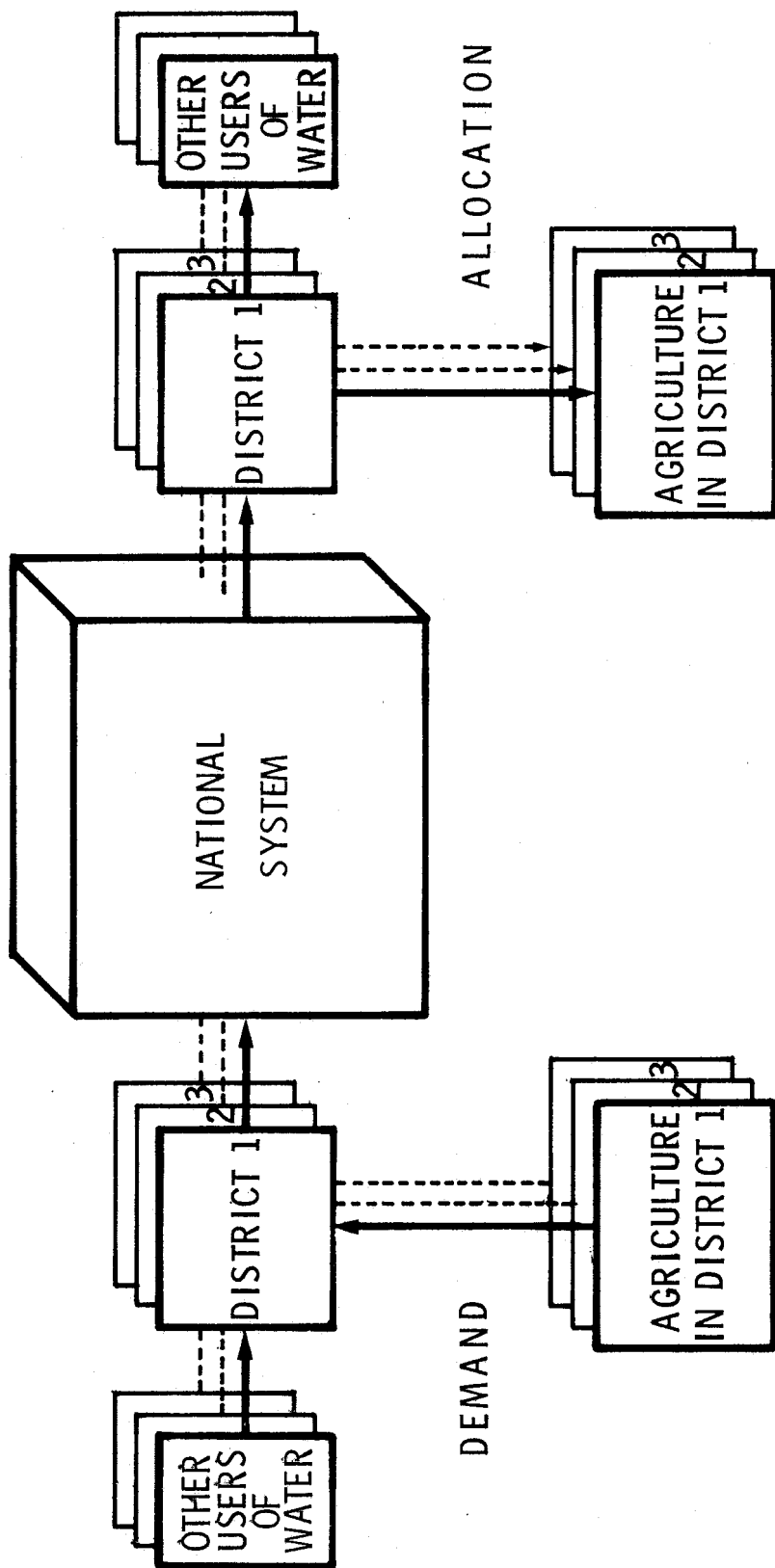

Fig. 11.2--Interaction between agriculture and water management

sources; then, taking into consideration the ability of the national system to move water around, a decision is made on how the requests can best be met. The water is then delivered to the various users, and the damages and costs are added up.

Figure 11.3 illustrates how our models simulate this activity.

At each time-step, the DM uses DISTAG twice for each district. The first time, the DM uses DISTAG to compute water demands, and to make an initial estimate of the salt concentration of any water discharged by the district. The second time, the DM uses DISTAG to compute crop damages, sprinkling costs, and a final estimate of salt concentrations.

The first time DISTAG is used, it uses the plot water model to compute agricultural water demands, and the plot salt model to compute discharges of salt from the plots into the surface water of the district.

- The plot water model, based on a formulation of Rijtema (Ref. 11.1), computes flows in a two-layer system of root zone and subsoil, taking into account the particular soil type in each layer, various flows to and from the soil (ditch infiltration, drainage, seepage, etc.), reduction in evapotranspiration, whether the plot is sprinkled or not, and groundwater. It computes the amount of surface water already there and then, if the plot has sprinklers, uses the procedure described in Chap. 12 to calculate the amount of water for groundwater or surface water sprinkling necessary to avoid damage (the demand). It also computes potential and actual evapotranspiration, the moisture content of the soil, drainage, and the groundwater level.
- For crops grown under glass, the plot salt model simulates a multilayer system in which the salt concentration increases with depth. For other crops, we assume salt mixes completely and uniformly in the root zone. We consider that salt enters the root zone via rain, sprinkling, and diffuse sources such as fertilizers and pesticides. It enters the subsoil through infiltration, and leaves the subsoil by drainage.

DISTAG combines the calculations of the plot water model with other district computations (runoff from urban areas, groundwater extractions, industrial extractions and discharges, flushing, etc.) to obtain an aggregate flow of both water and salt between each district and the national distribution system. It combines the calculations of the plot salt model with other sources of salt in the district (e.g., salt in urban runoff) to calculate the salinity of the surface water system of the district, and the amount of salt discharged (if water is discharged) to the national distribution system.

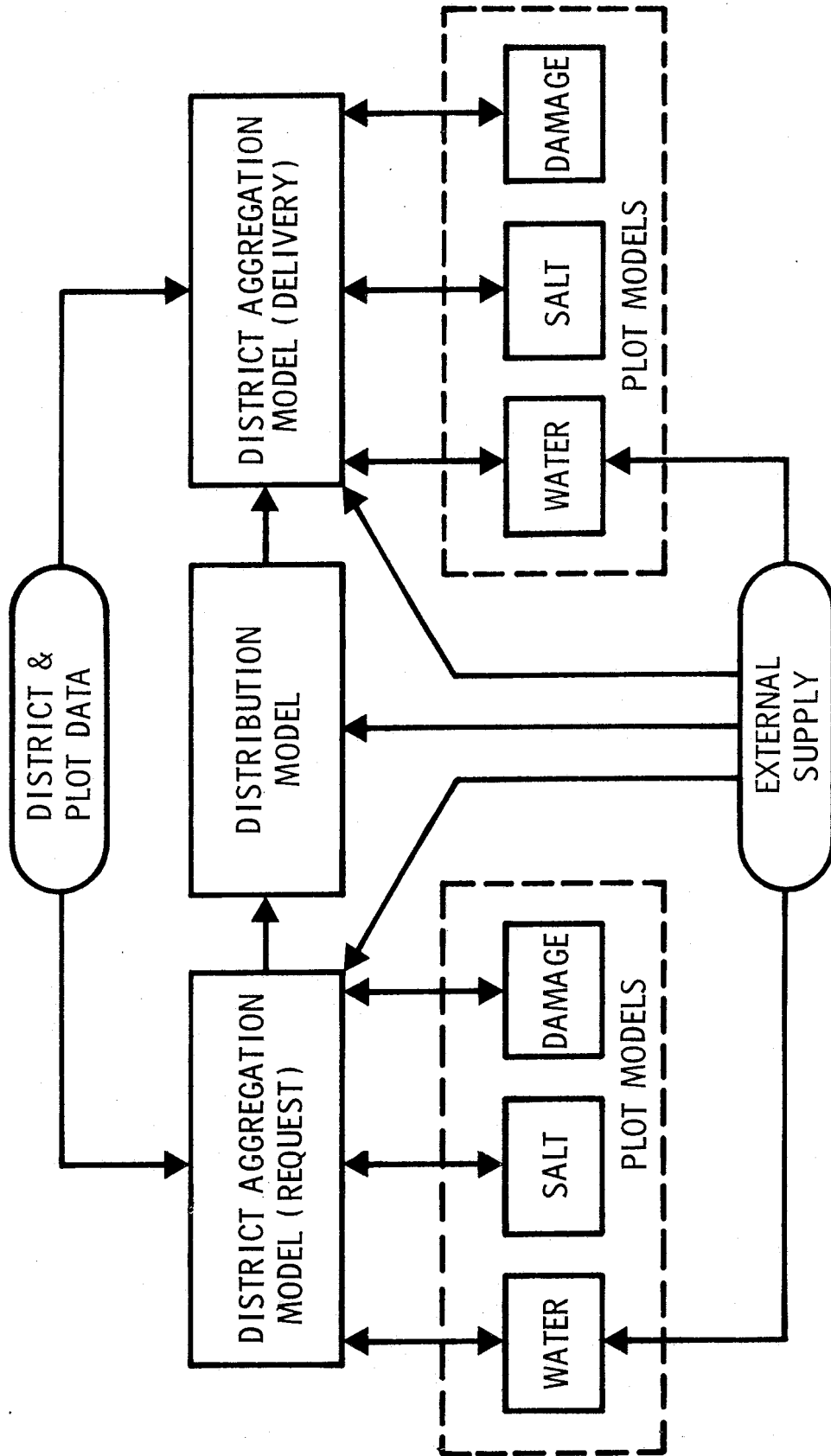

Fig. 11.3--Relation between agriculture models

After having used DISTAG to calculate agricultural surface water demands and salt discharges, the DM combines these demands with others at a national level, and compares these demands with the total amount of water available, taking into account the ability of the system to move water from one place to the next, and the established policy (being tested) for doing so. It then allocates this water to the districts. It uses the salt discharges computed earlier, combined with other sources of salt (e.g., the Rijn), to make a final estimate of the salinity of water that is extracted by the districts.

The second time DISTAG is used, it uses the plot water model to recompute how much surface water is actually consumed by agriculture, for any sprinkled plot that receives less water than it actually requested. For plots with groundwater sprinklers, it computes the amount of water extracted and the new groundwater level. DISTAG uses the plot salt model to determine the salinity of the root zone of all the plots. It uses the plot damage model to compute the fraction of each crop that is damaged.

- The plot damage model computes the fraction of the total crop that is damaged by drought and the fraction of the total crop that is damaged by salt independent of drought, and then combines the two fractions in such a way that no "double-counting" occurs. The fraction damaged in each time-step by drought depends on the ratio of the actual evapotranspiration divided by the potential evapotranspiration. The fraction damaged in each time-step by salt depends on salt concentration in the root zone.

Next, DISTAG computes monetary crop damage using crop prices that relate to the dryness of the year, as described in Chap. 13. It computes sprinkling costs using cost factors described in Chap. 12.

Finally, DISTAG computes the average groundwater level in each subdistrict, and writes it in a file of groundwater levels. This average is the weighted average of the groundwater level in each plot in the subdistrict, weighted by the area of the plot.

The large database used by these models was assembled with the help of many Dutch agencies.¹ Some 8700 data elements (e.g., land surface areas, water volumes) describe the geographic situation, 800 parameters characterize the different soil types, and over 3000 parameters describe characteristics of the various crops. These data are described in Chap. 6 of Vol. XII.

DISTAG and the three plot models are described in greater detail in Vol. XII.

11.4. VALIDATION

Throughout PAWN, we continually reexamined and attempted to improve the agricultural methodology. Data and parts of models were changed many times, although not all problems were solved in a completely satisfactory way. Although we devoted much time to testing the model, we lacked sufficient time and data to do a complete validation and sensitivity analysis. We describe a few of these matters in Chap. 7 of Vol. XII. In this section, we discuss how the agricultural and hydrologic computations compare with actual measurements, when it is possible to make these comparisons.

11.4.1. Comparing Water-Flow Computations with Actual Measurements

It is difficult to compare computational results at the plot level because very few measured data of this sort exist. We used DISTAG to evaluate the models on the basis of larger flows.

In the Highlands, we compared calculated flows with measured flows for a number of small rivers. The first time we did this, we found that the calculated annual flows were larger than the measured ones, and that the seasonal variation in the calculated flows was less than that actually observed. After some investigation, we made a number of small changes in the models, and adjusted some of the drainage parameters. The changes reduced the observed differences between calculated and measured flows, but some differences still remain.

In the Lowlands, we compared calculated discharges from several large districts with measured ones. For most of the districts, the agreement between calculated and measured flows was very good. The source of the few disagreements is not clear; however, the data suggest that some of the flows may have been incompletely measured.

Generally, the water-flow computations seem to match the measured ones with sufficient accuracy for PAWN.

11.4.2. Comparing Salinity Calculations with Actual Measurements

The salt concentrations observed in national and regional waters result from complex interactions among the many parts of the system. The only meaningful way to compare calculated salt concentrations with measured ones is to look at the results of the DM, which deals with interactions between districts and the distribution system. We compared the situation observed in 1976 with that predicted by our models. The match seemed reasonable with respect to the overall picture of more and less salty regions, and with respect to salt concentrations at nodes and districts. A more detailed validation could not be carried out, largely because our model's level of aggregation is not appropriate for localized aspects of salinity, and measured data are very sparse through time, while salt concentrations in fact vary considerably over time. Subject to these

qualifications, our results seem to be in agreement with actuality, and are accurate enough.

11.4.3. Comparing Crop Damage Calculations with Actual Measurements

Crop damage cannot be measured in a way that is fully comparable to our model calculations, because crop production levels also depend on factors not related to water management circumstances (e.g., damage due to disease). Much of the available crop price information is confounded by market effects. We compared our model with the "real world" by considering information that is more global than crop damage as reported by various agencies concerned with it.

We ran the DM for 1967, 1959, and 1976 and computed the drought and salt damage to several crops. Taking into account changes in total production levels in these years (in dry years, there is more sun, hence greater production if water is not a limiting factor), the damages calculated by the model were comparable to those actually reported, although sometimes a little too high.

11.5. THE DEMAND GENERATOR

DISTAG does not stand alone. It requires a main program to handle certain housekeeping functions (reading data, writing results, etc.). Such functions are normally provided by the DM, but in some instances we needed to make computations for isolated places, and we did not need to compute the associated flows in the national distribution system. To make such computations without using the DM, we created a stand-alone computer program called the demand generator (DEMGEN). DEMGEN handles the housekeeping necessary to run DISTAG, and writes its results for subsequent analysis. Thus, for some purposes, DEMGEN replaces the DM, but it cannot make "distribution-like" computations, such as constraining delivery of water for sprinkling due to low river discharges (i.e., making cutbacks in surface water sprinkling).

NOTE

1. Data were obtained from, or with the help of, the following agencies: Centraal Bureau voor de Statistiek (Central Bureau of Statistics); Koninklijk Nederlands Meteorologisch Instituut (Royal Dutch Meteorological Institute); Ministerie van Landbouw en Visserij (Ministry of Agriculture and Fisheries), including Instituut voor Cultuurtechniek en Waterhuishouding (Institute for Cultivation and Water Management Research), Landbouw Economisch Instituut (Agricultural Economics Institute), Landinrichtings Dienst (Land Development Department), and Stichting voor Bodemkartering (Agency for Soil Maps); Rijkswaterstaat; Rijksinstituut voor

Drinkwatervoorziening (State Institute for Drinking-Water Supply); Studiecommissie Waterbehoefte Land- en Tuinbouw (Study Committee for Water Demands of Agriculture and Horticulture); Instituut voor Toegepast Natuurwetenschappelijk Onderzoek (Institute for Applied Scientific Research).

REFERENCE

- 11.1. Rijtema, P. E., Soil Moisture Forecasting, Report 513, ICW, Wageningen, 1969.

Chapter 12

SPRINKLING

12.1. INTRODUCTION

In 1976 Dutch farmers planted crops on some 20,000 km² of land, only about 13 percent of which was sprinkled, either with surface water or groundwater. Nevertheless, at full capacity, the installed sprinkling equipment could deliver 550 m³ every second, or by simply replacing water lost due to evapotranspiration, it could use over 120 m³/s. Since the discharge of the Rijn in the summer of 1976 was often less than 1000 m³/s, sprinkling represented an appreciable strain on the supplies available that year.

The average annual cost of a sprinkler system ranges from 200 to 800 Dfl/ha, while average monetary yields of Dutch agriculture range from 2000 to over 10,000 Dfl/ha. Thus, the most expensive sprinkler system costs less than half the value of the least valuable crop. Since only 13 percent of the available land was sprinkled in 1976, a large growth of sprinkling may occur in the future. Sprinkling may then strain the supplies of water even more.

Policymakers can affect the amount of sprinkling. They can increase it by building canals that deliver surface water where it is not now available. They can decrease it by taxing the use of water or by limiting user withdrawals of surface water or groundwater. Many such policies were considered by PAWN.

To assess the costs and benefits of these policies, DISTAG needs:

- Sprinkling cost factors to estimate the labor and energy costs of sprinkling. (Another part of the analysis needs factors to estimate sprinkler investment costs.)
- Sprinkler operations parameters specifying the sprinkler operating policies to be followed, and a sprinkling algorithm to estimate how much water for sprinkling will be required by a particular plot given the sprinkling policy.
- Sprinkler scenarios that embody the assumptions about the future growth of sprinkling; these take into account various proposals for increasing the supply of surface water and for controlling extractions of groundwater, and predict what decisions farmers will make about the purchase of sprinkling equipment.

This chapter describes how we determined the sprinkling cost factors, how we represented sprinkler operations, and how we constructed sprinkler scenarios. (A detailed discussion of the first two topics is presented in Vol. XIII, while the third topic is covered in Vol. XIV.)

12.2. SPRINKLING COST FACTORS

A farmer who owns sprinkling equipment pays fixed costs (investment, maintenance) and variable costs (energy, labor). In a particular year, the costs partly depend on the weather, because that determines how much the system will be used. The average costs over a number of years depend on the size of the system, the size of the farm, the crop or mix of crops raised on the farm, the soil type, and whether the farm consists of a few large fields, many small ones, or something in between.

12.2.1. Representative Sprinkler Systems

A farmer can choose from a large number of possible sprinkler systems: permanently installed complete coverage systems, drip irrigation systems, portable pipe systems, portable hose-reel systems, etc. Because the latter two are the most widely used in the Netherlands, we used them exclusively in our sprinkling analyses.

The portable pipe sprinkler system (called the Buis system in the Netherlands) consists of one or more movable lateral pipes with multiple sprinkler heads spaced along them. The laterals are either connected to a main distribution pipe or take water from a ditch alongside the field. The system requires a water pump, driven by an electric motor or a tractor. To irrigate a field, the laterals are moved from one location to the next. The pipe segments that make up each lateral are uncoupled, carried to the next location, and recoupled there. The moving is a muddy, labor-intensive job. Capital investment costs are relatively low, but labor costs are large.

The hose-reel system (called the Haspel system in the Netherlands) consists of a long flexible hose with a sled-mounted sprinkler at one end, a large take-up reel onto which the hose is wound during sprinkling, a motor for winding the reel, and a tractor-driven pump to deliver water through the hose to the sprinkler. A main distribution pipe may be included. The hose, reel, and sprinkler sled are moved as a unit from one location to the next. Because the unit is heavy, a tractor is required to move it. Capital investment costs are high, but labor cost is low.

12.2.2. Sprinkler System Cost Functions for Fields

For each type of system, a large variety of system components are available for adjusting the system to a specific field. They differ in the area the system covers in a single application, the rate per unit of area at which water can be applied, the labor involved in moving the system from one part of a farm to another, and the size of the initial investment. For a particular farm, some systems will, on the average, cost less than all the others, but no one sprinkler system is optimal for all farms.

We developed a sprinkler system design and cost model for each of the two types of systems. The models reflect the technical characteristics and cost of commercially available sprinkling equipment. Design inputs specify the field size and shape, the water source, the source of pumping power, some system parameters, and selected cost trade-off variables. The model designs a feasible system (if possible), sizes the components, and calculates the labor and energy requirements. It then applies generalized cost-estimating relationships to estimate the investment and operating costs of the sprinkler system. It uses financial inputs--annual interest rate and useful lives of system components--to calculate annualized investment cost. It combines this with annual operating cost to obtain total annualized cost.

We applied this model to design and cost sprinkler systems for each of three hose-reel and five portable pipe system configurations on fields ranging in size up to 40 ha. For each type of system, the configurations distinguished between the water source and the source of pumping power. The annual operating cost for all of these systems was based on their applying 90 mm of water per year (an average amount). For each configuration and field size, we identified the specific system design with the lowest total annualized cost. Having identified the least-cost systems for each configuration, we prepared four cost functions: total investment, annualized investment, labor cost per move, and energy cost per millimeter of water sprinkled, all as a function of field size.

12.2.3. Sprinkling Cost Factors for Agricultural Regions

The cost functions are for particular fields. However, the plot water model does not make calculations for fields; rather, it computes water requirements for plots. A plot consists of a collection of scattered fields of different sizes, and the fields belong to different farms. Therefore each sprinkled plot contains a variety of different sprinkler systems, and the sprinkler system cost functions cannot be used directly to compute the costs of sprinkling a particular plot.

The distribution of field sizes for a given type of farm varies widely. Data describing field sizes were available for 14 large "agricultural regions" that had been defined by CBS (Centraal Bureau voor de Statistiek), the Central Bureau of Statistics. The sprinkler system allocation and cost model (SSACM) uses the field-size distributions and the cost functions (by field size) to compute the average cost of sprinkling each crop in an agricultural region, depending on the type of sprinkling (surface water or groundwater), and whether the sprinkling occurs in the Lowlands or the Highlands. The model allocates sprinkled areas to field size classes and selects sprinkler systems according to simple rules. In selecting between the two types of systems, it chooses the hose-reel system whenever the field size is greater than 15 ha. For smaller fields it selects whichever type costs less.

The model produces sprinkling cost factors for labor and energy and for annual fixed cost--annualized investment plus annual maintenance. These cost factors depend on the sprinkled area, which in turn depends on the sprinkling scenario. It is therefore necessary to apply SSACM for each sprinkling scenario.

For each type of sprinkling, SSACM estimates weighted average cost factors for 11 crop types in each of the 14 agricultural regions, given the total sprinkled area in each region. DISTAG computes sprinkler operating costs for plots using the operating cost factors for the agricultural regions to which the plots belong. This assumes that all the plots (with the same crop) in an agricultural region have the same field-size distribution so that the weighted average cost factors are appropriate for each plot. (The annual fixed costs for sprinklers are computed during the construction of sprinkler scenarios, as described below.)

12.3. REPRESENTATION OF SPRINKLER OPERATIONS

Sprinkling systems supplement rain in order to maintain soil moisture at a level that prevents crop damage. Farmers must decide when to start sprinkling, and how much to apply, with imperfect knowledge of future rain. The effort necessary to set up the sprinkling equipment on a field, and the costs of energy needed to run the equipment, are high. If a farmer guesses wrong about future rain, he may either spend a great deal of time and money in unnecessary sprinkling or lose some of his crop for having failed to sprinkle. The farmer continuously trades off potential crop damage and sprinkling costs. All the while, he is constrained by the technical capabilities of his sprinkler system and by other demands on his time.

12.3.1. Simulating Daily Sprinkler Operations

We developed a model of this behavior. The guesses about future rain and the need for sprinkling are replaced by a weather forecast that assumes a constant daily net moisture loss. The farmer begins sprinkling when the weather forecast is that the soil moisture in some section of the field will drop to a critical level by the time the farmer can reach it with the sprinkling equipment. He applies a constant amount at that location and moves his equipment to the next location. He makes a new forecast and predicts soil moisture levels to determine if he should continue sprinkling or wait.

The continuous trade-off between crop damage and sprinkling cost is represented by a sprinkler operating policy. The policy specifies the critical soil moisture level and the amount of water (mm) to apply per irrigation, the same amount being applied to all parts of the field. A farmer can choose to follow any of the possible alternative policies. We assume that once he has selected a policy, he will follow it every year, regardless of the weather conditions. We also

assume that he will follow a policy that does not vary with the life cycle of his crop.

The daily sprinkling model (DSM) simulates a Dutch farmer's operation of his sprinkler system each day of the entire six months of the growing season--April 1 through September 30. It uses daily rainfall and evapotranspiration data, sprinkler system characteristics, and some specification of a sprinkling policy, to simulate a farmer's use of sprinkling, day after day. It calculates the number of times the farmer moves his equipment and the amount of water sprinkled--data that are then used to calculate sprinkler system operating costs. It also calculates crop damage so that the total marginal cost of sprinkling (operating cost plus crop damage) can be obtained.

12.3.2. Optimal Sprinkling Policies

A sprinkling policy tells when to start sprinkling and how much water to put on a field when sprinkling starts. Selecting a policy involves choosing values for two sprinkling parameters, START and GIFT. START reflects the millimeters of water available in the root zone and is used to indicate a critical soil moisture condition. When the farmer estimates that some part of his field will dry out to START within the time he needs to get his equipment there, he starts sprinkling at once. GIFT, also measured in millimeters, is the amount of water to be applied during a single irrigation. In the Netherlands, GIFTS on the order of 20 mm to 30 mm are typical.

Sprinkling policies are selected to minimize the expected value of operating cost and crop damage. Both depend on the critical soil moisture level, START. Lower values for START mean less sprinkling and less sprinkling cost but more crop damage. If START is low, it takes a long time for the soil to dry out to that point, and the farmer will not sprinkle frequently. Hence, he saves on operating costs and water. However, if an extended dry period occurs, he runs a greater risk of not getting around the field in time to avoid damage, so the expected damage increases. A conservative farmer chooses a high value of START and, if it is high enough, he will be able to avoid almost all damage. In many instances, however, he will sprinkle when it is not really necessary. Consequently, he will be relatively wasteful of water and have higher operating costs.

We used the DSM to select optimal sprinkling policies for each relevant combination of crop type, soil group, and root zone depth. For each combination, we considered 21 different policies and their results for each of three years--a very wet year, a normal year, and an extremely dry year. The optimal policies were biased toward the wet year, while still performing well in the normal year. These policies, when applied in an extremely dry year using the plot water model, resulted in amounts of sprinkling water that appeared reasonable when compared with what farmers actually used in that year.

12.3.3. Decade Sprinkling Algorithm

Once the sprinkling policies had been selected, they had to be implemented in the plot water model. This model, especially when used in conjunction with the distribution model (DM), is large and expensive to run. To hold computing costs down, it operates with a time-step of a decade (ten days) rather than one day as the DSM does. Further, it considers plots, which are aggregates of fields, rather than individual fields and sections of fields; consequently, the information obtained each day in the DSM is not available in the plot water model.

The problem was to work with the more aggregate information available in the plot water model and still obtain sprinkling results comparable to those produced by the DSM. An algorithm requiring decade and plot data was hypothesized and tested. The amount of water used and the crop damage estimated with the algorithm were compared with similar estimates made by the DSM. The form and parameters of the algorithm were adjusted until the outputs from the DSM and the algorithm were similar. Thus, the DSM, which reflects as realistic an approach to sprinkling as we could devise, supplied the database to which we calibrated the sprinkling algorithm implemented in the plot model.

The decade sprinkling algorithm estimates the demand for sprinkling water in response to decade rain and evapotranspiration, given a sprinkling policy. This algorithm consists of three parts: The first imposes a daily weather pattern on the decade, the second calculates the sprinkling requirement, and the third calculates the amount of water lost to drainage. The weather pattern imposed on a decade divides the decade into three periods: a beginning dry period, a rain period, and an ending dry period. The length of each period, the daily rainfall during the rain period, and the daily evapotranspiration are based on the total rain, evapotranspiration, and the length of the decade. The sprinkling and drainage calculation follow the logic used in the DSM.

12.4. CONSTRUCTION OF SPRINKLER SCENARIOS

About half of the cultivated land of the Netherlands has access to ditches, canals, and other elements of the surface water distribution system, from which farmers can draw water for sprinkling if they own the necessary equipment. We call such land eligible for surface water sprinkling. Sprinklers now exist only on about 20 percent of the eligible area. Therefore we say the intensity of surface water sprinklers is 20 percent. (By intensity we mean the proportion of an eligible area on which sprinklers are installed.)

Groundwater can be extracted for sprinkling anywhere in the Netherlands, but this practice is rare in the Lowlands, where the groundwater is usually saline. In regions of the Netherlands where groundwater is fresh, groundwater sprinkling is not common, particularly where surface water is available for sprinkling, because groundwater sprinkling is more expensive and less flexible (less

flexible because, even when a nearby well already exists, access to water is easier from a web of surface water canals and ditches than from a well). Therefore, we will say that an area is eligible for groundwater sprinkling if and only if it is not eligible for surface water sprinkling. The current intensity of groundwater sprinklers is about 7 percent; that is, about 7 percent of the land that is not supplied from surface water is sprinkled from groundwater.

The amount of sprinklers can increase in two ways. First, the intensity can increase as farmers purchase additional equipment. Second, the area eligible for surface water sprinkling can increase. That is, the water distribution system can be changed to bring surface water to areas where it is not currently available, and farmers might purchase equipment to tap this new source.

A sprinkler scenario determines how much land has each type of sprinkling and identifies its location and crop type. We define a sprinkler scenario by specifying the surface water and groundwater sprinkler intensities as well as the area eligible for surface water sprinkling.

In this section, we first discuss how we determine optimal sprinkler intensities. Next we introduce "agricultural benefit multipliers." Then we define some alternative intensities. Finally, we describe generally how the scenarios themselves were produced, but defer their specification until Chap. 20.

12.4.1. Optimal Sprinkler Intensities

As sprinkler intensity increases, its benefits rise proportionally and its costs increase. Small fields are more expensive to sprinkle (per hectare) than large ones, however, and as sprinkler intensity increases, more and more smaller fields become sprinkled. Consequently, sprinkling costs increase at a faster rate than the benefits. The optimal intensity is the intensity that maximizes the expected net benefits to farmers, which we define to be the average loss (over many years) that can be prevented by sprinkling (its gross benefit) minus the average cost to purchase and operate the sprinklers. Practical considerations constrain the maximum sprinkler intensity to be a value somewhat less than one, called the maximum practical intensity. (The maximum practical intensities for each crop and agriculture region are reported in Vol. XIV.)

We computed optimal sprinkler intensities for each crop, on every type of soil, and in every district and hydrologic region in the Netherlands. One set of intensities was computed for surface water sprinkling and another set for groundwater sprinkling. Both were created assuming every area was eligible for each type of sprinkling, thereby permitting us to use them to evaluate plans for expanding, anywhere in the nation, the area eligible for surface water sprinkling. Because we used the same general procedure to compute the intensities

for both types of sprinkling, we will describe it only for surface water sprinkling.

To calculate optimal intensities for surface water sprinkling, the first step was to estimate, for every plot in the nation, the average losses per hectare that could be prevented by sprinkling and the average amount of sprinkling water required per hectare to prevent these losses. This could be done by analyzing all the plots with the demand generator (DEMGEN) for a series of 19 years on which we had complete weather data. The general procedure performed this series of runs twice--first with each plot unsprinkled and second with it completely sprinkled by surface water sprinklers. For each plot, the average losses that could be prevented by sprinkling would then be calculated by taking the losses when the plot is without sprinkling minus the losses with sprinkling for each year, averaged over the 19 years. The average amount of sprinkled water is also calculated for the 19 years.

The above procedure, while feasible, appeared prohibitively expensive. Instead, we ran the general procedure described above on merely a representative sample of plots. Using the calculated averages for crop loss per hectare on the unsprinkled plots and for amount of sprinkling water per hectare on the sprinkled plots, we developed regression equations that did a good job of estimating the results from a set of only four years. Next we made two DEMGEN runs, this time for all plots but only for the four years. One series had all plots unsprinkled, and the other had them sprinkled from surface water. We used the results of these runs with the regression equations to determine approximately, for each plot, the average losses per hectare prevented by sprinkling and the average amounts of water required per hectare. The average losses per hectare prevented by sprinkling were calculated by first applying the regression equations to the crop loss per hectare estimated in the series of runs for the unsprinkled plots and then subtracting the similarly estimated crop loss per hectare for the series of runs on the sprinkled plots.

The second step was to determine sprinkling cost factors for each crop in each agricultural region as a function of intensity. This was done by making a series of SSACM runs that varied the sprinkler intensity in equal steps from zero to the maximum practical intensity. These cost factors are on a per hectare basis.

The third step obtained, for each plot, the average sprinkling costs per hectare as a function of intensity. For each intensity, we selected the SSACM cost factors corresponding to a plot's crop and region. The average costs per hectare were found by adding the fixed cost factor to the average operating cost, which was determined by multiplying the operating cost factors for labor and energy times the average amount of water required per hectare.

The fourth step was to calculate, for each plot, the expected net benefits as a function of intensity. For each intensity, the average sprinkling costs per hectare and the corresponding taxes were

subtracted from the average losses prevented per hectare, and the difference was multiplied by the plot's area and the intensity (the fraction of that area with sprinkling).

The final step was to determine the optimal intensity for each plot, the intensity yielding the highest expected net benefits. This was done by inspecting the benefits as a function of intensity. As it turned out, in most places the optimal intensity was either zero or equal to the maximum practical intensity.

12.4.2. Agricultural Benefit Multipliers

We compared the optimal intensities with the intensities observed in the 1976 data. (A comparison was made only between the optimal surface water intensities and the current surface water intensities. Groundwater intensities were ignored because too little groundwater sprinkling is now taking place to allow a meaningful comparison.) For some crops, the optimal intensities were lower than the actual intensities. For other crops, they were higher. The difference could result from misestimation by our models, or from the fact that the observed intensities merely represent a point in the evolution toward optimal intensities. To investigate the cause of the differences, we computed, for each plot, the factor by which the gross benefits calculated in determining the optimal sprinkler intensity would need to be inflated or deflated before the optimal intensity exactly matched the observed intensity. Then we computed, for each crop, a weighted average of the factors. We call these averages the agricultural benefit multipliers. The following multipliers were found for the various crops:

Grass	2.01	Milling potatoes	0.96	Consumption potatoes	0.46
Fruit	1.27	Seed potatoes	0.90	Open-air vegetables	0.54
		Sugar beets	1.00	Trees	0.41
		Cereals	0.99		
		Cut corn	0.95		
		Bulbs	0.99		

As can be seen, for the middle group of crops the benefit multipliers are nearly one, and our estimated optimal intensities appear to agree with the observed intensities.

Consumption potatoes, open-air vegetables, and ornamental trees appear to be sprinkled less than optimally. For these crops, it may be that sprinkling is still in the process of growth, and optimal levels have not been reached. We may also have overestimated the gross benefits or underestimated the costs of sprinkling.

Grass and fruit crops appear to be sprinkled more than would be optimal. This suggests that we may have underestimated the gross benefits or overestimated the costs¹ of sprinkling these crops.

For fruit, sprinkling is used early in the growing season to protect the crop from frost. Our models ignore this benefit from installing sprinklers, which may be substantial.

For grass, the situation is more complex:

- The addition of sprinklers may enable increases in yield that are not reflected in our models. Consider an example: After grass has been grazed on or mowed, a farmer without sprinklers must wait for rain before he can apply fertilizer; meanwhile, the grass's growth is retarded. (Unless the chemical fertilizer is wet down when it is applied so that it sinks immediately into the soil, it remains on top of the soil and damages the crop.) With sprinklers, the farmer can apply fertilizer without having to wait for rain, thereby reducing growth retardation.
- We have valued grass at the cost of substitute fodder. But this may not be a good proxy for the value of grass to use in calculating the benefits of sprinkling. For example, under serious drought conditions the farmer may regard the value of milk/beef production at risk--or even the value of part of his herd--as the opportunity cost for grass, and hence as its value. Or, as another example, the increased grass yield possible with sprinkling permits the farmer to support a larger herd with a fixed amount of land. The farmer may value the increased yield in terms of potential increases in milk/beef production rather than in terms of a reduction in fodder costs.
- A farmer may acquire sprinklers even when it is not cost-beneficial so as to provide a kind of insurance. He may not be willing to risk having difficulty in obtaining substitute fodder or being unable to feed his herd.

12.4.3. Alternative Sprinkler Intensities

For use in our analysis, we defined three levels of sprinkler intensity: high, medium, and low. As the high level, we used the optimal intensities calculated above, except for grass and fruit. For them, we recalculated each plot's optimal intensity after applying the multiplier to the average gross benefits that sprinklers can produce.² These high intensities assume the following:

- For crops with benefit multipliers no larger than one, optimal intensities quite plausibly may be reached in the future.
- For grass and fruit, the differences in gross benefits accounted for by the multipliers represent benefits not taken into consideration by our models. These benefits are perceived by farmers to be real when they decide whether to install sprinklers.

The high sprinkler intensity reflects an optimistic view of future developments. Under it, nearly half of the currently eligible area would have sprinklers. (Recall that the 1976 intensity is around 13 percent.) Thus the high intensity amounts to more than tripling the current sprinkler intensity.

The low level of sprinkler intensity duplicates the current amount of sprinklers in areas currently eligible for sprinkling. To each plot not currently eligible, we assign the average sprinkler intensity for its crop in the same agricultural region.

The medium sprinkler intensity was calculated by simply taking the average of the high and low intensities.

12.4.4. Creating Sprinkler Scenarios

If new sprinkler intensities occur, and/or changes are made that create new eligible areas for surface water sprinkling (and thus reduce eligible areas for groundwater sprinkling), then we embody these assumptions in a sprinkler scenario. In practice, we specify such a scenario by increasing the area of plots that are already sprinkled, adding new sprinkled plots, and reducing the areas of unsprinkled plots by a corresponding amount. A computer program called PREPDM (preprocessor for the distribution model) takes surface water and groundwater intensities and eligible areas, and then changes the current plots accordingly.

For a given sprinkler scenario, PREPDM identifies, for all plots not currently sprinkled, the area eligible for surface water sprinkling and that eligible for groundwater sprinkling. It then takes the sprinkler intensity corresponding to the plot and type of sprinkling and calculates the amount of new sprinklers, if any, to install. While doing this, it also takes into account the amount and type of sprinklers already installed on the same crop in the same district and hydrologic region and with the same soil type. (The sprinkler scenarios used in PAWN are specified in Chap. 20.) The effects of pricing and regulation tactics, such as groundwater extraction charges and quotas on sprinkler scenarios, are reflected by a procedure described in Sec. 29.2.3.

NOTES

1. There is some controversy regarding how to estimate the labor portion of the sprinkling cost. Some people are inclined to consider the farmer's labor for sprinkling as free. Others claim that it should be valued quite highly, since the work is unattractive and there may be other demands on the farmer's time, and he might not be able to find time

for sprinkling. We believe that the farmer's time should be valued at the average wage for farm labor. If the farmer invests his own time, he should be rewarded appropriately. If he cannot find the time, he should be able to hire sprinkling labor. This view was adopted in our estimate of labor costs.

2. Even though the grass and fruit multipliers were computed for surface water sprinkling, we used the same multipliers to calculate the high groundwater intensities. We did so because it is not possible to reliably estimate separate multipliers for groundwater sprinkling, because too little of it is currently taking place. Moreover, the multipliers are assumed to represent benefits not accounted for by our models, as discussed above, and we have no reason to believe that the models neglect different factors for the two types of sprinkling.

Chapter 13

AGRICULTURAL BENEFITS

13.1. INTRODUCTION

If a farmer buys sprinklers, he will save money in a dry year. By considering the losses of his neighbors who did not buy them, he can estimate how much of his crop he might have lost. Using the prevailing price of that crop, he can estimate how much money he saved. By adding up his savings over a number of years, and comparing them with his sprinkling costs, he can calculate his net benefits of sprinkling, and see if he made a profit or a loss.

In PAWN we estimate the net benefits of sprinkling by simulating the above procedures. For each case we analyze, we estimate how much of each crop is saved by sprinkling and then multiply this quantity by the crop price we assume would prevail under those conditions. This gives us the gross benefits of sprinkling. We then subtract sprinkling costs to obtain the net benefits.

Two major factors affect the value of the agricultural crops grown in any given year: the external supply (of rain, surface water, and sunshine), and the water management policies in effect. The next two sections of this chapter discuss our procedures for capturing these two effects. First we discuss the crop price scenarios that account for the effect of external supply. Then we discuss BENCOMP, the benefits-estimating program we created to expressly account for the effects of Dutch water management policies on crop values.

The final section of this chapter discusses our use of the grass multiplier. This multiplier has a larger effect on the magnitude of the benefits we estimate for agriculture than any other assumption or parameter value.

13.2. CROP PRICE SCENARIOS

The external supply determines the maximum potential yield for each crop. If no damage occurs to a crop during the year, each hectare of crop will bring a certain number of Dutch guilders when it is harvested: We call this number, expressed in units of Dfl/ha, the crop price. A crop price scenario is simply a list of crop prices, one for each crop type.

Because the crop price scenario varies with the external supply, we needed to develop a crop price scenario to correspond to each external supply scenario used in our analysis. We first created crop price scenarios for two external supply scenarios other than those specified in Chap. 5. We selected these scenarios on the basis of how recent and how dry the year was:

- To obtain crop values for a year of "average" dryness, we used data from 1975 because it was the most recent year that was more or less normal (although a bit dry). We chose a recent year rather than an earlier one so that there would be less change in the structure of prices over the different crops between then and the time the analysis was being conducted.
- To obtain crop values for an "extremely dry" year, we used data from 1976 because it was both the driest year in our 47-year database and the most recent. (Although the DEX scenario defined in Chap. 5 is drier in terms of Rijn flows, it is an artificial scenario and so no data on crop values exist for it.)

To create these scenarios, we used published estimates of total production, and total land devoted to raising crops. We made adjustments for the fact that in neither year were the actual yields as high as the potential yield. (See App. A of Vol. XII for details.) These two scenarios are given in Table 13.1.

Table 13.1

ESTIMATES OF CROP VALUES FOR THE AVERAGE
YEAR AND THE EXTREMELY DRY YEAR
(In Dfl/ha)

Crop	Average Year	Extremely Dry Year
Grass	3,000	5,000
Consumption potatoes	10,000	16,250
Milling potatoes	3,833	5,833
Seed potatoes	13,500	20,300
Sugar beets	5,200	5,200
Cereals	3,150	3,150
Cut corn	3,600	6,000
Bulbs	27,400	30,140
Open-air vegetables	15,600	20,280
Fruits	10,400	10,400
Trees	42,800	42,800
Vegetables under glass	232,000	278,000
Flowers under glass	485,000	412,250

In most cases the potential value of the crops is greater in the extremely dry year. This is usually because the sun shines on the crops more in the dry year, causing faster growth and greater productivity. (Remember that the potential value of a crop is based on the assumption of no damage; that is, that sufficient water is available from some potential source to sustain the full potential growth of the crop.)

For several of the crops shown in Table 13.1, the potential value of the crop is assumed equal in the two scenarios. For example, ornamental trees suffered no apparent effects from the drought; hence we assume their values will be the same in both scenarios. In only one instance in the table--flowers under glass--is the dry-year price of a crop below the average-year price. We believe this occurred because the fair weather encouraged outdoor activities, reducing the time families spent indoors and reducing their demand for cut flowers.

To analyze cases based on scenarios other than the average or the extremely dry, we based our estimates of crop prices on the relative dryness of the year, using the amount of drought damage calculated by DEMGEN as the measure. If this damage was less than that of 1975, we used the 1975 crop price scenario. Otherwise, we interpolated between the 1975 and 1976 crop price scenarios, so that the difference in prices was directly proportional to the difference in drought damage.

13.3. BENEFIT COMPUTATION PROGRAM

In a given external supply scenario, which applies to the entire European Economic Community (EEC),¹ different Dutch water management policies cause Dutch crop production to vary. Since most of this production is sold in EEC-wide markets, Dutch policies cause changes in EEC-wide prices. (For the given external supply scenario, we assume that non-Dutch (EEC) water management policies, and hence non-Dutch production, remain constant.)

We created the benefits computation program (BENCOMP) to calculate the change in crop prices resulting from a new Dutch water management policy. BENCOMP also calculates the resulting net agricultural benefit of the policy and the distribution of that net benefit among farmers, consumers, and governments, both Dutch and foreign. (Chapter 19 discusses the general benefit-estimating principles that are reflected in BENCOMP and all of our other sector-by-sector procedures.)

13.3.1. BENCOMP Approach

BENCOMP uses the results of two runs of the DM, a base case and a comparison case. The base case represents the current water management policy, while the comparison case represents a new policy under study. Given data on these two cases, BENCOMP computes changes in crop prices and in the benefits to producers, consumers, and government that would occur if the water management policy of the base case were changed to that of the comparison case. The external supply scenario is always kept the same for the two runs; i.e., 1943 cases are compared only with the 1943 base case, and DEX cases only with the DEX base case.

From the two DM runs, BENCOMP obtains the variable costs and the benefits (prevented losses) from sprinkling, for each crop. BENCOMP also receives information on the cost of the new waterboard plans,

fixed costs of sprinkling, market information (prices, elasticities, demand and supply levels), and information about taxes and tax credits.

In computing and distributing benefits among producers, consumers, and government, BENCOMP allows for income taxes levied on producer profits, value-added taxes on production, and tax credits on certain capital costs incurred by producers. It apportions benefits between the Netherlands and the remainder of the EEC, and calculates price changes using a variety of data describing the agricultural market. These include: the size of the market (Dutch or EEC), the type of market (free or price-supported (supports are by the EEC)), and estimates of the response of consumers to price changes (what economists call the price elasticity of demand). The short-term response of production to price changes (the price elasticity of supply) is assumed to be zero: Once farmers have planted their crops in a given year, we assume they will do what they can to maximize their yield regardless of price changes.

BENCOMP thus provides improved estimates of net agricultural benefits. Some Dutch water management policies provide more water to agriculture than others, and therefore result in increased agricultural production. This tends to lower EEC market crop prices. Because the crop price scenarios represent the maximum potential yield in a particular external supply scenario with the current policy, they do not take such price changes into account. But BENCOMP estimates the change in crop prices that increased output might cause. It uses various input information on demand elasticities and market size and characteristics to adjust the estimates of agricultural revenues output by the DM. These inputs were acquired from a number of sources.

13.3.2. Inputs

BENCOMP uses three types of agricultural inputs: (1) information about agricultural damages and costs for the base case, (2) similar information for the comparison case, and (3) a set of fixed economic data related to the agriculture market and tax situation. The first two sets of data are case-specific and are generated by the DM. The third dataset contains economic data that do not vary with the policy being considered. It reflects our best perception of the current agriculture market and tax situation. As such, it is used in all BENCOMP runs. This dataset is fully documented in Vol. X; here we simply summarize its main features.

Four types of economic data are provided: information on market proportions, information on tax rates, coefficients to be used in allocating costs to producers and government, and information about price elasticities and type of market.

Market Proportions. The market proportions are particularly important in computing price changes as a result of yield changes. In turn,

these price changes determine the distribution of benefits between producers and consumers and also between the Netherlands and foreign countries. Two alternative viewpoints were taken: that of the EEC-wide market and that of the national market.

The EEC-wide market reflects the notion that the total EEC demand and supply interact in one market in which the Netherlands and the other EEC members participate. Since this market is very large, even substantial changes in Dutch crop yields will typically cause very small price changes. This will result in only limited transfers of benefits from producers to consumers and from the Netherlands to foreign countries. Hence this assumption tends to maximize total Dutch benefits and the producers' share of these.

The notion of the national market is to create a sort of lower bound on the market proportions by considering only the product flows associated with the Dutch market. For the actual PAWN analyses, the EEC-wide market assumption was used. The national market assumption was used only in some sensitivity analyses, where it was found that total Dutch benefits declined by only about 10 percent.²

Tax Rates. Three kinds of tax rates have been specified for both the Netherlands and foreign countries: (1) marginal income-tax rates; (2) value-added tax rates; and (3) tax-credit rates. Because no information about foreign countries was available, tax rates were set equal to Dutch tax rates.

Dutch income-tax rates are progressive, rising with each higher income interval. The marginal income-tax rate reflects the tax rate to be paid on an additional unit of income, or the tax rate saved due to an additional unit of deductible cost at a given income level. Usually, the marginal tax rate is substantially higher than the average. Marginal income-tax rates were set equal to 40 percent, which appears to be typical for Dutch farmers.

The normal value-added tax rate in the Netherlands is 18 percent. There are certain exceptions, however, one of which is the category of primary necessities of life, to which all agricultural products belong. The special rate for these products is 4 percent. The tax credit rate applies to investments in sprinkler systems. We estimated this rate based on information provided by LEI (Landbouw Economisch Instituut), the Agricultural Economics Institute.

Price Elasticities and Type of Market. Most of the required information on elasticities of supply and elasticities of demand for both the Netherlands and foreign countries and on the type of market (free or price-supported) existing for each crop type was obtained from LEI. (The elasticity of supply shows the sensitivity of production to an increase in price, whereas the elasticity of demand shows the corresponding sensitivity of sales. Economists define the elasticity of supply as the ratio of the percentage change in production to the percentage increase in price.)

All of the elasticities of supply were set to zero, reflecting our belief that in the short run a farmer will not respond to price changes by planting less or by refusing to sprinkle crops already planted. In the absence of any data, the situation in foreign countries was assumed to be the same as the Dutch situation.

Cost Allocation Coefficients.³ All cost changes must be explicitly taken into account in calculating net benefits. Three types of cost changes are involved in calculating agricultural benefits:

- Costs of waterboard plans
- Variable sprinkling costs (labor plus energy)
- Fixed sprinkling costs

The first two are considered tax-deductible items and are easily split between producers and the government. The fixed sprinkling costs are not so easy to handle. They consist of maintenance, depreciation, and interest.

Additional specialized procedures were required to allocate these costs. (See Vol. X for details.)

The waterboard plans appear in this file merely because they had to be included in the input data somewhere. The only calculation that BENCOMP actually carries out with these data is a cost allocation to producers and government based on the income-tax rate (60 percent to producers, 40 percent to government).

13.4. THE "GRASS MULTIPLIER"

In determining sprinkler intensities for grass and fruit, we used agricultural benefit multipliers greater than one because, as we argued in Chap. 12, we believed that they represented benefits not taken into consideration by our models but that farmers would perceive as real when they decide whether to install sprinklers. The question arose, however, whether we should also use these multipliers in calculating the agricultural benefits from alternative water management policies.

For fruit, we decided that it was not appropriate to use the multiplier for this purpose. First, the frost-protection benefit that we believe this multiplier represents is not really a benefit of water management policy. Second, because the extra benefit was relatively small, it could be neglected without much effect.

For grass, the situation was quite different. Because grass is the predominant "crop" in Dutch agriculture, using the multiplier and effectively doubling the value of grass would have an enormous effect on the magnitude of the agricultural benefits of water management policy. Nevertheless, believing that the extra benefit that the grass multiplier

represented was a real benefit of water management policy, we decided to use this multiplier as the reference assumption for our analysis. However, we also performed sensitivity analyses to test its effect on most of our major results to which it was relevant.

Whenever we used the multiplier with the DM, we merely doubled the value of grass in the crop price scenario. We also added a feature to BENCOMP so that we could input the grass multiplier separately and it would then calculate the agricultural benefits both with and without the multiplier. This allowed us to do sensitivity analysis on the effect of the multiplier without rerunning the DM or performing laborious hand calculations.

NOTES

1. The European Economic Community or "Common Market" is currently composed of nine member nations: Belgium, Great Britain, Denmark, France, Ireland, Italy, Luxembourg, the Netherlands, and West Germany.
2. The distribution of foreign benefits between producers and government is also approximate because of uncertainty over foreign tax rates. We have assumed that they are the same as Dutch tax rates.
3. Several assumptions affecting the allocation of costs were changed by the Dutch during their analysis to reflect improved information; for example, the influence of certain government subsidies on the allocation of waterboard costs to users. Although changing these assumptions somewhat alters the distribution of benefits among producers, consumers, and the government, it does not change the amount of benefits by crop at all.

Chapter 14

DRINKING-WATER COMPANIES

14.1. INTRODUCTION

Drinking water (DW) is produced in the Netherlands exclusively by public water companies called DW companies. They are obliged under Dutch law, specifically the Waterleidingwet or DW law, to produce enough DW to satisfy whatever is demanded for reasons relating to public health, and to maintain the quality of the DW at or above the minimum health standards prescribed by the law. The customers of DW companies are households, commercial entities, and, to a limited extent, industries. (Food-processing firms are required by law to use DW, and some firms cannot get enough groundwater (GW) to satisfy their demands for high-quality water.)

DW companies strive to use GW whenever possible in producing DW. With few exceptions, GW is clear, of high quality, appropriately cool for DW purposes, and has a pleasant taste. It is also the cheapest of all DW sources, requiring only aeration, single or double filtration, and (usually) softening, as well as pumping and distribution. The trouble is that not enough GW is available in some places to meet the DW demand, while in other places GW extractions are limited because of possible damage to agricultural crops and to the natural environment.

To make up the difference between the DW demanded and the GW available, DW companies turn to surface water (SW), which is much more expensive and less desirable than GW. Not only are SW sources often farther away from DW-company customers, thus entailing transportation (pipeline) costs, but also the sources are often more polluted, thus requiring extensive treatment before SW can be used as DW.¹

For several reasons, DW companies will find it more difficult in the future to meet their two main objectives: ensuring adequate DW supplies and maintaining the highest quality possible above the minimum standard. First, the demand for DW is expected to rise. Second, the demands for GW from other users (such as industry and agriculture) are also expected to grow. The increased competition for the available GW may mean that DW companies get less. In addition, GW extractions may be restricted in some areas to protect agriculture and the natural environment from damage caused by a drop in GW levels. Third, the quality of DW generally declines when the proportion of SW is increased to replace scarce GW. Finally, there are limits on the amount of SW that DW companies can obtain from their existing sources. To get more SW, DW companies will have to expand the capacity of existing facilities, such as reservoirs and treatment plants, or build new facilities. Such activities require considerable time and large investments, which in turn lead to increases in DW production costs and prices.

In PAWN, we considered several price and regulatory tactics to conserve GW. For example, we considered the regulatory tactic of imposing a quota on the amount of GW extracted. To determine the effect of such tactics on DW companies, who are major users of GW, we used a slightly modified version of a DW model developed by RID (the Rijksinstituut voor Drinkwatervoorziening, or State Institute for Drinking-Water Supply). We called this model RIDDWM (RID drinking-water model).

14.2. RID DRINKING WATER MODEL

RIDDWM was developed by RID in 1979. It was based on a more detailed region-based model that RID was using at the time. Its original purpose was to identify optimal choices of DW production projects and transportation routes based on data that RID developed for planning purposes.

Each province contains several DW companies, but RIDDWM simplifies reality by assuming a composite DW company in each province. Similarly, each province is assumed to contain only one large equivalent GW source, located an average of 10 km away from the DW company. If not enough GW is available within a province, then, depending on the costs, the deficit is made up with appropriately treated SW and/or DW transported from a neighboring province. The SW comes from reservoirs and treatment plants, which are called SW projects. As part of its input, RIDDWM receives a menu of SW projects--some are existing facilities, some are expansions to existing facilities, and some are new facilities--each with a specific maximum capacity and an annualized cost per cubic meter withdrawn.

RIDDWM is formulated mathematically as a linear program. It determines the least costly way of producing DW subject to three constraints: (1) no more GW is extracted from any provincial source than is available under its quota; (2) no more SW is extracted from any SW project than its maximum capacity; and (3) the demand for DW in each province is met exactly. Based on a network of pipes for transporting water, a menu of SW projects and their location, estimates of costs for every component, and DW demands for each province, the model in effect finds the least costly mix of GW and SW for meeting DW demands. In the process, it determines which SW projects should be built or expanded and how much SW will be extracted from each one, as well as the average, marginal, and total costs of supplying DW in each province.²

Table 14.1 lists the menu of 20 SW projects that RID provided to PAWN, along with their associated costs and maximum expansion capacities. Only six of these projects existed in 1977. The table indicates this by showing their 1977 capacity.

Table 14.1

SW PROJECTS, 1977 AND MAXIMUM CAPACITIES, AND UNIT COSTS

Acro- nym	Name of SW Project	Capacity (mcm/yr)		Unit Cost
		1977	Max.	(Dfl/m ³)
SLT	Spaarbekken Lettelbert		50	.70
STW	Spaarbekken Twente		57	.70
SMW	Spaarbekken Maas/Waal		100	.70
SYS	Spaarbekken IJsselmeer		500	.70
SZF	Spaarbekken Zuid-Flevoland		90	.70
SBB	Spaarbekken Biesbosch(a)	160	507	.60
SPH	Spaarbekken Philipsland		150	.70
SMA	Spaarbekken Markiezaat		200	.70
SBR	Spaarbekken Braakman	11	16	.70
SIB	Spaarbekken Itteren/Borgharen		60	.70
GHP	Grindgat Heel/Panheel		50	.60
DNH	Duininfiltratie Noord-Holland	104	150	.65
DZH	Duininfiltratie Zuid-Holland	70	110	.65
OGI	Oevergrondwater Lek		50	.35
OGM	Oeverinfiltratie Maas		50	.40
OGR	Oevergrondwater Roosteren		25	.35
PLW	Plassenwaterleiding Amsterdam	30	60	.65
IVE	Infiltratie Veluwe		500	.65
IGH	Infiltratie Groote Heide		20	.45
OPA	Oppervlaktewater Andijk	20	20	.70

SOURCE: RID.

NOTES: Unit costs are in 1977 guilders, and include capital replacement of the SW project, energy costs, and specific adjustments for particular SW projects; unit transport costs are not included. Acronyms for the SW projects are keyed to Fig. 14.1. Spaarbekken means "reservoir."

(a) Includes 7 mcm of Dordrecht reservoir capacity.

Figure 14.1 shows the RIDDWM network, with a composite DW company and GW source in each of the 12 provinces.³ (The province names and their abbreviations, which are used often in the study, are shown in Table 14.2.) The figure also shows their connections to the menu of 20 SW projects and 66 links or pipe segments for transporting water provided by RID. There are 38 pipes for transporting SW to DW companies, 12 for transporting GW to DW companies, and 16 for transporting DW among DW companies (the flow along these 16 pipes can be in either direction).

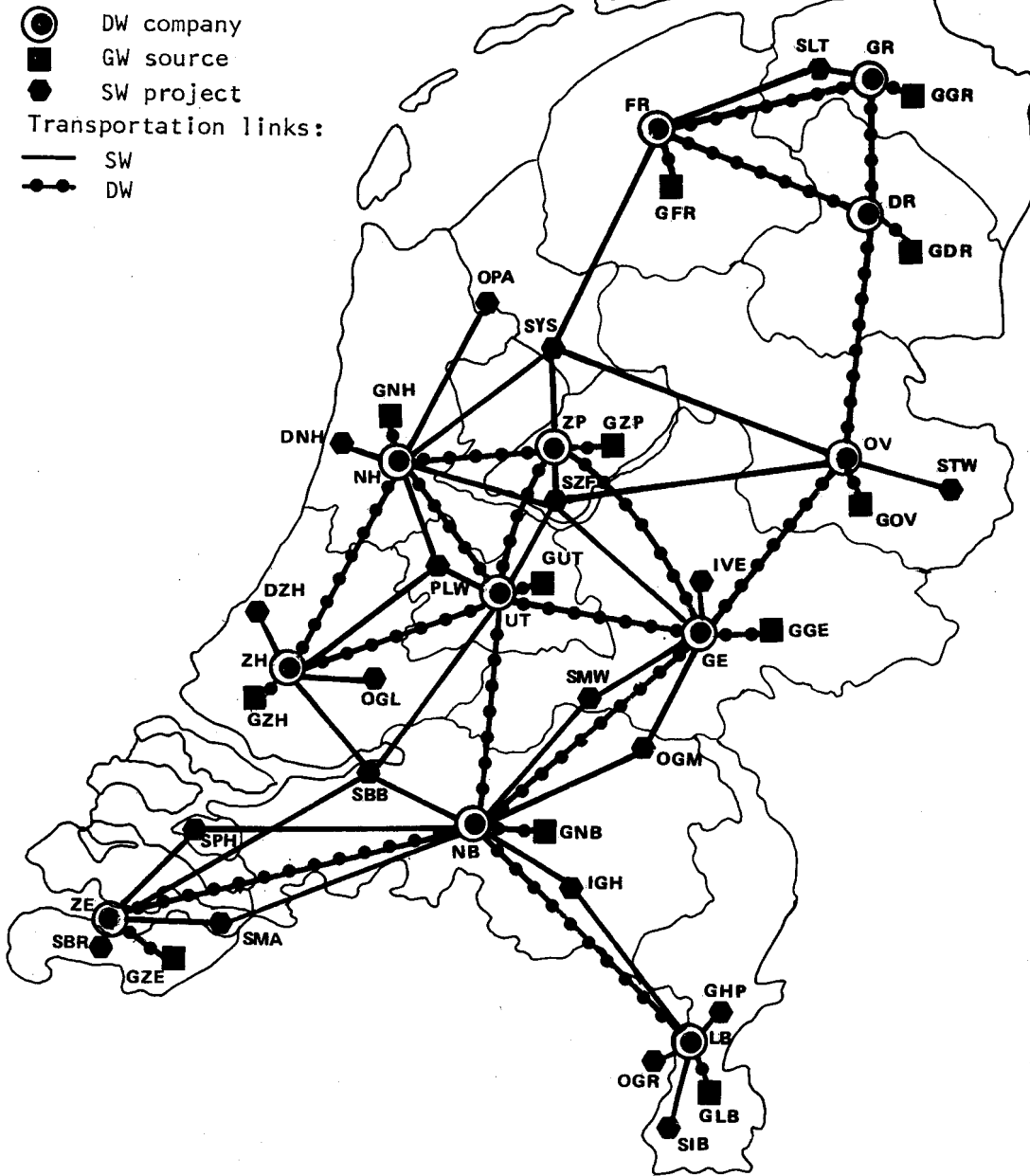

Fig. 14.1--RIDDWM network

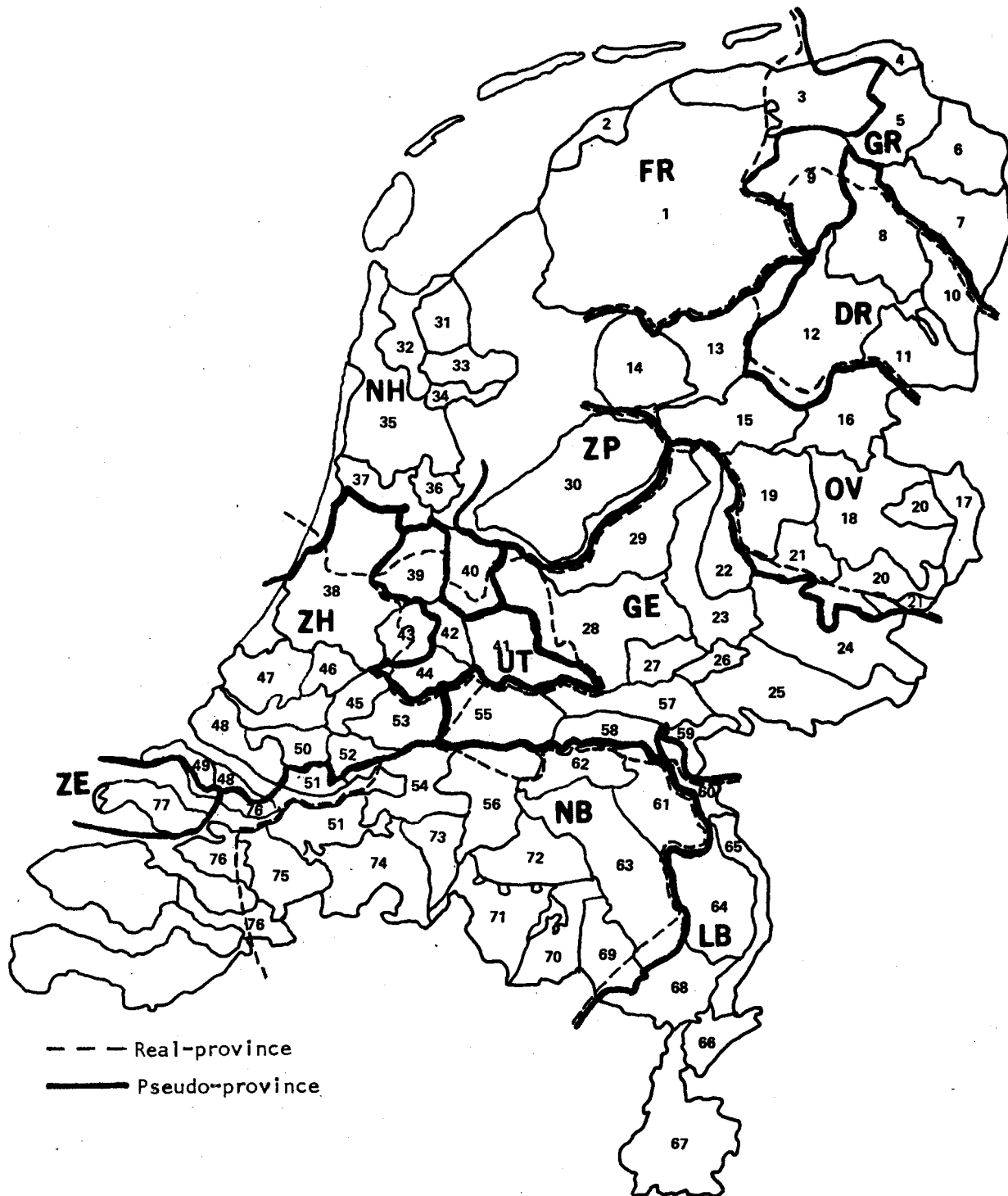

Fig. 14.2--Map showing real and pseudo-provinces

Table 14.2

PROVINCE NAMES AND ABBREVIATIONS

Name	Abbr
Groningen	GR
Friesland	FR
Drenthe	DR
Overijssel	OV
Gelderland	GE
Utrecht	UT
Zuid-IJsselmeerpolders(a)	ZP
Noord-Holland	NH
Zuid-Holland	ZH
Zeeland	ZE
Noord-Brabant	NB
Limburg	LB

(a) Special "province" created by PAWN.

To make RIDDWM consistent with the rest of PAWN, which conducted its analysis in terms of PAWN districts, we made one minor modification to RID's version of the model: We transformed the real Dutch provinces into pseudo-provinces; these are aggregates of districts that approximate the real provinces. This transformation allowed us to avoid splitting up the many districts that straddled provincial boundaries. But it required us to adjust the data by province both for DW demands and for the amount of GW extractable from the provincial source under the quota, but not for unit production or transportation costs. (See Vol. VII for additional details on RIDDWM.) Figure 14.2 shows the correspondence between real and pseudo-provinces.

NOTES

1. Further, reliance on SW sources makes DW companies vulnerable to intense pollution episodes, such as sudden increases in toxic substances resulting from either a shipping accident or an inadvertent but excessive industrial discharge.
2. It should be noted that because RIDDWM neglects local distribution costs and administrative overhead, the DW prices it calculates, based on marginal or average costs, are not fully comparable to real-world DW prices. As a result, the model gives better estimates of price changes than absolute prices.
3. To be consistent with other PAWN models, we treated the Zuid-IJsselmeerpolders as a separate "province," rather than combining them with one of the real provinces, as was done in RID's version of the model.

Chapter 15

INDUSTRY

15.1. INTRODUCTION

Although industrial firms extract appreciably less than do drinking-water (DW) companies, they are major users of groundwater (GW). Many firms extract GW directly from their own wells, and most use DW, much of which is made from GW.

In the future, the industrial demand for GW is expected to grow along with the economy, as is the GW demand of DW companies and agriculture. This increased competition for limited supplies of GW will probably mean either that less GW will be available for industrial firms or that they will have to pay more for it and for the DW they consume. (If DW companies are allowed less GW or if they produce more DW from the same amount of GW, the resulting DW will be more expensive because it will contain more SW, and SW costs more to process into DW than GW does.)

In PAWN, we examined several price and regulation tactics to conserve GW, or to allocate it more efficiently. For example, we considered imposing a charge (tax) of 0.20 Dfl/m³ on GW extractions by industry; this is the maximum charge being considered by the Dutch Parliament in a proposed GW management law. And, as a regulatory tactic, we investigated imposing quotas to limit the amount of GW that could be extracted in each district.

The PAWN tactics will affect the water use of industrial firms. When water becomes more expensive or less available, firms will probably modify their production processes or otherwise change business practices in order to consume less water. Such changes will usually cause an increase in the firms' costs, part or all of which may be passed on to customers in the form of increased prices. To investigate the effect of price and regulation tactics on industrial firms' water demands and production costs, PAWN developed and used the industry response simulation model (IRSM), summarized below and fully described in Vol. XX. (Because systematic data were lacking, we could not model changes in the quality of firms' intake water or of price and regulation tactics governing the quality of their water discharges.)

15.2. INDUSTRY RESPONSE SIMULATION MODEL

Industrial firms use GW for cooling and in various production processes.¹ If firms wish to reduce their withdrawal of GW, they have several general options. For cooling, they can recirculate the GW they currently use or they can replace it by either purchasing DW or running a pipe to the nearest source of SW. For process use, they can switch to either DW or SW, or in some instances they can reuse "spent"

cooling water as process water. Of course, for both their cooling and their process use of GW, firms also have the option of simply paying any GW charge--and incurring the resultant cost increase--without reducing GW extractions.²

When GW becomes more expensive or less available, industrial firms must choose a response. An industrial response, as we define it, is a combination of an option for cooling water with an option for process water. When cooling water is unsuitable for reuse as process water, we consider 12 alternative responses; each option for cooling water (pay the GW charge and continue to use GW, switch to SW, switch to DW, and recirculation) can be paired with each of the options for process water (pay the GW charge and continue to use GW, switch to SW, and switch to DW). Where cooling water can be reused as process water but the cooling demand is less than the process demand, there are three alternative responses, corresponding to the three options for process water just mentioned. When cooling water can be reused as process water and the cooling water demand is larger than the process water demand, we consider 12 more alternative responses; each of the three options for process water can be paired with each of the four options for cooling water, the latter supplementing the process water to meet the cooling demand. (Note that we distinguish the last 12 responses from the first 12 because they conserve different amounts of GW.) Altogether, there are 27 alternative responses.

In practice, however, not every alternative is available to every firm or industry. For example, it is illegal for firms in the food-processing industry to use SW because its quality is too low. And, of course, firms for which cooling water is unsuitable for process use cannot employ any of the 15 responses that reuse cooling water as process water.

IRSM simulates the behavior of industrial firms as they respond to a charge on GW extractions or an increase in the price of DW. In determining behavior, the model assumes that each firm will choose the least costly of its available alternatives.

IRSM incorporates the 27 alternative responses described above. For each alternative, IRSM contains a cost-estimating relationship (CER) that allows the model to calculate the alternative's cost for each firm from data on the firm's characteristics.

As input, IRSM receives a dataset containing information on about 1100 firms. For each firm, the dataset contains the firm's total GW extraction in 1976, the proportion used for cooling and the proportion used for process, the price currently paid for DW, and the distance to the nearest SW source. The dataset also indicates for individual firms which alternative responses are not available. As a separate input, IRSM receives industrial production growth rates, by industrial sector, for the period from 1976 to the year being analyzed. These rates are used to increase, correspondingly, the firms' basic GW extractions--those before the application of tactics--from the 1976 values in the dataset.

Given the GW charge to be imposed in each PAWN district, along with any increase in the DW price in each pseudo-province (which might affect the attractiveness of DW as a substitute for GW), IRSM evaluates the cost of every available alternative for each firm and then selects the least costly alternative as the firm's response. After choosing a response for each firm, IRSM produces a report showing the associated changes in both the firm's costs and its use of GW, DW, and SW, summarized by industry, district, and pseudo-province.

It should be noted that IRSM neglects certain DW costs. Specifically, IRSM estimates DW costs for only the extra DW that industry withdraws to replace GW, and not for the DW currently being used. Many of the water management policies considered, however, induce changes in the price of all DW. In those cases, we revise the IRSM cost estimates to reflect the full DW costs to firms. To do this, we multiply the amount of DW currently being used (documented in Vol. IV) by the change in the DW price, and add the result to the IRSM cost estimates.

IRSM is quite general. It consists essentially of a cost-minimizing algorithm and the set of generalized CERs. All detailed, firm-specific information is contained in the input dataset. That information was obtained primarily from the provincial governments and from many interviews with representatives of industrial associations and individual firms that are large users of water.

One version of IRSM was constructed before all the interviews had taken place. This became the "standard version" of IRSM, the one used in essentially all the analyses. After completing the interviews, we developed a "modified version" of IRSM, but time did not permit us to use it except for a few comparison runs. The modified version makes fewer inexpensive responses available to many firms. Thus, for a specified level of GW charge, it generally estimates smaller reductions in GW use and higher industrial costs than does the standard version.

We believe IRSM is reasonably accurate for GW charges of up to about 1.00 Dfl/m³, which is about an average price for DW. GW charges above that level probably would induce changes in technology and production that are not foreseen by and accounted for in IRSM.

15.3. USING IRSM FOR IMPACT ASSESSMENT

Although IRSM was developed to investigate the effect of GW extraction charges on industry, it was often used to examine the effect of imposing quotas that restricted GW extractions. To use IRSM for this purpose, we had to represent the quota in each district by an appropriate charge and to enter that charge into IRSM: If a sufficiently high charge is imposed on the GW extractions in a district, the firms in the district collectively will reduce their GW withdrawal to the desired amount. The problem with this approach is how to determine the appropriate GW charge, particularly because the industrial firms in the district will be competing not only with each other but with farmers and DW companies for the GW available under the quota.

To resolve this problem, we used another PAWN model, the response design model (RESDM), which is discussed in some detail in Chap. 25. Briefly, RESDM is made up from a model for DW companies (RIDDM, described in Chap. 14) that has one composite DW company in each pseudo-province, together with a simplified version of IRSM that aggregates the industrial firms and responses within each district. Given the GW extraction quotas and the GW charges (if any) to be imposed, RESDM determines the most economically efficient allocation of the available GW among industrial firms and DW companies.³ In doing so, it determines GW shadow prices for each district and optimal DW prices for each pseudo-province.

The GW shadow price for a district is the (common) value of one additional cubic meter of GW to each user. It is also the price each user should be willing to pay for that unit of GW. If all users are charged this price for each unit of GW, they should demand in total exactly the amount of GW available under the quota specified for the district.

Knowing the shadow-price equivalent to each district quota, we can now investigate the effect of quotas with IRSM. We take the RESDM-determined shadow price (representing the district quota) and enter it into IRSM as the GW charge for each district, and we enter the RESDM-determined DW price less the current GW price (from the IRSM input dataset) into IRSM as the increase in the DW price for each pseudo-province. IRSM then selects the least costly response for each firm and produces a report summarizing changes in the industrial firm's costs and its use of GW, DW, and SW, as described above. (In some cases we want to impose actual GW charges in addition to quotas. To do this, we add the imposed charge to the GW shadow price representing the quota and enter the result into IRSM as the GW charge for each district.)

Note that when we enter the district-by-district GW shadow prices into IRSM as GW charges, IRSM automatically includes them in its cost calculations. However, the shadow prices should not be counted as real costs to the firms unless one assumes that the government will actually impose the shadow prices as a means of allocating GW among industrial firms and DW companies. PAWN assumes instead that such allocation will be done by quotas (or licenses) issued by the government. Thus, we manually revise the cost estimates from IRSM to remove any shadow prices. IRSM separately reports the costs resulting from whatever we entered as the GW charge, which includes the shadow prices, the other response costs, and the total costs. We ignore the costs that IRSM reports as resulting from GW charges and recalculate them, exclusive of the shadow price, by taking IRSM's estimate of the amount of GW used by each firm in the district and multiplying it by the actual GW charge imposed in the district. We add this result to the other response costs to get a revised estimate of total costs.⁴ Note that if there is any increase in DW prices, the other response costs should also be revised, as described earlier, to reflect the effect of the increase on the cost of GW currently used by firms.

When IRSM is run with GW shadow prices and DW price increases from RESDM, its results correspond not to the current situation in the Netherlands but to a situation where water is allocated efficiently to its most highly valued uses.⁵ The GW withdrawals for each firm that IRSM calculates from the GW shadow prices can be considered quotas for the individual firms--quotas that the government could use if it decided to allocate GW among the industrial firms in an economically efficient manner.⁶

NOTES

1. Some industrial firms also use small amounts of GW for drinking and sanitary uses. Because we have little information on these uses, we ignore them in our calculations.
2. In theory, firms may reduce their levels of production or shut down entirely as a means of conserving GW. Because such actions are generally more costly than other options and are much more difficult to analyze, we have not considered them in PAWN.
3. RESDM did not consider farmers' demands for GW (used to sprinkle crops) in its allocation process. Instead, the farmers' demands were dealt with by specifying whether they had a priority on GW extractions. In most cases, we allowed industrial firms and DW companies to take as much GW as they wished, up to the quota, with the remainder available for farmers. In other cases, we let the farmers in a district take the average amount they would need, up to the quota, and industrial firms and DW companies could take only what was left. In these latter cases, we introduced the farmers' extractions as a reduction in the quotas given to RESDM.
4. Our estimates of industrial costs may be somewhat understated because they do not include GW prices or administrative costs for an allocating agency.
5. In the current situation, there is no district-, provincial-, or national-level optimization of GW use, either among firms or between firms and DW companies. IRSM was originally designed to analyze the effect of GW charges in the current situation. It simulates the cost-minimizing behavior of firms when their GW usage costs are increased by the amount of the charge, without requiring any inputs from RESDM. In PAWN, IRSM was seldom used in this mode. The most important instance, discussed in detail in Vol. VIII, was an investigation of the effect of imposing a nationwide charge on industrial extractions of GW, which concluded that "given the current situation, we estimate that a 0.20 Dfl/m³ charge on industrial extractions of GW, as has been proposed for the Netherlands, would reduce industrial use of GW

by about 100 mcm/yr, and would increase industrial costs by about 50 Dflm/yr."

6. This should be done with care because IRSM's CERs represent averages and thus may not be exact for specific firms. Estimates from IRSM can, of course, be improved by obtaining and incorporating more and better data on individual firms.

Chapter 16

ENVIRONMENT

16.1. INTRODUCTION

Water is vital to the state of the environment. The quality of water in a lake or stream largely determines what species of plant and animal life can thrive there, and it also strongly influences the composition of the terrestrial plant community, on which animals depend for food and shelter.

Water quality is also important to humans, of course. Drinking water, for example, must be free of toxic substances, and must meet certain standards of salinity, odor, and taste. Some industrial processes require water to meet rigorous quality standards, especially water used in food processing and in certain chemical processes. Fisheries depend on the fish being healthy, abundant, and free of accumulated pollutants that would make the fish unsalable. Waterborne recreation is encouraged by clean, clear water, and discouraged where the water is turbid or choked with aquatic weeds; polluted water can be hazardous to health.

In PAWN we dealt with the environmental aspects of water management by imposing water quality standards that reflect environmental concerns. It is simply too difficult to treat the environment more directly. We considered environmental concerns by calculating pollutant concentrations and then comparing them with standards motivated by those concerns. In a subsequent section, we shall define reference standards to serve as the basis of most of the analysis, and, for some pollutants, some alternative standards to use in sensitivity analysis.

There are two parts to our approach to modeling water quality. The first concerns the transport of pollutants in the PAWN network. This has been implemented in the distribution model (DM) (and, as discussed in a later chapter, in the managerial strategy design model as well). The quantities calculated are the concentration of each pollutant at each node in each time period, and the amount of each pollutant transported to and from each node, especially those nodes representing lakes.

The second part of our approach considers eutrophication in lakes. By eutrophication we mean a heavy growth of algae, called an algae bloom, which occurs in still waters but not in flowing water. Three methodology components are used in our study of eutrophication: a nutrient model, an algae bloom model, and a dissolved oxygen model. The quantities calculated include the size and species composition of the algae bloom in a lake and the oxygen depletion due to the bloom.

Changing groundwater levels may affect the environment, but because groundwater levels are calculated in the agriculture models, we do not discuss this issue in the present chapter.

16.2. WATER QUALITY ISSUES AND STANDARDS

Most water pollutants (in addition to salt and thermal pollution) fall into one of three categories: oxygen-consuming substances, substances that contribute to eutrophication, and toxic substances.

After consultation with numerous Dutch national and regional organizations, we selected eight water quality parameters for consideration in PAWN. In the DM we model the water transport of salt (represented by chloride), heat, and one water quality parameter from each of the above-named categories: biochemical oxygen demand, an index of oxygen-consuming substances; phosphate, a necessary nutrient in many eutrophication processes; and chromium, a heavy metal with toxic properties. Our eutrophication methodology also considers phosphate, as well as nitrogen, chlorophyll (a measure of the algae population), and dissolved oxygen. Other water quality parameters were excluded either because of lack of data or lack of a perceived problem. Among the excluded parameters were pesticides, bacteria, radioactivity, and accidental pollution (e.g., oil spills). (For details about our choice of water quality parameters and standards, see Vol. VI for eutrophication, Vol. XV for heat, and Vol. VA for the remainder.)

16.2.1. Salt (Chloride) Pollution

Saline water may reduce the quality or quantity of agricultural yields. It may corrode industrial equipment and household furnishings. At high concentrations, total dissolved solids are objectionable in drinking water because of possible physiological effects (e.g., high blood pressure), unpalatable taste, and unappealing appearance and odor. In environmental terms, salt intrusion into formerly nonsaline surface waters can damage the existing freshwater flora and fauna. However, most of the intrusion currently occurs in locations already "lost" from an environmental perspective (e.g., the Rotterdamse Waterweg and the Noordzeekanaal). Salinity from the Rijn may have more long-term and more widespread impacts.

It is interesting that in some areas a high salinity is considered desirable. Brackish-water ecological communities, which environmentalists are anxious to preserve, have developed along the shores of the Volkerak and the Oosterschelde. These areas are threatened by plans to dam off the Volkerak and the eastern end of the Oosterschelde, and convert them from the present tidal basins to a freshwater lake (the Zoommeer).

In PAWN we use the chloride concentration as a measure of salinity. There is reasonably general agreement that the chloride concentration should not exceed 200 mg/l [16.1], and we have adopted this limit as our reference standard. (The U.S. Environmental Protection Agency (EPA) criterion for a reasonable maximum level to protect consumers' drinking water is 250 mg/l.) However, RIN (Rijksinstituut voor Natuurbeheer, the State Institute for Nature Management), has

suggested location-specific chloride standards designed to preserve environmental values, and we have considered these in some of our investigations.

16.2.2. Thermal Pollution

Thermal pollution occurs when heat is discharged into a waterway. This increases the temperature of the water above the point it would have reached in the absence of heat discharges, the so-called natural temperature. The measure of thermal pollution used by the Dutch is the excess temperature, which is the rise in temperature of a water body above its natural temperature.

There are several reasons to be concerned about thermal pollution. The first reason is that an increase in temperature will decrease the amount of oxygen available in the water. It does so by reducing the solubility of oxygen, and by accelerating the decay of organic matter, a process that uses oxygen. (See Sec. 16.2.4.)

A second reason concerns the combined effects of increased temperature and toxic materials on fish. The available data suggest that organisms subjected to stress from toxic materials are less tolerant to temperature extremes. Because Rijn water, to take one example, contains significant concentrations of toxic materials, this consideration is relevant to the Netherlands.

The third reason is that temperature strongly influences the metabolism, growth rate, and reproduction of aquatic organisms. The larvae of certain species may be especially sensitive to temperature changes. The changes we are considering are well within the tolerance of species well adapted to an environment; but such changes can cause just enough additional mortality among the larvae of a marginal species to eliminate it from a habitat.

In PAWN, at the suggestion of the RWS, we adopted as our reference assumption a thermal standard of 3 deg C (degrees Celsius (Centigrade)) excess temperature in all waterways. Current Dutch law applies this standard only to the main rivers, and applies a standard of approximately 7 deg C to canals. In sensitivity analysis, we also investigated the effect of the current law, which is a less stringent standard. (Vol. XV describes the process of approximating the complex laws with these standards.)

16.2.3. Heavy Metal (Chromium) Pollution

Chromium is not an especially toxic material, and it is not present in Dutch waters at dangerous levels. However, other heavy metals such as mercury are quite toxic. After discussions with the Dutch, we chose to model chromium as a proxy for the behavior of heavy metals because chromium has been more extensively measured than other heavy metals. A provisional standard of 50 µg/l is suggested for

chromium in Ref. 16.1 (by $\mu\text{g}/\text{l}$ we mean micrograms per liter), which we adopted as our reference standard for PAWN. And a target standard of $10 \mu\text{g}/\text{l}$ is suggested, which we considered in sensitivity analysis. However, RIN suggested that we consider instead a standard of zero, that is, complete elimination of chromium from Dutch waters.

The zero standard reflects the opinion that regardless of how low the concentration of chromium (or of heavy metals generally) becomes, there is still some benefit to be realized by reducing it further. One reason for this view is that chromium is concentrated in aquatic organisms. There are reports, for example, that chromium is concentrated by factors of 1600 in benthic algae, 2300 in phytoplankton, 1900 in zooplankton, 440 in the soft parts of mollusks, and 70 in fish muscle. With such degrees of concentration, even low ambient chromium levels could result in dangerous tissue levels in the prey of such higher animals as birds, which depend on the aquatic organisms for food. Additionally, PAWN uses chromium as a proxy for all heavy metals, many of which are considerably more toxic than chromium. It could well be wise to limit the concentrations of these other substances to the greatest degree possible.

16.2.4. Biochemical Oxygen Demand (BOD)

Water often contains oxygen-consuming substances, which are generally not toxic but can cause environmental problems through oxygen depletion. Some of these substances are inorganic chemicals that consume oxygen as part of chemical reactions that occur naturally in the water. (Various iron and nitrogen compounds are common examples.) Other oxygen-consuming substances are any kind of dead organic matter, such as dead algae or partially treated human waste. These organic substances are digested by bacteria and converted to inorganic molecules, in a process called mineralization, during which oxygen is consumed. If the oxygen level in the water is sufficiently depleted by these processes, fish may die, and bad odor and appearance may result.

There are two common indexes for measuring the degree of pollution of this type. One is simply the amount of oxygen dissolved in the water. But the shortcoming of this index is that it measures only the present state of the water, and not its potential for further oxygen depletion. The other index attempts to remedy this shortcoming. It shows the amount of oxygen-consuming substances, but expressed in terms of the amount of oxygen they may potentially consume. It is determined by measuring the amount of oxygen consumed by a polluted water sample in a standard amount of time (usually five days) at a standard temperature (usually 20 deg C). This index is given the name biochemical oxygen demand (BOD).

The BOD standard is established on the basis of the risk of oxygen depletion. Fish embryonic and larval stages are especially vulnerable to reduced oxygen concentrations because their ability to extract oxygen from the water is not fully developed and they cannot move away from the adverse condition. Although many species can develop at

oxygen concentrations as low as 2.5 to 3 mg/l, some species suffer partial mortality or at least retarded development at oxygen concentrations even as high as 5 or 6 mg/l.

At water temperatures encountered in the Netherlands, it is rare that the amount of oxygen in the water will be less than 8 to 10 mg/l. A BOD concentration of 3 mg/l could reduce the oxygen concentration to no lower than 5 to 7 mg/l, even with no reaeration. A higher BOD concentration of 5 mg/l would still leave the oxygen concentration above 3 to 5 mg/l. There is general agreement that a standard of 5 mg/l BOD is about right, and from the above discussion it seems unwise to adopt a higher limit. In Ref. 16.1, two standards are proposed for most water quality parameters, a provisional limit and a target value. The provisional limit, currently being enforced, is the more lenient of the two. We use the provisional limit of 5 mg/l BOD as our reference standard, and the more stringent target value, 3 mg/l BOD, for some sensitivity analyses.

16.2.5. Phosphate

The main reason for controlling the phosphate concentration is to avoid eutrophication, by which we mean algae blooms of excessive size. A minor additional reason is to avoid interference with coagulation in water treatment plants. Accordingly, Ref. 16.1 gives water quality standards for phosphate. In PAWN, our reference phosphate standard is the provisional limit of 0.3 mg/l, and for some sensitivity analyses we adopt the target value of 0.05 mg/l.

16.2.6. Nitrogen

The major reason for limiting nitrogen concentrations is that nitrogen is a nutrient required by algae, but there are motives other than avoiding algae blooms for limiting the amount of nitrogen in the water in various forms. Ammonia, for example, can be toxic to fish in its un-ionized form. Another form, nitrite, should not be permitted in drinking water at concentrations above about 10 mg/l because its reactions with hemoglobin can reduce oxygen transport capability.

We consider Kjeldahl-nitrogen in the DM. This is the sum of most of the chemically active forms of nitrogen, and it is the nitrogen-related quantity on which we have the greatest amount of data. Reference 16.1 gives a provisional limit on the Kjeldahl-nitrogen level of 3 mg/l and a target value of 1 mg/l, which we adopt in PAWN for our reference and sensitivity analyses of nitrogen standards.

16.2.7. Chlorophyll (Algae)

The amount of algae is usually measured in terms of the chlorophyll concentration, because instruments are available that make such measurements simple. Imposing standards for chlorophyll is intended to

prevent the problems of excessive algae growth. One problem is that when algae die, they become a BOD load¹ and can cause the BOD problems discussed above. Also, some algae, particularly blue-greens, have a toxic effect on domestic animals. The growth of blue-green algae also results in turbid or scum-covered water. Finally, algae can interfere with water treatment by clogging filters and intakes. RIZA (Rijksinstituut voor Zuivering van Afvalwater, the State Institute for Wastewater Treatment) has therefore suggested two chlorophyll standards, a lenient standard (100 µg/l) and a strict one (50 µg/l).

16.2.8. Dissolved Oxygen

Earlier we discussed the problems associated with oxygen depletion due to BOD, and imposed standards on BOD as a result. But it is also possible to impose standards directly on the dissolved oxygen level. Reference 16.1 proposes a provisional range (rather than a single limit) for dissolved oxygen from 50 to 150 percent of saturation, and a target range from 80 to 120 percent of saturation. The ranges are expressed in terms of percent of saturation because the amount of oxygen present at saturation varies strongly with temperature, and hence even 100 percent oxygen-saturated water (evidently the ideal) would sometimes violate a standard expressed in terms of amounts. In addition, the percent saturation is a good measure of the ability of aquatic life to extract oxygen from the water.

16.3. POLLUTANT TRANSPORT IN THE NETWORK

16.3.1. Modeling Approach

The pollutants we consider in the DM are salt (represented by chloride), heat, chromium, BOD, and phosphate.² Our approach to modeling pollutant transport through waterways is very simple. We assume that pollutants are well mixed throughout the cross-section of a waterway, that they move downstream with the same velocity as the water without longitudinal diffusion, and that in each time-step the water-flows persist long enough that no memory persists of the flows or pollutant concentrations from the previous period. In lakes and reservoirs we assume that pollutants are mixed instantaneously, and that the concentration may change continuously throughout the time-step. Throughout the network, we assume that each pollutant either is conservative or decays according to first-order kinetic laws--that is, undergoes exponential decay. The rate of decay is unaffected by the presence of other pollutants, but it can depend on water levels or flows.

These assumptions give rise to a model that, for each pollutant separately, relates its concentrations at each node in the water management network (of the DM) to (1) the discharges of that pollutant into the nodes, (2) the flows of water in the links and into and out of nodes with storage, and (3) the pollutant's decay

rates in links and in nodes with storage. In this model, the flows and decay rates together define coefficients in a set of linear equations that relate the pollutant's discharges to its concentrations at the nodes. That is, once flows and decay rates are known, the pollutant's concentrations can be calculated from its discharges by solving a set of simultaneous linear equations.

For each pollutant, our objective is to calculate concentrations which can then be compared with the standards. To do so requires the other three elements of the model: water-flows, pollutant discharges, and decay rates. Water-flows are calculated by the DM. Pollutant discharges are determined by the scenario, as defined in a subsequent chapter. The decay rates for each pollutant are determined as described in the following sections.

16.3.2. Determination of Pollutant Decay Rates

To make the model operational, we need decay rates for each pollutant. The decay rates are intended to represent various mechanisms by which different pollutants are lost from the water over time. For example, heat undergoes exchanges with the air; bacteria digest BOD, converting it into nitrogen, phosphorus, etc., and consuming oxygen; and chromium and phosphorus are adsorbed on small particles that sink to the bottom.

For chromium, BOD, and phosphate, we determine the decay rates by a calibration process that takes the pollutant discharge inventory and observed concentrations for a particular year, and then adjusts the decay rates so as to obtain the best match between the observed and calculated concentrations, given decade-by-decade water-flows in the network from that year. We chose 1976 as the calibration year primarily because it was the driest year on which we had data, and in PAWN we were most concerned with dry years; also, it was the most recent year of the few for which we had data. (Because 1976 had higher water temperature and more sunlight than most years, factors to which biochemical reactions are generally sensitive, the decay rates we obtained might be somewhat larger than those appropriate for cooler years.)

For heat, the decay process is well understood, so the decay rates could be obtained directly from the literature. Finally, salt is generally recognized to be conservative, i.e., to have a decay rate of zero, so this was the value we used. (For a detailed discussion of the calculation of pollutant concentrations, see Vol. XI.)

Decay Rates for Chromium, BOD, and Phosphate. We estimated decay rates for chromium, BOD, and phosphate based on pollutant discharges and concentrations observed in 1976. Data on discharges of these pollutants into nodes and districts were compiled for PAWN by a team from RIZA, DHL, and WW (Directie Waterhuishouding en Waterbeweging, the Directorate for Water Management and Water Movement, within the RWS) from the new IMP survey completed in November 1978 and from various annual reports and water quality plans of regional water quality

boards.[16.2] Data on pollutant concentrations come from many sources. For state waters, we used concentrations reported in Ref. 16.3, consisting of approximately 260,000 observations at 193 locations covering the years 1970 through mid-1977. For regional waters, we used data from waterboards, water quality control boards, etc., consisting of approximately 20,000 observations at approximately 150 locations covering the years 1975 through 1977. From these observations, we obtained pollutant concentrations in border-crossing rivers, including the Rijn, the Maas, and the smaller rivers Roer, Swalm, Niers, and Overijsselsche Vecht. We also used observed pollutant concentrations in lakes and reservoirs at the beginning of the year as initial conditions. (All these data are presented in Vol. VA.)

To calculate pollutant concentrations at each node during a decade, we needed more than the inputs of pollutant described above. We also needed the coefficients in the linear equations mentioned above. In part, these are defined by the flow in waterways and by water levels in lakes and reservoirs provided by the DM for each decade. But the decay rates in waterways and lakes are also needed.

To estimate the decay rates, we used an iterative process. With trial decay rates, we ran the DM to calculate pollutant concentrations in each decade for the entire year of 1976, and noted systematic differences between the observed and calculated concentrations. Where calculated concentrations in an area were consistently higher than observed concentrations, increases in the decay rates of a few waterways would usually suffice to improve the agreement. We repeated the process of running the simulation, adjusting decay rates, and again running the simulation until no further improvement appeared possible.

Lack of data on pollutant concentrations in district waters prevented us from calibrating district decay rates. Thus, for each pollutant we assumed a single, conservative value for the decay rate in all districts.

Decay Rate for Heat. As mentioned before, our measure for thermal pollution is the excess temperature of the water. In effect, this is the concentration of the pollutant heat. Decay of this pollutant occurs when heat is lost from the water to the air.

The rate at which this occurs in a body of water is proportional to the body's surface area and the excess temperature, according to the exponential decay model used by the Dutch and adopted for use in PAWN. The decay rate, called the heat loss rate, is extremely variable. Depending on wind velocity, surface temperature, relative humidity, and the size and shape of the water body, it can easily vary by an order of magnitude [16.4]. On the advice of our Dutch colleagues, we have adopted a heat loss rate in the middle of the range.³

16.3.3. Additional Calibration for the IJssel Lakes

We found it impossible to reproduce the observed BOD concentrations in the IJssel lakes even using a zero decay rate. This is probably

due to internal loading of the lakes with BOD from algae blooms. We therefore introduced an extra BOD loading in the IJssel lakes of 2 g/m^2 of lake area per day, which we distributed over the year in proportion to the light intensity. We also assumed a BOD decay rate of 10 percent per day, which is consistent with values reported in the literature. These assumptions, which produced a reasonable fit with observed concentrations, imply that BOD concentrations in the IJssel lakes are largely determined by internally produced BOD.

We had similar difficulties in reproducing the observed phosphate concentrations in the lakes, and solved them in much the same way. Phosphate is taken up by growing algae, and some is released to the bulk water when the algae die. In addition, as we shall see in a later section, phosphate can be released from the sediment at the bottom of the lakes.

Because 1976 was warmer than most years, the extra BOD and phosphate loadings determined above may be somewhat higher than those appropriate for cooler years.

16.3.4. Shortcomings of the Calibrated Model

The calibrated model has shortcomings stemming from both the assumptions of the model itself and the quantity and quality of the data. Since the DM network is an aggregated representation of the actual surface water system, calculated concentrations may be averages of concentrations observed at many points. The problem is not severe for major rivers and canals, because each of these is represented by its own sequence of links in the network. An entire "bundle" of smaller waterways, however, may be represented by a single link of the network. If different waterways in the bundle have different pollutant concentrations in reality, the model will never notice.

The model assumptions of steady state in links and complete mixing at nodes may also lead to errors. Some links, especially those representing small waterways, may have very long residence times. Pollutants discharged at one end of such a waterway might not reach the other end for many decades. The model, however, assumes that pollutants pass through links fast enough to come to a steady state by the end of a decade. Similarly, the model assumes that a pollutant entering a lake will mix instantaneously and completely. In a lake the size of the IJsselmeer or the Markermeer, this is patently absurd; pollutant gradients are observed regularly in the IJsselmeer and other lakes. But as long as water-flows and pollutant discharges do not change so rapidly as to set up large, abrupt concentration gradients, these shortcomings are not critical.

The data have shortcomings also. In some districts and at some nodes, we have no observed pollutant concentrations. Chromium, especially, is measured at very few points. And pollutant discharges are given as annual totals, not distributed over the year. (Most of the data are presented and discussed in Vol. XI. The pollutant discharges into nodes are presented in Vol. VA, along with some additional details.)

16.3.5 Calculation of the Excess Temperature Table

Surface water is used for cooling in various industrial processes and in the generation of electricity. In the Netherlands, industrial waste heat discharges generally are small or occur in areas where the effects of those discharges can be neglected in general water management. In contrast to this, in power generation large quantities of water are pumped and large amounts of heat are discharged into surface waters. (As an illustration of the quantities involved, a modern unit of 500 megawatts (MW) discharges 20 m³/s with a heat content of 140 megacalories⁴ per second (Mcal/s) into the surface waters. Such a unit will raise the temperature of its discharge water by 7 deg.) PAWN therefore only considers thermal pollution from power plants.

The DM takes a user-supplied heat discharge at each of the 14 nodes with a power plant and an internally calculated excess temperature at the two nodes where the Rijn and Maas cross the Dutch border, and creates an excess temperature table with 16 rows and columns. The entry in row *i* and column *j* of the table shows the rise in temperature at node *j* resulting from the user-supplied heat discharge at power plant node *i* or, if node *i* represents the Rijn or Maas, resulting from the excess temperature calculated for node *j*.⁵ In the DM, the excess temperatures where the Rijn and Maas cross the border are calculated as functions of the water-flow, using curves presented in Vol. XV, which reflect tentative agreements with the countries upstream of the Netherlands that the excess temperature of the rivers is not to exceed 3 deg C at the Dutch border.

For the user-supplied heat discharge at each power plant node, we do not use the actual heat discharge from the power plant. Rather, we use a reference heat discharge of 1000 Mcal/s at each power plant node. To obtain the excess temperatures created by a heat discharge other than the reference, the row entries in the excess temperature table need only be scaled by the ratio of the new to the reference heat discharge. This scaling, and the final calculation of excess temperatures, is left to the electric power reallocation and cost model, described in a subsequent chapter. Note that the DM must calculate a different excess temperature table for each decade because the flows of water will differ by decade. These tables, one for each decade in the year, are deposited in a dataset for later use by the electric power reallocation and cost model.

16.4. EUTROPHICATION CONTROL IN LAKES

Technically, eutrophication means the aging of lakes or reservoirs. It occurs naturally in all waters, but during the past twenty years the process has been accelerated by man in many Dutch waters. With proper control, eutrophic waters can be productive, offering an enriched ecology, in comparison with noneutrophic waters, and opportunities for recreational and commercial fishing. Without control, eutrophic waters can be objectionable, primarily because of blooms of blue-green algae.

The Dutch strongly associate eutrophication with algae blooms--so much so that the two are considered almost synonymous. The objectionable symptoms of algae blooms include fluctuating oxygen levels, with occasional anaerobic episodes that produce bad odors and taste; toxic effects on domestic animals; aesthetic disturbances such as turbid or scum-covered water; and interference with water treatments, for example, by clogging of filters. In PAWN we wished to analyze the effectiveness of different eutrophication control tactics.

We have developed three methodology components for our study of eutrophication: a nutrient model, an algae bloom model, and a dissolved oxygen model. The nutrient model attempts to estimate the amounts of the nutrients phosphate, nitrogen, and silicon available to algae, given the nutrient loads entering a lake. The algae bloom model predicts the size and species composition of the algae bloom in each week of the year, as well as the total chlorophyll, given the amounts of nutrients and solar energy available to the algae. The dissolved oxygen model predicts the diurnal "sag" in the oxygen level that occurs during the dark nocturnal hours when algae can respire but not synthesize oxygen, and the potential oxygen depletion that could occur if the algae bloom were to collapse suddenly, leaving its biomass to be digested by bacteria. (Biomass is the dry weight of a biological substance; it indicates the amount of material to be digested.)

The planned relations among these models and the DM are illustrated in Fig. 16.1 by arrows. The dashed arrow from the DM to the nutrient model shows that nutrient loads flowing from the network into a lake, which are needed by the nutrient model, can be calculated by the DM. That the arrow is dashed implies that we have not used the DM as our source for these external nutrient loadings, but rather have relied on observations. We are not sufficiently confident of either the DM's predictions of nutrient loads or the nutrient model's abilities to make this linkage. The other dashed arrows also indicate potential linkages among the models that we have not made, for similar reasons. In fact only one such linkage was made, denoted by the single solid arrow showing that the BOD load in a lake due to algae was calculated by the algae bloom model and transferred to the dissolved oxygen model.

16.4.1. The Nutrient Model

Nutrients are important for eutrophication because the amount of algae in a lake or reservoir may be limited by the nutrient content of the water. (Or, of course, other factors may be limiting--see Sec. 16.3.2.) Accordingly, one approach to algae control is nutrient reduction. In fact, this is the most frequently applied approach in all parts of the world, and it is the main component in Dutch plans to control algae blooms.

Some eutrophication control tactics reduce nutrients by diverting or treating inflows of nutrients into the lake. Other tactics

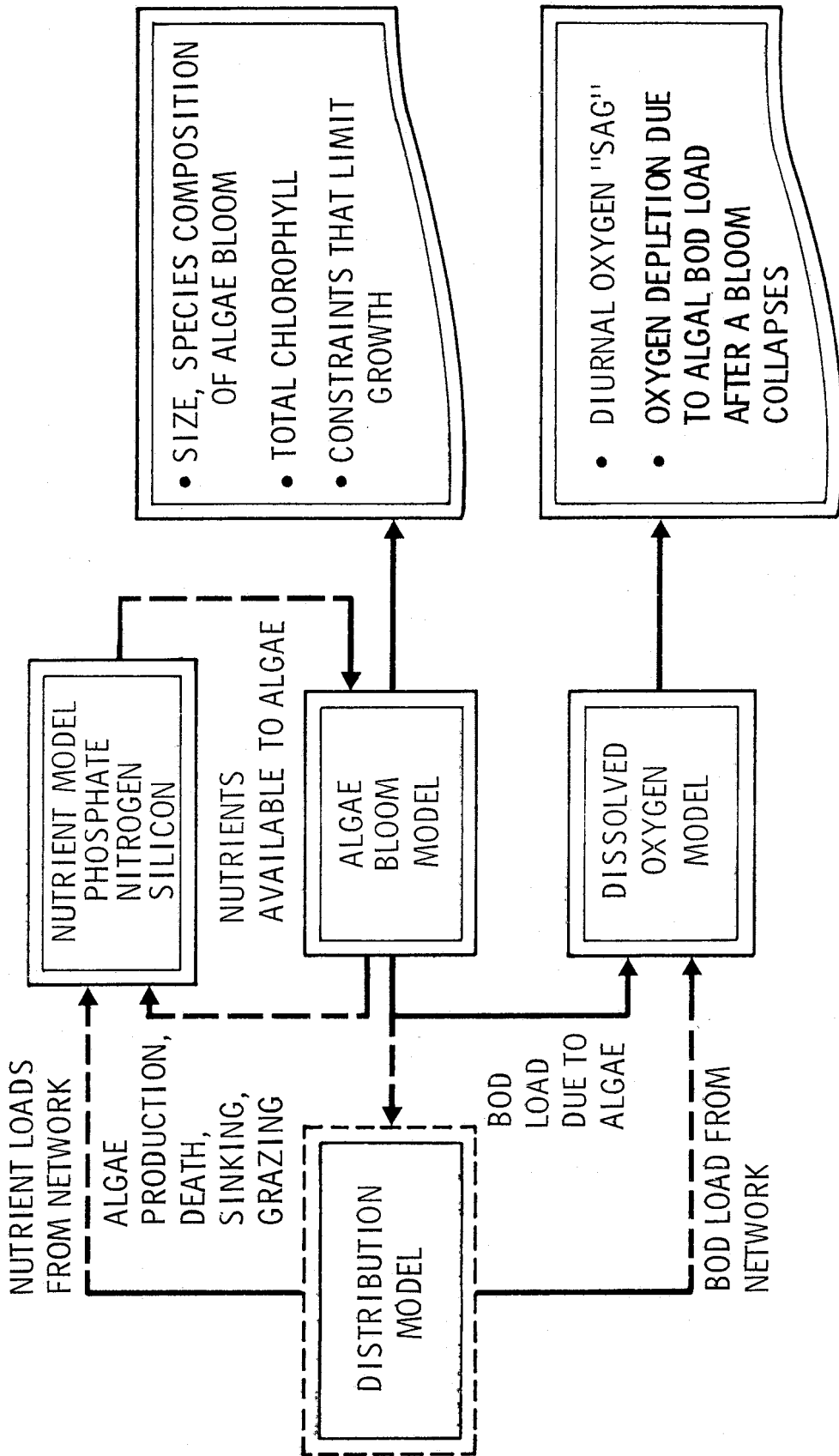

Fig. 16.1--Relations among eutrophication-related methodology components

precipitate nutrients to the lake bottom by the addition of appropriate chemicals, such as iron or aluminum compounds to precipitate phosphate. But the resulting change in the nutrient content of the lake water depends on complex chemical and biological interactions. Accordingly, we have used a nutrient model (called CHARON) that describes the relation between nutrient loads (flows into the lake), biological and chemical factors, and the nutrient concentrations.

The basis of the nutrient model is a model of chemical equilibria developed at Rand between 1960 and 1970 [16.5]. Extensions of the model were made for the WABASIM (Water BASIn Models) project, a combined project of the Delta Service of the RWS and the DHL, with Rand advisors. These extensions involved adding some nonequilibrium features--that is, slow reactions--to the model, and adding a representation of the lake bottom.

The present nutrient model calculates the composition of a column of water 1 m^2 in area and as deep as the lake under investigation, in contact with the air and with the bottom sediments. The important nutrient processes are the inflow and outflow of nutrient-bearing waters, the flux of nutrients from the bottom, the flux of nutrients to and from algae, the flux of nutrients in algae to the bottom, and the flux of phosphate adsorbed on particulate material to the bottom. In addition, there are nitrification and denitrification processes that particularly influence the availability of nitrogen to algae.

We calibrated the nutrient model with data from the Grote Rug drinking-water reservoir near Dordrecht. Grote Rug is the site of a long-term experiment in algae control. Three "rings" of Butyl rubber have been installed in the reservoir, each 46 m in diameter, with inflows and outflows in the same proportion to their volumes as are the total inflows and outflows of the reservoir to the reservoir volume. Thus, in physical and hydrological factors the rings are intended to mimic the reservoir as a whole.

Experiments have been conducted since 1975 to control phosphate by precipitation. Ring 1 is dosed with iron, as is the reservoir as a whole. Ring 2 is dosed with aluminum. Ring 3 is untreated, and hence contains "pure" Rijn water. In each ring and in the reservoir as a whole, extensive measurements are conducted on the weekly amount and species composition of algae and water and bottom chemistry. The data are among the most complete of their kind in the world.

We selected data from ring 2, 1977, for calibration. The processes included in the model were adequate to explain the events in that year quite well. Figure 16.2 illustrates this for phosphate; the match is as good for other nutrients, as well as for nonnutrient quantities such as pH. However, obtaining a reasonable fit of calculations to observations required that the flux of phosphate from the bottom sediments contribute almost one-fourth of the total calculated phosphate load. The remaining three-fourths of the load entered with the inflowing water. Thus, the bottom sediments do not act simply as a sink for phosphate.

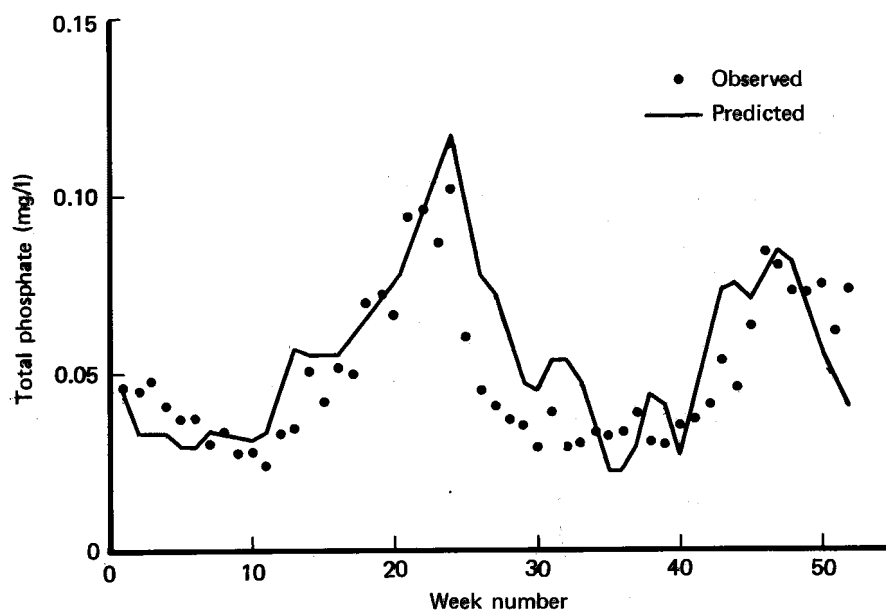

Fig. 16.2--Nutrient model calibration results for phosphate in Grote Rug, ring 2, 1977

We then attempted to validate the model using data from ring 3, 1976. The validation grossly underpredicted the nutrient content of the water after approximately week 30, as Fig. 16.3 shows for phosphate. We concluded that the underprediction was due to a phenomenon we had not included in the model, namely an explosive flux of nutrients from the bottom. Theoretically, this should occur when the top layer of the sediment, which is normally in an oxidized state, becomes reduced. The process is understood only qualitatively, and hence cannot be included in the model yet.

We are therefore convinced that nutrients, particularly phosphate, can be liberated from the bottom sediments--not merely trapped there. Moreover, nutrient release from the bottom occurs in both a normal, steady mode and in a sudden, explosive mode. This conclusion implies that the use of a phosphate reduction program as the sole means to limit algae blooms would have little immediate success. All of the phosphate reduction programs that have been suggested to date aim at reducing only the external sources of phosphate, and do nothing about phosphate release from bottom sediments. The bottom fluxes would therefore continue until that source of phosphate was depleted, a process requiring many years. During that time, the normal flux could support moderately large algae blooms, while explosive fluxes, if they occurred, could support extremely large blooms.

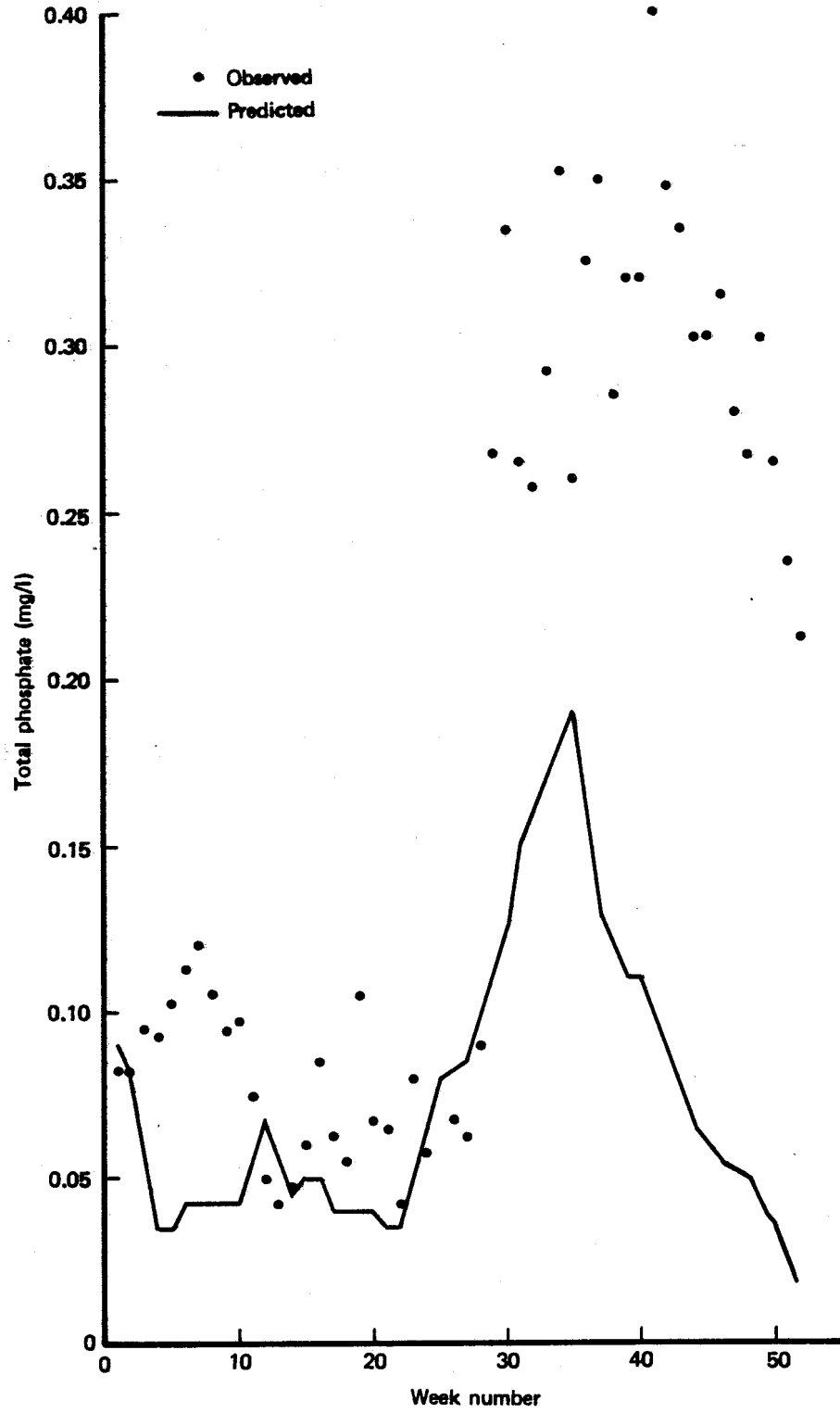

Fig. 16.3--Explosive flux of phosphate in Grote Rug, ring 3, 1976

16.4.2. The Algae Bloom Model

PAWN used an algae bloom model to analyze the effect on algae blooms of changing circumstances, including the introduction of control tactics.⁶ Developed under the WABASIM project, this model, called BLOOM II, is a modified and extended version of Rand's algae bloom model, which was applied to the Oosterschelde sea estuary by Bigelow et al. [16.6].

The algae bloom model uses linear programming to calculate the maximum possible algae bloom consistent with a given set of environmental conditions.⁷ The environmental conditions include the amounts of nutrients (phosphate, nitrogen, and silicon) and light energy available to the algae. The light energy is influenced by the light intensity at the surface, by the background extinction coefficient, which governs the rate of absorption of light per meter of water depth by nonalgal components of the water, and by the depth of the water. The model contains several species of algae, which differ in their requirements for nutrients and energy. Besides the bloom's size, the model also computes its species composition and the factors limiting its growth.

The environmental conditions are specified anew for each week of the year, and the model solves the new problem to determine that week's maximum bloom. We generally specified the environmental conditions on the basis of observations, but we also ran the model with conditions modified to reflect the effect of a tactic (e.g., increasing the depth by dredging). Calculations for succeeding weeks are independent, but the environmental conditions generally change slowly enough that, when plotted against time, the predicted bloom maxima form a reasonably smooth curve.

The algae bloom model was initially calibrated with data from the Grote Rug. Among the parameters that were varied during calibration, the most important was the natural mortality rate of algae. This is known to vary widely from week to week, for reasons unknown. Furthermore, the mortality rate often has a significant effect on the predictions of the model. This can be seen in Fig. 16.4. Figure 16.4a shows the calibration results for ring 2, 1977, using the measured natural mortality rate, while Fig. 16.4b shows the calibration results for ring 2, 1976, using a constant mortality rate, near the minimum rate observed in all the Grote Rug calibrations. We cannot use a measured week-specific and lake-specific rate in the model because none is available for the lakes we wish to study. We chose the minimum mortality rate because this will cause us to overestimate the size of the bloom, rather than underestimate it. We believe it is better to have some false alarms of large blooms than to miss some real alarms. Indeed, because factors not included in the model may sometimes be limiting, the model predictions tend to overstate the risk of large blooms.

We used the algae bloom model to investigate eutrophication control in eleven Dutch lakes, which are shown in Fig. 16.5. Six of the lakes are among the IJssel lakes: the IJsselmeer, Markermeer,

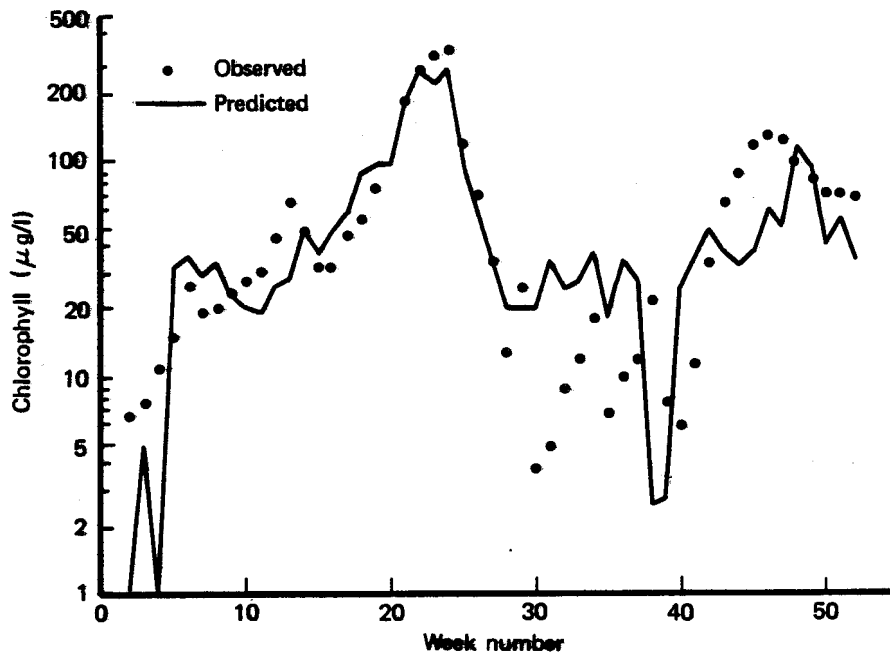

(a) Grote Rug, ring 2, 1977,
using measured weekly natural mortality rate

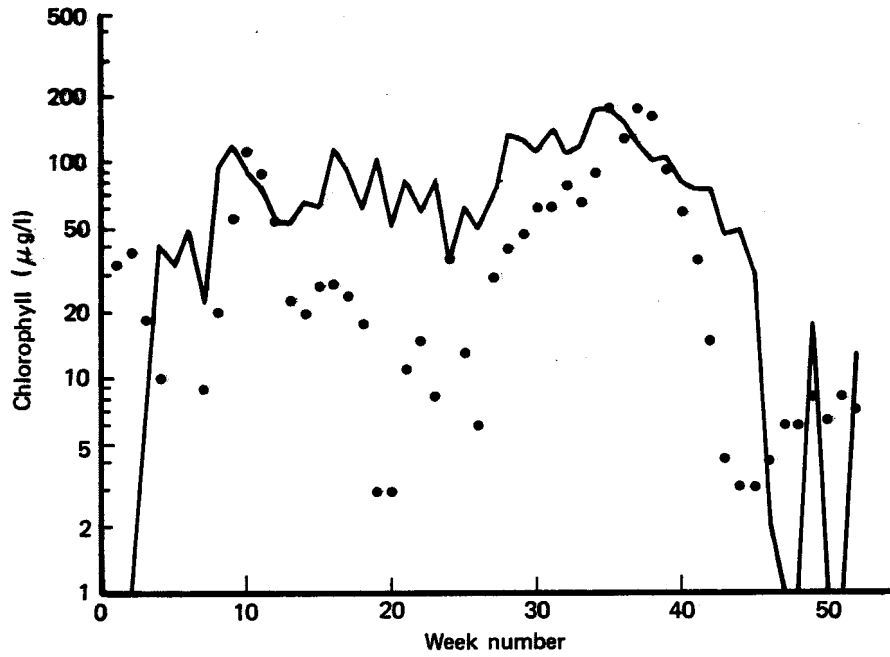

(b) Grote Rug, ring 2, 1976,
using constant (minimum) natural mortality rate

Fig. 16.4--Algae bloom model predictions versus observation

Veluwemeer, Wolderwijd, Gooimeer plus Eemmeer, and IJmeer. The Slotermeer is in the province of Friesland, just to the east of the IJsselmeer. The Westeinderplassen is a lake in the Midwest formed by peat excavations. The Stuwpannd Lith is the "lake" formed by the water impounded above the weir in the Maas at Lith. It is a lake during the summer, but during winter, when the Maas flow becomes large, it is merely another part of the river. The Haringvliet is in the Lower Rivers area. Finally, we considered the shallow part of the future Zoommeer that lies near Bergen op Zoom.

For each of these lakes except the Zoommeer, we performed calibrations with one or more years of observations. (The Zoommeer is not yet a freshwater lake, and hence there are no observations.) Some parameters were kept equal to their values from the Grote Rug calibrations. Other parameters were specified separately for each lake: for example, weekly concentrations of available nutrients; background extinction coefficients; and flushing rate (or, equivalently, residence time of the water). Of these, the background extinction coefficient was perhaps the most difficult to estimate. These lake-specific quantities were first estimated from direct observations, and later adjusted within their likely bounds of uncertainty to yield as good a match as possible between observed and calculated algae blooms.

Another lake-specific quantity was particularly difficult to measure: the biomass-to-chlorophyll ratio. Algae concentrations are ordinarily measured in terms of chlorophyll concentrations, whereas the algae bloom model estimates biomass. Only live algae cells contain intact chlorophyll, and different species of algae have different ratios of chlorophyll to biomass. That ratio varies even within a species, according to the size of an individual cell. In order to compare model predictions with real-world observations, we had to specify ratios of biomass to chlorophyll for each of our study lakes.

The calibration results for the study lakes fall into three categories. For the IJsselmeer, Veluwemeer (both 1975 and 1976), Wolderwijd (1975 and 1976), and Stuwpannd Lith, there was excellent agreement between predictions and observations. For the Gooi/Eemmeer, Haringvliet, and Slotermeer, there was only fair agreement. Agreement was poor for the Markermeer, IJmeer, and Westeinderplassen.

16.4.3. The Dissolved Oxygen Model

The purpose of the dissolved oxygen model (OXYMOD) is threefold: to predict the weekly dissolved oxygen concentration of a lake from the algal dynamics and the external BOD load; to estimate the effects of eutrophication control tactics on the oxygen budget; and to estimate the potential risk of severe oxygen depletion that might result from the sudden collapse of an algae bloom.

The model incorporates the following mechanisms for determining levels of dissolved oxygen. Oxygen is photosynthesized by algae during

daylight hours, and consumed by algal respiration during both day and night. Oxygen diffuses from the atmosphere into the water when the dissolved oxygen concentration is below saturation, and diffuses in the reverse direction when the dissolved oxygen concentration exceeds saturation. Oxygen is consumed by bacteria digesting dead algae and other oxygen-consuming substances (BOD). Oxygen is consumed by such substances in the bottom sediment at a highly variable rate, which we assume depends on temperature only. Finally, oxygen and BOD (the amount of oxygen-consuming substances) are transported into and out of the lake by water inflows and outflows.⁸

The model was calibrated with data from Grote Rug, ring 3, 1976. In general, its performance was satisfactory, typically showing differences smaller than about 1 mg/l between measured and predicted oxygen concentrations. (At saturation, the concentration is between 14 mg/l and 8 mg/l, depending on the temperature.) The predicted and measured values may differ partly because measurements are averages from three depths, or perhaps because measurements are not taken at the desired times of day.

The model represents these mechanisms as terms in a system of differential equations, which it solves analytically. It computes the daily average oxygen concentration in the middle of each week, the diurnal maximum and minimum values that indicate the magnitude of the algae-produced diurnal sag in the oxygen level, and, as an index of potential risk, the minimum oxygen level that would be achieved, week by week, if the bloom were to collapse suddenly.⁹

The model performs poorly in situations when the algae biomass as calculated from chlorophyll observations fluctuates rapidly. This may be due to imperfections in the model, or to errors in converting chlorophyll measurements to their equivalent in algae biomass.

NOTES

1. The term "load" is traditionally used to indicate the amount of some substance in the water; it is not the same as the concentration of the substance.
2. Nitrogen, another nutrient important to eutrophication, is also included in the DM, but decay rates were not estimated for it because of lack of time. It has been kept in the model, since input data for pollutant discharges were prepared for it and some future use of the model may make it worthwhile to go through the calibration process that determines decay rates. Without the decay rates, the DM produces values of nitrogen concentrations that are too high but may have some use as upper bounds to the actual concentration.

3. A test of the sensitivity of our results to changes in the heat loss rate (see App. E of Vol. VA) indicates that its value makes little difference except on the upper reaches of the Maas, along the Amsterdam-Rijnkanaal and Noordzeekanaal, and at the Burgemeermeer power plant. At Burgemeermeer, the effectiveness of the cooling circuit is significantly reduced when the heat transfer rate is set at the low end of its range. At the other locations, two sources of heat are close enough together that heat from the upstream source is swept to the downstream source before it is completely dissipated. The amount dissipated determines how much new heat can be added by the downstream source before the standard is exceeded there. How much is dissipated depends largely on the heat transfer rate. Everywhere else in the network, sources are far enough apart that heat from upstream is virtually all dissipated by the time it reaches any downstream heat source, regardless of the heat transfer rate.
4. A megacalorie is enough heat to raise the temperature of 1 m^3 of water 1 deg C.
5. In principle, we could calculate table entries for all of the network nodes, which would result in a 92 by 92 matrix for each decade. But it can be shown that at each node without a heat discharge but with a nonzero excess temperature, there is a node upstream of it which has a higher excess temperature. So long as the thermal standard applied at the downstream node is no more strict than the standard at the upstream node (i.e., so long as the standard is not 3 deg downstream and 7 deg upstream), meeting the standards at nodes with heat discharges will ensure that the standards are met everywhere.

Given the current water management system, there is only one instance in which water from a node with a 7-deg standard can flow into a node with a 3-deg standard. This occurs when the Amsterdam-Rijnkanaal is used to transport water north to the Markermeer. (This can be done via the pumping stations Zeeburg and Schellingwoude, located near the Oranjesluizen.) But the Markermeer is such a large body of water, and transfers heat so rapidly to the air through its large surface area, that it is impossible in a practical sense to violate the 3-deg standard there.

6. Strictly speaking, algae include some large waterborne plants as well as phytoplankton. In our methodology, we use "algae" to mean only phytoplankton, which are relatively primitive, single-cell, plantlike organisms.
7. The algae bloom model calculates the maximum rather than the actual size of the algae bloom because the largest blooms are the water manager's main interest and because otherwise more physiological knowledge about algae would have been required.

8. The model is based upon a dynamic oxygen model for rivers developed by Simonsen and Harremoes [16.7]. To apply it to lakes, the advection term in their model has been omitted.
9. To simulate the worst possible conditions for the oxygen level in case of a suddenly collapsing bloom, the model assumes that all algae die instantly and do not settle to the bottom sediment. This will indeed lead to the worst case because algae will die more gradually and because the rate at which bacteria digest dead algae, and hence the oxygen demand, is higher in the water than on the bottom.

REFERENCES

- 16.1. Ministerie van Veerkeer en Waterstaat, De Bestrijding van de Verontreiniging van het Oppervlaktewater: Indicatief Meerjarenprogramma 1975-1979 (The Combat against Surface-Water Pollution in the Netherlands: Prospective Multiyear Program 1975-1979), Ministry for Transport and Public Works, The Hague, 1975.
- 16.2. Unpublished information from various Dutch sources on pollutant discharges into Dutch waters (PAWN files DW-398 and DW-398A).
- 16.3. Kwaliteitsonderzoek in de Rijkswateren (Water Quality Research in Dutch State Waters), Rijksinstituut voor Zuivering van Afvalwater (State Institute for Wastewater Treatment, RIZA), Lelystad, The Netherlands. (Published yearly before 1971, quarterly thereafter).
- 16.4. Sweers, H. E., "A Nomogram To Estimate the Heat Exchange Coefficient at the Air-Water Interface as a Function of Wind Speed and Temperature: A Critical Survey of Some Literature," Journal of Hydrology, Vol. 30, 1976, pp. 375-401.
- 16.5. Shapley, M., and L. Cutler, Rand's Chemical Composition Program: A Manual, The Rand Corporation, R-495-PR, June 1970.
- 16.6. Bigelow, J. H., J. G. Bolten, and J. C. De Haven, Protecting an Estuary from Floods--A Policy Analysis of the Oosterschelde: Vol. IV, Assessment of Algae Blooms, A Potential Ecological Disturbance, The Rand Corporation, R-2121/4-NETH, April 1977.
- 16.7. Simonsen, J. F., and P. Harremoes, "Oxygen and pH Fluctuation in Rivers," Water Research, Vol. 12, 1978, pp. 477-489.

Chapter 17

POWER PLANTS

17.1. INTRODUCTION

Waste heat, a by-product of electric power generation, is usually discharged into the surface water. A large amount of discharged heat can cause environmental damage. To keep such damage within limits, the Dutch define thermal standards that specify allowable temperature increases of the surface water. We needed to calculate the additional costs that these standards cause for the power companies, and we wanted to know how these costs vary under different circumstances. This chapter summarizes our method of computing these costs. (The details are presented in Vol. XV.)

17.2. THE ELECTRIC POWER REALLOCATION AND COST MODEL

We used two models. The DM, as previously described, simulates the flow of water in the national distribution system, and calculates an excess temperature table for each decade showing how thermal discharges at each node in the system affect the temperature of every other node (see Sec. 16.3.5). The electric power reallocation and cost model (EPRAC) determines the least costly way to use the inventory of power plants to satisfy the demand for electric power without discharging enough heat at any node to violate the thermal standards. As part of this process, it uses the excess temperature table calculated by the DM, and a mathematically linear programming optimization technique, to calculate the additional costs to the power companies that are attributable to the thermal standards.

Electricity generation capacity for a recent year (1976) and for 1985 was provided by a nationwide organization (SEP¹) owned by the Dutch power companies. Power plant locations are shown in Fig. 17.1; the inventory includes all types (conventional, gas turbine, nuclear, combined cycle) powered by various fuels (oil, gas, coal, blast-furnace gas, uranium). We defined five regions and developed a schematization² of the main power transmission grid and the main line capacities received from SEP. (See Fig. 17.2.) Demand for electricity for 1976 and 1985 also was based on data provided by SEP, and the pattern used in PAWN accounted for seasonal, weekly, and daily variations in an approximate manner.

The linear programming optimization step in EPRAC considers the heat discharges at generating units as a function of the amount of power generated and selects the units that satisfy the demand for power in the least costly way. There are four kinds of constraints on this choice: Power production by each unit cannot exceed its maximum capacity; the demand for power in each of five regions of the Netherlands must be satisfied; the amount of power transmitted between regions must not



Fig. 17.1--Power plant locations

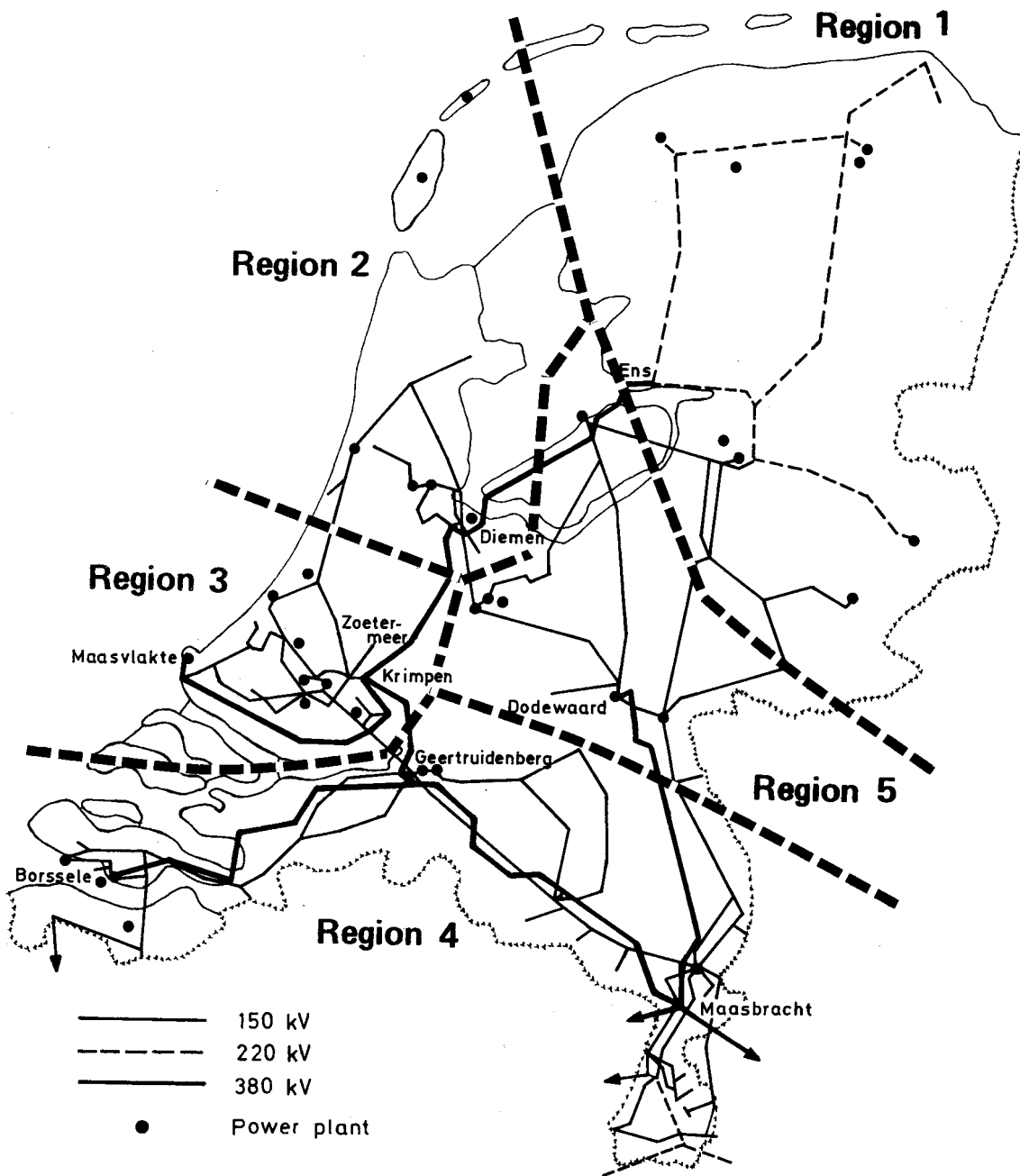

Fig. 17.2--Main power grid in 1976, showing regions

exceed the capacity of the transmission grid; and the thermal standard must be met at each point in the network. The only component of generating cost we have considered is the cost of fuel, since it is well known that this accounts for most of the variable cost of power production. EPRAC calculates the optimal generating schedule for two basic conditions: one in which the thermal standards are relaxed (the unconstrained case), and one in which they are imposed (the constrained case). The difference between the costs of the two cases is the cost attributable to the thermal standards.

The most important assumptions in EPRAC are that fuel cost is an appropriate measure of the total variable cost of power production, and that there are linear relationships among the amount of fuel burned, the amount of power generated, and the amount of waste heat discharged. Probably the most important neglected costs are start-up and shut-down costs. Neglecting them should make little difference, however, since EPRAC only changes the generating schedule at intervals of a decade (ten days). The linearity assumptions probably introduce little error, because linear programming tends to employ units either at full capacity or not at all. Relatively few units are employed at part load, where the power output and heat rejection rates per unit of fuel input vary from the constant values assumed in EPRAC. Both of these assumptions cause EPRAC to somewhat underestimate costs.

17.3. VALIDATION OF THE MODEL

Because the approach of the EPRAC model is somewhat crude, it was compared with a more sophisticated model in use by the Dutch power companies. (This model was unavailable to PAWN and would have been awkward for us to use, in any case, because it was designed for other purposes.) The additional costs attributable to the imposition of the thermal standards calculated by the two models compared favorably. Also, the power production units selected by the two models compared favorably. Gas turbine power plants are an exception, however, since the EPRAC model rejects power plants that have high fuel consumption rates, whereas the other model does not.

NOTES

1. NV Samenwerkende Elektriciteits-Productiebedrijven (Cooperative of Electric Power Producers), a company concerned with the production of power. It maintains the power grid, manages national production, and develops a national optimal production scheme.
2. The SEP disagrees with our schematization of the grid. Besides disapproval of our use of the 150-kV (kilovolt) lines for transmission between regions, they indicated that it would be more

accurate to consider the 380-kV lines as a kind of "pool" or "region" in itself, with all other regions spilling power into it or drawing power out as required. In this schematization, power would not be transmitted directly from region to region. Unfortunately, we received the SEP's advice on the schematization too late to incorporate it in our analysis. However, any error due to our incorrect schematization appears to be small, since in none of our cases did the amount of power transmitted from any region to any other come close to the capacity we used. Nor, in the cases we checked, would the transmissions have exceeded the capacities we would have used with the SEP schematization. However, they sometimes came quite close. Accordingly, it remains an open question whether the transmission capacity constraints truly do not matter.

Chapter 18

NATIONAL IMPACT CATEGORIES

18.1. INTRODUCTION

Previous chapters have discussed the impacts of PAWN tactics in different sectors, but some impacts occur to the Netherlands as a whole. Figure 18.1 shows four national categories of impacts in relation to the PAWN System Diagram (see Chap. 3), and the sections below discuss each category and how we assess its impacts.

18.2. ESTIMATING THE TOTAL ECONOMIC IMPACTS OF MAJOR INVESTMENTS IN WATER MANAGEMENT INFRASTRUCTURE

Some PAWN tactics represent major investments of money within the Netherlands. Those investments, such as those for dam or pumping station construction, usually require some domestically produced industrial outputs, some direct employment of labor, and some imports from other nations. They also typically induce a number of indirect or secondary effects. For example, pumping station construction requires steel and concrete, the fabrication of which in turn requires further employment and imports.

Major investments in specialized activities can easily strain the available resources, especially if the projects require specialized inputs or if they are located in a region of the country that is remote or to which access is difficult. If unemployment levels are low to begin with, the added demand can distort the labor markets or cause sudden increases in local wages. Some expensive projects that require many inputs and must be completed within one or two years often strain the input and labor markets both when they commence and when they are completed.

To determine and document the full effects of the PAWN water management policies, we developed techniques for estimating those short-term effects so that all the relevant dimensions of the alternative policies could be compared. We consider two types of short-term effects:

- Changes within the industrial sector, specifically changes in production, imports, wage payments, and employment; and
- Changes in governmental receipts from the value-added, business-profits, and personal-income taxes.

The major analytical tool developed for this purpose is an input-output (I-O) model of the Netherlands' economy. The model was developed from a 33-sector, interindustry transactions matrix for the

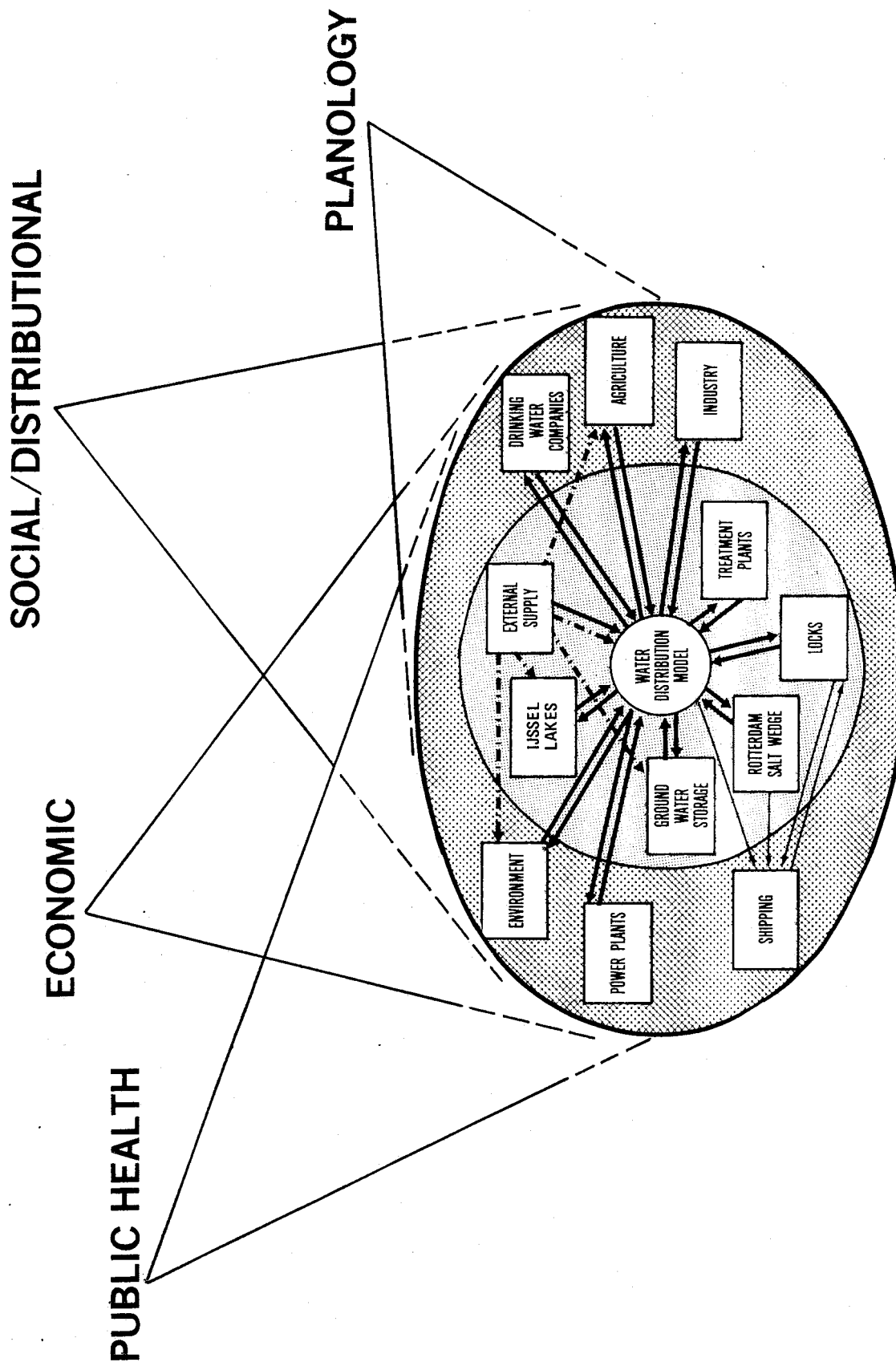

Fig. 18.1--PAWN system diagram: national impact categories

year 1975.¹ We input the matrix to the DHL computer and computed its inverse. This, coupled with several manual computations, yielded the "multipliers" needed for transforming direct investment expenditures into total, direct plus indirect, short-term effects.

The multipliers of foremost interest to our work are for the construction sector. Shown in the top row of Table 18.1, they indicate how an additional 1 Dflm/year expenditure in the construction sector would ultimately affect the Dutch economy. The table shows that the 1 Dflm expenditure would cause a total 1.54 Dflm increase in industrial production when all of the indirect and induced expenditures have been factored in. It would cause a 0.27 Dflm/yr increase in imports; raise the total wage bill for the country by 0.44 Dflm/yr; and, given all the assumptions of the model, cause an additional 19 man-years of labor to be employed (in all sectors combined).

Table 18.1

MULTIPLIERS FOR THE DUTCH ECONOMY

Type of Expenditure	Impacts of 1 Dflm/year Expenditure			
	Total Dutch Production	Value of Imports	Value of Wages	Number of Workers
Construction	1.54	0.27	0.44	19
Wetworks	1.63	0.31	0.34	15
Locks	1.83	0.31	0.40	17
Pumping stations	1.93	0.32	0.40	17

SOURCE: Disaggregation and inversion at DHL of CBS interindustry transactions table.

NOTE: The model is mathematically linear. To compute the effects of any "x" Dflm/year expenditure, simply multiply the above figures by x.

The construction sector as it is defined in the I-O accounts, however, does not adequately capture all of the water management investments of interest to us. Some of our projects are not typical of the regular or average type of construction activity undertaken in the Netherlands. To adapt the I-O model to suit our needs, we created linear combinations of the existing sectors to construct three new construction subsectors: wetworks, locks, and pumping stations.² The multipliers associated with these construction subsectors are shown in the lower rows of Table 18.1.

Given the multipliers, we begin the analysis of a case by taking its direct investment expenditures for major tactics and disaggregating them by year and by construction subsector. To determine the case's total economic impacts for a given year, we merely combine the expenditures by construction subsector for that year with the multipliers given above. (The details of this process are presented in Secs. E.1 and E.2, along with the resulting impacts. We generally

begin by considering the peak-year expenditures, which gives us an upper bound on the total economic impacts. If the results are large enough to be significant, we then examine years with lower expenditures.)

18.3. PUBLIC HEALTH

Because public health was a primary consideration in establishing the water quality standards discussed in Chap. 16, adverse effects should be minimal when these standards are met. As a proxy for the magnitude of adverse effects on public health, we calculate the frequency with which each standard would be violated at every node in the network.

We also calculate the percent of groundwater contained in drinking water. This provides an index of drinking-water quality and of its susceptibility to accidental pollutant spills.

18.4. PLANOLGY

The Dutch use the term "planology" for what in the U.S. would be called "land-use planning" or "regional planning." In PAWN, we use the number and extent of new facilities or changes in existing facilities as a proxy for the direct change in land use.

18.5. SOCIAL/DISTRIBUTIONAL IMPACTS

Nearly all policy analysis studies concentrate on aggregate impacts, that is, the impacts on the nation as a whole. But it is not only the size of the pie, but also the size and distribution of the pieces that are important to decisions affecting the physical and social welfare of many different individuals and groups. In PAWN, we therefore explicitly distinguish a special category of impacts--social/distributional impacts, which we usually call distributional impacts--that consider the uneven distribution of various impacts among different groups and locations.

Many of the distributional impacts are calculated directly by various models. For example, the DM calculates water quality concentrations at different locations, RESDM calculates the percentage of GW in DW by pseudo-province, and DISTAG calculates GW levels by drainage region. Some of the models estimate the monetary costs and benefits accruing to different groups and locations. Generally, these estimates require additional calculations to determine their actual distribution. For agriculture, this is done by the previously discussed BENCOMP program. The methodology for doing this for other sectors (and also providing the theoretical basis for BENCOMP) is discussed in the next chapter, which describes how to calculate the distribution of monetary costs and benefits among both domestic and foreign producers, consumers, and governments.

NOTES

1. The transactions matrix was taken from Nationale rekeningen 1977, Centraal Bureau voor de Statistiek, The Hague, Staatsuitgeverij, 1978, pp. 126-133.
2. Wetworks refers to the building of dikes, canals, harbors, and the like. It is similar to regular construction but employs a lower percentage of direct labor; more work is done with machines and subcontracted. Locks differ from regular construction in requiring more construction materials, metal products, basic metals and electrotechnical inputs, and less direct labor. We consider pumping stations to consist of 25 percent wetworks and 75 percent of another combination of the above inputs.

Chapter 19

ESTIMATING THE DISTRIBUTION OF MONETARY BENEFITS AND COSTS

The PAWN study develops and applies procedures for evaluating the benefits and costs of water management policies. The policies we study are designed to reduce the costs or increase the supply of water for at least some user groups. This reduces the users' (e.g., farmers') total costs and/or increases their productivity, thus increasing profits and perhaps lowering the prices charged for products. Reduced product prices will increase the welfare of those who purchase the products and will enhance the competitive position of the affected groups at the expense of competing producers and competing products, both Dutch and foreign. Increased profits will cause tax payments on profits to increase and hence the revenues of the government to increase.

Monetary benefits and costs are almost never spread evenly among regions and socioeconomic groups within a nation, or among nations. Usually, some groups benefit substantially more than others from a particular policy. In a perfectly functioning society, a surplus of total benefits over total costs would be sufficient to justify a project, since the benefits could always be redistributed in such a way that everyone would gain. In most actual situations, however, redistribution is costly, and often it is politically or administratively infeasible. In those instances, projects cannot be justified on aggregate benefits alone; knowledge of the distribution of the benefits and costs is a necessary input to the political decisionmaking process.

This chapter first summarizes our procedures for estimating the distribution of monetary benefits and costs among producers, consumers, and governments, both domestic and foreign. Then it summarizes our methods for tracing those effects on the budgets of typical Dutch families, since the individual and the family are the units that ultimately reap the benefits and pay the costs of all governmental actions. Complete documentation of these methods can be found in Vol. X.¹

19.1. INITIAL DISTRIBUTION OF SECTORAL BENEFITS AND COSTS²

Water management policies have immediate positive and negative effects on many sectors of the economy. PAWN has identified the agriculture sector, the drinking-water (DW) sector, the industrial sector, the shipping sector, and the electricity-generating sector as being especially important, and has developed models that suggest how certain water management policies would affect the operations and the outputs of those sectors. To compare the monetary effects for different sectors, and to aggregate them into a net total effect or a net Dutch effect, we need a benefit-cost estimating methodology that is general enough to cover all of the potential applications and flexible enough

so that irrelevant detail is not applied in sectors that have otherwise been modeled rather simply. We first discuss our general methodology and then describe how it was specifically applied in different sectors.

19.1.1. General Methodology

For each water management policy under investigation, we need to estimate the net benefits arising in every production sector. But it turns out that to accurately estimate the total benefit we must first--in actuality, simultaneously--estimate the separate effects on the producers whose costs or yields are directly affected, on competing producers (including foreign producers who compete with the Dutch), and on consumers, both in the Netherlands and in other countries that consume Dutch imports.

Accordingly, we construct an economic market model. A set of structural equations represent domestic (Dutch) supply (both directly and indirectly affected by the water management policy), the supply of imports, the domestic demand, and the competing export demand. Water management policies are assumed to affect the cost of a portion of the Dutch production--that is, to shift one of the supply functions. The model then traces the adjustments in all segments of the market. It yields estimates of the changes in producers' profits, changes in the economic well-being of consumers (what economists call "consumers' surplus"), and changes in governmental budgets.

To adequately describe all of the sectors identified above, our model has been made general enough to represent three kinds of markets: (1) competitive markets that are free of governmental and monopolistic influences, (2) markets with governmentally supported prices, and (3) markets with administered (privately, jointly set) prices. The model considers the budgets of both the Dutch government and the agricultural branch of the European Economic Community (EEC).

Most of the industrial and commercial sectors of the Dutch economy, and a significant portion of the agriculture sector, operate as competitive markets. In addition, we consider the public utility sectors that are studied--the production of DW and electricity--to be operated "as if" they were experiencing competitive pressures. One major difference between those and the former sectors is that we do not consider imports or exports of DW or electricity.

Our model is a static, linear representation of a market economy. Each solution of the model provides a complete set of market-clearing prices and quantities (that is, prices that result in sales, production, and consumption being equal) for each of the product groups identified. A water management policy is expressed in the model as a change in one or more of the supply functions: a change that can be thought of as either a yield increase for a fixed cost, a cost reduction when producing a fixed quantity, or some combination of the two. Re-solving the equation set using the altered supply function(s) yields the new, post-policy, market-clearing prices and quantities. Those values can then

be differenced from the initial values to provide estimates of the economic benefits and costs of the policy.³

In the competitive sectors, we assume Dutch supply and demand to represent relatively minor components of EEC-wide markets. Dutch water management policies--policies that affect only a small portion of total market supply--then cause only a small change in market price and sales. Therefore, most of the benefits (and costs) of the policies are retained within the Netherlands; most accrue to the directly affected producers; and little is passed on to consumers or competing producers. The change in market price, small as it is, induces a substantial redistribution of income from producers to consumers in the full EEC market. Those redistributions among non-Dutch producers and consumers in the EEC tend to nearly cancel each other, however, and the net effect of each policy is localized almost entirely within the Netherlands.

Many Dutch agricultural crops enjoy artificial price supports. Excess production is purchased by the EEC, while imports (from nonmember states) are discouraged by tariffs and restrictions. We model the markets for these crops by including both equations for governmental purchases (at fixed price levels) and accounting equations representing the budget position of the EEC farm control board.

Finally, in some sectors of the Dutch economy the government has delegated market power directly to producer groups. This is especially true for portions of the shipping market covering the Netherlands and large portions of Western Europe. In these markets producer associations set (common) prices explicitly and formally, with the full consent and force of the government behind them. The rationale for this policy is that demand for shipping is so insensitive to price changes that a monopolistically set, artificially high price will increase the total revenues of the carriers. Consequently, the carriers, most of whom are small, otherwise independent businessmen, stand to gain so long as they band together and support the associations.⁴

We model these price-administered markets by augmenting our competitive model with the price-setting equations of the monopoly-powered groups. This, in effect, causes two prices to be represented for those markets--the administered price and the implicit competitive price--and complicates the benefit-estimating procedures somewhat. We find, however, that few benefits or costs are generated in this third type of market.

19.1.2. Application to Sectors of the Dutch Economy

Since PAWN uses different conceptual and computer models to analyze the cost and performance of water management policies on the different sectors of the Dutch economy, we have had to apply our general benefit-estimating methodology differently in nearly every sector. We will discuss the specializing assumptions we adopted for the agriculture sector first, then those for shipping, electricity generation, and DW companies, and finally those we applied to the industrial sector.⁵

The Agriculture Sector. We created a computer program called BENCAMP to be the major tool in estimating the benefits of PAWN water management tactics. Since most of those benefits arise in the agriculture sector, and since we have a large number of computer-based agricultural models, BENCAMP focuses on that sector. With a little additional programming, it could be used to calculate the full range of total and distributed benefits for all of the PAWN sectors. BENCAMP is summarized in Chap. 13 and fully described in Vol. X.

The Shipping Sector. The shipping sector analysis is quite simple. Our shipping models compute the changes in operating costs and in fleet investment costs resulting from the introduction of PAWN water management tactics. We then simply compute the income-tax payments or credits arising from those cost changes. We do not use other benefit-estimating equations or distribute benefits between producers and consumers. We choose not to because of the uncertainty connected with estimates of those elasticities and the minor magnitude of the estimates.

Note that tactics affecting shipping costs affect the costs of Dutch and foreign ships alike. The PAWN shipping models compute costs for the total fleet. We then assume that Dutch shippers share in the cost in the same proportion as they share in the total tonnage carried. On the basis of the shipping market analysis reported in Chap. 6, we have used 62 percent as the Dutch share.

Electricity-Generating Firms. Our treatment of the benefits arising from cost changes in electricity generation is even simpler. We assume that no adjustments take place among either producers or consumers of electricity in response to the cost changes; and we assume that the full cost change is passed along to the consumers of the electricity. This keeps producer profits at zero, better reflecting the behavior of utilities in the real world. Finally, we assume there are no tax effects from these changes.

The DW Sector. Benefits were estimated in the DW sector under the assumption that all of the demands for DW are inelastic except the demand for DW as a substitute for GW in industrial processes, and that DW prices will be based on the marginal costs of production.

DW production models, described in other chapters (see Chap. 14), estimate changes in DW production, total costs, and marginal costs. Note that there are no international exports or imports of water; and that although marginal-cost pricing implies a surplus of revenue over costs for the DW companies, we assume that the entire surplus from this regulated public-service industry is passed on to the Dutch government. These conditions simplify the benefit calculations for this sector substantially.

The Industrial Sector. PAWN analyses of the impacts of water management policies on the industrial sector of the Dutch economy assume that industrial output will not change because of those policies. Changes in water costs, quality, and availability may,

however, induce substantial adjustments in the water use of firms. Firms may switch to alternative water sources (types), or they may reduce their total water-use requirements by either recirculating water or adopting other cooling processes (see Chap. 15).

Estimates of price changes and the distribution of benefits among producers, governments, and consumers, both domestic and foreign, are made by assuming an EEC-wide market for all industrial products. Because few of the important industrial products have effective price supports, most cost increases caused by water management policies will generate small but noticeable price increases. Under these circumstances it is estimated that less than 10 percent of the cost increases will be passed on to consumers. The small price increases also ensure that competing producers will receive only minor benefits.

19.2. DETERMINING THE ULTIMATE EFFECT ON FAMILY BUDGETS

This section describes our methods for taking the above-determined distribution of sectoral benefits and costs and estimating its ultimate distribution among households, by region and socioeconomic group.

Tracing the effects of water management policies to their ultimate recipients is a multistep procedure. A water management investment-- a new canal, say--reduces costs for farmers and shipping firms. A portion of those cost reductions is typically passed along in the form of lower food and transport prices. Finally, the effects concentrate in the budgets of individual families. Most households benefit from the lower food prices and from the lowered transport costs; and farm households benefit from increased income. Most households also incur the final burden of the cost of the project (the canal), both directly through personal taxes and indirectly through higher prices for many products caused by increased business taxes.

In determining the ultimate effect on budgets, we consider three component effects: (1) the effect on household income; (2) the effect on household expenditures; and (3) the effect on the taxes that the household pays.

Our water management policies increase the income of households that work on or own farms, at the same time that they increase costs for all households that must pay for piped-in water. In the instance of groundwater (GW) restrictions, they also lower profits in those industries and commercial firms that cannot, because of competitive pressures, increase their prices enough to offset the increased costs. We assume that those profit reductions will be immediately reflected in lower income for owners and shareholders.

The second effect experienced by households is changes in the prices charged for the products they consume. PAWN policies are estimated to lower the prices of some agricultural products. Those products are both consumed directly by households and used by business firms

to produce other products that in turn are consumed by households. Some PAWN policies increase the cost and thus the prices of industrial products, of DW, and of electricity produced by public utilities. Those products, especially the DW and electricity, are used by many other sectors of the economy, causing many secondary and tertiary price increases.

We use an input-output (I/O) model of the Dutch economy (the same model as that described in Chap. 18) to estimate an upper bound on the cumulative impact of policy-induced cost changes on the prices of all products that Dutch households consume. This analysis, as described in Vol. X, makes the extreme assumption that each firm passes all of its cost increases along as prices increase. Actually, many firms will probably not be able to raise prices enough to completely offset the cost increases. Competing firms, both foreign firms and Dutch firms that are unaffected by the policy changes, will force many affected firms to moderate or cancel their price increases. Thus, this procedure produces an overestimate of the expected price and budget effects. We find, however, that these price effects are always very small, and the imprecision in our estimates here has little effect, either qualitatively or quantitatively, on our estimates of total budget effects.

Finally, we look at tax effects. Households and firms pay the value-added tax on items they purchase, adding to their expenses and to government revenue. We investigate those effects on income and prices, as well as the effects of the business-profits tax on government revenues. Then, as a last step, we assume that any change in the governmental budget arising from any of the above effects, or from the investment in structures or operations connected with the policy, would be compensated for by offsetting changes in personal or business taxes. The type of tax chosen for change has an important effect on the net distribution of benefits and costs among households.

NOTES

1. Only monetary benefits and costs can be analyzed in this manner. Short-run, transitory effects are identified only if they contribute to our understanding of the magnitude and location of the ultimate, long-run effects. Although we look only at results for the average or the expected year, what PAWN calls the 1943 external supply scenario, the methodology presented is, of course, applicable to other situations.
2. The methods discussed in this section concern only user groups that represent some form of "business" organization: farmers, shipping, electricity-generating, DW production, or any of the many types of commercial and industrial firms present in the Netherlands or any country.

3. More aggregate effects, such as changes in national production and regional employment, are not covered by these methods. They are important only if they should differ significantly among policies or regions, due, for example, to differing employment rates. Such effects can and should be analyzed separately. Changes in imports and exports brought about by the altered competitive position of domestic firms, however, are among the direct market effects covered by the methodology documented here and in Vol. X.
4. The Organization of Oil Producing and Exporting Countries (OPEC) is a similar group, although it has a much smaller membership and, so far at least, has been able to police itself without formal (supra) governmental controls.
5. In their subsequent analyses, the Dutch made a number of minor changes in assumptions to better reflect how certain sectors deduct value-added tax or obtain tax credits for it.

Chapter 20

SCENARIOS

20.1. INTRODUCTION

To assess the impacts of a policy, we must first specify the circumstances in which it will be operating. The impacts and the rankings of policies may differ with circumstances--for example, if farmers greatly increase the amount of sprinkling equipment or if a treaty greatly decreases the amount of salt dumped into the Rijn.

Because we cannot know for certain what future circumstances will prevail, we examine the implications of a number of different possibilities called scenarios. Each scenario consists of factors (called scenario variables) outside the system, whose values will be determined by processes beyond the control of water management decisionmakers.

Quade [20.1] divides uncertainties about a policy's operating environment into two categories: stochastic uncertainties and real uncertainties. Stochastic (or statistical) uncertainties are due to random events. There is a known menu of possible outcomes, each with a known (or estimable) likelihood; only the actual outcome is uncertain. To the extent that the uncertainties in our study are stochastic, we can make statements about how likely the impacts are from implementing the various policies. Fortunately, the two most important determinants of surface water (SW) supply--river flows and rainfall--are stochastic uncertainties.

In the case of real uncertainties, such as the terms of future international treaties, we do not know and cannot estimate the complete menu of possible outcomes or their likelihoods. To deal with real uncertainties, we must make a range of assumptions about the values of their corresponding scenario variables.

For each scenario variable involving real uncertainty, we defined a reference assumption representing our choice of a benchmark for the variable's value. Depending on the variable, the benchmark may be an estimate of the most likely future value, the middle of a range of plausible values, or an extrapolation of current plans or trends. For a few of the scenario variables, we used only the reference values in our analyses. For most, however, we used the reference variables in much of our analysis but considered alternative values in an extensive sensitivity analysis. The alternative values usually represented one or both extremes of a range of plausible values, or some political milestone such as the proposed terms of a treaty or the target values of water quality standards.

In PAWN, we separate the overall scenario into four components:

- The external supply scenario
- The context
- The sprinkler scenario
- The rest of the scenario

We define each component and describe its variables and their alternative values in separate sections below.

20.2. EXTERNAL SUPPLY SCENARIOS

We defined the following five scenarios for external supply of SW:

DEX: An extremely dry scenario composed of actual rain and evaporation for 1976, minimum of the Rijn discharges for the three worst years--1934, 1949, and 1976--and other river discharges for 1976.

1959: A very dry scenario composed of actual 1959 rain, evaporation, and river discharges.

1943: A moderately dry scenario composed of actual measurements for that year.

1967: An average scenario composed of actual measurements for that year.

1965: An extremely wet scenario composed of actual measurements for that year.

The way in which these years were chosen is described in Chap. 5.

The values for the Rijn salt dump (defined in Sec. 5.3) come from whatever decade-by-decade salt-dump figures we adopt--that is, whatever salt dump is assumed in the "rest of the scenario" described in Sec. 20.5.

When we use a particular external supply scenario, we assume the corresponding crop price scenario. (See Chap. 13.)

20.3. CONTEXT

The context consists of variables whose values will be largely determined by the time frame under consideration because they arise from socioeconomic growth or from existing plans.

In PAWN, we considered two contexts: 1976 and the future--1985 or 1990, depending on the availability of data. Generally, we used the future context for our analysis; we used 1976 to calibrate most of our models. (This is not really a problem, because the future context as

defined here mainly implies somewhat larger water demands.) When we examined the impacts of a policy within a particular context, we assumed that the policy had had time to be implemented and take effect. Thus, viewing a policy in the 1976 context is like assuming that the policy has taken effect instantaneously in a world that looks like 1976 in terms of the variables reflected in that context.

The variables in the context component of the overall scenario are:

- Shipping fleet and shipment of goods
- Electricity demand, power plant inventory, and transmission grid
- SW demand by industry and drinking-water (DW) companies
- Basic DW demands
- Groundwater (GW) demands by industry

20.3.1. Shipping Fleet and Shipment of Goods

The scenario variables we used for shipping are listed below. The future context reflects a 1985 environment.

- Characteristics of the shipping network
- Size and distribution by class and type of the Dutch and total shipping fleets
- Specification of goods to be shipped between origins and destinations by type of commodity
- Sizes and types of vessels used in carrying each type of commodity between each origin-destination pair
- Maximum load factors for goods, by type and class of ship, for each origin-destination pair

We defined the shipping network in 1985 as the current network, with the addition of the changes planned and under construction, and some others now under consideration.

The description of the 1985 fleet was based on the fleet specifications developed for a shipping-cost study by the Dienst Verkeerskunde (DVK) of the RWS, the Nederlands Vervoerswetenschappelijk Instituut (NVI), and the Economisch Bureau voor het Weg- en Watervervoer (EBW).¹

The predictions of goods production and distribution, as well as transport mode selection, were made by the NVI and EBW for an earlier study commissioned by the European Economic Community (EEC). Table 20.1 compares projections of the 1985 total shipment of goods with actual data for 1976.

Values of the other scenario variables were specified by the Dutch using trend equations tempered by expert judgment. Further information on the specification of the 1985 scenario for the shipping fleet and shipment of goods is given in Chap. 6 and in Vol. IX.

Table 20.1

TRANSPORT OF GOODS BY INLAND SHIPPING:
ACTUAL SITUATION IN 1976 AND
PROJECTION FOR 1985

Component	Annual Cargo (million tons)	
	1976	1985
Domestic	94.116	119.265
International (in)	43.523	74.040
International (out)	93.793	176.286
International (through)	28.877	26.283
Total	260.309	395.874

20.3.2. Electricity Demand, Power Plant Inventory, and Transmission Grid

For both the 1976 and future contexts, we used the 1976 and 1985 electricity demands, the power plant inventory, and our schematization of the transmission grid, as described in Chap. 17.

20.3.3. SW Demand by Industry

In our analysis we used projected net extractions of SW by DW companies and industry for 1990.

Major industrial net extractions in 1976 were estimated to be 53 million cubic meters (mcm). For the 1990 context, we assumed that net extractions of SW by industry would increase to 138 mcm. This assumption was based on estimates by VEWIN (Vereniging van Exploitanten van Waterleidingbedrigven in Nederland), a trade association of Dutch DW companies. (See Ref. 20.2.) We calculated the appropriate breakdowns of these extractions and their corresponding discharges by PAWN node and district, as shown in Table 2.6 of Vol. II.

20.3.4. Basic DW Demands

Our models for analyzing the effect of tactics on DW Companies, RIDDWM and RESDM, require data on the basic demand for DW in each pseudo-province. For the future context, we used data on 1990 demands from RID. RID provided high and low estimates by real province, subdivided between industrial and nonindustrial (households and commercial firms) demands. We took the average of the two estimates and adjusted them to pseudo-provinces, as reported in Table 2.5 of Vol. IV. In some sensitivity analyses in policy design we considered a 10 percent reduction in DW demands, an amount that rough estimates indicate may be achievable without too much inconvenience.

For validating and calibrating our models, which was done for the 1976 context, we used data on actual 1976 DW production from VEWIN, but we adjusted it from real to pseudo-provinces. (See Table 2.4 in Vol. IV.)

20.3.5. Basic GW Demands by Industry

Our models for analyzing the effect of tactics on industrial firms, IRSM and RESDM, contain 1976 data on firms' basic demands for GW, i.e., those occurring before the application of tactics. To analyze some later year, these basic demands must be increased appropriately by providing industrial-production growth rates to the model for the intervening period. (We assume that industrial GW demands increase linearly with production.)

In PAWN, we considered two different growth rates. The central planning bureau (Centraal Plan Bureau, CPB) of the Dutch government developed two alternative growth rates for industrial sectors for the period 1976 to 1990. The high rates assume that the Dutch gross national product (GNP) grows at 4.3 percent a year. The low rates assume that GNP grows at 3 percent a year until 1980, and thereafter declines linearly to a zero rate in 1990. (The rates are given in Table 2.13 of Vol. IV.)

For the future context, we used the high rates because they stressed the system more and because, when forced to choose, we preferred to make conservative assumptions for estimating the costs of policies.

In some sensitivity analyses in policy design, we used the low rates as an alternative assumption. (We used zero growth rates when calibrating and validating the models for 1976, and in some detailed analyses for that year reported in Vol. VIII.)

In impact assessment, GW demands by DW companies are computed by the response design model (RESDM) on the basis of the basic DW demands mentioned above.

20.4. SPRINKLER SCENARIOS

We developed sprinkler scenarios for both SW and GW sprinkling. We will discuss the SW before the GW.

We used six sprinkler scenarios to represent the demand for SW for sprinkling crops. Each scenario combines a sprinkler intensity for each crop with a definition of the area made eligible for sprinkling by implementation of waterboard plans. Sprinkler intensity is the proportion of cultivated land with sprinkler equipment. Waterboard plans are technical tactics developed by the waterboards to improve the local SW supply system. In Chap. 22 we describe the analysis in which we screened a national survey of such plans to identify those that were promising. The scenario assumption under which these promising

waterboard plans are implemented is RALL; the scenario assumption under which none is implemented is RNONE.

Combinations of intensities and eligible areas produced six scenarios:

- SPRLOW-RNONE, which approximates the current situation in the Netherlands.
- SPRLOW-RALL, which assumes that the promising waterboard plans are implemented and that sprinkling at current levels of intensity is carried out in all areas thus made eligible for SW sprinkling, as well as in those currently eligible.
- SPRMED-RNONE, which assumes that no waterboard plans are implemented and that the sprinkler intensity is the average of low and high (current and optimal).
- SPRMED-RALL, which assumes that the promising waterboard plans are implemented and that the sprinkler intensity is the average of low and high.
- SPRHI-RNONE, which assumes that the sprinkler intensity is increased to the high (optimal) sprinkler intensity in all areas currently eligible for SW sprinkling.
- SPRHI-RALL, which assumes that the eligible area is expanded by implementing the promising waterboard plans, and that the sprinkler intensity in the eligible area is increased to the high sprinkler intensity.

Appendix C of Vol. XIV contains detailed descriptions of the sprinkler intensities and sprinkler scenarios used in the screening and impact assessment stages of analysis.

The six scenarios generate the following totals for sprinkler-eligible areas:

ELIGIBLE AREAS FOR SW SPRINKLERS

	<u>Area (ha)</u>	<u>Percentage</u>
Current total cultivated area	1,981,132	
Currently eligible for sprinkling (RNONE)	967,614	49
Eligible after waterboard plans (RALL)	1,248,302	63
Increase in eligible area		28

CULTIVATED AREAS WITH SW SPRINKLING EQUIPMENT (ha)

	<u>SPRHI</u>	<u>SPRMED</u>	<u>SPRLOW</u>
RNONE area sprinkled	466,628 (24%)	(not used)	193,326 (10%)
RALL area sprinkled	615,235 (31%)	430,527 (22%)	239,641 (12%)

There are corresponding sprinkler scenarios for GW sprinkling. For these, the eligible area is the complement of the eligible area chosen for the SW scenario--that is, we assume that GW sprinkling, which is more costly and less flexible, takes place only in those areas not eligible for SW sprinkling.

ELIGIBLE AREAS FOR GW SPRINKLERS

	<u>Percent of Total Area</u>
Area eligible for GW sprinkling when SW-eligible area is RNONE	51%
Area eligible for GW sprinkling when SW-eligible area is RALL	37%
Decrease in eligible area	27%

The GW sprinkler intensities have the same definitions, but the actual intensities are slightly lower because GW is more expensive. The intensities were calculated without the application of price and regulatory tactics to conserve GW--that is, without quotas or taxes on GW extractions. When such tactics are applied, the actual sprinkled area is less than implied by the intensities because less water was available or because it was more expensive.² However, we never reduce the sprinkled areas below the current ones, even if it means violating a quota.

When no waterboard plans are implemented (RNONE), the current sprinkled area of 70,721 ha amounts to 7 percent of the area eligible for GW sprinkling. If the waterboard plans are implemented (RALL), the amount of sprinkled area remains the same, but it constitutes a larger percentage--9 percent--of the smaller eligible area.

20.5. THE REST OF THE SCENARIO

The rest of the scenario contains those variables whose values will be determined primarily by decisionmakers other than those concerned directly with water management--for example, international treaty-making bodies or Dutch farmers.

We considered the following variables in this component of the total scenario:

- The Rijn salt dump
- Belgian measures affecting Maas supply
- The status of the Zoommeer and Grevelingen

- Miscellaneous variables
- Dutch sources of pollution
- Foreign sources of pollution
- Thermal pollution standards
- Other water quality standards

20.5.1. The Rijn Salt Dump

We used the equation in Chap. 5 to calculate the Rijn salt dump for 1976 without the treaty (311 kg/sec) and for 1985 with the treaty (305 kg/sec). Since the results were so close, we chose to be slightly conservative and used the larger value as our reference assumption. For sensitivity analysis in impact assessment, we also considered a high assumption corresponding to the 1985 trend without the treaty (365 kg/sec).

20.5.2. Belgian Control of Maas Supply

The Maas flows through Belgium before it reaches the Netherlands; the Belgians therefore control the amount of water that reaches the Netherlands. We considered how the average decade-flows to the Netherlands (reflected in the external supply component of the overall scenario) might be changed to reflect future developments.

Maas Treaty. The Dutch and the Belgians have been negotiating a treaty which provides for the construction of a number of reservoirs in Belgium in order to guarantee a minimum net Maas flow to the Netherlands of 28 m³/sec. This compares with a 1976 net Maas flow of 7 m³/sec. Since chances of concluding this treaty are small, our reference assumption was that it would not be ratified.

Other Factors. We also considered the effects of a Belgian hydroelectric power station on the Maas and of increased shipping on the Albertkanaal and found them relatively unimportant for our analysis.³

20.5.3. The Status of the Zoommeer and the Grevelingen

In 1953 a major undertaking called the Delta project was begun to protect the Delta area of the country from flooding by the North Sea. As the last phase of the project, in 1976 the Dutch Parliament adopted a plan for protecting the area surrounding the Oosterschelde, one of the estuaries in the area. According to the plan, the Oosterschelde is to be closed off from the North Sea by a storm-surge barrier. Furthermore, the current Oosterschelde will be divided into three basins separated by dams containing ship locks: a Western Basin, beginning at the storm-surge barrier and extending eastward; an Eastern Basin, located at the eastern end of the Oosterschelde and southern end of the Schelde-Rijnkanaal; and a Northern Basin, located in the Krammer/Volkerak, at the northern end of the Schelde-Rijnkanaal. (See Fig. 20.1.) Of these basins, the Western would remain salt water, while the Eastern and

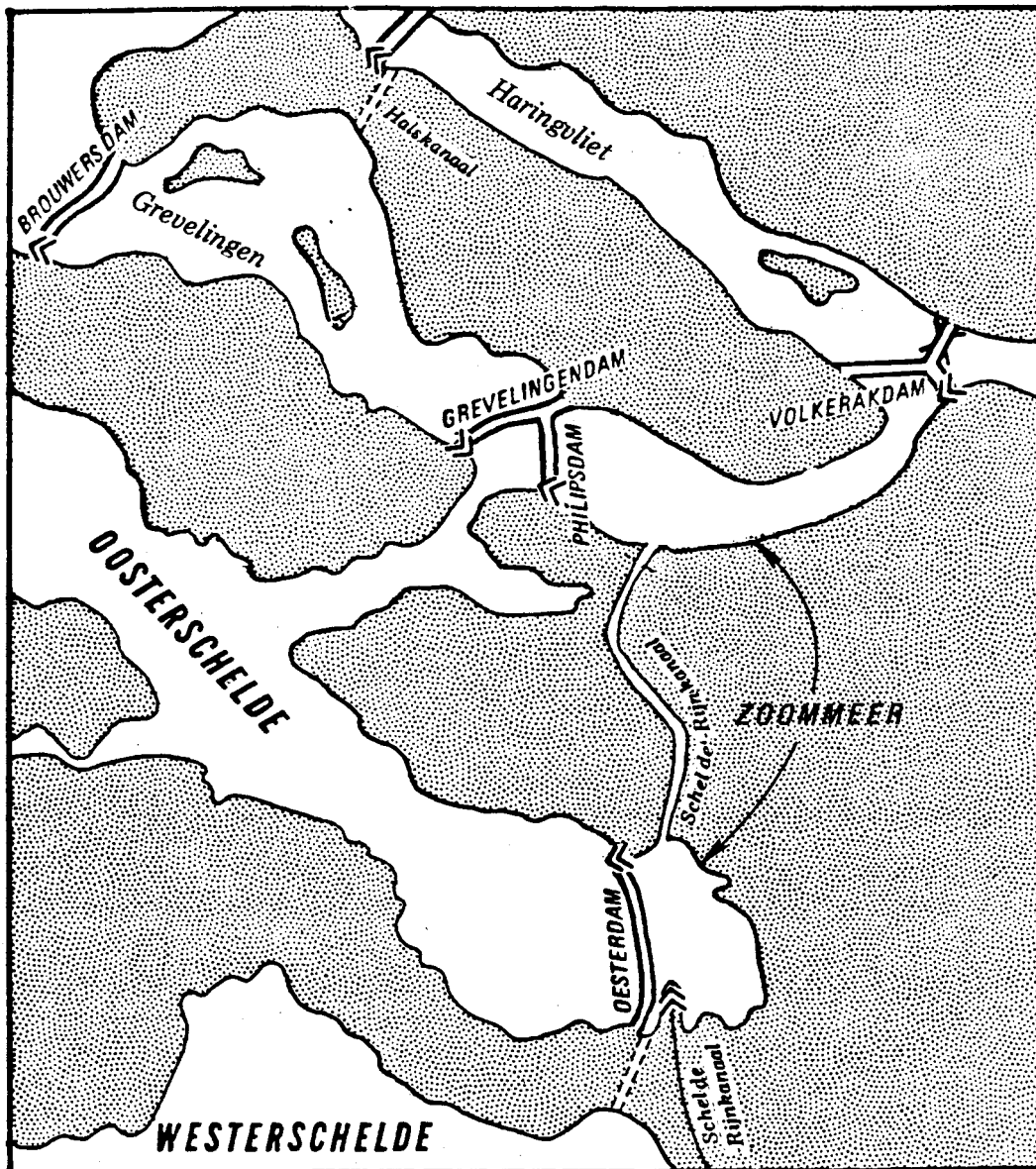

Fig. 20.1--Detail of area around the Zoommeer and Grevelingen

Northern (which together would be called the Zoommeer) would become fresh water.

The Philipsdam and Oesterdam, which will separate the Zoommeer from the Western Basin of the Oosterschelde, are in the process of being constructed. Therefore, our reference assumption was that the Zoommeer is fresh.

Another part of the Delta project involves the closure of the Grevelingen estuary. This estuary has already been closed off (the Grevelingendam was completed in 1965, and the Brouwersdam was completed in 1972), but a decision about whether to make the Grevelingen a freshwater lake has not yet been made. Our reference assumption was that the Grevelingen remains salt. We used this assumption as the reference in our analysis, but we did examine the benefits to agriculture in Schouwen-Duiveland of making the Grevelingen fresh and implementing a waterboard plan that would make most of the cultivated area of the island eligible for sprinkling with water extracted from the Grevelingen.

20.5.4. Miscellaneous Variables

Markerwaard. Toward the end of the 1800s, C. Lely, a civil engineer of the RWS, developed a plan for closing off the Zuiderzee estuary and converting it into a freshwater lake (the IJsselmeer), and for draining parts of the lake and converting them into polders (land areas surrounded by dikes, in which the water level in the ditches is controlled independently from neighboring areas). Five large polders were envisioned, which were to increase the area of the Netherlands by 6 percent. Four of the polders have already been completed (Wieringermeerpolder, 1930; Noordoostpolder, 1942; Oostelijk Flevoland, 1957; and Zuidelijk Flevoland, 1968).

The first phase of the construction of the fifth polder, the Markerwaard, has already been carried out. A dike (the Houtribdijk) has been constructed that divides the IJsselmeer into two lakes, the so-called Small IJsselmeer (referred to as the IJsselmeer in our analysis) and the Markermeer. However, changing views on, among other things, modification of the environment and population growth, have caused reconsideration of the plans for the Markerwaard. Our reference assumption was that the Markerwaard would not be implemented.

If the Markerwaard were to be built, the most important impact on water management would be on policies for setting the target levels of the IJsselmeer and Markermeer. As part of our screening analysis of level management policies for these lakes, we examined the implications for flood protection if the Markerwaard is not built.

Second Oostvaardersdijk. If the Markerwaard were to be constructed, the Houtribdijk would be continued in a southwestern direction, parallel to the western dike of Flevoland, which is called the Oostvaardersdijk.

That part of the Markerwaard dike is generally referred to as the second Oostvaardersdijk.

However, even if the Markerwaard is not built, the construction of this dike might still produce various benefits. If connected to the mainland of Noord-Holland north of Amsterdam, it would give additional protection against flooding to Flevoland, and it would separate a relatively fresh Markermeer from a more saline IJmeer. Presumably, the agricultural area in Noord-Holland that depends on the Markermeer for part of its SW supply would benefit from a lower salinity in that lake.

Since no decision on building this dike has yet been made, our reference assumption was that there was no second Oostvaardersdijk. However, in screening we did consider the construction of a second Oostvaardersdijk as a possible water management tactic, and compared its costs with its expected benefits. We found that the reduction in salinity losses that construction of the dike would provide was not enough to justify its annual fixed cost of 18.8 Dflm. (See Chap. 11, Vol. II, for detailed discussion.)

Dredging Below Tiel. The extraction of Waal water at Tiel in times of low water-flows causes sand to build up in the river below the withdrawal point. Dredging the Waal River bottom to improve shipping conditions is an untried procedure, and the RWS is inclined to approach it cautiously. They are concerned about the possible, but unknown, long-term effects on the river bottom and the effect of dredging on the safety of navigation. Our reference assumption is that dredging will be acceptable, but in screening we did consider the relative cost in shipping losses of letting the sediment build up.

20.5.5. Dutch Sources of Pollution

The amounts of phosphate, chromium, and BOD discharged by Dutch sources into Dutch waters were estimated for 1976 and projected for 1985 from a survey conducted in order to produce an updated Indicatief Meerjaren-programma (multiyear pollution control program), or IMP, and other data, as reported in Chap. 16. For the future context considered in our analysis, we used the projected 1985 discharges as the reference assumption; we considered no alternative because foreign sources create larger amounts of pollution. The 1976 discharges were used only to calibrate our models.

20.5.6. Foreign Sources of Pollution

Important amounts of phosphate, chromium, and BOD enter the Netherlands in border-crossing rivers. For the 1976 context, used only to calibrate our models, the concentrations in the Rijn, Maas, and smaller rivers at the border were obtained from direct observations.

For the future context reference assumptions, we adopted the same concentrations observed in 1976, except that in the months when the 1976

concentrations exceeded the standards that the International Commission of the Rijn has adopted for 1985, we replaced the observed concentrations with the standards. The standard for phosphate is 0.3 mg/l, for chromium 10 µg/l, and for BOD 10 mg/l. This amounts to assuming that pollution outside the Netherlands will not worsen, but will improve only enough to meet the internationally agreed-upon standards, as a potential result of German, Belgian, or French cleanup programs.

(The monthly concentrations of all three pollutants in both the 1976 context and the future context reference scenarios are given in Vol. VA.)

In a few sensitivity analyses, we consider a low assumption, where the standards for phosphate and chromium, and their effect on the concentrations of border-crossing rivers, is kept the same as in the reference, but the standard for BOD is reduced five fold to 2 mg/l, reflecting potential effects of the German cleanup program. (Historically, BOD, which is the easiest to clean up, has been considered the pressing problem.) We sometimes refer to this as the low Rijn BOD assumption.

We must point out that the pollutant concentrations at the border assumed for a given month will apply to a river regardless of the flow that is in the external supply scenario under consideration. For example, in the DEX external supply scenario there are months in which the Rijn flow is smaller than the Rijn flow in the corresponding month of 1976; in such a month, the concentration of each pollutant would be the same, so the amount entering the country would necessarily be smaller in DEX than in 1976. In general, a smaller amount of pollutant will enter the country in dry years, a larger amount in wet years.

For the salinities of the rivers other than the Rijn--Maas, Overijsselsche Vecht, Swalm, Niers, and Roer--we merely use the observed salinities for each decade of the year in the corresponding external supply scenario. (We use the 1976 salinities for DEX.) These rivers tend to be considerably less saline than the Rijn, with the occasional exception of the Roer, and their salinity is evidently not increasing with time.

20.5.7. Thermal Pollution Standards

In PAWN, at the suggestion of the RWS, we adopted as our reference assumption a thermal standard of 3 deg C excess temperature in all waterways. Current Dutch law applies this standard only to the main rivers, and applies a standard of approximately 7 deg C to canals. In sensitivity analysis, we also investigated the effect of the current law, which is a less stringent standard. (Volume XV describes the process of approximating the complex laws with these standards.)

20.5.8. Other Water Quality Standards in the Network

We cannot directly estimate the environmental effects of changes in chloride, chromium, BOD, and phosphate concentrations, but the effects

of each have been considered at length by others in the setting of water quality standards. As discussed in Chap. 16, our source for quality standards is the IMP 1975-1979 (Prospective Multiyear Program 1975-1979). The IMP has provided two different standards for chromium, BOD, phosphate, and chloride: the provisional limit, and a stricter standard called the target value. The provisional limits are the standards being enforced at present, and we have taken these to be our reference standards for PAWN. For each pollutant, we also look at three other standards, one (the target) stricter than the reference standard, the others more lenient (twice and three times the reference standard, respectively, except in the case of chloride). For chloride, we use 250 mg/l, which is the U.S. EPA criterion for a reasonable maximum in DW, and 300 mg/l, which reflects a 20 percent increase in this criterion. The four standards for each pollutant are shown in Table 20.2.

Table 20.2

WATER QUALITY STANDARDS

Standard	Chromium (µg/l)	BOD (mg/l)	Phosphate (mg/l)	Chloride (mg/l)
Target	10.0	3.0	0.05	150.0
Reference	50.0	5.0	0.3	200.0
2 x Reference	100.0	10.0	0.6	250.0(a)
3 x Reference	150.0	15.0	0.9	300.0(a)

(a) Clearly not 2 or 3 times the reference standard for chloride, as noted in the text.

We do not consider the standards for dissolved oxygen and chlorophyll discussed in Chap. 16 here because they are not needed for screening and, as shown in Chap. 27, are not relevant to impact assessment.

NOTES

1. De Kosteneffecten voor de Binnenscheepvaart van Wateronttrekkingen aan Rivieren en Kanaalen in Nederland, Report No. 901/654, NVI/EBW/ACB (Administratie Centrum voor het Beroepsvervoer), Rijswijk, July 1980.
2. See Sec. 29.2.3 for a discussion of how we generate GW sprinkler scenarios.
3. The Belgians are constructing a hydroelectric power station and a weir on the Maas at Lixhe, just south of the Belgian-Dutch border. The old weir, which was very leaky, let through 10 m³/sec when closed; the new weir could reduce the minimum Maas flow to 5 m³/sec. However, we chose not to consider this potential reduction because we thought it would have no important effect on Maas supply to the Netherlands.

It is expected that increased shipping traffic on the Albertkanaal will increase the net amount of water that Belgium extracts from the Maas to send down this canal. The current net extraction is 8 m³/s (15 m³/s is extracted just north of Monsin, but 7 m³/s is eventually returned for use in the Netherlands). A future net extraction of 12 m³/s is likely. We used an extraction of 12 m³/s in all of our supply scenarios.

REFERENCES

- 20.1. Quade, E. S., Analysis for Public Decisions, 2d ed., American Elsevier Publishing Company, Inc., New York and Amsterdam, 1982, p. 155.
- 20.2. MR-272 (unpublished PAWN memorandum), "Procedure for Developing Scenarios for Surface Water and Groundwater Extractions by Industry and by Drinking-Water Companies by District," April 1979.