

Master Thesis

# “A LOCALLY PRODUCIBLE PLASTIC PLATE PRESS FOR BOTTOM-UP RECYCLING IN LOW-RESOURCE SETTINGS”

A design assignment commissioned by  
The MMID Foundation

Graduate student  
Mark Bachrach

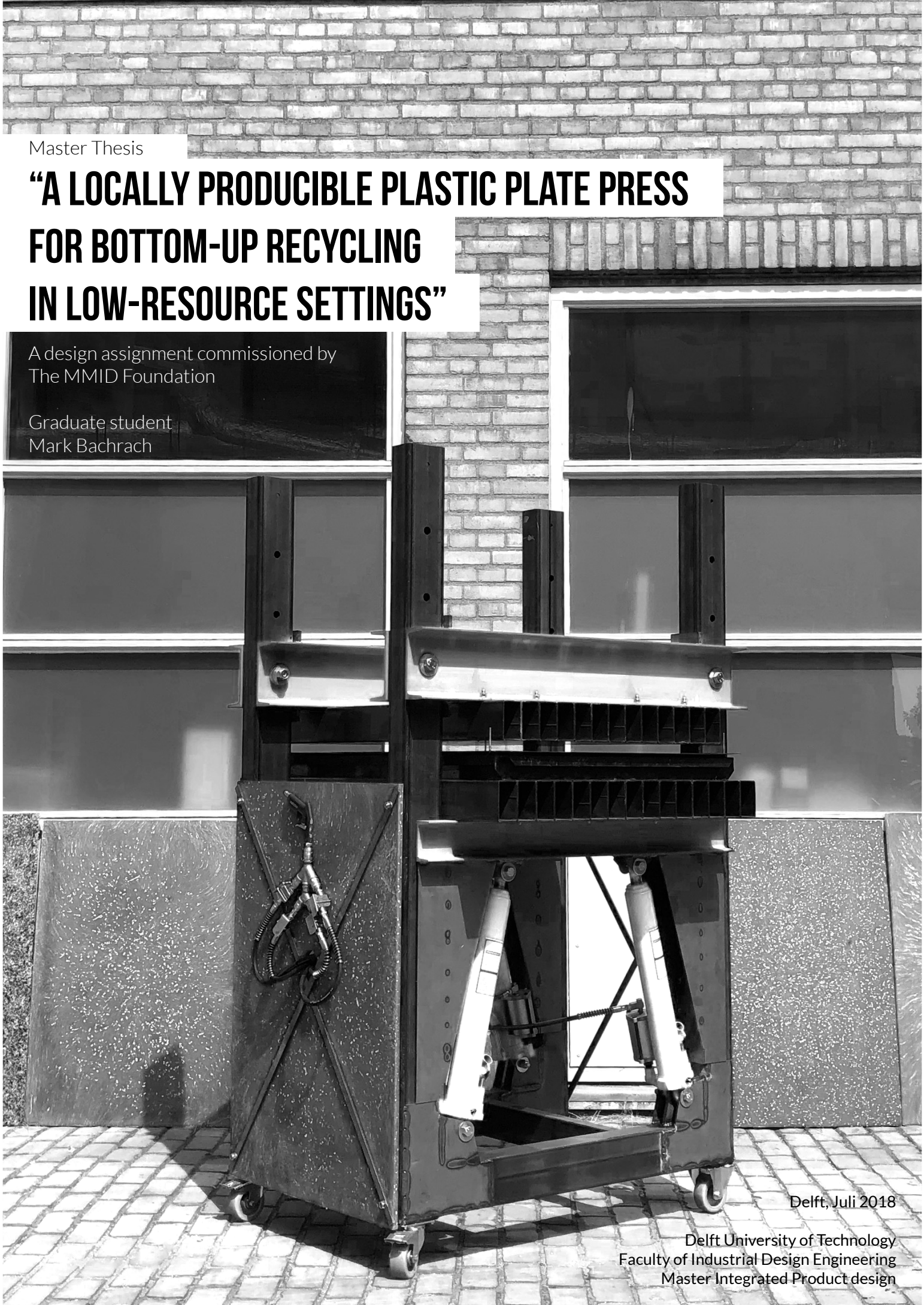

Delft, Juli 2018

Delft University of Technology  
Faculty of Industrial Design Engineering  
Master Integrated Product design

## Disclaimer

This master thesis is written in context of the master Integrated Product Design at the faculty of Industrial Design Engineering at the Delft University of Technology in The Netherlands.

May, 2018

## Graduate student

M.B. Bachrach  
Industrial design engineering  
Domselaerstraat 51H  
1093JP Amsterdam  
m.bachrach@gmail.com

Supervisory team

Chair: Dr. ir. Diehl, J.C.

Mentor: Ir. H. Kuipers

Mentor MMID Foundation: Ir. Scott Hoekstra

## Company

MMID Foundation  
Westvest 145  
2611AZ Delft  
T: +31 (0)15 2136736  
E-mail: [contact@mmidfoundation.org](mailto:contact@mmidfoundation.org)

If you used this work, attribute the MMID Foundation by linking to  
<http://www.mmidfoundation.org/>

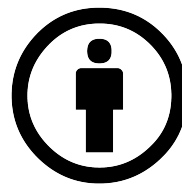
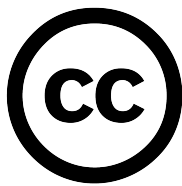

This work is licensed under a Creative Commons Attribution 4.0  
International License, except where otherwise noted.  
<https://creativecommons.org/licenses/by/4.0/>



# PREFACE

The document that you have started to read contains the most extensive project that I've ever completed. This master thesis tells the story of my graduation project and is written in the context of the master Integrated Product Design at the Faculty of Industrial Design Engineering at the Delft University of Technology.

During the project, I've mainly focussed on the practicalities of the design, the actual processing of plastic and the non-industrial materialisation. This is also what attracted me towards this project, I am a hands-on type of designer, and this project felt like it was intended to be executed by me. I found great joy in experimenting with melting plastic and the greatest joy in succeeding to press beautiful plastic plate material.

I am delighted that I was given the opportunity to work on this project by the MMID Foundation. It is incredible that MMID designers spend their free time on projects like these and are able to gather a budget for such a big project. The MMID design agency has provided me with a wonderful work environment to work on this project, and the MMID Foundation members have put a lot of trust in me to bring this project to a successful end, for which I am very grateful.

This report will guide you through the entire development process of the Plastic Plate Press, of which I am very proud to have produced it. I hope that it is able to impress you too.

Mark Bachrach  
Delft, May 2018

# ACKNOWLEDGMENTS

During my graduation project, many people helped me, without whom I would not have been able to produce the design that came to life. Therefore, I want to name and thank the following people specifically.

## **Scott,**

I really enjoyed working with you. You were very patient and always ready to help me out. I think we were a good match in keeping our cool, but what I appreciate most is that you always treated me as an equal en we were able to hang out as friends while you also were able to fulfil your role as my client and coach.

## **Rik,**

although you were not my coach officially, it felt like you were a little bit too and you too were always ready to help me out. We've had some really tough discussion and what amazed me and what I appreciate a lot is that every time that we had such a debate, it didn't influence the way we interacted afterwards. Also, thanks a lot for staying late so that I could press plates in the evening!

## **Henk,**

thank you for your guidance throughout the project and keeping it casual, your relaxed style of coaching suited me very well.

## **JC,**

thank you very much for always thinking ahead of the project and pointing out what opportunities and risks lay ahead, that is something that is not within my usual thinking pattern. Besides that, you helped me out when I got stuck even before I knew I got stuck, this was the most critical moment to help me out.

## **Inger,**

thank you very much for supporting me, especially during the last month of the project when I was not the most pleasant company.

## **All employees of MMID,**

thank you all for making me feel very welcome and for all of your willingness to help. Also, thank you for not complaining about the mess I made.

# EXECUTIVE SUMMARY

This project deals with two problems, which in combination ask for a single solution. The first problem being plastic waste accumulation in low resource areas and the second being that production and construction materials in these low-resource areas are often very expensive. When these two problems are combined, an opportunity arises to transform plastic waste into qualitative production/construction materials. This is something that is already being realised by numerous organisations all over the world, however, in the market of bottom-up recycling, multiple machine designs are available, but a plate press is still lacking. Therefore, the assignment that is set for this project is to:

*“Design a product for **maker-spaces in low-resource areas**, that can **transform plastic waste into qualitative plastic plate construction material**, and that can be **produced locally and operated by locals**.”*

While designing a new product for low-resource settings the challenges are to make it affordable, to design for local production to stimulate the local economy, to ensure that it can operate in the local infrastructure, to make it easy to maintain and repair with local resources and that local staff can operate it.

For this project, it is most important to find an affordable and accessible solution that can be realised with minimal technologies and readily available materials, and that is adaptable to multiple different contexts and resources. Therefore the design is focussed on functionality, embodiment, and production, while topics like user interaction and implementation are only treated superficially.

The design project is divided into 5 phases, analysis, experimentation, conceptualisation, synthesis and simulation. Also, the approach will be a very practical one. The design phase is focussed on designing a viable concept, which is then evaluated through prototyping. The earlier prototypes provide the needed confirmation and new insights to adapt the design and ready it for a Large-scale prototype. The full-scale prototype is built to confirm the scalability and to be able to evaluate and test the plates that can be produced. The final design also evaluated through consultations with the involved experts.

## Analysis

The analysis phase is used to gather insights to be able to find the right design direction and to find the initial design requirements. These provide the start and basis for the design phase. In the analysis among others, the following topics were researched:

- The problem of plastic waste
- Bottom-up plastic recycling
- Plastic waste
- Recycling processes
- Plastic recycling value
- Low-resource consequences.

This rendered the following critical insights:

- The “classic” Plate press design has already been executed.
- Thus other options are more interesting to look into.
- The separation of production process steps is worth looking into because of the energy and time efficiency.
- The PPP should be able to process at least PP and HDPE
- Focus on quality and affordability
- The design should be based on the lowest quality materials
- Safety is an important topic

The end of the analysis includes a survey that was set up to find out what potential users expect from a plastic plate press; this rendered the following crucial insights:

- Producing affordable and qualitative material is the primary driver.
- The press should be able to produce five plates per day
- The application intentions vary, but furniture is mentioned most often
- The aesthetics of the produced plates are a valuable property
- PP should be processable
- Demanding shredded input for the plate press is a realistic option.
- The plate size should near 1,22 x 1,22 x 12 mm
- The thickness tolerance should be around +/- 1mm
- The porosity should be minimised.

## Experimentation

In the experimentation, the general idea is: See how it works, instead of reading how it should work.

The experiments started with curiosity and along the way transformed into hypothesis testing. Sufficient proof was believed to be found; rendering conclusions on which the conceptualisation phase could build, of which the most crucial are:

- Pressure should be applied during the cooling process to restrain warpage and rippling
- A well-defined plate shape can be produced using a simple mould with a stopping edge.
- Shrinkage causes the plates to pull loose from the mould edge.
- Metal to plastic contact speeds up the melting process
- Sufficient pressing force can drive the air out of the plastic plate

## Conceptualisation

The conceptualisation phase starts by summarising the critical insights into comprehensible schematics; a function schematic and a program of requirements. Together these schematics provide the actual input for the generation of principle ideas, which are then used to create plate production process concepts. These are evaluated with the help of the project experts. Two of the concepts are chosen, and their feasibility is tested in simple prototypes. This proof of concept reveals the final choice for the plate production process concept that is further developed in the embodiment phase. The chosen concept is described as:

*“The plastic is melted in a mould in an oven, and when the plastic has melted completely, the mould is taken out and inserted in a plate pressing machine. The*

*plate press uses a force actuator to press two flatbeds together to press the molten plastic in a specified plate shape. When completely pressed, the mould is transferred to a simple cooling press that guards the shape during passive cooling."*

The benefits of this concept are:

- By using a single movement, the pressure distributes evenly and can be quickly applied.
- The oven can be insulated very well and is thereby heat efficient.
- Passive cooling lets the plastic cool down slowly and more evenly, and it allows for continuous production by freeing up the pressing device.

In the proof of concept prototype the following insights were gained:

- The quick application of uniform pressure allows the plastic to be pressed against the mould surfaces when it is still flowing and sticking, which causes smooth and continuous surfaces.
- Taking out the plastic while it is still warm causes it to warp
- The pressing concept works surprisingly well with very simple materials
- The cooling time seemed to decrease significantly when the mould was in touch with a large amount of metal indicating that with the right setup, the cooling process could be integrated into the press.

### Design research

Before the concept can be further developed in the embodiment phase, more detailed information about the functional needs, force requirements and human interaction are gathered in additional design research.

For each of the system elements, the functional requirements are analysed, and partial problems are identified. Also, the design scope is determined, which concludes that the oven is not developed in this project since existing ovens can fulfil its functionalities. The plate press and the mould are innovative in the way that there currently is no existing alternative and are therefore designed in this project.

Additional iterative prototyping was used to solve the partial problems concerning the mould design. This provided a clever cut-off-edge concept that proved to do a great job of cutting out the plate and defining its thickness.

Also, iterations on the cooling properties provided a manner of fast enough cooling without the need for a separate cooling press.

### Embodiment design

In the embodiment phase, all vagueness is taken away by supplying physical solutions that, together, form the product design. This process is split into two parts: The embodiment design of the mould and the embodiment design of the press. Each of these parts also contains multiple steps that are needed to transform the insights and needs into usable design elements.

The foremost requirement that has to be met is for the design to be producible with tools typically available in low-resource-settings. About which it was concluded that welding equipment, angle grinders, drill presses and hand drills are the only 'advanced' tools that can be counted upon.

The press and mould designs are adapted to the size of the oven that is available during this project (120x92cm) because the prototype will also rely on the available oven. Later it is concluded that in all future build cases, the oven will be a leading size factor.

All of the gathered insights and requirements are integrated into the CAD designs of the mould and the press and are presented in drawings and renders accompanied with explanations for all of the functionalities.

### Design Simulation & Evaluation

After and during the production of the prototype, the design is carefully evaluated. The evaluation consists of multiple steps that evaluate the design in multiple layers. First, the building process is discussed, and the valuable lessons learned from this process are transformed into design recommendations. Next, the user experience that is realised with the prototype is discussed and from it, more design improvements are gathered. The use of the machine, of course, also produced the first plastic plates which were then evaluated and compared to the plastic plate requirements. Besides these plastic plate requirements, more (secondary) requirements had to be fulfilled by the press, and also these were evaluated by checking off the Program of requirements. These four levels of evaluation include all internal sources of evaluation and additionally external minds were consulted to produce critiques.

The most critical design improvement requests all related to safety, ease of manufacturing, mould sturdiness and plastic plate release and were integrated into a new design.

The design improvements for the mould enforce new process dynamics that needed confirmation before they could be agreed upon. This confirmation is provided by pressing multiple plates and using the mould as intended. This provided the insight that the new mould design is indeed a vast improvement, not only are the plates easier removed, they also turn out better, with better-defined edges and even smoother surfaces. Next to that, the mould does not degrade as fast as the first design, and the mould holds so well it is expected that it will easily last for 50+ production cycles without significant maintenance.

In conclusion, the final design functions very well when it comes to plate quality, however, the safety, structural integrity and costs have to be further improved. Therefore a shortlist for continuation recommendations is also produced in the final chapter.

### Project Evaluation

In this final chapter, the project itself is evaluated by discussing the design process and identifying the elements of the process that were elementary in defining the outcome. These process elements can be regarded as success factors or as points of improvement. Therefore the design process discussion is followed by project continuation recommendations that will discuss the most critical work that is advised to follow-up on when others continue the project. Finally, to round the project off entirely, a designer reflection is presented which discusses the personal experience of the designer in this project.

# CONTENTS

<b>1. INTRODUCTION</b>	<b>8</b>
1.1. PROJECT STAKEHOLDERS	8
1.2. ASSIGNMENT	9
1.3. PROJECT GOALS AND SCOPE	10
1.4. DESIGN APPROACH & REPORT STRUCTURE	11
<b>2. ANALYSIS</b>	<b>12</b>
2.1. SETTING THE STAGE	13
2.1.1. The problem of plastic waste	13
2.1.2. Fábrica de Sabão	16
2.1.3. Bottom-up plastic recycling	18
2.2. PLASTIC AND RECYCLING ANALYSIS	22
2.2.1. Plastic waste	22
2.2.2. Recycling processes	26
2.2.3. Plastic recycling value	28
2.2.4. Melting plastic energy consumption	29
2.3. LOW-RESOURCE ANALYSIS	30
2.3.1. Low-tech machine building	30
2.3.2. Low-skill users	31
2.4. INFLUENCE MAP	31
2.5. DESIGN PARAMETER SURVEY	34
2.6. PLATE REQUIREMENTS	38
<b>3. EXPERIMENTATION</b>	<b>40</b>
3.1. DESIGN PARAMETER SURVEY	40
3.2. GRILL PRESS EXPERIMENTS	42
3.3. ALUMINIUM MOULD EXPERIMENTS	44
3.3.1. The aluminium mould	44
3.3.2. Defined plate shape	44
3.3.3. PP & HDPE - 5mm, 12 & 20mm	46
3.3.4. Forcing the air out	48
3.4. DISCUSSION & CONCLUSION	50
<b>4. CONCEPTUALISATION</b>	<b>51</b>
4.1. SYSTEM FUNCTIONSCHEMATIC	52
4.2. FIXED OR VARIABLE	52
4.3. PROGRAM OF REQUIREMENTS - CONCEPTUALISATION	52
4.4. IDEATION	54
4.5. CONCEPT DEVELOPMENT	55
4.6. CONCEPT EVALUATION	58
4.7. PROOF OF CONCEPT	60
4.8. CONCEPT DEFINITION	62
<b>5. DESIGN RESEARCH</b>	<b>63</b>
5.1. FUNCTION ANALYSIS	64

5.2. DESIGN SCOPE	64
5.3. PARTIAL PROBLEM SOLUTIONS	66
5.4. ITERATIVE PROTOTYPING & TESTING	68
5.4.1. Mould frame iterations	68
5.4.2. Cooing iterations	68
5.5. PRESSING FORCE	70
5.6. ERGONOMIC ANALYSIS	71
5.7. POR - EMBODIMENT	73
<b>6. EMBODIMENT DESIGN</b>	<b>75</b>
6.1. MOULDDDETAILING	75
6.1.1. Ease of manufacturing	75
6.1.2. Integration of additional functionalities	76
6.1.3. Dimensioning	76
6.2. MOULD DESIGN	78
6.3. PRESS DETAILING	80
6.3.1. Force actuator selection	80
6.3.2. General setup	82
6.3.3. Static setup	84
6.3.4. Sliding or Setting	86
6.3.5. Static simulation iterations	88
6.4. PLASTIC PLATE PRESS DESIGN	90
<b>7. DESIGN SIMULATION &amp; EVALUATION</b>	<b>94</b>
7.1. PROTOTYPE PRODUCTION LEARNINGS	97
7.2. PROTOTYPE USE LEARNINGS	98
7.3. PLATE RESULTS	100
7.4. POR - EVALUATION	102
7.5. CLIENT & EXPERT EVALUATION	102
7.6. COST ESTIMATION	103
<b>8. DESIGN</b>	<b>104</b>
8.1. THE IMPROVED DESIGN	106
8.2. DESIGN IMPROVEMENT CONFIRMATION	110
8.3. PLATE PRODUCTION PROCESS & COSTS	112
8.4. MACHINE BUILD PROCESS PROPOSAL	114
8.5. PROCESS SYSTEM PART REQUIREMENTS	116
8.6. DESIGN CONCLUSION	116
<b>9. PROJECT EVALUATION</b>	<b>119</b>
8.7. DESIGN PROCESS DISCUSSION	119
8.8. CONTINUATION RECOMMENDATIONS	121
8.9. DESIGNER REFLECTION	122
<b>10. REFERENCES</b>	<b>124</b>

# 1. INTRODUCTION

The Better Future Factory (BFF) and the MMID foundation decided to partner up, in order to realise the development of a Plastic Plate Press (PPP) for the maker-space of Fábrica de Sabão (FS) in Angola.

The BFF is a sustainable design and engineering studio that specialises in transforming waste streams into products, thermoplastic material waste streams are their speciality. They have started the development of a PPP earlier but had to stop the project due to limited resources.

The MMID foundation is a charity organisation utilising the effort and time of MMID employees to perform projects for good causes. The MMID Foundation has experience in the development of machines for industrial and consumer applications and now has taken it upon herself to drive the development of the PPP in a non-profit manner, while the BFF provides expertise in the field of plastic recycling.

A plastic plate press (PPP) is a machine that takes plastic as input material and produces a plastic plate or sheet with certain dimensions and properties. In most cases, a plate press processes the material by means of heat and pressure. In this project, the PPP should serve as a means for Fábrica de Sabão to turn waste into affordable production material. At the Fábrica de Sabão lies great opportunity to produce qualitative plastic plates from plastic waste, since construction materials in Angola are quite expensive (€60 for a 1220 x 2440 x 18 mm plywood board) and plastic waste is present in abundance. The goal is to make plastic plates to be used as construction material for a variety of applications and hopefully for furniture application since FS is already active in that field.

Fábrica de Sabão is an innovation hub in the middle of Cazenga, Angola, one of the largest slums in the world with some 800,000 people and a population density of 23,000 people per square kilometre (Fábrica de Sabão). Fábrica de Sabão is set up to leapfrog education challenges and drive socioeconomic inclusion and growth at all levels of society. The hub aims to narrow the gap between the formal and informal economy by encouraging needs-based innovation. The maker-space in Fábrica de Sabão is not only used to teach craftsmanship but is simultaneously used to produce products among which furniture made from CNC-milled plywood. The maker-space will be able to make use of a Plastic Plate Press to convert plastic waste into construction materials, that for example could replace the mentioned plywood in several cases. Fábrica de Sabão is chosen as subject for this project to have a tangible and definable goal, but ultimately the goal is to share the design in an open-source manner allowing the rest of the world to benefit from it.

## 1.1. PROJECT STAKEHOLDERS

Before the design-specific topics are discussed, it is essential to know how the project organisation is set up. Especially since this project is involved with quite some stakeholders of which the roles require some clarification, therefore the functions and relations of all stakeholders in this project are explained in this paragraph and accompanied by a graphic overview depicted in Figure 1-1.

The yellow outlined 'blob' in Figure 1-1 contains all

stakeholders that are directly involved in the graduation assignment executed by me, Mark Bachrach. This shows that the relation between MMID and MMID foundation results in a work environment in which lots of design expertise can be acquired from the MMID designers since MMID provides a workplace. Also, the better future factory will be available to extend their knowledge. However, their involvement is limited to just that. Of-course the TU Delft is involved in this graduation project and supplies guidance by means of a chair (J.C. Diehl) and a mentor (Henk Kuipers).

The blue outlined 'blob' contains all elements that have a direct influence on the design project. Next to the product designs and the designer (me), only MMID foundation has a direct influence on the design since they are the client for this design project. Next to that, the project budget is managed by MMID foundation, and they will have to approve all expenses. The MMID Foundation wants to help people and organisations that cannot afford a design agency but could benefit from one. They want to do good by supplying MMID's design expertise and the foundations budget that is generated out of donations.

Fabrica de Sabão was found to be a client that fits their profile, they are helping the Cazenga community and could really benefit from a design solution that allows them to expand their community work. Thus the MMID foundation uses their gifted budget to employ a graduate student that can put in lots of design hours, more than foundation members could, while the foundation ensures that MMID's expertise benefits the project.

The green outlined 'blob' in Figure 1-1 encompasses the recycling process that the Plastic Plate Press project should allow Fábrica de Sabão to realise. Together with FS's clients, the Cazenga community members, this is the design context. Note the dotted green line expanding the green 'blob' to include the plastic processing machines; FS intends to start with plastic recycling by means of existing (low-budget) plastic processing machines in the near future. Meaning that the current product-systems need to be taken into consideration.

The orange 'blob' holds the elements of the Precious Plastic (PrPI) product system community, which is focussed on a worldwide scale and already has a global reach. This makes PrPI very interesting to collaborate with since they have all the means and the right followers to spread an open-source build plan for the PPP. Again, do note the dotted line, showing that there lies great potential in PrPI adopting the PPP in their machine arsenal. What this means is that the PPP design should be adapted as much as possible to the needs of the potential builders, as long as it doesn't conflict with the needs of Fabrica de Sabão. Next to that, the online community can be used to gather insights concerning plastic processing, low resource machine building and contextual influences from all over the world.

- Precious Plastic is a nonprofit organisation that aims to make plastic recycling accessible to anyone in the world. They do this by providing build plans for plastic recycling machines, including a shredder, an injection moulding machine, a heated mould press and a filament extruder. -



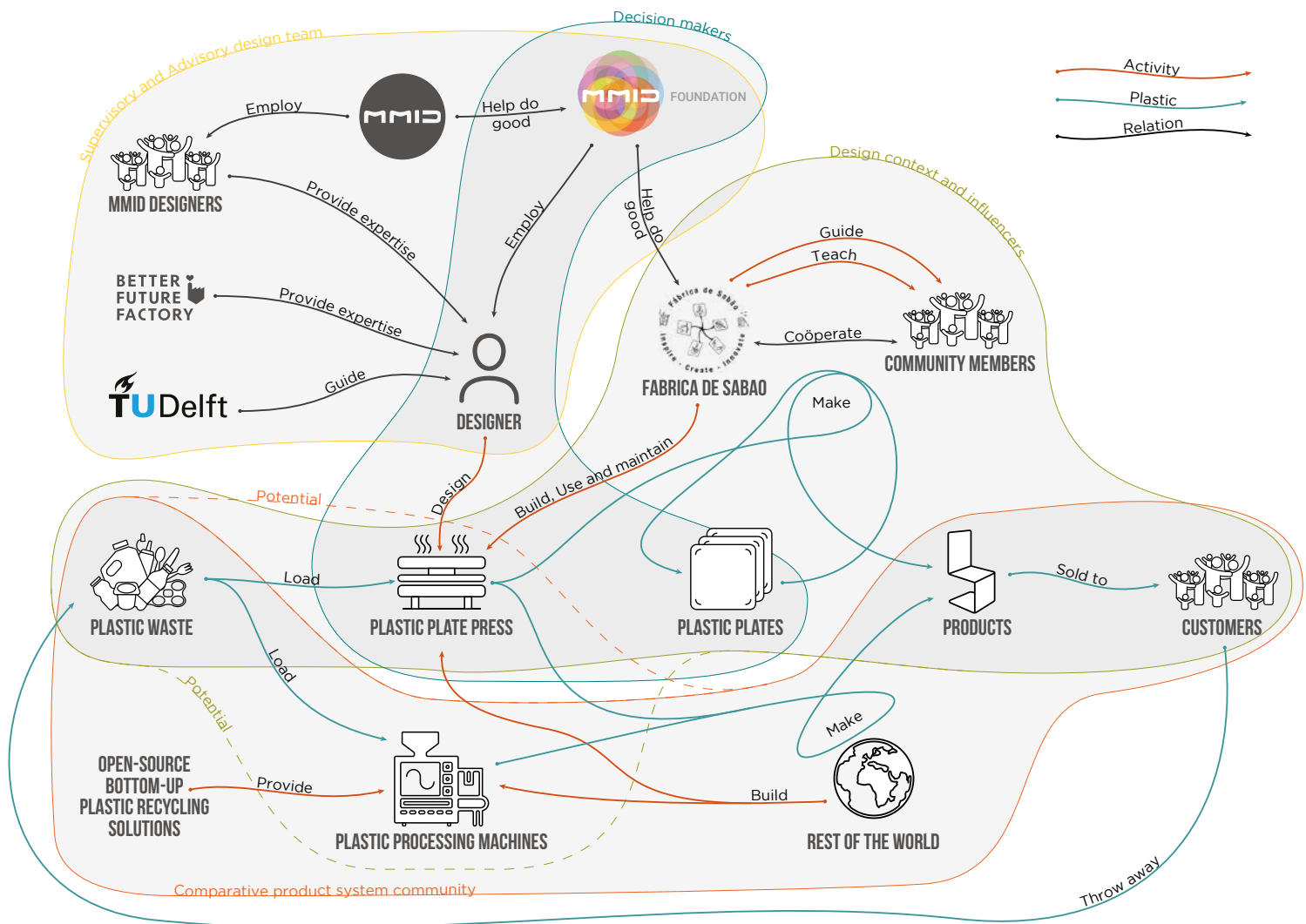

Figure 1-1, Project stakeholder overview

## 1.2. ASSIGNMENT

Now that the origin of the project and the stakeholder's involvements are clear, the actual design assignment can be explained. Most design assignments come from clients that for some reason want a specific product to be designed, but this 'reason' is often more important than the assignment itself, that's why the design problem is explained first, followed by how it logically demands the assignment.

The project deals with two problems, which in combination ask for a single solution. The first problem being plastic waste accumulation in informal settlements like the Cazenga slum (the home of Fábrika de Sabão) and other low resource areas. Since this problem is ongoing and getting worse, organisations like Fábrika de Sabão aim to show that waste has value. By doing so, they hope to create the incentive to treat waste with care and value it for its worth. This problem can, therefore, be reformulated as:

*"How to show the value of plastic waste to residents of low-resource-areas."*

This brings us to the second problem, which is related to

expensive production and construction materials in these low-resource-areas. Often the construction materials are unaffordable for residents of such places. This makes it very hard for the poor to buy or build qualitative products or structures. This problem can, therefore, be formulated as:

*"How to provide affordable qualitative construction materials in low-resource-settings"*

When these two problems are combined, an opportunity arises to transform plastic waste into qualitative production/construction materials. This is something that is already being realised by Numerous organisations all over the world, however, in the market of bottom-up recycling\*1, multiple machine designs are available, but a plate press is still lacking. While sheet material is such a widely applicable and well-known construction material, this is a significant gap to fill. Plate presses exist for professional and industrial application, as well as small DIY-designs for consumer enthusiasts in the Western World, but medium-sized ( $0.5m^2 < A < 2m^2$ ), OpenSource\*2 plate press designs are not yet available (Appendix A.1 presents an overview of currently available plastic plate presses). Therefore, the assignment that is set in this project, is to:

“Design a product for **maker-spaces in low-resource areas**, that can **transform plastic waste into qualitative plastic plate construction material**, and that can be **produced locally** and **operated by locals**.”

While designing a new product for low-resource settings (in this case a maker-space in an informal settlement in Angola) the specific local characteristics will have to be taken into account to make it a product that will be adopted and used successfully. Some of the challenges are for example to make it affordable, to design for local production to stimulate local economy, to ensure that it can operate in the local infrastructure (i.e., unreliable access to electricity), to make it easy to maintain and repair with local resources and that it can be operated by local staff.

In the analysis chapter, among other topics, the possibilities and limitations of low resource areas will be explored and the wishes of maker-spaces in low resource areas will be researched, resulting in a defined goal concerning the producible plastic plate material.

\*1 bottom-up recycling is recycling organised by local individuals, small communities or small organisations rather than state, region or city organised.  
 \*2 OpenSource Designs are designs for which the production schematics are made freely available and may be redistributed and modified.

### 1.3. PROJECT GOALS AND SCOPE

The previous paragraph explained what the assignment is and what problems the design solution should be solving. However, this graduation project has its limits relating to human resources, project duration and budget. Therefore it is important to determine what the project goals are. In consultation with both Fábrica de Sabão and the MIMD Foundation the following project goals were determined:

- A fully developed production process, able to produce plastic plate material, satisfying the wishes of Fábrica de Sabão.
- An evaluated and reproducible product design for each of the innovative physical parts of the proposed production process.

The exact wishes of Fábrica de Sabão and other plate requirements will be determined in the next chapter. As for what physical parts of the production process are innovative can only be determined when the design has been shaped, this follows in chapter 5 in which the design scope is determined.

Although the design scope awaits developments, the project scope was set at the start of the project since it is used to separate main issues from side issues. This division is needed to be able to reach the project goals within the project time span. For this project, it is most important to find an affordable and accessible solution that can be realised with minimal technologies and readily available materials, and that is adaptable to multiple different contexts and resources. Therefore the design is focussed on functionality, embodiment, and production, while topics like user interaction and implementation are only treated superficially. Figures 1-2 and 1-3 summarise this scope.

#### PROJECT FOCUS

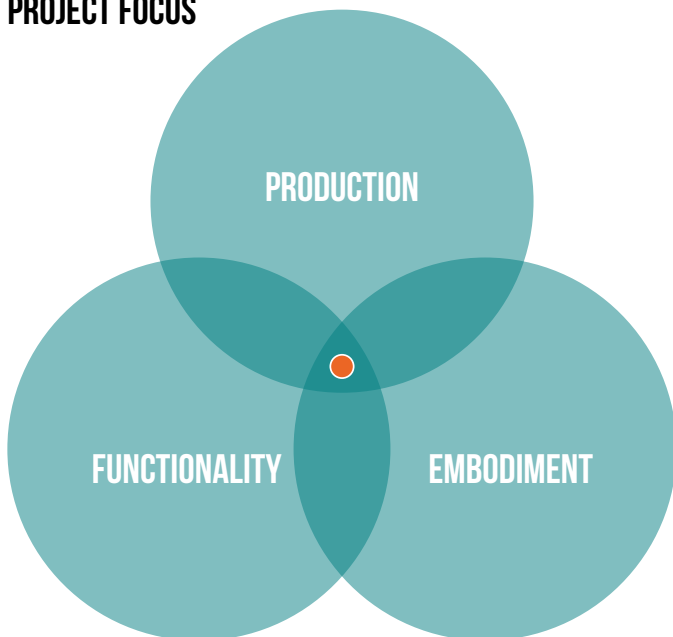

Figure 1-2, Project focus topics

#### DECISION DRIVERS

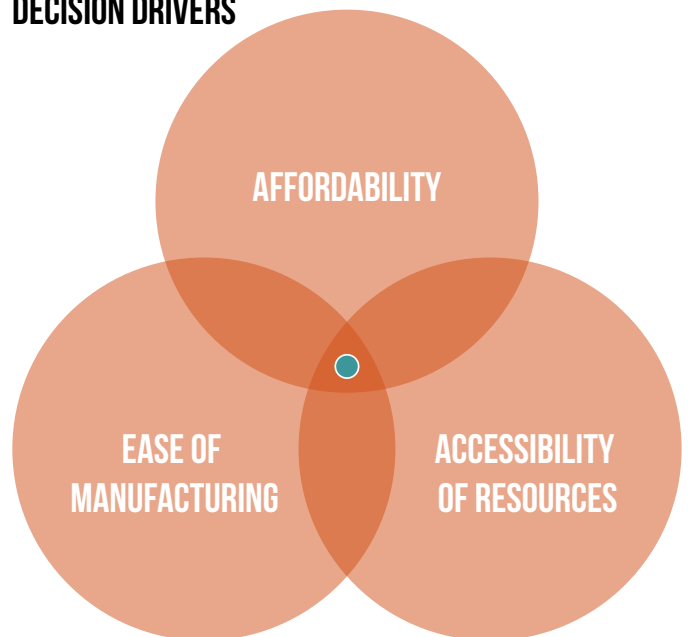

Figure 1-3, Project's main decision drivers

## 1.4. DESIGN APPROACH & REPORT STRUCTURE

This design project will be divided into 5 phases, analysis, experimentation, conceptualisation, synthesis and simulation. The approach will be a practical one. After initial web and literature research into the broader problem of plastic waste and the recycling of it, experimentation with simple materials should provide insight into the processing possibilities, challenges, and limitations of plastic waste. This experiential knowledge will be supplemented with knowledge from available experts. To conclude the analysis phase, the critical design parameters will be mapped and visualised. The resulting 'context and design definition tool' is used to facilitate the knowledge and opinions of all stakeholders involved and to come to a shared vision for a new PPP for low resource settings. This should result in a design definition sufficiently defined to start the design phases. Next to that, it provides a clear view of the possible differences for other maker-space contexts and the expected design consequences of those differences.

The design phase is focussed on designing (by experimenting) a viable concept, which is then evaluated through prototyping. The proof of concept prototype should provide the needed confirmation and new insights to adapt the design and ready it for a Large-scale prototype. The full-scale prototype is built to confirm the scalability and to be able to evaluate and test the plates that can be produced.

This "hands-on" approach is especially suited for this project since the result will be a build instruction for the machine, which the users, in the end, will build in the same "hands-on" manner. Next to that, DIY recycling plastic is not a field that has clear rules, instruction and guidelines and thus asks for empirical research.

The design trajectory will consist of three main phases: Ideation, conceptualisation, and embodiment. Each of which is started with a function analysis providing partial problem definitions and design requirements for in the (updated) program of requirements (POR). Next to that, the individual phases are supplemented with research and methodology suited explicitly for the design stages.

The final design will not only be evaluated in functionality testing with the prototype, but also through expert consultations with the involved experts.

To round of the project in the implementation phase the needed documentation is set up, providing a cost estimation and user, safety and build instructions, making the design ready for open-source sharing and improving.

The report structure does not precisely follow the chronological order of the design activities and design phases, to clarify this, the relation between them is depicted in Figure 1-4.

All non introductory chapters paragraphs conclude with a summation of conclusion concerning the design process and the program of requirements, generated in that report section. See below for an example.

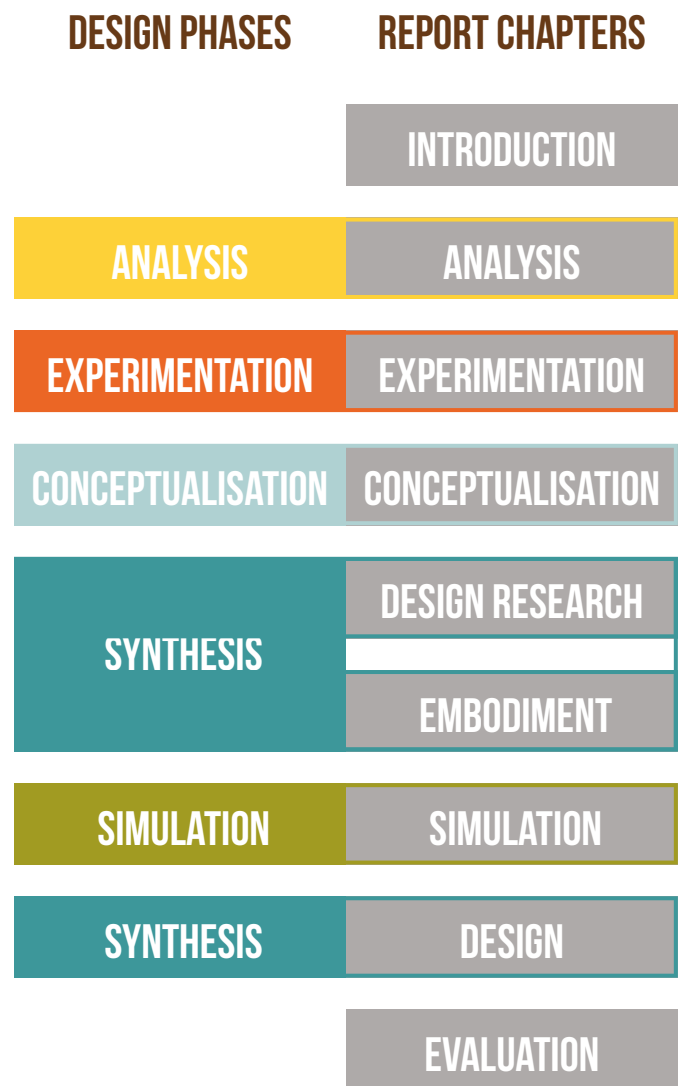

Figure 1-4, Design phase & Report correlation

# 2. ANALYSIS

The analysis phase is used to gather insights in order to be able to find the right design direction and to find the initial design requirements. These should provide the start and basis for the design phase. However, before the analysis can start, study topics need to be figured out. To do so, introduction meetings with all stakeholders were planned in which ongoing activities, first ideas, interesting analysis topics and speciality insights were shared and discussed. In addition, a brainstorm was organised with all project team members of MMID foundation. This resulted in an extensive list of analysis topics (See Appendix A.2) of which a selection was made to actually dive into. These subjects were analysed through desk research, followup meetings with the stakeholders and experts visits. The different topics are elaborated in this

chapter and divided into three paragraphs, each concluded with design requirements and project considerations. ‘Setting the stage’ elaborates on subjects that inherently belong to this project, ‘Plastic and recycling analysis’ elaborates on the essentials of plastic, plastic waste and the recycling of it, ‘Low-resource analysis’ elaborates on the influences the low resource part of this project has on the design. In the 4th paragraph, the insights are summarised into an Influence map that shows the relations between design parameter. In the 5th paragraph, a selection of the design parameters is used to construct a survey with which actual data from potential users is gathered and analysed. This analysis results in the plastic plate and plastic plate press requirements. Figure 2-1 summarises this approach.

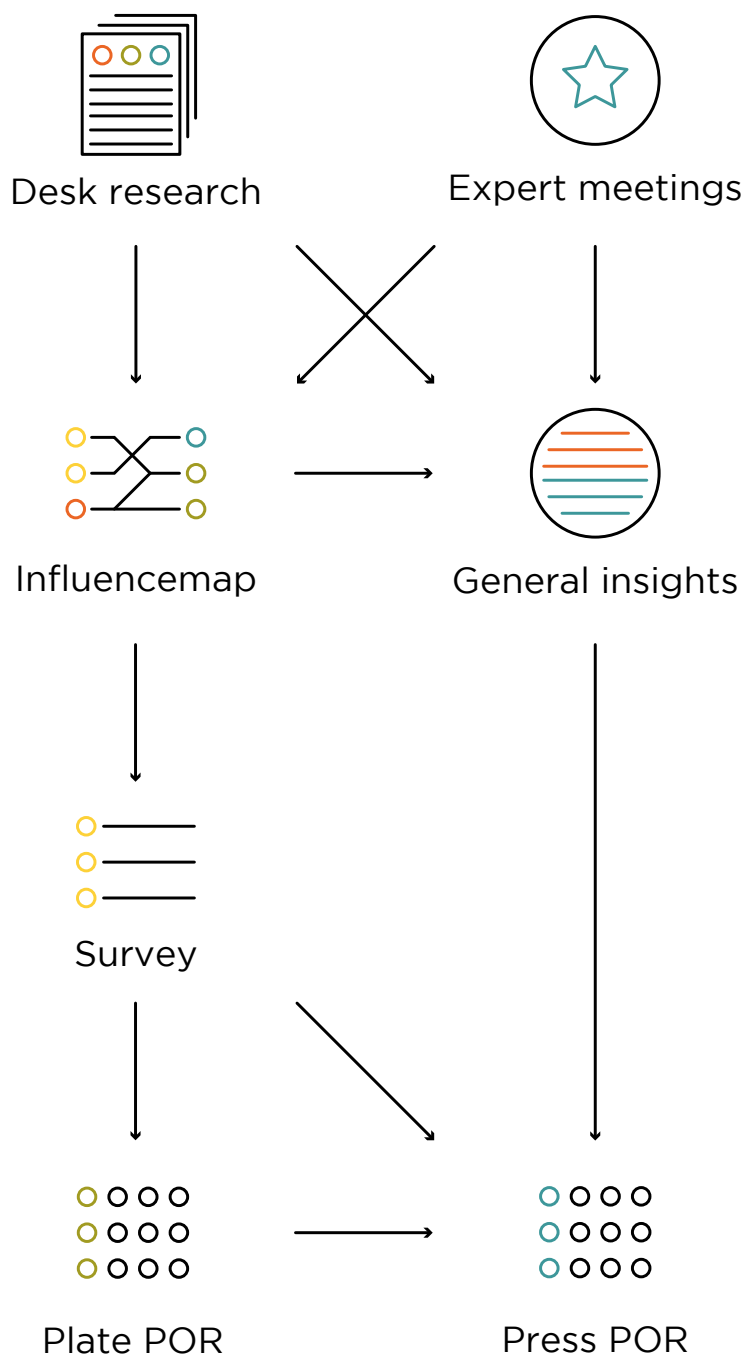

Figure 2-1, Analysis approach

## 2.1. SETTING THE STAGE

Setting the stage means to convey the general feeling of the situation, to prepare the listener for the story to come. That is why in this paragraph the project context and principles of the problem are explained. Starting with the problem of plastic waste, followed by an elaboration on Fabrica the Sabão and concluding with existing solutions.

### 2.1.1. The problem of plastic waste

In the previous chapter, the accumulation of plastic waste in low resource areas was mentioned as a design problem. How significant this problem is and what the implications are, is discussed in this paragraph, starting with the global problem of plastic waste.

#### Plastic waste, a global problem

The accumulation of plastic waste is a global problem and is also considered to be the epidemic of the 21st century. The two main influences for this epidemic are the immense amount of annually produced plastic and the mishandling of the plastic waste that is generated in production and use. In 2015, about 322 million metric tonnes of plastic was produced globally (The Plastic Industry, 2016). This number of global annual production has been steadily growing in an exponential manner up to this size since the start of plastic production in the 1950's, as can be seen in Figure 2-2. Since the start of production, the industry has produced an estimate of 8300 million tonnes of plastic of which only an estimate of 9% was recycled (Geyer et al., 2017). While most plastics take over 400 years to degrade (Parker, 2017) and just 12% of all plastic ever produced was incinerated (Geyer et al., 2017), today, around 7300 million metric tonnes (Mt) of plastic still roam the world in some form. All of this plastic is either in use, in stores, in production or laying around in cities, nature or landfills. Of course, these numbers are still growing. Currently, more than 300 Mt. of plastic is produced each year, and an average of 300 Mt. of plastic waste is generated each year. (Geyer et al., 2017)

For your understanding of these incomprehensible numbers, the amount of global annual plastic waste production, 300 Mt., is expressed in reference volumes:

- A solid layer of plastic, spread over the entire land area of the Netherlands, would be 7mm thick or when spread over the entire land area of Angola, 0.25 mm.
- A solid block of plastic with a base as big as a soccer field (100 x 50 m) would reach 60km up in the sky.
- About 288 solid empire state buildings could be moulded from that amount of plastic.

Ensia.com comments:

*"If the current production trend – approximately 5 percent increase per year – continues, another 33 billion metric tonnes of plastic will accumulate around the planet by 2050, further driving the need for better methods of collection and recycling."*

Geyer et. al. add:

*"Half of all plastic manufactured becomes trash in less than a year."*

These immense amounts of plastic waste production are very worrisome since unnecessary production adds CO2 emissions and the collection and cleanup efforts add even more. However plastic waste that is not collected or cleaned up at all is a cause for all kinds of environmental pollution all over the world. The map shown in Figure 2-3 shows the distribution of plastic waste production around the world and the portion of plastic waste that is mismanaged, meaning that it is not recycled, incinerated or adequately contained.

As can be seen clearly, the western world together with Asia accounts for the gross of the production and the less developed countries have large portions of mismanaged waste.

The consequences of all of this mismanaged waste are mostly related to harming the environment in the form of air, water and land pollution. The pollution in the ocean has a terrible impact on marine species. As a result, it can hurt the economy and food supply for communities that rely on fishing. Secondly plastic can damage groundwater sources. Plastic toxins in dumps and litter can seep into the groundwater, which people in low resource areas drink every day.

Next to the environmental pollution, landfills are taking up more and more space while the growing world population is fighting for the same land. Not only landfills are filling up, but plastic waste also accumulates in slums around the world in less developed countries. According to Medina (2010), this is the cause of many different health issues for residents of these slums.

The mismanagement of waste in developing nations is mainly due to the lack of proper infrastructure to effectively collect, categorise and recycle plastic waste in these regions. Residents can try their hardest to handle their plastic waste with care, but when there is no place to bring it to, what can one do. This situation causes communities to pile up the plastic waste in the streets or just outside the village, together with other waste or separated. When the piles get too big, they are set on fire, producing lots of toxic smoke and CO2 and wasting a valuable raw material.

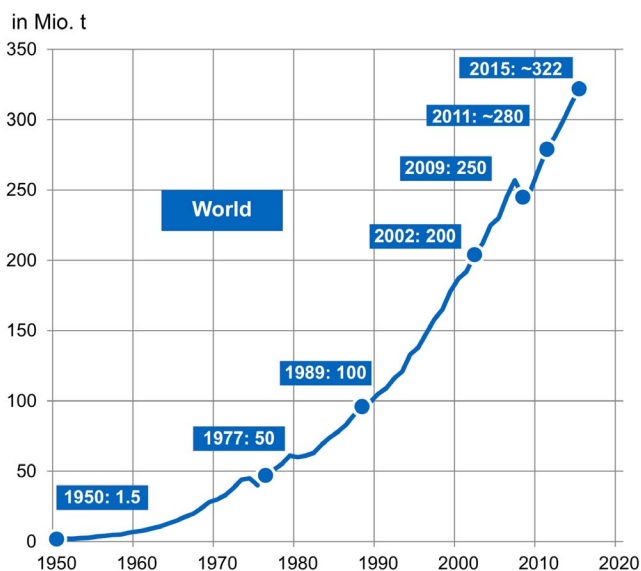

Figure 2-2, Annual plastic production, figure by Plastic Europe

Concluding, the plastic waste problem is an immense problem, which finds most of its roots in the developed world, which is responsible for almost two-thirds of the annual plastic production, while the consequences of waste accumulation affect the world as a whole. Most of the harmful effects have to do with mismanaged waste wondering the globe. This would suggest that recycling waste into new manageable products could be a solution to part of the problem. Of course, the management of the waste has to improve to be able to recycle the plastics that now cause adverse effects. However, by creating value from plastic waste, the plastic waste itself starts to gain value which should drive up the incentive to properly manage it. This way a system of bottom-up recycling is started in places where it is needed, filling (part of) the gap that is left by lacking industrial recycling and municipal waste handling.

### The plastic waste problem of Angola and Cazenga

It is hard to find detailed information about the plastic waste problems in Angola or the rest of Africa. What is clear however, is that production of plastic waste is relatively low in African countries, but the portions of mismanaged waste are very high. Often more than two-thirds of the plastic waste is mismanaged. In Angola, this is close to three quarters according to the Graphic by GRID-Arendal and Maphoto/Riccardo Pravettoni (Figure 2-3).

Koen Verpaalen, former project manager at Fábrica de Sabão, has organised plastic waste collection events and shared a photograph that illustrates the plastic waste problem in

Angola (see Figure 2-4). The coast of Angola has beautiful beaches which are filled with plastic waste, either washing ashore or dumped by locals.

In Luanda where Fabrica de Sabão is located, views as depicted in Figure 2-5, are, sadly enough, quite common. Koen Verpaalen from Fabrica de Sabão has indicated that a lot of the waste in the streets of Cazenga consists of plastic waste, for a large part packaging foils and food packaging. More concrete information and statistical data about the waste problem in Angola are sadly non-existent.

According to Koen, the residents of Cazenga, do care about their living environment, but the lack of other options, besides dumping waste on existing piles, hinders change. Without other easy options or real incentive, none of the community members has time, or money to do something about the problems or to change their current waste handling behaviour. Living in a slum is though enough as it is, without taking on communal issues.

Concluding, Angola clearly has a big waste problem caused by lacking waste collection infrastructure and community awareness. Creating an incentive for community members to separate and collect plastic waste could mean a lot for both the living environment as well as the ecological environment.

Figure 2-4, Plastic waste on the Angolan shore - Picture by Koen Verpaalen >^

Figure 2-5, Median strip waste dumps in Luanda, Angola  
Figure 2-6, - Picture by angoport.nl >v

Figure 2-3, Plastic waste produced and mismanaged - GRID-Arendal and Maphoto/Riccardo Pravettoni v

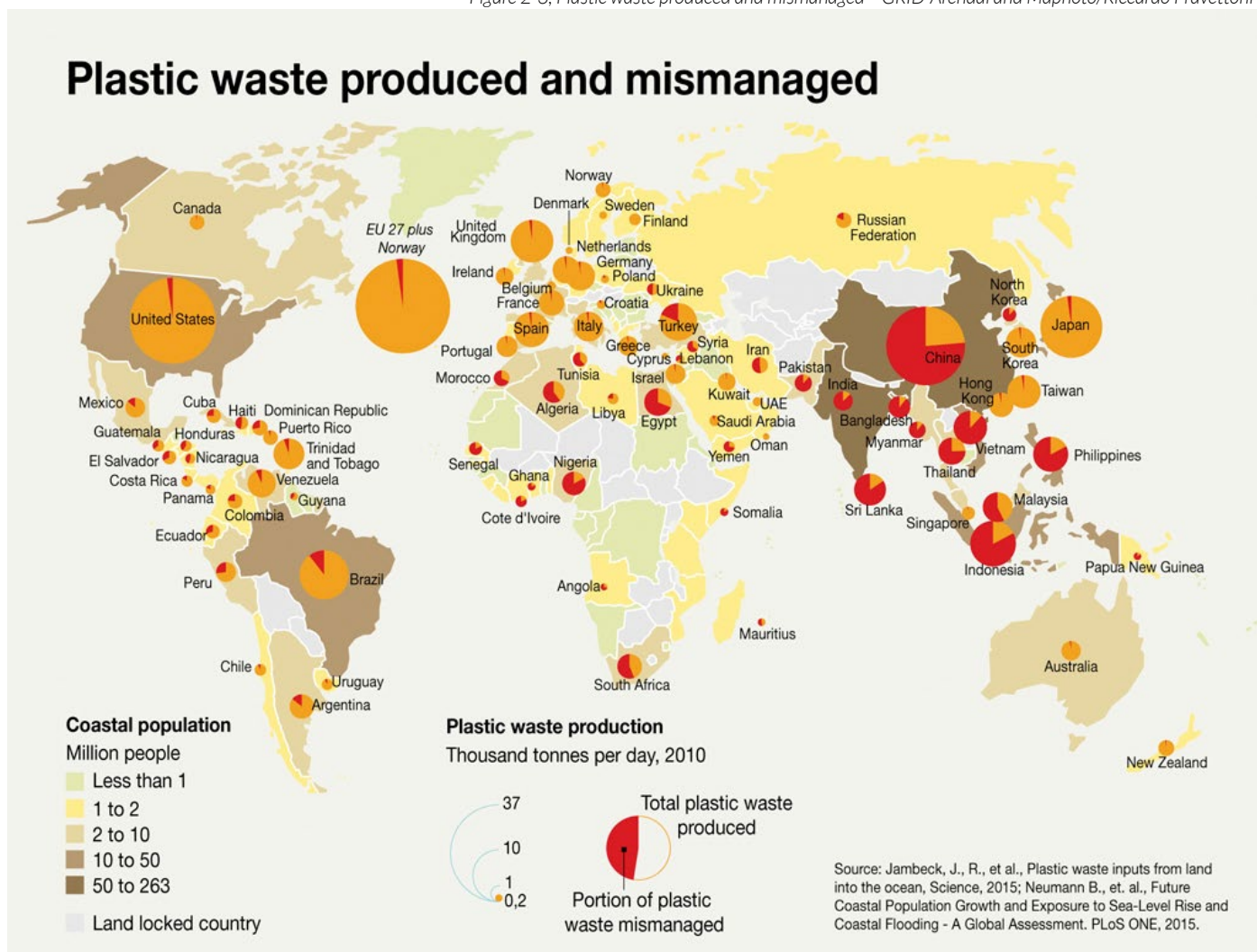



## 2.1.2. Fábrica de Sabão

Fábrica de Sabão plays a vital role in this project. Therefore it is essential to understand what kind of institution it is and what their goals, plans and possibilities are. Fábrica de Sabão will be the first to build a Plastic plate press according to the

instructions created in this project. Since Fábrica de Sabão is the only institution of which it is (almost) certain that they will build the plate press design, the design needs to fit their situation the best it can. This is only limited by the goal to share the design in an open-source manner asking to also take into account what other potential users want.



Figure 2-7, Fábrica de Sabão Flyover view - picture by fabricadesabao.co.ao

### Fábrica de Sabão about Fábrica de Sabão

*“Where once stood an abandoned soap factory now stands an emerging vibrant hub for sustainable innovation and entrepreneurship in Angola. Fábrica de Sabão is an ecosystem that aims to attract creative minds in arts, culture, craftsmanship, business and science to educate, train and mentor youth.*

*Fábrica de Sabão is a hybrid of an incubator and accelerator hub, co-working space and Maker-Space. It is also a cultural connector where creative explorations can thrive. Very soon, it will have its own local radio station and a residence program for visiting mentors and artists.*

*It is a hub to connect, learn, create and grow – a place for creative and sustainable social change.”*

(fabricadesabao.co.ao/en/about/)

### Vision

“Based on the belief that innovation is for everyone, Fábrica de Sabão is a model innovation hub designed to leapfrog education challenges and drive socioeconomic inclusion and growth at all levels of society.

For this reason, the hub is located in the heart of the largest slum in Angola, with some 800,000 people and a population density of 23,000 people per square kilometre. The hub aims to narrow the gap between the formal and informal economy by encouraging needs-based innovation.

Ultimately, Fábrica de Sabão is a place to foster creative-led enterprise. From nurturing young African startups to supporting niche urban manufacturing, the hub will bring together experts and mentors from around the world to share knowledge, harness creative ideas into tangible outcomes and help launch sustainable businesses in Angola.”

(fabricadesabao.co.ao/en/about/)

### What it’s actually like

In the soap factory, which is the literal translation of Fábrica de Sabão, is plenty of room, the large factory halls are filled with shipping containers that divide the open space into smaller rooms. This way they can provide office space for entrepreneurs and artists. Open spaces are used for workshops and other activities, and one of the halls is setup as Maker-space, to be shared with all in-house artists and entrepreneurs.

A quick scan through their website leaves a good impression (it is advised to take a look yourself, fabricadesabao.co.ao). However, more useful insights were gathered in telemeetings with Koen Verpaalen, a dutch (former) project manager at Fábrica de Sabão, who was involved from the start of the PPP project and Daniela Antonio, the current Maker-Space manager, who became the new contact person when Koen left Fábrica de Sabão.

Daniela explained that Fábrica helps community members to learn manufacturing & entrepreneurial skills. Next to that, Fábrica has their own in-house manufacturing with their





Figure 2-8, Fábrica de Sabão inside space division - picture by fabricadesabao.co.ao

own employees. In the near future, Fábrica wishes to share the facility with small entrepreneurs that started with the help of Fábrica de Sabão. They can then also share all of the facilities of the maker-space. The community members that are trained, are mostly young and inexperienced; often this is their first “job”.

### Production in the maker space

In the maker-space, products are produced by employees of Fábrica de Sabão with the primary goal of generating income for Fábrica de Sabão, but even more of the products are produced by independent entrepreneurs that use Fábrica de Sabão’s facilities. The facilities of the maker-space include welding gear and supporting metal working tools like grinders and a drills press. Next to that and more prominent, the maker-space has woodworking tools like a large CNC-router that can quickly cut out complex digital design. And of course, all the basics are present like simple hand tools and a

compressor providing compressed air.

Most of the manufacturing is based on designs from Creative Commons (CC), but new designs are also created by the community members and are shared through CC. This indicates that design capabilities are sufficient to adapt designs to new material or create entirely new designs specially made for the plastic plate material. The products that are produced in the maker-space are mostly sold to locals and local companies.

### Recycling for the maker space

Daniela explained that Fábrica de Sabão is also working on waste awareness in the Cazenga slum and because of it, they are setting up their own recycling hub, for collecting and sorting waste. Expected is that the plastic can be sorted by type, but Koen experienced in earlier collection activities that a significant portion of the plastic waste is hard to sort by type because there are no evident characteristics present.

Figure 2-9, Fábrica de Sabão’s Maker-Space - picture by fabricadesabao.co.ao



Therefore being able to recycle the unidentifiable mix could be very helpful, although sorting is, of course, better and the resulting products should be usable.

The Plastic Plate Press is wanted to be a new means for processing plastic acquired through this future recycling hub. Currently, there are no means for recycling the expected amounts of collected plastic waste. There are plans to buy a plastic shredder or build one after the design by Precious Plastic. However, a shredder doesn't produce usable construction material. Koen explained that together with other team members at Fábrica de Sabão, they realised that it would be very pleasing to do something with all of the plastic waste.

*"It would be fantastic if we could replace plywood, to use in furniture."*

(Koen Verpaalen)

Upon asking for the actual motivations, Koen answered: "Fabrica de Sabão wants a machine that transforms plastic waste into usable raw materials. In the 1st place because this produces a cheap material while the existing building materials are very expensive. In the second place to clean up the environment. Creating waste awareness is more important than the actual cleaning, which of course is also nice."

As mentioned, Fábrica de Sabão doesn't have the means to recycle the expected amounts of plastic collected by their recycling hub. However, they do already have some experience with processing plastic waste. They are producing 'New marble' tiles according to the design of the Better Future Factory, up til now they have been cutting up bottles by hand, which is one of the reasons a shredder is very welcome. Next to that both Koen and Daniela confirmed that Fabrica de sabão is interested in building or buying the machinery of precious plastics.

#### Conclusions for the design process

- It is worth looking into whether mixed plastics can be processed (see Paragraph 2.2.3)
- Furniture application requirements might be a realistic goal

- Plastic-type pollution and residual waste pollution should be taken into account
- Fábrica de Sabão and possibly other users, are expected to be willing to adjust their facility and preprocessing and collection efforts to fit the plate pressing process

#### Conclusions for the program of requirements

- PET is already processed in another process, making it a lower priority to be processable by the plate press
- Directly replacing 18mm plywood would be ideal, but thinner and smaller plates are still very valuable
- The plastic plates do not have to be a direct replacement for plywood.
- The design has to account for multiple different users with minimal experience

### 2.1.3. Bottom-up plastic recycling

The machine that is to be developed should, by assignment, allow individuals and initiatives to start creating plastic plate material from plastic waste, by themselves. Recycling on such a small and local scale is referred to as bottom-up recycling. This is not a new concept, and thus it is useful to gain an understanding of the current players in the market of bottom-up recycling and the developments that concern this project. By conducting web research followed by visiting 3 Dutch companies and interviewing persons of interest the following information has been collected.

#### Production development

In the world of bottom-up plastic recycling, there are lots of small initiatives and multiple companies that process plastic waste on a small scale. Most of these companies process a specific local waste stream into new products with added functional and/or aesthetic value. Waste Boards for example, collects bottle caps and transforms them into flamboyant penny boards, a specific type of skateboard, See Figure 2-10. Like most other initiatives they had to figure out how to recycle plastic in a non-industrial manner by themselves. With lots of experimenting, the process of moulding penny boards is being perfected, and the current process already renders saleable products. Jonathan Morrison, one of the founders of

Figure 2-10, A wasteboard - picture by wasteboards.com



Waste Boards, explained that people from the industry told them, one after another, that it couldn't be done. Also when he consulted University professors, they advised against pursuing small-scale self-organised production, because this would be too difficult. Waste Boards proved both the professors and the industry professionals wrong. Jonathan accounted this to curiosity and stubbornness and added that both the industry and the literature have standards that do not correspond with the practicalities of bottom-up recycling. He encourages everyone to start experimenting and to question the theoretical knowledge. (see Appendix A.3.5 for the full meeting excerpt)

### Process & tools export

Besides companies that use bottom-up recycling to produce their own line of products, there is also a (smaller) number of companies that not only develop and use a recycling process but also export the developed process and the corresponding tools. The Better Future Factory's New Marble is such a company. They have developed a process that transforms PET bottles into 'New Marble tiles', "produced from 100% recycled PET plastic waste. They can be used for wall applications like conventional ceramic tiles using conventional tile glue and grout. It is 40% lighter than normal tiles and has a warm feeling that makes it a perfect fit for bathrooms and other surfaces you touch." (newmarble.nl). Currently, they have set a project in Angola, at Fábrica de Sabão, and one in Sierra Leone for both of which they provided the specially developed tools that are needed to realise the recycling process. New marble thus provides others with 'machinery' to start bottom up recycling. This way they do not stand alone in recycling local waste streams, but by exporting knowledge and tools, other localities can join in on plastic cleanup.

Though when a technique is exported, it has to comply to other standards than when kept to oneself, especially when a technology is exported to developing countries, production, safety and use need to be accessible and very clear. This is something that the better future factory invested a lot of development time in.

Laura Klauss, from The BFF, explained that bottom-up recycling of PET is rare because processing PET is very complicated, that is one of the reasons why New Marble is so unique. The BFF also succeeded in scaling up the process, thus one would think plastic plate material is already realised, but this is not the case. Laura clarified that PET crystallises when cooling down slowly, turning it into a hard, stiff and brittle form, which is suitable for tiles, but less useful in other applications. Besides that, the developed process produces one smooth side and one rough lumpy side. When the same technique is used to process other plastics, the results are unsatisfying. Knowledge like this very valuable for this project and The BFF has gained lots of knowledge about handling waste streams and recycling plastic, part of which was shared and included in the plastic recycling analysis in the next paragraph.

(See Appendix A.3.1 for the full meeting excerpts)

### Open-Source recycling community

Next to companies like WasteBoards, New Marble and The Better Future Factory, there are also organisations that take sharing knowledge, skills and technologies to the next level. Precious Plastic is such an organisation.

*"Precious Plastic is a global community of hundreds of people working towards a solution to plastic pollution. Knowledge, tools and techniques are shared online, for free. So everyone can start (yes, you too!). We are independent, poor but free :) Hundreds of people all over the world contribute to the project with their skills & knowledge, single or monthly donations. Precious Plastic was started in 2013 by Dave Hakkens and is now at its third iteration (version) counting on dozens of people working on the project, remotely or on-site (somewhere below sea level in the Netherlands)."*  
(preciousplastic.com)

Figure 2-11, New Marble - picture by newmarble.nl



Precious plastic currently provides four machine designs online for free, together with video instructions for production, use, modifications and more. These machine designs, displayed in Figure 2-12, include (from left to right) a shredder, a filament extruder, an injection moulding machine, and a mould press. Where to find the materials to build them, tips for sorting plastic by type, troubleshooting, product design sharing and many other topics are shared on the, by now, very comprehensive community forum.

To visualise the spread and potential impact that Precious Plastic has established, two maps are shown in Figure 2-13. The first map displays all the people and organisations that would like to contribute to the Precious Plastic community (orange circles with raised hands, one of which is Fábrica de Sabão, the one in Angola). The second map displays all existing workspaces that are recycling plastic using the precious plastic machine designs.

Since both the PPP project and Precious Plastic are working towards a solution to plastic pollution by means of sharing open-source build plans of plastic processing machines, it seems more than logical to consider each others role, stakes and influence. That is why their product system was included in the project stakeholder map in Paragraph 1.3.

In a short meeting with the very busy Dave Hakkens, the founder of Precious Plastic, he agreed that it would be possible to share the Plastic Plate Press design, resulting from this project, through the online Precious Plastic platform.

However, Dave's team also developed a plastic plate press that is ready for sharing in Augustus 2018. Dave suggested that the design in this project could be an improvement of their design or take a different approach, but at least take into account all the learnings gained from precious plastic's plate press development.

Jerry de Vos, the (former) intern that was in charge of designing and constructing the plate press, kindly shared the following fundamental information about the plate press he developed. Unfortunately, he couldn't share visual materials. The plate press is set up to produce plates of 1x1m, 10mm thick. To do so, the plastic granulate is loaded on a heated press bed that is pressed upwards against a heated press roof, using a central hydraulic jack. The plate shape and thickness are limited by a square frame with the right thickness.

- The hydraulic jack has a pushing force of 8 ton, which translates to 72,5 kN. ( 1 ton  $\approx$  0.9072 tonne = 907.2kg  $\approx$  9 kN)
- The press bed and press roof are each heated with ceramic heat elements, consuming 3,6 kW each.
- The electronic components are powered by a 3-phase 230V 16A power connector.
- The setup cost them roughly 2000 euros to build.
  - Ca. € 400 for the construction.
  - Ca. € 600 for the aluminium flatbeds.
  - Ca. € 1000 for the electronics, heating elements and insulation.



The machine is capable of producing one plate per day, limited by heating and cooling times while they all occur in the same device:

- Preheating the machine while the flatbeds are pressed together takes 2 hours.
- When the plastic granulate is inserted, the melting and pressing process takes another 2 hours.
  - During these 2 hours, the flatbeds are pressed closer together every 15 minutes.
- When the press has completely closed, the heat is turned off and cooling starts, which needs at least 4 hours.
  - Often the plate was left to cool overnight, just to be sure.

(See Appendix A.3.3 for the full meeting excerpts)

### Conclusions

From the information described in this paragraph, project and design influencing conclusions were drawn. These are listed below. Some of these conclusions relate to analysis topics that are discussed in the next chapter.

### **Conclusions for the design process:**

- Practical experimentation may reveal more possibilities than the literature suggests
- The requirements resulting from production, maintenance and use standards in developing countries should be studied
- Both the BFF and WasteBoards as well as Precious Plastic, are excellent sources for process and machine development knowledge and theory and design evaluation.
- The precious Plastic community can be used to gather specific information about plastic waste and production possibilities from all over the world.

### **Conclusions for the program of requirements:**

- The “classic” Plate press design has already been executed. Thus other options are more interesting to look into.
- PET plate material can more or less be produced already. Thus other plastic types might be more deserving of a new solution.
- The separation of production process steps is worth looking into because of the energy and time efficiency.

Figure 2-12, Precious Plastic's Machine Arsenal - picture by PreciousPlastic.com v



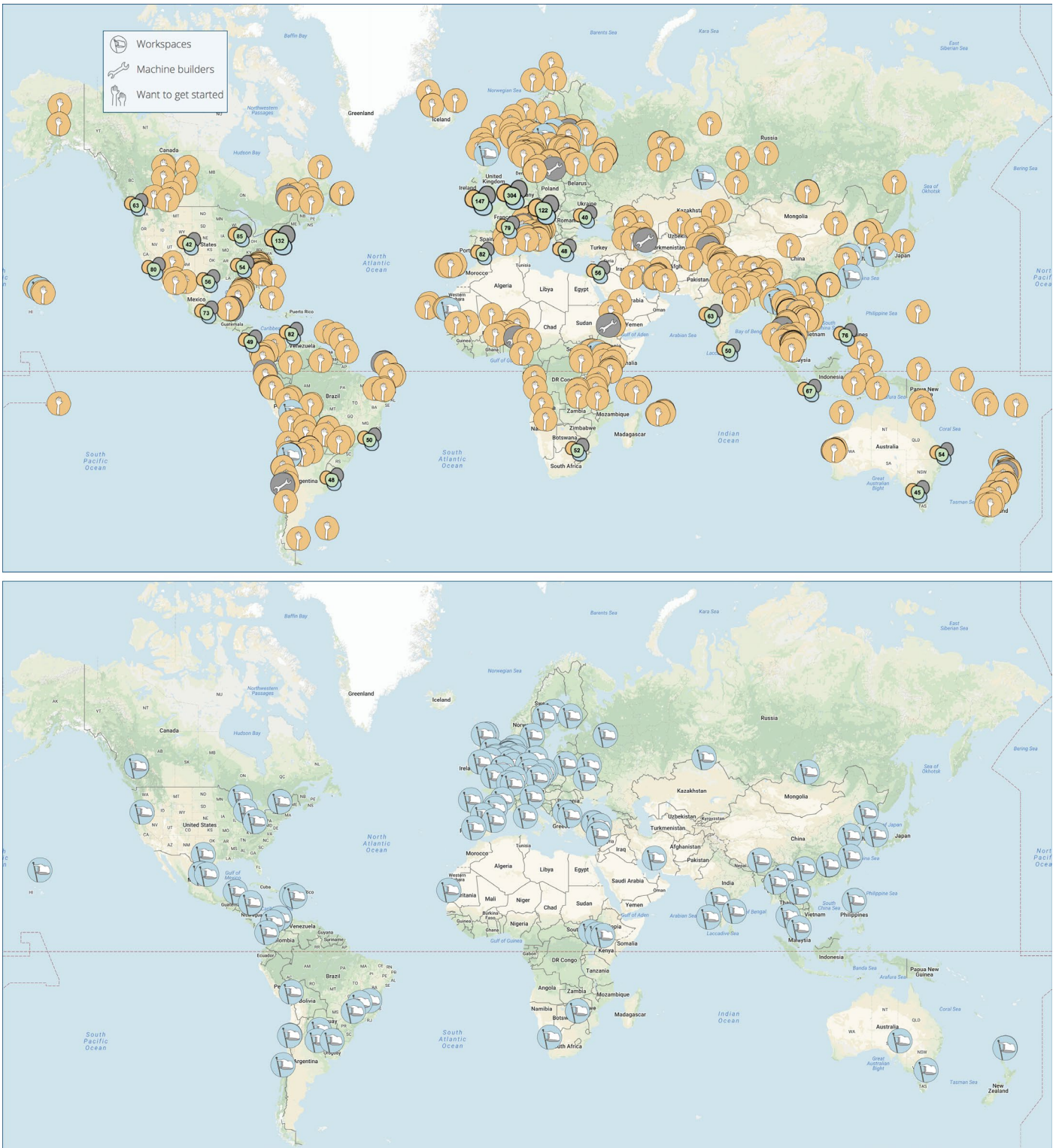

Figure 2-13, Precious Plastic's Community spread around the globe - picture by PreciousPlastic.com

## 2.2. PLASTIC AND RECYCLING ANALYSIS

With the newly gained insights in the project context, the general problem of plastic waste and bottom recycling, new questions arise: What is the actual content of plastic waste? How does the recycling of it work? What are the qualities of these plastics and what do we need to recycle it? These questions, and more, are answered in this paragraph.

### 2.2.1. Plastic waste

When close attention is paid to the content of ones trash bin in current days, soon will be realised that a substantial

portion of the trash consists of plastic waste. This becomes especially evident when waste is separated in the classic categories of GFT waste, glass, paper and residual waste. This is also something that was experienced during this project when plastic waste collection was set up in the MMID Office. Plastic waste collection bins were installed in the corner of the design office (see Figure 2-14), and all employees were asked to separate office waste and bring their plastic waste from home. This realised multiple goals, collecting actual plastic waste to experiment with, inducing plastic waste awareness with the employees, attracting attention for the project and experiencing the first steps in the recycling process; collecting and sorting. The recycling process will be elaborated in Paragraph 2.2.2.

The plastic collection efforts were limited to the seven most common type divisions of which Other and mixed (7♻️), PVC (3♻️) and LDPE (4♻️) were collected in a single bin. This was due to the, at that point already made decision to not design for processing those materials. More about this and other decisions about the design inclusive plastics is explained in

the next paragraph. Collection in this office organised manner gave some insight into the distribution of plastic type weight shares in the total amount of plastic waste. The collected plastic types ordered by yield turned out to be: PET, PP, HDPE, Mix and PS.



Figure 2-14, Self organised plastic collection in the MMID Office - picture by Mark Bachrach

Literature revealed what the domestic plastic waste content distribution in the UK in 2007 was. Figure 2-15, which is based on the findings of Wrap (2008), displays this distribution. It roughly corresponds to the office collection distribution, at least, when considering that in Foster’s samples, the majority of PET bottles were removed before the samples were analysed and HDPE and LDPE were combined under the single denominator of PE.

Based on these findings, also considering the PET bottles that have been removed from the sample, PET would be a logical choice to select as material to recycle into plastic plates. However, multiple experts (Dave Hakkens, Mathijs Stroober, Jerry de Vos and Laura Klauss) have advised against it. Also, experimentation, discussed in the next chapter (3. Experimentation), confirmed the processing difficulties of PET.

When looking at the plastic waste content data, the next logical selection for plastic types to design for, would be PE and PP. The reason for making a selection instead of including all plastic types is the difference in material properties of the plastic types. They each ask for different processing parameters and considerations; thus processing all kinds is more complicated. Developing a new production process with minimal resources is hard as it is. Therefore limiting the development to a single type of plastic, at first, is an acceptable and even logical decision. This was also suggested and thereby

### PLASTIC WASTE CONTENT UK 2007

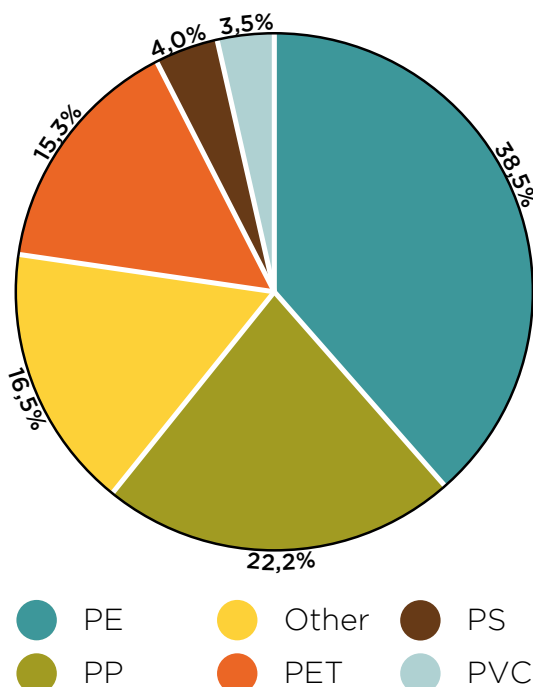

Figure 2-15, Based on data from Wrap 2008 - Figure by Mark Bachrach

confirmed by Laura from the BFF, who has years of experience in developing recycling processes. Nevertheless, it is also suspected that PP and PE can be processed similarly, thus pinpointing only one plastic type, might not be needed. This suspicion and the, just now discussed, differences in plastic type, are elaborated in the next paragraph. More information about plastic waste type availability at Fábrica de Sabão and other potential user locations is discussed in Paragraph 2.5.

### Commodity plastics

The majority of people regard plastic as a single material, but in reality, there are many different kinds of plastic. The first distinction that can be made is the difference between engineering plastic and commodity plastic. The class of engineering-plastics encompasses the widest variety of plastics, which can be specified, tweaked and engineered to perfectly fit the needs of the application. The plastics in this division can be regarded as uncommon and specialistic. The other main class of plastics, the commodity plastics, are the group of plastics that are most commonly used and are thus produced in the highest quantities. These plastics make up ca. 90% of all plastic that is produced globally (Plastics Europe 2015) and thus are the plastics that need to be concerned when recycling from the bottom up. In this paragraph, the main differences between the types are discussed and the selection of plastics to consider for pressing, is narrowed down. Next to that, specific material properties are discussed that are of great importance in this project.

### Commodity plastics properties overview

In Figure 2-16, an overview of the commodity plastics is displayed, listing the main material properties and common product examples made from the specific types. The data in this figure are used as reference data for calculation and to convey and gain general insight in and a feeling for the different materials. For example, by getting to know the example products, the materials are easily recognised when encountered in the flesh.

In Figure 2-16, two values were generated on behalf of this project, the example product weight equivalent (EPWE) and the litre melting energy (LME). The EPWE is an estimated value representing 1kg of material with a multiple of a typical example product. It is used to convey and gain a feeling for the amounts of waste needed to produce a product of a specific weight.

The LME is the amount of energy in Watt-hours needed to heat the specified type of plastic from 25 degrees centigrade up to its minimum melting temperature (also listed in Figure 2-16). The LME neglects heating efficiency, but it is still very useful for comparing the plastic types with one another. Figure 2-16 is also included in Appendix A.4, which also lists the sources information and the values.

### Plastic types to design for

In the previous paragraph, some suggestions for selecting plastic types to design for were already introduced. In this paragraph that reasoning is continued. To start with ABS (9⊕), which is sometimes also considered as a commodity plastic. When melted, ABS secretes toxic fumes. Therefore, it was excluded from consideration to design for before it was included in the overview. When further analysed, it was found that PVC and PS suffer the same condition, and thus they too were excluded as contender to be processed

in the plate pressing process. This is also a first suggestion towards excluding mixed plastics from the processing goals. Since the content will be unknown and, toxic fumes can thus be produced unknowingly. The production of toxic fumes is considered a problem because it is unknown how the machine operators and local institutions will deal with such safety risks. It is even expected that in many low resource settings, safety regulations and precautions are often ignored and regarded as an unnecessary hassle. A known example is welding with sunglasses, instead of a proper welding mask or helmet. More, about such low-resource design considerations, is discussed in Paragraph 2.3.

LDPE is the final plastic type to be excluded, mainly because the survey data that is reviewed at the end of this chapter points out that LDPE is not very common in the regions where the product will be used. The exclusion of the mentioned plastic types leaves PP and HDPE to be considered for processing. They will thus be experimented with in chapter 3. The now excluded plastics can still be tested with the final design. However, the exclusion in this stage only limits the design adaptations to the most logical and safe plastic types. When the design is finished, and tests reveal that other plastics can also be processed either with or without small modifications, then this is seen as an added benefit. Especially when considered that the design resulting from this project is only a first version that should be and will be improved by the Open Source community. The MMID Foundation and Precious Plastic share this opinion.

### Essential material properties to take into account

Next to the differences between the plastic types, they of course also share certain properties. Almost all thermoplastics—plastics that become mouldable when heated above a specific temperature and solidify again when cooled down—share two general thermal properties that will have essential consequences for this project. Those properties are a relatively low thermal conductivity and a relatively high thermal expansion.

Thermal conductivity expresses the ease of heat transfer through a material. Materials with a high thermal conductivity value, transfer heat well, they are also referred to as heat conductors. While in materials with a low thermal conductivity, heat transfer occurs slowly; these materials are referred to as insulators. All of the commodity plastics are good insulators, meaning that when exposed to a heat source, the heat is transferred slowly through the plastic. In comparison, steel is an excellent heat conductor, when one side of a steel rod is heated, the other end turns hot quite soon too. Thermal conductivity is expressed in Watts per meter Kelvin, which translates to a value that tells us how much Joules are transferred per second over the distance of 1 meter when there is 1 degree Kelvin of temperature difference. From this can be deduced that the parameters to work with are the heat travel distance and the temperature difference. Thus when the heat absorption speed needs to be increased, the travel distance should be decreased. This can be realised, for example by spreading the material instead of concentrating it in a compact volume. Another solution would be increasing the temperature difference, for example, heating the material with a heat source of a thousand degrees centigrade when heating only to 200 degrees. This solution however, contains two problems, one of which is related to











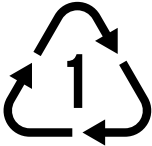

 <b>PET</b> POLYETHYLENE TEREPHTHALATE <b>PETE, A-PET, PETP</b>	 <b>HDPE</b> HIGH DENSITY POLYETHYLENE <b>PE-HD, PE</b>	 <b>PVC</b> POLYVINYL CHLORIDE <b>V</b>	 <b>LDPE</b> LOW DENSITY POLYETHYLENE <b>PE-LD</b>	 <b>PP</b> POLYPROPYLENE	 <b>PS</b> POLYSTYRENE	 <b>0</b> OTHER OR MIXED <b>? UNKNOWN ?</b>
Good gas & moisture barrier properties High heat resistance Clear Hard Tough Microwave transparent Solvent resistant Turns brittle hard and opaque when cooled slowly	Excellent moisture barrier properties Excellent chemical resistance Hard to semi-flexible and strong Soft waxy surface Permeable to gas Pigmented bottles stress resistant	Excellent transparency Hard, rigid (flexible when plasticised) Good chemical resistance Long term stability Good weathering ability Stable electrical prop. Low gas permeability Secretes toxic fumes when melted	Tough and flexible Waxy surface Soft - scratches easily Good transparency Low melting point Stable electrical properties Good moisture barrier properties	Excellent chemical resistance High melting point Hard, but flexible Waxy surface Translucent Strong Stress withening	Clear to opaque Glassy surface Rigid or foamed Hard Brittle High clarity Affected by fats and solvents Secretes toxic fumes when melted	There are other polymers that have a wide range of uses, particularly in engineering sectors. They are identified with the number 7 and OTHER (or a triangle with numbers from 7 to 19). Also mixes and unknwn plastics are collected in this group.
COSMETIC CONTAINERS  FOODJARS  MOUTHWASH BOTTLES  SINGEL USE DIRINKING BOTTLES  PREPARED FOOD TRAYS  SALAD DRESSIGN BOTTLES	BOTTLE CAPS AGRICULTURAL PIPE DETERGENT BOTTLES EXTRUDED PIPE GROCERY BAGS ICECREAM TUBS MILK/JUICE JUGS SAUCE BOTTLES SHAMPOO BOTTLES SHIPPING CONTAINERS	BLISTER PACKS BLOODBAGS CABLE SHEETING CARPET BACKING FLOOR TILES GARDEN HOSE MEDICAL TUBING OUTFOOR FURNITURE PLUMBING PIPE WINDOW FRAMES WIRES INSULATION ELECTRICAL PIPING	6-PACK RINGS BREAD BAGS DRY CLEANING BAGS GARBAGE BAGS HEAVY DUTY BAGS MOLDED LAB EQUIPMENT PLASTIC FOOD WRAP RECYCLING BINS SQUEEZEABLE BOTTLES TOYS	BOTTLE CAPS CEREAL LINERS COTTAGE CHEESE LINERS HINGED LUNCH BOXES KETCHUP BOTTLES MARGERINE CONTAINERS MEDICINE BOTTLES MICROWAVE OVENWARE PACKAGING TAPE POTATOCHIP BAGS RUBBERMAID CONTAINERS STRAWS	CD AND VIDEO CASES DISPOSABLE HOT DRINK CUPS DISPOSABLE COLD DRINK CUPS DISPOSABLE PLATES DRINKING GLASSES EGG CONTAINERS FOAM PACKAGING HINGED BAKERY CONTAINERS PACKING PEANUTS/NOODLES PLASTIC CUTLERY STYROFOAM YOGURT CONTAINERS	BABY BOTTLES CAR PARTS FIBREGLASS LARGE WATER BOTTLES TUPPERWARE WATER COOLER BOTTLES ABS (SOMETIMES 9) PLA PC PMMA PEEK ETC.
1 kg ≈ 50 Soda bottles (.5L) 	1 kg ≈ 70 Sauce bottles (.35L) 	1 kg ≈ 12.5m of electrical piping (Ø 16mm) 	1 kg ≈ 200 6-pack rings 	1 kg ≈ 555 Soda bottlecaps 	1 kg ≈ 300 Pieces of plastic cutlery 	<b>EXAMPLE PRODUCT WEIGHT EQUIVALENT (EPWE)</b>
<b>260 C°</b>	<b>177 C°</b>	<b>182 C°</b>	<b>121 C°</b>	<b>208 C°</b>	<b>177 C°</b>	<b>MINIMUM MELTING TEMP.</b>
<b>80 C°</b>	<b>75 C°</b>	<b>60 C°</b>	<b>70 C°</b>	<b>140 C°</b>	<b>95 C°</b>	<b>SOFTENING TEMPERATURE</b>
<b>300 C°</b>	<b>275 C°</b>	<b>184 C°</b>	<b>318 C°</b>	<b>315 C°</b>	<b>330 C°</b>	<b>DECOMPOSITION TEMPERATURE</b>
<b>0.145 W/M°C</b>	<b>0.482 W/M°C</b>	<b>0.220 W/M°C</b>	<b>0.335 W/M°C</b>	<b>0.140 W/M°C</b>	<b>0.126 W/M°C</b>	<b>THERMAL CONDUCTIVITY</b>
<b>70 · 10<sup>-6</sup>·1°C<sup>-1</sup></b>	<b>200 · 10<sup>-6</sup>·1°C<sup>-1</sup></b>	<b>80 · 10<sup>-6</sup>·1°C<sup>-1</sup></b>	<b>225 · 10<sup>-6</sup>·1°C<sup>-1</sup></b>	<b>150 · 10<sup>-6</sup>·1°C<sup>-1</sup></b>	<b>70 · 10<sup>-6</sup>·1°C<sup>-1</sup></b>	<b>LINEAR THERMAL EXPANSION</b>
<b>40 N/MM<sup>2</sup></b>	<b>20 - 30N/MM<sup>2</sup></b>	<b>80 - 110 N/MM<sup>2</sup></b>	<b>8 - 15 N/MM<sup>2</sup></b>	<b>40 - 45 N/MM<sup>2</sup></b>	<b>80 N/MM<sup>2</sup></b>	<b>FLEXURAL STRENGTH</b>
<b>30 - 45 N/MM<sup>2</sup></b>	<b>25 - 34 N/MM<sup>2</sup></b>	<b>50 - 60N/MM<sup>2</sup></b>	<b>9 - 28 N/MM<sup>2</sup></b>	<b>30 - 40 N/MM<sup>2</sup></b>	<b>40 - 65 N/MM<sup>2</sup></b>	<b>TENSILE STRENGTH</b>
<b>70 %</b>	<b>250 - &gt;500 %</b>	<b>20 - &gt;350 %</b>	<b>200 - 600 %</b>	<b>&gt;450 %</b>	<b>15 %</b>	<b>ELONGATION AT RUPTURE</b>
<b>127 WH</b>	<b>72 WH</b>	<b>88WH</b>	<b>46 WH</b>	<b>76 WH</b>	<b>88 WH</b>	<b>LITRE MELTING ENERGY</b>
<b>BRITTLE/TOUGH</b>	<b>TOUGH</b>	<b>RIGID/FLEXIBLE</b>	<b>FLEXIBLE</b>	<b>HARD/FLEXIBLE</b>	<b>BRITTLE</b>	<b>GENERAL QUALITY</b>

Figure 2-16, Commodity plastics info tableBased on data from CES Edupack - Figure by Mark Bachrach

the same heat conductivity property. A slow heat transfer rate also results in big heat difference inside the material since the outer layer is relatively quickly heated to the surrounding temperature, while the centre takes longer to heat up. Which brings us to the second problem, which is related to the decomposition temperature of plastics. Plastics start to burn or deteriorate at a high pace when heated above a specific temperature, the decomposition temperature, which is also listed in Figure 2-16 and Appendix A.4, together with the heat thermal conductivity values.

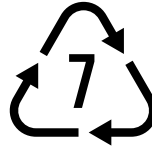
The second thermal property of importance, linear thermal expansion, expresses the amount of dimensional growth caused by temperature increase. This property is expressed in percentage per centigrade, which translates to a value that tells us how much a material will expand proportionally per degree centigrade. For example, a square plate of HDPE with dimensions of 1m x 1m x 10mm will roughly grow to be a plate of 1,04m x 1,04 m x 10,4mm when its temperature is increased by 200 degrees. In the decimal notation, it does not look like much, but 4 centimetres is a considerable length. This thermal expansion of course also works the other way around, thus when a freshly pressed plastic plate made of HDPE is cooled down (200 degrees), 1m will also turn into ca. 0,96 m. For size references see Figure 2-17. These effects need to be carefully incorporated into the design, especially when designing for a plate result with specific dimensions. Next to that, these shrinking effect will also prove useful when it comes to mould adhesion, when the plates are cooled down and shrink, contact with mould edges will cease, making it easier to take the plate out of the mould.

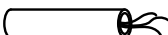
The thermal conductivity and the thermal expansion can together cause warpage in the product. Driven by thermal conductivity, temperature differences inside the material are caused, which then lead to different shrinkage amounts throughout the product. This can cause plastic plates to warp, which of course, needs to be prevented.

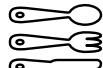
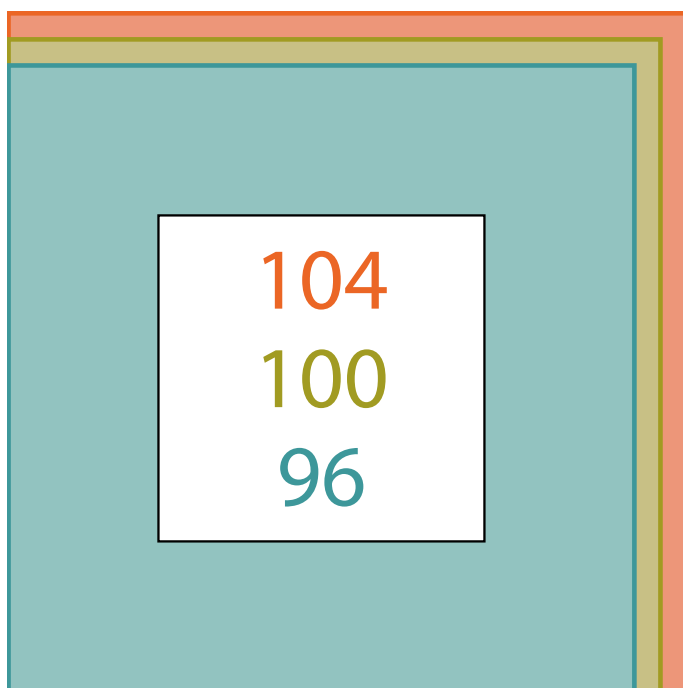

Figure 2-17, Based on data from CES Edupack - Figure by Mark Bachrach

#### Conclusions for the design process:

- The excluded plastic types are not considered in the design, but can still be tested with the final design

#### Conclusions for the program of requirements:

- The PPP should be able to process at least PP and HDPE
- The product needs to account for shrinkage during the cooling process
- The product needs to account for expansion during the heating process
- The product needs to deal with the low thermal conductivity of plastic
- The product needs to prevent warpage

### 2.2.2. Recycling processes

Next to essential information about plastic waste, plastic types and their properties, it is important to understand how plastic recycling processes are organised. Therefore the industrial process, as well as the bottom up recycling process, is discussed in this paragraph, followed by the expected recycling and production process that can be realised with the plastic plate press design.

In industrial recycling, the process consists roughly of the process steps displayed in Figure 2-18. The process steps displayed in the green arrows are the actual recycling process steps, the steps displayed in the other colours are context. The yellow arrow shows a possibility for in-house recycling of production waste, but this is only possible when recycling and production are executed within the same organisation. In industrial recycling, it is more common that a recycling factory takes care of the recycling process and sells their final product as raw material for production factories. In that case, production waste from external factories can be collected.

#### Each of the steps fulfils a function, the most important ones are explained:

- In the sorting step, plastic types are separated and often also colour groups divided. Also, residual non-plastic objects are removed.
- In the shredding step, the large pieces of waste are reduced to small flakes typically around or less than 2 cm<sup>2</sup>; this is needed to reduce the volume of the waste and to provide access to all surfaces for cleaning.
- In the washing step, all residues and other pollution are washed off; this is done after shredding to provide cleaning access to container products.
- In some processes, a second sorting step is introduced after shredding; this order is needed when sorting techniques based on floating differences or static charge are used.
- The drying step seems very obvious, but it is of more importance than suspected since most plastics have significant water absorption properties. When too much water resides within the molecular structure of the polymer, steam is produced in the melting process, which can cause voids in the final products.

Bottom-up recyclers use the same steps but most of the time skip pelletising since they can use the plastic flakes directly in production. For the same reason, their production waste can be directly returned to the sorting process.

See Figure 2-1.

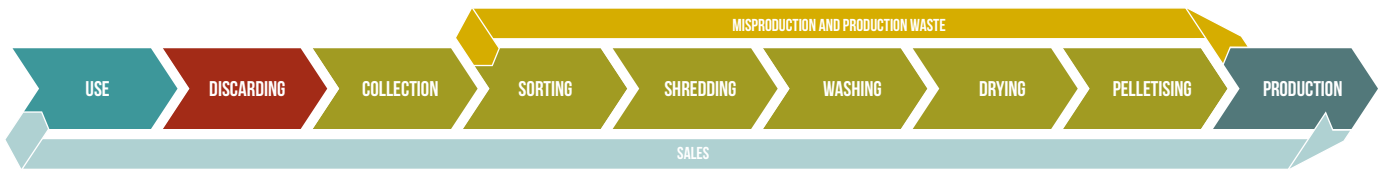

Figure 2-18, Industrial recycling process - Figure by Mark Bachrach

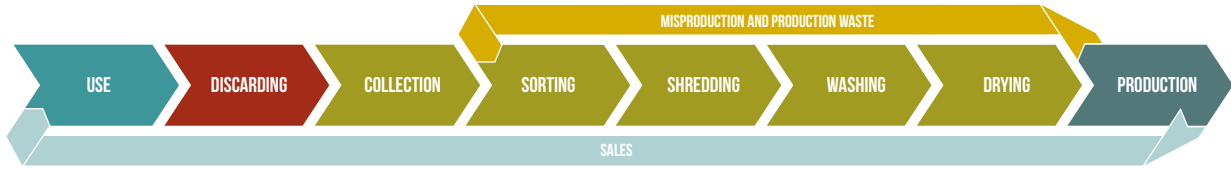

Figure 2-19, Bottom-up recycling process - Figure by Mark Bachrach

The main differences are apparently not found in the process steps; the difference lies in the machinery and the quality standards. Industrial recyclers need to be able to produce a product with reliable and uniform properties. Also, when selling recycled raw materials to the industry, the quality standards are set high. To be able to meet these standards advanced machinery is used for automated sorting, thorough cleaning and precise pelletising. Also with the vast quantities of plastic waste that are collected and processed, industrial recyclers can be picky with waste. Waste that doesn't comply with the standards is rejected and sent to the incinerator or elsewhere.

Bottom-up recyclers do not have to comply with the high industrial standards; they control their own standards. This allows them to work with less advanced machinery and accept waste of lesser quality. Also, more sorting and washing inaccuracies are permitted. Of course, the quantities that are recycled are much smaller than on an industrial scale, which contributes to less need for advanced mechanised machinery. This entirely complies with the typical bottom-up budgets. Instead, custom-made solutions are used, for which build plans and tips and tricks can be found, for example on the Precious Plastic community.

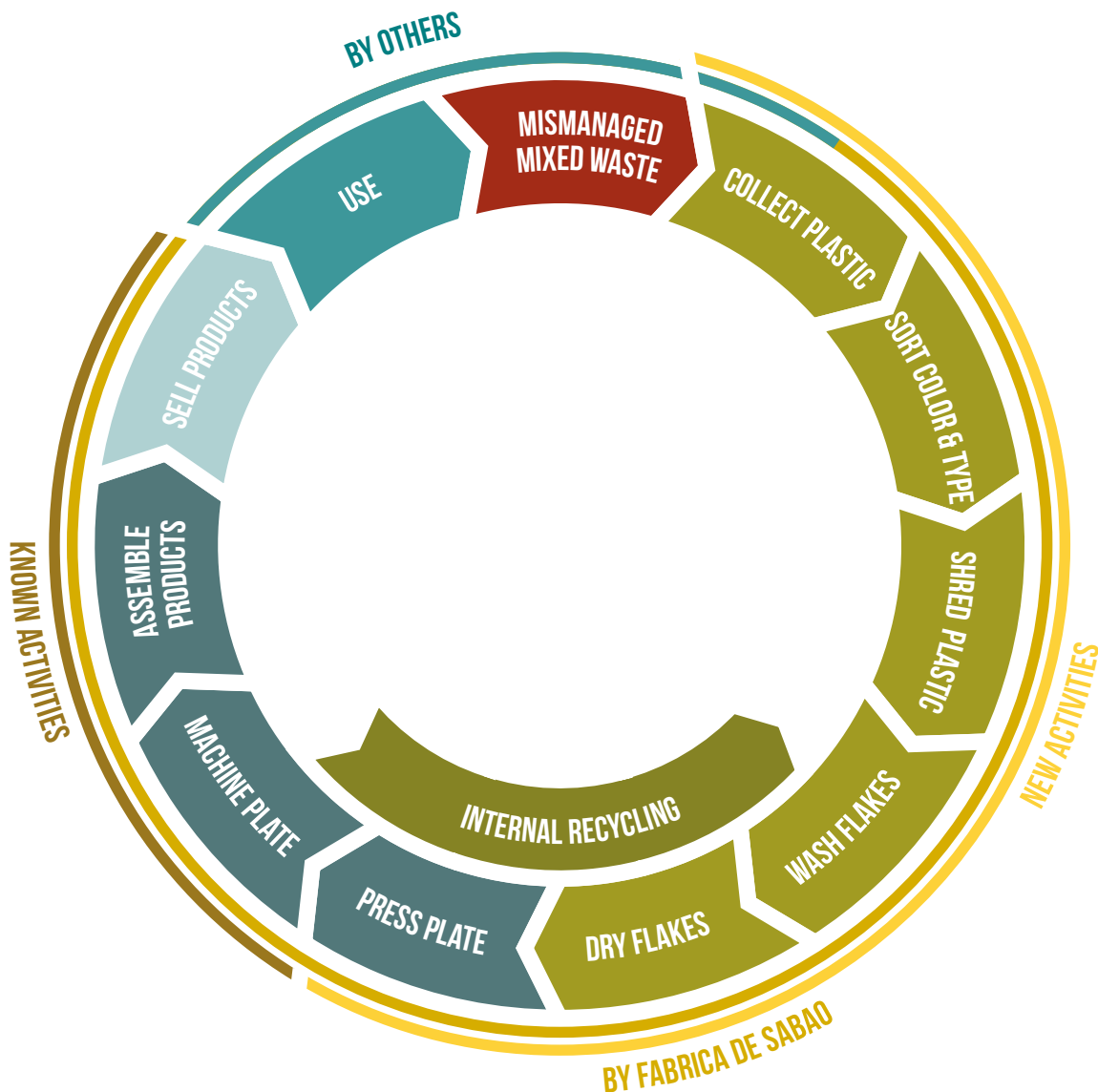

Figure 2-20, Expected recycling process at Fábrika de Sabão - Figure by Mark Bachrach

## Bottom-up recycling and production with a Plastic Plate Press

When a plate press is introduced as a link between the future bottom-up recycling process and the current furniture production of Fábrica de Sabão, it is expected that the process will follow the process steps as displayed in Figure 2-20.

A lot of new activities are introduced at Fábrica de Sabão but also the current production activities will stay in place. The plate press will, to some extent, have to conform to the needs of the existing production processes and fit the recycling process possibilities.

Although, while the recycling process is not yet in place, the plate press may also demand specific plastic input requirements. Daniela Antonio, the Maker-space manager at Fábrica de Sabão, has confirmed that they are willing to fit the recycling process to the plate press requirements. Of course, this needs to stay within manageable demands.

In a circular process it is difficult to point out where it starts and where it ends, but precisely that is needed in a project with limited resources. Therefore Figure 2-21 displays an early

design scope, which conveys what parts of the production cycle as a whole will be designed in this project.

The project is hereby limited to the plate pressing process and only the directly following and preceding process parts. An actual product design made from the plastic plate material is added as a bonus, that is only fulfilled when time allows it.

### Conclusions for the design process:

- Experimentation has to include comparable input material samples
- Bottom-up recyclers already use shredders, and shredder build plans are online available; thus the plate press may demand plastic flake input
- Specific demands for the input material are allowed but need to be realistic

### Conclusions for the program of requirements:

- The plate press has to account for input material pollution
- The plastic plate output needs to fit the secondary processing and application

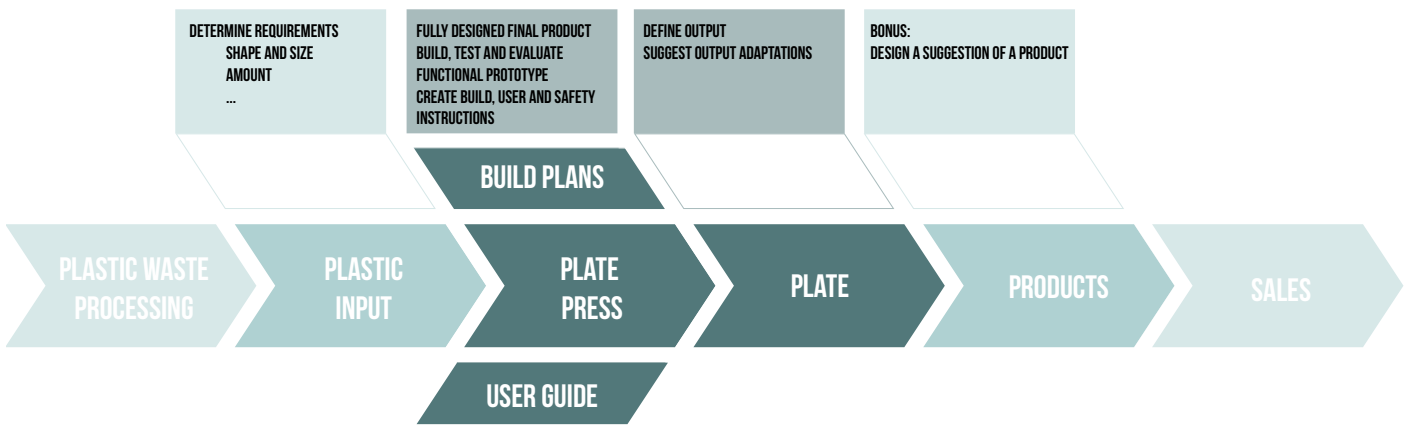

Figure 2-21, Early design scope - Figure by Mark Bachrach

### 2.2.3. Plastic recycling value

The complete value chain that can be realised with bottom-up recycling and a plate press results in an incentive for collecting plastic waste. This incentive is created through value assignment of plastic waste by the recyclers. Through producing products with value from plastic waste, the plastic waste itself has gained value. Recyclers that do not collect (enough) plastic waste themselves, could offer payment for plastic waste as if it were a raw material, which it has become. Figure 2-22 visualises the value chain reaction:

#### Recycling motives

From the different allocated values, the recycling motives can be distilled:

1. Producing affordable and qualitative construction materials
2. Producing unique products
3. Drive environmental cleanup; through incentive creation for others to collect plastic waste

What the primary motive is, depends per person and organisation. According to Koen Verpaalen, Fábrica de Sabão is primarily interested in the first motive. The other two are of course also gladly accepted and incorporated.

Most of the other potential plate press builders agree with this, which resulted from the survey that is discussed in Paragraph 2.5.

#### Mixed vs. Sorted

Koen from Fábrica de Sabão indicated that a lot of the plastic waste is hard to sort since plastic type indications are missing. When mixed plastics cannot be processed, it concurrently will not gain value, this, of course, is a loss. For this reason, it would be interesting to see if mixed plastics can be processed. However, mixed plastics cannot be un-mixed, considering that pure plastics are of the highest value, mixing plastics will decrease the value. Thus, it can be concluded that mixing plastics should be avoided. Also, the cause for discussing the mixing of plastics should be taken away. The produced product should, therefore, contain clear plastic type indications.

Opposing this reasoning is the fact that by excluding mixed plastics altogether, no value is assigned and thus no incentive to collect unrecognisable plastics is created. A mixed plastic product would still be better than leaving the plastics behind. This argument is the reason that it was needed to find out what the principal recycling motivation is. When concluded that recycling needs to comply with the motive of environmental cleanup, mixed plastic and other excluded plastics should be

included in the recycling process. However, this is not the case.

With the recycling motivation pinpointed on the production of affordable and qualitative construction materials, mixed plastics should definitely be excluded from the process. More so, since according to multiple experts (Jonathan, Laura, Leonard and Mathijs, see Appendix A.3), different types of plastic do not stick together very well. This would thereby compromise the plate quality. No to speak of the safety risk of melting unknown materials and the added production complexity.

**Good to know:**

ByFusion developed a machine to produce “ByBricks” from mixed plastic waste and thus provide a solution for differently motivated institutions and people. For more info, see byfusion.com

Conclusions for the design process:

- Focus on quality and affordability

Conclusions for the program of requirements:

- Focus on quality and affordability

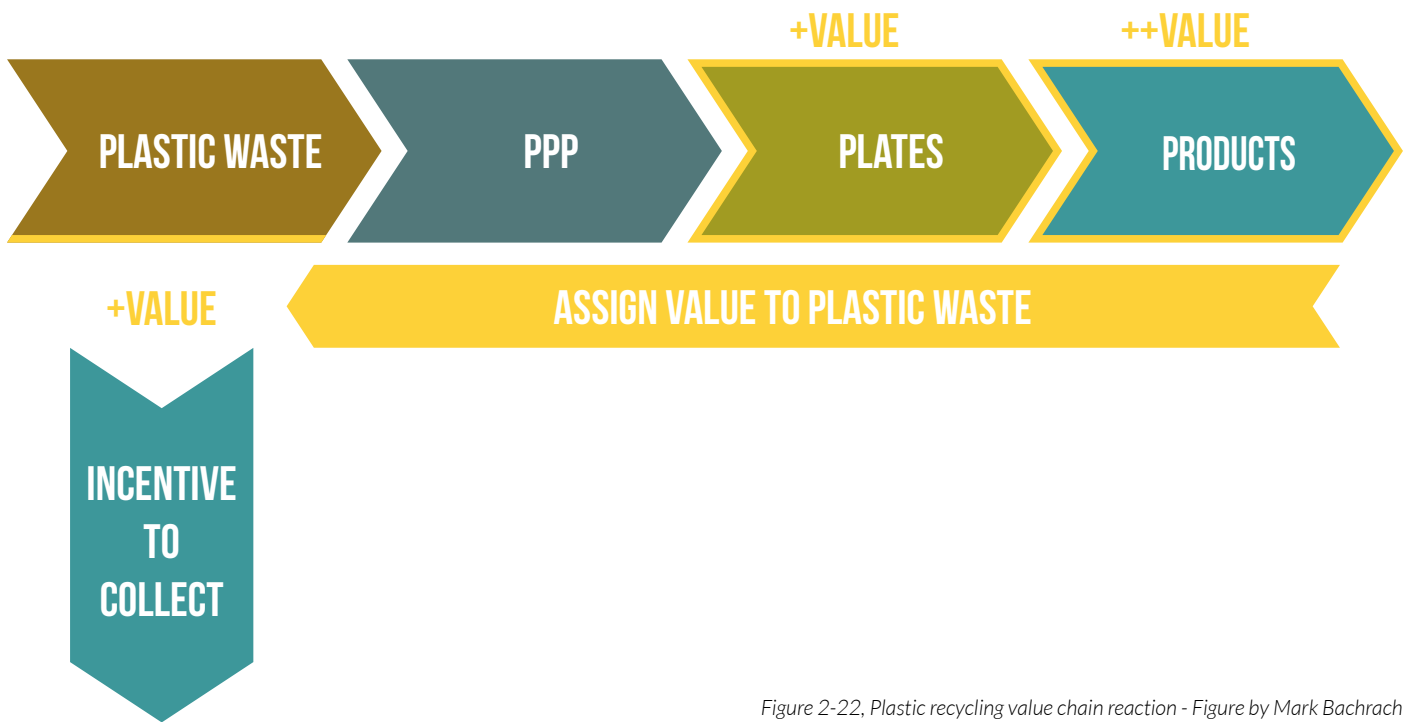

Figure 2-22, Plastic recycling value chain reaction - Figure by Mark Bachrach

### 2.2.4. Melting plastic energy consumption

To conclude the plastic and recycling analysis, an energy consumption calculation is discussed. The calculation estimates the energy needed to produce a plastic plate of 1220 x 1220 x 12 mm made from PP, which will turn out to be the production goal for the plate press design.

The calculation follows a simple formula, presented below. This formula is used to calculate the required heating energy to melt the amount of plastic needed to produce a solid plate of the mentioned dimensions. Next to that, the same formula is used to calculate the required heating energy to heat up two steel flatbeds (each 1300 x 1300 x 5 mm), that are assumed to be needed in the plate press design, based on the design made by Jerry de Vos as discussed in Paragraph 2.2.3.

Formula: 
$$E(kWh) = \frac{C \cdot \Delta T \cdot m}{3600000}$$

In which; E = Energy in kWh, C = Specific heat capacity, ΔT = Temperature increase, m = mass, given by plate volume and material density. C(steel) = 482.5, ρ(steel) = 8000. All plastic values were taken from Figure 2-16.

The calculation results in a required heat energy of 1.7 kWh for 16.5 kg PP, the flatbeds each add 1.8 kWh, summing up to a total of 5.3 kWh. In this example the machine parts consume two-thirds of the required energy, this confirms that melting

and cooling a plate in the same machine is indeed a waste of (a lot of) energy. Note that this calculation is based on assumptions and only produces a rough estimate; heat loss during the process is entirely neglected but would drive up the required energy.

When speculating and according to the calculation, a plastic plate could be melted in about half an hour when 10 kW of heating power is applied, however, plastics, in general, have low heat transfer coefficients, meaning that they do not conduct heat well, they are excellent insulators. This, in turn, means that the penetration of heat to a point deeper inside the plastic needs time. This can be sped up by increasing the temperature difference, but this is then again limited by the decomposition temperature of plastics.

Conclusions for the design process:

- Melting times are limited by material properties but can be influenced by the material distribution
- Energy efficiency can be increased by separating the heating and cooling processes

Conclusions for the program of requirements:

- Materials that heat up and cool down together with the plastic plates need to be minimised

## 2.3. LOW-RESOURCE ANALYSIS

Plastic processing is one side of the story; the other side is making sure that the product that provides the plate pressing functionality can be manufactured and used in low-resource settings. This means that the design needs to account for materials, production techniques and skills that are typically available in these low resource areas.

To find out what those materials, techniques and skills are, persons of interest, working in locations that cohere to the label of low-resource setting, were consulted. Also, a production house was visited in which people with minimal skills were in charge of production. From this, valuable information has been acquired, which is presented in the two topics in this paragraph.

### 2.3.1. Low-tech machine building

The general idea in this project is to provide a design explained in proper media to allow people or institutions in low resource settings to build the design themselves. Such a manner of manufacturing is known as distributed production since production is not centralised as it is with typical industrial manufacturing. When distributed production is chosen as production manner for a design, the design needs to account for the production possibilities in the expected production locations. In this case, low resource settings all over the world.

This manner of production was also implemented by Precious Plastic, who already provide five different machine designs suitable for distributed production in low resource settings. From their website, a lot can be learned about how to deal with the implications of distributed production. Next to that, Koen and Daniela from Fábrica de Sabão provided information about their local production possibilities. Also, Laura from The BFF was consulted because of her experience with the 'new marble' project, and Leonard Schurg, because of his experiences from the FlipFlopi project in Nigeria, which aims to build a seaworthy ship from plastic waste. The full meeting excerpts are found in Appendix A.3.

General notions:

- Keep it simple, when there are options, always choose the easy one, ( Laura & Leonard)
- Keep in mind that builders will want to take shortcuts, thus think of the shortcuts yourself (Leonard)

#### Materials

Both Laura and Leonard explained in a similar manner, that, when it comes down to it, almost anything can be imported, but at a price, these prices can be quite steep because of fluctuating currencies. Local supply is always preferred, but when specific parts are required and cannot be replaced with other locally available materials, they can be imported. Leonard Schurg, who has built a plank press in Nigeria, explained that in countries like Nigeria, large import orders have a chance of being confiscated by corrupt border control agents. For the right price, the shipment can be unconfiscated.

Laura advised that in general, people all over the world are familiar with steel production techniques, making steel an excellent material to design with. Also, according to Leonard, in most low-resource-settings, steel is affordable and available

in many forms. Not always all of the sizes of beams, profiles and sheet materials are available all the time. Therefore it would be beneficial to make sure that a range of standard sizes is applicable in the design, with only slight alterations for fitting it together. The implications and considerations of these alterations will then also have to be clearly explained. Thereby, steering towards an adjusted design that will still function properly.

Precious plastic deals with such considerations in a similar way. The machine designs are provided in precise technical drawings with specific materials, but, also the intended functionalities are explained in order to allow builders to make alterations without compromising the functionalities. For example, the electronics housing of the shredder that is shown in an explanatory video is made of an old jerry can. The instructions only explain; to make sure everything fits in the chosen enclosure, that all electronics are sufficiently insulated, and that the enclosure is properly secured to the frame. How these requirements are executed, is only shown as an example, but they are not leading. In one of the other instructional videos, Dave Hakkens explains how to build a compression moulding machine. He tells the viewers to attach the oven to the frame, and says:

*“You can use our files as a reference, but since all ovens are different in size, you might need to recalculate a few things.”*

The size availability does not only hold for construction materials, but also fasteners suffer this condition. According to both Koen & Daniela and Leonard, fasteners are relatively expensive, and size specifications should be treated with flexibility. According to this notion, it would be best to avoid fasteners altogether.

Besides specific size availability of construction materials and fasteners, the quality standard is also something that may differentiate a lot between different settings. In the western world, we are accustomed to high and uniform standards, in low resource areas-these standards may deviate a lot. Steel grades cannot always be fully trusted, and construction materials are often showing signs of wear before they arrive. Leonard Schurg said in a phone call:

*“Steel rods may have been bent when fallen off of a truck and bent back to be put with the others again.”*

About the quality standards, Laura added that manufacturing standards are also less precise and accountable than what the western world is used to. Therefore, it is essential to include maintenance possibilities in the design. She warned against welding everything together while welding is permanent and thus doesn't allow the replacement of parts. Typical non-permanent connections are realised through the use of fasteners, which are, like just mentioned better avoided. This results in conflicting advice, therefore the use of either connecting method should be considered with care. From this can be concluded that a balance between permanent and removable connections has to be made. Parts that are unlikely to fail can be welded together. When unsure if failure will occur, fasteners can best be used. Welding should then also be limited by part size, when welded parts become too

large they might be best split into subassemblies that are connected with removable fasteners. Of course, the choice between permanent or removable connections is also influenced by other factors, like sturdiness and precision.

### Production

Welding introduces the topic of production. In low resource settings, not only materials have their limits, even more so, production techniques are limited. The availability of manufacturing tools depends entirely on the location, sometimes semi-advanced machinery is available, but one cannot count on it. However, according to Laura, Koen and Leonard, in almost any setting, welding gear is available. Also, grinders, drills, and most hand tools will be available. However, that is where it ends. Of course, in many settings, other tools will also be available, but they cannot be counted upon. This limits design complexity severely since all parts need to be able to be cut with hand saws or a grinder. The upside of low resource settings is that hand labour is cheap. Putting someone to work on cutting out a part with a grinder may take somewhat longer than doing it with advanced machinery, but, it may turn out to be much cheaper.

In Precious Plastic's shredder design, a substantial part of the parts needs to be ordered from a CNC-cutting manufacturer. This would suggest that it is allowed to include more complex parts that are produced in this way. However, Dave and Jerry admitted that they were reluctant to include such an advanced manufacturing technique, but that they were unable to find another option. In conclusion, complex parts in need of advanced production techniques should be avoided, but when essential, compromises can be made.

#### **Conclusions for the design process:**

- When selecting, choose the easy or straightforward option.
- Locally available parts are preferred over import, but functional needs can justify importing certain parts.
- Permanent and removable connections should be balanced according to maintenance accessibility and affordability.
- Build instructions may leave room for construction choice, but the essential functional requirements need to be made clear.

#### **Conclusions for the program of requirements:**

- Steel is a suitable material to design with
- The design should account for varying fastener sizes and profile dimensions.
- The design should be based on the lowest quality materials, since quality standards and production precision cannot be counted upon.

### 2.3.2. Low-skill users

In the settings in which the product will be operating, the users will probably not have much knowledge about technical processes. Next to that, the survey discussed in Paragraph 2.5 indicates that the plastic plate press will function in settings where multiple users will use the machine, including users that use the machine only a few times. Both of these considerations implicate that the use of the machine should be made very easy and self-explanatory. Other, less apparent implications were analysed through visiting a sheltered workshop in Delft. In this workshop, people that cannot function independently in society are offered a safe

environment to work in and are guided in working as practical labourers. The work differs from cooking to bike repairs to woodworking and plastic recycling. The labourers are not used to this kind of work and are not trained for it in any way. This makes it suitable as replacement observation location for observing considerations to be made relating to machine operators with minimal prior knowledge or training.

During the visit, observations were made during a day of work together with the labourers, and two of the supervisors were interviewed. From this the following conclusions were drawn:

#### **Conclusions for the design process:**

- Murphy's law should be accounted for; Anything that can go wrong will go wrong at some point
- All safety hazards should be determined and eliminated

#### **Conclusions for the program of requirements:**

- Safety rules are forgotten; therefore safety should be inherent to the operating possibilities and not forced through rules
- Everything should work the way it is supposed to work or not work at all
- Everything should be simple and clear
- The design should provide one clear way of working that is not multi-interpretable; doing it wrong should not be possible

## 2.4. INFLUENCE MAP

The discussed insights, gained in the analysis, are part of the design influencers. To find the other essential design influencers, an Influence map has been created. The influence map maps the parameters that can play an essential part in defining the design, either by limiting or by demanding specific properties. In this kind of project, such a map can get very complicated. Therefore it has been constructed through following three steps, each of which resulted in a visualised map:

1. Identifying the main influence elements and their relations: The basic influence map
2. Creating a priority structure to entail a starting point and a decision flow path: The linear influence map
3. Expanding the main influence elements to specific influence elements: The detailed influence map

### The basic influence map

In the first step, four main influence elements were identified:

1. The (physical) context
2. The plastic waste (provided by the physical context)
3. The plastic plates (that are going to be produced)
4. The plate press (that is going to press the plates)

In the basic influence map displayed in Figure 2-23, not only influencers are displayed, but also the kind of influence is listed. What immediately becomes clear is that the context has only outwards influence and is not influenced itself. Hopefully the plastic plate press will ultimately have a positive influence on its physical context, but for now, that is left out of the equation. This lack of inward influences, however, indicates that the physical context is a good starting point for creating an influence hierarchy. This influence hierarchy is needed to remove influence loops that inhibit a decision making.

# BASIC INFLUENCE MAP

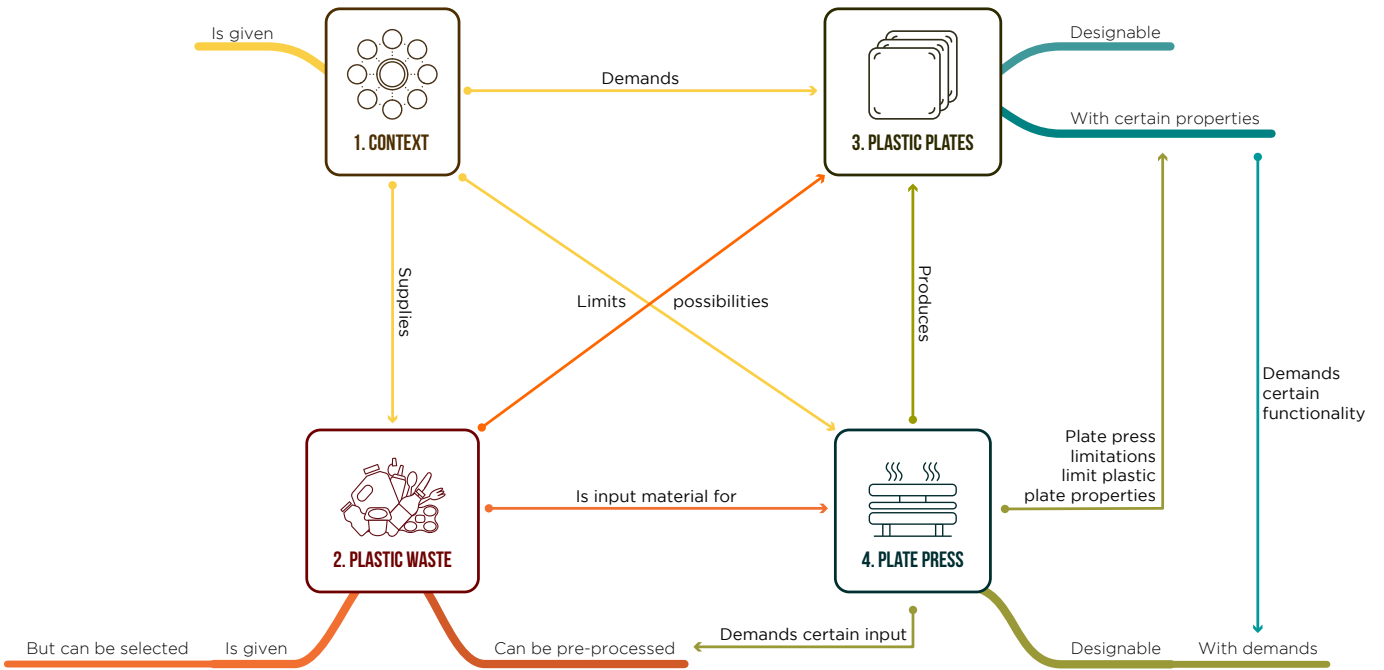

Figure 2-23, Basic Influence Map - Figure by Mark Bachrach

## The linear influence map

In the second step, the mentioned hierarchy is created, transforming the influence map from a circular structure to a linear one. In the linear influence map, depicted in Figure 2-24, backwards point influences are still present, which actually take away the idea of the hierarchy or linearity. However, the backwards pointing influences should be regarded as evaluations: When design decisions have been

made, it should be reviewed to find out whether the result of these decisions still correspond to the already defined elements. If not, the decisions need to be changed. Using the linear representation, it already has become clear what the right order of information acquisition and decision making is. In the next step, the essential design parameters will be identified.

# LINEAR INFLUENCE MAP

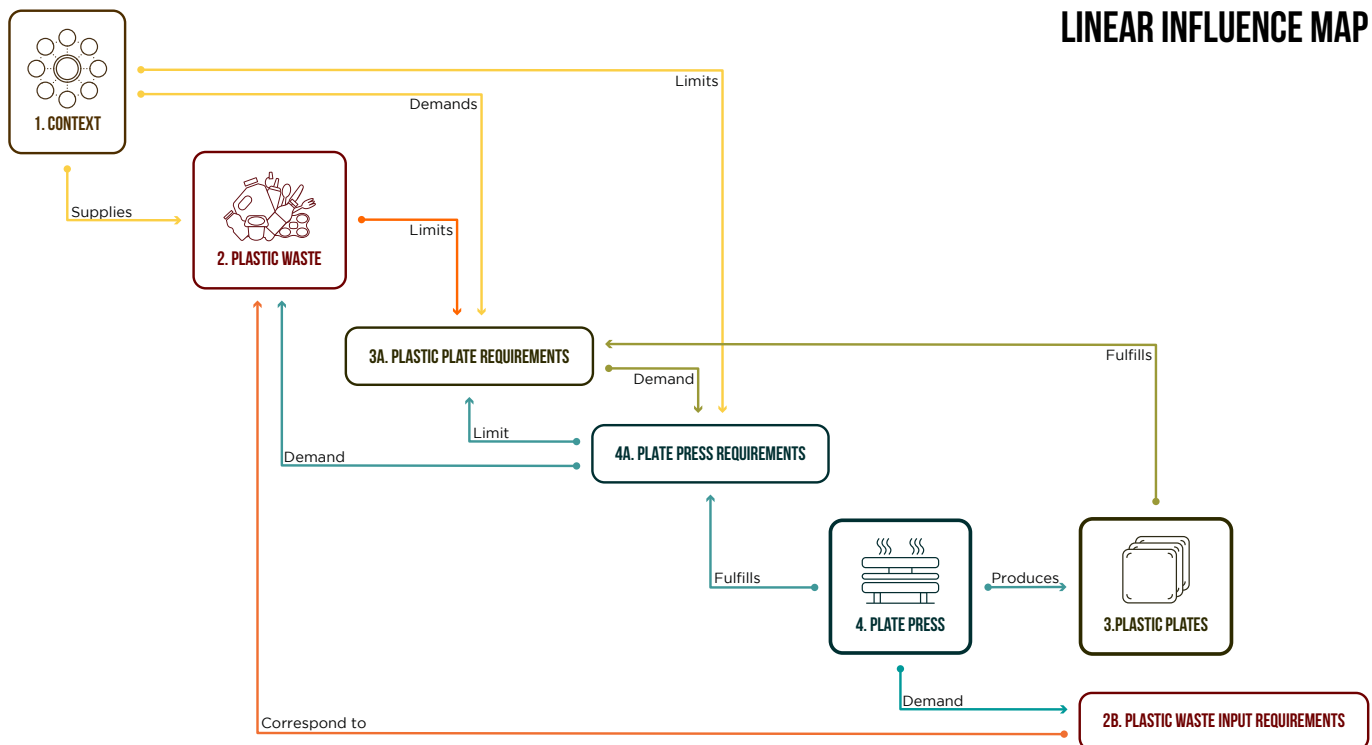

Figure 2-24, Linear Influence Map - Figure by Mark Bachrach



### The detailed influence map

In the third and final step, the main elements are split up into specific influence elements. From each of the elements, displayed in Figure 2-25, influence arrows flow to design defining elements, which in turn may influence other elements. The thicker the arrows, the more influence elements come together. The linear orientation of the previous map has been removed, however, influences only point forward in the order of the linear influence map.

As a result of detailing, this map has become very complicated. Luckily there is no need for complete comprehension by readers. It has been merely used as a tool to find the essential parameters on which the design depends. Later it can also be used to backtrack, what the consequences might be when specific design parameters are changed. With the identification of these parameters, the actual data about the parameters could be collected, which has been done through the design parameter survey that is discussed in the next paragraph.

## DETAILED INFLUENCE MAP

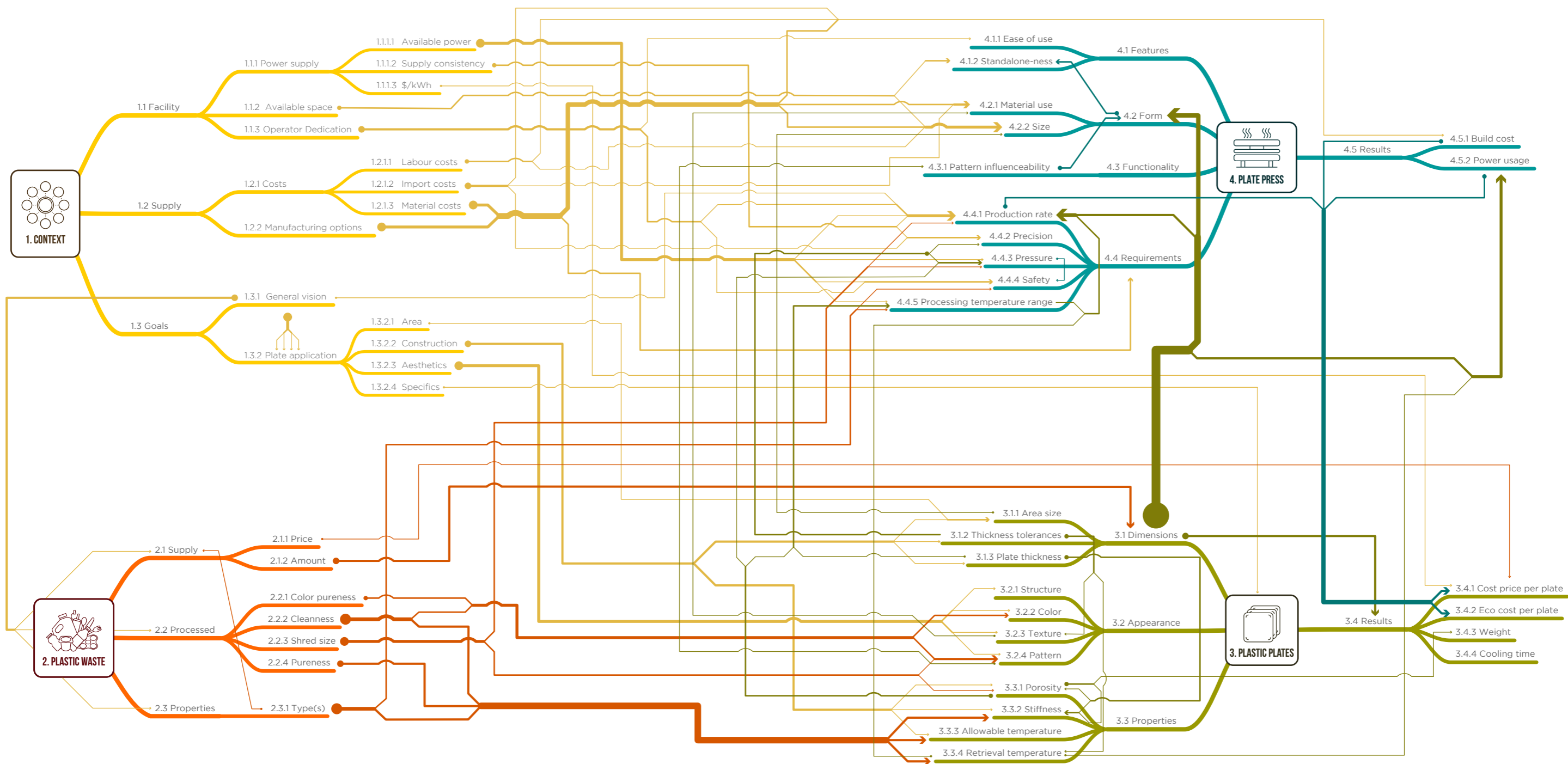

Figure 2-25, Detailed Influence Map - Figure by Mark Bachrach

## 2.5. DESIGN PARAMETER SURVEY

Through the use of the detailed influence map, the essential design parameters were identified. To figure out what the definitions of these parameters are, an online survey was set up. This survey was then sent out to potential plate press builders in low resource areas. They were identified, located and contacted with the help of the community member map of Precious Plastic (<https://map.preciousplastic.com>). This, of course, limits the survey candidates to precious plastic community members, but without their community, it would have been almost impossible to find a substantial amount of suitable candidates. On the following pages, graphical representations of the survey results are displayed followed by a list of conclusions that were drawn from these results. Appendix A.5 includes the survey itself, and the raw data is provided in Appendix A.6. For a limited time, the survey can also be found online at <https://mark171.typeform.com/to/yrgyP5>

### Conclusions from context Factors

1.2 For most respondents, producing affordable and qualitative material is the main driver. This suggests that the amount of plastic that can be processed is subordinate to the quality of the produced material.

#### **Quality trumps volumetric quantity**

1.3.1 The majority of the respondents have access to a 4kW power socket and almost half have access to a three-phase 10kW power socket. If possible the plate press machine should work with a maximum of 4kW. But when further tests and calculation point out that this is unrealistic, this limit might be stretched to three phase 10kW.

#### **Max 4kW with an option on 10kW**

1.3.2 None of the respondents have to deal with seriously lacking power reliability, which means that the plate press design doesn't have to account for power failures.

#### **Power failure does not need to be accounted for in the design**

1.3.3 Only a quarter of the respondents think that their power is expensive, this suggests that using electricity as power source is realistic for most users.

#### **Electricity can be used as power source**

1.4 The respondents have indicated different and multiple use frequencies for machine operators, this means that the design has to account for all situations that are represented by the survey respondents. The choice was made to ignore single occurrences.

#### **The user instructions have to be minimised, the ease of use optimised**

1.5.1 The outspoken majority 2/3 of the respondents indicate to plan on producing plates per batch, in most cases this is combined with other types of production cycles. Focussing on batch production would mean that downtime caused by failure is allowable and time in between batches can be used for maintenance. For both series production and batch production longer startup time is acceptable opposed to sample production and experimentation. Machine startup time is allowed to some extent.

#### **Easy maintenance access may balance downtime.**

1.5.2 When accounting for at least half of the respondents, production of between 5 and 10 plates per day should be realisable.

#### **The minimum production rate is 5 plates per day, around 10 per day is the stretch goal.**

1.6.1 Overall the respondents indicate that the realised aesthetics of the plastic plate are of great importance, meaning that the plate press should definitely be able to produce a well finished and predictable output.

#### **The plate press should produce a predictable output with a consistent finish.**

1.6.2 Overall the respondents indicate to expect the produced plates to provide surface area with reasonable constructive properties.

#### **Next to surface area, the produced plates should also provide predictable constructive properties like stiffness.**

1.6.3 The intended applications vary per respondent but mostly stay within the expected applications. What is interesting is that around a third of the respondents group is fine with applying the plates for whatever they are suited for, suggesting that creativity will solve the drawbacks.

# 1. CONTEXT

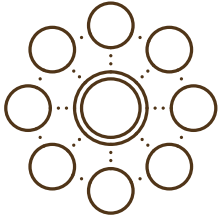

● / ● / ● Case study's respons/input  
 — / — / — Conclusion/decision indicators

## 1.1 SURVEY RESPONDENTS LOCATIONS

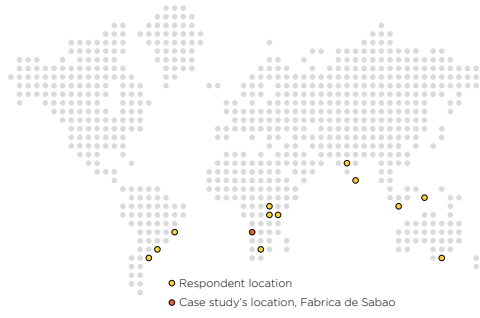

## 1.2 DRIVER

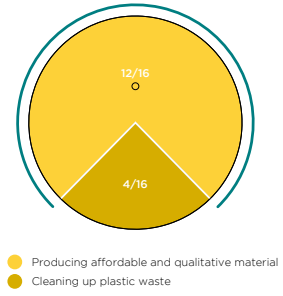

## 1.3.1 AVAILABLE POWER

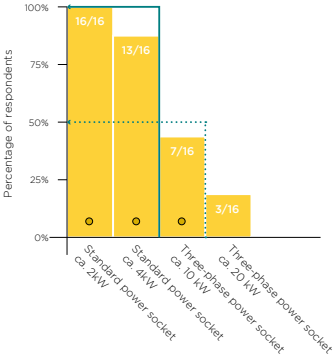

## 1.3.2 POWER RELIABILITY

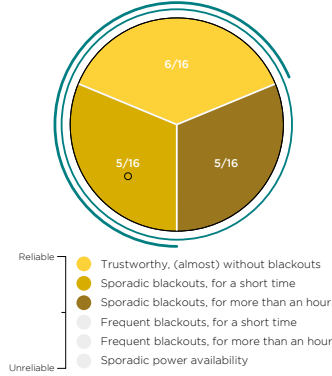

## 1.3.3 POWER COSTS

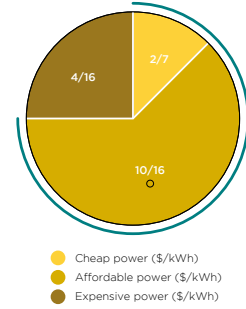

## 1.4 MACHINE OPERATOR USE FREQUENCY

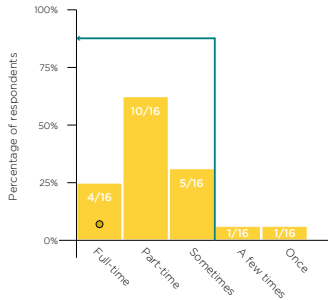

## 1.5.1 PRODUCTION TYPE

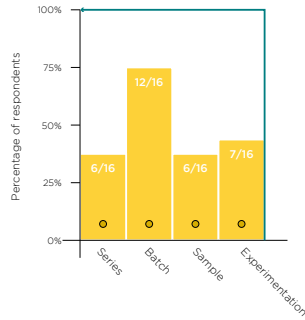

## 1.5.2 EXPECTED PRODUCTION RATE

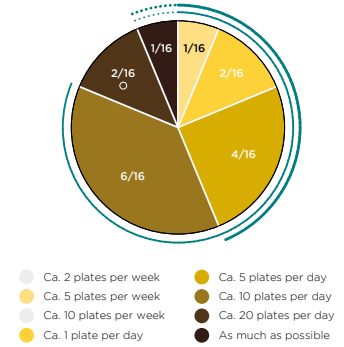

## 1.6.1 IMPORTANCE OF AESTHETICS

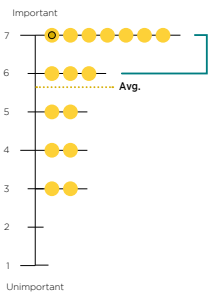

## 1.6.2 STRUCTURAL APPLICATION TYPE

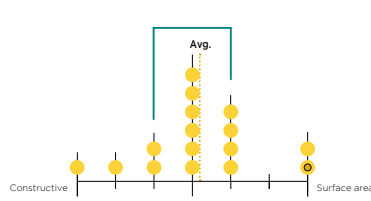

## 1.6.3 INTENDED PLATE APPLICATION

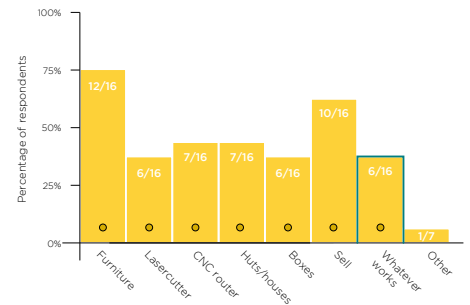

Figure 2-26, Survey result graphs, Contextual parameters - Figure by Mark Bachrach

## Conclusions from Plastic supply Factors

2.1.1 & 2.1.2 The ease of collection is highly dependent on the location and no generalisations can be made other than that PET and PP are present in most locations and are often easiest to collect. However, PET is believed to be especially hard to process.

**At least PP should be processable, the ability to process also other plastics is a stretch goal.**

2.1.3 The chosen case study context is not comparable to the other survey respondent when it comes to plastic supply amounts. For most the ideal weekly processing amount lays around 100kg per week, while for Fábrica de Sabão this nears 800kg/week. Differences will have to be bridged with varying production rates and times.

In extreme situations a 2nd machine may provide a solution. Next to that, graph 1.2 suggests that quality is more important than quantity.

**A processing capability of + 100kg/week is appreciated**

2.2 In most cases the plastic is acquired through self organised collections and often combinations of collection forms are used.

2.3 Almost all respondents sort their plastic by plastic type or try to by sorting on product type. Next to that more than half indicated that they also clean the plastic. Half of them always shreds the plastic.

**Specified pre-processing of the plastic waste is a realistic demand.**

2.4 All respondents have or intend to acquire a motorised shredder. however this might be influenced by the fact that all respondents were reached through the precious plastic network.

**Demanding shredded input for the plate press is a realistic option.**



## Conclusions from expected plate property factors

3.1.1 Choosing a functional plate length of 1220mm would satisfy about 80% of the respondents, considering that downscaling is expected to be easy and cutting plastic plates will provide the wanted sizes too.

**The plate press should be able to create plate outputs with a functional length up to 1220mm**

3.1.2 Choosing a functional plate width of 1220mm would satisfy about 80% of the respondents, considering that downscaling is expected to be easy and cutting plastic plates will provide the wanted sizes too.

**The plate press should be able to create plate outputs with a functional width up to 1220mm**

3.1.3 Choosing an adjustable plate thickness up to 6mm would satisfy about 60% of the respondents. However, Fábrica de Sabão has indicated that 12mm is the minimum that they need for their furniture application. Since 75% indicated to want to apply the plastic plates in furniture this is a realistic argument to set the goal for 12mm thickness. When tests indicate that the process will work for greater thicknesses, expanding the adjustability may be possible and could provide satisfying the wants of 80% of the respondents. Fábrica de Sabão has indicated that plates with smaller thicknesses will also have great value for their institution.

**The plate press should provide means to produce plates with a thickness up to 12mm the thickness should be adjustable in the design of the mould and/or machine or even per plate. The stretch goal is to provide adjustable thickness up to 18mm.**

3.2 A maximum thickness tolerance of +/- 1mm is sufficient for most of the respondents however higher precision is appreciated.

**The plate press should provide plates with a thickness tolerance of +/- 1mm or lower**

3.3 All respondents will be pleased when a smooth surface quality is realised, none of them prefer a textured surface.

**The produce plastic plates should have a smooth surface**

3.4 Slightly more than half of the respondents appreciate influence on the resulting colour pattern on the plastic plates that the press will produce. the other half don't mind

**The plate press should provide access to the plastic input spread as to provide means to influence the colour pattern of the plastic plates.**

3.5 The structural shape of the plastic plates can best be flat on all sides according to 2/3rds of the respondents. Adjusting the structural shape for each plate would be interesting according to 1 respondent.

3.6 2/3rds of the respondents wants the plates to be as solid as possible, while the others are also satisfied with a percentage of porosity. Earlier insight suggest that influencing the porosity is hard and superficial air bubbles are unwanted, these can best be avoided by driving out most bubbles.

**The porosity should be minimised.**

## 2.6. PLATE REQUIREMENTS

This chapter is concluded with the plastic plate requirements that follow from the analysis and are displayed in Figure 2-29. The plate press requirements are not yet listed since the following chapter will add to this list of requirements, after which the list is presented in chapter 4. conceptualisation.

The maximum warpage definition has not been mentioned before. However, it is based on measurements taken from plywood from local hardware stores. The minimal solidity has been mentioned before, but the target of at least 95%, has not. It is based on personal judgement.

# 3. PLASTIC PLATES EXPECTATIONS

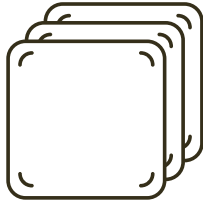

● / ● / ● Case study's respons/Input  
 — / — / — Conclusion/decision indicators

## 3.1.1 PLATE LENGTH

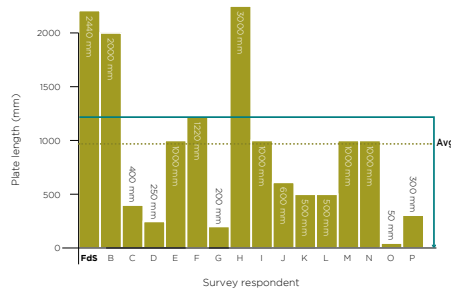

## 3.1.2 PLATE WIDTH

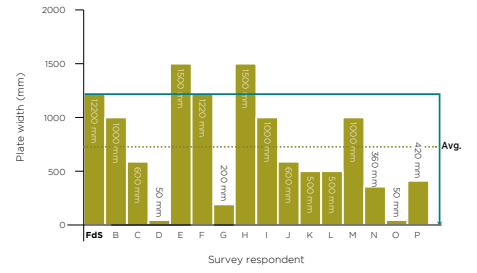

## 3.1.3 PLATE THICKNESS

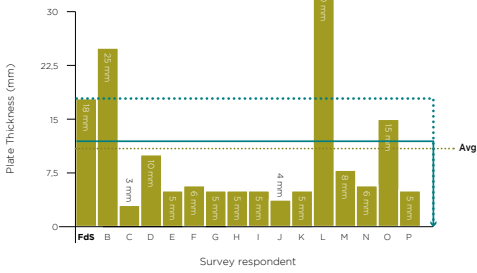

## 3.2 THICKNESS TOLLERANCE

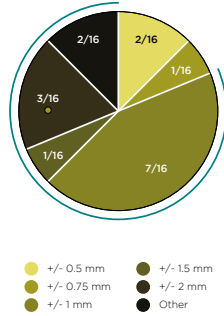

## 3.3 SURFACE QUALITY

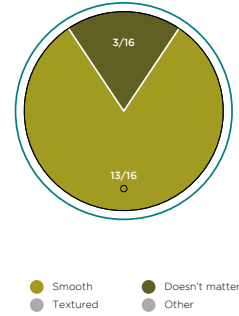

## 3.4 COLOR PATTERN

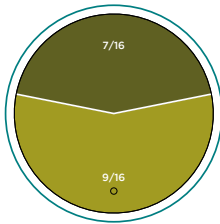

## 3.5 STRUCTURAL SHAPE

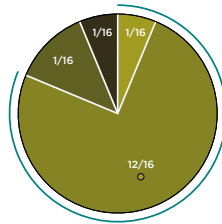

## 3.6 POROSITY

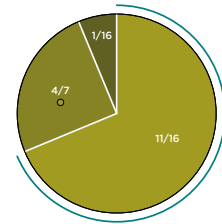
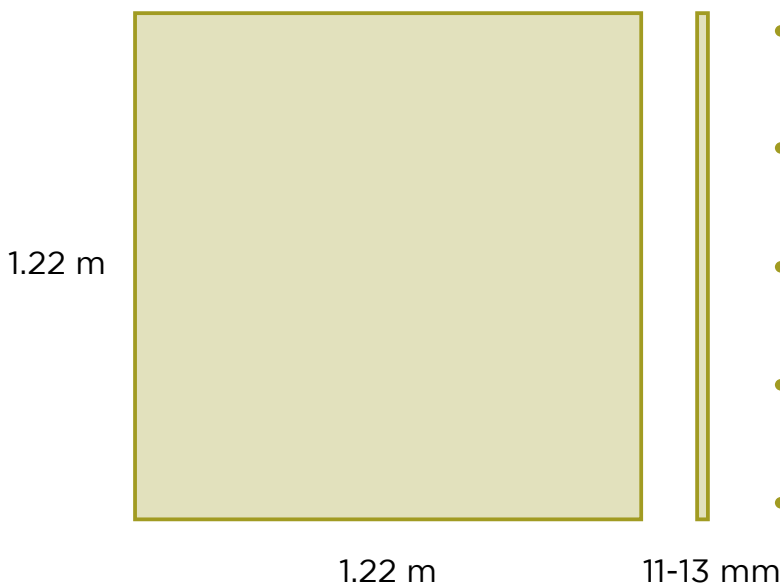

Figure 2-28, Survey result graphs, Plastic plate expectation parameters - Figure by Mark Bachrach



- Max 1mm thickness deviation from the target thickness, 12mm
- Maximum warpage of 6mm from end to end: half the thickness
- Maximum solidity/minimal porosity Atleast 95% material fill
- Flat on both sides, No inner structure
- Smooth surface, no texture

Figure 2-29, Plastic plate requirements - Figure by Mark Bachrach

# 3. EXPERIMENTATION

In the analysis, a more ordinary manner of information acquisition was used and presented. In this chapter however, a less common form of information gathering is presented; Experimentation. Experimentation can be defined as a series of practical activities, executed with curiosity as the main driver; What would happen if we do ...?

Having curiosity as its main driver, is what distinguishes experimentation from empirical research, in which the main driver is proving a specific hypothesis through a series of reproducible trials.

The reason for doing experiments comes from three sources; For one, this project is a practical project by nature. Secondly, all of the consulted experts strongly advised doing practical experimentation while the theory is complicated and not always accurate when it comes to low-tech solutions. Thirdly, the designer in this project is most familiar with the practical approach.

The general idea is: See how it works, instead of reading how it should work.

The experiments started with curiosity and along the way transformed into hypothesis testing. However, the experiments were not executed with isolated parameters and high accuracy nor in a repetitive manner, which disqualifies them for being treated as empirical research. Nevertheless, for this project, experiential conclusions are all that is needed. Sufficient proof was believed to be found; rendering conclusions on which the conceptualisation phase could build.

## 3.1. DESIGN PARAMETER SURVEY

As mentioned in the chapter introduction, the goals of the experiments transformed throughout the process. This transformation was more of a natural occurrence than a premeditated approach. But not all was left up to the natural flow of experimentation. While in the analysis several new questions had risen that could best be answered through experimentation. These questions were combined and supplemented in a very basic function schematic, which is displayed in Figure 3-1. The process steps that are displayed are a suggestion based on the preceding analysis and insights gained from expert meetings, found in Appendix A.3.

In the figure, uncertainties that need to be figured out are listed for each of the process steps. These uncertainties are the basis for the experimentation process.

The identified uncertainties were subsequently explored in the experiments that in turn provided new problems and theories to base the next experiment on. Together, the entire sequence led to the achievement of the goal of finding the essential process parameters that need to be correctly incorporated in the design. This sequence is portrayed in Figure 3-2. When linking these essential process parameters back to the influence map, a division can be made between input parameters, processing parameters and output parameters. The output parameters are defined in the plastic plate requirement list and thus are the goal to be achieved. The input and processing parameters are tweaked in the experiments in order to find the right parameters for achieving the plastic plate requirements. The optimal processing parameters that are found will then be included in the plate press requirements list.

Tipped by Laura Strauss from the BFF, experimentation started with a panini grill. This grill was a very cheap and accessible means to misuse as a mini plastic plate press. Laura's tip to start with as the first experiment, was to use the panini grill to melt cut-up household plastic waste between two layers of baking paper. This setup is used for the first experiment, with which the next paragraph will start. The following paragraphs will describe the setup of the experiments and explain the critical conclusions while the entire experimentation documentation is found in Appendix A.7.

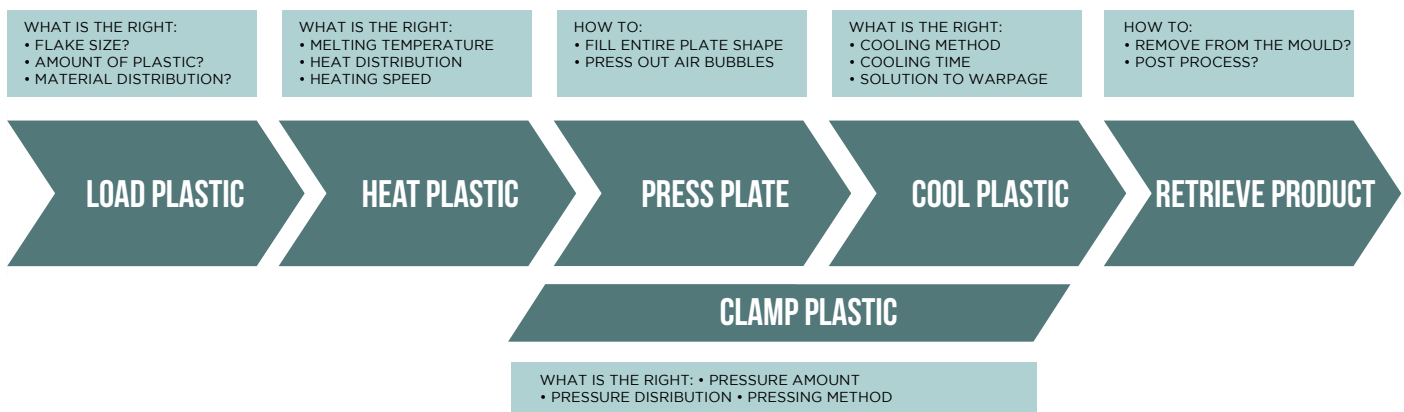

Figure 3-1, Plastic plate pressing process uncertainties - Figure by Mark Bachrach



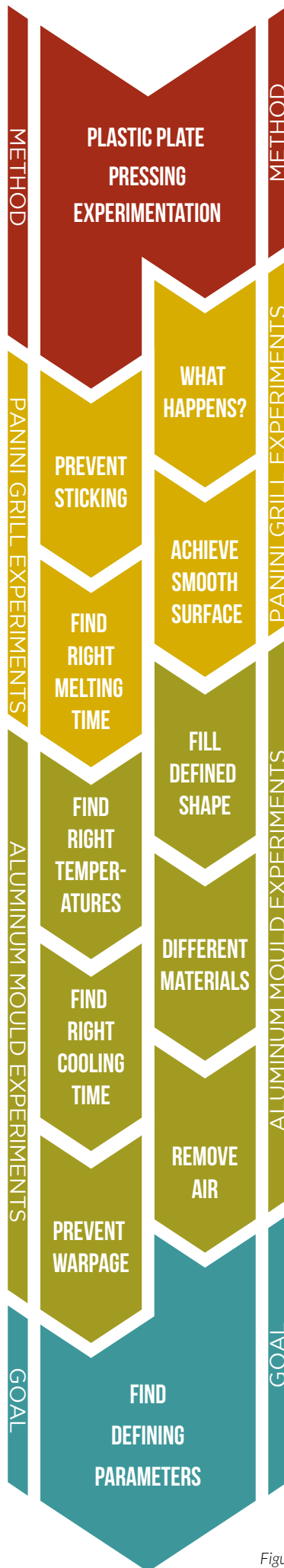

Figure 3-2, Experimentation approach - Figure by Mark Bachrach

## 3.2. GRILL PRESS EXPERIMENTS

The panini grill experiments were set up following Laura's tip, as explained in the preceding paragraph. The goals of the first experiments were; to see what will happen when plastic is molten in a heated "plate press", to get a feeling for the process, and to explore the plastic melting process.

Four consecutive experiments were executed, all three with use of the panini grill as heater and flatbed, on top of which a weight of 25 kg was put to apply pressure and spread the molten plastic. This setup is depicted in Figure 3-3-B. The four experiments also had varying parameters between them which are displayed in Table 3-1 together with the settings that were kept equal.

	Experiment 1.1	Experiment 1.2	Experiment 1.3	Experiment 1.4
<b>Material</b>	PP	HDPE	HDPE	HDPE
<b>Material form</b>	Not shredded	Not shredded	Result of Experiment 1.2	Not shredded
<b>Anti-sticking</b>	Baking paper	Tefal coating	Tefal coating	Tefal coating
<b>Heating temp.</b>	220-250	220-250	220-250	220-250
<b>Heating time</b>	ca. 60 min.	ca. 40 min.	ca. 40 min.	ca. 40 min.
<b>Cooling time</b>	2 hours	2 hours	4 hours	2 hours
<b>Cooling pressure</b>	25kg	-	25kg	25kg

Table 3-1, 1<sup>st</sup> Experiment series setup

### The executed process is as follows:

1. The panini grill is turned on and set to maximum power, 250 °C.
2. The plastic is placed on the flatbed. (A. in Figure 3-3)
3. The grill is closed, and the weight is placed. (B. in Figure 3-3)
4. Every 10 minutes the status is checked. (C. in Figure 3-3)
5. When the flatbeds are almost pressed to their minimal distance, the plastic is folded double and pressed again. (D, E & F in Figure 3-3)

6. When the flatbeds are pressed to their minimal distance, the power is turned off. (D. in Figure 3-3)
7. After some time of cooling, the plastic plate is retrieved. (G, H & I in Figure 3-3)
8. The lumpy edges are trimmed off to produce a rectangular plate. (J, K & L in Figure 3-3)

The resulting plastic plates, depicted in Figure 3-3, J, K & L, were reviewed, which rendered the results as listed in Table 3-2. Additional experiment documentation is found in Appendix A.7.

	Test 1.1	Test 1.2	Test 1.3	Test 1.4
<b>Surface quality</b>	very smooth	ripply	very smooth	very smooth
<b>Trapped air</b>	medium number of superficial bubbles avg. ca. 1-2 cm <sup>2</sup>	medium number of superficial bubbles avg. ca. 0.5-1 cm <sup>2</sup>	low number of superficial bubbles avg. ca. 0.5-1 cm <sup>2</sup>	high number of superficial bubbles avg. ca. 0.2 - 0.5 cm <sup>2</sup>
<b>Flatness</b>	no visual warpage	apparent visual warpage	no visual warpage	slight visual warpage

Table 3-2, 1<sup>st</sup> Experiment series results

From these four experiments and the resulting plastic plates, the following conclusions were drawn:

- Baking paper is not suitable as an anti-sticking material.
- The aluminium, Tefal coated, flatbeds are suitable as an anti-sticking solution.
- Un-shredded plastic waste traps large air bubbles inside the plastic plates.
- The application of pressure during the cooling process restrains warpage and rippling.
- Notches can be used to limit the thickness of the plate and to provide equal thickness.
- Thicker layers of plastic take longer to melt.

Also, the following theories were developed, to be tested in subsequent experiments:

- Plastic in contact with hot metal absorbs more heat than plastic in contact with air.
- A specified shape can be created by melting and pressing plastic inside a mould.
- Smoothly finished metal is suitable as an anti-sticking solution when also treated with a lubrication agent.
- The flatbed or mould surface quality is copied by the plastic plate

In the subsequent tests, the listed theories are tested, and the relevant conclusions are implemented or taken into account.



A



B



C



D



E

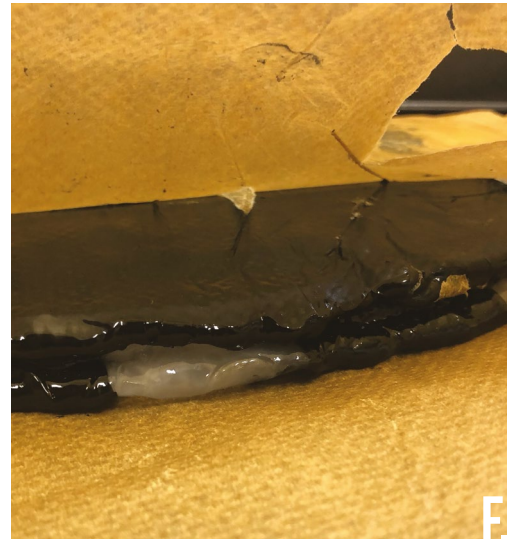

F



G

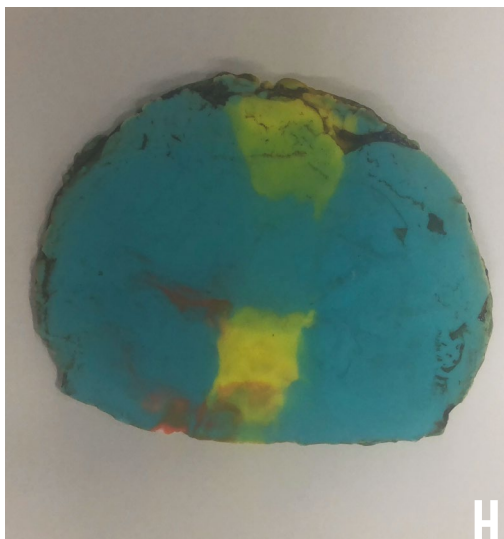

H

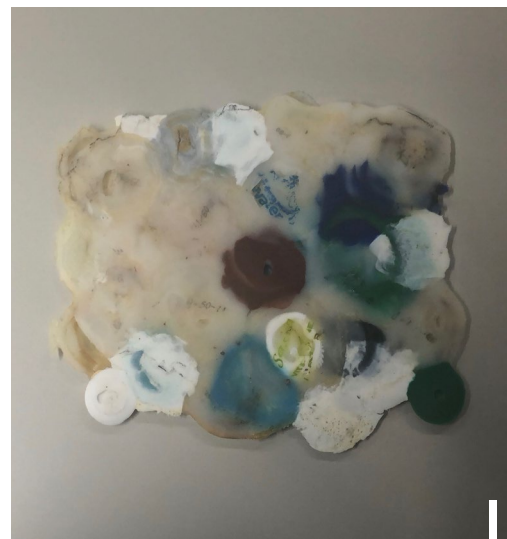

I



J



K



L

### 3.3. ALUMINIUM MOULD EXPERIMENTS

To continue the experiments a simple aluminium mould was designed and produced. It implements the new learnings while aiming to test the developed theories. The mould provided the means to press plates with specified dimensions and a specific thickness. Also, metal and plastic contact was increased, the smoothly finished metal as an anti-sticking solution was integrated, and the mould creates the opportunity to take the mould out of the heated press to cool. The mould was used to perform 15 subsequent experiments from which the main findings are discussed in this paragraph.

#### 3.3.1. The aluminium mould

The mould was designed to be able to set it up for the production of plates with a specific thickness. This thickness setting can be adjusted by adding mould edge layers. In the melting process, the lid is pressed down against the mould edge, which limits the thickness in this way.

The bottom of the mould and the lid are made from a flat and smooth slab of aluminium providing the theorised anti-sticking functionality and surface quality. The design of this mould is far from optimal, considering the amount of aluminium that is used which draws a lot of energy to heat up. However, for the experimentation purpose, it was very suitable because of the ease of assembly, disassembly, adaptability and thickness setting. The mould design is depicted in Figure 3-4, A - E.

The process that is realised with this mould is similar to the previously explained process. A few steps are replaced and added, resulting in the process as listed below and depicted in Figure 3-4, F - L.

#### Plate pressing process with aluminium mould:

1. The panini grill is turned on and set to maximum power, 250 °C.
2. The mould parts are sprayed with PTFE spray (a lubrication agent)
3. The right amount of plastic is weighed and placed in the bottom mould half. (F. in Figure 3-4)
4. The mould is closed off with the lid and placed on the flatbed, the grill is closed, and the weight is placed. (G. in Figure 3-4)
5. Every 10 minutes the status is checked. (H. in Figure 3-4)
6. When the mould has completely closed, the power is turned off, the mould is taken out, placed on a coaster and the weight is placed on top. (I. in Figure 3-4)
7. When the mould feels cold or lukewarm to the touch, it is pried open, and the plate is retrieved. (J & K in Figure 3-4)
8. If needed the flashing (excess, protruding, material) is cut off. (L. in Figure 3-4)

#### 3.3.2. Defined plate shape

The first experiment with the aluminium mould was executed to find out if a defined plate shape could be produced with the aluminium mould and the previously defined process. The required amount of input material was calculated by multiplying the plate volume by the density of the used material. This amount and the other process parameters are listed in Table 3-3.

The executed process is as follows:

1. The panini grill is turned on and set to maximum power, 250 °C.
2. The plasticfilled mould is placed on the flatbed. (Figure 3-4-F)
3. The mould and grill are closed, and the weight is placed. (Figure 3-4-G)
4. Every 20 minutes the status is checked. (Figure 3-4-H)
5. When the flatbeds are pressed to their minimal distance, the power is turned off and the mould is set aside to cool with the weight on top. (Figure 3-4-I)
6. After some time of cooling, the plastic plate is retrieved. (J, K, L in Figure 3-4)
7. The uneven edges are trimmed off to produce a clean rectangular plate. (J, K & L in Figure 3-4)

	Experiment 2
Thickness setting	5mm
Material	HDPE
Material form	Not shredded
Input weight	220g
Anti-sticking	Mould + PTFE-spray
Heating temp.	220-250 °C
Heating time	ca. 30 min.
Cooling time	2 hours
Cooling pressure	25kg

Table 3-3, 2<sup>nd</sup> Experiment setup

The resulting plastic plate, depicted in Figure 3-4, J, K & L, was reviewed, which rendered the results as listed in Table 3-4. Additional experiment documentation is found in Appendix A.7.

	Experiment 2
Surface quality	very smooth
Trapped air	medium number of superficial bubbles avg. ca. 1-2 cm <sup>2</sup>
Flatness	no visual warpage

Table 3-4, 2<sup>nd</sup> Experiment results

From this experiment and the resulting plastic plate, the following conclusions were drawn:

- Smooth finished metal treated with PTFE spray is a suitable as an anti-sticking solution.
- Un-shredded plastic waste traps large air bubbles inside the plastic plates.
- Un-shredded plastic waste takes up a lot of space.
- The application of pressure during the cooling process restrains warpage and rippling.
- A defined plate shape can be produced using a simple mould with a stopping edge.
- The plastic plate shrinks noticeably, which pulls the plate loose from the mould edge.

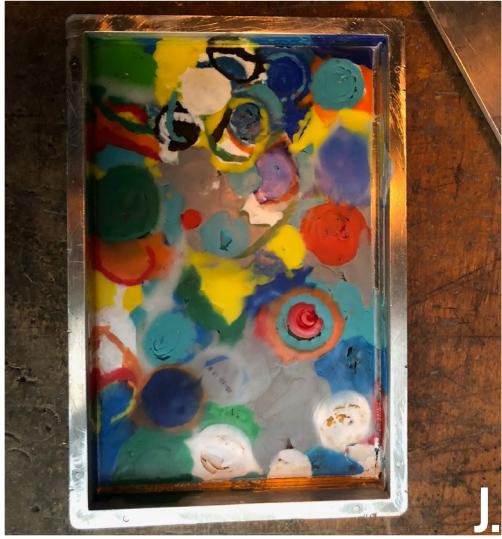
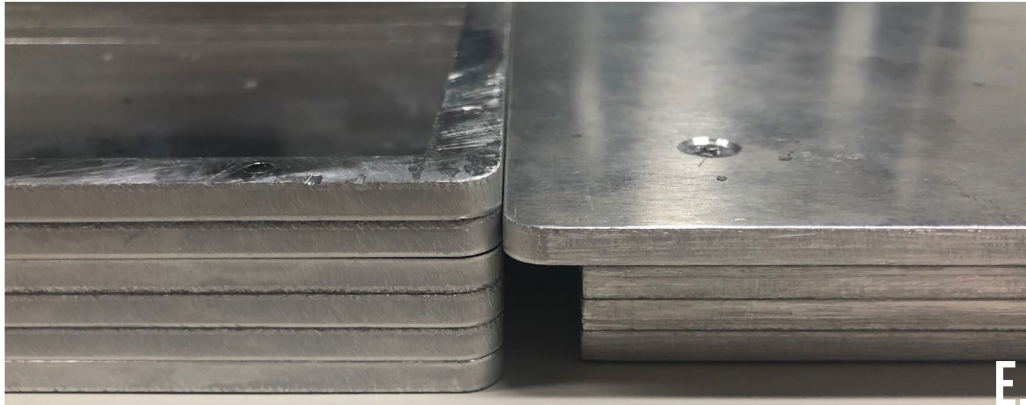
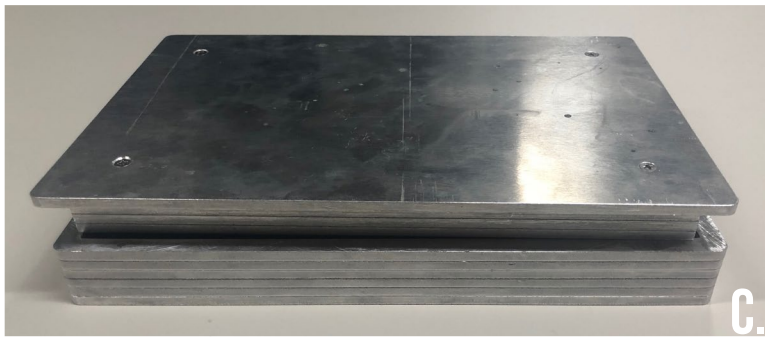
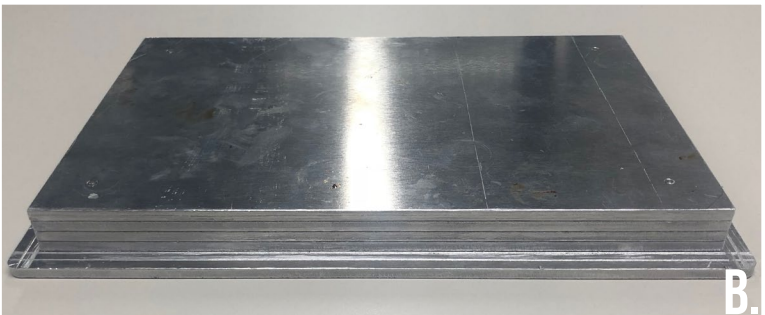
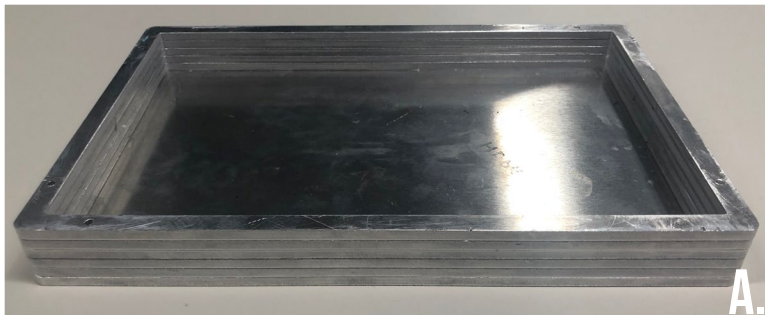

- The closed off mould, which also increases the metal to plastic contact, speeds up the melting process.

Also, the following theories were developed, to be tested in subsequent experiments:

- Shredding the plastic will decrease the amount and size of air bubbles inside the plastic
- Using shredded plastic as input material will decrease the melting time

In the subsequent tests, the listed theories are tested, and the relevant conclusions are implemented or taken into account.

### 3.3.3. PP & HDPE - 5mm, 12 & 20mm

Now that the basics of the simple plate pressing process seem to be working, the plastics that were selected for processing

in the analysis chapter are tested and compared. Also, the minimum, maximum and actual plate thickness goals are tested. Halfway through the experiments, it was concluded that trapped air continued being a problem. To prevent this problem, vent holes were introduced. It was theorised that creating an opening for excess plastic and air to flow out, would decrease the amount of trapped air. The vent holes were implemented by drilling twenty holes of 3mm diameter, equally spaced all round one of the mould layers, this layer could then be placed at a preferred layer height. Sadly this method only allowed a part of the excess plastic and trapped air to be released but not all. See Figure 3-5 -H.

In all of these experiments, the material was shredded, PTFE-spray was used as an anti-sticking agent, the melting temperature was between 200 °C and 250 °C and the pressure was applied by a 25kg weight.

	Experiment 4.1	Experiment 4.2	Experiment 5.1	Experiment 5.2	Experiment 6.1	Experiment 6.2
Thickness setting	5 mm	5 mm	20 mm	20 mm	12 mm	12 mm
Vent hole layer	-	-	-	5th	3rd	3rd
Material	HDPE	PP	PP	HDPE	HDPE	PP
Input weight	240	220	830	850	440	410
Heating time	20m	20m	1h	1h	40m	40m
Cooling time	1h	1h	12h	12h	4h	4h

Table 3-5, 4<sup>th</sup>, 5<sup>th</sup> & 6<sup>th</sup> Experiment series setup

Side note:

In experiment 3, a plate pressing process was tried out with PET; however, this was unsuccessful. The conclusions are not

of significance thus the experiment documentation is only presented in Appendix A.7.

The same holds for experiments with PS.

	Experiment 4.1	Experiment 4.2	Experiment 5.1	Experiment 5.2	Experiment 6.1	Experiment 6.2
Resulting thickness	5 - 6 mm	4.9 - 5.1 mm	20,5 - 26,5 mm	20 - 25mm	10.3 - 13 mm	10 - 11.5 mm
Expected weight	240	205	950	990	530	445
Actual weight	215	190	810	830	410	395
Percentage of air	10%	7%	15%	16%	23%	11%
Figure 3-5	A	B	C	D	E	F

Table 3-6, 4<sup>th</sup>, 5<sup>th</sup> & 6<sup>th</sup> Experiment series results

From these four experiments and the resulting plastic plates, the following conclusions were drawn:

- Shredded plastic takes up less space than un-shredded plastic; about 3-4 times the amount of space taken up by a solid plastic plate.
- Shredded plastic decreases the amount and size of air bubbles encapsulated inside the plastic plates.
- PP and HDPE can both be processed in very similar ways, resulting in promising plastic plates.
- PP has a lower viscosity than HDPE at the same processing temperature, thus flowing more smoothly.
- Shrinkage occurring during cooling causes the middle of the plates to sink in. (Figure 3-5-I)
- The plastic plates shrink themselves loose from the plastic that is trapped in the vent holes. (Figure 3-5-G)
- The plastic that creeps between mould layers gets the

mould stuck; thus undercutting geometry should be avoided.

- Plastic-type pollution causes surface quality defects; the 'alien' granules are easily torn off.

Also, the following theories were developed:

- Because the plastic is melted from the outside towards the inside, the outer-layers melt first. These outer layers melt together, creating a continuous surface that encapsulates all of the air that still resides between the un-molten granulate. During the continued melting process, the air gathers in big bubbles inside the plastic plate, while the viscosity and non-existent flow keep them in place.

Figure 3-5, Experimentation series 4,5 & 6 - Pictures by Mark Bachrach >



A.



B.



C.

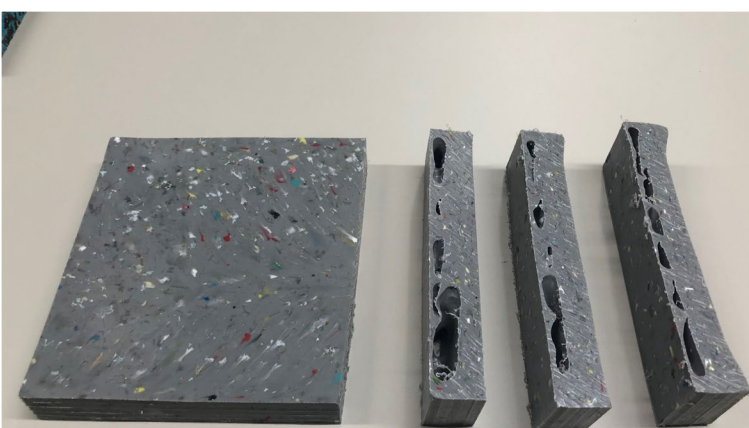

D.



E.

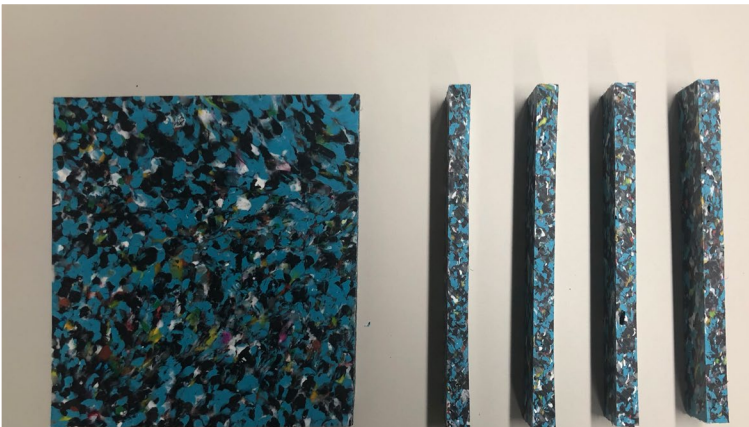

F.



G.

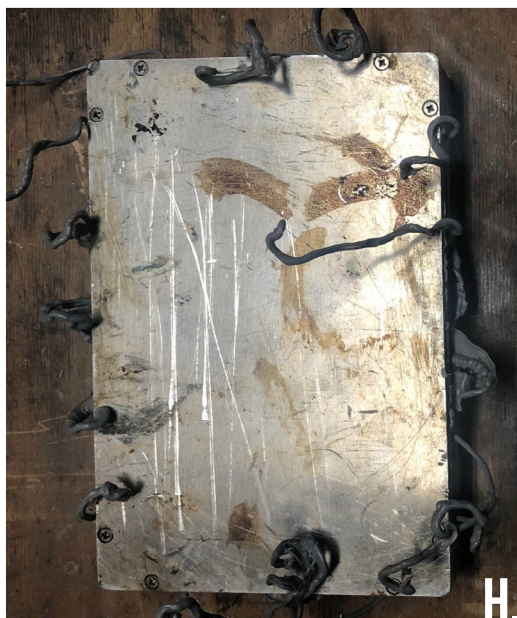

H.



I.

- The higher viscosity of HDPE makes it harder for air bubbles to move. Therefore more air is encapsulated. The lower viscosity of PP allows the plastic to flow more easily; thus bubbles are more likely to move to the vents where they can leave the mould.
- Cooling occurs from outside towards the middle; therefore the outer edges solidify before the middle of the plate does. While the middle is still fluid when the edges solidify, the material can flow away from the middle towards the shrinking edges. This effect results in the observed shape as depicted in Figure 3-5-I.
- Melting from the bottom might result in a pool of plastic that absorbs granulate when it is melting, leaving the air out.

### 3.3.4. Forcing the air out

In the most recent experiments, the encapsulated air inside the plastic plates was the most apparent problem. Therefore the following experiments were executed with the goal of finding a method to force the air out.

In experiment 7, a theory that was developed in the preceding experiments was tested; 'Melting from the bottom might result in a pool of plastic that absorbs granulate when it is melting; leaving the air out.'

In the experiment, the plastic was melted inside the mould but without putting the lid on it. When the plastic had melted completely, the mould was taken out, closed off with the lid, the weight was put on top, and it was set apart for cooling. As can be seen in Figure 3-6-G, it did not work as hoped for.

	Experiment 7	Experiment 8.1	Experiment 8.2
Thickness setting	20 mm	10 mm	10 mm
Vent hole layer	4th	2nd	2nd
Material	HDPE	HDPE	HDPE
Input weight	950	450	450
Heating time	1h 20m	1h 40m	40m
Cooling time	1h	1h	12h
Resulting thickness	22	8.55 - 10.1	8.3 - 10
Expected weight	928	390	386
Actual weight	783,4	369,3	378,2
Percentage of air	16%	5%	2%
Figure 3-6-	A, D, G	B, E, H	C, F, I

Table 3-7, 7<sup>th</sup> & 8<sup>th</sup> Experiment series results

**From these three experiments and the resulting plastic plate, the following conclusions were drawn:**

- Sufficient pressing force drives the air out of the plastic plate. (Figure 3-6-H, I)
- Pressing molten plastic in a cold mould does not render satisfying results. (Figure 3-6-D, G)
- The force that is needed to press the mould shut and force out the excess material and the encapsulated air is of considerable magnitude.

In experiment 8.1, the same theory was tested with an improved method:

The lid was left off of the mould, but this time also the top grill part was left off. After 20 minutes, the lid was preheated, and after another 20 minutes, it was put on the mould together with the top grill half. Then the assembly was heated for another hour. When the plastic was taken out to set apart for cooling, glue clamps were used to press the mould shut and force out the excess plastic and air. As can be seen in Figure 3-6-H, this did work as hoped for.

In experiment 8.2, the solution factor was singled out. This was needed since, in experiment 8.1, two factors could have been the success factor that succeeded in forcing the air out. The first factor being the staged melting method, the second factor being the added pressure from the glue clamps. In experiment 8.2 the standard melting procedure was followed, and when the plastic had melted entirely, the mould was pressed shut with use of the glue clamps. As can be seen in Figure 3-6-I, it worked as planned.

In all three experiments, HDPE was used, since it had suffered the most significant problem with trapped air. The process parameters that were not discussed were kept the same as in the preceding experiments. In table 3-7, the essential experiment parameters are listed.

**Also, the following theories were developed:**

- Cold mould parts solidify plastic on contact, which results in a rough, bulky and non-continuous surface. (Figure 3-6-D, G)
- The encapsulated air inside the molten plastic is forced out together with the excess material; the flow of the material is needed to transport the air out. (Popping and hissing sounds that interrupted the outflowing plastic were observed during the pressing process)

Figure 3-6, Experimentation series 7 & 8 - Pictures by Mark Bachrach >





A.



B.



C.



D.



E.

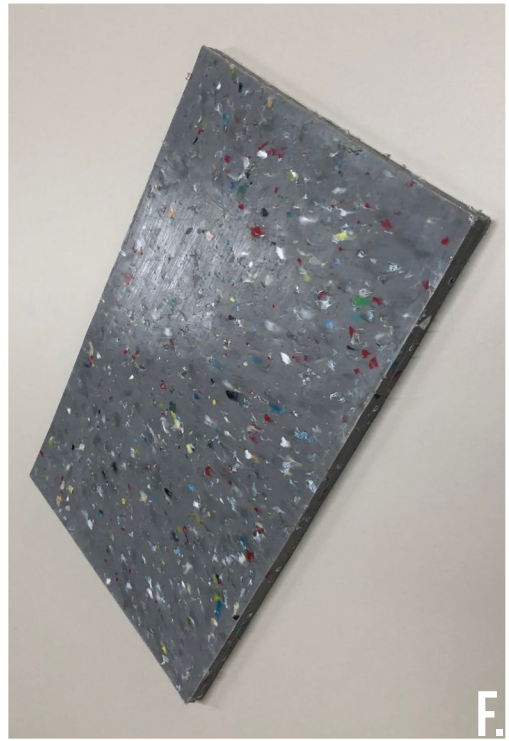

F.



G.



H.



I.

### 3.4. DISCUSSION & CONCLUSION

In the experiments, often multiple parameters were changed, by doing so, observations and progress were amplified, but singling out causes for specific results was made harder. To single out such causes, follow-up experiments were sometimes needed. This then again reduced the progress' efficiency. Overall it can be reasoned that as long as the experiments have explorative motivations, changing multiple parameters is a good thing, since then a lot of ground can be covered with a small number of experiments. However, when experiments are motivated by theory confirmation, they approach empirical research's hypothesis proving. In this case, only single parameters should be changed. That way, the cause and effect relationship can be singled out or proven. In hindsight, the setup of some of the experiments should have accounted for this reasoning. Nevertheless, it is also believed that the loose setup of the experiments allowed for fast and broad knowledge acquisition.

Besides, the loose setup of the experiments, the melting process is also a point of discussion since it was limited to a single heating method. By only using a grill-press as a heating source, the process was steered in a single direction. Using an oven, for example, might have revealed other insights. It could be reasoned that the decision to use a grill press initiated a linear conclusion and theory development, resulting in the conclusions that were discussed. Changing the starting point might result in a completely different conclusion and theory development chain. This notion is accepted because of project time limitations. When more time would have been available, the experimentation could have benefitted from a broader setup. After which, the conclusions and theories could be proven with specific and precise empirical research. It is essential to acknowledge that all of the conclusions presented in this chapter are based on single or few observations. Thus all of these conclusions should be regarded as assumptions. The assumptions are believed to represent reality, but this is not proven as of yet. However, it is believed that they will suffice for the basis of the conceptualisation. The conclusions that are essential in the design process are summarised in the following:

- Shredded plastic takes up less space than un-shredded plastic;
- about 3-4 times the amount of space taken up by a solid plastic plate.
- Compared to un-shredded plastic, shredded plastic decreases the amount and size of air bubbles encapsulated inside the plastic plates.
- The application of pressure during the cooling process restrains warpage and rippling.
- Notches can be used to limit the thickness of the plate and to provide equal thickness.
- Smooth finished metal treated with a lubrication agent is suitable as an anti-sticking solution.
- The application of pressure during the cooling process restrains warpage and rippling.
- A defined plate shape can be produced using a simple mould with a stopping edge.
- Shrinkage causes the plates to pull loose from the mould edge.
- A closed off mould increases the metal to plastic contact, which speeds up the melting process
- Shrinkage occurring during cooling causes the middle of the plates to sink in.
- The plastic that creeps between mould layers gets the mould stuck; thus undercutting geometry should be avoided.
- Sufficient pressing force combined with air and excess material vents, drives the air out of the plastic plate.
- Pressing molten plastic in a cold mould does not render satisfying results.
- The force that is needed to press the mould shut and force out the excess material and encapsulated air is of considerable magnitude.

# 4. CONCEPTUALISATION

The analysis and experiments have together provided a sufficient basis to start the conceptualisation with; the design goals are clear, and the minimum requirements are set. However, this chapter will start by summarising the critical insights into comprehensible schematics; a function schematic and a program of requirements. Next to that, a clear division is made between process parameters that are fixed and those that are adaptable, of which also the level on which they are adaptable is defined. Together these three schematics provide the actual input for the generation of principle ideas, which is realised through a creative session with MMID designers. The ideas that are generated are then used to create plate production process concepts, which are then evaluated with the help of the project experts. Two of the concepts are chosen, and their feasibility is tested in simple prototypes. This proof of concept reveals the final choice for the plate production process concept that will be further developed in the embodiment phase. The described conceptualisation process is depicted in Figure 4-1.

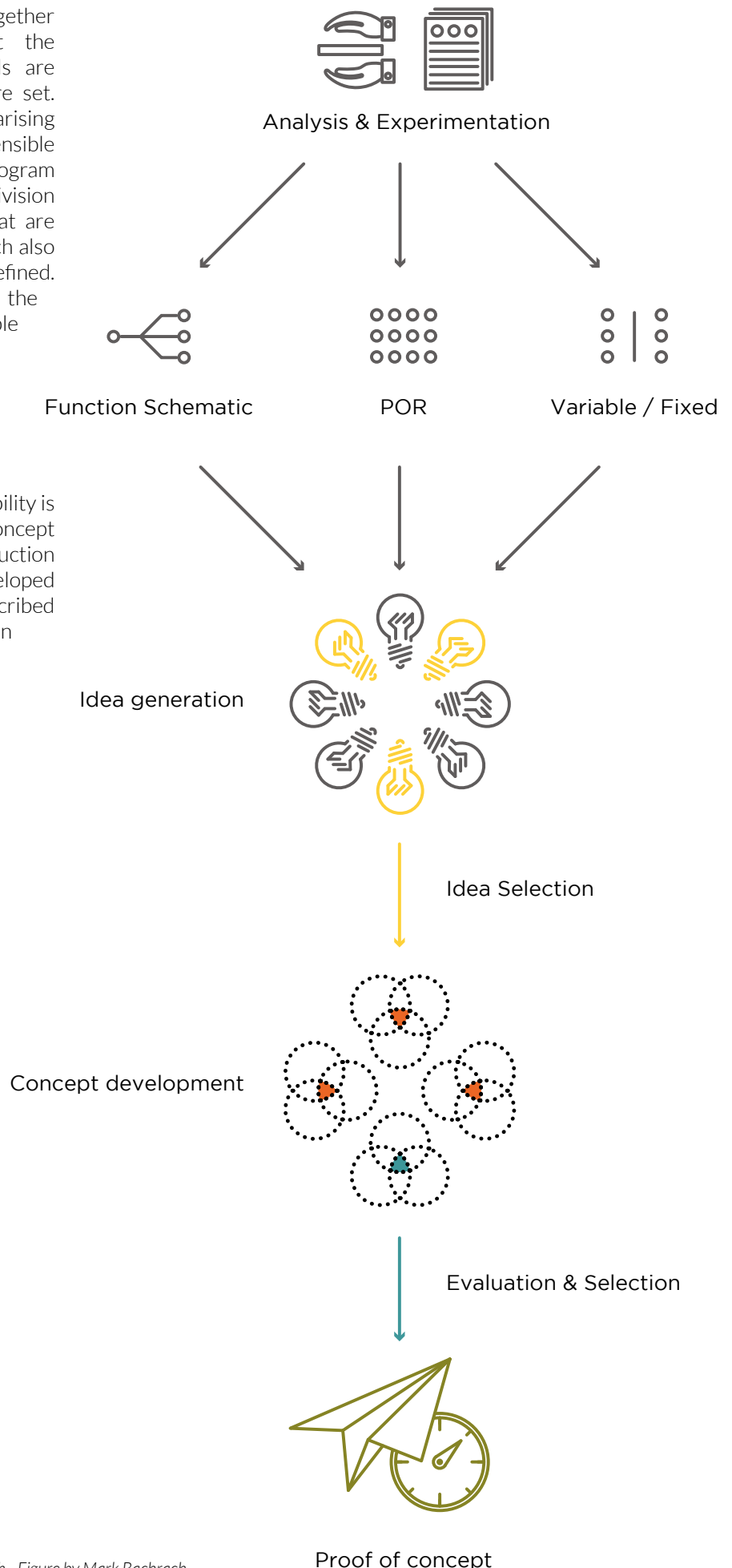

Figure 4-1, Conceptualisation Approach - Figure by Mark Bachrach

## 4.1. SYSTEM FUNCTION SCHEMATIC

Based on the analysis and experimentation the previously presented function schematic has been adapted and elaborated to encompass all expected functionalities (see Figure 4-2). Where possible, sub-function have been added, but the level of detail is deliberately held back to keep the solution space open. The numbered functions are linked to process steps and are numbered in chronological order. The lettered functions are system-wide functions that either facilitate other functions or are entwined with multiple other functions.

The functions in this schematic are later on used as input for the ideation.

## 4.2. FIXED OR VARIABLE

In the analysis, it was found out that different contexts have varying plastic plate wishes. To be able to both serve Fábrica de Sabão as well as other potential builders/user, adaptation possibilities should be included in the design. Of course, not all process parameters can be adaptable. Some design elements will be fixed, thereby providing a basis for the other functionalities. Other design elements should allow adaptations, variable inputs or settings. The division of these design elements and the level on which they should be adaptable is displayed in Figure 4-3.

Some of the design elements are incorporated in the ideation and afterwards in the concept development (Green in Figure 4-3). Other elements will be integrated during the embodiment phase (Blue in Figure 4-3). Again others, will not be integrated at all, but are merely present as a suggestion for future experimentation and development (Yellow in Figure 4-3). Finally, process and plastic plate properties are included that result from the combinations of the process parameters (Grey in Figure 4-3).

## 4.3. PROGRAM OF REQUIREMENTS - CONCEPTUALISATION

Based on the analysis and experimentation a program of requirements (POR) has been produced. Again, the level of detail is deliberately held back in order to keep the solution space open. Further specification and detailing is only needed for the embodiment phase. A more detailed POR will thus be presented in the following chapter, design research. The requirements in table 4-1 are listed with one or more paragraph numbers, in which the origination of the POR item can be found. A few of the items do not have such an origin; instead they are introduced based on design gut.

Category	Requirement for plate press system		
Genesis	Design	1	The concept should be easily adaptable to different dimensions
		Adaptation	
	Nature	2	The concept should be kept simple
	Production	3	The production techniques and materials should fit single unit production
		Lot size	
	Materials	4	The majority of the production materials should be easily available all over the world
		5	The concept should allow for production with a range of material dimensions
Technologies	6	The concept should be producible with simple technologies	
Budget	7	The concept should be realisable within the budget of \$ 2500	
Use	Safety	8	The concept should not be a safety hazard in principle
		9	The concept should be operable with a maximum of 2 persons
	Use		
	User interaction		
		10	The concept should provide 1 clear way of working that is not multi interpretable
Product itself		11	The concept should be able to produce plastic plates as specified in the plastic plate requirements
		12	The concept should provide the functions as listed in the function schematic
		13	The concept should be able to produce at least 5 plates per day
		14	The concept should apply evenly distributed pressure over the entire plate surface
		15	The pressure should withstand temperatures up to 270 C
		16	The concepts electrical energy consumption may not exceed 10kw
Maintenance and recovery		17	The concept should allow accessible maintenance possibilities

Table 4-1, POR - Conceptualisation

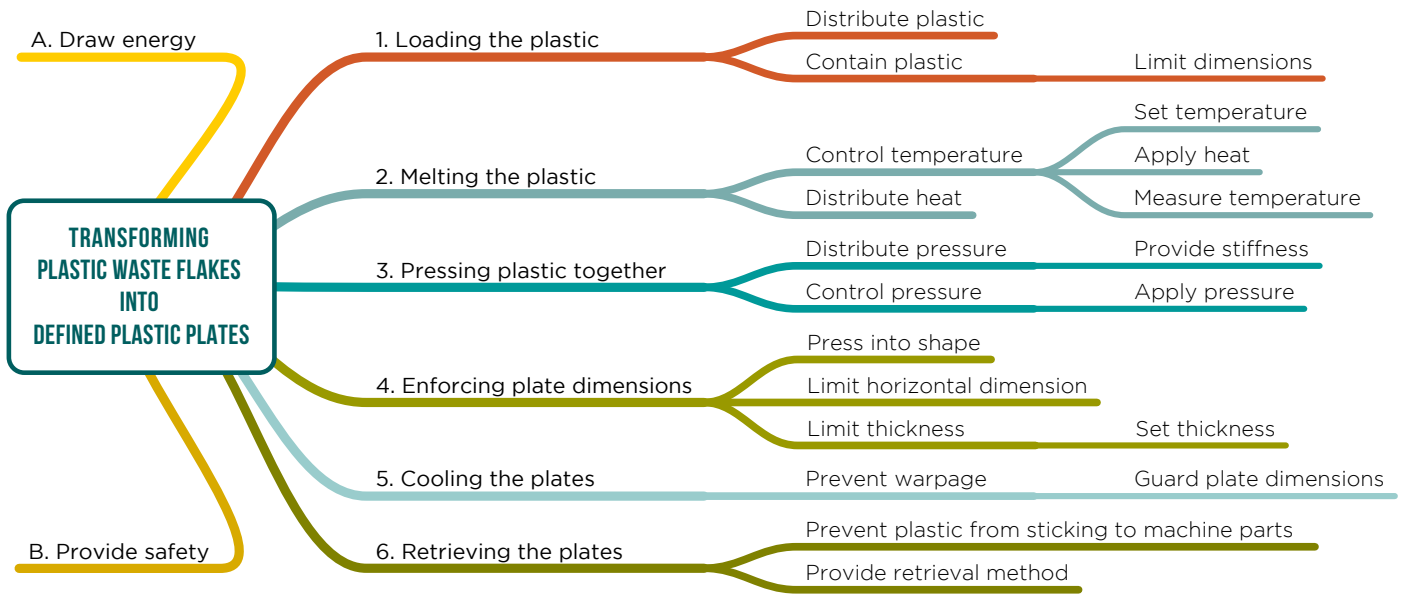

Figure 4-2, Basic function schematic of entire system - Figure by Mark Bachrach

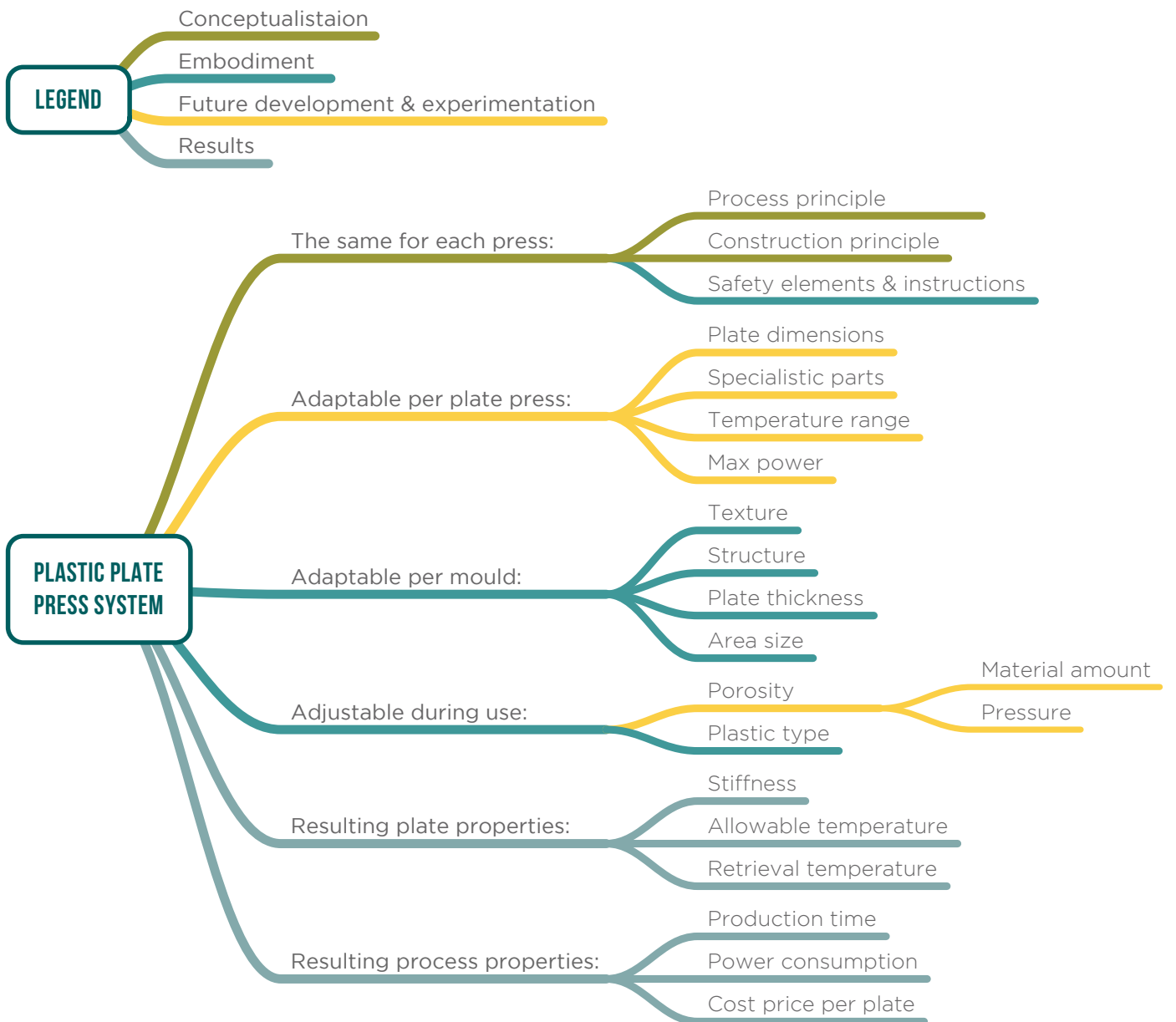

Figure 4-3, System property adjustability schematic - Figure by Mark Bachrach

## 4.4. IDEATION

In the ideation, partial solutions were generated for the fulfilment of the functional needs of the concept. These functional needs were expressed in 'How-To's', of which a selection was used as input for a creative session, see table 4-2. The creative session was set up with MMID designers as participants with the idea of outsourcing brain capacity, broadening the solution space and borrowing design experience. To realise this, a session plan was made. The

plan had to be very concise since the MMID designers were helping out in personal time. The result was a power session on the clock, which worked out quite well. The setting of the creative session is portrayed in Figure 4-4. The session plan is found in Appendix A.8.

The resulting ideas were evaluated, and a selection was made to be used for the concept development. The evaluation and selection were based on criteria that were generated in the creative session (see table 4-3) and by using insights gained in the experimentation and analysis phases.

### Creative session How to's

How to shape a plate?
How to melt plastic?
How to guard the plate shape while cooling?
How to exert pressure on a plastic filled plate mould?
How to transport hot and heavy moulds filled with molten plastic?

Table 4-2, Creative session How To's

### Creative session Criteria

Power efficiency
Plate quality
Required pressure
Safety
Simplicity of resources
Required operators
Simplicity of construction

Table 4-3, Creative session selection criteria



Figure 4-4, Creative session with MMID Designers - Picture by Mark Bachrach

## 4.5. CONCEPT DEVELOPMENT

With the selection of ideas that were developed and selected in the ideation, eight process principle concepts were developed. These concepts had to cohere to the program of requirements and fulfil the identified functions. The primary functions being; melting, pressing and cooling. This division is also made in the visualisation of the concepts, see Figure 4-5 on page 57. Some concepts combine functions, and others keep all main functions separated.

The level of detail in the produced concepts is kept low, while the concepts only focus on the process principle and not on the materialisation of those principles. This low level of detail should provide enough input for concept evaluation, while not drawing attention to irrelevant materialisation details. In the following, each of the concepts is explained, and they are displayed in Figure 4-5.

### Process principle concept 'A'

*- Rolling & Active Cooling -*

A simple oven heats a tray with plastic granulate in order to melt the plastic. When the plastic has melted completely, the tray is taken out and fed through a plate rolling device. The device uses rollers that press the plastic together. The rollers decrease the thickness step by step to the specified thickness. At the right thickness, active cooling freezes the plate in shape, while additional sets of rollers keep the plate straight and pressurised.

#### **The benefits of this concept are:**

- By using rollers, the pressure is localised, and thus less force is required.
- The oven can be insulated very well and is thereby heat efficient.
- Active cooling speeds up the cooling and thereby, decreases the number of moulds that are needed for continuous production.

### Process principle concept 'B'

*- Rolling & Passive Cooling -*

A simple oven heats a tray with plastic granulate in order to melt the plastic. When the plastic has melted completely, the tray is taken out and fed through a plate rolling device. The device uses rollers that press the plastic together. The rollers decrease the thickness step by step to the specified thickness. When completely pressed, the mould is transferred to a simple cooling press that guards the shape during passive cooling. In this cooling press, multiple moulds can be stacked for cooling.

#### **The benefits of this concept are:**

- By using rollers, the pressure is localised, and thus less force is required.
- The oven can be insulated very well and is thereby heat efficient.
- Passive cooling lets the plastic cool down slowly and more evenly, and it allows for continuous production by freeing up the rolling device.

### Process principle concept 'C'

*- Pressing & Passive Cooling -*

A simple oven heats a tray with plastic granulate in order to melt the plastic. When the plastic has melted completely, the

tray is taken out and inserted in a plate pressing machine. The plate press uses a force actuator to press two flatbeds together in order to press the molten plastic in a specified plate shape. When completely pressed, the mould is transferred to a simple cooling press that guards the shape during passive cooling. In this cooling press, multiple moulds can be stacked for cooling.

#### **The benefits of this concept are:**

- By using a single movement, the pressure distributes evenly and can be quickly applied.
- The oven can be insulated very well and is thereby heat efficient.
- Passive cooling lets the plastic cool down slowly and more evenly, and it allows for continuous production by freeing up the pressing device.

### Process principle concept 'D'

*- Heated pressing & Passive Cooling -*

A heated plate press simultaneously melts and presses plastic granulate in a plate mould. Only when all of the plastic granulate has melted, the press can completely close the mould. At that moment the mould contains a wholly filled plate shape. When completely pressed, the mould is transferred to a simple cooling press that guards the shape during passive cooling. In this cooling press, multiple moulds can be stacked for cooling.

#### **The benefits of this concept are:**

- By using a single movement, the pressure distributes evenly and can be gradually increased.
- By heating and melting at the same time, the viscosity is kept low during the pressing action, which decreases the required pressure.
- Passive cooling lets the plastic cool down slowly and more evenly, and it allows for continuous production by freeing up the pressing device.

### Process principle concept 'E'

*- Blob Pressing & Passive Cooling -*

A simple oven heats a bucket with plastic granulate in order to melt the plastic. When the plastic has melted completely, the bucket is taken out, and the plastic is inserted in a plate pressing machine. The plate press uses a force actuator to press two flatbeds together in order to press the molten plastic 'blob' into a specified plate shape. When completely pressed, the mould is transferred to a simple cooling press that guards the shape during passive cooling. In this cooling press, multiple moulds can be stacked for cooling.

#### **The benefits of this concept are:**

- By using a single movement, the pressure distributes evenly and can be quickly applied.
- The oven can be insulated very well and is thereby heat efficient.
- Because the plastic is melted in a more condensed volume, the oven can be kept relatively small.
- Passive cooling lets the plastic cool down slowly and more evenly, and it allows for continuous production by freeing up the pressing device.

Process principle concept 'F'

- *Heated Pressure cart* -

A long and sturdy tray is filled with plastic granulate, which is evenly distributed. Next, a cart, with rollers and heating elements, very slowly heats and presses the plastic as it slowly moves forward. When the cart has passed a certain length, a steel plate is put on top and screwed shut to guard the shape during passive cooling. This process produces a very long plate that can be cut into pieces afterwards. The pressing and melting process takes a full day and the cooling a full night.

**The benefits of this concept are:**

- By using rollers, the pressure is localised, and thus less force is required.
- By facilitating a single continuous process, there is no need for transporting hot and heavy, plastic filled, moulds.

Process principle concept 'G'

- *Vertical Extruder* -

A heating chamber melts plastic granulate until it droops out of the bottom when it reaches a sufficiently fluid state. The plastic is then rolled into the right shape and thickness in several steps, through multiple sets of rollers.

When the right thickness is achieved, active cooling freezes the plate in shape. When the right plate length has been produced, it is cut off and put away. During this continuous process, the heating chamber needs to be replenished at the top.

**The benefits of this concept are:**

- By using rollers, the pressure is localised, and thus less force is required.
- By facilitating a single continuous process, there is no need for transporting hot and heavy plastic filled moulds.
- The heating chamber can be insulated very well and is thereby heat efficient.
- Because the plastic is melted in a more condensed volume, the heating chamber can be kept relatively small.

Process principle concept 'H'

- *Injection Ram* -

A heating chamber melts plastic granulate. When the plastic has reached the right fluidity, a latch at the bottom is opened, and the plastic is pressed down into a plate-shaped mould. The plate mould is then removed, and the plate is put into a simple cooling press that guards the shape during passive cooling.

**The benefits of this concept are:**

- The heating chamber can be insulated very well and is thereby heat efficient.
- Because the plastic is melted in a more condensed volume, the heating chamber can be kept relatively small.
- Passive cooling lets the plastic cool down slowly and more evenly, and it allows for continuous production by freeing up the pressing device.

A.

B.

C.

D.

E.

F.

G.

H.

Figure 4-5, Proof of concept tests - Figure by Mark Bachrach >



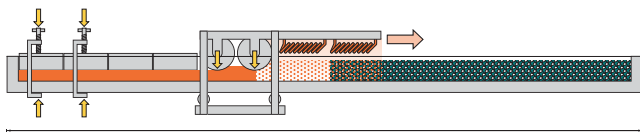
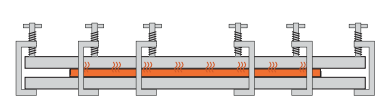
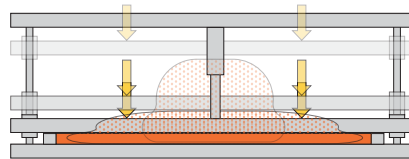
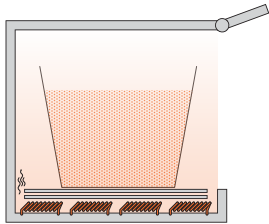
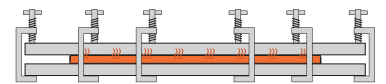
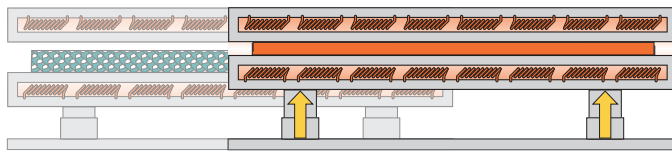
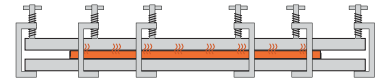
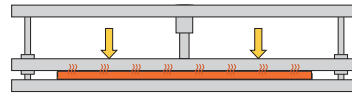
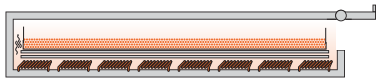
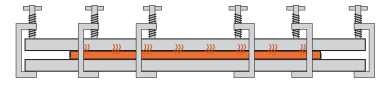
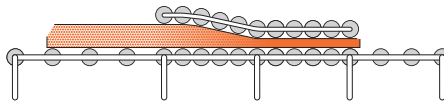
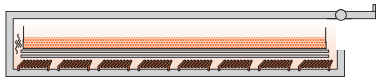
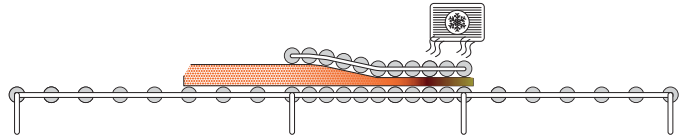
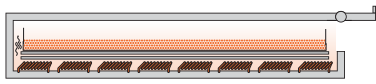

10m = 8 x 1,22m +

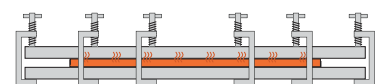
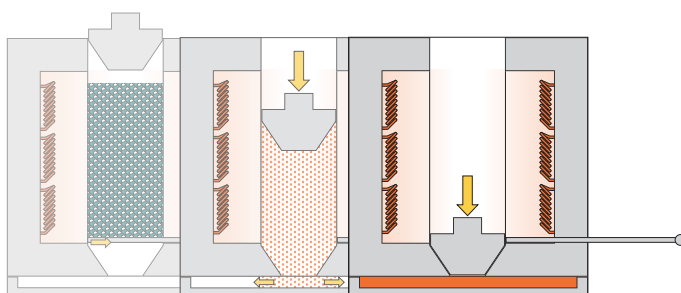
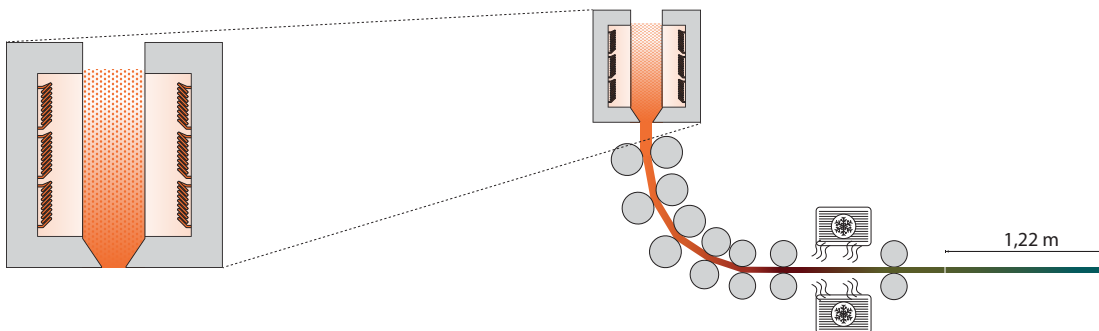
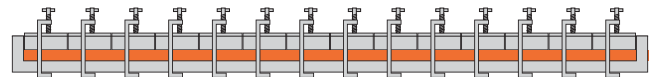

## 4.6. CONCEPT EVALUATION

In order to properly evaluate the concepts, two project experts were consulted; Laura Klauss from the Better Future Factory and Jerry de Vos from Precious Plastic. The concept visuals were used to explain the concepts to them and according to multiple evaluation criteria, the concepts were discussed. The resulting gained insights were then used to produce selection graphs that score the concepts on a selection of criteria. The graphs display an estimated score for each of the concepts on two criteria. The scores are displayed with an uncertainty expressed in the width and length of the representative ellipse. The actual score is believed to be somewhere inside the ellipse, although this is still not certain since non-existent matter is discussed.

The first graph (Figure 4-6) scores for all of the concepts on the most important criteria; process principle feasibility and low resource manufacturing feasibility. The upper right zone in the graph contains the concepts with the highest score on both criteria. This orange outlined square was decided upon to be the minimal feasibility requirement. Thus, the concepts that are contained in this zone for the largest part are therefore the only three concepts to be taken into consideration. Further evaluation with selection graphs will only discuss these three concepts.

Two more graphs compare the concepts on expected device properties and plate output properties.

Figure 4-7 displays the estimated scores for energy efficiency and plate production rate. Since concepts 'B' & 'C' use the same heating method, their score is also equal. As can be clearly seen, concept 'D' is expected to have a lower score on both energy efficiency as well as production rate, this expectation is backed by the experiences gained from Precious Plastic's plate press that closely resembles this concept. Because the heating and pressing steps are combined, energy efficiency concessions have to be made. Concept 'D' scores lower than the other concepts, and it is only partly contained in the red outlined 'go zone', which indicates the graph's area for sufficient scores. Therefore, concept 'D' is no longer considered as development choice. Adding to this is the fact that Precious Plastic has already developed a plate press following concept 'D's process principle and thus it is more interesting to focus on a new and hopefully better solution.

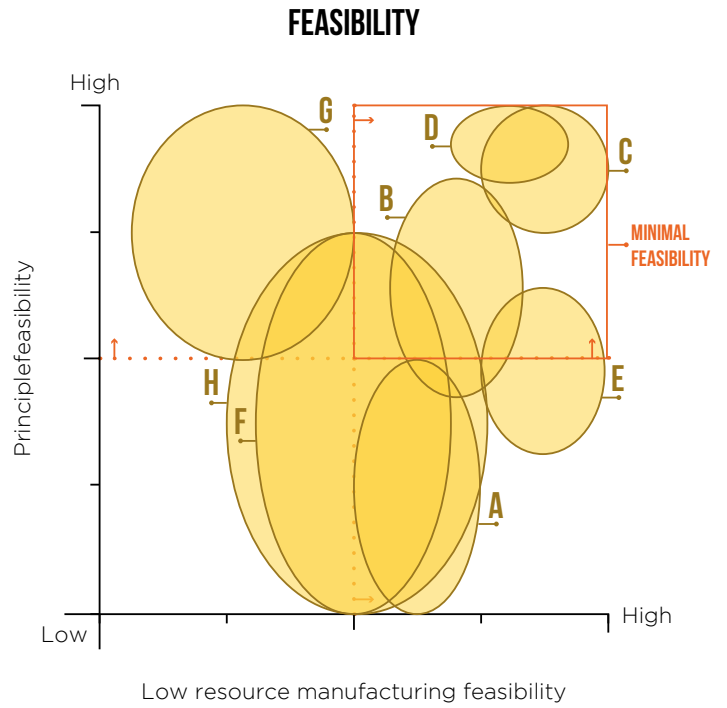

Figure 4-6, Concept selection graph, Feasibility - Figure by Mark Bachrach

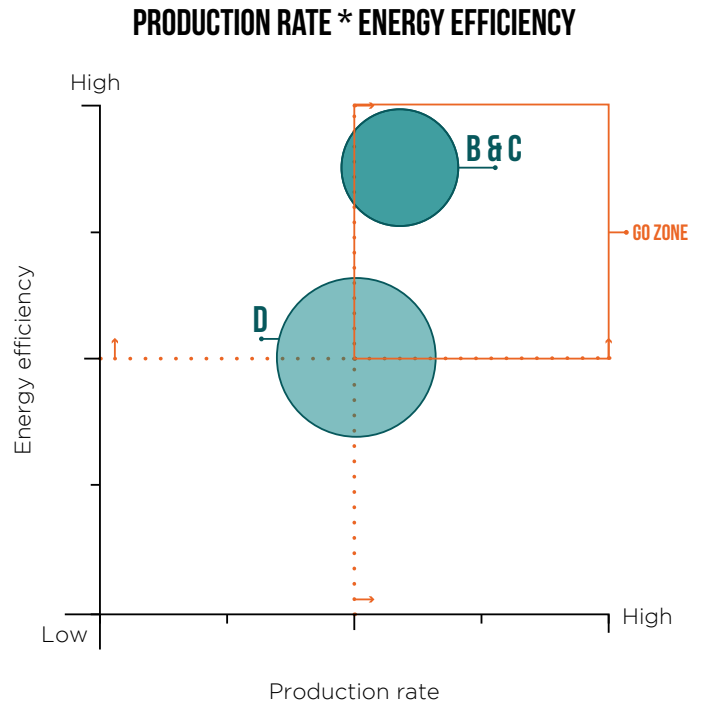

Figure 4-7, Concept selection graph, Production rate x Energy efficiency - Figure by Mark Bachrach

In a third graph (Figure 4-8), the estimated concept scores for output plate solidity and thickness variation are displayed. Here can be seen that both concepts are expected to uphold sufficient plate quality, but concept B is expected to produce the best plate results. This expectation is based on Laura and Jerry, whom both expected the rolling technique to produce the best plate quality. However, concept 'C' is also expected to be able to produce plates with sufficient quality.

Lastly, the costs were estimated, which is depicted in Figure 4-9. The uncertainty of the costs is considerable, which makes it hard to identify a define victor, but concepts C is expected to be executable with a lower budget. This is mostly due to the number of moving parts that need expensive and precise speciality components.

This cost comparison brings the decision to a tie, concept B scores better on expected plate quality and concept C is expected cost less. When considering the decision drivers that were determined at the start of this project (affordability, ease of manufacturing and accessibility of resources), the cost comparison should play a more significant role in making this decision.

However, when looking back at the design goal,

- *“Design a product for maker-spaces in low-resource areas, that can transform plastic waste into **qualitative plastic plate construction material**, and that can be produced locally and operated by locals.”* - ,

the plate quality should play a leading role in the decision. Because of this impasse, both concepts will have to be evaluated with a proof of concept that can reveal more about the actual properties. These proof of concepts are discussed in the next paragraph.

### PLATE SOLIDITY \* THICKNESS VARIATION

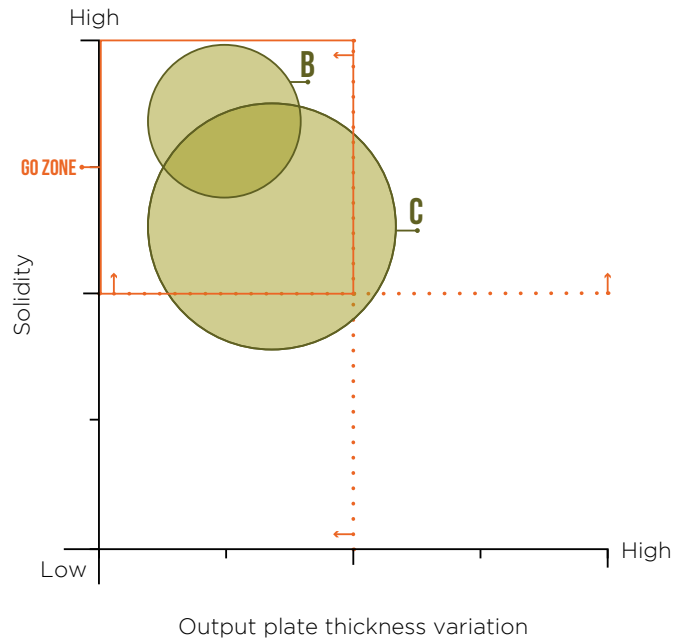

Figure 4-8, Concept selection graph, Plate solidity x Thickness variation  
- Figure by Mark Bachrach

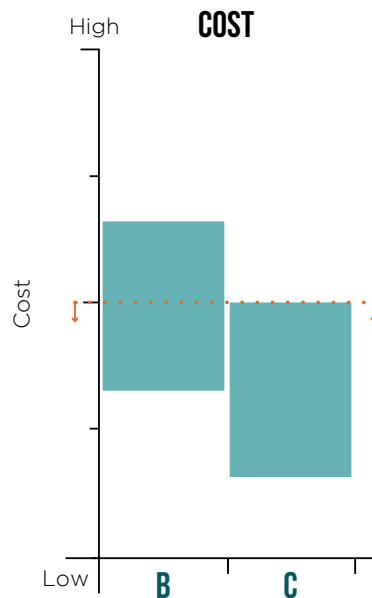

Figure 4-9, Concept selection graph, Cost  
- Figure by Mark Bachrach

## 4.7. PROOF OF CONCEPT

The evaluation and selection method discussed in Paragraph 4.6, resulted in an impasse, the method did not provide enough insights to make a choice. Therefore, a more concrete understanding of the concepts needs to be developed. This understanding can best be developed by materialising the concepts and by testing them on their functionality. This kind of model is called a proof of concept since their purpose is to prove that conceptual idea works in the physical world. This method is however limited by quick and dirty manufacturing methods that are available in the project facilities. But then again, this limitation resembles the manufacturing limitations that low resource areas have to deal with. Therefore the comparison that is made in this proof of concept face-off relies

on two proof of concept models that were crafted within a day using only the simplest materials at hand, combined with the best matching and available machinery to replace the rolling and the pressing machines.

A simple mould folded from sheet metal was crafted to be loaded with plastic granulate and put in an oven to melt. The mould consists of three parts, a bottom piece, a removable fence and a lid (see Figure 4-10-A, B). The fence was added in order to contain the voluminous plastic granulate when put in the oven and made removable to allow the pressing processes to press the plastic together without the fence in the way. Both the bottom mould half and the lid were crafted with a thickness limiting edge.

---

### Concept 'B'

As can be seen in Figure 4-10-C, a sheet metal roller was used as a replacement for the roll press concept (concept 'B'). To resemble the rolling process a plank was used to put the hot mould with melted plastic on; together they were pushed between the rollers that were turned simultaneously. The rolls were adjusted to the right thickness beforehand, and thus the rolling process pressed the plastic to the right thickness in a single motion. This process was executed three times with small improvement iteration while trying to reach the best possible result, which is displayed in Figure 4-10-E, F, G.

**During the pressing process the following critical insights were gained:**

- The rolling movement moves the plastic away from the pressure instead of building up pressure.
- Without the build-up of pressure, the plastic has no reason to fill all voids, this results in lousy surface quality and varying thicknesses
- The rolling process takes too much time, which causes substantial temperature differences and thus viscosity differences between the outer layer and the core of the plastic plates. In turn, this causes lousy spreading and surface quality, causing ripples and dimples in the top surface.

### Concept 'C'

As can be seen in Figure 4-10-D, a large hand press was used as a replacement for the cold pressing concept (concept 'C'). To resemble required stiffness, two fat slabs of metal were used to place the hot mould with melted plastic between. The resulting sandwich was pressed together using the handle of the hand press. The press was operated with maximum human force which pressed the plastic to the right thickness in a single motion. The right thickness was realised by the edge of the mould halves. This process was executed two times with small improvement iteration while trying to reach the best possible result, which is displayed in Figure 4-10-H, I, J.

**During the pressing process the following critical insights were gained:**

- The quick application of uniform pressure allows the plastic to be pressed against the mould surfaces when it is still flowing and sticking, which causes smooth and continuous surfaces.
- Taking out the plastic while it is still warm causes it to warp
- The pressing concept works surprisingly well with very simple materials
- The cooling time seemed to decrease significantly when the mould was in touch with a large amount of metal indicating that with the right setup, the cooling process could be integrated in the press.

---

### Concept choice

The lessons learned from the proof of concept face-off speak for themselves. Concept 'C' was very successful in producing a promising plate result with minimal resources while concept 'B' was not able to do the same. It could be argued that with extended development concept 'B' could also be lifted to a

satisfying level. However, with the limited time available for this project, the choice has to be made with the available insights. These insights clearly point out that concept 'C' is the most viable option and thus concept 'C' is chosen to further develop in the embodiment phase.

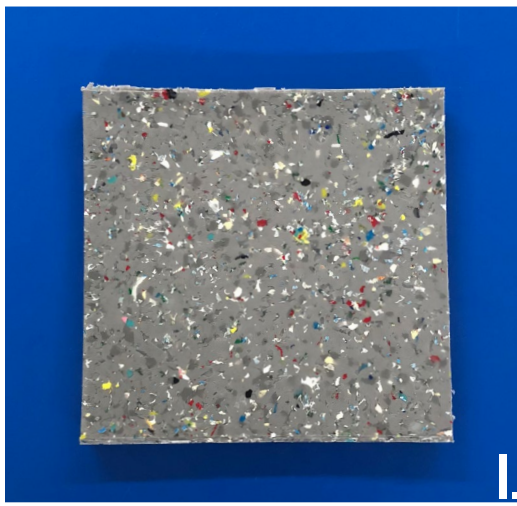
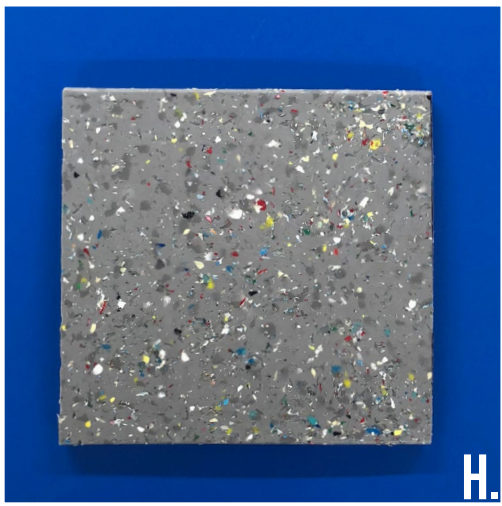
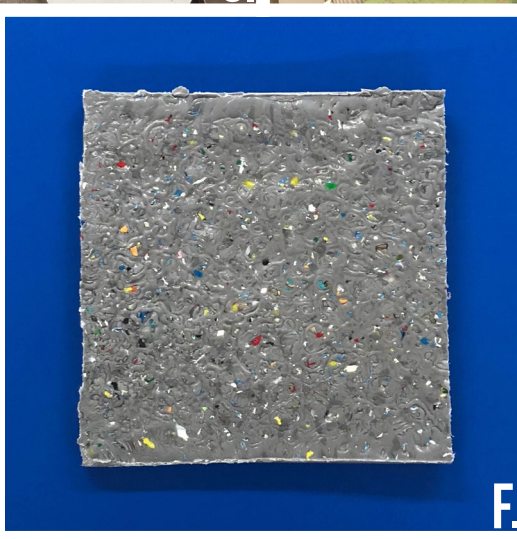
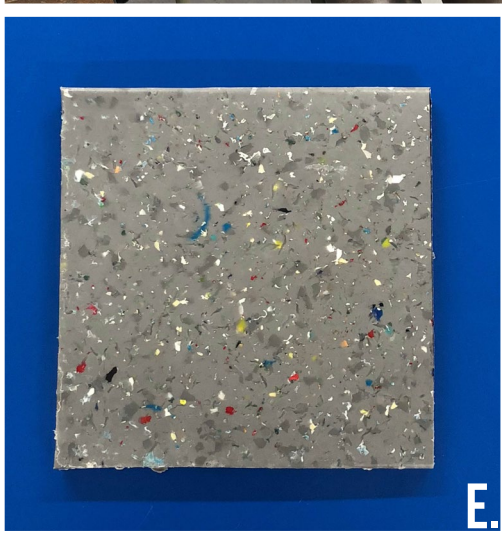

## 4.8. CONCEPT DEFINITION

The chosen concept is only minimally defined however the process that it needs to facilitate is clear. This process is once more depicted in Figure 4-11 in order to state clearly what the steps and product parts of the full plate pressing process are. This way there are no mishaps about the design.

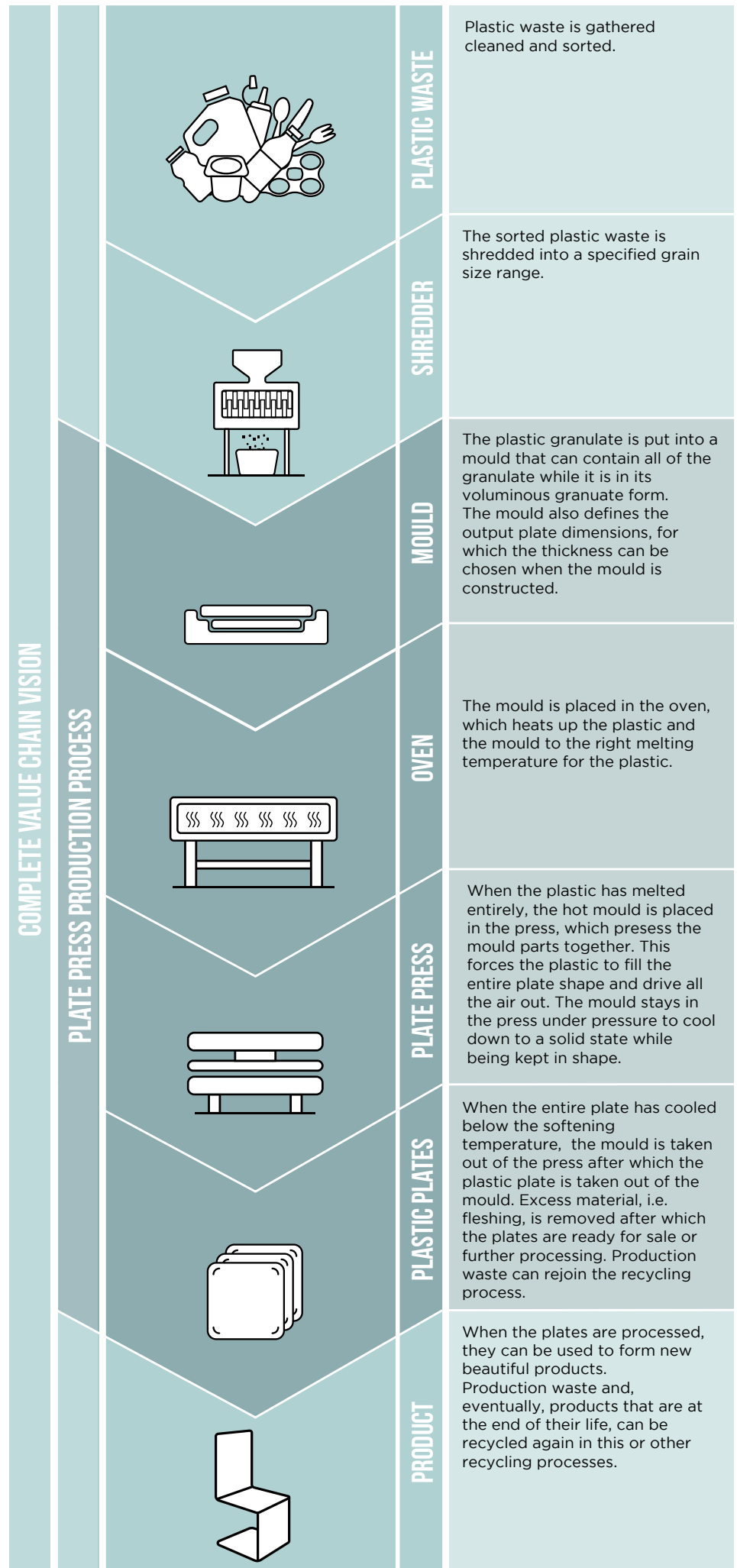

Figure 4-11, Design research approach  
- Figure by Mark Bachrach

# 5. DESIGN RESEARCH

The analysis and experiments have together provided a sufficient basis to start the conceptualisation with; the design goals are clear, and the minimum requirements are set. However, this chapter will start by summarising the critical insights into comprehensible schematics; a function schematic and a program of requirements. Next to that, a clear division is made between process parameters that are fixed and those that are adaptable, of which also the level on which they are adaptable is defined. Together these three schematics provide the actual input for the generation of principle ideas, which is realised through a creative session with MMID designers. The ideas that are generated are then used to create plate production process concepts, which are then evaluated with the help of the project experts. Two of the concepts are chosen, and their feasibility is tested in simple prototypes. This proof of concept reveals the final choice for the plate production process concept that will be further developed in the embodiment phase. The described conceptualisation process is depicted in Figure 5-1.

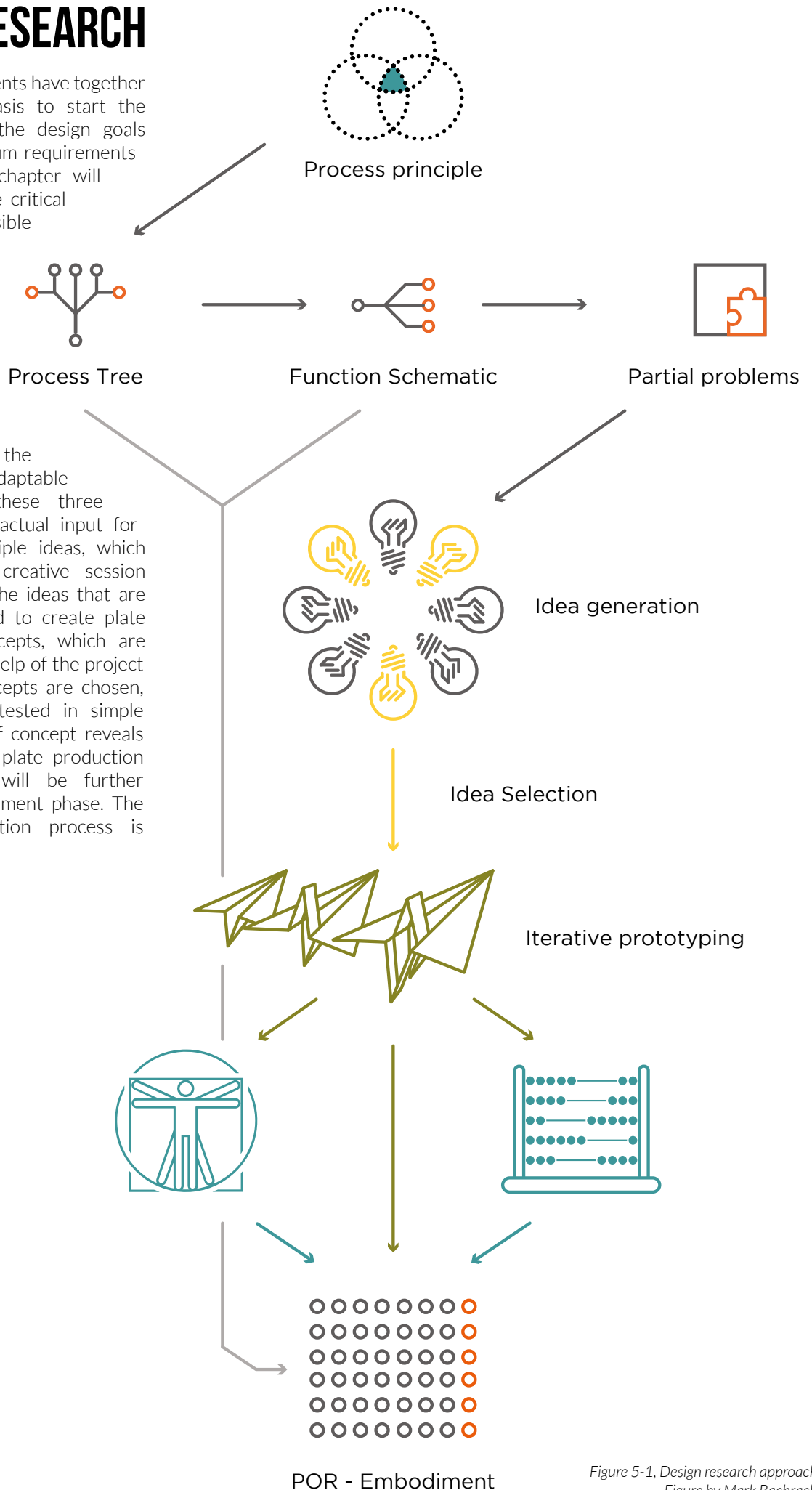

Figure 5-1, Design research approach  
- Figure by Mark Bachrach

## 5.1. FUNCTION ANALYSIS

To determine all of the functions that the product will have to fulfil, a function analysis has been executed. This was done by creating a process tree that describes all of the processes that the product will be involved with; from manufacturing up to use and maintenance. The full Process tree can be found in Appendix A.10, and an example section is shown in Table 5-1.

The 'use' part of the process tree was then used to initiate a function schematic that was subsequently further detailed until all functions were split up into elementary sub-functions that cannot be split any further. The full function schematic is displayed in Appendix A.11, and an example section is depicted in Figure 5-2.

The function analysis gives insight into the required functions of the complete plate pressing system and the separate system parts. Thereby it provides input to find the most prominent partial problems and a basis to decide the design scope on.

## 5.2. DESIGN SCOPE

The introduction chapter stated that the design scope could only be determined when all of the system component where known and that only the innovative system elements would be designed. In this stage in the design process those conditions are met, and thus the design scope is determined. Figure 5-3 shows the plastic plate production process and distinguishes the production system components. Of these components, two are shown on a darker background; these are the innovative system components that will be developed in the embodiment phase.

The oven is left out since existing ovens can fulfil its functionalities. Future users of the plate press can locally source an oven that meets their needs, it might even be possible to use a gas or fire oven, but this is something that will have to be tested. Such a test, however, is outside the scope of this project. For the continuation of the project, to facilitate tests and experiments, a suitable electric oven is bought.

The plate press and the mould that are going to be designed are innovative in the way that there currently is no existing alternative. Next to that, the challenge is to make sure that the designs can be produced with simple materials and tools that are available in low resource settings. The plastic plates that are produced are not highlighted as an innovative system component since they are the output of the system and not a part of the system itself. Of course, the Plastic plate output requirements have already been set



level 1	level 2	level 3	level 4
Use	Press the plastic plate	Transport the mould to the press	Protect hands against heat Move the mould to the press
		Insert mould into the press	Move the pressing surfaces apart Protect hands against heat Slide mould onto pressing surface
		Position the mould	Know what the right position is Take hold of the mould Move the mould to the right position
		Press the plate	Move the pressing surfaces on to the mould lid Increase the pressure Know when the pressure is right Stop increasing the pressure Lock the pressure/position
		Leave the plate to cool	(Turn on cooling device) Wait
		Retrieve the plate and mould	Unlock the pressure/position Move the pressing surfaces apart Take hold of the mould Pull the mould out

Table 5-1, Process Tree Section - Use

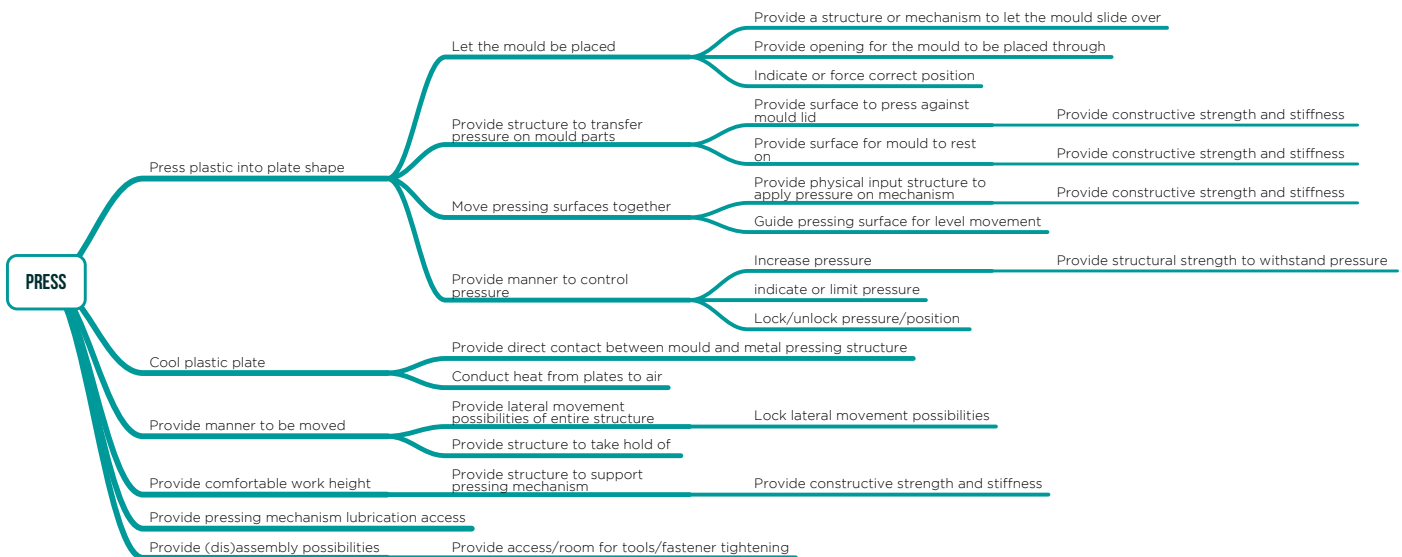

Figure 5-2, Function schematic section - Press - Figure by Mark Bachrach

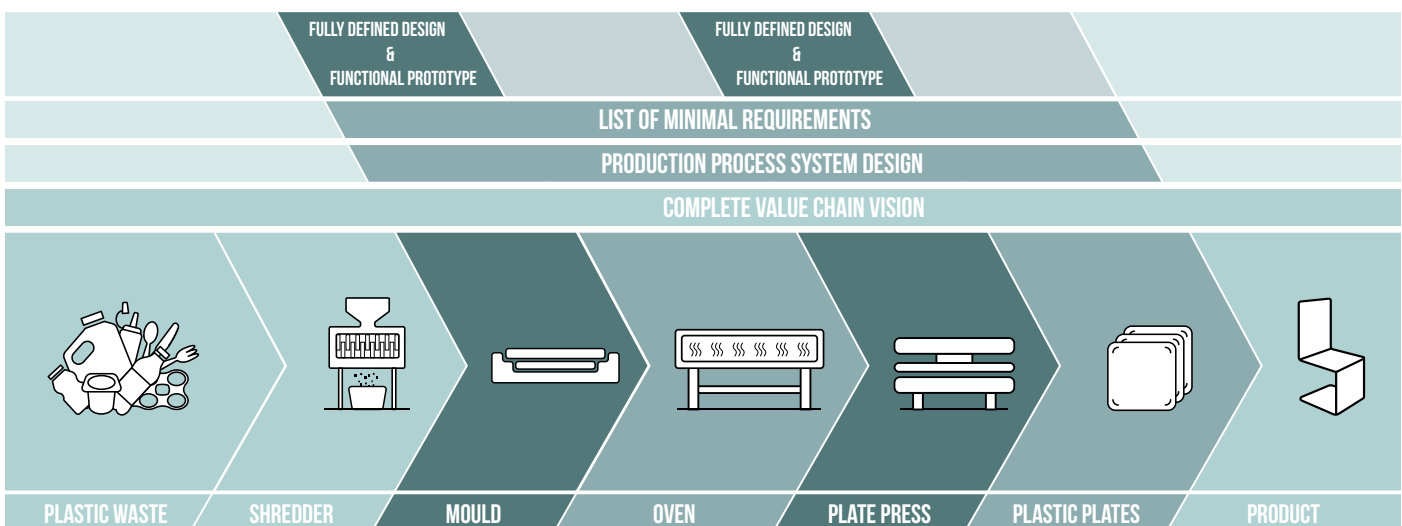

Figure 5-3, Design scope - Figure by Mark Bachrach

### 5.3. PARTIAL PROBLEMSOLUTIONS

In the newly produced function analysis, new functional needs were found to be fulfilled by the press and the mould. And since the concept does not include definitive physical solutions for these functional needs, solutions have to be generated for the individual problems before they can be integrated in the embodiment design. This is realised in several steps, starting with identifying the partial problems and defining them in 'How to's'. The 'How to's' concerning the plate press (Table 5-2) were used in a 'solo' ideation session to generate partial problem solutions to put in a morphological chart, see Figure 5-4. The 'How To's' concerning the mould (Table 5-3), were also used as input for the ideation session, but the resulting solutions were tested and improved in iterative prototype testing, which is elaborated in Paragraph 5.4.

From the morphological chart, a selection of solutions was made while keeping the decision drivers that were defined in Paragraph 1.3 in mind (Affordability, ease of manufacturing and accessibility of resources). The resulting selection is highlighted in Figure 5-4. The selection was mainly focussed on choosing the most straightforward option related to producibility and overall setup complexity. Secondly, the source-ability and affordability were weighed. The deciding feature for the force actuator selection, is the completeness of hydraulic cylinders, that are easily installed and completely functional without additional parts, almost plug-and-play.

**Plate press How To's**

How to Provide structural stiffness?
How to guide the pressing surface to provide level movement?
How to apply pressure to the mould?

Table 5-2, Plate press How To's

**Mould How To's**

How to provide a method to open the mould?
How to minimise the flashing connection thickness?

Table 5-3, Mould How To's

# Morphological Chart - Plastic plate press

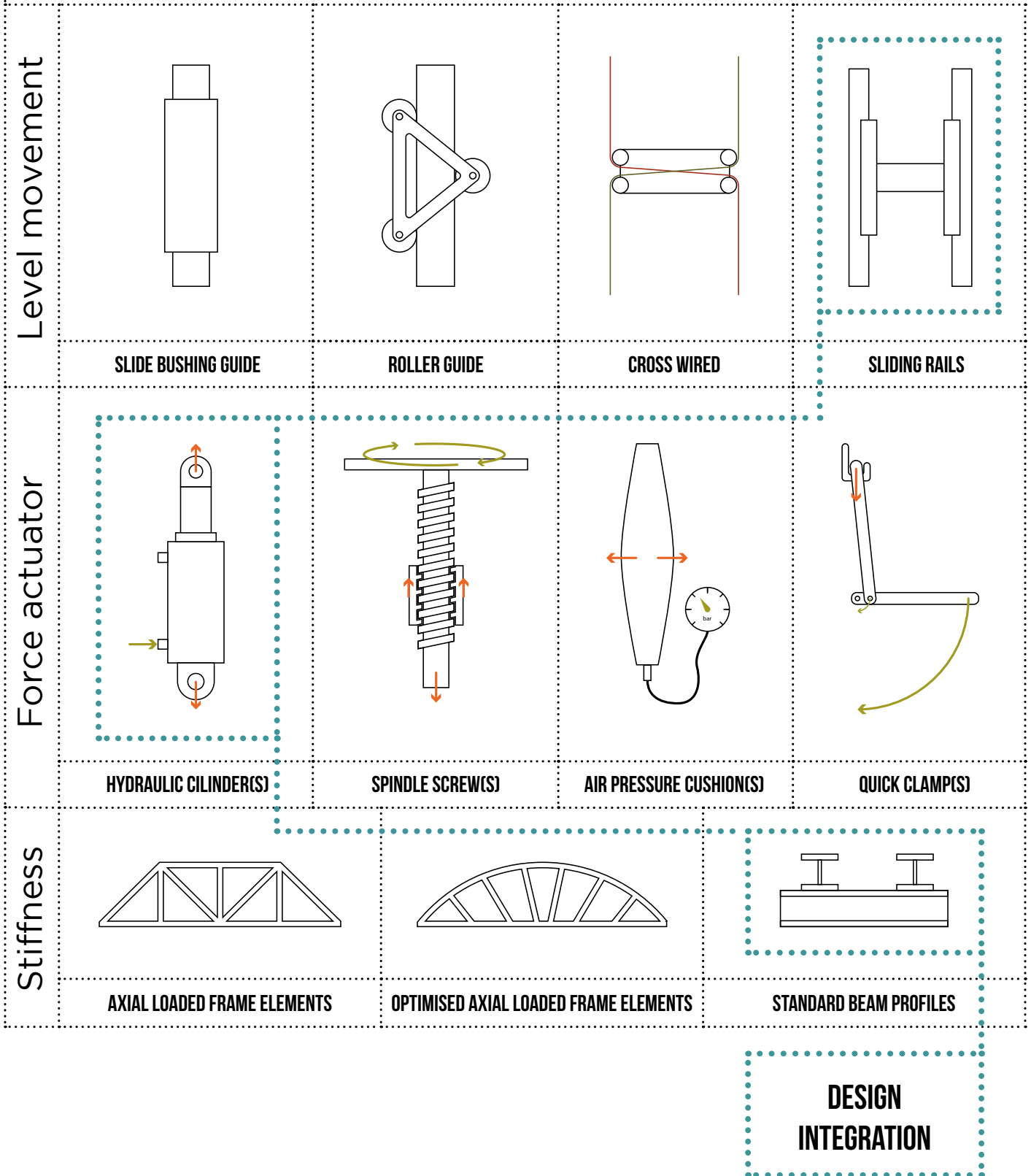

Figure 5-4, Morfological Chart - Figure by Mark Bachrach

## 5.4. ITERATIVE PROTOTYPING & TESTING

As mentioned in the previous paragraph, the partial problems concerning the mould design would be solved through iterative prototyping. First, the most straightforward options are put to the test, and the solution complexity is only increased when the tests point out that a better solution is needed. Next to the partial solution development, also a cooling suggestion acquired in the proof-of-concept-tests is put to the test.

Like in the experimentation phase, a general setup and process method were used and kept the same throughout subsequent tests. Only process details were altered to improve the plate results.

For the test setup, a pizza oven was bought (see Figure 5-6-A) to be used to heat up the mould and the plastic. The oven has two heating elements and can heat to a maximum of 500 °C, and is adjustable per single degree which is useful while only 230 °C are needed. Next to the oven, a book-press with a spindle screw was bought (see Figure 5-6-B) to press the mould parts together, the flatbed size of the press is 500 x 500 mm and the maximum force output is calculated in Appendix A.12.

With this setup in mind, a simple mould that would fit in the press was folded from sheet metal (see Figure 5-6-C, G, H, J) and a thickness limiting edge was put in place (see Figure 5-6-C, D, E, F). A square piece of sheet metal was cut out to be put on top as a lid (see Figure 5-6-J). A pressing block that would fit within the mould walls and onto the lid was crafted from wood-board to be able to press the lid down without the top press-bed crushing the mould walls (see Figure 5-6-C).

### 5.4.1. Mould frame iterations

In the mould frame iteration tests, subsequently, three frame edges were tested. The tests started with the most straightforward frame edge, a square section all-round like depicted in Figure 5-5-1. This test pointed out that the heating and pressing method functioned quite well, but the frame edge did not do an excellent job of cutting out the plate shape and defining the chosen plate thickness. The pressure build-up was insufficient, and thus the resulting plate ended up too thick, and the flashing was not cut off, as can be seen in Figure 5-6-M.

With the previous test in mind, a frame edge was fabricated that had a very small cut-off-edge, 2mm wide, while still providing enough strength and stiffness by having a fatter base, as can be seen in Figure 5-5-2. This small cut-off-edge was theorised to build up more pressure since the contact area was decreased significantly. This theory proved to be true since the plate result that was outputted, was cut-out perfectly and the plate thickness turned out as planned, see Figure 5-6-N. However, during fabrication of the frame edge, it was noted that it was much work with semi-advanced machinery to produce the specific section and therefore it would not be suitable for production in low-resource settings.

The third iteration was a simplification of the small cut-off-edge. The edge was integrated into the mould-tub, by only folding up a small edge that directly functioned as cut-off-

edge, see Figure 5-5-3 and 5-6-F. When filling the mould with plastic flakes, a first problem arose; The granulate towers high above the small edge and is not properly contained and thereby falls out of the mould very quickly, see Figure 5-6-I. When the plate was pressed, however, the mould seemed to do its job quite well. Only when the plate was finished cooling down, and it was taken out, the second problem showed itself; because the previously existing enclosing mould walls were now missing during the melting process, direct heat radiation burned the plastic, as can be seen in Figure 5-6-L. Next to these two problems that disqualify this design solution, the edge itself did do a great job of cutting out the plate and defining the plate thickness as can be seen in Figure 5-6-O.

Concluding, the small cut-off-edge concept (Figure 5-5-2 & Figure 5-6-E, H & N) has proven to do a great job of cutting out the plate and defining its thickness. However, the producibility should be improved to make it suitable for production in low-resource settings. This improvement will be realised in the embodiment design and will be tested in the large-scale prototype.

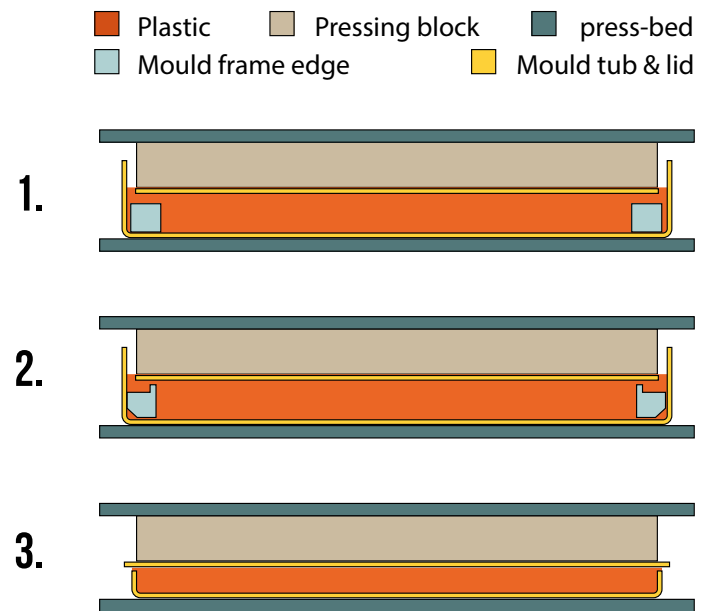
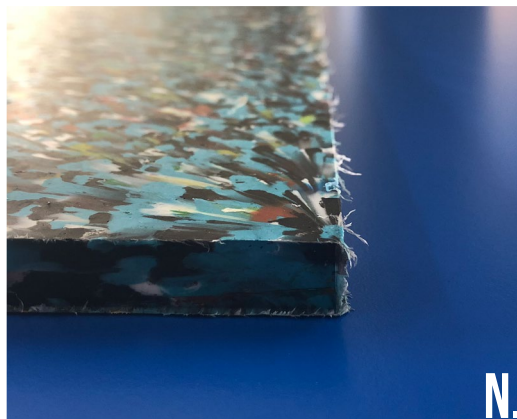
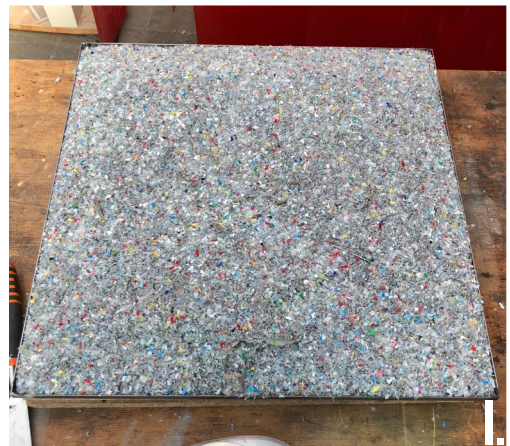
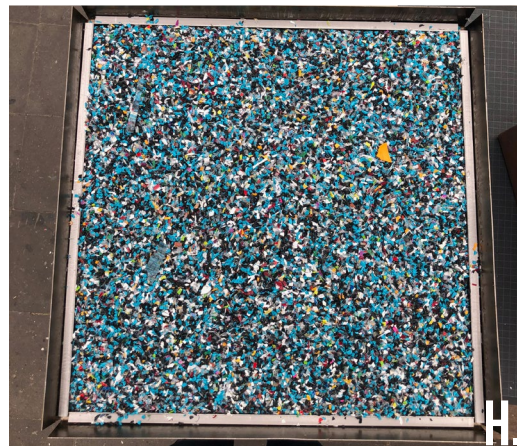
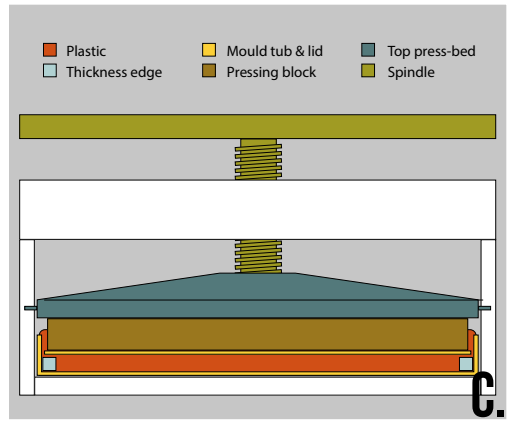
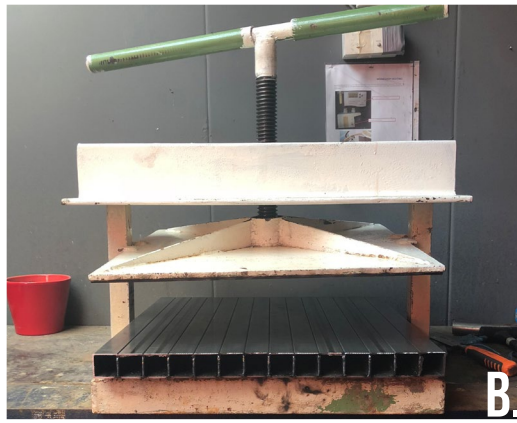

Figure 5-5, Frame edge iterations - Figure by Mark Bachrach

### 5.4.2. Cooling iterations

Together with the cut-off-edge iterations also cooling improvements were tested. At first, a wooden press-block was used to be able to press the mould lid down into the mould and against the cut-off-edge (see Figure 5-7-1). The resulting plate took almost 4 hours to cool down which is more than double the melting time. To improve this, the insulating wooden block was replaced by a heat conducting steel block (see Figure 5-7-2). This block was crafted by welding hollow square sections tightly next to each other. The hollow sections were chosen because they could bridge the distance needed to press the lid all the way down, while not resulting in a un-liftable slab of steel. An added benefit is the increased surface area from which heat can dissipate into the surrounding air. With the steel pressing-block in place, the heat is conducted from the plastic and the mould to the pressing block, and the steel press-beds. Thus the entire press-frame draws heat from the plastic and thereby helps it cool down. The plate that was pressed with this

Figure 5-6, Iterative prototyping tests - Pictures by Mark Bachrach >



steel pressing block in place cooled down in about 2 hours, which nears the melting time and already splits the cooling time in half. However, a slight residual warmth difference was noticed between the bottom, and the top of the plate and also slight warpage occurred when the plate was taken out of the mould. This warpage was attributed to the cooling difference that caused the difference in residual warmth and was most likely caused by the structure difference of the press setup. Therefore in the third iteration, a second hollow-steel-section-pressing-block was placed on top of the bottom press-bed (see Figure 5-7-3). The plate that resulted from this third setup cooled down in just below 2 hours and turned out almost perfectly straight. This is not only considered to be an acceptable result but a promising achievement, especially, since it is expected that the cooling time can be improved even more by blowing air through the steel section channels. It is expected that this will function as a heat sink since all the air that is surrounding the metal structure will be refreshed continuously and thus the heat can dissipate more efficiently. This mechanism will be implemented and tested in the large-scale prototype following after the embodiment design.

**Concluding, the embodiment design of the plate press should include:**

- A press-bed that has direct metal to metal contact with the mould
- Air channels that increase the cooling surface area of the press-bed
- Open ends on the air channels that allow for active ventilation

■ Plastic                      ■ Mould tub & lid                      ■ press-bed  
■ Steel square-tube press-block                      ■ Wooden press-block

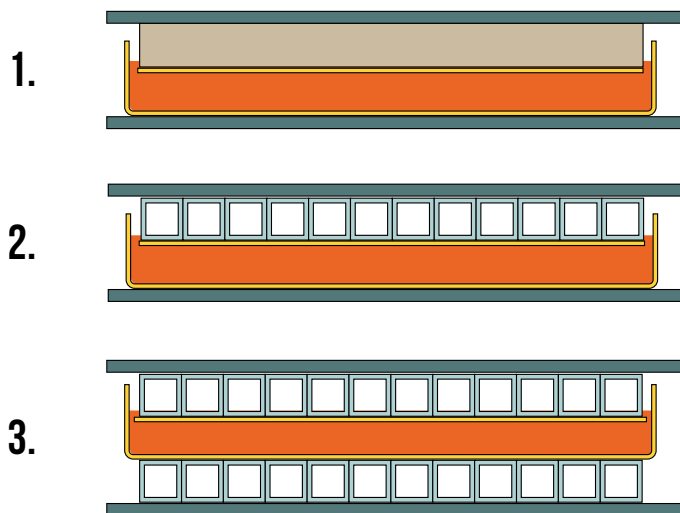

Figure 5-7, Cooling iterations - Figure by Mark Bachrach

### 5.5. PRESSING FORCE

With the final pressing setup resulting from the iterative prototyping tests, the achievable plate result satisfies the requirements that were set in Paragraph 2.6. Therefore the elemental process mechanics and parameters have to be copied and scaled up in the embodiment design. The one missing parameter is the pressing force, which is the driving force of the product to be designed and a lot of the design will depend on it: The structural components, the force actuator

and the press-bed stiffness, each have to conform to the pressing force.

Leonard Schurg suggested this pressing-force requirement, to be at least 64 Ton or 580 kN (remember 1 ton ≈ 0.9072 tonne ≈ 9 kN) for a surface area of 1.32m<sup>2</sup>, which translates to a pressure of about 0.44 MPa or 4,4 Bar (see Appendix A.3.4). For a plate of 1,22 x 1,22, this would mean that a pressing force of 655 kN or 720 Ton is needed, which is quite a lot.

The Plastic plate press system of Heat-MX (for more info see Appendix A.1.1) uses a total of 64 Ton or 580 kN of pressing force, this only result in a pressure of 0,2 MPa or 2 bar. For a plate of 1,22 x 1,22, this would mean that a pressing force of 290 kN or 32 Ton is needed, which is already less than half of what Leonard suggested.

When calculating the pressure that is applied by the press setup used in the prototype tests, the lowest pressure requirement is found. Only 0,175 MPa or 1,75 bar is applied according to the calculation found in Appendix A.12. Although this is the lowest pressure requirement suggestion, the calculation is believed to more likely result in an over estimated pressure than an underestimated one. Most importantly, is the fact that this setup does result in plastic plates that satisfy the requirements.

Like most decisions in this design project, the easiest executable and most affordable solutions are tried first and only when tests provide indications that the design can benefit from added complexity, a new solution is sought after. Thus a pressure requirement of a minimum of 0,18 MPa is put in the POR. This results in a force actuator output requirement of at least 268 kN or 30 Ton.

To put these force and pressure requirements into perspective, their weight equivalents are placed in A graph together with commonly known examples. See Figure 5-8

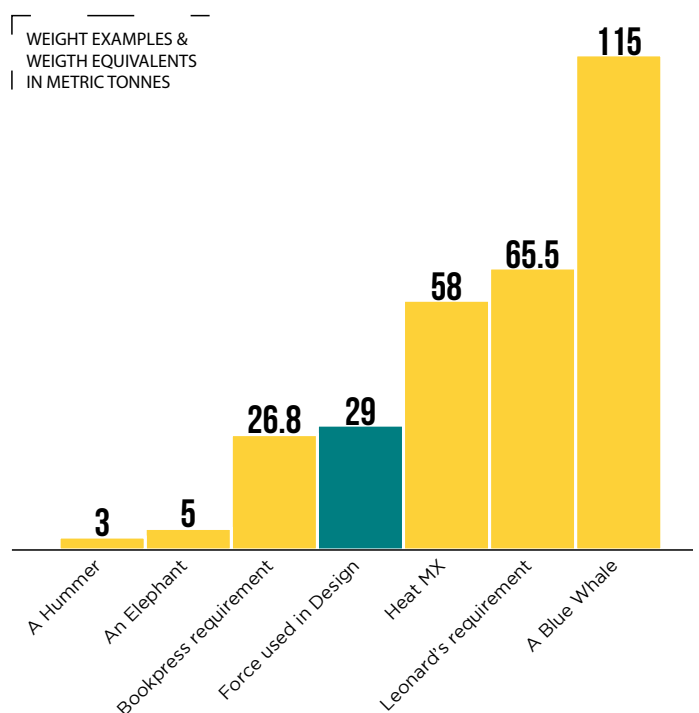

Figure 5-8, Force Perspective - Figure by Mark Bachrach

## 5.6. ERGONOMIC ANALYSIS

Although the project focusses on producibility, affordability and source-ability, the usability of the product cannot be neglected, and therefore the minimal requirements for acceptable user interactions and ergonomics have to be figured out. This is done by mapping the user interactions in regular use and attributing the relevant ergonomics related dimensions to them.

### User interaction

With the latest plate pressing process (used in the prototype testing) in mind, combined with the process tree that is found in Appendix A.10 and additions inspired by actual process experience, a user interaction map was created. This map is depicted in Figure 5-9 and includes all expected user interactions that are needed to complete the plate pressing process. The interactions that do not directly have to do with the products that are designed are 'greyed out', and a separate category is added for user interactions that do not fall within the process routine but are expected to occur on a regular basis. For each of the interactions that require dimensioning that is correctly adjusted to the user group, that dimension is listed with the interaction; these dimensions are displayed with a darker coloured map-branch.

Figure 5-9, User interaction map - Figure by Mark Bachrach v

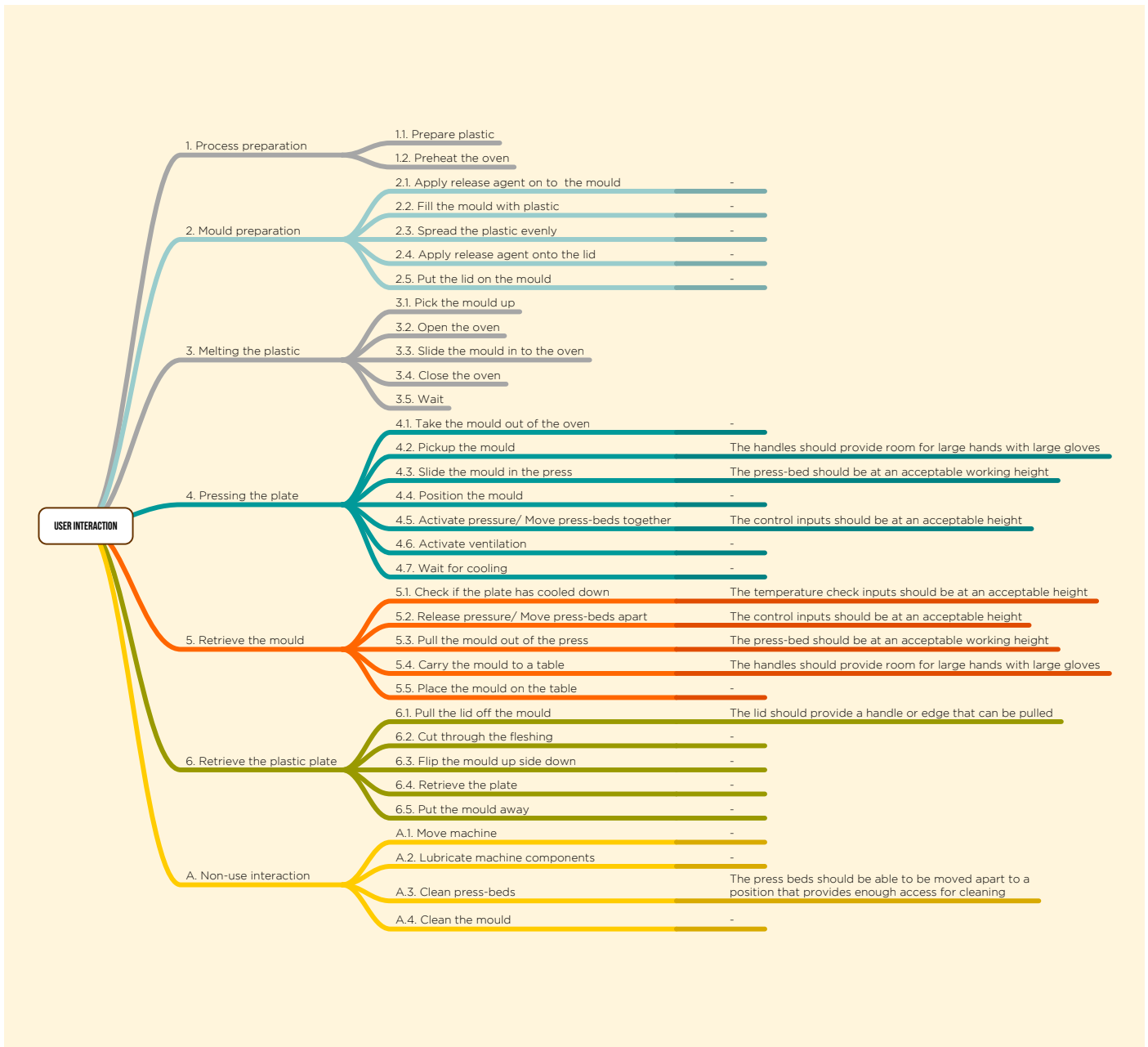

## User measurements

For each of the identified crucial dimensions the right values have to be found. In this design however, acceptable measurements are leading instead of optimal measurements. This is due to the hierarchy of decision drivers; producibility, affordability and source-ability each trump optimal usability. Nevertheless, if not limited by the other decision drivers, the optimal measurements should be enforced. Therefore, 3 values are listed for each of the dimensions; a minimum, an optimum and a maximum.

The user group in this case, is a wide group because potential users are found all over the globe and thus can be of any ethnical background. The one thing that can be safely assumed and is a limiting factor for the width of the potential user group, is age.

It is assumed that all users will be older than 16 and younger than 65. This means that the right dimensions have to be found in a dataset that compares to the user group that is defined as: Men and women of any ethnicity, between ages 16 and 65. A dataset with the required dimensions that complies to this population probably doesn't exist and is otherwise very hard to find therefore the next best and accessible dataset is used: Dined's human measures dataset for dutch adults, man + women aged 20-60 And for the hand width, Dined's human measures dataset for international adults, man + women. (dined.io.tudelft.nl)

In Table 5-4 the critical dimensions are listed with adhering origin, relevance and values and In Figure 5-10 and 5-11, the dimension ranges are visualised.

	Minimum	mm	Optimum	mm	Maximum	mm
The handles should provide room for large hands with large gloves	P95 Hand width without thumb	111	P99 Hand width without thumb	121	-	-
	P95 Fingertip thickness	20	P99 Fingertip thickness	23	-	-
	Glove thickness	10	Glove thickness	15	-	-
The press-bed and the temperature check and control inputs should be at an acceptable work height	P95 Fist height	875	P50 Elbow height standing	1084	P5 Shoulder height	1275
The press beds should be able to be moved apart to a position that provides enough access for cleaning	P50 Chest depth	301	P99 Chest depth	378	-	-

Table 5-4, Critical Human dimensions

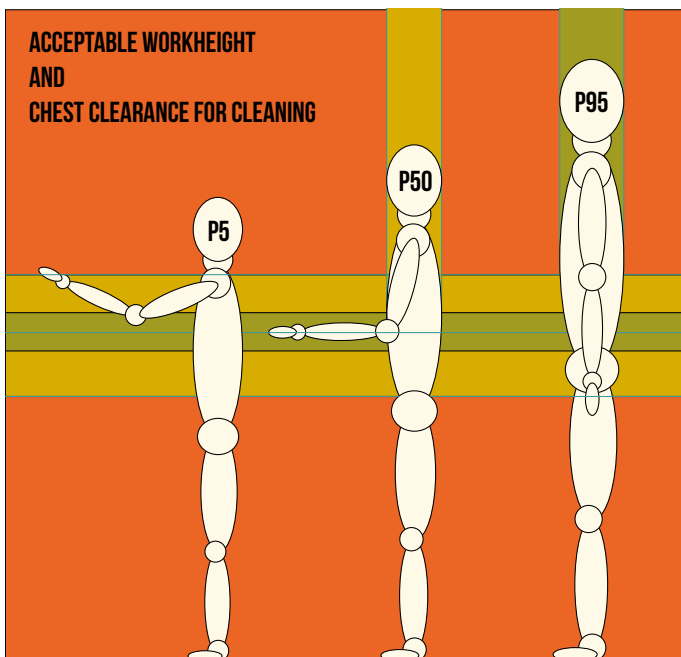

Figure 5-10, Bodily dimensions - Figure by Mark Bachrach

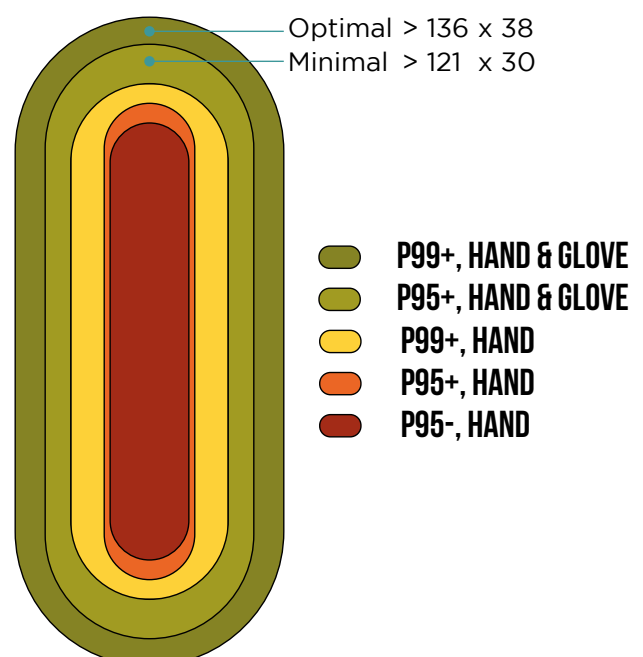

Figure 5-11, Hand & Glove dimensions - Figure by Mark Bachrach



## 5.7. POR - EMBODIMENT

In the program of requirements, the minimal requirements that have been set in the preceding analyses, design activities and experimentation are summarised. Nevertheless, the POR is not a standalone design guide for the product(s). The POR will, however, be useful to check if the design fulfils the

required functionalities.

The POR concludes most of the previous work and forms a basis for the embodiment design that is to come, therefore it is featured as a whole in Table 5-5.

Table 5-5, POR - Embodiment v

Category	Nr	Requirement for plate press system	Originates from
<b>Genesis</b>			
<b>Design</b>			
Adaptation	1	The design should be adaptable to different dimensions	Survey dimension wishes
Nature	2	The design should be kept simple	PrPI Forum, Leonard Schurg
<b>Production</b>			
Lot size materials	3	The production techniques and materials should fit single unit production	Distributed production, single product
	4	Most production materials should be easily available all over the world	Low resource build locations
	5	The design should allow for a range of plate thicknesses and profile dimensions	Leonard Schurg
Technologies	6	Advanced technologies should be avoided	Low resource build locations
<b>Assembly</b>			
<b>Method</b>			
Accessibility	7	The assembly should provide access to maintenance parts	Expert meeting Laura BFF
Connection	8	When optional, mechanical connections should be chosen over permanent joining	Expert meeting Laura BFF
	9	The design should allow for a range of fasteners to be used and not specify one specific type and size	Expert meeting Leonard Schurg
Necessity extra tools	10	The product should be able to be (dis)assembled with simple and accessible tools	Low resource build locations
	11	The product should be able to be disassembled in parts that weigh less than 30 kg	Design opinion
<b>Costs</b>			
Pricing	12	The product may not exceed a cost price of \$ 1200	Fábrica de Sabão
<b>Use</b>			
<b>Do not use</b>			
Safety	13	The product may not be a safety hazard when not in use	Expert meeting Frank stichting stunt
	14	The product should not allow for dangerous situations	Stichting stunt
<b>Use</b>			
<b>user interaction</b>			
Fulfilling function	15	The product should not be able to be used in inappropriate manners	Stichting stunt
	16	The product should explain its own use	Stichting stunt
<b>Manuals</b>			
Completeness	17	The build instruction should provide enough instructions for anyone with metal working experience to build the product	Design opinion
Language	18	All instruction should be provided in English	Design opinion
Consistency with appliance	19	The use instruction should be kept very simple and self explanatory	Stichting stunt
Clarity (illustrations and navigation)	20	Use and safety instructions should be visualised if possible	Logic, multi lingual
Safety device	21	Use and safety instructions should not be language dependent	Logic, multi lingual
	22	Safety should be inherent and not forced through behavioural rules	Stichting stunt
<b>Ergonomics &amp; interface</b>			
Interface form quantity	23	The product should be operable with a maximum of 2 persons	Design opinion
	24	The interface components should be comfortably reachable	Design opinion
	25	The interface components should not require force application that exceeds the comfortable limit	Design opinion
<b>Handling</b>			
Controls (handle etc.)	26	The product should provide 1 clear way of working that is not multi interpretable	Stichting stunt
	27	The product should provide grips that fit the force direction	Design opinion
	28	The product system should provide work height between 875 and 1275 mm from the ground.	Design opinion
Measurements	29	Handles used in the product system parts should have a clearance width of at least 121 mm	Ergonomic analysis

Category	Nr	Requirement for plate press system	Originates from
	30	Handles used in the product system parts should have a clearance depth of at least 30 mm	Ergonomic analysis
	Maximum weight	31 The product system should not require the user to carry more than 25 kg per person	ARBO
	Setting and adjustability	32 The product system should allow for design adaptations that fit the system components to a user fitting work height	Design opinion, multi context realisation
<b>Product itself</b>			
Primary function(s)	33	The product should be able to produce plastic plates as specified in the plastic plate requirements	Logic, Survey, Project goal
	34	The system should be able to process HDPE & PP	Survey
Secondary function(s)	35	The product should produce plastic plates with minimal need for postprocessing	Design opinion
	36	The product should prevent plastic to grip around mould parts preventing them to be released/opened/removed.	Experimentation
	37	The product should cool a plastic plate as fast as the next melts or faster	Optimal Series productions
	38	The plate output thickness should be adjustable by mould design/inlay	Survey, Laura Klauss BFF
<b>Performance</b>			
Speed/number of revolutions	39	The product system should be able to produce at least 5 plates per day	Survey
Pressure/temperature	40	The product system should withstand temperatures up to 250 C	Max plastic processing temperature
Energy consumption	41	The systems electrical energy consumption may not exceed 10 kW	Survey
<b>Interaction with environment</b>			
Maximum weight	42	Each of the system components should be movable by a maximum of 2 people	Design opinion
Covering against influences	43	The design of the product should allow for the application of a protective coating	Design opinion
Compatibility	44	The plate mould design should be adaptable to the oven size	Multi context realisation
<b>Maintenance and recovery</b>			
Detection of defects	45	Defects should be easily visible by preserving clear line of sight to all main components	Logic
Cleanable lubrication	46	Lubrication should be possible without disassembly	Design opinion
Substitutability & repairability	47	Removable joining techniques should be chosen over fixed joining methods	Laura Klauss BFF
<b>System elements</b>			
<b>Oven</b>			
Primary functions	48	The oven should be able to heat up to a temperature of at least 230 C	Melting temperatures
Secondary functions	49	The oven should fit the size of the mould for the wanted plate size	Principle idea
Performance	50	The oven should be able to operate continuously for 8 hours	Full work day
<b>Fan</b>			
Primary functions	51	The fan should be able to blow air through the press-bed air channels	Iterative prototyping
Performance	52	The fan should be able to operate continuously for 8 hours	Full work day
<b>Mould</b>			
Primary functions	53	The mould should provide enough enclosing structure to contain the amount of plastic granulate needed for a solid plate	Experimentation
	54	The mould should contain a cutoff edge that minimises the contact area with the lid and provides pressure concentration on this edge	Iterative prototyping
Secondary functions	55	The mould design or parts of the design should be able to be adapted to a different plate thickness	Survey
	56	The mould should be disassemble-able to be able to clean it.	Experimentation
performance	57	The mould should last for at least 50 plates	Design opinion
Costs	58	The mould should cost less than \$ 100,-	Design opinion
<b>Press</b>			
Primary functions	59	The product should apply evenly distributed pressure over the entire plate surface	Test conclusions
	60	The product should be able to exert a pressure of at least 0.18 Mpa	Forca calculation Iterative prototyping
Secondary functions	61	The press beds should provide direct metal to metal contact with the mould	Iterative prototyping
	62	The press beds should contain air channels that increase the cooling surface area of the press-bed	Iterative prototyping
	63	The press-bed's air channels should have open end that allow for (active) ventilation	Iterative prototyping

# 6. EMBODIMENT DESIGN

In the embodiment phase, no more external insights are gathered. Instead, all the gathered insights and requirements are integrated into an embodiment design. All vagueness is taken away by supplying physical solutions that, together, form the product design. This process is split into two parts: The embodiment design of the mould and the embodiment design of the press. Each of these parts also contains multiple steps that were needed to transform the insights and needs into usable design elements.

Since a specific plastic plate definition is set as a production goal, this design phase works backwards from there, and thus the mould is the starting point.

## 6.1. MOULDDDETAILING

The mould's overall composition was already defined in the prototype iterations, therefore, what was left to do was to precisely define how the parts are produced, how they fit together and what the right dimensioning is. In the prototype iterations, it was found out that the production of some of the mould parts was too complicated and thus had to be redesigned. This has to be done first.

### 6.1.1. Ease of manufacturing

The first requirement that has to be met is for the design to be producible with tools typically available in low-resource-settings. With that minimal requirement fulfilled, also a straightforward manufacturing process should be sought after. From multiple experts (see Appendix A.3) and confirmation from Daniela Antonio (see Appendix A.3.2) was concluded that welding equipment, angle grinders, drill presses and hand drills are the only 'advanced' tools that can

be counted upon. A lathe or a milling machine can thus not be used, and after consultation with Daniela Antonio, also the sheet-metal bending-brake and sheet-metal scissors had to be excluded. Thread cutting, on the other hand, is allowed although the cutting bits are expensive and thus the size variation should be limited.

These manufacturing limitations need to be integrated into the mould design, which is done by looking at a section of the setup and identifying and replacing or eliminating problematic elements. A section drawing of the original setup is displayed in Figure 6-1 with change request indicators and next to it, the improved design is depicted with change integration indicators.

#### Producibility issues:

- A. The voids in the section have to be created with a milling machine, which is not available.
- B. The bend would have to be created with a bending brake.
- C. The bolt that was used is of an uncommon size that is hard to source (M2.5)

#### Integrated improvements:

- D. The cut-off-edge consists of a 2mm thick sheet metal strip that is intermittently welded to the mould-frame
- E. The mould-frame is introduced to connect all other parts to. It is made from a standard square 10mm rod
- F. M3 bolts are introduced to fix the mould-side-walls to the mould-frame
- G. The bend is removed, and the mould-tub is split up in a baseplate and sidewalls
- H. The M2.5 bolt is replaced by an M3 bolt

### ITERATIVE PROTOTYPING SETUP

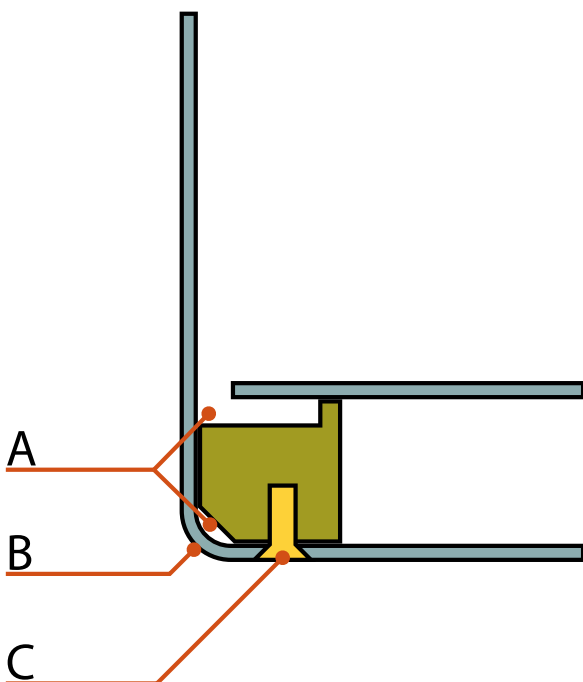

### IMPROVED PRODUCTIVITY

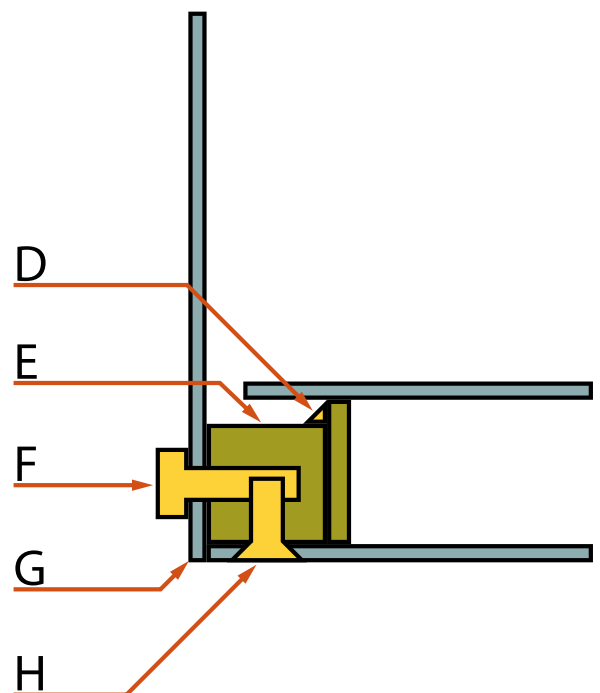

Figure 6-1, Mould frame edge improved producibility - Figure by Mark Bachrach

## 6.1.2. Integration of additional functionalities

In the design research, additional functionality requirements were generated of which four functions have to be integrated into the mould design. Of course, while integrating these functions, the producibility also has to be kept in mind.

### The functions to be integrated are:

- A. Providing a manner to take hold of the lid and to be able to remove it from the mould.
- B. Ensuring that excess plastic that is forced out during the pressing operations cannot grip around the lid.
- C. Providing a manner to take hold of the mould and to lift it up or move it around.
- D. Providing a manner to disassemble the mould in parts that are easily cleanable.

The lettering in this summation corresponds to the indicators that are used in Figure 6-2, which features a section of the mould design with the added embodiment parts that fulfil the mentioned functions. Below the section in the figure, a partly transparent top view supplies additional information about the geometry of the design. This top view also clarifies the arrangement of the seemingly overlapping bolts that are displayed on top of each other in the preceding section views. Each of the functionality integrations is explained in the following summation of which the time letters correspond to those in the figure:

- A. A flange that is attached to the lid and extends beyond the mould's sidewalls is added to allow the user/operator to take hold of this flange and with it pull the lid out of the mould and apart from the produced plastic plate.
- B. A sidewall is also added to the lid to connect the flange to the side while at the same time providing a barrier against up-curling plastic that would otherwise grip around the lid.
- C. A simple handle is created from sheet metal that is welded together (or bent in shape if the bending stools are available). On three sides of the mould, two handles are welded to the mould's sidewalls (C2).
- D. Using bolts to connect the sidewalls and the baseplate to the frame-edge allows the use/operator to take the mould apart for cleaning or to take out a plate that got stuck for unforeseeable reasons.

## 6.1.3. Dimensioning

Now that the main setup of the mould is clear, the right dimensions have to be enforced. The right dimensions are dependent on six influences:

- The plastic plate dimensions
  - These dimensions result from the mould cavity and are set as a goal in the plastic plate requirements
- The thermal expansion of the mould and the plastic
  - These result in shrinkage from the hottest and most expanded status of the mould and plastic that results in a particular plate dimension after cooling down.
- The plastic granulate voluminosity
  - requires a certain height of the moulds side walls
- The ergonomic requirements
  - these were defined in the design research and should be integrated as such

## INTEGRATION OF ADITIONAL FUNCTIONALITIES

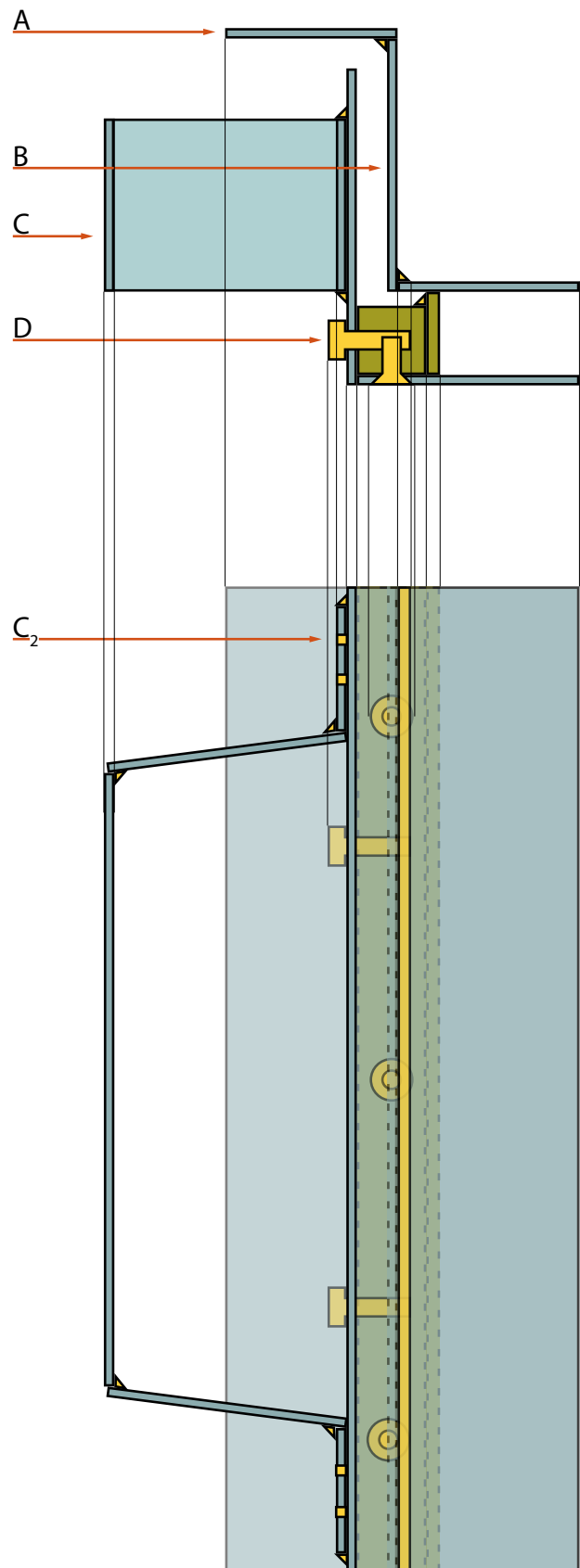

Figure 6-2, Mould functionality integration - Figure by Mark Bachrach

- The plate press dimensions
  - The top press-bed will have to fit in the lid while it is constructed from standard steel beam sections; thus only certain size increments are possible.
- Tolerance and play
  - All of the parts have to allow for certain production tolerances but also account for production tolerances in the plate press by integration play on parts that have to fit together smoothly.

### Thermal expansion

Thermal expansion causes the steel of the mould to expand 0,001175 %/°C (linear thermal expansion coefficient of steel 11 - 12,5 \*10<sup>-6</sup> m/(m\*K) - engineeringtoolbox.com). Thus the mould cavity will be larger in all directions when the plate is pressed; this expansion determines the volume of plastic that will shrink when cooled down. This shrinkage is the negative thermal expansion which results in 0,02 per cent per °C for HDPE, which has the highest thermal expansion of all commodity plastics (See Appendix A.4). With this transformation stated, the only missing variable now is the temperature difference for which an estimate of 200 °C is used (230°C melting temperature minus 30°C room temperature).

When a plate of 1220 x 1220 x 12 mm is the goal, the shrinkage of the plastic itself demands a mould cavity of that size multiplied by 200 \* 0,0002, which results in 1268,8 x 1268,8 x 12,48 mm.

These dimensions, however, undergo a second transformation caused by the expansion of the mould itself that will have to expand to this size when heated up by 200 °C. Thus it can be smaller when manufactured: 11,75 \*10<sup>-4</sup> \*200 = 0,235%, resulting in 1265,8 x 1265,8 x 12,45.

Nevertheless, the local production in low resource settings does not allow for such precision; thus these dimensions can be rounded off to half a millimetre. 1266 \* 1266 \* 12,5

### Plastic granulate voluminosity

While pressing plates in the experimentation and iterative prototyping, it was found out that the granulate is approximately four times more voluminous than the solid plate; thus the side wall will need to be at least four times taller than the predetermined plate thickness. 12,5 \* 4 = 50 mm

### The plate press dimensions

In the next paragraphs the embodiment design of the press will be discussed, and there it will be determined that rectangular hollow sections will be used to form the press beds. The chosen sections are of the size 100x60 which influences the mould size in just one direction, the width, this is because the sections can be cut to any length. 1266/60 ≈ 21, when using 21 sections, 6 mm will be left over, but the radii on the outermost sides are also subtracting from the pressing surface. These radii will be around 5mm each, and thus the total mission width is 16mm, which can be compensated by spacing each of the sections 1 mm apart resulting in a width increase of 19mm. This 'spacing' is also an excellent way of integrating production tolerances in the press-bed, by doing so the individual section width is less critical, and only the total width is specified and implemented.

### Tolerance and play

To make sure that the top press-bed fits in the lid, two millimetres of play is used on each side, and the same is integrated for the fitting of the lid in the mould-tub. Figure 6-3 Shows section view of the mould and the relevant dimensions.

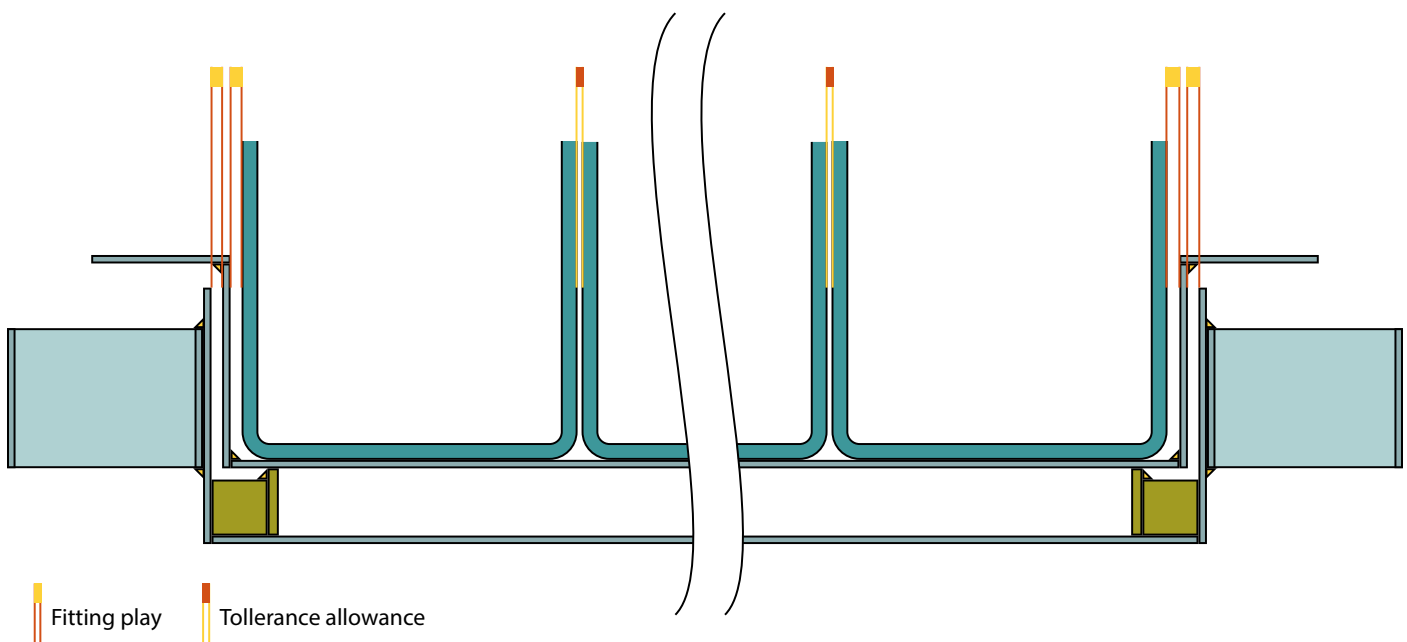

Figure 6-3, Tolerance and play integration - Figure by Mark Bachrach

## 6.2. MOULD DESIGN

In this final paragraph about the mould design, the actual integration of all design elements is shown in renders of the 3D computer model and in line drawings to clarify in detail. The design is adapted to the size of the oven that is available during this project because this first design is made to build a prototype that can confirm the functionality of the design. The pizza oven has an oven chamber of 1200 x 920 x 220; thus the mould is dimensioned to the maximum size that will still fit in the oven chamber. This means that also the design and prototype of the press will be adapted to the dimensions that function together with the mould.

It is believed that the size adaptation does not compromise the validity of the prototype testing since the mould solutions are not strictly dependent on the total size of the mould.

Figure 6-4 shows a render of the design, Figure 6-5 depicts a complete exploded view drawing, and Appendix A.13 features a technical drawing of the assembly.

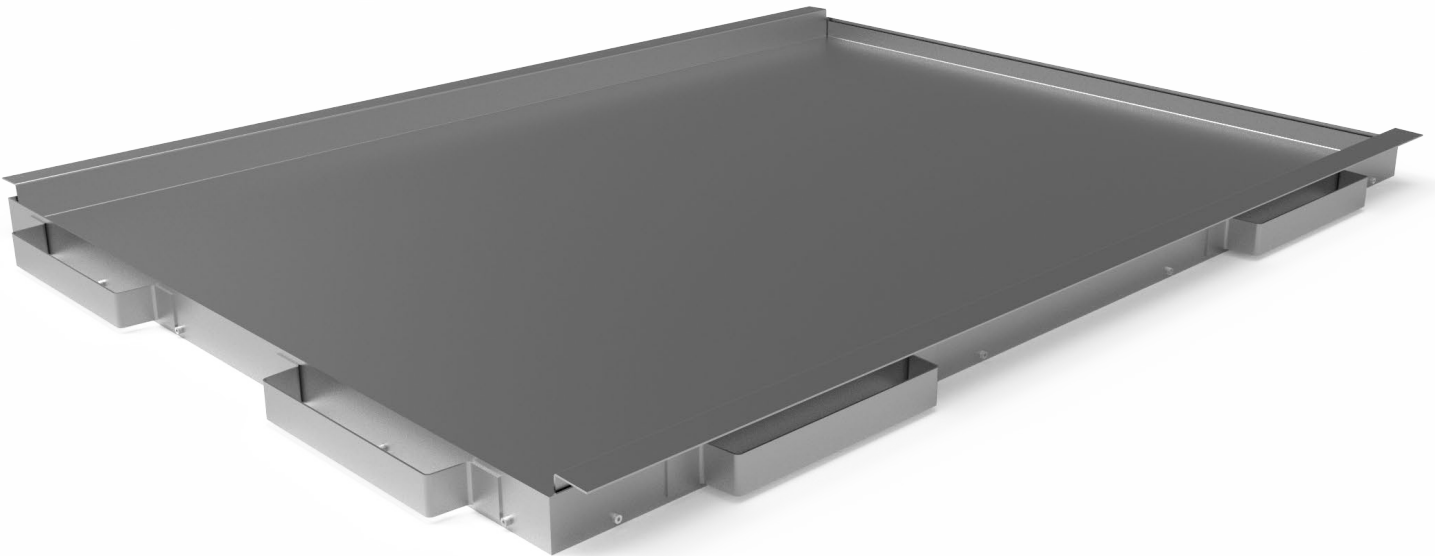

Figure 6-4, Mould design Render - Figure by Mark Bachrach

- Weld connection
- Position indication
- Fastener axis

LID

HANDLE

SIDE-WALL

FRAME & CUT-OFF-EDGE

M3 BOLT

BASE-PLATE

M3 COUNTERSUNK BOLT

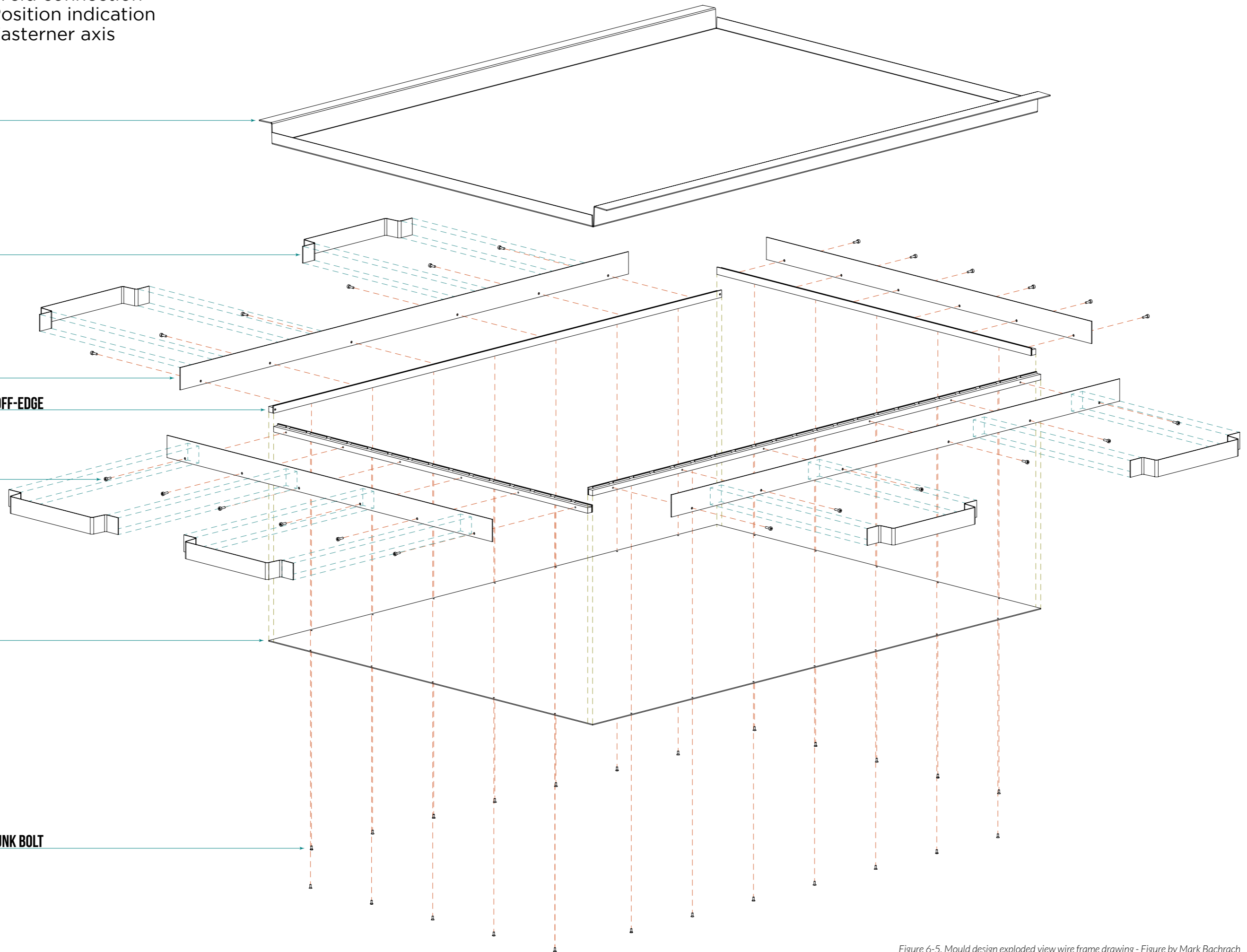

Figure 6-5, Mould design exploded view wire frame drawing - Figure by Mark Bachrach

### 6.3. PRESS DETAILING

The overall design of the press is so far only dictated by the book press that was used during the iterative prototyping. The general setup of the book press is therefore used as a reference and a starting point.

In the design of the book press, the essential functions that the press will have to fulfil are embodied by four main parts. These parts will have to be translated into parts for the plastic plate press design. Figure 6-6 shows the identification of those parts in the book press.

In the following paragraphs about the embodiment design of the plastic plate press, the design structure of these main parts will be explained, starting with the force actuator. The force actuator has the least design freedom since it will be a sourced part. The other parts will have to be fitted to the chosen actuator, and thus the actuator is the right starting point.

#### 6.3.1. Force actuator selection

In the design research chapter, a morphological chart was presented in which the choice for the force actuator was defined to be a hydraulic cylinder. This choice was made because of the relative ease of instalment which allows the parts to be connected to it to stay as simple as possible. Also, the system seclusion of hydraulic cylinders results in a low need for maintenance and cleaning and the completeness

of the cylinders ensure that no additional parts are needed besides the cylinders, opposed to for example a spindle, which needs custom fitting solutions for both the end nut as well as the guidance nut. All of these arguments combined also result in a lower cost price, which is also one of the primary decision drivers.

These benefit can however only be realised if the right cylinder can be found. The cylinder needs to fit the force requirements, the price range and needs to be source-able all around the world.

The minimum pressure requirement has been calculated in the previous chapter to be 1,8 bar which results in a force requirements of at least 268 kN for plates of 1.22 m by 1.22 m and a force requirements of 158 kN for plates of 1.10 m by 0.8 m, which is the size of the mould that is going to be prototyped.

Since the design goal is to be able to produce plates of 1220 x 1220 x 12 mm, the higher requirements are chosen to fulfil. This will allow for the prototype design to be scaled up without a need for other cylinders.

The price limit is difficult to decide upon, but as a first suggestion a fourth of the total allowable cost price is granted since the force actuator is 1 of the four main parts;  $\$ 1200 / 4 = \$ 300$ .

With these requirements in place, the search was set out. International websites were used to look for hydraulic

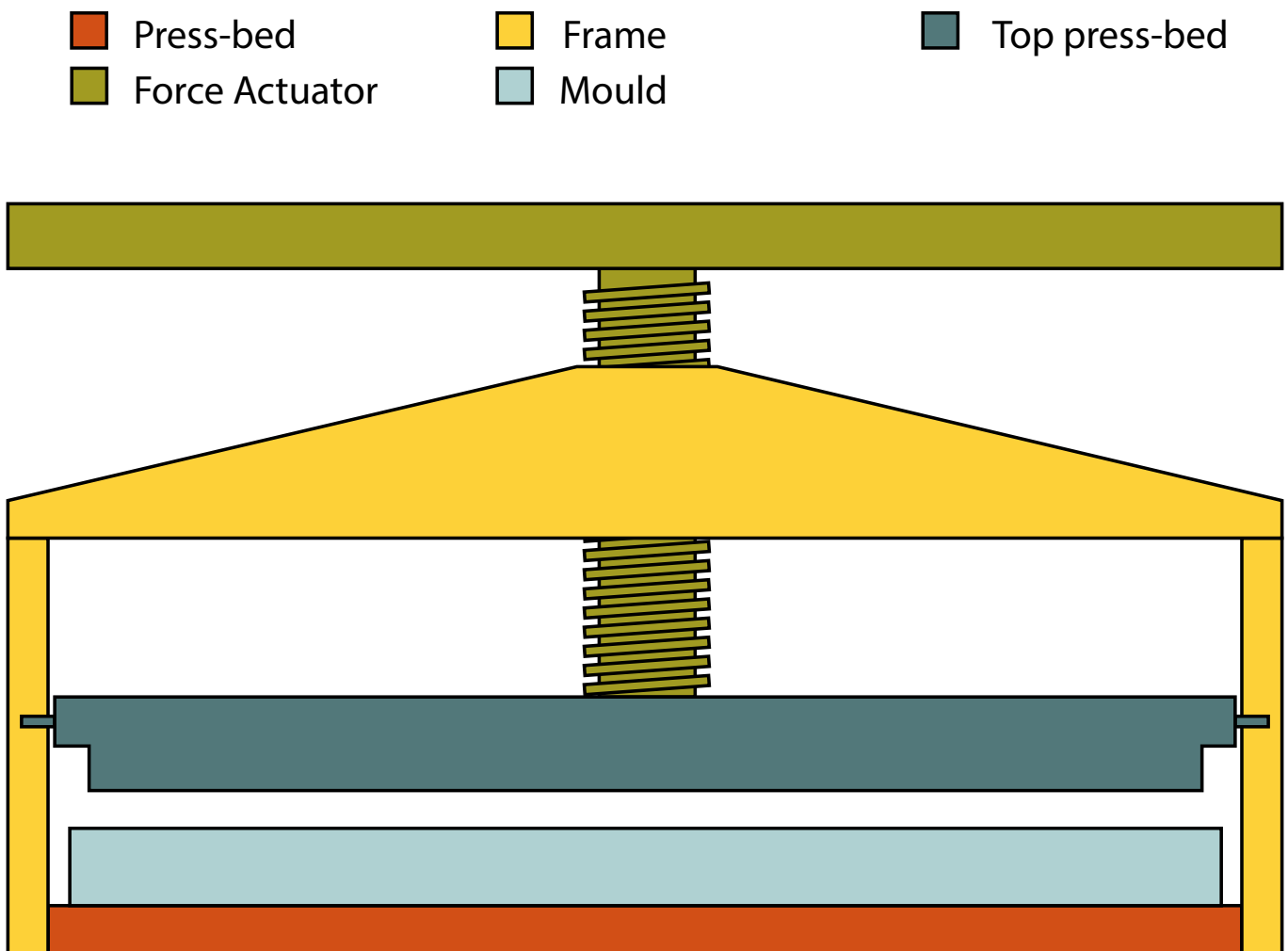

Figure 6-6, Main Part identification according to Book Press - Figure by Mark Bachrach



cylinders, and soon it was found out that the most affordable cylinders are bottle jacks, which are often used in auto garages to lift up cars or press bearings in fittings. Also, longer bottle jacks were found that are used in engine hoists. In the analysis, it was also found that car parts or garage tools are an excellent source of materials since cars and garage tools are global common goods, and thus are good for the sourceability. For these reasons, a bottle jack was chosen as force actuator, what bottle jacks are and what kinds are available is explained in Appendix A.14.

### Press application

In the press, a jack stroke of 10-20 cm would be enough to provide access for placing the mould and pressing it shut since the current mould design will only be 45mm tall and when filled with plastic, will most likely not exceed a height of 10 cm. However, because of the cleaning access requirement as discussed in the previous chapter, it should be possible to move the press beds apart for at least 30cm. Other means than jack extension length can also realise this, but, it would be very convenient if the cylinders could realise this feature.

The same holds for the option of a jack with a pneumatic air pump, which is not demanded by the design requirements, but it is a very convenient option that adds to the usability of the product. Next to that, when it is chosen to use multiple jacks, the activation can be centralised by linking the pneumatics.

When it comes to force-output, single small jacks can be found that satisfy the needs, 30-ton jacks or 32-ton jacks would suffice and are available within the price range. However long ram jacks are not found for the required force output.

When considering these three arguments, logic would demand a single small jack of 30 or 32 ton, since only they satisfy all the requirements, although not the wishes. However, the other options only satisfy the wishes and not

the force requirement or at least, not by themselves. When multiple jacks are used, also the long ram jacks can satisfy all the requirements. For example, when four 8-ton jacks are used, 32 tons of force can be realised (29 tonnes).

The choice between a single powerful jack or multiple weaker jacks thus needs to be made. This consideration of multiple jacks may seem un-logical since four weaker jacks are more costly than a single, stronger, jack. However, there is a good reason to look into this option. The force distribution from 1 central point to a large surface area has different structural requirements than the force distribution from 2 or 4 points to a large surface area. Figure 6-7 depicts two simplified situations in a free-body diagrams (FBD) with corresponding shear force diagrams (SFD) and bending moment diagrams (BMD). The distributed force indicated with  $W_p$  represents the pressure that is put on the mould,  $F_A$  represents the force generated by the single bottle jack of 32 tonnes, and  $F_B$  &  $F_C$  each represent two bottle jacks of 8 ton totalling to 16 ton each. This doubling is done because of the simplified 2D representation in which the 3rd dimension is compressed in a single layer.

In the diagrams can be seen that the maximum shear force and maximum bending moment can be significantly decreased by choosing multiple load points instead of a single centralised load. Keeping the maximum bending force as low as possible is essential in this design since bending deformations in the press-beds will result in thickness deviations in the plastic plates. These deviations may not exceed the defined tolerance requirement of +/- 1 mm, and thus the bending deformations may not exceed this limit. This can only be realised by integrating sufficient stiffness into the press beds and thus lower bending moments allow for less stiffness which allows for smaller beam profiles and less material. All of these consequences result in less material use, less complexity and lower costs which all are very much wanted.

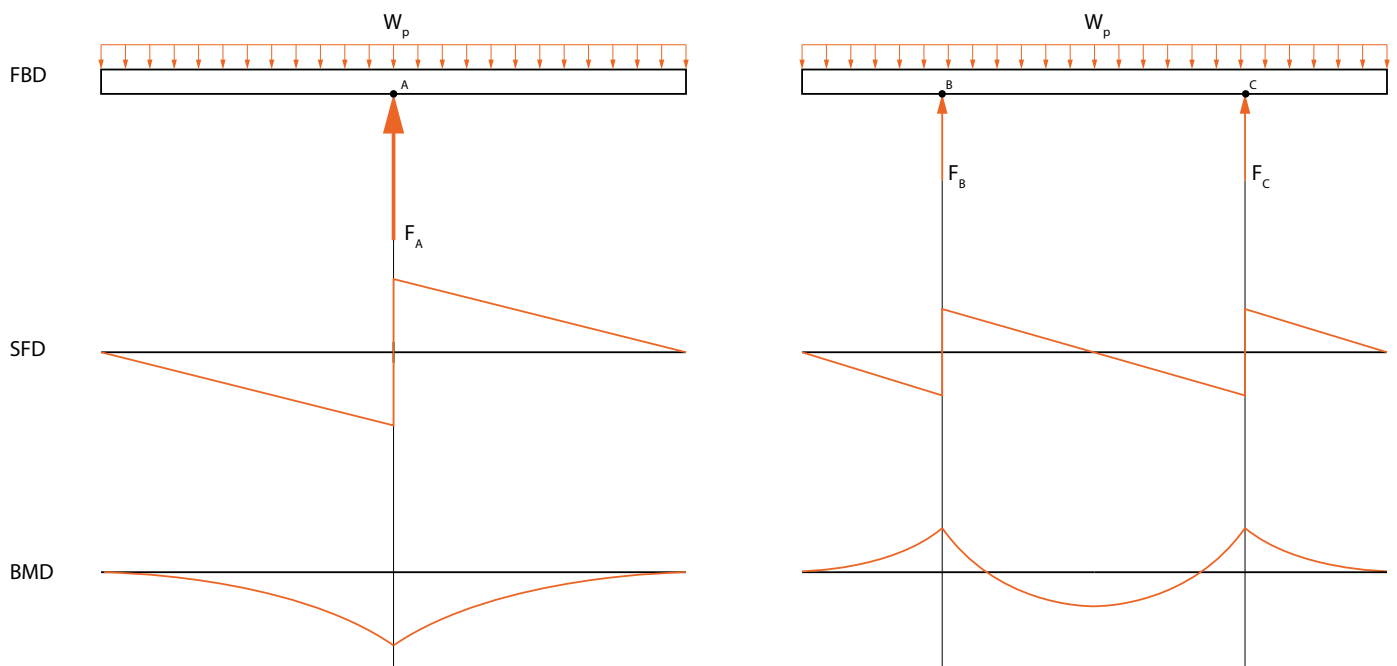

Figure 6-7, Load scenario comparison - Figure by Mark Bachrach

## Concluding

Four 8-ton long ram jacks with air pumps are chosen as force actuators as long as costs allow it. This choice is made based on the following arguments:

- Multiple load points are beneficial to the design as opposed to a centralised load point.
- Extended ram jacks have a long stroke (more than 30 cm), which allows for easy cleaning access positioning.
- Air pumps allow the activation of the jacks to be centralised and by it, the jacks can be operated by a single person.
- Four jacks, each with a maximum lifting force of 8 tons, total to 29 tonnes of pressing force which satisfies the required 26,8 Tonnes
- 8-ton long ram jacks are commonly used in engine hoists, making them source-able almost anywhere on the globe
- Most of the available 8-ton long ram jacks have two single axle fixtures, each on one end of the device, making them very easy to install.

8-ton long ram jacks can be bought locally in the Netherlands for € 70,- per piece, totalling to € 280,- for four units, which is just below budget. Ordering from china, similar units can be bought for below \$ 50,- per piece (alibaba.com).



Figure 6-8 shows a picture of a typical 8-ton long ram jack with an air pump, more information about such a hydraulic jack is found in user and safety manuals such as the one by harbor freight (8 ton air/hydraulic long ram - jack Set up and operating inStructions, 2006).

## 6.3.2. General setup

Now that the force actuators are decided upon, the surrounding structures can be designed. First, the general setup is discussed after which each of the main structural components is further developed and discussed in detail. In Figure 6-9 a simplified general setup is visualised. In this setup, a few things have already been decided and are explained in the following.

### Tilted jacks

In the general setup depicted in Figure 6-9, one immediately notices that the hydraulic jacks are placed under an angle. This is done to provide optimal load setups in both the frame (yellow) and the bottom Press-bed (Red). This way the frame is primarily subject to extension and compression in its structural components and the bending moments are minimised by placing the load connection as near as possible to the axial member's pivot point. From these points, the hydraulic jacks follow a tilted path to the connection points on the bottom press-bed, which are placed closer to the middle to minimise the bending moments in this part as well. What the optimal placement is for these connection points is further discussed in the following paragraphs.

### Pressing upwards

The quick eye also notices that the hydraulic jacks will push the bottom press-bed upwards against the top press-bed when the jacks are activated. This is opposite to the reference situation of the book press that was used, which presses the top press-bed down. This change is made because the hydraulic jacks only work in a single direction. They can push with a substantial force, but cannot actively retract. To retract the rams to their starting position, a force is needed. This is supplied by the weight of the press-bed, while it sits on top of the jacks. If it were chosen to let the hydraulic jack push the top press-bed down, an additional system would have to be integrated to move the bed back up.

### Extended frame

Also in need of explanation is that the frame extends beyond the height of the top press-bed without any structural needs. This extension is introduced to allow the bottom press-bed to push the top-press-bed upwards up to the full extension of the jacks. This can of course only be done by first removing fasteners that are fixating the top press-bed. This 'full-extension' feature is integrated into the design to allow users to access the middle of the press-beds for cleaning purposes.

Figure 6-8, 8 ton long ram jack - Figure by harbourfreight.com

### Press-bed guidance

Beside the frame extension, also the extension on the bottom press-bed sides is noticeable. It was already suggested in the Function-analysis that the press would need guidance features to keep the press-bed level during translation. Moreover, in the previous chapter, it was decided that guidance rails would fulfil this need. The guidance extensions that are visualised in Figure 6-9 in red, are intended to grip around the frame and slide along the pillars and thereby providing guidance. The proper functioning of these guidance elements is further discussed in Paragraph 6.3.4.

### Setup origin

Finally, the overall setup itself might require some elucidation. Existing hydraulic presses inspired it, as can be seen in Figure 6-10, their general setup consists of a U-shaped frame (upside down) and two connected C-beams that grip around the frame pillars and can be fixed in height with a rod or bolt. The structure has been used as inspiration for the plastic plate press design since the hydraulic presses have very similar functions and have a well-established design that is very similar across the entire market.

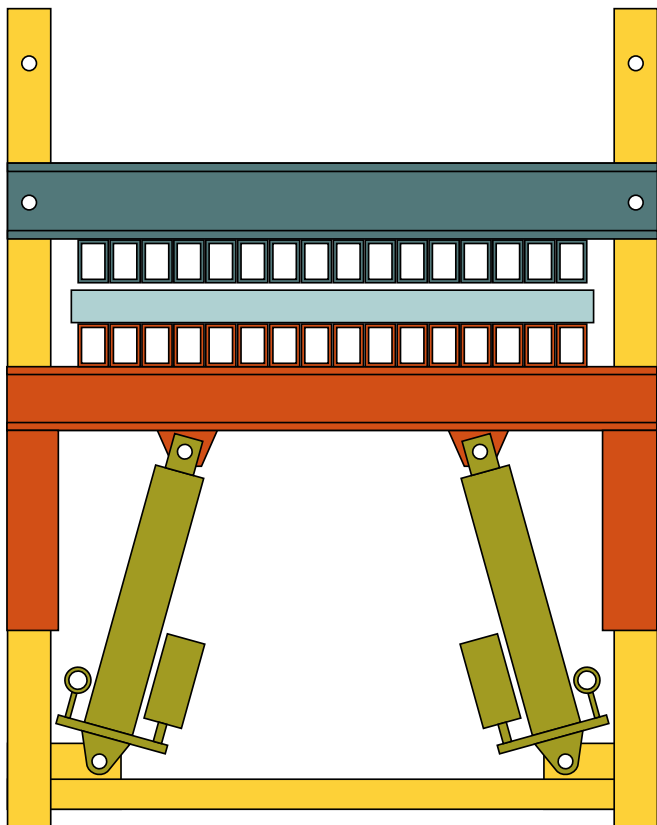

Press-bed      Frame      Top press-bed  
Force Actuator      Mould

Figure 6-9, General setup for press design - Figure by harbourfreight.com



Figure 6-10, Common hydraulic press example - Figure by northerntool.com

### 6.3.3. Static setup

In the general design setup, three components were identified as the main components to be designed. The functions of these components are evident as well as their place in the overall system, but their specific structure has yet to be defined.

Although, it has already been decided that each of the components will be built up from standard steel profiles and beams. In this paragraph, the static setup of each of the three main components is analysed, and from it, a starting point is generated to base the integrated embodiment design on. This integrated embodiment design will be defined in 3D CAD software and analysed and developed by FEM analyses. In Figure 6-11 the general setup is split into three static setups that will be discussed separately in the following.

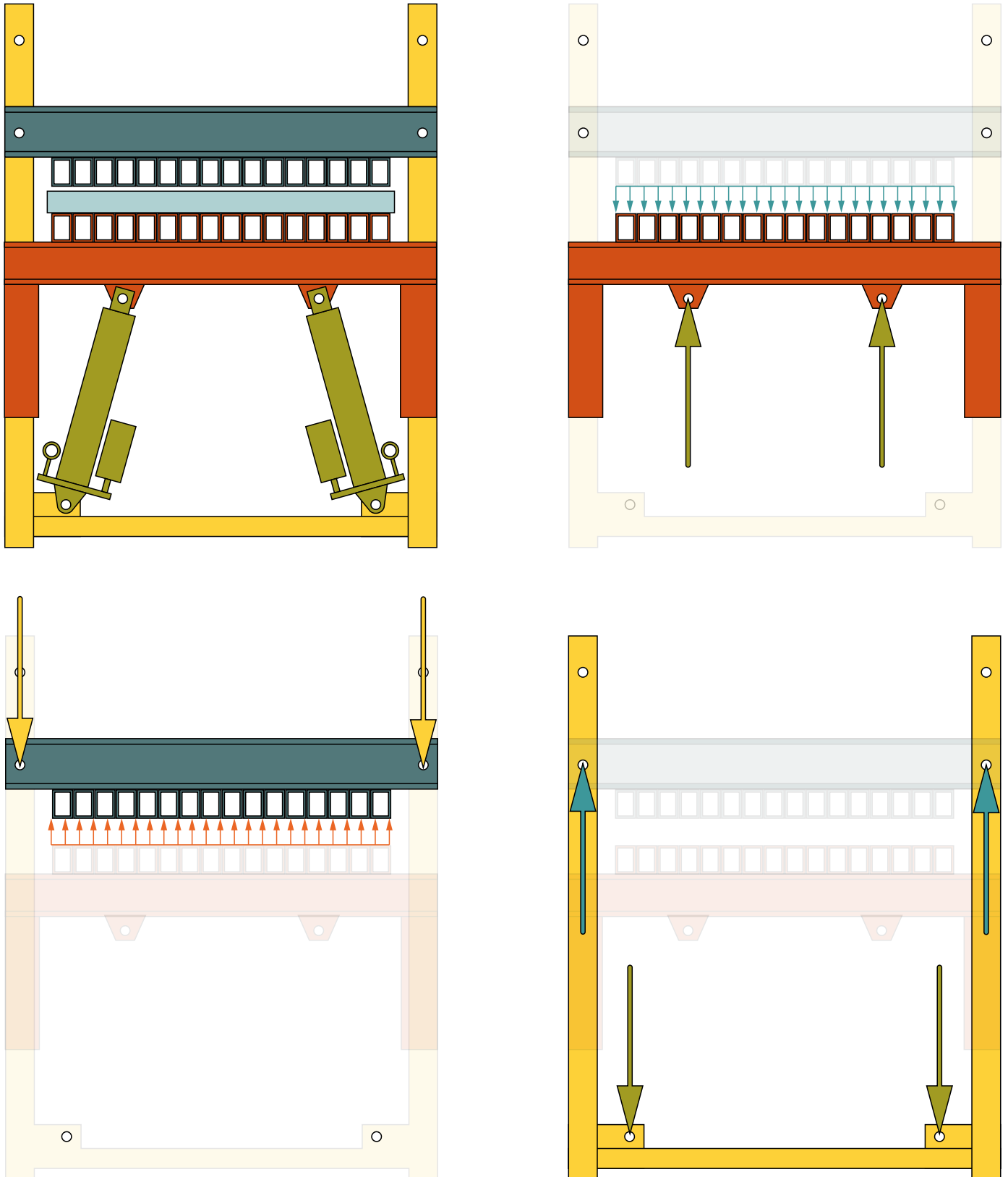

Figure 6-11, load situations on main parts - Figure by Mark Bachrach

### Bottom press-bed

The press-bed's primary function is to deliver a uniformly distributed force onto the mould by transforming the point loads supplied by the hydraulic jacks. This transformation should be realised through the stiffness of the press-bed. This stiffness will not be perfect, and therefore the setup should be optimised towards minimal deformation. In this case, the deformation will result from bending moments inside the beams or profiles that will be used; thus the setup for the minimal internal bending moment should be found.

A simplified static setup of the bottom press-bed is depicted in Figure 6-12. In the simplification, only the vertical forces are taken into account since the horizontal forces will cancel each other out, and they will be only a fraction of the vertical forces. In the figure, 'L' is the length or width of the bottom side of the mould that delivers the resultant load  $P_R$  that is evenly distributed on the top side of the press-bed. This resultant load,  $P_R$ , results from the upwards force of the 4 Hydraulic jacks combined. In this simplified 2D representation,  $F_p$  represents the force of 2 hydraulic jacks, and two pairs are each connected to the pressed in point 'A' and point 'B'.

Assuming that the supports are stiff, that the resultant load on the press-bed will be uniform and that the press-bed will behave equally under positive or negative bending moments, the objective is to balance all resulting maximum bending moments;  $M_{cant}$  and  $M_{mid}$ .  $M_{cant}$  is equal on both sides because of the setup's symmetry.

The balance is found when the middle part of the press-bed (indicated with 'b') has a length of  $2\sqrt{2}$  times the length of the cantilever parts of the press-bed (indicated with 'a').

This ratio is found by calculating the cantilever required to counter half of the bending moment resulting from the uniform load along the doubly supported beam:

$$\begin{aligned}
 M_{mid} &= \frac{qL_{mid}^2}{8} - M_{cant} & L_{tot} &= 2L_{cant} + L_{mid} \\
 M_{cant} &= \frac{qL_{cant}^2}{2} = \frac{M_{mid}}{2} = \frac{qL_{mid}^2}{16} & L_{tot} &= 2L_{cant} + 2\sqrt{2}L_{cant} \\
 \therefore L_{mid} &= 8L_{cant}^2 & L_{tot} &= (2 + 2\sqrt{2})L_{cant} \\
 L_{mid} &= 2\sqrt{2}L_{cant} & L_{cant} &= \frac{L_{tot}}{(2 + 2\sqrt{2})} \\
 & & L_{mid} &= L_{tot} - 2L_{cant}
 \end{aligned}$$

For a mould with  $L_{tot} = 1.3m$  this would result in:

$$\begin{aligned}
 L_{cant} &= \frac{L_{tot}}{(2 + 2\sqrt{2})} = \frac{1.3}{(2 + 2\sqrt{2})} = 0.269239... \\
 L_{mid} &= L_{tot} - 2L_{cant} = 1.3 - 2 \frac{1.3}{(2 + 2\sqrt{2})} = 0.761522...
 \end{aligned}$$

This ratio will be used as a basis for the integrated embodiment design of the Press-bed, which is elaborated in Paragraph 6.4.

### Top press-bed

The top press-bed's primary function is to deliver a uniformly distributed force onto the mould by transforming the point load pulling forces of the frame-pillars. This transformation should be realised through the stiffness of the press-bed. This stiffness will not be perfect, and therefore the setup should be optimised towards minimal deformation. In this case, the deformation will result from bending moments inside the

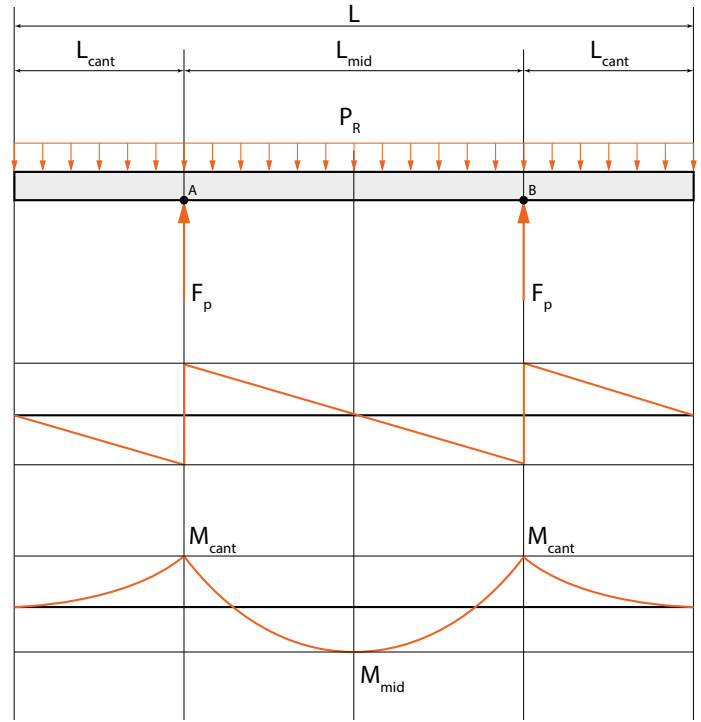

Figure 6-12, Static setup bottom press-bed, FBD, SFD & BMD - Figure by Mark Bachrach

beams or profile that will be used. Thus, again, the setup for the minimal internal bending moment should be found. However, the setup is forced by the general setup and cannot be changed. Therefore, a beam that can provide sufficient stiffness has to be found based on the allowable deformation. FEM analyses in the following paragraph will produce this.

In Figure 6-13 the static setup is displayed with shear and bending moment diagrams in which can be seen that the maximum bending moment can be expected in the middle of the press-bed.

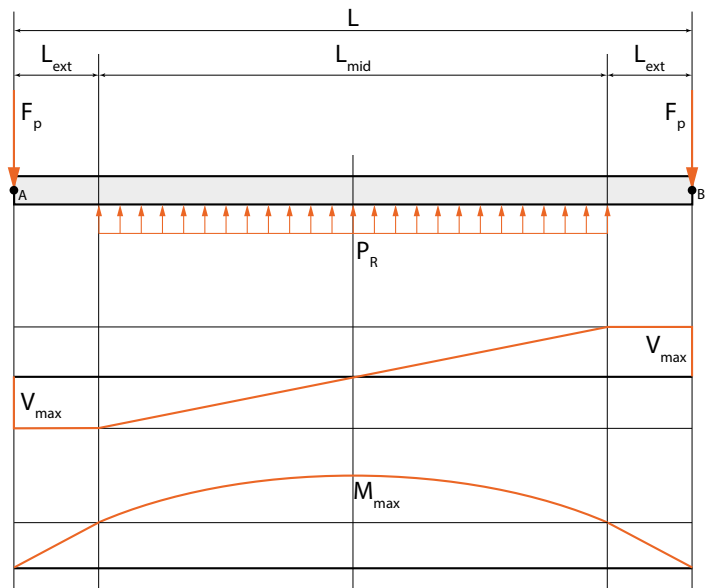

Figure 6-13, Static setup Top press-bed, FBD, SFD & BMD - Figure by Mark Bachrach

## Frame

The frame's primary function is to keep the fixtures of the hydraulic jacks and the top press-bed in place while the jacks apply their force on both ends. The frame will only have to provide enough strength to withstand the forces.

By placing the jack connections as close to the corners as possible the bending moments are minimised and are therefore not considered. This leaves only axial forces to be considered as can be seen in Figure 6-14, which displays the simplified static setup. Axial forces do not result in any shear forces or bending moments instead there is only tensile stress to be considered. This will be analysed with FEM and discussed in the following.

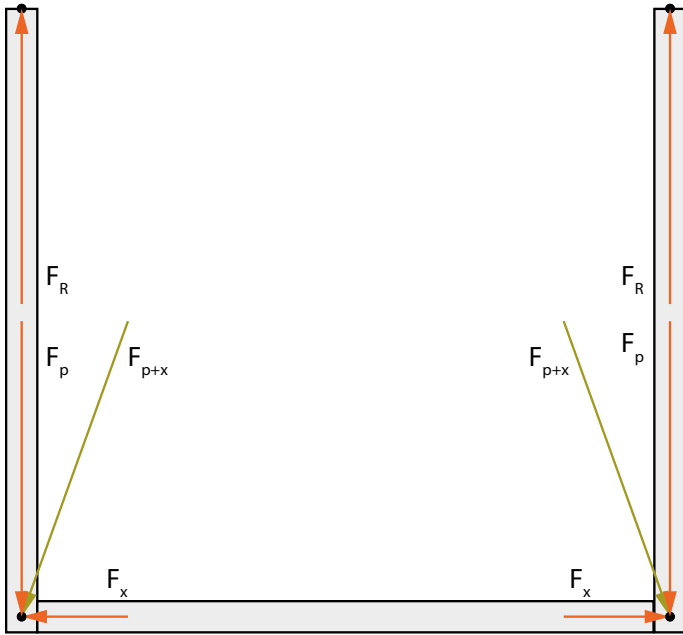

Figure 6-14, Static setup frame, FBD - Figure by Mark Bachrach

## 6.3.4. Sliding or Setting

Before the first CAD model can be generated, the guidance system needs a closer look. The chosen guidance system is a sliding-rail which will be embodied by an extruded C-shape that fits around the frame-pillars. This seems to be the most straightforward manner of embodying a sliding-rail with the chosen materials. However to make it work it should be found out when the rails provide smooth sliding and when they will get stuck. This all has to do with the length of the sliders and the distance between the sliding rails and the force that is generating the movement.

In some design cases a sliding effect is needed, e.g. guide-rails, and in other instances, a setting effect is required, e.g. glue clamp. The difference lies in the dimension 'a' and 'd' (see Figure 6-15) and the friction coefficients of the used materials, the force magnitude has no influence. Figure 6-15 depicts a simplified 2D representation of the guidance system in which  $F_p$  is the vertical force that is supplied by 1 of the cylinders.

When the force and moment equations are solved, the result is a formula that will produce the minimum length of 'a' to make sure that the system will slide and not get stuck. This formula originates from the math as displayed in Appendix A.15 and is as follow

$$a = k(2d - b)$$

'k' is the friction coefficient between the materials that slide along each other. For steel, for example, this could be 0.6

When the values,  $k = 0.6$ ,  $b = 1.3\text{m}$  &  $d = L_{\text{mid}} + L_{\text{cant}} = 1.03\text{m}$ , are used, a minimal length 'a' of 456 mm is produced.

This length is a reference length since the exact measurements of the design are not yet clear. When these dimensions are apparent, the formula should be used to find the right length for 'a'.

Do note that the gravitation force is neglected in this calculation, but is expected to have a negligible effect.

To check the theory, a quick-and-dirty scale-model was made with the same dimensional ratios to see if the system would indeed slide and not set. The physical model, which is shown in Figure 6-16, confirmed the sliding property of the system.

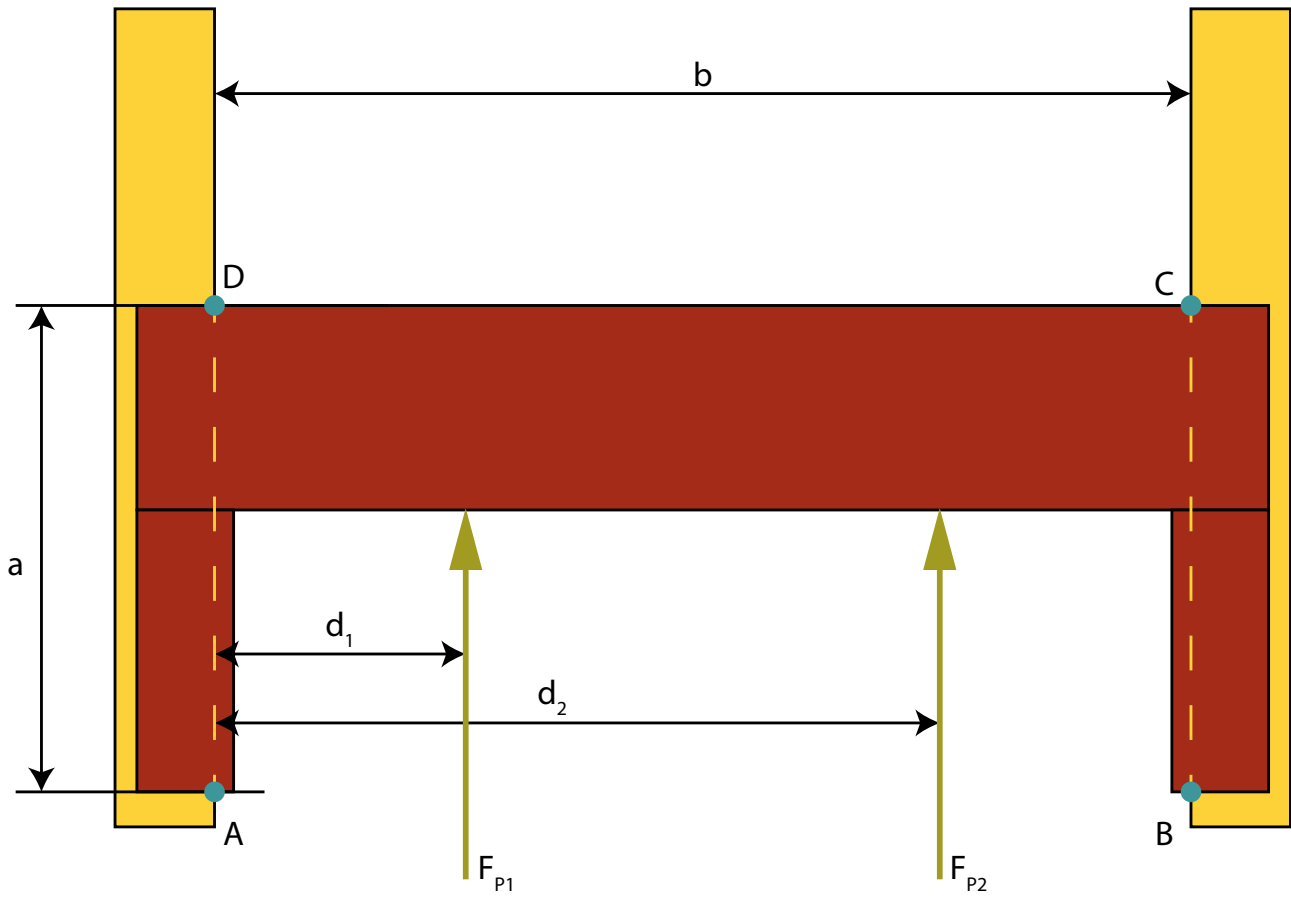

Figure 6-15, Sliding or setting calculation variables - Figure by Mark Bachrach



Figure 6-16, Sliding or setting scale model - Picture by Mark Bachrach

### 6.3.5. Static simulation iterations

For the static simulation iterations, a simple setup was created in 3D CAD software for each of the main components. With the use of gut feeling, one of the standard beam profiles was chosen for each of the beam segments in the design as can be seen in Figure 6-17-F, G & I, for respectively the bottom press-bed, the top press-bed and the frame. Small additions in the designs were modelled to be able to assign the simulation forces to the right segments. Moreover, then the simulations were run with the actual force magnitudes. For both the press beds the deformation was the leading optimisation factor which wasn't allowed to exceed a maximum of 1mm. When the simulation results produced greater deformations than the allowed maximum of 1 mm, the design was adapted by integrating larger beam profiles with an increment of one standard size. This step was repeated until the right deformation limit was achieved. These final deformation simulation results for both press-beds are displayed in Figure 6-17-A & B and C & D for respectively the bottom and top press-bed.

In a next step, the simulations were rerun, but this time with a safety factor of 1.5 as a multiplier for the applied force

magnitudes. For this set of simulations, not the deformation was leading but the Von Mises Stress, which indicates if the structure will fail under the load. It was expected that this would not be the case since the bending allowance that was set as a goal already resulted in very heavy beam profiles. Indeed the simulation provided results that confirmed the sufficient strength of the structure. As can be seen in Figure 6-17-E, F, G, H & I.

Do note that each of the critical stress simulations also included small areas that were indicated with very high stresses that would suggest that the structure would fail locally. These hotspots, however, were always very small and only present at sharp corner points. Consultation with MMID's Simulation expert resulted in the confirmation that these tiny hotspots can be ignored since the steel in these locations will most likely deform under the load until the material is arranged in such a way that the stresses are lowered. This reasoning only holds for tiny hotspots and steel structures.

Table 6-1 displays the essential simulations variables.

	Deformation optimisation	Failure under stress optimisation
Leading output value	Deformation in mm	Von Mises stress in MPa
Materials	Low Carbon steel	Low Carbon steel
Safety factor	1	1.5
Simulation force	4x 80 kN	4x 120 kN
Value Limit	0.5 mm	200 MPa

Table 6-1, essential simulation variables





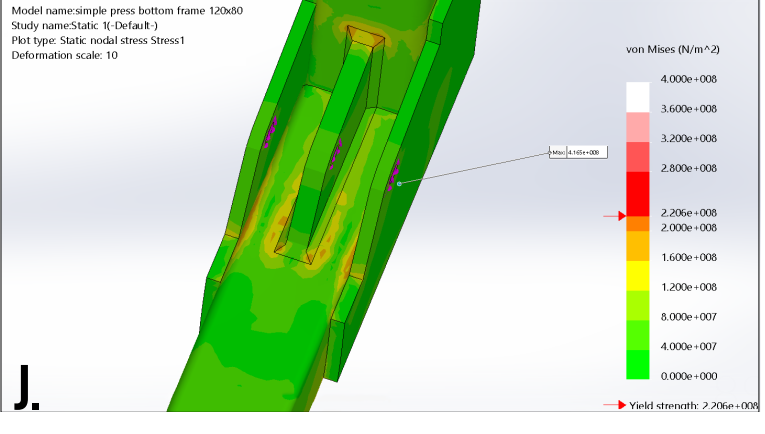
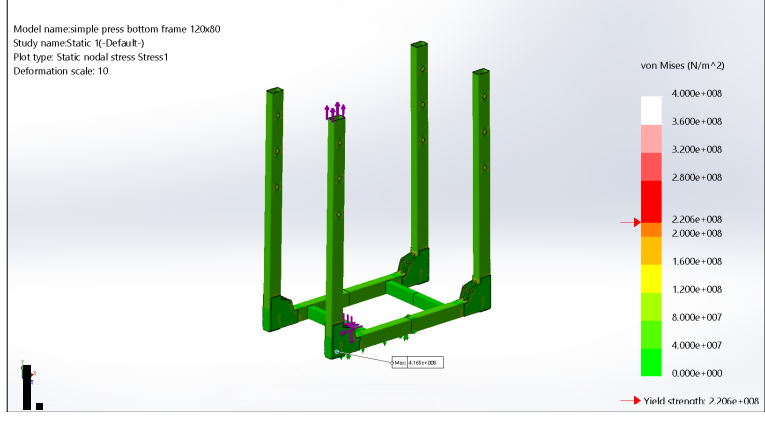
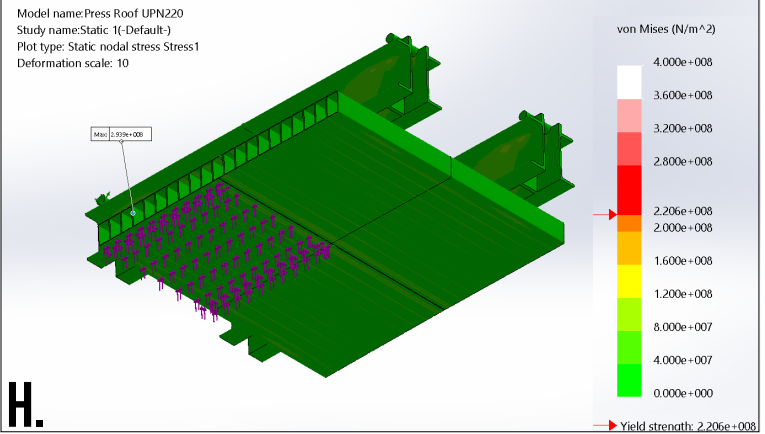
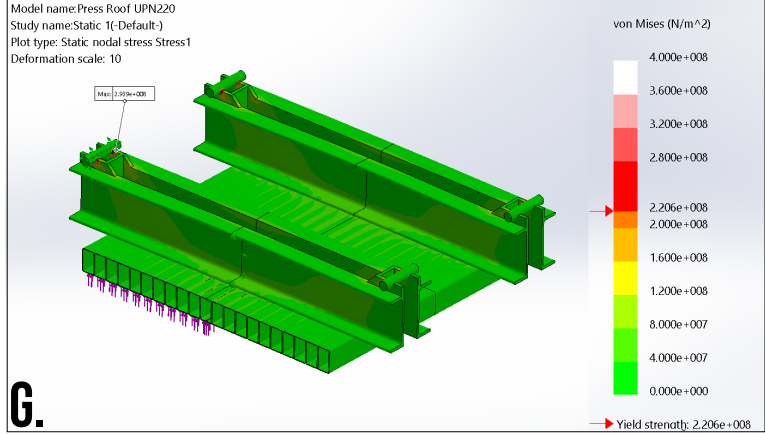
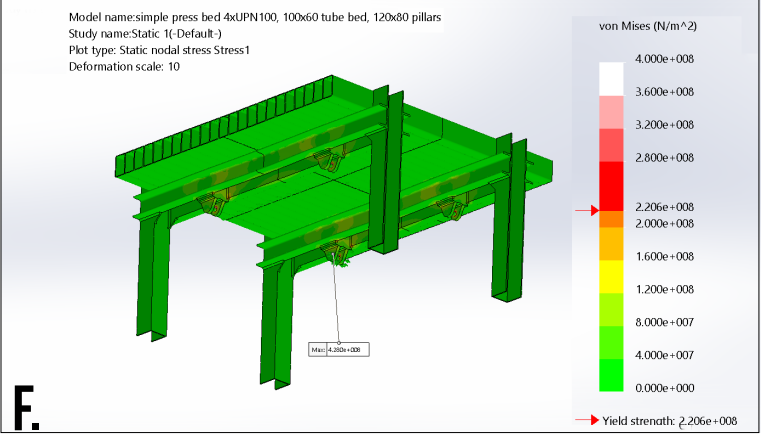
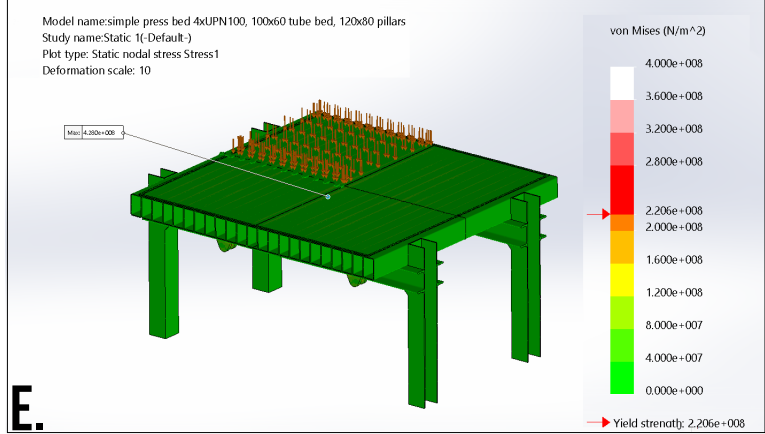
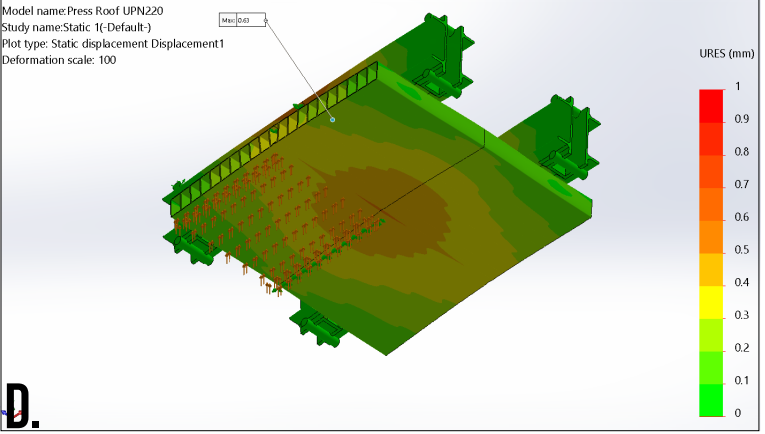
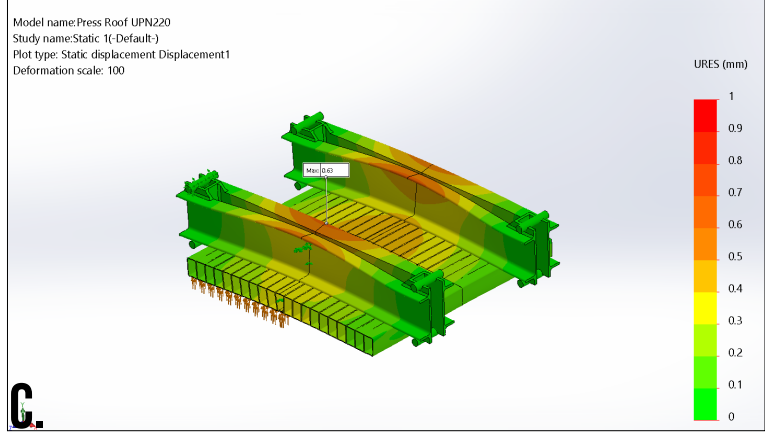
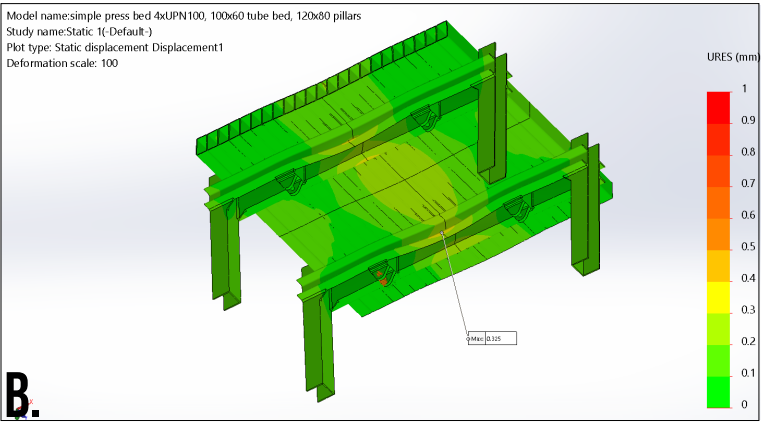
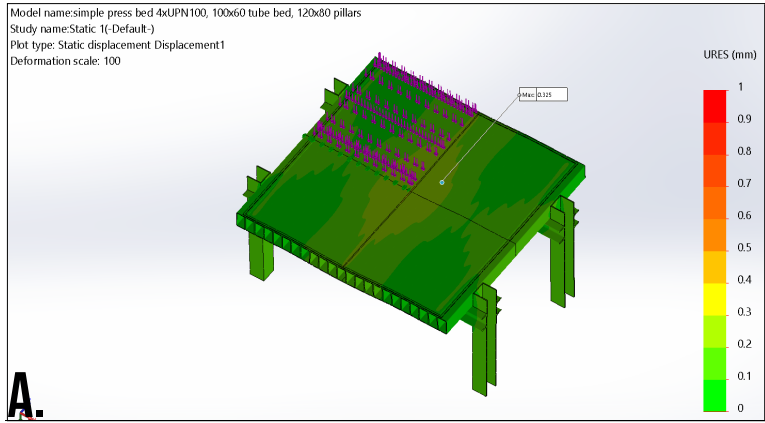

## 6.4. PLASTIC PLATE PRESS DESIGN

In this final paragraph about the embodiment design of the plate press' first large-scale prototype, the actual integration of all design elements is shown in renders of the 3D computer. The design that was constructed in the static simulation iterations was integrated with all feature requirements that were listed in the preceding chapters. When designing, it was kept in mind that the parts would be cut (out) with a grinder and therefore only straight and accessible cutting geometries are included. Next to this and the feature integrations, the design was also adapted to the size of the mould prototype design since this design will be materialised in a full-scale prototype. To make sure that the prototype can provide useful insights, also the steel beam section sizes were adapted to the press size using the same simulation iteration steps. It is believed that the size adaptation does not compromise the validity of the prototype-testing since the solutions that are size dependent have been scaled down too. The resulting design then evaluated with one of the senior design engineers of MMID to judge whether the design would be safe to build and test. From this evaluation minor alterations were generated and integrated. These change requests were related to buckling of the frame's bottom corner pieces (Figure 6-19 and feature list Nr. 22) and the buckling and bending of the bottom press-bed's slide guides (Figure 6-19 and feature list Nr. 10 & 21).

The design that resulted from the feature integrations, the size adaptation and the safety evaluation is displayed in Figure 6-18, and in Figure 6-19 all noteworthy design features are indicated with numbers that correspond to the numbers of the explanations that are produced below. Additionally, an assembly drawing is included in Appendix A.16. The design documentation up til this phase in the design trajectory is kept at a need-to-know-level, and only the final design will be provided with a complete set of technical drawings.



Figure 6-18, Press Design render - Figure by Mark Bachrach

## Design feature list corresponding to numbering in Figure 6-19:

1. The frame pillars are connected with steel strips to provide a countermeasure against the pillars being pressed apart when the top press-bed is lifted to 1 of the three fixing heights.
2. The frame pillars include three sets of holes to let the user(s) fixate the top press-bed on the preferred height. The Top pressed can be lowered and lifted by removing the fixing bolts and operating the cylinders.
  1. The lowest setting is used for pressing with minimal displacement needs to complete the pressing process
  2. The middle setting is used when more oversight and manoeuvrability are preferred during the pressing process
  3. The highest setting is used to provide maximum access to the press-bed surfaces for maintenance or cleaning purposes.
3. Four M20 bolts are used to fix the top press-bed in place, and nylon lock nuts are used to ensure that they will not loosen through machine vibrations.
4. Big open-ended rectangular sections are used to provide stiffness in the lateral direction and to allow for active ventilation. When air is blown through the sections, they will function as a heat sink.
5. The opening that is provided to slide the mould in is well balanced between easy access and minimal press movement.
6. The sliding guide extends for the longest possible length to provide extra smooth sliding
7. To provide access to the bolt heads of the bolts that fix the cross scaffolds in place, a hole is integrated at the inside of the frame. It is dimensioned in such a way that the bolt and a tool can be inserted and used for tightening.
8. The C-beam that is used is of a conventional size (UNP 100) that should be easy to source almost anywhere in the world.
9. The cross scaffolds are placed to keep the pillars parallel during the production of the frame, and during assembly of the press, when finished, the cross helps to keep pillars straight and level when the top press-bed is moved to a different height.
10. The sliding guides are reinforced with triangular shaped steel plates that prevent the sliding guides from bending inwards.
11. Smaller rectangular sections are used to connect the two U-shaped frame parts
12. The sliding guides also serve as feet for the bottom press-bed. This way it always returns to the same height when the jacks are lowered. Because of it, the jacks are not under any load when the bed is lowered and can thus be easily installed or removed for maintenance or replacement.
13. Each of the four bottom corners of the frame makes use of two identical corner pieces that are used to reinforce the connection of the rectangular sections that the frame is made of. In these corner pieces, also the holes for the hydraulic jack fasteners are integrated, and of course, they also serve as end-stops for the bottom press-bed-feet.
14. The bottom bolts for fixing the cross scaffolds are inserted at the bottom of the open-ended frame pillar and are then welded in place before the open end is closed off.
15. The bottom open ends of the pillars are closed off with closing plates which can be fitted with feet or wheels to either make the machine itself moveable or provide access for a forklift or pump wagon to move the machine when needed. The pillars are also dimensioned to fit through a standard door with a 2m walkthrough height, with wheel or feet of 10cm included.
16. Simple connection plates are used to connect the C-beams of the top press-bed to each other in two parts that fit around the frame pillars. They also keep the top press-bed entered when the fixing bolts are not in place.
17. The top press-bed C-beams are chosen of a larger but still common size that should be source-able in most parts of the world.
18. The press-beds each consist of common rectangular sections that are welded together in three sets, two identical side sets and a middle set. This separation is upheld to make sure that the weldment-parts do not exceed a liftable weight. Each of the sub-assemblies is bolted to the C-beams with two bolts at both ends. The middle sub-assembly is bolted to the inner C-beams.
19. The bottom press-bed is built up the same way as the top one but is two sections wider to provide a larger area for the mould to sit on.
20. The hydraulic jack rams are connected to a small and straightforward weld assembly that doubles as a C-beam connection piece. The bolts that are used are chosen at the largest size that fits through the shaft hole that is provided by the jack (M16).
21. The triangular slide guide reinforcement plates are closed off with an extra plate to keep the triangular plates from buckling under pressure.
22. Also, the corner pieces are closed off with an extra plate to keep the corner plates from buckling under pressure.
23. In the middle between the corner piece plates, an extra thick plate is placed as middle corner piece that provides extra support to the jack fixing bolt.

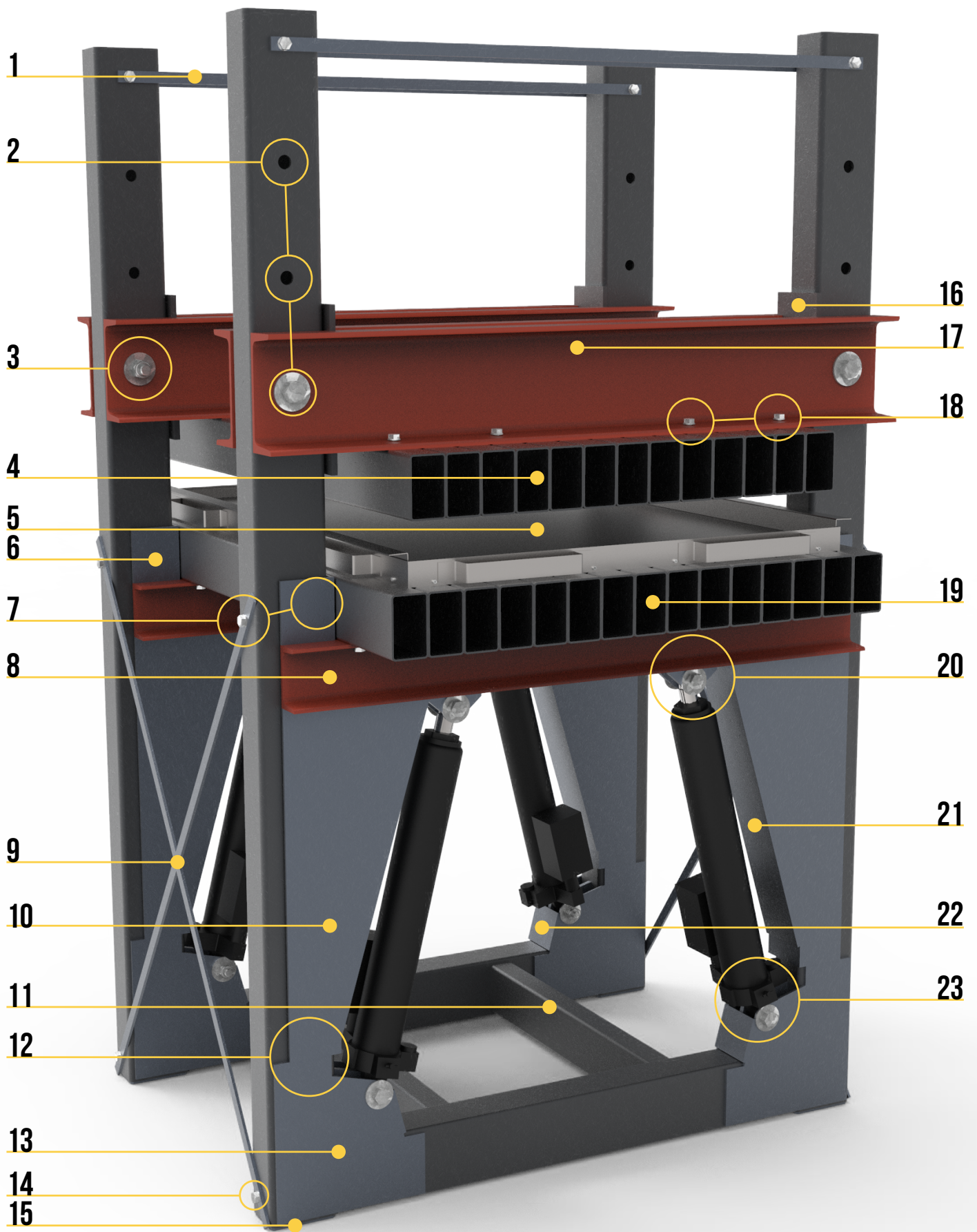

Figure 6-19, Press feature indication - Figure by Mark Bachrach

# 7. DESIGN SIMULATION & EVALUATION

In this chapter, the simulation of the design by means of a prototype (see Figure 7-2 for the press prototype & Figure 7-3 for the mould prototype) is discussed and evaluated. The evaluation consists of multiple steps that evaluate the design in multiple layers. First, the building process is discussed, and the valuable lessons learned from this process are transformed into design recommendations. Next, the user experience that is realised with the prototype is discussed and from it, more design improvements are gathered. The use of the machine, of course, also produced the first plastic plates which were then evaluated and compared to the plastic plate requirements. Besides these plastic plate requirements, more

(secondary) requirements had to be fulfilled by the press and also these were evaluated by checking off the POR-items, noting down that they still had to be integrated or revising them because of newly gained insights. With these four levels of evaluation done, all internal sources of evaluation have been handled, but of course, it is always interesting to let external minds produce critiques. To do so, two videos were created; one of which is about the machine building process and the other about the pressing process. With these videos as discussion material, the project experts and Fábrica de Sabão were consulted and asked for feedback. The videos are found by following the links below or by scanning the QR-codes in Figure 7-1.



Figure 7-1, Video QR-Codes - Figure by Mark Bachrach

With the internal and external evaluations combined only one evaluation measure is missing, and that is the cost estimation of the design. This final evaluation layer is included in the second last paragraph of this chapter, and the chapter is

concluded by a summary of all of the design recommendations that were produced by the combined evaluation efforts discussed in this chapter.

Figure 7-2, Full-scale Prototype - Picture by Mark Bachrach >







## 7.1. PROTOTYPE PRODUCTION LEARNINGS

During the building process of the large-scale prototype, a lot of new insights were gained. These insights mostly concerned ease of assembly and assembly accuracy and are explained in the following.

### Tolerance multiplications

The press-bed and press-roof rectangular section tubes have larger dimension variations than expected. The long sides of the sections are arching outwards by almost 1mm; thus when two tubes are placed next to each other, this results in a total width that is 2mm wider than expected from the ideal situation. Thus, when 15 tubes are placed next to each other, this results in a total width that is 28 mm wider than expected. By clamping the beams tightly together, this added width can be reduced to ca. 6mm; to be safe, a tolerance of at least +12mm should be integrated into the design, especially since one of the general lessons learned is that extra room is less of a problem than too little room.

### Precision and adjustments

During assembly, it is hard to stick to ultimate precision especially since the raw materials already have small defects and each of the parts will have dimension tolerances. Adding to the precision difficulties are the temperature changes that are caused by welding and induce warpage and other deformations. Even with all the right precautions, these effects cannot be nullified, and thus they have to be integrated into the design as well.

Especially the manufacturing process can account for these precision issues. By choosing to fit new parts to existing parts, the dimension variations can be taken into account, while trying to fit two parts together based on prescribed dimensions is much harder. This especially holds for welding assemblies, since welds cannot be adjusted when they are already applied. Fasteners, however, can be adjusted; thus, two welding assemblies should be fitted to each other with adjustable fasteners that compensate precision defects with fitting play.

Next to these adaptations, all of the fastener holes can be widened, by a few millimetres, while this would still allow the connections to be securely fixated but also allows for larger dimension deviations.

### Guidance and Play

The amount of play assigned to the sliding parts was chosen quite broadly to make sure that the sliding parts had no chance of locking itself in place because of a too tight fit. However, the play only has to account for the tolerance of a single tube and can thus be chosen more precisely. With this in mind, the play can be changed from 3mm all around to 1mm all-around. This would result in more stable guidance while still providing enough play to allow small defects to pass through. When the available rectangular section tubes that are used as pillars suffer larger defects, during assembly a more substantial play can still be realised by increasing the welding gaps slightly.

### Threaded Holes

Thread cutting is a process that takes up much time since it needs to be done carefully and precisely. Therefore it is wise to remove all threaded holes that are not essential. If possible, the inessential threaded holes should be replaced by a weld and if a removable joint is required a bolt and nut might be an option.

### Anti-buckling-plates

The anti-buckling-plates that were included in the design were left out in the prototype since it was expected that they might not be needed and they would have added extra material and time to the production. Later after testing and plate production, it was confirmed that the plates were indeed unnecessary.

### Plate thicknesses and welding

With simple welding gear that maximum weldable plate thickness turned out to be 5mm and this was already a real stretch for the available gear. The thicker plates and C-sections had a thickness of around 10mm, and the welds that were produced to fix the parts together are improper and ugly welds. In the design, this was already accounted for, and thus none of these welds is loaded with high forces. However, where possible, the plate thicknesses should be limited to 5mm to provide proper weldability for simple welding gear.

## 7.2. PROTOTYPE USE LEARNINGS

In the use-video that was mentioned in this chapter's introduction, the general plate pressing process is shown, but some specifics are not made clear. The essential particulars are summarised first and then the lessons learned from using the plate press for a couple of times are explained.

### Plate pressing process specifics:

1. The oven is preheated to 230 °C.
2. The mould is cleaned if dirty and eventual rough patches are polished again.
3. All of the moulds surfaces that will make contact with molten plastic are treated with a releasing agent.
  - Vaseline has been found to be the most affordable option.
4. A specific amount of plastic granulate is weighed off.
  - This amount is calculated by the multiplying the plate volume by the density of the material and adding an extra 5%. The additional 5 per cent is needed to:
    - o Compensated for inaccuracy in the density.
    - o Fill the mould voids that are not part of the plate.
    - o Create flow during the pressing step, which is beneficial to the surface quality.
5. The plastic granulate is put into the mould and is spread evenly.
  - Roughly even is fine.
6. The lid is put on top of the plastic granulate.
7. The oven is opened, and the mould is placed in the oven.
8. After 1 hour the mould is taken out of the oven, turned around (frontside/backside) and placed back.\*
9. After another 45 minutes, the mould is taken out of the oven and place in the press.
10. The mould is carefully aligned with the top press-bed.
11. Each of the release valves of the hydraulic jacks is checked to be fully closed.
12. The press is pressed shut by applying pneumatic pressure until the hydraulic jacks come to a halt and the air pumps no longer pump.
13. By hand, the jacks are pumped until excessive force is required to pump the jacks further.
14. A fan is activated and pointed to blow through both of the press-beds.
15. After 1.5 hours the release valves of the hydraulic jacks are open-end by half a turn each to let the press-bed return to resting position.
  - Immediately afterwards the valves are closed again to prepare the press for the next plate.
16. The mould is removed from the press and placed on a

workbench.

17. The lid is taken off, and the plate is removed
  - If needed, protruding excess plastic is removed with a chisel or pliers before the lid can be removed.
  - If the lid sticks to the plate very firmly and is not easily removed, the middle can be pressed down with one hand while the other hand pulls on the lid edges to peel the lid of the plate piece by piece.
  - If the lid cannot be removed, the mould can be disassembled, and the separate parts can be cut loose from the plastic.

During the execution of the plate pressing process as described in the preceding list and shown in the use-video the following insights were gathered:

### Mould frame sturdiness

After multiple uses, the excess plastic that stuck to the mould after the plate had already been removed became harder to remove. As a result more force was exerted on the mould parts and because of it, some of the mould frame bolts that connect the frame parts to the baseplate were ripped through the baseplate. Next to that, on some occasions the plastic plate that was produced would stick to one of the frame edges and when it was broken off, the frame edge partly turned with it, also bending the baseplate and pulling the countersunk bolt-heads through the base plate, in this case, the plastic plate worked like a crowbar. Because of these effects, it would be wise to strengthen the frame edge connections, strengthen the baseplate itself and integrate a solution to guard against torsional forces on the frame edges.

### Mould handles

The handles deformed very quickly when they were pulled on or pushed against instead of only held for lifting. The design doesn't account for horizontal forces, which are commonly exerted on the handles during use. The same handles are also quite sharp when the mould is picked up barehanded, which is done more often than expected. However, the worst problem resulting from the current handle design is that the geometry is perfect for trapping and clinging to excess plastic that is forced out of the mould during the pressing process, see Figure 7-4.

For the mentioned reasons, the handle design should be adapted to; provide better strength in the horizontal directions, provide a comfortable grip for lifting the mould and provide a geometry that does not trap or cling to molten plastic.



Figure 7-4, Plastic stuck in mould handle - Picture by Mark Bachrach

## Cut-off edge joining

The cut-off edge fulfils its primary function very well, but the method of joining the steel strip to the frame bar is not ideal. In the current design, the steel strips are welded to the frame bars only along the top side with intermittent welds. The weld protrusions are in the way of cleaning and scraping off plastic residue, see Figure 7-5. Also, when the plastic sticks to the edges somewhat aggressively, the steel strips can be partly bent upwards when the plastic is forcefully pulled off, see Figure 7-6.

To solve these problems a new and better joining-solution has to be integrated into the improved mould design.



Figure 7-5,  
Plastic stuck on welds  
- Picture by Mark Bachrach



Figure 7-6,  
Cut-off-edge bending upwards  
- Picture by Mark Bachrach

## Sticking to the lid

The releasing solution of the mould lid should be improved since applying release agent to the lid does not work like expected. The release agent that is applied as part of the current releasing solution is theorised to either drip off or evaporate during the melting process. This would explain why the plates do come loose from the base plate and not from the lid. Polishing the steel was tried out as a solution and turned out to work very well and to be a cheap and cost-effective.

## Burned plastic

In the iterative prototyping phase, it was found out that direct heat radiation easily burns the plastic granulate (see Figure 5-6-L in Paragraph 5.4), which is unwanted. To prevent this, the side-walls were heightened and the lid was extended beyond these sidewalls. However, on this large scale, the mould and the lid deform also on a large scale when they are heated. The expansion of the steel causes the lid and the mould to curl around one of their diagonals (see Figure 7-7). When the deformations of the mould and the lid are different or around different diagonals, a large opening is created that exposes part of the granulate which is then easily burned by direct heat radiation from the oven spirals. To prevent this, a manner to connect the lid and the mould in such a way that this opening will not be created should be integrated into the

improved mould design.

## Voluminous granulate

Some granulate turned out even more voluminous than expected which created the need for even taller side walls.

## Mould's overall sturdiness

Overall, the mould should be made more sturdy to ensure a product that can last for more than five process cycles; the goal is to make it last at least 50 cycles and hopefully more. Providing that the release properties of the mould are improved also help the durability since the rough removing handlings are one of the causes that the mould suffers from fast and harsh wearing down. For example, the thin sidewalls are often completely covered by plastic that bulges out of the mould by during the pressing process. This plastic grips around the sidewalls from two sides on a vast surface area, which makes it very hard to remove when solidified.

## Extra

- Whether all of the plastic has melted can't be seen or checked during the melting process, only after pressing and cooling the result will show if all went well. A checking solution would be great although not essential.
- It is hard to see whether the pressing movement occurs level when the press is operated; this would, however, be an insightful feedback system.
- The pressing force is not fed back in any way, and the additional pressure increase by hand is halted based on gut feeling; a feedback system for the pressure would also be very useful.
- The correct positioning of the mould is not forced but requires small adjustments by hand and eyesight. Physical guides that force the mould in the right position would be handy.
- The actual pressing operation is executed by a single user, but the second operator is around for assistance with most other tasks. Because of this, it would be possible that the second operator places his hand somewhere dangerous while the first operator activates the press. It would be wise to rule this possibility out by design.
- It is easily forgotten to close one of the release valves and when this has happened this is also easily overlooked since there are no visual indications. Clear indicators that show whether the valves are closed would be a good addition. A system that prevents activation when not all valves are closed would of course be even better.

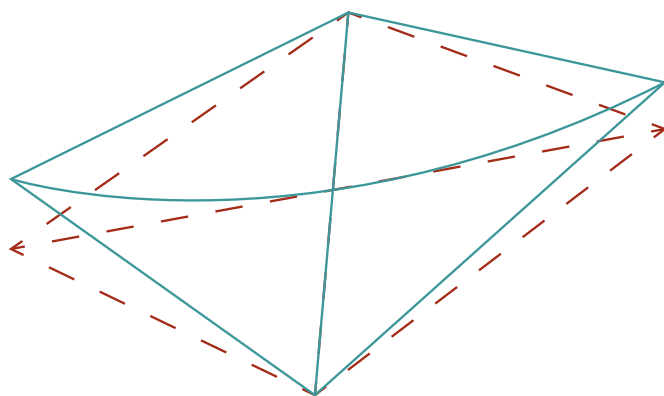

Figure 7-7, Curled up lid deformation - Figure by Mark Bachrach

## 7.3. PLATE RESULTS

To test the prototype, six plates were attempted to be pressed of which four usable results came forth. Two of the attempts failed because of power outages caused by the local power setup and the high power demand of the oven. This problem was solved by using the oven on half of its capacity. The four plates that were produced in the right way are discussed in this chapter. In the tests, three different granulates were used and in each subsequent test slight alterations were applied to the process, but in general, the process as described in the previous paragraph was upheld. In Figure 7-8 three of the plates are displayed the fourth is very similar to the third, blue, plate and is therefore not displayed separately. The plates were pressed in the order from left to right in Figure 7-8.

### First plate

A red, green and blue granulate mixture was used to press the first plate (Figure 7-8-A, D, G & J), this granulate contains not only a mixture of colours but also a mixture of plastic types, most likely PP and HDPE with different kinds of fillers. For the first plate to ever be pressed with the prototype, it was quite the achievement since a well-defined plate was produced that only had a few defects. With this first press, it was concluded that the releasing solution of the lid was not sufficient while the plate stuck to the lid very tightly. When ripping the two apart, both the lid and the plate were damaged, the damage to the plate can be seen in Figure 7-8-J. This damage is also related to the multi-material nature of the granulate, which is very likely the cause for the flaky delimitation. Also, the flakiness around the edges as seen in Figure 7-8-G is theorised to be a result of this multi-material granulate. However, besides the surface quality and sticking difficulties, the plate satisfies almost all the plate requirements that have been set in the analysis:

- The thickness variation was measured to be between 11.3 and 12.6 which complies with the +/- 1 mm thickness variation limit.
- A cut through the middle of the plate revealed only a few very small air-bubbles, that seemed to comply to the limit of 95% solidity although this is difficult to measure.
- Also, the warpage stayed within the limits that were put down, although a little warpage was in place this did not exceed half the plate thickness.

### Second plate

The second plate that was pressed was pressed from pure black HDPE granulate. This granulate consisted of machining shavings and was therefore extra voluminous. Most likely the extra volume was the cause for slower heat penetration which in turn is expected to be the cause for not wholly melting in the two hour melting time. The effects can be seen in Figure 7-8-B, E, H & K. The surface is not entirely closed and is instead interrupted by dimples, and some parts of the plate still have an un-molten flaky surface structure, see Figure 7-8-K. Nevertheless, a cut through the middle of the plate reveals an almost perfect solidity, see Figure 7-8-H. In future testing with HDPE a longer melting time should be tested, this hopefully improves the surface quality.

In the pressing-process of the black HDPE plate, one more alteration was made; the release agent on the lid was changed from Vaseline spray to silicon spray. This, however, did not

render any better releasing results. The plate still stuck to the lid very tightly and the lid was again slightly damaged when pulled off. The plate, however, did not delaminate this time since this time the single-material nature of the granulate did not provide layers to be delaminated.

### Third plate

For the third plate again a different granulate was used, this time a pure PP granulate of blue colour with a little bit of white pollution. Next to the change in material, also another change in releasing solution was made, this time, Teflon foil in the form of reusable baking foil sheets was taped to the lid. The result was terrific, although the foil was ruined after a single use. This makes the solution not usable since the foil is very expensive; 20€ of foil was used to press a single plate. Nevertheless, a beautiful plate was pressed that was almost perfect in every way. The only defect was a small patch on the bottom side of the plate that did not entirely melt and resulted in a patch where the granulate structure is still visible, see the top of Figure 7-8-F and Figure 7-8-L. This melting defect was later solved by implementing an extra process step that consists of turning the mould frontside-back halfway through the melting process, as mentioned in the previous paragraph. It turned out that the 'door'-side of the oven melts the plate less effective than the closed-off backside.

### Fourth plate

The fourth plate that was pressed turned out perfectly and proved the final lid-release-solution to be very effective. The lid was sanded to a near-polished surface smoothness with G350 sand-paper. This resulted in an easily removable lid and a very smooth surface quality.

### Conclusion

The plates that can be produced with the current design of the mould and the press can fulfil the plastic plate requirements. The possible improvements that have been identified relate to processing specifics and the ease of use. This means that the core process principle is confirmed to work sufficiently.

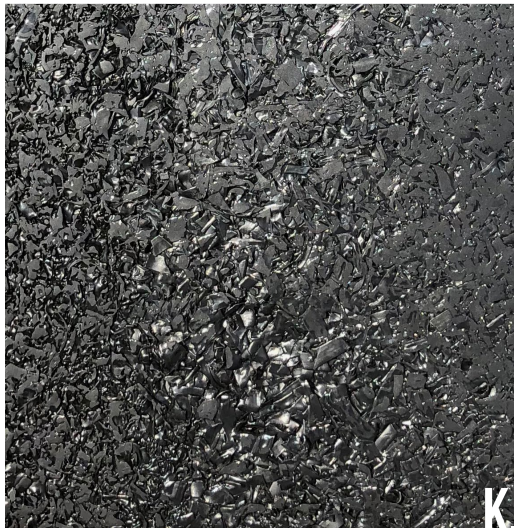
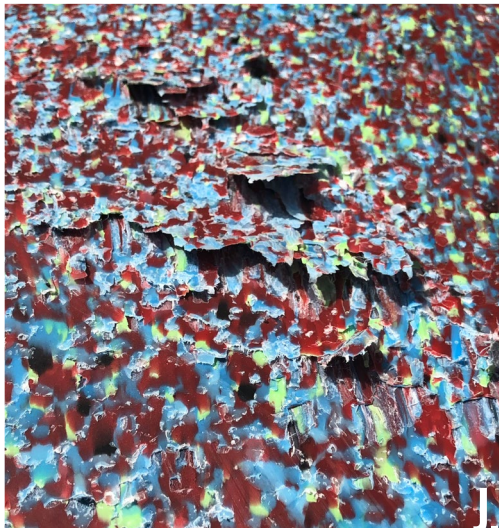
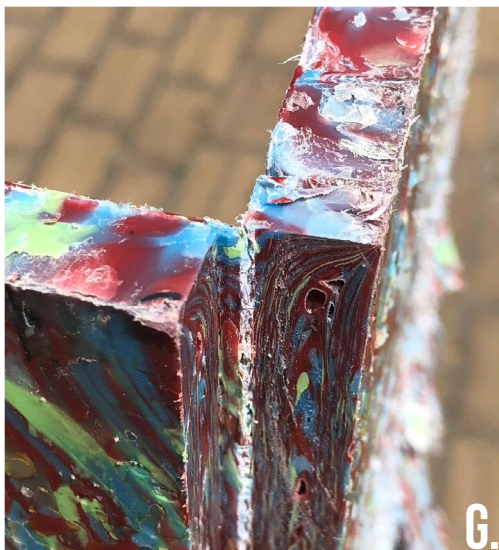
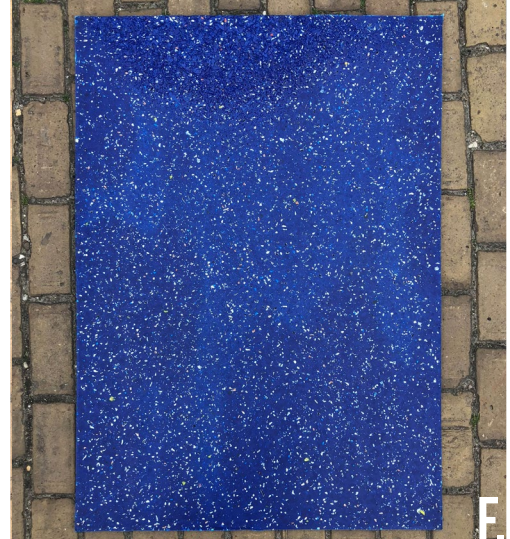
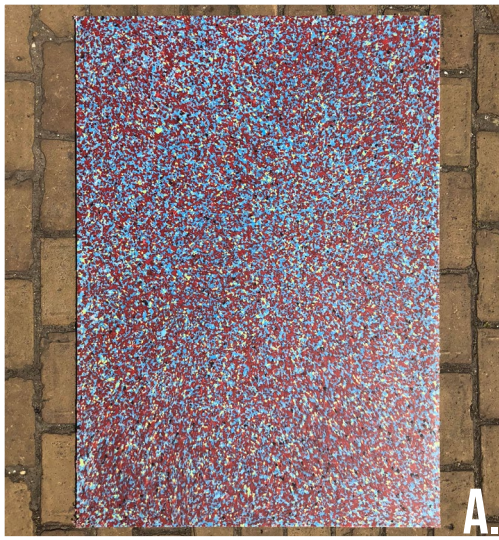

## 7.4. POR - EVALUATION

Next to the building process, use and production results, another essential evaluation measure is the compliance with the program of requirements. Each of the requirements of the POR that was presented in Paragraph 5.7 was revisited,

and it was evaluated if the prototype fulfils the requirement. Of the 63 requirements 15 requirements were not entirely met, these requirements are listed in Table 7-1 and provided with an explanation.

Do note that the requirements related to costs are left out and evaluated in one of the following paragraphs.

POR Item Nr.	Requirement	Fulfilled by prototype?	Explanation
9	The design should allow for a range of fasteners to be used and not specify one specific type and size.	Partly	Some of the bolts require a specific size others can be exchanged. It turned out that it was not realistic to apply this requirement to all fasteners.
14	The product should not allow for dangerous situations.	No	This is not realistic, but it can and should be improved.
15	The product should not be able to be used in inappropriate manners.	No	This is not a realistic requirement.
16	The product should explain its own use.	No	In hindsight this requirement should not have been included in the POR.
22	Safety should be inherent and not forced through behavioural rules.	No	This is not realistic, but it can and should be improved.
26	The product should provide 1 clear way of working that is not multi interpretable.	??	This is still unknown and could be tested in a user test.
32	The product system should allow for design adaptations that fit the system components to a user fitting work height.	Partly	This is limited by the size of the cylinders.
33	The product should be able to produce plastic plates as specified in the plastic plate requirements.	Partly	It is expected that the prototype design is scaleable to the plastic plate requirement size.
34	The system should be able to process HDPE & PP.	Partly	PP is proven to work well, HDPE needs more exploration.
36	The product should prevent plastic to grip around mould parts preventing them to be released/opened/removed.	No	The mould design should be adapted to better fulfil this requirement.
38	The plate output thickness should be adjustable by mould design/inlay.	Partly	Although not tested or proven, it is expected that this is possible within a certain range.
39	The product system should be able to produce at least 5 plates per day.	No	4 is expected to be possible when logically adding production times.
41	The systems electrical energy consumption may not exceed 10 kW.	Partly	The oven used in the current setup is rated at 12kW maximum, but is operated at half of its capacity. Either way, this depends on the oven which is part of the system but not part of the design.
53	The mould should provide enough enclosing structure to contain the amount of plastic granulate needed for a solid plate.	Partly	This strongly depends on the granulate but the enclosing structure of the mould can and should be stretched a little bit more.
57	The mould should last for at least 50 plates.	No	The current mould design is already worn down a lot while it was only used for 6 presses.

Table 7-1, POR Check - Unfulfilled requirements

## 7.5. CLIENT & EXPERT EVALUATION

As mentioned in the introduction of this chapter, two video's were created and shared to be able to show the design to external parties and to ask for feedback based on those movies. This was primarily intended to gain feedback from remote parties like Fábrica de Sabão & Leonard Schurg but also from other parties that would otherwise not have been able to witness the build or use processes. These other parties are Laura from the Better Future Factory and Tijs, who is a producibility designer at MMID. In the following, the evaluation activities are shortly discussed, and the relevant feedback is summarised.

### Fábrica de Sabão

Maybe the most important evaluation of all is the evaluation with Fábrica de Sabão who will be the first to build a plate press as designed in this project. To gather the right feedback, the discussed videos were sent to Fábrica de Sabão together with a BOM-list (as provided in Appendix A.17) and a collection of photos of the plate results and the corresponding measurements. At Fábrica de Sabão Daniela Antonio reviewed all of the media with her team, which includes their plastic expert, the sourcing manager, the machine builders and the welders. In a phone call the feedback was discussed by roughly following the following subjects:

- Feasibility of the plate production process

- Safety risk of the plate production
- Plate results
- Producibility of the parts
- Feasibility of the assembly
- Source-ability of the materials
- Design adaptation
- Production time

In general, the entire team was delighted with the results and the machine design. They were not worried at all about any safety risks and were confident that the machine could be safely operated at their facility. The plate production process was also clear to them, but they were a little bit disappointed with the production rate of 4 plates per day. However, they were suggesting to build multiple machines and thereby increase the production capacity. This turned the attention to producibility about which there were several comments. The machine builders mentioned that they would cut off all plate geometry that is intended as form fit fingers since they will have to cut all plate material by hand with grinders and longer straight cuts are therefore preferred. This means that also the narrow cut-off edge strips will be cut by hand, but they were sure that they could make precise enough cuts.

The welders also mentioned that they would make small adjustments to the parts themselves, but that this would not have to change in the design, these adjustments would relate to chamfered edges that allow for cleaner welds. Also, the adjusted cuts could stay the same in the design since they can

easily see how the format fingers can be excluded.

The sourcing manager had been able to find all of the materials or suitable replacements, but they were still weighing options for sourcing the hydraulic jacks. Also finding a suitable oven would not be a problem according to Daniela, but now that they had seen the design and the production processes, they too were planning on finding a suitable oven first and then adapt the design to the right size. The smaller adaptations, needed for slight differences in the materials, they were sure to be able to do themselves too.

Finally, the manufacturing time estimation was discussed, with the knowledge that the assembly of the prototype took just over a week, the machine builders and welders estimated that the preparation of the materials would take about a week of work for one employee and they would need another week of work for the assembly. Also, the design adaptations and material sourcing activities would add between half or one full week of work. They added that a second machine would probably be built in half the time.

Concluding,

For Fábrica de Sabão the design will suffice as it is, although it is expected that the feedback was somewhat reserved out of politeness. Therefore it is wise to interpret the suggestions more strongly; thus the straight cut lines should be indicated in the product drawings as an extra option, and all plate material should be revisited to see if they can be simplified and optimised for producibility. Also, the narrow metal strips might benefit from being cut in shorter sections.

### Better Future Factory

For the evaluation with Laura Klauss from the better Future Factory, the same media were shared, and the same topics were discussed. Only this time Laura also came to visit to see the plates and press in real life.

Laura was quite impressed with plate results and did not have much to say about the machine design. The general notion was: If it works, it works. When pressed for feedback Laura mentioned that the product could benefit from some extra finishing touches like integrating the controls somewhat better, closing off regions that don't need accessing and adding use cues or safety and instruction icons.

### Leonard Schurg

Also, Leonard was sent the video's as discussion material, and again the same feedback topics were handled. He was very pleased with the plate results that can be achieved with the prototype, and he was positive about the chances that people in low resource areas would be able to build the press according to the design as long as they are able to make

adjustments that might be forced by the available materials. However, he agreed that there was indeed room for these adaptations.

### Design evaluation

To gain extra feedback about the actual design setup, the design geometry and the producibility, one of MMID's producibility designers, Tijs, was asked to do a technical design review. Tijs was presented with the same media as the others but was also supplied with the 3D CAD model. He used 2 hours of personal time to review the design. From this review, the following sums up the most important notions:

- The Frame's bottom corner plates are over complicated and can be geometrically simplified to simplify the production.
- The cross scaffolds and top connection bars are too weak to fulfil their function and can thus be left out or should be strengthened
- The anti-buckling plates have been left out in the prototype, and it seems like they are not needed, but it might be wise to include them in the design as a precaution, especially for the jack fixtures.
- In the event that one of the bolts break under pressure and parts fly off, this could cause significant injury. Thus it is wise to block the possible line of flight to the operator or ensure that the bolts are contained in a different manner.

## 7.6. COST ESTIMATION

In the correspondence with Fábrica de Sabão about the design evaluations, it was discussed that they would provide price estimates for all the items in the BOM-lists. However, at the time of writing this has not yet happened; therefore replacement data has been sourced online. This new data, together with the process specifics and design insights, were used to produce a cost estimation for the plate press and the moulds. The full cost estimation table is presented in Appendix A.19, and below in Table 7-2, the essential results are provided.

Although the cost estimations are based on replacement data from mostly dutch sources, this estimation provides the insight that the cost requirements have not been met and are not even close. The mould is twice as expensive as was allowed and the press almost twice as expensive. From this insight two conclusions can be drawn, of which it is believed that both are relevant:

- The press design has to be adapted to lower costs
- The cost requirements were not realistic

Product	QTY	Max price by POR	Price
Mould once*	1	-	€ 55,15
Mould each**	3***	€ 100,00	€ 219,01
Press	1	€ 1200,00	€ 2102,95
Oven	1	-	€ 750,00
<b>Complete system</b>	<b>1</b>	<b>-</b>	<b>€ 3565,13</b>

Table 7-2. Cost estimation of entire plate pressing system

\*'Mould once' is used to express the costs that have to be made to start producing moulds

\*\*'Mould each' is used to express the costs that have to be made for each mould that is produced.

\*\*\*3 Moulds are included in the cost estimation because the use of three moulds facilitates the optimal series production cycle.

(See Appendix A.20 for the series production scenario from which this conclusion was drawn)

## 8. DESIGN

In this chapter, the final design improvements are discussed, and the improved design is presented. After that, the prototype confirmation of some of the upgrades is discussed, and in subsequent paragraphs also the build and use processes are explained.





Figure 8-1, Improved Plastic plate Press Design Render- Figure by Mark Bachrach

## 8.1. THE IMPROVED DESIGN

Because of time limitations at the end of this project, only a few of the most critical design improvement requests were selected from the long list that was produced in the evaluation. These improvements are all related to safety, ease of manufacturing, mould sturdiness and plastic plate release and were integrated into a new design. The design is again fitted to the available oven since a few of the improvements are also tested again with the use of functional prototypes and the oven size of Fábrika de Sabão has yet to be decided. Figure 8-4 displays a render of the improved Press design with indications for the improved features that are explained in the following summation with the corresponding numbering. Figure 8-6 displays a rendering of the improved mould design also including improvement indicators that correspond to the explanations in the summation. Furthermore, both the designs are entirely detailed in a technical drawing package that is included in Appendix A.21 and A.22.

### 1. Press upgrades (Figure 8-4)

- 1.1. 'Press Guards' are integrated that block the direct path between the 'danger zone' and the users. This way it is challenging to get burned or squashed. The press guards that are indicated by 1.1 are hinged around bolts on the side so that they can be put down when the mould is inserted and put up directly afterwards. (See Figure 8-2 for the closed configuration)
- 1.2. The 'frame corner pieces' have been geometrically adjusted to provide more straightforward manufacturing; All cutlines are reachable with a grinder, and all dimensions are expressed in straight lines and whole millimetres.
- 1.3. A bottom plate has been included that can be fabricated from the first plate productions, it is included to provide a small storage-space for plate pressing related tools.
- 1.4. The design is now standard with feet that lift it off the ground to allow access for a forklift or pump wagon. They can be sawn off if wheels are preferred.
- 1.5. A side plate is included to provide attachment geometry for the pneumatic hoses and controls, the picture shown in Figure 8-3 clarifies this. This 'Side Plate' doubles as a guard between the operator and the pressing mechanism. Again, the direct path between the possibly dangerous elements and the user is blocked. This plate can also be produced from a plastic plate produced by the machine itself.
- 1.6. The 'Press Guards' are also installed on the sides of the machine, for the same reason as the earlier mentioned ones; only these do not have to be moveable. They are displayed as partly translucent as this is the preferred but not necessary option.
- 1.7. In Figure 8-3, the pneumatic control valves are visible. It was chosen to leave the lockable valves on the air hoses of each of the jacks and put another non-lockable air pistol on the splitter as the central valve. When all valves are locked, the air pistol can be triggered to activate all pumps at once and as soon as it is released the pumps stop. This is an important safety measure, while if the central valve can also be locked, the press will keep on pressing until it reaches its maximum pressure.



Figure 8-2, Improved Design - Closed 'Press Guards' - Figure by Mark Bachrach



Figure 8-3, Improved Design - Side plate with pneumatic control placement - Picture by Mark Bachrach

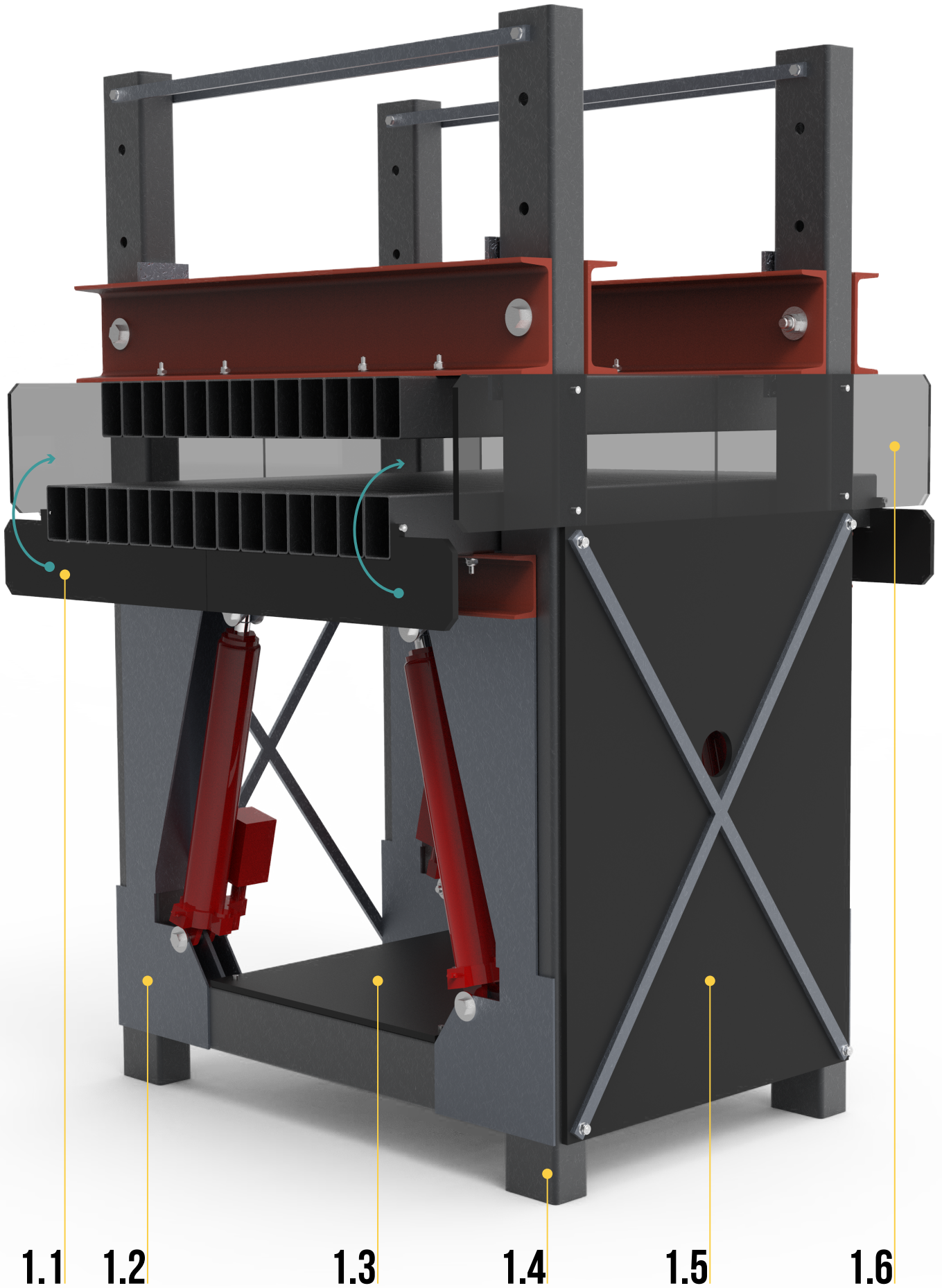

Figure 8-4, Improved Plastic Plate Press Design upgrade indications - Figure by Mark Bachrach

## 2. Mould upgrades (Figure 8-6)

- 2.1. The improved mould-lid is entirely welded together from simple sheet metal cutouts that have straightforward dimensioning. The side that touches the metal is sand polished to the required smoothness for easy releasing.
- 2.2. The sidewalls of the mould lid are all slightly tilted to provide easy detachment from the excess plastic that climbs up along the wall during the pressing process.
- 2.3. All seams are welded shut and ground sanded smooth.
- 2.4. The frame assembly is improved on sturdiness by using thicker plate metal and a wider frame-bar. The attachment to the base plate is improved by selecting a thicker plate (2mm), using larger bolts (M2.5 → M3), cutting the distance between bolts in half and alternating the bolts' width position in two rows. These improvements are also visualised in Figure 8-5. In it, it can also be seen that other bolts are removed and replaced by welds to make the production more straightforward. However most important is the improved plastic flow path that ensures the easy removal of the lid and production waste. The downside is a heavier and more expensive mould.
- 2.5. The repeating holes that are visible in the rendering are integrated to provide that the cut-off-edges can be spot welded to the frame-bars, the result needs to be ground and sanded smooth again.
- 2.6. All sharp corners of the mould are cut off to prevent by standing people and object from getting damaged.
- 2.7. The handles are replaced by simple but very sturdy grip edges that are made from standard angle sections.
- 2.8. Bolt pins are integrated that provide a manner to attach the mould and the lid to each other, this way they cannot curl apart during the melting process.

All of the detailing of these improvements is provided in the technical drawings in Appendix A.21.

### ORIGINAL

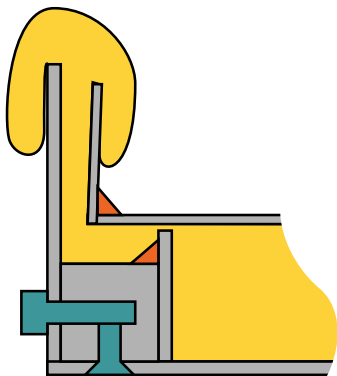

### IMPROVED

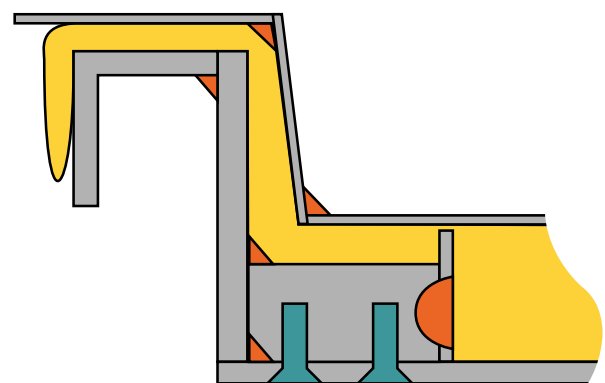

Steel part

Bolt

Weld

Plastic

Figure 8-5, Improved mould design setup comparison - Figure by Mark Bachrach

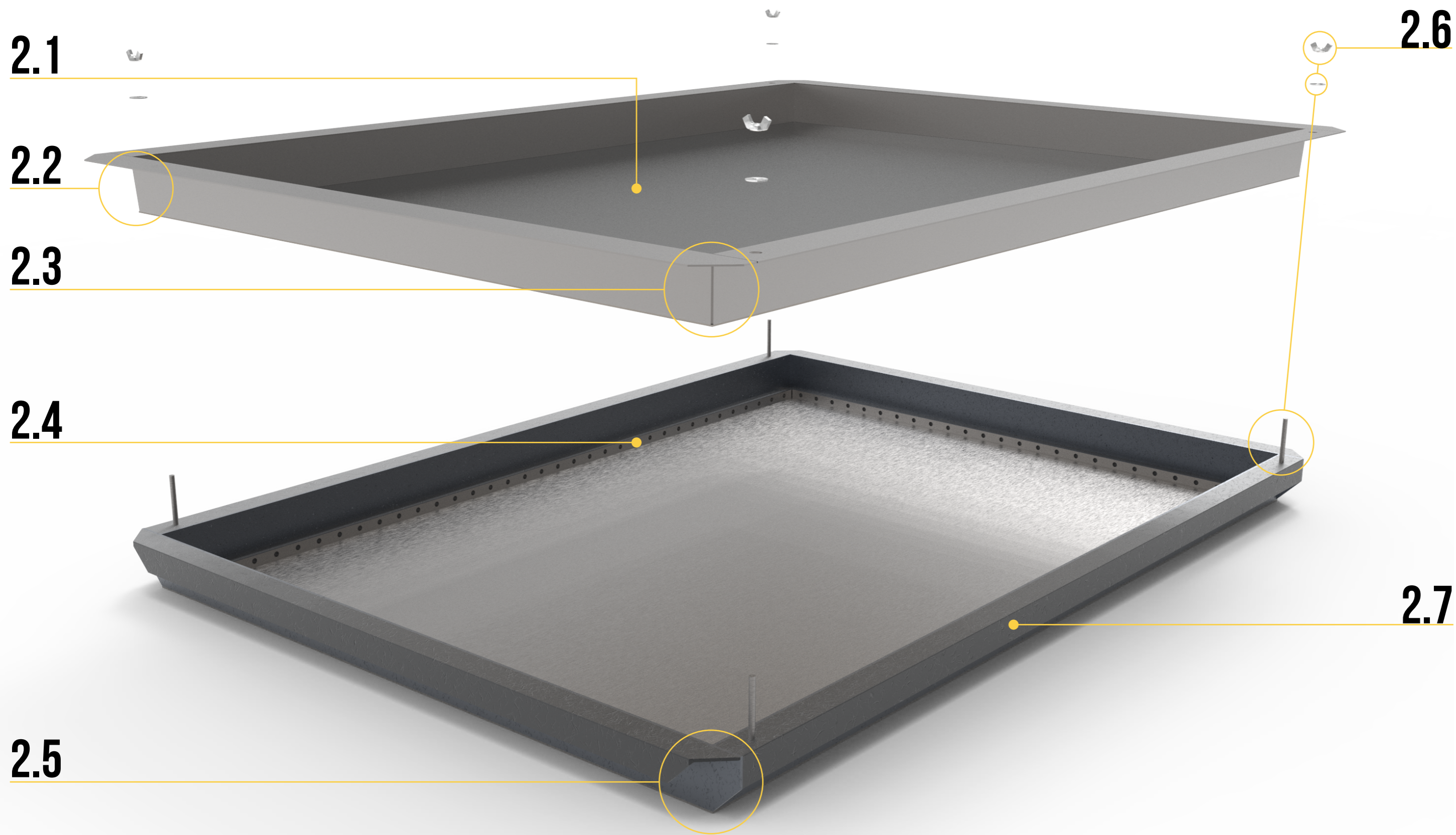

Figure 8-6, Improved mould design - Upgrade indicators - Figure by Mark Bachrach

## 8.2. DESIGN IMPROVEMENT CONFIRMATION

Most of the design improvements in for the press design are straightforward enough to be able to judge that they are improvements without physical confirmation. Therefore only the side plate and pneumatic control attachments were materialised, this was actually done before the digital design integration was made. This order was followed to find the right placement of the holes and attachment. The result was shown in Figure 8-3.

Opposed to the press improvements, the mould improvements enforce new process dynamics that needed confirmation before agreeing on them. This was done by pressing multiple plates and using the mould as intended. This provided the insight that the new mould design is indeed a vast improvement, not only are the plates easier removed, they also turn out better, with better-defined edges and even smoother surfaces. Next to that, the mould has not degraded as much as the first mould did after the same amount of use. The mould holds so well that it is expected that it will easily last for 50+ production cycles without significant maintenance.

With the new mould test, also a plate was pressed with HDPE granulate, which confirmed that this also works and renders excellent results. The central question was whether the releasing solutions were sufficient to withstand the stickiness of HDPE and it turns out that they are. Figure 8-7 displays the HDPE plate result.

Figure 8-8 displays the new mould prototype and one of the plates that was produced with it. Also, by following the link or Qr-code featured in Figure 8-9, a new video is found, showing the improved plate production process.

### PLASTIC PLATE PRESS PROCESS MOVIE



<https://youtu.be/YyfputUXCDO>

Figure 8-9, Movie QR-code - Figure by Mark Bachrach

Figure 8-8, Improved mould prototype & PP plate - Pictures by Mark Bachrach >

Figure 8-7, HDPE plate result - Pictures by Mark Bachrach v

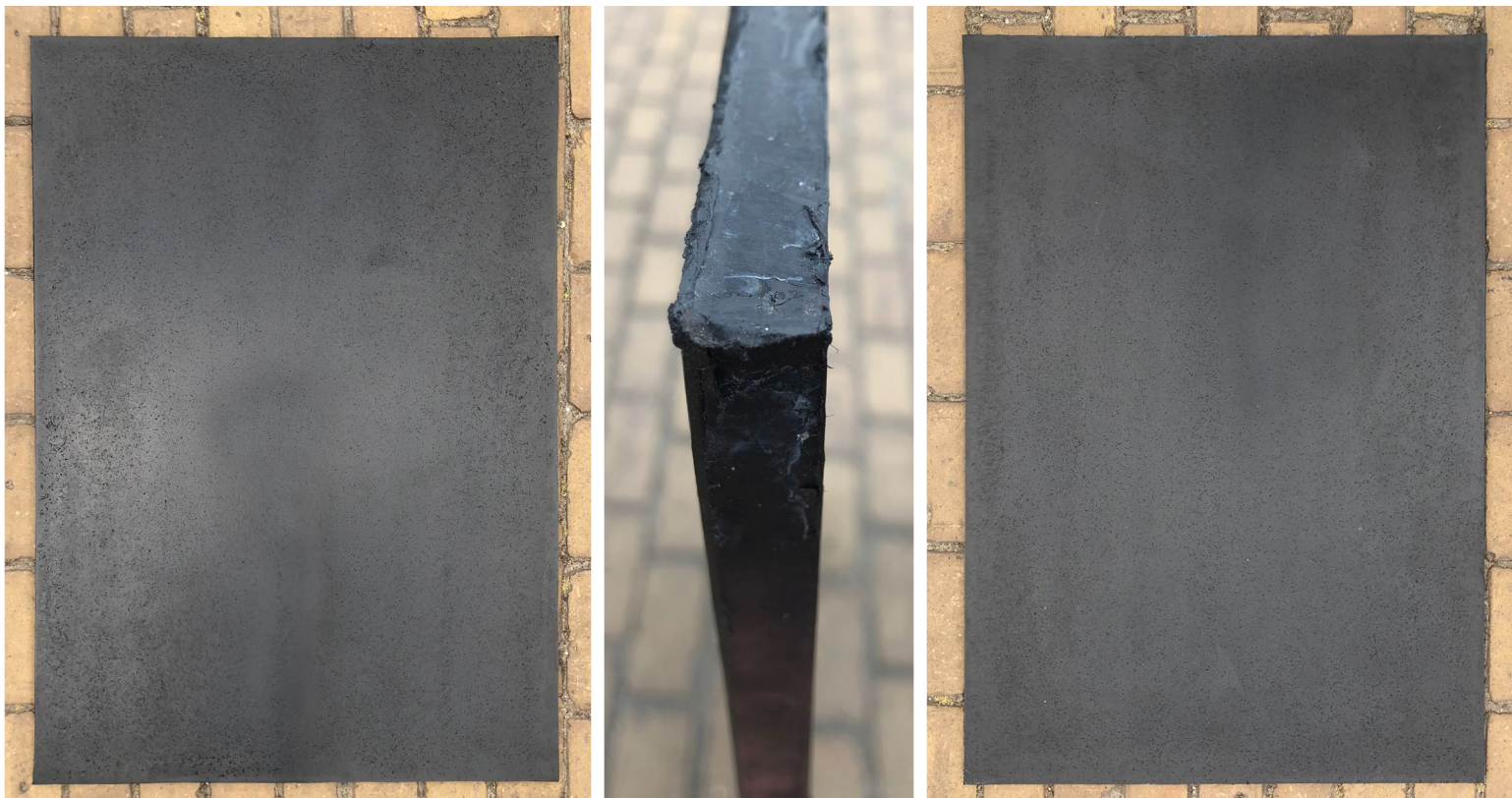

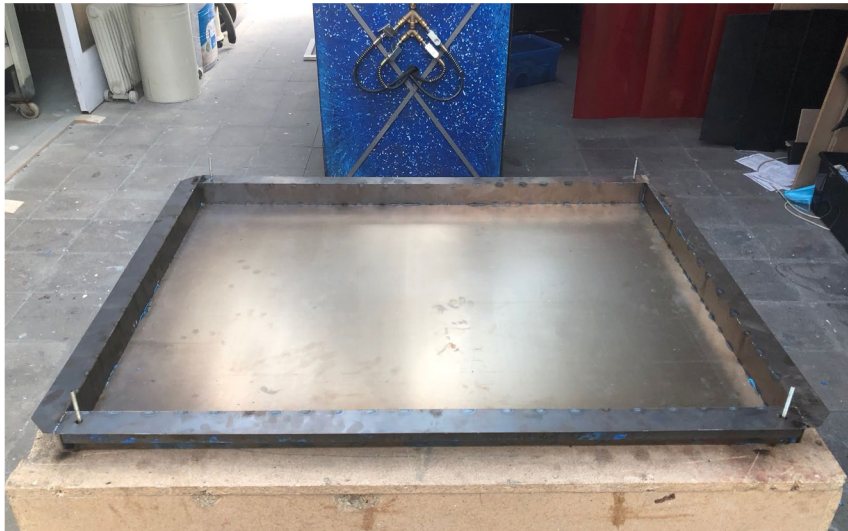
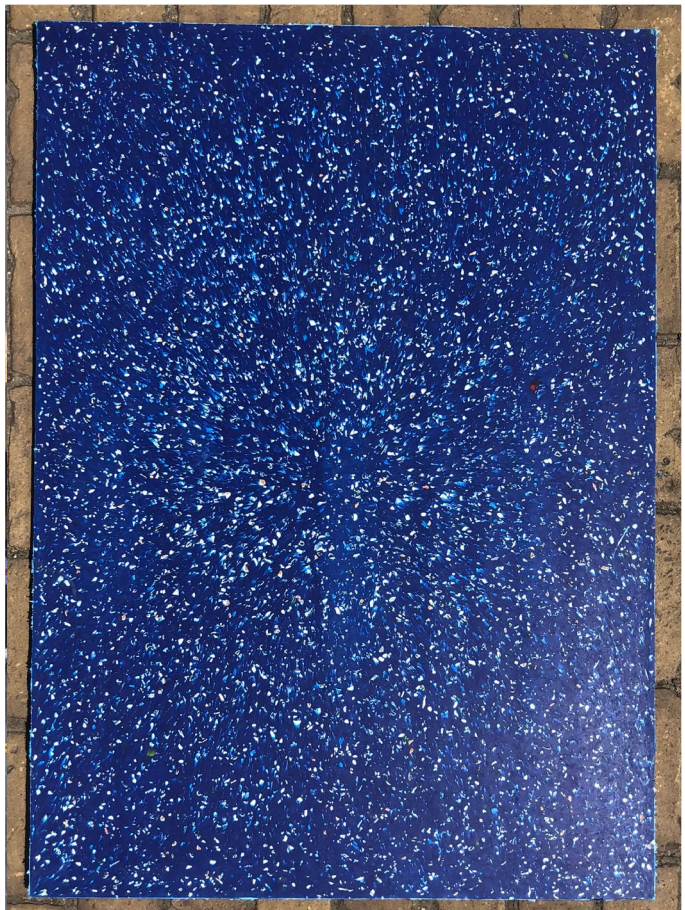
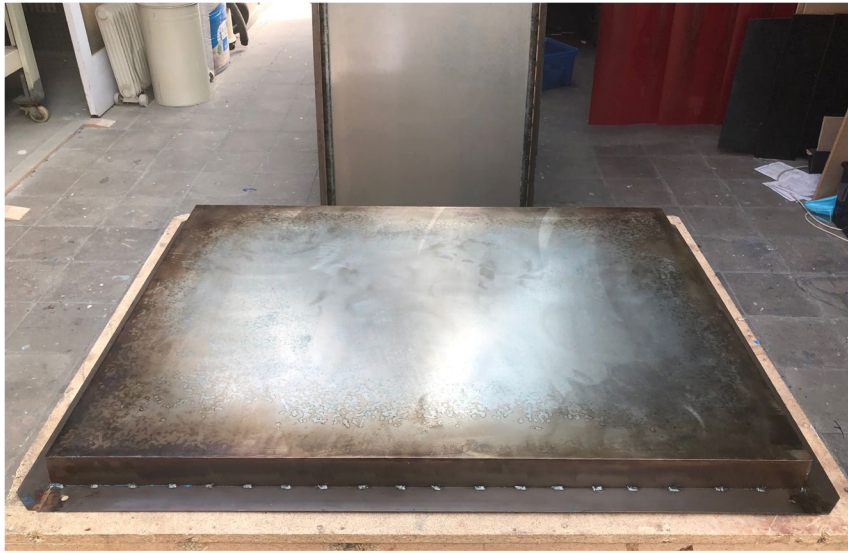
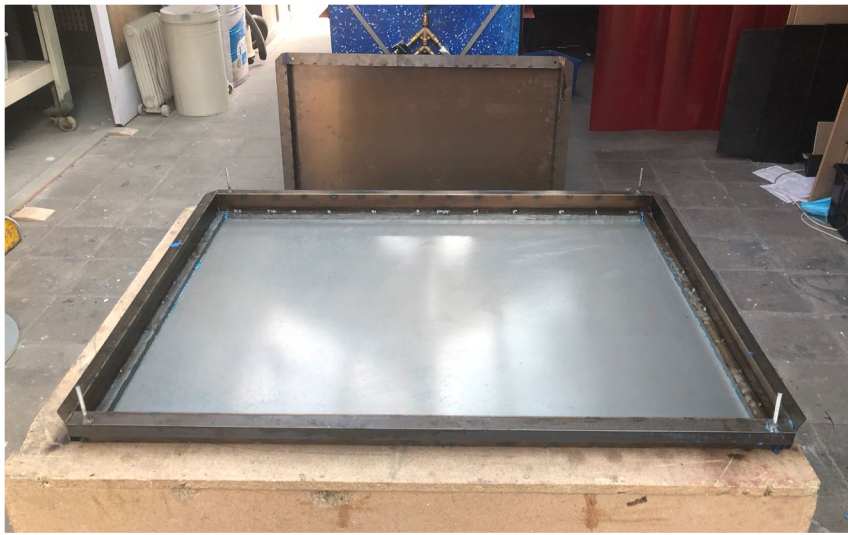

### 8.3. PLATE PRODUCTION PROCESS & COSTS

With the design that has been created a plate pressing process can be realised as shown in the video that was mentioned in the previous paragraph. However, there might still be some details that are unclear, so to sum up all essential process specifics, a process infographic was produced, which is presented in Figure 8-10.

The colours that are used refer back to the analysis in which the same colour scheme was used to indicate the process sections. Also, a value graph is integrated, which shows how the value increases during the entire process.

With the process as shown in Figure 8-10 a maximum of 4 plates can be created in a working day of 8 hours, this series

production cycle is elaborated in the series process scenario in Appendix A.20. The costs of this production cycle are summed up in Table 8-1 which also produces an estimated cost price for the plastic plates. In the cost-calculation can be seen that the mould write off makes up just over a third of the of costs. The number can be reduced if the lifespan of the mould is extended or by reducing the manufacturing price of the mould. Next in line is the write-off of the press, which can be reduced in the same way.

It has to be noted that this calculation is based on multiple variables and estimates that can strongly influence the resulting costs. For example, the lifespan of the mould has been set at 50 cycles, but this is entirely unknown and as of yet and might, in reality, be double or half.

	Unit	\$/unit	Units per plate	Cost per plate
Power	kWh	€ 0,06	6	€ 0,33
Plastic granulate	kg	€ 0,20	10	€ 2,00
Labour	hr	€ 3,00	0,5	€ 1,50
Mould write-off	Mould	€ 232,80	0,02	€ 4,66
Oven write-off	Oven	€ 750,00	0,001	€ 0,75
Press write-off	Press	€ 2102,95	0,001	€ 2,10
Maintenance	hr	€ 3,00	0,2	€ 0,60
<b>Total</b>				€ 11,94

Table 8-1, Plastic Plate COst Price Calculation

#### Values explained

kWh price is based on Bungane, 2016

Plastic granulate price is based on intel from Fábrica de Sabão.

Write-off units per plate are expressed in total lifetime cycles/1 cycle and are esteems based on gut feeling.

Maintenance is an estimate based on use experience.

Power units are estimated by the following formula:

$$\frac{12^*}{2^{**}} \cdot 2^{****}$$

\* Maximum power rating of the oven

\*\* Running the oven on half power

\*\*\* Maintaining temperature is done by switching on and of

\*\*\*\* 2 hours of use



VALUE ▶

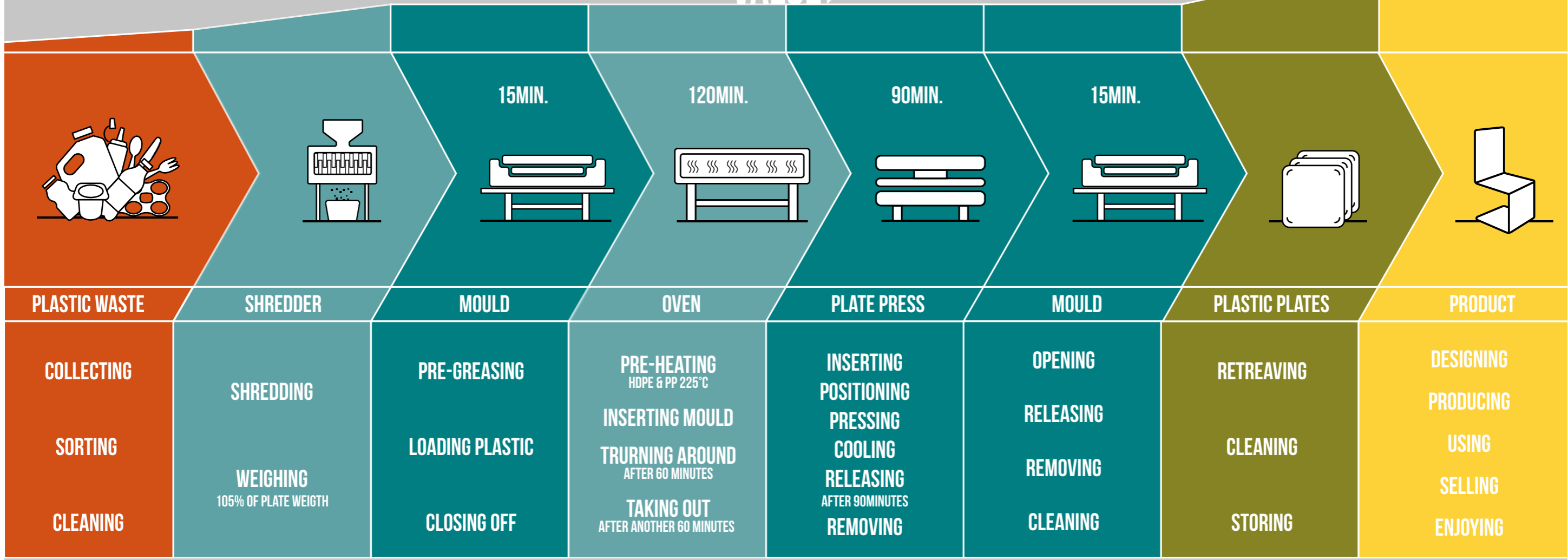

## 8.4. MACHINE BUILD PROCESS PROPOSAL

When one plans to build a plate press after the design that was produced in this project, a few essential steps have to be made to ensure a successful building process. In this paragraphs these steps are listed and explained.

- It has to be decided what the acceptable plate size range is.
  - This needs to be a range because it is unlikely that the exact size will be realised
- A suitable oven needs to be found and bought
  - This oven needs to be the at least 15 cm broader and longer than the minimum plate size that has been decided upon.
- If the plate size deviates for more than 20% from the design, the design needs to be recalculated and adapted.
  - It is expected that the design will be scaleable in length by adding U shaped frame parts and extra hydraulic cylinders while the bending allowance on the UNP-beams most likely limits the width of the design.
  - Of course, when the area size exceeds a certain limit, the pressing force requirement needs to be scaled with it.
- The source-able materials need to be inventoried, and design adaptations need to be made to compensate for any deviating materials.
- The mould design and Top-Press-bed design have to be matched for the right fitting.
- The materials can be bought, and the press can be built

The structural requirements of the press restrict the design adaptations; therefore a good understanding of the structural setup is required, and significant changes need to be thought through very well. For significant changes, the strength of the main components needs to be recalculated, and when the adapted design has been built, it has to be tested on maximum strength in a safe manner before it can be used.

Smaller design adaptation limits are provided in the materials list in appendix A.17, when possible the safe range of deviating replacement materials are provided. This list could be extended after further development.



## 8.5. PROCESS SYSTEM PART REQUIREMENTS

Besides the use and build process of the designed products, also the required additional products have to comply with specific requirements. These are listed below.

### 1. Plastic input

1.1. The Plastic input needs to be shredded to a maximum voluminosity of 5 times the massive solid state

### 2. Oven

2.1. The oven needs to be able to heat up to at least 225 °C

2.2. The oven needs to be able to operate for 8 hours in a row

2.3. The oven needs to have an oven chamber with a height of at least 12 times the plate thickness

2.4. The oven needs to have an oven chamber with a length of at least the plate length + 15 cm

2.5. The oven needs to have an oven chamber with a width of at least the plate width + 15 cm

### 3. Compressor

3.1. The compressor needs to be able to produce at least 6 bar of air pressure

3.2. The compressor needs to be able to produce at least 50 litres of air.

Figure 8-13 displays the oven that was used during this project, a second-hand pizza oven, bought for € 650

## 8.6. DESIGN CONCLUSION

With the info that was presented in this chapter, the plate press system is completed. However also a lot of improvements still have to be integrated and more design activities in the continuation of this project are crucial to the success of this project and the design. Therefore continuation recommendations are produced in the next chapter. Nevertheless, it is believed that the design shows very promising results and with the right efforts the design can bring beautiful plastic plates to life in low-resource settings all over the world.

Figure 8-12, One of the best plate results - Picture by Mark Bachrach >

Figure 8-13, The Pizza oven that was used during the project  
- Picture by Mark Bachrach v



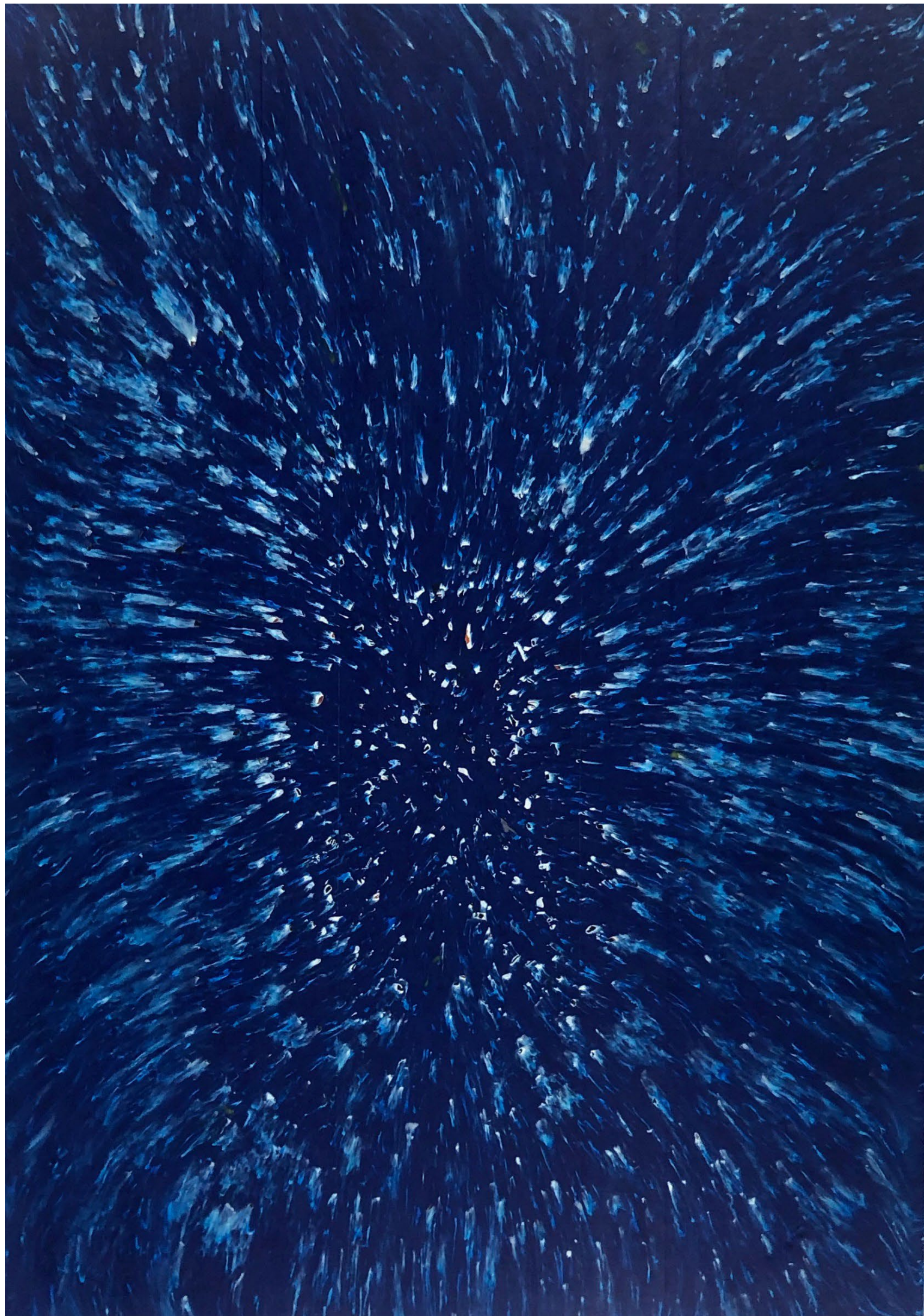



# 9. PROJECT EVALUATION

In this final chapter, the project itself is evaluated by discussing the design process and identifying the elements of the process that were elementary in defining the outcome. These process elements can be regarded as success factors or as points of improvement. Therefore the design process discussion is followed by project continuation recommendations that will discuss the most critical work that is advised to follow-up on when others continue the project. Finally, to round the project off entirely, a designer reflection is presented which discusses the personal experience of the designer in this project.

## 8.7. DESIGN PROCESS DISCUSSION

In this design process discussion, each of the design phases is discussed separately and the paragraph is concluded with a discussion about the process in general.

### Analysis

The analysis part of this project was clearly structured, and within that structure, the essential analysis topics were identified and elaborated. However, the analysis did not reach beyond the straightforward topics and questions. In general, the answers were sought for the relevant question, but no new questions were found or sought. Of course, this level of insight was sufficient for this project, but it might have been interesting to find out more and broaden the analysis with the unknown topic. The results of this path are of course unknown and whether it would have been beneficial to the project or crucial to an improved design will remain unknown.

The analysis topics that were discussed did provide relevant general and specific insights that were crucial design process that followed, and in that point of view, the analysis was successful. However, in hindsight, some topics should have been added, for example, a literature review of industrial press processes and plate production.

Also, a more detailed exploration of the requirements of different potential users would have been beneficial to the project. A better-defined user or producer in the case of the machine build, would also have been insightful since in the current setup it is still somewhat vague for whom the design is specifically intended.

The design is made for Fábrica de Sabão and where possible adapted to make broad adoption possible, but what sets Fábrica de Sabão apart from the majority is not clear enough. This also has to do with the difficulties in communication with a remote client. Again in hindsight, it would have made sense to visit Fábrica de Sabão to experience better how the facility works, what the possibilities are and to experience the work culture. Then again, the impact of this costly endeavour is and will stay unknown.

In general, the nature of the project and the mindset of the designer have been functional, technical and practical from the start of the project and this is reflected in the analysis topics and execution, which is not necessarily a bad thing.

< *Figure 9-1, Plate in mould, nicely cutout & shrunken loose*  
- Picture by Mark Bachrach

### Experimentation

In the concluding paragraph of the experimentation chapter, the most important topics of discussion have already been mentioned. However, there are a few things to add. In general, the experimentation was a great success since it produced a lot of useful insights. The discussion at the end of the chapter mentions that the conclusions are based on incidental observations which might lead to conclusions that are not true. However, the conclusions have resulted in a design that was successful in producing beautiful plastic plates thus therefore alone, the experimentation, in its executed form was a success. However, in future experimentations activities, some improvements can be implemented. The most significant improvement would be to define and document the experiment setup precisely beforehand and research what the relevant process variables are to control and which to extract. Another substantial improvement would be to standardise the visual documentation and direction of the produced samples.

With the execution of the experiments in this project, reconstructive work had to be executed afterwards to be able to compare all of the results and to provide uniform documentation.

### Conceptualisation

In general, the conceptualisation phase was experienced as a short and crammed up phase in which all of the insights had to be moulded in concept in a quick tempo. This was mostly due to a combination of big goals that were set with a deadline on short terms. The end goal of a large-scale functional prototype might have been a bit much for a project with this time span (5months, turned into 7months). This was already experienced at the start of the conceptualisation, which was therefore crammed into a short period.

At the time, the goal was also rediscussed and could have been changed. However, it was believed that it was necessary for the client and the potential builders/user that a fully developed design was produced. It was reasoned that the design would provide enough functionality to start building and producing, and from the experiences, new insights and redesigns would follow. The online community would continue the work.

This reasoning still holds and is one of the core principles of open-source sharing, however, if something is wrong with the core principle of the design, this is not as easily redesigned. Nevertheless, if the development would have been halted at a very well developed concept but without embodiment design, it would have been unlikely that potential users in low-resource settings would be able to produce an embodiment design. That is why it was chosen to keep the goal as it was and condense the conceptualisation phase.

The compact conceptualisation phase resulted in quick and dirty designing that did not leave room for a broad and surprising solution space. In turn, this has resulted in a very simple and straightforward solution and excludes the new and innovative. This sounds a bit sad, but might also be fitting the practical nature of this project.

One of the promising concepts that was almost selected as the concept to develop did have some innovative elements, but these elements also made the potential functionality

unsure. After testing the principle in a proof of concept the concept was rejected, however, with some additional effort, the concept might have proven to work very well, and this opportunity has been skipped, which might be a mistake. This and other un-explored opportunities are less likely to be explored now that a functional design is provided. This is the drawback of the path that has been chosen.

### Synthesis

In the synthesis, the different stages each have a different quality. To start off, the design research was a beneficial and necessary stage that provided just the right missing information that was needed to synthesise the design. This was a practical and robust stage, especially the iterative prototyping provided bright and straightforward solutions to elemental problems. The use of the book press and the mould development in the prototyping stage were vital elements in the synthesis of which the effects are clearly reflected in the final design. The other subjects in the design research chapter are also essential but less noteworthy. Although, it has to be noted that the decision making information for the partial solutions is a bit lacking. These decisions were carefully weighed but, not documented very well.

The embodiment phase that followed the design research was effective and practical but also closed off. It might hard to judge whether the embodiment was executed well since the process is not very well communicated. This is also hard to do since development and implementation are entwined in the modelling process.

The most important notion is that the general setup is well theorised and developed, which is also clearly communicated, but it might have been advantageous to gather external insights from experts to include into the design. Overall, the synthesis is quite straightforward, which also feels a bit simplistic and like there are still some stones left unturned.

An exceptional realisation during this phase was that the requirements that were set were malleable since the physical feasibility was leading. This meant that some requirements turned out to be wishes instead of hard requirements. For example, the goal was set to produce plastic plates of 1,22m x 1,22m, but in the end, it turned out that it was more logical to let the plate size depend on the available oven size. This way the plate size requirement turned into a wish and the oven into the limiting factor. In other cases, the ease of realising and affordability may also trump requirements. For example, the current cost estimation estimates the costs to be more than double the cost requirement. Thus, if it turns out that these costs cannot be brought down enough, either the cost or the size requirements have to be adjusted.

Lastly, one subject is utterly missing from the embodiment phase and in fact from all other phases. This is the subject of corrosion and endurance. In the project, this has not been mentioned, handled or integrated into the design but in reality is a factor that plays an important role. All of the steel that is used will start to rust, and eventually, this will probably cause the machine to fail in some way. Also, the repetitive loading and the process vibrations of the machine will, in the long run, have adverse effects on the structural integrity. Therefore, it would be wise to research these effects or at least inform potential users of the lack of knowledge about the consequences.

### Simulation

The simulation phase also has strong and weaker parts. The build and use processes of the machine were executed by the designer himself which provided a lot of useful insights that could only have been gathered in this way. Therefore this was a precious part of the simulation. It evaluated the producibility as well as the functionality of the design. However, this type of evaluation is very one-sided since all of the insights come from a single person that is already an expert on the subject and can be easily blind sighted. Of course, therefore, the external evaluations by the client and the project experts were also included in the process. However, these evaluations did not provide in-depth insights, although also very useful feedback was generated. For in-depth insights into the build and use processes, these processes need to be executed by others than the designer himself. This could have been set up for the use-process but was not done because of time limitations. However, this was indeed planned for the build process in an actual low-resource setting, at Fábrica de Sabão, but sadly this was cancelled because of organisational difficulties. Both evaluation methods will most likely produce a lot of new and valuable insight, and therefore it is very much advised to do this as soon as possible, but this will also occur naturally when the first machine is built and used by one of the open source community members.

The prototype that has been built does confirm the functionality of the prototype design, but it is questionable if it confirms that the design can be scaled up to a size that would be able to press plates of 1,22 x 1,22. This is also why the final design is produced using the dimensioning of the prototype. So it is left to the open source community to find out how scalable the design is.

Next to the scalability, at the very end of the project, some new issues with the prototype came to light. Extended testing revealed problems with the hydraulic jacks, of which one started leaking. This might be because of the out of sync movement and the vibrations during the pressing process. Therefore, it might be worth it to revisit the choice to use a single jack. With a smart redesign, this could still work, cleaning access should then be provided with a, and also the static load setup should be rethought.

Concluding, the recommendations that were produced in the simulation and evaluation phase, were very relevant, so much so, that the most important of them were redesigned and integrated into the design. These last improvement really made a difference, especially in the mould design, which was at first not acceptable and eventually became the cherry on the pie.

### General

Whether the process, in general, was a success, can be evaluated by reflecting on the design goal that was set at the start of the project:

“Design a product for maker-spaces in low-resource areas, that can transform plastic waste into qualitative plastic plate construction material, and that can be produced locally and operated by locals.”

When looking at each of the highlighted elements in the design goal, it found out that most of them have been worked



towards and have been integrated into the design as best as possible. However, the word maker-spaces feels a bit left untouched. This is not just a feeling; the entire subject has been skipped; what is a maker-space and what does it mean to design for a maker-space? Well, it is believed that most of the implications have been taken into account, but this cannot be said with certainty since the subject has not been explored. Of course, the nature of the product already implicates that it is not for home use and it is doubtful that the product will be used anywhere else than in a maker-space. It might even be so that putting the product in a space will turn it into a maker-space. Nevertheless, this subject should have been explored even if it had a minor role. Other than that, all of the highlighted elements in the design goal have adequately been included into the design, although it has not yet been confirmed that the product is indeed locally producible and operable by locals.

Next to the goal completion, the process, in general, can be judged on other levels. For instance the effectiveness of doing almost all design activities individually. Apart from the analysis in which multiple experts were consulted, the rest of the design stages did not make much use of external help. For example, including more external minds in the ideation and concept development could have enriched the solution space. Moreover, in a later stadium, more experts could have been included to acquire advice on construction solutions and force application. Also, industrial plastic processing and recycling experts could have added significant value in multiple stages. This is clear void in the process in general. However, it has to said that a lot has been accomplished in the time that was available. This amount of progress enforced a certain hurry that also explains the shortcomings of the process. Also, the concept development, small-scale testing and embodiment design stage could have benefitted from extra design time and more elaborated design cycles. But, then again, time limitations have consequences, and it is believed that for the large part, the right choices were made in selecting what to do and what to skip.

For example, it was already decided in an early stage that the optimisation of the plate production process and handling of the different materials would have to be optimised by users themselves, who will also be experimenting within the possibilities of the design. This is something that is in the nature of both open-source sharing and the work ethics of a maker-space.

As the conclusion of the entire design process, it would have been fascinating to reflect on the Influence map that was produced in the analysis and the improved it with the current knowledge. This might result in a very insightful document that would help future development. Sadly but also justifiably, this came second to integrating the design improvements that were discussed in chapter 8.

## 8.8. CONTINUATION RECOMMENDATIONS

In conclusion to the preceding paragraph, project continuation recommendations are produced in this paragraph. Foremost, it is advised to follow up on the design recommendations that were produced in the simulation and design evaluation chapter and have not yet been integrated into the improved design. In any further project continuation, it is recommended to reevaluate these recommendations and integrate the ones that are still found relevant. Next to that, the effects of repetitive loading and vibrations on the structural integrity should be researched as mentioned in the preceding and the reason for failing hydraulic jacks should be figured out.

Besides the functional improvements, a cost reduction should be realised, or maybe a smaller, budget, version of the press can be developed.

Secondly, it is advised to test the machine for an extended period and produce a lot of plastic plates, this way all the possibilities and the downsides of the machine will come to the surface. With these new insights, a new and improved version can be designed and shared. A valuable addition to this hands-on approach would be to include external parties into the testing to also test the machine on actual local producibility and user understanding. Additionally, the plate results that are produced should be tested on mechanical properties, and if needed the process and machine properties can be optimised towards producing plates with improved mechanical properties. Of course, when doing so, experts from the industry and literature on plastic and plate production techniques should be consulted.

Sharing the machine design has always been the goal of this project and thus should also happen as soon as possible, especially since it is expected that by sharing, a lot of other minds will start to evaluate and improve the design. However, before this can happen, it is advisable to execute a complete Failure Mode and Effect Analysis to make sure that there are no significant and apparent safety risks in using or producing the machine. Next to that, the build- and use-documentation need to be finalised, and a safety instructions document should be produced.

Hopefully, when the right additions have been made, and the design is shared through the right channels, many communities in low-resource settings can start producing plastic plates and will help to improve the product.

## 8.9. DESIGNER REFLECTION

In this final evaluation paragraph, I'll reflect on the project and myself as the designer from a personal point of view.

During this project, I've learned plenty of things about plastic, machine building and other project subjects, but I've also learned a lot about myself as a designer and as a person. This project was not only the first time that I had to manage and execute an entire project by my self, but it was also the first time that I worked in a professional design environment. The latter of the two was also one of the reasons that I chose to do this project since I had never done an internship. Working within the walls of the MMID Design agency has completely changed my mind about design agencies in a positive manner, which is a very welcome incidental insight.

At the start of the project, I had a hard time to find the right starting points and to make sense of the project variables. I think this had to do with my inexperience with project management and the fact that I've always been able to rely on team members to discuss these kinds of things. And also this time I needed some guidance to find the right direction. My chair, JC Diehl, helped me a great deal by advising to figure out the critical design variables and to make sense of the interrelated subject complexity. When doing precisely that, the logical starting points could easily be figured out, and I could make sense of the project. This has learned me a lot about the importance of the broad understanding of a subject and the interrelated sub-topics.

After that bottleneck, there were no more specific obstacles but my own shortcomings. One of the most noteworthy things that was a recurring problem for me was time management. I've known for a long time that planning isn't my strong suit, but during this project, I've figured out why. Time and time again I overestimate my own work capacity. Planning what to do and when to do it is not the problem, but estimating how long it will take to do a specific task, is something that I can't get right. Up until the last moment of this project, I kept on planning too many tasks in a too short of time. I think that this is partly because, during all of the design projects I've done so far, I've worked together in groups. Therefore I am used to work also being done by others, which results in the experience of faster progress. It seems like I've developed a very optimistic view on task duration, and thus I keep overestimating my capabilities. I've improved on this during the project, but I've still much to learn. The most useful things that I've learned to help my planning are setting day and week goals to guard myself against perfectionism and to be able to identify running out of schedule in early stages. Also including tasks that can be skipped when necessary can create room in a schedule that is running out.

Another shortcoming is my disliking of reading and writing. Combined with my lust for tinkering, this results in a lot of doing and testing without documenting. In the end, this came back to bite me while I had to reconstruct all documentation that was missing, and this had piled up to an immense load of work. Escaping the documentation is never an option, so it is better to do small bits in-between than everything at once at the end. This goes against my feeling that documentation keeps me from doing what is important, but I found that the right way to deal with this is to only very concisely document

the main decision together with the options that were weighed and the drivers that drove the decision. This way all crucial information is saved and when coming back to the decision, the decision can be redone with all the right info.

Another drawback of my enthusiasm for doing is that more than once I've done things before thinking about it which resulted in failing tests or unusable results. This has learned me to 'think twice and cut once' or at least it should have. Because in a later stadium this lesson had to be re-learned as 'Think twice and weld once'.

In general, I should try to more often switch the order of doing and thinking into thinking and then doing. This was again confirmed when I felt hurried to finish the embodiment design and started developing a topology optimised design structure, after two weeks of iterations I came to the conclusion that the chosen direction was not going to work and I had to start over with a new design direction. This time I started exploring simplified options before diving in deep as advised by my coach from the MMID Foundation, Scott Hoekstra. This works very well and proved that taking the time to think can save a lot of time.

Besides learning to cope with my own shortcomings, I've also learned to deal with the shortcomings of others. This mostly had to do with the communication with Fábrica de Sabão, which started off a bit difficult, eventually turned around into a well-maintained connection and at the end of the project started to lack again. Because of these fluctuations, some improvisation was required, and new ways of communicating had to be invented. For example, asking for information almost never resulted in receiving information, but asking to review information worked nearly every time.

Looking back I feel like there is more to the project than I could write in this report, which is probably due to my enthusiasm about the project. I have truly enjoyed working on this topic especially while doing all sorts of test with melting plastic and while iterating on prototypes. This is something that I am good at and find the most enjoyable thing about designing and researching and this project was perfect for exploiting that enthusiasm. In this project almost all of the things that I am committed to, were combined: Designing, Tinkering, Sustainability and Social Sustainability. I am delighted that I got the chance to work on this project and I hope that the design will go a long way



# 10. REFERENCES

- 8 ton air/hydraulic long ram - jack Set up and operating inSTRUCTIONS. (2006). 10th ed. [ebook] Harborfreight. Available at: <https://manuals.harborfreight.com/manuals/94000-94999/94562.pdf> [Accessed 13 Jun. 2018].
- alibaba.com. (2018). **8 Ton Hydraulic And Air Long Ram For Engine Hoist Shop Crane Jack - Buy Hydraulic Jack,Long Ram Jack,Long Ram Pump Product on Alibaba.com.** [online] Available at: [https://www.alibaba.com/product-detail/8-Ton-Hydraulic-and-Air-Long\\_60729875855.html?spm=a2700.galleryofferlist.normalList.132.913964eaNq1h6](https://www.alibaba.com/product-detail/8-Ton-Hydraulic-and-Air-Long_60729875855.html?spm=a2700.galleryofferlist.normalList.132.913964eaNq1h6) [Accessed 27 Jul. 2018].
- Bungane, B. (2016). **Different power tariffs among the SADC region members | ESI-Africa.com.** [online] esi-africa.com. Available at: <https://www.esi-africa.com/different-power-tariffs-in-among-the-sadc-region-members/> [Accessed 6 Jul. 2018].
- Conserve Energy Future. (2018). **Causes, Effects and Solutions of Plastic Pollution - Conserve Energy Future.** [online] Available at: <https://www.conserve-energy-future.com/causes-effects-solutions-of-plastic-pollution.php> [Accessed 27 Jul. 2018].
- Earth Eclipse. (2018). **Plastic Waste: Environmental Effects of Plastic Pollution | Earth Eclipse.** [online] Available at: <https://www.eartheclipse.com/environment/environmental-effects-plastic-pollution.html> [Accessed 27 Jul. 2018].
- engineeringtoolbox.com. (2018). **Coefficients of Linear Thermal Expansion.** [online] Available at: [https://www.engineeringtoolbox.com/linear-expansion-coefficients-d\\_95.html](https://www.engineeringtoolbox.com/linear-expansion-coefficients-d_95.html) [Accessed 27 Jul. 2018].
- Geyer, R., Jambeck, J. and Lavender Law, K. (2017). **Production, use, and fate of all plastics ever made. 1st ed.** [ebook] advances sciencemag. Available at: <http://advances.sciencemag.org/content/3/7/e1700782/tab-pdf> [Accessed 27 Jul. 2018].
- Medina M. (2010). **Solid wastes, poverty and the environment in developing country cities.** Helsinki, Finland: United Nations University, World Institute for Development Economics Research.
- Parker, L. (2017). **A Whopping 91% of Plastic Isn't Recycled.** [online] news.nationalgeographic.com. Available at: <https://news.nationalgeographic.com/2017/07/plastic-produced-recycling-waste-ocean-trash-debris-environment/> [Accessed 27 Jul. 2018].
- Plastic Pollution Coalition. (2017). **NEW Global study shows the production, use, and fate of all plastics ever made.** [online] Available at: <http://www.plasticpollutioncoalition.org/pft/2017/7/20/new-global-study-shows-the-production-use-and-fate-of-all-plastics-ever-made> [Accessed 27 Jul. 2018].
- Plastics – the Facts 2016. (2016). [ebook] PlasticsEurope. Available at: <https://www.plasticseurope.org/application/files/4315/1310/4805/plastic-the-fact-2016.pdf> [Accessed 27 Jul. 2018].
- Reubold, T. (2016). **8 maps show plastic's impact on the world's oceans – and what's being done about it.** [online] Ensia. Available at: <https://ensia.com/photos/plastics-impact-worlds-oceans-outlined-8-maps/> [Accessed 27 Jul. 2018].
- Statista. (2018). **Global plastic production | Statista.** [online] Available at: <https://www.statista.com/statistics/282732/global-production-of-plastics-since-1950/> [Accessed 27 Jul. 2018].
- The Plastic Industry. (2016). [ebook] Berlin: PlasticsEurope. Available at: <https://committee.iso.org/files/live/sites/tc61/files/The%20Plastic%20Industry%20Berlin%20Aug%202016%20-%20Copy.pdf> [Accessed 27 Jul. 2018].
- Wrap (2008). **Domestic Mixed Plastics Packaging Waste Management Options.** [online] Banbury: Wrap. Available at: <http://www.wrap.org.uk/sites/files/wrap/Mixed%20Plastic%20Final%20Report.pdf> [Accessed 27 Jul. 2018].



An aerial photograph of a forest with a white rectangular text box centered over it. The forest floor is covered in a dense layer of fallen leaves and branches, creating a complex, textured pattern. The text is centered within the white box.

Master Thesis

“A locally producible plastic plate press  
for bottom-up recycling  
in low-resource settings”

A design assignment commissioned by  
The MMID Foundation

Graduate student  
Mark Bachrach

Delft, Juli 2018

Delft University of Technology  
Faculty of Industrial Design Engineering  
Master Integrated Product design