



Delft University of Technology

Document Version

Final published version

Citation (APA)

Peschard Navarrete, R. (2023). *Brine2Beton: Recovery of Desalination Brine to Produce Mixing Water Brine and Concrete Accelerator Brine Used as Raw Materials for 3D Printable Concrete: Design Report*. [EngD thesis, Delft University of Technology]. Delft University of Technology.

Important note

To cite this publication, please use the final published version (if applicable). Please check the document version above.

Copyright

In case the licence states "Dutch Copyright Act (Article 25fa)", this publication was made available Green Open Access via the TU Delft Institutional Repository pursuant to Dutch Copyright Act (Article 25fa, the Taverne amendment). This provision does not affect copyright ownership.

Unless copyright is transferred by contract or statute, it remains with the copyright holder.

Sharing and reuse

Other than for strictly personal use, it is not permitted to download, forward or distribute the text or part of it, without the consent of the author(s) and/or copyright holder(s), unless the work is under an open content license such as Creative Commons.

Takedown policy

Please contact us and provide details if you believe this document breaches copyrights. We will remove access to the work immediately and investigate your claim.

This work is downloaded from Delft University of Technology.

Brine2Beton: Recovery of Desalination Brine to Produce Mixing Water Brine and Concrete Accelerator Brine Used as Raw Materials for 3D Printable Concrete

Engineering Doctorate

Design Report

Rogelio Peschard Navarrete

TU Delft



Brine2Beton: Recovery of Desalination Brine to Produce Mixing Water Brine and Concrete Accelerator Brine Used as Raw Materials for 3D Printable Concrete

Design Report

By

Rogelio Peschard Navarrete

in partial fulfilment of the requirements for the degree of

Engineering Doctorate
in Civil & Environmental Engineering

at the Delft University of Technology,
to be defended publicly on Wednesday December 6, 2023 at 4:00 PM.

| | | |
|-------------------|---------------------------------|-------------|
| Supervisor: | Prof. Dr. Ir. Henri Spanjers | TU Delft |
| Thesis committee: | Prof. Dr. Ir. Oguzhan Çopuroglu | TU Delft |
| | Dr. Ir. Bas Heijman | TU Delft |
| | Dr. Noura Chehab | Enowa, NEOM |

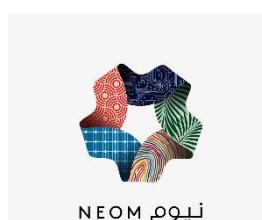

Contents

| | |
|---|------|
| Executive Summary..... | iv |
| Nomenclature..... | viii |
| List of Figures..... | ix |
| List of Tables..... | x |
| Chapter 1: Introduction and Design Brief..... | 1 |
| 1.1. Introduction..... | 1 |
| 1.2. Literature Review..... | 2 |
| 1.2.1. Concrete..... | 3 |
| 1.2.2. Desalination Brine..... | 6 |
| 1.3. Problem Analysis..... | 12 |
| 1.4. Research Contribution..... | 12 |
| 1.5. Research Objective and Questions..... | 13 |
| 1.5.1. Research Objective..... | 13 |
| 1.5.2. Research Questions..... | 13 |
| 1.5.3. Execution of Project..... | 14 |
| Chapter 2: Design of Brine Optimization Process for Producing Mixing Water Brine and Concrete Accelerator Brine | |
| 16 | |
| 2.1. Overview of the Delft Design Map..... | 16 |
| 2.1.1 Objectives..... | 17 |
| 2.2. Project Framing..... | 17 |
| 2.3. Supply Chain Imbedding..... | 18 |
| 2.3.1. Consumer Wants – Product Concept..... | 18 |
| 2.3.2. Product Concept – Property Function..... | 25 |
| 2.3.3. Input-Output structure..... | 27 |
| 2.3.4. Subprocesses allocation..... | 28 |
| 2.4. Process Technology..... | 32 |
| 2.4.1. Task Network..... | 32 |
| 2.4.2. Unit Network..... | 34 |
| 2.5. Process Engineering..... | 36 |
| 2.5.1. Process integration, equipment design and operability integration..... | 36 |
| 2.6. Final design..... | 41 |
| Chapter 3: Techno-economic evaluation..... | 43 |

| | |
|---|----|
| 3.1. Techno economic evaluation and business case objectives | 43 |
| 3.2. Methodology..... | 43 |
| 3.2.1. SuperPro Designer® model inputs, parameters, and assumptions for techno-economic evaluation..... | 43 |
| 3.2.2. Sensitivity Analysis | 45 |
| 3.2.3. Environmental impact assessment | 46 |
| 3.3. Results | 47 |
| 3.3.1. Techno-economic results and comparison of proposed designs | 47 |
| 3.3.2. Sensitivity Analysis Results..... | 50 |
| 3.3.3. Environmental Assessment Results | 56 |
| 3.4. Discussion..... | 57 |
| 3.4.1. Criteria comparison from techno-economic evaluation results | 57 |
| 3.4.2. Economic Benefits of Using Brine for the Production of 3DPC..... | 58 |
| 3.4.3. Limitations..... | 59 |
| 3.5. Conclusions | 60 |
| Chapter 4: Risk Management..... | 61 |
| 4.1. Risk Management Assessment Objectives..... | 61 |
| 4.2. Methodology..... | 61 |
| 4.2.1. Failure mode and Effect Analysis Methodology | 61 |
| 4.2.2. Boundary conditions | 62 |
| 4.2.3. Undesired events | 62 |
| 4.2.4. Modes of Failures, Effects and Root Causes | 63 |
| 4.2.5. Severity..... | 63 |
| 4.2.6. Probability of Occurrence | 63 |
| 4.2.7. Detectability | 64 |
| 4.3. Results & Discussion | 64 |
| 4.3.1. Risk Priority Number comparison for the proposed designs..... | 64 |
| 4.3.2. Actions and responsibilities | 67 |
| 4.3.3. Limitations..... | 71 |
| 4.3.4. Risk Management Recommendations | 71 |
| 4.4. Conclusions Risk Management | 72 |
| Chapter 5: Conclusions and Recommendations | 74 |
| 5.1. Conclusions | 74 |
| 5.2. Recommendations | 78 |
| References | 80 |
| Appendix | 89 |

| | |
|---|-----|
| Appendix A: CAPEX and OPEX Breakdown for Proposed Brine Optimization Designs | 89 |
| Appendix B: SuperPro Designer Economic Model Definitions and Equations..... | 92 |
| Appendix C: PRHEEQC simulation results | 96 |
| Appendix D: FMEA Table..... | 99 |
| Appendix E: List of Brines used as Concrete Accelerator Brine for the concrete printing experiments | 101 |
| Acknowledgments..... | 102 |

Executive Summary

NEOM is planning to build a desalination plant for the production of drinking water. The main disadvantage of desalination is the production of brine. Improper disposing of brine into the environment can have negative repercussions, and brine management can be complex due to its inherent characteristics. Brine treatment can be energy-intensive, and usually, the goal is to avoid producing any further waste that could be discharged into the environment.

In this study, it was proposed to utilize desalination brine as a raw material for the production of 3D printable concrete. The project was conducted in collaboration with the Materials & Environment Department at TU Delft, which was responsible for all the technical experiments related to the utilization of desalination brine for the production of 3D printable concrete. The concrete experiments served as the starting point establishing the requirements for the brine.

Two types of brines were required based on the printing setup used in the experiments. The first brine replaced mixing water where the overall concentration of ions should be relatively low, in comparison to other brines. This brine was given the name of mixing water brine (MWB). To determine the requirements for the MWB, the 3-1st RO Feed Brine from NEOM was selected based on its composition. Then, this brine was mixed at different ratios with tap water to obtain MWB with different concentrations. The different MWBs were tested to determine the impact on the material properties of concrete. The best combination resulted in a MWB consisting of 50% tap water and 50% 3-1st RO Feed Brine. This MWB composition was determined as the required one and remained constant for the rest of the concrete experiments.

The second brine required for printing was used to replace commercial concrete accelerator. One type of commercial concrete accelerator is mainly composed of a high concentration of calcium chloride. Several brines from NEOM with high concentrations of chloride and/or calcium were selected and tested to investigate their impact on the material properties of concrete. This brine was given the name of concrete accelerator brine (CAB). A total of nine different brines were utilized as CAB to assess their impact on the material properties of concrete. Based on the experimental results, the top three brines were chosen as CAB to further develop a technical design for producing the required MWB and CAB to be used in the production of 3D printable concrete at NEOM.

The Delft Design Map was implemented to develop the process designs for producing the MWB and the CAB required for the concrete. Three brine optimization processes (BOP) were developed for producing the MWB and the CAB, while also considering the technical requirements that need to be established at NEOM. The brines selected for the CAB were the monovalent brine, the mechanical vapor recompression (MVR) brine, and a mixture of 60% CaCl₂ brine from the boron clarifier and 40% CaCl₂ brine after Mg removal. The advantage of these brines was that minimal changes were required before they were used for the printing process. The brine requirements were based on the results from the concrete experiments.

The most important parameter to consider was the brine temperature. For the MWB, the temperature range proposed was between 20-30 °C, and the recommended target temperature was 25 °C. The MWB brine is mixed with cement, and temperatures higher than 30 °C could negatively impact the 3D printing process. In the case of the CAB, a temperature range of 20-40 °C was proposed, and the recommended target temperature was also 25 °C. The CAB is mixed with supplementary cementitious materials and aggregate; no cement is added. As there is no cement, the recommended temperature range is higher in comparison to the MWB. Potential problems with the printing process may arise if the temperature of both the CAB and the MWB is too high.

For the conceptual designs of the three BOP, no complex or emerging treatment technologies were required, since the brine became the raw material for the printing process, and no additional changes in the ion composition was required. The technologies implemented were technologies that are available full-scale in the industry, and they have been tested under various conditions (e.g., pumps, storage tanks, and heat exchangers). A technology readiness level (TRL) of six was allocated to the proposed BOP designs. This score was assigned because the proposed designs still need to be tested under actual conditions at NEOM with the real brine. To increase the TRL, it is advised to integrate the BOP with NEOM's desalination plant pilot, brine complex, and 3D concrete printer. This will enable validation of the design and optimization based on newly acquired data. The three proposed BOP designs should produce the brine for the printing process, while simultaneously adhering to NEOM's zero liquid discharge regulations.

The techno-economic evaluation, the environmental assessment, and the risk assessment were performed to compare the three proposed BOP solutions and further help NEOM with selecting the BOP and the brines to be coupled with the printing process in the future. For the techno-economic evaluation, the three BOPs were modelled in SuperPro Designer to estimate the costs of the project. The estimations of CAPEX and OPEX of the three designs were compared, and net present value analysis was also modelled to incorporate the impact of time on the project. The Monovalent brine BOP was the most favourable solution based on the CAPEX and OPEX. The MVR brine BOP was the most expensive solution due to the additional requirement of a heat exchanger for cooling the brine.

A profitability analysis was done to determine the minimum revenue required to make the project profitable and also to determine the potential value of the CAB and MWB. In the profitability analysis, the MWB was valued the same as drinking water, given its function as a substitution. The pricing of the CAB was treated as a variable to assess its impact on profitability when the product is sold. Additionally, the CAB replaces the function of commercial concrete accelerator, which can cost about €550-600 per ton. In the model, the selling price of the CAB was never selected to be higher than the price of commercial concrete accelerator. From the net present value, it was determined that the minimum CAB selling price required to make the Monovalent brine BOP and the Calcium Chloride brines BOP profitable was €48 /m³, and for the MVR brine BOP, it was €58 /m³. Any

selected selling price for the CAB above those values showed to make the project profitable, which can also help with selecting the market value of the brine used as a concrete accelerator for 3D printable concrete.

For the environmental assessment, a gate-to-gate life cycle assessment for the three BOPs was performed. For the assessment, it was assumed that the process would be powered by 100% renewable energy as mandated by NEOM; therefore, the emissions associated with energy consumption were assumed to be zero. For the chemical consumption, it was also estimated to be zero since no chemicals are needed in the BOPs for the production of the CAB and MWB. For the consumption of freshwater for all three BOPs, it was determined that 0.5 m³ of fresh water is required to produce 1 m³ of MWB. For the three BOPs, no solid or liquid waste is produced and discharged into the environment. Consequently, impact factors were not estimated, as the contribution from the BOPs is expected to be zero.

For the risk assessment, a failure mode and effect analysis (FMEA) were performed to identify any potential risks that can potentially impact the feasibility of using brine for 3D concrete printing. The FMEA scope concentrated on comparing the three BOPs and identifying potential undesired events that could impact the feasibility of utilizing brine for 3D printable concrete. Three undesired events were found under the proposed boundary conditions. The first undesired event was the reduced production of CAB, which could harm the economic feasibility of the project. The second undesired event was the leakage of brine leading to losing product and environmental contamination. The last undesired event was the contamination of CAB leading to negative impacts on the material properties of concrete. For all three undesired events, the root causes for the different risks were identified, and the severity, occurrence, and detectability were scored according to the FMEA methodology. To assess the risk of corrosion and scaling, the different brines were modeled in PHREEQC to calculate the saturation indices of multiple compounds, providing an initial understanding of corrosion and scaling. Subsequently, incorporating the detectability, occurrence, and severity, the risk priority numbers were calculated to identify which risks would require more attention for mitigation or preventing the undesired events.

The FMEA showed that the MVR brine BOP would pose more challenges due to the high concentrations of the various ions present that could lead to scaling or corrosion and also because this design includes an additional heat exchanger for cooling, which can be prone to fouling. However, all three BOPs have technologies that have been widely studied, and multiple options to prevent and mitigate the potential risks already exist. There was not one risk identified that could potentially impede the implementation of the recommended BOPs to produce the required brine for 3D printable concrete. However, the proposed brine optimization process still needs to be tested with the real brine to further validate the results and further minimize potential risks.

The studies demonstrated that any of the three proposed BOPs can be effectively implemented at NEOM to produce the CAB and MWB for 3D printable concrete production. Taking all results into account, the calcium chloride brines BOP is recommended as the optimal choice for producing the best CAB and MWB for 3DCP. It

is recommended to integrate the BOP with the pilot testing for the desalination plant and the 3D concrete printing process to further validate the results in this study. Furthermore, incorporating the findings from this study with the additional work at NEOM is expected to aid in identifying further potential benefits or critical bottlenecks that must be addressed before constructing a full-scale plant. Overall, the study demonstrated the successful utilization of brine in the production of 3D printable concrete.

Nomenclature

3DPC- 3D Printable Concrete

3DPC- 3D Printable Concrete

BC-Brine Concentrator

BOP-Brine Optimization Process

CAB- Concrete Accelerator Brine

COAXY-Calcium Oxychloride Compounds

C-S-H- Calcium Silicate Hydrates

DDM- Delft Design Map

ED- Electrodialysis

FC-Freeze Crystallizer

FMEA-Failure Mode and Effect Analysis

FO- Forward Osmosis

IRR- Internal Rate of Return

KSA- Kingdom of Saudi Arabia

LCA- Life Cycle Assessment

MCr-Membrane Crystallization

MD-Membrane Distillation

MED-Multi Effect Distillation

MOAXY- Magnesium Oxychloride Compounds

MSF- Multi Stage Flash

M-S-H- Magnesium Silicate Hydrates

MVR -Mechanical Vapor Recompression

MWB- Mixing Water Brine

NF- Nanofiltration

OARO-Osmotically Assisted Reverse Osmosis

PBM- Pumpable Brine Mixture

PCM- Pumpable Cementitious Mixture

PRO-Pressure Retarded Osmosis

ROI- Return of Investment

RO-Reverse Osmosis

RPN-Risk Priority Number

SCMs- Supplementary Cementitious Materials

SI-Saturation Index

WAIV- Wind-Aided Intensified Evaporation

ZLD- Zero Liquid Discharge

List of Figures

| | |
|---|----|
| Figure 1 study approach to develop the required design for optimizing the brine for 3DPC and design evaluation for design selection. The top three best brines were selected to create three process designs for the project (e.g. Design A, B, and C). | 15 |
| Figure 2 Black box diagrams showing the inputs and outputs of (a) NEOM's desalination plant, (b) NEOM's Brine Complex and (c) 3D concrete printing. | 20 |
| Figure 3 Schematic of 3D concrete printer with rheology/hydration control through the use of two different mixtures. . | 24 |
| Figure 4 Black box diagrams of brine optimization process coupled with 3D concrete printing process showing the inputs and outputs for (a) monovalent brine, (b) MVR brine, and (c) Calcium Chloride brines. | 28 |
| Figure 5 Sub-processes diagram integrating desalination brine with the 3DPC process. (a) Monovalent Brine Design. (b) MVR Brine Design. (c) Calcium Chloride Brines Design. Blue boxes represent all of the processes that need to be design and constructed at NEOM for the implementation of desalination brine with 3d printable concrete. The green and red boxes show the input and the outputs of the different subprocesses presented. The Blue dashed line shows the boundary condition for the brine optimization process..... | 29 |
| Figure 6 Task and Unit Network developed for the (a) Monovalent brine, (b) MVR Brine, and (c) the calcium chloride brines. The black boxes represent the several tasks that need to be competed to change the brine before it is sent to for printing. the Dashed green boxes show the units allocated to the different tasks. These units need to be design to complete the proposed tasks per unit..... | 33 |
| Figure 7 Dimensions for storage tank for CAB and MWB. | 36 |
| Figure 8 Flow diagram of BOP for (a) Monovalent brine design, (b) MVR brine design, and (c) Calcium Chloride brines design. | 37 |
| Figure 9 P&ID for (a) CAB monovalent brine design, (b) CAB MVR brine design, (c) CAB calcium chloride brines design and (d) MWB for all three CAB designs..... | 40 |
| Figure 10 NPV at different selling price of CAB for the proposed designs. | 48 |
| Figure 11 Project revenue at different CAB selling price for proposed designs. | 48 |
| Figure 12 CAB selling price impact on the profitability analysis for the three proposed brine designs. (a) Gross Margin, (b) Internal Rate of Return, (c) Return of Investment and (d) Payback time..... | 49 |
| Figure 13 Final cost contribution of CAB per cubic meter of concrete produced depending on the CAB selling price. | 50 |
| Figure 14 Sensitivity analysis results for (a) CAPEX and (b) OPEX. Blue bars represent the change by -25% and orange bars represent the change by +25%. | 52 |
| Figure 15 Sensitivity Analysis results for the profitability analysis. (a) Gross Margin, (b) IRR, (c) ROI and (d) Payback Time. Blue bars represent the change by -25% and orange bars represent the change by +25%..... | 53 |
| Figure 16 Sensitivity analysis results for NPV. Blue bars represent the change by -25% and orange bars represent the change by +25%. | 54 |
| Figure 17 Micro and Macrofouling, adapted from Envaqua, 2022..... | 70 |

List of Tables

| | |
|---|----|
| Table 1 Impact of major ions found in seawater and desalination brine on the hydration of cement. Table adapted from the findings of the review by Li et al., 2021. | 4 |
| Table 2 Different standard limits for water quality used in the production of unreinforced concrete. The concrete standards can have multiple values recommended depending on the country of origin of the standard. Table adapted from Reddy Babu et al., 2018. | 5 |
| Table 3 Scientific articles providing insight on the implementation and challenges of membrane based technologies used for desalination and brine treatment. | 7 |
| Table 4 Scientific articles providing insight on the implementation and challenges of thermal based technologies used for desalination and brine treatment. | 8 |
| Table 5 Scientific articles providing insight on the implementation and challenges of other technologies used for desalination and brine treatment. | 9 |
| Table 6 Scientific articles providing insights on the implementation of zero liquid discharge. | 11 |
| Table 7 Expected brine composition produced at NEOM's desalination plant. | 21 |
| Table 8 Composition of brine used as mixing water brine. | 22 |
| Table 9 Composition of brines produced at NEOM's Brine Complex. The name of the upstream source brines is referred to as the same name used at NEOM in the scheme of the Brine Complex. | 23 |
| Table 10 Brines selected from NEOM to further develop the brine production design required for 3DPC. The mixing water brine is a mixture of 50% water and 50% brine. For the concrete accelerator brine three different brines were selected and compared. | 24 |
| Table 11 Material composition of concrete with brine for the production of 3DPC. The material composition was developed at TU Delft. | 25 |
| Table 12 Proposed product specifications for the mixing water brine. Mixing water standard for unreinforced concrete and the water quality from the Netherlands and NEOM are presented as a reference baseline. | 26 |
| Table 13 Composition of brines used as CAB and commercial calcium chloride concrete accelerator for baseline comparison. | 27 |
| Table 14 Flow, temperature, and pH of brines and water used as CAB and MWB. | 34 |
| Table 15 Design labels and capacity of units. | 38 |
| Table 16 Multi-criteria for comparing technical outputs from the impact of the brine on the material properties of concrete and the technical aspects of the BOP. | 41 |
| Table 17 Parameter input for techno-economic evaluation in SuperPro Designer®. | 44 |
| Table 18 In-model SuperPro Designer factors and brines and water cost (in euros/m ³) tested for the sensitivity analysis and their respective default model value for the baseline case scenario. Additional definitions and more information on the factors can be found on appendix B. | 46 |
| Table 19 CAPEX and OPEX summary for the BOP proposed design options. | 47 |
| Table 20 Baseline case values the three brine optimization processes options. | 51 |
| Table 21 Sensitivity analysis results of the changes in production costs of water and brines for the MVR and Calcium Chloride Brines Designs. | 55 |
| Table 22 Multi-criteria comparison for the technical, economic, and environmental attributes of proposed brine optimization designs. | 57 |
| Table 23 Severity Scores for FMEA, adapted from Ben-Daya and Raouf, 1996. | 63 |
| Table 24 Occurrence score rating for FMEA, adapted from Ben-Daya and Raouf, 1996. | 63 |
| Table 25 Detectability scores rating for FMEA, adapted from Ben-Daya and Raouf, 1996. | 64 |
| Table 26 Risk Priority Number comparison for the undesired event of "reduction of CAB production" for the proposed designs. | 65 |

Table 27 Risk Priority Number comparison for the undesired event of "Brine leakage, product loss, and environmental contamination" for the proposed designs. 66

Table 28 Risk Priority Number comparison for the undesired event of "CAB and MWB contamination or change in composition" for the proposed designs..... 67

Table 29 Actions to mitigate and prevent risks. 68

Table 30 Comparison from the techno-economic evaluation and risk management assessment of proposed brine production design processes for 3D printable concrete..... 72

Table 31 Summary of multi-criteria comparison developed in the previous chapters for the final selection of the BOP to be implemented at NEOM. The specific numbers correspond to the actual value of the criteria. The criteria with no specific values were ranked with the "+" symbol. An allocation of "+++" means that the specific design ranked the best for the specific criteria. 76

Chapter 1: Introduction and Design Brief

1.1. Introduction

NEOM, a Saudi Arabian Public Investment Project, has set a vision on creating a new model of sustainable living. Currently this project is developing a new semi-autonomous region in the province of Tabuk, Saudi Arabia. Just like in any society, water will play an important role for the communities and industries at NEOM. NEOM will depend on desalination for the production of drinking water, however this means that brine will be produced. The aim of this Engineering Doctorate (EngD) project is to create a water treatment process to optimize the water quality of the desalination brine which will be used for the production of 3D printable concrete (3DPC). Several challenges will need to be addressed before implementing this new novel technique to manage desalination brine.

As we work towards sustainability, one of the most challenging problems to overcome will be water scarcity. One method to help us battle water scarcity is desalination. Recovering fresh water from the sea is now possible thanks to the innovation of several technologies, however the biggest drawback of desalination is the production of brine. Not all of the seawater is recovered as fresh water, the other fraction produced is the brine, which contains all of the constituents that were removed during the desalination process.

Due to the higher concentrations of different constituents, from salts to pollutants, improper disposal of brine poses an environmental hazard. Proper management of brine will become more and more important as the construction of desalination plants continue to increase. However, as developments continue to emerge, we have realized a potential benefit of brine. Due to the higher concentrations of different constituents, it is possible to recover resources with market value from the brine. Depending on the water quality of the brine and the technologies used, the resources that could be recovered can range from minerals, salts, metals, chemicals, and even energy. Implementing a treatment process to recover all water and resources from the brine either produced by desalination or industrial processes is known as Zero liquid Discharge (ZLD) (Muhammad Yaqub and Lee, 2019). Further developments are needed to implement ZLD, but this is an important step towards sustainability and a circular economy.

Industries are responsible for large amounts of water consumption. Virtually every industry requires water to fulfil its tasks. Concrete is the most widely construction material used, around 25 gigatons of concrete are produced per year (Petek Gursel et al., 2014). One of the main components in concrete is water, depending on the design of the concrete the water required can range around 180 to 330 kg of water per cubic meter of concrete produced (Paul et al., 2018). Additionally, cement is responsible for around 2.6 gigatons of CO₂ emissions per year (Mehta, 2010). Due to these challenges, it is of interest to create a more sustainable concrete where less CO₂ emissions are produced and reducing the amount of potable water required for the production of concrete.

Researchers have been working on developing more sustainable concrete. One of the fields that have been explored is the impact on concrete properties when other types of water are used, such as seawater and desalination brine (Gokulanathan et al., 2021). In the instance of seawater used for concrete production, one of the main disadvantages for concrete is that it cannot be reinforced with steel rebar since it can lead to corrosion to the steel reinforcements, which could lead to problems with the infrastructure integrity and safety (Gokulanathan et al., 2021). That is just one example of an issue of using seawater for concrete production, research continues to be done to try to overcome challenges like this when it comes to using non-potable water for concrete. This project will continue the conversation about using brine for the production of concrete.

The project was done in collaboration with the Materials & Environment Department at Delft University of Technology in order to overcome the several problems, such as removing unwanted constituents from the brine, before implementing desalination brine for the production of 3D printable concrete. The main objective of the project will be to use the brine for the production of 3DPC, but from a water perspective the goal will be to create a treatment scheme that optimizes the quality of the brine that will be used for the 3D printable concrete. As mentioned sustainability is an important parameter to consider, therefore the design of the proposed treatment process delivered at the end of the EngD project will be assessed to determine all of the benefits and potential limitations of using brine for 3DPC before it is implemented in the coming years as a full scale technology.

1.2. Literature Review

Both desalination and concrete production are widely studied topics where the fundamental knowledge has been established over the years. This part of the project is more focused on the

desalination/brine treatment instead of the mechanics of 3D printable concrete, therefore the approach of this literature review was to include the studies that were relevant about brine treatment. However due to the nature of the project, some literature review about concrete and the role of water in concrete was included to provide more context to the topic and define how both topics relate to each other.

1.2.1. Concrete

General overview of water quality impact on concrete material properties

Understanding the material properties of concrete is imperative to understand and define the role of brine in the production of 3DPC. Concrete is composed of water, cement, aggregate, supplementary cementitious materials, and admixtures (Neville and Brooks, 2010). Each of these constituents play an important role in the production of concrete and their interactions can easily become complicated. The role of water in concrete production is crucial, the silicates and the aluminates present in Portland cement react in the presence of water and form products of hydration. Over time these hydration products produce a firm and hard mass (Neville and Brooks, 2010). The concentration of different ions can have a different impact on the hydration of cement, therefore impacting the material properties of concrete (Li et al., 2021).

Additionally, several studies have used alternative types of water to make concrete. Using seawater for concrete production has been extensively studied in order to find an alternative to the use of potable water for concrete production (Gokulanathan et al., 2021; Li et al., 2021). The review by Li et al., (2021) clearly summarized the impacts of the most common ions found in seawater on the material properties of concrete. The ions reported to have an influence on cement hydration, microstructure, and mechanical strength of concrete, are chloride, sodium, sulfate, magnesium, calcium, and carbonate ions (Etxeberria et al., 2016; Gokulanathan et al., 2021; Li et al., 2020, 2021; Montanari et al., 2019). Table 1 summarizes some of the possible impacts the major ions found in seawater can have on the hydration of the cement. The aforementioned ions are also commonly found in seawater and desalination brine (Li et al., 2021; Panagopoulos et al., 2019). A main take away message from the review by Li, is that chloride ions dominate the hydration mechanism of concrete. Sulfates ions can also pose a negative impact on the concrete, the maximum allowable concentration of sulfate depends on the regulation but it is usually less than 1500 mg/L (Reddy Babu et al., 2018). The concentration of sulfate ions in seawater and

desalination brine can be significantly higher than the recommended limits (Li et al., 2021; Panagopoulos et al., 2019). Additionally, the presence of humic or other organic acids, which can be present in desalination brine, can be detrimental to the properties of concrete (Neville and Brooks, 2010). Table 2 shows the tolerable limits of different constituents found in water according to different standards used for the production of concrete. Therefore using seawater or desalination brine directly for the production of concrete needs to be done with caution.

Table 1 Impact of major ions found in seawater and desalination brine on the hydration of cement. Table adapted from the findings of the review by Li et al., 2021.

| Ion | Possible impacts of Ion on cement hydration |
|-----------|---|
| Chloride | <ul style="list-style-type: none"> • Formation of Friedel’s salts through the interaction with calcium-aluminate hydrates. • Formation of calcium oxychloride compounds (COAXY). COAXY formation can lead to volumetric expansion and be responsible for deterioration of mechanical properties. COAXY is mainly formed in the presence of CaCl₂ and MgCl₂ but NaCl is relatively benign in this case. • Absorption of chloride by calcium silicate hydrate (C-S-H) gels at high Ca/Si ratio <p>The aforementioned mechanisms can lead to an increase in hydration kinetics which can lead to rapid heat evolution leading to higher autogenous shrinkage, reduction of setting time, and the cement hardens faster with higher compressive strength and refined pore structure.</p> |
| Sulfate | <ul style="list-style-type: none"> • Sulfate will bind to alumina and/or C-S-H gel. As a results it can form ettringite. <p>Sulfate attack is unwanted and it can cause release of bound chloride. Sulfate can also disrupt the interactions of chloride with the hydration products.</p> |
| Carbonate | <ul style="list-style-type: none"> • When exposed to carbonation (CO₂ concentration of 20%) the chloride bound in the alumina and C-S-H gel will be released into the pore solution <p>The chloride binding ability will no longer be present in the carbonated cement.</p> |
| Sodium | <ul style="list-style-type: none"> • Unstable sodium ions can be absorbed by C-S-H by reaction with silanol groups. |

| | |
|-----------|--|
| | It is suggested that sodium has no specific interaction with the cement hydration products. |
| Magnesium | Can increase the binding capacity of chloride by the following mechanisms: <ul style="list-style-type: none"> • $Mg(OH)_2$ can precipitate and the decrease in pH can lead to the formation of magnesium silicate hydrate (M-S-H). • It can cause the formation of magnesium oxychloride compounds (MOAXY) |
| Calcium | Can increase the binding capacity of chloride by the following mechanisms: <ul style="list-style-type: none"> • The precipitation of $Ca(OH)_2$ and the decrease in pH will increase the solubility of Ca^{2+} which leads to the formation of higher CA/Si C-S-H with higher chloride content . • Can cause the formation of COAXY. • Fridel's salt will be formed when higher concentrations of calcium are present and when the cement is blended with alumina rich supplementary cementitious materials |

Table 2 Different standard limits for water quality used in the production of unreinforced concrete. The concrete standards can have multiple values recommended depending on the country of origin of the standard. Table adapted from Reddy Babu et al., 2018.

| Constituent | Tolerable Limits |
|---|-----------------------------|
| pH | 3 >5 6 6-8 7-9 |
| Total Solids (mg/L) | 50000 5000-10000 4000 |
| Suspended Solids (mg/L) | 2000 |
| Dissolved Solids (mg/L) | 50000 2000 <6000 |
| Organic Solids (mg/L) | 200 |
| Inorganic Solids (mg/L) | 3000 |
| Total Alkalinity (mgCaCO ₃ /L) | 500 1000 |
| Sodium Carbonates and Bicarbonates (mg/L) | 2000 |

| | |
|--|------------------------------------|
| Carbonate (mg/L) | 1000 |
| Bicarbonate (mg/L) | 400 |
| Sodium, Potassium, Calcium, and Magnesium (mg/L) | 2000 |
| Sulphates (mg/L) | 400 600 1000 2000 3000 |
| Chlorides for Plain Concrete (mg/L) | 360 500 2000 4500 |
| Chlorides for Reinforced Concrete (mg/L) | 500 1000 |
| Zinc (mg/L) | 100 500 600 |
| Copper (mg/L) | 500 600 |
| Lead (mg/L) | 100 500 600 |
| Manganese (mg/L) | 500 600 |
| Phosphate (mg/L) | 100 |
| Nitrates (mg/L) | 500 |
| Sugars (mg/L) | 100 |
| Turbidity (mg/L) | 2000 |
| H ₂ SO ₄ (mg/L) | 6250 |
| HCl (mg/L) | 10150 |
| Oil and Grease (mg/L) | 50 |

Using non-potable water for concrete production has been widely studied, but to the authors knowledge it the use of brine for the production of 3DPC has not been reported. From a water standpoint the biggest challenge will be to find the optimum water quality needed for the 3DPC production and determining the right treatment process to get the necessary brine water quality.

1.2.2. Desalination Brine

The greatest challenge of desalination is the management of produced brine. Brine can be difficult to treat due to the high concentration of different constituents and additionally disposing the brine into bodies of water can have negative impacts on the environment (Missimer and Maliva, 2018).

On the other hand, researchers have proven that several resources with market value can be recovered through technological applications (Zhang et al., 2021b). The following sections summarize the possible techniques to treat brine and the different types of resources that can be recovered.

Brine Treatment Technologies and Resource Recovery

Two major categories of technologies are typically implemented for brine treatment, membrane based technologies and thermal based technologies (Panagopoulos et al., 2019). Reference Table 3 summarizes the membrane based technologies and Table 4 summarizes the thermal based technologies. Other types of technologies are also being implemented as pre-treatment to treat the brine more effectively (Vanoppen et al., 2016). Reference Table 5 summarizes the other technologies that can also be implemented for brine treatment.

Table 3 Scientific articles providing insight on the implementation and challenges of membrane based technologies used for desalination and brine treatment.

| Technology | Sources |
|----------------------|--|
| Nano Filtration (NF) | (Caltran et al., 2020; Hilal et al., 2005, 2015b; Van Linden et al., 2020; Reig et al., 2016) |
| Reverse Osmosis (RO) | (Al-Najar et al., 2020; Gude, 2018; Joo and Tansel, 2015; Lattemann and Höpner, 2008; Lior and Kim, 2018; Malaeb and Ayoub, 2011; Missimer and Maliva, 2018; Muhammad Yaqub and Lee, 2019; Panagopoulos et al., 2019; Reig et al., 2016; Sathish and Jegadheeswaran, 2021; Toth, 2020; Vanoppen et al., 2016; Wachinski, 2013) |
| Forward Osmosis (FO) | (Al-Najar et al., 2020; Gude, 2018; Joo and Tansel, 2015; Lutzmiah et al., 2014; Martinetti et al., 2009; Muhammad Yaqub and Lee, 2019; Panagopoulos et al., 2019) |

| | |
|---|---|
| Membrane Distillation (MD) | (Abdel-Karim et al., 2021; Adham et al., 2013; Alkhudhiri et al., 2012; Gude, 2018; Ji et al., 2010; Kayvani Fard et al., 2016; Martinetti et al., 2009; Muhammad Yaqub and Lee, 2019; Panagopoulos et al., 2019; Sanmartino et al., 2017; Tufa et al., 2015) |
| Osmotically Assisted Reverse Osmosis (OARO) | (Al-Najar et al., 2020; Bartholomew et al., 2017; Panagopoulos et al., 2019; Peters and Hankins, 2019) |
| Pressure Retarded Osmosis (PRO) | (Helfer et al., 2014; Panagopoulos et al., 2019; Shi et al., 2021) |
| Electrodialysis (ED) | (Al-Amshawee et al., 2020; Mei and Tang, 2018; Panagopoulos et al., 2019; Reig et al., 2016; Tongwen, 2002; Tufa et al., 2015; Xu and Huang, 2008) |
| Membrane Crystallization (MCr) | (Das et al., 2021; Panagopoulos et al., 2019; Yadav et al., 2022) |

Table 4 Scientific articles providing insight on the implementation and challenges of thermal based technologies used for desalination and brine treatment.

| Technology | Sources |
|---|--|
| Multi Stage Flash Distillation (MSF) | (Lattemann and Höpner, 2008; Panagopoulos et al., 2019; Toth, 2020) |
| Brine Concentrator (BC) | (Azimibavil and Jafarian, 2021; Moharramzadeh et al., 2021; Panagopoulos et al., 2019; Rezvani Dastgerdi and Chua, 2021) |
| Multi Effect Distillation (MED) | (Alhaj et al., n.d.; Panagopoulos et al., 2019; Shahzad et al., 2014) |
| Wind-Aided Intensified Evaporation (WAIV) | (Gilron et al., 2018; Panagopoulos et al., 2019) |

| | |
|-----------------------------|---|
| Freeze Crystallization (FC) | (Lewis et al., 2010; Panagopoulos et al., 2019; Randall and Nathoo, 2015; Rane and Padiya, 2011) |
| Brine Crystallizer (BCr) | (Chen et al., 2021; von Eiff et al., 2021; Panagopoulos et al., 2019; Vassallo et al., 2021; Zhang et al., 2021a) |
| Spray Dryer (SD) | (Hamawand et al., 2017; Panagopoulos et al., 2019) |

Table 5 Scientific articles providing insight on the implementation and challenges of other technologies used for desalination and brine treatment.

| Technology | Sources |
|--------------------|--|
| Ion Exchange (IEX) | (Al Abdulgader and Rushd, 2020; Caltran et al., 2020; Gräber et al., 2021; Hilal et al., 2015a; Van Linden et al., 2020; Liu et al., 2021; Vanoppen et al., 2016; Venkatesan and Wankat, 2011) |
| Adsorption | (Al Abdulgader and Rushd, 2020; Ghenai et al., 2021; Ma et al., 2018; Mohammed et al., 2019; Qasem and Zubair, 2019; Shahzad et al., 2018; Sztékler et al., 2020) |

As indicated from the previous tables there are several technologies that can be used for brine treatment and these technologies can have different functions. They can be used for recovering permeate water, concentrating/diluting the brine, recovering solids, and removing specific constituents. The application of these technologies depends on the water quality of the influent brine and the target water quality of the effluent and also what target resources are of interest to recover. The technologies can be implemented in different combinations in order to achieve the desired goal.

Each technology offers an original advantage, but also each of them have different drawbacks. Additionally, most of these technologies tend to be energy intensive, which will be an important

factor to consider for the final design. It is imperative to define the right goals and boundary conditions for the project in order to select the best technologies to achieve the required water quality needed for the production of 3DPC. For this project recovering brine with the optimum quality for the production of 3DPC is desired, however recovering resources could provide additional assets as well.

Zero Liquid Discharge

Zero liquid discharge (ZLD) is considered a strategy for wastewater management that can reduce water contamination and enhance water supplies (Muhammad Yaqub and Lee, 2019). Zero liquid discharge defines the conditions where the treatment process needs to recover all resources and do not discharge any brine effluent or contaminants back into the environment. This can be done by creating a treatment scheme that is composed of the several technologies mentioned in the previous section. The brine quality of the influent will impact the design but also what resources can be recovered. Reference Table 6 summarizes some information on the implementation of ZLD.

Table 6 Scientific articles providing insights on the implementation of zero liquid discharge.

| Sources | Comments |
|---|---|
| (Bello et al., 2021; Cipolletta et al., 2021; Das et al., 2021; Muhammad Yaqub and Lee, 2019; Panagopoulos et al., 2019; Yadav et al., 2022; Zhang et al., 2021b) | Review articles about ZLD and resource recovery. |
| (Spanjers, 2021) | Recovering different resources from different industrial wastewaters. Different treatment schemes where ZLD approach was taken. |
| (Martínez et al., 2020) | Techno-economic evaluation of hybrid membrane system (RO, FO, and OARO) for ZLD. |
| (Panagopoulos, 2022) | Techno-economic evaluation of 5 treatment schemes using different membrane technologies. |
| (Ahmed et al., 2020) | Review on energy consumption of different desalination technologies and different treatment schemes. |
| (Sharan et al., 2021) | Super critical water desalination using high temperature heat pump. ZLD desalination. |
| (Chen et al., 2021) | ZLD with a hybrid humidifier-dehumidifier treatment system. |
| (Najafi et al., 2019) | Techno-economic evaluation of a hybrid solar-conventional energy supply in a zero liquid discharge WWTP. |
| (Azimibavil and Jafarian, 2021) | Heat transfer evaluation and techno-economic assessment of brine concentrators. |

Different approaches to implement ZLD with different treatment goals have been studied as seen from Table 6. Most of the ZLD treatment schemes are energy intensive processes which can lead

to higher costs, this is still one of the main challenges to overcome for this strategy. Additionally, some of the technologies are not mature enough for full scale implementation, more pilot scale studies are necessary to validate several technologies. Repurposing the brine for the production of 3DPC can be a new brine management strategy that could fall in line with ZLD strategies.

1.3. Problem Analysis

For the Brine2Beton project the overall goal is to incorporate brine into the production of 3D printable concrete. For the EngD project the main focus will be on the treatment technologies needed to optimize the brine quality for the production of 3DPC. The impact of different types of water on the material properties of concrete have been well studied in the past. However most of the studies concentrate on the water use as either mixing water or curing water. To the authors knowledge no studies have been published on the use of desalination brine for the production of 3D printable concrete. As mentioned in the literature review the water quality for the production of concrete is an important condition to consider. This poses the question of what is the optimum water quality of the brine that yields the best material properties for the concrete. No guidelines for water quality have been implemented for 3D printable concrete since it is still an emerging technology.

The required water quality of the brine is unknown therefore finding the right treatment scheme will also be a challenge that needs to be solved. Additionally this application creates a new opportunity to manage the brine and treat it as a resource instead of just recovering other resources from the brine (e.g. recovering $Mg(OH)_2$). Finally, since a new treatment scheme will be made for this original solution, it will be important to assess the feasibility of the design.

1.4 Research Contribution

This novel method of using desalination brine for 3DPC could provide several benefits. Firstly, it creates a new and sustainable way to manage desalination brine and to use brine directly as a resource. In the case of the concrete, the use of brine as a chemical additive can be beneficial for 3D printing because it has the potential to modify the material properties as desired and as a result it will improve the efficiency of the printing process. Additionally, brine will potentially be replacing the use of chemical additives needed for the printing process, therefore reducing the amount of materials needed.

One of the goals is to create a sustainable concrete. From a sustainability perspective the CO_2 emissions and the use of water, materials, and energy are important attributes that help determining

sustainability. Potentially less potable water would be needed since brine will be added to the concrete mixture. Potentially, less cement will be required for the mixture since the properties of concrete will be enhanced by the brine. Reducing the amount of cement can help reduce the amount of CO₂ emissions emitted by the cement.

Potentially water and materials will be used more efficiently with the solutions developed in this project. Energy is another important attribute for sustainability, the potential benefits in terms of energy are not known so it will be an important attribute to keep in mind to ensure that the contributions of the project will align with the goals of NEOM to develop more sustainable living.

1.5. Research Objective and Questions

1.5.1. Research Objective

The overall objective of the Brine2Beton project is to successfully implement desalination brine into the production of sustainable 3D printable concrete. Therefore, the outcome of this EngD research project shall be a design of a treatment process to optimize the brine quality needed for the production of sustainable 3D printable concrete. The following research questions were derived from this objective and from the literature review.

1.5.2. Research Questions

One main research question is proposed, additionally there are five sub-research questions developed to aid and find the solution to the main research question:

What is the treatment process necessary for optimizing the quality of the brine produced at the NEOM desalination plant and NEOM's brine complex, needed for the production of 3D printable concrete?

1. What is the required water quality for the production of 3D printable concrete?
2. What are brine treatment alternatives considering zero liquid discharge and resource recovery for the optimal production of 3DPC?
3. What is the environmental impact of the treatment process created for the optimization of the brine water quality?
4. How can we increase the feasibility of the implementation of 3D printable concrete with desalination brine?
5. What are the potential technical, social, economic, environmental, and safety benefits of using desalination brine for the production of 3D printable concrete?

1.5.3. Execution of Project

In total the report consists of five chapters that cover the different goals of the project. Additionally the results from the 3D printed concrete experiments were used as a basis to identify the technical requirements needed for the brine. The findings from the concrete experiments can be found on the working packages delivered to NEOM. Figure 1 shows a flowchart diagram that summarizes the execution of the project and the structure of the report :

1. Chapter 1 introduces the initial framing of the project and the relevance of recovering desalination brine for the production of 3D printable concrete.
2. Chapter 2 covers the technical requirements needed for the optimal brine for 3D printed concrete. Based on the requirements, The process design for the optimal brine production and implementation of brine for 3D printable concrete were developed. Three different design processes were created for comparison. The Delft Design Map was utilized to develop all of the brine optimization processes.
3. Chapter 3 covers a techno-economic evaluation for the three proposed brine optimization processes. The economic evaluation was used to compared the three brine optimization processes and to determine the economic feasibility of implementing the desalination brine for the production of 3D printable concrete. Additionally, an environmental assessment was conducted to determine any environmental benefits or pitfalls in the proposed brine optimization processes.
4. Chapter 4 consists of a failure mode and effects analysis (FMEA). The FMEA was conducted to identify any potential risks that could impact the feasibility and the implementation of the project. Additionally, risk mitigation actions were developed in order to prevent or reduce any risks or undesired events.
5. Chapter 5 compiles the general conclusions of the project and the overall insights obtained in the project to aid with the final selection of the brine optimization process to be implemented and coupled with the production of 3D printable concrete. Additional recommendations were developed for the future development of the project.

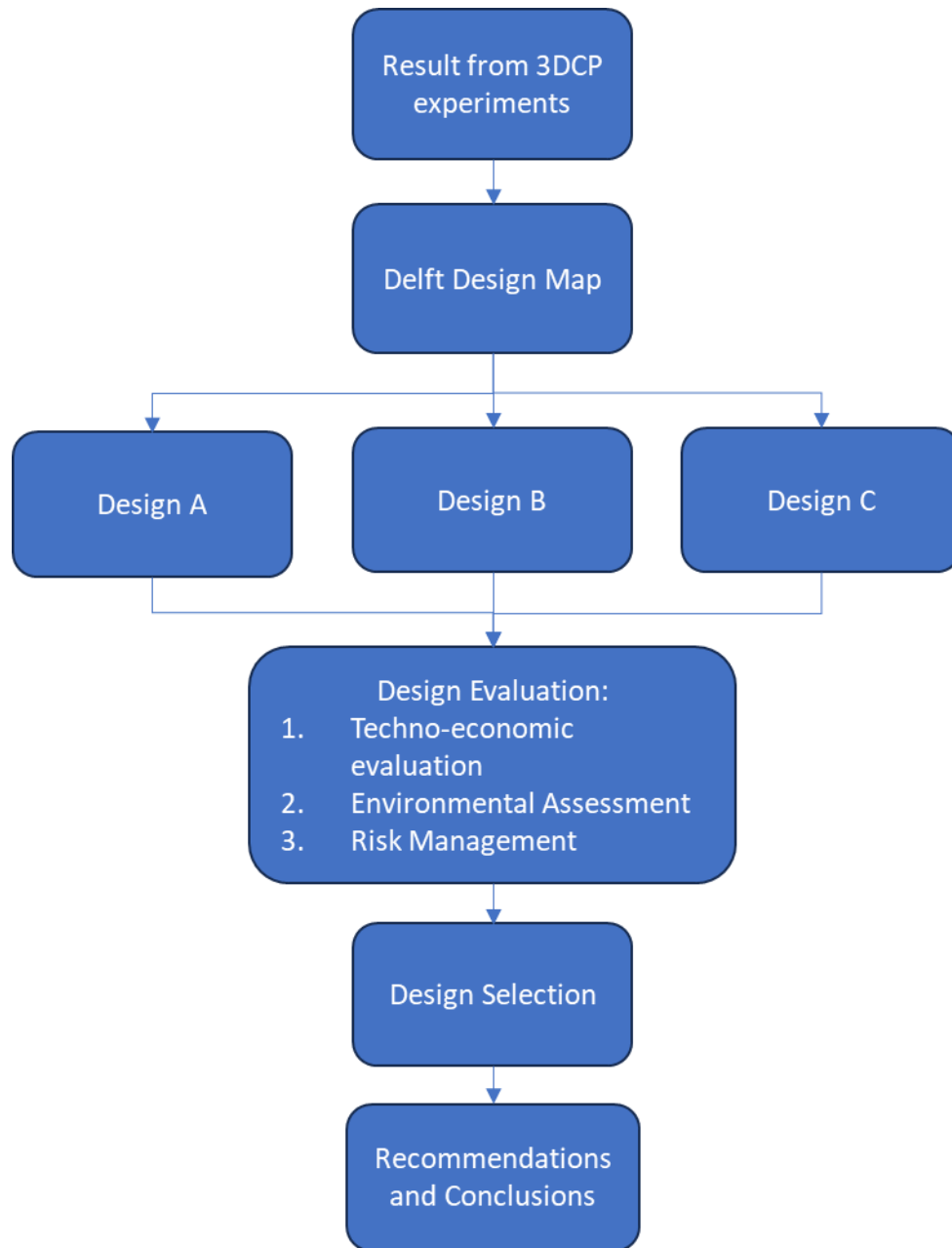

Figure 1 study approach to develop the required design for optimizing the brine for 3DPC and design evaluation for design selection. The top three best brines were selected to create three process designs for the project (e.g. Design A, B, and C).

Chapter 2: Design of Brine Optimization Process for Producing Mixing Water Brine and Concrete Accelerator Brine

2.1. Overview of the Delft Design Map

The Delft Design Map (DDM) provides a structured framework to develop multiple and complete design concepts. The DDM consists of five major parts; Framing, supply chain embedding, process technology, process engineering, and final design. For the project framing the main objective is to properly define the problem and the scope of the project and develop a project brief. For the supply chain imbedding the main objective to determine the needs of the stakeholders, define the technical specifications for the products that needs to be developed in the project and start identifying important processes along the supply chain. For process technology the main objective is to define the required tasks that need to be completed to create the product (e.g. change in temperature, reactions, mixing, etc.), then grouping those tasks into units that can be design (e.g., compounds mixing and chemical reactions can occur in the same unit), and finally is conceptualizing the units. For the process engineering the main objective to start developing different design concepts that will satisfy all of the previous needs developed in the DDM. Process engineering consists of designing the equipment, defining the operability of the design and providing the appropriate flow diagrams required. For the final design the main objective is as implied of properly selecting the best design to be further developed and constructed. The DDM structure from Harmsen et al., 2018 was implemented as the following for this chapter:

1. Project Framing:
2. Supply chain imbedding:
 - a. Customer Wants - Product Concept
 - b. Product Concept – Property Function
 - c. Input- Output structure
 - d. Sub-processes
3. Process technology:
 - a. Task Network
 - b. Unit Network
 - c. Process Integration
4. Process engineering:

- a. Equipment Design
 - b. Operability Integration
5. Final Design:

2.1.1 Objectives

The objective of this chapter is to aid with answering the following research questions:

What is the treatment process necessary for optimizing the water quality of the brine produced at the NEOM desalination plant and NEOM's brine complex, needed for the production of 3D printable concrete?

1. What is the required water quality for the production of 3D printable concrete?
2. What are brine treatment alternatives considering zero liquid discharge and resource recovery for the optimal production of 3DPC?

2.2. Project Framing

As mentioned in Chapter 1, the overall objective of the Brine2Beton projects is to use the desalination brine as a raw material for the production of 3D printable concrete. To achieve this, determining the required brine quality and composition is highly important. Once this is achieved then a proper brine optimization process (BOP) needs to be designed and developed.

The scope of this report is the development of the brine optimization process. The design specifications of NEOM's desalination plant, NEOM's brine complex and the 3D concrete printing facility are not included in this report. However, it is highly important to consider them to properly develop the brine optimization process.

Additionally, four major stakeholders were active in the development of this project. The stakeholders were ENOWA, NEOM's water and energy company who was responsible for sharing relevant information regarding the desalination plant and the brine complex. NEOM's Design and Construction team, that was responsible for sharing relevant information regarding the goals and objectives of 3D printing at NEOM. TU Delft Materials & Environment department, that was responsible for developing required technical information through experiments about 3D printable concrete with brine. Finally, TU Delft's Water Management & Environmental Engineering department, that was responsible for synthesizing all of the information provided by the other stakeholder in order to develop the design solution for NEOM, which is presented in this report.

The quality and the composition of the brine are crucial for the implementation of the brine into the concrete and it will also dictate what kind of treatment technologies will be required to change and optimize the brine for the printing process.

2.3. Supply Chain Imbedding

2.3.1. Consumer Wants – Product Concept

Project needs were identified from several stakeholder meetings along the completion of the project. An overview of important stakeholder needs are presented on the list below:

- ENOWA:
 - Develop an innovative new solution for brine management.
 - Identify how much brine will be allocated for this new brine management technique.
 - Ensure the design solution complies with the strict environmental and sustainability guidelines.
 - Determine the economic benefits of using brine for concrete and the overall profitability of the project.
- NEOM's Design & Construction team:
 - Ensure that the costs of the brine production do not harm the cost of concrete production.
 - Interested in creating more sustainable concrete and try to reduce the construction emissions.
- TU Delft Materials & Environment Department:
 - Utilize different brines for the 3DPC experiments.
 - Characterize the impact of the brine on the material properties of 3DPC.
- TU Delft Water Management & Environmental Engineering Department:
 - Increase the knowledge on relevant brine information from the desalination plant and the brine complex.
 - Water and brine technical requirements for 3DCP.
 - 3DCP experiment results to determine the required brine quality for 3DPC.

This stakeholder needs served as a starting point to further develop other project aspects like the brine product specifications presented the following sections. Additionally, understanding NEOM's desalination plant, brine complex and the 3D printing process provided further required insight for the development of the BOP.

Figure 2 shows very simple black box diagrams for the desalination plant, the brine complex and the 3D printing process. As seen in the diagram two major brines are produced at the desalination plant which then are processed in the brine complex. The goal of the brine complex is to further recover water and other resources that have commercial value. In the brine complex there are several brines that are produced which also served as a starting testing point for the 3DPC experiments. For the 3D printing the input materials are the solid raw materials (cement, aggregate, and supplementary cementitious materials (SCMs)), water, and chemical admixtures that can help modify the material properties of concrete as needed. For this project the brine replaced the mixing water and the concrete accelerator (a chemical admixture) . These diagrams shows the basic input and outputs that served as a starting point to develop the technical requirements for the BOP.

(a)

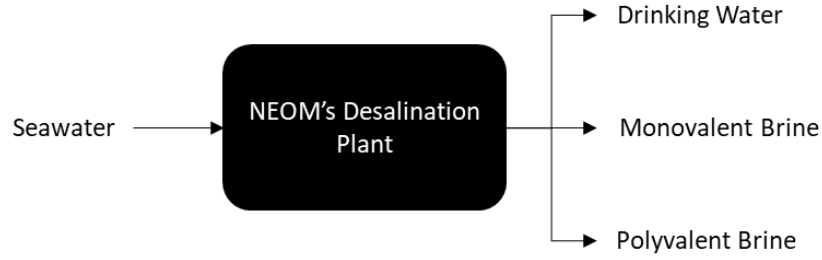

(b)

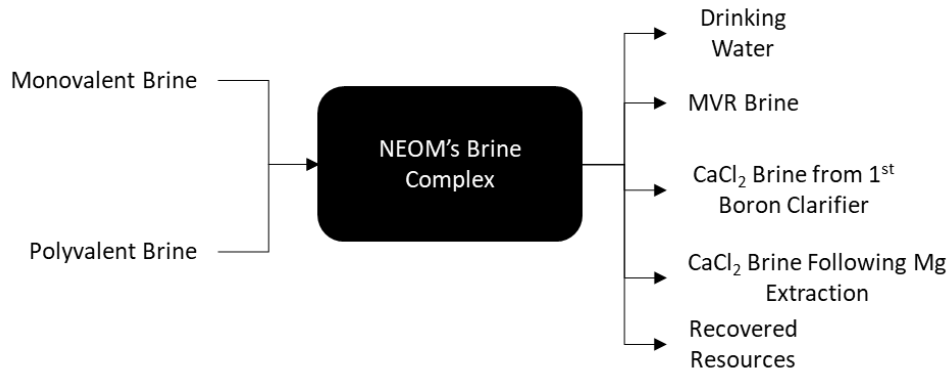

(c)

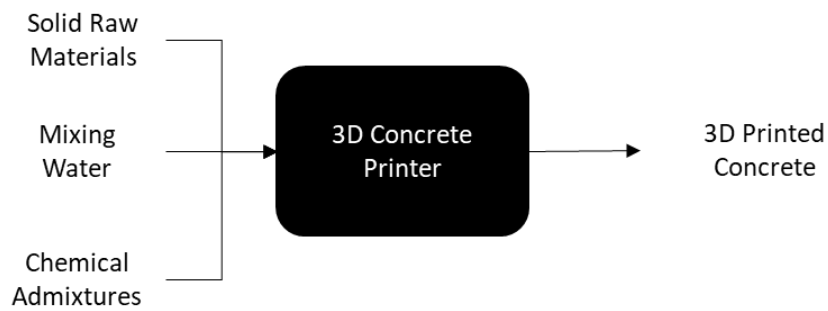

Figure 2 Black box diagrams showing the inputs and outputs of (a) NEOM's desalination plant, (b) NEOM's Brine Complex and (c) 3D concrete printing.

Brine composition from NEOM's Desalination Plant

From the desalination plant two major brines are produced; the monovalent brine and the polyvalent brine. As explained in Chapter 1 the impact of different types of water (e.g. seawater, wastewater effluent, etc.) on the material properties of concrete have been studied. Additionally, a previous study performed by the Materials & Environment Department used brine for the production of 3DPC concrete (Chen et al., 2022). Based on this the brines having high concentrations of chloride and calcium and low concentrations of magnesium and sulphate were desirable for the 3DPC experiments. Based on this initial criteria the monovalent brine was selected, while the polyvalent brine was discarded due to the high concentration of sulphate and magnesium. The monovalent brine was used as a concrete accelerator brine (CAB). Table 7 shows the composition the brines.

Table 7 Expected brine composition produced at NEOM's desalination plant.

| Constituent [mg/L] | Monovalent Brine | Polyvalent Brine |
|-------------------------------|-------------------------|-------------------------|
| NH ₄ ⁺ | 0.03 | 0.01 |
| K ⁺ | 2,126 | 791.9 |
| Na ⁺ | 40,877 | 15,030 |
| Mg ²⁺ | 433 | 12,543 |
| Ca ²⁺ | 496.7 | 3,158 |
| Sr ²⁺ | 9.1 | 60.6 |
| Ba ²⁺ | 0.05 | 0.44 |
| CO ₃ ²⁻ | 1.5 | - |
| HCO ₃ ⁻ | 46.4 | 28.9 |
| NO ₃ ⁻ | 0.03 | 0.01 |
| F ⁻ | 2.8 | 1.0 |
| Cl ⁻ | 66,946 | 42,959 |
| Br ⁻ | 223.9 | 82.8 |
| SO ₄ ²⁻ | 52.8 | 30,936 |
| PO ₄ ³⁻ | 0.03 | 0.01 |
| Boron | 14.7 | 5.8 |
| CO ₂ | 5.0 | 95.3 |
| TDS | 111,235 | 105,600 |

For the mixing water brine, it is more desired to have a lower concentration of ions in general in comparison to other brines. The Polyvalent brine was also discarded for this application, but NEOM provided the 3-1st RO Feed Brine. This was tested to replace the mixing water and further develop the specifications required for the final BOP. Table 8 shows the composition of the 3-1st RO Feed Brine.

Table 8 Composition of brine used as mixing water brine.

| Constituent (mg/L) | 3-1 st RO Feed Brine |
|-------------------------------|---------------------------------|
| NH ₄ ⁺ | 0.01 |
| K ⁺ | 751.1 |
| Na ⁺ | 14415 |
| Mg ²⁺ | 152.2 |
| Ca ²⁺ | 174.6 |
| Sr ²⁺ | 3.19 |
| Ba ²⁺ | 0.02 |
| CO ₃ ²⁻ | 0 |
| HCO ₃ ⁻ | 15.6 |
| NO ₃ ⁻ | 0.01 |
| F ⁻ | 0.99 |
| Cl ⁻ | 23607 |
| Br ⁻ | 79.1 |
| SO ₄ ²⁻ | 18.6 |
| PO ₄ ³⁻ | 0.01 |
| Boron | 5.96 |
| CO ₂ | 5 |
| TDS | 39226 |

Additional brines and composition from NEOM's Brine Complex

The monovalent and the polyvalent brines are further processes at NEOM's Brine Complex. As a result along the treatment process, the brine changes in composition and it creates new brines that can be used for 3DPC. For the concrete experiments three more brines were selected and tested. The composition of these brines are presented on Table 9. These brines were used as CAB.

Table 9 Composition of brines produced at NEOM's Brine Complex. The name of the upstream source brines is referred to as the same name used at NEOM in the scheme of the Brine Complex.

| Characteristics of Upstream Source | Concentrated Brine out of MVR | CaCl ₂ Brine From 1st Boron Clarifier | CaCl ₂ Brine Following Mg Extraction |
|---|-------------------------------|--|---|
| Likelihood of early availability | High | High | Normal |
| Flowrate at 500 MLD desal. Capacity m ³ /d | 123,191 | 2,141.9 | 11,258 |
| Density (kg/m ³) | 1.141 | TBD | TBD |
| Temperature (°C) | 70 | 35 | 50 |
| TDS (mg/L) | 252,521 | 51,555.08 | 243,058.18 |
| pH | 6.24 | 9.00 | 9.00 |
| Calcium (mg/L) | 1,128.40 | 15,472.91 | 86,086.98 |
| Chloride (mg/L) | 151,981 | 34,248.99 | 154,174.90 |
| Magnesium (mg/L) | 979.14 | 0.16 | 0.27 |
| Sulfate (mg/L) | 119.43 | 0.02 | 25.44 |
| Total Hardness (mg CaCO ₃ /L) | 6,850.01 | 19,605.90 | 214,986.39 |
| Ammonium (mg/L) | 0.00 | TBD | TBD |
| Potassium (mg/L) | 4,804.00 | 5.82 | 613.53 |
| Sodium (mg/L) | 92,777 | 74.52 | 994.39 |
| Lithium (mg/l) | 0.70 | TBD | 2.11 |
| Strontium (mg/L) | 20.56 | 0.01 | 142.26 |
| Barium (mg/L) | 0.12 | TBD | 0.06 |
| Rubidium (mg/L) | 0.51 | TBD | 1.45 |
| Bicarbonate (mg/L) | 0.00 | 0.38 | 0.03 |
| Nitrate (mg/L) | 0.00 | TBD | TBD |
| Fluoride (mg/L) | 6.31 | 0.02 | 8.72 |
| Bromide (mg/L) | 505.98 | 0.59 | 715.58 |
| Phosphate (mg/L) | 0.00 | TBD | TBD |
| Boron (mg/L) | 32.32 | 82.61 | 51.09 |
| Silicon Dioxide (mg/L) | 12.52 | 0.01 | 0.02 |

3D Concrete Printing Water and Brine Requirements

There are two functions (mixing water and concrete accelerator) for the brine that can be applied to 3D concrete printing. These functions were also derived from the printing process (Figure 3). The mixing water is used to mix with cement, aggregates and supplementary cementitious materials. The concrete accelerator is used to change the setting time of the concrete in order to increase the buildability of the 3DPC. The concrete accelerator is mixed with the SCMs and

aggregates. Mixing water and concrete accelerators are products widely used in the construction industry, the amount of water and concrete accelerator used changes from project to project.

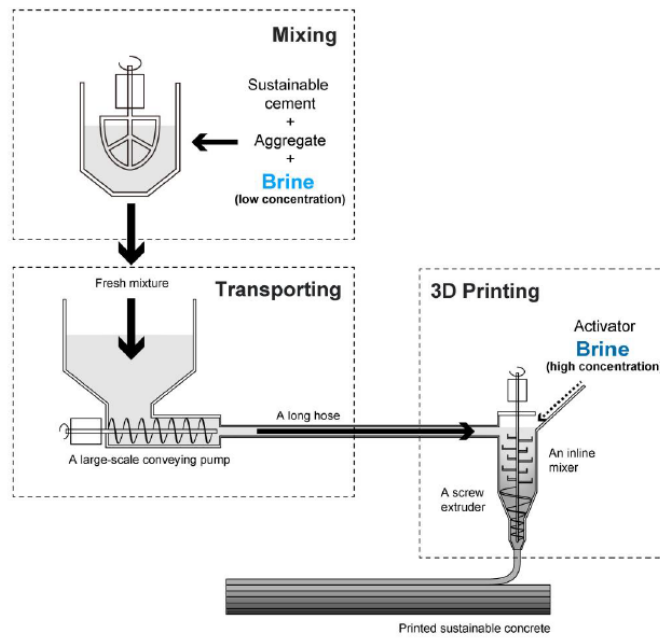

Figure 3 Schematic of 3D concrete printer with rheology/hydration control through the use of two different mixtures.

Based on the printer set-up outlined in this project (Figure 3), two different types of brines were required to replace mixing water and the concrete accelerator used in the concrete mixture. From the experimental results one brine was selected as a mixing water brine to replace drinking water, and the top three brines were selected as a concrete accelerator brine to replace the commercial concrete accelerator (Table 10).

Table 10 Brines selected from NEOM to further develop the brine production design required for 3DPC. The mixing water brine is a mixture of 50% water and 50% brine. For the concrete accelerator brine three different brines were selected and compared.

| | |
|----------------------------|--|
| Mixing Water Brine | <ul style="list-style-type: none"> • 50% 3-1st RO Brine + 50% Tap water |
| Concrete Accelerator Brine | <ul style="list-style-type: none"> • Monovalent Brine • MVR Brine • 60% CaCl₂ Brine from 1st Boron Clarifier + 40% CaCl₂ Brine Following Mg extraction |

In the case of 3D concrete printing, the brines become the valuable resources, however it is important to determine a selling price that can provide revenues for the project and that are attractive market prices for the construction industry to accept these alternative products instead of the water and commercial concrete accelerator.

Currently NEOM is expected to have a 3D concrete printing demand of approximately 250,000 cubic meters of concrete per year. Based on the concrete composition developed Table 11 and the concrete demand at NEOM, the yearly demand of 35,000 cubic meters of MWB and 37,500 cubic meters of CAB were calculated. The concrete mixture is composed of two cementitious mixtures: the pumpable brine mixture (PBM) and the pumpable cementitious mixture (PCM). The mixing ratio of PBM to PCM to make the concrete is 1:1.

Table 11 Material composition of concrete with brine for the production of 3DPC. The material composition was developed at TU Delft.

| Materials (unit: kg/m ³) | CEM I 52.5R Portland cement | Limestone | Calcined clay | Mixing water brine | Concrete accelerator brine | sand (0.125- 0.25 mm) | sand (0.25- 0.5 mm) | sand (0.5- 1 mm) | sand (1-2 mm) | Superplasticizer |
|--|--------------------------------------|-----------|------------------|--------------------------|----------------------------------|--------------------------------|------------------------------|---------------------------|---------------------|------------------|
| PCM | 500 | 167 | 334 | 280 | 0 | 280 | 520 | 180 | 20 | 7 |
| PBM | 0 | 1000 | 0 | 0 | 300 | 280 | 520 | 180 | 20 | 0 |

Three possible design solutions for producing the CAB were developed to meet the expected concrete production demand. Each of the designs are based on the three CAB presented on Table 10.

2.3.2. Product Concept – Property Function

From the 3DPC experiments the required MWB composition that worked best was a mixture of tap water and the 3-1st RO Feed Brine. The ratio of tap water to 3-1st RO Feed Brine was 1:1. Additionally, temperature experiments were performed. The experiment revealed that the material properties would be negatively impacted for the PCM if the temperature was greater than 30 °C. No potential issues for the material properties of the PCM were identified at temperatures between 20-30 °C . The recommend temperature for the MWB is 25 °C. The effect of pH on the material properties of the PCM was not tested. However, the impact of pH on concrete is well studied (Mehta and Monteiro, 2006), due to the high quantity of MWB required for the PCM it was recommended that the pH was at least 7 or higher. Table 12 summarizes the product specifications developed for the MWB. Additionally, the recommended standards for mixing water used for unreinforced concrete, the water quality from the Netherlands, and the water quality from NEOM are presented as a baseline reference.

Table 12 Proposed product specifications for the mixing water brine. Mixing water standard for unreinforced concrete and the water quality from the Netherlands and NEOM are presented as a reference baseline.

| Parameter | Unit | Mixing Water Standards (unreinforced concrete) | Water Evides Netherlands | Water NEOM | 3-1 st RO Feed Brine | Mixing Water Brine (Target) |
|-------------|-------------------|--|--------------------------|------------|---------------------------------|-----------------------------|
| Dosage | kg/m ³ | N/A | 70 | 70 | 70 | 280 |
| Potassium | mg/L | 2000 | N/A | N/A | 751.1 | 375.55 |
| Sodium | mg/L | 2000 | 32 | 200 | 14415 | 7207 |
| Magnesium | mg/L | 2000 | 6.9 | 0 | 152.2 | 76.1 |
| Calcium | mg/L | 2000 | 45 | 120 | 174.6 | 87.3 |
| Bicarbonate | mg/L | 2000 | 120 | N/A | 15.6 | 7.8 |
| Chloride | mg/L | 360-4500 | 47 | 250 | 23607 | 11803 |
| Bromine | mg/L | N/A | N/A | N/A | 79.1 | 39.55 |
| Sulphate | mg/L | 400-3000 | 43 | 250 | 18.6 | 9.3 |
| TDS | mg/L | <50000 | N/A | N/A | 39226 | 19613 |
| Temperature | °C | N/A | 13.5 | 25 | ~25 | ~25 |
| pH | N/A | 6-9 | 7.97 | 6.5-8.5 | ~7.46 | ~7 |

For the CAB used in the PBM, a total of nine brines were tested in the 3DPC experiments (the complete list of concrete accelerator brines can be found on Appendix E). Several brines worked efficiently as a CAB for the production of 3DPC, but the top three were selected. Based on the selected brine different designs for the BOP were developed, which is further explained in the following section. Just like the PCM, the impact of brine temperature was studied to look at the impact on the material properties of the PBM. For the PBM the temperature had less of an impact on the material properties because there is no cement present on the PBM. A brine with temperature range between 20-40 °C was acceptable for the PBM. The recommended temperature was also selected to be 25 °C. For the pH it is also recommended to be at least 7 or higher. Table 13 shows the composition of the different brines selected as CAB for the PBM. Additionally, the composition of commercial calcium chloride concrete accelerator is presented as a baseline reference.

Table 13 Composition of brines used as CAB and commercial calcium chloride concrete accelerator for baseline comparison.

| Parameter | Units | Market concrete accelerators | MVR Brine | CaCl ₂ Brine | Monovalent Brine |
|---|-------|------------------------------------|--------------------------------|-------------------------------|-------------------------------|
| Dosage | N/A | 10-20 mL/kg cementitious materials | 300 kg/m ³ concrete | 300kg/m ³ concrete | 300kg/m ³ concrete |
| Concentration CaCl ₂ | % | ~30% | 0.41% | 10.5% | 0.18% |
| Total Cl concentration | % | <25% | 15.19% | 10.08% | 6.69% |
| Total Ca concentration | % | ~8.18% | 0.11% | 5.65% | 0.05% |
| Total Na concentration | % | 0 | 9.28% | 0.05% | 4.09% |
| Total Mg concentration | % | 0 | 0.10% | 0% | 0.04% |
| Total SO ₄ ²⁻ concentration | % | 0 | 0.012% | 0% | 0.005% |
| Total Alkalinity concentration | % | 1.5% | 0% | 0% | 0.005% |
| Total Organics concentration | % | 0% | TBD | TBD | TBD |
| pH | N/A | 5 to 8 | 8.0 | ~9-10 | ~7.5 |
| Target Temperature Range | °C | >5 | 20-40 | 20-40 | 20-40 |
| Physical state | N/A | Liquid solution | Liquid solution | Liquid solution | Liquid solution |

2.3.3. Input-Output structure

In the context of the project the mixing water and the commercial concrete accelerator will be replaced by different brines. As mentioned by the product specifications developed and the results from the concrete experiments, three brines worked the best as concrete accelerator. Figure 4 shows the Input -Output structure for the brine optimization process coupled with the 3D printing process.

(a) Monovalent Brine

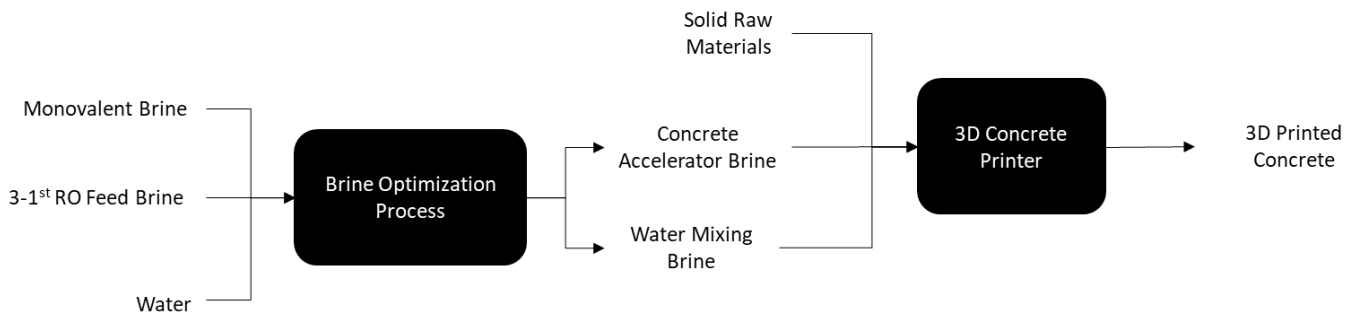

(b) MVR Brine

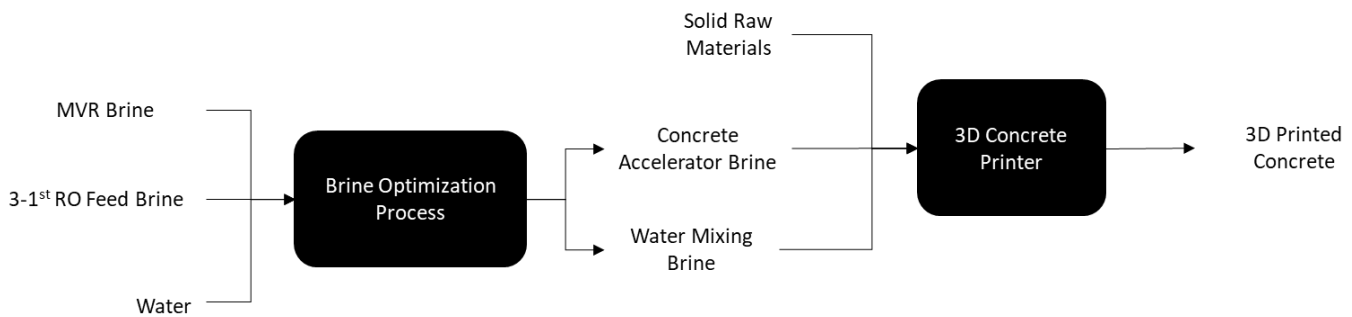

(c) Calcium Chloride Brines

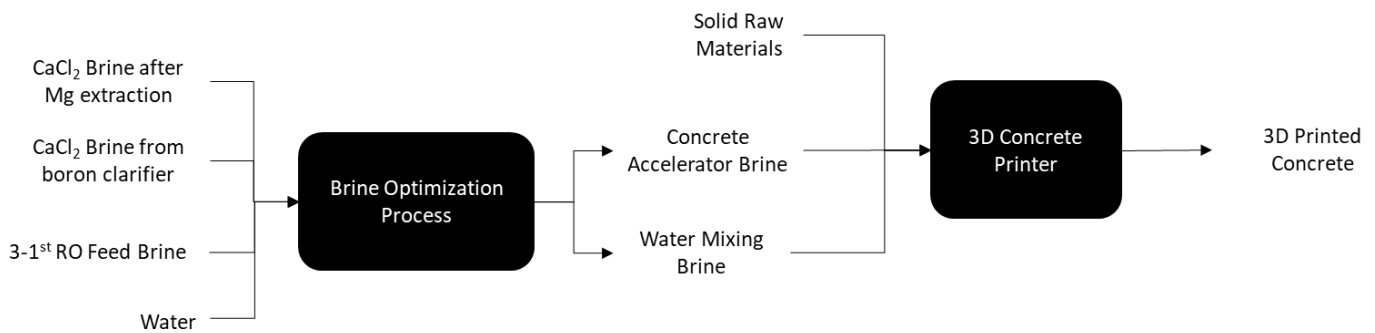
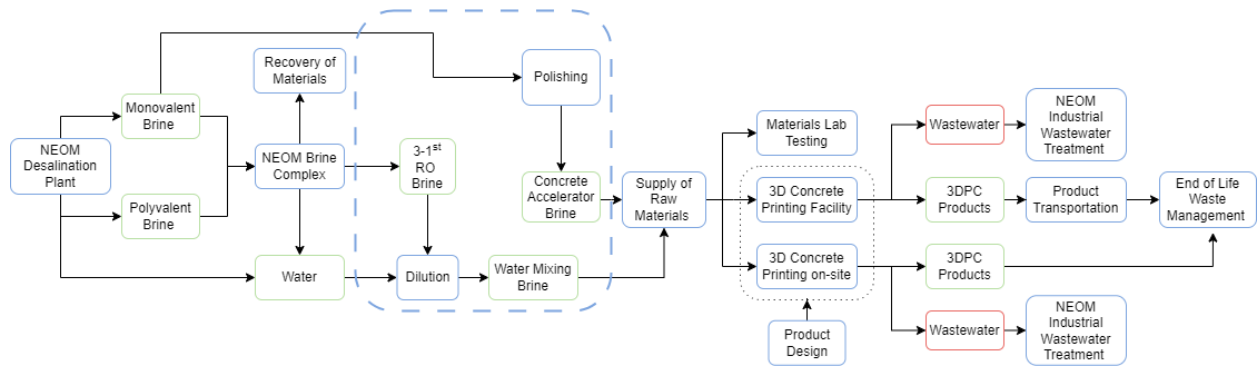

Figure 4 Black box diagrams of brine optimization process coupled with 3D concrete printing process showing the inputs and outputs for (a) monovalent brine, (b) MVR brine, and (c) Calcium Chloride brines.

2.3.4. Subprocesses allocation

The sub-processes diagrams presented on Figure 5 represent all of the important processes (blue boxes) at NEOM that need to be designed, constructed, and considered for the entire implementation of using desalination brine for the production of 3DPC. Three diagrams were developed based on the brines selected for the production of the CAB.

(a) Monovalent Brine Design



(b) MVR Brine Design

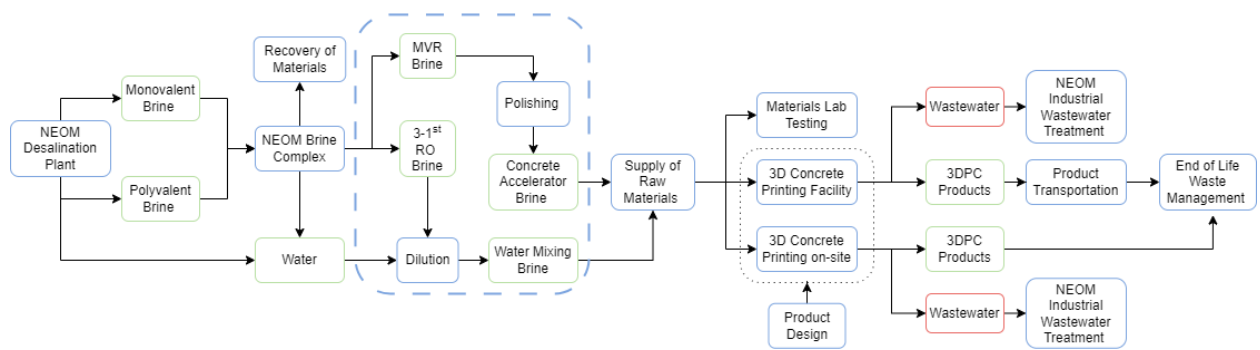

(c) Calcium Chloride Brines Design

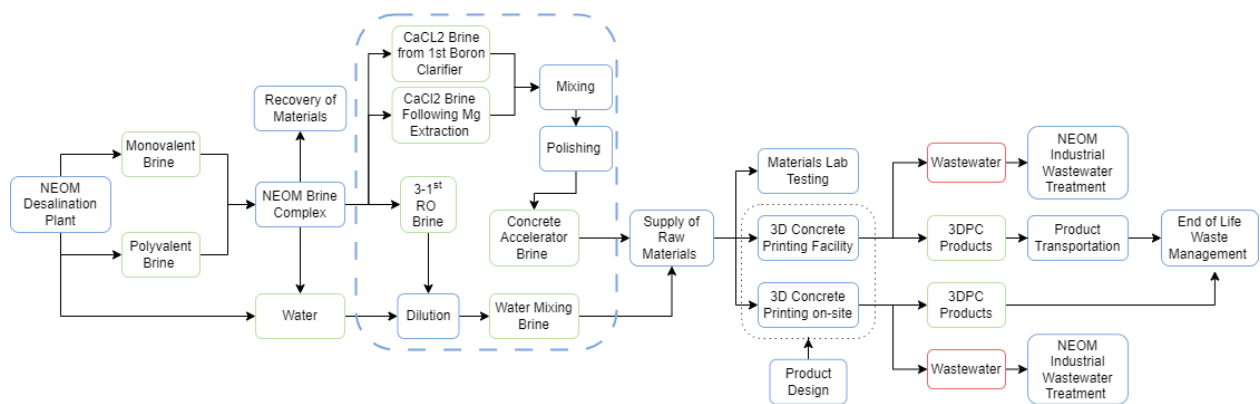

Figure 5 Sub-processes diagram integrating desalination brine with the 3DPC process. (a) Monovalent Brine Design. (b) MVR Brine Design. (c) Calcium Chloride Brines Design. Blue boxes represent all of the processes that need to be design and constructed at NEOM for the implementation of desalination brine with 3d printable concrete. The green and red boxes show the input and the outputs of the different subprocesses presented. The Blue dashed line shows the boundary condition for the brine optimization process.

NEOM's desalination plant

The first sub-process is NEOM's desalination plant where the main product is drinking water produced from seawater. Additionally, the monovalent and the polyvalent brine are produced as a by-product from the desalination process. Both brines are transported to NEOM's brine complex where they are further treated and other resources are recovered.

NEOM's brine complex

NEOM is planning to build a brine complex to further treat the monovalent and the polyvalent brines being produced at the desalination plant. The brine complex consists of an unique arrangement of thermal and membrane based technologies. Throughout the treatment scheme several brines are produced. For the sub-process diagram (b) the concentrated brine out the MVR is required for the design. For the sub-process diagram (c) the CaCl_2 Brine From 1st Boron Clarifier and the CaCl_2 Brine Following Mg Extraction are required for the Design.

For the production of the pumpable cement mixture a combination of drinking water and 3-1st RO feed brine is needed to make the mixing water brine. The combination consists of 50% water and 50% 3-1st RO feed brine.

Resource recovery from NEOM's brine complex

Drinking water and several other commercial minerals and salts (e.g. gypsum) are recovered and they are sold back into the market. Drinking water either from the desalination plant or the brine management plant will be needed for the pumpable cement mixture and for cleaning of the 3D printer.

Polishing

For the polishing sub-process the most important aspect is to modify the concrete accelerator brine according to the product specifications developed. No ion removal is required for the three selected brines, the most important aspect is to comply with the required temperature of the brine required for the printing process.

Dilution

In the case of the mixing water brine, the ion concentration of the 3-1st RO Feed Brine needs to be reduced. Dilution with drinking water was proposed as a solution to achieve the change of concentration required to produce the mixing water brine. Just like the polishing step, it is important to maintain the brine at the required temperature as defined by the product specifications.

Mixing

The sub-process of mixing brines is required for the calcium chloride brines design. For this solution it is a mix of 60% CaCl₂ brine from the boron clarifier and 40% CaCl₂ brine after Mg removal are required. The design needs to account for the appropriate brine flow and ensure that the conditions are met according to the product specifications for the CAB.

Supply of raw materials

Once the MWB and CAB for printing are produced, they need to be distributed to be used for the 3D printing process. Additionally the solid materials (e.g., cement, aggregate, SCMs, etc.) need to be also distributed to the printing facility.

3D Concrete printing facility

Two production location options could be available for 3D printing. The first option would be at a printing facility where the printing location can be more controlled (e.g. controlling the temperature, relative humidity, etc.). At this location the brine can be transported either via trucks or through pumping and piping to the facility. If the facility is located near the BOP, then piping and pumping might be a more cost efficient solution than transportation with trucks.

3D Concrete Printing on-site

The second production location can be done anywhere within NEOM. The region of NEOM is expected to be roughly the size of Belgium. Transporting the required amount of brine per print via truck in IBCs might be the best solution to print on site whenever it is required.

Materials Lab Testing

Quality control of the CAB, MWB and the 3DPC needs evaluation in order to ensure quality to the costumers. For the brine monitoring along the process can be implemented but also samples should be taken and analyzed to ensure the proper brine quality is used for the concrete production. For the concrete proper material characterization would likely be needed to ensure the material properties of the product are met for the 3D printing projects.

Product Design

The design of the 3DPC products is a very important step to determine the scale of the printed product and therefore the amount of material required. Additionally, the printing time of the project can be a parameter constraint for the amount of brine that can be allocated for the printing process. Having multiple printers to allocate more brine for printing can be a solution but the costs need to be incorporated into the business case to ensure the techno-economic feasibility of the project.

End of life waste management

Concrete tends to have a long lifespan and it is known for its durability properties. However, some printed products might get damaged or might need to be replaced over a period of time. Due to NEOM's strict zero waste policy, it is important to recover materials from the printed concrete (e.g., recycled aggregate) to reuse those materials at the beginning of the printing process or for other industrial or commercial application.

NEOM water reclamation plant

Proper cleaning and maintenance are required for the printing machine after each print. It is important to determine the amount of water required for cleaning and to collect, characterize and recover resources from the wastewater that will be produced. Another possible solution would be to recover the cleaning water, treat it, and use it again in the process for cleaning. This could help minimizing the amount of drinking water required for the cleaning process.

2.4. Process Technology

2.4.1. Task Network

As mentioned in the sub-processes diagram, multiple complex technical processes need to be accounted for to successfully implement desalination brine for 3DPC. The scope of this project is only on the brine optimization process inside the blue dashed line in Figure 5. The task network (Figure 6) was derived from the Sub- process diagram and the product specifications. The tasks in the black boxes are the required physical and chemical changes required to produce the CAB and MWB for the 3DPC. As noted in Figure 6 the required tasks can change depending on the brine selected for the production of CAB, due to the initial conditions of the brine. For the MWB they are all the same tasks because the same brine was selected for the three design options for the BOP. Based on the tasks the equipment units can be design with the intention of completing the task. Additionally, multiple tasks can be combined into one unit (e.g., Mixing and Storage can be completed in one unit).Figure 6 also shows the allocation of the design units for the different tasks developed. In total there are five units per BOP Design.

(a) Monovalent brine

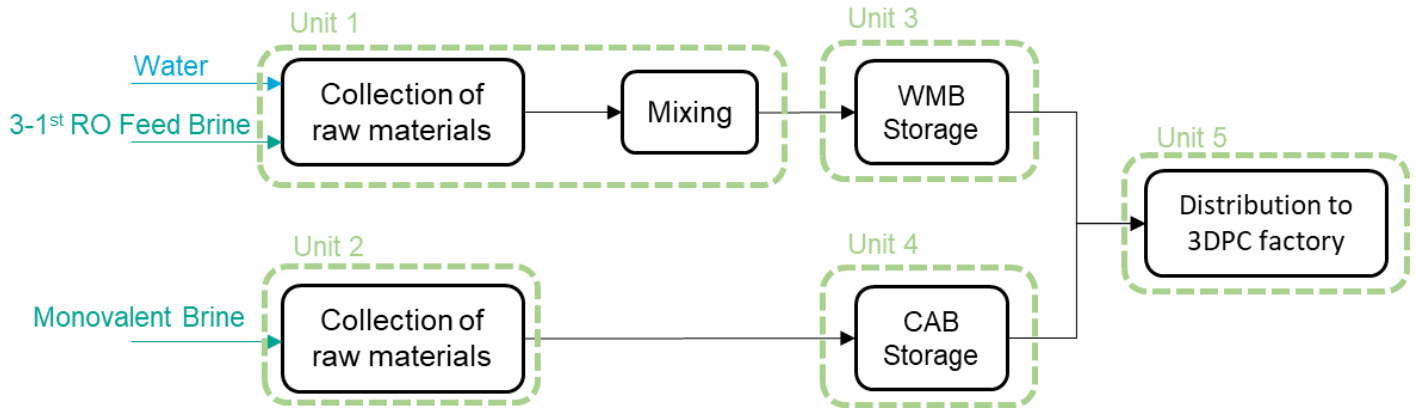

(b) MVR Brine

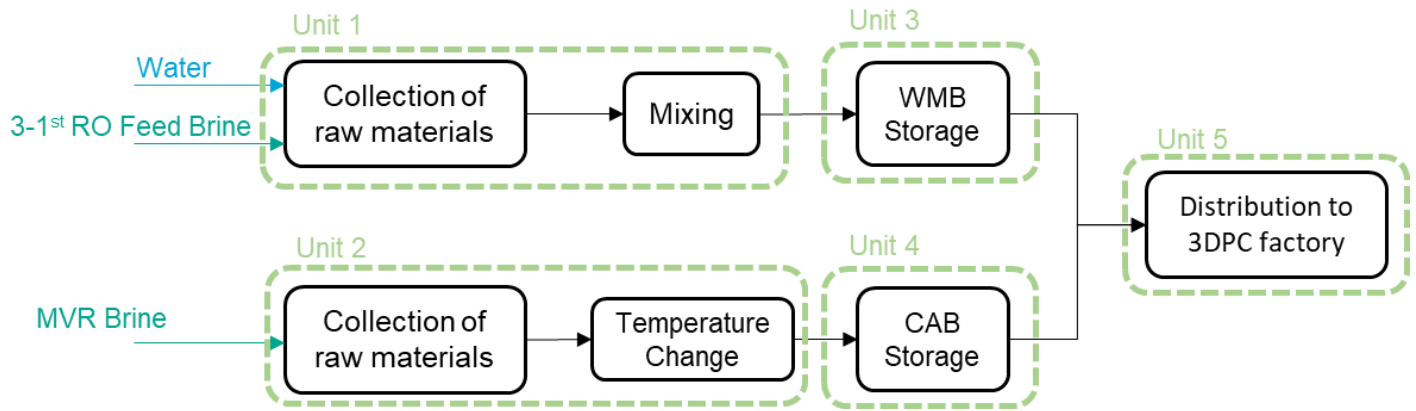

(c) Calcium Chloride Brines

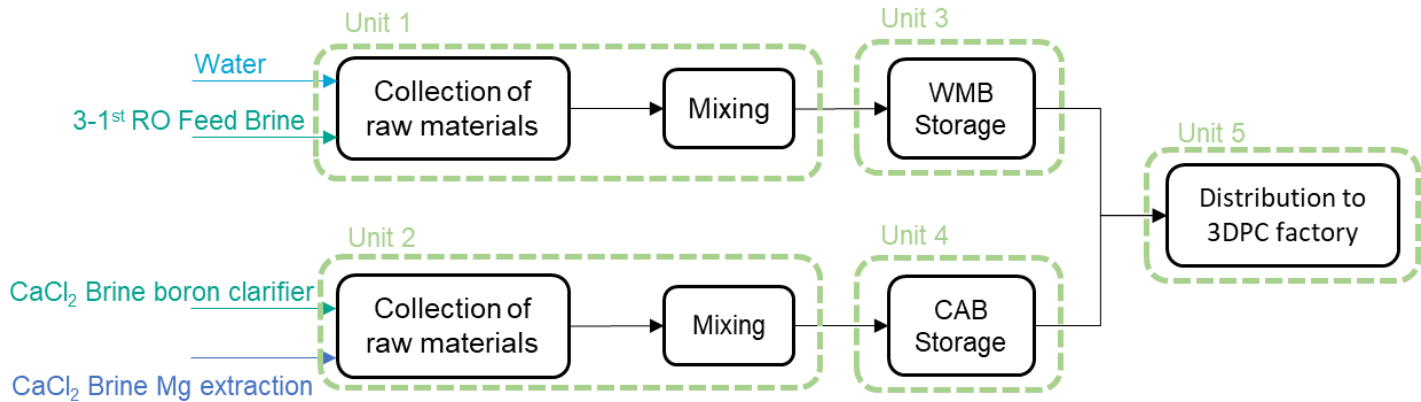

Figure 6 Task and Unit Network developed for the (a) Monovalent brine, (b) MVR Brine, and (c) the calcium chloride brines. The black boxes represent the several tasks that need to be completed to change the brine before it is sent to for printing. The Dashed green boxes show the units allocated to the different tasks. These units need to be design to complete the proposed tasks per unit.

2.4.2. Unit Network

For the unit design it is important to define the operation mode for the BOP. In the case of continuous operation the CAB and the MWB can be produced and transported to the 3D Printing Facility. With this option the design can have a smaller footprint if desired depending on the pumping rate and the HRT selected. On the other hand the printing process is operated in batch mode, meaning that the brine is only required during printing. Therefore the operation mode is partly dictated by the operation of the printing process since the brine cannot be continuously fed nonstop and mixed to produce concrete.

The BOP in batch operation was designed to comply with the required tasks previously presented. Additionally, the expected 3D concrete printing demand and the concrete composition was used to determine the required brine flow for the BOP. One batch per day was selected to cover 100% of the printing demand. Table 14 shows the required flow and the initial and the required, temperature, and pH of all the brines Selected for the three BOP designs.

Table 14 Flow, temperature, and pH of brines and water used as CAB and MWB.

| Influent materials for CAB and MWB production | Flow (m ³ /day) | Initial Temperature (°C) | Target Temperature (°C) | Temperature Range (°C) | pH (Expected) | pH (Synthetic Brine) | Target pH |
|---|----------------------------|--------------------------|-------------------------|------------------------|---------------|----------------------|-----------|
| Monovalent Brine | 103 | 33 | 25 | 20-40 | 6.60 | 7.52±0.03 | >7 |
| MVR Brine | 103 | 77 | 25 | 20-40 | 6.24 | 8.00±0.07 | >7 |
| CaCl ₂ brine from boron clarifier | 61.8 | 35 | 25 | 20-40 | 9.0 | 10.39±0.02 | >7 |
| CaCl ₂ after Mg extraction | 41.2 | 50 | 25 | 20-40 | 9.0 | 9.96±0.04 | >7 |
| 3-1 st RO Feed Brine | 47.9 | 33 | 25 | 20-30 | 6.26 | 7.52±0.27 | >7 |
| Water | 47.9 | 25 | N/A | N/A | N/A | N/A | N/A |

Unit 1 Design for all three BOP design Options

For producing the MWB the raw materials needed are the 3-1st RO Feed Brine and water to dilute the brine by 50%. The influent flow required for both is 47.9 m³/day. The system is design for one batch per day therefore the flow per batch is also 47.9 m³ for the 3-1st RO Feed Brine and water.

These two materials need to be properly mixed in order to change the concentration of the brine. Several options can for mixing the two fluids can be implemented. The implemented solution was to incorporate a static mixer in the piping while the two fluids are collected and pumped to the storage unit.

Additionally, the brine and the water need to be pumped to be collected and transported to the storage unit before the MWB brine is used for the printing process. A corrosive resistant pump should be selected to help mitigate the risk of corrosion damage.

Unit 2 Design options for Monovalent brine design and calcium chloride brines design

For the monovalent brine for the unit 2 the only requirement was to pump to transport and collect the required flow. In the case of the Calcium Chloride Brines design, the two brines needs to be mixed similarly like unit one for the production of MWB. A static mixer can be placed in the piping and then the mixed brine can be sent to the storage unit. The required influent flows were presented on Table 14.

Unit 2 Design options for MVR Brine Design

For the MVR brine design the temperature change from 77 °C to 25 °C is required before the brine is used for printing purposes. Two options for cooling where considered, a heat exchanger for cooling and underground storage at lower temperatures. The heat exchanger option was selected to ensure the proper temperature can be obtained since the impact of temperature on concrete can be sensitive and it can impact the material properties of concrete.

Unit 3 and Unit 4 Design options for the three BOP options

Unit 3 and 4 consist on proper storage For the CAB and MWB. The storage needs to have the capacity to handle the flow of the CAB and MWB per batch per day. The dimensions of the tank can be seen on Figure 7. Six tanks are required to handle the flow of the MWB and the CAB.

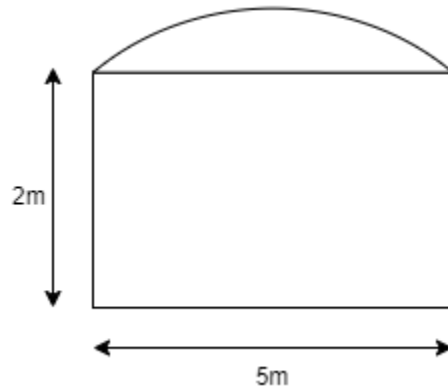

Figure 7 Dimensions for storage tank for CAB and MWB.

Unit 5 Design options for the three BOP options

The main task that needs to be completed for unit 5 is the distribution of the CAB and MWB. This unit can be split into two pumps (one for the MWB and one for the CAB). The distribution process was excluded from the design because it is outside of the proposed boundary conditions. Three possible options can be considered for the distribution once the location of the 3D Printing Facility is known. The first option could be to package the brine in smaller containers and distribute them via trucks. The second option would be to transport the brine in bulk in a water truck from the BOP to the printing facility. The last option would be to distribute the brines via a piping and pumping distribution system. All three options pose their own technical and economic challenges so they would have to be considered properly before deciding how to distribute the brine.

2.5. Process Engineering

2.5.1. Process integration, equipment design and operability integration

For the three BOP designs the units were integrated together to develop the initial designs for the production of CAB and MWB. Figure 8 shows the process scheme of the BOP proposed, these were modelled in SuperPro Designer for the techno-economic evaluation presented in the following chapter.

(a) Monovalent Brine Desing

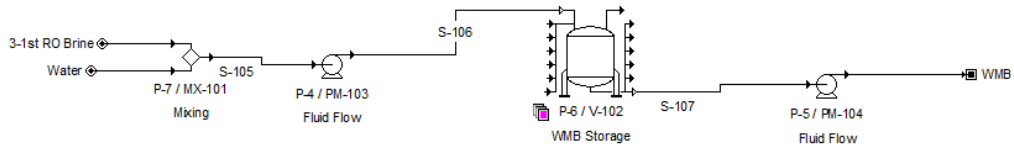
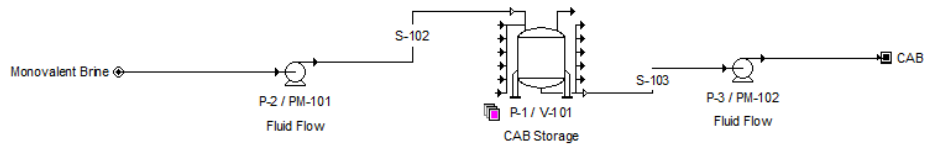

(b) MVR Brine Design

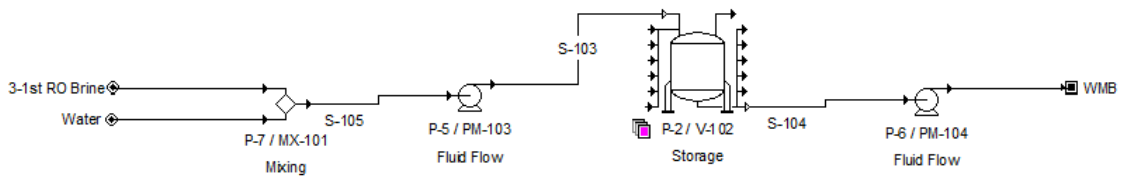
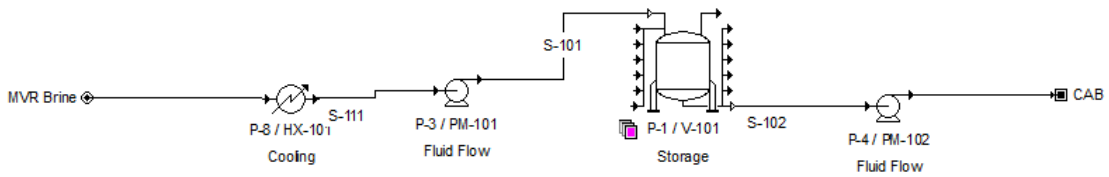

(c) Calcium Chloride Brines Design

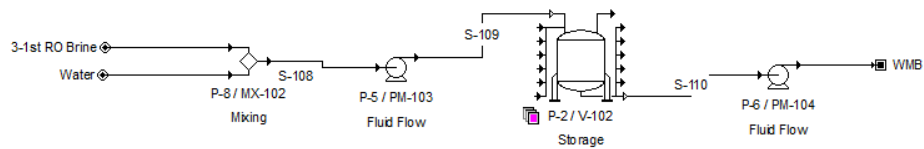
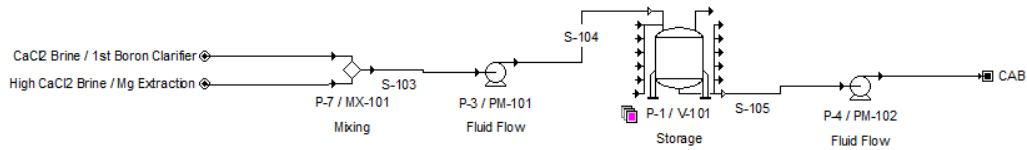

Figure 8 Flow diagram of BOP for (a) Monovalent brine design, (b) MVR brine design, and (c) Calcium Chloride brines design.

The required size and capacity of the pumps, storage, and heat exchanger (for the MVR Brine Design) are presented on Table 15.

Table 15 Design labels and capacity of units.

| Name | Type | Quantity | Size (Capacity) | | |
|--------|------------------|----------|-------------------------|----------------------|--------------------------------|
| | | | Monovalent Brine Design | MVR Brine Design | Calcium Chloride Brines Design |
| PM-101 | Centrifugal Pump | 1 | 4.02 kW | 4.02 kW | 4.02 kW |
| PM-102 | Centrifugal Pump | 1 | 4.02 kW | 4.02 kW | 4.02 kW |
| PM-103 | Centrifugal Pump | 1 | 3.80 kW | 3.80 kW | 3.80 kW |
| PM-104 | Centrifugal Pump | 1 | 3.80 kW | 3.80 kW | 3.80 kW |
| HX-101 | Heat Exchanger | 1 | N/A | 96.39 m ² | N/A |
| V-101 | Tank | 3 | 39.2 m ³ | 39.2 m ³ | 39.2 m ³ |
| V-102 | Tank | 3 | 39.2 m ³ | 39.2 m ³ | 39.2 m ³ |

Figure 9 shows the piping and instrumentation diagram for the proposed BOP designs.

(a) Monovalent brine design for CAB

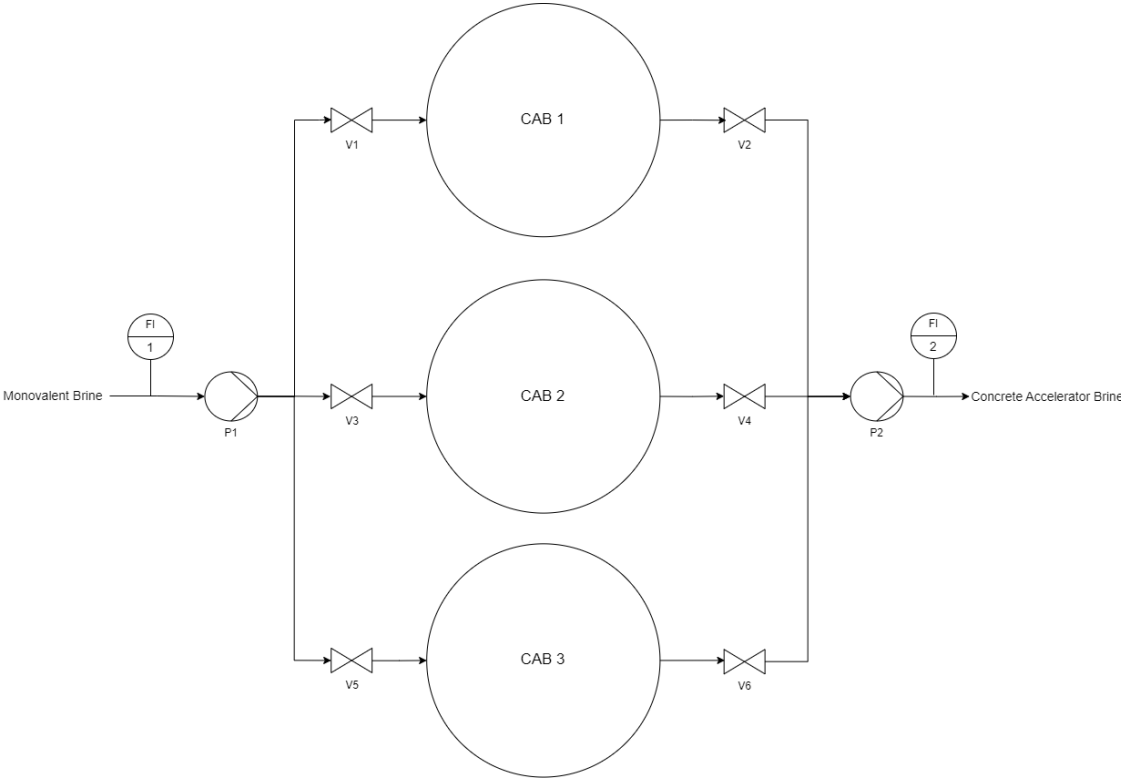

(b) MVR brine design for CAB

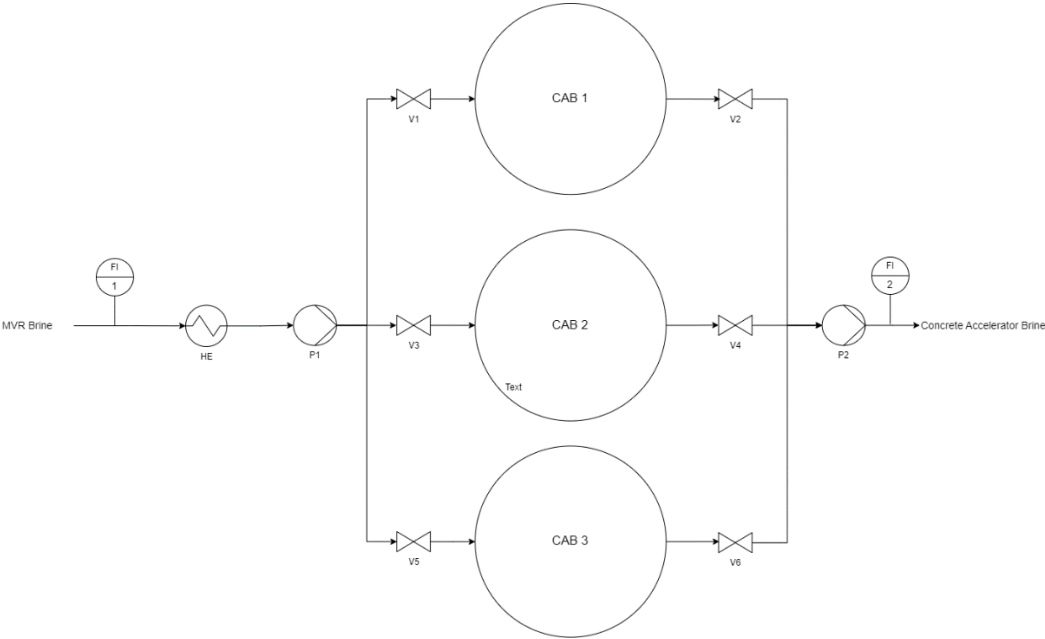

(c) Calcium Chloride Brines design for CAB

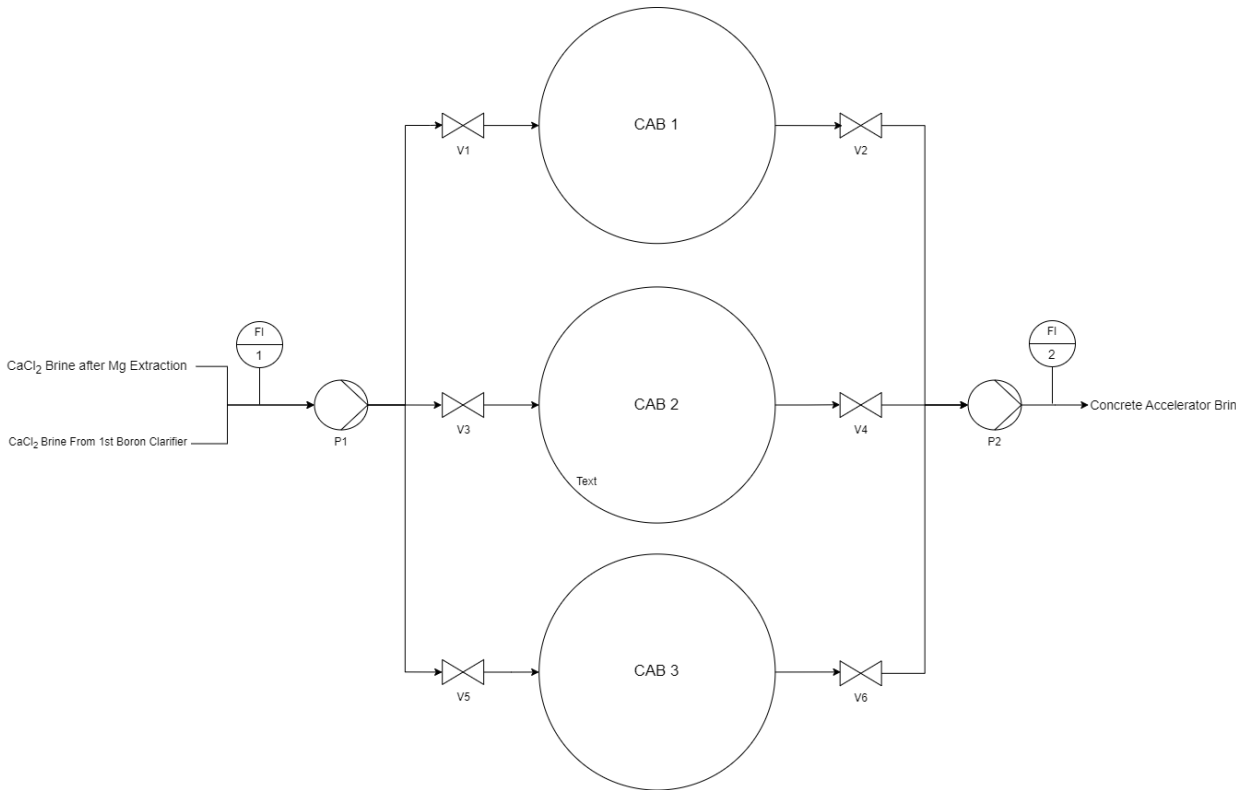

(d) Mixing Water Brine design for all three brines used as CAB

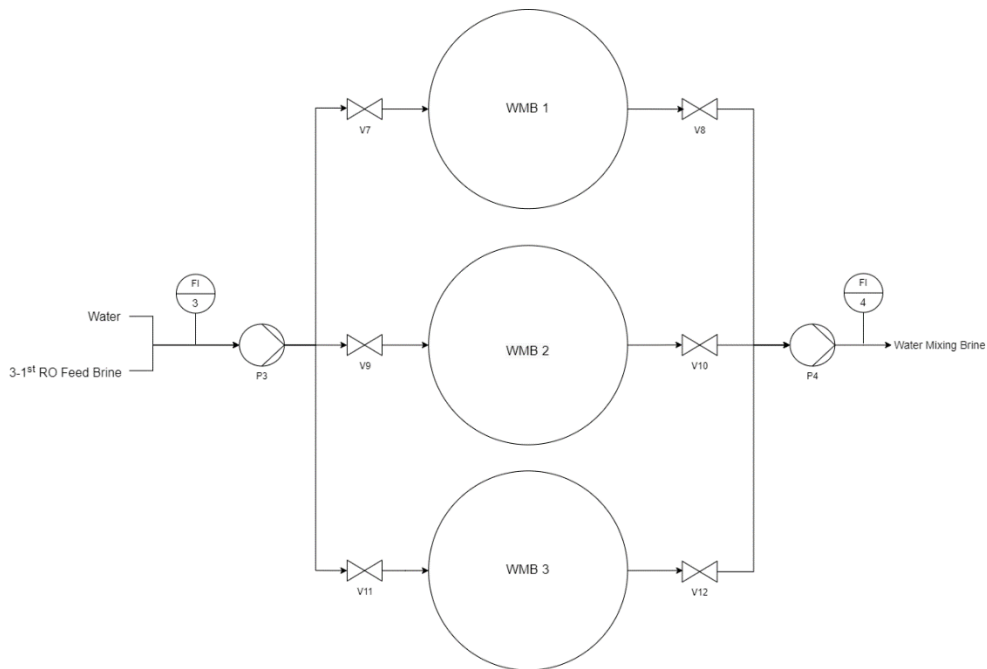

Figure 9 P&ID for (a) CAB monovalent brine design, (b) CAB MVR brine design, (c) CAB calcium chloride brines design and (d) MWB for all three CAB designs.

For the batch operation, the pumping flow selected was 103 m³/h for the pumps used for the production of CAB. The pumping flow selected was 96 m³/h for the pumps used for the production of MWB. The batch time selected for the storage was 22 hours, under the assumption that only one batch will be needed per day. However the batch time can be changed and optimized in the future in the case the expected demand of 3D printable concrete increases. If more brine is required than the expected than the number of batches per day can be increased and the tank can be filled and emptied more often, as required. For the process optimization the future distribution system implemented needs to be considered to developed the best available results.

If the system reaches its maximum capacity by reaching the maximum batches per day , them the system can be replicated and extended. If the demand of concrete exceeds the expectations that the operation can no longer be optimized, then either increasing the storage and pumping capacity can be done or and additional process can be constructed.

2.6. Final design

The three BOPs meet the requirements to produce the required CAB and MWB for the 3D printing process. Selecting the final design to be implemented at NEOM is still required. Table 16 shows a multicriteria analysis summarizing and comparing the technical results from the concrete experiments and additional criteria for the BOP design options.

Table 16 Multi-criteria for comparing technical outputs from the impact of the brine on the material properties of concrete and the technical aspects of the BOP.

| Category | Criteria | Monovalent Brine Design | Calcium Chloride Brines Design | MVR Brine Design |
|-----------|-------------------------------------|-------------------------|--------------------------------|------------------|
| Technical | PBM Dynamic Yield stress (Pa) | 1621.8 | 2021.2 | 2082.3 |
| | PBM Plastic Viscosity (Pa.s) | 14.4 | 23.6 | 34.6 |
| | Concrete Initial Setting Time (min) | 105.7 | 69.5 | 66.0 |
| | Concrete Buildability (17 layers) | Yes | Yes | Yes |
| | Concrete Static Yield Stress (Pa) | 54.7 | 38.4 | 173.6 |
| | 28 Days Compressive Strength (MPa) | 36.3 | 38.4 | 31.7 |
| | Brine Availability | +++ | + | ++ |
| | BOP Technology Readiness Level | 6 | 6 | 6 |
| | Zero Liquid Discharge | Yes | Yes | Yes |

The concrete experiments showed that all of the three brines functioned successfully as concrete accelerator and helped improve the 3D printing process. Additionally, the BOPs were composed of very well-known technologies (e.g., pumps, heat exchangers). There was no need to further change the composition of the brines by removing or concentrating certain ions. A Technology readiness level of six was allocated to the three designs because these technologies have been implemented in relevant environments, like a full scale desalination plant. However, the composition of the brines are unique to NEOM, therefore these technologies still need to be validated with the real brine once it is available.

Further validating the technology via pilot or demo testing can provide additional data to optimize the proposed designs. A current limitation is the current development of the desalination plant and NEOM's brine complex. Any potential changes in design that impact the proposed brines for the production of CAB and MWB needs to be considered. Integrating the BOP with either the desalination plant or the brine complex needs to be considered since these processes have a dependency on each other.

Overall all three options fulfill the required technical specifications to produce the brine for the 3DPC. Additional information is needed to select a final BOP to be developed at NEOM. The following chapter expands on the Techno-economic evaluation comparison for the three proposed brine optimization processes.

Chapter 3: Techno-economic evaluation

3.1. Techno economic evaluation and business case objectives

A techno-economic evaluation was conducted in order to complete the following project objectives:

1. Conduct an economic analysis comparing the three brine designs developed, based on the brines selected as CAB.
2. Determine a selling price for the CAB in order to make the brine optimization design profitable and that it can compete with the market price of the commercial concrete accelerator.
3. Identify other potential benefits that can improve the business implementation of the using desalination brine for 3DPC.
4. Identify any potential bottlenecks that could have an impact on the implementation of desalination brine for the production of 3DPC.
5. Aid NEOM with providing additional insight for the selection of the final brine optimization design.

The aim of this objectives is to help answer the following questions research questions:

1. What is the environmental impact of the treatment process created for the optimization of the brine water quality?
2. How can we increase the feasibility of the implementation of 3D printable concrete with desalination brine?
3. What are the potential technical, social, economic, environmental, and safety benefits of using desalination brine for the production of 3D printable concrete?

3.2. Methodology

3.2.1. SuperPro Designer® model inputs, parameters, and assumptions for techno-economic evaluation

The built-in economic model of SuperPro Designer® was used to perform the techno-economic evaluation. The model estimated the CAPEX and the OPEX based on the design and the

operational parameters in the model. Table 17. shows the model parameters and the values used for the cash flow analysis and the profitability analysis.

Table 17 Parameter input for techno-economic evaluation in SuperPro Designer®.

| | |
|-------------------------------|------|
| Construction Period (months) | 6 |
| Startup Period (months) | 1 |
| Project Lifetime (years) | 15 |
| Inflation (%) | 4 |
| NPV interest (%) | 7 |
| Annual Operating Time (hours) | 7920 |
| Batches per year | 360 |

For the profitability analysis the production cost of the Monovalent brine was assumed to be equal to the production cost of drinking water in Saudi Arabia (€0.68/m³), since brine is a by-product from NEOM’s desalination plant. It was assumed that the production value of the MVR brine and the calcium chloride brines were 25% higher than the production value of water since these brines are produced at NEOM’s brine complex where the brines from the desalination plant are furthered processed and changed by additional technologies.

For the MWB the selling price was assumed to be the same as drinking water in Saudi Arabia (€0.86/ m³). The mixing water brine is replacing the function of the drinking water in the concrete therefore if it becomes more expensive than the cost of drinking water it will no longer become an attractive option to use this brine for concrete. The selling price of the MWB was maintained constant for the three proposed designs.

The CAB is replacing the function of commercial concrete accelerator. The selling price of commercial calcium chloride accelerator ranges between 550-600 €/ton. The selling price of the CAB was treated as a variable in the three models. This was done to first identify the minimum selling price required to make the project profitable by obtaining a positive net present value (NPV) in the cash flow analysis. Second, it was used to determine an attractive price that does not increase

the final value of the 3DPC significantly and that remains a competitive price against the commercial concrete accelerator.

3.2.2. Sensitivity Analysis

A sensitivity analysis was performed to account for the uncertainty and determine what parameter had the most impact on the techno-economic evaluation model. The selling price of the CAB was maintained as a constant at 60 € /m³ for the baseline case scenario. SuperPro Designer has a built in economic model to determine the project expenses and the profitability. The model uses several factors to estimate the CAPEX and the OPEX of the design. The model default values for the factors were used for the baseline case scenario (Table 18). For the sensitivity analysis the factors were changed by $\pm 25\%$ (Harmsen et al., 2018) to determine the impact on the outcome of the economic evaluation. The impact of the production cost of water and the different brines was also taken into consideration for the sensitivity analysis. The values of the production cost of water and the brines used for the baseline case scenario are reported on Table 18. These values were changed by $\pm 25\%$ to determine the impact on the economic evaluation for the three proposed designs. Additional information on the factors definition from the SuperPro manual can be found on Appendix B.

Table 18 In-model SuperPro Designer factors and brines and water cost (in euros/m³) tested for the sensitivity analysis and their respective default model value for the baseline case scenario. Additional definitions and more information on the factors can be found on appendix B.

| Factors | Value | Factors (cont.) | Value (cont.) |
|-----------------------|-------|---|---------------|
| Piping | 0.35 | Construction | 0.35 |
| Instrumentation | 0.4 | Contractor's Fee | 0.05 |
| Insulation | 0.03 | Contingency | 0.1 |
| Electrical Facilities | 0.1 | Unlisted Equip. Installation Cost | 0.5 |
| Buildings | 0.45 | Unlisted Equip. Purchase Cost | 0.2 |
| Yard Improvement | 0.15 | Water | 0.68 |
| Auxiliary Facilities | 0.4 | 3-1st RO Brine | 0.68 |
| Engineering | 0.25 | Monovalent Brine | 0.68 |
| Construction | 0.35 | MVR Brine | 0.85 |
| Contractor's Fee | 0.05 | CaCl ₂ Brine 1st Boron Clarifier | 0.85 |
| Contingency | 0.1 | CaCl ₂ brine Mg extraction | 0.85 |

The impact of the factors on the economic model was only studied for the Monovalent brine design, since the three models have the same mathematical relationships as seen on Appendix B. The impact of the production cost of water and the different brines was studied for the three proposed brine optimization designs since the cost and the mass balances varies between the three designs.

3.2.3. Environmental impact assessment

A gate-to-gate life cycle assessment (LCA) was performed to assess the environmental impact of the brine optimization designs . The inputs for the analysis were the energy, water, and chemical consumption. For the source of energy it was assumed that 100% renewable energy will power the

brine optimization designs by the time of construction. The CO₂ emissions for the brine optimization designs were calculated based on the energy and mass balance and the assumptions previously stated.

3.3. Results

3.3.1. Techno-economic results and comparison of proposed designs

Table 19 shows the calculated CAPEX and OPEX for the three brine designs. The MVR brine had the highest CAPEX and OPEX due to the extra required heat exchanger used for cooling. Both the monovalent brine design and the calcium chloride brines design required identical units. However, it was assumed that the production cost of the calcium chloride brines would be higher, therefore explaining the slight increase in CAPEX and OPEX for the calcium chloride brines design in comparison to the monovalent brine design. The specific CAPEX and OPEX breakdown for the three designs can be found on Appendix A.

Table 19 CAPEX and OPEX summary for the BOP proposed design options.

| Design Option | CAPEX (€) | OPEX (€/year) |
|--------------------------------|--------------|------------------|
| Monovalent Brine Design | 4,194,000 | 1,609,000 |
| MVR Brine Design | 5,188,000 | 1,935,000 |
| Calcium Chloride Brines Design | 4,197,000 | 1,637,000 |

Figure 10 Shows the minimum selling price of the CAB required to make the project profitable. For the monovalent brine design the minimum selling price required is €48/m³, for the calcium chloride brines is €49/m³, and for the MVR brine design is €58/m³. Increasing the selling price of the CAB further will increase the project revenues (Figure 11) and the profitability.

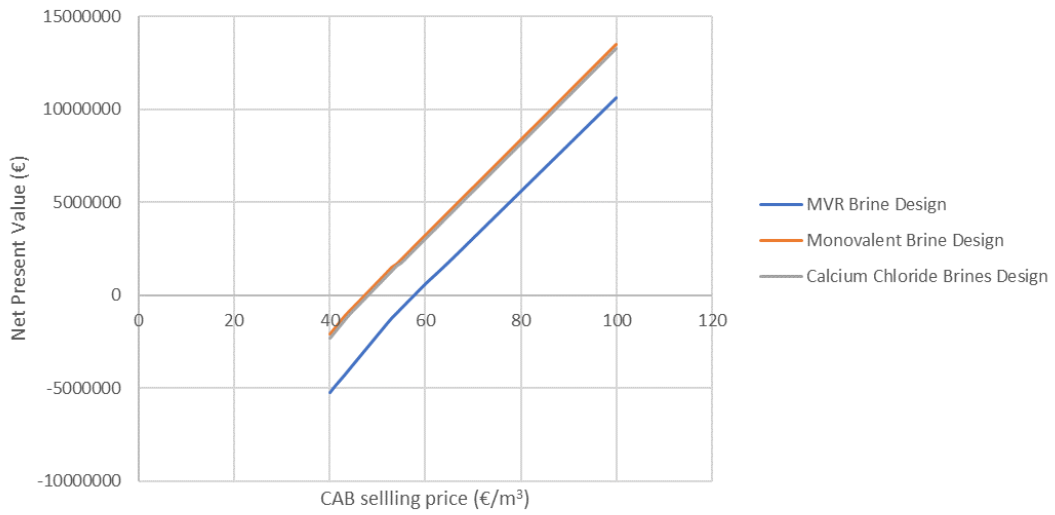

Figure 10 NPV at different selling price of CAB for the proposed designs.

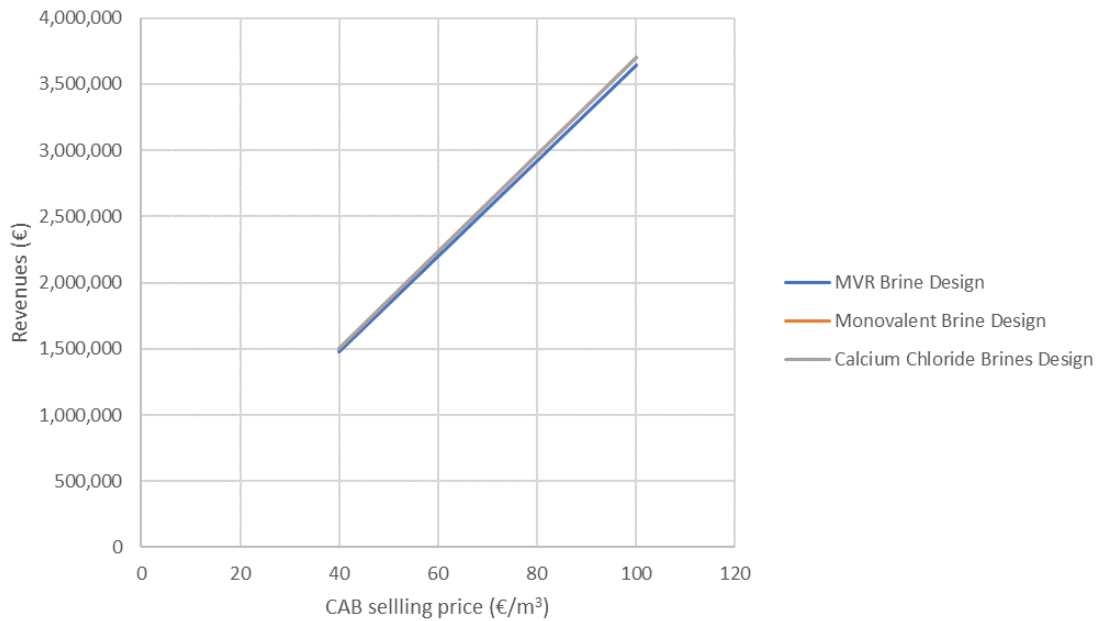
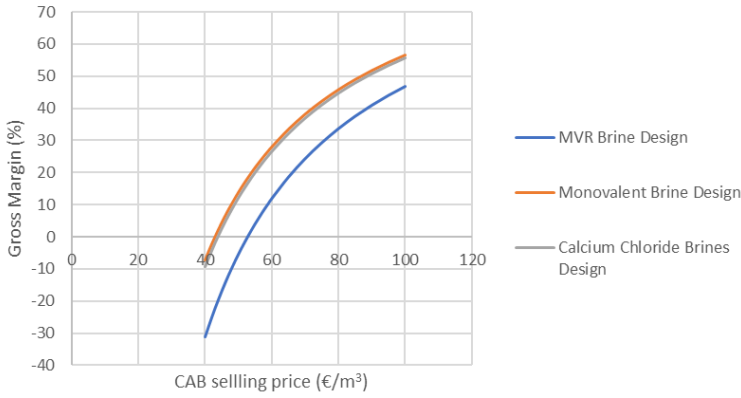

Figure 11 Project revenue at different CAB selling price for proposed designs.

For the profitability evaluation the gross margin, the internal rate or return (IRR), the return of investment (ROI), and the payback time were calculated for the three designs at different CAB selling price. Figure 12 shows the results of these parameters for the different design scenarios.

(a) Gross Margin



(b) IRR

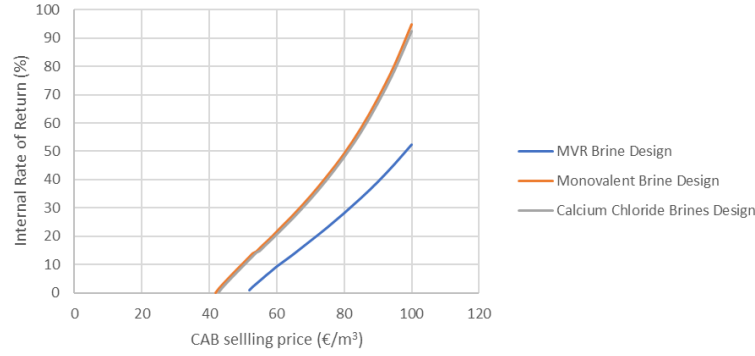

(c) ROI

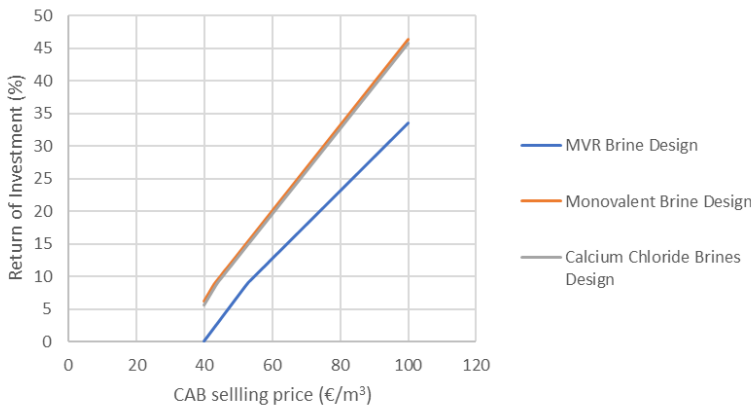

(d) Payback Time

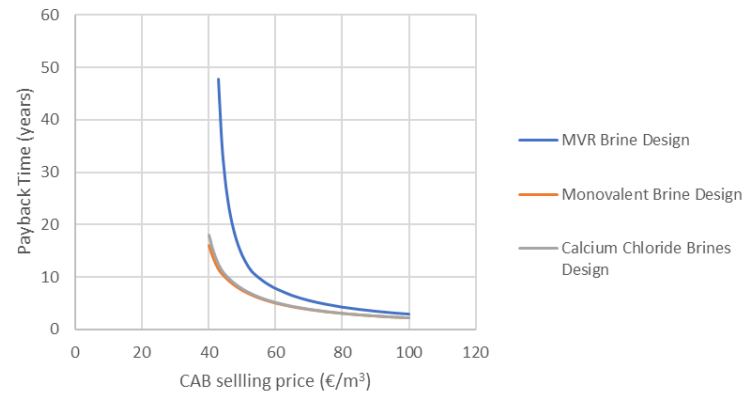

Figure 12 CAB selling price impact on the profitability analysis for the three proposed brine designs. (a) Gross Margin, (b) Internal Rate of Return, (c) Return of Investment and (d) Payback time.

As noted in the four graphs the MVR curves for the MVR Brine Design are shifted to the right in comparison to the other designs. This shift is explained by the higher CAPEX and OPEX of the MVR Brine Design. Regardless of this difference, all three options show that the project can be profitable at an appropriate CAB selling price. Just like the NPV analysis, the gross margin provides additional insight on selecting the minimum CAB selling price to have revenue leftover after considering the costs of the project. Based on these figures the most profitable design is the Monovalent brine design at all CAB selling prices.

A price higher than €60/m³ seems to be a good starting point for all three designs since, the payback time drops below 10 years for all three projects, the gross margin is higher than 10%, the IRR is higher than 10%, and the ROI is higher than 12%. However, increase the selling price of the CAB will also increase the price of the 3DPC, which could have a negative impact on the

business case from NEOM's Design and Construction team who are responsible of implementing 3D concrete printing.

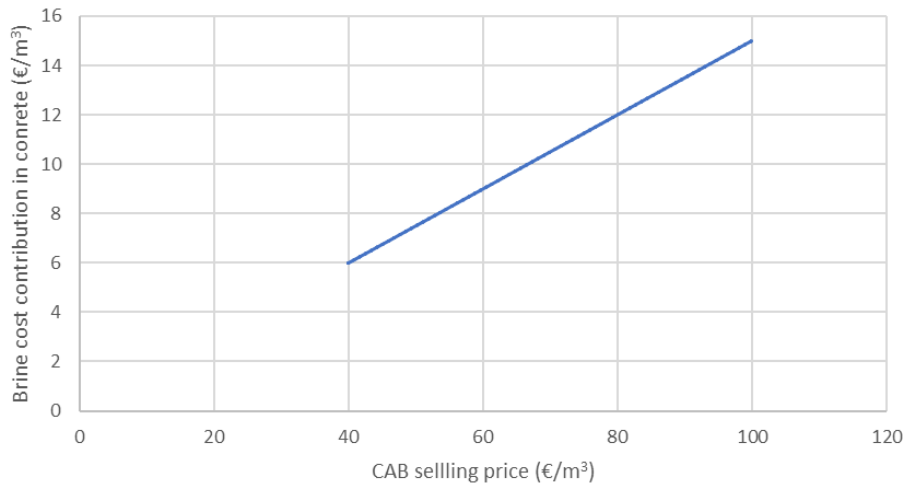

Figure 13 Final cost contribution of CAB per cubic meter of concrete produced depending on the CAB selling price.

Figure 13 shows the impact of the CAB selling price on the final material price contribution on the concrete produced. It will cost around €9 per cubic meter of concrete produced at a CAB selling price of €60/m³. A cubic meter of concrete costs around €200 per cubic meter of concrete (U.S Bureau of Labor Statistics, 2023), meaning that the CAB selling price has a small impact on the overall costs of concrete. Additionally the selling price is lower than the cost of commercial calcium chloride concrete accelerator (€550-600/ton), which can make the brine an attractive alternative.

3.3.2. Sensitivity Analysis Results

Table 20 shows the baseline values for the different output variables tested in the sensitivity analysis. Figure 14 to Figure 16 and

Table 21 show how each of the different input variables in the model impacted the results for the three brine optimization processes.

Table 20 Baseline case values the three brine optimization processes options.

| Design | CAPEX (€) | OPEX (€/year) | Gross Margin (%) | ROI (%) | Payback Time (years) | IRR (%) | NPV (€) |
|--------------------------------|-----------|---------------|------------------|---------|----------------------|---------|-----------|
| Monovalent Brine Design | 4,196,000 | 1,631,000 | 26.98 | 19.65 | 5.09 | 20.75 | 3,062,000 |
| MVR Brine Design | 5188000 | 1935000 | 11.93 | 12.68 | 7.89 | 9.28 | 594000 |
| Calcium Chloride Brines Design | 4197000 | 1637000 | 26.7 | 19.53 | 5.12 | 20.51 | 3018000 |

The CAPEX varied by a maximum of approximately $\pm 6\%$, and the OPEX by approximately $\pm 2\%$ (Figure 14). Increasing the model parameters by 25% revealed that the project remained profitable, regardless of the increase in CAPEX and OPEX.

Figure 15 shows the results of the sensitivity analysis on the profitability analysis. The IRR was the variable that showed the highest sensitivity, the maximum variation was around $\pm 11\%$. The selling cost of the CAB remained constant for the sensitivity analysis; however, as demonstrated in the previous section, increasing the selling price significantly increased the profitability of the project. So if the actual costs of the project are higher in comparison to the baseline scenario, then the selling price of the CAB can be increased higher than 60 €/m^3 .

(a) CAPEX

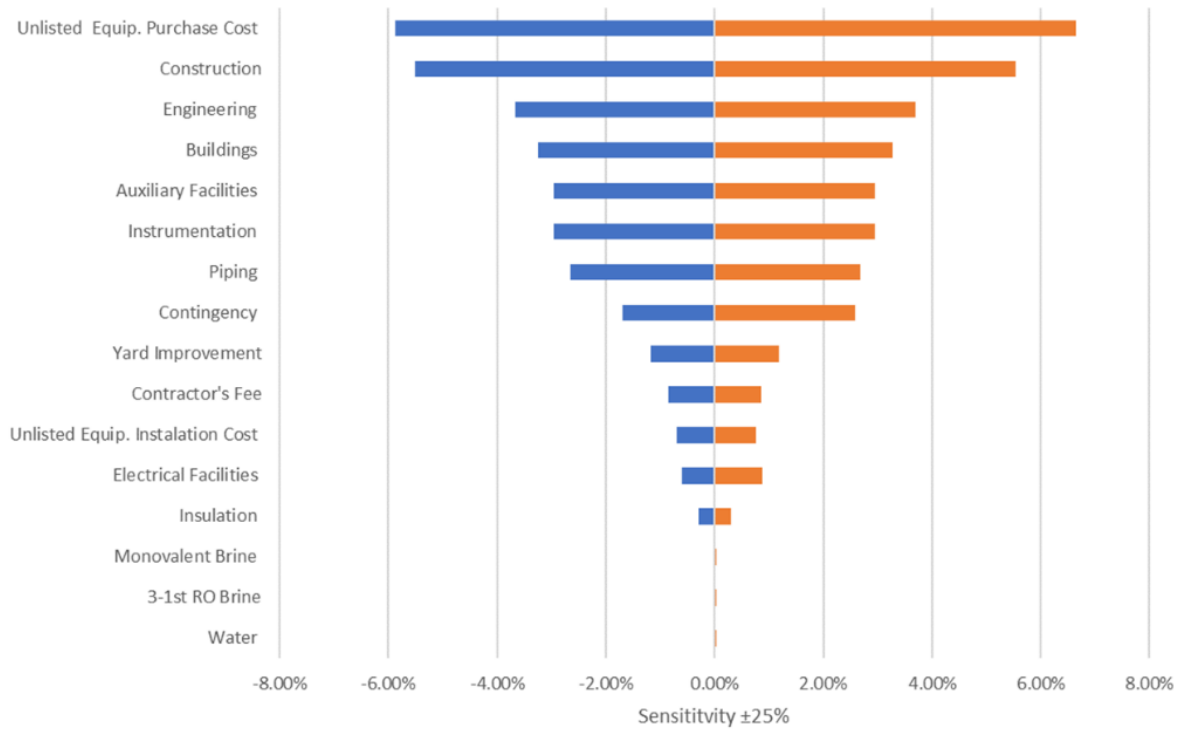

(b) OPEX

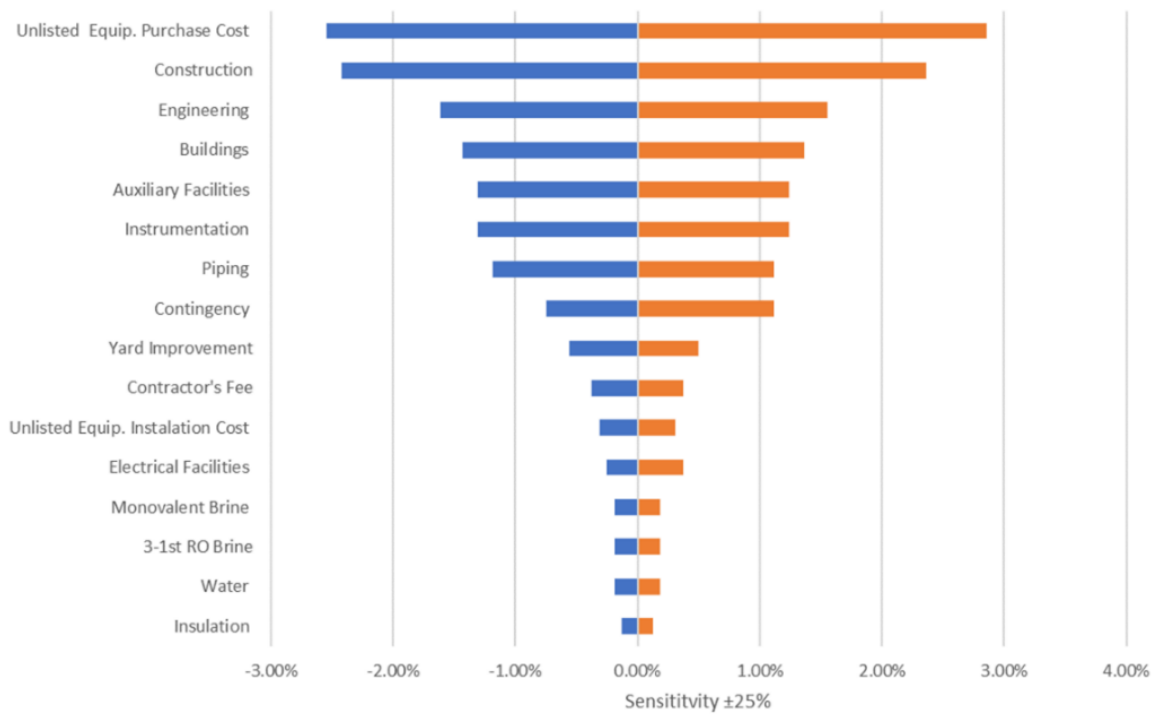
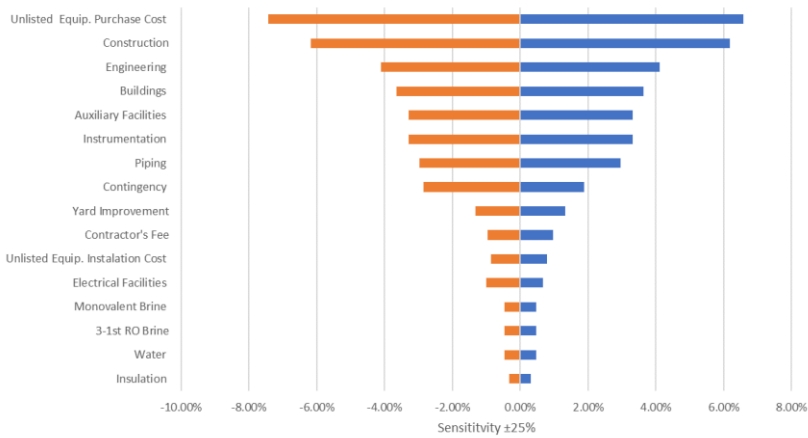
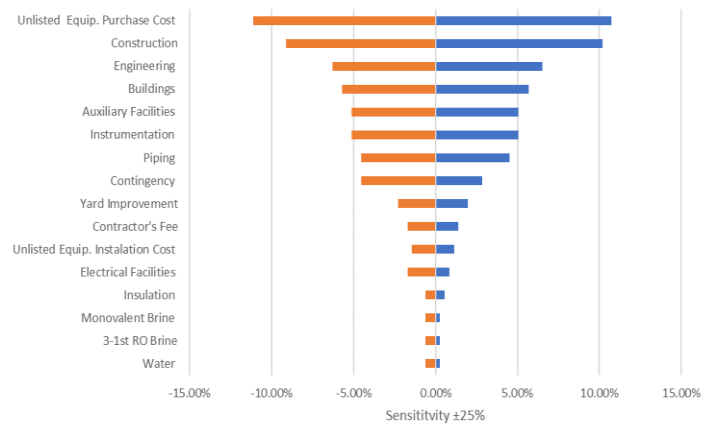

Figure 14 Sensitivity analysis results for (a) CAPEX and (b) OPEX. Blue bars represent the change by -25% and orange bars represent the change by +25%.

(a) Gross Margin



(b) IRR



(c) ROI

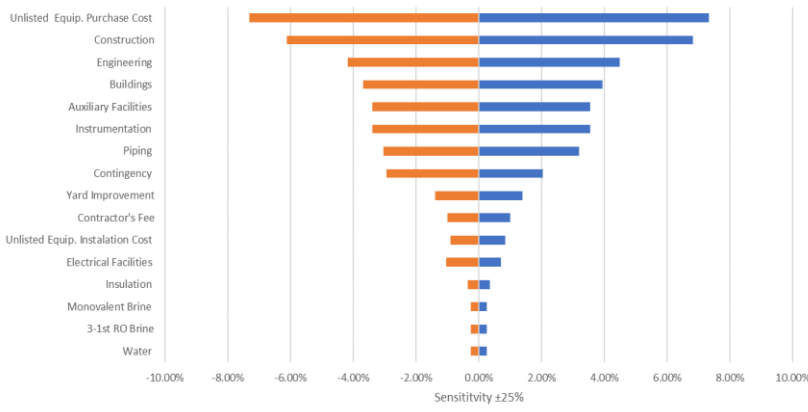

(d) Payback Time

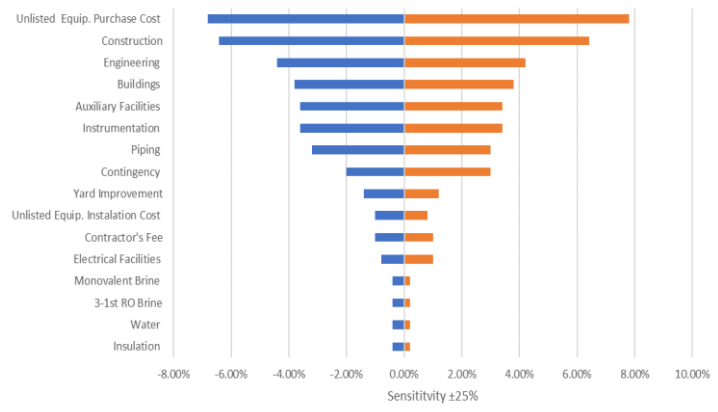

Figure 15 Sensitivity Analysis results for the profitability analysis. (a) Gross Margin, (b) IRR, (c) ROI and (d) Payback Time. Blue bars represent the change by -25% and orange bars represent the change by +25%.

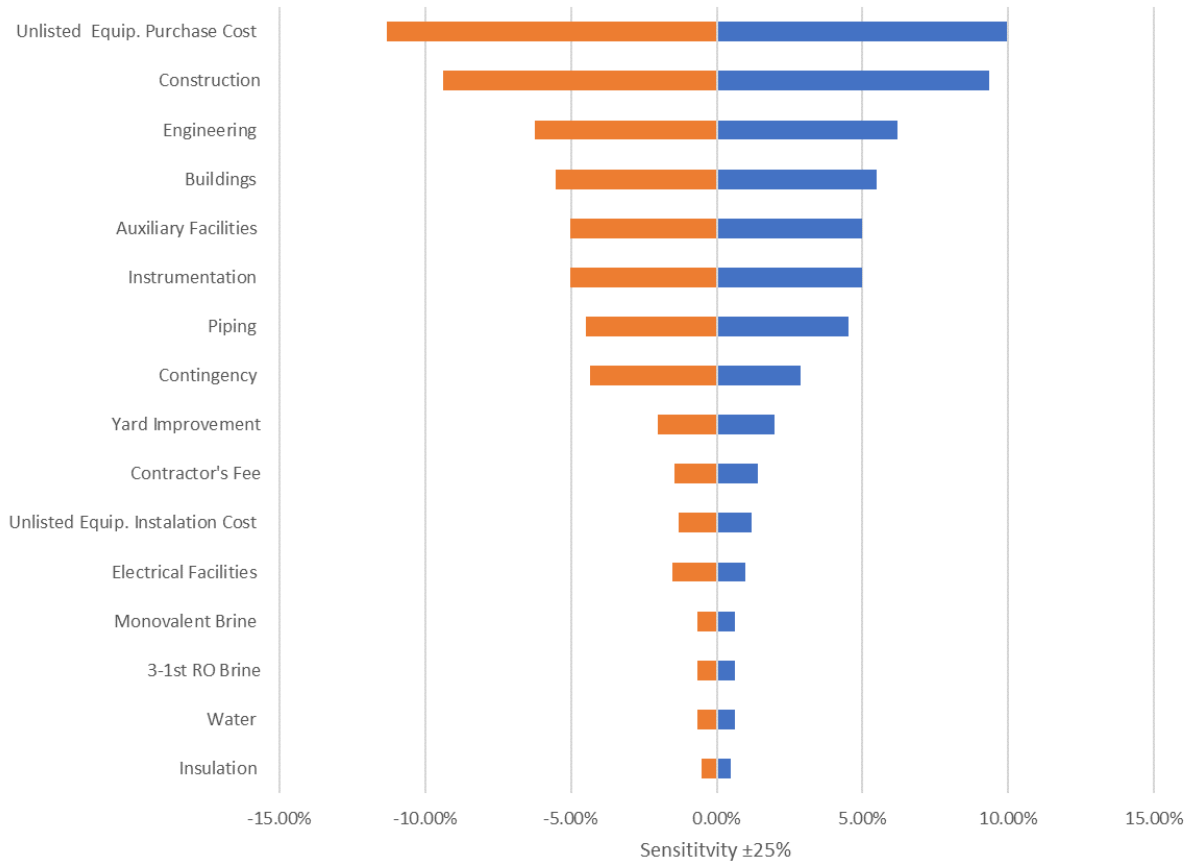

Figure 16 Sensitivity analysis results for NPV. Blue bars represent the change by -25% and orange bars represent the change by +25%.

Figure 16 shows the changes of the NPV in the sensitivity analysis, the maximum variation was around $\pm 12\%$. The final result of the NPV for all scenarios was always a positive value, further suggesting that the project is profitable regardless of the changes in costs. The previous figures showed the impact of the production value of water and monovalent brine on the economic model of the monovalent brine design

Table 21 shows the sensitivity analysis results due to changes in the production costs of the MVR and calcium chloride brines. The production costs of the brines revealed a small impact ($< 3\%$, with the exception of the NPV for the MVR brine design) on both the costs and the profitability of the project. The final production costs of water and brine depend and can change, upon the completion of the desalination plant and NEOM's Brine Complex. A significant increase in the production cost of brine might not hinder the economic feasibility and implementation of the proposed designs.

Table 21 Sensitivity analysis results of the changes in production costs of water and brines for the MVR and Calcium Chloride Brines Designs.

| Sensitivity | -25% | 25% |
|---|--------|--------|
| CAPEX | | |
| MVR Brine | -0.02% | 0.02% |
| CaCl ₂ Brine 1st Boron Clarifier | -0.02% | 0.00% |
| High CaCl ₂ brine Mg extraction | 0.00% | 0.00% |
| OPEX | | |
| MVR Brine | -0.36% | 0.41% |
| CaCl ₂ Brine 1st Boron Clarifier | -0.31% | 0.37% |
| High CaCl ₂ brine Mg extraction | -0.12% | 0.12% |
| Gross Margin | | |
| MVR Brine | 2.85% | -2.93% |
| CaCl ₂ Brine 1st Boron Clarifier | 0.92% | -0.89% |
| High CaCl ₂ brine Mg extraction | 0.32% | -0.28% |
| ROI | | |
| MVR Brine | 0.87% | -0.95% |
| CaCl ₂ Brine 1st Boron Clarifier | 0.54% | -0.49% |
| High CaCl ₂ brine Mg extraction | 0.20% | -0.15% |
| Payback time | | |
| MVR Brine | -0.89% | 0.89% |
| CaCl ₂ Brine 1st Boron Clarifier | -0.41% | 0.61% |
| High CaCl ₂ brine Mg extraction | -0.20% | 0.20% |
| IRR | | |
| MVR Brine | 1.94% | -2.69% |
| CaCl ₂ Brine 1st Boron Clarifier | 1.14% | -0.82% |
| High CaCl ₂ brine Mg extraction | 0.59% | 0.00% |
| NPV | | |
| MVR Brine | 9.26% | -9.26% |
| CaCl ₂ Brine 1st Boron Clarifier | 1.23% | -1.23% |
| High CaCl ₂ brine Mg extraction | 0.42% | -0.42% |

3.3.3. Environmental Assessment Results

The gate-to-gate LCA analysis focused on the environmental impact of the production process of the CAB and the MWB. The total CO₂ emissions from the energy consumption are zero for the three proposed designs, due to the assumption that all three designs will be fully powered by renewable energy.

For the consumption of drinking water, all three designs require 0.5 cubic meters of drinking water per cubic meter of MWB produced. For the monovalent brine design and the calcium chloride brines design the consumption of drinking water is zero per cubic meter of CAB produced. However, for the MVR design the heat exchanger requires either cooling water or a cooling agent. The SuperPro Designer model estimated that around 9.84 cubic meters of cooling water are required for the production of one cubic meter of CAB. An alternative solution to reduce the water consumption for the MVR design will be to construct underground storage to reduce the temperature below 40 °C. An economic comparison between the two MVR solutions would be required to determine what option is more financially feasible.

No additional chemicals or liquid waste are produced during the production process of the proposed designs. Additionally, no solid waste is produced during the production of CAB and MWB. However, on a cradle-to-grave LCA analysis the end of life waste management of the different units (e.g., pumps, storage tanks, etc.) needs to be taken into account. Extending the life of the units through appropriate asset management could help with mitigating potential environmental risks.

The Impact factors (e.g., acidification, global warming potential, eutrophication, etc.) were not included in the gate-to-gate LCA analysis. The impact factors were omitted since most of the input factors are zero or close to zero and there is no waste discharge into the environment. Based on these results both the Monovalent brine design and the calcium chloride brines design have the same environmental impact, but these results will likely change when all of the Sub-processes (Figure 7.4.) are considered in a cradle-to-grave LCA analysis. Assuming that the environmental impact from the desalination plant and from NEOM's brine complex are constant, then the monovalent brine design would be a better design option since the monovalent brine is not processed further at NEOM's brine complex like the MVR brine. Completing a cradle-to-grave LCA is recommended once the final designs of all the sub-processes are completed. Additional

economic gains could potentially be implemented when the final estimation on CO₂ emissions is calculated.

3.4. Discussion

3.4.1. Criteria comparison from techno-economic evaluation results

All Three designs showed to be profitable options from the techno-economic evaluation. The economic and environmental assessment provide more insight for selecting an appropriate design solution that can be implemented at NEOM. A multi-criteria comparison for the three designs is presented on Table 22. This comparison provides an overview that includes the economic, and environmental criterion.

Table 22 Multi-criteria comparison for the technical, economic, and environmental attributes of proposed brine optimization designs.

| Category | Criteria | Monovalent Brine Design | Calcium Chloride Brines Design | MVR Brine Design |
|---------------|---------------------------|-------------------------|--------------------------------|------------------|
| Economic | CAPEX | +++ | ++ | + |
| | OPEX | +++ | ++ | + |
| | Gross Margin | +++ | ++ | + |
| | IRR | +++ | ++ | + |
| | ROI | +++ | ++ | + |
| | Payback Time | +++ | ++ | + |
| Environmental | CO ₂ emissions | +++ | ++ | + |
| | Water Consumption | +++ | ++ | + |
| | Chemical Consumption | +++ | ++ | + |

All three designs worked for the implementation of 3DPC, but the combination of the calcium chloride brines proved to be the most efficient as a concrete accelerator (Chapter 2 and from concrete experiments) and further improving the printing process. A possible bottleneck that needs to be considered is the ongoing development of NEOM's brine complex. The design of the brine complex has not been completed making the availability of this brine an uncertainty. The final availability of the brines could be the one of the major decision making factors for the future implementation of the project.

The monovalent brine has the "lowest" efficiency (Chapter 2 and from concrete experiments) in comparison to the other brines but it ranked higher on the other criterion. This brine is being

produced at the desalination plant whose design and construction are closer to completion. Using this brine also will have an impact on the design of the brine complex, because the monovalent brine is further processed there. Further decreasing the amount of monovalent brine that goes into the brine complex will decrease the capacity of the brine complex which can lead to a reduction of CAPEX and OPEX of the brine complex. If this brine is selected for the production of concrete, the potential impact on the brine complex needs to be considered to identify and quantify other potential economic benefits.

The MVR brine also showed better technical results as a concrete accelerator in comparison with the monovalent brine and almost as good as the calcium chloride brines. This brine might also be widely available once the brine complex is completed. This design had higher costs due to the required cooling and it ranked lower on the environmental impact analysis. However, the project is still profitable and the operation and design could be further optimized to improve the profitability and reduce the environmental impact.

3.4.2. Economic Benefits of Using Brine for the Production of 3DPC

In the context of this project the brine itself becomes two valuable products and this has two economic and financial implications. The first one is that the brine can be sold and revenue is created as presented earlier in the report. The second is that it is no longer treated as a waste that has to be disposed of. This means that NEOM will be saving the costs of brine disposal which can total up to \$580 Million per year in KSA for all of the brine that is produced at NEOM. This additionally saves all of the negative environmental impacts of disposing the brine in a landfill (e.g., the emissions of transporting the brine).

When it comes to brine management processes, the implementation of ZLD is centered around the extraction of salts and minerals, serving as the primary revenue-generating product (Muhammad Yaqub and Lee, 2019). In comparison to those projects, the utilization of brine for concrete requires minimum changes, whereas in the other scenario, more complex and energy-intensive technologies such as crystallizers and evaporators are indispensable (Zhang et al., 2021b). These additional technologies can significantly increase the costs of the project which can make the profitability of the project very challenging (Morillo et al., 2014). Additionally, due to the high energy consumption required for these scenarios, the environmental impact could be higher in comparison with the proposed designs in this study (Al-Karaghoul and Kazmerski, 2013; Morillo et al., 2014).

In the context of 3D concrete printing there are also some economic benefits. In the case of the MWB the selling price cost is the same as drinking water but since most of the revenues come from the CAB then the MWB could be sold a bit cheaper than water to make the product more competitive and attractive in the market. In the case of the CAB the selling price was below the price of commercial calcium chloride concrete accelerator (€ 550-600/ton). This provides NEOM a lot of flexibility at selecting a final selling price for the CAB which can increase the revenues without significantly increasing the final production cost of concrete and make this a very attractive alternative product on the market.

There are two future research prospects that can further provide economic benefits. Currently the printing set-up used at NEOM does not match the printing set-up used for the printing experiments at TU Delft. The printing machine has to be modified to handle two mortars and to have a static mixer installed at the printing nozzle. Additionally, coating against corrosion could be implemented on the printing device to mitigate the potential risk of corrosion since the brine contains high concentration of chloride ions. These changes on the printing device could potentially be patented and sold to future external clients trying to implement 3DPC with brine to create a new revenue stream.

Another research prospect is to recover construction materials at the end-of-life of a 3D concrete printed product. The benefits of this project would be in increasing the circularity of the production process and reducing the environmental footprint even further. The waste management and the construction sector can lead the project.

New services can be developed once the project is successfully implemented at NEOM. The Gulf region and other counties are increasingly relying on desalination for the production of drinking water, therefore creating a need for desalination brine management. NEOM can develop a service to conduct proper feasibility studies of using desalination brine for the production of 3DPC. The water quality of the brine will vary depending on the water quality of the seawater and of the desalination process. The project and the designs cannot be replicated identically in different regions. Replicating a similar feasibility study for clients around the globe could become a potential service to further increase the profitability.

3.4.3. Limitations

One aspect that was not considered in the techno-economic model was the dynamic change in the 3D concrete printing demand over the years. The proposed designs were created for the current

maximum demand projected at NEOM; however, over the years this demand will likely change, especially when NEOM is fully constructed. On the other hand, the designs operate on batch mode where they produce one batch per day. The production cycle can be easily change to increase the amount of batches per day in case the production demand increases. In this scenario no additional units would need to be constructed so there would be no additional CAPEX, the operational costs might increase but mainly from the additional use of energy required for operation. The additional batches produced will also increase the revenue and the profitability of the project.

In the scenario of a decrease in demand, then the production can be controlled accordingly but the revenues from the project will decrease. The development of extra services would become more crucial in these scenarios to ensure other revenue streams are created that are independent from the production of the CAB.

3.5. Conclusions

The three proposed brine optimization processes showed to be profitable options, the monovalent brine being the best economic and environmental option. Selling the CAB at a minimum price of 60 €/m³ revealed a good starting point for making the project profitable without increasing the production price of concrete significantly. The additional insight provided should aid with the final selection of brines for the production of 3D printable concrete.

Chapter 4: Risk Management

4.1. Risk Management Assessment Objectives

For the risk management assessment the following objectives were set :

1. Identify the potential risks for the three proposed designs.
2. Quantify the risks and provide risk mitigation recommendations for the proposed designs.
3. Provide risks comparison between the proposed designs to aid NEOM with the final design selection.

The aim of this objectives is to help answer the following research questions:

1. How can we increase the feasibility of the implementation of 3D printable concrete with desalination brine?
2. What are the potential technical, social, economic, environmental, and safety benefits of using desalination brine for the production of 3D printable concrete?

4.2. Methodology

4.2.1. Failure mode and Effect Analysis Methodology

The failure mode and effect analysis (FMEA) was used to systematically assess the three proposed brine optimization processes in order to identify the potential risks and develop a risk mitigation strategy. The FMEA is intended to be applied during the development of the product and its design stages (Ben-Daya and Raouf, 1996). The FMEA consists of the following steps to identify potential risks:

1. Define the undesired events that will severely impact the process.
2. Identify the modes of Failure that can cause the undesired event to occur.
3. Describe the negative effects that these Failure modes can cause in the process.
4. Identify the root causes that can cause the effects to occur.
5. Rate the severity of the root cause.
6. Determine the probability of occurrence for the root causes.
7. Determine the likely hood of detectability for the root causes.
8. Calculate the Risk Priority Number (RPN) based on the severity, occurrence, and detectability.

9. Prioritize the risks that need to be mitigated based on the RPN.
10. Develop risk mitigation strategies.
11. Optimize the design.

These steps were applied to the proposed designs to achieve the proposed objectives presented on the previous section. Four different brines produced at NEOM (Monovalent brine, MVR, CaCl_2 brine from the 1st boron clarifier, and CaCl_2 brine after the Mg extraction) were selected as the raw material to produce the CAB.

The brines vary in composition, therefore corrosion and scaling will vary between the three proposed designs. PHREEQC was used to model the different brines to determine the saturation index (SI) of several minerals. The results from the model are presented in Appendix C. Based on these results, it was deduced that the Monovalent brine was more prone to corrosion, followed by the MVR brine, and lastly the CaCl_2 brines. Regarding the risk of scaling, the CaCl_2 brines were proven to be more susceptible, followed by the MVR brine and lastly the Monovalent brine. These results were used to rank the severity and the occurrence of these risks for the FMAE analysis.

The three brines are annotated on the FMEA table, as it can be seen in Appendix D, to distinguish the impact between corrosion and scaling. Additionally, as the MVR brine design includes a heat exchanger for cooling during the process, the risks from the heat exchanger were only applicable to this design.

4.2.2. Boundary conditions

Only the brine optimization processes producing MWB and CAB were investigated for the risk management assessment. The sub-process diagram presented in Chapter 2, shows the different design sub-processes that need to be implemented and considered to implement the desalination brine to produce 3D printable concrete.

4.2.3. Undesired events

Three undesired events were identified for the brine optimization processes. The occurrence of these events can have a negative impact on a technical, environmental, safety and health, and economic aspects of the project. The undesired events are presented below:

1. Reduced production of CAB
2. Leakage of brine and environmental contamination
3. Contamination of CAB that can negatively impact the material properties of concrete.

4.2.4. Modes of Failures, Effects and Root Causes

The modes of failure, effects and root causes that can lead to the undesired events are presented in the FMEA table found in appendix D.

4.2.5. Severity

The severity rating of the root causes were done according to the FMEA rating presented in Table 23. Additionally, the impact on safety, health, environment, economic, and technical were considered to aid with the proper selection of the severity score allocated to each root cause, as seen in Appendix D.

Table 23 Severity Scores for FMEA, adapted from Ben-Daya and Raouf, 1996.

| Severity | Score |
|-----------------------------------|-------|
| Customer will probably not notice | 1 |
| Slight annoyance | 2-3 |
| Customer dissatisfaction | 4-6 |
| High degree of dissatisfaction | 7-8 |
| Safety-regulatory consequences | 9-10 |

4.2.6. Probability of Occurrence

The occurrence score allocation for each of the root causes on the FMEA table was done according to Table 24. The calculated SI values from PHREEQC presented in Appendix C, were used as additional information to allocate the appropriate score for scaling and corrosion caused by the different brines.

Table 24 Occurrence score rating for FMEA, adapted from Ben-Daya and Raouf, 1996.

| Chance of occurrence | Score | Occurrence Rates |
|--------------------------|-------|------------------|
| Remote chance of failure | 1 | 0 |
| Low failure rate | 2 | 1/20,000 |
| | 3 | 1/10,000 |
| Moderate failure rate | 4 | 1/2,000 |
| | 5 | 1/1,000 |
| | 6 | 1/200 |
| High failure rate | 7 | 1/100 |
| | 8 | 1/20 |
| Very high Failure rate | 9 | 1/10 |
| | 10 | 1/2 |

4.2.7. Detectability

The scoring of the detectability was done in accordance with Table 25.

Table 25 Detectability scores rating for FMEA, adapted from Ben-Daya and Raouf, 1996.

| Chance of not detecting a fault | Score | Probability (%) of an individual defect reaching the costumer |
|---------------------------------|-------|---|
| Remote | 1 | 0-5 |
| Low | 2 | 6-15 |
| | 3 | 16-25 |
| Moderate | 4 | 26-35 |
| | 5 | 36-45 |
| | 6 | 46-55 |
| High | 7 | 56-65 |
| | 8 | 66-75 |
| Very High | 9 | 76-85 |
| | 10 | 86-100 |

4.3. Results & Discussion

4.3.1. Risk Priority Number comparison for the proposed designs

The calculated RPN values are presented in the FMEA table in Appendix D. A high RPN value means that more attention needs to be paid to mitigate any associated risk. Table 26 to Table 28 summarize the high RPN values (RPN > 100) for the different failure modes and root causes considering the three undesired events mentioned. Additionally, the different designs can be compared for the three undesired events. Overall, the biggest risk seems to be the risk of corrosion and scaling. However, the rating was different between scaling and corrosion since the severity changes in relation to the undesired event. For example, the severity of scaling is higher in the case of CAB contamination, in relation to the severity of scaling for the undesired event of brine leakage. The different RPNs were able to provide additional insight into the three undesired events. The MVR brine design has a heat exchanger used for cooling as seen on the schematic diagram given in Appendix A. That is why the RPN for the other two designs for the heat exchanger are zero. Overall, the MVR brine design had a higher RPN for corrosion and scaling. The SI calculated by PHREEQC (Appendix B) of magnesium minerals (Chrysotile and Sepiolite) had a value higher than 1, indicating that precipitation of these minerals can occur which can result in scaling. In the case of corrosion, most of the other minerals and components present in the MVR brine had a

saturation index less than -1. More specifically sulfur had a saturation index of -17.07. The latter calculations, can indicate that the MVR brine could be more prone to corrosion.

The monovalent brine was less prone to corrosion in comparison with the MVR brine. The monovalent brine does not seem to be very prone to scaling; however, the risk is not zero since magnesium and calcium are still present in the brine. The calcium chloride brine is more likely to show scaling from magnesium, however the concentration of magnesium is relatively low (~0.20 mg/L) in this brine in comparison with the concentration of calcium which is significantly high (~86,086.98 mg/L). However, the concentration of other elements are relatively low and hence, not a lot of calcium compounds can be formed to lead to severe scaling issues. Regarding the risk of corrosion, the risk seems to be lower in the case of the calcium chloride brine in comparison with the other two brines.

Table 26 Risk Priority Number comparison for the undesired event of "reduction of CAB production" for the proposed designs.

| Undesired Event | Failure Mode | Root Cause | RPN | | |
|-----------------------------|-----------------------|------------|------------|-----|------------------|
| | | | Monovalent | MVR | Calcium Chloride |
| Reduction of CAB Production | Pump Failure | Corrosion | 180 | 252 | 120 |
| | | Scaling | 100 | 210 | 150 |
| | Electrical Failure | Fire | 180 | 180 | 180 |
| | Pipe Damage | Corrosion | 180 | 252 | 120 |
| | | Scaling | 100 | 210 | 150 |
| | Heat Exchanger Damage | Corrosion | 0 | 252 | 0 |
| | | Fouling | 0 | 240 | 0 |
| | | Scaling | 0 | 210 | 0 |

The reduction of CAB production could potentially harm the economic feasibility of the project. A significant reduction of CAB produced and sold would reduce the revenues from the project since they are linearly correlated. Besides corrosion and scaling, the potential electrical failure could cause a stop or reduce the production rate of CAB. The biggest risk that could potentially cause the latter, is the risk of a fire. However, the occurrence of a fire is relatively low compared to the risk of other root causes.

Table 27 Risk Priority Number comparison for the undesired event of "Brine leakage, product loss, and environmental contamination" for the proposed designs.

| Undesired Event | Failure Mode | Root Cause | RPN | | |
|--|-----------------------------|------------|------------|-----|------------------|
| | | | Monovalent | MVR | Calcium Chloride |
| Brine leakage, product loss, environmental contamination | Pump Failure/Damage | Corrosion | 210 | 288 | 144 |
| | | Scaling | 120 | 240 | 175 |
| | Storage Tank Failure/Damage | Corrosion | 210 | 288 | 144 |
| | | Scaling | 120 | 240 | 175 |
| | Pipe Damage | Corrosion | 210 | 288 | 144 |
| | | Scaling | 120 | 240 | 175 |
| | Heat Exchanger Damage | Corrosion | 0 | 210 | 0 |
| | | Fouling | 0 | 200 | 0 |
| | | Scaling | 0 | 175 | 0 |

In the occurrence of brine leaking, the negative impact would be mainly towards the environment and the economic feasibility of the project. If substantial amounts of brine are leaked, then it could potentially have a negative impact on the soil quality due to the high concentration of salts (Al-Hazmi et al., 2023). If small quantities of brine are spilled then proper actions need to be taken to minimize or prevent any risk of environmental contamination. In the case of economic feasibility, is the economic impact is similar to the previous undesired event, in which the loss of product will linearly decrease the revenue of the project.

Table 28 Risk Priority Number comparison for the undesired event of "CAB and MWB contamination or change in composition" for the proposed designs.

| Undesired Event | Failure Mode | Root Cause | RPN | | |
|--|-----------------------------|----------------------|------------|-----|------------------|
| | | | Monovalent | MVR | Calcium Chloride |
| CAB contamination or change in composition | Pump Failure/Damage | Corrosion | 180 | 252 | 120 |
| | | Scaling | 100 | 210 | 150 |
| | Storage Tank Failure/Damage | Corrosion | 180 | 252 | 120 |
| | | Scaling | 100 | 210 | 150 |
| | | Microorganism Growth | 160 | 160 | 160 |
| | Pipe Damage | Corrosion | 180 | 252 | 120 |
| | | Scaling | 100 | 210 | 150 |
| | | Microorganism Growth | 160 | 160 | 160 |
| | Heat Exchanger Damage | Corrosion | 0 | 252 | 0 |
| | | Fouling | 0 | 240 | 0 |
| | | Scaling | 0 | 210 | 0 |
| | | Microorganism Growth | 0 | 160 | 0 |

For the last undesired event, the contamination of the final brine products can have a negative impact on both the health of individuals and the economic feasibility of the project. Microorganism growth can pose a severe threat to the health of workers, especially in the case of the cooling system for the MVR brine design. Legionella growth and exposure of workers are possible if the conditions are favorable in the cooling system. This could pose severe health impact, therefore the risk needs to be prevented and mitigated as much as possible. Additionally, the contamination of brine with organics can potentially harm or change the material properties of concrete. Concrete standards for the production of unreinforced concrete recommend that the concentration of organic matter should be below 200 mg/L (Reddy Babu et al., 2018). A Highly contaminated brine will have to be discarded which will cause a reduction in the revenue. Additional costs might also arise since any discarded brine would need to be treated and managed according to the zero liquid discharge regulations at NEOM.

4.3.2. Actions and responsibilities

Corrosion, scaling, fouling, and microorganism growth are very well studied phenomena with already multiple options to mitigate the risks they might pose. Table 29 shows a list of multiple

actions that can be taken to control the risks presented. However, some of these mitigation techniques need to be carefully selected because if selection is done improperly, that might cause further damage. In the case of mitigation through chemical dosage, the type of chemicals used and the concentrations need to be accounted for in case they could end in the brine used for the concrete production. There is a possibility that these chemicals might have an impact on the material properties of the concrete, and hence they need to be accounted for.

Table 29 Actions to mitigate and prevent risks.

| Risk | Actions for risk mitigation and prevention | References |
|----------------------------|--|---|
| Corrosion | <ul style="list-style-type: none"> • Use of corrosion resistant materials • Applications of coatings • Cathodic protection • Sacrificial nodes • Application of chemical corrosion inhibitors | (Flynn, Daniel J. Nalco, 2009) |
| Scaling | <ul style="list-style-type: none"> • pH depression • Softening • Chemical treatment • Antiscalant dosing | (Flynn, Daniel J. Nalco, 2009) |
| Microorganism Growth | <ul style="list-style-type: none"> • Changing operational conditions • Cleaning in place • Use of oxidizing biocides • Use of nonoxidizing biocides • Use of biodispersants and biodetergents | (Flynn, Daniel J. Nalco, 2009) |
| Fouling for heat exchanger | <ul style="list-style-type: none"> • Mechanical Cleaning • Thermal treatment/thermal backwash • Implementation of screens and strainers • Ultrasonic vibration • Electrical shock • Oxidizing antimicrobials • Nonoxidizing antimicrobials • Appropriate heat exchanger design and selection | (Flynn, Daniel J. Nalco, 2009; Müller-Steinhagen, 1999; Veolia, 2023) |

For corrosion, the mitigation strategy can start by selecting the appropriate material, usually stainless steel. An additional coating layer can be implemented for protection. In terms of chemical dosing, polyphosphate could be used for corrosion and scaling control as well. The required dosing of polyphosphate is relatively low, around 0.5 mg/L (Flynn, Daniel J. Nalco, 2009); the impact of the phosphate on the material properties of concrete is expected to be negligible due to the low dosing. The recommended tolerable limit for phosphate used in mixing water for unreinforced concrete is less than 100 mg/L (Reddy Babu et al., 2018).

Scaling mitigation can be done by controlling the system's pH, temperature, and pressure to prevent saturated minerals from precipitating. It can also be done by treating the water and removing the ions responsible for scaling, typically calcium and magnesium. The removal of calcium is not an option since the calcium concentration is important for the changes of the material properties of concrete required for the 3D printing process. Additionally, adding a treatment technology (e.g., ion exchange) to remove calcium or magnesium will likely end up creating a new brine stream that will need to be also treated to comply with the zero liquid discharge regulations at NEOM. The last option for corrosion mitigation would be to dose antiscalants like polyphosphate. As mentioned, the benefit of polyphosphate is that it can work for both corrosion and scaling mitigation.

The addition of chemicals needs to be justified and executed properly for multiple reasons. From a technical point of view, the appropriate dosage concentration of chemicals needs to be determined as overdosing can cause additional issues or even promote the risks of scaling and corrosion (Flynn, Daniel J. Nalco, 2009). Any residual chemicals will also have to be accounted for to determine if these added chemicals will have any impact on the concrete. From an economic standpoint, it will be an added cost whoever this is typically justified by the savings of avoiding scaling and corrosion. In some systems the costs of corrosion and scaling can escalate to millions of dollars (Olsen et al., 2000). From a sustainability perspective, the chemical consumption would have to be considered in terms of emissions emitted by the production and transportation in a cradle-to-grave LCA.

Under the appropriate conditions microorganisms can grow and thrive. Operational parameters are important to be considered while trying to avoid the growth of microorganisms. For example, mesophilic bacteria thrive at temperatures between 20 and 45 °C, a temperature required for the production of CAB and MWB. Other operational parameters like retention time, pH, and dissolved

oxygen can also have a considerable influence on the microorganism growth. Additionally, the composition of the brine plays a role in the potential growth of microorganisms. For example, algae can thrive when nitrogen or phosphorus are present in the system at the right concentrations. In case the brine becomes contaminated, biocides can be used to eradicate any unwanted microorganisms in the system by conducting a cleaning in place procedure.

Fouling is a complex phenomenon to which multiple variables can contribute and influence the degree of fouling (Envaqua, 2022). Figure 17 shows the different mechanisms that can impact micro and macrofouling in a cooling system. For the MVR brine design, the risk of fouling can pose a significant risk for the heat exchanger for cooling. If the MVR brine design is selected, proper precaution measures will need to be taken. Additionally, for the FMEA table the risks were investigated independently however, e.g., corrosion can increase the changes of fouling in the system and vice-versa (Flynn, Daniel J. Nalco, 2009).

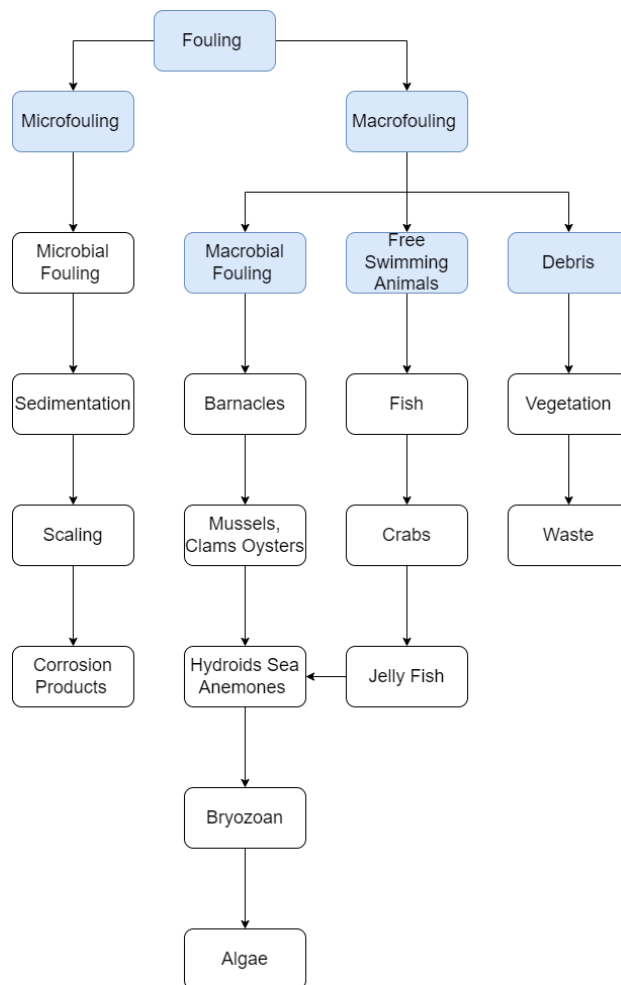

Figure 17 Micro and Macrofouling, adapted from Envaqua, 2022.

The MVR brine design is placed after NEOM's brine complex as seen in the sub-process diagram in Chapter 2. Due to this reason the brine is already processed at the desalination plant and the brine complex, which will likely remove the source mechanisms (e.g., mussel contamination from seawater, waste in the system) that can potentially cause any macrofouling in the cooling system. The system is expected to be more prone to microfouling due to corrosion, scaling, and/or microbial growth. Different actions will have to be taken depending on the mechanisms causing the fouling. Unfortunately, fouling is usually not detected until it shows signs of malfunction in the system. Proper monitoring and expertise will be required to handle fouling.

4.3.3. Limitations

The FMEA study completed is a qualitative study; more information, experiments and data need to be gathered to perform a quantitative research with results that can provide more insight into the propensity of the possible risk and how to further improve the design against any risk. Additionally, the risks were treated as independent from each other, while in an actual system multiple risks can arise at the same time or the occurrence of one risk could potentially trigger another. A quantitative risk management method will be required once more data and information are available. However, this study aimed at identifying the possible root causes that can lead to the undesired events presented.

4.3.4. Risk Management Recommendations

The RPN comparison between the three designs provided further insight to aid with the most suitable design selection. Table 30 shows the criteria and comparison developed from the risk management study. While all three designs are still viable options that can be implemented at NEOM, the MVR brine design seems to be the least favorable option due to the additional risks considering the heat exchanger and since the brine could be more corrosive and prone to scaling compared to the other two options. In terms of risks, the calcium chloride brine option seems to be the most promising option. This design might be more prone to scaling, however this risk is probable low due to the lack of carbonate, sulphate and other ions that can precipitate along with the calcium. Pilot trials and additional testing might be required to provide more data that can further analyze these risks. Additionally, The calcium chloride brine had the best technical results for the material properties of the 3D printable concrete and thus it is proven to be a very favorable design option.

Table 30 Comparison from the techno-economic evaluation and risk management assessment of proposed brine production design processes for 3D printable concrete.

| Category | Criteria | Monovalent Brine Design | Calcium Chloride Brines Design | MVR Brine Design |
|----------|-----------|-------------------------|--------------------------------|------------------|
| Risks | Corrosion | ++ | +++ | + |
| | Scaling | +++ | ++ | + |
| | Fouling | +++ | +++ | + |

Once the brines are produced at NEOM, additional testing will be required to improve the implementation of the design. For example, different materials can be tested to reduce the risk of corrosion. If chemicals are to be used, then additional research will be required to identify the right dosage concentration of the chemical in question and to determine if any change in brine composition will impact differently the material properties of brine. Once a pilot is in place, the operation should be closely monitored to optimize the process and reduce the potential risks.

4.4. Conclusions Risk Management

The FMEA presented in this study, provided additional information to evaluate the proposed brine designs developed, with the goal of producing the CAB and MWB required for 3D concrete printing. The scope of the study was to identify potential risks and their root causes that can reduce the feasibility of using brine for the production of concrete. The major risks identified for the three designs were corrosion, scaling and contamination of the brine with microorganisms. Additionally, for the MVR brine design the potential risk of fouling was identified for the heat exchanger placed in this design. On the other hand, these risks are widely studied and multiple options to prevent and mitigate the risks are available. Pilot studies can further provide the data required to identify the necessary actions to prevent the risks more effectively, however this study provides an initial risk mitigation framework that can be used for further development.

Beyond the identification of risks, the study provided extra information that can assist with the final selection of the brine optimization process that can be implemented at NEOM. In general, the MVR brine design is prone to encountering a higher degree of risks, primarily because of the brine's composition and the heat exchanger involved in the design. The calcium chloride brine design is the best design option according to the results from the FMEA study. However, no major risks were identified that can make any of the brine optimization processes obsolete. Any option

can be implemented successfully at NEOM while still taking the proper actions required to mitigate any associated risks.

Chapter 5: Conclusions and Recommendations

5.1. Conclusions

This study showed that three possible brine optimization processes could be implemented successfully to produce the required brine for the production of 3D printable concrete. The concrete experiments also showed that minor modifications, mainly for the temperature are needed. Removal, concentration of the brine, or recovery of other resources were not required therefore additional brine treatment technologies like crystallizers, concentrators, and membrane technologies were not required.

The other important aspect was that the design and the operation was dictated by the technical requirements from the 3D printable concrete process. Batch operation was selected to accommodate the according to the required printing process. Additionally the amount of brine allocated for the printing is also limited to the demand of 3D printable concrete. This solution can successfully manage the brine but it will not cover the entire expected production of brine needed. 3D printable concrete is still a specialized type of concrete so increased the applicability of brine in the general production of concrete can be beneficial to manage more of the produced brine at NEOM. If different requirements are developed from the concrete industry then multiple brines with different compositions could be used to satisfied the different needs in the construction industry.

The study showed that multiple technical design options can be implemented while also complying with Zero Liquid Discharge mandates and without creating new waste streams. This was also due to the different brines that worked as a concrete accelerator.

In the study it was shown that a range of brine characterizations can be successfully applied and depending on the boundary conditions of the concrete requirements some can work better than others. In the context of 3D printable concrete it was shown that a brine for concrete accelerator and a brine for mixing water were required. For the mixing water brine there was a maximum limit concentration for chloride of 11,803 mg/L. For the other ions it was not conclusive what was the specific limit for the mixing water brine. Additional research would be required to look at the specific concentrations and how it would impact the different mechanisms that alter the material properties of concrete if an specific limitation needs to be found.

In the case of the concrete accelerator brine, multiple brines worked sufficiently to aid with the 3D concrete printing process. This made it harder to define specific ranges so not one final target concentration was defined. However, the experiments with all of the different brines created sufficient information to understand how the concrete material properties will behave depending on the selected brine used as a concrete accelerator. Further defining concrete requirements at NEOM can aid with selecting which brine or brines can be used for the production of 3D printable concrete. One clear observation was the temperature requirements for both the concrete accelerator brine and the mixing water brine. High brine temperatures (>30 °C) can impact the printing process and cause issues like clogging in the pumps of the 3D printer.

The results from the concrete experiments, the technical design for the BOP, the techno-economic evaluation, and the risk management evaluation provided additional input to select the brines produced at NEOM and the final BOP to be selected for construction in the future. These assessments also showed additional insights on the feasibility of applying the concrete accelerator brine and the mixing water brine to produce 3D printable concrete. All three proposed designs for the BOP met the desired requirements, there was no potential bottleneck that could impact the implementation of the BOP. However, there were significant differences between the three options. Table 31 summarizes the criteria comparison for the technical, economic, environmental, and risks developed in the previous chapters.

Table 31 Summary of multi-criteria comparison developed in the previous chapters for the final selection of the BOP to be implemented at NEOM. The specific numbers correspond to the actual value of the criteria. The criteria with no specific values were ranked with the “+” symbol. An allocation of “+++” means that the specific design ranked the best for the specific criteria.

| Category | Criteria | Monovalent Brine Design | Calcium Chloride Brines Design | MVR Brine Design |
|---------------|-------------------------------------|-------------------------|--------------------------------|------------------|
| Technical | PBM Dynamic Yield stress (Pa) | 1621.8 | 2021.2 | 2082.3 |
| | PBM Plastic Viscosity (Pa.s) | 14.4 | 23.6 | 34.6 |
| | Concrete Initial Setting Time (min) | 105.7 | 69.5 | 66.0 |
| | Concrete Buildability (17 layers) | Yes | Yes | Yes |
| | Concrete Static Yield Stress (Pa) | 54.7 | 38.4 | 173.6 |
| | 28 Days Compressive Strength (MPa) | 36.3 | 38.4 | 31.7 |
| | Brine Availability | +++ | + | ++ |
| | BOP Technology Readiness Level | 6 | 6 | 6 |
| | Zero Liquid Discharge | Yes | Yes | Yes |
| Economic | CAPEX | +++ | ++ | + |
| | OPEX | +++ | ++ | + |
| | Gross Margin | +++ | ++ | + |
| | IRR | +++ | ++ | + |
| | ROI | +++ | ++ | + |
| | Payback Time | +++ | ++ | + |
| Environmental | CO ₂ emissions | +++ | ++ | + |
| | Water Consumption | +++ | ++ | + |
| | Chemical Consumption | +++ | ++ | + |
| Risks | Corrosion | ++ | +++ | + |
| | Scaling | +++ | ++ | + |
| | Fouling | +++ | +++ | + |

For the technical results the calcium chloride brines acted as the best concrete accelerator in comparison to the other two brines. The highest concrete compressive strength was obtained with this brine, which can be a benefit while developing 3D printable concrete products and projects. The second brine that worked the best as a concrete accelerator was the MVR brine and lastly the monovalent brine.

A general advantage of the three designs is that complex brine management technologies (e.g., membranes, crystallizers, evaporators, etc.) are not required. This was possible from the concrete experiments that clearly quantified the technical value of brine as a concrete accelerator. The omission of brine management technologies also adds the benefit of not creating new waste streams and minimizing the amount of technology replacement and maintenance over the lifetime of the BOP. The technology readiness level can easily be increased by having pilot to test the real brine and further validating the conceptual process design presented in this study.

Based on the results from the techno-economic evaluation, the best BOP option is the monovalent brine design. All three options were profitable, and the selling price of the CAB can be adjusted to obtain the maximum profits while still having a competitive product in the market. Based on the economic assessment the second best option was the calcium chloride brines BOP. This option was slightly less profitable (approximately by 3.2%) in comparison to the monovalent brine design because it was assumed that the initial production costs of the calcium chloride brines from NEOM's brine complex would be higher than the production costs of the monovalent brine from the desalination plant. In the case of the MVR brine design the costs were higher due to the additional heat exchanger required to modify the temperature. This design was less profitable by approximately 35.2% in comparison to the monovalent brine design.

From an environmental standpoint, all of the options met the requirements of Zero Liquid Discharge and to not generate new waste streams. The biggest drawback found was the water consumption required for cooling in the MVR brine design. For the monovalent brine design and the calcium chloride brines design for the gate-to-gate LCA, the results were the same. However if you considered a cradle-to-grave LCA, then the results will likely vary, especially since the monovalent brine comes from the desalination plant and the calcium chloride brines come from the brine complex. If the monovalent brine design is selected then the brine used for the concrete will not have to be further processed at the brine complex, meaning that the emissions and material consumptions from the brine complex will be omitted.

Lastly for the risk assessment the MVR brine will likely be the most challenging brine to manage for two reasons. The first reason is due to the brine composition itself. This brine has really high concentration of ions that can cause scaling and corrosion and also more variety of ions are present in comparison to the calcium chloride brines. The second reason is the additional risks from the heat exchanger, in particular the risk of fouling. The risk of fouling is completely omitted in the

other two design options. The main difference in the risks comes from the composition of the three different brines, close attention needs to be placed to further quantify and mitigate any potential risks.

All design solutions developed for the BOP proved to be acceptable solutions that can be implemented at NEOM. However all of the results presented clearly indicate the differences between the solutions. The MVR brine design shows to be the least preferable solutions from the economic, environmental, and risk assessments. The monovalent brine solution and the calcium chloride brines solution had similar results for the economic, environmental, and risk assessments, the biggest distinction was from the technical results of the impact of the brine on the material properties of concrete. Based on this study the best BOP to be implemented at NEOM could be the calcium chloride brine design.

5.2. Recommendations

The conceptual design presented is quite simple but further validation needs to be done to optimize the design. Additionally, only synthetic brine was used for concrete experiments. The presence of chemicals like antiscalants from the desalination process or the brine complex were not taken into consideration. The presence of organic chemicals could have a negative impact on the material properties of concrete. It is important to first validate the results of the concrete experiments with the real brine that can have a more complex water matrix than the synthetic brine.

Once the results are validated with the real brine, then the next step would be to determine if changes need to be done to the conceptual design of the BOP. If no changes are required to the design, then a pilot can be commissioned to validate the proposed BOP. It is recommended that the pilot of the BOP is coupled with the pilot of the desalination plant or the brine complex and then with the printing process. Coupling these processes in a pilot scale as presented in the sub-process diagram will allow to identify any potential bottlenecks at any step of the process (From brine production until 3D printable concrete production). Additionally, the pilot data collected can be utilized to optimize the process design (e.g., the storage sizing) , the operation (e.g., the amount of batches per day), and the risk mitigation strategies for full scale implementation.

The risk management can be further expanded and it can be coupled with the techno-economic evaluation by quantifying the economic risks and creating asset management solutions to expand the lifespan of the design and creating a proper maintenance strategy to reduce and prevent risks.

Additionally, a cradle-to-grave LCA of all process needs to be further develop to quantify any environmental impacts. The results of the LCA can also be used to further expand on the social and economic benefits of using brine for 3D concrete printing. Comparing to the current processes used in the market has to be done with caution. A proper base case scenario needs to be developed if the proposed technical solution is going to be compared with another solution. Overall this study successfully showed the first step of applying desalination brine for the production of 3D printable concrete.

References

- Abdel-Karim, A., Leaper, S., Skuse, C., Zaragoza, G., Gryta, M. and Gorgojo, P.: Membrane cleaning and pretreatments in membrane distillation – a review, *Chem. Eng. J.*, 422(March), 129696, doi:10.1016/j.cej.2021.129696, 2021.
- Al Abdulgader, H. and Rushd, S.: Advancements in unconventional seawater desalination technologies, *Corros. Fouling Control Desalin. Ind.*, 71–95, doi:10.1007/978-3-030-34284-5_4, 2020.
- Adham, S., Hussain, A., Matar, J. M., Dores, R. and Janson, A.: Application of Membrane Distillation for desalting brines from thermal desalination plants, *Desalination*, 314, 101–108, doi:10.1016/j.desal.2013.01.003, 2013.
- Ahmed, F. E., Hashaikeh, R. and Hilal, N.: Hybrid technologies: The future of energy efficient desalination – A review, *Desalination*, 495(August), 114659, doi:10.1016/j.desal.2020.114659, 2020.
- Al-Amshawee, S., Yunus, M. Y. B. M., Azoddein, A. A. M., Hassell, D. G., Dakhil, I. H. and Hasan, H. A.: Electrodialysis desalination for water and wastewater: A review, *Chem. Eng. J.*, 380(March 2019), doi:10.1016/j.cej.2019.122231, 2020.
- Al-Hazmi, H. E., Mohammadi, A., Hejna, A., Majtacz, J., Esmaili, A., Habibzadeh, S., Saeb, M. R., Badawi, M., Lima, E. C. and Maĳinia, J.: Wastewater reuse in agriculture: Prospects and challenges, *Environ. Res.*, 236(May), doi:10.1016/j.envres.2023.116711, 2023.
- Al-Karaghoulı, A. and Kazmerski, L. L.: Energy consumption and water production cost of conventional and renewable-energy-powered desalination processes, *Renew. Sustain. Energy Rev.*, 24, 343–356, doi:10.1016/j.rser.2012.12.064, 2013.
- Al-Najar, B., Peters, C. D., Albuflasa, H. and Hankins, N. P.: Pressure and osmotically driven membrane processes: A review of the benefits and production of nano-enhanced membranes for desalination, *Desalination*, 479(November 2019), doi:10.1016/j.desal.2020.114323, 2020.
- Alhaj, M., Hassan, A., Darwish, M. and Al-Ghamdi, S. G.: A techno-economic review of solar-driven multi-effect distillation, , doi:10.5004/dwt.2017.21297, n.d.
- Alkhudhiri, A., Darwish, N. and Hilal, N.: Membrane distillation: A comprehensive review, *Desalination*, 287, 2–18, doi:10.1016/j.desal.2011.08.027, 2012.
- Azimibavil, S. and Jafarian, A.: Heat transfer evaluation and economic characteristics of falling

film brine concentrator in zero liquid discharge processes, *J. Clean. Prod.*, 285, 124892, doi:10.1016/j.jclepro.2020.124892, 2021.

Bartholomew, T. V., Mey, L., Arena, J. T., Siefert, N. S. and Mauter, M. S.: Osmotically assisted reverse osmosis for high salinity brine treatment, *Desalination*, 421(December 2016), 3–11, doi:10.1016/j.desal.2017.04.012, 2017.

Bello, A. S., Zouari, N., Da'ana, D. A., Hahladakis, J. N. and Al-Ghouti, M. A.: An overview of brine management: Emerging desalination technologies, life cycle assessment, and metal recovery methodologies, *J. Environ. Manage.*, 288(August 2020), 112358, doi:10.1016/j.jenvman.2021.112358, 2021.

Caltran, I., Rietveld, L. C., Shorney-Darby, H. L. and Heijman, S. G. J.: Separating NOM from salts in ion exchange brine with ceramic nanofiltration, *Water Res.*, 179, 115894, doi:10.1016/j.watres.2020.115894, 2020.

Chen, Q., Akhtar, F. H., Burhan, M., M. K. and Ng, K. C.: A novel zero-liquid discharge desalination system based on the humidification-dehumidification process: A preliminary study, *Water Res.*, 207, 117794, doi:10.1016/j.watres.2021.117794, 2021.

Chen, Y., Toosumran, N., Chehab, N., Spanjers, H. and Çopuroğlu, O.: Feasibility study of using desalination brine to control the stiffness and early-age hydration of 3D printable cementitious materials, *J. Clean. Prod.*, 378(June), 134522, doi:10.1016/j.jclepro.2022.134522, 2022.

Cipolletta, G., Lancioni, N., Akyol, Ç., Eusebi, A. L. and Fatone, F.: Brine treatment technologies towards minimum/zero liquid discharge and resource recovery: State of the art and techno-economic assessment, *J. Environ. Manage.*, 300(May), 113681, doi:10.1016/j.jenvman.2021.113681, 2021.

Das, P., Dutta, S. and Singh, K. K.: Insights into membrane crystallization: A sustainable tool for value added product recovery from effluent streams, *Sep. Purif. Technol.*, 257(September 2020), 117666, doi:10.1016/j.seppur.2020.117666, 2021.

von Eiff, D., Wong, P. W., Gao, Y., Jeong, S. and An, A. K.: Technical and economic analysis of an advanced multi-stage flash crystallizer for the treatment of concentrated brine, *Desalination*, 503(December 2020), 114925, doi:10.1016/j.desal.2020.114925, 2021.

Etxeberria, M., Gonzalez-Corominas, A. and Pardo, P.: Influence of seawater and blast furnace cement employment on recycled aggregate concretes' properties, *Constr. Build. Mater.*, 115, 496–505, doi:10.1016/j.conbuildmat.2016.04.064, 2016.

Ghenai, C., Kabakebji, D., Douba, I. and Yassin, A.: Performance analysis and optimization of hybrid multi-effect distillation adsorption desalination system powered with solar thermal energy for high salinity sea water, *Energy*, 215, 119212, doi:10.1016/j.energy.2020.119212, 2021.

Gilron, J., Ramon, E., Assaf, N. and Kedem, O.: Wind-aided intensified evaporation (WAIV): An environmentally sustainable method for brine management, Elsevier Inc., 2018.

Gokulanathan, V., Arun, K. and Priyadarshini, P.: Fresh and hardened properties of five non-potable water mixed and cured concrete: A comprehensive review, *Constr. Build. Mater.*, 309(October), 125089, doi:10.1016/j.conbuildmat.2021.125089, 2021.

Gräber, Y., Nativ, P. and Lahav, O.: A pre-treatment concept for increasing the recovery ratio of coastline BWRO plants, while providing Mg²⁺ in the product water, *Desalination*, 515(April), doi:10.1016/j.desal.2021.115202, 2021.

Gude, V. G. 1978-T. A.-T. T.-: Emerging technologies for sustainable desalination handbook LK - <https://tudelft.on.worldcat.org/oclc/1031847455>, [online] Available from: <http://www.dawsonera.com/depp/reader/protected/external/AbstractView/S9780128167120>, 2018.

Hamawand, I., Lewis, L., Ghaffour, N. and Bundschuh, J.: Desalination of salty water using vacuum spray dryer driven by solar energy, *Desalination*, 404, 182–191, doi:10.1016/j.desal.2016.11.015, 2017.

Harmsen, J., Swinkels, P. L. J. and de Haan, A. B.: Product and Process Design, Walter de Gruyter GmbH., 2018.

Helfer, F., Lemckert, C. and Anissimov, Y. G.: Osmotic power with Pressure Retarded Osmosis: Theory, performance and trends - A review, *J. Memb. Sci.*, 453, 337–358, doi:10.1016/j.memsci.2013.10.053, 2014.

Hilal, N., Al-Zoubi, H., Mohammad, A. W. and Darwish, N. A.: Nanofiltration of highly concentrated salt solutions up to seawater salinity, *Desalination*, 184(1–3), 315–326, doi:10.1016/j.desal.2005.02.062, 2005.

Hilal, N., Kochkodan, V., Al Abdulgader, H., Mandale, S. and Al-Jlil, S. A.: A combined ion exchange-nanofiltration process for water desalination: I. sulphate-chloride ion-exchange in saline solutions, *Desalination*, 363, 44–50, doi:10.1016/j.desal.2014.11.016, 2015a.

Hilal, N., Kochkodan, V., Al Abdulgader, H. and Johnson, D.: A combined ion exchange-nanofiltration process for water desalination: II. Membrane selection, *Desalination*, 363, 51–57,

doi:10.1016/j.desal.2014.11.017, 2015b.

Intelligen: SuperPro Designer Manual, , (908), 2021.

Ji, X., Curcio, E., Al Obaidani, S., Di Profio, G., Fontananova, E. and Drioli, E.: Membrane distillation-crystallization of seawater reverse osmosis brines, *Sep. Purif. Technol.*, 71(1), 76–82, doi:10.1016/j.seppur.2009.11.004, 2010.

Joo, S. H. and Tansel, B.: Novel technologies for reverse osmosis concentrate treatment: A review, *J. Environ. Manage.*, 150, 322–335, doi:10.1016/j.jenvman.2014.10.027, 2015.

Kayvani Fard, A., Rhadfi, T., Khraishah, M., Atieh, M. A., Khraishah, M. and Hilal, N.: Reducing flux decline and fouling of direct contact membrane distillation by utilizing thermal brine from MSF desalination plant, *Desalination*, 379, 172–181, doi:10.1016/j.desal.2015.11.004, 2016.

Lattemann, S. and Höpner, T.: Environmental impact and impact assessment of seawater desalination, *Desalination*, 220(1–3), 1–15, doi:10.1016/j.desal.2007.03.009, 2008.

Lewis, A. E., Nathoo, J., Thomsen, K., Kramer, H. J., Witkamp, G. J., Reddy, S. T. and Randall, D. G.: Design of a Eutectic Freeze Crystallization process for multicomponent waste water stream, *Chem. Eng. Res. Des.*, 88(9), 1290–1296, doi:10.1016/j.cherd.2010.01.023, 2010.

Li, P., Li, W., Yu, T., Qu, F. and Tam, V. W. Y.: Investigation on early-age hydration, mechanical properties and microstructure of seawater sea sand cement mortar, *Constr. Build. Mater.*, 249, 118776, doi:10.1016/j.conbuildmat.2020.118776, 2020.

Li, P., Li, W., Sun, Z., Shen, L. and Sheng, D.: Development of sustainable concrete incorporating seawater : A critical review on cement hydration , microstructure and mechanical strength, *Cem. Concr. Compos.*, 121(May), 104100, doi:10.1016/j.cemconcomp.2021.104100, 2021.

Van Linden, N., Shang, R., Stockinger, G., Heijman, B. and Spanjers, H.: Separation of natural organic matter and sodium chloride for salt recovery purposes in zero liquid discharge, *Water Resour. Ind.*, 23(September 2019), 100117, doi:10.1016/j.wri.2019.100117, 2020.

Lior, N. and Kim, D.: Quantitative sustainability analysis of water desalination – A didactic example for reverse osmosis, *Desalination*, 431(September 2017), 157–170, doi:10.1016/j.desal.2017.12.061, 2018.

Liu, Z., Haddad, M., Sauv e, S. and Barbeau, B.: Alleviating the burden of ion exchange brine in water treatment: From operational strategies to brine management, *Water Res.*, 205(September),

doi:10.1016/j.watres.2021.117728, 2021.

Lutchmiah, K., Verliefe, A. R. D., Roest, K., Rietveld, L. C. and Cornelissen, E. R.: Forward osmosis for application in wastewater treatment: A review, *Water Res.*, 58(0), 179–197, doi:10.1016/j.watres.2014.03.045, 2014.

Ma, H., Zhang, J., Liu, C., Lin, X. and Sun, Y.: Experimental investigation on an adsorption desalination system with heat and mass recovery between adsorber and desorber beds, *Desalination*, 446(August), 42–50, doi:10.1016/j.desal.2018.08.022, 2018.

Malaeb, L. and Ayoub, G. M.: Reverse osmosis technology for water treatment: State of the art review, *Desalination*, 267(1), 1–8, doi:10.1016/j.desal.2010.09.001, 2011.

Martinetti, C. R., Childress, A. E. and Cath, T. Y.: High recovery of concentrated RO brines using forward osmosis and membrane distillation, *J. Memb. Sci.*, 331(1–2), 31–39, doi:10.1016/j.memsci.2009.01.003, 2009.

Martínez, J., León, E., Baena-Moreno, F. M., Rodríguez-Galán, M., Arroyo-Torralvo, F. and Vilches, L. F.: Techno-economic analysis of a membrane-hybrid process as a novel low-energy alternative for zero liquid discharge systems, *Energy Convers. Manag.*, 211(March), 112783, doi:10.1016/j.enconman.2020.112783, 2020.

Mehta, K. P. and Monteiro, P. J. M.: *Concrete Microstructure, Properties, and Materials*, Third Edit., edited by McGraw-Hill., 2006.

Mehta, P. K.: Sustainable cements and concrete for the climate change era - A review, 2nd Int. Conf. Sustain. Constr. Mater. Technol., 1–10, 2010.

Mei, Y. and Tang, C. Y.: Recent developments and future perspectives of reverse electrodialysis technology: A review, *Desalination*, 425(September 2017), 156–174, doi:10.1016/j.desal.2017.10.021, 2018.

Missimer, T. M. and Maliva, R. G.: Environmental issues in seawater reverse osmosis desalination: Intakes and outfalls, *Desalination*, 434(April 2017), 198–215, doi:10.1016/j.desal.2017.07.012, 2018.

Mohammed, R. H., Mesalhy, O., Elsayed, M. L. and Chow, L. C.: Assessment of numerical models in the evaluation of adsorption cooling system performance, *Int. J. Refrig.*, 99, 166–175, doi:10.1016/j.ijrefrig.2018.12.017, 2019.

Moharramzadeh, S., Ong, S. K., Alleman, J. and Cetin, K. S.: Parametric study of the progressive freeze concentration for desalination, *Desalination*, 510(December 2020), 115077,

doi:10.1016/j.desal.2021.115077, 2021.

Montanari, L., Suraneni, P., Tsui-Chang, M., Khatibmasjedi, M., Ebead, U., Weiss, J. and Nanni, A.: Hydration, Pore Solution, and Porosity of Cementitious Pastes Made with Seawater, *J. Mater. Civ. Eng.*, 31(8), 04019154, doi:10.1061/(asce)mt.1943-5533.0002818, 2019.

Morillo, J., Usero, J., Rosado, D., El Bakouri, H., Riaza, A. and Bernaola, F. J.: Comparative study of brine management technologies for desalination plants, *Desalination*, 336(1), 32–49, doi:10.1016/j.desal.2013.12.038, 2014.

Muhammad Yaqub and Lee, W.: Zero-liquid discharge (ZLD) technology for resource recovery from wastewater: A review, *Sci. Total Environ.*, 681, 551–563, doi:10.1016/j.scitotenv.2019.05.062, 2019.

Najafi, A., Jafarian, A. and Darand, J.: Thermo-economic evaluation of a hybrid solar-conventional energy supply in a zero liquid discharge wastewater treatment plant, *Energy Convers. Manag.*, 188(December 2018), 276–295, doi:10.1016/j.enconman.2019.03.059, 2019.

Neville, A. M. and Brooks, J. J.: *Concrete Technology*, Second Edi., Pearson Education Limited., 2010.

Panagopoulos, A.: Techno-economic assessment and feasibility study of a zero liquid discharge (ZLD) desalination hybrid system in the Eastern Mediterranean, *Chem. Eng. Process. - Process Intensif.*, 178(January), 109029, doi:10.1016/j.cep.2022.109029, 2022.

Panagopoulos, A., Haralambous, K. J. and Loizidou, M.: Desalination brine disposal methods and treatment technologies - A review, *Sci. Total Environ.*, 693, 133545, doi:10.1016/j.scitotenv.2019.07.351, 2019.

Paul, S. C., van Zijl, G. P. A. G. and Gibson, I.: A review of 3D concrete printing systems and materials properties: current status and future research prospects, *Rapid Prototyp. J.*, 24(4), 784–798, doi:10.1108/RPJ-09-2016-0154, 2018.

Petek Gursel, A., Masanet, E., Horvath, A. and Stadel, A.: Life-cycle inventory analysis of concrete production: A critical review, *Cem. Concr. Compos.*, 51, 38–48, doi:10.1016/j.cemconcomp.2014.03.005, 2014.

Peters, C. D. and Hankins, N. P.: Osmotically assisted reverse osmosis (OARO): Five approaches to dewatering saline brines using pressure-driven membrane processes, *Desalination*, 458(January), 1–13, doi:10.1016/j.desal.2019.01.025, 2019.

Qasem, N. A. A. and Zubair, S. M.: Performance evaluation of a novel hybrid humidification-

dehumidification (air-heated) system with an adsorption desalination system, *Desalination*, 461(December 2018), 37–54, doi:10.1016/j.desal.2019.03.011, 2019.

Randall, D. G. and Nathoo, J.: A succinct review of the treatment of Reverse Osmosis brines using Freeze Crystallization, *J. Water Process Eng.*, 8, 186–194, doi:10.1016/j.jwpe.2015.10.005, 2015.

Rane, M. V. and Padiya, Y. S.: Heat pump operated freeze concentration system with tubular heat exchanger for seawater desalination, *Energy Sustain. Dev.*, 15(2), 184–191, doi:10.1016/j.esd.2011.03.001, 2011.

Reddy Babu, G., Madhusudana Reddy, B. and Venkata Ramana, N.: Quality of mixing water in cement concrete "a review, *Mater. Today Proc.*, 5(1), 1313–1320, doi:10.1016/j.matpr.2017.11.216, 2018.

Reig, M., Casas, S., Gibert, O., Valderrama, C. and Cortina, J. L.: Integration of nanofiltration and bipolar electrodialysis for valorization of seawater desalination brines: Production of drinking and waste water treatment chemicals, *Desalination*, 382, 13–20, doi:10.1016/j.desal.2015.12.013, 2016.

Rezvani Dastgerdi, H. and Chua, H. T.: A new zero-liquid-discharge brine concentrator using a Cascaded Fluidised Bed Ice Slurry Generator, *Desalination*, 520(September 2019), 115344, doi:10.1016/j.desal.2021.115344, 2021.

Sanmartino, J. A., Khayet, M., García-Payo, M. C., El-Bakouri, H. and Riaza, A.: Treatment of reverse osmosis brine by direct contact membrane distillation: Chemical pretreatment approach, *Desalination*, 420(May), 79–90, doi:10.1016/j.desal.2017.06.030, 2017.

Sathish, D. and Jegadheeswaran, S.: Evolution and novel accomplishments of solar pond, desalination and pond coupled to desalination systems: a review, Springer International Publishing., 2021.

Shahzad, M. W., Ng, K. C., Thu, K., Saha, B. B. and Chun, W. G.: Multi effect desalination and adsorption desalination (MEDAD): A hybrid desalination method, *Appl. Therm. Eng.*, 72(2), 289–297, doi:10.1016/j.applthermaleng.2014.03.064, 2014.

Shahzad, M. W., Burhan, M., Ang, L. and Ng, K. C.: Adsorption desalination-Principles, process design, and its hybrids for future sustainable desalination, Elsevier Inc., 2018.

Sharan, P., McTigue, J. D., Yoon, T. J., Currier, R. and Findikoglu, A. T.: Energy efficient supercritical water desalination using a high-temperature heat pump: A zero liquid discharge

desalination, *Desalination*, 506(March), 115020, doi:10.1016/j.desal.2021.115020, 2021.

Shi, Y., Zhang, M., Zhang, H., Yang, F., Tang, C. Y. and Dong, Y.: Recent development of pressure retarded osmosis membranes for water and energy sustainability: A critical review, *Water Res.*, 189, 116666, doi:10.1016/j.watres.2020.116666, 2021.

Spanjers, H.: Sustainable Industrial Water Use: Perspectives, Incentives, and Tools, *Sustain. Ind. Water Use Perspect. Incent. Tools*, doi:10.2166/9781789060676, 2021.

Sztekler, K., Kalawa, W., Nowak, W., Mika, L., Gradziel, S., Krzywanski, J. and Radomska, E.: Experimental study of three-bed adsorption chiller with desalination function, *Energies*, 13(21), 1–13, doi:10.3390/en13215827, 2020.

Tongwen, X.: Electrodialysis processes with bipolar membranes (EDBM) in environmental protection - A review, *Resour. Conserv. Recycl.*, 37(1), 1–22, doi:10.1016/S0921-3449(02)00032-0, 2002.

Toth, A. J.: Modelling and optimisation of multi-stage flash distillation and reverse osmosis for desalination of saline process wastewater sources, *Membranes (Basel)*, 10(10), 1–18, doi:10.3390/membranes10100265, 2020.

Tufa, R. A., Curcio, E., Brauns, E., van Baak, W., Fontananova, E. and Di Profio, G.: Membrane Distillation and Reverse Electrodialysis for Near-Zero Liquid Discharge and low energy seawater desalination, *J. Memb. Sci.*, 496, 325–333, doi:10.1016/j.memsci.2015.09.008, 2015.

U.S Bureau of Labor Statistics: PPI Commodity data for Nonmetallic mineral products-Concrete products, not seasonally adjusted. *Concrete Products*, [online] Available from: <https://data.bls.gov/pdq/SurveyOutputServlet>, 2023.

Vanoppen, M., Stoffels, G., Buffel, J., De Gusseme, B. and Verliefde, A. R. D.: A hybrid IEX-RO process with brine recycling for increased RO recovery without chemical addition: A pilot-scale study, *Desalination*, 394(2016), 185–194, doi:10.1016/j.desal.2016.05.003, 2016.

Vassallo, F., La Corte, D., Cancilla, N., Tamburini, A., Bevacqua, M., Cipollina, A. and Micale, G.: A pilot-plant for the selective recovery of magnesium and calcium from waste brines, *Desalination*, 517, 115231, doi:10.1016/j.desal.2021.115231, 2021.

Venkatesan, A. and Wankat, P. C.: Simulation of ion exchange water softening pretreatment for reverse osmosis desalination of brackish water, *Desalination*, 271(1–3), 122–131, doi:10.1016/j.desal.2010.12.022, 2011.

Wachinski, A. M.: Membrane processes for water reuse LK -

<https://tudelft.on.worldcat.org/oclc/905865240>, McGraw-Hill Professional, New York ; SE - xvii, 441 p. : illustrations ; 24 cm., 2013.

Xu, T. and Huang, C.: Electrodialysis-based separation technologies: A critical review, *AIChE J.*, 54(12), 3147–3159, doi:10.1002/aic.11643, 2008.

Yadav, A., Labhsetwar, P. K. and Shahi, V. K.: Membrane distillation crystallization technology for zero liquid discharge and resource recovery: Opportunities, challenges and futuristic perspectives, *Sci. Total Environ.*, 806, 150692, doi:10.1016/j.scitotenv.2021.150692, 2022.

Zhang, C., Shi, Y., Shi, L., Li, H., Li, R., Hong, S., Zhuo, S., Zhang, T. and Wang, P.: Designing a next generation solar crystallizer for real seawater brine treatment with zero liquid discharge, *Nat. Commun.*, 12(1), 1–10, doi:10.1038/s41467-021-21124-4, 2021a.

Zhang, X., Zhao, W., Zhang, Y. and Jegatheesan, V.: A review of resource recovery from seawater desalination brine, *Rev. Environ. Sci. Biotechnol.*, 20(2), 333–361, doi:10.1007/s11157-021-09570-4, 2021b.

Appendix

Appendix A: CAPEX and OPEX Breakdown for Proposed Brine Optimization Designs

Table A.1 CAPEX breakdown for Monovalent Brine Design.

| | |
|--|------------------|
| A. Total Plant Direct Cost (TPDC) (physical cost) | |
| 1. Equipment Purchase Cost | 641.000 |
| 2. Installation | 283.000 |
| 3. Process Piping | 224.000 |
| 4. Instrumentation | 257.000 |
| 5. Insulation | 19.000 |
| 6. Electrical | 64.000 |
| 7. Buildings | 289.000 |
| 8. Yard Improvement | 96.000 |
| 9. Auxiliary Facilities | 257.000 |
| TPDC | 2.130.000 |
| B. Total Plant Indirect Cost (TPIC) | |
| 10. Engineering | 532.000 |
| 11. Construction | 745.000 |
| TPIC | 1.278.000 |
| C. Total Plant Cost (TPC = TPDC+TPIC) | |
| TPC | 3.408.000 |
| D. Contractor's Fee & Contingency (CFC) | |
| 12. Contractor's Fee | 170.000 |
| 13. Contingency | 341.000 |
| CFC = 12+13 | 511.000 |
| E. Direct Fixed Capital Cost (DFC = TPC+CFC) | |
| DFC | 3.919.000 |

Table A.2 OPEX breakdown for Monovalent Brine Design.

| Cost Item | € | % |
|--------------------------|------------------|---------------|
| Raw Materials | 48.000 | 2,96 |
| Labor-Dependent | 845.000 | 51,81 |
| Facility-Dependent | 737.000 | 45,19 |
| Consumables | 0 | 0,00 |
| Waste Treatment/Disposal | 0 | 0,00 |
| Utilities | 1.000 | 0,04 |
| Transportation | 0 | 0,00 |
| Miscellaneous | 0 | 0,00 |
| Advertising/Selling | 0 | 0,00 |
| Running Royalties | 0 | 0,00 |
| Failed Product Disposal | 0 | 0,00 |
| TOTAL | 1.631.000 | 100,00 |

Table A.3 CAPEX breakdown for MVR Brine Design.

| A. Total Plant Direct Cost (TPDC) (physical cost) | |
|--|------------------|
| 1. Equipment Purchase Cost | 791.000 |
| 2. Installation | 358.000 |
| 3. Process Piping | 277.000 |
| 4. Instrumentation | 317.000 |
| 5. Insulation | 24.000 |
| 6. Electrical | 79.000 |
| 7. Buildings | 356.000 |
| 8. Yard Improvement | 119.000 |
| 9. Auxiliary Facilities | 317.000 |
| TPDC | 2.637.000 |
| B. Total Plant Indirect Cost (TPIC) | |
| 10. Engineering | 659.000 |
| 11. Construction | 923.000 |
| TPIC | 1.582.000 |
| C. Total Plant Cost (TPC = TPDC+TPIC) | |
| TPC | 4.220.000 |
| D. Contractor's Fee & Contingency (CFC) | |
| 12. Contractor's Fee | 211.000 |
| 13. Contingency | 422.000 |
| CFC = 12+13 | 633.000 |
| E. Direct Fixed Capital Cost (DFC = TPC+CFC) | |
| DFC | 4.852.000 |

Table A.4 OPEX breakdown for the MVR Brine Design.

| Cost Item | € | % |
|--------------------------|------------------|---------------|
| RawMaterials | 54.000 | 2,79 |
| Labor-Dependent | 849.000 | 43,86 |
| Facility-Dependent | 912.000 | 47,15 |
| Consumables | 0 | 0,00 |
| Waste Treatment/Disposal | 0 | 0,00 |
| Utilities | 120.000 | 6,20 |
| Transportation | 0 | 0,00 |
| Miscellaneous | 0 | 0,00 |
| Advertising/Selling | 0 | 0,00 |
| Running Royalties | 0 | 0,00 |
| Failed Product Disposal | 0 | 0,00 |
| TOTAL | 1.935.000 | 100,00 |

Table A.5 CAPEX breakdown for the Calcium Chloride Brines Design.

| A. Total Plant Direct Cost (TPDC) (physical cost) | |
|--|------------------|
| 1. Equipment Purchase Cost | 641.000 |
| 2. Installation | 283.000 |
| 3. Process Piping | 224.000 |
| 4. Instrumentation | 257.000 |
| 5. Insulation | 19.000 |
| 6. Electrical | 64.000 |
| 7. Buildings | 289.000 |
| 8. Yard Improvement | 96.000 |
| 9. Auxiliary Facilities | 257.000 |
| TPDC | 2.130.000 |
| B. Total Plant Indirect Cost (TPIC) | |
| 10. Engineering | 532.000 |
| 11. Construction | 745.000 |
| TPIC | 1.278.000 |
| C. Total Plant Cost (TPC = TPDC+TPIC) | |
| TPC | 3.408.000 |
| D. Contractor's Fee & Contingency (CFC) | |
| 12. Contractor's Fee | 170.000 |
| 13. Contingency | 341.000 |
| CFC = 12+13 | 511.000 |
| E. Direct Fixed Capital Cost (DFC = TPC+CFC) | |
| DFC | 3.919.000 |

Table A.6 OPEX breakdown for the Calcium Chloride Brines Design.

| Cost Item | € | % |
|--------------------------|------------------|---------------|
| Raw Materials | 54.000 | 3,33 |
| Labor-Dependent | 845.000 | 51,62 |
| Facility-Dependent | 737.000 | 45,02 |
| Consumables | 0 | 0,00 |
| Waste Treatment/Disposal | 0 | 0,00 |
| Utilities | 1.000 | 0,04 |
| Transportation | 0 | 0,00 |
| Miscellaneous | 0 | 0,00 |
| Advertising/Selling | 0 | 0,00 |
| Running Royalties | 0 | 0,00 |
| Failed Product Disposal | 0 | 0,00 |
| TOTAL | 1.637.000 | 100,00 |

Appendix B: SuperPro Designer Economic Model Definitions and Equations

The following are the definitions of the economic factors used in the SuperPro designer model as presented in the software manual (Intelligen, 2021):

Equipment Purchase Cost (PC): this is the vendor's selling price of major equipment. It excludes items such as taxes, insurance, delivery and installation. It is also known as the free-on-board (FOB) cost. For a preliminary economic analysis, the purchase cost of equipment is typically estimated based on cost correlations. SuperPro Designer provides correlations for estimating the purchase cost of major listed (modeled) equipment. The user may also provide his/her own cost values or cost correlations for all listed (modeled) equipment; for more details on these options, see 'Purchase Cost of Listed Equipment' on page 9-8 below. In SuperPro Designer, PC is calculated at the section level. For each section, the user may also specify the purchase cost of unlisted (overlooked) equipment as a factor of the section's PC. Generally, a section's PC will be the sum of the purchase costs of listed and unlisted equipment for that section.

Installation Cost: this cost item refers to the in-place construction of equipment at the new plant site and includes the cost of foundations, slabs, supports, and local equipment services. For a preliminary economic analysis, the installation cost of listed (modeled) equipment can be estimated by multiplying the corresponding purchase cost by a suitable factor; for more details, see 'Installation Cost of Listed equipment' on page 9-9. In SuperPro Designer, the installation cost is calculated at the section level. For each section, the user may also specify the installation cost of unlisted (overlooked) equipment as a factor of the corresponding purchase cost of unlisted equipment for that section. Generally, a section's installation cost will be the sum of the installation costs of listed and unlisted equipment for that section.

Process Piping Cost: this cost item incorporates the cost of process fluid piping that connects the equipment, as well as connections to the main utility headers and vents. Included are valves, piping supports, insulation, and other items associated with equipment piping. For a preliminary economic analysis, this cost is typically estimated by multiplying PC by a suitable factor. In SuperPro Designer, this cost is calculated at the section level as a factor of the section's PC.

Instrumentation Cost: this cost item includes the costs of transmitters and controllers (with all required wiring and tubing for installation), field and control room terminal panels, alarms and enunciators, indicating instruments both in the field and in the control room, on-stream analyzers,

control computers and local data-processing units, and control room display graphics. For a preliminary economic analysis, this cost is typically estimated by multiplying PC by a suitable factor. In SuperPro Designer, this cost is calculated at the section level as a factor of the section's PC.

Insulation Cost: this cost item includes the cost of insulation and painting, which is usually included in the cost of installation and piping. In low temperature plants, however, insulation cost can become unusually high. An insulation surcharge is recommended for such plants. For a preliminary economic analysis, this cost is typically estimated by multiplying PC by a suitable factor. In SuperPro Designer, this cost is calculated at the section level as a factor of the section's PC.

Electrical Cost: this cost item refers to the cost of electrical facilities. These includes battery limits substations and transmission lines, motor switch gear and control centers, emergency power supplies, wiring and conduit, bus bars, and area lighting. Separate equipment estimation is required for electrolytic installations. For a preliminary economic analysis, this cost is typically estimated by multiplying PC by a suitable factor. In SuperPro Designer, this cost is calculated at the section level as a factor of the section's PC.

Buildings Cost: this cost item includes the cost of process towers, subsidiary concrete slabs, stairways and catwalks (not equipment-specific), control rooms and other battery limits buildings (e.g., change rooms, cafeteria, furnished offices, warehouses, etc.). It also incorporates the costs for non-electric building services as well as for a variety of safety related items. For a preliminary economic analysis, this cost is typically estimated by multiplying PC by a suitable factor. In SuperPro Designer, this cost is calculated at the section level as a factor of the section's PC.

Yard Improvement Cost: this cost item refers to the costs of excavation, site grading, roads, fences, railroad spur lines, fire hydrants, parking spaces, and others. For a preliminary economic analysis, this cost is typically estimated by multiplying PC by a suitable factor. In SuperPro Designer, this cost is calculated at the section level as a factor of the section's PC.

Auxiliary Facilities Cost: this cost item includes the cost of satellite process-oriented service facilities that are vital to the proper operation of the battery limits plant. An example of an auxiliary facility is a steam plant. For a preliminary economic analysis, this cost is typically estimated by multiplying PC by a suitable factor. In SuperPro Designer, this cost is calculated at the section level as a factor of the section's PC.

Engineering: this cost item includes the preparation of design books that document the whole process (e.g., the design of equipment, specification sheets for equipment, instruments, auxiliaries, etc., the design of control logic and computer software, the preparation of drawings) and other engineering-related costs. For a preliminary economic analysis, this cost is typically estimated by multiplying TPDC by a suitable factor. In SuperPro Designer, this cost is calculated at the section level as a factor of the section's total direct cost.

Construction: this cost item includes the costs associated with the organization of the total construction effort. They do not include the cost of construction labor. This is incorporated in direct cost items that involve construction. For a preliminary economic analysis, this cost is typically estimated by multiplying TPDC by a suitable factor. In SuperPro Designer, this cost is calculated at the section level as a factor of the section's total direct cost.

Contractor's Fee: this is the contractor's profit. It should be added even if a corporation does its own construction, because the construction division is expected to show a profit. For a preliminary economic analysis, this cost is typically estimated by multiplying TPC by a suitable factor. In SuperPro Designer, this cost is calculated at the section level as a factor of the section's total direct and indirect costs.

Contingency: the more speculative a process is, the more likely it is that key elements have been overlooked during the project's early stages. This cost attempts to compensate for missing elements. However, even advanced-stage estimates will include a contingency to account for unexpected problems during construction, such as strikes, delays, and unusually high price fluctuations. For a preliminary economic analysis, this cost is typically estimated by multiplying TPC by a suitable factor. In SuperPro Designer, this cost is calculated at the section level as a factor of the section's total direct and indirect costs.

Table B. 1 SuperPro Designer Equations for cost estimation and profitability analysis adapted from Intelligen, 2021.

| Equation Number | Equation |
|-----------------|---|
| 1 | <i>Total Equipment Purchase Cost (PC)</i> <i>= Listed Equipment Purchase Costs + Unlisted Purchase Equipment Cost</i> |
| 2 | <i>Unlisted Equipment Purchase Cost = 0.20 × PC</i> |
| 3 | <i>Direct Fixed Capital (DCF) = Direct Cost (DC) + Indirect Cost (IC) + Other Cost (OC)</i> |
| 4 | <i>DC = PC + Installation + A + B + C + D + E + F + G</i> |
| 5 | <i>Piping (A) = 0.35 × PC</i> |
| 6 | <i>Instrumentation (B) = 0.40 × PC</i> |
| 7 | <i>Insulation (C) = 0.03 × PC</i> |
| 8 | <i>Electrical Facilities (D) = 0.10 × PC</i> |
| 9 | <i>Buildings (E) = 0.45 × PC</i> |
| 10 | <i>Yard Improvement (F) = 0.15 × PC</i> |
| 11 | <i>Auxiliary Facilities (G) = 0.40 × PC</i> |
| 12 | <i>Installation = Installation of Listed Equipment Cost + Installation of Unlisted Equipment Cost</i> |
| 13 | <i>Installation of Unlisted Equipment Cost = 0.50 × Unlisted Equipment Purchase Cost</i> |
| 14 | <i>Indirect Costs (IC) = Engineering + Construction</i> |
| 15 | <i>Engineering = 0.25 × DC</i> |
| 16 | <i>Construction = 0.35 × DC</i> |
| 17 | <i>Other Costs (OC) = Contractor's Fee + Contingency</i> |
| 18 | <i>Contractor's Fee = 0.05 × (DC + IC)</i> |
| 19 | <i>Contingency = 0.10 × (DC + IC)</i> |
| 20 | <i>Gross Profit = Revenues – Annual Operating Costs</i> |
| 21 | <i>Net Profit = Gross Profit – Taxes + Depreciation</i> |
| 22 | <i>Gross Margin = $\frac{\text{Gross Profit}}{\text{Revenues}} \times 100$</i> |
| 23 | <i>Return of Investment = $\frac{\text{Net Profit}}{\text{Total Investment}} \times 100$</i> |
| 24 | <i>Payback Time = $\frac{\text{Total Investment}}{\text{Net Profit}}$</i> |
| 25 | $NPV = \sum_{k=1}^N \frac{NCF_k}{(1+i)^k}$ <p>Where: i: interest rate NCF_k: net cash flow in year k N: Project lifetime (years)</p> |

Appendix C: PRHEEQC simulation results

Table C 1 PHREEQC simulation results for the Monovalent Brine. The table shows the output for the saturation index of multiple minerals that could cause scaling or carrion depending on the value of the saturation index.

| Phase | SI** | log IAP | log K(| 306 K, 1 atm) |
|-----------------|-------|---------|--------|-------------------|
| Quartz | -0.47 | -4.37 | -3.9 | SiO2 |
| Chalcedony | -0.91 | -4.37 | -3.46 | SiO2 |
| Cristobalite | -1.11 | -4.37 | -3.26 | SiO2 |
| Fluorite | -1.56 | -12.02 | 10.46 | CaF2 |
| SiO2(am-ppt) | -1.7 | -4.37 | -2.67 | SiO2 |
| SiO2(am-gel) | -1.72 | -4.37 | -2.65 | SiO2 |
| Barite | -2.06 | -11.93 | -9.87 | BaSO4 |
| Halite | -2.22 | -0.6 | 1.62 | NaCl |
| Gypsum | -2.91 | -7.52 | -4.61 | CaSO4:2H2O |
| Celestite | -2.94 | -9.55 | -6.61 | SrSO4 |
| Anhydrite | -3.1 | -7.5 | -4.39 | CaSO4 |
| MgF2 | -3.82 | -11.99 | -8.17 | MgF2 |
| Mirabilite | -4.58 | -5.33 | -0.75 | Na2SO4:10H2O |
| Epsomite | -5.46 | -7.54 | -2.07 | MgSO4:7H2O |
| SrF2 | -5.51 | -14.07 | -8.56 | SrF2 |
| Thenardite | -5.51 | -5.23 | 0.28 | Na2SO4 |
| Brucite | -9.14 | 7.18 | 16.32 | Mg(OH)2 |
| BaF2 | 10.65 | -16.46 | -5.8 | BaF2 |
| Mg(OH)2(active) | 11.61 | 7.18 | 18.79 | Mg(OH)2 |
| Periclase | -13.7 | 7.19 | 20.89 | MgO |
| Sepiolite | -14 | 1.24 | 15.24 | Mg2Si3O7.5OH:3H2O |
| Portlandite | 15.07 | 7.15 | 22.22 | Ca(OH)2 |
| Sepiolite(A) | 17.54 | 1.24 | 18.78 | Mg2Si3O7.5OH:3H2O |
| Chrysotile | 18.49 | 12.81 | 31.3 | Mg3Si2O5(OH)4 |
| Ba(OH)2:8H2O | 21.52 | 2.63 | 24.15 | Ba(OH)2:8H2O |
| Lime | 24.65 | 7.16 | 31.81 | CaO |
| O2(g) | 44.37 | 36.1 | 80.47 | O2 |

Table C 2 PHREEQC simulation results for the MVR Brine. The table shows the output for the saturation index of multiple minerals that could cause scaling or carrion depending on the value of the saturation index.

| Phase | SI** | log IAP | log K(| 298 K, 1 atm) |
|--|--------|---------|--------|---|
| Chrysotile | 11.31 | 43.51 | 32.2 | Mg ₃ Si ₂ O ₅ (OH) ₄ |
| Sepiolite | 7.78 | 23.54 | 15.76 | Mg ₂ Si ₃ O ₇ .5OH:3H ₂ O |
| Sepiolite(A) | 4.76 | 23.54 | 18.78 | Mg ₂ Si ₃ O ₇ .5OH:3H ₂ O |
| Halite | 0.95 | 2.55 | 1.6 | NaCl |
| Quartz | 0.84 | -3.16 | -4 | SiO ₂ |
| Chalcedony | 0.39 | -3.16 | -3.55 | SiO ₂ |
| Cristobalite | 0.19 | -3.16 | -3.35 | SiO ₂ |
| Barite | 0 | -9.98 | -9.98 | BaSO ₄ |
| Brucite | -0.26 | 16.58 | 16.84 | Mg(OH) ₂ |
| SiO ₂ (am-ppt) | -0.42 | -3.16 | -2.74 | SiO ₂ |
| SiO ₂ (am-gel) | -0.45 | -3.16 | -2.71 | SiO ₂ |
| Celestite | -0.94 | -7.56 | -6.62 | SrSO ₄ |
| Gypsum | -1.07 | -5.68 | -4.61 | CaSO ₄ :2H ₂ O |
| Anhydrite | -1.14 | -5.5 | -4.36 | CaSO ₄ |
| Fluorite | -1.85 | -12.35 | -10.5 | CaF ₂ |
| Mg(OH) ₂ (active) | -2.21 | 16.58 | 18.79 | Mg(OH) ₂ |
| Mirabilite | -3.45 | -4.57 | -1.11 | Na ₂ SO ₄ :10H ₂ O |
| Epsomite | -3.88 | -6.01 | -2.13 | MgSO ₄ :7H ₂ O |
| Thenardite | -3.95 | -3.63 | 0.32 | Na ₂ SO ₄ |
| MgF ₂ | -4.08 | -12.21 | -8.13 | MgF ₂ |
| Periclase | -4.91 | 16.67 | 21.58 | MgO |
| SrF ₂ | -5.84 | -14.42 | -8.58 | SrF ₂ |
| Portlandite | -6.36 | 16.44 | 22.8 | Ca(OH) ₂ |
| BaF ₂ | -11.01 | -16.83 | -5.82 | BaF ₂ |
| Ba(OH) ₂ :8H ₂ O | -13.19 | 11.2 | 24.39 | Ba(OH) ₂ :8H ₂ O |
| Lime | -16.17 | 16.53 | 32.7 | CaO |
| Sulfur | -17.07 | -19.21 | -2.14 | S |
| H ₂ S(g) | -21.57 | -29.58 | -8.01 | H ₂ S |
| BaS | -33.62 | -17.44 | 16.18 | BaS |
| O ₂ (g) | -62.53 | 20.56 | 83.09 | O ₂ |

Table C 3 PHREEQC simulation results for the Calcium Chloride Brines. The table shows the output for the saturation index of multiple minerals that could cause scaling or carrion depending on the value of the saturation index.

| Phase | SI** | log IAP | log K(3 | 11 K, 1 atm) |
|--|-------|---------|---------|---|
| Chrysotile | 2.9 | 33.59 | 30.69 | Mg ₃ Si ₂ O ₅ (OH) ₄ |
| Portlandite | 1.26 | 23.07 | 21.81 | Ca(OH) ₂ |
| Brucite | 1 | 16.96 | 15.96 | Mg(OH) ₂ |
| Fluorite | -0.09 | -10.53 | -10.44 | CaF ₂ |
| Gypsum | -1.79 | -6.39 | -4.6 | CaSO ₄ :2H ₂ O |
| Mg(OH) ₂ (active) | -1.83 | 16.96 | 18.79 | Mg(OH) ₂ |
| Anhydrite | -1.92 | -6.33 | -4.42 | CaSO ₄ |
| Halite | -2.58 | -0.95 | 1.63 | NaCl |
| Celestite | -2.8 | -9.4 | -6.6 | SrSO ₄ |
| Barite | -3.22 | -13.02 | -9.8 | BaSO ₄ |
| Periclase | -3.43 | 16.99 | 20.42 | MgO |
| Quartz | -4.83 | -8.66 | -3.83 | SiO ₂ |
| SrF ₂ | -5.06 | -13.61 | -8.55 | SrF ₂ |
| Chalcedony | -5.26 | -8.66 | -3.4 | SiO ₂ |
| Cristobalite | -5.47 | -8.66 | -3.2 | SiO ₂ |
| SiO ₂ (am-ppt) | -6.04 | -8.66 | -2.62 | SiO ₂ |
| SiO ₂ (am-gel) | -6.06 | -8.66 | -2.6 | SiO ₂ |
| Sepiolite | -6.99 | 7.89 | 14.88 | Mg ₂ Si ₃ O ₇ .5OH:3H ₂ O |
| Ba(OH) ₂ :8H ₂ O | -7.84 | 16.13 | 23.97 | Ba(OH) ₂ :8H ₂ O |
| Lime | -8.11 | 23.1 | 31.2 | CaO |
| MgF ₂ | -8.45 | -16.64 | -8.19 | MgF ₂ |
| Mirabilite | -9.57 | -10.07 | -0.5 | Na ₂ SO ₄ :10H ₂ O |
| | - | | | |
| Thenardite | 10.02 | -9.77 | 0.25 | Na ₂ SO ₄ |
| | - | | | |
| Epsomite | 10.61 | -12.65 | -2.04 | MgSO ₄ :7H ₂ O |
| | - | | | |
| Sepiolite(A) | 10.89 | 7.89 | 18.78 | Mg ₂ Si ₃ O ₇ .5OH:3H ₂ O |
| | - | | | |
| BaF ₂ | 11.43 | -17.22 | -5.79 | BaF ₂ |
| | - | | | |
| O ₂ (g) | 17.29 | 61.38 | 78.67 | O ₂ |

Appendix D: FMEA Table

Table D 1 FMEA table with calculated RPN .

| Undesired Event | Failure Mode | Effects | Root Causes | Safety | Health | Environment | Economic | Technology | S | O | D | RPN | |
|--|---|---|---|------------|--------|-------------|----------|------------|---|---|-----|-----|-----|
| Reduction of CAB Production | Pump Failure | Reduction in pump efficiency. material loss leading to damage in the system. Cavitation damage can lead and increase the risk of corrosion | Cavitation | 0 | 0 | 0 | 2 | 2 | 4 | 3 | 3 | 36 | |
| | | Material Weakening, material damage and leaking, change in material properties which can lead to more issues, contamination of fluids, reduction in pump efficiency and lifespan. | Monovalent Corrosion | 1 | 0 | 0 | 3 | 2 | 6 | 5 | 6 | 180 | |
| | | | MVR Corrosion | 1 | 0 | 0 | 3 | 3 | 7 | 6 | 6 | 252 | |
| | | | CaCl ₂ Corrosion | 1 | 0 | 0 | 3 | 1 | 5 | 4 | 6 | 120 | |
| | | | Monovalent Scaling | 1 | 0 | 0 | 3 | 1 | 5 | 4 | 5 | 100 | |
| | | | MVR Scaling | 1 | 0 | 0 | 3 | 3 | 7 | 6 | 5 | 210 | |
| | | | CaCl ₂ Scaling | 1 | 0 | 0 | 3 | 2 | 6 | 5 | 5 | 150 | |
| | | Leaking, reduction of pump lifespan | Pump breakage from mechanical stress | 1 | 0 | 1 | 2 | 1 | 5 | 3 | 6 | 90 | |
| | leaking, can cause additional damage to the pump | Seal failure | 0 | 0 | 0 | 1 | 1 | 2 | 2 | 5 | 20 | | |
| | Electrical Failure | Unwanted fire. Safety hazard. Structural damage, Damage equipment causing temporary or permanent stop in production | Fire | 2 | 2 | 2 | 2 | 2 | 1 | 0 | 2 | 9 | 180 |
| | | Damage equipment causing temporary or permanent stop in production | Equipment failure due to mechanical issues | 0 | 0 | 0 | 2 | 2 | 4 | 3 | 8 | 96 | |
| | | Voltage fluctuations that can cause the equipment malfunction | Grid overload | 1 | 0 | 1 | 2 | 2 | 6 | 2 | 8 | 96 | |
| | | Controlled and scheduled production stop to ensure proper maintenance | Equipment maintenance and upgrades | 1 | 0 | 1 | 2 | 1 | 5 | 4 | 8 | 160 | |
| | Pipe Damage | Severe damage from corrosion that can cause pipe element replacement, could lead to leakage of brine. | Monovalent Corrosion | 1 | 0 | 0 | 3 | 2 | 6 | 5 | 6 | 180 | |
| | | | MVR Corrosion | 1 | 0 | 0 | 3 | 3 | 7 | 6 | 6 | 252 | |
| | | | CaCl ₂ Corrosion | 1 | 0 | 0 | 3 | 1 | 5 | 4 | 6 | 120 | |
| | | | Monovalent Scaling | 1 | 0 | 0 | 3 | 1 | 5 | 4 | 5 | 100 | |
| | | Change in pipe Geometry that can change and reduce the flow in the system. Clogging in the system that can lead to other potential damages in the system | MVR Scaling | 1 | 0 | 0 | 3 | 3 | 7 | 6 | 5 | 210 | |
| | | | CaCl ₂ Scaling | 1 | 0 | 0 | 3 | 2 | 6 | 5 | 5 | 150 | |
| | Higher pressure than the designed pressure can cause pipe rupture resulting in leakage and temporary halt in the production | Excessive Pressure | 2 | 1 | 0 | 1 | 1 | 5 | 2 | 7 | 70 | | |
| | Heat Exchanger Damage | Scale film formation can lead to a decrease in thermal performance, energy efficiency and system reliability. As the scale film increases the problems can become more severe. | Scaling | 1 | 0 | 0 | 3 | 3 | 7 | 6 | 5 | 210 | |
| | | | Micro and macrofouling can lead to a decrease in thermal performance, energy efficiency and system reliability. Different fouling mechanisms exist which can lead to several issues | Fouling | 1 | 2 | 0 | 3 | 2 | 8 | 5 | 6 | 240 |
| | | Reduced system reliability and system damage over prolonged damage from thermal stress due to sudden temperature changes. | Thermal Stress | 1 | 0 | 0 | 1 | 1 | 3 | 3 | 3 | 27 | |
| | | Reduced system reliability and system damage over prolonged damage from mechanical stress and/or fatigue | Mechanical Stress and/or fatigue | 1 | 0 | 0 | 1 | 1 | 3 | 3 | 3 | 27 | |
| material loss leading to damage in the system. Cavitation damage can lead and increase the risk of corrosion | | Cavitation | 0 | 0 | 0 | 1 | 1 | 2 | 3 | 3 | 18 | | |
| Material Weakening, material damage and leaking, change in material properties which can lead to more issues, contamination of fluids. | | Corrosion | 1 | 0 | 0 | 3 | 3 | 7 | 6 | 6 | 252 | | |
| Brine leakage, product loss, environmental contamination | | Pump Failure/Damage | Reduction in pump efficiency. material loss leading to damage in the system. Cavitation damage can lead and increase the risk of corrosion | Cavitation | 0 | 0 | 0 | 1 | 1 | 2 | 4 | 3 | 24 |
| | Material Weakening, material damage and leaking, change in material properties which can lead to more issues, contamination of fluids, reduction in pump efficiency and lifespan. | | Monovalent Corrosion | 1 | 1 | 2 | 1 | 2 | 7 | 5 | 6 | 210 | |
| | | | MVR Corrosion | 1 | 1 | 2 | 1 | 3 | 8 | 6 | 6 | 288 | |
| | | | CaCl ₂ Corrosion | 1 | 1 | 2 | 1 | 1 | 6 | 4 | 6 | 144 | |
| | | | Monovalent Scaling | 1 | 1 | 2 | 1 | 1 | 6 | 4 | 5 | 120 | |
| | System clogging, reduction of flows, pump efficiency and lifespan, contamination of product, change in material properties, material damage and leaking. | | MVR Scaling | 1 | 1 | 2 | 1 | 3 | 8 | 6 | 5 | 240 | |
| | | | CaCl ₂ Scaling | 1 | 1 | 2 | 1 | 2 | 7 | 5 | 5 | 175 | |
| | Leaking, reduction of pump lifespan | | Pump breakage from mechanical stress | 1 | 0 | 1 | 1 | 1 | 4 | 4 | 7 | 112 | |
| | leaking, can cause additional damage to the pump | Seal failure | 1 | 0 | 1 | 1 | 1 | 4 | 4 | 6 | 96 | | |
| | Storage Tank Failure/Damage | Material Weakening, material damage and leaking, change in material properties which can lead to more issues, contamination of fluids, reduction in storage lifespan. | Monovalent Corrosion | 1 | 1 | 2 | 1 | 2 | 7 | 5 | 6 | 210 | |
| | | | MVR Corrosion | 1 | 1 | 2 | 1 | 3 | 8 | 6 | 6 | 288 | |
| | | | CaCl ₂ Corrosion | 1 | 1 | 2 | 1 | 1 | 6 | 4 | 6 | 144 | |
| | | | Monovalent Scaling | 1 | 1 | 2 | 1 | 1 | 6 | 4 | 5 | 120 | |
| | | Scaling film formation that can lead to reduction in system reliability, damage in the system leading to leakage , clogging, and contamination of the brine | MVR Scaling | 1 | 1 | 2 | 1 | 3 | 8 | 6 | 5 | 240 | |
| | | | CaCl ₂ Scaling | 1 | 1 | 2 | 1 | 2 | 7 | 5 | 5 | 175 | |
| | Improper operation can lead to an overflow in the system leading to brine leakage. | Overflowing | 1 | 1 | 2 | 1 | 1 | 6 | 3 | 6 | 108 | | |
| Pipe Damage | Severe damage from corrosion that can cause pipe element replacement, could lead to leakage of brine. | Monovalent Corrosion | 1 | 1 | 2 | 1 | 2 | 7 | 5 | 6 | 210 | | |
| | | MVR Corrosion | 1 | 1 | 2 | 1 | 3 | 8 | 6 | 6 | 288 | | |
| | | CaCl ₂ Corrosion | 1 | 1 | 2 | 1 | 1 | 6 | 4 | 6 | 144 | | |
| | | Monovalent Scaling | 1 | 1 | 2 | 1 | 1 | 6 | 4 | 5 | 120 | | |

| | | | | | | | | | | | | |
|--|---|---|---|----------------------|---|---|---|---|---|-----|-----|-----|
| | Change in pipe Geometry that can change and reduce the flow in the system. Clogging in the system that can lead to other potential damages in the system Higher pressure than the designed pressure can cause pipe rupture resulting in leakage and temporary halt in the production | MVR Scaling | 1 | 1 | 2 | 1 | 3 | 8 | 6 | 5 | 240 | |
| | | CaCl ₂ Scaling | 1 | 1 | 2 | 1 | 2 | 7 | 5 | 5 | 175 | |
| | | Excessive Pressure | 1 | 1 | 1 | 1 | 1 | 5 | 3 | 6 | 90 | |
| | Heat Exchanger Damage | Scale film formation can lead to a decrease in thermal performance, energy efficiency and system reliability. As the scale film increases the problems can become more severe. | Scaling | 1 | 1 | 2 | 1 | 3 | 8 | 6 | 5 | 240 |
| | | Micro and macrofouling can lead to a decrease in thermal performance, energy efficiency and system reliability. Different fouling mechanisms exist which can lead to several issues | Fouling | 1 | 2 | 1 | 2 | 2 | 8 | 5 | 5 | 200 |
| | | Reduced system reliability and system damage over prolonged damage from thermal stress due to sudden temperature changes. | Thermal Stress | 1 | 0 | 0 | 1 | 1 | 3 | 3 | 3 | 27 |
| | | Reduced system reliability and system damage over prolonged damage from mechanical stress and/or fatigue | Mechanical Stress | 1 | 0 | 0 | 1 | 1 | 3 | 3 | 3 | 27 |
| | | material loss leading to damage in the system. Cavitation damage can lead and increase the risk of corrosion | Cavitation | 1 | 0 | 0 | 2 | 1 | 4 | 3 | 3 | 36 |
| | Material Weakening, material damage and leaking, change in material properties which can lead to more issues, contamination of fluids. | Corrosion | 1 | 1 | 2 | 1 | 3 | 8 | 6 | 6 | 288 | |
| | CAB contamination or change in composition | Pump Failure/Damage | Material Weakening, material damage and leaking, change in material properties which can lead to more issues, contamination of fluids, reduction in pump efficiency and lifespan. | Monovalent Corrosion | 0 | 1 | 0 | 2 | 3 | 6 | 5 | 6 |
| | | | MVR Corrosion | 0 | 1 | 0 | 2 | 4 | 7 | 6 | 6 | 252 |
| | | | CaCl ₂ Corrosion | 0 | 1 | 0 | 2 | 2 | 5 | 4 | 6 | 120 |
| System clogging, reduction of flows, pump efficiency and lifespan, contamination of product, change in material properties, material damage and leaking. | | | Monovalent Scaling | 0 | 1 | 0 | 2 | 2 | 5 | 4 | 5 | 100 |
| | | | MVR Scaling | 0 | 1 | 0 | 2 | 4 | 7 | 6 | 5 | 210 |
| | | | CaCl ₂ Scaling | 0 | 1 | 0 | 2 | 3 | 6 | 5 | 5 | 150 |
| Storage Tank Failure/Damage | | Material Weakening, material damage and leaking, change in material properties which can lead to more issues, contamination of fluids, reduction in storage lifespan. | Monovalent Corrosion | 0 | 1 | 0 | 2 | 3 | 6 | 5 | 6 | 180 |
| | | | MVR Corrosion | 0 | 1 | 0 | 2 | 4 | 7 | 6 | 6 | 252 |
| | | | CaCl ₂ Corrosion | 0 | 1 | 0 | 2 | 2 | 5 | 4 | 6 | 120 |
| | | Scaling film formation that can lead to reduction in system reliability, damage in the system leading to leakage, clogging, and contamination of the brine | Monovalent Scaling | 0 | 1 | 0 | 2 | 2 | 5 | 4 | 5 | 100 |
| | | | MVR Scaling | 0 | 1 | 0 | 2 | 4 | 7 | 6 | 5 | 210 |
| | | | CaCl ₂ Scaling | 0 | 1 | 0 | 2 | 3 | 6 | 5 | 5 | 150 |
| | | | Microorganism Growth | 2 | 2 | 1 | 2 | 1 | 8 | 5 | 4 | 160 |
| Pipe Damage | | Severe damage from corrosion that can cause pipe element replacement, could lead to leakage of brine. | Monovalent Corrosion | 0 | 1 | 0 | 2 | 3 | 6 | 5 | 6 | 180 |
| | | | MVR Corrosion | 0 | 1 | 0 | 2 | 4 | 7 | 6 | 6 | 252 |
| | | | CaCl ₂ Corrosion | 0 | 1 | 0 | 2 | 2 | 5 | 4 | 6 | 120 |
| | | Change in pipe Geometry that can change and reduce the flow in the system. Clogging in the system that can lead to other potential damages in the system | Monovalent Scaling | 0 | 1 | 0 | 2 | 2 | 5 | 4 | 5 | 100 |
| | | | MVR Scaling | 0 | 1 | 0 | 2 | 4 | 7 | 6 | 5 | 210 |
| | | CaCl ₂ Scaling | 0 | 1 | 0 | 2 | 3 | 6 | 5 | 5 | 150 | |
| | Higher pressure than the designed pressure can cause pipe rupture resulting in leakage and temporary halt in the production | Excessive Pressure | 1 | 0 | 0 | 1 | 1 | 3 | 3 | 3 | 27 | |
| | Microorganism Growth | 2 | 2 | 1 | 2 | 1 | 8 | 5 | 4 | 160 | | |
| Heat Exchanger Damage | Scale film formation can lead to a decrease in thermal performance, energy efficiency and system reliability. As the scale film increases the problems can become more severe. | Scaling | 0 | 1 | 0 | 2 | 4 | 7 | 6 | 5 | 210 | |
| | Micro and macrofouling can lead to a decrease in thermal performance, energy efficiency and system reliability. Different fouling mechanisms exist which can lead to several issues | Fouling | 0 | 1 | 1 | 2 | 4 | 8 | 5 | 6 | 240 | |
| | Material Weakening, material damage and leaking, change in material properties which can lead to more issues, contamination of fluids. | Corrosion | 0 | 1 | 0 | 2 | 4 | 7 | 6 | 6 | 252 | |
| | | Microorganism Growth | 2 | 2 | 1 | 2 | 1 | 8 | 5 | 4 | 160 | |

Appendix E: List of Brines used as Concrete Accelerator Brine for the concrete printing experiments

Table E 1 Concrete accelerator brines composition used for 3DPC experiments.

| Synthetic Brine (mg/L) | Mono | Mono x2 | MVR | Mono + gypsum | High CaCl ₂ | 50% high | | 40% high | | 25% high | | Low CaCl ₂ |
|---|------------------|------------------|-----------------|-----------------------|------------------------|---------------------|---------|---------------------|------------------|---------------------|-------|-----------------------|
| | | | | | | % CaCl ₂ | % low | % CaCl ₂ | % low | % CaCl ₂ | % low | |
| NaHCO ₃ (mg/L) | 64.04 ±0.30 | 127.8 ±0.74 | 0 | 64.03 ±0.06 | 0 | 0 | 0 | 0 | 0 | 0 | 0 | 0 |
| NaCl (mg/L) | 101,803 ±2.45 | 203,608 ±3.73 | 231,15 5 ±0 | 101,852. 03 ±45.49 | 2434 | 1311 | 1086 | 749 | 188 ±0.39 | | | |
| MgCl ₂ ·6H ₂ O (mg/L) | 3605.7 ±2.25 | 7223.3 ±19.31 | 8203 ±2.01 | 3603.4 ±1.59 | 0 | 0 | 0 | 0 | 0 | 0 | 0 | 0 |
| KCl (mg/L) | 4052.3 ±1.60 | 8107.9 ±1.62 | 9151 ±0.56 | 4054 ±1.84 | 1282 | 647 | 520 | 330 | 12 ±0.29 | | | |
| CaCl ₂ ·2H ₂ O (mg/L) | 1806.4 ±3.81 | 3623.3 ±19.44 | 4138±1 .14 | 1804.6 ±0.94 | 258,42 5 | 156,363 | 135,951 | 105,332 | 54,301 ±11.58 | | | |
| Na ₂ SO ₄ (mg/L) | 78.33 ±0.39 | 156.1 ±0.28 | 176 ±0.81 | 77.46 ±1.13 | 0 | 0 | 0 | 0 | 0 | | | 0 |
| NaBr (mg/L) | 287.71 ±0.53 | 577 ±0.95 | 652 ±0.22 | 286.7 ±0.15 | 988 | 494 | 395 | 247 | 0 | | | 0 |
| CaSO ₄ ·2H ₂ O (mg/L) | 0 | 0 | 0 | 2501.3 ±1.15 | 0 | 0 | 0 | 0 | 0 | | | 0 |
| EC ^{25°C} (mS/cm) | 160.13 ±2.26 | 261.25 ±22.07 | 265.52 ±43.8 | 153.9 ±6.26 | 166.27 | - | - | - | 78.44 ±0.77 | | | |
| pH | 7.52 ±0.03 | 7.28 ±0.07 | 8.00 ±0.07 | 7.45 | 9.69 | - | - | - | 10.39 ±0.02 | | | |

Acknowledgments

Usually I am not fond of clichés due to their lack of originality, but in this case I'll allow this one; it really took a village to be able to accomplish all of this work and more. Which means that I have an entire village to give my thanks, for their support, their guidance, their patience, their laughter, their inspiration and their constant belief in me to accomplish everything that was required during all of these academic years.

I would like to thank all of my committee members for unanimous support since the first day of the EngD. I would like to thank **Henri Spanjers** for all of his constant support during my time at TU Delft. I've been lucky to have been working with him for almost five years, he has encouraged me to tackle my work with genuine curiosity and he has been graceful enough to have patience to train his ears and get accustomed to discussing a million different aspects of my work while I speak at a rate of a million words per second.

I would like to thank **Oguzhan Çopuroglu** for always providing the precise comments that I needed to improve my work and help bridging between the world of concrete and water.

I would like to thank **Noura Chehab** for including me in this challenging project where I was able to grow immensely as a professional, which helped me build stronger foundations for the future of my professional career. Also thank you for the hospitality and help during my trip to NEOM, it will be exciting to see how our work will play a small but significant role there.

Additionally there was the rest of the Brine2Beton team who was also a privilege to work with. Immense thanks to **Yu Chen** whose impressive knowledge on 3D printable concrete became the main pillar in moving forward the project but to also start building that required bridge in this complex multidisciplinary project. I would like to thank **Mohammed Alsindi** and **Ali Alghazal** for always been enthusiastic collaborators in this project and for helping with all NEOM related aspects that were important for this project.

Six years ago I would have not imagined of being here in The Netherlands at TU Delft accomplishing an engineering doctorate. After five years, TU Delft has become an integral part of my life which has welcomed me and guided me every step of the way. I would like to thank all of the professors that have helped me and who have encouraged and challenged my ideas during my masters and the EngD. Special thanks to **Jules van Lier, Bas Heijman, Merle de Kreuk, Martine van den Boomen, Doris van Halem, Boris van Breukelen, and Luuk Rietveld**. Also I would like to thank the brilliant EngDs, PhDs, and master's students and staff that I've had the privilege to work with, collaborate, and that form part of the water management and environmental engineering department. It is beyond inspiring to be surrounded by so many brilliant individuals in these last five years. They are the reason they make this department so prestigious. I would like to give special thanks to all of EngD friends **Erik, Karim, Pedja, Luc, Mark, Silvy, Arash, Claudia, Lina, and Erick**, it has been an immense joy to have

worked with you and to see each one of you thrive. To all the brilliant staff that has helped me throughout the years, thanks to **Jane, Fleur, Patricia, Armand, Mariska, Rielle, Fleur, Louise, Helene, and Jasper.**

I am forever grateful for all of the kind and patience friends that have given me more than what I could have asked for. Thanks to the best support system anyone could have asked for, to **Anastasia, Valeria, Diana, Judith, Frank, Clifford, Kirsten, Lindsey, Shlok, Dennis, Akemi, Selin, Maria, Sara, Diana P, Jonathan, Katja, Guus, Devanita, Jasper, Jane, Sebastian, Rob, Vasilina, Ioanna, Fabrizia, Helena, Ron, Solee, Thomas, Monica, Gaby, Cesar, Monique, Linnaea, Zhe, Sanjana, Nina, Seth, Carrie, Sophie, Jeffrey, Elise, Madeleine, Rodrigo, Simon, Austin, Amy, Sara, Talley, Elsa, Ana Valeria, Elyssa, Maria Sarela, Elyssa, Sofia.** Thank you for lifting me up in all the unique ways only you know how.

One could definitely argue that none of this could have been accomplished without the family. This would have been completely true for my case. This time I would to immensely thank my grandparents who have been my number one fans since the very beginning. Specially I would like to thank my **Abuelo Pepe** for having the most contagious childlike enthusiasm that filled him with pride. To my other grandparents **Rogelio, Irma, and Tere,** I wish they would still be here to thank them immensely in person. Lastly to my parents **Jose and Maria,** and my siblings, also **Jose and Maria,** thanks for everything. The amount of words to express all of gratitude would double the size of this thesis report, but for now million thanks for always being there for me.