

*lessons on the theory of Dom Hans van der Laan*

**the aesthetics of proportion**



**graduation research by Joppe Douma**

*TU Delft 2018*

*Tutor: Peter Koorstra*





# table of content

## introduction

fascination  
problem statement  
method

## theory

ground ratio - the plastic number  
measuring system  
mass and space - nearness  
from inside to outside - cell, court & domain  
the wall  
symmetry and eurythmy  
superposition and juxtaposition  
open and closed - window arrangements and column-spacings  
tools - the abacus, form-bank and thematismos  
material, light and color

## application

measuring system  
formbank  
domain  
unit and cell  
positioning of walls  
window arrangements and column-spacings

## reflection and conclusions

what are the valuable lessons we can draw from the theory of Dom Hans van der Laan?

what are the boundaries and tolerances within this proportional system?

## set of analyses

### *plastic number*

house Naalden - Dom Hans van der Laan

entrance Roosenberg Abbey - Dom Hans van der Laan

stool design - Dom Hans van der Laan

house Kreijl - Gerard Wijnen

### *pleasant proportions*

Casa del fascio - Giuseppe Terragni

Restauro di palazzo Tentorio - Massimo Ferrari, Enrico de Benedetti and others

Classical example - parthenon

### *questionable proportions*

Bundner Kunst Museum - Barozzi Veiga

## **fascination**

I think everyone knows the experience of climbing a sand dune to find the impressive view of an immense beach and measureless sea. It's almost too much to take in. For a moment you can even lose yourself.

These kind of experiences led the architect and monk Hans van der Laan to investigate how we search for grip in the immense space.

Based on our perceptual abilities, the human discernment, he developed the systematic proportional series of the Plastic Number. Through this he aims to create an order that can directly communicate with our abstract rational understanding of space, thus make it readable.

It's about the relation between the different parts which together compose a harmonious space.

Growing up in a house designed with these principals, my fascination for this theory grew more and more as I began with studying architecture in Delft. I became curious about the ideas behind this theory and especially about the effect of designing with a measuring system.

In this graduation work, I attempt to explain and illustrate the theory in a approachable way as well as I demonstrate the link with the application in design practice.





## **problem statement**

The relevance of thinking consciously about proportions and dimensions comes forth out of a discrepancy between measuring and perceiving.

The way we design and build now is largely based on the metric system, but we don't perceive space in meters or centimeters, let alone millimeters. We read our environment by relating objects to each other, by comparing and by differentiating. If we want to respond to this as an architect, we have to know what proportions and which differences in size we see and perceive as important.

After years and years of research and experiments, Dom van der Laan came up with his proportional system and proved with his monasteries that designing like this can result in an architecture with an ultimate experience of a space. The order, stillness and calmness have an extraordinary effect.

His small number of built work is known and highly esteemed and some have even become a pilgrimage for architects. Yet it is still rather unclear how the potential of the theory can be applied in the architectural practice.

What is still missing in existing literature is a comprehensible, accessible way to get acquainted with the theory and the application of it.

## questions

The two leading questions for this research are as follows:

- *What are the fundamental ideas behind the theory and what valuable lessons can we draw from them?*
- *How can the Plastic Number be applied in architecture practice?*

Throughout the research and design it is important to keep testing the relevance of this theory. To be able to give a more critical reflection in the end, I also ask the following question:

- *What are the boundaries and tolerances within this proportional system?*

## method

The first part of the research will be an **introduction on the theory**, in which I will elaborate on the origin of the proportional series of the Plastic Number. Furthermore I will explain and visualize the aspects of the theory of which I think they have a value for today's architecture.

In addition to this theoretical part, I will also write about the sensory experience of the architecture of Dom Hans van der Laan in relation to colour, light and material.

This will be followed up by an **application manual** which gives a simplified step by step approach on how to actually use this system in practice.

Having this knowledge, I can give a **critical reflection** on the theory and determine what elements or lessons are relevant for today's architecture.

A broad **set of analyses** of various designs made during the research is added at the end of the booklet.

It must be said that trying to summarize such a complex, rich theory in a short and simple way is a bit contradictory. Therefore I must acknowledge this work is not fully comprehensive. Instead, it tries to focus on the important aspects that have a direct link with the implementation in architecture practice, so that I can give useful starting points to start with designing using the Plastic Number.

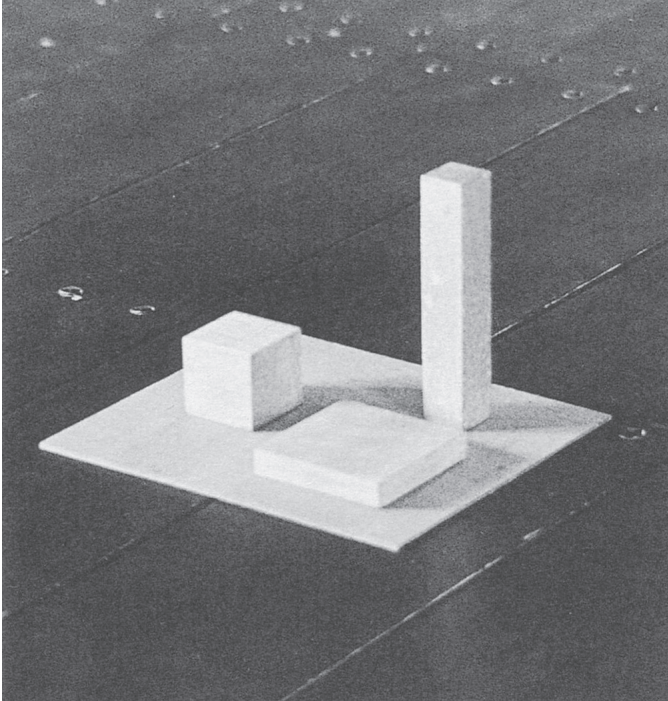

- 1. ground ratio - the plastic number**
- 2. measuring system**
- 3. mass and space - nearness**
- 4. from inside to outside - cell, court & domain**
- 5. the wall**
- 6. symmetry and eurythmy**
- 7. superposition and juxtaposition**
- 8. open and closed - window arrangements and column-spacings**
- 9. tools - abacus, thematismos and the form-bank**
- 10. material, light and color**

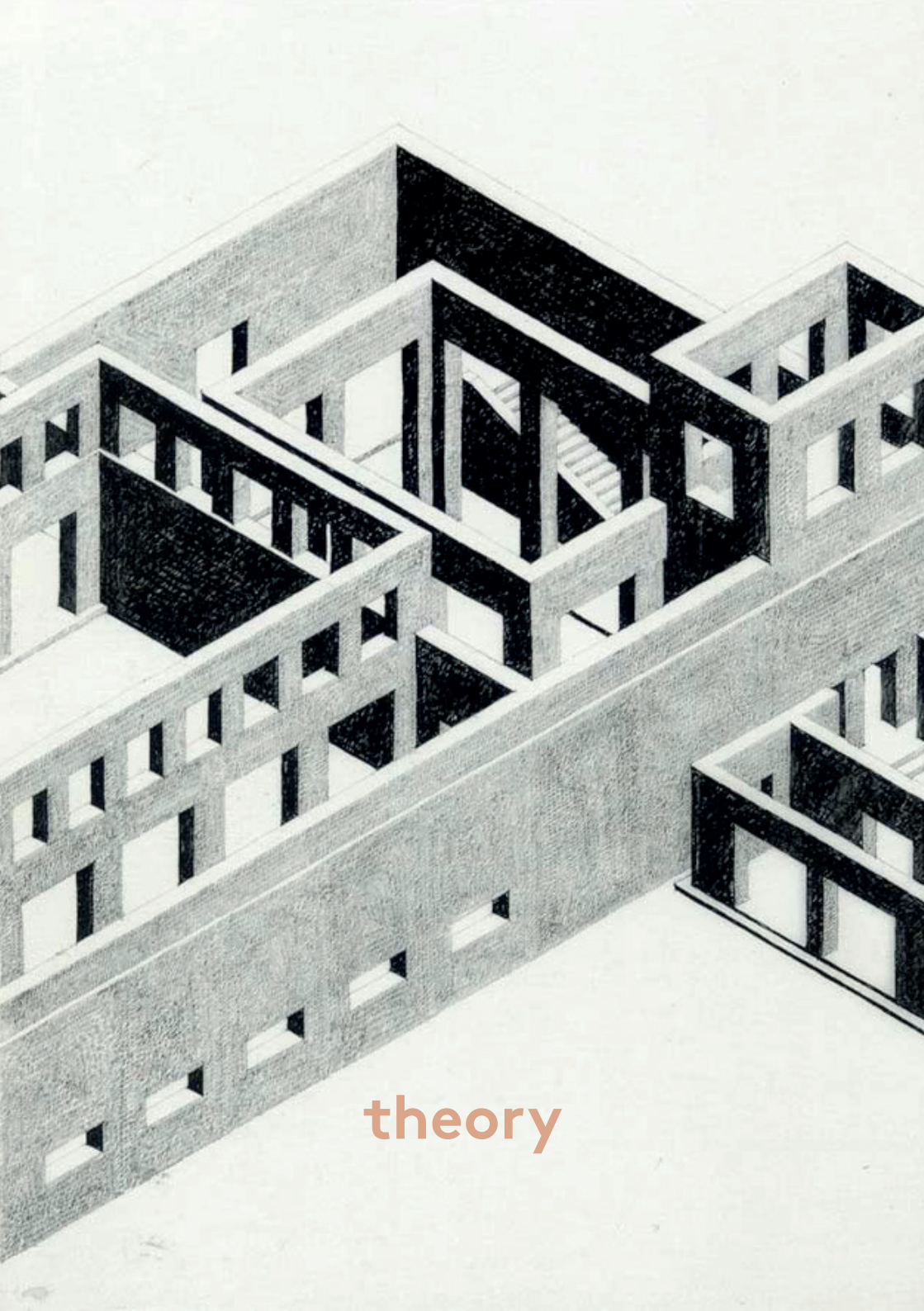

theory

## 1. ground ratio - the plastic number

*When do we distinguish unequal parts and clearly name the difference?*

When we divide something through the middle in two parts, only one size counts, because the two parts are equal. But if we start dividing into unequal parts, it becomes a matter of measuring and comparing. Dom van der Laan was interested in the question when we determine difference in sizes as clearly distinguishable. He concluded that this readable difference occurs when one part is nearly a third larger than the other, the mutual relationship being about 3:4 (Voet, 2017).

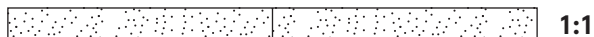





We know a rich use of measuring systems in our art and architecture history. The most used and well known is probably the Golden Ratio. To get a better understanding of the Plastic Number, a comparison between the Golden Ratio and the Plastic Number is made. They both have a mathematic origin and result in a sequence of numbers, but they have also considerable differences.

### *The Golden Ratio*

The mathematical formula of the Golden Ratio results in the ground ratio **1:1,618**.

As seen in the figure, the formula relates to two dimensions. Therefore it's not considered appropriate for architecture according to Dom van der Laan.

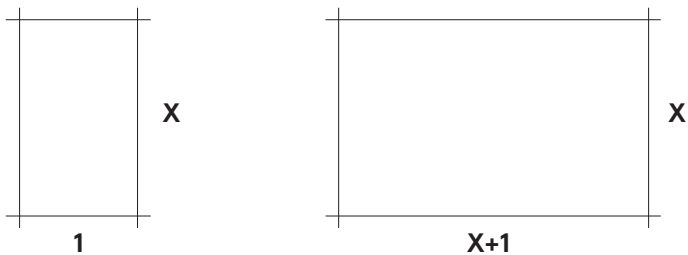

$$1:X = X:(X+1) \rightarrow X^2 = X+1$$

$$X = 0,618 \text{ or } X = 1,618$$

**1:1,618..**

*The Plastic Number*

One could say Dom van der Laan discovered the Plastic Number out of dissatisfaction with the Golden Ratio. He found a way to translate the formula into one that relates to three dimensions. If you calculate this, you reach the ground ratio **3:4**

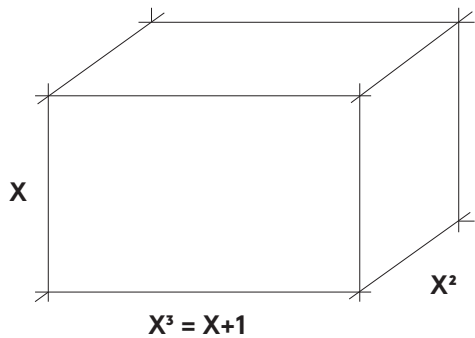
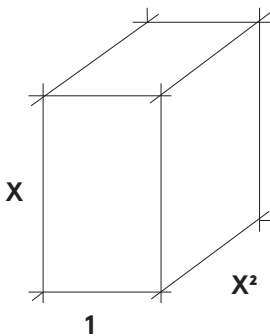

$$1:X = X:X^2 = X^2:(X+1) \rightarrow X^3 = X+1$$

$$X = 0,755 \text{ or } X = 1,325$$

**3:4**

Furthermore, Dom van der Laan claimed that the Golden Ratio didn't allow for a harmonious continuous subdivision. When dividing AB into AC and CB according to the Golden Ratio and subsequently divide CB into CD and DB, the result is two equal parts: AC and CD (Voet, 2017).

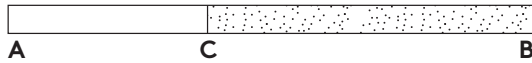

$$AB:BC = BC:CD$$

$$CD = AC$$

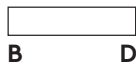
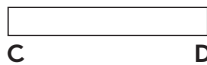
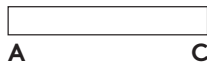
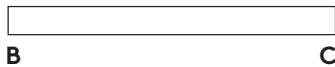
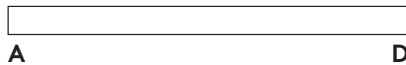

When dividing AB according to the Plastic Number, the result is a continuous subdivision without equal parts. The six segments produced by the two subdivisions are all interrelated by approximately 3:4.

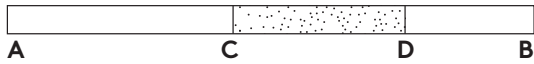
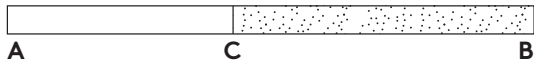

$$\begin{aligned}
 AB:AD &= AD:BC \\
 &= BC:AC \\
 &= AC:CD \\
 &= CD:BD
 \end{aligned}$$

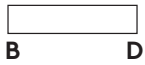
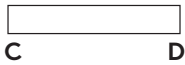
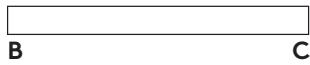
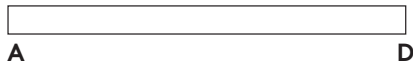
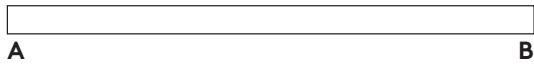

### *The Golden Ratio*

The sequence of numbers according to the Golden Ratio is called the Fibonacci sequence. It's characterized by the fact that every number after the first two is the sum of the two preceding ones.

$$1 \quad 1 \quad 2 \quad 3 \quad 5 \quad 8 \quad 13 \quad 21 \quad 34 \quad 55 \quad 89 \quad 144 \quad 233 \quad 377$$

$2+3 = 5$                        $34/21 = 1,618$   
**1:1,618**

### *The Plastic Number*

The sequence of the Plastic Number is characterized by two terms that together are not the sum of the following number, but the one after that.

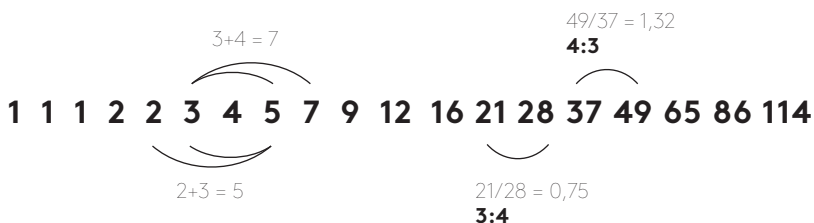

In contrast to the Fibonacci sequence, which has fixed numbers, you can also start the Plastic Number sequence with another number. In the sequence below, you can see the ground ratio clearly between  $75^{1/2}$  and 100.



### *Order of size*

The idea of an order of size can be easily explained by an experiment Dom van der Laan did with his students. To explain how we differentiate, round off and order sizes, he made a sorting test with 36 pebbles.

It is impossible for our human mind to really get through the individual size of things. If we see a lot of pebbles, we know that all stones have their own size, but it is impossible to form an image of each of these sizes. So what we automatically do is categorize certain groups of sizes, which belong together within a limit and are considered the same size (Van der Laan, 1977).

In our minds we automatically form families of stones that we think belong together. We can see they diver in size, but we cannot 'name' the exact difference.

So within an order of size one finds measures that have a meaning to each other because they relate each other and thus can be compared.



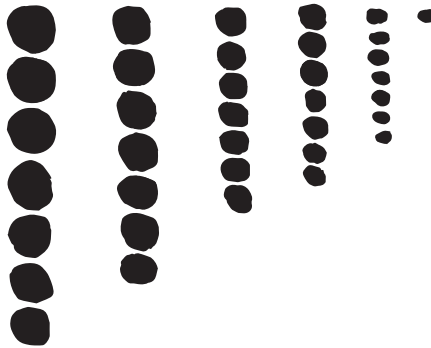
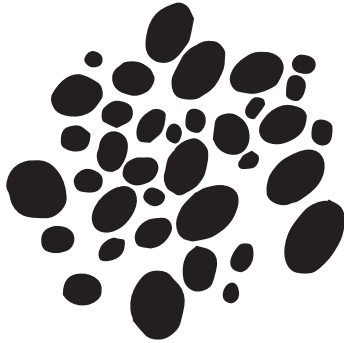

To avoid comparing two sizes that are too far apart, Dom van der Laan introduces the term “order of size”, so that within this order or family, the sizes are still relatable.

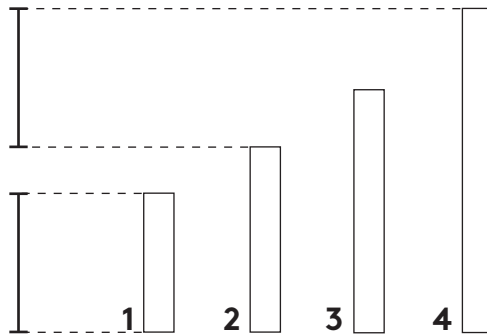

Starting with a sequence of four following terms according to the Plastic Number, the sum of the first two is the fourth, thus the biggest size.

The sum of the differences between 2 and 3, and between 3 and 4 is also equal to 1.

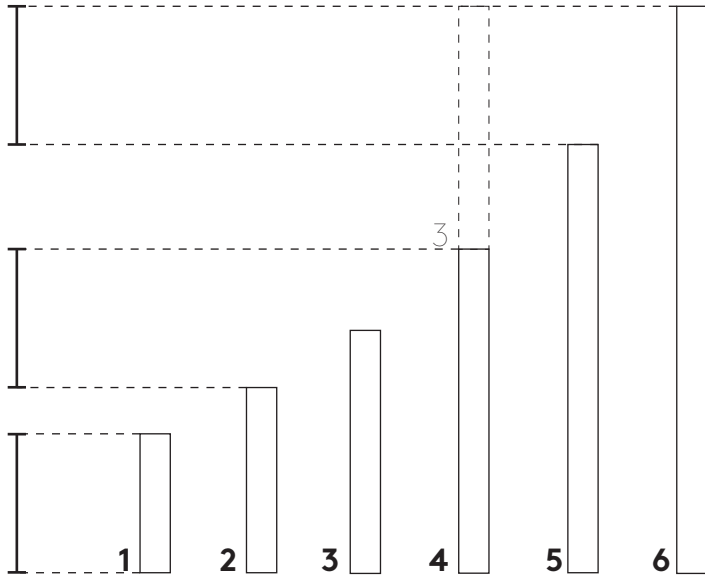

In a similar way, the sequence can be extended to six terms. The sum of 3 and 4 is equal to 6. Resulting in a sequence in which the difference between the two biggest terms is equal to the smallest term 1.

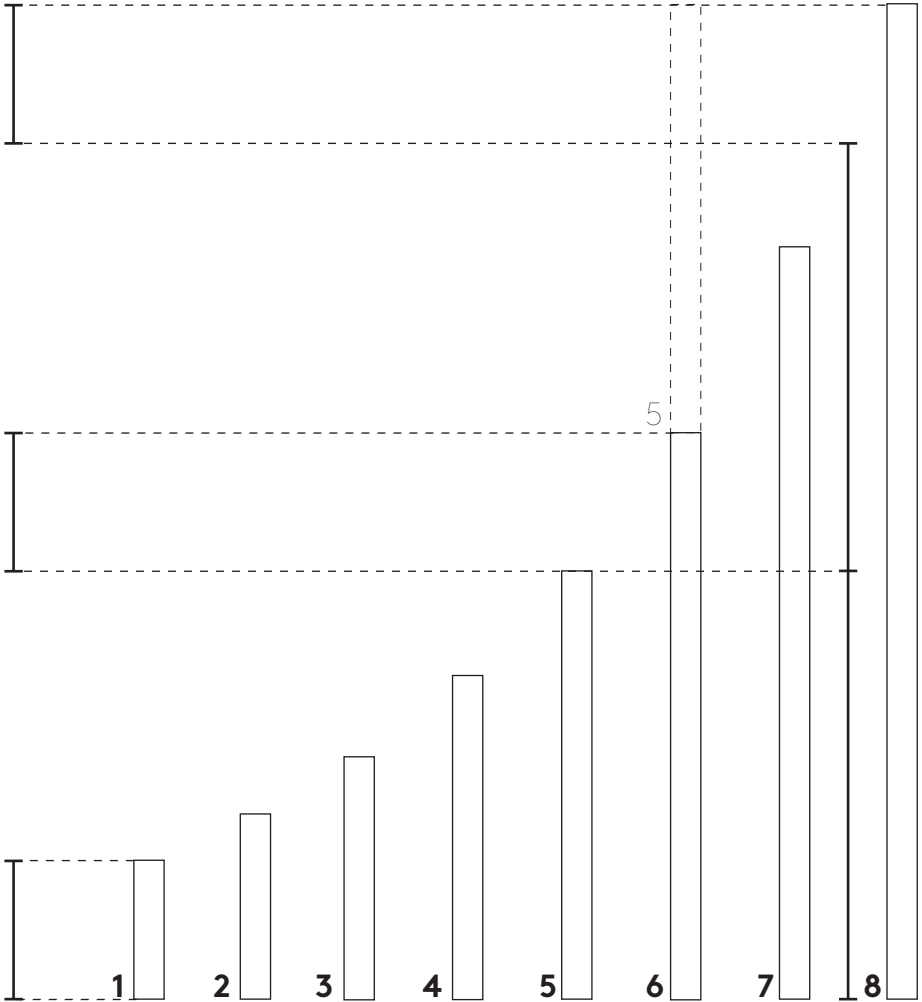

Finally, the order of size is concluded with two more terms, resulting in a family of 8 sizes. The eighth term is the sum of term 5 and 6 and 7 times the unit 1. It's the last size that is still relatable to the unit 1. (Van der Laan, 1977).

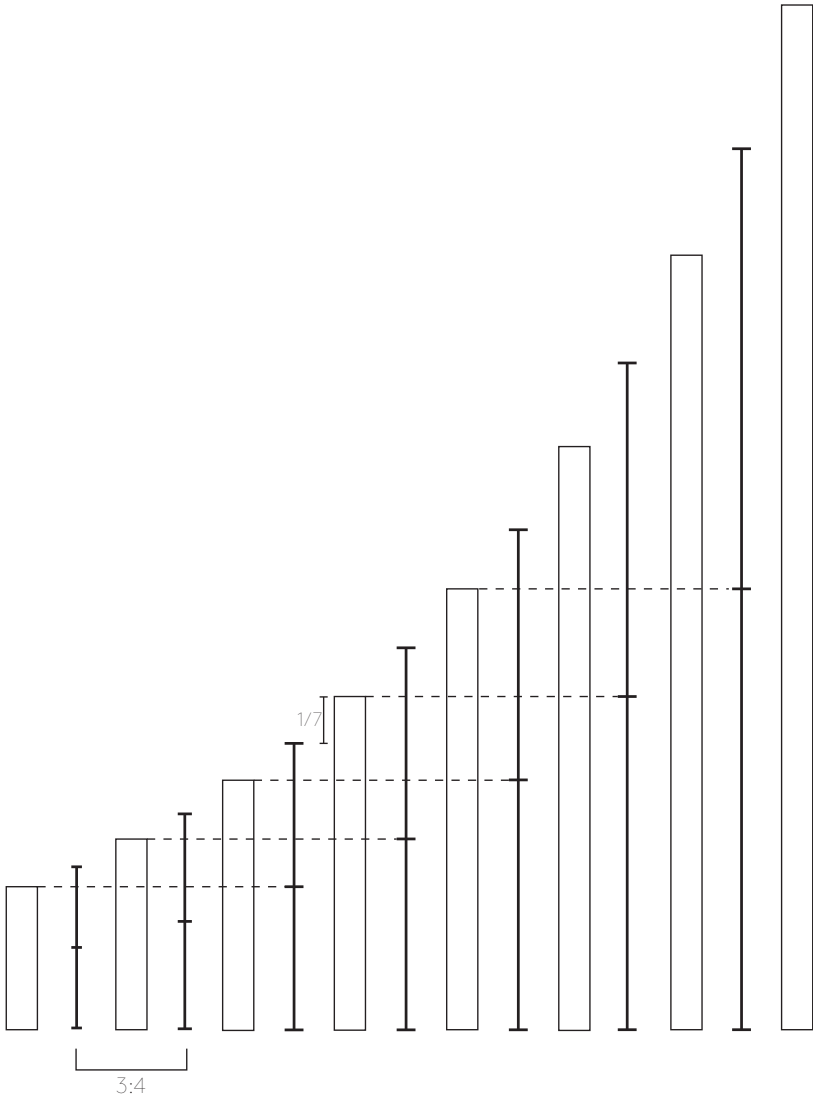

To create more options and refine the system, Dom van der Laan added a underlying sequence of derived sizes. The derived sequence consists of doubled authentic sizes, and is also related through 3:4. The difference between an authentic size and its derived size is  $1/7$  of its size (Voet, 2017).

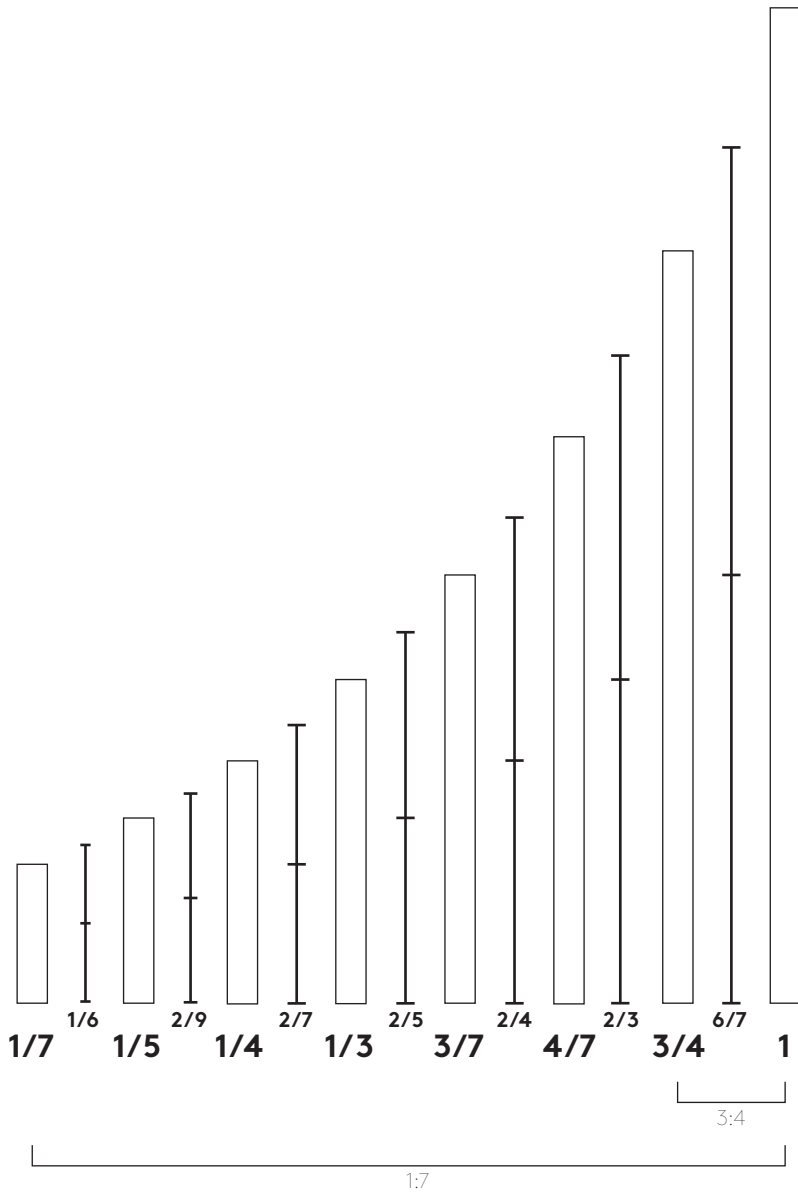

To give the sizes countable values, Dom van der Laan uses fractions that approximate the multiplication with the ground ratio.

### *Concluding summary*

The order of size is a sequence of eight authentic measures, accompanied by their derived measures. The measures are all related by 3:4. The smallest and biggest measure relate as 1:7. 1:7 is therefore maximum difference between two measures so that they can still be compared.

## 2. measure system

### *Order of size - measure system*

The sequence of the Plastic Number can eventually be translated into concrete numbers that can be used in the metric system.

Dom van der Laan formulated three successive orders of size, with both the authentic and derived measures.

For the first order, Dom van der Laan chooses to begin with 100 as the smallest unit.

The sequence has a couple of “rules”, from which we can built up the concrete numbers. If you divide 100 through the ground ratio (0,755) you will get the next number. In a series of four numbers it's also said that the sum of the first two is equal to the fourth number. So  $100+132,5=232,5$ .

We also know that the biggest number, the eighth term, is seven times bigger than the starting unit. Note that 716 is more than  $100 \times 7 = 700$ . This is because 716 is a composition of seven times 100 plus 14 and 2, the smallest units of the two underlying orders. If you want to know why exactly, I would recommend you to read *Architectonic Space*, chapter VIII.

For the derived measures, we know that the difference between the biggest authentic size and it's derived size is equal to the smallest unit. So  $716 - 616 = 100$ .

A derived measure is  $6/7$  of the authentic measure, and also the exact double of a lower authentic measure.  $132,5 \times 2 = 265$  for example (Van der Laan, 1977).



This results in the three measure systems as shown in the figure below.

The way of using these measuring systems can be compared with the keys of a piano that are chosen to make a harmonic composition (Voet, 2017).

### order I

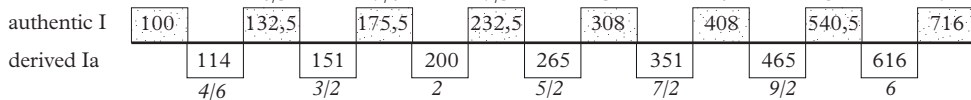

### order II

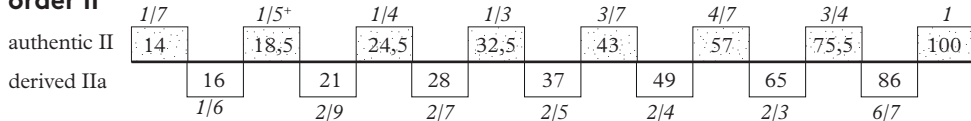

### order III

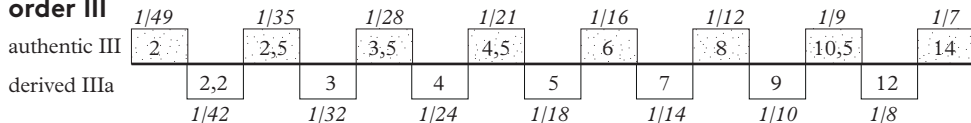

### 3. mass and space - nearness

The concept of 'nearness' can be explained through a simple example:

Imagine two blocks with a certain distance from each other, and a certain distance between you and the blocks. The distance between the blocks is independent on the size of the blocks, so is the distance between you and the blocks. So if we take bigger blocks, the distance between the blocks and the distance between you and the blocks remains the same. But we feel or perceive a different distance. We feel closer to the bigger blocks than we do to the smaller ones and the distance between the two big blocks also seems smaller than the distance between the small blocks, regardless of the fact that the actual distances are the same in both cases.

This is why Dom van der Laan introduces the term 'nearness'. The distance between two block is independent on their size, but their nearness is closely connected to their size by a direct ratio.

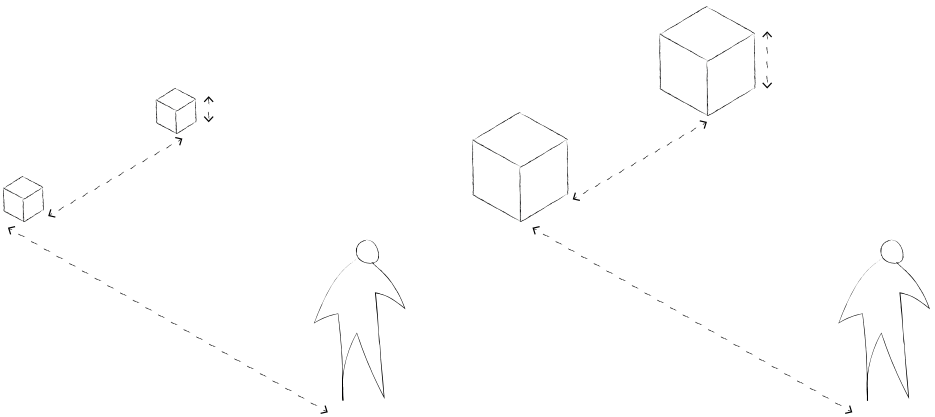

It seems that nearness is not affected when we heighten or widen the blocks, keeping the same distance. As long as the thickness of the elements remains the same, the mutual nearness will too. However, the mutual nearness will change as soon as the thickness is changed, regardless of the same distance. The nearness of two massive forms is thus dependent on the distance between them and their size in the direction of that distance (Van der Laan, 1977, p.41).

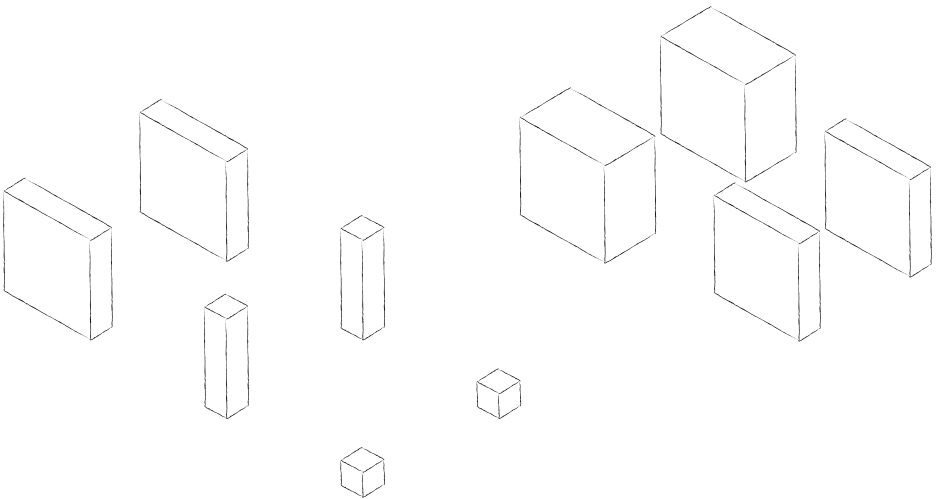

#### 4. from inside to outside - cell, court, domain

The natural outside space is unlimited and measureless, but the architectonic space has, of course, a limited perimeter. To relate these limitations to our human actions, Dom van der Laan introduces the 'experience-space'. Through different scales he defines three spheres:

- \* personal work space, towards the intimate space
- \* walking space, for meeting
- \* visual field, towards the outside

Translated to the architecture we call these spheres from small to large: cell, court and domain. These three scale levels are interconnected with the three orders of size. The cell is in this way the yardstick for the court, as is the court for the domain.

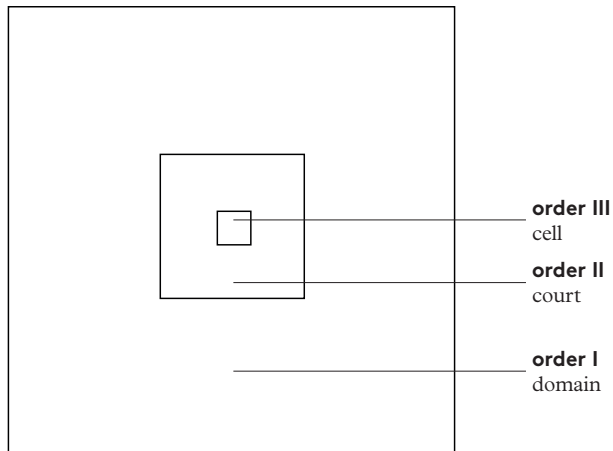

## 5. the wall

Because of the principle of nearness, Dom van der Laan assigns great importance to the visibility of the thickness of the wall, and is thus shown where possible. Without seeing the thickness of a wall, one cannot understand the relation with the wall to the space. A good dimensioned space should be made recognizable with three dimensional elements, only seeing the surfaces is not helping us understanding the space.

The cell is defined by walls, so that the wall is the yardstick for the space. As explained earlier, the maximum difference between two measures is 1:7 so that they can still be compared. So the distance between the walls is approximately seven times their thickness in an ideal situation.

In a bigger space, you can make a subdivision of which the size is part of the family of sizes of the wall, but also of the family of sizes of the whole space.

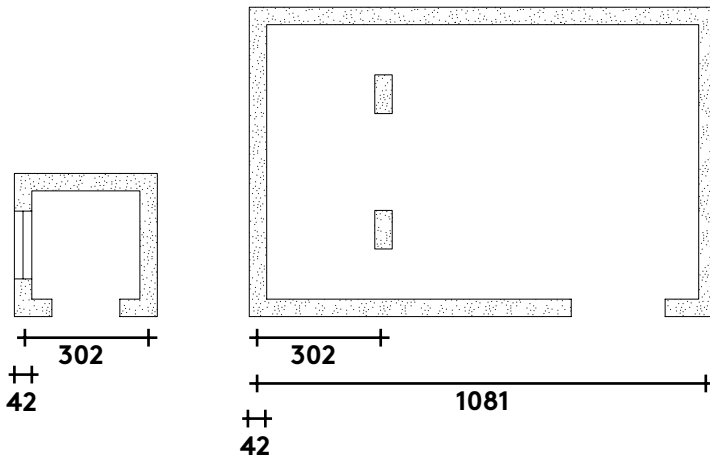

## 6. symmetry and eurythmy

Symmetry is about comparing two sizes in the same direction, for example the lengths of different forms.

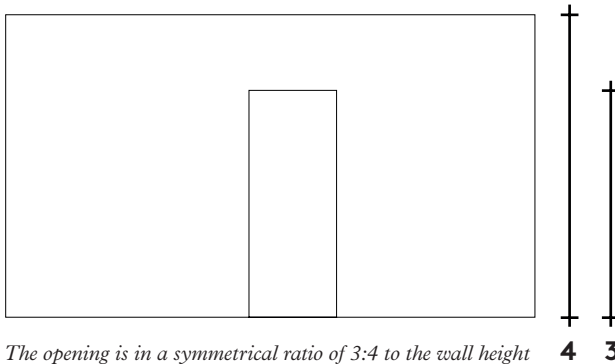

In this sense is not about how we know the term symmetry now; as two identical halves. Introducing this term, Dom van der Laan refers to how the Ancients used the term: as the indication of correct, harmonic proportions of all parts of a work, from the smallest part to the whole (de Haan & Haagsma, 2010, p.100).

An eurythmic ratio is about comparing the sizes of different directions within one form.

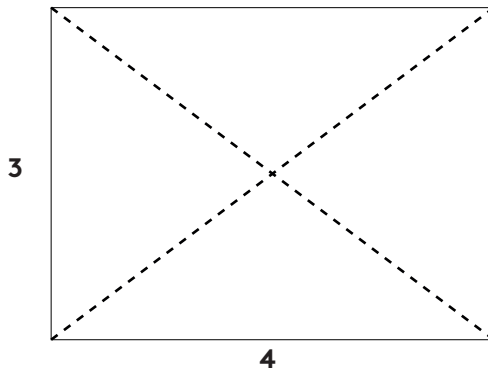

*The ratio between width and height within one form is 3:4*

Symmetry is therefore more about the size (quantity) of things, whereas eurythmy is more about the form (quality) of things.

*authentic symmetrical proportions*

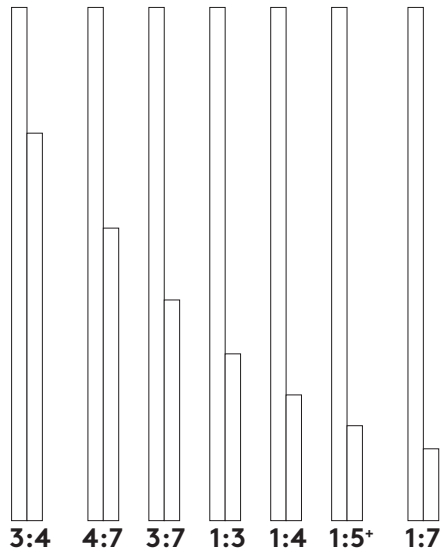

*derived symmetrical proportions*

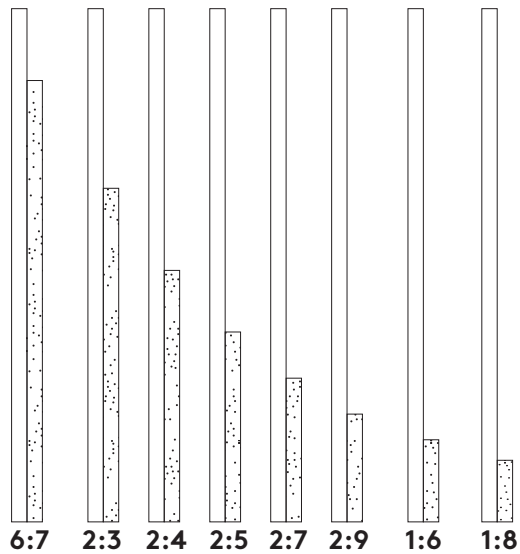



*authentic eurythmic proportions*

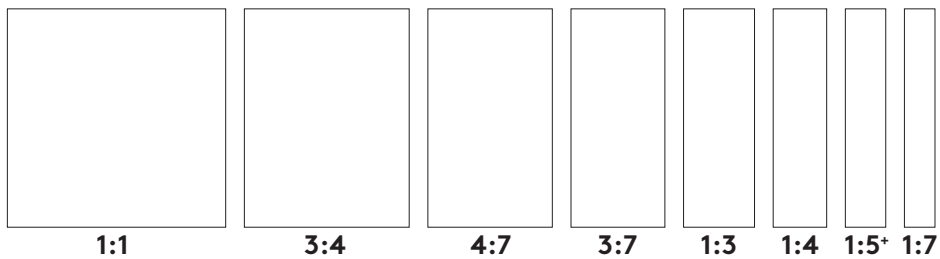

*derived eurythmic proportions*

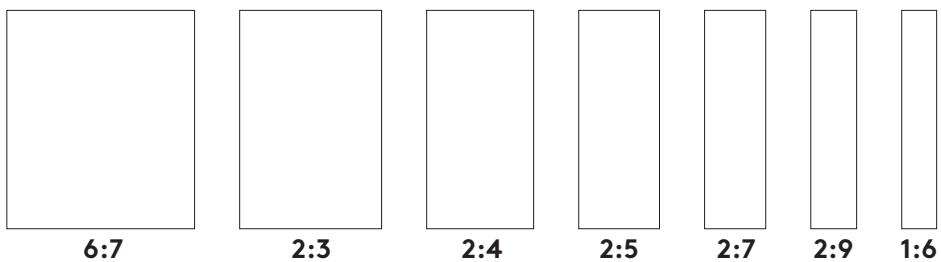

## 7. superposition and juxtaposition

For ratios where the measurements are in the same direction, one can make a distinction between superposition and juxtaposition.

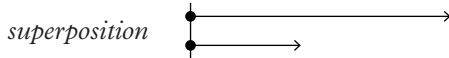

In a superposition we see that the whole is compared with a part that has been taken from it. It's about the expression of that part compared to the whole, so the difference between the whole and the part is inferior. The whole and the part are in ratio and don't relate to the difference. It should be clear that the smaller size is part of the whole: the bigger the difference, the stronger the ratio.

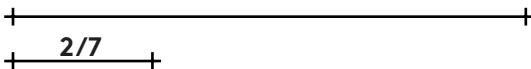
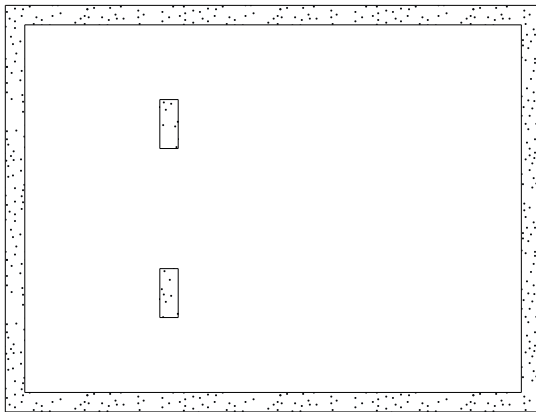
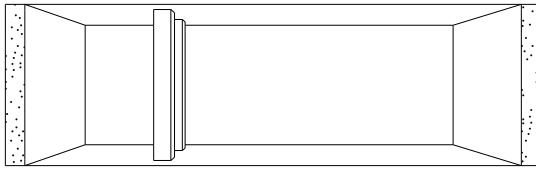

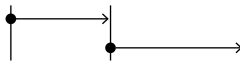
*juxtaposition* 

In a juxtaposition, the whole is divided in two or more parts that are compared with each other. It's not about the whole anymore, it has made way for the parts.

Each size should act as a part, so the difference between them should not be too big.

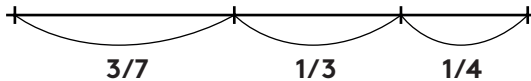
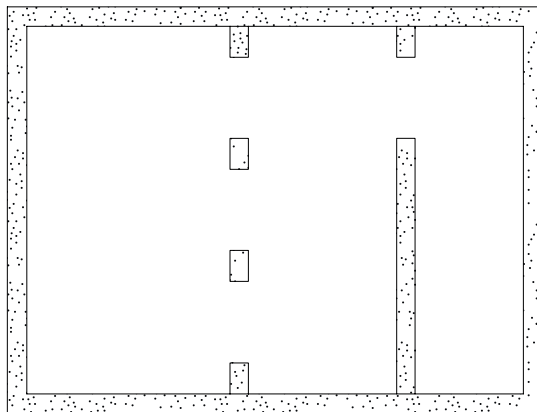
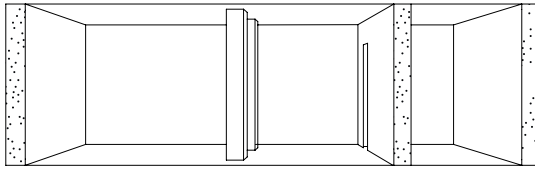

*authentic superpositions*



*derived superpositions*

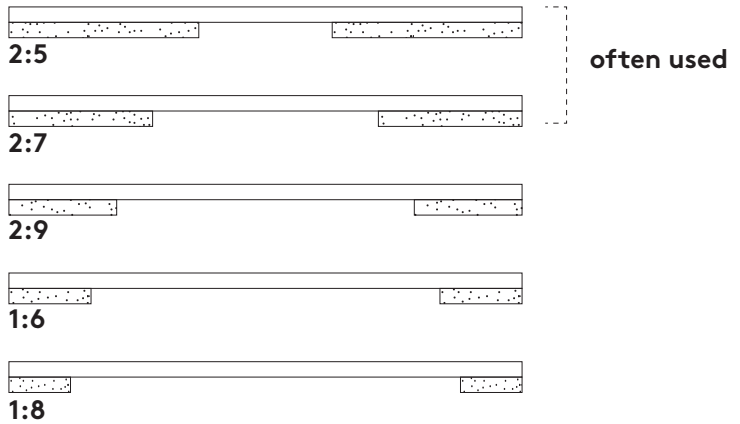

*authentic juxtapositions*

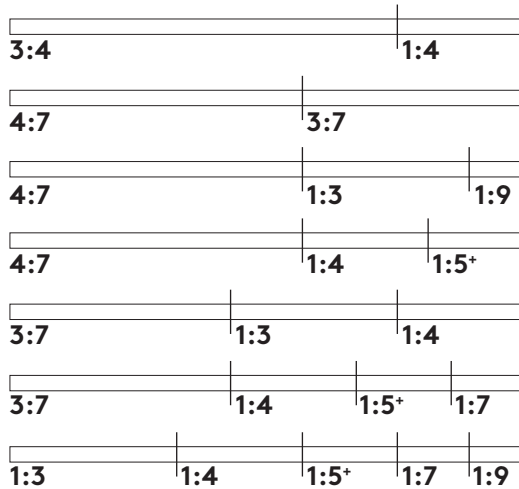

*derived juxtapositions*

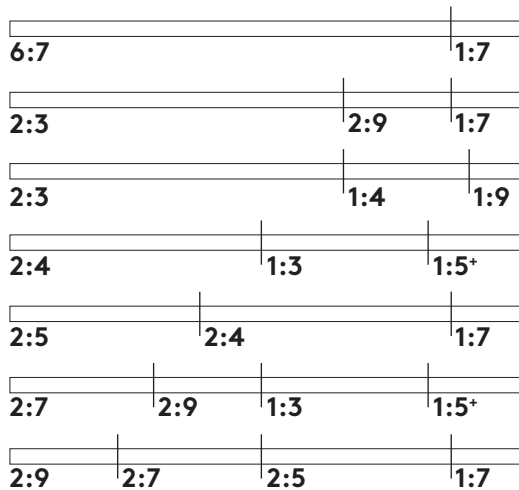

## margins

In the examples of juxtapositions, we see combinations of measures that together form the whole. If we take for example the authentic juxtaposition  $4:7 - 1:4 - 1:5^+$ , and take 100 as the whole. It's subdivided in  $57 + 24,5 + 18,5 = 100$ , according to the numbers in the measuring system.

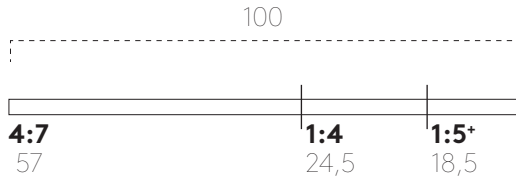

It's also possible to make a juxtaposition of a repetition of measures. In the measure system, you can see that  $1:3$  of 100 is  $32,5$ , which is not exactly  $1:3$  of course. Dividing the whole in equal parts according to the system will result in a margin. Dividing in three or in five gives the following margins:

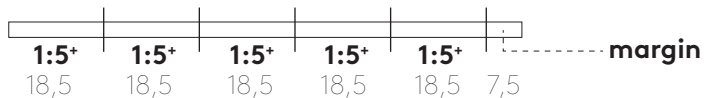
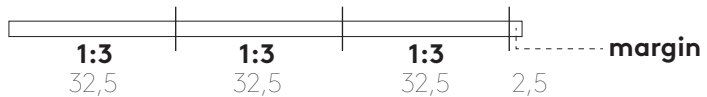

These margins are exactly what makes the system interesting. It prevents the system from becoming monotonous and provides room to play with - and in a way manipulate - the system. It invites the architect to play with the possibilities. It is ofcourse possible to divide the margin over all parts, so that they will be equal. More interesting though, is to deal with the margin in such way, that it emphasizes a certain part.

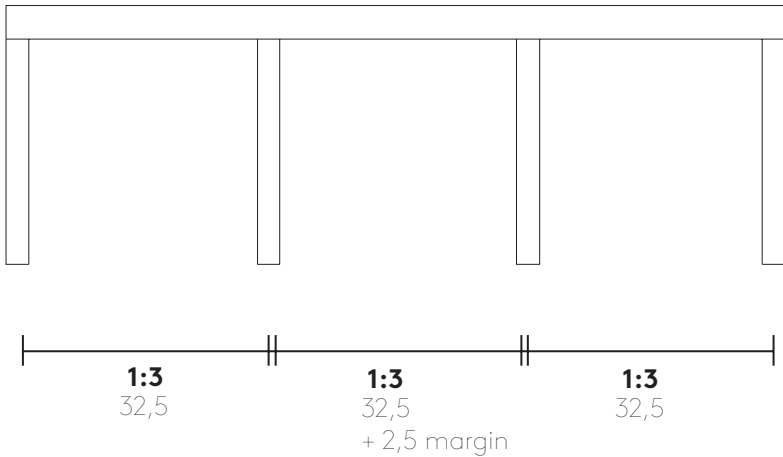

## 8. open and closed - window arrangements and column-spacings

Depending on the relative size of the openings in a wall, Dom van der Laan calls them window arrangements or column-spacings.

Smaller openings in a wall are window arrangements.

The measurements of the opening are defined and the measurements of the remaining wall are subordinate; the wall serves as a background against which the openings stand out.

When the opening becomes bigger and exceeds the border of 3:4, he speaks of column-spacings. The wall-pieces become more clear as a frame and make the form of the opening disappear.

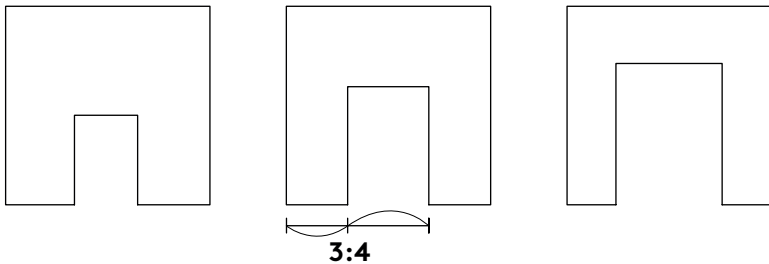





*column-spacings*

Derived from Vitruvius, Dom van der Laan proposed five column-spacings with a certain relation between the column width and the column distance (measured between the centres of the columns). In this way, the columns are determined, while the openings result from this.

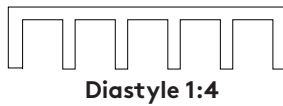
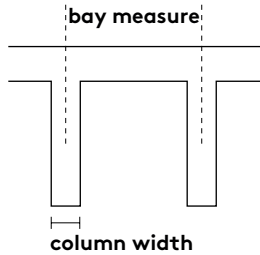

*window arrangements*

Dom van der Laan also proposes five window arrangements. The width of the window is determined and is in relation with the bay measure.

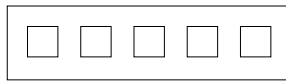
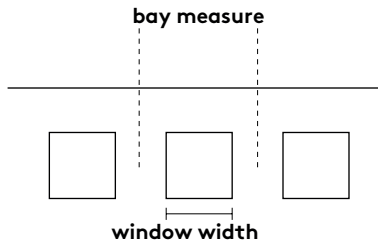

**4:7**

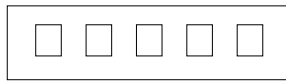

**2:4**

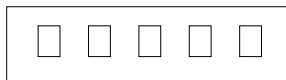

**3:7**

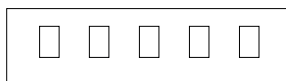

**2:5**

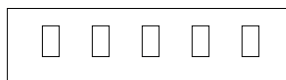

**1:3**

## 9. tools - abacus, thematismos and form-bank

To train the knowledge of the basic principle of seeing and the proportions of the plastic number, Dom van der Laan developed several tools which he used to design and teach.

### abacus

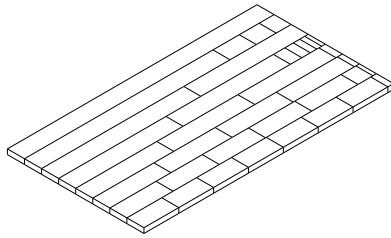

The Abacus was intended to give an insight in the successive orders of the plastic number. 38 bars show the interrelation of differentiated sizes in one direction, and thus shows all the symmetrical proportions.

### thematismos

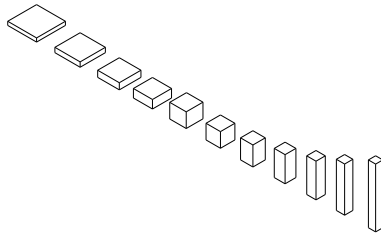

Thematismos consists of 11 blocks of different forms (slabs, blocks and bars) with all equal volumes. According to Dom van der Laan, buildings should be composed as an ensemble with clearly distinguishable volumes like these.

## form-bank

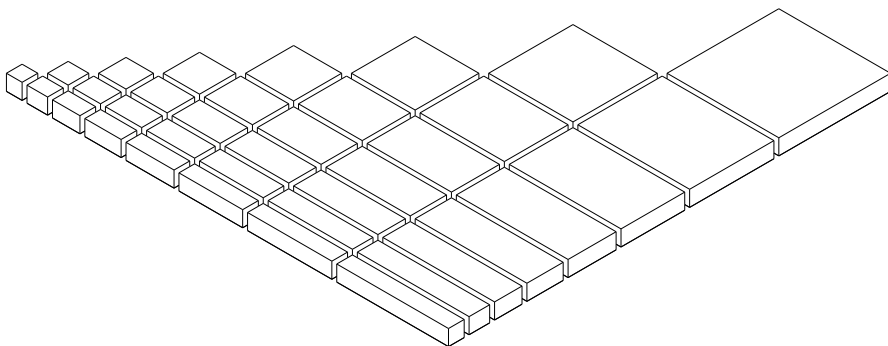

The form-bank shows the eurythmic proportions, related to the height, width and length of a form. It consists of 36 different forms; 10 blocks, 10 slabs, 10 bars and 6 neutral, white forms. The form-bank will be elaborated in the following pages.

# blocks

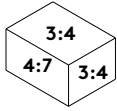

*core block*

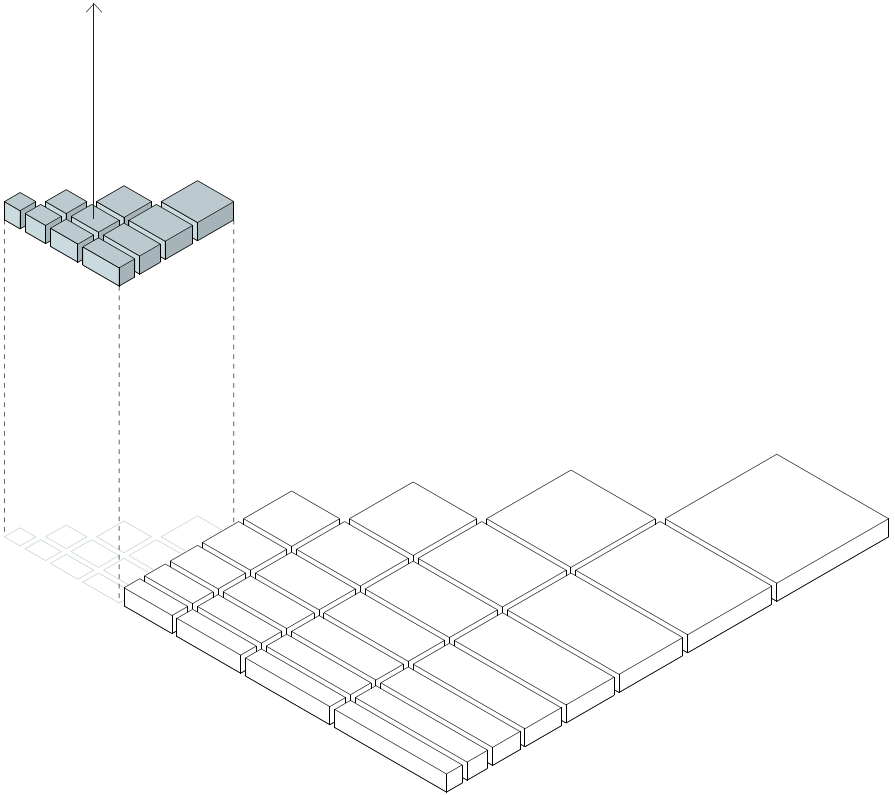

# slabs

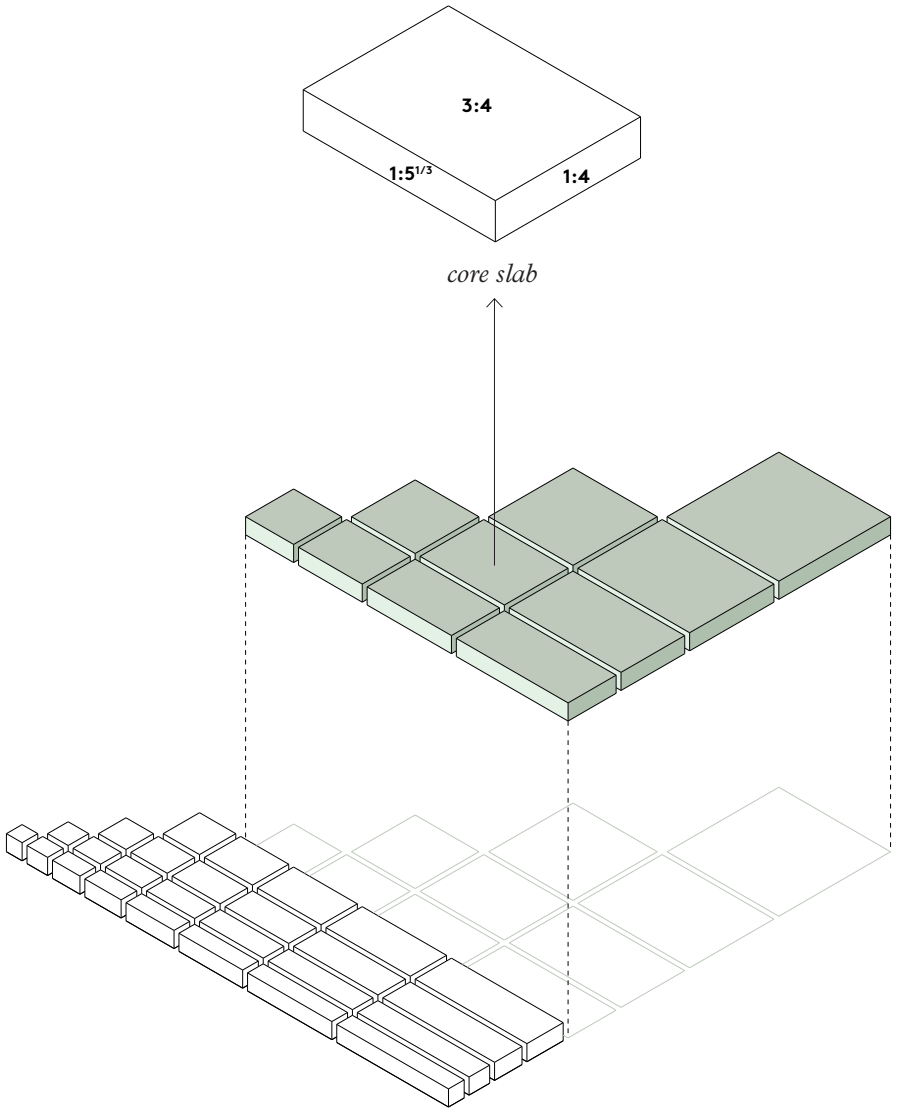

# bars

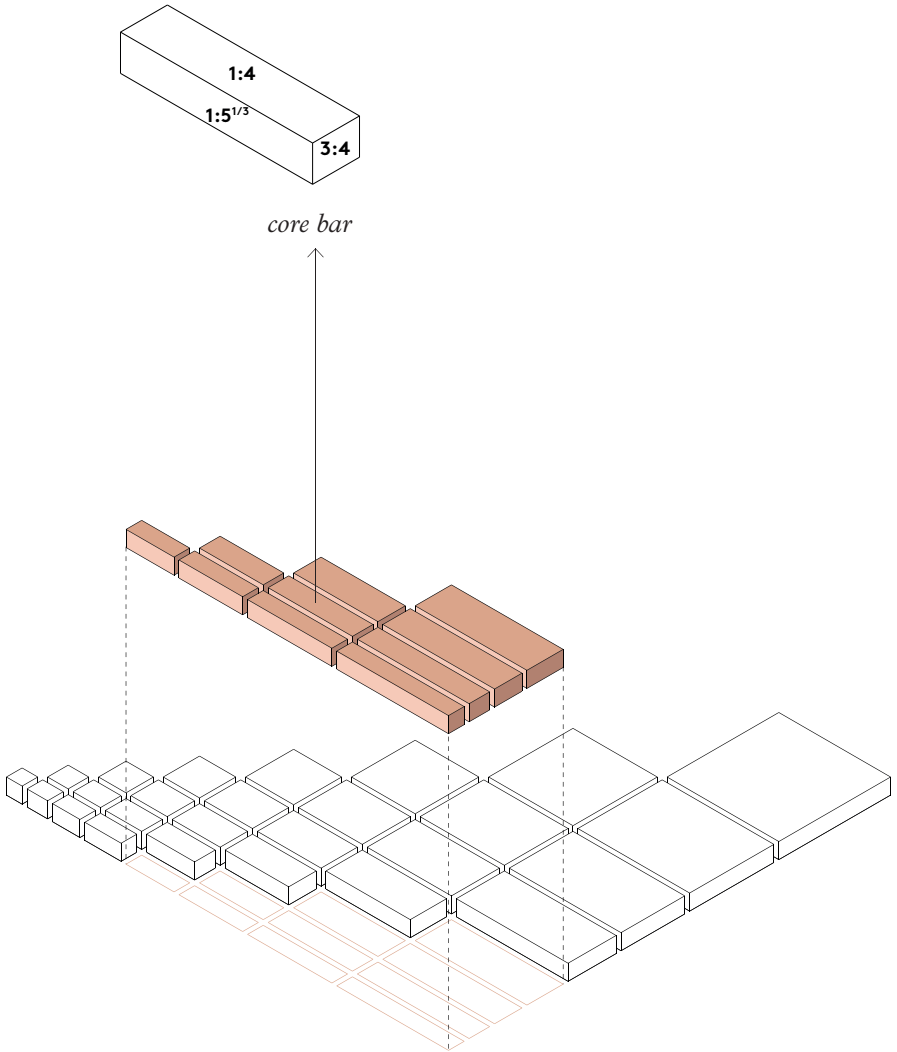



# white forms

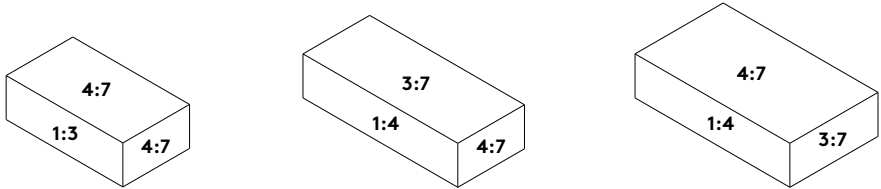

*three most important white forms*

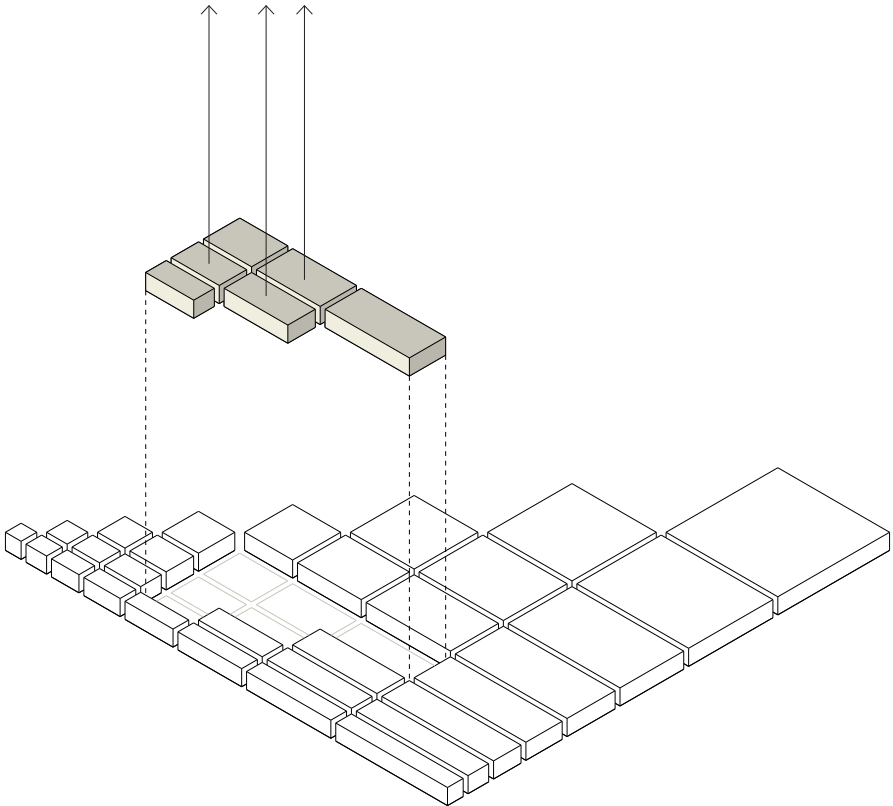

core forms

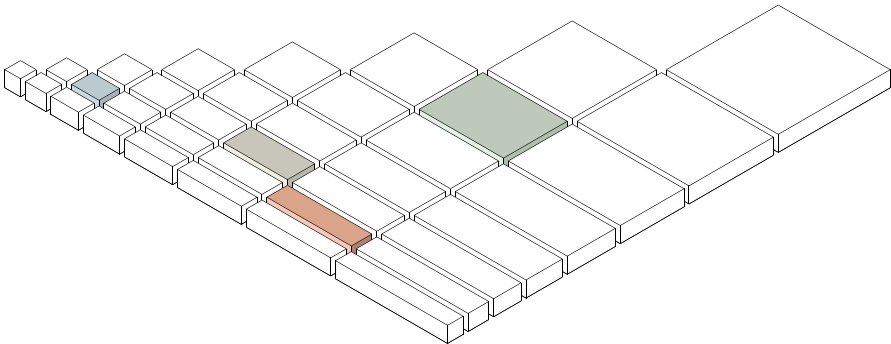
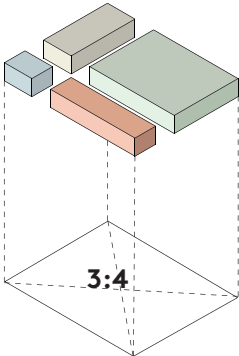

*Overview of all the blocks, slabs, bars and white forms in the form-bank with their corresponding proportions.*

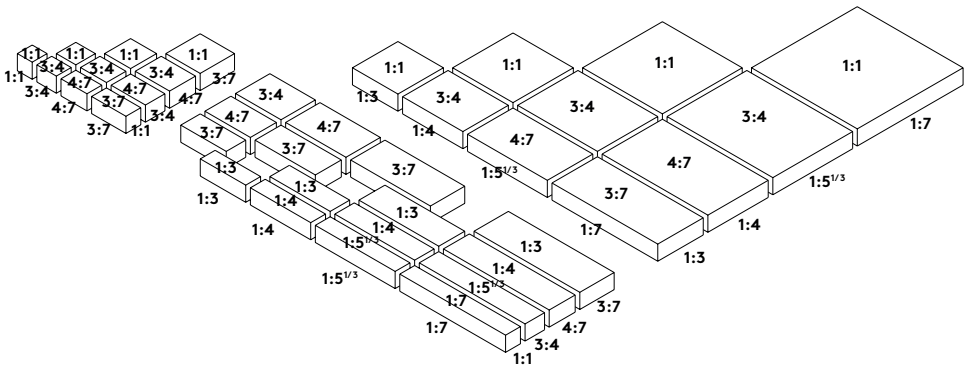

## 10. material, detail, light and color

Although Dom van der Laan never mentioned these aspects in his books, they became essential in his architecture.

### *Material and detail*

With spaces constructed of heavy bricks and clear lines, the architecture of Dom van der Laan has a formal, sober and elementary language. But the absence of ornamentation doesn't mean he didn't carefully detail every element of the building to achieve the desirable expression.

As son of an architect, Dom van der Laan got acquainted with the primal Dutch construction materials such as brick and wood. He, and also his students, show a high level of craftsmanship in the detailing of these materials.

The details however, should not be imposed, so that they always support the coherence of the whole. The focus is not on a theory, but on craftsmanship and testing material effects on site (Voet, 2017, p.103).

Without decoration there is a clear transition and distinction between walls, floors and ceilings, so that the harmonious proportions can be best experienced. The use of simple finishing materials make the space even more tangible. The main construction is built up out of brick, on main walls and the most important massive parts finishes were applied to make masonry walls work stronger as a plane - and thus the shapes as volumes - while the structure of the bricks remains visible. The secondary walls or ceilings are often finished with wooden planks (de Haan & Haagsma, 2010, p.77).



*Brick, wood, concrete and stone as main materials*



*Detail of rough concrete windowsill with carefully detailed built-in gutters.*



*Clear distinction between floor, wall and ceiling*

*Light*

Open and closed, light and shadow are intrinsic to the architecture of Dom van der Laan. The shifting rhythms, accompanied by their shadows guide one through the building.

*“Because of the articulated series of openings, daylight illuminates the space at different intensities. It creates patterns of its own through a pronounced light/dark shadow play. Because of the rough finishing of the spaces, the light plays with the effect of the subtle topography of the surfaces, bringing the architecture to life. No other elements form distractions. With this attention to tectonic qualities, this sacred space receives a formal focus, but one that draws upon one’s physicality or corporality. Spirituality in this sense is evoked by the materiality of space.”*

Caroline Voet on Roosenberg Abbey in *A House for the Mind*, 2017







### *Color*

Another indispensable characteristic of the architecture of Dom van der Laan is the use of color. Although, he was not responsible for this himself. The beautiful shades of grey-blue and grey-green are the work of color advisor Wim van Hooff. He spent over 50 years experimenting with applying color in the built environment and researched the effect on space and form. According to Van Hooff, the use of color has to make the architecture more readable.

Structure and brightness are of great importance, they can greatly weaken or strengthen the perception of a form. For Van Hooff, it was really important that the colors of the wall, floor and ceiling together have a mutual interaction, so that they enhance the readability of a space. The same tint for all surfaces will weaken the experience of a space, whereas contrasting colors will distract from the actual architecture. One will see only color instead of form.

Walls should preferably make a calm impression. If all walls are treated equally - the same color, same brightness and the same structure - the space can be optimally experienced. Only the daylight has the power to distinguish in darker or lighter walls (de Haan & Haagsma, 2000, p.35)

The secondary walls are an exception to the same treatment. As they are built up in a different material (usually wood) they are also given a different color, so that the main structure is made clearer.

The color of floor and ceiling must clearly differ, otherwise there is a risk of the feeling being sandwiched. The floor is preferably chosen as the darkest element. The ceiling in turn works best as the closure of a room when it is clearly darker than the walls. This is not necessary though, difference in structure can be enough in some cases. However, the ceiling must be measurably lighter than the floor, so that the bearing character of the floor is even more supported (de Haan & Haagsma, 2000, p.39).

However, he emphasized the importance of looking at each situation separately, because each space is uniquely influenced by various factors. Van der Laan and Van Hooff tested many color samples on site to achieve the desirable effect.

For Van Hooff, a color in itself had little value, it was about composing a harmonious use of color in which all colors would form a satisfying whole. In fact, this is also what Van den Laan had in mind with his architecture with the Plastic Number: architecture in which all elements relate to each other and form a harmonious whole.



With the help of an design example, I will explain the implementation of the most important aspects of the theory step by step.

**1. measuring system**

**2. form-bank**

**3. domain**

**4. unit and cell**

**5. positioning of walls**

**6. window arrangements and column-spacings**

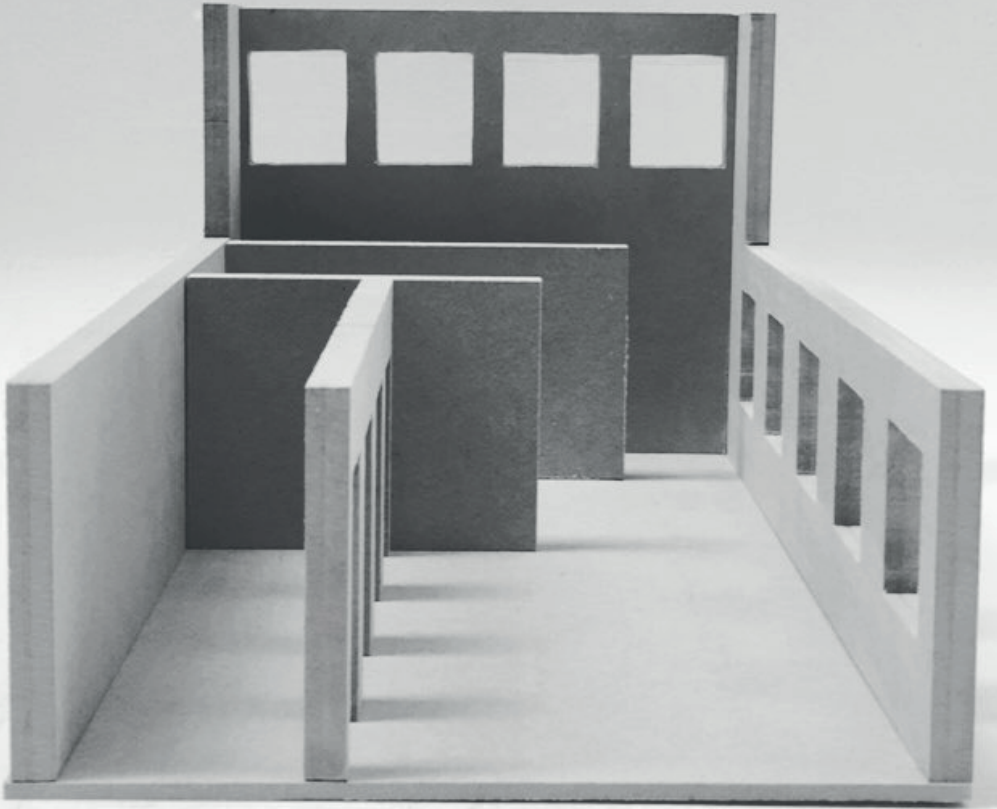

**application of the theory**

## 1. measuring system

In this design example of a small space, I use two successive orders of size in the measure system. It starts with 32 as wall thickness, which in turn defines the size of the cell: 228.

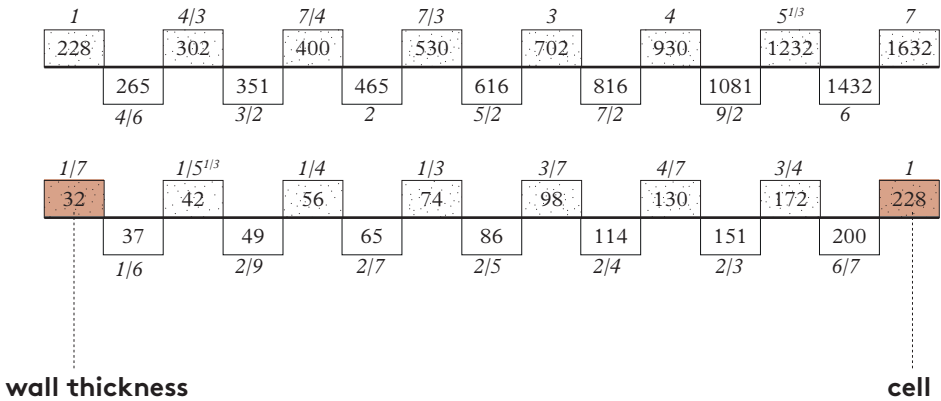



## 2. form-bank

For the general form of the space, I took a white form from the form-bank. Resulting in a floorplan relating as 4:7, front elevation of 3:7 and side elevation of 1:4.

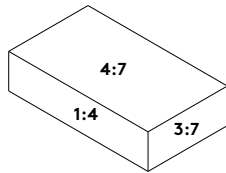

*design theme: white form*

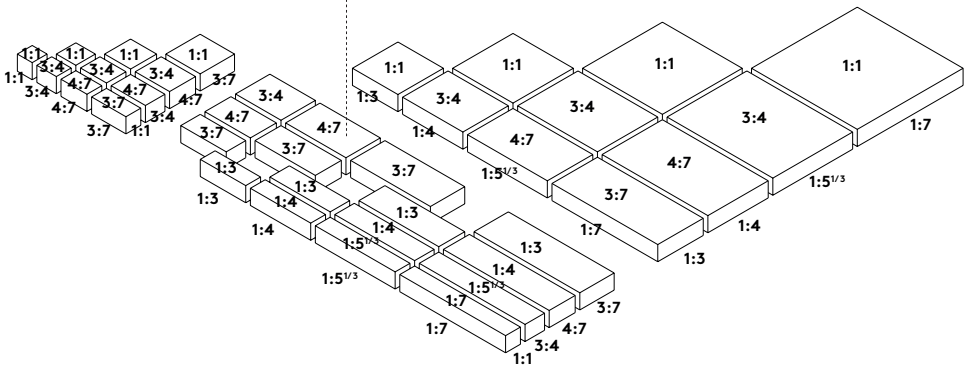

### **3. domain**

Putting the floorplan in concrete measures, results in a space of 702 by 1232 cm and a height of 302 cm.

I took the specific formula of the half-space as a starting point for this design. It's derived from the hall-space; a typical church structure with a gallery on both sides.

Dom van der Laan used the formula of the half-space - with only one gallery - for various rooms like the library and refectory.

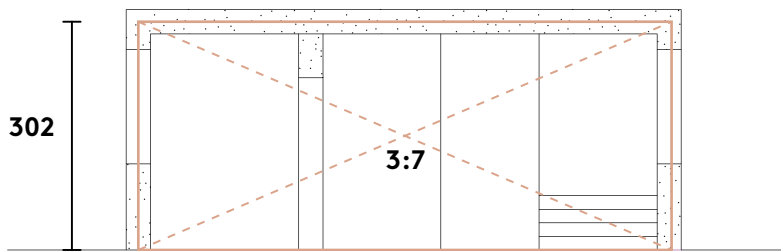
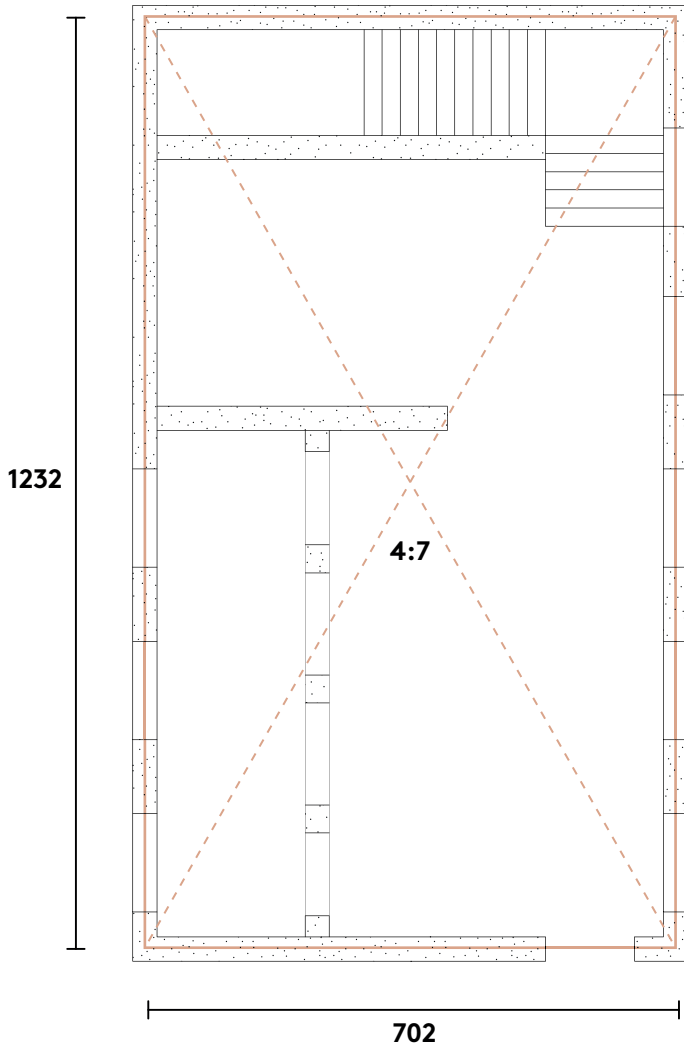

#### 4. unit and cell

The wall thickness is the measuring unit for the cell, which is ideally seven times the wall thickness. Here, the wall thickness is 32, so that the distance between the two walls is 228. In order to have a 3:4 plan, the other direction of the cell becomes 172. Like this, the cell is proportioned like the core block of the form-bank.

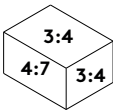

*core block*

The cell is then extended into a gallery. The width of the gallery, 228, is 1:3 of the width of the space. Normally the gallery is placed as a superposition with a stronger ratio than 1:3. In this case, the 1:3 is part of a juxtaposition explained on the next page.

**172**  
1/7 of 1232

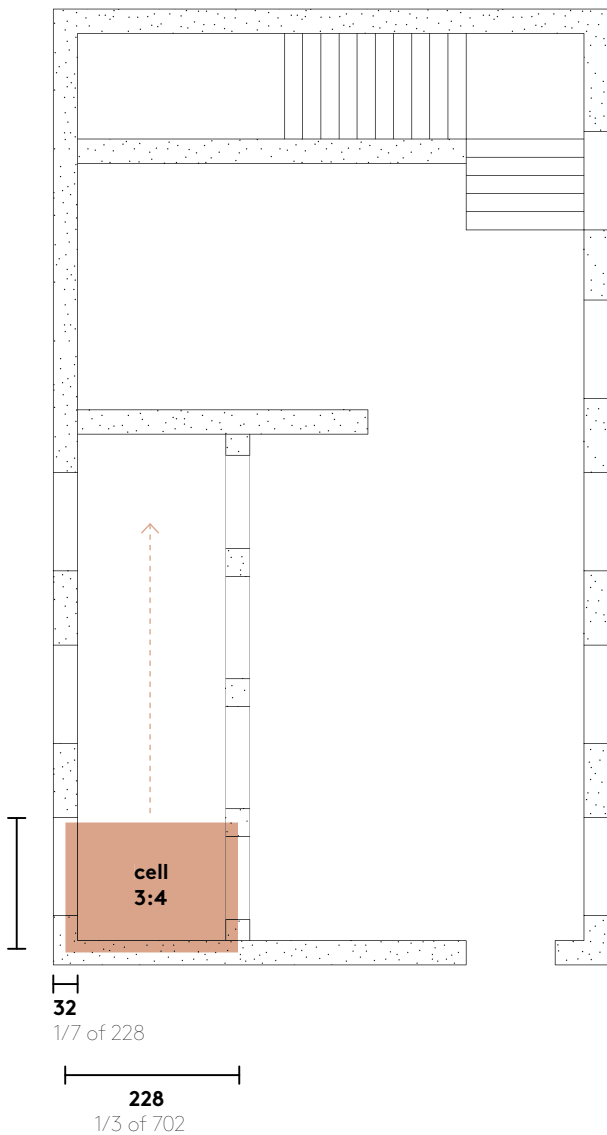

## 5. positioning of walls

The width of the space is divided in a authentic juxtaposition of 1:3 - 3:7 - 1:4. The gallery, the wall perpendicular on it and the stairwell are placed on these lines.

In the direction of the length of the space, the gallery is stopped at the harmonic mean of the whole length. The harmonic mean represents the ground ratio of 3:4 (one part is  $\frac{3}{7}$  and the other  $\frac{4}{7}$ ). The stairwell is positioned as a strong superposition of 1:7 of the whole length of the space.

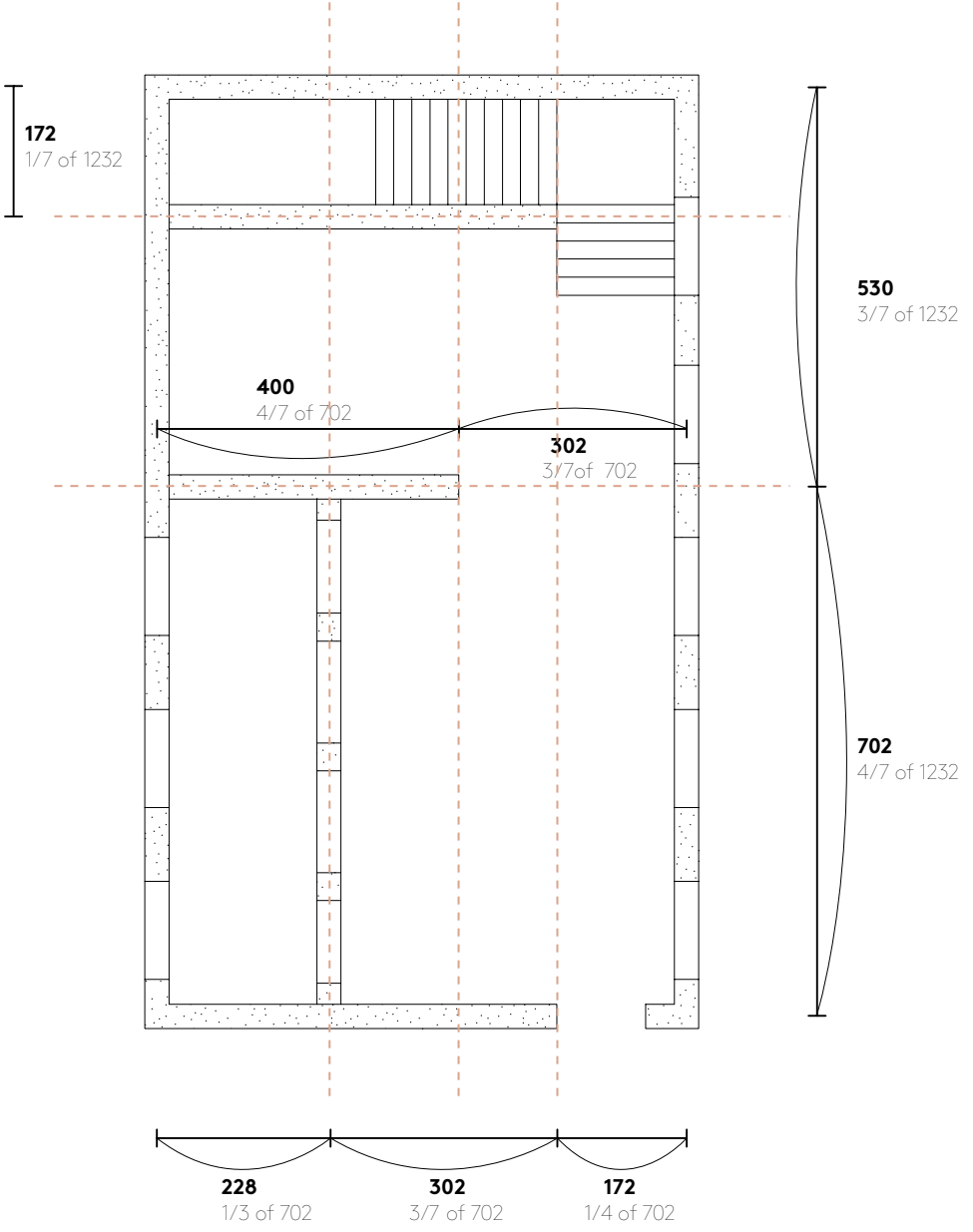

## 6. window arrangements and column-spacings

### *Window arrangement*

The openings on the facade side are placed as window arrangements. The relation between the bay measure and the window width is  $130:228 = 4:7$ .

Taking a bay rhythm of  $1:5^+$ , leaves a considerable margin that is put on the side of the stairs.

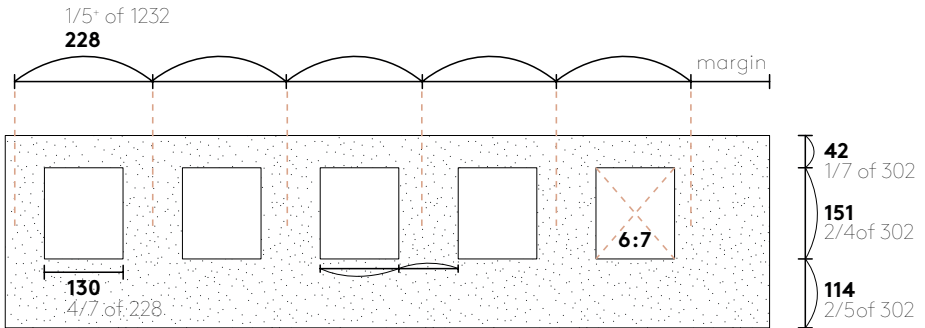

### *Column-spacing*

The pillars of the gallery are dimensioned like the “Araeostyle” with a relation between column width and bay measure of  $2:9$ .

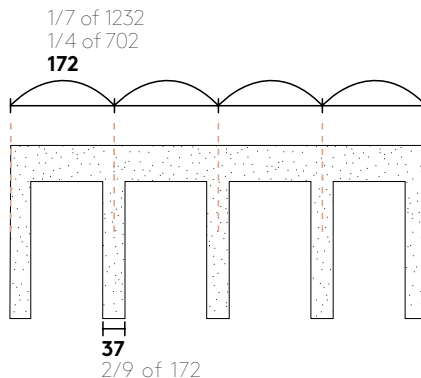



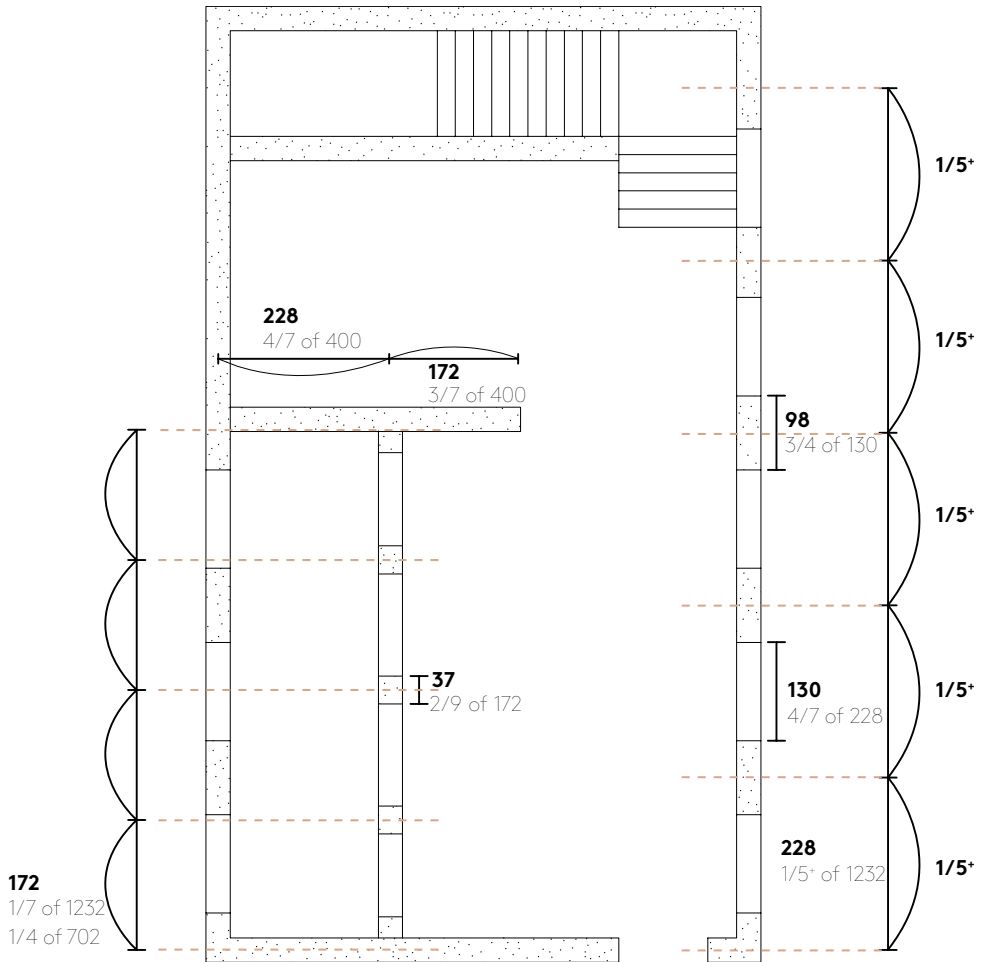

That architecture can have an influence on the human body and our sensory perception is acknowledged by most people. We feel a certain satisfaction through the structure of cognizable forms that show measure and order. Buildings with proportions that are perceived as pleasant, therefore, correspond to the way our mind functions.

Dom van der Laan tries to capture the way our mind works in a proportional system to achieve fundamental architecture. He makes us aware of the idea how we deal with seeing, how we count, measure and perceive space. This is perhaps one of the most important lessons.

Regardless of whether you decide to design with or without a proportional system; it's essential to be conscious about the way we experience and thus how we choose to dimension space.

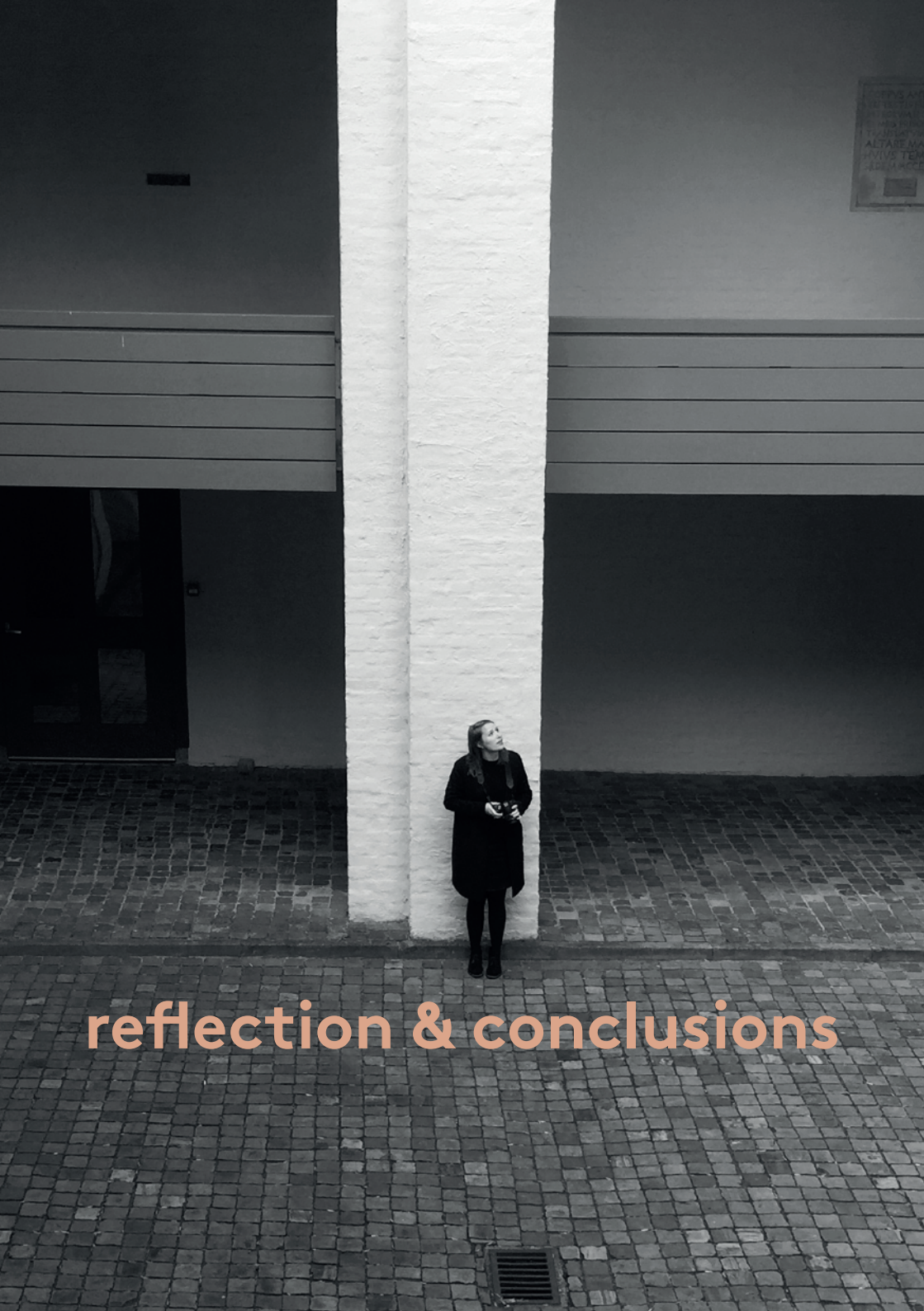

reflection & conclusions

## **What are the valuable lessons we can draw from the theory of Dom Hans van der Laan?**

A common misconception is to see this theory as dogmatic. It's not the only way to achieve beauty, nor it is a guarantee to beauty.

It's far from a ready made recipe. It's up to the creative and intuitive mind to compose a good design. In order to get a sense of the application, one needs to practice and train the eye. Only then you can be creative in shifting rhythms and creating overlays, which make the architecture of Dom Hans van der Laan so interesting.

With too little knowledge about the theory, it's hard to see the possibilities and designing with the Plastic Number may feel like a limitation.

As the Plastic Number series is not bound to fixed numbers, it's an extremely flexible system.

It's incredibly important to be aware of how we dimension things, and that it should never be based solely on practical aspects.

## **What are the boundaries and tolerances within this proportional system?**

The system knows a considerable tolerance, in which the same effect can be achieved. Dom van der Laan stated that the minimum difference we can perceive is around 2%, so for each measure in the measure system there is a tolerance of this percentage. In this way you can shift a bit with the measures according to practical requirements.

Another question is if one needs to apply the system in a consistent way throughout the project in order to achieve the desirable effect. Or would it be enough to partially implement the system, or use certain elements of the theory?

These questions are hard to answer, as it comes with subjective issues. During the design process following this research I will try to formulate a more critical reflection on the application of the theory and the direct results from it.

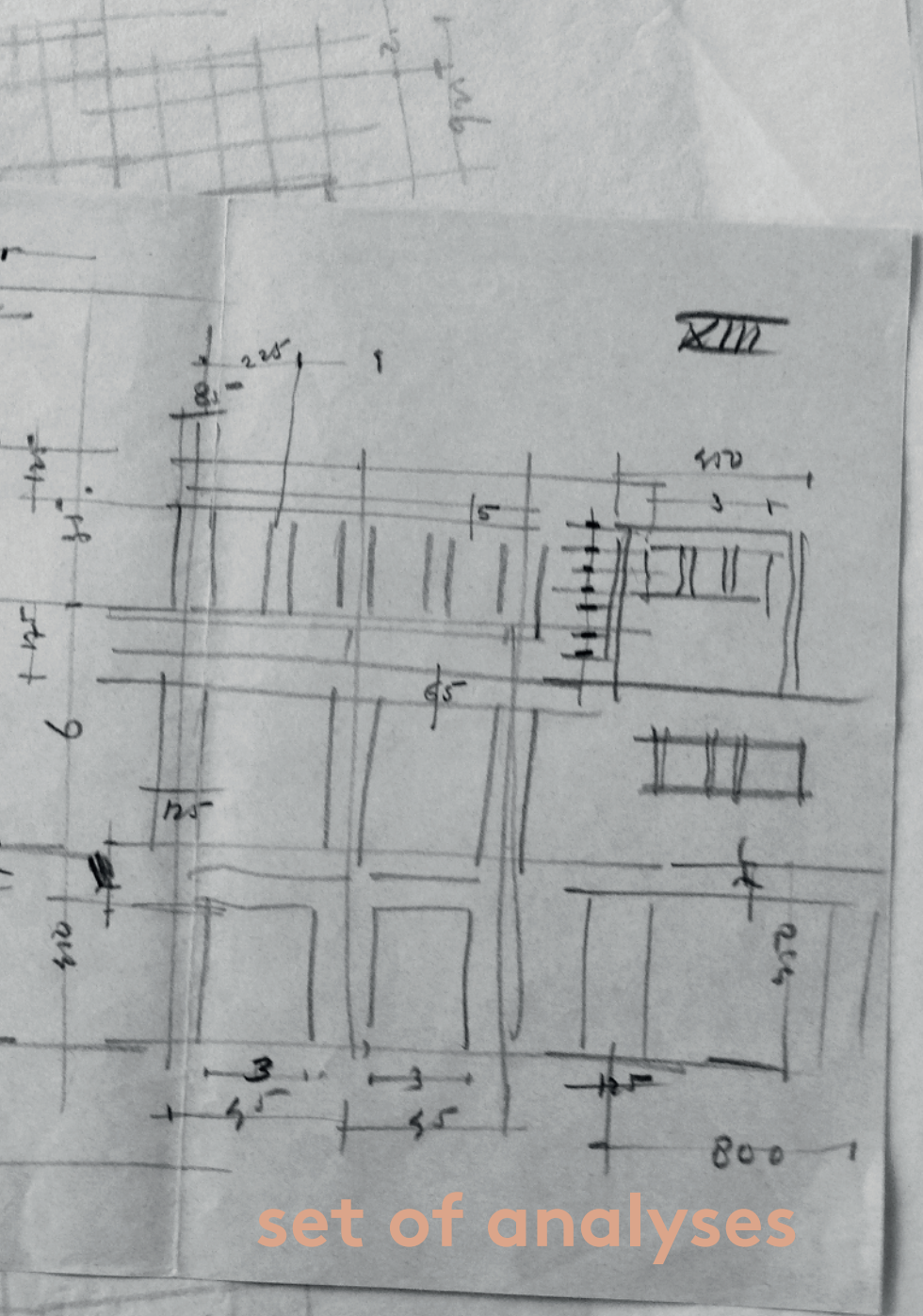

set of analyses

During this research I made multiple short analyses. On the one hand to unravel the use of the Plastic Number, on the other hand to get a grip on the importance and relevance of proportions in general. This resulted in this appendix with a threefold of analyses:

### **1. plastic number**

House Naalden - Dom Hans van der Laan

Entrance Roosenberg abbey - Dom Hans van der Laan

Stool - Dom Hans van der Laan

House Kreijl - Gerard Wijnen

### **2. pleasant proportions**

Casa del Fascio - Giuseppe Terragni

Restauro di palazzo Tentorio - Massimo Ferrari, Enrico de Benedetti and others

Classical example - parthenon

### **3. questionable proportions**

Bundner Kunst Museum - Barozzi Veiga

## Plastic Number

House Naalden - Dom Hans van der Laan



Dom van der Laan presented a model of this house in 1978 as a birthday present for his good friend Jos Naalden. Van der Laan didn't like the light and modern house designed by Jaap Bakema and proposed to make something better. Van der Laan finished his most important book just a year before and this house gave him the chance to express and test his theory in practice.



*Design theme*

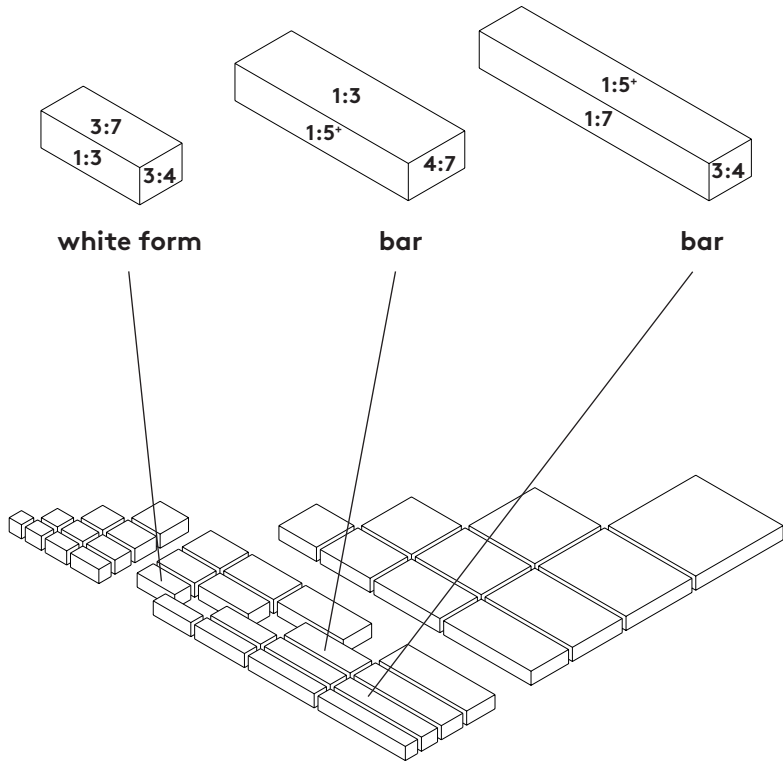

For the composition of the volumes of this house, Dom van der Laan picked three forms from the form-bank. Two bars and one white form.

## Measuring system

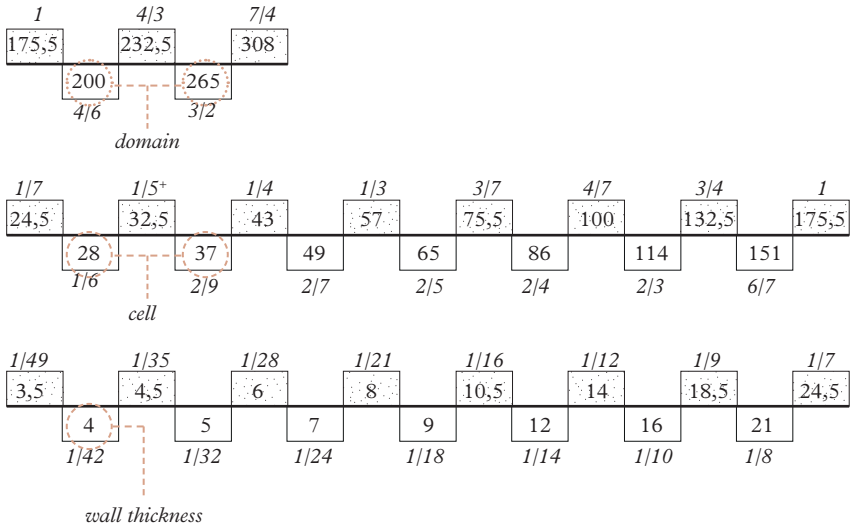

The measure system on itself is relative, so any arbitrary size can occur as the starting unit. Dom van der Laan usually chooses to take the wall thickness as unit; the yardstick for the rest of the sizes. In the figure above you see the characteristic measures for the wall thickness, the cell and the domain. Each of which in turn are multiplied by 7.

In the rest of the analyses drawings, you will see how the sizes of the measure system are applied in the design.

*Main measurements*

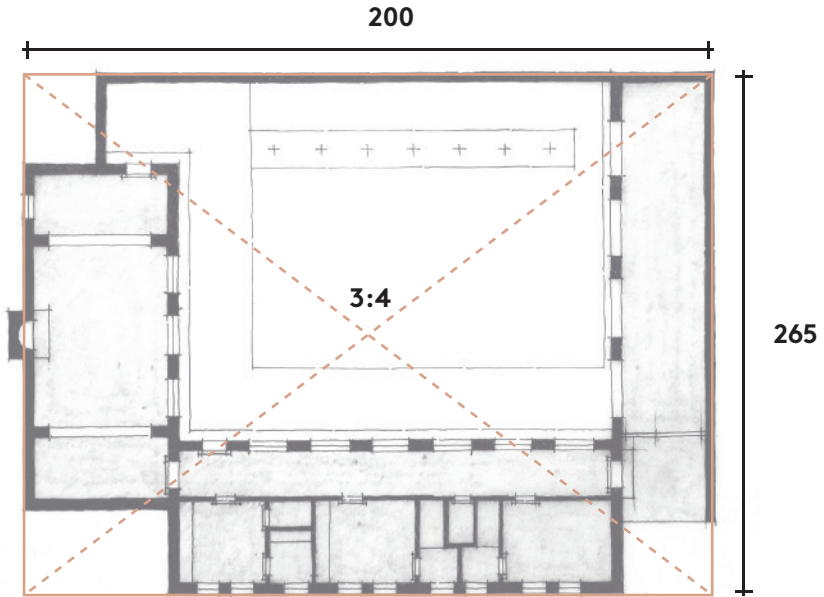

The main dimensions of the domain are 20x26,5 meter. Two sizes that relate through the ground ratio of 3:4.

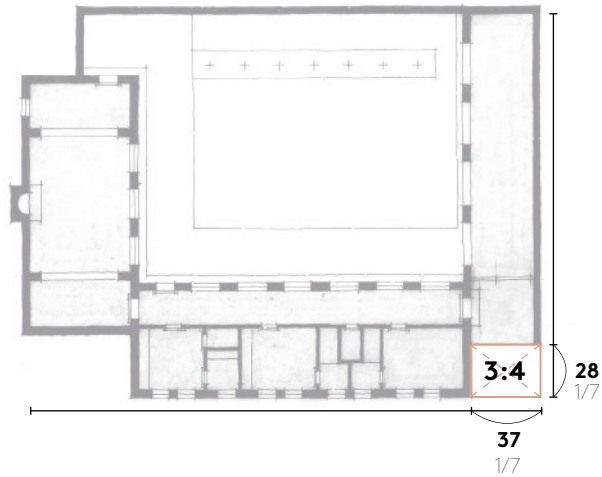

The surface of the cell functions as unit for the domain and relates as 3:4. The length and width are 1/7 of the length and width of the domain.

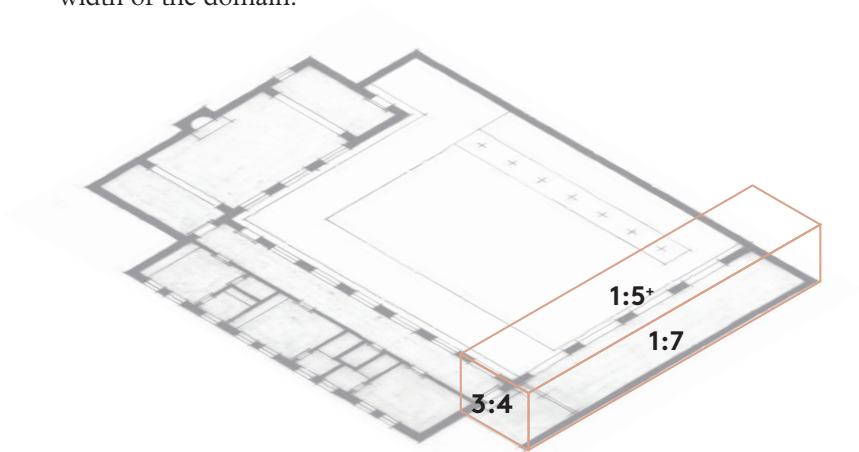

The retaining 6/7 of the domains length is filled in with a bar shaped block from the form-bank. It's an open gallery that also functions as carport.

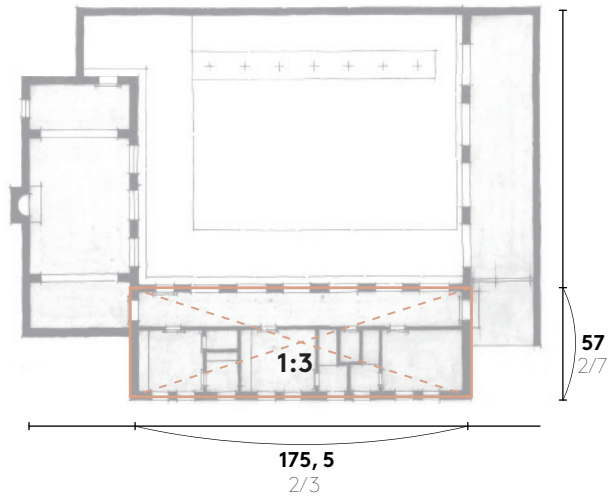

This wing hosts the hallway and other smaller functions. The width is  $\frac{2}{7}$  of the domains width and the length is  $\frac{2}{3}$  of the domains length. It results in a surface that relates as 1:3 in the floorplan.

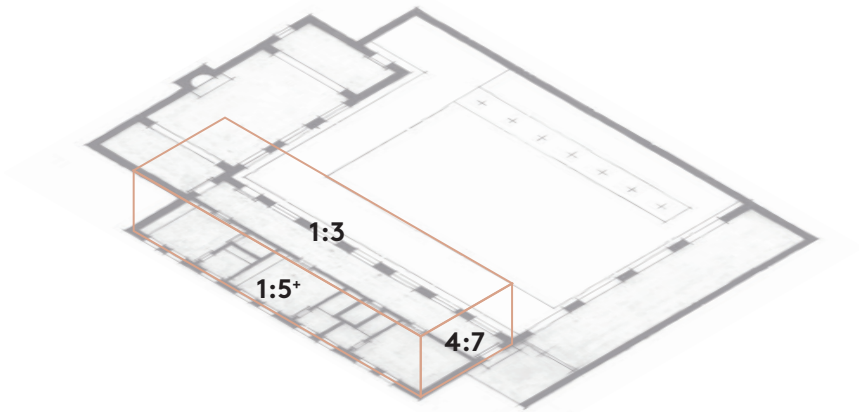

The three dimensional translation is again a bar shaped block from the form-bank, but goes already a bit in the direction of a white form.



The “hall”, or livingroom is measured as  $\frac{1}{5}$  of the domains length, and  $\frac{2}{3}$  of the domains width. Resulting in the often used ratio of  $3:7$ .

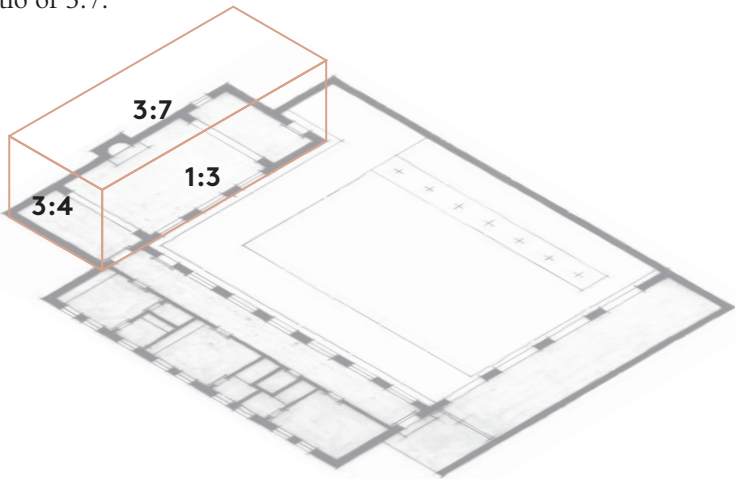

The volume of the livingroom is a so called white form from the form-bank. It’s a neutral form; in between bar, block and slab. These forms are very expressive and important in architecture according to Dom van der Laan.

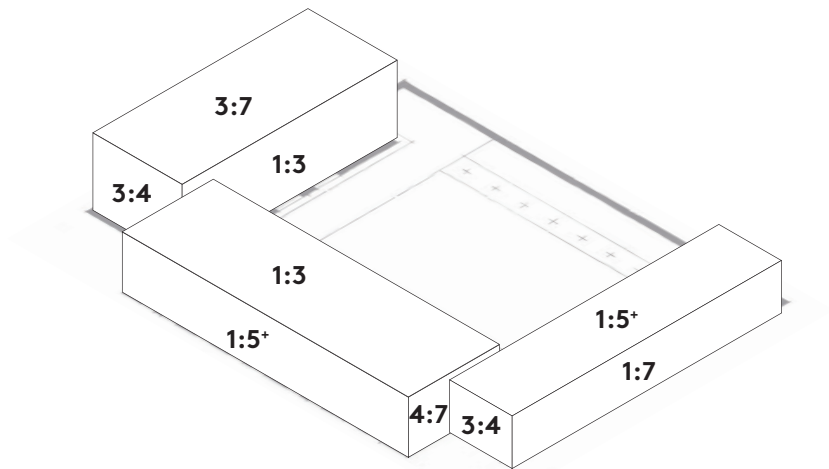

The ensemble is composed from three volumes of the form-bank which together enclose a courtyard. The volumes differ in height and size to emphasize the different functions and perception.

## Plastic Number

Entrance Roosenberg Abbey - Dom Hans van der Laan





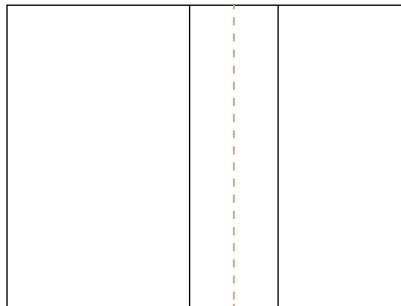
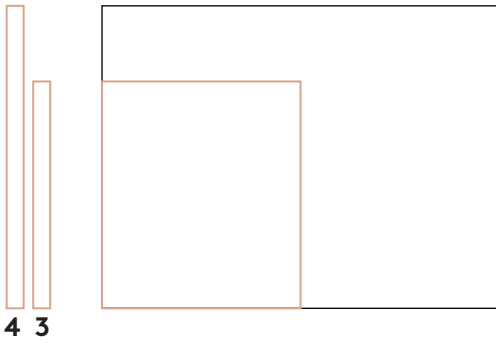
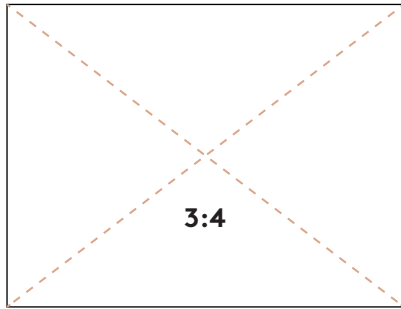

## Plastic Number

Stool - Dom Hans van der Laan



Dom van der Laan took design with the plastic number even to the level of furniture, candle holders and clothing. The characteristic form of this little stool is also the starting point for the tables, benches and desks.

## Design theme

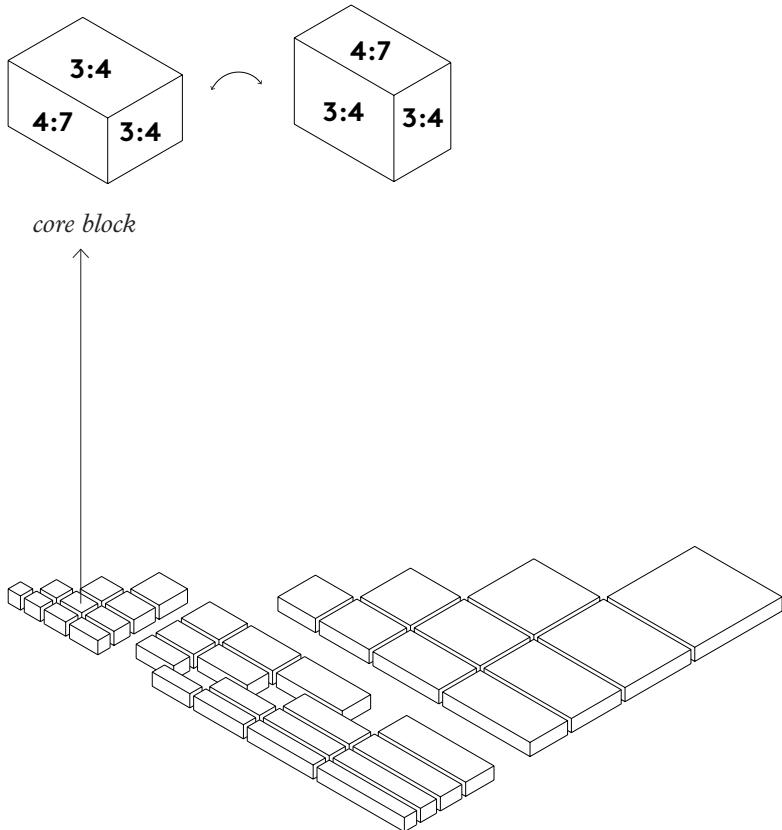

## Measuring system

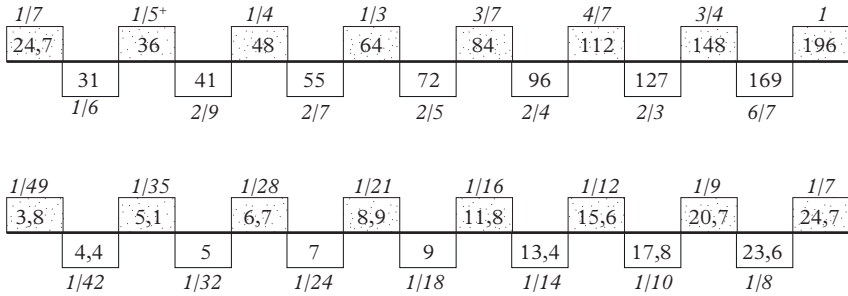

Because of ergonomic reasons, Dom van der Laan took the height as starting point. Starting from this size, he determined all the other sizes in the measuring system. Resulting in two orders of size with their authentic and derived measures.

If you look at the drawing, you see that almost all the measures can be found back in the measure system. Because of practical reasons, he modified some sizes a bit, but never more than a little percentage.

The biggest size of the system is 196, which he uses for the table. He divided this size in 14 equal elements of 14cm, which results also in the use of planks of 14cm in the stool.

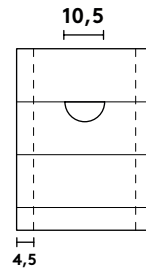
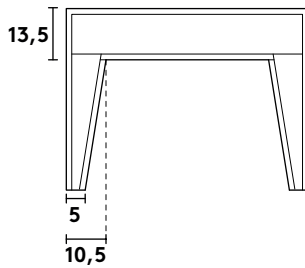
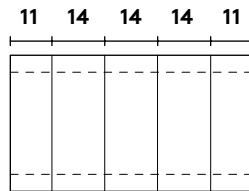
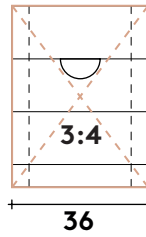
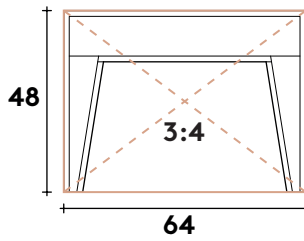
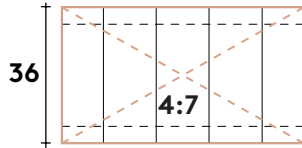

## Plastic Number

House Kreijl - Gerard Wijnen

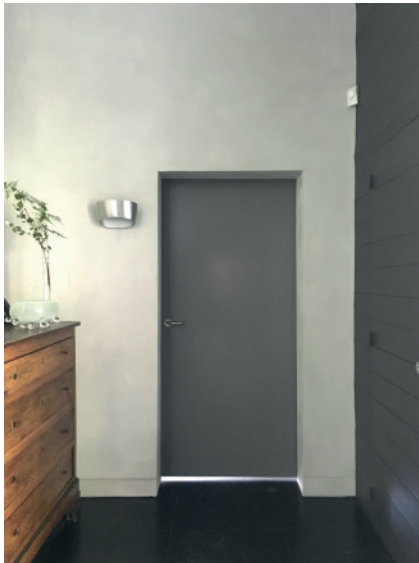

Gerard Wijnen was a student of Dom Hans van der Laan and among some others he was responsible for the design of multiple “Bossche School” buildings.

In the following images I show the main setup of the volumes and the most important ratios.

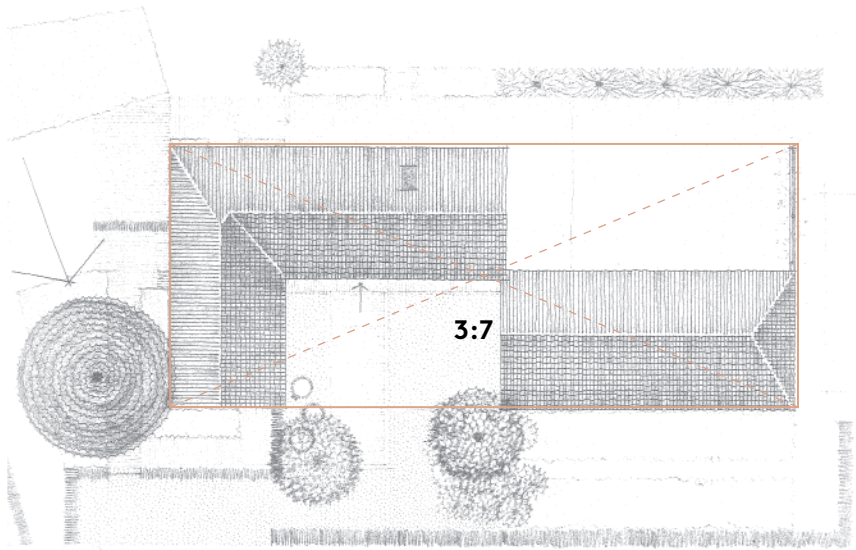

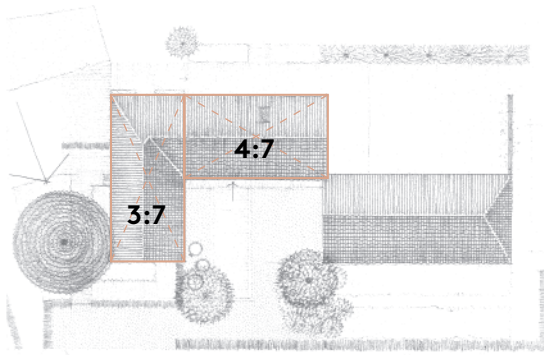
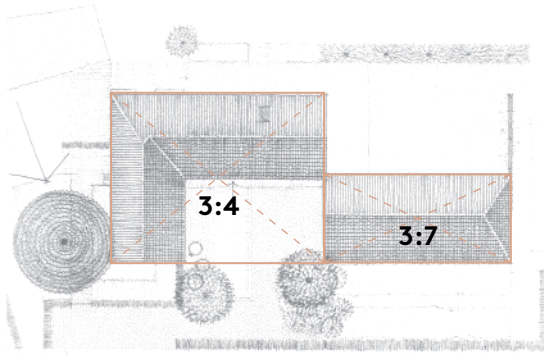



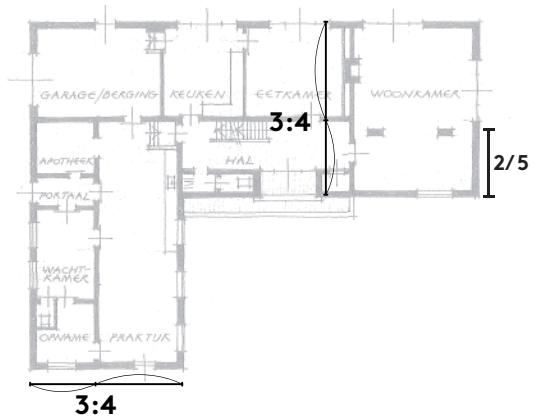
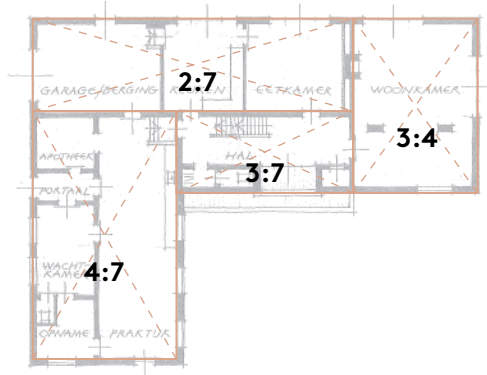

## pleasant proportions

Casa del Fascio - Giuseppe Terragni



I remembered this building as clear and geometrical, but really aesthetically pleasing. The plan is square, and the height of the building is half the base. The other subdivisions and rhythms are match exactly with the ratios of the plastic number. Which confirms the positive effect on well chosen proportions.

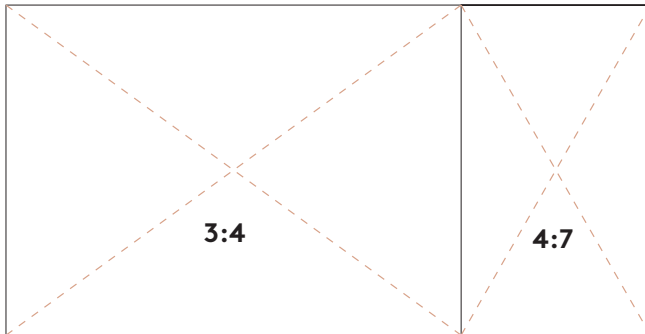
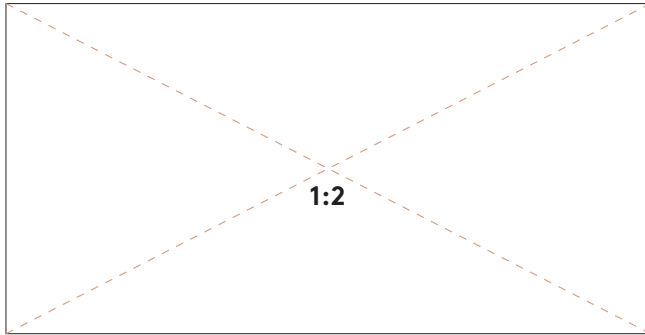

**1:7**

**2:7**

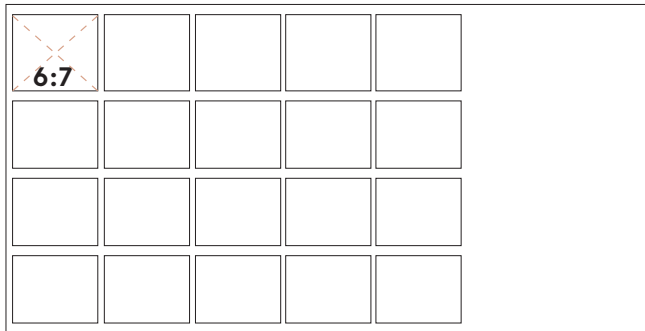

## pleasant proportions

Restauro di palazzo Tentorio - Massimo Ferrari, Enrico de Benedetti and others



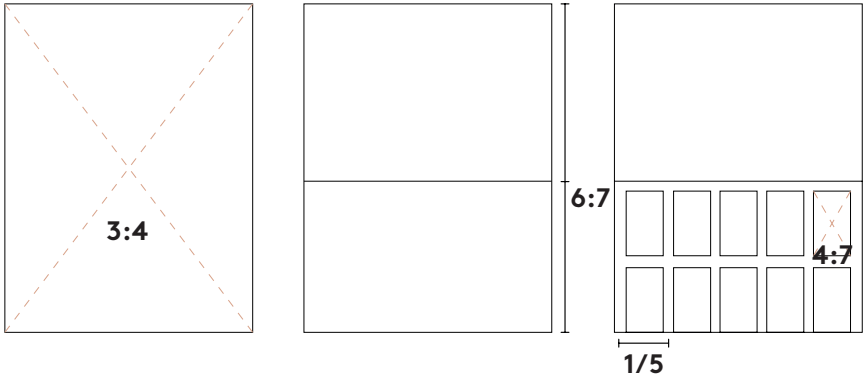

This building seemed like a well proportioned design. Maybe even a bit too strict, which makes it a bit boring. But the overall dimensions give a pleasing effect. By checking the ratios it's again visible that the series of the plastic number can be found back.



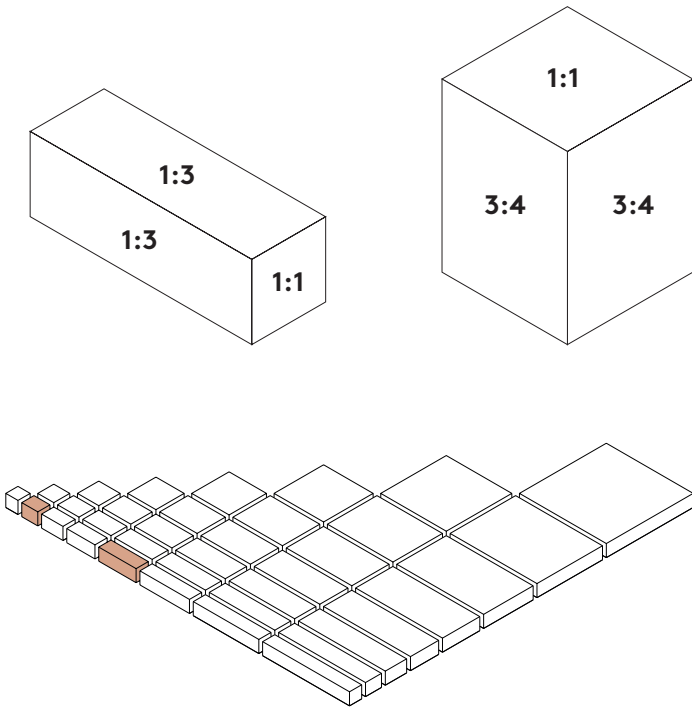

Also the three-dimensional configuration of the building can be found back in the form-bank. It's a combination of a bar and a block.

## classical example

Parthenon

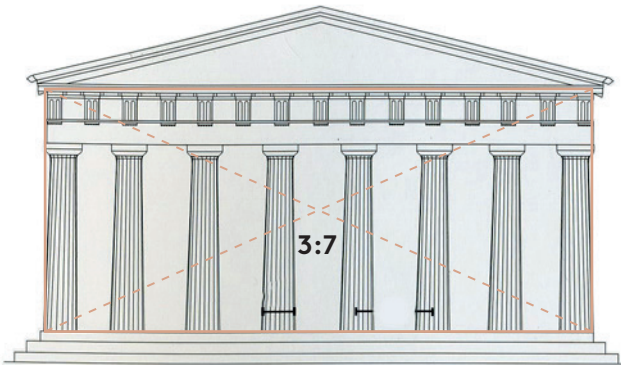
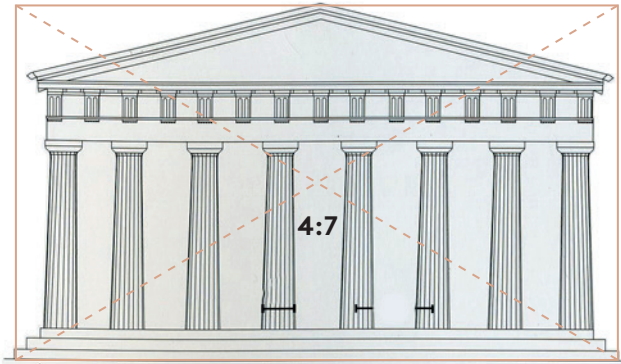



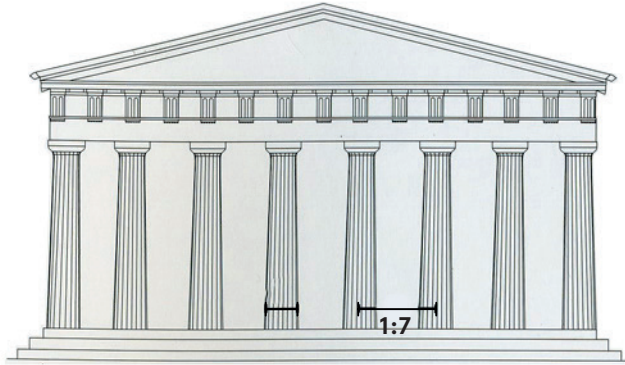

**Pycnostyle 2:5**

In the beginning of his search to a fundamental proportional system, Dom van der Laan studied the classical examples. Here he found already first prove for his ratios.

## questionable proportions

Bundner Kunst Museum - Barozzi Veiga



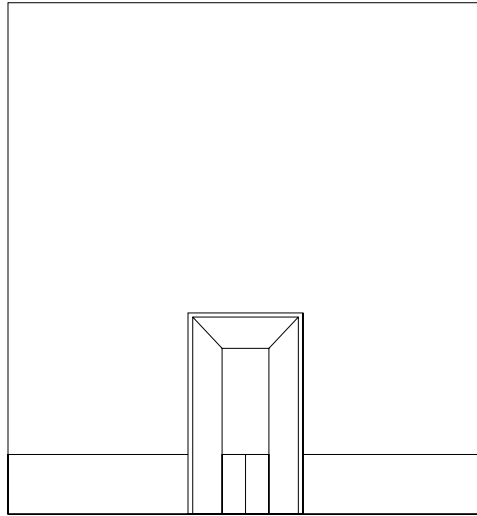

I'm taking this building as example that feels a bit off to me. What causes that feeling?

You can see the building is not a perfect square, but the difference between is just too small to really differentiate the two sizes from each other. Even the tiled part without the plinth is not perfectly square.

If it wasn't for the people in the picture, it would be hard to judge the scale of the building. The big element around the door misleads the eye, tricking it to perceive the plinth lower than it is in reality.

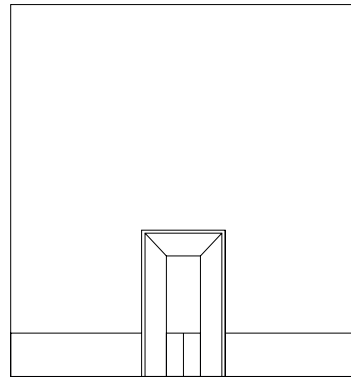
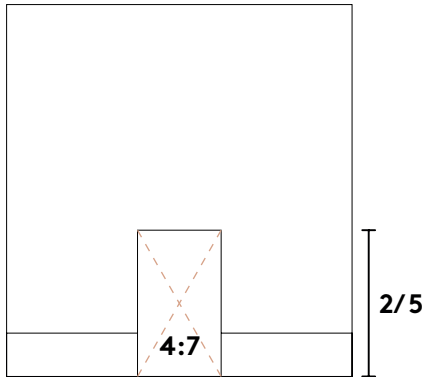
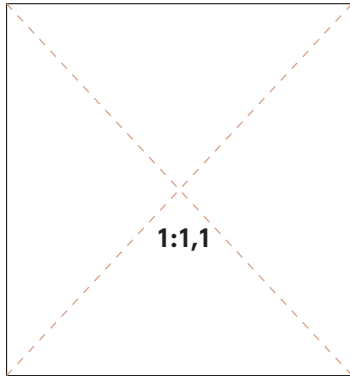

Checking the dimensions, it shows that the proportions are indeed not the most logical options.

By making some alternatives according to the Plastic Number, I tried to test the effect of different proportioned variants. When asking various people, the original one was often picked as least pleasant.

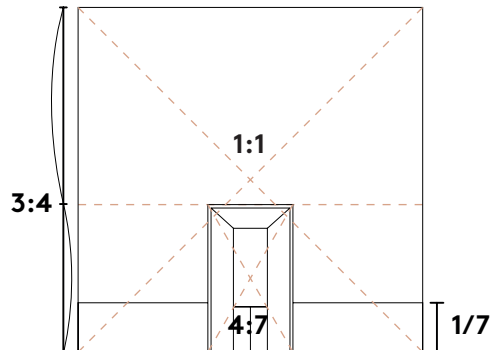
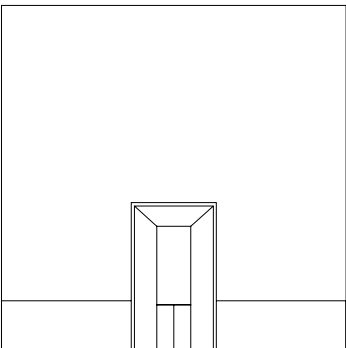
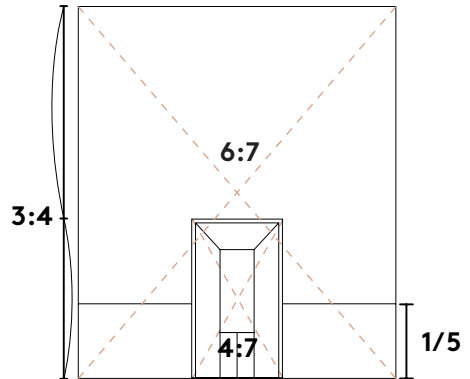
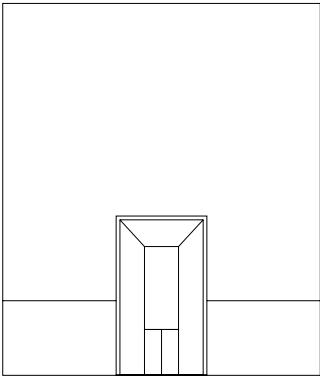
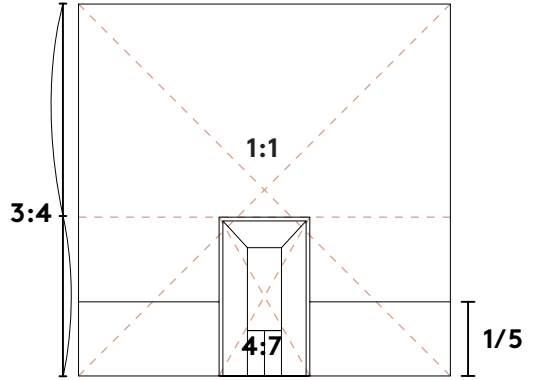
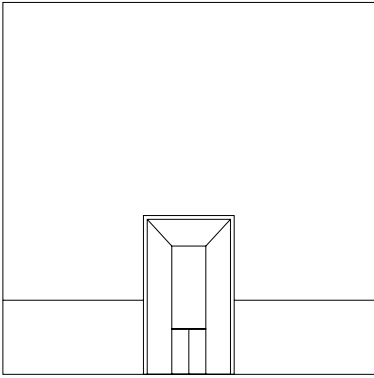

## **sources**

**Dom van der Laan, H.,** (1977). *De Architectonische ruimte: Vijftien lessen over de dispositie van het menselijk verblijf*. Leiden: E.J. Brill

**de Haan, H., & Haagsma, I.** (2000). *Wim van Hooff, Vakman, polychromeur, Kleur en architectuur*. Amsterdam: Stichting Fonds BKVB

**de Haan, H., & Haagsma, I.** (2010). *Gebouwen van het plastische getal : een lexicon van de 'Bossche School'*. Haarlem: Architext

**Voet, C.,** (2017). *Dom Hans van der Laan. A house for the mind: A design manual on Roosenberg Abbey*. Antwerp: Flanders Architecture Institute

**Voet, C.,** (2016). *Dom Hans van der Laan. Tomelilla*. Amsterdam: Architectura & Natura



