





Aiming to improve the design process of retrofit options  
increasing thermal indoor comfort during heat waves  
and enhancing long-term building thermal resilience.

# Introduction

increased frequency and intensity of future heat waves

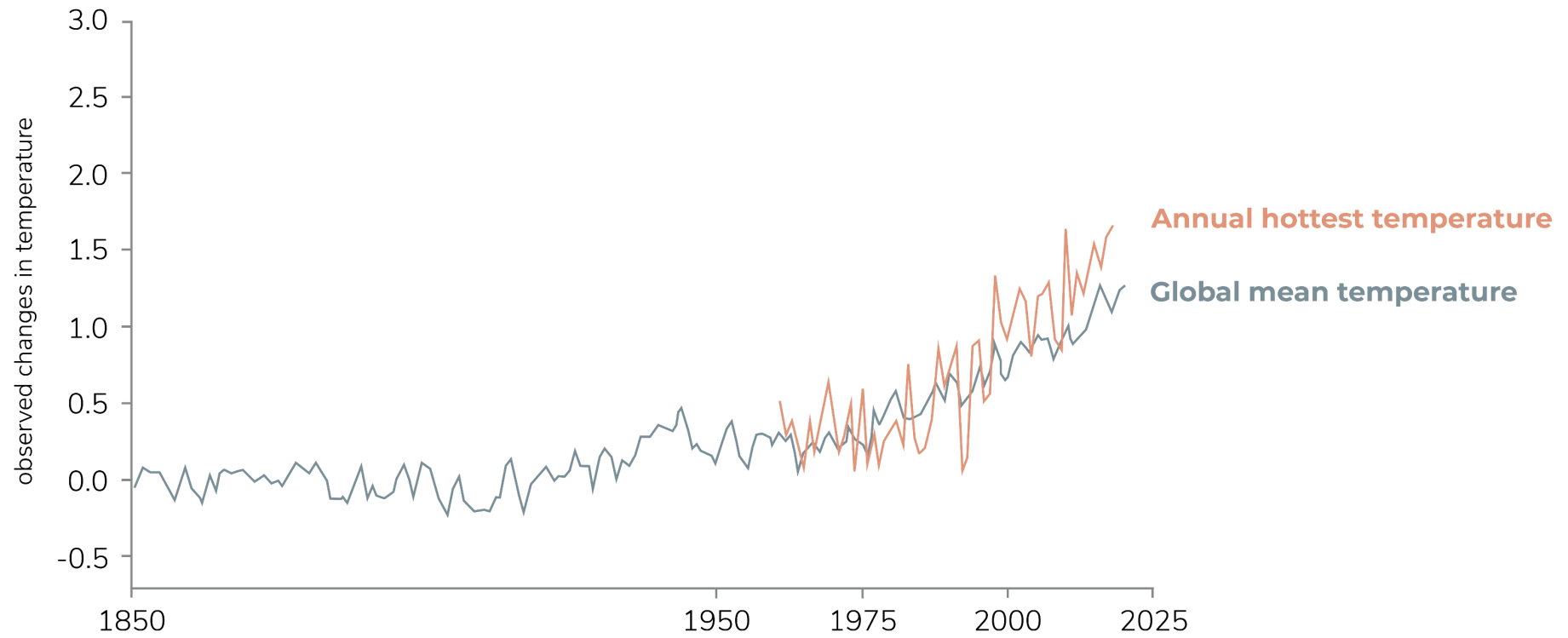

# Introduction

heat stress on the ecosystem, the built environment and humankind

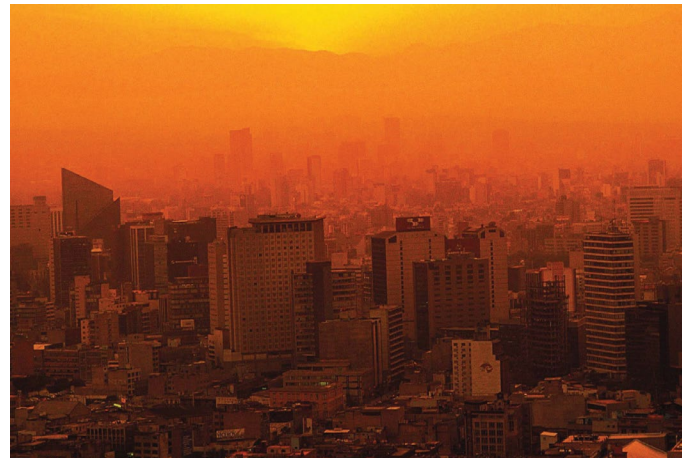

# Introduction

heat stress on the ecosystem, the built environment and humankind



# Introduction

heat stress on occupants

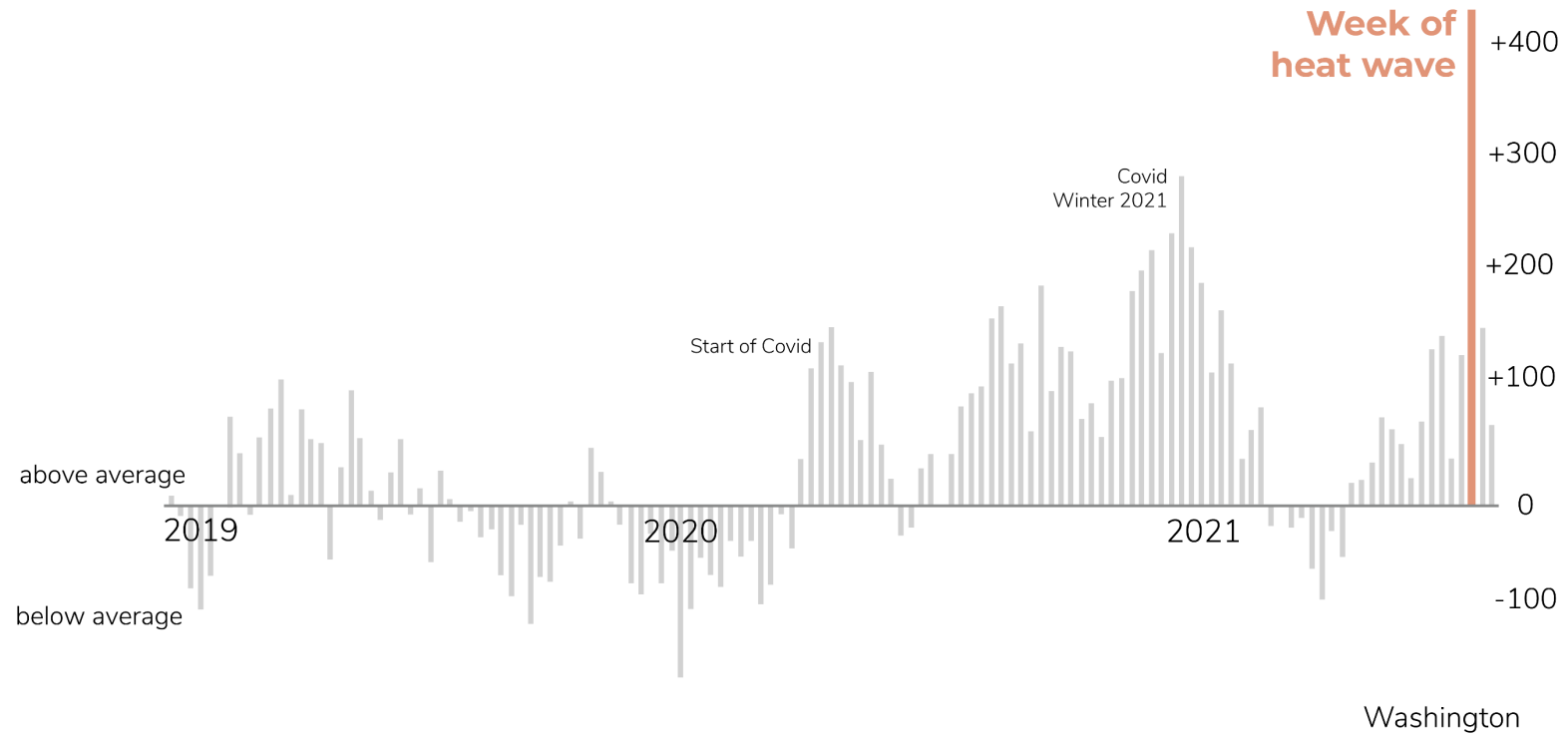

# Introduction

heat stress on occupants



# Research relevance

facade functions

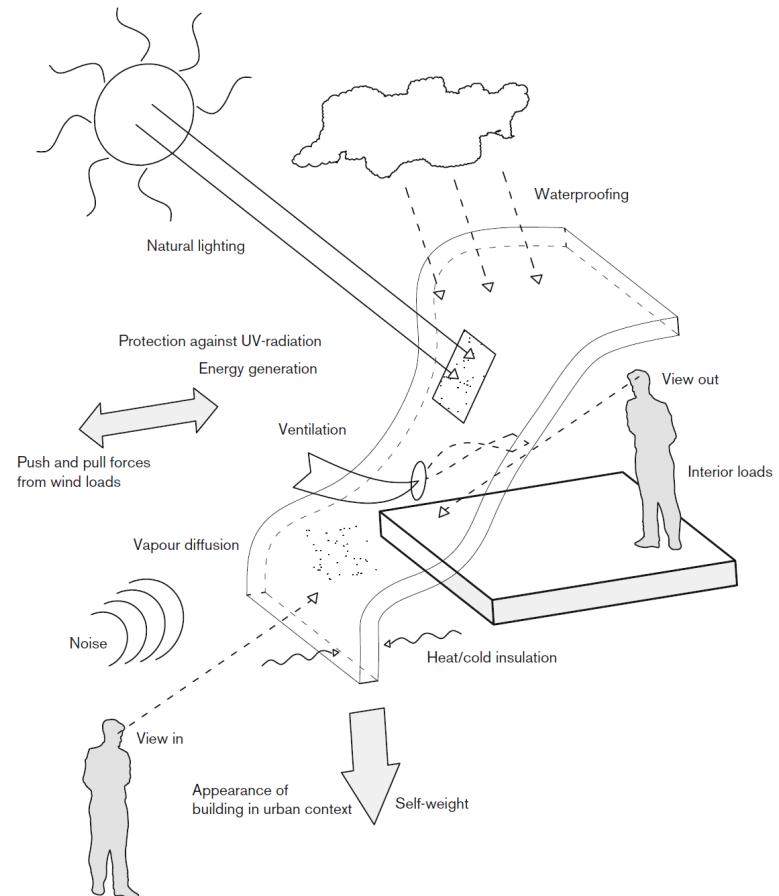

# Relevance

UN goals

“inclusive, safe, **resilient** and sustainable cities and human settlements”

## **Problem statement**

missing standards and regulations

but...

**guidelines and methods  
for the design of  
thermal resilient façades  
are not existing.**

# Research objectives

decision-making process

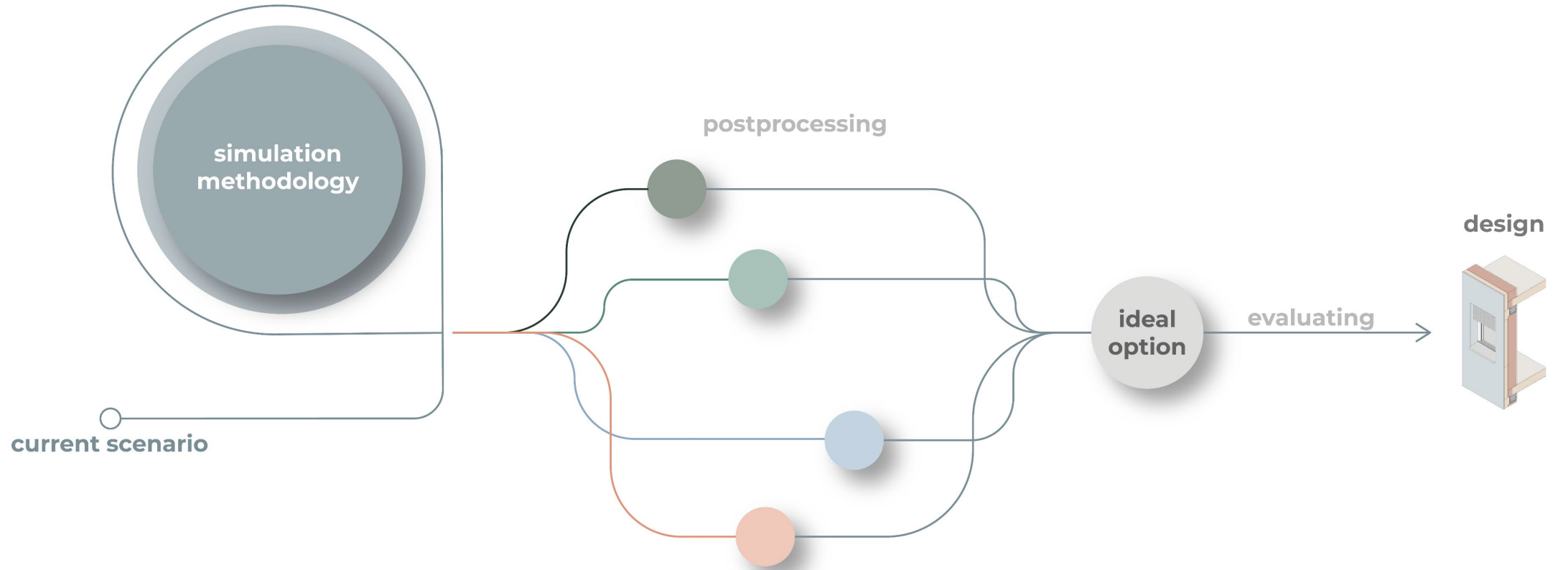

# Research questions

main research question

“How can we **evaluate** the **influence of façades** on **building thermal resilience** during heat waves?”

# Research questions

sub questions

- 1 How do **future climate-related heat waves** change **building requirements** for **façade** constructions?

# Research questions

sub questions

- 1 How do **future climate-related heat waves** change **building requirements** for **façade** constructions?
- 2 How is the **influence of facades** on **building thermal resilience** to **extreme heat assessed**?  
What are **commonly** used **metrics**?

# Research questions

sub questions

- 1 How do **future climate-related heat waves** change **building requirements** for **façade** constructions?
- 2 How is the **influence of facades** on **building thermal resilience** to **extreme heat** assessed?  
What are **commonly** used **metrics**?
- 3 How could current **assessment methodologies** of building thermal resilience be **improved**?

# Research questions

sub questions

- 1 How do **future climate-related heat waves** change **building requirements** for **façade** constructions?
- 2 How is the **influence of facades** on **building thermal resilience** to **extreme heat** assessed?  
What are **commonly** used **metrics**?
- 3 How could current **assessment methodologies** of building thermal resilience be **improved**?
- 4 What are **relevant façade parameters** to be **considered** for **retrofitting improving occupants' thermal comfort** during **extreme heat events**?

# Research questions

sub questions

- 1 How do **future climate-related heat waves** change **building requirements** for **façade** constructions?
- 2 How is the **influence of facades** on **building thermal resilience** to **extreme heat** assessed?  
What are **commonly** used **metrics**?
- 3 How could current **assessment methodologies** of building thermal resilience be **improved**?
- 4 What are **relevant façade parameters** to be **considered** for **retrofitting** improving occupants' **thermal comfort** during **extreme heat events**?
- 5 What are the most important **façade parameters influencing resilience indicators**?

# Research questions

sub questions

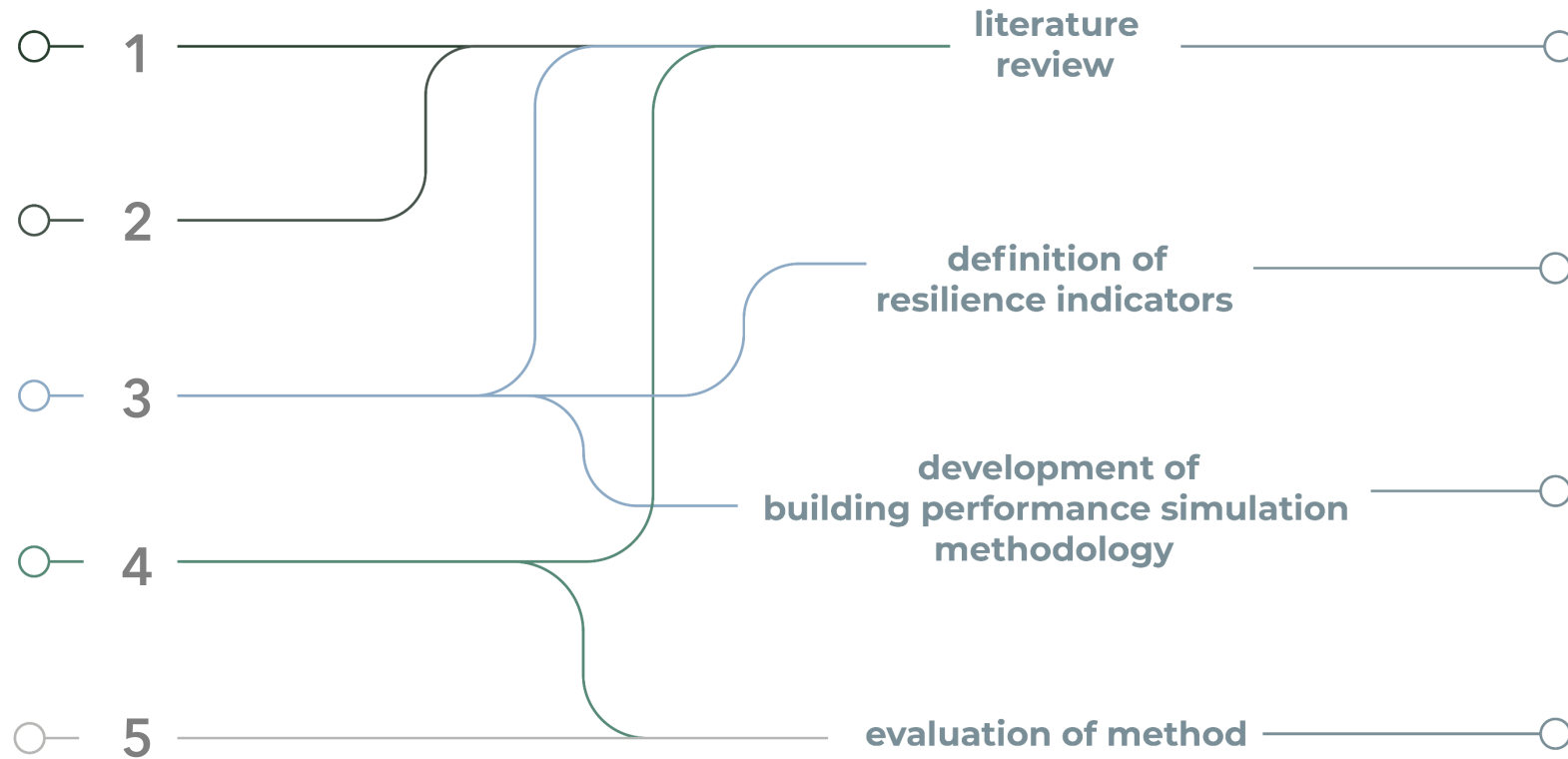

# Research outline

- literature review **1**
- definition of resilience indicators **2**
- development of simulation methodology **3**
- simulation set up and definition of case study **4**
- sensitivity analysis **5**
- postprocessing **6**
- final evaluation **7**
- design **8**
- conclusion **9**

# Research outline

- literature review **1**
- definition of resilience indicators **2**
- development of simulation methodology **3**
- simulation set up and definition of case study **4**
- sensitivity analysis **5**
- postprocessing **6**
- final evaluation **7**
- design **8**
- conclusion **9**

# Research outline

- literature review 1
- definition of resilience indicators 2
- development of simulation methodology 3
- simulation set up and definition of case study 4
- sensitivity analysis 5
- postprocessing 6
- final evaluation 7
- design 8
- conclusion 9

# Research outline

- literature review **1**
- definition of resilience indicators **2**
- development of simulation methodology **3**
- simulation set up and definition of case study **4**
- sensitivity analysis **5**
- postprocessing **6**
- final evaluation **7**
- design **8**
- conclusion **9**

# Research outline

- literature review **1**
- definition of resilience indicators **2**
- development of simulation methodology **3**
- simulation set up and definition of case study **4**
- sensitivity analysis **5**
- postprocessing **6**
- final evaluation **7**
- design **8**
- conclusion **9**

literature review

**1**

definition of resilience indicators

**2**

development of simulation methodology

**3**

simulation set up and definition of case study

**4**

sensitivity analysis

**5**

postprocessing

**6**

final evaluation

**7**

design

**8**

conclusion

**9**



**What is „resilience“?**

# Resilience definition

terminology

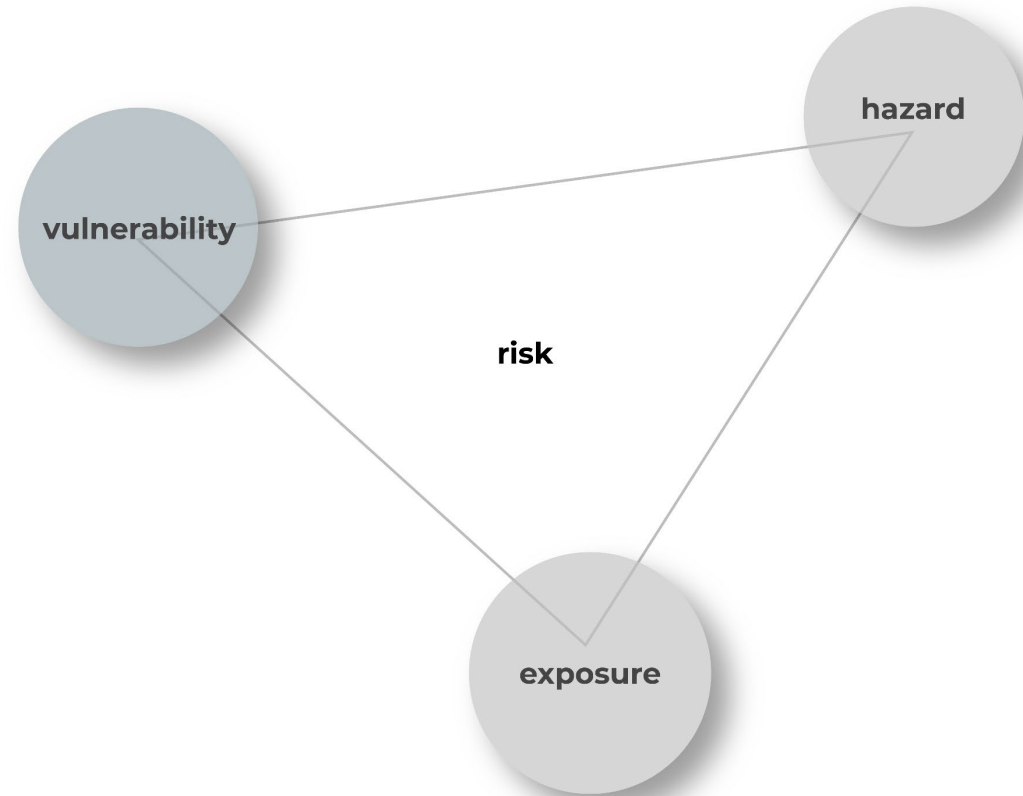

# Resilience definition

terminology



# Assessment methodology

quantitative

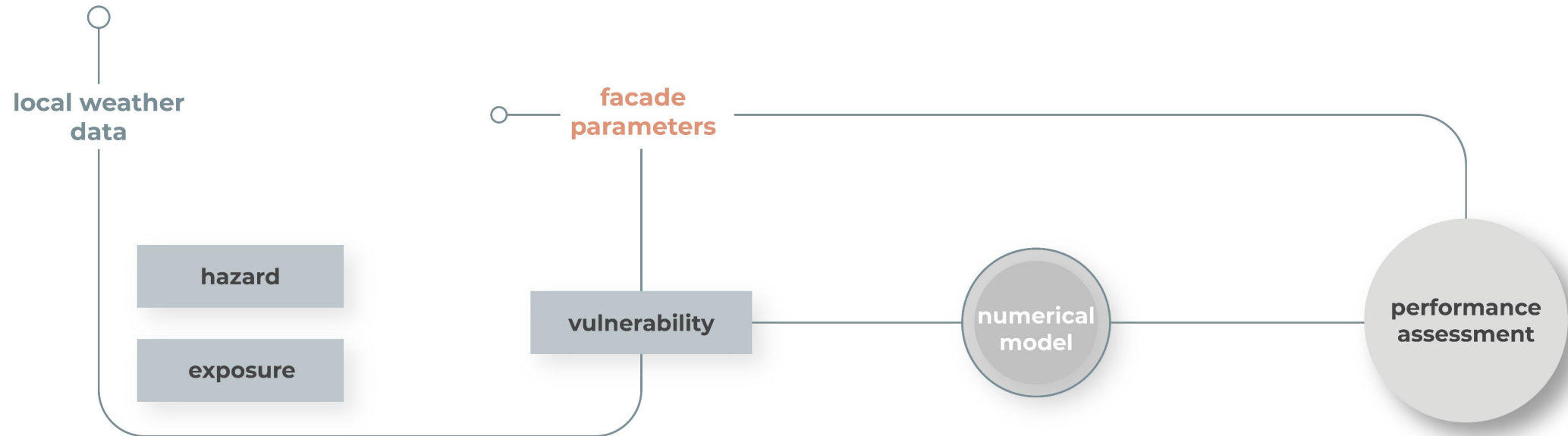

# Assessment methodology

heat wave hazard

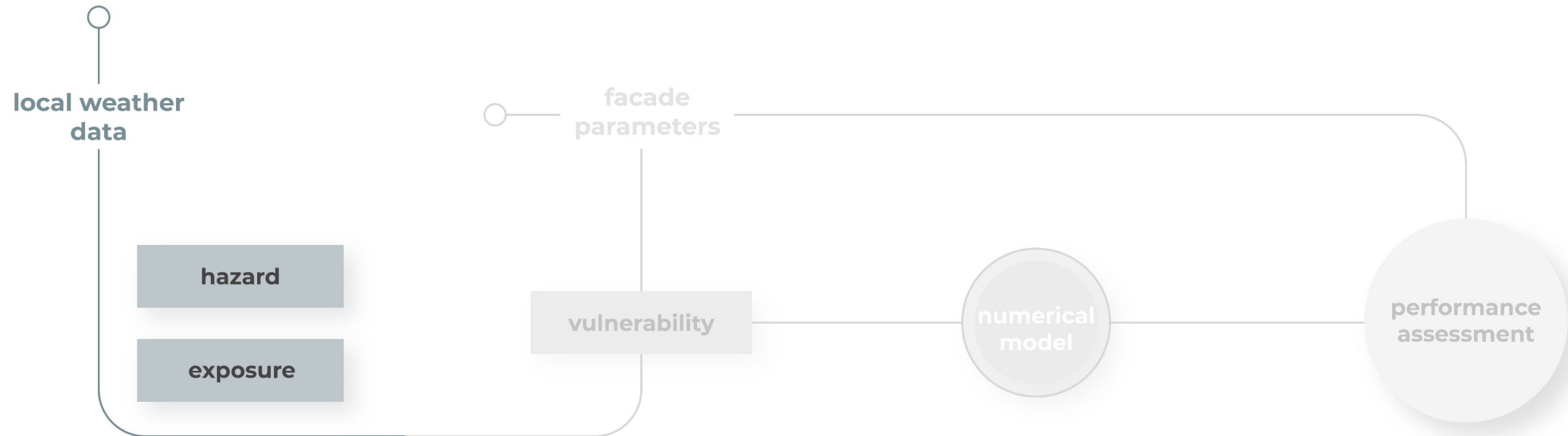

# Heat wave definition

**heat waves are periods consecutive days with excessively hotter conditions than normal**

Pattenden, 2003; Trigo, 2005

# Heat wave definition

characteristics of waves

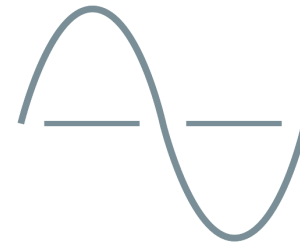

# Heat wave definition

characteristics of waves

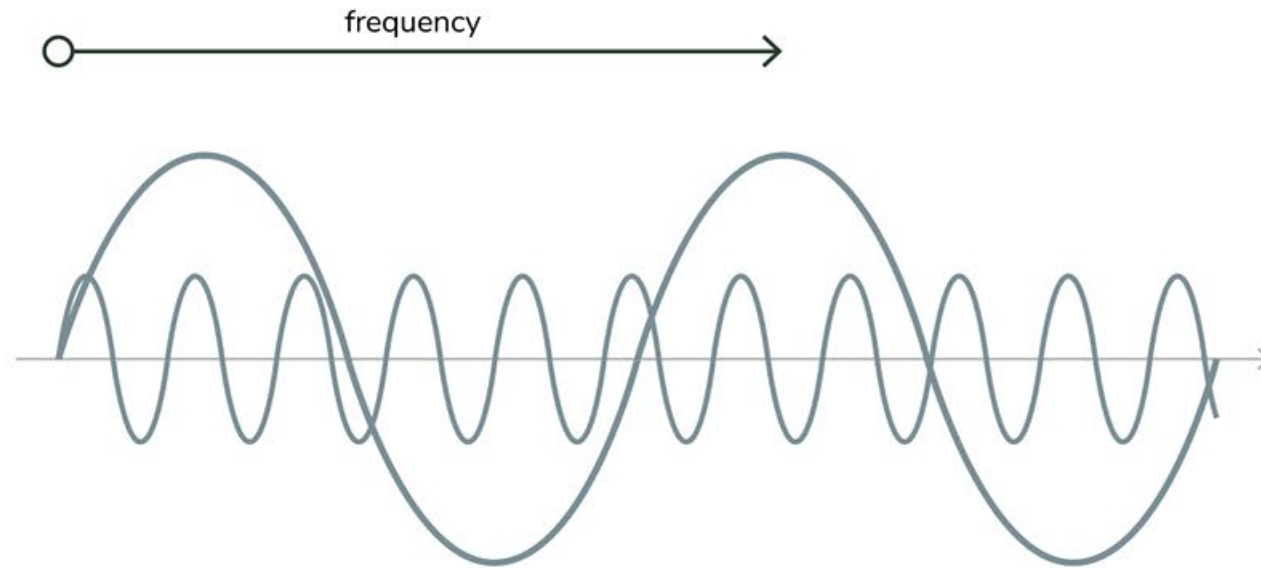

# Heat wave definition

heat wave indices

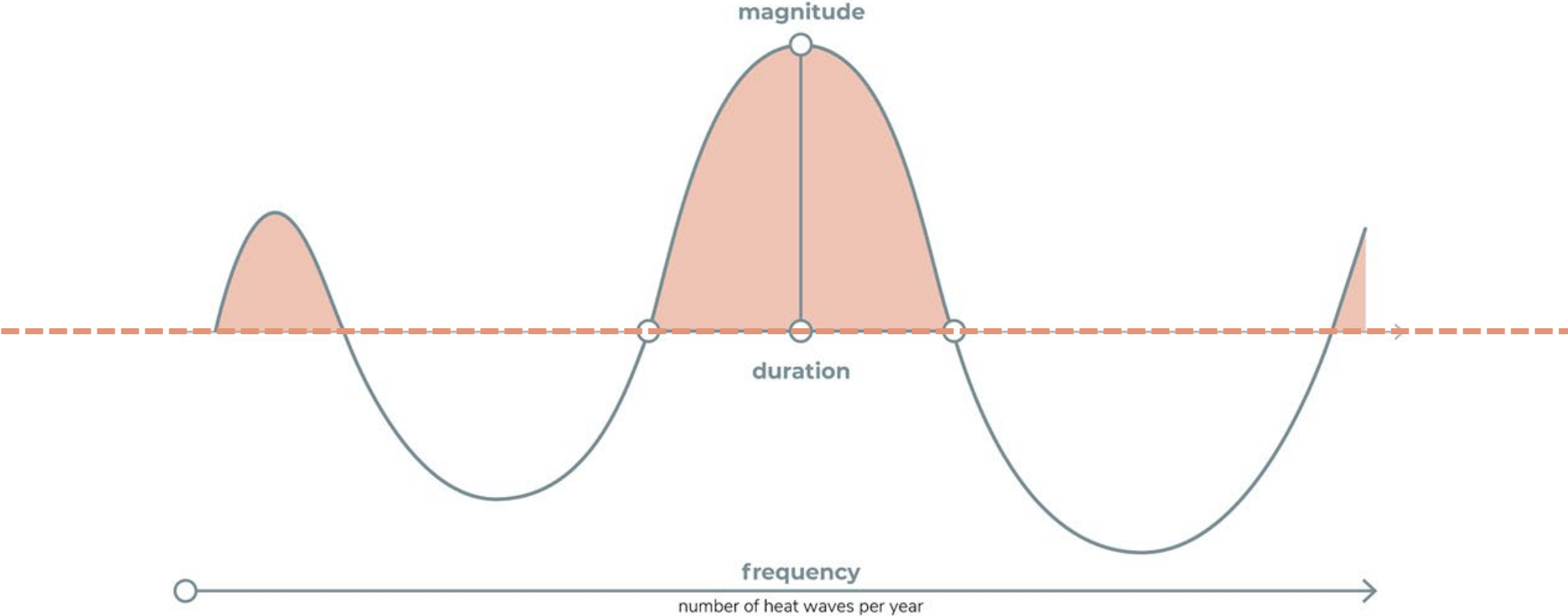

# Assessment methodology

identification of facade parameters

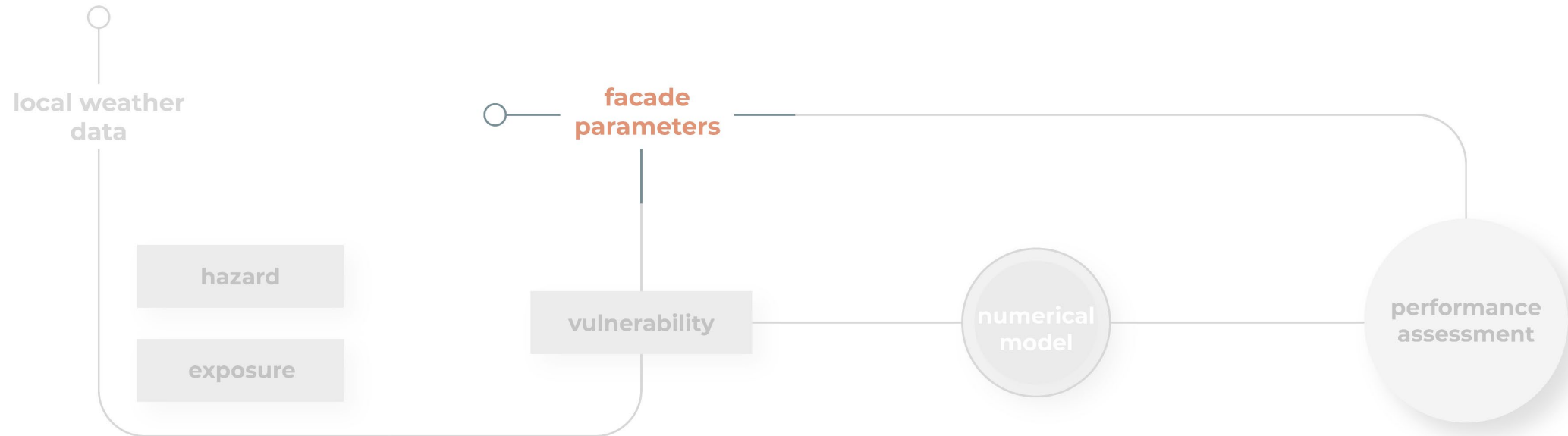

# Heat transfer

three principles

**conduction**

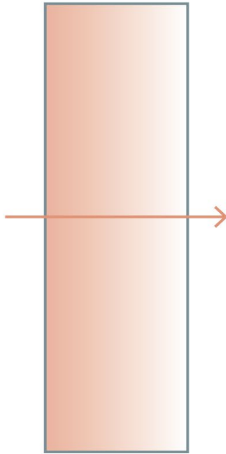

**convection**

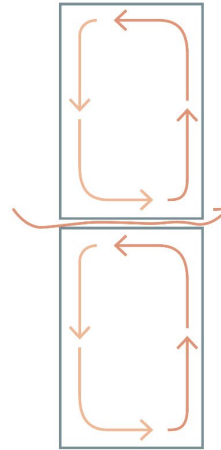

**radiation**

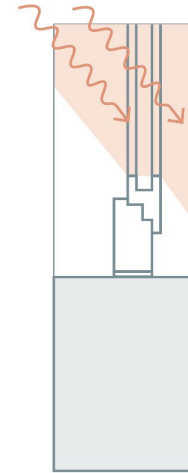

# Heat transfer

three principles

**conduction**

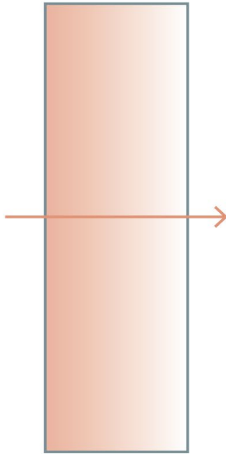

**convection**

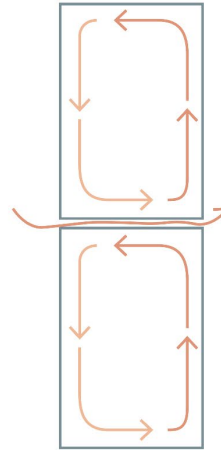

**radiation**

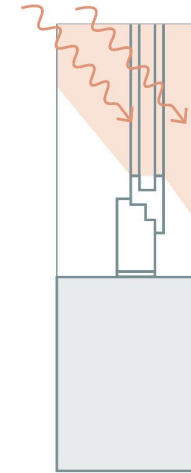

# Heat transfer

three principles

**conduction**

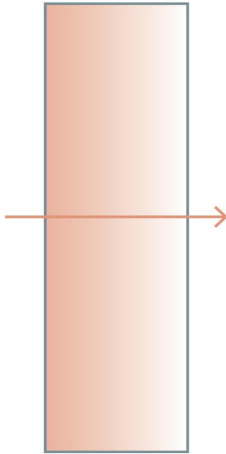

**convection**

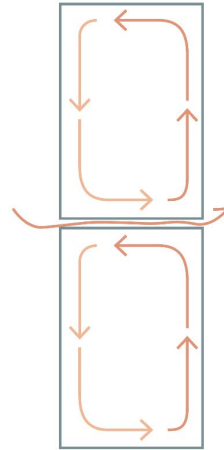

**radiation**

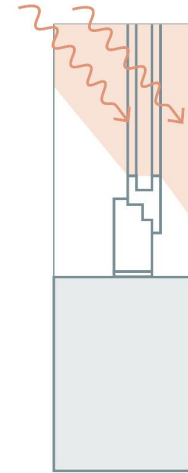

# Heat transfer

relevant facade parameters

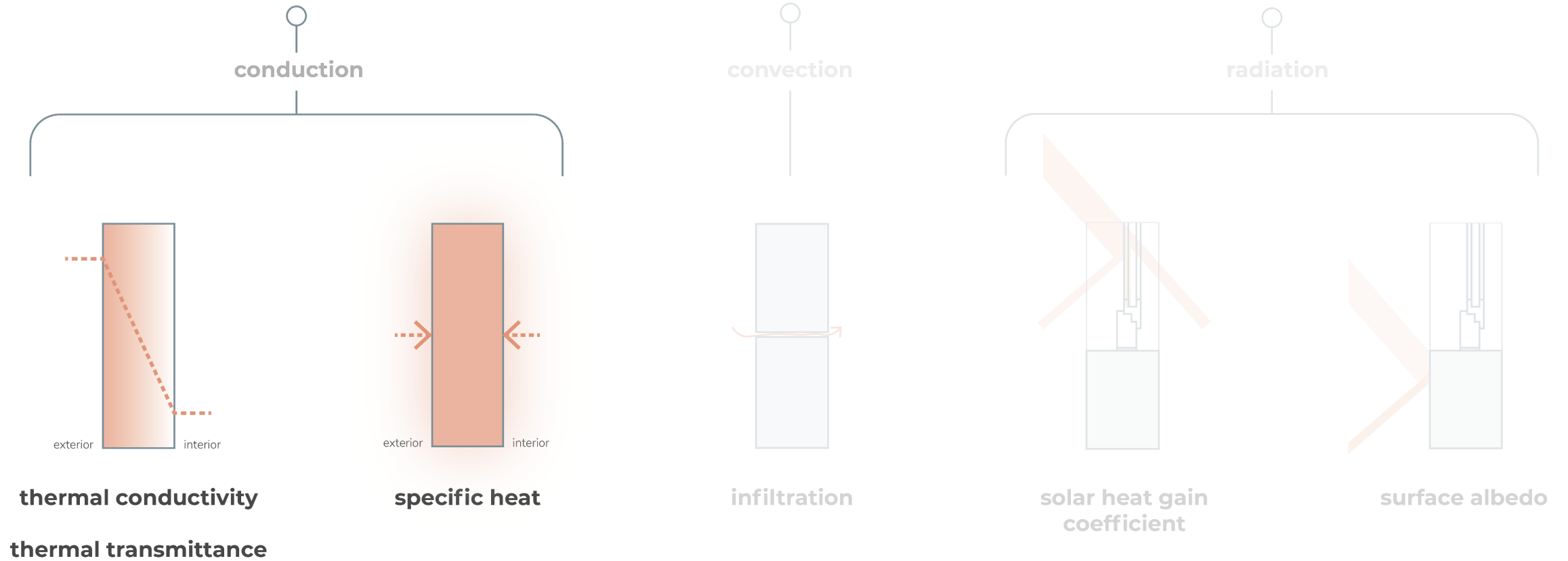

# Heat transfer

relevant facade parameters

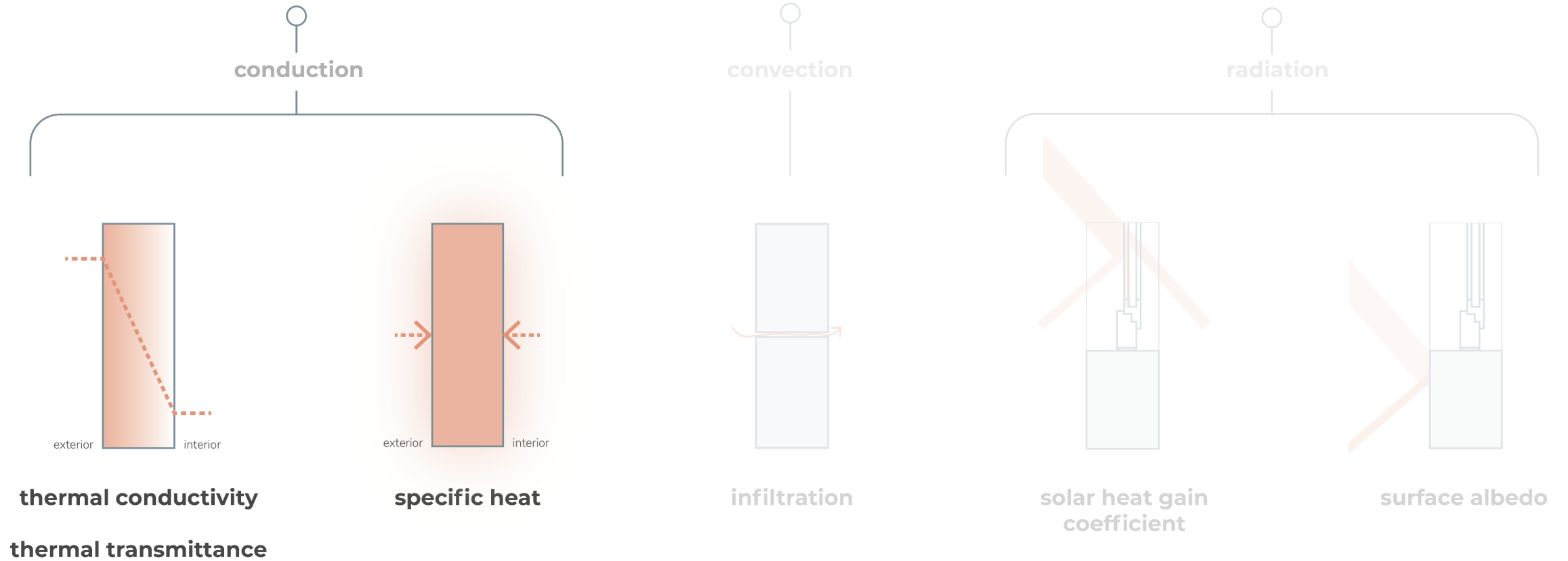

# Heat transfer

relevant facade parameters

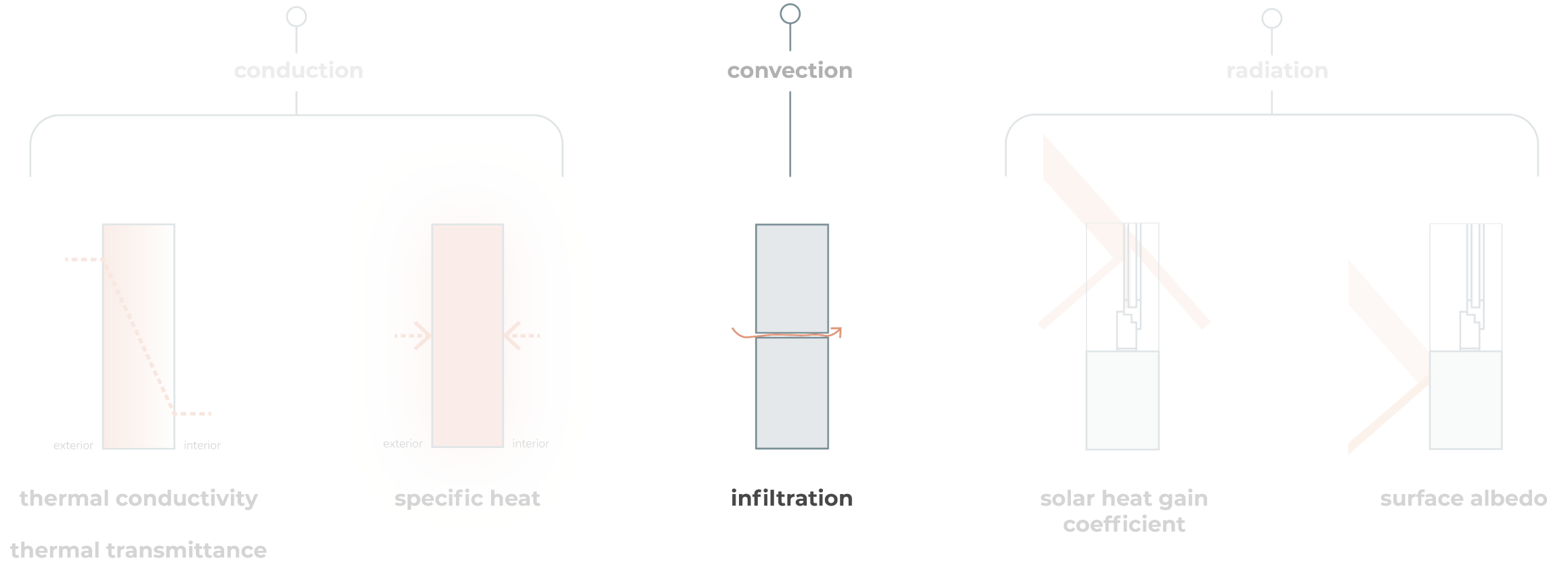

# Heat transfer

relevant facade parameters

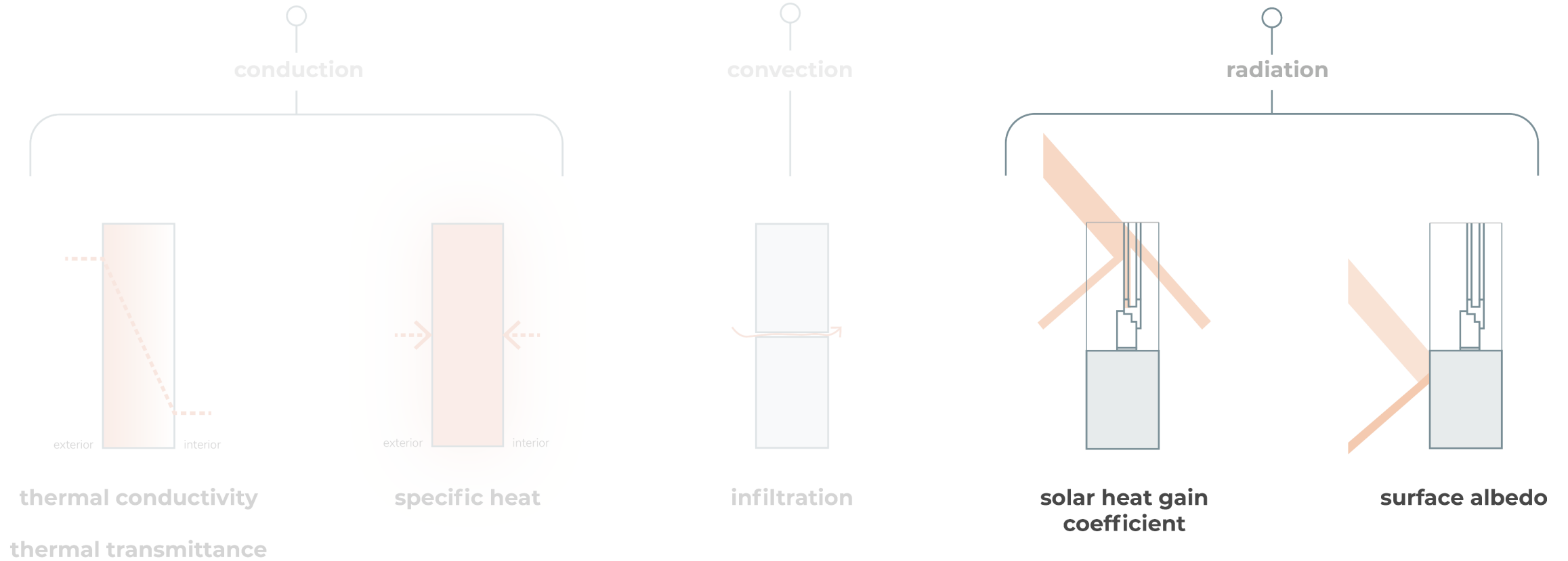

# Assessment methodology

performance assessment

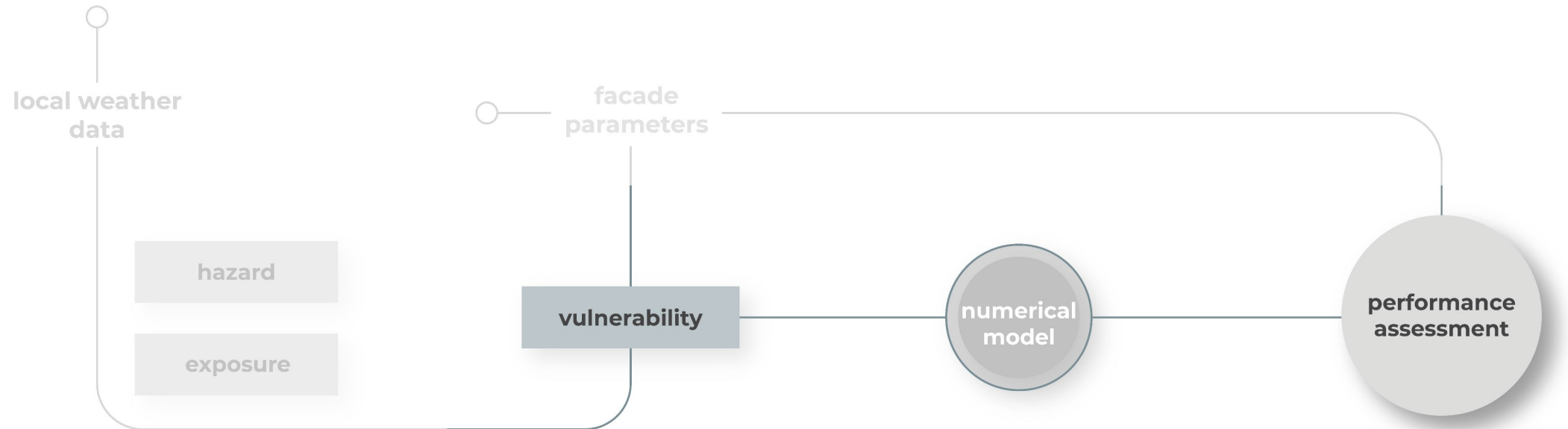

# Assessment methodology

resilience terminology

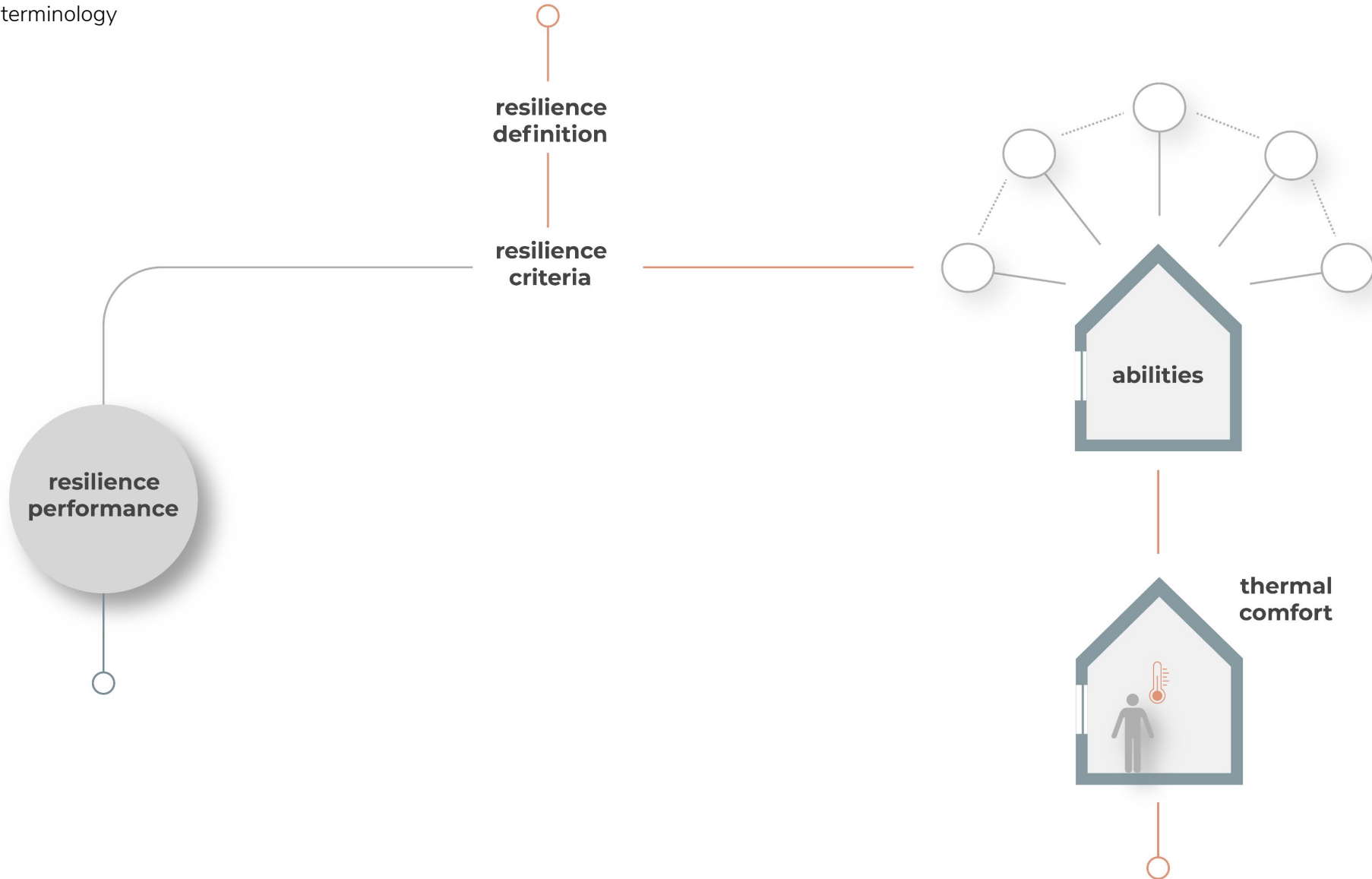

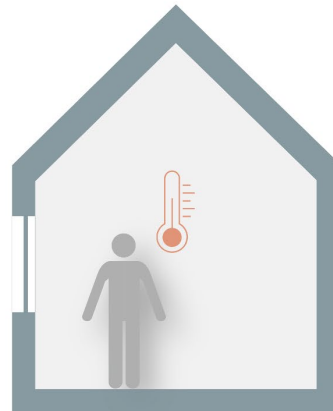

**thermal comfort**

# Literature review

important findings – thermal comfort metrics

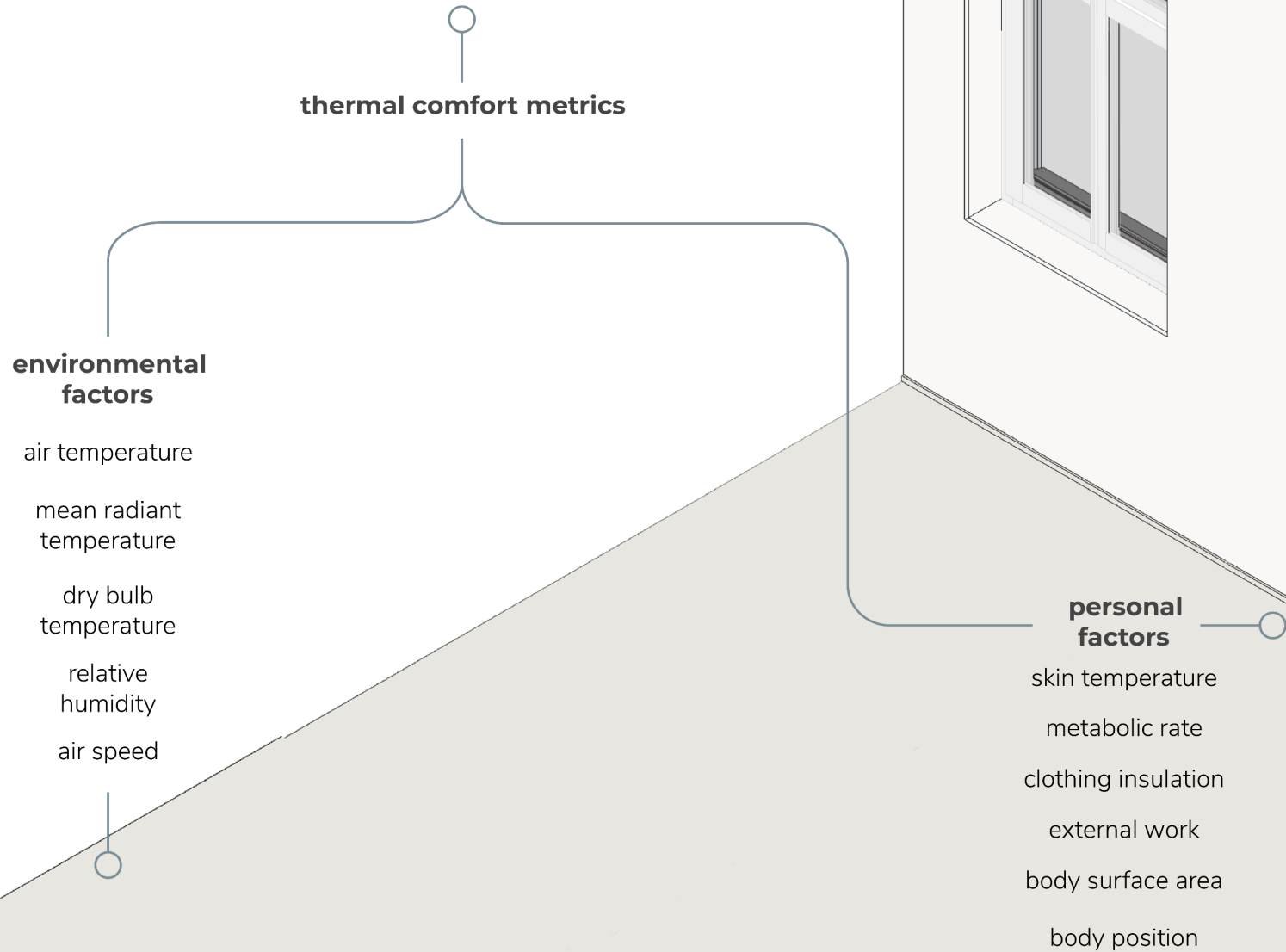

# Literature review

important findings – SET



**Standard effective temperature (SET)**

mean radiant temperature

dry bulb temperature

relative humidity

air speed

metabolic rate

clothing insulation

external work

body surface area

body position



**equivalent temperature** which **hypothesizes** a standard environment to embody **multi-factor effects** comprehensively

(Ji et al., 2022)

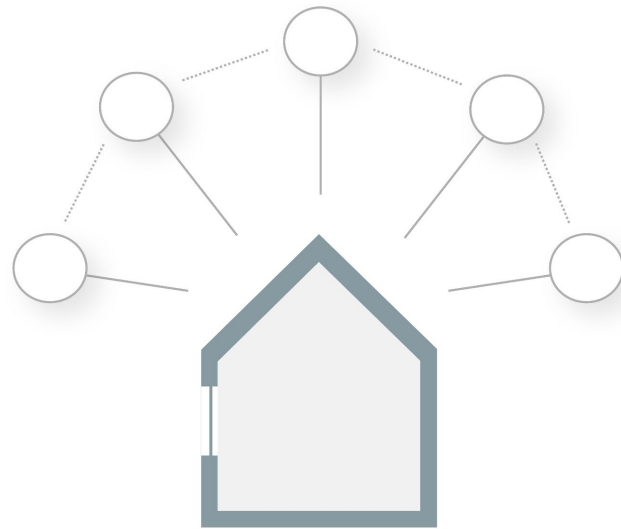

**abilities**

# Resilience criteria

translation of resilience criteria to indices

preparation

absorption

adaptability

recovery

durability

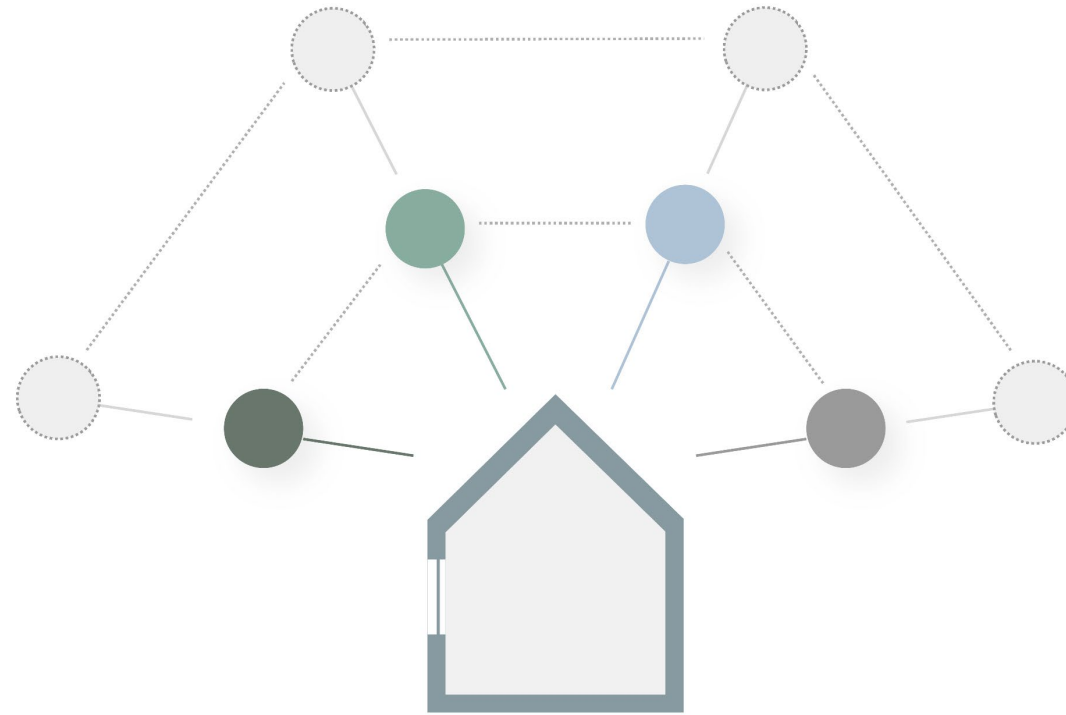

**proposal**

literature review **1**

definition of resilience indicators **2**

development of simulation methodology **3**

simulation set up and definition of case study **4**

sensitivity analysis **5**

postprocessing **6**

final evaluation **7**

design **8**

conclusion **9**



# Resilience performance graph

incl. resilience stages

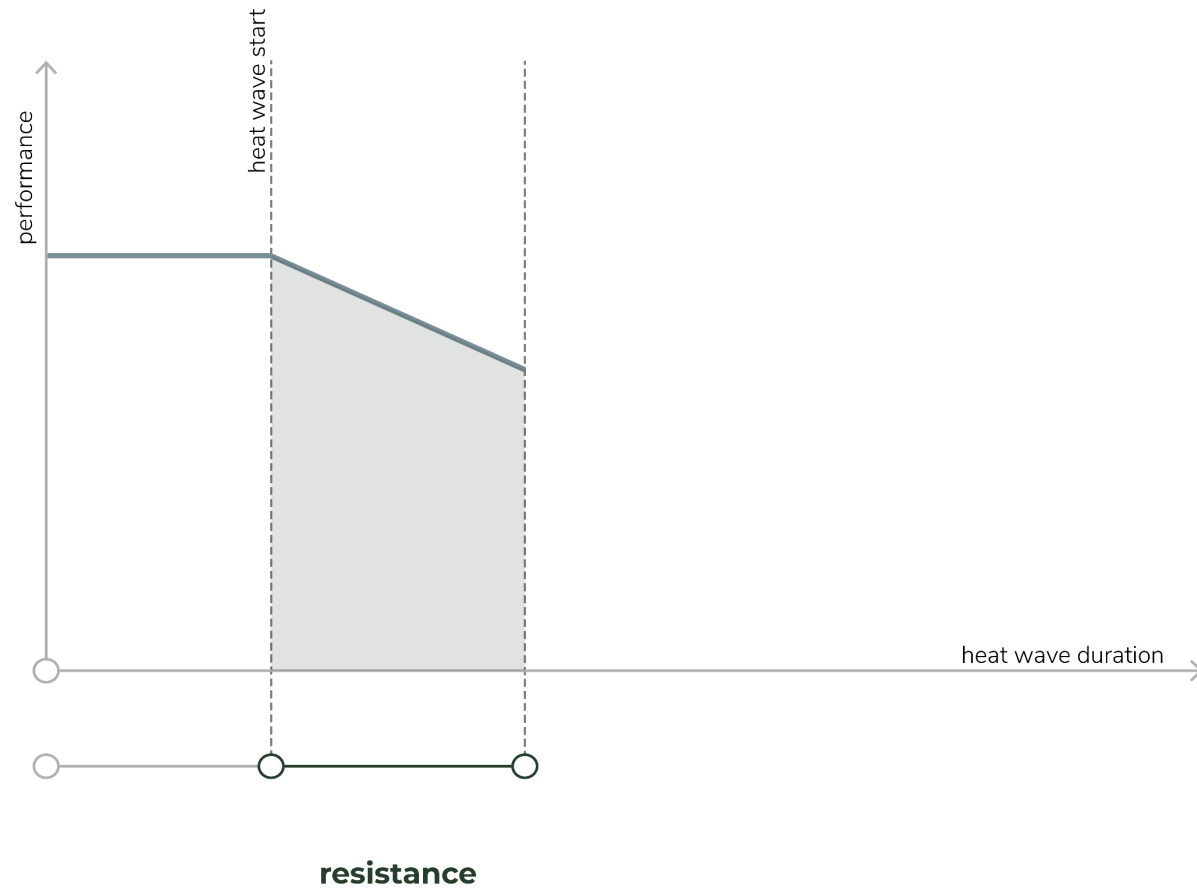

# Resilience performance graph

incl. resilience stages

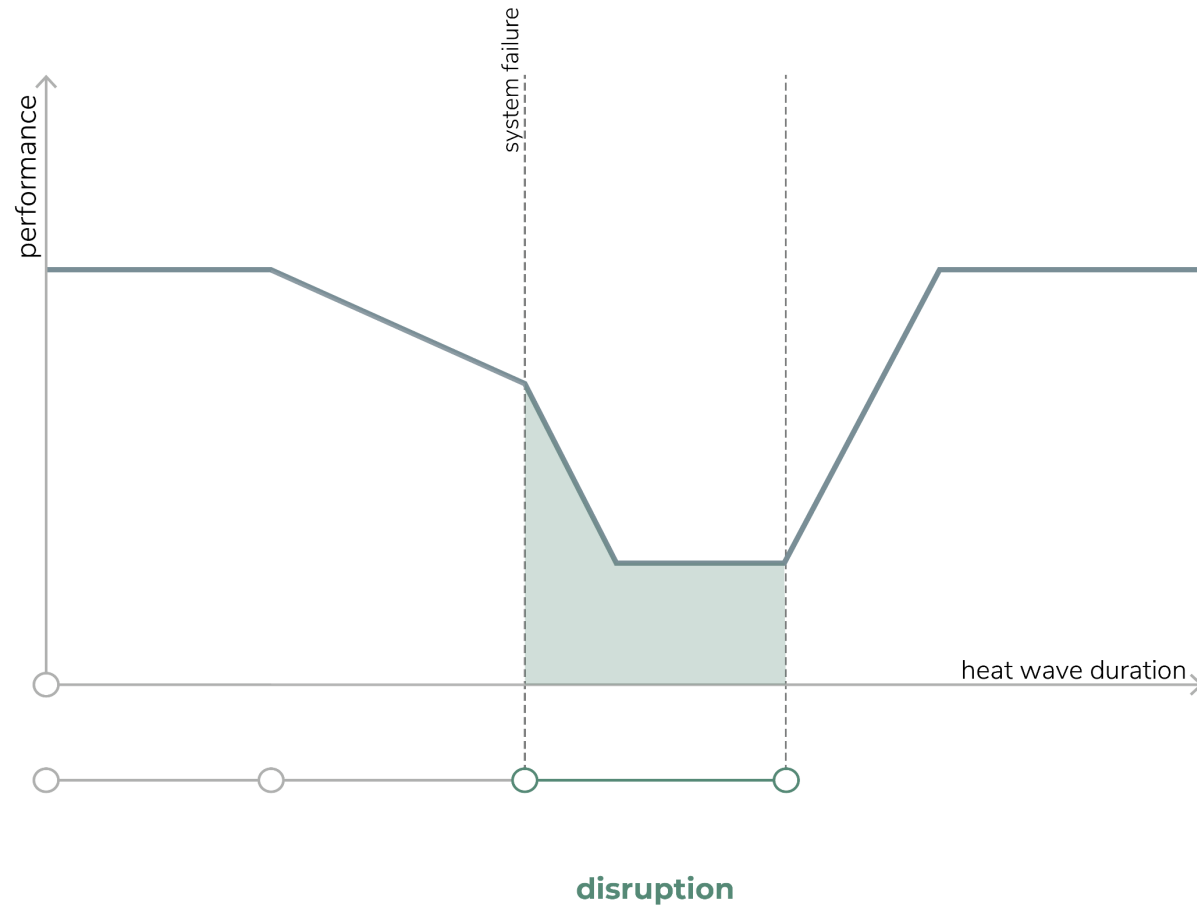

# Resilience performance graph

incl. resilience stages

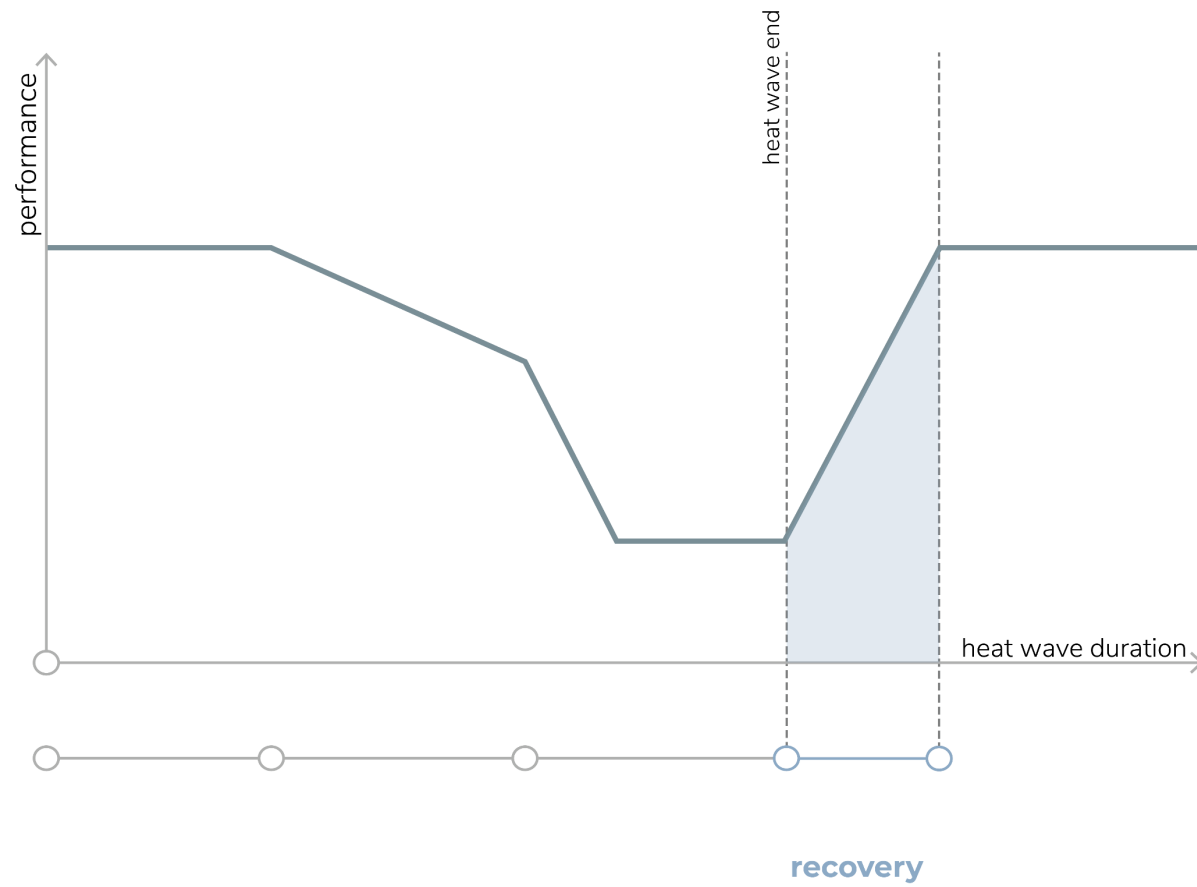

# Resilience performance graph

incl. resilience stages

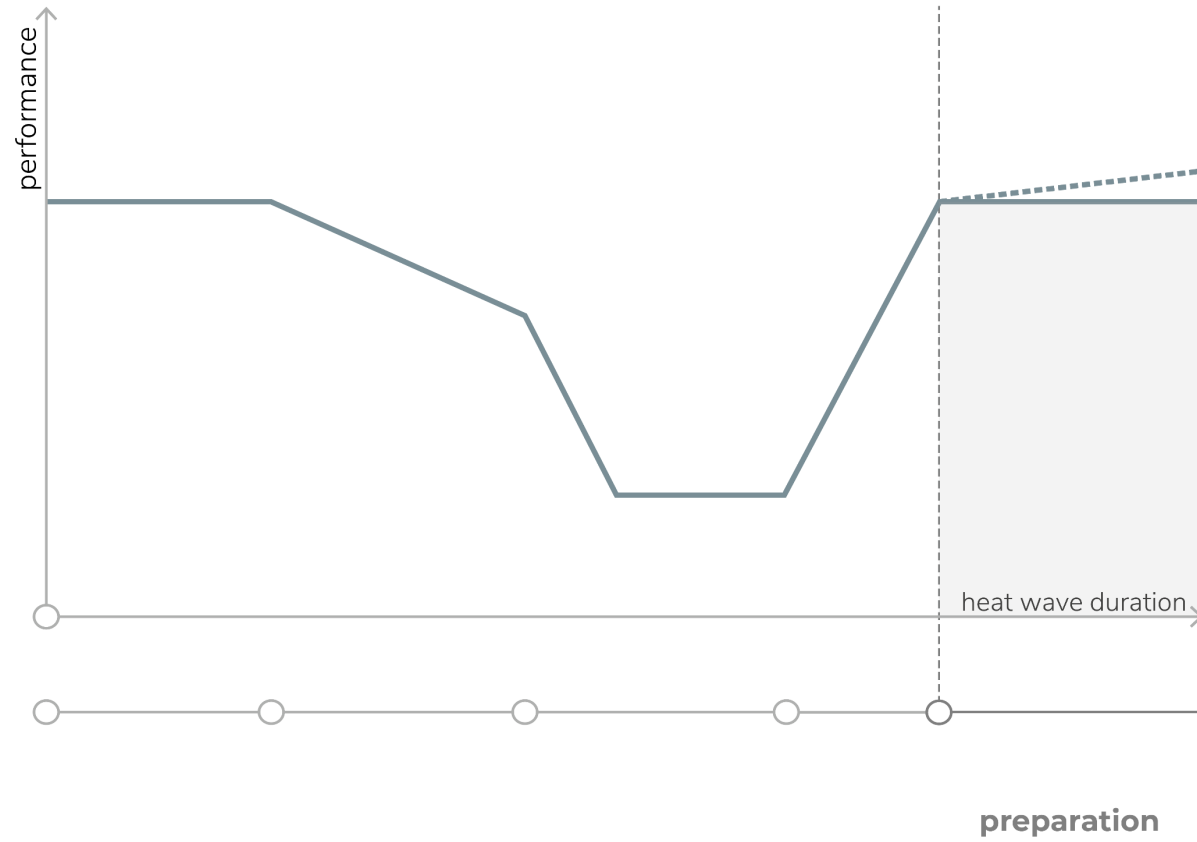

# Resilience definition

cyclic

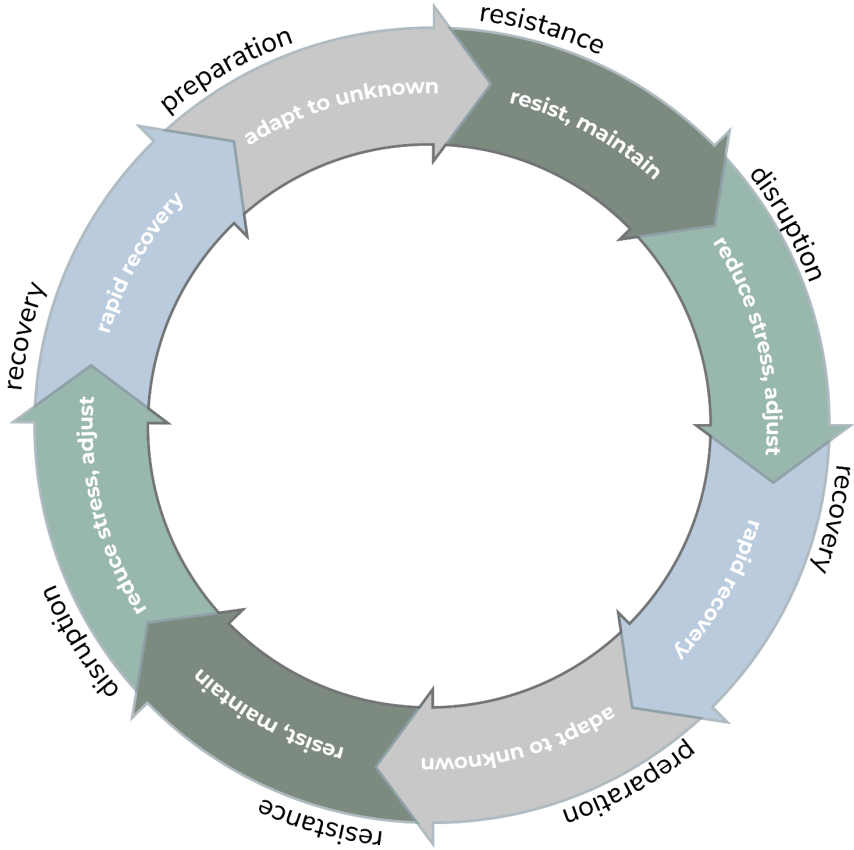

# Resilience definition

resilience indicators

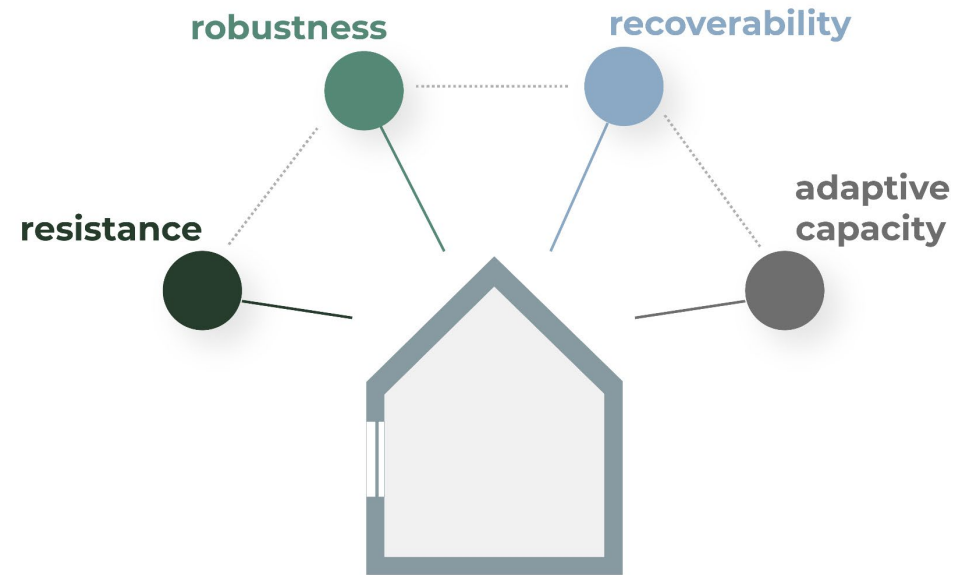

# Resilience indicators

resistance

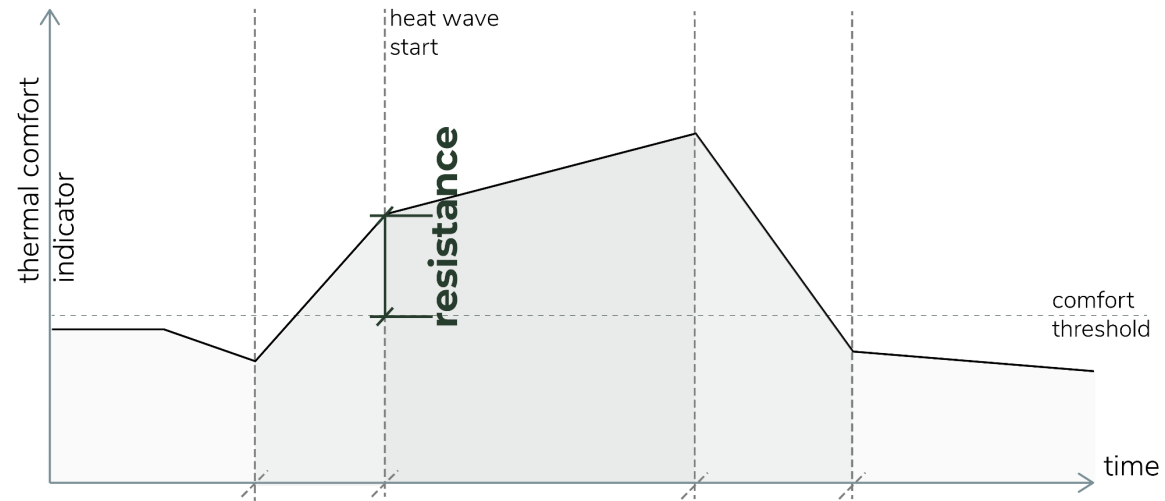

# Resilience indicators

robustness

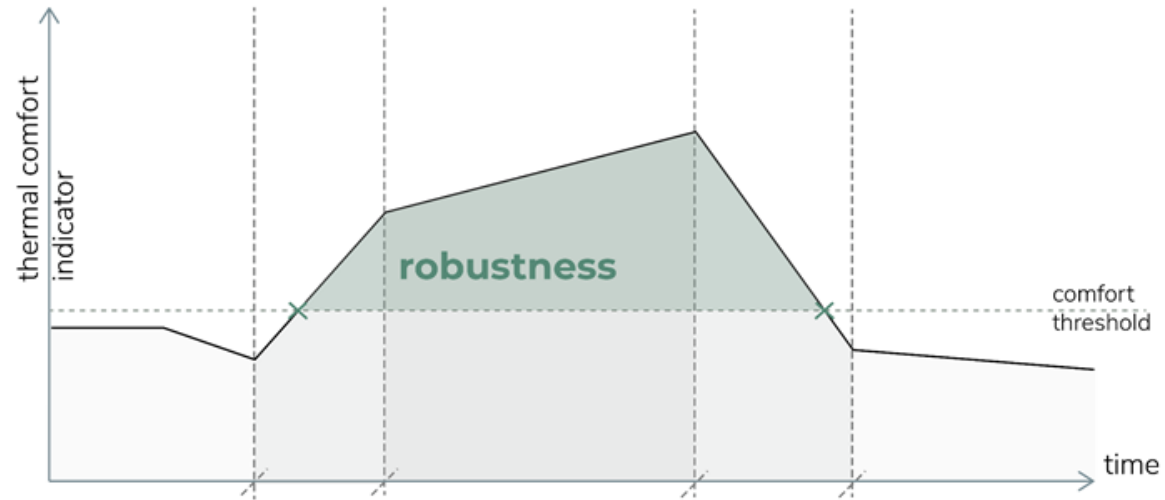

# Resilience indicators

recoverability

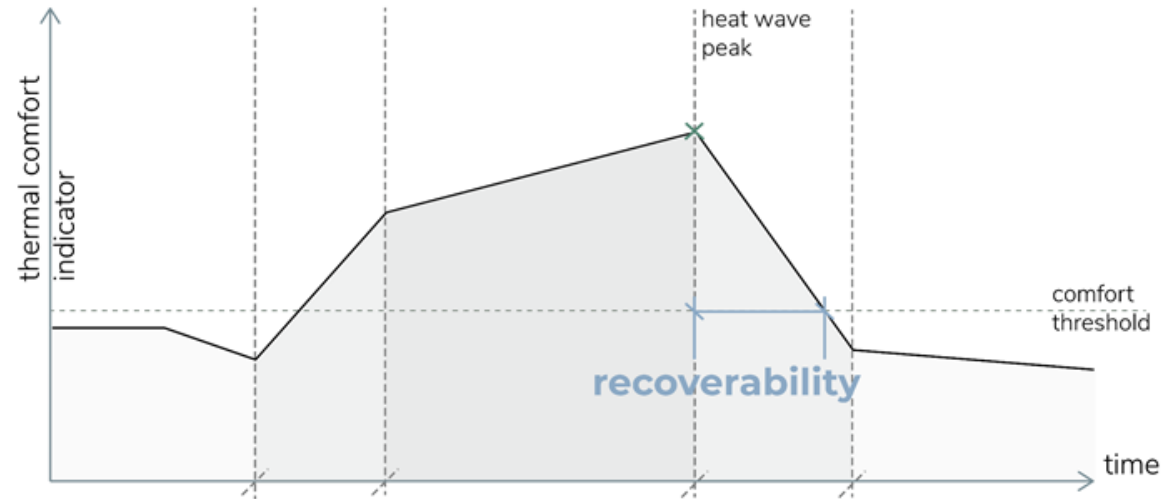

# Resilience indicators

adaptive capacity



- literature review 1
- definition of resilience indicators 2
- development of simulation methodology 3
- simulation set up and definition of case study 4
- sensitivity analysis 5
- postprocessing 6
- final evaluation 7
- design 8
- conclusion 9



# Assessment methodology

quantitative

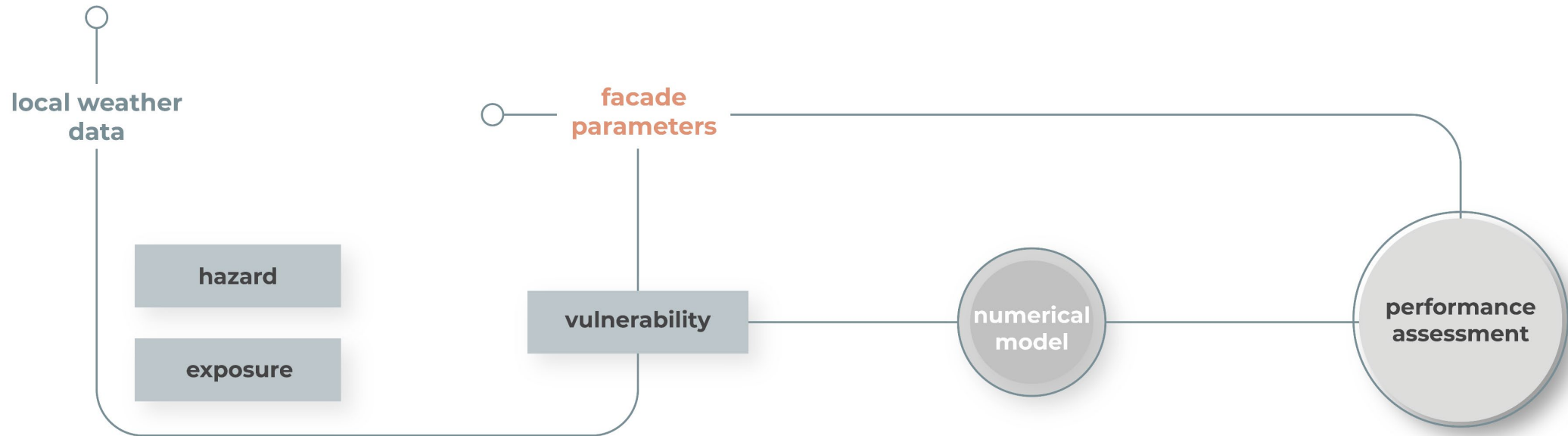

# Simulation methodology

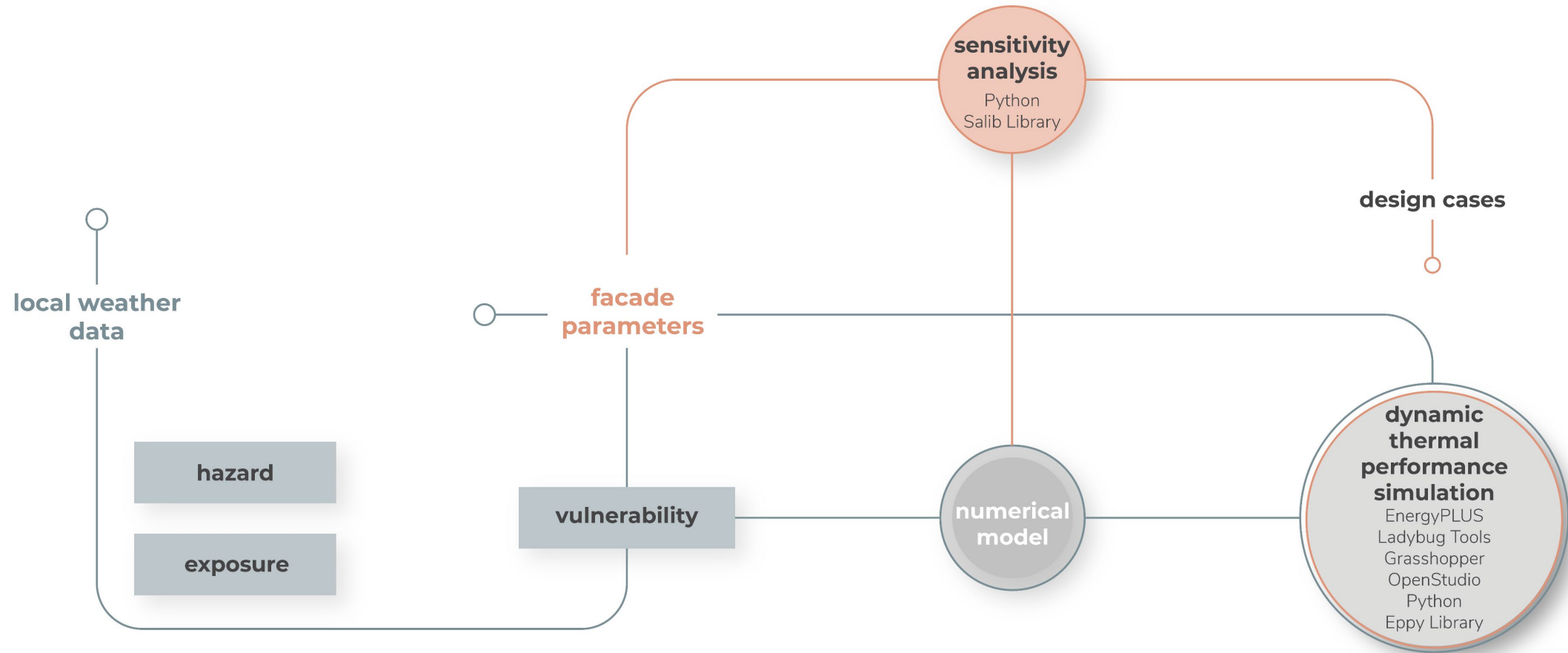

# Simulation methodology

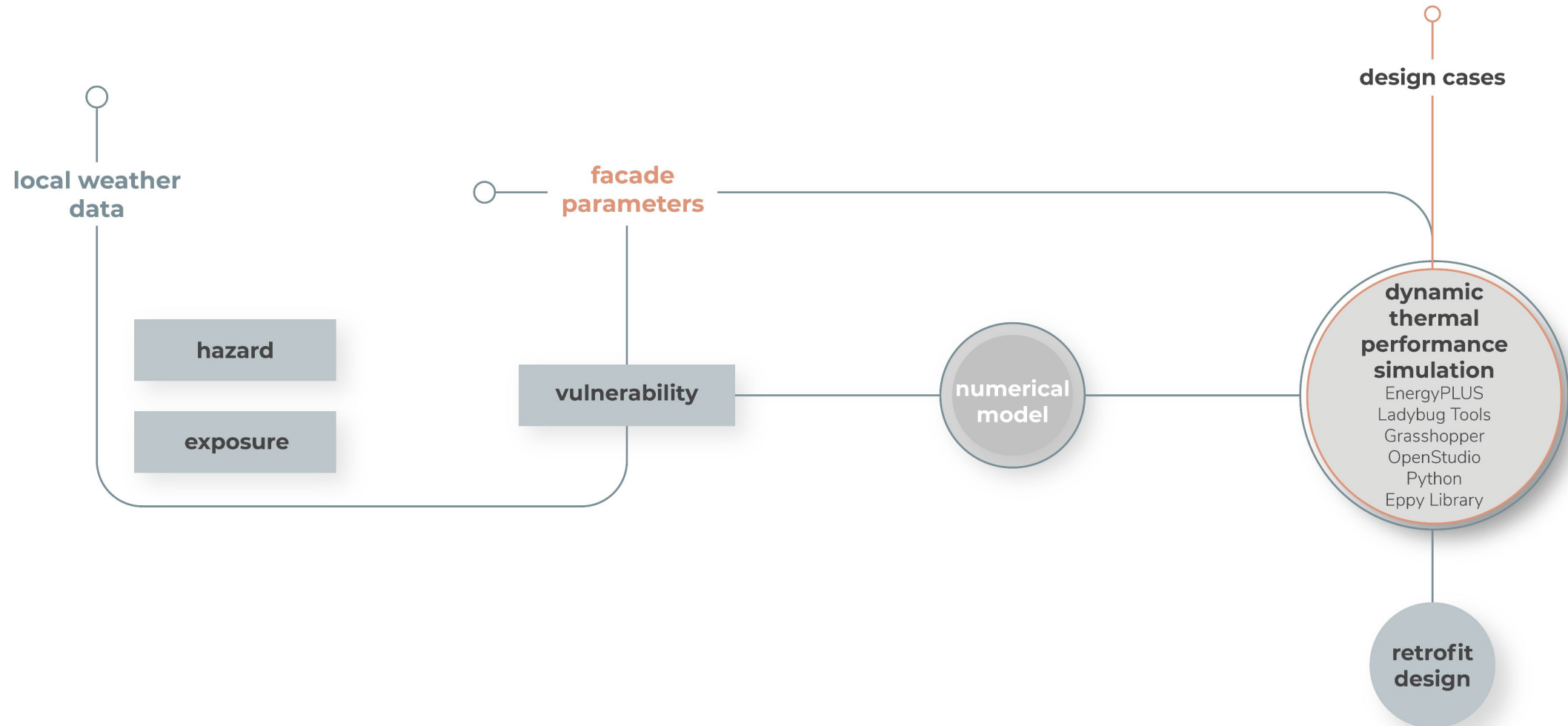

- literature review 1
- definition of resilience indicators 2
- development of simulation methodology 3
- simulation set up and definition of case study 4
- sensitivity analysis 5
- postprocessing 6
- final evaluation 7
- design 8
- conclusion 9



## Case study location



# Heat wave

threshold definition

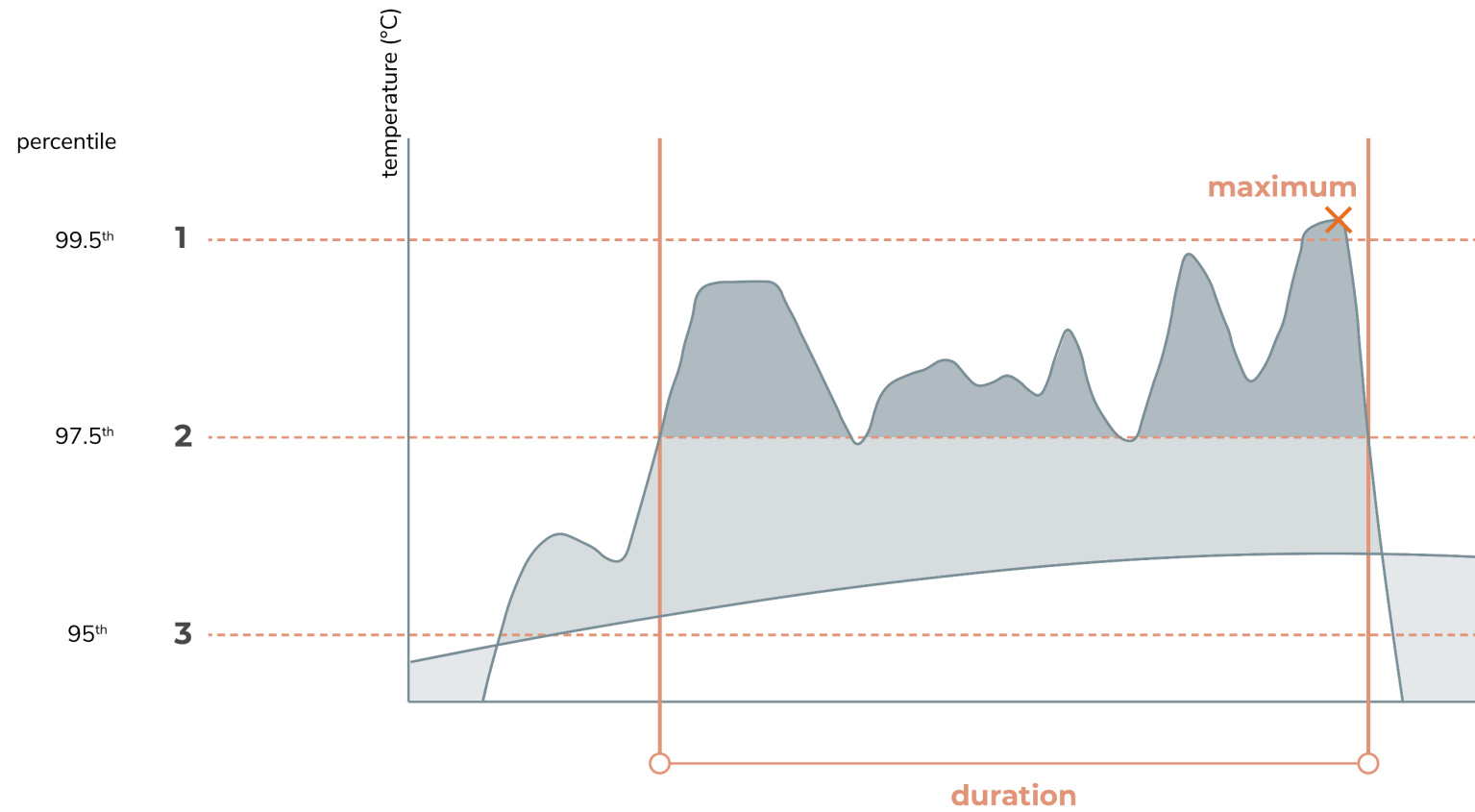

# Weather data

development of EPW

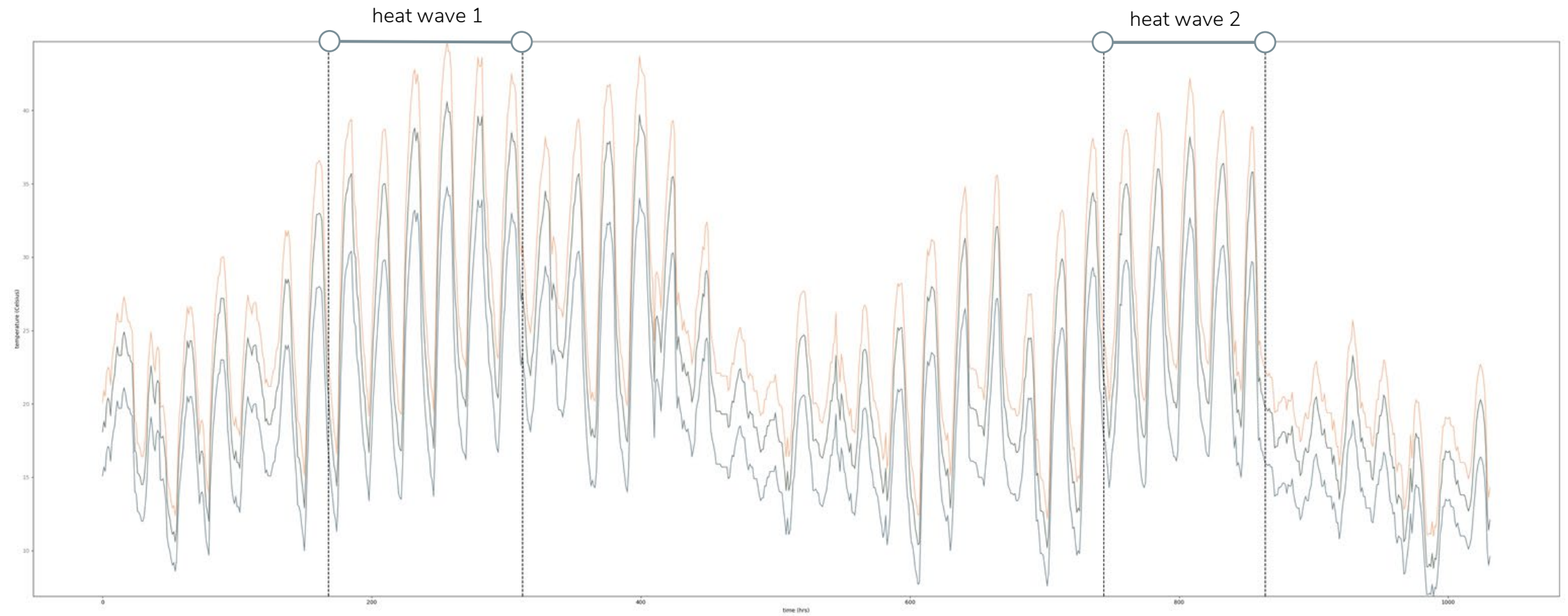

# Introduction case study

Location in Munich

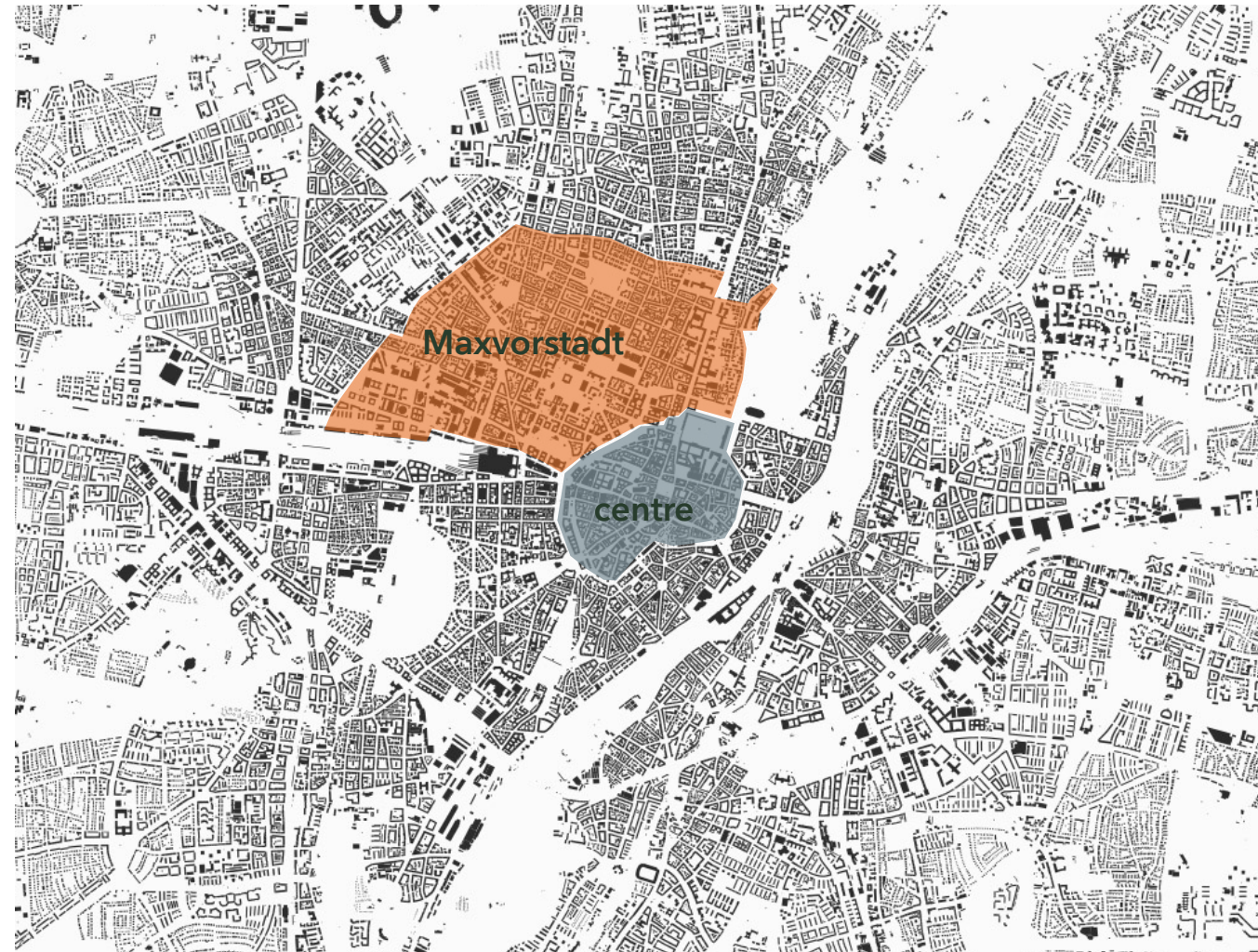

# Introduction case study

Location Maxvorstadt



# Introduction case study

Archetype facade

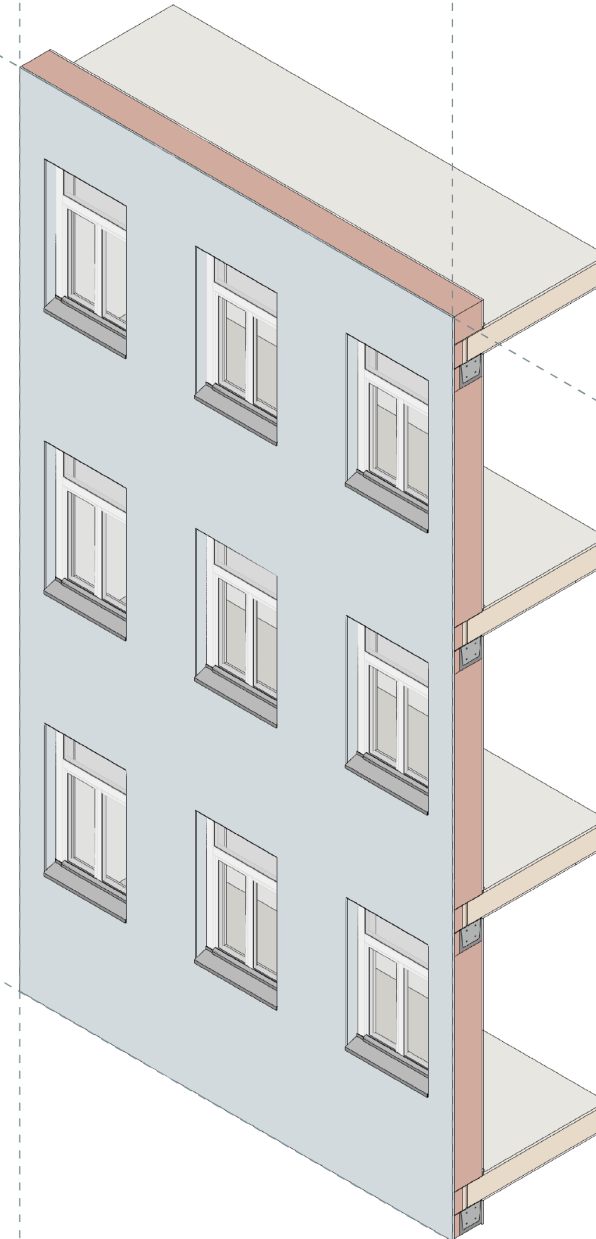

# Base case simulation set up

Fixed parameters

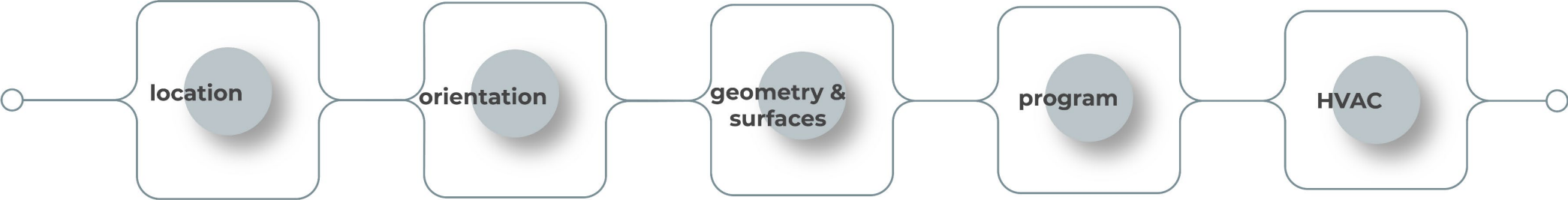

# Base case simulation set up

Exterior wall construction - material properties

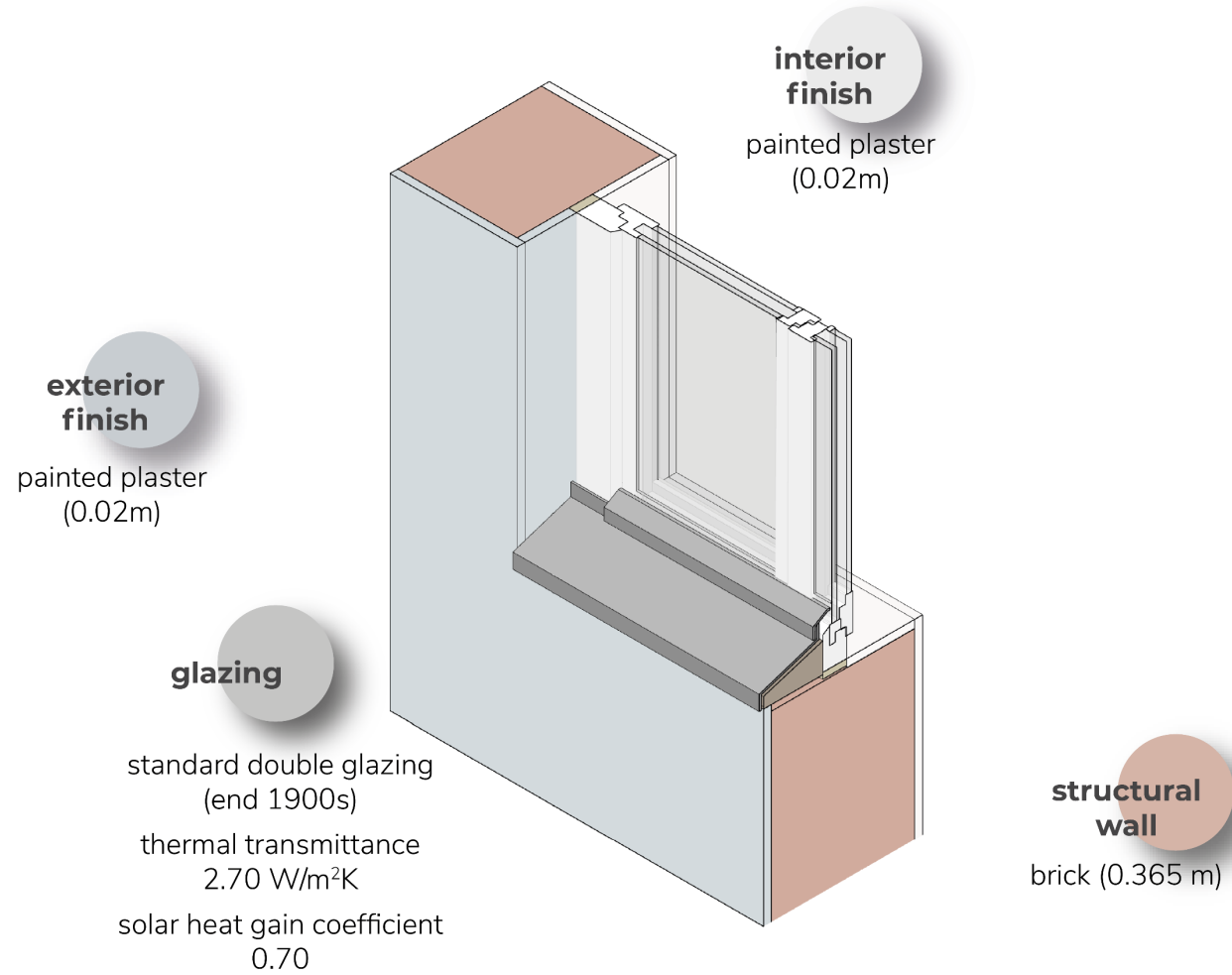

# Base case simulation set up

Choice of parameters for retrofit

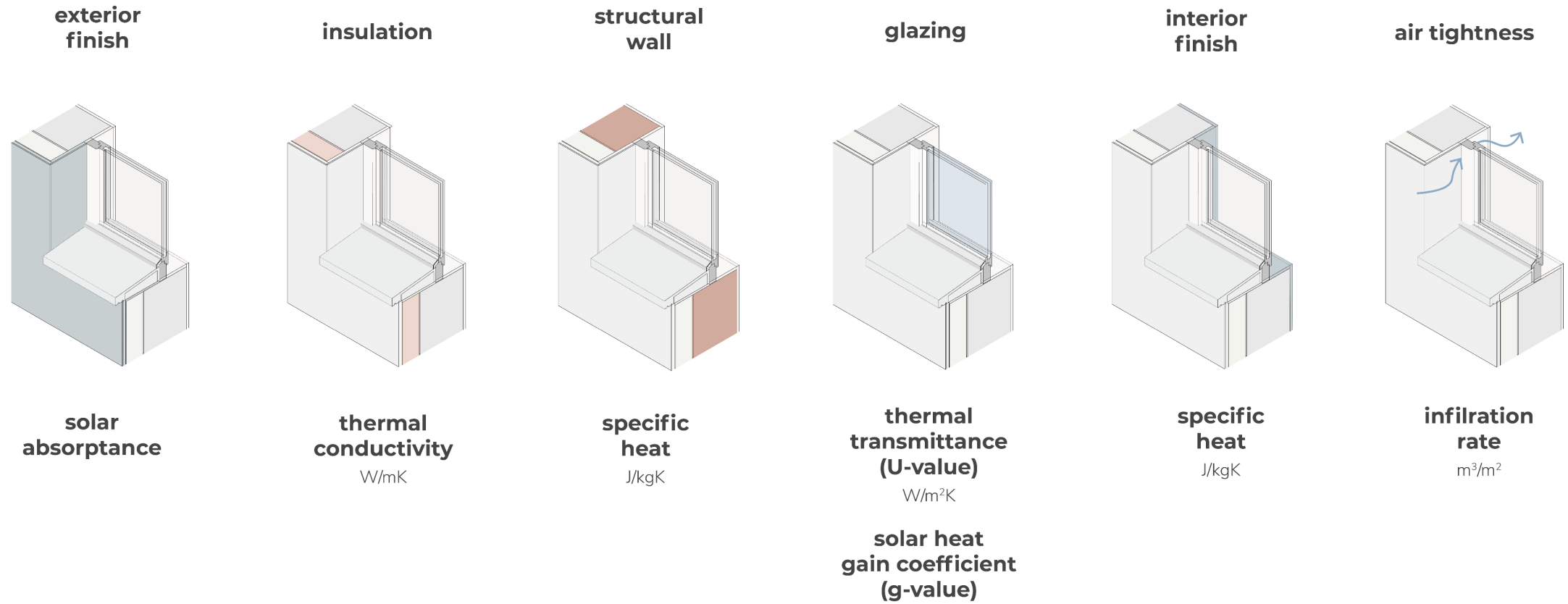

# Sensitivity analysis workflow

input

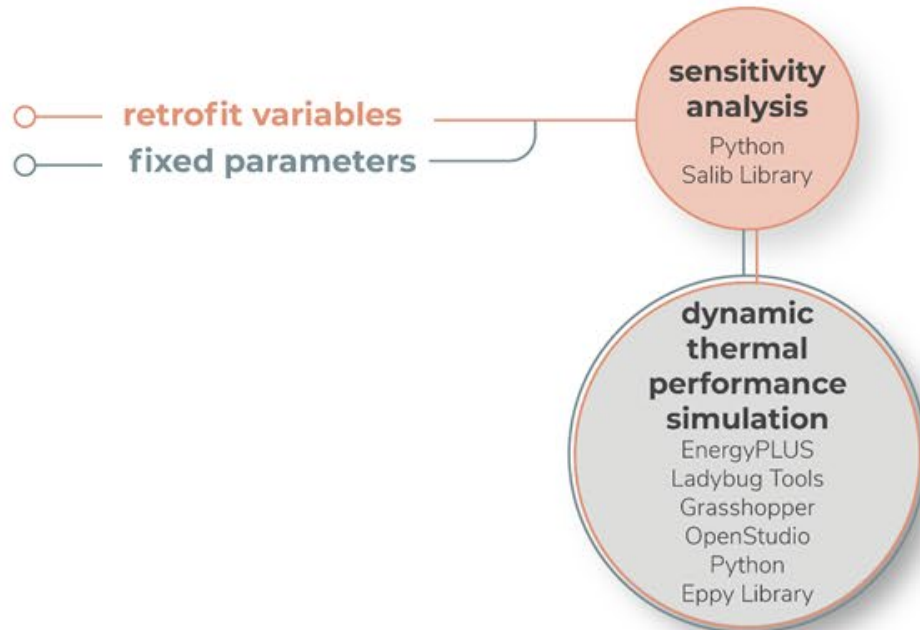

# Sensitivity analysis workflow

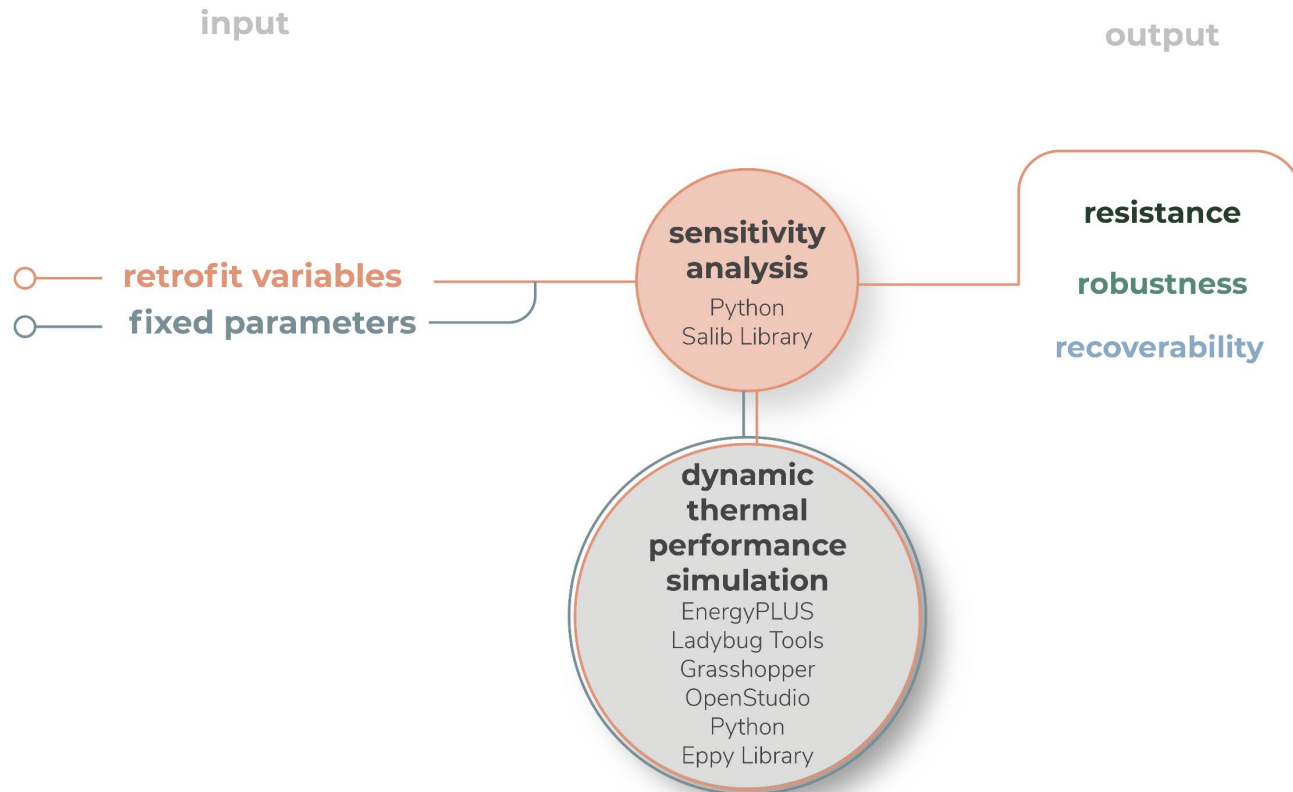

# Sensitivity analysis workflow

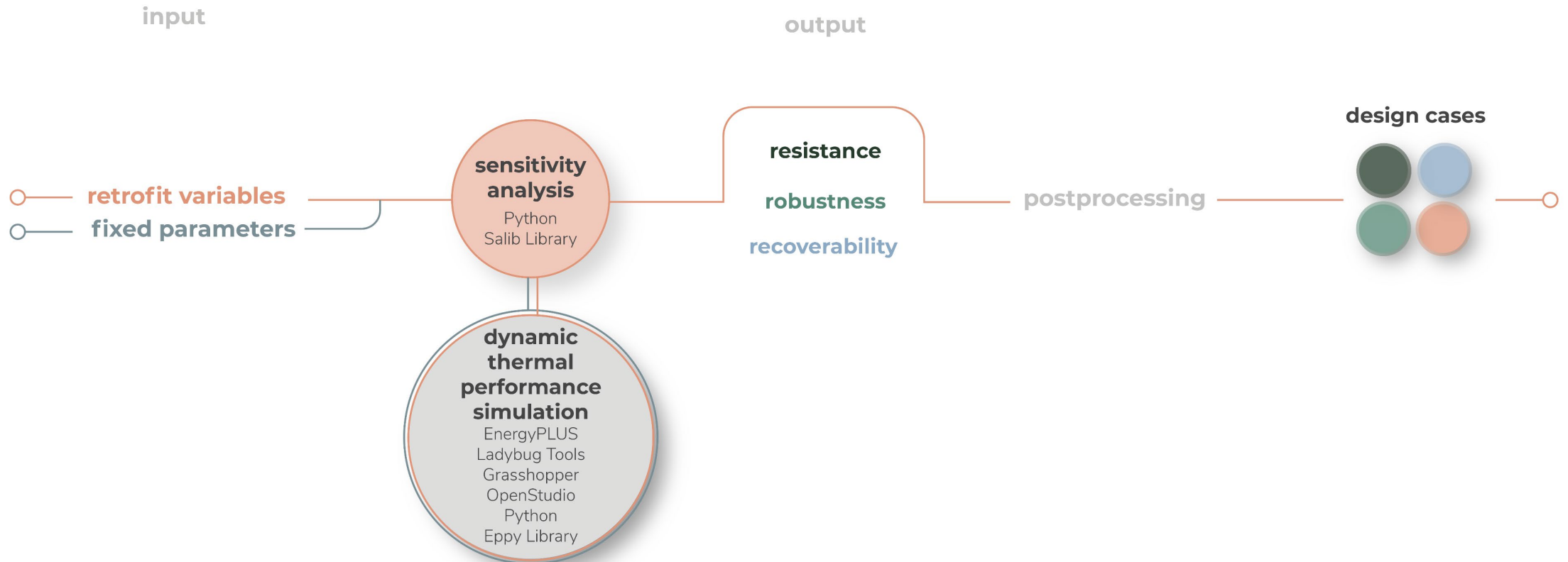

# Sensitivity analysis variables

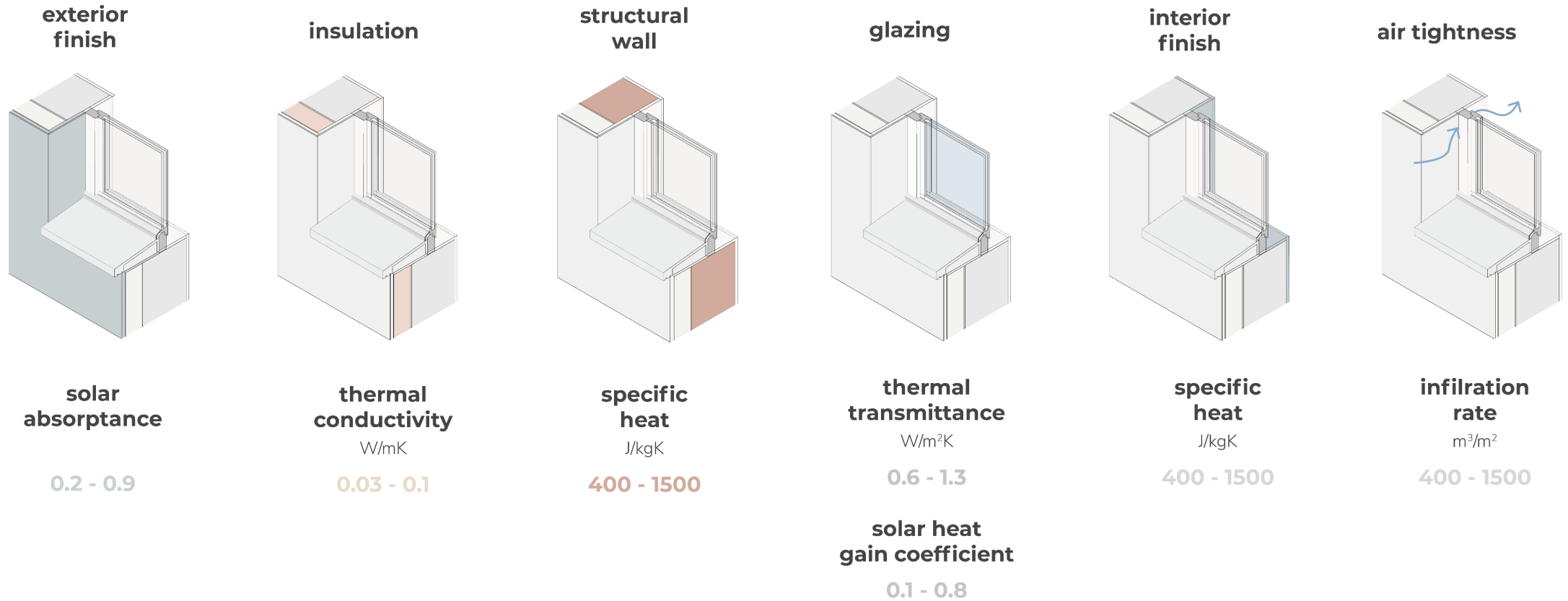

# Sensitivity analysis outcome

$S_{total}$ ,  $S_{direct}$  per index outcome

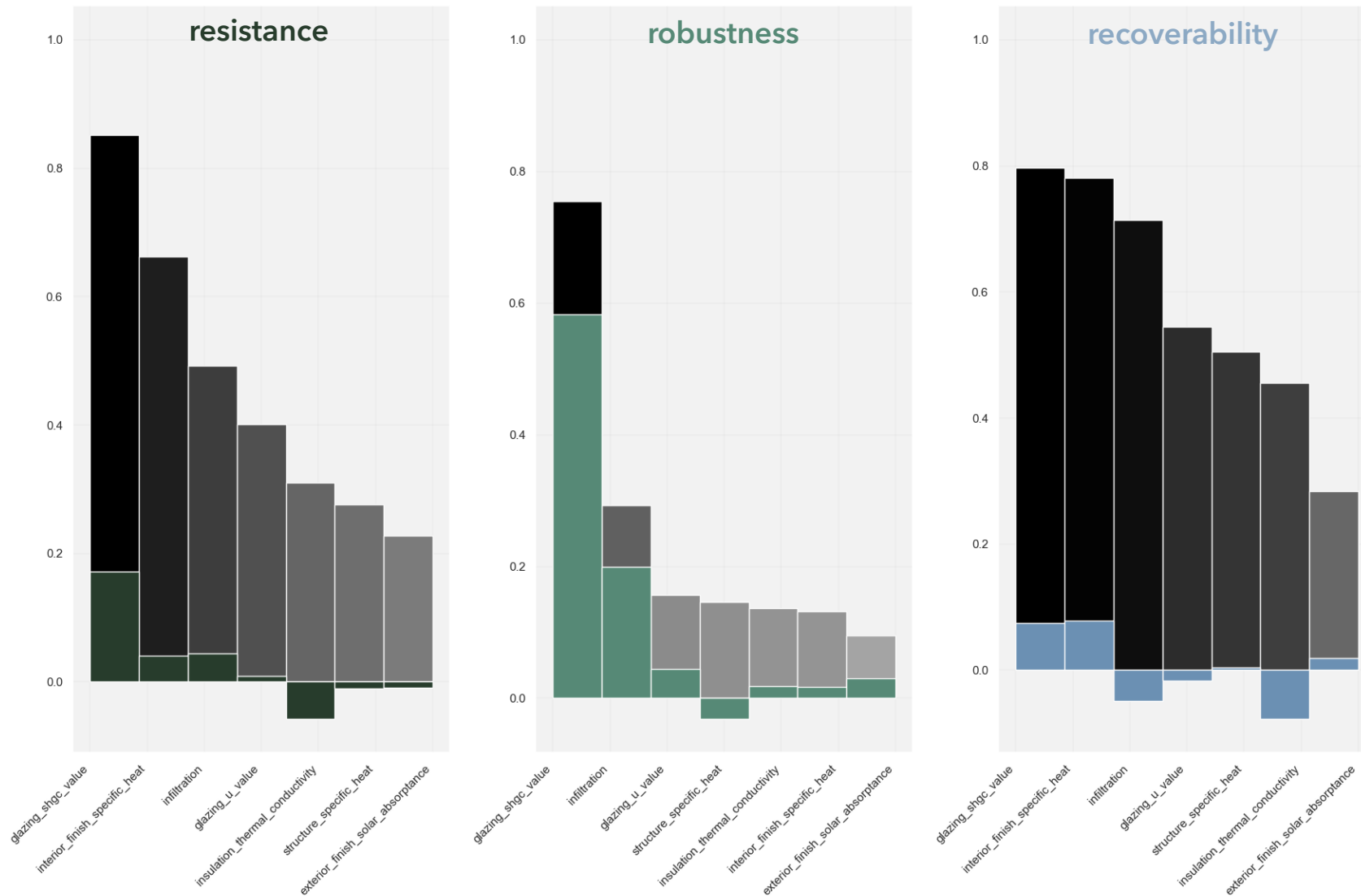

# Sensitivity analysis outcome

Sorted variables

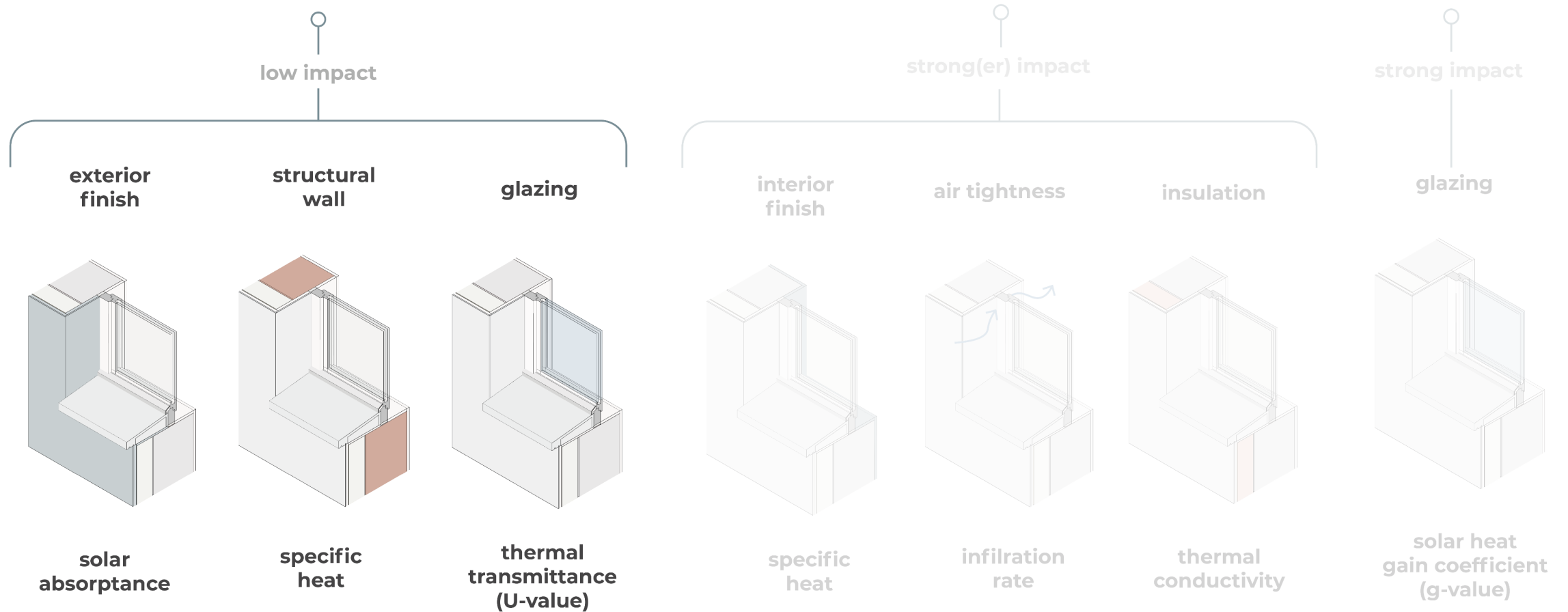

# Sensitivity analysis outcome

sorted variables

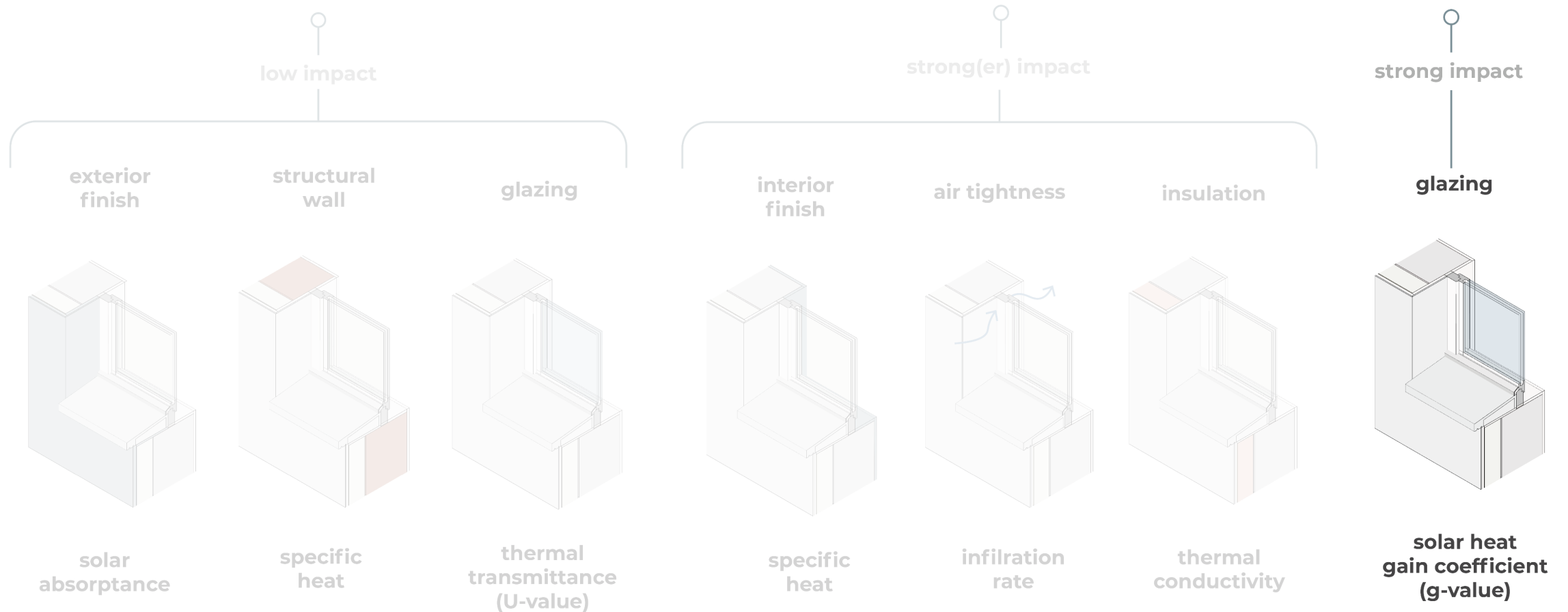

# Sensitivity analysis outcome

sorted variables

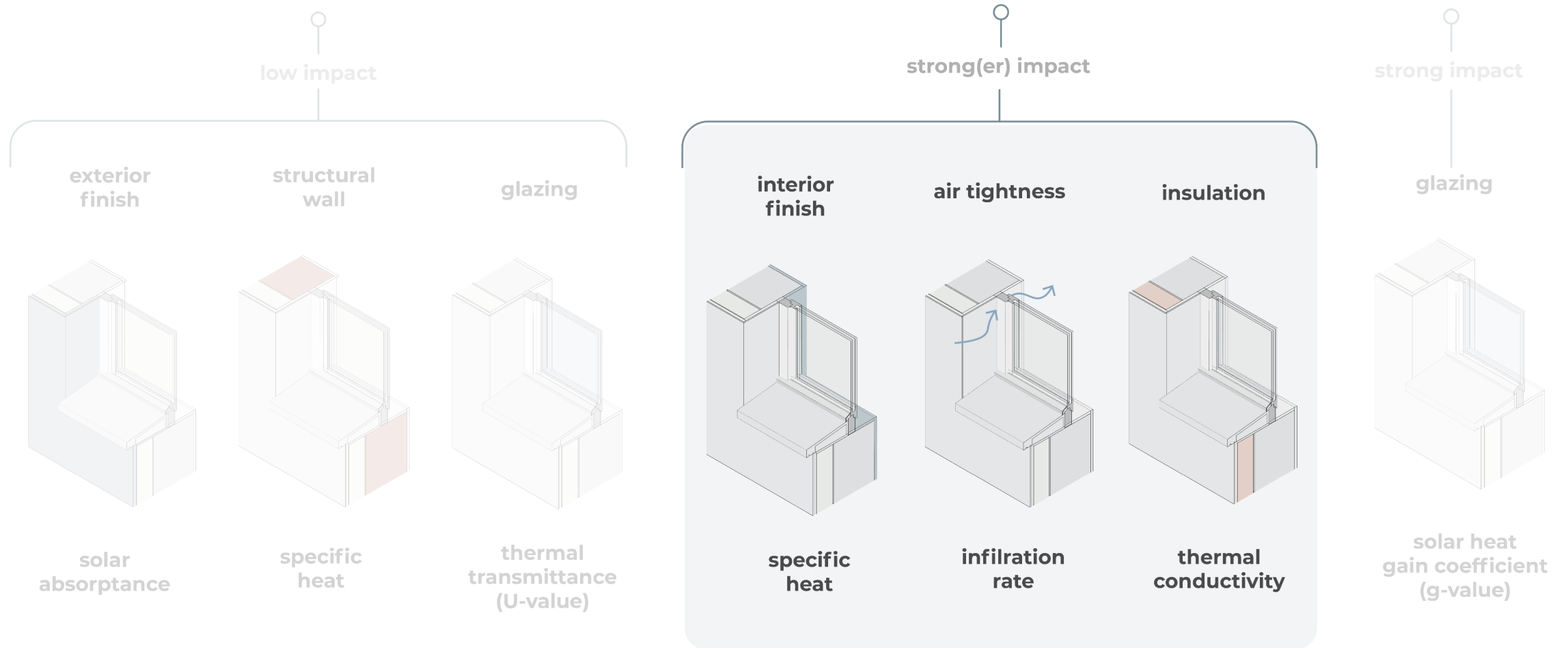

# Sensitivity analysis outcome

variables values – best performing scenarios

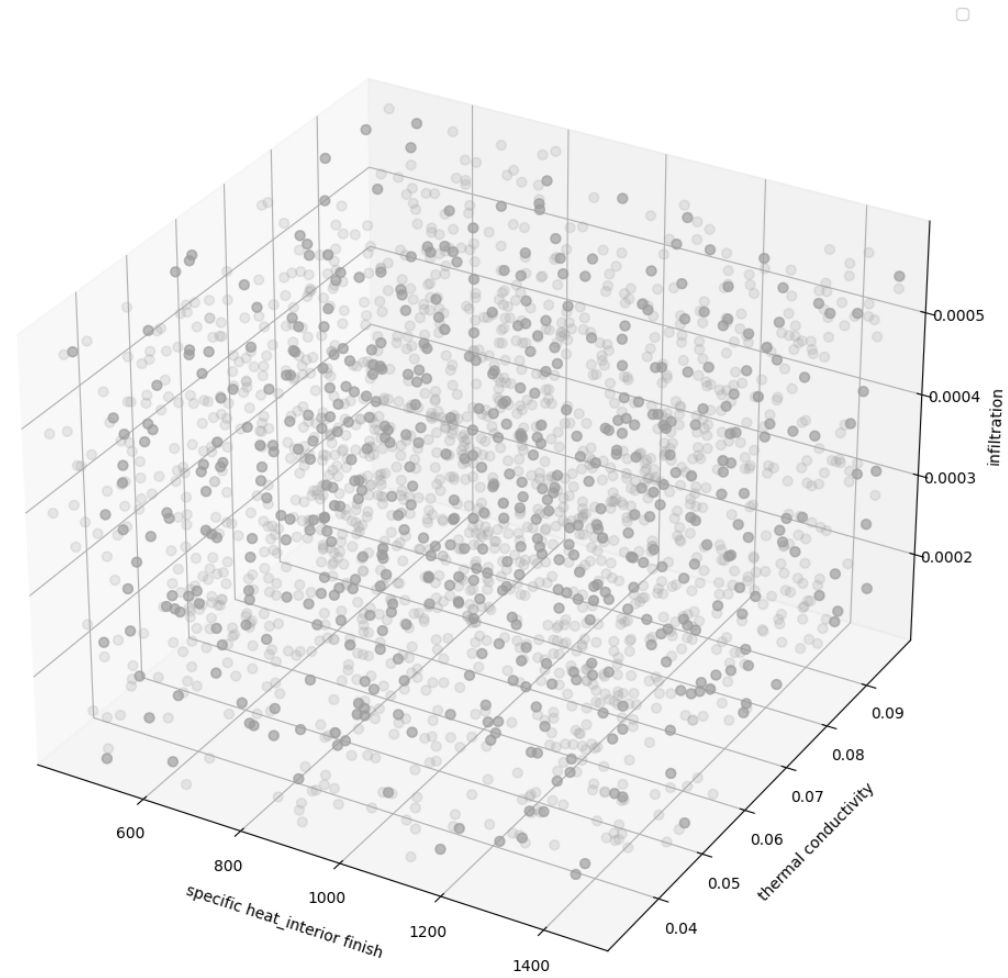

# Sensitivity analysis outcome

variables values – best performing scenarios

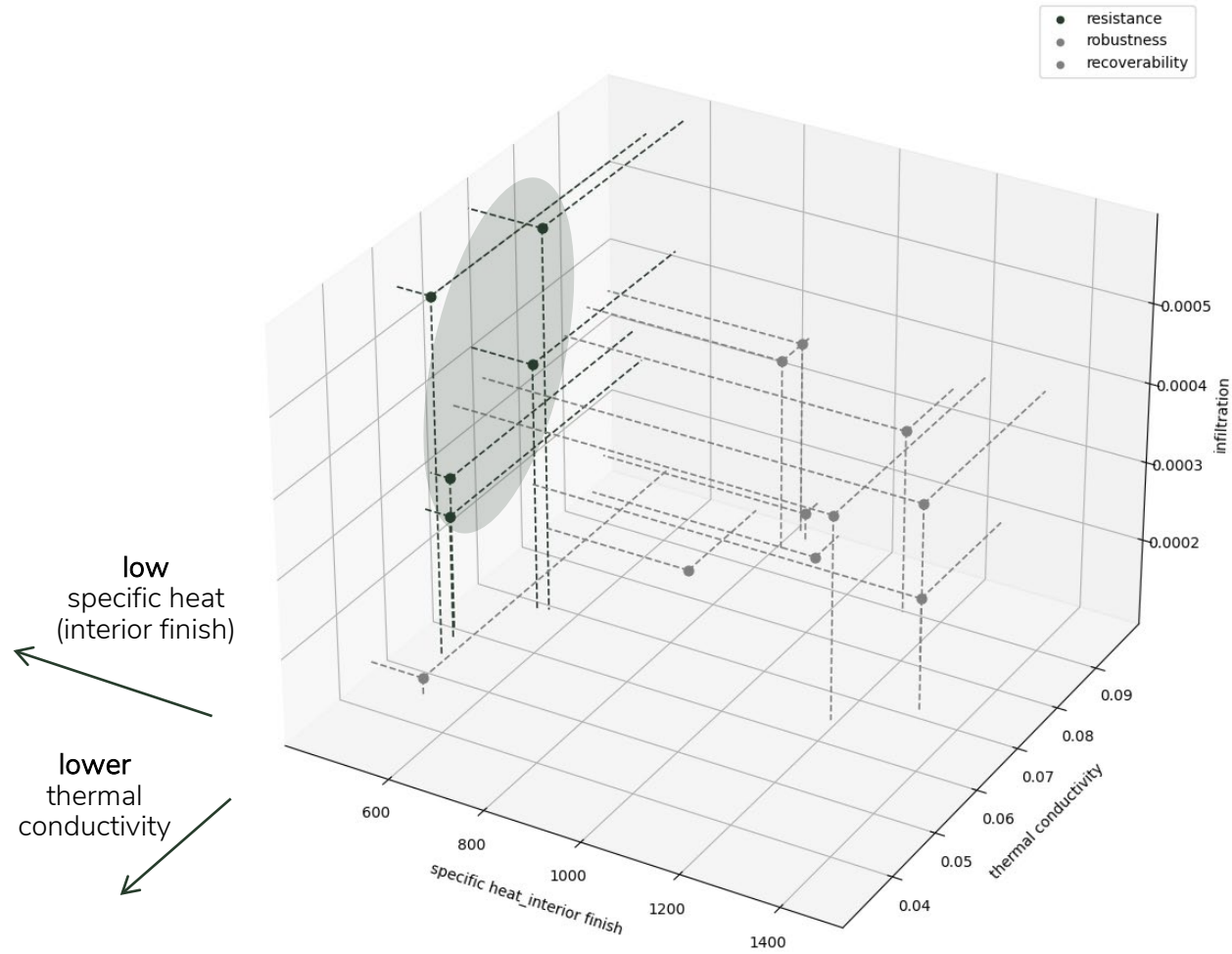

# Sensitivity analysis outcome

variables values – best performing scenarios

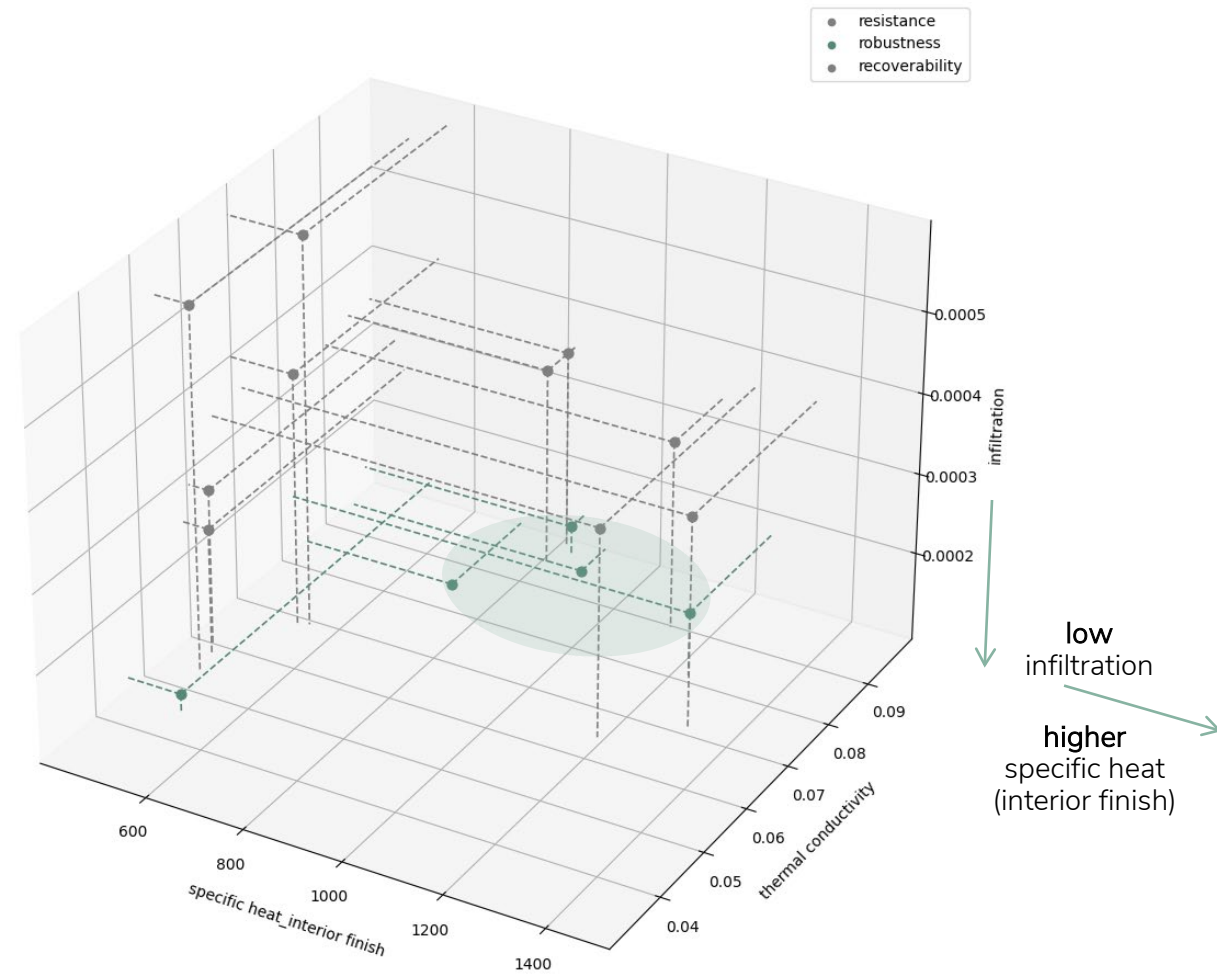

# Sensitivity analysis outcome

variables values – best performing scenarios

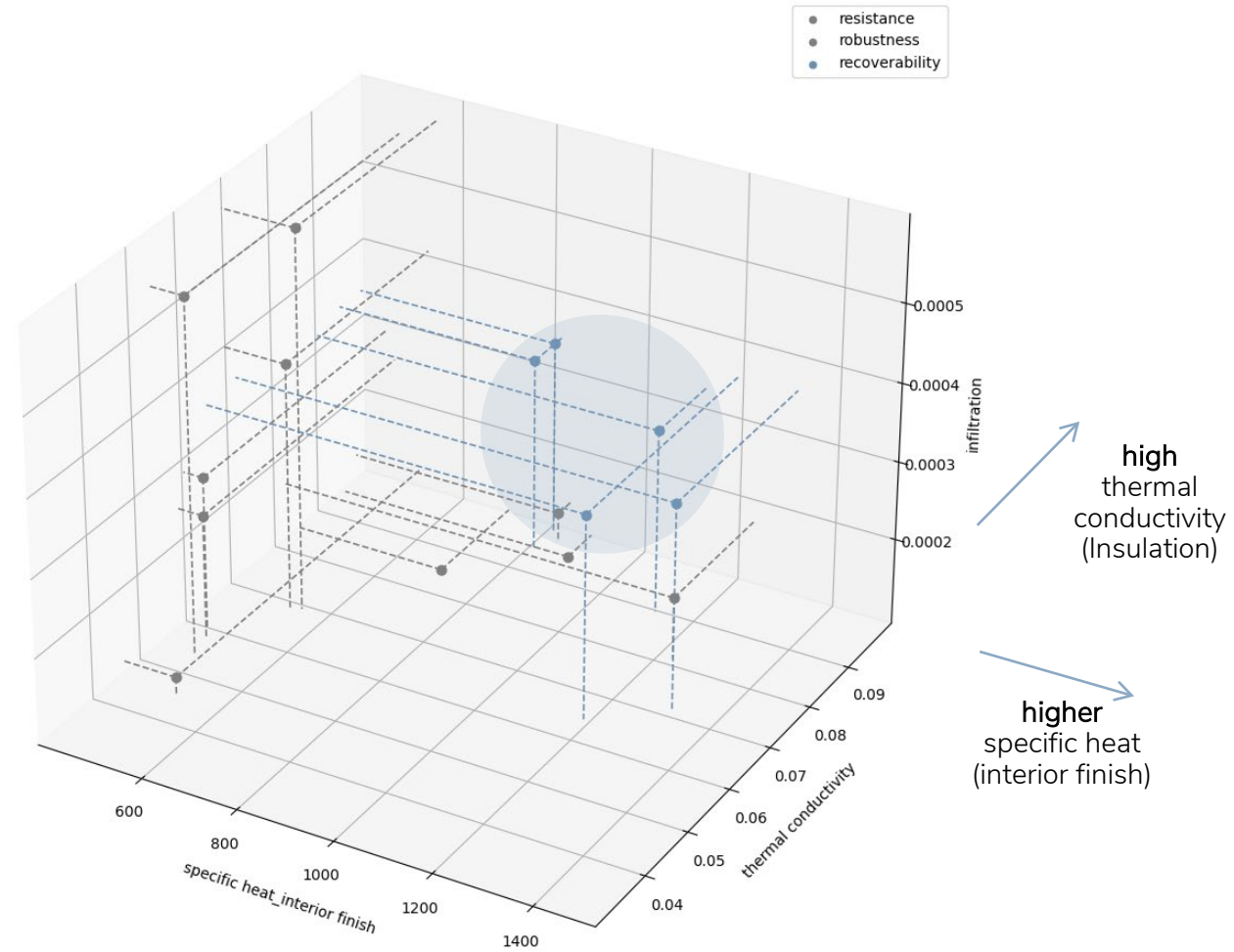

# Sensitivity analysis outcome

Variable values

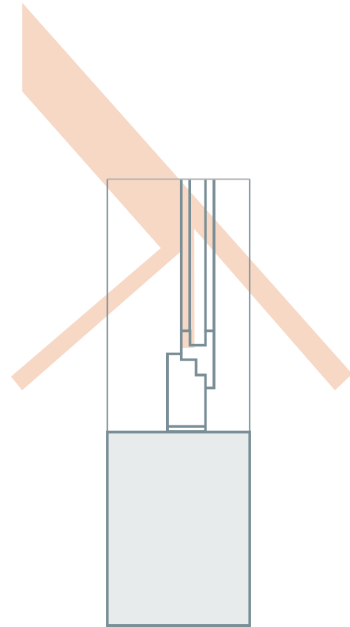

**solar heat gain coefficient**

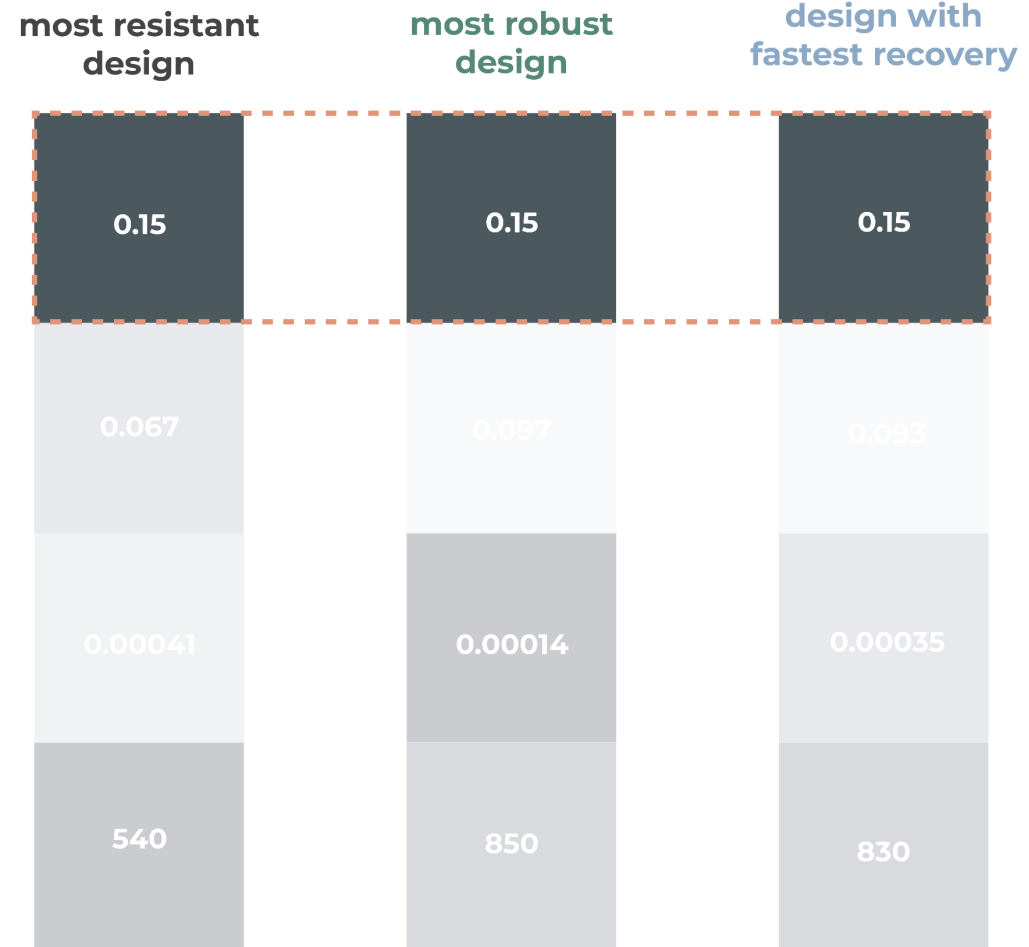

# Sensitivity analysis outcome

Variable values

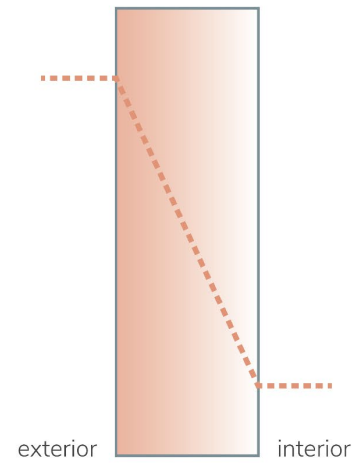

**thermal conductivity**

**most resistant design**

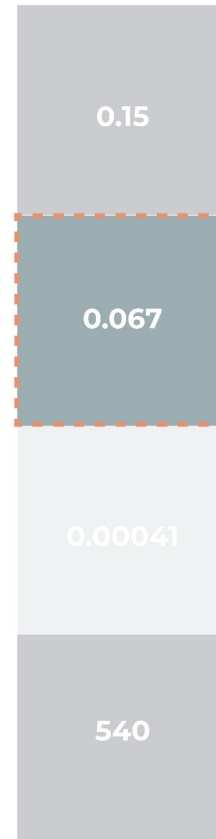

**most robust design**

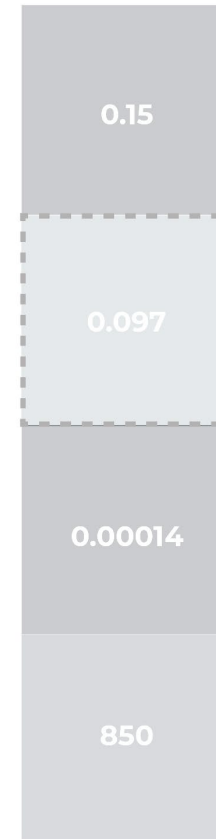

**design with fastest recovery**

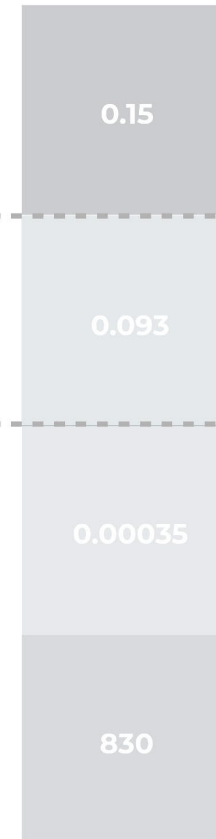

# Sensitivity analysis outcome

Variable values

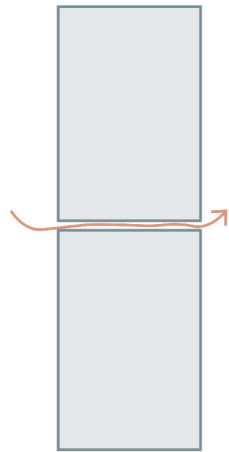

**infiltration**

**most resistant design**

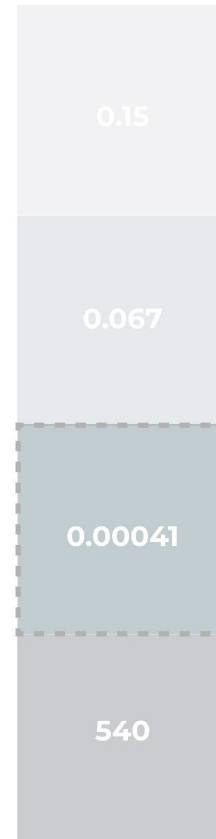

**most robust design**



**design with fastest recovery**



# Sensitivity analysis outcome

Variable values

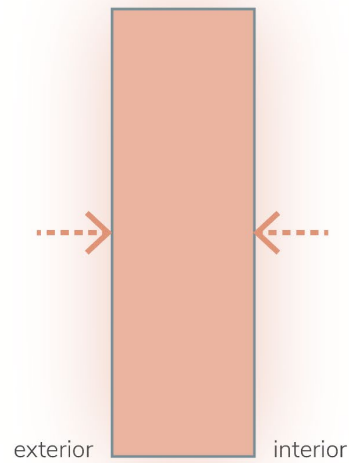

**specific heat**

**most resistant design**

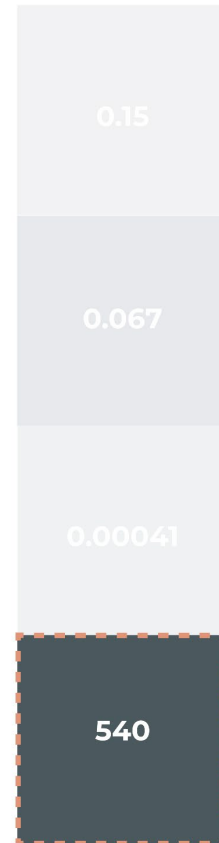

**most robust design**

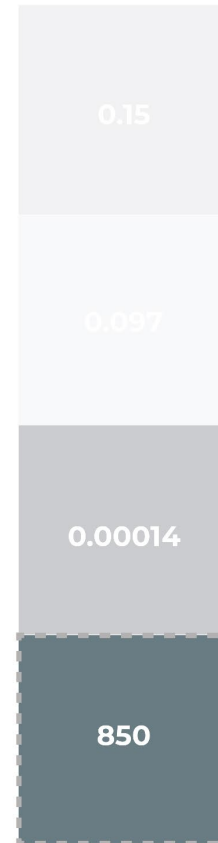

**design with fastest recovery**

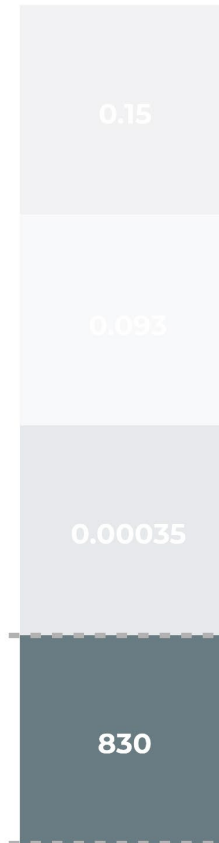

# Sensitivity analysis outcome

performance per resilience index

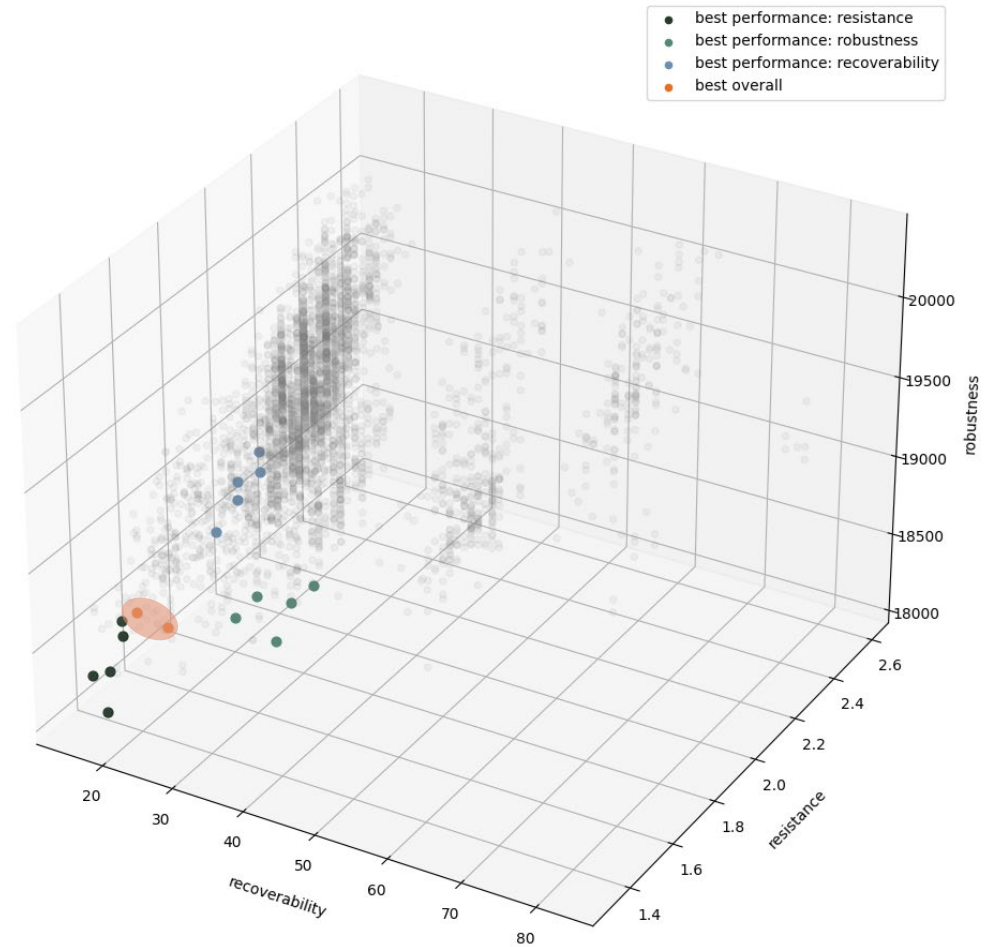

# Sensitivity analysis outcome

variables sensitivities – direct impact

resistance



robustness



recoverability

# Sensitivity analysis outcome

variables sensitivities – direct impact



# Sensitivity analysis outcome

variables sensitivities – direct impact

overall best performing

=

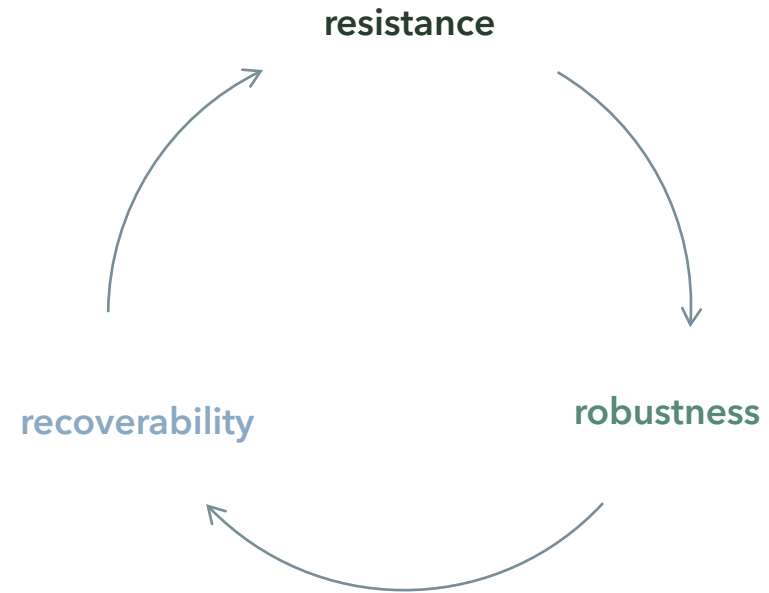

- literature review 1
- definition of resilience indicators 2
- development of simulation methodology 3
- simulation set up and definition of case study 4
- sensitivity analysis 5
- postprocessing 6
- final evaluation 7
- design 8
- conclusion 9



# Final evaluation

Future resilience index

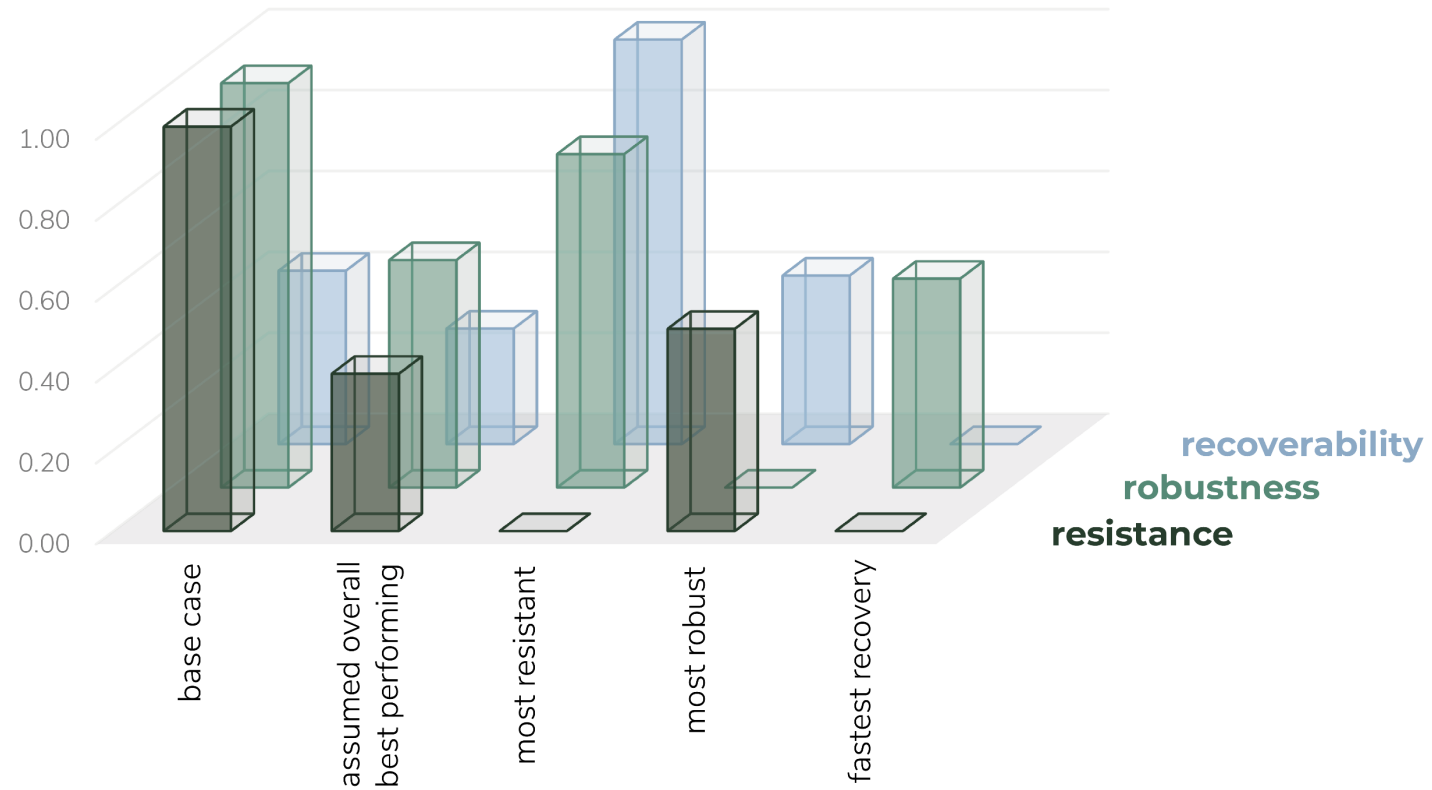

# Final evaluation

Future resilience index

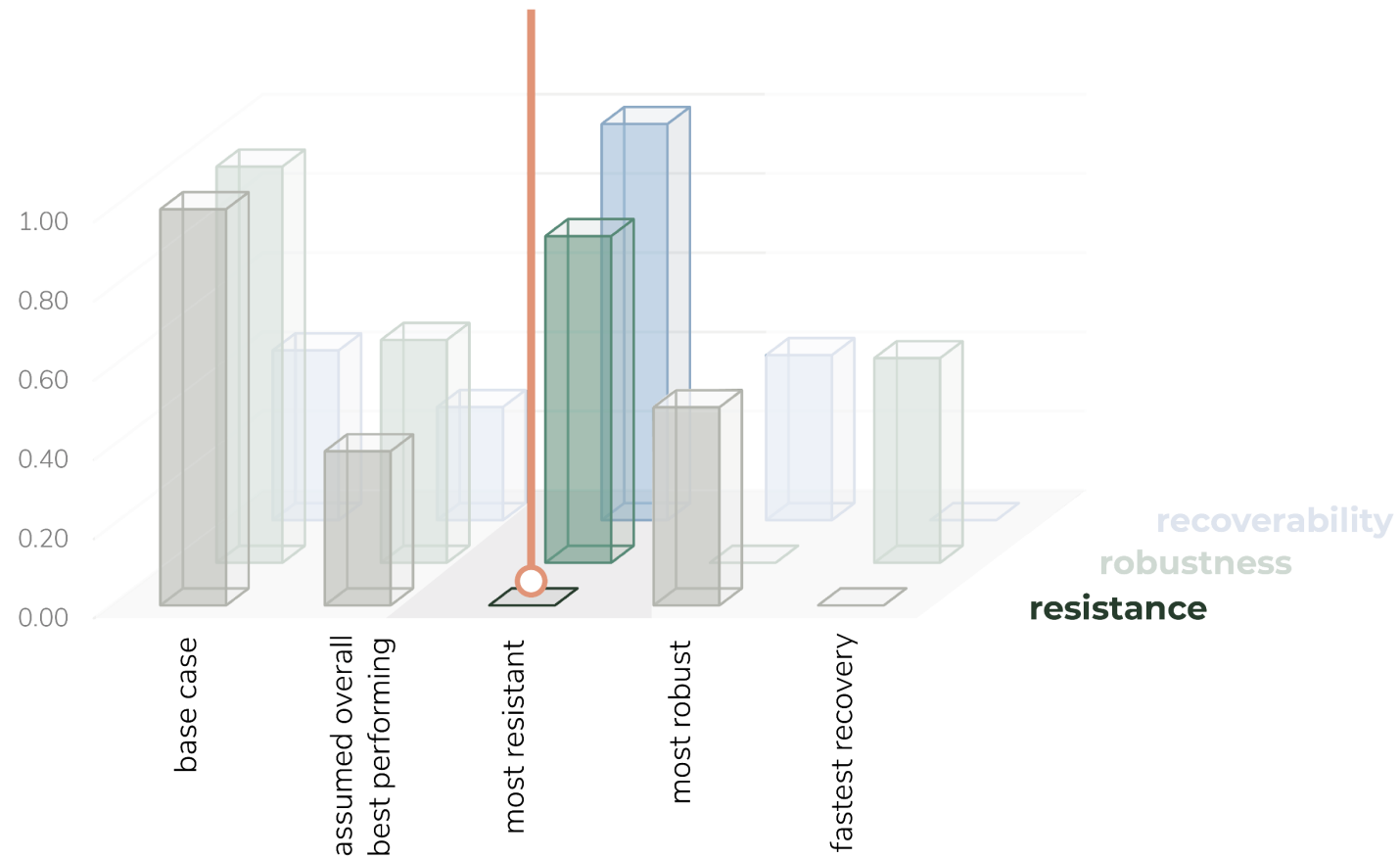

# Final evaluation

Future resilience index

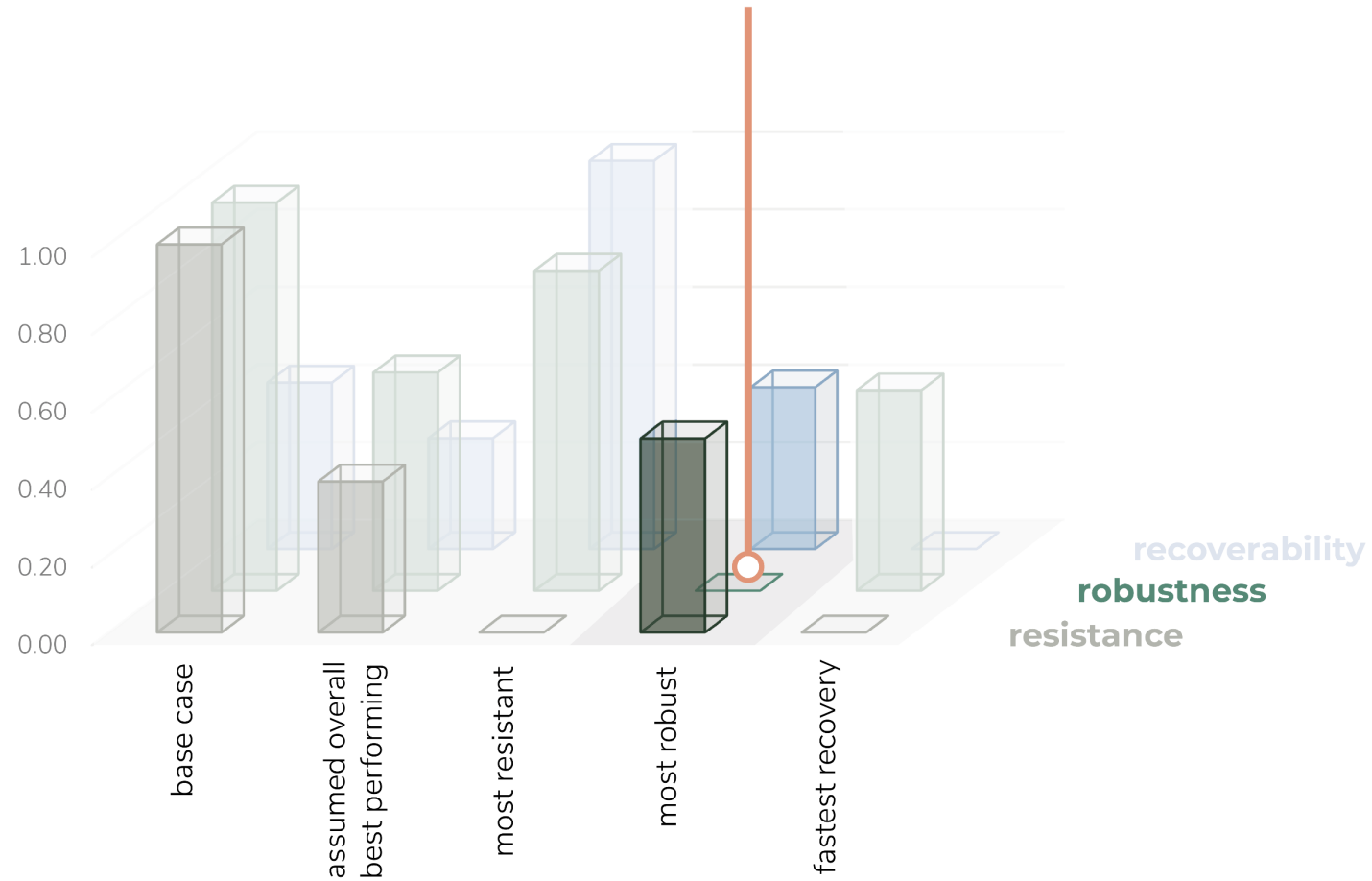

# Final evaluation

Future resilience index

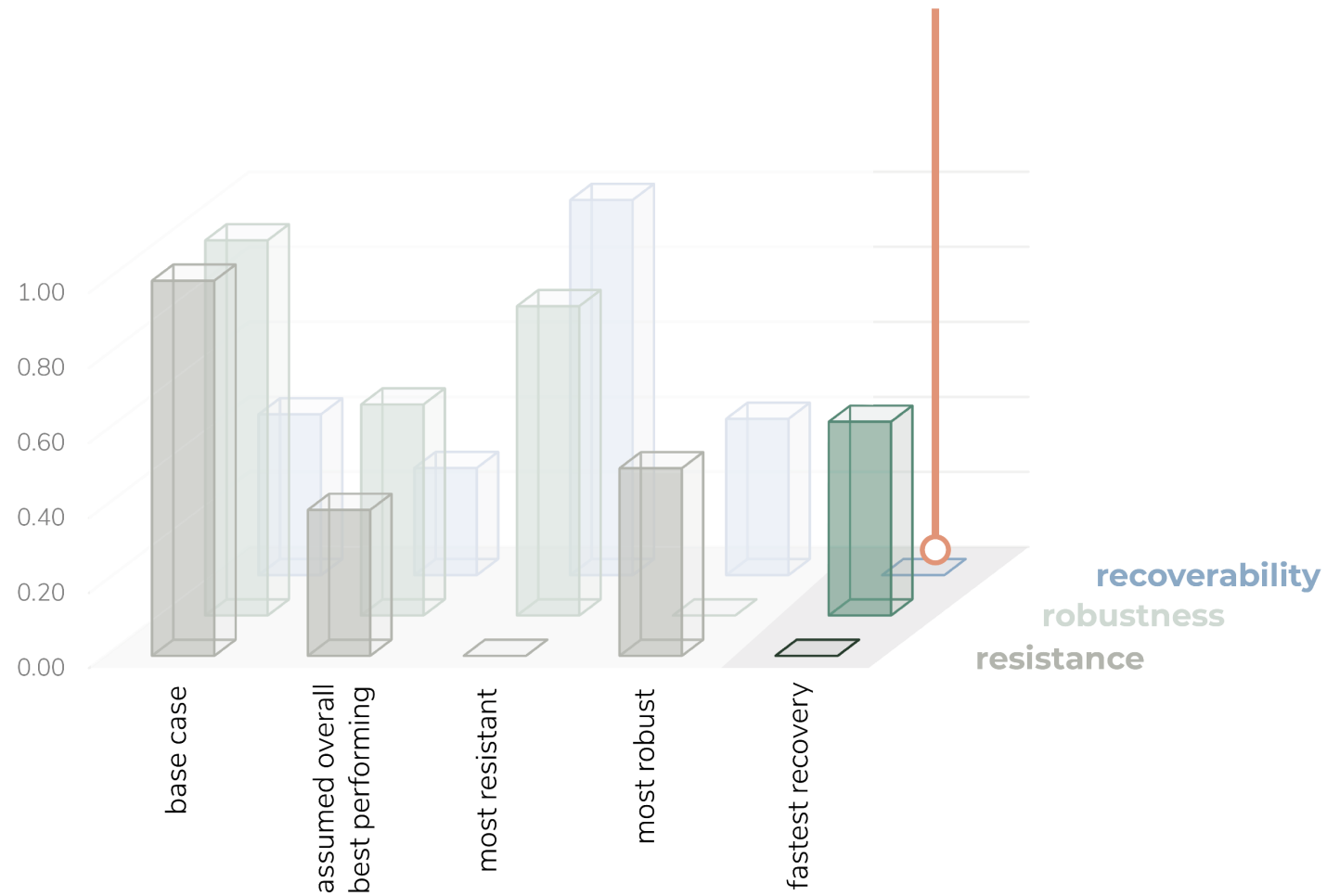

# Final evaluation

SET hourly data – performance

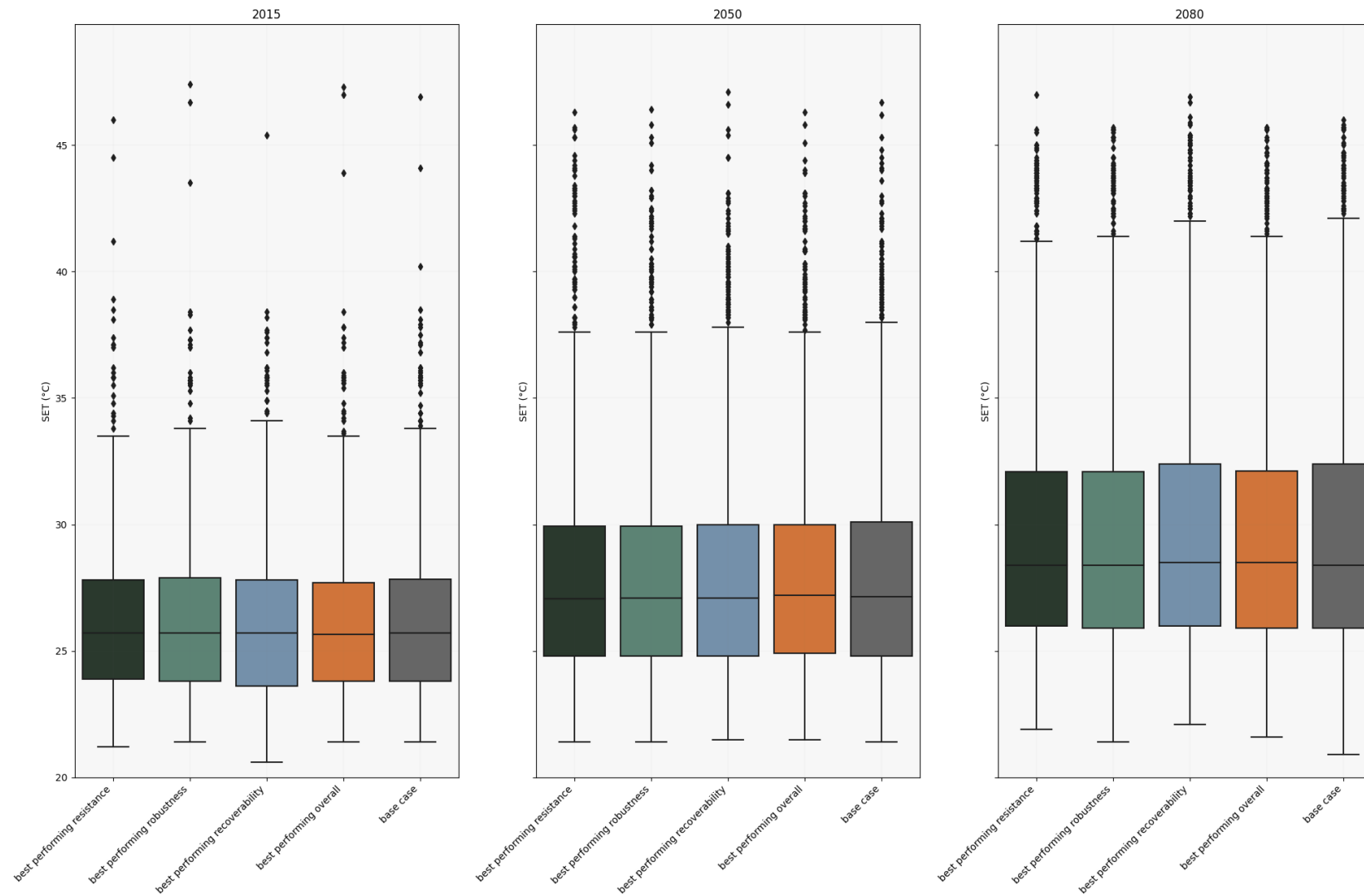

# Final evaluation

SET hourly data – performance

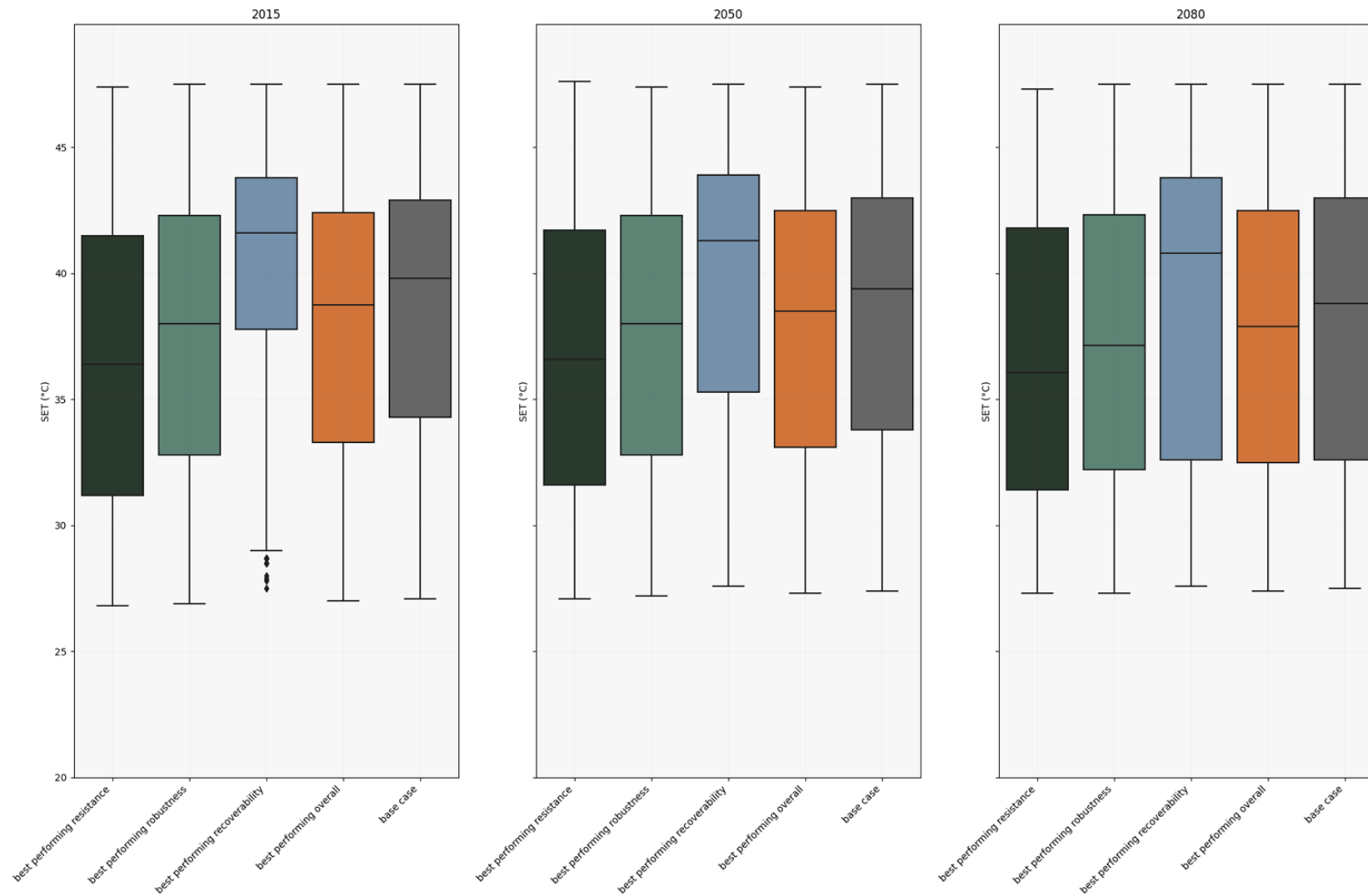

# Final design

recommendations

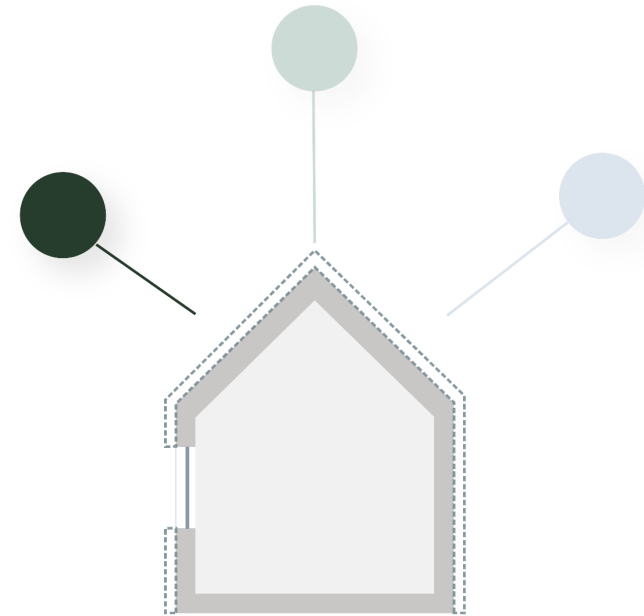
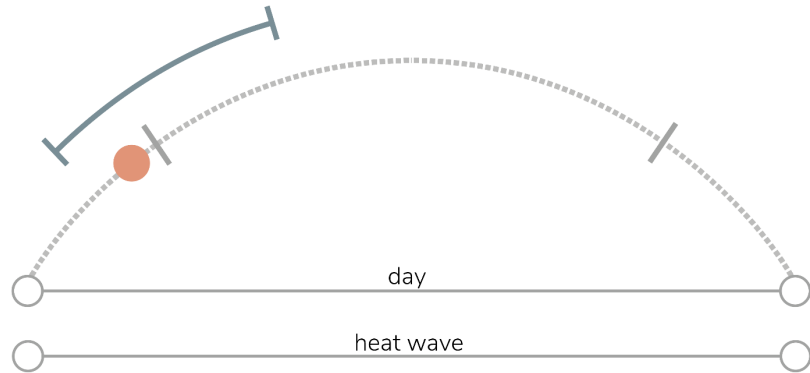

**resistance**  
robustness  
recoverability

# Final design

recommendations

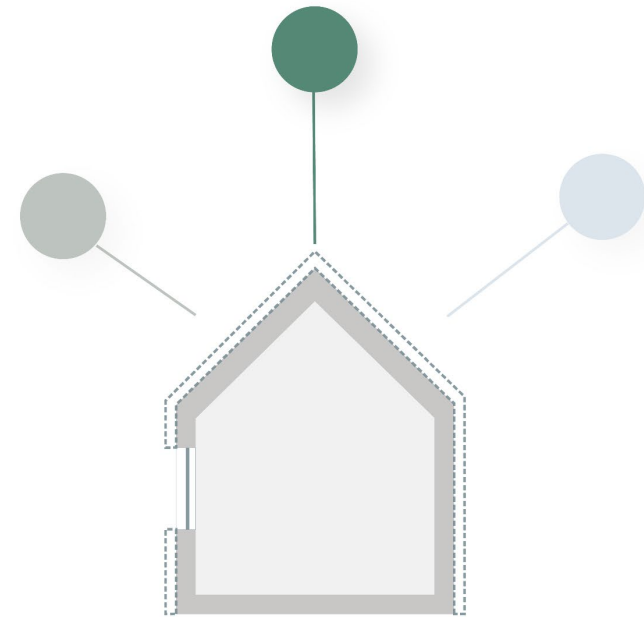
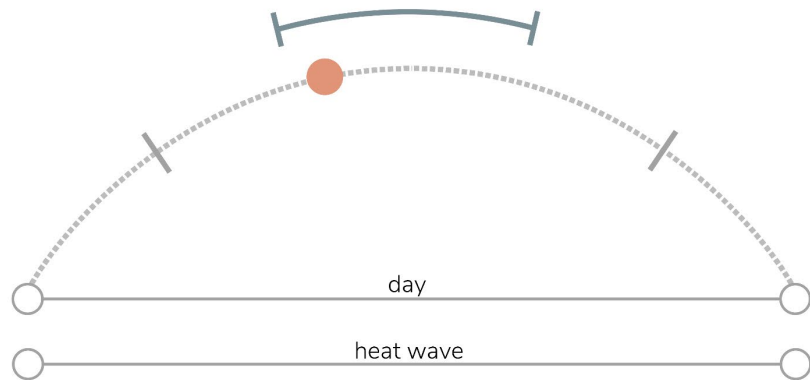

resistance  
**robustness**  
recoverability

# Final design

recommendations

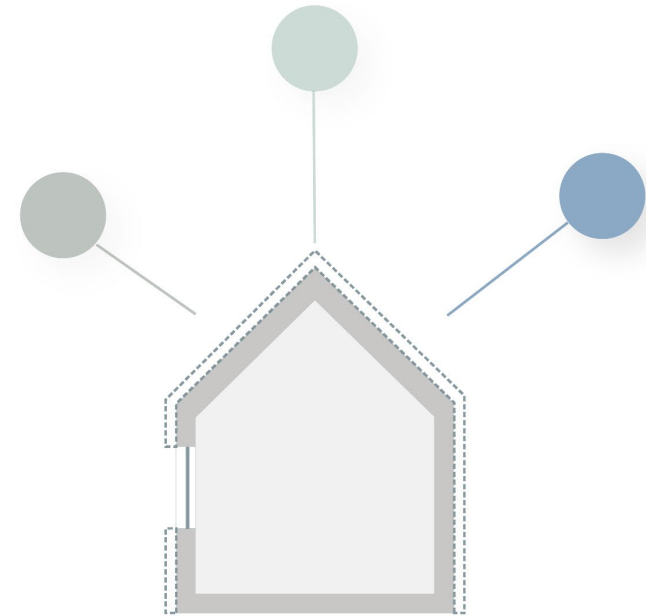
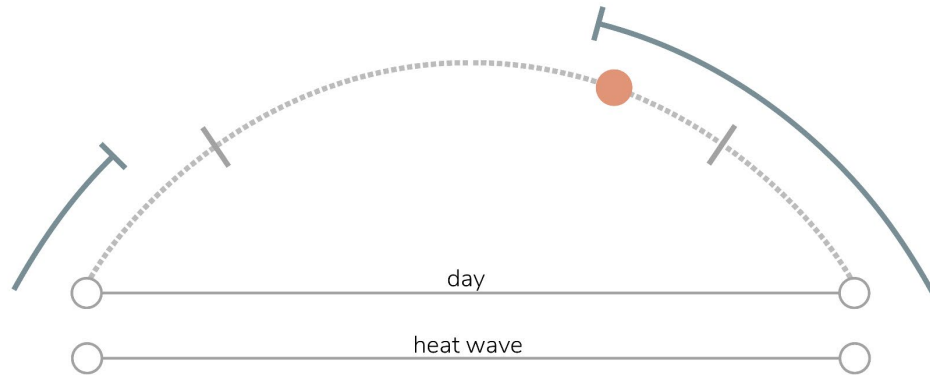

resistance  
robustness  
recoverability

# Final design

phase change material

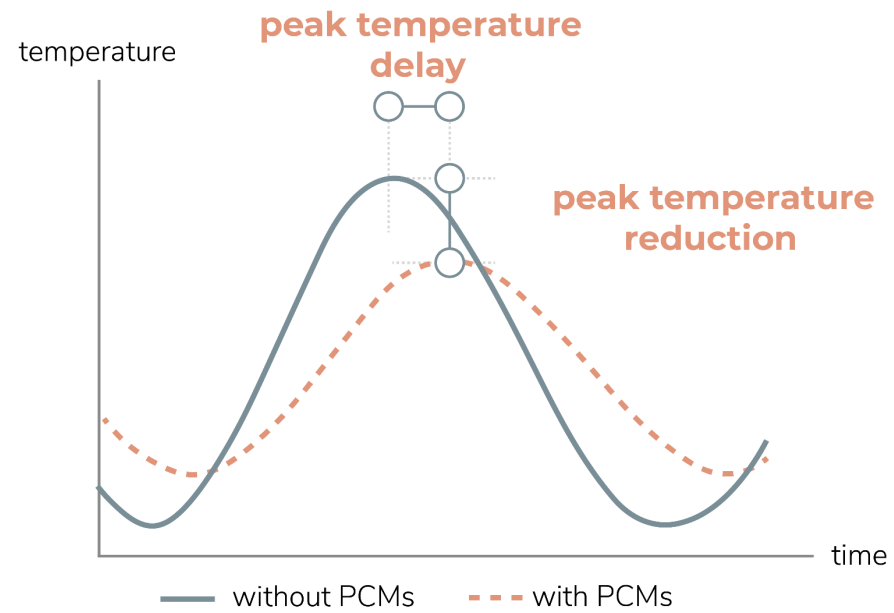

- literature review 1
- definition of resilience indicators 2
- development of simulation methodology 3
- simulation set up and definition of case study 4
- sensitivity analysis 5
- postprocessing 6
- final evaluation 7
- design 8
- conclusion 9



# Final design

recommendations

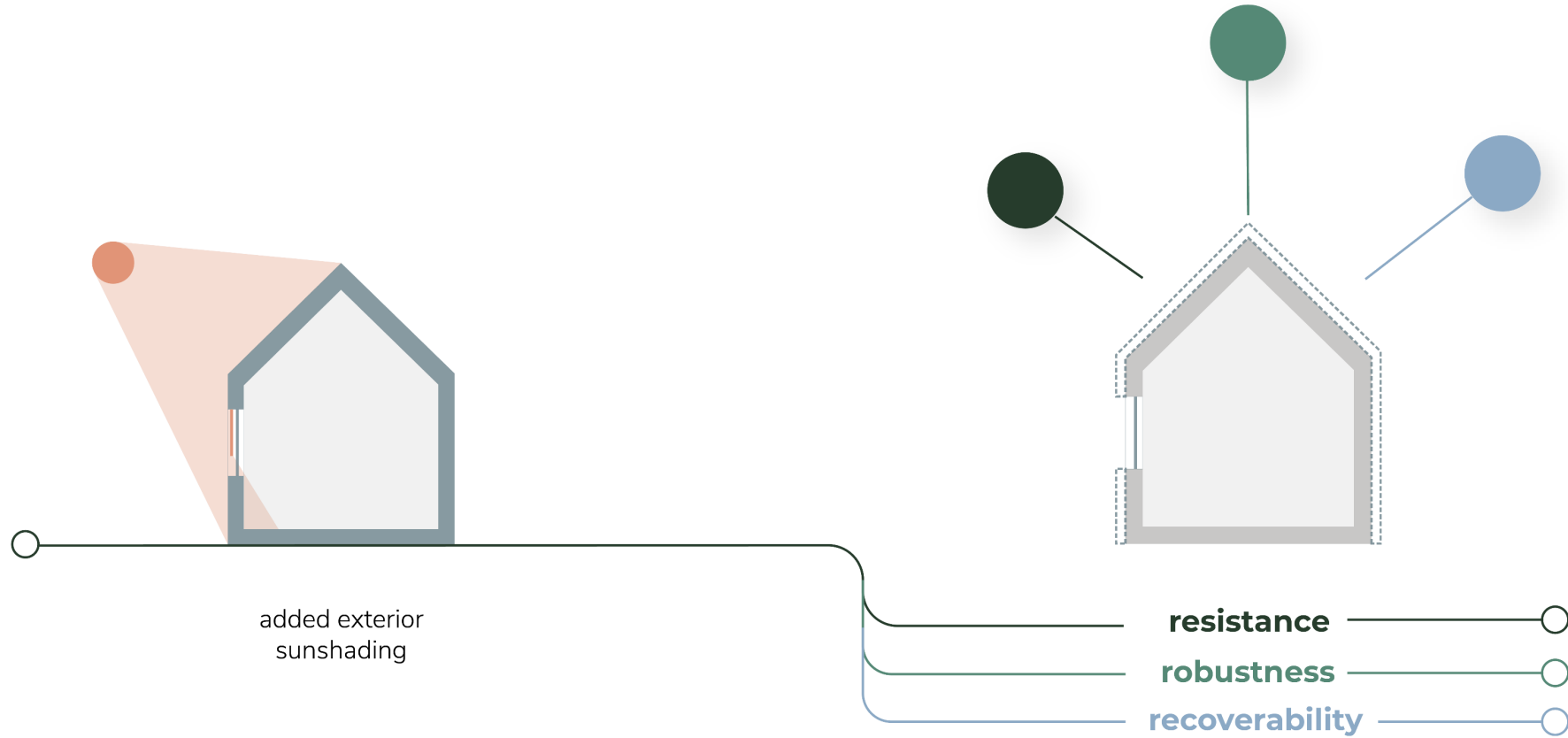

# Final design

recommendations

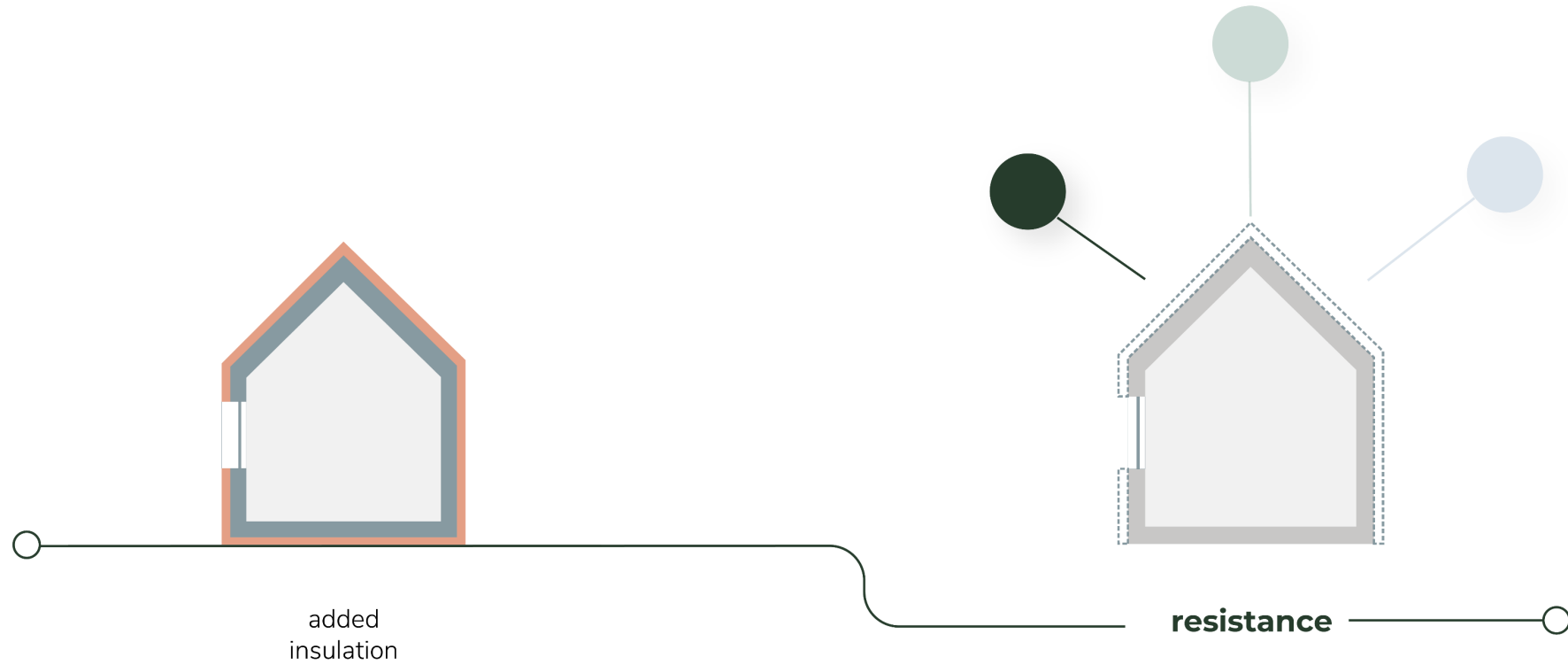

# Final design

recommendations

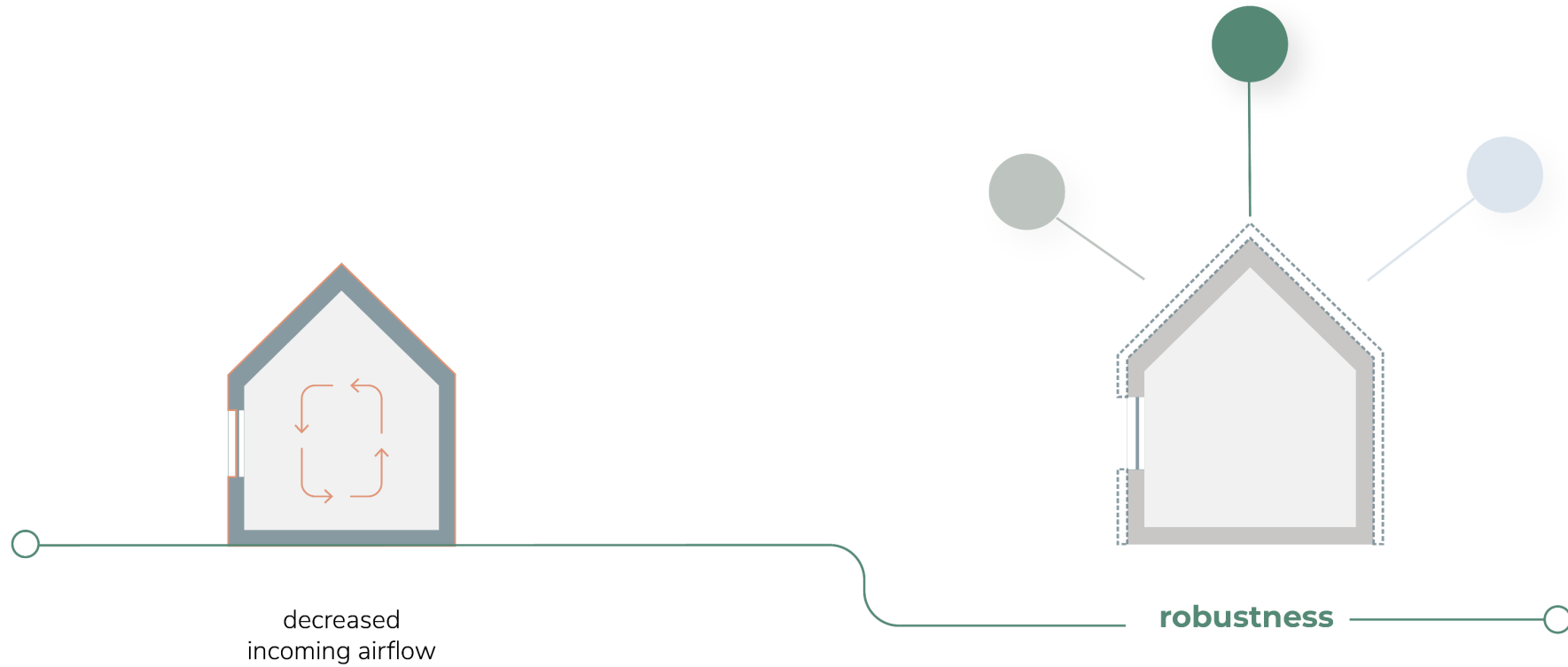

# Final design

recommendations

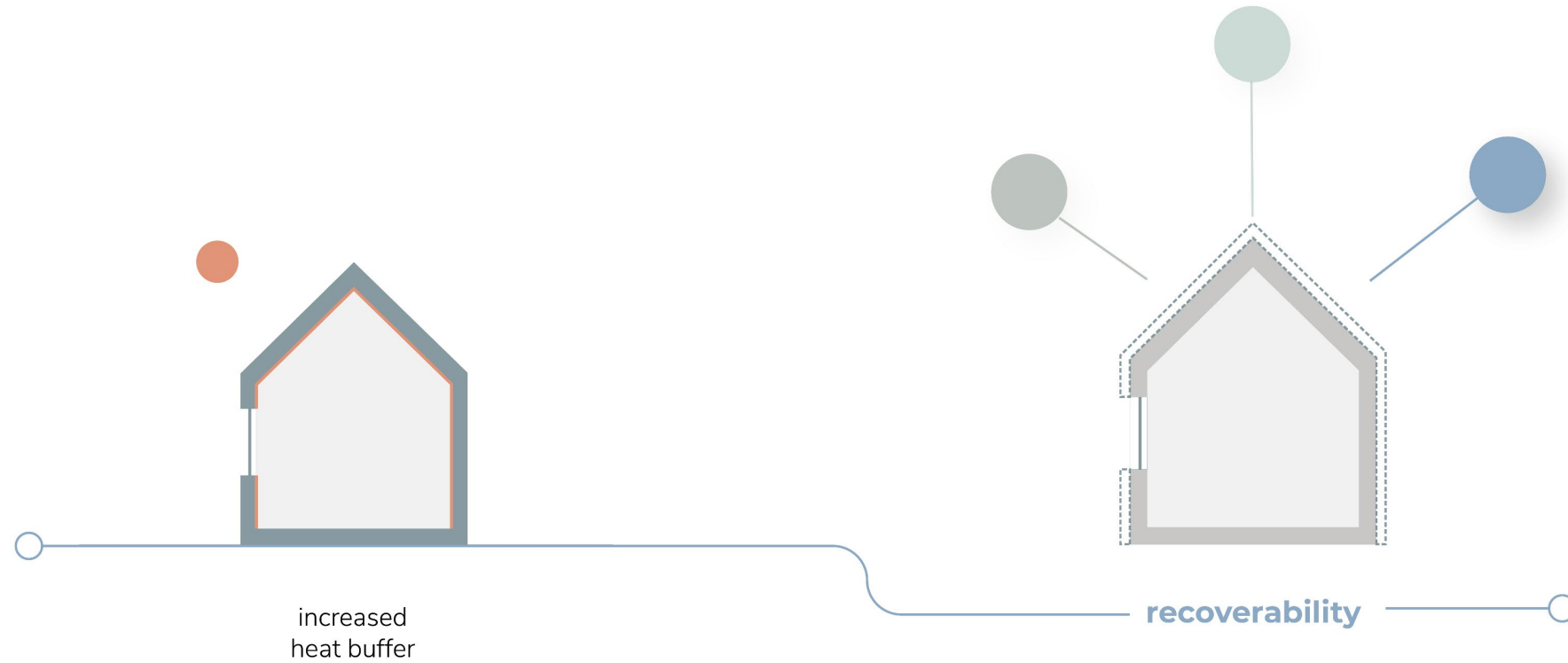

# Final design

recommendations

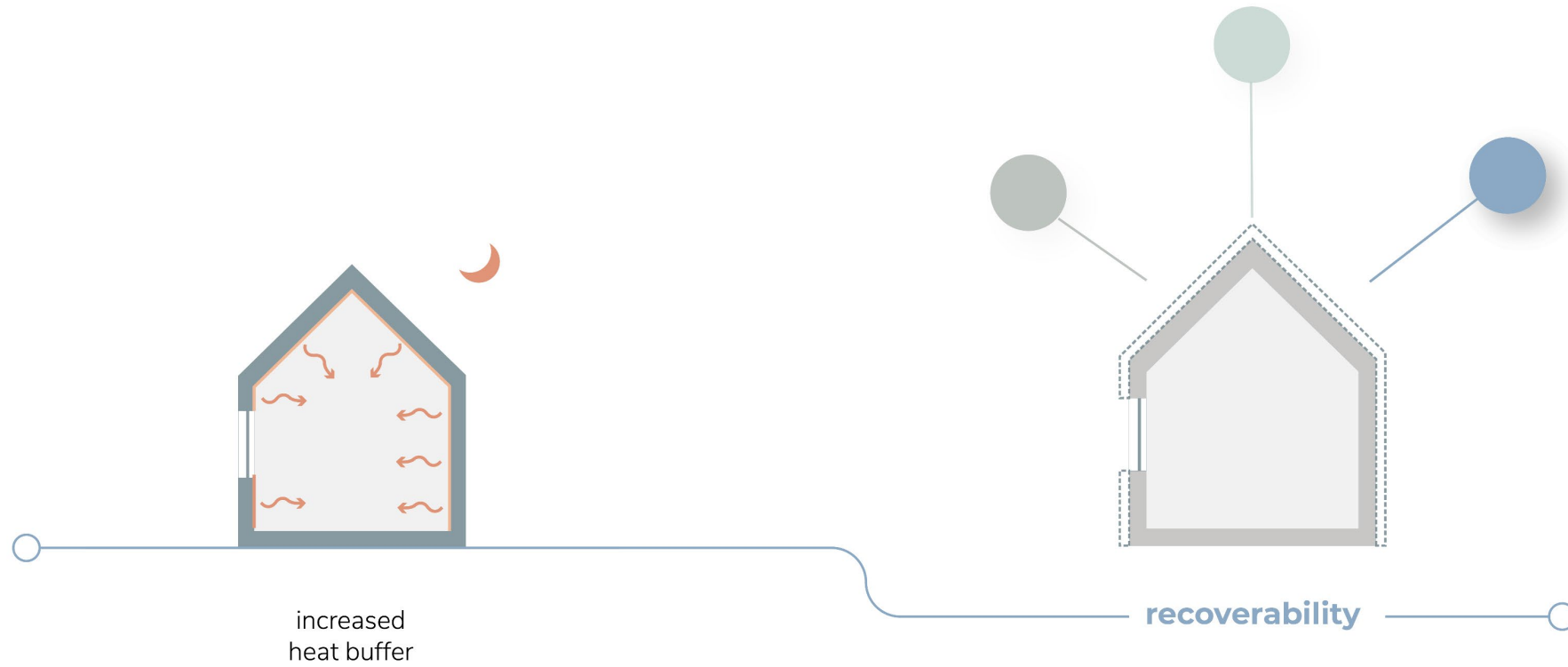

# Final design

current state vs. retrofit

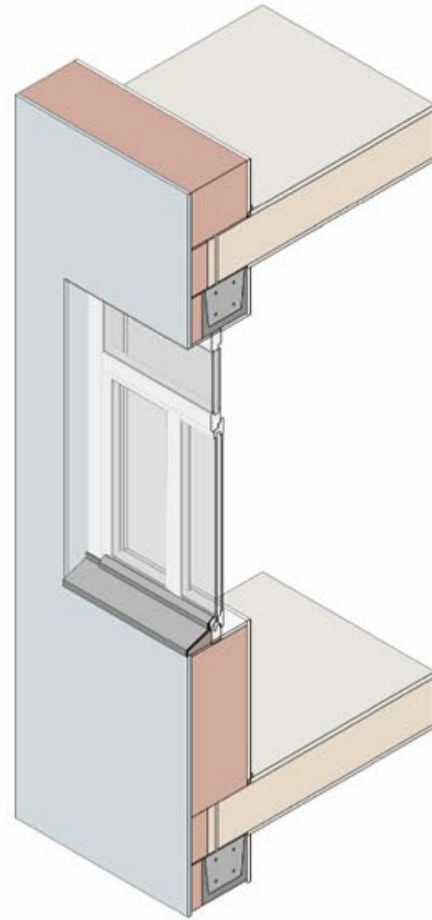

**current state**

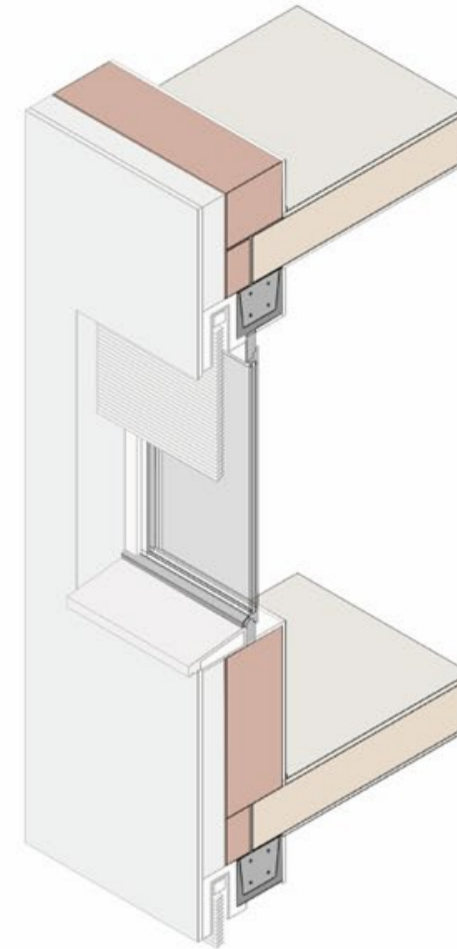

**retrofit**  
window replacement

**robustness**

# Final design

current state vs. retrofit

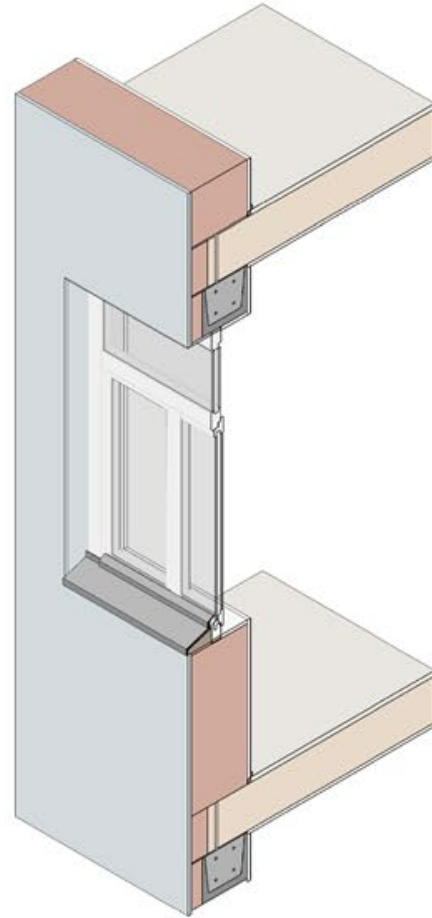

**current state**

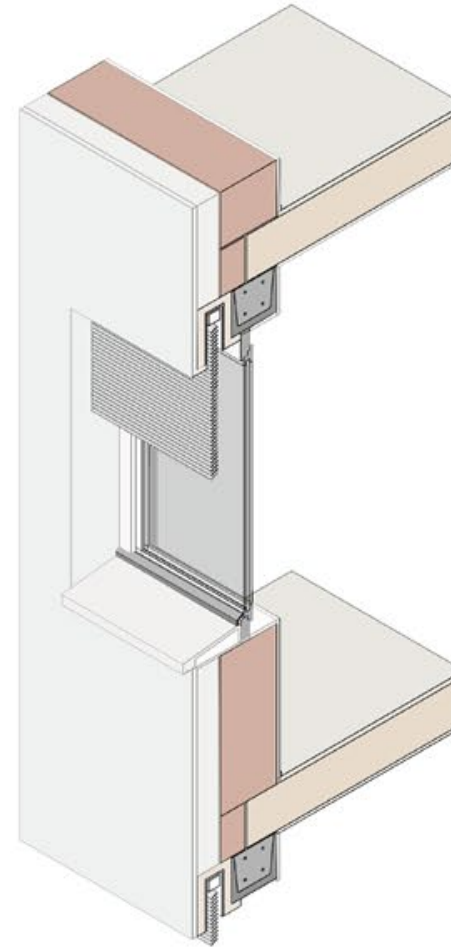

**retrofit**  
addition sunshade

**resistance**  
**robustness**  
**recoverability**

# Final design

current state vs. retrofit

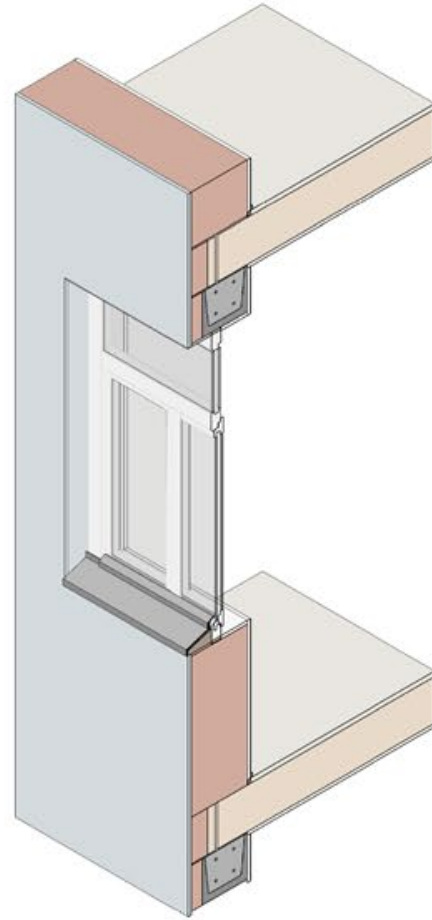

**current state**

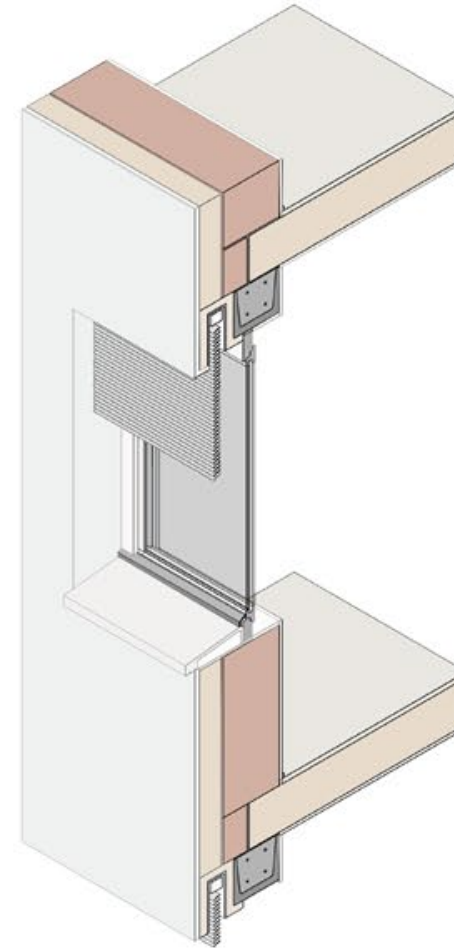

**retrofit**  
addition insulation

**resistance**

# Final design

current state vs. retrofit

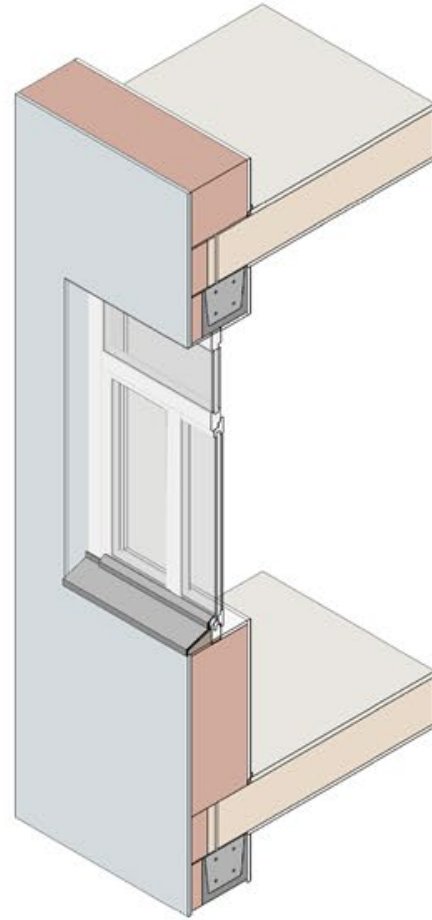

**current state**

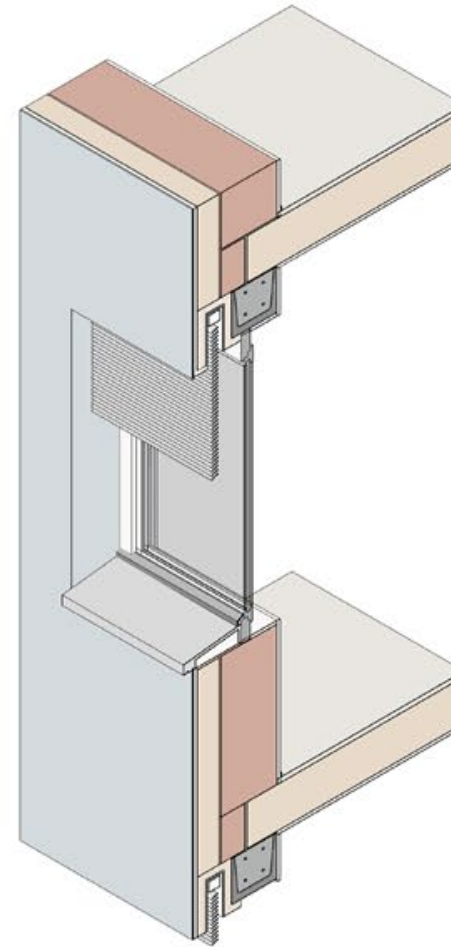

**retrofit**  
addition insulation

**recoverability**

# Final design

evaluation



# Final design

evaluation

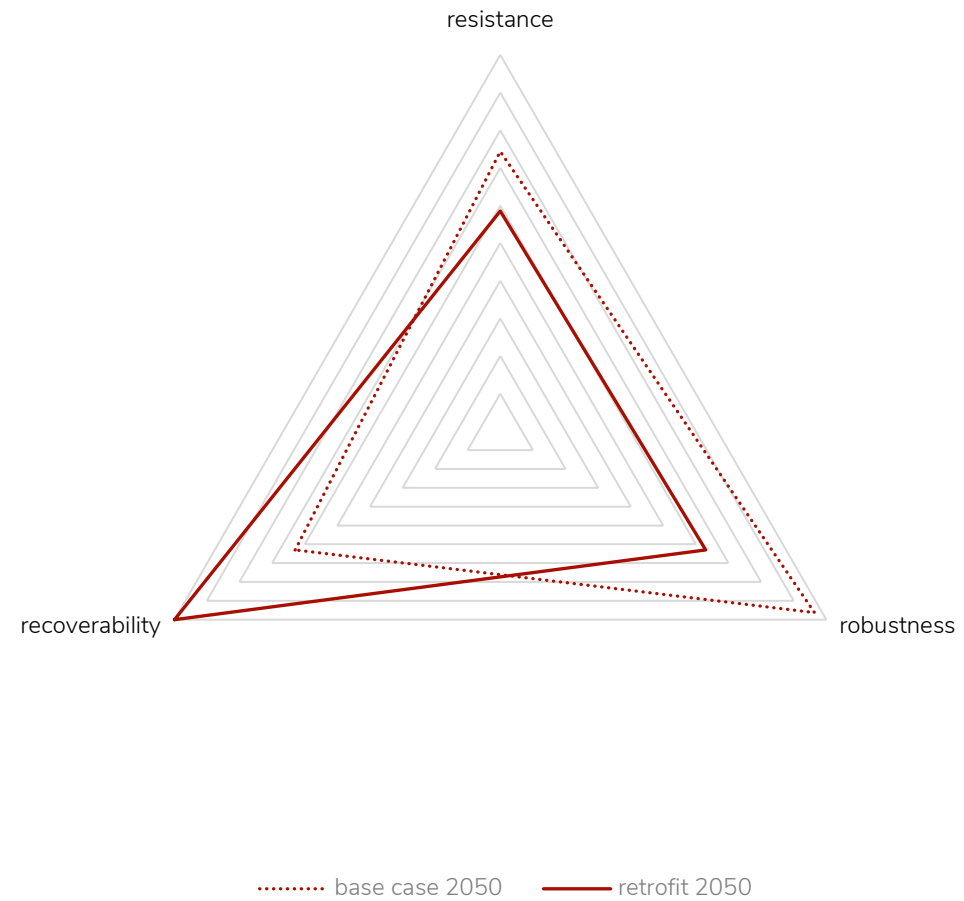

# Final design

evaluation

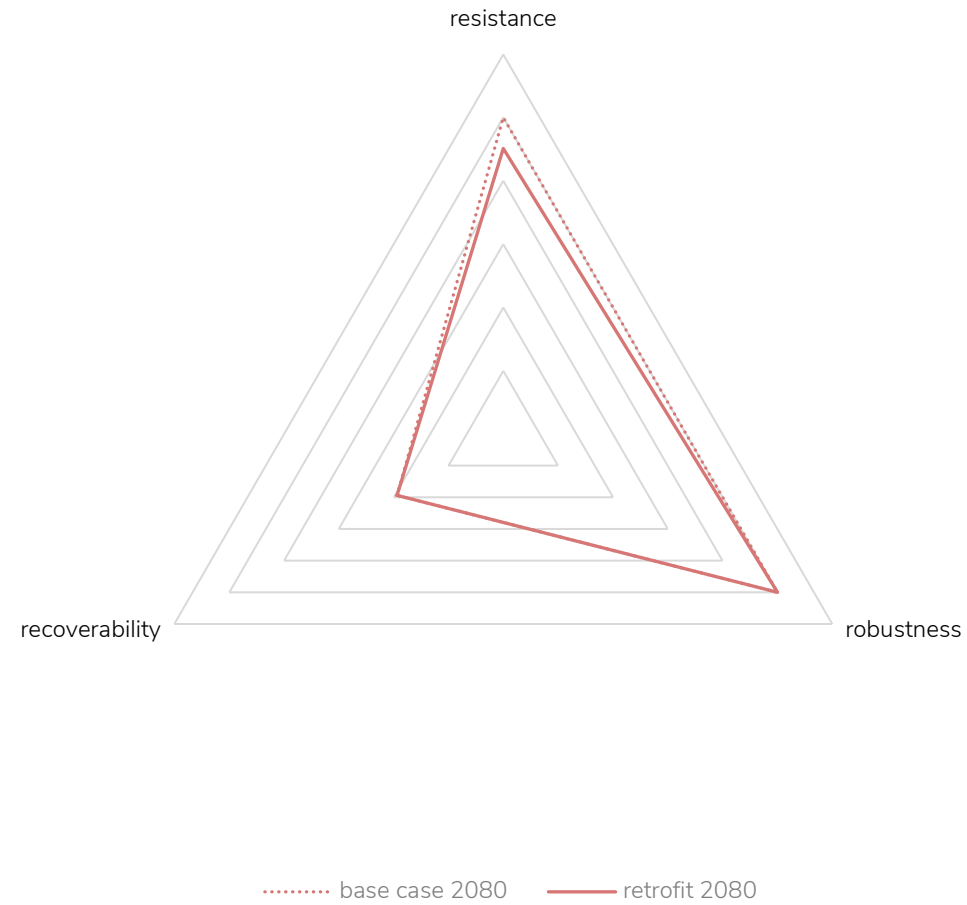

- literature review **1**
- definition of resilience indicators **2**
- development of simulation methodology **3**
- simulation set up and definition of case study **4**
- sensitivity analysis **5**
- postprocessing **6**
- final evaluation **7**
- design **8**
- conclusion **9**



# Conclusion

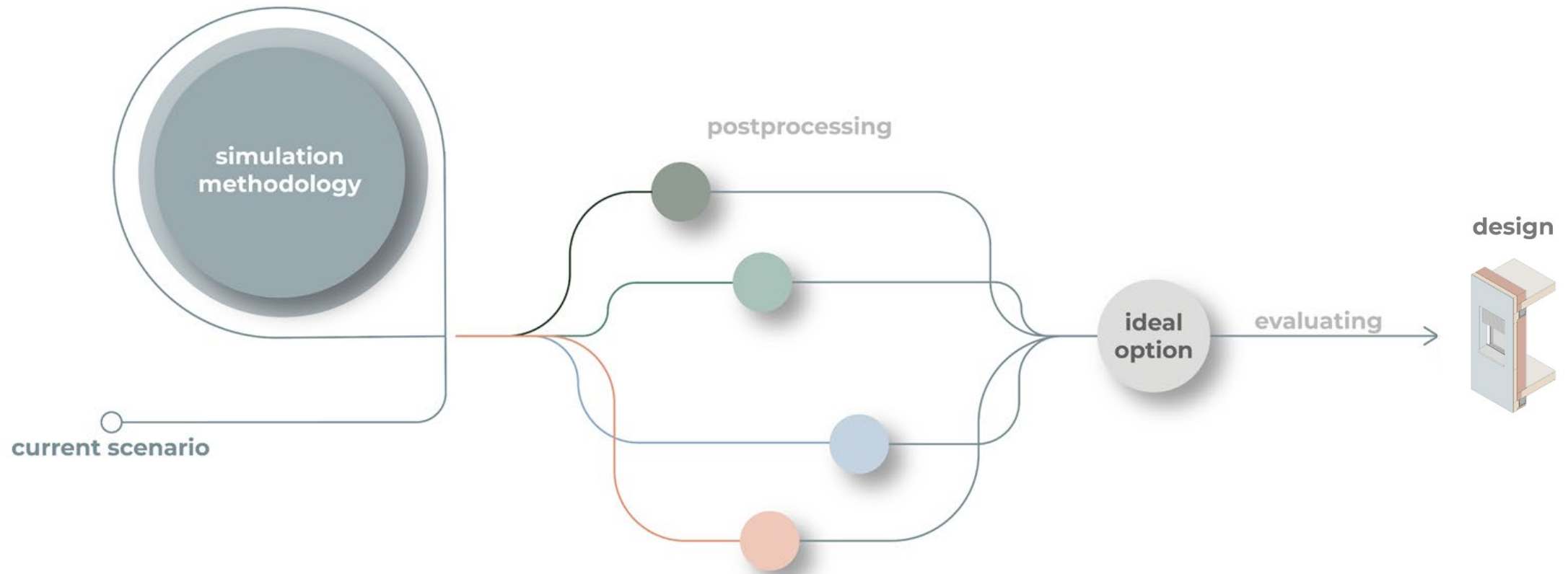

# Conclusion

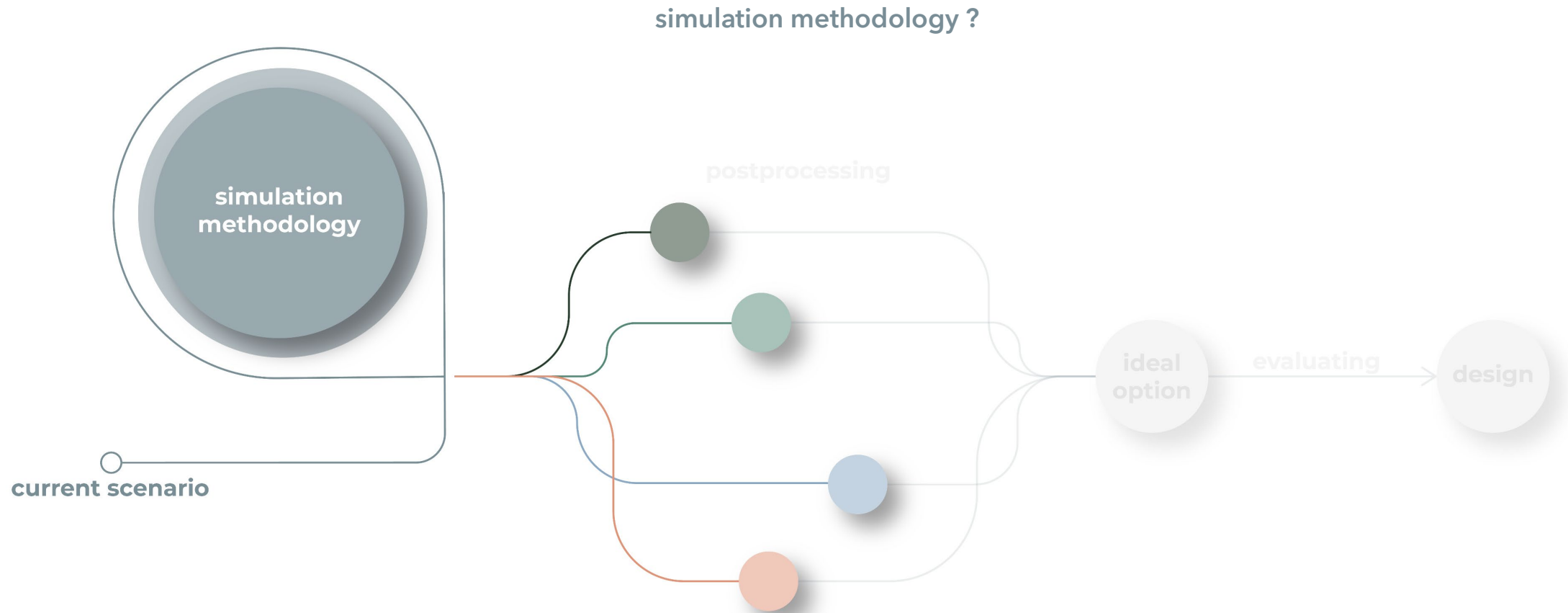

# Conclusion

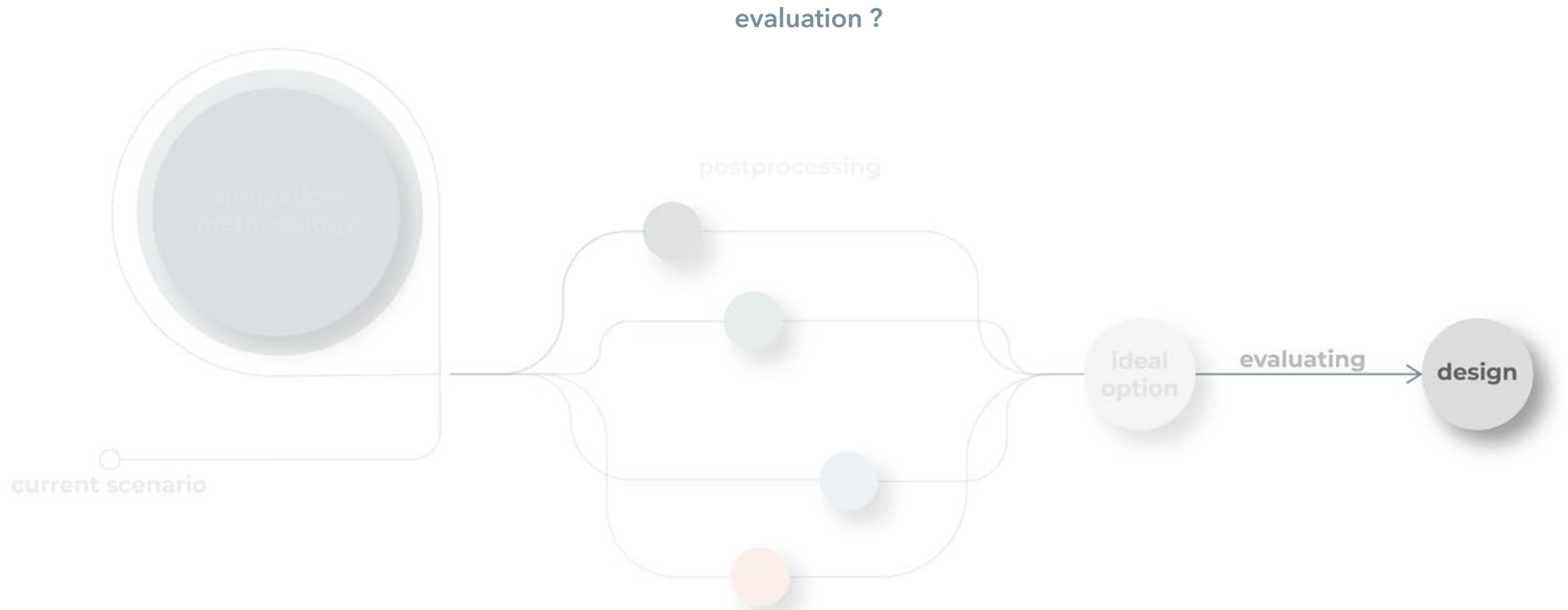

# Conclusion

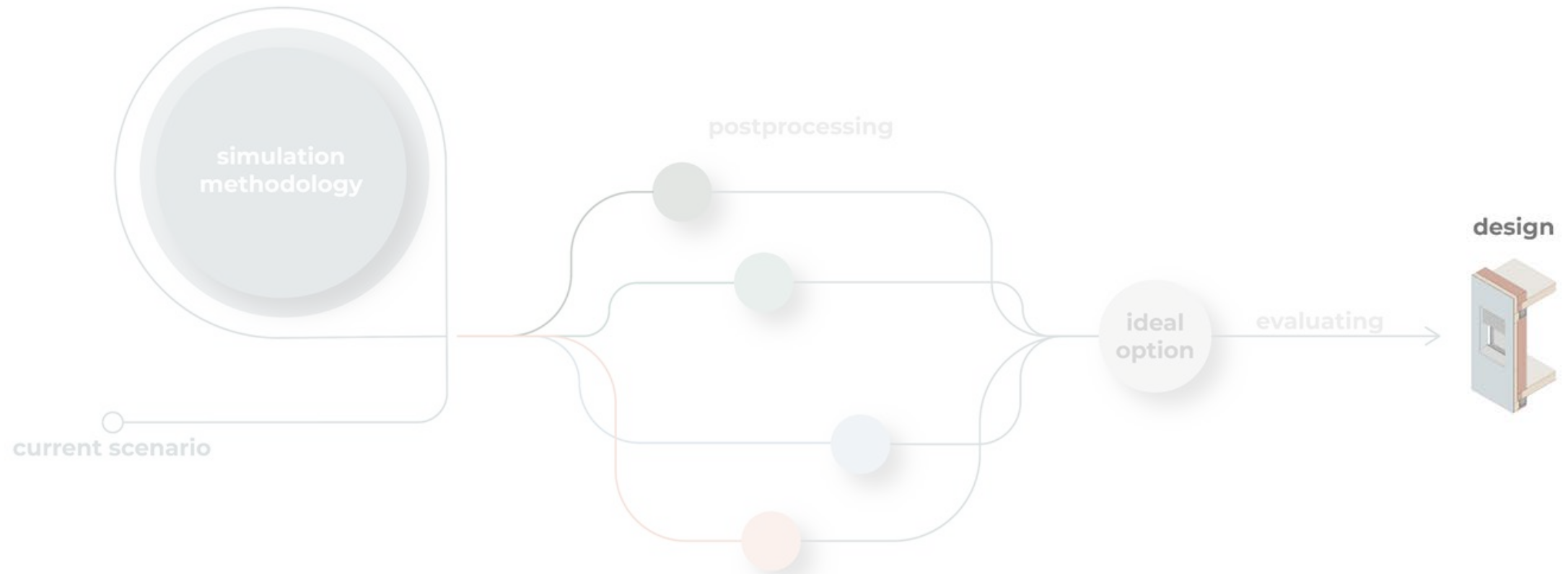

# Future challenges

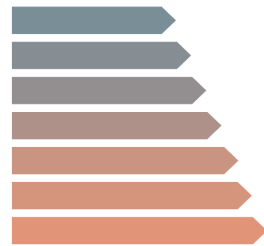

**thermal resilience  
classification**

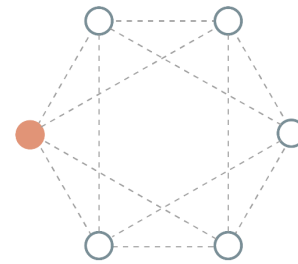

**multi-criteria  
decision-making**

Thank you

## resources

Al-Absi, Z. A., Mohd Isa, M. H., & Ismail, M. (2020). Phase Change Materials (PCMs) and Their Optimum Position in Building Walls. *Sustainability*, 12(4), 1294. <https://doi.org/10.3390/su12041294>

Fischer, E. M., & Schär, C. (2010). Consistent geographical patterns of changes in high-impact European heatwaves. *Nature Geoscience*, 3(6), 398–403. <https://doi.org/10.1038/ngeo866>

Ji, L., Shu, C., Laouadi, A., Lacasse, M., & Wang, L. (Leon). (2022). Quantifying improvement of building and zone level thermal resilience by cooling retrofits against summertime heat events. *Building and Environment*, 229, 109914. <https://doi.org/10.1016/j.buildenv.2022.109914>

Ji, W., Zhu, Y., Du, H., Cao, B., Lian, Z., Geng, Y., Liu, S., Xiong, J., & Yang, C. (2022). Interpretation of standard effective temperature (SET) and explorations on its modification and development. *Building and Environment*, 210, 108714. <https://doi.org/10.1016/j.buildenv.2021.108714>

Junk, J., Goergen, K., & Krein, A. (2019). Future Heat Waves in Different European Capitals Based on Climate Change Indicators. *International Journal of Environmental Research and Public Health*, 16(20), 3959. <https://doi.org/10.3390/ijerph16203959>

Knaack, U., Klein, T., Bilow, M., & Auer, T. (2014). *Façades: Principles of Construction*. Birkhäuser.

Koffi, B., & Koffi, E. (2008). Heat waves across Europe by the end of the 21st century: Multiregional climate simulations. *Climate Research*, 36, 153–168. <https://doi.org/10.3354/cr00734>

Lassandro, P., & Di Turi, S. (2019). Multi-criteria and multiscale assessment of building envelope response-ability to rising heat waves. *Sustainable Cities and Society*, 51, 101755. <https://doi.org/10.1016/j.scs.2019.101755>

Nairn, J. R., & Fawcett, R. (2013). Defining heatwaves: Heatwave defined as a heat-impact event servicing all community and business sectors in Australia. *Centre for Australian Weather and Climate Research*.

Perkins, S. E., & Alexander, L. V. (2013). On the Measurement of Heat Waves. *Journal of Climate*, 26(13), 4500–4517. <https://doi.org/10.1175/JCLI-D-12-00383.1>

Pattenden, S. (2003). Mortality and temperature in Sofia and London. *Journal of Epidemiology & Community Health*, 57(8), 628–633. <https://doi.org/10.1136/jech.57.8.628>

Robinson, P. J. (2001). On the Definition of a Heat Wave. *Journal of Applied Meteorology*, 40(4), 762–775. [https://doi.org/10.1175/1520-0450\(2001\)040<0762:OTDOAH>2.0.CO;2](https://doi.org/10.1175/1520-0450(2001)040<0762:OTDOAH>2.0.CO;2)

Schünemann, C., Son, S., & Ortlepp, R. (2022). Heat resilience of apartment buildings in Korea and Germany: Comparison of building design and climate. *International Journal of Energy and Environmental Engineering*, 13(3), 889–909. <https://doi.org/10.1007/s40095-022-00476-7>

Seneviratne, S. I., X. Zhang, M. Adnan, W. Badi, C. Dereczynski, A. Di Luca, S. Ghosh, I. Iskandar, J. Kossin, S. Lewis, F. Otto, I. Pinto, M. Satosh, S.M. Vicente-Serrano, M. Werner, & B. Zhou. (2021). Chapter 11: Weather and Climate Extreme Events in a Changing Climate (Climate Change 2021: The Physical Science Basis. Contribution of Working Group I to the Sixth Assessment Report of the Intergovernmental Panel on Climate Change, pp. 1513–1766). Cambridge University Press.

Sun, K., Specian, M., & Hong, T. (2020). Nexus of thermal resilience and energy efficiency in buildings: A case study of a nursing home. *Building and Environment*, 177, 106842. <https://doi.org/10.1016/j.buildenv.2020.106842>

Sun, K., Zhang, W., Zeng, Z., Levinson, R., Wei, M., & Hong, T. (2021). Passive cooling designs to improve heat resilience of homes in underserved and vulnerable communities. *Energy and Buildings*, 252, 111383. <https://doi.org/10.1016/j.enbuild.2021.111383>

Ted Kesik & Liam O'Brien. (2019). *Thermal Resilience Design Guide*. John H. Daniels Faculty of Architecture, Landscape, and Design.

Zhang, C., Kazanci, O. B., Levinson, R., Heiselberg, P., Olesen, B. W., Chiesa, G., Sodagar, B., Ai, Z., Selkowitz, S., Zinzi, M., Mahdavi, A., Teufel, H., Kolokotroni, M., Salvati, A., Bozonnet, E., Chtioui, F., Salagnac, P., Rahif, R., Attia, S., ... Zhang, G. (2021). Resilient cooling strategies – A critical review and qualitative assessment. *Energy and Buildings*, 251, 111312. <https://doi.org/10.1016/j.enbuild.2021.111312>

Trigo, R. M. (2005). How exceptional was the early August 2003 heatwave in France? *Geophysical Research Letters*, 32(10), L10701. <https://doi.org/10.1029/2005GL022410>

Zuo, J., Pullen, S., Palmer, J., Bennetts, H., Chileshe, N., & Ma, T. (2014). Impacts of heat waves and corresponding measures: A review. *Journal of Cleaner Production*, 92, 1–12. <https://doi.org/10.1016/j.jclepro.2014.12.078>