

HYBRID TIMBER CONSTRUCTION TECHNOLOGY

Investigation in a **hybrid building construction technique**, that could be encoded in a digital tool, by maximizing the use of **local building materials** such as natural timber, in seismic zone of Meghalaya, India.

Investigation in a hybrid building construction technique, that could be encoded in a digital tool, by maximizing the use of local building materials such as natural timber, in seismic zone of Meghalaya, India.

by

Krittika Agarwal

This thesis is submitted in partial fulfillment of the requirements for the degree of Master of Architecture, Urbanism and Building Sciences at the Technical University of Delft

For Building technology track

Thesis guides:

Dr. Michela Turrin | Design informatics

Dr. Fred. A. Veer | Materials sciences and Structure Design

Delegate board of examiner:

Dr. R.J.Kleinhans

Krittika Agarwal
krittikaag@gmail.com

AR3B025 - Sustainable Design Graduation Studio
Faculty of Architecture and Built Environment
Technical University of Delft

2018-2019

Dedicated to the people of Shillong

Acknowledgements

Foremost, I would like to express my sincere gratitude to my supervisors – Dr. Michela Turrin and Dr. Fred.A.Veer for their continuous support through the whole research process. Their guidance has helped me understand critical issues related to the subject and its applicability beyond academic boundaries. Also, I am grateful for their active support in arranging for the test laboratories and technical aid from various departments at the TUDelft, without which this thesis would not have been possible. Special gratitude also goes to the staff of the model workshop at the Faculty of architecture, who aided in manufacturing of the timber test models, their patience and expertise with woodworking was commendable.

I am especially thankful to the Government of Meghalaya, India for sharing statistics, plans and schemes related to the current situation of the Built Environment of Shillong, which is of utmost importance for validity of this research proposal. I also extend my gratitude to Prof. B.K.Tiwari, North Eastern Hill University (NEHU), Shillong, for providing valuable insights about the practical situation of the context and Mr. Sanjeev Shankar for sparing his valuable time and being resourceful. Their inputs were of great importance for establishing the initial background research.

I am hugely appreciative to Prof. Pradeep Kumar Ramancharla for putting me in contact with Mr. Pulkit Velani of the Earthquake Engineering Research Center, IIIT Hyderabad, India. Their final guidance helped in proper understanding of the calculations specific to the Indian building codes.

Special mention goes to Mr. Jorn de Jong, Structures team Leader, ARUP, for enlightening me about the current technological advancements in timber construction. I am also hugely appreciative to Mr. Michele Palmieri, Senior seismic engineer, ARUP, for showing interest in my work and sharing critical aspects on seismic engineering which have broadened my aspects in the practical field with respect to this research.

Finally, my utmost gratitude to my family- mom, dad and brother for their unconditional support at all times through the journey. Also, my dear friends Ivneet, Shubhranshu, Yammuna, Ammar, Prithvi who have always been available for emotional as well as technical help at all times. Ashish Negi for his insights in graphic design and aid in psychological stability. Premith Satish for his special aid during the 3D model prototyping. This thesis would not have been possible without their support.

I am thankful to all the people who have believed in my work and supported me through the process of my development.

Preface

'We are in a unique moment in architectural and building engineering history when shifting world needs us to question some of the fundamentals of how we have built for the last century and how we will build in the next'

- (Green, 2012).

Recent research by the Intergovernmental Panel on Climate Change (IPCC) indicates that wood-based wall systems have 10–20% less embodied energy as compared to the traditional concrete systems. Given its capacity to store carbon in the long run, current innovations all over the world have triggered a race to build efficient tall wood buildings. However, the potential innovations to revolutionize the building industry comes with its own challenges - to address a large scale sustainable development, regional adaptation of the technology, urbanization and to significantly contribute to the vast housing needs by building higher. Following the global trend of using reinforced concrete and steel as main building materials, the hill station of Shillong in India is getting transformed into a 'concrete jungle'. The latest analysis drawn for the Shillong master plan 2035 shows that during the last decade, Shillong city has shown a large scale unregulated urbanization. Statistics show that the decadal growth of urban population in the state for 1991-2001 was 37.51% which is higher than the country's average of 31.2% (Government of Meghalaya, 2017). Most of the residential housing units now are of reinforced concrete type buildings (Government of Meghalaya, 2018) consisting of 3-4 stories. While the city, shares the history of earthquakes of the Himalayan seismic belt, the quality and planning of built fabric demands a very high attention.

However, this was never a problem of the past as the local construction technique was using lightweight materials, in harmony with the natural environment and seismic hazard. This palate of building materials consisted of timber, bamboo and limestone found abundantly in the region. Sadly, the new urban and semi-urban landscape is gradually dispensing with the time-tested and earthquake safe technology, in a rush to build faster, cheaper and higher. Thus, the vulnerability of the region gives us an opportunity to deeply understand the current issues and rethink the possibilities of alternate means to rejuvenate the built environment.

This research is an attempt to dive into the history of Shillong and learn about the methods adopted to fight the natural disaster and question the possibilities of revival of the old building technology, using local building materials. The availability of these natural building resources for the purpose of proposed construction technique have been validated depending upon the requirements of the rising population. Also, a resource procurement scheme has been formulated to ensure that there is no 'encroachment' on the environment and sustainability is achieved by wholistic management of resources from the roots. Following this, an attempt has been made to re-develop the construction technique, called 'Assam-type', which is fading in the region. Inspiration has been drawn from the Japanese timber construction technology, which was also the mother of the 'Assam-type' construction. Also, contemporary methods of timber construction, which are relevant to the context have been explored and their applicability have been reasoned. Various ideas of the past and present have been juxtaposed to develop a construction technology which fulfills the urban demands whilst responding to the fragility of the region. The construction technique has been developed in accordance with the national building bye-laws of India. Since the structural calculations have been made as per the prescribed methods within an academic framework, it is recommended that the results are verified by qualified person before actually implementation. It should also be noted that this construction technique is a concept proposal, where the experiments were not made using the original species, hence the numbers have been extrapolated with respect to various theories. There is a vast scope of further in-depth scientific analysis of the proposed concept.

While the world is progressing at a rapid pace in reviving their vision for further construction systems. This research is also one of the firsts for the targeted region. It is thus important to share and spread the output of such research with the concerned professionals. Thus, an important part of the research framework was to develop a digital tool that could be easily used by the local designers. An attempt has been made to encode the basic design logic of this research in a simple computational design tool. The tool (script) has been made in grasshopper which is a popular software amongst young designers. The main aim of this tool is to approximate the possibilities of structural sizing, number of floors and components of the timber frame at initial design phase, given the input of the building footprint and preferred grid-size. Given this, the structural concept can be architecturally articulated under sound knowledge of seismic design principles equipped by the designer. It is envisioned that making such a tool, which can be easily downloaded and used, eases the integration of technological concept at an early design phase, thus capturing a wider user base. It is of paramount importance to spread, share and ease the usage of the results of such a research for a wholistic technological growth of a region.

As, the research deals in developing a construction technology for 'future', a futuristic approach is very subjective, assumptions can be taken to any extent for which there is no limit. Thus for this research 'future' for the development of construction system can be accounted for the immediate years from the present time. This is important for validating the application of technology advancements happening worldwide and accounting for the relevance of chosen methods in the current context. Taking all the above aspects into account this research presents the possibilities of the locally available natural materials (particularly timber) to create a hybrid construction technology and encoding its design logic in an easy to use tool for the region.

CONTENTS

Symbols	16
Introduction	19
1. CONTEXT	20
1.1 Historical background	23
1.1.1 The traditional Khasi house	23
1.1.2 The great earthquake of 1897	25
1.1.3 Evolution of the 'Assam type' construction technique	26
1.2 The posed problem in current scenario	27
1.2.1 Current building technology	27
1.2.2 Population and housing	28
2. THE NEED FOR SCIENTIFIC INTERVENTION	31
3. RESEARCH FRAMEWORK	34
3.1 Research questions	35
3.2 The goal	36
3.3 Research methodology	36
3.3.1 Pre-design	36
3.3.2 Design	37
3.3.3 Post-design	37
3.4 Time planning	39
Background information	40
4. CONTEXTUAL DATA ANALYSIS	42
4.1 Prospects for housing in Shillong Master Plan	43
4.1.1 Inference for prospects for housing in Shillong Master Plan	46
4.2 Availability of local building materials	47
4.2.1 Timber as a resource	49
4.2.2 Limestone as a resource	58
4.2.3 Bamboo as a resource	60
4.2.4 Inference for natural building material availability in Meghalaya	62
5. TIMBER AS A BUILDING MATERIAL	64
5.1 Types of timber products in construction	66
5.2 Fire resistance	69
5.3 End of life scenarios	70
5.4 Types of timber construction techniques	71
5.5 Inference on timber as a building material	73
6. CASE STUDIES	74
6.1 Traditional Japanese wooden construction technique	76
6.1.1 The Yakushiji project - lessons from Japanese temple renovation	77

6.1.2 Japanese pagoda - Macro analysis	82	8.10.3 Primary beam-secondary beam joinery	173
6.1.3 Japanese pagoda - Micro analysis	84	8.10.4 Primary beam and secondary beam to core joinery	174
6.1.4 Relevance of traditional Japanese technique in given context	85	8.10.5 Eave joinery	174
		8.10.6 Facade concept	175
6.2 Modern methods of hybrid timber construction	87	8.11 FEA for global structural verification	175
6.2.1 The stadhuis, Waugh Thistleton Architects	90	8.11.1 Modelling system	176
6.2.2 Tamedia office building, Shigeru Ban Architects	91	8.11.2 Model calibration	177
6.2.3 The Druk White Lotus School, ARUP	92	8.11.3 Final structural validation	178
6.2.4 The W350, Nikken Sekkei	93		
6.2.5 Relevance of modern timber construction in given context	94		
		9 Digital tool	180
7. ARCHITECTURAL PRINCIPLES OF SEISMIC DESIGN	96	9.1 Target user group	182
7.1 Common terms related to an earthquake	98	9.2 Formulation of the design logic for digital tool	184
7.2 Important properties of a building related to seismic design	98	9.2.1 The processing procedure of digital tool	186
7.3 Seismic force resistant systems	100	9.2.2 Inputs	186
7.4 Integration of seismic principles in architectural design	103	9.2.3 Outputs	187
7.5 Analysis of 'Assam type' house with respect to seismicity	110	9.2.4 Data processing logic	188
		9.3 Pseudocode of design logic	192
		9.4 Developing the digital tool in grasshopper3d	198
Conclusion on background information	114	9.5 Product catalogue concept	202
		9.6 Limitations of the digital tool output	203
Research by design	116		
		10 Assembly sequence of hybrid timber construction	204
8. Hybrid construction technology	120	11 Conclusion of research by design	208
8.1 Preliminary grid-size determination	122	12 Limitations of proposed hybrid timber construction technology	209
8.2 Structural member sizing	123	13 Future works	210
8.2.1 Load case of slab for structural sizing	124		
8.2.2 Secondary beam structural sizing	125	Appendices	
8.2.3 Primary beam structural sizing	128	Appendix A - Karamba3D model setup	212
8.2.4 Column structural sizing	132	Appendix B - Cross-section for varied grid sizes	213
8.2.5 Sizing for varied grid sizes	139	Appendix C - Laboratory test set-up	216
8.2.6 Sizing for fire- charring	139	Appendix D - 4-point bending test results	219
8.3 Column design	141	Appendix E - Digital tool- grasshopper script	222
8.3.1 Box column structural sizing	143	Appendix F - Compression test results of softwood used for prototyping	223
8.3.2 Response of box column detail during the testing	144	Appendix G - Seismic load calculation	225
8.4 Primary and secondary beam design	145	Appendix H - FEA for seismicity, Ansys setup	233
8.5 Joinery design	145	Appendix I - Nomenclature code for column-primary beam joinery	237
8.5.1 Column-primary beam joinery design	148	Appendix J - Assembly sequence of hybrid timber construction	238
8.6 Laboratory test of timber joinery	162	Appendix K - Product fabrication catalogue (concept)	264
8.6.1 Vertical compression test of softwood prototype for final joinery	162		
8.6.2 Lateral load test under cyclic loading of softwood prototype for final joinery	164	Bibliography	272
8.7 Scaling the actual loading capacity of the column-primary beam joinery	166		
8.8 Validating the global structure based on joinery's vertical loading capacity	167		
8.9 Validating the global structure based on joinery's lateral loading capacity	168		
8.10 Concept design of other joints and details	172		
8.10.1 Column-primary beam joinery variants	172		
8.10.2 Column-concrete foundation joinery	173		

Symbols

The symbols and annotations given below apply to the provision of vertical load calculations provided in section 8.2 and 8.3 (Bureau of Indian standards, 2016).

B = width of the beam, mm	K_2 = modification factor for change in duration of loadings
C = concentrated load, N	K_8 = constant equal to $0.584\sqrt{E/f_{cp}}$
D = depth of the beam, mm	K_9 = constant equal to $\pi/2\sqrt{UE/(5q*f_{cp})}$
d = dimension of least side of column, mm	L = span of a beam, mm
d_1 = least overall width of box column, mm	M = maximum bending moment in beam, N-mm
d_2 = least overall dimension of core in box column, mm	p_1 = ratio of the thickness of compression flange to the depth of the beam
E = modulus of elasticity in bending, N/mm ²	Q = static moment of area above or below the neutral axis about neutral axis, mm ³
f_{ab} = calculated bending stress in extreme fibre, N/mm ²	q = constant for particular thickness of plank
f_{ac} = calculated average axial compressive stress, N/mm ²	q_1 = ratio of the total thickness of web or webs to the overall width of the beam
f_b = permissible bending stress on the extreme fibre, N/mm ²	S = unsupported overall length of column, mm
f_{cn} = permissible stress in compression normal (perpendicular) to grain, N/mm ²	t = nominal thickness of planks used on forming box type column, mm
f_{cp} = permissible stress in compression parallel to grain, N/mm ²	t' = thickness of main member, mm
H = horizontal shear stress, N/mm ²	U = constant for a particular thickness of the plank.
I = moment of inertia of a section, mm ⁴	V = vertical end reaction or shear at a section, N
K = coefficient of deflection depending upon type and criticality of loading on beam	W = total uniform load, N
K_1 = modification factor for change in slope of grain	δ = Deflection at the middle of the beam, mm
	Z = section modulus of the beam, mm ³

The symbols and annotations given below apply to the provision of seismic load calculations provided in section 8.9 and appendix G (Bureau of Indian standards, 2016).

A_h = design horizontal earthquake acceleration coefficient.	L = dimension of a building in a considered direction
A_k = design horizontal earthquake acceleration spectrum value for mode k of oscillation.	M_k = modal mass of mode k
b_i = plan dimension of floor i of the building, perpendicular to the direction of earthquake shaking.	n = number of storeys or floors
d = base dimension of the building in the direction in which the earthquake shaking is considered, m	P_k = mode participation factor for mode k
DL = response quantity due to dead load	Q_i = lateral force at floor i
F_{roof} = design lateral forces at the roof due to all modes considered	Q_{ik} = design lateral force at floor i in mode k
F_i = design lateral forces at floor i due to all modes considered	R = response reduction factor
g = acceleration due to gravity	S_a/g = design/response acceleration coefficient for various rock or soil sites based on appropriate natural period
h = height of structure, m	S_i = lateral shear strength of storey i
h_i = height measured from the base of the building to floor i	T = undamped natural period of oscillation of the structure, s
I = importance factor	T_a = approximate fundamental period, s
K_i = lateral translational stiffness of storey i	T_k = undamped natural period of mode k of oscillation, s
	T_1 = fundamental natural period of oscillation, s
	V_b = design seismic base shear
	\bar{V}_b = design base shear calculated using the

approximate fundamental period T_a

V_i = peak storey shear force in storey i due to all modes considered

V_{ik} = Shear force in storey i in mode k

V_{roof} = Peak storey shear force in the top storey due to all modes considered

W = seismic weight of the building

W_i = seismic weight of the floor i

Z = seismic zone factor

ϕ_{ik} = mode shape coefficient at floor i in mode k

λ = peak response (like member forces, displacements, storey forces, storey shears or base reactions) due to all modes considered.

λ_k = absolute value of maximum response in mode k

INTRODUCTION

1

THE CONTEXT



Figure 1.1: Location of Shillong (source: www.mapsopensource.com)

Introduction to context

Shillong is the capital city of the state of Meghalaya situated in the North Eastern part of India as shown in figure 1.1. It came into existence in 1864 when the British transferred the district headquarters of the Khasi and Jaintia Hills from Sohra (Cherrapunji). Prior to this, it was a small village situated on the site of centuries old Khasi habitat. After it was chosen as the headquarters for the province of Assam, the town experienced rapid growth in population and buildings (Mittal, et. al, 2008). The growth of the region showed a quantum leap when it formed an autonomous state in 1972, after India gained independence in 1947. After which the state has witnessed a rapid growth in population as well as a boost in urbanization.

The Shillong plateau is located in one of the most seismically active regions in the world. Figure 1.2 shows the global seismic hazard map. Shillong plateau is squeezed between two major plate boundaries, that is the Indian-Burmese plate in the east and the Indian-Eurasian plate in the north (Baro, Kumar, & Ismail-Zadeh, 2018). The region has 4 sources of seismic disturbance (1) the Shillong Plateau-Assam Valley Zone (SPAVZ), (2) the Indo-Burma Ranges Zone (IBRZ), (3) the Bengal Basin Zone (BBZ), and (4) the Eastern Himalayas Zone (EHZ). These 4 regions as described by Baro, et.al. are different with respect to the rupture characteristics, geology, tectonic features, the plate movement rate and thickness of overburden. The area has witnessed several earthquakes due to the presence of these zones, figure 1.3 shows the 4 seismic zones and the major earthquakes caused by them in the region. One that happened in 1897, marked number 9 in figure 1.3, measured a magnitude of 8.1 during which the town was completely destroyed (Mittal, et. al, 2008). Ambraseys and Bilham described it as the largest intraplate event in the last two centuries in India and state that similar earthquakes will no doubt recur as the region is linked to the Himalayan thrust faulting. Thus, it is highly predicted that the region will experience such a calamity

in future. Such earthquakes also trigger landslides in the region, blocking roadways and increasing the fragility of the ground. The blockage of waterways, formation of lakes and heavy damage to masonry structures have also been reported in the region (Baro, Kumar, & Ismail-Zadeh, 2018). Thus, it is important to realize the extent of seismic hazard potential that could be caused in near future. It is important to educate the locals and especially the concerned professionals in the region about the possibilities of damage (Baro, Kumar, & Ismail-Zadeh, 2018).

In the long run, the understanding of the history of the built fabric, the reasons behind the vast devastations due previous tremors and changes in the attitude of the locals towards the built fabric after the earthquakes is of utmost importance. The seismic hazard of the region is something that cannot be ignored, given the degrading current building practices, the potential damage due to earthquake is rapidly increasing. There is an urgent need to technologically upgrade the system of our overall construction industry to pave the path to safety in future.

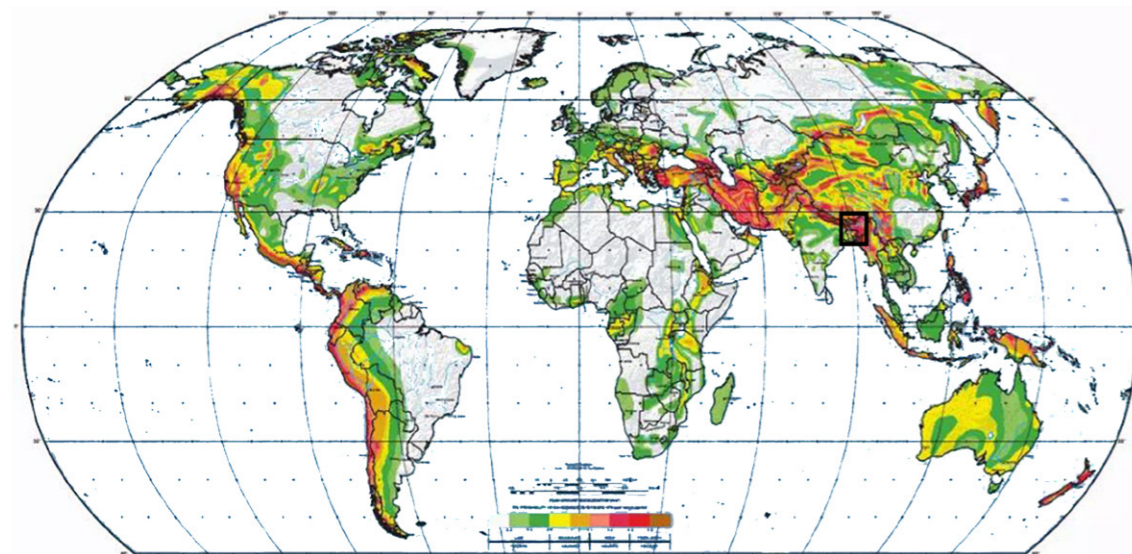


Figure 1.2: Global Seismic map (Produced by global seismic hazard programme).

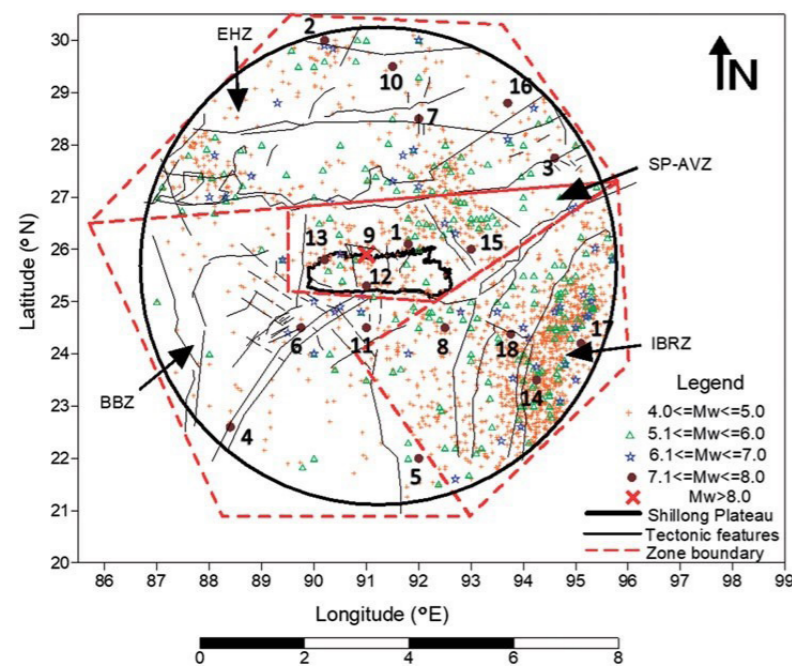


Figure 1.3: Seismotectonic map of the Shillong Plateau showing four seismic source zones, Earthquake epicenters from the declustered catalogue, and active fault lines. Numbers in the figure represent significant EQs; 1- 825EQ (M-8.0); 2-1411EQ (M-7.7); 3-1697EQ (M-7.2); 4-1737EQ (M-7.2); 5-1762EQ (M-7.5); 6-1787EQ (M-7.8); 7-1806EQ (M-7.7); 8-1869EQ (M-7.5); 9-1897EQ (M-8.1); 10-1915EQ (M-7.1); 11-1918EQ (M-7.6); 12- 1923EQ (M-7.1); 13-1930EQ (M-7.1); 14-1938EQ (M-7.2); 15-1943EQ (M-7.2); 16-1947EQ (M-7.7); 17-1954EQ (M-7.7); 18-1957EQ (M-7.0). Image and data copied from (Baro, Kumar, & Ismail-Zadeh, 2018).

1.1 Historical background

'There is much to learn from architecture before it became an experts art... Instead of trying to 'conquer' nature, as we do, they welcome the vagaries of climate and the challenge of topography.'

-(Tshumi, 1964).

The journey of habitat making has been a continuous phenomenon. It is a derivative of the environment and human psyche. As the human intellect developed, the character of their habitat was modified to suit their requirements. However, the environment has changed at a slower pace as compared to the human intellect in the scale of time. The starting point of this investigation has been a conviction to trace and interpret the different systems of ideas, events and influence that have inspired the local people to create and modify their habitat. To investigate on how the systems of thought have catalyzed its evolution, under the environment and technological constraints. The following diagram shows the major events that have influenced the architectural history of the region, the most important of all being:

- The arrival of foreign settlers that paved the road of connection to outside world resulting in foreign influence in the built form.
- The major earthquake of 1897 which led to innovation in earthquake resistant building system.
- Finally the pall of industrialization and globalization that led to the standardization of reinforced concrete construction technology throughout the world in late 19th century.

The anatomy of the traditional hut is discussed in detail below, followed by a brief explanation event of 1897 earthquake which led to a complete revolution in the building form.

1.1.1 THE TRADITIONAL KHASI HOUSE

The traditional Khasi house is a derivative of decades of evolution based on climatic, geological and social factors. With least influence from outside, this form a pure example which reflects the lifestyle and knowledge of the locals. The house was made using locally available materials like stone, wood and thatch. Various joineries were developed for construction and the use of iron nails were forbidden. Specific wood was used for structural frameworks, internal walls, flooring and wooden pegs. Although, the construction rules and features of the traditional Khasi hut are associated to traditional myths, yet every aspect of it has a logical relevance which is discussed as follows.

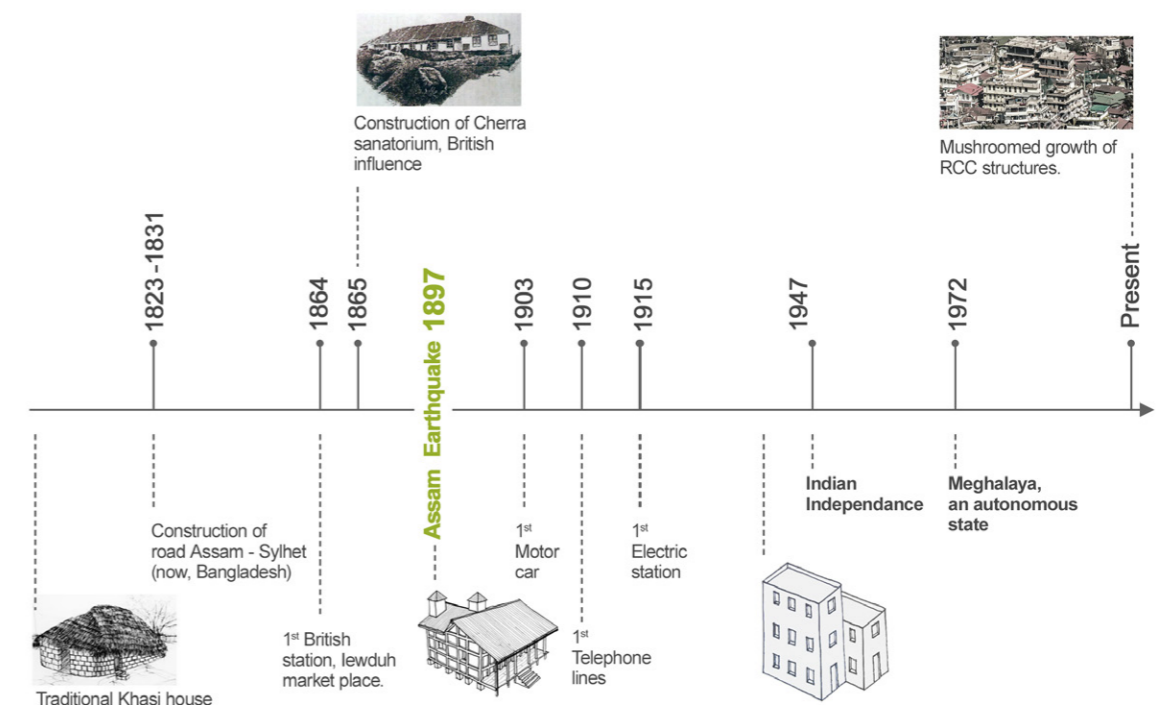


Figure 1.4: Historical timeline of major events that influenced building technology in the region.

- The boundary wall and interface between private and public:- The house compound is directly connected to the village road, the boundary wall is 500mm high and bounds the compound on three sides. The openness of the boundary is very inviting and its impact on privacy of the dwellers is negligible. no. 1 and 2 in figure 1.5 show the interface and boundary wall of the habitat. There was no restriction as to whoever enters the compound (neighbors and even animals).
- The entrance of the house- Shyngkup- It is the place that is on level with the outside. There is also a storage space for the farm equipment on either side of the walkway as can be seen in the plan. The animals are allowed to enter till this point.
- The raised platform-Shahksew- it is made to stop the animals from getting inside the house. Moreover, the step-up creates a feeling of rising into a more divine space i.e, close to the hearth.
- The central hearth- Rympei- It is the core of a Khasi house and has a lot of traditional significance. Technically it keeps the house warm. no. 7 in figure 1.5 represents the rympei, all the family activities happen around it. The area surrounding the rympei is called the nengpei. It is where the activity takes place. The hearth also helps in preserving household articles from pests and the humidity. Storage space is created on top of the fireplace.
- The sleeping niche- ling kyndong- the sleeping niches are present in the periphery of the house. No other activity is possible in the iing kyndonh because of the size. no. 8 in figure 1.5 shows the sleeping niche.
- The washing area- Tyndur- the washing area is an interface between outside and inside as shown in the figure. It may be placed on either side of the house. The water and washing equipment are kept in this area. Generally the tyndur leads to the pigsty or animal shelter.
- The rest of the compound is used by the family members for other activities like sitting, playing or drying of clothes. Moreover the future expansion generally happens within the compound, i.e. when the elder daughter moves out of the house after getting married, the new house that she makes may be within the mother's house compound or in an adjacent empty plot of land if it is available.

In a study done by B.I.O Dahunsi et.al., several earthquake characteristics have been inherited in the configuration of the traditional Khasi house. The study has been summarized by Harsha Sridhar as follows:

- While maintaining a good flexibility, the structural framework of the buildings are separated from the walls and tied together. Stone wall variants of these traditional Khasi houses may have failures during moderate to large earthquake due to out of plane loading, thereby causing an outward failure. But the timber frame of the roof is held by wooden columns rather than stone walls, which causes the roof to be intact. The occupants are thus protected since the building maintains integrity.
- Light materials are generally used to make the roof therefore minimal fatalities are expected from falling roof. Also, the buildings are placed on short columns that help to reduce the effect of lateral loading and protect them from high amplitude and high frequency motions.
- The form is symmetrical with negligible sharp corners. Stress concentrations are avoided at the corners due to the oval shape of the traditional building, which is a major cause of failure, especially around beam-column junctions.
- In practice, the traditional people do not use nails for construction, similar to those traditions prevalent in China, where mortised joints are mainly used. It is believed that this increases the energy dissipation of the joints and allows the structure to deform and redistribute the lateral loads exerted on the frame. Seismic loading is further dissipated by allowing the tongues and groves to slide of building components.
- The modern building codes recommend that buildings should not be located in the summit of the hills, especially those prone to liquefaction and landslides in earthquake prone regions. This is a traditional practice of the Khasis.

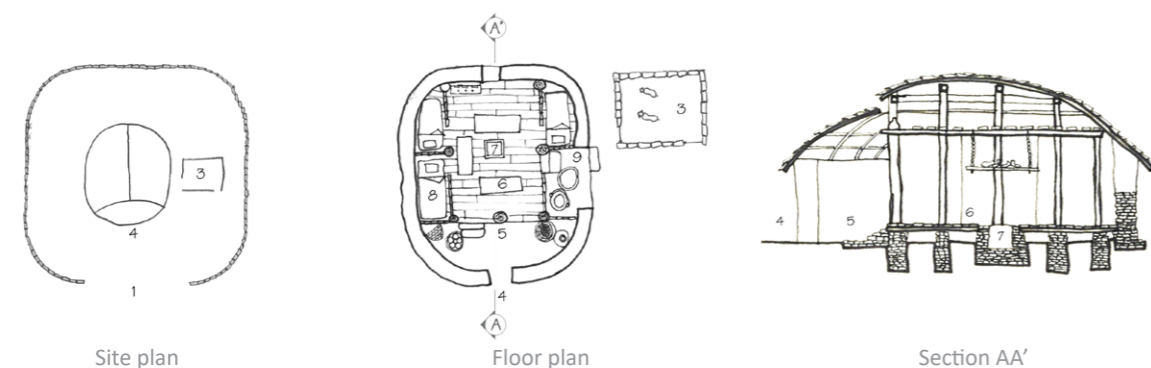


Figure 1.5: The traditional house form, plans and section.

Despite the fact that the traditional built form has been evolved to accommodate certain seismic features, yet it did not prove its efficiency when the catastrophic as strong as the earthquake of 1897 stroke the region. The heavy stonewalls of the traditional huts had collapsed which took a heavy toll on property and lives. The intensity, impact and architectural resultant of the 1872 earthquake are explained in the following section 1.1.2. Thus, a new building solution was sought after. The desperate need for a shelter, which incorporated modern features like electricity and importantly safe and affordable structure, led to development of a new technology.

1.1.2 THE GREAT EARTHQUAKE OF 1897

The 'Assam earthquake', as it is commonly called, holds a prominent place among the great earthquakes of the world because of its large magnitude, the large area over which it caused damage, liquefaction, and landslides (Ambraseys & Bilham, 2003). The Governor General of the region in 1897, Sir Henry Cotton describes the earthquake as follows, 'It was in the evening there was a rumbling underground noise followed by a light tremor. This was followed within seconds by a shock of such intensity that all masonry buildings were instantly leveled to the ground. The earth trembled so violently that the newly built catholic churches, the houses and the iron bridges on streams collapsed. The government house was a heap of ruins, not one stone standing upon another, and all the masonry houses of Shillong were in a similar plight.... Kindly Samaritans whose houses had not been so completely wrecked as ours found us food.... Most took shelter as they could find it in the wooden cricket-ground pavilion, which had not subsided, and in sheds in the bazaar: others were in their mat-walled stables or coach houses'.

Ambraseys & Bilham mention that the earthquake had a magnitude between $8 < M < 8.1$ and is the largest known Indian intraplate earthquake. Other authors claim the magnitude to be 8.7. Later studies made by Roger Bilham and Philip England showed that the rupture of a buried reverse fault approximately 110 km in length and dipping steeply away from the Himalaya caused the northern edge of the Shillong plateau to rise violently by at least 11 m during the earthquake. The stress drop implied by the rupture geometry and the prodigious fault slip of 18 ± 7 m explains epicentral accelerations observed to exceed 1g vertically and surface velocities exceeding 3 m/s. Although very less and reliable information is available about the intensity of the earthquake, Mr.F.Smith of geological Survey of India who was stationed in Shillong at the time was of opinion that the earthquake was so violent that the whole of the damage as done in the first 10 – 15 seconds of the shock. It was reported that all stone buildings collapsed, and about half ekra built houses (wooden frame, reed walls covered with plaster) were ruined, but plank houses (wooden frames covered with plank walls, resting unattached on the ground) were untouched (Kalita, retrieved on 12/2018). A similar conclusion made by Ambraseys and Bilham is that timber and lath constructions performed to claim minimal fatalities and appeared to be almost indestructible. Since most of the houses in the epicentral area of the 1897 earthquake were built from timber and lath methods, less than 1500 fatalities were reported (Ambraseys & Bilham, 2003).



Figure 1.6: a) The Shillong market before and b) after the earthquake; c) ruins of governors house d) ruins of a cottage owned by a British. (Image source: https://www.seismosoc.org/Publications/SRL/SRL_79/srl_79-3_hs_esupp/).

1.1.3 EVOLUTION OF THE 'ASSAM TYPE' CONSTRUCTION TECHNIQUE

The earthquake was studied by the learned Japanese seismologist, Professor Omori, who was specially sent by his Government in 1897 to inquire and report about the earthquake because it was very different from those earthquakes that took place in Krakatoa, Japan (National institute of disaster management, 2011). Apprehensive of a similar calamity, safer structures were needed to substitute the heavy traditional stone houses which had formed the pattern of the early Shillong houses.

The earthquake of 1897 thus brought in a great change in the construction of overall structures in the region. With the aid of professor Omori, the British introduced a new lightweight construction system adopted from the Japanese, using local materials. Professor Omori of Japan proposed a house form in which the whole structure became a timber frame resting on stone foundations (Kharwanlang, 1989). The walls were made of bamboo reinforcement ("ekra" or reed wall) covered with lime and sand plaster' (Kharwanlang, 1989). 'The roof was made of teak shingles painted red' (Hussain, 2005). However the use of corrugated tin sheets for roofing continued. The British built form inspired the local Khasis; the plan of the house was modified by placing the hearth (fire-place) in a corner in the living rather than the center. The kitchen was pushed towards the end and the chimney also found its place in the living. The plan had shifted from an oval to a rectangle L-shaped or T-shaped. New features like the verandah formed the intermediate zones between inside and outside. The Governors house had two spires, which became a standard architectural feature of Shillong Houses' (Hussain, 2005). Houses, public buildings, churches and jails had been rebuilt.

This 'Assam-type' design has proved successful, over the years, in withstanding earthquakes (National institute of disaster management, 2011). The strengths that influence earthquake safety of this construction technique has been summarized by Kaushik and Babu:

- Architectural aspects such as good plan, shape, small openings, proper location of openings, and small sized projections and overhangs.
- Structural features such as walls and roofs are light weighted, wall-to-wall connections were proper connected (in case of formal construction) and good quality and strong materials were used.
- Flexible connections (bolting, nails, grooves, etc) were made between various wooden elements at different levels.

The 'Assam-type' construction is also listed in the World housing encyclopedia published by the Earthquake Engineering Research Institute, USA and its overall seismic vulnerability is rated at 'type F = very low and type E=low' (Kaushik & Babu, 2012). However, this construction falls under the non-engineered category of buildings. An analysis of the structural and architectural features of this construction has been detailed in section 7.5.



Figure 1.7: Image of an Assam type construction in Shillong.

1.2 THE POSED PROBLEM IN CURRENT SCENARIO

The earthquake of 1897 resulted in a revolution in the construction technology which proved its perseverance in the scale of time. The institutional development along with framing of laws and mitigation strategies started in late 1950's and earthquake-engineering concepts have been applied to numerous major projects in high seismic regions in the country since then (Jain & Nigam). However, with the passage of time, the memories of the catastrophes have slowly faded, and in words of Jain and Nigam, over the years the dynamism to update our seismic codes and construction technology seems to have been lost; leading to an acute problem to accommodate the rising population safely in the current building scenario. The issues have been explained in the following section.

1.2.1 CURRENT BUILDING TECHNOLOGY

The northern part of India, the Himalayan frontal arc, is one of the most seismically active intracontinental regions on earth, where four great earthquakes, i.e., the 1897 Shillong earthquake, the 1905 Kangra earthquake, the 1934 Bihar-Nepal earthquake and the 1950 Assam earthquake, were recorded in a short period of 53 years (Unk18). Figure 1.8 shows the extent of area shaken by the 1897 earthquake and location of major Himalayan ruptures in past 200 years (Bilham & England, 2001).

A major concern in India with respect to the seismic safety is the development of Indian seismic codes whereby it lacks the incorporation of modern seismic concepts (Jain & Nigam). Again, in view of Jain.S, in discussions with his professional colleagues throughout the country and the messages posted on the discussion forum of the Structural Engineers Forum of India (www.sefindia.org) depict that many unsafe buildings are continuously being built in different cities and towns. He suggests that a vibrant earthquake industry wherein earthquake-related services and products could be conveniently made available within the country on a commercial basis is yet to develop.

The country is going through a major development phase wherein infrastructure is being added at an unprecedented pace. The global dynamics have forced the construction system to shift from the lightweight Assam-type construction to the reinforced concrete frame structures in the region. It is a great opportunity to ensure that all new infrastructures comply with seismic requirements. Unfortunately, on referring the published documents, discussions and newspaper articles on the current infrastructural situation it is proved that, this is not happening, some of which is discussed in section 1.2.2. Given the current scenario, in words of Ambraseys and Bilham, a repetition of the Assam earthquake today would have a great impact on modern multi-story buildings, bridges and other long- period structures, in the near- and far-field. Thus addressing the vulnerability of the region, it is important to investigate on the existing situation of the built fabric that will decide the fate of our future and generations to come.

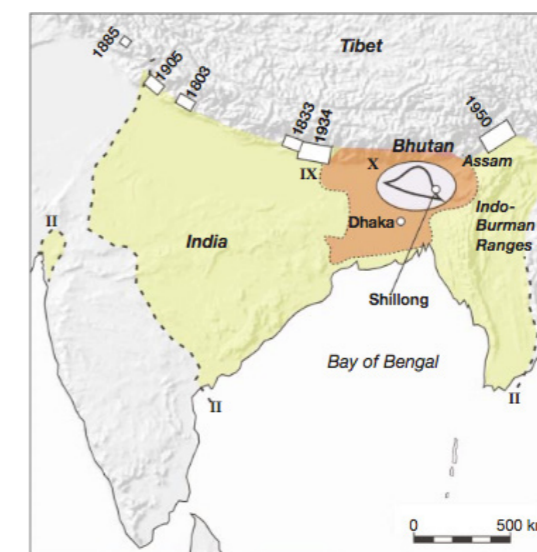


Figure 1.8: The colored region shows the area shaken by the great 1897 Assam earthquake, and location of major Himalayan ruptures in the past 200 years are marked in years. The maximum intensity of the earthquake was felt within the ellipse in the orange region. The 'Mexican-hat' shape of the epicentral region mapped in orange corresponds to the strike of the causal subsurface rupture and the area which witnessed major masonry structure damage. While people in the green region felt the earthquake, no major infrastructural damage was reported (Bilham & England, 2001).

1.2.2 POPULATION AND HOUSING

It is known that the population of the state is on a rise. Statistics show that the decadal growth of urban population in the state for 1991-2001 was 37.51% which is higher than the country's average of 31.2% (Government of Meghalaya, 2017). Further, the trend of concentration of urban population in the State continues to be in the urban agglomeration of the capital city. The individual growth rate of Shillong has been 19.83% during the last census decade 1991-2001 (Government of Meghalaya, 2017). It is expected that the increasing trend of urbanization will continue in the near future. Figure 9 shows that the overall increase of 24.3% in projected population of the state between 2011-2020 (Government of Meghalaya, 2017).

The latest analysis drawn for the Shillong master plan 2035 show that during the last decade, the city has shown a large scale unregulated urbanization and credible commercial expansion attracting a mass number of migrants to the city including poor, filing the demand for affordable housing and municipal division. Shillong is currently the only major urban center of the entire state. Also, statistics show that the distribution of population in the town of Shillong Urban Agglomeration constitutes about 59.2% of the total urban population (Government of Meghalaya, 2017), creating a concentrated growth in the capital city. The increase in population has intensified the pace of development both horizontally and vertically in the form of multistoried buildings (Government of Meghalaya, 2018). Table 1.1 shows the picture that emerged as a result of studies conducted during the preparation of the Master Plan (2015 – 2035) for the existing land use pattern officially covered under the Shillong urban region.

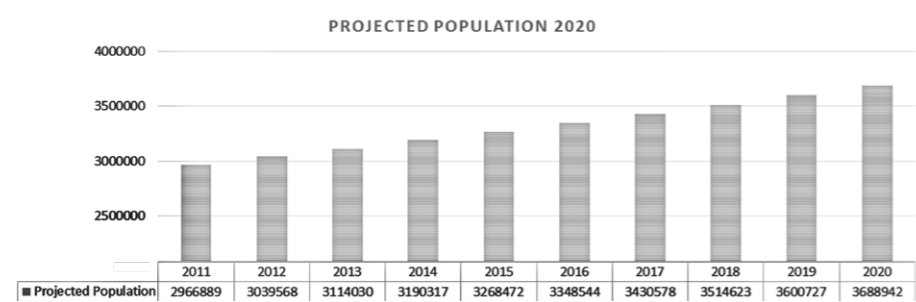


Figure 1.9: Projected population of Meghalaya 2011-2020 (Government of Meghalaya, 2017).

Land use	Existing Land Use				
	Area in hectares (1991-2011)	Area in hectares 2015	Increase in area	Percentage to total developed area (2015)	Percentage to total area
Residential	2662.78	3388.51	725.73	52.32	16.33
Commercial	56.62	83.28	26.66	1.36	0.40
Circulation	783.36	1112.97	329.61	17.18	5.36
Mixed Use	-	133.73	133.73	2.06	0.64
Public and Semi Public	1083.88	818.91	- 264.97	12.64	3.95
Special Area/ security	779.33	809.33	30.00	12.50	3.90
Industrial	10.00	10.00	0.00	0.15	0.04
Recreational	118.13	118.13	0.00	1.79	0.57
Sub total = developed area		6474.86			
Vacant	6650.90	7932.34	1281.44		38.23
Primary Activity	803.07	874.20	70.50		4.20
Protective and Undevelopable	4451.93	5468.60	1016.67		26.38
Total	17400.00	20750.00		100	100

Table 1.1: Existing Land Use in the Shillong Master Plan (2015-2035) (Government of Meghalaya, 2018).

It can be noted from table 1.1 that about 50% or 3388.51 hectares of the total developed area covered by the Master Plan is under residential use. That accounts for the major chunk of the uncontrolled mushroomed growth of the built fabric. The residential development of the city has grown much beyond the municipal limits due to non-availability of buildable land within the municipal area. The affordable housing and service standards set by the plans have not been able to keep pace with the increasing population, which is leading to increase in poor housing stock, congestion and obsolescence (Government of Meghalaya, 2018). Thus, the research aims to focus in the housing sector. Sadly, the new urban and semi-urban landscape is gradually dispensing with the time-tested and earthquake safe Assam-type housing. Most of the residential housing units now are of reinforced concrete type buildings (Government of Meghalaya, 2018) consisting of 3-4 stories. Figure 1.10 shows a view of Shillong.

The 2001 Census report of the state claims that the condition of houses used for residence and other purposes in the urban areas shows that 60.8% are in good condition, 34.7% in livable condition and 4.5% in a dilapidated condition. However, the regular phenomena of light tremors feature the headlines in local newspapers and scientific reports contradict this claim. Kharpran in his attempt to study the vulnerability of buildings in one region of Shillong city has identified the characteristic that haphazard multi-story structures with very few narrow exits, surrounded by strong and reinforced cement and fabricated steel will hardly allow few people to escape, if and when disaster strikes. Electrical wiring connections are faulty. Many constructions have encroached into public roads and footpaths. A simple glance at all these features will land us in a similar situation with Nepal when a high intensity earthquake strikes (Kharpran, 2016). Further, the newspaper article from The Shillong Times, after the minor earthquake in July 2016 reports damages to an administrative building in Shillong – ‘wide cracks have developed in the MPSC building (horseshoe building) with a large number of cracks appearing on the front portion of the building which are hard to miss’. Another clipping of The Shillong Times reported minor damages like breaking of glass windows, collapsing of masonry walls and even ‘a wall mounted TV coming off’. When the earthquake of 6.7 M had struck Manipur, the neighboring state, in 2016 it was reported that ‘the tremble also caused cracks in Meghalaya police headquarters and the North Eastern Indra Gandhi Regional Institute of Health and Medical Sciences (NEIGRIHMS)’. While there is hardly any news of casualties; reports on minor damages, panic and minor injuries are common. Compensating these events, regular building audits for important buildings are conducted in the city but no report on concrete action for retrofitting of these buildings have been found. Also noting the fact that, while the case of important buildings in the city are highlighted, the actual fate of the major chunk of the privatized built fabric is yet unknown. The reasons for the vulnerability of these structures could be:

- Firstly, in order to meet the pace of shelter requirements and maximize profits, builders compromise on the quality of the building. These builders may not adhere to the building codes and also may not follow the instructions and specifications approved by the authorities leading to a sub-standard construction.
- The urban development authorities are overburdened with tasks and thus the quality control during construction phase is left on the mercy of the builders.
- Buildings constructed outside the jurisdiction of the municipal authorities are difficult to be monitored.
- Importantly, there is no alternative construction technology for the modern urban environment that can perform in lines of the efficient ‘Assam-type’ construction.

In a reported interview with Jayanta Pathak of the civil engineering department at the Assam Engineering College, there are discussions on appraisal of the faded construction technique – Assam-type house and its potentiality to emerge again as one of the most sustainable earthquake safe housing forms. The advantage of its lightweight, eco-friendly and earthquake safe features have been proved in time. However, its limit with space constraints, verticality and low building heights, which do not correspond to the building-by-laws and modern urban requirements, has not encouraged further building of these structures in the city. The complete obsolescence of the Assam-type construction is due to the lack of research in order to upgrade the technology to meet the changing demands of the dynamic urban environment, incorporation of modern facilities and meeting the aspiration of city dwellers.

It is understood from the above statistics that population will continue to grow and that there is an urgent need to upgrade our building technology. Experience all over the world has shown that traditional building construction methods, which have evolved over a long period, could enhance better understanding of possible solutions to problems that confront mankind at present time (Mittal, et.al. 2008). The Assam-type construction provides an opportunity for scientific development and a hope for a safe and sustainable building environment. As it has been wisely said that, “*Earthquakes do not kill, falling buildings do*”.

2



Figure 1.10: Current situation of mushroomed structures in Shillong. (Source: www.alamy.com, image id – J82H91)

THE NEED FOR SCIENTIFIC INTERVENTION

Sustainability is vital for the well being of our planet and society. The most often quoted definition comes from the UN World Commission on Environment and Development: ‘Sustainability means meeting our own needs without compromising the ability of future generations to meet their own needs’. Sustainability is a holistic approach that considers ecological, social and economic dimensions, recognizing that all must be considered together to find lasting prosperity. From the environmental aspect ecological integrity needs to be preserved while balancing all the systems comprising the environment (University of Alberta, n.d.). In the past few decades, sustainability has become a major concern in building design and construction. Buildings are responsible for nearly half of all energy consumed in the United States (Skidmore, et.al, 2013). The carbon emissions associated with a building come from the energy consumed during the life of the building and the carbon emissions associated with the construction of the building. In words of Skidmore, Ownings and Merrill the carbon emissions associated with the construction of the building are referred to as the ‘embodied carbon footprint’ of the building. The total carbon footprint of the building is the sum of the operational carbon emissions and embodied carbon emissions. The ratio of embodied to operational carbon is typically 10-30% depending on the type of building and lifespan (Skidmore, et.al, 2013). A scrutiny in the field reveals that the production of structural materials is the leading contributor of the embodied carbon footprint. These facts suggest that the structural engineering design is a key factor affecting the embodied carbon footprint of the building (Skidmore, et.al, 2013).

The fragile state of our environment today has caused the architectural and building engineering practices to question the history and how will it transcend to the future (Green, 2012). For more than a century, mid-rise and tall buildings all over the globe have been built mainly in concrete and steel, conquering even the deepest settlements of the present day humans. The same has led to the shift in the material palate in Shillong from the Assam-type to reinforced concrete. Nevertheless, as building materials, concrete and steel have been very good choices and will continue to be important materials in building construction of the future. The question then arises; why do we need an alternative to concrete and steel for our making buildings, and is it the time to change or revise the way we build?

In words of Michael Green, the answer is simply climate change. Both concrete and steel have a large carbon footprint and their production is highly energy intensive. Concrete production represents roughly 5% of world carbon dioxide emissions, the dominant green house gas (Green, 2012). In essence the production and transportation of concrete represents more than 5 times the carbon footprint of the airline industry as a whole (Green, 2012). Recent research by the intergovernmental panel on climate change (IPCC) indicates that wood-based wall systems entail 10–20% less embodied energy than traditional concrete systems and that concrete-framed buildings entail less embodied energy than steel-framed buildings. Figure 11 shows the embodied carbon of building materials used in common scenarios.

The production of steel and glass requires temperatures of up to 3,500°F, which is achieved with large amounts of fossil fuel energy (American wood council). Also, cement is a material that needs 1 to 1.5 metric ton of lime; uses a lot of energy for its production, around 4000MJ/metric ton and releases 0.8 to 2 metric ton of carbon dioxide to the atmosphere to produce the clinker (Kumar et al, 2006).

Further, to complete the picture it is important to consider the Life cycle assessment (LCA) studies for environmental impacts of materials over their entire lives. Although the progress in technology has provided a method to recycle concrete, yet it involves a rather complex setup. For recycling concrete, it has to be sorted on site to remove products that are not concrete or masonry. Then they need to be transported to the recycling plant, which is generally situated far from the central region of the city away from the building site. These recycling plants need special machinery to sort the metal aggregates and make it re-usable. This system only works with initial heavy investments and stringent monitoring to channel all the waste concrete, both of which are a problem in a context like Shillong. Otherwise, at the end of its lifecycle, reinforced concrete residues are normally sent to the landfills.

Thus the scenario today's age answer the need for re-evaluating the fundamentals of our building materials. Just as other industries like the automobile, energy sector, and aeronautics are working towards an innovation for sustainable living, the building industry also has to match the pace of innovation. The solutions have to be invented or re-imagined to revolutionize the building sector and address the cons of climate change, urbanization and sustainable development to significantly satisfy the growing population of humans. Further, taking the special case of Shillong, its historical success story in construction with timber and local availability gives us a strong base to re-investigate. Perhaps wood being one of the oldest and most natural building materials on earth would have a more positive environmental impact than materials that are highly energy intensive. In addition wood's ability to store carbon makes it a very unique competitor to steel and concrete as a structural building material (Green, 2012). These characteristics of

wood make it an excellent material which is a low-carbon alternative to many others widely used in construction and consumer goods.

However, for wood to structurally perform at greater heights than previously envisioned, it must be cost competitive and safely perform structurally. Positively, present innovations throughout the world have triggered a race to innovate efficient wood buildings. Various researches have progressed in field of fire-safety and tall timber construction. The applicability of these innovations will be experimented and their relevance can be tested in the seismic region of Shillong. The researches can be further developed to suit the local dynamic requirements of the region. Just as wood has been a desirable building material since the distant past, it has a potential to make an essential contribution to a sustainable future.

“Increasing the global forest land base and increasing the capacity of each forest, while using them as a sustainable supply of wood for building materials and fuel to offset the need for other energy-intensive materials and fossil fuels represent an important carbon mitigation option over the long term.”

– UN Food and agricultural organization 2010 report.

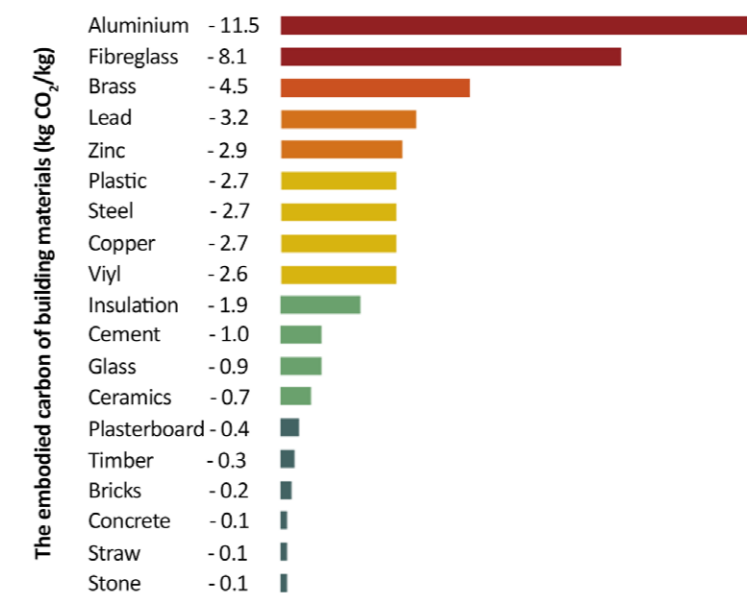


Figure 2: Note from author- this figure is intended as a beginners guide. Detailed estimation involves considerable complexity for each product. Figures for metals assume virgin material. Data source: Inventory of Carbon & Energy (ICE) database. Downloaded from shrinkthatfootprint.com.

3

RESEARCH FRAMEWORK

3.1 Research questions

Main research question

In light of the seismic risks in the region, the posed problem of housing shortage due to rapid urbanization, increase mushrooming of unregulated unsafe structures and the justified need for scientific intervention due to long term environmental hazards in using the current common building materials (concrete and steel), the following is the main research question:

How can we develop a construction technology, for the seismic prone region of Shillong, comprising of a hybrid structural system by maximizing the quantitative use of local building materials such as timber, and how can the design logic of such a technique be made available for the local concerned professionals of the region?

Sub-research questions

The main research objective needs to be supported by various facts and considerations, which will be elaborated by answering the following sub-questions in the following sections:

Sub-questions to be answered during the **background research**:-

1. What is the extent (in terms of quantity) of housing demands in Shillong?
- To know the feasibility of this research and to check if there is a real need for housing in Shillong.
2. How do we sustainably acquire the local timber (*Shorea robusta* and *Pinus kesiya*), bamboo (*ikra*) and limestone for the proposed bulk construction?
- To know if there is enough resources available to meet the demands, if no, then what methods have to be adopted to ensure a sustainable chain of material procurement. Also, what are the long term consequences of extracting these building materials.
3. What can be learned from the traditional Japanese timber construction methods and its relevance in the proposed context?
- To understand the principles used by the Japanese carpenters by means of case studies and understand their scientific relevance. To understand the extent to which we can use their methods to develop the proposed construction technology.
4. Can the current technological advancements in tall wood building construction be applicable and aid in designing the structure in Shillong?
- To understand the recent innovations in timber construction technology, understanding the driving force behind such innovations. What are the basic principles of modern day timber construction? How relevant are the global innovations to the proposed context?
5. What are basic principles of seismic design?
- To develop an understanding behind the logic and technical aspects of seismic design. Also, an analysis on how the traditional 'Assam-type' construction inherits such seismic resistant features.

Sub-questions to be answered during the **research by design** phase:-

6. Keeping in mind the urban requirement of multiple floors (current permissible building height 15m), How high can we safely build by maximizing the quantitative use of local building materials with least amount of industrial processing?
- To determine the maximum floors, with respect to various grid-sizes, that can be built with the considered natural building material (timber) within the framework of safe limits of the National bye-laws of India.
7. What joineries and details are necessary for such kind of timber construction?
- To conceptually determine the important details necessary for the proposed timber construction. While studies on one important joinery is to be elaborated in order understand in depth timber as a construction material and the functioning of such timber joineries. Given the time-frame, the other

joineries will be conceptualized based on the lessons learned from the experiments from that one joinery.

8. Is it possible to integrate the design logic of construction technique in a computational tool, which can aid designers to determine the possibilities of the timber structure? If yes, then how and detailed to what extent?

- How can the design logic be translated into a design tool, like a grasshopper script which can easily be used by designers in their early design stage. What are the parameters or boundary conditions which determine the development of such kind of design tool? What is the freedom that could be given to basic users versus the advanced users for using such kind of a tool?

3.2 The goal

The main goal of the research is to firstly develop a structural system by maximizing the use of the locally available natural building materials (timber - Shorea robusta and Pinus kesiya, ikra and limestone). Secondly, an attempt will be made to encode the design logic of this construction technique in a computational tool which can aid the local designers in an early design phase using this building material. These two primary goals will be determined and governed by the practical factors like material procurement and constructability, seismicity of the region and important aspects like fire-resistance, National byelaws and architecturally acceptable design.

Finally, aiming to re-develop and share the timber construction technology, which suits the contemporary urban requirements of building higher with a seismic resistant characteristic, whilst complying with the larger global vision of a holistic sustainable future.

3.3 Research methodology

This academic investigation is proposed through a process of research by design. The process of research by design involves critical inquiry by testing of ideas, materials and technologies. It involves innovative conceptual development and product evolution whilst complying with cultural, social, economic, aesthetic and ethical issues. The entire research process is broadly classified into 3 main stages described below:

3.3.1 Pre-design

The pre-design phase will comprise of analysis and investigation of task, context and potential avenues for research and design (Rogemma, 2016). It will importantly include a feasibility check by verification that the problematic situation can be addressed through scientific or engineering methods of inquiry. This topic validation will be followed by formulation of a hypothesis, plotting the research questions and planning a realistic timeline for execution of study. The following two fields of scientific theoretical research and understanding the physical context will be covered at this phase which will aid in the initiation of the design phase.

Context study-

- Understanding the local physical characteristics of the place.
- Understanding the historical background and the dynamic forces that led to the architectural development of the region.
- Understanding the political scenario and policies that will affect the practical applicability of the research.
- Collection and interpretation of reliable scientific data and statistics for population growth and housing demands.

Literature research -

Acquisition and organization of relevant scientific data and case studies related to traditional and modern

means of timber construction. The scope has been specially extended to:

- Understanding the traditional Japanese construction methods and its relevance in contemporary context.
- Understanding the advancements in tall wood building construction and its relevance in the context of Shillong.
- Understanding the basic principles of seismic design.

3.3.2 Design

The design stage will consist of continual weaving between problem and solution in an iterative movement between inquiry and proposal. The design options could pose new questions to research and outcomes could be valued through the technological impacts and societal benefits. An attempt will be made to validate the final design based on structural stability, using software simulations, to meet the standards set for seismic design. The design process has been divided into four phases:

- **Concept design** – The concept design phase will consist of exploring the possibilities in design by brainstorming and initial testing of ideas. It will include production of multiple variations of construction techniques as an initial step to answer the questions asked in the pre-design phase.
- **Lab testing**- Parallel to concept design, the laboratory tests will be conducted to simultaneously test the prototypes and understand the behavior of the material and proposed joinery. This will help in a deeper comprehension of the feasibility of the proposed concept.
- **Detail design** – This stage involves critical evaluation of the experiments performed in the concept design stage. This stage will involve judging, choosing and picking the best alternative from the experiments. The resolution of design will be further increased by focusing in detailing the critical aspects. A holistic design will be created at a conceptual level. Further this design logic will be encoded in a grasshopper script with an aim of developing a user friendly interface for the input and the output.
- **Simulations**- Simulations comprise of testing the design output in virtual environment governed by scientific variables and mathematical values to validate the functionality of the proposal. Simulation aids in formulation of the concept design and evaluation of the detailed design. It is an iterative process. Simulation will include testing the seismic performance of the global structure by FEM analysis, using software packages like Karamba3D and Ansys.

3.3.3 Post-design

In the post-design phase, the results that will be the final syntheses of the work has to be documented in detail and supported by facts that led to certain decisions during the process. The impact for a wider community, both academic and social, needs to be made manifest and the new knowledge, developed during the design process, has to be made available for a wider audience. This requires a strategic and conscious communication skill. The aim of final output will comprise of a report, 3D model, computational tool (grasshopper script) and physical models. However, the final decision of the deliverables will also depend on their relevance after the design process.

Research methodology flowchart

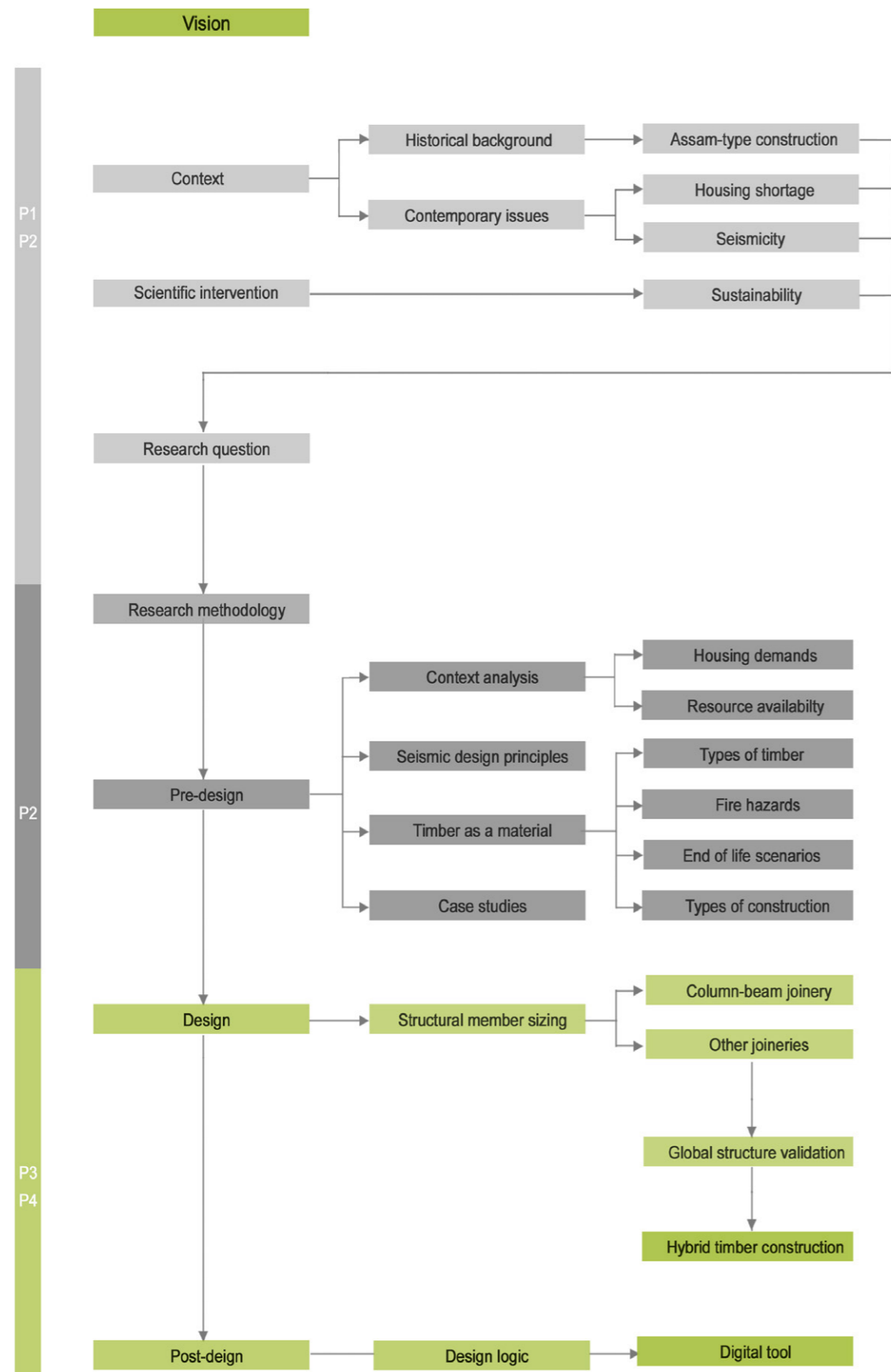


Figure 3: Research methodology diagram

3.4 Time planning

Table 3 shows the intended workflow for the academic term of master thesis programme.

DATE	Pre-design				Design			Post-design	
	Research formulation	Topic validation	Context study + travel	Theoretical literature research	Concept design	Detail design	Simulations	Compilation	Final Deliverables
3 Sep									
10 Sep									
17 Sep									
24 Sep									
1 Oct									
8 Oct									
15 Oct									
22 Oct									
29 Oct									
5 Nov									
12 Nov									
19 Nov									
26 Nov									
3 Dec									
10 Dec									
17 Dec									
7 Jan									
14 Jan									
21 Jan									
28 Jan									
11 Feb									
18 Feb									
25 Feb									
4 Mar									
11 Mar									
18 Mar									
25 Mar									
1 Apr									
8 Apr									
15 Apr									
22 Apr									
29 Apr									
6 May									
13 May									
20 May									
27 May									
3 June									
10 June									
17 June									
24 June									
1 July									
8 July									

Table 3: Workflow timeline

BACKGROUND INFORMATION

Introduction to background information

The literature covers a wide variety of theories, this review will focus on three major themes that emerge as the most important fields for this research. Firstly, the research is setup in a context, therefore it is of utmost importance to understand the background as the development of the design and various choices will be made with relevance to the region. The success of final results will also be judged on the basis of applicability and relevance to the context. This includes a thorough research in terms of the actual contextual problem, it's scale, the number of people to be catered, the availability of local resources and the government policies that will affect the final proposal in the region. A part of this has already been discussed in the introduction, while the rest are elaborated in the following sections. The second major research area includes a study about the timber construction technology. The research aims to focus on the traditional Japanese method of timber construction and the current innovations in the field. It involves analysis of the construction process and its relevance in the given scenario. The analysis also includes selection of a system that is best suited for the region after critical comparison between the various methods. Thirdly, the literature study also includes an overview of the seismicity and the scientific reasoning behind the design principles for seismic prone regions.

The research includes selecting published documents, studies and case studies with respect to their importance to the topic based on substantial literature search. The collection of primary contextual data also includes several interviews of officials and locals conducted during the two week stay in the city of Shillong. Other sources of data collection include documents, journals, books, interviews and patents, acquired from reliable scientific sources and authorized institutions.

4

CONTEXTUAL DATA ANALYSIS

4.1 Prospects for housing in Shillong Master Plan

The master plan of Shillong 2035 has been taken as guidance for the development of this research. However, the Master Plan of Shillong 2035 is still under review, the lack of data in certain fields has been fulfilled by adopting the calculation methods and prospects of Master plan 1991-2011.

Population estimates are necessary to assess various needs of the city including requirement of land for various uses such as housing, commerce, recreation, health, education, industry and infrastructure. It is understood from the previous sections that the rising population is the root cause of major urban problem in the city of Shillong. The reasons for the future need of housing as indicated by Government of Meghalaya in 2018 are as follows:

- The predicated rise in the population figures resulting from increased and new economic activities inviting large immigration and the natural increase of the base population.
- Redevelopment of substandard housing from the existing stock.
- A drop in the number of persons per housing unit as a result of the natural trend in the reduction of family sizes with the adaptation of the urban way of life.

The data on projected population has already been explained in section 1.2.2 and figure 1.9 portrays the projected population of 2020 which has shown an overall increase of 24.3% between 2011-2020 (Government of Meghalaya, 2017). These figures have been used to estimate the housing requirements for the Master Plan of Shillong 2035. Although, the projections up till 2020 are available, the projections for 2035 have not been available for the purpose of this research. Also, at an interview with the Director of Ministry of Urban affairs of Shillong, it was learnt that due to the pressure in availability of land in the Shillong agglomeration, the calculations for housing was a balance between the population to be accommodated and the percentage of total land that could be spared for housing. In his opinion the lack of land to adjust the exodus of growing population is a major challenge for the authorities. Table 4.1 shows the total developed area under residential in the master plan of 1991-2011 and 2015-2035.

Total master plan area of 174 sq. km was covered in master plan 1991-2011. The master plan area has been increased to 207.50 sq. km in master plan 2015-2035, thus there is an increase of 33.5 sq. km. However, the quantities of the area of housing have not yet been specified in master plan 2015-2035. If estimated from the previous example of 1991-2011, the housing percentage to total proposed developed area was approximately- 60% (60.85%). Considering this: 60% of 33.5 sq. km = 20.1 sq. km or 2010 hectares could be estimated as the new proposed housing requirements for 2035 master plan.

Adding the possible proposed hectares to backlog from 1911-2011 = 2010 + 1706.76 hectares
A total housing requirement approximation of 3716.76 hectares can be made.
(Note: this calculation for the new housing requirement by 2035 has been made for the academic purpose of the research and is not the actual number specified by the Government of Meghalaya).

The total area under the master plan 2015-2035 has been divided into two major regions:

- The New Shillong township
- Existing Shillong City

Master plan	Landuse	Total developed area in hectares (existing)	Total proposed area in hectares
1991-2011	Residential	2662.78	5095.27
2015-2035	Residential	3388.51	New area still under consideration by the Government. In addition a balance of 1706.76h from pervious proposal needs to be considered.

Table 4.1: Area under residential in master plan.

The development of each of the above two regions has been divided into four stages in the timeline, a) Phase 1 (2016-2020), b) Phase 2 (2021- 2025), c) Phase 3 (2026-2030) and d) Phase 4 (2031-2035). Further, depending upon the economic status of the population, the housing units are categorized into three types. They include a) LIG – Low-income group, b) MIG – Mid-income group and c) HIG – high-income group. However, the Master plan has not defined the characteristics of housing for each typology. An average of 5 persons per household has been estimated to determine the number of households. The following table 4.2 shows the number of units proposed for each category under each phase of development.

Phase	New Shillong Township			Existing Shillong City		
	LIG	MIG	HIG	LIG	MIG	HIG
2016-2020	49500			-	-	-
2021-2025	5000	3000	500	5000	2500	1000
2026-2030	10000	10000	2425	2000	2500	1000
2031-2035	9750	4325	4000	750	425	325
Total	24750	17325	6925	7750	5425	2325

Table 4.2: Proposed number of households in Master Plan 2015-2035 (Government of Meghalaya, 2018)

In addition to the above information it is mentioned that the first phase will cater to a population of 247412 people (and @ 5 members per household, 49500 units have been estimated).

Reversing the calculation,

The total number of households including the new Shillong township + existing Shillong city = 64500.

Since, it is given that the numbers are calculated on basis of 5 members per household.

Therefore, the housing for the total number people that the master plan 2015-2035 is catering to = (64500 x 5) = 322500

And, 322500 + 247412 (given from phase 1) = 569912 people

Now, as per the Urban and regional development plans formulation and implementation guidelines devised by National Ministry of Urban Development, the city of Shillong is classified as a large city. Table 4.3 shows the classification of urban settlements based on the population.

Serial no.	Classification	Sub-category	Population Range	Governing Local Authority	Number of Cities as per Census of India, 2011
1	Small Town	Small Town I	5,000 - 20,000	Nagar Panchayat	7467
		Small Town II	20,000- 50,000	Nagar Panchayat/ Municipal Council	
2	Medium Town	Medium Town I	50,000 - 1,00,000	Municipal Council	372
		Medium Town II	1,00,000 - 500,000	Municipal Council	
3	Large City	-	5,00,000 – 10,00,000	Municipal Corporation	43
4	Metropolitan City	Metropolitan City I	10,00,000 – 50,00,000	Municipal Corporation/ Metropolitan Planning Committee	45
		Metropolitan City II	50,00,000 - 100,00,000	- Same -	5
5	Megapolis	-	< 100,00,000	- Same -	- Same -

Table 4.3: shows the classification of urban settlements based on the population (Ministry of Urban development, India, 2015).

For overall planning approach, the Ministry of Urban development India has specified the population density norms based on persons per hectare depending upon the settlement type. It is also mentioned that fixation of density norms should be based on carrying capacity analysis focusing on parameters like space per person, access to facilities, available piped water per capita, mobility and safety factors and the task should be settlement specific (Ministry of Urban development, India, 2015). In case of Shillong, it is classified as a large city. Table 4.4 shows the developed area average densities.

Settlement type	Persons per hectare (pph) in	
	Plain areas	Hilly areas
Small towns	75-125	45-75
Medium towns	100-150	60-90
Medium towns	100-150	60-90
Metropolitan cities	125-175	100-150
Megapolis	More than 200	-

Table 4.4: Developed area average densities (Ministry of Urban development, India, 2015).

However, the Master plan is catering to the residential needs of 569912 people @ 5 people/unit. And total assumed area available for residential development = 3716.76 hectares.

This shows that the number of people to be accommodated per hectare = (569912/3716.76) = 153.3 persons per hectare.

It can be seen that inspite of Shillong being a hilly region; the area allotted per person is within the limits of the plain areas. This densification of population may be because of the lack of space in the Shillong city. Figure 4.1 shows the landuse map of Master plan 1991-2011 highlighting the allotted region for residential. (As already mentioned, the Master plan 2015-2035 is still under formulation; hence the older version 1991-2011 has been used for the purpose of the study).

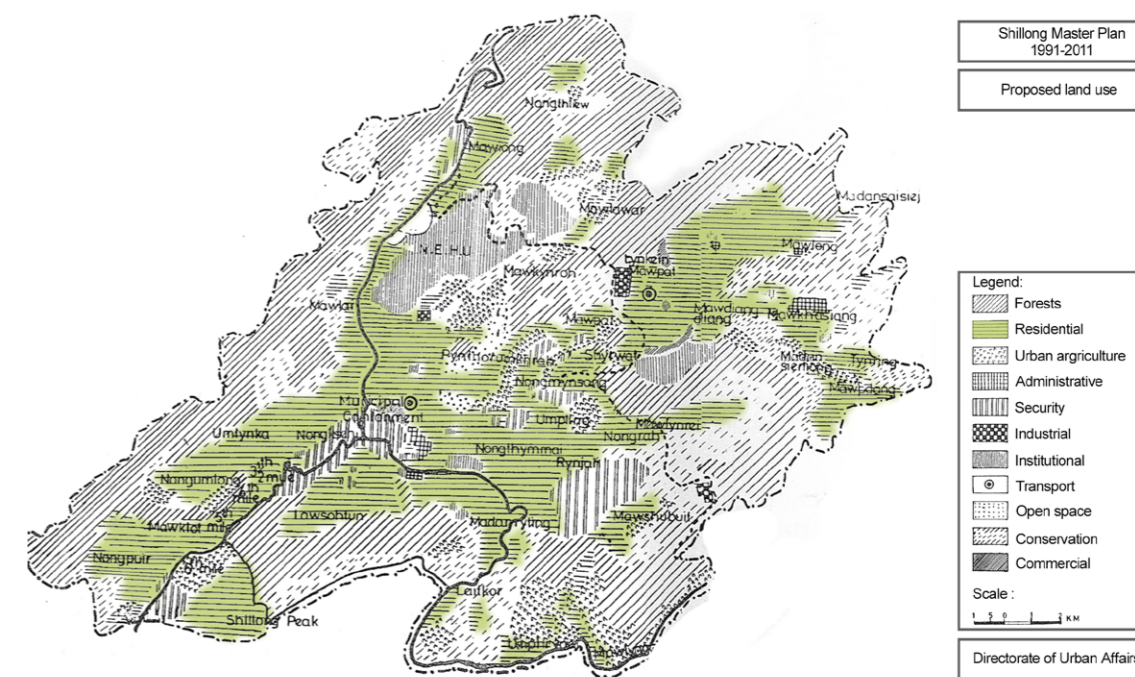


Figure 4.1: Land use map for Master Plan 1991-2011 (Produced by Governemnet of Meghalaya).

Government housing schemes - It is apparent that substantial housing shortage looms in Urban Shillong and a wide gap exists between the demand and supply of housing, both in terms of quantity and quality (Government of Meghalaya, 2018). The residential facilities provided by Government to its employees are very limited and there is no rental housing facilities available either by Government or public agency. Hence, the rental houses available in the market are owned by private individuals (Government of Meghalaya, 2018). Various policies have been formulated at both national and state level. Most of the policies are directed to support the lower income group and economically weaker sections of the society. Some of major housing schemes are:

Government of India:

- Smart Cities (Shillong is nominated as one of 100 cities in the country for the smart city development scheme)
- Atal Mission or Rejuvenation and Urban Transformation (AMRUT)
- Pradhan Mantri Awas Yojna
- National Urban Livelihoods Mission (NULM)
- Lump Sum provision Scheme for the benefit of North Eastern Region including Sikkim

Government of Meghalaya:

- Chief Minister Housing Assistance Programme

It can be seen that many housing scheme have been introduced by the central government. However, no reports have been found for their success story of implementation and execution in the state of Meghalaya. The scheme provided by the state Chief Minister Housing Assistance Programme is mainly for the LIG. This scheme has set standards for a single story house, in which construction materials are provided at subsidized rate and no contractor must be involved in its construction. The lack of open source statistical data in terms of the number of people housed in the urban region under these schemes make it difficult for evaluation.

4.1.1 Inference for the prospects for housing in Shillong Master Plan

It is clearly mentioned in the housing strategy (Mater plan 2015-2035) that a drop in the number of persons per housing unit is expected as a result of the natural trend in the reduction of family sizes with the adaptation of the urban way of life. However, no provision for alternatives of smaller family units has been considered in the Master plan 2015-2035.

- Thus in this research, the design configuration will aim to cater to alternatives of house sizes i.e. household units for 1 person, 3 people and 5 people. For the total height of construction, the Meghalaya building byelaws have specified that upto 4 floors with a maximum height of 15 meters are permitted (Government of Meghalaya, 2011). Also, buildings having 3 floors or more should have a provision for elevators.

- The aim of the research is to develop the construction technology to meet the requirements of greater building heights, within the limits of the bye-laws. It can be seen from the housing scenario that most of housing requirements are fulfilled by the Private sector where the owner of the land and a contractor is involved. Although the housing schemes are available, but not much has been shared about the success of the implementation.

- Thus, looking at the broad picture, the research will focus on developing the design for the larger mass of population dwelling under the private sector. As the research aims to develop the technology for multiple stories, it will need certain expertise in the field rather than a 'DIY' method.

4.2 Availability of local building materials

The advent of new materials in architecture has led to abandonment of old materials. However, many generations have worked and experimented together to perfect the use of these traditional techniques, which have withstood the test of time (Sagheb, et.al, 2011). Hence, it is unwise to disregard this rich heritage that we have inherited. Rather, the logic and science behind the older methods and materials should be revised and its applicability, in consonance with the new materials in today's day and age, should be questioned.

Extraction of natural resources for building construction consumes energy and environmental degradation contributes to global warming. In the life cycle of a building, transportation plays a major role – it includes deporting the extracted materials to the processing units, transferring the processed goods to the building site and after the end of life again transporting it to the landfill or recycling. Transporting the materials to the site constitutes 6-8% of total greenhouse gas emissions for a project (Landry, 2011). Using the materials that are locally available significantly reduces the travel distance and hence reduces carbon emissions. It can be seen from the example of the Assam-type construction that all the building materials were locally sourced. The main construction materials were: timber (Shorea robusta and Pinus kesiya) for the structural system, bamboo (ikra – thin bamboo shoots) for making infill walls and limestone plaster. These materials are found in the rich forests and limestone caves within the state. The extraction of materials in earlier times was not a concern because they were mostly harvested to satisfy the local needs of a smaller population and they were not exploited for commercial reasons.

The current situation demands to accommodate the large population that was not the case in the past. Thus, even the quantity of material extraction will be in a large sum. Taking all these factors into account it is important to understand the state of the environment, the available resources, practices of preservation of natural diversity and the enforcement of laws that will aid in sustainable maintenance of natural environment. However, due to current concerns of deforestation and illegal mining practices it is important to establish a sustainable and safe system for procurement of these materials locally. Figure 4.2 shows an image of a dismantled wall panel from the Assam-type construction which depicts the harmonious composition of three locally available building materials. The following sections elaborate the current scenario of the three major local construction materials and ways of sustainably procuring them for the proposed revival of a healthy construction technology.

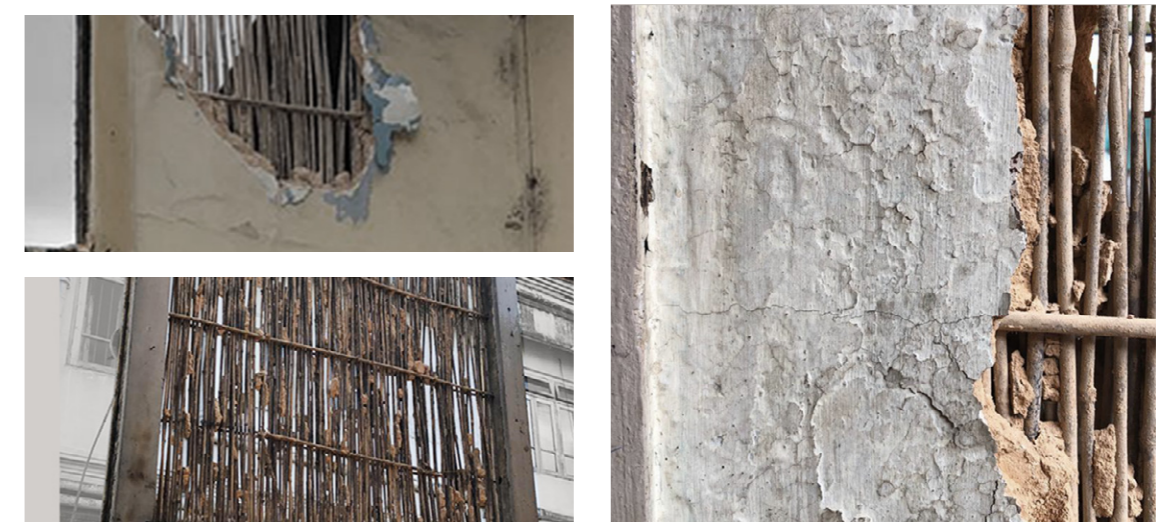
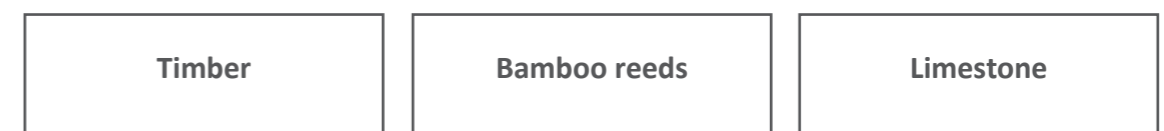


Figure 4.2: The use of timber supports, bamboo in-filled walls and lime plaster in the Assam-type house in Shillong.

4.2.1 Timber as a resource

The biggest issues for wood are not around the products themselves, but access to the wood fiber, addressing forestry-based concerns and managing broad-acre resource issues particularly maintenance of biodiversity, land clearing for food production and illegal harvesting of wood products for cash profits. The international wood sector and markets focus on sustainable forest management to address these issues. Global awareness on deforestation and certification of sustainably sourced wood is encouraging designers and customers to confidently procure quality timber (Khatib, 2016).

4.2.1.1 Timber in Meghalaya

The state of Meghalaya has a history of a huge diversity of flora and fauna. The richness and variety of vegetation ranging from sub-tropical to tropical is due to diverse topography and variations in rainfall, soil and temperature (Tiwari & Kumar, 2008). Also, Meghalaya falls under the biodiversity hotspots of the world, which means that the area has “at least 1500 endemic plant species and having lost at least 70 per cent of their original habitat extent”. Thus, special attention is needed to preserve the biodiversity of the region. The following sections elaborate the current scenario of timber industry in Meghalaya.

Based on the interpretation of satellite data pertaining to the state forest report, 2017, the forest cover in the state is 17146 sq. km which is 76.45% of the states geographical area. The total carbon stock of forest in the state is 155.840 million tones (571.413 million tones of CO2 equivalent) (Forest survey of India, 2017). The forests in India are classified into 5 major categories depending upon the canopy density. The table 4.5 defines the 5 categories and figure 4.4 shows the forest cover map of Meghalaya.

Class	Description
Very Dense forest	All lands with tree canopy density of 70% and above.
Moderately dense forest	All lands with tree canopy density between 70% - 40%.
Open forest	All lands with tree canopy density between 40% - 10%.
Scrub	Degraded forest lands with canopy density less than 10%
Non-forest	Lands not included in any of the above classes

Table 4.5: Forest cover classified in terms of canopy density classes (Forest survey of India, 2017).

Although the state has a rich inheritance of green cover, as per the Forest and Environment department of the state, only 6.56% of the total forest area or 1027.20 sq.km is under the control of the Government authority. This 6.56% of the forest area is categorized into reserved forests, protected forests, national parks and wild life sanctuaries. Rest of the area is either private or clan or community owned and is under the indirect control and management of the Autonomous District Councils. The following sections elaborate on the forest ownership and management.

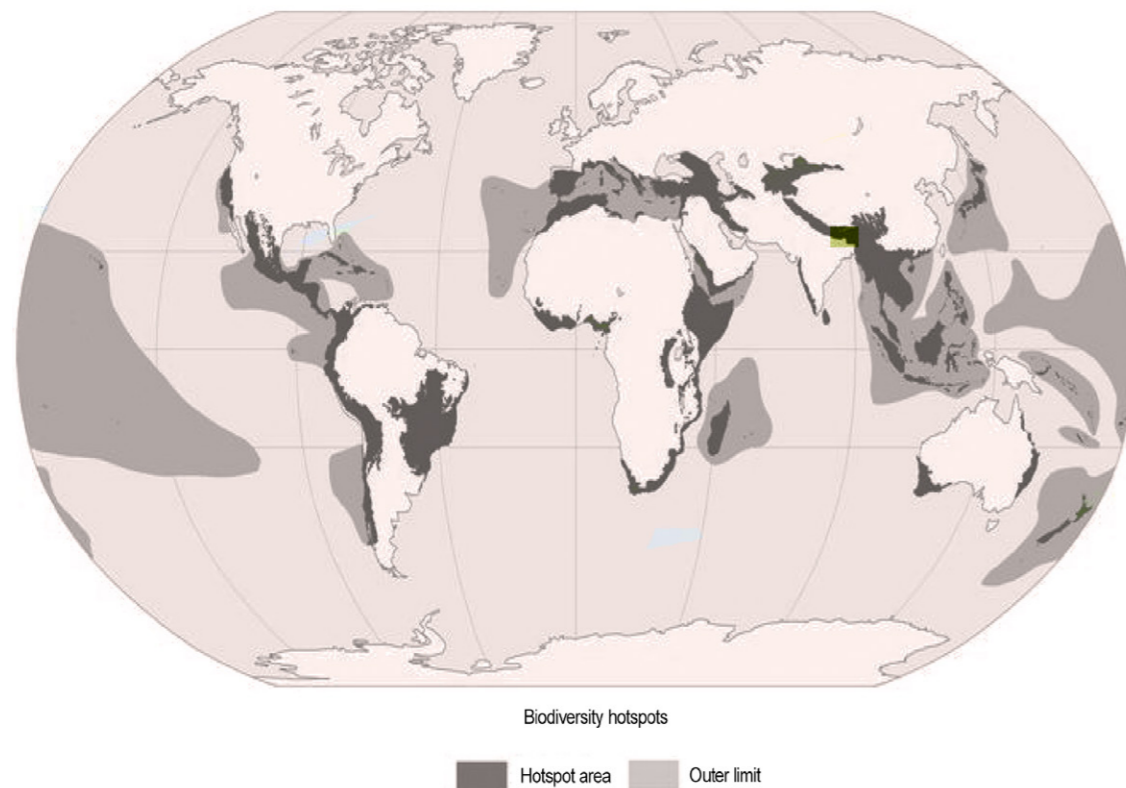


Figure 4.3: Biodiversity hotspots map of the world

(Image source: Mittermeier RA, Turner WR, Larsen FW, Brooks TM, Gascon C (2011) Global biodiversity conservation: the critical role of hotspots. In: Zachos FE, Habel JC (eds) Biodiversity hotspots: distribution and protection of conservation priority areas. Springer, Heidelberg. Retrieved from: <http://www.biodiversity-z.org/content/biodiversity-hotspots>).

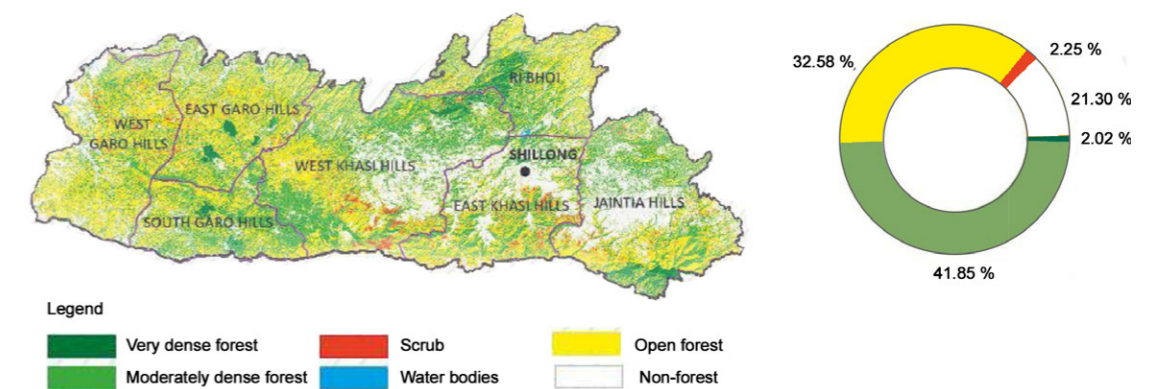


Figure 4.4: Forest cover map of Meghalaya and pie chart showing % of forest cover (Forest survey of India, 2017).

4.2.1.2 Forest ownership in Meghalaya (Tiwari & Kumar, 2008)

During the pre-colonial era majority of the forests in the state were managed and controlled by the community and traditional institutions. Forests, including water bodies, were managed as a common property resource, accessible by all the people living within the jurisdiction of the traditional institutions. After the introduction of “so called” scientific management, large tracts of forests were notified as reserve forests thus bringing in a change in the ownership of forests. Another significant development, which had significant impact on the ownership of forests, was the establishment of district councils and subsequent enactment of Autonomous District Council (Management and Control of Forests) Act (1958). The Act provided a definition and classification of the forests in the state and requires that them to be registered with the respective district council.

In the past few decades, large areas of community forests have been converted into private property, particularly in areas where the practice of shifting cultivation has stopped. Many of these areas have been converted into plantations and have become private property. Such instances are very common in South Garo Hills and Ri Bhoi Districts of the state. However, due lack of cadastral survey in the state, data and authentic record pertaining to the private ownership of forests are not available. In the government records, all such forests are mentioned as unclassified forest. The Sixth Schedule of the Constitution of India defines the official classification of forests based on ownership. Forestland can be broadly classified into one of six categories. These are

- i) Forest land owned, controlled and managed by clans, lineage, families or individuals
- ii) Forest land owned, controlled and managed by community say village durbar
- iii) District Councils forest
- iv) State Government forests (Reserve Forest and protected forests)
- v) Forestland owned, controlled and managed by religion-based organizations
- vi) Forestland owned, controlled, and managed by 22 autonomous institutions or agencies.

As per the records of the State Forest Department, the forests of Meghalaya have been classified into six categories based on the ownership. The area in sq.km. covered by each category in the state of Meghalaya is given in Table 4.6.

	Type of forest	Area (sq. km)
i)	Government Forests (including Reserved Forests, National Parks and Sanctuaries)	993.0
ii)	Unclassed forests	7,146.5
iii)	Private forests	384.0
iv)	Protected forests	179.0
v)	Village forests	25.9
vi)	Community forests	768.0

Table 4.6: Classification of forests based on ownership (Data as per 2008 report by Tiwari, et.al)

However, based on the local methods of forest management, the forests in Shillong are classified into the following categories (Tiwari & Kumar, 2008):

- i) Private Forests: These forests belong to clans or joint clans and are grown on inherited recognized private lands (Ri-Kynti).
- ii) Law Ri-Sumar: These forests belong to an individual clan or joint clans and are grown on inherited or village or common raid lands.
- iii) Sacred groves (Law Lyngdoh, Law Kyntang, Law Niam): These forests are set aside for religious purposes and are managed by the Lyngdohs (religious heads) or other persons to whom the religious ceremonies for the particular locality are entrusted.
- iv) Prohibited Forest (Law Adong) and Village Forest (Law Shnong): These are village forests reserved for the village and managed by the Sirdars, or headman with the help of the village dorbar.
- v) Protected forests: These are areas already declared protected for the growth of trees for the benefit of the local inhabitants and also forests that may be so declared by rules under this Act.
- vi) Green block: These are forests belonging to an individual family or clan or joint clans and raid lands already declared as Green Block by Government for aesthetic beauty and water supply of the town of Shillong and its suburbs and also forests that may be so declared by rules under this Act.

- vii) Raid Forests: These are forests looked after by the heads of the Raid and are under the management of the local administrative head.
- viii) District Council Reserved Forests: These are forests that may be so declared by the Executive Committee, under this Act or the rules made there under.
- ix) Unclassed Forests: These are forests known as unclassified state forests before the commencement of the Constitution of India. They are directly managed and controlled by the Government and include any other forest(s) not falling within any of the above classification. However, most forests falling in this category are either under the control and management of village communities or under shifting cultivation. This situation of land ownership in the state has made a very complicated situation for efficient management of forests as most of it is left in the hands of private parties. It can also be noted that the largest area falls under unclassified forests, which means that there is no clear ownership of the land. The local residents of the village generally claim these forest lands for purpose of shifting agriculture or harvesting forest products. Both these practices are unsustainable as they are not scientifically managed. In order to protect the forest encroachment the government has enacted various laws which are listed below.

4.2.1.3 Policies and rules for forest management

The following are the laws enacted by the Central Government of India and the state government to preserve the forests:

- The Forest Conservation Act, 1980 is an important act which prohibits the deletion of a reserved forest or the diversion of forestland for any non-forest purpose. It prevents the illegal cutting of trees in a forest without prior approval of the government (Ministry of Urban development, India, 2015).
- Wildlife Protection Act, 1972
- The United Khasi and Jaintia Hills Autonomous District (Management and Control of forest) Act, 1958.
- Garo Hills Autonomous District Council Forest Act, 1958
- The Garo Hills Regulation, 1882 (Regulation 1 of 1882)
- Meghalaya Forest Regulation (Application and Amendment) Act, 1973
- Meghalaya Forest (Removal of Timber) Regulation Act, 1981 was specially enforced by the state government to control the removal of timber from the forests and exports outside the state from the private forests. It is also provided that ‘controlled’ felling can be permitted by legally getting the license from the District council (Forest department of Meghalaya) after a private party gets a ‘working plan’ formulated. The working of ‘working plan’ is explained further.
- Meghalaya Tree Preservation Act, 1976
- Meghalaya Protection of Catchment Areas Act, 1990
- The Bengal Cruelty to Animal Act, 1869
- The Meghalaya Wild Animal and Birds Protection Act, 1971 (Act 9 of 1971)
- Garo Hill District (Forest) Act, 1958
- Forest (Conservation) Rules, 1981
- The Wildlife (Transaction and Taxidermy) Rules, 1973
- The Wildlife (Stock declaration) central Rules, 1973
- The Wildlife (Protection) Licensing (additional matters for consideration) Rules, 1983

Since most of the forests in the state of Meghalaya are private, it was important for the authorities to formulate a policy and method for sustainable maintenance and extraction of our natural resource that can be maintained with the aid of these private bodies or owners. Clause 23 of the Forest Conservation Act, 1980 states that ‘working plans, for forest divisions shall be prepared by the State Governments and approved from the Government of India’. The principles of the ‘working plan’ management in India are sustainable forest management and recognized and innovative silvicultural practices. In this the private owner or manager of the forest region should initiate the preparation of the working plan/scheme by approaching the Ministry of Environment & Forests which is authorized by the Government of India to approve the working plans for an area. Timber harvesting is not permitted in any forest area without an approved working plan/scheme from the designated authority. While a detailed working plan is prepared for large areas such as forest division, working schemes are prepared for smaller areas for a specific purpose or areas like private, village, municipal, cantonment forests, etc (Tiwari & Kumar, 2008). Working schemes have the all the important principles and rules of the working plan which also have be monitored by qualified departments designated by the Ministry of Environment & Forests. It includes a detailed inspection of the forest area, characteristic study of its properties based on scientific theories and formulation of a technical harvesting system of the forest products which will not destroy the natural system of the forest. The figure 16 summarizes the different stages of a working plan.

It can be seen that the 'working plan' is an efficient method because a qualified technical person on scientific basis individually scrutinizes every forest and a forest management plan is formulated for harvest of forest products. As per the report by Prof. BK Tiwari, the state of Meghalaya has a total of 75 saw mills legally registered under the working plan scheme with the state government. However, there is no source of 'internationally certified timber' in the region. Though most of the saw mills are concentrated in the western part (Garo hills) of the state, it was informed by environmental researchers in the region that the well managed forests under the working scheme are limited and concentrated in the eastern region (Jaintia Hills). Also, the number of mills operating in the region are higher as a good number have not been registered and are functioning illegally (Tiwari & Kumar, 2008).

It can be seen that the 'working plan' is an efficient method because a qualified technical person on scientific basis individually scrutinizes every forest and a forest management plan is formulated for harvest of forest products. As per the report by Prof. BK Tiwari, the state of Meghalaya has a total of 75 saw mills legally registered under the working plan scheme with the state government. However, there is no source of 'internationally certified timber' in the region. Though most of the saw mills are concentrated in the western part (Garo hills) of the state, it was informed by environmental researchers in the region that the well managed forests under the working scheme are limited and concentrated in the eastern region (Jaintia Hills). Also, the number of mills operating in the region are higher as a good number have not been registered and are functioning illegally (Tiwari & Kumar, 2008).

4.2.1.4 Timber trade

The forest of Meghalaya is a rich source of timber, bulk of which originates from private forests. Timber trade is a vital component of the economy of Meghalaya (Tiwari & Kumar, 2008). At higher altitudes of the Khasi and Jaintia Hills, pine trees abound. There is abundance of luxuriant Sal (*Shorea robusta*) forests offering quality construction timber in the lower reaches of the Garo Hills. The forests of the state are the source of livelihood for many, who do not have any alternate options. Labour is needed in extraction and processing of timber, collection and marketing of non-timber forest products, charcoal making and government sponsored afforestation projects.

There is a huge demand of timber in the state for various industries. In rural regions, locals use timber as firewood and house construction. In urban regions like Shillong, timber is demanded for furniture making, door and window frames and interior works. The government discourages the use of mass timber for construction purposes. Relating this to the previous studies of the Assam type construction, the discouragement by the government for timber construction in urban regions might be one of the reasons for the boom in the alternate building material. However, this has not reduced the high demand for timber for industrial use. The forest-based industries in the neighboring states of Assam need a high quantity of timber for production of plywood and matchwood. Also a fairly good income margin has encouraged illicit felling of trees for producing charcoal, which is a major raw-material for the ferro-quartzite industries in

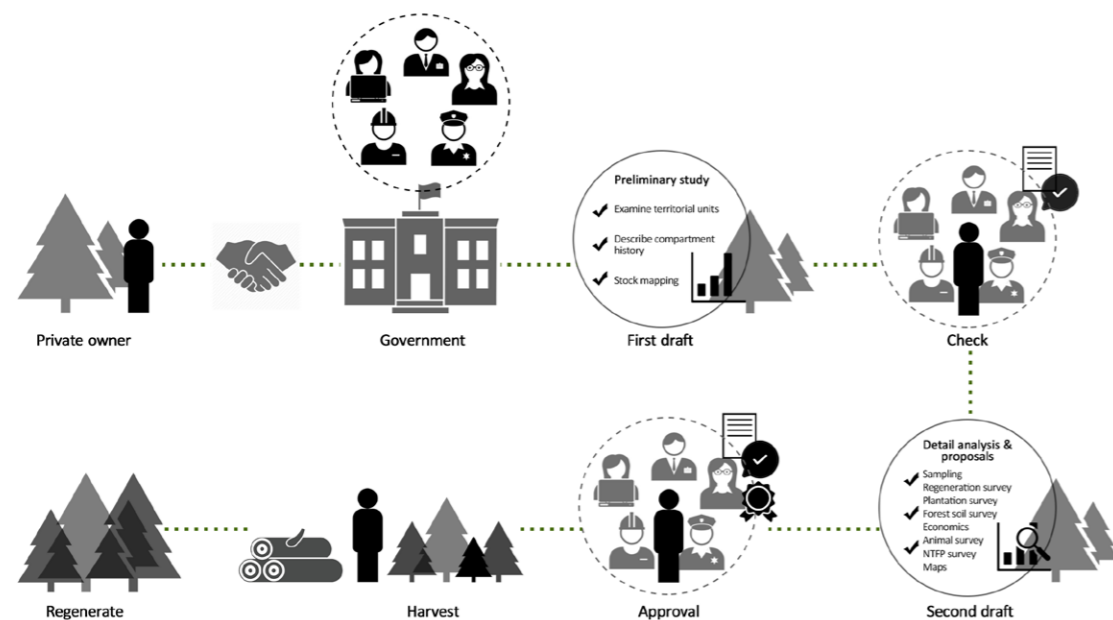


Figure 4.5: Flowchart of the process of a working plan/scheme. (Icon source: thenounproject.com, iconfinder.com)

the state (Tiwari & Kumar, 2008).

As per the rules of the Forest Conservation Act, 1980 the movement of timber either by road, rail or waterways is strictly prohibited from in the north-eastern region of India, including Meghalaya. Due to this law an illicit timber trade is prevalent along the Indo-Bangladesh border. In a detailed study by Prof. B K Tiwari, the modus operandi of the timber smugglers in the state is that they cut trees at night, mark them with initials known to their counterparts at the receiving end and float the timber on the waterways which act as passage for transportation. This is particularly done during the monsoon period. The amount of timber seized during this process is alarming and most often the seized timber is left in the remote jungles due to lack of transportation. Sadly, very little of the illegal trade is detected while the larger lot is successfully smuggled by the dealers.

Despite the presence of laws, it is difficult to control the illegal and uncontrolled felling of trees for export. The major reason of this being that most of the forest is under private ownership, making it difficult for the authorities to directly manage the resource. Table 4.7 shows the data for the total forest cover within the state of Meghalaya since 1987 (the first forest survey in India was conducted in 1989).

	2017	2015	2013	2011	2009	2007	2005	2003	2001	1999	1997	1995	1993	1991	1989	1987
VDF	417	449	449	433	0	410	338	168								
MDF	9555	9584	9689	9775	0	9501	6808	6323	5681	5925	4044	4045	3305	3305	3427	5749
OF	7290	7184	7150	7067	0	7410	9842	10348	9903	9708	11613	11669	12464	12570	12263	10762
Total	17262	17217	17288	17275	0	17321	16988	16839	15584	15633	15637	15714	15769	15875	15690	16511

Table 4.7: VDF – Very dense forest, MDF – Moderately dense forest and OF – Open forests. The visual interpretation technique was employed for forest cover interpretation before 1999 and Digital image processing and remote sensing was employed after 2001. Forest cover in the state of Meghalaya (Forest survey of India, 1987-2017).

It can be seen from the table that although the overall forest cover is slowly increasing, the state of the very dense forests (VDF), which house several species, are decreasing. It is outlined the report by the Forest Survey of India that the main reasons for deforestation in the state of Meghalaya is due to the traditional Shifting culture practices, the huge market of illegal timber trade, mining and developmental activities. The slight annual rise in the forest cover is due to the implementation of various afforestation practices throughout the state in abandoned lands by the Government. It was also mentioned in the 1999 forest survey report that afforestation was made by planting – 18.2% Sal (*Shorea robusta*) and 8.9% Pine (*Pinus kesiya*) which have a high monetary value in the building sector (These species were previously used in the construction of Assam type house).

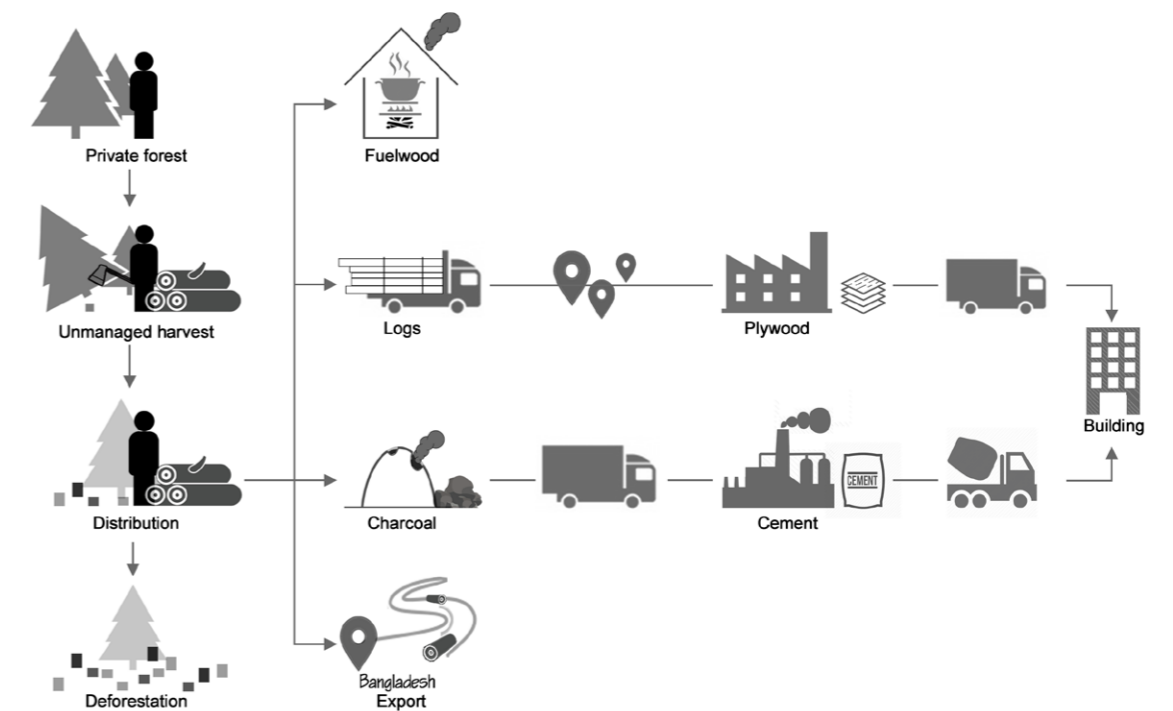


Figure 4.6: Existing condition of timber trade in the Meghalaya. (Icon source: nounproject.com, iconfinder.com, freepik.com)

4.2.1.5 Inference for timber availability in Meghalaya

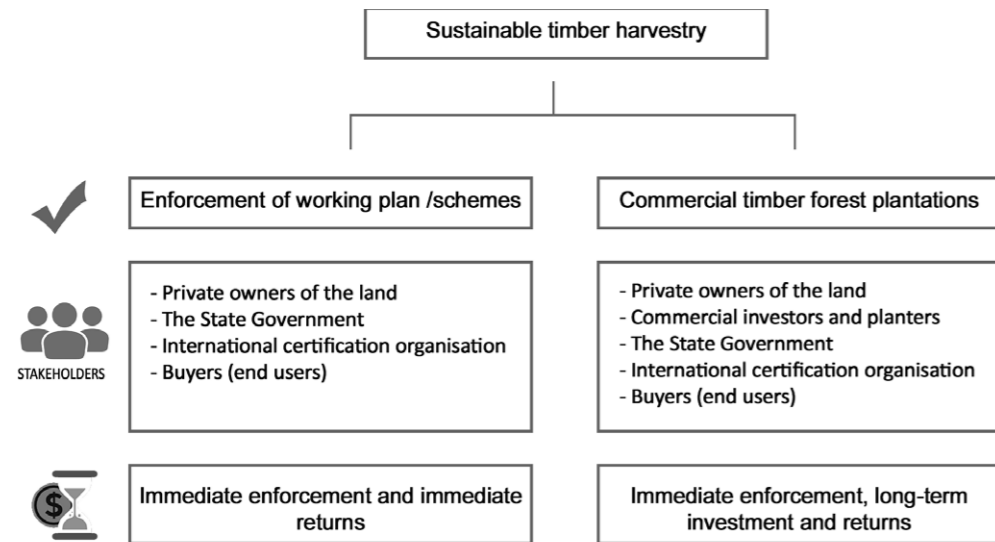


Figure 4.7: Proposals for sustainable timber harvest in Meghalaya.

The increasing awareness worldwide in benefits of using timber for construction have already been outlined in section 2. Also, it can be seen that the state of Meghalaya is adored with a huge resource of timber. From the past experiences in the region and being inspired by the sustainable forest harvest programmes taking place in other parts of the world, Meghalaya can be brought to forefront in timber production and usage. Also, the climate and soil conditions are favorable for the growth of timber industry. Through research input and introduction of appropriate technology and management, the productivity of the forests can be increased manifold and thereby create new employment opportunities for the people in all sectors of state's economy and also help maintain a healthy ecosystem (Tiwari & Kumar, 2008). Thus, a large movement with the help of private individuals and the government can aid in setting up a sustainable timber industry. Also, certification from third party international organizations like the Forest Stewardship Council (FSC) and Programme for Endorsement of Forest Certification (PEFC) will ensure a strict discipline in protection of the biodiversity whilst ensuring a working of scientific forest harvest in the region. Following this, a hope for mass timber construction can be witnessed in the state of Meghalaya. Analyzing the dynamic forces within the state, the following two methods can be proposed for the for initiation of sustainable timber harvest in a large scale:

Enforcement of working plans/schemes:

This is the current method of sustainable forest management proposed by the Government of India and the existing forests form a part of the supply chain for timber. To ensure a continuous timber supply, the harvest must be below the sustainable regeneration capacity of the forest. The studies made on prevalent tree species and their life cycle assessment aids in calculating the time for felling and selective cutting. In this case the forest regenerates naturally by itself or saplings are planted to preserve the natural biodiversity. Not only this, the scientific harvest of matured forests can aid in trapping carbon if used in making long-term products like buildings (Ramage, et al., 2017). Also, small diameter trees can be removed from managed forests to improve the quality of the matured trees and reduce the likelihood of forest fires. Since, Meghalaya already has a huge reserve of forests, a conscious intervention will not harm the environment. This method needs very less investment and large economic returns can be expected immediately, as soon as working plans are formulated, as matured timber is already present in the forests of Meghalaya. There is no waiting time for the timber to mature as in the case of artificially planted commercial forests.

Inspiration can be taken from the case of Canada, whose strong laws, farsighted management and the compulsion for regeneration of all harvested lands has made it a world leader in production of certified timber (Natural Resources Canada, 2018). Also, a continuous maintenance and updating of database on existing forest cover and regeneration helps to control the commercial activities. Thus by enforcing the management plan for the forests within the jurisdiction of state forest department and an efficient mechanism for transfer of technology and management skills to forest owning communities, biomass productivity of forests can be increased and their degradation can be avoided. Also, on acquirement of managed timber, the mass timber construction can be promoted in urban areas in order to step forward

in a holistic long-term sustainable commitment.

Commercial timber plantations:

While the working plans talk about sustainable management of natural forests, the commercial timber plantations are concerned with planting of selected species of high economic values in designated area for the purpose of commercial harvest. The economic market can be judged by the fact that in 2000, although plantations accounted for only 5% of the total global forest, yet it was estimated that they supplied nearly 35% of the world's total round wood (United Nations Environment Programme, 2010). In this method companies and entrepreneurs acquire the degraded lands for generating profits by means of sustainably managed forest farms. The famous Chinese proverb expresses the opportunity that lies within the practice of commercial plantations (Faruqi, et.al., 2018):

*"The best time to plant a tree was 20 years ago.
The next best time is now."*

This practice demands an initial monetary investment in taming the farms and a long return time for the first harvest, generally 30-50 years depending upon the species and climatic conditions. After the first year of harvest a continuous income can be ensured provided that the forests are managed sustainably. A longer rotation time improves the structural qualities of timber (Ramage, et al., 2017). Generally, monoculture is practiced in case of commercial planting. However, studies have shown that planting the correct combination of multiple species aids to create a healthier forest environment and also speeds up the growth. Also, certain species can also be modified to yield greater strengths depending upon the purpose of plantation.

Meghalaya has a huge scope for establishment of the commercial tree plantations. Given that the region has a high area of barren land due to the traditional culture of shifting cultivation (locally the practice is called – jhum) and the favorable climatic conditions, the state has an excellent potential for the setup for this industry. The government takes a lot of initiatives for afforestation; if this practice is clubbed with the interests of commercial enterprises it can yield high economic prosperity along with an ensured regeneration of the forests. At the same the local communities can be employed in these farms to ensure a harmonious work culture. The system also aids in flourishing of a healthy living environment, creating recreational opportunities, providing other food and forest products and most important mitigating climate change by storing carbon and improving air quality (Faruqi, et.al., 2018).

Specifically taking the case of the capital city Shillong, table 1 of the master plan 2015-2035 shows that 26.38% of the total land under the Shillong agglomeration is undevelopable. This adds up to 5468.60 hectares that includes forests and water bodies and areas meant for conservation (Government of

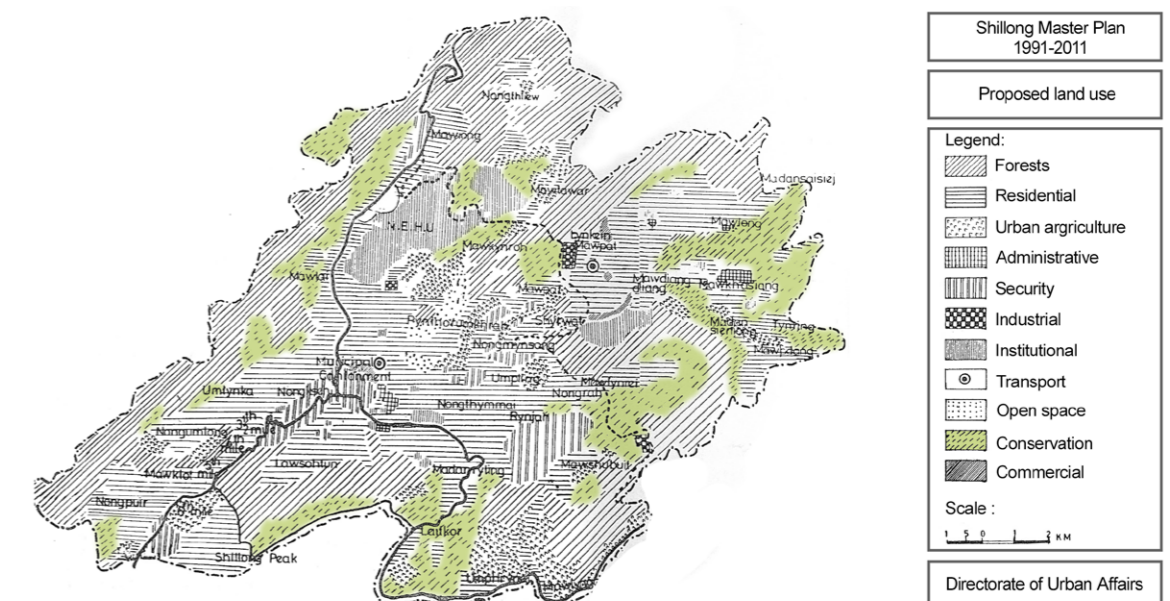


Figure 4.7: Proposed Master Plan (1991-2011), area under conservation (Proposed by Government of Meghalaya).

Meghalaya, 2018). This land is categorized into undevelopable because of steep slopes and land liable to sliding. The master plan is encouraging activities like growing fruits, market gardening, zoological gardens and botanical gardens in these lands. Also the conservation of these lands includes afforestation in degraded patches. These areas can thus be seen as opportunity for practicing commercial timber plantations. It is also mentioned in the Master plan that if these areas are provided with infrastructure facilities than many conservation areas can be put to use. The slope gradients and accessibility can be analyzed by qualified people and tree plantations can be initiated. As this tree plantation will have a positive environmental impact, they can thrive in the urban environment adding the health and economy to the city. Figure 4.7 shows the proposed area under 'conservation' in the master plan of Shillong.

It is already mentioned that the two main species used in construction of Assam-type house are:

- Shorea robusta (Sal)
- Pinus kesiya (Khasi pine).

While sal is used for the structural members, pine is used for the wall members, internal partitions, flooring and roofing panels. Both sal and pine have been managed under various silviculture practices in other parts of the country (Gupta). Also, both sal and pine demand light for their development. Light helps in increasing photosynthesis and accelerates the decomposition of litter on the ground (Gautam & Devoe, 2006). Table 4.8 shows certain physical properties of the two species. Besides timber for construction industry, plywood and veneers, both sal and khasi pine yield other non-forest products like:

- Sal – Resin is used to produce paints and varnishes. Seed oil is used for lighting and cooking. Oil has medicinal properties and used for ear and skin diseases and leaves are used for making plates and cups (Anupama, 2016).
- Khasi Pine – Used as fuelwood, for production of charcoal and torches. Resin is used for production of turpentine used in paint industry and rosin for production of soap, paper and glue.

Finally the benefits of forestry can be judged from an environmental and commercial perspective for the overall wellbeing of our society. Depending upon the species and physical conditions it can be seen that average forest harvests range from 25-60 years, in terms of human time scales. However, if compared to other mineral resources used in building construction like rocks, ores and soils, which require many centuries of production to maintain the earth's supply chain, timber is much easier to replace. In this view, timber as a building material is very sustainable (Ramage, et al., 2017). Figure 4.8 shows the proposed timber management diagram in the state of Meghalaya.



Scientific Name	Shorea Robusta	Pinus Kesiya
Local name	Sal	Khasi Pine
Altitude	Few meters above sea lvl. to 1500m	800 to 1200m
Average harvesting time	40-60 years	25-30 years
Tree height	30-40 m	25-35m
Mean annual increments (MAI)	2.8–11.2m ³ /ha (changes with age)	10-30 m ³ /ha
Average trunk diameter	81-90 cm	100-120 cm
Stems per hectare @ 12-14 years	928	300
Density	720 kg/m ³	400-750 kg/m ³
Modulus of Elasticity @ 12% moisture content	15890 MPa	5700-20700 MPa
Image of the tree leaves		
(Source Sal - http://www.botanicimage.com , Pine- http://en.wikipedia.org)		

Table 4.8: Comparison in properties of Sal and Khasi Pine.

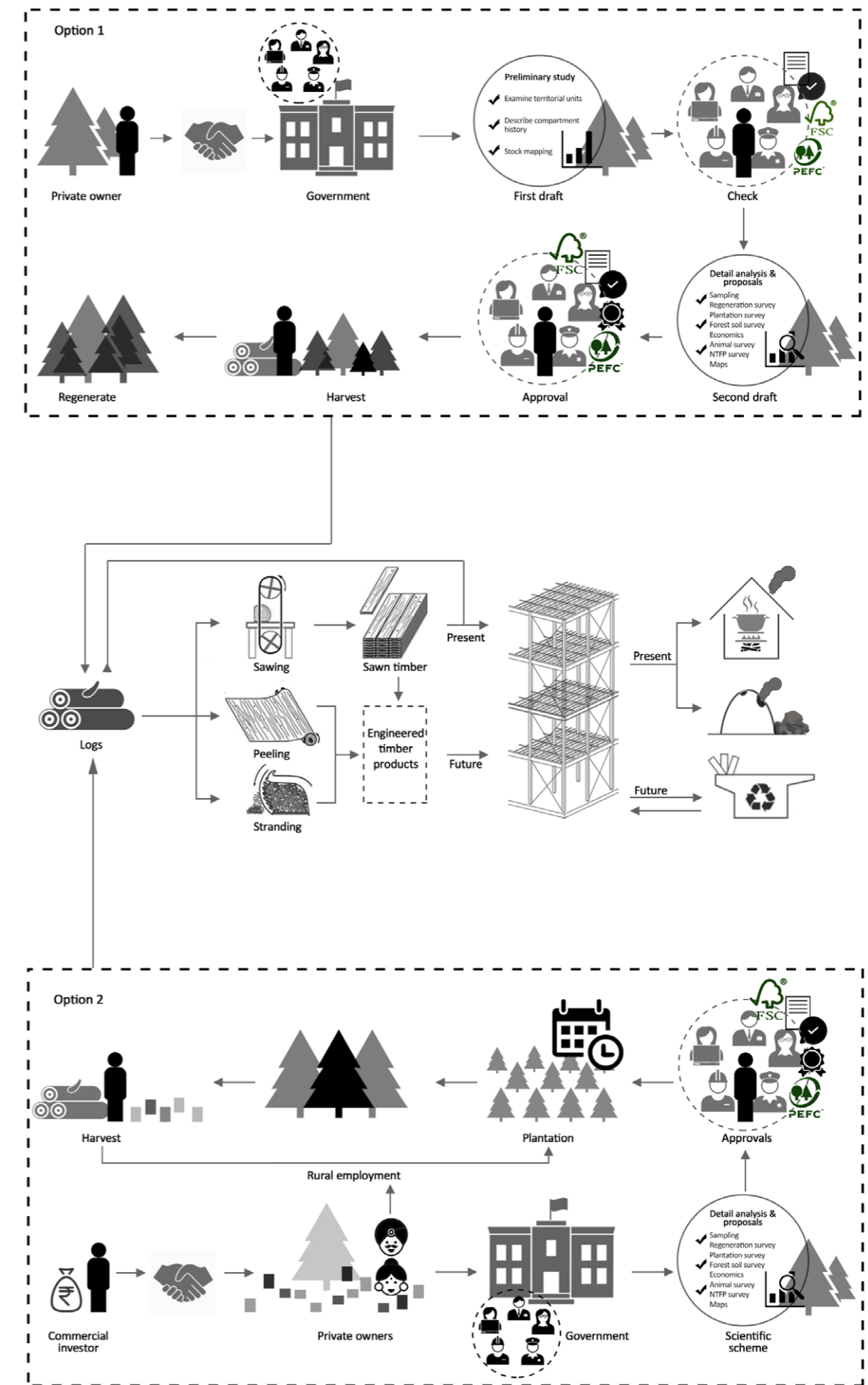


Figure 4.8: Proposed timber management for the state of Meghalaya, from the cradle to end of life. (Icon source: nounproject.com, iconfinder.com, flaticon.com, freepick.com, dreamstime.com, bedroomsplusonline.co.uk)

4.2.2 LIMESTONE AS A RESOURCE

In the Assam type construction system, lime was the main component of the plaster composition along with sand and water. The significant use of lime was established because of its locally available abundant reserves. Meghalaya has 14959 million tones which accounts for 9% of the total lime reserves in India (Singh & Lamare, 2017). As per the classification by the Government of Meghalaya most of this is of cement, metallurgical and chemical grade. Also in the present times, due to the shift in construction technology to concrete structures, a huge demand for cement has erupted. This has led in exploitation of the natural resource in Meghalaya. A large cement industry flourishes in the state on the basis of limestone availability. As per the data provided in Master plan 1991-2011, currently 34 units of mineral based cement industries are registered in the state. Meghalaya has 12% of the total cement grade limestone reserves of the country. Also India is the second largest producer of cement in the world after China (Singh & Lamare, 2017). While lime is sent to nearby paper industries, it is locally used for white-washing walls of houses. Not only this, Meghalaya also exports huge quantities of limestone to other countries. International boundaries and distances have not stopped encroachers to extract maximum, its extent is seen in the establishment of a 17 km long conveyor belt specially built to transfer limestone from quarries in Meghalaya to a cement plant in Bangladesh. Figure 4.9 shows the image of the conveyor belt.

The economic progress of the state due to the established of cement industry and limestone mining cannot be denied. The industry is a huge source of employment and livelihood for the rural people in the state. On the other hand, mining activities and cement plants have become a source for acute environment problems in the region (Singh & Lamare, 2017). Various problems have been reported by localities and scholars have presented studies on the environmental impact of limestone mining in Meghalaya.

4.2.2.1 Environmental impact of limestone mining

The complicated scenario of private land ownership in Meghalaya has already been explained in section 4.2.1.2 and its affect extends even in the field of mining. Since private parties own most of the reserves, mining is carried to maximize the profits. This has led in adoption of unscientific and degrading methods of mining despite the presence of mining laws and procedures in the state (Singh & Lamare, 2017). Further there is a lack of land reclamation by these private parties. The problem is aggravated due to the presence of huge cement plants in vicinity. It was stated in a report that the problems caused due to cement plants are more than mining (Singh & Lamare, 2017). Both the two combined; affect the terrestrial and aquatic ecosystems of the region and beyond. The loss of drinking water sources was reported due to the discharge of effluents from the factories and washing away of sediments into natural water bodies and increased content of minerals and solid particles in the water. Also these cement industries require huge quantities of water which has affected the ground water resources in certain regions. Activities like drilling, blasting, loading and transportation generate dust which increases the suspended particulate matter (SPM) causing air pollution. Also, various machines that are involved in the above processes like bulldozer, drillers, dumpers and transportation vehicles which add to the pollution levels. While the locals practiced rain water harvesting, it was reported that deposition of dust on the roof due to establishment of cement plants caused a decline in the tradition. Also the dust falling on soil increases its pH and that on the leaves cause injury or death to the plants due to blocking of sunlight (Singh & Lamare, 2017). The decline in number of fishes were also reported by inhabitants. Thus it can be concluded that we have caused nature to pay a heavy toll to fulfill the aim of meeting the growing demands of the world. Figure 4. shows the current status of limestone in Meghalaya.



Figure 4.9: Left – 17 km conveyor belt built by Lafarge group for transporting limestone across Indo-Bangladesh border. Right - extracted limestone in a quarry. (Source: <http://i.imgur.com/cWYPvYU.jpg> and thefinancialexpress.com)

4.2.2.2 Inference for limestone availability in Meghalaya

The use of lime plaster is already known from Assam type house dating back to 1900's. However, mining was never an environmental problem in the past because small quantities were extracted and used locally for edible and plaster purposes (Singh & Lamare, 2017). As compared to temperatures greater than 1300 C for production of cement, lower temperatures are needed - 800-1000 C, for production of lime stone for plaster. Also, the carbon emission in cement production is simply incomparable to that of lime. It can be said that by following strict methods of mining, using upgraded machinery, treating effluents before discharge and following latest technology; the impact of mining on the environment can be reduced. Also, reclaiming the wastelands and practicing afforestation can help in revival of the environment. Private owners should be directed by the Government to adopt the laws.

Sadly, in the current context the demand for cement on a worldwide basis cannot be stopped, since a large number it is the basis of a large economical development. As the world is slowly adopting sustainable methods of building and the technology for alternative materials are progressing, the need for harmful materials like cement will subside. However, for now the only thing that we can do is post care treatment of the nature. While in the case of Shillong we can promote the use of natural limestone plaster, which will reduce the demand for cement and by doing so, we can take one step forward towards sustainability.

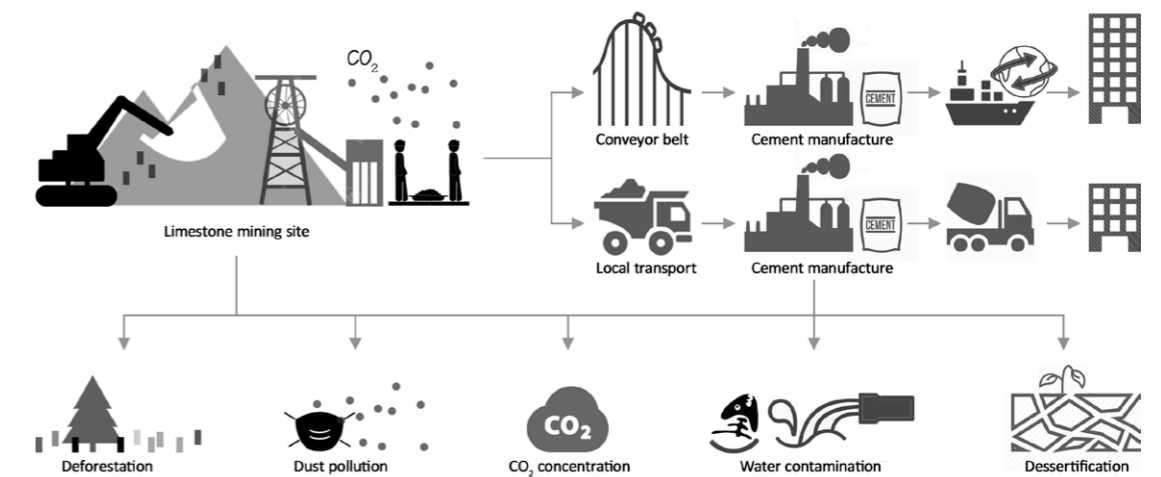


Figure 4.10: Current status of limestone mining in Meghalaya. (Icon source: nounproject.com, iconfinder.com, flaticaon.com, freepick.com, dreamstime.com, fotosearch.com, shareicon.net, clipartmax.com, 123RF.com).

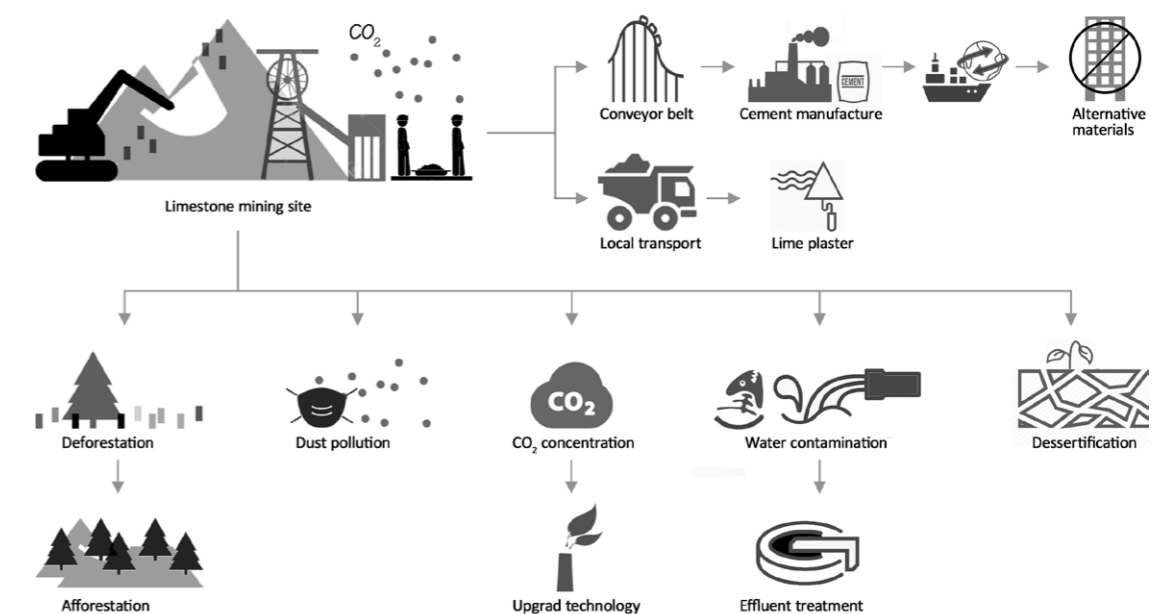


Figure 4.11: Proposed scheme for lime mining and practices for upgrading the environmental quality. (Icon source: nounproject.com, iconfinder.com, flaticaon.com, freepick.com, dreamstime.com, fotosearch.com, shareicon.net, clipartmax.com, 123RF.com)

4.2.3 BAMBOO AS A RESOURCE

The final important building material in construction of the Assam-type house is bamboo. Bamboo was used to make wall panels as shown in figure 4.2. Its physical property of being lightweight and abundant local availability were major reasons for its use in construction. Although the use of bamboo in Assam-type construction is limited to non-load bearing wall panels, bamboo was used in multiple ways for constructing other houses and small furniture in the region. In the low altitudes, where humidity and temperature levels are high in most part of the year, bamboo mats were used for making walls of the huts of rural dwellers, figure 4.12 and 4.13 shows examples of this kind of use. Also, bamboo is very important in the socio-cultural and economical context of Meghalaya. It is the main material for making tradition handicrafts, like mats, baskets, bags, bins, etc. in the entire region, which is a source of livelihood for many. It is also used for making equipment for cattle rearing, fishing, musical instruments and agriculture, figure 4.13 shows some of the bamboo handicrafts in Meghalaya.

Bamboo's diversity in terms of size, lightweight yet strong, hard and straight make it amenable to versatility of use (Forest survey of India, 2017). It's fast growing, renewable, enhances carbon sequestration and bio-diversity conservation properties entails its potential for a sustainable use in construction industry. Meghalaya has 5943 sq.km of bamboo bearing area (Forest survey of India, 2017). Despite the huge resource, the bamboo industry in Meghalaya is still at a pre-mature state and is limited to small-scale domestic industries producing handicrafts. Also, as a byproduct of globalization, the increase in construction with reinforced concrete has caused a decline in construction of bamboo houses in the rural regions. Construction with these modern materials is also associated with the 'status' of an individual and 'bamboo is considered a poor man's material' (Sharma, 2010). In the urban regions bamboo is used for scaffolding during construction process. Further, it was learnt from the local masons in the region that the declining demand of ikra (bamboo) in construction sector slowly crippled the existence of bamboo farms which flourished previously. The economic model for ikra bamboo is no longer existent and very few farms or wild ikra are used in extremely rural regions. Also its use as a structural material in urban areas of Meghalaya is still unknown, other than the small bamboo huts which are temporarily made by the economically weaker sections on encroached lands. The huge resource of bamboo as a construction material is untapped, and the industry has a great potential of development. Although, the government of Meghalaya encourages the use of bamboo, however it is not included in the specifications and schedules approved by the Government agencies (Vengala, Mohanthy, & Raghunath). Also its harvest schemes have not been very well incorporated in working plans. Also, the private owners give a preference to timber because of its higher economic value. The major reasons for this drawback of this material may be the lack of technical knowledge and facilities to incorporate the material in modern construction technology, lack of authentic design data, lack of testing labs and scientific research centers for studies of local species (Vengala, et.al.). This leaves the material to be dependant on vernacular methods and techniques of construction which is not gaining importance in urban regions. Thus, to gain the confidence in bamboo as a building material, scientific research needs to be promoted and engineering standards have to be set to meet the levels of modern day evaluations and performance assessment (Sharma, 2010).



Figure 4.12: Left: Bamboo mat wall with mud plaster, Middle – Interior of a stilted house showing permeable floor, Right – Interior showing a bamboo loft. The above images are examples of bamboo uses in neighboring areas. [Source: (Nag & Gondane)].

4.2.3.1 Inference for bamboo availability in Meghalaya

As already mentioned bamboo was an important element in construction of the Assam type house. Although not structural, but the material played an important role in innovation of an overall lightweight structure which ultimately affects the design of structural members. Revival in use of bamboo in construction sector can be initiated by getting inspired by other parts of the world where research in bamboo as a construction material is developing. These new technologies and innovations can be studied and its applicability in the region of Shillong can be judged. An economic business model can be developed by educating the locals and bamboo based industries like engineered laminates and panels can be promoted by the government. The methods of using bamboo in construction are innumerable. However, for the purpose of this research bamboo will primarily be used for developing the wall panels, whilst the main structural element still being made of timber. The reason for this is that there is still a lack of data on the structural properties of locally available bamboo as compared to that of timber. Also, the fact that the assam-type has withstood the test of time, it has been considered a role model for this research. Various methods of creating wall panels from bamboo will be experimented, like using ikra directly or enhancing its performance by layering it with mats or metal fly-mesh. However, before this the bamboo industry has to be promoted to setup a business model for the sustainable building resource.

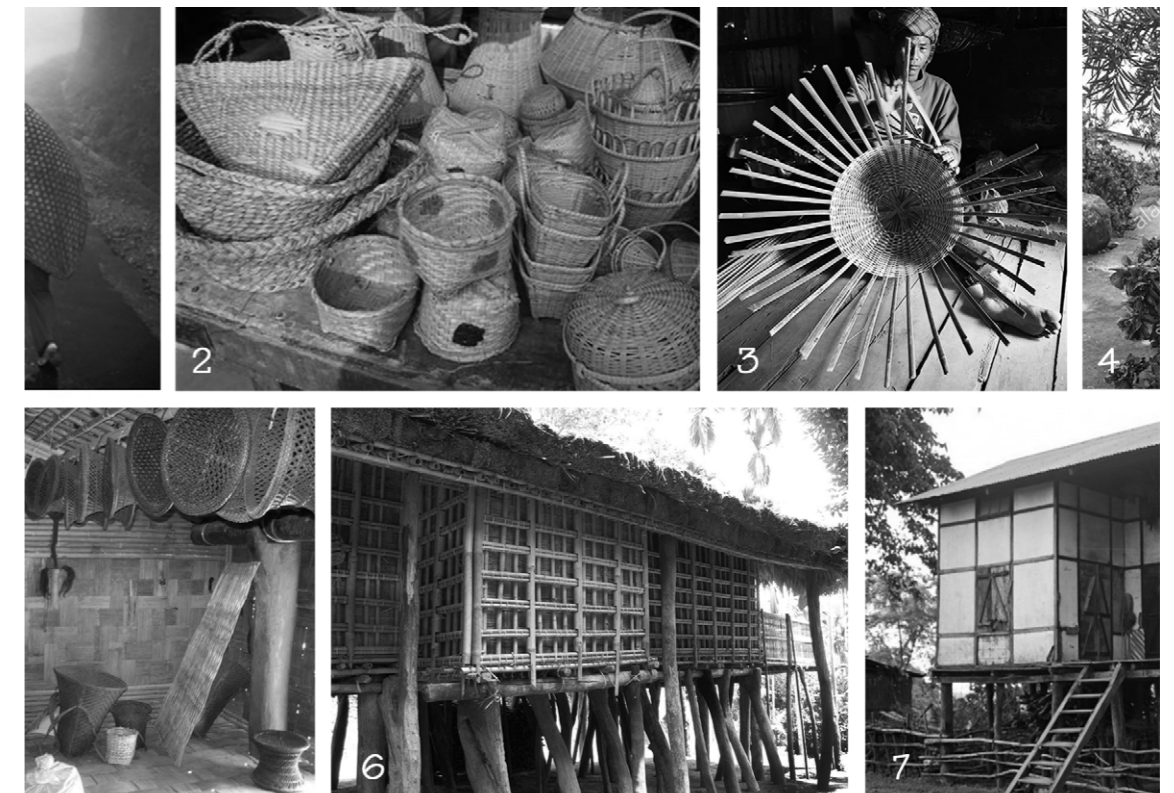


Figure 4.13: 1) Traditional bamboo umbrella (knup) (Image source: www.epaperbeta.timesofindia.com), 2) Traditional bamboo baskets (Source: www.meghalayaonline.in), 3) Woman weaving a basket (Source: www.dawn.com), 4) Bamboo dustbin in a village (Source: www.alamy.com), 5 & 6) Garo houses in Meghalaya (Source: www.medium.com), 7) Assam type house (Source: www.housing.com).

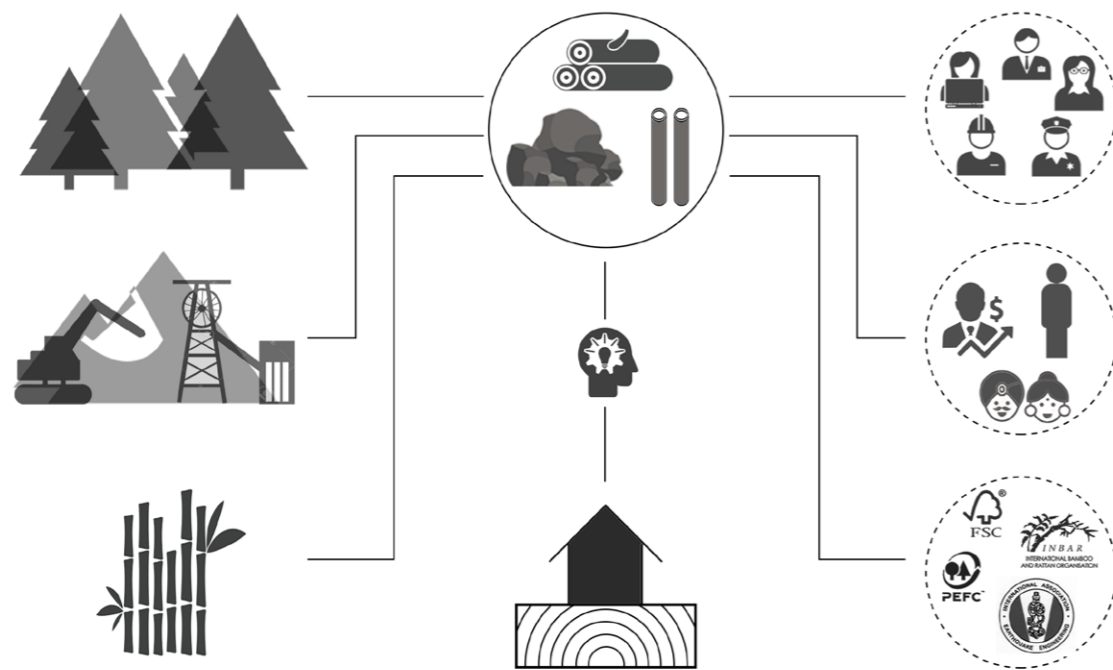


Figure 4.14: Rethinking the building technology in Shillong, Meghalaya. (Icon source: nounproject.com, iconfinder.com, flaticon.com, freepick.com, dreamstime.com, fotosearch.com, shareicon.net, clipartmax.com, 123RF.com, the logos of organisations have been downloaded from their websites.)

4.2.4 Inference for natural building material availability in Meghalaya

Efficient technologies were developed by our ancestors, in response to the surrounding environment, using local materials that provided the best shelter (Sharma, 2010). Historically, these materials were used to ease transportation and were climate responsive. With the advent of modern facilities and efficient means of transport, we have overlooked the historical reasons for development of the 'indigenous' methods of building and have taken the world resources for granted. In the scale of geological timeline, anthropogenic affects is causing a collapse of the entire ecosystem on planet earth. Thus it is time that our practices are revised and thought is given to the way we live.

The current availability of the three main building materials has been indicated in the above study. It is learnt that although the materials are locally available in abundance, its misuse due to unsustainable means of over-extraction, as in case of timber and limestone has led to negative environmental and social impacts. On the other hand, Bamboo as a building resource has not been tapped. Also the massive use of modern building materials like reinforced concrete, will take an irreversible toll on nature. Sadly, the devastation is not localized and due to the concentration of such activities all over the world, it has become a global concern. The alarming state has led to the understanding that such unhealthy building activities have to be halted at local levels to fight the global problem of climate change.

I believe that making a holistic effort to improve our system can revive our ecosystem whilst still sufficing our needs for existence. A combined effort has to be made by the government and the locals with the aid of various international organizations for an effective functioning. The right materials have to be used in the right place at right time in a right way. Figure 26 shows a schematic rethinking system in the state of Meghalaya for revival of the construction technology that can improve the overall built environment and provide a safe shelter to live in.

5

TIMBER AS A BUILDING MATERIAL

Introduction to timber as a building material

Wood has been used as a construction material since the dawn of man. Its use can be traced back to the primitive times, extending to the great civilizations till the current times. Humans all over the world have used wood as a primary construction material, some have used it in basic form while some have mastered the art of working with wood. For centuries, people had built massive wooden structures to glorify their existence. However, with the advent of modern materials like concrete and steel, wood was out of vogue. Human were able to built higher and stronger with the advancement of modern construction system, establishing his presence on earth. Stephen Hawking once commented:

“ We are very, very small, but we are profoundly capable of very, very big, things”

The victory of humans has been set in the scale of time by conquering the planet earth. Our activities have surpassed the handling capacity of our planet and it is well known that we need to act before it gets too late. Sadly our obsession with modern comforts will make it difficult to go back to the lives when were living in harmony with nature. Therefore the only option we are left with is to re-develop. We can get inspired by our past and step into a future when human activities are in consonance with nature.

This research is an attempt to re-develop the use of wood, which was a major construction material in the region of Shillong 100 years ago. The positive aspects of using wood in construction as compared to other building materials, have already been elaborated in the above sections. However, in order to ‘re-develop’ one must study the past, learn from the context, analyse the reasons for development, question its relevance in the presence and formulate new methods by combining history with innovation for use in future. In the context of wood, many people have used it in different ways. This section elaborates on the understanding wood as a building material. The kinds of wood available, construction techniques, fire safety and end of life scenario of timber as a building material.

5.1 Types of timber products in construction

The evolution of timber industry has come a long way through the history of mankind. Before beginning to build with wood it is important to understand the history of development of wood in construction and the forces which led to change in systems. People have used timber for construction in various forms in different parts of the world. Over the last few decades, technological innovation and the development of new products have given rise to a number of structural systems that go beyond the limits of traditional wood construction (Dangel, 2017). This section briefly describes the types of timber products that are available in the construction market.

There are many ways of categorizing the types of timber construction. Different agencies, classify the construction based on different criteria, for example, the International Code Council has its own criteria based on safety, height and timber products. However, for the purpose of this research structural timber will be classified based on the manufacturing process. Structural timber is that which transfer loads and comprise the main load bearing system of a building. It can be divided into two broad categories: non-engineered and engineered wood. Non-engineered wood is a type of heavy timber construction which has been used for centuries, in this, natural wood is sawn and used for construction without undergoing massive mechanical treatments, the inherent structural properties of the timber species are used for calculations. On the other hand, engineered wood is a recent innovation in which the sawn timber is further processed mechanically or chemically to produce the end product for structural use. The structural properties of these products can be very different from that of the tree species. Engineered wood products include glue laminated timber (glulam), cross laminated timber (CLT), parallel strand lumber (PSL), laminated veneer lumber (LVL) and many more. This list is increasing as companies are investing resources in innovation of high performance timber based systems. Depending upon the strength, each of these may be further classified into different types. Figure 27 shows the various types of timber products in construction. It can be seen that the non-engineered timber consists of logs or sawn wood, while other engineered products need a second step of processing. The processing enhances the performance of the material by increasing the strengths and workability. The different types of engineered products are defined below:

- **Glue-laminated timber (glulam)** – It is a structural timber which is composed by gluing at least 2 laminations parallelly. It may comprise of multiple boards lying side by side with finished surfaces. It is used for fabrication of curved and long beams whose size is limited by means of transport (Ramage, et al., 2017).
- **Cross-laminated timber (CLT)** – It is made by stacking a minimum of 3 layers of sawn softwood one on top of another. Layers are glued at right angles to each other.
- **Brettsapfel panels** – It is also called ‘dowel-lam’, in this hardwood dowels are used to connect the softwood panels. The dowels having a moisture content of 8% is fixed into the softwood having moisture of 12-15% to create the tight bond without the need for glue.
- **Stress laminated timber** – In this, the panels are made by pre-stressing the laminates using metal. The laminates are effectively spliced together by friction created by the pre-stressed compression.
- **Nail laminated timber** – The individual lumbers are stacked on edge and fastened using nails at each layer.
- **Chemically treated timber** - In this process, a high or low pressure is applied on the timber to allow the chemical to penetrate deep inside offering long-lasting protecting. These chemicals are used to increase the durability of wood, especially its performance against fire.
- **Plywood** – Plywood consists of thin sheets of wood glued together in alternating directions of grains.
- **Laminated veneer lumber** - A reconstituted dimensional timber that is commonly twice the strength of dimensional timber of the same species manufactured from rotary peeled veneers of spruce, pine or douglas fir. Commonly the veneer grain is oriented in a single direction but cross-grained sections are also manufactured to offer tailored mechanical properties. Lengths of short veneer are jointed end-to-end with a scarf joint allowing limitless dimensional lengths (Ramage, et al., 2017).
- **Oriented strand board** – It is similar to particleboard in which the flakes of wood are compressed together by adding adhesives.
- **Laminated strand panels and I-joists** - They are more expensive and deeper than solid timber joists of an equivalent strength and stiffness. The composite I- Joists are more dimensionally stable due to their homogeneous OSB web and the relatively small dimension of the solid timber or LVL flanges.
- **Structural insulating panels** - Structural prefabricated sandwich panels consisting of an insulation layer encased between two skins of fiber or oriented strand board.
- **Fibreboard** – Wooden chips or shavings are bonded by compression using resin and formed into stiff sheets.

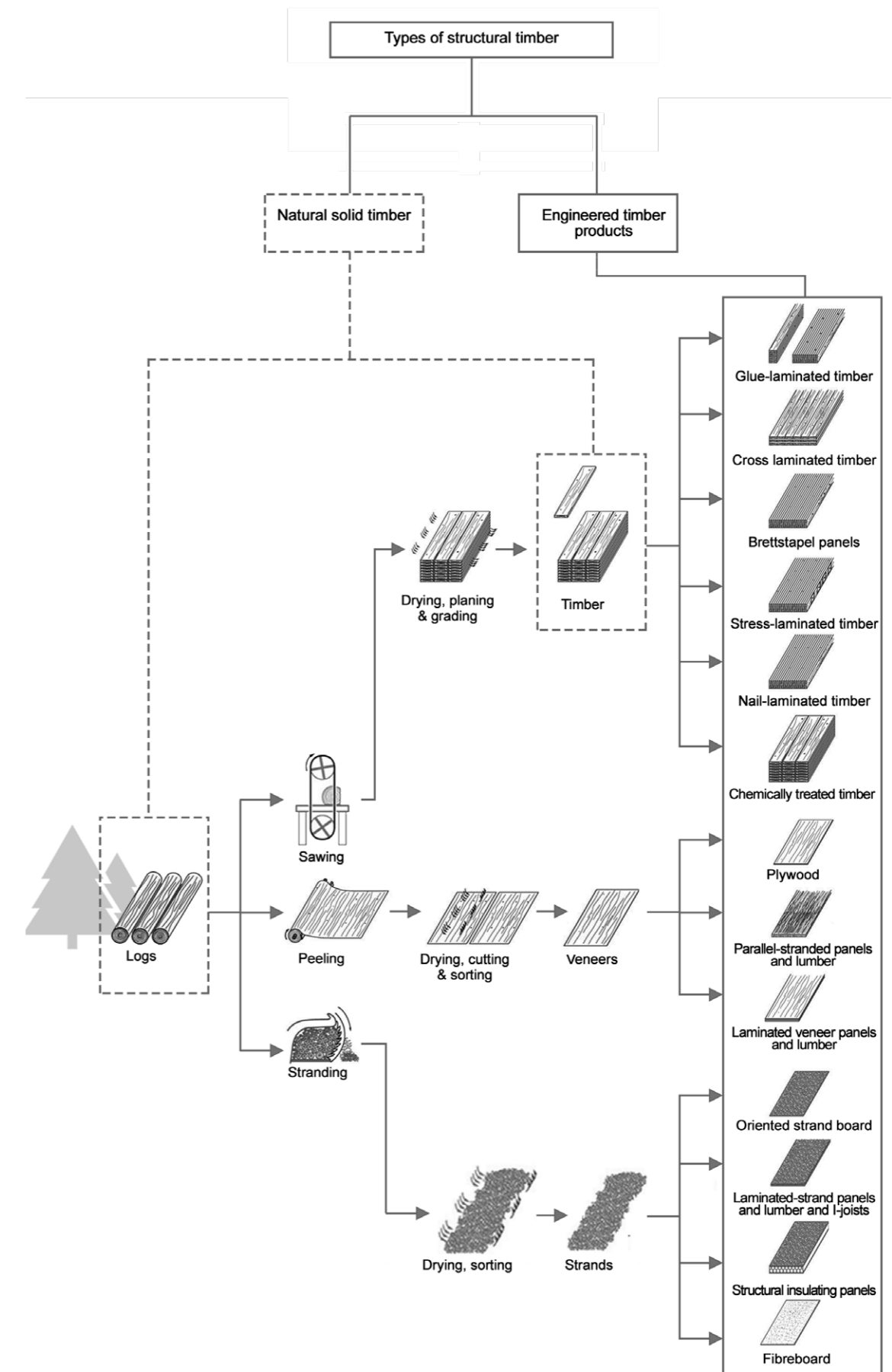


Figure 5.1: Classification of structural timber based on the degree of processing [source: (Ramage, et al., 2017)].

With additional processing, engineered timber products gain superior structural properties as compared to natural solid timber. These properties enable timber to compete with other materials. Further other inherent problems like shrinkage and swelling is minimized in engineered timber. The manufacturers of wood-based composites are able to satisfy market requirements for strong, dimensionally stable products that are suitable for large spans (Dangel, 2017). Table 5.1 shows the comparison between natural solid timber and engineered timber. However, this strength comes with an additional cost of using adhesive as seen in most of the above cases. These adhesives have negative impacts on the embodied energy and cause trouble at the 'end of the life' of the product (Ramage, et al., 2017). Figure 5.2 shows the increase in embodied energy for some of the above examples. Also, it this processing comes with an additional cost of transportation of the raw materials to the manufacturing plants and delivery of finished products to the site (Ramage, et al., 2017). While manufacturing plants are situated in Europe or Scandinavia, countries like UK have to import most of the products, which significantly adds up to the carbon footprint (Ramage, et al., 2017). Thus, the selection of the type of timber should be based on various critical factors like local availability of the chosen engineered/solid wood, total distance of transportation, the height of the building i.e. the physical strengths needed, technological advancement in the proposed region and environmental impact of the chemicals used in the treatment. These factors account for the total carbon emissions associated with the construction and the end of life scenario for a product.

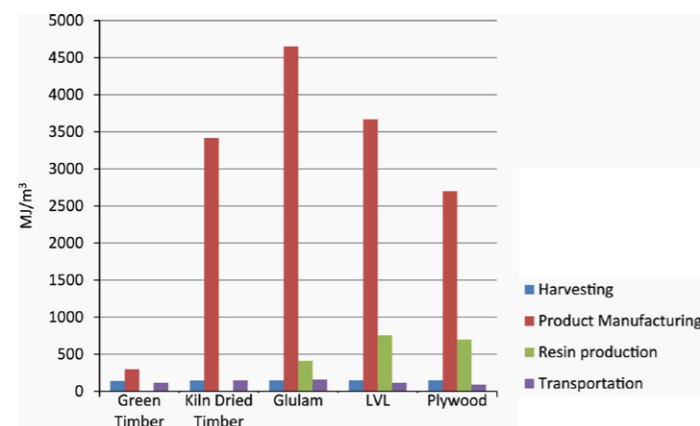


Figure 5.2: Typical embodied energy of construction timber products based on data from (Ramage, et al.)

	Natural solid timber construction	Engineered timber construction
Strength	Dependent on the properties of the tree species, naturally inherited.	Can be altered by using various adhesive, thickness, number of layers and manufacturing process.
Imperfections	Contains natural imperfections like knots, which might affect the structural stability. (Unless logs are directly used).	Does not contain imperfections, even if one member has knots, the lamination process balances it stabilizing the strengths.
Member length	Limited to natural height of tree.	Limits w.r.t. transportation and manufacturing.
Moisture	They may swell up if exposed to excessive moisture, affecting the joineries.	Physical state does not change with change in moisture.
Fire-hazards	They have to be treated or sized accordingly to limit fire hazards.	The fire treatment is generally done during the manufacturing and the products are designed confine to building bye-laws.
Manufacturing	No major manufacturing process is needed other than drying. Traditional methods of treatment are generally used.	Has to undergo a technical manufacturing process which differs with products.
Installation	The joineries have to be crafted. The overall assembly takes longer as compared to engineered timber.	They perform like prefabricated modular systems, hence the assembly is very fast.
Embodied Energy	3 MJ/kg (www.techtonica-online.com)	<5 MJ/kg (www.techtonica-online.com)
Building height	Less than that of engineered wood.	W350 - highest timber tower of the world of 350m has been proposed in Japan.
End of life	Can be easily disposed, if not contaminated with chemical treatments.	If glue is used as a binder then the end of life must be carefully planned to reduce the environmental impact.

Table 5.1: Comparison between natural solid timber and engineered timber

5.2 Fire resistance

The vulnerability of wooden structures with respect to fire is the most important consideration when designing. This is especially critical in our dense urban regions where the buildings are placed very close to each other, making the chances of fire spreading very easy. However, wood has a natural property of fighting with fire. As designers, we should understand these inherent properties to maximize its use while designing. It is known that wood is a poor conductor of heat. And does not begin to burn until it reaches a temperature of about 300°C (575°F) (Seike, 1977). Also, even if the temperatures reach 300°C, the heart of the wooden member will remain little affected and will continue to support the load as it was intended to support.

Although, steel-frame construction appears safer at first because it is itself non-flammable, during a fire but actually steel is a good conductor of heat and a very hot steel staircase cannot be easily cooled in fire using water (Seike, 1977). However, the strength of timber is reduced by 50% at 100°C as compared to that of 20°C (Ramage, et al., 2017). It should be noted that if a timber member is connected using a steel joinery, then steel being a good conductor of heat might degrade the strength of the structural system. In these cases special care must be taken to insulate the steel joineries. Various alternatives like fire-resistant paints have also been developed to improve the performance of the material. In addition to the typical 'active' fire protection systems (automatic sprinkler systems, fire alarm and detection systems), there are two primary design approaches to assessing acceptable structural passive fire protection measures in a Mass Timber building a) charring method, b) encapsulation method (Green, 2012).

- **Charring method:** Heavy timber or mass timber construction have sufficient mass of wood such that a char layer can form (incomplete combustion) and that in turn, helps to insulate the remaining wood from heat penetration. Once ignited, structures classified as "heavy timber" or the non-engineered timber, exhibit excellent performance under actual fire exposure conditions. Due to the ability of wood to form a protective char layer during combustion, the fire-resistance rating of large-sized members can be calculated based on minimum structural thicknesses and the remaining sacrificial thickness available for charring (Green, 2012).
- **Encapsulation method:** In this alternative fire-rated materials are used to insulate the underside of floors and generally throughout the building, in order to meet the 'non-combustible' construction to satisfy the building codes. Such materials, like fire rated gypsum board can be used to protect wood shafts and issues associated with vertical flame spread (Green, 2012). The use of timber in larger structures relies on fire engineering design to ensure that the building can retain its structural integrity for sufficient time either for building occupants to be evacuated, or for the fire to be extinguished (Ramage, et al., 2017).

The use of timber in larger structures relies on fire engineering design to ensure that the building can retain its structural integrity for sufficient time either for building occupants to be evacuated, or for the fire to be extinguished (Ramage, et al., 2017).

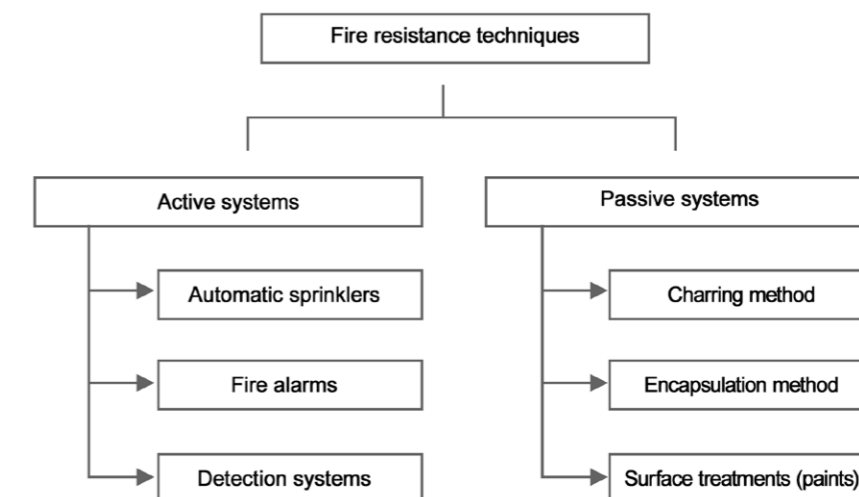


Figure 5.3: Broad classification of fire resistant techniques in timber construction.

5.3 End of life scenarios for timber construction

The end of life scenario is as important as the manufacturing process of a product. In order to ensure ‘sustainable yield’ in the case of wood, the design should be such that the total lifespan of the product should match (atleast) the rotation periods of timber (Ramage, et al., 2017). Hence, in construction, the lifespan should be greater than 30 years to ensure sensible use of material; structures whose use is greater than 100 years can be healthy for our environment (Ramage, et al., 2017). Wood can be used in an order of priority to prolong the lifespan: wood-based products, re-use, recycling, bioenergy, and disposal. Figure 5.4 shows the order of possible main scenarios established by the European Parliament (Ramage, et al., 2017).

Reuse – From waste to product: This is the best option after the end of life of a wooden product, in which the material is reshaped for a less demanding purpose. The products should be so designed that it can be disassembled with ease and re-used in the next generation of product (Ramage, et al., 2017).

Recycle – From waste to resource: If the wood is not qualified for further use, then it can be reprocessed as a fibrous material for making other new wood-based products. These products are raw-materials for other manufacturing purposes. Such a framework corresponds to the ‘recycling’ phase framework (Ramage, et al., 2017).

Recover – From waste to energy: If above of the two methods are not possible then wood can be burnt to produce energy. However, contaminated wood such as treated wood, painted wood, or chipboards containing adhesives (e.g. formaldehyde glue), can only be used for energy generation in special stations equipped with appropriate combustion facilities, while clean wood wastes without being contaminated with harmful substances are allowed to be burned in normal power stations or private stoves (Ramage, et al., 2017). Also the lifespan of the burnt wood should be considered in order to make the energy recovering process carbon neutral. Energy recovered from short term rotation forest products may have a negative impact on the environment because of the increase in carbon emission factor.

Dispose – No choice: Landfill is the least favored end-of-life scenario. It not only fails to recover energy from wood products, but also has to pay for the cost on landfill practices. However, treated wood wastes containing hazardous components and the ash disposed from wood burning have to go to landfill (Ramage, et al., 2017).

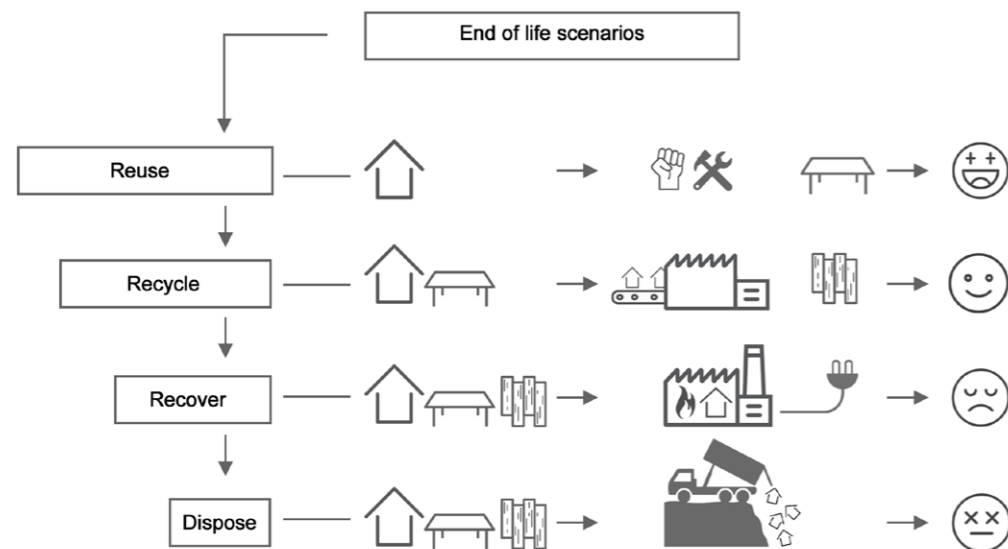


Figure 5.4: Possible end life scenarios for wood (Ramage, et al., 2017). (Icon source: Vectorworks.com, nounproject.com, freeicons.com).

5.4 Types of timber construction techniques

While Europe was enhancing the mason’s art, Japan was advancing with its techniques in wooden construction (Seike, 1977). It is remarkable to see that certain monuments have survived the natural forces despite the lack of tensile strength of steel and concrete, much before the advent of all the analytical and mathematical basics of earthquake design. Also, it is known that timber construction is gaining importance due to the global awareness on environmental complexities. There is a sudden boom and craving to revive wooden structures, this has led to invention in various structural wooden construction systems which can challenge the modern materials whilst meeting the demands of contemporary urban issues. Thus, it is important to learn about these inventions and analyze the applicability of these technological advancements in the region of Shillong. The most prevalent historic techniques and contemporary systems are discussed below. Figure 5.5 shows the major types of timber construction.

Log construction – This is one of the oldest wood construction techniques in the world. The wooden logs are stacked horizontally and corners are interlocked using notched joints. These stacked logs do the job of structural walls and creates the insulated enclosure. Log buildings can be expected to settle, since the timber members are loaded perpendicularly to the grain, a dimension in which they are particularly susceptible to shrinkage. Therefore, the detailing of connections to other building materials and around openings should make allowance for considerable movement (Dangel, 2017). However, the single layer log wall does not comply with the modern day standards of comfort like thermal and acoustical insulation, hence it needs great modification in the envelope if constructed today.

Timber frame or sawn wood construction – As the name suggests it is a traditional method of construction using the sawn timber. It was probably the next generation after the log construction. The heavy structural members were cut in shape, generally square or rectangle cross-section, and fitted together using various joinery techniques. These joints were fastened using wooden pegs (dowels) or nails. Diagonal members were also used to strengthen the frames. Japans joinery techniques are well known for their efficiency. Some of their joinery principles are discussed in section 6.1. However, heavy timber framing in its traditional form is no longer commonly employed for the construction of buildings today, but innovative engineered wood products and computer-controlled fabrication tools offer expanded opportunities for the development of new typologies based on its construction principles (Dangel, 2017).

Light frame construction – The need for rapid expansion of buildings in first half of 19th century led to the development of light-weight construction in the United States. Also with the aid of industrialization, production of cheap nails and quick sawing of logs was possible, with unskilled labour and minimal tools. In the earliest version of light frame construction studs, which continuously ran from foundation to roof, were erected with intermediate floors between them. This construction is called balloon frame construction. However, the continuous gaps between the studs made fire spread very easy, also the length made assembly inconvenient. Thus, in response to this problem, the stud size was reduced to single floor and the studs for next level rested on the slabs. This eased the work as members were shorter. Also the slabs acted as barriers for floor to floor fire resistance. Later these floor slabs were replaced by stronger elements like I-joists and glulam beams (Dangel, 2017).

Panel construction – While the balloon construction was developed in US, Europe was inspired and innovations with timber panels were made in the last quarter of 20th century. This was more of a pre-fabricated construction technique in which the members were crafted at the carpenter’s and assembled on site. Due to transportation issues, the members were sized one-story tall. Solid sawn or glue-laminated lumbers were used for support, while walls were made of insulated panels of OSB, gypsum board, fiberboard or other engineered products. This housing type gained popularity with the pre-fabrication manufacturers.

Frame construction with engineered timber – This is a modified version of the heavy frame construction with sawn timber in the older times. The typical column beam framework, with bracings forms the main structural system. In order to achieve the large spans and fancy designs, engineered timber products like glulam, CLT and other ate used. The joineries are made from metal specially designed to withstand large loads. Frame construction distinguishes itself from other timber construction systems by the fact that the system’s load-bearing function is completely separated from that of spatial enclosure (Dangel, 2017). Also this construction enables multiple ways of mounting the envelope, giving more freedom to the architects. This construction has gained a lot of popularity and is crossing boundaries in innovation of the tall timber structures.

Solid timber construction - As homogeneous structural products, solid timber components exhibit exceptional strength, making them suitable for the construction of tall buildings. Through the use of industrialized manufacturing methods, high levels of prefabrication, and rapid on-site assembly, solid timber construction systems are able to exploit the advantages of a modern factory set-up (Dangel, 2017). The single-ply or multi-ply engineered timber products are generally used for construction of these types of assemblies. Higher degrees of prefabrication may include integration of thermal, acoustical and fire insulation along with the onsite installation of windows, waterproofing, and exterior cladding (Dangel, 2017). This construction is also being used with steel and concrete to increase efficiency.

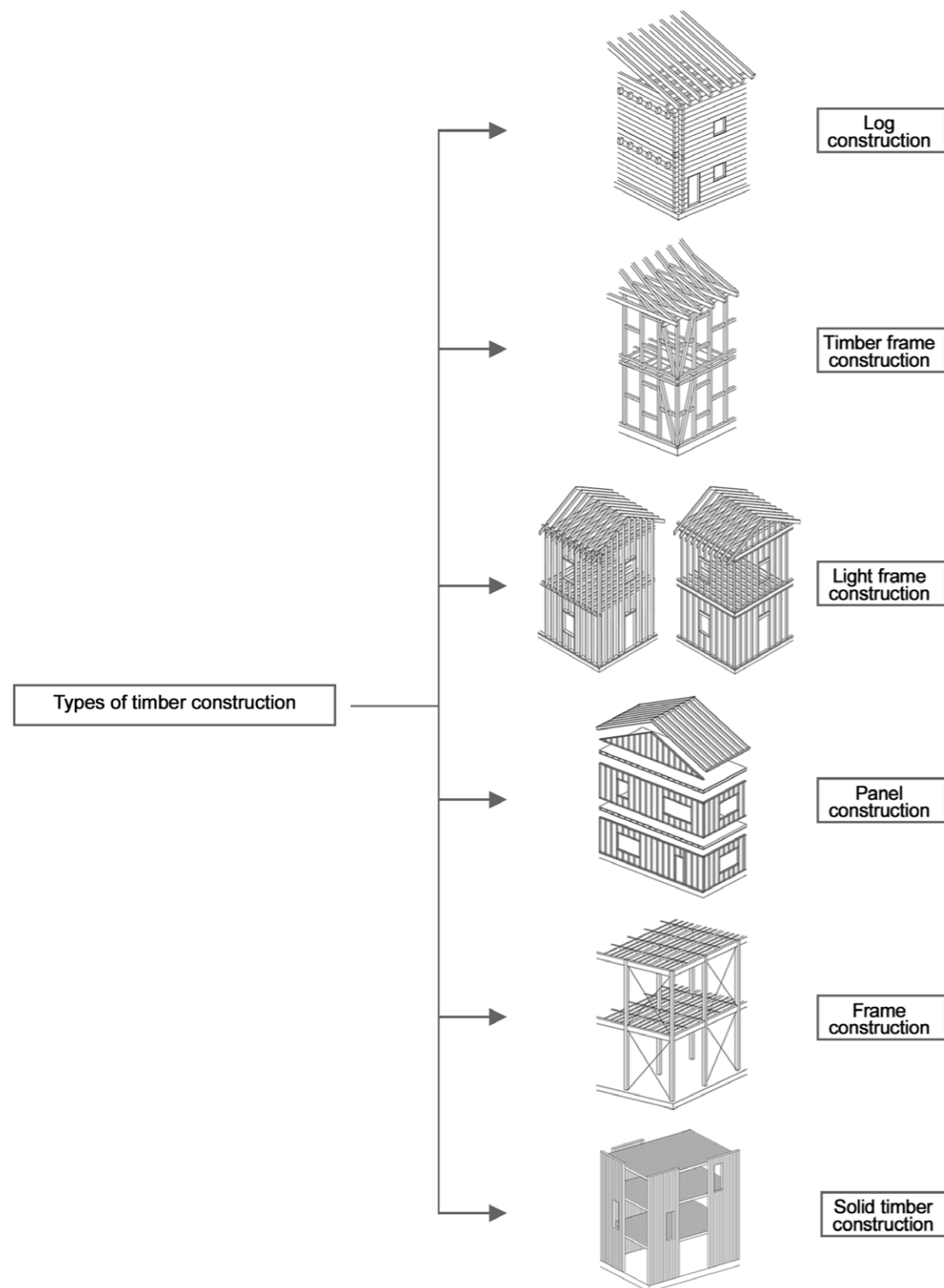


Figure 5.5: Types of timber construction techniques. [Classification source: (Dangel, 2017)]

5.5 Inference for timber as a building material

Timber is readily available in most parts of the world, we can use it as a potential building material. However, with advancement of technology it can be used in multiple ways in multiple forms. Since, the purpose of this research is to use the timber in its natural state, the natural timber logs and planks will be taken for further design consideration. The engineered timber is beyond the scope of this research. The investigation made on the different types of construction and their consequences will impact the final designing. Also, the different methods for fire-resistance will be used in combination for a safe structure. The passive design technique of charring method will be incorporated in the design wherever possible, while the encapsulation method will be considered for other areas.

Finally, the natural timber used for construction does less harm to the environment as compared to engineered timber. Thus, it is easy to re-use, recycle or even dispose the natural timber elements. The design should be such that it avoids use of harmful adhesives for structural supports.

It should be mentioned that timber has various aspects associated to its materiality of which not all have been explained in detail in the above chapters. These include aspects related to its behavior with respect to moisture, direction of grain, settlement issues, water-proofing, protection against insects and final timber finishing. Each of these can be a broad topic in its own, some of these aspects are important to this research and will be introduced as implemented in the design phase.

6

CASE STUDIES

Introduction to case studies

In order to understand the working of the construction technology, two extreme cases from different eras were chosen for the purpose of this study. The two construction techniques include the Japanese pagodas and concepts of modern day tall timber innovations.

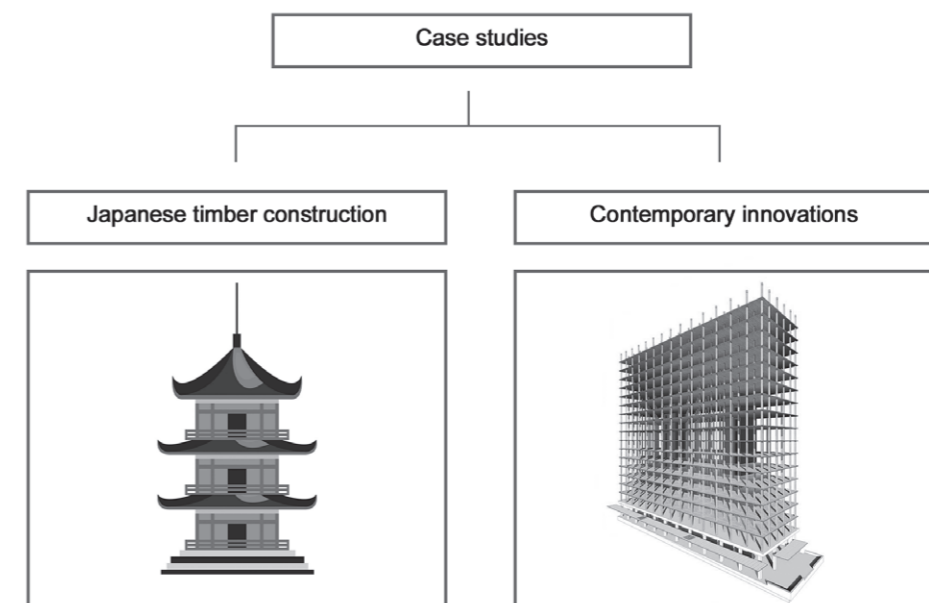


Figure 6.1: Relevant categories of wooden construction techniques for the purpose of this research. (Icon source: Vectorstock.com and popularsource.com)

6.1 Traditional Japanese wooden construction technique

The relevance of studying Japanese wooden construction techniques can be judged by its influence on the Assam-type construction technique. Its importance is not only in use of the wood, which today is scientifically considered a sustainable building material, but also its efficiency in seismic performance which is a major concern in the context of this research. The study is important to understand the basic principles of Japanese construction which aided in the design development of the successful construction technique in a different region and an attempt to question its applicability in the context of this research.

The first question was why was wood chosen as the main construction material in Japan, while other parts of the world was working with stone and clay for brickmaking? Researches show that that Japan has a volcanic soil which is not best suited for brick making (Seike, 1977). Also, Japan was then endowed with seemingly endless resource of forest which was looked up as a potential building material. In words of Kiyosi Seike, the abundance encouraged an almost exclusive concentration on wood construction. Also, on slowly mastering the material, the Japanese found other advantages of using it. The Japanese have experienced destructive earthquakes and typhoons. Thus, wooden properties were harnessed to fight these forces of nature. The properties include (Seike, 1977):

- The lesser mass of wood as compared to stone and brick make it better to withstand earthquakes.
 - The joints were developed to act like shock absorbers, which is not possible in stone or brick construction.
 - Also, the native species of Japan offered natural resistance to termite, bacteria, fungi and insects.
- The design of a typical structure with deep overhanging eaves protected the wooden structure from decay.

The overall Japanese architecture is endowed with several architectural principles that are worth studying. The spacial quality of Japanese houses and their modular method of planning and design is outstanding in the field of architecture. However, for the purpose of this research, focus has been given to the interesting case of the pagodas, which are reported to be relatively flexible structures, and their characteristic of being multiple story adds to the complexity, instigating curiosity in the field of seismic design. Another Japanese temple renovation project - The Yakushiji was studied to understand the ideology of Japanese wood working. The case study has been classified into two broad categories:

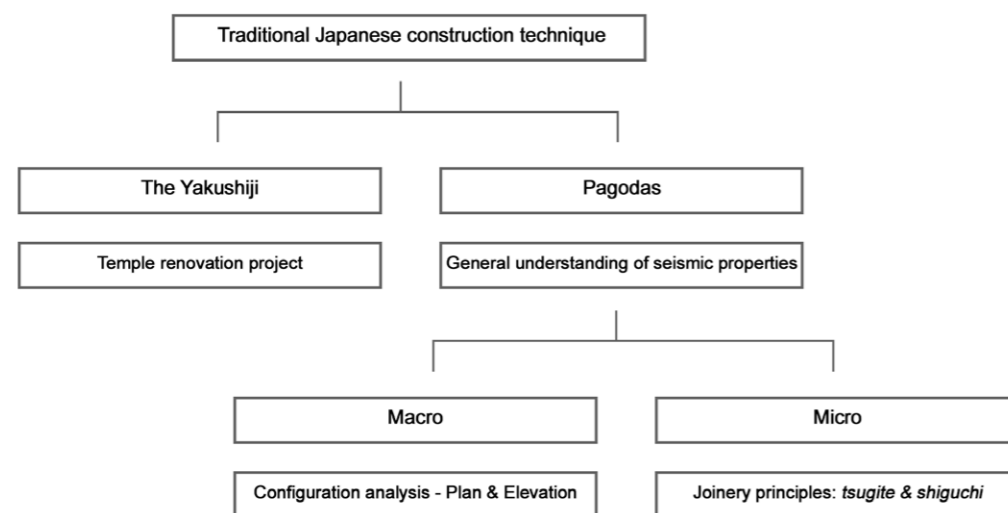


Figure 6.2: Classification of study of traditional Japanese construction techniques.

6.1.1 The Yakushiji project - Lessons from Japanese temple renovation

The ancient craft of carpentry in Japan is considered sacred and has been passed down for generations. The Japanese wood craft represents ages of refinement and design evolution, where the most profound aspects have been maintained and the rest have been slowly modified in time (Brown, 2013). Azby Brown has documented this art of Japanese carpentry through a temple renovation project – The Yakushiji, by a master carpenter. The principles for wood working shared in this documentation have been important for the development of this research. It was learnt that along with the physical and mental capability of the builder and the cultural influence, the art of wood working relies on the selection of the right forest, the tree, the time of cutting, material properties and limitation, the direction of grain and cellular structure. The final form of Japanese Temple is the result of interaction between physical and abstract patterns derived from a network of decisions (Brown, 2013).

The Yakushiji project was handled by the skilled master carpenter Nishioka. His dedication to the art was inherited from his grandfather. The Yakushiji project was completed in 698 AD and it one of the original seven major temples of Nara, making it one of the most important traditional structures. The Yakushiji is a temple complex consisting of a group of buildings – hall, pagodas and gates. The key to timber design is to harmonize the detail and proportional relationships. Brown explains the classification of proportions into two major categories, first the proportions of the site and second the proportion of the building components. It is also cited that the temple layouts could be governed by the proportional system depending upon the height of a pagoda, which in turn governs the spacing between columns, corridors, distance between floors, member sizes and finally the joinery. Figure 6.3 shows the architectural design governed by the system of proportions in the Japanese temple complex.

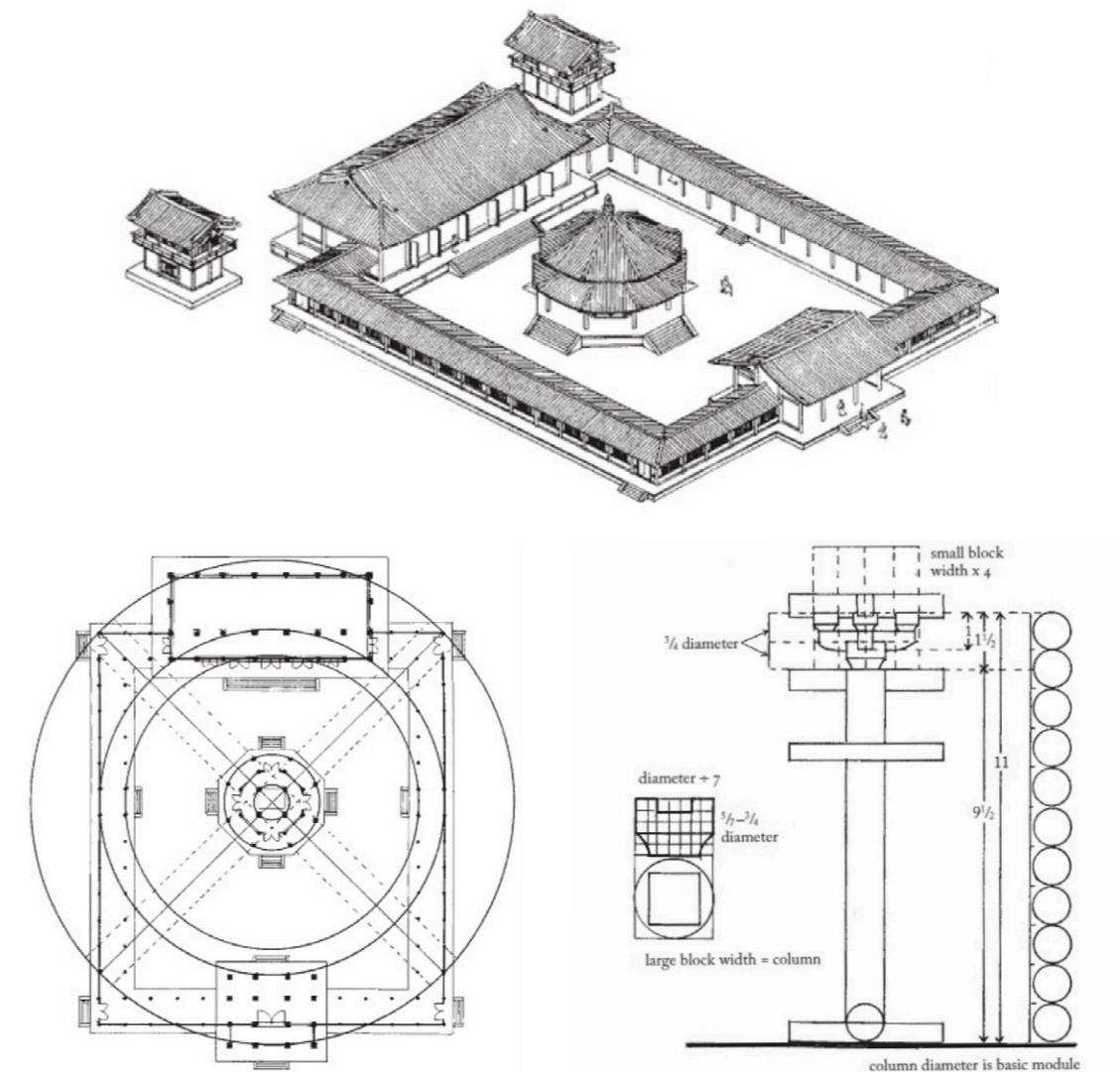


Figure 6.3: Top- Axonometric view of Sanzo-in temple complex. Left - Proportional diagram of plan. Right - Proportional diagram of column. Image source: Brown, 2013.

Another important aspect of Japanese timber construction was selecting the right wood from the forest. As it was believed that the location of the tree in the forest determines its structural properties, the timber above the midpoint of the mountain are the thickest and the strongest and should be used for structural purposes. While, those growing in the valleys should be used for (non-structural) ceilings and finishing works as shown in figure 6.4. Also, it is known that the tree naturally grows to resist gravity, such that it is thicker and denser at the bottom and thinner and lighter at the crown. Thus the orientation of the structural member in a building should be in accordance to the growth of the tree, such that in columns the base is always down while the crown end is on top as depicted in figure 6.5. While the horizontal members should be joined crown to crown (Brown, 2013). Also, timber is a material that breathes and shrinks. It's movement must be taken into consideration while designing. The characteristic of this movement is dependent on the direction of grain of the lumber as shown in figure 6.6, thus milling should be done to minimize the shrinkage and related distortions should be predicted and incorporated in the design (Brown, 2013).

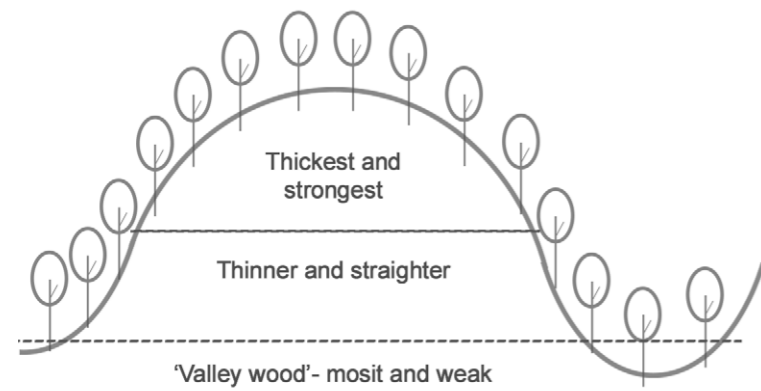


Figure 6.4: Characteristic of wood with respect to its location on the mountain. Source: (Brown, 2013).

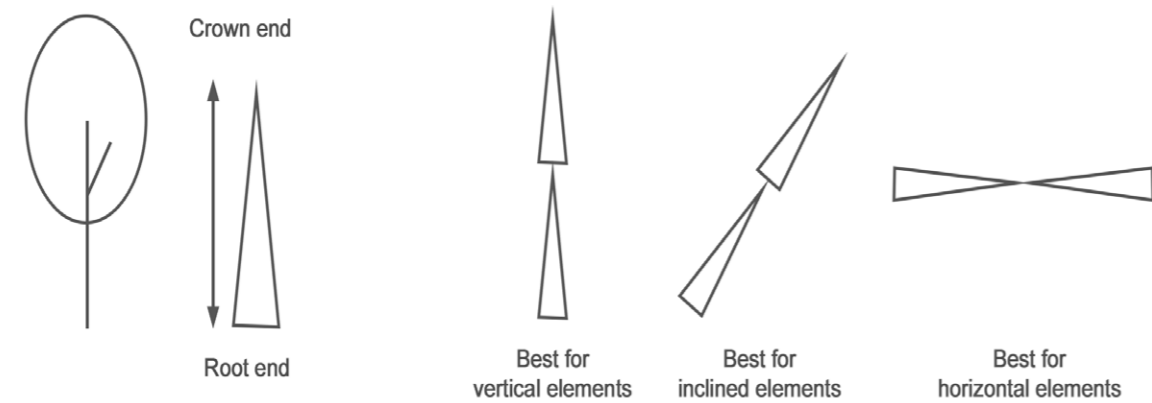


Figure 6.5: Joining of structural members with respect to its growth direction. Source: (Brown, 2013).

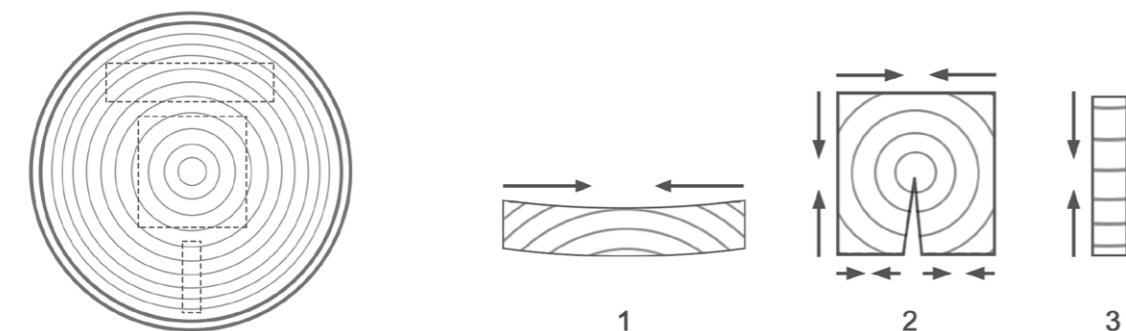


Figure 6.6: Arrows show the direction of shrinkage with respect to the grain direction, where no. 3 is most suitable for structural application. Source: (Brown, 2013).

Finally, all the time-tested design principles are used for the construction of a Japanese timber structure. There are various intricate details behind the design ideology and choice of certain methods which lead to the final form. Figure 6.7 shows the making of a Japanese hall which is a part of the temple complex, the illustrations have been sourced from works of Brown, 2013.

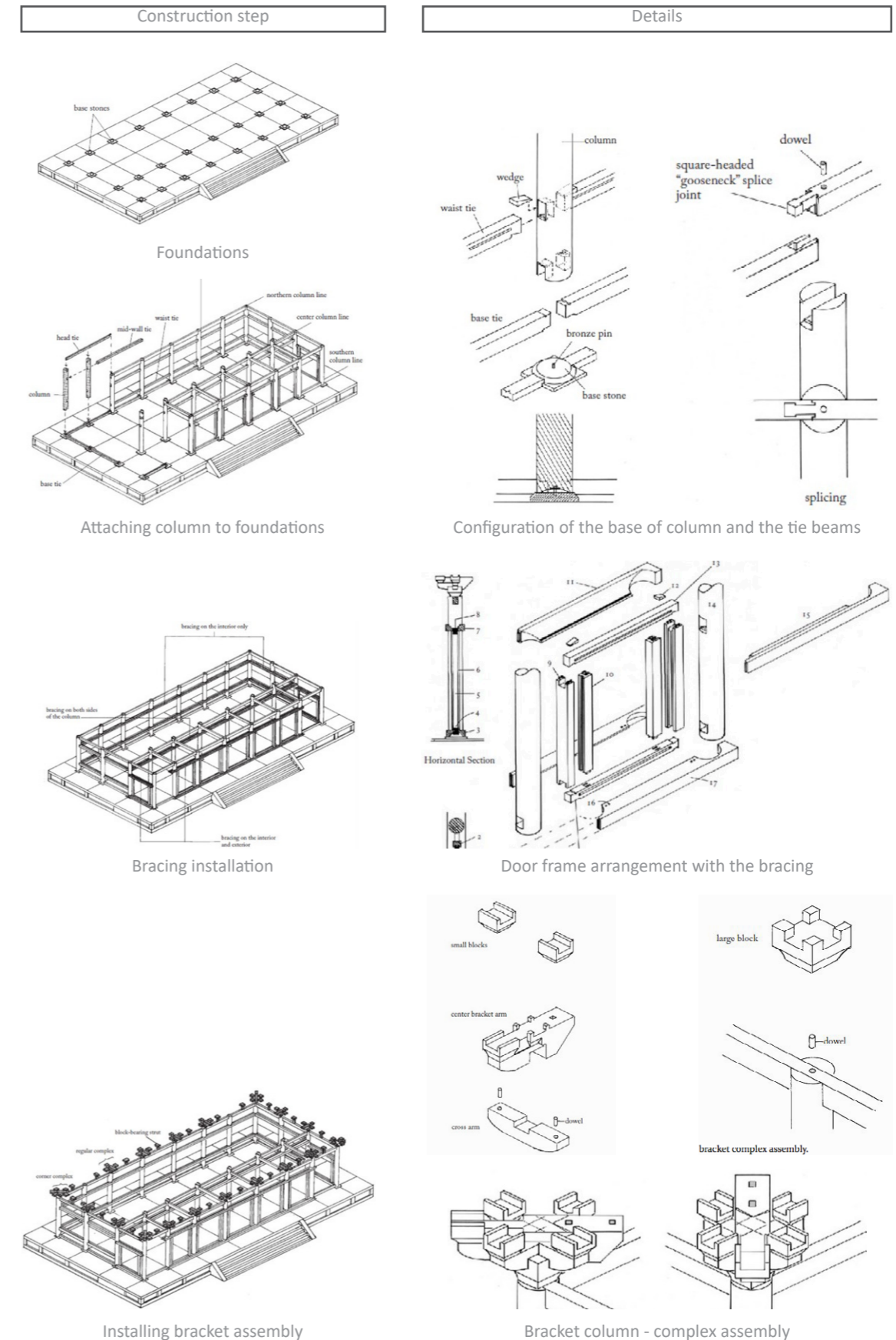
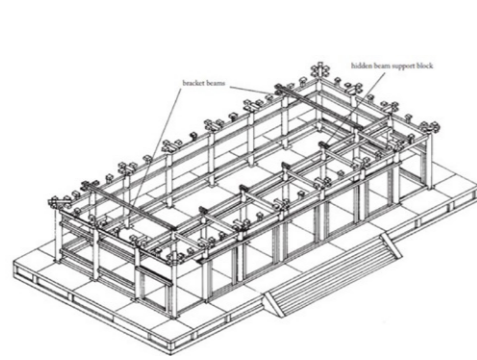
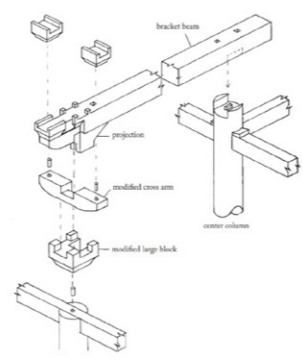


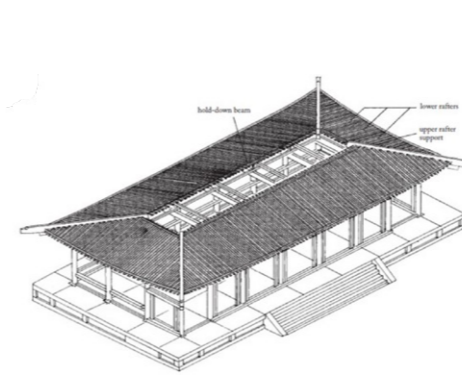
Figure 6.7: Construction sequence of the traditional Japanese hall. (Illustration source: brown, 2013)



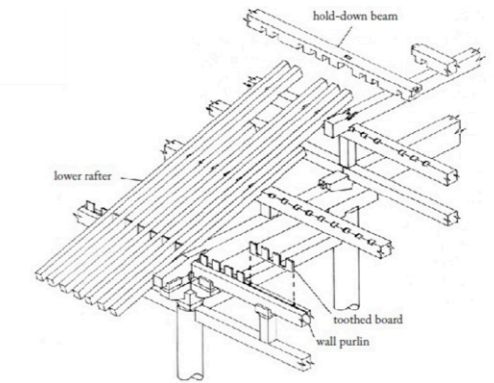
After installing bracket assembly



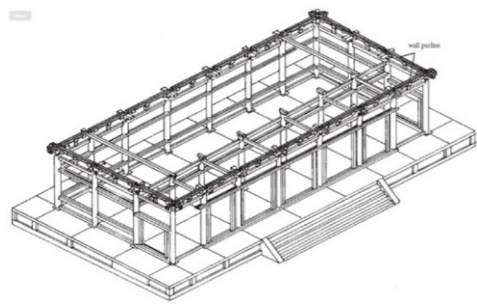
The bracket end detail of a bracket beam



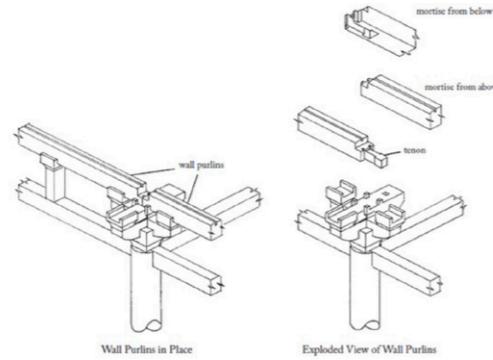
Installing lower and upper rafter supports



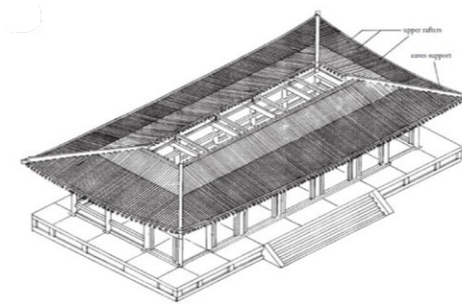
Upper and lower rafter support detail



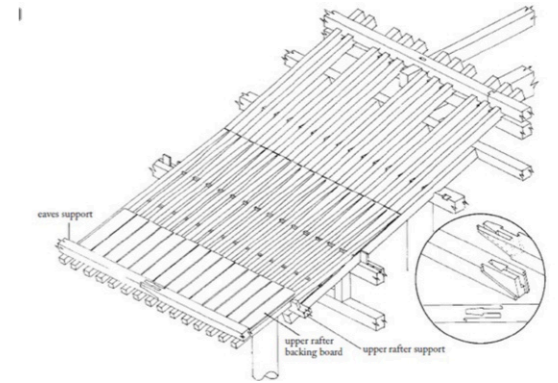
Installing wall purlins



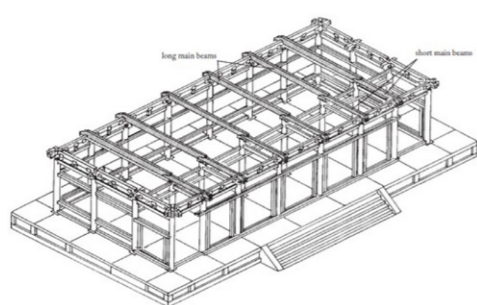
Wall purlin detail



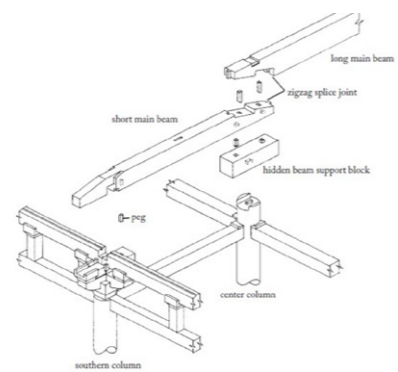
Installing upper rafter and eaves support



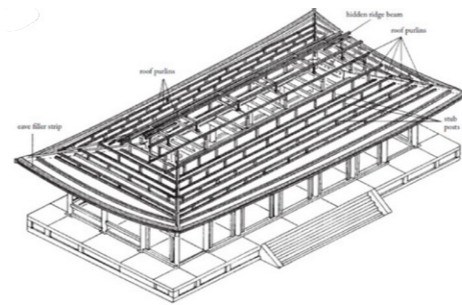
Assembly of the upper rafters and eaves support



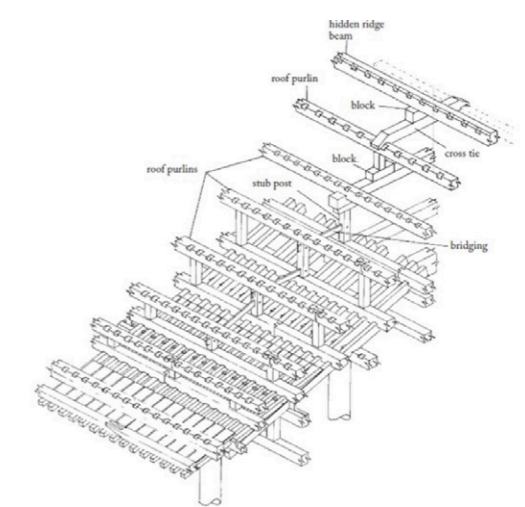
Installing main beams



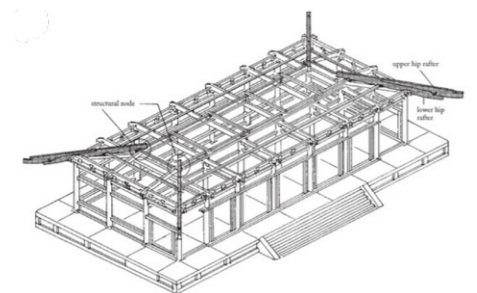
Main beam assembly



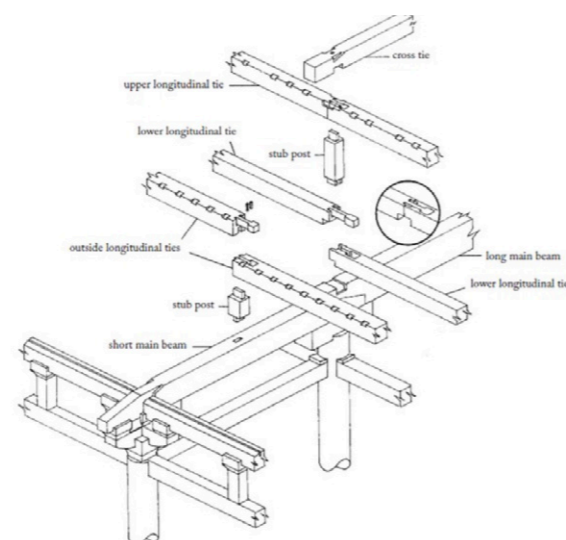
Installation of roof structure



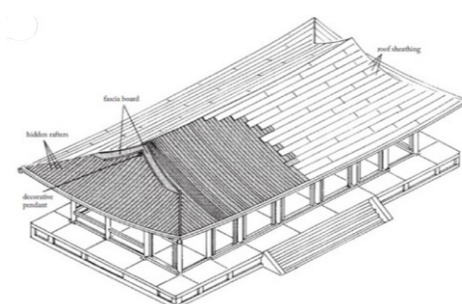
Roof structure assembly



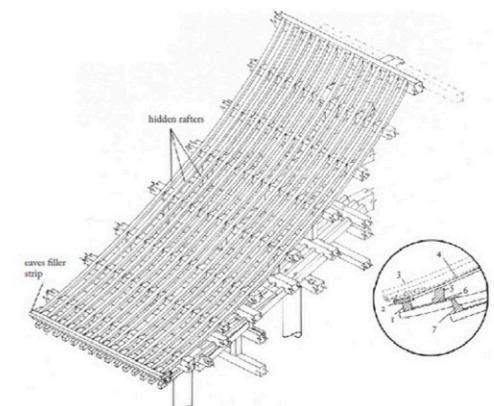
Installing corner main beams and ties



Assembly of stub posts, longitudinal ties and cross-ties



Installing rafters and sheathing



Rafter assembly

Figure 6.7 (contd.): Construction sequence of the traditional Japanese hall. (illustration source: brown, 2013)

Figure 6.7 (contd.): Construction sequence of the traditional Japanese hall. (illustration source: brown, 2013)

6.1.2 Japanese Pagoda - Macro Analysis

The configuration of a building is of vital importance for seismic design. Although, configuration depends on many factors like the geometry, site boundaries, climate, light, urban requirements, geology and architectural statements, here we specifically analyse it from a structural perspective. Generally, the building shape and size comprises the configuration, but seismic performance also includes the nature and location of structural members (Arnold & Reitherman, 1925).

The important features identified by experts in the horizontal and vertical arrangement of structural members in the section are as follows:

- The central column – shinbashira, is independent of surrounding structural frames, which is suspended like a pendulum the top of structure. There are multiple examples of this column either touching the ground or supported by a girder on an upper story as shown in figure 6.8. It is said that the unusual resistance of the central column is based on its capacity to oscillate like a cantilever beam during an earthquake (Tanabashi, 1960). The members of the floor are loosely attached to the central column such that each story is constrained from swinging too far in any direction by hitting internally against this central fixture (The Economist, 1997). When a story collides with the central column, a part of the energy is dumped into this massive central pillar that dissipates in down to the ground. This swaying of the Shinbashira with other members is also called a ‘snake dance’; it is shown in figure 6.10.

- Another feature is that the stories are not attached to one another; they are stacked up in a pile where the joints are loosely fitted in the wooden brackets. This allows the stories to independently sway around.

- It can also be noted that the height of each floor gradually decreases, this aids to reduce the successive weights of each story as the tower goes higher, minimizing the quantity of Force on upper story, the proportions are shown in figure 6.8.

- Another critical feature of its peripheral structural column composition is that, because the floors are tapering, the vertical columns are not aligned one above the other (The Economist, 1997). They do not carry the load from top to bottom at one go, which is against the feature of contemporary seismic design rules. This may be featured to locally dissipate the energy by movement of members.

- Recent studies also show that the long eaves also aid in horizontal movement during an earthquake, improving the structural performance of the pagoda (The Economist, 1997).

Certain configuration features of seismic design can also be observed in the planning of the pagodas. It can be seen the plan is symmetrical in all directions and equal number of columns are placed along each side, this ensures that equal amount of force is transmitted through each of the column. This reduces the overall torsional forces within the structure and keeping it stable during the earthquake. Also, like in section, the plan is slowly reducing in size as the tower tapers to the top, reducing the overall mass where acceleration reaches maximum. Figure 6.9 shows the proportions of a typical pagoda plan.

Thus the seismic features can be summarized as follows (Arnold & Reitherman, 1925):

- Pagodas have sufficient strengths to withstand lateral forces.
- Pagodas can suffer a lot of deformations before failure. This is because of the material property of wood. Wood has a capacity to bend and wrap when subjected to a force and move to its former shape when the force is reduced (Karlovic, 2017).
- Pagodas can provide a large amount of structural damping by the moving its members independently.

These features make a pagoda stand out in the field of seismic design as shown in figure 6.10. The efficiency of the material and the design make a pagoda comparable to a ductile frame building of modern times (Arnold & Reitherman, 1925).

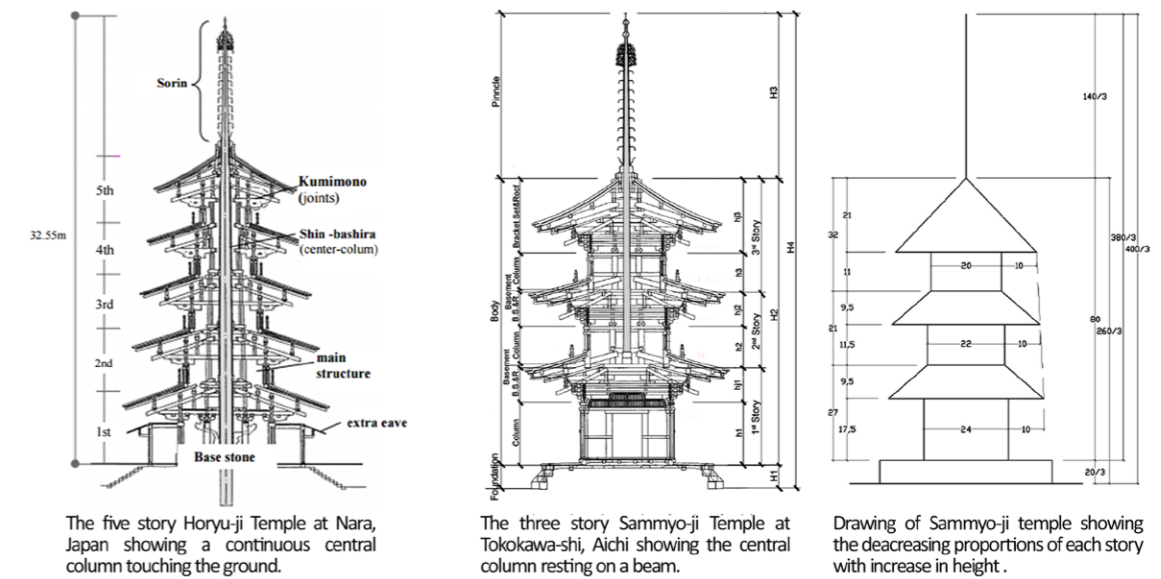


Figure 6.8: Sections of a five storey and three storey pagoda in Japan. (The sections are representations of the structure and are not drawn to scale with respect to each other). [Image source: Left- (Karlovic, 2017), middle and right - (Zhang, Tang, Xue, & Xun, 2015)].

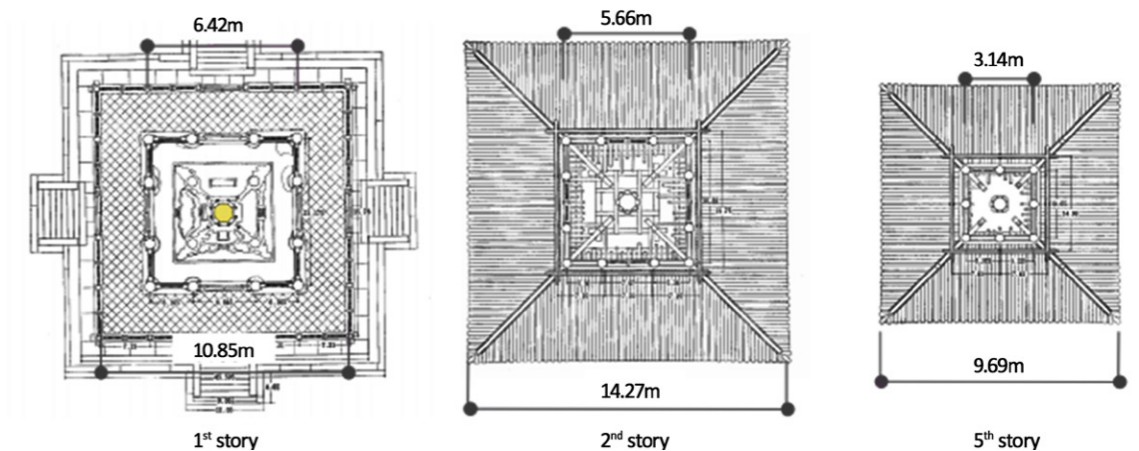


Figure 6.9: Plans of the five storey Horyu-ji Temple at Tokokawa, Japan. [Image source: (Karlovic, 2017)]

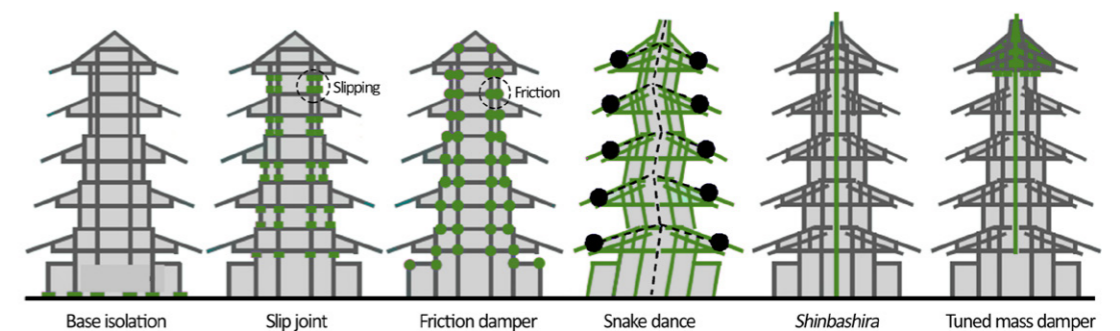


Figure 6.10: Seismic features in a Pagoda. [Image source: (Karlovic, 2017)].

6.1.3 Japanese Pagoda - Micro Analysis

The affect of wooden joineries in the seismic performance of a Japanese building can already be judged in the above section. The movement at different junctions is granted by crafting the joints in such a way that they allow freedom at individual level. Japanese joineries are the DNA of their architecture which make it outstanding from all other wooden construction techniques in the world.

Wooden joineries have been based on the practical aspects of material length, physical and chemical properties which change with respect to climate and age. It is important to understand these aspects and shortcomings in order to truly reason the design of a joinery. Since biologically, the girth and height of a tree is limited, the joinery techniques and bonding materials are needed to join one length to another. Also, natural materials might have unforeseen defects like knots in wood, which affect the strength of a joint, the scale of the affect differs from place and species. Another very important feature of wood is that the strength of timber will vary with the direction of stress (Seike, 1977). Also, wood is sensitive to humidity, its affect depends upon the dimension and the method used to dry and season it (Seike, 1977). Wood can shrink in multiple directions after it dries but the maximum shrinkage is generally witnessed in the direction parallel to the annual rings (Seike, 1977). Thus Japanese masons utilized these properties of wood to design joineries. For example, if a carpenter has to join two members with grains running in different directions, then special care must be taken so that the joints do not shrink apart when the wood dries out. Also a joint should be so designed that it can transmit or absorb energy and bear the burden despite its small cross-section. Thus, cutting methods were formed such that, the surface area of contact between the two members is maximized, which in turn increases the load bearing efficiency (Seike, 1977). Japanese joineries have been formulated in such a way that they do not need metals or adhesives (Kanasaki & Tanaka, 2013).

The Japanese joinery technique is broadly classified into two types: The tugite and the shiguchi. While tugite is a technique to increase the length by joining two pieces together, shiguchi is the technique of joining members at an angle. These two methods make up the entire catalogue of wood joineries.

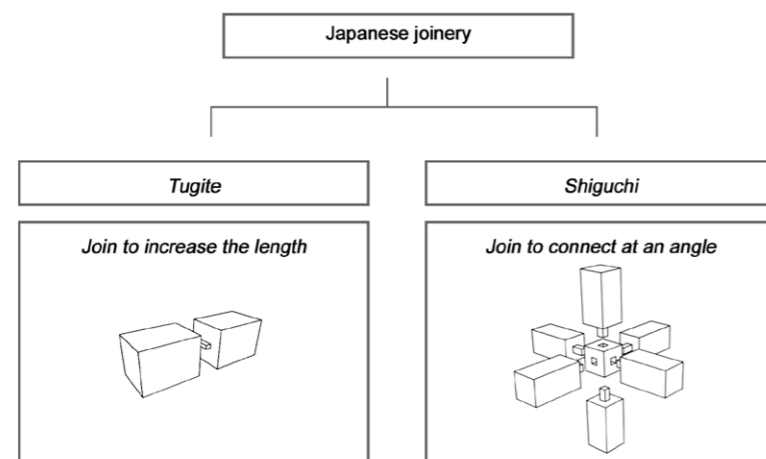


Figure 6.11: Classification of joinery in traditional Japanese construction techniques (Kanasaki & Tanaka, 2013).

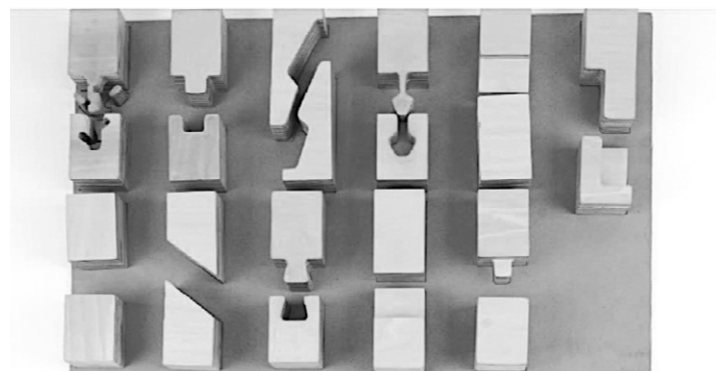


Figure 6.12: Basic shapes of tugite and shiguchi (Kanasaki & Tanaka, 2013).

The tugite and shiguchi are made up of 10-20 types of shapes, some of these shapes are shown in Figure 6.12. The skill of wood artisan is of utmost importance as it is he who selects the type of shape based on his experience and then composes it to make the connection. The shapes are selected on the basis of functionality, position in the structure and fabrication feasibility.

As already mentioned that the joineries must be designed to bear the stresses, care must be taken to choose an appropriate location for placing a joint in the member. It is necessary that a tugite – connecting joint is made where the least stress will occur (Seike, 1977). The joint must have resistance in the direction of gravity and in the direction opposite the joining direction of the materials. Figure 6.13 shows the possible tugite and shiguchi joints that can be used to connect members in a wooden construction. Around 200 of such shapes have been identified (Kanasaki & Tanaka, 2013).

6.1.4 Relevance of traditional Japanese technique in given context

The efficiency and technological advancement of the Japanese in the field of seismic design is time proven. They took into account both efficient configuration schemes at a macro level and detailed it with precision in the micro level to create a holistic ductile structure. Also it is a fact that a lot of skill and practice is needed to accurately craft these joints. Carpenters were trained for years in Japan before could be given a title of an artisan. In today's context it will be difficult to rely on training the carpenters for years before they could be given the job. Also, crafting complicated joints by hand will significantly add up to the construction timeline and expense, making the project infeasible. The joineries have to be made with perfect precision in one go to avoid wastage of material. Thus, the need for these complex joints can be questioned in today's context. However, the difficulty level of each joinery varies. As in the case of the 'Assam type house' the simplest tenon and mortise joints were introduced to enhance the earthquake performance. The difficulty level of the joineries can be analysed and various types can be juxtaposed to create new variations suited to today's skills of less trained carpenters.

Another reason for development of these complex joineries in Japan was the lack of metal (Seike, 1977). Even if it was available, metal was very expensive and used for making special objects. Hence the development of these metal-less joineries was due to an unavoidable economic situation. However, in today's context where metal fish plates, clamps, straps, angles and bolts are readily and cheaply available; it is more efficient to make quick joints by reinforcing metal or even glue rather than crafting complicated unreinforced joineries (Seike, 1977). Structurally, these metal members are ductile, hence are able to deform before snapping, this adds strength to the joinery. The efficiency of a joinery can be judged by the ratio of the strength of the connection to the strength of the member it connects (Ramage, et al., 2017). Figure 6.14 shows the strength of different connections. However, it should be noted that though glued connections are proved to be the strongest, it comes with its own problems of environmental impact.



Figure 6.13: Typical types of traditional Japanese joineries (Kanasaki & Tanaka, 2013).

The strength of new connection methods has surpassed the traditional techniques. Also, due to the extra time taken to craft the complicated traditional Japanese joints, it can be said that using these joints solely in large-scale projects in today's age by manual crafting of timber might be difficult. However, with the advancement in technology, CNC milling machines can also be used to produce these joints that are accurate up to a fraction of a millimeter. Also, they can sculpt multiple pieces in a very short time as compared to manual crafting. Thus, CNC milling is a viable option for efficient production of the traditional Japanese joints, only that it comes with an additional cost of machinery installation, energy requirements and technically skilled professionals for operation. Figure 6.15 shows a CNC milling machine.

However, the relevance of installing CNC milling machines just to craft the complicated joineries in the context of Shillong is questionable. Although efficient, but these CNC milling machines need an initial amount of huge monetary investments. Also going by the scale of proposal, many such CNC machines have to be installed to meet the requirements of the market. Further, an area will have to be allotted where large-scale manufacturing can be done using these machines and professionals have to be trained to operate them. It is already known that a normal carpenter in today's age can make secure connections using metal reinforcements. The region of Shillong has a lot of cheap labor who can be trained to produce these easy yet efficient connections. Hence it can be concluded that in the given scenario the use of the complicated Japanese joineries is no longer feasible, both in terms of cost and craftsmanship. But the old ways can be modified and redesigned to create hybrid solutions suited to the available human and monetary resources in the given context.

Finally, it should be mentioned that the principles of Japanese timber construction like the rule of proportions is vital for the further stages of this research. Section 8.5 shows the exploration of the hybrid construction technology on the basis of these Japanese timber design principles, for contemporary urban environment of Shillong.

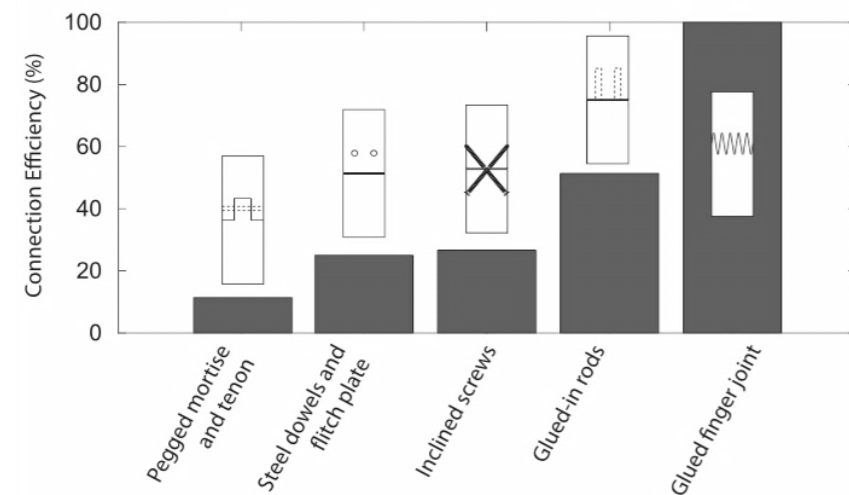


Figure 6.14: Efficiency of connections between 100 mm by 200 mm timber members transmitting a tensile axial force. [Data source: (Ramage, et al., 2017)].



Figure 6.15: Left – 5 axis CNC milling machine (northwoodmachine.com). Right – CNC milling on wood in progress (https://www.youtube.com/watch?v=xtDLmrrmX3Q).

6.2 Modern methods of hybrid timber construction

The efficiency of a 1400 year old Japanese construction technology has been discussed in the above section, it has passed the test of time by withstanding seismic tremors of 7.0M more than 46 times in the humid climate. Also, the importance of wood as a construction material is proved in our drive towards sustainability. In this light, timber is making a new come back in the field of building technology and the global timber industry is going through a tremendous innovative transformation. Innovation is progressing in the field of structural timber, thermal and acoustical performance of timber skins, fire ratings, prefabricated elements, assembly processes and building end of life. The building byelaws in many countries are under consideration to keep pace with the breakthroughs in the timber industry. Japan and several EU countries are in the forefront of 'wood first policies' and Canada and London are on their way to put mass timber in their standards (Ramage, et al., 2017). Oregon was the first to legalize mass timber high-rise buildings amongst the US states (archdaily.com). These policies encourage the environmental performance assessments of buildings by encouraging the use of wood in construction (Ramage, et al., 2017). Not only the building bye laws are being revised but great care is taken that the timber used for construction comes from well managed certified sources.

The fashion of building taller with timber has already set various nations across the globe on a competition. Few countries have already managed to add the tall timber tower to their urban skyline whilst some have announced the coming of one. Figure 6.16 shows some of the important tall timber projects either proposed or already constructed in the world. While various small and mid-rise timber constructions are sprouting everywhere. It can be seen that, as countries compete to build the tallest timber building in the world, new innovation in the field is in demand. Also, the timber construction has picked up trends because the countries are striving to meet their goals on sustainability by reducing their carbon emissions.

Most of these modern tall timber constructions are hybrid structures. This is because the buildings today need to match up the comfort requirements of modern man in terms of acoustics, fire-safety, thermal insulation and structures of course. Every material has its own advantages and disadvantages. Which means that the best of mechanical properties of multiple materials is used to create the hybrid system. For instance the tall timber constructions combine the compressive strength of solid wooden panels with the ductility and stiffness of steel to give an efficient structure. Wood products are strategically used for their strong attributes as required for both the gravity and lateral systems. Steel beams are used interchangeably with wood as a part of the gravity system, but more importantly, for the lateral system where they can be well proportioned to resist lateral forces as well as contribute to the building stiffness. In addition, the steel beams can be easily detailed to provide the necessary ductility and suitably proportioned (as reduced beam sections) to limit the potential amount of loading under a seismic event (Green, 2012). Concrete on the other hand is generally used in foundations where moisture content is very high. Using

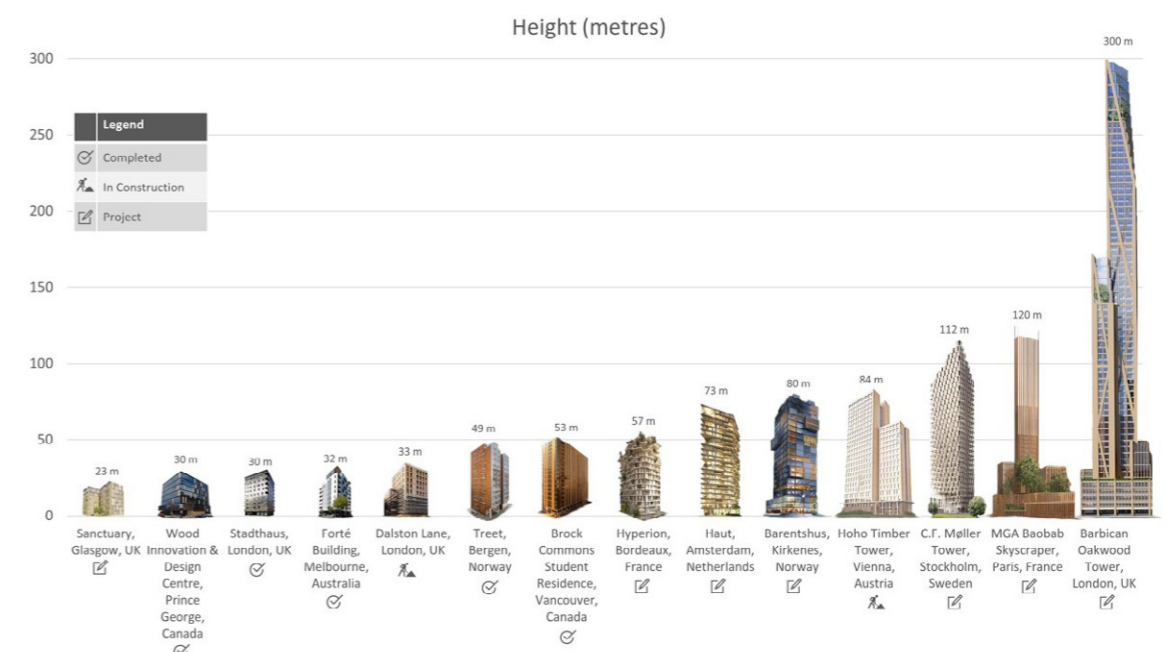


Figure 6.16: High-rise timber towers in world [Source: Confederation of timber industries - 2017].

multiple materials sometimes increases the efficiency of assembly and eases prefabrication. Also multiple construction techniques and details can be developed to suit the local requirements of a junction. Also, various combinations of fire resisting systems, i.e., both charring and encpsuation methods, can be used to optimize the structure/joint. Although timber is the major construction material, small quantities of other materials help to reduce the cost and increase the performance of construction. The level of hybridization depends upon multiple factors like the height of the building, the local bye-laws, geological and climatic conditions, purpose of the building and availability of materials. Various designers have figured out multiple ways to maximize the potential of the combination of materials whilst trying to reduce the ecological footprints. Figure 6.17 shows four concepts of a mass timber construction of different heights presented by mgb Architecture + Design.

While the above proposal mainly shows use of engineered timber panels along with steel members for additional support, another proposal by SOM, in their timber tower project shows use of concrete beams for strengthening the structure. Figure 6.18 shows different details for additional support proposed by different designers. It can be learnt that there is no 'best way' to detail the structure and the industry is still on its way to experiment with different resources. Figure 6.18 shows only two examples of one joinery, whilst there are multiple possibilities of using various materials in different junctions. Thus in this plethora of multiple choices the designer has to pick the right material and technique based on critical contextual aspects.

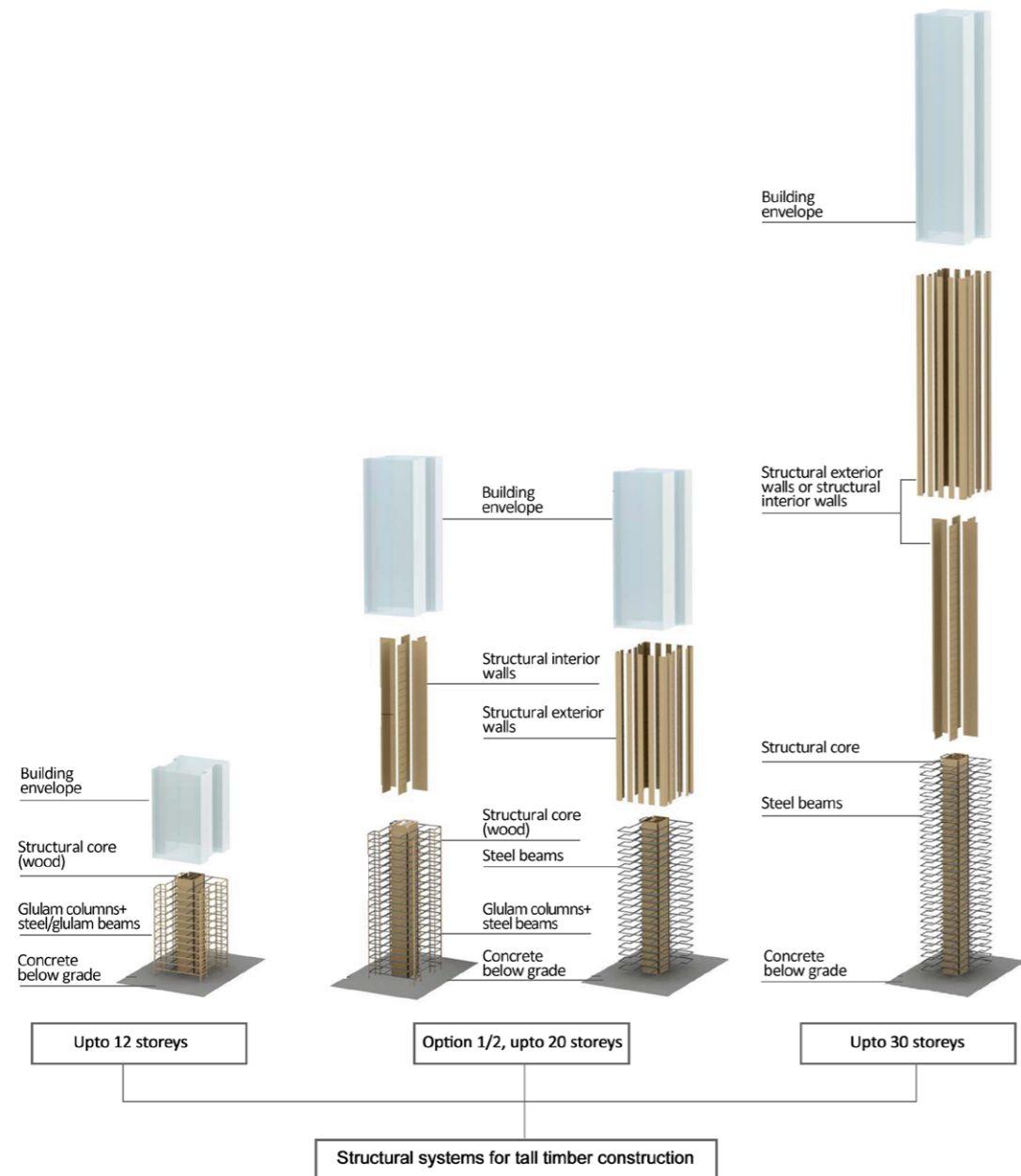


Figure 6.17: Different structural systems with increasing height of the building. Systems proposed by: mgb Architecture+Design (Green, 2012).

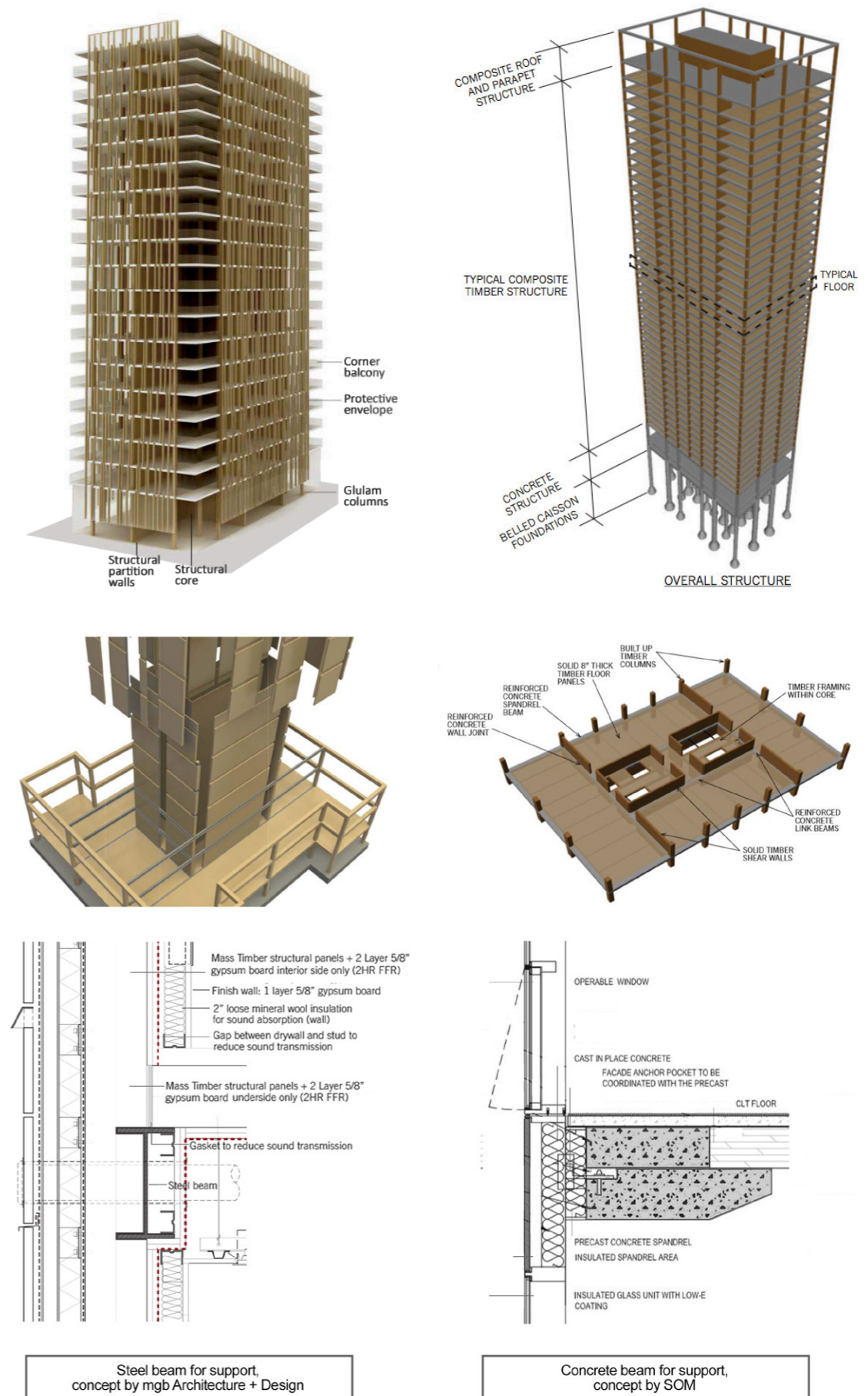


Figure 6.18: Different structural concepts for additional support proposed by mgb Architecture+Design and SOM [Source: (Green, 2012) & (Skidmore, et.al., 2013)].

6.2.1 The Stadhaus, Waugh Thistleton Architects

Location: Hackney, London
 Year: 2009
 Height: 29m
 Type: Housing

Being the first tall timber tower made of pre-fabricated cross-laminated timber panels, the Stadhaus has set an example for the world in the field of sustainable developed using mass timber as a construction material (wikipedia, 2018). The slabs, load bearing walls, stairs and lift shafts are all made of timber. While the timber core provides structural stability, the insert balconies with structural balustrades adds strength to the exterior structural walls. The project was constructed in 49 weeks and replaces the use unsustainable materials like concrete and steel. This project also leads the international movement in timber construction (Waugh Thistleton Architects, 2009).



Figure 6.19: Exterior view of the Stadhaus. (<http://waughthistleton.com/murray-grove/>)

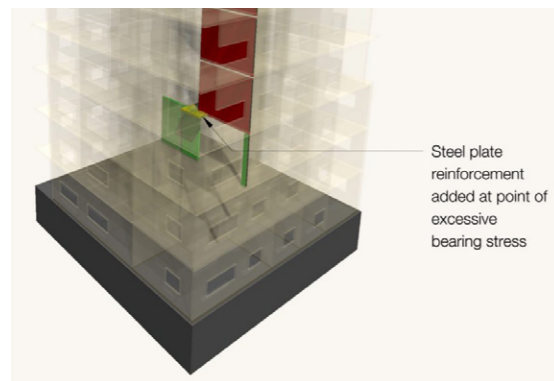


Figure 6.20: Connection detail. (<https://techniker.co.uk/stadhaus>)

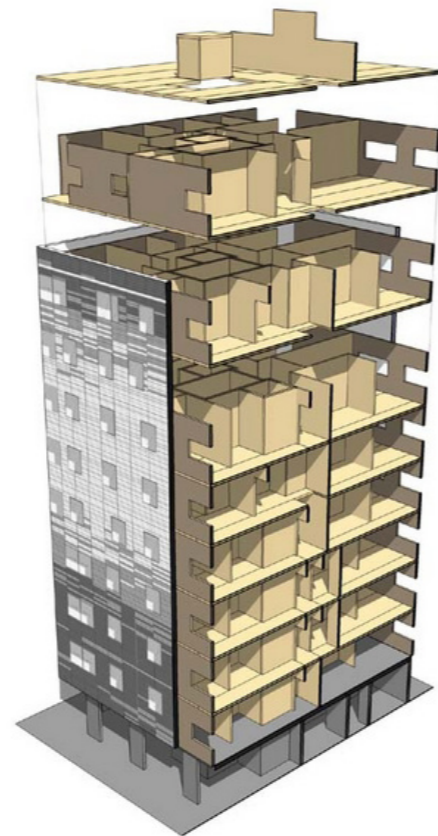


Figure 6.21: Section showing the structural system. (<http://www.cbd.si/en/design#prettyPhoto/0/>)



Figure 6.23: Construction progress. (<http://www.klhuk.com/portfolio/residential/stadhaus,-murray-grove.aspx>)



Figure 6.24: Interior view. (<http://www.klhuk.com/portfolio/residential/stadhaus,-murray-grove.aspx>)

6.2.2 Tamedia office building, Shigeru Ban Architects

Location: Zurich, Switzerland
 Year: 2013
 Height: 50m
 Type: Office building

The tamedia office building was conceptualised by Shigeru Ban architects. Its innovative connection system makes it stand out from all the timber construction projects. These joineries have been designed without the use of metal connections and adds to the architectural character of the space. Further the use of timber in construction adds to the sustainable value of the building. The use of glass in facade and modern interiors complement the contemporary requirements and jells with the urban requirements of the city landscape. This case study is a bold example of the possibilities of timber connections for tall structures. (Source: archdaily.com and dezeen.com)



Figure 6.25: Exterior view of Tamedia Office building. (<https://www.glassdoor.co.in/Photos/Tamedia-Office-Photos-IMG877849.htm>)



Figure 6.26: Connection detail. (https://images.adsttc.com/media/images/5304/281e/e8e4/4ee8/ac00/00c5/large_jpg/TAMEDIA_187.jpg?1392781540)

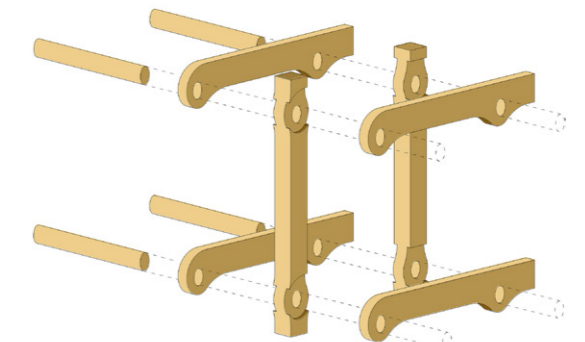
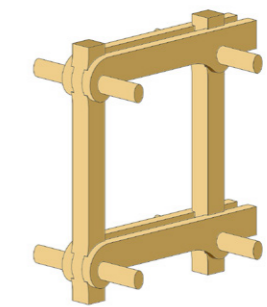


Figure 6.27: Connection diagram. (https://images.adsttc.com/media/images/5304/2af5/e8e4/4ee8/ac00/00cc/large_jpg/Timber_Detail_Axon.jpg?1392782056)



Figure 6.28: Construction progress. (https://images.adsttc.com/media/images/5304/25f8/e8e4/4ee8/ac00/00b6/large_jpg/D1.jpg?1392780753)

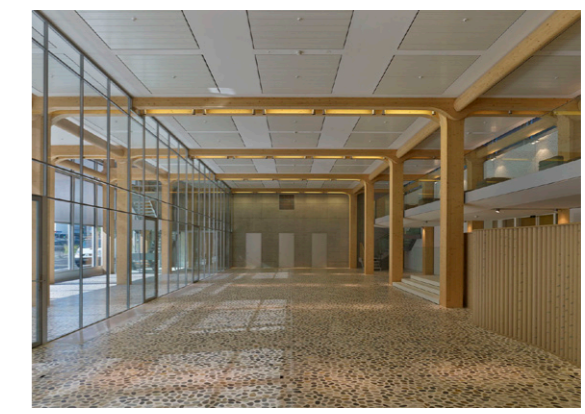


Figure 6.29: Interior view. (https://images.adsttc.com/media/images/5304/288d/e8e4/4ec6/9a00/0100/large_jpg/TAMEDIA_144.jpg?1392781437)

6.2.3 The Druk White Lotus School, ARUP

Location: Ladakh, India
 Year: Ongoing, (building in stages)
 Height: Single storey
 Type: Educational building

Given an extraordinary remote context with limited building material and monetary resources whilst located on the seismic region of India, the Druk White Lotus School is an excellent example of using natural timber for construction. The project is carried by ARUP from the beginning. The school has been built with locally available materials, with natural timber consisting the main structural system. The innovative construction system and energy use of this building has set an example of a low-cost sustainable construction system. This case study holds important relevance to this research because of its apt technological solution in the given rural region (Arup).



Figure 6.30: Exterior view of the Druk white Lotus School. (<https://www.dwls.org/sustainability/buildings-photo-gallery.html#prettyPhoto>)



Figure 6.31: Roof detail. (<http://www.solaripedia.com/files/639.pdf>)



Figure 6.33: Interior view. (<http://www.buffalo.edu/content/dam/www/news/imported/hires/DrukSchool1.jpg>)



Figure 6.32: Concept diagram. (<https://www.slideshare.net/RajdeepDhar7/the-druk-white-lotus-school-presentation>)



Figure 6.34: Construction progress. (https://images.adsttc.com/media/images/5304/25f8/e8e4/4ee8/ac00/00b6/large_jpg/D1.jpg?1392780753)

6.2.4 The W350, Nikken Sekkei

Location: Tokyo, Japan
 Year: Proposed
 Height: 350m
 Type: Mixed use

An ambitious proposal of a 350m tall timber tower was made by Sumitomo Forestry in association with architects Nikken Sekkei. It is the tallest conceptualized timber tower in the world comprising of a hybrid structural system (archdaily, 2019). While timber would comprise 90% of the total building material, steel will be used to accommodate the high seismic activity of the region (dezeen, 2019). The columns and beams are proposed of timber and the bracing is proposed of steel tubes. The proposal is a breakthrough in architecture inspiring innovation in mass timber construction and combating global sustainability issues.



Figure 6.35: Exterior view of the W350. (https://images.adsttc.com/media/images/5a85/ffc5/f197/ccbe/1700/001f/large_jpg/image.jpg?1518731201)



Figure 6.36: Braced tube structure detail. (https://images.adsttc.com/media/images/5a85/ffce/f197/ccbe/1700/0020/large_jpg/Brace-Tube-Structure-Sumitomo-Forestry-Wooden-Skyscraper.jpg.860x0_q70_crop-smart.jpg?1518731211)

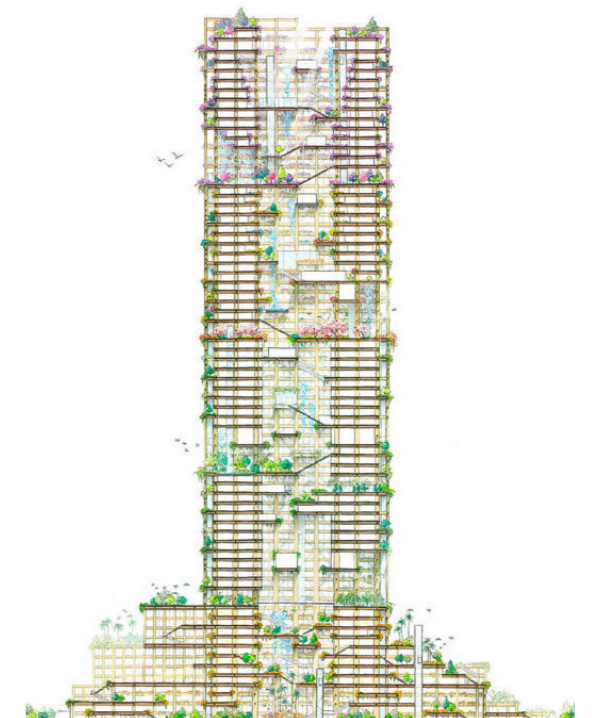


Figure 6.37: Concept diagram. (https://images.adsttc.com/media/images/5a85/ffbb/f197/ccbe/1700/001e/large_jpg/sumitomoringyo_W350-4.jpg?1518731191)



Figure 6.38: Exterior view. (https://images.adsttc.com/media/images/5a85/fff4/f197/cc64/3c00/0008/large_jpg/W350-Project-by-Sumitomo-Forestry-4-889x490.jpg?1518731249)



Figure 6.39: Interior view. (<https://www.archdaily.com/889142/japan-plans-for-supertall-wooden-skyscraper-in-tokyo-by-2041/5a85ffedf197-cbe17000027-japan-plans-for-supertall-wooden-skyscraper-in-tokyo-by-2041-photo>)

6.2.5 Relevance of modern timber construction in given context

The efficiency of wooden construction has brought it back to limelight. However, on analyzing the broad picture it is understood that this large-scale modern timber industry comprises of huge investment and technologically advanced system which aid in creating a closed loop for lifecycle of a timber construction. It is important to realize that each step in the lifecycle is very important to fulfill the final aim of sustainability, without which the whole purpose of the idea gets destroyed. It is learnt that the sustainability assessments largely depend on the context. Thus it is critical to analyze the region and understand the quality and quantity of the local resources.

From the understanding of the types of timber available in today's world, it was learnt that the wooden products have been modified to great strengths and workability. Also, the processes involved in manufacturing and after life treatment are technological advanced. This processing needs added energy. Figure 6.40 shows an example of the life cycle of a modern day timber construction. The need for this advanced technology comes from the necessity to build high in the worldwide competition. However, in regions where low or medium rise building are in demand, as in case of Shillong, resources can be saved by using timber closer to its natural form. The energy efficiency of timber from sustainability aspect is improved if the processing is reduced. As described in Section 5 a large proportion of the energy expended in processing engineered wood products is in drying and production of adhesives (Ramage, et al., 2017). Further disposal of these adhesive treated products needs scientific control.

Now Shillong is a technologically backward region, which currently does not have a modern timber industry setup. If modern timber construction using engineered wood is proposed, then a huge investment will be needed in importing these materials from across the seas which does not solve the purpose of 'sustainability'. The setting up of these timber industries will require huge time and monetary investments. Also, if such products like glulam, CLT, LVL or OSB's are used which are made of adhesives, a separate recycling unit has to be setup which scientifically treats them afterlife. Thus, not only manufacturing but also the disposal of these highly engineered products is a problem in the given context of Shillong. Though we can aspire for an economic development of the timber product industry in future, the current resources provide us with non-engineered sawn wood.

Nevertheless, the alternative means of using non-engineered timber is a silver lining in the region of Shillong. The past techniques can be reinvented to suit the current requirements. Also, researches in the field of non-engineered wood show that it is also possible to avoid even the use of a sawmill, by using green round wood in construction (Ramage, et al., 2017). By avoiding cutting the grain, this retains the structure formed by the tree. Keeping the timber closer to its natural form in this way may also reduce the weakening effects of knots, since the tree has naturally formed load paths around them, but connecting these circular cross sections is challenging. These challenges can be dealt-with in the design process. Natural methods of fire resistance like charring can be explored. Also, currently, most of the used wood goes into the landfill at the end of life. It is known that the state of Meghalaya has a demand for fuel-wood, thus these products can replace fresh timber to fulfill the local demands of fuel. Another potential is the use of the waste wood in production of charcoal, though this process needs further investigation but it can still be thought off. Furthermore, using mechanical fasteners and avoiding adhesives could facilitate end-of-life disassembly and material recovery. This would promote the deconstruction and reuse of wood buildings rather than conventional demolition and landfill practices (Dangel, 2017). While the other technological advancement in the region should be promoted, the alternative model of using sawn wood can be put to use for initiation of the timber market in the region. Figure 6.41 shows the potential life cycle system of wood construction in the current context.



Figure 6.40: Life cycle of a modern wood construction (Dangel, 2017).

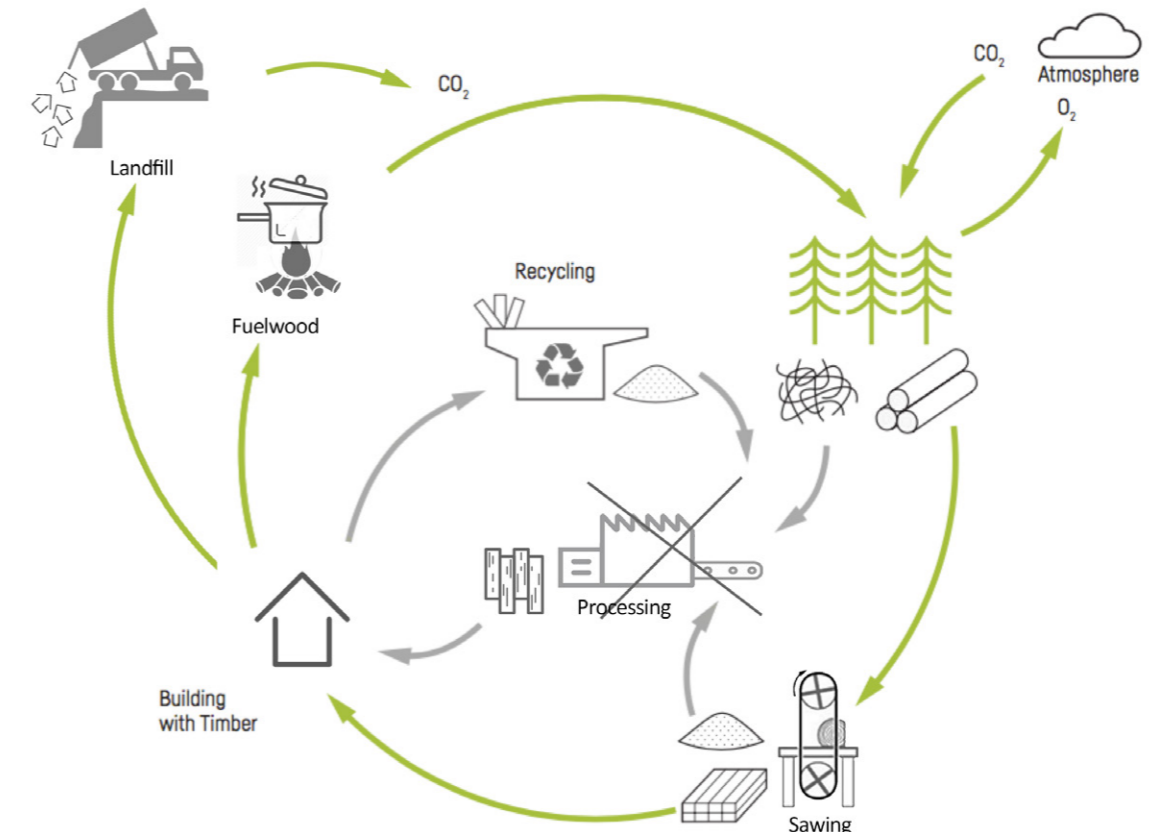


Figure 6.41: The potential life cycle system of wood construction based on the current context of Shillong.

7

ARCHITECTURAL PRINCIPLES OF SEISMIC DESIGN

Introduction to architectural principles of seismic design

The earth's crust is in a continuous state of motion. It has come a long way through the geological timeline of millions of years from the superstructure Pangaea to form the seven continents that we live in today. This dynamic movement of the earth's crust is known as continental drift or tectonic plate movement (Charleson, 2008). In our common language, this movement is called an earthquake. Earthquakes occur when large amounts of thermal energy that radiates from the earth's core, power the convection currents in the earth's mantle to generate forces which are large enough to drift the continents (Charleson, 2008). The drifting of the continents or plates can cause the crust of the earth to fracture, this fracture is called a fault. In words of Andrew Charleson, the point on the fault surface area considered the center of energy release is termed the focus, and its projection up to the earth's surface, a distance known as the focal depth, defines the epicenter. Figure 7.1 shows the common terms used in earthquake.

This release of energy, which causes the fault, generates different kinds of motion on the surface of the earth. The surface motion travels as horizontal or vertical waves. As per the classification of Arnold and Reitherman, these waves are divided into four categories: a) P-wave b) S-wave c) Love wave and d) Rayleigh wave. Figure 7.1 shows the four types of waves created by a fault rupture. Out of these the P-wave is the most dangerous, it travels and spreads the fastest @ 8km/sec (Arnold & Reitherman, 1925). The horizontal movements do more harm to a building than a vertical movement (Charleson, 2008). It is difficult to predict the kind and direction of wave during an earthquake. The kind of soil and rock layers in a region also affects the magnitude, amplification and type of surface movement. For example, alluvial and mud soils experience four and nine times the amplification as compared to a granite bed (Arnold & Reitherman, 1925). Seismographs are used to measure the ground motions. Various scales are used in different regions of the world to judge the intensity or magnitude of the earthquake. The Richter scale is based on the maximum amplitude of the seismic waves recorded on a seismograph. While intensity scales like the Modified Mercalli (MM) scale is based on the subjective judgment on the effect of earthquake on the surroundings. Different countries have different basis of judgement.

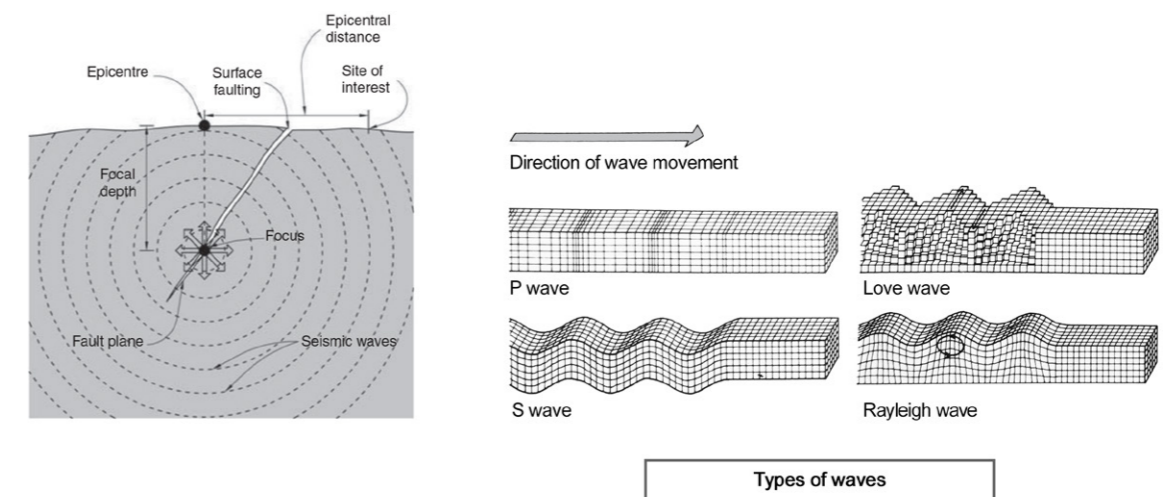


Figure 7.1: Important terminology for an earthquake (Charleson, 2008). Types of waves (Arnold & Reitherman, 1925).

7.1 Common terms related to an earthquake

(The understanding of the terms has been adopted from the definitions by Arnold and Reitherman, 1925):

Liquefaction: This is a condition in which the soil changes its state from a solid to liquid, in order to release the energy and varies with the type of soil.

Displacement: it refers to the distance of movement of a particle from its rest position.

Velocity: It refers to the rate of ground motion, it is measured in inches or meter per second.

Acceleration: It is the rate of change of velocity. It is commonly measured in g-the acceleration of a free falling body due to the earth's gravity (Arnold & Reitherman, 1925).

Inertia force: It is Newton's second law of motion and is the primary equation of seismic resistance i.e., When acceleration is multiple by the mass, it results in a force that should be resisted by a building. Where, F is the inertial force, M is the mass of an object and a = acceleration due to gravity.

$$F = m \times a$$

Center of mass (COM): The point on an element at which the sum of gravitational forces act (Charleson, 2008). In other terms, it is the point where if a force is applied it moves in the direction of the force without rotating (Wikipedia.org, 2019; center of mass).

Return period: The average time period of recurrences between two earthquakes in a region (Charleson, 2008).

7.2 Important properties of a building related to seismic design

Weight: The inertia force in a building is a derivation of mass and acceleration. Mass is the most important property of a building that directly determines the affect of an earthquake. The higher the mass, the greater the force.

Natural period of vibration: The time taken for a building to travel back and forth once is called the natural period of vibration. As the building vibrates in consecutive natural periods, its effect changes, the maximum affect on the building is felt in the first few modes of vibration. Figure 7.2 graphically shows the meaning and effect of the natural period of vibration on buildings. The natural period of vibration is dependent on: the weight of the building, the height of the building and the type of structural system provided to resist the forces (Charleson, 2008). The natural period of vibration of the ground also affects the build. The soil generally has a natural period of vibration between 0.5 and 1 second (Arnold & Reitherman, 1925). It is advisable that the buildings natural periods do not match that of the soil. Arnold and Reitherman have very clearly explained the relation of the structural system and the soil condition with the natural period of vibration:

'In general, a more flexible, longer period design may be expected to experience lesser force, proportionately, than a stiffer building if the site is composed on a bedrock, which will efficiently transmit short period of vibrations while filtering out longer period of vibrations. By contrast, since it is difficult for a layer of soft alluvium several hundred feet deep to vibrate rapidly, even though the input motion from the bedrock beneath it may be high frequency, a stiffer building may have much less response than one with a longer period.'

Damping: The amplitude of vibrations slowly decay due to the friction taking place inside various element of the building. This decay of vibration with each successive cycle is called damping. Damping largely depends upon the building materials, connection design and the configuration of structural and non-structural elements (Arnold & Reitherman, 1925). Wood provides greatest damping as compared to reinforced concrete and steel (Charleson, 2008). Damping absorbs the energy from earthquakes, reducing

the movement of the building. There are multiple ways of looking at damping. Higher the damping coefficient, higher the resistance of the building. However, recently codes are looking at positive aspects of flexibility during an earthquake, this results in an extended non-structural damage with increase in levels of the structure (Arnold & Reitherman, 1925).

Ductility: It is the physical property of the building material to expand or contract. It is the opposite of brittle. It is the capacity of the material to deform before it breaks. The material reaches its elastic limit before permanently deforming plastically. Concrete is a brittle material, that is, it fails suddenly without showing any deformation (Arnold & Reitherman, 1925). However, different materials can be combined, like steel and concrete to improve ductility. The proportions of the members, connections and end conditions affect the overall ductility of a structure (Arnold & Reitherman, 1925). Ductility increases the affect of damping in a building (Charleson, 2008).

Strength: It is the capacity of a building to resist bending moments and shear forces. The building should resist the loads without exceeding a certain stress. If the strength is maintained in two orthogonal directions, then it is safe for horizontal loads from other directions. A seismic force can be resolved into two orthogonal components which are resisted by structure with strength parallel to those directions (Charleson, 2008).

Stiffness: It can be measured by the deflection. Stiffness is the capacity of a building to resist horizontal deflection more than what is permitted (Arnold & Reitherman, 1925). It can be said that the stiffer the object, the smaller the natural period of vibration, therefore greater the concentration of seismic forces (Charleson, 2008). In scientific terms, stiffness is proportional to the moment of inertia of a member (I). $I = bd^3/12$, b is the member width or breadth, and d its depth measured parallel to the direction of the force being resisted. Thus, the stiffness is dependent on the proportions of the structural members.

Both strength and stiffness are the most important characteristic of a structural system which affects the overall performance during an earthquake.

Torsion: The two important terms that explain the concept of structural torsion are the center of mass (COM) and the geometric center or center of rigidity (COR) of the object. If the COM coincides with the geometric center then the structure is said to be in balance, cancelling out moments from all directions. However, if the supports are unequally placed or sized, the COR moves away from the COM resulting in creation of torsion induced horizontal deflections. Figure 7.3 shows the affect of misbalance in a structure due to oversizing of columns in one direction.

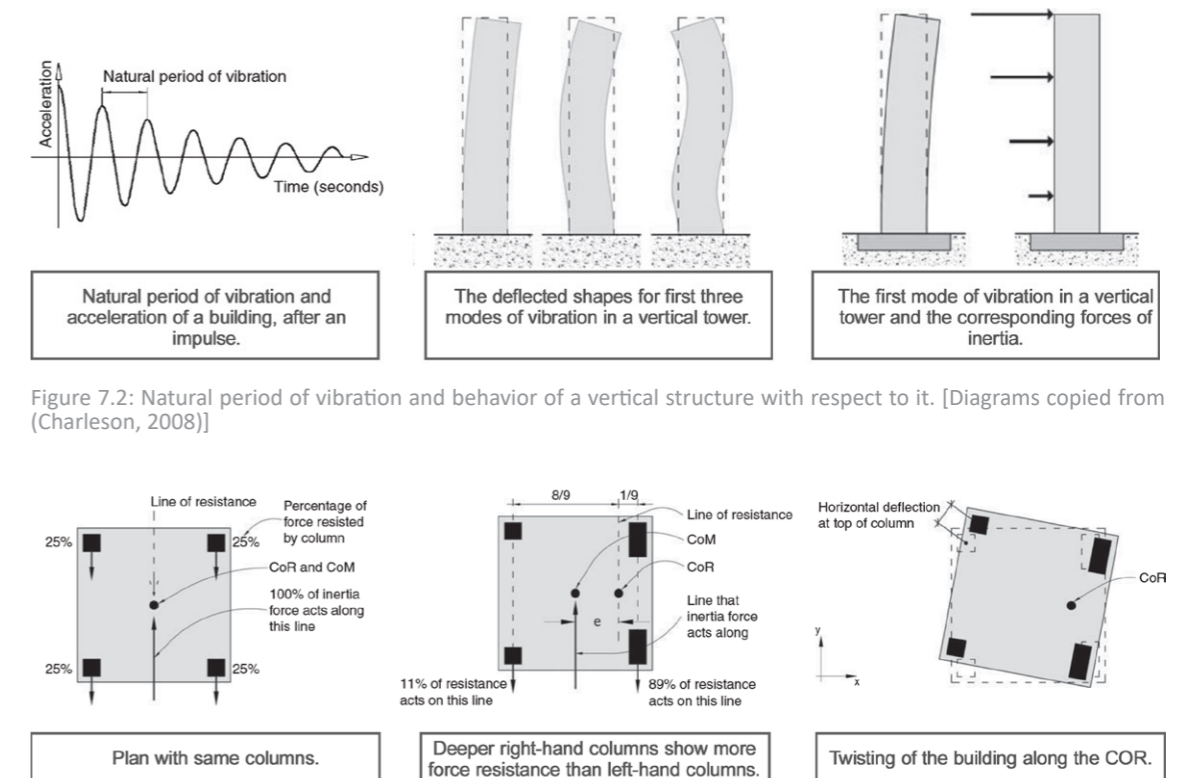


Figure 7.2: Natural period of vibration and behavior of a vertical structure with respect to it. [Diagrams copied from (Charleson, 2008)]

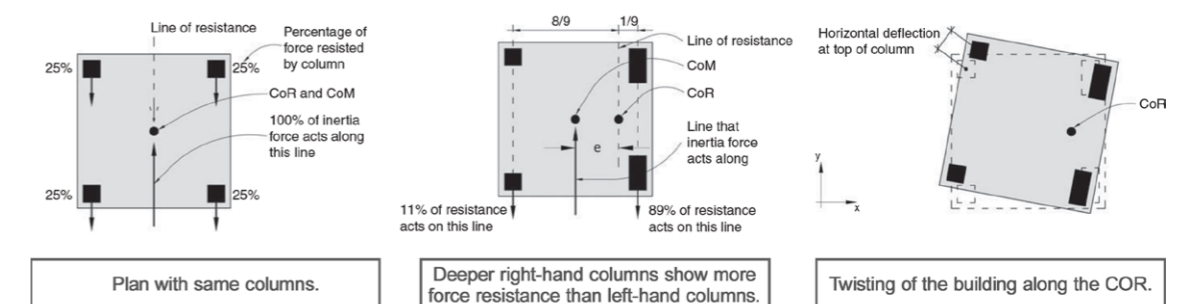


Figure 7.3: Effect of eccentricity on the torsional deflection in a structure [Diagrams copied from (Charleson, 2008)].

7.3 Seismic force resistant systems

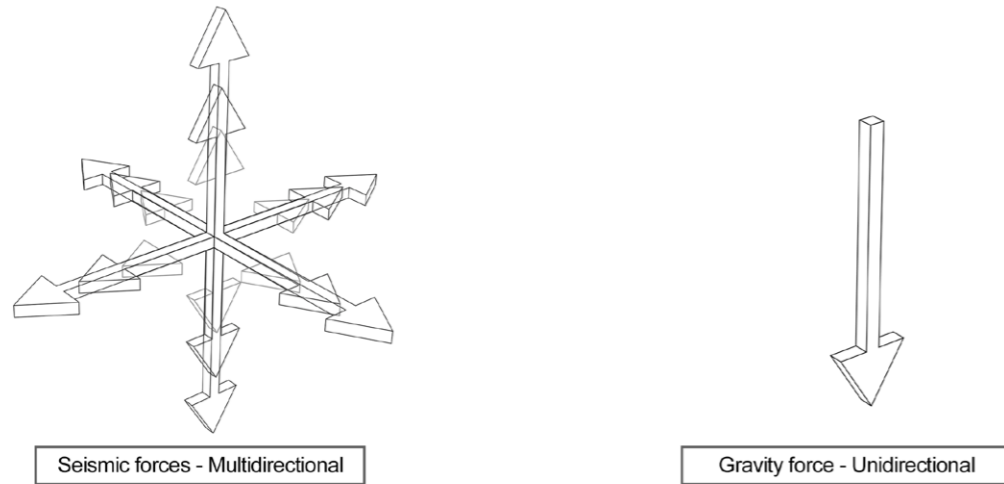


Figure 7.4: Directionality of forces [Image source: (Arnold & Reitherman, 1925)]

In order to understand how the building resists forces, it is important to first establish an understanding on the paths taken by forces in a structure. The path is the route taken through the internal elements of a building by a force to travel from the top to bottom and into the ground. The structural elements should be strong enough to firstly withstand the force and secondly, safely transfer it to its adjoining members (Charleson, 2008). Different structural systems i.e. trusses, arches, column-beams, etc. have different methods of transferring forces. Both path and junctions need special care so that the forces can smoothly flow both horizontally, as in case of roofs, or vertically as in case of columns.

In a general scenario, buildings are designed to vertically transfer loads, i.e., the gravitational loads. However, in case of a seismic loading condition, the building must withstand load from multi-direction. Seismic forces are very dynamic, complex and unpredictable. Figure 7.4 shows the contrast between a gravity force and a seismic force.

Thus, the horizontal and vertical members of a structure under seismic loading has to be designed for forces in all directions, making the situation complicated. It is a common practice in which the architect places the structural members with respect to the spatial quality and the structural engineer sizes those members. Hence, the conceptual principles of the resistance systems should be well understood and incorporated during the design stage for development of a technically sound architectural design. The failure of this understanding can lead to devastating affects during a catastrophe or expensive sizing and solutions on behalf of the structural engineer. The two major objectives for a seismic structural design are to save human lives during a catastrophe and to minimize the extent of damage during small tremors (Charleson, 2008). The objective can be achieved by providing strength and ductility to the structure. As per the study by Arnold and Reitherman, the resisting system can be broadly classified into four categories: a) Shear walls, b) Braced frames, c) Moment-resisting frames and d) Diaphragms, as shown in figure 7.5. The combination of the above systems in an appropriate configuration comprises the structural system. The designer is responsible for making the correct choices with the help of structural consultant.

Shear walls: These are vertical walls which take the load from diaphragms and transfer it down. If imagined in a reverse direction, they act like a cantilevered slab. They are so designed that they resist horizontal forces whilst transferring vertical loads. Reinforced concrete shear walls have proven the best resisting systems from the past experiences (Charleson, 2008). Due to the inherent stiffness and ease

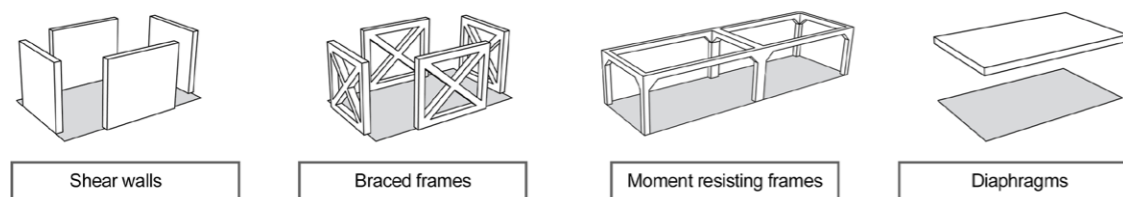


Figure 7.5: Types of seismic force resisting structural systems [Image source: (Arnold & Reitherman, 1925)]

of construction, shear walls are popular building elements amongst structure engineers to increase the seismic strength of a structure. Also, the configuration of shear walls is of vital importance, failure of which might lead in formation of torsional forces.

While designing shear walls it is of utmost importance to note that shear walls can handle horizontal forces from only one direction, that is, the direction of its length. When subjected to out-of-plane forces along the length, a shear wall is very weak and has the likelihood of collapsing. Figure 7.6 shows the affect of out-of-plane forces. Also, for the shear wall to function effectively as one entity, it should be a continuous member from top to bottom without any holes on its surface. If holes are provided then coupling beams have to be provided to tie the shear walls together (Charleson, 2008). Figure 7.6 shows the action of coupling beams. Another important concept in structure design is the creation of fuses. Fuses are junction or regions that are specially designed to withstand high amounts of forces. In the case of shear walls, the coupling beam can be a fuse or the junction of the shear wall close to the foundation, where tension and compression is maximum. Figure 7.6 shows the location of structural fuse.

Braced frames: They act in a similar way as the shear walls, although their strength might be less depending upon the design of the details (Arnold & Reitherman, 1925). Many types of bracing can be done with diffent materials, keeping in mind the flexibility of the system. Figure 7.7 shows common configurations of bracings. Diagonal members of a bracing must be allowed to compress or elongate or deflect which would aid in dispersing energy whilst saving the main structural elements from damage. The detailing of bracing is of utmost importance because they should be able to transfer the loads across the section. Bracing can be compared to a vertical truss system, thus they should be strong enough to resist buckling of the main members (Charleson, 2008). Wood and steel are common materials for bracing. While steel is known for its ductility, wood can be used for low-rise, lightweight construction (Charleson, 2008). Also, wood will have larger cross sections to resist buckling of its adjacent members. Finally, bracings can also incorporate fuses to dissipate energy, however, the design of such fuses need greater engineering skills.

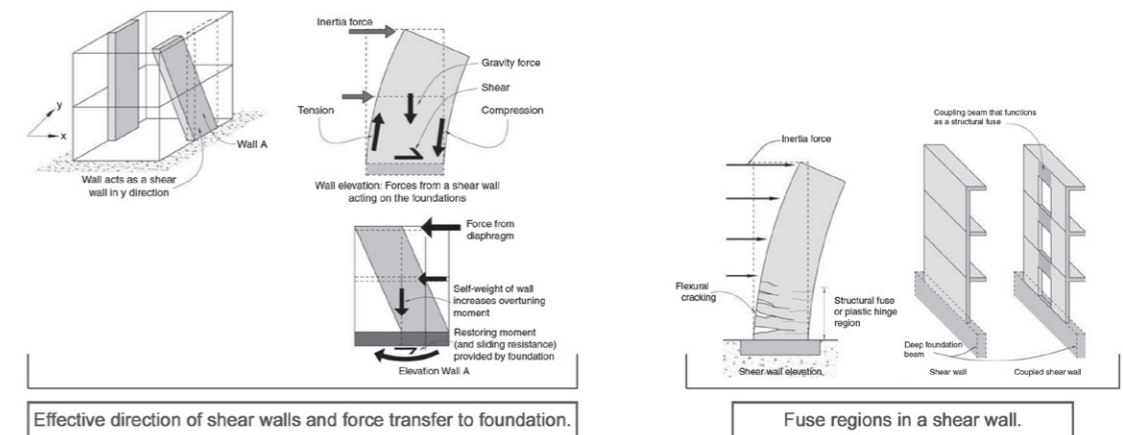


Figure 7.6: Effective direction in a shear wall and involving fuse regions for improved structural performance. [Diagrams copied from (Charleson, 2008)].

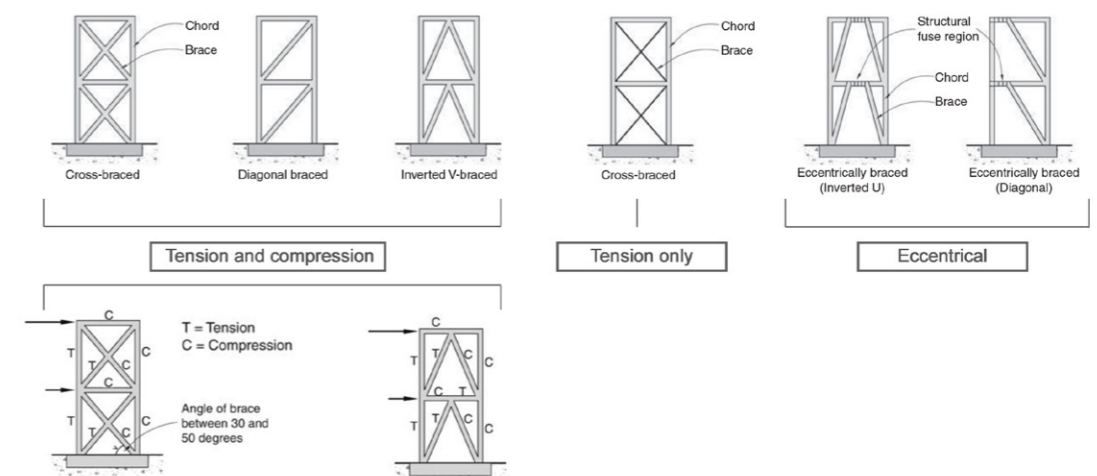


Figure 7.7: Types of braced frames [Diagrams copied from (Charleson, 2008)].

Moment resisting frames: This is the most common type of construction system in today's world, also known as column-beam structures. The three important principles of this construction system are that the beams transfer horizontal loads to the columns, the columns transfer it down vertically without buckling and finally the conversion of load from horizontal to vertical takes place in the column-beam junction which means that they are highly stressed and need special attention (Charleson, 2008). The behavior of a moment frame greatly depends on its configuration. Figure 7.8 shows the basic vertical and horizontal configuration. Moment resisting frames are a popular choice for designers because they provide greater freedom in internal configurations with minimum barriers, unlike shear walls and braced frames, which resist movement in a space (Arnold & Reitherman, 1925).

Like shear walls, moment frames as an individual entity can act only in one direction, unless combined with other frames to act at right angles (Charleson, 2008). Another important factor is the proportion of column depth to beam depth ratio, that is, the strength of the column versus the strength of the beam. For seismic design purposes it is important that the columns should be stronger than the beams to prevent the 'pancaking' effect during an earthquake. The span between the columns should be such that the beam is not heavier than the column, this means that the length of the column should be proportionate to the span. Also, the columns should be continuous from top to bottom in order to prevent deviation of load paths which creates concentration of stresses. Figure 7.8 shows the effect of column-beam configuration on overall structural deflection. Lastly, the joints should be so designed that they can withstand the loads, whether pinned or stiffened.

Diaphragms: While the shear walls, bracings and moment frames mainly deal with vertical forces, the diaphragms deal with the horizontal forces. They are the primary members in transfer of forces in seismic force path, it is a beam acting horizontally. Diaphragms work parallel with collectors, ties and bond beams to transfer the loads from horizontal to vertical. Diaphragms may be rigid or flexible depending upon the material and connections. Concrete diaphragms are stiff and tend to resist in-plane forces acting horizontally, minimizing deflection, this is an example of rigid diaphragm. On the other hand, timber diaphragms combined with masonry or steel supports can form flexible diaphragms provided their connections are flexible and composed of light trussed decking. If diaphragms are too thin, then rafters or joists should be provided for the out-of-plane stability to prevent buckling (Charleson, 2008). Figure 7.9 shows the functioning of rigid and flexible diaphragms.

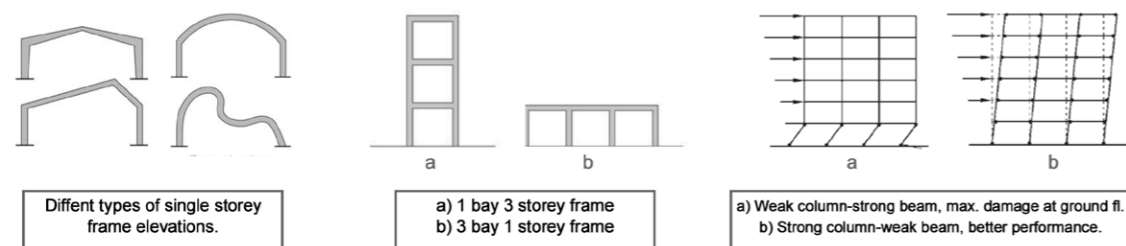


Figure 7.8: Types of moment frames and response of column-beam strength to forces [Diagrams copied from (Charleson, 2008)]

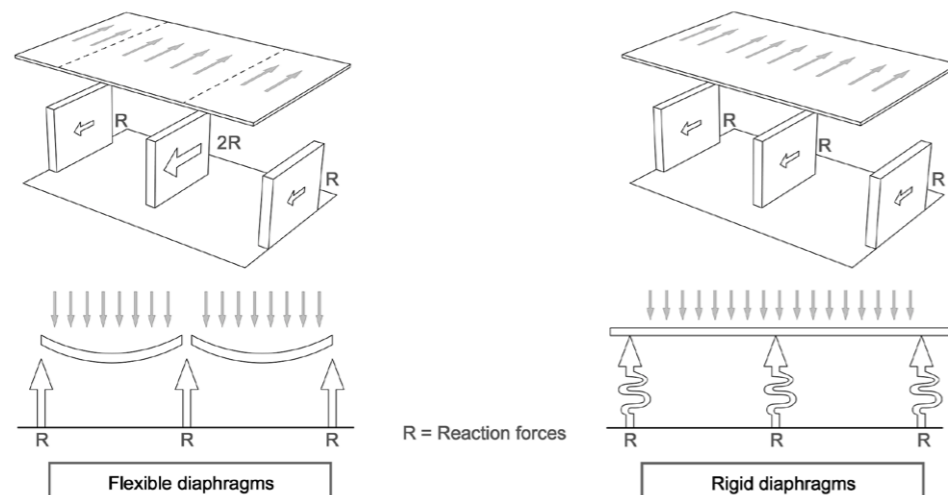


Figure 7.9: Rigid and flexible diaphragms. [Image source: (Arnold & Reitherman, 1925)]

Although, diaphragms form the main paths of horizontal forces, the area has penetrations or holes due to unavoidable architectural features like staircases, elevators, life shafts and skylights. The size and location of these penetrations is of utmost importance to the effectiveness of load transfers (Arnold & Reitherman, 1925). Wherever these penetrations exist, the area should be enclosed by stiffening beams or girders which act like collectors for the loads. Large penetrations should be located where they do not jeopardize the ability of a diaphragm to transfer its forces to the vertical structure that stabilizes the building. Penetrations are, therefore, best located in areas of either low bending moment or shear stress (Charleson, 2008). Figure 7.10 shows the affect of penetrations on diaphragms.

While those shown in figure 7.10 are all for simple diaphragms, there are conditions in which the vertical loads are also transferred to other vertical members via horizontal movement. Such diaphragms are called transfer diaphragms. Figure 7.11 shows such kind of movement of forces. Due to additional loading of vertical forces, transfer diaphragms have to tackle additional stresses and need to be stronger, without penetrations. Due to their less direct force paths that potentially lead to increased seismic damage, transfer diaphragms and any associated vertical structure need to be designed very carefully (Charleson, 2008).

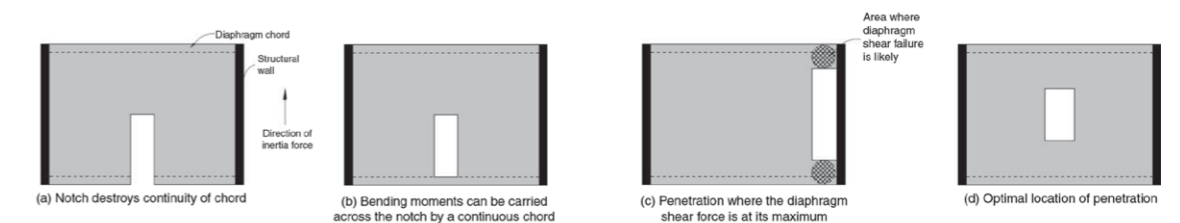


Figure 7.10: Affect of location and size of a penetration on the diaphragm [Diagrams copied from (Charleson, 2008)]

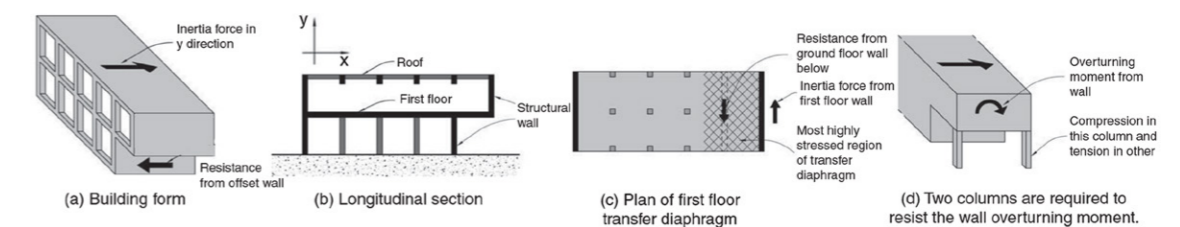


Figure 7.11: Functioning of transfer diaphragms [Diagrams copied from (Charleson, 2008)].

7.4 Integration of seismic principles in architectural design

The elements which make up a seismic structure have been discussed in the above section, but the most important part lies in the configuration of these elements to create a spatial composition that defines the space for end user. This composition is made by the designer that is subjective to his discretion. It is important for the structural principles to be integrated with the architectural design at the early stages for an optimal design solution in a seismic zone, since the choice of the structural system not only defines the force paths but it is the main ingredient for architectural expression. Having knowledge of the design principles for efficient seismic structural performance aids the designer to make appropriate choices while composing the structural elements.

It is also seen that the choice of construction materials also affects the seismic system. Thus effective choice of building materials can also aid in an improved performance. This has already been seen in case of using wood, because of its lightweight characteristic, it attracts less forces of inertia, thus damping the vibrations. Some important principles of seismic design that affects the architectural language highlighted by Arnold and Reitherman are as explained in the following section.

Scale: This factor explains the problem of the size, that is, as the scale of the building increases the forces increase. Also, the configuration of structure would change with a change in scale. It is not valid if a system used for a single storey wooden house is simply scaled up into a massive wooden structure. Many considerations have to be added like increase in forces, availability of materials, quantity and joineries. Also, as the size increases the alternatives for structural solution decrease (Arnold & Reitherman, 1925). In case of a small wood frame house, which is lightweight and has low internal forces, it will have lesser

spans relative to the floor area. Which also means that there will be more walls or members to distribute the load making the structure stable (Arnold & Reitherman, 1925). However if the number of floors or the spans is increased, extra structural system has to be introduced to tackle the increase in forces.

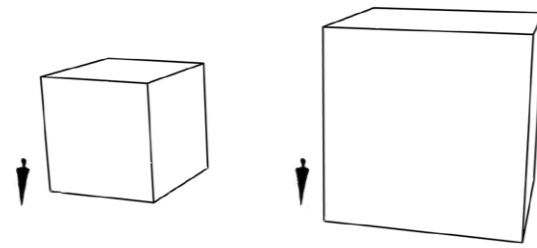


Figure 7.12: The scale of the building affects the composition of the structural system

Height: Similar to the affect of scale, the increase in height increases the acceleration the structure. Increasing the height is equivalent to increasing the span of a cantilever beam (Arnold & Reitherman, 1925). As the building grows taller, its natural period of vibration increases. Along with the height the other factors that have to be considered are the height to depth ratio, storey heights, kinds of structural systems, materials used and the horizontal and vertical mass distribution (Arnold & Reitherman, 1925). Change in any of the above factors will change the natural period of vibration, hence affecting the building performance.

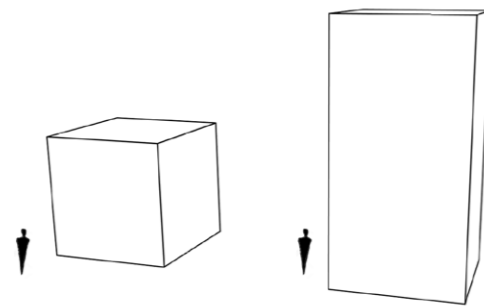


Figure 7.13: The increase in height increases the overall lateral forces.

Horizontal size: Just as the increase in height matters, the change in horizontal size can cause the loads to go out of control. That is the building will stop functioning as one unit. Studies indicate that pre-existing stresses and earthquake induced settlement stresses are greater in large span buildings which have long horizontal spans. Lateral forces induce these stresses (Arnold & Reitherman, 1925). Thus, various systems are needed to stabilize the forces in the longer direction, special care must be given to the span of the diaphragms by adding shear walls or frames.

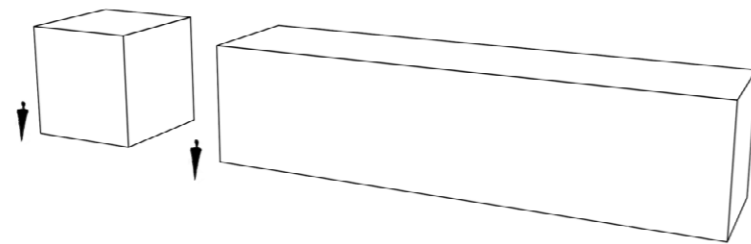


Figure 7.14: Increase in horizontal size increases lateral forces.

Proportion: The proportion of a building plays a very important role in determining its stability. The most important factor in stabilizing a tall building is the slenderness ratio, that is, height/depth ratio (Arnold & Reitherman, 1925). It is mentioned in studies that the overturning effects of an earthquake will increase with increase in slenderness of a building and compressive stresses on the outer columns may increase drastically. The redundancy in proportion might also be caused due to the shape of the plot, in such cases the forces on tall building have to be specially analysed and balance by tuning the structural system.

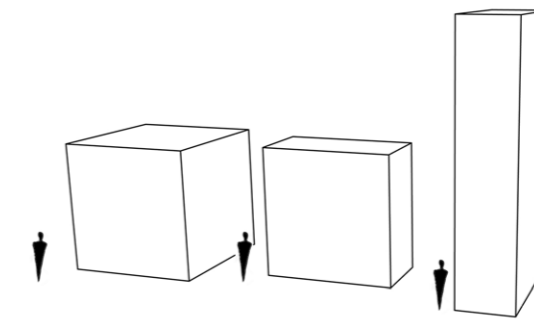


Figure 7.15: Changes in depth by height ratios changes the structural behavior.

Symmetry: This involves the geometric shape of a structure. Symmetry can be achieved along one axis, two axis or n number of axis. A building can be horizontally as well as vertically symmetrical, which architecturally means that it is identical about an axis. However, Structural symmetry is achieved when the Center of mass and center of resistance coincide at the same point (Arnold & Reitherman, 1925). We say that symmetrical configuration is preferred to ease the distribution of lateral forces. This is because asymmetry leads in eccentricity, causing concentration of forces in few junctions ultimately leading to torsion. Also symmetry does not refer only to an outward shape of the building, but it also means the internal structural configuration and the design of details which are able to equally bear the loads. Example, if one column is stronger than the other, both being of the same shape and size, the torsional forces would develop and the stronger column will be bound to carry more loads. Symmetry should ensure equal distribution of forces throughout the structure.

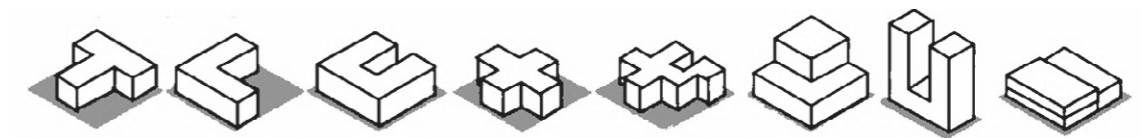


Figure 7.16: Symmetry needs to be achieved both horizontally and vertically, the above are examples of different configurations both symmetrical and asymmetrical, each having different implication in the structural system. [Diagrams copied from (Arnold & Reitherman, 1925)].

Structural plan density: It can be defined as the total area of all vertical structural elements comprising of columns, walls and braces, divided by the gross floor area (Arnold & Reitherman, 1925). In a typical contemporary building this ratio is very low, with the advent of modern technology we have been able to span large with minimum area of footprint. This has given us a greater advantage on maximizing the use of floor area as very less is wasted on the structural elements. However, this was never the idea in the past, the thick stonewalls extended down to the ground floor, offering stability to the structure. Not only this, but the wall on lower floors had an increased thickness to take the added loads of successive floor. This even distribution of mass made the older buildings seismically safe and that is one reason why they still stand. While the footprint of modern buildings at ground level can be as low as 2%, structures like the St. Peters Rome has 25%, Santa Sophia Istanbul and Pantheon have about 20%, while the Taj Mahal has 50% (Arnold & Reitherman, 1925). The stability of these structures lies in the fact that the forces have sufficient direct routes to travel down and they do not have to take shortcuts or squeeze along a narrow path.

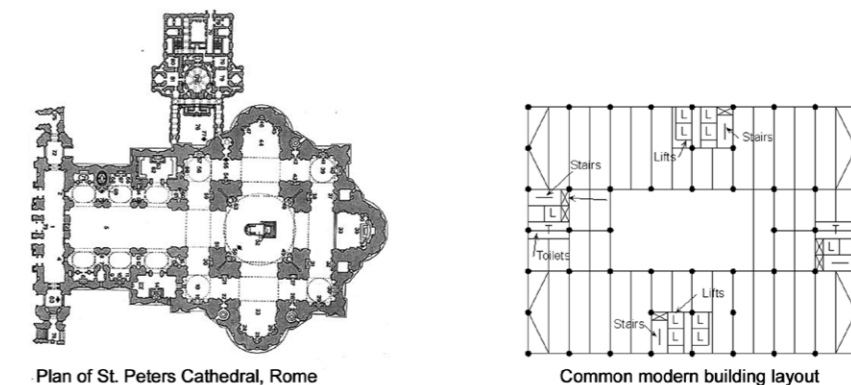


Figure 7.17: The different structural densities of building from different eras. (Image source: www.courses.umass.edu; www.steelconstruction.info)

Corner: Often having corner windows is considered a fashion and its presence is appreciated in contemporary architectural statements. However, it may not be favourable in a seismic prone area. This is because the corners experience problems due to orthogonal effects. Especially during a diagonally oriented ground motion, which may induce stresses on the rest of the structure because absence of a member in the corner (Arnold & Reitherman, 1925).

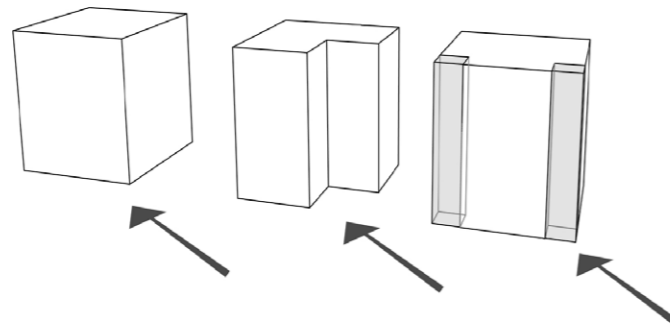


Figure 7.18: The effect of seismic force acting in a diagonal direction can have severe affects in case of corner windows or lack of structural supports to handle the force.

Redundancy: This is an approach in which substitute structural elements are provided in addition to the main structural system. In this the extra elements are so placed that they get activated if action is needed providing extra support. Excellent examples for redundant behavior are mentioned by Arnold and Reitherman, first is the functioning of a spider web, which do not collapse even if half of the strings are broken and second, airplanes can manage to fly even if small holes are punctured on their body (Arnold & Reitherman, 1925). A similar approach of providing substitutes should be taken while configuring a building.

Configuration: Last but the most important factory in achievement of a seismic structure is the configuration. A lot has already been spoken about it in the above sections and each element, whether size, proportion, symmetry, etc. is related to configuration. In words of Christopher Arnold, proper configuration is the only guaranteed way of removing earthquake threat. The more irregular a building, the more difficult it is to predict its behavior. Configuration involves the 3-Dimensional imagination of flow of forces through the system. Christopher Arnold, who has written extensively about configuration issues states: 'while configuration alone is not likely to be the sole cause of building failure, it may be a major contributor. Historically, before the use of steel and reinforced concrete construction, good configuration was one of the major determinants of good seismic performance' (Arnold & Reitherman, 1925).

However, the inspiration of contemporary architects is the principles of modern architectural design which were developed in the 19th century. It is of no doubt that those aspirations have produced marvels in the field of architecture but it has a different aspect when analysed from seismic point of view. Firstly, the idea of using 'pilots', that is, elevating the ground on thin columns does no good to the structure, from the historical examples it is learnt that the more the supports on the ground, the better the structural performance. Second is the incorporation of 'roof-gardens', this merely means adding extra weight on the top of the structure and then finding ways to direct those forces down to the ground. Third is the 'free plan', which means minimizing the number of internal walls and keeping the space as free or open as possible. This leads to increase in spans and weak diaphragms. Fourth is the 'continuous glazing', which leads in elimination of peripheral structural elements, which are the most important members for resisting torsional forces. Lastly the 'free façade', demands the exterior to feel as light as possible. The desire of these modern features can be judged on the basis of its implication in a seismic zone. Thus, the choices in design must be carefully planned or substituted with an efficient configuration system.

Configuration concepts can be divided into two major categories:

- a) horizontal configuration
- b) vertical configuration.

The horizontal configurations deal with the horizontal movement of forces within the structural system. It can be classified into five main categories as per the categorization of Andrew Charleson, they have already been briefly discussed in the above sections. The summary of irregularities include:

- Torsional affects
- Re-entrant corners
- Diaphragms discontinuities
- Out-of-plan offsets
- Non-parallel systems or symmetry

The vertical configurations constitute the elevation and sectional design of the structure, considering vertical transfer of forces. The massing of the building greatly influences the vertical configuration. The irregularities for vertical configuration as explained by Andrew Charleson include:

- Soft storey formations
- Short columns
- Discontinuous and off-set walls
- Setbacks

Since the categories of horizontal configurations have already been explained in the above sections, the following describes the irregularities and problems related to vertical configurations.

Soft storey formations: The condition of column-beam strength has already been explained in the above sections. Soft storey are formed when one storey is more flexible or weaker than the other. The columns of weaker storeys experience severe damage and can cause collapse of the structure above it. Unfortunately, the condition of soft storey formations in ground floor is a common phenomenon and can be caused due to common architectural practices. Figure 7.19 shows the various reasons leading to formation of ground floor soft stories and few solutions that could help solve the problem.

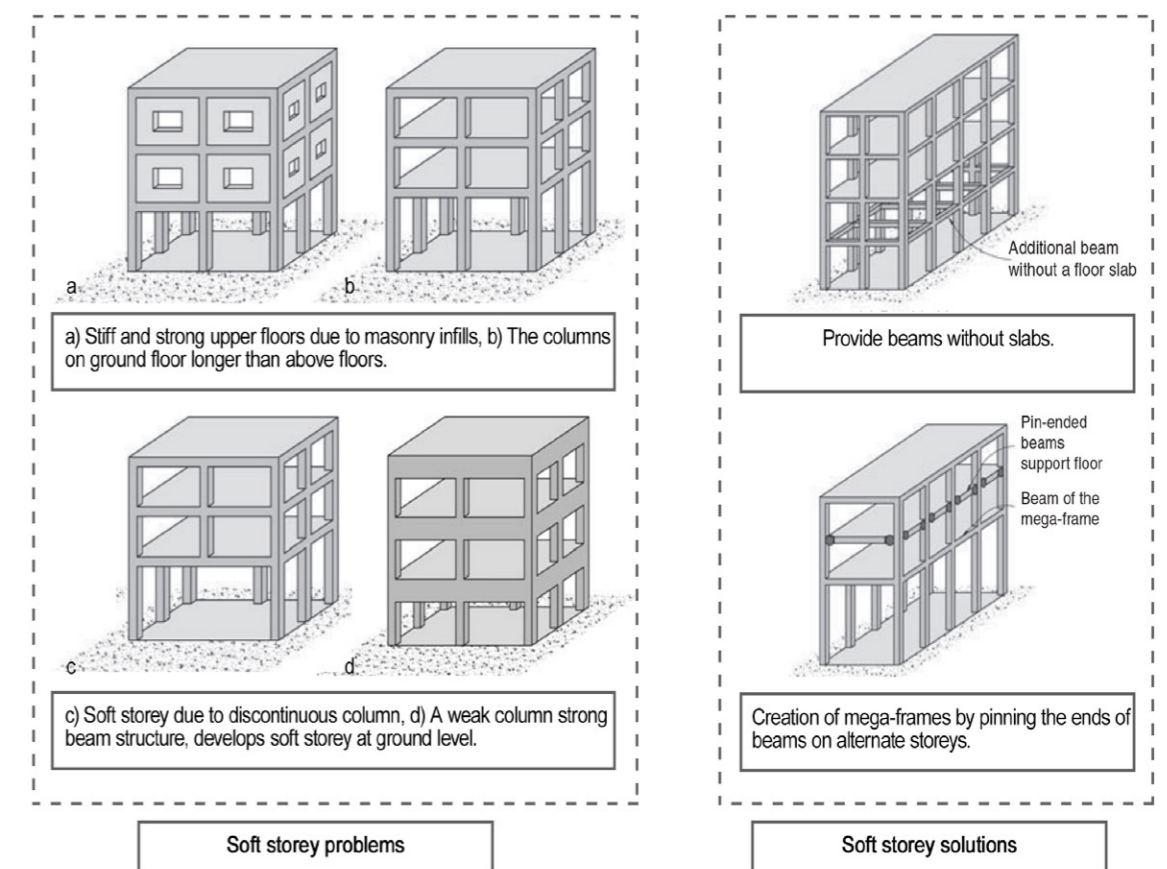


Figure 7.19: Soft storey formations and solutions [Diagrams copied from (Charleson, 2008)].

Setbacks: Setback is a condition in which the dimensions of a plan on the upper storeys reduce in a multi-floor building (Charleson, 2008). This is a very common phenomenon in tall building design. Although this aids in reducing the weight on upper floors, but if the mass is not equally distributed or if the structural elements are not proportionately configured it can create torsional affects. The whole building should be considered one and the COM and COR should be effectively balanced. Figure 7.20 shows certain conditions of setbacks.

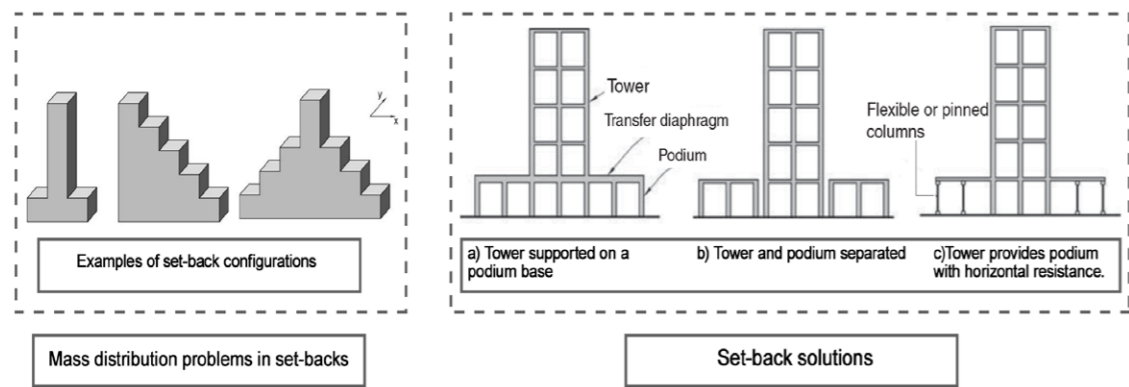


Figure 7.20: Set backs causing mass distribution problems and solutions to tackle the effects [Drawings copied from (Charleson, 2008)]

Short columns: This condition is caused due to unequal lengths of the column. It is known that the stiffness of the column is sensitive to its length (Charleson, 2008). In the case of short column phenomena, the shorter columns tend to bear more loads as compared to the longer columns, thus causing eccentricity in force paths. This eccentricity can cause torsion movements in the structure causing the weaker column to collapse. In our case the short column will tend to collapse faster because it is stiffer than the longer ones. Another reason for this may be the infill of non-structural masonry walls to a certain height. This leads to

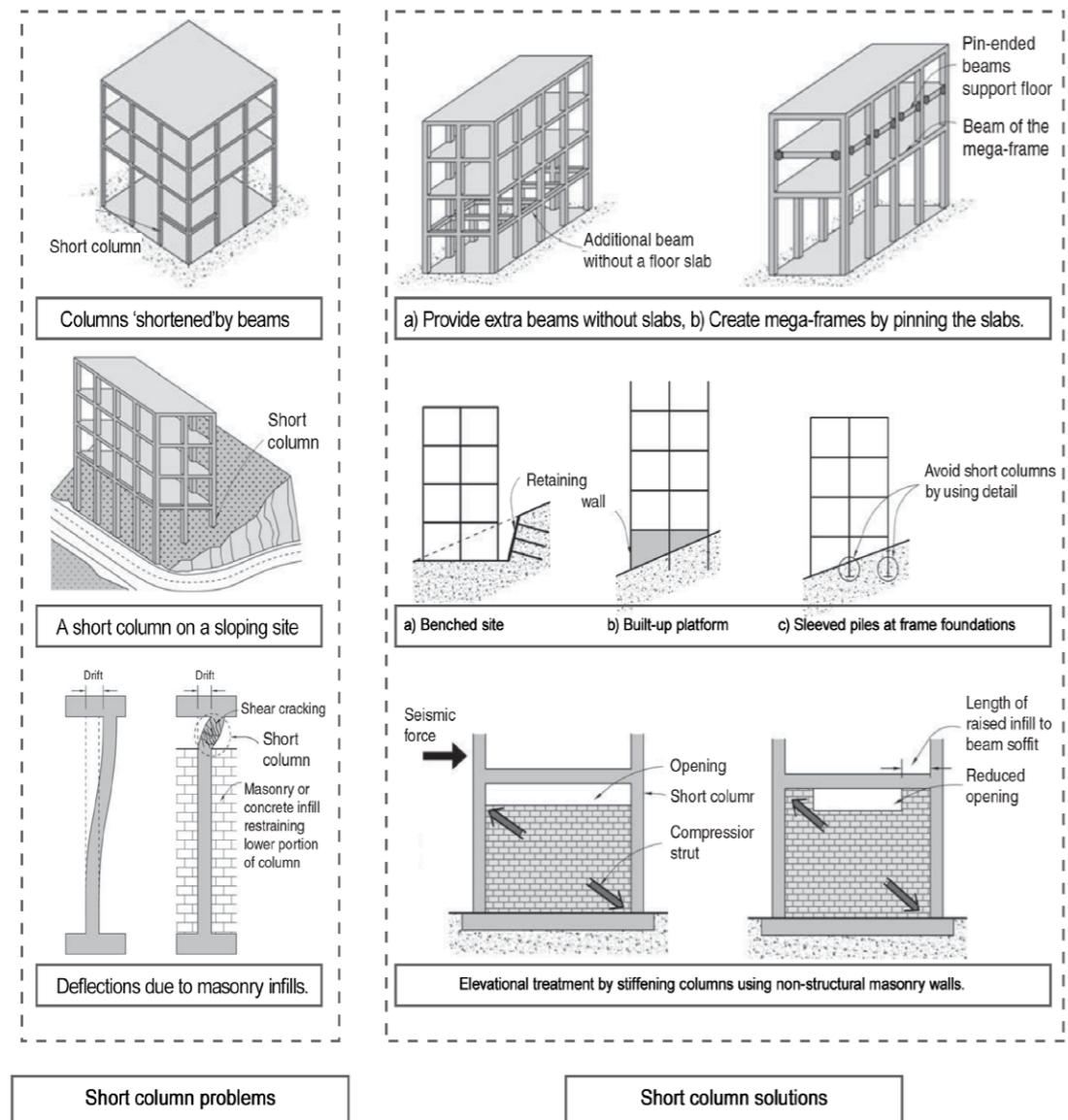


Figure 7.21: Short column causes and solutions [Diagrams copied from (Charleson, 2008)].

stiffening of the columns till a certain height allowing freedom of movement to the rest of the column. Figure 7.21 shows the conditions of short column formation and certain ways to tackle these issues. It can be noted that creating mega frames or adding additional beams handles issues of short columns in the ground floor. While the short columns in the hilly areas can be dealt by creating retaining walls so as to equalize the length of the columns, stiffening the foundations by using shear walls or increasing the depth of the foundation such that it acts like a column.

Discontinuous walls: This is a problem in which the structural members carrying the load on top are not continuous till the bottom. This causes the force to change its path and find alternate ways of travelling through the structure. The reasons of discontinuous wall conditions may be due to puncture in shear walls at lower levels for making doors, creating architectural expressions of staggering walls or cantilevering floors. When approaching the design of an element with a discontinuity such as having holes in structural walls, it is crucial that designers first identify the ductile overload mechanism. One way to handle such complexities would be to design fuses so that damage occurs in a specially detailed area preventing collapse of the whole structure. Figure 7.22 shows the features and ways of mitigating discontinuous walls.

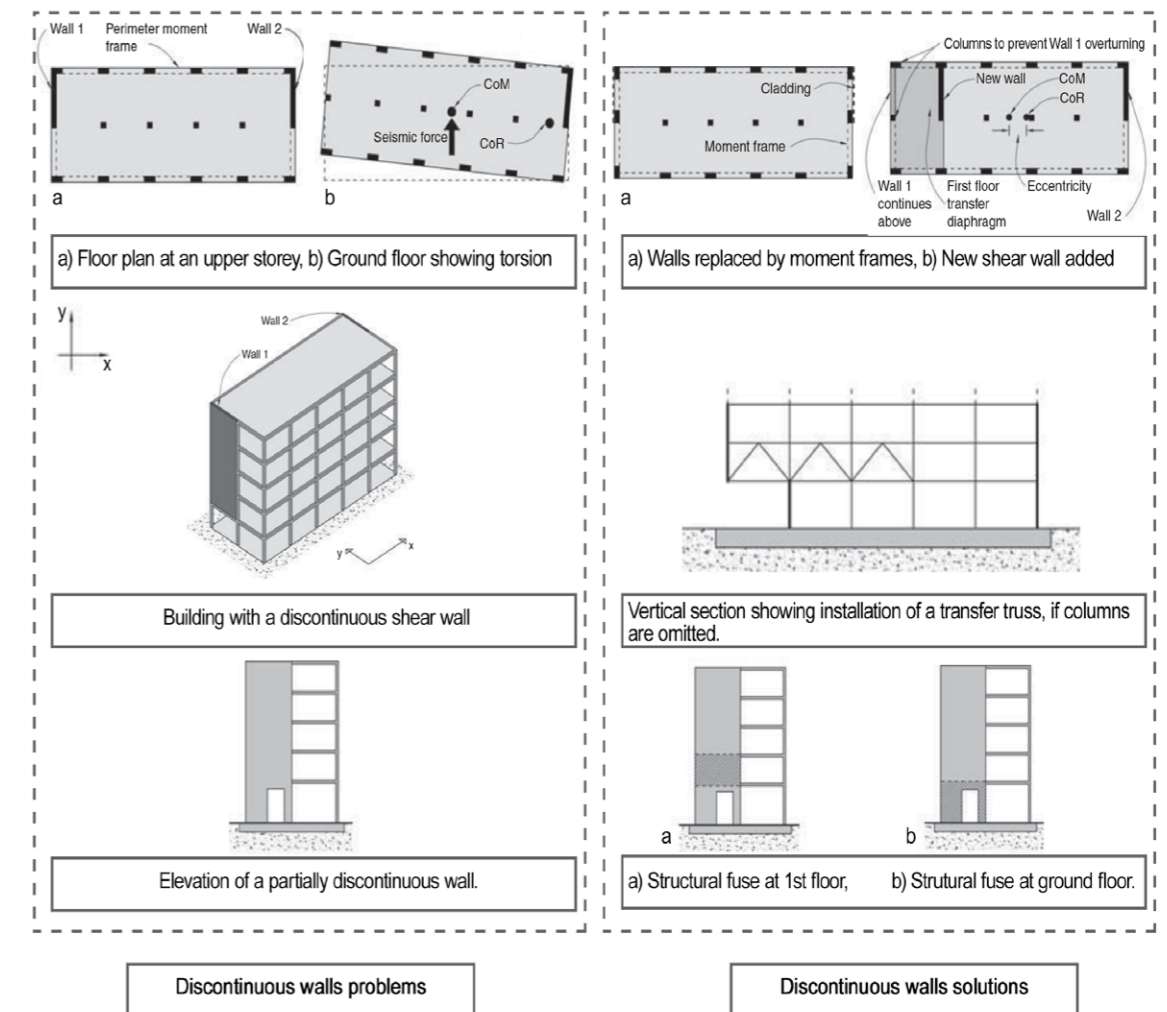


Figure 7.22: Discontinuous walls causes and solutions [Diagrams copied from (Charleson, 2008)]

7.5 Analysis of the Assam type house'with respect to seismicity

The efficiency of the Assam type construction system in terms of seismic performance has been mentioned quiet often in this report as well as the studies conducted by scholars. Also, the system has proved itself practically in the scale of time. This section elaborates on the analysis of the Assam type construction based on the architectural principles of seismic design.

For the purpose of this analysis a sample house, which was under demolition, was picked at the site and basic measurements of the building was taken. While the earliest of 'Assam-type' construction originally began with one-storey, this sample house consisted of two stories. This house is an example of a later improvisation to the construction system when people started building two floors. Figure 7.24 shows sections of a single storey and a double storey house. The sample house is an excellent way to understand the juxtaposition of modern materials like concrete with traditional materials like timber, which had started at a very early face when the need of building higher had started in the city. However, the actual measurements were limited to the sectional members and vertical configuration of the house. Thus, there is a lack of data for the horizontal configuration of the same house. For the purpose of analysis of horizontal configurations, architectural drawings have been borrowed from other scholarly works.

The difference in scale of the above two houses can be judged, while the single storey houses comprised of one floor, they were lighter and were built on stone foundations. The rest of the structure were made completely out of timber, there was no use of concrete or steel, other than nails for fixing the joints. However, its larger counterpart, which emerged later as the requirements of the people grew, has use of materials like concrete in columns and floors. The following sections elaborate on the configuration and working of the two storey house. The seismic analysis is divided into two parts: Horizontal analysis and vertical analysis. Figure 7.23 shows images of the two storey house while it was getting dismantled on site.



Figure 7.23: Images of the measured Assam-type construction on site, dismantling of the construction was in process.

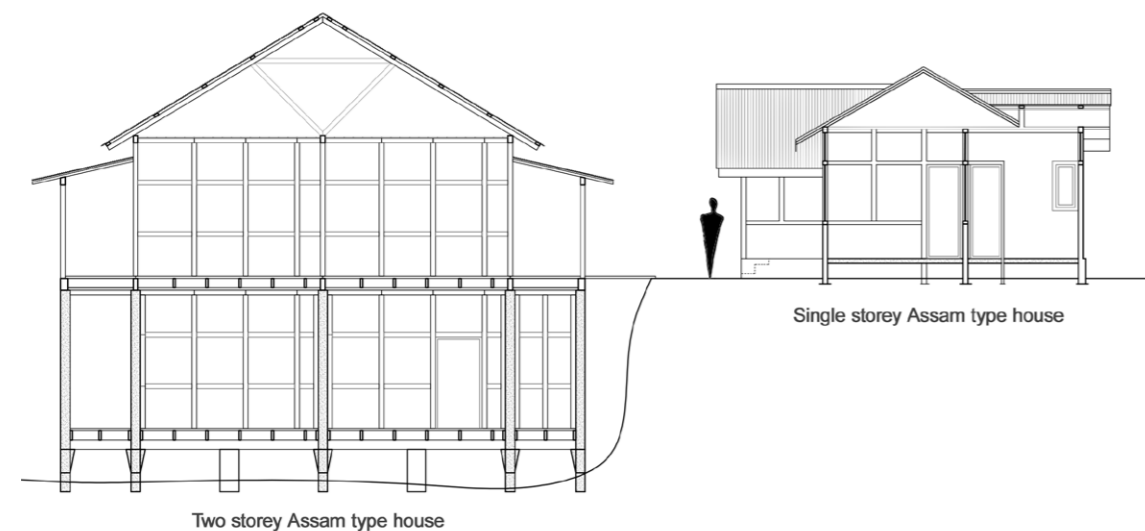


Figure 7.24: Examples of Assam-type construction technique. The dimensions of two storey structure have been attained from on site measurements, while the dimensions of single storey has been borrowed from the documentation of World Housing Encyclopedia. [Source of single storey Assam-type drawing: (Kaushik & Babu, 2012)].

The first step in understanding the composition of the construction is to identify the materials used in construction. It can be noticed that the foundations and the columns on first floor are made of reinforced concrete while the rest of the structure is made of structural timber will bamboo infill and lime-sand plaster. Two types of timber have been used in the construction – Sal (*Shorea robusta*) and Khasi pine (*Pinus kesiya*). The properties of the two have already been discussed in section 4.2.1.5 It is noted that while sal is used in regions that are exposed to outer environment and in areas which bear the main loads, Khasi-pine is used mainly in the wall panels of interiors. This may be because of the durability properties between the two, as Sal is known to have better properties of water resistance as compared to the Khasi-pine. While concrete which is water resistant is used for foundations. The roof support system is made of timber and covered with G.I sheets. The wall panels are made of ikra (thin bamboo) infill and plastered with lime-sand mortar. Figure 7.25 shows the placement of different building materials in the section of the house.

Vertical configuration analysis:

The vertical section has been analyzed on the basis of the architectural principles studied in the above section. The following are important criteria for the seismic performance of the Assam-type, these have been graphically explained in figure 7.26:

a) Equal floor heights: It can be seen that the height of both the floors are nearly equal. The difference in height measured at site is of 200mm which is not much, this difference may be unintentional because of the kind of joineries used. Also, this negligible variation is seen in the upper level height which does not increase the stresses on the ground floor. This equality in height has not caused formation of soft stories.

b) Uniform section: This means that the mass is equally distributed on major load bearing members. It can be seen that the size of the walls are same, which means that the forces acting on each load-bearing member is same. This avoids concentration of stresses in a particular member, ensuring no generation of weak spots.

c) Short spans: This is a very important feature of the 'Assam-type' construction system. The overall spans of the members are limited to 3-4 m. This is mainly due to the limits in the size of the wooden members available in the market. The additional feature to that is the panels further divide the spans in small parts creating a gridded network. This helps in distribution of loads to multiple members instead of concentrating the paths in one member, leading to a situation of low unit stresses per member. Also, short spans of the spans increase the workability during the fabrication process. It was told at site that the panel sizes were determined by the lengths of the ikra bamboo available in the market, according to

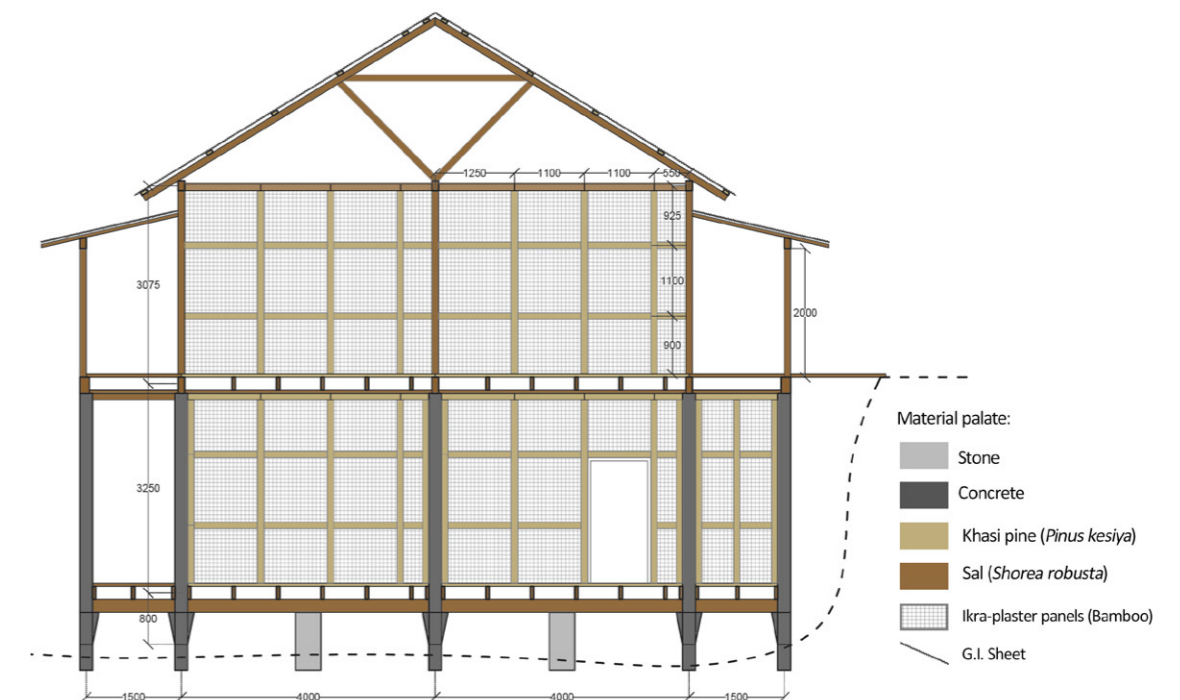


Figure 7.25: Different materials used in the construction of Assam-type house. All dimensions are in mm.

them it was easier to carry 1 m long bundles of ikra bamboo from farms to the sites. Whatever, the reason for these short spans of the panels may be, they aid in maintaining an efficient load distribution system. Also, this paneling process aids in development of the 'redundancy' principle, which means that failure of one shorter span will not lead in collapse of other members, as the forces will have secondary paths to travel. However, the main columns where the load paths merge should be strong enough. This merging of load paths from smaller members to the main beams happens through an efficient joinery system which is explained later.

d) Direct load paths: It can be seen that every member is supported by a member beneath, which means, there were no cantilevers or formation of transfer diaphragms. This ensured that the forces always have a direct path to travel. The light-weight construction also induced lesser forces of inertia on the members. An extraordinary feature observed in the foundation was the additional support of stone foundation at the center of the wooden plinth beam. This stone support was placed at the center where bending moments are maximum.

Horizontal configuration analysis:

Like the vertical section, the geometry was horizontally well configured to meet the demands of seismic region. Though many shapes of 'Assam-type houses have been registered like square shape, L-shape or even cross-shaped, the system has performed fairly well during times of an earthquake. The reason for this is that there is the load paths are broken into smaller span members. Also, the internal walls are placed at every 3-4 m which provides additional support to the whole structure. This creates identical resistance on both orthogonal axis. A typical plan of a single storey Assam-type construction is shown in figure 7.27.

Finally the joints of the Assam-type house have been inspired from the traditional Japanese techniques. Though the simplest form of joinery has been used in the construction. The detail provided sufficient stability with room for movement during an earthquake. Figure 7.28 shows certain details of the joinery. It can be seen that though nails were used in connection, they were not the primary mode of connection, that is, the members were cut into shape and joined then nails were used for additional strengthening. The used of glue is not known in the construction of joineries. These movement between the members in a joinery caused friction due to rubbing which helps in releasing energy during an earthquake.

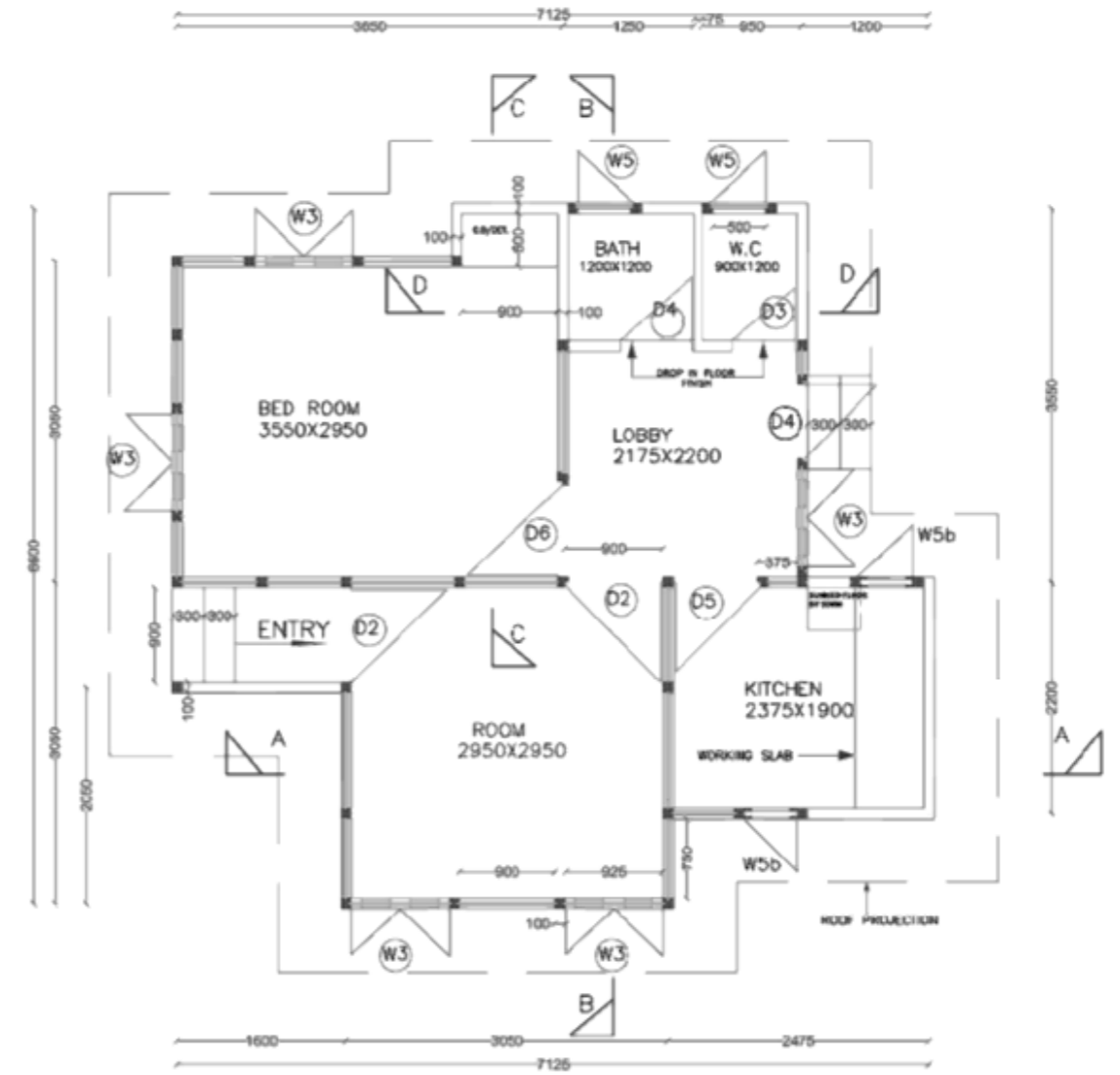


Figure 7.27: Plan of a typical Assam-type construction. [Image source: World housing encyclopedia (Kaushik & Babu, 2012)].

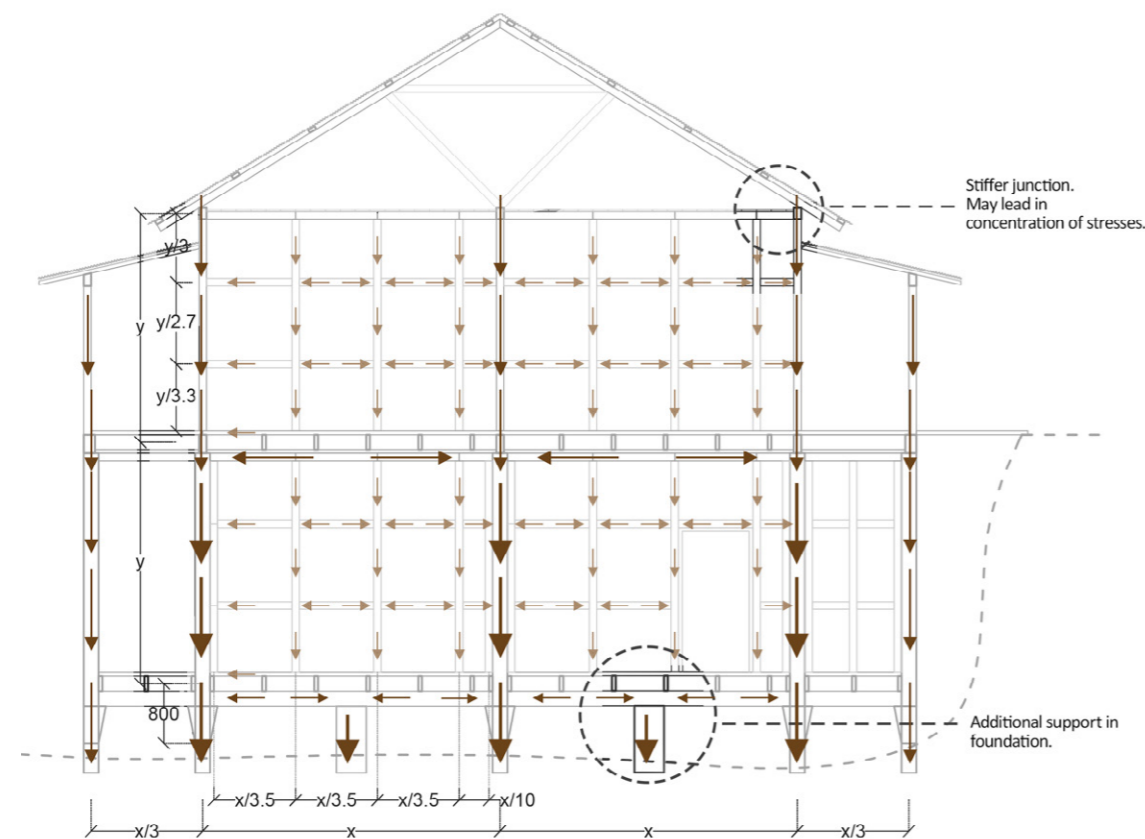


Figure 7.26: Vertical load paths and proportions of the members.



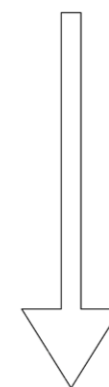
Figure 7.28: a) Connection of the Ikra panel to the wooden columns, b) The plaster sticks on the rough surface of bamboo, c) The central tie that runs through the vertical bamboo sticks is inserted into a hole in the wooden member, letting it free to move, d) metal wire or bamboo threads are used to ties the horizontal members of the bamboo together, e) a groove is cut on the horizontal wooden members which run above and below the thin bamboo sticks, the sticks slide into this groove which acts like a channel. The wooden member is then connected to the vertical posts.

Conclusion on background information

The research done in background research is inclusive of the site visit, which involves first hand collection of urban data and latest master plan proposals at source. From the site visit, it was learnt that an illegal timber trade market prevailed in the region and despite the prevalence of strict laws; the smuggling is out of control. In case of limestone, the abundance in availability of 'cement grade' limestone has caused various companies both local and international to set up cement factories whose uncontrolled discharge of waste is leading to environmental degradation. On the other hand, the plethora of natural bamboo is underutilized in the building sector. On analysis of these three building material resources and on comparing with advanced management practices in other parts of the world it can be concluded that on diverting these resources towards the building sector directly can save the environment in the long run. However, special care must be taken to balance the demand and supply of resources from nature, especially in case of timber. Further, the statistical data collected from the Government on the urban development showed the inefficiency of the authorities in meeting their set goals. The housing goals specially were not met in the 1991-2011 Master Plan, the balance of which has to be accounted for in the 2015-2035 plans. Also, as per the reports, the housing shortage is bound to grow. As explained in section 4.1 an attempt has been made by the authority to densify the city way beyond the limits of the central government procedures. This is the last resort left for the government to accommodate the growing population. Therefore, densification is only possible by building higher structures in whatever space is allotted for residential use as per the master plan. It can thus be inferred that the new construction method should not only be safe but also tall, whilst addressing these urban issues.

The desktop research included learning of the latest timber construction technological advancement worldwide and architectural principles of seismic design. It was learnt these latest techniques have their own pros and cons on comparing to the traditional means. While we can be build taller and stronger with engineered timber products, its manufacturing is still a concern in developing countries. The use of adhesives in these new materials makes its disposal an environmental issue. Further the technical setup for working with these highly prefabricated members need huge investments that is a question in many parts of the world. Also, it is understood that though timber in its natural form is weaker and more susceptible to fire hazards, there are methods of mitigating these problems by incorporating mechanisms related to charring and encapsulation in the design. Structures using non-engineered timber can be designed by filtering the relevant techniques from the traditional methods of wood-working, particularly that learnt from the case of the 'Assam-type'. Also, the modern understanding of seismic resistance principles can aid in development of advanced construction systems using the basic tools and materials.

Background information



Research by Design

RESEARCH BY DESIGN

Introduction to research by design

This research is driven by the conviction to witness a positive amendment of the built environment of Shillong. The inspiration for which is drawn by my past experiences, things learnt and seen in the region and the urge to meet rational living standards in consonance with the environment. The region is stung with problems as discussed in previous sections, which are widely spoken about and published in newspapers every now and then, yet the lack of initiation of scientific research in the field is impairing local technological growth. Various ideas, feelings, theories, practices, resources and opinions observed around the region over the period of time have been a driving force in commencement of this research proposal.

With a rich history, stark culture and abundant resources, Shillong has a potential to portray its own capacity by scientific juxtaposition of its assets. This proposition is the inspiration for the design of the proposed construction technology. The design ideas have been piloted by the practices happening locally, personal experiences of what could be possible and how to reach a larger audience in the region. Further, the contextual study of resource availability, literature research on timber as a building material, the advancement of Japanese construction system, innovations in contemporary timber buildings and investigation of the seismic design principles form the scientific basis of conceptualization of the design. Thus, springing from the background information, the design of the construction technology and digital tool is finally directed by the iterative laboratory tests, structural calculations and computational simulations.

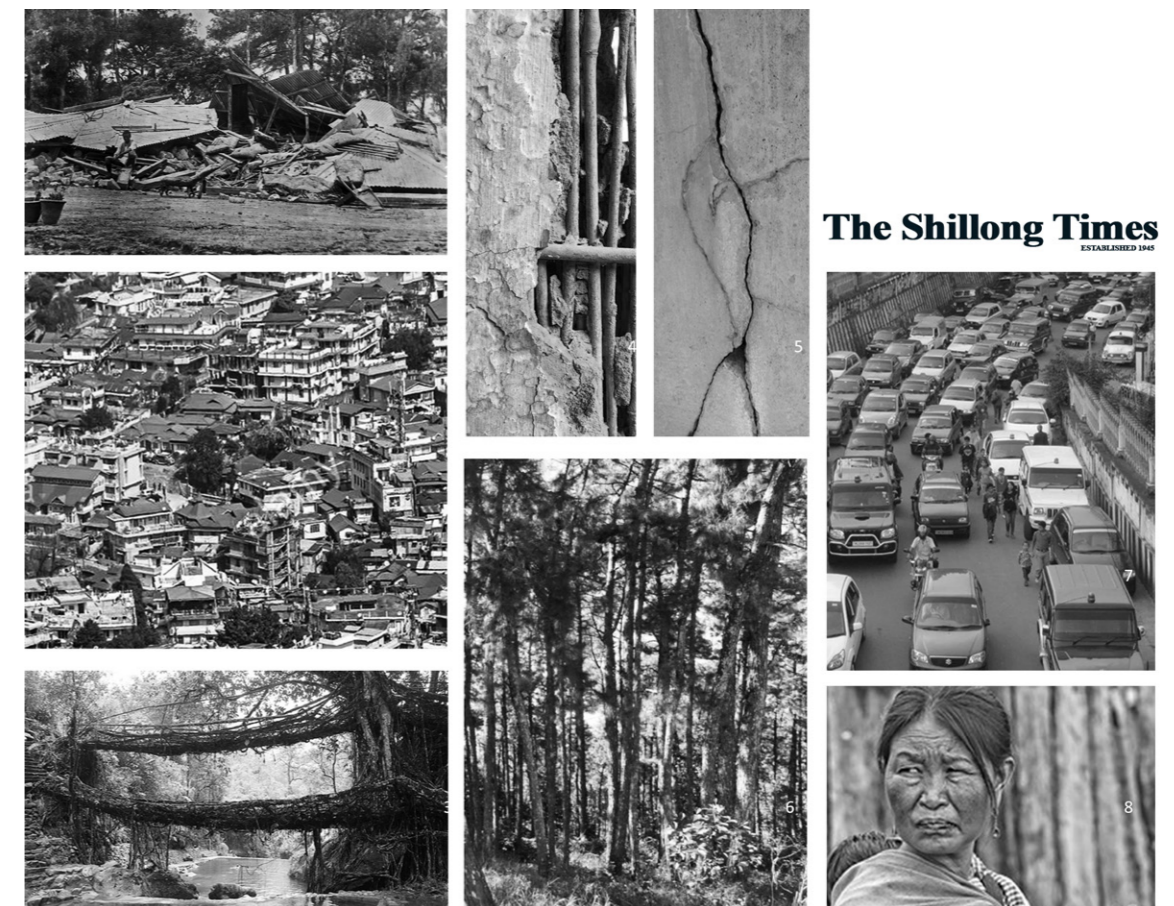


Figure 8.1: Image sources 1) <https://shillongnews.in/all-you-need-to-know-about-1897-meghalaya-earthquake/> 2) <https://www.alamy.com/stock-photo-shillong-from-shillong-peak-meghalaya-india-142657677.html> 3) https://en.wikipedia.org/wiki/Living_root_bridges#/media/File:Living_root_bridges,_Nongriat_village,_Meghalaya2.jpg 4) self 5) <https://www.buildera.com/earthquake-how-crack-monitors-save-lives-structures-white-paper> 6) <http://chainz06.blogspot.com/2011/11/sight-seeing-shillong.html> 7) <https://meghalayetimes.info/lack-of-solution-in-sight-fueling-towns-traffic-congestion/> 8) <https://hiveminer.com/Tags/shillong%2Cwoman>

Research by design - methodology

The vision of the hybrid timber construction technology and digital tool has determined the research methodology. While background research was conducted in the pre-design phase, the first step of actual research by design composed of the preliminary structural member sizing based on the conceptualization of grid sizes. The structural members here include the columns, primary and secondary beams. The structural sizings includes calculation of imposed loads (dead + live) and determination of member dimensions as per the guidelines specified in the National Building Code (NBC) of India. The NBC-2016 has been referred for this purpose. The determination of structural sizes leads to the need of developing the various joints for connecting the different members to each other. These joineries have been designed with the understanding of the background research and capacity diagnosed by laboratory tests. While the most important joinery of connecting the columns to the primary beams was studied in detail, the other joineries were conceptually developed based on the analysis drawn from the lab test of the former. The lab experiments included iterative tests of both 3D printed PLA models and softwood models. Finally, the characteristics of the developed joineries and members were conceptually model for a global seismic simulation, to assess the validity of the whole proposed structural system. Parallely, the design logic of structural sizing and the conceptualized joints were encoded in a grasshopper script which could be used as a digital tool by any designer of the region for visualizing the hybrid timber construction at an early design phase. This whole procedure is schematically depicted in figure 8.2.

The methodology has been elaborated in further sub-sections as follows:

8 Hybrid construction technology

- 8.1 Preliminary grid-size determination
- 8.2 Structural member sizing
- 8.3 Column design
- 8.4 Primary and secondary beam design
- 8.5 Joinery design - detail
- 8.6 Laboratory test of timber joinery
- 8.7 Scaling the actual loading capacity of the column-beam joinery
- 8.8 Validating the global structural based on vertical load capacity of column-primary beam joint.
- 8.9 Validating the global structural based on lateral load capacity of column-primary beam joint.
- 8.10 Concept design for other joints and details
- 8.11 Finite Element analysis for global structure verification

9 Digital tool

- 9.1 Target user group
- 9.2 Formulation of the design logic for digital tool
- 9.3 Pseudocode of design logic
- 9.4 Development of digital tool in grasshopper3D
- 9.5 Product catalogue concept
- 9.6 Limitations of the digital tool output

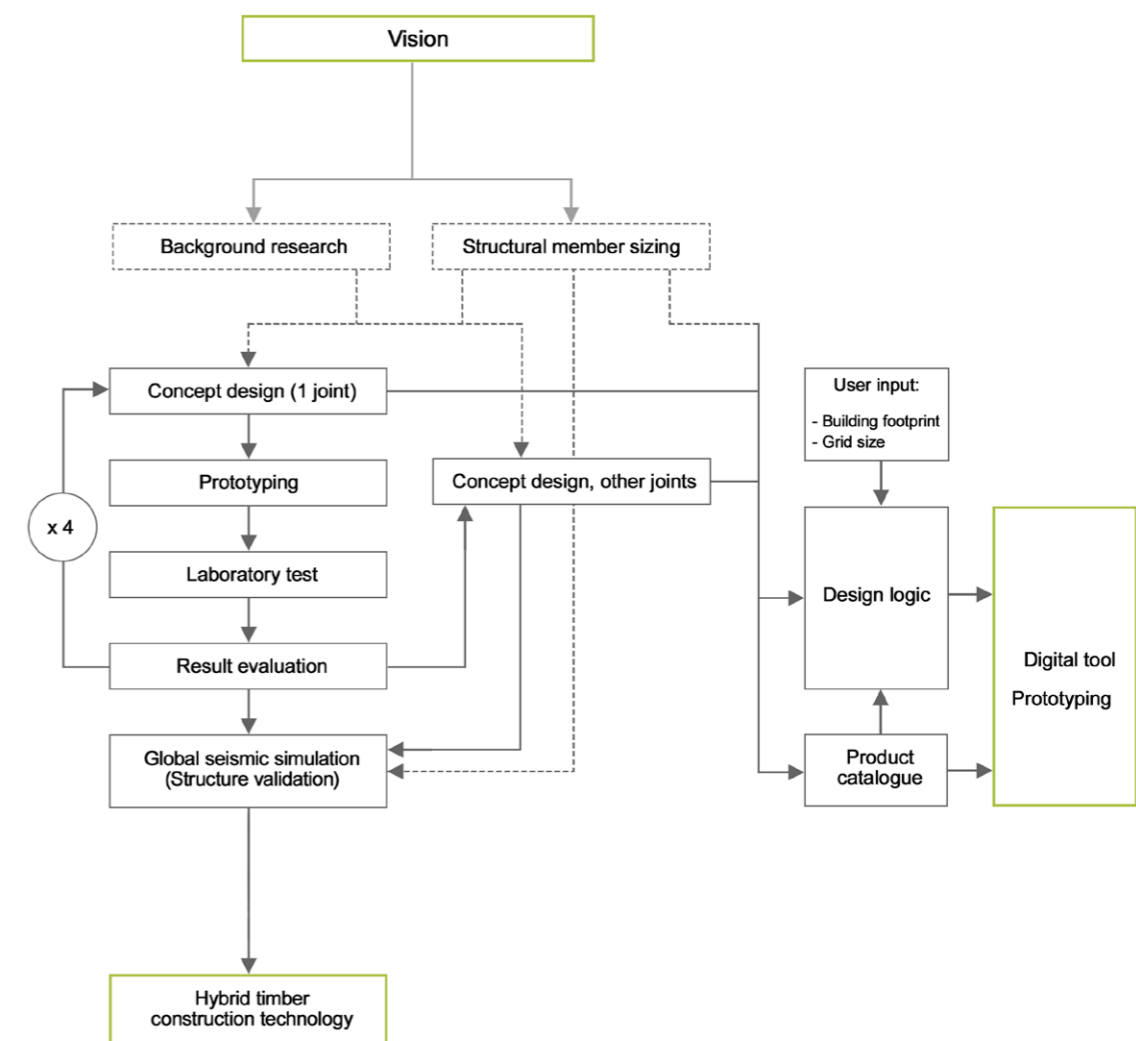


Figure 8.2: Schematic diagram showing the research by design methodology and the process followed to achieve the vision.

8

HYBRID CONSTRUCTION TECHNOLOGY

Introduction to hybrid construction technology

The idea of the hybrid construction technology is to use the locally available building materials for construction, whilst reducing the use of processed building materials like concrete and steel which have a high carbon footprint. Direct inspiration has been drawn from the time-tested 'Assam-type' construction prevalent in the region, which uses timber as the main structural material and bamboo and limestone as façade elements. This research focuses specially on the development of the structural system using timber in combination with concrete and steel joints where required. The further sections elaborate in detail the steps taken for realizing the proposed scheme.

8.1 Preliminary grid-size determination

Before starting any construction, it is important to preconceive the building typology, the target population, vision of the client, technical contextual data and site analysis. For this research, it is determined from the background study in section 4.1, that the current urban requirement in Shillong is of a housing typology. This is the starting point for determining the kind of spaces needed for functioning of the building. The minimum clear spaces needed in a building directly determines the grid sizes. It is important to determine these permanent systems in a building which serve it mechanically and remain substantially unchanged during the course of lifetime if a building. The important spatial elements of the proposed building include the habitable rooms, the staircases and the lift-pits. While other services like plumbing, electricity, HVAC, acoustics also form an important part of the building, their requirements in terms of space is generally adjusted within the grid-sizes of the former three major spatial elements. Thus, these 3 have been analyzed as per the national bye laws for minimum spatial requirements and the data has been compared to extrapolate the minimum grid-size for preliminary design of structure. Further changes or increase in grid size will directly influence the structural member sizes and the calculations have been presented in appendix B.

Habitable room sizes

Part 3 of the National building code-2016 specifies in detail the spatial requirements of a typical housing typology. The minimum sizes of a habitable room are presented in table 8.1:

Minimum	Plots upto m ²	Plots > 50m ²
Area	7.5 m ²	9.5 m ²
Width	2.1 m	2.4 m
Height	2.75 m	2.75 m

Table 8.1: Habitable room sizes as per Part 3, Section 12 of NBC-2016. (Government of Meghalaya, 2011).

Consideration of any size larger than those presented in table 8.1 will be left to the designer by means of either structural or architectural articulation of the spaces. However, it has been inferred from the above table that the minimum bench mark to be set for a habitable room size for the proposed hybrid construction technology is 9.5m². In order to simplify the numbers for the purpose of this research and calculations, the habitable grid-size of 3m x 3m or 9m² has been taken into consideration as shown in figure 8.3.

Staircases

Similarly, the National Building codes also specify the minimum requirements for staircase design as per the building category. Part 4, section 3, clause 3.1 of NBC-2016 provides for the classification of building based on the occupancy. As per the proposed typology, the building falls under the primary categorization of Group A – Residential and sub-categorization into A-4 Apartment houses. The clause 4.4.2.4.3.1 provides for the minimum dimensions of staircases, where the minimum width of the tread of the staircase should be 300mm (including nosing) and maximum height of riser should be 150mm (Bureau of Indian Standards, 2016). The clause 4.4.2.4.3.2 provides for the minimum width of the staircase for building type A-4 as 1.25m. Now, it is assumed that the floor to floor height of a residential building is 3m. Upon calculation it is estimated that the minimum grid dimension in plan of a staircase in the proposed typology will be 3m x 4m as shown in figure 8.3.

Lift shafts

Given that the proposal is for a multi-storey residential building, it is mandatory to provide an elevator access for structures with three floors or more as per the Meghalaya building bye laws (Government of Meghalaya, 2011). Lift shafts also form an important part of the space requirement, as it needs a certain clear span to technically function. Table 24 of NBC 2016, volume 2, part 8, section5, clause 8.3 provides for the maximum net car areas of various passenger loads that could be considered in building design. Taking the information given in this table as bench mark, the maximum possible capacity of 29 passenger lift has been taken into account. It is mentioned that the maximum net inside car area for a 29 passengers lift should be 4.18m². Thus, a clear span of 2m can be considered for size determination.

It is important to determine the starting point of design, that is, fixing a grid size. The minimum clear spans for various building components have been taken into consideration to determine the basic grid-size. The base grid size should be such that all basic components can be adjusted in the given clear span within the structure. Any grid-size larger than this could be possible within the structural capacity of the building material. Thus, for this research the minimum spans presented in figure 8.3 have been analyzed to produce a grid size of 3m x 4m. This grid size has been used for further structural calculations presented in the following sections.

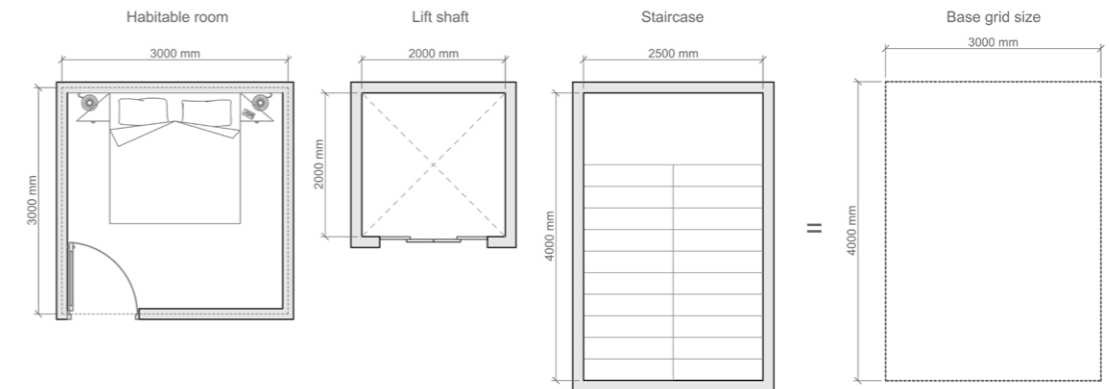


Figure 8.3: Minimum clear spans for different building components as per the Building bye laws.

8.2 Structural member sizing

For the purpose of structural sizing, section 3A- Timber of Indian National building codes have been used along with the theory on simplified design of structural wood provided by Harry Parker (Parker, 1979).

The combinations and locations of loads have been considered for design as per the specification of clause 6.4.2 of national Building Codes. Wind and seismic forces cannot be considered simultaneously. Two species of trees, that had been traditionally used in Assam-type, Shorea Robusta (Sal) and Pinus Kesiya (Khasi Pine), have been used for the construction of the proposed timber structure. While Pinus kesiya is used for lower load capacities only in the indoors, Shorea robusta is used for major structural support systems both indoors and outdoors. Three main structural members have been considered for structural design in the proposed construction technology and they have been considered for sizing in the following order:

- 1) Secondary beams
- 2) Primary beams
- 3) Columns

Table 8.2 shows the mechanical properties as mentioned in national building codes and use of each species in different structural parts of the proposed timber construction.

Species		Average density at 12% moisture content.	Modulus of elasticity (All grades and all locations) x 10 ³	Functions
		Kg/m ³	N/mm ²	
Softwood	Pinus Kesiya	513	7.38	Flooring/wooden planks
				Secondary Beams
Hardwood	Shorea Robusta	805	12.67	Primary beams
				Columns
				Structural joineries

Table 8.2: Application of the two species in different parts of the structural system and data as per NBC (Bureau of Indian Standards, 2016).

Table 8.3 shows the safe permissible stresses of the two species as per National building codes.

Since the structure is aiming specially for earthquake loads, the permissible stresses provided by table 8.3 have to be multiplied by a factor of K_2 as per clause 5.4.2 of NBC for different durations of design load.

K_2 (modification factor for change in duration of loading under earthquake) = 1.33

As per the codes the factor is also applicable to modulus of elasticity when used for designing of timber columns (Bureau of Indian Standards, 2016). Table 8.4 shows the revised permissible stresses for consideration under the modified factor of K_2 .

Species	Permissible stress for grade I, N/mm ²								
	Bending tension along grain, extreme fibre Stress			Shear all locations		Compression parallel to grain		Compression perpendicular to grain	
Botanical name	Inside location	Outside location	Wet location	Horizontal	Along grain	Inside location	Outside location	Inside location	Outside location
Pinus Kesiya	8.9	7.4	5.9	0.6	0.7	5.8	5.2	1.5	1.2
Shorea Robusta	16.9	14.0	11.2	0.9	1.3	10.6	9.4	4.6	3.5

Table 8.3: The safe permissible stresses of the two species as per National building codes (Bureau of Indian Standards, 2016).

Species	Modified permissible stress for grade I under K_2 (values from table 14 * 1.33), N/mm ²								
	Bending tension along grain, extreme fibre Stress			Shear all locations		Compression parallel to grain		Compression perpendicular to grain	
Botanical name	Inside location	Outside location	Wet location	Horizontal	Along grain	Inside location	Outside location	Inside location	Outside location
Pinus Kesiya	11.837	9.842	7.847	0.798	0.931	7.714	6.916	1.995	1.596
Shorea Robusta	22.477	18.62	14.896	1.197	1.729	14.098	12.502	6.118	4.655

Table 8.4: The safe permissible stresses of the two species as per Table 11, section 3A of National building codes after application of K_2 modification factor due to change in duration of loading under earthquakes.

8.2.1 Load case of slab for structural sizing

A preliminary concept design of the slab consisting of a layer of wood planks, concrete and marble flooring has been taken into consideration for load calculation. The schematic diagram is shown in figure 8.4. Load cases and material properties considered for slab as presented in table 16. The value of live load has been taken from National Building Code, Table 1 (clause 3.3.1), the value of uniformly distributed loads for corridors, passages, staircases including fire escapes and store rooms, which is maximum under the residential buildings has been considered for the overall purpose of load design, however prescribed loads for room is 2 KN/m².

Assumed slab grid size as explained in section 8.1 is 3m x 4m.

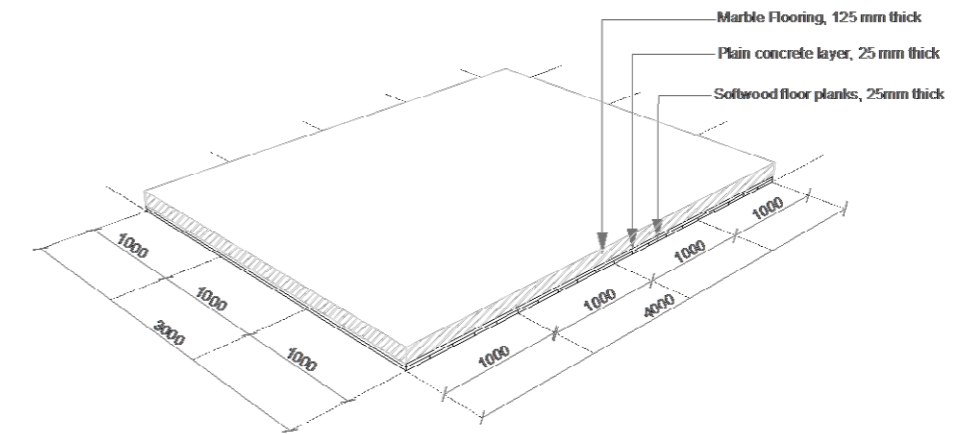


Figure 8.4: Schematic diagram of the slab for loading

	Material	Density	Thickness	Weight/ per unit area
		KN/m ³	m	KN/m ²
Dead load	Marble tiling	27	0.0125	0.3375
	Plain concrete	23.5	0.025	0.5875
	Softwood (Pine) floor planks	5.03	0.025	0.12575
Live load *				3
Total				4.05075

Table 8.5: Load case values for the slab

8.2.2 Secondary beam structural sizing

The secondary beam supports the slab. The secondary beam is made of softwood – Pinus Kesiya as mentioned already in table 8.2. As the grid size is 3x4m, the secondary beams are made to run along the shorter span as shown in figure 8.5. It should be noted that number of secondary beams will determine the size determination of individual member. However, for the purpose of this research, inspiration has been drawn from the traditional 'Assam type house' in which the center to center distance between two secondary beams is approximately 1000mm. This is also directly dependent on the availability and easy handling of smaller wooden floor planks of 1000-1200mm, which rests directly above the secondary beam in the traditional setup.

As per clause 6.5.1 of National Building Codes (NBC), all timber structural beam members must be investigated for the following:

- Bending strength
- Maximum horizontal shear
- Deflection

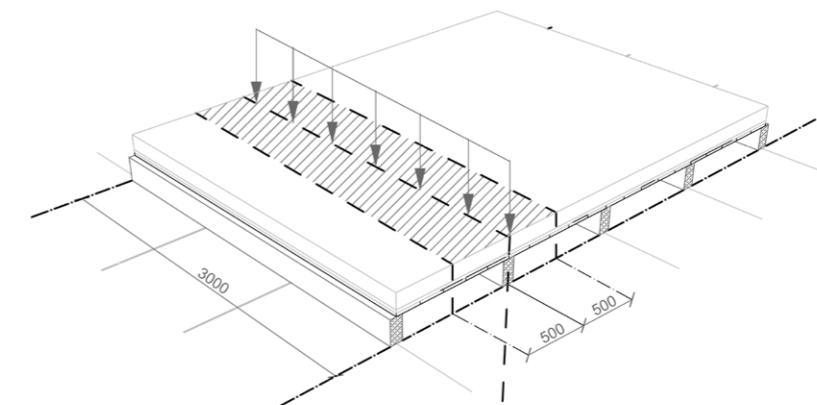


Figure 8.5: Diagram showing the configuration of secondary beams for primary structural calculations.

The sizing of secondary beams has been done in the following steps:

- Step 1: Load calculation
- Step 2: Horizontal shear verification
- Step 3: Deflection check
- Step 4: Flexural strength check

Step 1: Load calculation

The various load cases shown in table 8.5 are taken into consideration for calculating the total uniformly distributed load (UDL) on a secondary beam.

$$\text{Total actual load of slab} = 4.05 \text{ KN/m}^2 \quad \dots \text{ (From table 16)}$$

A cross section of 100 x 200 mm has been taken for the first structural design iteration of secondary beam.

Therefore, cross-sectional area = (100x200) mm² = 20000 mm² or 0.02 m².

Volume of each secondary beam = cross-sectional area x length = 0.02 x 3 m³ = 0.06 m³.

Self-weight of beam = Density x volume = 513 kg/m³ x 0.06 m³ = 30.78 kg.

Load due to self-weight of 1 secondary beam = 0.302 KN or (0.302/3) = 0.101 KN/m

Considering safety factor of 2 on the dead load including the self-weight of the beam. It is already mentioned that the value of live load has been taken from upper limit, thus no safety factor is added to it.

Effective load after application of safety factor = (dead load x 2) + live load = (1.05 x 2) + 3 = 5.1 KN/m².

Effective self-weight of secondary beam = Load due to self-weight x 2 = 0.101 x 2 = 0.202 KN/m.

Now, it can be seen from figure 8.5 that the load of slab is actually distributed among 5 secondary beams in the design scheme. Thus, each secondary beam is actually supporting the load of an area of 3m x 1m.

Hence, total effective uniformly distributed load along the length of the secondary beam = W

$$W = [(\text{effective dead load} \times \text{unit area}) + \text{self-weight of beam}] \times \text{length of beam}$$

$$W = [(5.1 \times 1) + 0.202] \times 3 \text{ KN} = 15.906 \text{ KN}$$

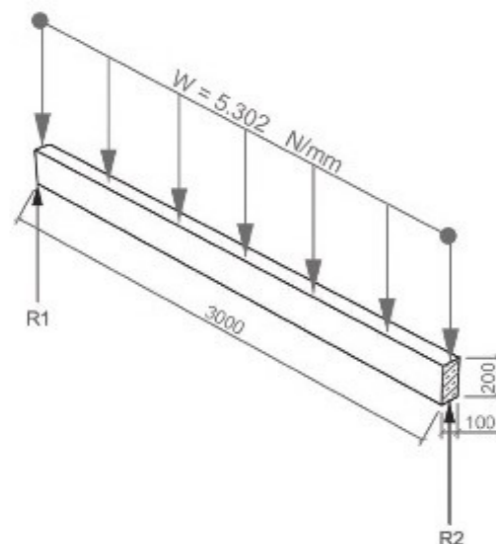


Figure 8.6: Load distribution on a secondary beam

Step 2: Horizontal Shear verification

The horizontal shear, H, for rectangular beams, as per clause 6.5.7.1 from part 6 of NBC is given as:

$$H = 3V/2bD \quad \dots \text{ (equation 1)}$$

Where, H = horizontal shear, V = vertical end reaction in N, b = width of beam in mm, D = depth of beam in mm.

For uniformly distributed loads, the formula for V is given as:

$$V = W/2 [1 - (2D/l)] \quad \dots \text{ (equation 2)}$$

Now, putting values in equation 2,
W = 15.906 KN or 15906 N
D = 200 mm
L = 3000 mm

Therefore,

$$V = 15906/2 [1 - (2*200/3000)] = 6892.6 \text{ N}$$

Now, putting values in equation 1,

$$H = (3*6892.6)/(2*100*200) = 0.52 \text{ N/mm}^2$$

As per table 8.4, maximum permissible horizontal shear (in all directions) for Pinus Kesiya = 0.798 N/mm².

Since **H = 0.52 < allowable 0.798 N/mm²**, the secondary beam is safe with respect to horizontal shear.

Step 3: Deflection check

Maximum permissible deflection for flexural members, as per NBC, shall not exceed 1/240 of the span. However, it is also mentioned that beams supporting brittle members like gypsum ceilings, slates, tiles and asbestos sheet shall not exceed 1/360 of the span (Bureau of Indian Standards, 2016). It is assumed that in this case no brittle materials are used, and the allowable deflection is taken as 1/240.

$$\text{Allowable deflection} = \text{Span}/240 = 3000/240 \text{ mm} = 12.5 \text{ mm}$$

General formula for deflection as per part 6 NBC clause 6.5.10.1 = δ

$$\delta = (KWL^3)/EI \quad \dots \text{ (equation 3)}$$

Where, K value = 5/384 for beams supported at both ends with uniformly distributed load, W = total effective uniformly distributed load in N, L = span of beam in mm, E = modulus of elasticity in N/mm² and I = moment of inertia of a section.

As per table 8.2, modulus of elasticity for Pinus kesiya in all directions, E = 7.38 N/mm²

Moment of inertia of a section for a rectangular cross section,

$$I = (bd^3)/12 = (100*200^3)/12 \text{ mm}^4 = 66,666,666.7 \text{ mm}^4 \text{ or } 0.67 \times 10^8 \text{ mm}^4$$

Putting values in equation 3,

$$\delta = ((5/384)*15906*3000^3)/(7.38*0.67*10^8) \text{ mm} = 11.37 \text{ mm}$$

Now, **$\delta = 11.37 \text{ mm} < \text{permissible deflection of } 12.5 \text{ mm}$** , thus the secondary beam is safe with respect to deflection.

Step 4: Flexural strength

As per table 8.4, maximum allowable flexural strength or maximum bending tension along grain for extreme fiber stress or $f_b = 9.842 \text{ N/mm}^2$.

As per part 6, clause 6.5.3 of NBC, the flexural strength = f_{ab}

$$f_{ab} = M/Z \quad \dots \text{(equation 4)}$$

Where, M= maximum bending moment in a beam Nmm and Z = section modulus of a rectangular cross-section in mm³.

$$M = (W*L)/8 = (15906 * 3000)/8 = 5964750 \text{ N mm}$$

$$Z = bd^2 / 6 = (100*200^2) / 6 = 666,666.67 \text{ mm}^3$$

Putting values in equation 4,

$$f_{ab} = 5964750/666,666.67 = 8.9 \text{ N/mm}^2$$

Hence, $f_{ab} = 8.9 \text{ N/mm}^2 < \text{permissible value of } 9.842 \text{ N/mm}^2$, thus the secondary beam is safe with respect to the flexural stress.

Thus, the given cross sectional dimension of 100mm x 200mm for the secondary beam has passed all the three requirements of the national building bye-laws. However, it should be noted that the mentioned calculations are for an assumed load cases, and these figures should be reconsidered in case of any load or member sizing change.

8.2.3 Primary beam structural sizing

The secondary beams rest on the main primary beam running along the 3x4m grid. This primary beam is made of hardwood, Shorea robusta. The primary beam is simply supported at both ends for the purpose of calculation. For the initial sizing a cross-section of 200mm by 350mm is assumed and checked for the various parameters as mentioned above. Also, along with the load of secondary beams, an additional load of the wood and reed wall has been added for the load calculations as these walls rest on the primary beam as shown in figure 8.7. However, it should be noted that the weight of the reed wall, which is elaborated below under load calculations, has been taken based on dimensions in the traditional method of wall construction. Since this thesis specially focuses on just the structural system, there is scope for further development in the wood and reed wall design. The change in loads due to change in façade system will therefore have to be reconsidered.

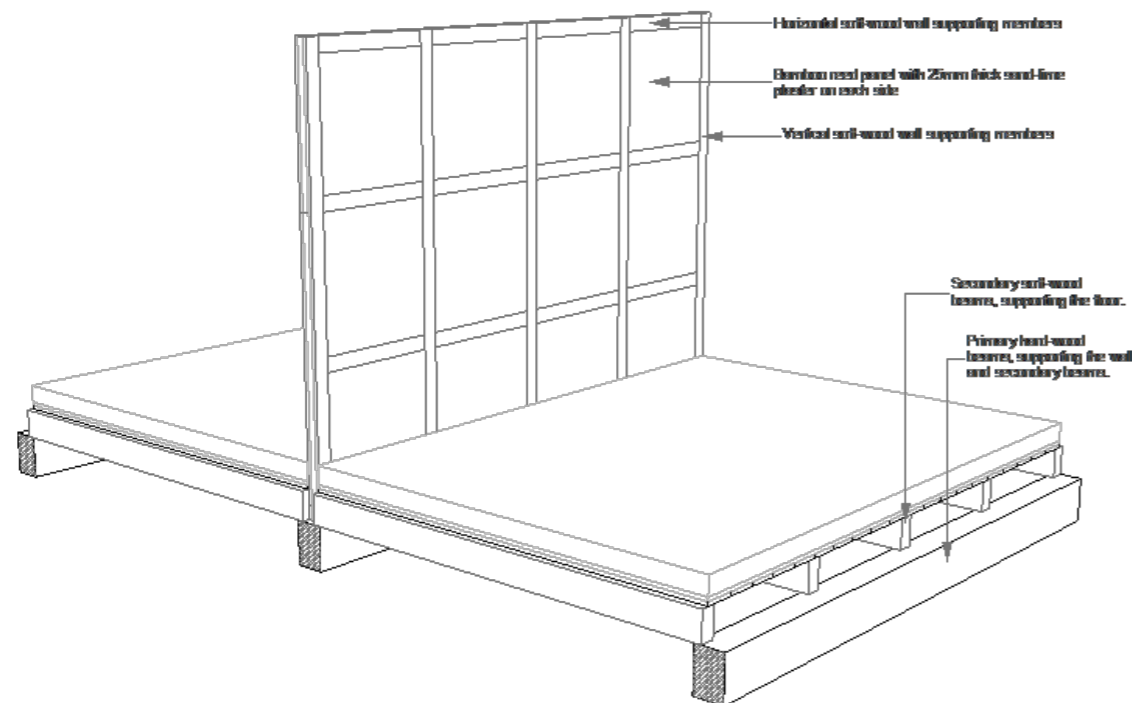


Figure 8.7: Image showing the secondary beam and the wooden-reed wall resting on the primary beam.

The sizing of primary beams has been done in the following steps:

- Step 1: Load calculation
- Step 2: Horizontal shear verification
- Step 3: Deflection check
- Step 4: Flexural strength check

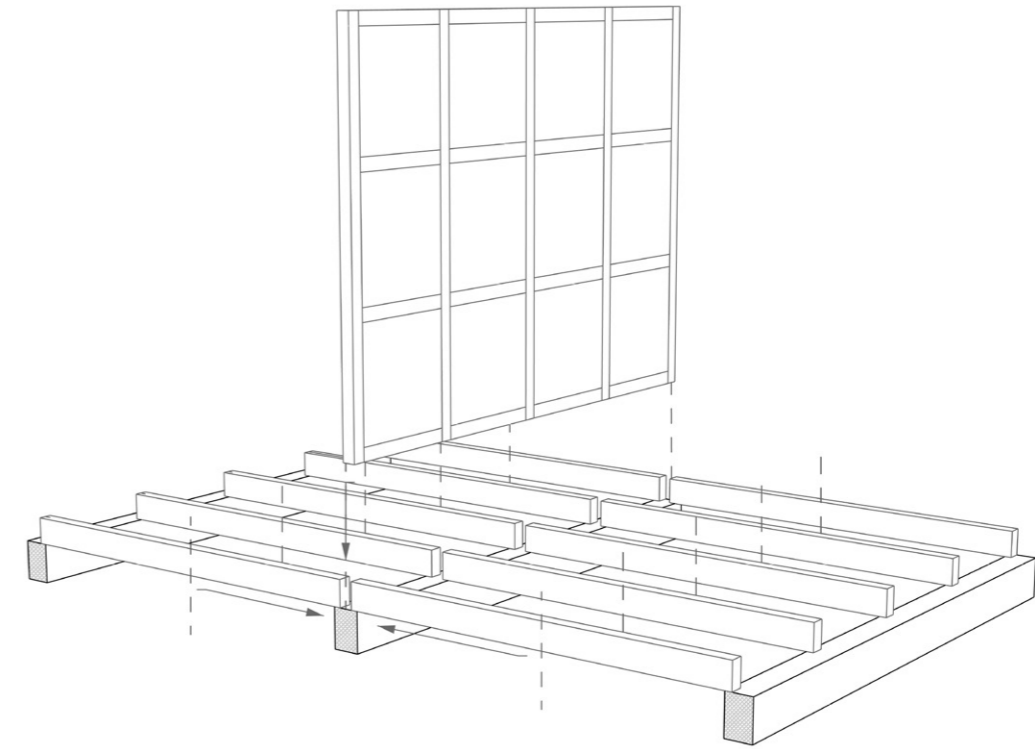


Figure 8.8: Half the load of each secondary beams on either side are transferred to the primary beam as a point load. Also, the load of the wall is transferred to the primary beam as a uniformly distributed load.

Step 1: Load calculation

Load case 1: Load of secondary beam resting on the primary beam. For each secondary beam, half of the total load is delivered to the primary beam on each side, thus load from an individual secondary beam = $15906/2 \text{ N} = 7953 \text{ N}$. Since, two secondary beams rest on one primary beam as shown in figure 8.8, the load at this point = $7953 \times 2 \text{ N} = 15906 \text{ N}$.

Load case 2: Load of wood frame + reed wall is taken into account. Table 8.6 shows the detailed calculation of the internal wall and the placement of the members in a wall is shown in figure 8.8. This composition is an approximation of the traditional setup comprising of horizontal and vertical wooden members which act as rails for the reeds, the reed panels are plastered on both sides by lime-mud plaster.

Material		Cross sectional area (m ²)	Density (kN/m ³)	Length of member * total number of members (m)	Load (kN)
Softwood frame	Vertical	$0.1 \times 0.1 = 0.01$	5.03	$3 \times 5 = 15\text{m}$	0.7545
	Horizontal	$0.1 \times 0.1 = 0.01$	5.03	$4 \times 4 = 16\text{m}$	0.8048
Lime-mud plaster		12	15.1	$[0.025 \text{ (thickness)}] \times 2 = 0.05$	9.06
Reed panel			0.0314 (kN/m ²)		0.3768
Total load					10.9961
Uniformly distributed load/m = $(10.9961/4)$					2.75 kN/m
Safety factor				2	
Final load considered for primary beam design = (2.75×2)					5.5 kN/m

Table 8.6: Load calculation for load case 2 or internal wall on the primary beams.

Load case 3: Self weight of the beam. A size of 200mm by 350mm has been taken for the structural design iteration of the primary beam cross-section.

Hence, cross sectional area of primary beam = 70,000mm² or 0.07m².

Therefore, self-weight kN/m = cross-sectional area * density = 0.07m² * 7.89kN/m³ = 0.5523 kN/m.

Safety factor = 2

Final self-weight of primary beam = 0.5523 * 2 kN/m² = 1.1046 kN/m².

It should be noted that a safety factor of 2 has been considered for the load calculation of the walls because no additional loads of modern installation (both thermal and acoustical) have been considered in the materials of the wall. Thus, this safety factor accounts for the predicted extra loads to be added in future. Also, safety factor of 2 has been considered on the self-weight of the primary beam. While no safety factor for the point loads from secondary beam have been considered at this stage as the load calculation for the secondary beam already takes into considered safety factors.

$$\text{Total load on the primary beam} = \text{Load case 1} + \text{Load case 2} + \text{Load case 3}$$

Or, total load on the primary beam = Point load (Load case 1) + Uniformly distributed loads (Load case 2+ Load case 3), as shown in figure 8.9.

Total Uniformly distributed loads (Load case 2+ Load case 3) = 5.5 + 1.1046 kN/m = 6.6 kN/m.

Total load on the primary beam = 15.9 kN + 6.6 kN/m

Step 2: Horizontal Shear verification

The horizontal shear, H, for rectangular beams, as per clause 6.5.7.1 from part 6 of NBC is given as:

$$H = 3V/2bD \quad \dots \text{(equation 1)}$$

Where, H = horizontal shear, V = vertical end reaction in N, b = width of beam in mm, D = depth of beam in mm.

Splitting the total load on the primary beam into 2 = [(15.9 * 5) + (6.6*4)]/2 = 52.95 kN

V = 52.95 kN or 52950 N

b = 200 mm

D = 350mm

Applying values in equation 1,

$$H = (3 * 52950) / (2 * 200 * 350) = 1.135 \text{ N/mm}^2$$

As per table 8.4, maximum permissible horizontal shear (in all directions) for Shorea robusta = 1.197 N/mm².

Since **H = 1.135 < allowable 1.197 N/mm²**, the primary beam is safe with respect to horizontal shear.

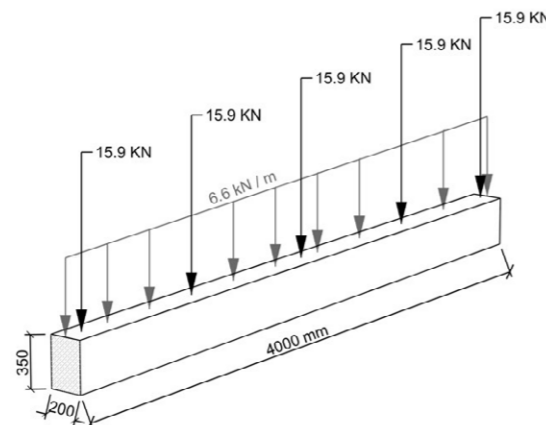


Figure 8.9: Schematic diagram of load cases on primary beam.

Step 3: Deflection check

Maximum permissible deflection for flexural members, as per NBC, shall not exceed 1/360 of the span for beams supporting brittle members like gypsum ceilings, slates, tiles and asbestos sheet (Bureau of Indian Standards, 2016).

$$\text{Allowable deflection} = \text{Span}/360 = 4000/360 \text{ mm} = 11.1 \text{ mm}$$

For primary beam two deflection cases have been considered:

1) Deflection due to point loads, δ_1

2) Deflection due to uniformly distributed load, δ_2

General formula for deflection due to 3 point loads:

$$\delta_1 = (19WL^3)/384EI \quad \dots \text{(equation 5)}$$

It should be noted here that the two point loads acting at the two extreme edges have been neglected because its affect on the deflection is negligible.

Where, W = 15900 N, L = 4000 mm, E = modulus of elasticity in N/mm² and I = moment of inertia of a section.

As per table 8.2, modulus of elasticity for Shorea robusta in all directions, E = 12.67*10³ N/mm²

Moment of inertia of a section for a rectangular cross section,

$$I = (bd^3)/12 = (200*350^3)/12 \text{ mm}^4 = 714583333.33 \text{ mm}^4 \text{ or } 0.0007145833 \text{ m}^4$$

Putting values in equation 5,

$$\delta_1 = (19*15900*4000^3)/(384*12.67*10^3*714583333.33) = 5.56 \text{ mm}$$

General formula for deflection due to uniformly distributed loads as per part 6 NBC clause 6.5.10.1 = δ_2

$$\delta_2 = (KWL^3)/EI \quad \dots \text{(equation 3)}$$

Where, K value = 5/384 for beams supported at both ends with uniformly distributed load, W = total effective uniformly distributed load in N, L = span of beam in mm, E = modulus of elasticity in N/mm² and I = moment of inertia of a section.

As per table 8.2, modulus of elasticity for Shorea robusta in all directions, E = 12.67*10³ N/mm²

Moment of inertia of a section for a rectangular cross section,

$$I = (bd^3)/12 = (200*350^3)/12 \text{ mm}^4 = 714583333.33 \text{ mm}^4 \text{ or } 0.0007145833 \text{ m}^4$$

Putting values in equation 3,

$$\delta_2 = ((5/384)*(6.6*4000)*4000^3)/(12.67*10^3*714583333.3) \text{ mm} = 2.43 \text{ mm}$$

Total deflection, $\delta = \delta_1 + \delta_2 = (5.56 + 2.43) \text{ mm} = 7.99 \text{ mm}$

This deflection value derived from analytical calculation was also verified using the FEM software Karamba3D in grasshopper, which is a plugin for Rhino. The model was setup using the beam modelling component in karamba3D and the properties of Shorea robusta were used to customize the material used as input for the calculation. The detailed values and the grasshopper script is attached in appendix a. First order analysis was used to derive the results of deflection. Figure 8.10 shows the image of the beam

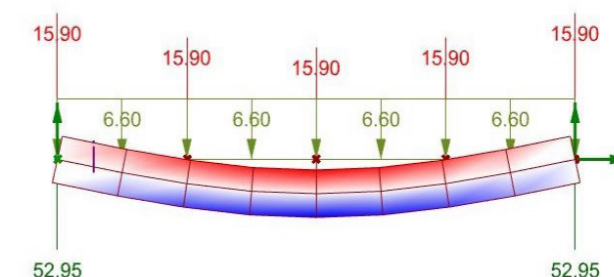


Figure 8.10: Image of the primary beam analysis from Karamba3D

model.

It can be noted from table 8.7 that the deflection value derived from Karamba3D is very close to that of the analytical calculation. Both of these values are below the safe limits of 11.1 mm, thus the primary beam is safe with respect to deflection.

Element	Deflection (mm)		
	Analytical calculation	Karamba3D value	Permissible limit as per codes
Primary beam	7.99	7.16	11.1

Table 8.7: Deflection values for primary beam using different methods

Step 4: Flexural strength check

As per table 8.4, maximum allowable flexural strength or maximum bending tension along grain for extreme fiber stress for outside location or $f_b = 18.62 \text{ N/mm}^2$.

As per part 6, clause 6.5.3 of NBC, the flexural strength = f_{ab}

$$f_{ab} = M/Z \quad \dots \text{(equation 4)}$$

Where, M= maximum bending moment in a beam N mm and Z = section modulus of a rectangular cross-section in mm^3 .

M, has been calculated at the center of the beam where bending moment is maximum. Bending moment has been calculated in two steps, M1 for the point loads and M2 for the uniformly distributed load.

$$M1 = 31.8 \text{ kN m, and } M2 = (W*L^2)/8 = (6.6 * 40002)/8 = 13,200,000 \text{ N mm or } 13.2 \text{ kN m}$$

$$M_{max} = M1 + M2 = (31.8 + 13.2) = 45 \text{ kN m or } 45*10^6 \text{ N mm}$$

And, $Z = bd^2 / 6 = (200*350^2) / 6 = 4083333.33 \text{ mm}^3$

Therefore, $f_b = (45*10^6)/4083333.33 = 11.02 \text{ N/mm}^2$

Hence, $f_b = 11.02 \text{ N/mm}^2 < \text{permissible value of } 18.62 \text{ N/mm}^2$, thus the primary beam is safe with respect to the flexural stress.

Thus, the given cross sectional dimension of 200mm x 350mm for the primary beam has passed all the three requirements of the national building bye-laws. However, it should be noted that the mentioned calculations are for an assumed load cases, and these figures should be reconsidered in case of any load or member sizing change.

8.2.4 Column structural sizing

Figure 8.11 shows the composition of the main structural members where the primary beam rest on the column. The load from the primary beam is transferred to the column via a joinery. However, for the purpose of simplification of load calculation on the column and determining the column size, it is assumed that the beams directly rest on the column.

The load from four primary beams are transferred into each column. It should be noted that the case for the columns located in the periphery of the building and the corner of the building will be different as there will be three and two primary beams resting on each column respectively. However, for the purpose of load calculation and member sizing, the column with maximum loads, i.e, inner columns with 4 primary beams resting on it, has been taken forward.

The NBC has classified columns into 3 categories depending upon its slenderness ratio. The 3 categories are (Bureau of Indian Standards, 2016):

- Short column - where slenderness ration does not exceed 11
- Internediate column – where slenderness ratio is between 11 and K_8
- Long columns – where slenderness ratio is greater than K_8

Where K_8 is a constant,

$$K_8 = 0.584\sqrt{E/f_{cp}} \quad \dots \text{(equation 6)}$$

Where, E = modulus of elasticity in N/mm^2 and f_{cp} = permissible stress in compression parallel to grain. From table 13, for Shorea robusta, $E = 12.67*10^3 \text{ N/mm}^2$ and $f_{cp} = 12.502 \text{ N/mm}^2$.

Putting values in equation 6,

$$K_8 = 0.584\sqrt{(12.67*10^3)/12.502} = 18.59$$

Now,

The slenderness ratio of the column which is given by S/d in NBC, where S = length of the column in mm and d = smallest dimension of the column in x or y direction.

Therefore, $\text{Slenderness ratio} = S/d \quad \dots \text{(equation 7)}$

Here, S = 3000 mm which is constant (floor to floor height) and hence the various slenderness ratio for possible values of d have been tabulated in table 8.8.

Slenderness ratio	D = 200mm	D = 250 mm	D = 300 mm	D = 350 mm	D = 400 mm
S/d, S = 3000 mm	15	12	10	8.5	7.5

Table 8.8: slenderness values for different possible cross sections of the column.

Classifying the above columns into short, intermediate and long columns based on the criteria set by NBC, as shown in table 8.9.

Slenderness ratio	D = 200mm	D = 250 mm	D = 300 mm	D = 350 mm	D = 400 mm
S/d, S = 3000 mm	15	12	10	8.5	7.5
Classification of columns	Intermediate	Intermediate	Short	Short	Short
$K_8 = 18.59$	$11 < 15 < K_8$	$11 < 12 < K_8$	$10 < 11$	$8.5 < 11$	$7.5 < 11$

Table 8.9: Classification of columns based on the criteria set by the NBC section 3A part 6.6

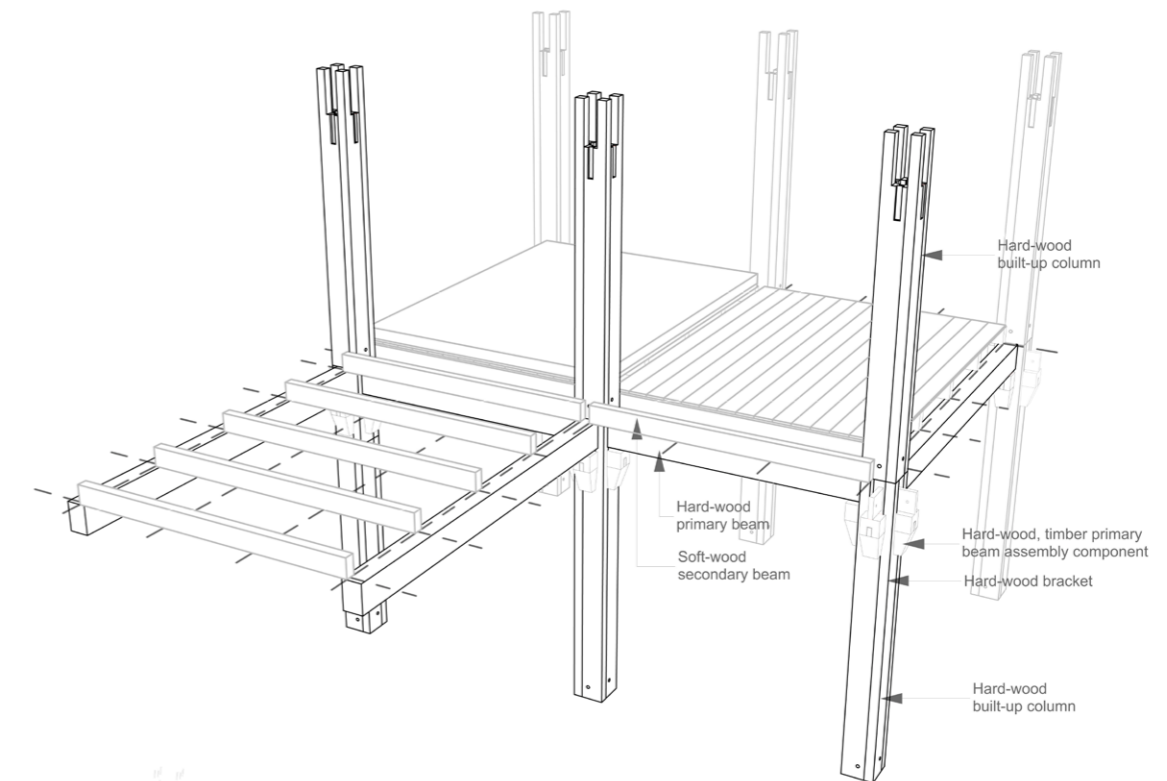


Figure 8.11: Diagram showing composition of columns and primary beams, supported by the joinery.

f_c is the permissible compressive stress as per NBC. f_c is dependent on the slenderness ratio of the column.

For short column,

$$f_c = f_{cp} \quad \dots(\text{equation 8})$$

Therefore, putting value of f_{cp} in equation 8, $f_c = f_{cp} = 12.502 \text{ N/mm}^2$.

For intermediate column,

$$f_c = f_{cp} [1 - \{(S/(K_g * d))^4\} / 3] \quad \dots(\text{equation 9})$$

Substituting the values of $S=3000\text{mm}$, $K_g = 18.59$, $f_{cp} = 12.502 \text{ N/mm}^2$ and various values of d in equation 9, the permissible compressive stresses for columns with different cross-section have been provided in table 8.10.

Slenderness ratio	D = 200mm	D = 250 mm	D = 300 mm	D = 350 mm	D = 400 mm
S/d, S = 3000 mm	15	12	10	8.5	7.5
Classification of columns, where $K_8 = 18.59$	Intermediate	Intermediate	Short	Short	Short
	$11 < 15 < K_8$	$11 < 12 < K_8$	$10 < 11$	$8.5 < 11$	$7.5 < 11$
f_c in N/mm^2	10.74	11.78	12.502	12.502	12.502

Table 8.10: tabulation of f_c as per the classification of columns and application of equation 8 and 9.

The allowable load on each column has been calculated on basis of the formula provided by (Parker, 1979) and the formulas provided in NBC section 3A part 6.6 for f_c .

$$\text{Allowable load} = f_c * \text{cross section area} \quad \dots(\text{equation 10})$$

Tabulating the values of various allowable loads according to the varying cross-section of the columns in table 8.11.

Slenderness ratio	D = 200mm	D = 250 mm	D = 300 mm	D = 350 mm	D = 400 mm
Cross-section area = D^2	40000 mm^2	62500 mm^2	90000 mm^2	122500 mm^2	160000 mm^2
S/d, S = 3000 mm	15	12	10	8.5	7.5
Classification of columns, where $K_8 = 18.59$	Intermediate	Intermediate	Short	Short	Short
	$11 < 15 < K_8$	$11 < 12 < K_8$	$10 < 11$	$8.5 < 11$	$7.5 < 11$
f_c in N/mm^2	10.74	11.78	12.502	12.502	12.502
Allowable load, N	429600	736250	1125180	1531495	2000320
Allowable load, kN	429.6	736.25	1125.18	1531.5	2000.32

Table 8.11: tabulation of allowable load as per equation 10.

Now, that we have the allowable load for different cross-sections, the total columns on each floor can be calculated and the best suitable cross section can be picked from table 8.11, depending upon the maximum allowable load.

As shown in figure 8.12, the reaction forces of one end of each primary beam will be taken into account. This means that half the loads of the individual primary beams and a quarter of forces of the slabs are transferred into one column.

The main aim here is to calculate the loads on each column which varies according the floor. A total of 6 storey has been taken into account for the purpose of this design. Thus, column sizes for 6 floors have to be calculated. Square solid cross-sections of Shorea robusta have been taken as the initial basic column cross-section design for simplification of load calculations. The loads have been calculated from the topmost floor, i.e. the sixth floor to the bottom-most floor, i.e the ground floor.

Load on 6th floor column:

The cross-section of 200x200 mm has been taken for the purpose of the column cross-section on 6th floor.

$$\text{Total load} = \text{self weight of the column} + \text{load of each of the 4 primary beams} \quad \dots(\text{equation 11})$$

$$\text{Self weight of the column} = \text{Volume} * \text{density} \quad \dots(\text{equation 12})$$

Where,

Volume = cross-section*length = $(200*200)*3000 \text{ mm}^3 = 120000000 \text{ mm}^3$ or 0.12 m^3
Density of Shorea robusta as per table 8.2 = 805 kg/m^3 .

Putting values in equation 12,

Self-weight of the column = volume*density = $0.12*805 \text{ kg} = 96.6 \text{ kg}$ or 0.95 kN .

Now,

Reaction forces at each end of a primary beam = 52.95 kN ... (from the calculation of V in above section)

Total load on column from primary beams = reaction force from each primary beam * 4 = $52.95 * 4 = 211.8 \text{ kN}$

Putting values in equation 11,

$$\text{Total load} = \text{self weight of the column} + \text{load of each of the 4 primary beam} = (211.8 + 0.95) \text{ kN} = 212.75 \text{ kN} .$$

Since the allowable load for a cross-section of 200x200 mm is 429.6 kN as per table 8.11, which is $> 212.75 \text{ kN}$, therefore this cross section is safe with respect to loading.

Load on 5th floor column:

The cross-section of 200x200 mm has been taken for the purpose of the column cross-section on 5th floor.

$$\text{Total load} = \text{self weight of the column} + \text{load of each of the 4 primary beams} + \text{total load of column on 6th floor} \quad \dots(\text{equation 13})$$

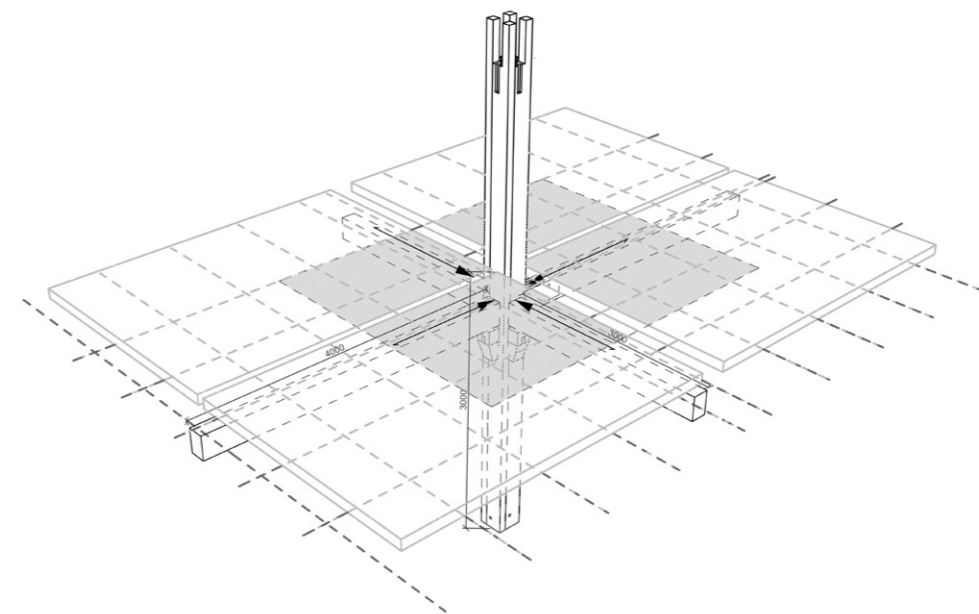


Figure 8.12: Schematic diagram showing the load area for individual column and the junction where the 4 primary beams rest on the column.

$$\text{Self weight of the column} = \text{Volume} * \text{density} \quad \dots(\text{equation 12})$$

Since the cross-section is same as that of 6th floor, the calculation for self-weight remains the same, also the load from the primary beams in constant for every floor.

$$\text{Self-weight of the column} = \text{volume} * \text{density} = 0.12 * 805 \text{ kg} = 96.6 \text{ kg or } 0.95 \text{ kN}.$$

Total load on column from primary beams = reaction force from each primary beam * 4 = 52.95 * 4 = 211.8 kN

Now, substituting the above values in equation 13,

$$\text{Total load} = \text{self weight of the column} + \text{load of each of the 4 primary beams} + \text{total load of column on 6th floor} = 0.95 + 211.8 + 212.75 \text{ kN} = 425.5 \text{ kN}$$

Since the allowable load for a cross-section of 200x200 mm is 429.6 kN as per table 8.11, which is > 425.5 kN, therefore this cross section is safe with respect to loading.

Load on 4th floor column:

The cross-section of 250x250 mm has been taken for the purpose of the column cross-section on 4th floor.

$$\text{Total load} = \text{self weight of the column} + \text{load of each of the 4 primary beams} + \text{total load of column on 5th floor} \quad \dots(\text{equation 13})$$

$$\text{Self weight of the column} = \text{Volume} * \text{density} \quad \dots(\text{equation 12})$$

Self-weight of the column = volume*density=(0.25*0.25*3)*805 kg = 150.9 kg or 1.48 kN.

Since the load from the primary beams in constant for every floor.

Total load on column from primary beams = reaction force from each primary beam * 4 = 52.95 * 4 = 211.8 kN

Now, substituting the above values in equation 13,

$$\text{Total load} = \text{self weight of the column} + \text{load of each of the 4 primary beams} + \text{total load of column on 5th floor} = 1.48 + 211.8 + 425.5 \text{ kN} = 638.8 \text{ kN}$$

Since the allowable load for a cross-section of 250x250 mm is 736.25 kN as per table 8.11, which is > 638.8 kN, therefore this cross section is safe with respect to loading.

Load on 3rd floor column:

The cross-section of 300x300 mm has been taken for the purpose of the column cross-section on 3rd floor.

$$\text{Total load} = \text{self weight of the column} + \text{load of each of the 4 primary beams} + \text{total load of column on 4th floor} \quad \dots(\text{equation 13})$$

$$\text{Self weight of the column} = \text{Volume} * \text{density} \quad \dots(\text{equation 12})$$

Self-weight of the column = volume*density=(0.3*0.3*3)*805 kg = 217.35 kg or 2.13 kN.

Since the load from the primary beams in constant for every floor.

Total load on column from primary beams = reaction force from each primary beam * 4 = 52.95 * 4 kN = 211.8 kN

Now, substituting the above values in equation 13,

$$\text{Total load} = \text{self weight of the column} + \text{load of each of the 4 primary beams} + \text{total load of column on 4th floor} = 2.13 + 211.8 + 638.8 \text{ kN} = 852.73 \text{ kN}$$

Since the allowable load for a cross-section of 300x300 mm is 1125.18 kN as per table 8.11, which is > 852.73 kN, therefore this cross section is safe with respect to loading.

Load on 2nd floor column:

The cross-section of 300x300 mm has been taken for the purpose of the column cross-section on 3rd floor.

$$\text{Total load} = \text{self weight of the column} + \text{load of each of the 4 primary beams} + \text{total load of column on 3rd floor} \quad \dots(\text{equation 13})$$

$$\text{Self weight of the column} = \text{Volume} * \text{density} \quad \dots(\text{equation 12})$$

Self-weight of the column = volume*density=(0.3*0.3*3)*805 kg = 217.35 kg or 2.13 kN.

Since the load from the primary beams in constant for every floor.

Total load on column from primary beams = reaction force from each primary beam * 4 = 52.95 * 4 kN = 211.8 kN

Now, substituting the above values in equation 13,

$$\text{Total load} = \text{self weight of the column} + \text{load of each of the 4 primary beams} + \text{total load of column on 3rd floor} = 2.13 + 211.8 + 852.73 \text{ kN} = 1066.66 \text{ kN}$$

Since the allowable load for a cross-section of 300x300 mm is 1125.18 kN as per table 8.11, which is > 1066.66 kN, therefore this cross section is safe with respect to loading.

Load on 1st floor (ground floor) column:

The cross-section of 350x350 mm has been taken for the purpose of the column cross-section on 3rd floor.

$$\text{Total load} = \text{self weight of the column} + \text{load of each of the 4 primary beams} + \text{total load of column on 2nd floor} \quad \dots(\text{equation 13})$$

$$\text{Self weight of the column} = \text{Volume} * \text{density} \quad \dots(\text{equation 12})$$

Self-weight of the column = volume*density=(0.35*0.35*3)*805 kg = 295.84 kg or 2.9 kN.

Since the load from the primary beams in constant for every floor.

Total load on column from primary beams = reaction force from each primary beam * 4 = 52.95 * 4 kN = 211.8 kN

Now, substituting the above values in equation 13,

$$\text{Total load} = \text{self weight of the column} + \text{load of each of the 4 primary beams} + \text{total load of column on 2nd floor} = 2.9 + 211.8 + 1066.66 \text{ kN} = 1281.36 \text{ kN}$$

Since the allowable load for a cross-section of 350x350 mm is 1531.5 kN as per table 8.11, which is > 1281.36 kN, therefore this cross section is safe with respect to loading.

Figure 8.13 summarizes the above calculation for ascending loads and the cross-section of the columns from top to bottom in the proposed timber construction system.

8.2.5 Sizing for varied grid sizes

The calculations in the above sections were made for a fixed base grid size of 3m by 4m. By following the same calculation procedure, the sizes of structural members for other combinations of grid sizes have been calculated and presented in table 8.12. The floor to floor height = 3m, i.e. the z-direction, has been kept constant in the calculation. The table shows the gradual increase in size of the members. It can be noted in table 8.12 that the largest member size considered here is 400x400mm, though theoretically calculations could be made for member sizes that are larger, but it is not a practical approach as there are limitations to natural material procurement. The detailed calculations for various grid-sizes were performed in Microsoft excel and the members have been validated for the horizontal shear, flexural strength and deflection by analytical calculation. The detailed excel sheet for the calculation for column, primary beam and secondary beam has been attached in appendix B.

However, it should be noted that the larger the size of the timber, the difficult it is to procure the material. As older trees, which are rare and takes longer to cultivate, will be needed for large structural dimensions. Also, as grid size increases the need for a single piece of tall wooden members increase, this increases the transportation problem of long timber members. Also, the workability reduces as the timber size increases. Hence the grid size should not be selected with respect to the architectural considerations but also possibilities about the procurement of the timber, market conditions and judgement on workability.

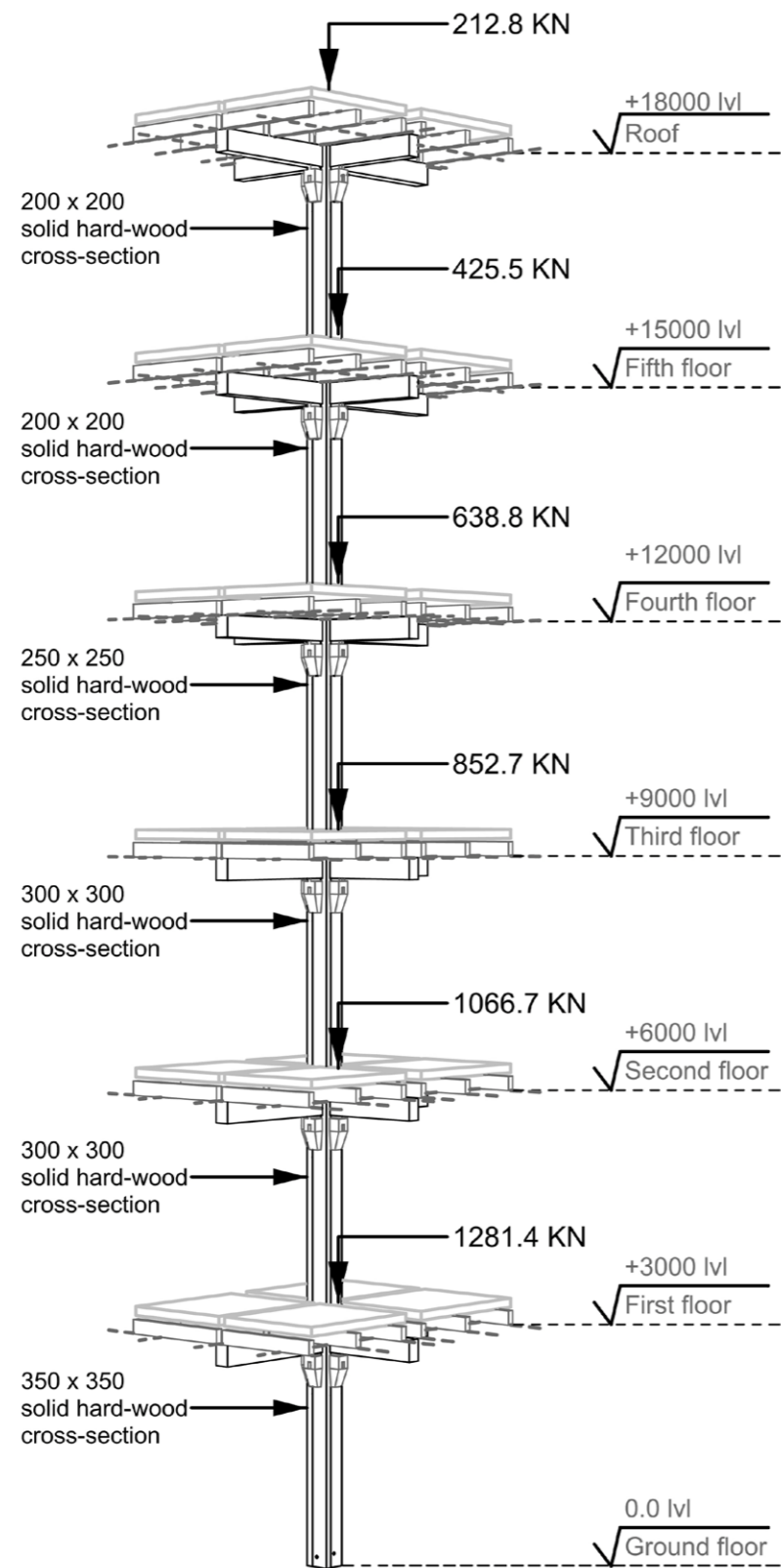


Figure 8.13: Schematic diagram showing the loads on columns for the proposed 6 storey timber construction.

Grid size, mm		Secondary beam cross-section, mm	Primary beam cross-section, mm	Column solid cross section, mm					
X axis (Secondary beam)	Y axis (Primary beam)			Ground floor	1st floor	2nd floor	3rd floor	4th floor	5th floor
3000	4000	100x200	200x350	350x350	300x300	300x300	250x250	200x200	200x200
	4500	125x200	225x350	350x350	350x350	300x300	250x250	250x250	200x200
	5000	100x200	275x350	400x400	350x350	300x300	300x300	250x250	200x200
3500	4000	150x200	225x350	350x350	350x350	300x300	250x250	250x250	200x200
	4500	175x200	250x350	400x400	350x350	300x300	300x300	250x250	200x200
	5000	150x200	250x375	400x400	350x350	350x350	300x300	250x250	200x200
4000	4000	150x250	250x350	400x400	350x350	300x300	300x300	250x250	200x200
	4500	150x250	275x350	400x400	350x350	350x350	300x300	250x250	200x200
	5000	150x250	275x375	400x400	400x400	350x350	300x300	250x250	200x200
4500	4000	175x250	275x350	400x400	350x350	350x350	300x300	250x250	200x200
	4500	175x250	275x375	400x400	400x400	350x350	300x300	250x250	200x200
	5000	175x250	300x375	x	400x400	350x350	300x300	250x250	200x200
5000	4000	175x275	275x375	400x400	400x400	350x350	300x300	250x250	200x200
	4500	175x275	300x375	x	400x400	350x350	300x300	250x250	200x200
	5000	175x275	300x400	x	x	x	350x350	250x250	200x200

Table 8.12: Structural member sizes for multiple combinations of grid

8.2.6 Sizing for fire – charring method

The different methods of fire protection have already been discussed in section 5.2. It was learnt that there were two prominent means of fire resistance passive and active systems. While active systems are applied in a later stage of design, it is important that some provision is also made for passive fire resistance of the structural members to meet the safety requirements of the residents. As discussed there are many methods of fire-fighting techniques and they have to be used in combination with each other to create an effective fire design scheme. In this section the charring method has been elaborated, as inclusion of this method affects the size of structural members. It is important that the load bearing timber elements need additional timber sizing for structural adequacy during fire (Timber Development Association (NSW), 2010). The calculations have been elaborated herewith.

The building typology – residential apartments with 3 or more families, proposed in this thesis falls under the subdivision A-4 for building classification based on occupancy type for fire prevention, under the National Building code of India part 4, section 3.1. Table 1 of NBC provides the fire resistance ratings for different elements of the buildings some of which have been provided in table 8.13, it can be seen that the main structural members should have a minimum fire-rating of 120min. For the charring method an additional effective depth, d_e can be calculated using equation 14. This equation has been taken from the guidelines given in the technical design guide for fire design by the Forest and Wood products Australia.

$$d_e = C * t + 7.5 \quad \dots(\text{equation 14})$$

Structural element	Fire resistance rating (min)
Fire separation assemblies (like fire check doors)	120
Fire enclosures of exits	120
Shafts for services, lofts, hoist way and refuse chutes	120
Vertical spaces between adjacent tenant spaces	60
Dwelling unit separation (load bearing)	60
Dwelling unit separation (non-load bearing)	30
Interior bearing walls, partitions, columns, beams, girders, trusses and framing, supporting more than one floor	120
Walls supporting structural members	60
Floor construction	60

Table 8.13: Fire resistance ratings of structural and non-structural members as per National Building Code -India, part 4.

Where, d_e = calculated effective depth of charring in mm, C = notional charring rate in mm/min and t = time period in minutes.

$$C = 0.4 + (280/D)^2 \quad \dots(\text{equation 15})$$

Where, D = timber density at a moisture content of 12% in kg/m^3 for Shorea robusta as per table 8.2= 805 kg/m^3 . Putting value in equation 15,

$$C = 0.4 + (280/805)^2 = 0.52 \text{ mm/min}$$

Where, D = timber density at a moisture content of 12% in kg/m^3 for Pinus Kesiya as per table 8.2= 513 kg/m^3 . Putting value in equation 15,

$$C = 0.4 + (280/513)^2 = 0.7 \text{ mm/min}$$

Now, Different values of d_e have been calculated and presented in table 8.14 for respective different values of t for each of the two species. Putting values of respective C and t in equation 14:

$d_e = C*t + 7.5$	Species		t (min)				
			30 min	60 min	90 min	120 min	240 min
	Shorea robusta	$C = 0.52 \text{ mm/min}$	23.1 mm	38.7 mm	54.3 mm	69.9 mm	132.3 mm
	Pinus kesiya	$C = 0.7 \text{ mm/min}$	28.5 mm	49.5 mm	70.5 mm	91.5 mm	175.5 mm

Table 8.14: Calculation of d_e

Now, it is known from table 8.14 that the required fire resistance ratings for the structural members which are made of Shorea robusta is 120 min, which means that the structural members will need an additional sizing of 69.9 mm, over and above the sizes calculated for load transfer. While in the case of secondary beams which are made of Pinus kesiya the structural member size will need an additional size of 91.1 mm. However, actually the loads have already been calculated with a safety factor of 2, and extending the size further for the sake of fire safety will make the design too conservative and will increase the safety margins of the member sizes far more than what is actually needed. This will also add to the cost and the overall weight of the building, which is of concern with respect to seismic design. Also, increasing the member sizes, especially columns whose cross-section is already 350mm by 350mm, means that older trees will have to be used which is difficult to procure. Hence, charring method will be applied in places where there is scope of adding additional material in structural members. This has been elaborated in the further sections during the design phase.

An alternative to charring method is using fire retardant coatings which are readily available for wood. Various companies are producing chlorine free, non-corrosive, non-halogenated, non-toxic and environment friendly polymer-based resin coatings. One such example is the FRCT company. Such coatings can be used where the possibilities of using charring method is limited. Another alternative method for fire resistance is known as encapsulation method, in which various materials like gypsum board or plaster, asbestos insulation, wood wool slabs, etc. can be used to cover the structural members. The detailed thickness of multiple combinations of such materials have been specified in Table 12 of NBC under part 4. As per NBC-2016, Part 4 table 12, the columns or other important structural members can be clad with a layer of 12.7mm or 13mm plasterboard and finished with lightweight aggregate gypsum plaster to achieve a fire protection resistance of 60min. Thus, multiple methods have been proposed in the design in combination to the charring method to achieve the fire safety ratings as per the National Building codes.

Introduction to design

The ideology of design is very subjective and complex. While science could be the backbone for development of a design, the psychological effects associated with it is important to ensure a success story of its acceptance in the market. While fulfilling the technical facets, a design has to provide physical, social and psychological comforts. History has set many examples of brilliant scientific inventions that could have possibly changed the world we live in, yet their social and commercial failure have only given them a place in museums or archives. Thus, when it comes to design it is important to set a balance between the two extremes of the wild imaginations of what could be possible and the boredom in human tendency to stay in comfort zone. This ideology of creating a balance between wild and practical, technically advanced and comfortable, universal yet customizable and subtle yet effective, has been the driving force for this research by design. The scientific proposal should be such that it can easily slip into the existing system without much altering the current lifestyle of the people. Since the proposal is for a construction technology for mass production, the proposal should also have characteristics of standardization and easy production.

8.3 Column design

The grid-size of 3m by 4m with 6 storey and 18m high building has been taken as the initial basis for design conceptualization. First, the design of the structural members have been conceptualized, followed by their joineries. The following sections elaborate on aspects of the detail design procedure.

Though square cross-sections were assumed for columns for ease of load calculations. However, from the perspective of design, there is no limit in the number of possibilities for the shape of the cross-section. Table 8.15 shows only three common variants of cross-section that are commonly available in the market that could possibly have the same cross-sectional area but different shapes. These shapes respond differently to various parameters which have been elaborated in table 8.15. It can be said that there is no single best answer to a design question. Thus, the qualities of the various types could be integrated to form one design. Also, as mentioned in the design ideology, it is important for the design to be psychologically comfortable for the client. As per the structural calculations, it is possible to use smaller cross-sections of







Shape	Square column	I – section / Joist	Cross section
			
			
Material availability	Difficult to procure a single solid block of tree trunk. Only old trees can be used.	Cross-section of younger trees can be used to make the columns.	Cross-section of younger trees can be used to make the columns.
Ease of column joinery	Easy	Moderate	Moderate
Efficient utilization of material in mechanical terms	Low	Medium	High
Symmetry in design. (non-symmetrical cross-section may cause torsional movements)	Symmetrical in both axis.	Non-symmetrical (different behavior in x & y axis)	Symmetrical in both axis.
Surface area exposure for fire	Least	Medium	Highest
Psychological comfort for structural stability (dependent on historical way of building)	Very comforting	Not sure as it does not match a traditional looking column.	Not sure as it does not match a traditional looking column.

Table 8.15: Comparison of different types of possible cross-sections for the timber columns.

solid columns on upper floors. However, this might create a visual disturbance for the people living in the building with different column sizes. The slender columns on upper floors will give a feeling of weakness when compared with the thicker column in the base, this might trigger a psychological effect of living in a weak house for those on upper floors, though that might not be the case scientifically. Thus, the design principle determined for the columns is such that it creates visual harmony in the structure, whilst still reducing the material on different floors. Taking this concept forward, the idea of a hollow or box column was proposed, in which all the columns could visually have the same dimensions as that of the solid column, while saving on the material as it hollow inside. Also, a box column is made of smaller cross-sections which is easier to procure and handle as compared to a single large solid cross-section.

The next step was to develop a feasible connection system for the pieces of the box column. The works of Konrad washman were a source of inspiration for the concept of box column joinery design. His ideas of using standard elements to create complex structures were of great importance. The design of the joinery should be such that it could be adjusted with the change in size of column. The elements which form the component should comprise of repetitive units whose simple combination results in the required product. Figure 8.14 shows the initial inspirations for the box column design. Multiple connection design options for connecting members to form a box column were conceptualized. Various alternatives for connections using metal plates, glued joints, wooden dowels and nuts and bolts were explored. The final design is as a result of experimentation, consists of 4 same parts which could be connected to form the column. It avoids the need of any third joining material like adhesives or metal, thus standardizing the components. Also, the individual part is designed based on the system of proportions of the tenon and mortise joinery as shown in figure 92, thus this design could be adapted to a member of any size. The final proposed column joinery design, as shown in figure 8.15, has additional advantages of geometrical symmetry and easy assembly.

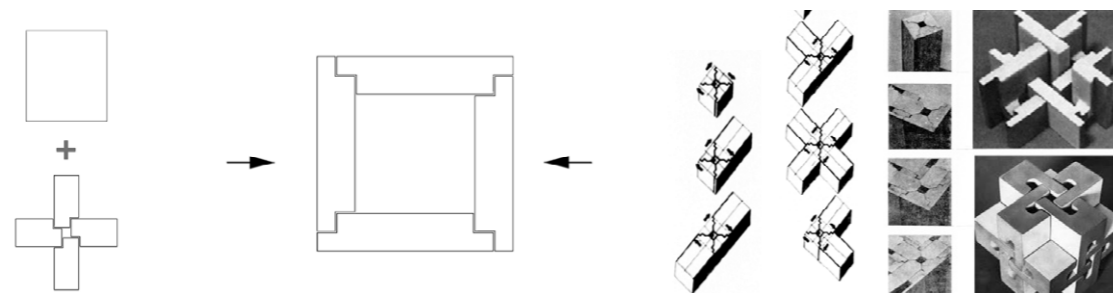


Figure 8.14: First inspirations of column cross-section design. Combinations of multiple types of cross-section and connection design inspired by works of Konrad Wachsmann. Image source: sciELO.conicyt.cl and reserachgate.net.

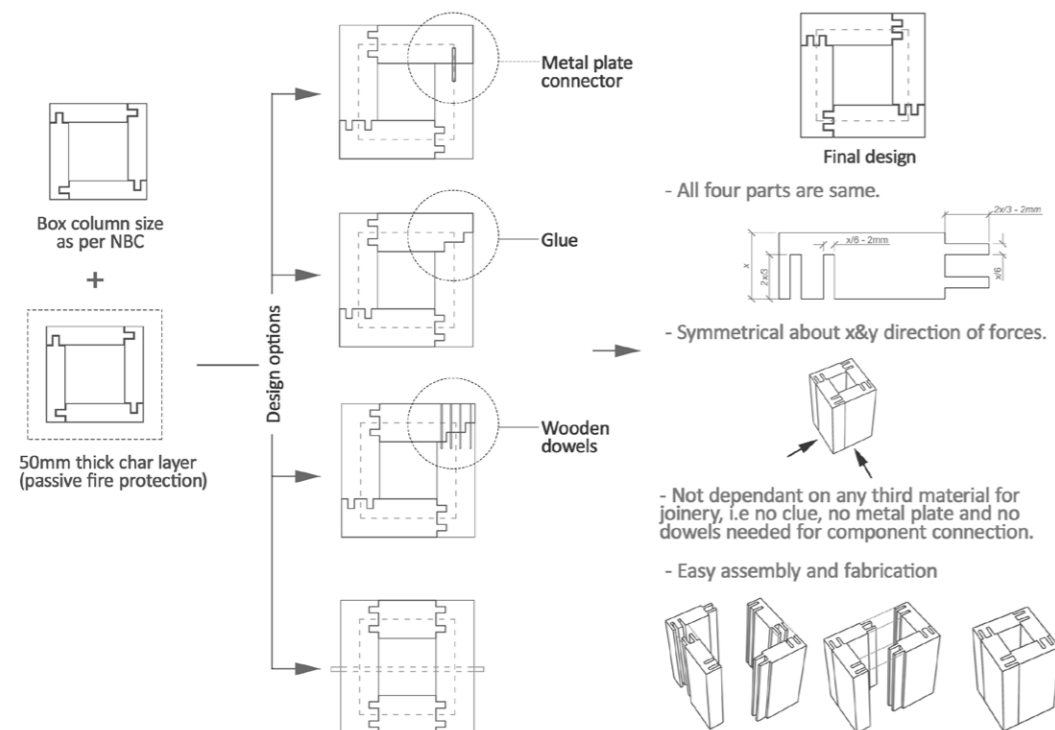


Figure 8.15: Design development of box column and characteristics of final iteration.

8.3.1 Box column structural sizing

The proposed hollow or box column has been validated for structural strength. The NBC-2016 has provisions for calculations of permissible loads of box columns. It is already determined that the outer perimeter of the column cross-section should be the same for all floors, that is, each side is 350mm and a provision of atleast 30min of passive fire resistance was set as bench mark for the box column design. As per calculations in section 11.2.6, a 30min char layer for Shorea Robusta will need a thickness of 23.1mm or 25mm. Once, this was fixed, multiple iterations of calculations were made to achieve the final thickness of column cross-section. The final cross section consists of 350mm on each outer side, 100mm internal depth and 150mm for each side of hollow core. Figure 8.15 illustrates the net dimensions for structural calculations as 300mm for each outer side, 75mm internal depth and 150mm of each side for hollow core.

The final load capacity of the proposed cross-section has been calculated as per NBC-2016. Section 6.6.2.1. The first step as per the codes is calculation of the constant K_g , where

$$K_g = \pi/2 \sqrt{(U \cdot E) / (5 \cdot q \cdot f_{cp})} \quad \dots(\text{equation 16})$$

Where, U and q are constants for the thickness of plank, E = modulus of elasticity N/mm² and f_{cp} = permissible stress in compression parallel to grain, N/mm²

As per section 6.6.2.5 of NBC, it is assumed that U = 0.6 and q = 1 for plank thickness of 75mm. It should be noted that the U and q values have only been specified for plank thickness upto 50mm, thus the values 0.6 and 1 are for plank thickness of 50mm. Assuming other values for constants could lead to over estimation of load capacity hence, a conservative approach has been taken to determine the loads.

It is known that E = 12.67x10³ N/mm² and f_{cp} = 12.502 N/mm², from table 8.2 and 8.4. Putting values in equation 16,

$$K_g = \pi/2 \sqrt{(0.6 \cdot 12.67 \cdot 10^3) / (5 \cdot 1 \cdot 12.502)} = 17.32$$

Now, as per figure 8.16, d_1 = least overall width of box column = 300mm and d_2 = least overall dimension of core in box column = 150mm and let S = unsupported overall length of column = 3000mm

Calculating for the slenderness of the box column by using the provision given in section 6.6.21 of NBC, where, column is short if $S/\sqrt{(d_1^2 + d_2^2)} < 8$, column is intermediate if $8 < S/\sqrt{(d_1^2 + d_2^2)} < K_g$ and column is long if $S/\sqrt{(d_1^2 + d_2^2)} > K_g$.

Here,

$$S/\sqrt{(d_1^2 + d_2^2)} = 3000 / \sqrt{(300^2 + 150^2)} = 8.9$$

Thus, the column is an intermediate column, since $8 < 8.9 < 17.32$. the permissible compressive stress for intermediate column is given by the formula,

$$f_c = q \cdot f_{cp} \cdot [1 - 1/3 (S / (K_g \sqrt{(d_1^2 + d_2^2)}))]^4 \quad \dots(\text{equation 17})$$

Putting values in equation 17,

$$f_c = 1 \cdot 12.502 [1 - 1/3 (3000 / (17.32 \sqrt{(300^2 + 150^2)})]^4 = 12.21 \text{ N/mm}^2$$

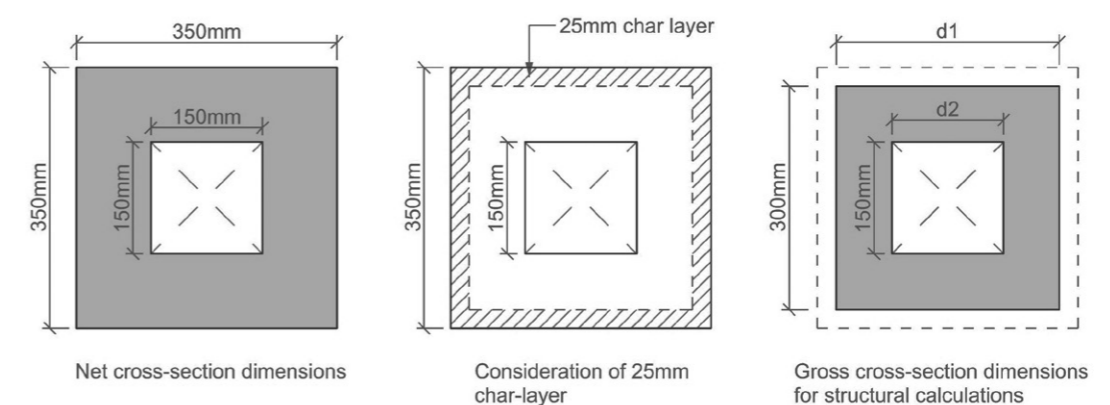


Figure 8.16: Cross-section determination of box column for structural consideration

The allowable load that could be supported by a cross-section of a given column is given in (Parker, 1979) where,

$$\text{Allowable load} = f_c * \text{cross section area} \quad \dots(\text{equation 10})$$

Here, cross section area = 67500 mm², thus,

Allowable load on the box column = 12.21 * 67500 = 823879.45 N or 823.88 kN

It can be concluded that in the 3x4m grid, the proposed dimensions for built-up box column is valid for upto first 3 floors from the top. It can be seen in figure 8.13 that the load on 4th floor from the top is 852.7 kN, which is > the maximum capacity of 823.88 kN of the box column. Hence for floors below the 3rd floor from top, solid cross-sections of 350mm x 350mm will be used as a cross-section. The applicability of the 2 different column cross-sections, that is the box and solid, will vary with the floor levels as the grid-size changes. This is directly dependent on the maximum load capacity of the column cross-section and the actual loads falling on each column with respect to the number of floors. The different loads on columns for varied grid sizes have been elaborated in appendix b. Based on the loads falling on each column, it is decided if a box column or a solid column needs to be placed in that storey. Finally, the research by design provides for 2 standardized column types of timber species Shorea robusta for the proposed timber construction system.

8.3.2 Response of the box-column detail during the joinery testing

Though no special laboratory tests were made specifically to check the performance of the box column design, inferences can be drawn from what was observed during the experiment performed for other joineries. The set-up of the experiment has been provided in appendix c. Figure 8.17 shows the experiments performed on joineries made of two materials, experiments 1 and 2 were of 3D printed PLA models, while experiment 3 is of softwood model. With respect to the behavior of the box column in the test, it can be said that no specific failure was observed in the joinery detail of the box column, though the corner of the wood model broke due to the presence heartwood in the section. It should be mentioned, as also observed from the tests, that the strength of wood also depends on presence of heartwood, knots, direction and straightness of grains. While the bottom columns made of softwood, as shown in figure 8.17, has failed mainly due to buckling and material split rather than the failure in joinery, the PLA models are still intact. It is also observed that the joinery failed at the material limits, this is discussed in detail in following sections. It can be concluded from the tests that the joinery detail for connecting the parts to form a timber box column works.



Figure 8.17: Effect of compression test on the box column joinery during the experiments.

8.4 Primary beam and secondary beam design

The primary and secondary beam comprise of solid rectangular cross-sections for research as shown in figure 8.18. While the primary beams are made of hardwood Shorea robusta, the secondary beams are proposed to be made of softwood Pinus kesiya. The maximum dimension (depth) of the primary beam for the basic structural grid-size 3m x 4m is 350 mm, while for secondary beam is 200mm. Since there are limitations to the clear height of habitable rooms, the attempt was to keep the design of the beams as shallow and compact as possible after considering the structural properties of the material. Thus, simple solid timber cross-sections of required depth as provided in appendix B for varied grid-sizes are used for making the primary and secondary beam of the proposed timber construction technology.

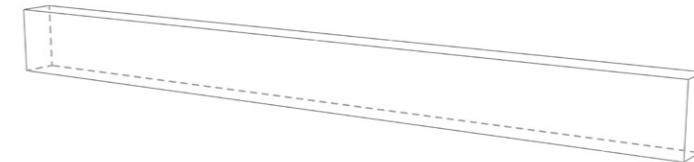


Figure 8.18: Primary and secondary beam design comprising of rectangle cross-section.

8.5 Joinery design

The individual members are connected to each other at junctions which are of vital importance. The strength of a structure most importantly depends on its joineries. By fact, no matter how strong the building material is, a weak joinery can lead to a complete collapse of a system. This fact is specially important for timber construction.

In timber construction, the joinery is the weakest part, thus the efficacy of a timber structure is determined by the robustness of a joinery. The art of timber construction lies in its details. The development of timber joineries have an existence since the primitive times in human history. In words of Brown, 2013 timber as a building material 'represents, rather, millennia of refinement and evolution in design where the most profound aspects have been retained and rest modified slowly over time' (Brown, 2013). Nevertheless, after having been over-shadowed by the modern construction materials in past 100 years, timber is making a comeback as the future material of the building industry. With this, the development of details have been triggered in the field, such that the best properties of modern construction materials could be exploited to efficiently join the timber members. The wisdom of past can be combined with the modern technological advances to create the connections. Valle'e, et.al. 2013, have mentioned that the designers have a series of methods to connect timber elements. Firstly, the timber members could be joined by direct contact as the Japanese used this technique, Secondly, the members could be joined using mechanical fasteners. Thirdly, the loads can be transmitted in these joineries using adhesives, a method which has gained a stir in recent years. Schober and Tannert, 2016, have mentioned that besides these three classes of joints, theoretically it is possible to combine these and achieve a connection, which could be referred to as 'hybrid' in research. Such hybrid connections use two or more principles of timber joineries to achieve a connection. This research looks into multiple concepts of timber construction, using different materials and their properties to conceptualize a 'hybrid' construction system. The following sections briefly discuss the design principles for timber connections used for conceptualised various joineries.

The Rule of proportions for timber joinery formulation

Proportions have been used to dimension timber members since the past and its understanding has been perfected and proved over time. To a certain extent these rules of proportions have become standards for wood construction, which have helped humans to shape timber all over the world. These proportions can be combined together to form a series of configurations which comprise the connection. In one way it is easy to work with proportions as the rules can be applied to different scales of timbers. The Japanese had extraordinary library of such rules of proportions of somethings of a large scale as a site to something as detailed as a wood joint. Certain aspects of the rule of proportions have already been discussed under section 6.1, of the traditional Japanese timber construction. Figure 8.19, shows the rule of proportions for a column design in a Japanese temple (Brown, 2013). The rules of proportions have been developed for even the minute details like a tenon-mortise joint as shown in figure 8.20. They make design ideology modular and unitless which ease their universal applicability and acceptance. These rules presented in

figure 8.19 and figure 8.20 have been directly used for the design development of column-beam joinery for this research.

The rule of balance and equilibrium

As the proportions are important for dimensioning a timber structure, the rule of balance is important for the stability of the global structure. It is easiest when the rule of balance is applied to the individual details which comes together to form the whole structure. Theoretically it means equal distribution of weight in all directions. As per mathematics this can be translated to keeping the center of mass and the geometric center together. This aspect has also been explained in section 7.3. Thus, the rule of balance is structurally important as it associated with maintaining the weight in equilibrium.

Balance of joineries is of special importance in seismic scenarios. The joints should be designed in such a way that allows dissipation of energy along any of the 3 axis, which maintaining the equilibrium. If the joint

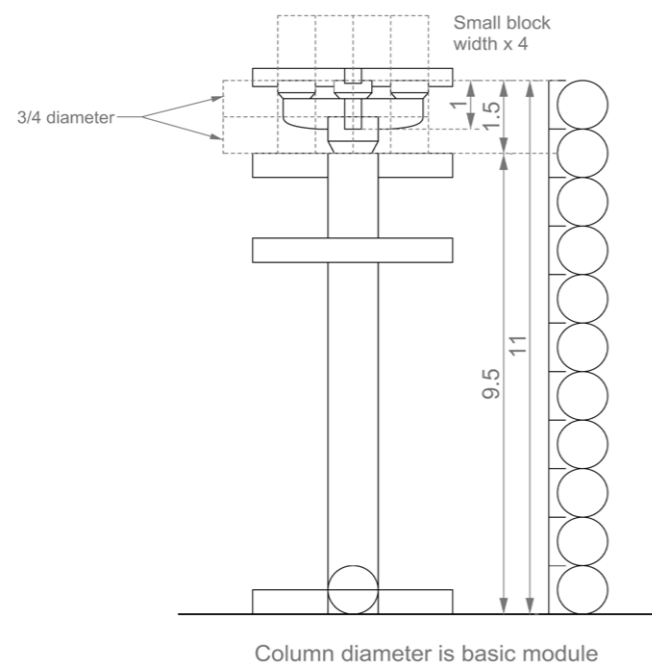
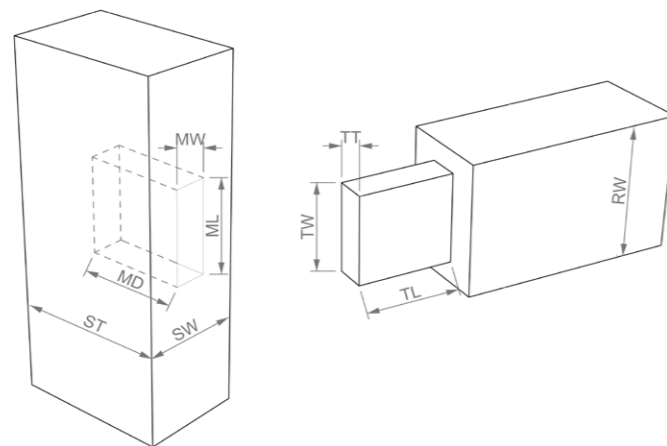


Figure 8.19: Column proportions as per an extract from a Japanese column and capital design rule, image source - (Brown, 2013).



ML = mortise length TL = tenon length ST = stock thickness MD = 2/3 ST
 MW = mortise width TW = tenon width SW = stock width MW = 1/3 SW
 MD = mortise depth TT = tenon thickness RW = rail width thickness ML = 2/3 RW
 TL = MD - 1/8"

Figure 8.20: Rules of proportion for tenon-mortise joinery, image source - <https://www.canadianwoodworking.com/tipstechniques/mortise-and-tenon>

is not balanced then it may cause localized stresses leading to failure of the system. Figure 8.21 shows certain Japanese timber joinery details used for a temple renovation project. It can be seen that here balance is achieved by following the rule of symmetry in the structure.

Using a combination of connection techniques

While traditionally, it was common to use only one type of timber connection locally prevalent in a region, the modern timbers have seen combinations of different methods and materials to connect timber members. Over the years rules have also been established for these 'hybrid' methods of connections. The National building code of India also specifies the rules of timber joinery using steel connectors. Figure 8.22 shows certain methods of using steel for connecting timber. In a similar fashion other metals like brass, aluminum, adhesive etc. also have shown their appearance in timber joineries. The scope of this topic is very vast as these metals connections can be further sub-categorized with respect to their joinery technique like using nails, nuts and bolts, rivets or dowels as shown below. Similarly, the adhesive joineries can also be sub-categorized in terms of their chemical composition and connection method. Using the timber design principles of proportions and balance, this research specially focuses on using metal connectors along with the direct contacts for joinery design. Adhesives are promising when it comes to transfer of load by increasing the contact surface though strong binding between the members. However, its limitation in environmental concerns and difficulty in have made it a third choice over the other methods.

The success of a joint depends on the species of the wood, quality, age, seasoning time, moisture content of both the surroundings and the wood, grain direction and knots and other deformities. It is also learnt that joinery design in timber is governed by the other extraordinary properties, as it is a material that breathes. Unlike steel and concrete, timber has the power to control moisture in the indoors and also timber settles much more as compared to its other competitors. Thus, with these additional benefits comes additional complication of timber joinery design. The following sections elaborate on the joinery design for the hybrid-construction technology proposed for the seismic zone of Shillong.

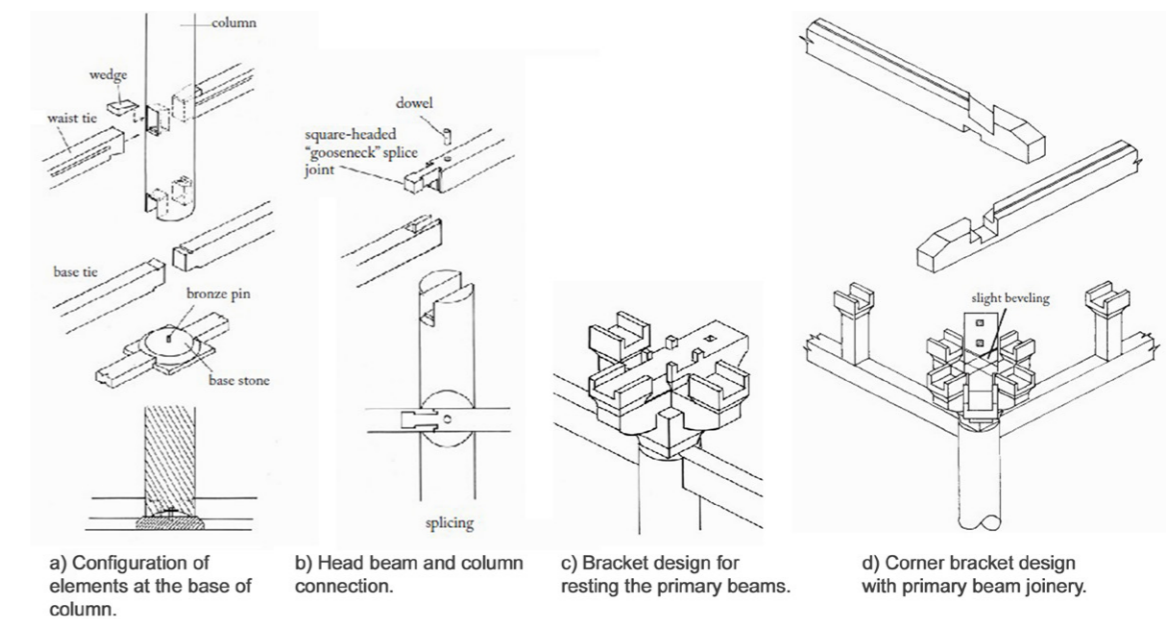


Figure 8.21: Joinery details from the documentation of The Yakushiji renovation project in Japan, (Brown, 2013)

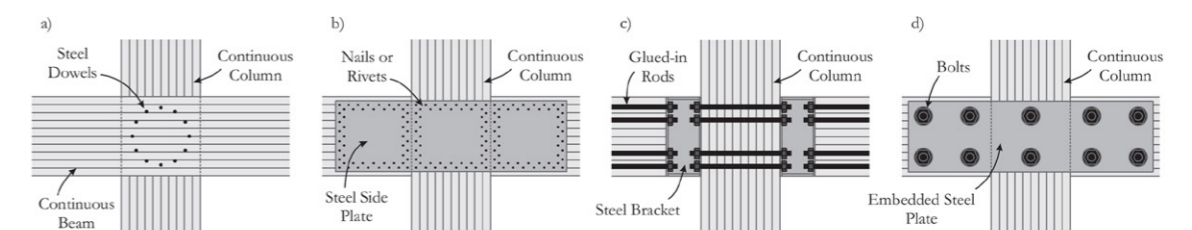


Figure 8.22: Timber joinery using different types of steel connectors, image source - (Gohlich, 2015).

8.5.1 Column-primary beam joinery design

The column-primary beam joint is the most important connection for assembling the whole structure. It forms a node between 6 members and functions as a major route for load transfer, as shown in figure 8.23. This node is responsible for both vertical and horizontal stability of the structure. While the initial design idea was influenced by the background research discussed above, the improvements on multiple iterations were followed by the studying the analysis and comparisons of laboratory test results.

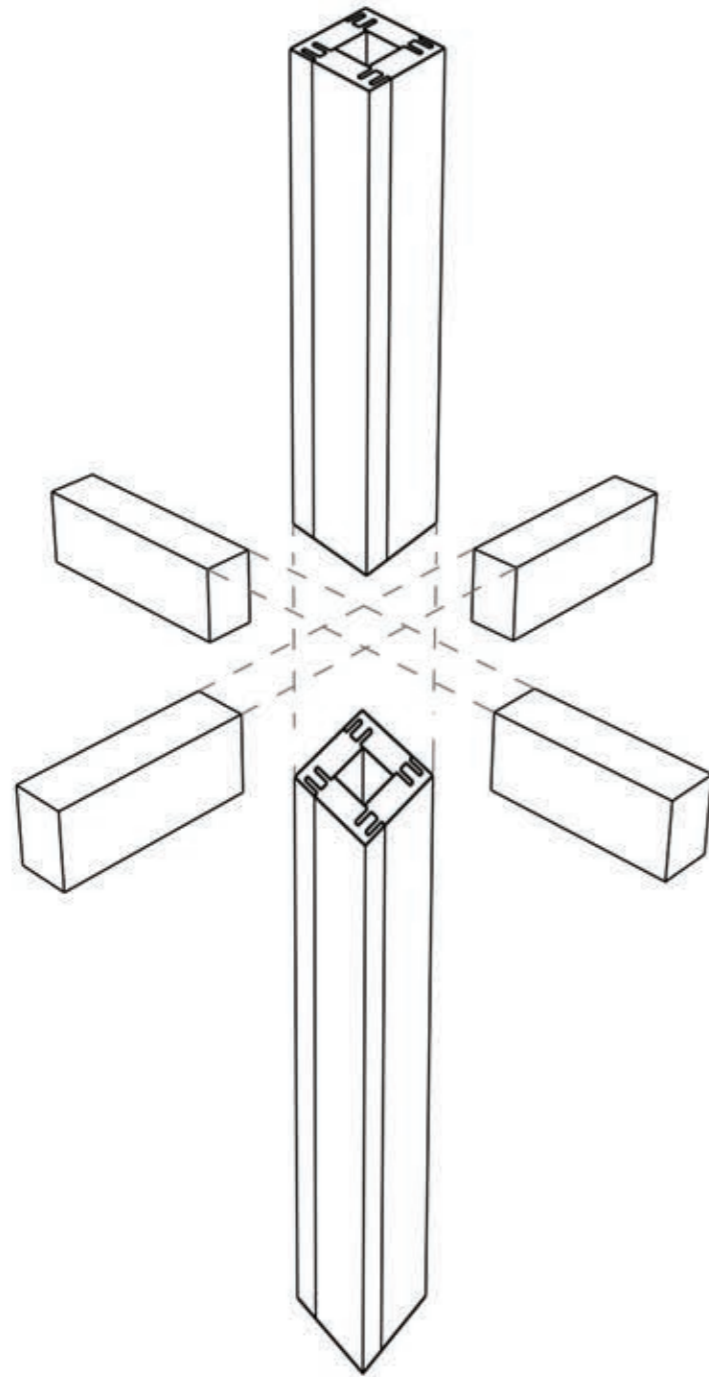


Figure 8.23: Location of joinery for columns and primary beams.

8.5.1.1 First design iteration

The first design idea was such that the primary beams rest on the lower columns and transfer load by means of contact. The upper column should directly transfer the load on the lower column to reduce the effect of settlement in timber, that is, the upper column should not directly rest on the primary beams which are loaded perpendicular to grain direction. Also, the vertical load transfer between columns should be independent of the horizontal load transfer. An attempt was made by interlocking the 4 primary beams with each other. The first two interlock with each other using the tenon-mortise join and the other two perpendicular beams come and connect on the first two from either direction forming the bond. In order to tighten the connection between the primary beam and the lower column, wooden dowels were introduced, which could be pressed into the gap. A steel connector is used connect the upper column to the base column. Figure 8.24 shows the concept design of the 1st iteration.

This design iteration was discarded mainly because the tenon and mortise joinery for the second set of primary beams were not fitting the rules of proportion. This is because the design was faulty such that there was not enough space for the connection, also the primary beams were not symmetrical.

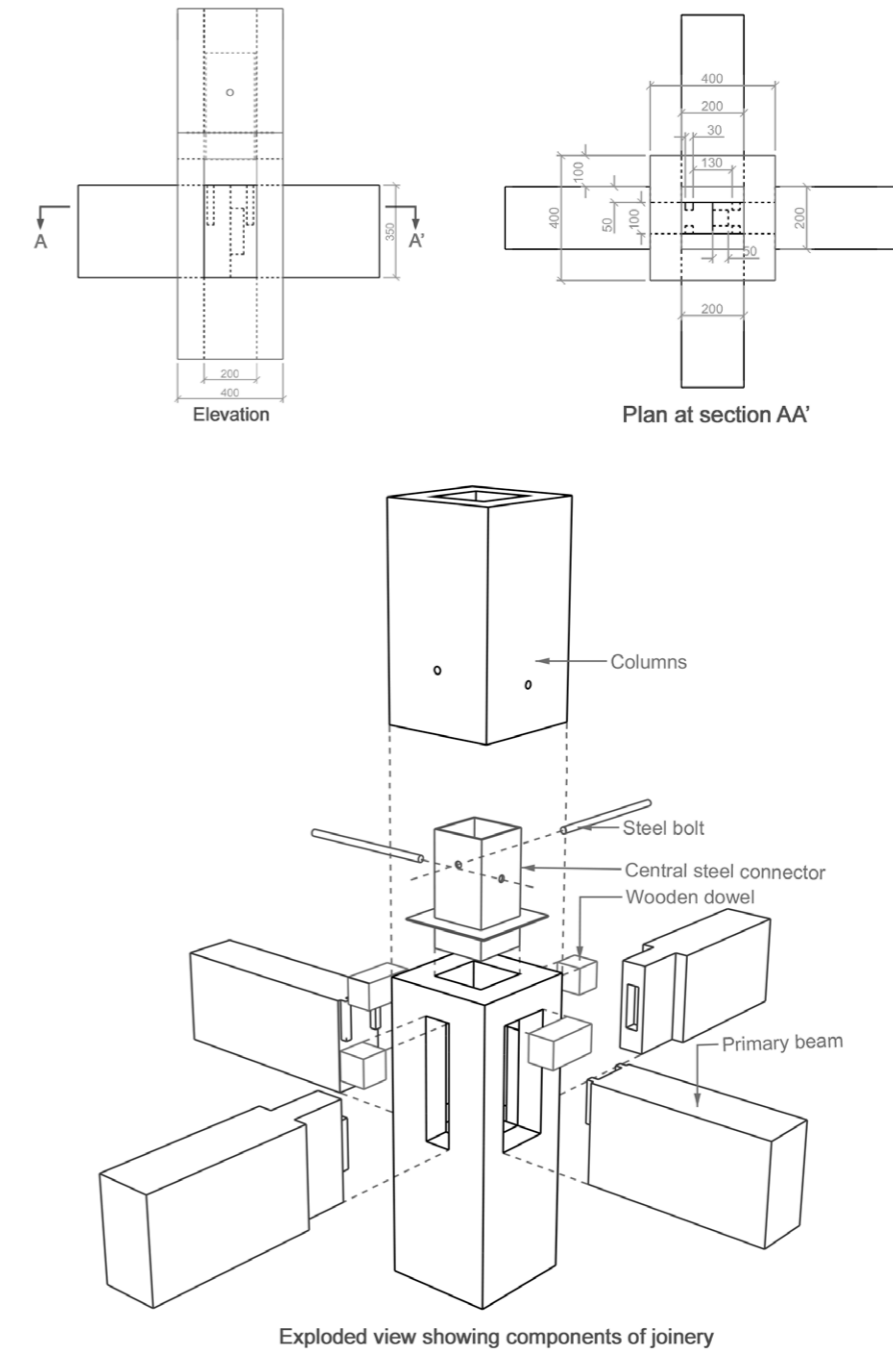


Figure 8.24: Plan, elevation and exploded view of the first iteration of joinery design.

8.5.1.2 Second design iteration

The problem of tenon-mortise joint of the two primary beams was resolved in this design iteration. An alternative connection solution was proposed, in which a central wooden dowel connector was used to attach all the four primary beams in groups of two. Here, the initial idea of direct vertical and horizontal load transfer was fulfilled whilst complying to the rules of proportion of the tenon-mortise joint. Figure 8.25 illustrates the second proposal.

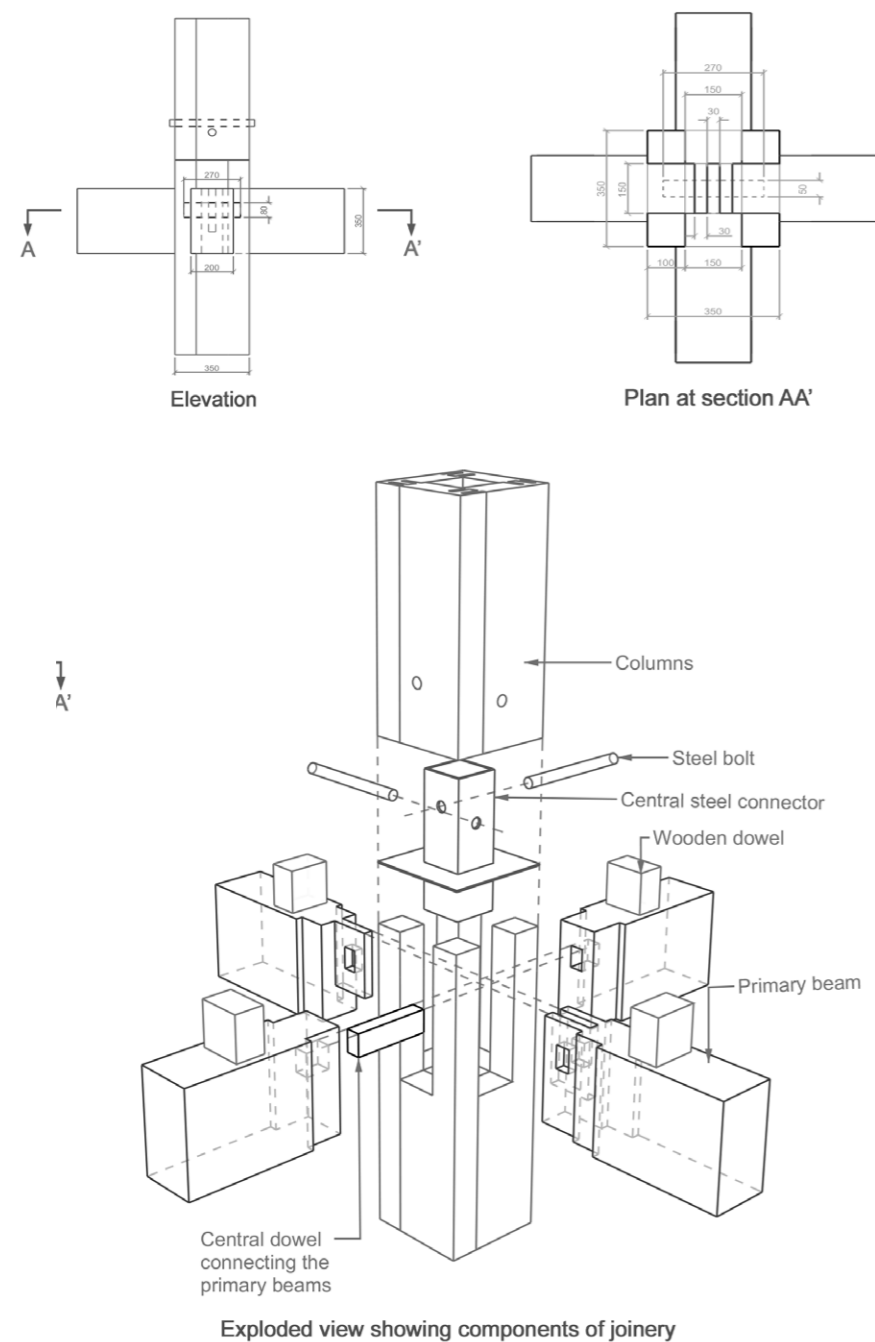


Figure 8.25: Plan, elevation and exploded view of the second iteration of joinery design.

Compression test of second design iteration

A 3D printed prototype of scale 1:7.5 of the second design proposal was tested in compression to study the behavior and failure pattern of the joinery. Though the response of a PLA model will be different to that of a wooden model, as the material properties of PLA is very different to that of wood. The 3D printed tests were good for quick study of the joinery behavior. The detailed test setup of the laboratory test and specifications of the PLA model is explained in appendix C.

The model shattered in one go at a maximum load of 14.8 kN as shown in the graph in figure 8.29. This shows that this joinery as a whole has a limited ductility. Though, ductile behavior is largely dependent on the material, the result of this design iteration is compared with others in following sections. However, the tests show that the central dowel connection is very efficient as the connection was intact after the model shattered as shown in figure 8.28. The overall damage in the joinery was low because other than one primary beam and one edge of the lower column, the rest of the parts were intact.

Limitations of PLA test specimen 1, design module 2: It should be mentioned here that the tests results greatly depends upon the quality of 3D print, presence of defects and undulations in the print, the precision in the 3D printed model assembly (gaps between the parts). Later, it was realized that even the direction of 3D printing affects the behavior of the model. Irregularities in connection can cause stress concentrations which act as weak points in the joints. In this model where the joineries were not fitting properly, the surfaces were manually sanded. These created rough surfaces and irregularities which could have stress concentrations and affect the overall result of the model.

The lessons learnt from this experiment were taken into account and rectifications were incorporated in the next design iteration. The strength of this joinery was directly dependent on the central wooden connector of the primary beams. Though this model did not show any major fault during the test, the overall validity of the design was questioned with respect to the disassembly during repairs, manufacturing and fabrication of the joinery parts. There was no provision for disassembly and part replacement in future. Also, it was observed that the joinery lacked symmetry and part standardization which means that manufacturing different types of primary beams for each joinery will cause extra efforts during the manufacturing and assembly process.

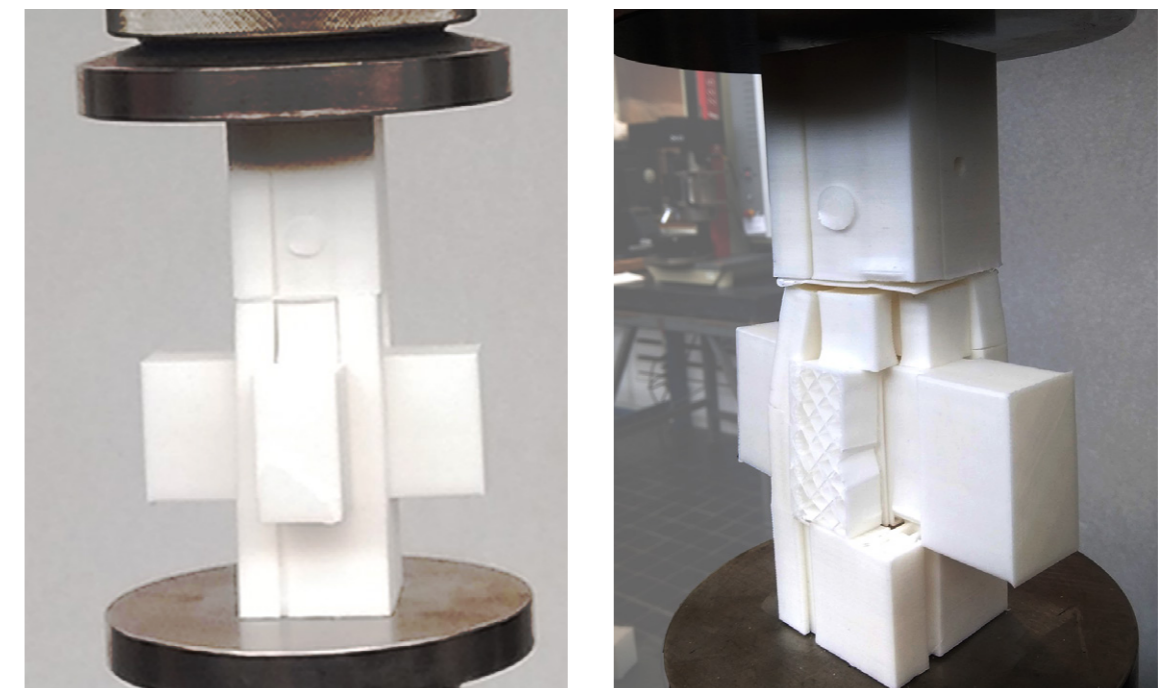


Figure 8.26: Before and after images of compression test specimen 1 – PLA

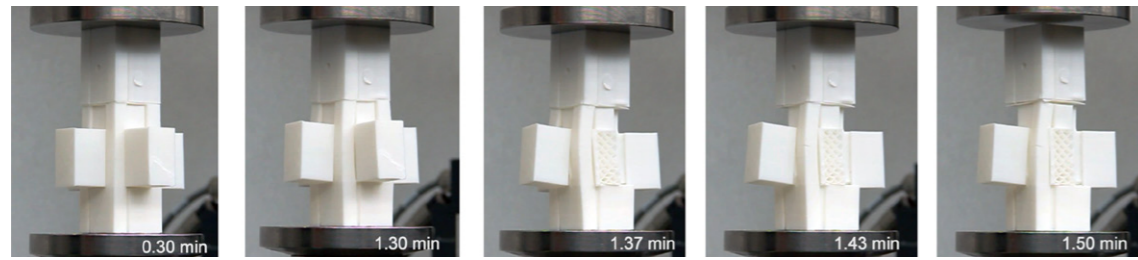


Figure 8.27: Response sequel of compression test specimen 1 – PLA

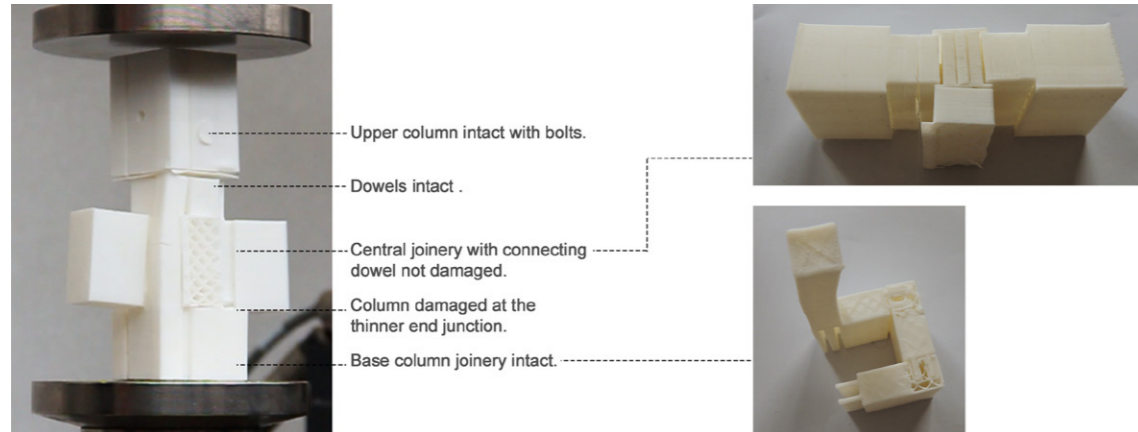
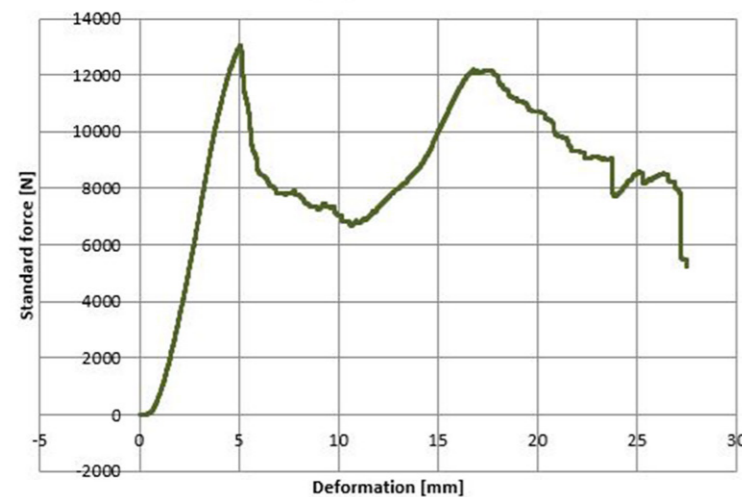


Figure 8.28: Analysis of parts after compression test.



-14789 N or 14 kN

Factors affecting the result

- Scale model 1:7.5.
- Printing had some defects, i.e. the base where the raft was removed was not completely flat.
- Certain members not fitting-in properly, i.e. gaps of 1-2mm between joints.
- Certain parts were sanded to fit it in, causing alteration in the surface.

Figure 8.29: Result of the compression test. Graph showing the compressive force and the yield strength of the joinery.

8.5.1.3 Third design iteration

The drawbacks of the second design were addressed in this third design iteration. Though it is not possible to replace the columns at any given point of time, this design to a certain extent provides for the replacement of primary beams. Direct inspiration has been drawn from the Japanese column-beam assembly system, where wooden brackets are used to rest the beams on the column. This design is very different from the previous iterations as here the bracket forms the main junction or connector of the primary beams with the columns. This means that in case of localized damage, any primary beam can be removed from the brackets without affecting the assembly of any other beam in any other bay. The upper column is connected to the system using a steel connector. The members are additionally fastened using threaded rods and bolts as shown in figure 8.30.

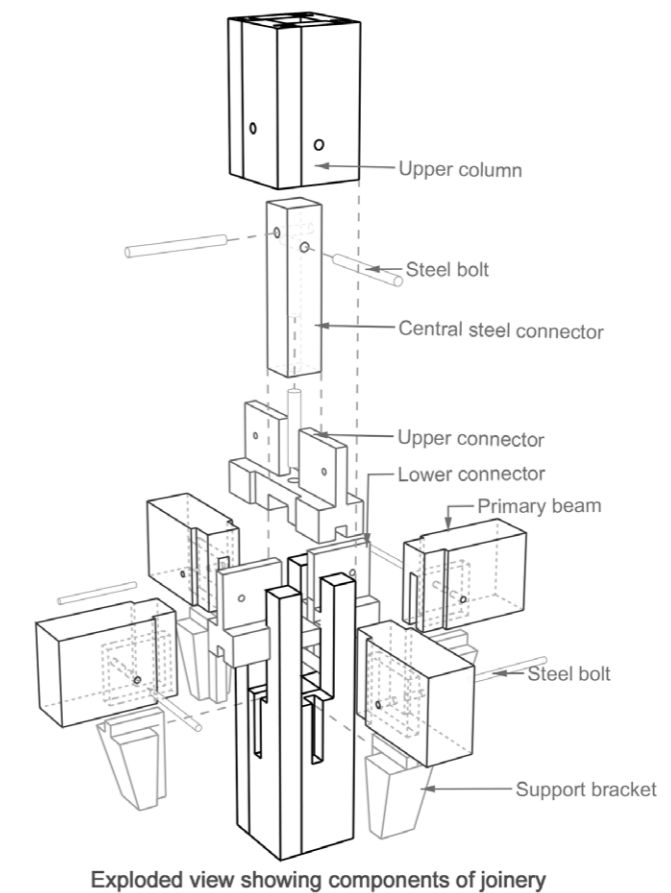
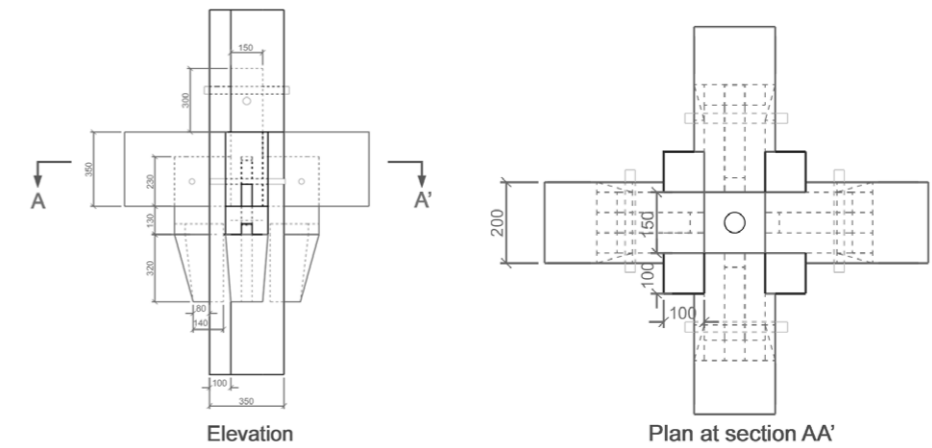


Figure 8.30: Plan, elevation and exploded view of the third iteration of joinery design.

Compression test of third design iteration

Similar to the second iteration, a 3D printed prototype of scale 1:7.5 of the third design proposal was tested in compression, to study the behavior and failure pattern of the joinery. The detailed test setup of the laboratory test and specifications of the PLA model is explained in appendix C.

The model took a maximum load of 13kN as shown in the graph presented in figure 8.34. Though the maximum force was less by 1000 N as compared to the previous specimen, this design showed ductile properties and is thus considered to be safer as the breakage was smoother. The ductile behavior can be seen from the graph shown in figure 8.34. This behavior could be observed because of the close of initial gaps between the parts due to the compression and a development of the global strength because of increase in contact between the parts. The failure was not sudden. However, it should be mentioned that the central joinery was more destroyed in this specimen in comparison to previous specimen 1. The central dowel acted as a major binder in holding the central brackets together during the test. However, the lower brackets did not prove very effective due to weak connection with the column, this problem is rectified in the fourth design iteration. Also, there were evident stress concentration which caused damage at certain points. The thin vertical region in the base column which directly supports the upper column, showed major buckling during the test as shown in figure 8.33.

Limitations of PLA test specimen 2, design module 3: The limitations of this PLA model test are the same as that of the previous model.

The lessons learnt from this experiment were taken into account and rectifications were incorporated in the next design iteration. This design answered the problems of symmetry and fabrication as now the design of all the primary beams are same, hence the production can be standardized. It also provides a room for localized repair and replacement of primary beams if needed in future, without disassembly of the global structure. However, the laboratory tests showed a large buckling along the thin members of the base column capital. This could be because of the fact that there was a continuous seam along the junction comprising of the boundary of the brackets and the column junction. This minute detail of the continuous seam was rectified in the next iteration. Also, the lower brackets to support the central bracket did not have a strong connection with the column, this was handled in the next design phase.

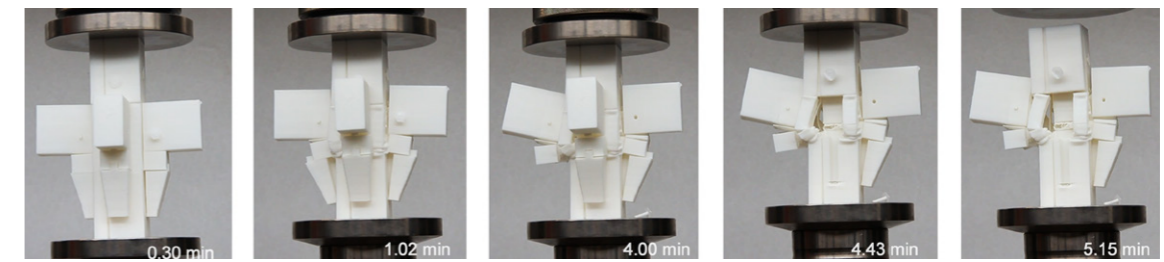


Figure 8.32: Response sequel of compression test specimen 2 – PLA

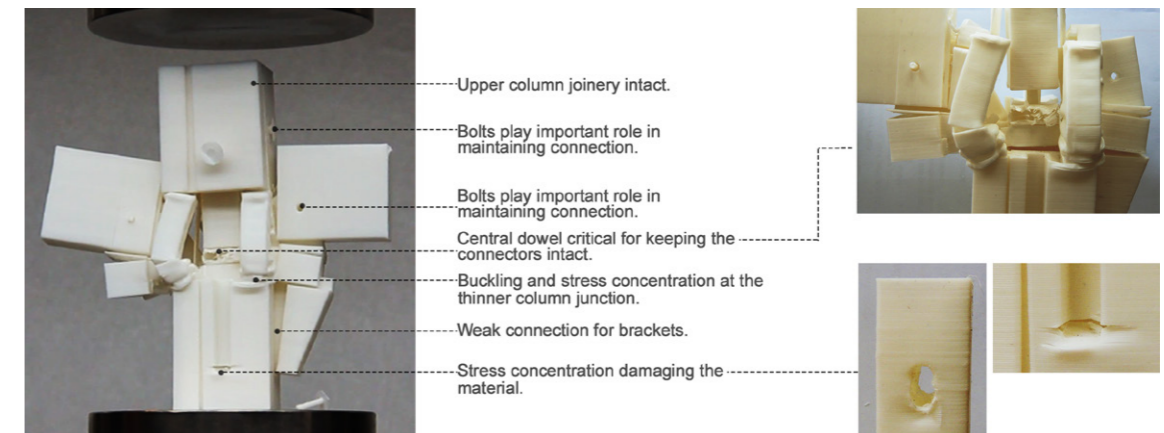


Figure 8.33: Analysis of parts after compression test.

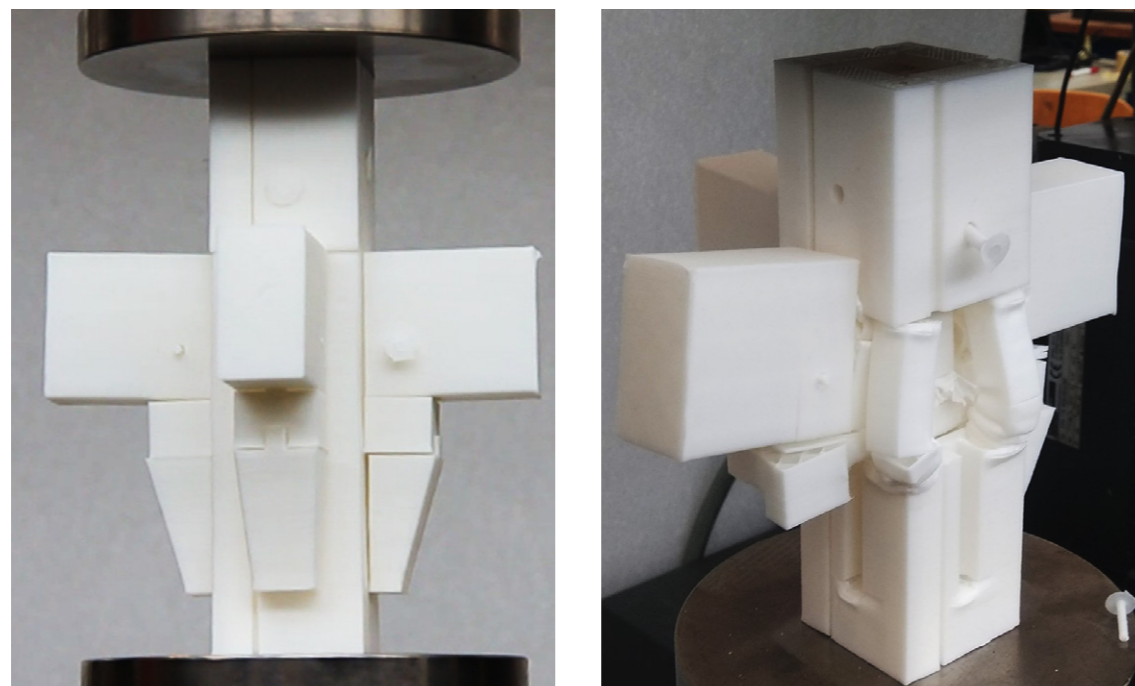


Figure 8.31: Before and after images of compression test specimen 2 – PLA

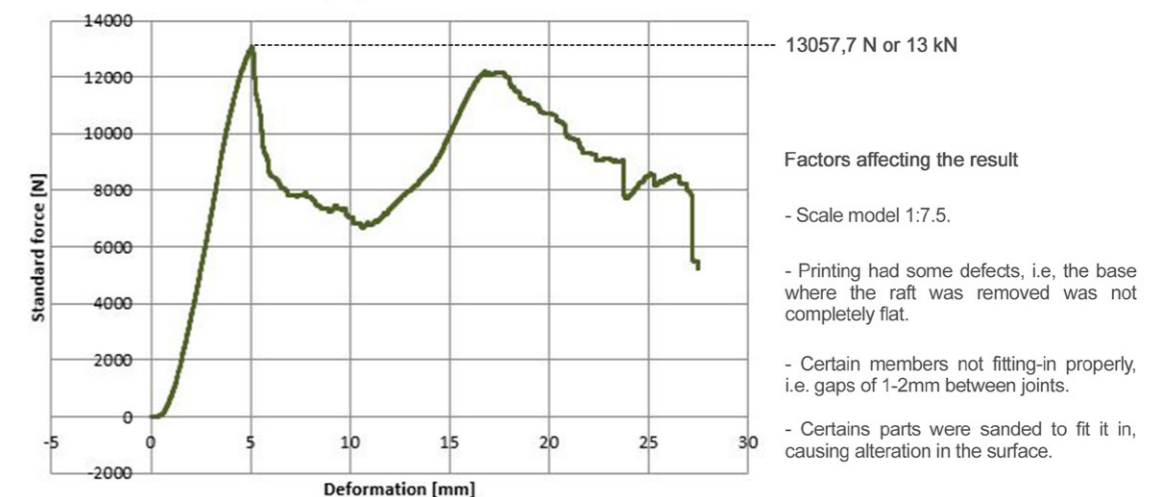


Figure 8.34: Result of the compression test. Graph showing the compressive force and the yield strength of the joinery.

8.5.1.4 Fourth design iteration

The fourth design iteration focuses on overall design strengthening based on the observations made during the laboratory test. This includes firstly, extending the brackets down such that the continuous seam between the junction, which caused buckling of column capital, is broken. Addition of dovetail joint to connect the lower brackets to the column to improve the connectivity. Addition of a central cross in the hollow of the lower column, to provide additional support to the central bracket. Double bolts to connect the primary beams to bracket to avoid rotation. Figure 8.35 illustrates the fourth design iteration. The overall design was an improved version in terms of supports, connections and additional contact for load transfer.

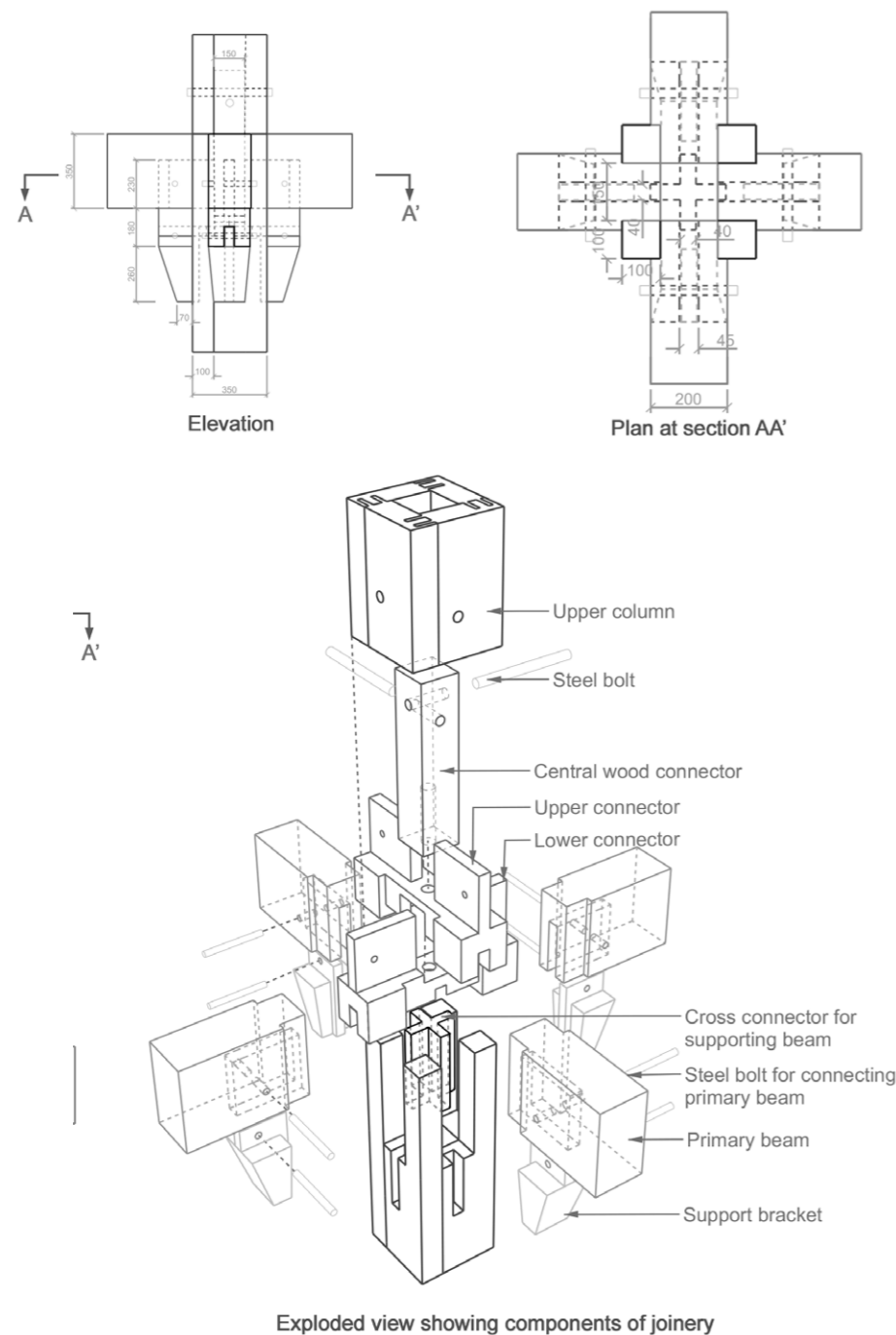


Figure 8.35: Plan, elevation and exploded view of the third iteration of joinery design.

Compression test of fourth design iteration

A 3D printed prototype of scale 1:7.5 of the fourth design proposal was tested in compression, to study the behavior and failure pattern of the joinery. This model was different from the previous test models with respect to the print direction of the grains. While the other two models were printed horizontally, the grain direction of this model was the same as that proposed for timber. Printing the model in a different direction caused assembly problems and many parts had to be sanded to joint them together, this caused the connections between the parts to be of very low quality. Also, this model lacked the top column, hence there could be slight deviation in the result. The detailed test setup of the laboratory test and specifications of the PLA model is explained in appendix C.

The model withstood a maximum load of 12,6 kN as shown in figure 8.39. It should be mentioned here that this test was different from the two previous prototypes because firstly, the upper column was missing and secondly, the 3D print of parts was done in actual direction of the proposed timber grain and thirdly this model had more imperfections and part misfits as compared to the previous two models before the test. The reason of the decrease in strength could be because of the low quality of 3D print. However, the overall joinery maintained its integrity at the end of the test. There was no major global damage, other than damage in one junction as shown in figure 8.38. Also, the parts did not break off or fly suddenly during the test. This model showed a lower ductile behavior as compared to its previous, but that could be because of the quality or 3D print direction.

Limitations of PLA test specimen 3, design module 4: It should be mentioned here that the test results greatly depend upon the quality of 3D print, presence of defects and undulations in the print, the precision in the 3D printed model assembly (gaps between the parts). It was observed that even the direction of 3D printing affects the behavior of the model. Irregularities in connection can cause stress concentrations which act as weak points in the joints. In this model where the joineries were not fitting properly, the surfaces were manually sanded. These created rough surfaces and irregularities which could have stress concentrations and affect the overall result of the model.

Thus, the model showed an overall improvement in performance through a series of 4 design iterations. Performance was improved on the basis of parts standardizations and easy assembly, repair and maintenance criteria, failure modes and load transfer.

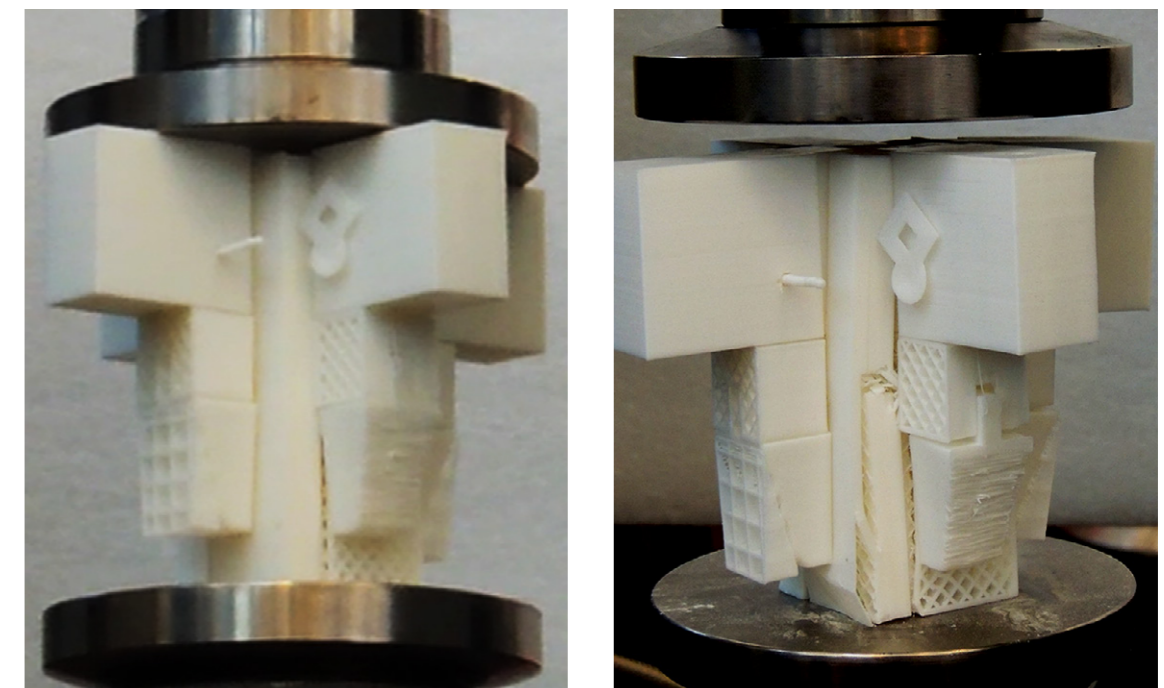


Figure 8.36: Before and after images of compression test specimen 23-PLA

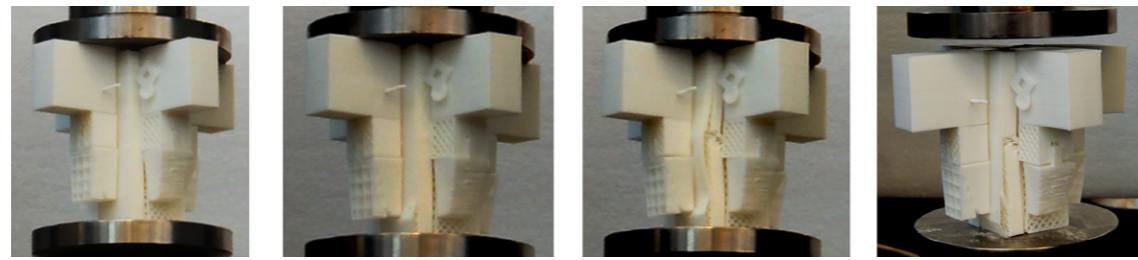


Figure 8.37: Response sequel of compression test specimen 3 – PLA

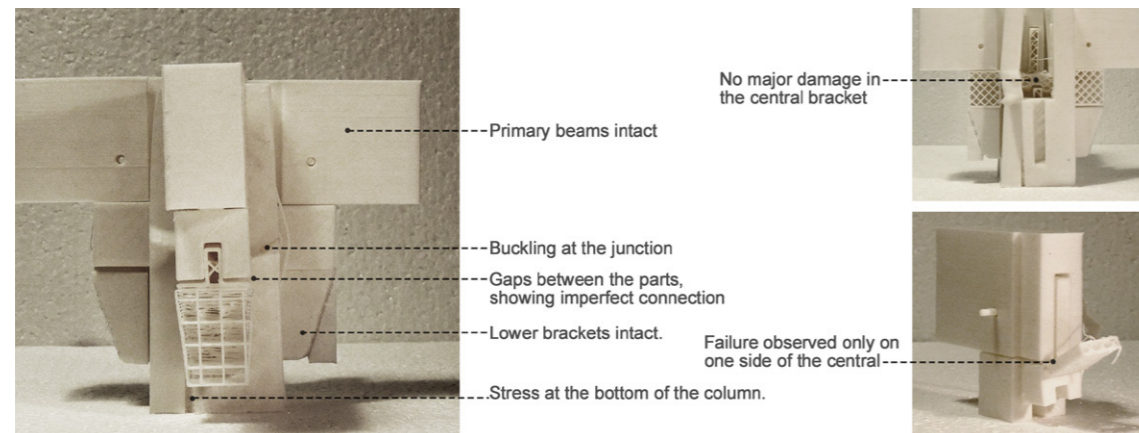


Figure 8.38: Analysis of parts after compression test.

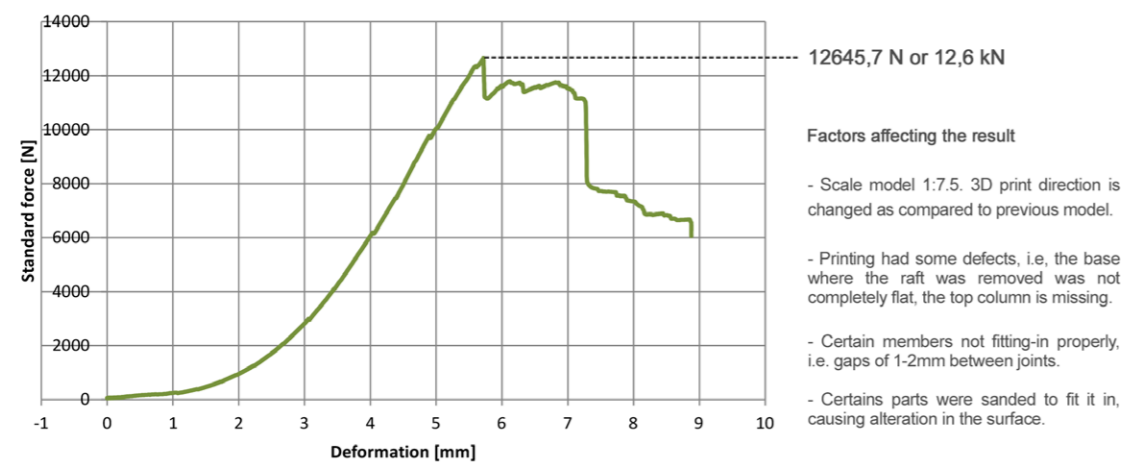


Figure 8.39: Result of the compression test. Graph showing the compressive force and the yield strength of the joinery.

Column-primary beam joinery design summary

Table 8.16 summarizes the result of the 4 design iterations. The fourth iteration for the column-primary beam joinery was chosen as the final design after comparing its performance with the others. To further understand the behavior of the proposed design, a softwood prototype of scale 1:5 was tested. This test was important as the test data was extrapolated to judge the vertical and lateral load bearing capacity of the joinery which was further used to set the limits of the global performance of the structure.

	First iteration	Second iteration	Third iteration	Fourth iteration
Joinery design				
Maximum Load	-	14 kN	13 kN	12.6 kN
Load paths	Limited	Limited	Increased surface area	Increased area and contact bonding
Failure behaviour	-	Sudden breakage	Ductile behaviour	Ductile behaviour
After test integrity	-	Central connector intact, primary beams broken	Stability dependent on the central dowel	Overall joinery intact, damage in the main bracket
Symmetry	No	No	Yes	Yes
Standardization	No	No	Yes	Yes
Repair facility	No	No	Yes	Yes

Table 8.16: Comparison amongst the performance of the four design iterations.

8.5.1.5 Final design – Softwood prototype test

The model was fabricated using softwood. The choice of wood was limited by the constraint that the prototype had to be made under academic setup, use of hardwood was not allowed in the university model workshop. However, the power tools available in the workshop were used for the fabrication process. Working drawings, with detailed dimensions of all the parts of the joinery, were made to ease the fabrication process. Figure 8.41 shows the different parts that have to be fabricated for the joinery and figure 8.42 shows the step by step procedure of the assembly sequence of these parts. The test was done for gravity loads as well as horizontal cyclic loads for seismic activity. These tests are elaborated in further sections.



Figure 8.40 Final timber prototype

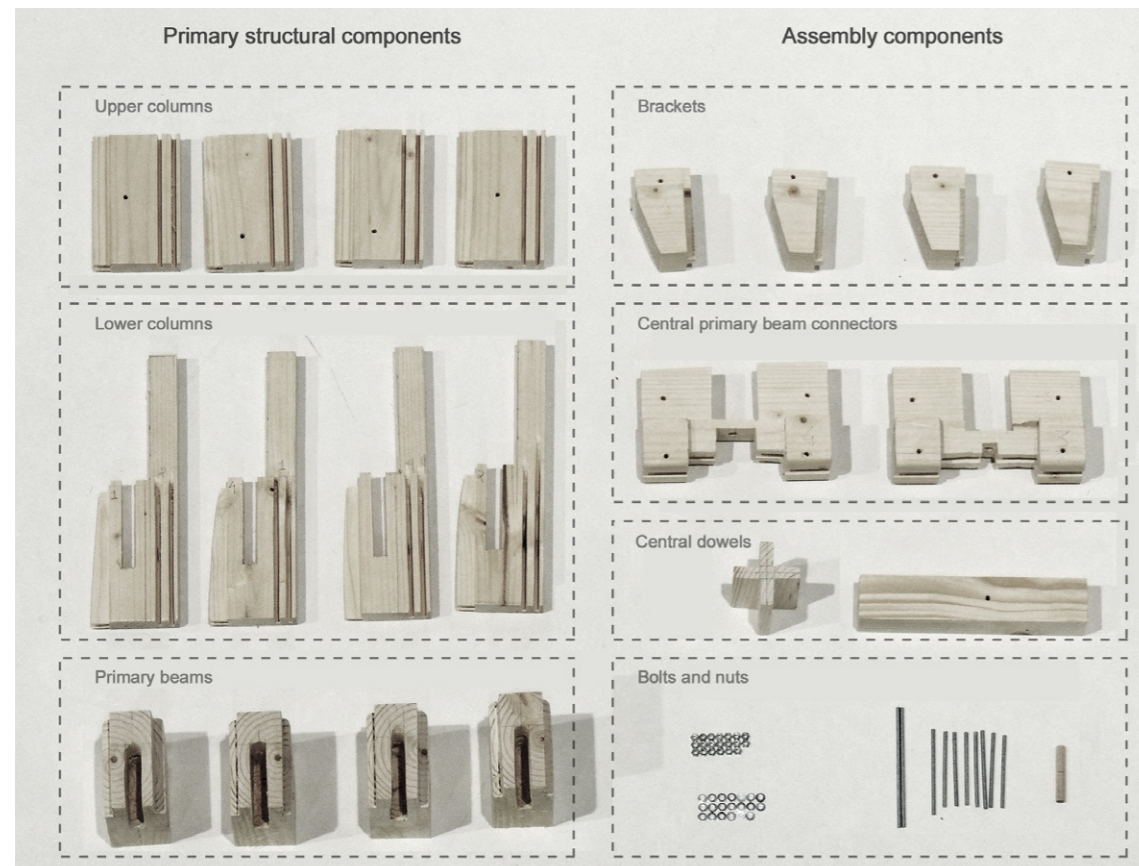


Figure 8.41: Assembly sequence of the joinery.

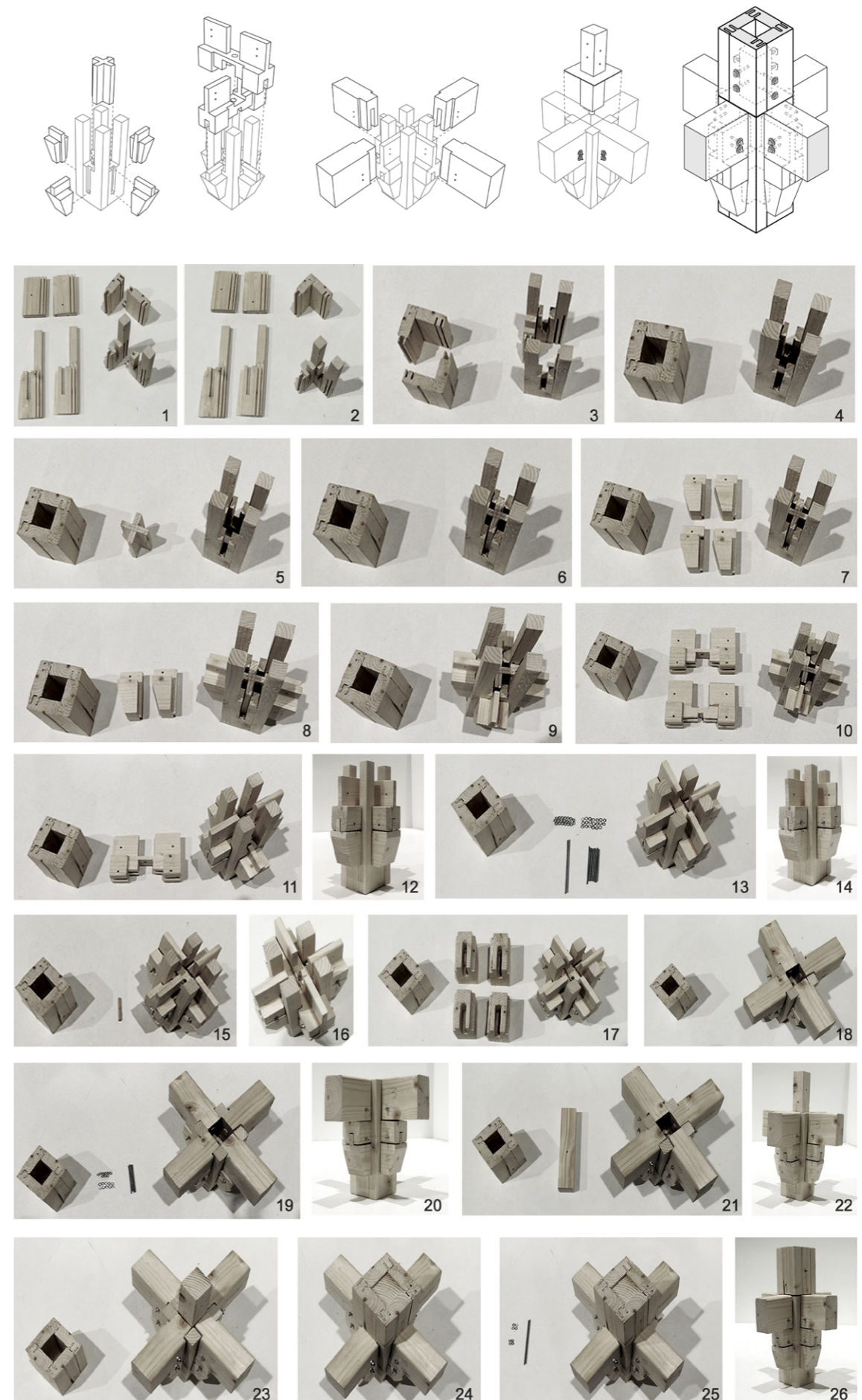


Figure 8.42: Assembly sequence of the joinery.

8.6 Laboratory test of timber joinery

8.6.1 Vertical compression test of softwood prototype for final joinery design

A softwood prototype of scale 1:5 of the final design proposal was tested in compression, to extrapolate the final vertical load bearing capacity of the joinery. In terms of design, this model was the same as that of the one proposed in fourth iteration. The setup of the laboratory test is same as that for the PLA and explained in appendix C. Figure 8.43 shows the images of before and after the test of softwood prototype.

The maximum load at which the model failed was 55 kN. However, considering the safety limits for plastic deformation a standard force of maximum 48kN has been set as bench-mark as shown in figure 8.46. Since the model was made manually, the contact surfaces were not perfectly smooth which could have affected the performance. It should be mentioned here that this model was made of a wood that had a heartwood, this is a defect in the material and its affect was also observed in the results. On comparing the overall performance, though the same joinery, the integrity of the model was not preserved as that of its PLA counterpart in fourth design iteration. Rather, similar to the response of third iteration model test, major buckling and material split was observed at the base column capital. The major loss of connection was caused due to the failure of the central bracket. Also, like in the third iteration, the central dowel played an important role in holding the model together at the end of the test. Damages and member failures were observed along the grains of the heartwood in the members because the core of the heartwood was very soft. Figure 8.45 shows the behavior of the prototype after the test.

Limitations of softwood test specimen, final module 4: It should be mentioned here that the tests results greatly depends upon the quality of the wood, the direction of the grain, presence of manufacturing and material defects. Also, manual fabrication of wood specimens take a lot of time and may not be an option for rapid prototyping. In this model where the joineries were not fitting properly, the surfaces were manually sanded. These created rough surfaces and irregularities which could have stress concentrations and slightly affect the behavior of the model.

Inference from the compression test of the final model: The design of the final column-primary beam joinery proves satisfactory. Failures in the model were caused due to fabrication and material defects. The tests prove the fact that the timber grain direction determines the strength of the joinery in connections. The major cause of the loss in central connection was due to split in fibers along the grains of the softwood, thus causing a material failure. Thus, most importantly, the efficiency of the proposed joinery is proved by the fact the failure of the joinery was due to the failure of the material. Appendix F shows the results of

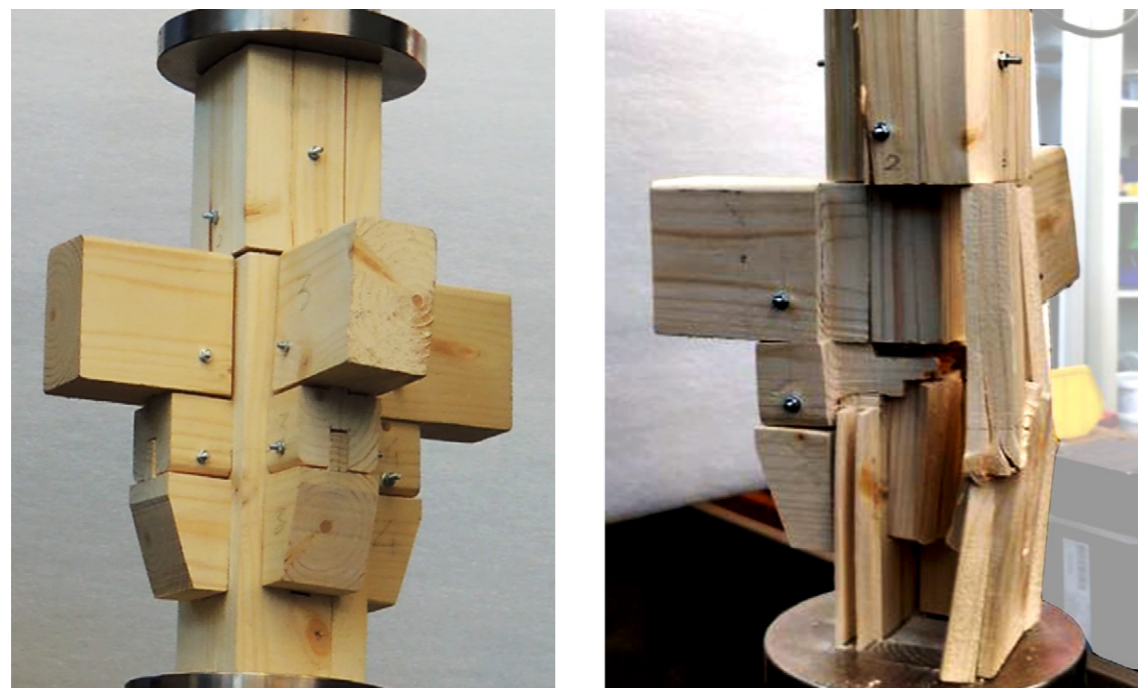


Figure 8.43: Before and after images of compression test specimen 3 – softwood

the compression tests conducted on sample softwood pieces. It can be observed that the cubes failed at a load of 43 kN on being loaded parallel to the grain, which is very similar to the failure value – 48 kN of the proposed joinery. Thus, the design of the proposed timber joinery does not weaken the overall structural assembly, given the fact that the manufacturing quality is maintained.

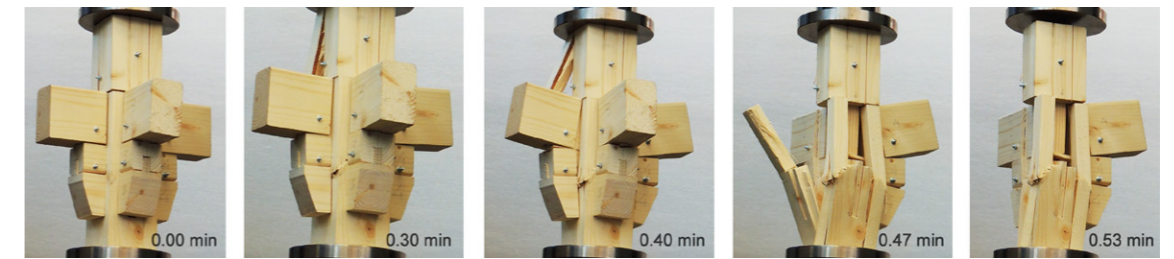


Figure 8.44: Response sequel of compression test specimen 3 – softwood

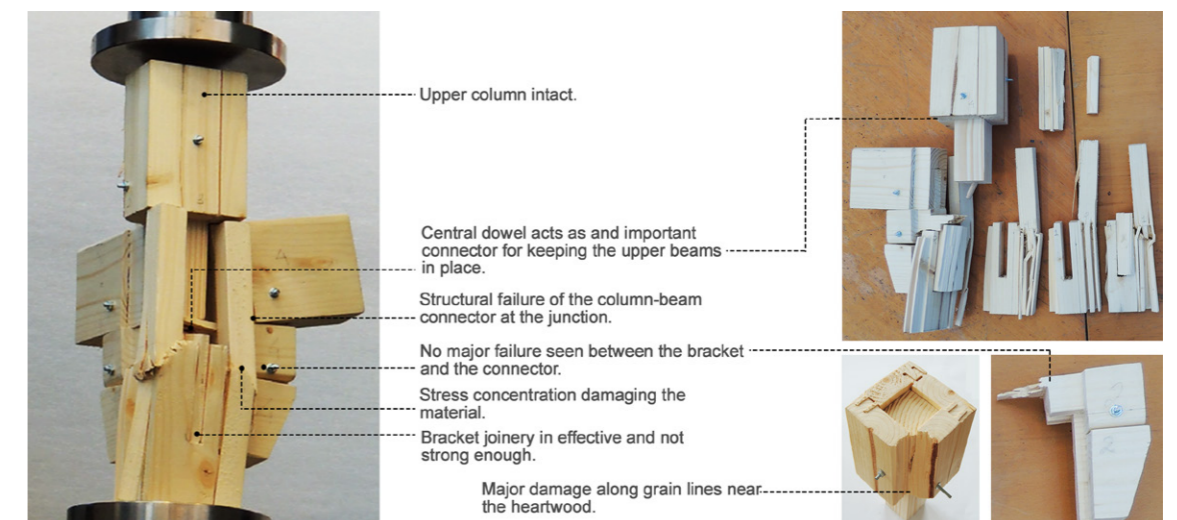


Figure 8.45: Analysis of parts after compression test.

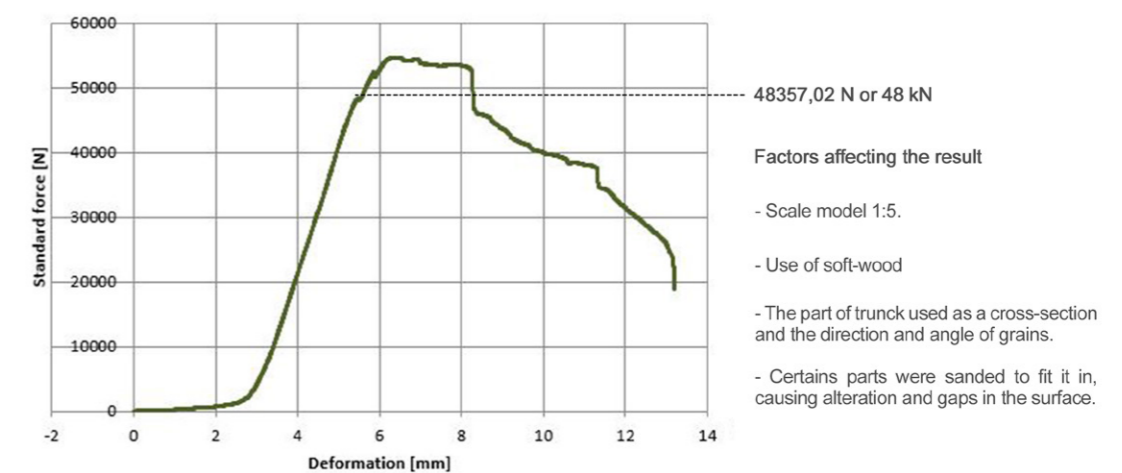


Figure 8.46: Result of the compression test. Graph showing the compressive force and the yield strength of the joinery.

8.6.2 Lateral load test under cyclic loading of softwood prototype for final joinery

A prototype of scale 1:5 of the final design proposal was made from the same softwood as that for the vertical compression test. The aim of the test was to identify the maximum loading capacity of the proposed joinery under cyclic lateral loads and observe the behavior of the joinery when subjected to seismic forces. The detailed test set-up is explained in appendix h, special metal supports were fabricated to hold the softwood model laterally in place during the loading. The model was subjected to 3 different magnitudes of cyclic loads. The test comprised of alternate 10 sec of loading and 10 sec of rest, for 10 cycles. Figure 8.47 shows the before and after images of the lateral cyclic load test.

The test results are presented in figure 8.50. The loads were gradually increased on observing the performance of the joinery. At first the model was subjected to a cyclic load of 2.5 kN. As no damage was observed in 2.5 kN, the loading was doubled to 5 kN for the second series of cyclic loading. It was observed that certain noises of slight cracking were heard during the 2nd loading but no visual damage was seen and the model was intact. Thus, the next attempt was made for a load of 7.5 kN. Figure 8.48 shows the response sequel of the model under the 3rd loading case. In this the primary beam and the bracket connection was lost, the central dowel was loosened, and minor splits were observed along the metal bolts in the brackets. However, inspite of these minor damages the global integrity of the model was maintained when the model was straitened after the test, this is shown in figure 8.49.

Limitations of softwood seismic test, final module 4: This seismic test was performed by tilting the whole joinery and placing it laterally. However, in an ideal situation the force should be applied laterally, while the joinery standing in its original position. Due to unavailability of such a test facility in the given academic framework, this experiment was an alternative to the original seismic lateral load tests. Placing the model laterally could affect the result and behavior of the model. Also as mentioned in the vertical load test, the results greatly depends upon the quality of the wood, the direction of the grain, presence of manufacturing and material defects. Also, manual fabrication of wood specimens take a lot of time and may not be an option for rapid prototyping. In this model where the joineries were not fitting properly, the surfaces were manually sanded. These created rough surfaces and irregularities which could have stress concentrations and slightly affect the behavior of the model.

Inference from the lateral loading test of the final model: The design of the final column-primary beam joinery proves satisfactory under cyclic loading conditions. As mentioned earlier the mdl maintained its integrity after the test. Since, the model failed at 7.5kN, a benchmark of 5kN has been set as the ultimate lateral strength of this joinery. This also complies with the principle that a joinery is 1/10 as strong in the lateral direction to that in vertical. Since a load capacity of 48 kN was set for vertical loading, 1/10 of 48kN



Figure 8.47: Before and after images of 3 simultaneous lateral cyclic loading test for specimen 4 – softwood

= 4.8 kN which is very close to the 5kN lateral load capacity. It should be mentioned here that this 5kN is safe as the model is stands stable after the test. Further for the 3rd cyclic load test an ambitious load of 7.5 kN was directly applied. It is possible that the material could have faired at loads between 5kN and 7.5kN. This also leads to slight underestimation of the capacity of the joinery.

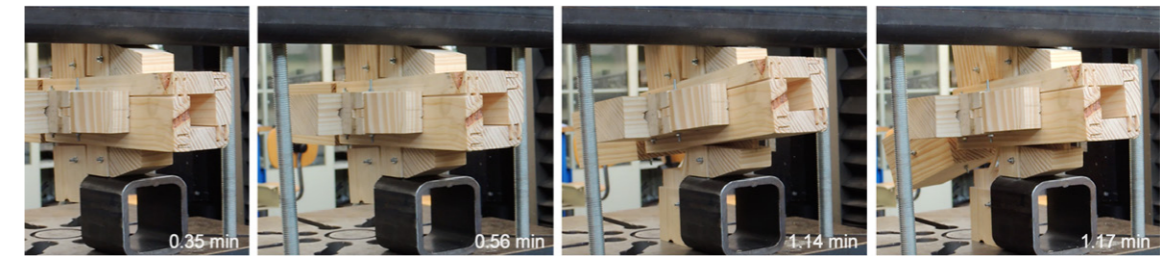


Figure 8.48: Response sequel of 3rd lateral compression test under 7.5 kN of loading in specimen 4 – softwood

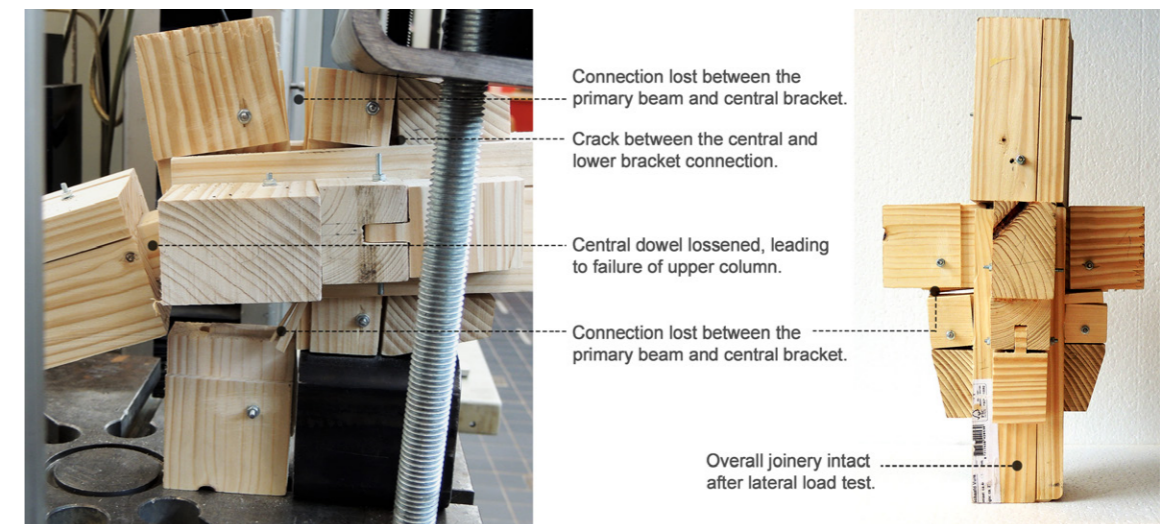


Figure 8.49: Analysis of parts after compression test.

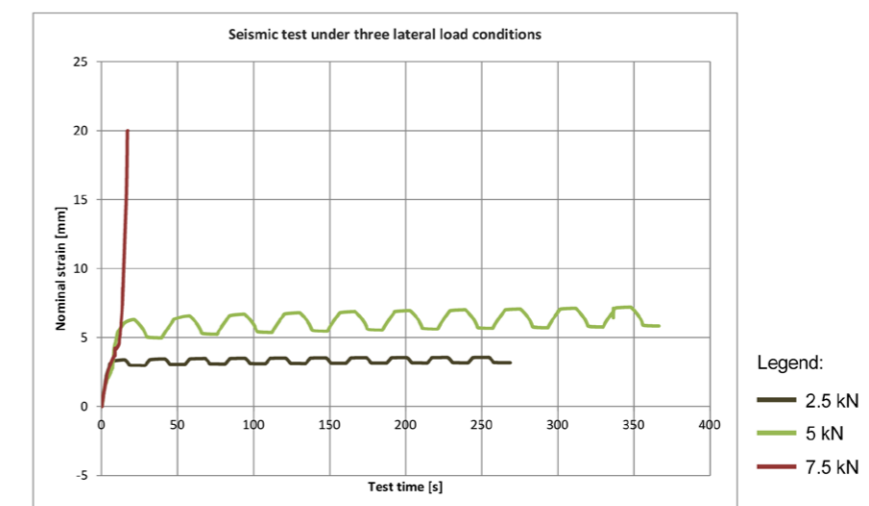


Figure 8.50: Result of the compression test. Graph showing the compressive force and the yield strength of the joinery.

8.7 Scaling the actual loading capacity of the column-beam joinery

Experimental models are based on the condition of similarity, such that they obey the same physical laws during a test (Jha, 2004). The prototype made for the purpose of this test obeys the law of dimensional similarity such that it is homogeneously scaled to a factor of 0.2 and the model has a material similarity such that a different member (species) of the same material family (timber) was used for the test. Thus, the results of the prototype are valid for scaling under the two major boundary conditions:

- The models were at a scale of 1:5
- Softwood was used for the test material.

The prototype has to be scaled for the maximum vertical and lateral force. Maximum values set as benchmark for the prototype come from the above two laboratory experiments and the values are as follows:

Maximum vertical load for prototype = 48 kN
Maximum lateral load for prototype = 5 kN

In order to estimate the allowable vertical and lateral force of the actual joinery, scaling laws were used to extrapolate the data. The following scaling factor for force has been employed (Jha, 2004):

$$\lambda_{Force} = \lambda_{length}^2 \times \lambda_{Mod. of elasticity} \quad \dots(\text{equation 18})$$

where,

$\lambda_{length} = 5$, given that the model is at a scale of 1:5, and

$$\lambda_{Mod. of elasticity} = \frac{\text{Modulus of elasticity of actual material}}{\text{Modulus of elasticity of prototype}} \quad \dots(\text{equation 19})$$

Now,

The modulus of elasticity of the proposed actual material, local hardwood timber species Shorea Robusta is known to be $12.67 \times 103 \text{ N/mm}^2$. The modulus of elasticity of the softwood used for prototype is $13.35 \times 103 \text{ N/mm}^2$. The derivation of the modulus of elasticity of the softwood used for prototype has been done using a 4-point bending test and is discussed in detail in appendix D. It should be mentioned here that the test results show that the modulus of elasticity of the softwood is more than the proposed hardwood. This is because the value of the hardwood is taken from the National Building Code of India, where the strengths are specified considering a large safety margin between the actual capacity and the specification. This is done to accommodate any material or construction defects that could occur in the market since timber is a natural material and its properties differ slightly from place to place. It is possible that the Modulus of Elasticity of 12.67 N/mm^2 belongs to the lowest spectrum of the tested samples in the bye laws, thus highly underestimating the capacity of this material. On the other hand, the softwood was tested using only one of the market lots and the average of the maximum values has been taken, this leaves no space for safety margin. Thus, it is practically not possible that the softwood used for testing has a higher modulus of elasticity than that of the proposed hardwood. However, since the Young's modulus of the two species, one used for prototype and one proposed in similar, for the purpose of this research it is assumed that:

Modulus of elasticity of actual material = Modulus of elasticity of prototype = $13 \times 103 \text{ N/mm}^2$
(on rounding off 12.67 to 13 N/mm^2 and 13.35 to 13 N/mm^2)

Therefore, putting values in equation 19,

$$\lambda_{Mod. of elasticity} = 1$$

Substituting the determined values in equation 18,

$$\lambda_{Force} = \lambda_{length}^2 \times \lambda_{Mod. of elasticity} = 5^2 \times 1 = 25$$

Hence the force values should be scaled by a factor of 25. The final allowable load on the proposed timber

column-beam joinery for the hybrid construction technology=

Maximum vertical load for proposed column-beam joinery = $48 \text{ kN} \times 25 = 1200 \text{ kN}$
Maximum lateral load for proposed column-beam joinery = $5 \text{ kN} \times 25 = 125 \text{ kN}$

It should be mentioned here that these values also include a margin of safety as the values have not been scaled by the modulus of elasticity for the reasons mentioned above. In reality it is assumed that the joineries made of hardwood, will have larger strengths than that set as the loading bench mark for the purpose of this research.

8.8 Validating the global structure based on the vertical loading capacity of the column-primary joinery

Now, the maximum load capacity of this column-beam joinery has been determined as 1200 kN. This can be compared to the loads determined by structural calculations in section 8.2.4 to validate the global structural functionality for the proposed column-beam design. Figure 8.51 shows the comparison between the loads calculated for each floor for a 3m x 4m grid, 6 storey building and the proposed capacity of the column-beam joinery.

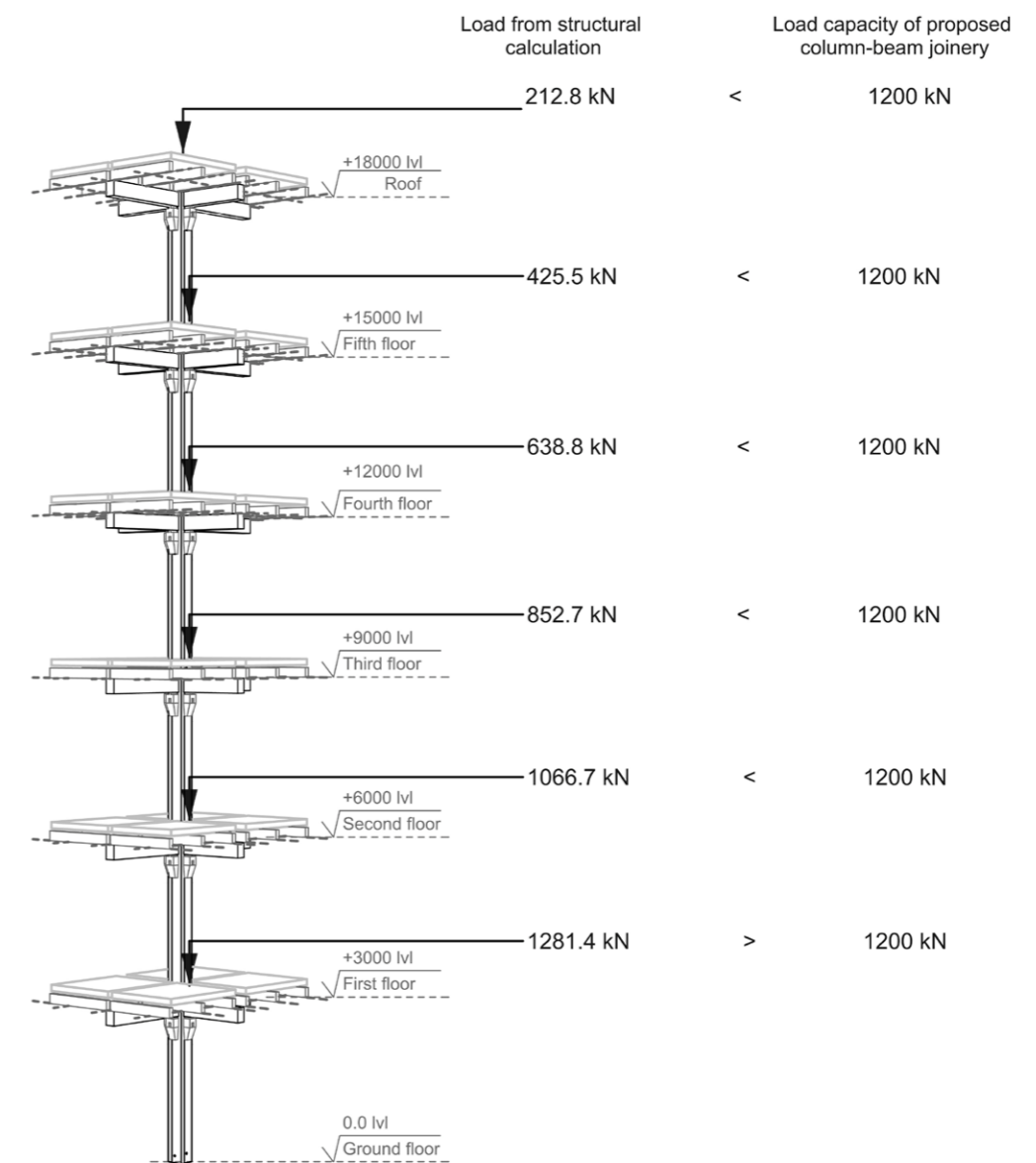


Figure 8.51: Structural validation of 3m x 4m grid, 6 storey timber structure on the basis of maximum loading capacity of the proposed column-beam joinery.

It can be noted from figure x that the capacity of the joinery is greater than the imposed loads for all floor cases other than the ground floor. However, the loads on ground is increasing marginally by 7% of the maximum allowable limit, the marginal increase in loading capacity has been considered valid given the fact that all structural calculations have been made with a safety factor of 2 and also, the maximum loading capacity of the joinery has been determined considering a safety margin. Thus, as per this research a 6 storey structure of 3m x 4m grid size, using the local timber Shorea robusta and Pinus kesiya, is valid under vertical loads.

Similar process has been followed to determine the structural validity of different grid-sizes using the same construction material. Appendix b elaborates on the load calculations for different grid-sizes. These loads have been compared with the maximum load capacity, 1200 kN of the proposed column-beam joinery to deduce the possible number of floor heights for a given combination of grid-size by the following criteria:

All floors in which the load on column exceeds more than the maximum permissible loading capacity of the column-primary beam joinery (1200 kN) are deemed to be discarded.

Table 8.17 shows the table of the possible floor heights, for each grid-size combination using the above criteria. It should be noted that certain load cases for possible number of floors within 10% tolerance range of 1200kN have also been considered in this table.

Grid size, mm		3000			3500			4000			4500			5000		
		4000	4500	5000	4000	4500	5000	4000	4500	5000	4000	4500	5000	4000	4500	5000
Secondary beam cross-section, mm		100x200	125x200	100x200	150x200	175x200	150x200	150x250	150x250	150x250	175x250	175x250	175x275	175x275	175x275	175x275
Primary beam cross-section, mm		200x350	225x350	275x350	225x350	250x350	250x375	250x350	275x350	275x375	275x350	275x375	300x375	275x375	300x375	300x400
Column solid cross section, mm	5th floor	200x200	200x200	200x200	200x200	200x200	200x200	200x200	200x200	200x200	200x200	200x200	200x200	200x200	200x200	200x200
	4th floor	200x200	250x250	250x250	250x250	250x250	250x250	250x250	250x250	250x250	250x250	250x250	250x250	250x250	250x250	250x250
	3rd floor	250x250	250x250	300x300	250x250	300x300	300x300	300x300	300x300	300x300	300x300	300x300	300x300	300x300	300x300	350x350
	2nd floor	300x300	300x300	300x300	300x300	300x300	300x300	300x300	350x350	350x350	350x350	350x350	350x350	350x350	350x350	400x400
	1st floor	300x300	350x350	350x350	350x350	350x350	350x350	350x350	350x350	350x350	400x400	400x400	400x400	400x400	400x400	400x400
	Ground floor	350x350	350x350	400x400	350x350	400x400	400x400	400x400	400x400	400x400	400x400	400x400	400x400	400x400	400x400	400x400

Table 8.17: Possible number of floors for various grid combinations, the green colour in load cases shows its validity with respect to the 1200kN maximum capacity.

8.9 Validating the global structure based on the lateral loading capacity of the column-primary beam

Since the proposal is for a seismic region, the joinery has to be validated for lateral loads. The lateral load on each joinery along different floor height is evaluated and its validity is tested against the 125kN benchmark of the proposed timber column-beam joinery. For the purpose of the lateral load calculation under seismic conditions, the national building code of India has been followed. The following section elaborates on the lateral load calculations and the joinery validation.

Lateral load calculation under seismic condition

The national codes of India for earthquake design - IS 1893 (Part 1) :2002 and the NBC 2016 have been referred to for calculating the lateral loads. Two methods have been mentioned in the national codes for structural verification- namely:

- a) The equivalent static method
- b) Dynamic analysis – response spectrum method

Although there are other methods of analysis like the time history method, but above two have been detailed in the codes. It is mentioned in part 6, section 1 – paragraph 5.4.6 of the NBC 2016 that the equivalent static method ‘shall be applicable for regular building with height less than 15m in Seismic zone

2’. Since the location of the research proposal is located in zone 5 as per the Indian seismic earthquake zone classification, the actual structure validity is done using the response spectrum method.

It should be noted that in terms of calculation, the equivalent static method is much quicker. Thus, making the process of iterative calculations much faster. However, the equivalent static method is much more conservative as compared to the response spectrum, this is also proved by the calculations shown in appendix i. This means that in no case will the lateral forces be underestimated by using the equivalent static method. Thus, for the purpose of estimating the limits of the structure with respect to the designed joinery, the following calculation of equivalent static method has been followed.

Equivalent static method

Since, lateral load calculations are directly dependent upon the depth of the building, a common case of building consisting of 3m x 4m grid-size and 5 x 6 bays has been taken into consideration as shown in figure 8.52.

Design conditions for calculation:

Grid-size – x-direction: 3m, y-direction: 4 m

No. of bays- x-direction: 5, y-direction:6

Total number of floor = 6, Total height of the building = h = (3X6) m = 18m

Soil condition of site: Medium stiff soil sites

Lateral force is being calculated for y direction.

Depth of the building for calculation in y-direction= d = grid size in y-direction x number of bays in y-direction = 4 x 6m = 24m

The vertical loads for the purpose of calculation of lateral seismic forces have been used from that of section 8.2.4.

Depth of the building for calculation in y-direction= d = grid size in y-direction x number of bays in y-direction = 4 x 6m = 24m

Calculation procedure:

As per section 5.4.6.2 of National Building Code of India - 2016 (NBC), the approximate fundamental translational natural period T_a of oscillation, in seconds, shall be estimated by the following expression for ‘all other buildings’:

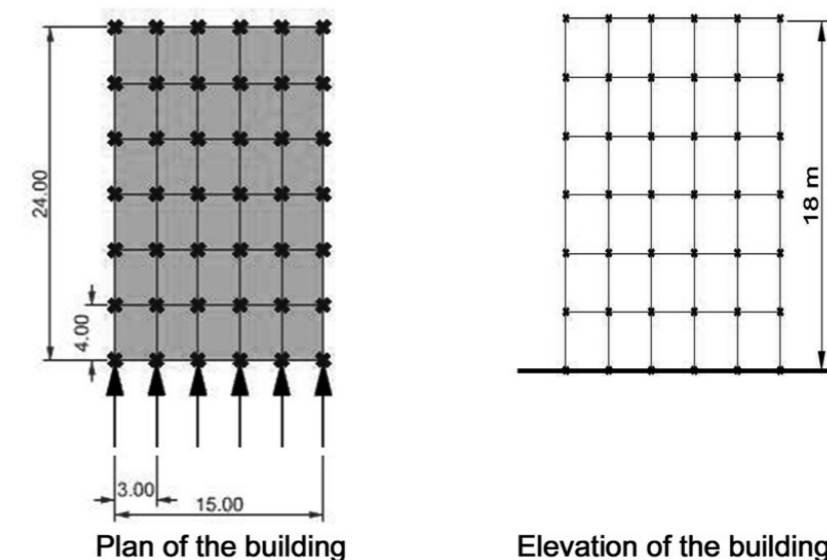


Figure 8.52: Structural concept diagram – plan and elevation, of the building for estimating lateral loads

$$T_o = (0.09h)/(v(d)) \quad \dots \text{(equation 20)}$$

Where, h = height of the building in m and, d = depth of the building in m.

Applying values in this equation 1 to obtain T_a ,

$$T_a = 0.09 \cdot 18 / (\sqrt{24}) = 0.33 \text{ s}$$

Now, the design base shear V_b along any principal direction of a building shall be determined by:

$$V_b = A_h \cdot W \quad \dots \text{(equation 21)}$$

Where, A_h = design horizontal acceleration coefficient value, using approximate fundamental natural period T_a along the considered direction of shaking. And W = seismic weight of the building.

As per section 5.3.4.2 of NBC, the design horizontal seismic coefficient, A_h is given by -

$$A_h = \{(Z/2) \cdot (S_a/g)\} / (R/I) \quad \dots \text{(equation 22)}$$

Where, Z = seismic zone factor, (S_a/g) = design acceleration coefficient for different types of soil, R = response reduction factor and I = importance factor of the building.

The values of all the above parameters have been given in the codes depending upon the condition and specifications of the proposed building. The following are the values derived from various tables in NBC.

$Z = 0.36$, as per table 42 (clause 5.3.4.2), as the building falls under seismic zone 5
 $(S_a/g) = 2.5$ for $T_a = 0.33\text{s}$, as per figure 12A (clause 5.3.4.2), as the assumed soil type is medium stiff soils.
 $R = 1.5$ for framed timer construction
 $I = 1$, for residential structures

Substituting all the above values in equation 22:

$$A_h = \{(0.36/2) \cdot (2.5)\} / (1.5/1) = 0.3$$

For calculating the value of W , the load conditions for calculating the vertical forces in previous sections have been used. Table 8.18, summarizes the calculation of total weight of the building.

Load on one slab (1-bay)	x-direction (secondary beam direction)	y-direction (primary beam direction)	area	Load of slab	Total load due to slab	Load of primary beam	Load on secondary beam	Total load of slab
	m	m	m ²	kNm ²	kN	kNm	kN	kN
	3	4	12	4.05	48.6	6.6	26.4	77.4
Total weight of all slabs (all bays)	number of bays in x-direction	number of bays in y-direction	total number of bays					Total weight of slabs
	5	6	30					2322
Weight of columns	number of columns in x-direction	number of columns in y-direction	total number of column per floor			Self Weight of one column (largest column size taken)		Total weight of all columns
	6	7	42			kN		121.8
Starting from top	Distance from ground							Seismic Weight
Unit	m							kN
	h							W
1	18							2322
2	15							4765.8
3	12							7209.6
4	9							9653.4
5	6							12097.2
6	3							14541
								Total weight of building kN
								50589

Table 8.18: Calculation of weight of the floor

Thus, it can be seen from table 8.19, that $W = 50589$ kN.

Substituting the values of A_h and W in equation 21,

$$V_b = A_h \cdot W = 0.3 \cdot 50589 = 15176.7$$

Now, as per section 5.4.6.3 of NBC, the Design base shear (V_b) computed above shall be distributed along the height of the building and in plan at each floor. The vertical distribution of base shear at different floor levels is given by the expression:

$$Q_i = [(Wh^2) / (\sum_{j=1}^n W_j h_j^2)] V_b \quad \dots \text{(equation 23)}$$

Where, Q_i = design lateral force at floor i , W_i = seismic weight of floor i , h_i = height of floor i measured from base and n = number of storeys in the building.

The division of the loads in plan is determined by the number of joints or nodes on each floor. Which in our case = $6 \times 7 = 42$ nodes.

Therefore,

$$\text{lateral load on each joint} = (\text{total load per floor} / \text{number of nodes per floor})$$

Table 8.19, shows the estimation of Q_i and the division of lateral loads in plan.

Thus, it can be seen that the maximum lateral load on the joineries located on 5th floor is 92 kN which is < 125 kN of the estimated maximum strength of the joinery.

Starting from top floor levels	Distance from ground (m)	Seismic Weight (kN)	$Q_i = [(Wh^2) / (\sum_{j=1}^n W_j h_j^2)] V_b$			Lateral Load at each join (kN)
	h	W	Wh ²	V _b	Q _i	
1	18	2322	752328	15176.7	2711.37	64.56
2	15	4765.8	1072305	15176.7	3864.55	92.01
3	12	7209.6	1038182.4	15176.7	3741.57	89.09
4	9	9653.4	781925.4	15176.7	2818.03	67.1
5	6	12097.2	435499.2	15176.7	1569.53	37.37
6	3	14541	130869	15176.7	471.65	11.23
Total weight of building in kN		50589	4211109			

Table 8.19: Calculation of lateral loads on each storey and each node in the building.

Hence, as per the static equivalent method, this joinery is valid for the considered case (given grid-size, floors and bays) of the timber building.

It should be noted here that the load values are dependent upon the depth of the building. The calculation presented above can be made for various sizes of building footprint. It should be noted that with increase in the number of bays in any direction, the building stiffness will also increase, thus improving the overall performance of the building. Upon, iterative calculations of increasing the bay size, it was realized that the value of lateral forces stay below 125 kN for a building depth as large as 400m. This situation is unrealistic as there are limitations to plot sizes as per government regulations and construction scenario in the urban condition of Shillong. However, it can be concluded that this joinery is sufficient for the lateral forces on proposed timber construction, given the common sizes of residential plots in the urban region of Shillong. If in any case, the lateral forces of the building increase the permissible lateral force 125 kN of the proposed joinery, then the number of storeys could be reduced, grid-size kept to a minimum of 3m x 4m or even architectural intervention by splitting the building or creating expansion joints can help. *Finally, it can be concluded, that given the boundary conditions, the proposed design for column-primary beam joinery is valid under vertical and lateral loading condition for hybrid timber construction technology.*

8.10 Concept design for other joints and details

The above section describes in detail the procedure for development of one joinery. However, in actual scenario several such joineries come together to form the structure of a building. Given the academic time-frame, it is beyond the scope of this research to develop all other joineries as much in detail as the column-primary joinery. However, for the purpose of presenting a holistic design concept for the 'hybrid timber construction technology', other details have been conceptualized. It is highly recommended that the details presented in this section undergo detailed scrutiny by the concerned before market application, as they have not been tested or structurally analysed under any condition.

The other important joineries for the hybrid timber construction technology include:

- Variants of the column-primary beam joinery
- Column-concrete foundation joinery
- Primary beam to secondary beam joinery
- Primary beam and secondary beam to core joinery
- Eave joinery
- Facade detail

Further, some of these will have multiple variations depending upon the location in the building. Further sections give a brief concept of what could be possible with respect to each of the above categories.

8.10.1 Column-primary beam joinery variants

While the main concept of this joinery has been presented in detail in section 8.5, there will be multiple variations of the design depending upon its location in the building. This means that variation with respect to location – center, edge, terrace or corner junction and variation with respect to connecting combinations of hollow and solid columns. Figure 8.53 illustrates these different variations.

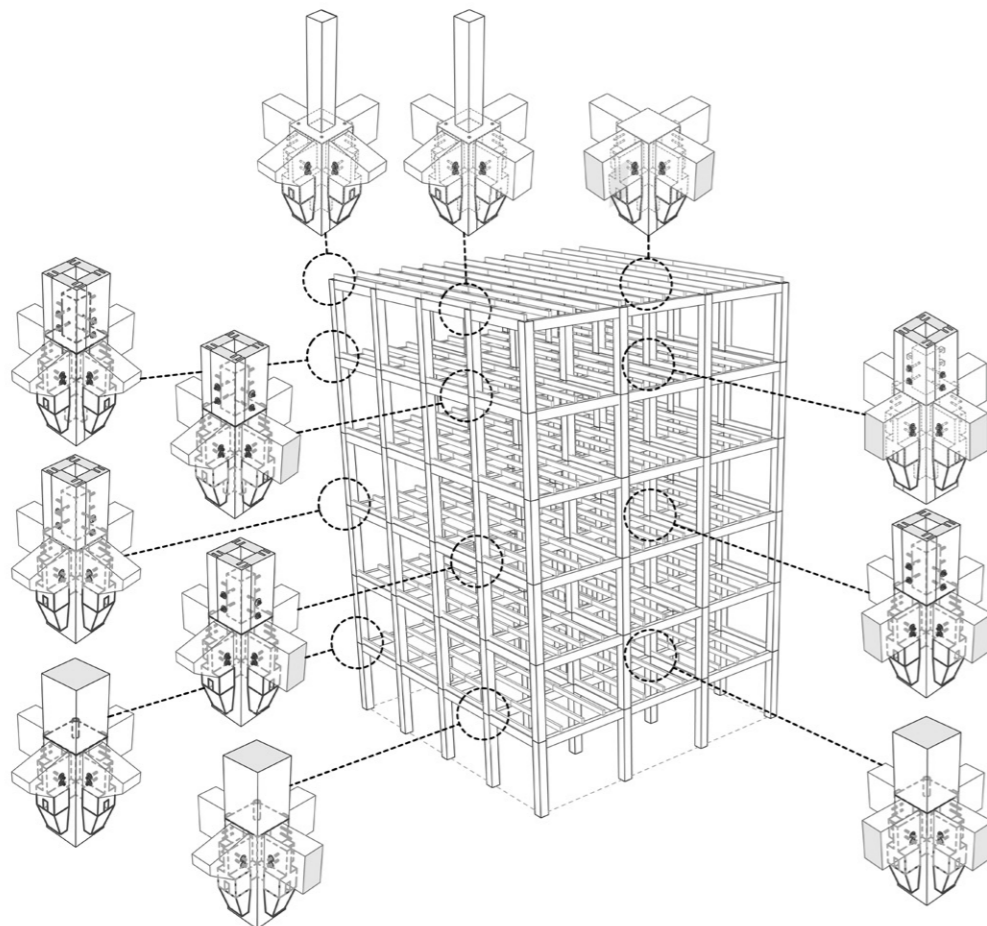


Figure 8.53: variations of column-primary beam joinery depending upon the location in the building.

8.10.2 Column-concrete foundation joinery

The foundations are made of concrete because of their durability against moisture, these foundations have to be connected to timber columns. The timber column could be either hollow or solid depending upon the load conditions. Figure 8.54 shows a concept for column-foundation joinery using steel connector.

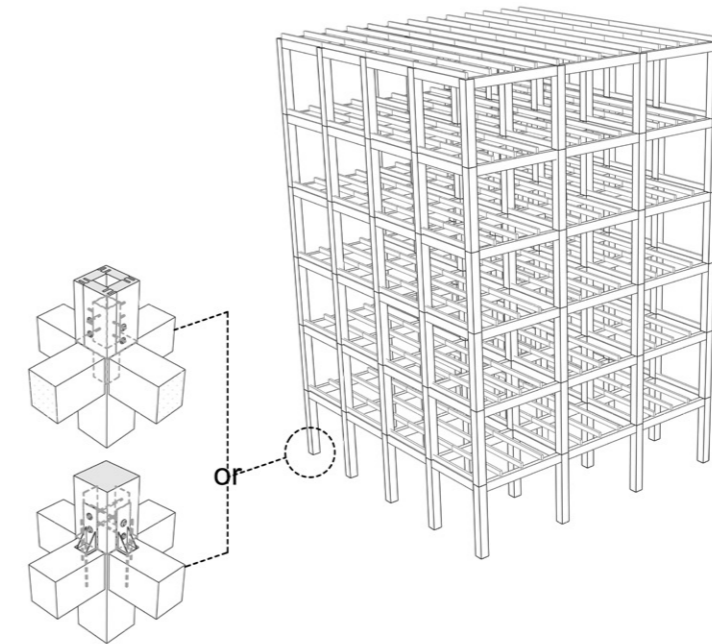


Figure 8.54: Two variations of the column-foundation joinery depending upon the type of base column.

8.10.3 Primary beam – secondary beam joinery

The secondary beams rest on the primary beams. They have to be connected such that the load from secondary beams is easily transferred to the primary beam. An integrated steel connector is proposed such that it aids in assembly of the two beams along with the installation of the wooden member for the wall. This joinery varies slightly with respect to its location in the building, being in the center or the periphery as shown in figure 8.55.

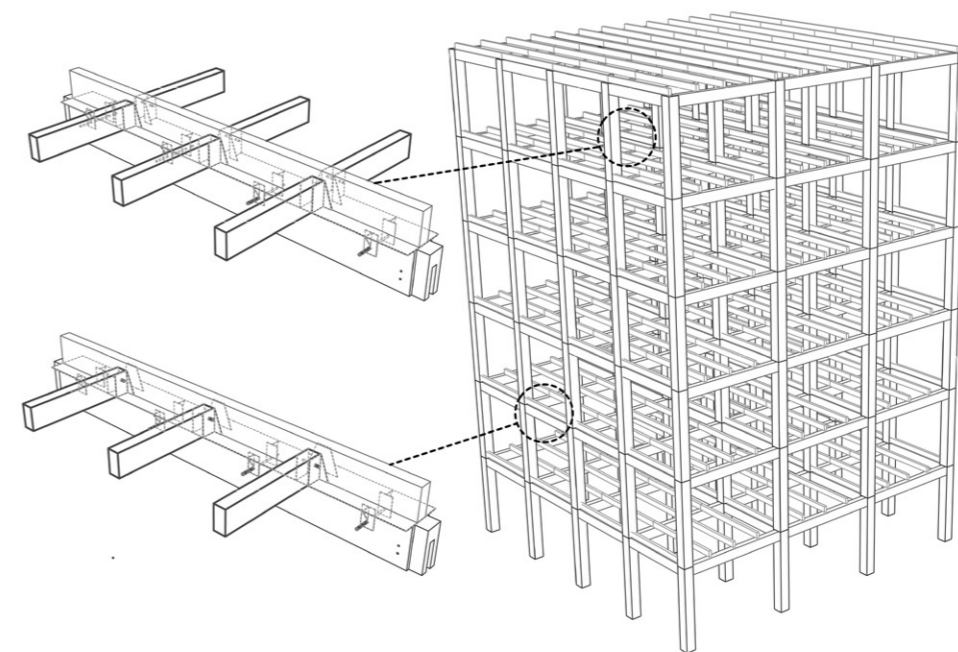


Figure 8.55: variations of primary beam-secondary beam joinery depending upon the location in the building

8.10.4 Primary beam and secondary beam to core joinery

The presence of a concrete core is evident given the fire regulations in the region. Thus, the timber primary beams have to rest on this concrete core. It is a crucial junction because the detail should accommodate for differential settlement between the timber and concrete. Figure 8.56 shows a concept for this joinery.

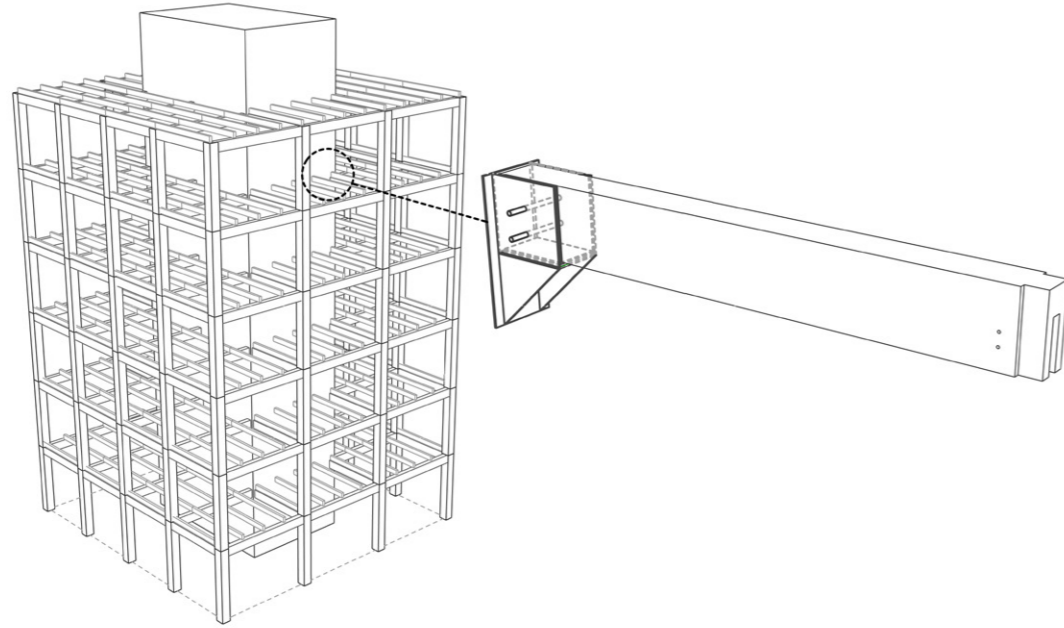


Figure 8.56: variations of primary beam-secondary beam joinery depending upon the location in the building

8.10.5 Eave joinery

It is known from literature that the timber members should be protected from direct moisture. This is important in the context which is subjected to heavy rainfall. Thus, the eaves form an important element of long term building maintenance and performance. Figure 8.57 shows a concept for this joinery.

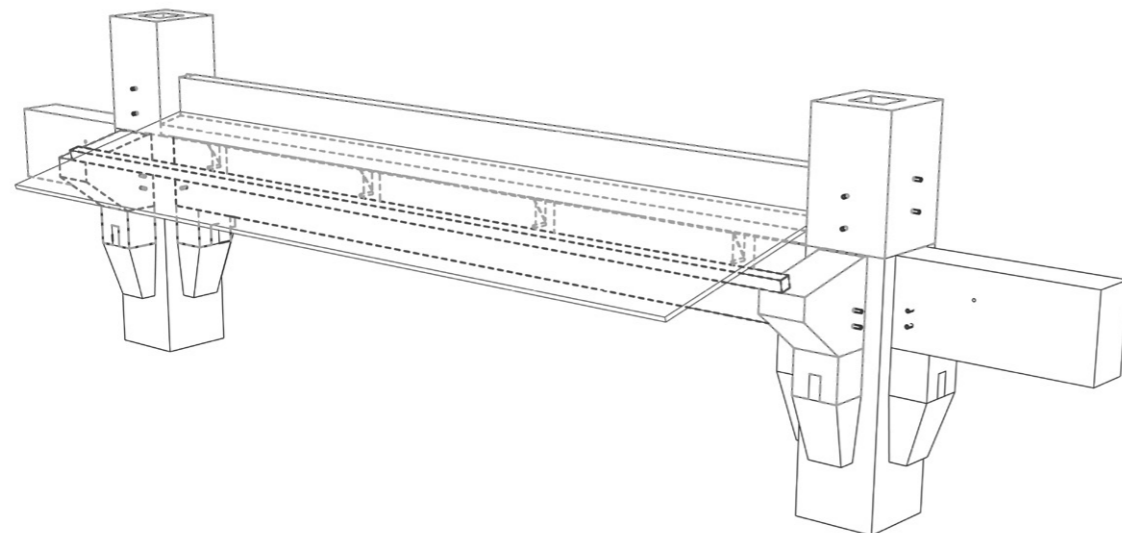


Figure 8.57: connection of eave to the peripheral beams, supported on the column-beam node.

8.10.6 Façade detail

The facade forms an important part of any construction. Not only from the thermal comfort but its response with respect to the structure. For the purpose of this project the time-tested façade detail has been proposed. It is made of locally available bamboo reeds (ikra), timber frame and lime stone plaster. It is light weight hence contributed to an enhanced seismic performance. The same wall concept can also be used for internal partitions, hence aiding in standardization. However, there is a lot of scope of research in this façade with respect to thermal performance. Figure 8.58 shows how the traditional wall of the 'Assam type' construction could be a façade for a multi-storey timber building.

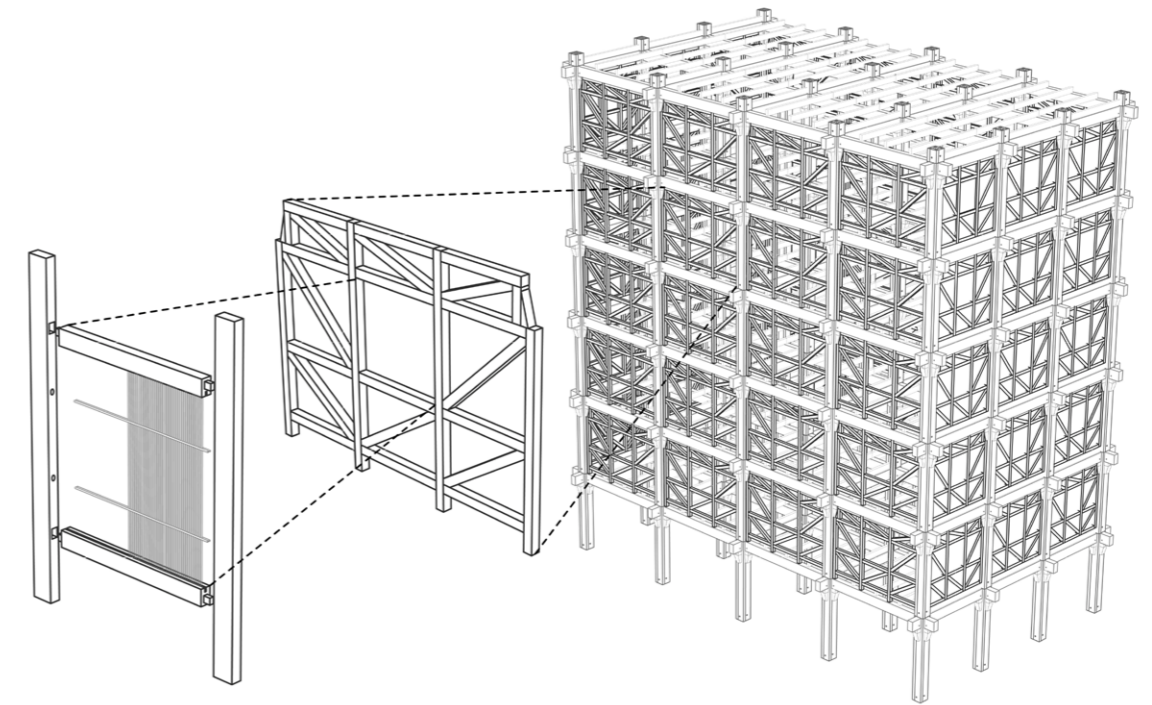


Figure 8.58: variations of primary beam-secondary beam joinery depending upon the location in the building

8.11 Finite Element Analysis for global structure verification

The proposed joineries bring together the timber members to create a 'hybrid timber construction technology'. The response of a joinery has been studied in detail in section 8.5 and its validity has been tested by the laboratory experiments and seismic calculations. However, it is also very important to observe the global structural behavior of the proposed system given the fragile seismic condition of the region. The global structural behavior is studied with respect to the overall deflection and the response of the structure during a seismic event. The deflections have to be validated with respect to the permissible limits of the National Building Code of India.

The global structure was verified using Finite Element analysis (FEA). For this purpose, Ansys 19.2 Edu-pack was chosen, given its availability in the university and a strong student support and discussion forum. As mentioned in the National Building Code of India the structure has to be validated using the dynamic analysis method - response spectrum, for seismic condition of the given region. The FEA was a three-step procedure which is discussed in detail in the following sections:

1. Firstly, choosing a modelling system to represent proposed geometry in Ansys.
2. Secondly, a simplified structural model had to be calibrated with respect to the analytical calculations.
3. Finally, simulating the proposed structural geometry and result verification.

8.11.1 Modelling system

Ansys has a vast library of 200 types of modelling elements (Dufour, 2003). The choice of correct element is of vital importance for accuracy and most importantly, quick outputs in the given timeframe. Table 8.20 shows the basic classification of element types in Ansys. The structural system proposed in this research comprises of simple column and beam organization attached to each other at junction. This system can be idealized to a grid of center lines or a wireframe of column and beams. Given this simplification, the structure can be represented as linear line elements. In Ansys this is known as beam 3/44 or beam 188 as shown in the above table. Structural simplification increases computational efficiency which is an important criterion for this research. Line elements can mimic the structural behavior such that they can carry axial loads, shear, bending and torsional forces (Dufour, 2003). Further, the actual cross-sectional properties are virtually attached to these line elements which mimic the reality.

It should be mentioned here that the choice of modelling with line elements was also determined by its accuracy in terms of connections or joints. As the line elements join at one point or node, there are less chances of inaccuracy of joining these elements, i.e., rigid connections are made at the junctions, hence ensuring a reliable model calibration. This is further elaborated in the next section where different types of connections are compared. Figure 8.59 shows the translation of the proposed structural system to line elements for FEA in Ansys.

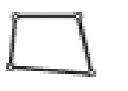










Element Order	2D Solid	3D Solid	3D Shell	Line Elements
Linear	PLANE42, PLANE182 	SOLID45, SOLID185 	SHELL63, SHELL181 	BEAM3/44  BEAM188 
Quadratic	PLANE82/183  PLANE2 	SOLID95/186  SOLID92/187 	SHELL93 	BEAM189 

Table 8.20: Different types of elements for FEA modelling. Source: (Dufour, 2003).

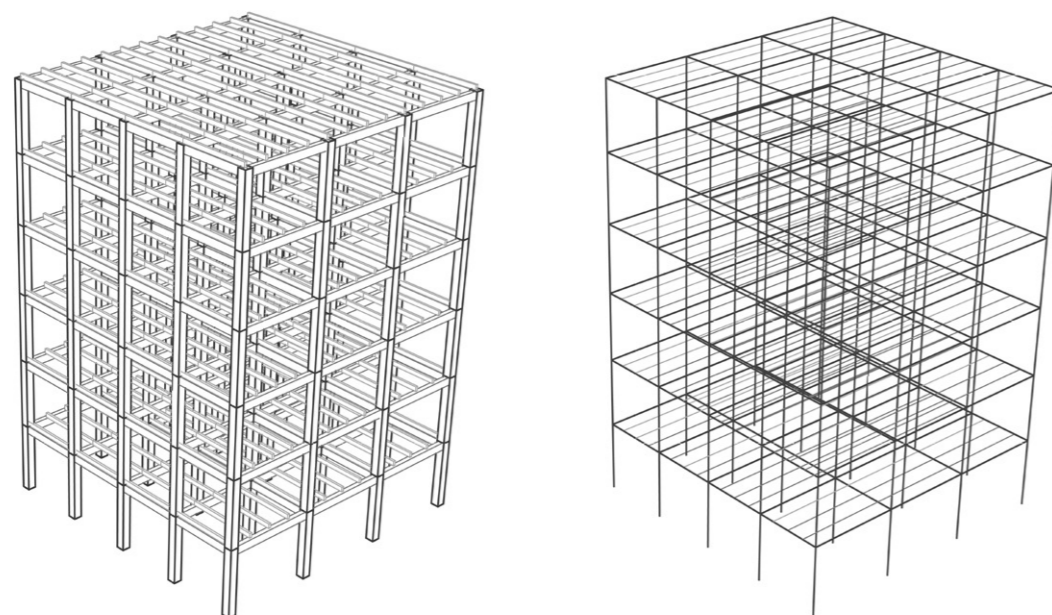


Figure 8.59: Conversion of the 3D structural geometry to a linear line element diagram for FEA in Ansys.

8.11.2 Model calibration

Model calibration can be defined as the process of adjusting the boundary conditions or parameters in the computational virtual environment to reduce the margin of uncertainties between the reality and the predictions. This is the most important step in any FEA on which determines the validity of results. The main aim of model calibration is to match the results on a simplified scheme, such that those settings can be used for simulating complex configurations which is difficult for analytical calculation.

Though there are various methods of model calibration, for the purpose of this research the model is calibrated with the analytical calculation as per the guidelines of the National building code of India. As mentioned in section 8.9 and appendix G, the NBC of India elaborates on detailed calculation for the response spectrum method. Also, Ansys has a provision for the response spectrum structural analysis in its workbench. Thus, the numerical model of response spectrum is calibrated to get as close as possible to the analytical calculation of response spectrum.

6 models have been used for the validating the calibration. The models have been calibrated on the basis of the time-period and the maximum deflection of a structure as per the response spectrum analysis. The procedure of the analytical calculation of the response spectrum method is as per IS 1893 (Part 1):2002 and the NBC – 2016. The detailed procedure for calculation is explained in appendix i. This calculation has been repeated for the 6 sample models and the results of the time-period and deflection from analytical calculation are shown in table 8.21.

The ansys model was thus calibrated to get as close as possible to the time-period and deflection provided in table 8.21. Since the modelling system was determined to be linear line element as discussed in previous section 8.7.1, the three major parameters that determine the output of a FEA line element model are:

- The material properties, particularly value of young's modulus and density.
- The dimensions of the model elements
- The type of joinery/connection at the node which connect the elements

The first two parameters are the same in the calculation and the FEA setup in Ansys. Thus, the model was tested for different types of joineries at the nodes which connect the building line elements. The column-beam joinery should be such that it mimics the proposed system and matches the analytical calculation. Three types of connections were used to test the model as shown in table 8.22.

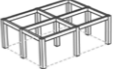

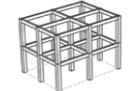
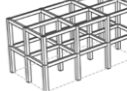
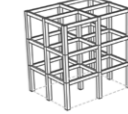
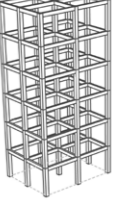
	1	2	3	4	5	6
Calibration models						
Degree of freedom (DOF)	1	1	2	2	3	6
Time period (s)	0.05	0.03	0.071	0.071	0.1	0.198
Deflection (mm)	0.3	0.163	3.13	3.23	7.9	30.6

Table 8.21: Analytical calculation for deflection and time-period, of 6 models, using the Response spectrum method as per NBC and IS 1893.

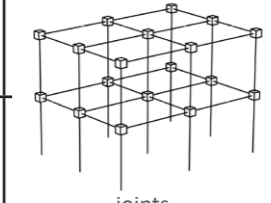
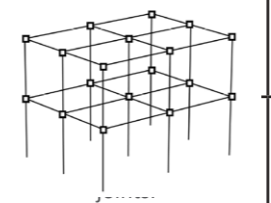
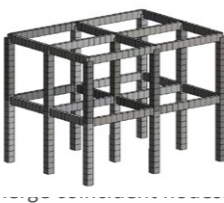
Connection type	Solid node	Point node	Mesh intersection
			
Description			

Table 8.22: Different types of element connections methods in Ansys.

Given that all other parameters are constant the test simulations were made using the 3 different types of joinery. Appendix H elaborates on the material input and model setup for response spectrum earthquake analysis in Ansys. The results of the 3 different node connections for the each of the 6 models shown in table 8.23. We can infer from the values given in table 8.23 that modelling using point node gives values closest to that of the analytical calculation. Also, the accuracy ranges between 12% - 20% for point node as compared to the other two having deviation of up-to 300%. It should be noted that the analytical calculations are based on various assumptions determined by local bye-laws, however, the numerical simulation on Ansys is determined by global standards at large. Also, the process of analytical calculations includes rounding off the numbers which can lead to inaccuracies in the final value. However, it should be noted that the values obtained from FEA using the point node exceed the values of analytical calculation. Hence in this case the results from FEA will not underestimate the deviation, when viewed from the point of structural validation. The results achieved by using the point node connection in FEA simulation in Ansys is considered valid for the purpose of this research and is used for final structural validation.

Model no. (table 32)	Analytical calculation (table 32)		Solid node		Point node		Mesh intersection	
	Time period (sec)	Deflection (mm)	Time period (sec)	Deflection (mm)	Time period (sec)	Deflection (mm)	Time period (sec)	Deflection (mm)
1	0.05	0.3	0.035	0.31	0.035	0.31	-	-
2	0.03	0.16	0.03	0.24	0.032	0.24	-	-
3	0.07	3.13	0.07	1.74	0.073	3.65	0.112	10.16
4	0.07	3.23	0.054	1.5	0.074	3.82	0.111	11.18
5	0.1	7.9	0.07	1.9	0.105	8.96	0.177	23.84
6	0.198	30.6	0.11	8.47	0.212	36.89	0.384	104.67

Table 8.23: FEA in Ansys workbench using response spectrum method for model calibration using 3 connection types for 6 models.

8.11.3 Final structural validation

The proposed 'hybrid timber construction technology' includes elements like the core which will determine the overall structural performance. Also, in reality the geometry will consist of a greater number of bays than those models tested for calibration. For the purpose of judgement 3 cases for housing were planned, based on different core locations. However, the number of apartments per-floor, the grid-size of 3x4m and 6 stories were constant in all 3 layouts, the size of apartments vary slightly given the placement of core. Planning has been done on the minimum spatial requirements provided in the NBC-2016. Figure 8.60 shows the 3 proposed cases for structural validation.

The 3 types of core are a) central core, b) corner core (however, this has been extended to form the central part of the building to follow the principle of symmetry) and c) detached core. These were simulated in Ansys under the response spectrum given the actual loading conditions, as per section 8.2 and the proposed local building materials. The junction where the primary beams meet the core are considered

as fixed support, while the rest are modelled as point nodes. Table 8.24 shows the results of the final FEA simulations. From the results it can be noticed that the building with central core performs the best and is structurally more rigid as compared to the other two. The building with the detached core, or simply timber construction shows maximum amount of deformation. It can be concluded that concrete core adds to the global strength of the proposed timber construction along with the additional benefits of fire safety. However, the maximum deflection for all the 3 cases is below the allowable permissible limits, hence the structure is valid.

It should be mentioned that in this case FEA does not include energy dissipation through damping in the members, which add to the overall structural performance. Also, the analytical calculation provided in the Indian bye-laws are standardized for 5% damping, which could be inaccurate for the proposed timber structure. Also, the joints have currently been modeled as rigid joints without consideration of actual frictional energy dissipation, this also affects the final output. It should be mentioned that this analysis is a rough approximation of what could be possible, an in-depth study of the joineries have to be made to accurately predict the global performance. Nevertheless, the numbers prove the validity of the structure and opens up a large possibility of research in this area.

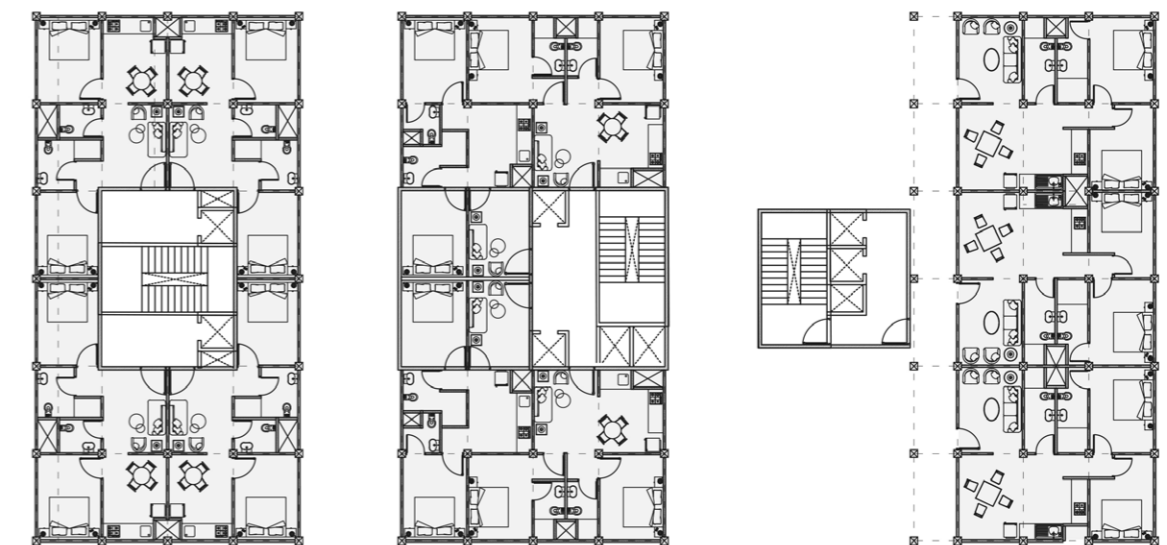


Figure 8.60: 3 types of plans with a) central core b) corner extended core c) detached core.

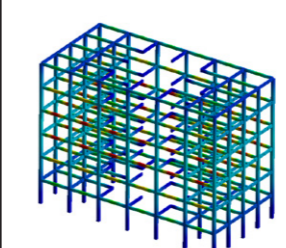
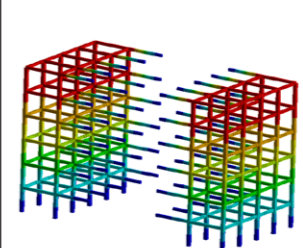
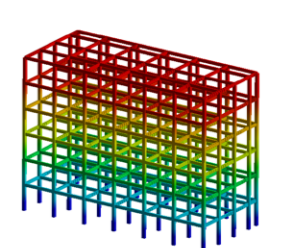
	Central core	Corner core (extended)	Detached core
Building case			
Time period for mode 1	0.046 sec	0.181 sec	0.245 sec
Maximum deflection in y-axis	0.47 mm	27.11 mm	48.37 mm
Allowable deflection (0.004*building height)	72 mm	72 mm	72 mm

Table 8.24: FEA results for response spectrum for the 3 test cases.

9

DIGITAL TOOL

Introduction to the digital tool

For the greater benefit of the society, the initial ideology was 'to share what is learnt' through the process of this research by design. Such researches could aid in technical advancement of the region, if further worked upon. Though the timber construction technology proposed in this academic research is at a nascent stage, it is believed that implementation of such a proposal could indeed revolutionize the built environment of the region and add to the global goal of sustainable development.

Since the research comprises of scientific details, it has been proposed that it reaches the local population through the trained professionals of the region, who are qualified to judge the technicalities presented in this research. This academic research is limited to very few aspects like structural design, thus it is recommended that the professionals add their multi-disciplinary knowledge to further develop this technology before putting it out in the market. Also, the construction technology needs architectural articulation based on the needs of end user, thus the professionals will play an important role in chain of practical implementation of this research.

The design logic which has been developed in this course of research, has been encoded in a digital tool. It is aimed that this tool should be easily accessible, have an easy to use interface and inform the professionals of the structural possibilities of this hybrid timber construction technology, as well as quick visualization of the structural system. The scope of development of this tool includes encoding the structural design logic in an existing software package which is commonly used by professionals in the region. Though there are multiple software packages available in the design and construction industry, Grasshopper3d which is an inbuilt plug-in in Rhinoceros 3D computer application, has been used for the purpose of this design tool. The Rhinoceros 3D, commonly called Rhino, is commercially available for use and is popular amongst professional in the architecture industry. The aim of the development of the digital tool in this research has been to develop an interface which is very easy for a professional to use. The following sections elaborate on the concept and working of this digital tool.

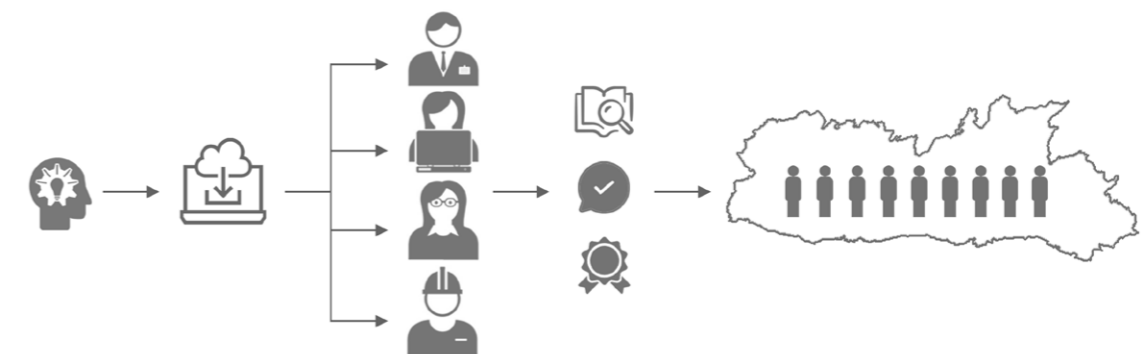


Figure 9.1: Digital tool user group concept.

9.1 Target user group

The design logic of this research comprises of multiple layers of data processing ranging across a diverse methodology which includes abstraction of concepts, extraction of specifics, analytical calculations and numerical simulations. Since, the hybrid timber construction technology is the result of this intertwined multidimensional methodology, its design logic has to be simplified for the purpose of encoding in a digital tool. This simplification leads to elimination and merging of certain steps in the design process, which in turn determines the capacity or output of the digital tool. The elimination includes processes like laboratory testing and structural simulations, which were the part of original design process, while the merging includes pre-calculation of structural sizes. These have been elaborated in further sections. This simplification to a large extent is a result of conscious judgement based on the technical boundary conditions and personal choices of the developer which determines the degree of freedom given to the user in the digital tool.

The degree of freedom is the extent of liberty given to the user with which he/she can influence the output of a given design logic. Based on the degree of freedom there are two types of users:

- a) Basic user
- b) Advanced user

A person can choose to be a basic or advanced user depending upon his/her intentions and desired output from the determined design logic. While the advanced user has the freedom to customize the output by influencing any design parameters at a given time in the design process, the basic user has to work under a given set of boundary conditions with limited freedom of input in the design process. However, the advanced user is bound to follow the step by step methodology of the design logic and customize the inputs of this research to get the final desired output. This can be a tedious task as the advanced user has to go through the process of calculations and simulations which were a part of this research. The basic user on the other hand can work with pre-determined boundary conditions and controlled output, without the need to get into the tedious calculations and simulations involved in a design process to generate quick data of the construction technology.

For this research, the digital tool caters to the basic user group.

While the advanced user has to follow the process of this research and steps elaborated in previous sections to get the output. The basic user can use the digital tool with the pre-coded design logic to get the output. Though the basic user has limitations to freedom in influencing the output, he/she can quickly visualize the structural aspects of hybrid timber construction technology at an early design phase.

As the digital tool targets the basic user group, it is aimed that the user interface is as simple as possible, whilst providing the output of a structural 3 Dimensional grid of the timber construction framework as shown in figure 134. The user input in the digital tool comprises of two parameters:

- a) Building footprint – polyline or curve
- b) Structural grid dimension in plan (column location in x & y axis) – choose from given possibilities, where x axis represents the secondary beam direction and y-axis represents the primary beam direction,

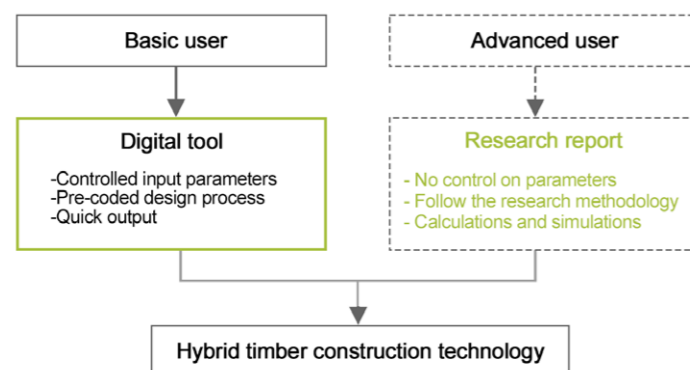


Figure 9.2: Types of users for the hybrid timber construction technology.

this is further explained in following sections.

The output of digital tool comprises of:

- a) The number of possible bays in the given building footprint
- b) The number of possible storeys with respect to the input of grid-size
- c) The cross-sections of the column, primary and secondary beams
- d) The list or names of joineries based on location of the building
- e) Concept 3D model of the timber frame structure.

It has to be noted that the final output of the design tool comprises of a structural system that needs post-processing to a large extent before being delivered to the end user. The output of this design tool should be used only for the initial design phase, proceeded by detail verification of the proposal and addition of all other necessary details. The user or the professional has to be aware that the post processing includes architectural planning considering the given column grid, addition of all service elements including the core, plumbing, electrical, fire-fighting, HVAC, etc. Inclusion of these other elements will also affect modification of the building produced by the design tool. Further, it should be noted that as the main area of focus of this research was in the structural field, further works has to be made on the thermal, acoustical and other physical comfort properties to ensure a wholistic working of the proposed technology. Figure 9.4 shows the conceptual diagram of important systems to be integrated during the post-processing phase.

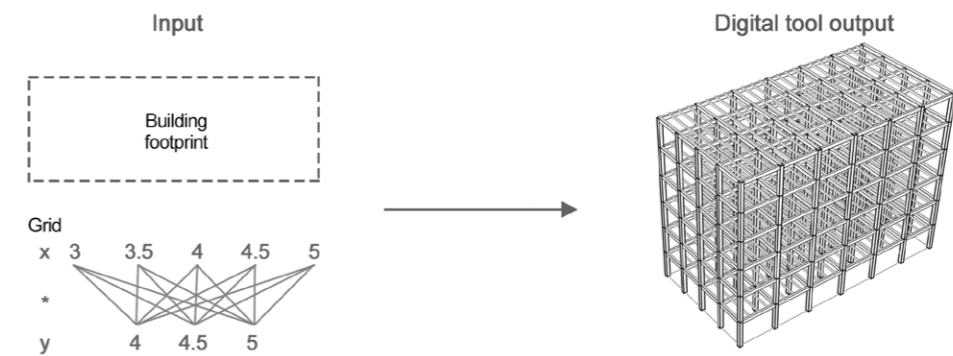


Figure 9.3 graphically shows the input (building footprint and grid) and output (timber structural system) of the digital tool.

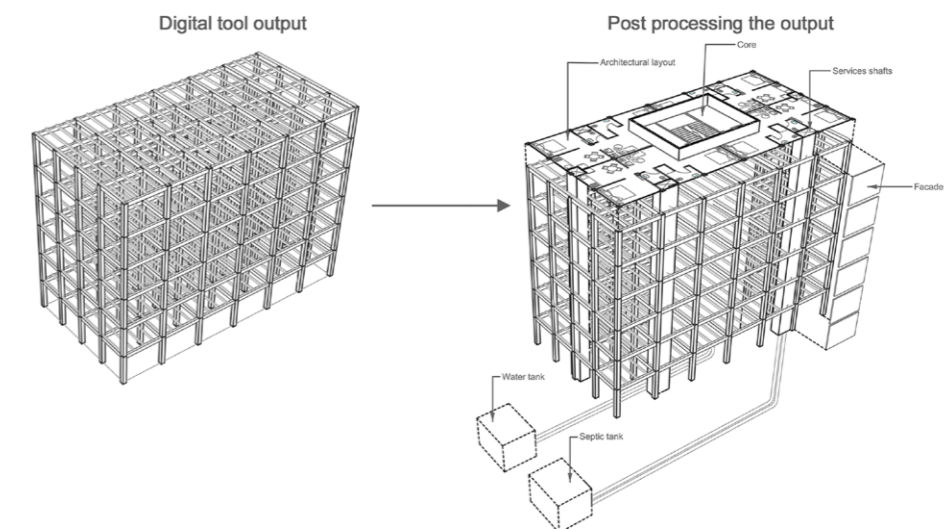


Figure 9.4: Post processing of the digital tool output by the user group.

9.2 Formulation of design logic for digital tool

In order to formulate a design logic for a construction technology firstly it is important to understand all the steps involved in the traditional or the general method of designing. Followed by which it is important to know what is physical end product of the design. A building design procedure, to a certain extent, could be standardized based on the common routines followed by practitioners in the region in the present times. However, this procedure could vary with the scale of the project and from place to place. Figure 9.5 shows an overview of the basic steps involved in building construction process. Though important steps which involve the planning and designing of architectural features, building envelope, building physics, construction logistics, etc. have not been elaborated in this scheme, and certain steps could be iterative, it is a basic representation of commonly followed design procedure.

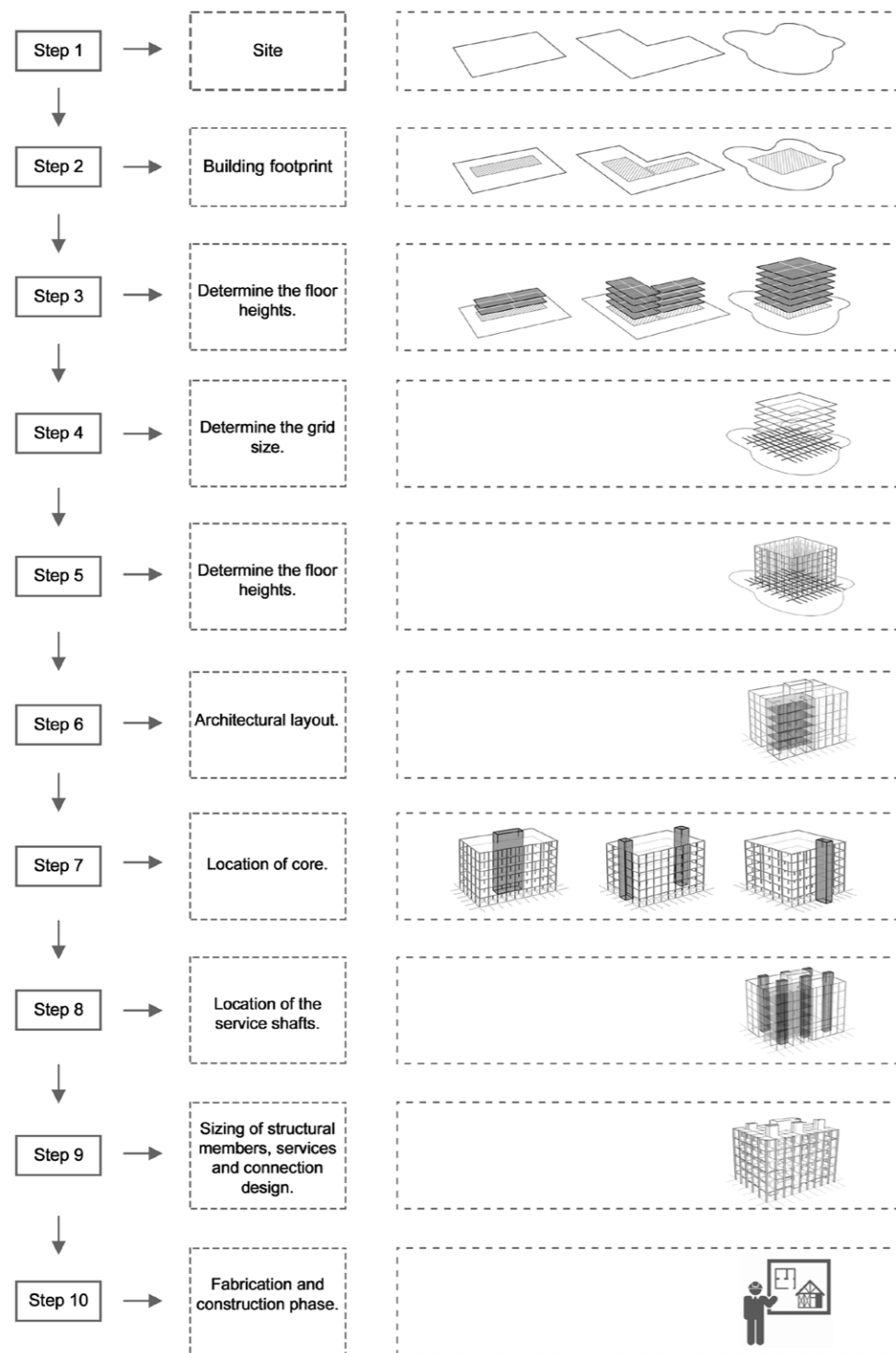


Figure 9.5: Flowchart of commonly practiced building design procedure (fabrication logo source: the nounproject.com)

Figure 9.5 shows a standardized procedure for a traditional building design in the architecture industry, however with the use of the proposed digital tool, there will be a shuffling of this procedure whereby the pre-determination of structural sizes will precede the architectural design. Figure 9.6 shows the location or role of digital tool in the building design process, the steps covered by the tool and its influence on the overall building design procedure.

The location of the digital tool in the design process is important to understand how the input, that is the grid-size and the footprint, gets converted to the output, that is the structural members sizes; as one knows what ingredients are available for the processing.

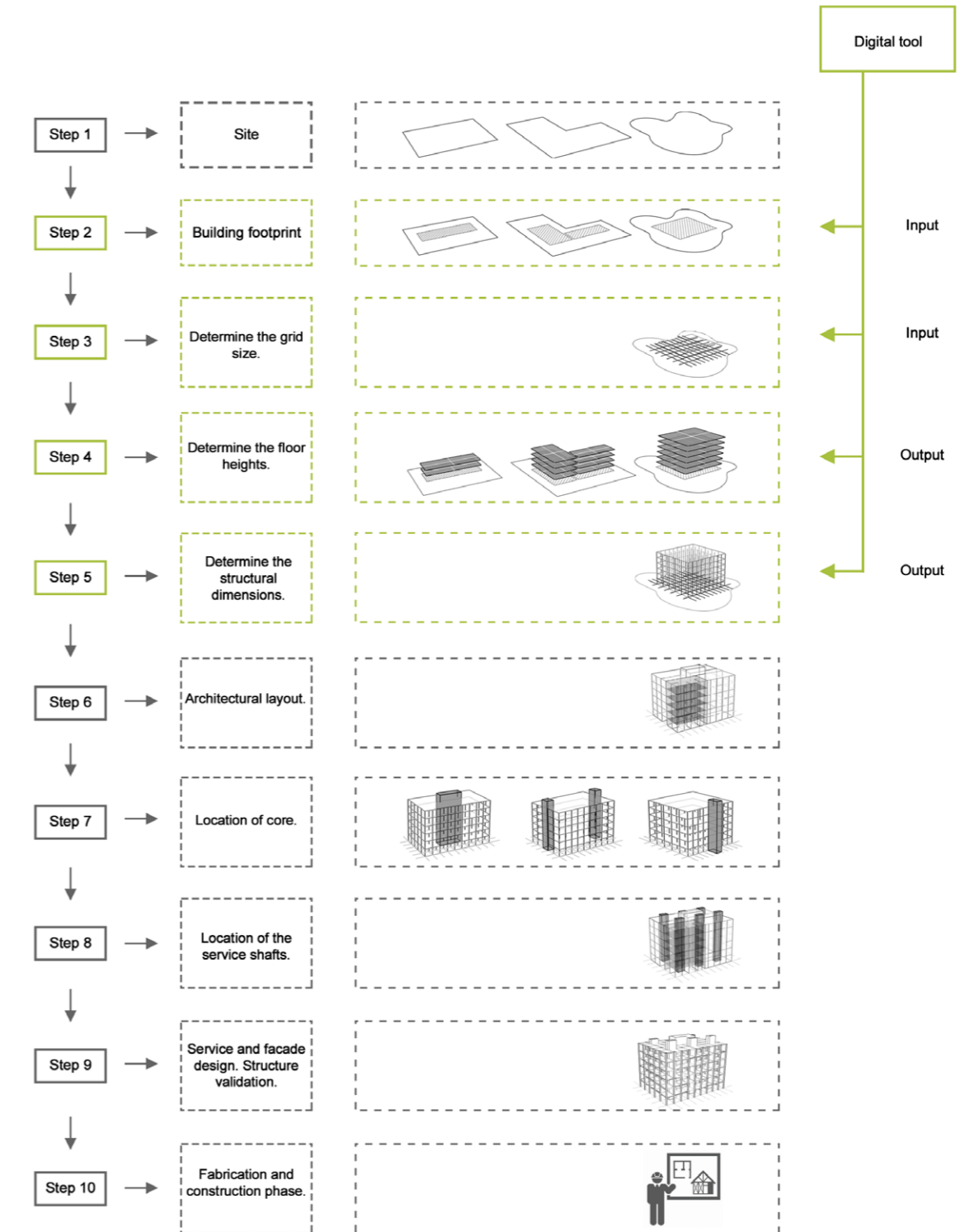


Figure 9.6: Location of the digital tool in the process of building design procedure.

9.2.1 The processing procedure of digital tool

The logic that goes behind this processing is directly determined by the research by design procedure for the hybrid timber construction elaborated in section 8. However, the data from the analysis of the experiments, analytical calculations and numerical simulations have been extrapolated in such a way that they can be coded in the digital tool. It should be mentioned that it is not feasible to run the softwares like Ansys, in the processing procedure of the digital tool. Thus, inferences drawn from the results of these steps have to be pre-coded in the digital tool. These inferences determine the limitations, which are elaborated in further sections, of the digital tool in terms of output. It is also known that the hybrid timber construction technology consists of multiple connections. Therefore, a connection identification system was derived with respect to the location of the connections in the building. The aim of this connection identification system was to systematically arrange the nomenclature of the connections in the digital tool such that it is readable for the user and also does not take a toll on the time taken for the computing.

The tool has been designed under the following boundary conditions:

- The unit of the digital tool is in meters, i.e., all the sizes of the members have been coded are in meters.
- The materials of the structural members are already taken into consideration in the design calculation and the user does not have the freedom to change or modify the properties of these materials.
- The floor to floor height of each storey is a constant of 3m and the maximum proposed height of this construction technology is 18m, consisting of 6 storeys.

9.2.2 Inputs

It must be noted that certain rules have been set for the functioning of the digital tool which are associated with its technical functioning. The first rule includes that the input of the building footprint should always be a right-angled quadrilateral, which leads to the case that the input can only be rectangle or a square. If in any case the building footprint consists of any other geometry than a rectangle or square, it should be simplified to a rectangle or square for input in this digital tool as shown in figure 9.7.

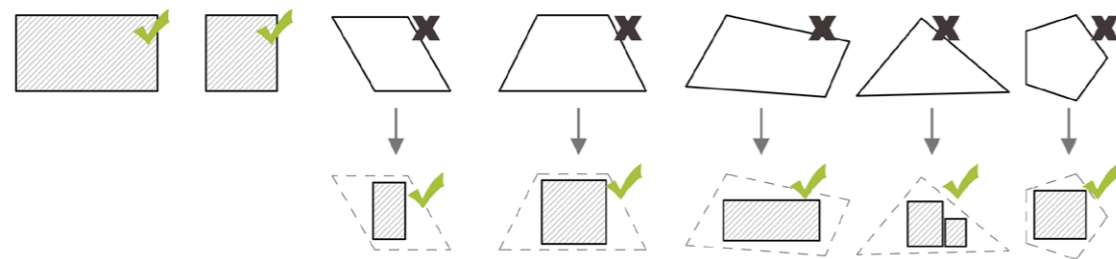


Figure 9.7: Rule for inputting a right angled quadrilateral.

Secondly, the digital tool is designed for the input of only one building footprint at a time. There might be cases for a given site condition which demands more than one building, in this case the design tool should be used to determine the construction system for one building at a time.

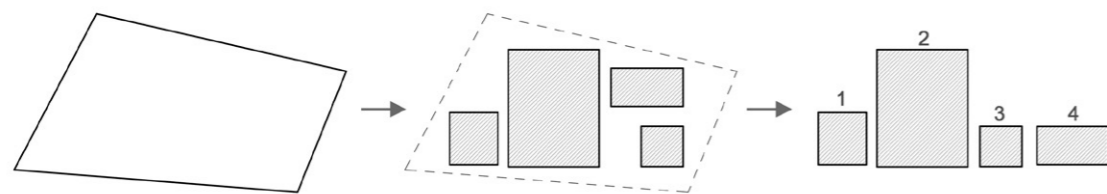


Figure 9.8: Rule for inputting one quadrilateral.

Thirdly, the input of the footprint which is a quadrilateral should always be a polyline drawn in the fashion starting from a point - positive x, positive y, negative x and negative y direction as shown in figure 9.9. This is because in terms of computational language the polylines comprise of vectors which have a direction,

and the digital tool has limitation in understanding the direction of these vectors. Any other input of quadrilateral constructed in any other direction will give unwanted results, that is results which deviate from the actual building footprint. Figure 9.9 shows how the output of the plan has shifted with respect to the starting point of the quadrilateral and the direction of drawing the polyline.

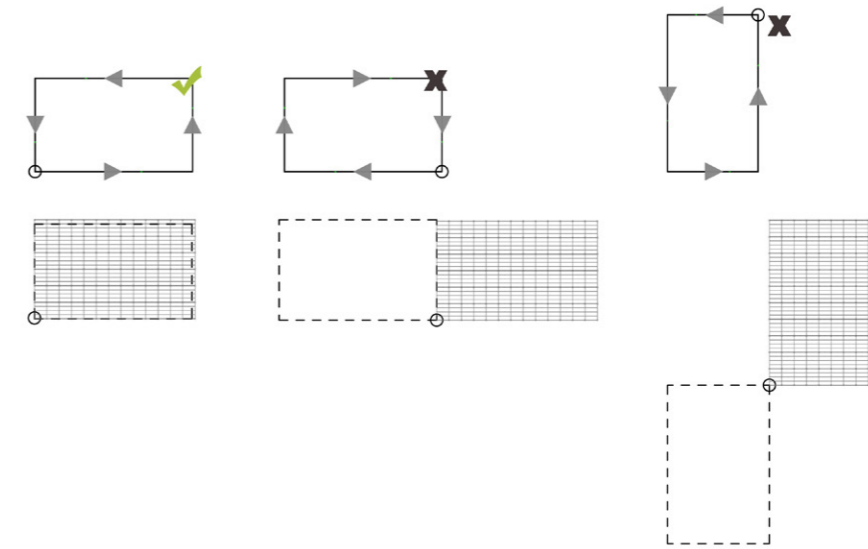


Figure 9.9: Rule for drawing the polyline in correct direction with respect to the starting point, which will determine the location of the output of the digital tool as shown in the lower diagram.

Fourthly, the input of grid size comprises of a choice from 15 combinations in the digital tool. Theoretically, N number of combinations are possible for the grid size, however, the minimum spans based on the minimum spatial requirements of 3m x 4m, as explained in section 8.1 and the maximum spans of 5m by 5m that can be practically achieved in terms of material availability and material capacity have determined the limits. Figure 9.10 shows the possible combination sizes with the digital tool.

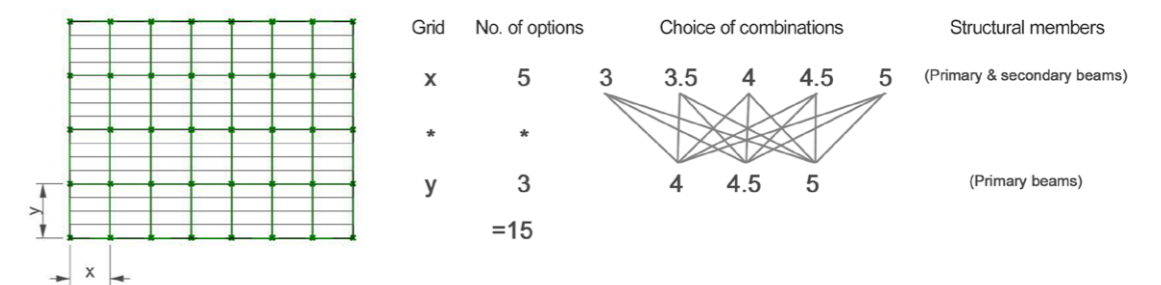


Figure 9.10: Grid size input choices.

9.2.3 Outputs

The digital tool has two categories of output:

- the structural member sizes of column, primary beam and secondary beam
- the nomenclature system for 4 joineries.

The structural member sizes consist only of the cross-sectional dimensions which are the result of structural calculations presented in section 8. The tool outputs the geometrical cuboids which are devoid of any joinery articulation. For the columns specifically, the digital tool does not output a hollow column wherever applicable, rather the identification of type of column is accommodated in the nomenclature system. Thus, the digital tool outputs the approximate visual structural system given the grid-dimensions. Also the digital tool automatically determines the building height for a given grid-size.

The nomenclature system has been established to identify the joinery with respect to various junctions. Only 4 joineries have been incorporated in this tool, namely:

- Column joinery (for box column)
- Column to primary beam joinery
- Column to foundation joinery
- Secondary beam to primary joinery

The incorporation procedure and the nomenclature logic have been elaborated in further sections. However, the same logic could be used to introduce other joineries in a building. Further in order for the user to access the details, a link is provided to a catalogues which elaborates particularly the fabrication process of each joinery. Figure 9.11 shows the output of the digital tool, which was developed in grasshopper3D for this research, comprising of the cross-section of various members and the nomenclature.

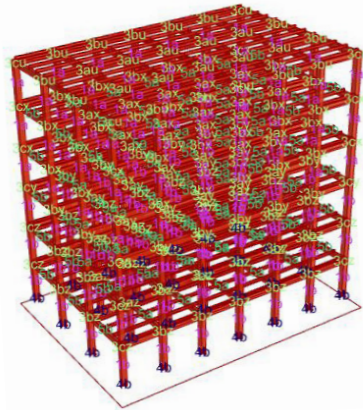


Figure 9.11: Digital tool output in grasshopper3D.

9.2.4 Data processing logic

Taking the two given inputs, the building footprint and the grid-size, the digital tool uses the logic and the findings of research by design to process the data. The processing is done in the following steps:

- Determining the number of bays.
- Determining the structural sizes of the members.
- Determining the possible floor heights.
- Determining the location of various joineries and their nomenclature system

Each step is further elaborated in detail.

1) Determining the number of bays: A bay can be defined as the number of grids in x and y direction. This is directly dependent on the building footprint size, that is the length of each side (x or y) of the quadrilateral and the grid size in x and y direction. The number of bays in along each length (x or y) can be determined by the following relationship:

$$\text{Number of bays along side } a = (\text{Total length of side } a \text{ of the quadrilateral}) / (\text{Grid size along side } a)$$

This expression is used to directly determine the number of bays depending upon the footprint of the building and the given input of the grid-size.

2) Determining the structural sizes: The digital tool aims to output the structural dimensions of the columns, primary beams and secondary beams. It should be mentioned here that structural dimensions include only the overall cross-sectional size of the members. The actual design of the cross-section, joineries and details related to each member are not included in the visual output of this tool; rather they have been accommodated in the joinery nomenclature system.

The structural sizes are most importantly dependent upon the material properties, the length of members, the loading conditions and the provisions given in the national building code of India. It is already assumed that the columns and primary beams are made of local hardwood, Shorea Robusta and secondary beams are made of Pinus Kesiya. Section 8.2 elaborates the detailed procedure to determine the structural sizes for a certain set of given condition. It can be seen that Karamba3D, an FEA plugin for software grasshopper3D

<pre> Primary beam: if (x==3 and y==4): a=-0.100 to 0.100' b=0 to -0.35' if (x==3 and y==4.5): a=-0.1125 to 0.1125' b=0 to -0.35' if (x==3 and y==5): a=-0.1375 to 0.1375' b=0 to -0.35' if (x==3.5 and y==4): a=-0.1125 to 0.1125' b=0 to -0.35' if (x==3.5 and y==4.5): a=-0.125 to 0.125' b=0 to -0.35' if (x==3.5 and y==5): a=-0.125 to 0.125' b=0 to -0.375' if (x==4 and y==4): a=-0.125 to 0.125' b=0 to -0.35' if (x==4 and y==4.5): a=-0.1375 to 0.1375' b=0 to -0.35' if (x==4 and y==5): a=-0.1375 to 0.1375' b=0 to -0.375' if (x==4.5 and y==4): a=-0.1375 to 0.1375' b=0 to -0.35' if (x==4.5 and y==4.5): a=-0.1375 to 0.1375' b=0 to -0.375' if (x==4.5 and y==5): a=-0.150 to 0.150' b=0 to -0.375' if (x==5 and y==4): a=-0.1375 to 0.1375' b=0 to -0.375' if (x==5 and y==4.5): a=-0.150 to 0.150' b=0 to -0.375' if (x==5 and y==5): a=-0.150 to 0.150' b=0 to -0.4' else: print 'If error message is displayed check grid-size input' </pre>	<pre> Secondary beam: if (x==3 and y==4): a=-0.0500 to 0.0500' b=0 to 0.200' if (x==3 and y==4.5): a=-0.0625 to 0.0625' b=0 to 0.2' if (x==3 and y==5): a=-0.05 to 0.05' b=0 to 0.2' if (x==3.5 and y==4): a=-0.075 to 0.075' b=0 to 0.2' if (x==3.5 and y==4.5): a=-0.0875 to 0.0875' b=0 to 0.2' if (x==3.5 and y==5): a=-0.075 to 0.075' b=0 to 0.2' if (x==4 and y==4): a=-0.075 to 0.075' b=0 to 0.25' if (x==4 and y==4.5): a=-0.075 to 0.075' b=0 to 0.25' if (x==4 and y==5): a=-0.075 to 0.075' b=0 to 0.25' if (x==4.5 and y==4): a=-0.0875 to 0.0875' b=0 to 0.25' if (x==4.5 and y==4.5): a=-0.0875 to 0.0875' b=0 to 0.25' if (x==4.5 and y==5): a=-0.0875 to 0.0875' b=0 to 0.25' if (x==5 and y==4): a=-0.0875 to 0.0875' b=0 to 0.275' if (x==5 and y==4.5): a=-0.0875 to 0.0875' b=0 to 0.275' if (x==5 and y==5): a=-0.0875 to 0.0875' b=0 to 0.275' else: print 'If error message is displayed check grid-size input' </pre>
---	---

Figure 9.12: Python code for determining cross-section sizes of structural elements for respective grid-size.

has also been used in the process. Also, the procedure demands validity with respect to horizontal shear, flexural strength and deflections, thus the calculations are an iterative process till a balance between the permissible limits and the desired configuration is achieved. This is a complex process in whole.

Given that the digital tool caters to specific grid size options. The structural dimensions for these different combinations have been pre-calculated and coded in the digital tool, the code is shown above in figure 9.12. The structural calculations for these 15 combinations of grid-sizes are shown in appendix B. It is known from the research by design of columns of the proposed construction technology that all the columns have the same visual appearance irrespective of its composition, i.e., box or solid column; thus they all measure the same 350mm by 350mm on the outer edge. Hence, for the purpose of the digital tool output, irrespective of the grid-size, all the columns display a structural size of 350mm x 350mm. However, the cross-sections change for primary and secondary beam with respect to the change in grid-size as seen in appendix B. In order to accommodate this change with change in input in the digital tool, the sizes have been coded in the digital tool. The coding has been done in computational language using the conditional statement of 'if', by which the tool can execute the command of determining structural member sizes given the input of grid-sizes. The code used in the digital tool for this purpose is shown in figure 9.12, where a is the breadth of the cross-section in meters and b is the depth of the cross-section in meters for the given grid combination of x & y.

3) Determining the possible floor heights: The loads on each floor for each grid size have already been determined in the structural calculation in section 8.2. These loads have been used to determine the column cross-sections as shown in appendix B. Now, the columns and beams are joined together at the node shown in section 8.5. This node design has been presented and tested under compression and under cyclic loading whose results are also shown in section 8.5. From these laboratory tests, the maximum loading capacity of this node has been determined (calculations shown in section 8.7) to be 1200 kN. Section 8.8 details the concept of determining the number of floors given a certain the capacity of the column-beam joinery and the grid-size. This aspect has been coded in the digital. The conditional statement of 'if' has been used here to determine the output in the digital tool. The code is shown below in figure 9.13, where output= a represents the number of storeys for given grid combination of = x & y.

```

Number of storeys:  if (x==3 and y==4):
                    a=6
                    if (x==3 and y==4.5):
                        a=5
                    if (x==3 and y==5):
                        a=4
                    if (x==3.5 and y==4):
                        a=5
                    if (x==3.5 and y==4.5):
                        a=4
                    if (x==3.5 and y==5):
                        a=4
                    if (x==4 and y==4):
                        a=4
                    if (x==4 and y==4.5):
                        a=4
                    if (x==4 and y==5):
                        a=3
                    if (x==4.5 and y==4):
                        a=4
                    if (x==4.5 and y==4.5):
                        a=3
                    if (x==4.5 and y==5):
                        a=3
                    if (x==5 and y==4):
                        a=3
                    if (x==5 and y==4.5):
                        a=3
                    if (x==5 and y==5):
                        a=3
                else:
                    print 'If error message is displayed check grid-size'

```

Figure 9.13: Python code for determining the number of floors for respective grid-size.

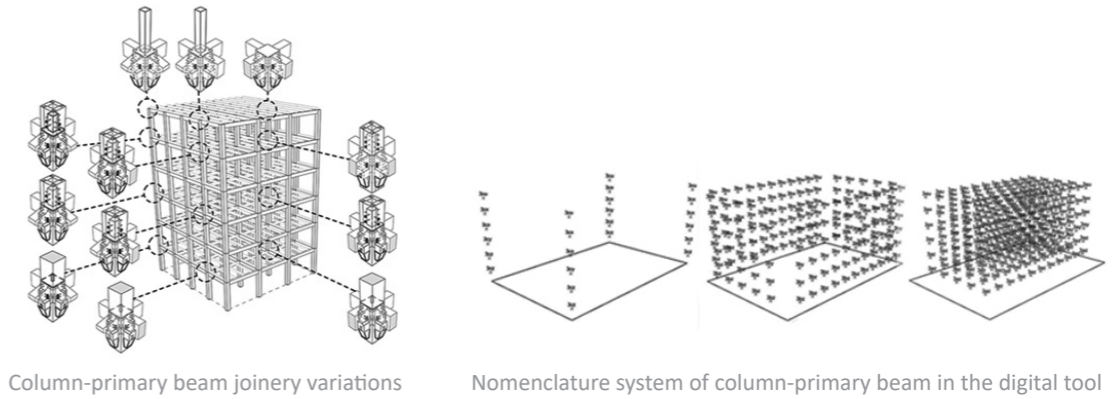
4) Determining the location of various joineries and their nomenclature system: The digital tool also aims to tell the user of the location and type of important joineries for the construction technology. Section 8.10 elaborates on the conceptual proposals of various joineries. Though an actual building construction comprises of complex connections, this digital tool takes into account only 4 of which have been conceptualized in section 8.10, where the digital tool does not have provision for the location of a core and its connections. This is beyond the scope of the digital tool as explained in the introduction of section 9.2 as the location of core, shafts and services comes in post-processing of the digital tool. Thus, only the following joineries have been taken into account:

- Joinery Series number
- 1 Column joinery (for box column)
 - 3 Column to primary beam joinery
 - 4 Column to foundation joinery
 - 5 Secondary beam to primary joinery

These joineries have further sub-divisions based on their location in the building, example central location, edge or corner location. The nomenclature of these joineries are as follows:

- 1 - Column
- 1a Hollow (box) column
- 1b Solid column
- 3 - Column-Primary beam joinery
- 3ax Column (hollow to hollow)-primary beam, center location
- 3ay Column (hollow to solid)-primary beam, center location
- 3az Column (solid to solid)-primary beam, center location
- 3au Column (hollow)-primary beam, center-terrace location
- 3bx Column (hollow to hollow)-primary beam, edge location
- 3by Column (hollow to solid)-primary beam, edge location
- 3bz Column (solid to solid)-primary beam, edge location
- 3bu Column (hollow)-primary beam, edge-terrace location
- 3cx Column (hollow to hollow)-primary beam, corner location
- 3cy Column (hollow to solid)-primary beam, corner location
- 3cz Column (solid to solid)-primary beam, corner location
- 3cu Column (hollow)-primary beam, corner-terrace location
- 4 - Column-concrete foundation joinery
- 4a Column (hollow)-concrete foundation joinery
- 4b Column (solid)-concrete foundation joinery
- 5 - Primary beam-secondary beam joinery
- 5a Primary beam-secondary beam joinery, center locations
- 5b Primary beam-secondary beam joinery, edge locations

It can be noted that certain joineries have a double suffix - xa, while some have one - a. This depends upon the number of parameters governing the design. For example, table 9.1 shows the concept nomenclature system for the column-primary beam joinery. Where, the number 1,2,3,4,5 represents the joinery name, a, b or c determines the location with respect to center, edge or corner and x, y, z represent the location with respect to connections between the different types of columns. The location of these joineries has been determined in the digital tool with respect to the intersection points and junctions of elements. Figure 9.14 graphically shows the location of different columns and joineries with respect to location in a building.



Column-primary beam joinery	Hollow column to hollow column	Hollow column to solid column	Solid column to solid column	Always hollow, terrace joint
Series 3	x	y	z	u
Center location				
	3ax	3ay	3az	3au
Edge location				
	3bx	3by	3bz	3bu
Corner location				
	3cx	3cy	3cz	3cu

Table 9.1: nomenclature system for column-primary beam joinery based on the location and type of column.

The nomenclature system for the various joineries consists of these abbreviations which outputted in the digital tool. The digital tool has a provision of an external link to a catalogue for identification of these joints via the labelled abbreviations. This catalogue details out the fabrication and assembly sequence of the joineries. Section 9.5 further elaborates on the concept and functioning of the product catalogue.

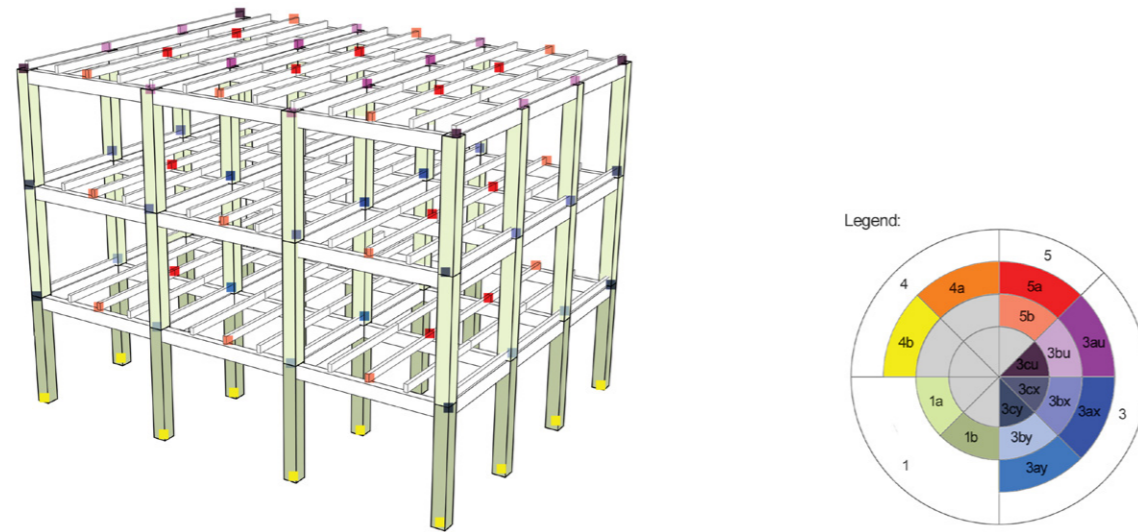


Figure 9.14: Location of various joineries in the building

9.3 Pseudocode of design logic

In order to convert the design logic explained in section 9.2 to a digital tool, the data-processing logic has to be translated to a programming language such that the computer understands. This translation is a three-step procedure whereby the design logic is first written as a pseudocode and this pseudocode is further developed into the computational language. Pseudocodes are simplified version of computational programming which are written for human understanding. Writing a pseudocode eases the computational coding or scripting and implementing the actual programming language in terms of mathematical notations. The pseudocode should be such that it can be translated to different programming languages as per the need.

The design logic has been developed into a pseudocode in the same order as the sequence of data processing logic elaborated in section 9.2. The pseudocode has been developed for two parts:

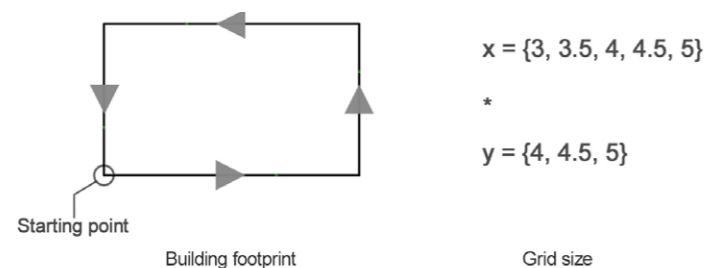
- Generating the structural elements or the geometry from the given input
- Using the locations on the structural geometry created above to generate the nomenclature system for joineries.

The following is the pseudocode for the proposed digital tool which encodes the design logic of the hybrid timber construction technology.

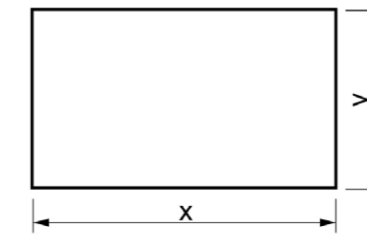
Generating the structural elements or the geometry from the given input:

//Step 1: Specify the Input-

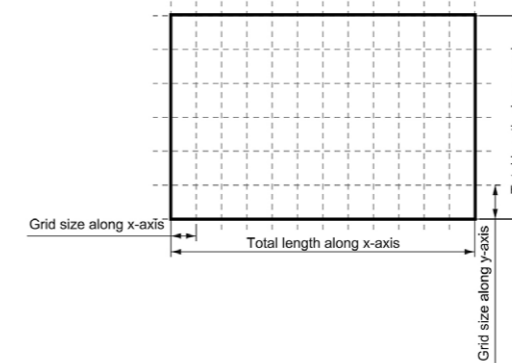
- Building footprint - as a simple rectangle (rectangle can be a polyline, or a set of points with the correct direction of vectors)
- Grid size - Choice from a set of available numbers. X axis = {3, 3.5, 4, 4.5, 5} and Y axis = {4, 4.5, 5}



//Step 2: Deconstruct the building footprint- identify the lengths of the vectors in x and y direction (axis).

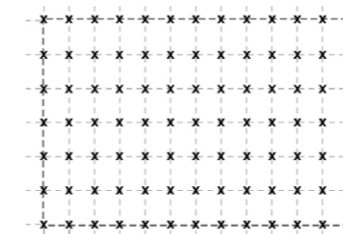


//Step 3: Determine the number of bays in x and y direction (axis) - Divide the lengths of each side of rectangle along each axis calculated in step 2, by the input of grid-size for each axis specified in step 1b. The formula for the calculation of the number of bays has been specified in section 9.2.4.

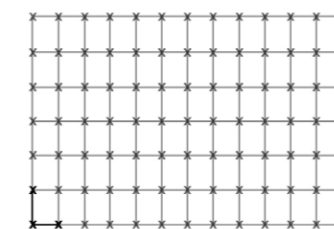


//Step 4: Generate the location of columns - Take the starting point (vertex) of the rectangle and create a series of points in the x and y axis. The series is created with respect to the grid-size of each axis and number of bays in the respective axis, that is,

- Total number of points in a direction = total number of bays (from step 3) + 1
- Distance between the points = grid size (from step 1b)



//Step 5: Generate the center lines of the primary beams - Join the series of points (created in step 4 along the x and y axis) to get the lines between them.



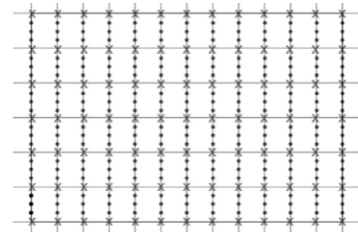
//Step 6: Specify the number of secondary beams with respect to the length of the primary beam - The number of secondary beams per length of the primary beam, have been pre-determined or assumed for the purpose of this construction technology. It should be noted that all the structural calculations have

been based on this pre-assumed number of secondary beams. The number of secondary beams vary with the length of the primary beams where, the length of the actual primary beam supporting the secondary beam = grid size input in the y-direction (step 1b). The following condition is given, where a= number divisions for secondary beams, with y=length of primary beam as input in step 1b.

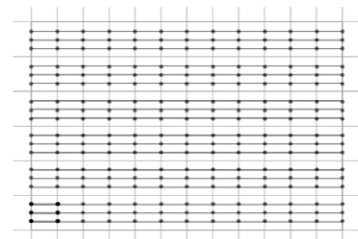
```
if (y==4):
  a=4
if (y==4.5):
  a=4
if (y==5):
  a=5
```

It should be noted here that actual number of secondary beams per bay = a +1.

//Step 7: Create the starting points of the secondary beams: Divide the length of the primary beam in y-direction (Step 2) by the number of divisions, value of a, specified in step 6.



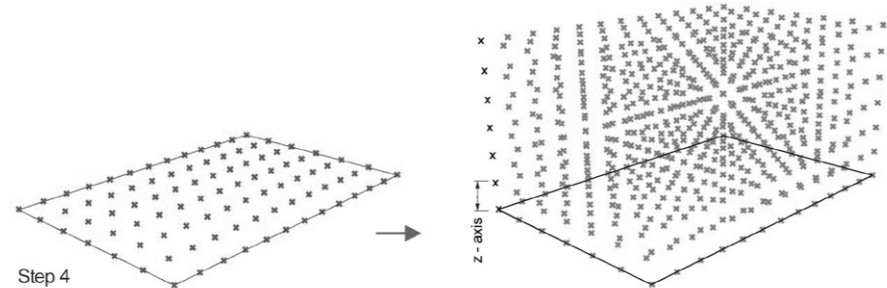
//Step 8: Create the center lines for secondary beams: Join the points for the secondary beam created in step 7 to get the lines between them such that these lines are along x-axis, (perpendicular to primary beams on y-axis).



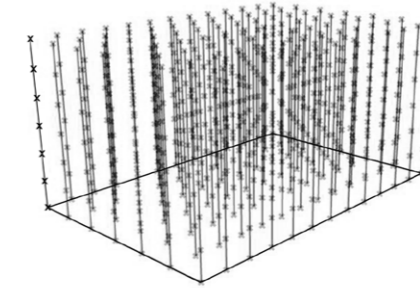
//Step 9: Specify the number of floors: In this step the number of possible floors is determined with respect to the input in grid-size. A code of 'if' statement is written to specify the number of floors for given grid size.

//Step 10: Create the column points for different storeys: It should be mentioned here that the floor to floor height of the proposed construction system is assumed to be 3m. Thus the column points created in step 4 are multiplied in a series along z-axis. Where,

- a) Total number of points along the z-axis = number of floors specified in step 9
- b) Distance between the points = 3m

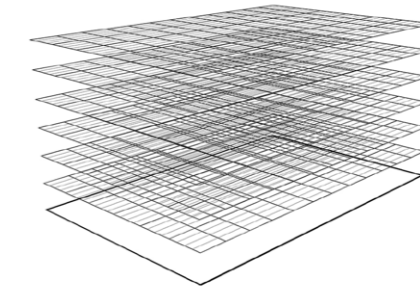


//Step 11: Create the center line of the columns: The points generated in step 10 are connected using lines in the z-direction.



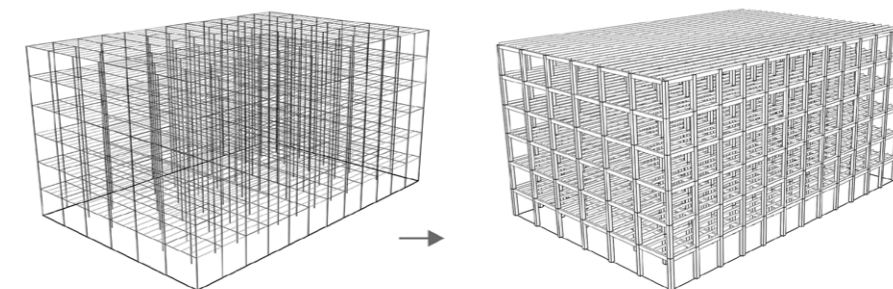
//Step 12: Create the secondary bema and primary beams on all floors: the lines generated for primary beams in step 5 and the line generated for secondary beams in step 8 are copied in the same series as that for column points in step 10. Where,

- a) Total number of lines along the z-axis = number of floors specified in step 9
- b) Distance between the lines = 3m



//Step 13: Assigning cross-section thickness to columns, primary beams and secondary beams: The center lines generated for the columns, primary beams and secondary beams are used as reference to assign their respective cross-section. The design logic behind assigning the cross-section and the code of the detailed input of the thickness has already been discussed in section 8.2.4. Multiple ways can be used to generate the cross-section thickness, such as

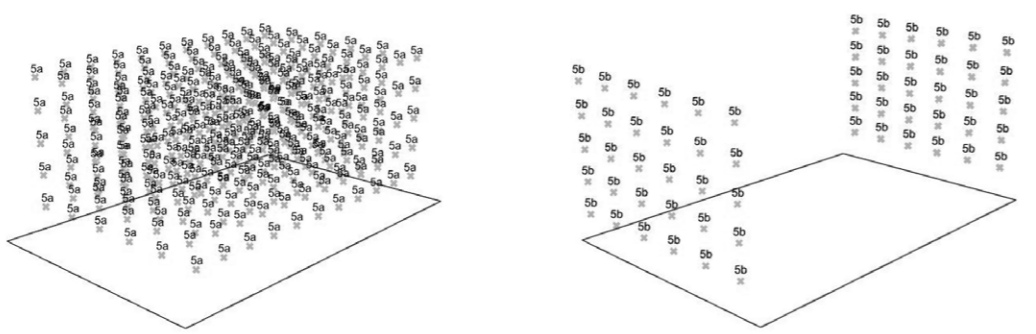
- a) Generating a plane of needed size, perpendicular to the center lines and extruding these planes along the lengths of their respective center lines.
- b) Generating rectangles at the starting points of these elements and lofting them along the length.



//Step 14: Final output is the 3D visualization of the structural system for the hybrid timber construction technology.

Using the structural geometry created above to generate the nomenclature system for joineries.

//Step 15: Nomenclature of the columns: It is already mentioned in section 8.3 that there are two types of



//Step 19: Linking the digital tool to the product fabrication catalogue: It was mentioned the digital tool design concept that the nomenclature system has to be linked to a booklet which details out the joinery dimensions and fabrication process. For this, a link is attached in form of text to the tool such that it can be easily accessed by the operators from anywhere. The detailed concept for the product catalogue is elaborated in section 9.5.

Thus, the final output comprises of the 3D view of the structural system of the hybrid timber construction technology.

9.4 Developing the digital tool in grasshopper 3D

The design logic that was converted to a pseudocode can be converted into a computer programme using any computational language. For the purpose of this research it has been integrated in the software-grasshopper3D which is a visual programming addon for Rhino. Given its popularity amongst young designers, easy commercial availability and its visual programming user friendly interface, grasshopper3D was chosen for formulating the final design tool of the hybrid timber construction technology. The logic of pseudocode presented in section 9.3 has been translated into a grasshopper script to generate the required output. Additionally, the following plugins for grasshopper3D have been used in the development of digital tool: pufferfish version 2.2.0.0 and TTtoolbox version 1.9.6353.

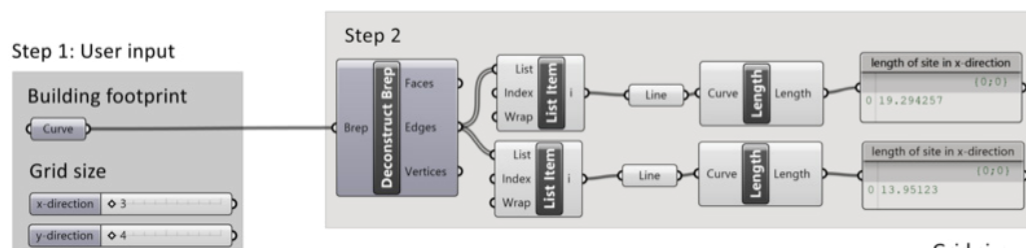
The following shows the step by step of translating the pseudocode into a grasshopper design tool:

Step 1: Inputs – A curve component is used to refer the building footprint polyline, while sliders with pre-coded options for the grid, are used to input the grid-size in x and y direction.

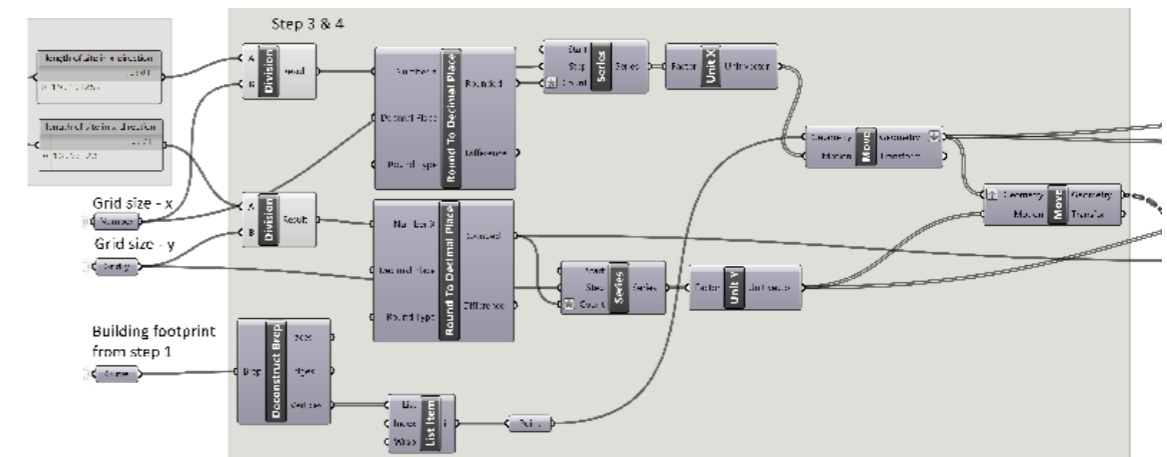
Step 1: User input



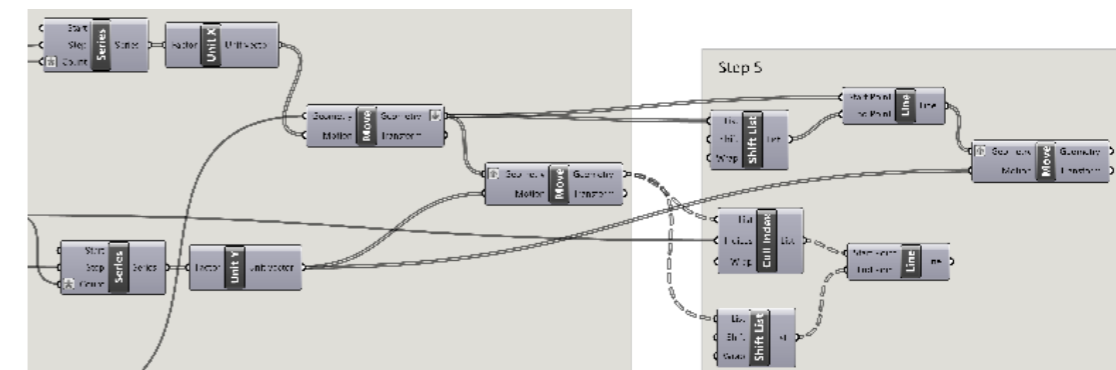
Step 2: The curve input, or building footprint, is deconstructed using the deconstruct B-rep component and the lengths of each side of the rectangle is determined.



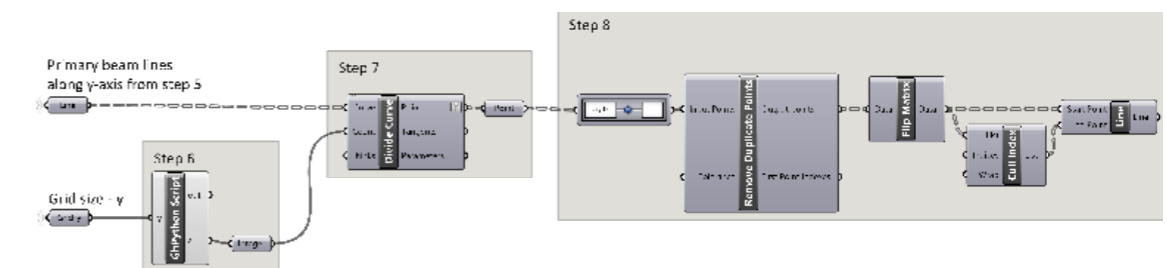
Step 3 and 4: The number of bays in each direction are determined by using the formula given in section 9.2.4. The points for the columns are generated using the number of bays required and the grid-size.



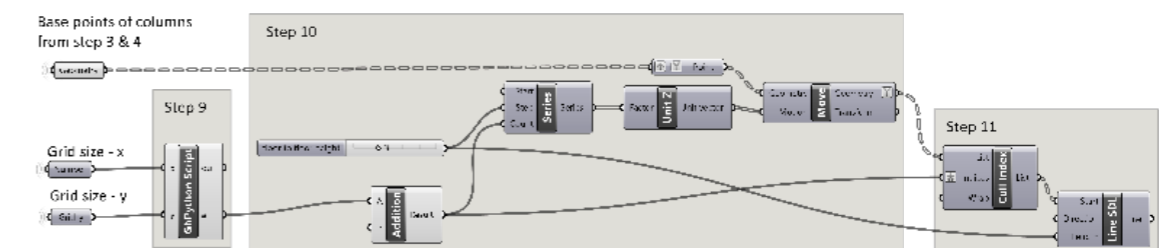
Step 5: The center lines of the primary beams are determined by joining the points created in step 3 and 4.



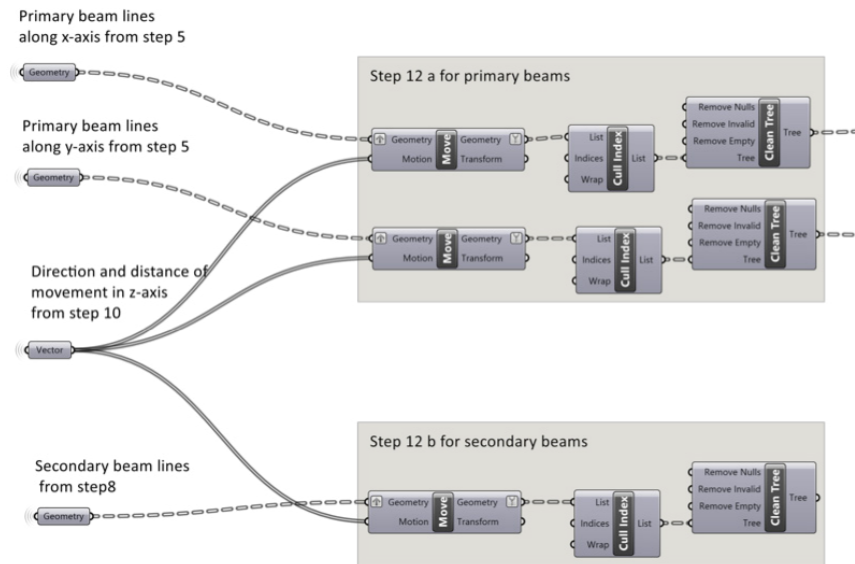
Step 6, 7 and 8: Inserting the python code for identification of number of secondary beams needed along a given length of primary beam. Dividing each primary beam in the y-axis to generate the points for the secondary beams and creating the lines for the secondary beams by joining these points.



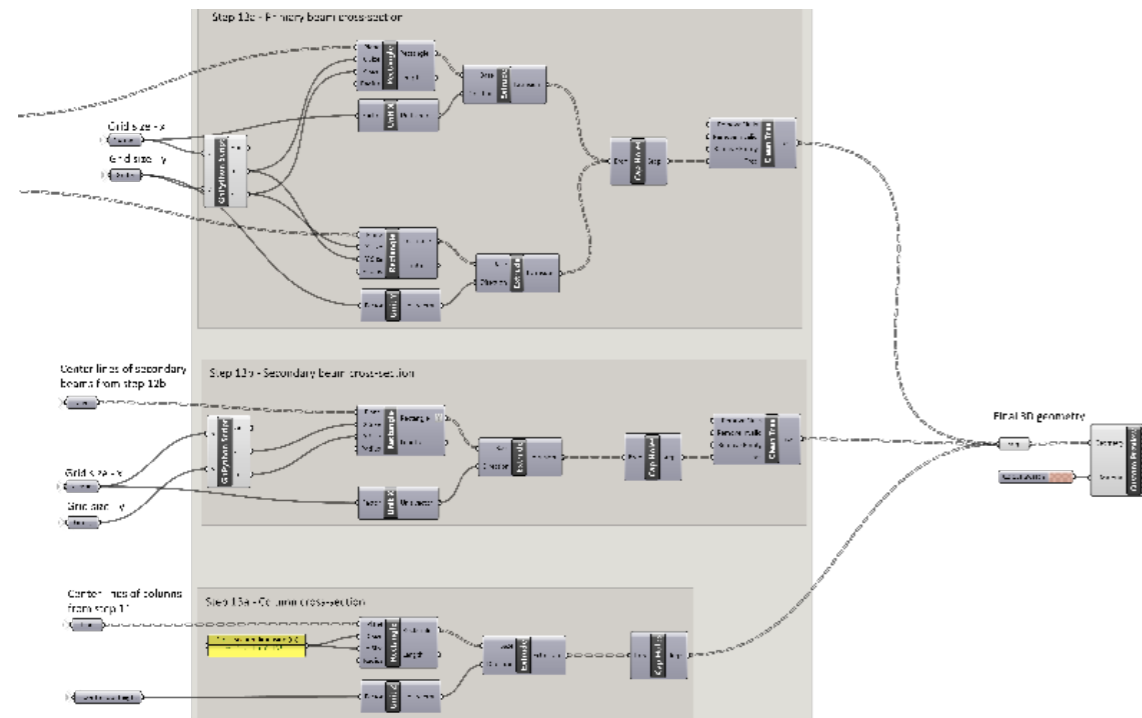
Step 9, 10 and 11: Specifying the number of storeys with respect to the grid size input, by inserting the code in python. Moving the geometry of the column points in series in z-axis to create the base points for columns on all floors. The points created are used as base to generate the center lines of the columns, 3m long along the z-direction.



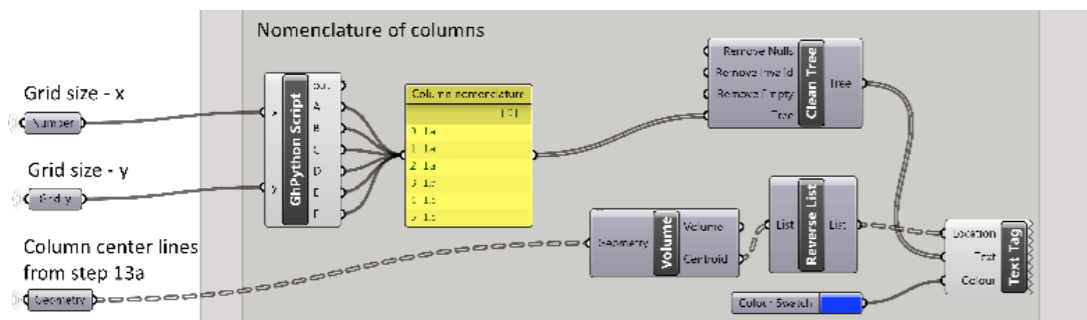
Step 12: The lines for primary beams generated in step 5 and the lines for secondary beams generated in step 8 are multiplied in series over the floor storeys.



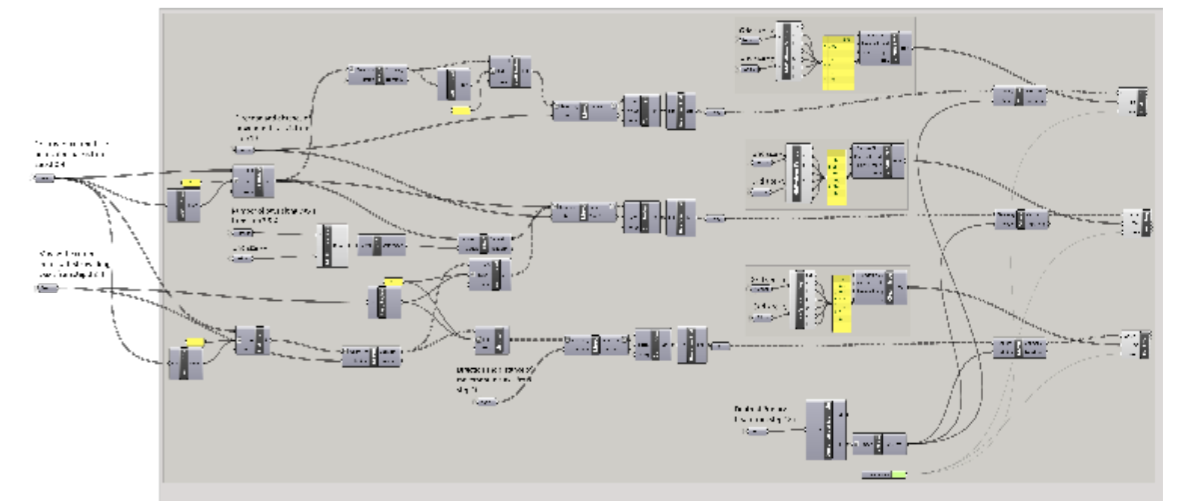
Step 13 and 14: Once all the center lines are determined. Python is used for coding all the values for cross-sections for primary and secondary beams and value is specified for columns. These determine the output with respect to the desired grid-size. The final 3D geometry is then produced.



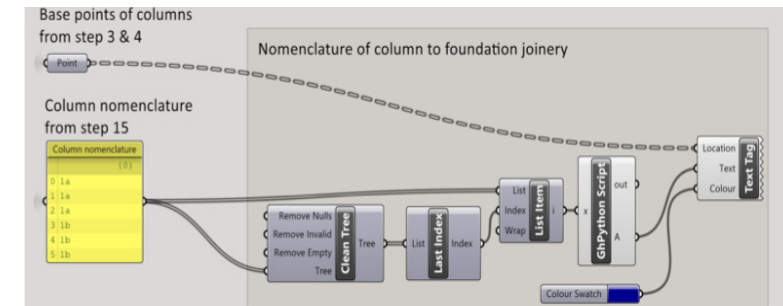
Step 15: Nomenclature of the columns is done by separating the points on the basis of code inserted in python.



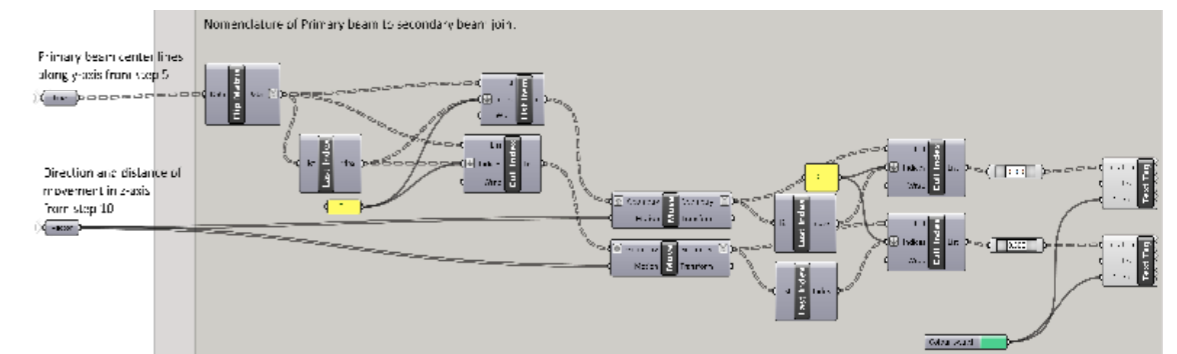
Step 16: Nomenclature of the column-primary beam joinery is done by separating the points and inserting identification numbers of these points in python.



Step 17: Nomenclature of the foundation joinery is done by separating the points on the basis of code inserted in python



Step 18: Nomenclature of the columns is done by separating the points on the basis of code inserted in python



Appendix E shows the overall compiled grasshopper script for the digital tool.

9.5 Product catalogue concept

The product catalogue is the legend to the nomenclature of joineries provided in the digital tool. It elaborates on the fabrication process of the members and joineries used in the hybrid timber construction technology. It shows in detail the dimensions of the parts needed to manufacture each joinery and the detailed assembly process. Figure 9.15 shows an example of the working of the product catalogue. Each joinery is explained by means of its elevation, plan, 3D view with detailed assembly procedure and the parts required for its making. The fabrication drawing for each part required for a joinery is further explained in detailed by elaborating its dimensions.

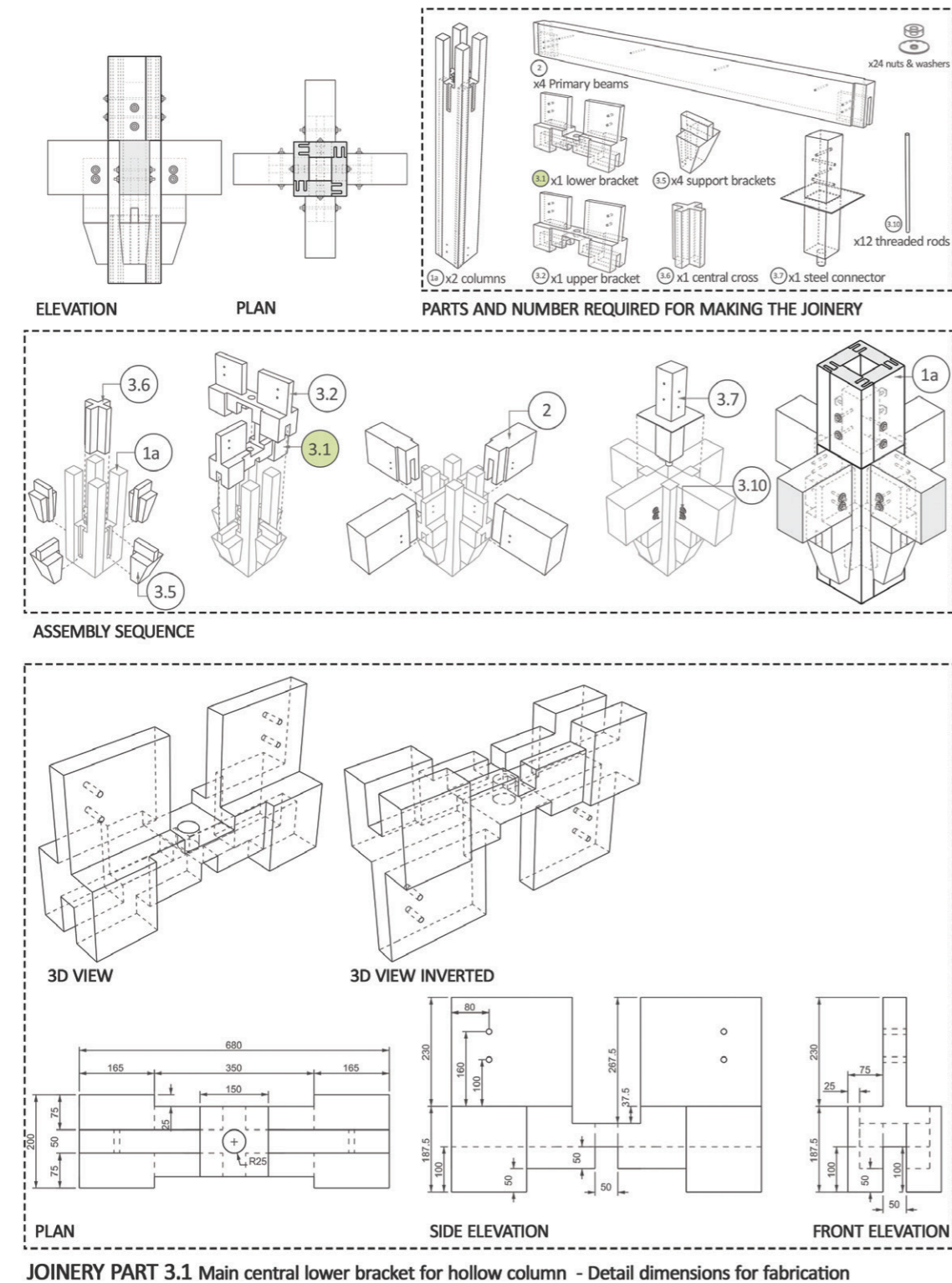


Figure 9.15: Grid size input choices.

It is to be noted that the joinery follows a system of proportions, the example presented herewith is for a column size of 350x350mm and primary beam size of 200x350 mm. This could be proportionately scaled to the desired sizes. However, it should be noted that scaling cannot be done indefinitely, the limits considered for this design should be within the cross-section dimensions specified for various grid sizes as shown in appendix B.

For ease of access to the users of the digital tool, the link of this production catalogue is provided in the tool. Figure 9.16 shows the provision of link as provided in grasshopper tool. The concept catalogue is attached in appendix K.

The link to the concept product catalogue is:

https://drive.google.com/file/d/19XGI3MXWdyTMMcaVhpwreaVsEE3oJ_bv/view?usp=sharing

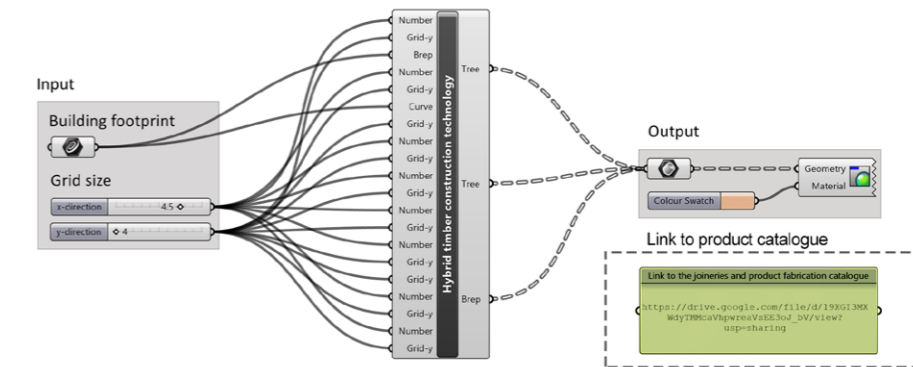


Figure 9.12: Final digital tool in grasshopper showing the provision for product catalogue link.

9.6 Limitations of the digital tool output

The final output of the digital tool has certain limitation which have been elaborated in the following points:

- The number of bays in the given building footprint with respect to the grid-size has a limitation with respect to the last bay. The digital tool functions best when the dimensions of the building footprint are in multiples of grid size. However, if this is not the case then the digital tool is programmed to round-off the footprint dimension to the nearest multiple of the input grid dimension. This condition might lead the last bay, in either x or y direction, to fall short or exceed the given building footprint. This condition can be adjusted in the post-processing phase whereby the professional or the designer might choose to accommodate the additional length of the last bay in the second last or adjust this length in the overall grid-size.
- The number of possible storeys with respect to the input of grid-size is limited by the capacity of the joinery in this hybrid timber construction. A different joinery can lead to the change in performance of the structure.
- The digital tool is designed in unit meters, hence if other units are used as inputs, the tool will not output the desired results.
- The visual cross-sections of the column, primary and secondary beams, produced by the digital tool does not include the actual joineries, details and fabrication process.
- The list or names of joineries based on location of the building, does not include all the joineries like those associated with the core and shafts. It does not include the actual geometry of the joinery and their fabrication process, a product fabrication catalogue has to be referred for the details with respect to the joinery nomenclature in the digital tool.
- Concept 3D model of the timber frame structure does not include core, shafts and other important components of building design. These have to be taken into account by the professional at the post-processing phase.

10 Assembly sequence of the hybrid timber construction

The hybrid timber construction proposed in this research is set up in the context - Shillong, India, which currently does not support facilities for automation and technological advanced construction system. This is because automation needs a large investment and thus the market relies on the manual labour force which is readily available in the region. Given this situation, the assembly sequence has been proposed using the current local practices of the region. This includes manual handling and on-site fabrication of the building parts. Figure 10.1 summarizes the assembly concept of the proposed hybrid timber construction. This sequence is elaborated in appendix J.

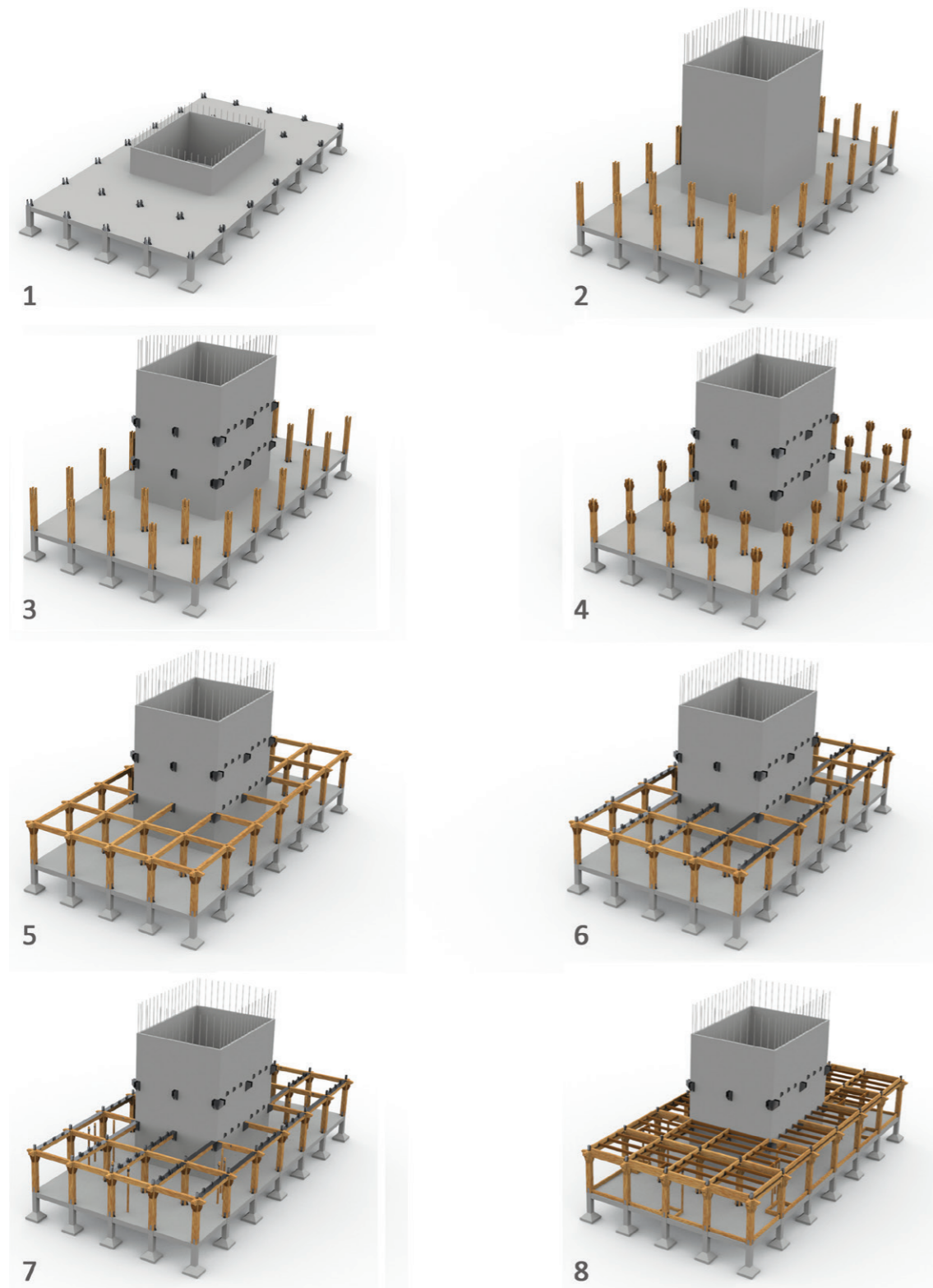


Figure 10.1: Summary of assembly sequence of hybrid timber building.

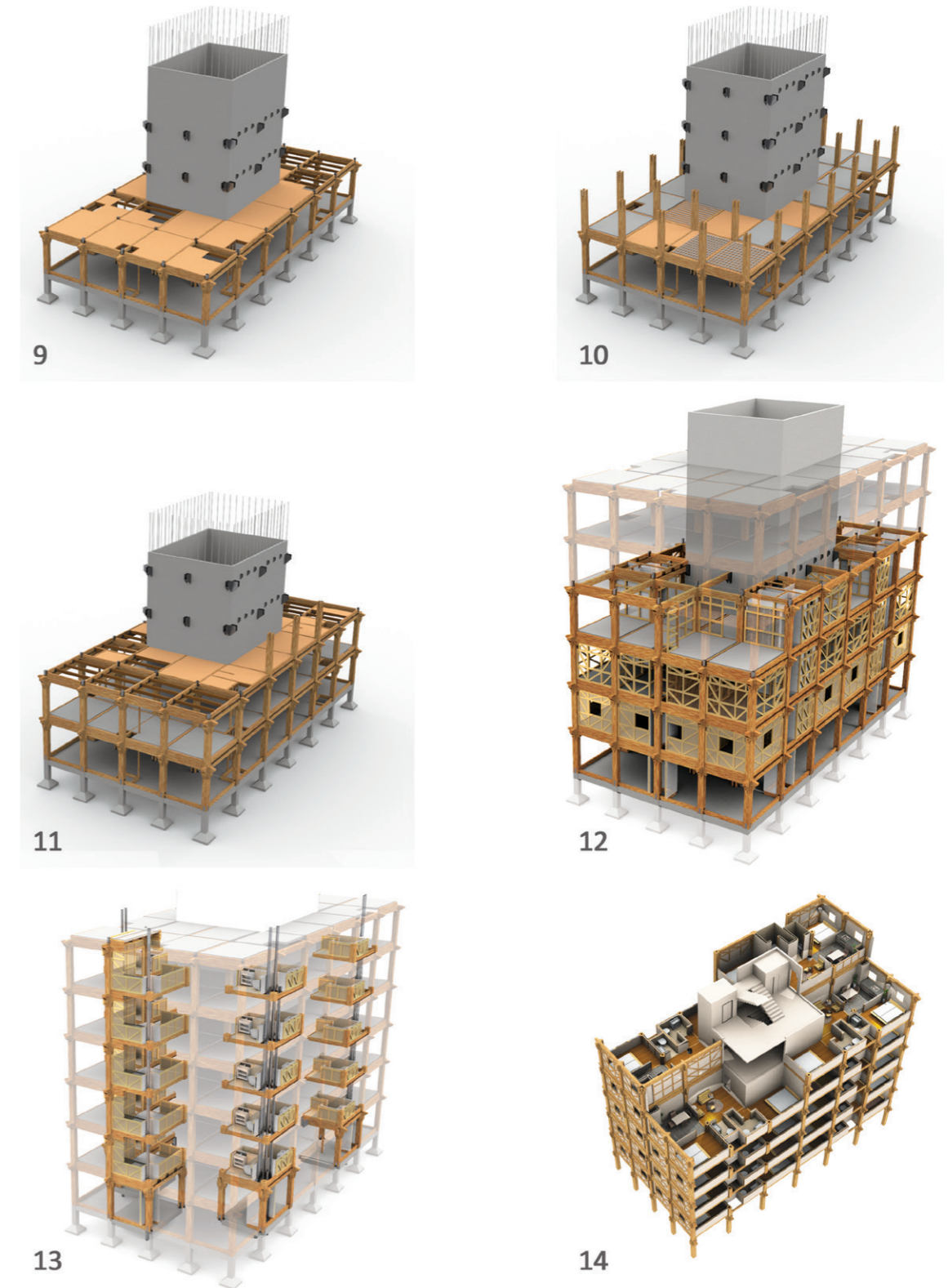


Figure 10.1 (contd.): Summary of assembly sequence of hybrid timber building.

Replacement of primary beam

The possibility of repairing the structural elements is vital for the long term functionality of any building. This was also considered while designing the column-primary beam joinery. Two possible methods have been proposed, first by removing the upper slab and completely replacing the beam and second, replacing the primary beam without moving the top slab and replacing the beam with a connector. Figure 10.2 shows the procedure for replacement of a primary beam.

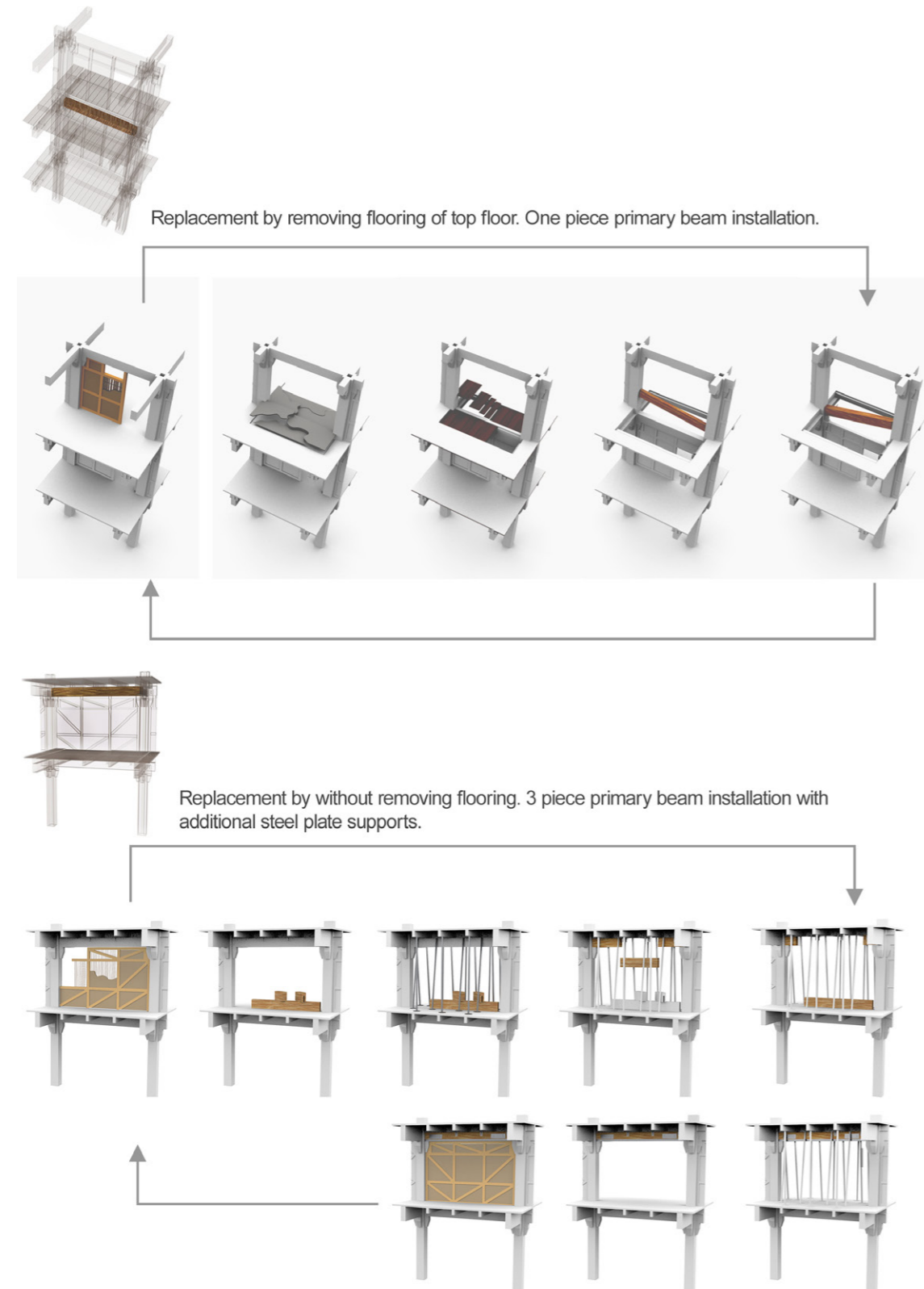


Figure 10.2: Replacement of a primary beam.



Figure 10.3w: Proposed timber construction system.

11 Conclusion of research by design

Inspiration was drawn from the background research to redevelop the traditional 'Assam-type' construction technology for the contemporary urban context of the seismic region of Shillong. As the proposal for such kind of a technology is driven by an idea that is first of its kind in the region, the design had to be approached from the scratch. An innovative way of approaching the design was looked upon for of a multi-storey construction using an uncommon building material – natural timber.

Fortunately, timber has a long history in the building industry, for which it holds a section in the building codes. Particularly, the Indian bye-laws, local to the region, have been used for the purpose of this research and its validity. Certain boundary conditions were set for the design development, this included fixing grid-sizes, maximum aimed building height, building typology and load cases. The rules thus presented were applied for the initial structural member sizing and design of the joineries. Inspiration was also drawn from the traditional 'Assam-type' construction prevalent in the region, the Japanese timber design techniques and the latest advancements in timber technology globally. The principles of proportions and earthquake resistance in 3-Dimension were considered for the design formulation. Firstly, the member sizes for the secondary beams, primary beams and columns were calculated. However, it was realized that the regulations provided limited types of loading calculation formulas, e.g. there was no method for deflection calculation of a beam under 3-point loads. In such cases the calculations were made by the online calculators and values were directly used. Next, the column and beam member sizes obtained from the structural calculations were used as basis for designing the joinery. Simultaneously physical compression tests were performed on various iterations which helped in a thorough understanding of the failure modes and the design strength. The first 3 iterations of the design were tested on a scale – 1:7.5 of 3D printed PLA model. Although not the same material as that of the proposed timber, yet these initial rapidly prototyped model tests were very important for the prediction of the failure behavior. As the PLA model could take a load of 1.2 tons, it was considered a success and further time investment was made in fabrication of a timber model for testing. Also, the failure modes of the PLA models were studied to upgrade the design.

A softwood model, scale 1:5, was fabricated manually at the model hall of the university, unfortunately, hard-wood could not be used because it was against the rules of the university laws. Vertical compression test was made on a softwood model, this could take a load of 4.5 ton. The failure modes were studied and also the design strengths could be predicted. The next step in the process was to check the same wooden joinery for horizontal cyclic loads, which mimics the earthquake shaking. This was again done by a laboratory experiment. The load capacity of the final joinery was determined – vertical 1200 kN and lateral 125 kN. These values were then used to determine the possible number of floors, maximum 6, for various grid-sizes. These results of the softwood model was used to predict the results for the hardwood. Based on the lessons learnt other joints in the timber construction, which includes, the column to foundation joinery, secondary beam on primary beam, core and staircase design were conceptualized. However, it was beyond the scope of this thesis to perform the mechanical tests of all of the above joineries in the given time-frame. A concept of a wholistic design was proposed by combining all the elements designed throughout the research. The scheme was tested for global performance under seismic condition using the FEA. Validation was done with respect to the allowable limits of the National building bye laws of India. Upon the successful validation of the 'hybrid timber construction technology', the design logic of this structural system was encoded in a digital tool for the local designers as the target user group. This tool was made in grasshopper3D which is commonly used by designers in contemporary building industry. The user interface was kept simple with two inputs to determine the structural possibilities if this construction. The inputs include building footprint and the grid-size, while the outputs include the structural sizes of the columns, primary and secondary beams and the joinery numbers. Further elaboration on the joinery numbers can be accessed by a product catalogue via an online link presented in the grasshopper definition. This product catalogue details the fabrication process of the joineries proposed in the structure.

Finally, the digital tool encodes the findings of this research – 'hybrid construction technology using local timber' and is available to the local designers for future works.

12 Limitations of proposed hybrid timber construction technology

The source for the contextual background research has been the latest documents available online as well as the legal procurement of data from the Government of Meghalaya. However, due to lack of persistence in updating the latest statistical data in various Government portals and unavailability of documents due to confidentiality, there were gaps in information. These gaps were fulfilled by making assumptions with reference to previous works of the authorities. Such assumptions have a possibility of over or under exaggeration of values, which might lead to discrepancies in results. Also, the research is being conducted in a region where scholarly works and technical testing on natural resources are limited. There is a lack of data on the mechanical properties of the potential natural materials found in the region. Though the materials have been used in the past, the lack of technical data has led to making assumption based on similar materials in other regions. Thus, the results achieved after simulations may vary, the results can be validated in future after enough technical studies are made in the region.

The research is being conducted solely for academic purpose under the framework of the university in a time-bound programme. There are limitations to the monetary resources and the collection of localized data. Since the research is being conducted in the university campus, the limitation to availability of test facilities due to lack of physical samples of natural materials has limited the validation of the design results to computer simulations. It has to be noted that the level of these simulations for validation of the construction system has been kept at a basic level, given the timeframe the major area of focus will be in development of the technique itself. Further, limitation on the simulation is the lack of quantitative measurement scales designed for testing such natural materials. Most of the standards set worldwide are based on the performance of concrete and steel. Since every natural material has its own characteristic properties the validation of results based on the standards of other materials like concrete and steel is questionable.

The research focuses in development of a construction technology for housing typology especially for the urban condition of Shillong. Up to the best of my knowledge and on interviewing the locals, it was found that no such research has been done till date. Though many assessments on the present building technology and the traditional housing types have been made, no alternative solution has been proposed using natural materials for the present urban context. Thus, there is a lack of data in this field, as the research is the first of its kind. Thus, references on similar grounds from other parts of the world were used to develop the process.

The proposed construction technology is a wholistic concept of what could be possible using the local timber. Thus, this research is an overview and there is a lot of scope of in-depth research in the development of joineries, experimentation with different combinations of materials, acoustical and thermal comfort, manufacturing and assembly procedures. For the same reason it is recommended that it should go under technical scrutiny in the above fields before actual implementation. Nevertheless, the proposal is valid for initial design stage. It should be noted that the design choices made in this research is a lot more conservative than actual, this is because of the safety factors induced at various steps like structural calculations, fire safety and also designing components considering second life support systems in case of localized failures. This has indeed pushed the sizes to maximum safety limits. The FEA simulations made for validating the proposal has been made without considering damping and frictional energy dissipation. This is due the fact that such detail simulations take a lot of time, which was beyond the scope of this thesis. Also, there are limitations to the validation procedure provided in the National Building code of India, as the acceleration data is provided for a standardized 5% damping. Also, the response reduction factor for seismic calculations has been taken as 1.5 which is akin to that of unreinforced masonry. These criteria again show the underestimation of the strength of the proposal v/s reality.

13 Future works

This research proposes a hybrid timber construction system for the seismic region of Shillong, India. Since this research proposes a broad concept about the possibilities of multi-storey building using natural timber, potential researches can be developed in multiple disciplines to develop this technology. This research can be applied to different locations having similar contextual design parameters.

This thesis looked into the testing of the column-primary beam joinery only. Thus in immediate future, further scientific work concerns a deeper structural analysis of various other joineries and testing the global structural system with respect to the damping and frictional properties. The numerical model developed for simulation could be calibrated closer to reality. Also, the calculations presented in this research are very conservative, hence a detailed study could improve the efficiency of the material. It will be best if the compression tests are done using the actual local species instead of others. The horizontal shake table tests were not made in this research, it will be brilliant if the proposed construction could be tested for seismic activity. The field of building physics also has a great potential. The acoustics and thermal comfort levels, which was beyond the scope of this research, must be thoroughly investigated. Importantly the facade needs to develop in consonance with these insulative properties. Important details like the water proofing needs to be thought off, as well as provision of other building elements like terraces and balconies could be researched further.

The digital tool developed in this research could be enhanced by giving more possibilities to the user. This could include increase in the number of grid-size combinations, inclusion of joineries, possibility for the tool to tackle complex building footprints, choice of building floor height given the structural possibilities. Inclusion of facades and other important building components which helps the designer visualize the output better. Also, the choice of the location of core. The tool has been coded in the Rhino plugin – grasshopper, however, the tool could be coded in various other softwares to widen the target user group. Finally, once the structural analysis is through, there is possibility to publicity release this tool so that it does what it was intended to do.

In the long run, the inclusion of parallel production techniques like CNC milling could be incorporated in the production process to ease the fabrication of complicated joineries. The proposed timber construction system in this research has a great potential to tackle the environmental problems associated with the current building practices, given this, it can be realized in the markets which poses the contextual parameters. Finally, the energy savings and carbon footprint of this timber construction can be calculated to examine the sustainable efficiency of this proposal and its contribution in the global struggle to combat climate change.

APPENDIX

Primary beam cross-section calculation

Primary beam spans	mm														
	4000	4500	5000	4000	4500	5000	4000	4500	5000	4000	4500	5000	4000	4500	5000

Primary beam cross-section	b = breadth mm d = depth mm														
	200	225	275	250	250	275	275	275	275	275	275	275	275	275	275
	350	350	350	350	375	350	350	350	350	375	350	375	350	375	400

Reaction force at each end of the beam (karamba)	V = kN														
	52,95	59,35	65,2	59,6	67,12	72,66	66,76	75,15	81,43	73,65	82,55	89,76	80,56	90,61	98,03

Horizontal shear	Allowable horizontal shear N/mm ²															
	Calculated	1,197	1,197	1,197	1,197	1,197	1,197	1,197	1,197	1,197	1,197	1,197	1,197	1,197	1,197	1,197
		0,00113	0,00113	0,00102	0,00114	0,00115	0,00116	0,00114	0,00117	0,00118	0,00115	0,0012	0,0012	0,00117	0,00113	0,0012
	1,135	1,130	1,016	1,135	1,151	1,163	1,144	1,171	1,184	1,148	1,201	1,197	1,172	1,133	1,225	

Deflection	Allowable deflection = Span/360														
	Actual deflection (karamba)	7,16	10,405	13,7	7,1446	10,574	13,4075	7,127	10,65	13,61	7,113	11,684	13,705	5,676	9,36

Maximum bending tension along grain for extreme fiber stress or fb	Allowable fb = M/Z (W*1/8)/(bd ² /6) N/mm ²														
	Calculated fb	18,62	18,62	18,62	18,62	18,62	18,62	18,62	18,62	18,62	18,62	18,62	18,62	18,62	18,62
	11,02	12,36	12,393	14,996	12,572	13,1242	11,003	12,677	13,325	10,993	12,128	13,4115	11,9866	12,122	12,831

Column cross section

Secondary beam spans	3000					4000					4500				
	Primary beam spans	4000	4500	5000	4000	4500	5000	4000	4500	5000	4000	4500	5000	4000	4500

Load on 5th floor Cross section	kN														
		211,8	237,4	260,8	238,4	268,48	290,64	267,04	300,6	325,72	294,6	330,2	359,04	322,24	362,44
	200*200	200*200	200*200	200*200	200*200	200*200	200*200	200*200	200*200	200*200	200*200	200*200	200*200	200*200	200*200

Load on 4th floor Cross section	kN														
		423,72	474,92	521,72	476,92	537,08	581,4	534,2	601,32	651,56	589,32	660,52	718,2	644,6	725
	200*200	250*250	250*250	250*250	250*250	250*250	250*250	250*250	250*250	250*250	250*250	250*250	250*250	250*250	250*250

Load on 3rd floor Cross section	kN														
		637	713,8	784,65	716,8	807,69	874,17	803,37	904,05	979,41	886,05	992,85	1079,37	968,97	1089,57
	250*250	250*250	300*300	250*250	300*300	300*300	300*300	300*300	300*300	300*300	300*300	300*300	300*300	300*300	350*350

Load on 2nd floor Cross section	kN														
		850,93	953,33	1047,58	957,33	1078,3	1167,71	1072,54	1207,55	1308,03	1183,55	1325,95	1441,31	1294,11	1454,91
	300*300	300*300	300*300	300*300	300*300	350*350	300*300	350*350	350*350	350*350	350*350	350*350	350*350	350*350	400*400

Load on 1st floor Cross section	kN														
		1064,86	1193,63	1311,28	1198,63	1349,68	1461,25	1342,48	1511,05	1637,54	1481,05	1659,94	1804,14	1620,14	1821,14
	300*300	350*350	350*350	350*350	350*350	350*350	350*350	400*400	400*400	400*400	400*400	400*400	400*400	400*400	400*400

Load on ground floor Cross section	kN														
		1279,56	1433,93	1575,87	1439,93	1621,95	1755,68	1613,31	1815,44	1967,05	1779,44	1993,93	2145,17	1946,17	2197,17
	350*350	350*350	400*400	350*350	400*400	400*400	400*400	400*400	400*400	400*400	400*400	400*400	400*400	400*400	400*400

Appendix C : Laboratory test set up

The compression test was done for two kinds of prototype a) 3D printed PLA model, scale 1:7.5 and b) softwood model, scale 1:5. While the PLA models were used to understand the failure mode and behavior of the proposed joinery, the actual results (load capacity) of the softwood model was used for calculation purpose.

The following is the procedure for the laboratory test setup:

Step 1:

a) 3D printing the prototype

The prototypes were printed using the Prusa-i3 3D printer and the software - Repetier host was used for model calibration.

Material used – PLA.

Model infill - 10% (this is important for the behavior of the model, as the infill determines the strength. An infill of 10% was chosen to mimic the property of timber which states that a timber member is 10 times stronger when loaded parallel to grain, than when perpendicular to grain.)

Print direction - While the first 3 specimen were printed as per the ease of fabrication; the 4 PLA specimen was printed in the proposed grain direction. The behavior of the results show that the print direction is vital to understand the failure modes during the compression tests, as the splitting of grains occur in the print direction and affects the overall performance of the prototype.

Print settings:

Adhesion type – brim

Quality – 0.4 mm

Support type – varies

Feed-rate – 75

Bed-temperature – 80

Extruder temperature - 120

Figure below shows the print progress of the prototype.

or, b) Fabrication of softwood model

The softwood model was fabricated using locally available timber in the model workshop of the university. Certain power tools were user for cutting the pieces of wood, however the major part of crafting the joineries were done using chisels and hammer. Also, the connections were hand-sanded to attain a greater level of precision. It is also possible to use CNC milling for prototyping, however to check the feasibility of manual fabrication of the proposed joinery and budget constraints, the model was hand made.

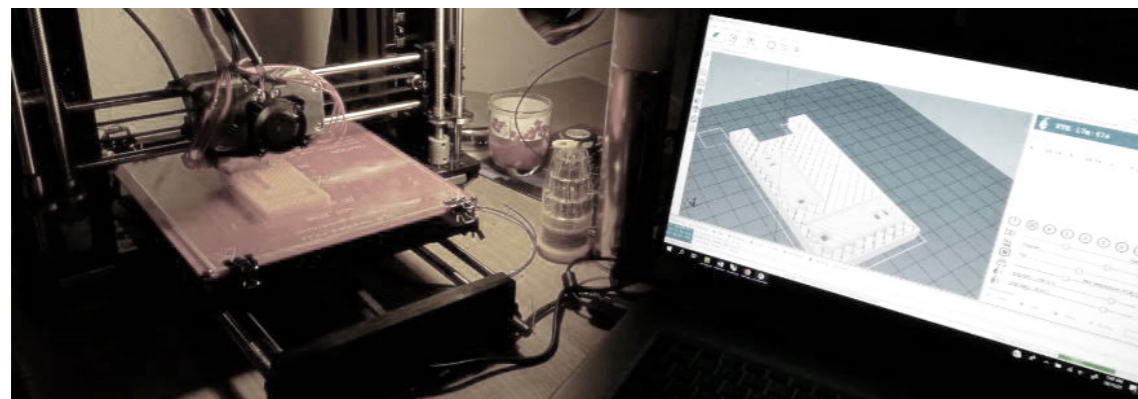


Figure C.1: Showing 3D printing of the prototype. (Image courtesy: Premith Satish)

Step 2: Compression test of the model

The test was executed in the university under the guidance of Prof. F.A.Veer, who also tuned the machine as per the demands of this research. The machine zwick z-100 was used for compression tests and the results were recorded by the test expert software. It should be noted that this test can only be performed with the aid of experience personal due to the necessity of expertise during the test and safety issues.

a) Vertical loading - test for gravity loads.

The model is placed in the center of the platform such that the load is equally distributed on the surface of contact and at a slow pace. Starting from 0.5 kN, the loads were gradually increased in every step till the failure of the model. Figure C.2 below shows the placement of model in the machine. The results of displacement recorded by the software are then exported to an excel sheet for further analysis of the data.



Figure C.2: Showing the test setup for vertical loading using Zwick/ Z100

b) Lateral loading - test for seismic loads

While the same machine was used for the lateral load test, a special setup was required to hold the model horizontally stable during the test. For this a heavy hollow steel section was fabricated that could be connected to the base of the machine with the help of bolts. The model was made to rest on a piece of smaller steel section. The bolts were tightened to sandwich the model between these steel sections, and load was applied through a wooden piece of log into the model. It was important that there was no movement in the model, especially due to insufficient clamping, during the load application. Figure C.3 shows the arrangement to clamp the model horizontally.

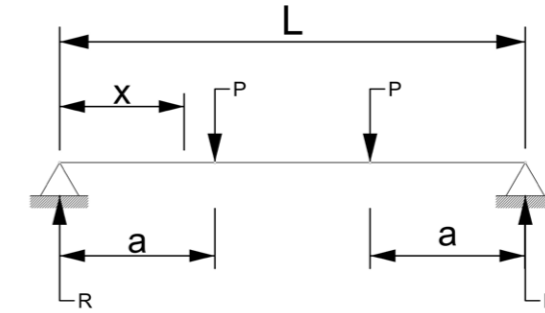
The softwood model was used for the lateral load test. The test comprised of alternate 10 sec of loading and 10 sec of rest, for 10 cycles. As in the vertical loading, the load magnitude was increased with the [performance of the model. At first a load of 2.5kN was applied for first 10 Cycles, followed by 5kN in the next 10 cycles and finally 7.5 kN, which caused the failure. It should be mentioned that this method of load test is an alternative to the actual shake table tests executed for such structural analysis. However, due to unavailability of the lab and restrictions for 1:1 prototyping in this research, the test was limited to what is already explained.



Figure C.3: showing the test setup for lateral loading using Zwick/ Z100

Appendix D : 4-point bending test results

4-point bending test for checking the properties of the softwood wood used for prototyping.
Test setup scheme:



Where, P = total concentrated load, a= 55mm, L = 220mm.

Equation for calculation of young's modulus, E from 4-point bending test (Structx, 2019) and

$$E = \frac{\Delta P a (3L^2 - 4a^2)}{(\Delta \delta * 24 * I)}$$

Where,

A = distance to pint load, m

E = modulus of elasticity, MPa

I = second moment of area, m⁴

L = span length under consideration, m

M= maximum bending moment, kNm

P = total concentrated load, kN

R = reaction load at bearing point, kN

V= maximum shear force, kN

δ = deflection or deformation, m

X = horizontal distance from reaction point, m

For the purpose of this research 5 specimens of softwood were tested on 4-point bending. The specimens were of equal sizes. However, these were of the same market lot. Special equipment was needed for the 4-point bending test which was supplied by the structure department of the Faculty of Architecture under the guidance of my mentor, Dr. F.A.Veer. The figure D.1 shows the image of a specimen (number 5), after deformation due to the 4-point bending test. Followed by table D.1 that shows the results of these 5 specimens:

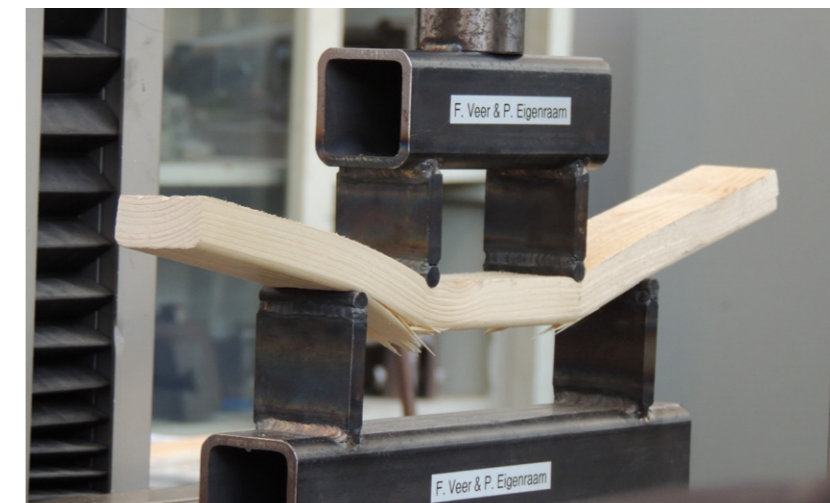


Figure D.1: Showing the after test form of specimen 5

Specimen	Dimensions (cm)	Test results
1	4.2 x 2.2 x 27.5	
2	4.1 x 2.1 x 27.5	
3	4.2 x 2.2 x 27.5	
4	4.2 x 1.8 x 27.5	

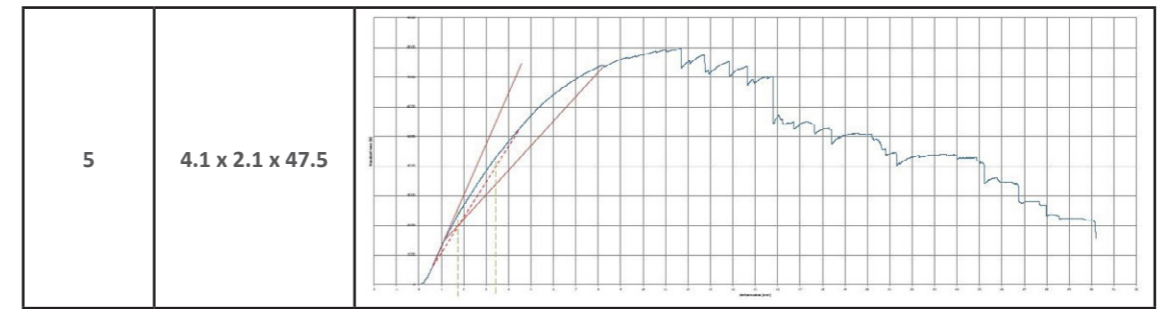


Table D.1: Results for 4-point bending test

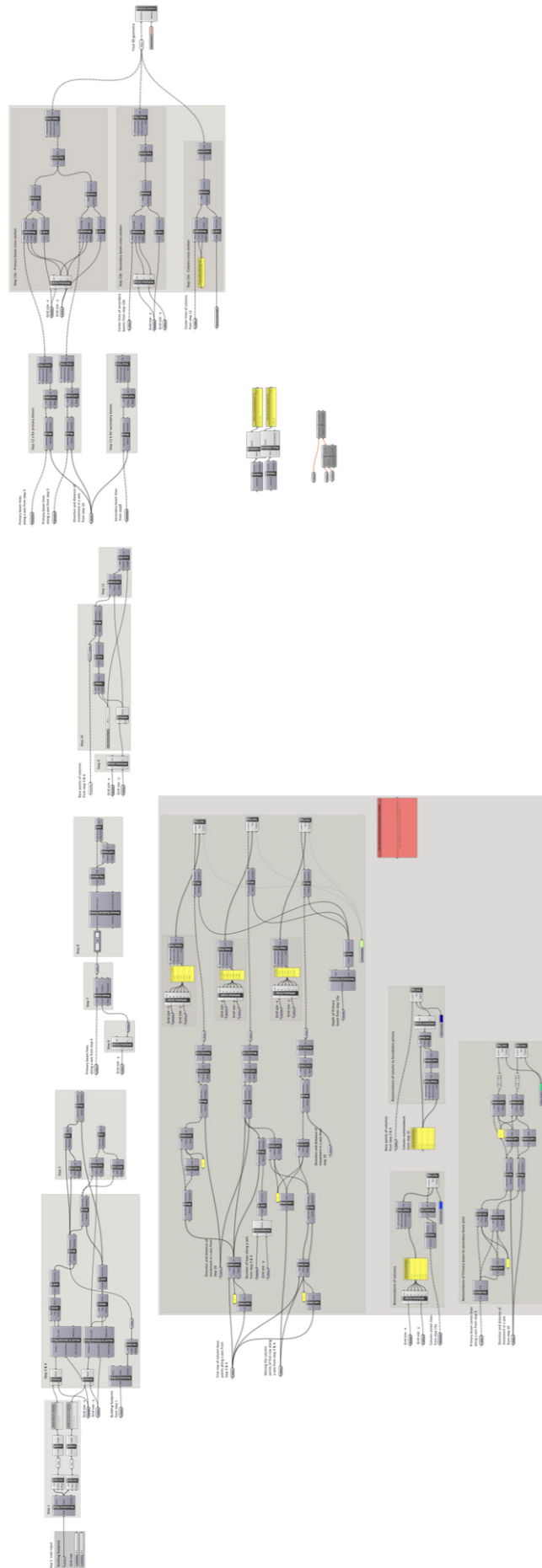
Wood has a property of plastic deformation, hence for the purpose extrapolating the data for maximum load for a given range of deflection, a middle line of average slope was drawn between the two linearities of, the elastic and plastic deformation range. This is shown in the above graphs where the dotted red line was manually drawn between two red lines and the green lines show the deformation values for a set range of force. These values have been used to calculate the young's modulus for the softwood used for the prototype. The table D.2 shows the calculation.

The test shows the extraordinary property of wood to slowly deform under a loading condition, i.e., wood is not at all brittle. It shows how safe wood could be for construction as any fault can be visually detected due to deformation in the material. The ductile property was exaggerated particularly in test specimen 5, where the piece did not shatter till the last moment. It is learnt from this experiment that the major failure occurs due to fiber split in timber members. While any other deformity like presence of knots and heartwood could cause weakness in the member. The values derived from this experiment are used for the structural validation of the proposed column-primary beam joinery presented in section 8.7.

	Specimen properties			Results from lab test						Test setup			Young's modulus = E
	Specimen	Second moment of area		Load = P			Deformation = δ			L	a	3L ² - 4a ²	$E = \frac{\Delta P * a * (3l^2 - 4a^2)}{\Delta \delta * 24 * I}$
		b	d	I = bd ³ / 12	P1	P2	ΔP	δ1	δ2				
	mm	mm	mm ³	N	N	N	mm	mm	mm	mm	mm	mm	
1	41	21	31641,75	4000,00	2000,00	2000,00	3,50	2,10	1,40	220	55,00	133100	13771,17409
2	42	22	37268	4000,00	2000,00	2000,00	2,55	1,45	1,10	220	55,00	133100	14880,95238
3	42	22	37268	4000,00	2000,00	2000,00	2,50	1,35	1,15	220	55,00	133100	14233,95445
4	41	18	19926	4000,00	2000,00	2000,00	4,40	1,90	2,50	220	55,00	133100	12246,14407
5	41	21	31641,75	4000,00	2000,00	2000,00	3,40	1,74	1,66	220	55,00	133100	11614,2432
													13349,29364

Table D.2: Calculation for the estimated Youngs modulus of the tested soft-wood = 13349 N/mm²

Appendix E : Digital tool - grasshopper script



Appendix F : Compression test of softwood used for prototyping

Local softwood was used for prototyping the timber column-beam joinery. The timber was procured from the local hardware store in Delft, The Netherlands. Since the specifications of the softwood was not provided by the retailer, a compression test was performed to identify the load bearing capacity and understand the failure modes of the wood. This was done by testing square pieces of the specimen in three different directions of the grain. The table F.1 shows the result of the compression test. The test set-up is same as that mentioned in appendix B.

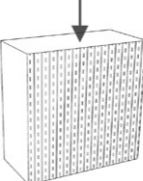
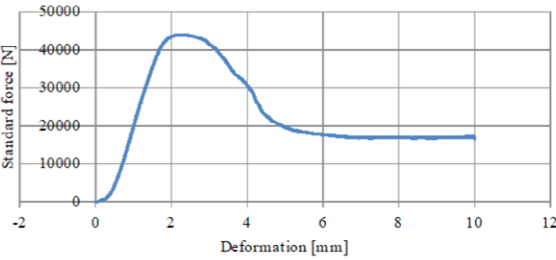
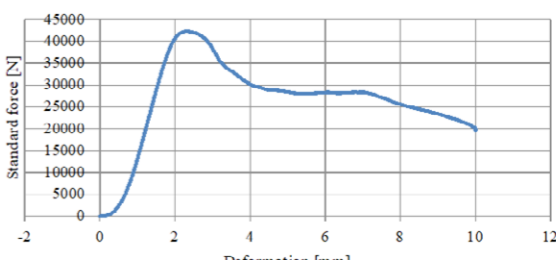
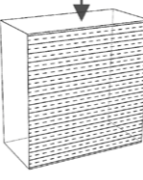
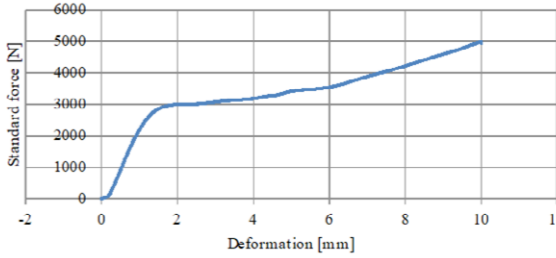
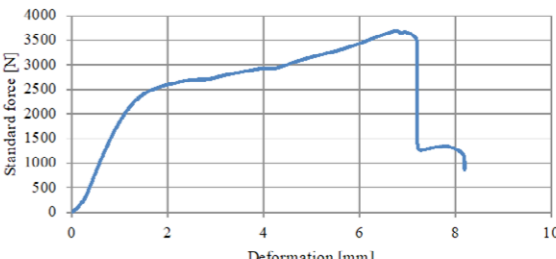
Loading condition	Size (mm)	Results	Maximum load (N)	Average load (N)
Parallel to grain 	44 x 41 x 19	Specimen 1 	43959	43131
	43.5 x 43.5 x 19	Specimen 2 	42303	
Perpendicular to grain 	44 x 43 x 23	Specimen 3 	4987,8	4339,28
	44 x 43 x 19	Specimen 4 	3690,75	

Table F.1: Results for compression test of softwood cubes

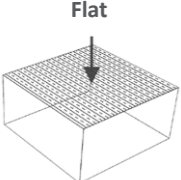
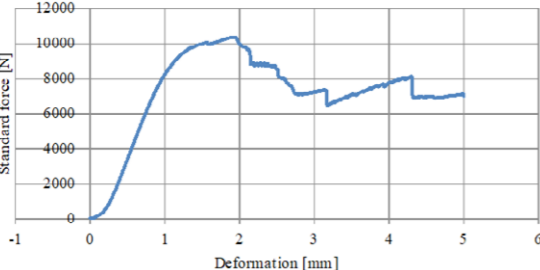
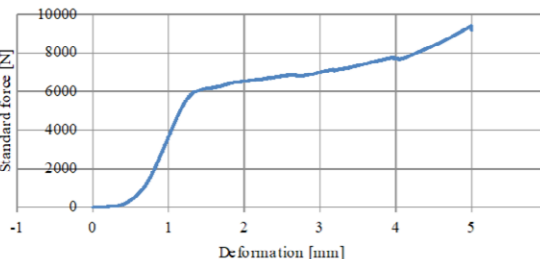
	44 x 44 x 19	Specimen 5 	10379
	44 x 44 x 19	Specimen 6 	9402,95
			9890,5

Table F.1 (contd.): Results for compression test of softwood cubes

Inference: It can be seen that the loading capacity of the wood tested parallel to the grain is 43,1 kN, while perpendicular to the grain is 4,3 kN. This test proves the theory that the strength of timber perpendicular to the grain being 1/10 of its strength parallel to the grain. It was observed in all cases that the failure began along the fibers, i.e., the fibers split leading to breakage as shown in figure F.1 below.

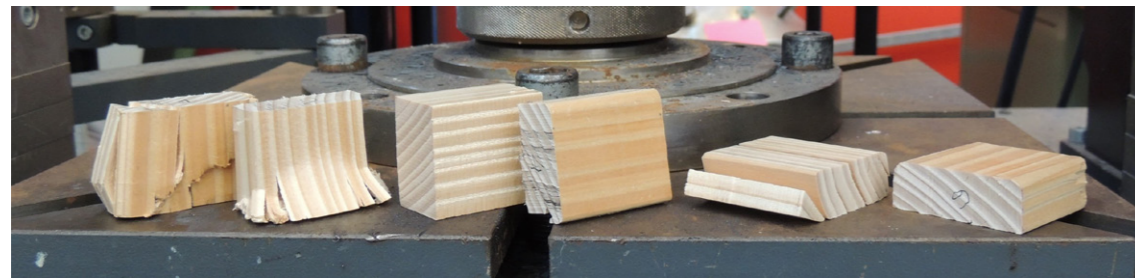


Figure F.1: Final results of the 6 specimens in the order of their test.

The results drawn from the test of these square softwood pieces have been compared with the results of the tests for column-primary beam joinery presented in section 8.6.

Appendix G : Sesimic load calculation

The national codes of India for earthquake design - IS 1893 (Part 1) :2002 and the NBC 2016 have been referred to for calculating the lateral loads. Two methods have been mentioned in the national codes for structural verification- namely:

- The equivalent static method
- Dynamic analysis – response spectrum method

The following example has been used to illustrate the calculation procedure. This procedure was repeated for multiple iterations as discussed in section 8.11 for model calibration.

Seismic load and displacement calculation example:

Plan and elevation of a two-storey residential building is shown in figure G.1. The building is made of timber - walnut wood. In this example only the dead-load of the columns and beams have been taken into consideration. The building is in Shillong – zone 5 as per IS codes.

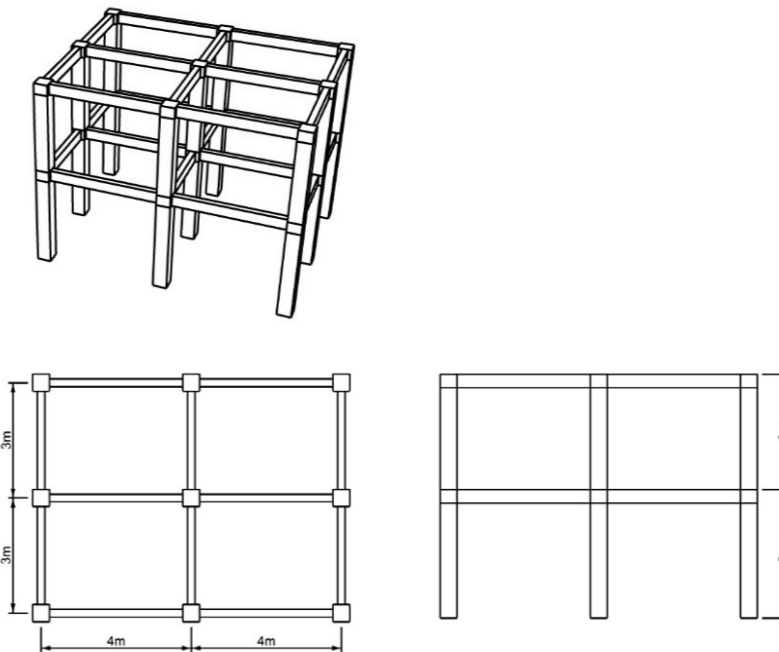


Figure G.1: 1) Plan of building, b) elevation of building c) 3-D view of members considered for the weight calculation.

Design conditions:

Grid-size – x-direction: 4m, y-direction: 3 m
 No. of bays- x-direction: 2, y-direction:2
 Total number of floor = 2,
 Floor to floor height = 3m, Total height of the building = $h = (3 \times 2) \text{ m} = 6\text{m}$
 Cross-sections Column size = 350 x 350 mm, Beam size = 200 x 350mm
 Soil condition of site: Medium stiff soil sites

Material properties:

Youngs modulus of walnut wood = $E = 12700 \text{ Mpa}$; Density = 612 kg/m^3 (values extracted from Ansys)
 Lateral force is being calculated for y direction.

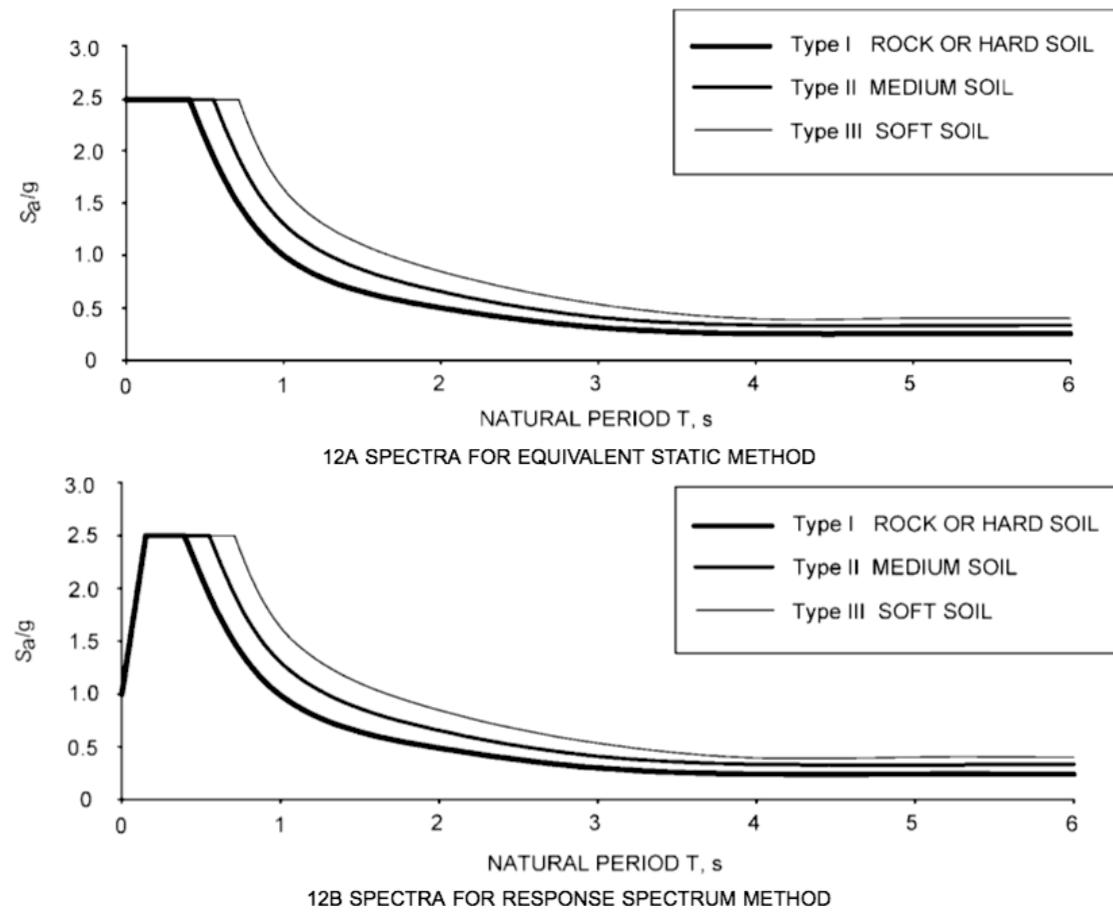


Figure G.2: Design acceleration coefficient (S_a/g) (corresponding to 5% damping) as per IS 1893:2002

Load calculation procedure

Members considered for load = Beams and columns

Load calculations for beam-

Cross section area of 1 beam = $0.2 \times 0.35\text{m}^2 = 0.07 \text{ m}^2$

Length of 1 beam in x direction = 4m, total number of beams in x-direction per floor = 6
Therefore, Total length of beams in x direction = $4 \times 6 = 24\text{m}$

Length of 1 beam in y direction = 3m, total number of beams in x-direction per floor = 6
Therefore, Total length of beams in x direction = $3 \times 6 = 18\text{m}$

Total length of beams = $24 + 18 \text{ m} = 42\text{m}$

Total volume of beams = cross-section area x length = $0.07 \times 42 = 2.94 \text{ m}^3$

Mass of beams per floor = volume x density = $2.94\text{m}^3 \times 612\text{kg}/\text{m}^3 = 1799.28 \text{ kg}$

Load calculations for columns-

Cross section area of 1 column = $0.35 \times 0.35\text{m}^2 = 0.1225 \text{ m}^2$

Length of 1 column = 3m, total number of columns per floor = 9

Therefore, Total length columns = $3 \times 9 = 27\text{m}$

Total volume of columns = cross-section area x length = $0.1225 \times 27 = 3.3075 \text{ m}^3$

Mass of columns per floor = volume x density = $3.3075 \text{ m}^3 \times 612\text{kg}/\text{m}^3 = 2024.19 \text{ kg}$

Total mass of one floor = Mass of columns + Mass of beam = $1799.28 + 2024.19 \text{ kg} = 3823.47 \text{ kg}$

Or total weight of one floor = $m \times g = 3823.47 \times 9.8 = 37.5 \text{ kN}$

Total seismic weight of 2 storey building = $37.5 \times 2 \text{ kN} = 75 \text{ kN}$

Static analysis - Equivalent static method

Depth of the building for calculation in y-direction = $d = \text{grid size in y-direction} \times \text{number of bays in y-direction} = 3 \times 2\text{m} = 6\text{m}$

As per section 5.4.6.2 of NBC, the approximate fundamental translational natural period T_a of oscillation, in seconds, shall be estimated by the following expression for 'all other buildings':

$$T_a = (0.09h)/(v(d)) \quad \dots \text{(equation 1)}$$

Where, h = height of the building in m and, d = depth of the building in m.

Applying values in this equation 1 to obtain T_a ,

$$T_a = 0.09 \times 6 / (v(6)) = 0.2 \text{ s}$$

Now, the design base shear V_B along any principal direction of a building shall be determined by:

$$V_B = A_h * W \quad \dots \text{(equation 2)}$$

Where, A_h = design horizontal acceleration coefficient value, using approximate fundamental natural period T_a along the considered direction of shaking. And W = seismic weight of the building.

As per section 5.3.4.2 of NBC, the design horizontal seismic coefficient, A_h is given by -

$$A_h = \{(Z/2) * (S_a/g)\} / (R/I) \quad \dots \text{(equation 3)}$$

Where, Z = seismic zone factor, (S_a/g) = design acceleration coefficient for different types of soil, R = response reduction factor and I = importance factor of the building.

The values of all the above parameters have been given in the codes depending upon the condition and specifications of the proposed building. The following are the values derived from various tables in NBC.

$Z = 0.36$, as per table 42 (clause 5.3.4.2), as the building falls under seismic zone 5

$(S_a/g) = 2.5$ for $T_a = 0.2\text{s}$, as per figure G.2 (from clause 5.3.4.2 of NBC), the assumed soil type is medium stiff soils.

$R = 1.5$ for framed timer construction

$I = 1$, for residential structures

Substituting all the above values in equation 3:

$$A_h = \{(0.36/2) * (2.5)\} / (1.5/1) = 0.066$$

Thus, it can be seen from above calculation that the total weight of the building = 75 kN

Substituting the values of A_h and W in equation 2,

$$V_B = A_h * W = 0.066 * 75 = 4.95 \text{ kN}$$

Now, as per section 5.4.6.3 of NBC, the Design base shear (V_B) computed above shall be distributed along the height of the building and in plan at each floor. The vertical distribution of base shear at different floor levels is given by the expression:

$$Q_i = [(Wh^2)/(\sum_{j=1}^n W_j h_j^2)] V_B \quad \dots \text{(equation 4)}$$

Where, Q_i = design lateral force at floor i , W_i = seismic weight of floor i , h_i = height of floor i measured from base and n = number of storeys in the building.

Table G.1, below shows the estimation of Q_i and the division of lateral loads in plan.

Starting from top floor levels	Distance from ground	Seismic weight			Storey shear forces	Storey shear forces cummulative sum
	m	kN			kN	kN
	h	W	Wh ²	V _B	Q _i	V _i
2	6	37.5	1350	4,95	3,96	3,96
1	3	37.5	337,5	4,95	0,99	4,95
	Sum Wh ²		1687,5			

Table G.1: Calculation of lateral loads on each storey in the building.

Storey shear forces are calculated as follows (last column of the table G.1) and depicted in figure G.3.

$$V_2 = Q_2 = 3.96 \text{ kN}$$

$$V_1 = V_2 + Q_1 = 3.96 + 0.99 = 4.95 \text{ kN}$$

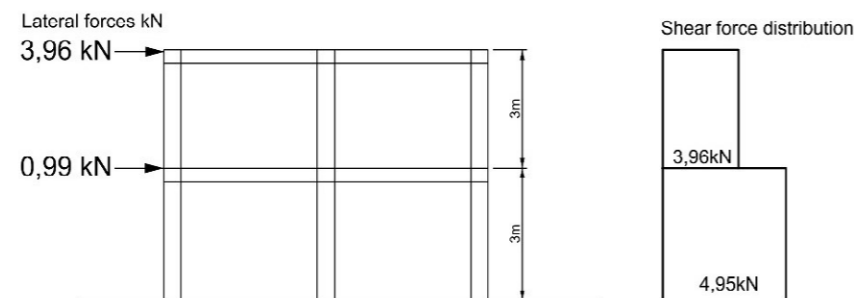


Figure G.3: 1) Plan of building, b) elevation of building c) 3-D view of members considered for the weight calculation.

Dynamic analysis - Response spectrum method

Calculation of seismic mass

Mass of first floor = $M_1 = 3823.47 \text{ kg}$ (as per the calculation shown in previous sections)

Mass of second floor = $M_2 = (\text{Mass of columns}/2) + \text{Mass of beams} = (2024.19/2) + 1799.28 \text{ kg} = 2811.375 \text{ kg}$

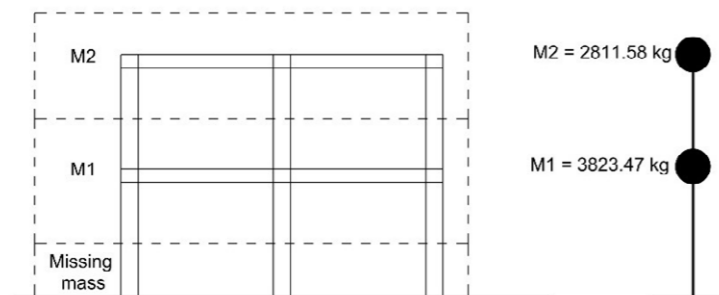


Figure G.4: shows the concept of mass consideration for the various floors.

Calculation of floor stiffness

Stiffness of one column, k , is given by the formula :

$$K = 12EI/h^3 \quad \dots(\text{Equation 1})$$

Where, E = Youngs modulus, I = moment of inertia = $(bd^3/12)$ and h = height of the column.

In our case,

$E = 12700 \text{ MPa}$, $H = 3\text{m}$ or 3000mm , $b = 350\text{mm}$, $d = 350\text{mm}$

$$I = (350 \times 350^3 / 12) = 1250520833 \text{ mm}^4$$

Putting all the above values in equation 1

$$\text{Stiffness value of 1 column} = K = ((12 \times 12700 \times 1250520833) / 3000^3) = 7058.495 \text{ N/mm} \text{ or } 7058495 \text{ N/m}$$

Now,

Stiffness value of floor = stiffness value of 1 column X number of columns in 1 floor

Total number of column in 1 floor = 9

Therefore,

$$\text{Stiffness value of floor 1 and floor 2} = k_1 = k_2 = (7058495 \times 9) = 63526458.33 \text{ N/m}$$

Calculations for natural frequencies and modal shapes

Establishing mass matrix,

$$M = \begin{bmatrix} M_1 & 0 \\ 0 & M_2 \end{bmatrix} = \begin{bmatrix} 3823.47 & 0 \\ 0 & 2811.58 \end{bmatrix} \text{ kg}$$

Establishing stiffness matrix,

$$K = \begin{bmatrix} k_1 + k_2 & -k_2 \\ -k_2 & k_2 \end{bmatrix} = \begin{bmatrix} 127052916.6 & -63526458.32 \\ -63526458.32 & 63526458.32 \end{bmatrix} \text{ N/m}$$

Solving the Eigen equation,

$$|K - \lambda M| = 0, \quad \dots(\text{equation 2})$$

where, $\lambda = \omega^2$ and ω = natural frequency

Putting values in equation 2, and solving for λ

$$\Rightarrow \left| \begin{bmatrix} k_1 + k_2 & -k_2 \\ -k_2 & k_2 \end{bmatrix} - \lambda \begin{bmatrix} M_1 & 0 \\ 0 & M_2 \end{bmatrix} \right| = 0$$

$$\Rightarrow \begin{bmatrix} 127052916.6 & -63526458.32 \\ -63526458.32 & 63526458.32 \end{bmatrix} - \lambda \begin{bmatrix} 3823.47 & 0 \\ 0 & 2811.58 \end{bmatrix} = 0$$

$$\Rightarrow \begin{bmatrix} 127052916.6 & -63526458.32 \\ -63526458.32 & 63526458.32 \end{bmatrix} - \begin{bmatrix} 3823.47\lambda & 0 \\ 0 & 2811.58\lambda \end{bmatrix} = 0$$

$$\Rightarrow \begin{bmatrix} 127052916.6 - 3823.47\lambda & -63526458.32 \\ -63526458.32 & 63526458.32 - 2811.58\lambda \end{bmatrix} = 0$$

$$\Rightarrow (127052916.6 - 3823.47\lambda)(63526458.32 - 2811.58\lambda) - (-63526458.32 * -63526458.32) = 0$$

$$\Rightarrow 8071221813000000 - 242891507600\lambda - 357193393400\lambda + 10774510.35\lambda^2 - 4035610907000000 = 0$$

$$\Rightarrow 10774510.35 \lambda^2 - 600084901000\lambda + 4035610906000000 = 0$$

Solving the quadratic equation for λ , we get:

$$\lambda_1 = 7824.25 \text{ and } \lambda_2 = 47870.615$$

Now,

$$|K - \lambda M|\phi = 0, \quad \dots(\text{equation 3})$$

$$\Rightarrow \begin{bmatrix} 127052916.6 - 3823.57\lambda & -63526458.32 \\ -63526458.32 & 63526458.32 - 2811.58\lambda \end{bmatrix} \begin{bmatrix} \phi_1 \\ \phi_2 \end{bmatrix} = 0$$

Solving for, $\lambda_1 = 7824.25$

$$\Rightarrow \begin{bmatrix} 127052916.6 - 3823.57 \times 7824.25 & -63526458.32 \\ -63526458.32 & 63526458.32 - 2811.58 \times 7824.25 \end{bmatrix} \begin{bmatrix} \phi^{11} \\ \phi^{12} \end{bmatrix} = \mathbf{0}$$

$$\Rightarrow \begin{bmatrix} 97137131.45 & -63526458.32 \\ -63526458.32 & 41529557.48 \end{bmatrix} \begin{bmatrix} \phi^{11} \\ \phi^{12} \end{bmatrix} = \mathbf{0}$$

$$\Rightarrow 97137131.45 \phi^{11} - 63526458.32 \phi^{12} = 0$$

$$\Rightarrow -63526458.32 \phi^{11} + 41529557.48 \phi^{12} = 0$$

Let $\phi^{12} = 1$, for solving the above two equations.

Therefore, $\phi^{11} = 0.65$

$$\text{Or, } \begin{bmatrix} \phi^{11} \\ \phi^{12} \end{bmatrix} = \begin{bmatrix} 0.65 \\ 1 \end{bmatrix}$$

Solving for, $\lambda_2 = 47870.615$

$$\Rightarrow \begin{bmatrix} 127052916.6 - 3823.57 \times 47870.615 & -63526458.32 \\ -63526458.32 & 63526458.32 - 2811.58 \times 47870.615 \end{bmatrix} \begin{bmatrix} \phi^{21} \\ \phi^{22} \end{bmatrix} = \mathbf{0}$$

$$\Rightarrow \begin{bmatrix} -55978943.73 & -63526458.32 \\ -63526458.32 & -71055791.93 \end{bmatrix} \begin{bmatrix} \phi^{21} \\ \phi^{22} \end{bmatrix} = \mathbf{0}$$

$$\Rightarrow -55978943.73 \phi^{21} - 63526458.32 \phi^{22} = 0$$

$$\Rightarrow -63526458.32 \phi^{21} - 71055791.93 \phi^{22} = 0$$

Let $\phi^{22} = 1$, for solving the above two equations.

Therefore, $\phi^{21} = -1.12$

$$\text{Or, } \begin{bmatrix} \phi^{21} \\ \phi^{22} \end{bmatrix} = \begin{bmatrix} -1.12 \\ 1 \end{bmatrix}$$

Hence, mode shapes are:-

$$\text{Mode 1} = \begin{bmatrix} \phi^{11} \\ \phi^{12} \end{bmatrix} = \begin{bmatrix} 0.65 \\ 1 \end{bmatrix}, \text{ and Mode 2} = \begin{bmatrix} \phi^{21} \\ \phi^{22} \end{bmatrix} = \begin{bmatrix} -1.12 \\ 1 \end{bmatrix}$$

Since, $\lambda = \omega^2$, therefore natural frequencies are:-

$$\omega_1^2 = \lambda_1 \Rightarrow \omega_1 = \sqrt{\lambda_1} \Rightarrow \omega_1 = \sqrt{7824.25} \Rightarrow \omega_1 = 88.45 \text{ rad/sec}$$

$$\omega_2^2 = \lambda_2 \Rightarrow \omega_2 = \sqrt{\lambda_2} \Rightarrow \omega_2 = \sqrt{47870.615} \Rightarrow \omega_2 = 218.79 \text{ rad/sec}$$

Now, natural period of vibration = $T = 2\pi/\{\omega\}$

$$T_1 = 2\pi/\{\omega_1\} = 2\pi/88.45 = 0.071 \text{ sec}$$

$$T_2 = 2\pi/\{\omega_2\} = 2\pi/218.79 = 0.029 \text{ sec}$$

Calculation of modal participation factor

Storey level	Seismic weight (W_i), kN	Mode - 1		
		ϕ_{i1}	$W_i \phi_{i1}$	$W_i \phi_{i1}^2$
2	27.57	1	27.57	27.57
1	37.5	0.65	24.375	15.84
$\sum W_i = 65.07 \text{ kN}$			$\sum W_i \phi_{i1} = 51.945$	$\sum W_i \phi_{i1}^2 = 43.41$
Modal mass $M1 = [\sum W_i \phi_{i1}]^2 / \sum W_i \phi_{i1}^2 = 51.945^2 / 43.41 = 62.16 \text{ kN}$				
% of total weight = $(62.16/65.07) \times 100 = 95.5 \%$				
Modal participation factor, $P2 = \sum W_i \phi_{i2}^2 / \sum W_i \phi_{i2}^2 = -14.43/74.61 = -0.193$				

Storey level	Seismic weight (W_i), kN	Mode - 2		
		ϕ_{i2}	$W_i \phi_{i2}$	$W_i \phi_{i2}^2$
2	27.57	1	27.57	27.57
1	37.5	-1.12	-42	47.04
$\sum W_i = 65.07 \text{ kN}$			$\sum W_i \phi_{i2} = -14.43$	$\sum W_i \phi_{i2}^2 = 74.61$
Modal mass $M1 = [\sum W_i \phi_{i2}]^2 / \sum W_i \phi_{i2}^2 = 14.43^2 / 74.61 = 2.79 \text{ kN}$				
% of total weight = $(2.79/65.07) \times 100 = 4.3 \%$				
Modal participation factor, $P2 = \sum W_i \phi_{i2}^2 / \sum W_i \phi_{i2}^2 = -14.43/74.61 = -0.193$				

$S_a/g = 1+15T$ for $T < 0.10 \text{ s}$, medium soil

Therefore, S_a/g (for $T = (1+15 \times 0.071) = 2.065$) = 0.55

Also, from IS 1893, it is given for seismic zone 5, zone factor = $Z = 0.36$. Importance factor for residential building = 1 and response reduction factor for timber frame construction = 1.5. Substituting all the above values in the equation,

$$A_{h(1)} = \left\{ \left(\frac{0.36}{2} \right) * (0.55) \right\} / \left(\frac{1.5}{1} \right) = 0.066$$

$$Q_{ik} = A_{h(k)} \phi_{ik} P_k W_i = 0.066 \times 1.2 \times \phi_{ik} W_i = 0.0792 \phi_{ik} W_i$$

Mode 2:-

$$T_1 = 0.029 \text{ sec}$$

$S_a/g = 1+15T$ for $T < 0.10 \text{ s}$, medium soil

Therefore, S_a/g (for $T = (1+15 \times 0.071) = 1.4$) = 0.75

Also, from IS 1893, it is given for seismic zone 5, zone factor = $Z = 0.36$. Importance factor for residential building = 1 and response reduction factor for timber frame construction = 1.5. Substituting all the above values in the equation,

$$A_{h(1)} = \left\{ \left(\frac{0.36}{2} \right) * (0.75) \right\} / \left(\frac{1.5}{1} \right) = 0.09$$

$$Q_{ik} = A_{h(k)} \phi_{ik} P_k W_i = 0.09 \times -0.193 \times \phi_{ik} W_i = -0.01737 \phi_{ik} W_i$$

Lateral load calculation by modal analysis – SRSS method

Storey level	Weight, W_i (kN)	Mode-1 [$Q_i = 0.0792 \phi_{ik} W_i$]		
		ϕ_{i1}	Q_{i1} (kN)	V_{i1} (kN)
2	27.57	1	2.18	2.18
1	37.5	0.65	1.93	4.11

Storey level	Weight, W_i (kN)	Mode-2 [$Q_i = -0.01737 \phi_{ik} W_i$]		
		ϕ_{i2}	Q_{i2} (kN)	V_{i2} (kN)
2	27.57	1	-0.48	-0.48
1	37.5	-1.12	0.73	0.25

Combining the values of different modes by SRSS method, as per clause 7.8.4.4 of IS 1893:2002. The contribution of different modes are combined by Square root of the sum of the squares (SRSS) using the following relationship,

$$V_i = \sqrt{V_{i1}^2 + V_{i2}^2} \quad \dots(\text{equation 5})$$

And, storey lateral forces due to all considered modes are calculated by, $F_i = V_i - V_{i+1}$

The results have been calculated as follows,

Storey level	Vi1	Vi2	Combined shear force, Vi (kN), as per eq 5	Combined lateral force, Fi (kN)
2	2.18	-0.48	2.23	2.23
1	4.11	0.25	4.12	1.89

Comparison between the equivalent static method and the response spectrum (SRSS) method and calculation of relative displacement.

Storey level	Equivalent static method		Response spectrum (SRSS) method	
	Shear force, Vi (kN)	Lateral force, Fi (kN)	Shear force, Vi (kN)	Lateral force, Fi (kN)
2	3.96	3.96	2.23	2.23
1	4.95	0.99	4.12	1.89

Now as per IS 1893:2002, When a dynamic analysis is used for force estimation and if the design base shear V_b estimated by the dynamic analysis is less than the design base shear V_b estimated by static method, then the design base shear V_b shall be multiplied by a factor of V_d/V_b .

$V_d = 4.95, V_b = 4.12$; therefore, scale factor = $V_d/V_b = 4.95/4.12 = 1.2$

Actual shear force for design by response spectrum:-

$V_{i2} = 2.23 \times 1.2 = 2.68 \text{ kN or } 2680 \text{ N}$
 $V_{i1} = 4.12 \times 1.2 = 4.94 \text{ kN or } 4940 \text{ N}$

Top floor displacement of each mode:

Top floor displacement = Participation factor (Pi) x Modal shape of top storey for that mode ($\phi^1 2$) x Displacement as per response spectra

$(S_d) = P_i \times \phi^1 2 \times S_d$ (equation 6)

Mode 1:

$P_i = 1.2, \phi^1 2 = 1, \omega_1^2 = 7824.25$ (from above calculation),

$S_d = S_d / \omega_1^2$...(equation 7)

S_d/g as per response spectrum diagram = $1+15T$, for $T < 0.10s$; here. $T = 0.0721$ (from above calculation)

$S_d/g = (1+15 \times 0.0721) = 2.0815$

$S_d = 2.0815 \times g = 2.0815 \times 9.8 \text{ m/s}^2 = 20.3987 \text{ m/s}^2$ (where g = acceleration due to gravity)

Putting values in above eq. 7,

$S_d = 20.3987 / 7824.25 = 0.00261 \text{ m}$

Putting values in above eq. 6,

Top floor displacement as per mode 1 = $P_i \times \phi^1 2 \times S_d = 1.2 \times 1 \times 0.00261 = 0.00313\text{m or } 3.13\text{mm}$

Appendix H : FEA for seismicity - Ansys setup

The finite element analysis for validity of the global structure was made in Ansys workbench. Ansys workbench version 19.2 (academic license) was used for this research. The response spectrum analysis is done in 3 steps as shown in figure H.1:

- Firstly, establishing a model for static structural analysis
- Secondly, setting up the modal analysis
- Thirdly, superposing the modal results to achieve the response spectrum.

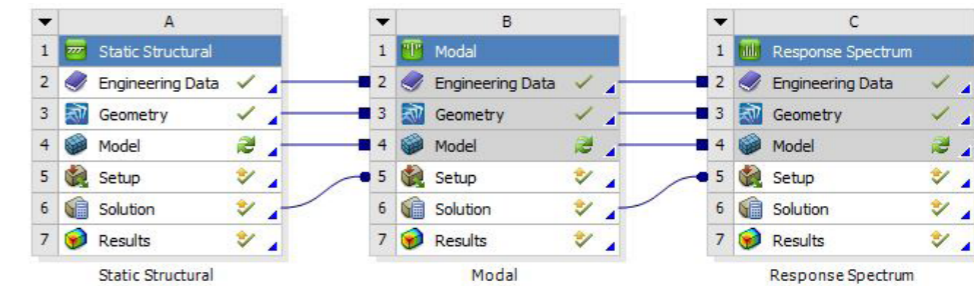


Figure H.1: FEA on Ansys, simulation steps.

As mentioned in section 8.11.1, the linear line elements -beam 188 was chosen for modelling the geometry. Three types of nodal connections, the solid node, the point node and the mesh intersection were used for joining the members which gave different results. This setup explains the method of analysis using the point node which gave the closest results to the analytical calculations. The following is the procedure for ansys setup:

Step 1: Importing the 3D line drawing from Rhino3D.

The initial geometry was modelled in rhino and imported to Ansys workbench. The model was such that the single lines represented the columns and the beams.

Step 2: : Assigning cross-section to line elements in space-claim.

Space-claim is the inbuilt geometry editing tool in Ansys. The imported Rhino geometry comprises of single lines, thus the cross-sections are assigned to the respective members in space-claim as shown in figure H.2. Also, the geometry should be check for errors in this platform before further steps.

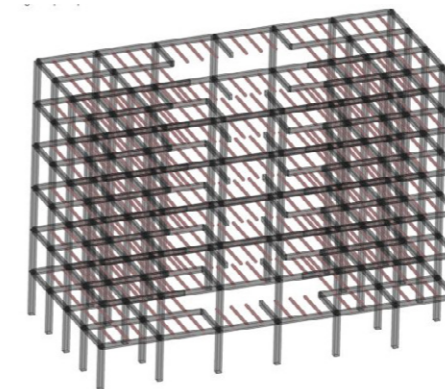


Figure H.2: Ansys model after application of cross-sections to line elements in space claim.

Step 3: Building the material in ansys.

Ansys has a large inbuilt library of materials with properties. However, since local timber species were used for this research, new materials were created by inputting the material properties - Young's modulus and the density. Figure x shows the material input in Ansys, however the other properties were not altered for this research, as their affect is assumed to be negligible in the required calculations and due to the lack of data.

Step 4: Assigning materials to the cross-section elements.

This is the first step in ansys workbench where workbench displays the materials that were chosen for

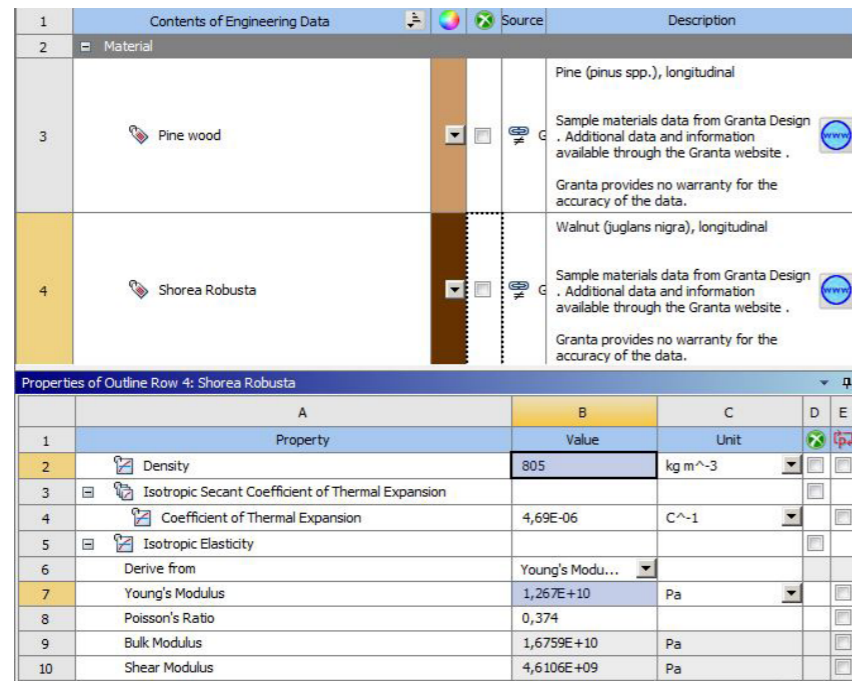


Figure H.3: Choosing/building the materials for the model from the materials library in ansys.

the model from the engineering data sources, as shown in figure H.3. The cross-sections defined in spaceclaim are assigned the respective materials.

Step 5: Specifying the connections.

This is the most important step in the simulation setup as it directly affects the results. The point node was defined using the fixed connections in which the vertices of the end of the lines were chosen as the connection points between the elements. Figure H.4 shows the example of the connection of the top floor columns and beams to the lower floor column at one node/vertex. This procedure was repeated for all the fixed connections.

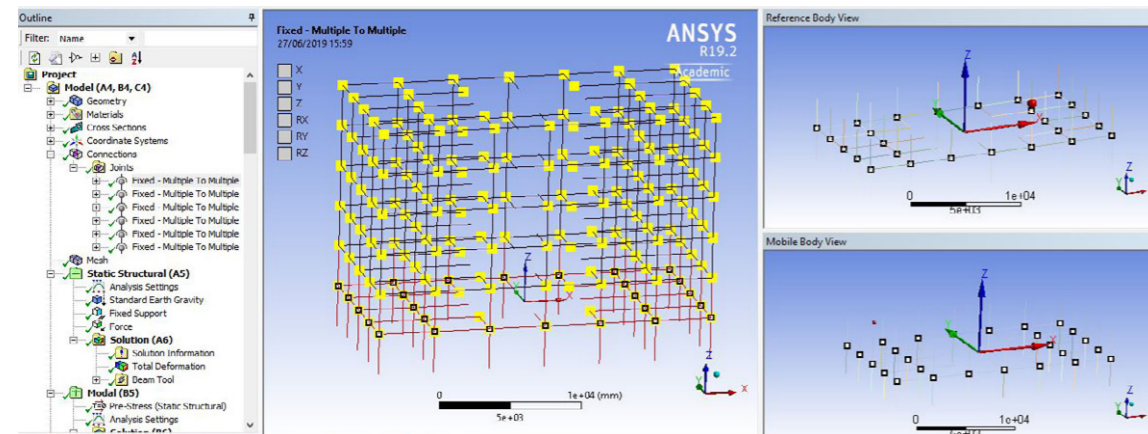


Figure H.4: Specifying connection type (fixed joints) at the nodes in Ansys.

Step 6: Meshing the geometry

The correct mesh resolution is important to establish an accurate FEA for this research the automatically generated mesh proved to be enough. Also, there was a limitation in the number of nodes for structural analysis in the academic version, hence a finer meshing could not be achieved. Thus, the mesh thus generated was used for further analysis.

Step 7: Specifying the fixed support and forces for the purpose of static structural analysis.

This is the first step for actual FEA. The fixed supports are defined at the end vertex of the lowest columns, where they are connected to the foundation. The force is specified in two categories a) standard earth gravity and b) Imposed live loads. The direction is downwards (-z) and the magnitude is calculated as per the loading conditions specified in section xx. For the purpose of this simulation a load case of 101500 was imposed on all the primary beams, while gravity loads on all members of the building.

Step 8: Running the simulation.

The successful completion of the static structural simulation proves the correct setup of the FEA model and is ready for the actual modal analysis. Important aspect is to turn on the large deflections before the analysis for accuracy of the results.

Step 9: Modal analysis.

This is the first step for the seismic analysis of the structure. The number of modes must be specified for structural analysis. It is recommended that the number of modes should be such that the mass participation factor reaches at least 90% at the end of modal simulation, this is generally achieved by gradually increasing the number of modes and running iterative simulations till the required results are achieved. The modal analysis generates frequencies for each mode as shown in figure H.5, which is then used as input for the response spectrum analysis.

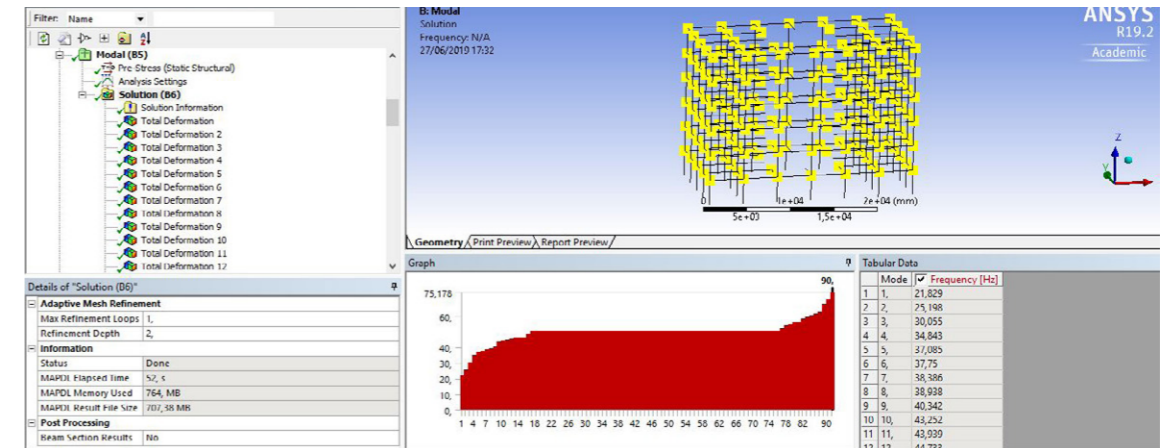


Figure H.5: Modal analysis setup in Ansys.

Step 10: Response spectrum analysis.

The response spectrum analysis is the final step in this simulation which generates the final results - global deflection of the building is the required direction. Analysis settings include specifying the 'mode combination type' which in our case is the SRSS method, as this method was also used in the analytical calculation. The second important input includes the acceleration (RS acceleration) values on the basis of which the software calculates the frequency for each mode. In this research the acceleration values have been derived from the Indian building codes (IS 1893) and calculated as follows:

Figure G.2 in appendix G shows the S_a/g graph provided in the IS codes, using this graph the acceleration values for different time-periods were calculated. The acceleration values are provided in table below. However, Ansys has the input of frequency = f and S_a . It is known that:

$$frequency = 1/time-period$$

Using this equation, the time-period provided in the above table were converted to frequency for the respective values of S_a/g . Further the data is scale by 9806,6 to compensate the value of gravity as provided in the building codes. The figure below shows the input values of S_a in ansys, corresponding to the table H.1 provided below.

Time period = T (s)	Frequency = 1/T (Hz)	Acceleration values = S_a/g
0,01	100	1
0,0625	16	1,4
0,125	8	2,35
0,1625	6,153846154	2,5
0,25	4	2,5
0,375	2,666666667	2,5
0,5	2	2,5
0,5625	1,777777778	2,5

0,625	1,6	2,3
0,75	1,333333333	1,8
0,875	1,142857143	1,5
1	1	1,3
1,125	0,888888889	1,125
1,25	0,8	1
1,375	0,727272727	0,9
1,5	0,666666667	0,8
1,625	0,615384615	0,775
1,75	0,571428571	0,75
1,875	0,533333333	0,685
2	0,5	0,625

Table H.1: Calculation of frequency and acceleration (S_g/g) values for input in Ansys.

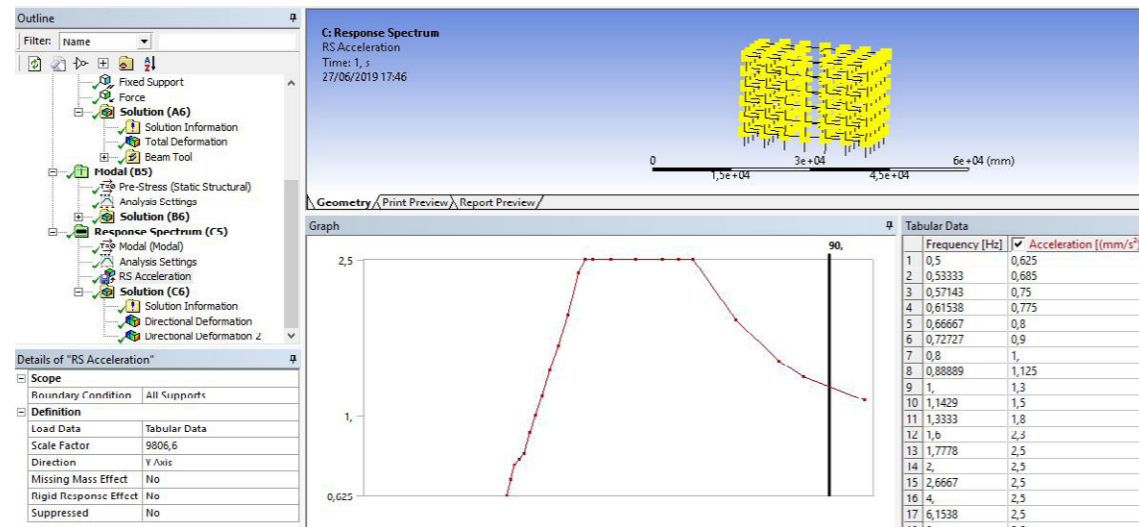


Figure H.6: Inputting the values from table H.1 in Ansys.

Next it is important to specify the direction of analysis, x, y or z and the required direction of deflection. Finally, the response spectrum simulation generates the results for the deflection as shown in figure H.7.

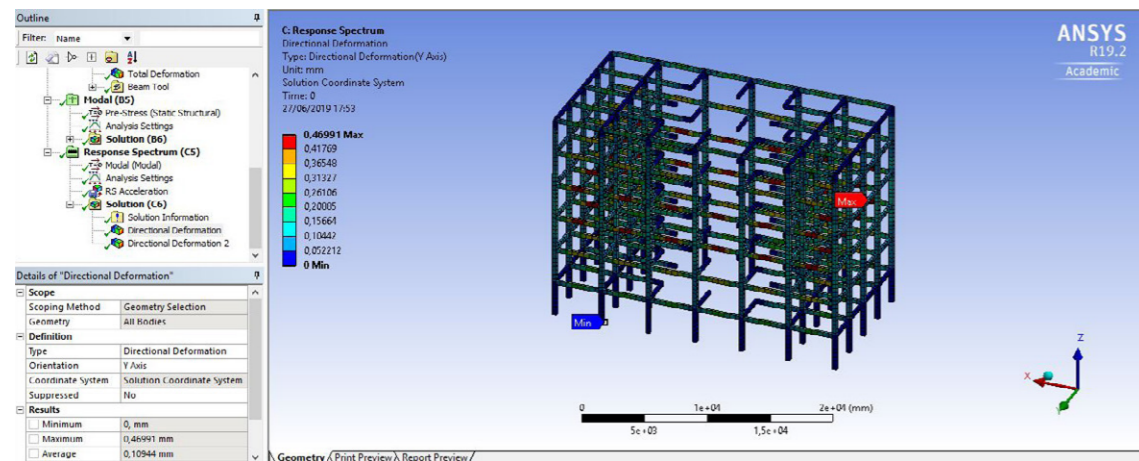


Figure H.7: Final result after simulation in Ansys.

For the center points:

```

if (x==3 and y==4):
  A='3au'
  B='3ax'
  C='3ax'
  D='3ay'
  E='3az'
  F='3az'
if (x==3 and y==4.5):
  A='3au'
  B='3ax'
  C='3ax'
  D='3ay'
  E='3az'
if (x==3 and y==5):
  A='3au'
  B='3ax'
  C='3ax'
  D='3ay'
  E='3az'
if (x==3.5 and y==4):
  A='3au'
  B='3ax'
  C='3ax'
  D='3ay'
  E='3az'
if (x==3.5 and y==4.5):
  A='3au'
  B='3ax'
  C='3ax'
  D='3ay'
  E='3az'
if (x==3.5 and y==5):
  A='3au'
  B='3ax'
  C='3ax'
  D='3ay'
  E='3az'
if (x==4 and y==4):
  A='3au'
  B='3ax'
  C='3ax'
  D='3ay'
if (x==4 and y==4.5):
  A='3au'
  B='3ax'
  C='3ax'
  D='3ay'
if (x==4 and y==5):
  A='3au'
  B='3ax'
  C='3ax'
if (x==4.5 and y==4):
  A='3au'
  B='3ax'
  C='3ax'
  D='3ay'
if (x==4.5 and y==4.5):
  A='3au'
  B='3ax'
  C='3ax'
if (x==4.5 and y==5):
  A='3au'
  B='3ax'
  C='3ax'
if (x==5 and y==4):
  A='3au'
  B='3ax'
  C='3ax'
if (x==5 and y==4.5):
  A='3au'
  B='3ax'
  C='3ax'
if (x==5 and y==5):
  A='3au'
  B='3ax'
  C='3ax'
    
```

For the edge points:

```

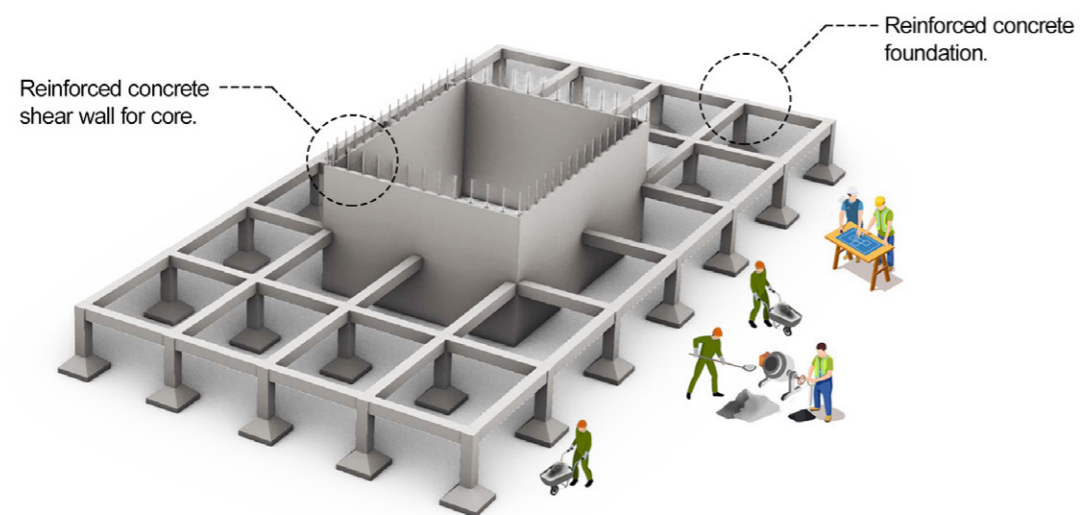
if (x==3 and y==4):
  A='3bu'
  B='3bx'
  C='3bx'
  D='3by'
  E='3bz'
  F='3bz'
if (x==3 and y==4.5):
  A='3bu'
  B='3bx'
  C='3bx'
  D='3by'
  E='3bz'
if (x==3 and y==5):
  A='3bu'
  B='3bx'
  C='3bx'
  D='3by'
  E='3bz'
if (x==3.5 and y==4):
  A='3bu'
  B='3bx'
  C='3bx'
  D='3by'
  E='3bz'
if (x==3.5 and y==4.5):
  A='3bu'
  B='3bx'
  C='3bx'
  D='3by'
  E='3bz'
if (x==3.5 and y==5):
  A='3bu'
  B='3bx'
  C='3bx'
  D='3by'
  E='3bz'
if (x==4 and y==4):
  A='3bu'
  B='3bx'
  C='3bx'
  D='3by'
if (x==4 and y==4.5):
  A='3bu'
  B='3bx'
  C='3bx'
  D='3by'
if (x==4 and y==5):
  A='3bu'
  B='3bx'
  C='3bx'
if (x==4.5 and y==4):
  A='3bu'
  B='3bx'
  C='3bx'
  D='3by'
if (x==4.5 and y==4.5):
  A='3bu'
  B='3bx'
  C='3bx'
if (x==4.5 and y==5):
  A='3bu'
  B='3bx'
  C='3bx'
if (x==5 and y==4):
  A='3bu'
  B='3bx'
  C='3bx'
if (x==5 and y==4.5):
  A='3bu'
  B='3bx'
  C='3bx'
if (x==5 and y==5):
  A='3bu'
  B='3bx'
  C='3bx'
    
```

For the corner points:

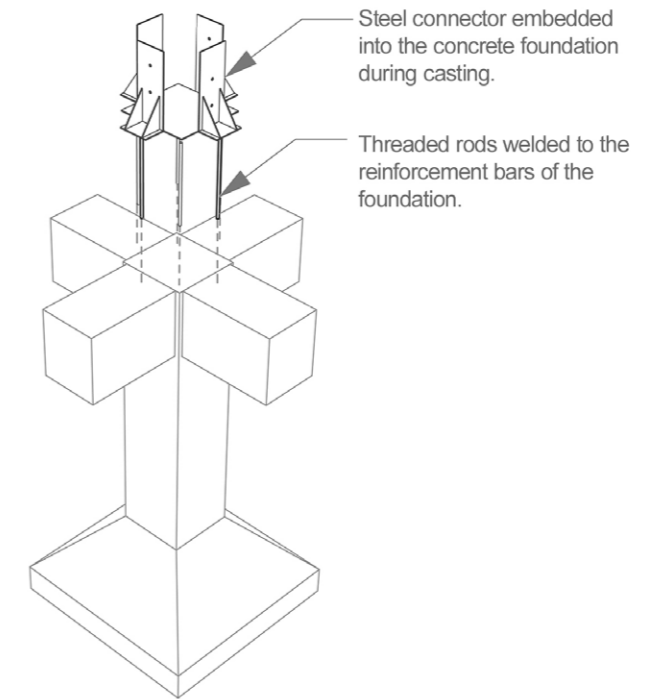
```

if (x==3 and y==4):
  A='3cu'
  B='3cx'
  C='3cx'
  D='3cy'
  E='3cz'
  F='3cz'
if (x==3 and y==4.5):
  A='3cu'
  B='3cx'
  C='3cx'
  D='3cy'
  E='3cz'
if (x==3 and y==5):
  A='3cu'
  B='3cx'
  C='3cx'
  D='3cy'
  E='3cz'
if (x==3.5 and y==4):
  A='3cu'
  B='3cx'
  C='3cx'
  D='3cy'
  E='3cz'
if (x==3.5 and y==4.5):
  A='3cu'
  B='3cx'
  C='3cx'
  D='3cy'
  E='3cz'
if (x==3.5 and y==5):
  A='3cu'
  B='3cx'
  C='3cx'
  D='3cy'
  E='3cz'
if (x==4 and y==4):
  A='3cu'
  B='3cx'
  C='3cx'
  D='3cy'
if (x==4 and y==4.5):
  A='3cu'
  B='3cx'
  C='3cx'
  D='3cy'
if (x==4 and y==5):
  A='3cu'
  B='3cx'
  C='3cx'
if (x==4.5 and y==4):
  A='3cu'
  B='3cx'
  C='3cx'
  D='3cy'
if (x==4.5 and y==4.5):
  A='3cu'
  B='3cx'
  C='3cx'
if (x==4.5 and y==5):
  A='3cu'
  B='3cx'
  C='3cx'
if (x==5 and y==4):
  A='3cu'
  B='3cx'
  C='3cx'
if (x==5 and y==4.5):
  A='3cu'
  B='3cx'
  C='3cx'
if (x==5 and y==5):
  A='3cu'
  B='3cx'
  C='3cx'
    
```

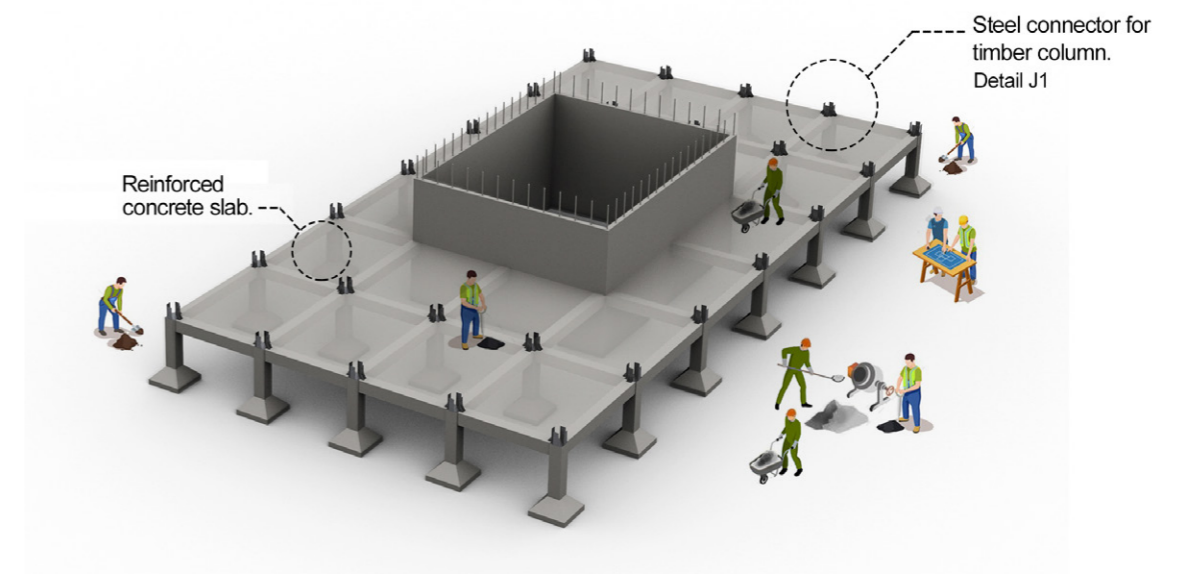
Appendix J : Assembly sequence of hybrid timber construction



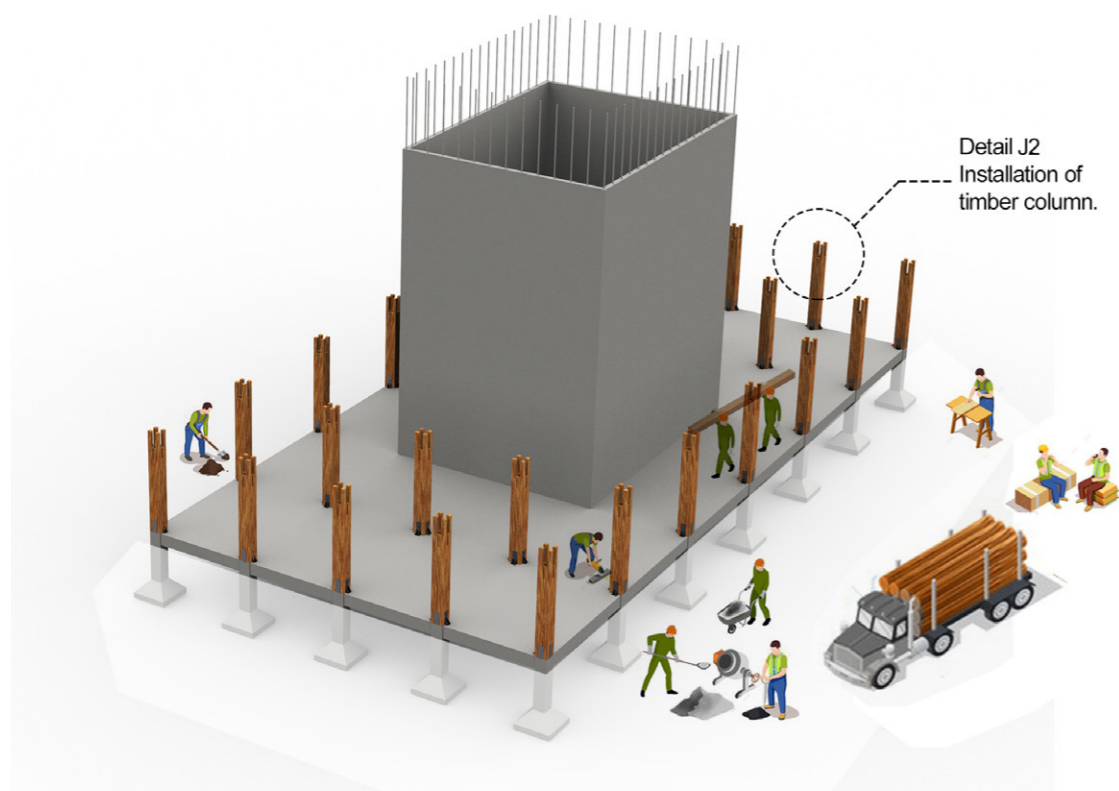
Column and core concrete foundation, plinth beam.



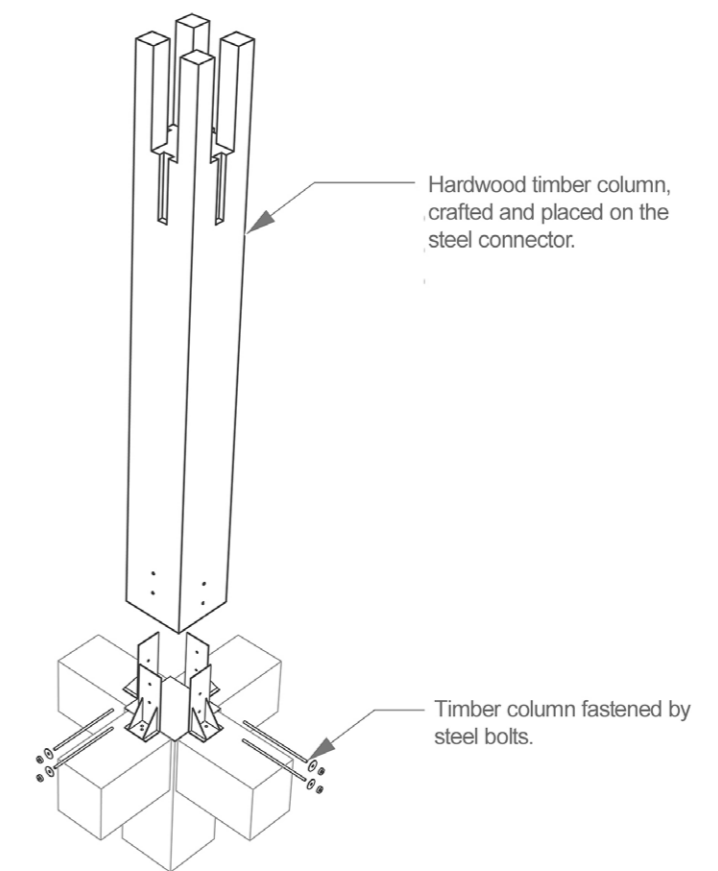
Detail J1: Steel connector to foundation.



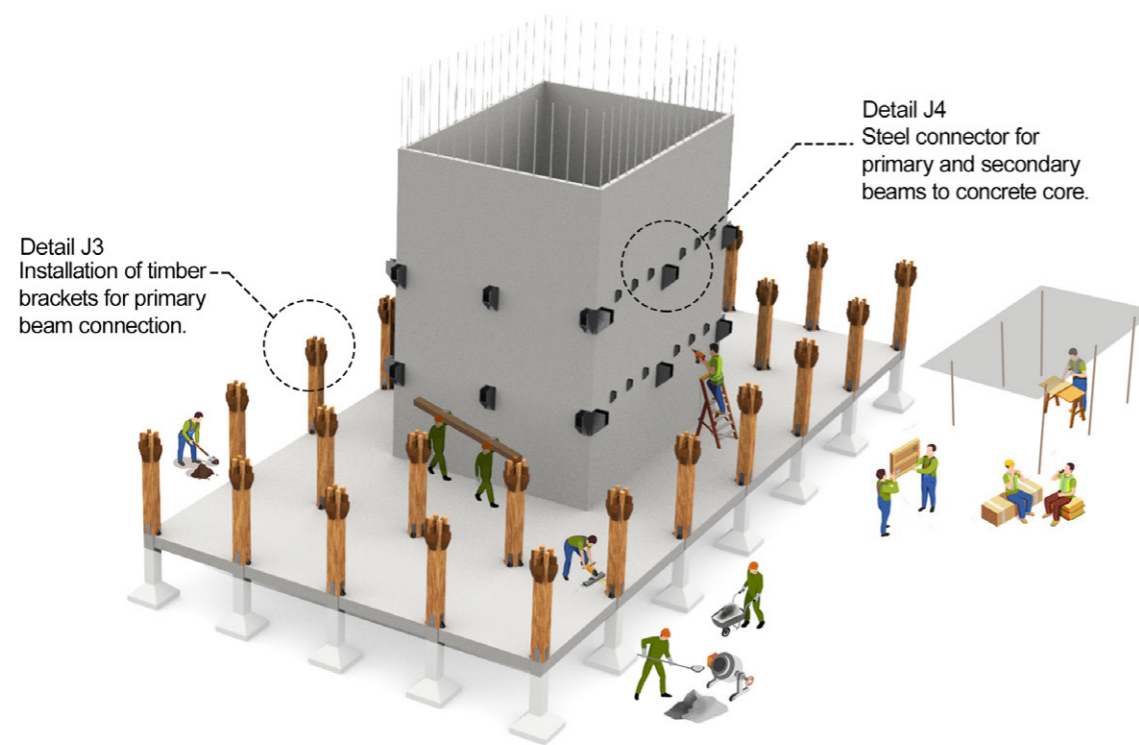
Concrete slab and steel connectors for columns.



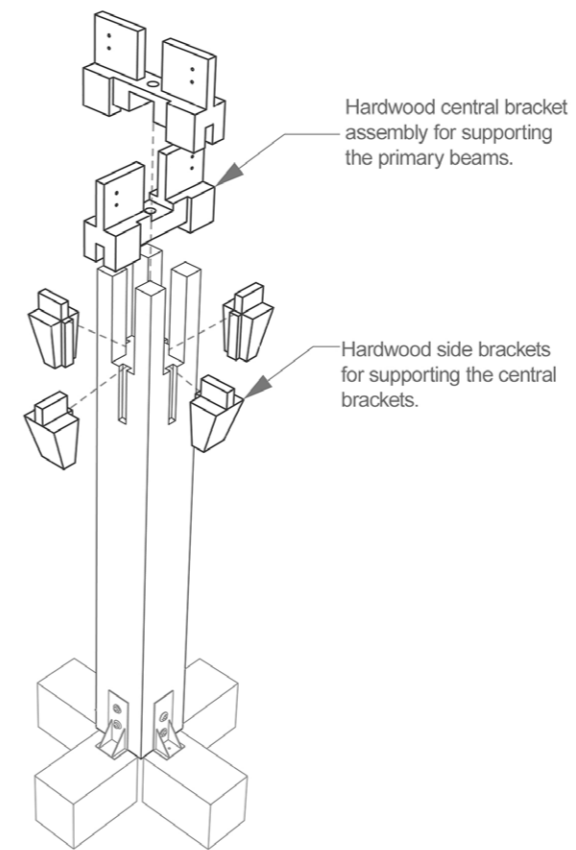
Timber column installation & filling the foundation pit.



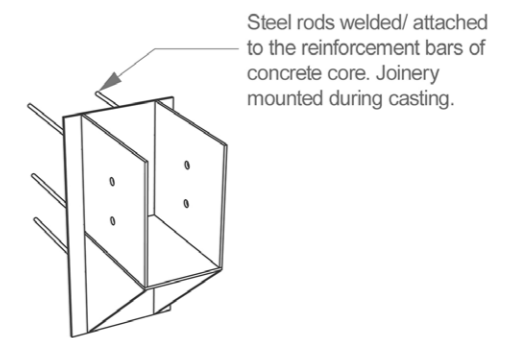
Detail J2: Timber column to concrete foundation.



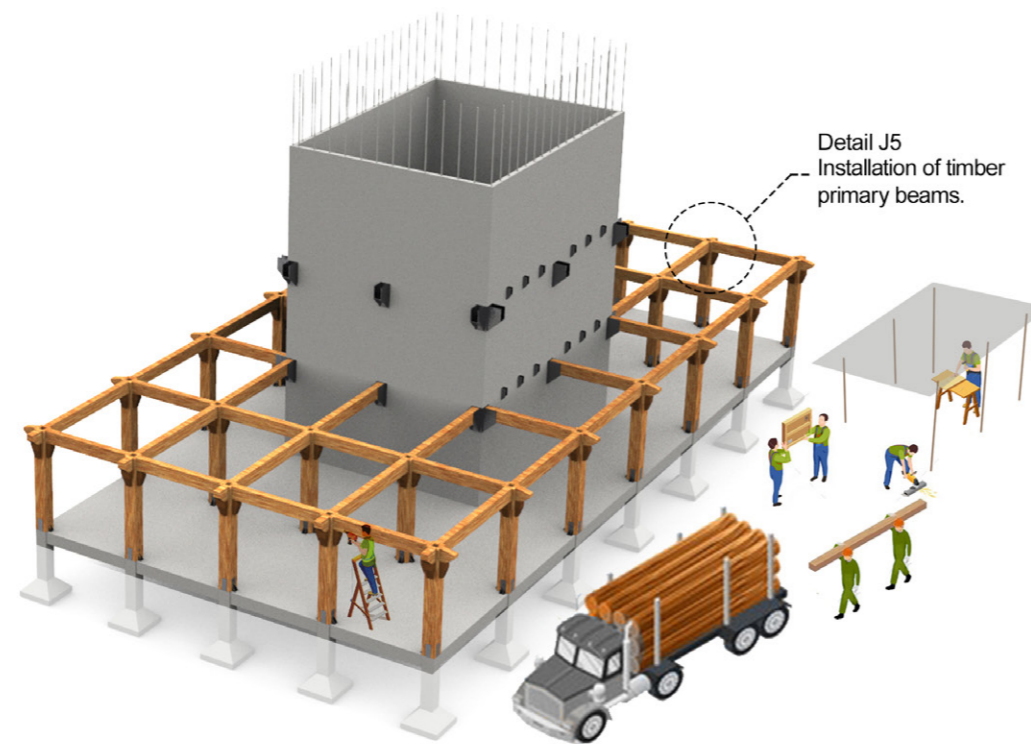
Column capital and beam connector installation.



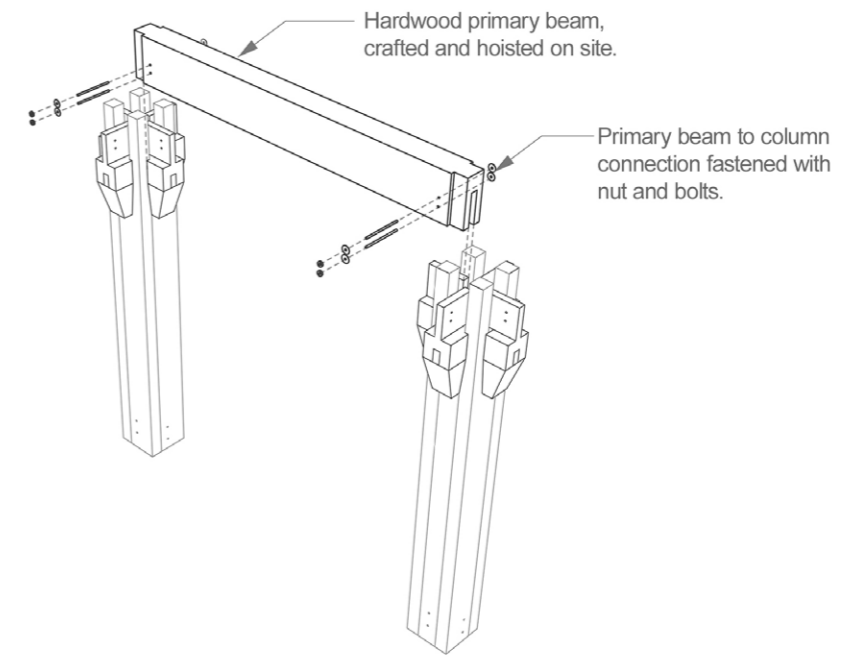
Detail J3: Timber capital brackets installation



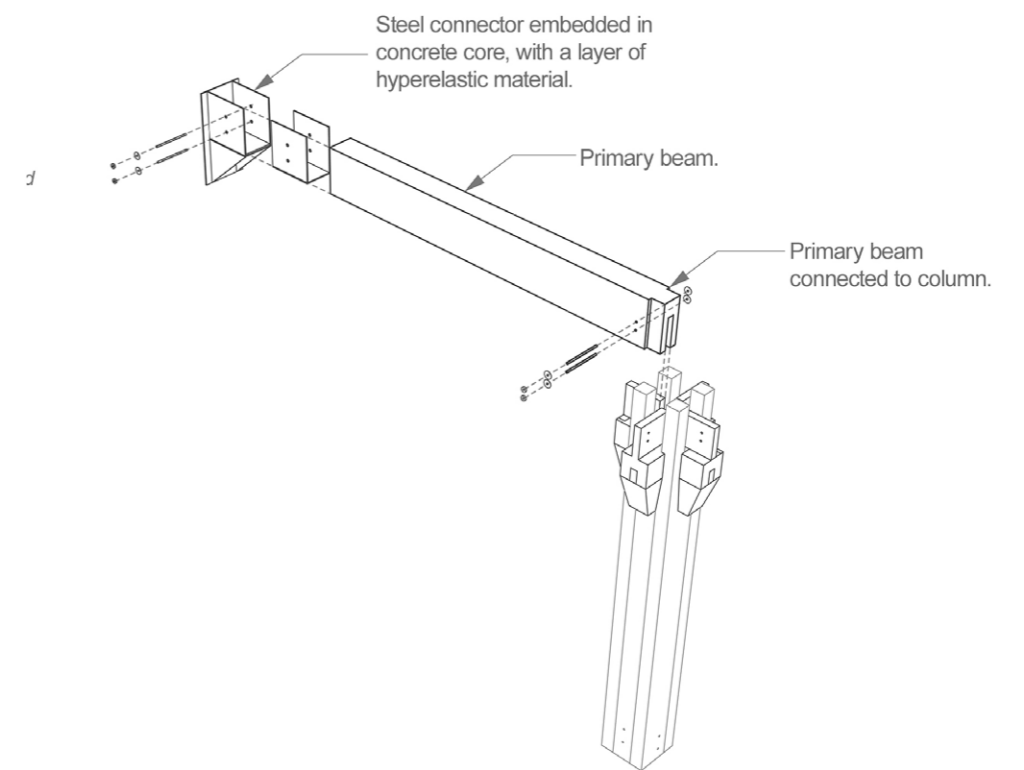
Detail J4: Beam to core connector installation



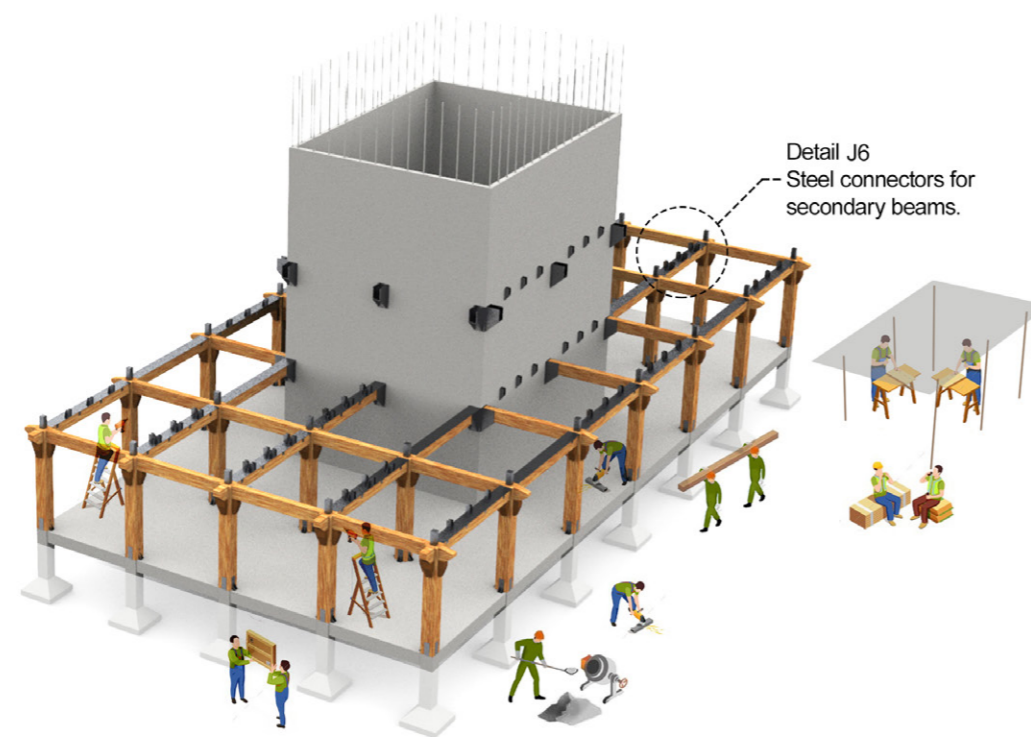
Primary beam installation.



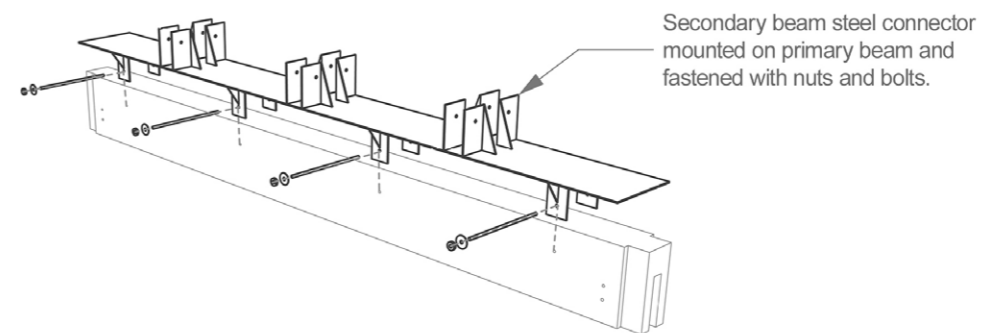
Detail J5a - Primary beam to column to column installation



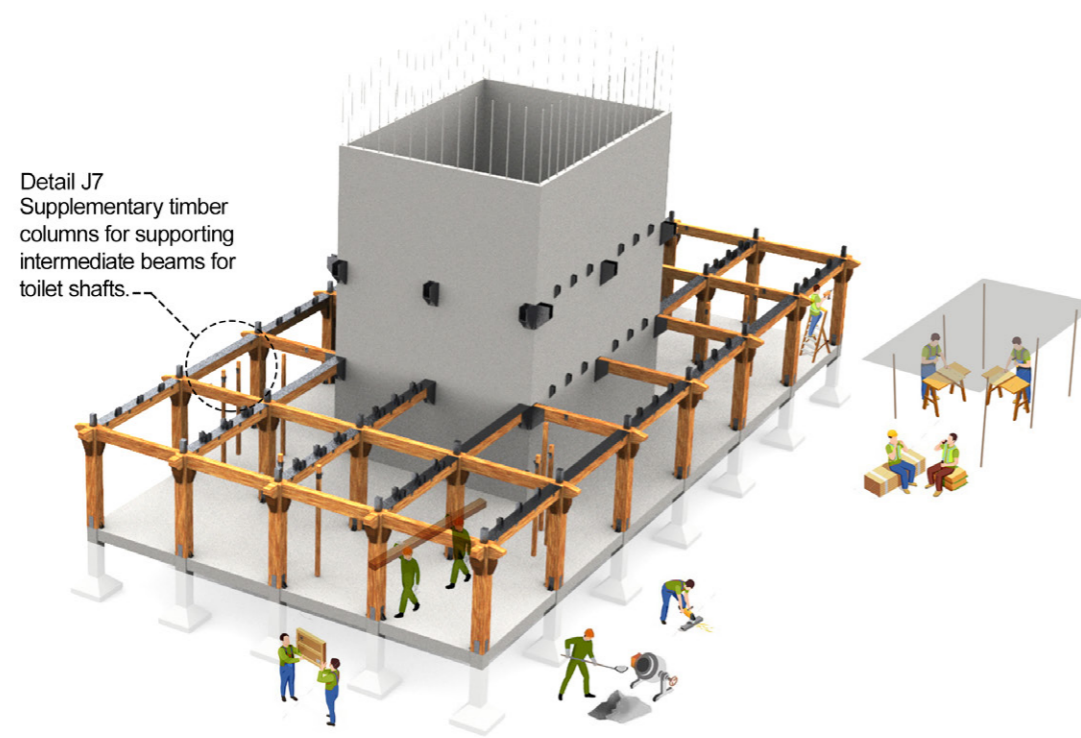
Detail J5b - Primary beam to column to core installation



Secondary beam steel connector installation.

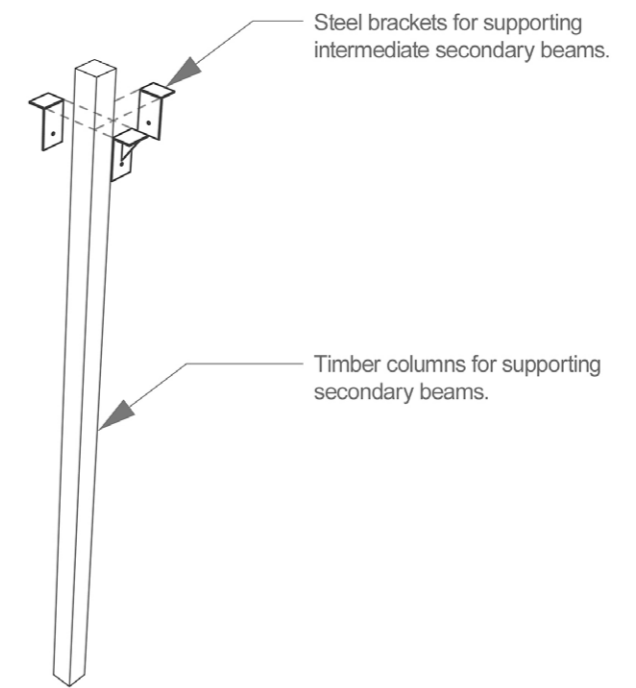


Detail J6: steel connector to primary beam



Detail J7
 Supplementary timber
 columns for supporting
 intermediate beams for
 toilet shafts.

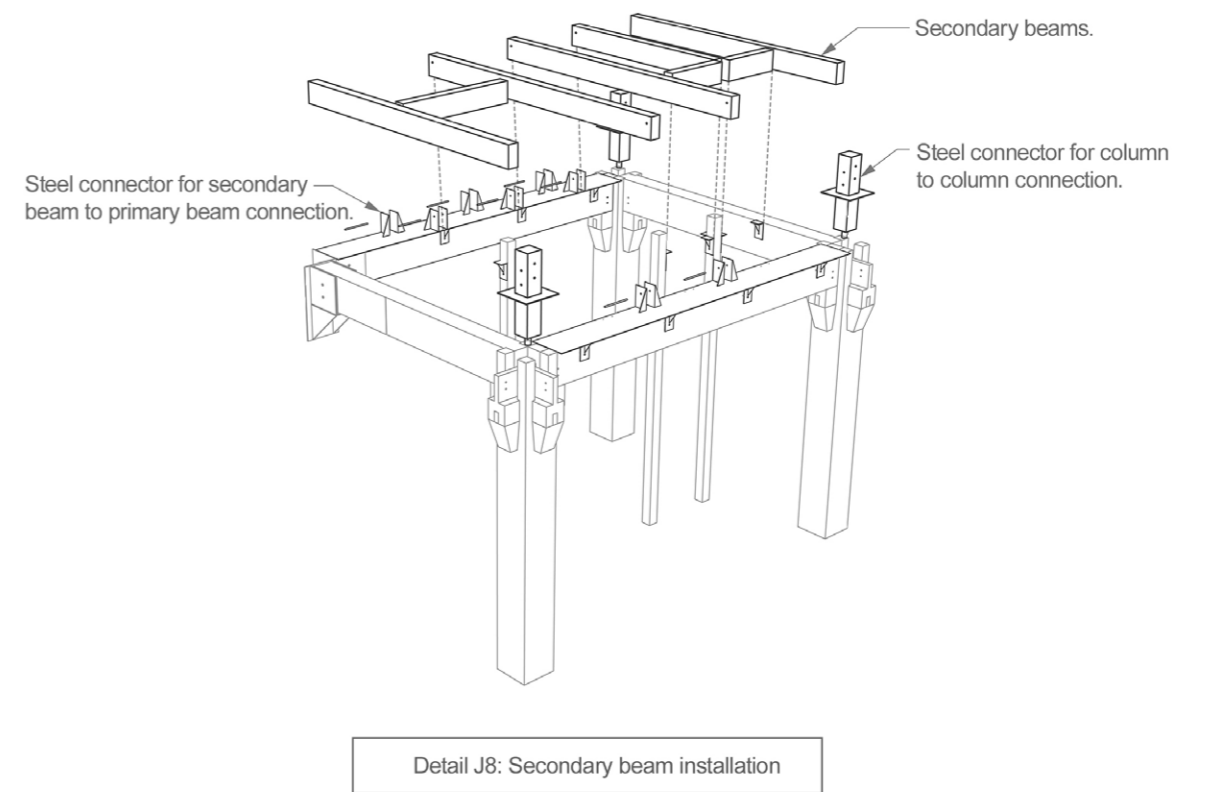
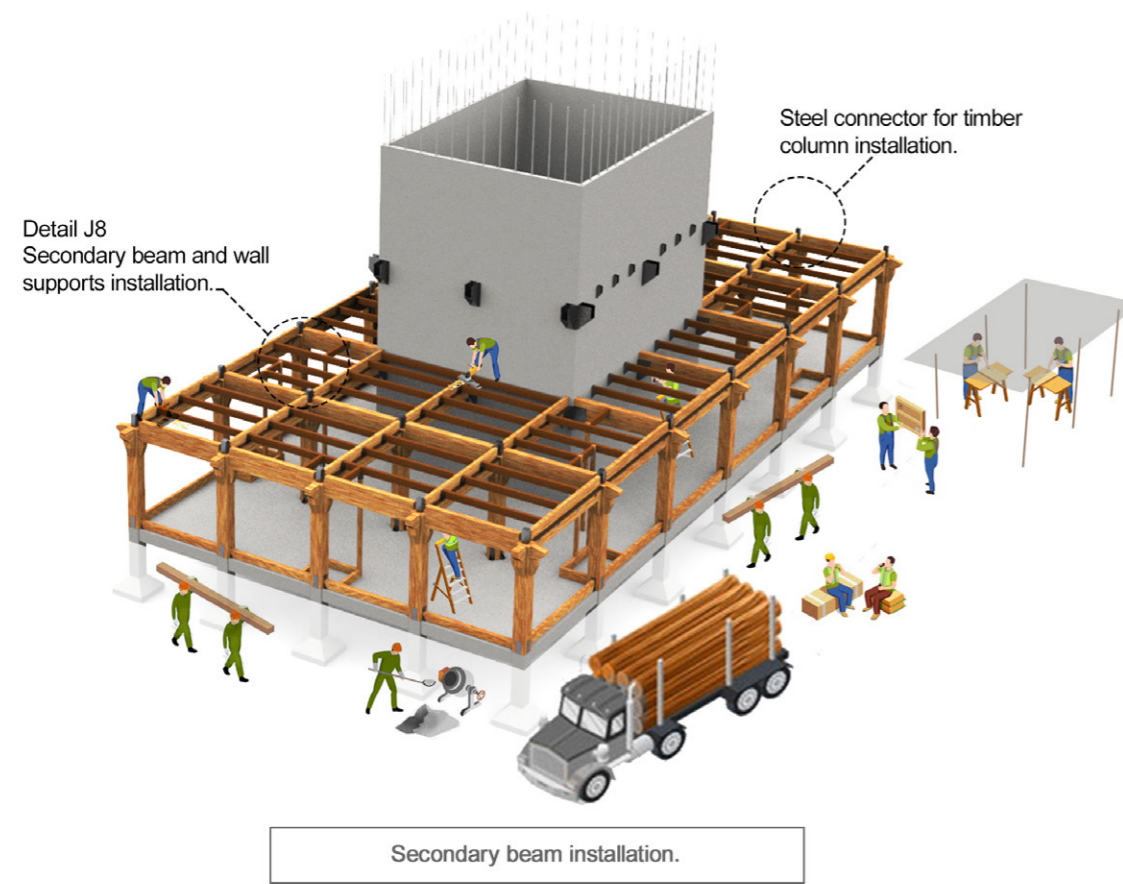
Timber supports for intermediate secondary beams.

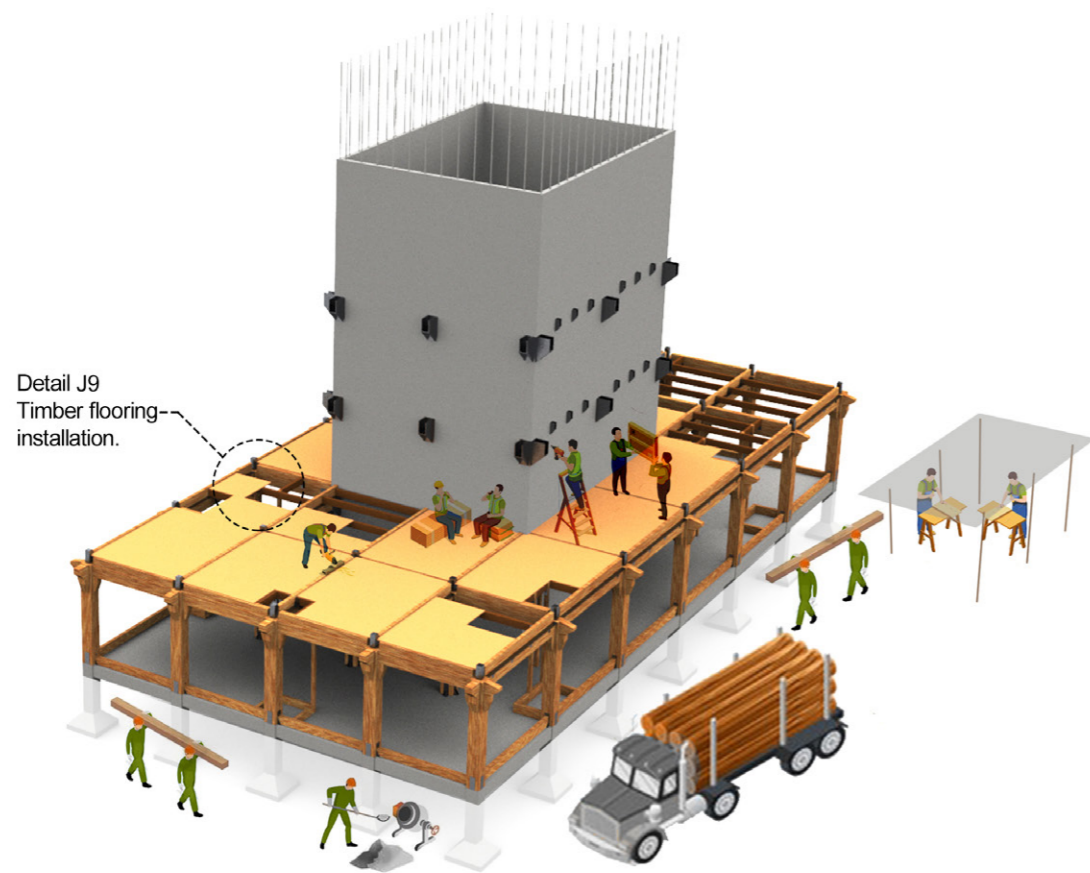


Steel brackets for supporting
 intermediate secondary beams.

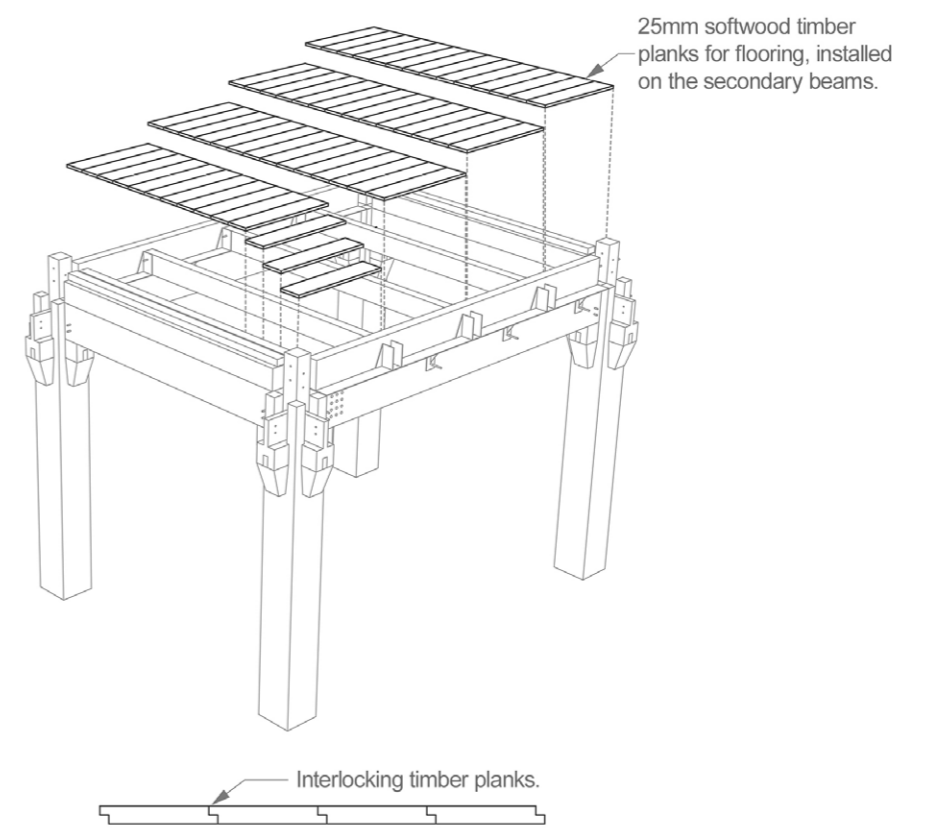
Timber columns for supporting
 secondary beams.

Detail J7: Steel connector to primary beam

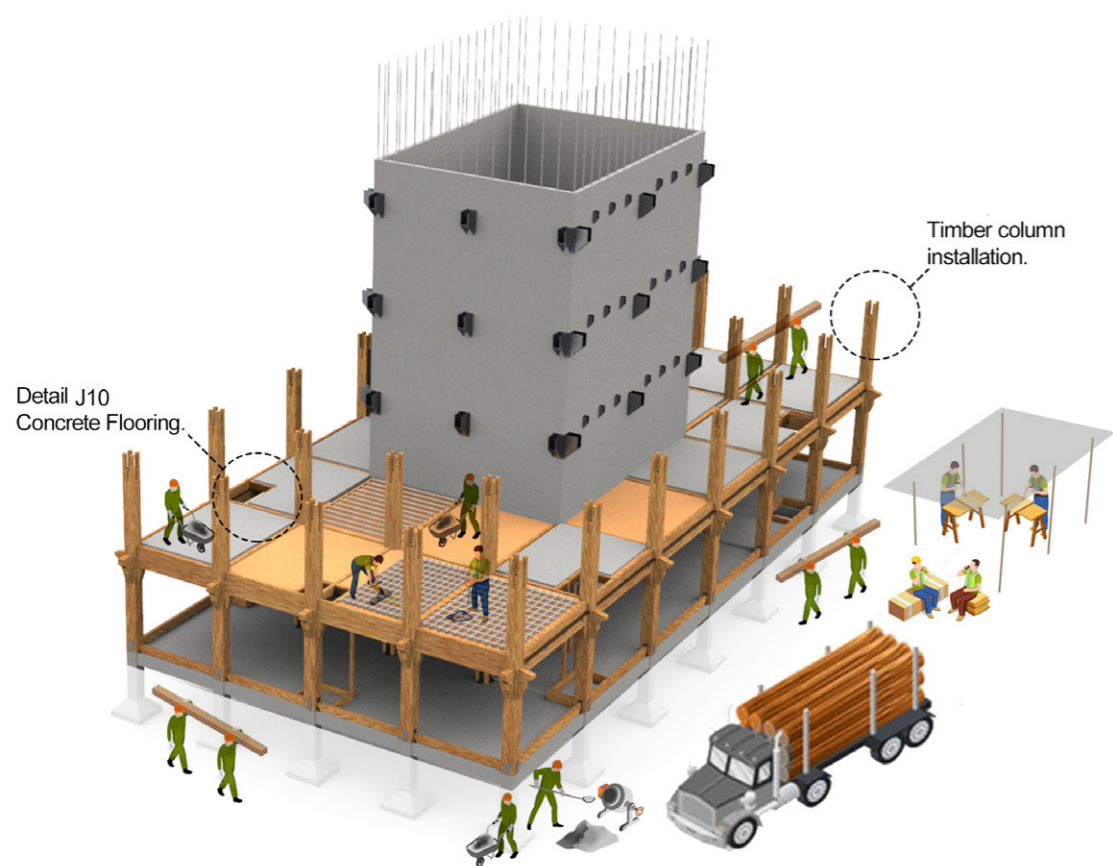




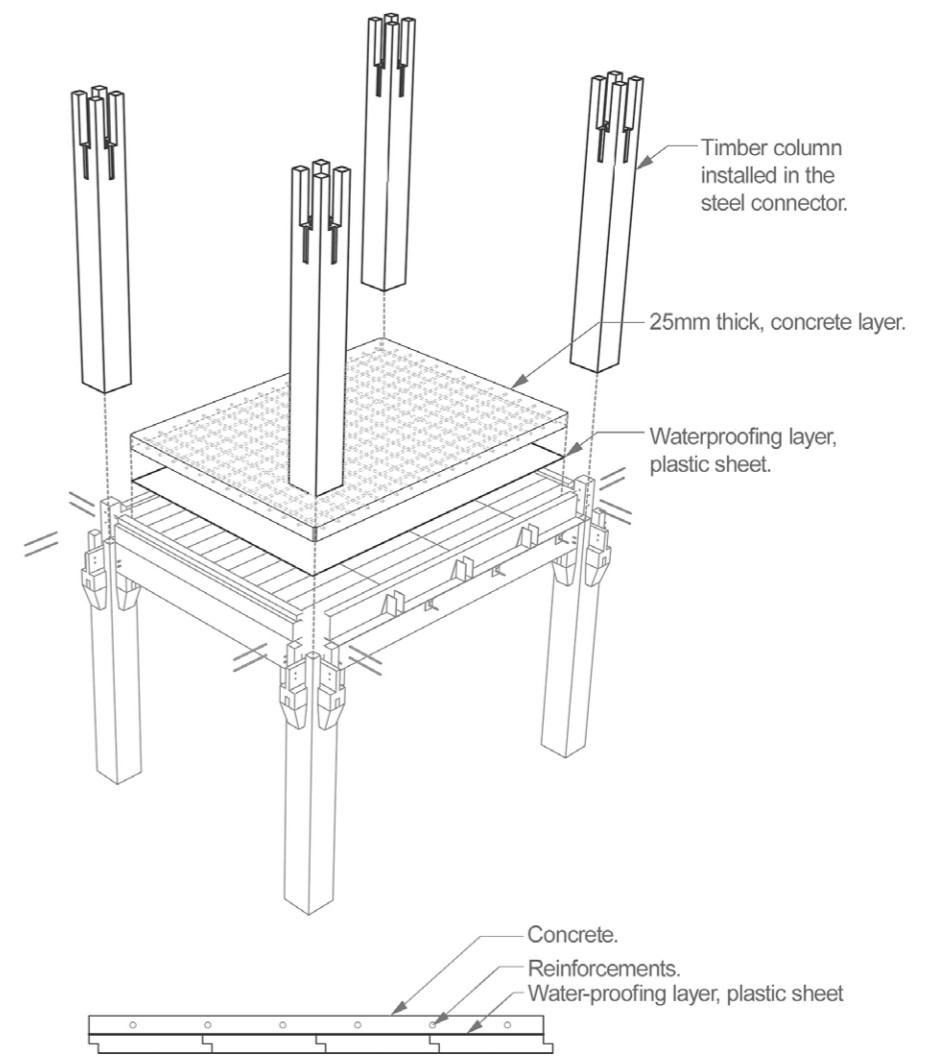
Floor planks installation.



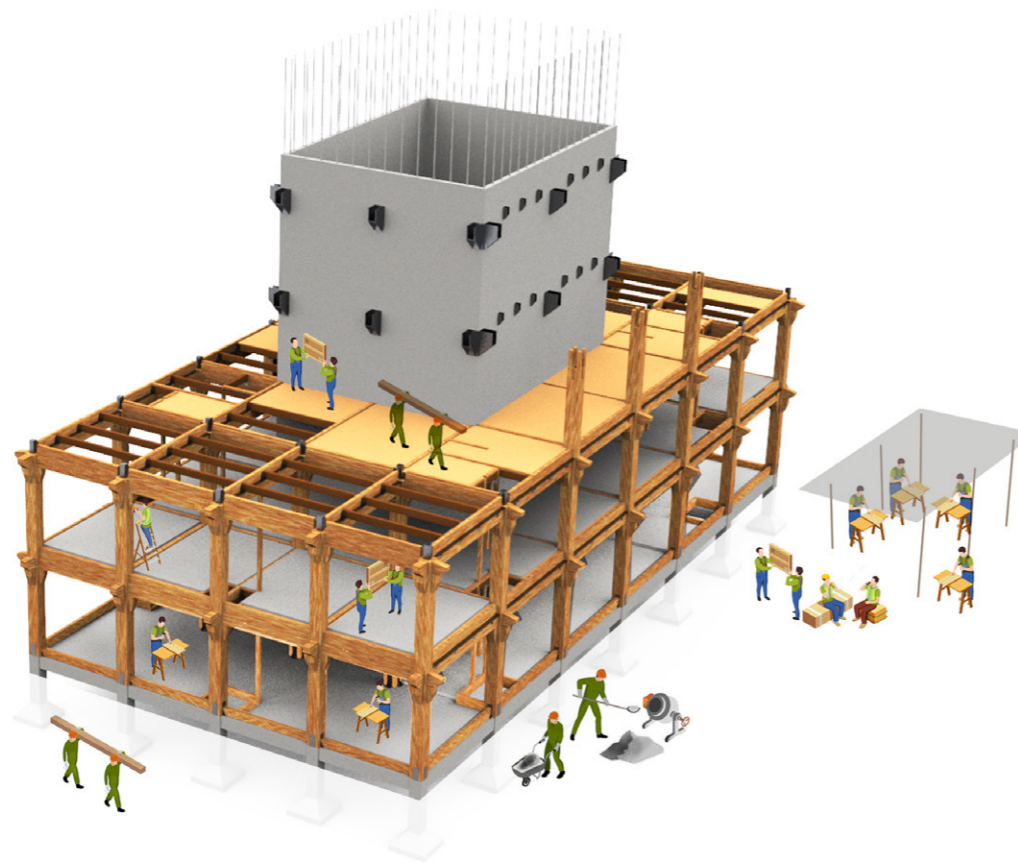
Detail J9: Flooring installation



Concrete floor installation.



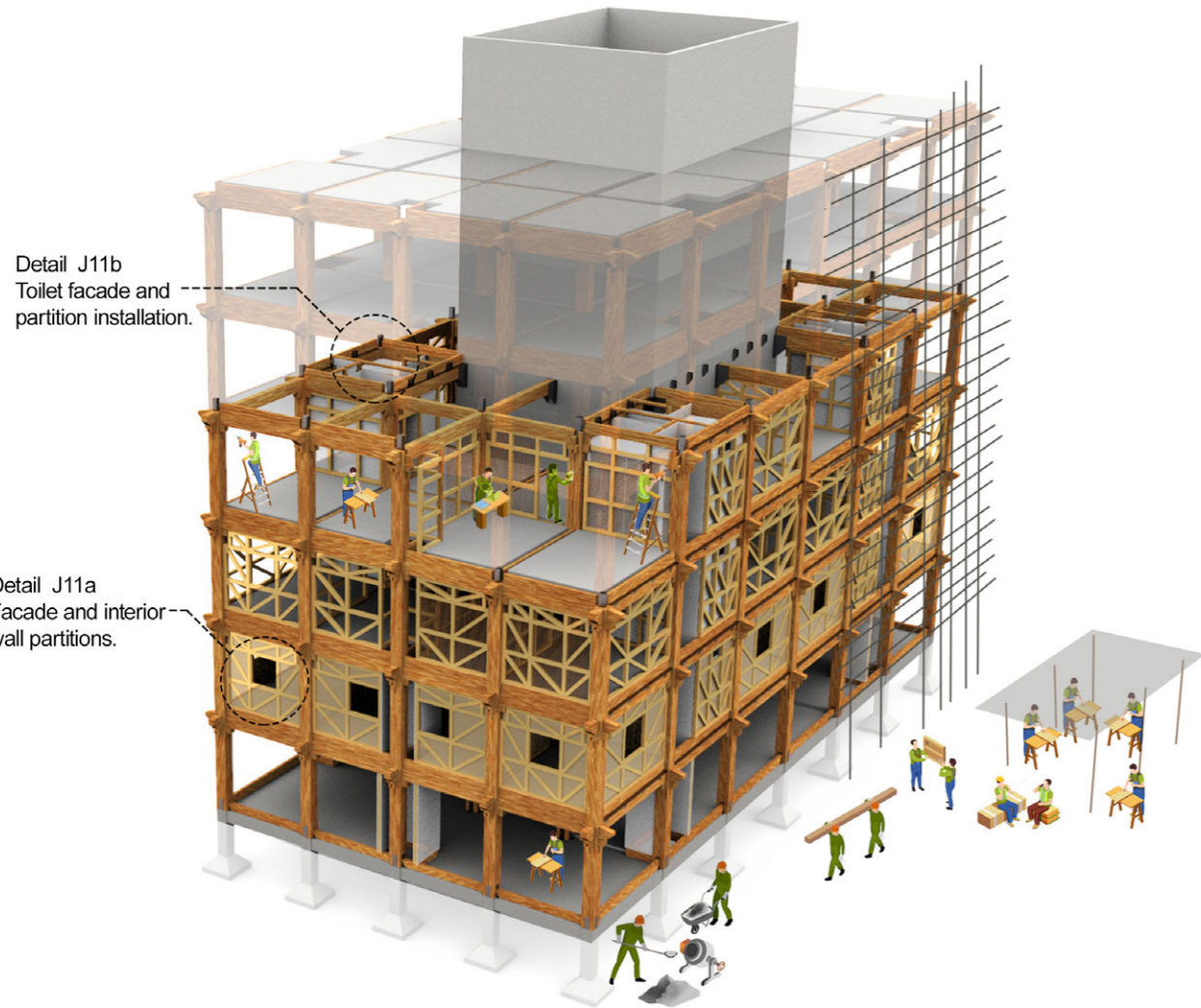
Detail J10: Casting concrete slab and fixing the top floor columns



Construction progress.



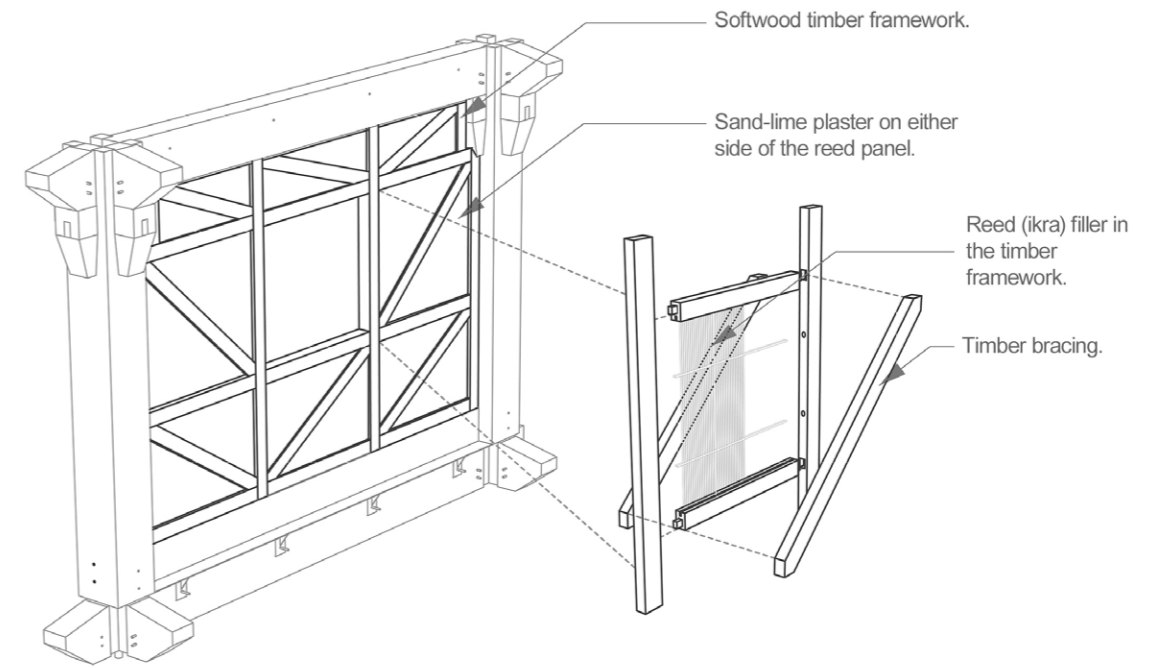
Construction progress.



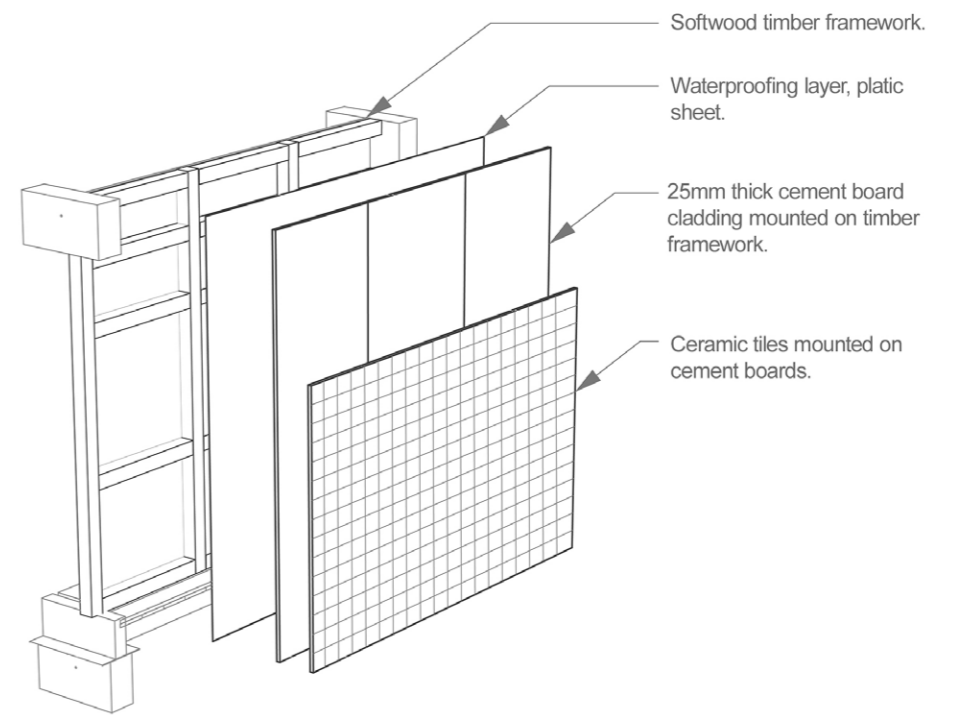
Detail J11b
Toilet facade and
partition installation.

Detail J11a
Facade and interior
wall partitions.

Facade, exterior and interior wall installation.

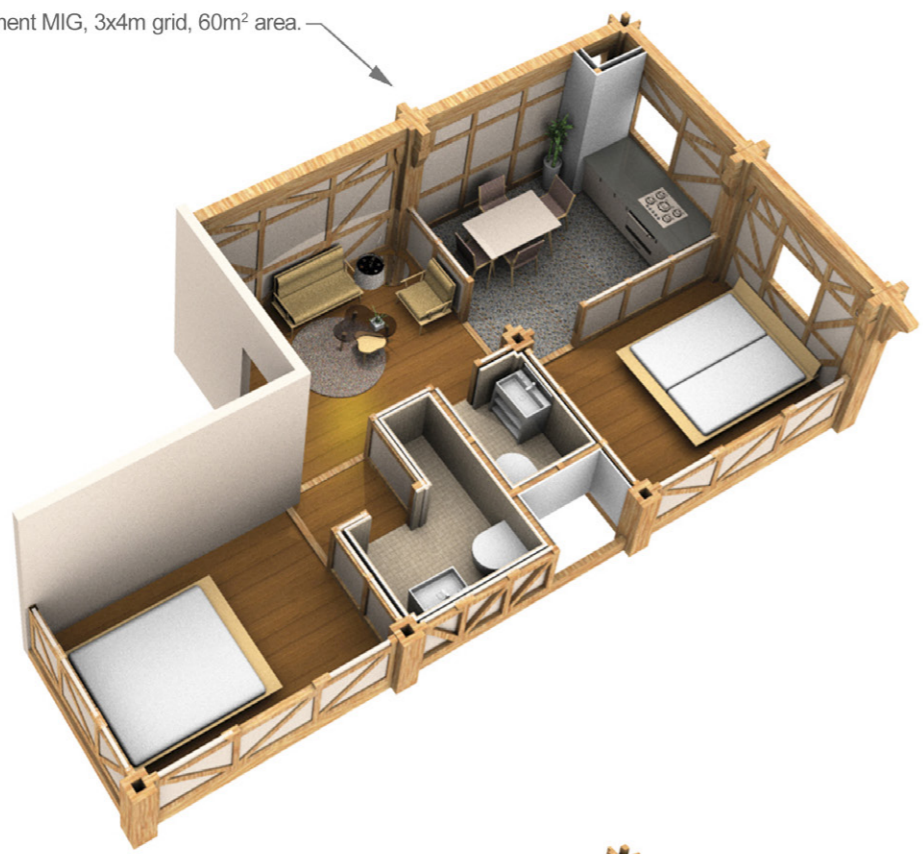


Detail J11a: Exterior wall and interior partitions

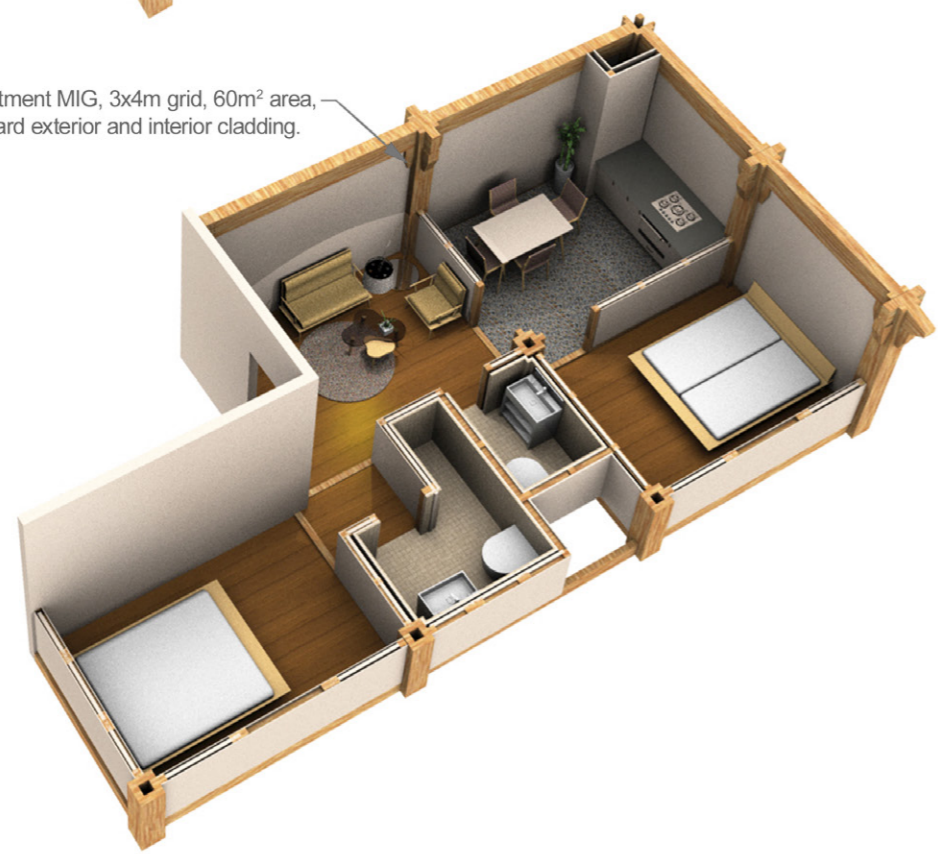


Detail J11b: Toilet wall and interior partitions

2 bedroom apartment MIG, 3x4m grid, 60m² area.



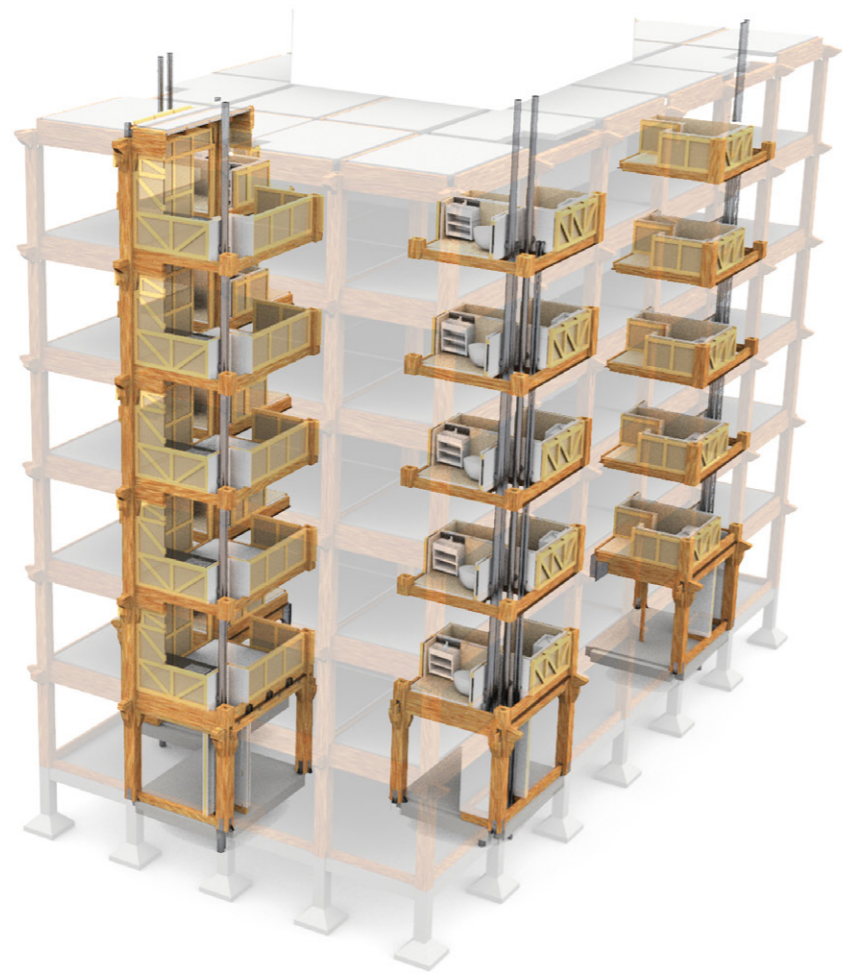
2 bedroom apartment MIG, 3x4m grid, 60m² area, with gypsum board exterior and interior cladding.



Interior furniture and fixture installation. Wall finishes.




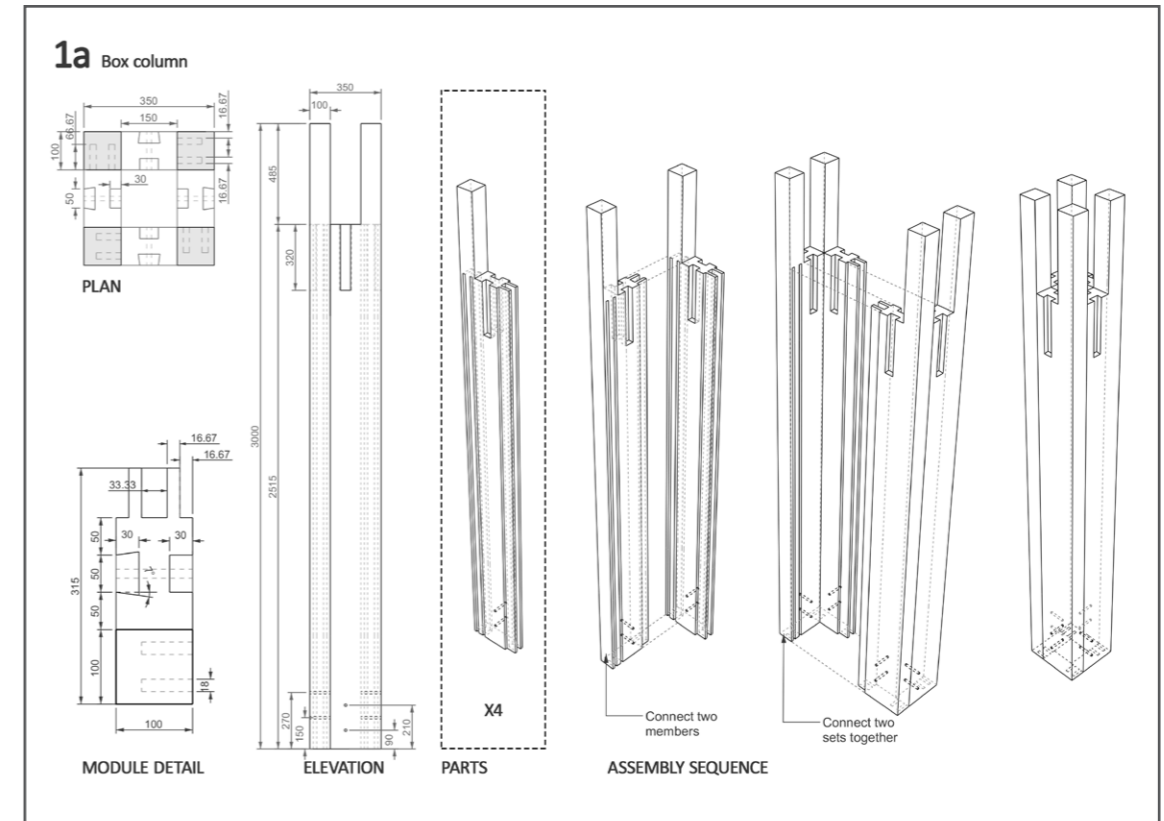
Life in the timber building




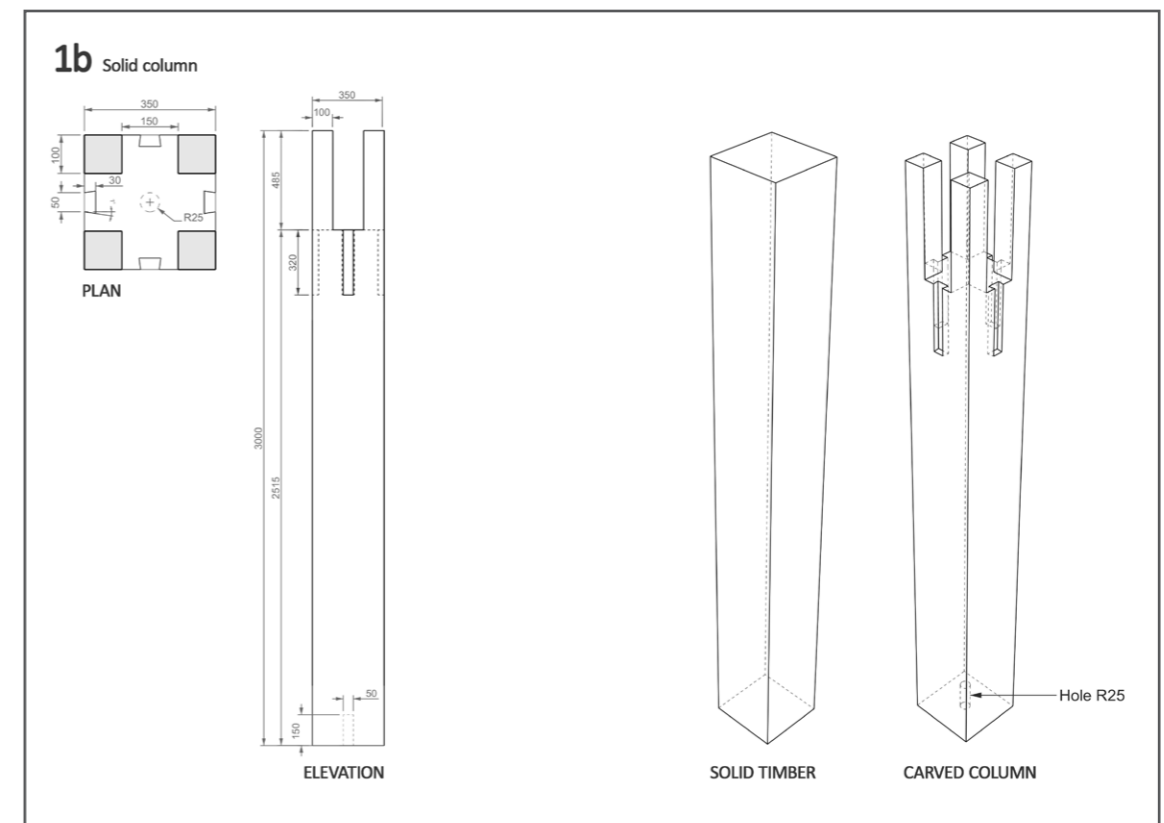
Plumbing system installation.



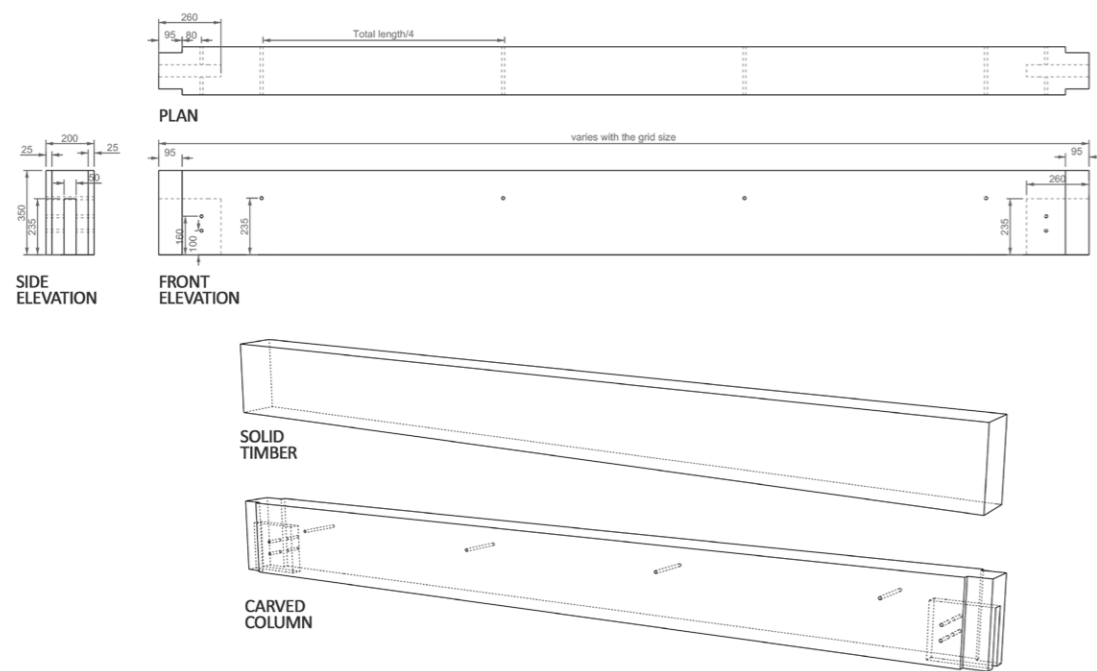
CONTENTS	PRODUCT SERIES	PRODUCT NUMBER	PRODUCT	PAGE NO.
 <p>Hybrid timber construction</p> <p>PRODUCT FABRICATION CATALOGUE</p>	1	-	Column	
		1a	Hollow (box) column	
		1b	Solid column	
	2	-	Primary beam	
	3	-	Column-Primary beam joinery	
		3ax	Column (hollow to hollow)-primary beam, center location	
		3ay	Column (hollow to solid)-primary beam, center location	
		3az	Column (solid to solid)-primary beam, center location	
		3au	Column (hollow)-primary beam, terrace location	
		3bx	Column (hollow to hollow)-primary beam, center location	
	3by	Column (hollow to solid)-primary beam, center location		
	3bz	Column (solid to solid)-primary beam, center location		
	3bu	Column (hollow)-primary beam, terrace location		
	3cx	Column (hollow to hollow)-primary beam, center location		
	3cy	Column (hollow to solid)-primary beam, center location		
	3cz	Column (solid to solid)-primary beam, center location		
	3cu	Column (hollow)-primary beam, terrace location		
	3.1	Parts of column-Primary beam joinery		
		3.1	Main central lower bracket for hollow column	
		3.2	Main central lower bracket for solid column	
		3.3	Main central upper bracket for hollow column	
		3.4	Main central upper bracket for solid column	
		3.5	Side brackets	
		3.6	Central supporting cross	
		3.7	Steel connector for hollow to hollow column	
		3.8	Steel connector for hollow to solid column	
		3.9	Steel connector for terrace joinery	
		3.10	Threaded rods, nuts and washers	



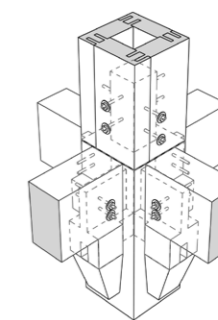
CONTENTS	PRODUCT SERIES	PRODUCT NUMBER	PRODUCT	PAGE NO.
 <p>Hybrid timber construction</p> <p>PRODUCT FABRICATION CATALOGUE</p>	4	-	Column-concrete foundation joinery	
		4a	Column (hollow)-concrete foundation joinery	
		4b	Column (solid)-concrete foundation joinery	
		Parts of column-concrete foundation joinery		
		4.1	Steel connector for hollow column	
		4.2	Steel connector for solid column	
		4.3	Threaded rods, nuts and washers	
	5	-	Primary beam-secondary beam joinery	
		5a	Primary beam-secondary beam joinery, center locations	
		5b	Primary beam-secondary beam joinery, edge locations	
	Parts of primary beam-secondary beam joinery			
	5.1	Steel connector for central locations		
	5.2	Steel connector for edge locations		
	5.3	Threaded rods, nuts and washers		
6	-	Primary beam to core joinery		
	Parts of primary beam-core joinery			
	6.1	Steel connector		
	6.2	Threaded rods, nuts and washers		
7	-	Secondary beam to core joinery		
	Parts of secondary beam-core joinery			
	7.1	Steel/timber connector		
	7.2	Threaded rods, nuts and washers		



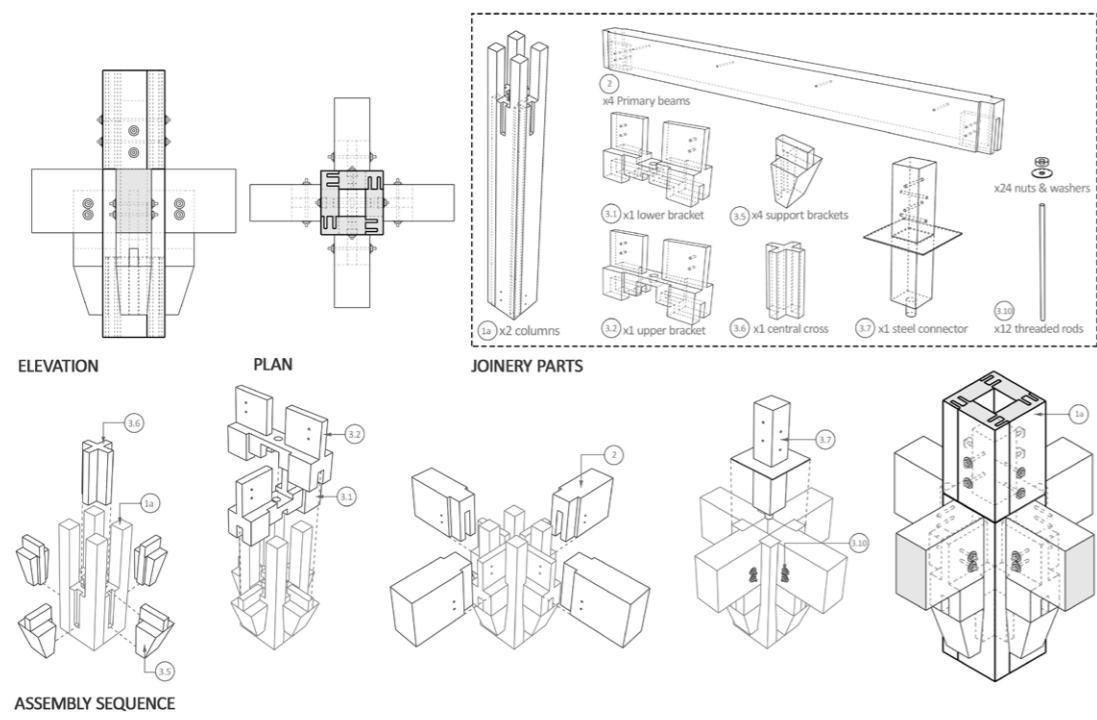
2 Primary beam



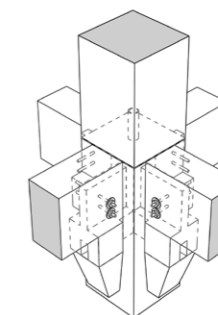
3ay Column (box column to solid column) and primary beam connector



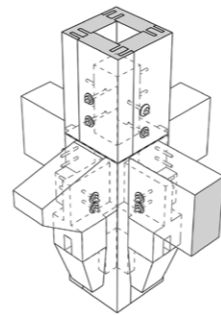
3ax Column (box column to box column) and primary beam connector



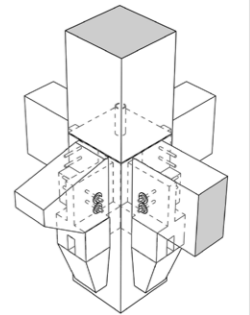
3az Column (solid column to solid column) and primary beam connector



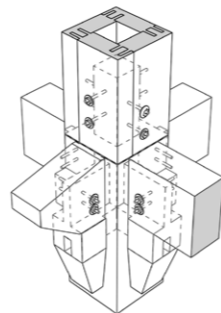
3bx Column (hollow column to hollow column) and primary beam edge connector



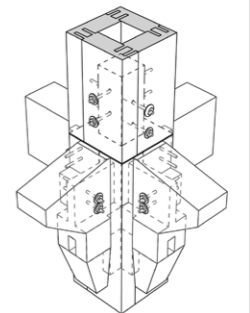
3bz Column (solid column to solid column) and primary beam edge connector



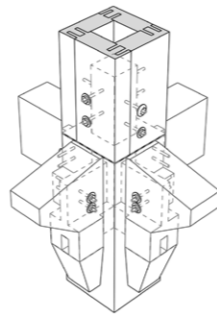
3by Column (hollow column to solid column) and primary beam edge connector



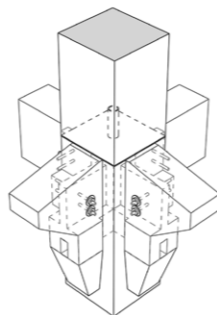
3cx Column (hollow column to hollow column) and primary beam corner connector



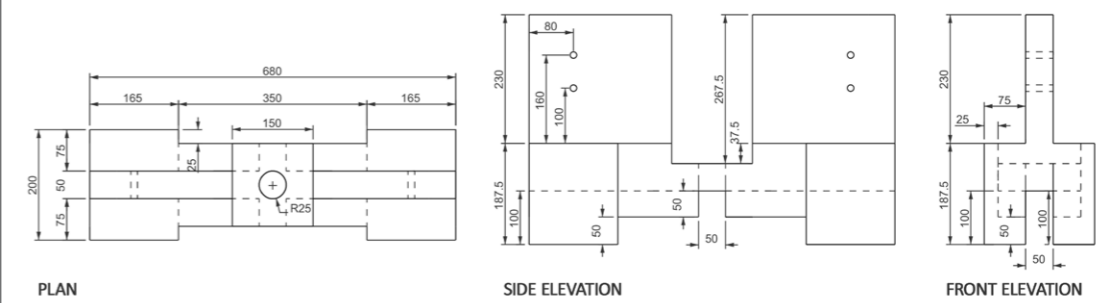
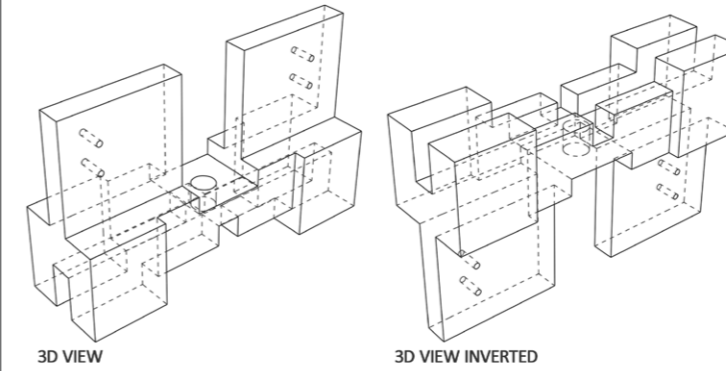
3cy Column (hollow column to solid column) and primary beam corner connector



3cz Column (solid column to solid column) and primary beam corner connector



3.1 Main central lower bracket for hollow column



Bibliography

- Ambraseys, N., & Bilham, R. (2003, 04). Reevaluated Intensities for the Great Assam Earthquake of 12 June 1897, Shillong, India. Retrieved 12 2018, from Researchgate: https://www.researchgate.net/publication/238592402_Reevaluated_Intensities_for_the_Great_Assam_Earthquake_of_12_June_1897_Shillong_India
- American wood council. (n.d.). Evaluating the Carbon Footprint of Wood Buildings . Retrieved 12 2018, from awc.org: <https://www.awc.org/pdf/education/gb/ReThinkMag-GB500A-EvaluatingCarbonFootprint-1810.pdf>
- Anupama. (2016, 07 07). Sal tree (Shorea robusta) Information and Uses. Retrieved 12 28, 2018, from Bimbima: <https://www.bimbima.com/ayurveda/sal-tree-shorea-robusta-information-and-uses/49/>
- Arnold, C., & Reitherman, R. (1925). Building configuration and seismic design. USA: Wiley-interscience.
- Arya, A. S., Boen, T., & Ishiyama, Y. (2014). Guidelines for earthquake resistant non-engineered construction. UNESCO. UNESCO.
- Baro, O., Kumar, A., & Ismail-Zadeh, A. (2018, August 25). Seismic hazard assessment of the Shillong Plateau, India. Retrieved May 2019, from Taylorand Francis online: <https://doi.org/10.1080/19475705.2018.1494043>
- Bilham, R., & England, P. (2001, 04 12). Plateau ‘pop-up’ in the great 1897 Assam earthquake. *Nature*, 410.
- Brown, A. (2013). The genius of Japanese carpentry (Vol. First). Hong-Kong: Tuttle Publishing.
- Bureau of Indian Standards. (2016). National Building code of India (Vol. 1). New Delhi, India: Bureau of Indian Standards.
- Charleson, A. (2008). Seismic design for architects (Vol. 1). Elsevier.
- Cotton, S. H. (1911). India and home memories. 352. T.F.Unwin, from the University of California.
- Dangel, U. (2017). Turning point in timber construction. Germany: Birkhäuser .
- Dufour, p. (2003). Common element types for structure analysis. Retrieved 2019, from Belcan engineering group, Inc: http://www.lubanren.net/weblog/zb_users/upload/Struct_Element_Types.pdf
- Faruqi, S., Wu, A., Brolis, E., Ortega, A. A., & Batista, A. (2018). The business of planting trees. The nature conservancy. World resource institute.
- Forest survey of India. (2017). STATE OF FOREST REPORT 2017. Ministry of Environment & Forests, Dehradun.
- Gautam, K. H., & Devoe, N. H. (2006, 1 26). Ecological and anthropogenic niches of sal (Shorea robusta Gaertn. f.) forest and prospects for multiple-product forest management – a review,. *Forestry: An International Journal of Forest Research*, 79(1), 81-101. Retrieved from Oxford Academic: <https://doi.org/10.1093/forestry/cpi063>
- Gohlich, R. (2015). Development of an Innovative Hybrid Timber-Steel Moment-Resisting Frame for Seismic-Resistant Heavy Timber Structures. Master Thesis, Carleton University Ottawa, Ontario, Civil Engineering.
- Government of Meghalaya. (2008). Meghalaya State Development reports. Retrieved 2018, from Report, planning department, government of Meghalaya: http://megplanning.gov.in/MSDR/urban_development.pdf
- Government of Meghalaya. (2011). The Meghalaya Building byelaw. Retrieved 12 2018, from megurban: <http://megurban.gov.in/laws/building.pdf>
- Government of Meghalaya. (2017). Statistical handbook Meghalaya. Directorate of economics and statistics. Shillong: Government of Meghalaya.
- Government of Meghalaya. (2018). Shillong master plan 2035. Meghalaya urban development authority. Shillong: Unpublished.
- Government of Meghalaya, Department of housing. (2017). Chief minister's housing assistance programme. Government of Meghalaya, Department of housing.
- Green, M. C. (2012). The case for tall wood buildings. mgb Architecture+Design.
- Gupta, S. (n.d.). Quantification of Indicators for Sustainable Forest Management of Sal (Shorea robusta) selection forests in Western Himalaya, India. PCCF Punjab, India, Forest Complex, Sector – 68, Mohali, Punjab, India .
- Hershdorfer, S. A., Hook, C. B., & Hoover, G. N. (1964). Buildings as systems. Master thesis, Massachusetts Institute of Technology, Department of Architecture.
- Hussain, I. (2005). From residency to Raj Bhawan (Vol. 1). Delhi: Regency publications.
- Jain, S. (2005, 11 10). The Indian earthquake problem. *Current science*, 89(9).
- Jain, S. K., & Nigam, N. C. (n.d.). HISTORICAL DEVELOPMENTS AND CURRENT STATUS OF EARTHQUAKE ENGINEERING IN INDIA. 12WCEE 2000. Kanpur: Indian institute of technology.
- Jha, A. (2004). Dynamic testing of structures using scale models. Concordia University, Department of mechanical and industrial engineering. Library and archives canada.
- Kakkad, M., & Sanghvi, C. (2011). Comparative Study of Bamboo (Ikra) Housing System with Modern Construction Practices . National Conference on Recent Trends in Engineering & Technology . B.V.M. Engineering College, V.V.Nagar,Gujarat,India .
- Kalita, J. (n.d.). The great assam earthquake of 1897. Retrieved 12 20, 2018, from Assam portal: <http://www.assam.org/content/great-assam-earthquake-1897>
- Kanasaki, K., & Tanaka, H. (2013). Traditional Wood Joint System in Digital Fabrication . eCAADe- 2013 Computation and Performance . 1, pp. 711-717. Delft Institute of Technology.
- Karlovic, A. (2017, 09 8). Shinbashira — pagoda’s exceptional earthquake resistance. Retrieved 12 30, 2018, from medium.com: <https://medium.com/konsiteo-today/shinbashira-pagodas-exceptional-earthquake-resistance-9d7e3eac1d6d>
- Kaushik, H. B., & Babu, R. K. (2012). “Assam-type House”, World Housing Encyclopedia Report No. 154. Retrieved 2018, from Researchgate: https://www.researchgate.net/publication/319816174_Assam-type_House_World_Housing_Encyclopedia_Report_No_154_Published_by_Earthquake_Engineering_Research_Institute_EERI_USA_and_International_Association_for_Earthquake_Engineering_IAEE_Japan
- Kharpran, P. F. (2016, 10). Building Vulnerability Assessment for Hazards Management. *International Journal of Science and Research (IJSR)* , 5(10).
- Kharwanlang, B. (1989). Khasi vernacular architecture. Academic, School of planning and architecture, Architecture, New Delhi.
- Khatib, J. M. (Ed.). (2016). Sustainability of Construction Materials (2nd edition ed.). Cambridge, UK: Woodhead Publishing.
- Kumar S, K. R. (2006). Innovative Methodologies for the Utilisation of Wastes from Metallurgical and

Allied Industries.

Landry, K. (2011, March). CONSTRUCTION HAS A COSTLY CARBON FOOTPRINT. Retrieved December 2018, from Helix.northwestern.edu: <https://helix.northwestern.edu/blog/2011/03/construction-has-costly-carbon-footprint>

Ministry of Urban development, India. (2015, 01). URBAN AND REGIONAL DEVELOPMENT PLANS FORMULATION AND IMPLEMENTATION (URDPFI) GUIDELINES. Retrieved 12 2018, from <http://mohua.gov.in: http://mohua.gov.in/upload/uploadfiles/files/URDPFI%20Guidelines%20Vol%20I.pdf>

Mittal, B. I. (2008, 06). Earthquake resistant characteristics of traditional Khasi houses in Shillong, India. Retrieved 12 2018, from Researchgate: https://www.researchgate.net/publication/255483692_Earthquake_resistant_characteristics_of_traditional_Khasi_houses_in_Shillong_India

Nag, S., & Gondane, A. (n.d.). Architecture of North East India: Vernacular Typologies. Retrieved 12 29, 2018, from Academia.edu: https://www.academia.edu/6055160/Architecture_of_North_East_India_Vernacular_Typologies

National institute of disaster management. (2011). Earthquake risk mitigation strategy in north-east India. In P. Chakrabarti, & C. Ghosh (Ed.). Guwahati.

Natural Resources Canada. (2018, 09). Is timber being harvested sustainably? Retrieved 12 2018, from Natural Resources Canada website: <https://www.nrcan.gc.ca/forests/report/harvesting/16494>
Olorunnisola, A. (2017). Design of structural elements with tropical hardwoods. Springer.

Pandey, H. K. (2013). Artificial regeneration of sal (*Shorea robusta*). Government of Chattisgarh, India, Chattisgarh forest department.

Parker, H. (1979). Simplified design of structural wood (Vol. 3). USA: John Wiley and sons.

Ramage, M. H., Burrige, H., Wicher, M. B., Fereday, G., Reynolds, T., Shah, D. U., . . . Scherman, O. (2017, 02). The wood from the trees: The use of timber in construction. Contents lists available at ScienceDirect Renewable and Sustainable Energy Reviews, 68(1), 333-359. Retrieved from Elsevier.com: <https://doi.org/10.1016/j.rser.2016.09.107>

Richard, M. (2013). ASSESSING THE PERFORMANCE OF BAMBOO STRUCTURAL COMPONENTS . University of Pittsburgh , SWANSON SCHOOL OF ENGINEERING .

Rogemma, R. (2016). Research by design: Proposition for a methodological approach. University of technology, Sydney, Australia, Faculty of design, Architecture and building, Sydney.

Sagheb, A., Vafaeihosseini, E., & Ramancharla, P. K. (2011). The Role of Building Construction Materials on Global Warming. National Conference on Recent Trends in Civil Mechanical Engineering. Hyderabad, India: Centre for Earthquake Engineering International Institute of Information Technology.

Schober, K.-U., & Tannert, T. (2016). Hybrid connections for timber structures. Published Online: Springer-Verlag Berlin Heidelberg.

Seike, K. (1977). The art of Japanese joinery. (Y. Yobuka, & R. M. Davis, Trans.) Weatherhill/Tankosha. Seismic Vulnerability and Traditional Housing Practice in Assam. (n.d.). Retrieved 2018, from <http://shodhganga.inflibnet.ac.in/bitstream/10603/195596/13/13.chapter%204.pdf>

Shankar, S. (2014). Potentialities of an indigenous environment. Retrieved 2018, from <http://www.sanjeevshankar.com/: http://www.sanjeevshankar.com/pdf/Potentialities-Of-An-Indigenous-Environment-Sanjeev-Shankar2014.pdf>

Sharma, B. (2010). SEISMIC PERFORMANCE OF BAMBOO STRUCTURES. PhD Thesis, University of Pittsburgh, Graduate Faculty of Swanson School of Engineering.

Singh, O. P., & Lamare, E. R. (2017). Limestone mining and its environmental implications in Meghalaya, India. North-Eastern Hill University, Department of Environmental Studies. Shillong: Research gate.

Skidmore, O. a. (2013, 05). Timber tower research project. Retrieved 12 23, 2018, from SOM: <file:///Users/Krittika/Downloads/timber-tower-final-report-and-sketches.pdf>

Sridhar, H. (n.d.). Appropriate and affordable rural housing for Meghalaya. Ministry of Rural Development, GOI and UNDP.

Structx. (2019). Simple Beam - Two Point Loads Equally Spaced. Retrieved from Structx: https://www.structx.com/Beam_Formulas_009.html

Tanabashi, R. (1960). Earthquake resistance of traditional Japanese wooden structures. World conference on earthquake engineering. 2. Tokyo: Science Council of Japan.

The Economist. (1997, 12 18). Why pagodas don't fall down. Retrieved 12 30, 2018, from The Economist: <https://www.economist.com/christmas-specials/1997/12/18/why-pagodas-dont-fall-down>
Timber Development Association (NSW). (2010). Timber-framed Construction for Multi-residential Buildings Class2&3. Wood solutions Australia. Forest and Wood Products Australia.

Tiwari, B., & Kumar, C. (2008). Forest products of Meghalaya. NorthEastern Hill University, Department of Environmental studies, Shillong.

Tshumi, B. (1964). Architecture without architects. New York: University of new Mexico press.

United Nations Environment Programme. (2010, 01 06). Forest loss. Retrieved 12 28, 2018, from United Nations System-wide Earthwatch: <https://web.archive.org/web/20100106001800/http://earthwatch.unep.net/emergingissues/forests/forestloss.php>

University of Alberta. (n.d.). What is sustainability. (O. o. sustainability, Editor) Retrieved 12 22, 2018, from [mcgill.ca: https://www.mcgill.ca/sustainability/files/sustainability/what-is-sustainability.pdf](https://www.mcgill.ca/sustainability/files/sustainability/what-is-sustainability.pdf)
Vengala, J., Mohanthy, B. N., & Raghunath, S. (n.d.). Seismic performance of Bamboo housing— an overview. Retrieved 12 29, 2018, from [worldbamboo.net: https://worldbamboo.net/wbcx/Sessions/Theme%20Architecture%20Engineering%20Social%20Housing/Vengala,%20Jagadish%20et.%20al.pdf](https://worldbamboo.net/wbcx/Sessions/Theme%20Architecture%20Engineering%20Social%20Housing/Vengala,%20Jagadish%20et.%20al.pdf)
Waugh Thistleton Architects. (n.d.). Murray Grove. Retrieved from [waugh thistleton architects: http://waughthistleton.com/murray-grove/](http://waughthistleton.com/murray-grove/)

Wood products council. (2011). Designing for earthquakes, wood design and building serie. Retrieved 12 2018, from [www.woodworks.org: http://www.woodworks.org/](http://www.woodworks.org)

Zhang, Y., Tang, H.-S., Xue, S., & Xun, Y. (2015, 05). Investigation into the Architectural Design of a Traditional Japanese Wooden Pagoda. Journal of Asian Architecture and Building Engineering.

Retrieved 12 2018, from http://shodhganga.inflibnet.ac.in/bitstream/10603/92693/13/13_chapter%207.pdf

https://www.academia.edu/33286134/ANSYS_Tutorial_Earthquake_analyses_in_workbench

<https://nptel.ac.in/courses/105101004/downloads/04%20Chapter.pdf>

<https://www.youtube.com/watch?v=G1ziw2U0XZ4&t=237s>

<https://www.youtube.com/watch?v=kFfpI2uK6rQ>