

Doctoral Thesis  
Stockholm, Sweden 2015

# Efficient Simulation Methods of Large Power Systems with High Penetration of Renewable Energy Resources

Theory and Applications

Ebrahim Shayesteh



# Efficient Simulation Methods of Large Power Systems with High Penetration of Renewable Energy Resources

Theory and Applications

Ebrahim Shayesteh

Doctoral thesis supervisors:

Prof. Lennart Söder, Kungliga Tekniska Högskolan

Members of the Examination Committee:

Prof. Filip Johnsson, Chalmers University of Technology

Prof. Andres Ramos, Universidad Pontificia Comillas

Dr. Zofia Lukszo, Technische Universiteit Delft

Dr. Staffan Norrga, Kungliga Tekniska Högskolan

Dr. Ulf Brännlund, Powel Company

This research was funded by the European Commission through the Erasmus Mundus Joint Doctorate Program, and also partially supported by the KTH Royal Institute of Technology.

TRITA-EE 2015:004

ISSN 1653-5146

ISBN 978-91-7595-421-9

Copyright © Ebrahim Shayesteh, 2015

Printed by: US-AB 2015

# Efficient Simulation Methods of Large Power Systems with High Penetration of Renewable Energy Resources

Theory and Applications

PROEFSCHRIFT

ter verkrijging van de graad van doctor  
aan de Technische Universiteit Delft,  
op gezag van de Rector Magnificus prof. ir. K.C.A.M. Luyben,  
voorzitter van het College voor Promoties,  
in het openbaar te verdedigen  
op vrijdag 6 februari 2015 om 10:00 uur

door

Ebrahim Shayesteh

geboren te Borojen, Iran

Dit proefschrift is goedgekeurd door de promotoren:

Prof.dr. Lennart Söder, Kungliga Tekniska Högskolan  
Prof.dr.ir. Paulien M. Herder, Technische Universiteit Delft, promotor

Samenstelling promotiecommissie:

Prof. Filip Johnsson, Chalmers University of Technology  
Prof. Andres Ramos, Universidad Pontificia Comillas  
Dr. Zofia Lukszo, Technische Universiteit Delft  
Dr. Staffan Norrga, Kungliga Tekniska Högskolan  
Dr. Ulf Brännlund, Powel Company

Keywords: Power system simplification, power system reduction, power system aggregation, power system equivalencing, renewable energy resources, wind power modelling, storage allocation problem, spinning reserve determination, multi-area power system analyses, power system operation and planning, electricity market analysis.

ISBN 978-91-7595-421-9

Copyright © Ebrahim Shayesteh, 2015, Stockholm, Sweden. All rights reserved. No part of the material protected by this copyright notice may be reproduced or utilized in any form or by any means, electronic or mechanical, including photocopying, recording or by any information storage and retrieval system, without written permission from the author.

Printed by: US-AB 2015

## SETS Joint Doctorate

The Erasmus Mundus Joint Doctorate in **Sustainable Energy Technologies and Strategies**, SETS Joint Doctorate, is an international programme run by six institutions in cooperation:

- Comillas Pontifical University, Madrid, Spain
- Delft University of Technology, Delft, the Netherlands
- Florence School of Regulation, Florence, Italy
- Johns Hopkins University, Baltimore, USA
- KTH Royal Institute of Technology, Stockholm, Sweden
- University Paris-Sud 11, Paris, France

The Doctoral Degrees issued upon completion of the programme are issued by Comillas Pontifical University, Delft University of Technology, and KTH Royal Institute of Technology.

The Degree Certificates are giving reference to the joint programme. The doctoral candidates are jointly supervised, and must pass a joint examination procedure set up by the three institutions issuing the degrees.

This Thesis is a part of the examination for the doctoral degree.

The invested degrees are official in Spain, the Netherlands and Sweden respectively.

SETS Joint Doctorate was awarded the Erasmus Mundus **excellence label** by the European Commission in year 2010, and the European Commission's **Education, Audiovisual and Culture Executive Agency**, EACEA, has supported the funding of this programme.

The EACEA is not to be held responsible for contents of the Thesis.



## Abstract

Electrical energy is one of the most common forms of energy these days. Consequently, electric power system is an indispensable part of any society. However, due to the deregulation of electricity markets and the growth in the share of power generation by uncontrollable renewable energies such as wind and solar, power system simulations are more challenging than earlier. Thus, new techniques for simplifying these simulations are needed. One important example of such simplification techniques is the power system reduction.

Power system reduction can be used at least for four different purposes: a) Simplifying the power system simulations, b) Reducing the computational complexity, c) Compensating the data unavailability, and d) Reducing the existing uncertainty. Due to such reasons, power system reduction is an important and necessary subject, but a challenging task to do. Power system reduction is even more essential when system operators are facing very large-scale power systems and when the renewable energy resources like hydro, wind, and solar have a high share in power generation.

This thesis focuses on the topic of large-scale power system reduction with high penetration of renewable energy resources and tries to pursue the following goals:

- The thesis first reviews the different methods which can be used for simplifying the power system studies, including the power system reduction. A comparison among three important simplification techniques is also performed to reveal which simplification results in less error and more simulation time decrement.
- Secondly, different steps and methods for power system reduction, including network aggregation and generation aggregation, are introduced, described and discussed.
- Some improvements regarding the subject of power system reduction, i.e. on both network aggregation and generation aggregation, are developed.
- Finally, power system reduction is applied to some power system problems and the results of these applications are evaluated.

A general conclusion is that using power system simplification techniques and specially the system reduction can provides many important advantages in studying large-scale power systems with high share of renewable energy generations. In most of applications, not only the power system reduction highly reduces the complexity of the power system study under consideration, but it also results in small errors. Therefore, it can be used as an efficient method for dealing with current bulk power systems with huge amounts of renewable and distributed generations.

## Sammanfattning

Elektrisk energi är nuförtiden en av de vanligaste formerna av energi. Följaktligen är elkraftsystem en oumbärlig del av varje samhälle. I och med elmarknadens avreglering och tillväxten av icke styrbar förnybar energi, som t.ex. vind och sol, så är simuleringar av elsystem mer komplicerade än tidigare. Därför behövs nya metoder för att förenkla dessa simuleringar. Ett viktigt exempel på sådana förenklingsmetoder är reducerade modeller.

Reducerade modeller kan användas för åtminstone fyra olika syften: a) förenkla simuleringar av elsystem, b) Minska beräkningskomplexitet, c) Kompensera för saknade data, och d) Minska den befintliga osäkerheten. Reducerade modeller för elsystem är därför ett viktigt och nödvändigt ämne, som dock innebär praktiska utmaningar. Reducerade modeller är ännu viktigare när systemoperatörer står inför storskaliga elsystem och när förnybara energikällor som vattenkraft, vindkraft och solenergi har en hög andel av elproduktionen.

Denna avhandling fokuserar på temat reducerade modeller av storskaliga elsystem med hög andel av förnybara energikällor och försöker uppnå följande mål:

- Avhandlingen granskar först de olika metoder som kan användas för att förenkla studier av elsystem, inklusive reducerade modeller. En jämförelse mellan tre viktiga förenklingsmetoder utförs också för att visa vilka förenklningar som resulterar i minst fel och den största minskningen av simuleringstiden.
- För det andra introduceras, beskrivs och diskuteras olika steg och metoder, inklusive elnäts- och kraftverksaggregering för att ta fram reducerade elsystemmodeller.
- Vissa förbättringar utvecklas avseende reducerade modeller, d.v.s. både nätverks- och kraftverksaggregering.
- Slutligen tillämpas reducerade modeller på utvalda elsystemproblem och resultaten av dessa tillämpningar utvärderas.

En generell slutsats är att förenklingsmetoder - och då i synnerhet reducerade modeller - ger många viktiga fördelar vid studier av storskaliga elsystem med en hög andel förnybara energikällor. I de flesta tillämpningar ger de reducerade modellerna en ansevärd minskning av komplexiteten för det studerade problemet, samtidigt som de orsakar mindre fel. Därför kan de användas som en effektiv metod för att hantera dagens och framtida elsystem med stora mängder förnybar och distribuerad elproduktion.



# Acknowledgement

This project was carried out within the Erasmus Mundus Joint Doctorate in Sustainable Energy Technologies and Strategies (SETS Joint Doctorate) and was funded mainly by European Commission Erasmus Mundus Doctoral Fellowship and partially by KTH Royal Institute of Technology. I would like to express my gratitude towards all partner institutions within the program as well as the European Commission for their support.

There are many people who helped me in various ways to accomplish this work, for which I am grateful. First of all, I would like to deeply thank my supervisors Professor Lennart Söder and Assistant Professor Mikael Amelin for giving me the opportunity to perform this PhD as well as supporting me during the last four years. I am truly grateful to my advisors Professor Benjamin F. Hobbs and Professor Antonio J. Conejo for kindly helping me to direct my research in a fruitful direction and providing me valuable feedback. I would like to thank Assistant Professor Dennice F. Gayme and Associate Professor Madeleine Gibescu for their generous hospitality and fruitful discussions during my mobility period in Johns Hopkins and TU Delft Universities. I would like to acknowledge Professor Mehrdad Ghandhari for his kind support.

My special thanks to my colleagues at KTH, Johns Hopkins, and TU Delft Universities for the friendly atmosphere and interesting discussions that we had during lunch and coffee breaks.

Above all, I would like to express my heartfelt gratitude to my lovely wife, my parents, and my parents-in-law for their endless love, support, and encouragement.



# Contents

## Contents

<b>1</b>	<b>Introduction</b>	<b>1</b>
1.1	Background . . . . .	1
1.2	Challenges and Motivation . . . . .	2
1.3	Aims and Scope . . . . .	6
1.4	Scientific Contributions . . . . .	7
1.5	List of Publications . . . . .	8
1.6	Thesis Outline . . . . .	10
<b>I</b>	<b>Power System Reduction Theory</b>	<b>13</b>
<b>2</b>	<b>Power System Simplification Techniques</b>	<b>15</b>
2.1	Background . . . . .	15
2.2	Scenario Reduction . . . . .	16
2.3	System Aggregation . . . . .	23
2.4	Problem Reformulation . . . . .	23
2.5	Problem Decomposition . . . . .	24
2.6	Validating Studies for the Proposed Multi-Dimensional Power System Reduction . . . . .	25
2.7	Simulation Results and Discussion . . . . .	27
<b>3</b>	<b>A Review on Power System Aggregation</b>	<b>31</b>
3.1	Background . . . . .	31
3.2	The History of Power System Equivalents . . . . .	32
3.3	Power System Aggregation Steps . . . . .	32
3.4	Network Aggregation . . . . .	33
3.5	Generation Aggregation . . . . .	37
<b>4</b>	<b>Contributions to the Network Aggregation</b>	<b>43</b>
4.1	Introduction . . . . .	43
4.2	A Comparison on Two Partitioning Methods . . . . .	46

CONTENTS

4.3	Improved REI Equivalent . . . . .	51
4.4	An Improved Network Aggregation for Planning Power Systems with Correlated Wind and Loads . . . . .	62
<b>5</b>	<b>Contributions to the Generation Aggregation</b>	<b>73</b>
5.1	Simulation of Total Wind Power Production . . . . .	73
<b>II</b>	<b>Power System Reduction Application</b>	<b>85</b>
<b>6</b>	<b>Applications of the Network Aggregation</b>	<b>87</b>
6.1	Frequency Control . . . . .	87
6.2	Storage Allocation . . . . .	95
<b>III</b>	<b>Closure</b>	<b>101</b>
<b>7</b>	<b>Conclusions and Future Work</b>	<b>103</b>
7.1	Conclusions . . . . .	103
7.2	Future Work . . . . .	106
	<b>Bibliography</b>	<b>107</b>
<b>IV</b>	<b>Publications</b>	<b>121</b>

# Chapter 1

## Introduction

*In this chapter, the background and necessities behind the simplification of the power system analyses as well as the goals of this project are given. Then, the differences between the project purposes and the previous studies in the area of consideration are described. Finally, the outline of the dissertation and scientific contributions of the project are presented in terms of publications.*

### 1.1 Background

The power system is one of the largest and most complicated engineering systems in the world. The main task of the system is to generate, transmit, and distribute the electrical energy to consumers while satisfying some technical power system constraints. Three important examples of such constraints are 1) keeping the balance between the power generation and consumption, 2) limiting the bus voltage in allowable range, and 3) restraining the lines' overloading.

The first steam powered power system was developed by Thomas Edison on Pearl Street in New York City in 1882. The Pearl Street Station initially powered around 3,000 lamps for 59 customers and its size was limited to 800 meters. Due to its unique properties like high transmission efficiency, easy usage, simple and fast changing to other energy forms, and etc., electrical energy became the most common energy form within a few years. Consequently, the number of electric power companies and their size have dramatically grown and resulted in traditional power systems.

Traditional power systems are very complicated and interconnected systems and consist of three main sections called and responsible for generation, transmission, and distribution of electric power. The predominant power generation in many of these systems is the thermal power generation coming from burning the fossil fuels.

Introduction of electricity markets in the last decades of the 20th century changed the structure of the traditional power system by unbundling the generation, transmission, and distribution sections. Therefore, unlike the traditional power system, in which the system operator monitors and controls all three sections simultaneously, in the market environ-

ment, generation and distribution sections are operating through competition of different companies. The Independent System Operator (ISO) is responsible for handling the electricity market to insure the power system constraint, e.g. generation/consumption power balance, voltage restrictions, and transmission flow limits. The ISO, sometimes called TSO (abbreviated for Transmission System Operator), should also guarantee the power system security and reliability through scheduling the power generations and establishing the ancillary service' markets.

The need for higher technical efficiency together with the competition for lowering the electricity price motivate the neighboring electricity markets to connect their power grids and harmonize their market rules. As a result, compared to the conventional power systems, the size of the modern power systems has significantly increased. To sum up, power system restructuring not only imposes the economic issues in power system, but it also increases the size of power systems by connecting small systems. By doing so, electricity market increases the complexity of power system analyses and raises the need for new power system simulation methods.

On the other hand, due to the concerns regarding the climate changes and lack of fossil energies, the share of power generation by renewable energy resources such as wind power and solar power has rapidly increased in recent years [1]. According to [2], renewable energy resources have the potential to produce 68% and 100% of all electricity consumed in Europe by 2030 and 2050, respectively. Nevertheless, variable and uncontrolled behavior of these new power generation resources can cause many technical implications and incorporate a wide range of interesting questions, e.g. weather analysis, to the power system studies [3–5].

In conclusion, to study the contemporary power systems, power system engineers are facing bulk power systems with very high penetration of renewable energy resources. This thesis considers such power systems and discusses the challenges in simulation of them. It is, then, tries to suggest some techniques for moderating these challenges.

## 1.2 Challenges and Motivation

Simulation of power system has always required many elaborations. Two important examples of such challenges in the traditional power systems are the computational complexity and response time requirement of power system simulations as well as unavailability of detailed information of the studied and neighboring systems. The main reasons for the computational complexity and response time requirement are 1) the large size of power system, 2) numerous components in the system, and 3) large number of interconnections to neighboring systems [6–15], while, data unavailability is resulted from 1) restriction of the information to a certain control area and 2) lack of data observability by neighboring systems.

As it was mentioned in the previous section, in comparison to the traditional power systems, modern power systems have two important differences which make their simulations even more challenging. First, the size of them has significantly grown and, second, the

amounts of uncertainty and variability have considerably increased. These characteristics are described more clearly in the following.

The first characteristic of recent power systems is the large size of them. This is firstly due to the growing electricity consumptions. Secondly, proliferation of distributed generation and associating networks enlarge the size of power systems. Thirdly, by introduction of electricity market to power system and integration of economic issues to the technical aspects of power system, the need for higher economic efficiency and competition was further felt. In addition, it is also technically more efficient to have connections among different power systems since, e.g., it increases the total system dynamic inertia and reduces the needed reserve in each system. Thus, neighbouring electricity markets start connecting to each other and result in large-scale power systems. Two examples of such bulk systems are the western interconnection of North America and the regional group Continental Europe. The western interconnection of North America comprises 14 US states, two Canadian provinces, and a Mexican state. Its coordinator is the Western Electricity Coordinating Council (WECC) who monitors the compliance of its operators with reliability standards. Figure 1.1 shows the WECC as a region of the North American Electric Reliability Corporation (NERC) [16]. The regional group Continental Europe, the grid of which is depicted in Figure 1.2 [17], includes the power system of 24 European countries, each with one or more system operators while the European Network of Transmission System Operators for Electricity (ENTSO-E) plays a monitoring and coordination role [18–20]. The trend of the regional group Continental Europe is even to bigger markets and 15 EU-states and 12 Mediterranean countries have agreed to form a free energy trade area [18]. These two example systems clearly show that the size of modern power systems has considerably

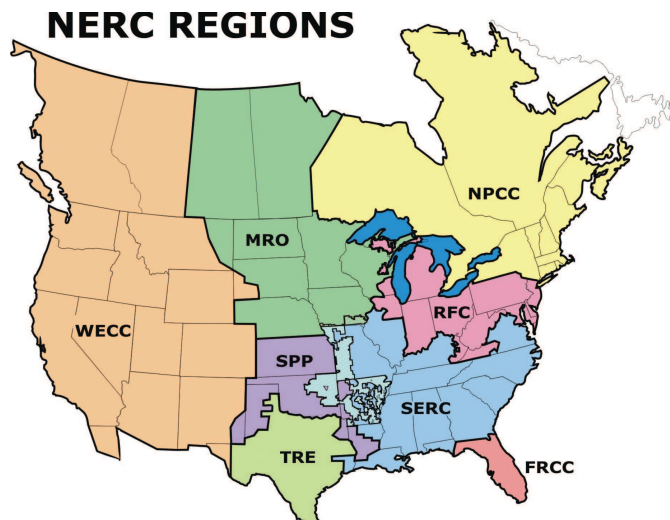

Figure 1.1: The territory of WECC connected to other regions of the NERC [16].

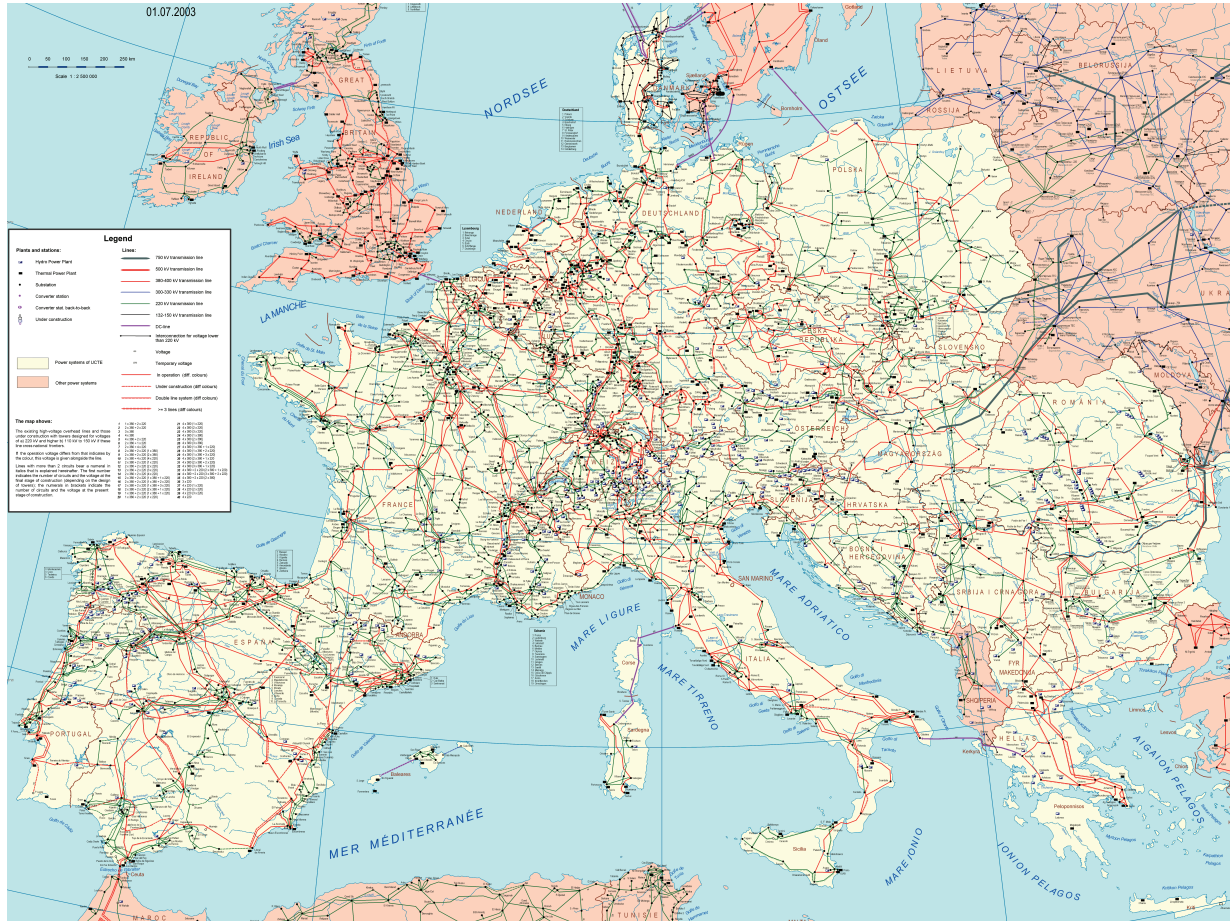

Figure 1.2: The grid of the regional group Continental Europe [17].



grown.

The second characteristic of modern power systems is that the amounts of variability in short-term power system studies as well as the amounts of uncertainty in long-term power system studies have significantly increased. Some of the important reasons for such high variability and uncertainty are described in the following.

Penetration of renewable energy resources is the main reason for increment in the level of variability and uncertainty in power system generation [1, 21–24]. When compared to thermal power generations, variable renewable energy resources have low operation cost and low pollution. In addition, unlike the fossil fuels, there is no concern regarding the termination of these energies. Due to such advantages, the share of renewable energy resources in generation of electric power has considerably increased in modern power systems. However, there are many dynamic and static technical issues related to integrating variable renewables into power systems that should be studied. From a dynamic point of view, integrating large amounts of renewables can lead to stability and power quality problems due to the unpredictable and uncontrollable nature of these resources [3, 25, 26]. From a static view point, on the other hand, renewable energy has increased the variability of net loads [4, 5]. This is mainly due to the unpredictable and uncontrollable behaviour of these resources. In addition, renewable energies are mostly connected to the distribution sector and high penetration of these resources may change the normal direction of power flow. This means that the electric power flows from generation sector to the consumers in the distribution sector in traditional power systems. However, in the predominantly renewable generated power systems, the structure of distribution system has changed due to connection of renewable generations to this section. This means that in addition to short-run load and equipment availability scenarios, scenarios of renewable power production also need to be considered for systems with high renewable penetration [4, 5, 25, 27]. In order to capture the spatial and temporal variability and correlations of renewable production across a large region, hundreds or even thousands of hours per year may need to be simulated. Otherwise, estimates of the impacts of new generation or transmission investments may be distorted.

Flexibility of power consumptions, also known as demand response programs, is the second important source of variability and uncertainty in modern power systems. This variation capability has resulted from the smartness of distribution grids and consumers's tendency to participate in electricity market. Higher elasticity of consumers to the electricity price, more variability and uncertainty in power system consumption. Thus, these resources increase short-term forecast errors and net load variability in power systems.

Longer term uncertainties in technology costs and performance, fuel prices, demand growth, and public policies are also other reasons for increasing the variability and uncertainty in power systems.

Extensive variability and uncertainty mean that the system planners have to simulate and analyze hundreds or even thousands of scenarios for their large-scale power system.

To sum up, simulations of modern power systems not only have the challenges of traditional power system simulations, but their complexities also have even multiplied due to expansion of electricity markets and renewable energies. Having a very large size, lack of observability, high amounts of variability and uncertainty, the need for studying numerus

scenarios, and nonlinearity of power flow equations are some examples of existing complications in simulation of modern power systems. The main focus of this thesis is to study, apply, compare, and improve the possible techniques for simplification of power system studies.

### 1.3 Aims and Scope

The main objective of this thesis is to study the efficient simplification techniques used for simulation of current bulk power systems with multi-scenario simulations as well as large share of renewable generation. In this regard, we limit our investigations only to static power system analyses rather than the dynamic ones. In addition, we consider both planning and operation analyses in our research.

There are a number of methods for simplifying the power system simulations in the literature. Four effective example of these methods, used for dealing with the current large and multi-scenario power systems, are 1) reducing the number of scenarios, 2) obtaining an aggregated equivalent for the system, 3) simulating a simpler version of the system by relaxing some of the constraints, and 4) decomposing the problem in consideration and using the parallel simulations [28–39]. Each of these methods has attracted the attention of many researchers. For instance, different algorithms and selection criteria are used and compared regarding the scenario reduction method in [31–35]. References [28–30, 36] study various procedures and measures for aggregating the network of the large power system in order to obtain a small equivalent one. Making the power system optimizations simpler, using different relaxations or neglecting some of the constraints, is introduced as an useful method for large power system studies in [37–39]. In [40], different decomposition methods, used in engineering and science applications, are fully described based on their application in for example linear, nonlinear, and mixed integer programming.

It is, of course, obvious that using any of the simplification methods would cause some errors in the simulation results. For instance, decrease in accuracy resulting from high scenario reduction is mentioned in [35]. An assessment regarding the usefulness of DC linearization and the validity of its simulation results is made in [41]. In [42] and [43], the accuracy of some network aggregation methods is evaluated and areas for improvement are suggested. However, since these different simplification techniques have not previously been evaluated together, they still need to be compared to illuminate which of them leads to more errors in power system simulations. Therefore, in the first step, this thesis attempts to fill the void by studying and comparing some of these methods in the study of large-scale power systems with numerous scenarios.

In the next steps, due to very wide scope of each simplification technique, we limit the outlook of our research only to the second technique and try to investigate different power system equivalents and develop further equivalencing approaches. In this regard, network aggregation and generation aggregation, as two important sections of equivalent determination, are explained in the second and third steps, respectively. In the second step, where we consider the network aggregation, network partitioning and network equivalencing are studied.

Step three explains the generation aggregation in terms of generation types, i.e. conventional and renewable generations. Wind power is considered as an example of renewable energy resources and its total production is estimated via aggregation approaches.

In the last step, the thesis focuses on the applications of the power system equivalents. In this respect, applications of network aggregation to frequency control and storage allocation are assessed.

## 1.4 Scientific Contributions

The scientific contributions of this thesis in terms of different studied areas can be summarized as follows:

### **Power system simplification techniques:**

- **C1** An extended comparison of three important simplification techniques, i.e. scenario reduction, network aggregation, and DC linearization, is performed and a multi-dimensional power system reduction technique is proposed. To do so, the three simplification techniques are applied to four common types of power system studies, namely optimal power flow, stochastic unit commitment, generation expansion, and transmission expansion. The results are compared in terms of simulation errors and simulation time.

### **Network aggregation theory:**

- **C2** A new partitioning algorithm based on graph theory is proposed and its simulation results on Power Flow (PF) and Optimal Power Flow (OPF) are compared to the ones of an optimization-based partitioning method. The first method uses research carried out in spectral partitioning, whereas the second method is formulated as a constrained min-cut problem, ensuring connectedness within the areas and balanced areas and is solved as a linear optimization program.
- **C3** An improved version of the previously used Radial - Equivalent - Independent (REI) equivalent is developed for multi-area modeling of power systems. The REI method is improved by taking into account the uncertainties in generation units and transmission lines and by defining an optimization method for tuning the features of buses and lines in the reduced system. Having made these improvements, we can obtain an adaptive REI equivalent which will adjust itself according to the availability of generators and lines.
- **C4** An ATC-based system reduction for planning power systems with correlated wind and loads is suggested and tested on a realistic large power system. The method is based on partitioning the original large system into smaller areas and making a reduced equivalent for each area. The partitioning is based on available transfer capability (ATC) between each pair of network buses. Because ATC depends on

net load conditions, separate partitions are defined for subsets of similar load and wind conditions, significantly enhancing the accuracy of optimal power flow solutions. Compared to the single-equivalent system, accuracy is improved with only a negligible increase in simulation time.

#### **Generation aggregation theory:**

- **C5** An algorithm for estimating the total wind power production of some wind units with correlated wind speeds is proposed. It is assumed in the proposed method that only historical data for produced power of these wind power units are available, which is usually the case in reality. Unlike the previous works in this area, the proposed method suggests not only a simple process, but also an acceptable accuracy for calculating the total wind power production.

#### **Network aggregation application:**

- **C6** An algorithm for calculating the required amount of spinning reserve in large multi-area power systems is proposed. Using this algorithm, each area of the system is first modeled by an equivalent system, obtained by the REI method and a multi-area REI equivalent is obtained for the multi-area system. A cost-benefit analysis is then performed to determine the spinning reserve requirements of both the original and equivalent multi-area systems. The cost-benefit algorithm takes into account the security constrained unit commitment (SCUC) and the security constrained economic dispatch (SCED). Finally, the proposed multi-area REI equivalent is evaluated by comparing the spinning reserve in the original multi-area system with that in the equivalent system.
- **C7** A three-stage algorithm for AC OPF based storage placement in large power systems is suggested. The first step involves network reduction whereby a small equivalent system that approximates the original power network is obtained. The AC OPF problem for this equivalent system is then solved by applying an Semi-Definite Relaxation (SDR) to the non-convex problem. Finally, the results from the reduced system are transferred to the original system using a set of repeating optimizations. The efficacy of the algorithm is tested through case studies using two IEEE benchmark systems and comparing the solutions obtained to those of DC OPF based storage allocation.

## **1.5 List of Publications**

Most parts of this doctoral thesis is based on the material of the appended publications. These publications are listed as follows.

**Publication I**

**E. Shayesteh**, B. Hobbs, and M. Amelin, "Scenario reduction, network aggregation, and DC linearization: which simplifications matter most in market simulations?", submitted to *IEEE Transactions on Power Systems*.

**Publication II**

C. Hamon, **E. Shayesteh**, M. Amelin, and L. Soder, "Two partitioning methods for multi-area studies in large power systems", *International Transactions on Electrical Energy System*, 2014.

**Publication III**

**E. Shayesteh**, C. Hamon, M. Amelin, and L. Soder, "REI method for multi-area modeling of power systems", *International Journal of Electrical Power & Energy Systems*, Vol. 60, pp. 283-292, 2014.

**Publication IV**

**E. Shayesteh**, B. Hobbs, M. Amelin, and L. Soder, "ATC-Based System Reduction for Planning Power Systems with Correlated Wind and Loads", *IEEE Transactions on Power Systems*, Vol. 30, pp. 429-438, 2015.

**Publication V**

**E. Shayesteh**, M. Amelin, and L. Soder, "Power system equivalents for spinning reserve determination in multi-area power systems", submitted to *Energy*.

**Publication VI**

**E. Shayesteh**, D. Gayme, and M. Amelin, "System Reduction Techniques for Storage Allocation in Large Power Systems", submitted to *International Journal of Electrical Power & Energy Systems*.

Table 1.1 shows in what publications various generation sources, prices, and mathematical tools are considered.

Table 1.1: Items considered in the various publications.

	Publication					
	I	II	III	IV	V	VI
Wind power	✓		✓	✓		
Electricity market	✓			✓	✓	
Deterministic modeling		✓				✓
Stochastic modeling	✓		✓	✓	✓	
Time series	✓				✓	✓
Linear optimization	✓	✓			✓	
Nonlinear optimization	✓		✓	✓		✓

## 1.6 Thesis Outline

The outline of thesis is based on a partition into four parts. The first part includes chapters 2-5 and mostly deals with the theoretic issues regarding power system simplification and specially the power system reduction theory (which is the main focus of this thesis), while, the second part, including chapter 6, evaluates the applications of power system reduction. The third parts is indicated in chapter 7 and provides the conclusions and future works, whereas, publications are given in the last part.

The chapters can be summarized as follows:

**Chapter 2** reviews different techniques, previously used for simplifying the power system studies. Then, a representative of each technique is simulated and the errors resulted from applying different categories to four common power system studies are compared.

**Chapter 3** focuses only on one of the simplification techniques reviewed in the previous chapter which is the main goal of this thesis. This simplification technique is the power system aggregation, also known as power system equivalencing, methods. In this chapter, generation aggregation and network aggregation are introduced as two important sections for obtaining an appropriate power system equivalent. Then, different steps, needed to be considered, in power network aggregations are introduced. These steps can simply be divided into network partitioning and network equivalencing. Different methods for any of these two steps are also presented in this chapter. Finally, the generation aggregation methods in terms of generation types are discusses. In this regard, generation sources are divided into conventional (thermal) power generations and renewable energy resources, and, the aggregation process for each type is described.

**Chapter 4** introduces three important contributions of this thesis in case of network aggregation, as the first section of power system aggregation. These contributions are: a) Comparison of two new network partitioning methods, b) Proposing an improved REI equivalent for network equivalencing, and c) Suggesting an improved network aggregation algorithm for planning power systems with correlated wind and loads.

**Chapter 5** reviews the contribution of the thesis on generation aggregation topic, the second section of power system equivalencing. This contribution is to develop an algorithm for approximating the total wind power production of some wind power units with correlated wind speeds.

**Chapter 6** investigates two applications of network aggregation methods in large-scale power systems, studied in this thesis. These applications include: a) Frequency control via spinning reserve determination and b) Storage allocation. The simulation results of these applications are also discussed in this chapter.

**Chapter 7** closes the thesis by summarizing the conclusions and suggesting the future possible areas of extending and continuing the work.

The contributions of the appended publications are spread among the different chapters of the thesis in Table 1.2.

Table 1.2: Distribution of the contributions of appended publications among different chapters of the thesis.

	Publication					
	I	II	III	IV	V	VI
Chapter 2	✓					
Chapter 3						
Chapter 4		✓	✓	✓		
Chapter 5						
Chapter 6					✓	✓
Chapter 7						

Additionally, figure 1.3 provides a review on different aspects of power system simplification studied in this thesis. In this figure, the contribution subject of each publication is also emphasized. The red color in this figure indicates the contribution in the area of power system reduction theory, while the green color shows the contribution regarding the application of power system reduction.

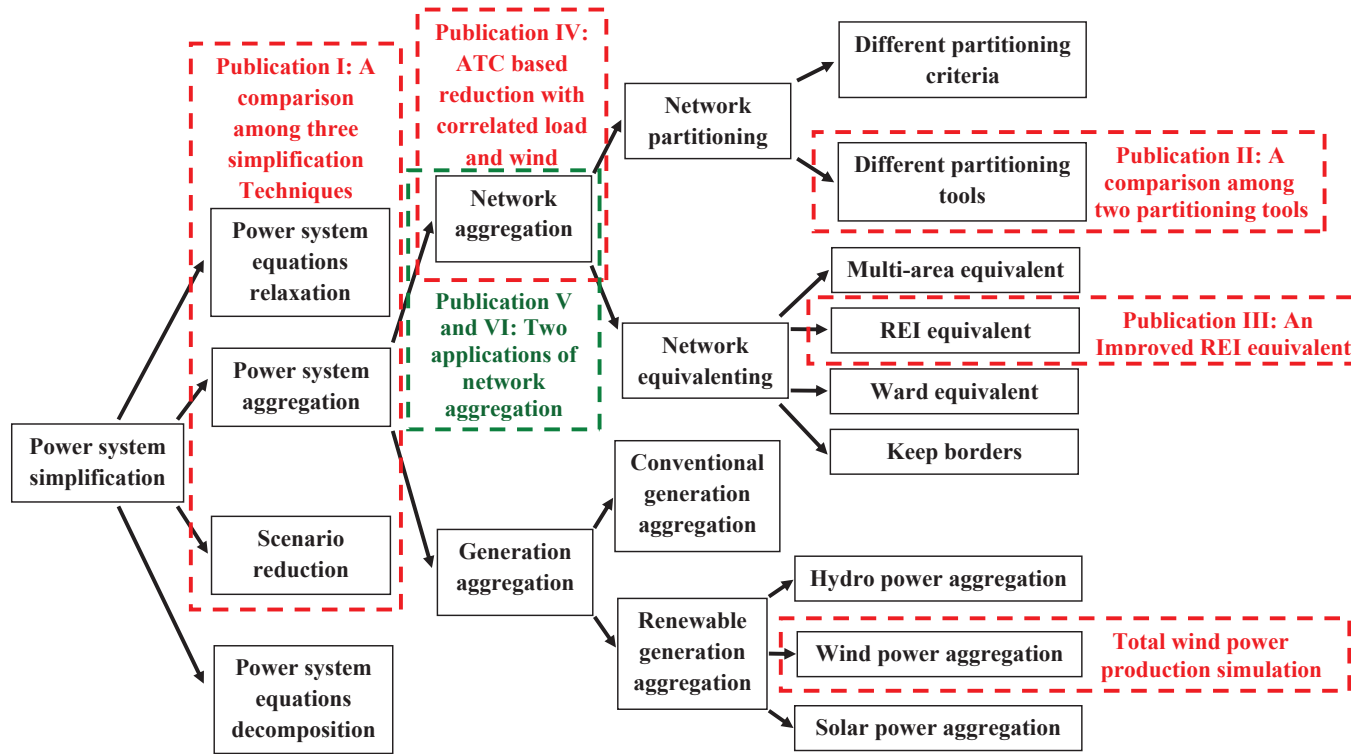

Figure 1.3: A review on different aspects of power system simplification studied in this thesis including the contribution subject of each publication.



## **Part I**

# **Power System Reduction Theory**



## Chapter 2

# Power System Simplification Techniques

*In this chapter, some of the important and common techniques for simplifying the power system studies are explained. Then, the simulation results of a comparison among them are reviewed and advantages and disadvantages of each simplification technique are discussed.*

### 2.1 Background

As it was mentioned in the previous chapter, power system studies present computational challenges due to the growing size of systems, the increased role of variable renewable production, and the presence of important long run uncertainties in economic, technical, and policy conditions. As a result, various simplifications are made to power systems models to make their solution practical for large systems with multiple renewable and long-run scenarios. Scenario reduction, system aggregation, problem reformulation, and problem decomposition are some important simplification techniques that have been widely investigated in the literature. However, in order to minimize errors from simplifications, it is important to compare and understand the errors that each can cause in power system analyses.

This chapter, first, reviews the aforementioned simplification techniques. Then, a multi-dimensional power system reduction technique based on some of these simplification techniques is proposed and different aspects of it are compared. In this regard, we use forward scenario selection since it is a suitable example of scenario reduction algorithms for the selection of a limited number of scenarios. For system aggregation, a two-stage aggregation algorithm is used. In the first stage of this algorithm, we partition the power network into a number of areas, based on a so-called similarity matrix, which shows the strength of connection between each pair of the network buses. The partitions obtained are then used to aggregate the original network. Finally, DC formulation of power flow equations is chosen as a widely used power system reformulation.

The main focus of the proposed comparison is on the static simulations of power system studies, especially in relation to power system operation and planning. In order to

widen the scope of the comparison, different power system studies such as Optimal Power Flow (OPF), Stochastic Unit Commitment (SUC), Generation Expansion Planning (GEP), and Transmission Expansion Planning (TEP) are compared, and the results of the multi-dimensional power system reduction applied to all these studies are evaluated with respect to the accuracy of the results and the simulation time required.

## 2.2 Scenario Reduction

The first technique for simplifying power system studies is to decrease the number of simulated scenarios needed to be considered due to high levels of uncertainty. One important reason for power system uncertainties is variability and unpredictability in the generation of renewable energy resources, such as wind and solar powers, which are subject to weather conditions [44–46]. In addition, the flexibility of system loads in relation to the electricity price has caused more uncertainty [23, 24]. Given such uncertainties, we need to increase the number of scenarios taken into account in power system studies. However, scenario reduction technique can suggest a set of scenarios with results close to the results of all initial scenarios. Different algorithms have been suggested and used to decrease the number of scenarios. Some examples are: backward scenario reduction, forward scenario selection, scenario tree construction, and clustering-based scenario reduction [31–35].

### **Backward Scenario Reduction**

In the backward scenario reduction, the most unimportant scenario is deleted in a loop until a predefined number of scenarios are removed [34]. This algorithm will be efficient if the number of preserved scenarios are higher than the number of removed scenarios. Figure 2.1 shows the algorithm of the backward scenario reduction just for those who are interested in the detailed information about this technique [34].

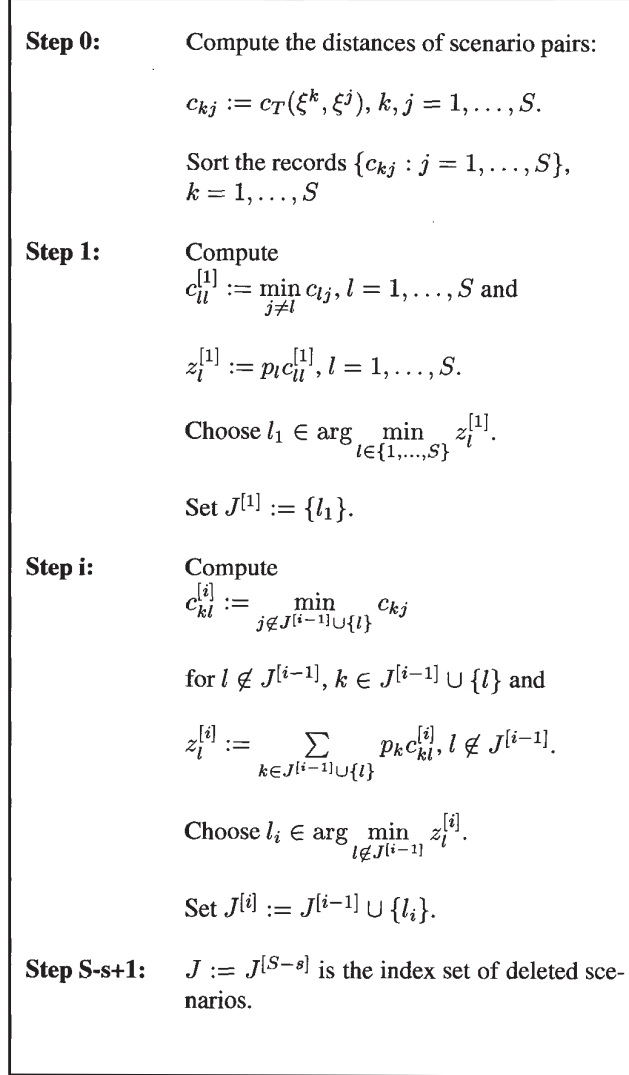

Figure 2.1: The algorithm of the backward scenario reduction [34].

### Forward Scenario Selection

On the other hand, if the number of preserved scenarios are relatively small when compared to the total number of the original scenarios, it will be more efficient to use the loop for selecting the most important scenario [34]. This strategy is indeed the basic fundamental

of the second conceptual algorithm, named the forward scenario selection algorithm. The algorithm of the forward scenario selection is presented in figure 2.2.

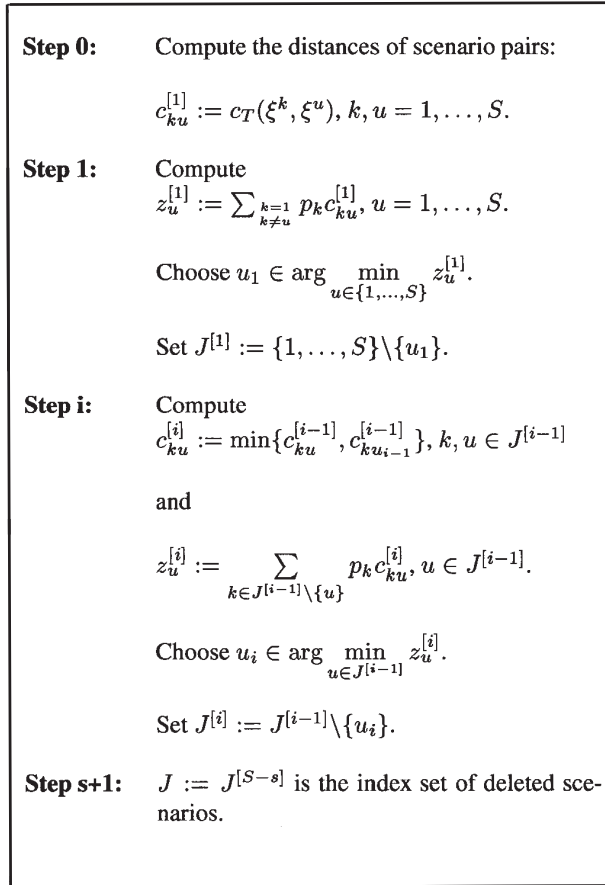

Figure 2.2: The algorithm of the forward scenario selection [34].

### Scenario Tree Construction

The scenario tree construction algorithm finds an abstract version of the scenarios according to the uncertainty behaviour over time. This algorithm is specially useful for approximation of scenarios in a multi-stage stochastic programming model, in which an optimal decision for each node of the scenario tree is determined using the given information available at that point. Figure 2.3 describes the algorithm of the scenario tree construction [34]. In this algorithm, the scenario tree is constructed by reducing the number of nodes, for which the maximal reduction strategy (**mrs**) is used as a similarity measure at each time interval of the time horizon. The readers are referred to [31–35] for the detailed information.



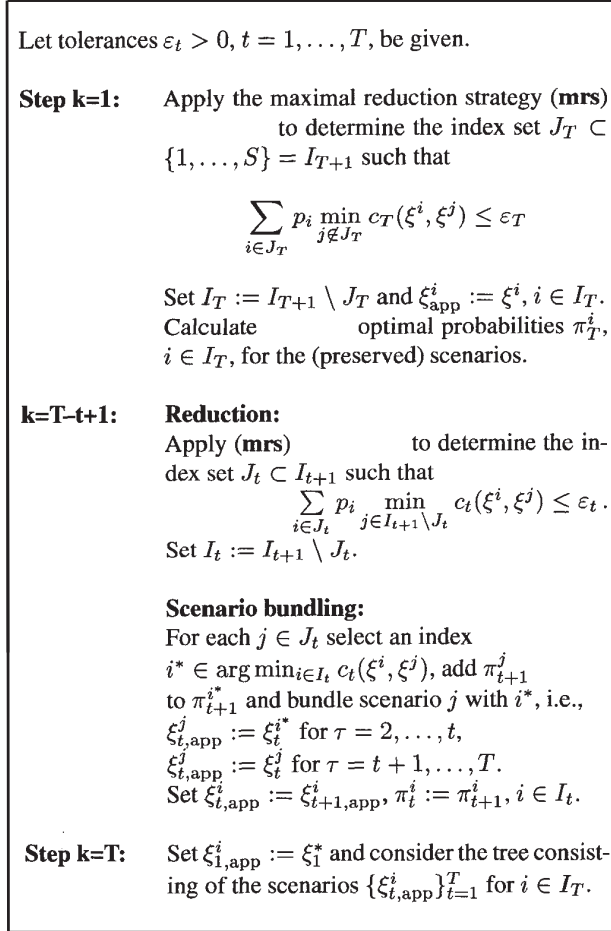

Figure 2.3: The algorithm of the scenario tree construction [34].

### Clustering-Based Scenario Reduction

In the clustering-based scenario reduction, the similar scenarios, which have the distance smaller than a predefined tolerance, are first classified into a scenario sets. The scenarios of each scenario set are, then, merged and define a cluster. Finally, a representative (or focal scenario) is associated to each cluster. The probability of each cluster is also determined based on the number of scenarios in each cluster.

The flowchart of the clustering-based scenario reduction is presented in figure 2.4 [31].

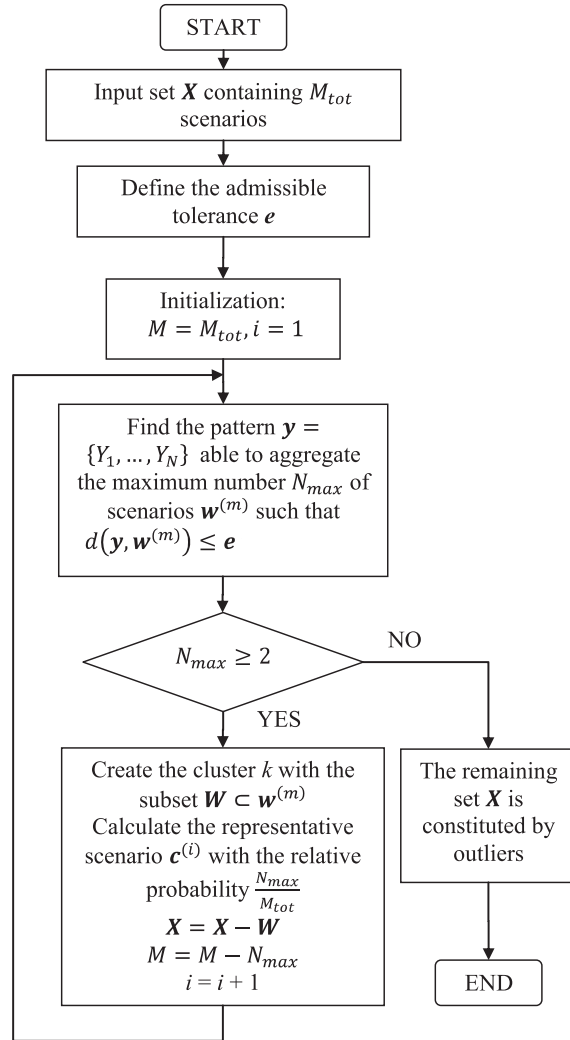

Figure 2.4: The flowchart of the clustering-based scenario reduction [31].

Among these algorithms, the forward scenario selection is a useful method for selecting a limited number of scenarios out of a large number of the initial scenarios, i.e., the idea behind this algorithm is to select a small group of the scenarios which should provide a solution as close as possible to the one given by the initial scenarios. Thus, this algorithm is selected as a representative of scenario reduction techniques for the sake of comparison among different power system simplification techniques in the present study.

### 2.3 System Aggregation

The large size of the power systems is another challenge for simulation of them which increase the complexity of power system studies. The main reasons for the increasing size are the growing demand for electricity, the planning of new lines and generators, and the interconnection between different electricity markets to attain higher technical and economic efficiencies. An important simplifying technique for studying the large power systems is system aggregation.

Another important application of this technique against the other simplification techniques is that it can also be used in cases detailed information of system is not available or necessary to used [47]. In such cases, the computational difficulty of the simulations may be not a problem, while, data unavailability may increase the simulation complexity. One example of such cases is the planned but not constructed generators and lines. For instance, construction of a new generator in an area may be decided but its exact location may still be unknown. In this case, many scenarios for the generator's location should be considered while using an aggregated version of the system in the studied area can prevent multi-scenario analysis.

Power System aggregation can be divided into different steps, each of which has various methods. These steps together with their corresponding methods are explained in the next chapter in detail. Thus, in this chapter we skip these details and only emphasize on the implemented method in the considered multi-dimensional power system reduction.

The considered multi-dimensional power system reduction of this research uses the Available Transfer Capability (ATC) values among different buses as the partitioning criterion for network aggregation in the multi-dimensional power system reduction technique. The reason for using ATC is that the main goal of this study is to compare different system simplification methods for technical studies such as OPF and SUC, and/or economic studies such as GEP and TEP. Therefore, the selected partitioning criterion should have a bearing on both these aspects. ATC values show the additional possible power transfer between different system buses. Thus, they are physical variables, and can be used for OPF and SUC studies. Meanwhile, if the ATC between two buses is high, it means that extra power can transfer between them, and the electricity price is the same for both of them. Therefore, even for GEP or TEP analyses, such buses can be put in the same sub-system.

### 2.4 Problem Reformulation

The third important simplifying method, which is used to increase the efficiency of the power system computations, obtains a simpler version of power system problems by using physical rules, mathematical equations, or optimization relaxations. One of the most commonly used approximation methods for power system studies is DC linearization, that is to use the DC power flow equations (instead of the AC ones). The AC power flow equations are given in equations 2.1 and 2.2 as follows:

$$P_k = \sum_{j=1}^N |V_k| |V_j| (G_{kj} \cos(\theta_k - \theta_j) + B_{kj} \sin(\theta_k - \theta_j)) \quad (2.1)$$

$$Q_k = \sum_{j=1}^N |V_k| |V_j| (G_{kj} \sin(\theta_k - \theta_j) - B_{kj} \cos(\theta_k - \theta_j)) \quad (2.2)$$

Where:

- $P_k$  Active power of bus  $k$ .
- $Q_k$  Reactive power of bus  $k$ .
- $|V_k|$  Voltage magnitude at bus  $k$ .
- $B_{kj}$  Susceptance (the imaginary part of admittance) between buses  $k$  and  $j$ .
- $G_{kj}$  Conductance (the real part of admittance) between buses  $k$  and  $j$ .
- $\theta_k$  Voltage angle at bus  $k$ .
- $N$  Total number of buses.

Through the use of DC linearization, all the transmission resistances are approximated to zero, the voltage magnitude of all buses fixed to one per unit (p.u), and all the sine functions replaced by their angles [48]. Thus the equations 2.1 and 2.2 are replaced with equation 2.3 as follows:

$$P_k = \sum_{\substack{j=1 \\ j \neq k}}^N B_{kj} (\theta_k - \theta_j) \quad (2.3)$$

The most important advantage of such approximation is that it makes the nonlinear power system equations into a linear formulation. The simulation of this linear formulation is much easier and faster than that of original nonlinear equations. This method is used in this study as a representative algorithm for the third power system simplifying technique.

## 2.5 Problem Decomposition

Problem decomposition can also be used as a useful simplification technique in power system studies. Different decomposition techniques are classified in [40] based on their applications in different programming models. In this regard, these techniques are discussed in terms of a) linear programming with complicating constraints, b) linear programming with complicating variables, 3) nonlinear programming, and d) mixed-integer programming. Reference [49] also reviews and provides the algorithms of some of the common decomposition methods, used for solving the mixed integer linear programming. These explained methods in this reference includes: a) Cutting-plane method, b) Dantzig-Wolfe method, and c) Lagrangian method.

Although it would be more interesting to include one of the aforementioned decomposition methods in our comparison, we decided to exclude this simplification technique from our multi-dimensional reduction comparison and suggest this inclusion in our future work.

## 2.6 Validating Studies for the Proposed Multi-Dimensional Power System Reduction

In order to compare the three techniques for power system simplification, they need to be applied to different power system studies and the results will be evaluated to see which simplification technique causes more errors than the others in each of the studies.

Four different power system analyses are chosen for this purpose. A short description of these studies is given below.

### Optimal Power Flow (OPF)

The main idea of OPF is to determine the generation of different generators such that all loads are supplied and an objective function, such as total operation costs and total system losses, is minimized. In the electricity market analysis, the objective function of the OPF problem is to maximize social welfare based on generators' and demands' bids. The formulation of this OPF problem in hour  $t$  is as follows.

$$\max_{V_k(t), P_j^g(t), P_i^d(t)} \left\{ \sum_{i=1}^N [b_i(t)P_i^d(t)] - \sum_{j=1}^G [b_j(t)P_j^g(t)] \right\} \quad (2.4)$$

$$P_k^g(t) = P_k^d(t) + Re \left\{ V_k(t) \sum_{i=1}^N y_{ki}^* V_i^*(t) \right\} \quad (2.5)$$

$$Q_k^g(t) = Q_k^d(t) + Im \left\{ V_k(t) \sum_{i=1}^N y_{ki}^* V_i^*(t) \right\} \quad (2.6)$$

$$|V_k(t)y_{ki}^*V_i^*(t)| \leq S_{ki}^{max} \quad (2.7)$$

$$V_k^{min} \leq |V_k(t)| \leq V_k^{max} \quad (2.8)$$

$$P_j^{min} \leq P_j^g(t) \leq P_j^{max} \quad (2.9)$$

$$Q_j^{min} \leq Q_j^g(t) \leq Q_j^{max} \quad (2.10)$$

Where:

- $b_i(t)$  Bid of demand  $i$  at time  $t$ .
- $b_j(t)$  Bid of generator  $j$  at time  $t$ .
- $P_d^k(t)$  Consumed active power at bus  $k$ , time  $t$ .
- $Q_d^k(t)$  Consumed reactive power at bus  $k$ , time  $t$ .

- $P_g^k(t)$  Generated active power at bus  $k$ , time  $t$ .  
 $Q_g^k(t)$  Generated reactive power at bus  $k$ , time  $t$ .  
 $y_{ki}$  Admittance between buses  $k$  and  $i$ .  
 $N$  Total number of load buses.  
 $G$  Total number of generator buses.

The objective function 2.4 is social welfare, defined as the sum of the demands' bids minus the sum of generators' bids. Constraints 2.5 and 2.6 keep the active and reactive power balance at each bus. The line flow limits, bus voltage limits, and generation limits are guaranteed by 2.7- 2.10, respectively.

### Stochastic Unit Commitment (SUC)

The second power system study under consideration is SUC. SUC is an operation/planning problem associated with the scheduling and the generation dispatching of the generators in some load/renewable scenarios, and has a time horizon ranging from hours to days. The outcome of the SUC problem determines which generators should be available at each time interval of the time horizon. The formulation of SUC problem is as follows [21, 50–52].

$$\max_{V_k(t), P_j^g(t,s), u_j(t)} \left\{ \sum_{t=1}^T \sum_{s=1}^S \sum_{j=1}^G \pi(s) \cdot [c_{j2}(P_j^g(t,s))^2 + c_{j1}P_j^g(t,s) + c_{j0}] + \sum_{t=1}^T \sum_{j=1}^G [(ws_j(t).wsc_j) + (cs_j(t).csc_j)] \right\} \quad (2.11)$$

$$P_k^g(t,s) = P_k^d(t,s) + Re \left\{ V_k(t,s) \sum_{i=1}^N y_{ki}^* V_i^*(t,s) \right\} \quad (2.12)$$

$$Q_k^g(t,s) = Q_k^d(t,s) + Im \left\{ V_k(t,s) \sum_{i=1}^N y_{ki}^* V_i^*(t,s) \right\} \quad (2.13)$$

$$|V_k(t,s)y_{ki}^*V_i^*(t,s)| \leq S_{ki}^{max} \quad (2.14)$$

$$V_k^{min} \leq |V_k(t,s)| \leq V_k^{max} \quad (2.15)$$

$$u_j(t).P_j^{min} \leq P_j^g(t,s) \leq u_j(t).P_j^{max} \quad (2.16)$$

$$u_j(t).Q_j^{min} \leq Q_j^g(t,s) \leq u_j(t).Q_j^{max} \quad (2.17)$$

$$cs_j(t) \geq u_j(t) - \sum_{h=t-T_{cs,j}}^{t-1} u_j(h) \quad (2.18)$$

$$ws_j(t) \geq u_j(t) - u_j(t-1) - cs_j(t) \quad (2.19)$$

$$\sum_{h=t-T_{on,j}^{max}}^t u_j(h) \leq T_{on,j}^{max} \quad (2.20)$$

Where:

$s$	Index of scenarios, running from 1 to $S$ .
$c_{j0,1,2}$	Cost function constants of generator $j$ in time $t$ .
$u_j(t)$	Binary variable, equal to 1 if generator $j$ is on in time $t$ and 0 otherwise.
$cs_j(t)$	Binary variable, equal to 1 if generator $j$ has a cold start-up in time $t$ and 0 otherwise.
$ws_j(t)$	Binary variable, equal to 1 if generator $j$ has a warm start-up in time $t$ and 0 otherwise.
$\pi(s)$	Probability of scenario $s$ .
$S$	Total number of scenarios.

The objective function 2.11 is to minimize the operational cost which is the expected cost of all generators and the start-up costs. Constraints 2.12 - 2.17 are similar to 2.5 - 2.10, but are updated for the SUC problem. Constraints 2.18 and 2.19 define the terms related to the cost of cold and warm start-ups. It is assumed in 2.18 and 2.19 that the generator will have a cold start-up if it is off for a period longer than  $T_{cs,j}$ . The maximum on-time for each generator is assured in 2.20. In this formulation, the minimum on-time, the maximum and minimum off-time, and the shut-down cost are ignored for the sake of simplicity.

### Generation Expansion Planning (GEP)

Like the SUC problem, the last two studies under consideration, namely GEP and TEP problems, are related to power system planning. The scope of these studies is, however, larger than that of SUC. The goal of these studies is to evaluate the economic feasibility of constructing a new line or generator. For an economic evaluation of GEP, for instance, the candidate buses for constructing a new generator are selected and the price outcomes are patterned by simulating the system in all scenarios. The candidate bus with a higher price outcome will then be selected for the location of the planned generator.

### Transmission Expansion Planning (TEP)

In the TEP problems, some candidate lines are considered. All scenarios are then simulated for each candidate twice, one with the line itself and one without. Next, the reduction in the system operating costs by adding the line is calculated. Finally, a diagram of these reduced costs is drawn for each line, and the lines which reduce the system costs most significantly should be built.

## 2.7 Simulation Results and Discussion

In this section, the proposed multi-dimensional power system reduction technique is applied to two IEEE test systems [53] to compare the results of the different simplification techniques on the four power system studies in question.

For a comparison of the OPF, GEP, and TEP studies, the IEEE 118-bus system with 200 scenarios of renewable generation and loads is applied. This system is, however, too large for the SUC study, with its formulation being a mixed integer programming problem and its

use of many scenarios. Instead, we use the IEEE 30-bus system with 22 scenarios of wind generation and loads to compare the impact of simplification techniques on the SUC. Load scenarios are generated through normal randomizing the load values in these two standard IEEE systems. Correlation coefficients used for wind power scenario generation vary from 0.7 to 1 based on the distance between wind units.

The SUC problem is optimized using GAMS 23.6 while the other studies are executed with MATLAB R2010. These are run on a PC with an Intel Core i5 CPU 2.53 GHz processor and 4.00 GB installed memory (RAM).

In order to compare the effects of the different simplifying techniques on OPF, GEP, and TEP, the following steps are required. First, the IEEE 118-bus system with the original 200 scenarios is simulated and the result of this simulation is considered as a benchmark for the evaluation of the simplifying techniques. In the second step, forward scenario selection is applied three times to the original set of 200 scenarios, yielding three sets of scenarios with 20, 5, and 1 scenarios, respectively. In the third step, four different levels of network aggregation are applied on the IEEE 118-bus system, resulting in four equivalent systems with 66, 46, 26, and 15 buses, respectively. Thus, in total there are 5 network systems and 4 scenario sets, including the original network and 200 scenarios, and 20 different combinations of networks and scenario sets. In the last step, each of these 20 combinations is simulated two times, once with an AC formulation and once with the linearized DC simplification (without losses), resulting in 40 cases. Finally, the results of all the cases are compared with those of the baseline system (AC formulation, 200 scenarios, 118 buses) in order to assess which simplifying technique causes more errors in the results of the OPF, GEP, and TEP problems.

A similar procedure is followed to compare the effects of the simplifying techniques on SUC in IEEE 30-bus system. This means that the SUC problem is applied to the IEEE 30-bus system with the original 22 scenarios and the result obtained is used as the baseline to validate the results of the simplification techniques in the next steps. Three scenario sets including 12, 6, and 3 scenarios are then selected, and two aggregated networks, which have 15 and 6 buses, are obtained. The SUC is used to simulate all 12 possible combinations of scenario sets and aggregated networks. With a few exceptions, which will be explained below, all these are run with the DC approximation alone. The reason for this is that we are unable to solve to optimality the stochastic mixed integer nonlinear AC SUC problem in all cases. The results are then compared to see whether it is scenario reduction or network reduction that has a greater effect on the simulations in relation to the baseline (30 bus, 22 scenario) system.

A summary of the simulation results are presented in Table 2.1, however, the readers are the extended version of them as well as information about the scenario sets and aggregated networks can be found in Publication I. The simplification techniques are compared in terms of both simulation errors and simulation time. The simulation results, for which the errors resulted from the simulation are compared, include mainly the economic indices such as total system costs, plant construction profits, and line construction savings. However, technical indices such as system losses, EENS, generation/commitment of generators are also considered in this comparison. In this table, STR and LRE are abbreviated for Simulation Time Reduction and Low Resulting Error, respectively.



Table 2.1: The comparison summary of applying different power system simplification techniques to considered power system studies.

Simplification technique	Scenario reduction		System aggregation		DC linearization	
	Time	Error	Time	Error	Time	Error
OPF (Cost, Losses, Generation)	+++	--	++	---	+	-
SUC (Cost, EENS, Commitment)	+	---	++	-	+++	-
GEP (Prices, Plant Profits)	+++	--	++	--	+	-
TEP (Line Cost Savings)	+++	--	++	---	+	-

Computational time reduction: +++ is best

Error in estimation of performance indices: --- is worst

The following conclusions, strictly speaking, apply only to our particular case studies, which were based on two IEEE reliability test systems, and might not apply to other situations.

First, the table shows that scenario reduction yields an acceptable level of accuracy while decreasing computation times in power flow studies as well as generation and transmission investment analyses that use OPF models for production costing. However, scenario reduction is more distorting and results in less computational efficiency gains in SUC. Second, given present computational capabilities, DC linearization is essential for stochastic unit commitment, although advances in parallel computation and decomposition may make AC-based SUC more practical in the future. Third, network aggregation can also be useful in OPF and SUC for reducing simulation times without the risk of making major errors.

Although our results are system specific, we can nonetheless make the following general conclusion: depending on the type of study and on the particular system, any of the simplification methods can either cause large errors, negligible errors, or something in between. Which simplification method is most appropriate will likely depend on the power system study under consideration, and so users of economic models should test for the impact of simplifications on their conclusions.



## Chapter 3

# A Review on Power System Aggregation

*This chapter describes the different procedures and steps needed for aggregation of large power system. The provided review is based on the previous literature in the area of power system aggregation and equivalents.*

### 3.1 Background

Before the introduction of competitive markets, system operators modeled all connections between their power system and external systems as some new border buses and they were faced with a system of the same order as that of the internal system [54]. However, as it was explained in detail in the chapter 1 (i.e. the introduction chapter), the competitive environment in power systems and international power transactions have resulted in a general trend in the electrical power industry towards harmonizing the market rules and analyzing all tightly connected systems as one bulk power system.

In addition, the increasing penetration levels of renewable energy sources such as wind and solar, and their corresponding uncertainties have made power systems modeling and simulation more challenging. For instance, generation of these renewable units is a random variable since it is influenced by weather conditions, and thus needs to be modeled using different scenarios.

Although modeling these scenarios means a considerable increase in the computational burden, there is no doubt that large-scale power systems must be simulated and analyzed. This may be done using supercomputers with detailed models. A better solution, however, is to find an aggregated equivalent system which can approximate the behavior of the actual system itself, especially if many scenarios (e.g. expansion planning and/or solar or wind power installations) need to be studied. The main focus of this chapter is to study and classify the previously presented equivalent system.

### 3.2 The History of Power System Equivalents

The basic concepts of equivalent power systems are described in [6, 54]. These concepts have been widely adopted and used in different power system studies. The following references give some examples of the implementation of system equivalents in power system studies.

In [9, 55], power system equivalents are developed for on-line and off-line power system security analysis. Reference [56] considers using power system equivalents for simulation of power system contingencies. Reference [57] discusses load flow equivalents, which are used for approximating power flow studies in large-scale power systems. State estimation issues are combined with power system equivalents in a so-called state estimation based equivalent [58]. In [59], different power system equivalencing techniques are compared and modified. Reference [60] reviews the practical experience with power system equivalents, assessing the advantages and drawbacks of using power system equivalents at a number of utility control centers.

In [13, 29, 61–64], the equivalent of a large-scale power system is obtained based on multi-area modeling. In these investigations, some criteria like reliability and security indices are selected. The original system is considered as a bulk power system consisting of some interconnected areas, each of which is then replaced by an equivalent with fewer buses and lines. The objective is that the multi-area model should give results as close as possible to the results of the original system for the selected criteria. For example, reference [61], using an analytic characterization of the system failure modes, explains a model for reliability evaluation of multi-area generation system. Reference [29] proposes an algorithm to determine the equivalent reactance of the inter-area lines of a reduced system, based upon the zonal power transfer distribution factors of the original system.

It is suggested in [62] to use a steady-state equivalent of a power system for real-time operation, obtained by applying Radial Equivalent Independent (REI) method for the reduction of the electrical network. [63] introduces an approach, for total transfer capability (TTC) computation, for multi-area power system modeling, taking line contingencies into consideration. The solution is to use a network decomposition approach based on REI equivalents. Some methods regarding power system partitioning are suggested and used in [13, 64–66].

### 3.3 Power System Aggregation Steps

Generally, finding an appropriate aggregated power system equivalent involves two important sections. First, aggregating the power network and, second, aggregation of power system generators.

The first section, network aggregation, is also known as bus aggregation and network reduction and means finding a smaller network for the power system which includes less number of buses and lines. As a result of this section, generators and loads in the omitted buses are only shifted to the retained buses. The second step, on the other hand, is generation aggregation and means obtaining an equivalent for the generators which after network

aggregation are located at the same bus. It also includes the cases in which the power network is ignored and overall generation capacity in the system needs to be approximated. An example of such cases for total wind power production will be given in Chapter 5.

A review on any of two aforementioned sections of power system aggregation are explained in the following.

### 3.4 Network Aggregation

Network size reduction through aggregation, the focus of this thesis, involves replacing the original large-scale power system by a reduced equivalent, which has many potentially valuable applications [67].

A common strategy for reducing the size of large power networks is to first partition the system into smaller areas. Then equivalent electrical characteristics are determined for aggregate buses within each partition and connections among the partitions [68]. These steps are separately explained below.

#### Network Partitioning

The first step for aggregation of a large-scale power system is to partition the power network into some sub-networks (also called areas). This partitioning can be done through different methods. Some network reduction methods assume the area borders known. This can be either done through assuming the geographic borders as area borders or using the expert experiences for doing the partitioning without any calculation. However, the more efficient ways is to use 1) reasonable partitioning criteria and 2) appropriate partitioning tools to define the area borders.

- **Power system partitioning criteria**

Different criteria can be used for partitioning the network of a bulk power system. These criteria can be classified into different types. One of the common classifications is to, first, divide the aggregation algorithms into dynamic- and static-based partitioning criteria. Then, to create a further division for any of these two main groups. The static-based criteria can be used for power flow calculations as well as power system operational and planning analysis, while, the dynamic-based ones are used for studying the dynamic effects, e.g. a) off-line transient stability analysis with large disturbance, b) off-line dynamic stability analysis with small disturbance, and c) on-line security assessment in large scale power systems.

According to this classification, the static-based partitioning criteria are, then, divided again into market- and technical-based types. Although there are some difference between the properties of various system aggregations, they all have the same basic principle, which is to find a similarity measure for the system buses and then to partition the system into some sub-systems based on this similarity criterion. The similarity criterion varies according to the purpose of the analysis in question. For instance, the LMP-based or PTDF-based aggregations are suitable for the electricity

market analyses, while aggregated systems based on voltage or admittance matrices are applicable to power flow or OPF studies [28].

- **Power system partitioning tools**

In addition to the partitioning criterion, one should also have a partitioning tool for splitting the network of the power system. Similar to the partitioning criteria, there are also a number of tools which can be used for network partitioning. Two important examples of them, more emphasized in this thesis, are optimization- and graph theory-based tools.

In the optimization-based method, the partitioning criterion which defines the similarity between each pair of the system buses is used as an input, and, it is tried to maximize the intra-area similarities or minimize the inter-area similarities. However, the slow convergence speed and stocking in the local optima are the main challenges of this method. An extended optimization-based tool for power network partitioning is proposed in the next chapter.

The graph theory-based partitioning tools, on the other hand, use the buses and lines of the power system as vertices (V) and edges (E) of the graph, respectively, and define the set of  $G=(V,E)$  for identifying the network. The network partitioning can, then, be formulated as minimizing the sum of all cut values and the minimum cut is found through, e.g., clustering methods. A new graph theory-based method for network partitioning in the large power system is developed in the next chapter. As it will be explained in detail, the main disadvantage of graph theory-based tools is their inflexibility. For instance, it is not possible to control the size of partitions or minimize the number of border buses by these tools.

### **Network Equivalencing**

Once the network of the large power system is partitioned, in the second step, each partition needs to be modeled through a smaller equivalent network. The network equivalencing can be done in different ways. Three important and popular methods for obtaining the equivalent network is presented here.

- **Multi-area equivalent with DC tie-lines**

Multi-area equivalent with DC tie-lines is an easy method for obtaining the equivalent for the power system, the network of which was previously partitioned. According to this method, the intra-area transmissions of all areas are ignored and it is assumed that the unlimited power can flow between the buses of each area. In addition, it is assumed that the power transfer among areas are totally controllable, i.e., the area tie-lines are assumed to be DC links. Figure 3.1 shows how the network of a power system is, first, partitioned into three areas and, then, modelled with a multi-area equivalent.

It should be noted that the multi-area model mentioned here is only a particular type of the power system equivalents, while, the word multi-area is a general expression and can be applied to a variety of power system models. For instance, an interconnected power system that includes more than one control area and a corresponding system operator for each area is also defined as a multi-area power system [18–20, 69]. Each control area can itself be divided into more than one area. In this multi-area power system, each operator is responsible for controlling flows within their area’s grid as well as monitoring and coordinating power transactions with other control areas. Moreover, there is usually a coordinator for the entire system who plays different roles in different multi-area systems. The western interconnection of North America and the regional group Continental Europe, explained and depicted in chapter 1, are two examples of these multi-area systems.

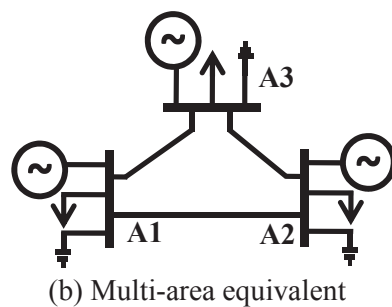
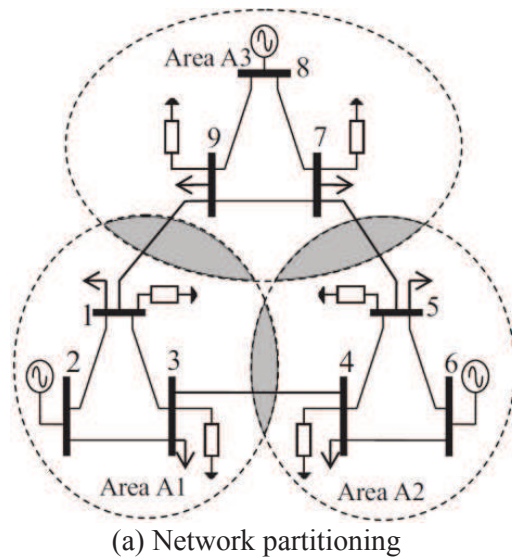

Figure 3.1: Steps for obtaining the multi-area equivalent for an example power system [70].

- **REI equivalent**

The usual procedure for obtaining the REI equivalent (abbreviated for Radial, Equivalent and Independent) for a power system is to partition the system into an internal and an external system. The former is the part of the power system which should be modelled in detail, while, the latter should be reduced via REI equivalent. The connecting buses between the internal and external systems are considered as the border buses. In order to obtain the REI equivalent of the external system, first, the results of a Power Flow (PF) or Optimal Power Flow (OPF) is considered as the initial point. Then, two new virtual buses, known as virtual generator bus and virtual load bus, are added to the system and all generators and load are shifted to the virtual generator and virtual load buses, respectively. The admittances connecting the virtual buses to the other buses of the system are determined by the initial PF/OPF results. Finally, the buses of the external system are removed via admittance reduction techniques. Figure 3.2 shows different steps for obtaining the REI equivalent. An improved REI equivalent, including the detailed description of all steps, will be provided and compared to the existing REI equivalents in the next chapter.

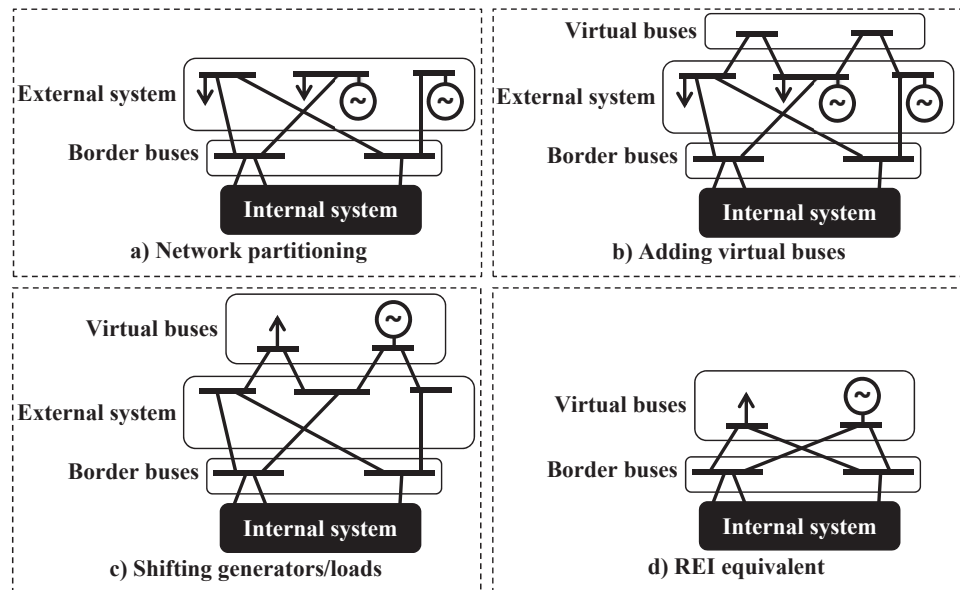

Figure 3.2: Steps for obtaining the REI equivalent for an example power system.

- **Ward equivalent**

Similar to the REI equivalent, a Ward equivalent is also obtained through an initial PF/OPF. In addition, the buses in the original power system are divided into internal,



external, and border buses. Nevertheless, the difference between the REI and a Ward equivalents is that there is no virtual buses in a Ward equivalent and all generators and buses will also be modelled through admittances. Therefore, on the one hand, a Ward equivalent can provide a simpler equivalent for the external system, while, on the other hand, its accuracy may be less than the REI equivalent. An example of Ward equivalent is illustrated in figure 3.3.

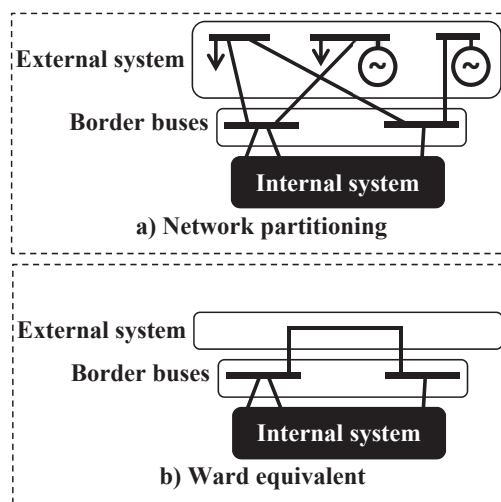

Figure 3.3: Steps for obtaining the Ward equivalent for an example power system.

It should be noted that we only explained the basic multi-area, REI, and Ward equivalents here and the extended version of these equivalents have been investigated in many studies, some of which were mentioned in the literature review of section 3.2.

### 3.5 Generation Aggregation

The second section of power system aggregation is generation aggregation. Generation aggregation may be done because of different reasons and, consequently, via different procedures. After network aggregation, for instance, some of the generators may be shifted to the same bus. This is specially the case in REI equivalent. In such cases, one may use the generation aggregation to merge the generators at the same bus. Another application of the generation aggregation is a power system study in which the transmission system is ignored and total generation capacity of a system is needed. Two examples of such cases are obtaining the total generation capacity of each area in multi-area equivalent and power system reliability analysis considering only the generation section.

The generation aggregation can be divided into two parts according to the generation type, i.e. conventional generations and renewable generations. These parts are briefly explained in the following.

### **Conventional Generation Aggregation**

Power generation in the conventional generation is usually controllable. Thus, if some conventional generators are located at the same bus or if they are at different buses but we ignore the transmission limitation between them, the power generation capacity of them can simply be summed and used as the aggregated generation capacity. It should, however, be noted that a new cost function based on the cost functions of the aggregated generators needs to be obtained for the obtained generator. Nevertheless, an important observation in this case is the type of power system study in which the aggregated generation is used. This means that if the total generation capacity is the only important parameter in the considered power system study, the above generation aggregation can be used, while, in power system studies in which the on/off status of each generator is also important, the original generators cannot be replaced by only one generator with the generation capacity equal to the aggregated generation capacity of all original generators. An example for the latter is power system unit commitment study. The purpose of the unit commitment is to determine which generator should be on in each time interval of the studied period. Thus, not only is the generation capacity of original generators important in the unit commitment, but the on/off status of them also is a required output in this study. As a result, more advanced generation aggregation methods are needed in this study. On the other hand, in the PF/OPF studies, the on/off status of generators is an input rather than an output. Therefore, only the generation capacity is important in these studies and the summation of the generation capacity of all the original generators can be used to replace the original generators.

### **Renewable Generation Aggregation**

Unlike the fossil fuels (the power source in conventional electricity generation), the renewable energy sources (such as run-of-the-river hydro, wind, and solar energies) cannot be stored. Thus, the produced electric power by renewable energy sources are not fully controllable and, therefore, aggregation procedure described for conventional generation cannot be implemented for them. In addition, due to concerns regarding the climate changes and lack of fossil fuels, the penetration of renewable energy resources has considerably increased in the modern power systems. Thus, it seems necessary to find an appropriate aggregation method for the renewable generations. Generation aggregation of three important renewable energies is discussed in the following.

#### **• Hydro power aggregation**

Hydro power plays an important role in providing electricity in countries like Norway, Brazil, Canada, and Sweden. These countries generate the majority of their

electricity from hydro systems and include very large hydro power systems. Another challenge which increase the complexity of these large hydropower systems is that their hydro power plants are also highly linked. As an example, the schematic of a Swedish hydropower system is presented in figure 3.4.

The different methods used for simplifying hydropower systems in the literature can be classified into three categories as a) Energy-based aggregation, b) Optimization/Heuristic methods, and c) Aggregation-decomposition methods.

In energy-based aggregation, hydro power plants of the original hydropower system are aggregated in a single plant. This equivalent hydro power plant represents the whole system inflows, reservoir contents, and outflows by energy [72–74]. The sum of energy production capabilities of all plants are then used to define the potential energy of the equivalent plant. Similarly, the potential energy inflow to the equivalent reservoir is defined as the sum of all reservoir energy inflows in the original hydropower system [74–77]. The advantage of this technique is the large reduction in complexity and simulation time. However, its drawback is ignoring the individual constraints of the original hydro power plants [78]. Thus, the application of this method is limited to the cases in which the aggregated hydro power plants have similar reservoir and inflow characteristics [78]. Otherwise, the hydro power generation may be overestimated. Another disadvantage of this method is that representing all variables of the hydro power plants with just energy values cannot properly represent the fluctuations of them [75]. The flexibility of a single-reservoir equivalent may be limited by ramping constraints, but implementation of such constraints can rise new challenges.

In the second method, optimization and heuristic methods, such as dynamic programming, network flow, fuzzy techniques, and genetic algorithms, are used to change the problem formulation or the solution procedure [75, 78–82]. The advantage of these methods is that detailed representation of all hydro power plants can be used. However, most of these approaches do not guarantee the quality of the solution attained [78]. Specifically, many of these methods, such as genetic algorithms, only provide local optima and global optimality is not guaranteed [78]. Also, using dynamic programming for systems with many reservoirs may be extremely challenging because of dimensionality issues [79].

In aggregation-decomposition methods, the optimization of a hydropower system with  $N$  reservoirs is decomposed into  $N$  sub-problems. In any of these  $N$  sub-problems, one of the reservoirs in the original system is modelled in detail and optimized assuming known the energy contents of the other  $N-1$  reservoirs [78, 80, 83]. The advantage of this method over the aggregation method is that local constraints of each hydro power plant can be represented. However, similar to heuristic approaches, global optimality cannot be guaranteed. Another drawback of this method is that its computational burden increases linearly with  $N$  and, therefore, it is not efficient to use the method for hydropower systems with long chain of hydro power plants [80].



A new type of aggregation approach was proposed in [74], in which an equivalent hydropower system was considered and its parameters adjusted to mimic the working of the original hydropower system. In order to model hydro bottlenecks, one of the original hydro power plants is kept and an equivalent for the rest of hydro power plants is obtained. Similar to the traditional aggregation approach, this two-station equivalent has the advantage of complexity reduction while representing some of the local constraints, e.g. hydro bottlenecks. In addition, unlike the heuristic and aggregation-decomposition approaches, the proposed two-station equivalent has no limitation for approximating large hydropower systems.

- **Wind power aggregation**

Unlike the hydro power, which can be stored in reservoirs for a short time and scheduled over a time period, there is no control on wind power generation. Thus, usually all power generated by wind turbines are used by the connected power system. Due to this reason, wind power can be modelled as a negative load in power system studies. By doing so, having the wind power in the system only increases the challenges in forecasting the load uncertainties. However, considering the correlation coefficients among the wind speeds of different wind turbines, can increase the forecasting challenges. Thus, approximating the total wind power production of some wind power units with correlated wind speeds still is valuable. To do so, an algorithm is developed and tested in chapter 5.

- **Solar power aggregation**

Similar to the wind power, the traditional method for modelling the solar power is to consider it as a negative load. However, as it is demonstrated in [84], obtaining a separate aggregated model for a number of solar cells not only reduces active and reactive errors compared to the traditional way but also represents a more accurate trajectory behavior.



## Chapter 4

# Contributions to the Network Aggregation

*This chapter reviews the performed studies of this thesis on the topic of network aggregation and explains the improvements which have been suggested by this thesis in the field of network aggregation.*

Three important studies are performed in this thesis for improving the previous network aggregation methods. The first one focuses on the network partitioning and compares the application of two common partitioning techniques for defining the network partitions (or areas) in a large-scale power system, while, the second one investigates the network equivalencing issue and suggests some improvements for expanding the application of the REI equivalent. The third study considers both network partitioning and equivalencing and proposes an improved network aggregation for planning power systems with correlated wind and loads. These three studies are fully explained in the following sections.

### 4.1 Introduction

Simulations of production costs, flows, and prices are crucial inputs to generation and transmission planning studies. To calculate average system performance for many alternatives over long time periods, it is necessary to simulate large numbers of hourly combinations of renewable production and loads across large regions. As this is usually impractical for full network representations of such systems, aggregation of buses and lines is desirable.

As it was mentioned in the previous chapters, network aggregation includes two key steps. The first step is power network partitioning, whereas the second one is network equivalencing. These two steps are more clearly reviewed in this chapter and some improvements in these regards are suggested.

Several methods have already been applied to the partitioning of power systems into areas (the first step of network aggregation). For existing power systems, a natural parti-

tion is to use the price areas in countries where these are defined by the system operators. These coincide with geographical borders or control areas between the countries and, usually, with bottlenecks inside a country if a national power system has several price areas. This partitioning is well adapted for, e.g. market studies, because the price areas share common rules. However, the geographical areas encompassed by the price areas are wide, and are not necessarily adapted to other types of studies such as the example given above. Therefore, systematic methods to partition power systems need to be investigated. Additionally, the multi-area modeling may produce better results if the area regions are defined according to the system's physical conditions such as line flows, line capacities, and line admittances.

If the system's physical conditions are concerned, methods used for power system partitioning can be divided into two groups based on whether they are used for dynamic reduction or static reduction [28]. (See [85] for a review of both groups, as well as existing software tools.) Dynamic reduction methods are defined as those that try to obtain an equivalent for synchronous machines whose transient stability behavior is close to the original machines [85]. Coherency- and synchrony-based methods are examples of dynamic aggregation approaches, in which partitioning is done by aggregating machines that have tendency to swing together [68]. However, as mentioned above, we focus here on static aggregation, in which network topology and economics and their effect on congestion instead are crucial for partitioning the system.

Partitioning methods for static reduction of large power systems can be further subdivided into system- and market-based methods. System-based methods use physical properties of power system such as admittance, line flow, voltage magnitude, and voltage angle for partitioning, while market-based methods base partitioning on economic outputs such as electricity prices [15,28,29]. Ward and REI methods using the load flow results are mentioned as two examples of system-based partition methods, while LMP (Local Marginal Price) and PTDF (Power Transfer Distribution Factor) tools are used for market-based partitioning in [15,28,29,63,86].

Besides a partitioning criterion, the core of any aggregation method is its algorithm for system partitioning. Optimization is used for that purpose in [87,88]. The choice of objective function is important in designing the algorithm. In [87], for instance, a multi-objective approach attempts to minimize the largest number (across areas) of buses and lines in any single area, as well as to minimize the largest number of tie lines between any two areas. The intention is to create a partition with similarly sized areas and similar numbers of tie-lines between areas. In [88], on the other hand, use of one of two partitioning objectives is proposed. In the first, total intra-area admittance is maximized, while the second minimizes the differences among bus voltages within each area. Unfortunately, all the optimization aggregation approaches are computationally burdensome.

The objective of getting partitions of balanced sizes and few inter-area links is used in [89] and [90], which solve the associated non-linear minimization problem with simulated annealing and genetic algorithms, respectively. Another approach is proposed in [13,14,64], where the electrical network is seen as a graph whose weighted connectivity matrix is taken as being the admittance matrix. For partitioning the network into  $k$  areas, the first  $k$  eigenvectors of the connectivity matrix are calculated and the buses are distributed into the



areas according to their coordinates in the state space formed by these  $k$  first eigenvectors. The studies differ in what algorithm they use to sort the buses according to their coordinates: [64] uses the leader algorithm and [13] and [14] use a modified centroid sorting method, based on a  $k$ -means algorithm.

The partition problem as formulated in [64] could also be solved directly as a linear optimization problem, but the computational time increases dramatically when dealing with large systems, and the identified areas may not be internally connected. Besides, in the three articles [13, 14, 64], the obtained partitions can be unbalanced in size (with areas containing very few buses) and, thus, some post-processing step is necessary. To overcome such shortcomings, some other partitioning methods, which have been applied in other fields, can be used. These methods give promising results in partitioning with balanced sizes while ensuring internal connectedness of the areas. In particular, a class of methods called spectral clustering was used with success for image segmentation, data clustering and design of integrated circuits, [91–93], but has not been applied to power systems before.

In the studies performed in the next sections of this chapter, we propose partitioning methods based on both the optimization and the graph theory techniques. In addition, we mainly use the power system technical criteria such as admittance and transmission capacity for partitioning the power network.

The second step after identifying the areas is to model them by an equivalent network. Some of the common methods for equivalencing the original areas such as REI and Ward equivalents were reviewed in the previous chapter. In this chapter, however, we mainly focus on the REI equivalents and implement and modify this class of equivalents.

It should be noted that in all three studies of this chapter, both the network partitioning and network equivalencing steps need to be implemented. Nevertheless, in the first study, the focus is on the first step and two new partitioning methods are compared, while in the second study, the focus is on the second step and improving the REI equivalent. The third study, on the other hand, uses both the network partitioning and network equivalencing steps, but suggests to model a power system with more than one equivalent when enormous scenarios should be considered. Table 4.1 summarizes the partitioning tools, partitioning criteria, and contribution focuses of the three studies performed in this chapter.

Table 4.1: A summary on the partitioning tools, partitioning criteria, and contributions focuses of the three studies performed in this chapter.

Study	Partitioning tool	Partitioning criterion	Contributions on step 1	Contributions on step 2	Other contributions
Study 1 (Section4.2)	Both optimization and graph theory	Admittance	Comparing two partitioning methods	Improving REI equivalent	Proposing multi-equivalents
Study 2 (Section4.3)	Optimization	Admittance			
Study 3 (Section4.4)	Graph theory	Both admittance and power flow			

## 4.2 A Comparison on Two Partitioning Methods

### Motivation

In the first study, application of spectral clustering to power systems will be introduced. Compared with [13, 14, 64], the method presented here makes use of advances in the mathematical theory lying behind spectral partitioning, and leads directly to partitions with balanced sizes. In addition, an extension of the formulation from [64] as a linear optimization problem is proposed. It ensures balanced areas and connectedness within the areas while keeping the computation time reasonable. In both cases, the admittance matrix is taken into consideration, which has the advantage, compared with [89] and [90], of not only considering the connectivity of the network but also the admittances of the electrical lines defining this connectivity.

As it was mentioned earlier, the REI equivalents are used in the second step (network equivalencing) in this study.

The use of these equivalents in multi-area studies is, then, justified by previous works that have been carried out using them, for example in [94] where the equivalents were validated by comparing reliability indices, in [95] where it was used in interchange scheduling and in [96] for calculating the total transfer capacities.

Together with the use of REI equivalents, the two partitioning methods developed in this study are comprehensive ways of developing multi-area models, starting from a detailed electrical network; gathering nodes that are topologically close in the sense of the admittance matrix into areas; and applying REI equivalencing to each of these areas to finally obtain a simplified model of the electrical network. The contribution of this research lies in the first step: partitioning a power system into areas. In the second step, the existing REI equivalencing method has been chosen in the scope of this study, but other equivalents may be chosen for other purposes.

### Problem Description

In the following, we consider a power system with  $n$  buses and we want to identify  $a$  areas,  $A_1, \dots, A_a$ .

The topological structure of a power system is determined by buses and electrical lines. Let  $V$  be the set of all buses and  $E$  be the set of all lines. The lines are described by their admittance and by which buses they connect: each line  $(n, m)$  of  $E$  connecting buses  $n$  and  $m$  has an admittance  $y_{n,m}$ . Let  $G = (V, E)$  be the graph defined by the vertices (buses) in  $V$  and the edges (lines) in  $E$ . In the following, vertices, nodes and buses on the one hand and edges and lines on the other hand will be used interchangeably.

The connectivity between two vertices can be described by the admittance connecting them. A long electrical line has usually a large impedance and, therefore, a small admittance, which is why the absolute value of the admittances can be used as a connectivity measure. In graph theory terms, the admittances correspond to the weights of the edges [97].

Given the topology of the system, identifying areas in the power system is identical to identifying areas in the graph  $G$ . This can be done by using partitioning techniques from graph theory. However, before deciding upon which technique to use, a criterion to identify which buses to aggregate in the same area must be defined. Given the admittance matrix, it is natural to seek after gathering buses that are strongly connected in the same area, and to identify inter-area lines as the ones that link weakly connected buses, which are likely to be long lines, by our definition of connectivity. This definition of areas has been used in power systems and other fields in the previously cited works [13, 14, 64, 91–93]. In the case of power systems, the long lines are also the ones likely to get large voltage drops and to be run close to the transmission limits under operation. Hence, the buses in one given area must be as connected as possible to one another, whereas the connections between buses in different areas must be as weak as possible. This means that we want to minimize the sum of the admittances of all inter-area lines and maximize the sum of the admittances of all intra-area lines. Because the sum of the admittances of all lines in the system takes a given value, independent of any partitioning, the two problems are equivalent.

Mathematically, the value of the cut between one area,  $A_i$ , and the rest,  $\bar{A}_i$  can be defined as, [64],

$$\text{cut}(A_i, \bar{A}_i) = \frac{1}{2} \sum_{n \in A_i, m \in \bar{A}_i} y_{n,m}. \quad (4.1)$$

The problem can then be formulated as minimizing the sum of all cut values to find the minimum cut, or MinCut in the following,:

$$\min \sum_{i=1}^a \text{cut}(A_i, \bar{A}_i). \quad (4.2)$$

Two issues may arise from this formulation as described above in the introduction:

1. “Unbalanced area” issue: the objective function in (4.2) will naturally lead to one large area and all the other areas with just one node, therefore creating very uneven areas [98].
2. “Non-connectedness” issue: the obtained areas may not be internally connected, thus leading to more areas than initially wanted.

Two approaches to solve (4.2) while addressing these two issues are presented in the next sub-sections.

### Approach 1: Spectral Partitioning

The first partitioning approach considered here is a graph theory-based method, called the spectral method. We briefly summarize the method here; details are available in [98, 99], and Publication II. The basic concept of spectral partitioning rests on the analogy that the second vibrational mode of a vibrating string divides the string into two parts [99].

The first step in spectral partitioning is to define a similarity matrix for the studied system showing the strength of connection among different nodes of the system graph. "Strength of connection," however, can be defined in various ways, and here we use admittance values among buses. Defining the similarity values between each pair of system buses, the weighted adjacency matrix  $W = (w_{n,m})_{n,m=1,N}$  is calculated as follows. If buses  $n$  and  $m$  are not connected, then  $w_{n,m}=0$ , otherwise  $w_{n,m}$  is equal to the similarity values (here admittance value) between the two buses. Diagonal elements of  $W$  are assumed to be zero and the matrix is symmetric, i.e.,  $w_{n,m}=w_{m,n}$ . The degree matrix  $D$  is then defined as a diagonal matrix with elements equal  $d_n = \sum_{m=1}^N w_{n,m}$ . Using the  $D$  and  $W$  matrices, the unnormalized graph Laplacian matrix  $L$  is then defined as  $L = D - W$ . After that, the normalized graph Laplacian matrix  $L_{sym}$  is calculated as  $D^{-1/2}LD^{-1/2}$ . It is proven in [98] that  $L_{sym}$  is positive semi-definite and has  $N$  nonnegative real-valued eigenvalues. In the second step, the popular  $k$ -means clustering algorithm is applied to the first  $a$  eigenvectors corresponding to the first  $a$  eigenvalues of the graph's Laplacian matrix  $L_{sym}$  to partition the system into  $a$  partitions. Reference [98] compares alternative graph Laplacian matrices and algorithms.

It can be noted that the unnormalized Laplacian matrix  $L$  has the same structure as the admittance matrix in case of power systems, where the shunt reactors, the shunt capacitors, the line chargings and the phase shift angles of transformers have been omitted: the diagonal elements are equal to the opposite of the sum of all other elements in the considered row (and column) of the admittance matrix. Therefore, by using the admittance matrix as the unnormalized Laplacian matrix  $L$  to then calculate the normalized Laplacian  $L_{sym}$ , it is completely reasonable to apply the spectral partitioning method to power networks.

## Approach 2: Constrained Optimization

The second approach seeks at dividing a large power system in some areas in a way that the total internal admittance be maximized, or, equivalently, that the total inter-area admittance be minimized. It is actually a constrained formulation of the min cut given in (4.2). Here, constraints to ensure balanced area sizes and connectedness within the areas are added to address the two previously mentioned issues.

In this approach, we use the power system's admittance matrix as the weight function in the optimal  $k$ -decomposition algorithm introduced in [64]. Since the admittance value between two buses shows the electrical connectivity between them, using the admittance values as the weight function will cause the buses with large transmission capacity to be placed in the same area, and those with low transferring capacity to be placed in different areas. The goal of the optimal  $k$ -decomposition algorithm is to decompose a weighted, undirected graph into  $k$  clusters, such that these  $k$  clusters are weakly connected [64]. In order to solve the optimal  $k$ -decomposition problem, it is suggested in [64] that one may approximate this problem by a spectral approach, relying on the eigenvalues of the Laplacian of the graph. However, this approximation results in a sub-optimal solution [64]. Instead, we adopted the following approach which solves the optimal  $k$ -decomposition problem in [64] without any approximation. Two binary variables,  $A$  and  $S$  matrices, are introduced. The  $A$  matrix shows which buses belong to each area, and the  $S$  matrix deter-

mines if two buses belong to the same area. For example, if buses 1, 2, and 3 belong to areas 1, 1, and 2, respectively,  $A_{1,1}$ ,  $A_{2,1}$ , and  $A_{3,2}$  as well as  $S_{1,2,1}$  are equal to one, while the other elements of these two matrices related to buses 1 - 3 are zero. Using these two matrices, the  $k$ -decomposition problem in [64] can be formulated as a linear optimization problem as follows

$$\max \sum_{i=1}^a \sum_{n=1}^N \sum_{m=1}^N S_{n,m,i} y_{n,m} \quad (4.3)$$

$$\text{s.t. } A_{n,i} + A_{m,i} \leq 2S_{n,m,i} + 1, \forall n, m, i, \quad (4.4)$$

$$A_{n,i} + A_{m,i} \geq 2S_{n,m,i}, \forall n, m, i, \quad (4.5)$$

$$\sum_{i=1}^a A_{n,i} = 1, \forall n, \quad (4.6)$$

$$\sum_{n=1}^N A_{n,i} \geq N_{\min}, \forall i, \quad (4.7)$$

$$\begin{aligned} C_{n,m} + \sum_{p_1=1}^N (A_{p_1,i} C_{n,p_1} C_{p_1,m}) \\ + \sum_{p_1=1}^N \sum_{p_2=1}^N (S_{p_1,p_2,i} C_{n,p_1} C_{p_1,p_2} C_{p_2,m}) \\ \geq S_{n,m,i}, \forall n, m, i, \end{aligned} \quad (4.8)$$

where

$a$  is the desired number of areas;

$N_{\min}$  is the minimum of buses per area;

$S$  is a binary matrix whose elements  $S_{n,m,i}$  are equal to 1 if buses  $n$  and  $m$  belong to area  $i$ , and 0 otherwise;

$A$  is a binary matrix whose elements  $A_{n,i}$  are equal to 1 if bus  $n$  belongs to area  $i$ , and 0 otherwise;

$y_{n,m}$  is the admittance between buses  $n$  and  $m$ ;

$C$  is a binary matrix whose elements  $C_{n,m}$  are equal to 1 if there is an electrical line between buses  $n$  and  $m$ , and 0 otherwise.

The number of areas and the minimum size of the areas can be chosen freely in this method, whereas the only parameter for the spectral partitioning method of section 4.2 is the number of areas. Equation (4.3) defines the objective function, which is the sum of all intra-area admittances. Equations (4.4) and (4.5) define the relation between the  $S$  and  $A$  matrices. Equation (4.6) guarantees that each bus belongs only to one area, while (4.7) makes sure that the total number of buses in each area is more than a given minimum size,

thus preventing cutting out only one node. Equation (4.8) ensures the internal connectedness of each area, in the sense that, for every pair of nodes in an area, there exists a path between these nodes using only nodes of this area. Without this constraint, areas can be cut in several disconnected components, thus leading to a solution of the problem in (4.3) with more areas than decided. In this equation, the connectivity is defined either by a direct connection, or one bus between two considered buses, or two buses between two considered buses. However, for having large areas, this constraint should be expanded to consider longer paths between the buses in each area. Constraints (4.7) and (4.8) are what differentiates this formulation with the original one in [64]: they ensure balanced sizes across the areas and connectedness within each area.

The partitioning problem formulated as a linear program is flexible, in the sense that the objective function can be changed or more constraints added to tune the methods and refine the partition if this is wanted. This distinguishes it from the spectral partitioning method where no constraints could be added.

In order to illustrate the flexibility of the constrained optimization formulation, the problem of finding the partitions with as few border buses as possible can be considered. This problem cannot be solved by the spectral partitioning method. The corresponding formulation as a constrained optimization problem is:

$$\min \sum_{n=1}^N B_n \quad (4.9)$$

$$\text{s.t. constraints (4.4) – (4.8)} \quad (4.10)$$

$$K_{n,m} = \sum_{i=1}^a S_{n,m,i}, \forall n, m, \quad (4.11)$$

$$B_n = \sum_{m=1}^N (C_{n,m}(1 - S_{n,m})), \forall n. \quad (4.12)$$

In (4.9),  $B_n$  refers to the number of buses connected to bus  $n$  but which are not in the same area as bus  $n$ . So,  $B_n$  refers to all border buses, connected to bus  $n$  and should be kept in the reduced system. Also,  $K$  in (4.11) is a binary matrix, whose elements  $K_{n,m}$  are one if buses  $n$  and  $m$  are located in a same area. Constraint (4.12) also defines the  $B_n$  based on the elements of  $C$  and  $K$  matrices.

### Simulation Results and Discussion

Different simulations are performed in Publication II on the two partitioning methods described above to clarify the advantages/drawbacks of each method. A summary of these simulations are provided in the following, while, the readers are referred to Publication II for the detailed results.

The two partitioning methods are used to get the two three-area partitions of the IEEE 118-bus system. The results of both partitioning methods are presented in figure 4.1.

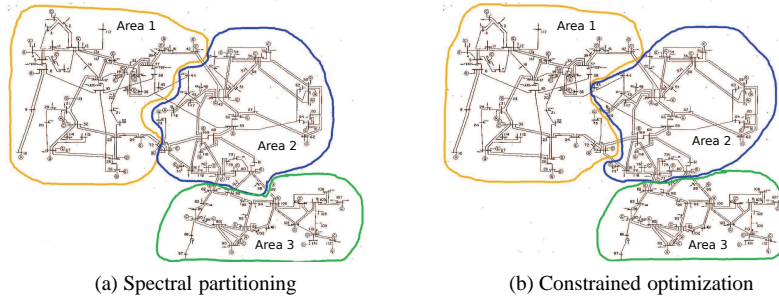

Figure 4.1: Partition of the IEEE 118 bus system into three areas, by spectral partitioning and constrained optimization

The REI equivalencing method is then used to model the three areas for the two partitions and the equivalent systems are evaluated through applying 1000 PF and OPF studies.

To summarize the results of these evaluations, the spectral partitioning method uses steps that can be carried out very rapidly on a modern computer, such as the computation of the eigenvalues, and is therefore much faster than the constrained optimization method. However, partitioning by solving the optimization problem is more flexible, since constraints on the areas can be added and the objective function tuned in the formulation of the problem as was shown in border bus minimization formulation.

### 4.3 Improved REI Equivalent

#### Motivation

Despite the advantages of using REI equivalents, there are several issues that are not properly addressed in previous studies. The first one is about the characteristics of the new lines and buses created during the calculation of the equivalent, such as their voltage limits and line capacities. Second, previous studies rarely consider outages of the system components in obtaining former REI equivalents. Finally, the impacts of high wind penetration on REI equivalents are not studied, nor are the resulting uncertainties which increase the variability in power generation and transmission. The above concerns suggests that there is a need for a systematic method for system partitioning as well as for a power system equivalent which is fine-tuned and which includes the system component outages.

In this study, the power system will be partitioned into a pre-determined number of areas through optimization, using admittance matrix. Using an improved REI method, each area will then be modeled by a reduced system. The REI method is improved by taking into account the uncertainties in generation units and transmission lines and by defining an optimization method for tuning the features of buses and lines in the reduced system. Having made these improvements, we can obtain an adaptive REI equivalent which will adjust itself according to the availability of generators and lines. Finally, the obtained equivalent will be evaluated in one thousand Monte Carlo scenarios, where the generators' and lines'

availability as well as changes in load and wind generation are sampled. Discrepancies between the results of original system and those of the new and of the old REI equivalent systems are used as accuracy indicators to highlight the higher accuracy of the proposed REI method.

The proposed equivalent can be used by system operators and electricity market participants to analyze their power systems. In order to use the proposed REI equivalent, however, the system data should be available, including the admittance matrix of the original system, as well as the information regarding the uncertainties in generators, lines, and the demands of the system. In addition, since the proposed equivalent is obtained by using the admittance matrix and power flow studies, application of this equivalent is limited to static power system studies rather than dynamic issues.

### Partitioning Method

The focus of this study is on the second step of network aggregation, i.e. network equivalent rather than the network partitioning. However, the first step of any power system analysis based on network aggregation is to use a suitable algorithm for splitting the power system into areas. Thus, we also need to use one of the network partitioning methods for defining the area borders. In this study, the network partitioning is performed using the constrained optimization formulated in the previous section, i.e. optimization (4.3) - (4.8). However, it is also possible to use other partitioning methods.

### Former REI Equivalent

After partitioning the system into a certain number of areas, each of these areas should be modeled with an appropriate equivalent. In this study, REI equivalent is chosen.

The basic concepts of the REI equivalent were mentioned in chapter 3. Nevertheless, since the contribution of this study is to improve this equivalent, we need to review the process of obtaining the REI equivalent for a multi-area power system more precisely. Thus, in this sub-section, we first review the previous REI equivalent, named former REI in this study, and then explain the suggested improvements.

The REI equivalents were originally developed by Paul Dimo [100, 101]. They have also been used in previous multi-area studies, for example in [13, 94]. In order to obtain the REI equivalent for a multi-area power system, the following procedure should be followed.

Border buses are defined as buses which have at least one interconnection with a bus in another area. In each area, the border buses are kept, while all the other buses are aggregated and replaced by one new load bus and one new generation bus. The buses to be aggregated will be referred to as non-essential buses. The steps to create the former REI equivalent of one area, whose border buses and non-essential buses have been identified, are as follows. Starting from a solved power flow, the first step is to calculate all injections at the non-essential buses,  $i$ , and replace them by admittances,  $Y_{0,i}$ . These admittances and the corresponding injected currents are:



$$Y_{0,n} = -\frac{S_n^*}{|V_n|^2} \quad (4.13)$$

$$I_n = \frac{S_n^*}{V_n^*} \quad (4.14)$$

The superscript \* denotes the complex conjugate. At some buses, there can be both load and generation injections. In this case, the two injections are separated, and thus two admittances are computed for the buses in question. All these admittances have one end connected to one non-essential bus, and the other end grounded. These grounded ends are conceptually gathered into two common buses: one for all admittances coming from loads and one for those coming from generators. The second step is to create two new buses, the first one aggregating all productions and the second one aggregating all loads. The apparent power injections at these two buses are defined as the sum of the apparent power injections at all the non-essential buses they replace:

$$S_{g,tot} = \sum_{n=1}^{N_{g,a}} S_n \quad (4.15)$$

$$S_{d,tot} = \sum_{n=1}^{N_{d,a}} S_n \quad (4.16)$$

Where:

$N_{g,a}$  Total number of generator buses in area  $a$ .

$N_{d,a}$  Total number of demand buses in area  $a$ .

The injected currents from the two newly created buses must be, respectively:

$$I_{g,tot} = \sum_{n=1}^{N_{g,a}} I_n \quad (4.17)$$

$$I_{d,tot} = \sum_{n=1}^{N_{d,a}} I_n \quad (4.18)$$

In order for the currents to have these values, the voltages at the two new buses must be, respectively:

$$V_{g,tot} = \frac{S_{g,tot}}{I_{g,tot}^*} \quad (4.19)$$

$$V_{d,tot} = \frac{S_{d,tot}}{I_{d,tot}^*} \quad (4.20)$$

Finally, the new generation bus is connected to the common grounded end of the admittances from the non-essential generation buses through an admittance  $Y_{g,tot}$ , and the new load bus to the common grounded end of the admittances from the non-essential load buses through  $Y_{d,tot}$ . The currents  $I_{g,tot}$  and  $I_{d,tot}$  must flow through these admittances whose values must then be:

$$Y_{g,tot} = \frac{S_{g,tot}^*}{|V_{g,tot}|^2} \quad (4.21)$$

$$Y_{d,tot} = \frac{S_{d,tot}^*}{|V_{d,tot}|^2} \quad (4.22)$$

The zero power balance network is defined by the two new common ground buses with the admittances linking them to the non-essential buses, and the two new load and generation buses with the admittances linking them to the common ground buses. This network is lossless for the injections defined in the power flow used to build it. An example of the creation of a zero power balance network for an area with two border buses and three non-essential buses can be found in figures 4.2 and 4.3.

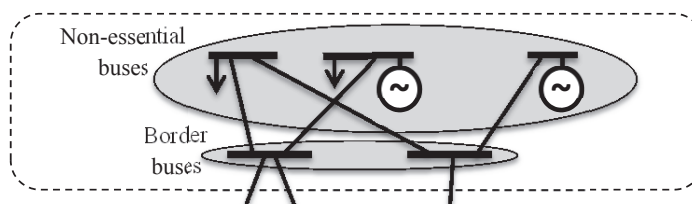

Figure 4.2: Original area system.

During the creation of the zero power balance network, the injections at the non-essential buses are aggregated and moved to the two new generation and load buses. Furthermore, there is no injection at the new common ground buses. Therefore, the non-essential buses and the ground buses can be eliminated by network reduction, leaving an equivalent network where only the border buses and the two newly created generation and load buses are retained. For the example in figure 4.3, the area after network reduction is illustrated in figure 4.4.

The reader who is interested in getting further details about the REI equivalents is referred to [62, 85, 102]. One important observation regarding the equivalent calculation is the conflict between its accuracy and its efficiency. If the original system is partitioned into a large number of areas, each area will contain fewer buses and the total number of border buses will be larger. As a result, fewer buses will disappear when computing the REI equivalents. The overall equivalent of the power system in question will therefore provide more accurate simulation results. In contrast, if the original system is partitioned into a small number of areas, it will lead to a smaller equivalent system and therefore a

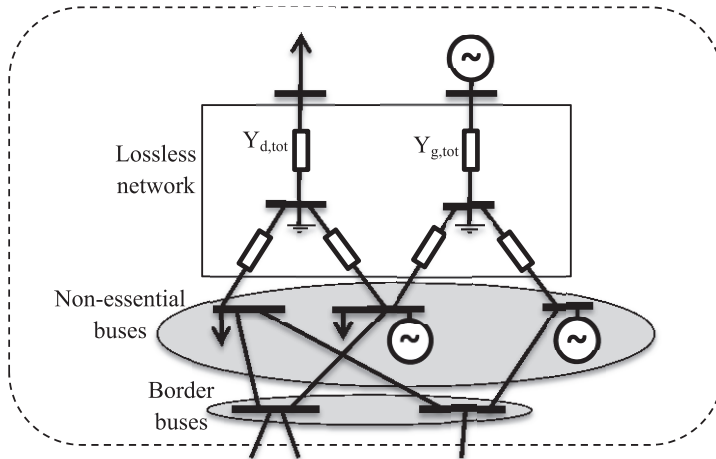

Figure 4.3: Zero power balance network.

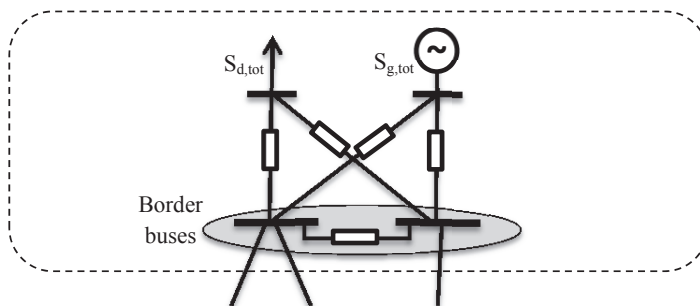

Figure 4.4: Area after network reduction.

lower computational burden when simulations are performed for this equivalent. Thus, the selection of the appropriate number of areas,  $a$ , and the appropriate size of the equivalent system depends on the desired accuracy and efficiency. The trade-off between these two factors should be considered when defining the suitable equivalent.

### Extended REI Equivalent

- **Considering uncertainty in the REI equivalent**

The REI equivalent presented in the previous section, called former REI in this study, does not consider the uncertainties in the statuses of the lines and generators, which may arise as outages in these components or fluctuations of wind generation. In our study, the REI equivalent has been extended to take such cases into account. To do so, the power flow results of a number of probable states of the system - instead

of only one - are used for replacing the generators and loads with corresponding admittances. Accordingly,  $V_i$ ,  $I_i$ , and  $S_i$  in equations (4.13) - (4.18) are replaced by the following values:

$$V_n = \sum_{k=1}^K p_k \times V_{n,k} \quad (4.23)$$

$$I_n = \sum_{k=1}^K p_k \times I_{n,k} \quad (4.24)$$

$$S_n = \sum_{k=1}^K p_k \times S_{n,k} \quad (4.25)$$

In the former REI equivalent, power flow results of one operating point are used to obtain the admittance values of the equivalent system, while following (4.23) - (4.25),  $K$  operating points of the original system are involved in obtaining the REI equivalent. These  $K$  operating points are obtained by sampling the probability distributions for the loads, wind power, and the outage rates of transmission lines and generators. The outage rates are supposed to be independent of the probability distributions of the loads and wind power. Let  $k$  be one of the  $K$  cases, and assume that the outage rate in this case is  $q_k$  while the outcomes of wind power and the loads occur with a joint probability equal to  $\pi_k$ . Then, the probability of this scenario is  $p_k = q_k \pi_k$ . The outcome of the outage rates determines the statuses of the lines and generators. A power flow is solved with these statuses and the outcomes of the loads and wind power, giving the values  $V_{i,k}$ ,  $I_{i,k}$  and  $S_{i,k}$  in equations (4.23) - (4.25). This improvement makes it possible to use the REI equivalent model not only for the base case of the system but also for all possible combinations of lines and generators. It should, however, be mentioned that for the system partitioning, it is assumed that a fixed admittance matrix is used, with all lines available, and line outages do not change the system partitioning. With this assumption, when updating the REI equivalent due to the unavailability of lines or generators, one does not need to change the topology of REI equivalent, but to adjust the admittance values in this extended REI equivalent.

- **Fine tuning the component properties in REI equivalent**

When the REI equivalents are computed for the areas, new intra-area lines with new admittances appear, with the transmission limits not clearly set. The common approach in multi-area modelling is to neglect the internal transmission constraints within the areas [61, 103]. Although such an approach may be reasonable, our method obviously increases the accuracy of the REI equivalent by taking into account the transmission limits of the intra-area lines of the reduced areas.

Moreover, in the former REI method, there is no mechanism for determining the voltage limits in new generator and load buses. These two issues are addressed in this

study via the following mechanism. Since power transfer between two neighbouring buses is a direct function of the admittance value between them (see (4.26)), the elements of the admittance matrix of the reduced equivalent system could be used to define the internal transmission limits in each area.

$$P_{n,m} = \text{Re} \{ V_n \times y_{n,m}^* \times V_m^* \} = f(y_{n,m}) \quad (4.26)$$

Where:

$P_{n,m}$  Transferred power from bus  $i$  to  $j$ .

$V_n$  Voltage phasor at bus  $n$ .

$y_{n,m}$  Admittance value between buses  $i$  and  $j$ .

For this purpose, an  $a \times a$  matrix, called  $M$  matrix, is introduced and its elements are multiplied by the admittances of the corresponding area to calculate the maximum line capacities in that area. For example, element (1,1) of this  $M$  matrix will be multiplied by the admittance values of each internal line in the first area to define the line limits of the area. Furthermore, element (1,2) of the  $M$  matrix can be similarly multiplied by the admittance values of the lines between the first and second areas to determine the limits of the lines between areas one and two. It is clear that this matrix should be in the order of  $a \times a$  and its off-diagonal elements are symmetric. The elements of this matrix as well as the voltage limits in generator and load buses can be considered as optimization variables and will be adjusted through a kind of optimization, namely adjusting optimization. The objective function and the constraints of this optimization are expressed in equations (4.27) - (4.33).

$$\min \sum_{k=1}^K P_k \times \left( w_T \times \left[ \sum_{i_1=1}^a \sum_{i_2=1}^a |OT_{i_1,i_2,k} - ET_{i_1,i_2,k}| \right] \right) \quad (4.27)$$

$$w_C \times |OC_k - EC_k| + w_L \times |OL_k - EL_k|$$

$$s.t. \quad OT_{i_1,i_2,k} = \sum_{\substack{n=1 \\ n \in i_1}}^N \sum_{\substack{m=1 \\ n \in i_2}}^N OP_{n,m,k}, \forall i_1, i_2, k, (i_1 \neq i_2) \quad (4.28)$$

$$ET_{i_1,i_2,k} = \sum_{\substack{n=1 \\ n \in i_1}}^N \sum_{\substack{m=1 \\ n \in i_2}}^N EP_{n,m,k}, \forall i_1, i_2, k, (i_1 \neq i_2) \quad (4.29)$$

$$OL_k = \sum_{n=1}^N (OP_{n,k}^g - OP_{n,k}^d) \quad (4.30)$$

$$EL_k = \sum_{n=1}^N (EP_{n,k}^g - EP_{n,k}^d) \quad (4.31)$$

$$\left\{ \begin{array}{l}
\min \quad OC_k = \sum_{n=1}^{N_g} [b_n \times OP_{n,k}^g] \quad (a) \\
s.t. \quad OP_{n,k}^g = OP_{n,k}^d + \text{Re} \left\{ V_{n,k} \times \sum_{m=1}^N y_{n,m}^* \times V_{m,k}^* \right\}, \forall n \quad (b) \\
\quad OQ_{n,k}^g = OQ_{n,k}^d + \text{Im} \left\{ V_{n,k} \times \sum_{m=1}^N y_{n,m}^* \times V_{m,k}^* \right\}, \forall n \quad (c) \\
\quad \sqrt{OP_{n,m,k}^2 + OQ_{n,m,k}^2} \leq OS_{n,m,max}, \forall n \quad (d) \\
\quad |V_n|_{\min} \leq |V_{n,k}| \leq |V_n|_{\max}, \forall n \quad (e) \\
\quad OP_{n,\min} \leq OP_{n,k}^g \leq OP_{n,\max}, \forall n \quad (f) \\
\quad OQ_{n,\min} \leq OQ_{n,k}^g \leq OQ_{n,\max}, \forall n \quad (g)
\end{array} \right\}, \forall k \quad (4.32)$$

$$\left\{ \begin{array}{l}
\min \quad EC_k = \sum_{n=1}^{N_g} [b_n \times EP_{n,k}^g] \quad (a) \\
s.t. \quad EP_{n,k}^g = EP_{n,k}^d + \text{Re} \left\{ V_{n,k} \times \sum_{m=1}^N y_{n,m}^* \times V_{m,k}^* \right\}, \forall n \quad (b) \\
\quad EQ_{n,k}^g = EQ_{n,k}^d + \text{Im} \left\{ V_{n,k} \times \sum_{m=1}^N y_{n,m}^* \times V_{m,k}^* \right\}, \forall n \quad (c) \\
\quad \sqrt{EP_{n,m,k}^2 + EQ_{n,m,k}^2} \leq ES_{n,m,max}, \forall n \quad (d) \\
\quad |V_n|_{\min} \leq |V_{n,k}| \leq |V_n|_{\max}, \forall n \quad (e) \\
\quad EP_{n,\min} \leq EP_{n,k}^g \leq EP_{n,\max}, \forall n \quad (f) \\
\quad EQ_{n,\min} \leq EQ_{n,k}^g \leq EQ_{n,\max}, \forall n \quad (g) \\
\quad ES_{n,m,max} = |y_{n,m}| \times \sum_{i_1=1}^a \sum_{i_2=1}^a [m_{i_1,i_2} \times A_{i_1,n} \times A_{i_2,m}], \forall n, m \quad (h) \\
\quad |V_{gd}|_{\min} \leq |V_{d,k}| \leq |V_{gd}|_{\max}, |V_{gd}|_{\min} \leq |V_{g,k}| \leq |V_{gd}|_{\max} \quad (i)
\end{array} \right\}, \forall k \quad (4.33)$$

Where:

$EC_k$  Operation cost of the equivalent system for contingency  $k$ .

$EP_{i,k}^d$  Demand of  $i$ -th bus of the equivalent system for contingency  $k$ .

$EP_{i,k}^g$  Active generation of  $i$ -th bus of the equivalent system for contingency  $k$ .

$EQ_{i,k}^g$  Reactive generation of  $i$ -th bus of the equivalent system for contingency  $k$ .

$ES_{i,j,max}$  Maximum apparent power transferred from bus  $i$  to  $j$  in equivalent system.

$EL_k$  Loss in the equivalent system for contingency  $k$ .

$EP_{i,j,k}$  Active transferred power from bus  $i$  to  $j$  for contingency  $k$  in equivalent system.

$EQ_{i,j,k}$  Reactive transferred power from bus  $i$  to  $j$  for contingency  $k$  in equivalent system.

$ET_{a1,a2,k}$  Total transferred power from area  $a1$  to  $a2$  for contingency  $k$  in equivalent system.

- $OC_k$  Operation cost of the original system for contingency  $k$ .
- $OP_{i,k}^d$  Demand of  $i$ -th bus of the original system for contingency  $k$ .
- $OP_{i,k}^g$  Active generation of  $i$ -th bus of the original system for contingency  $k$ .
- $OQ_{i,k}^g$  Reactive generation of  $i$ -th bus of the original system for contingency  $k$ .
- $OS_{i,j,max}$  Maximum apparent power transferred from bus  $i$  to  $j$  in original system.
- $OL_k$  Loss in the original system for contingency  $k$ .
- $OP_{i,j,k}$  Active transferred power from bus  $i$  to  $j$  for contingency  $k$  in original system.
- $OQ_{i,j,k}$  Reactive transferred power from bus  $i$  to  $j$  for contingency  $k$  in original system.
- $OT_{a1,a2,k}$  Total transferred power from area  $a1$  to  $a2$  for contingency  $k$  in original system.
- $w_C$  Cost weight factor used in adjusting optimization to set the accuracy of getting the same operation cost in original and equivalent systems.
- $w_L$  Loss weight factor used in adjusting optimization to set the accuracy of getting the same total losses in original and equivalent systems.
- $w_T$  Transmission weight factor used in adjusting optimization to set the accuracy of getting the same transferred power among areas in original and equivalent systems.

The objective function (4.27) is to calculate the weighted absolute deviation between the results of AC OPF in the original system and those in the equivalent system. The first term concerns the difference between the transferred powers among the areas, the second one shows the difference in operation costs, and the last one exhibits the difference between the losses in both systems. Three weighting factors can be used to normalize the objective function items. Constraints (4.28) and (4.29) define the transferred powers among the areas in the original and equivalent systems, respectively, while in (4.30) and (4.31) the same applies for system losses.

One essential point regarding adjusting optimization is that there are two internal optimizations as the constraints on this optimization. These internal optimizations are the AC OPF in the original and equivalent systems, as specified in (4.32) and (4.33), respectively. In these two internal optimizations, constraint (a) defines the objective function of AC OPF which is the sum of all generation costs and should be minimized. Equations (b) and (c) keep the active and reactive power balance at each bus. Equation (d) guarantees the line flow limit while (e), (f), and (g) check the limitations of the voltage magnitude, active power, and reactive power at each bus. It can be seen that the second internal optimization, equation (4.33), has two more constraints. Constraint (h) of equation (4.33) defines the maximum apparent power transferred from bus  $n$  to  $m$  in the equivalent system by multiplying the admittance value between these two buses by the element of the  $M$  matrix which corresponds

to the areas of these two buses,  $m_{i1,i2}$ . It should be noted that the elements of the  $M$  matrix and the maximum apparent powers are fixed parameters in the internal optimization, while being optimization variables in the external optimization. Likewise, in constraint (i) of equation (4.33), which controls the voltage magnitude in the new generator/demand buses, the maximum and minimum voltage magnitudes are fixed parameters in the internal optimization, and optimization variables in the external optimization.

• **A review of the advantages of the extended REI equivalent**

The advantages of the extended REI equivalent over the former REI equivalent can be summarized as follows:

- The parameters of the former REI equivalent are obtained based on one operating point of the original system, whereas various operating points are used in the extended REI equivalent. This allows the latter to consider variations in power generation and consumption as well as outages in transmission lines and generators.
- Unlike the former REI, the proposed method takes into account the intra-area transmission limits, and consequently increases the accuracy of the REI equivalent for estimating the behaviour of the original system.
- An adjusting optimization is introduced for defining the unknown parameters of the REI equivalent, such as the voltage limits of new generator and load buses. Thus, compared to the former REI equivalent, the extended REI equivalent can be better tuned so as to provide more accurate simulation results.

The whole procedure of the proposed method in this study can be summarized in three steps. First, the number of areas and the minimum number of buses per area were selected. The area borders were then defined through partitioning optimization. Finally, each area was modeled by the improved REI equivalent, and adjusting optimization was used to define the properties of the REI equivalent obtained.

### Simulation Results and Discussion

The suggested methodology was applied to two IEEE test systems to evaluate its effectiveness. Both the former and the extended REI equivalents were computed so as to assess the new extended REI equivalent. For simulation of partitioning optimization, solver CPLEX in GAMS software was used, while adjusting optimization was solved with the help of MATPOWER toolbox as well as some other minimization functions of MATLAB [53].

Since two important improvements have been introduced here (i.e. applying contingencies and tuning the properties), three systems were subsequently considered in simulations to examine the results of these improvements separately. Method 2 involves only the first improvement, which means the REI equivalent is obtained, taking into account possible contingencies, whereas no adjusting optimization being applied. Method 3 involves only the second improvement, using the adjusting optimization to obtain the REI equivalent,



while no contingency being considered. Method 4 considers both of these improvements at the same time. Finally, method 1 deals with the former REI equivalent and is applied to evaluate the three methods suggested above.

Detailed simulation results of all methods, including a) the considered load/wind scenarios, b) the simulation results of power network partitioning and adjusting optimization, and c) comparison of the simulation times of all methods are presented in Publication III. However, a summary of these results is give in the following.

Simulations results for all of the considered methods and for both case systems are summarized in Tables 4.2 and 4.3. These results include power transfers across areas, total operation costs, and total system losses. For each of these factors, the average values of the differences between the results of the proposed method and those of the original system in Monte Carlo scenarios are presented. Correlated sampling technique [104] is used for calculating the average differences. According to this technique, we first calculated the simulation results of the original system and of all REI equivalent systems, obtained by the four methods, for each Monte Carlo scenario. Next, we calculated the absolute values of the differences between the results of all the four equivalent systems and those of the original system for this special Monte Carlo scenario. Finally, the average of all these absolute values was computed for each outcome.

Table 4.2: Normalized difference between the results of the equivalent systems and those of the original system for the IEEE 30-bus system obtained by Monte Carlo simulation (%).

Variable	Method 1	Method 2	Method 3	Method 4
Power Transfer from area 1 to 2	14.87	2.71	2.84	2.23
Power Transfer from area 1 to 3	65.69	3.91	5.30	4.81
Power Transfer from area 2 to 3	58.65	11.93	11.66	7.94
Total Operation Cost	3.33	0.09	0.22	0.06
Total Loss in the System	12.29	4.37	10.42	2.60

Table 4.3: Normalized difference between the results of the equivalent systems and those of the original system for the IEEE 118-bus system obtained by Monte Carlo simulation (%).

Variable	Method 1	Method 2	Method 3	Method 4
Power Transfer from area 1 to 3	95.40	36.97	9.55	11.38
Power Transfer from area 2 to 3	11.71	3.13	7.59	7.29
Total Operation Cost	1.90	0.46	1.02	0.79
Total Loss in the System	12.07	7.99	5.50	3.75

To summarize, for the IEEE 30-bus system, method 4 gives the best REI equivalent for all outputs except power transfer between areas 1 and 3. This means that both improvements considered in the study result in a better equivalent for this system. The same can be said of the IEEE 118-bus system in terms of system losses. However, if total opera-

tion costs or power transfer is considered important, the results are different. Therefore, to choose among methods 2-4, one should prioritize the method which has the best result regarding the variable considered as the most important.

Although there is variation in terms of the accuracy of the different output variables, with the use of methods 2-4, they have all provided much better results than those produced by the former REI method. This means that both improvements proposed in this study provide better equivalent models for the original systems in terms of estimating system losses, operation costs, and power transfer across areas.

#### **4.4 An Improved Network Aggregation for Planning Power Systems with Correlated Wind and Loads**

##### **Motivation**

In this study, we propose an improved power system aggregation method for creating multi-area representations of power systems that yields more accurate estimates of the quantities required by planners when they need to consider enormous scenarios. To do so, similar to the previous studies, a large power system is first partitioned into areas. An equivalent for each partition is created. And, finally a complete equivalent for the original system is obtained. Nevertheless, an important difference between this study and the previous studies is that the mentioned process is repeated for each of several scenario groups that represent similar scenarios of renewable output, loads, and outages. Tailoring the equivalent for different conditions increases the fidelity of the approximation to the original full network, as we show in the case studies.

To summarize, the partitioning and equivalencing method proceeds as follows in this study. First, the large scale power system is divided into smaller areas based on a suitable partitioning criterion that accounts for renewable, load, and outage conditions. The criterion is based on available transfer capability (ATC) between each pair of buses. Next, the internal system of each area is replaced by a smaller equivalent. To create the equivalents, the border buses of each area are kept and the internal buses are eliminated by a network reduction method. Then, the whole reduced system is simulated, calculating the generator dispatch, power transferred among areas, electricity prices by area, total system losses, and total operations cost. The results of this simulation are then compared to a simulation of the original network in order to assess the accuracy of the obtained equivalent.

The contributions of our method relative to previous work [15,28,29,63,67,86] concern both power network partitioning and power network reduction (equivalencing). Regarding system partitioning, the first innovation of our method is that it does not require the user to prespecify certain information. It is unnecessary for the user to pre-define the partitioned areas (unlike [15,63,67]), as our procedure automatically optimizes the areas based, in part, on congestion patterns. Nor is the user required to pre-select contested lines (unlike [86] which iteratively uses expert judgment to choose congested lines to retain in the system prior to aggregating buses into areas), although, as we explain below, the user has the option of doing so. The second innovation regarding partitioning is the use of ATC as the criterion

for dividing the system into areas (unlike [28] and [29]). This allows both economic and technical aspects of the system to be considered. The third innovation is that our method uses an efficient and effective graph partitioning approach, spectral method [98], to analyze the ATCs and partition the system buses into subareas.

Turning to innovations regarding equivalencing of subsystems, they include the following. First, unlike previous studies that consider just one area at a time and create a network equivalent that consists of a detailed model of the area together with aggregations of neighboring areas, we obtain an equivalent subsystem for each of several areas and then create one equivalent for the whole system by joining the area equivalents. This allows us to study the interactive effects of areas on each other more accurately. The second innovation of our method is its differentiation of the aggregation by system load, wind, and/or equipment availability conditions, which affect ATC and thus the economic coupling of different areas. We do this by clustering hours with similar conditions and obtaining various scenario groups. By creating separate network reductions for each scenario group and modeling the original system with more than one equivalent system, more accurate simulation results are obtained.

### Problem Description

In this study, similar to the previous studies, the partitions are determined based on electrical and other characteristics and then an equivalent is obtained for each partition. However, this partitioning can be constrained by the user, for instance if the system operator is concerned with power transfers or potential lines between two particular areas of the system. In such cases, the partition can be constrained so that the areas of concern are preserved as separate areas; further, even particular buses or lines might be prohibited from being aggregated with others. An example of such a case is given in our case study, below.

Additionally, unlike the partitioning methods in [15, 28, 29, 63, 67] which consider one area at a time and simulate only generators and loads in the studied area while generators and loads in neighboring areas are modeled just with admittances and buses, our method, in contrast, models generation and loads in all areas simultaneously.

For the sake of network partitioning, Papaemmanouil and Andersson [28] argue that a combination of market- and system-based methods is the best approach to power system partitioning. We agree, and in order to reflect both of these aspects, we use ATC values between different buses as the partitioning criterion in the method of this study. ATC represents possible power transfers between buses and therefore is a function of the network's physical properties. However, network economics are strongly tied to ATC, because if the ATC between two buses is high, power transfers between them are facilitated, and therefore their electricity prices will tend to be similar.

We propose to use the ATC matrix, which includes the ATC value between every possible pair of buses, as the similarity matrix in spectral partitioning, an approach that has not been proposed previously for power system aggregation.

Figure 4.5 is a flow chart for our implementation of this partitioning algorithm. In addition, our overall procedure is shown in figure 4.6. This flowchart includes steps for identifying the scenario groups, calculating the ATC matrix for each scenario group, sys-

tem partitioning by the spectral method, and reducing the internal system of all obtained partitions for calculating the final equivalent.

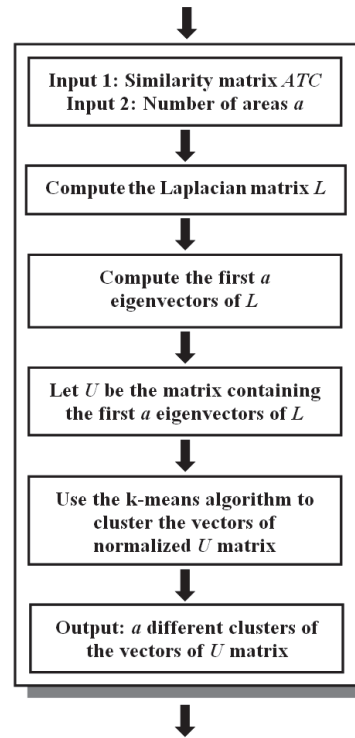

Figure 4.5: Flowchart for power system partitioning portion of the proposed aggregation method.

### Proposed Algorithm Description

The proposed overall aggregation method for making equivalents for large scale power systems, suitable for static power system studies, involves four steps as follows (figure 4.6).

- **Step 1: Group Scenarios**

Due to variability in power system loads, equipment availability, and renewable energy production, system planners often study hundreds or even thousands of load and production scenarios. In addition, since we obtain system equivalents using ATC which in turn depends on system conditions, the set of system scenarios should be divided into similar groups by clustering or other approaches. A distinct network aggregation can then be created for each group (Steps 2 - 4).

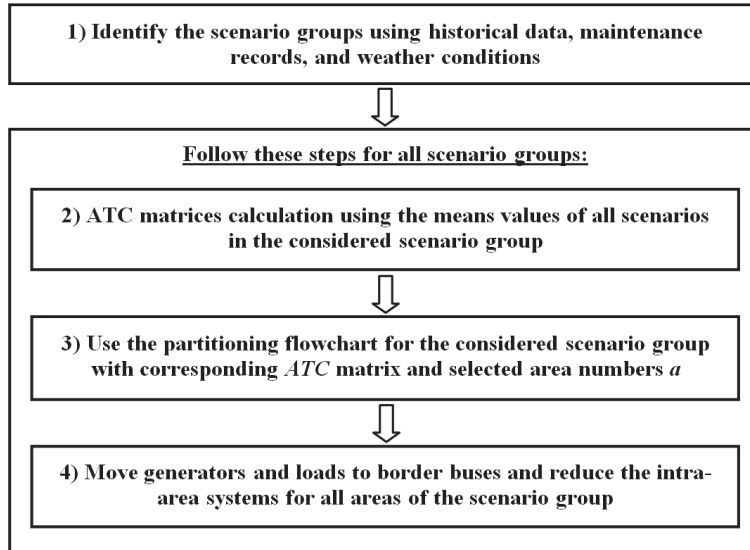

Figure 4.6: Complete flowchart of the proposed method for making equivalents for large power systems.

Historical load and wind data and maintenance records can be inputs to developing scenarios [32, 34, 105, 106]; experimental design methods can be used to define a set of scenarios that matches the statistical moments or other characteristics of past data [107, 108] or to reduce the required number of randomly generated scenarios [32, 33]. It is crucial, for instance, to consider relationships among wind outputs at different sites (e.g., based upon correlations of wind speeds), as well as among loads at different buses. In the case studies of this papersection, we consider past wind and load data over a study period and divide the study period into subperiods according to the level of load and wind production. Then the correlation coefficients among different loads and wind power generators are calculated within different subperiods. Finally, wind and load scenarios for each scenario group are generated based on the corresponding correlations [105, 109]. The number of scenario groups depends on the study period and the desired accuracy. The longer the study period or the greater the variability in system conditions, the greater the number of scenario groups that should be considered to attain the desired accuracy of network aggregation results.

An important observation regarding the scenarios in different scenario groups is that they are obtained based on the historical data of the system and are used by the method to partition the system and develop the equivalent systems. Then for each equivalent system, optimal power flows are solved using loads and renewable generation patterns that are similar to the patterns assumed in defining the equivalents. In order to obtain accuracy improvements from tailoring the equivalent system to

system load and variable generation conditions, it is necessary to assume that data used in the OPF calculations are comparable to the historical data.

• **Step 2: ATC matrices calculation: Group Scenarios**

After identifying the scenario groups, an expected ATC matrix is calculated for each group. One way to do this is to calculate the ATC matrix for each scenario in a group and calculate the probability-weighted average over the scenarios. But this calculation requires a significant effort, which conflicts with our goal of making the system analysis faster. So, instead of calculating the ATC for each scenario in the group, we suggest that only one ATC calculation be done for each group, using the mean load, wind, and perhaps equipment availability values within each scenario group. This limits the number of ATC matrices to be calculated to the number of scenario groups. The obtained ATC values between each of the pairs of buses for a group defines the ATC matrix to be used as that group's similarity matrix in the power system partitioning procedure of figure 4.5. Equation (4.34) is used to calculate the ATC between buses  $n$  and  $m$  in scenario group  $sg$  [110, 111].

$$ATC_{sg}(n, m) = TTC_{sg}(n, m) - TRM_{sg}(n, m) - CBM_{sg}(n, m) - ETC_{sg}(n, m), \forall sg, n, m \quad (4.34)$$

In (4.34),  $TTC$  stands for Total Transfer Capability, referring to the total power which can be transferred between two buses that causes no thermal overloads, voltage limit violations or voltage collapse.  $TRM$ , for Transmission Reliability Margin, is the amount of transfer capability reserved, accounting for the reliability of the transmission system.  $CBM$ , the Capacity Benefit Margin, is the amount of the transfer capability kept to ensure access to generation between interconnected systems, considering generation reliability requirements.  $ETC$  (from [111] and [112]) stands for existing transmission commitments which denotes the existing flows in MW. To make the ATC calculation easier, it is suggested in [112, 113] to approximate (4.34) with (4.35):

$$ATC_{sg}(n, m) \approx TTC_{sg}(n, m) - ETC_{sg}(n, m), \forall sg, n, m \quad (4.35)$$

The result of this step is an expected ATC matrix for each of the defined scenario groups.

The potential importance of extreme or worst case scenarios in planning can be reflected in the above procedure in two ways. First, it is possible to define scenario groups that include only extreme scenarios, or even to define a single extreme scenario of interest as a separate scenario group. This results in having some scenario groups with extreme mean values, which ensures that ATCs reflect those conditions. Second, although the conditional means for load and wind in each group are used for

ATC calculations, more extreme conditions (from among the scenarios in the group) would be considered in the OPF or other studies conducted using the equivalent system.

Security criteria can be readily considered when calculating the ATC matrix for each scenario group by constraining the network flows in the ATC calculation through direct imposition of an  $N - 1$  criterion, or by randomizing the availability of generators and line [111, 113]. However, for simplicity, security indices are not considered in the ATC calculations of this study and we only consider variations in winds and loads in those calculations.

- **Step 3: Partitioning the system for each scenario group: Group Scenarios**

In this step, the calculated ATC matrices are used as inputs to the power system partitioning procedure summarized by the flowchart of Fig. 1. In addition, for each scenario group, the number of areas  $a$  into which the system should be divided also needs to be defined. Selection of this number depends on both the desired accuracy and available computational capability. Accuracy is relevant because the higher the desired accuracy, the greater the number of areas should be selected, while the computational capability limits the number of areas that can be considered. If the original system is partitioned into a larger number of areas, each area will contain fewer buses and the total number of border buses will be larger. Therefore, fewer buses will be eliminated in the equivalent system and the equivalent should provide more accurate simulation results. On the other hand, a larger equivalent system will impose more computational burden in the simulations. Thus, there is a trade-off between the desired accuracy and computational effort when selecting the appropriate number of areas  $a$ .

- **Step 4: Reducing intra-area systems and obtaining the final equivalent**

After the areas for a particular scenario group ( $sg$ ) are defined, the next step is to reduce the internal system of each area to a smaller set of (near) equivalent buses. To do so, all the buses in each area are divided into two sub-sets: essential and non-essential buses. The essential buses are predefined by the user and include all border buses and critical buses that the user has a particular interest in and wishes to preserve, while all other buses go to non-essential group. A critical bus might be selected because flows on one or more of its lines might be of concern (for instance, to monitor flows and exchanges between two areas of interest, or because a line might be added to that bus). Then, in order to reduce the intra-area system as much as possible, the generators and loads in non-essential buses are each allocated to their closest border bus, defined as the border bus to which it has the strongest electric connection based on the admittance matrix of intra-area system. For instance, this means that for each non-essential generator bus, the border bus in its area that has the highest connecting admittance to the generator's bus is identified and the generator is moved to that border bus.

A network reduction method is then used for each area and eliminates all non-border buses by updating the admittance matrix elements of that intra-area system as follows [15,28].

$$Y_{Original} = \begin{pmatrix} Y_{E,E} & Y_{E,N} \\ Y_{N,E} & Y_{N,N} \end{pmatrix} \quad (4.36)$$

$$Y_{Reduced} = \begin{pmatrix} Y_{E,E} - Y_{E,N}Y_{N,N}^{-1}Y_{N,E} \end{pmatrix} \quad (4.37)$$

The  $Y_{E,E}$  and  $Y_{N,N}$  represent the parts of admittance matrix of the original system including the essential and non-essential buses, respectively. The  $Y_{E,N}$  (and  $Y_{N,E}$ ) also includes the connecting admittances among the essential and non-essential buses.

By removing the non-essential buses in all areas, only the essential buses remain in each area. So, the number of the total remaining buses across all areas depends both on the number of areas to which the whole system is divided as well as the number of essential border buses in each area. The final obtained system is used as the equivalent for the original large scale power system in static studies.

### Simulation Results and Discussion

To evaluate the proposed method, the IEEE 118-bus test system and Polish 3120-bus power system are aggregated below and the quality of the resulting production cost estimates are assessed relative to the original network. Historical data from the Swedish system are used to generate simulated wind power time series for these test systems [114]. Simulations are done using the MATLAB R2010a software.

Three cases are considered for each of the two systems, each involving a different method. Their results are then compared to the original, full network.

- **Case 1: Admittance-based fixed partitions**

This case is based on [68], in which the admittance matrix is used as the similarity matrix when partitioning the system.

- **Case 2: ATC-based fixed partitions**

The proposed ATC matrix-based method here is applied to the test systems but all the system scenarios are contained in a single scenario group ( $SG = 1$ ).

- **Case 3: ATC-based changing partitions**

This case divides the system scenarios into three scenario groups ( $SG = 3$ ), and one equivalent system is obtained for each group based on the ATC matrix of that group.

Thus, the first two cases each yield one network reduction apiece, while the third case yields three reductions. Comparing the three cases allows us to explore the impact of partition method on the accuracy of results, as well as the effect of tailoring the aggregation to subgroups of scenarios.



For all three cases, we simulate production costs, prices, load flows, and losses for the equivalent systems. We then compare those results with those for the original network to assess the error resulting from aggregation. The detailed simulation results of this study can be found in Publication IV, however, a review on this results in given here.

As an example of the results, figure 4.7 shows the best partitions of the IEEE test case for the first two scenario groups of Case 3 (ATC-based changing partitions). They are very different because the ATC matrices resulting from Step 2 differ greatly.

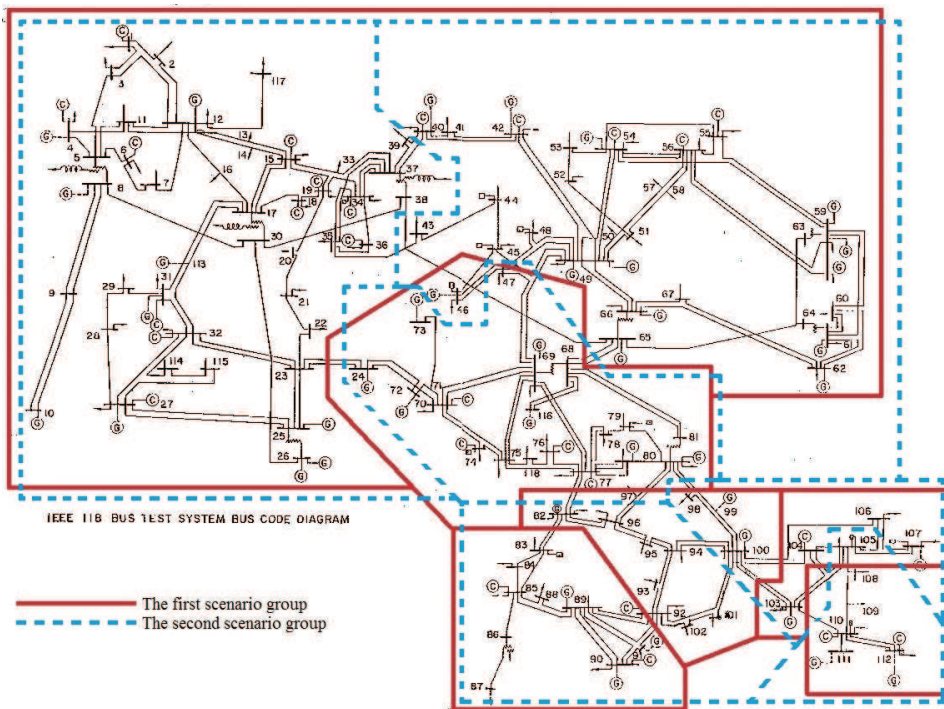

Figure 4.7: The best partitioning for Case 3 (ATC based changing partitions), the first and second scenario groups, area number  $a = 6$ .

The obtained equivalents for the three cases are tested to assess their accuracy relative to the original unaggregated net-work for both the IEEE test and Polish systems. In this comparison, we use an AC optimal power flow (OPF) to simulate both the original and equivalent systems for each of the sampled 150 hours. Based on those results, we calculate the normalized error resulting from the approximation, expressed as the average (absolute value) percentage of the original (unaggregated network) values. Tables 4.4 and 4.5 show the normalized error for the three cases for the IEEE 118-bus system and Polish 3120-bus system, respectively.

It can be seen from these tables that methods based on admittance and ATC-matrices

Table 4.4: normalized error in the results of equivalent systems obtained for IEEE 118-bus system using different partition methods.

Case number	Total operation cost of the system (%)	Total losses of the system (%)	Average inter-area transferred power (%)	Bus electricity prices (%)	Reduction in OPF solution time (%)
Case 1	0.64	12.07	52.43	3.71	9.4
Case 2	0.58	11.82	18.54	2.18	6.7
Case 3	0.31	4.75	2.20	0.56	1.2

Table 4.5: normalized error in the results of equivalent systems obtained for Polish 3120-bus system using different partition methods.

Case number	Total operation cost of the system (%)	Total losses of the system (%)	Average inter-area transferred power (%)	Bus electricity prices (%)	Reduction in OPF solution time (%)
Case 1	0.06	13.67	64.28	1.39	92.4
Case 2	0.53	27.12	29.78	8.44	91.5
Case 3	0.02	0.26	8.97	0.34	90.8

with fixed partitions (Cases 1, 2) yield different results. For the IEEE 118 bus system, using ATC-based fixed partitions (Case 2) gives much better results, especially for power transfers. But for the Polish system, the admittance-based method (Case 1) is more accurate in most cases, particularly for total cost and prices. However, for both systems, Case 3 is most accurate: using ATC-matrices with changing partitions reduces errors by up to an order of magnitude or more relative to Cases 1 and 2. This can be due to very different power flows in different scenario groups, which results in distinct system partitions among the scenario groups. This effect can clearly be seen in figure 4.7 where the areas change considerably between scenario groups 1 and 2.

To compare the computational speed of the three simulation approaches, the last column of Tables 4.4 and 4.5 shows the percent reduction in simulation time of the equivalent systems compared to AC OPF for the original system. This reduction is net of the time required to obtain the equivalent network, which is greater for the ATC method because of the need to obtain pairwise ATC values to populate the ATC matrix. But for large systems, this disadvantage of the ATC methods is negligible because the improvements in OPF solution times dwarf the times needed to obtain the reduced system. This is most evident for the large, Polish system, where computation times were reduced by more than 90%; for the 118 bus IEEE network, however, time savings were small, indicating that the effort required to reduce the network in that case is difficult to justify.

To conclude, the examples showed that whether (1) admittance-based or (2) ATC-based partitioning (same for all scenarios) is better depends on the system. However, (3) ATC-based partitioning with different partitions for different scenario groups yielded large reductions in errors for network flows, production costs, nodal prices, and resistance losses. This is because the congestion patterns for different sets of net load conditions can differ tremendously. These results imply that system partitioning should be differentiated by system condition, and that ATC-based partitioning can result in large improvements in es-

*4.4. AN IMPROVED NETWORK AGGREGATION FOR PLANNING POWER SYSTEMS WITH CORRELATED WIND AND LOADS*

71

estimates of system behavior while significantly lowering computation times relative to the original network.



## Chapter 5

# Contributions to the Generation Aggregation

*This chapter discusses the performed study of this thesis on the topic of generation aggregation by reviewing the analysis completed in this area.*

Regarding the generation aggregation, we have focused on the aggregation of renewable energy resources in this thesis, rather than the conventional generation. An important analysis is considered in the area of renewable energy aggregation. This study considers the total wind power calculation and suggests an algorithm for approximating the total wind power production of some wind power units with correlated wind speeds. This analysis is summarized in the following.

### 5.1 Simulation of Total Wind Power Production

#### Background

Nowadays, wind power is considered as an important option for electricity generation in many power systems and any power system study needs to take this type of production into account when designing the future system. However, modeling the wind power production is more challenging than other power plants since it depends on wind speed and, therefore, includes more uncertainties. This means that when compared to the thermal power generations, wind power has not the possibility of storing and controllability which result in more challenges for modeling it. In addition, in many power system simulations like Monte Carlo study, many random scenarios should be generated for the production of all system power plants and in case of wind power plants, different wind speed correlation among various sites should be considered in generating random scenarios for wind power production and only few measurements cannot be directly used when future wind power will be spread out over larger areas. So, to be able to estimate the wind power production variability as precisely as possible, wind speed distribution for all wind units as well as the correlation coefficients among them should be clearly known.

One important application of having such estimation of the total wind power production for some wind power units is power system reliability analyses and in particular multi-area reliability calculations. The concept of multi-area reliability was investigated by Pereira in [61] and especially by Singh in [103, 115–118]. According to these papers, different power production levels and their probability distribution for each generator should be known and considered in reliability indices calculation. In case of wind generation, not only the wind speed probability distributions but also the correlation coefficients among all wind power units should be known to obtain the probabilistic distribution of total wind power production. This issue is more challenging in multi-area reliability simulation because in addition to considering the wind correlation inside each area, wind correlations among different areas should also be considered in obtaining the probability distribution for total wind power production of each area.

It should be mentioned that like other natural phenomena, at least, two types of correlation can be defined for the wind speed, called temporal and spatial correlation [119–122]. The temporal correlation defines the coherency between the values of a wind speed at an especial wind site in different time moments. In contrast, the spatial correlation describes the relationship among wind speeds at different wind sites [122]. In this study, we have only focused on spatial correlation and the time-series based correlations are not of interest while the method can be further developed to include the temporal correlations also in future works.

Different issues related to wind power production are considered in many papers and reports, previously. For instance, wind speed forecasting and probability distributions, used for wind speed modeling, are introduced in [123] and [124]. Based on these references, there are various distribution functions which can be used for wind speed approximation though Rayleigh and Weibull distributions are the usual distribution functions, used for wind speed simulations. According to [123], selecting one model for wind speed depends on the application and, therefore, different models give different results for various wind power studies.

Some techniques for generating correlated Rayleigh and correlated Weibull random numbers are presented in [125–127]. These techniques, which mostly generate correlated random numbers for the communication theory purposes, show that, unlike the Normal distribution, it is not so easy to generate correlated random numbers based on Rayleigh and Weibull distributions. This difficulty is due to complicated mathematical and programming processes, required for simulating mentioned algorithms in these papers.

In [128] and [129], the impacts of wind power production modeling on power system operational analysis like economic dispatch and thermal generation unit commitment are investigated. The former has used the estimated Weibull distributions for wind speed simulation while in the latter, historical data of 18 locations in Netherland are used for modeling the wind power production.

In [130–133], wind power modeling, suitable for reliability studies, is described. It is emphasized in [130] that, firstly, finding suitable wind speed model is very important to obtain the wind power production model for wind power unit in reliability evaluation. And, secondly, there is a need for a significant amount of historical data and effort to do this wind speed simulation and to develop a realistic wind speed model for a geographic

site. The wind speed, in a one year period, is modeled by a multiple-states Markov process in [132]. But, because of the large number of wind speed states in an annual time series, K-means clustering technique is used to classify the wind speed states and decrease the numbers of model situations.

According to the literature, wind power production modeling as well as evaluation of its impacts on power system studies cannot thoroughly be performed unless wind speed behavior is truly simulated. In addition, although it seems that wind power production modeling and its impacts on different power system studies are adequately discussed in the literature study, the lack of a simple and straightforward method for simulating the correlated wind power units is highly felt. This means that if wind power production impacts on power system studies want to be acceptably analyzed, it should be easily possible to generate simulation scenarios for correlated wind power productions. Furthermore, since the wind power production correlation is resulted from wind speed correlation, a simple algorithm, simpler than the ones introduced in [125–127], should be proposed for correlated wind speed modeling. However, as it was mentioned above, wind speed distribution is usually simulated by either Rayleigh or Weibull distributions, for both of which it is not easy to generate correlated random numbers based on some predefined correlation coefficients.

In this section, total wind power production of correlated wind power units is approximated by a simple but exact algorithm. To do so, first, wind speed distribution function of each unit is approximated by a normal distribution function rather than Rayleigh or Weibull distributions. The mean value and standard deviation of this normal function will be determined such that wind power production of this unit, calculated by sampling the obtained normal distribution for wind speed and applying this normal distribution to wind power curve, becomes as close as possible to the original wind power production of this special unit, computed by historical data. By finishing the first step, each wind power unit has one normal distribution for its wind speed, which gives approximately the same wind power production as historical data for that unit. The next step is finding the correlation coefficients among wind speeds of all units and calculating the total wind power production. In this study, it is suggested to consider the correlation coefficients among computed normal wind speeds equal to correlation coefficients among wind power productions, calculated based on historical data. By this consideration, it is possible to calculate the total wind power production of all units. Once total wind power production is calculated by simulating the proposed algorithm, it should be compared to the total wind power production, computed by historical data, to illustrate the algorithm effectiveness.

Also, the wind speed correlation coefficient versus distance curve will be plotted, as an additional testing survey, and compared with the results of similar studies like [134–137] to clarify the accuracy of the considered assumptions of proposed algorithm for modeling the wind power unit behavior.

The difference between total wind power production, simulated using the method proposed in this section, and the one obtained in previous studies like [130–133] is that here, historical wind power productions rather than historical wind speeds, which are often available in power systems records, are used for calculating total wind power production. Also, there is no need to use the Markov model for enumerating all possible combined statuses of wind power turbines for obtaining the production probability distribution of all wind

sites. And finally, unlike the introduced algorithm in some of these papers, which should have some assumptions for the correlations among wind speeds, the correlations among wind power productions are used here, which make more sense from the accuracy and obtainability viewpoints.

### Overview of the Proposed Algorithm

To simulate the wind power production, the wind power curve, which determines the produced wind power versus wind speed and is shown in figure 5.1, can be used [138]. To be able to use this curve for calculation of wind power production, wind speed distribution for all wind power units and wind farms should be known. These wind speed distributions can be obtained based on historical data. However, calculating wind speed distribution based on historical data is not so easy since historical data usually include generated wind power rather than wind speed. This means that the number of measurement tools and resources on wind power production, measured in MW, is much more than wind speed measurements and resources, measured in m/s, from both quantity and availability viewpoints [114, 139–142].

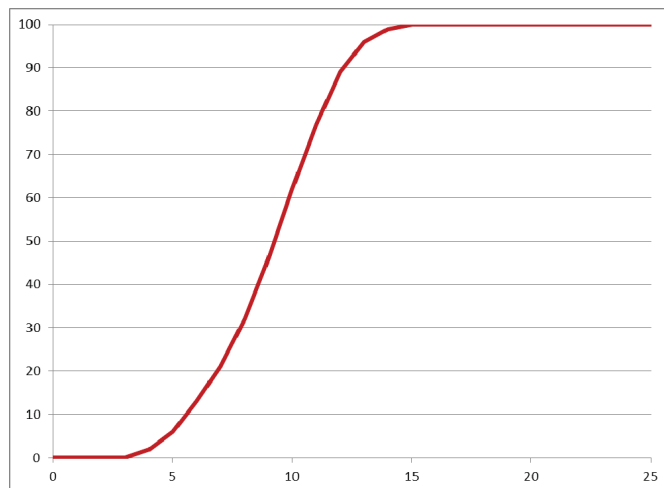

Figure 5.1: Wind power curve which determines the produced wind power in percent versus the wind speed in m/s.

The more important problem arises from the need for simulating correlated wind power production, which is the case in reality. The real produced power of wind units come from correlated wind speeds and the generated scenarios for simulating wind power production should also be calculated based on correlated wind speed scenarios. Nevertheless, as it can be seen in figure 5.2 and equations 5.1 and 5.2, wind speed distributions are usually approximated either by Rayleigh distribution or Weibull distribution [123] and defining correlation coefficient for these distributions and generating correlated wind speed scenarios



based on these two distributions can be a very complicated and tricky task to do [125–127]. Equations 5.1 and 5.2 describe the mathematic formulations of Rayleigh and Weibull distributions, respectively:

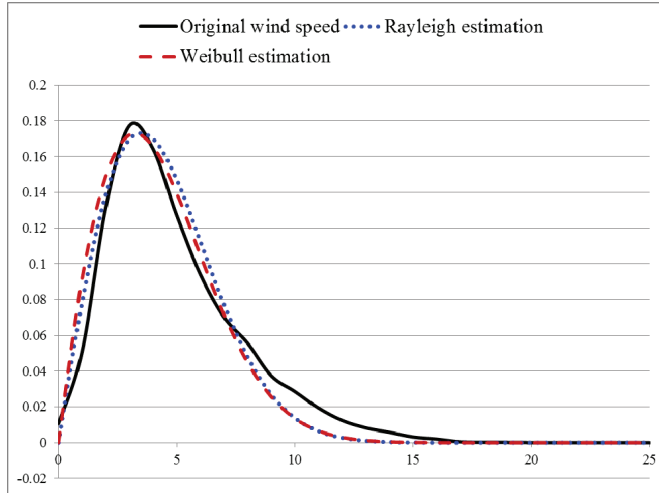

Figure 5.2: Approximating the wind speed distribution by Rayleigh distribution and Weibull distribution.

$$f_{\text{Rayleigh}}(ws) = \frac{\pi}{2} \frac{ws}{ws_{\text{mean}}^2} \exp \left[ -\frac{\pi}{4} \left( \frac{ws}{ws_{\text{mean}}} \right)^2 \right] \quad (5.1)$$

$$f_{\text{Weibull}}(ws) = \frac{k}{A} \left( \frac{ws}{A} \right)^{k-1} \exp \left[ -\left( \frac{ws}{A} \right)^k \right] \quad (5.2)$$

Where:

- $ws$  Wind speed value over the time.
- $ws_{\text{mean}}$  Mean value of wind speed.
- $k$  Shape parameter of Weibull distribution.
- $A$  Scale parameter of Weibull distribution.

Approximating the wind speeds of different sites with some normal distributions and generating correlated wind speed scenarios using these normal distributions is introduced in this chapter as another but much easier solution which will be discussed in following.

In this method, it is assumed that the historical data of wind power production for some units as well as wind power curve for all of these units are available. First, the expected value and variance of produced wind power is calculated for each unit using historical data. Then, for each unit, the corresponding wind speed is estimated by a normal distribution.

The mean value and standard deviation of this normal distribution is determined through an optimization such that the expected value and variance of produced power, obtained by simulating considered normal distribution, are as close as possible to the calculated expected value and variance, obtained by historical data, for that unit. After finishing this step, one normal distribution is found for the wind speed of each wind unit. Generating some sample scenarios for wind power production of each unit and apply them to this normal distribution, the probability density function (PDF) of wind speed and amount of production for that unit can be simulated. However, if total wind power production of all units is needed, the correlation coefficients among all of these normal distributions should be known.

It should be noted that produced power for each wind unit is directly related to the wind speed of that unit; so, it is suggested in this thesis to consider the correlation coefficients among wind power productions as correlation coefficients among wind speed distributions. This means that the correlation coefficients among wind power productions are calculated from historical data and used for generating correlated wind speed scenarios. Figure 5.3 demonstrates the complete flowchart of the proposed algorithm used in this section.

### Proposed Algorithm Formulation

It was mentioned in the previous part of this section that the mean value and standard deviation of normal distribution function which approximates the wind speed distribution of each unit is determined through an optimization. This optimization is presented in the following equations. The letter O in these equations stands for the word original which refers to obtained variables based on historical data. Letter S, on the other hand, is stands for the word simulated and refers to variables which are calculated by sampling the considered normal distribution for the wind speed of each unit.

$$\min_{wsmu, wssd} \left[ (opmu - spmu)^2 + (opvr - spvr)^2 \right] \quad (5.3)$$

$$s.t. \quad spmu = \sum_{p=0}^P q(p) \cdot p \quad (5.4)$$

$$spvr = \sum_{p=0}^P q(p) \cdot (spmu - p)^2 \quad (5.5)$$

$$q(ws) = \frac{1}{wssd\sqrt{2\pi}} \exp^{-\frac{(ws-wsmu)^2}{2wssd^2}}, \forall ws \quad (5.6)$$

$$q(p) = \sum_{\substack{ws=0 \\ wpc(ws)=p}}^{WS} q(ws), \forall p \quad (5.7)$$

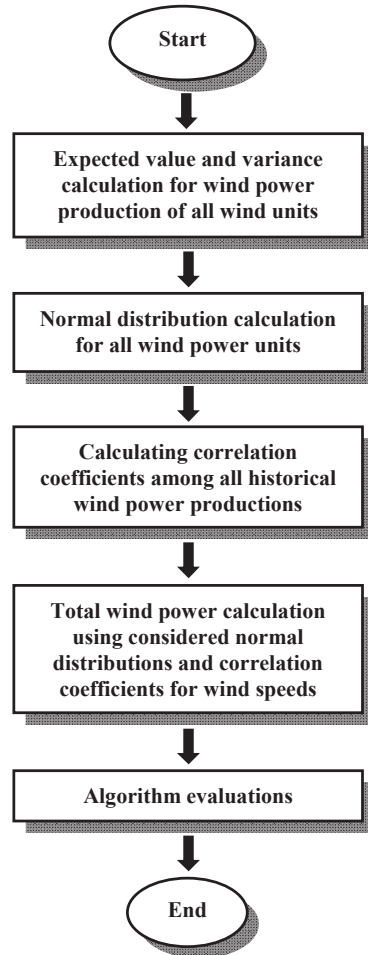

Figure 5.3: The complete flowchart of the proposed algorithm used for for estimating the wind speeds with normal distributions and using correlation coefficients among historical wind power productions for these normal distributions for wind power production simulation.

Where:

- $opmu$  Mean value of original wind power production.
- $spmu$  Mean value of simulated wind power production.
- $opvr$  Variance of original wind power production.
- $spvr$  Variance of simulated wind power production.
- $p$  Power production of the unit which varies from 0 to  $P$ .

$q(p)$	Probability of producing $p$ (MW) by the unit.
$P$	Maximum wind power production of the unit.
$ws$	Wind speed value which varies from 0 to $WS$ .
$WS$	Maximum value of wind speed for the unit.
$wsmu$	Mean value of considered normal distribution function for wind.
$wssd$	Standard deviation of considered normal distribution function for wind.
$q(ws)$	Probability of wind speed equal to $ws$ (m/s).
$wpc(ws)$	Produced power based on wind power curve when wind speed is equal to $ws$ (m/s).

The objective function 5.3 is the sum of squared differences between the expected value and variances of original wind power production, obtained from historical data, and the expected value and variance of simulated wind power production, obtained from using considered normal distribution function for wind speed in wind power curve.

Constraints 5.4 and 5.5 define the expected value and variance for the simulated wind power production while wind speed probability and production probability are given in 5.6 and 5.7, respectively. According to 5.6, the wind speed probability is obtained by a normal distribution function; and  $wsmu$  and  $wssd$  are the corresponding mean value and standard deviation of this normal distribution function.

### Proposed Algorithm Evaluation

The proposed algorithm, presented in the previous sub-section, estimates the wind speed of each wind turbine with a normal distribution function and also suggests considering the correlation coefficients among these functions equal to correlation coefficients among wind power productions. However, these considered assumptions should be somehow evaluated to reveal the algorithm effectiveness. To do so, two different surveys are performed. The first one is to calculate the PDF for whole produced wind power while the second one is to calculate the wind speed correlation based on distance.

The PDF can be calculated either from the historical data or by using the considered normal distribution functions for wind speed and correlation coefficients among them. The former is done by adding the historic production of all units for each hour and computing the PDF of historic aggregated production. The latter, on the other hand, can be performed by sampling the computed normal distributions for wind speed of all units, calculating the corresponding produced powers by wind power curve for all sampled wind speeds, adding produced powers of all units for each hour, and, finally, computing PDF for sampled aggregated production. The difference between these two PDFs shows the accuracy of algorithm for correlated wind power simulation.

Calculating the wind speed correlation versus distance and comparing it with the result of other references is considered as another measure of accuracy in this study. To do so, the location distances among all studied units are calculated and sorted. According to these sorted distances, the corresponding correlation coefficients among wind speeds, which were considered equal to correlation coefficients among produced wind powers, are sorted as well. Then, the obtained correlation versus distance curve can be compared with other similar research.

The results of applying all of the above evaluating studies on a test case are presented in the next sub-section.

## Simulation Results and Discussion

### Proposed Algorithm Implementation Results

Data of Swedish wind power plants from 1992 to 2002 are used to simulate the proposed algorithm in this thesis [114]. To do so, these wind power plants are divided into four areas according to Nord pool spot market divisions, figure 5.4. Five units are selected from each area to test the algorithm. Equations 5.3 - 5.7 are applied to each of these units to calculate the mean value and standard deviation of the estimated normal distribution function for wind speed of that unit. Table 5.1 gives the results of this application for the selected five units in the first area. In this table, WPP and OND are abbreviated for wind power production and obtained normal distribution, respectively.

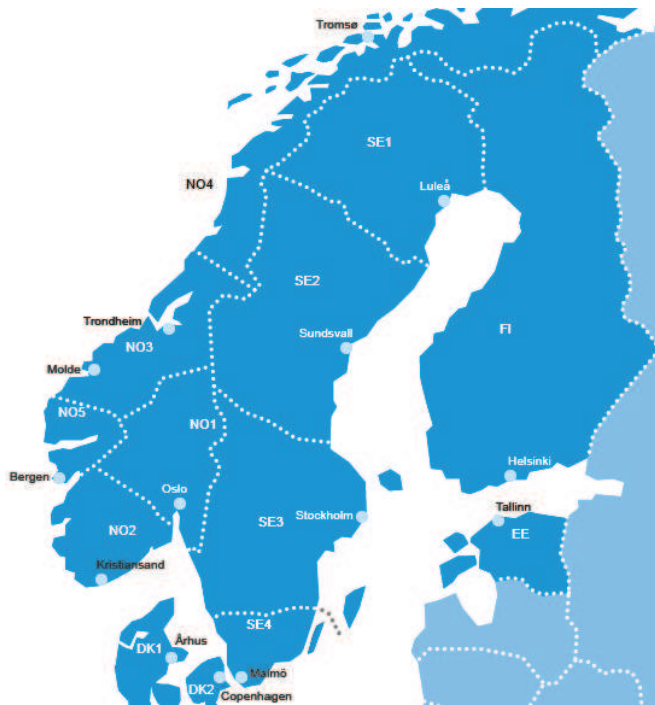

Figure 5.4: Four Sweden electricity areas according to Nord pool spot market [143].

### Proposed Algorithm Evaluation Results

In this part, approximating wind speeds with normal distributions and considering wind speeds correlations equal to correlations among produced powers is evaluated. To do so, total produced power in each area is calculated twice; once by sampling the computed

Table 5.1: Results of implementing equations 5.3 - 5.7 to the five wind power units in the first area for estimating the wind speed of each unit with a normal distribution function.

Variable	Unit1	Unit2	Unit3	Unit4	Unit5
Mean value for the OND (m/s)	6.94	6.48	6.09	6.77	5.92
Standard deviation for the OND	3.89	3.96	4.18	3.93	4.72
Expected value for the historical WPP (MW)	9435.07	2829.58	1348.06	3030.95	1242.86
Variance of the historical WPP	10814353.50	1163056.74	300441.14	1190519.67	253722.73
Expected value for the simulated WPP (MW)	9435.07	2829.50	1348.08	3031.01	1242.86
Variance of the simulated WPP	10814347.10	1163121.10	300435.29	1190544.55	253724.44

normal distribution for wind speed and once again based on the historical data. The result is shown in figure 5.5.

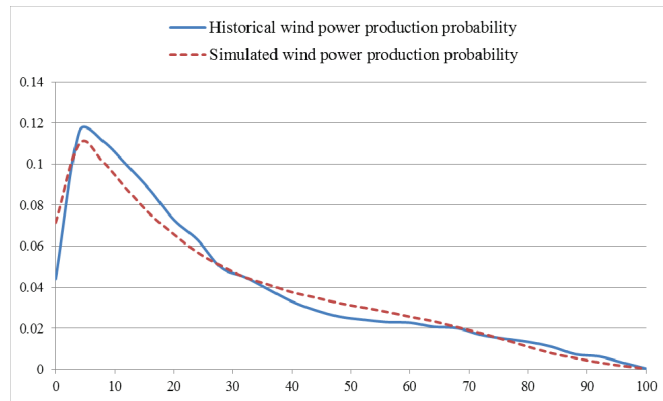

Figure 5.5: Probability distribution functions for historical and simulated wind power productions of all 20 wind power units.

By comparing the simulated total wind power production and original wind power production in this figure it can be seen that the obtained normal distribution function for wind speeds and considered correlation coefficients among them have resulted in a very good results and these two curves have at most only 5% difference. Therefore, using the proposed algorithm for produced wind power simulation not only makes wind power analyzes much easier, but also it provides an adequate accuracy in the obtained results.

On the other hand, it was mentioned earlier that the correlation versus distance curve is depicted and compared with the similar studies as another testing survey for the proposed algorithm. Since 20 wind power units are involved in simulations, there are totally 190 possible bilateral correlations among them. Figure 5.6 shows these correlation coefficients based on their corresponding distances as well as their fitted curve.

For the sake of evaluating the obtained curve for wind correlation versus distance, this curve is compared with some similar results from other studies [134–137]. Comparing this

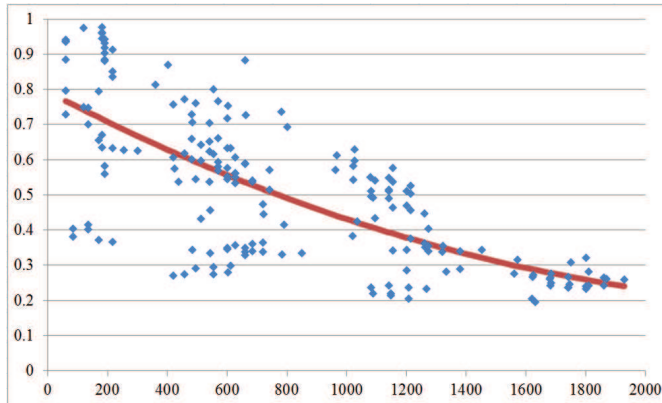

Figure 5.6: Correlation coefficients of wind power generation among all 20 wind power units based on their corresponding distances in km as well as the fitted curve.

curve with, e.g., figure 5.7 from [134], clarifies the good accuracy of considered assumption regarding wind speed correlation coefficients.

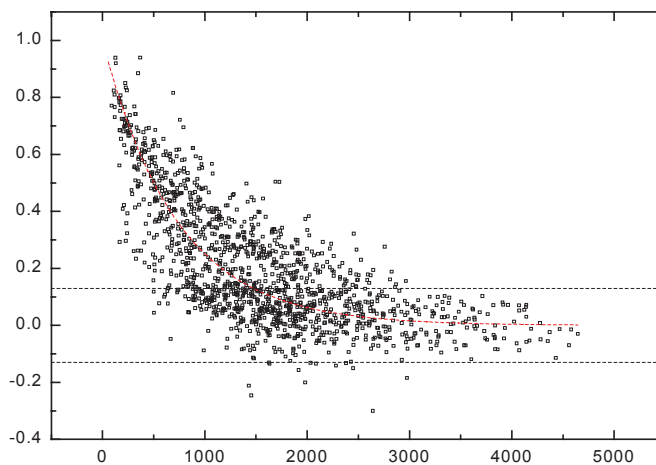

Figure 5.7: Correlation coefficients of wind speed among different wind sites based on their corresponding distances in km as well as the fitted curve.

Another interesting point regarding the obtained fitted curve for wind correlation versus distance is that not only it can be used for calculating the correlation coefficients among wind speed at different sites, but it may also be used for estimating the correlations among total wind power production of different areas. To check this issue, the correlation coefficients among total wind power production of four Swedish areas at each year of the

considered 10-year period as well as the fitted curve obtained by correlation coefficients among all 20 wind power units in figure 5.6 are plotted and compared in figure 5.8. Since six possible correlations can be obtained among four areas and for each of these possible correlations 10 different years are studied, totally 60 correlations versus distance blue points exist in figure 5.8. In this figure, the distance between two areas is calculated as the average distances among each pair of wind power units in these two areas.

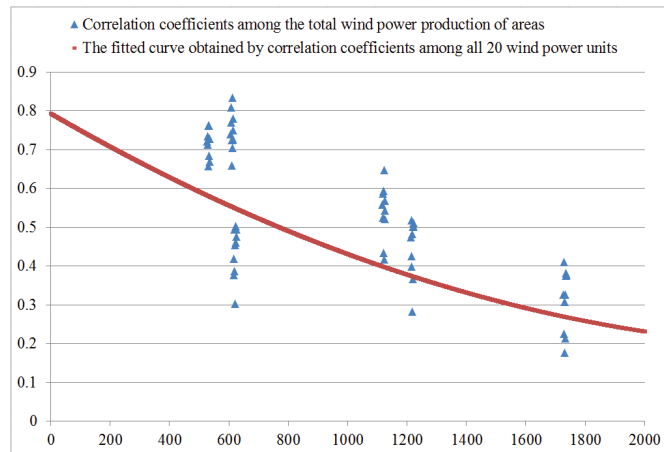

Figure 5.8: Comparing the correlation coefficients among the total wind power production of areas and the fitted curve obtained in figure 5.6.

One important advantage of this estimation is that in order to study the total wind power production in different areas, there is no need to simulate all the wind power units and calculate the correlation coefficient among them.



## **Part II**

# **Power System Reduction Application**



## Chapter 6

# Applications of the Network Aggregation

*Two important applications of the network aggregation are studied in this chapter. The considered problems, to which the network aggregation is applied, are a) Frequency control through spinning reserve provision, and b) Storage allocation.*

Network aggregation can be used for many purposes such as releasing the complexity of the problem, reducing the amount of uncertainties, and compensating the data unavailability. Due to these reasons, network aggregation may be applied to different power system studies, specially the ones which suffer from high complexity, high uncertainty, and data unavailability. Two important example of such power system studies are considered in this chapter and application of network aggregation on them is investigated. The first study, for which the network aggregation is used, is frequency control via the spinning reserve determination, while the second one is storage allocation. These studies are separately discussed in the following sections.

### 6.1 Frequency Control

#### Background

According to NERC, security, as a part of reliability, refers to the ability of the power system to withstand unexpected disturbances [144]. By this definition, it is not possible to maintain system security unless there are sufficient spinning reserves. Calculating the amount of spinning reserve needed in a power system is, however, a challenging task. This section focuses on spinning reserve calculation in multi-area power systems.

Different methods for determining spinning reserve requirements have been proposed in previous studies. For example, [145] describes an offline cost-benefit method, which is based on the cost of reserve provision and the benefit derived from its availability to determine the required spinning reserve. In [146], Loss Of Load Probability (LOLP) is used in a hybrid deterministic-probabilistic approach to set the optimal amount of reserve.

A fixed amount of reserve is imposed by some market operators on the basis of operator experience [147]. Some other markets use the deterministic methods, based on N-x criterion [148]. Reference [149] employs probabilistic indices. The combined deterministic-probabilistic method and the cost-benefit method are utilized to determine the reserve value in [150] and [151], respectively. In the use of these methods mentioned above, however, there is a tradeoff between accuracy and computational complexity. This means that, on the one hand, some of these methods, such as the experimental ones, do not require great computational capacity, and thus give fast results, which are, nevertheless, not based on accurate analyses. On the other hand, those involving systematic procedures may provide more reliable results, but they require complicated mathematic calculations. The cost-benefit method, for instance, solves a mathematical optimization problem at the expense of high computational complexity, which in turn may jeopardize the efficiency of the method when it is applied to large power systems.

It is also questionable whether the cost-benefit method is applicable to a large multi-area power system which comprises a number of large sub-systems (control areas). In the multi-area system, each control area has a system operator which is responsible for controlling its own power grid and power transfers to the other areas, while a central coordinator organizes all system operators [18], e.g. European Network of Transmission System Operators for Electricity (ENTSO-E) in Regional Group Continental Europe. In such a multi-area system, it is economically efficient to determine the spinning reserve requirements that consider the coordination of all control areas. To do so, all the areas of the original multi-area system should be simulated simultaneously, which leads to high computational complexity.

To test the efficiency of the cost-benefit method, we carried out a Security Constrained Unit Commitment (SCUC)-based cost-benefit analysis to calculate the reserve value for the IEEE 30-bus system. In this analysis, only 12 scenarios were considered, and the simulation was run over a 24-hour time period. The test was done on a PC which has processor Intel Core i5 CPU with 4 GB RAM. Simulation of this small system took around 7 hours. In addition, it was not possible to test this method on the IEEE 118-bus system using the same PC. The results of the test highlight the challenges of determining spinning reserve requirements in large multi-area systems with a great number of scenarios.

In this section, we propose a solution to the problems associated with the cost-benefit method through obtaining an equivalent model of the multi-area power system in question, which can be used to accurately estimate the reserve value in the original system. For the sake of network aggregation, following steps are considered. First, since the purpose of this study to suggest a solution method for reserve calculation in large multi-area systems, it is assumed that the partitions are pre-determined and, therefore, no network partitioning is performed in this study. In order to obtain the equivalent system for each partition, as the second of network aggregation, the REI method is used in this study [8, 15, 85, 101, 152, 153]. This means that unlike the previous studies which use one equivalent for the whole system, we keep the border buses between areas and obtain one equivalent for each of the areas in the multi-area power system. Then, we use the developed multi-area REI equivalent system to estimate the amount of spinning reserve required by the original system.

To summarize, the main contributions of this study are as follows. First, power system equivalents are applied to decrease the complexity and computational burden involved in determining spinning reserve in large multi-area systems. Second, a multi-area REI equivalent is obtained for the original multi-area power system. Last but not least, the proposed multi-area REI equivalent is utilized to approximate the total amount of spinning reserve required by the original multi-area system as a whole and the amount needed by each of the areas within the system.

### Proposed Method Description

This study presents a cost-benefit analysis that takes into consideration Security Constrained Unit Commitment (SCUC) and Security Constrained Economic Dispatch (SCED) in order to determine the spinning reserve required by a multi-area power system. Accordingly, the objective function of the cost-benefit method used in this study considers the cost of the power system both in its normal state of operation (where all components of the multi-area power system are available) and under various contingencies.

The objective function and constraints of reserve calculation by SCUC-based cost-benefit analyses can be formulated as follows:

$$\min \left\{ \begin{array}{l} \sum_{t=1}^T \sum_{i=1}^N [\pi_n \cdot C_n(t, i) + \sum_{k=1}^K \pi_k \cdot C_k(t, i, k)] \\ + \sum_{t=1}^T \sum_{i=1}^N \sum_{k=1}^K [\pi_k \cdot ENS_k(t, i, k) \cdot VOLL(t, i)] \\ + \sum_{t=1}^T \sum_{i=1}^N [C_{su}(t, i) + C_{sd}(t, i)] \end{array} \right\} \quad (6.1)$$

$$s.t. \quad ENS_k(t, i, k) = D_n(t, i) - D_k(t, i, k), \forall k, t, i \quad (6.2)$$

$$P_k(t, i, k) = P_n(t, i) + R_k(t, i, k), \forall k, t, i \quad (6.3)$$

$$P_n(t, i) = D_n(t, i) + \sum_{l=1}^{L_i} [P_n(t, l)], \forall t, i \quad (6.4)$$

$$P_k(t, i, k) = D_k(t, i, k) + \sum_{l=1}^{L_i} [P_k(t, l, k)] + ENS_k(t, i, k), \forall k, t, i \quad (6.5)$$

$$\underline{P}(i) \cdot u(t, i) \leq P_n(t, i) \leq \overline{P}(i) \cdot u(t, i), \forall t, i \quad (6.6)$$

$$\underline{P}(i) \cdot u(t, i) \leq P_k(t, i, k) \leq \overline{P}(i) \cdot u(t, i), \forall k, t, i \quad (6.7)$$

$$P_n(t, l) \leq \bar{P}(l), \forall t, l \quad (6.8)$$

$$P_k(t, l, k) \leq \bar{P}(l), \forall k, t, l \quad (6.9)$$

$$C_n(t, i) = a(i) \cdot P_n(t, i) + b(i), \forall t, i \quad (6.10)$$

$$C_k(t, i, k) = a(i) \cdot P_k(t, i, k) + b(i), \forall k, t, i \quad (6.11)$$

$$C_{su}(t, i) = su(t, i) \cdot suc(i), \forall t, i \quad (6.12)$$

$$C_{sd}(t, i) = sd(t, i) \cdot sdc(i), \forall t, i \quad (6.13)$$

$$su(t, i) - sd(t, i) = u(t, i) - u(t-1, i), \forall t, i \quad (6.14)$$

$$\sum_{h=t-T_{max}^{on}(i)}^t u(h, i) \leq T_{max}^{on}(i), \forall t, i \quad (6.15)$$

$$\sum_{h=t-T_{min}^{on}(i)+1}^t su(h, i) \leq u(t, i), \forall t, i \quad (6.16)$$

$$\sum_{h=t-T_{max}^{off}(i)}^t u(h, i) \geq 0, \forall t, i \quad (6.17)$$

$$\sum_{h=t-T_{min}^{off}(i)+1}^t sd(h, i) \leq 1 - u(t, i), \forall t, i \quad (6.18)$$

Where:

$C_n(t,i)$	Generation operation cost in time $t$ and in bus $i$ for normal state of system.
$C_k(t,i,k)$	Generation operation cost in time $t$ and in bus $i$ for contingency $k$ .
$C_{sd}(t,i)$	Shut-down cost in time $t$ and in bus $i$ .
$C_{su}(t,i)$	Start-up cost in time $t$ and in bus $i$ .
$D_k(t,i,k)$	Demand value in time $t$ and in bus $i$ for contingency $k$ .
$D_n(t,i)$	Demand value in time $t$ and in bus $i$ for normal state of system.
$ENS_k(t,i,k)$	Energy not supplied in time $t$ and in bus $i$ for contingency $k$ .
$P_k(t,l,k)$	Transferred power in time $t$ and in line $l$ for contingency $k$ .
$P_n(t,l)$	Transferred power in time $t$ and in line $l$ for normal state of system.
$P_k(t,i,k)$	Generated power in time $t$ and in bus $i$ for contingency $k$ .
$P_n(t,i)$	Generated power in time $t$ and in bus $i$ for normal state of system.
$R_k(t,i,k)$	Generated reserve in time $t$ and in bus $i$ for contingency $k$ .
$S_i$	Apparent power in load bus $i$ .
$S_j$	Apparent power in generation bus $j$ .
$u(t,i)$	Binary variable equal to 1 if generator of bus $i$ in time $t$ is on and 0 otherwise.
$sd(t,i)$	Binary variable equal to 1 if generator of bus $i$ has a shut-down in time $t$ and 0 otherwise.
$su(t,i)$	Binary variable equal to 1 if generator of bus $i$ has a start-up in time $t$ and 0 otherwise.
$a(t,i)$	Coefficient of squared power for generator of bus $i$ .
$b(t,i)$	Coefficient of power for generator of bus $i$ .
$\pi_k$	Probability of contingency $k$ .
$\pi_n$	Probability of normal state of system.
$sd_c(i)$	Shut-down cost for generator of bus $i$ .
$su_c(i)$	Start-up cost for generator of bus $i$ .
$T_{\max}^{\text{on}}(i)$	Maximum on time for generator of bus $i$ .
$T_{\min}^{\text{on}}(i)$	Minimum on time for generator of bus $i$ .
$T_{\max}^{\text{off}}(i)$	Maximum off time for generator of bus $i$ .
$T_{\min}^{\text{off}}(i)$	Minimum off time for generator of bus $i$ .
$VOLL(t,i)$	Value of lost load in time $t$ and in bus $i$ .

The objective function 6.1 represents the sum of system costs under normal and contingency operations plus the cost of load disconnection. The first term is the operation cost of the power system in its normal state multiplied by the probability of this state plus the sum of system operation costs under different contingencies weighted by their corresponding probabilities. The second term represents the value of disconnected load by the sum of expected energy not supplied, multiplied by the corresponding value of lost load. The last term corresponds to the start-up and shut-down costs of the SCUC.

Constraints 6.2 and 6.3 specify the calculation of ENS and spinning reserve, respectively. 6.4 and 6.5 present power balance equations at all buses under normal and contingency situations. Constraints 6.6 and 6.7 ensure that if a generator is running, it runs within the minimum and maximum limits of power output under normal and contingency operations. Constraints 6.8 and 6.9 limit the  $l$ -th line flow, and constraints 6.10) and 6.11 provide linear definitions for the operation cost of the system in different conditions.

Start-up and shut-down costs are given in 6.12 and 6.13. Equation 6.14 defines variables related to system start-up and shut-down [154]. Finally, 6.15 and 6.16 guarantee the maximum and minimum on-time for each generator, while constraints 6.17 and 6.18 ensure the maximum and minimum off-time.

The SCED-based cost-benefit method for calculating the spinning reserve is similar to the SCUC-based one; the only difference between the two is that all constraints and terms related to on/off states of generators that are considered in the latter are absent in the former. The formulation of reserve determination using cost-benefit analyses considering SCED is as follows:

$$\min \left\{ \begin{array}{l} \sum_{t=1}^T \sum_{i=1}^N [\pi_n \cdot C_n(t, i) + \sum_{k=1}^K \pi_k \cdot C_k(t, i, k)] \\ + \sum_{t=1}^T \sum_{i=1}^N \sum_{k=1}^K [\pi_k \cdot ENS_k(t, i, k) \cdot VOLL(t, i)] \end{array} \right\} \quad (6.19)$$

$$s.t. \quad 6.2 - 6.5, 6.8 - 6.11$$

$$\underline{P}(i) \leq P_n(t, i) \leq \overline{P}(i), \forall t, i \quad (6.20)$$

$$\underline{P}(i) \leq P_k(t, i, k) \leq \overline{P}(i), \forall k, t, i \quad (6.21)$$

SCUC differs from SCED in that the former is used for long time period frames and the latter for short-time periods. In addition, SCED provides Local Marginal Prices (LMPs) using the dual variables, which are not considered by SCUC [148]. The reason is that the problem solved by formulations 6.1 - 6.18 is dealt with as a mixed integer programming (MIP) and prices in electricity markets, which are given by the dual variables associated with the optimization problem (in SCUC), are not provided by any MIP solvers since it is not easy to define the dual formulation for a MIP problem.

### Multi-Area REI Equivalent

This section proposes to use a multi-area REI equivalent to approximate the spinning reserve required by each of the areas which the original multi-area system comprises. To obtain such a multi-area REI equivalent, the REI method is first used to produce an equivalent of each area, and the border buses between areas are kept intact. All the equivalents thus obtained are then connected to form a multi-area REI equivalent.

### Simulation Results and Discussion

The proposed multi-area REI equivalent is applied to two IEEE test systems to determine the spinning reserve requirements by the SCUC- and SCED-based cost-benefit method. To do so, the REI equivalent is used to obtain an equivalent for each of the areas in these two systems and the multi-area REI equivalent corresponded to each IEEE system is obtained.



Next, the cost-benefit method is used to calculate the spinning reserve requirements in both the original and equivalent power systems. Finally, the obtained reserve values for all the areas in the original system are compared to those in the equivalent system to examine whether the equivalent system should have similar behavior as that of the original system. The SCUC-based cost-benefit method is tested on the IEEE 30-bus system and the SCED-based one on the IEEE 118-bus system. As it was mentioned earlier, in this study, we do not consider the network partitioning step and different areas of the original multi-area power system are assumed as the partitions. Nevertheless, for the case studies, it is assumed that the IEEE test systems are multi-area systems with three areas, whereas in realistic multi-area power systems, the area boundaries are known.

Detailed simulation results of our study including the territory containing all the areas under consideration for the two test systems, obtained multi-area REI equivalents, and computed spinning reserve in original and equivalent multi-area systems can be found in Publication V. However, a summary of the results is provided below.

Figures 6.1 and 6.2 present the total amount of reserve required by the IEEE 30- and 118-bus systems, respectively, at each time interval.

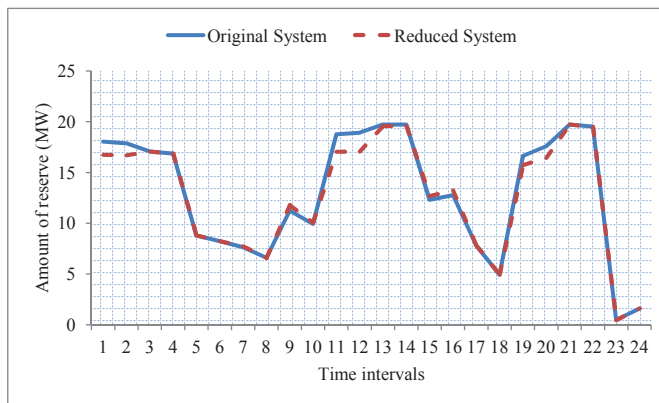

Figure 6.1: Reserve amount in IEEE 30-bus test system.

It is clear from the results of both test systems that the equivalent systems can accurately estimate the amount of reserve requirements in the original systems. However, in order to examine the accuracy of the algorithm for calculating the spinning reserve needed in each area, the results of one area from each test system are presented in figures 6.3 and 6.4.

According to the results, it is clear that for each area under study, the equivalent system provides results close to those of the original system. In the IEEE 30-bus system, the error rate in estimating the reserve value needed in one area is similar to that required by the whole system. Nevertheless, in the case of the IEEE 118-bus system, the error rate in one area is higher than that in the whole system.

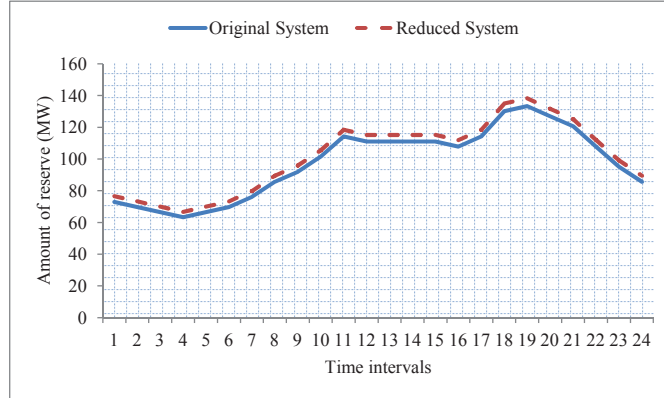

Figure 6.2: Reserve amount in IEEE 118-bus test system.

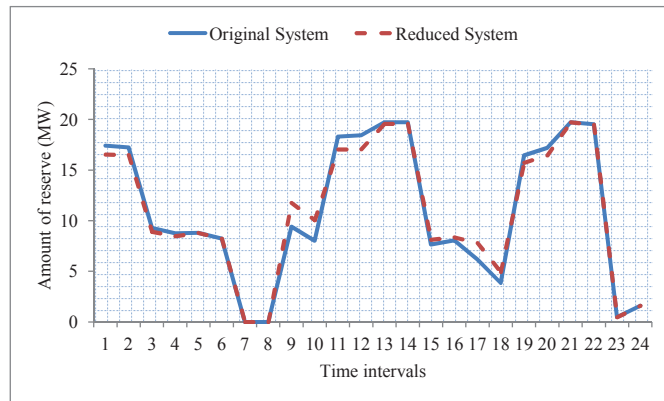

Figure 6.3: Reserve amount in area 3 of IEEE 30-bus test system.

To conclude, one can see that not only does the use of power system equivalents decrease the complexity and computational burden in simulation, but it also estimates the amount of reserve requirements in the original system with reasonable accuracy.

Regarding the simulation time needed for calculating the reserve, it should be noted that applying the equivalents on the IEEE 30-bus system by the SCUC-based cost-benefit method has reduced the simulation time by around 65%. The simulation time is reduced by around 33% for the IEEE 118-bus system with the use of the SCED-based cost-benefit method. Therefore, even in a small system such as the IEEE 30-bus system, which is replaced by a 15-bus equivalent, the simulation time has been considerable reduced. In other words, it is efficient to use equivalents for reserve calculation by the SCUC-based cost-benefit method. Likewise, the reduction in the simulation time needed for the IEEE

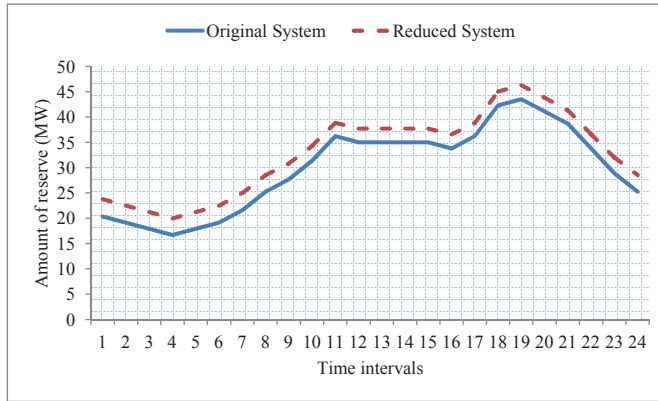

Figure 6.4: Reserve amount in area 3 of IEEE 118-bus test system.

118-bus system shows that it is also desirable to use the equivalent system for reserve calculation by the SCED-based cost-benefit method. It should be noted that the ratio between the number of buses in the multi-area REI equivalent and original multi-area system decreases as the size of the original system increases. For instance, this ratio is around 0.5 and 0.19 for the IEEE 30- and 118-bus systems, respectively. Therefore, it may be more valuable to apply the proposed method to larger multi-area power systems such as the realistic ones, given that it reduces the simulation time more significantly.

## 6.2 Storage Allocation

This section provides an approach for reducing the computational complexity of an OPF based storage allocation problem. In this regard, the network aggregation method explained earlier in chapter 4 is used to simplify the OPF based storage allocation problem.

### Background

Optimal Power Flow (OPF) plays an important role in power system planning and operations. It is used for determining operating parameters, such as bus voltages as well as real and reactive power flows, such that an objective function like total system losses or generation costs are minimized. One important application of OPF which has recently been studied in e.g. [155–159] is energy storage scheduling and allocation. This application can help maintain the power balance against uncertainty in demand and generation variation caused by the addition of renewable energy [156, 157]. However, including energy storage in OPF increases the complexity of the OPF problem by adding the dimension of time to the optimization.

Nevertheless, even the basic OPF problem is nonlinear and non-convex, thus direct applications of nonlinear optimization methods provide no guarantee that the obtained so-

lution is the global optimum [160, 161]. Sub-optimal solutions can lead to higher costs and inefficiency in power system operations. There has been great deal of research into different solution techniques for the OPF problem. Linear approximations, for example, use operational knowledge and mathematical approximations to linearize the OPF problem. The most common linear approximation is the DC OPF, which assumes that the voltage angle differences between different buses in the network are small, the lines are lossless (i.e. their resistances are negligible) and that the voltage magnitudes are constant (usually 1 p.u.) [48]. On the other hand, heuristic algorithms, such as branch and bound algorithms (B&B) seek the global optimal solution of OPF by partitioning the search space of the problem [37]. Some other heuristic methods like decomposition techniques use the structure of the problem to subdivide it into some simpler sub-problems [40]. Convex relaxations, such as Second-Order-Cone Relaxations (SOCR) or Semi-Definite Relaxations (SDR) [65, 162–165] approximate the original OPF problem by relaxing the problem search space to a larger convex space that is known to have a globally optimal solution, under some technical conditions [164]. However, the global optimum of this relaxed problem does not necessarily lie in the solution space of the original OPF problem. Sufficient conditions for the relaxed problems to have the same solution as the original problem (i.e. for the relaxation to be exact) are described in [165]. The SDR and SOCR have recently been shown to be equivalent [166]. These relaxations are exact for a number of different network topologies including all of the IEEE benchmark examples [165, 167–169].

One important challenge to the wide spread application of the SDR approach to solve the OPF problem is that semi-definite programming (SDP) algorithms can be computationally intensive [170]. Thus, solving SDPs for large systems over multiple time steps will require decomposition algorithms or other fast solution methods such as those discussed in e.g. [171, 172].

SDP based approaches have been generalized to solve the AC OPF with storage problem [155] and to determine optimal allocation of storage in the network [173]. However, this application adds to the computational requirements because it requires an optimization both over the network and a time horizon.

This section provides an alternative approach for reducing the computational complexity of an OPF based storage allocation problem. Rather than using a distributed algorithm to solve the OPF with storage problem, as is proposed in [171, 172] for the static OPF problem, we instead propose using a system reduction technique. The storage allocation problem is particularly amenable to system reduction because in many situations there is a small set of candidate buses for locating the energy storage resources in a large system. Thus, it is not necessary to consider the rest of the system buses in the allocation problem and a technique that allows merging the rest of the system buses to the candidate buses and evaluating this reduced system may prove valuable.

The proposed procedure involves a three-stage algorithm, where we first reduce the original large system to a smaller equivalent system. In the second stage, this equivalent system is solved using an SDP. Finally, the solution obtained for the equivalent system is transferred to the original system using a set of repeating optimizations for all of the merged buses. In each of these optimizations, one of the merged buses is replaced by its original network and the storage assigned to this merged bus is distributed over this

network.

### Proposed Method Description

Detailed description and formulation of the proposed three-stage algorithm used to solve the OPF based storage allocation problem discussed above is presented in Publication VI. Nevertheless, this sub-section summarizes these three stages as follows.

- **Stage 1: Power System Reduction** The system reduction that comprises the first stage of the three-stage algorithm proposed herein requires a suitable partitioning criterion and an associated algorithm. In what follows, we provide a short description of the criterion and algorithm.

The first step in partitioning the system is finding a functional relation among the system buses. This relationship can be represented by a so-called similarity matrix which shows the strength of connection between each pair of the system buses. This similarity matrix can be obtained based on static, dynamic, or economic aspects of the power system [28]. In this study, we select two static similarity matrices because they consider not only the generation and consumption at each bus but also the underlying structure of the power network. The network structure is particularly important for power system allocation problems. The considered similarity matrices are the admittance matrix and available flow capacity for all system lines.

- **Stage 2: The Storage Allocation Problem** OPF based storage scheduling and allocation throughout the network has been previously addressed in studies such as [155–157, 173]. Unlike the typical OPF problem, the OPF with storage problem requires a simulation over a time period. In the second stage of the proposed algorithm, the AC OPF with storage problem is considered and solved for the equivalent system by applying an SDR to the non-convex problem, in order to guarantee a global optimal solution of the problem.
- **Stage 3: Transferring the Solution of Equivalent System to the Original System** The third stage of the proposed three-stage algorithm obtains the storage allocation solution for the original problem from that of the equivalent system. The procedure involves a set of repeating optimizations whereby the merged buses are replaced with their original systems one at a time and then combined with the remainder of the reduced system. At each step, the storage allocation optimization is repeated to obtain a solution that distributes the storage capacity of the merged bus over its disaggregated. Thus, the number of repeating optimizations needed to obtain the storage allocation for the original system is limited to the number of merged buses in the equivalent system.

The proposed three-stage algorithm can be applied as follows. Suppose that a system has 100 buses and its reduced equivalent system has five merged buses, each made up of 20 buses from the original system. The second stage of the algorithm solves the storage

allocation problem for the 5 bus reduced system. The solution to the original system is obtained by performing, five repeating optimizations for each 24 bus system resulting from replacing the each merged bus with its original 20 bus system. Therefore, instead of having one SDP with 100 buses and 24 time steps, the algorithm leads to six smaller optimization problems. Although the number of SDPs that need to be solved is increased to six in this example, the total computation time is much less. In addition, it may be impossible to solve the SDP for original 100 bus system with a large number of time periods. These advantages will be made more concrete in the case studies described in the next section.

### Simulation Results and Discussion

In this part, the proposed three-stage algorithm is evaluated. All the simulations are performed using MATLAB 2010a using the YALMIP toolbox with the SDP solver SeDuMi of [174, 175]. The computational speeds are based on a PC with an Intel Core i5 CPU 2.53 GHz processor and 4.00 GB of RAM.

Detailed simulation results of our study including accuracy evaluation of the power system reduction step as well as application of the full three-stage algorithm to the storage allocation problem in two IEEE test systems are given in Publication VI. Nevertheless, simulation results of two buses of the IEEE 30-bus system are chosen as examples to illustrate the results; the results at other buses show similar agreement. Figures ?? and ?? compare the storage flow and storage level at buses 29 and 30 of the IEEE 30-bus system obtained after applying the three-stage algorithm to the values computed from solving the full system using both the AC and DC OPF formulations.

These figures show that the AC OPF based storage allocation in the equivalent system (represented by the dashed red line) provides closer results to the ones of AC OPF based storage allocation in the original system (represented by the solid blue line) in compare with the results of DC OPF based storage allocation in the original system (represented by the dotted green line). Thus, more accurate simulation results are achieved when using the three-stage algorithm than with the DC OPF formulation.

Regarding the simulation time, both the DC approximation and the three-stage algorithm can significantly reduce the computational burden of OPF based storage allocation. However, the computational time reduction achieved using the DC formulation is much higher than that obtained by the three-stage algorithm. For instance, the simulation time for the three-stage algorithm applied to the IEEE 30 bus system is around 140 seconds while the simulation time of the original is 3126 seconds and 5 seconds for the AC and DC OPF formulations, respectively.

To summarize the simulation results, it should be noted that implementing the proposed algorithm provides more accurate results than using the DC formulation while the latter results in a higher reduction in the simulation time. Thus, there is tradeoff between the accuracy and computational time that one has to make in deciding between the approaches.

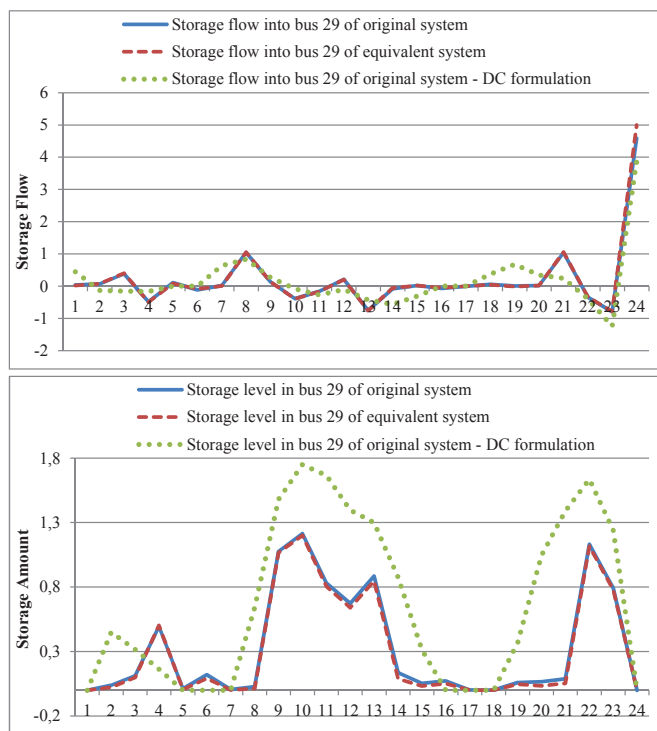

Figure 6.5: The final storage flow and final storage levels at bus 29 of the IEEE 30 bus test network and the corresponding equivalent system.

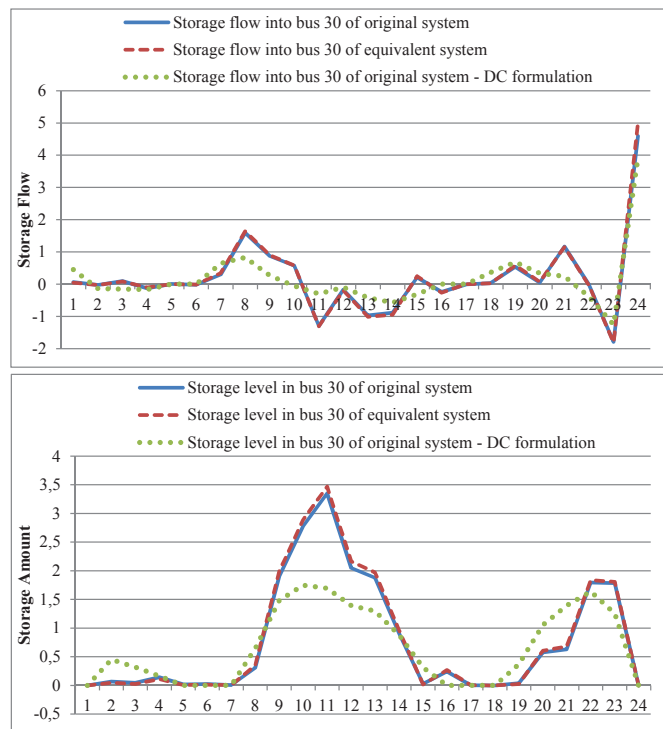

Figure 6.6: The final storage flow and final storage levels at bus 30 of the IEEE 30 bus test network and the corresponding equivalent system.



## **Part III**

# **Closure**



## Chapter 7

# Conclusions and Future Work

*In this final chapter, conclusions of this thesis are drawn and ideas for future work are discussed.*

### 7.1 Conclusions

The main focus of this thesis is studying large-scale power system with high penetration of renewable energy resources. The thesis, therefore, tries to review, evaluate, and compare the existing methods for simplifying analysis of considered systems. In addition, the thesis suggests some improvements on the existing methods and proposes efficient algorithms for simplifying the simulation of bulk power systems with high share of renewable energies. Among all existing methods for simplifying the power system studies, the thesis concentrates on the system aggregation and develops some contributions both on theory and application of the selected method. To do so, a number of studies are performed in this thesis. Accordingly, each study resulted in some conclusions. Therefore, these conclusions are classified based on different studies as follows:

- **A comparison among different power system simplification techniques:** In the first study, an extended comparison of three important simplification techniques, i.e. scenario reduction, network aggregation, and DC linearization, is performed by applying these three techniques to four common types of power system studies, namely optimal power flow, stochastic unit commitment, generation expansion, and transmission expansion. It can be concluded from the simulation results that the selection of an appropriate simplification technique depends to a great extent on the power system study under consideration, and there is no consistent result concerning which type of simplification distorts study results more. For instance, DC linearization ignores system losses in OPFs, resulting in erroneous total cost estimates, but in our examples linearization causes relatively little error in SUC and expansion studies. Scenario reduction reduces OPF computational times with little error but is less effective for SUC. Network aggregation reduces computation effort more than DC linearization in OPF and expansion studies, but induces little distortion unless there

are few scenarios. Therefore, the general conclusion is that depending on the type of study and on the particular system, any of the simplification methods can either cause large errors, negligible errors, or something in between. Which simplification method is most appropriate will likely depend on the power system study under consideration, and so users of economic models should test for the impact of simplifications on their conclusions.

- **A comparison between two network partitioning methods:** In this study, the simulation results of two partitioning methods, in which the graph theory and optimization are respectively used, for studying the Power Flow (PF) and Optimal Power Flow (OPF) are compared. It can be concluded that the graph theory-based partitioning method seems more adapted to quickly identify buses that have a natural connection due to the topology of the system. Used with appropriate equivalencing methods, it allows for quick and systematic creation of multi-area models. The constrained optimization formulation can also be used when computational time is not an issue, or when more flexibility (e.g. controlling the partition's sizes) is needed in the definition of the areas. Hence, wide application and speed are the advantages of using the graph theory-based method, while the simple application and flexibility are the benefits of applying constraint optimization-based one.
- **Improving the REI equivalent:** In the third study, an improved version of the previously used Radial - Equivalent - Independent (REI) equivalent is developed for multi-area modeling of power systems. To do these improvements, the uncertainties in generation units and transmission lines are taken into account and an optimization method for tuning the features of buses and lines in the reduced system is proposed. The results of the simulated case systems show that the REI recommended estimated the original system more effectively than did the former REI. However, the time needed for simulation by the proposed method is longer than that by the former REI method. This issue becomes especially challenging for small case systems, such as the IEEE 30-bus system, in which obtaining and simulating the proposed equivalent may need even more time than does the original system. One suggestion for reducing this problem is to update the partitioning techniques used for defining the areas of the system. Nevertheless, for power systems like the IEEE 118-bus system or larger ones, using the proposed equivalent method results in a reduction in the simulation time of the system. It is thus worthwhile to use the proposed method in modeling the emerging large power systems, resulted from inter-connections between different electricity markets with high risk rates.
- **ATC-based power system reduction:** This study suggests an ATC-based system reduction for planning power systems with correlated wind and loads. The method partitions the original system into smaller areas based on ATC between each pair of network buses and makes a reduced equivalent for each area. Due to ATC dependency to net load conditions, separate partitions are defined for subsets of similar load and wind conditions, significantly enhancing the accuracy of optimal power flow solutions. These results imply that partitioning the original system using the

ATC values between each pair of network buses as well as changing the system partitions based on system conditions can result in large improvements in estimates of system behavior while significantly lowering computation times relative to the original network.

- **Total wind power estimation:** This study proposes an algorithm for estimating the total wind power production of some wind units which have correlated wind speeds, in which the only input to the method is the historical data for produced power of these wind power units. According to the results of this study, it can be concluded that it does not make high errors if wind speed distribution for each wind power unit is approximated by a normal distribution function. Additionally, it is acceptable to assume the correlation coefficients among these normal distribution wind speeds to be equal to corresponding correlation coefficients among historical produced wind powers.
- **Spinning reserve determination using network aggregation:** Spinning reserve calculation in large multi-area power systems is considered in this study and an algorithm is proposed for simplifying this purpose. According to this algorithm, each area of the system is first modeled by an equivalent system, obtained by the REI method and a multi-area REI equivalent is obtained for the multi-area system. Then, a cost-benefit analysis is performed to determine the spinning reserve requirements of both the original and equivalent multi-area systems. Finally, the proposed multi-area REI equivalent is evaluated by comparing the spinning reserve in the original multi-area system with that in the equivalent system. It can be concluded from the results that the spinning reserve value calculated for the equivalent system accurately approximates that for the original system, with the use of both SCUC- and SCED-based cost-benefit methods. Moreover, network aggregation results in a considerably longer reduction of simulation time for the SCUC problems compared to SCED problems.
- **Storage allocation in large-scale power systems:** In the last study, network aggregation is used to reduce the computational burden of AC OPF based storage placement in large power systems and a three-stage algorithm is suggested. In the first stage, network reduction is used whereby a small equivalent system that approximates the original power network is obtained. Secondly, the AC OPF problem for this equivalent system is solved by applying an Semi-Definite Relaxation (SDR) to the non-convex problem. Finally, the results from the reduced system are transferred to the original system using a set of repeating optimizations. The full algorithm is validated using the two IEEE networks and compared to the results obtained using a DC OPF formulation. The simulation results suggest that the system reduction based algorithm provides very accurate results for the OPF based energy storage allocation problem and can greatly reduce the computational complexity.

## 7.2 Future Work

Challenges and studies associated with simulation of large-scale power systems have been studied for quite a long time. However, high penetration of uncontrollable renewable energy resources and inclusion of economic topics into the technical issue of power systems, have increased the complications of these challenges and constituted ground for further research and more studies in this area. Consequently, the list of future work can be long. For instance, developing the flexible equivalents and further improvement to multi-equivalent techniques, which can follow the deviations in the original system conditions, are interesting topics which can be further studied in the future. Additionally, proposing multi-objective equivalents which can be used for more than one application is acknowledged.

Performing many simulations on the topics of system aggregation and renewable energy modelling allows us to suggest some future works in continue to the works performed in this thesis as follows:

- In our first study, where we compared different simplification techniques, we did not include all of these techniques and only selected three important ones, i.e. scenario reduction, system aggregation, and DC linearization. However, there are other simplification techniques like problem decomposition and etc which can be included in the proposed comparison. Therefore, a more general comparison among different simplification techniques may be performed.
- Again, in the first study, we compared the simplification techniques by applying them only to four power system studies, i.e. OPF, SUC, GEP, and TEP. Nevertheless, other power system studies such as Power Flow (PF) and etc can be involved in the proposed comparison. Thus, it is suggested to use other power system studies for evaluation of the considered simplification techniques.
- Regarding the power system equivalents, we mainly focused on the REI equivalent in our simulations. However, it is suggested to use the other equivalents like the Ward equivalent in system aggregations and compare the results with our results.
- On the topic of generation aggregation, we only worked on aggregation of renewable generation since aggregation of thermal generation is more straightforward. However, it is also appreciated to consider the thermal generation aggregation and proposes the structured method for it.
- In this thesis, we study some applications of the power system aggregation. However, the application of system aggregation may be even more studied by using the aggregation methods for other power system studies like reliability calculations.
- In our power system modelling, we mainly considered the transmission and generation levels. Nevertheless, the power distribution system also needs to be aggregated and suitable equivalents for it should be obtained.
- Last but not the least, we only focuses on power system static analyses, while dynamic equivalents for the system can also be obtained.

## Bibliography

- [1] A. H. van der Weijde and B. F. Hobbs. The economics of planning electricity transmission to accommodate renewables: Using two-stage optimisation to evaluate flexibility and the cost of disregarding uncertainty. *Energy Economics*, 34(6):2089–2101, November 2012.
- [2] E. Troster, R. Kuwahata, and T. Ackermann. European grid study 2030/2050. Technical report, energynautics GmbH, Commissioned by Greenpeace International, January 2011.
- [3] J. A. Pecas Lopes, N. Hatziargyriou, J. Mutale, P. Djapic, and N. Jenkins. Integrating distributed generation into electric power systems: A review of drivers, challenges and opportunities. *Electric Power Systems Research*, 77(9):1189–1203, July 2007.
- [4] Y. Vardanyan and M. Amelin. The state-of-the-art of the short term hydro power planning with large amount of wind power in the system. In *2011 8th International Conference on the European Energy Market (EEM)*, pages 448–454. IEEE, May 2011.
- [5] North American Electric Reliability Council (NERC). Accommodating high levels of variable generation. April 2009.
- [6] J. B. Ward. Equivalent circuits for power-flow studies. *Transactions of the American Institute of Electrical Engineers*, 68(1):373–382, July 1949.
- [7] J. F. Dopazo, M. H. Dwarakanath, J. J. Li, and A. M. Sasson. An external system equivalent model using real-time measurements for system security evaluation. *IEEE Transactions on Power Apparatus and Systems*, 96(2):431–446, March 1977.
- [8] Savu C. Savulescu. Equivalents for security analysis of power systems. *Power Apparatus and Systems, IEEE Transactions on*, (5):2672–2682, 1981.
- [9] C. N. Lu, K. C. Liu, and S. Vemuri. An external network modeling approach for on-line security analysis. *Power Systems, IEEE Transactions on*, 5(2):565–573, 1990.
- [10] F. C. Aschmoneit and J. F. Verstege. An external system equivalent for on-line steady-state generator outage simulation. *IEEE Transactions on Power Apparatus and Systems*, (3):770–779, 1979.

- [11] R. R. Shoults and W. J. Bierck Jr. Buffer system selection of a steady-state external equivalent model for real-time power flow using an automated sensitivity analysis procedure. *IEEE Transactions on Power Systems*, 3(3):1104–1111, 1988.
- [12] H. Kim and A. Abur. Enhancement of external system modeling for state estimation. *IEEE Transactions on Power Systems*, 11(3):1380–1386, 1996.
- [13] V. H. Quintana and N. Muller. Partitioning of power networks and applications to security control. In *IEE Proceedings C (Generation, Transmission and Distribution)*, volume 138, pages 535–545. IET, 1991.
- [14] N. Muller and V. H. Quintana. A sparse eigenvalue-based approach for partitioning power networks. *IEEE Transactions on Power Systems*, 7(2):520–527, 1992.
- [15] E. C. Housos, G. Irisarri, R. M. Porter, and A. M. Sasson. Steady state network equivalents for power system planning applications. *IEEE Transactions on Power Apparatus and Systems*, (6):2113–2120, 1980.
- [16] North American Electric Reliability Corporation (NERC). Available at <http://www.nerc.com/>.
- [17] The electricity transmission system operator in Romania (Transelectrica). Available at <https://www.transelectrica.ro/en/web/tel/ret-continental-europe/>.
- [18] O. Makela. Literature report on security of multi-area power systems. Master's thesis, Power System Lab, ETH Zurich, June 2011.
- [19] Western Electricity Coordinating Council (WECC). Available at <http://www.wecc.biz/>.
- [20] Y. Phulpin, M. Begovic, M. Petit, J.-B. Heyberger, and D. Ernst. Evaluation of network equivalents for voltage optimization in multi-area power systems. *IEEE Transactions on Power Systems*, 24(2):729–743, May 2009.
- [21] E. Constantinescu, V. M. Zavala, M. Rocklin, S. Lee, and M. Anitescu. Unit commitment with wind power generation: Integrating wind forecast uncertainty and stochastic programming, September 2009.
- [22] Accommodating high levels of variable generation. Technical report, North American Electric Reliability Council (NERC), April 2009.
- [23] Q. Wang, J. Wang, and Y. Guan. Stochastic unit commitment with uncertain demand response. *IEEE Transactions on Power Systems*, 28(1):562–563, February 2013.
- [24] C. Zhao, J. Wang, J.-P. Watson, and Y. Guan. Multi-stage robust unit commitment considering wind and demand response uncertainties. *IEEE Transactions on Power Systems*, 28(3):2708–2717, August 2013.



- [25] M. J. Hossain, T. K. Saha, and N. Mithulananthan. Impacts of wind and solar integrations on the dynamic operations of distribution systems. In *2011 21st Australasian Universities Power Engineering Conference (AUPEC)*, pages 1–6, Queensland, Australia, September 2011. IEEE.
- [26] A. A. Bayod-Rujula. Future development of the electricity systems with distributed generation. *Energy*, 34(3):377–383, March 2009.
- [27] S. Wang. Reliability assessment of power systems with wind power generation. *Master of Science thesis report, Electrical Engineering Department, North Carolina State University*, 2008.
- [28] A. Papaemmanouil and G. Andersson. On the reduction of large power system models for power market simulations. In *17th Power Systems Computation Conference (PSCC)*, pages 1308–1313, Stockholm, Sweden, August 2011.
- [29] X. Cheng and T.J. Overbye. PTDF-based power system equivalents. *IEEE Transactions on Power Systems*, 20(4):1868–1876, November 2005.
- [30] HyungSeon Oh. A new network reduction methodology for power system planning studies. *IEEE Transactions on Power Systems*, 25(2):677–684, May 2010.
- [31] J. Sumaili, H. Keko, V. Miranda, A. Botterud, and J. Wang. CLUSTERING-BASED WIND POWER SCENARIO REDUCTION.
- [32] W. L. de Oliveira, C. Sagastizabal, D. D. Jardim Penna, M. E. Pineiro Maceira, and J. M. Damazio. Optimal scenario tree reduction for stochastic stream flows in power generation planning problems. In *EngOpt 2008 - International Conference on Engineering Optimization*, Rio de Janeiro, Brazil, June 2008.
- [33] J. M. Morales, S. Pineda, A. J. Conejo, and M. Carrion. Scenario reduction for futures market trading in electricity markets. *IEEE Transactions on Power Systems*, 24(2):878–888, May 2009.
- [34] N. Grawe-Kuska, H. Heitsch, and W. Romisch. Scenario reduction and scenario tree construction for power management problems. In *2003 IEEE Bologna Power Tech Conference Proceedings*, volume 3, Bologna, Italy, June 2003. IEEE.
- [35] J. Dupacova, N. Grawe-Kuska, and W. Romisch. Scenario reduction in stochastic programming. *Mathematical Programming*, 95(3):493–511, March 2003.
- [36] C. S. Chang, L. R. Lu, and F. S. Wen. Power system network partitioning using tabu search. *Electric power systems research*, 49(1):55–61, 1999.
- [37] Ajit Gopalakrishnan, Arvind U. Raghunathan, Daniel Nikovski, and Lorenz T. Biegler. Global optimization of optimal power flow using a branch & bound algorithm. In *Communication, Control, and Computing (Allerton), 2012 50th Annual Allerton Conference on*, pages 609–616. IEEE, 2012.

- [38] Joshua A. Taylor and Franz S. Hover. Conic relaxations for transmission system planning. August 2011.
- [39] Yuandong Ji and Benjamin F. Hobbs. Including a DC network approximation in a multiarea probabilistic production costing model. *Power Systems, IEEE Transactions on*, 13(3):1121–1127, 1998.
- [40] A. J. Conejo, E. Castillo, R. Minguez, and R. Garcia-Bertrand. *Decomposition techniques in mathematical programming - engineering and science applications*. Springer, 2006.
- [41] D. Van Hertem, J. Verboomen, K. Purchala, R. Belmans, and W. L. Kling. Usefulness of dc power flow for active power flow analysis with flow controlling devices. In *8th IEE International Conference on AC and DC Power Transmission (ACDC)*, 2006.
- [42] Di Shi. *Power System Network Reduction for Engineering and Economic Analysis*. PhD thesis, Arizona State University, 2012.
- [43] E. Shayesteh, C. Hamon, M. Amelin, and L. Soder. REI method for multi-area modeling of large power systems with high wind penetration. *International Journal of Electrical Power and Energy Systems*, 60:283–292, 2014.
- [44] Keith E. Casey, Benjamin F. Hobbs, Dariush Shirmohammadi, and Frank A. Wolak. Benefit-cost analysis of large-scale transmission for renewable generation: Principles & california case study. In *Power Engineering Society General Meeting, 2007. IEEE*, pages 1–3. IEEE, 2007.
- [45] Adriaan Hendrik van der Weijde and Benjamin F. Hobbs. The economics of planning electricity transmission to accommodate renewables: Using two-stage optimisation to evaluate flexibility and the cost of disregarding uncertainty. *Energy Economics*, 34(6):2089–2101, November 2012.
- [46] North American Electric Reliability Council (NERC). Accommodating high levels of variable generation. 2009.
- [47] A. Bose. The effects of external modeling errors on on-line security analysis. *IEEE Transactions on Power Systems*, 1(1):227–231, February 1986.
- [48] F. C. Schweppe, M. C. Caramanis, R. D. Tabors, and R. E. Bohn. *Spot Pricing of Electricity*. Kluwer, Boston, 1988.
- [49] Matthew Galati. *Decomposition methods for integer linear programming*. Lehigh University, 2010.
- [50] Yang Wang, Qing Xia, and Chongqing Kang. A novel security stochastic unit commitment for wind-thermal system operation. In *Electric Utility Deregulation and Restructuring and Power Technologies (DRPT), 2011 4th International Conference on*, pages 386–393. IEEE, 2011.

- [51] S. A. H. Bahreyni, M. A. Khorsand, and S. Jadid. A stochastic unit commitment in power systems with high penetration of smart grid technologies. In *Smart Grids (ICSG), 2012 2nd Iranian Conference on*, pages 1–6. IEEE, 2012.
- [52] Long Zhao, Bo Zeng, and Brian Buckley. A stochastic unit commitment model with cooling systems. *IEEE Transactions on Power Systems*, 28(1):211–218, February 2013.
- [53] Ray Daniel Zimmerman, Carlos Edmundo Murillo-Sanchez, and Robert John Thomas. MATPOWER: Steady-state operations, planning, and analysis tools for power systems research and education. *IEEE Transactions on Power Systems*, 26(1):12–19, February 2011.
- [54] F. F. Wu and A. Monticelli. Critical review of external network modelling for online security analysis. *International Journal of Electrical Power & Energy Systems*, 5(4):222–235, October 1983.
- [55] J. Machowski, A. Cichy, F. Gubina, and P. Omahen. External subsystem equivalent model for steady-state and dynamic security assessment. *Power Systems, IEEE Transactions on*, 3(4):1456–1463, 1988.
- [56] P. Sanderson, R. Curtis, D. Athow, C. N. Lu, K. C. Liu, and C. Letter. Real time complete model estimation for contingency study: field experience. *Power Systems, IEEE Transactions on*, 6(4):1480–1484, 1991.
- [57] S. Deckmann, A. Pizzolante, A. Monticelli, B. Stott, and O. Alsac. Studies on power system load flow equivalencing. *IEEE Transactions on Power Apparatus and Systems*, PAS-99(6):2301–2310, November 1980.
- [58] A. Monticelli and Felix F. Wu. A method that combines internal state estimation and external network modeling. *Power Apparatus and Systems, IEEE Transactions on*, (1):91–103, 1985.
- [59] Efthymios Housos and Guillermo Irisarri. Real time results with on-line network equivalents for control center applications. *Power Apparatus and Systems, IEEE Transactions on*, (12):4830–4837, 1981.
- [60] L. Oatts. External network modeling-recent practical experience. *IEEE Transactions on Power Systems*, 9(1), 1994.
- [61] G. C. Oliveira, S. H. F. Cunha, and M. V. F. Pereira. A direct method for multi-area reliability evaluation. *Power Systems, IEEE Transactions on*, 2(4):934–940, 1987.
- [62] T. E. Dy Liacco, S. C. Savulescu, and K. A. Ramarao. An on-line topological equivalent of a power system. *IEEE Transactions on Power Apparatus and Systems*, PAS-97(5):1550–1563, September 1978.

- [63] L. Min and A. Abur. Total transfer capability computation for multi-area power systems. *IEEE Transactions on Power Systems*, 21(3):1141–1147, August 2006.
- [64] H. K. Temraz, M. M. A. Salama, and V. H. Quintana. Application of partitioning techniques for decomposing large-scale electric power networks. *International Journal of Electrical Power & Energy Systems*, 16(5):301–309, 1994.
- [65] X. Bai and H. Wei. A semidefinite programming method with graph partitioning technique for optimal power flow problems. *International Journal of Electrical Power & Energy Systems*, 33(7):1309–1314, September 2011.
- [66] M.A. Tomim, T. De Rybel, and J.R. Marti. Extending the multi-area thevenin equivalents method for parallel solutions of bulk power systems. *International Journal of Electrical Power & Energy Systems*, 44(1):192–201, January 2013.
- [67] M. Arnold, S. Knopfli, and G. Andersson. Improvement of OPF decomposition methods applied to multi-area power systems. In *2007 IEEE Lausanne Power Tech*, pages 1308–1313. IEEE, July 2007.
- [68] S. Tiptipakorn. A spectral bisection partitioning method for electric power network applications. *Master Report, Department of Electrical and Computer Engineering, University of Wisconsin-Madison*, 2001.
- [69] L. Min. *Decomposition algorithms for multi-area power system analysis*. PhD thesis, Texas A&M University, 2007.
- [70] M. Granada Echeverri, J. M. Lopez Lezama, and J. R. Sanchez Mantovani. Decentralized AC power flow for multi-area power systems using a decomposition approach based on lagrangian relaxation. *Revista Facultad de Ingenieria*, (53):225–235, 2013.
- [71] Swedish water control company Vattenregleringsforetagen. Angermanalven hydro system schematics. Available at: [http://www.vattenreglering.se/vrf/hemsida/bilder.nsf/WviewSysimages/2012-04-20\\_AVF\\_schematisk\\_bild-enkel.pdf/\\$file/2012-04-20\\_AVF\\_schematisk\\_bild-enkel.pdf](http://www.vattenreglering.se/vrf/hemsida/bilder.nsf/WviewSysimages/2012-04-20_AVF_schematisk_bild-enkel.pdf/$file/2012-04-20_AVF_schematisk_bild-enkel.pdf), 2012.
- [72] G. da Cruz Jr and S. Soares. Non-uniform composite representation hydroelectric systems for long-term hydrothermal scheduling. *Power Systems, IEEE Transactions on*, 11(2):702–707, 1996.
- [73] M. E. P. Maceira, V. S. Duarte, D. D. J. Penna, and M. P. Tcheou. An approach to consider hydraulic coupled systems in the construction of equivalent reservoir model in hydrothermal operation planning. In *17th Power Systems Computation Conference, Stockholm*, 2011.
- [74] Lennart Soder and Jonas Rendelius. Two-station equivalent of hydro power systems. In *PSCC 2005: 15th Power Systems Computation Conference*, 2005.

- [75] Joao Luiz B. Brandao. Performance of the equivalent reservoir modelling technique for multi-reservoir hydropower systems. *Water Resources Management*, 24(12):3101–3114, September 2010.
- [76] N. V. Arvanitidis and Jakob Rosing. Composite representation of a multireservoir hydroelectric power system. *Power Apparatus and Systems, IEEE Transactions on*, (2):319–326, 1970.
- [77] N. V. Arvanitidis and J. Rosing. Optimal operation of multireservoir systems using a composite representation. *Power Apparatus and Systems, IEEE Transactions on*, PAS-89(2):327–335, 1970.
- [78] V. R. Sherkat, R. Campo, K. Moslehi, and E. O. Lo. Stochastic long-term hydrothermal optimization for a multireservoir system. *Power Apparatus and Systems, IEEE Transactions on*, (8):2040–2050, 1985.
- [79] Bo Tong, Qiaozhu Zhai, and Xiaohong Guan. An MILP based formulation for short-term hydro generation scheduling with analysis of the linearization effects on solution feasibility. *IEEE Transactions on Power Systems*, 28(4):3588–3599, November 2013.
- [80] H. Duran, C. Puech, J. Diaz, and G. Sanchez. Optimal operation of multireservoir systems using an aggregation-decomposition approach. *Power Apparatus and Systems, IEEE Transactions on*, (8):2086–2092, 1985.
- [81] Yong-Gang Wu, Chunying Ho, and Ding-Yo Wang. A diploid genetic approach to short-term scheduling of hydro-thermal system. *Power Systems, IEEE Transactions on*, 15(4):1268–1274, 2000.
- [82] E. Gil, J. Bustos, and H. Rudnick. Short-term hydrothermal generation scheduling model using a genetic algorithm. *IEEE Transactions on Power Systems*, 18(4):1256–1264, November 2003.
- [83] Chao-an Li, Rui Yan, and Jing-yan Zhou. Stochastic optimization of interconnected multireservoir power systems. *Power Systems, IEEE Transactions on*, 5(4):1487–1496, 1990.
- [84] A. Samadi, L. Soder, E. Shayesteh, and R. Eriksson. Static equivalent of distribution grids with high penetration of pv systems. *Submitted to the IEEE Transactions on Smart Grids*.
- [85] Federico Milano and Kailash Srivastava. Dynamic REI equivalents for short circuit and transient stability analyses. *Electric Power Systems Research*, 79(6):878–887, June 2009.
- [86] D. Tylavsky, Y. Qi, Y. Zhu, D. Shi, W. Schulze, R. Zimmerman, D. Shuler, J. Yan, and D. Shawhan. Essence of structure preserving (ESP) network reductions for engineering and economic analysis of high penetration of renewables. In *CERTS Reliability & Markets*, Cornell University, NY, US, August 2013.

- [87] G. Angeline Ezhilarasi and K. S. Swarup. Network partitioning using harmony search and equivalencing for distributed computing. *Journal of Parallel and Distributed Computing*, 72(8):936–943, August 2012.
- [88] G. Quaranta. Model for simulation of the nordic electricity market. *Master of Science thesis, Department of Electrical Engineering, KTH Royal Institute of Technology*, February 2001.
- [89] M. R. Irving and M. J. H. Sterling. Optimal network tearing using simulated annealing. *Generation, Transmission and Distribution, IEE Proceedings C*, 137(1):69–72, 1990.
- [90] H. Ding, A. A. El-Keib, and R. Smith. Optimal clustering of power networks using genetic algorithms. *Electric Power Systems Research*, 30(3):209 – 214, 1994.
- [91] C.H.Q. Ding, Xiaofeng He, Hongyuan Zha, Ming Gu, and H.D. Simon. A min-max cut algorithm for graph partitioning and data clustering. In *Proceedings of the 2001 IEEE International Conference on Data Mining*, pages 107–114, 2001.
- [92] Jianbo Shi and J. Malik. Normalized cuts and image segmentation. *IEEE Transactions on Pattern Analysis and Machine Intelligence*, 22(8):888–905, 2000.
- [93] L. Hagen and A.B. Kahng. New spectral methods for ratio cut partitioning and clustering. *IEEE Transactions on Computer-Aided Design of Integrated Circuits and Systems*, 11(9):1074–1085, September 1992.
- [94] A. D. Patton and S. K. Sung. A transmission network model for multi-area reliability studies. *Power Systems, IEEE Transactions on*, 8(2):459–465, 1993.
- [95] Michal L. Oatts, Sam R. Erwin, and Jack L. Hart. Application of the REI equivalent for operations planning analysis of interchange schedules. *Power Systems, IEEE Transactions on*, 5(2):547–555, 1990.
- [96] Liang Min and A. Abur. REI-Equivalent Based Decomposition Method for Multi-Area TTC Computation. In *Transmission and Distribution Conference and Exhibition, 2005/2006 IEEE PES*, pages 506–510. IEEE, 2006.
- [97] C.H. Papadimitriou and K. Steiglitz. *Combinatorial optimization: algorithms and complexity*. Dover Pubns, 1998.
- [98] U. von Luxburg. A tutorial on spectral clustering. *Statistics and Computing*, 17(4):395–416, September 2007.
- [99] P. Kabelikova. Graph partitioning using spectral methods. *Master of Science thesis, Dept. Computer Sci., VSB, Technical Univ. of Ostrava*, May 2006.

- [100] Florean Predan. Practical method for finding power system parameters as necessary for analysing the operating regimes of adjacent interconnected systems. *International Journal of Electrical Power & Energy Systems*, 44(1):441–444, January 2013.
- [101] P. Dima. *Nodal analysis of power systems*. Taylor & Francis, 1975.
- [102] S. C. Savulescu. *Real-Time Stability Assessment in Modern Power System Control Centers*. Wiley, March 2009.
- [103] Panida Jirutitijaroen and Chanan Singh. Reliability constrained multi-area adequacy planning using stochastic programming with sample-average approximations. *IEEE Transactions on Power Systems*, 23(2):504–513, May 2008.
- [104] R. Billinton and A. Jonnavithula. Composite system adequacy assessment using sequential monte carlo simulation with variance reduction techniques. *IEE Proceedings Generation, Transmission and Distribution*, 144(1):1–6, January 1997.
- [105] L. Wu, M. Shahidehpour, and T. Li. Stochastic security-constrained unit commitment. *IEEE Transactions on Power Systems*, 22(2):800–811, May 2007.
- [106] J. Sumaili, H. Keko, V. Miranda, A. Botterud, and J. Wang. Clustering-based wind power scenario reduction technique. In *17th Power Systems Computation Conference (PSCC)*, Stockholm, Sweden, August 2011.
- [107] Y. Feng and S. M. Ryan. Scenario construction and reduction applied to stochastic power generation expansion planning. *Computers & Operations Research*, 40(1):9–23, January 2013.
- [108] A. J. Conejo, M. Carrion, and J. M. Morales. *Decision Making Under Uncertainty in Electricity Markets*. Springer, New York, 2010.
- [109] M. Kaut and S. W. Wallace. Evaluation of scenario-generation methods for stochastic programming. *Pacific Journal of Optimization*, 3:257–271, 2007.
- [110] North American Electric Reliability Council (NERC). Glossary of terms used in nerc reliability standards. October 2011.
- [111] North American Electric Reliability Council. Available transfer capability definition and determination. June 1996.
- [112] B. Mozafari, A. M. Ranjbar, A. R. Shirani, and A. Barkeseh. A comprehensive method for available transfer capability calculation in a deregulated power system. In *2004.(DRPT 2004). Proceedings of the 2004 IEEE International Conference on Electric Utility Deregulation, Restructuring and Power Technologies*, volume 2, pages 680–685. IEEE, April 2004.

- [113] J. W. Stahlhut, G. T. Heydt, and G. B. Sheble. A stochastic evaluation of available transfer capability. In *2005. IEEE Power Engineering Society General Meeting*, pages 3055–3061. IEEE, 2005.
- [114] Svenska Kraftnat (Swedish National Grid). Sweden wind power production in 2009. Available at: <http://www.svk.se/Start/English/About-us/>.
- [115] Alex Lago-Gonzalez and Chanan Singh. The extended decomposition-simulation approach for multi-area reliability calculations. *Power Systems, IEEE Transactions on*, 5(3):1024–1031, 1990.
- [116] C. Singh and Q. Chen. Modeling of energy limited units in the reliability evaluation of multi- area electrical power systems. *Power Systems, IEEE Transactions on*, 5:1364–1373, 1990.
- [117] Y. Li and C. Singh. A direct method for multi-area production simulation. *Power Systems, IEEE Transactions on*, 14(3):906–912, 1999.
- [118] Panida Jirutitijaroen and Chanan Singh. Reliability and cost tradeoff in multiarea power system generation expansion using dynamic programming and global decomposition. *Power Systems, IEEE Transactions on*, 21(3):1432–1441, 2006.
- [119] M. C. Alexiadis, P. S. Dokopoulos, and H. S. Sahsamanoglou. Wind speed and power forecasting based on spatial correlation models. *Energy Conversion, IEEE Transactions on*, 14(3):836–842, 1999.
- [120] A. Pares-Sierra. Temporal and spatial variation of the surface winds in the gulf of california. *Geophysical Research Letters*, 30(6), 2003.
- [121] Y. Gao and R. Billinton. Adequacy assessment of generating systems containing wind power considering wind speed correlation. *IET Renewable Power Generation*, 3(2):217, 2009.
- [122] K. Murray, B. Haasbroek, C. Strydom, R. Heath, L. Slabbert, A. Snyman, and B. Moloi. National toxicity monitoring programme for surface waters, chapter five: Spatial and temporal correlation. Technical Report 1.23, South African National Water Quality Monitoring Programme Series, March 2005.
- [123] Eugene C. Morgan, Matthew Lackner, Richard M. Vogel, and Laurie G. Baise. Probability distributions for offshore wind speeds. *Energy Conversion and Management*, 52(1):15–26, January 2011.
- [124] Hafzullah Aksoy, Z Fuat Toprak, Ali Aytek, and N Erdem Unal. Stochastic generation of hourly mean wind speed data. *Renewable Energy*, 29(14):2111–2131, November 2004.



- [125] Le Chung Tran, Tadeusz A. Wysocki, Alfred Mertins, and Jennifer Seberry. A generalized algorithm for the generation of correlated rayleigh fading envelopes in wireless channels. *EURASIP Journal on wireless communications and networking*, 2005(5):801–815, 2005.
- [126] L. M. Novak. Generating correlated weibull random variables for digital simulations. In *Rec. 1973 IEEE Conf. Decision and Control including the 12th Symposium on Adaptive Processes*, pages 156–160, 1973.
- [127] D.W. Matolak, I. Sen, and W. Xiong. Generation of multivariate weibull random variates. *IET Communications*, 2(4):523, 2008.
- [128] John Hetzer, David C. Yu, and Kalu Bhattarai. An economic dispatch model incorporating wind power. *IEEE Transactions on Energy Conversion*, 23(2):603–611, June 2008.
- [129] Bart C. Ummels, Madeleine Gibescu, Engbert Pelgrum, Wil L. Kling, and Arno J. Brand. Impacts of wind power on thermal generation unit commitment and dispatch. *IEEE Transactions on Energy Conversion*, 22(1):44–51, March 2007.
- [130] R. Karki, P. Hu, and R. Billinton. A simplified wind power generation model for reliability evaluation. *IEEE Transactions on Energy Conversion*, 21(2):533–540, June 2006.
- [131] Ahmad Salehi Dobakhshari and Mahmud Fotuhi-Firuzabad. A reliability model of large wind farms for power system adequacy studies. *IEEE Transactions on Energy Conversion*, 24(3):792–801, September 2009.
- [132] A.P. Leite, C.L.T. Borges, and D.M. Falcao. Probabilistic wind farms generation model for reliability studies applied to brazilian sites. *IEEE Transactions on Power Systems*, 21(4):1493–1501, November 2006.
- [133] Roy Billinton and Wijarn Wangdee. Reliability-based transmission reinforcement planning associated with large-scale wind farms. *IEEE Transactions on Power Systems*, 22(1):34–41, February 2007.
- [134] G. Giebel and N. G. Mortensen. Effects of large-scale distribution of wind energy in and around europe. In *presented at the Riso National Laboratory, Gregor Czisch, ISET*.
- [135] S. Gloor. A report on the correlation between wind speed and distance for 12 wa wind speed datasets. Technical report, Available at: <http://www.oz-energy-analysis.org/docs/StephenGloor-CorrelationAnalysis12WAWindDataSets-July2010.pdf>.
- [136] Warren Katzenstein and Jay Apt. The cost of wind power variability. *Energy Policy*, 51:233–243, 2012.

- [137] T. Adams and F. Cadieux. Wind power in ontario; quantifying the benefits of geographic diversity. In *presented for the IESO Wind Power Standing Committee*, January 2009.
- [138] M. Magnusson, R. Krieg, M. Nord, and H. Bergstrom. Power fluctuations of wind power - a study on wind energy production time variation. Technical Report 04:34, ELFORSK Energimyndigheten, December 2004.
- [139] Nord Pool Spot Electricity Market. Wind power production in nord pool electricity market. Available at: <http://www.nordpoolspot.com/Market-data1/Power-system-data/Production1/Wind-Power/ALL/Hourly1/>.
- [140] The Wind Power. Wind turbines and wind farms database. Available at: <http://www.thewindpower.net/>.
- [141] Elia (Belgium high-voltage transmission system operator). Wind-power generation data. Available at: <http://www.elia.be/en/grid-data/power-generation/wind-power>.
- [142] National Wind Watch. Real-time wind production - various regions. Available at: <http://www.wind-watch.org/documents/real-time-wind-production-various-regions/>.
- [143] Nord Pool Spot Electricity Market. The bidding areas in the day-ahead auction on nord pool spot. Available at: <http://www.nordpoolspot.com/How-does-it-work/Bidding-areas/>.
- [144] Esteban Gil and Ignacio Aravena. Evaluating the contribution of intermittent generation to power system adequacy at different demand levels. In *Power and Energy Society General Meeting (PES), 2013 IEEE*, pages 1–5. IEEE, 2013.
- [145] A. Sheokand, I. Maheshwari, and N. K. Yadav. Optimal spinning reserve capacity in power market. *International Journal for Scientific Research & Development*, 1:1447–1451, 2013.
- [146] Amir Motamedi and Mahmud Fotuhi-Firuzabad. Determination of spinning reserve in restructured power systems using a hybrid deterministic/probabilistic approach. In *5th International Conference on Electrical and Electronics Engineering*, pages 5–9, 2007.
- [147] Jyothilal Nayak Bharothu and G. Venkatesh. Reduction of damping oscillations of power systems with combinational operation of LFC & AVR in single area. *American Journal of Electrical and Electronic Engineering*, 2(2):27–39, 2014.
- [148] Guide to Operating Reserve. Marketplace training. Available at: [www.IESO.ca](http://www.IESO.ca).
- [149] National Grid. Operating the electricity transmission networks in 2020.

- [150] Mahmud Fotuhi-Firoozabad and M. Rashidi-Nejad. Allocation of spinning reserve among generating units using a hybrid deterministic/probabilistic approach. In *Power Engineering, 2004. LESCOPE-04. 2004 Large Engineering systems Conference on*, pages 81–7a. IEEE, 2004.
- [151] A. Ahmadi-Khatir and R. Cherkaoui. A probabilistic spinning reserve market model considering DisCo different value of lost loads. *Electric Power Systems Research*, 81(4):862–872, April 2011.
- [152] T. E. Dy Liacco, S. C. Savulescu, and K. A. Ramarao. An on-line topological equivalent of a power system. *Power Apparatus and Systems, IEEE Transactions on*, PAS-97:1550–1563, 1978.
- [153] S. C. Savulescu. *Real-time stability assessment in modern power system control centers*. Wiley-IEEE Press: 1st edition, 2009.
- [154] D. Rajan and S. Takriti. Minimum up/down polytopes of the unit commitment problem with start-up costs. *IBM Res. Rep.*
- [155] Dennice Gayme and Ufuk Topcu. Optimal power flow with large-scale storage integration. *IEEE Transactions on Power Systems*, 28(2):709–717, May 2013.
- [156] Aouss Gabash and Pu Li. Active-reactive optimal power flow in distribution networks with embedded generation and battery storage. *IEEE Transactions on Power Systems*, 27(4):2026–2035, November 2012.
- [157] Stephen Carr, Giuliano C. Premier, Alan J. Guwy, Richard M. Dinsdale, and Jon Maddy. Energy storage for active network management on electricity distribution networks with wind power. *Renewable Power Generation, IET*, 8(3):249–259, 2014.
- [158] Christos Thrampoulidis, Subhonmesh Bose, and Babak Hassibi. Optimal placement of distributed energy storage in power networks. *arXiv preprint arXiv:1303.5805*, 2013.
- [159] Yoash Levron, Josep M. Guerrero, and Yuval Beck. Optimal power flow in microgrids with energy storage. *IEEE Transactions on Power Systems*, 28(3):3226–3234, August 2013.
- [160] Bernard C. Lesieutre, Daniel K. Molzahn, Alexander R. Borden, and Christopher L. DeMarco. Examining the limits of the application of semidefinite programming to power flow problems. In *Communication, Control, and Computing (Allerton), 2011 49th Annual Allerton Conference on*, pages 1492–1499. IEEE, 2011.
- [161] Javad Lavaei, Anders Rantzer, and S. H. Low. Power flow optimization using positive quadratic programming. *Proc. 18th IFAC World Congr*, 2011.
- [162] H. Wei and X. Bai. Semi-definite programming-based method for security-constrained unit commitment with operational and optimal power flow constraints. *IET Generation, Transmission & Distribution*, 3(2):182–197, February 2009.

- [163] Xiaoqing Bai, Hua Wei, Katsuki Fujisawa, and Yong Wang. Semidefinite programming for optimal power flow problems. *International Journal of Electrical Power & Energy Systems*, 30(6-7):383–392, July 2008.
- [164] Etienne de Klerk. Exploiting special structure in semidefinite programming: A survey of theory and applications. *European Journal of Operational Research*, 201(1):1–10, February 2010.
- [165] Javad Lavaei and Steven H. Low. Zero duality gap in optimal power flow problem. *IEEE Transactions on Power Systems*, 27(1):92–107, February 2012.
- [166] S. Bose, S. H. Low, and K. M. Chandy. Equivalence of branch flow and bus injection models. In *Proceedings of 2011 50th Annual Allerton Conference on Communication Control and Computing Allerton*, Monticello, IL, 2012.
- [167] Masoud Farivar and Steven H. Low. Eng. & appl. sci, caltech, pasadena, CA, USA. In *Decision and Control (CDC), 2012 IEEE 51st Annual Conference on*, pages 3672–3679. IEEE, 2012.
- [168] Masoud Farivar and Steven H. Low. Branch flow model: Relaxations and convexification - part I. *IEEE Transactions on Power Systems*, 28(3):2554–2564, August 2013.
- [169] Masoud Farivar and Steven H. Low. Branch flow model: Relaxations and convexification - part II. *IEEE Transactions on Power Systems*, 28(3):2565–2572, August 2013.
- [170] A. Atamturk, C. Chen, and S. Oren. Conic relaxations of alternating current optimal power flow (acopf). In *Proceedings of FERC Software Conference*, Washington, DC, USA, June 2012.
- [171] Albert Lam, Baosen Zhang, and David Tse. Distributed algorithms for optimal power flow problem. *arXiv preprint arXiv:1109.5229*, 2011.
- [172] Daniel K. Molzahn, Jesse T. Holzer, Bernard C. Lesieutre, and Christopher L. DeMarco. Implementation of a large-scale optimal power flow solver based on semidefinite programming. *IEEE Transactions on Power Systems*, 28(4):3987–3998, November 2013.
- [173] Subhonmesh Bose, Dennice F. Gayme, Ufuk Topcu, and K. Mani Chandy. Optimal placement of energy storage in the grid. In *CDC*, pages 5605–5612, 2012.
- [174] J. Lofberg. Yalmip: A toolbox for modeling and optimization in matlab. In *Proceedings of CACSD Conference*, Available: <http://control.ee.ethz.ch/joloeff/yalmip.php>, Taipei, Taiwan.
- [175] Jos F. Sturm. Using SeDuMi 1.02, a MATLAB toolbox for optimization over symmetric cones. *Optimization methods and software*, 11(1-4):625–653, 1999.

For KTH Royal Institute of Technology:  
**DOCTORAL THESIS IN ELECTRICAL ENGINEERING**  
TRITA-EE 2015:004  
[www.kth.se](http://www.kth.se)

ISSN 1653-5146  
ISBN 978-91-7595-421-9