

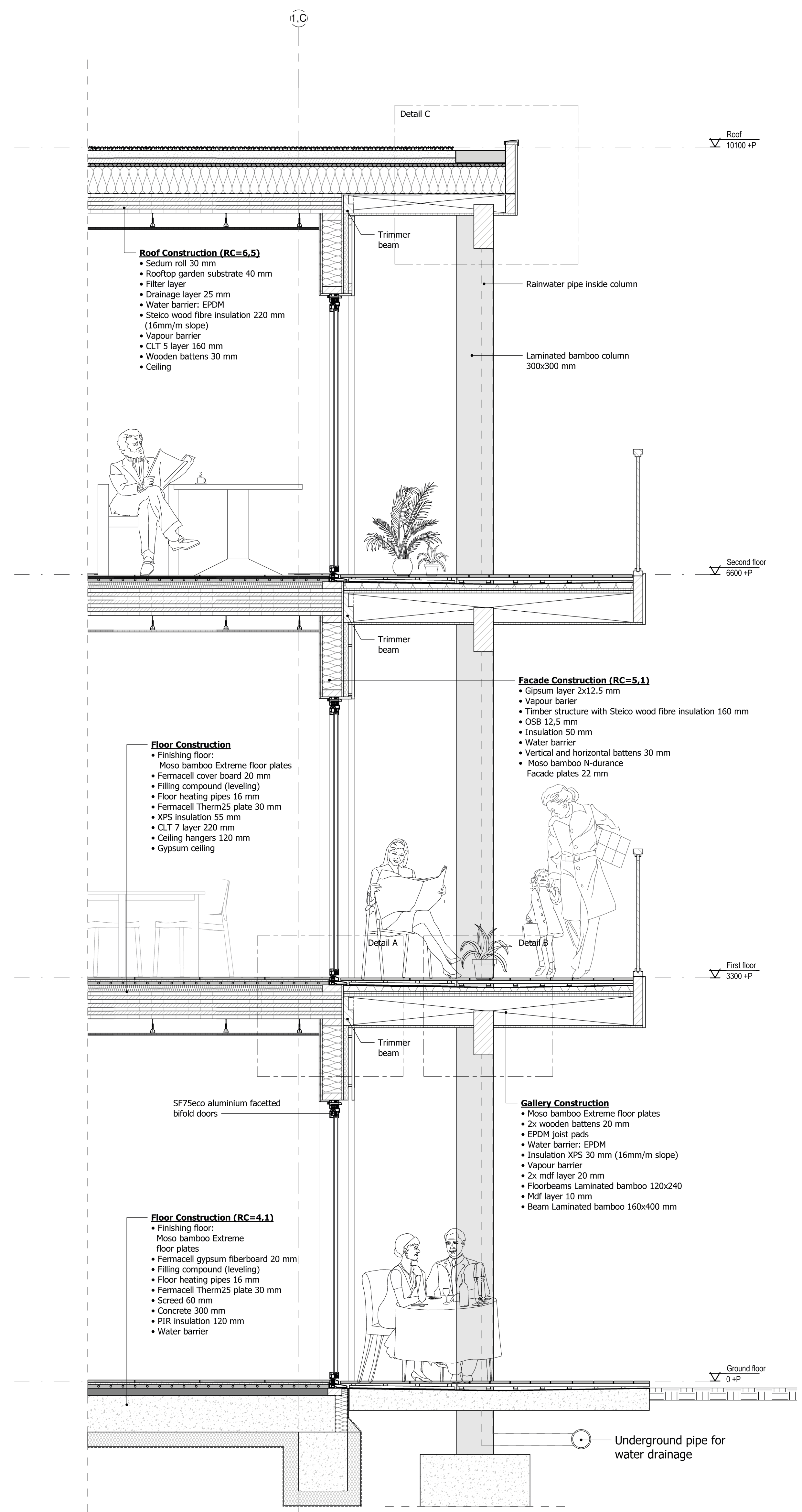

FACADE
1:20

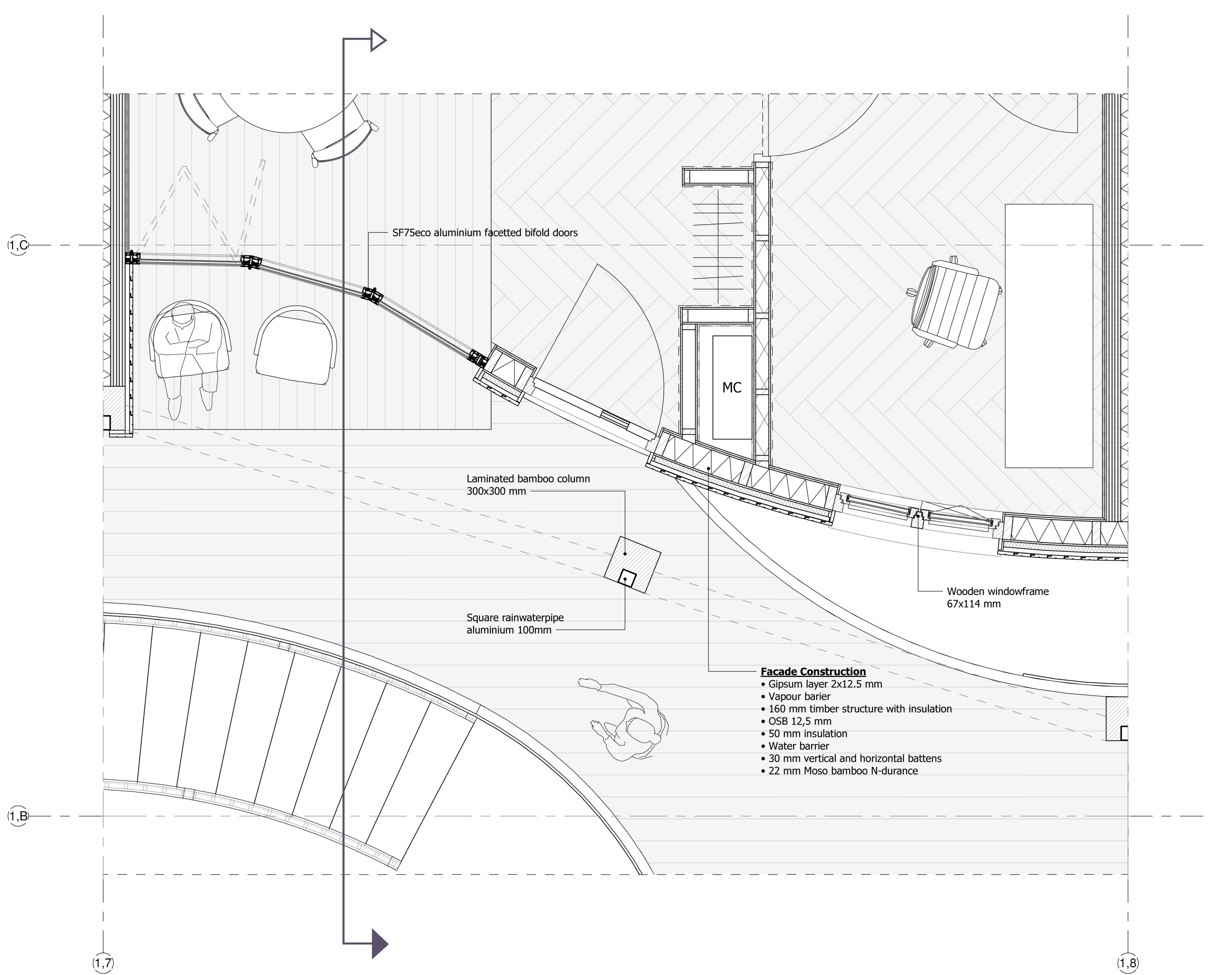

FACADE SECTION
1:20



PLAN FRAGMENT
1:20

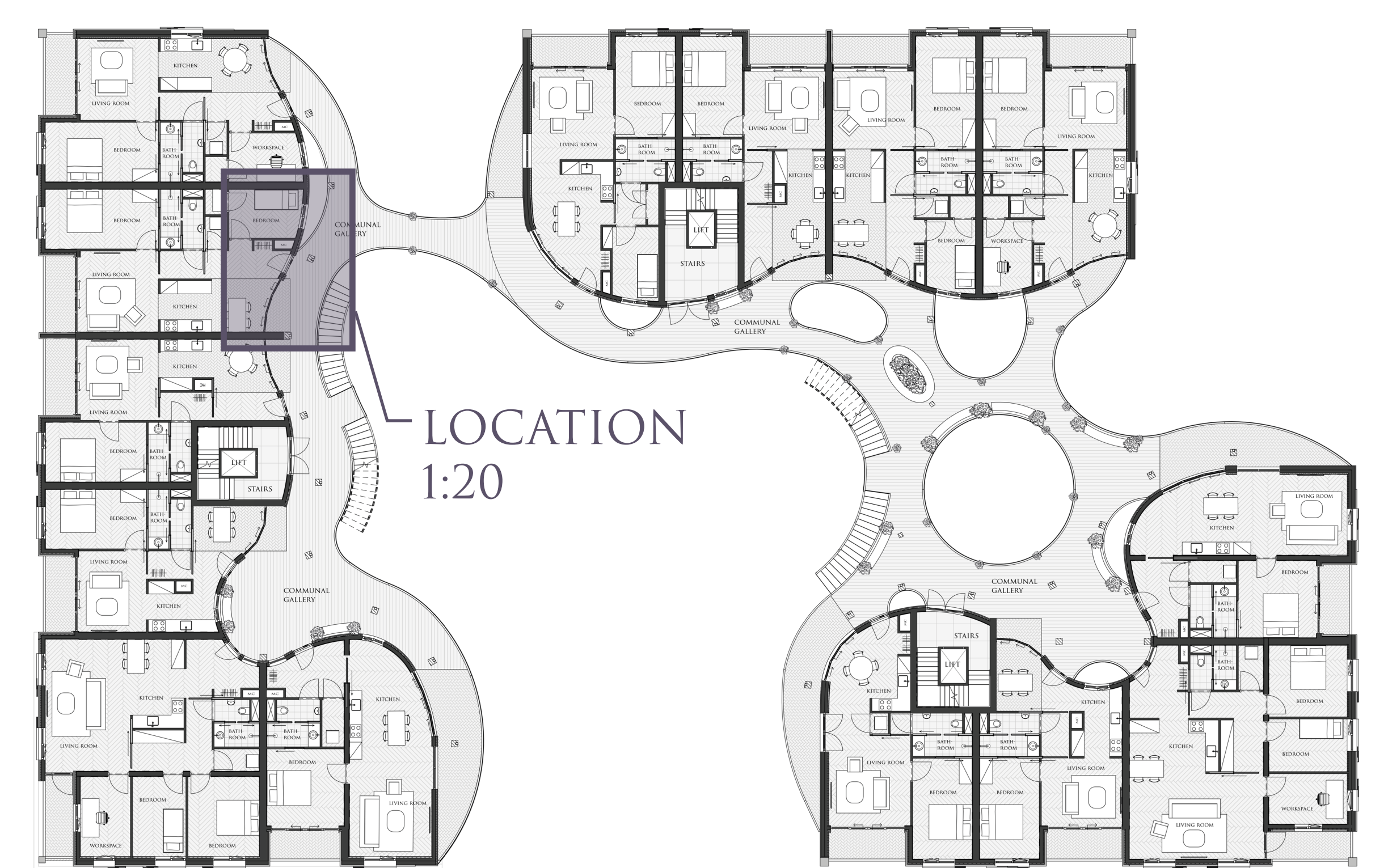

GROUND FLOOR PLAN

LOCATION
1:20

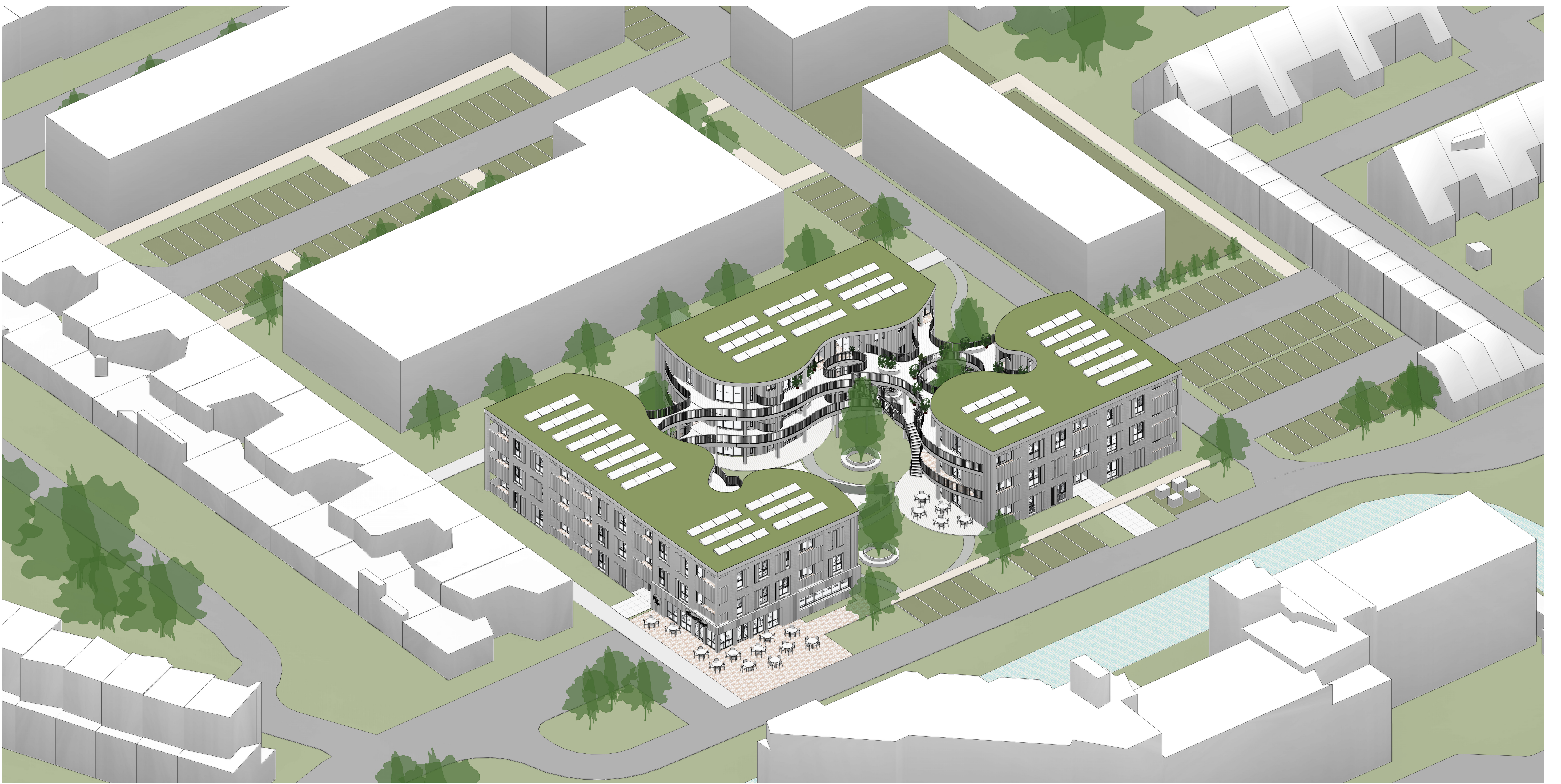

HOME IN HOUTWIJK

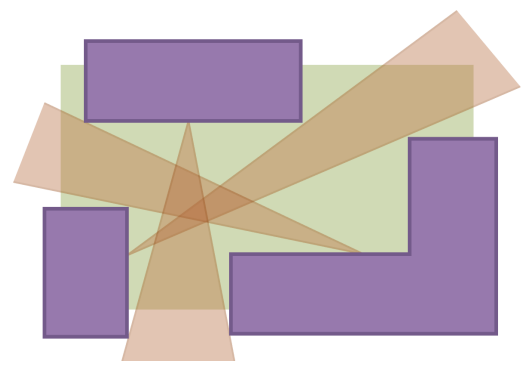

1. Sightlines/clear overview



2. Organic/soft forms:

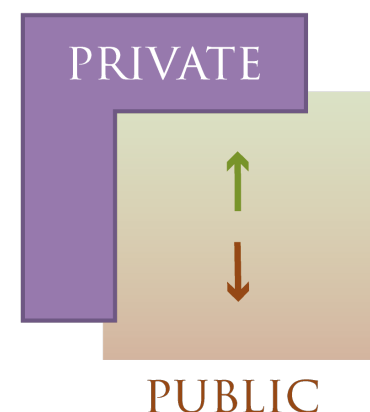

3. Layered privacy

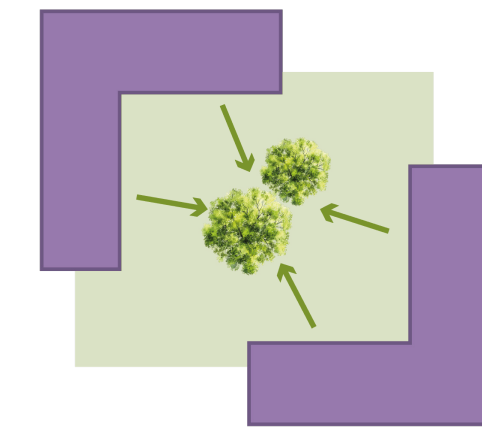

4. Oriented to greenery

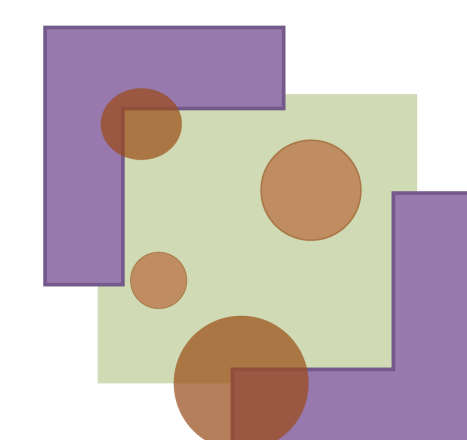

5. Formal and informal meeting places

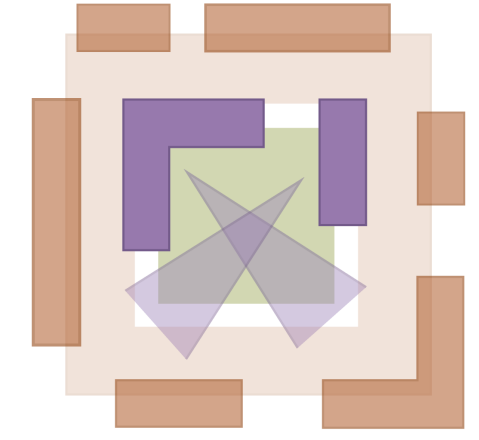

6. Openness to neighbourhood

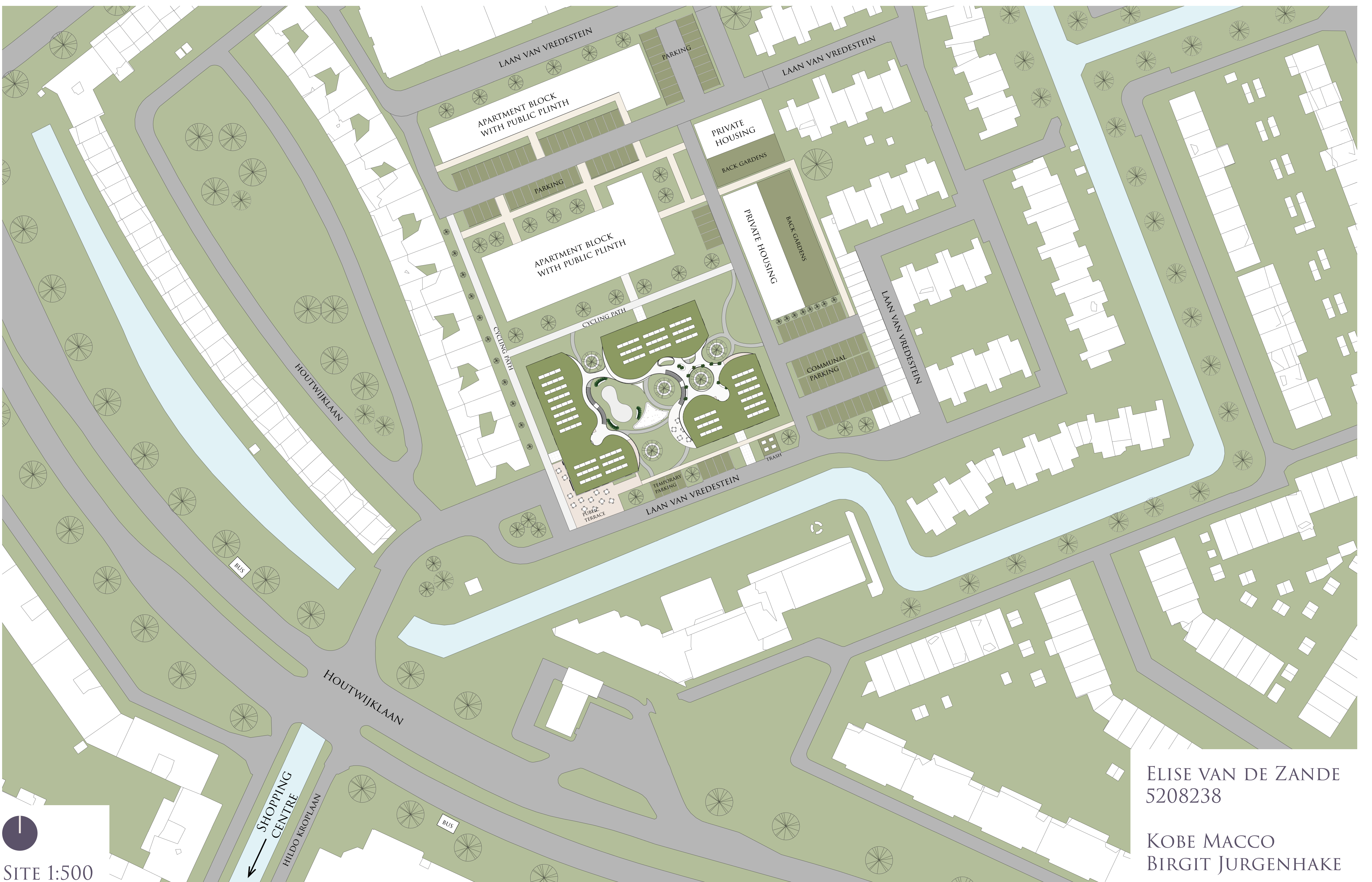

SITE 1:500

ELISE VAN DE ZANDE
5208238

KOBE MACCO
BIRGIT JURGENHAKE

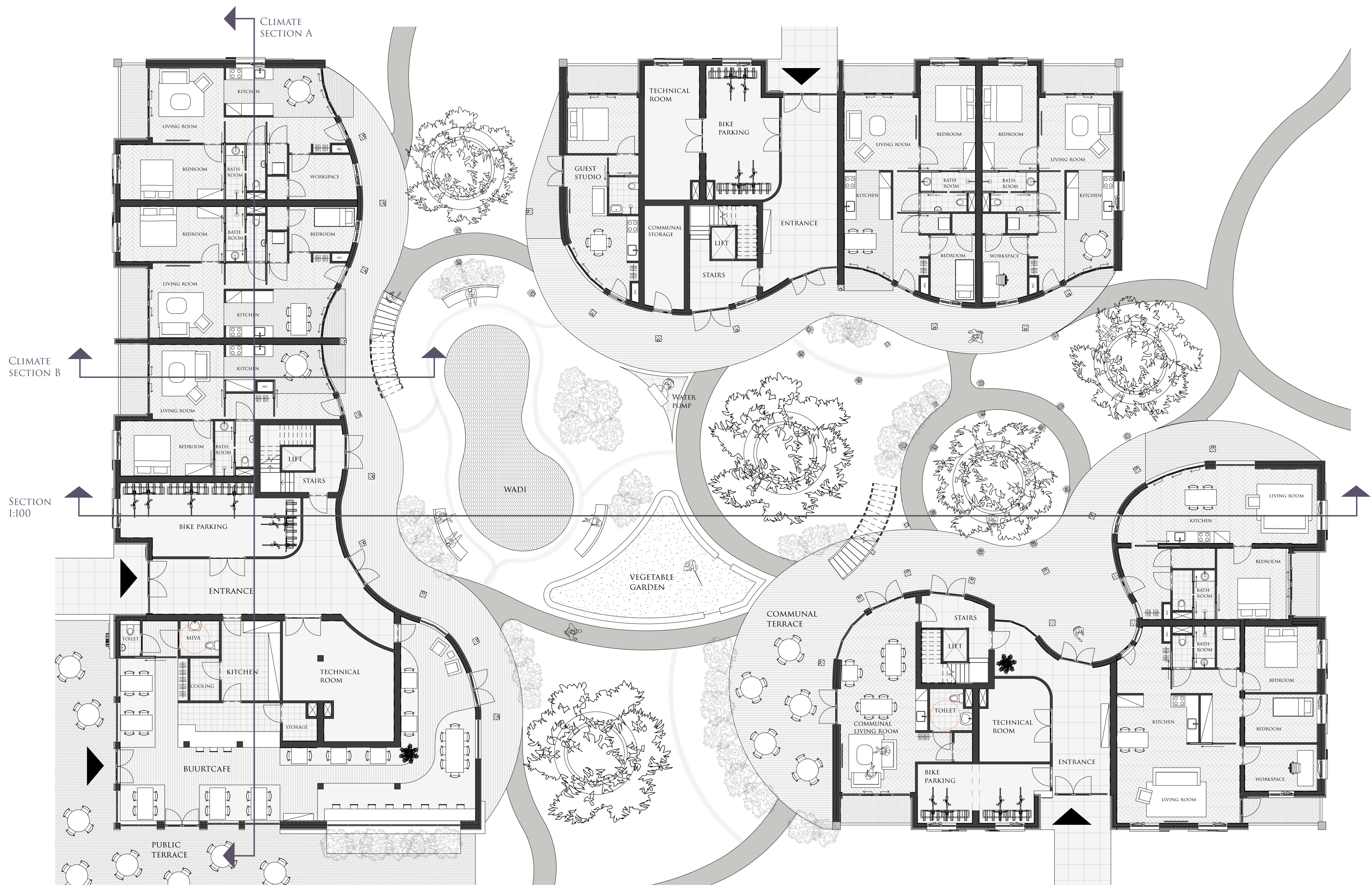

GROUND FLOOR
1:100

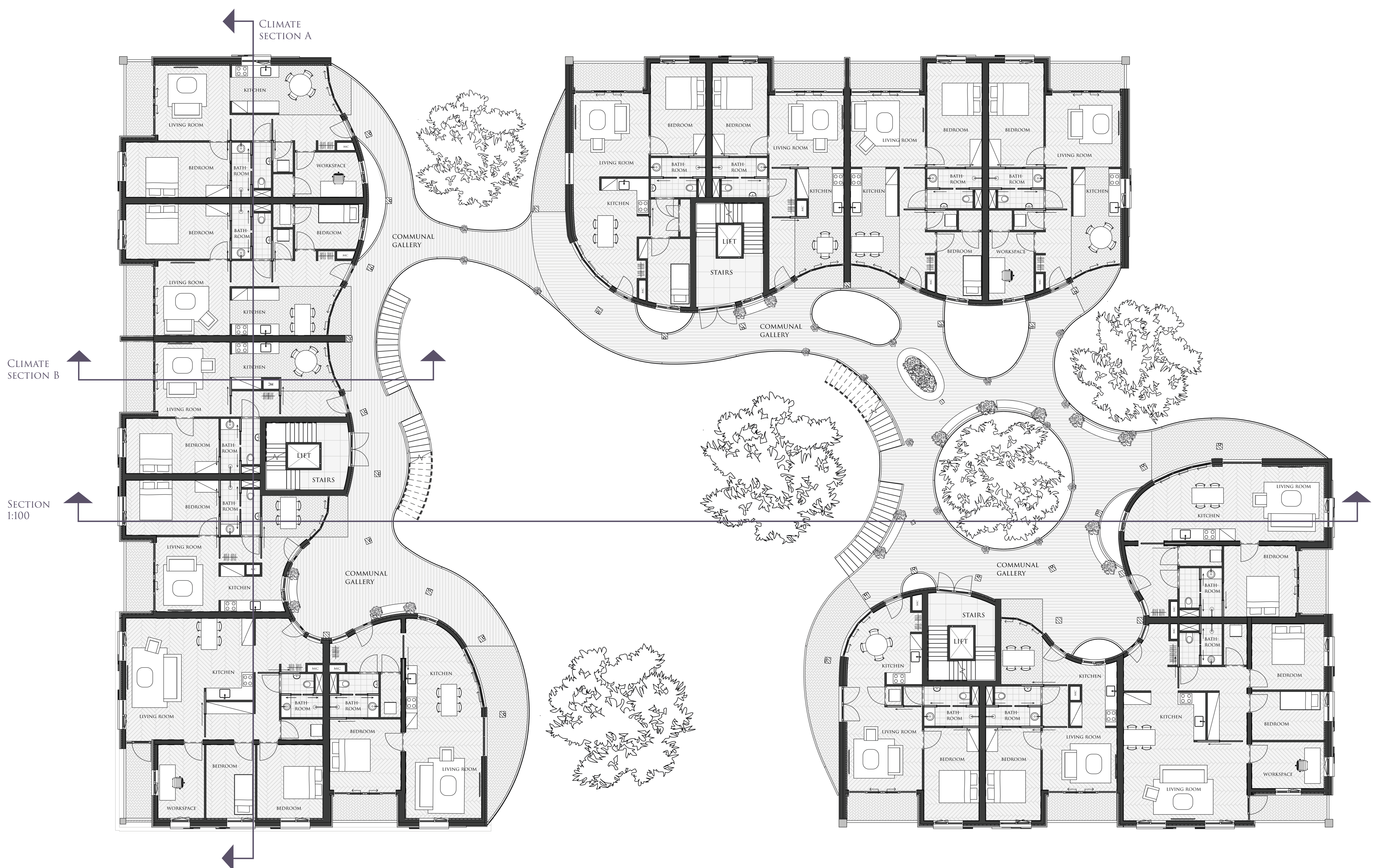

FIRST/SECOND FLOOR
1:100



SECTION 1:100



WEST FACADE
1:100

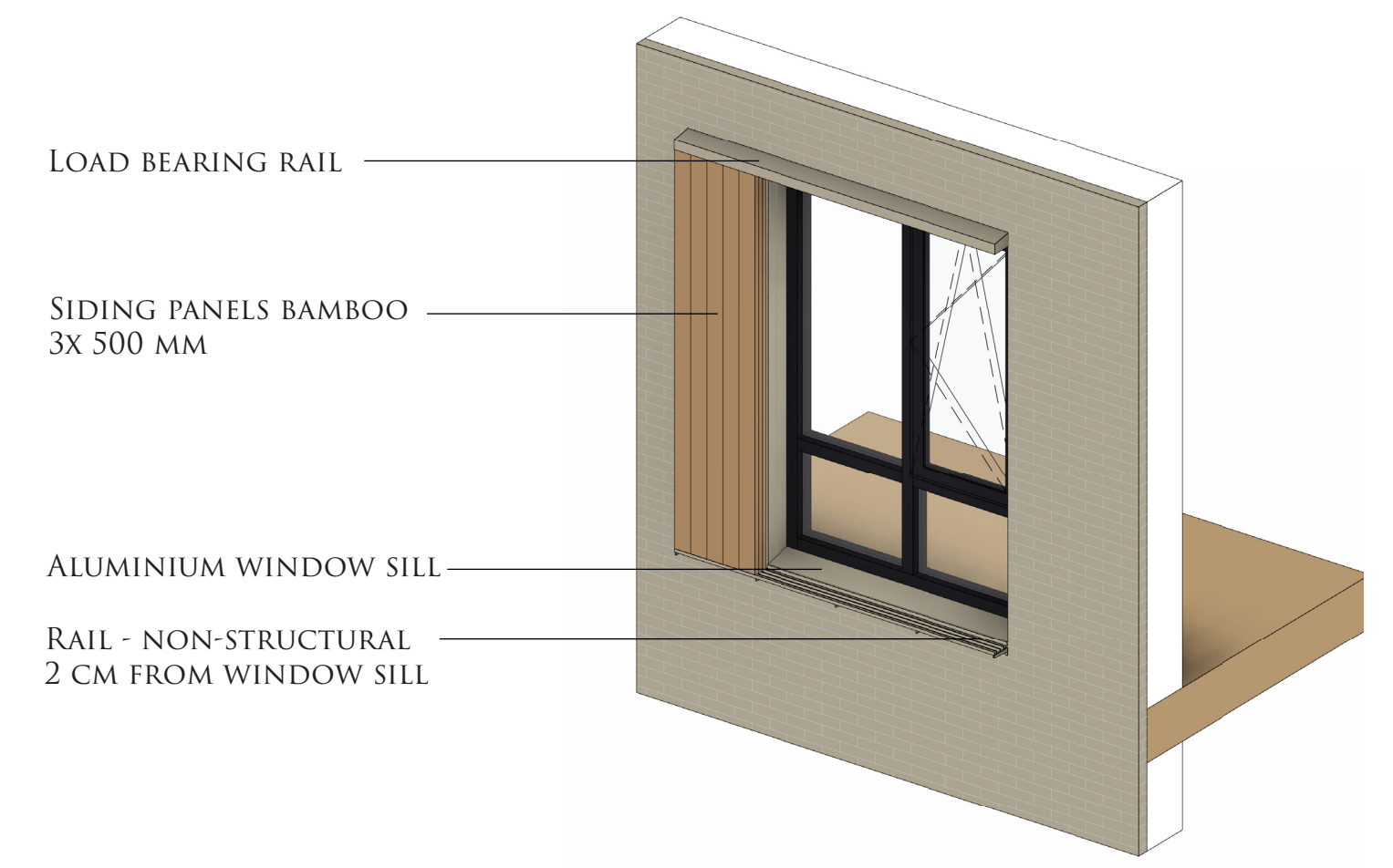

SLIDING PANELS
FOR SUNSHADING
OPEN



SOUTH FACADE
1:200

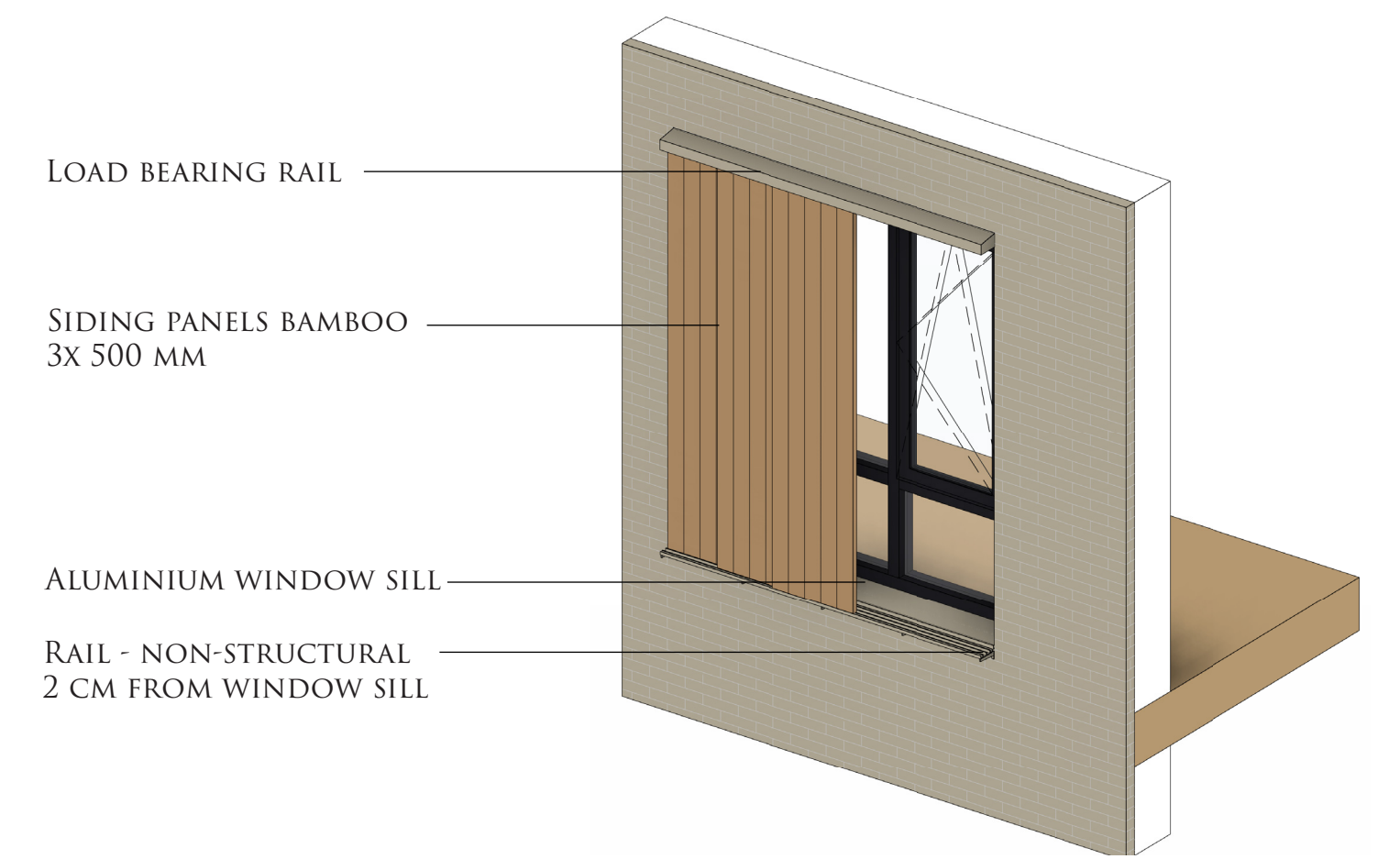

SLIDING PANELS
FOR SUNSHADING
CLOSED



EAST FACADE
1:200



NORTH FACADE
1:200



EAST FACADE COURTYARD
1:100

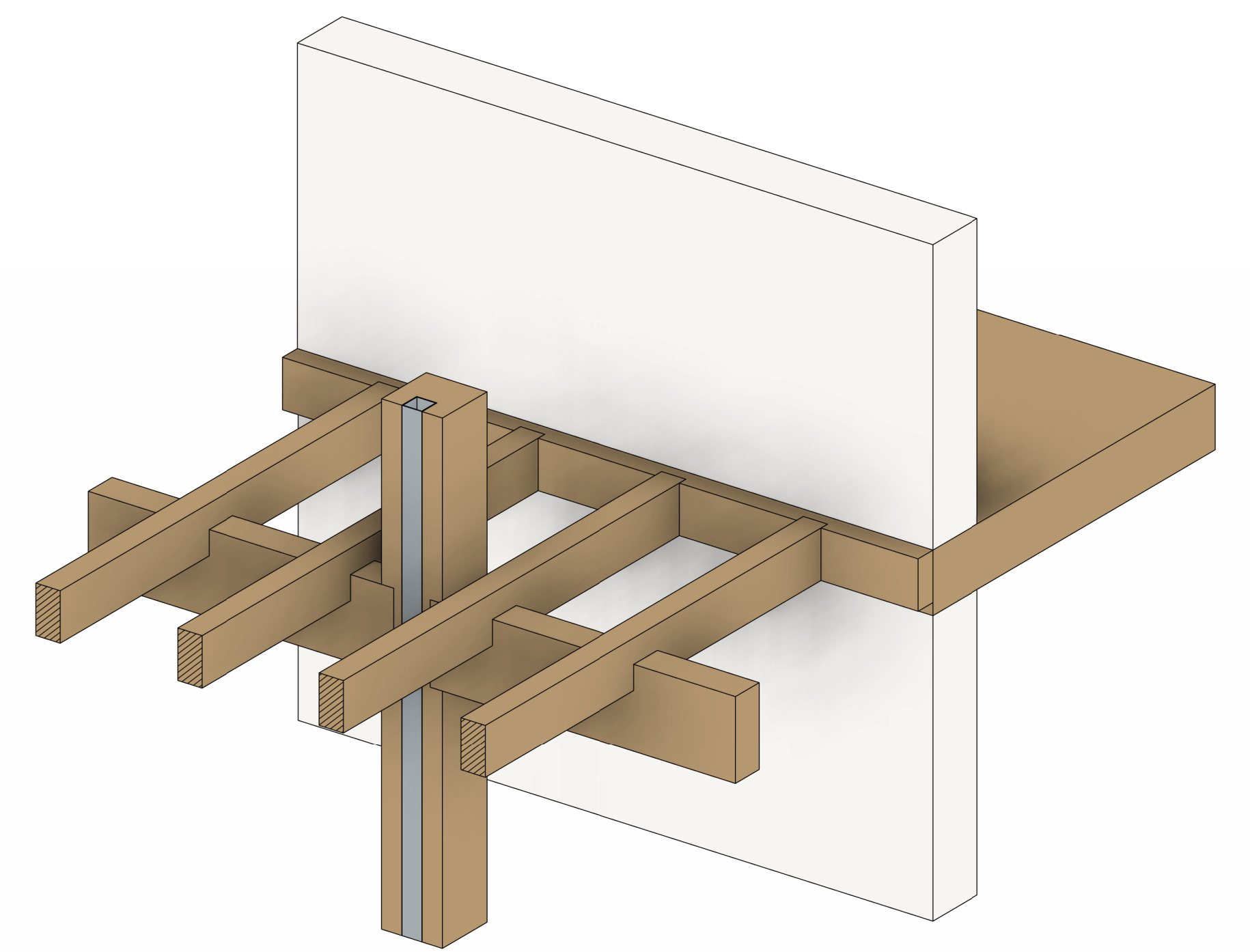

3D DETAIL
CONSTRUCTION GALLERY



NORTH FACADE COURTYARD
1:200



SOUTH FACADE COURTYARD
1:200

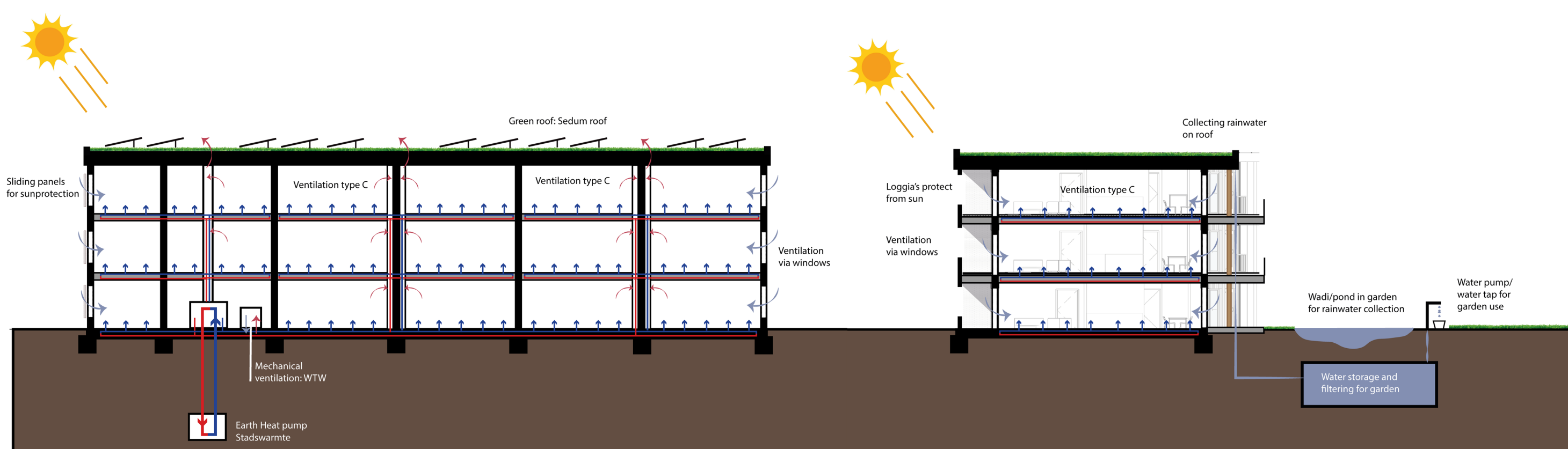

CLIMATE SECTION A
SUMMER

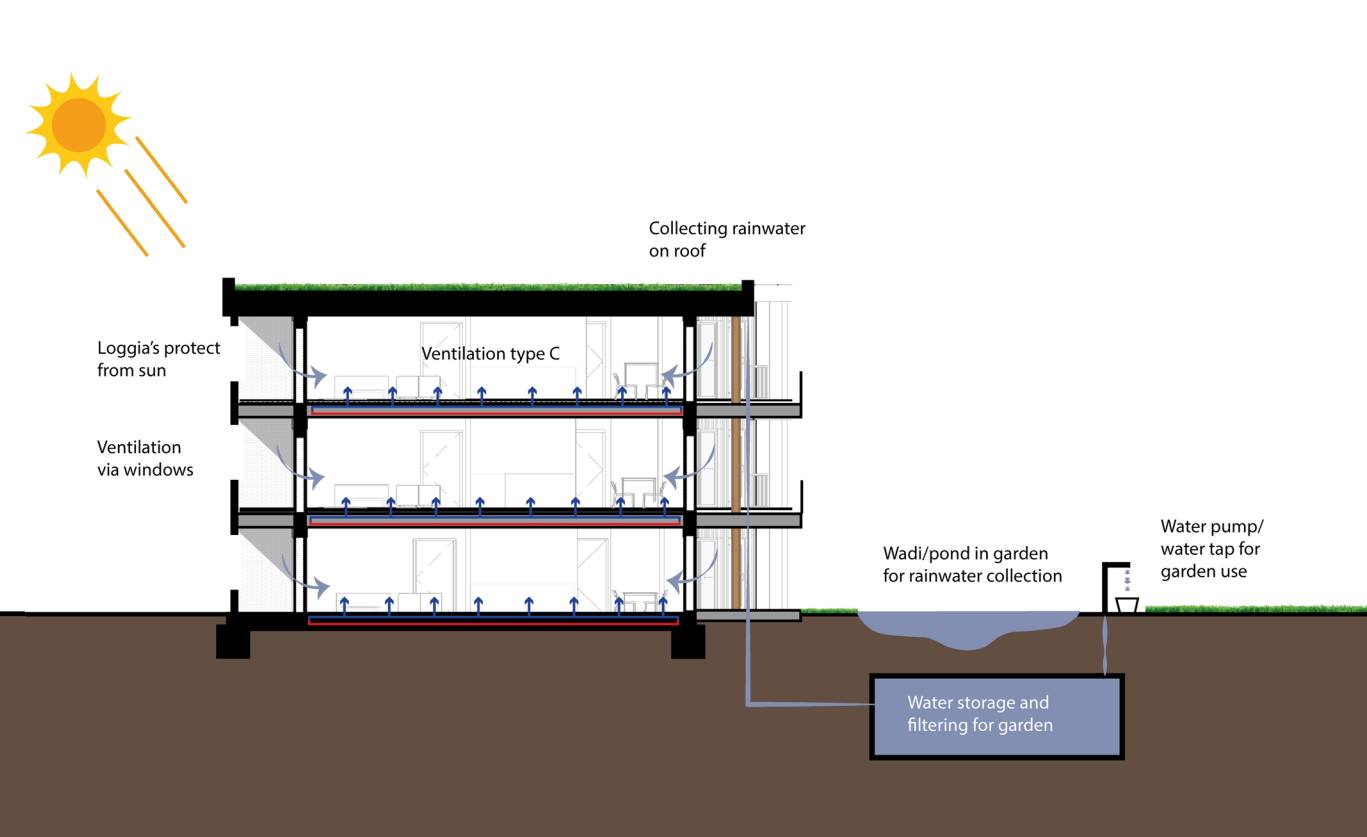

CLIMATE SECTION B
SUMMER

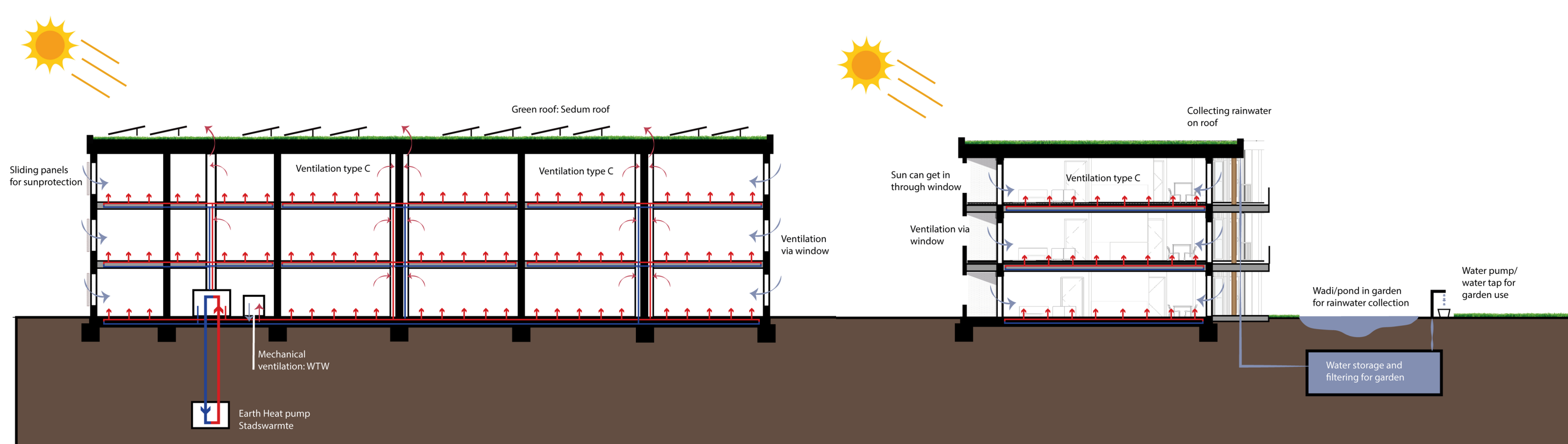

CLIMATE SECTION A
WINTER

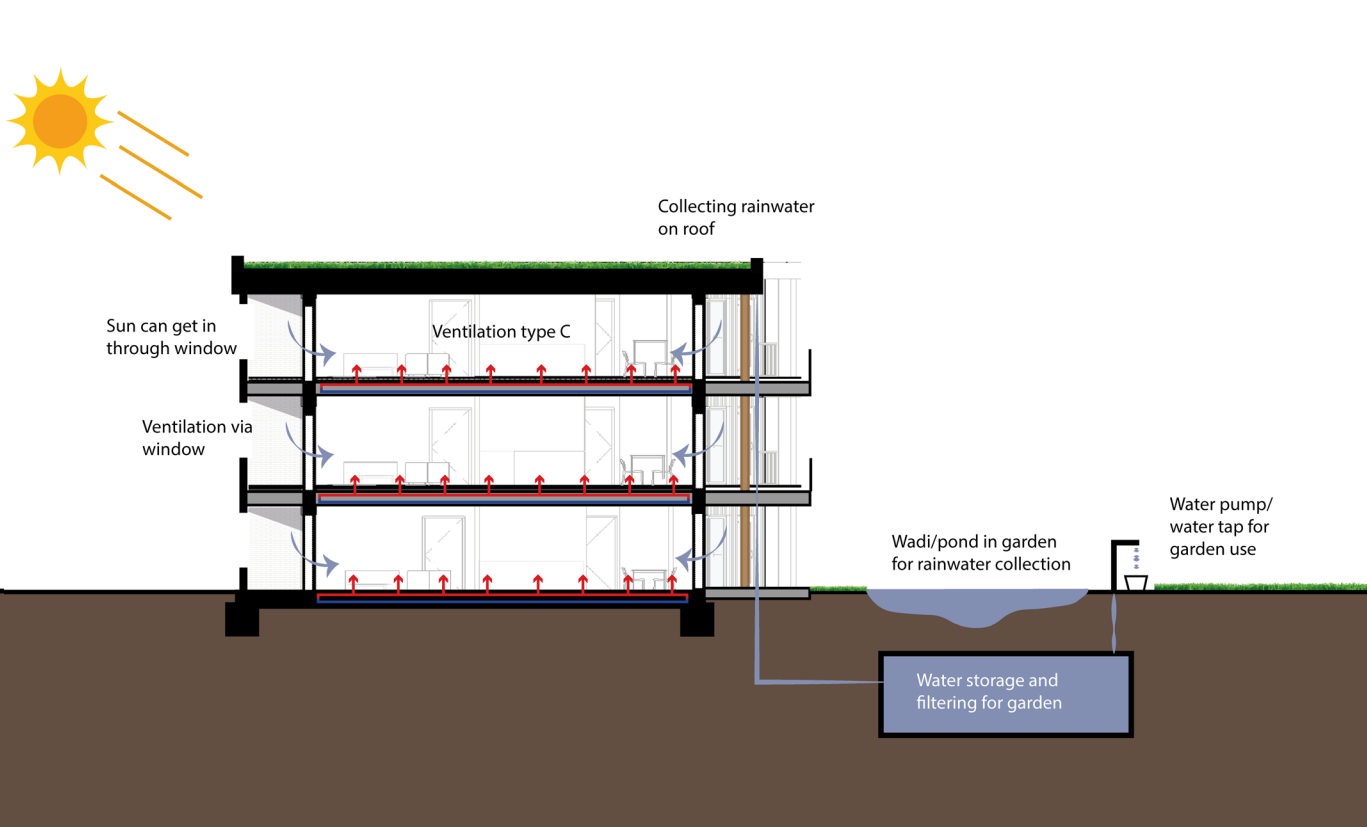

CLIMATE SECTION B
WINTER

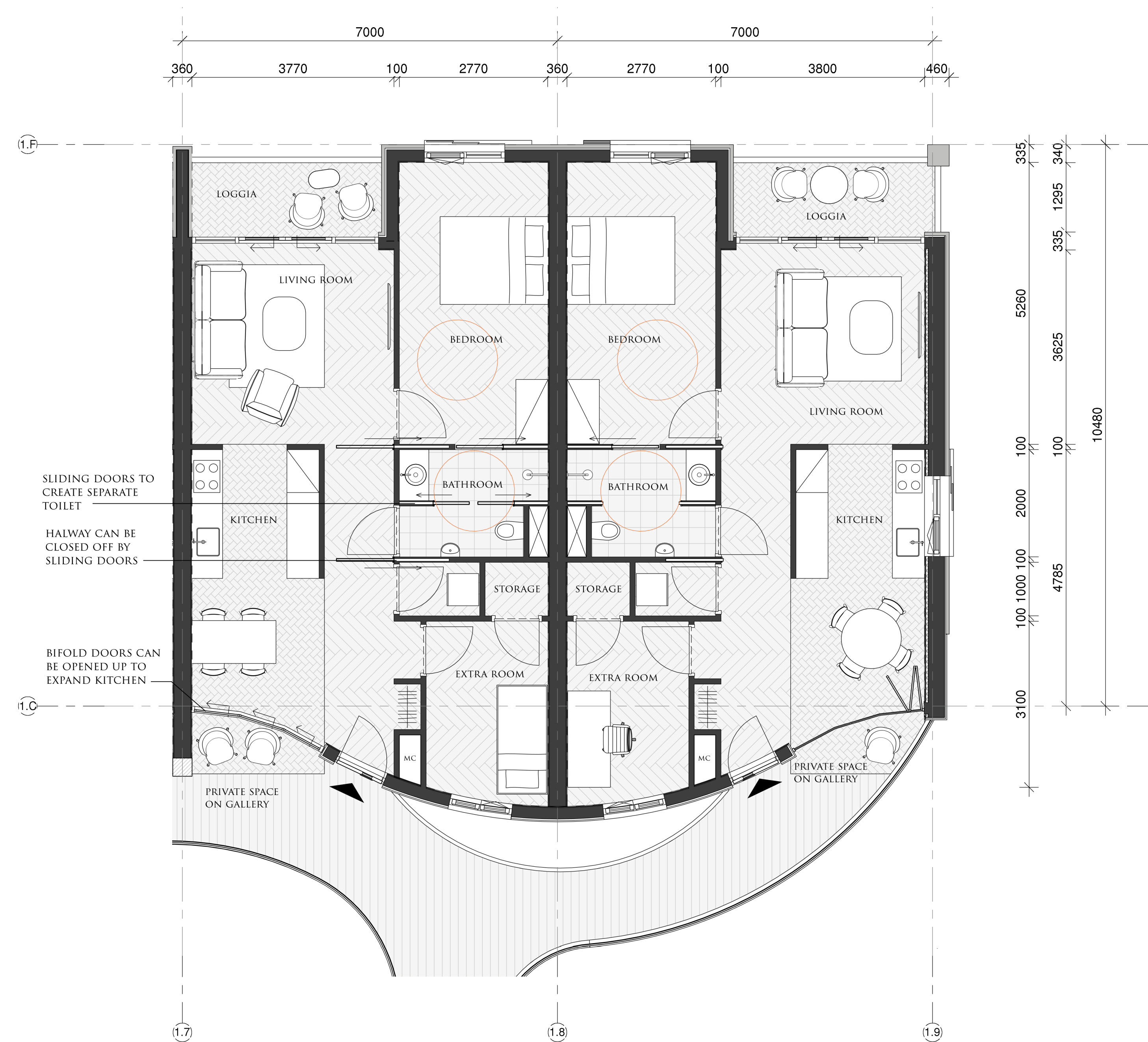

PLAN APARTMENT
1:50

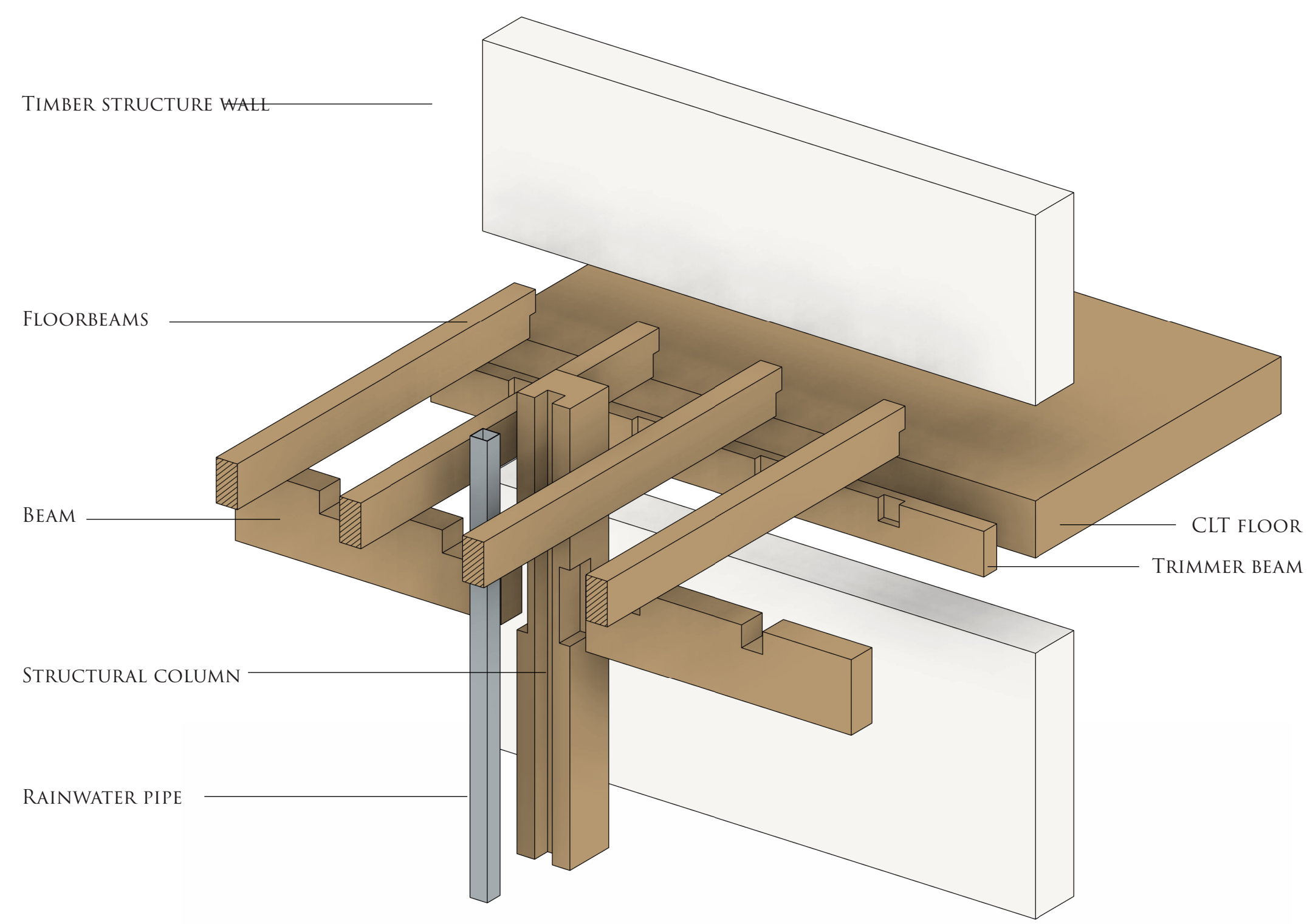

3D DETAIL
CONSTRUCTION GALLERY

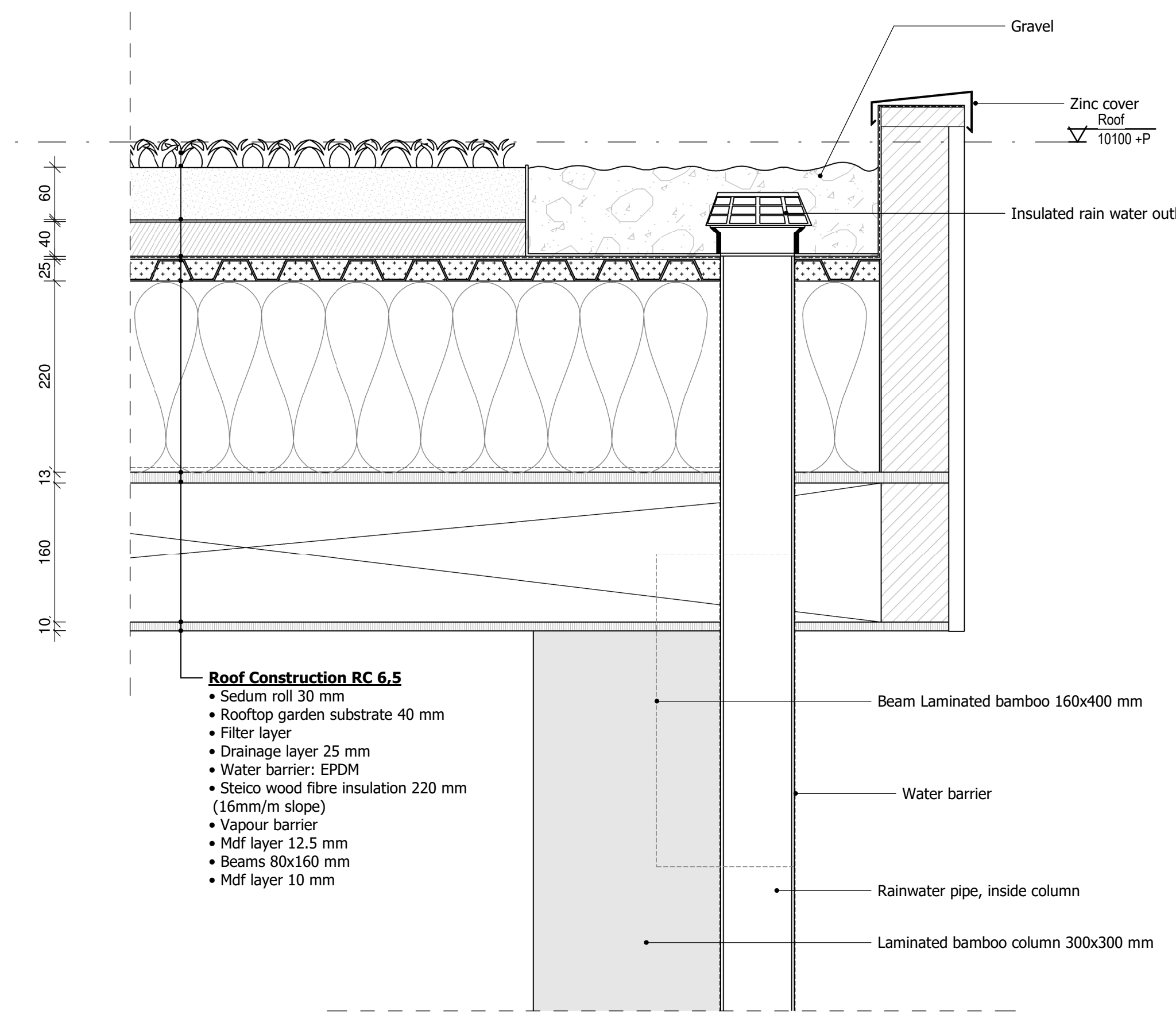

DETAIL C
1:5

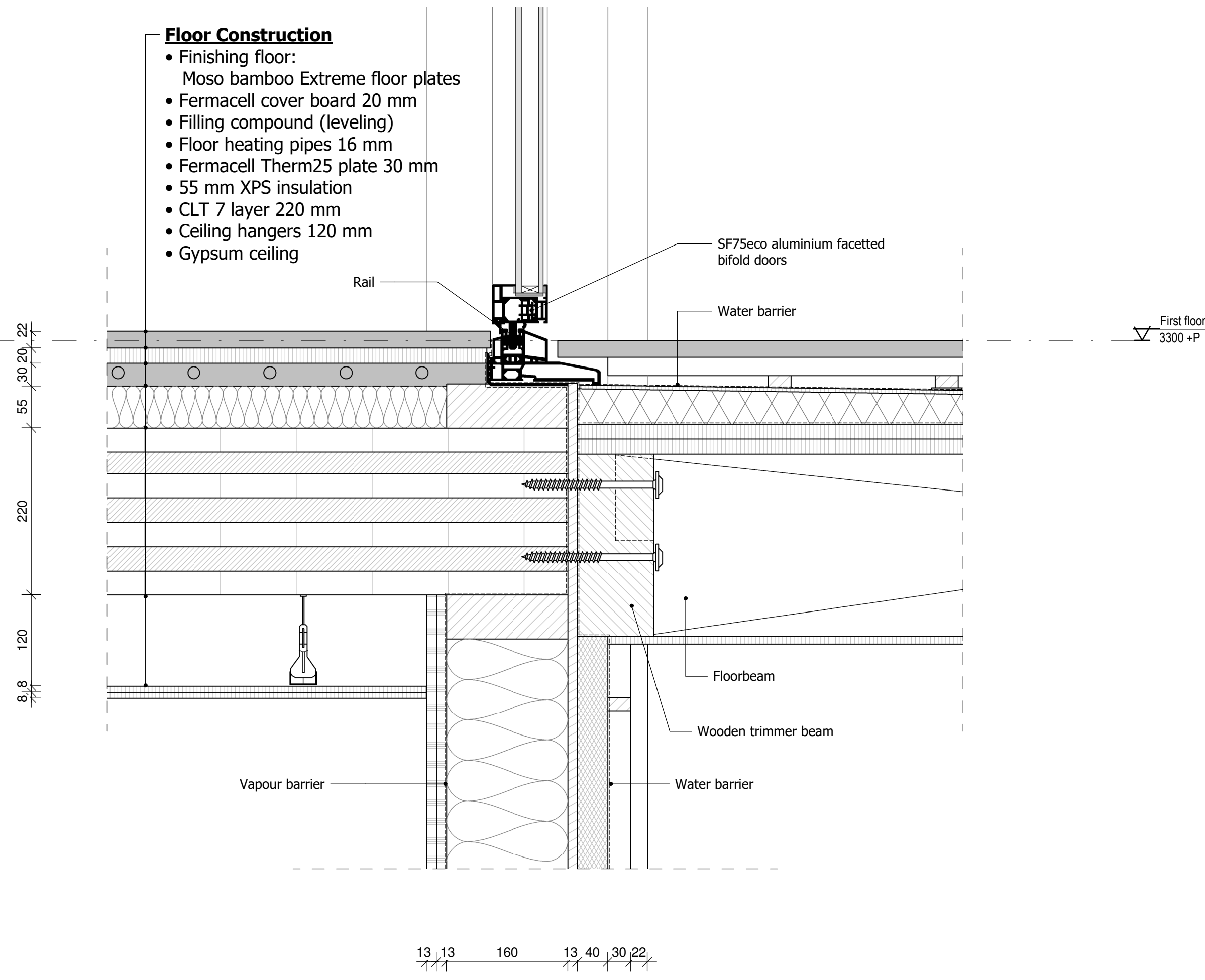

DETAIL A
1:5

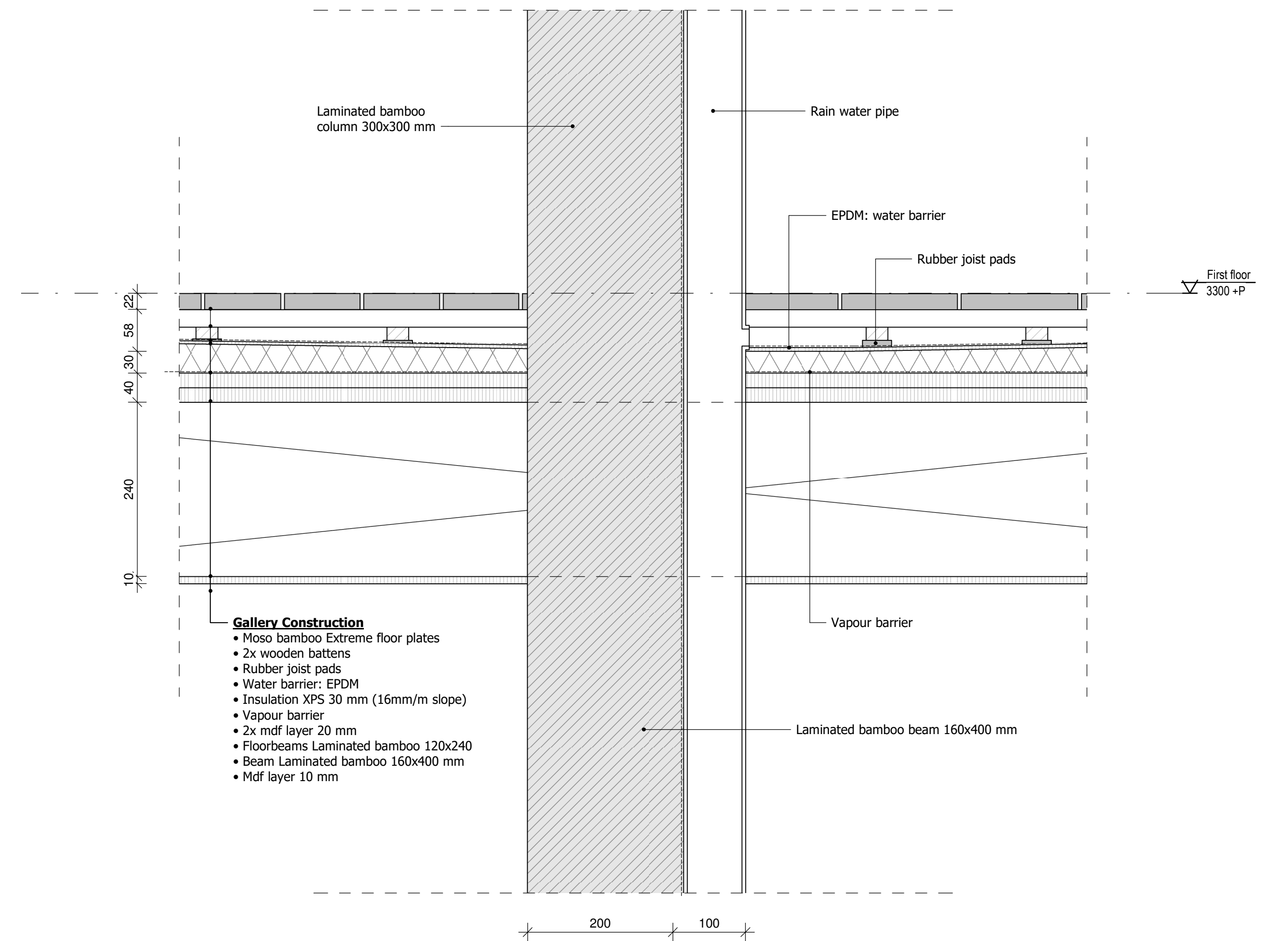

DETAIL B
1:5

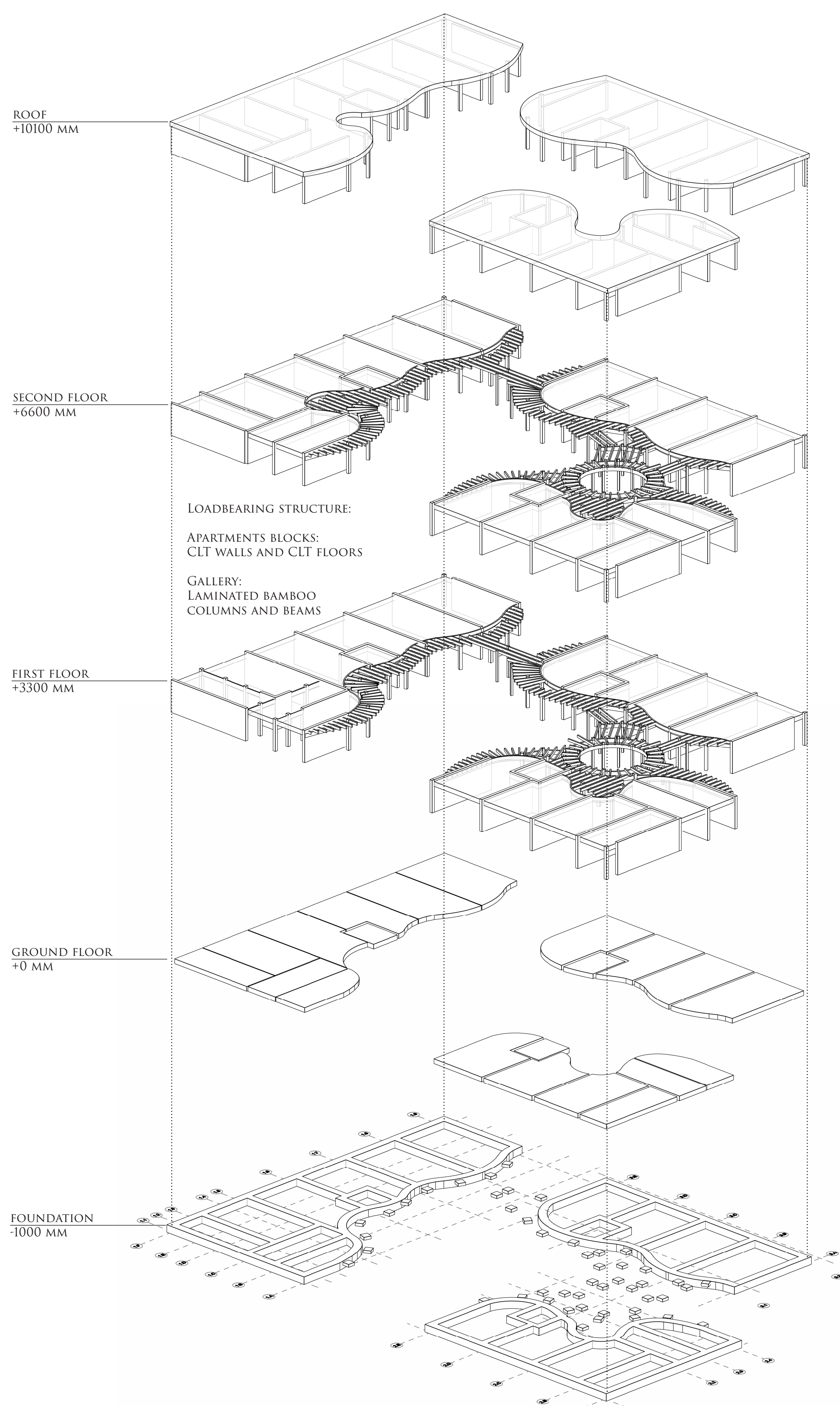

AXONOMETRY CONSTRUCTION

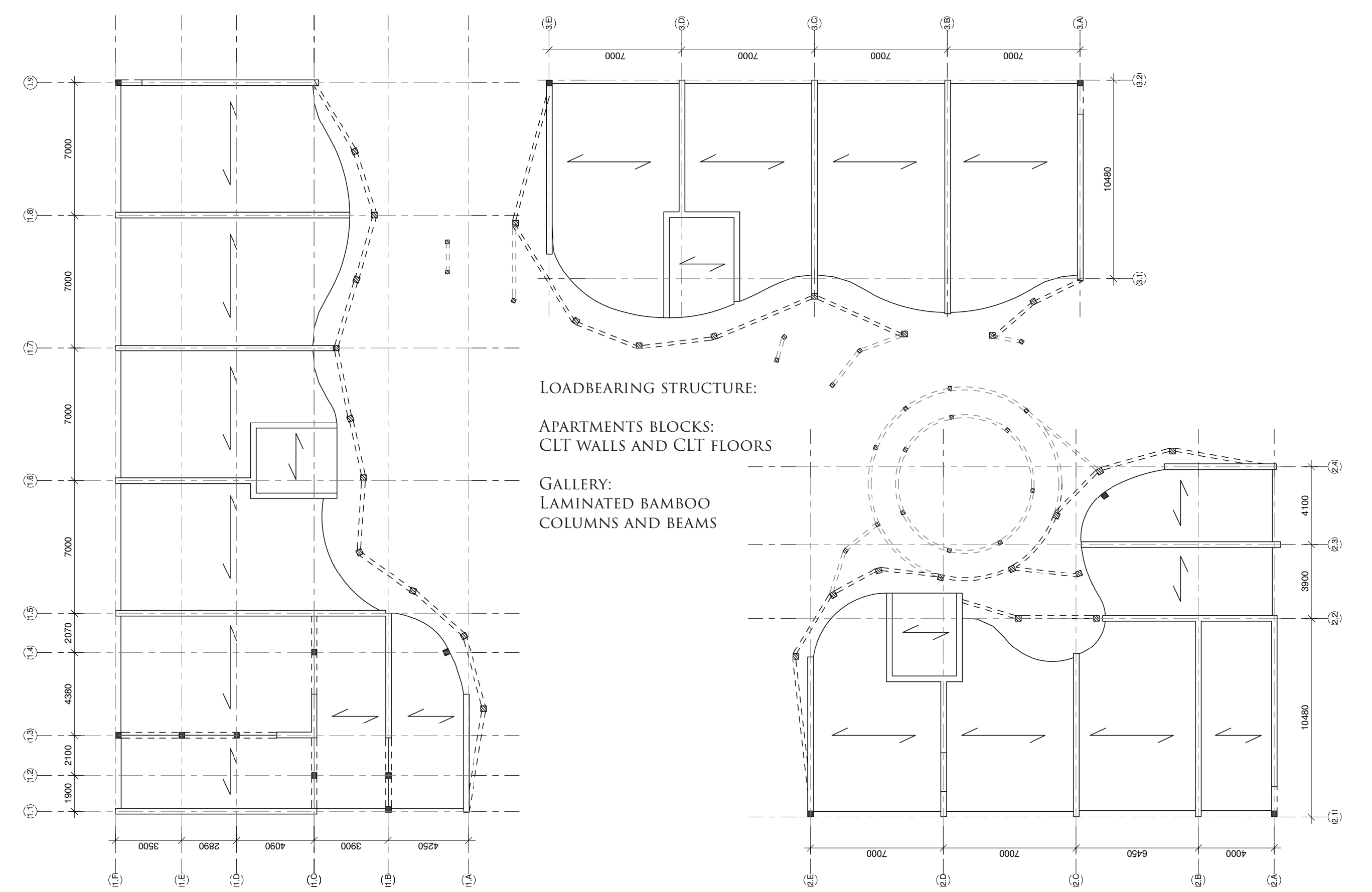

CONSTRUCTION PLAN GROUND FLOOR
1:200

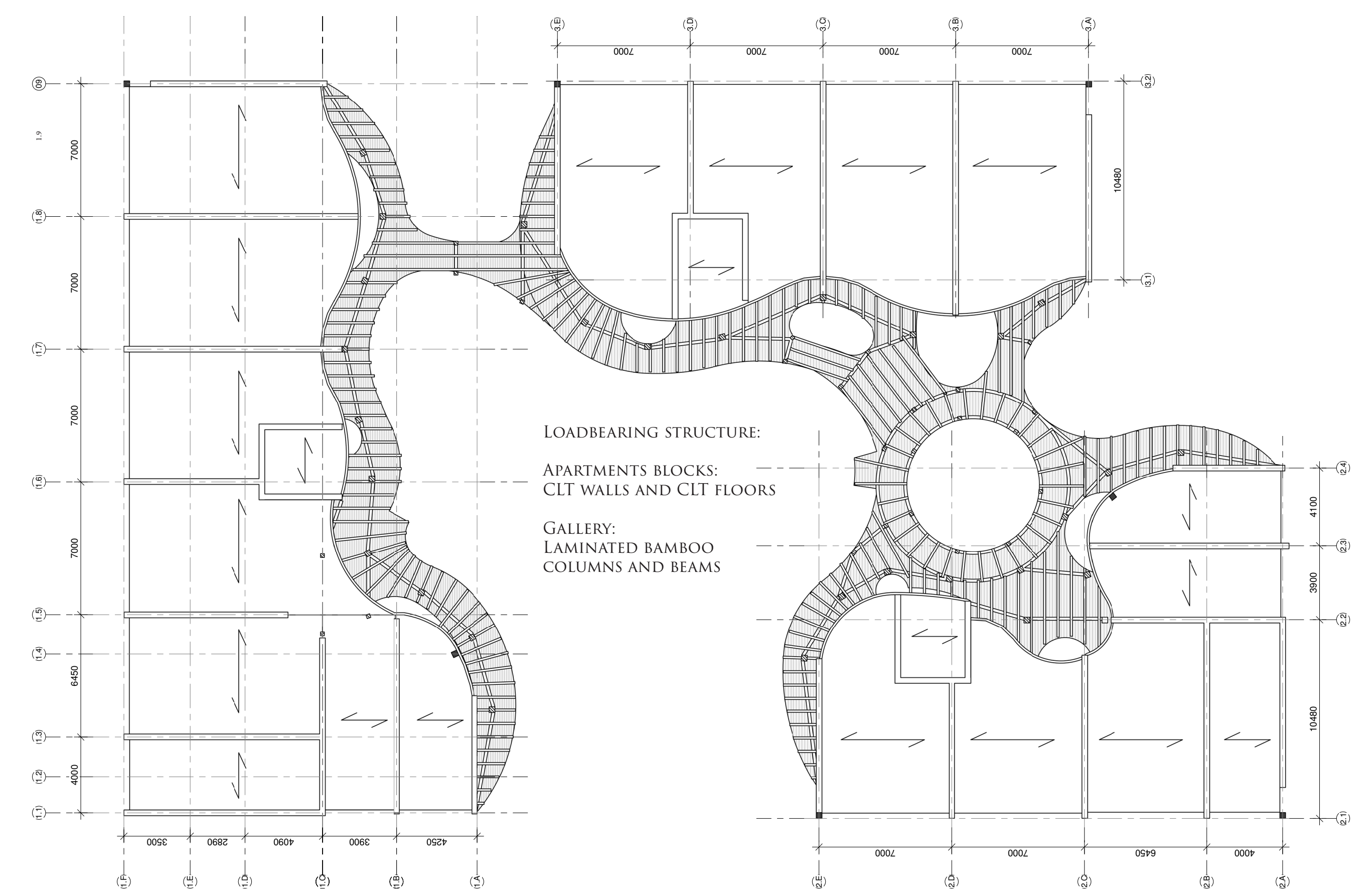

CONSTRUCTION PLAN FIRST/SECOND FLOOR
1:200