

The Space of Dynamic Informality

Jiayun Xu | 4718305

research
a study of marginal space and informal practice

The Margins

_the blank space that surrounds the contents on a page,
the free space beyond the written order of things

_related to the urban and architectural point of view,
the margin exists as a leftover of the building attempt, an additional functionless amount of space...
in the meantime, beyond predetermined regulations and built structures

_a "hidden" layer of urban fabric; unnoticed

_informal practices: temporary occupation / longer inhabitation,
thus the marginal spaces are also in constant change

_two main categories:
thresholds; leftover spaces

Baku's (formal) Urban Fabric
along the Railway

0 100 200 400 800

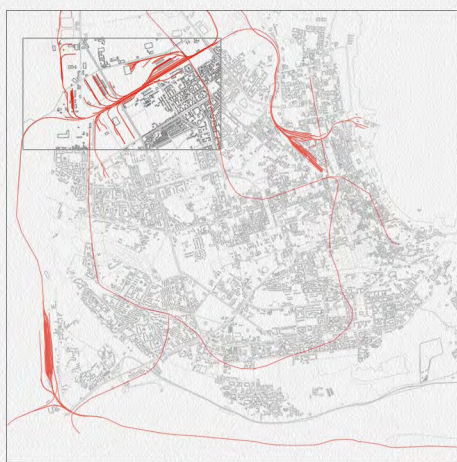



Baku's Marginal spaces
along the Railway



Temporary Use / Occupy



Inhabitation

(informal) human practices
happen spontaneously in the margins

Temporary Use / Occupy

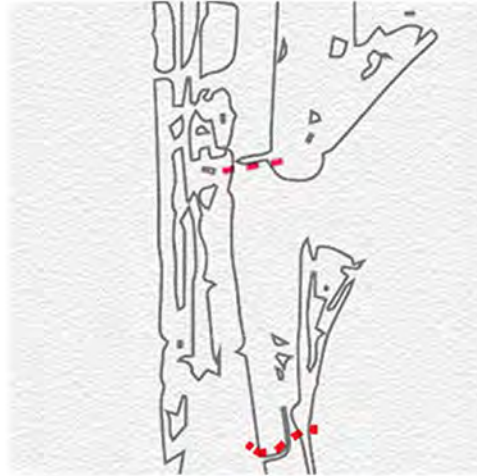

Inhabitation

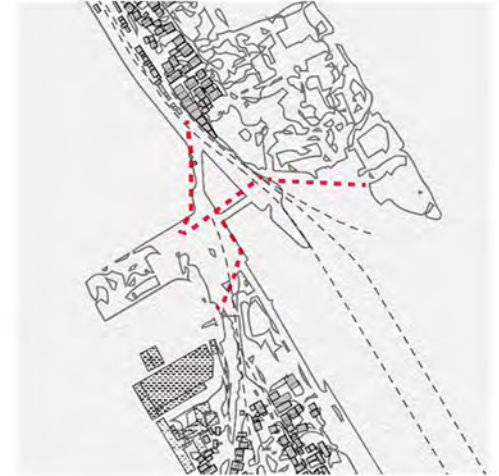
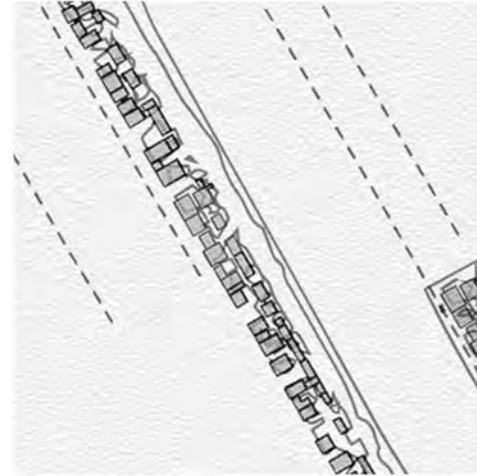

with human practices accumulated,
the margins tend to form some linkages (with neighbors)
and expand outwards



Inventory Catalog

Thresholds

threshold

Thresholds are transitional spaces. They are the waiting area between one point in time and space and the next. It is not the destination but a intermediate state / Office, when we are in liminal spaces we have the feeling of just being on the verge of something.

Image: a self-built housing area located in an enclosure in between the railway

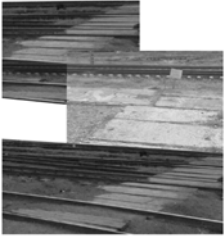



in-between space

A transition area, from one independent area / object to another

Image: railway in between two (former) self-built residential areas, which have no direct connection, so that people use the railway as a road, to go from one block to the opposite one







interstitial space

A relatively private space within or around the public area, usually in an unorthodox corner and has informally occupied.

Image: a self-built housing area located in an enclosure in between the railway

Left-over spaces

vacant land / void

Land which is now vacant and could be redeveloped without treatment including demolition, clearing of flood structures of foundations and building.

Image: a land-to-be built







terrain vague

An unused area of land, waste ground, not built

Image: a grassland in between the railway track and factory/old built housing area







non-place & its vacuum

Non-place act as an instrument, purely functional, people pass by and nobody feels emotionally attached to.

Vacuum emerges when some kind of barrier exists what otherwise be accessible space to pedestrians.



Image: under a viaduct highway

left-over space

Usually being a part of the construction plan, but in the actual process, a space just is left-over



Image: left-over spaces of the railway

edge space

Space at the edge of channel urban space / construction



Image: a water-filled wasteland in between the railway and a linear self-built residential area

temporary place

A vacant / unused land has been temporary occupied



Image: a camp tent, in a vacant ground inside the woods along the railway

free zone / autonomous zones

A space where nobody claims its ownership, and their spontaneous occupation starts to take place, forming a spontaneous micro-community outside the formal world.

Image: a partially self-built housing area under the overpass of former industrial structure

Experiment - Generation 1

Abstraction

threshold

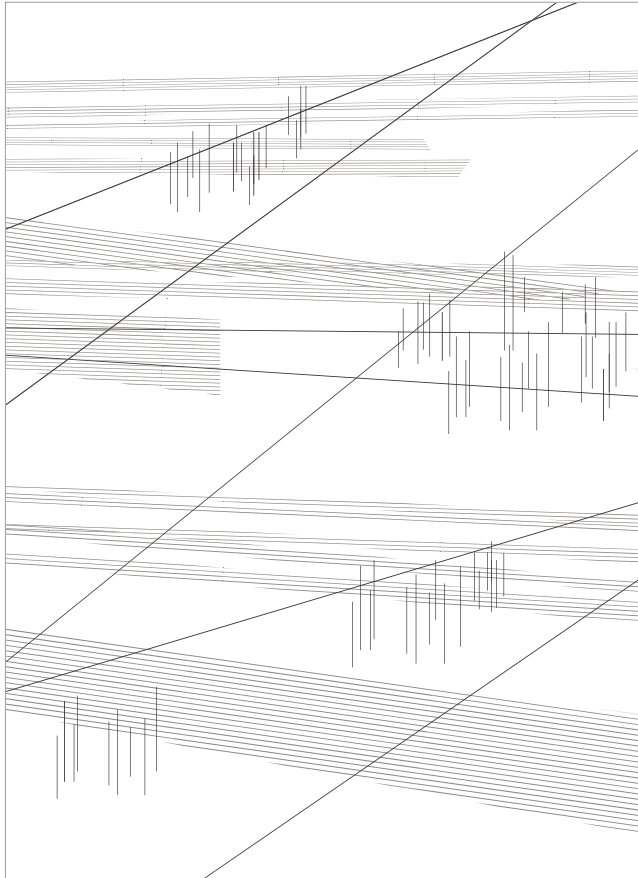

in-between space

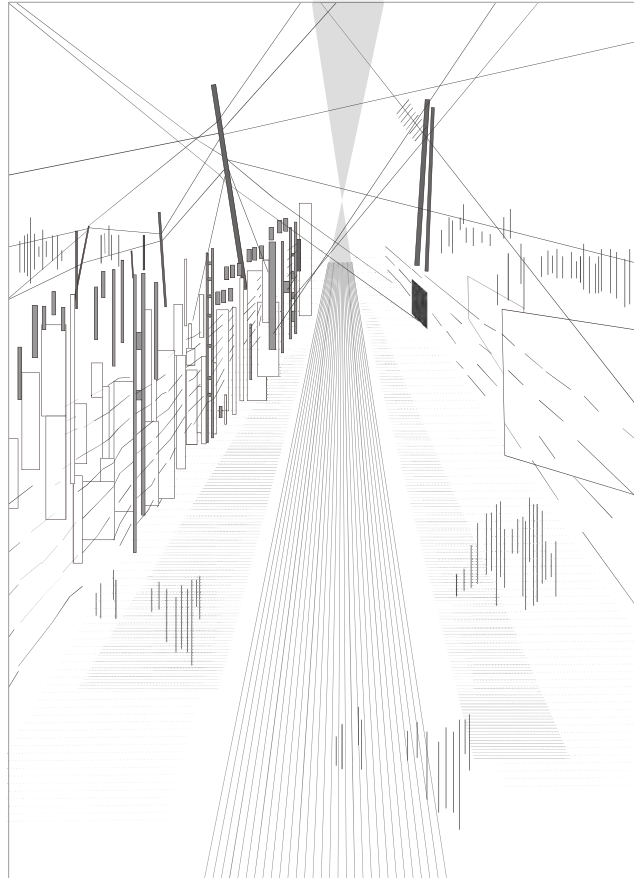

interstitial space

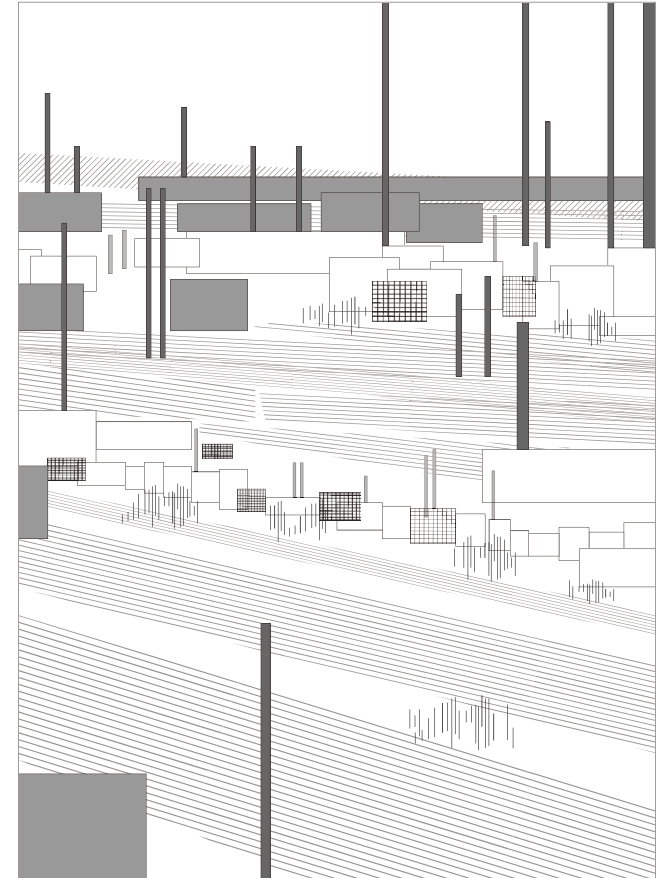

Thresholds

Experiment - Generation 1 Abstraction

void

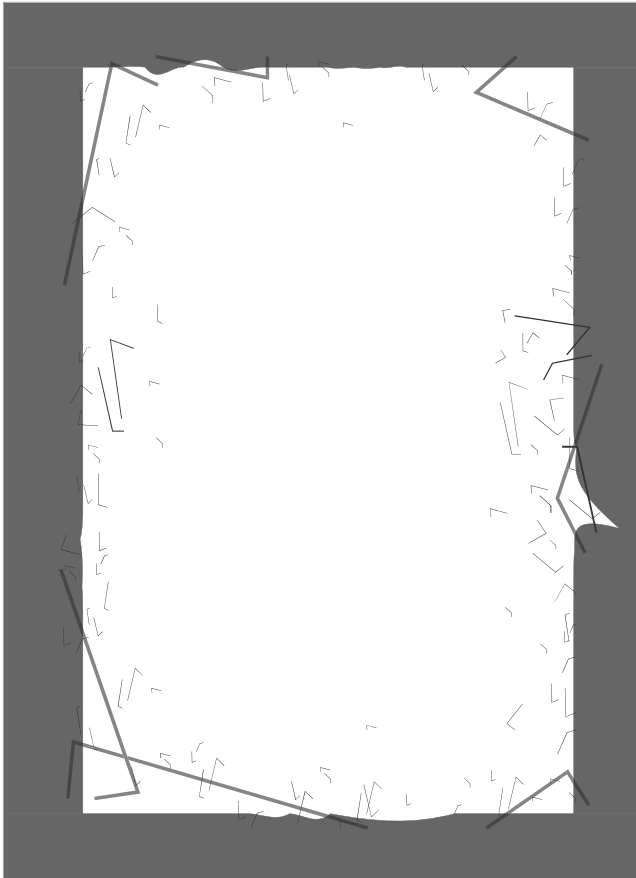

terrain vague

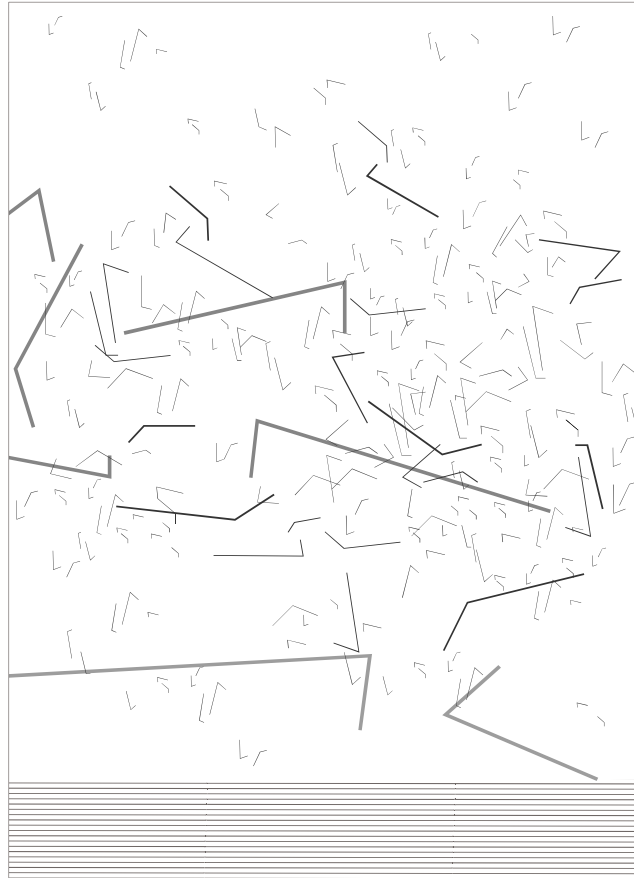

non-place & its vacuum

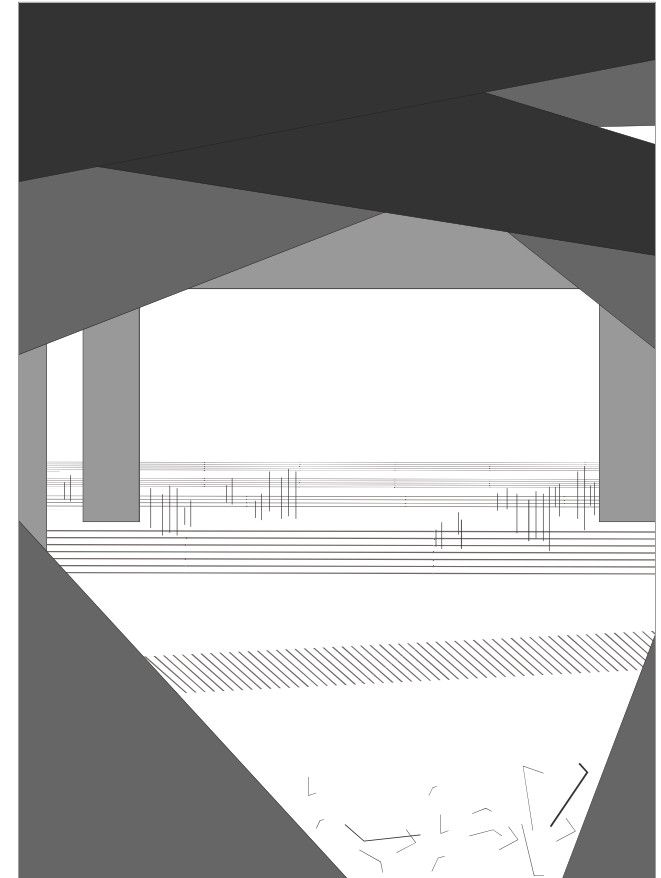

Leftover Spaces

Experiment - Generation 1 Abstraction

leftover space

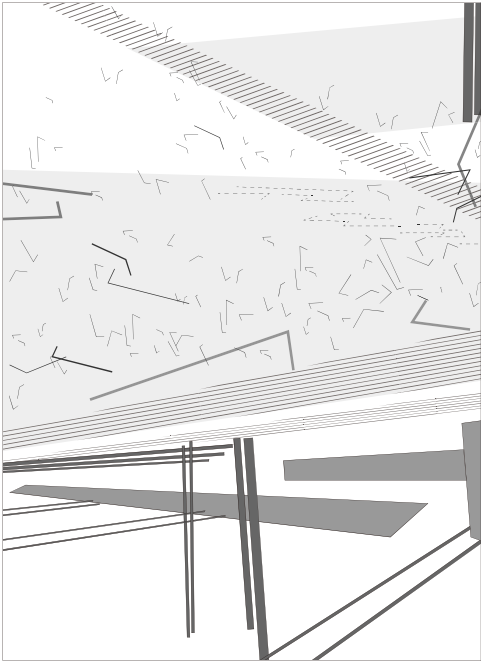

edge space

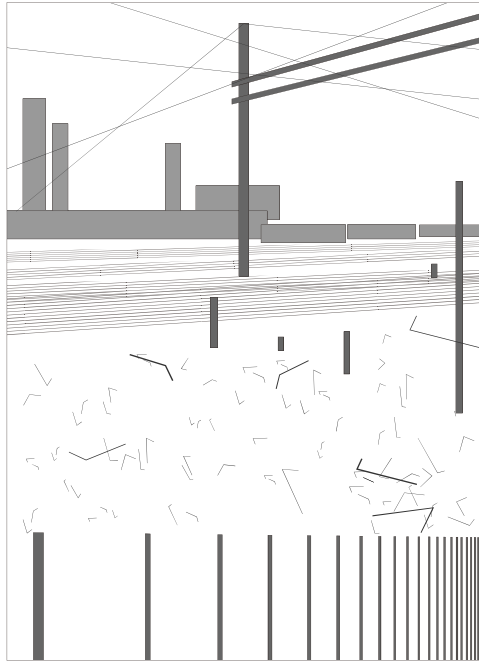

temporary place

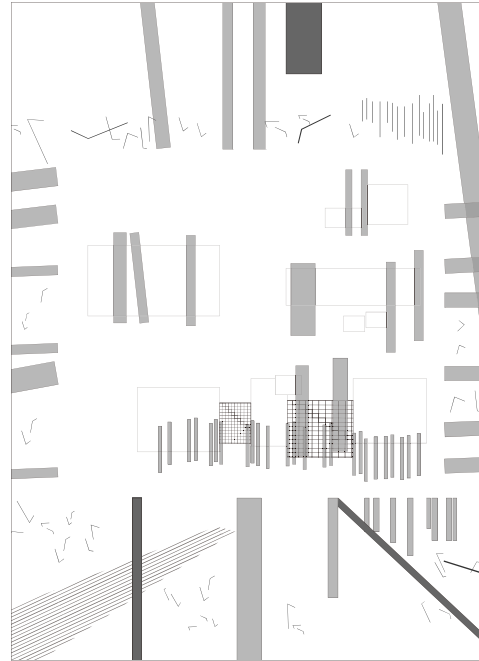

free zone

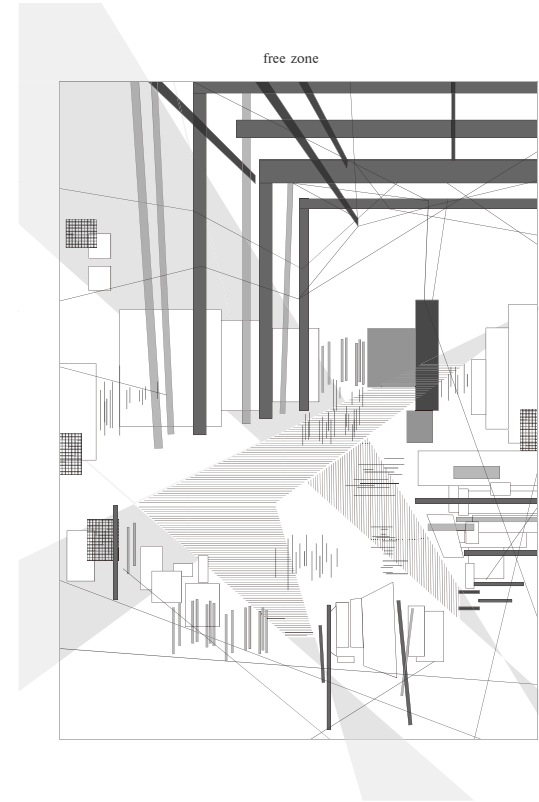

Leftover Spaces (>>> Free zone)

Experiment - Generation 3 - Intuitive Architectural Understanding

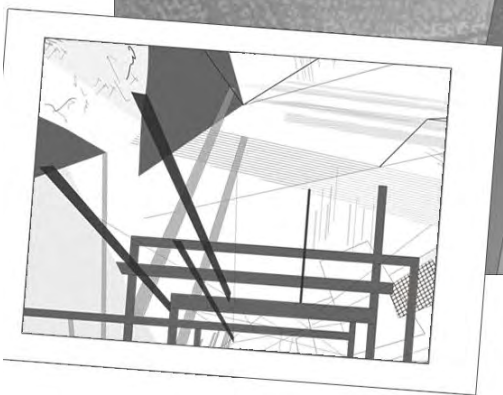
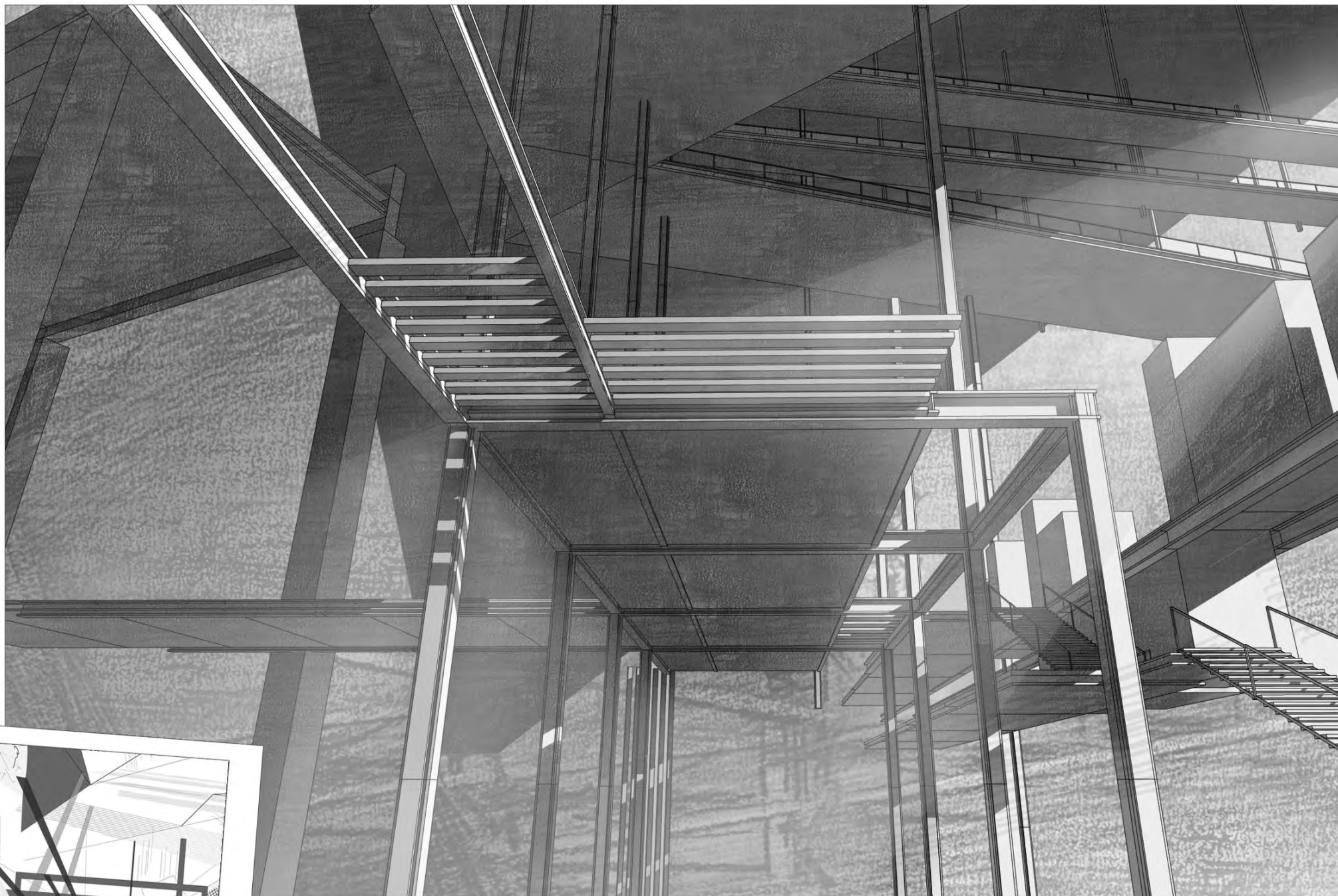

Experiment - Generation 3 - Intuitive Architectural Understanding

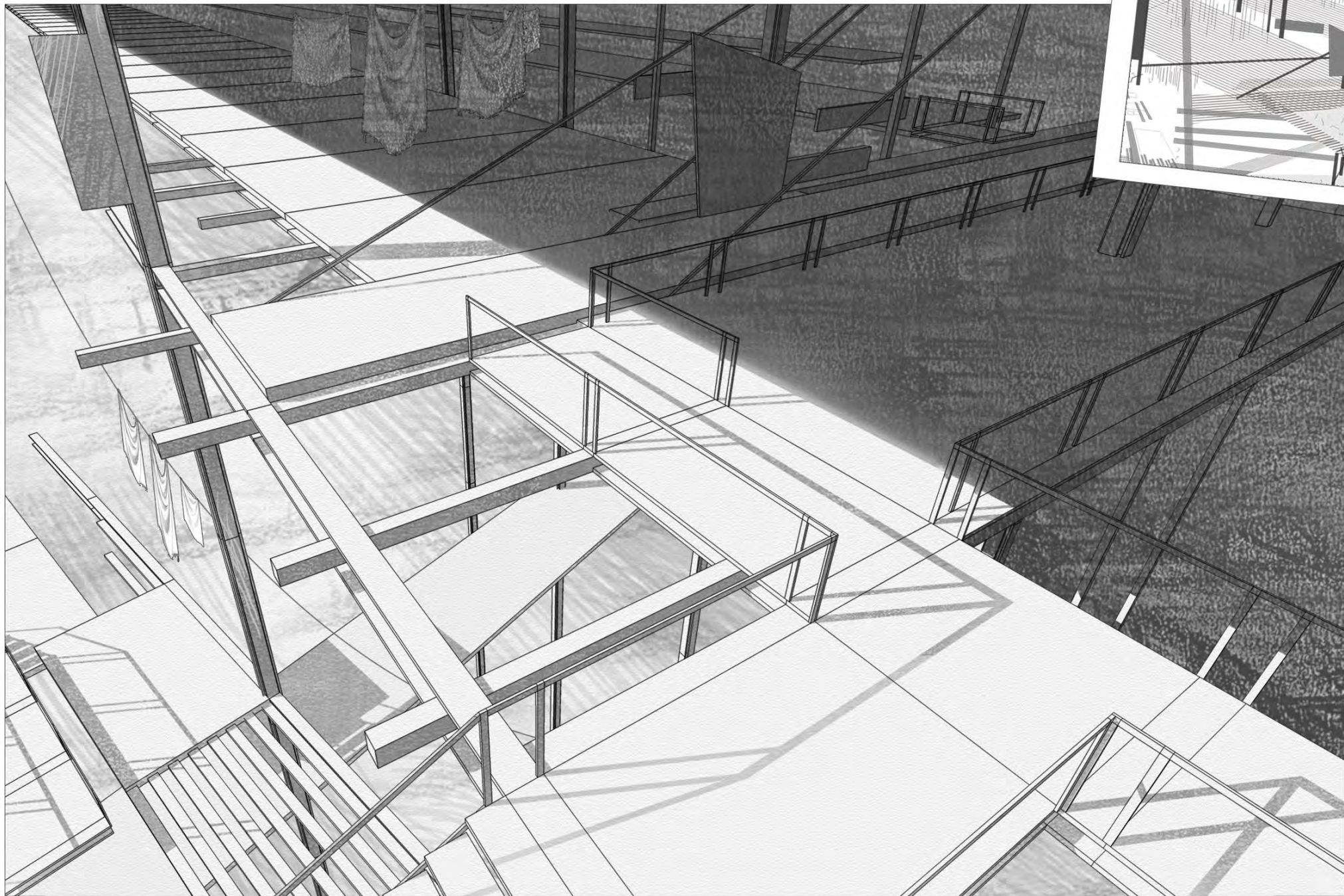

Experiment - Generation 3 - Intuitive Architectural Understanding

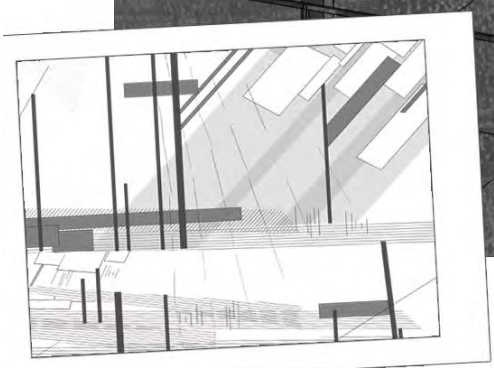

Experiment - Generation 3 - Intuitive Architectural Understanding

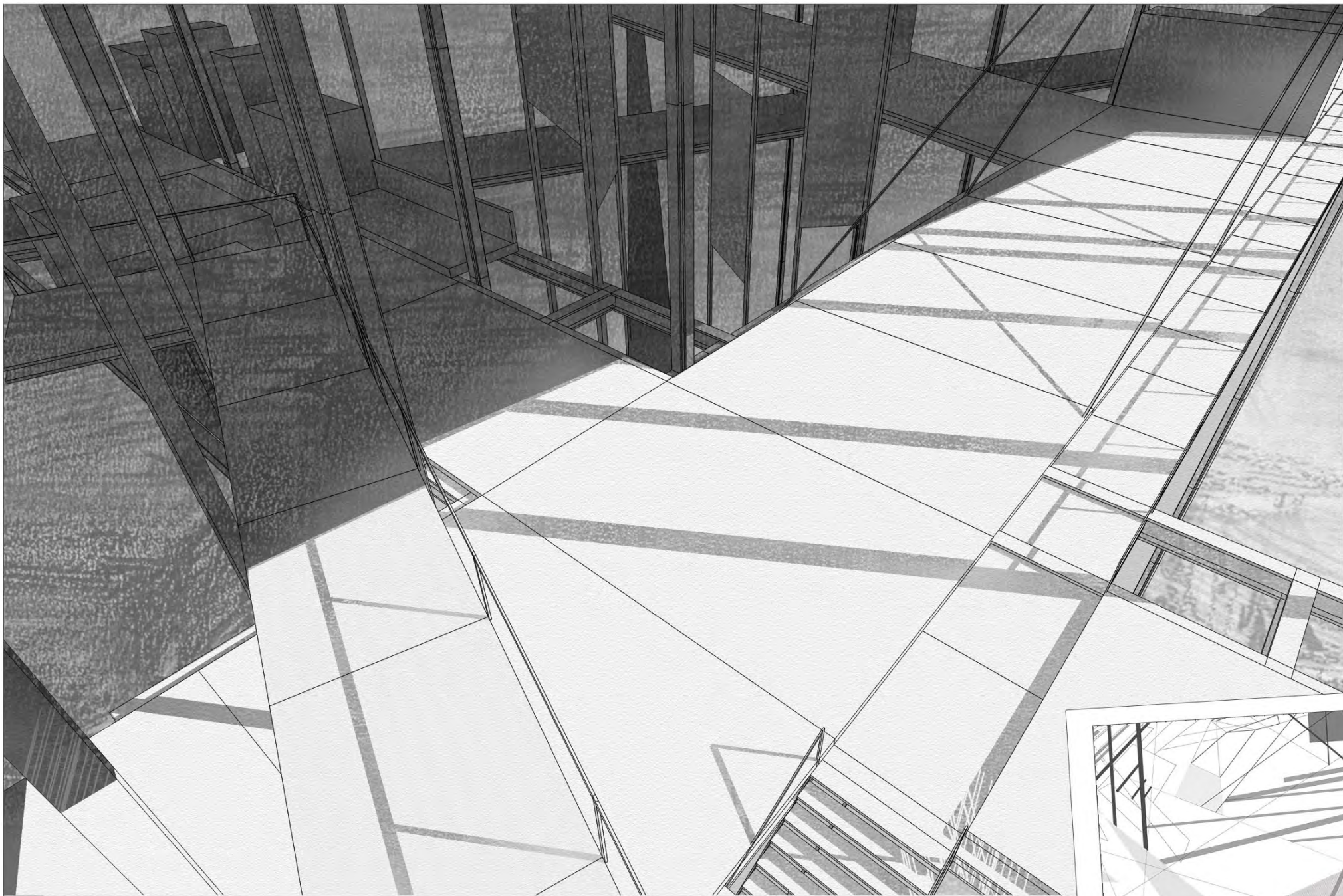

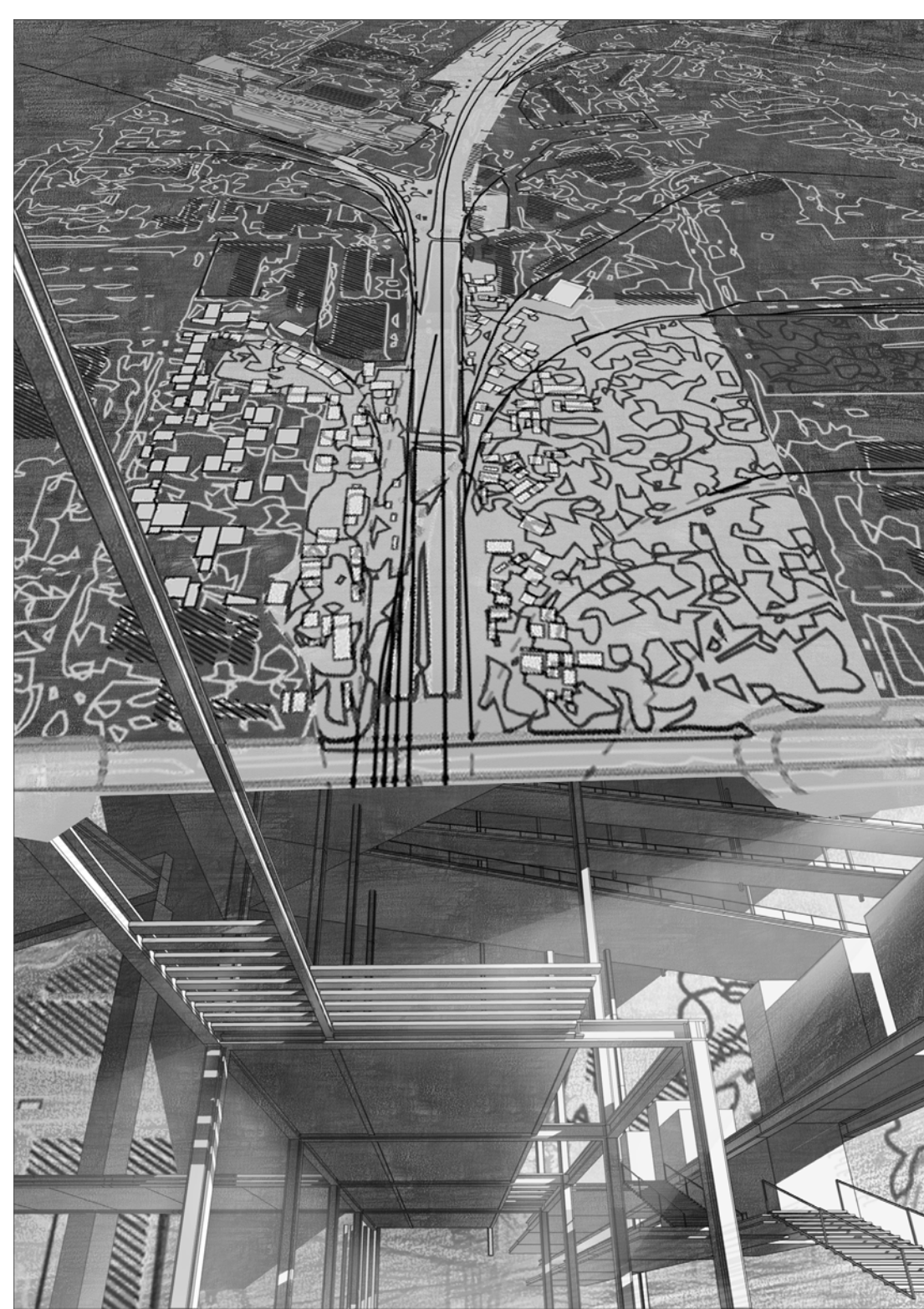
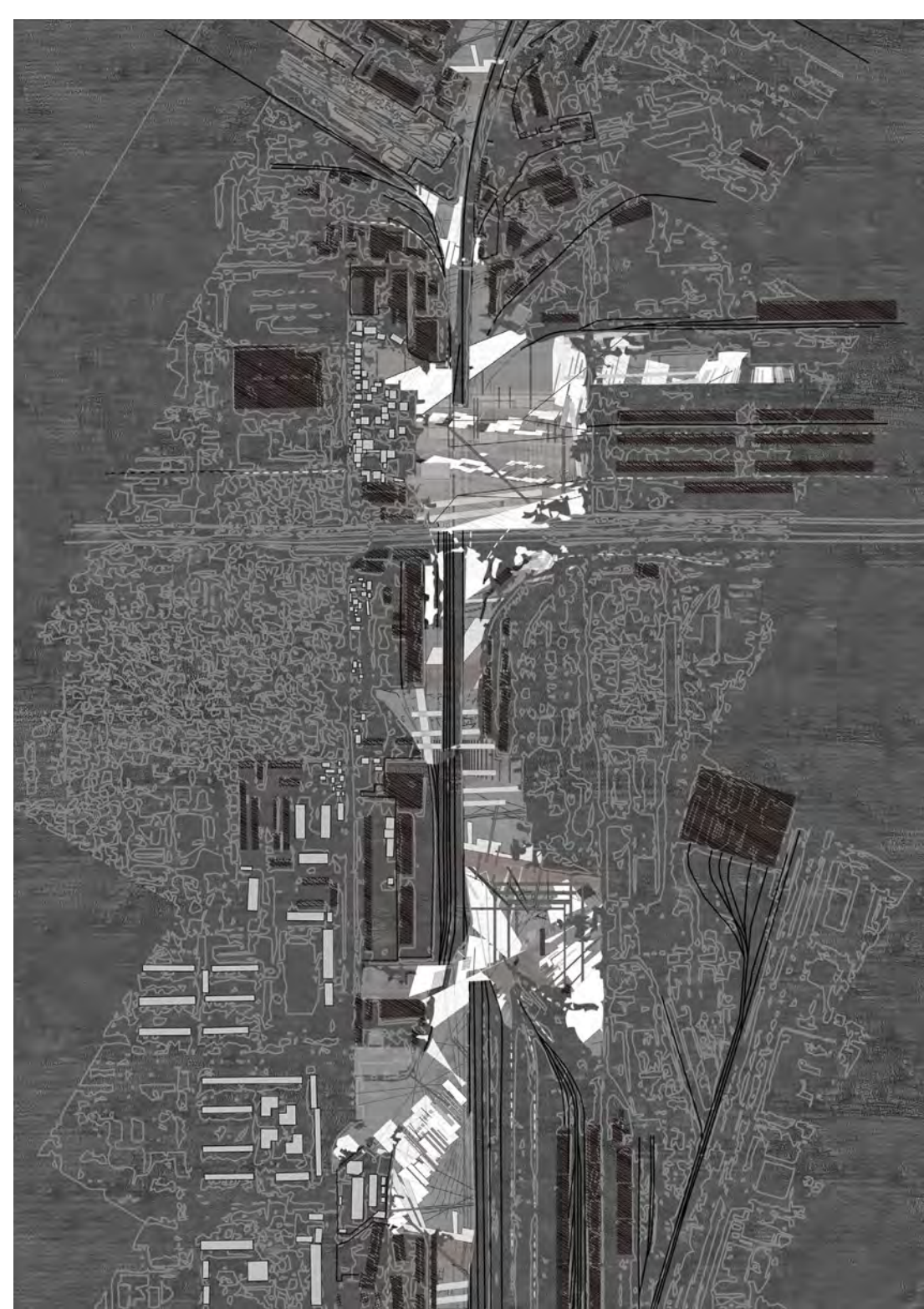

- **Fragments and the bigger whole:** The margins are edges of formal urban construction, which make the margins have deep relations and dependences with the urban fabric nearby. The relationship between them is like parasites and their host, fragments and the collective body.
- **User-led and diversity:** They continually obtain diverse and ever-changing meanings when their users occupy and organize them.
- **Inclusive and inventive:** The margins are available for everyone. While they are all inventors of their own lives.
- **Dynamic and unstable:** The margins are autonomous spaces, repeatedly changing the occupants, being deconstructed and being organized again.

I applied the theories and image study methods from my research to the new practice. In a complex block with potential in Tbilisi, I introduce a set of infrastructure, which offers marginal spaces available for occupation and use. The characteristics I've concluded in research should also reflect in the materialization:

- Fragments and the bigger whole: marginal spaces exist based on bigger infrastructure system, available for people's use.**
- User-led and diversity: spatial configurations result from people's needs and uses.**
- Inclusive and inventive: various components and tools provided.**
- Dynamic and unstable: everything is flexible for reassembling.**

**SYNTHESIS DRAWING
OF VARIOUS ABSTRACT INFORMAL SCENES**

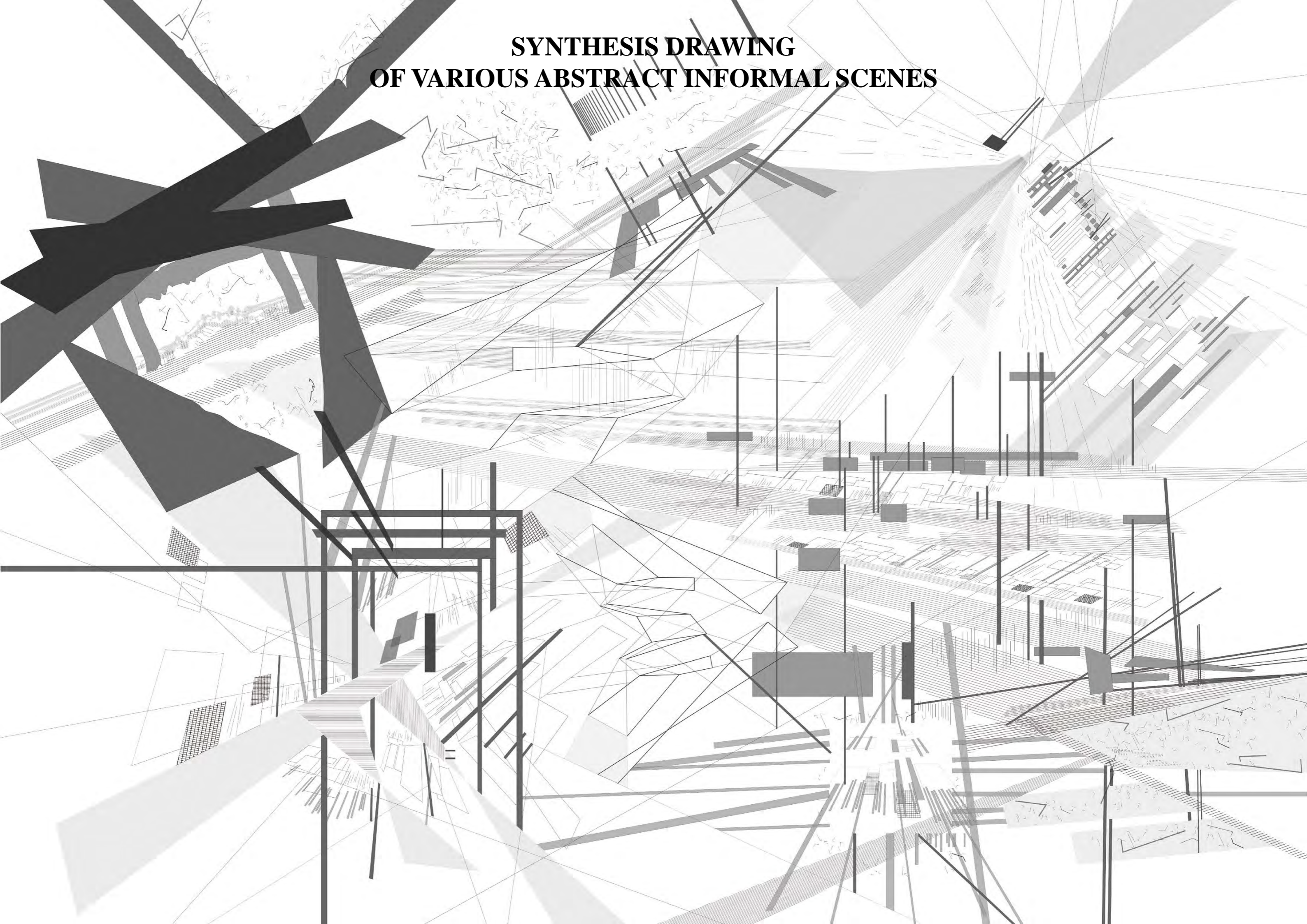

FORMAL ELEMENTS

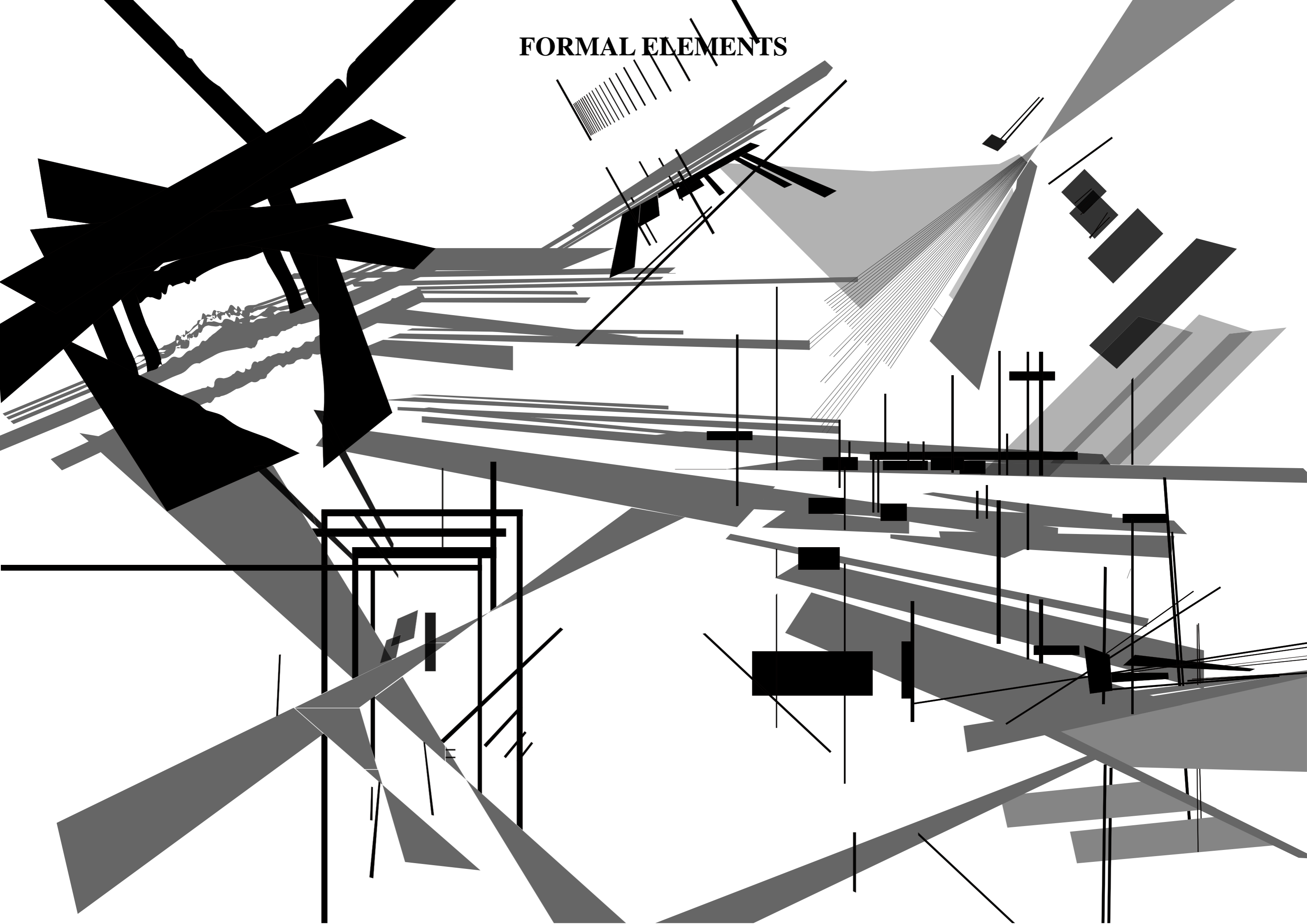

INFORMAL ELEMENTS

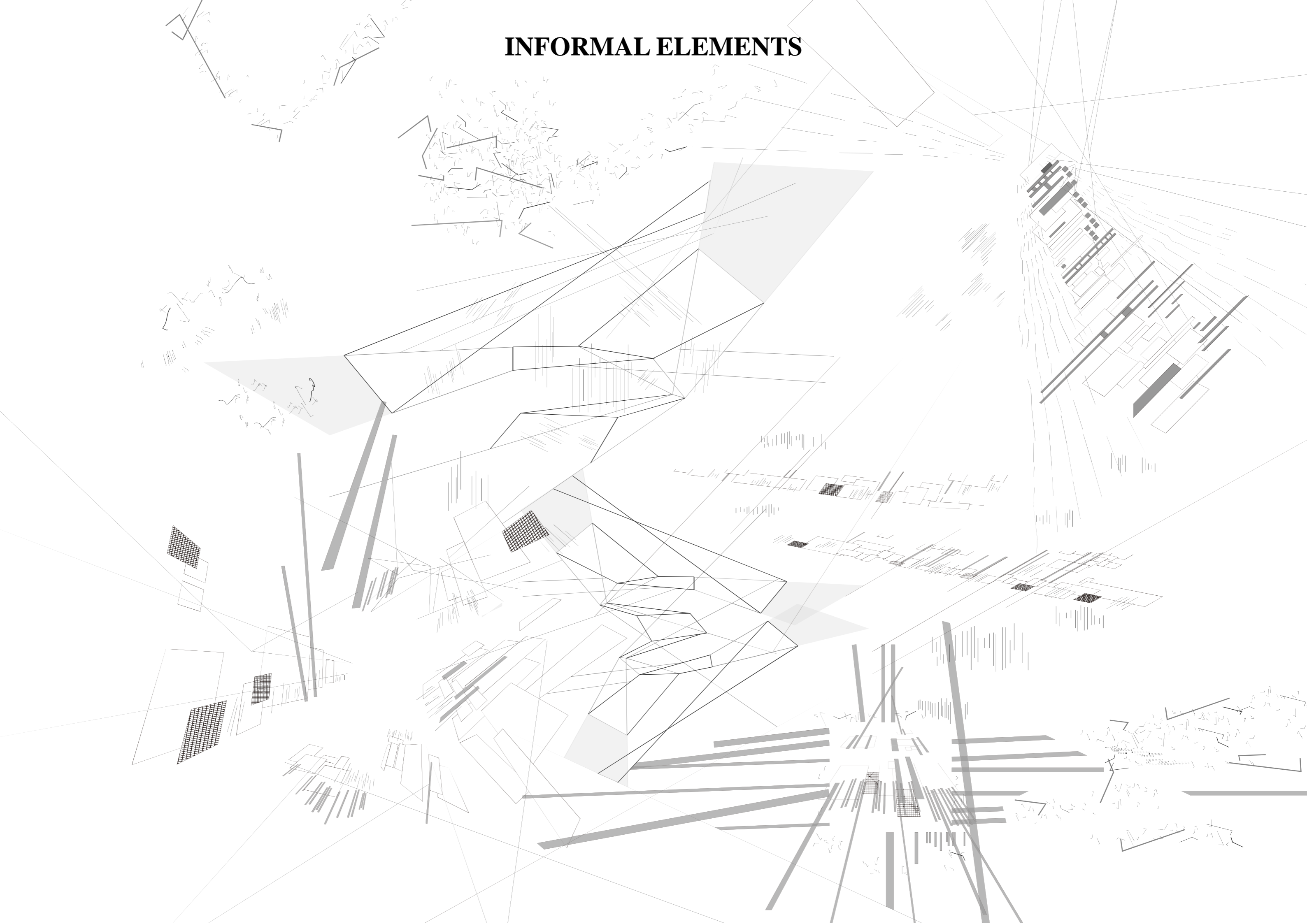

PHASE I

Context

A collection of site elements

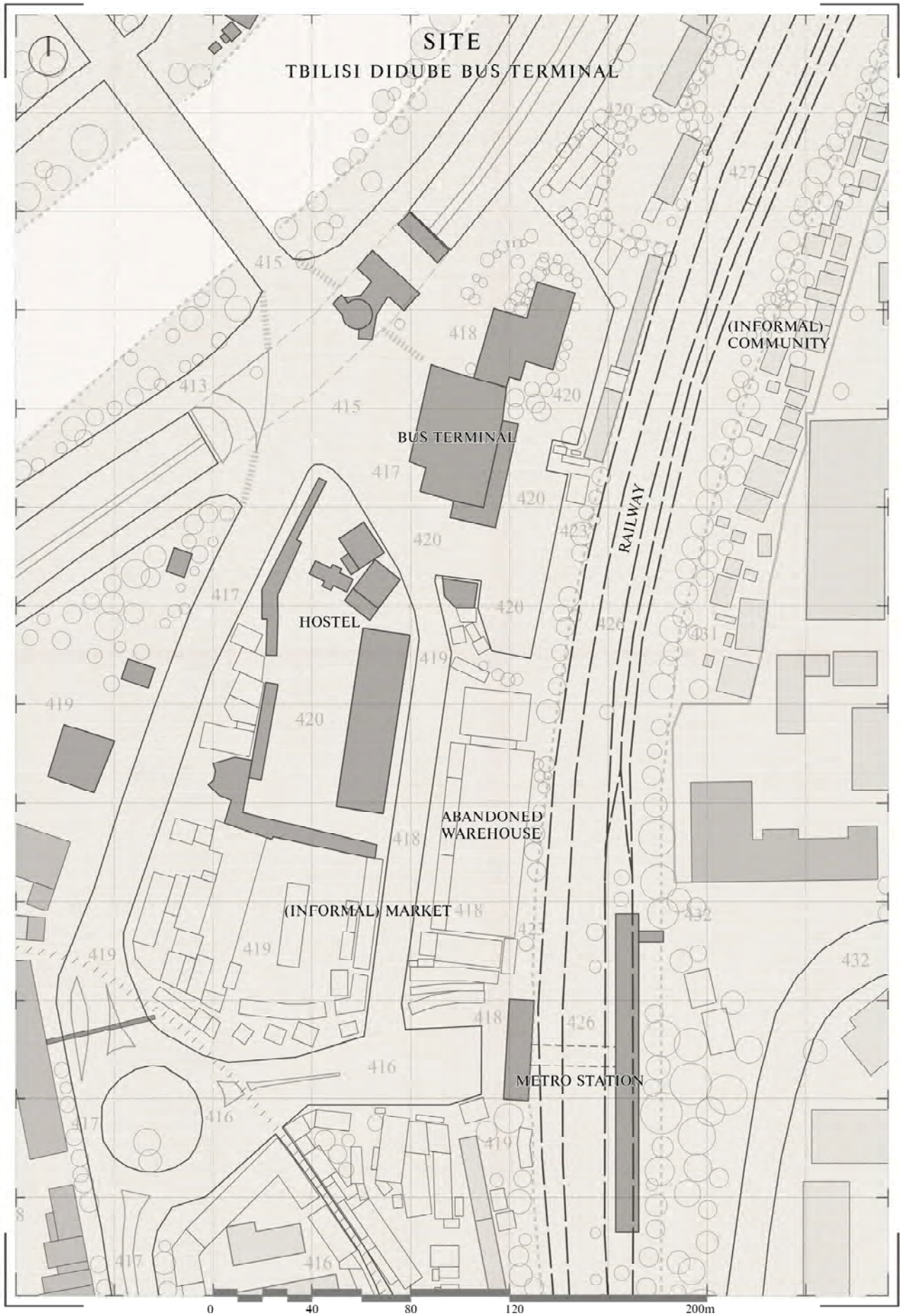

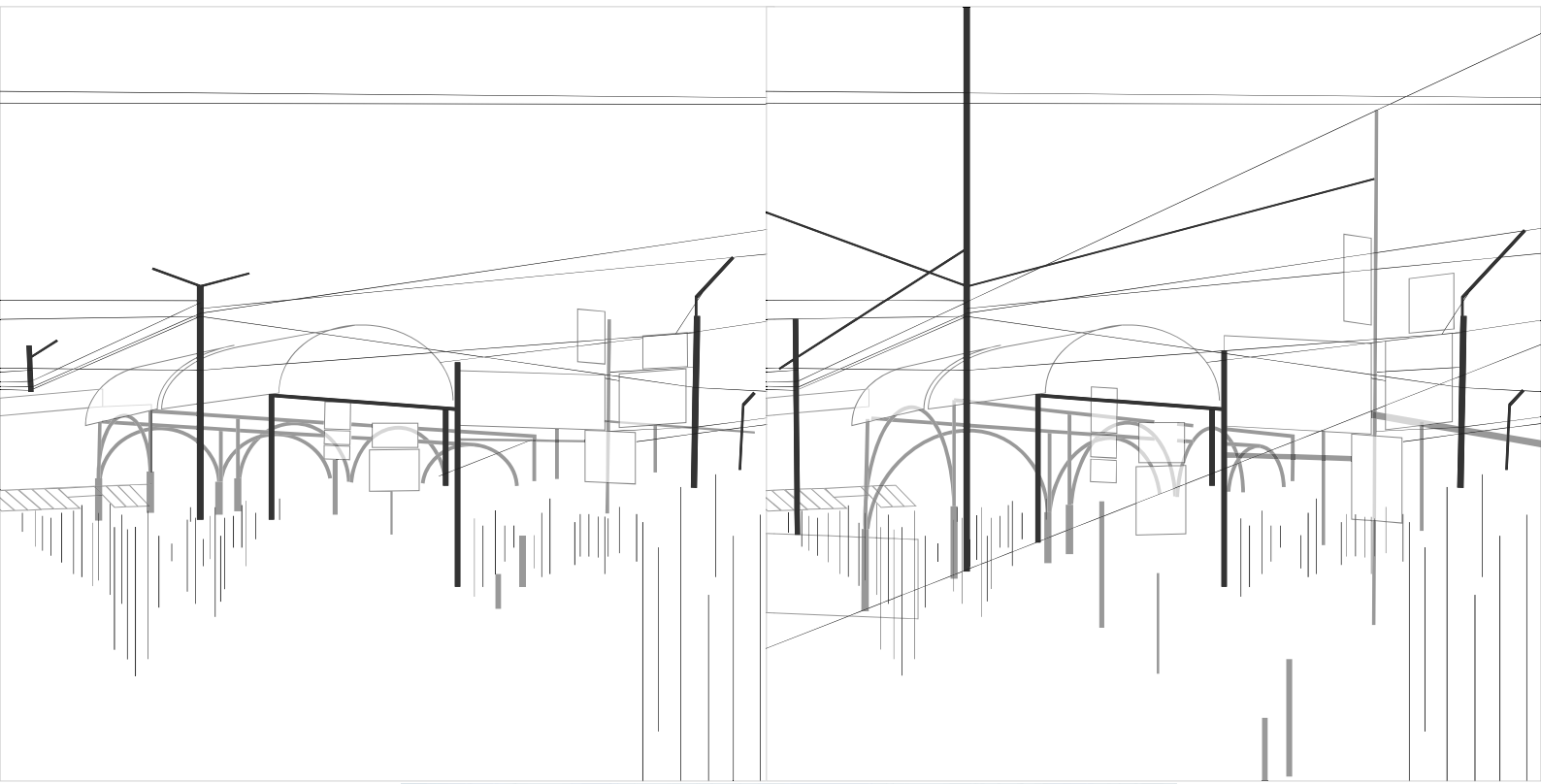

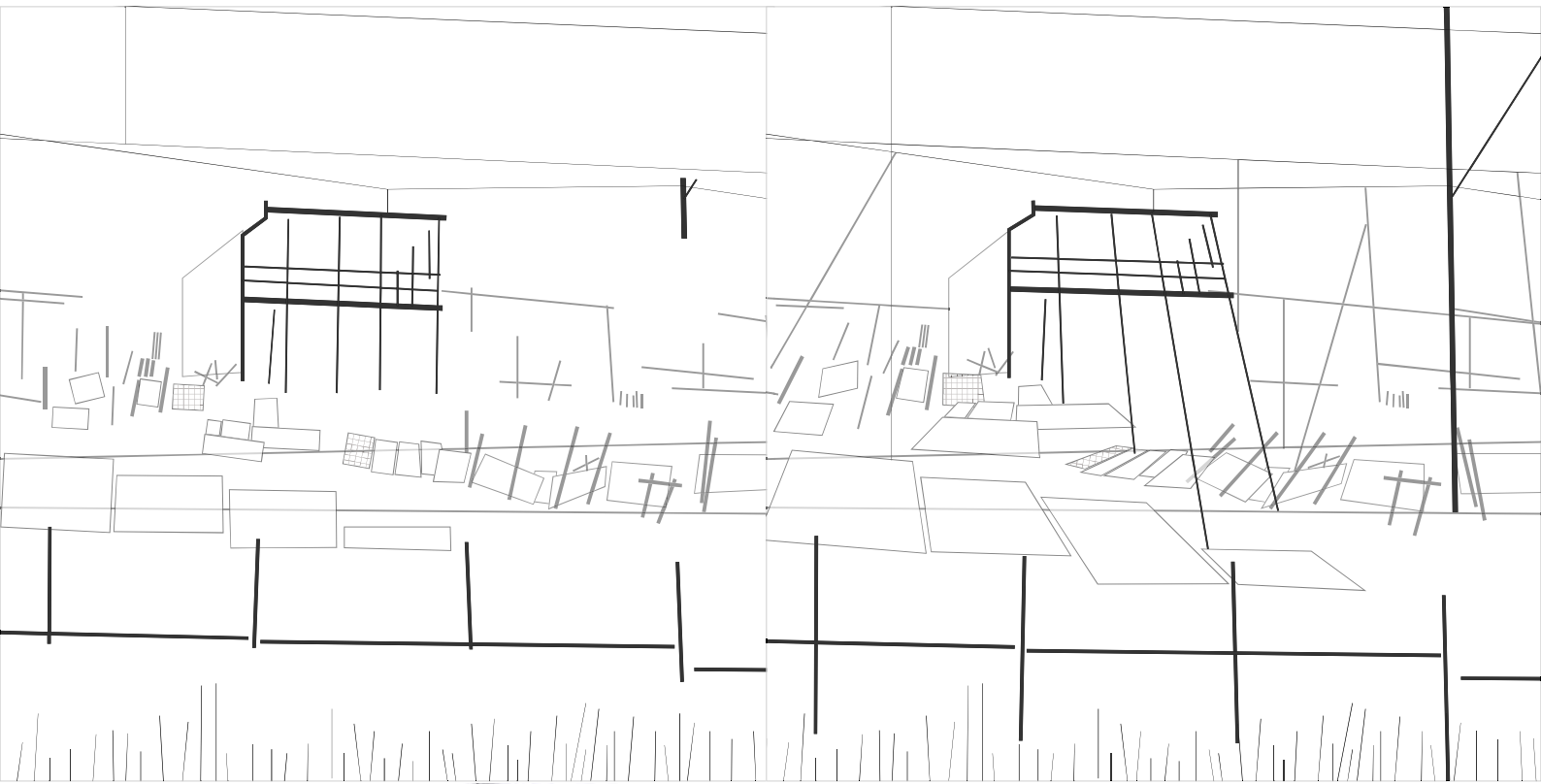

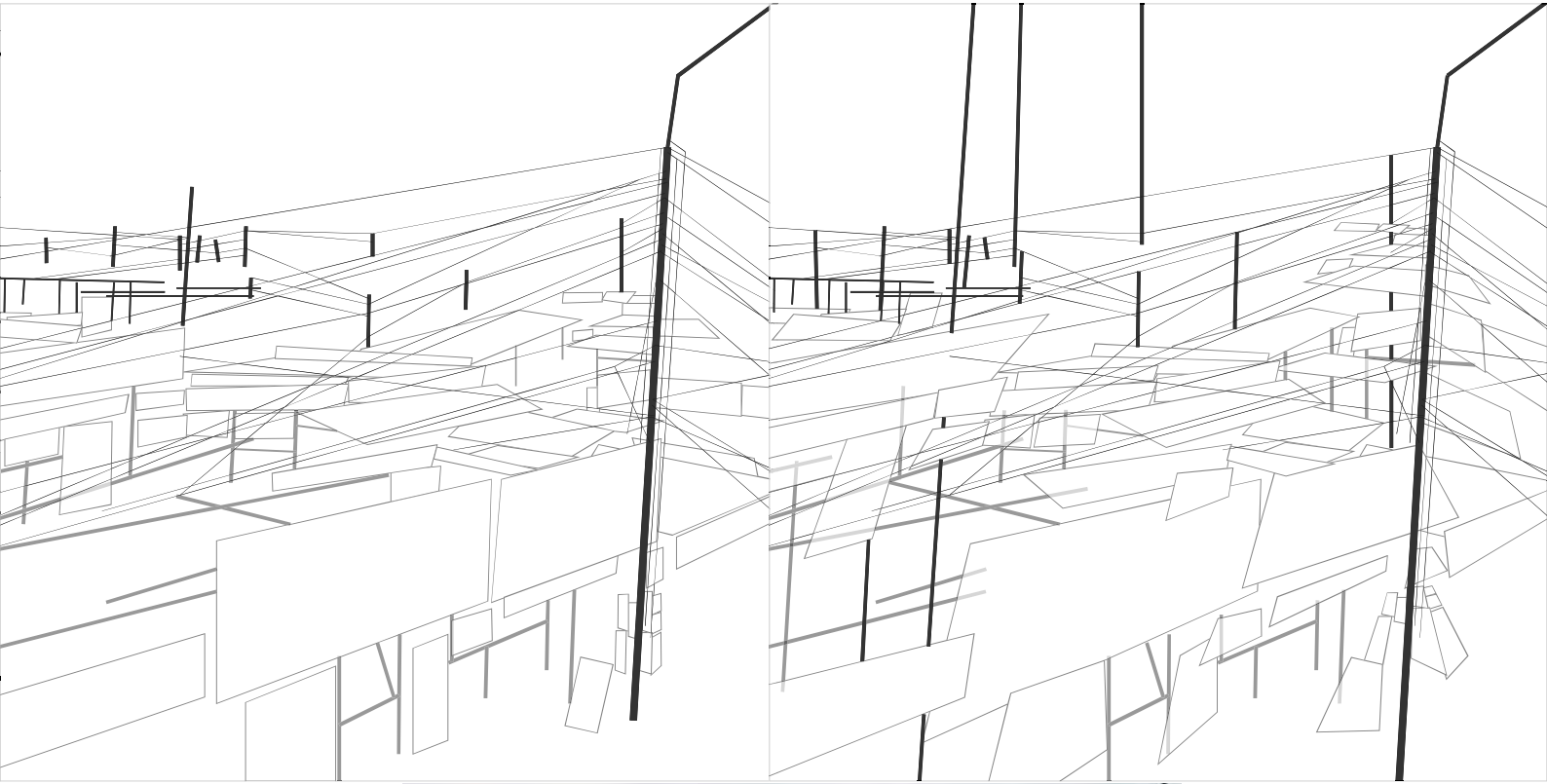

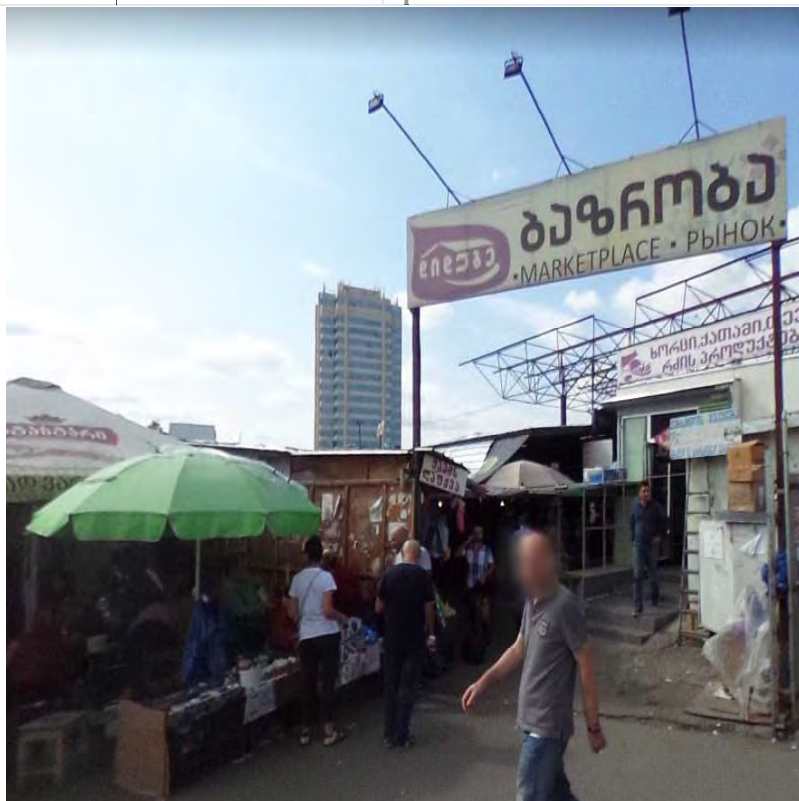
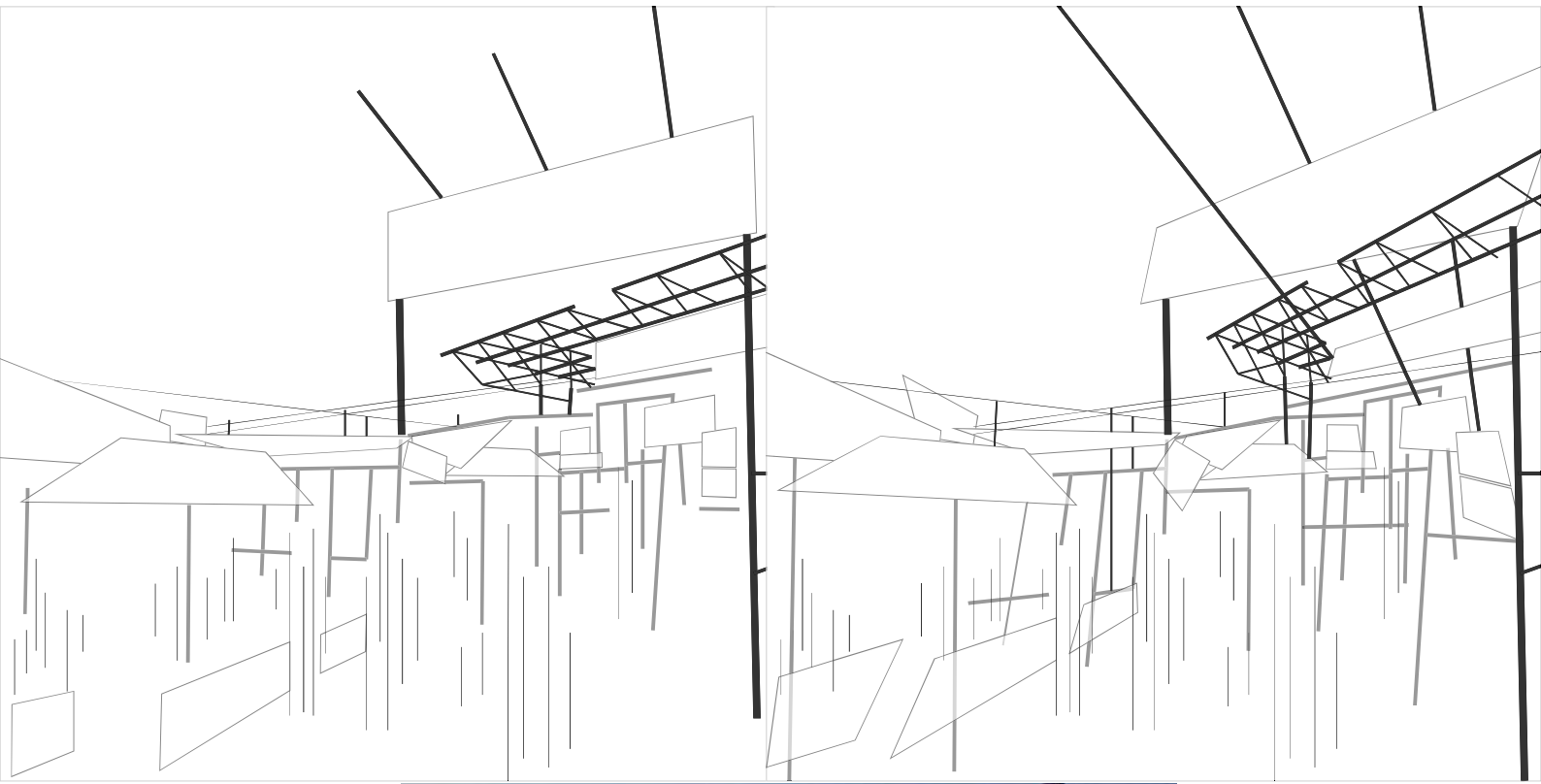

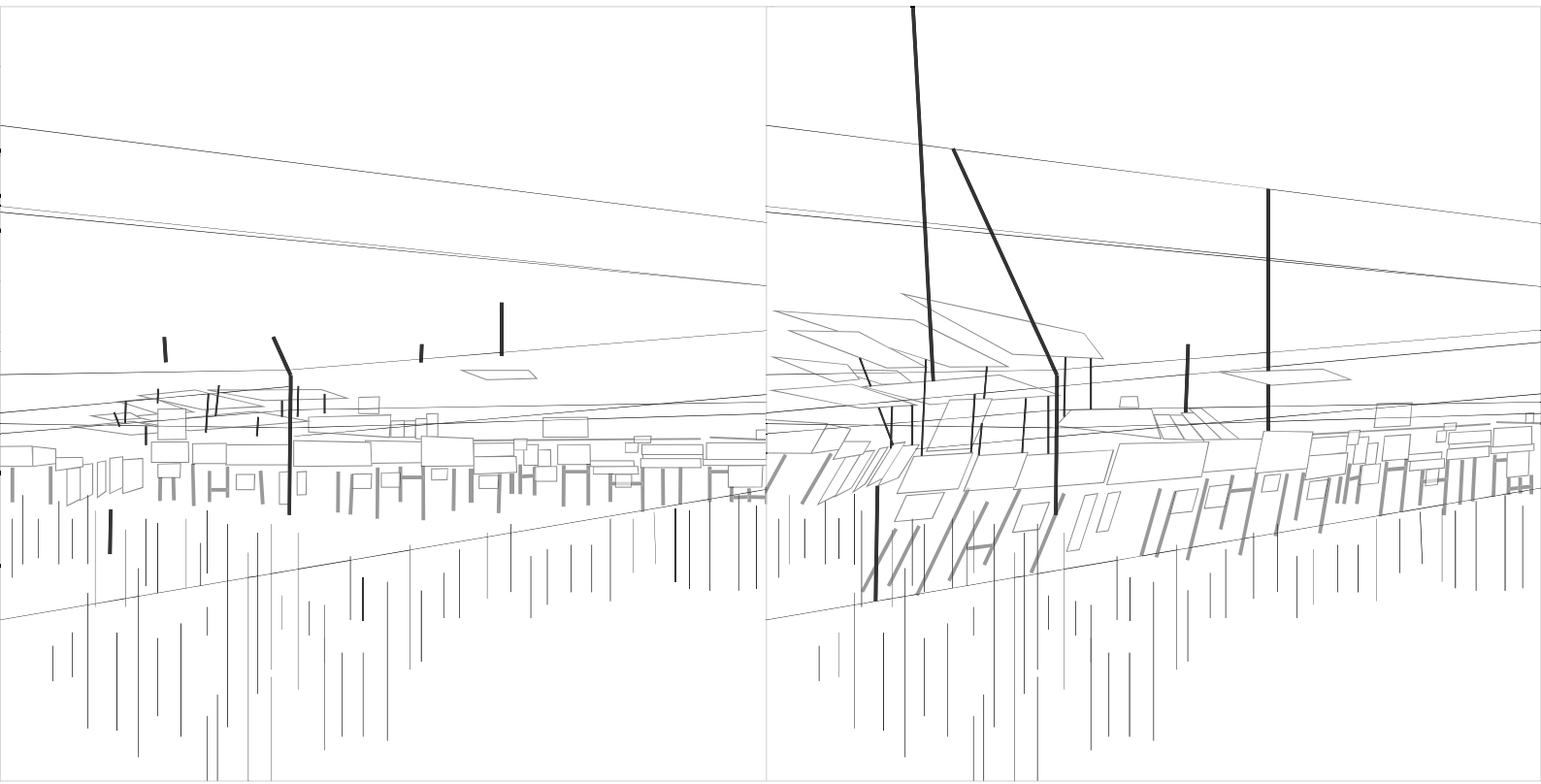

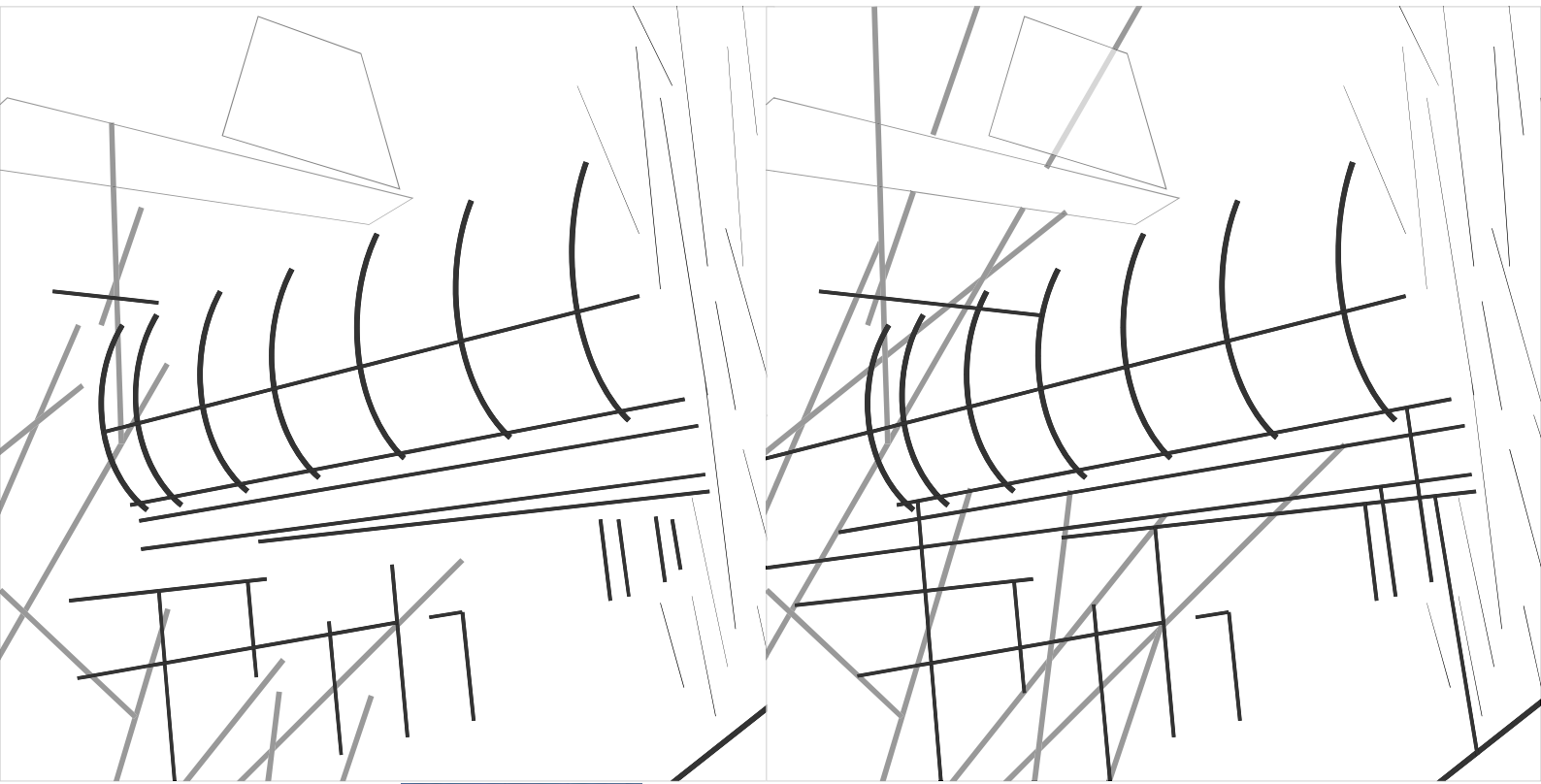

analysis & experiment
based on drawing and interpretation

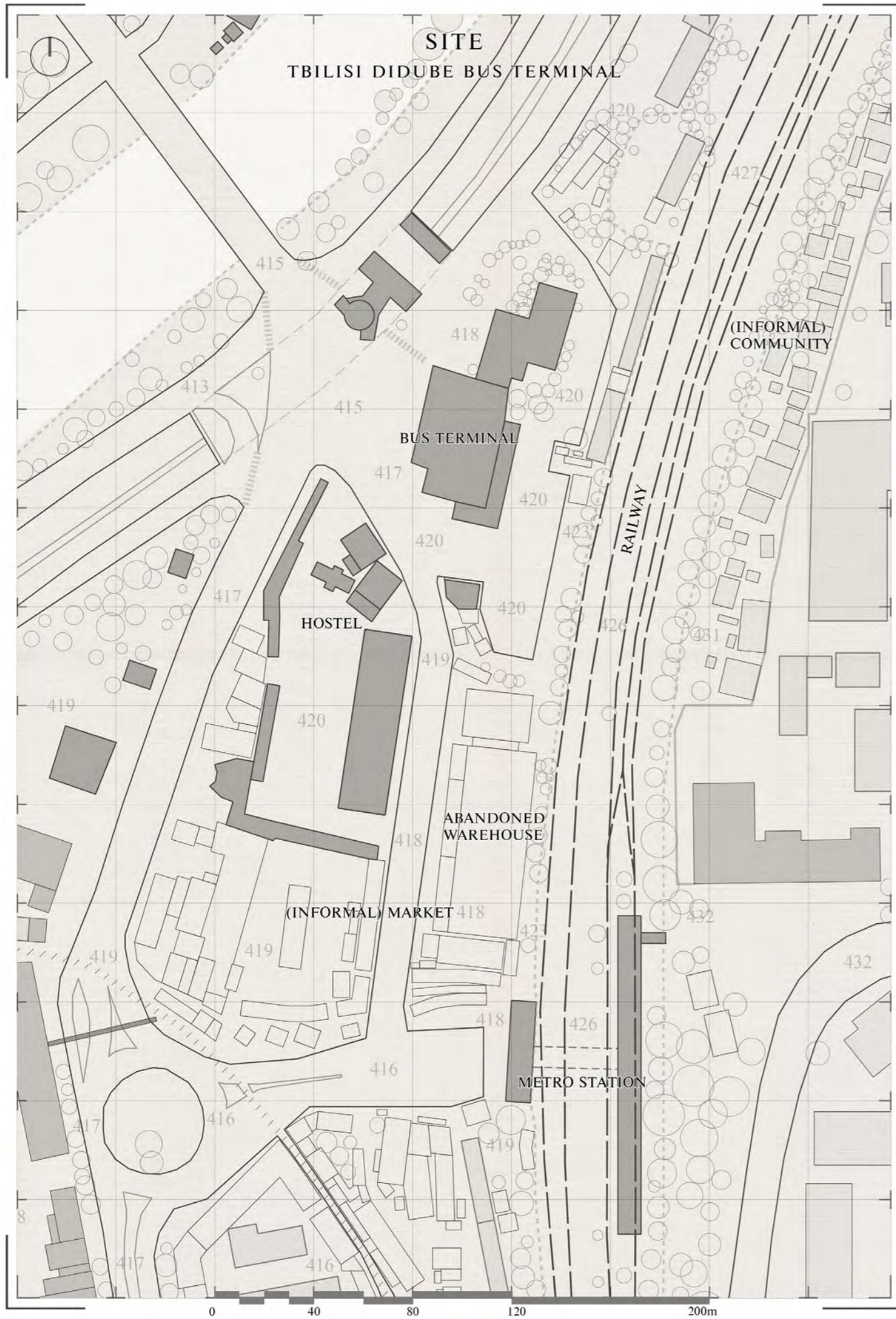

FLOW ANALYSIS
ABOUT MOVEMENTS OF PEDESTRIANS AND CARS

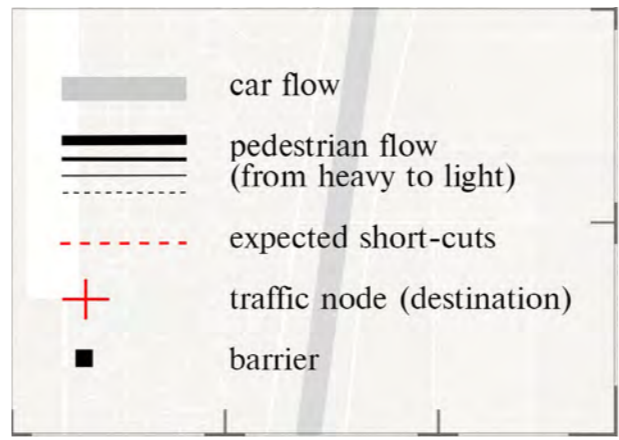
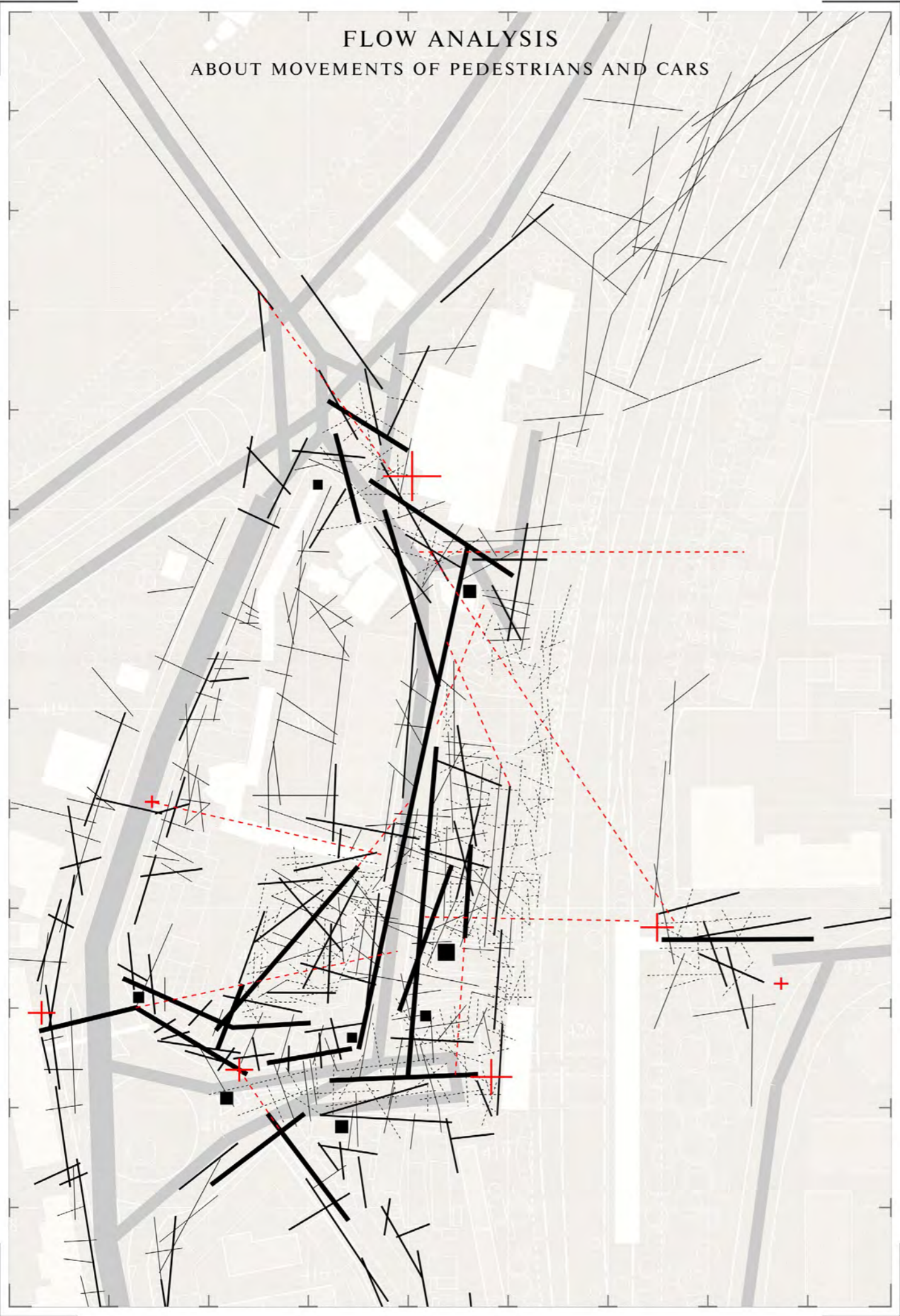

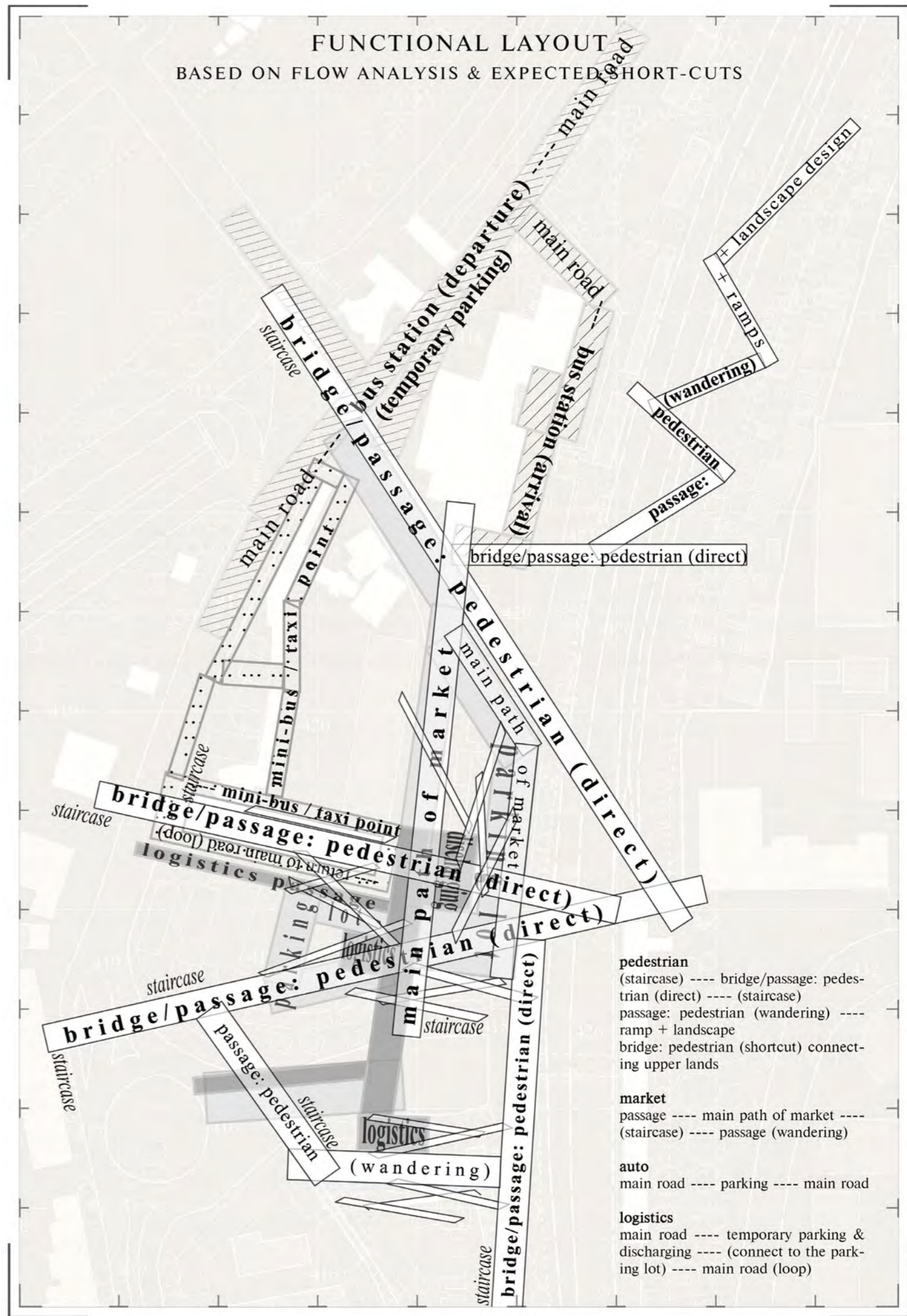
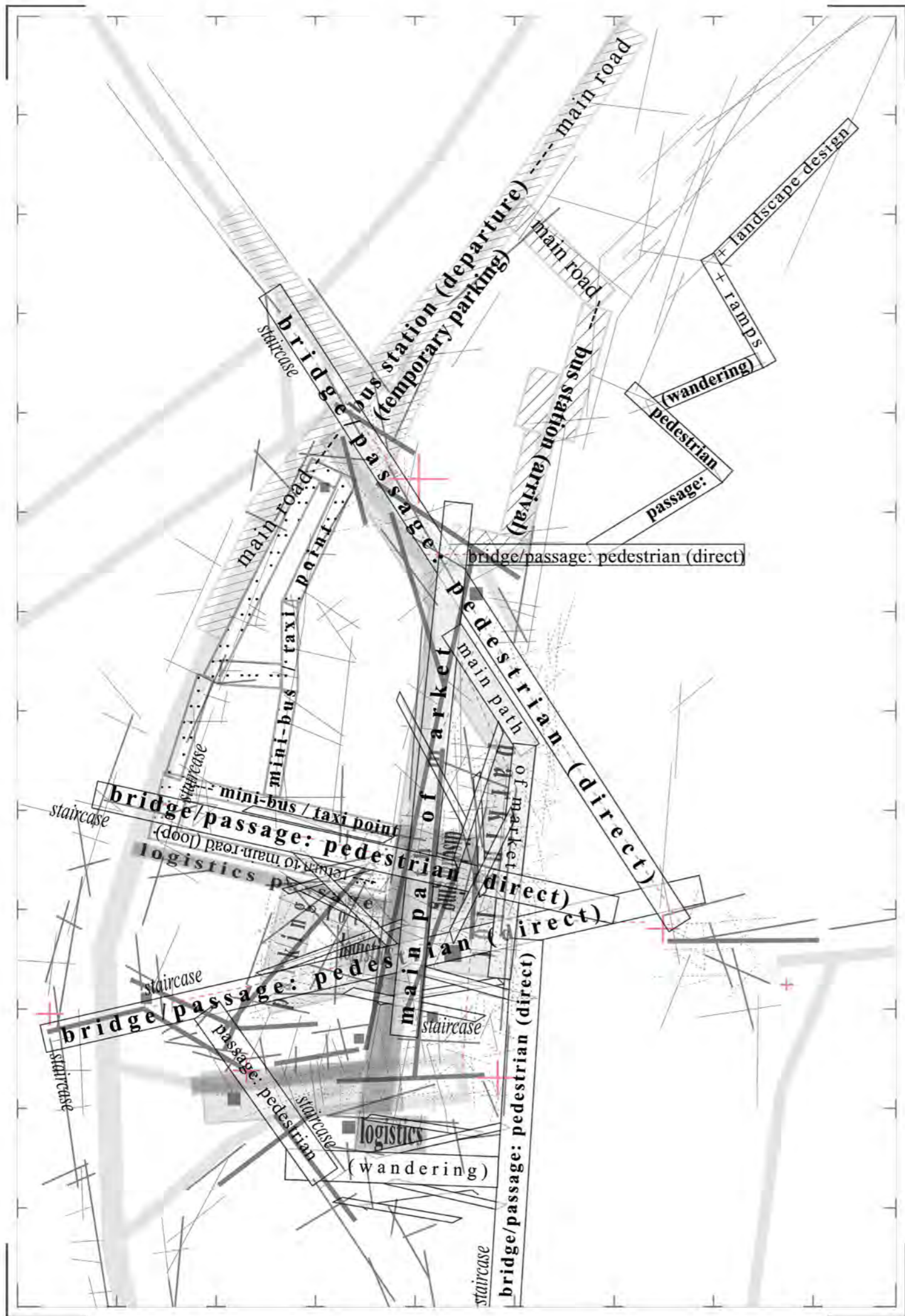

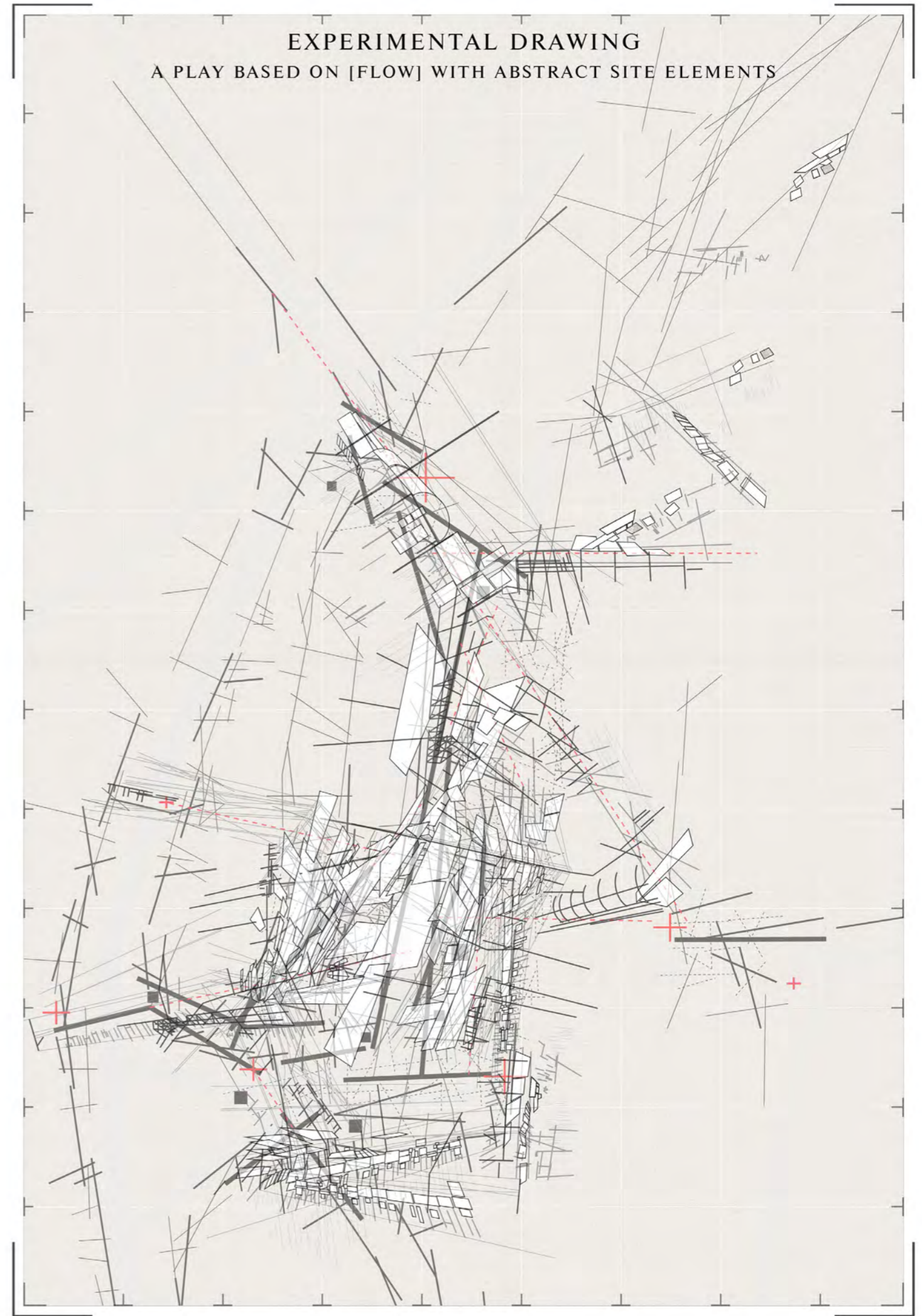
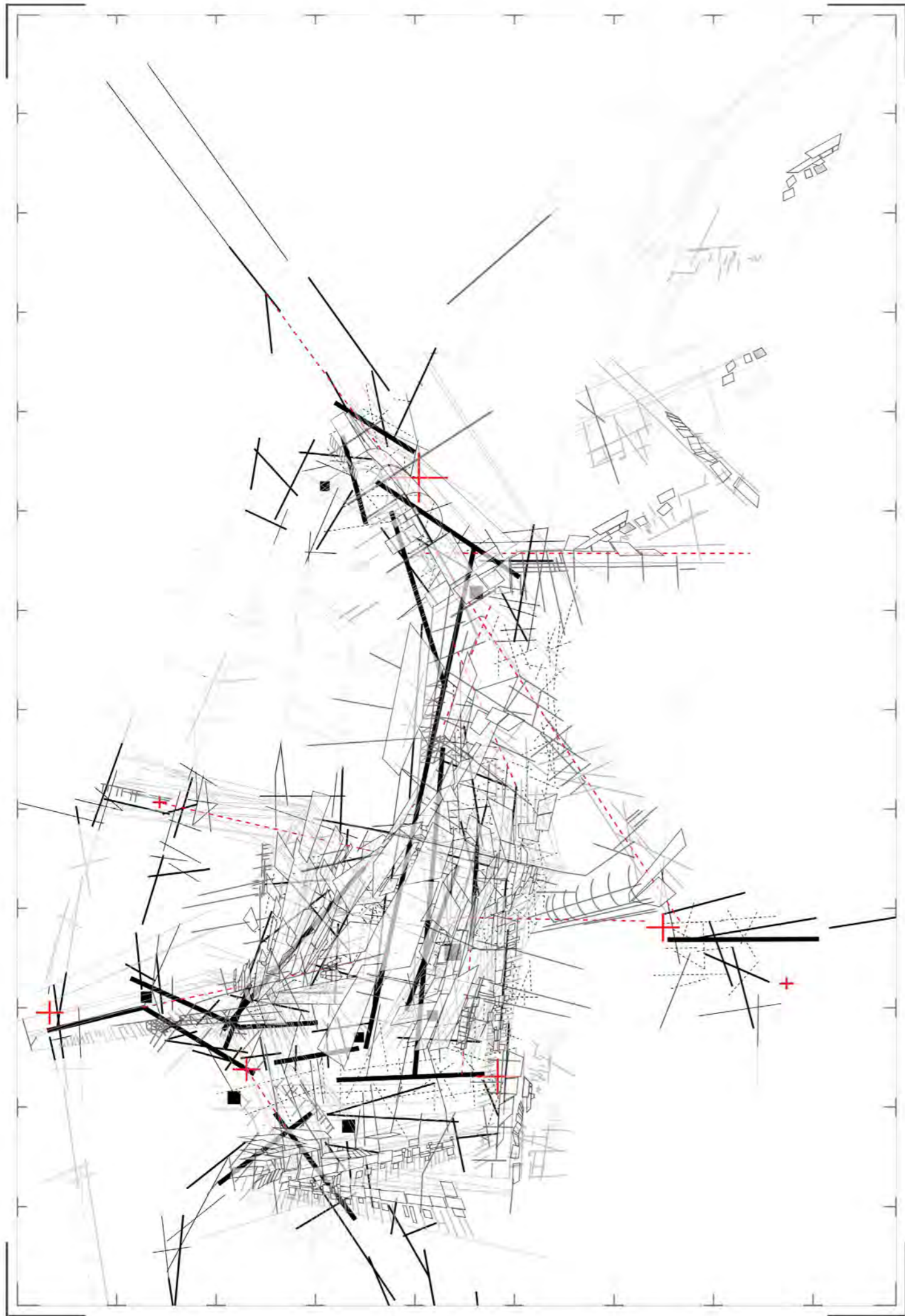

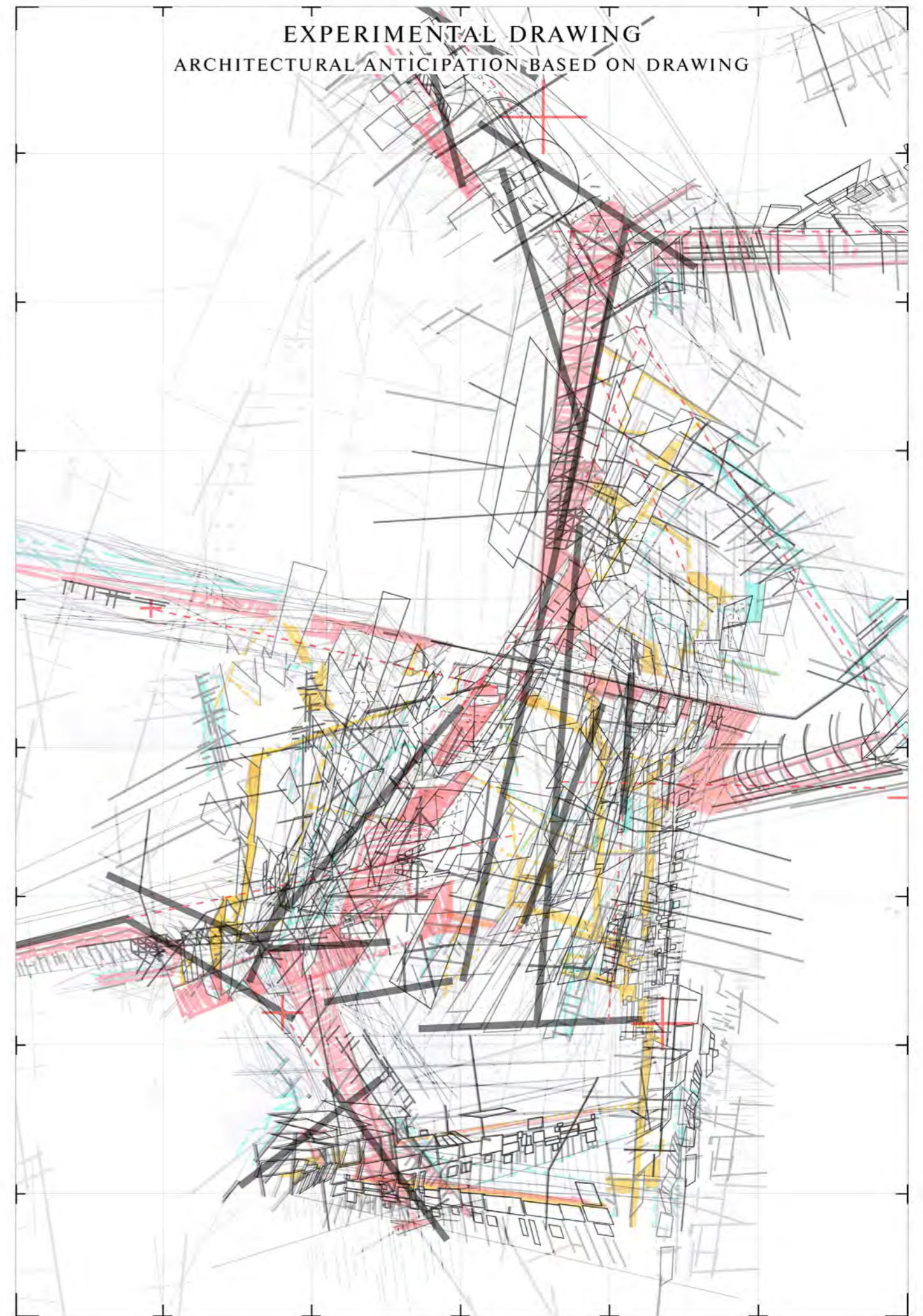
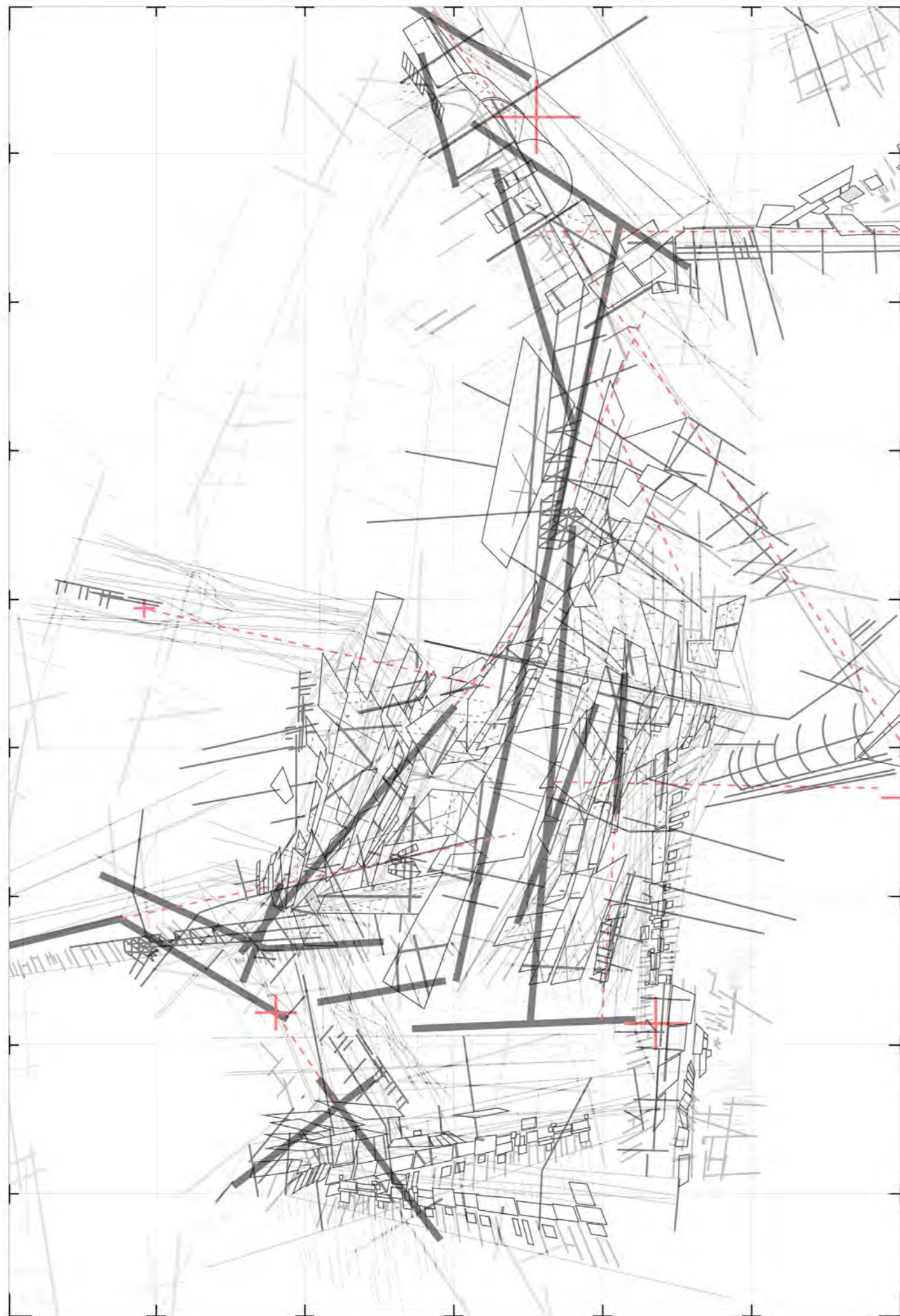

catalog
formal | informal

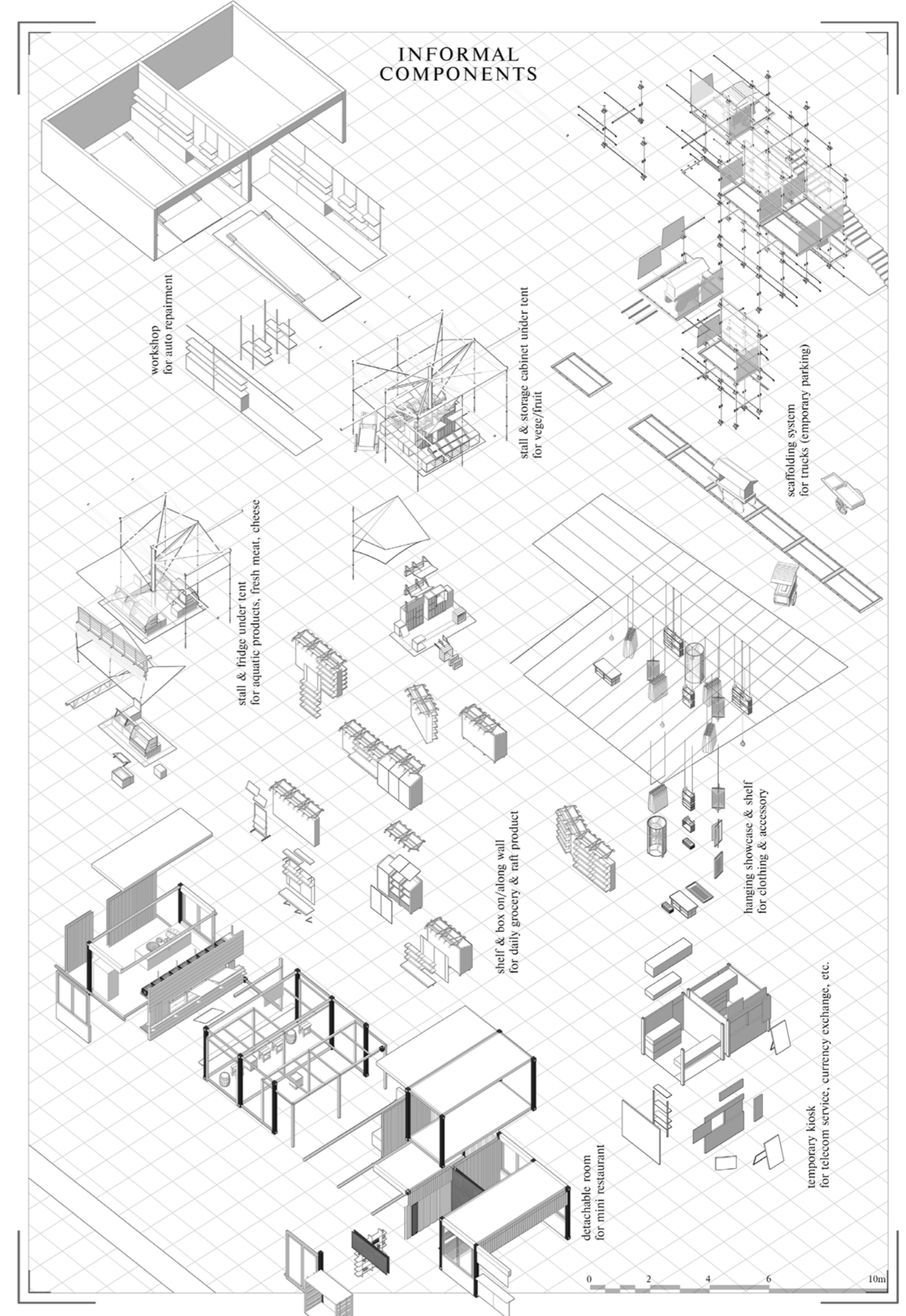
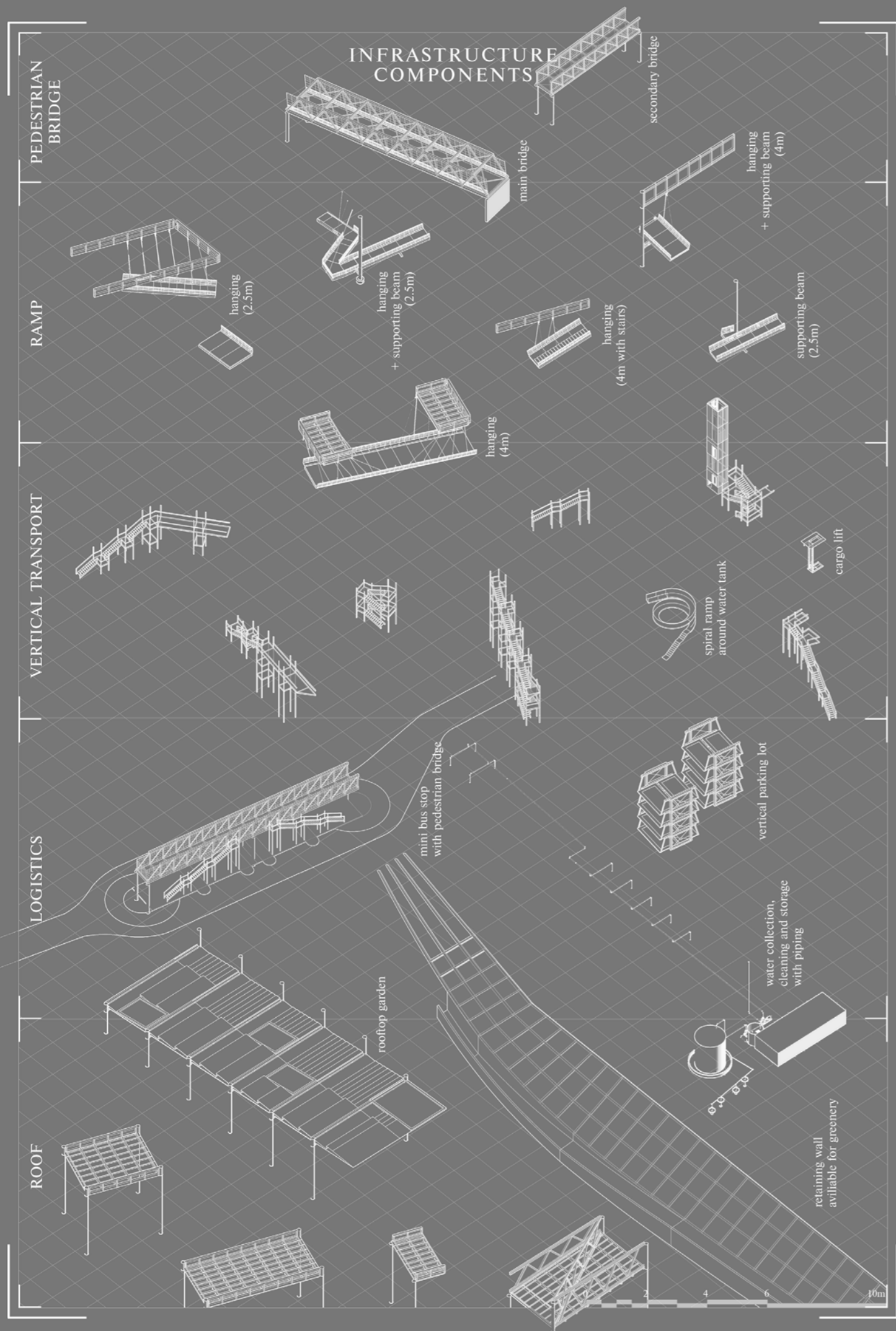

VERTICAL TRANSPORT

RAMP

PEDESTRIAN
BRIDGE

INFRASTRUCTURE
COMPONENTS

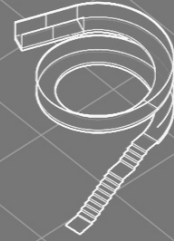
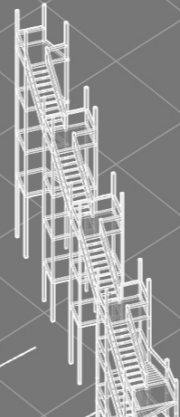
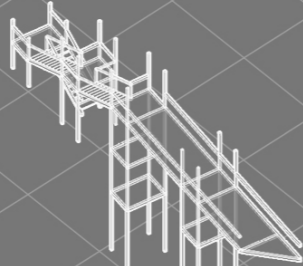
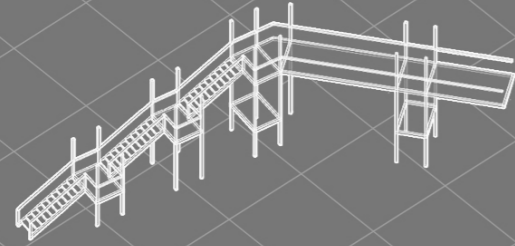

spiral ramp
around water tank

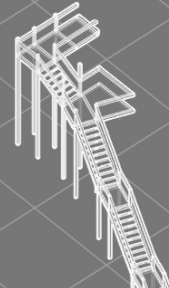

cargo lift

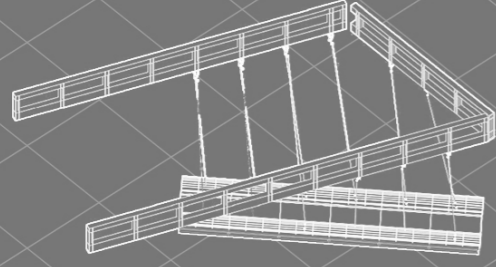

hanging
(2.5m)

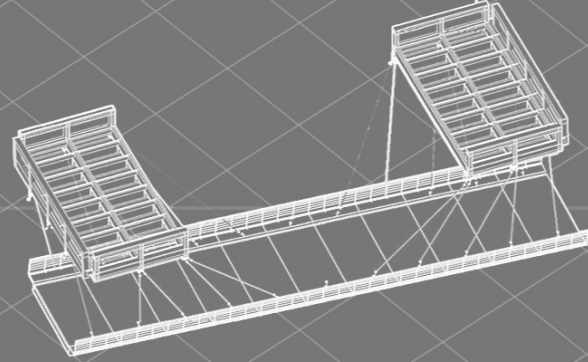
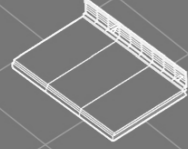

hanging
(4m)

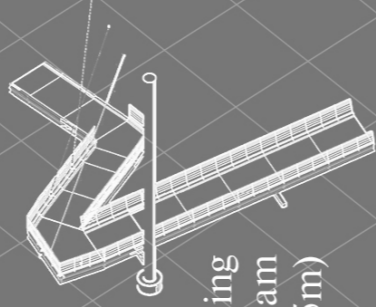

hanging
+ supporting beam
(2.5m)

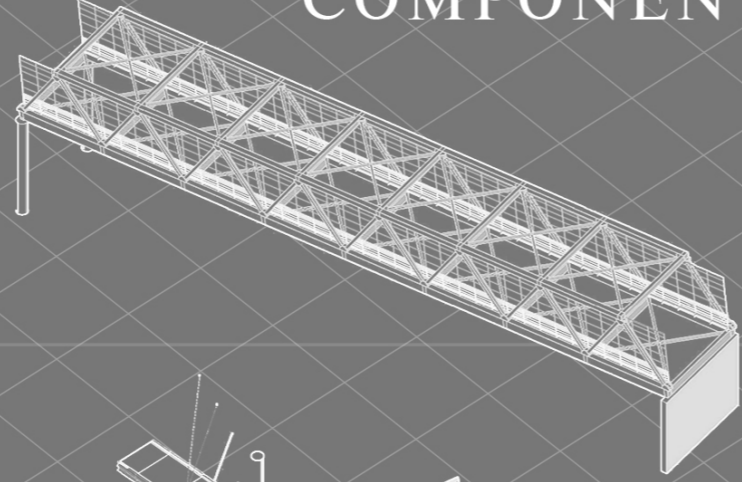

main bridge

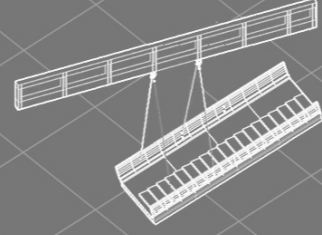

hanging
(4m with stairs)

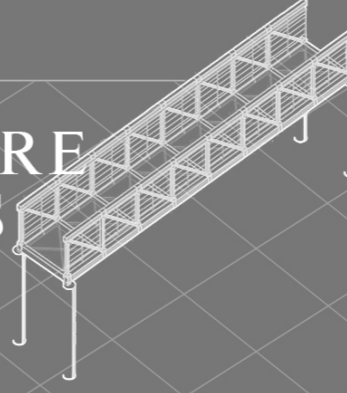

secondary bridge

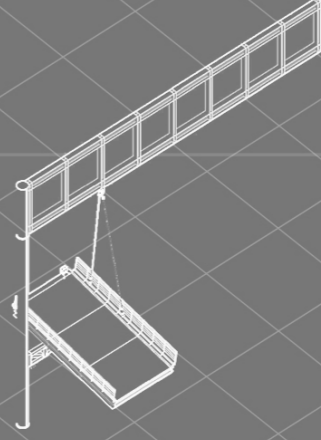

hanging
+ supporting beam
(4m)

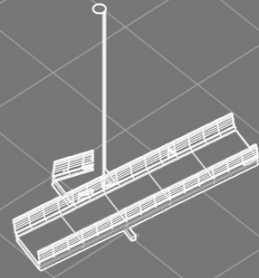

supporting beam
(2.5m)

LOGISTICS

ROOF

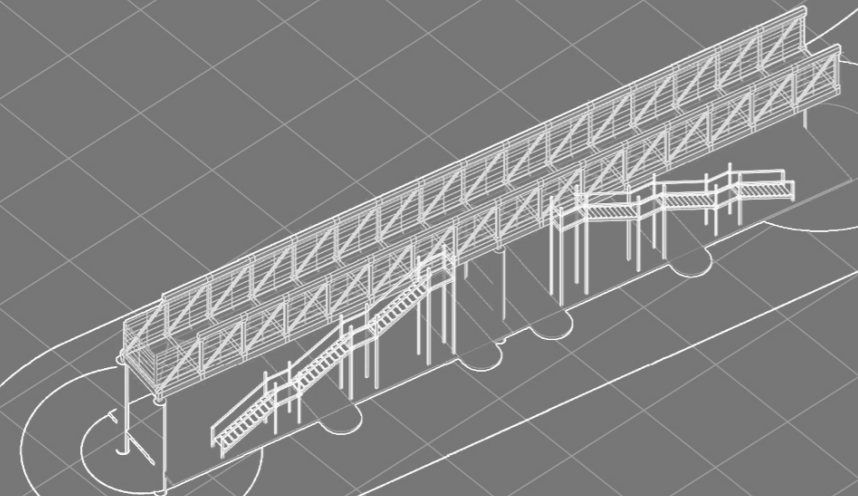

mini bus stop
with pedestrian bridge

rooftop garden

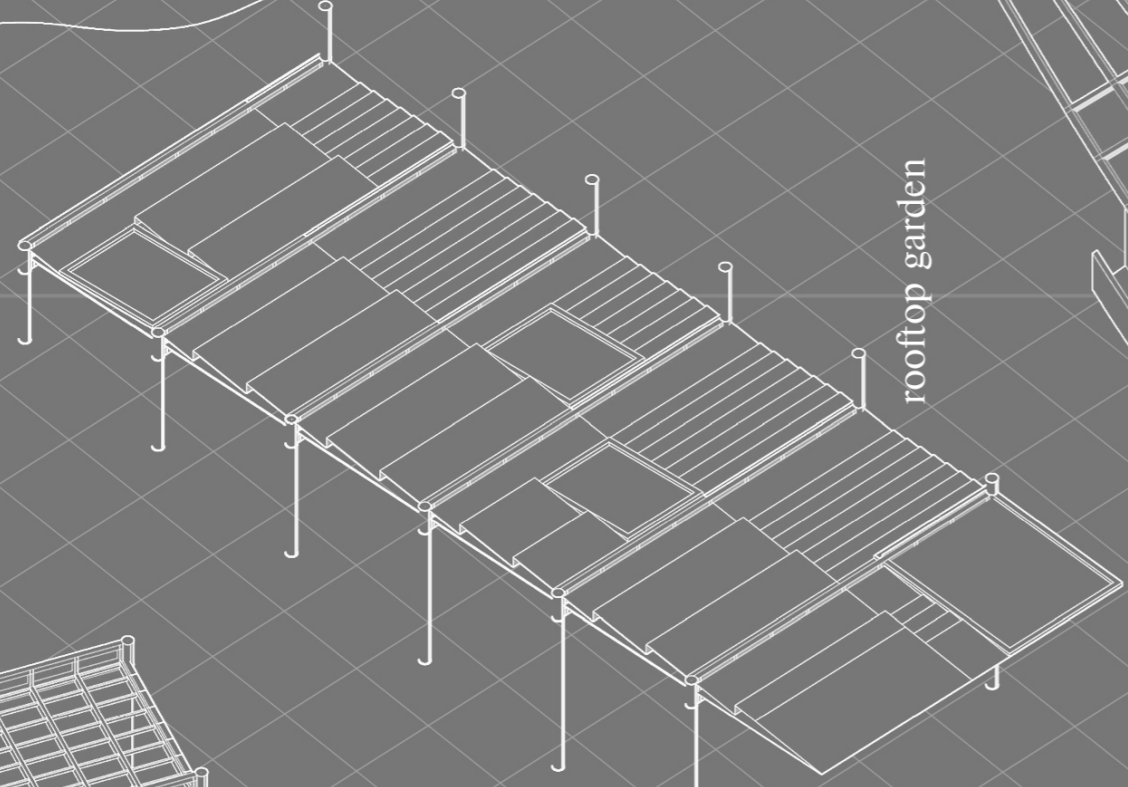

vertical parking lot

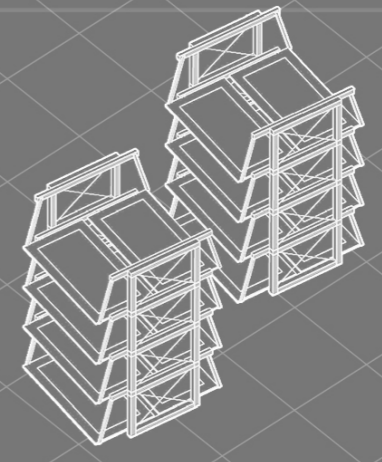

water collection,
cleaning and storage
with piping

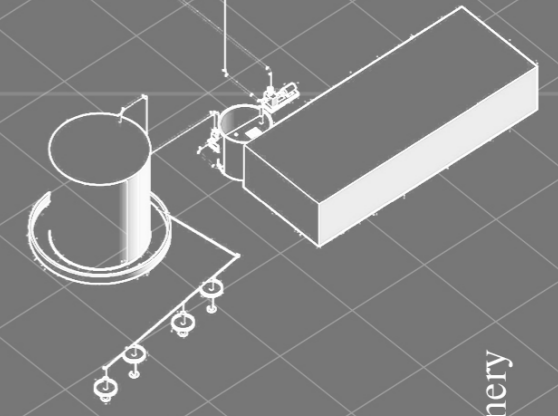

retaining wall
available for greenery

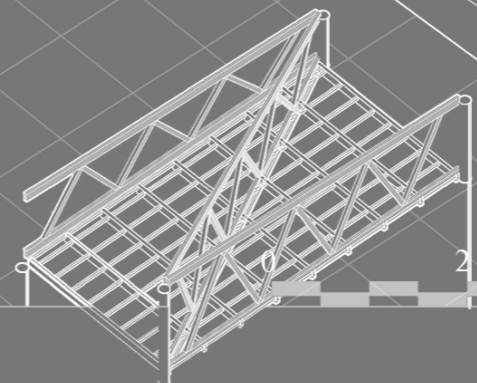

[TENT]
VEGETABLES / FRUITS / ...

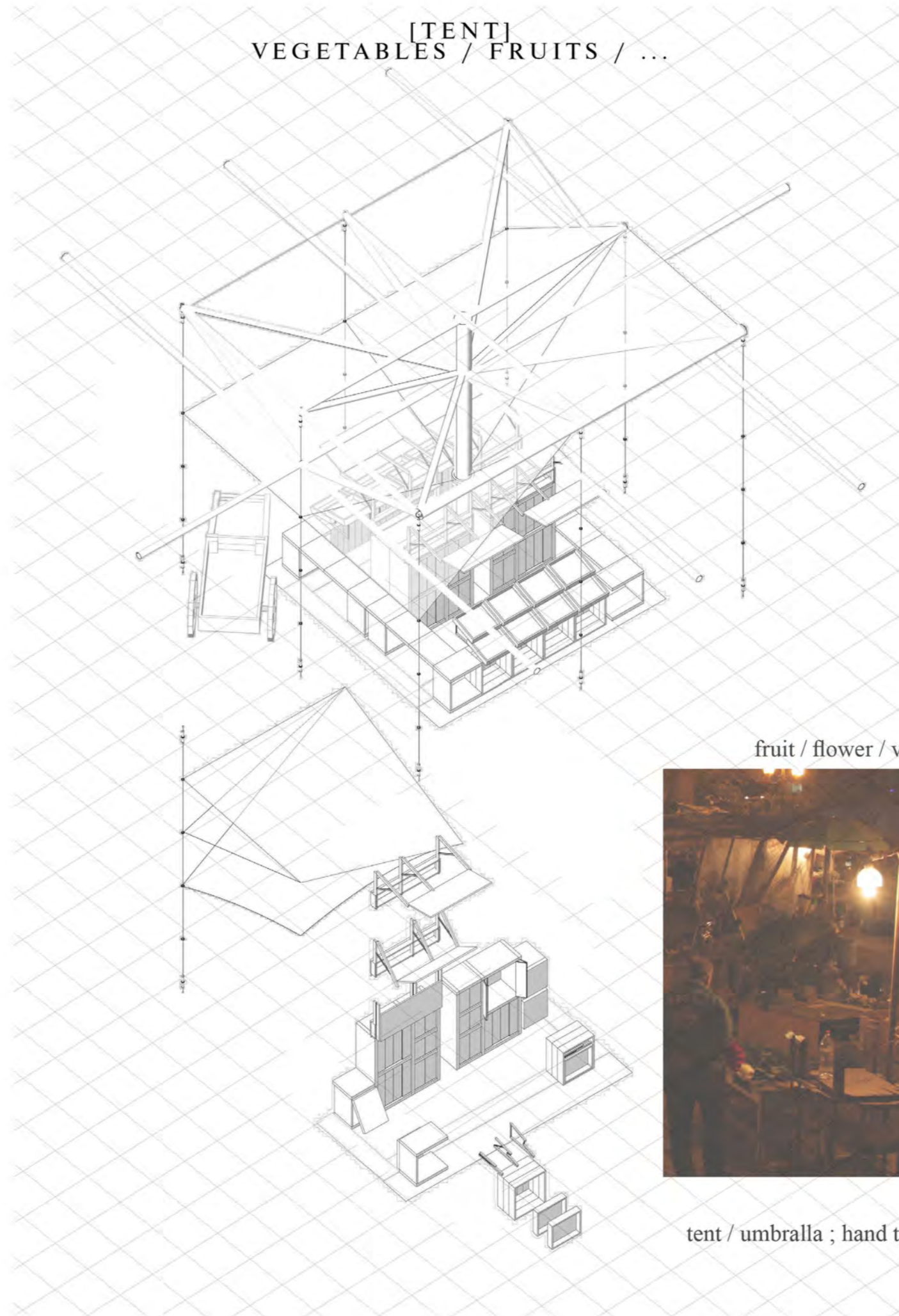

fruit / flower / vegetable

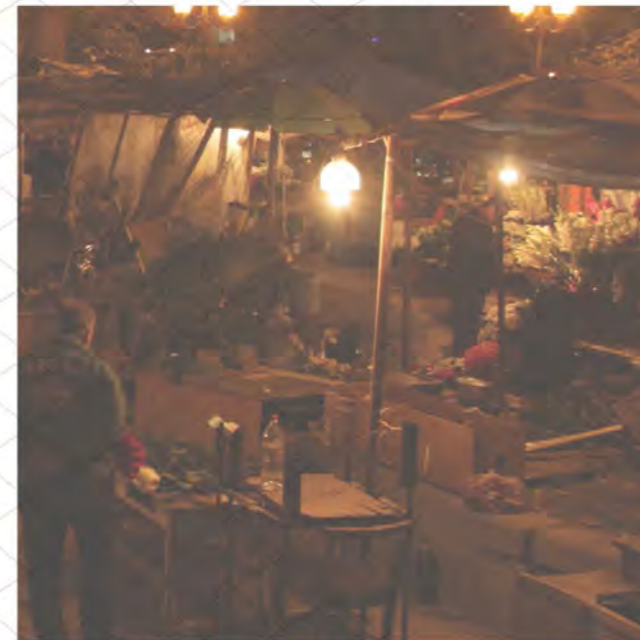

tent / umbralla ; hand truck; no storage

[TENT]
FRESH MEAT / FISH / ...

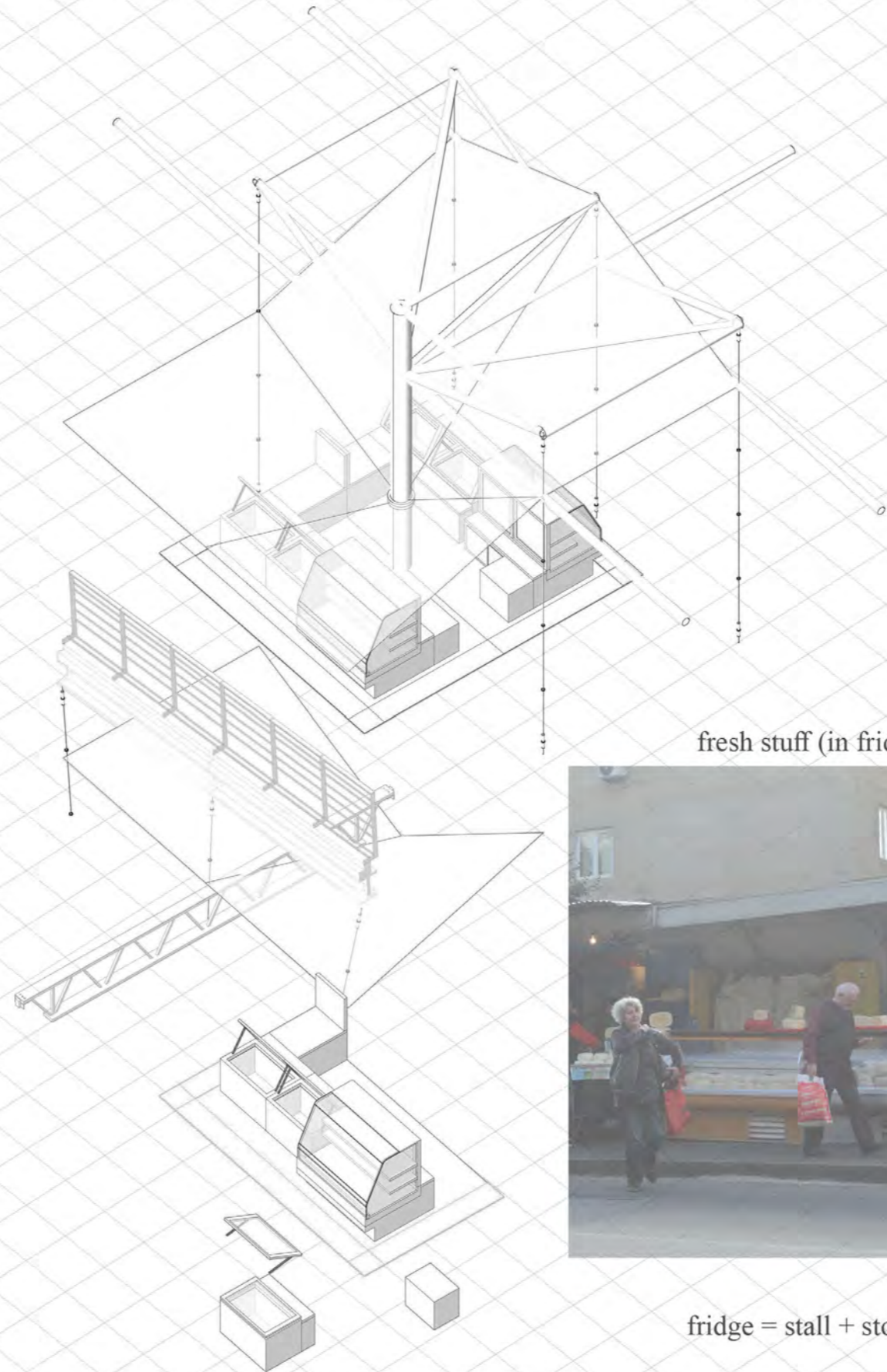

fresh stuff (in fridge)



fridge = stall + storage

[BOX/WALL]
GROCERY

daily grocery

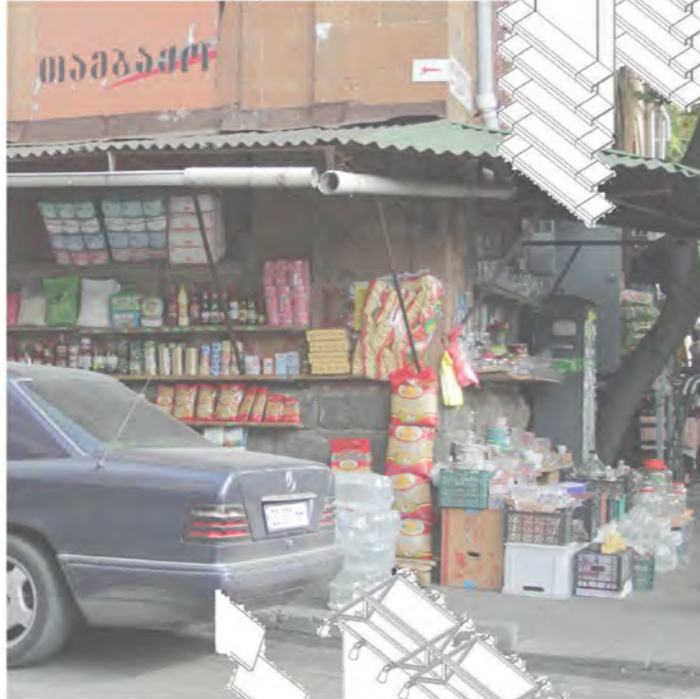

spices / grain / oil

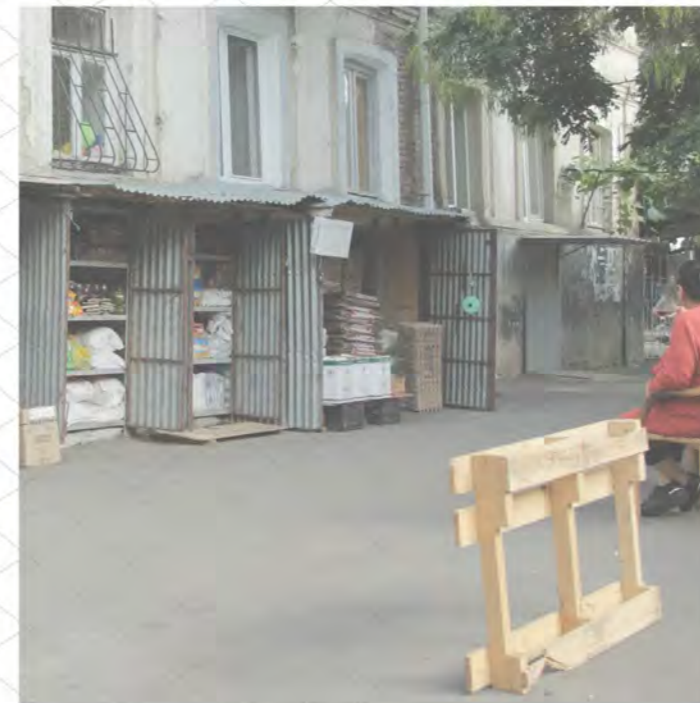

goods on wall (shelf) ; storage? truck?

storage + stall box (open/close)

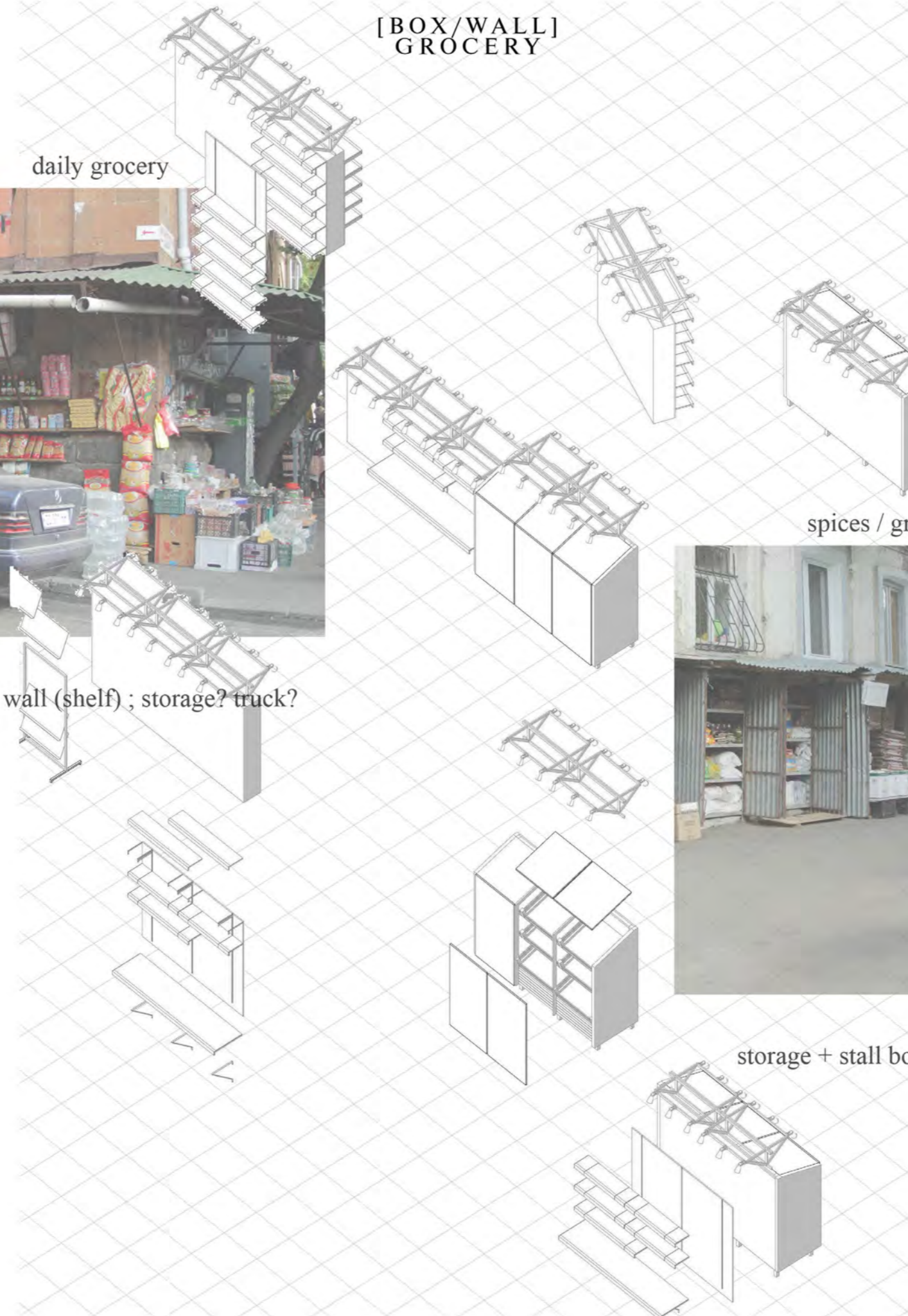

[HANGING]
CLOTHING / ACCESSORY

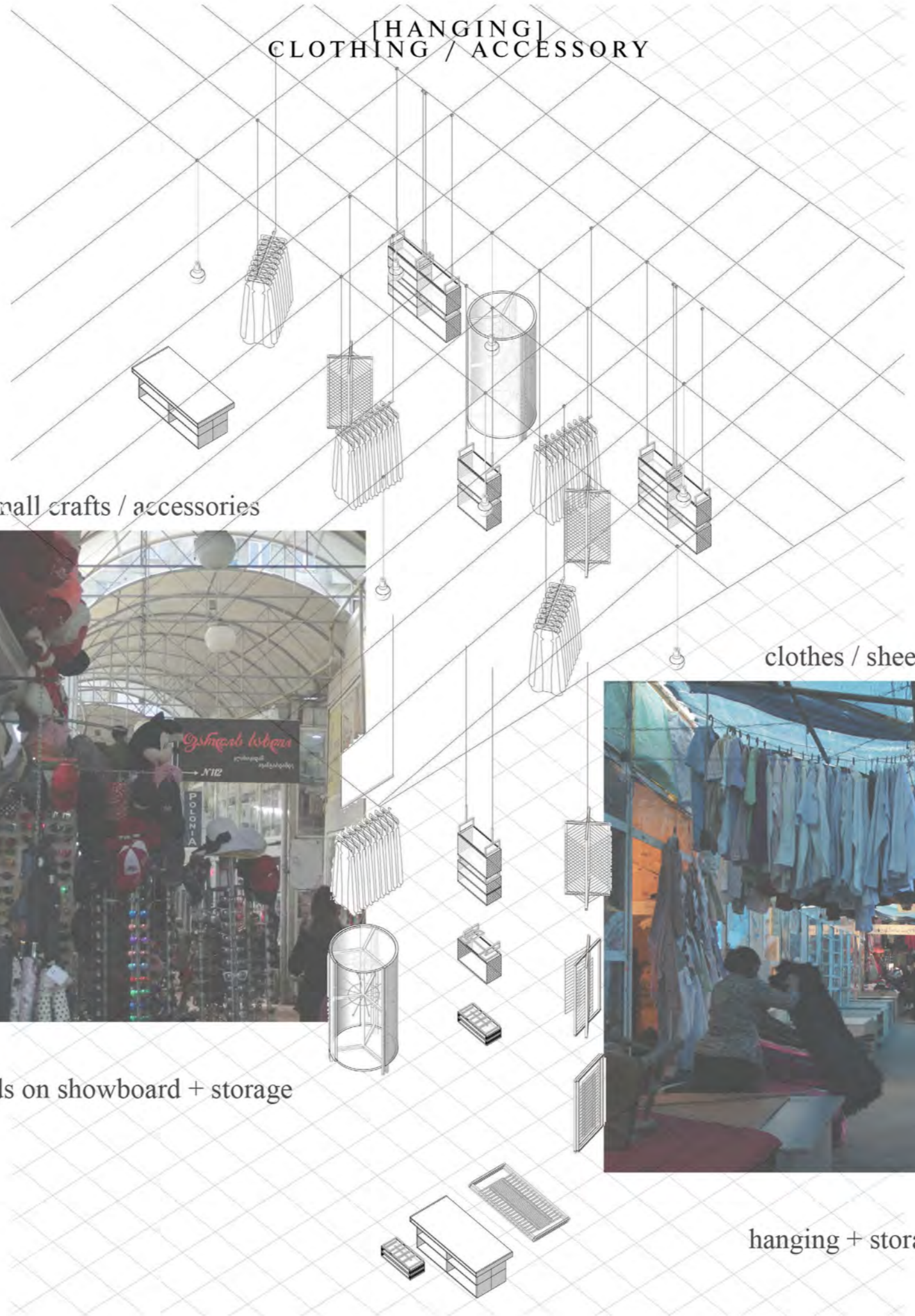

small crafts / accessories

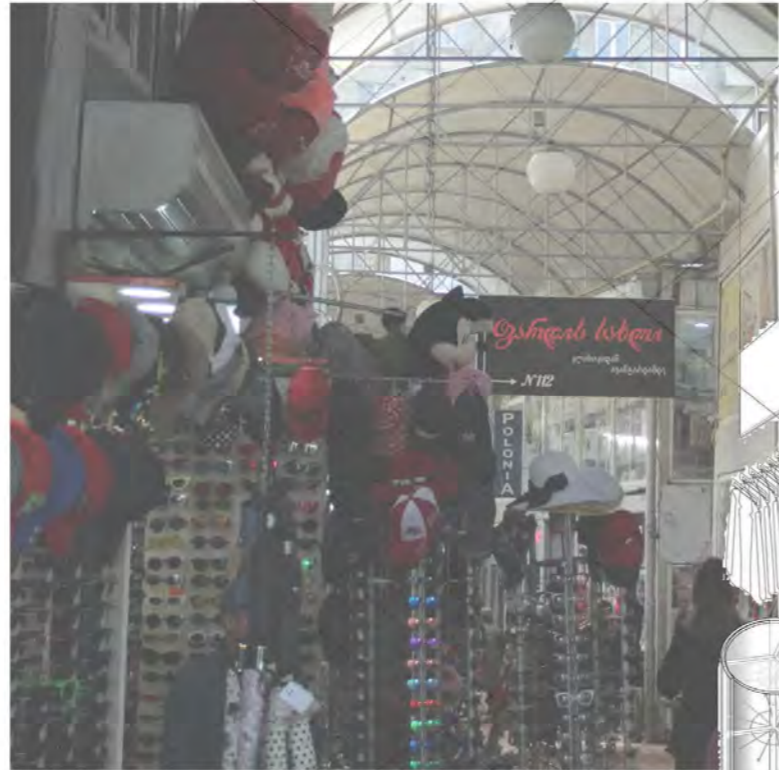

goods on showboard + storage

clothes / sheets

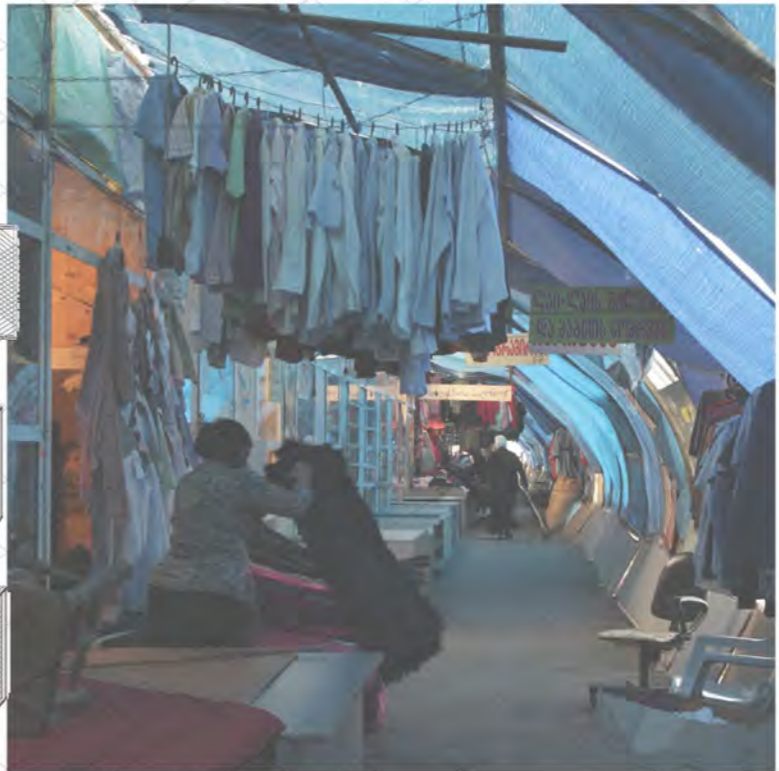

hanging + storage

[SCAFFOLDING (FOR OCCUPY)]
FOODTRUCK / TEMPORARY STALL

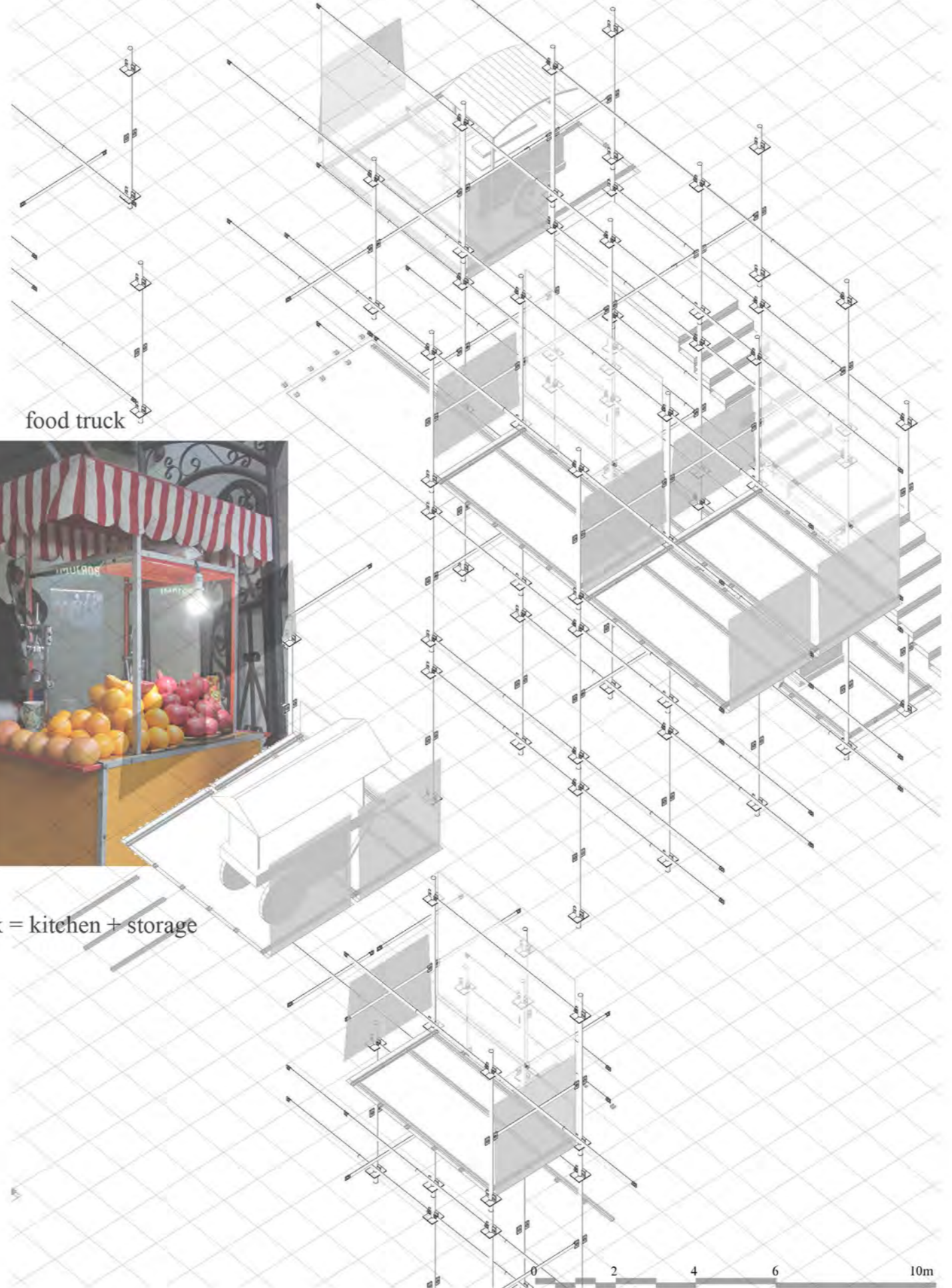

food truck

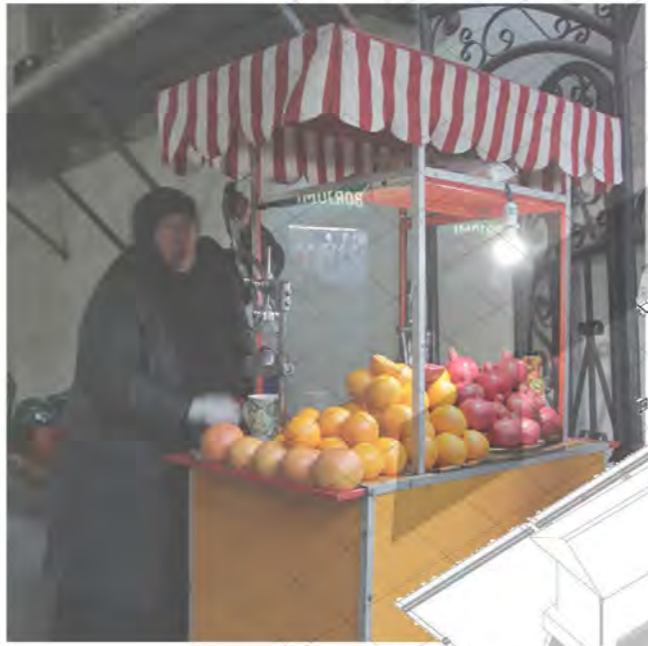

truck = kitchen + storage

0 2 4 6 10m

[ROOM]
RESTAURANT

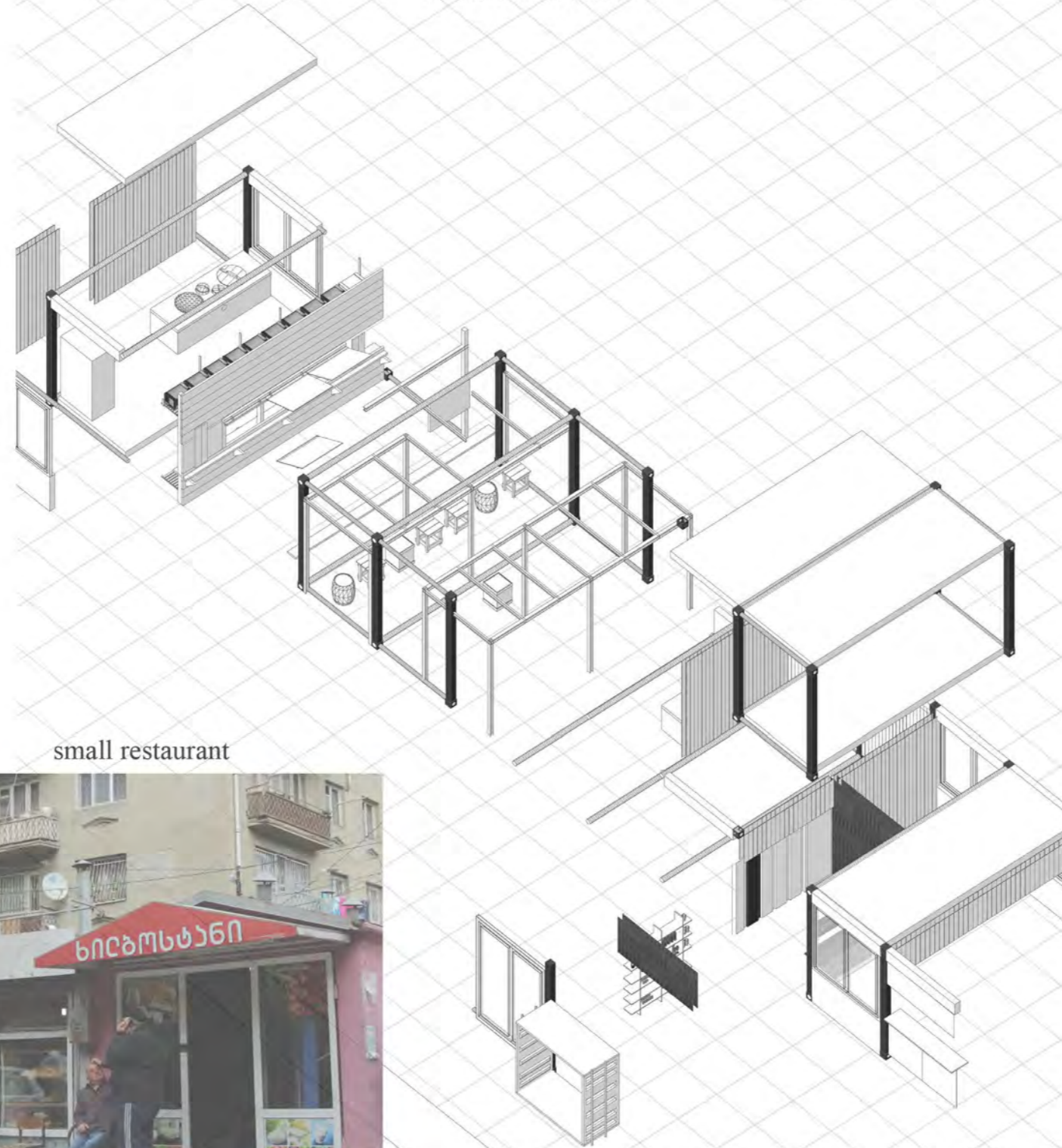

small restaurant



kitchen + dining space + equipment

[ROOM]
KIOSK / CURRENCY EXCHANGE / TELECOM / ...



currency exchange / telecom



kiosk + ad. panels

[ROOM]
AUTO REPAIRMENT

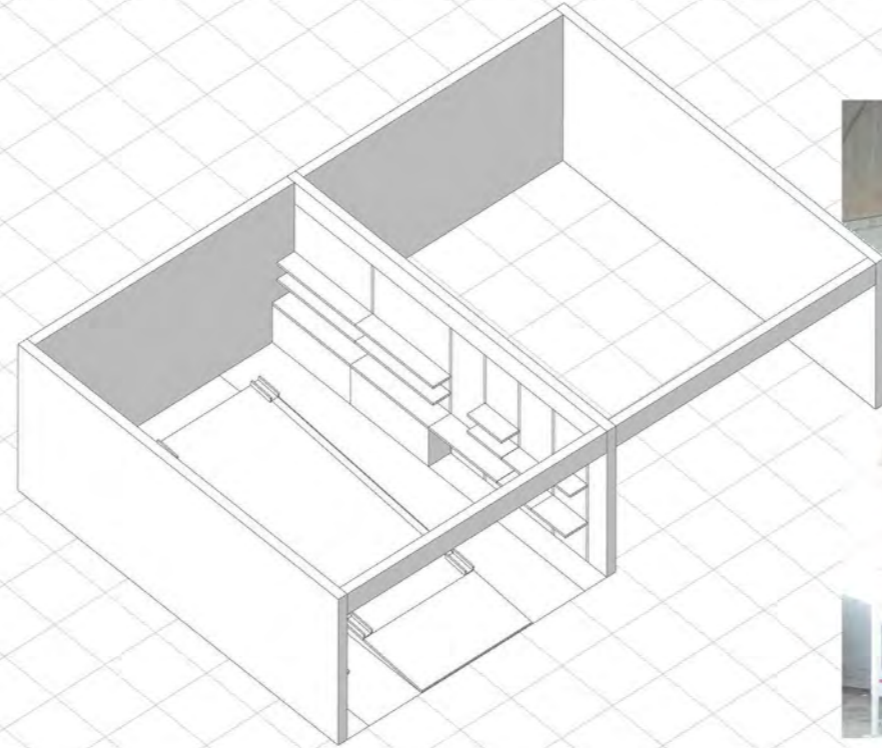

auto repairment



"garage"

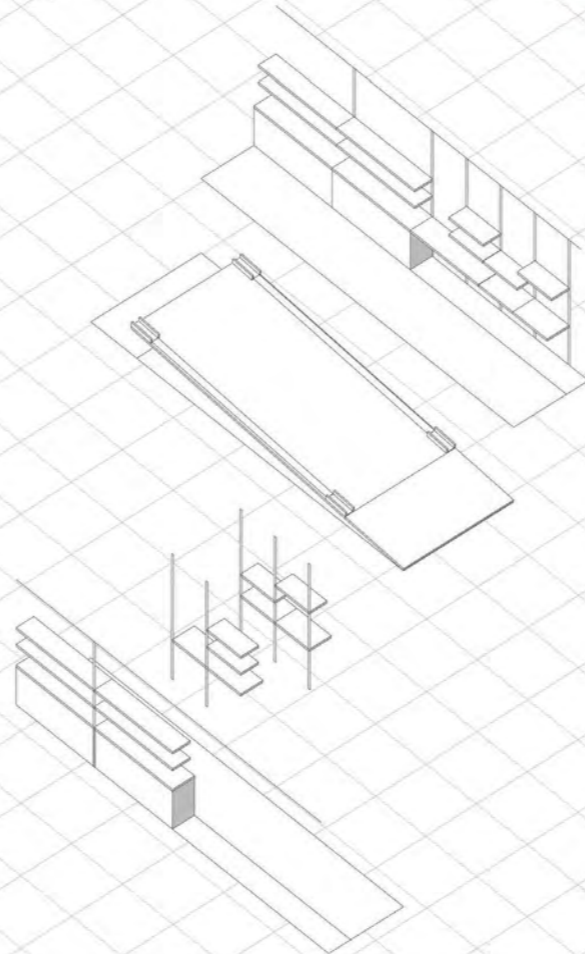

synthesis

formal | informal

[INDEPENDENT]

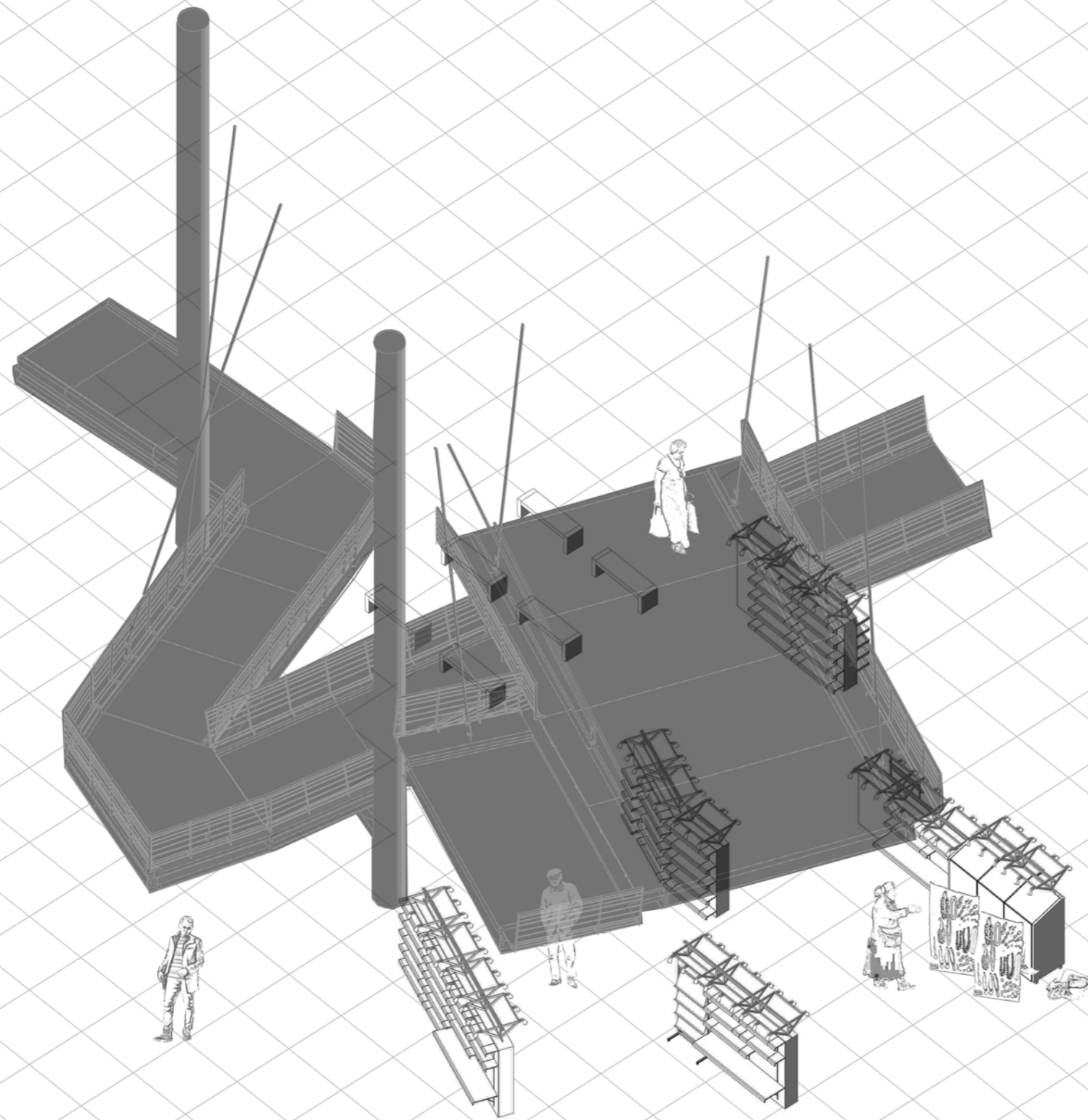

[ONTOP/ATTACHED TO]

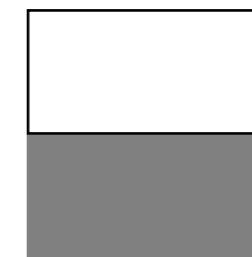
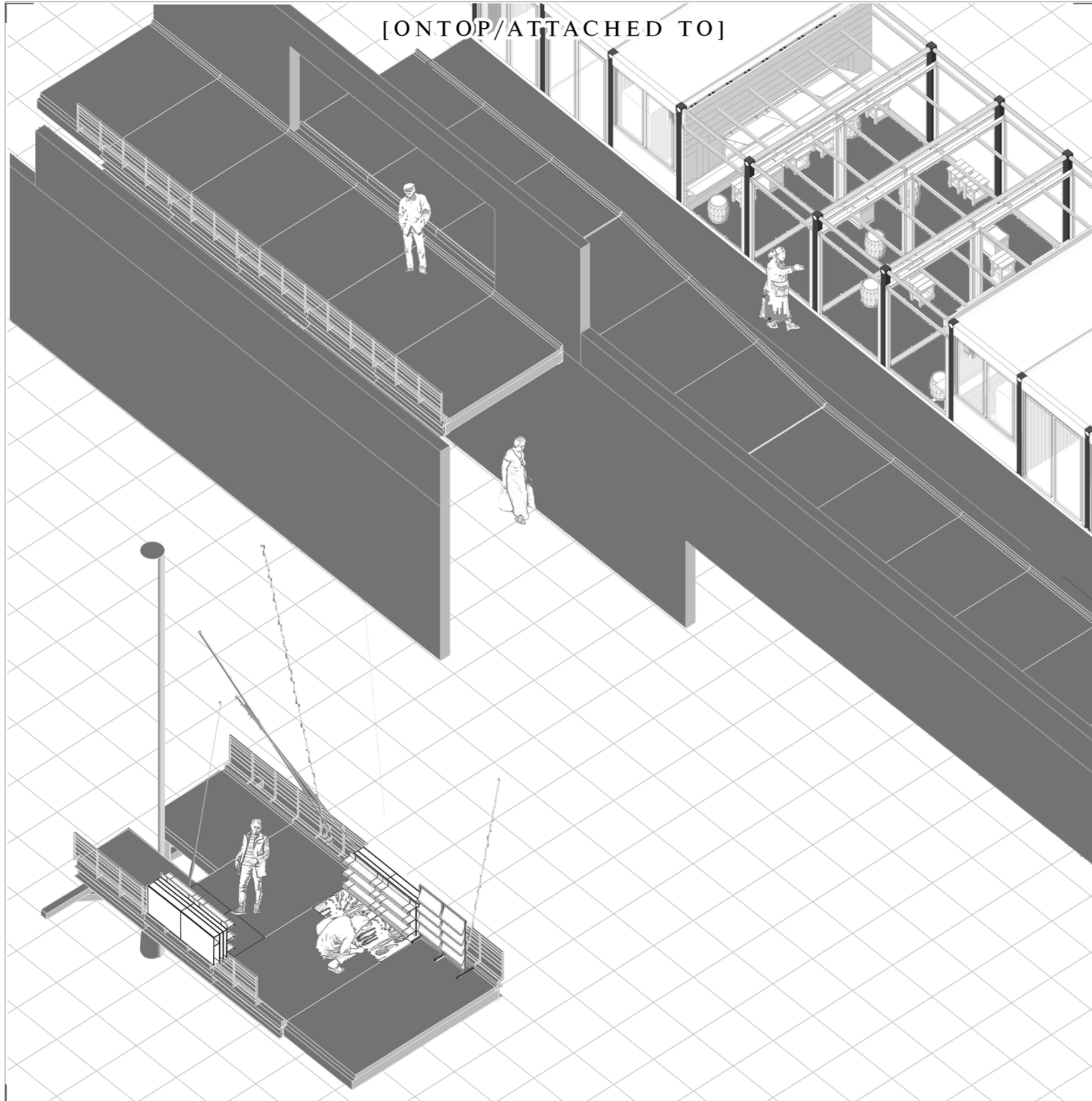

[INTERWEAVING]

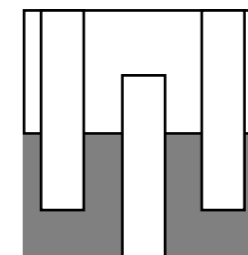
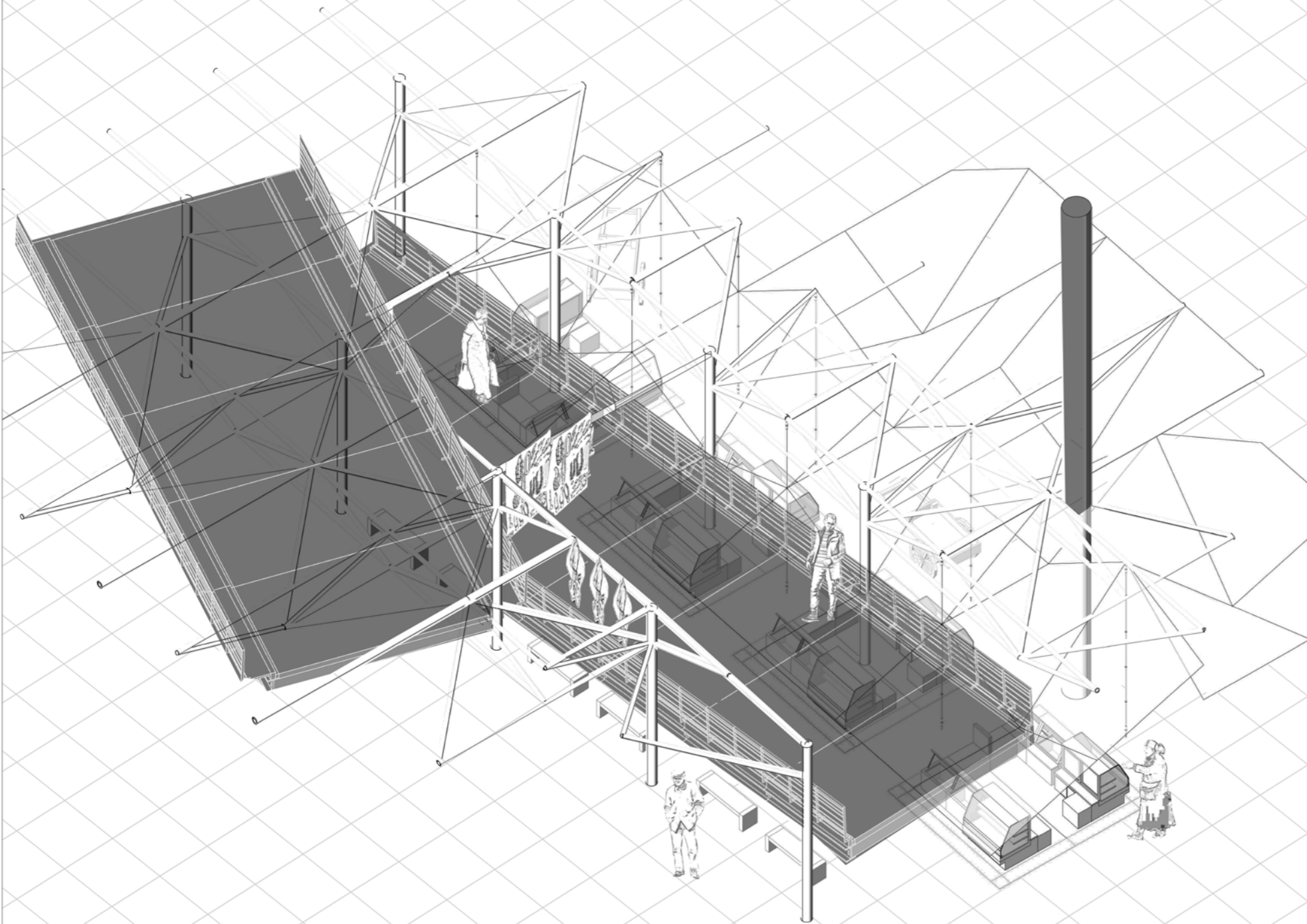

SYNTHESIS PLAN

[FORMAL] PART AND [INFORMAL] PART WITH 3 TYPES OF RELATIONSHIP

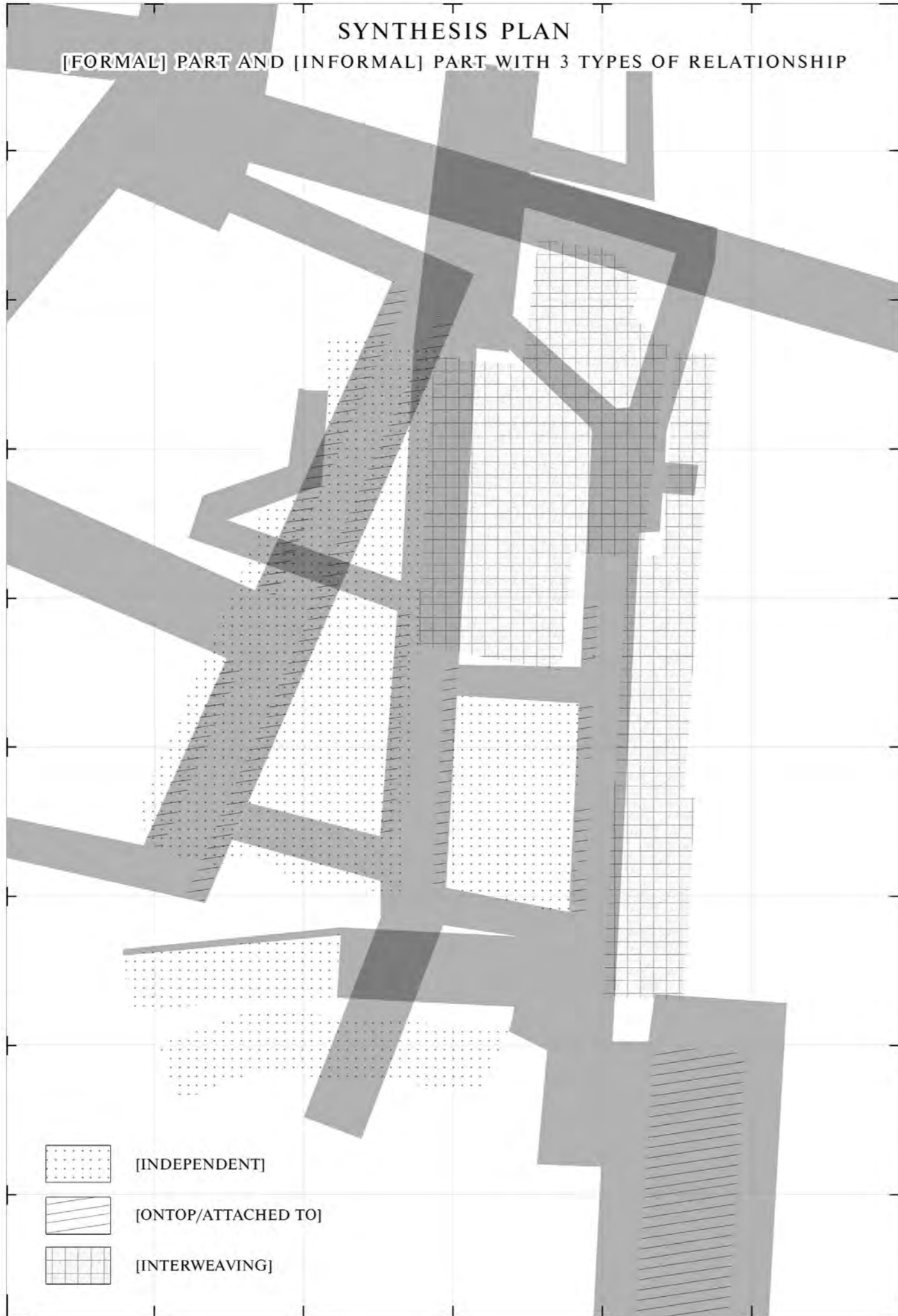

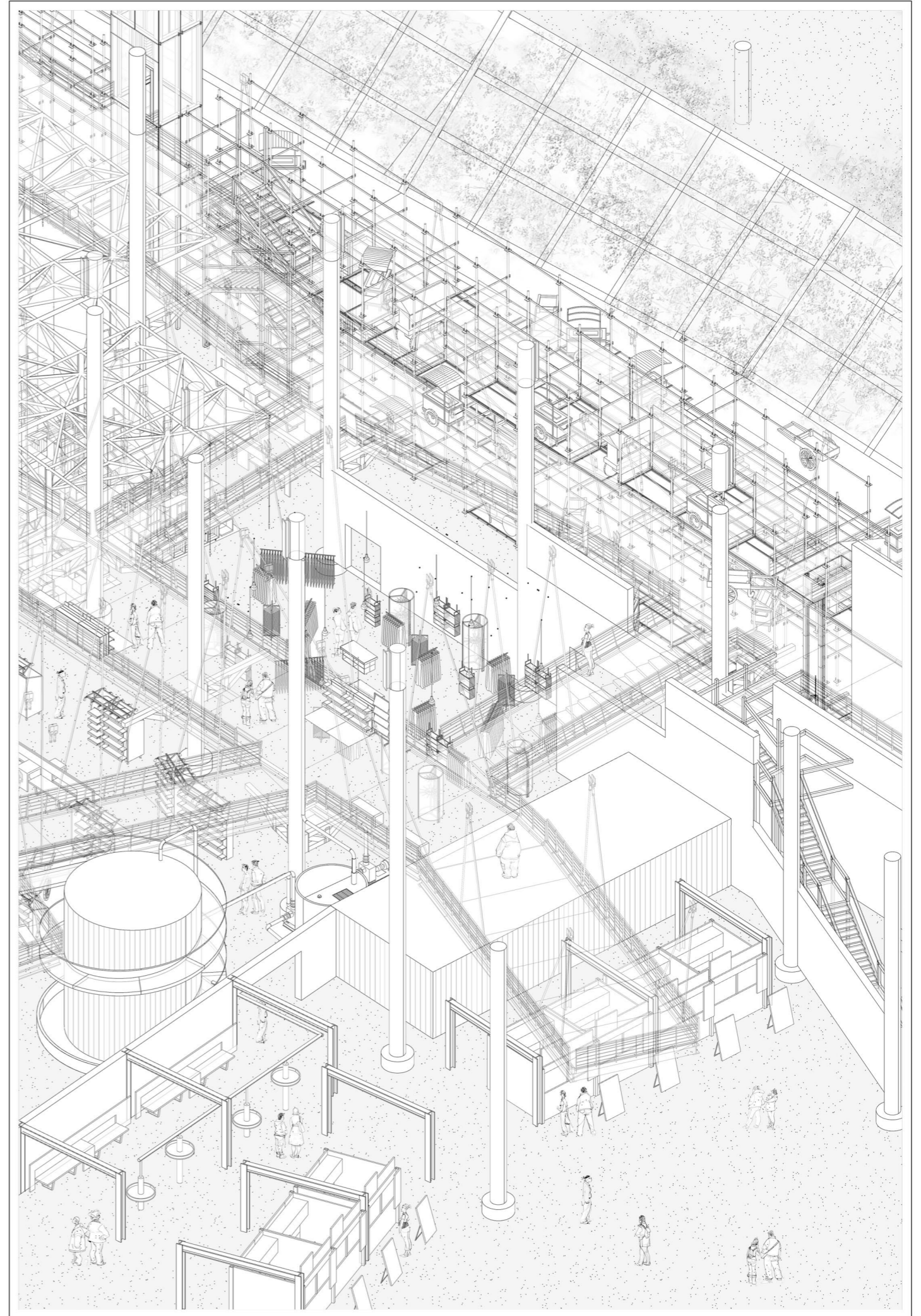
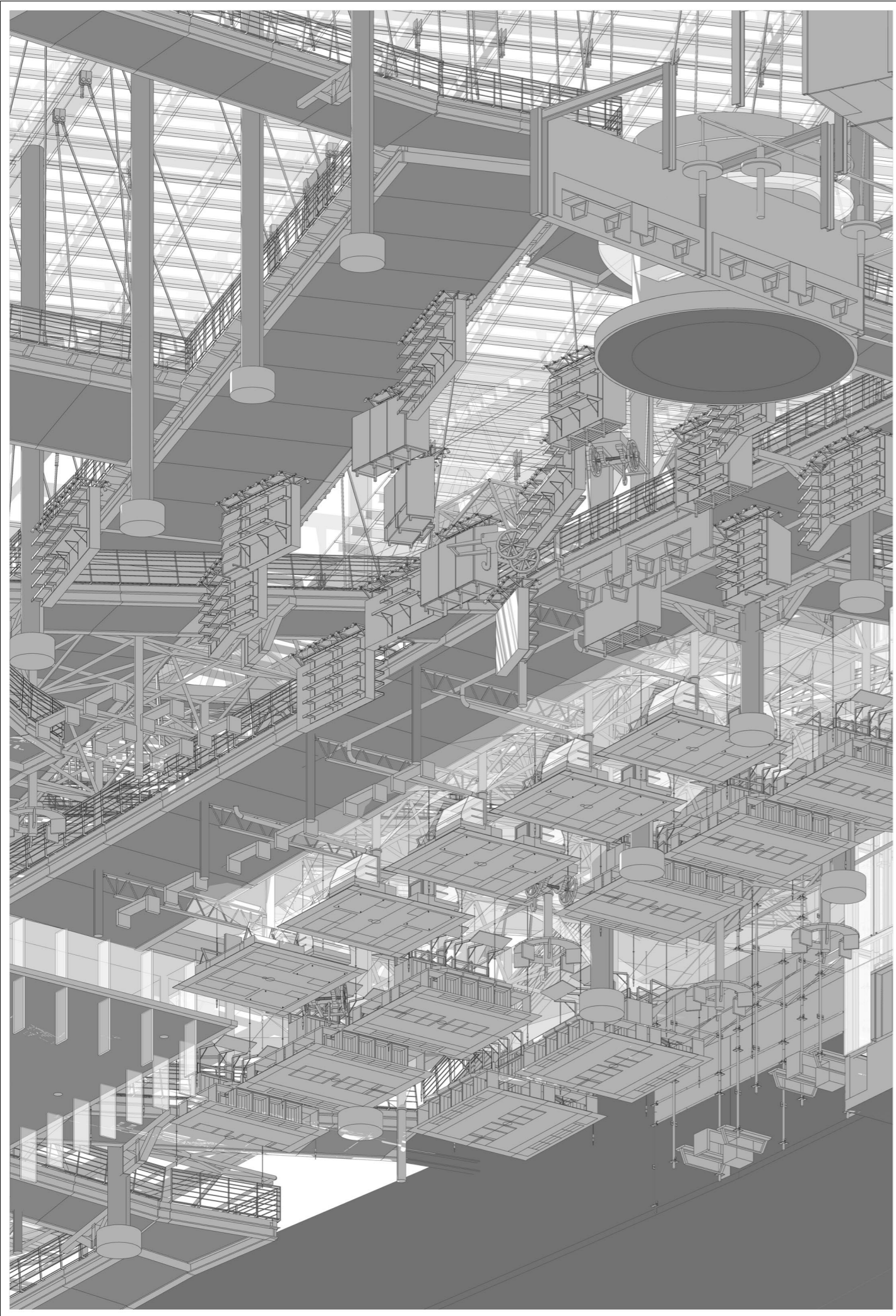



SYNTHESIS PLAN
FROM DRAWING TO ARCHITECTURAL ASSEMBLAGE

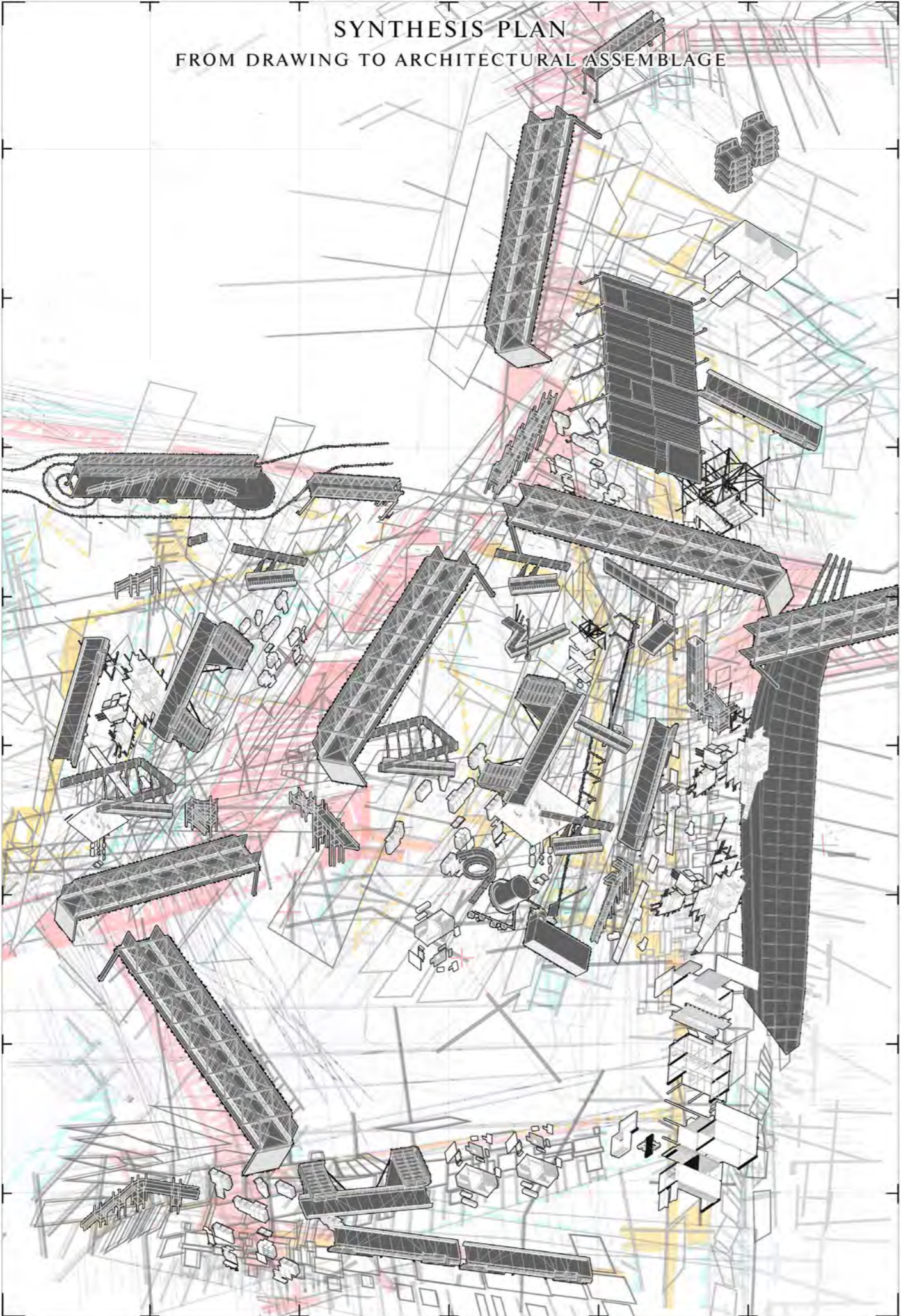

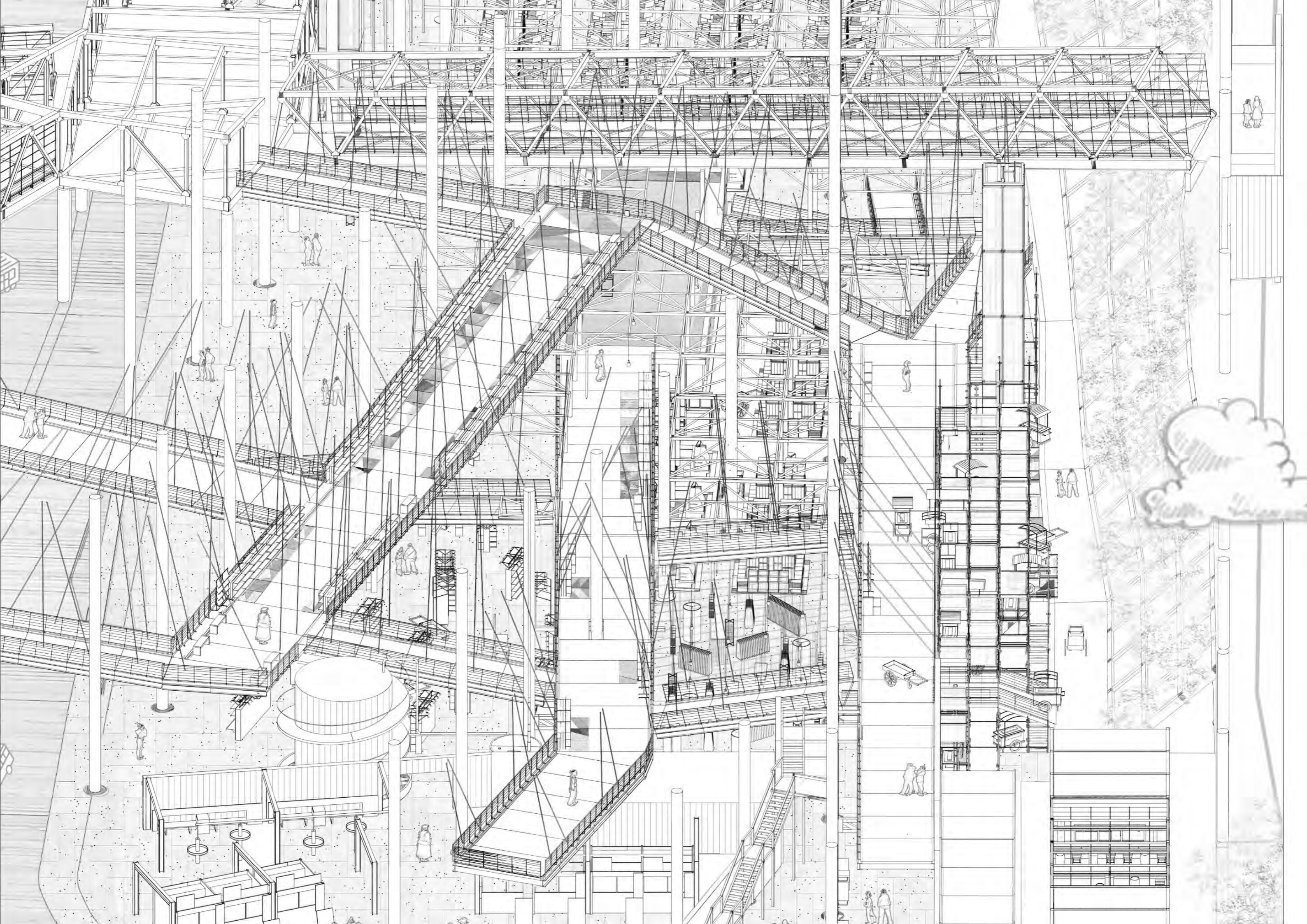

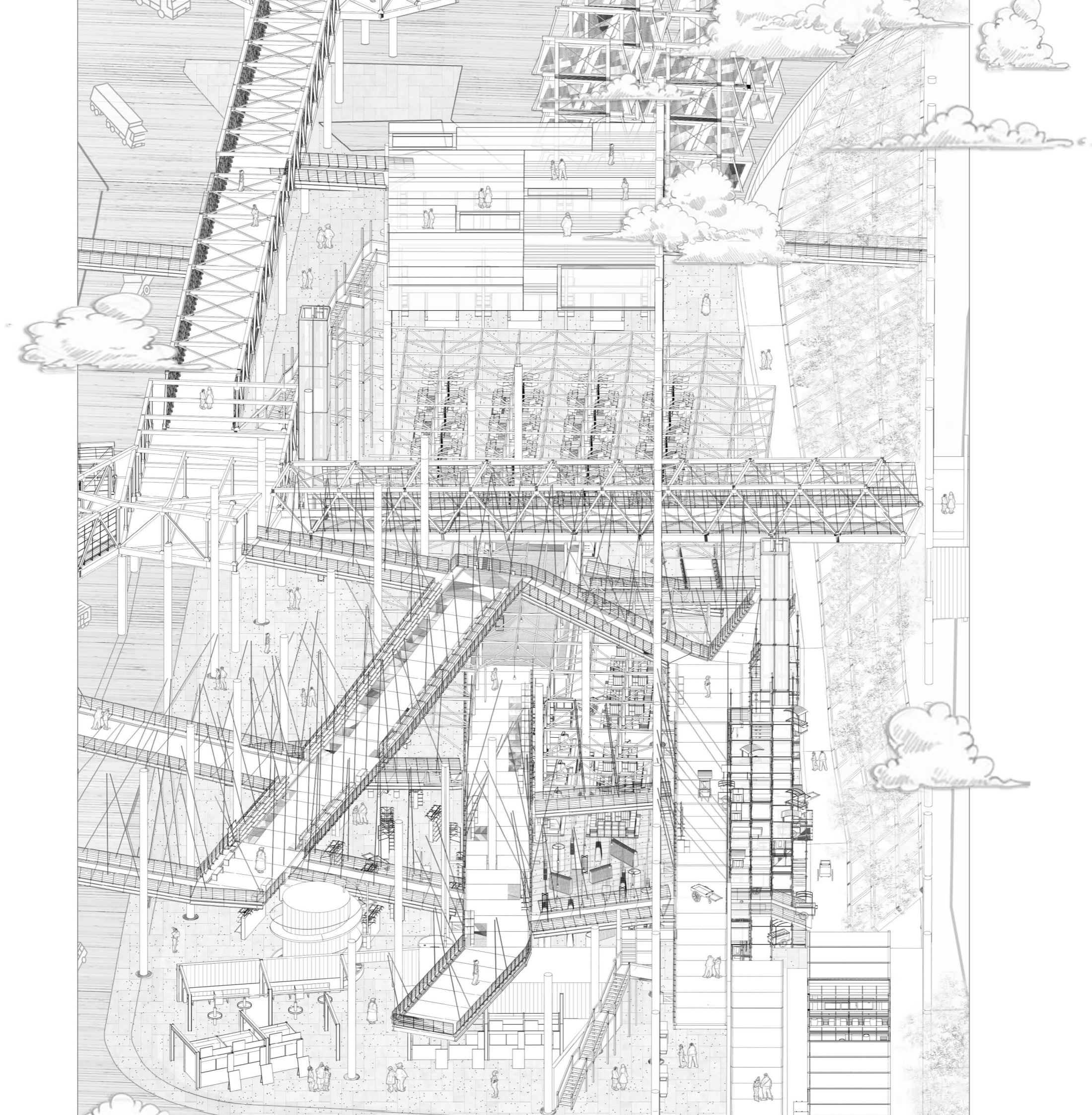

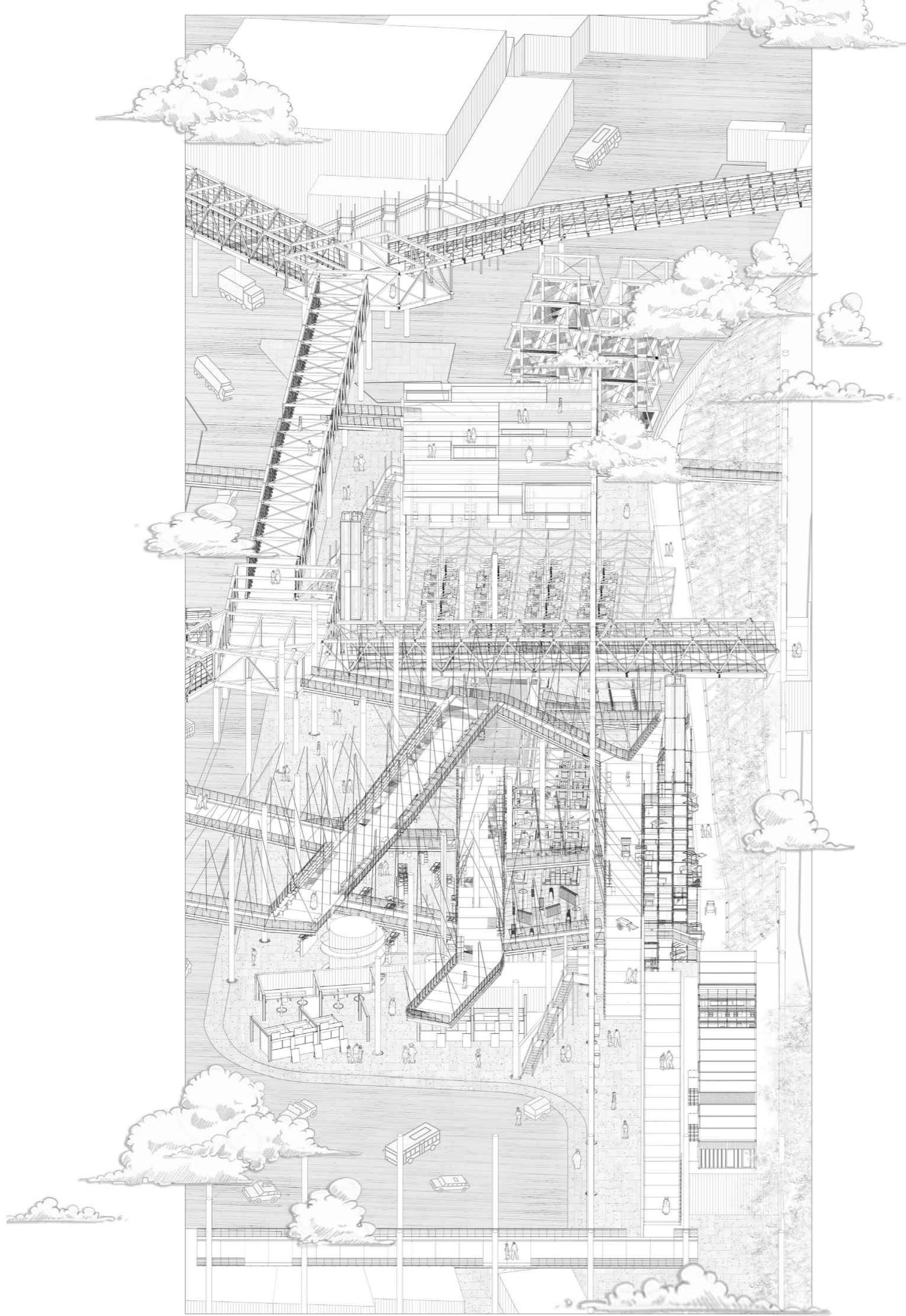



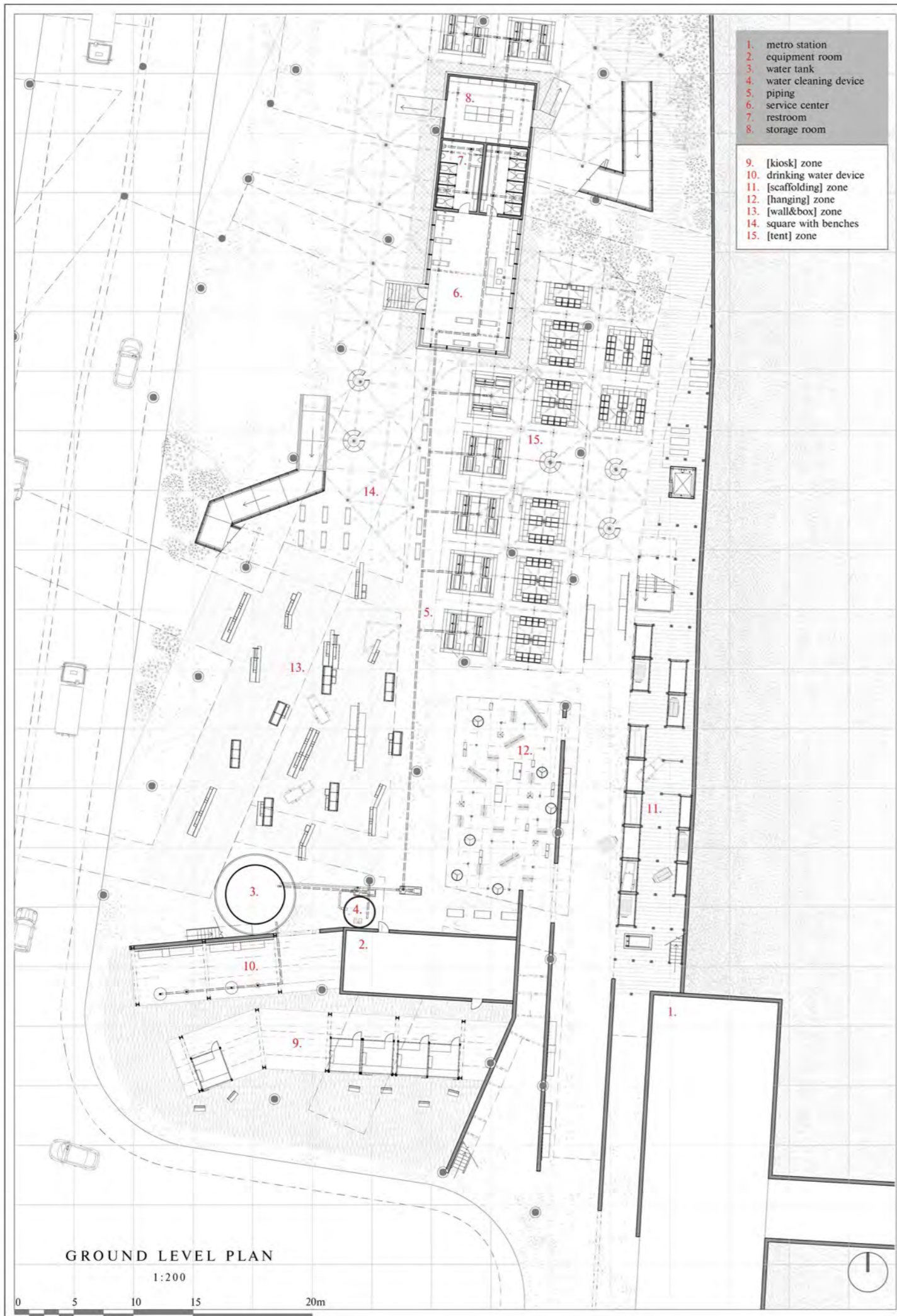

- 1. metro station
 - 2. equipment room
 - 3. water tank
 - 4. water cleaning device
 - 5. piping
 - 6. service center
 - 7. restroom
 - 8. storage room
-
- 9. [kiosk] zone
 - 10. drinking water device
 - 11. [scaffolding] zone
 - 12. [hanging] zone
 - 13. [wall&box] zone
 - 14. square with benches
 - 15. [tent] zone

- 1. metro station
 - 2. equipment room
 - 3. water tank
 - 4. water cleaning device
 - 5. piping
 - 6. service center
 - 7. restroom
 - 8. storage room
-
- 9. [kiosk] zone
 - 10. drinking water device
 - 11. [scaffolding] zone
 - 12. [hanging] zone
 - 13. [wall&box] zone
 - 14. square with benches
 - 15. [tent] zone

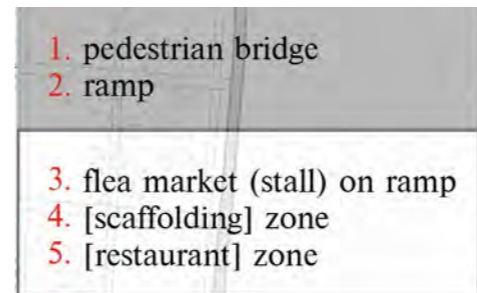
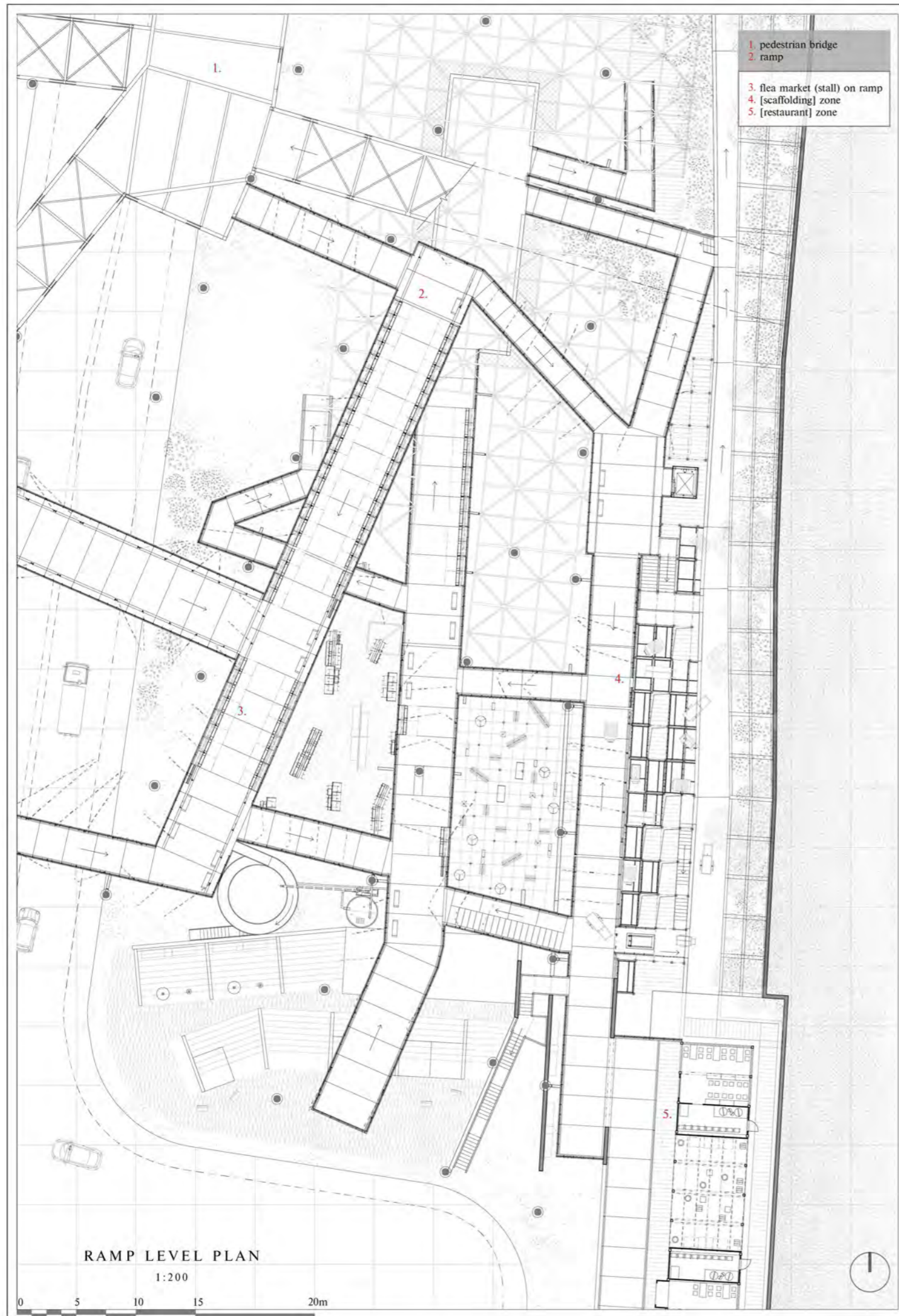



1 panorama cafe
2 to the pedestrian bridge crossing railway

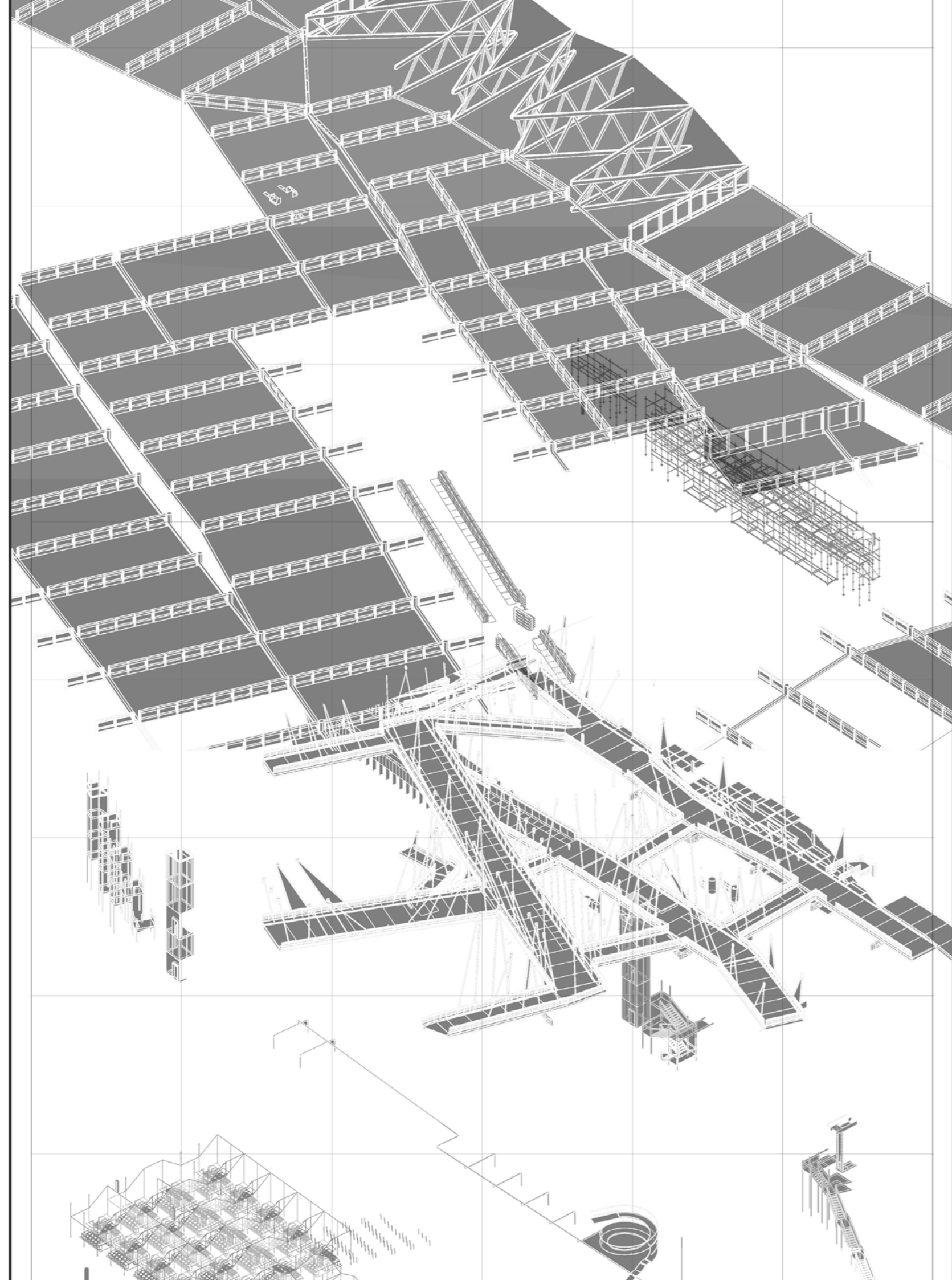

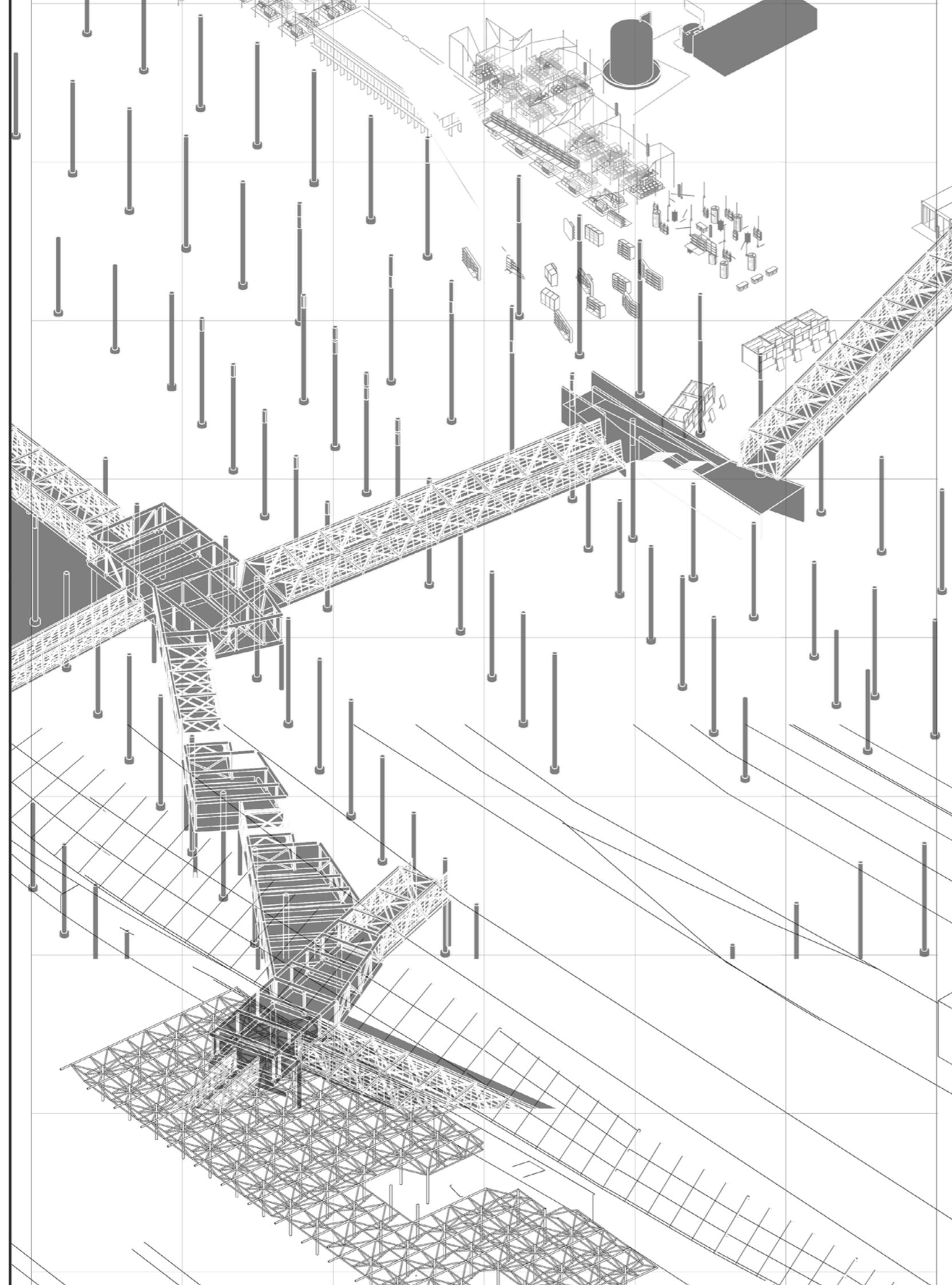

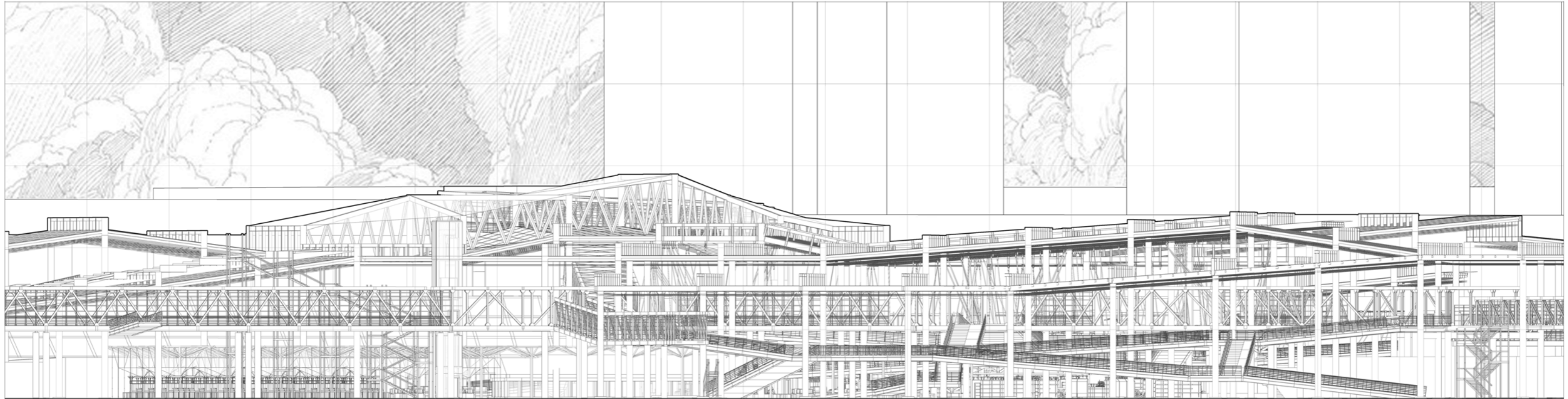

ELEVATION (MARKET AREA)

1:200

0 8 16 32m

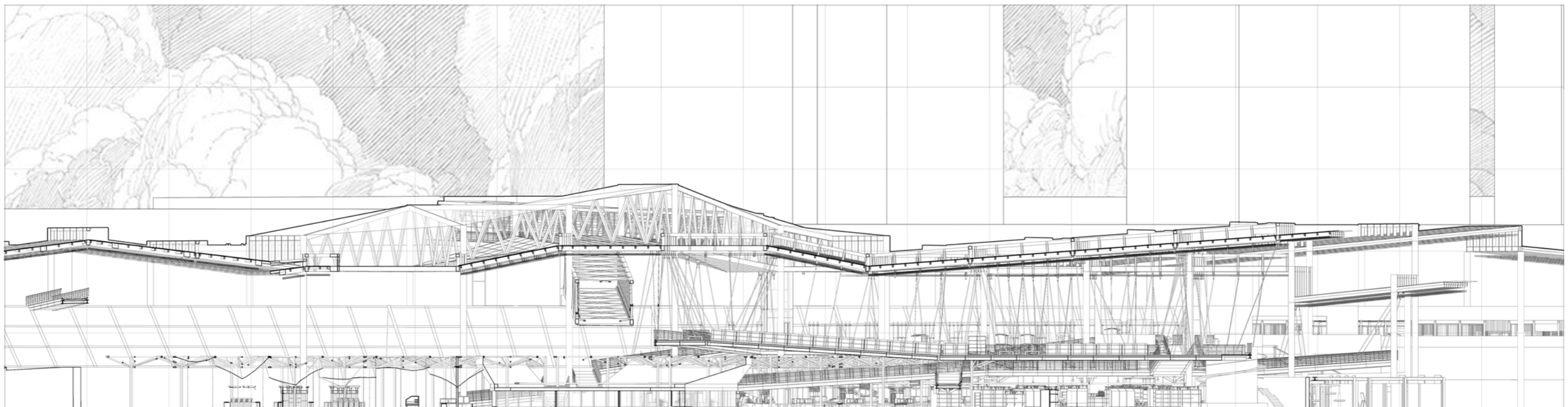

SECTION (MARKET AREA)

1:200

0 8 16 32m

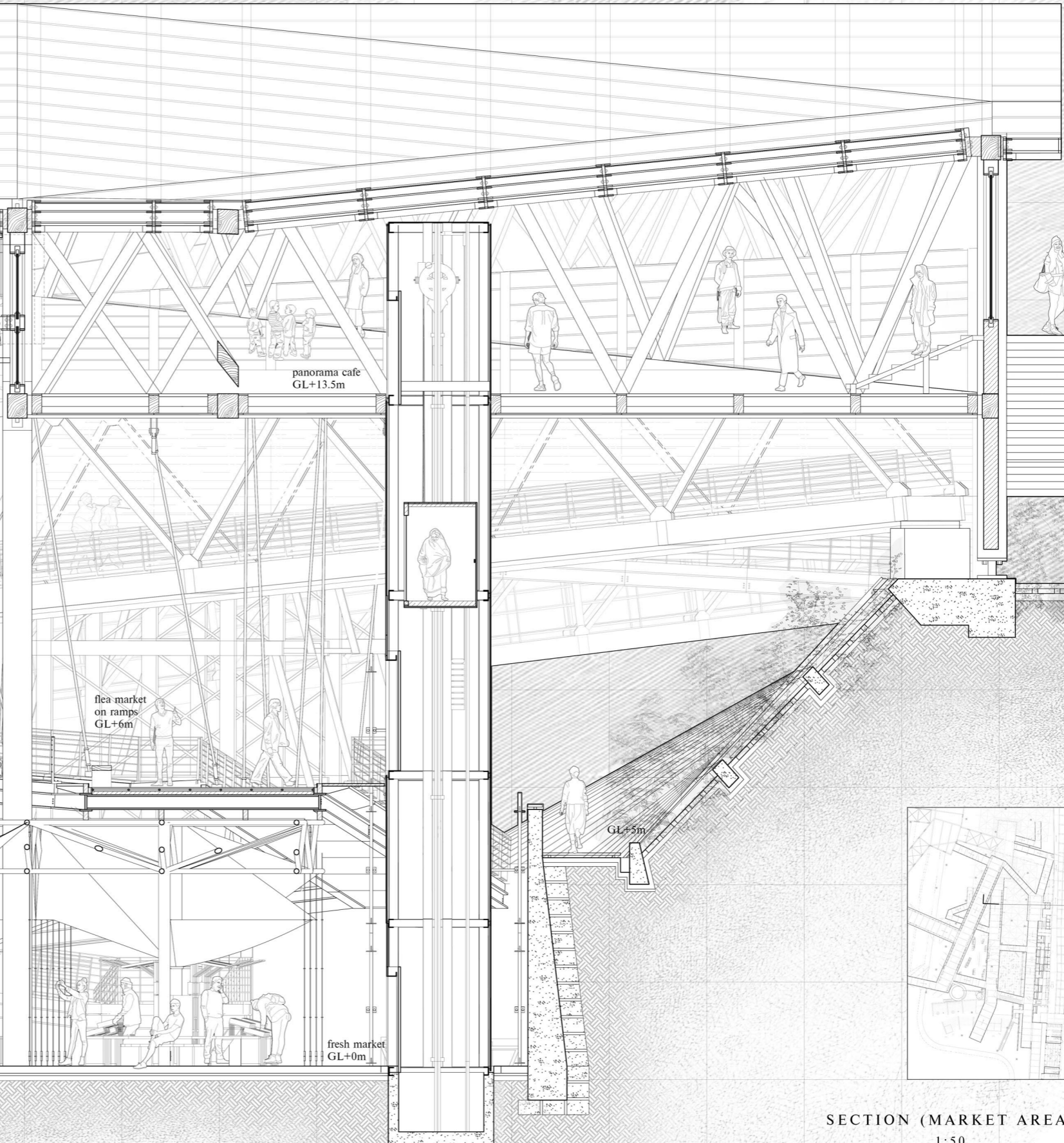
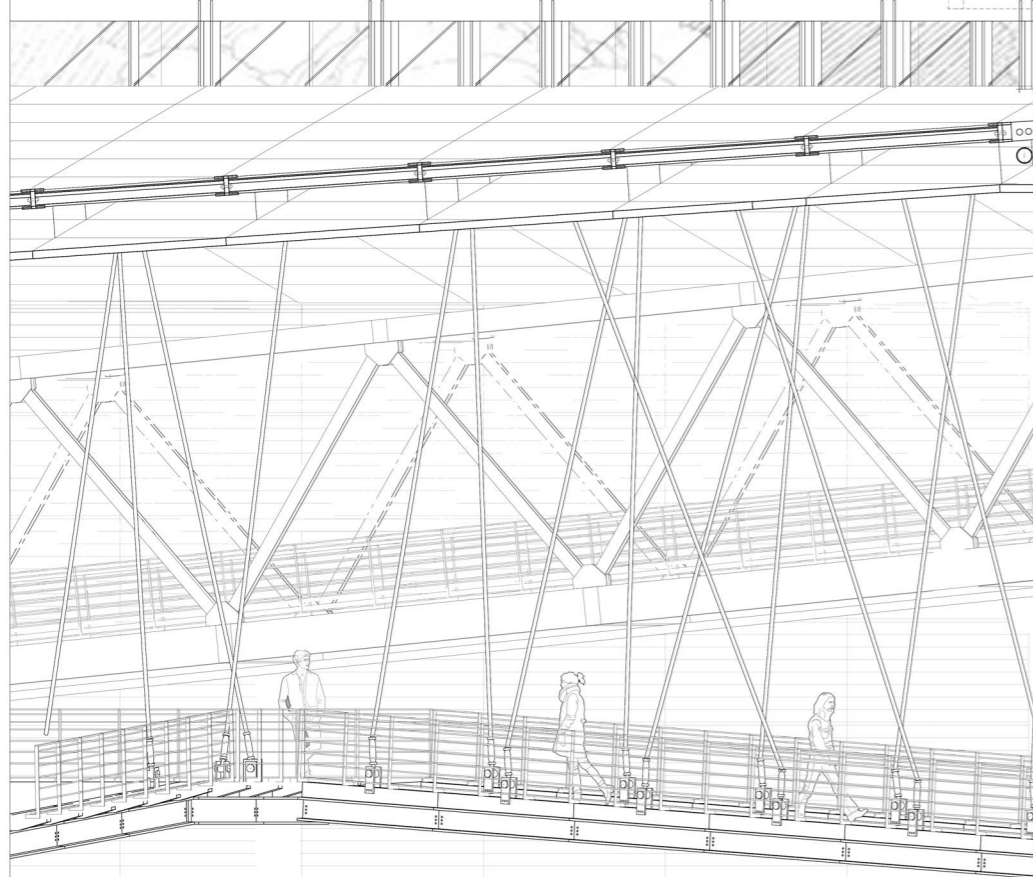
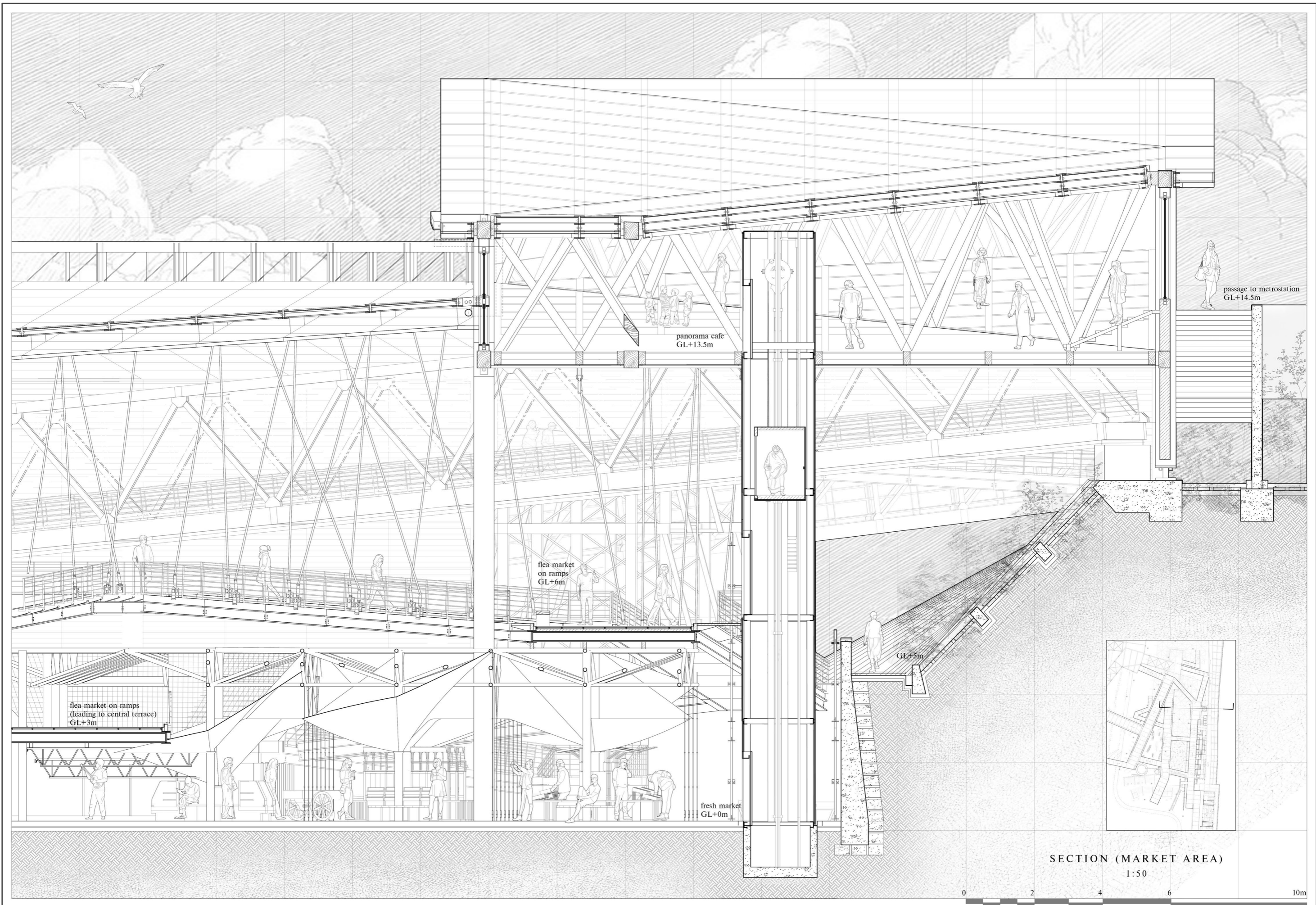

passage to metrostation
GL+14.5m

panorama cafe
GL+13.5m

flea market
on ramps
GL+6m

flea market on ramps
(leading to central terrace)
GL+3m

fresh market
GL+0m

GL+5m



SECTION (MARKET AREA)
1:50

0 2 4 6 10m

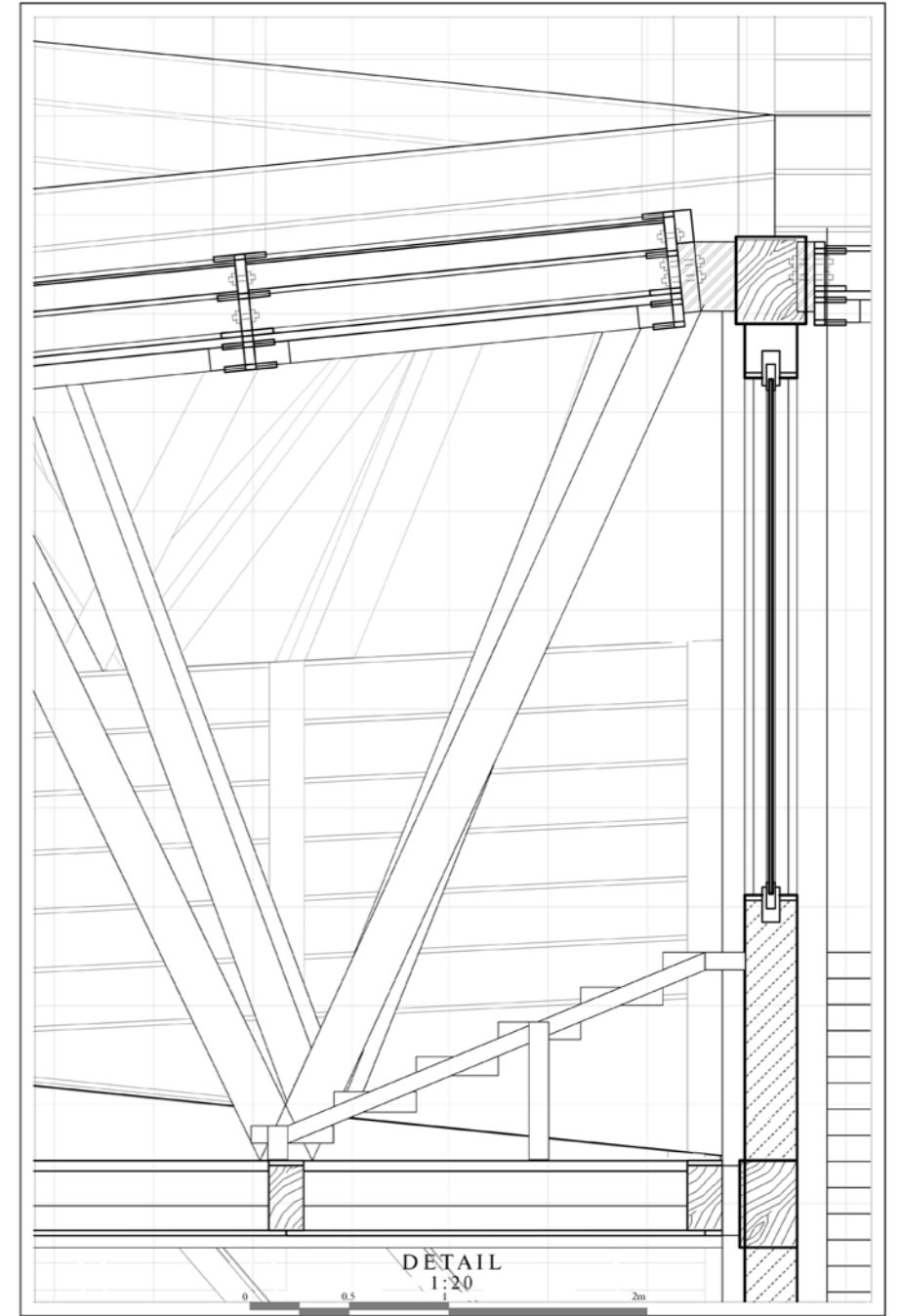
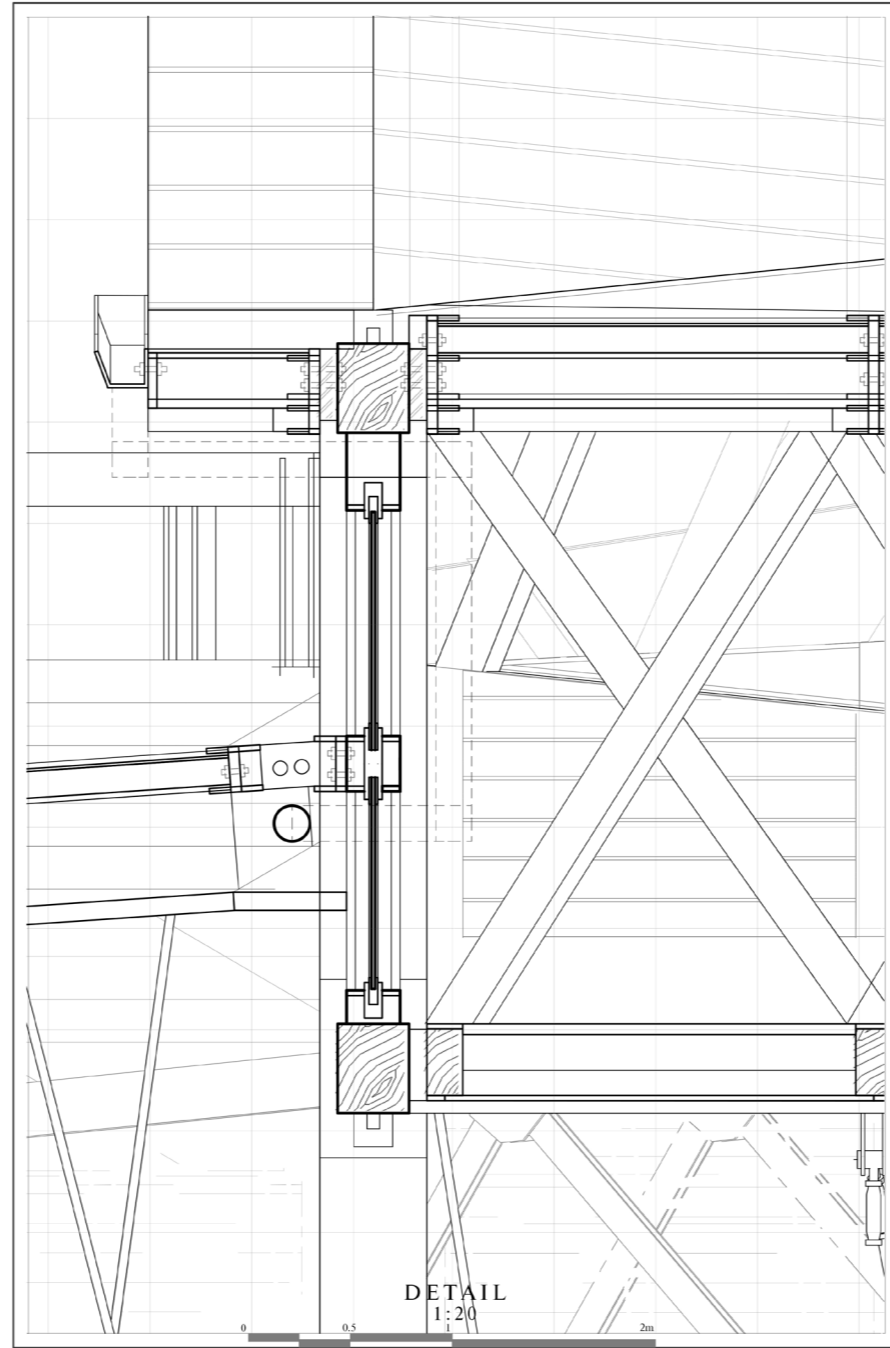
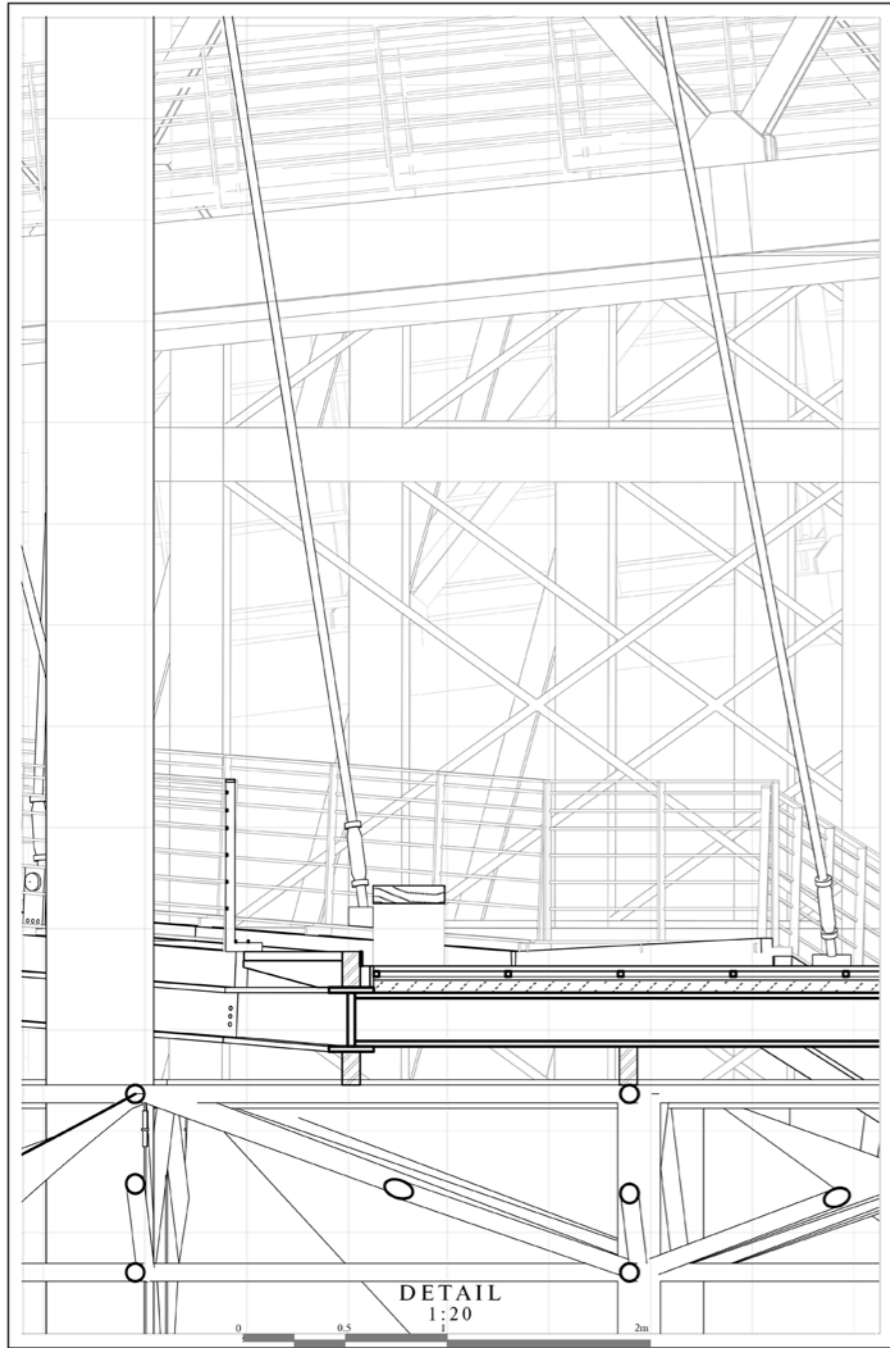

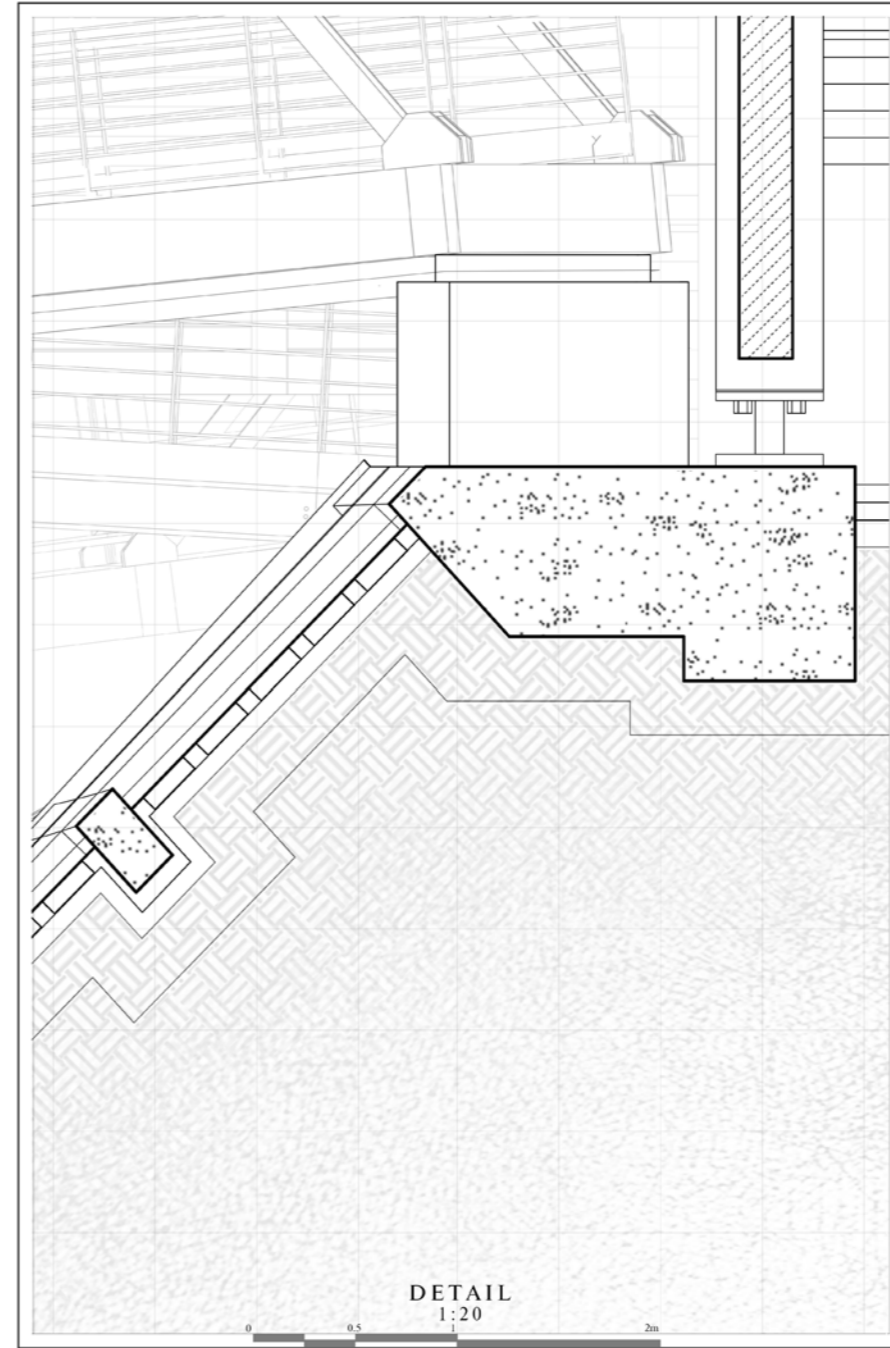
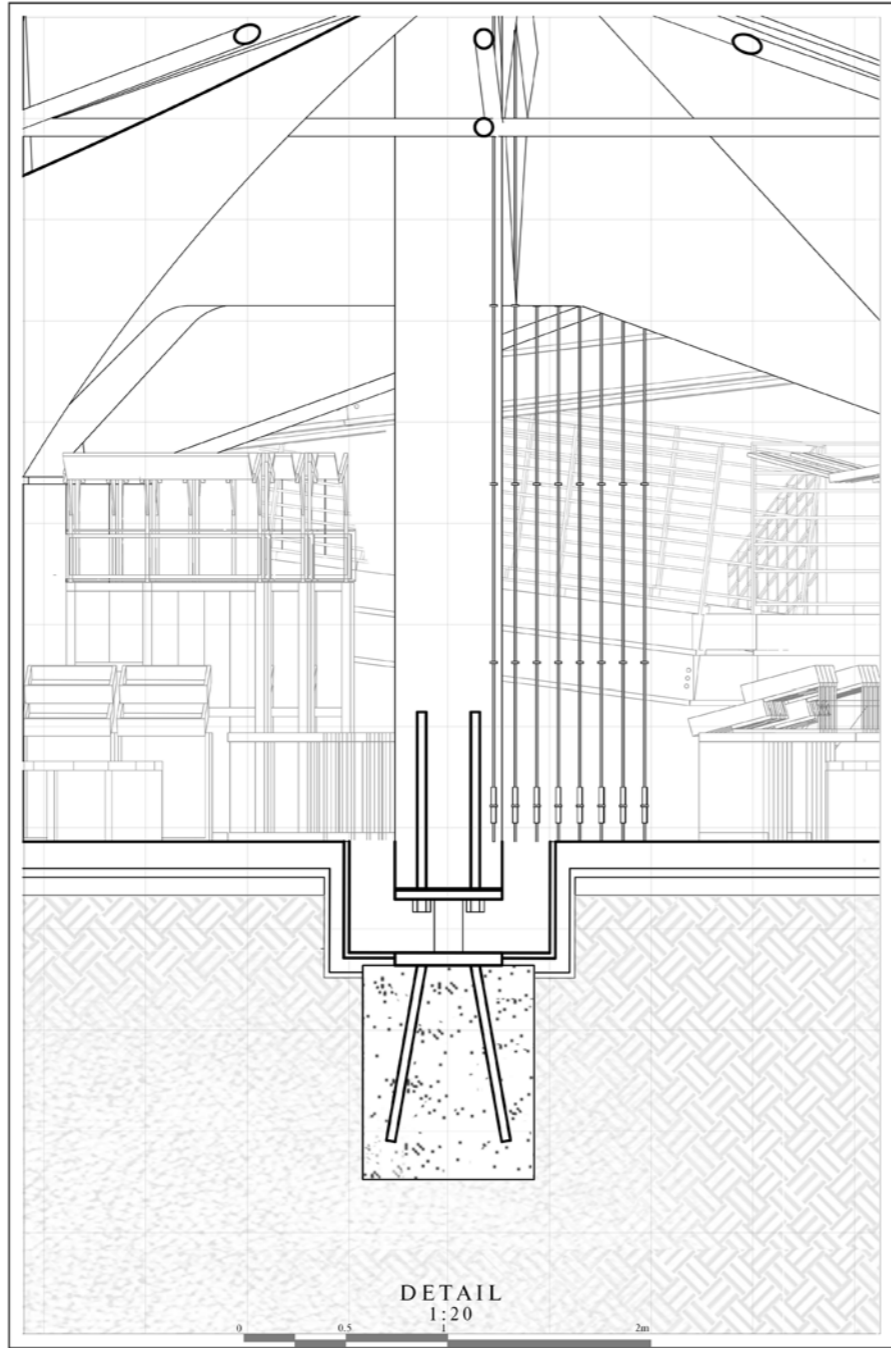

ROOF DETAIL
[SHADING]

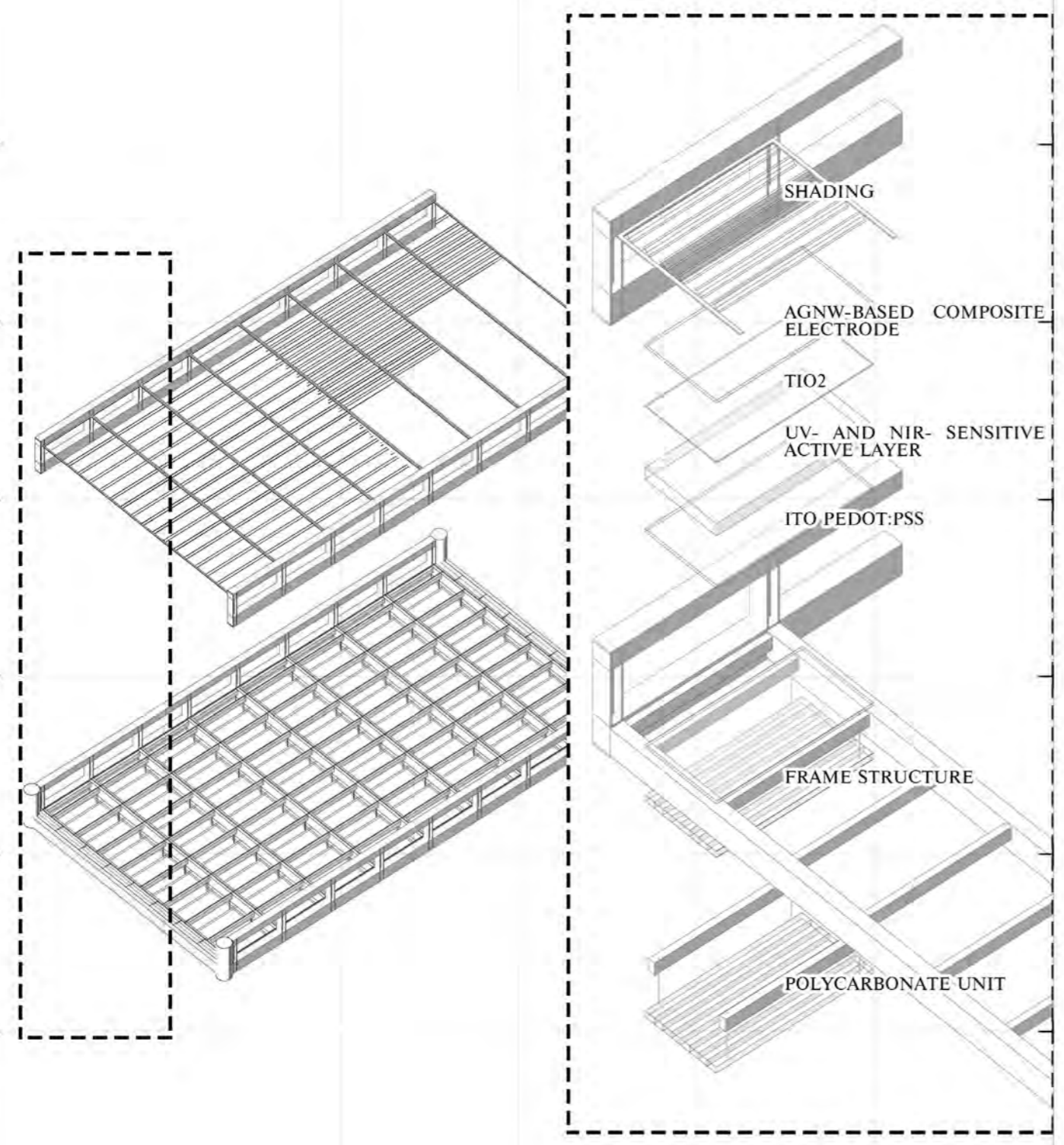

ROOF DETAIL
[ROOFGARDEN]

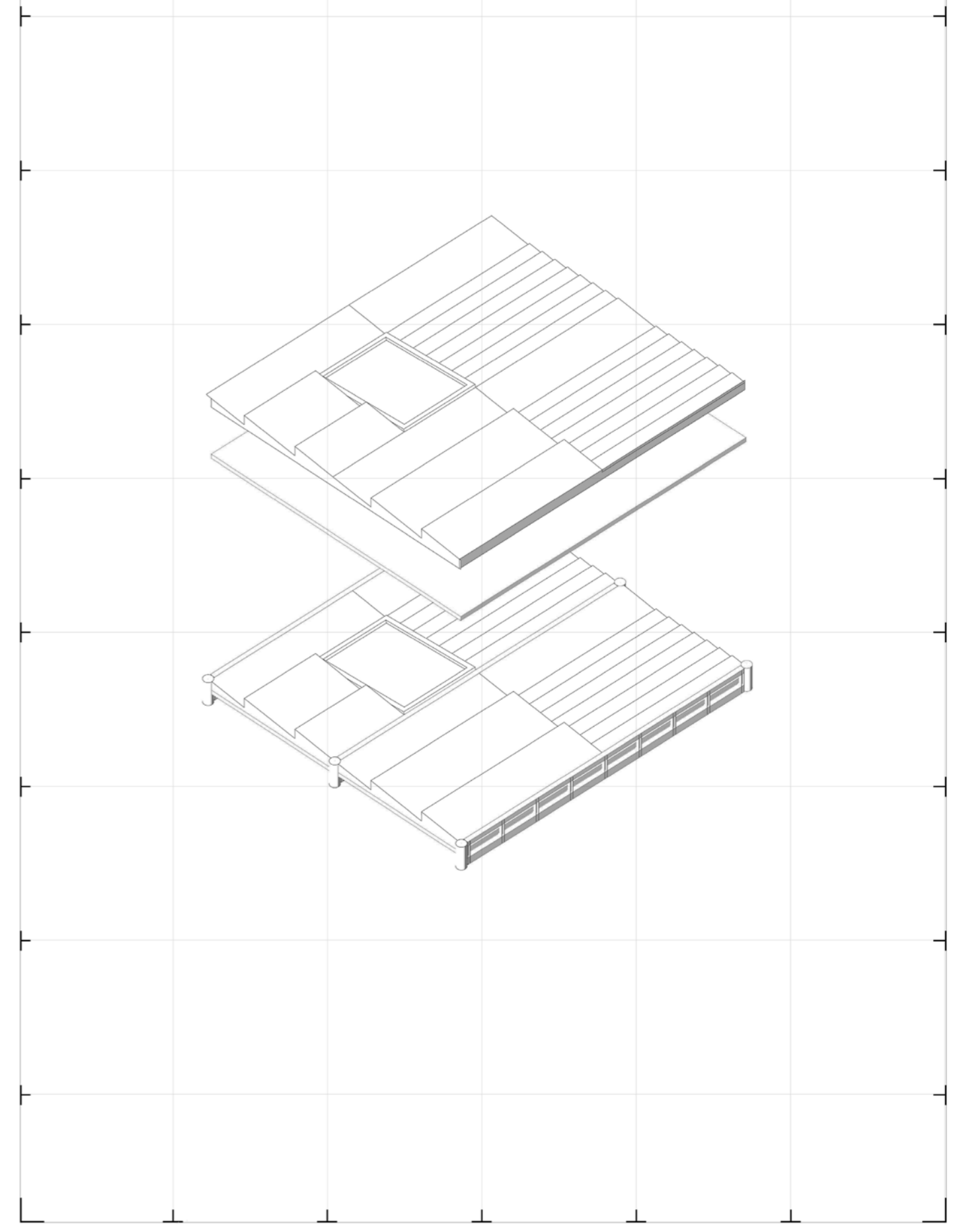

ROOF DETAIL

[SPACE WITHIN THE ROOF (CENTRAL PARONAMA CAFE)]

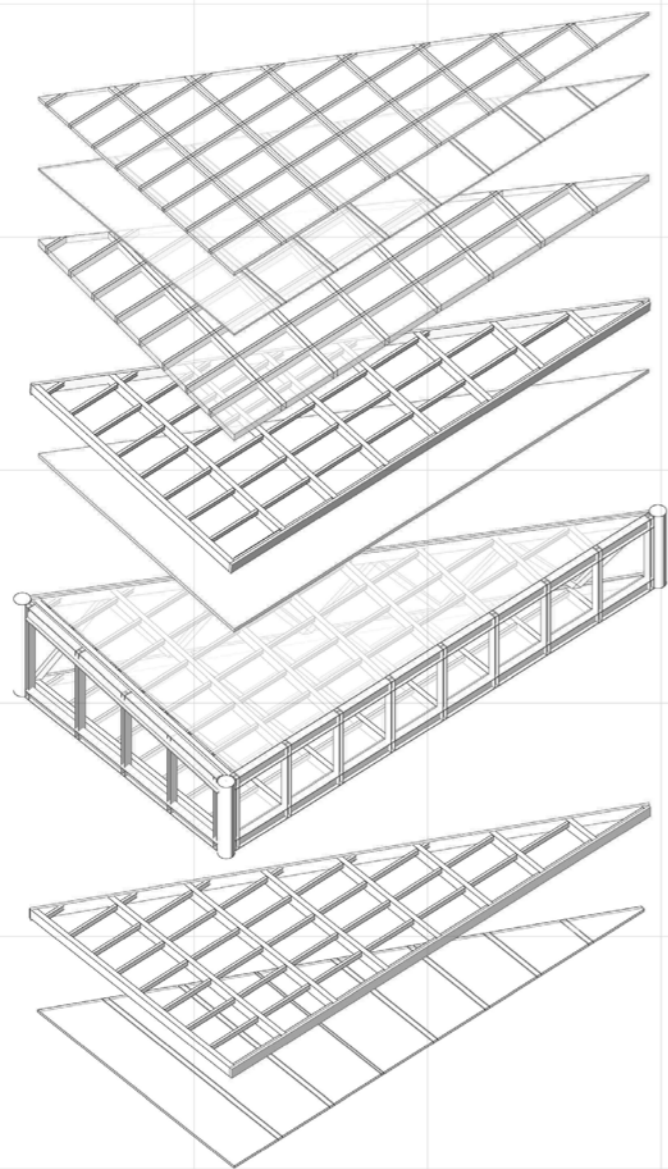

AGNW-BASED COMPOSITE ELECTRODE

TiO₂ UV- AND NIR- SENSITIVE ACTIVE LAYER

ITO PEDOT:PSS

FRAME STRUCTURE

MIRROR

TRUSS

FRAME STRUCTURE

STRENGTHENED GLASS

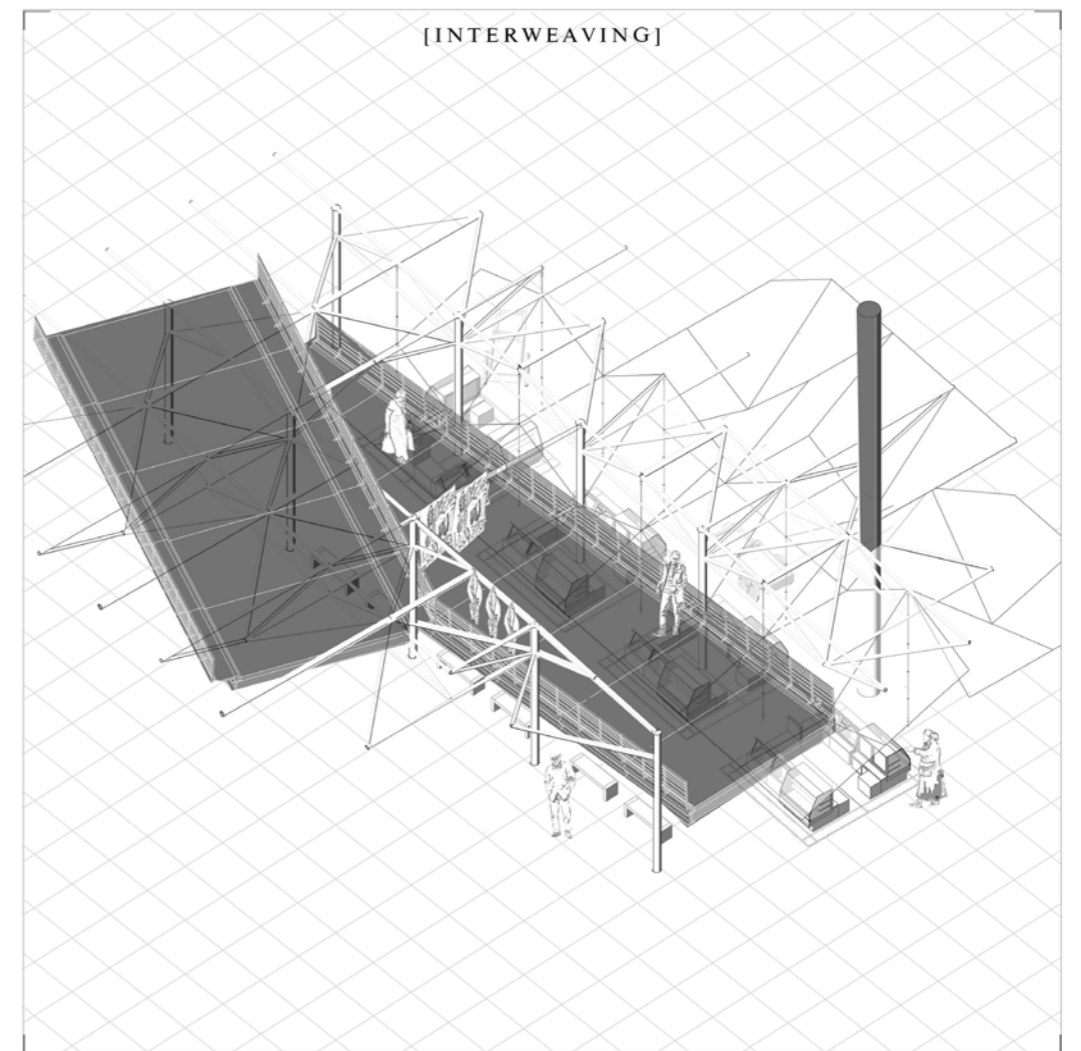

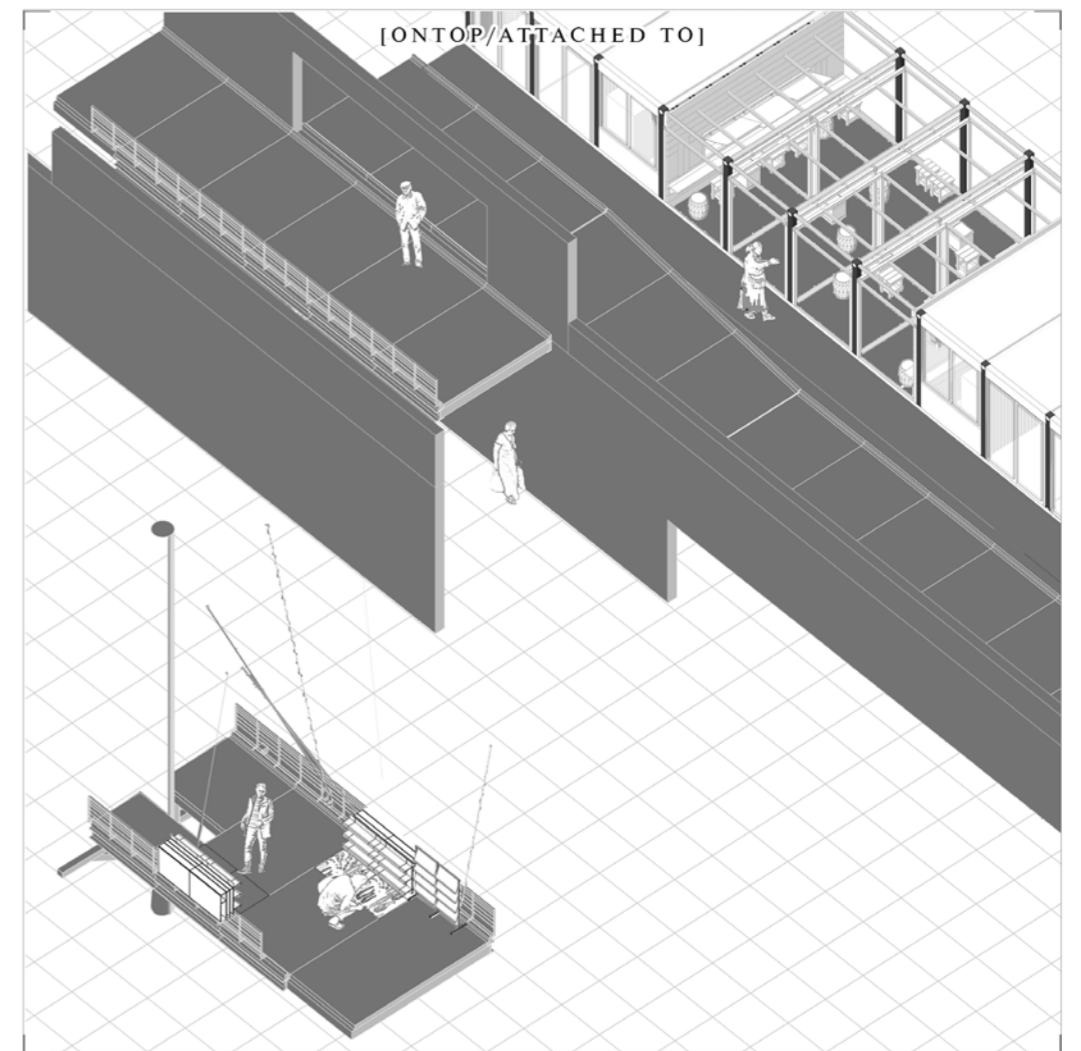
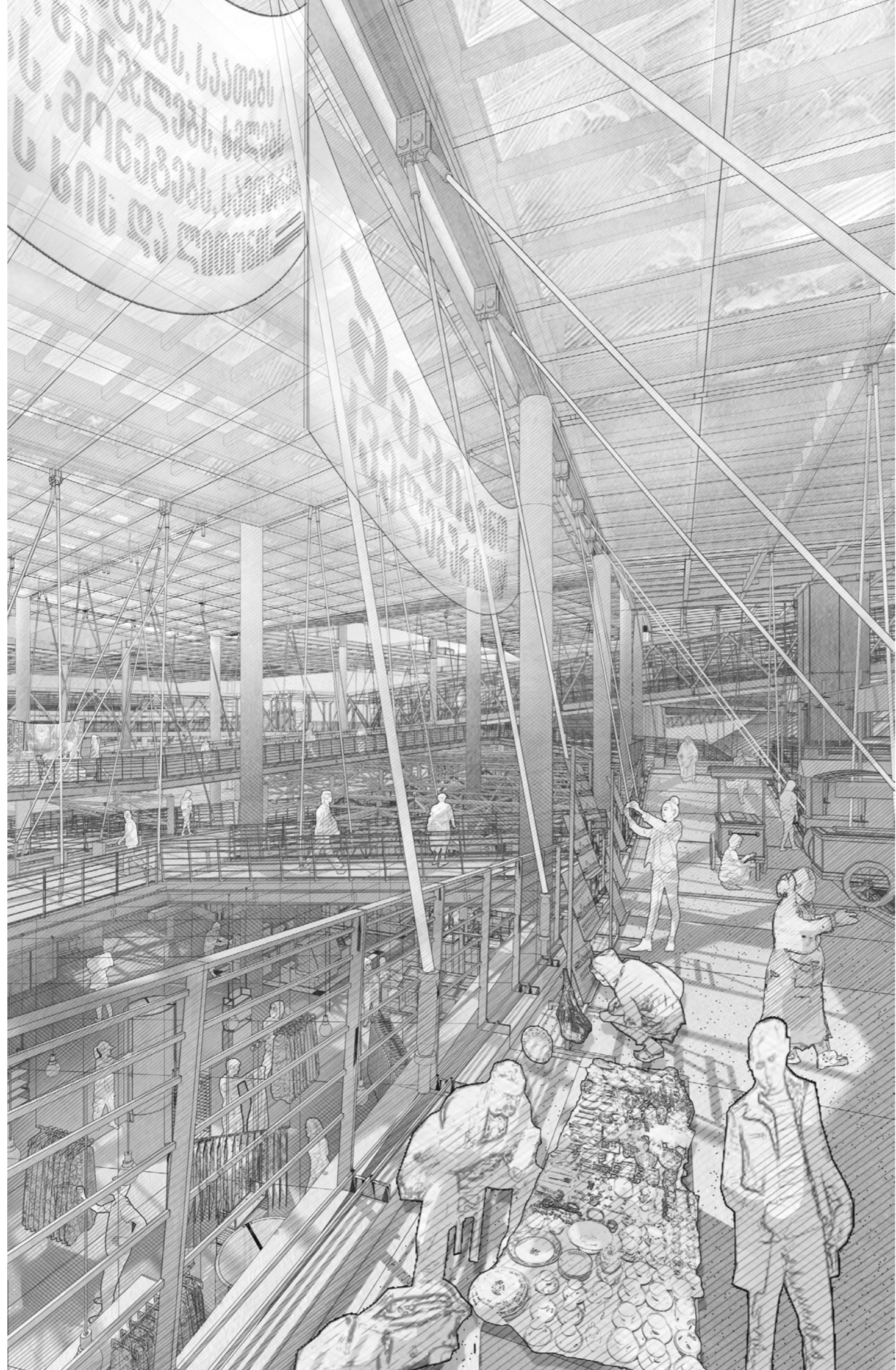

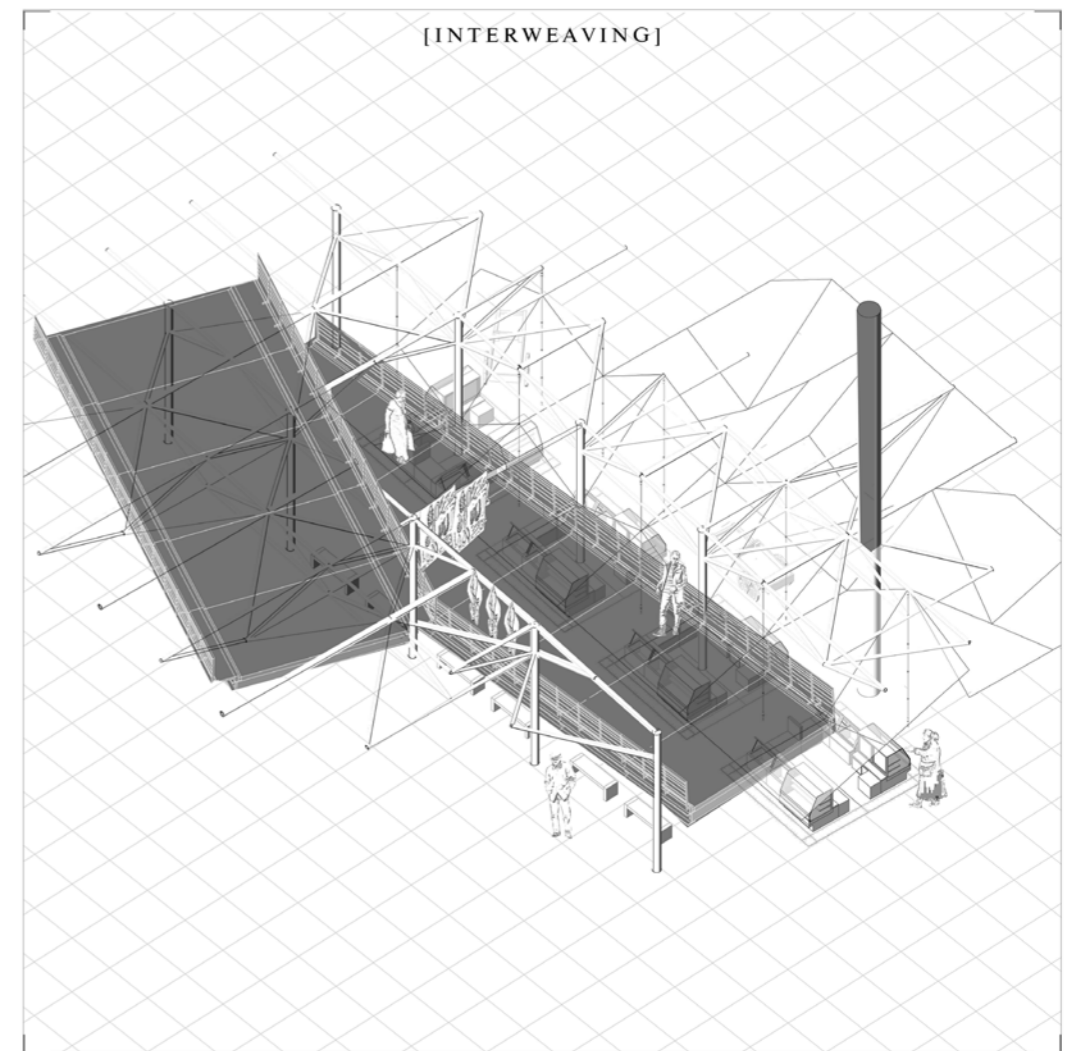

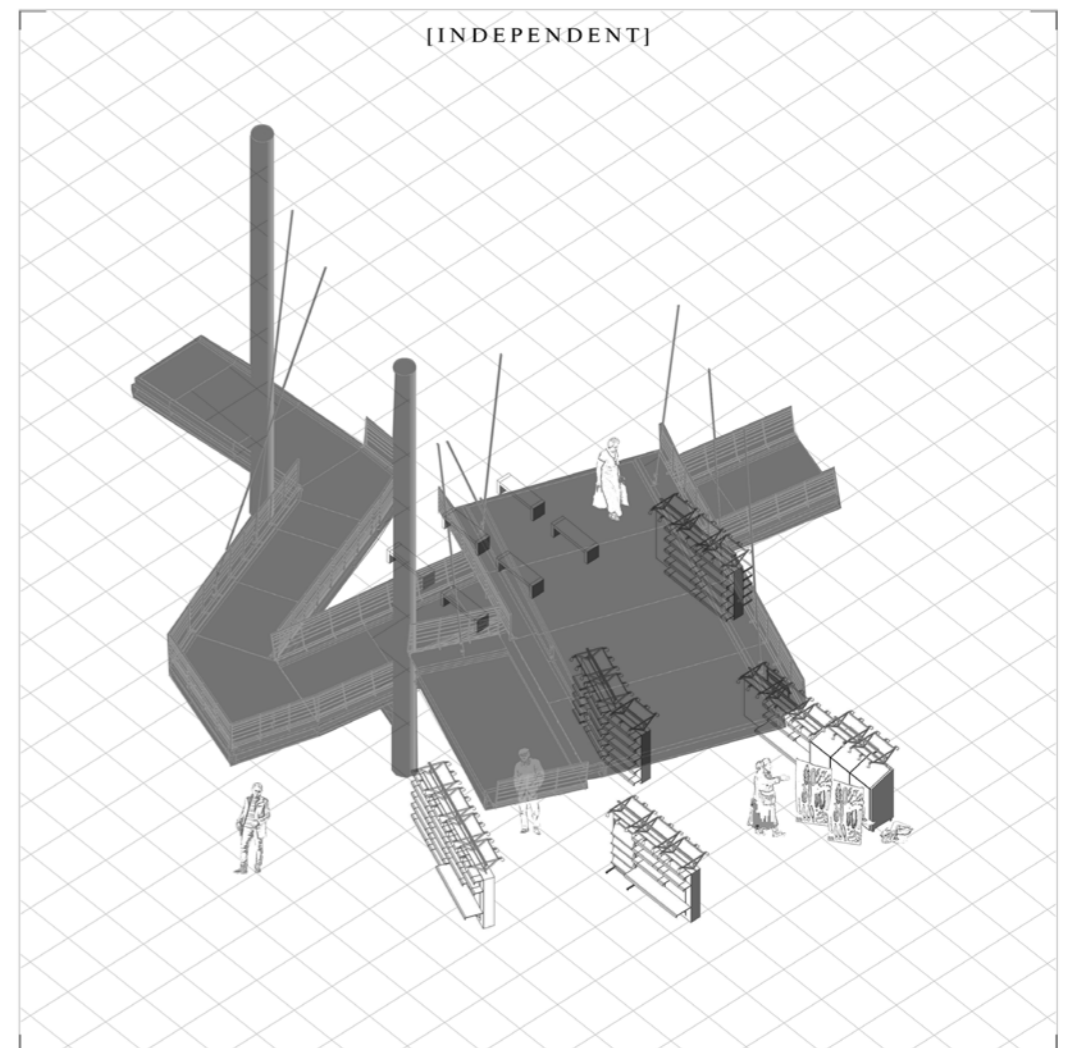
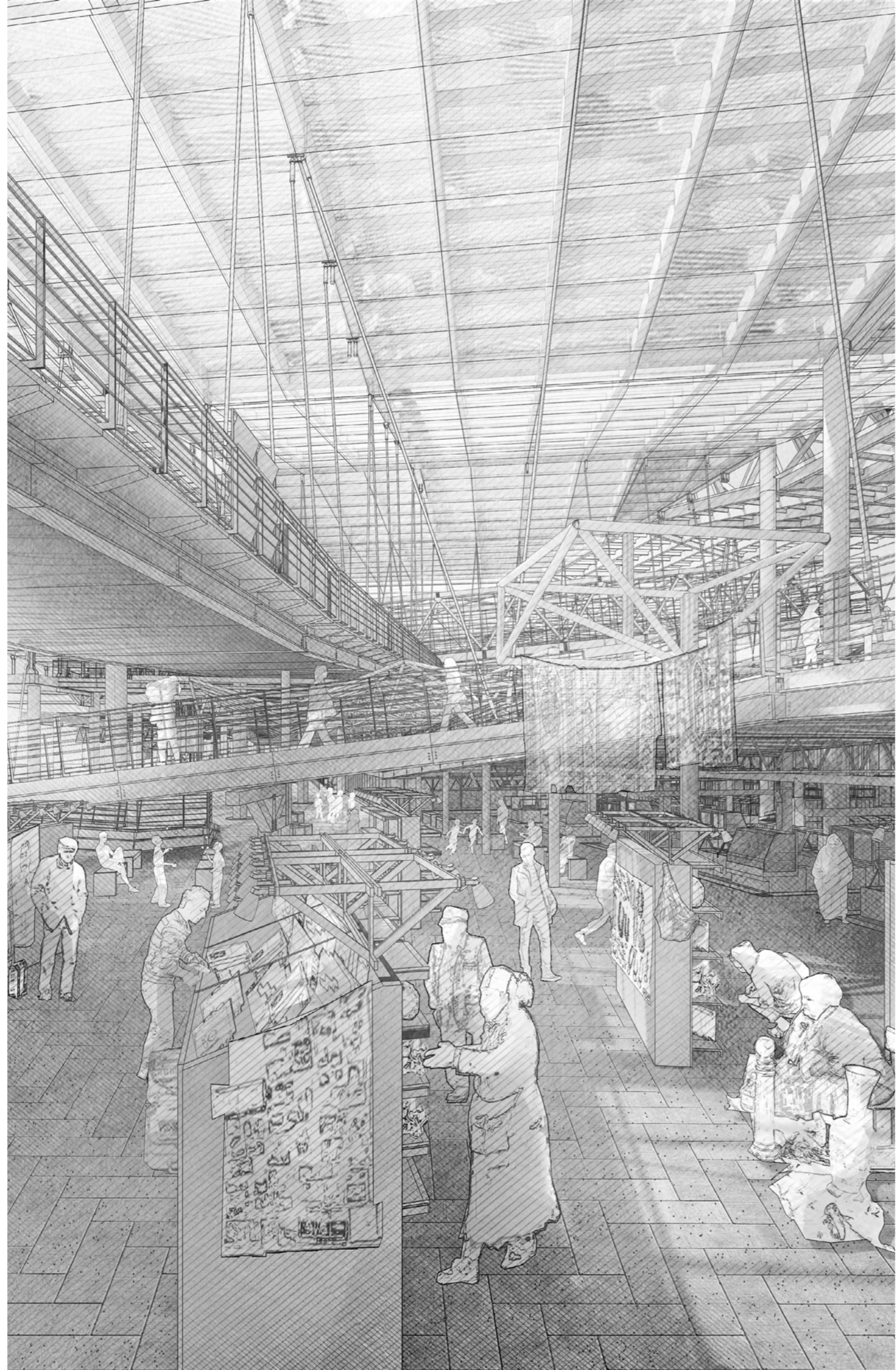

The Space of Dynamic Informality