



reFAB

**UrbanMining
MakerSpace**

reFAB

UrbanMining MakerSpace

**Architectural Engineering
Graduation project**

P5 Presentation

Charalampos Grivokostopoulos

S.Number: 4523229

ResearchTutor: Pieter Stoutjesdijk

Design Tutor: Roel van de Pas

BT Tutor: Paddy Tomesen

TU Delft, 2018

powered by innovation
INTECTURE 

Research

Problem Statement

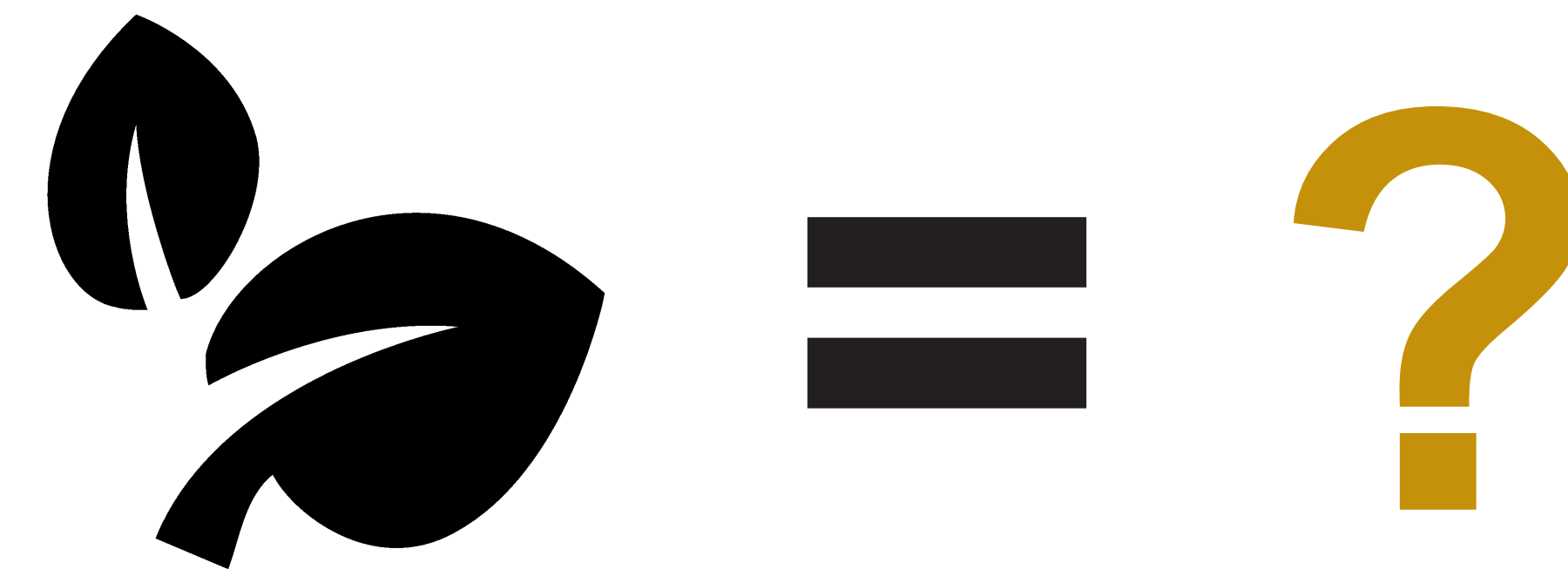

- Pollution
- Raw Material Scarcity
- Essential Needs in Elementary Infrastructure

Cities consume **75%**
of the world's resources

Construction sector is responsible for **45%**
of the planet's raw material consumption,

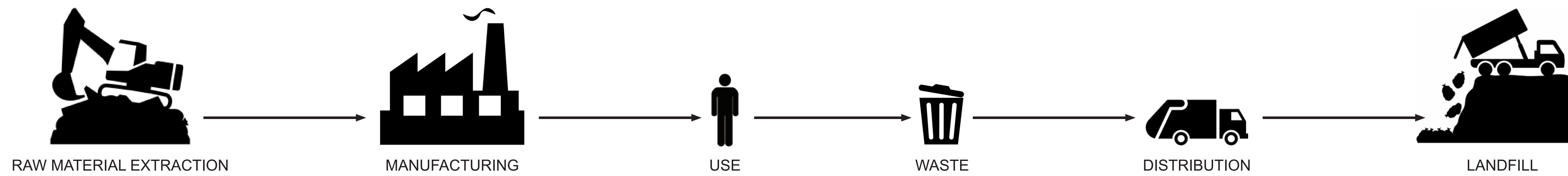

Linear Mentality of Production: Extract, Manufacture, Consume, Discard

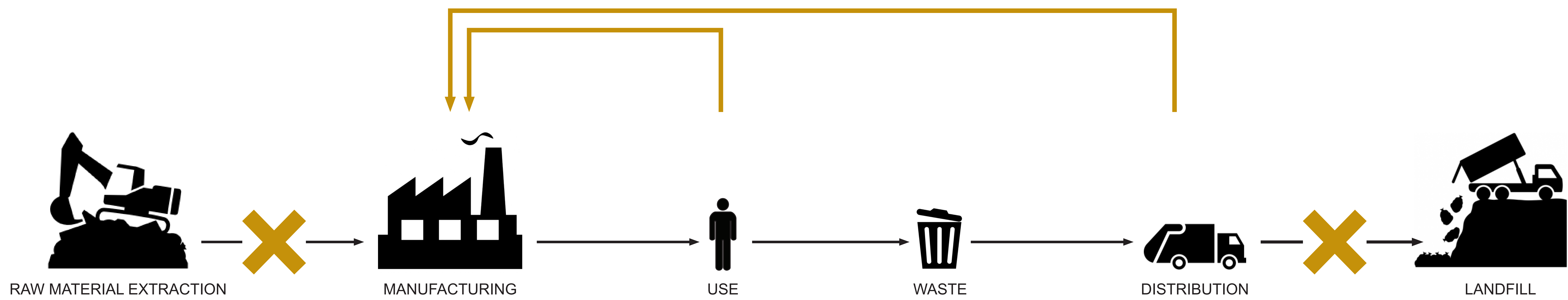

Circular Mentality of Production: Reduce, Reuse, Recycle, Recover

Objective

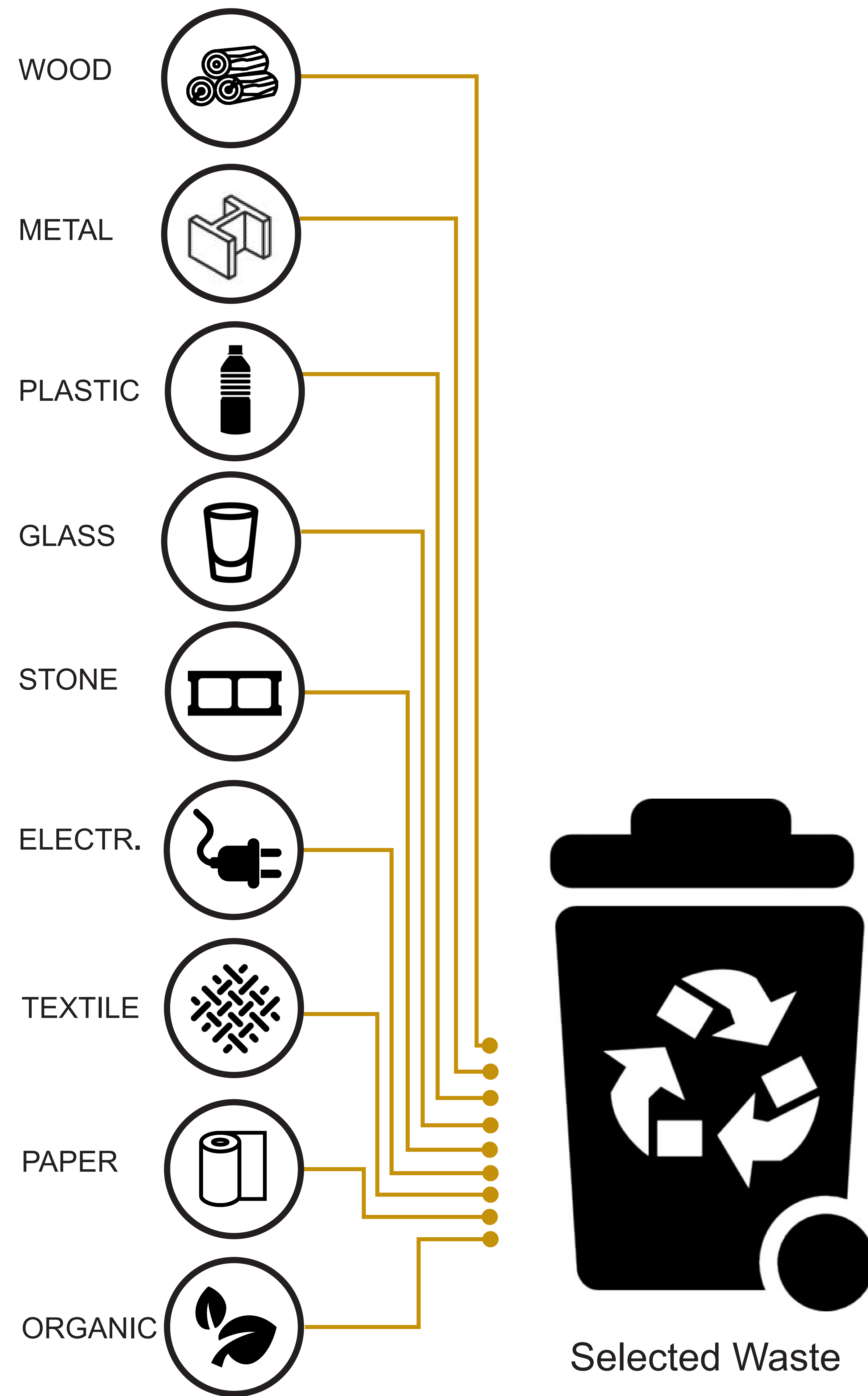

Integrate salvaged elements as raw material input in advanced manufacturing processes

reFAB Lab's Operational Components

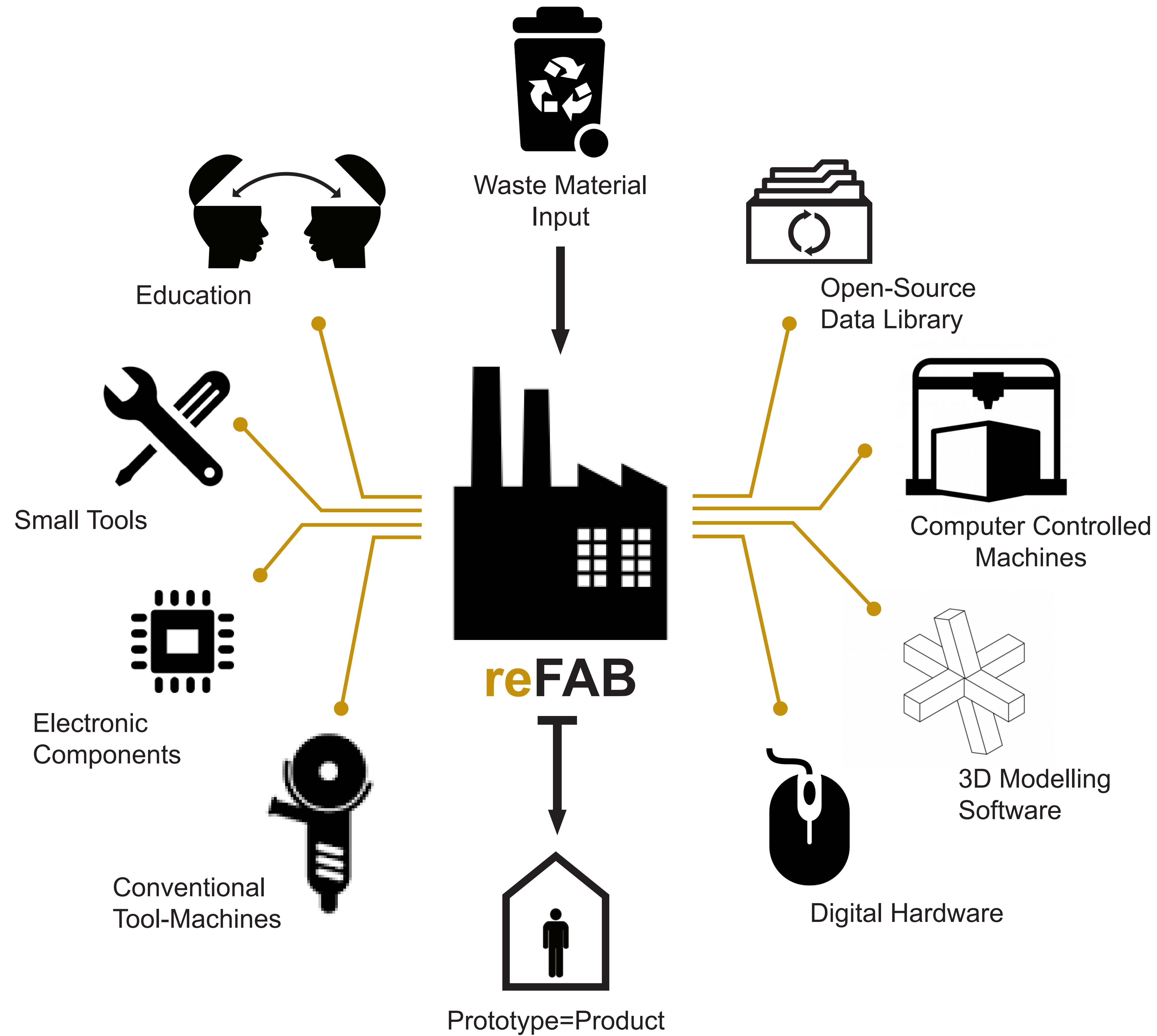

Urban Living Lab Characteristics

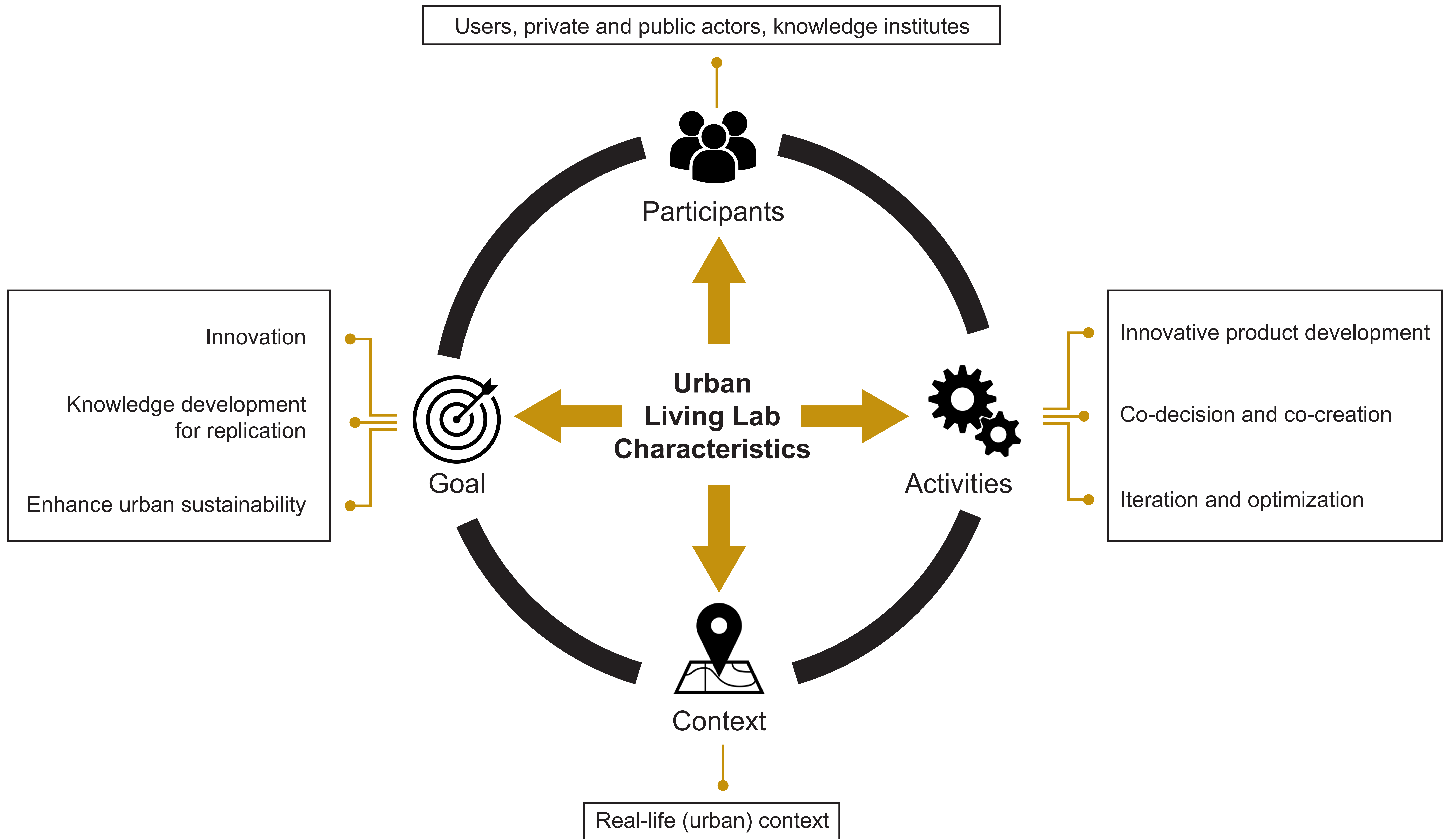

reFab Operational Agenda



Research

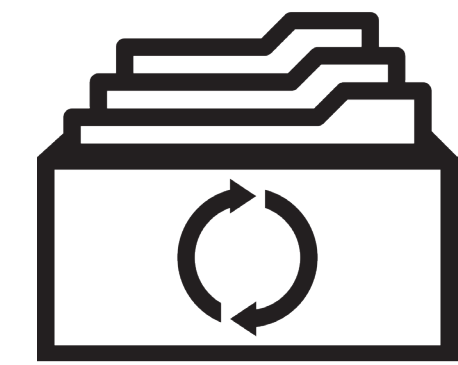

Data-base Development

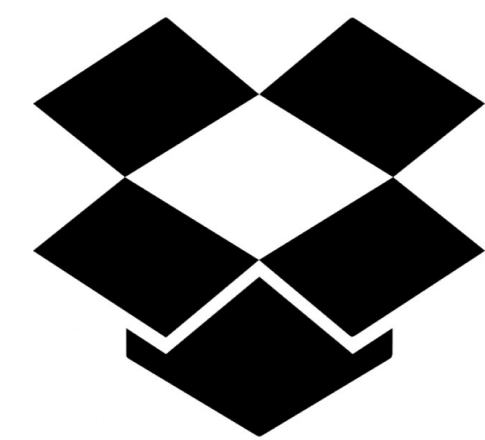

Product Development



Material Testing



Storage



Commerce



reFab Commerce

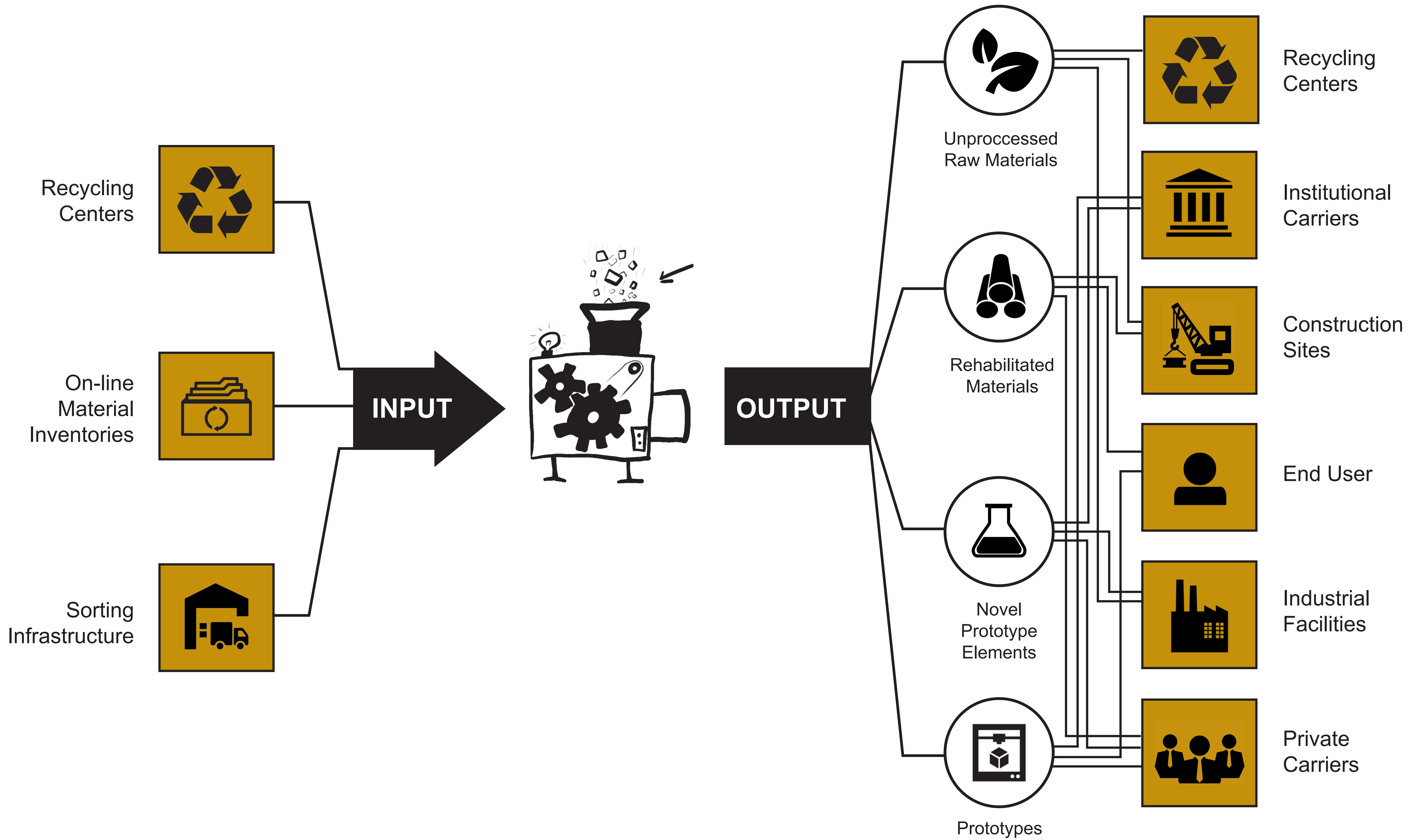

reFAB Lab's Product Development Process

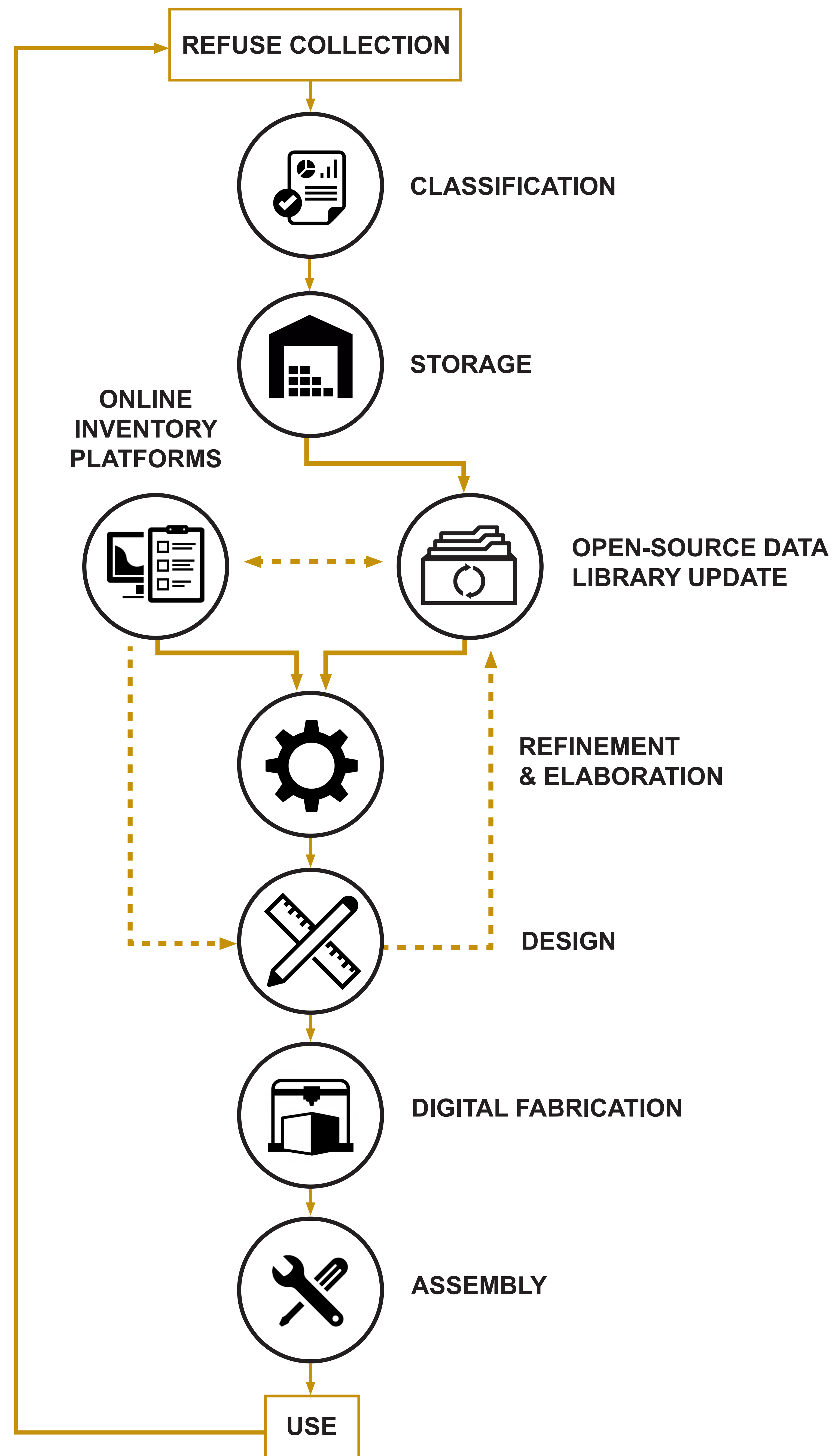

Start the reFAB...

- 
1. Prepare your knowledge background on the topic
 2. Find host agency
 3. Secure funding
 4. Select your partnerships
 5. Find and prepare context
 6. Equip, implement and commission the reFAB lab
 7. Train your partners and future trainers
 8. Identify first projects
 9. Do it

...reFAB Network Expansion

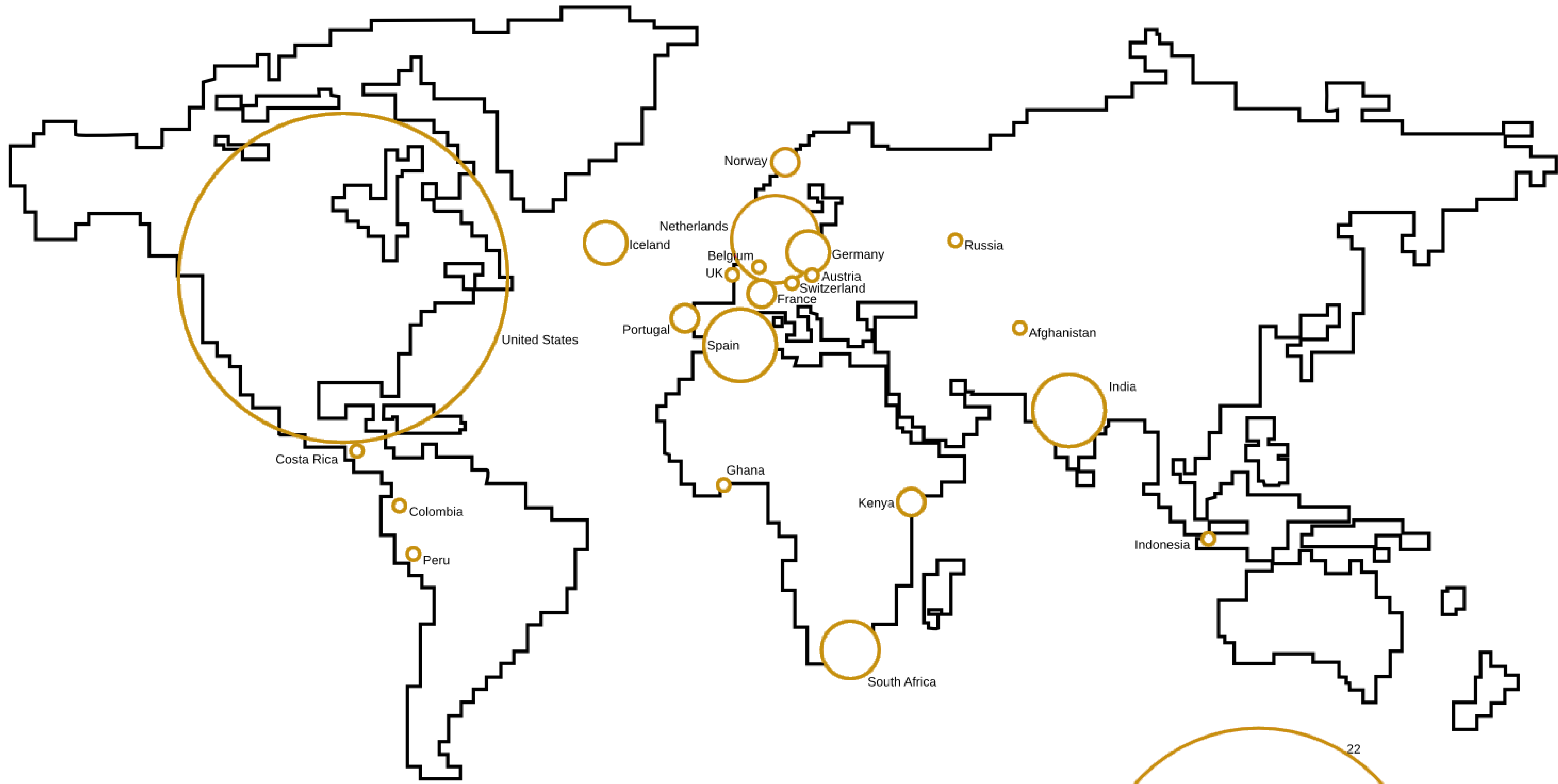

Fab Lab Network

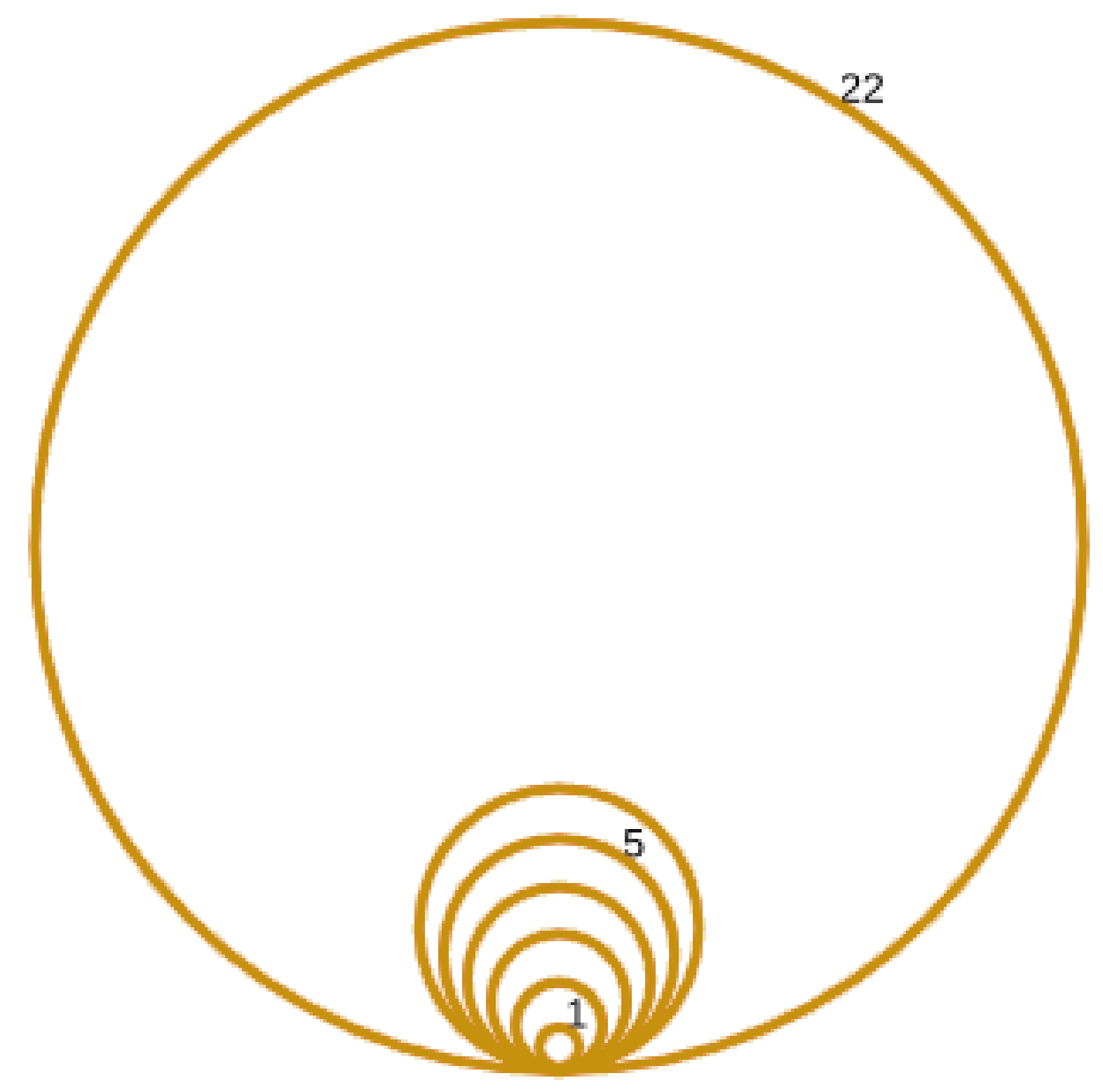

Number of Labs per Country

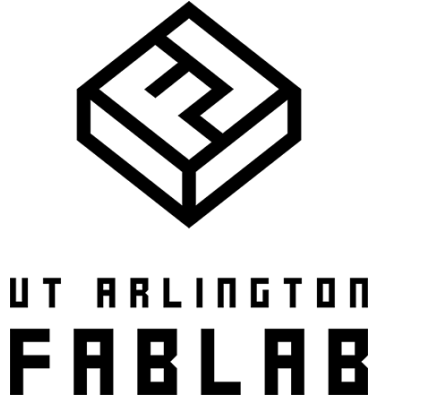

Choice of First Implementation

The chicken and egg affair

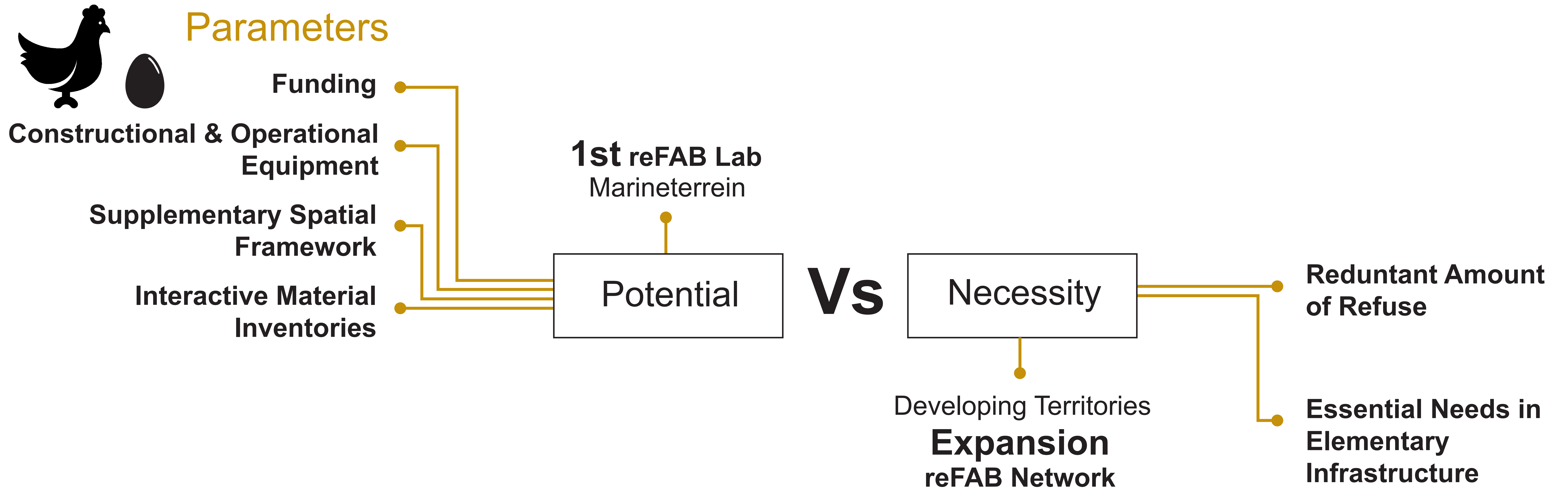



Initial Area Of Focus

Bandung City:

Area: 167,7km²

Population: 2,6 million

Density: 15.000/km²



Bandung Subcenters: Recommended areas of intervention

**Intensevely
developing cities
with reduntant
quantity of waste**

Mumbai - India

Bandung - Indonesia

Lagos - Nigeria

Hong Kong - China

Rio de Janeiro - Brasil



**Current
Area Of Focus**
City of Amsterdam

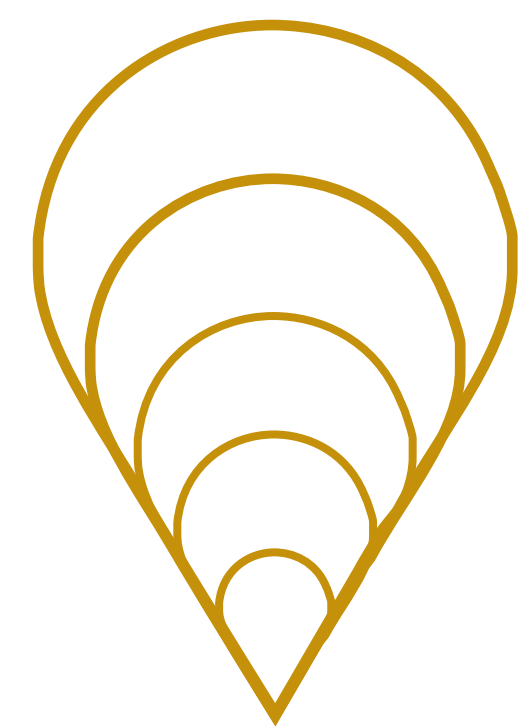

Scale of Unit's
Infrastructure

reFab Lab Network 

ReFab Network Development

- Concentration of fundamental capital
- Context inquiry and investigation
- Supplementary operational/or and spatial framework inquiry
- Research on disused materials resources available in the territory and inventory formation
- Preliminary design layout of the prospective infrastructure [elementary framework to new parties & captivation of stakeholders]
- Permanent personnel requirements estimation

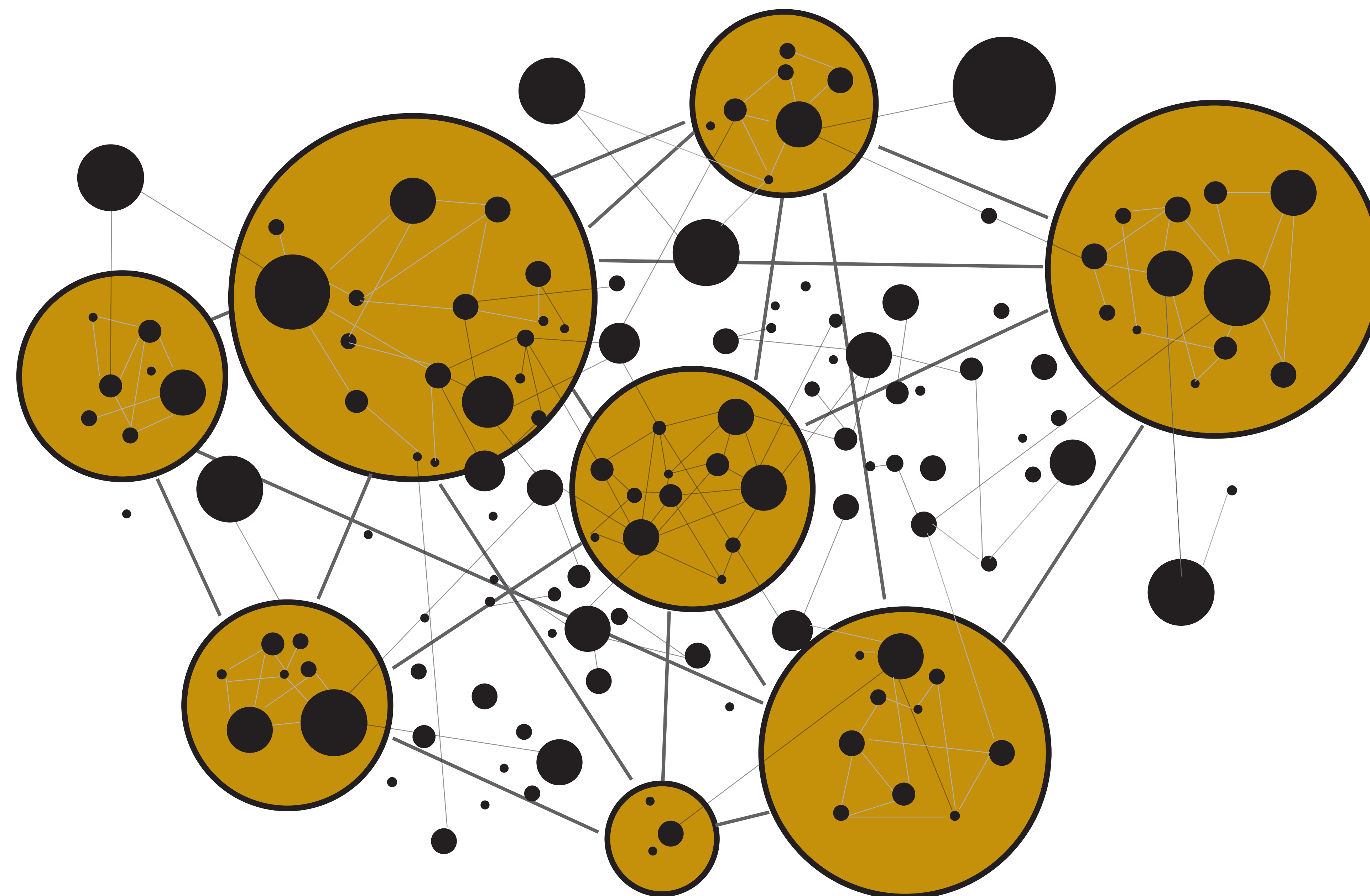

Overall design intention

The composition of a heterogeneous materiality integral design that responds to the implementation of a sustainable and self-developing spatial framework that intends on utilizing advanced production methods through for the employment of refuse as the new raw material source.



Literature



Case Studies



Web Search



Experiment



Preceding Research



Interviews

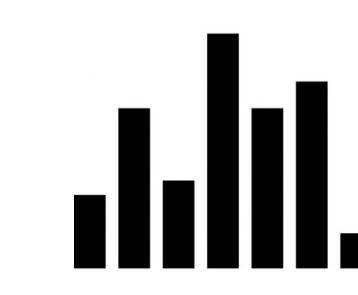

Diagrams

Methodology

Disused Materials

Digital Fabrication

Parameters

- Funding
- Constructional & Operational Equipment
- Supplementary Framework
- Regulated Open-Source Inventories
- Redundant Amount of Refuse
- Infrastructure Deficiency
- Insufficient Educational Framework

Choice of Context

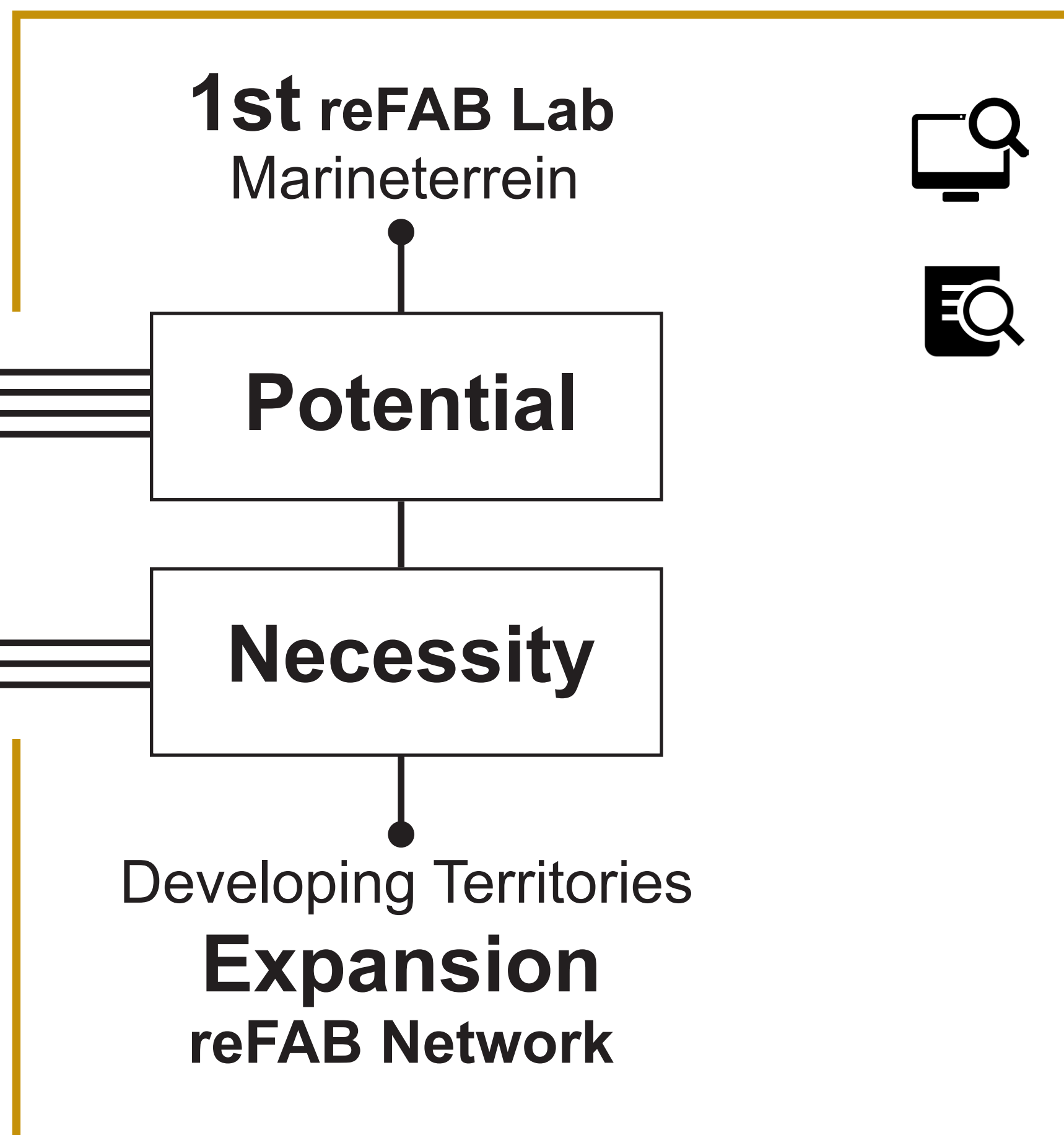

Operational Program

- Definition
- Spatial Requirements
- Supplementary Framework
- Flexibility
- Expansion

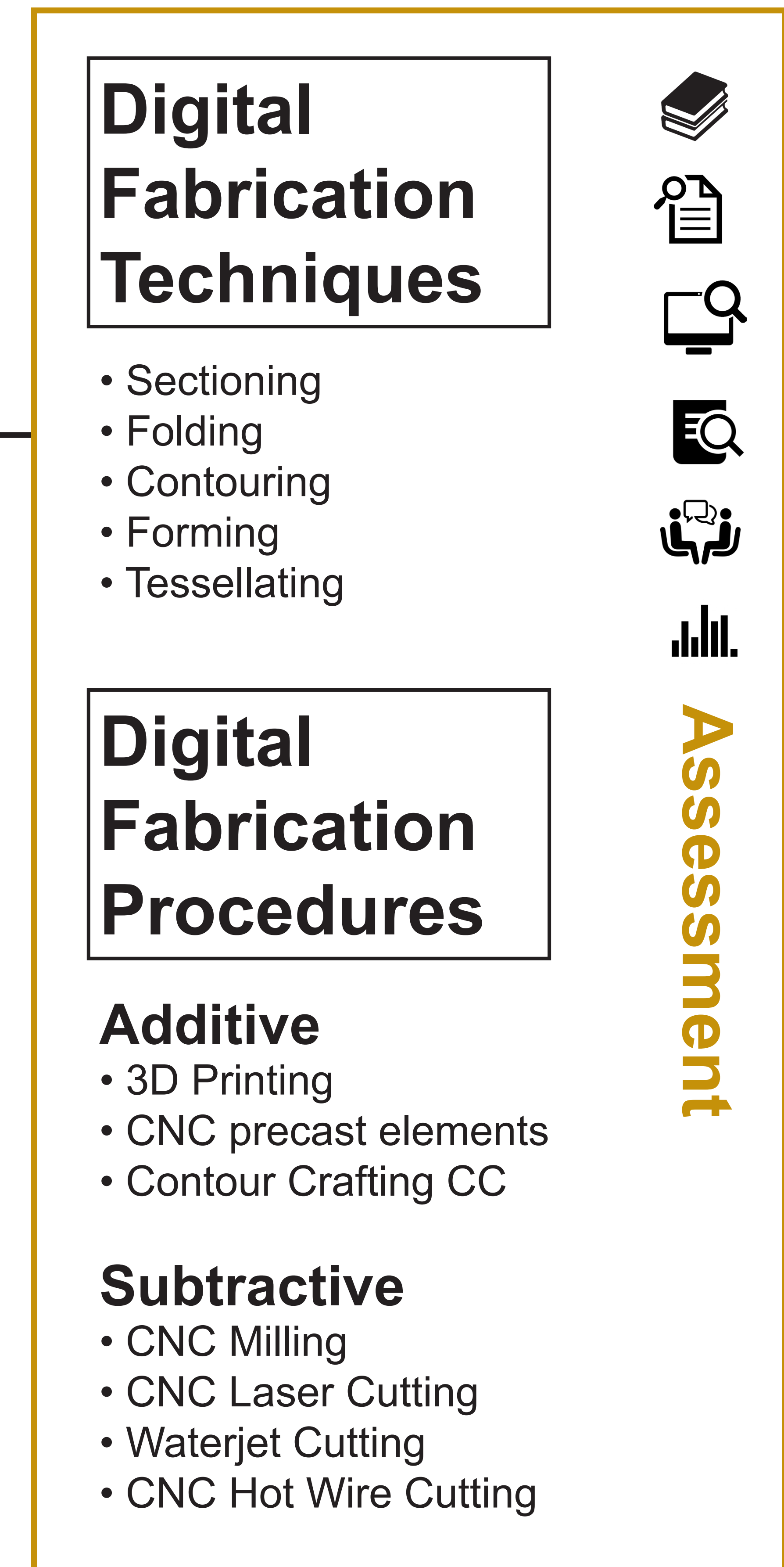
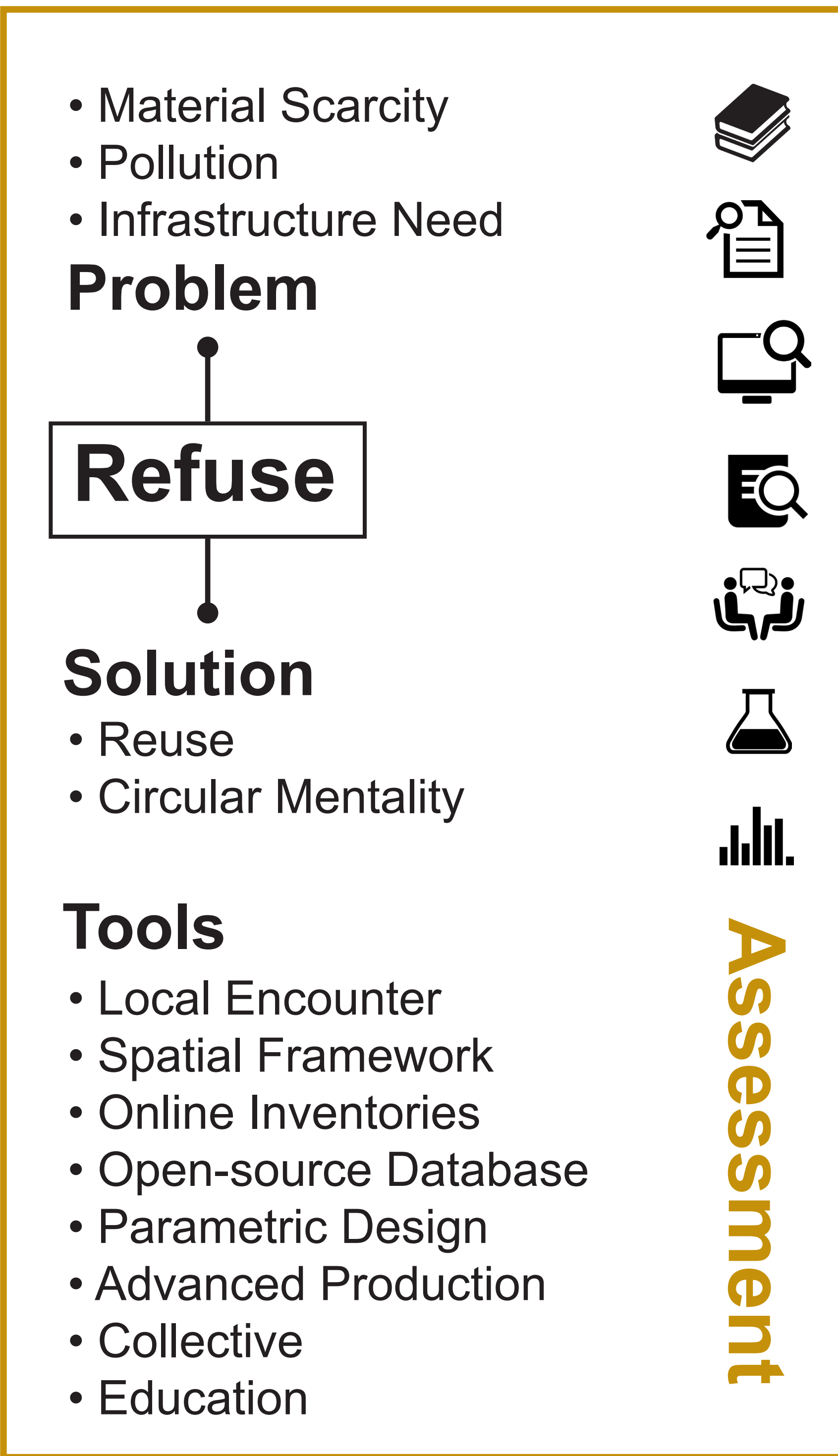

Conclusions

Overall Evaluation

&

Design Strategy

Research

Building elements from recycled materials assessment



ECOR



Paper Waste Brick



Bagasse Particle Board



Newspaper Wood



Bitublock



Fly Ash Cement

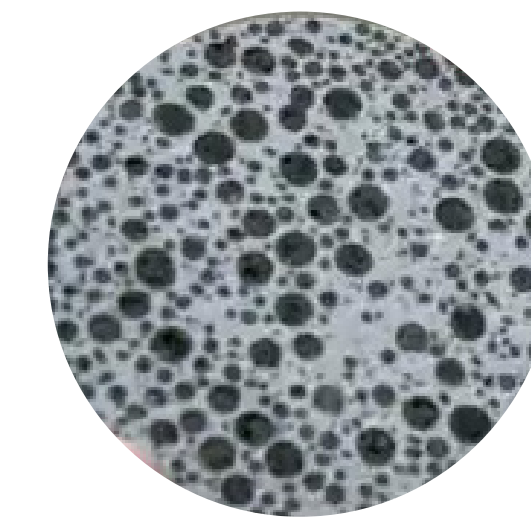

Self-Healing Concrete

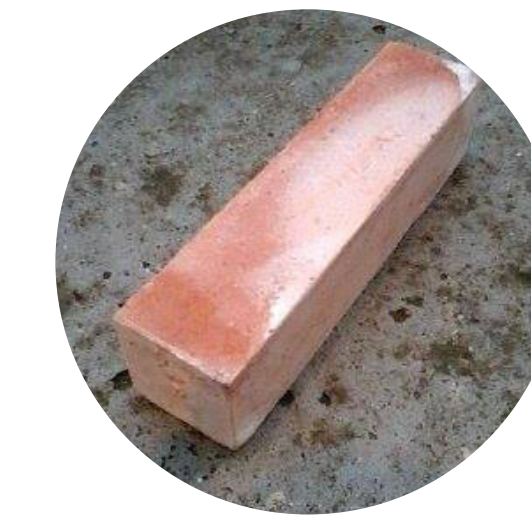

Clay & Slag Brick



Stonecycling Brick

Developed by	Noble Environmental Technologies	Spain's University of Jaen	Universities of India	Vij5 and Mieke Meijer	Dr. John Forth	UNKN	Bacterial Mineral Precipitation, TUDelft	TNO, Delft	Tom van Soest
Waste Origin	cardboard, newspaper, office paper, discarded wood chips, residual agricultural fibers including Bovine Processed Fiber (BPF), kenaf, oat, coffee, coconut, and other waste fibers	paper waste and by-products of the paper industry and waste water purification	sugar mills by-product	newspapers	recycled glass, incinerated sewage sludge ash (ISSA), quarry fines, MSW Incinerator bottom ash (MSWI BA), construction and demolition waste and other recycled aggregate	fine powder which is a byproduct from burning pulverized coal in electric generation power plants, a residue left at the end of the coal combustion process	construction market and micro-organisms laboratory development	clay material and slag deriving from the ferrometallurgical industry	demolition sites
Composition	100% Bio-based material converted from waste cellulose fiber, pressure, and heat	paper waste and waste from water purification, mixed in a ceramic blend (clay) and pressurized	bagasse fiber residual pulp from sugarcane	Newspaper and a type of adhesive (UNKN)	mix of coarse, fine and filler particles, ratios dependent on the feedstock material and desired product properties	fly ash and Blast Furnace Slag (BFS) mixed with lime and water it forms a compound similar to Portland cement	concrete in addition to microfibers and calcium carbonate precipitating micro-organisms	geopolymers from metakaolin, slag, NaOH and waterglass	pulverized recycled building materials (not provided composition)
Application	interior, furnishings, signage, displays, packaging, consumer products, artwork, storage, shelving etc.	conventional building construction	core material for laminated floors, replacing high-density and expensive wood fiberboard	panelling, furniture and interior equipment	load and non-load bearing construction units such as concrete and clay based building blocks	loadbearing construction and all building purposes	ideal for sewer, underground retainers for hazardous waste etc. building purposes	loadbearing construction and all building purposes	both interior and exterior applications on building construction
Waste Comp. Availab.	● ● ● ● ●	● ● ● ● ●	● ● ● ● ○	● ● ● ● ●	● ● ● ● ●	● ● ● ○ ○	● ● ○ ○ ○	● ● ○ ○ ○	● ● ○ ○ ○
% Waste Composite	● ● ● ● ●	● ● ● ○ ○	● ● ● ● ○	● ● ● ○ ○	● ● ● ● ●	● ● ○ ○ ○	● ○ ○ ○ ○	● ● ○ ○ ○	● ● ● ○ ○
Manufact. Facility	● ● ● ○ ○	● ● ○ ○ ○	● ● ● ● ●	● ● ● ● ○	● ● ○ ○ ○	● ● ○ ○ ○	● ○ ○ ○ ○	● ● ○ ○ ○	● ● ○ ○ ○
Structural Efficiency	● ● ● ○ ○	● ● ○ ○ ○	● ○ ○ ○ ○	● ● ● ○ ○	● ● ● ● ○	● ● ● ○ ○	● ● ● ○ ○	● ● ● ● ○	● ● ● ○ ○
Thermal Insulation	● ● ● ○ ○	● ● ● ● ○	● ● ● ○ ○	● ● ● ● ○	● ● ● ○ ○	● ● ● ○ ○	● ● ● ○ ○	● ● ○ ○ ○	● ● ● ○ ○
Acoustic Insulation	● ● ○ ○ ○	● ● ● ○ ○	● ● ○ ○ ○	● ● ○ ○ ○	● ● ● ○ ○	● ● ● ○ ○	● ● ● ○ ○	● ● ○ ○ ○	● ● ● ○ ○
Fire Resistance	● ● ● ○ ○	● ● ● ● ●	● ● ○ ○ ○	● ● ○ ○ ○	● ● ● ○ ○	● ● ● ● ○	● ● ● ● ○	● ● ● ● ○	● ● ● ● ○
Waterproof Efficiency	● ● ● ● ○	● ● ● ● ○	● ○ ○ ○ ○	● ● ● ● ○	● ● ● ● ○	● ● ● ● ●	● ● ● ● ●	● ● ● ● ●	● ● ● ● ●
Cost Effective	● ● ● ○ ○	● ● ● ● ○	● ● ● ● ○	● ● ● ○ ○	● ● ● ○ ○	● ○ ○ ○ ○	● ○ ○ ○ ○	● ● ○ ○ ○	● ● ○ ○ ○
Optimiz. Potential	UNKN	optimized through alternative, green products as sewage sludge, brewing by-products, olive, producing biodiesel etc.	mix with pMDI resin as a bonding agent and wax as dimensional stabilizer for laminated floor and furniture applications	UNKN	possible future changes due to product quality protocols may make current potential waste inputs more attractive	optimum amount of fly ash varies not only with application, but also with composition and proportions in the mixture	development of capsules with properties to survive the mixing process and release the healing agent	concerning durability description accelerated tests are required to estimate the material behaviour in its lifecycle	UNKN
Additional Estimation of the Product	+ no toxic adhesives, additives, formaldehyde, or other sources of off-gassing + bonds well with virtually any adhesive, coating, treatment, laminate or veneers + 75% lighter than conventional panels	+ requires less time of baking than conventional bricks - poor in mechanical strength - adhesion and forming difficulties following the production procedure	+ manufacturing process on a commercial scale + substitute for wood + lightweight	+ resemble the aesthetics of real wood	+ low carbon footprint and high recycled content generate price advantages + the adaptable process conditions appears highly suited to a wide range of wastes and the more inconsistent nature of waste characteristics - Heavy metals may be present in some of the aggregate wastes.	+ contains various heavy metals and toxic elements which are usually allowed to disperse in the atmosphere or is dumped in a landfill - Fly ash is a pozzolanic material, expensive replacement for Portland cement	+ self-repairs cracks in concrete structures + substantial savings, especially in steel reinforced concrete	+ utilizes by-products + low condensation in CO ₂ - early stage of research - cost related uncertainty	+ meet today's industry requirements and can be used for both the interior and exterior of buildings + produced from various types of waste, and combined in different ways to create new colours, textures, shapes and sizes



Saw Dust & Rice Husk Building Brick



Rice Husk Ash Concrete (RHA)



Fungi-brick



Recycled Glass Brick



Replast Brick

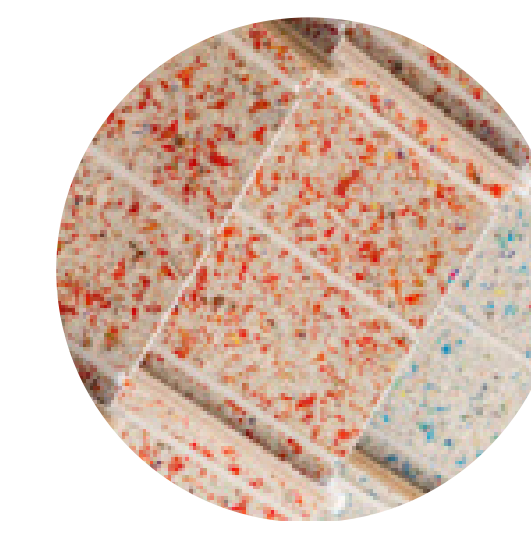

Beverage Carton Brick



Polli-Brick

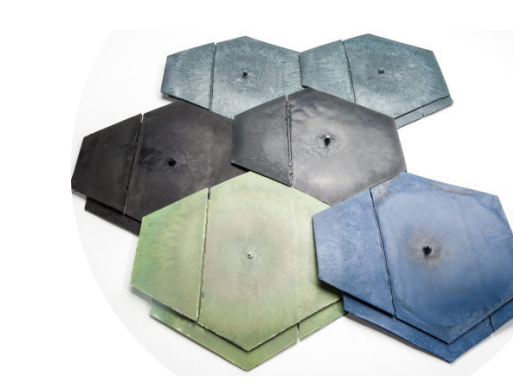

'Pretty Plastic' Tile



Plastic Bag Brick

Developed by	UNKN	India	Mycologist Philip Ross	Japan's GRC, Beecycle, Kingston	Byfusion	ReWall	Miniwiz	Materia	Carter Zufelt, Wasted
Waste Origin	fine powder which is a byproduct from burning pulverized coal in electric generation power plants, a residue left at the end of the coal combustion process	by-product of burning the outer shell of the paddy that comes out as a waste product during milling of rice	corn stalks, hemp, and mycelium grow into solid objects in about five days with no added energy (can be composted at the end of the installation)	hydro-thermally solidified materials from breaking down glass waste into sand grade	all kinds of plastic from landfills and recycling facilities	beverage carton packages from landfills	plastic bottles from landfills and recycling facilities	locals who separate their waste, through WASTED and through visitors, who can bring plastic instead of a ticket when entering FabC-city	milk containers, tupperware, oil/shampoo/detergent bottles, and mainly plastic bags
Composition	cast from fluorogypsum binder/plaster using saw dust, rice husk and exfoliated vermiculite	rice ash as admixture for concrete	chopped-up corn stalks, hemp, and mycelium	30-70% pozzotive glass replacing sand as admixture to cement	mix of shredded unsorted plastics	shredded and pressed material of 100% beverage cartons (paper, polyethylene and aluminum)	mechanically recycled plastic of type PET from drinking bottles	sorted, washed, grinded and moulded recycled plastic of type PET, HDPE and PE	plastic bags of type HDPE
Application	bricks, flooring tiles and plastering	special concrete mixes, high performance concrete, high strength, low permeability concrete	interior and exterior application on building construction	bricks, tile blocks, floor materials, outdoor furniture	interior and exterior application on building construction	initially intended for interior cladding, but also various exterior applications	panelling, interior and exterior application on building construction	panelling slates and tiles, interior and exterior application	brick for interior and exterior application
Waste Comp. Availab.	● ● ● ○ ○	● ● ● ● ○	● ● ● ● ○	● ● ● ○ ○	● ● ● ● ●	● ● ● ● ●	● ● ● ● ●	● ● ● ● ○	● ● ● ● ●
% Waste Composite	● ● ● ○ ○	● ● ○ ○ ○	● ● ● ● ○	● ● ● ○ ○	● ● ● ● ●	● ● ● ● ●	● ● ● ● ●	○ ○ ○ ○ ○	● ● ● ● ●
Manufact. Facility	● ● ○ ○ ○	● ● ● ○ ○	● ● ● ○ ○	● ● ● ○ ○	● ● ● ● ●	● ● ● ○ ○	● ● ○ ○ ○	● ● ○ ○ ○	● ● ● ● ●
Structural Efficiency	● ● ● ● ○	● ● ● ● ●	● ● ● ● ●	● ● ● ● ○	● ● ● ● ●	● ● ● ○ ○	● ● ● ● ○	● ● ● ● ○	● ● ● ● ○
Thermal Insulation	● ● ● ● ○	● ● ● ● ○	● ● ● ● ○	● ● ● ○ ○	● ● ● ● ○	● ● ● ○ ○	● ● ● ● ○	● ● ● ○ ○	● ● ● ○ ○
Acoustic Insulation	● ● ● ○ ○	● ● ● ○ ○	● ● ● ○ ○	● ● ● ○ ○	● ● ● ● ○	● ● ● ● ○	● ● ● ○ ○	● ● ● ○ ○	● ● ● ○ ○
Fire Resistance	● ● ● ○ ○	● ● ● ● ○	● ● ● ● ○	● ● ● ● ○	● ● ○ ○ ○	● ● ○ ○ ○	● ● ● ● ○	● ● ● ○ ○	● ● ○ ○ ○
Waterproof Efficiency	● ● ● ● ○	● ● ● ● ○	● ● ● ● ●	● ● ● ● ○	● ● ● ● ●	● ● ● ● ●	● ● ● ● ●	● ● ● ● ●	● ● ● ● ○
Cost Effective	● ● ● ○ ○	● ● ● ○ ○	● ● ● ● ○	● ● ● ○ ○	● ● ● ● ○	● ● ● ● ○	● ○ ○ ○ ○	● ○ ○ ○ ○	● ● ● ● ○
Optimiz. Potential	further studies on fire resistance and standardization, also addition of waste lime sludge may add economy	study on applications of RHA as repair mortars, coatings and soil stabilization	dial in different material properties of the bricks by changing variables, tune the material for permanent structures	integral pigment can be applied to the mix to further enhance the brick, by offering more design possibilities	improvement of product's production method and appearance for promotion reasons	UNKN	UNKN	UNKN	further ways of interlocking process and moulding shapes in regard to the need of assembly
Additional Estimation of the Product	+ lightweight + FG binder is cheaper than the lime and cement binders	+ carbon neutral green product + reduces the consumption of cement due to blending + considered a class apart from all other mineral admixtures due to its unique microstructure and the resultant benefits in concrete and its multi various application possibilities	+ 100% organic and compostable + stronger, pound for pound, than concrete + super-strong, water-, mold- and fire-resistant + grown and formed into just about any shape	+ artificial super-light aggregate + approximately 95% of coal Btu energy equivalent is saved + endless aesthetic possibilities	+ requires no adhesives + LEED certification + 95% lower greenhouse emissions (GHG) compared to concrete block + flexibility in shape - in some cases need additional support - appearance	+ no additional adhesives + waterproof due to its initial intended production reason - low mechanical strength	+ the 3D strong self-interlocking structure without chemical adhesives + translucent + 1/5 of standard curtain wall systems + lightweight + UV protection + scratch-resistant and easy to clean - process economically efficient in mass manufactured on-site	+ chemical resistant + lightweight + scratch resistance - moderate UV resistance - not renewable	+ HDPE has a high strength-to-density ratio, is widely accessible, and can be found in an abundance of colors + very simple production process - not yet applied and tested in building construction

The evaluation of the properties of each recovered material composite has been made with main criteria in accord to its application potential, in comparison with the other recycled products, and in regard to the evaluation of data provided from their developer, eco-friendly carriers and general web resources

Digital Manufacturing Technologies Analysis

Advanced Manufacturing Technologies

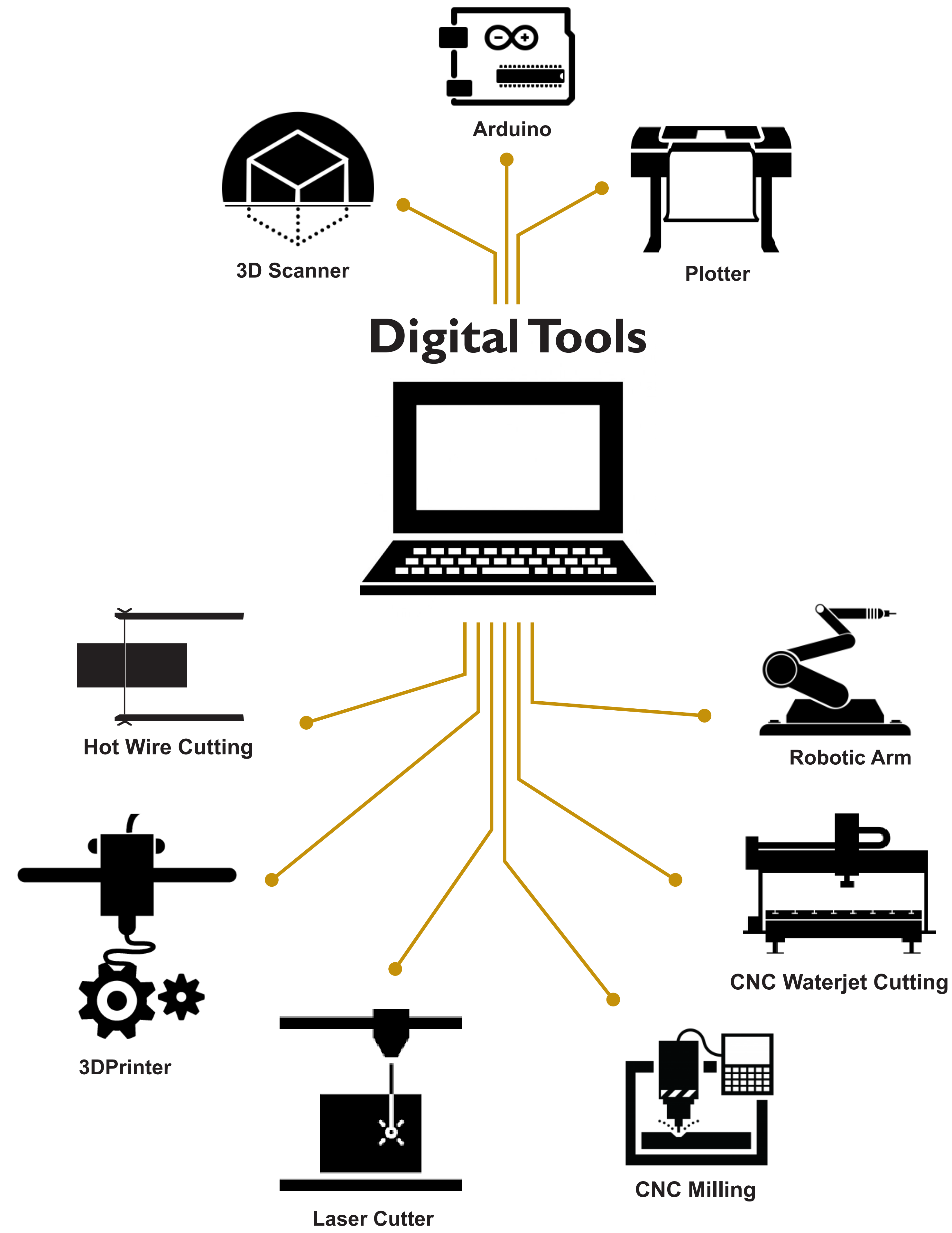

Digital Fabrication Technologies

Overview & Evaluation

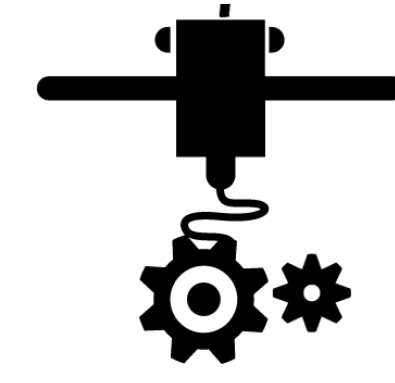

3D Printing

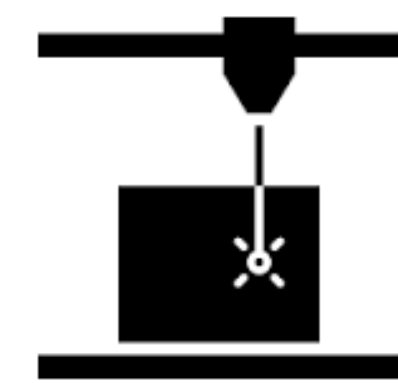

CNC Laser Cutting

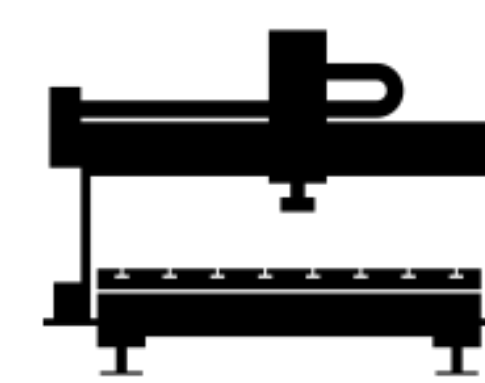

CNC Waterjet Cutting

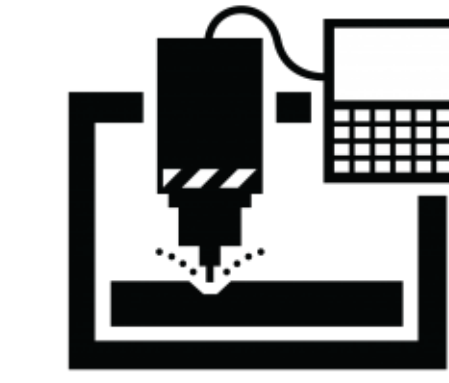

CNC Milling



Hot Wire Cutting

Advantages	<ul style="list-style-type: none"> + Waste plastic utilization + No waste are produced + No molds + Material variety + Form freedom 	<ul style="list-style-type: none"> + Precision + Demountable + Bearing structure ability + Engraving ability + Lightweight + Customization + No adhesives and joinery required 	<ul style="list-style-type: none"> + Demountable + Bearing structure ability + Customization + Thick material cutting ability 	<ul style="list-style-type: none"> + Demountable + Customization + Engraving + Software variety + No adhesives and joinery required 	<ul style="list-style-type: none"> + Form freedom + Customization + Large volume geometries + Lightweight
Disadvantages	<ul style="list-style-type: none"> - Not demountable - Not bearing 	<ul style="list-style-type: none"> - Waste production - Energy consumption - Speed - Limited size components 	<ul style="list-style-type: none"> - Water consumption - Speed - Waste production 	<ul style="list-style-type: none"> - Waste production - Limited size components 	<ul style="list-style-type: none"> - Difficulty in waste utilization - Not demountable - Short material variety - Waste production - Not structural
Materials	<ul style="list-style-type: none"> • Plastic • Concrete • Ceramics • Aluminium 	<ul style="list-style-type: none"> • Plywood • MDF • Metal • Plastic • Cardboard • Various depended on machine 	<ul style="list-style-type: none"> • Wood • Plastic • Foam • Ceramics • Metal • Paper 	<ul style="list-style-type: none"> • Wood • Metal [Various & Aluminium] • Cardboard 	<ul style="list-style-type: none"> • Polystyrene • Styrodure
Waste Material Input	<ul style="list-style-type: none"> • Plastic [transformed through a melting and extrusion process to a new polymeric filament] • Ceramics 	<ul style="list-style-type: none"> • Metal [transformed though melting process into a new sheet] • Plastic [transformed though melting process into a new sheet] • Wood [in the case of solid panel or by transforming wood in a by-product] 	<ul style="list-style-type: none"> • Metal [transformed though melting process into a new sheet] • Plastic [transformed though melting process into a new sheet] • Wood [in the case of solid panel or by transforming wood in a by-product] 	<ul style="list-style-type: none"> • Metal [transformed though melting process into a new sheet] • Wood [in the case of solid panel or by transforming wood in a by-product] 	<p>Rare cases of integrating a waste product</p>
Energy Consumption	Depended on machinery and material	100kW	37kW & depending on pump	18kW	Depended on machinery and material
Material Thickness	Approx. 6x6m printing size	max. 400mm	max. 350mm	Approx. 250mm	Depended on the wire structure
Dig.Fabrication Speed	Depended on machinery and material	max. 300m/min	max. 35m/min	Approx. 10m/min	Depended on machinery and material
Finish Independency	● ● ○ ○ ○	● ● ● ● ○	● ● ● ● ●	◎ ○ ○ ○ ○	● ● ● ○ ○
Overall Production Speed	● ● ● ● ○	● ● ● ○ ○	● ● ○ ○ ○	● ○ ○ ○ ○	● ● ○ ○ ○
Waste Production	● ○ ○ ○ ○	● ● ● ● ○	● ● ● ● ○	● ● ● ● ○	● ● ● ● ○
Mat. Emb.Energy Economy	● ● ● ○ ○	● ○ ○ ○ ○	● ● ○ ○ ○	● ○ ○ ○ ○	● ● ○ ○ ○
Sustainability	● ● ● ● ○	● ● ● ○ ○	● ● ● ○ ○	● ● ● ○ ○	● ● ○ ○ ○
Material Variability	● ● ● ○ ○	● ● ● ● ○	● ● ● ● ○	● ● ● ● ○	● ○ ○ ○ ○
Waste Mat. Integration	● ● ● ● ○	● ● ○ ○ ○	● ● ○ ○ ○	● ○ ○ ○ ○	◎ ○ ○ ○ ○
Waste Pre-elab. Independ.	● ● ● ○ ○	● ● ○ ○ ○	● ● ○ ○ ○	● ● ○ ○ ○	◎ ○ ○ ○ ○
Product Recycling Capacity	● ● ● ○ ○	● ● ○ ○ ○	● ● ○ ○ ○	● ● ○ ○ ○	● ○ ○ ○ ○
Demountability	● ○ ○ ○ ○	● ● ● ● ●	● ● ● ● ●	● ● ● ● ●	● ● ○ ○ ○

3D

2D

2D

2D + 3D

2D + 3D

Salvaged material rehabilitation & other processes

preceding refuse integration in manufacturing processes

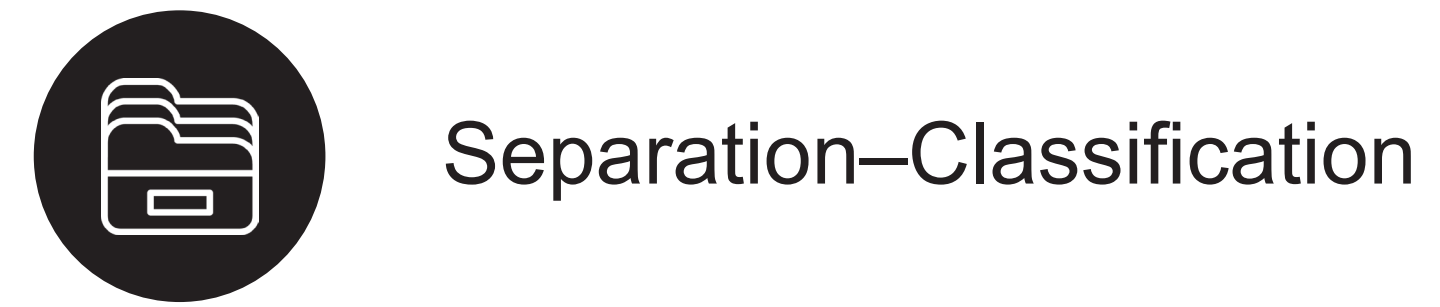

Separation-Classification

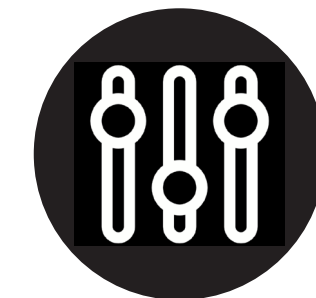

Parametric Design



Cleaning



Cutting-Shredding

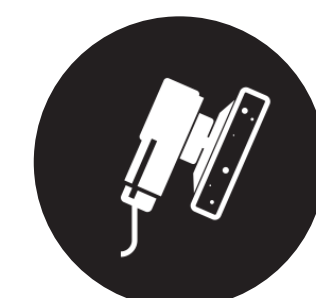

Furbish



Heating



Melting

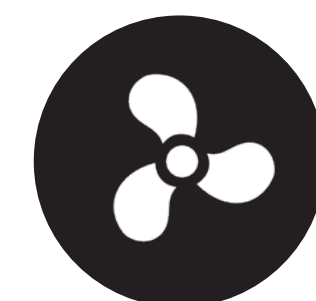

Cooling

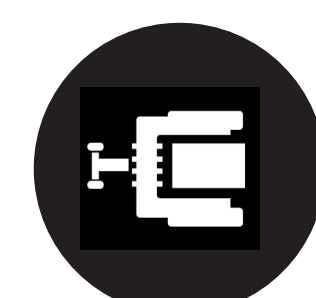

Compressing



Additives

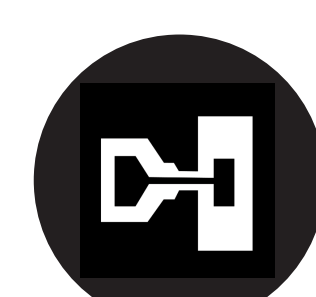

Casting



Other amendments

General overview & integration of refuse as raw material input in fabrication processes

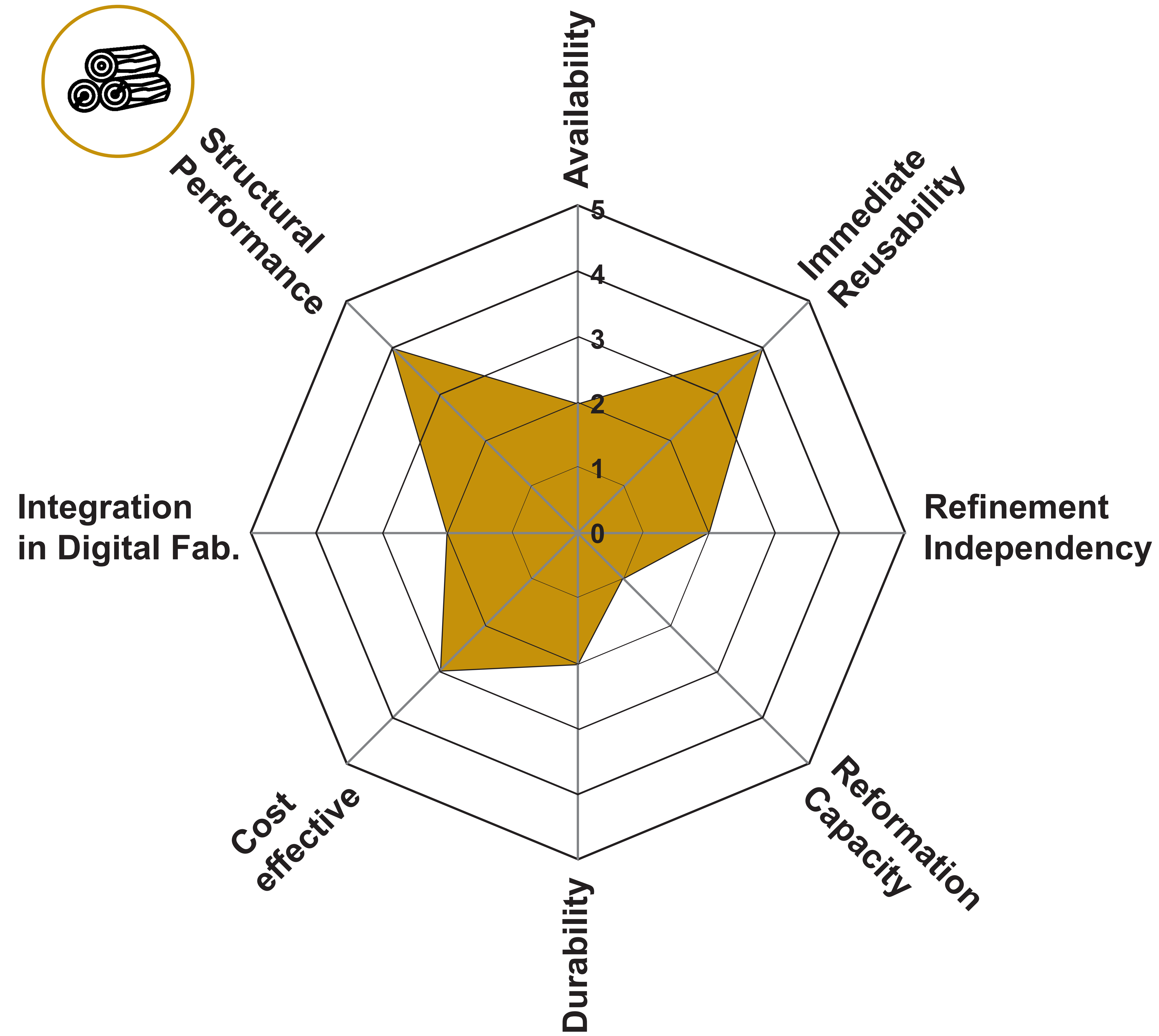
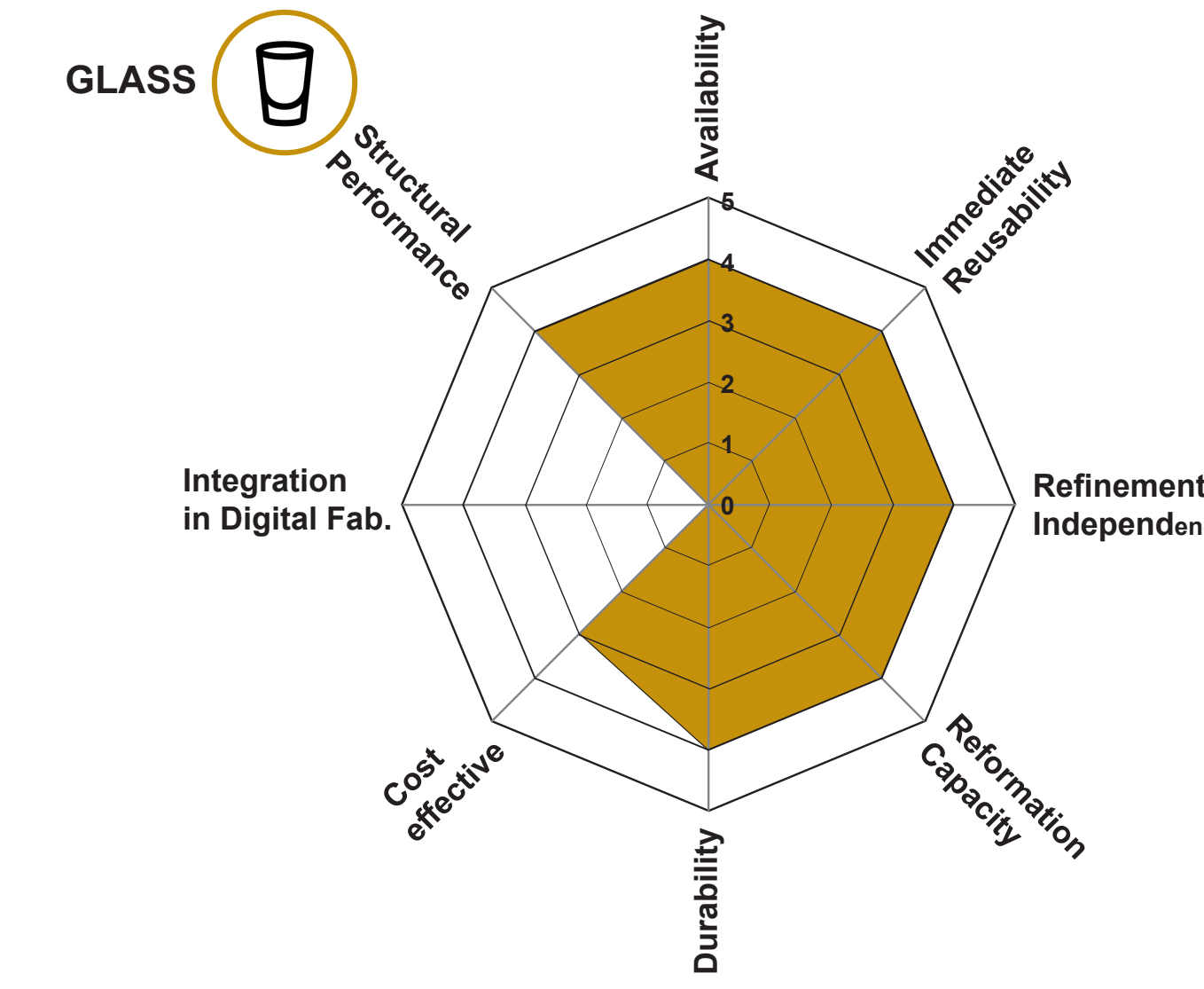
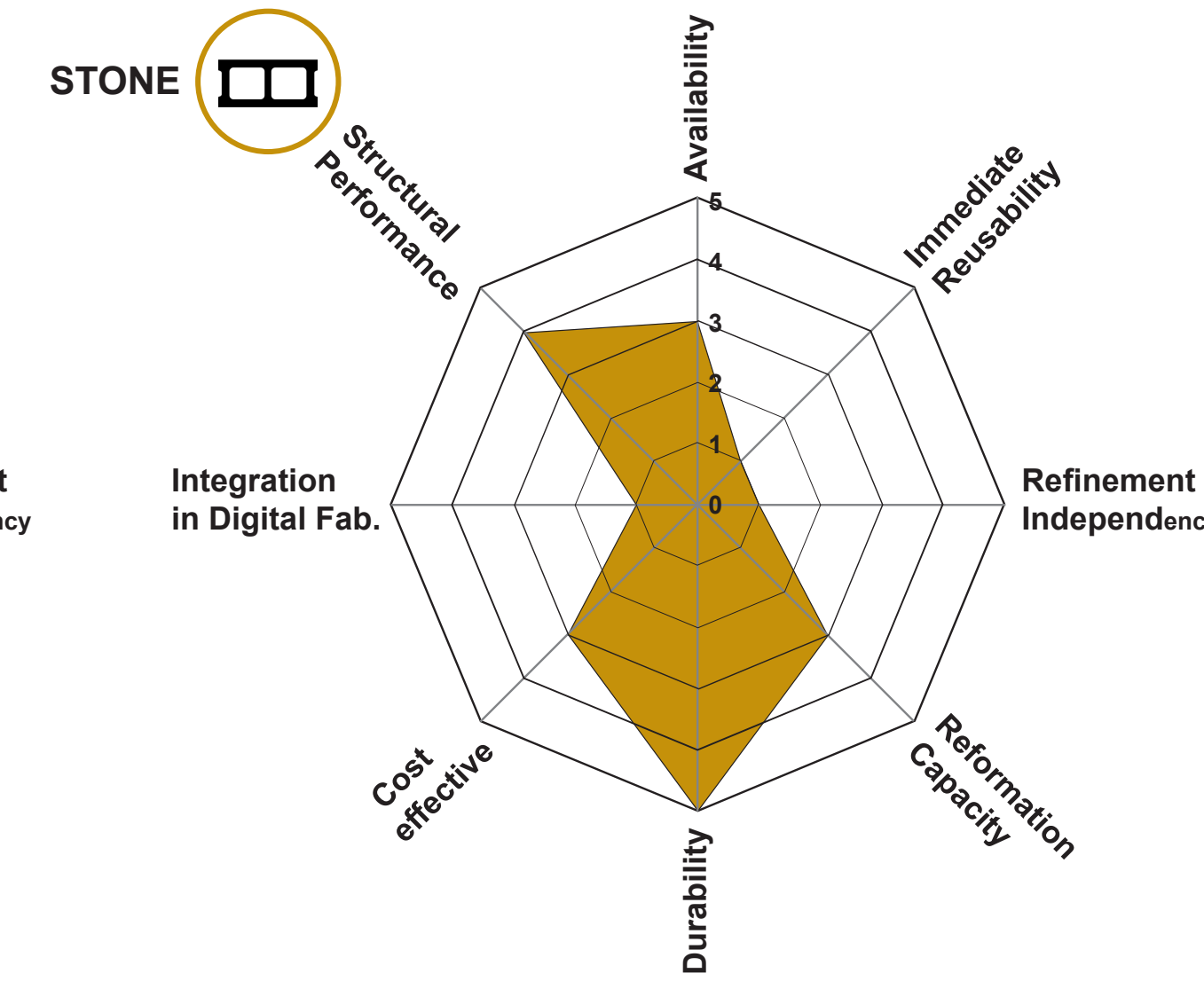
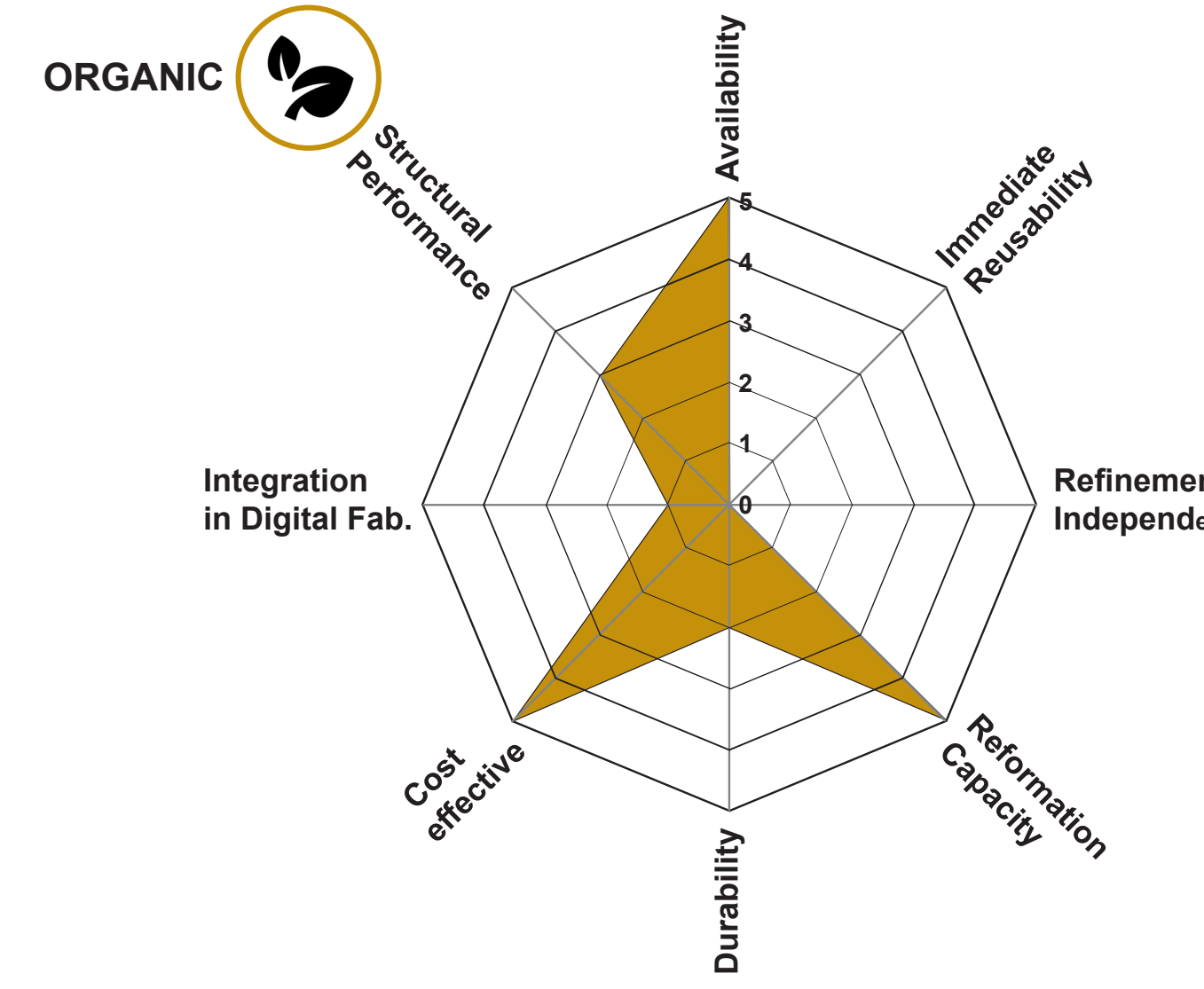
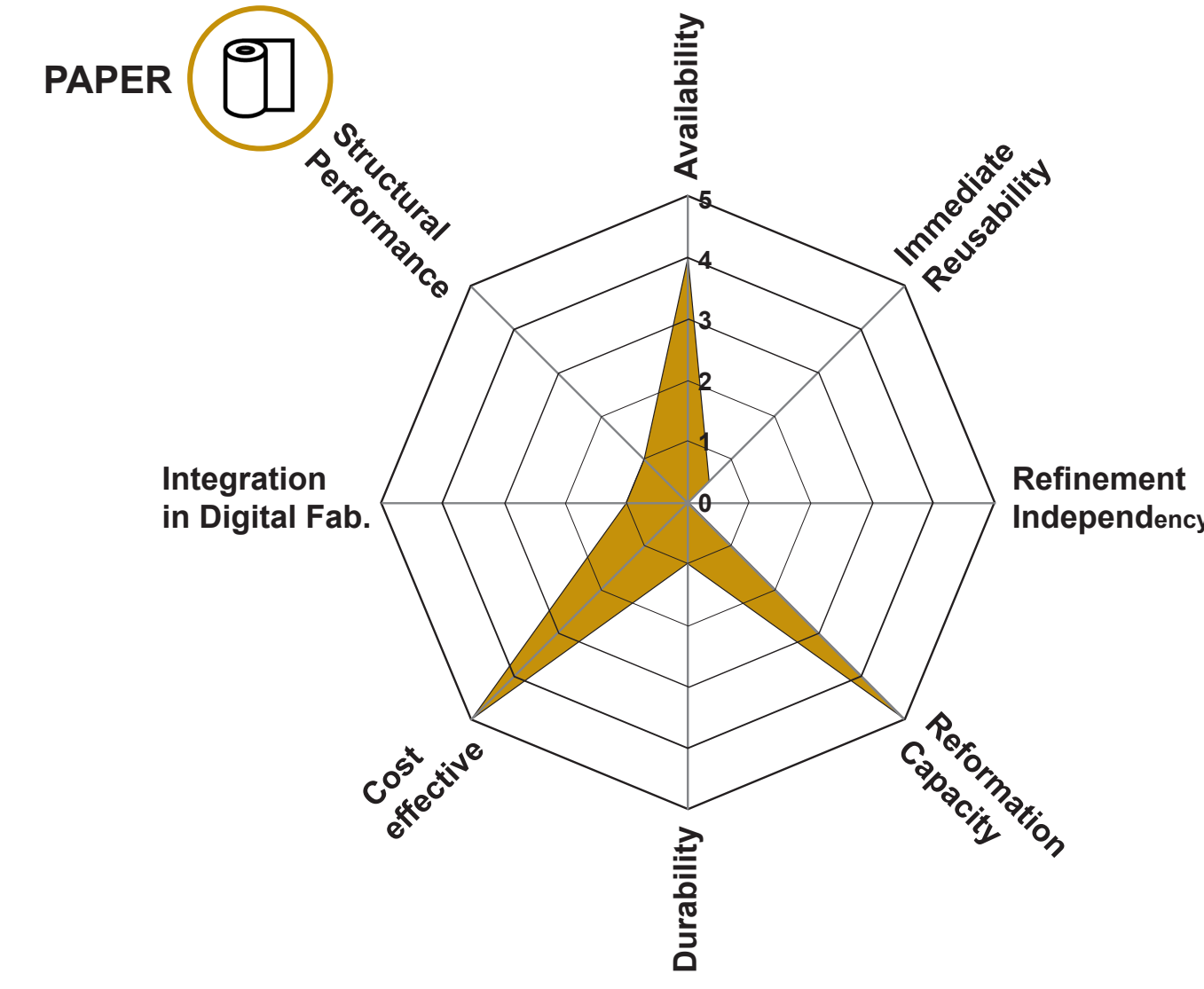
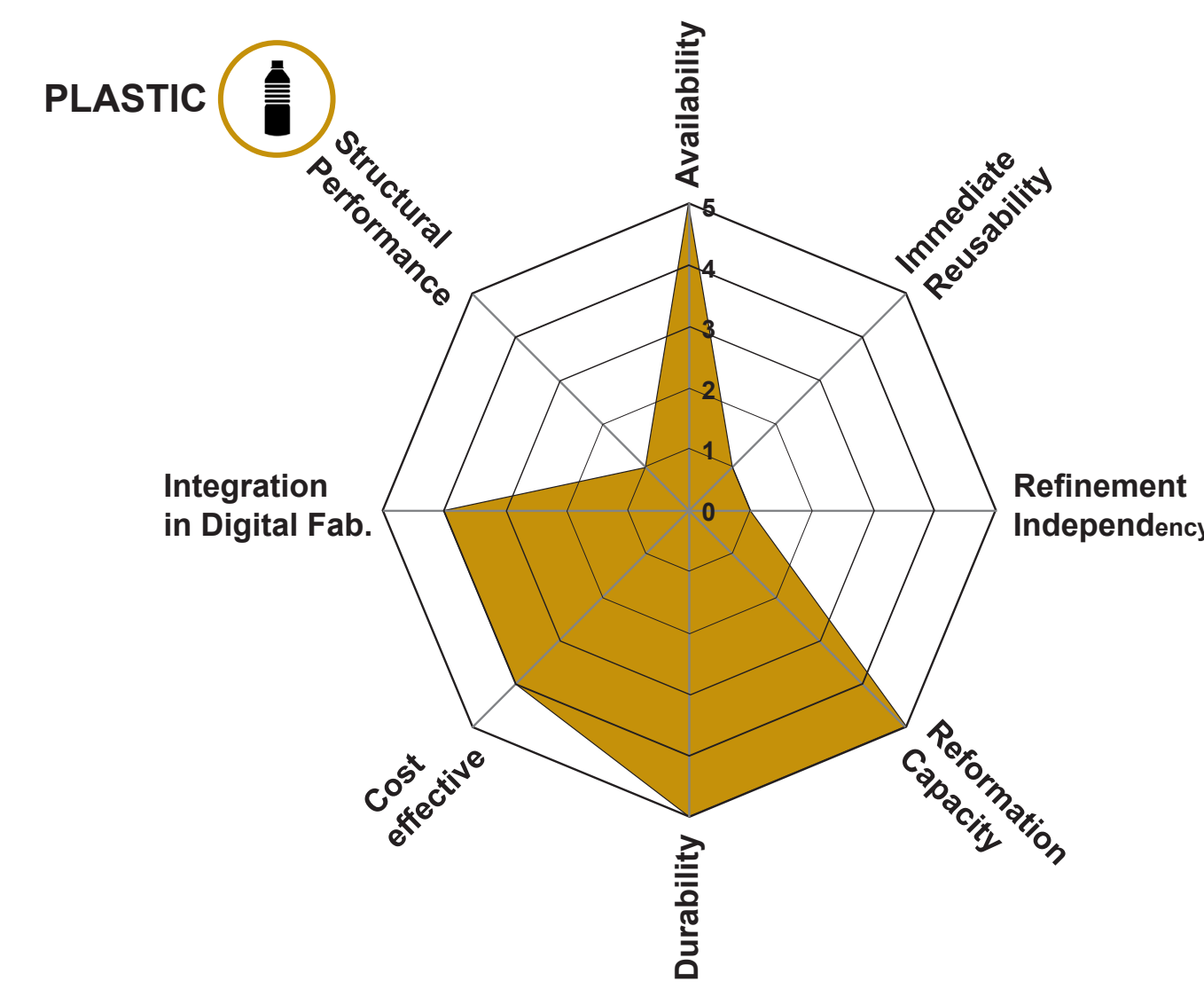
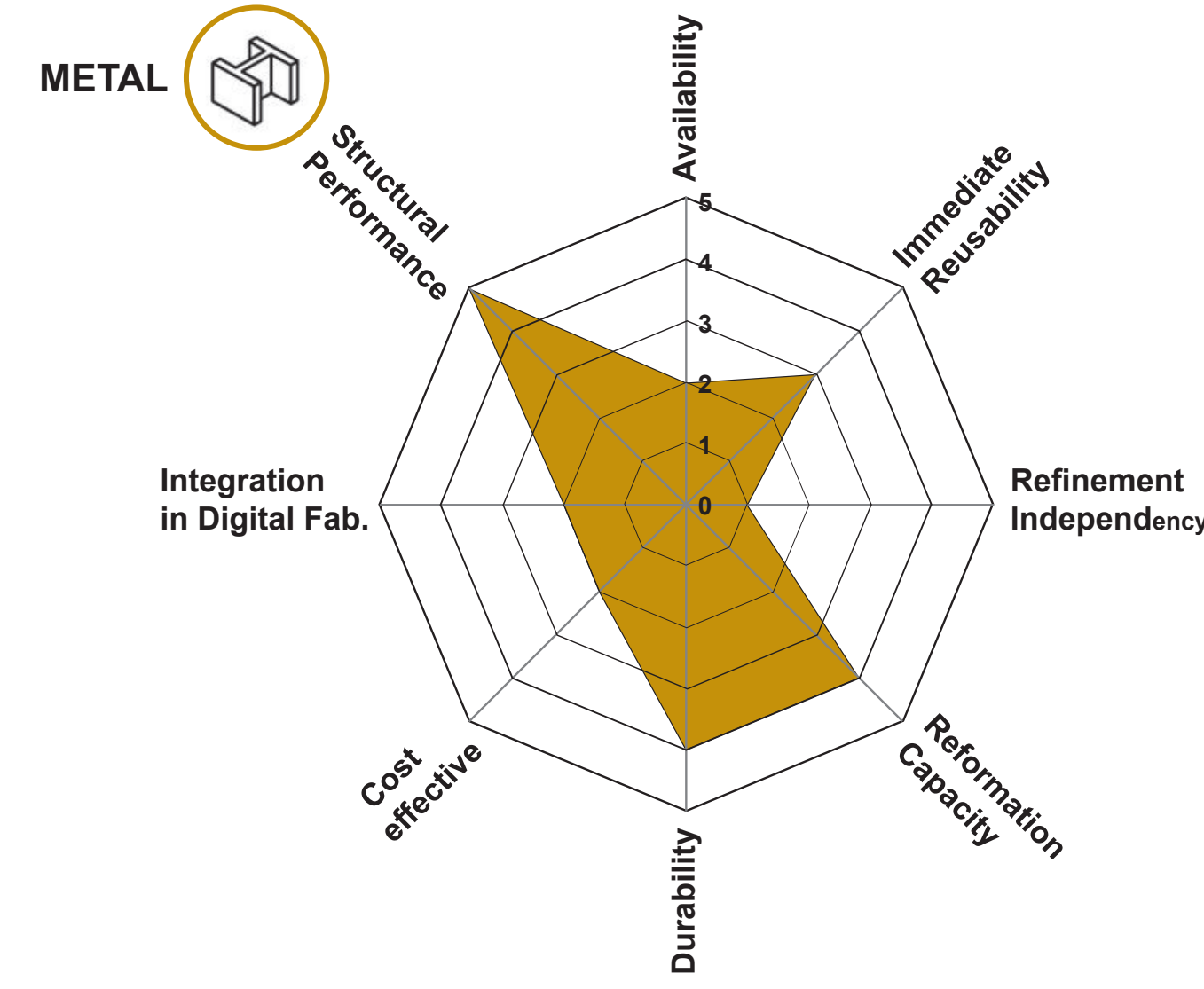



PLASTIC

Plastic Bags Brick



- 100% recycled



- Waterproof



- No glues & chemicals

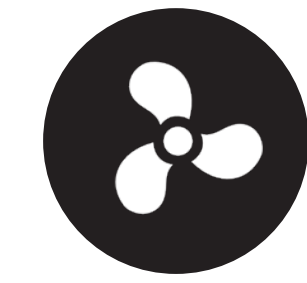

- Wide availability of raw material

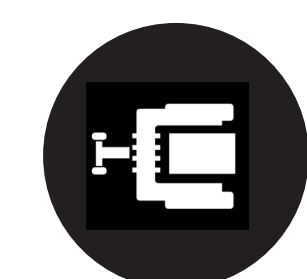

- Recyclable



- Household equipment

- Easy to produce

- Transparent ability

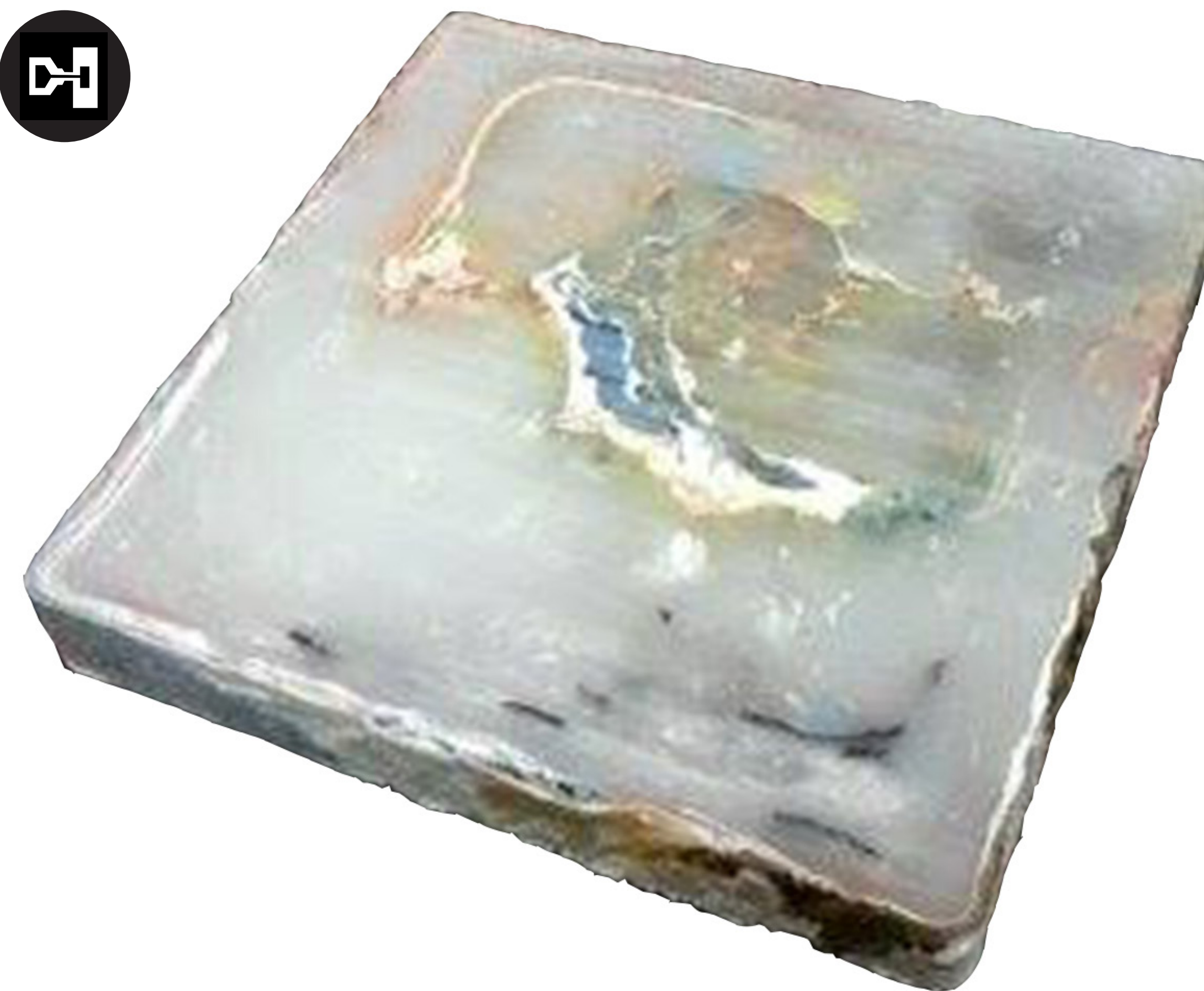

Tool

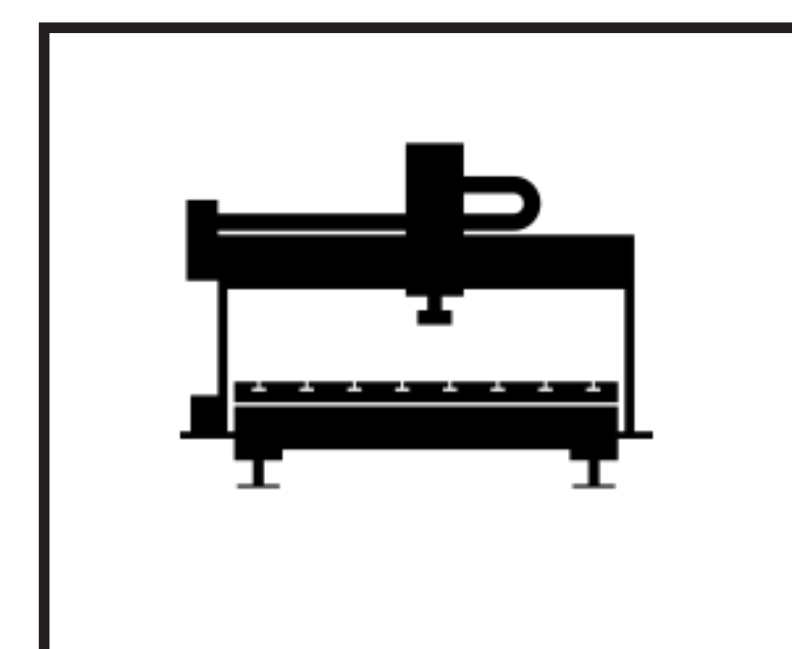



Translucent Component
produced by recycled
plastic bags type [HDPE]

New 3D Printing
Polymeric
Fillament from
Disposed Plastic
through the employment of
melted shredded material
in an injection machine
process

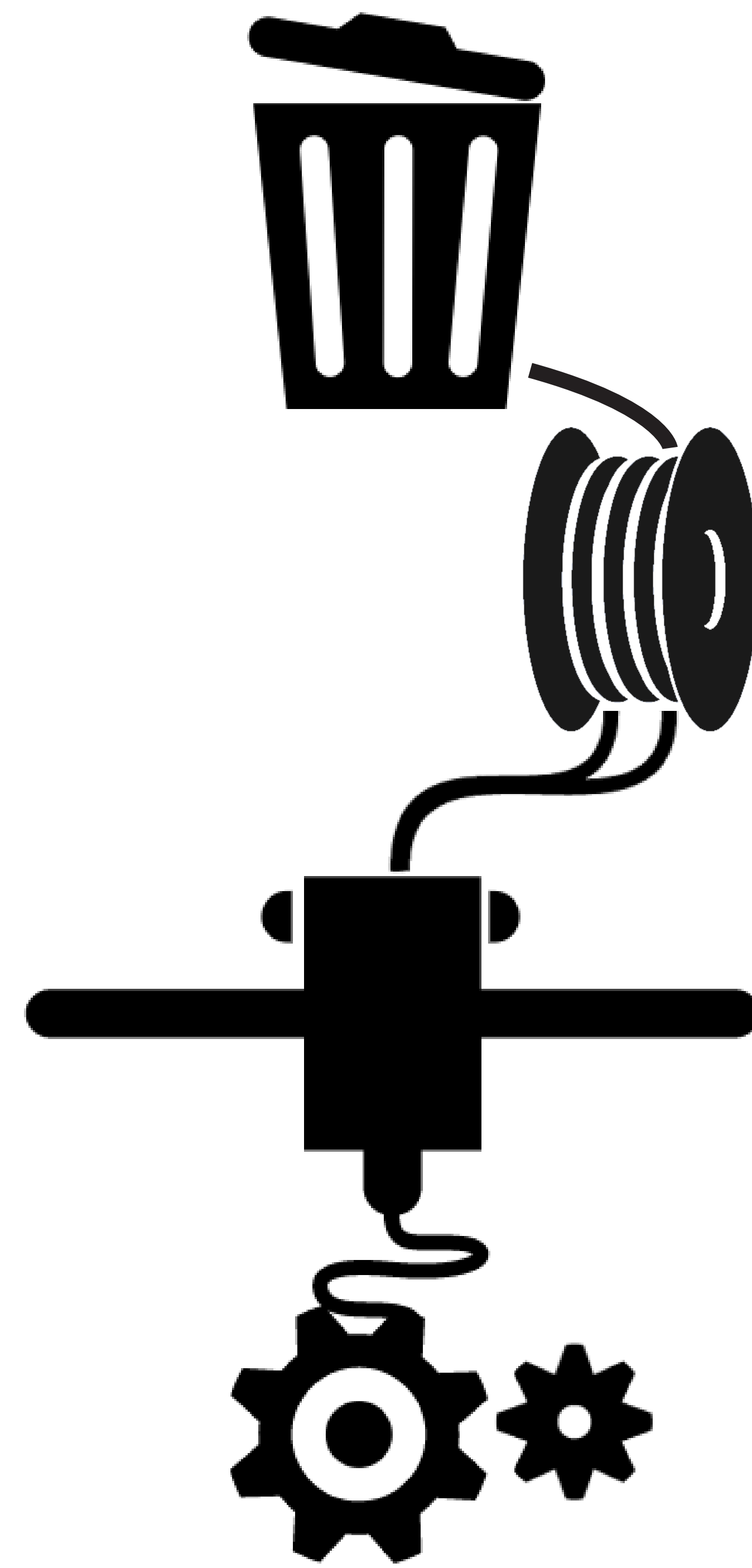

3D Printing Polymeric Filament from Recycled Plastic Bottle Caps Process

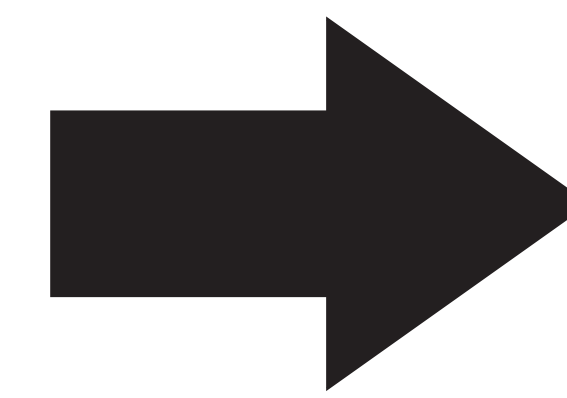
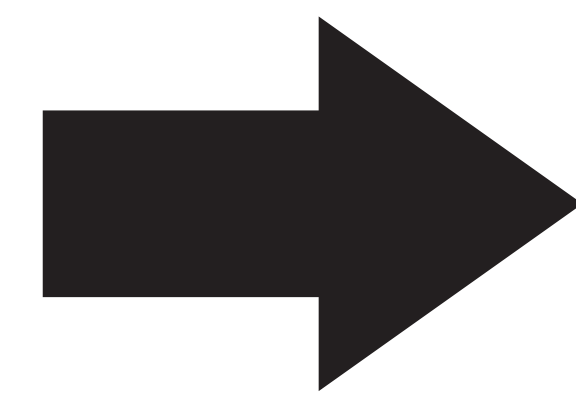

3DPrinted Plastic Facade Component Characteristics

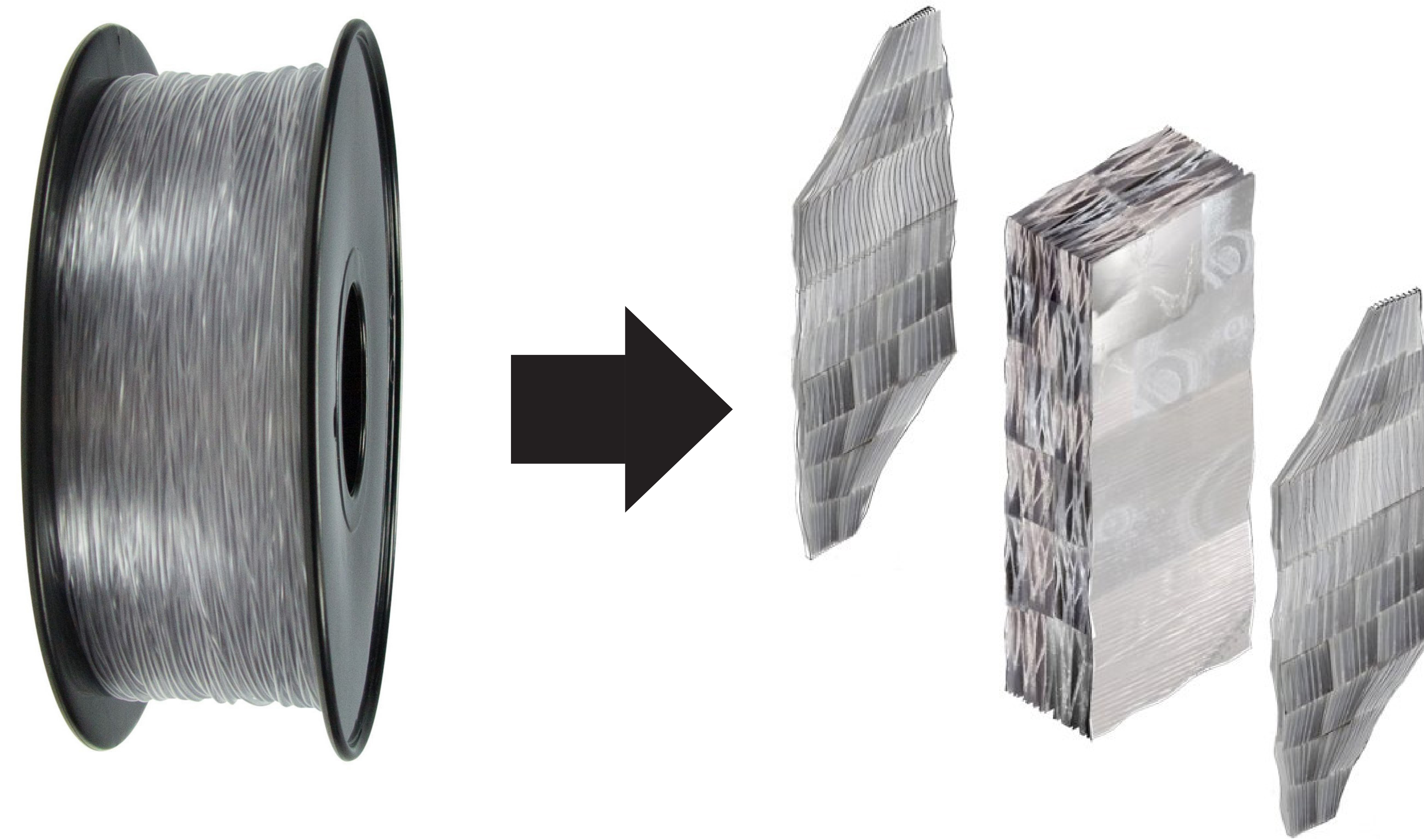

- Recycling Plastic Bottle Caps Type [PET]



- Translucency

- Insulation



- Lightweight

- Demountable

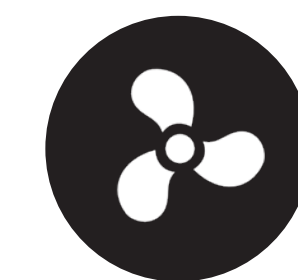

- Interlocking Ability - No Fixings

- Heat Storage Fluid Channels

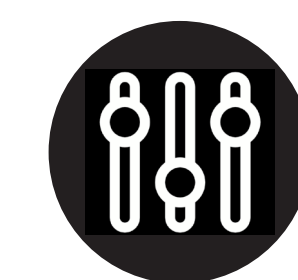

- Production Time Optimized Cavities

- Timber Framework Integration

Tool

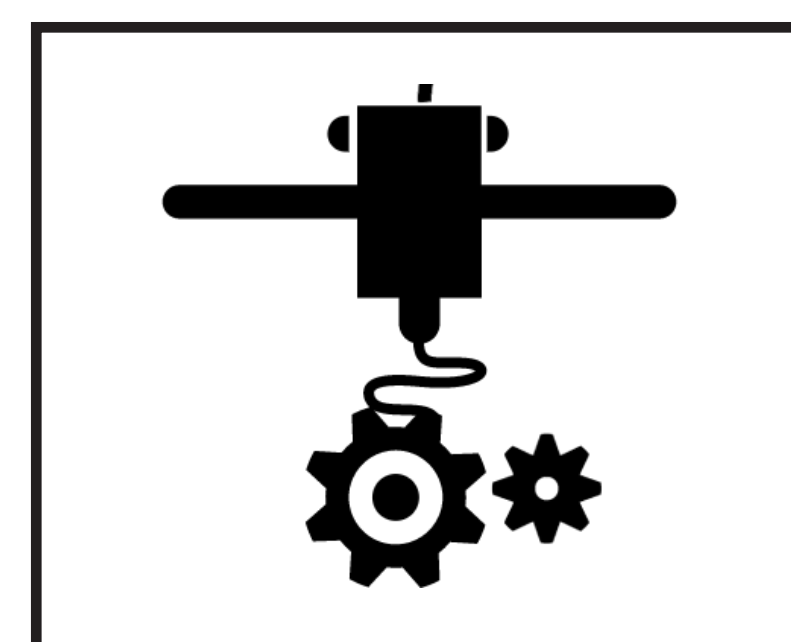

D.I.Y. Plastic Recycling Machines

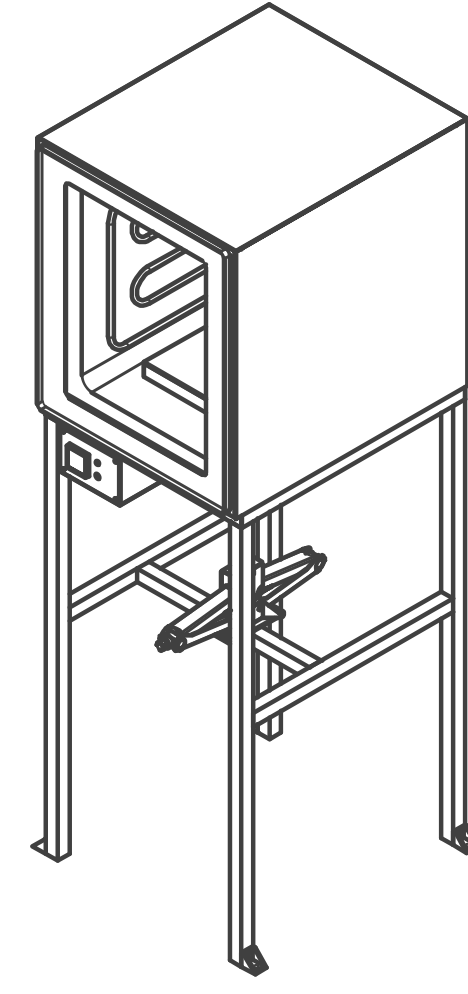

Compression

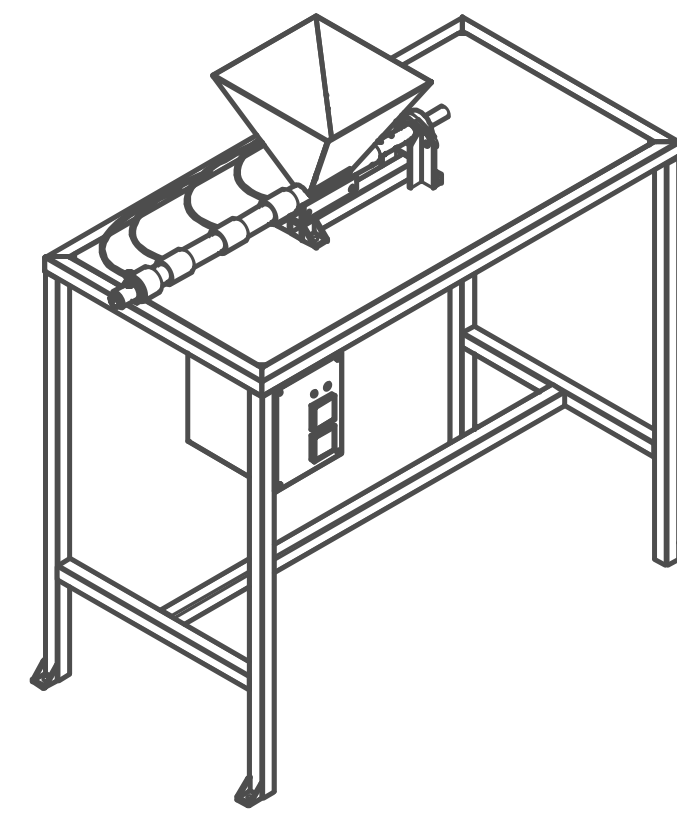

Extuder

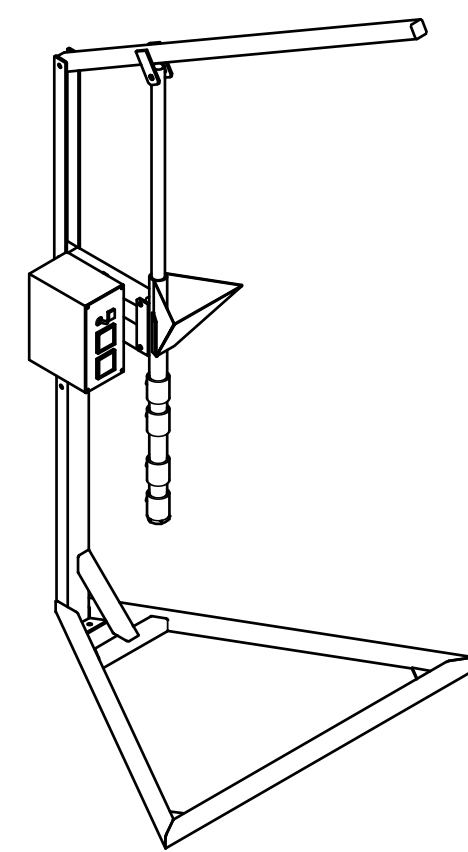

Injection

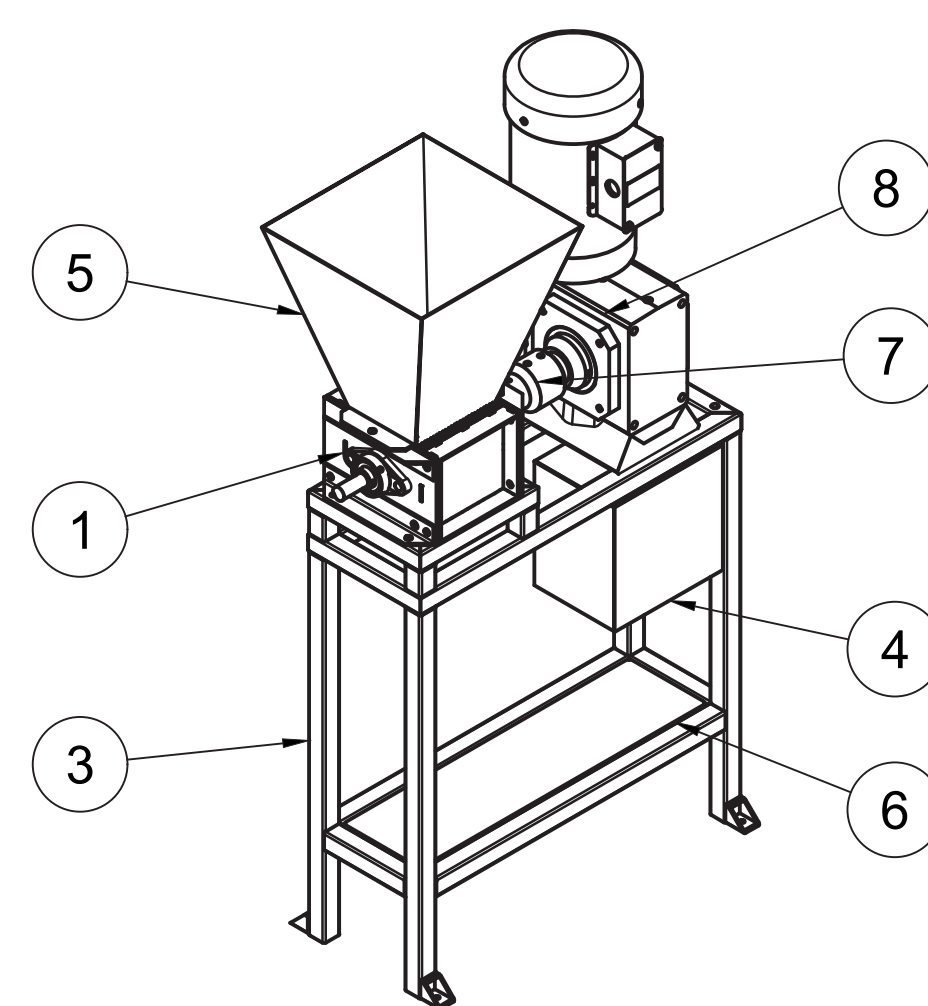

Shredder

WOOD

Common Salvaged Timber Types































Sheets

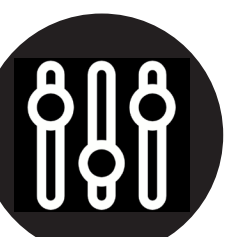

Beams & Planks

Patchwork Methods

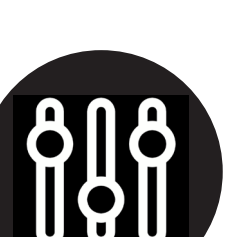
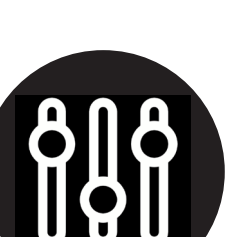

- | | | | | | |
|-----------------------------------------------------------------------------------------------------|-------------------------------------------------------------------------------------------------------------------------------------------|---------------------------------------------------------------------------------------------------------------------------------------------|-----------------------------------------------------------------------------------------------------------------------------------------|-----------------------------------------------------------------------------------------------------------------------------------------------------|---------------------------------------------------------------------------------------------------------------------------------------------------|
|  Regular pattern |  Irregular pattern of variable size & thickness timber |  Polygon regulated pattern of same thickness components |  Regulated pattern of certain dimension categories |  Irregular pattern of variable size, but same thickness timber |  Regular pattern of variable size, but same thickness timber |
|  |  |  |  |  |  |
|  |  |  |  |  |  |
| |  |  |  |  |  |
| | |  |  |  |  |
| | |  |  |  |  |

Parameters Influencing Variable Size Timber Framework Construction

- Number of Components
- No Standardization
- Regulation of Multiple Parameters

Steps of Timber Framework Construction Optimization

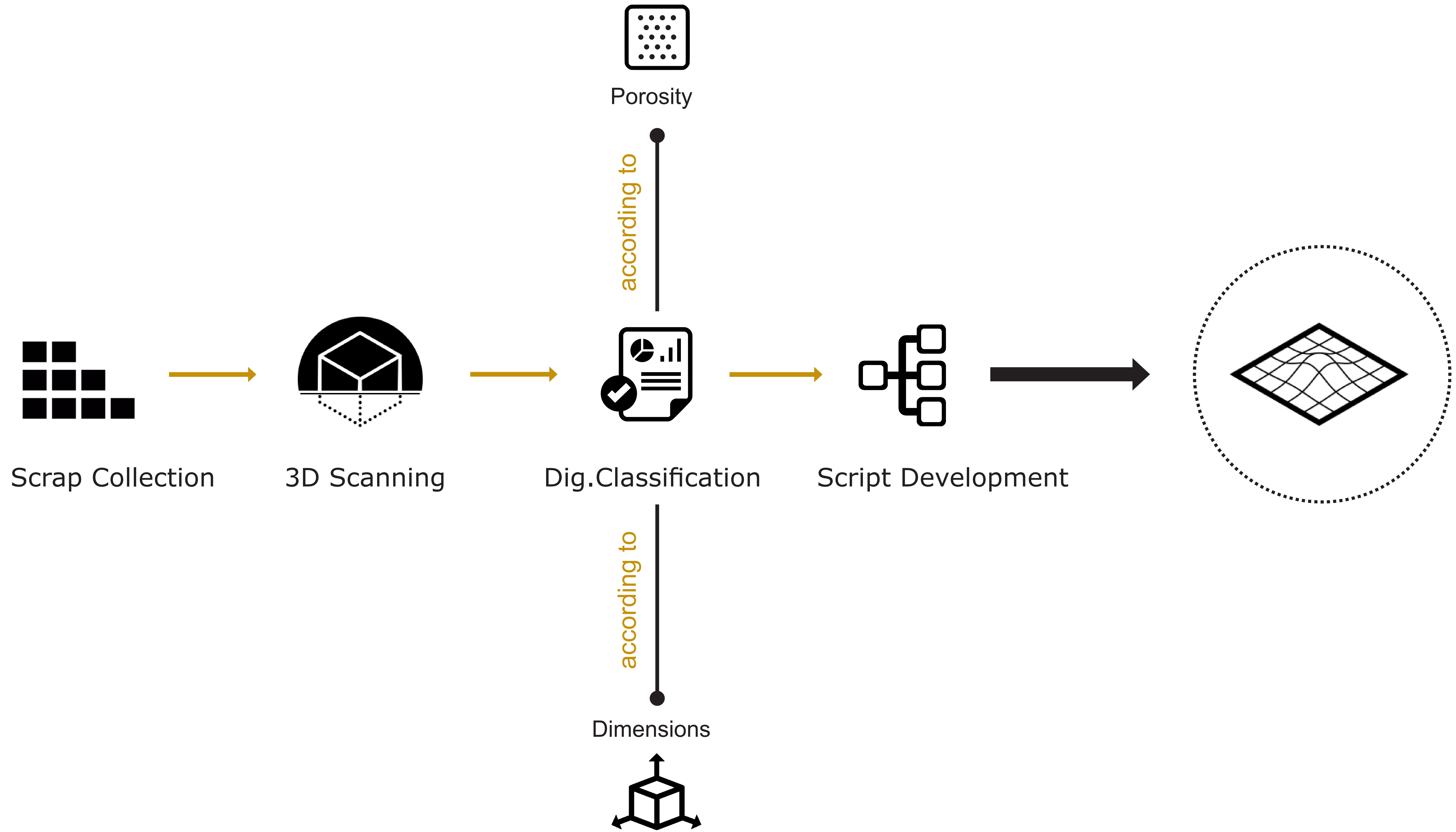

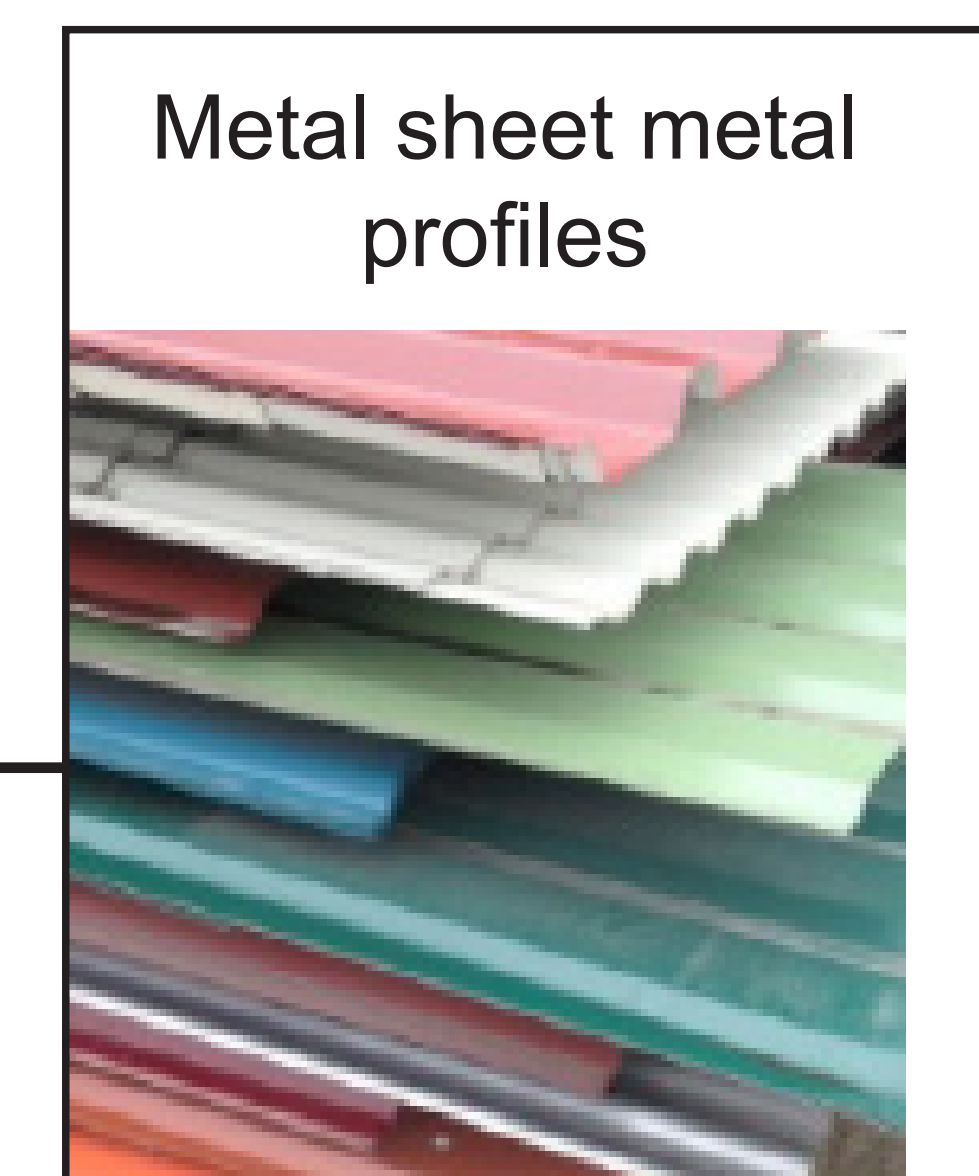
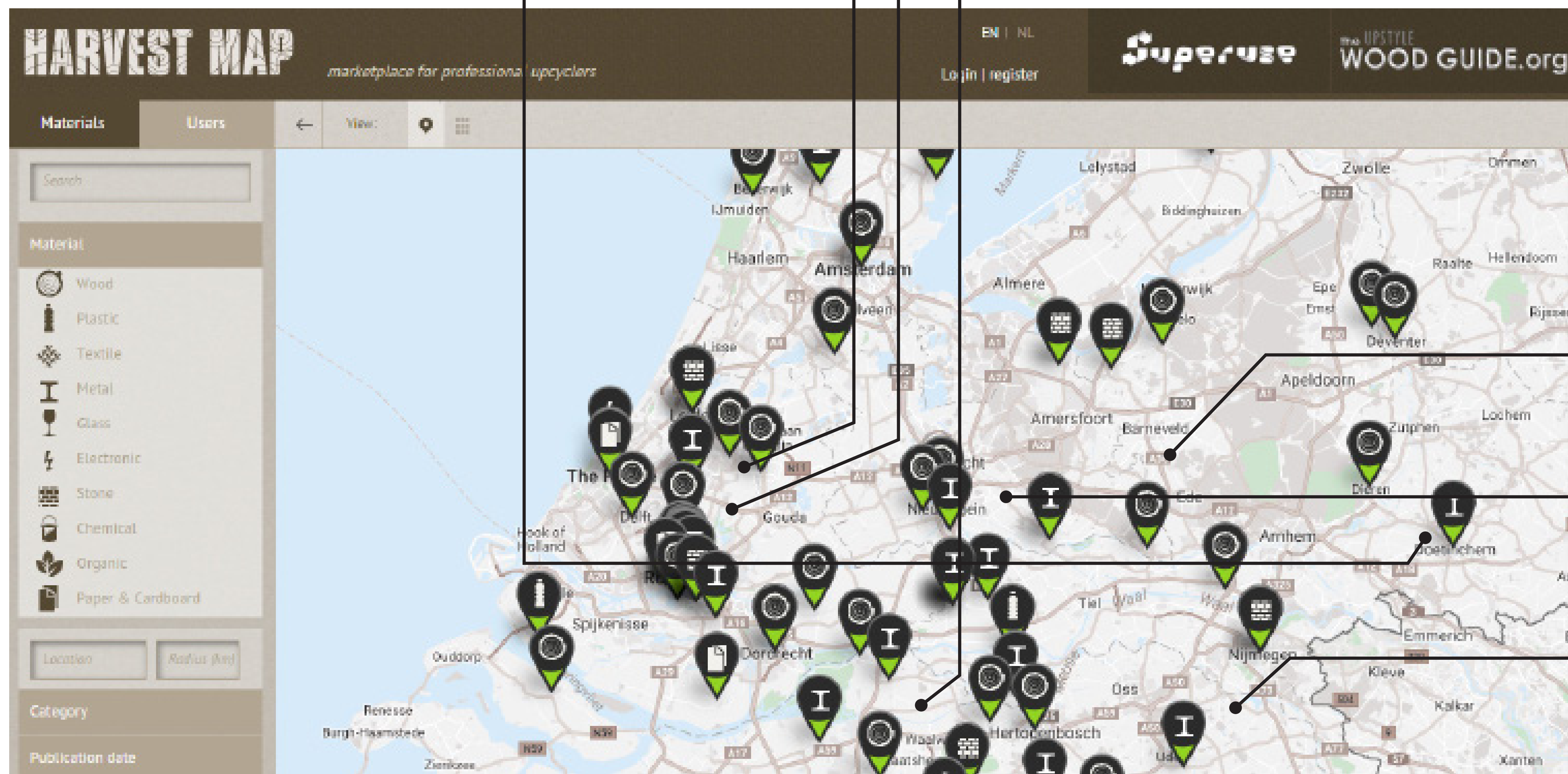
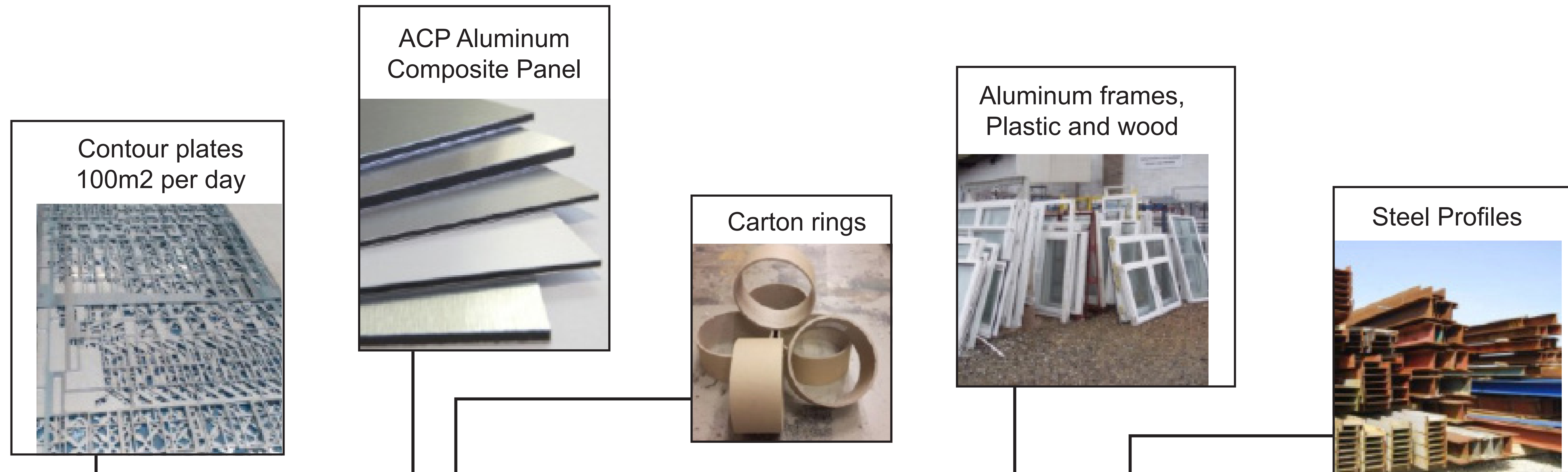

Material Logistics Optimization
 [On-line Databases & Material Inventories]

Design

reFab Site Requirements

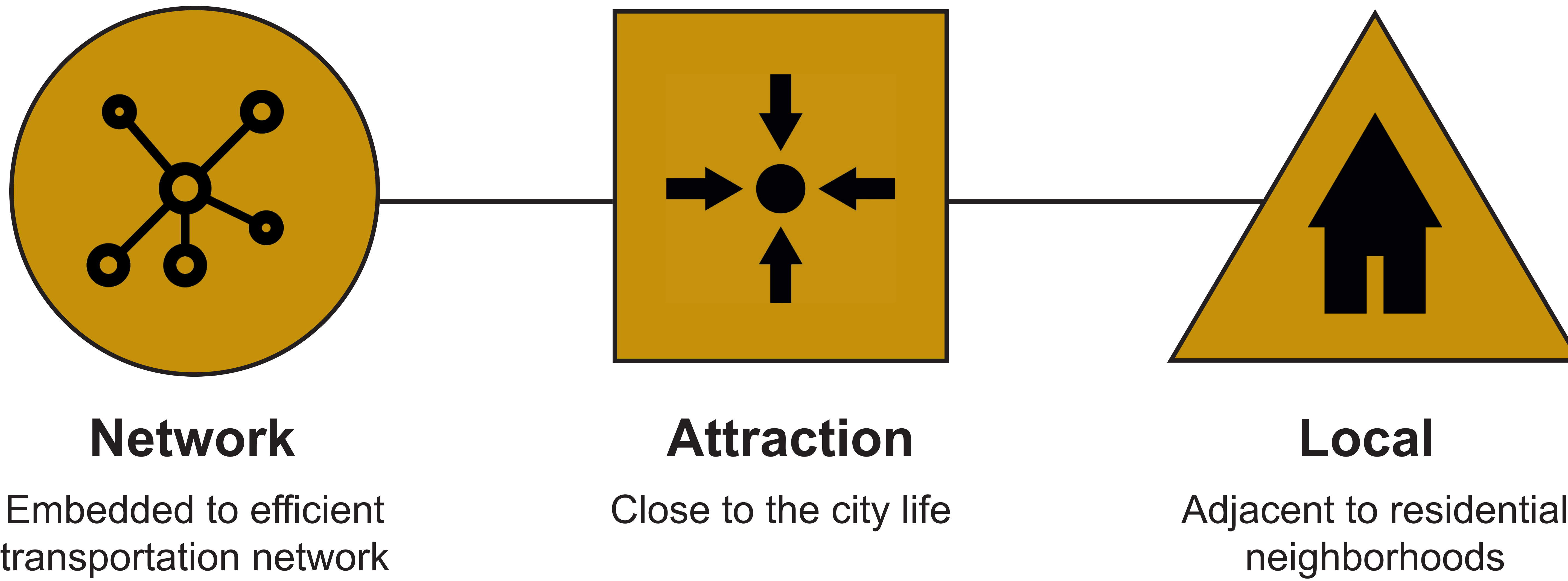



**Current
Area Of Focus**
City of Amsterdam



1st
reFAB
Amsterdam

AMS Research Agenda

Research portfolio overview

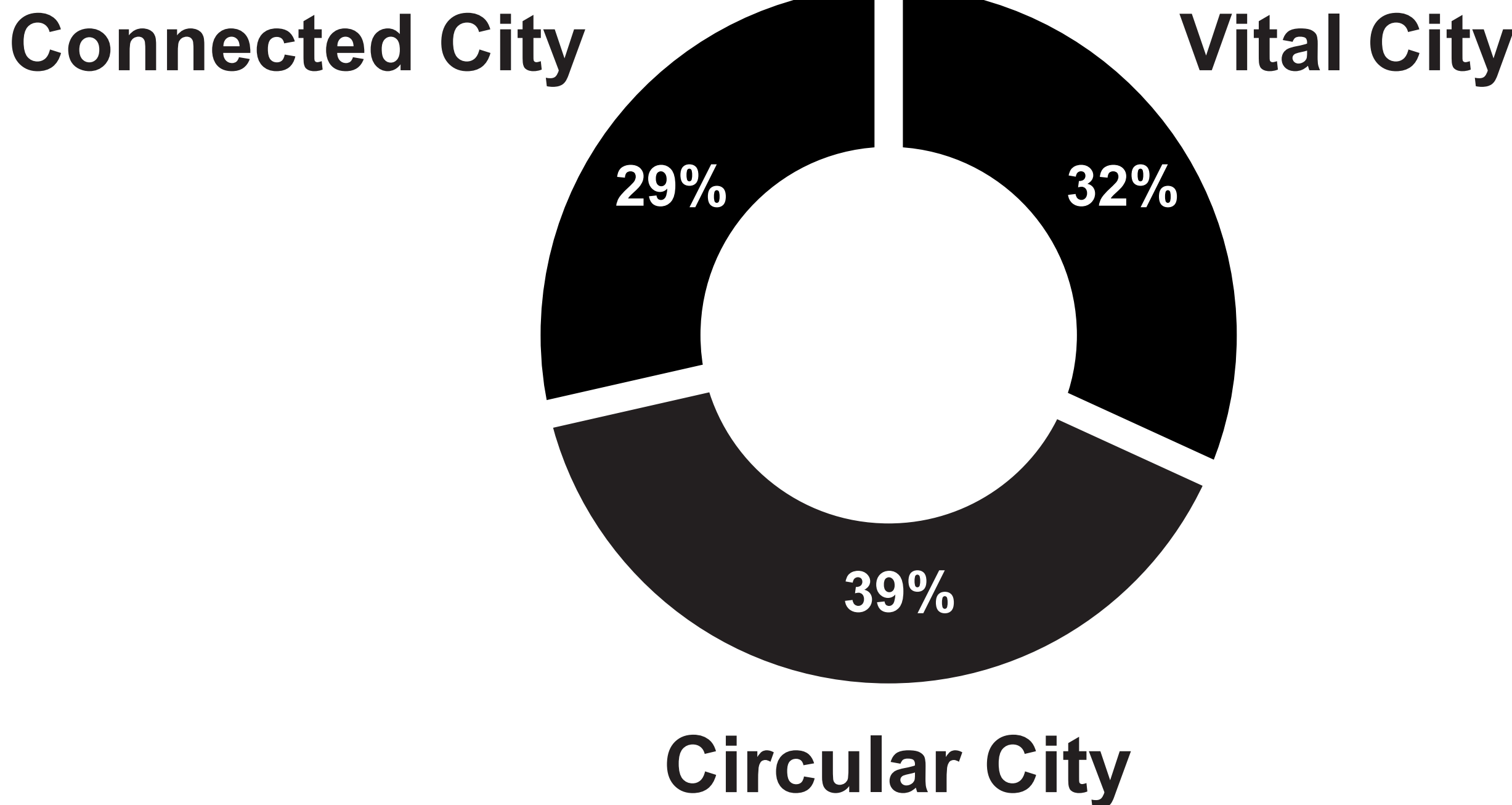

Max. resource investment

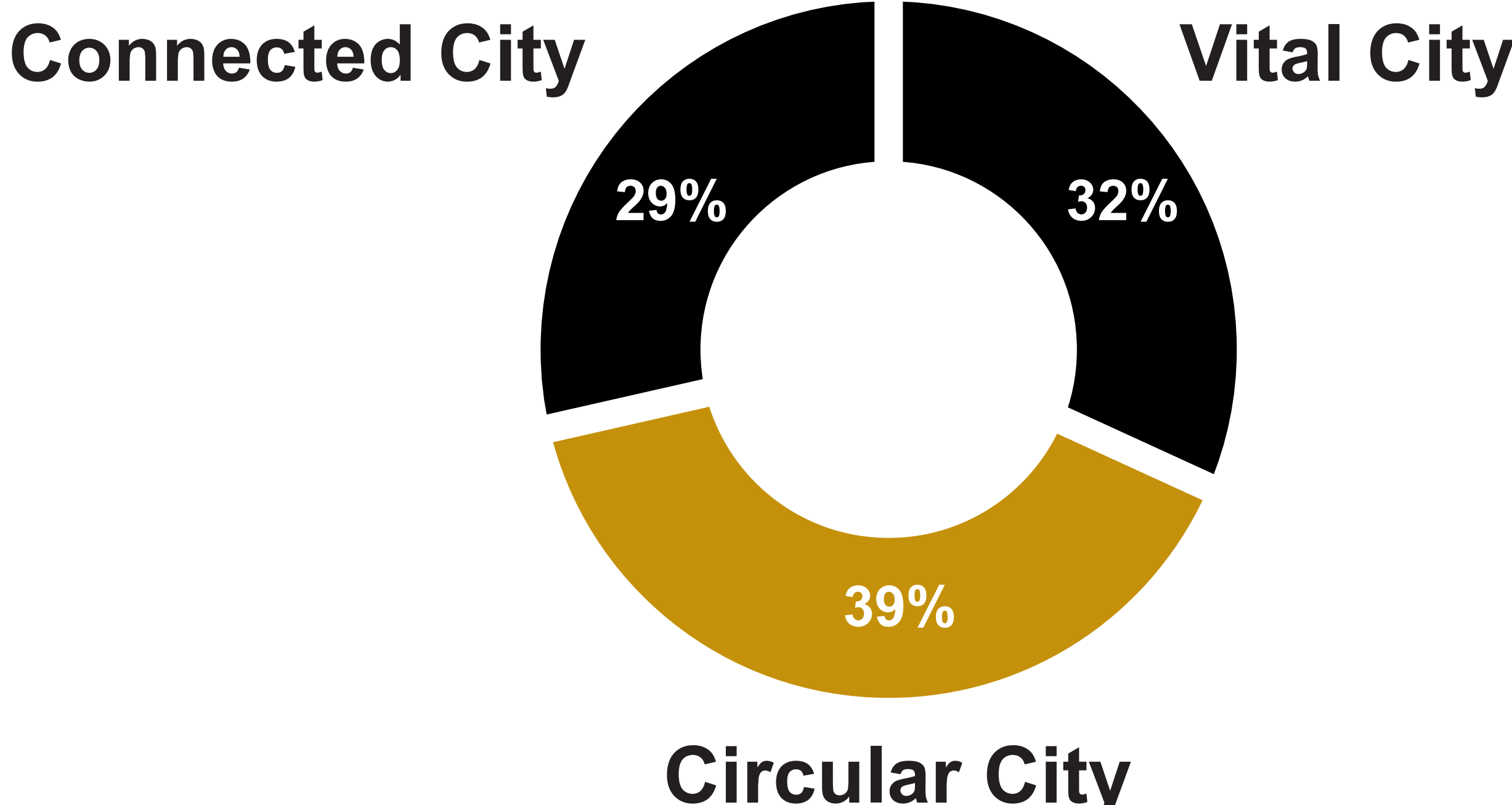

% budget per research theme

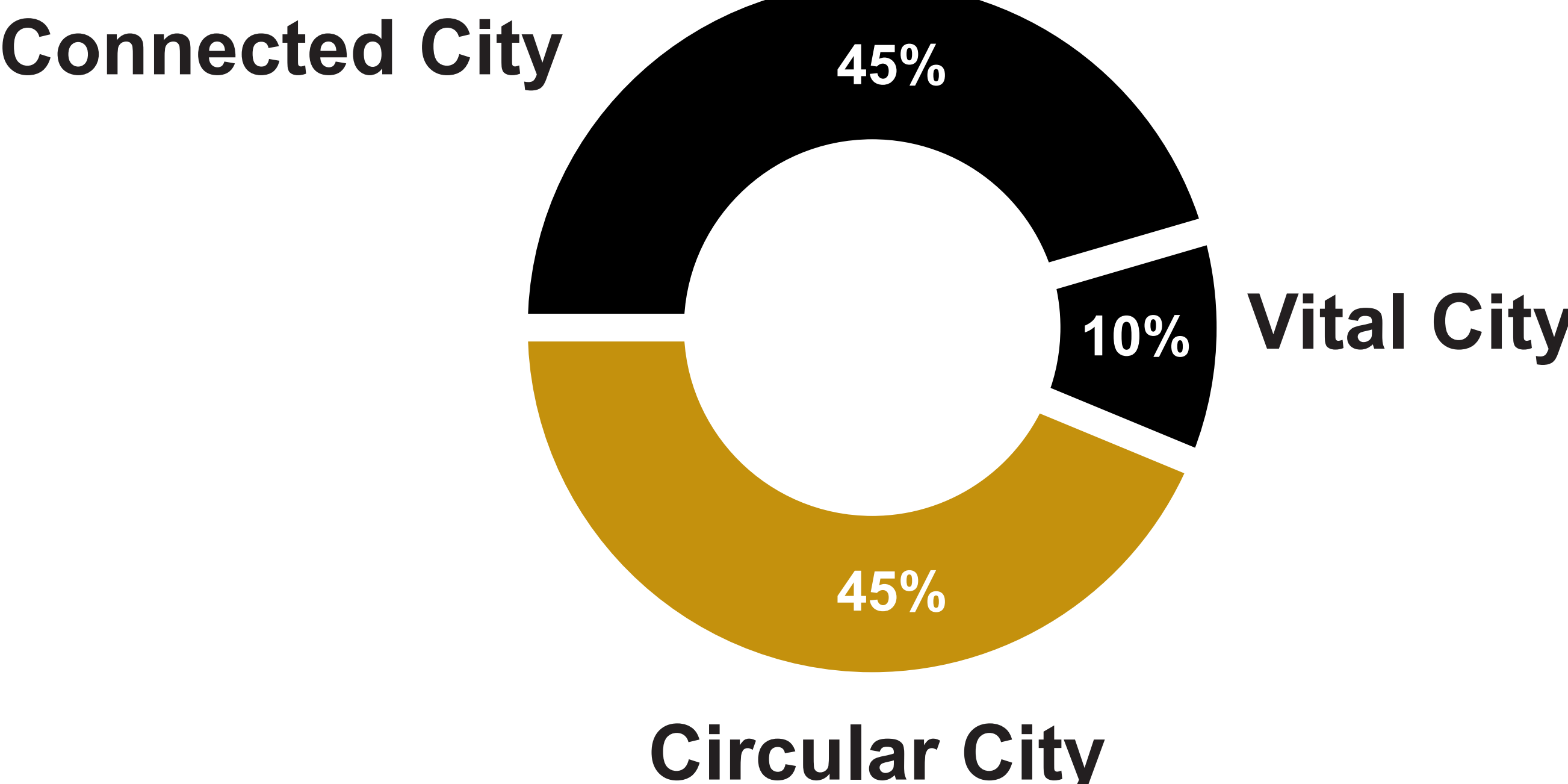



MakerSpaces Located in Amsterdam

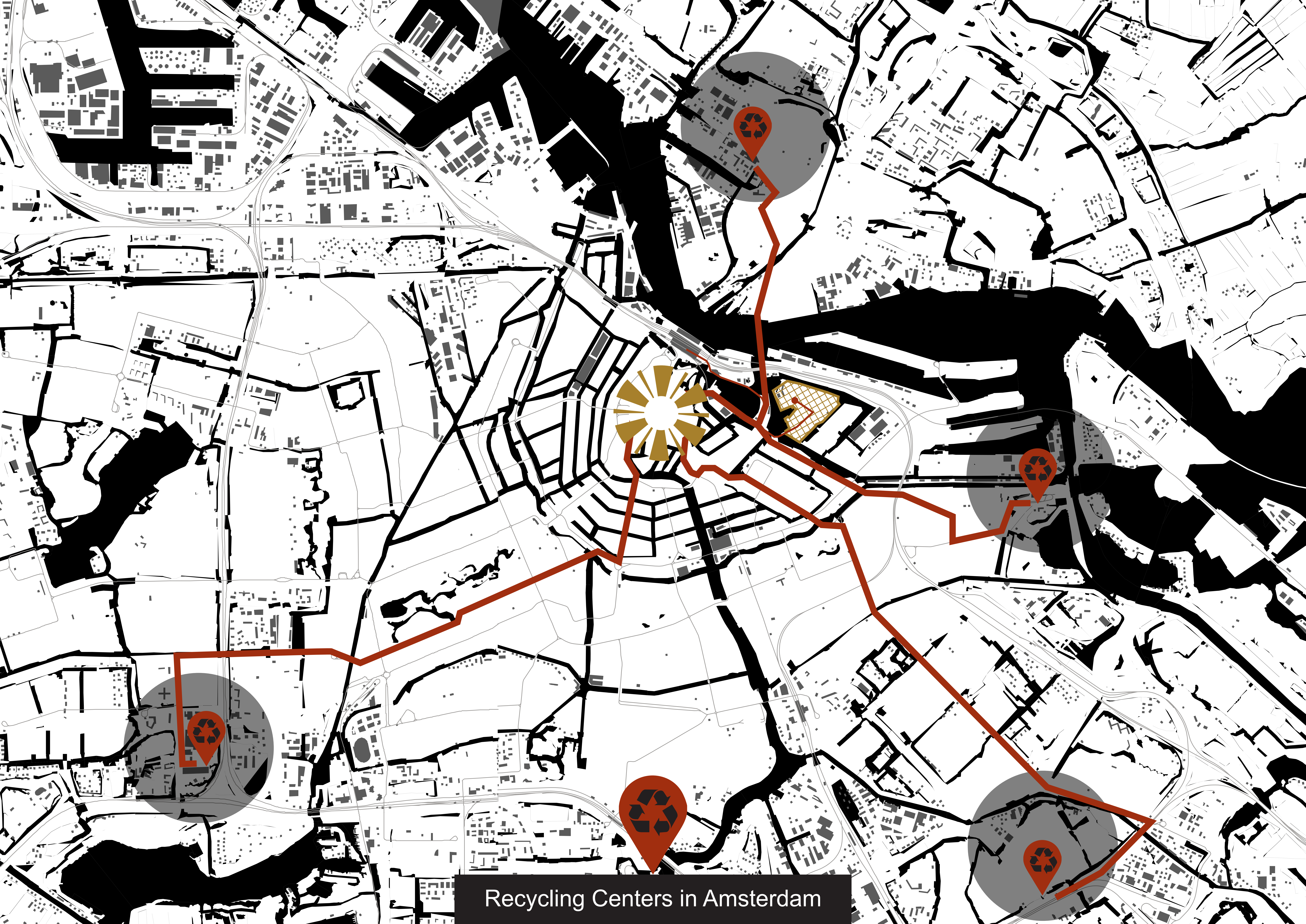

Recycling Centers in Amsterdam



Proposal [reFab Network Development]

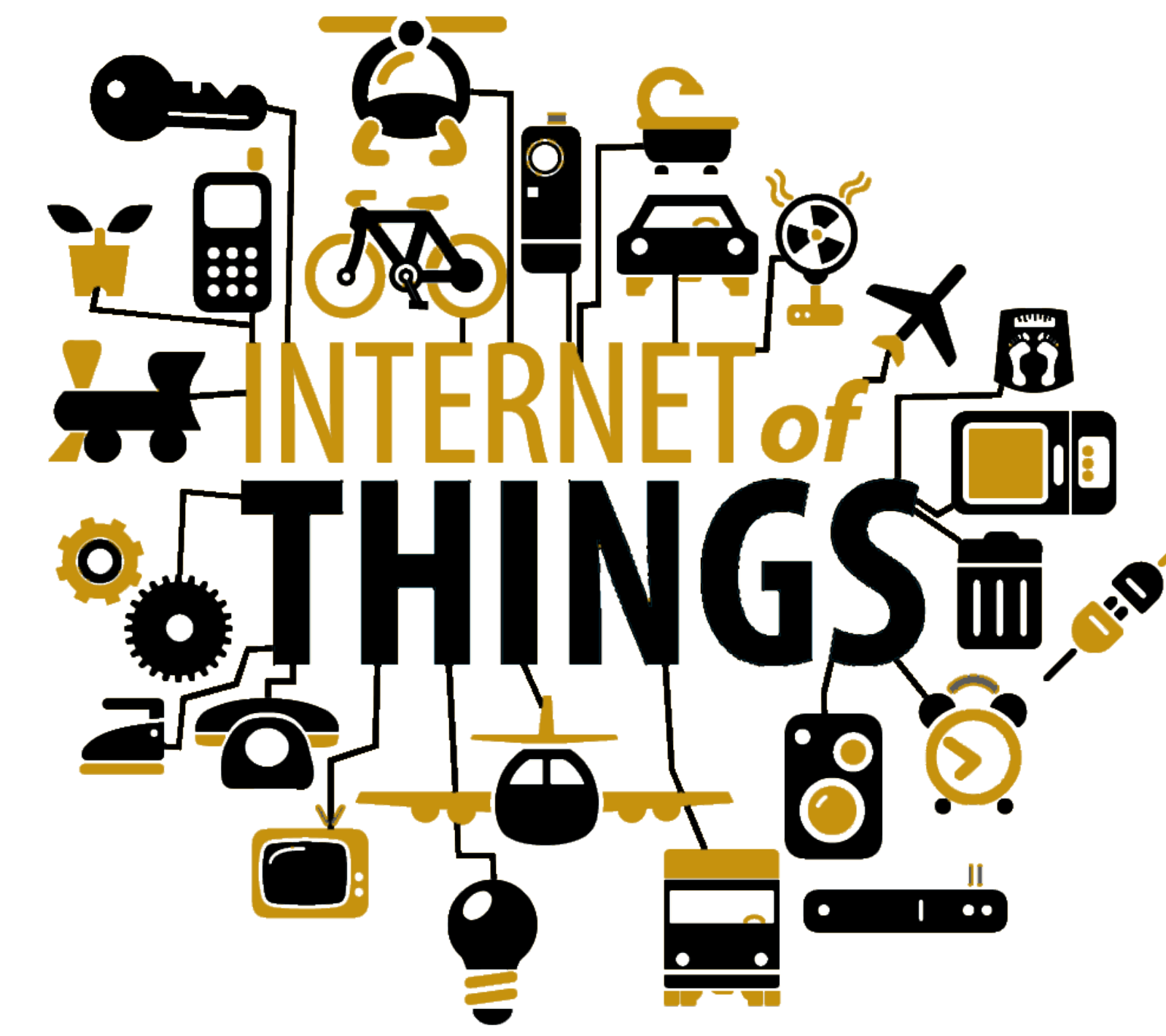

reFab Connection with IOT Route

A route aligned with beacons that constitutes a testing area for applications such as:

- Public way finding
- iBeacon signing
- Tourist routes
- Points of interest
- Existing apps augmentation with additional data



Marineterrein

Amsterdam

“Amsterdam has the ambition to be a frontrunner towards circular economy.”

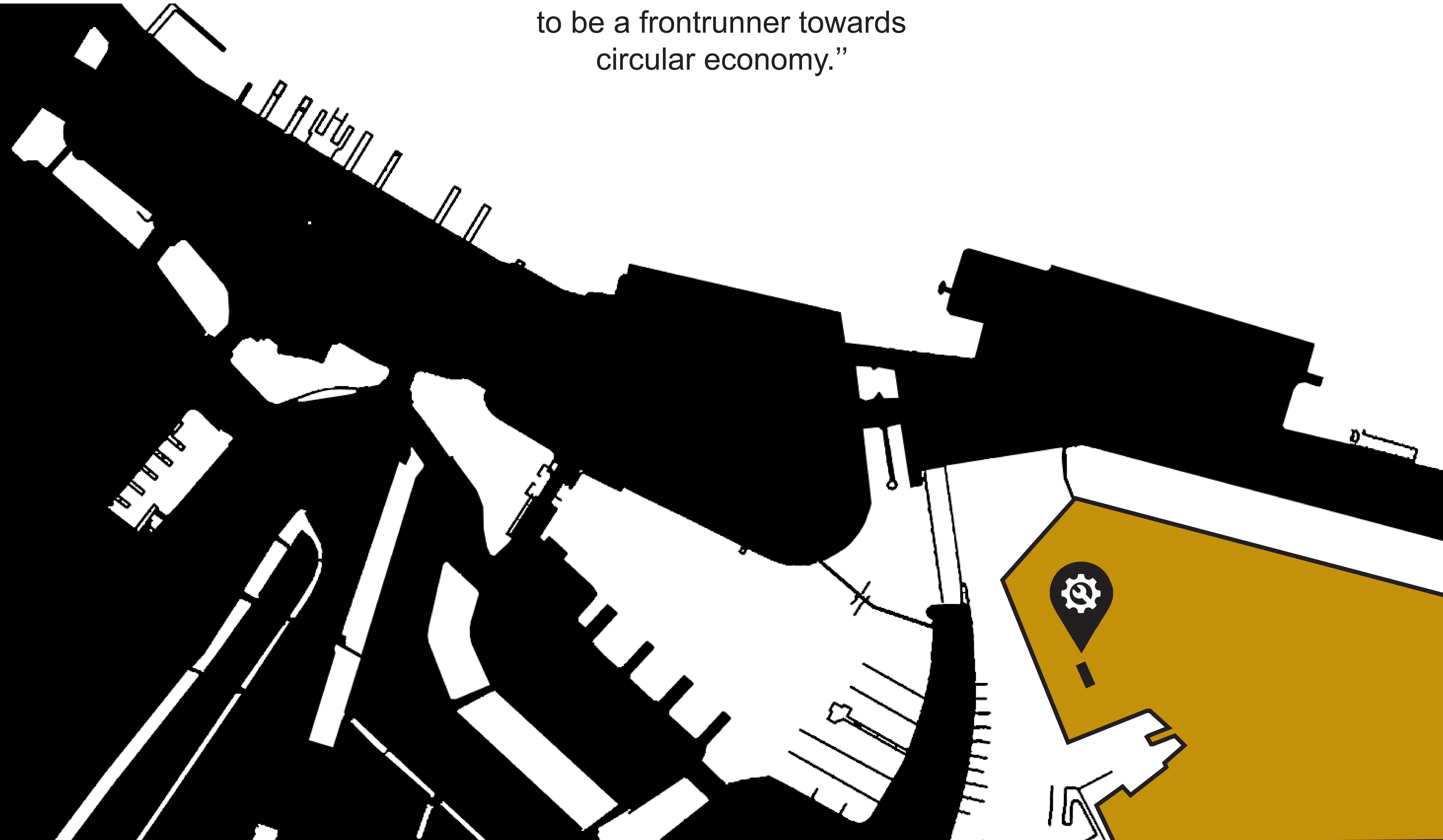



Area of Focus

Marineterrein in the City of Amsterdam

1. Empty Space

70% ground for intervention

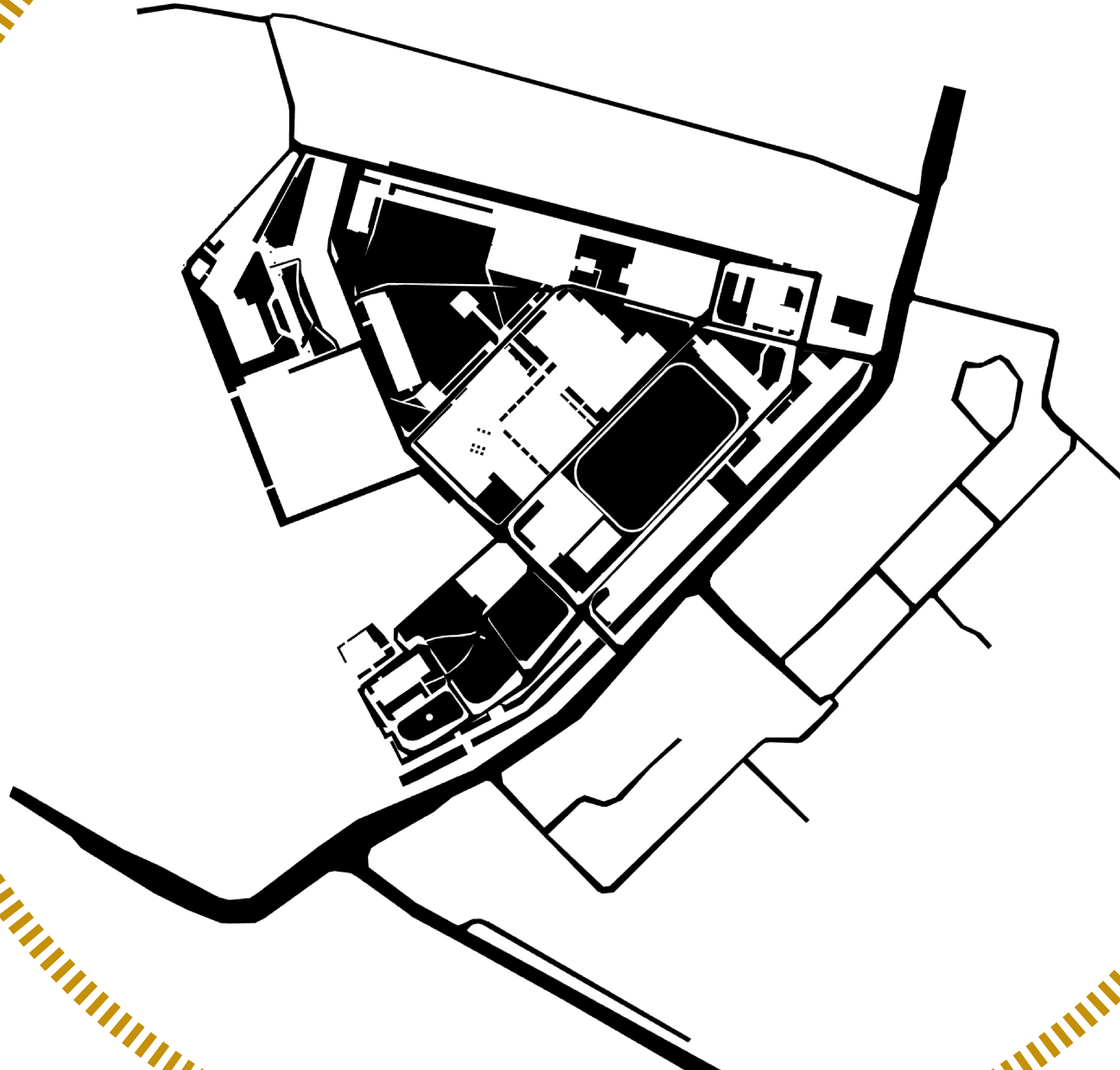

1. Marine Area
2. Waterpark
3. Innovative Workshop

2. Boundaries & Access

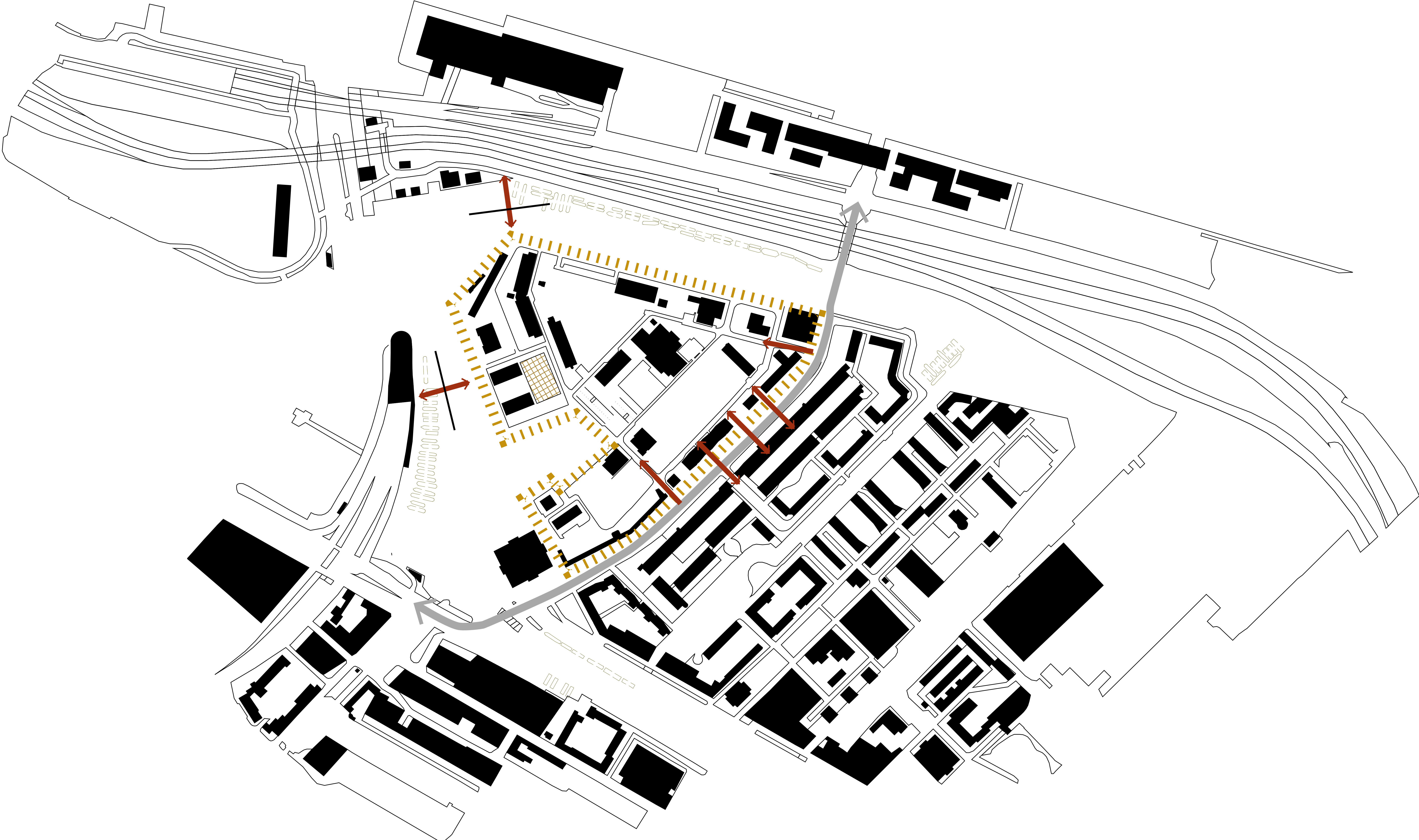

3. Circulation



Site of Implementation

Operational Supporting Framework

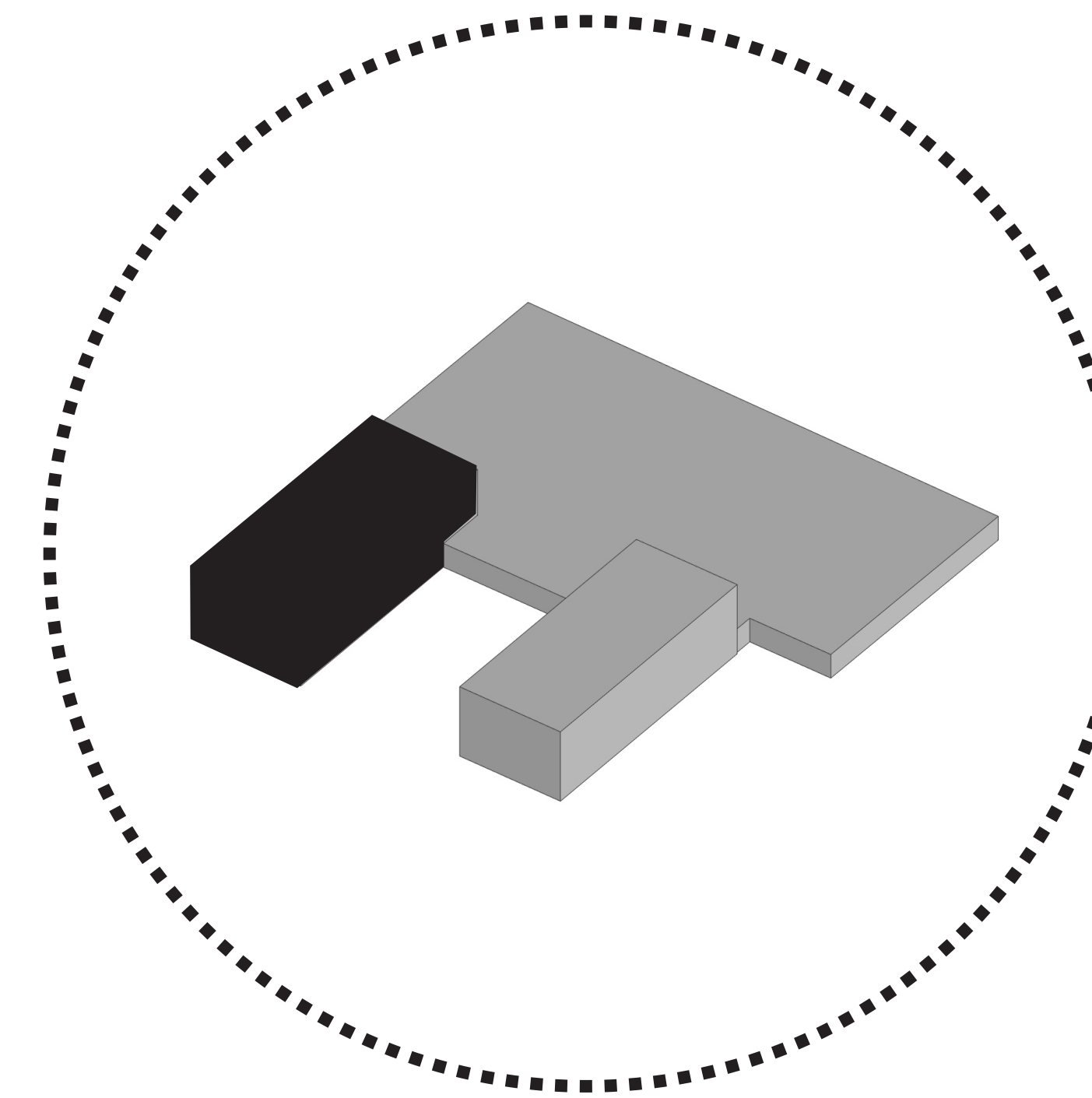

Makerversity Spatial Infrastructure

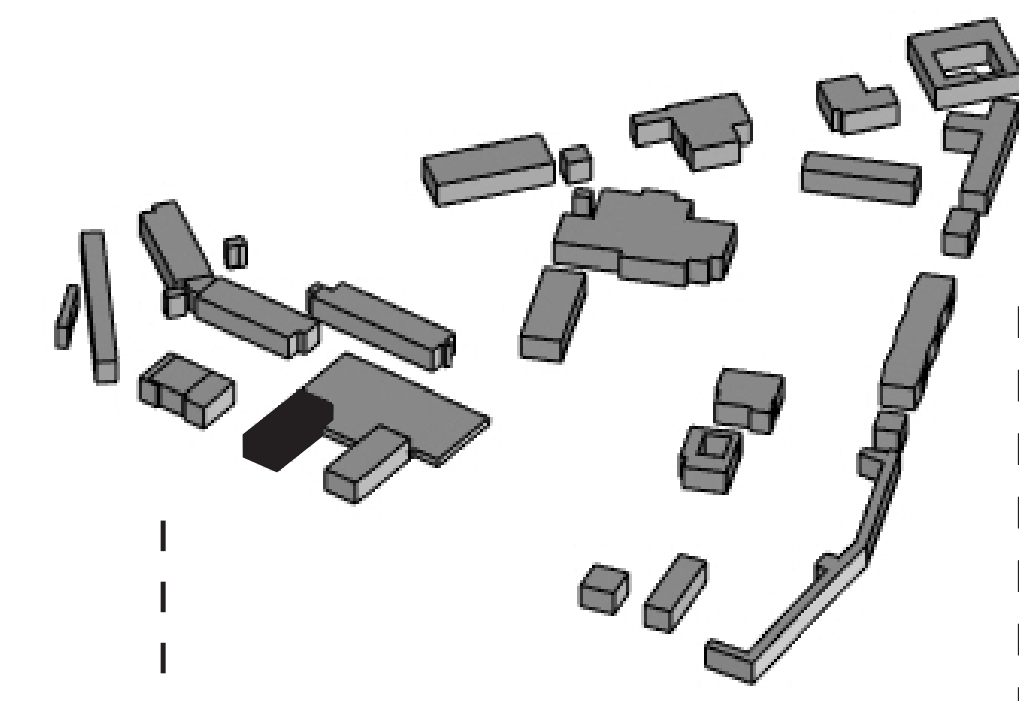

Building Mass

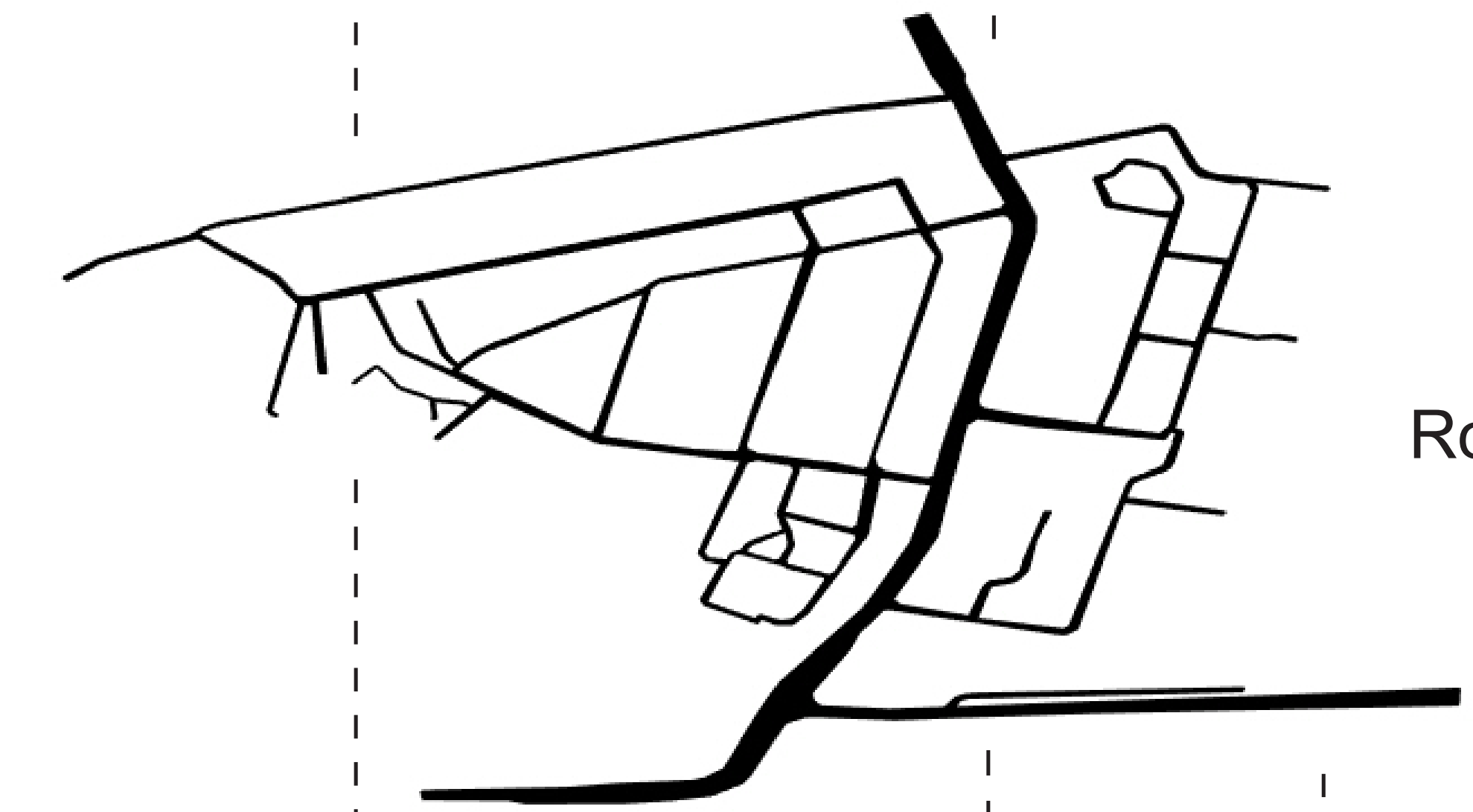

Road Network

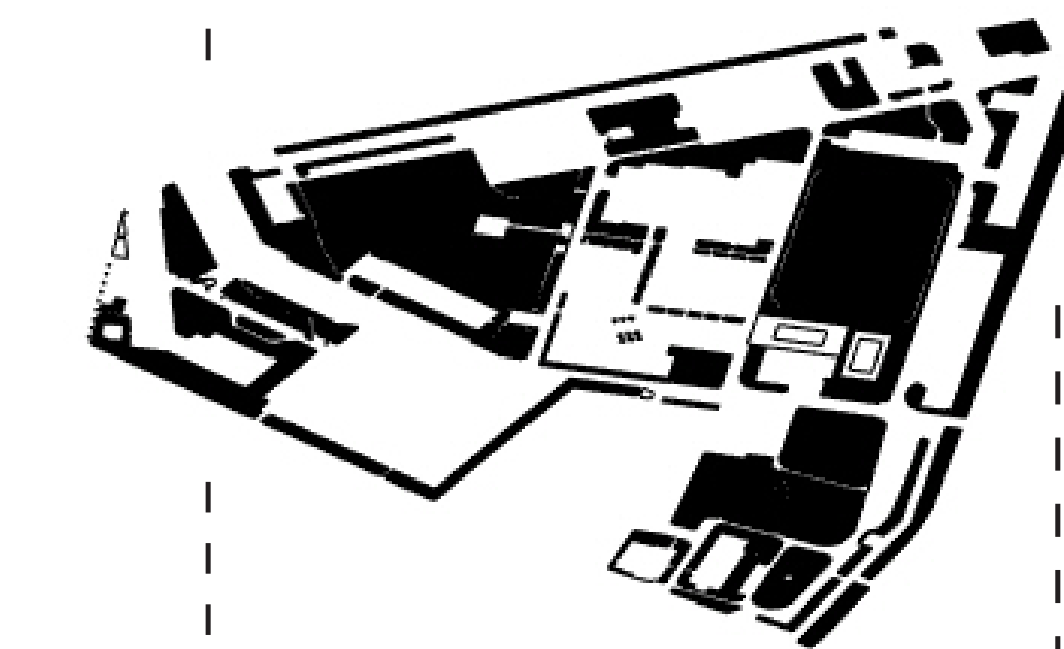

Green Space

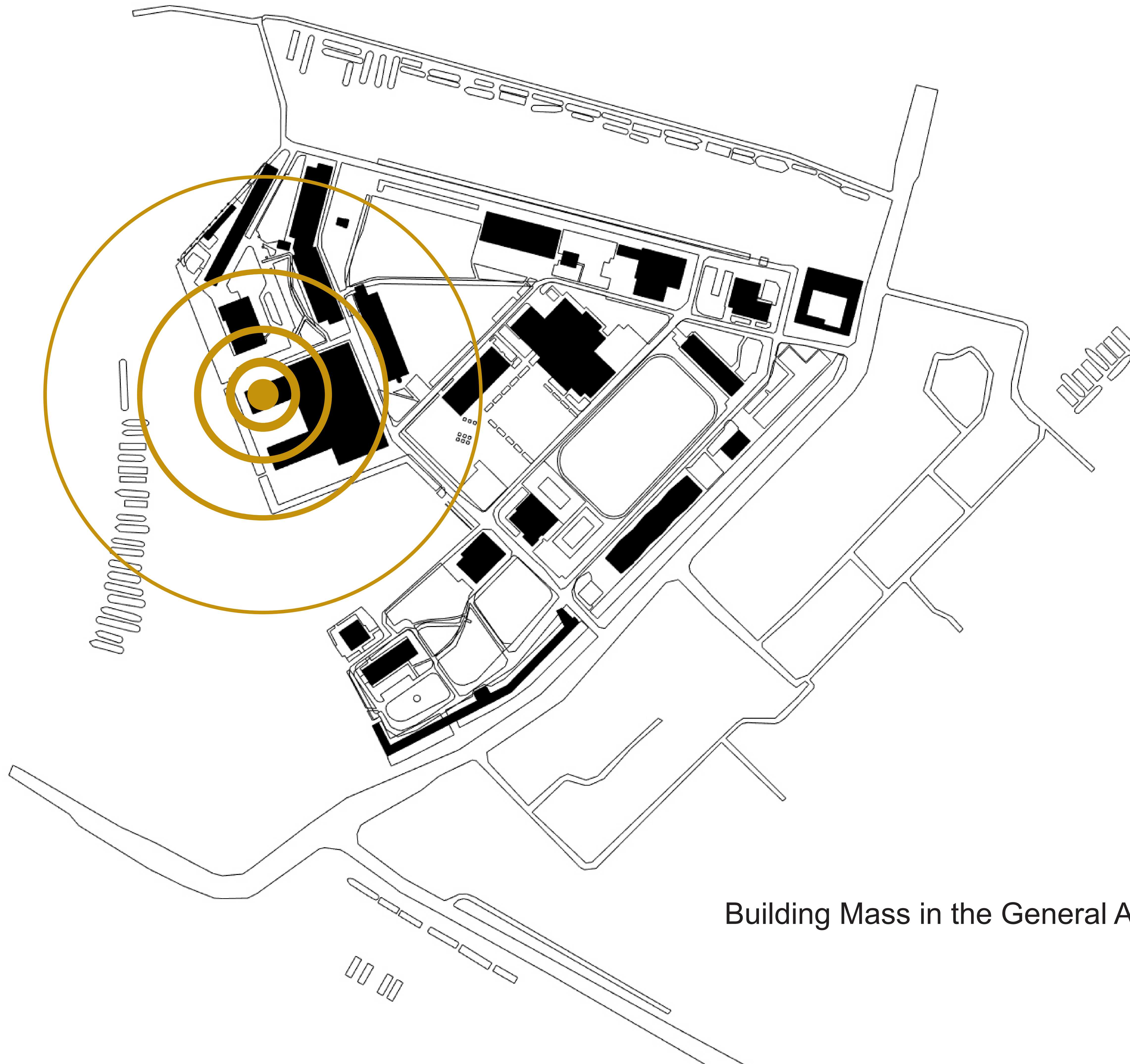
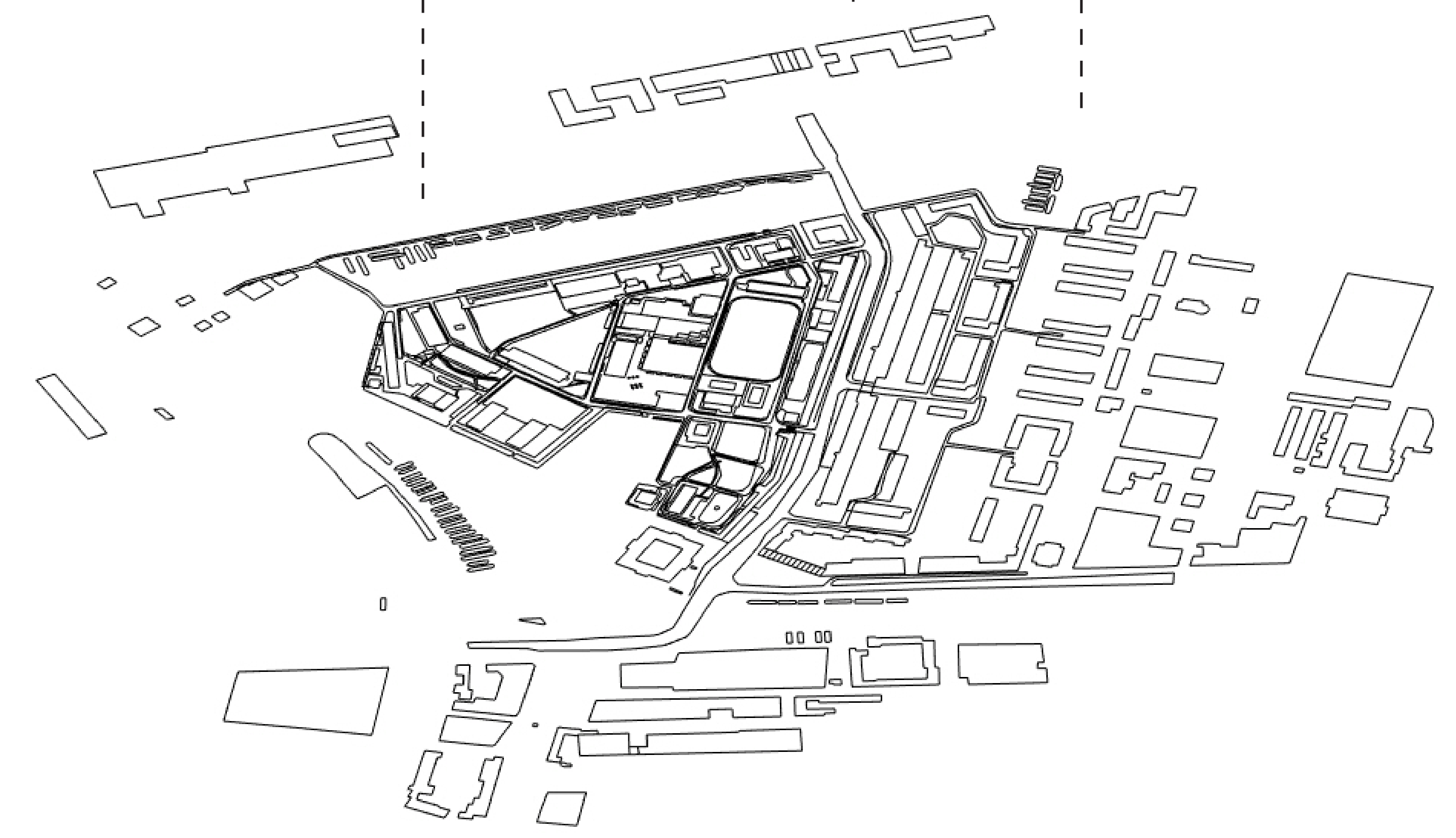

Building Mass in the General Area of Investigation & Location of Interest

reFAB Main Infrastructure Setting

in regard to supporting spatial & operational framework

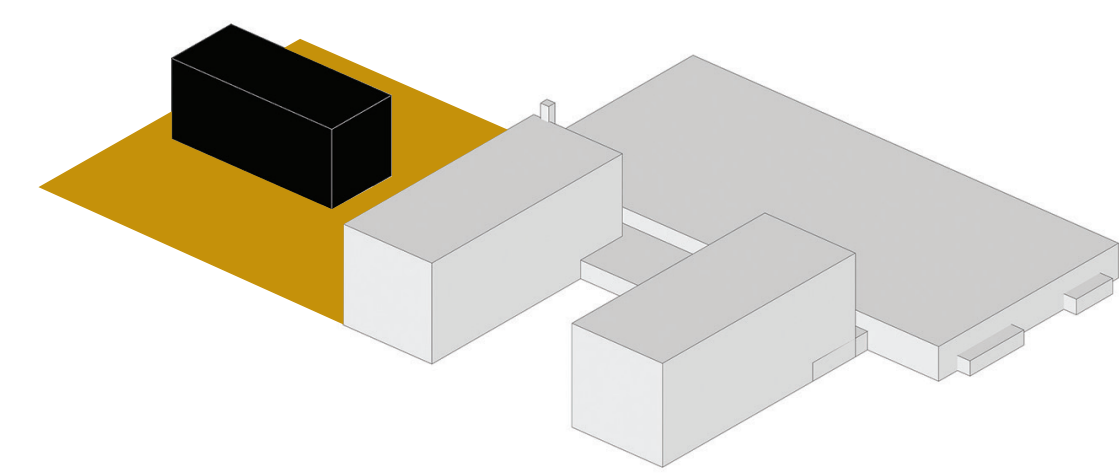

Independent Structure

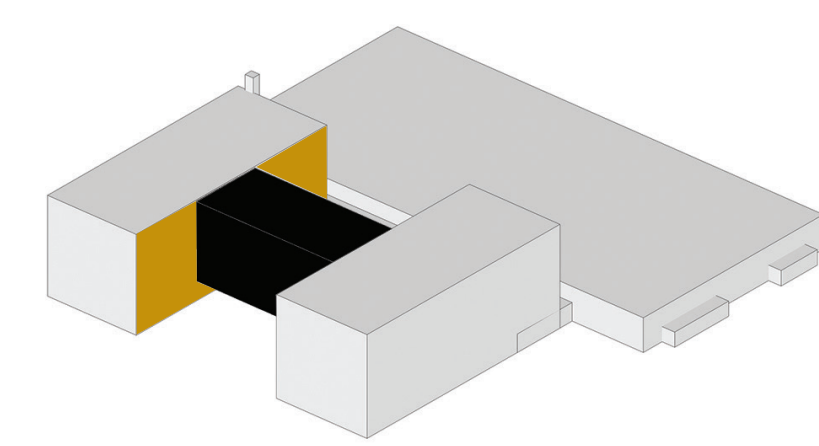

Infill Intervention

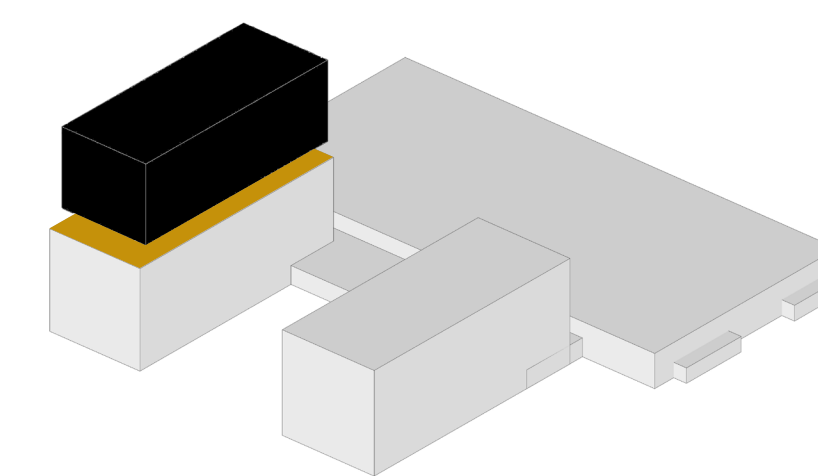

On-top Expansion

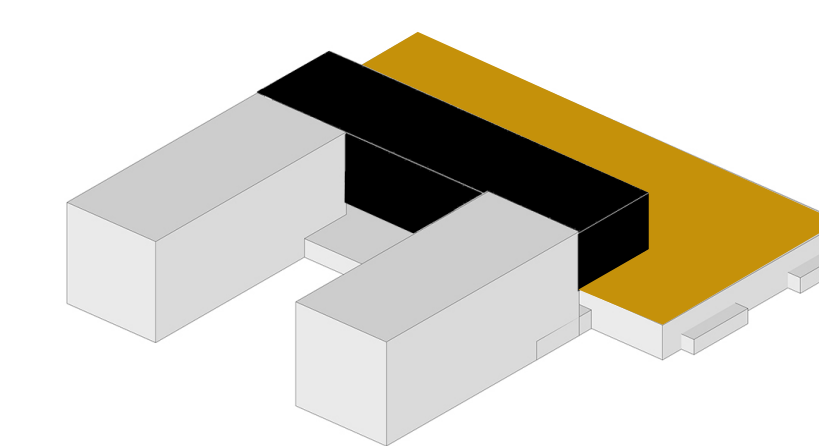

Low Volume Expansion

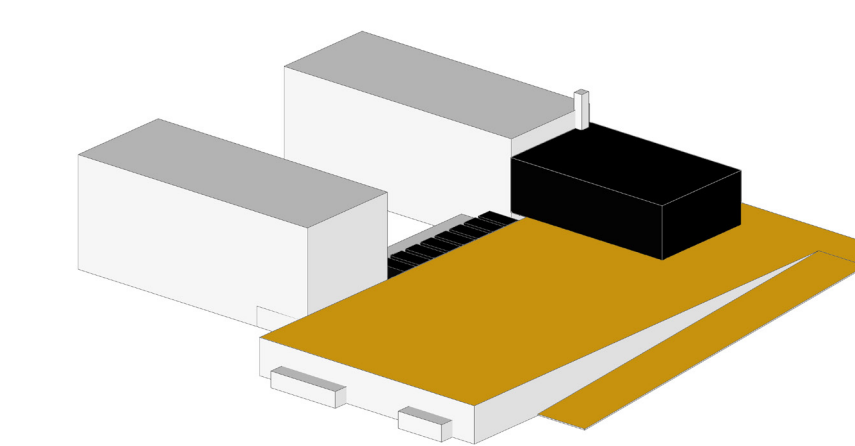

Potential Intervention

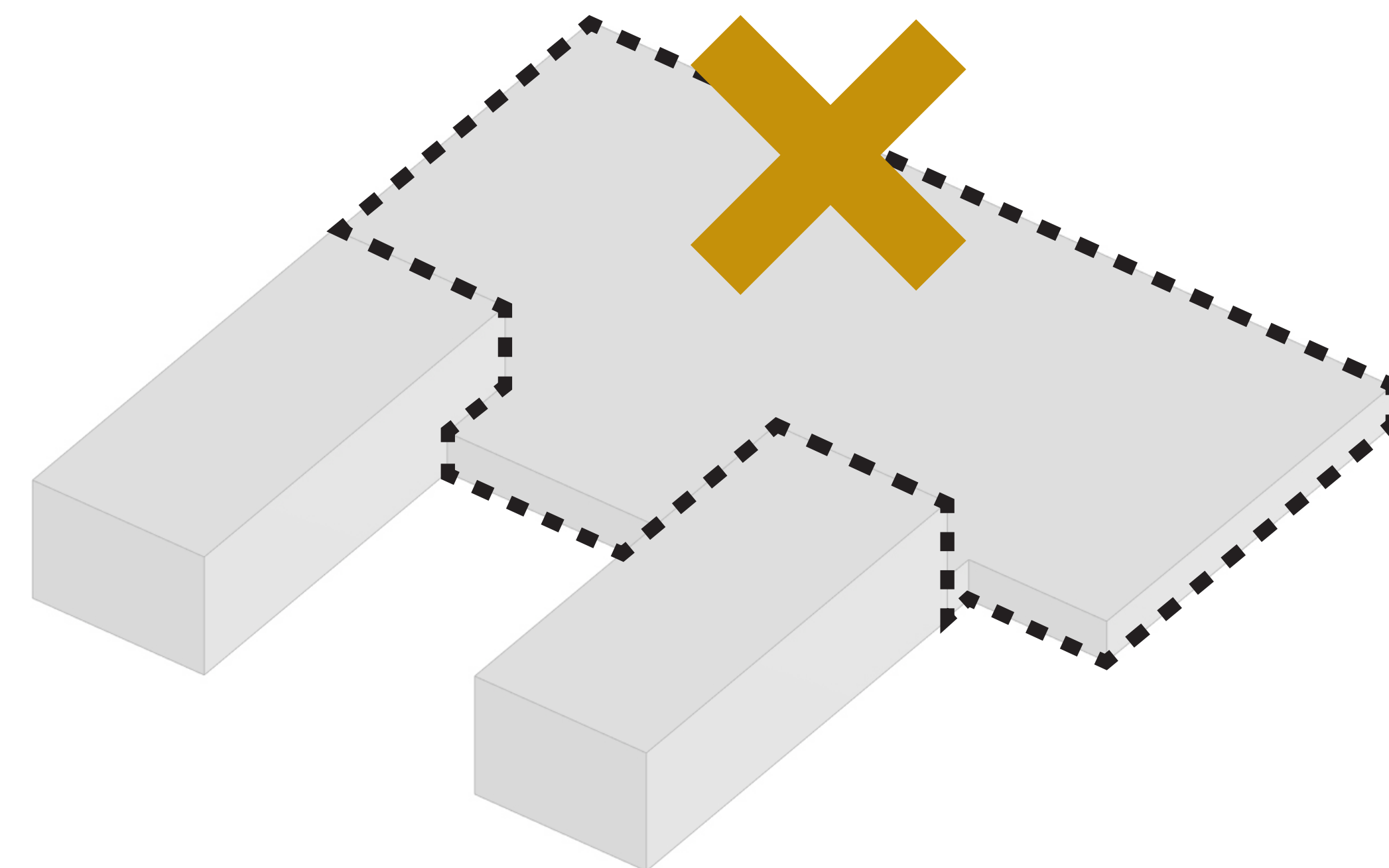
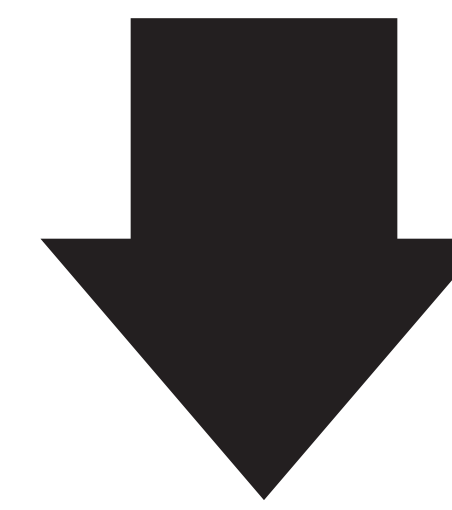

Refuse Collection & Sorting Infrastructure





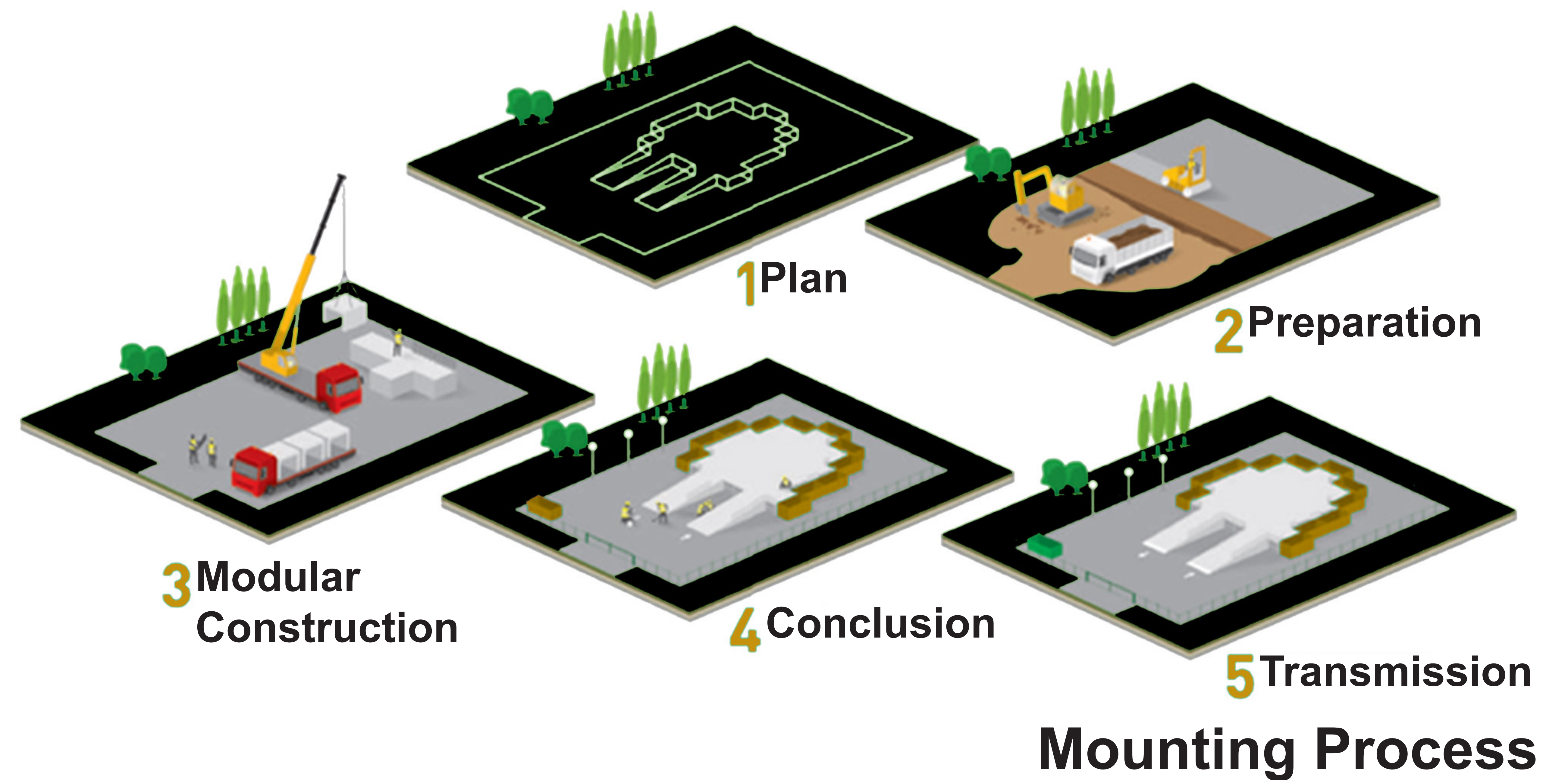



Concrete modular system comprised by an elevated platform and two ramps, as well as a number of waste containers each directed for a certain type of discarded material

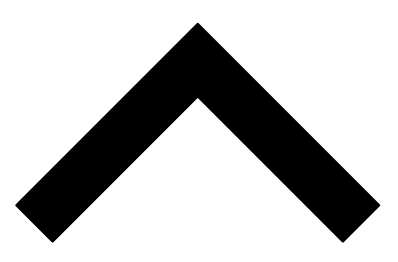

Shorting Platform Spatial Development Assessment

in plot of 2160m² available area & 6x6m Grid

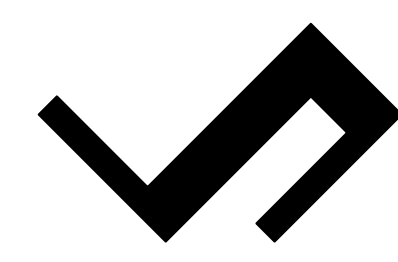
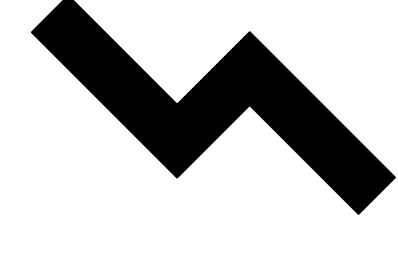

								
Overall Platform Area	720	1188	648	1584	648	648	1224	1728
MRF & Storage Area [m²]	288	864	288	864	468	216	864	1296
Waste container Capacity	8	8	11	6	12	7	8	10
Plot Coverage	33.33%	54.07%	30%	73.33%	30%	30%	56.66%	80%
Drivers Routing	● ● ● ● ●	● ● ○ ○ ○	● ● ● ● ○	● ● ● ○ ○	● ● ○ ○ ○	● ● ○ ○ ○	● ● ● ● ○	● ● ○ ○ ○
Pedestrian Routing Capacity	● ● ● ○ ○	● ● ● ○ ○	● ○ ○ ○ ○	● ● ● ○ ○	● ● ○ ○ ○	● ○ ○ ○ ○	● ● ● ● ○	● ● ● ● ○
Alternative Funcion Capacity	● ● ○ ○ ○	● ● ○ ○ ○	● ● ○ ○ ○	● ● ● ○ ○	● ● ○ ○ ○	● ● ○ ○ ○	● ● ● ● ○	● ● ● ● ○

Vertical Grid Expansion

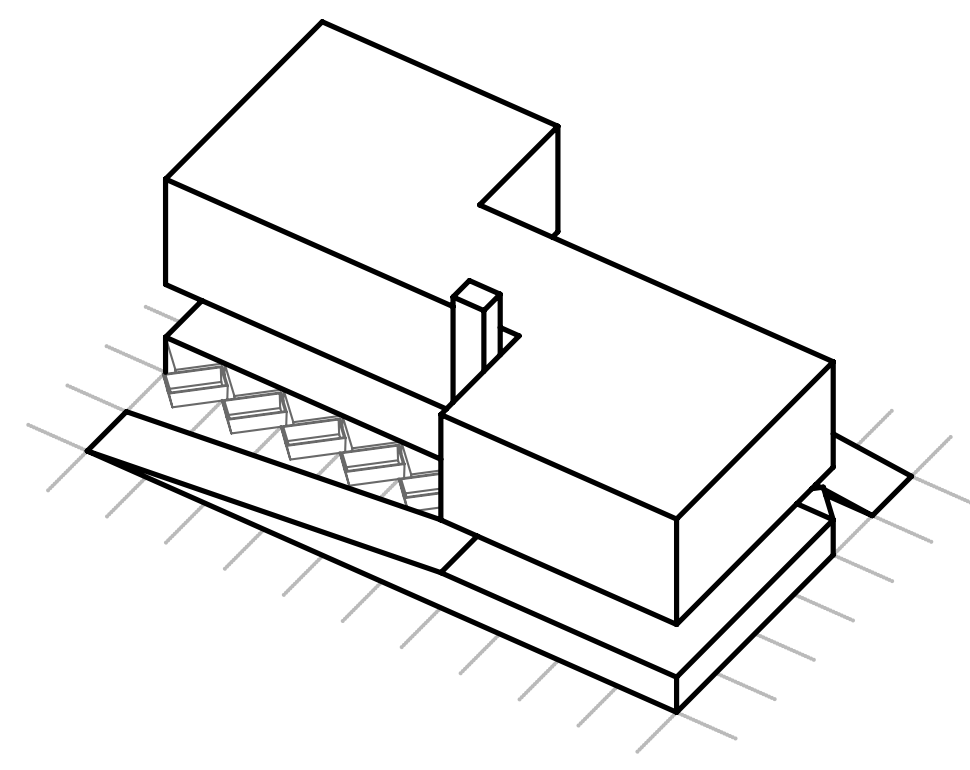
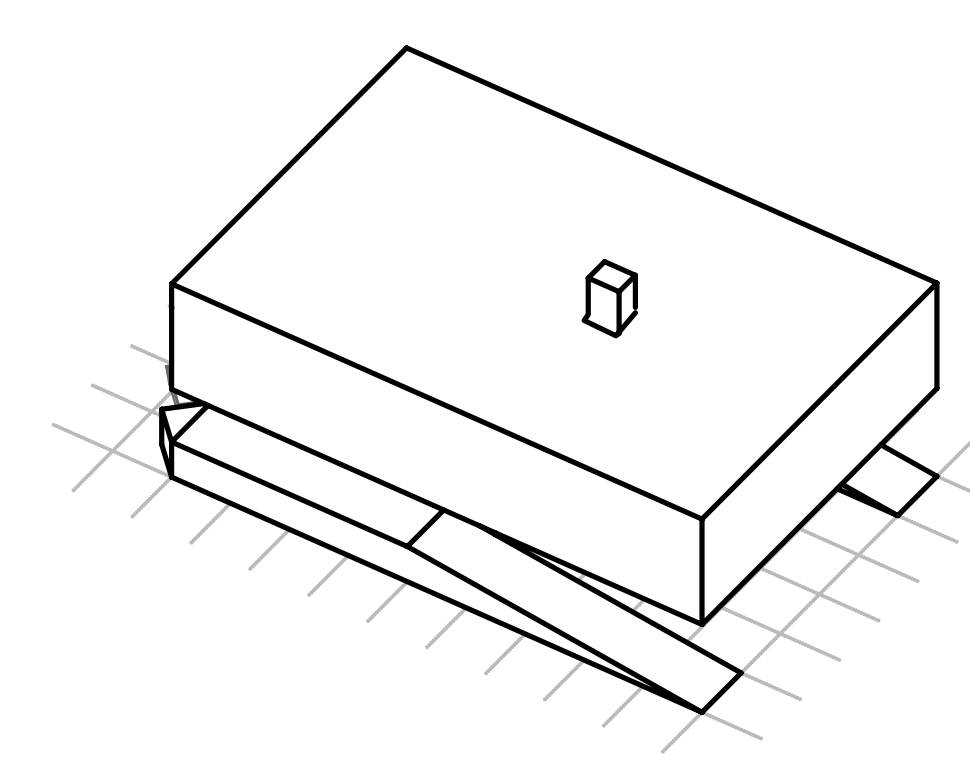
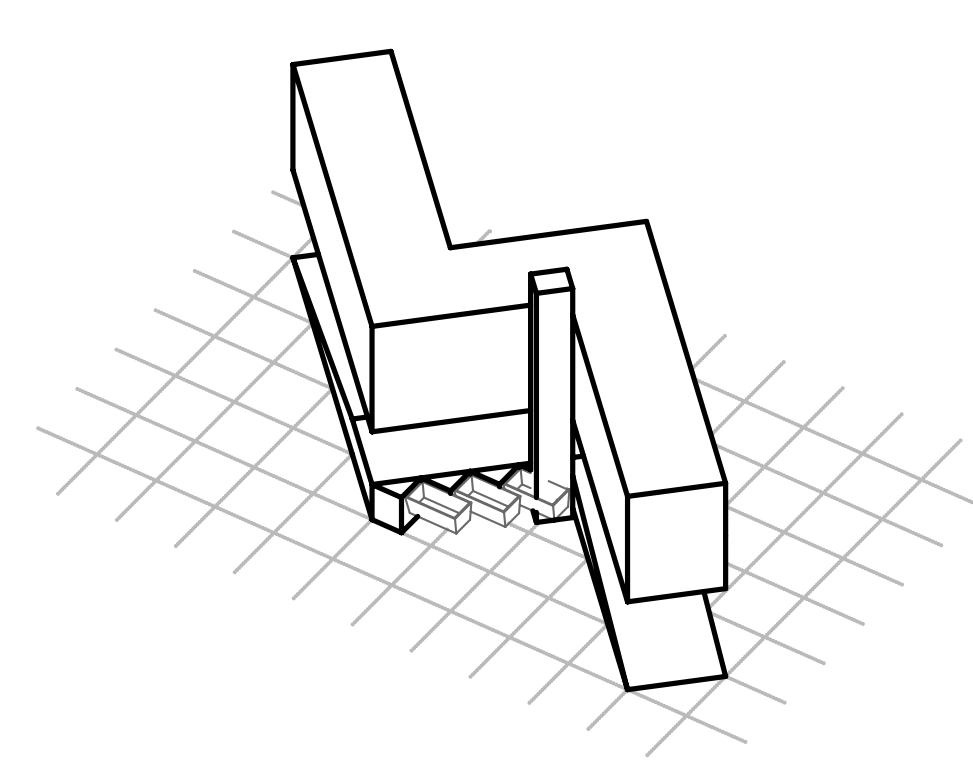
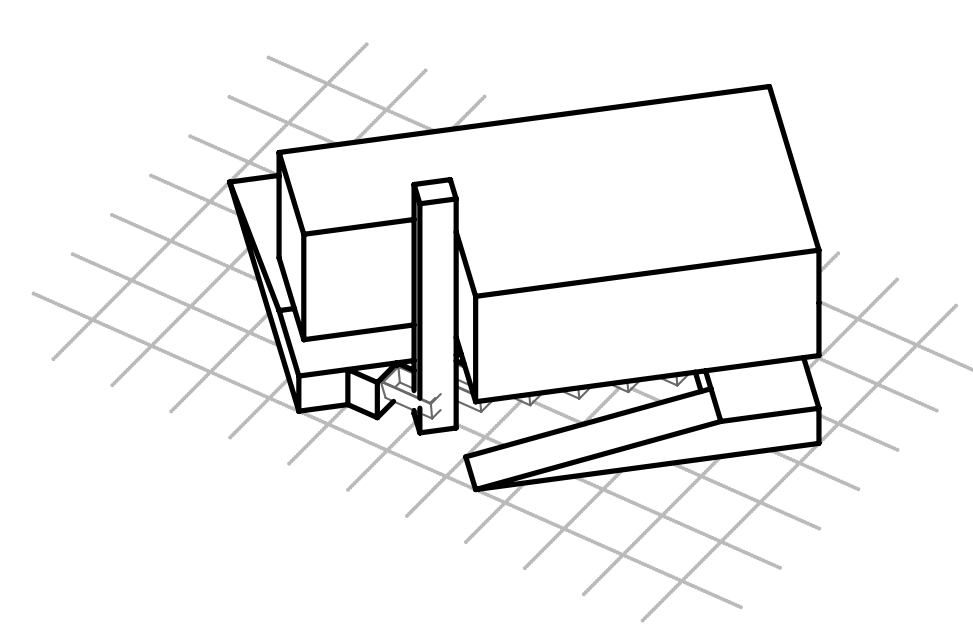
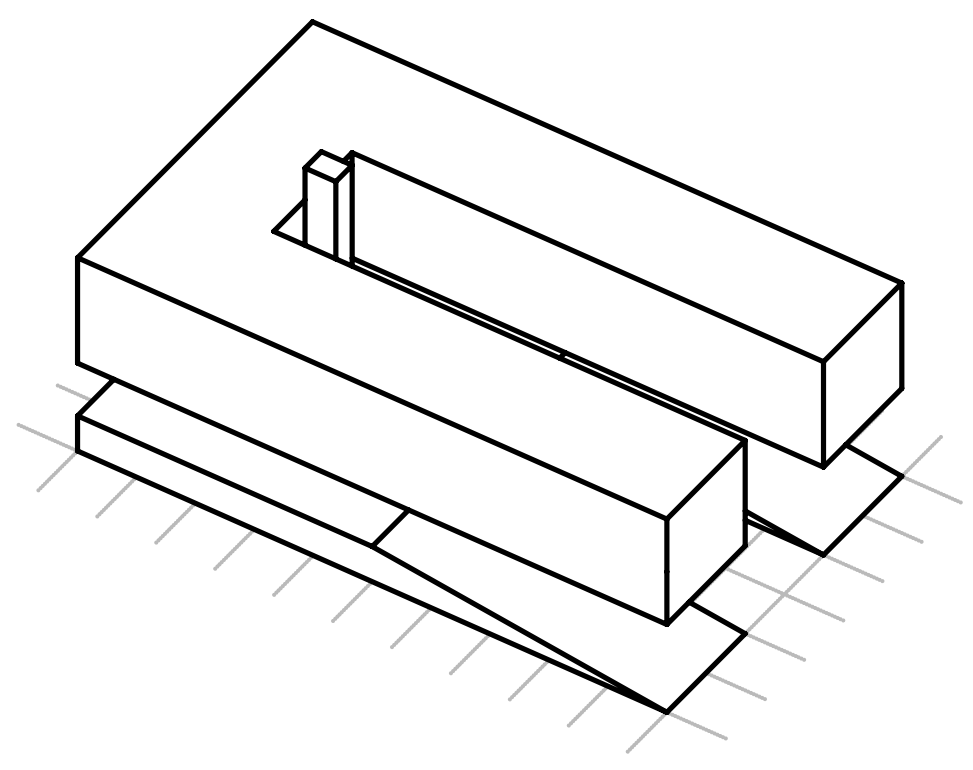
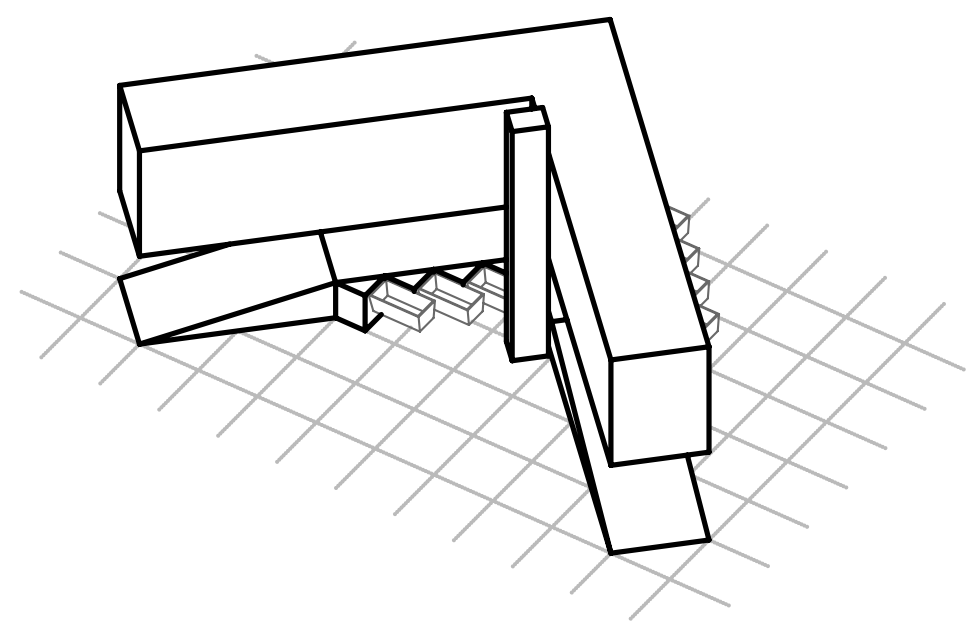
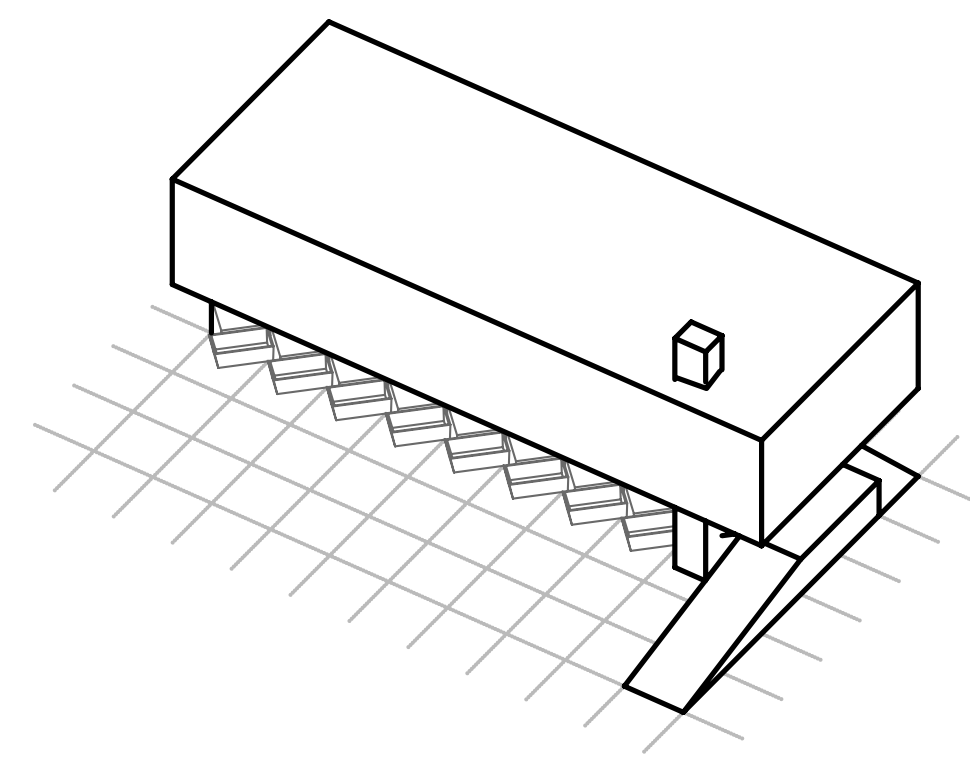
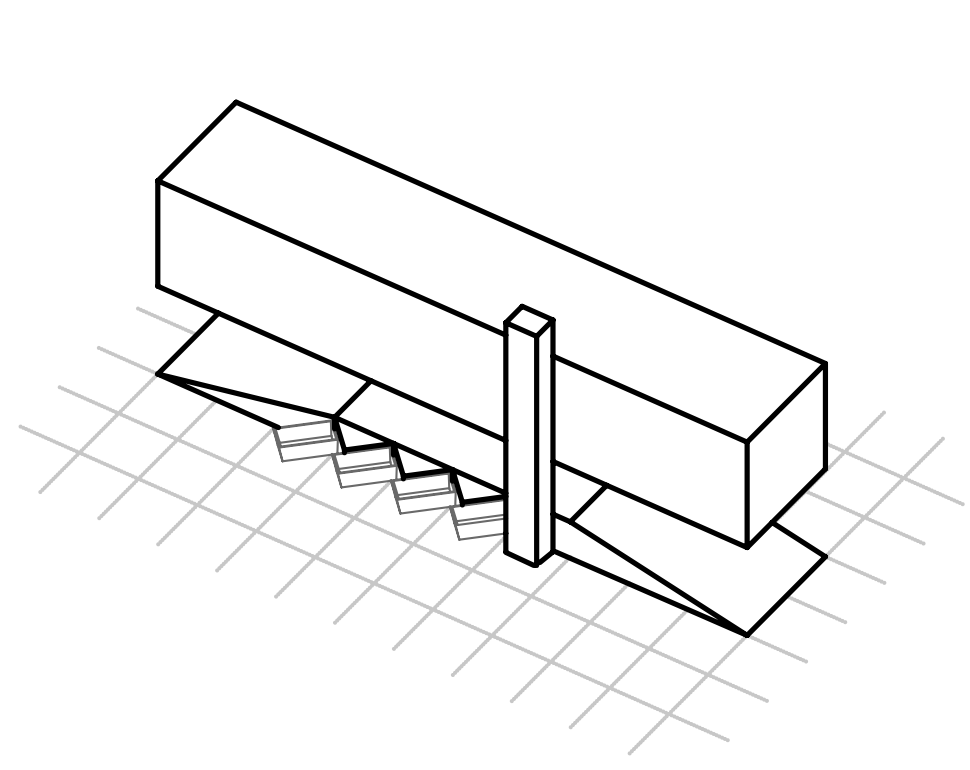

Program Requirements

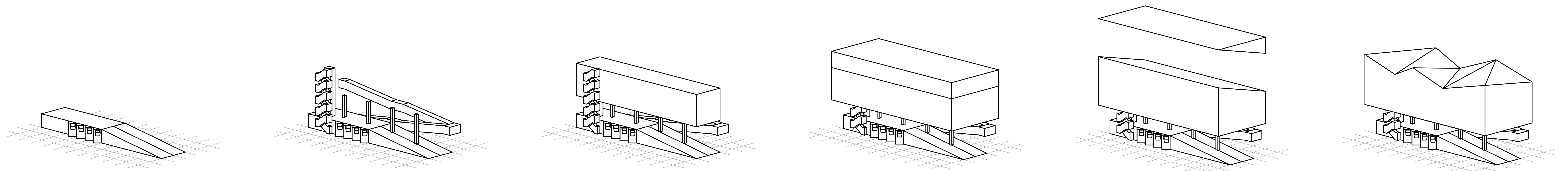
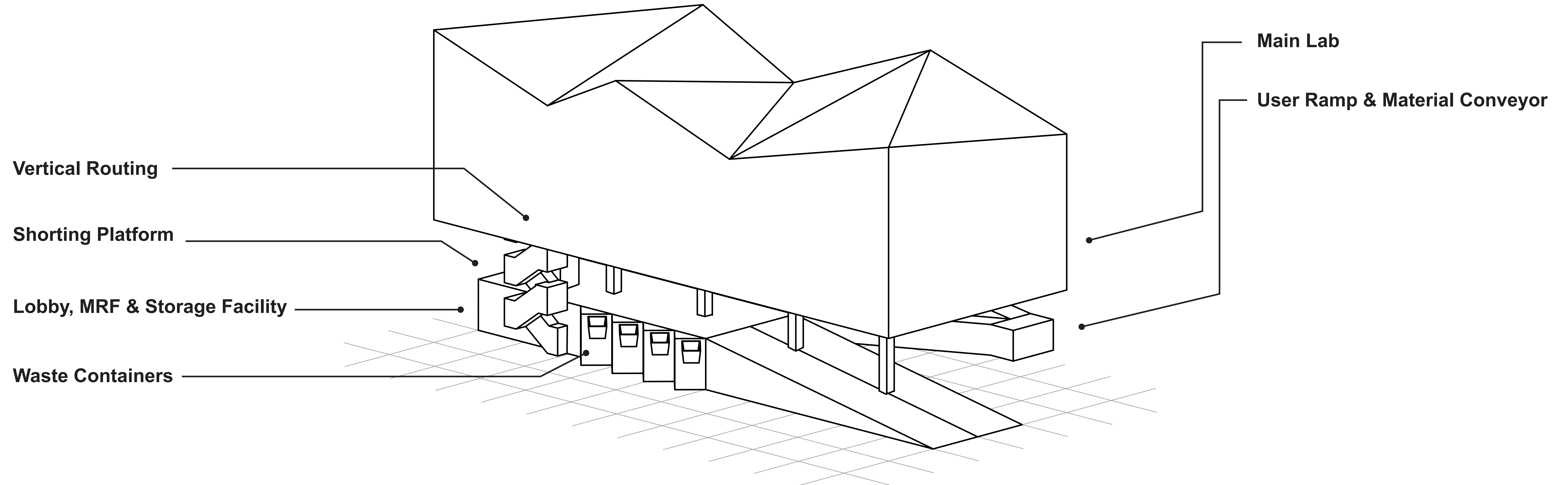

Schematic Building Configuration Development

Parameters

Influencing the Roof Formation

Precipitation



Sun Path

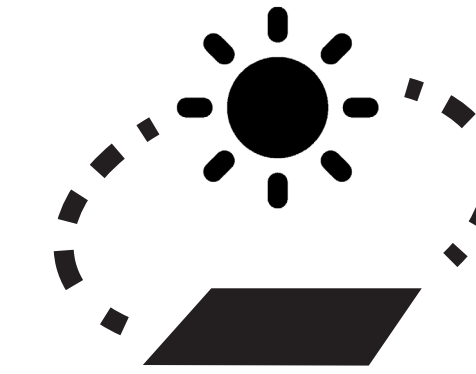

Wind Direction

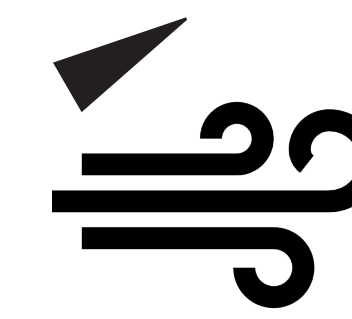

Wind Speed

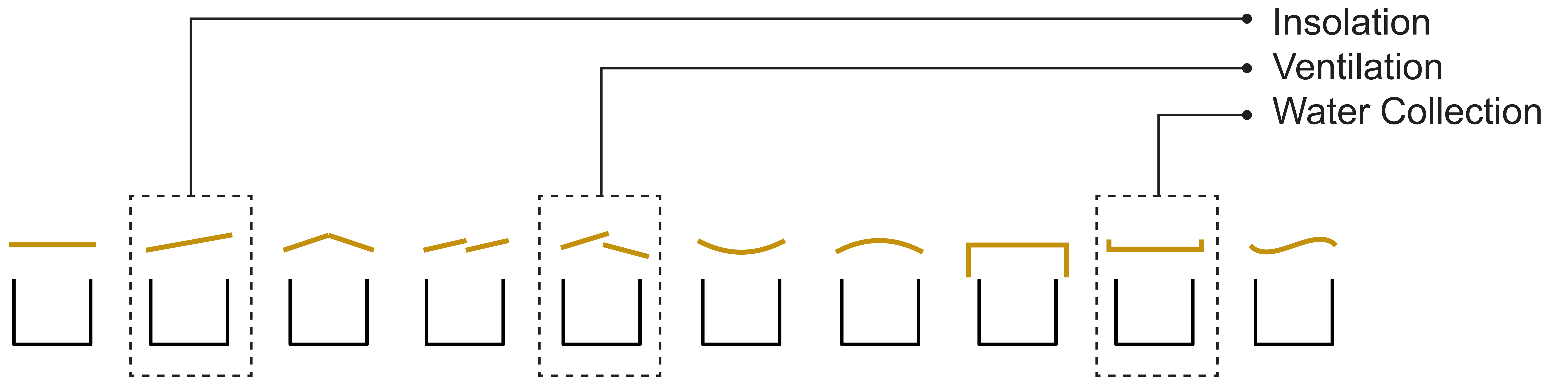
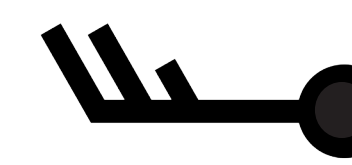

Roof typologies in accord to climatic criteria

Program

Ring-Ramp Routing Floorplan Connection

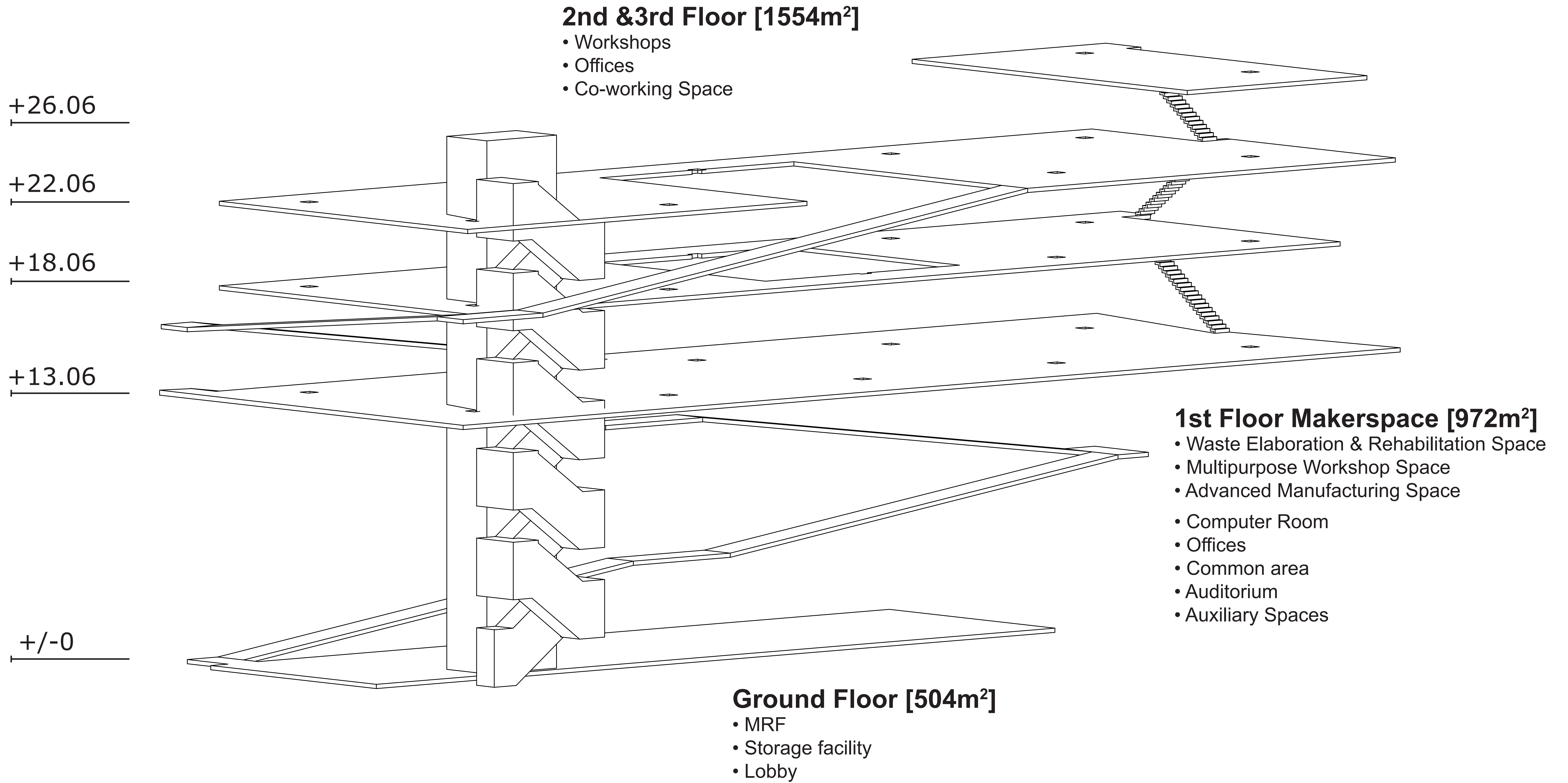

Floorplans

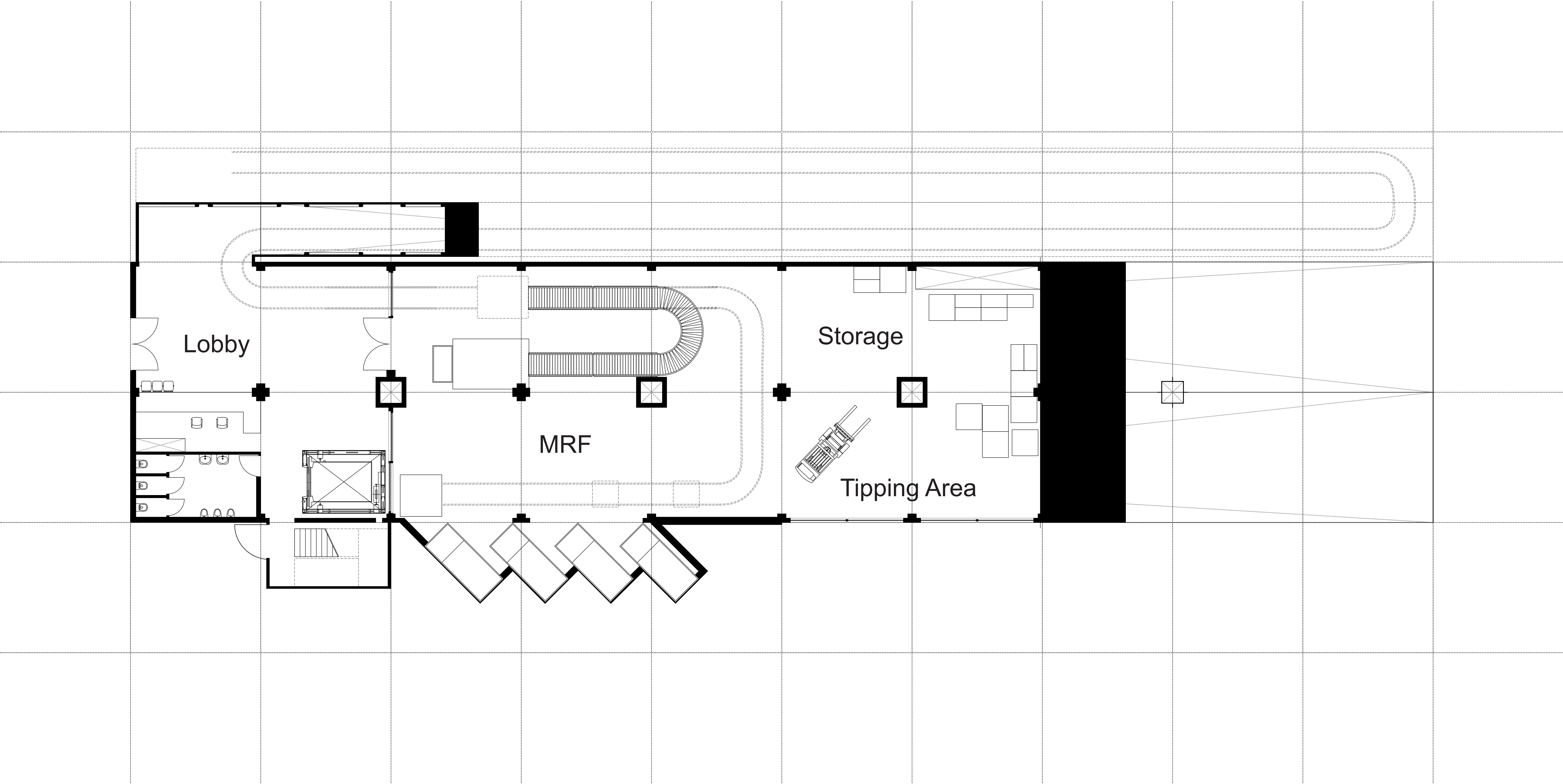

Ground Floor

Kitchen

Shop

Auditorium

Machinery Worksop

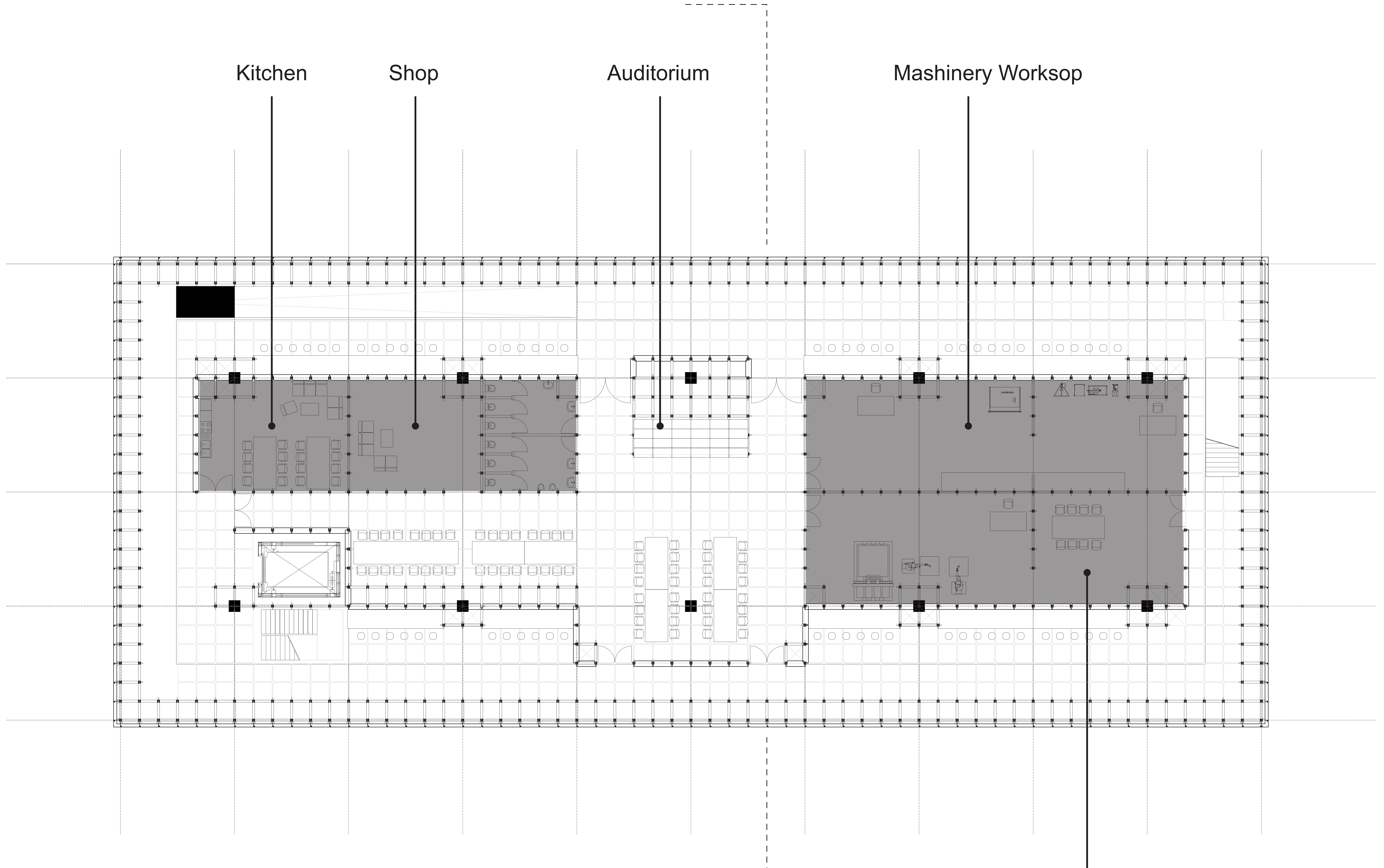

1st Floor

Digital Manufacturing Space

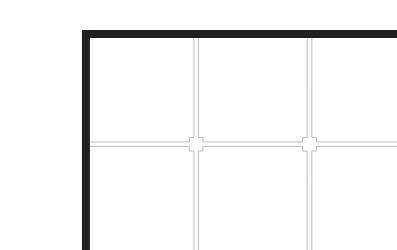

Flexible Co-working Space

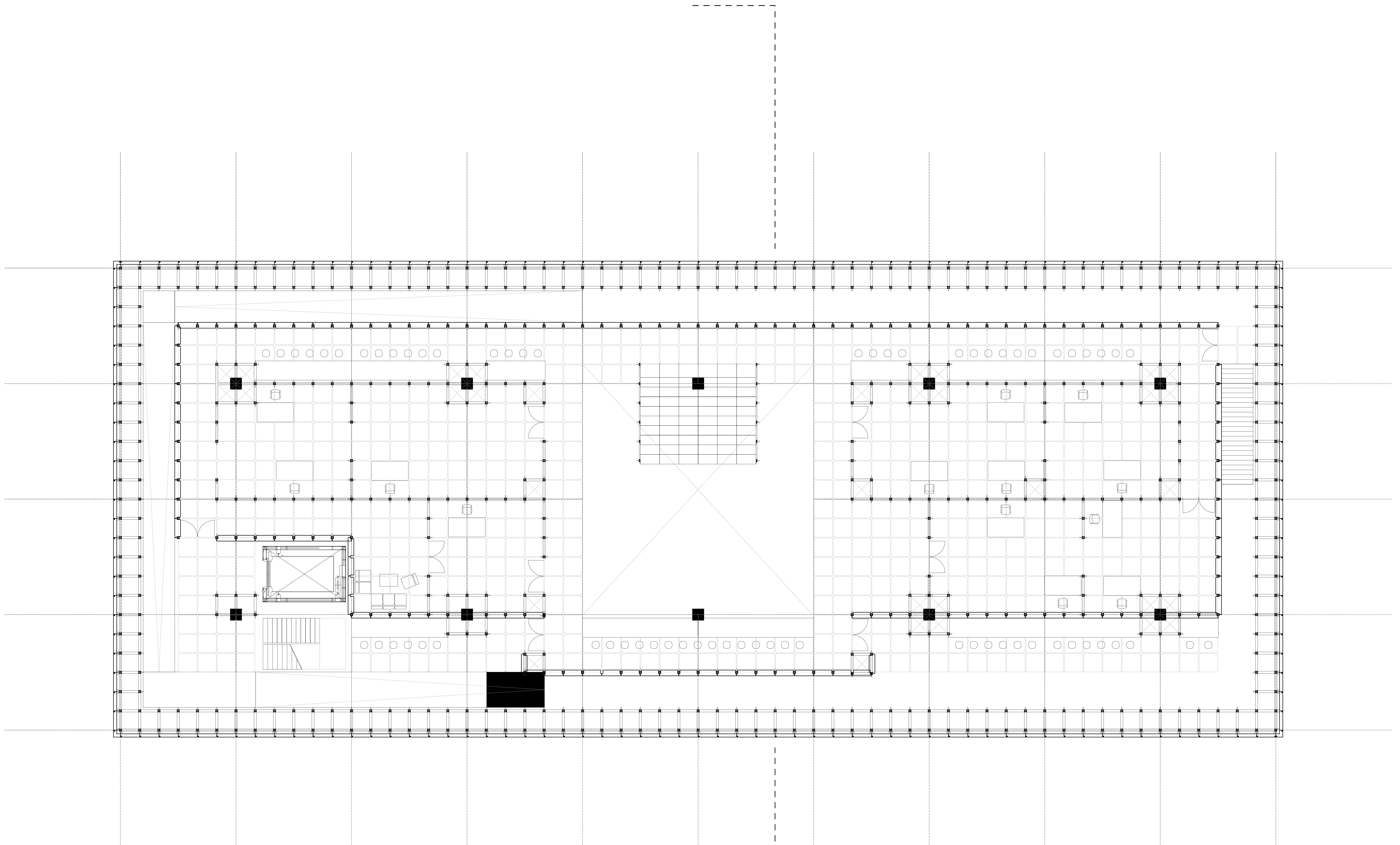

2nd Floor

 Flexible Co-working Space

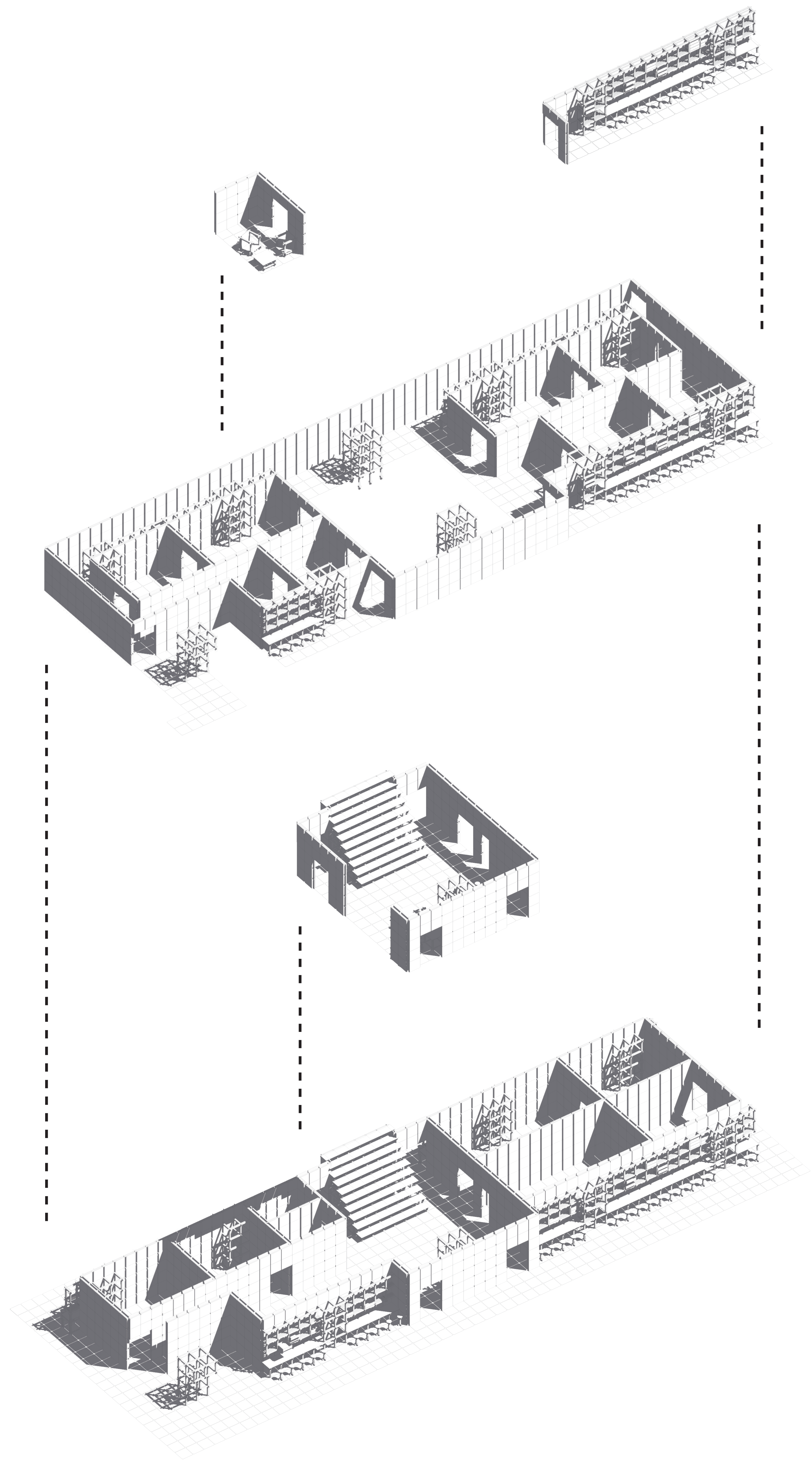

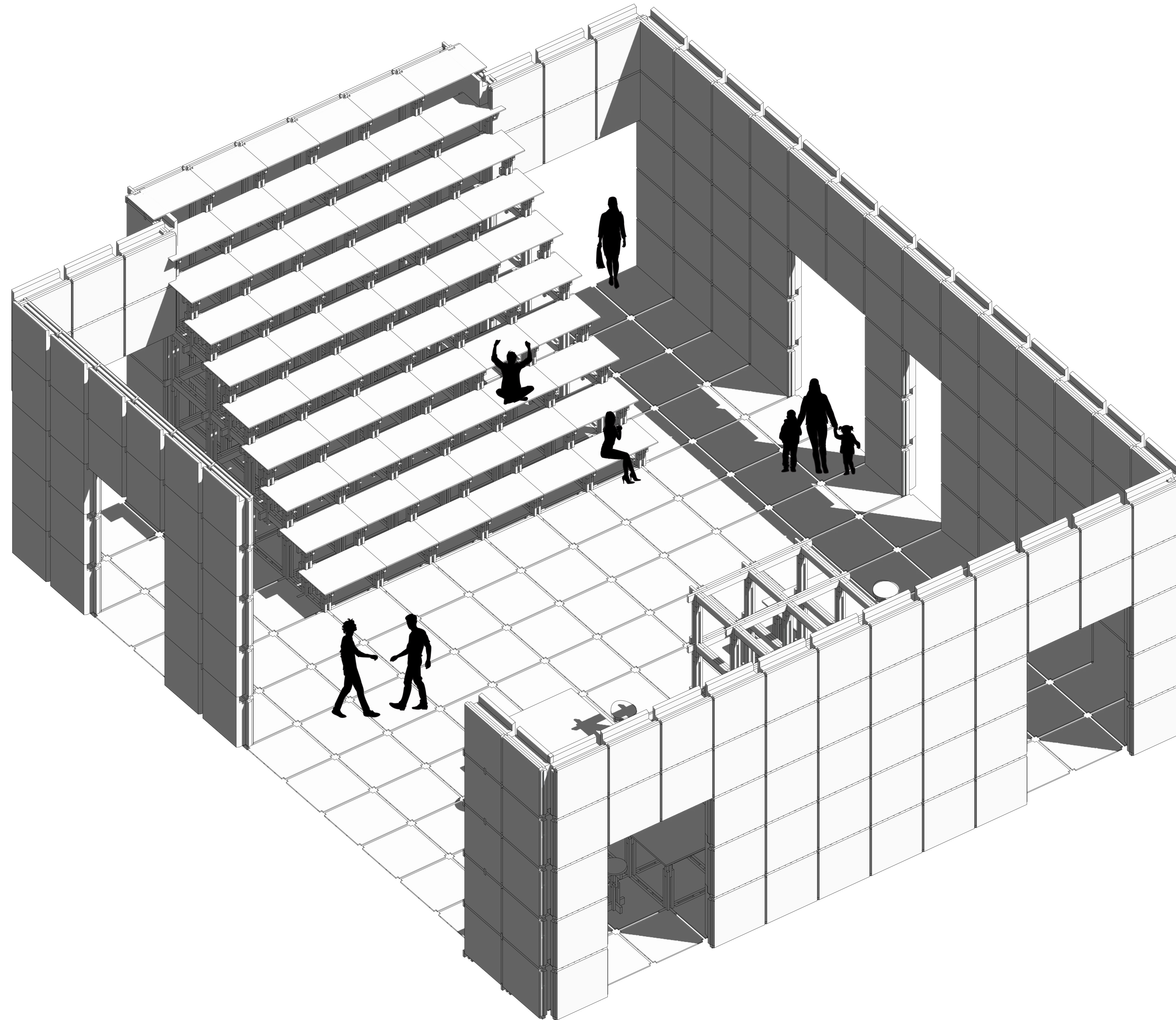

Common flexible core space & Demountable auditorium

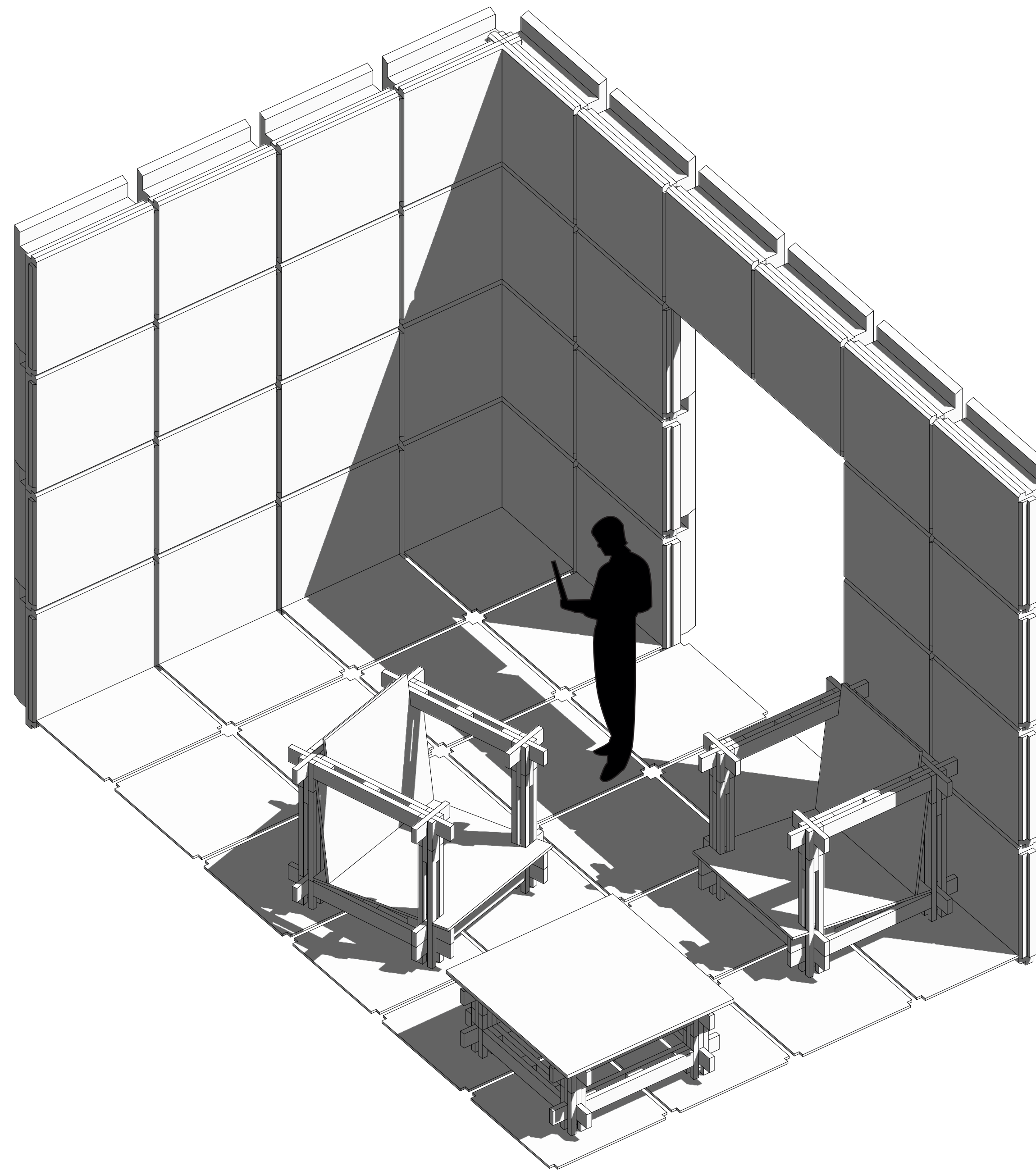

Shared space & Sitting room

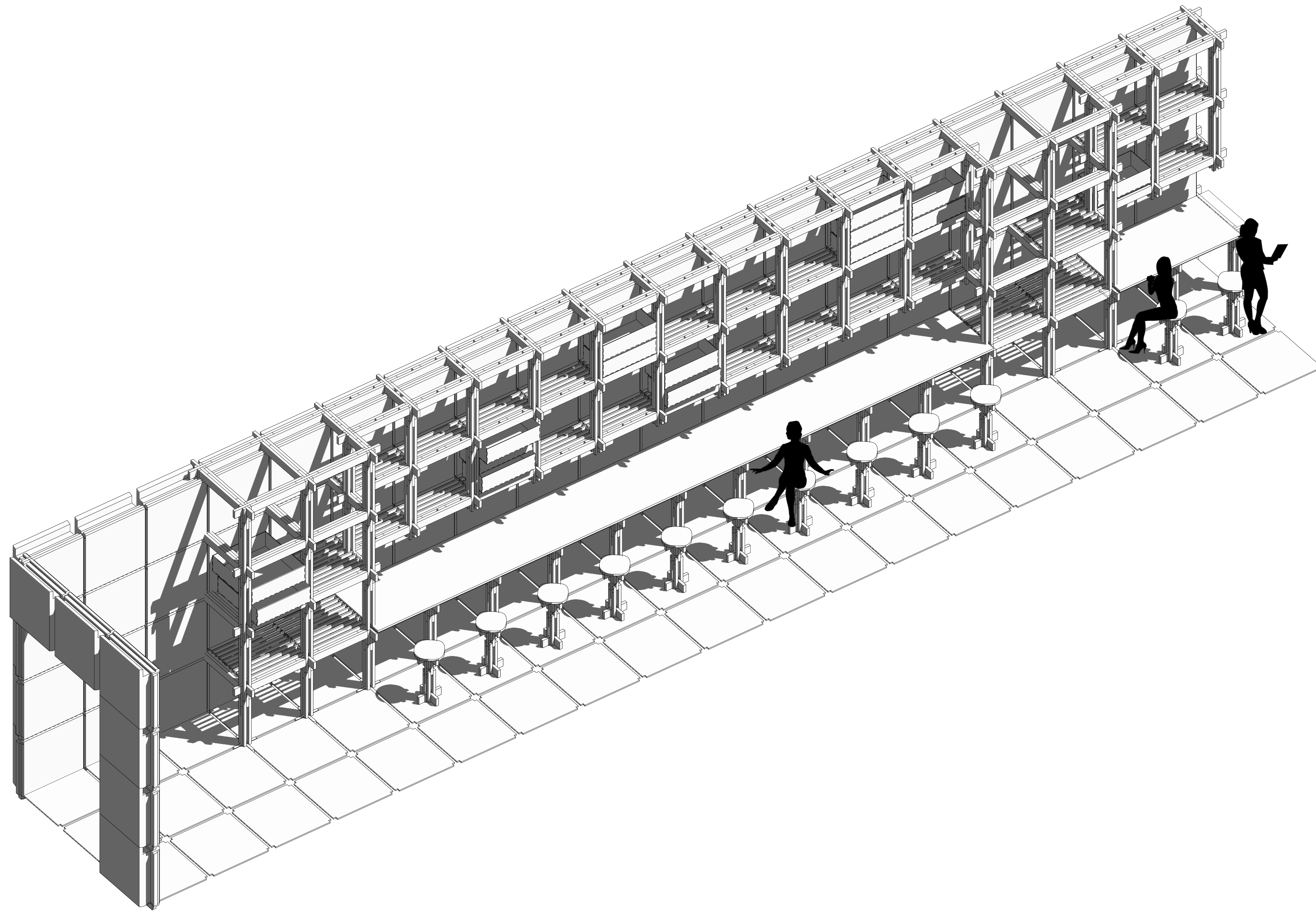

Co-Working Space & Hot tables



Student



Individual Personal Interest



Professional

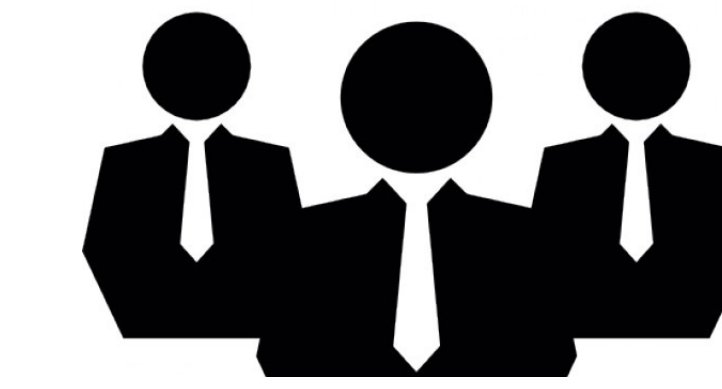

Start-Up Company



MRS-MRF Employ

	Student		Individual Personal Interest		Professional			Start-Up Company			MRS-MRF Employ
	Basic	Benefit	Basic	Benefit	Basic	Standart	Benefit	Basic	Standart	Benefit	
Privacy Level	● ○ ○ ○ ○	● ● ● ○ ○	● ○ ○ ○ ○	● ● ● ○ ○	● ● ○ ○ ○	● ● ● ○ ○	● ● ● ● ○	● ● ● ● ○ ○	● ● ● ● ○	● ● ● ● ●	◎
Membership Fee	Free	45 euros	45 euros	150 euros	175 euros	250 euros	750 euros	300 euros	750 euros	1250 euros	Month Salary: 2.200 euros [net amount]
Working Space	Co-working hot desk	Reserved Desk	Co-working hot desk	Reserved Desk	Co-working hot desk	Reserved Desk	2nd level Privacy access in shared creative space	Reserved Desk	2nd level Privacy access in shared creative space	Private room in 2nd level shared creative floor	Depended on machinery and material
Demanded Area [m²]	9	20	9	20	15	24	42	24	36	72	◎
Technical Appliances	Sink	Sink-Exhaust facility	Sink	Sink-Exhaust facility	Sink	Sink-Exhaust facility	Sink-Exhaust facility-Radiator	Sink	Sink-Exhaust facility	Sink-Exhaust facility-Radiator	◎
Conventional Machinery Space Accessibility	36 hours per month	100 hours per month	36 hours per month	100 hours per month	36 hours per month	100 hours per month	Full time	36 hours per month	100 hour per month	Full time	◎
Dig.Fabrication Equipment Access	24 hours per month	72 hours per month	24 hours per month	72 hours per month	24 hours per month	72 hours per month	100 hours per month	24 hours per month	72 hours per month	100 hours per month	◎
Salvaged Material Access	◎	● ● ○ ○ ○	◎	● ● ○ ○ ○	● ● ○ ○ ○	● ● ● ○ ○	● ● ● ● ○	● ● ○ ○ ○	● ● ● ○ ○	● ● ● ● ○	◎
Seminars-Workshops	Free events or 50% discount per case	Free events or 50% discount per case	Free events or payment per case	Free events or 50% discount per case	Free events or payment per case	Free events or payment per case	Free events or 50% discount per case	Free events or payment per case	Free events or payment per case	Free events or 50% discount per case	All
Urban Farming Access Facilities [Flexible]	Visitor	Cultivating processes	Visitor	Cultivating processes	Visitor	Cultivating processes	Collection potential	Visitor	Cultivating processes	Collection potential	Full Time



North-West Elevation

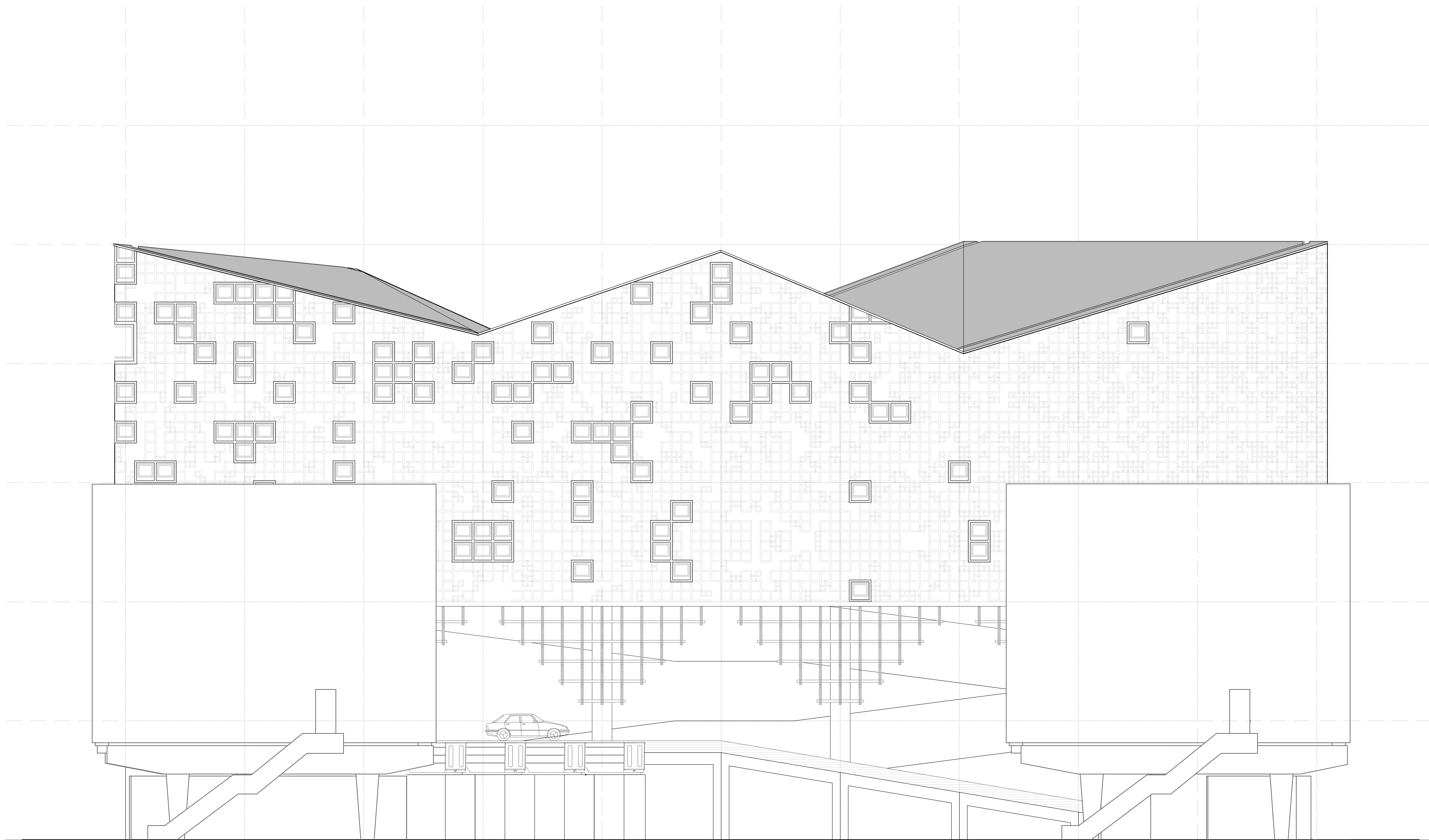

South-West Elevation

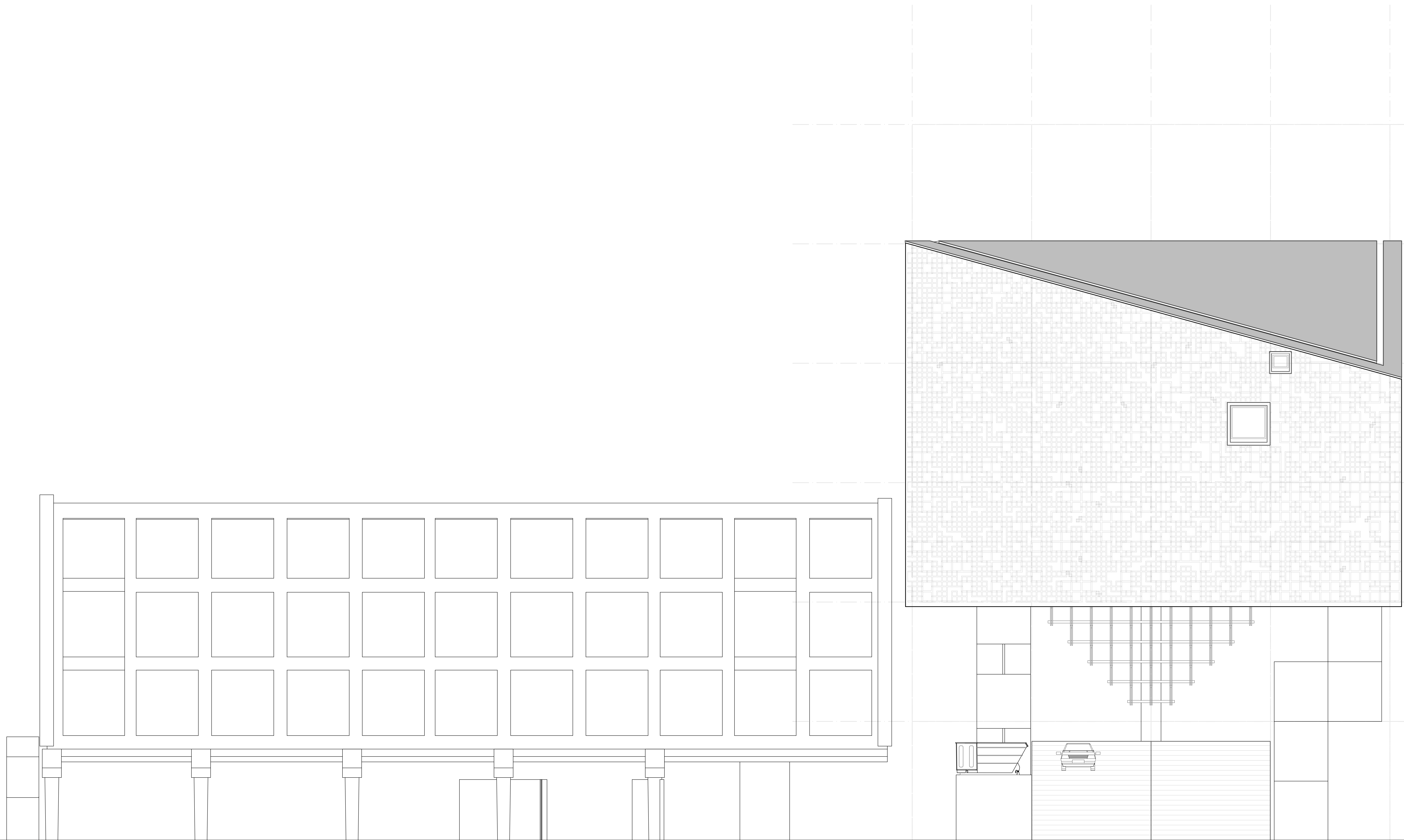

South-East Elevation



North-East Elevation

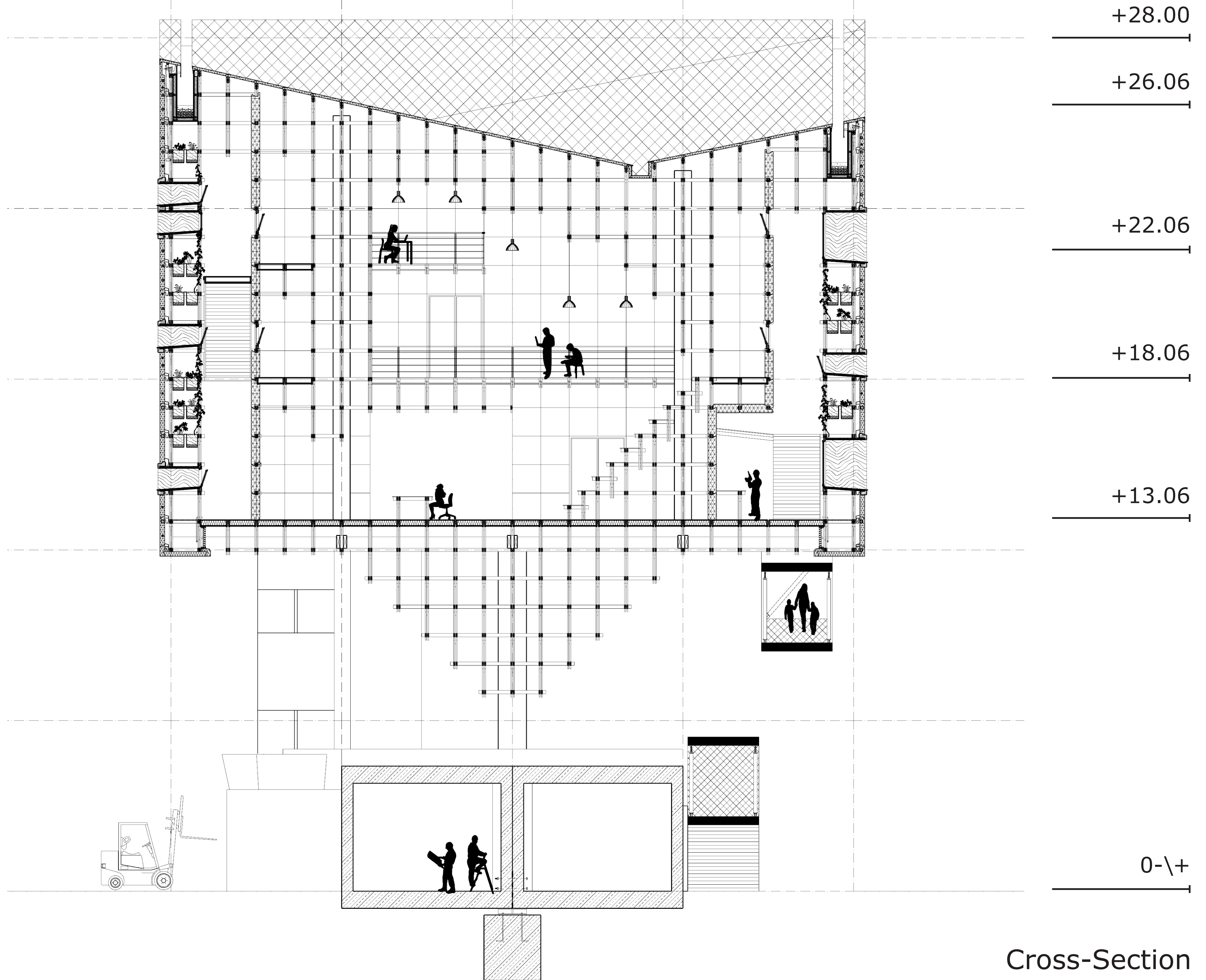

Cross-Section

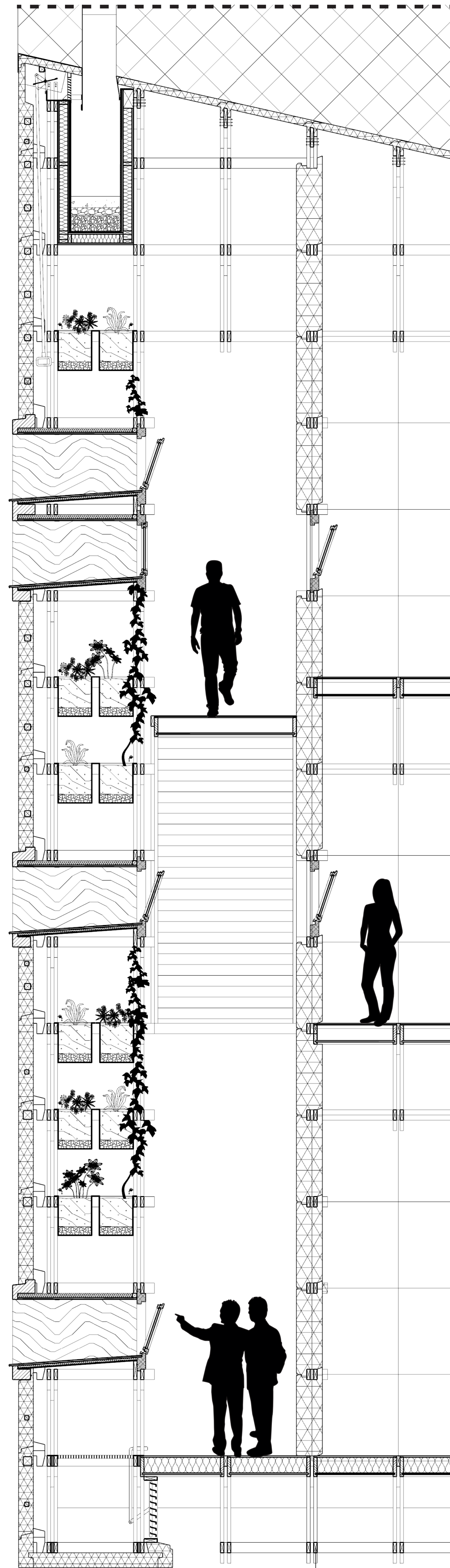

Double-Skin Facade

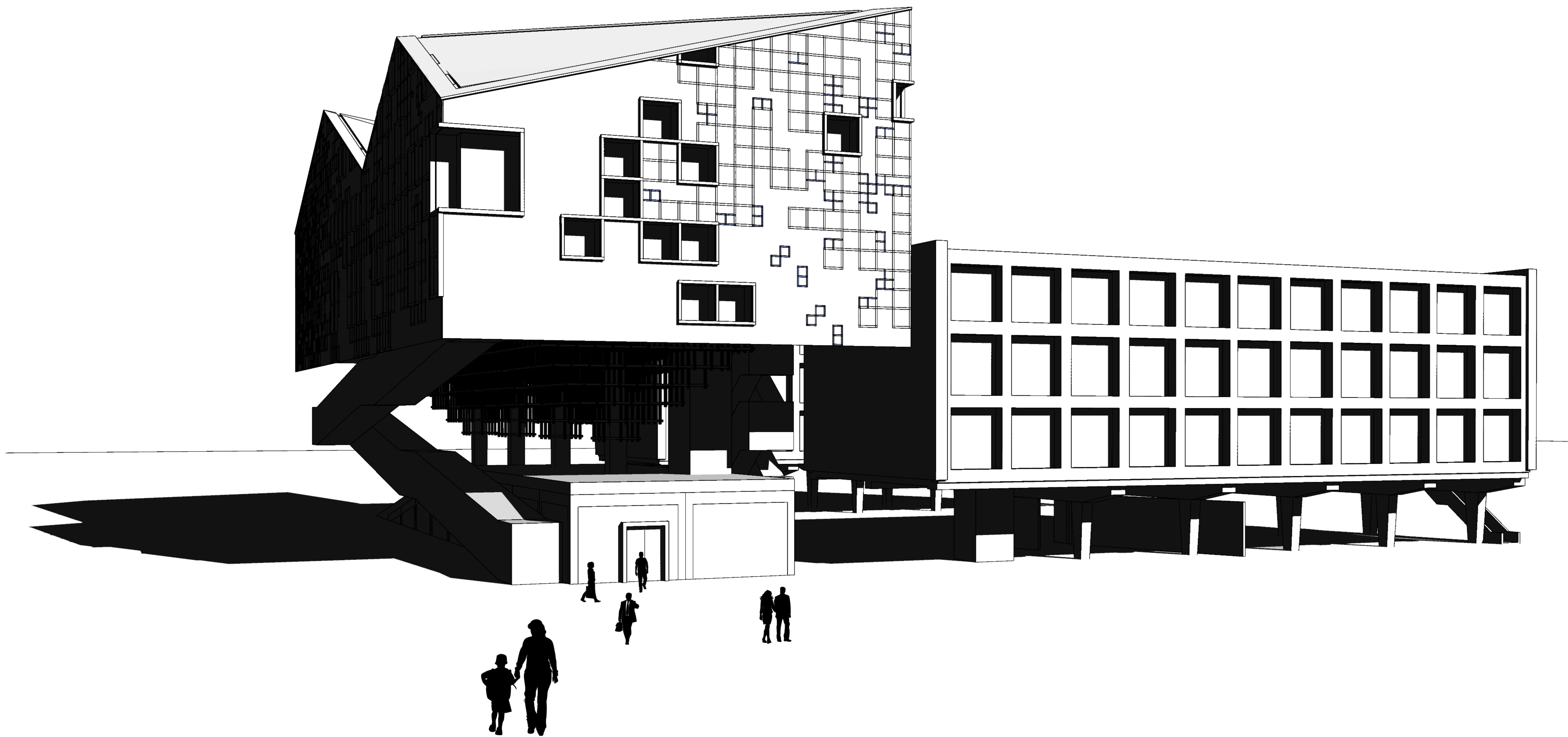

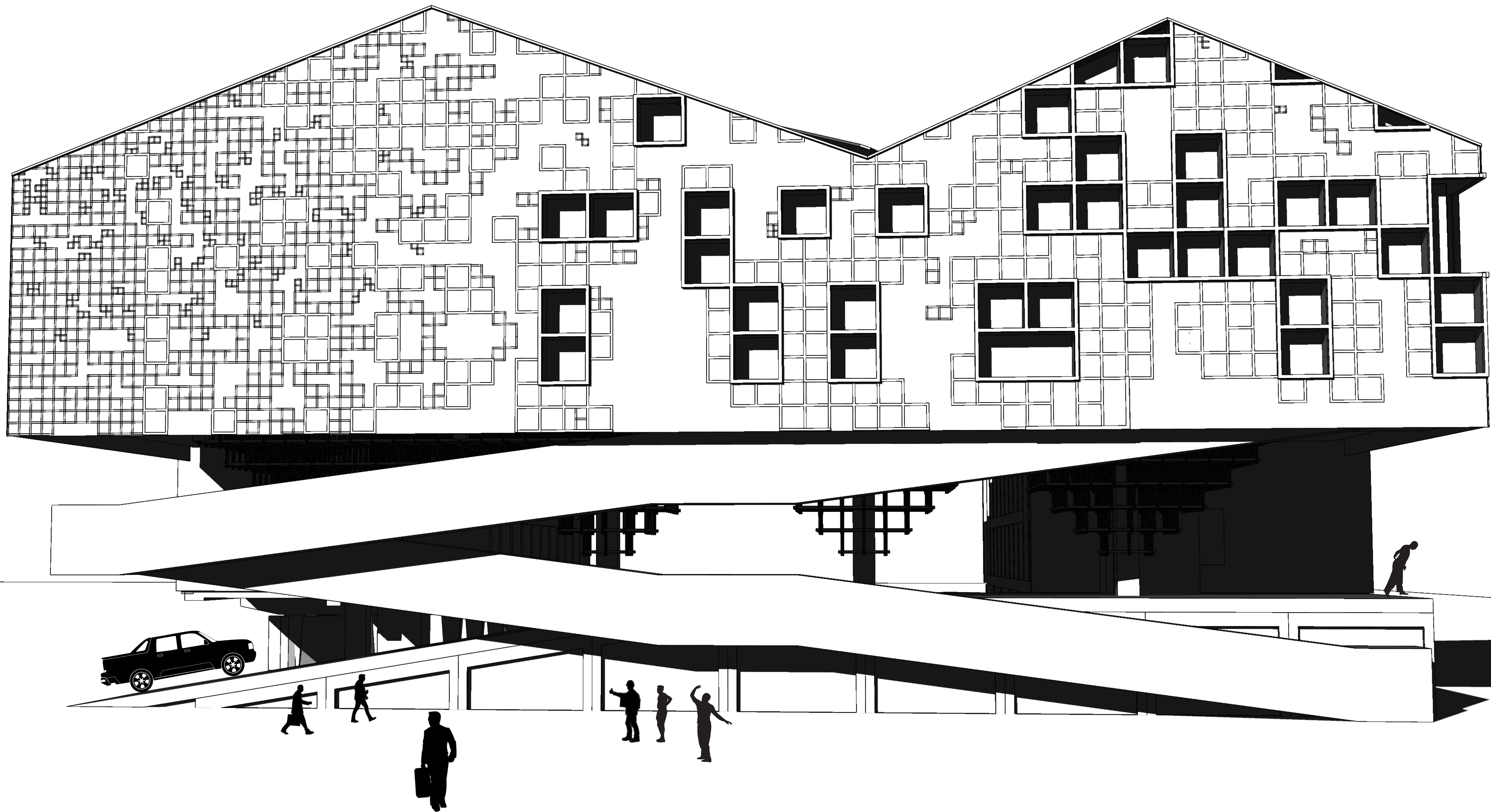

Details

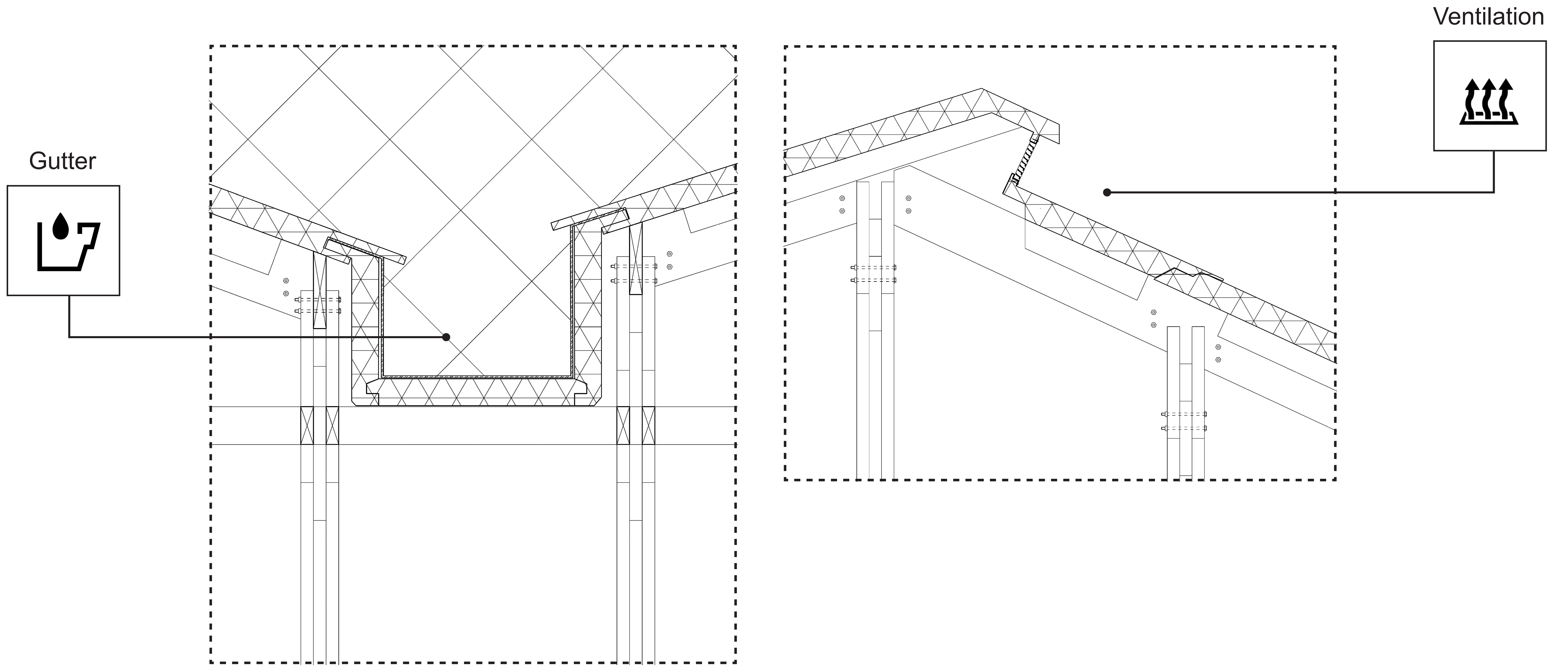

Operable
Ventilation

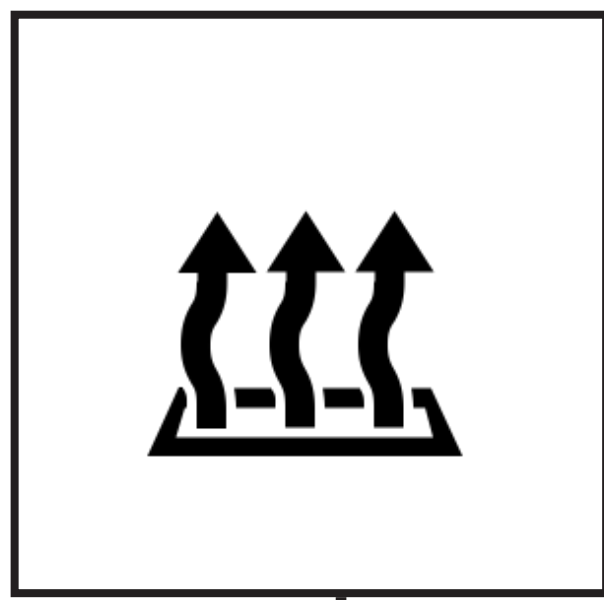

Natural Water
Filtration System

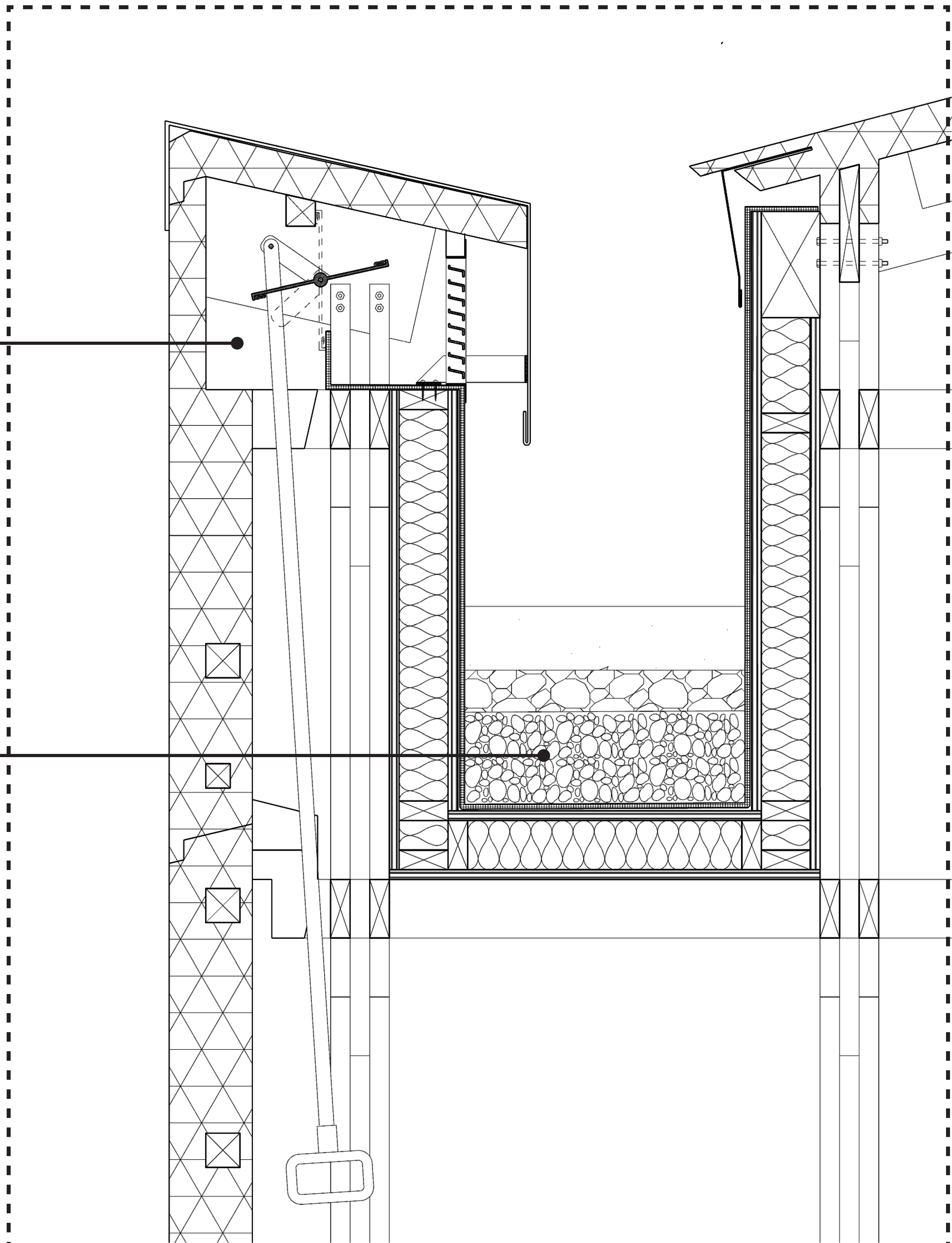
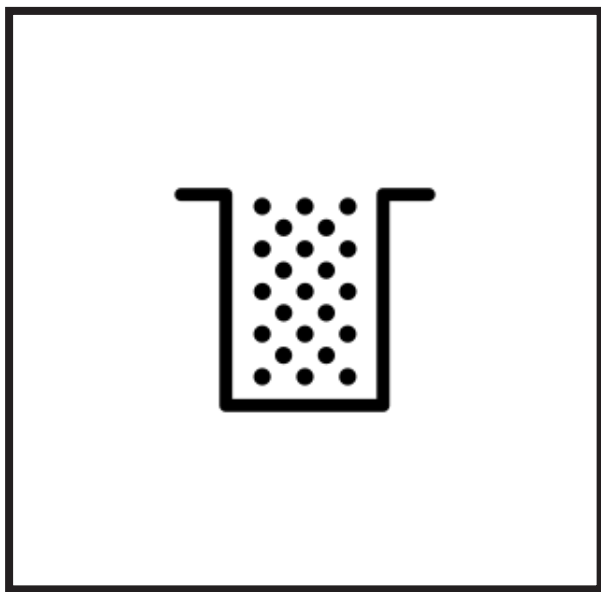

Vegetation

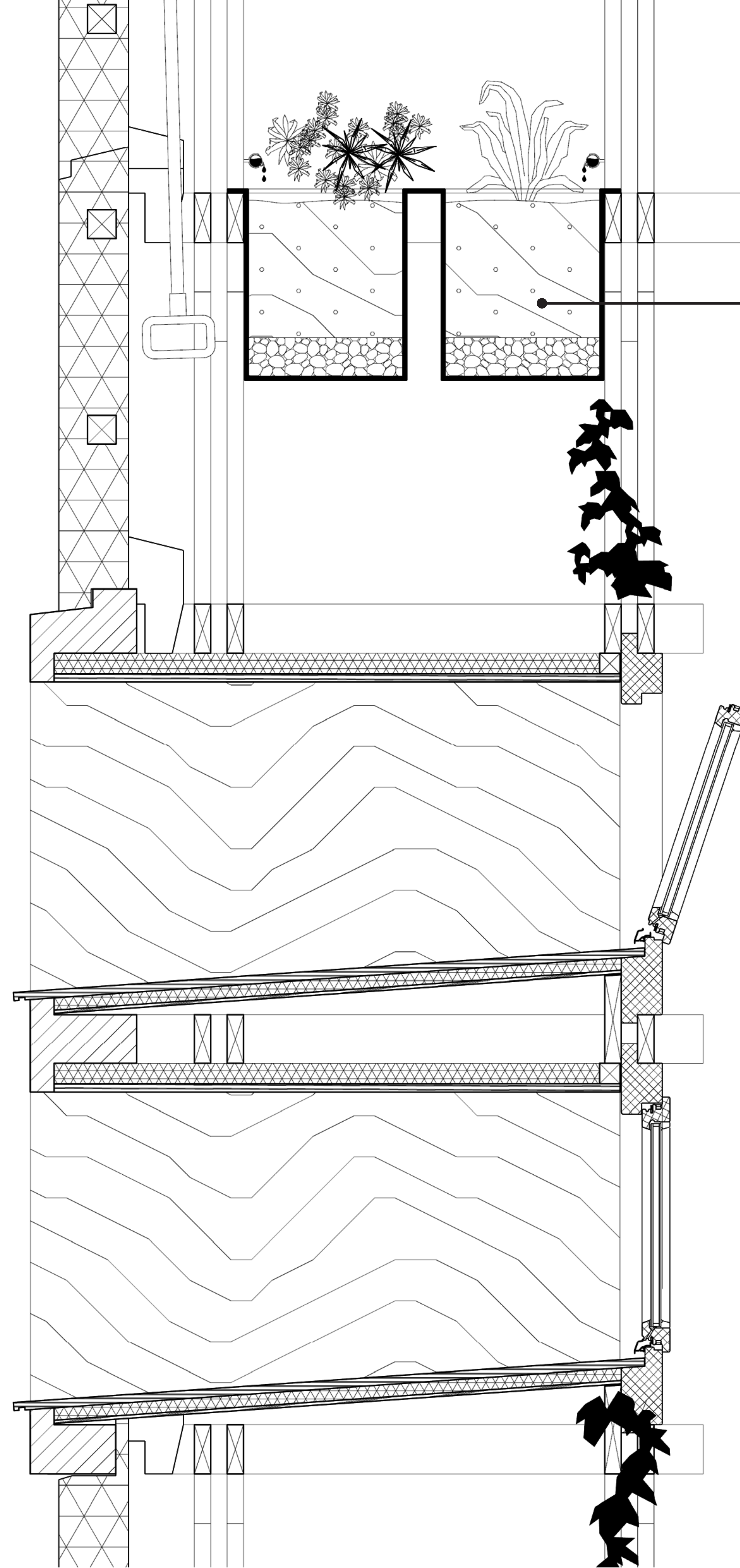
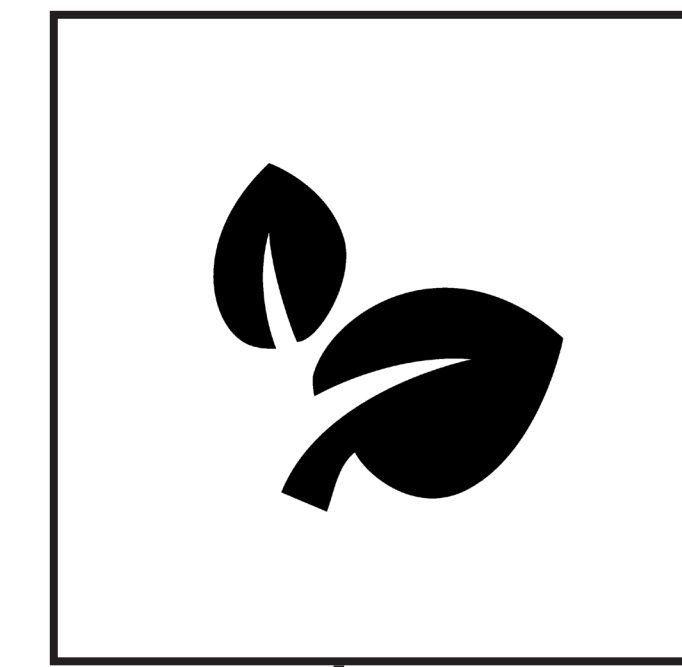

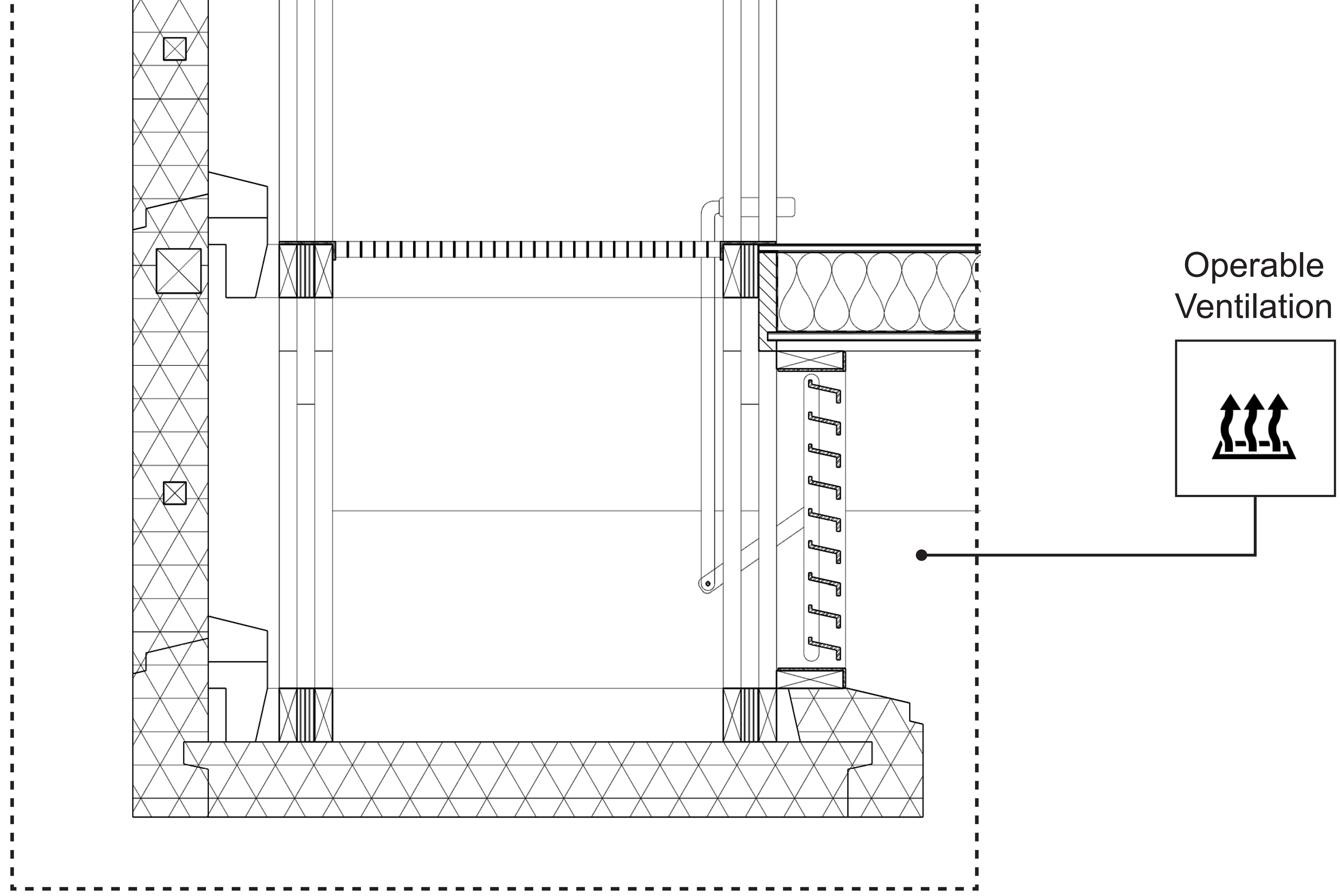

Second-Skin Facade Intermediate Space Qualities

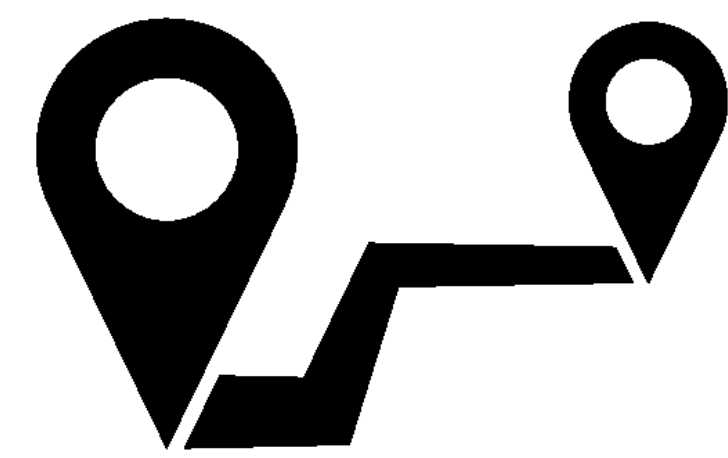

Routing

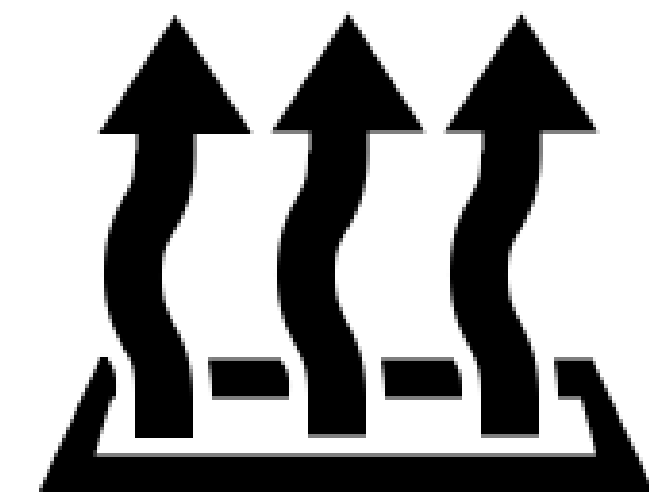

Ventilation



Making Space



Vegetation



Break

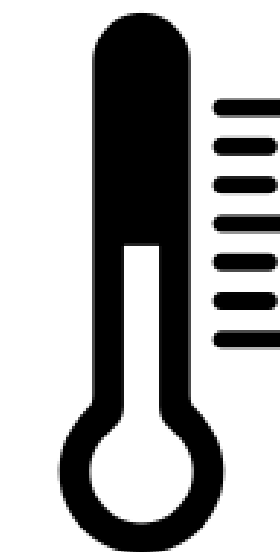

Climate Control

Climate Control Diagrams

Summer [day]

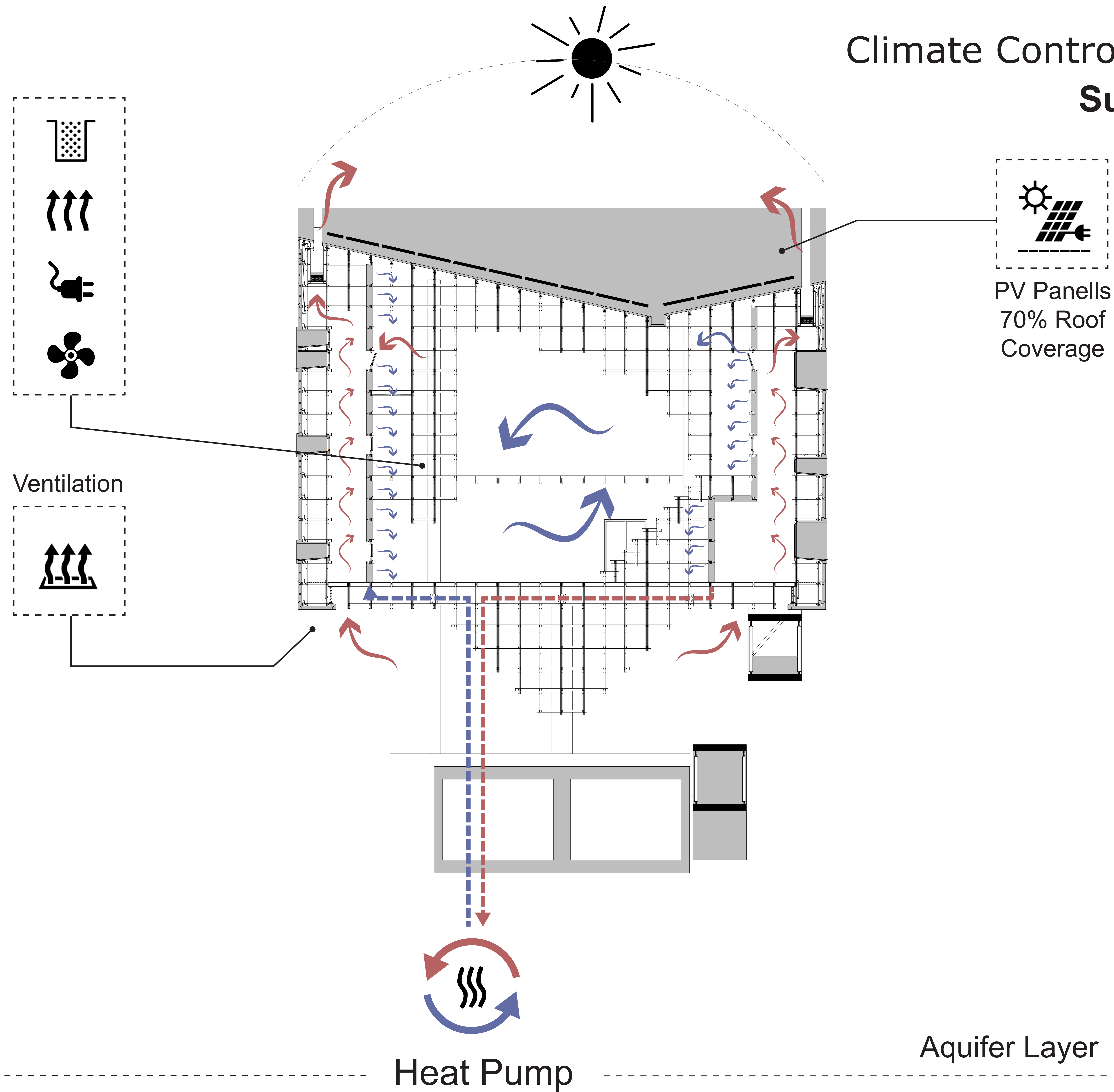

Icons representing ventilation and electrical components:

- Filter icon
- Upward arrows icon
- Electrical plug icon
- Fan icon

Ventilation

Icon representing ventilation:

- Upward arrows icon

Icon representing PV panels:

- Sun icon
- PV panel icon
- Electrical plug icon

PV Panells
70% Roof
Coverage

Heat Pump

Aquifer Layer

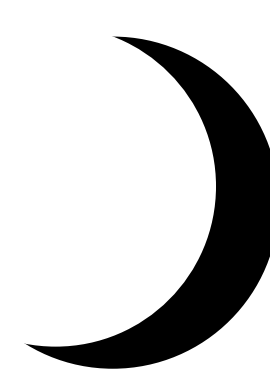

Summer [night]

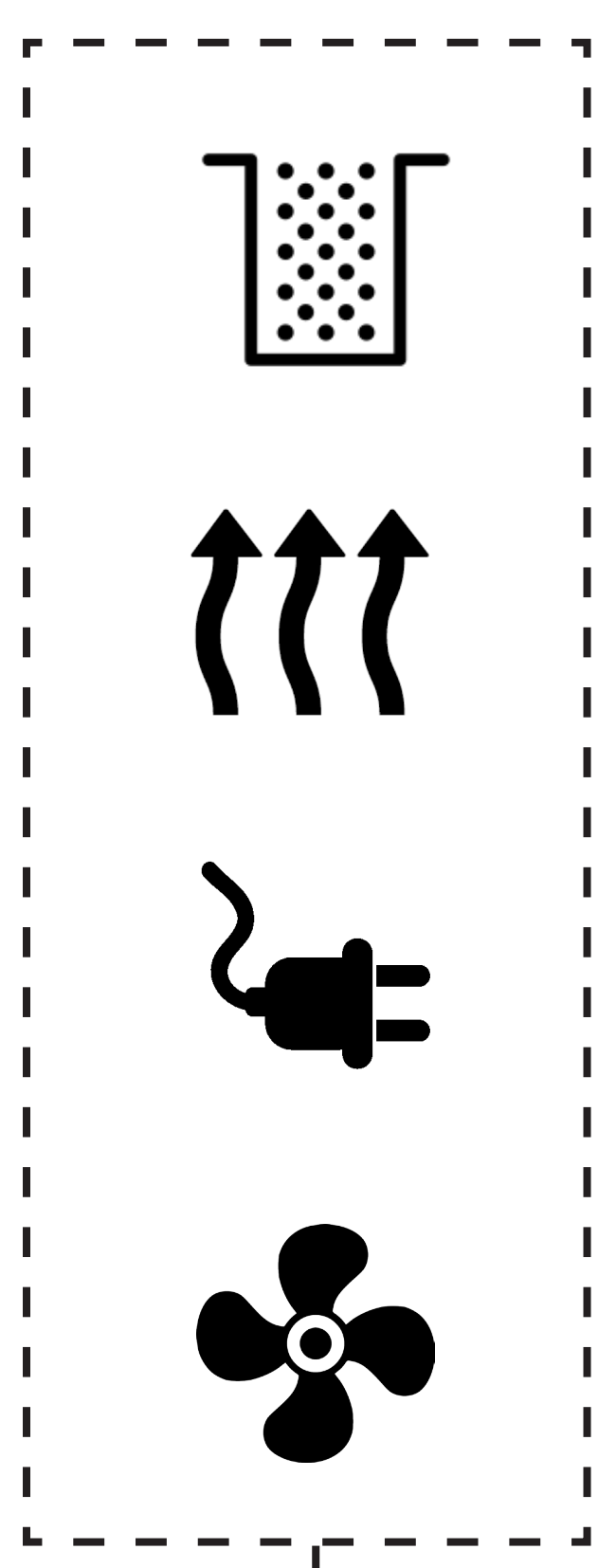

Ventilation

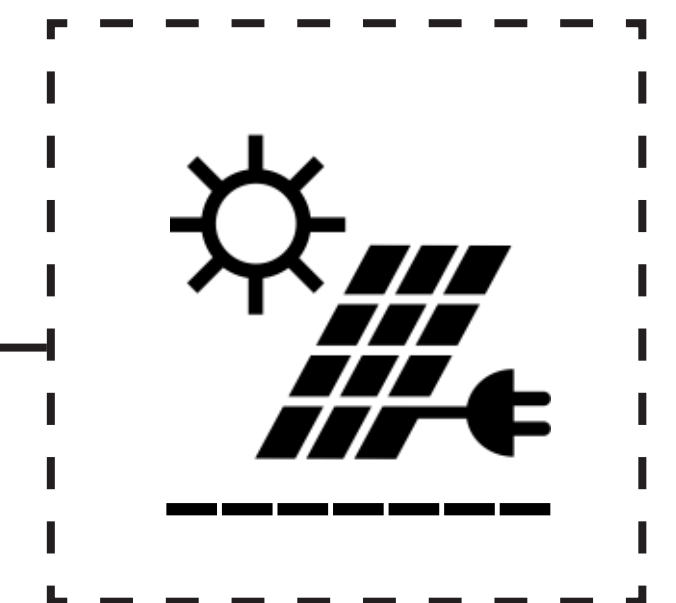
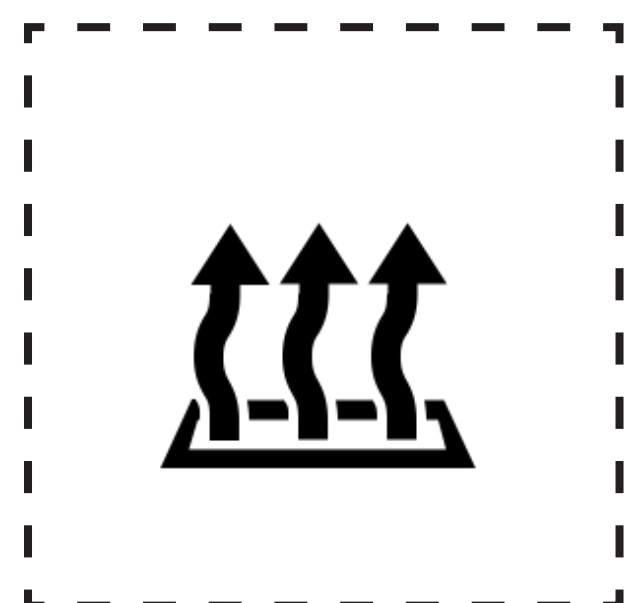

PV Panells
70% Roof
Coverage

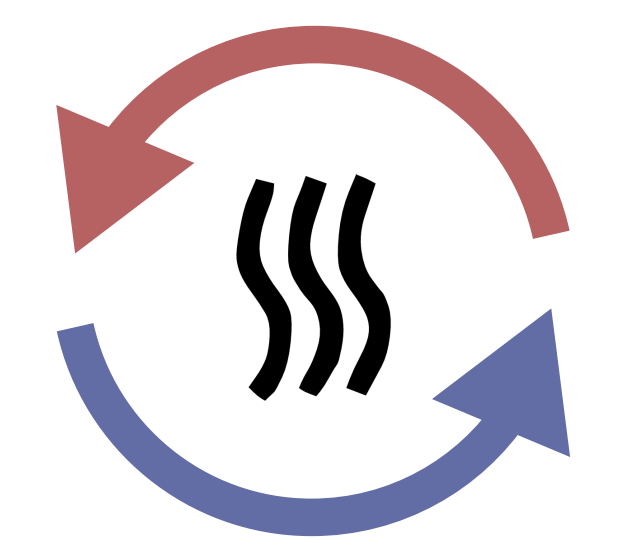
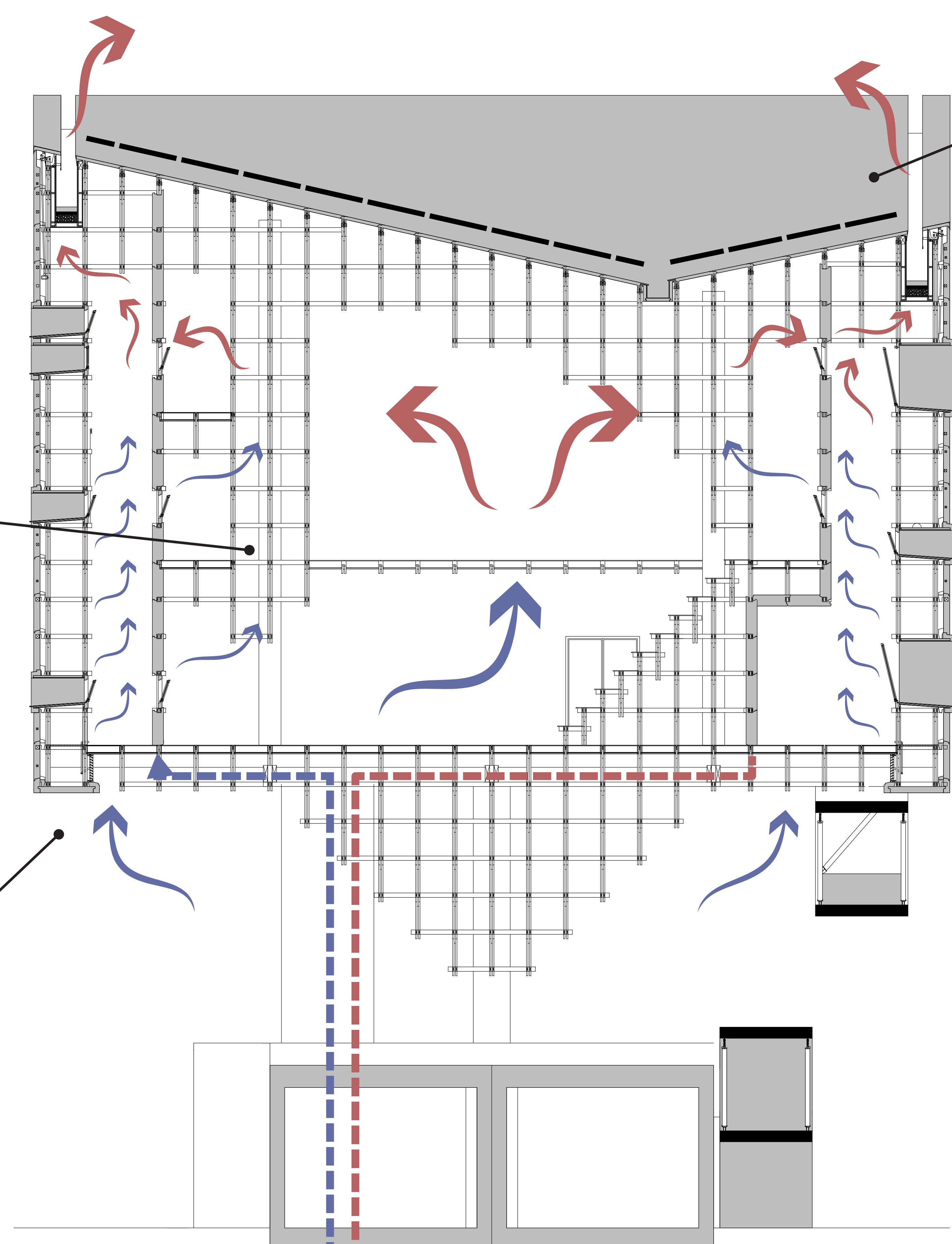

Heat Pump

Aquifer Layer



Winter

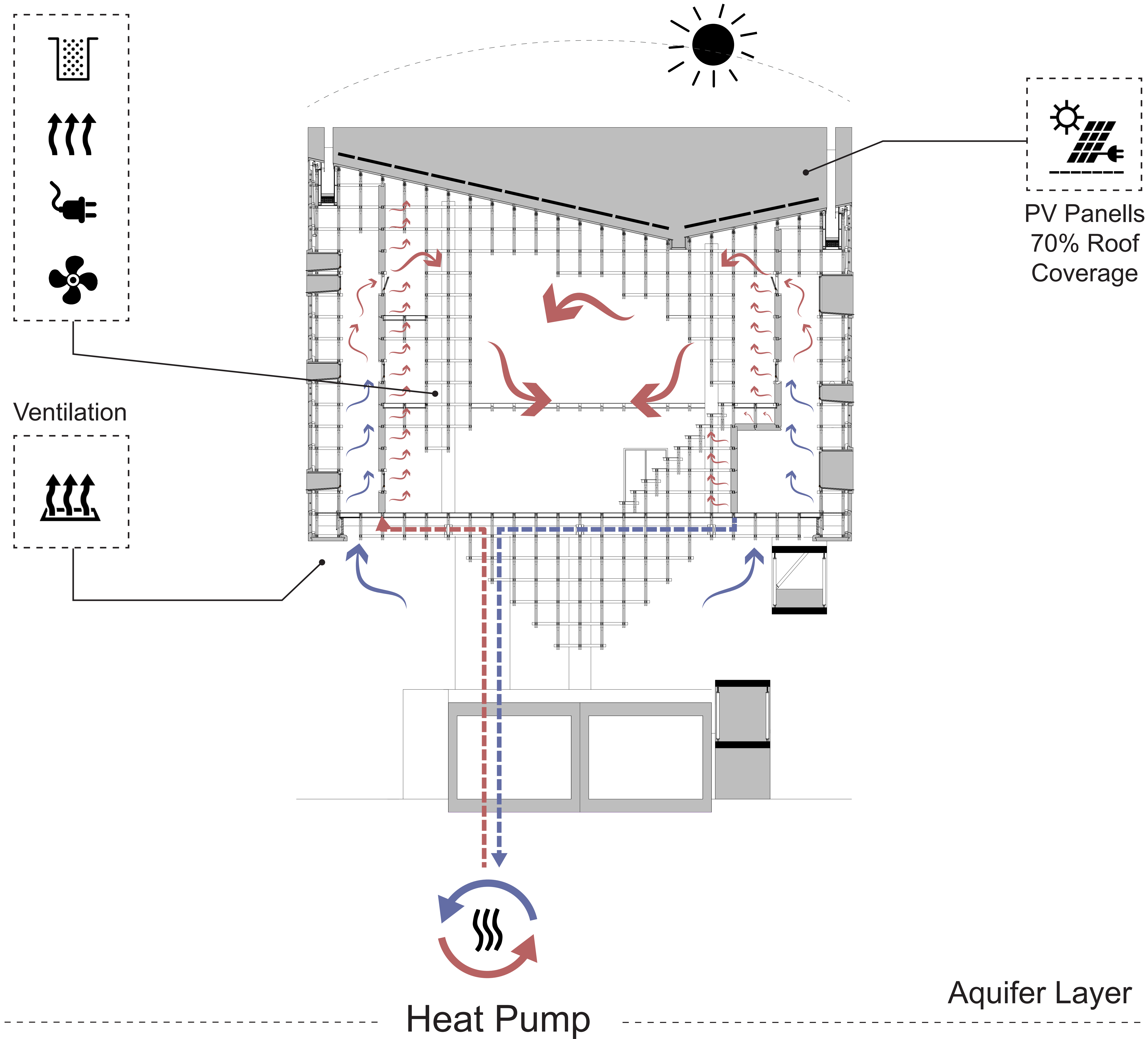

Structural Design Strategy

reFAB Construction Methods

& Design Strategy

Main Construction Criteria

Sustainable 

Recyclable 

Demountable 

Modular 

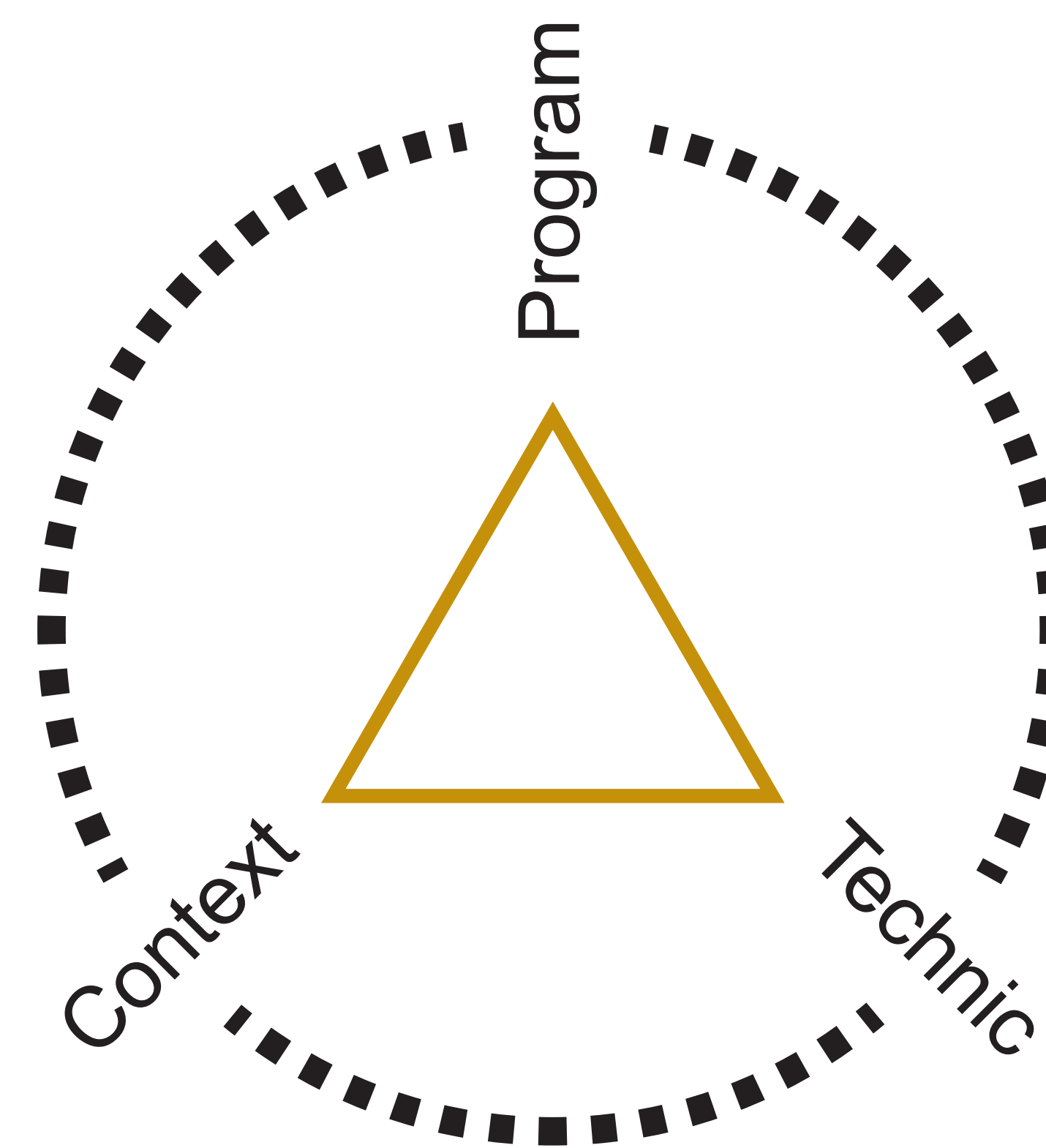

Demountable Framework in order to:

- Expand
- Optimize
- Adapt
- Migrate

Modular Structural System Principle

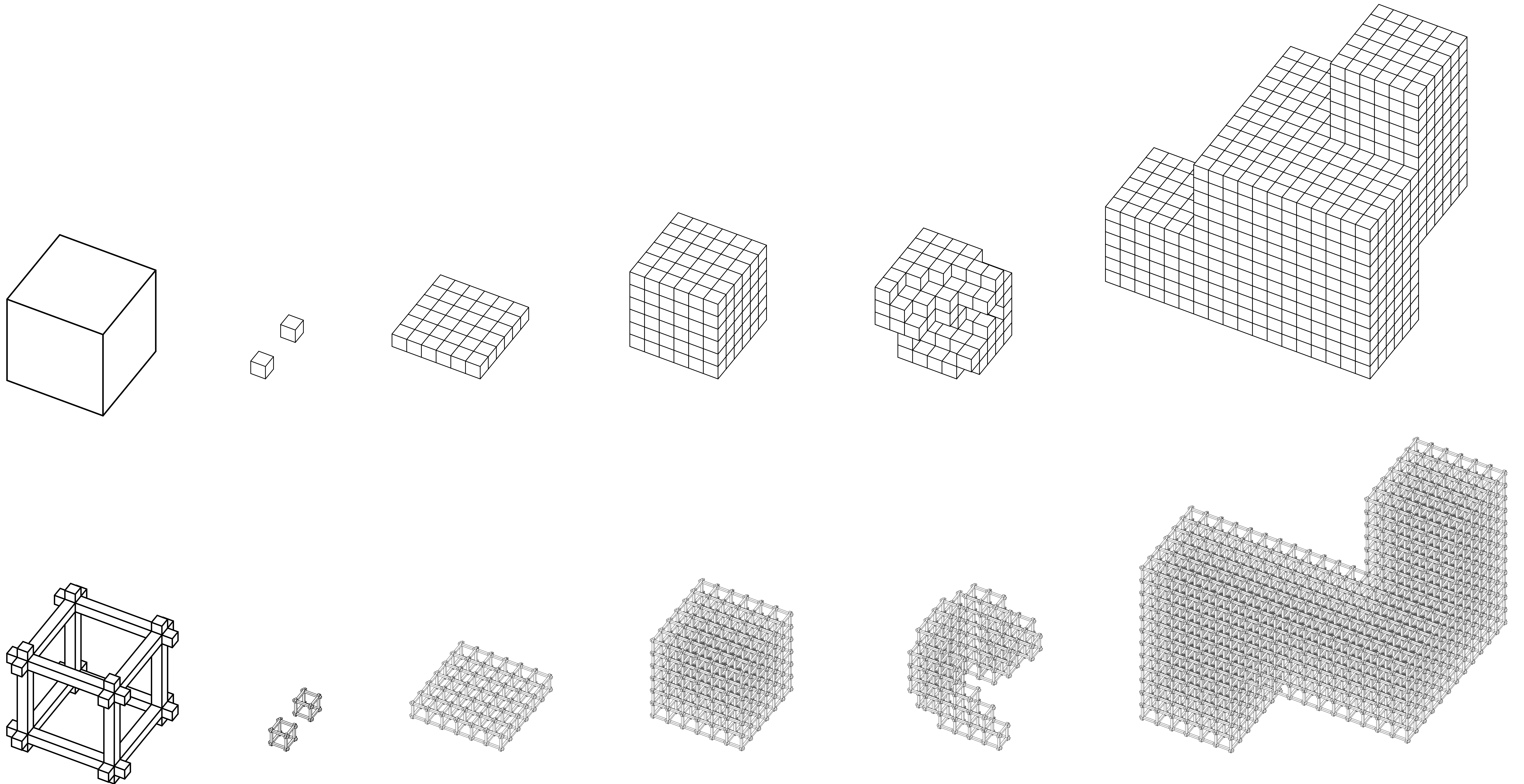

6x6m² Workunits Spatial Development Potentials

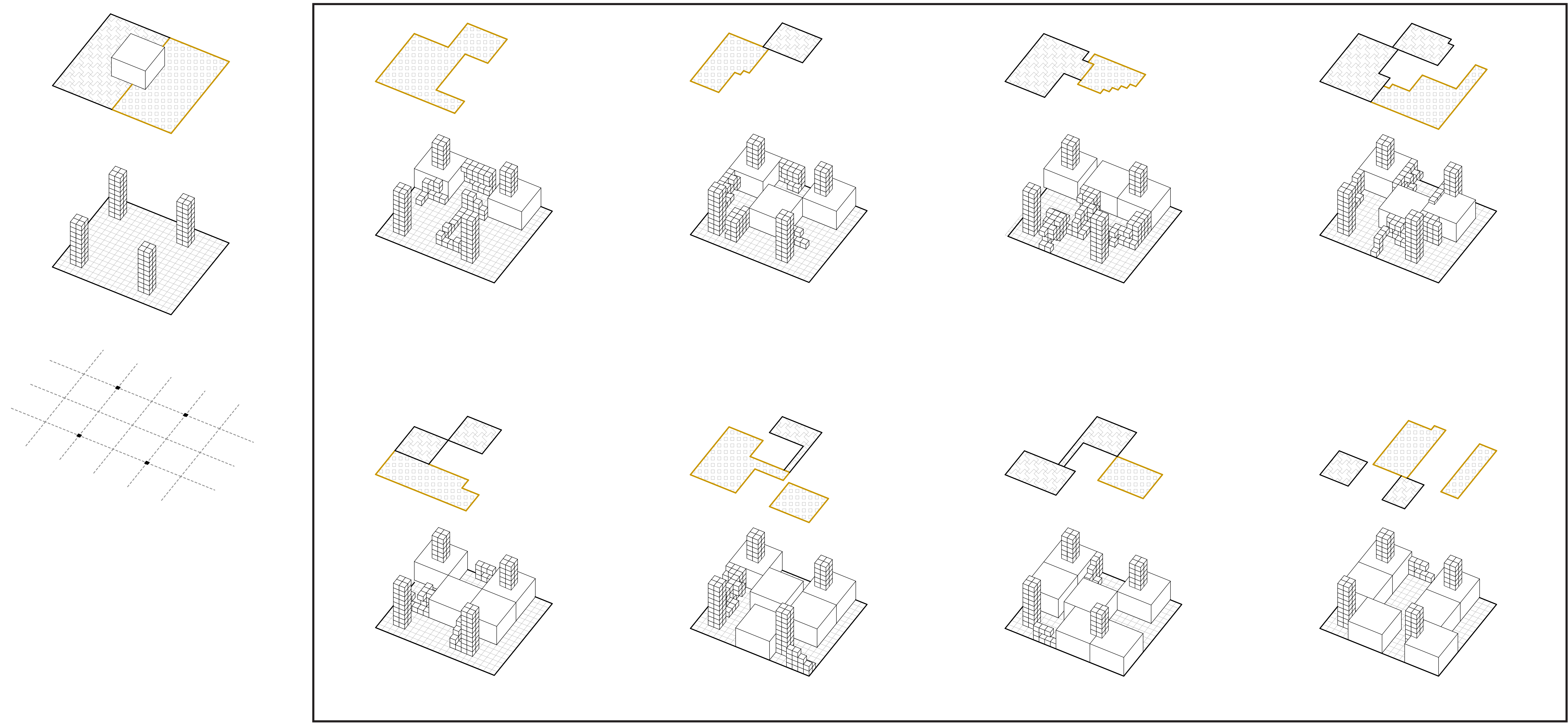

-  Private Working Studios
-  Technical Appliances Cores & Modular Components
-  Flexible Semi-Private Space
-  Flexible Shared Space

Variable Size Workunits Spatial Development Potentials

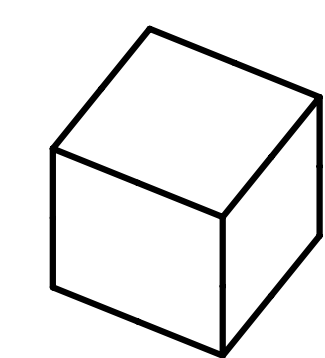
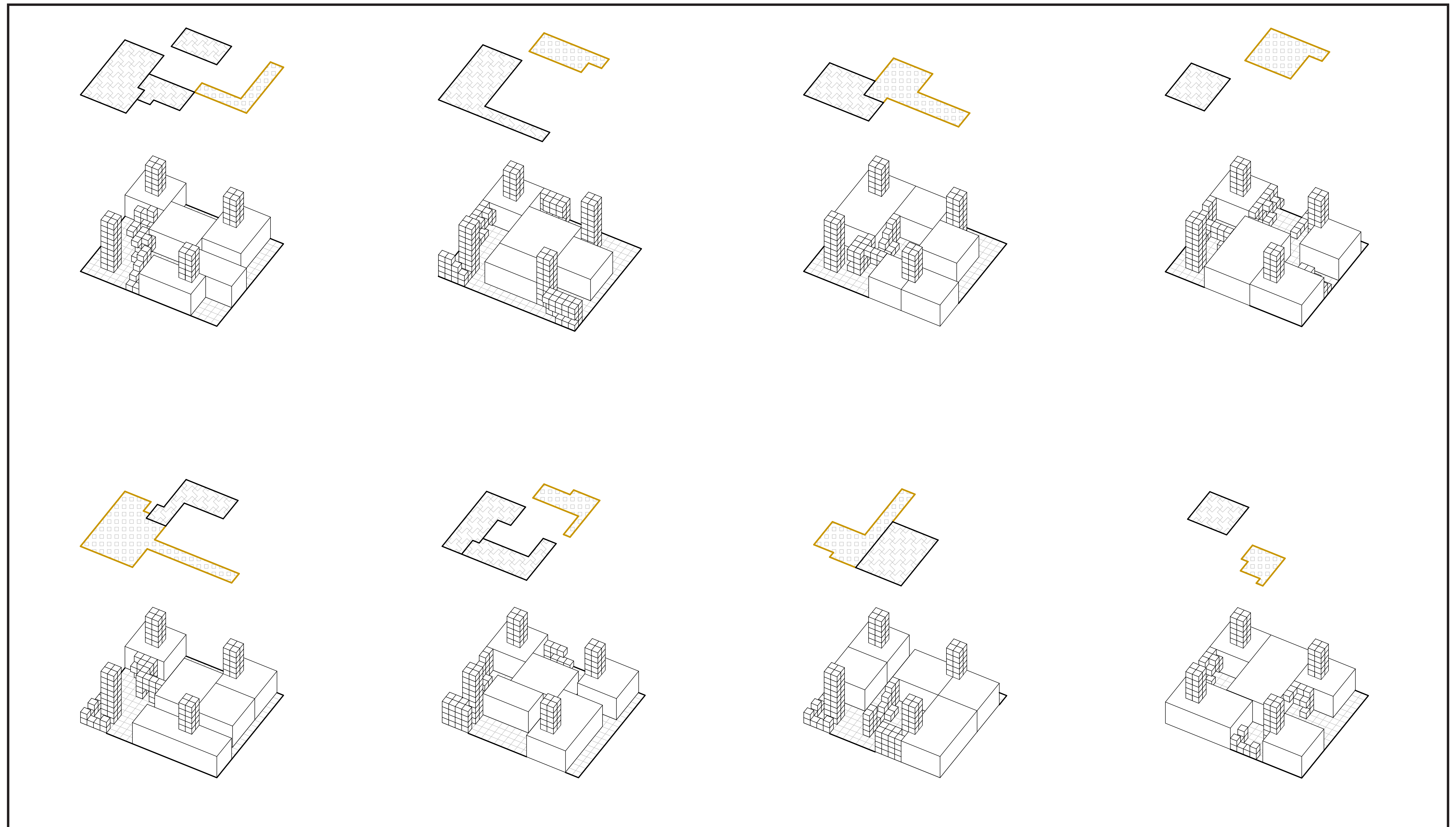
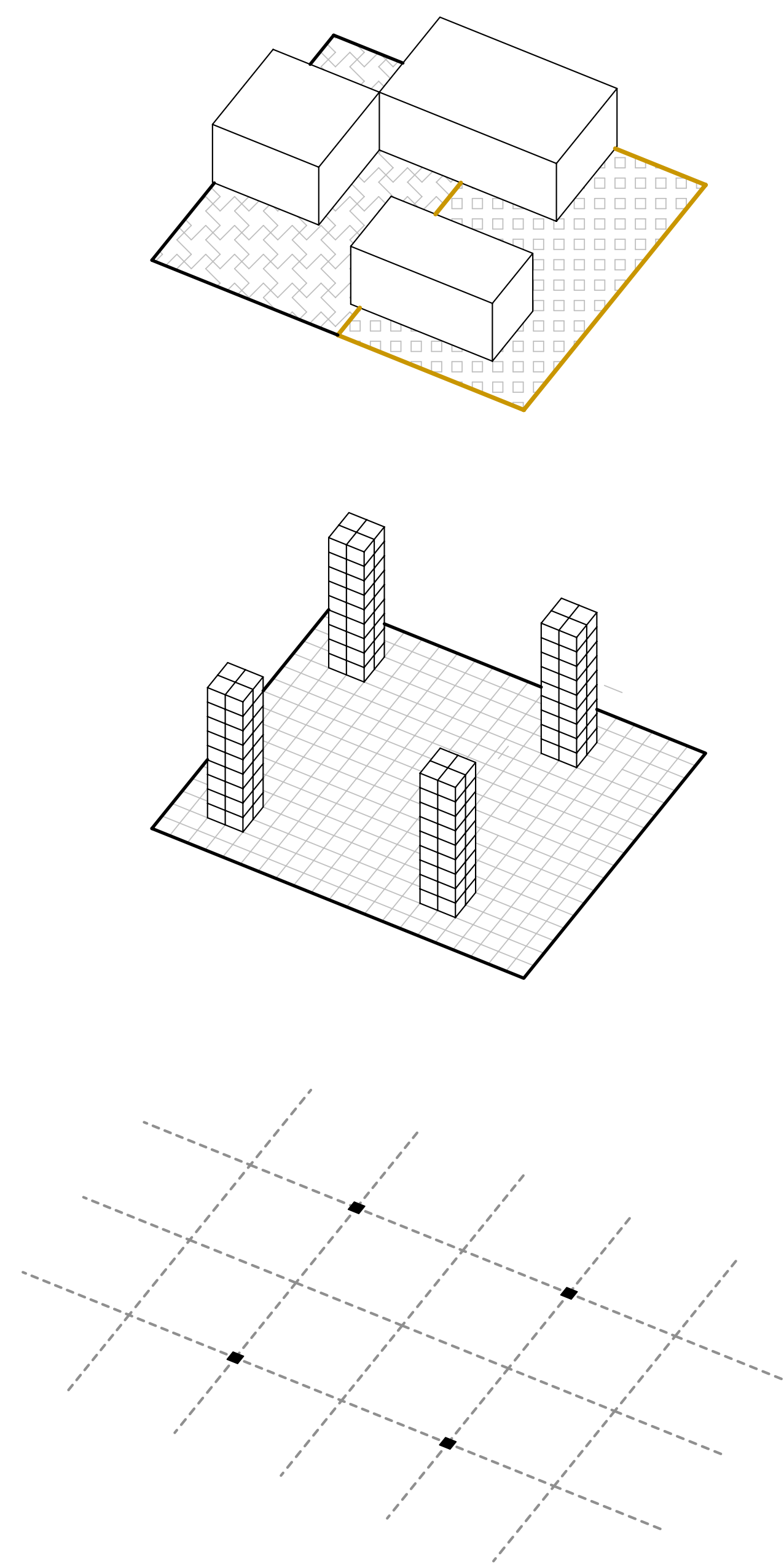

Private Working Studios

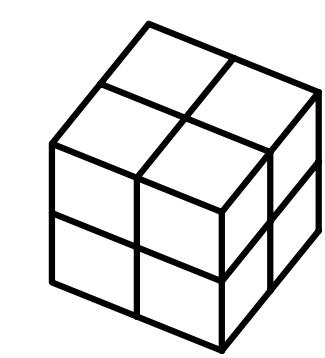

Technical Appliances Cores & Modular Components



Flexible Semi-Private Space



Flexible Shared Space

Demountable Framework of Salvaged Timber Parameters

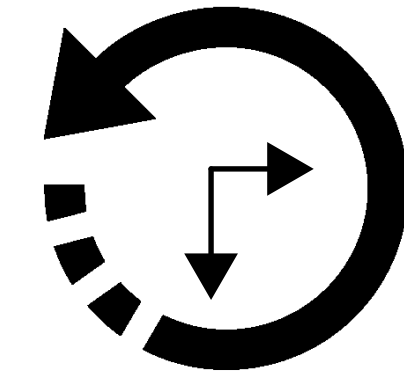

Fluctuating Life-cycle

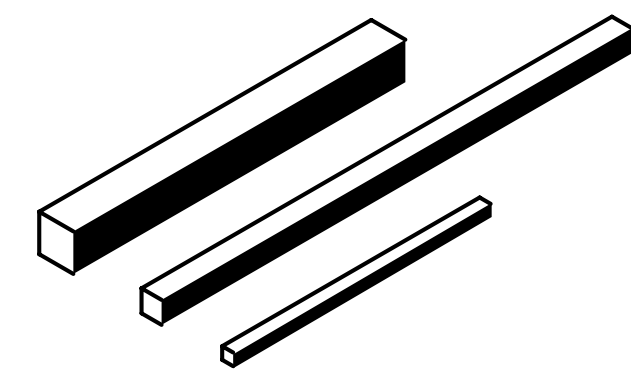

Variable Dimensions

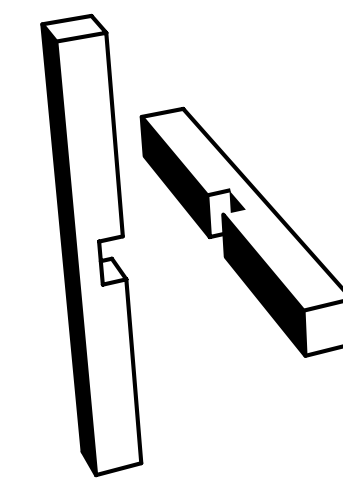

Interlocking Ability

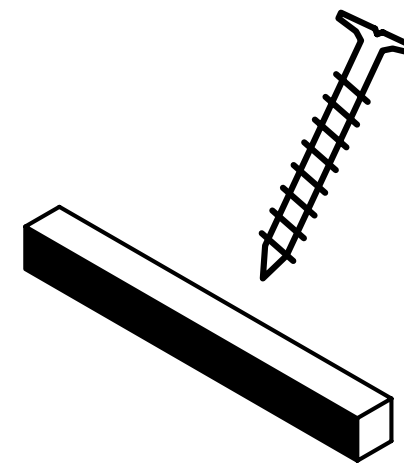

Fixings Minimization

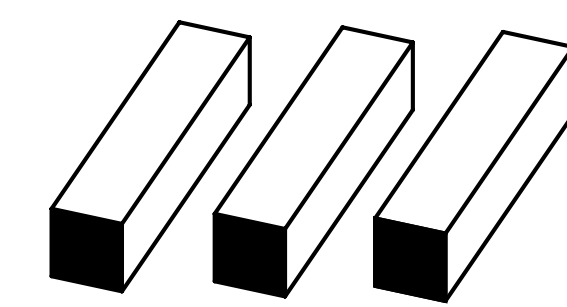

Variable Types & Quality

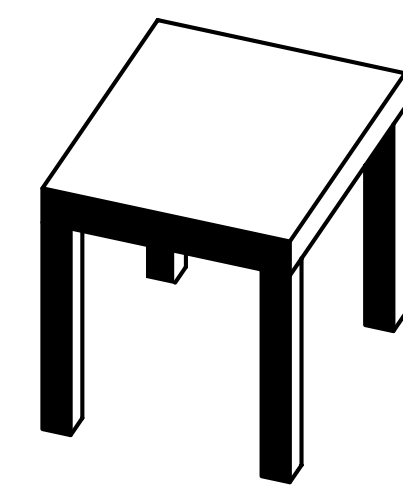

Robust Joinery

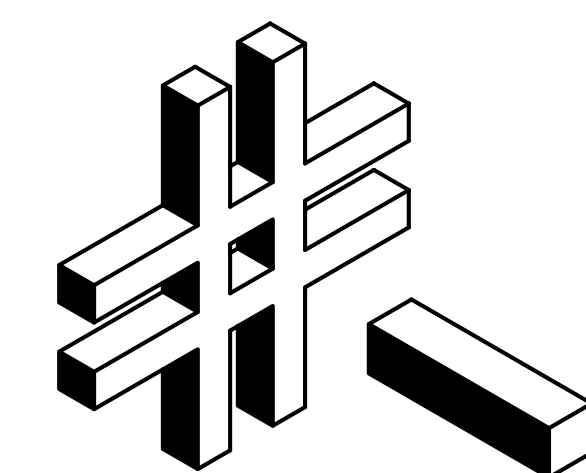

Plug-In Modular Function

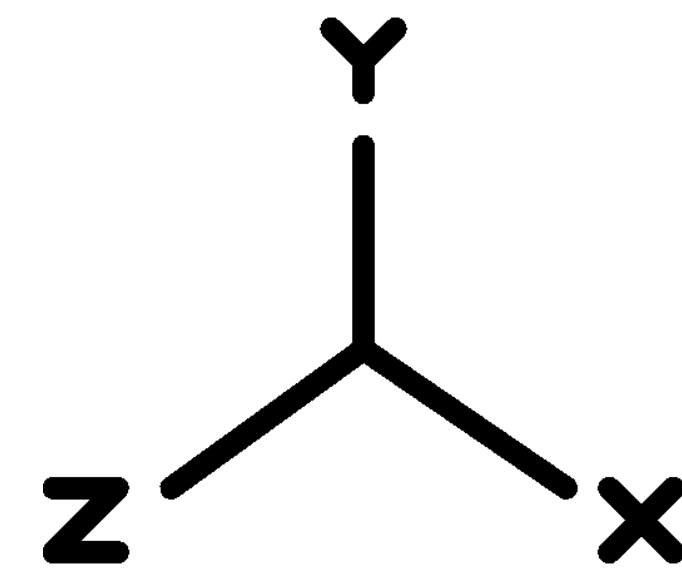

Timber Joints in x,y,z Directions Study

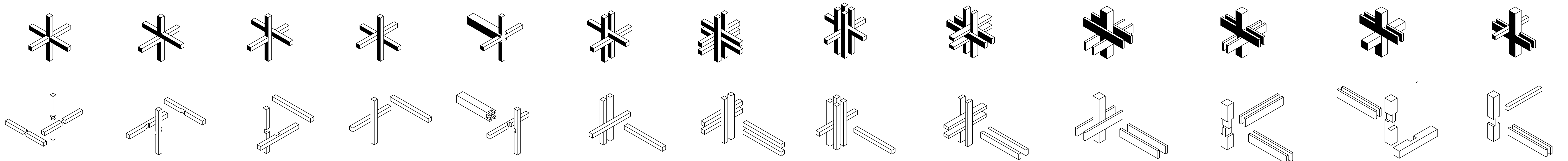

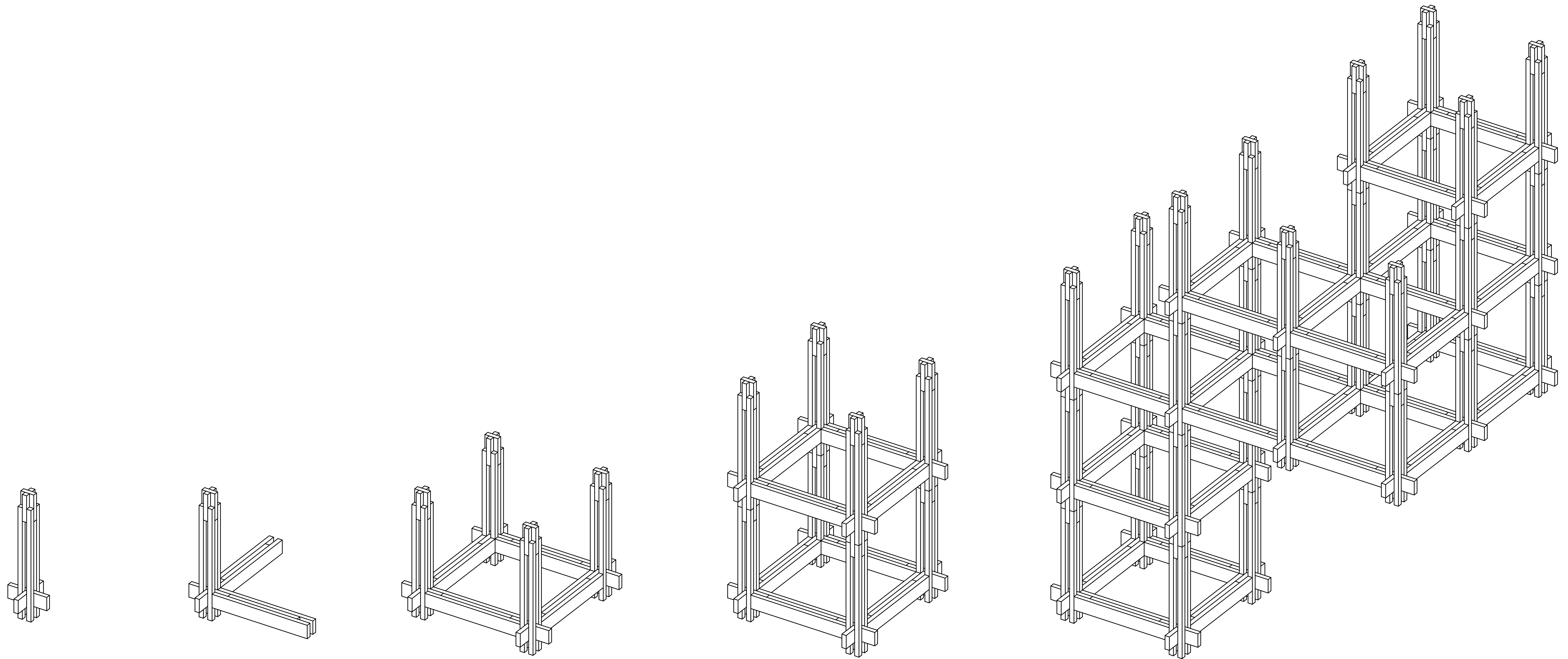

Main Modular Component Development

Different Interlocking Beam Components

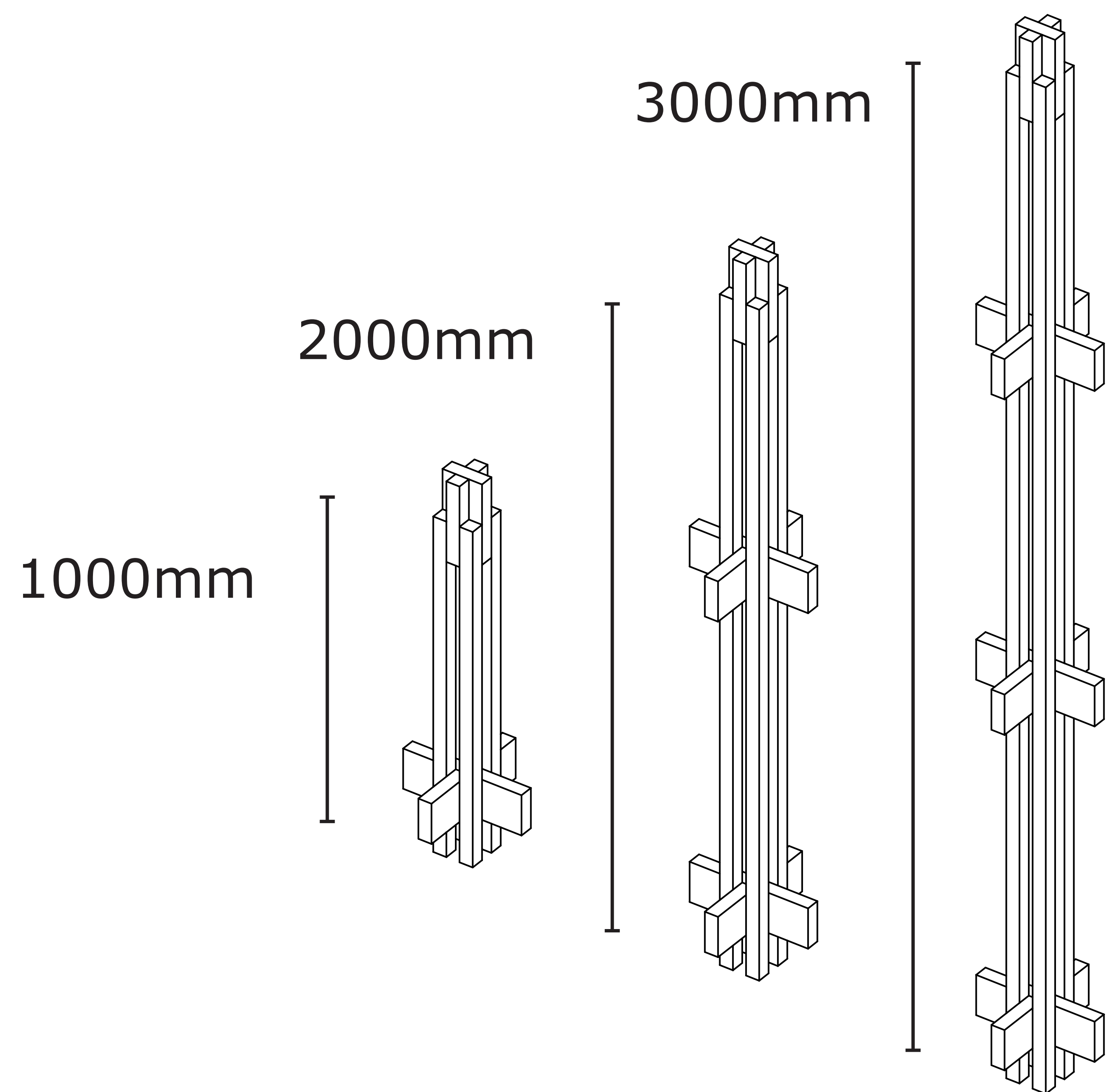
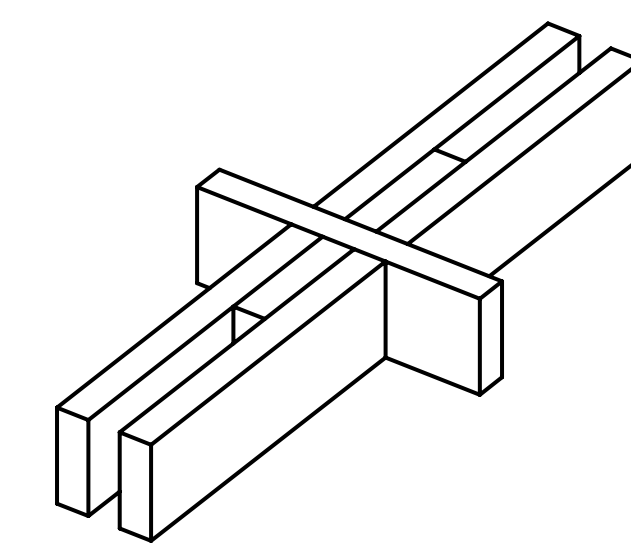
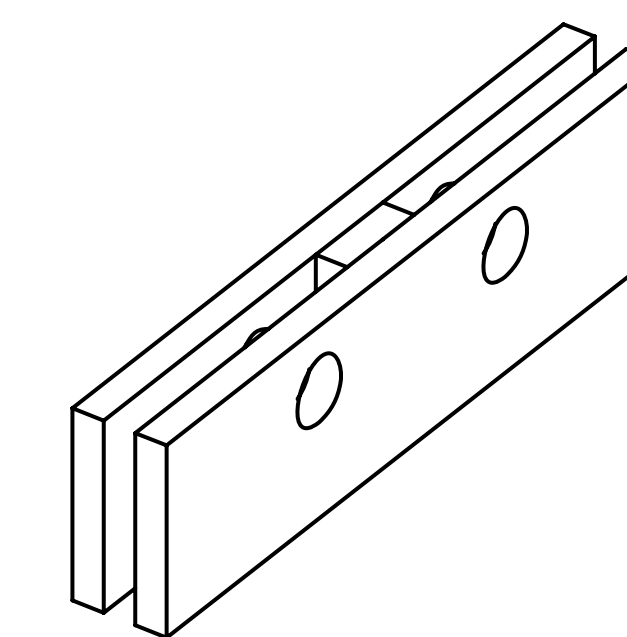
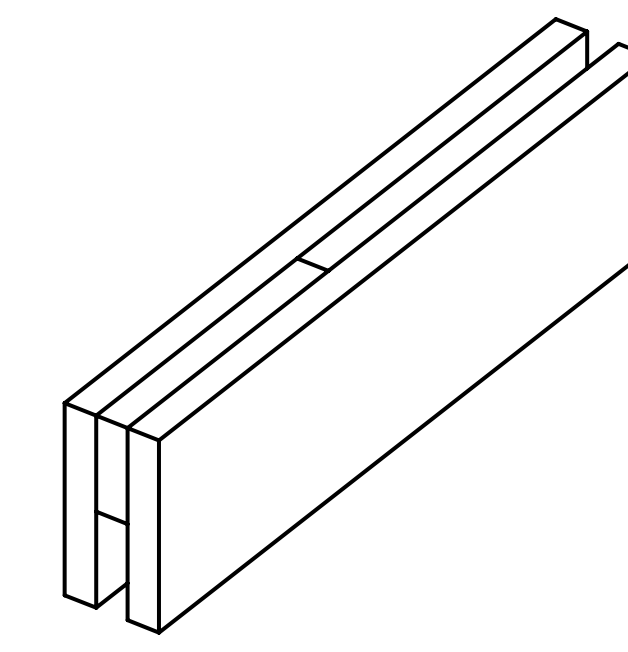
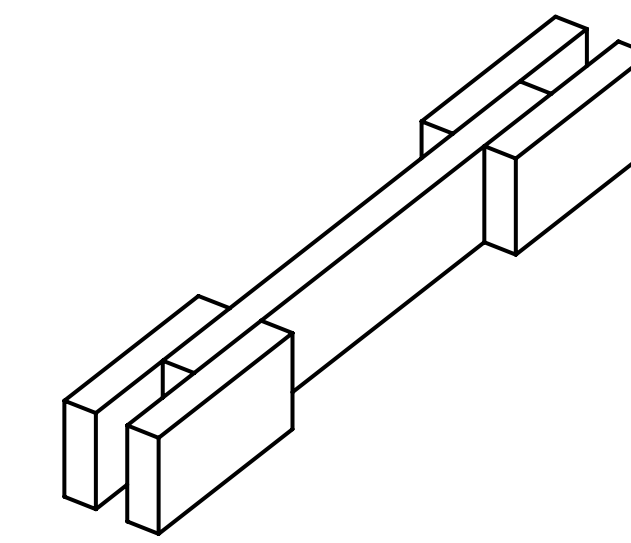
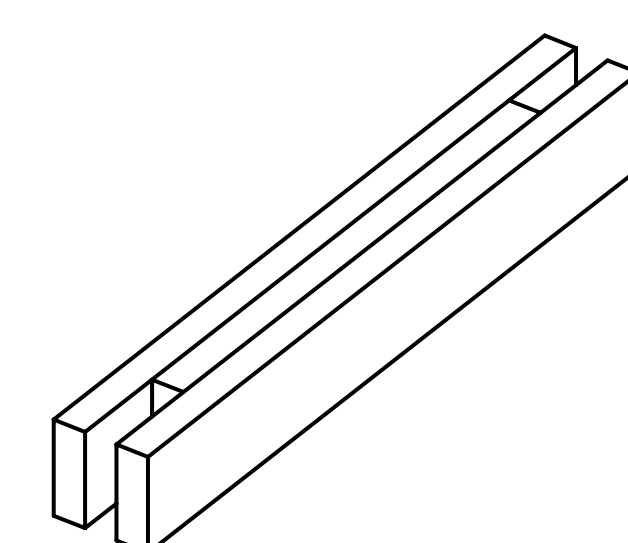
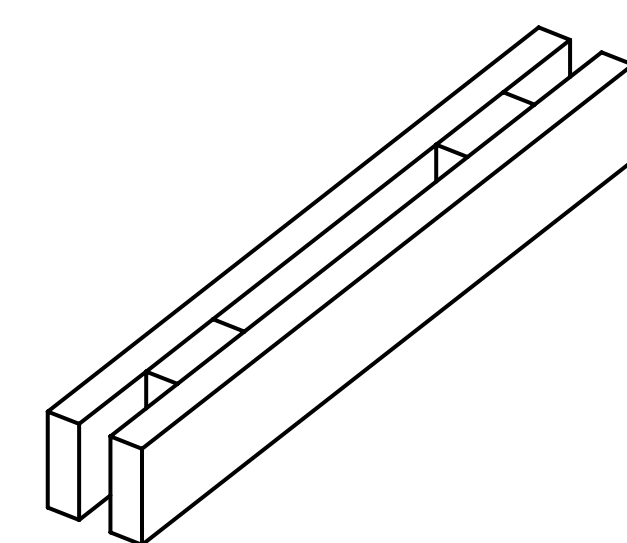
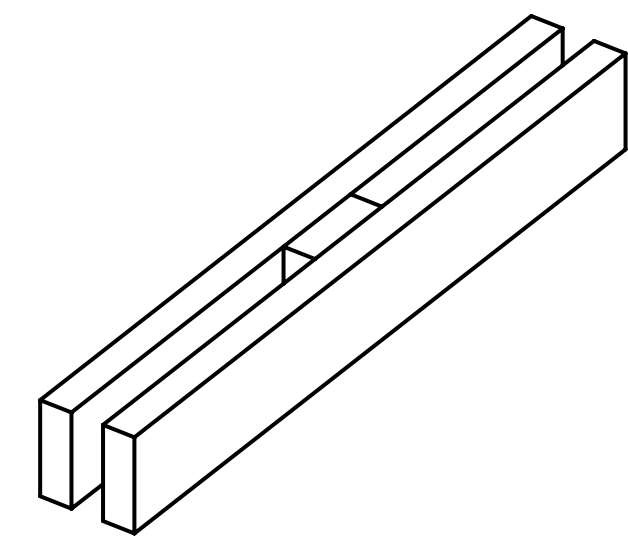
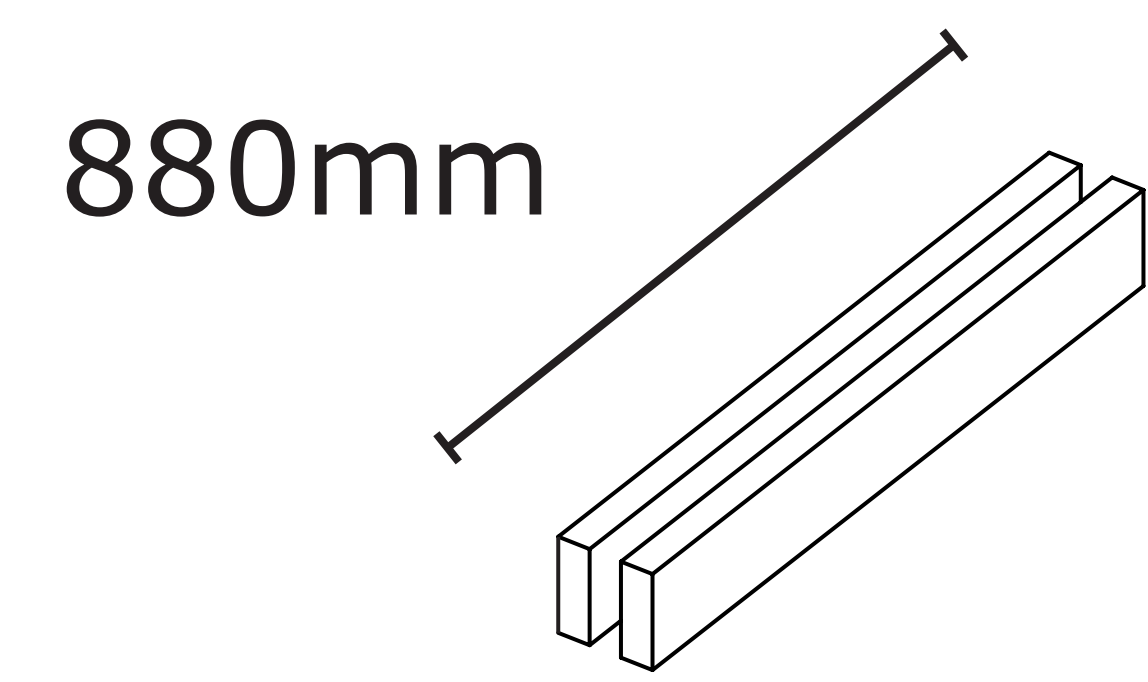

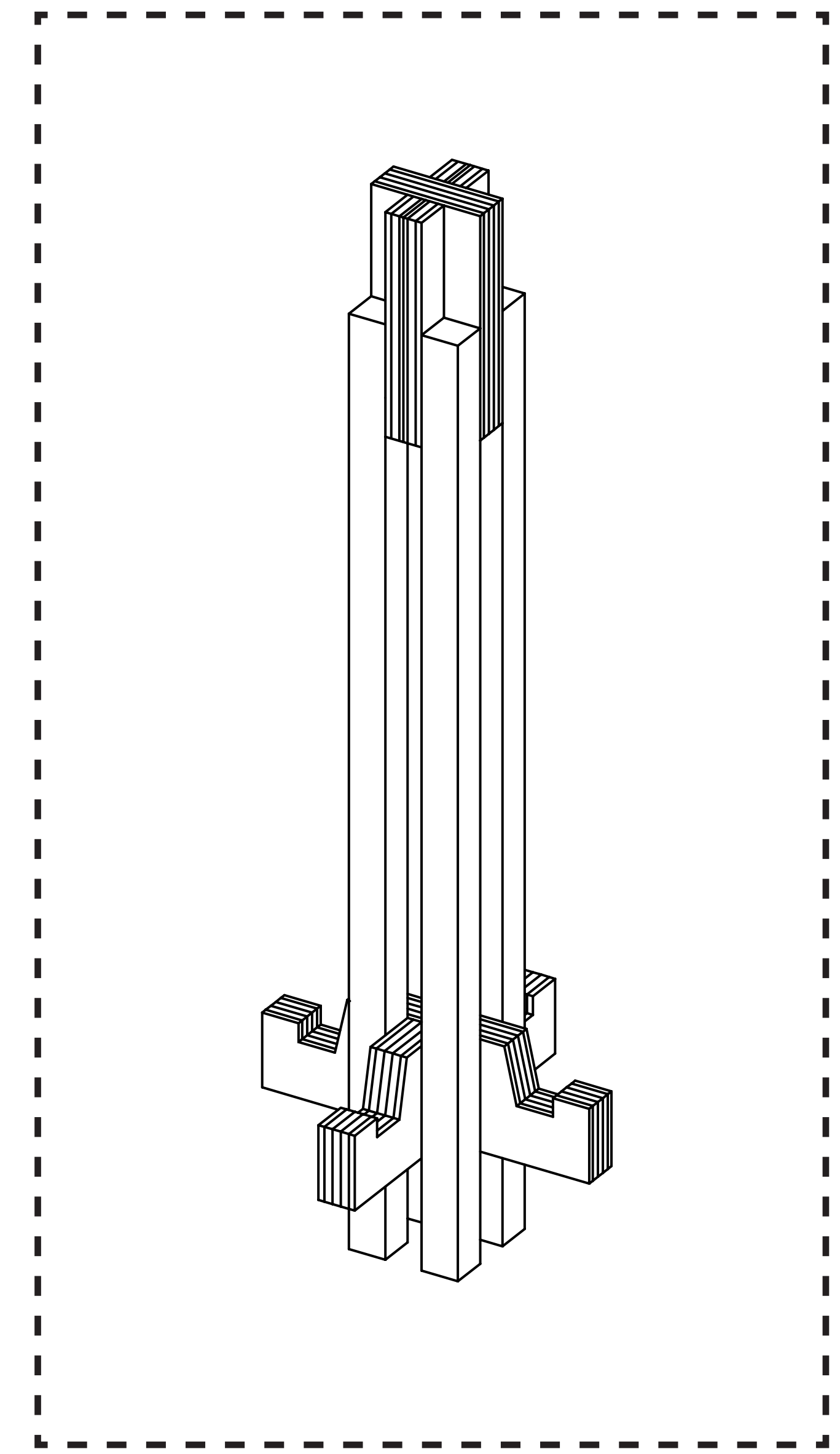
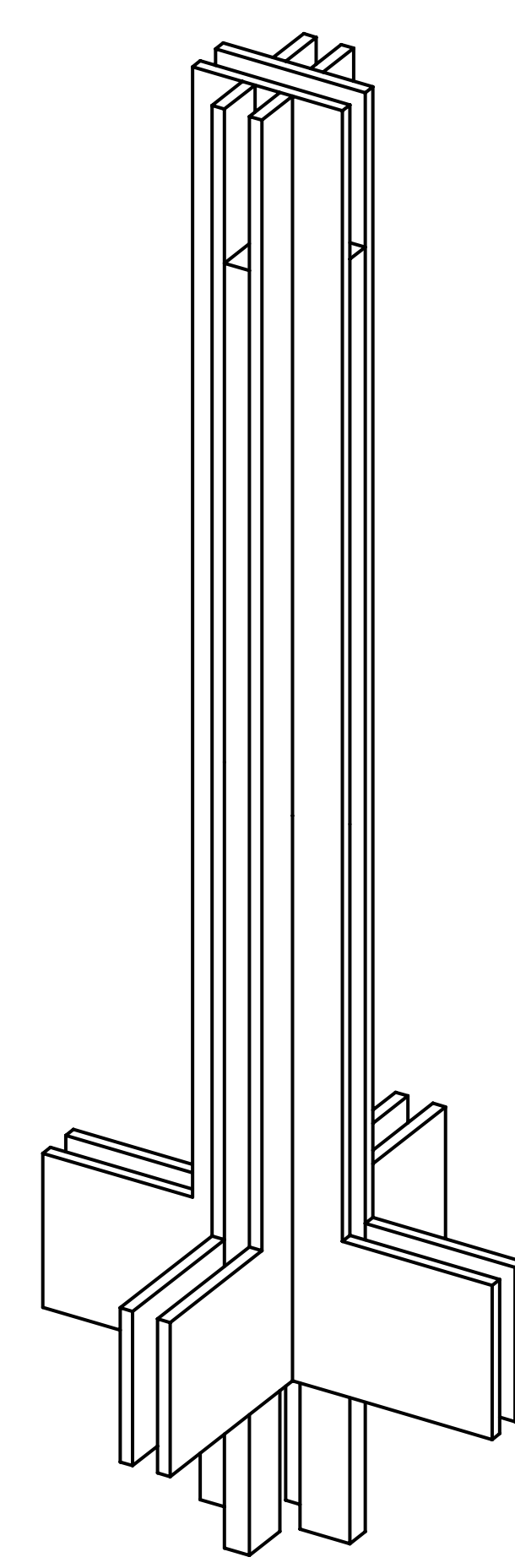
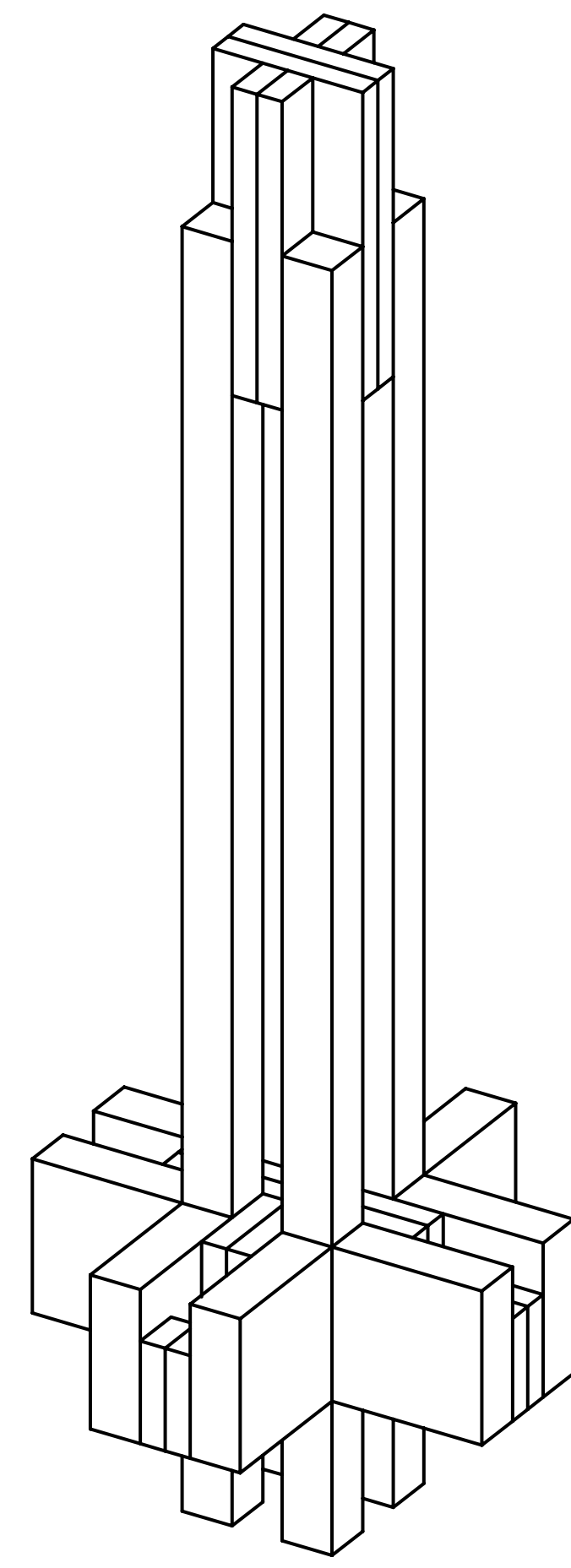
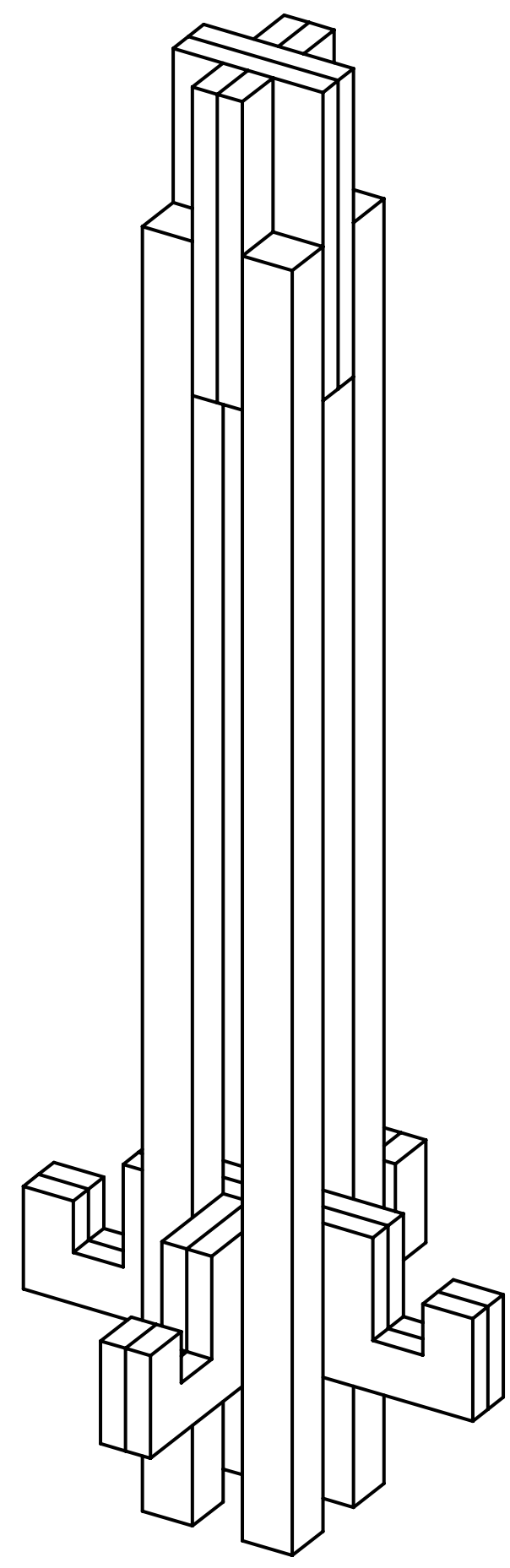
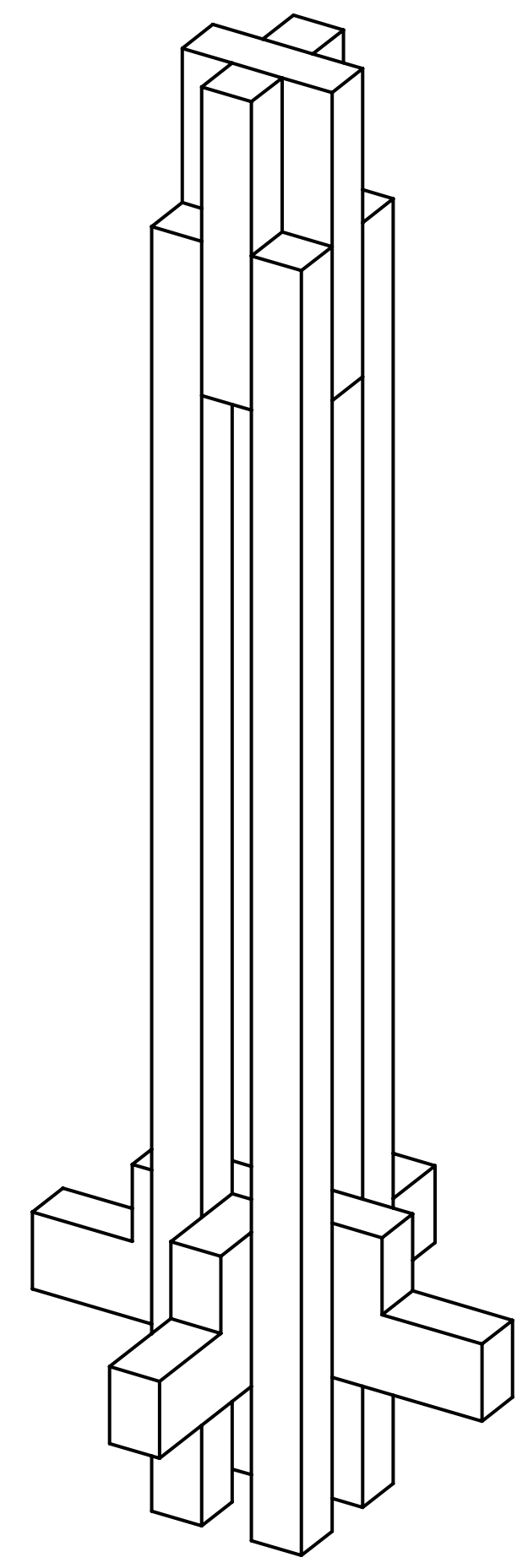
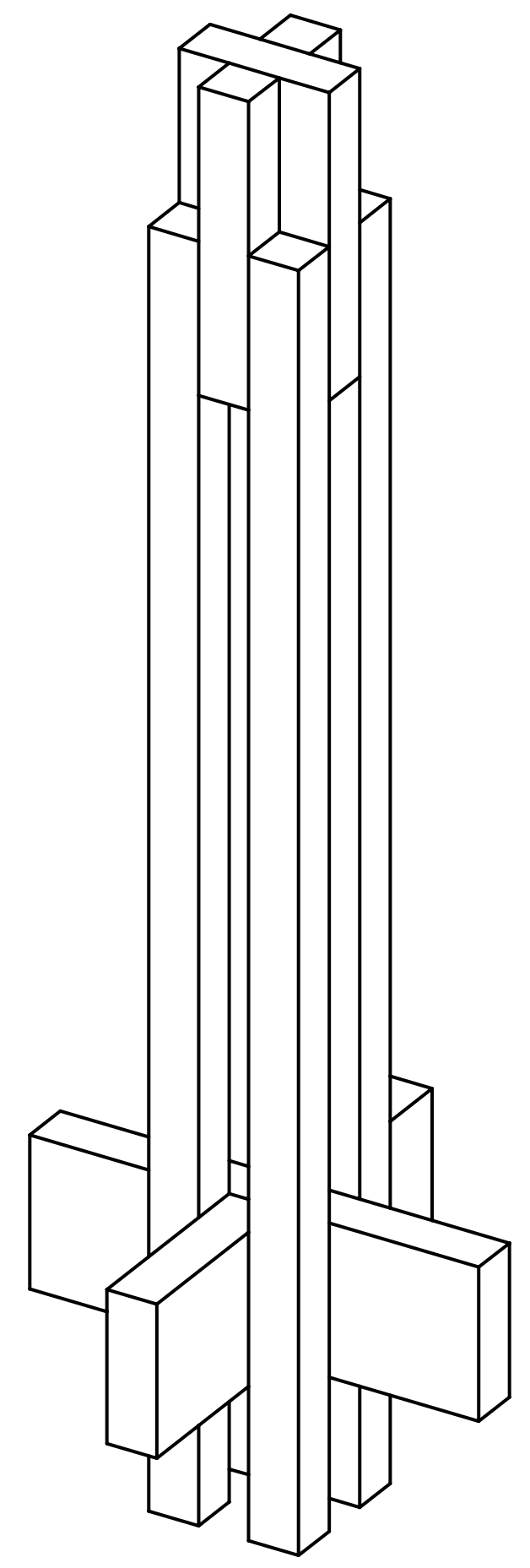

Component Optimization

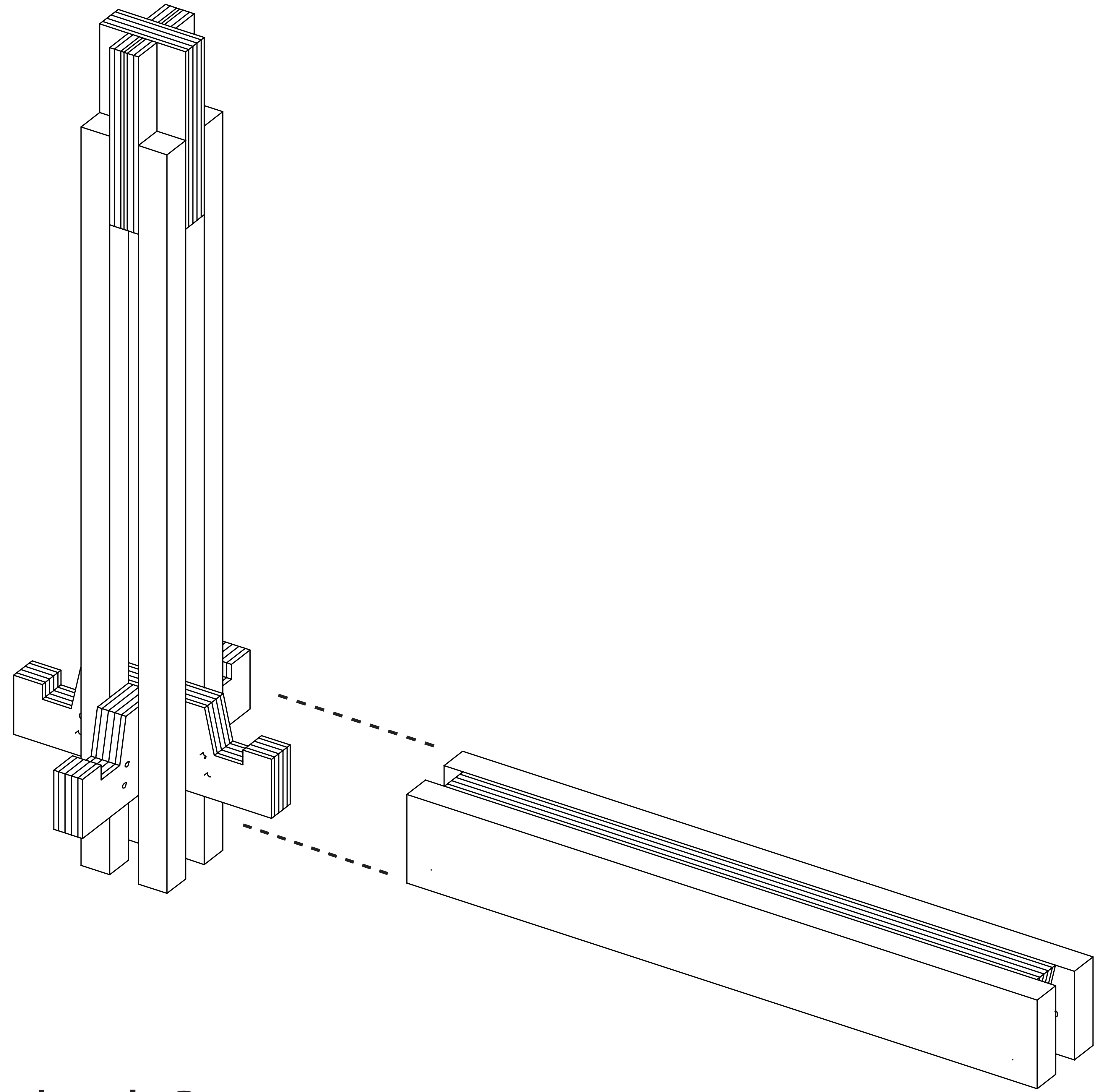

Resulted Component

CNC Cut 5 layer Laminated
Multiplex Joints: 6.5mm
9mm
9mm
9mm
6.5mm

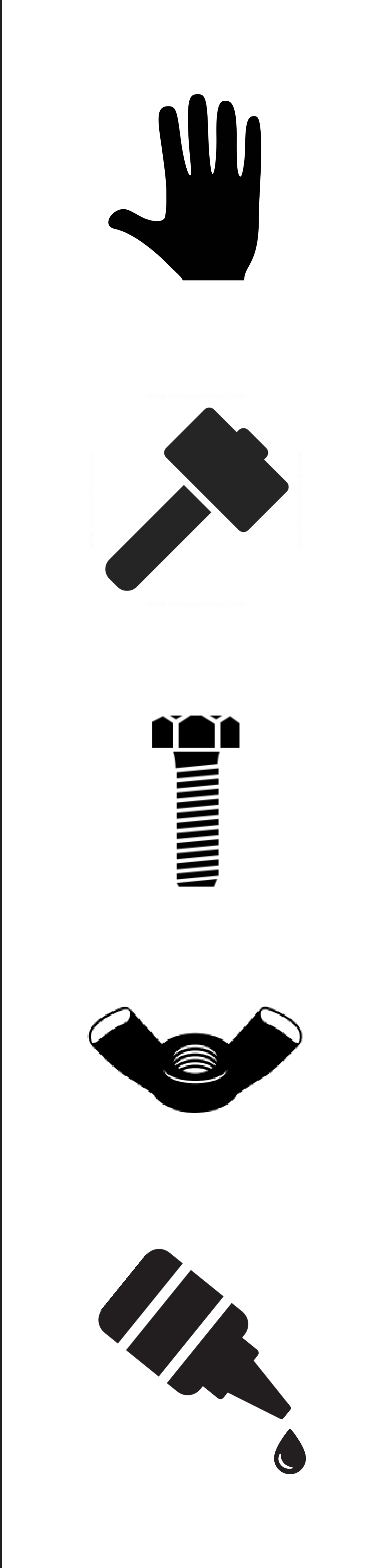
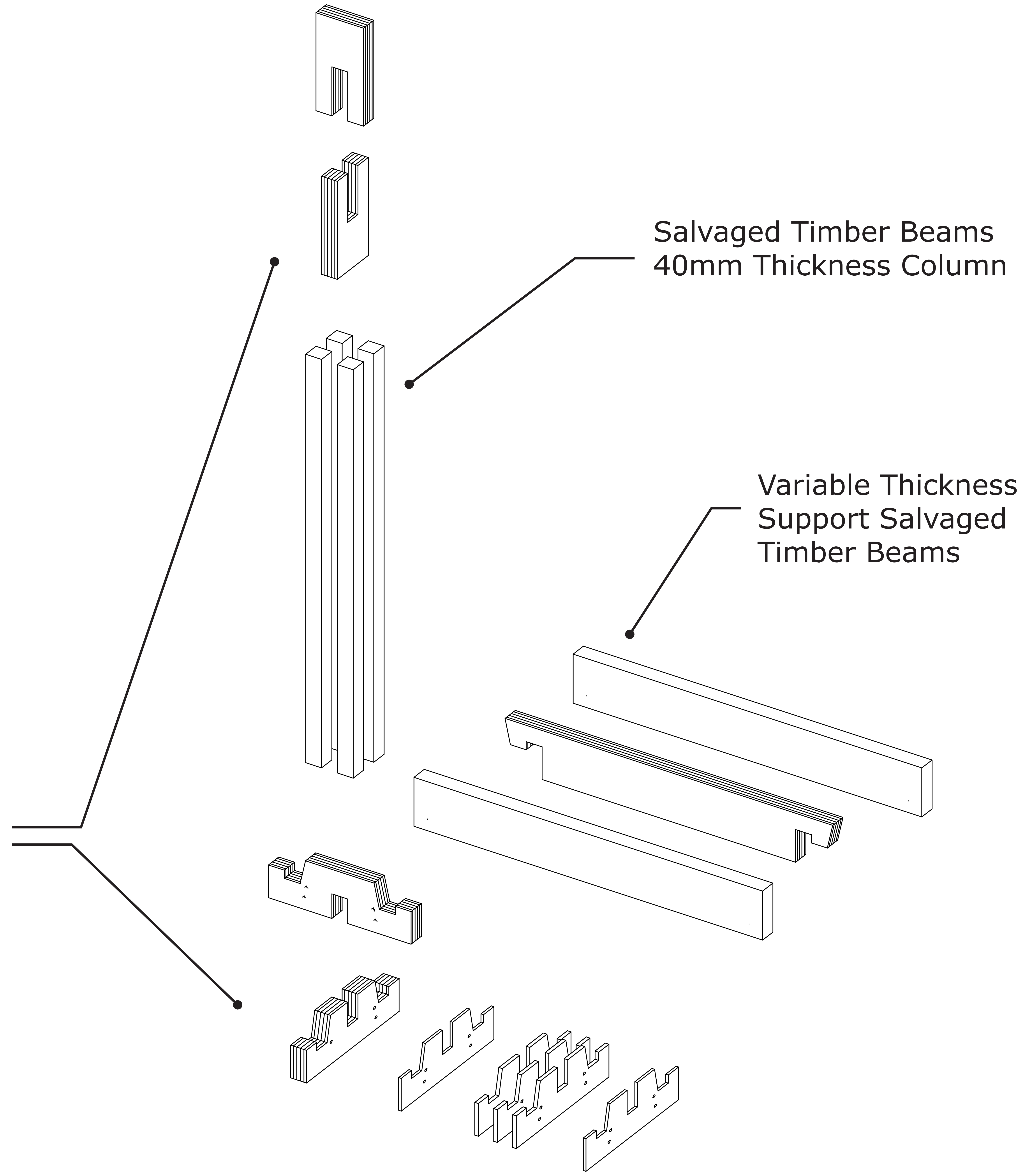

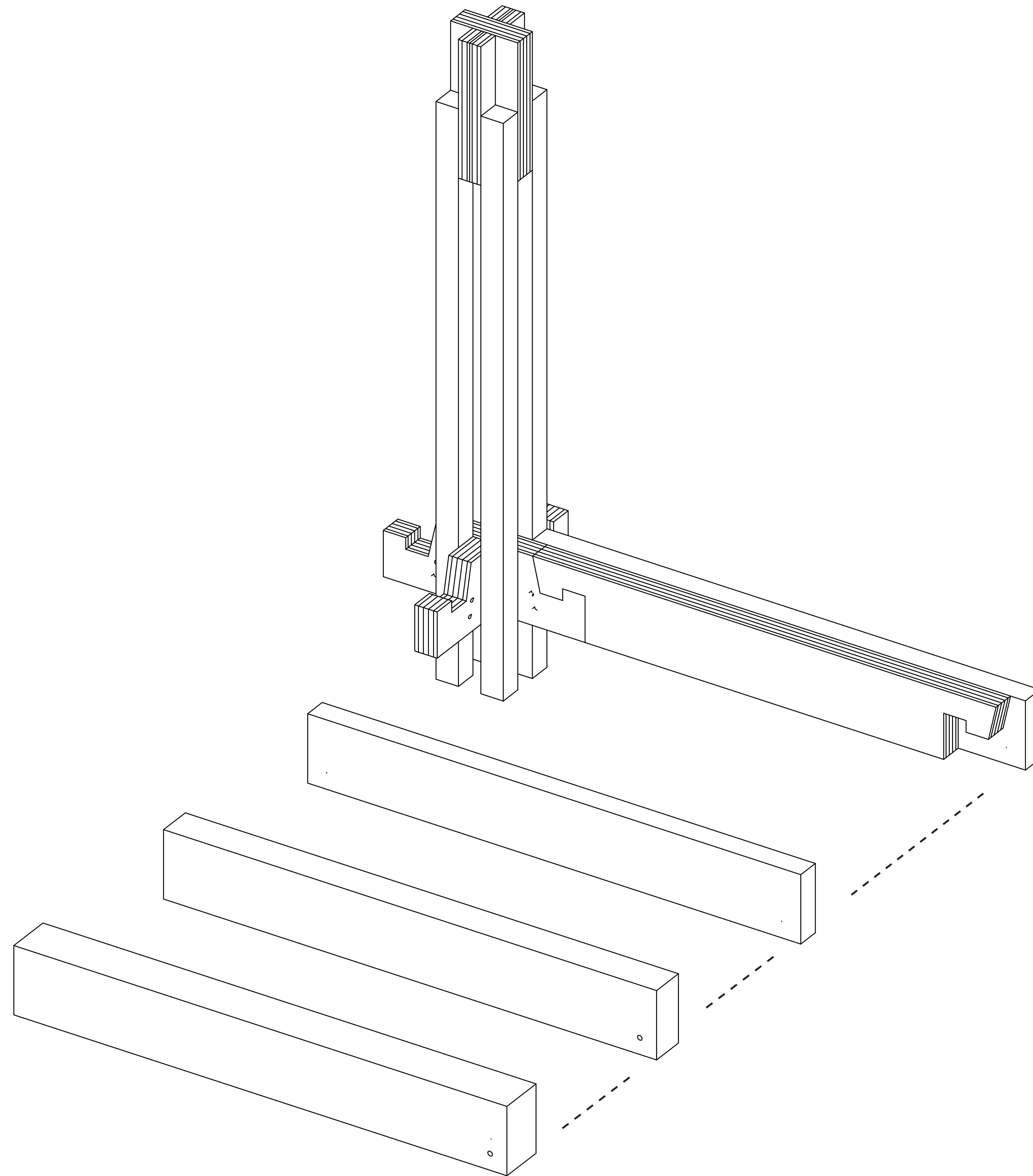

Variable Size Timber Beam Joining System

Modular System Building Elements

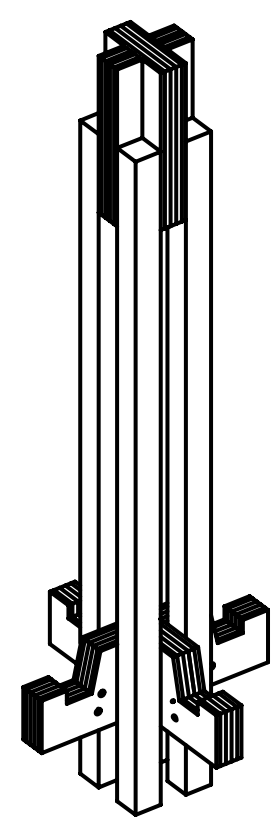

1. Main Component

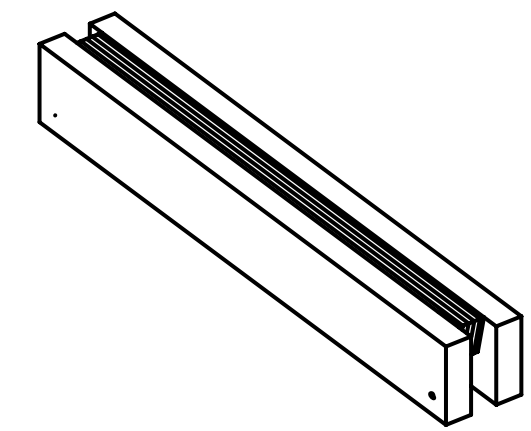

2. Expansion Beam

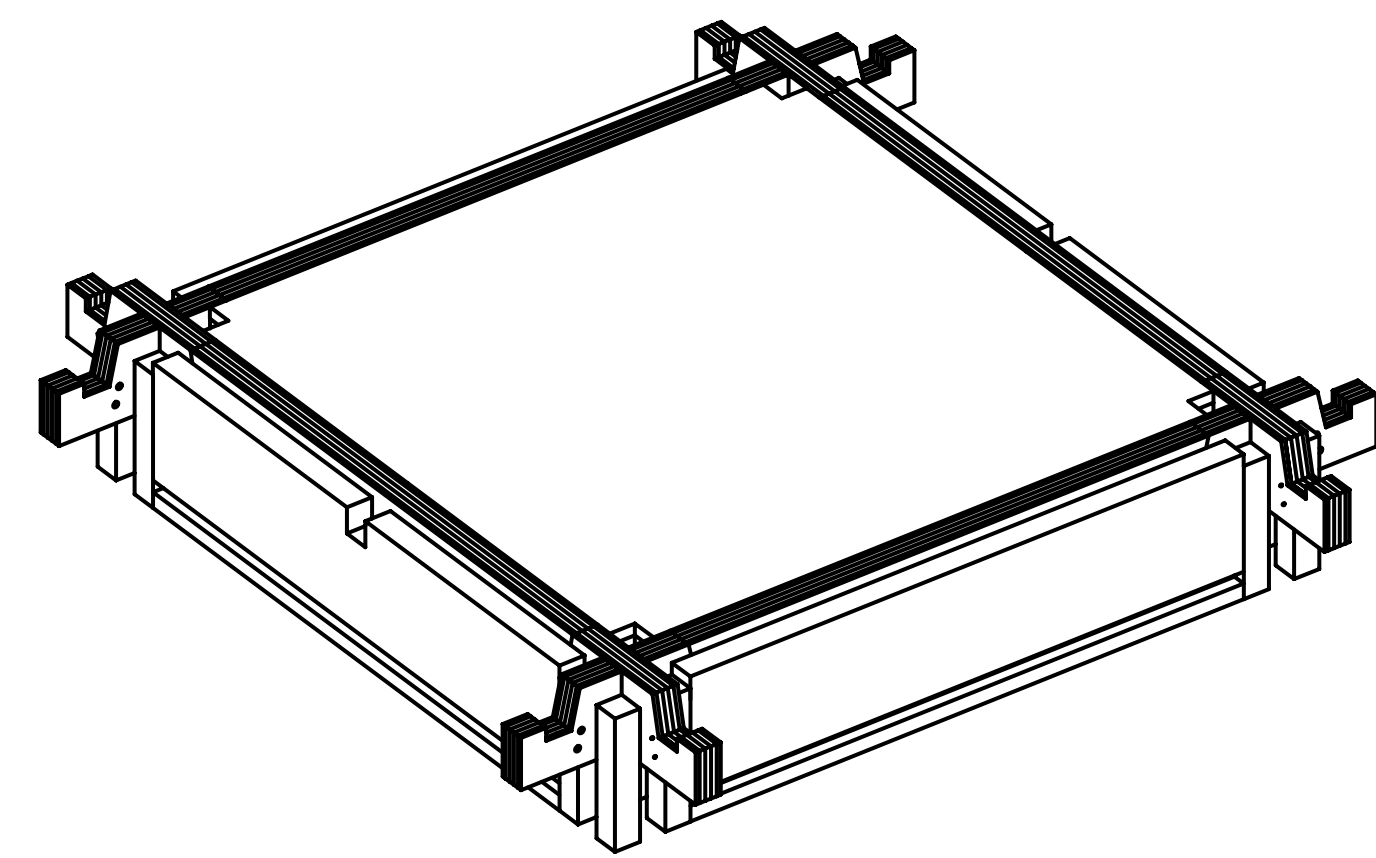

3. Floor Component

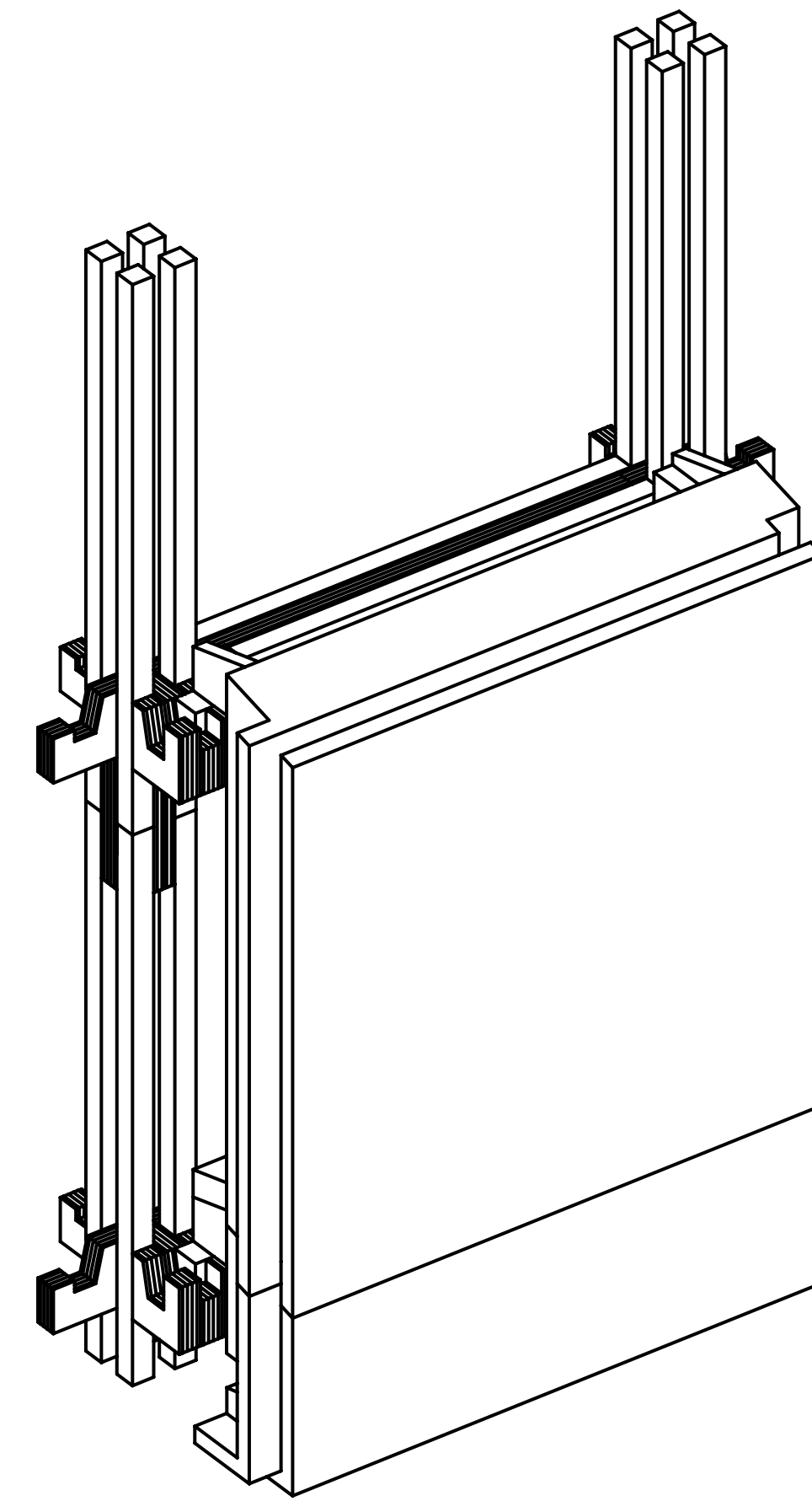

4. Exterior Facade Plastic Component

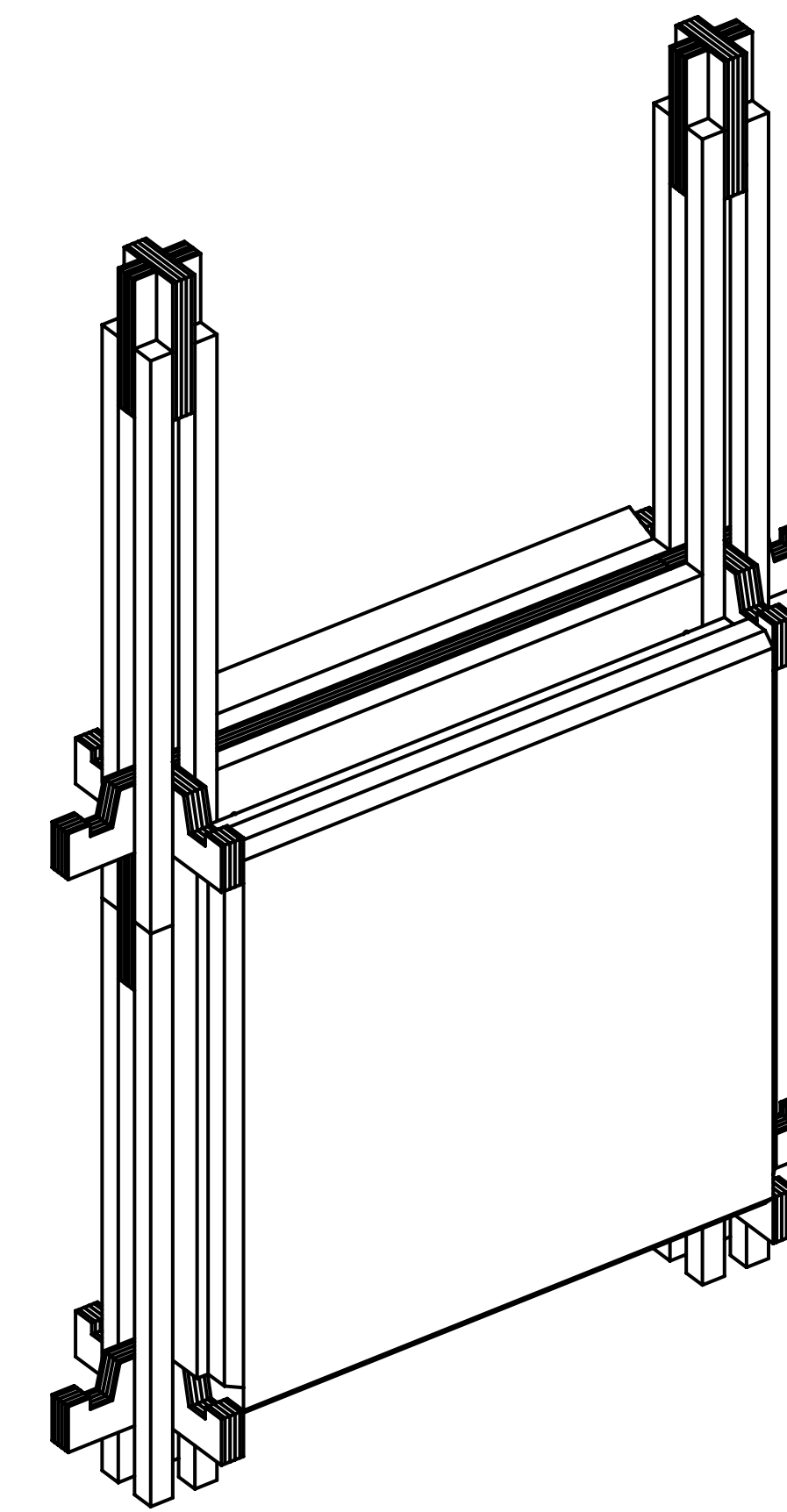

5. Interior Facade Component

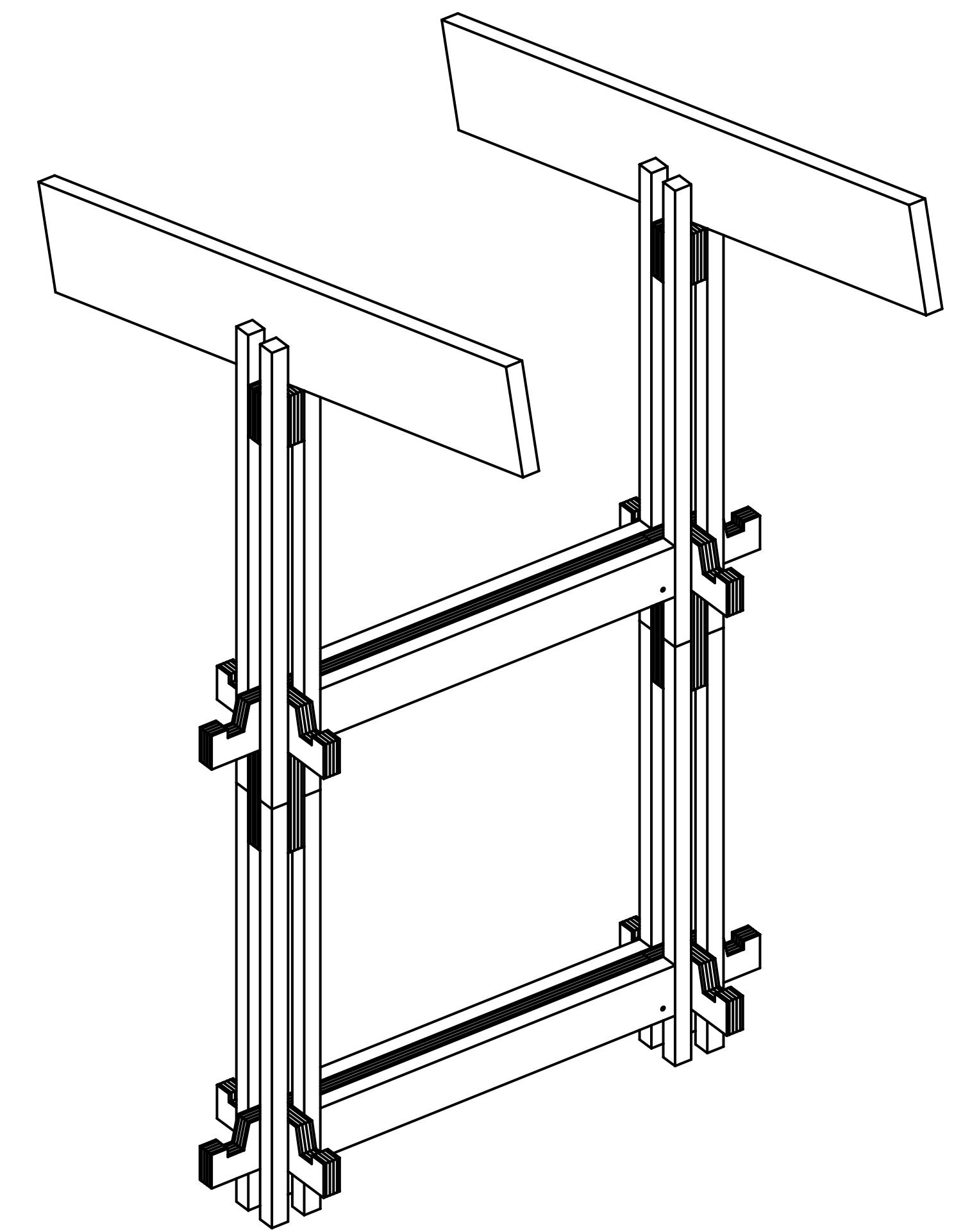

6. Roof Connection

Floor Component

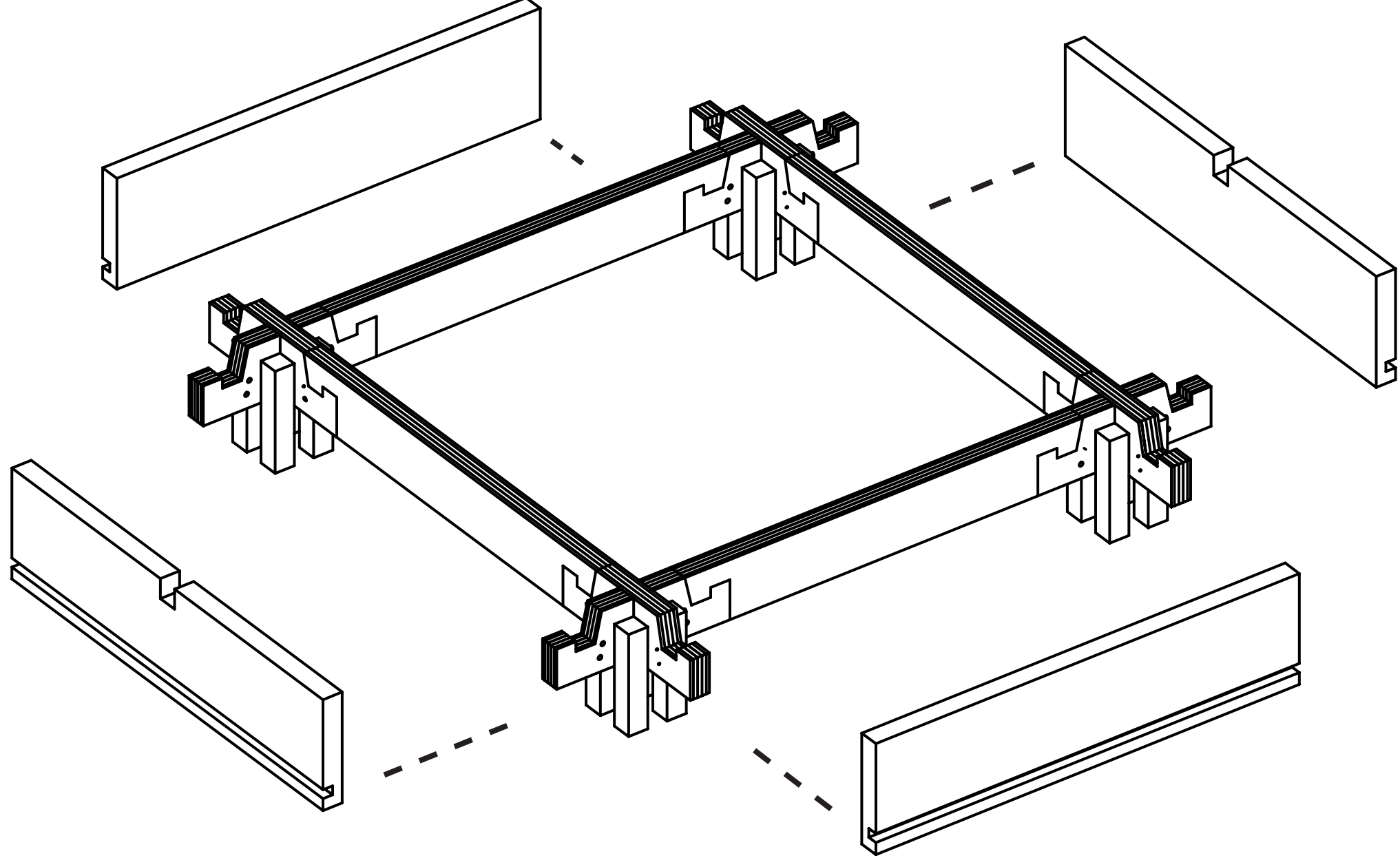
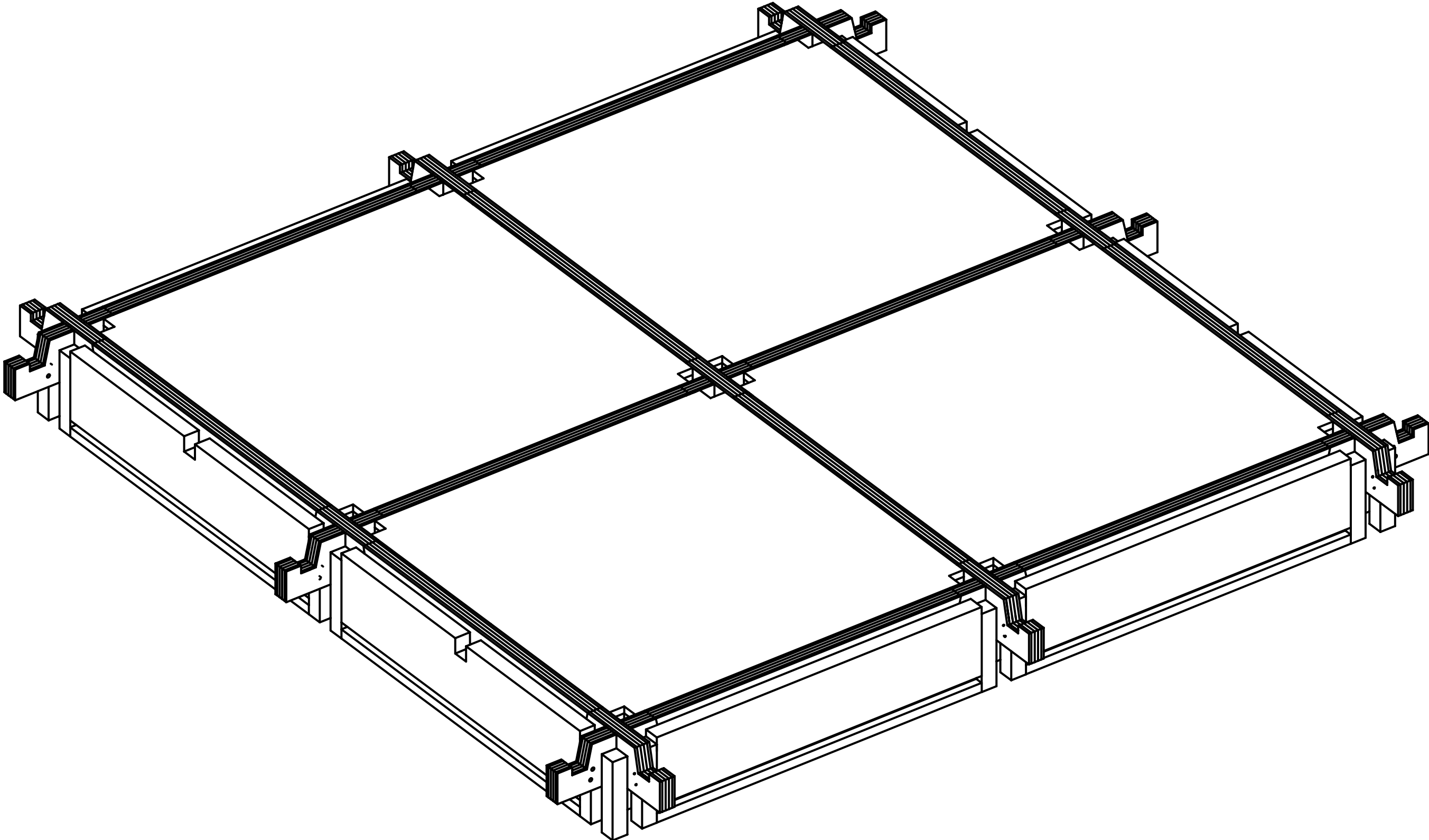
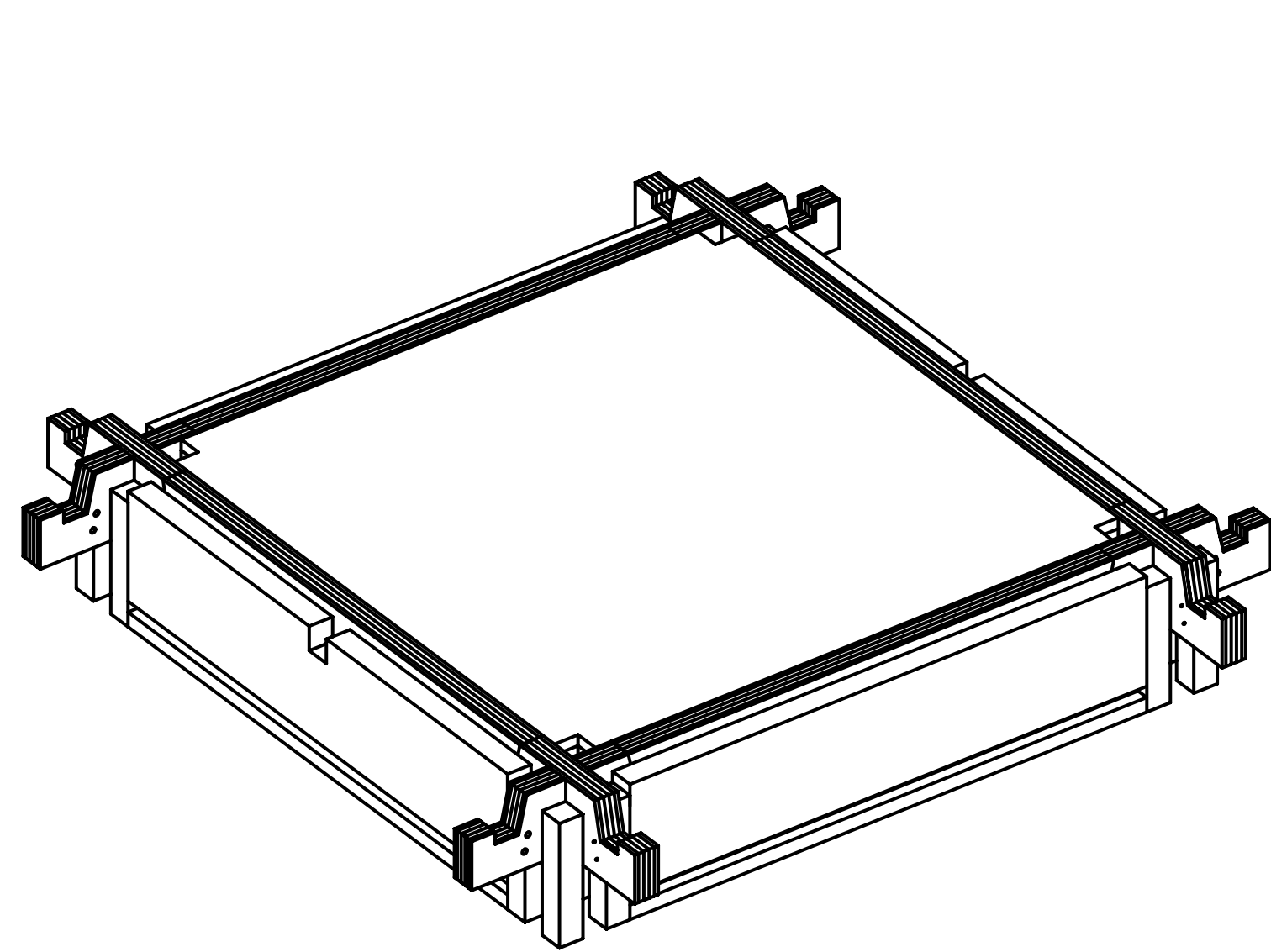
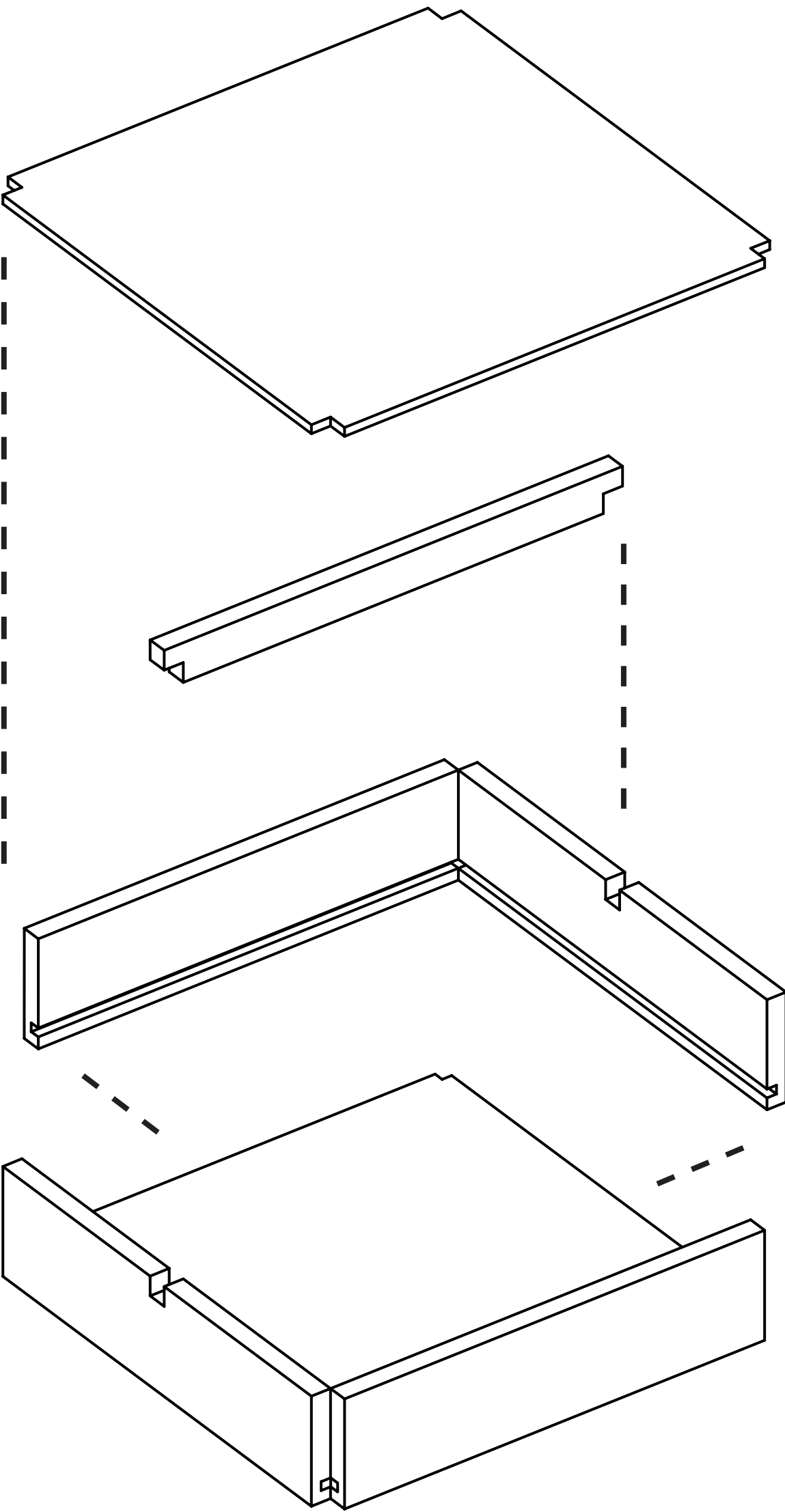
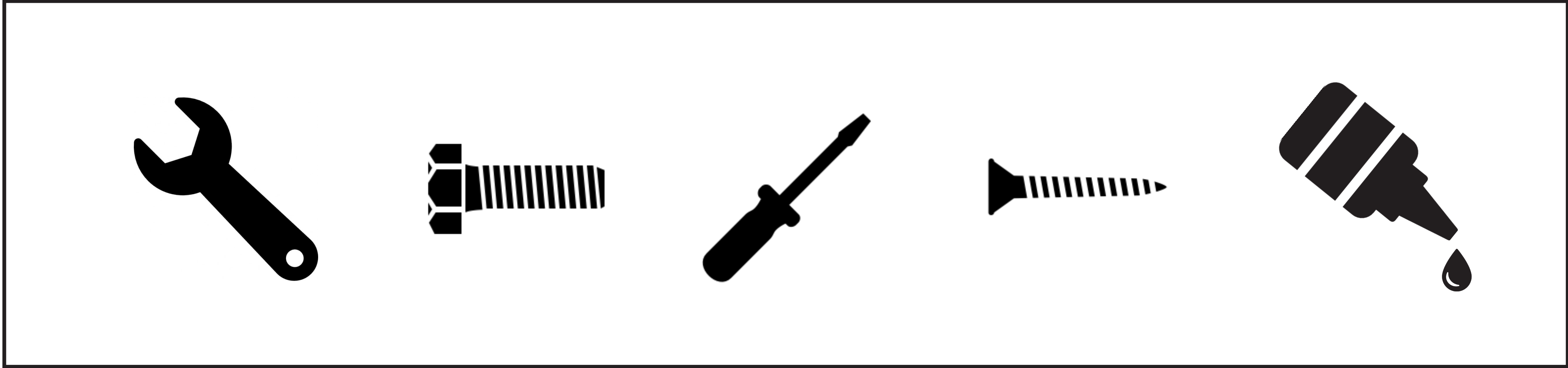
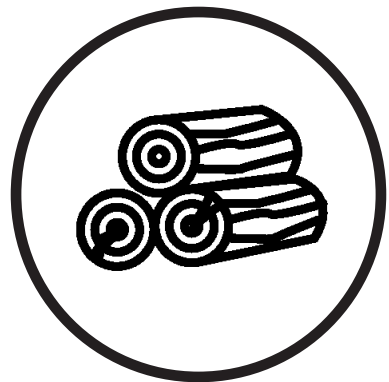

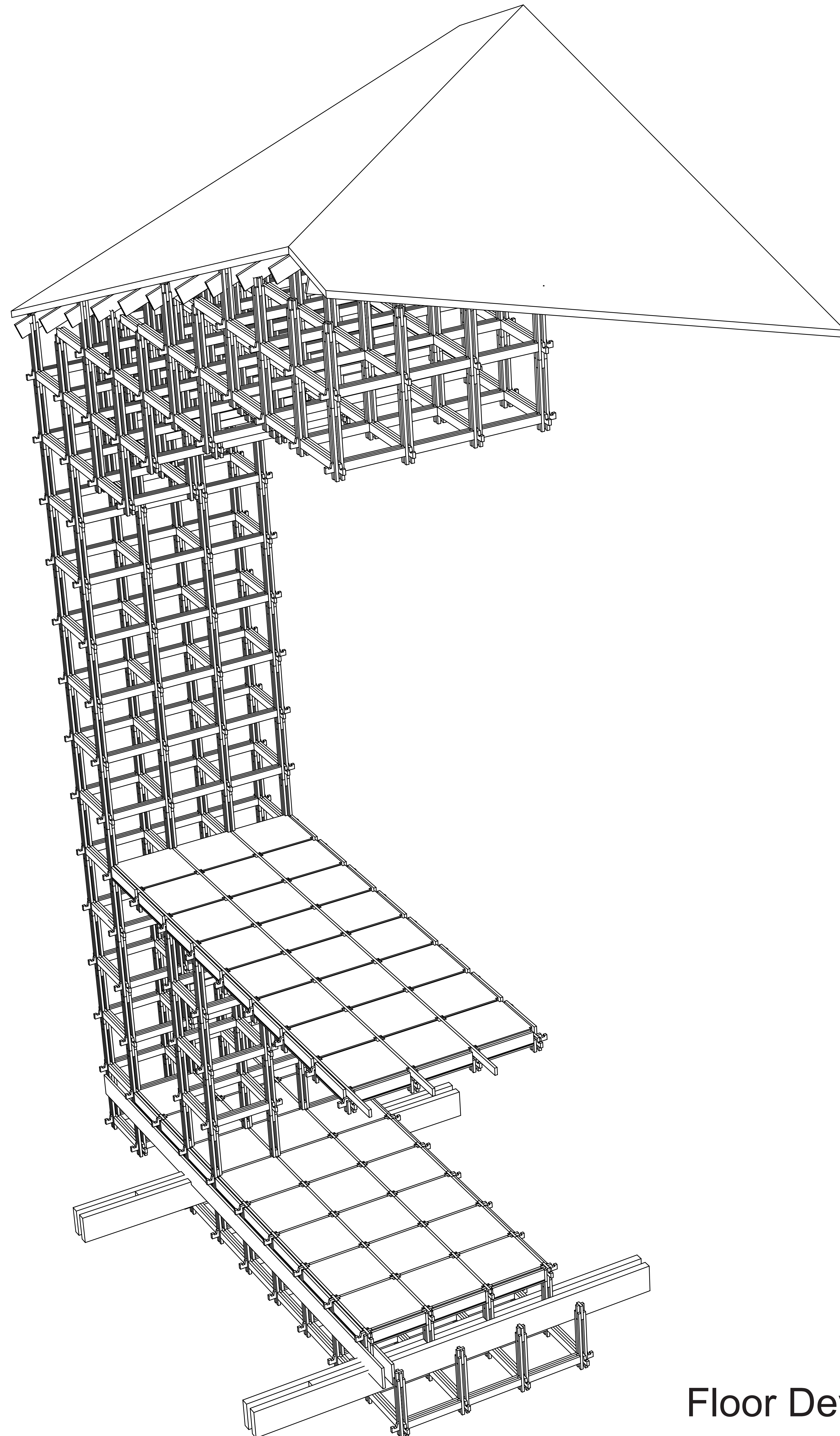

Floor Development Buliding Fragment

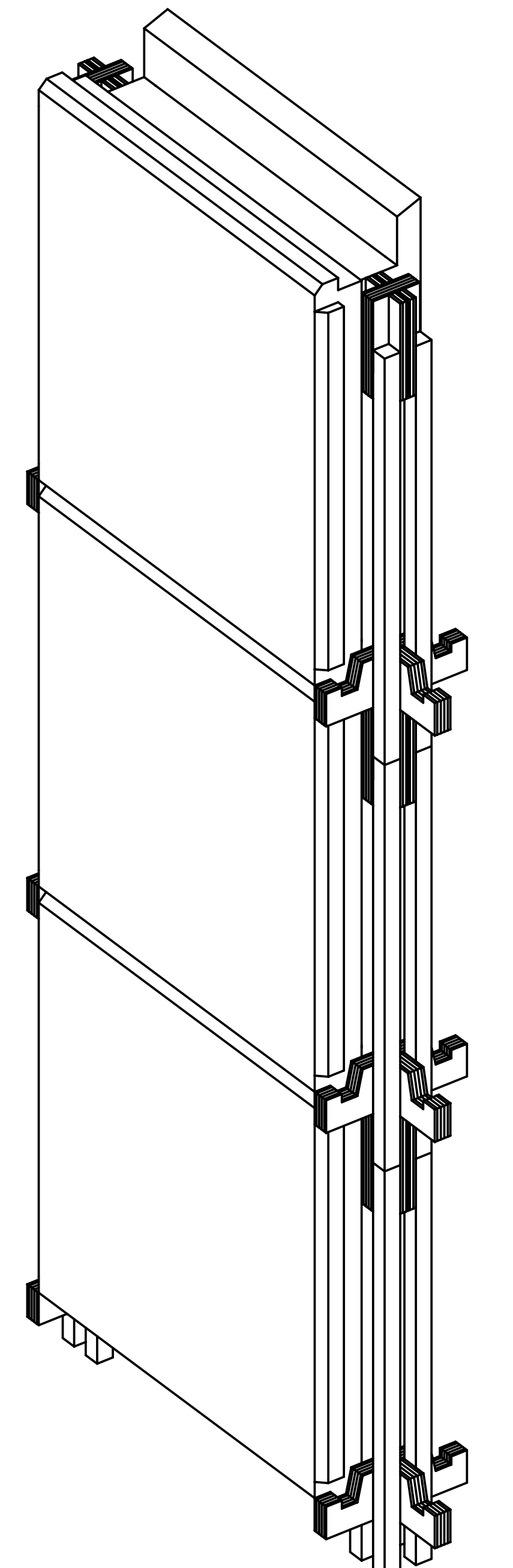
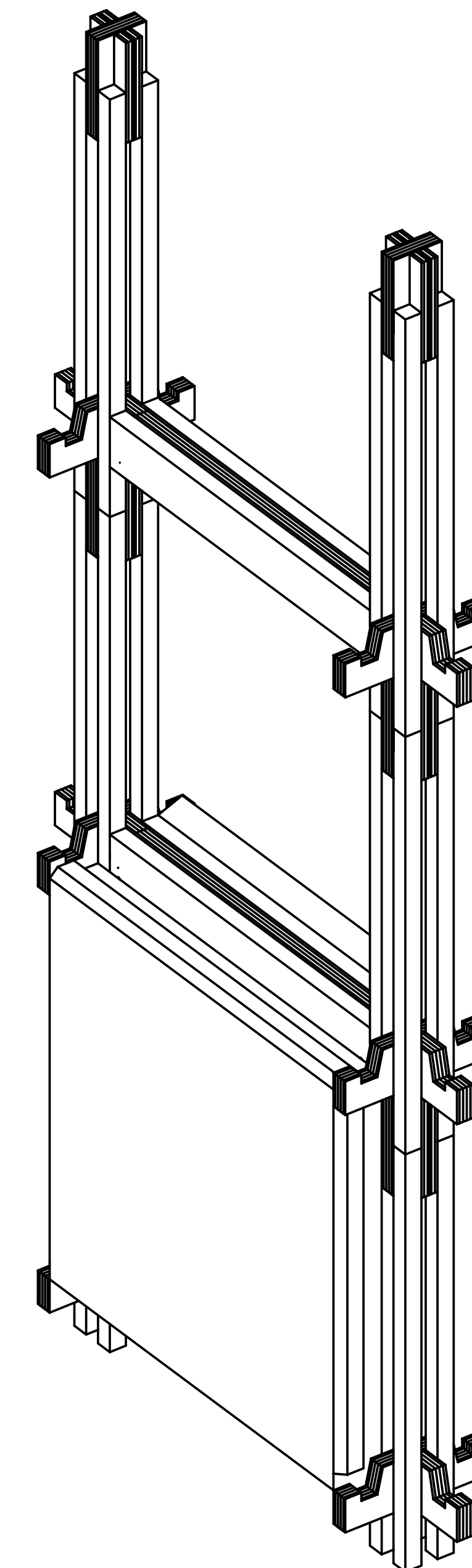
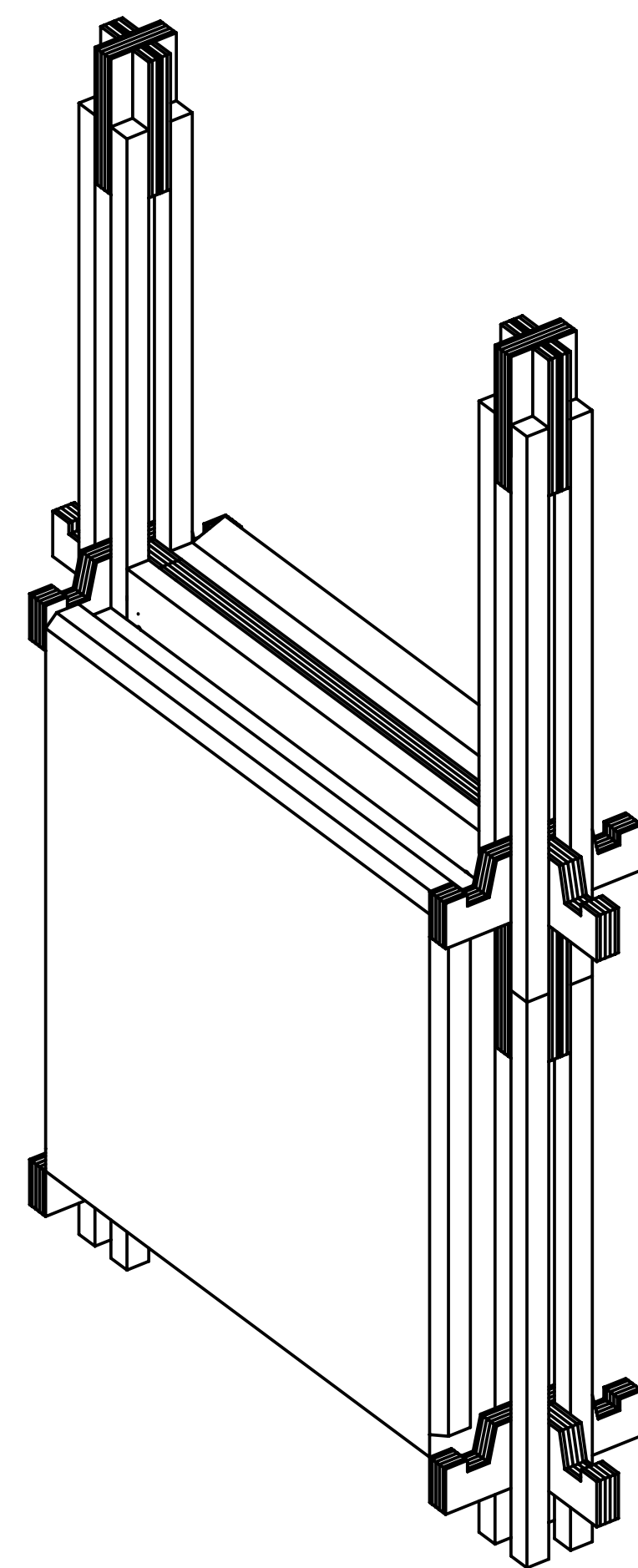
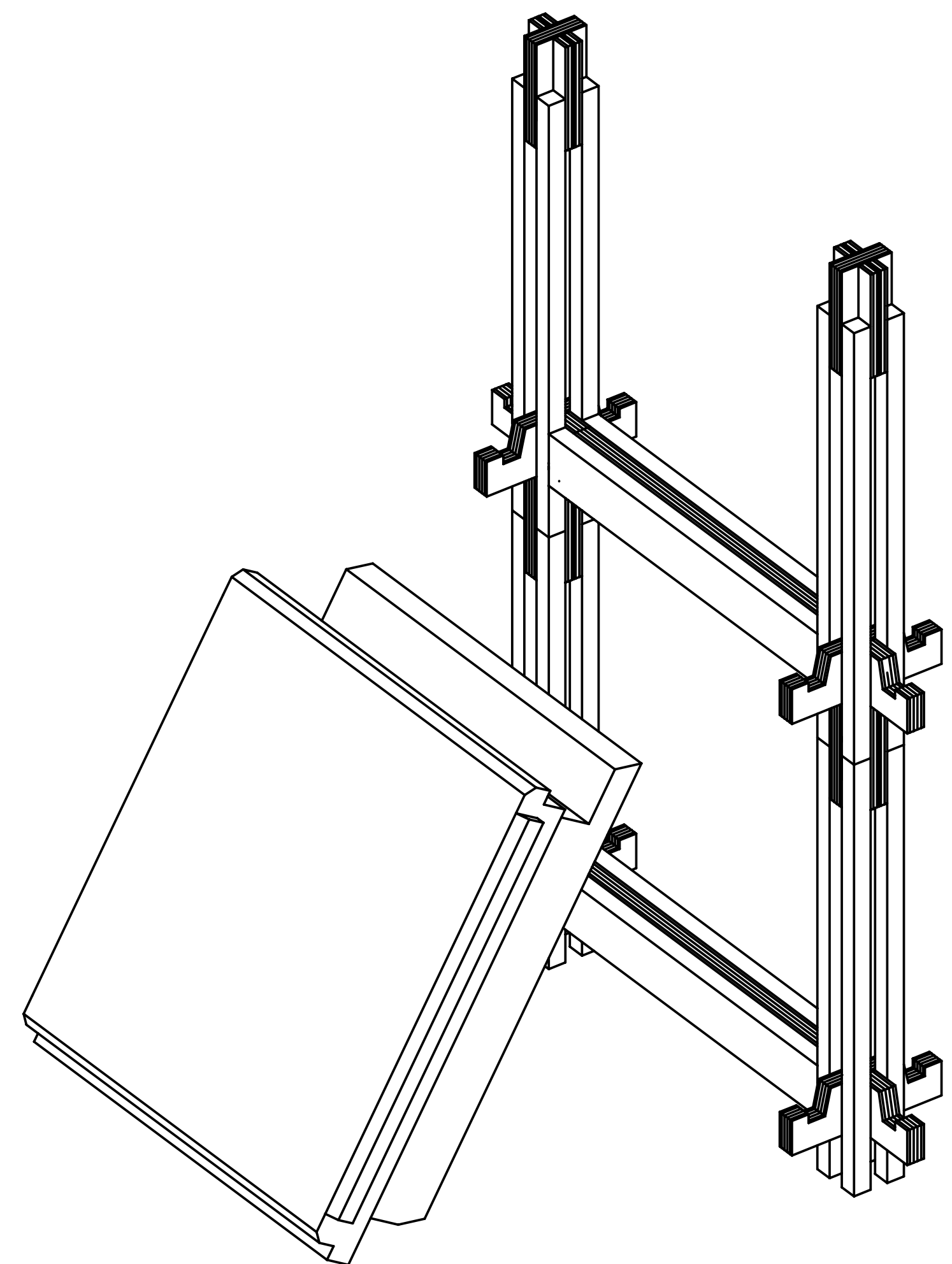
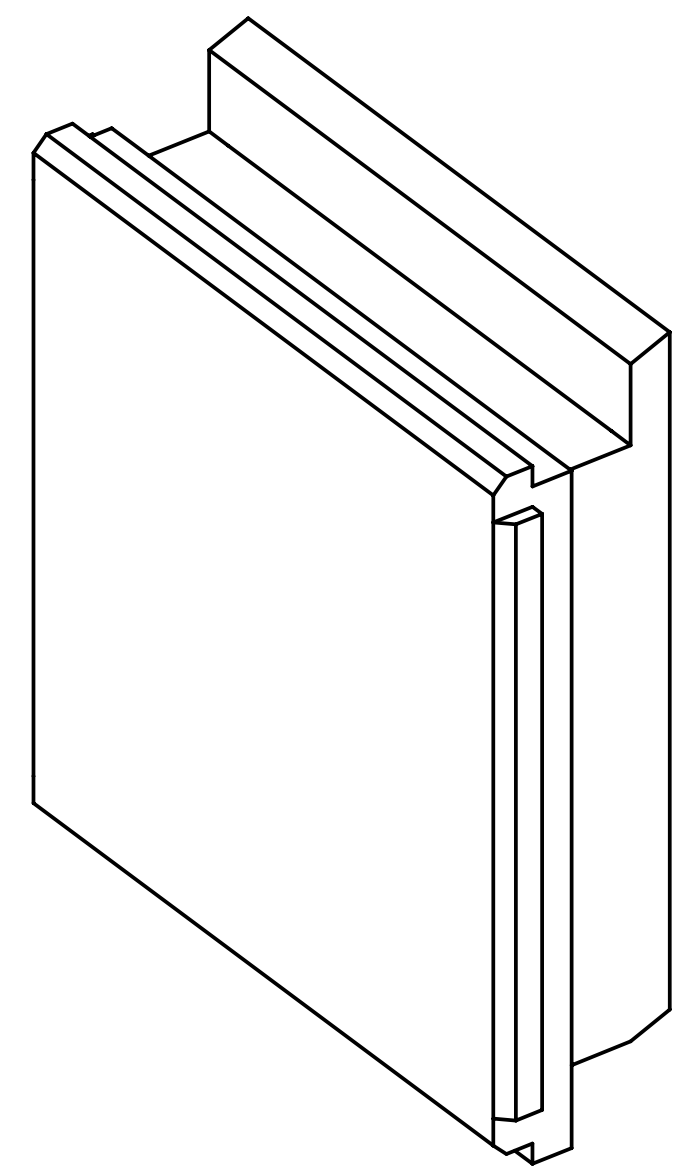
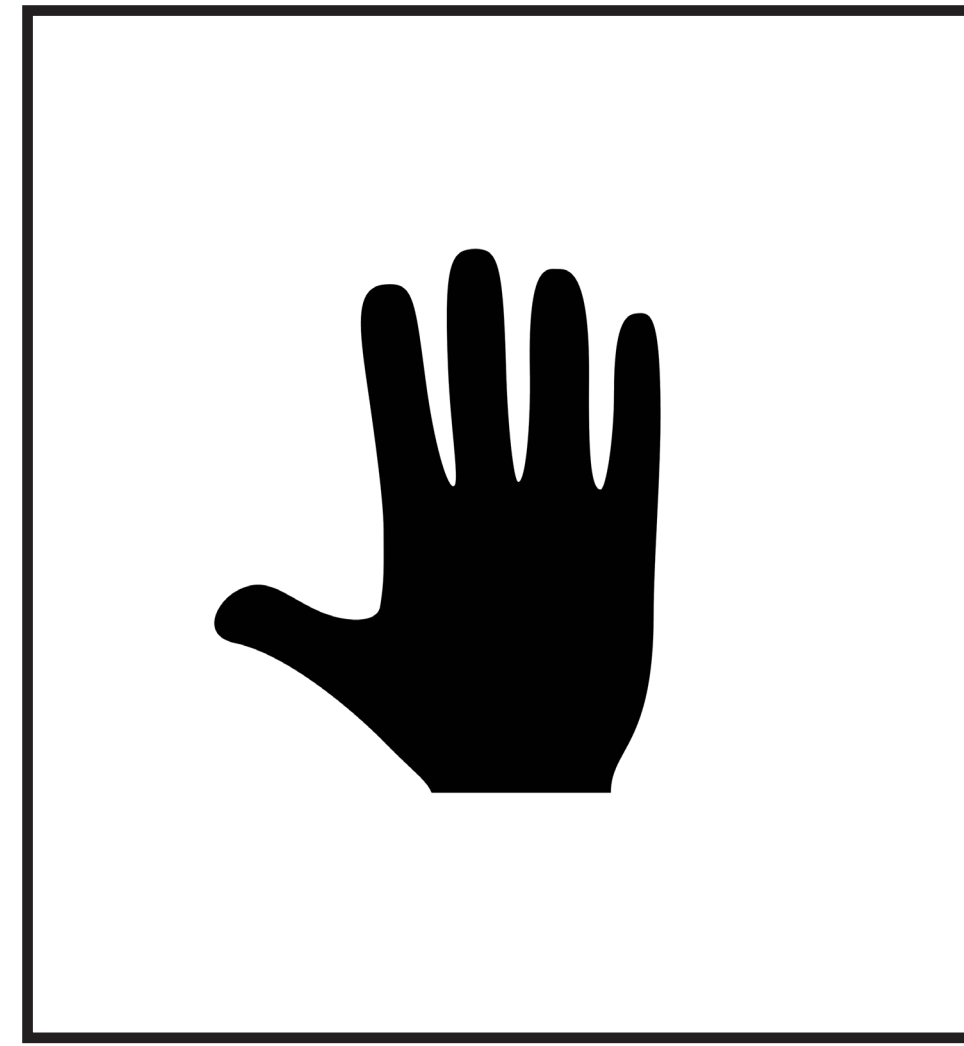

Interior Facade Plastic Component



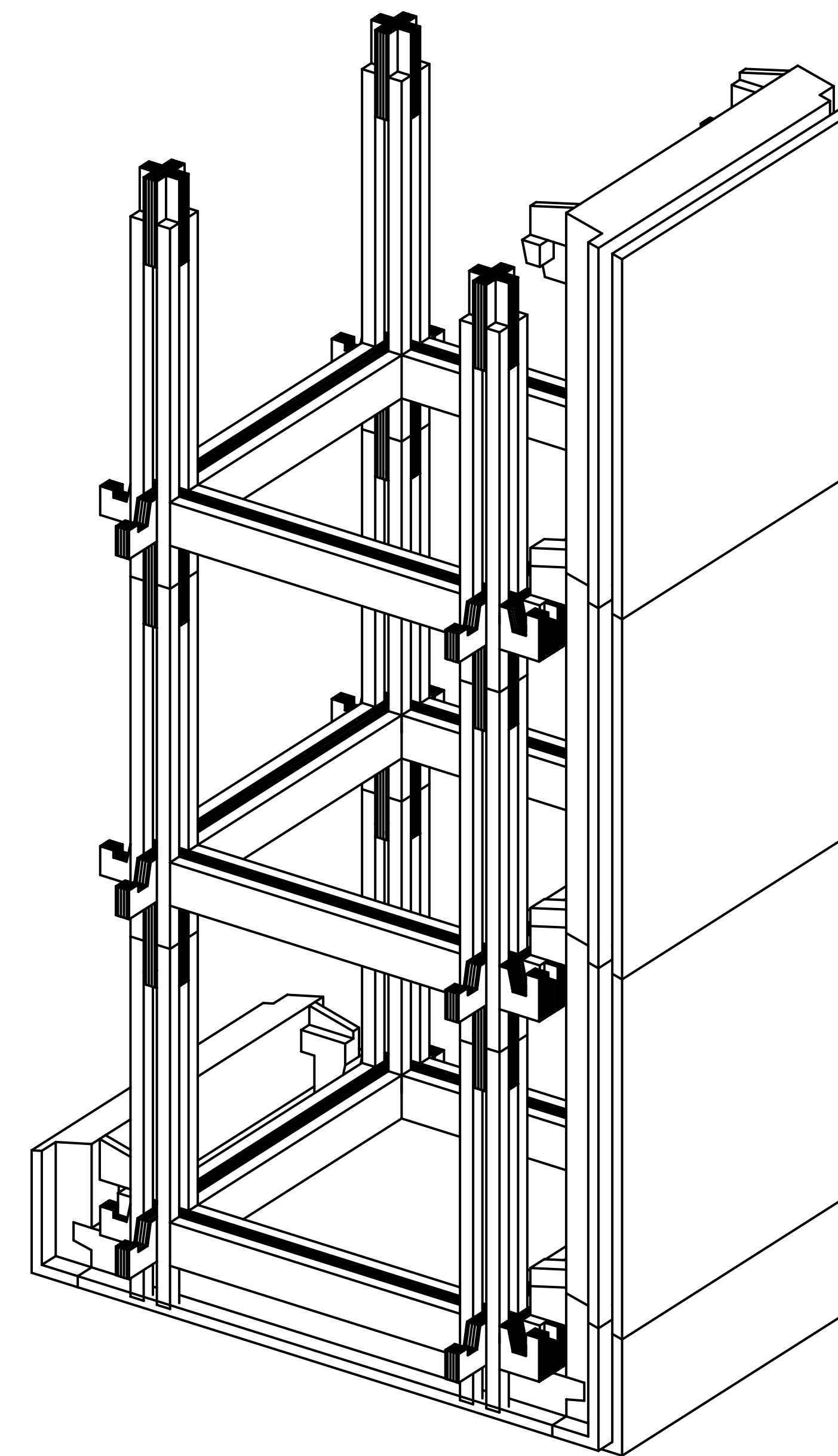
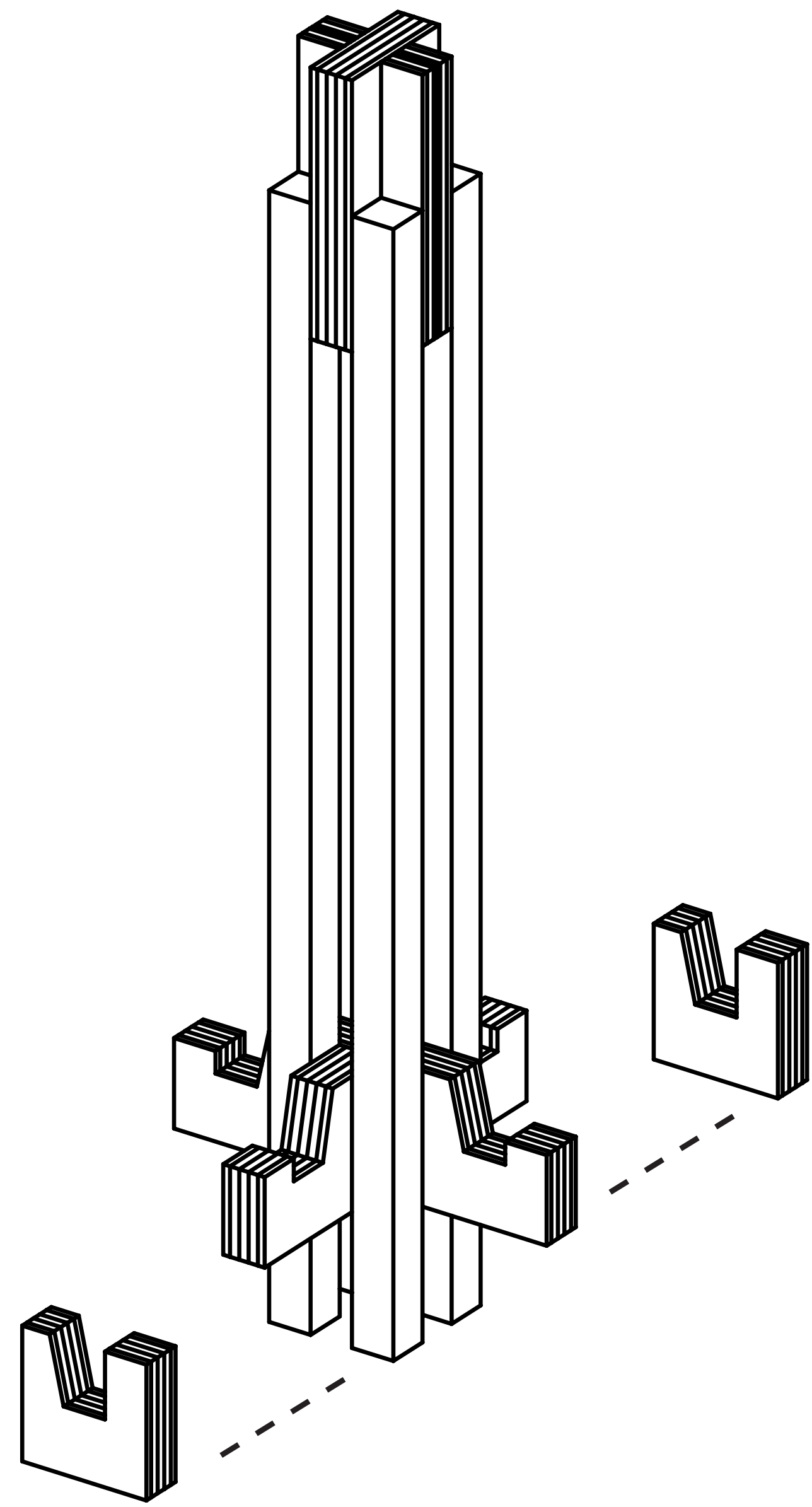
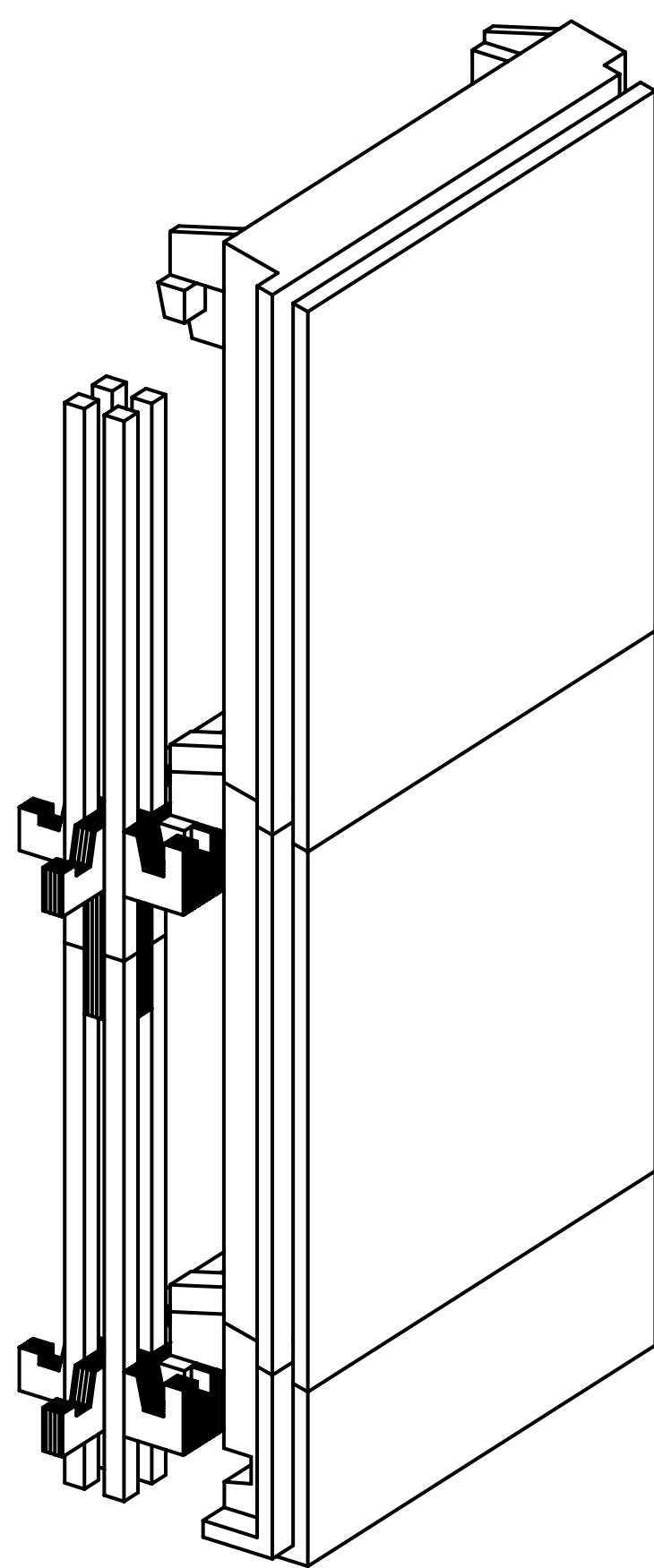
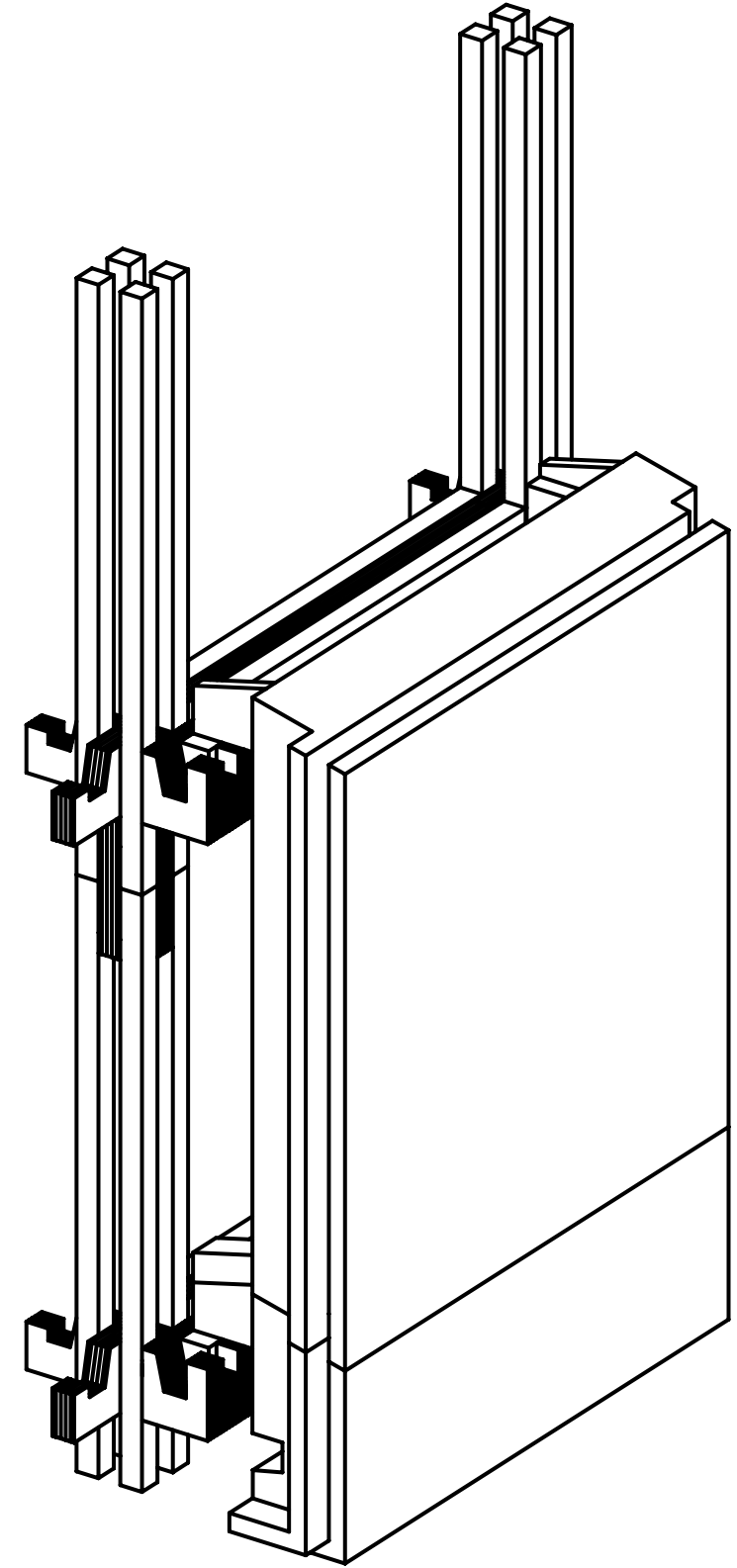
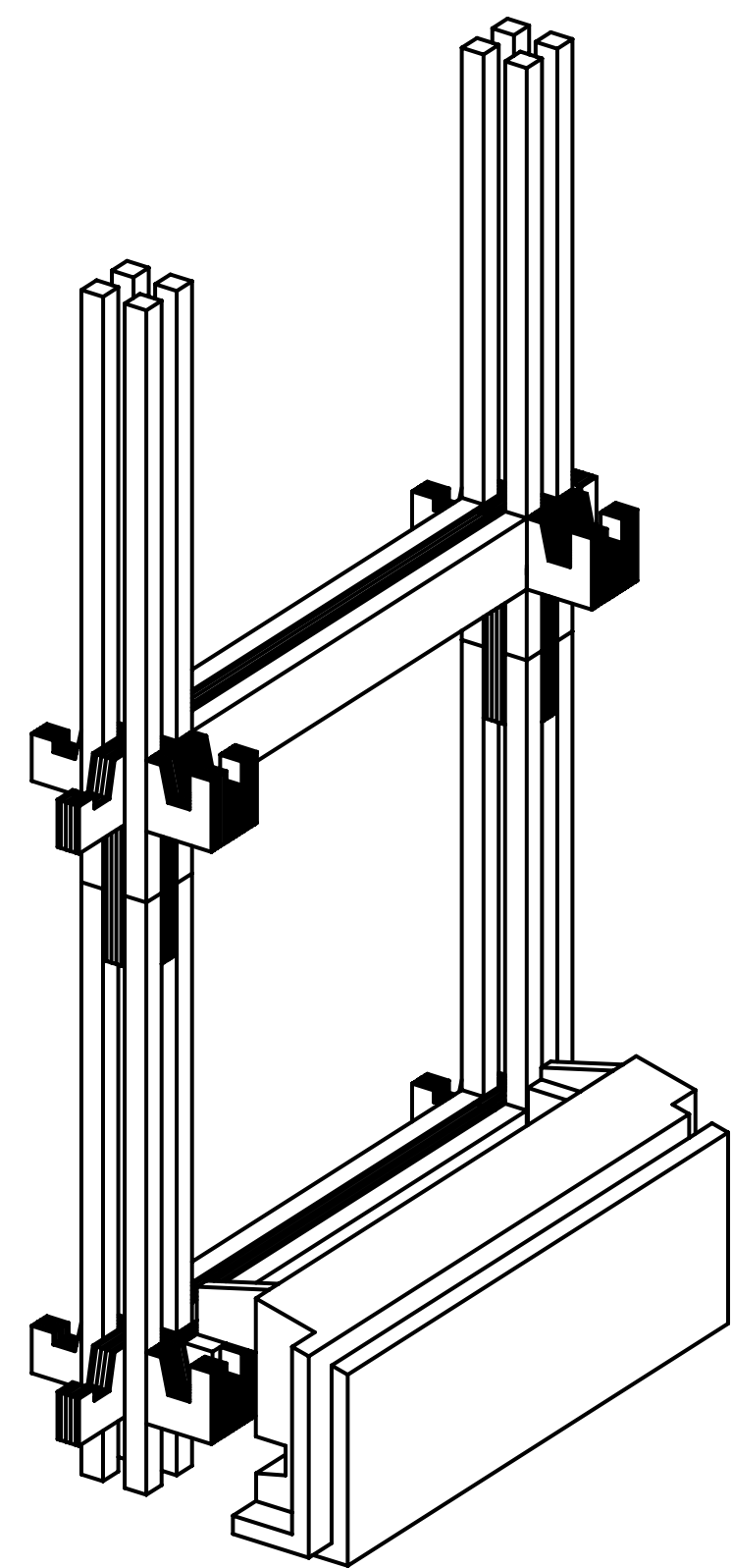
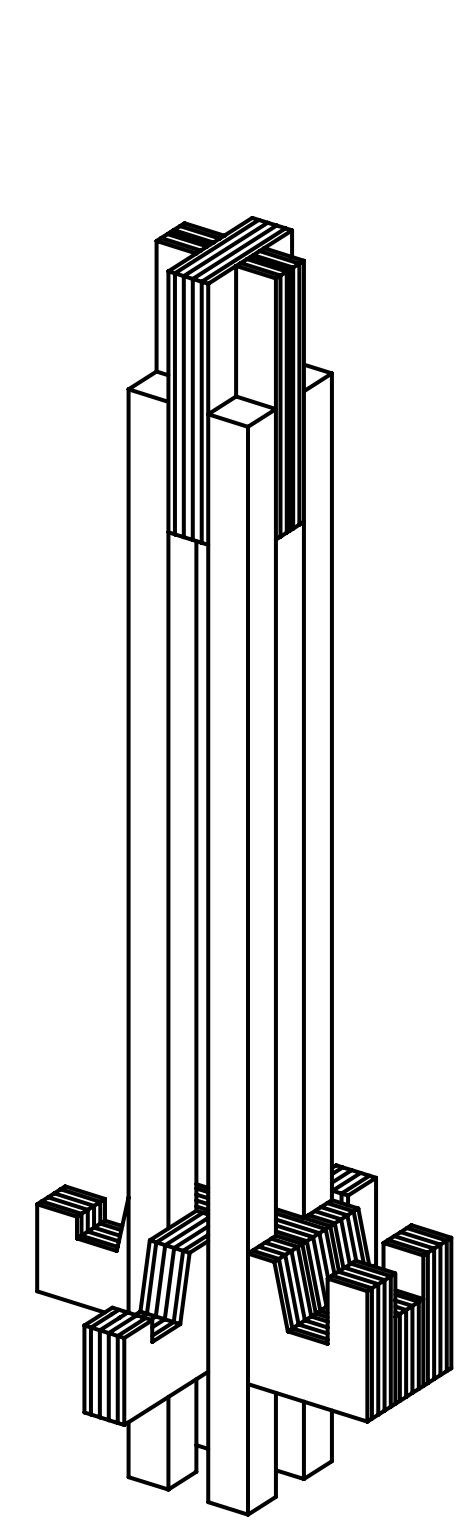

Exterior Facade Plastic Component

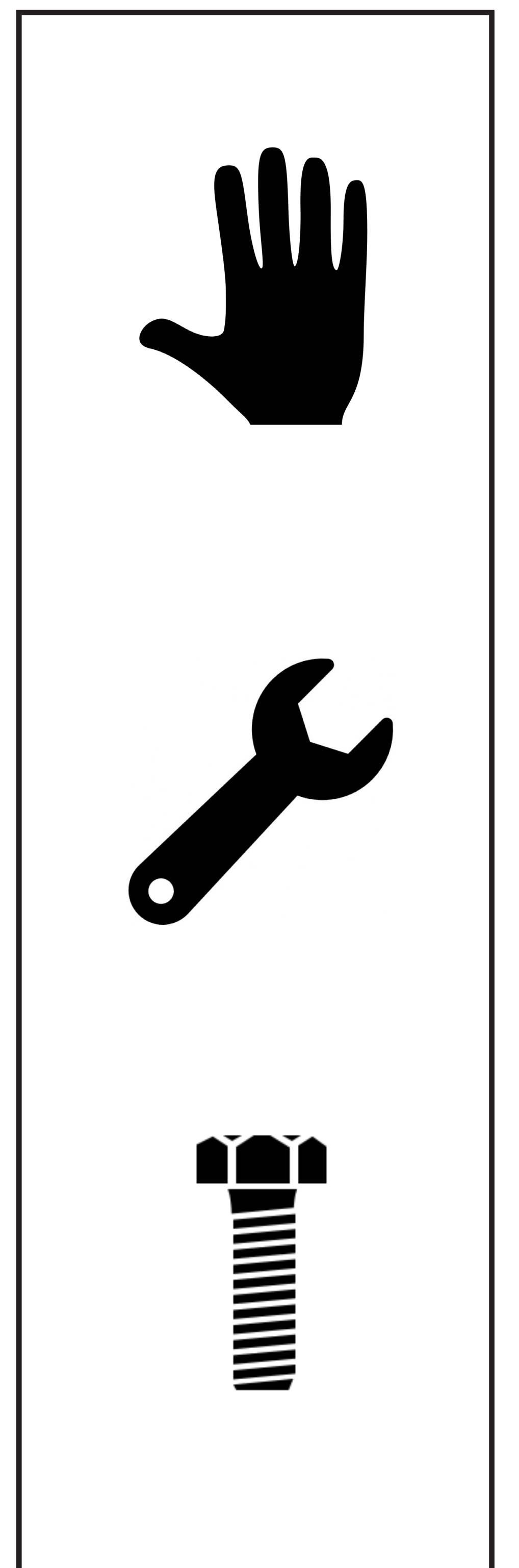

Variable Size Timber Framework Integration

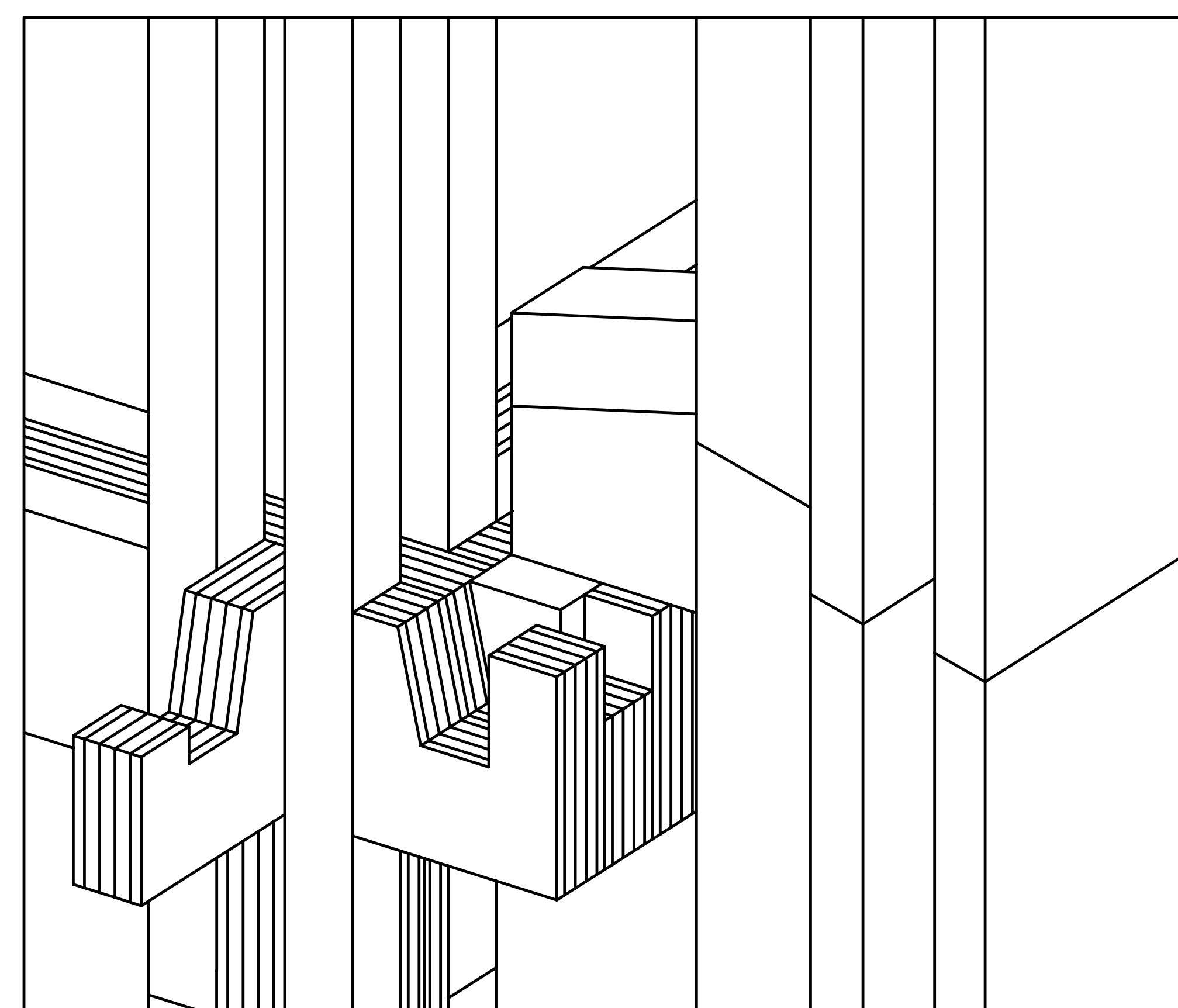
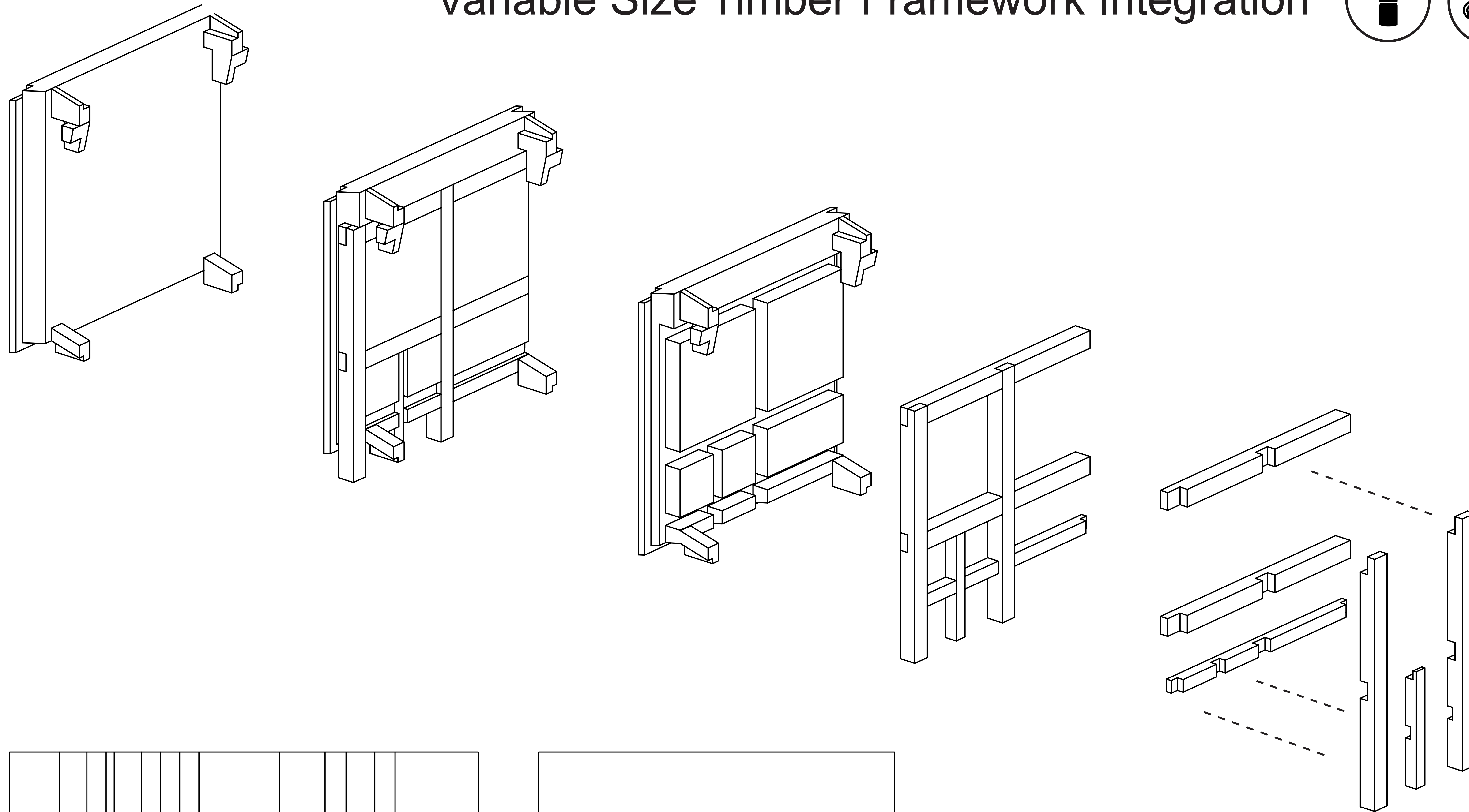
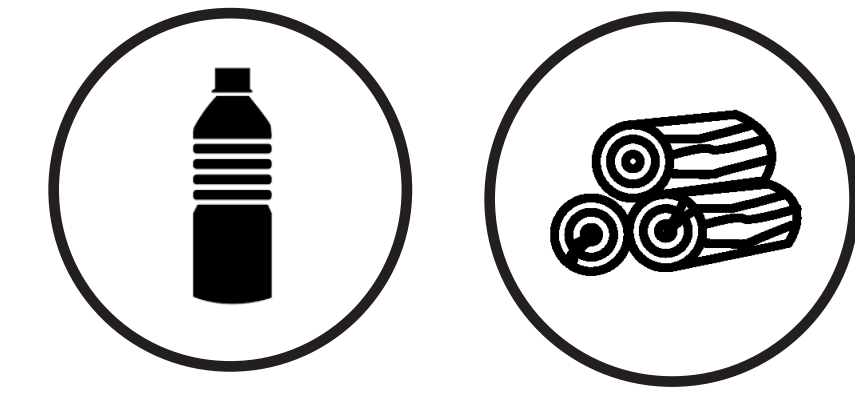

Detail Connection with main frame

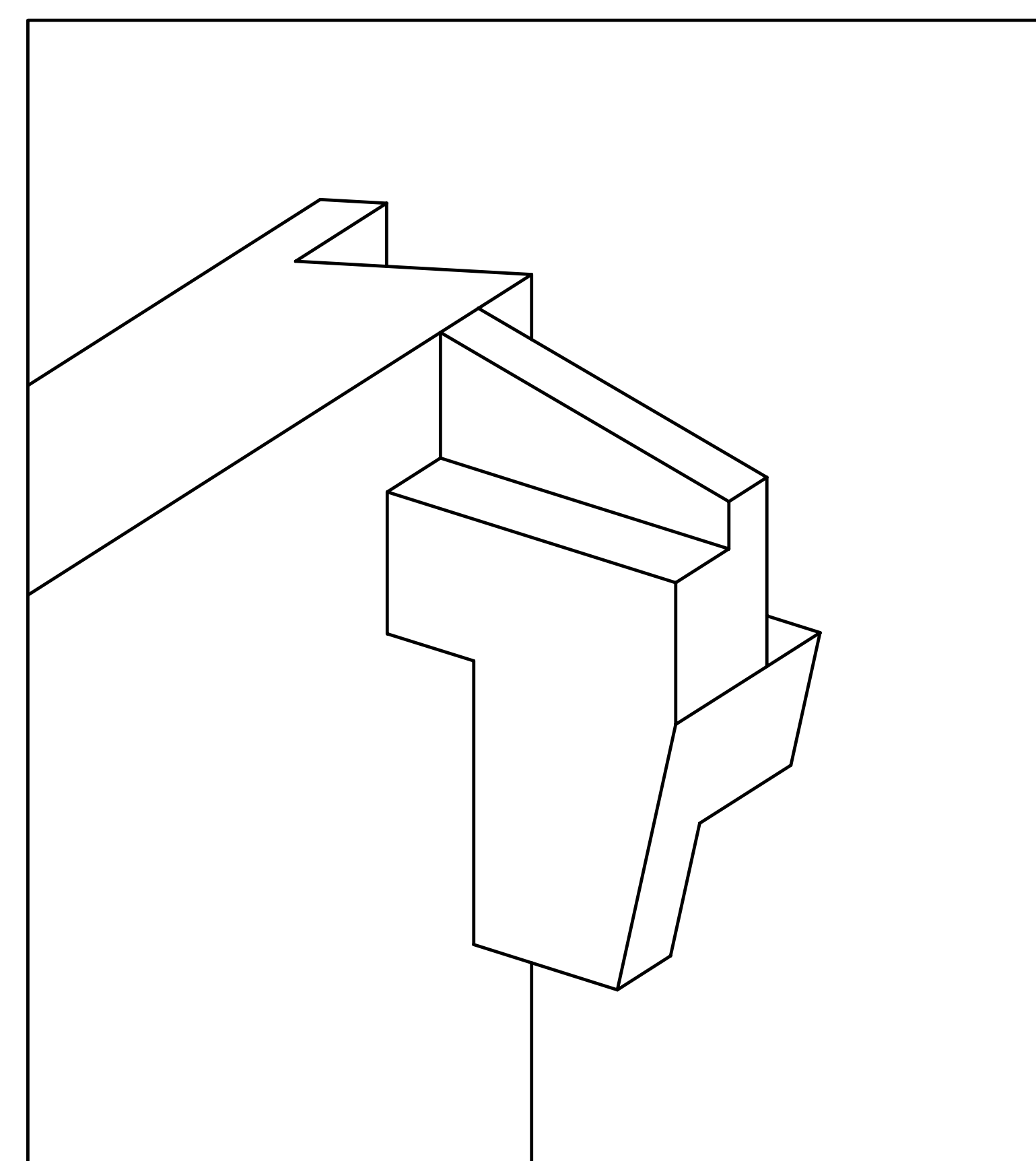

Plastic Joint Detail

Exterior Facade Timber Framework

- Regulating Insolation
- Fluctuating Life-cycle
- Reuse Salvaged Wood
- Variable Timber Types & Dimensions

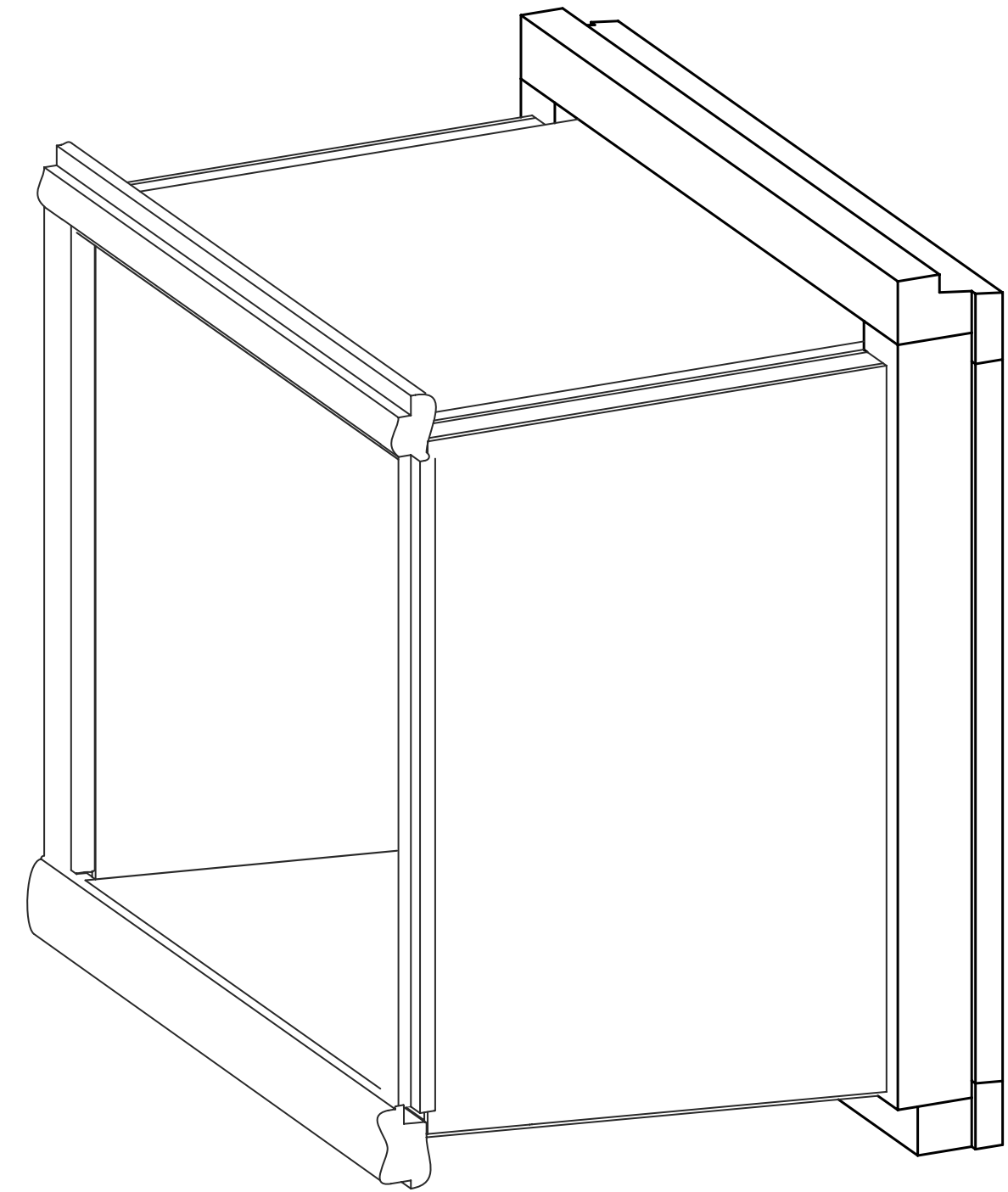
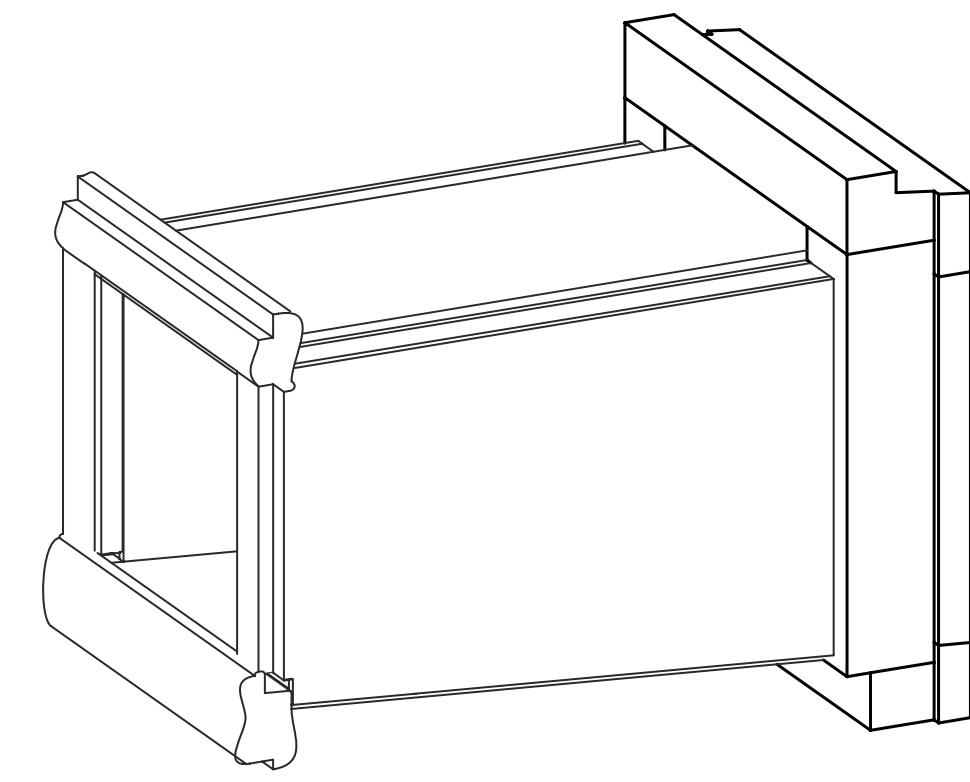
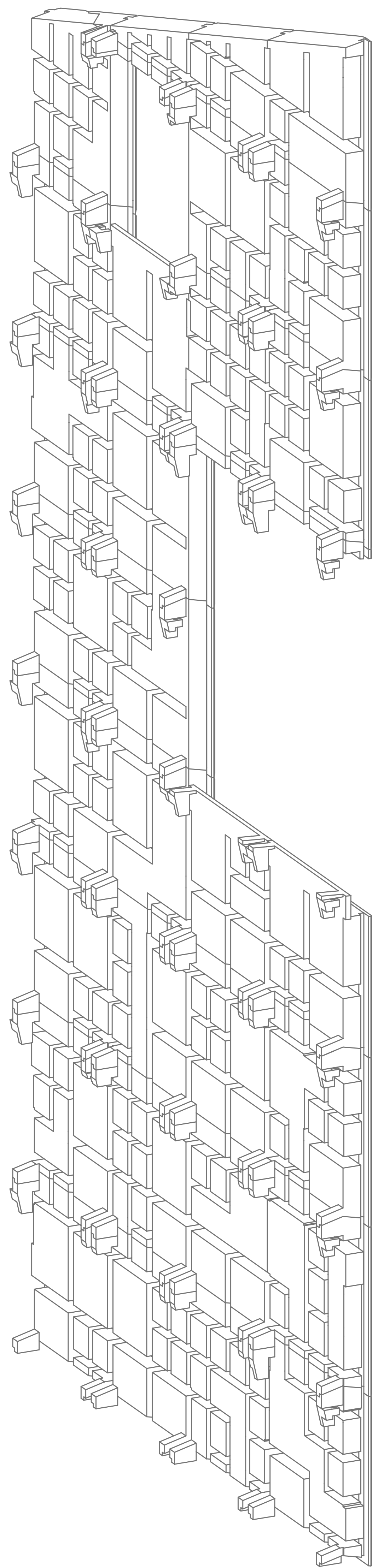
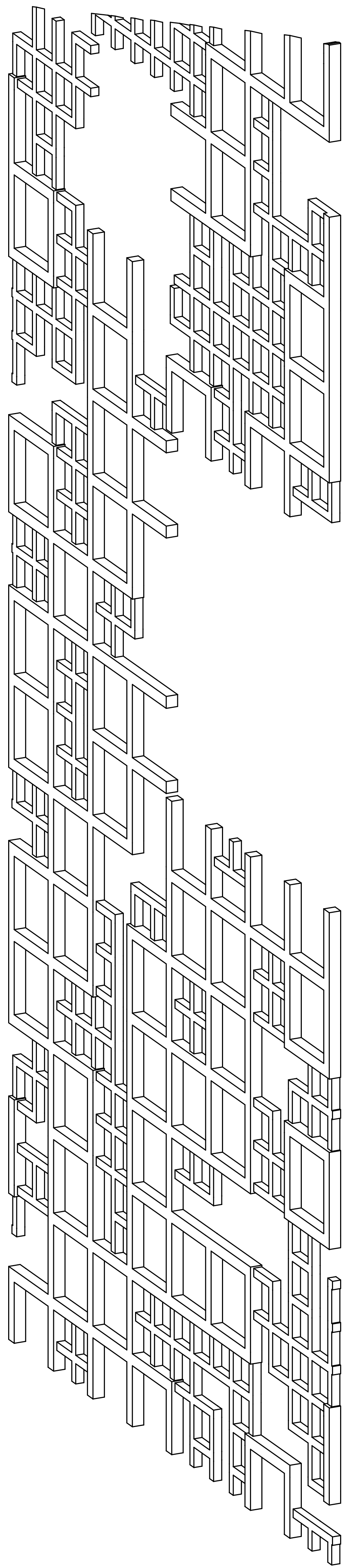
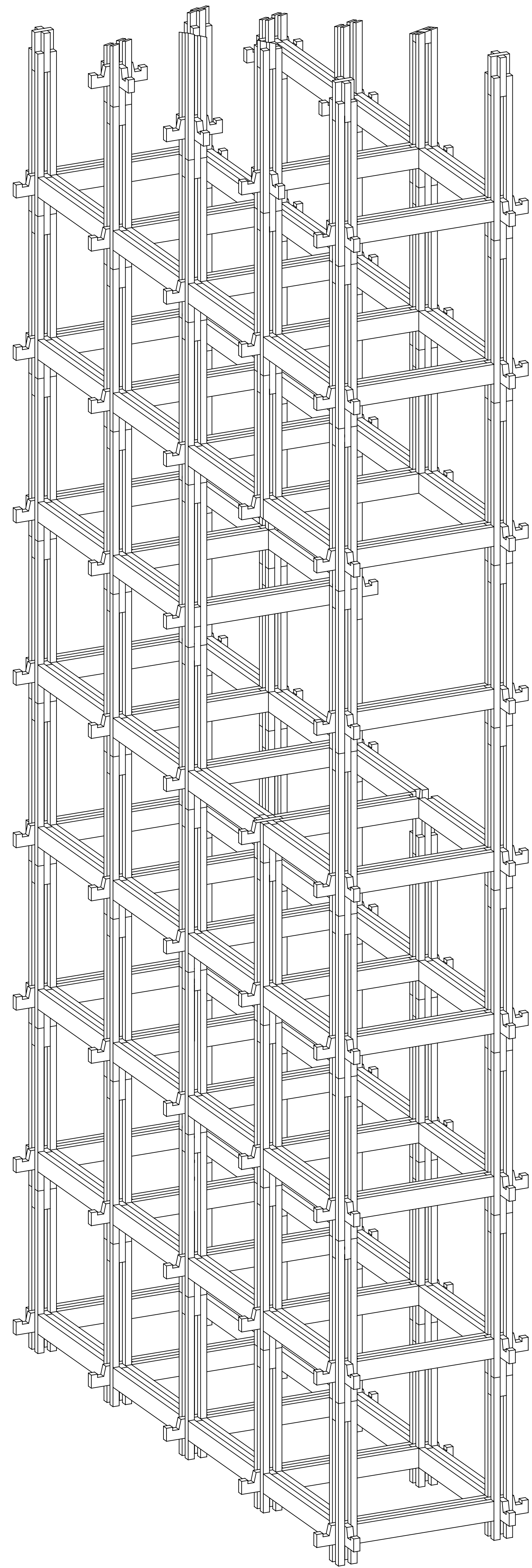

Fluctuating Timber Framework Sealing

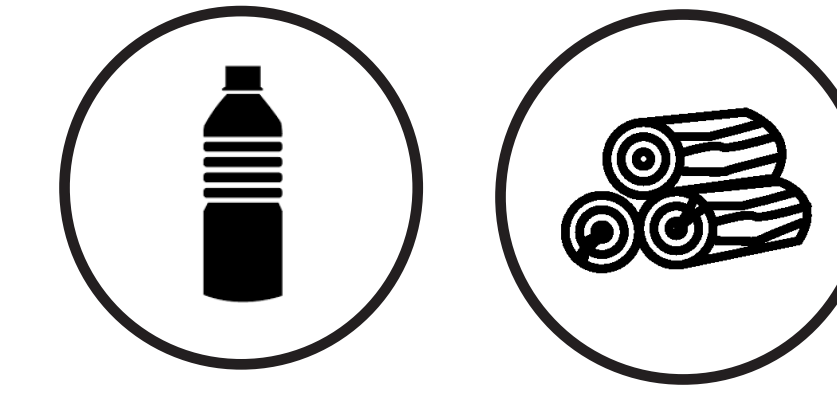

- Roof Support
- Minimize Number of Modular Components
- Variable Length Timber Retail Beams
- Demountable
- Mechanical Equipment Integration
- Facilitate Visitation
- Component Replacement
- Aesthetics

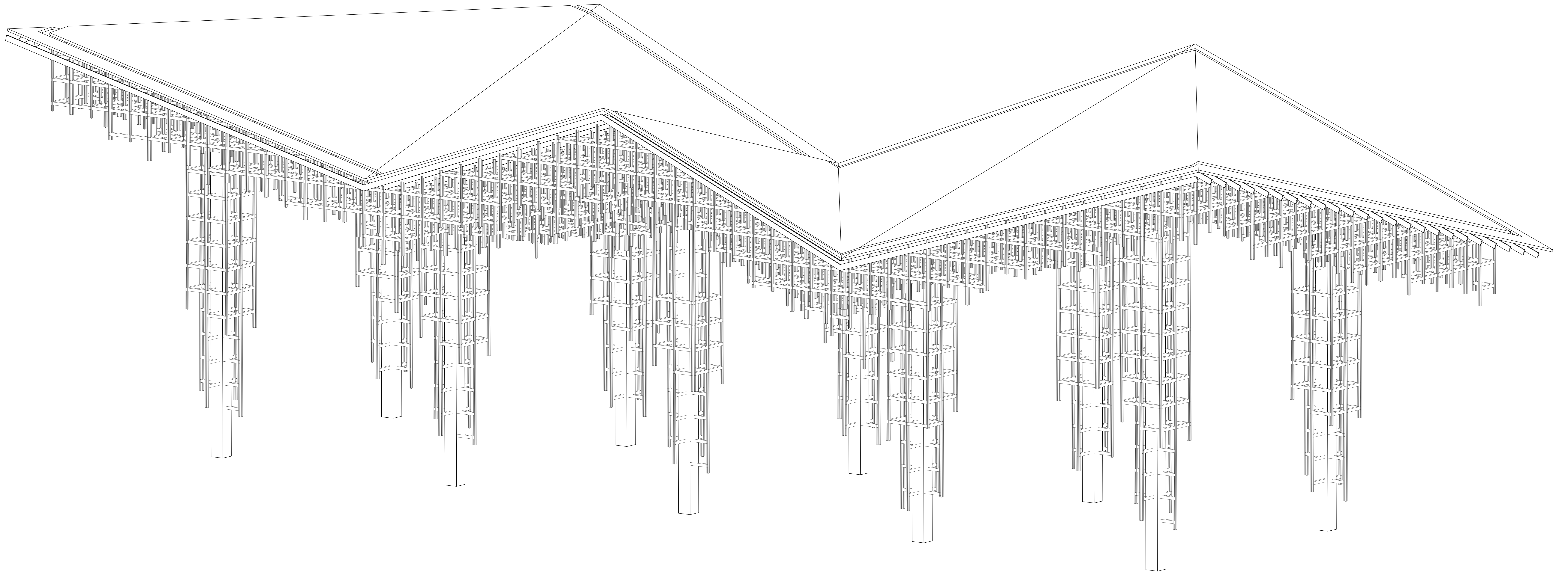

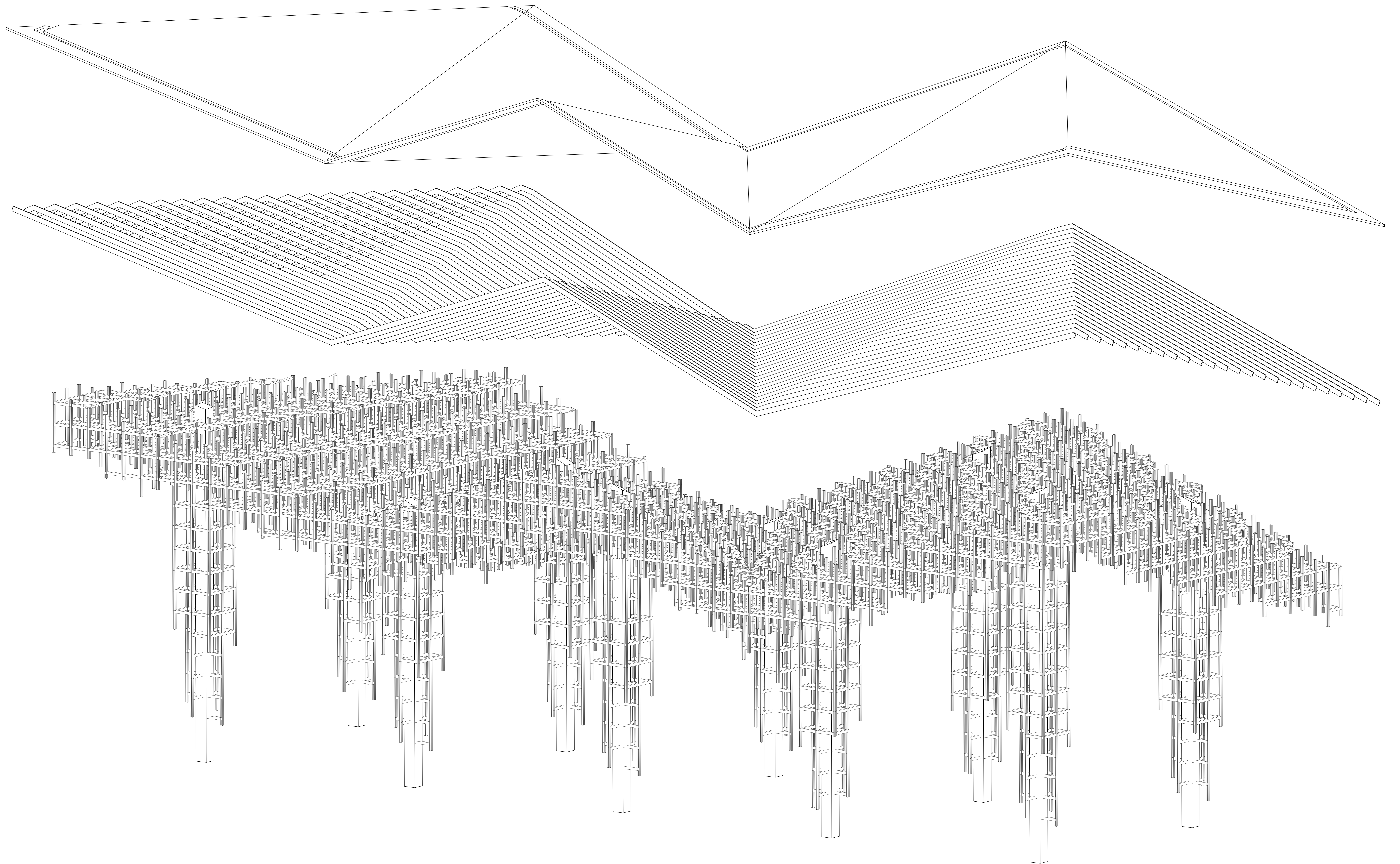

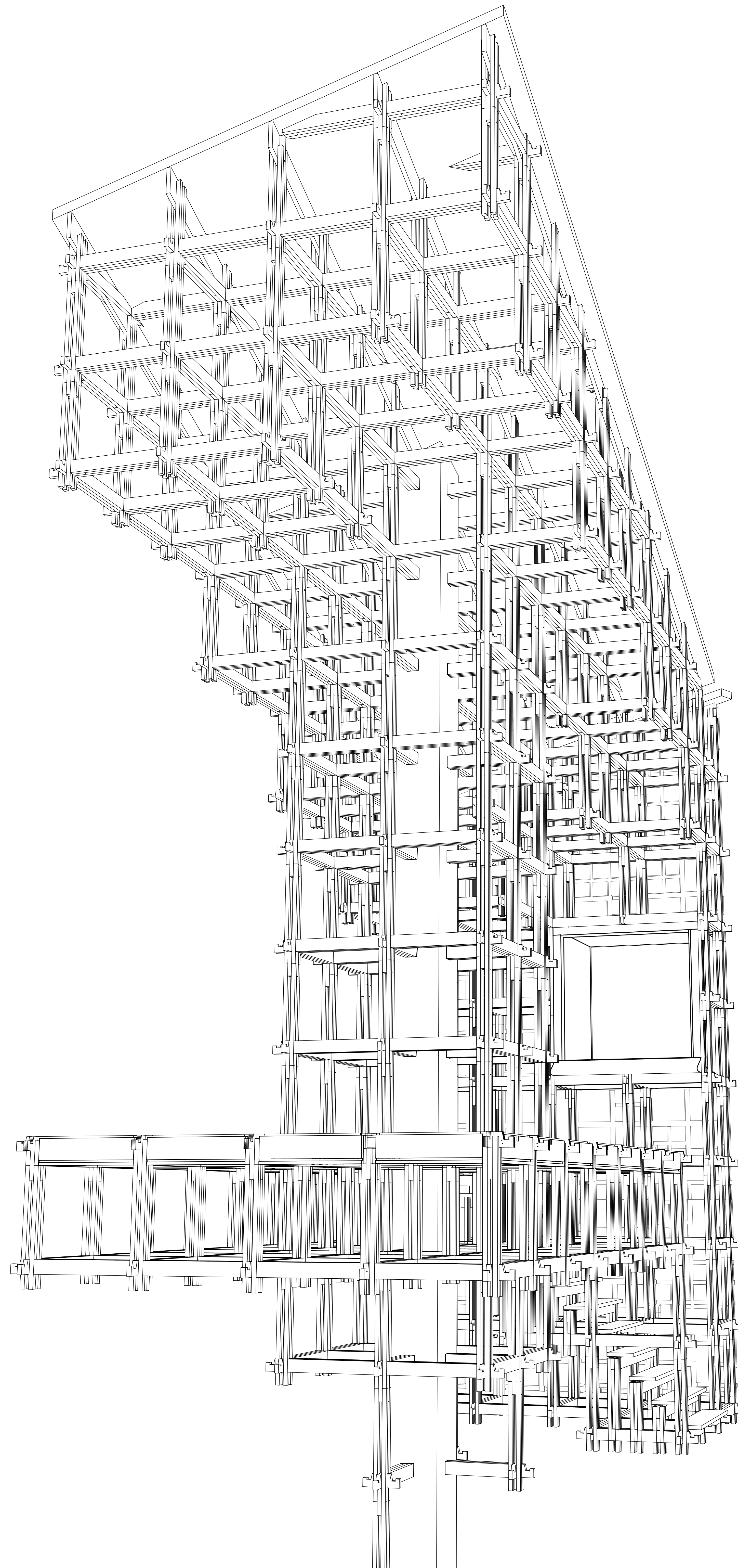

Bulding Fragment of South-East Facade

Main Loadbearing Column System

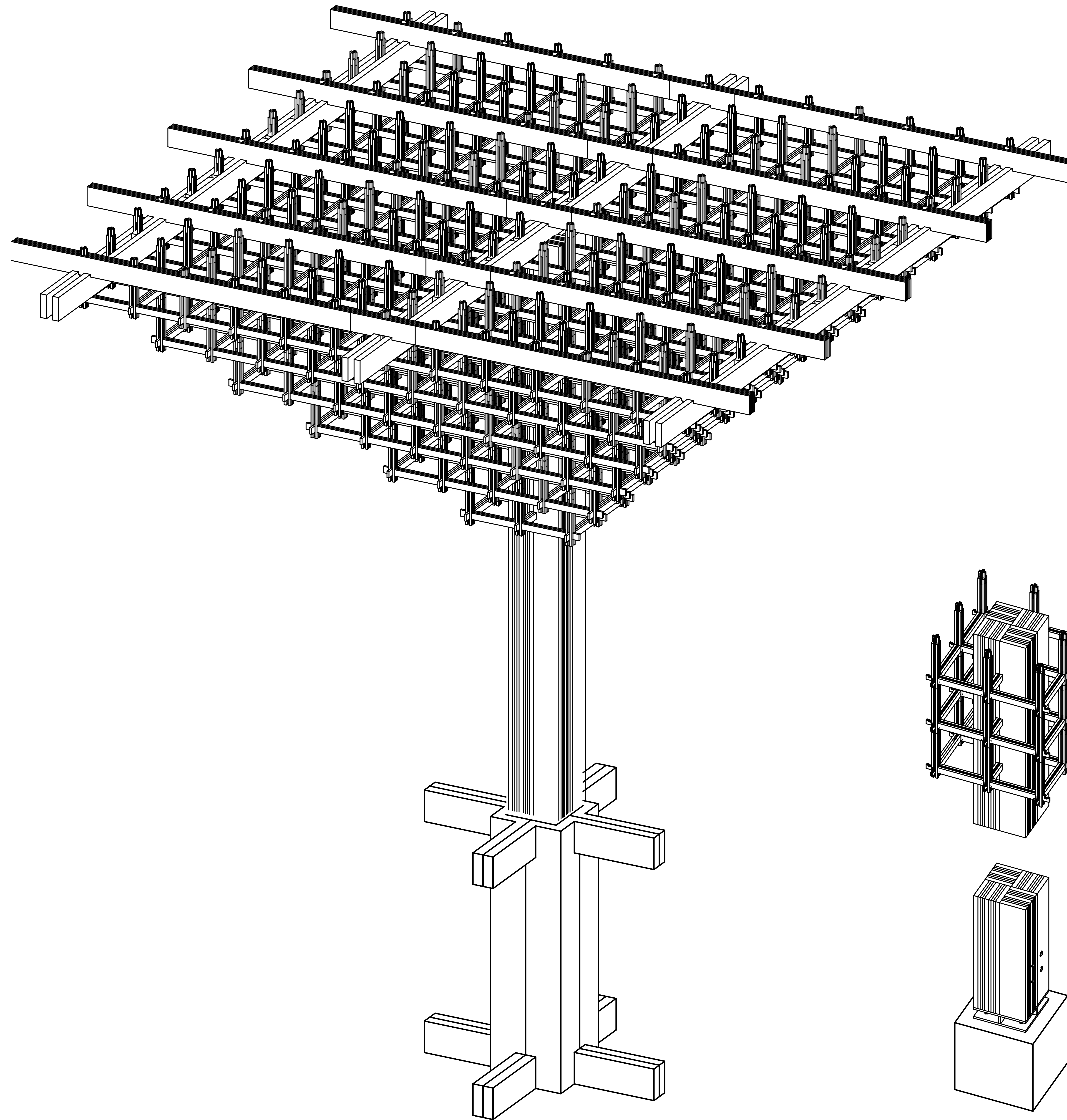
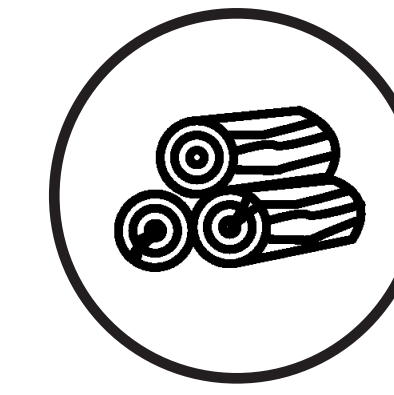

Concrete Support of Platforms Concrete Modular System

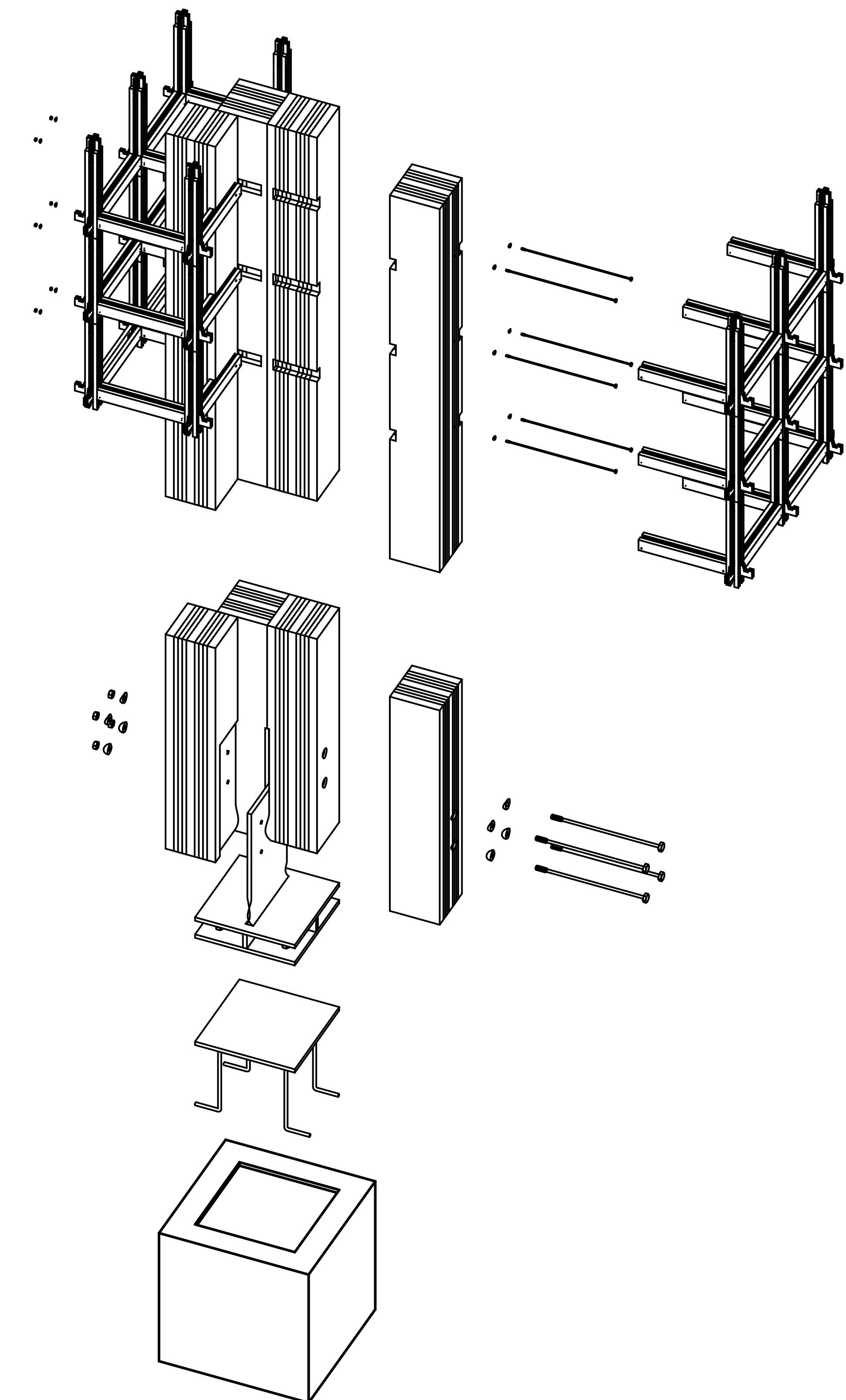

Foundation Detail

Modular Furniture

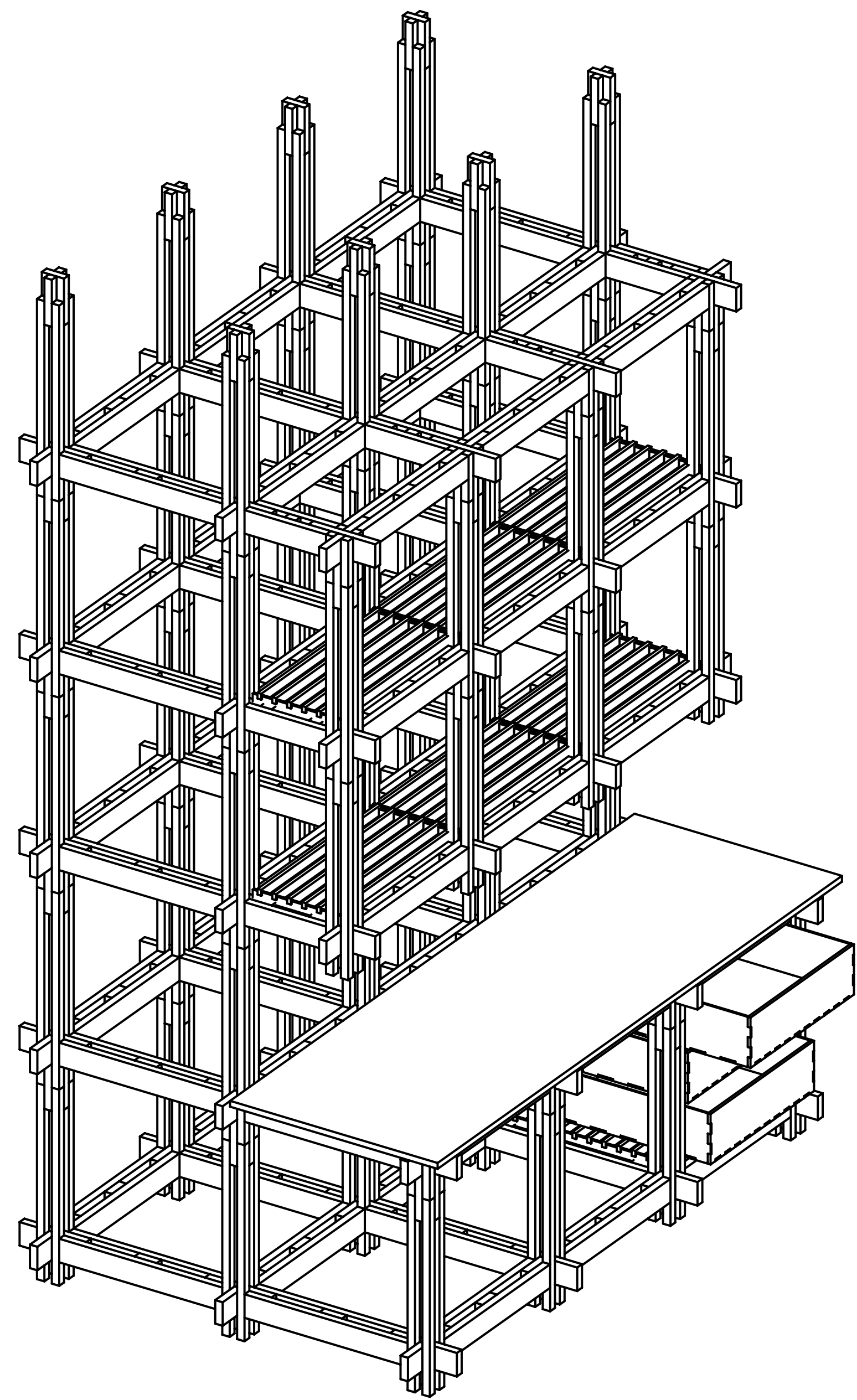

1. Work Station

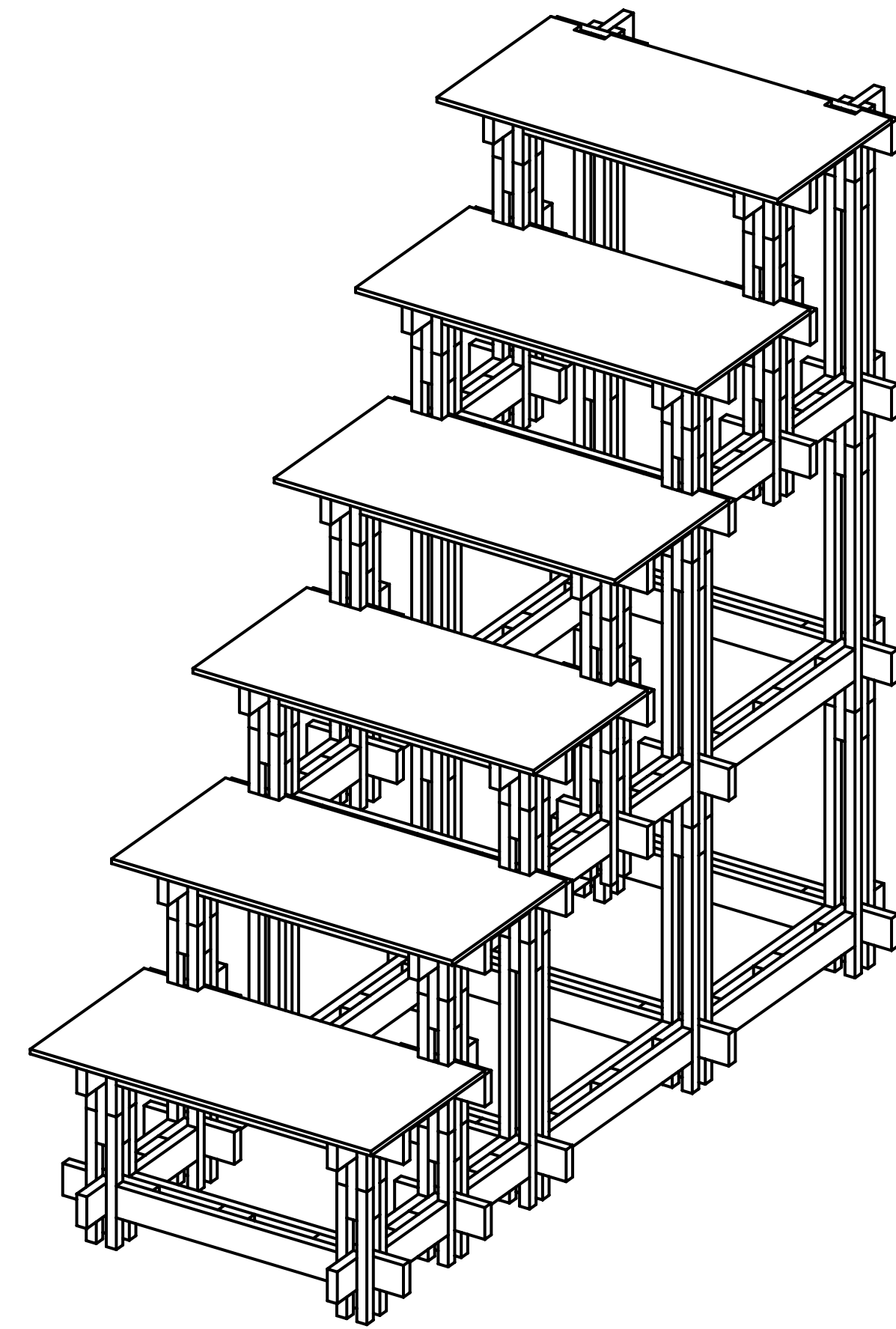

2. Auditorium

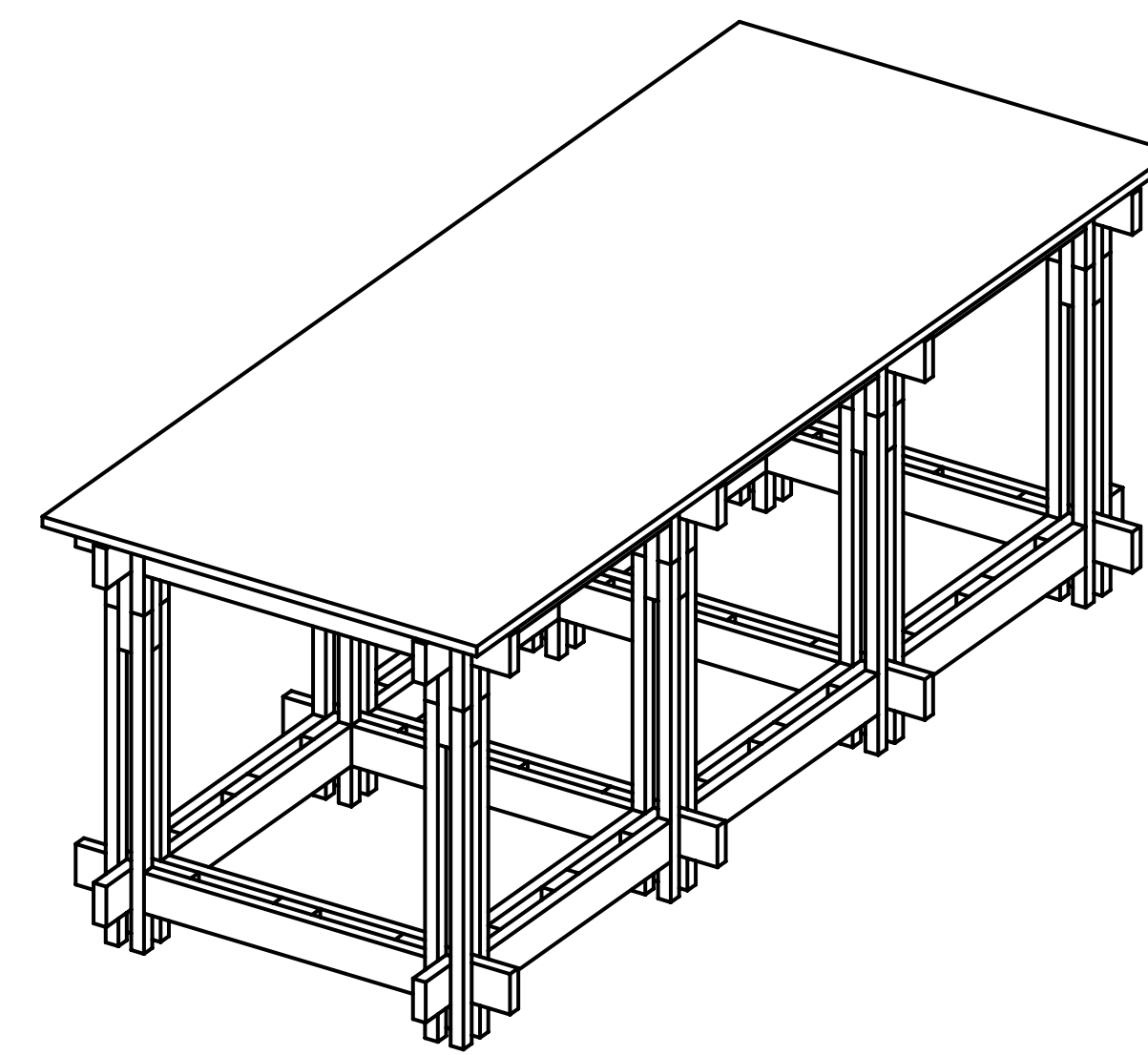

3. Working Bench

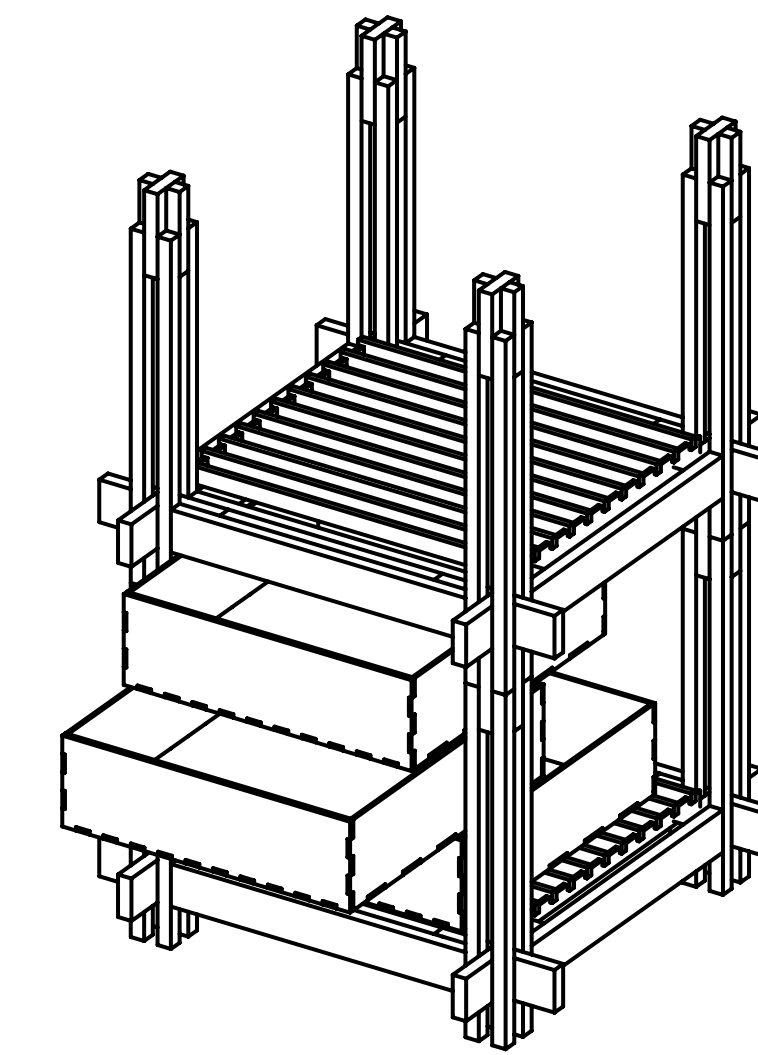

4. Self & Drawers

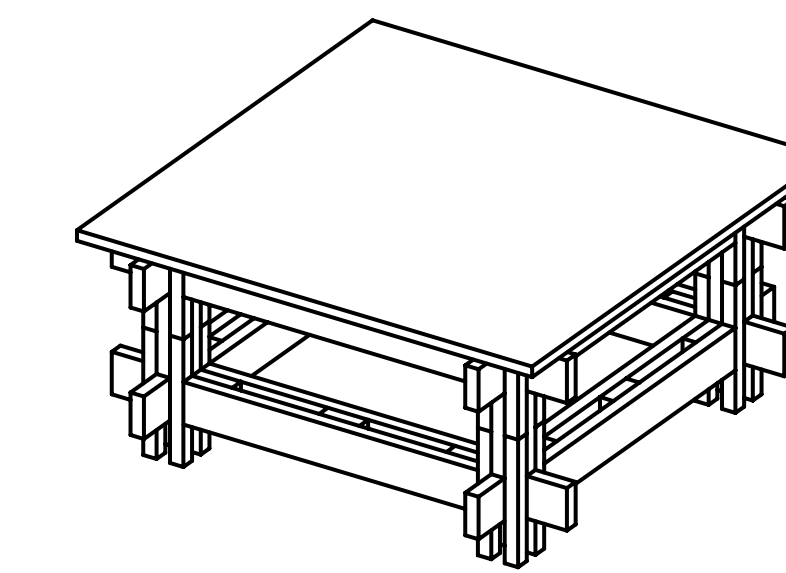

5. Coffee Table

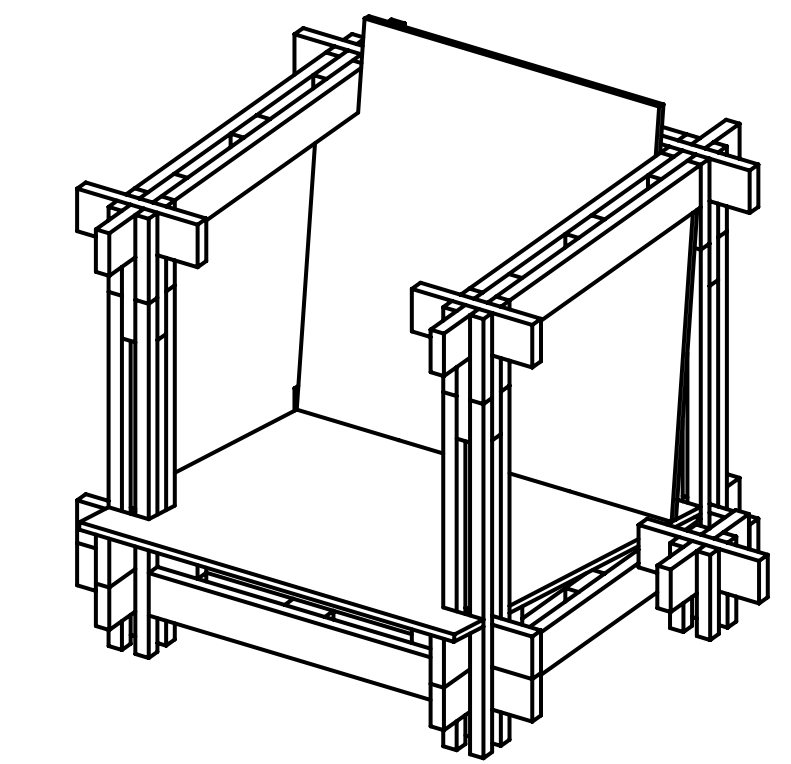

6. Armchair

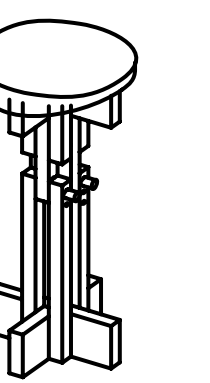

7. Stool

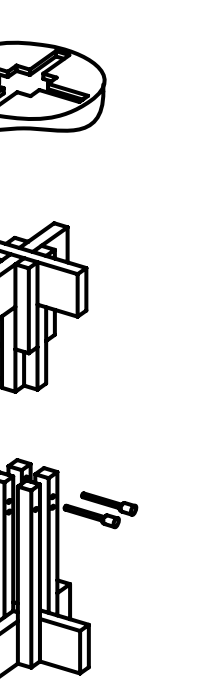
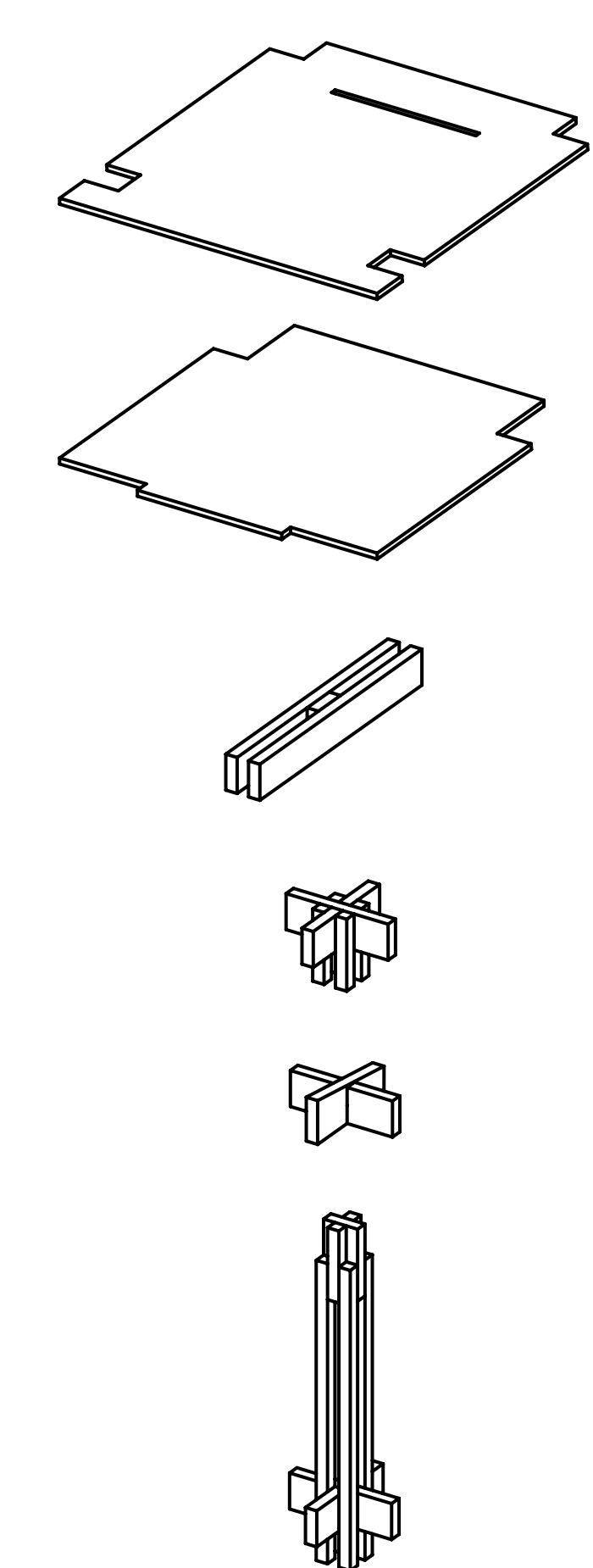
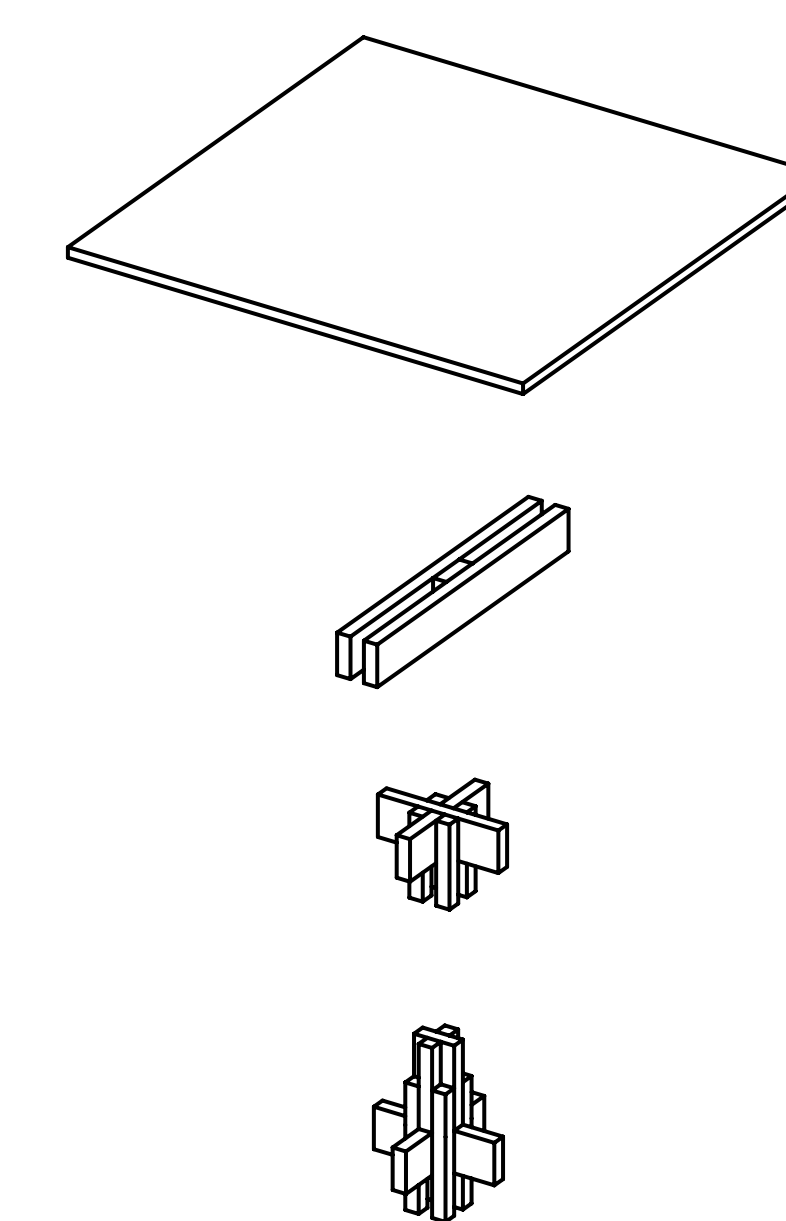
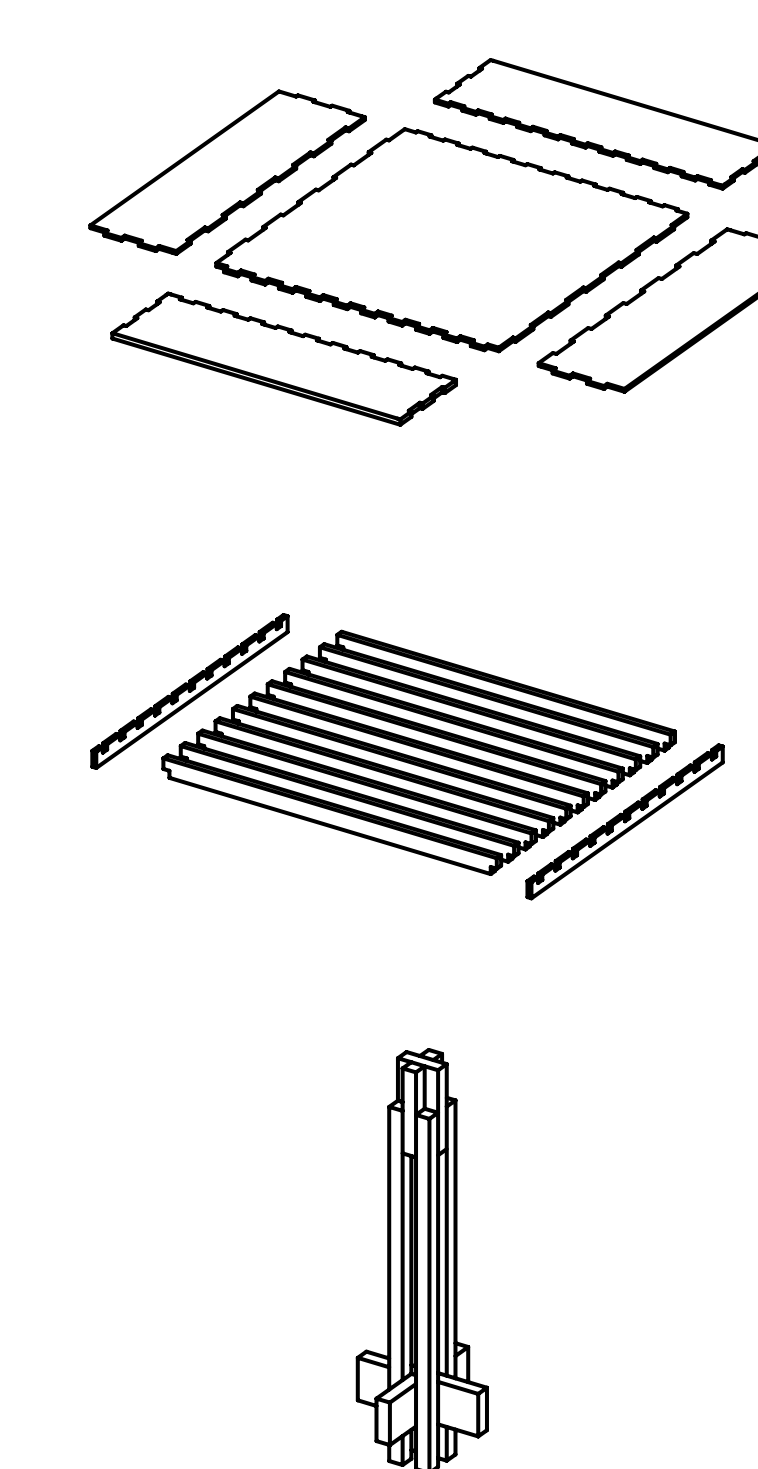
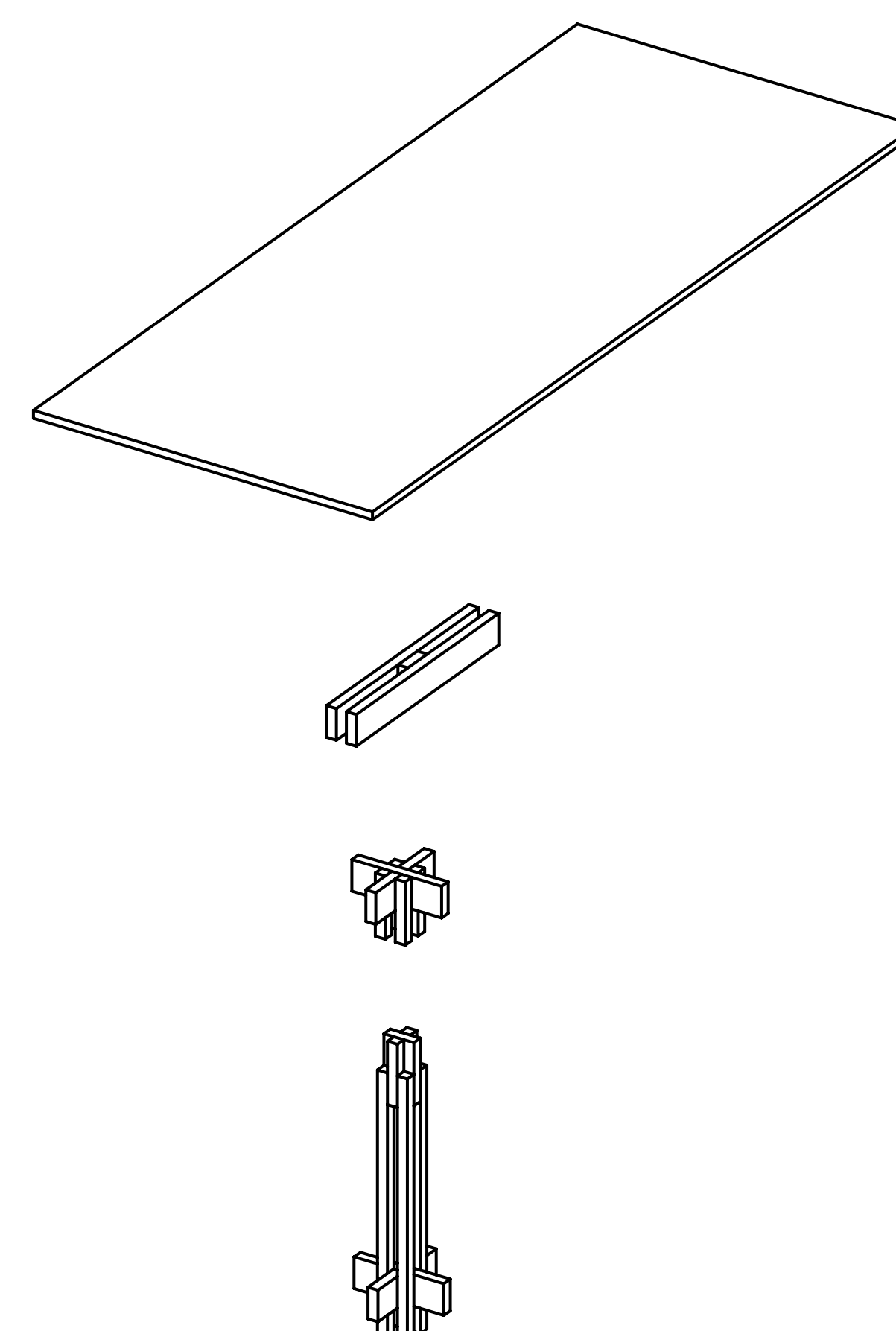
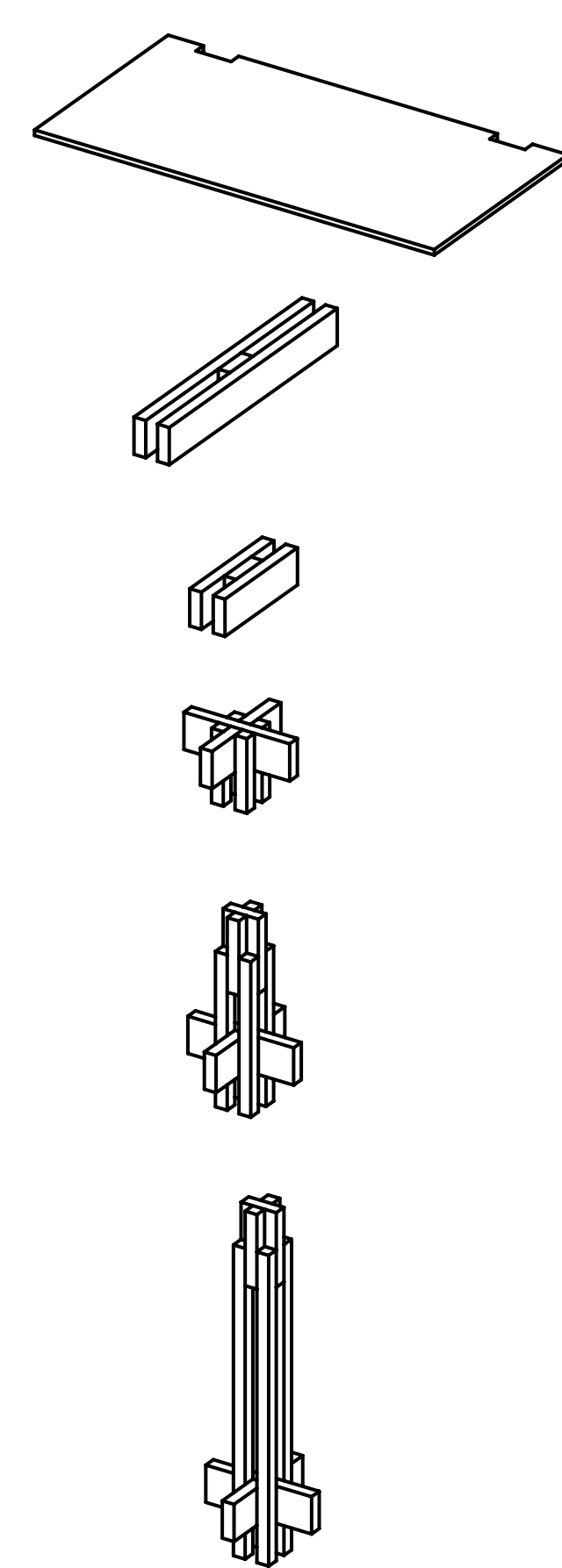
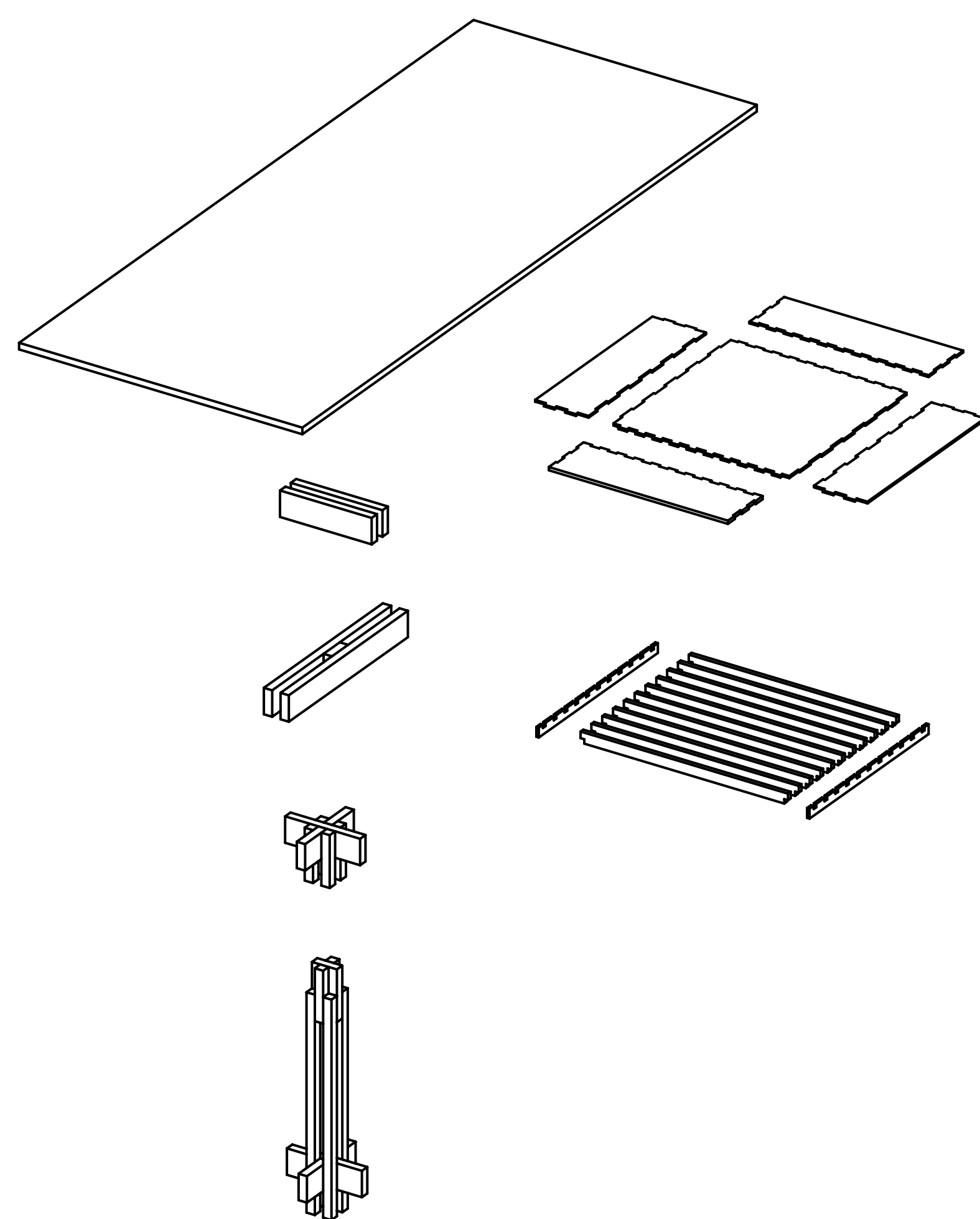

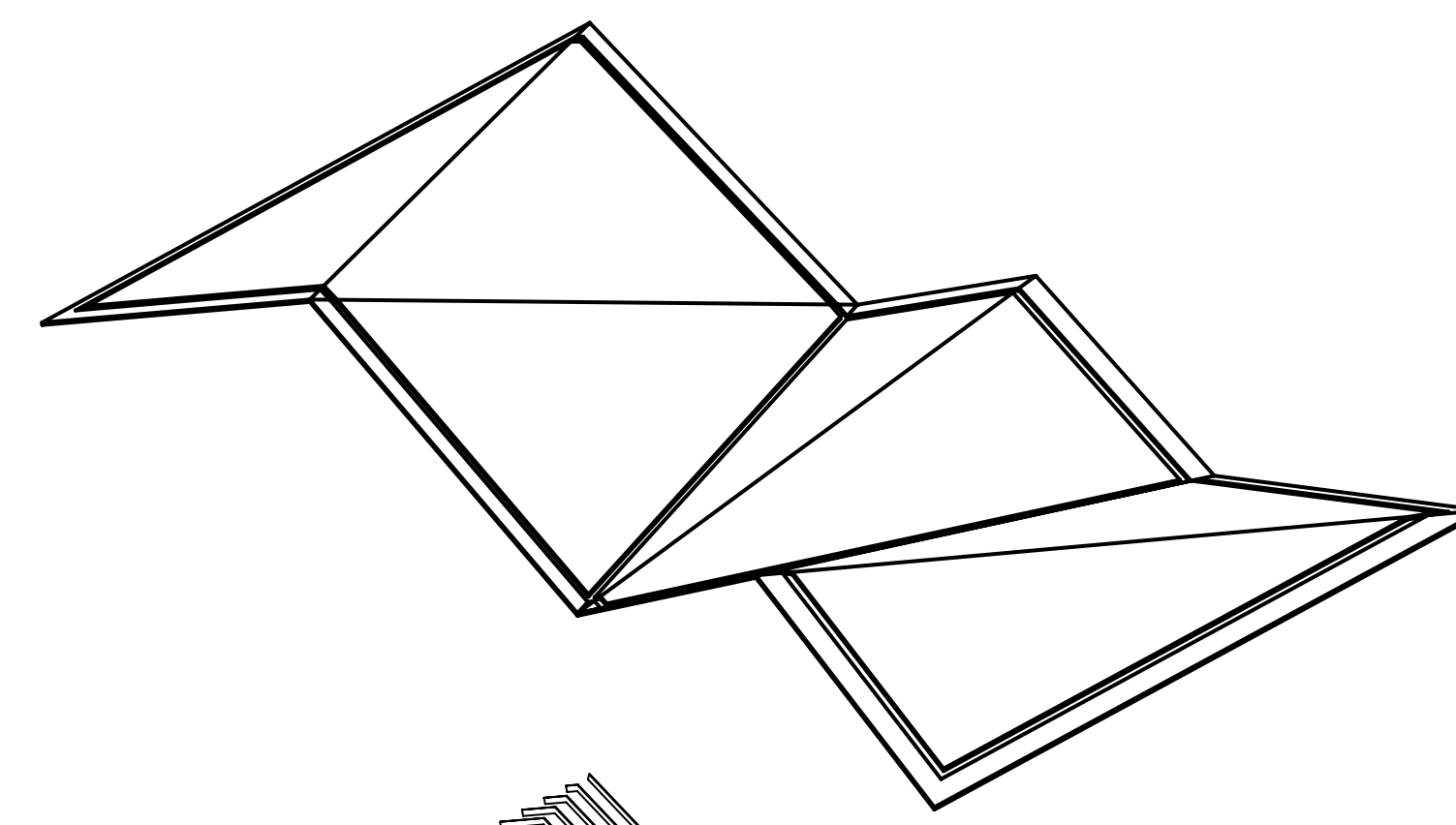

Plastic Roof Tiling

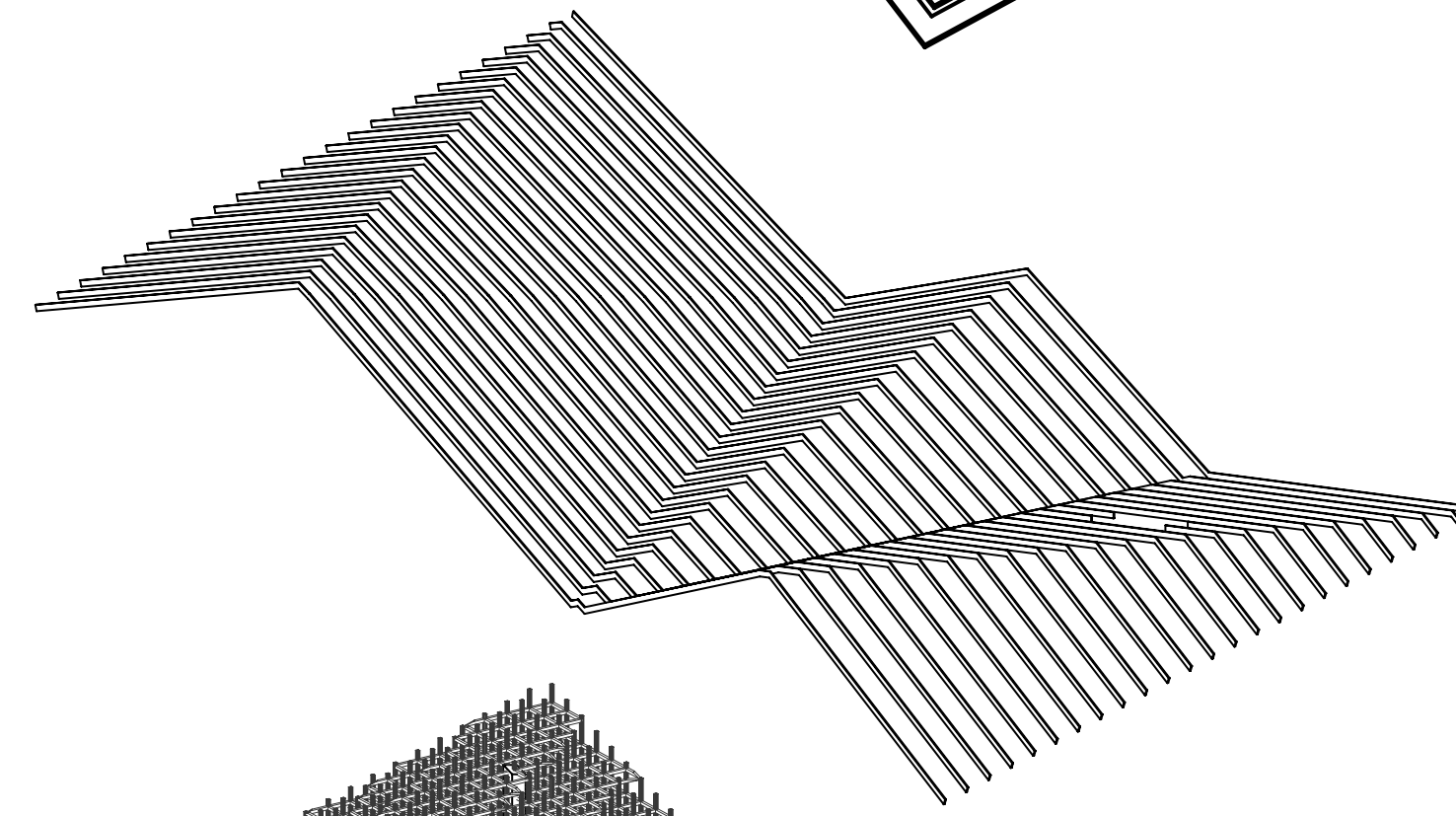

Timber Roof Supporting Beams

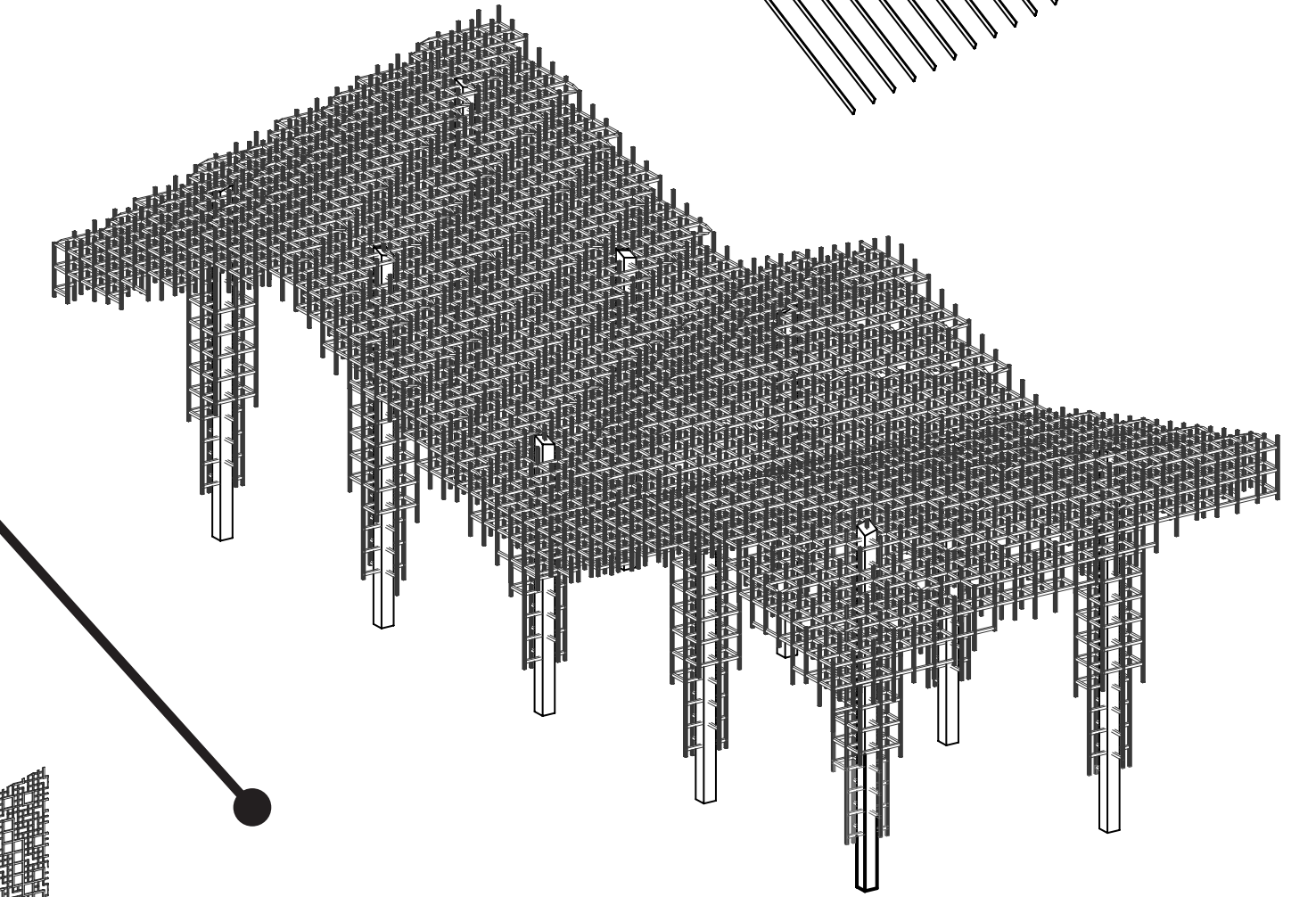

Timber Fluctuating Sealing

Timber Floor Formation

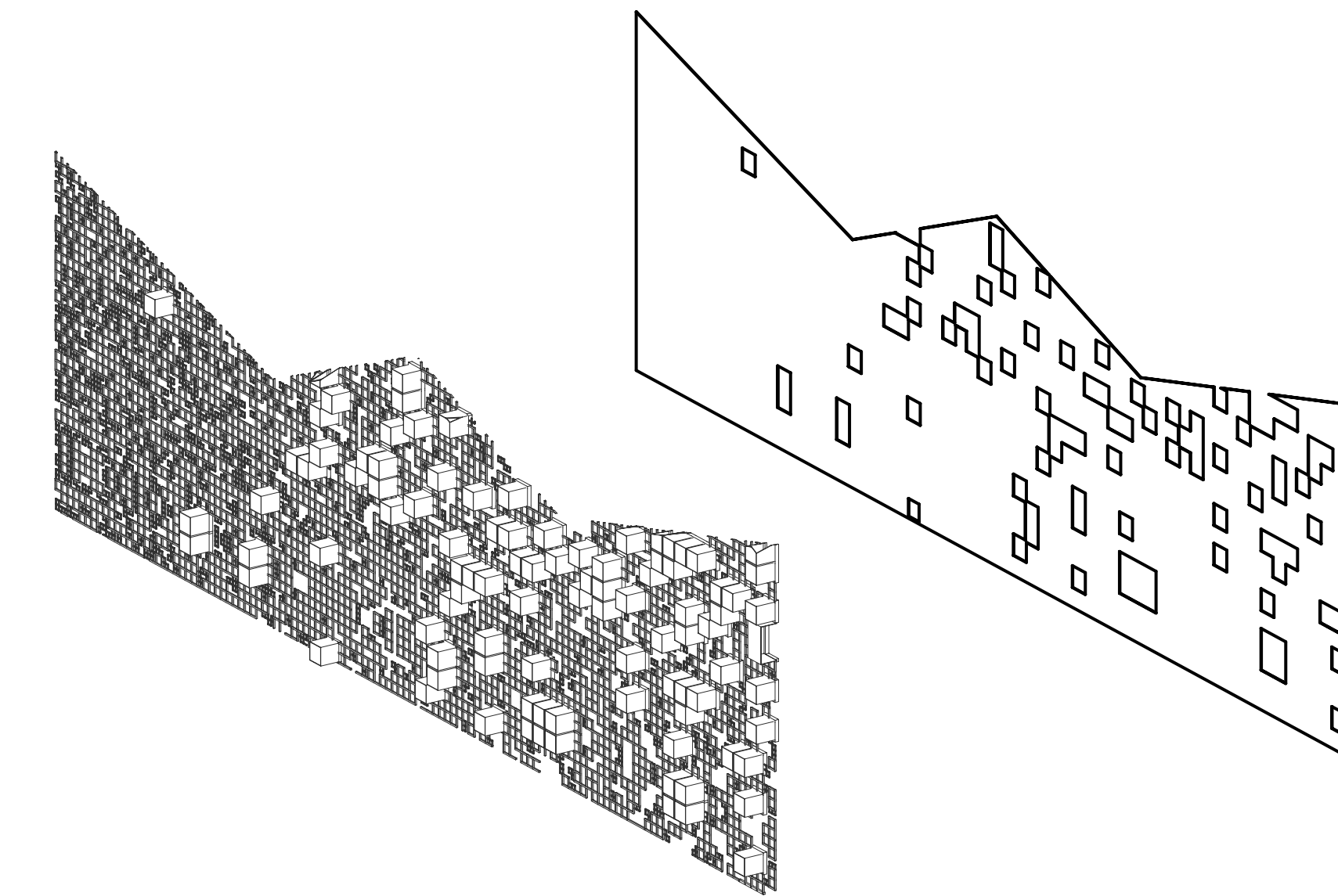
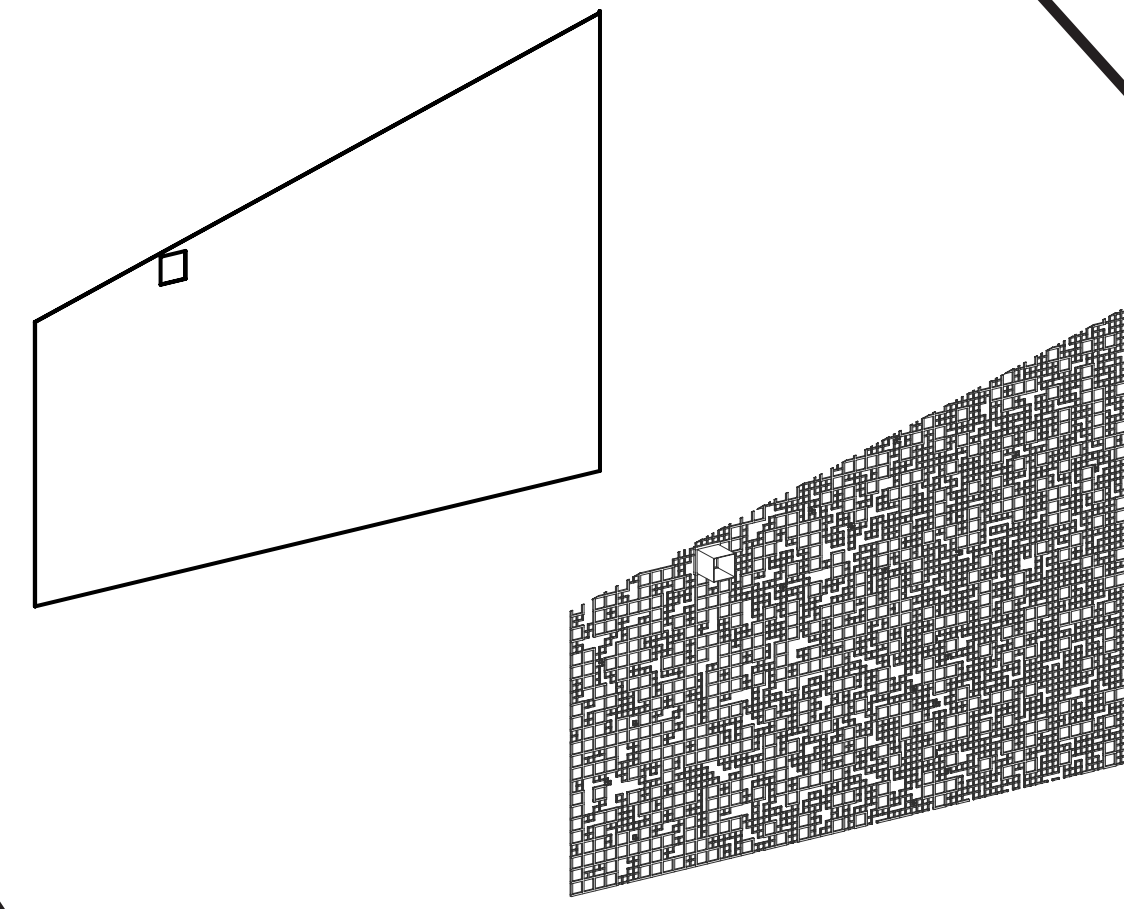

Timber Framework Facade Pattern

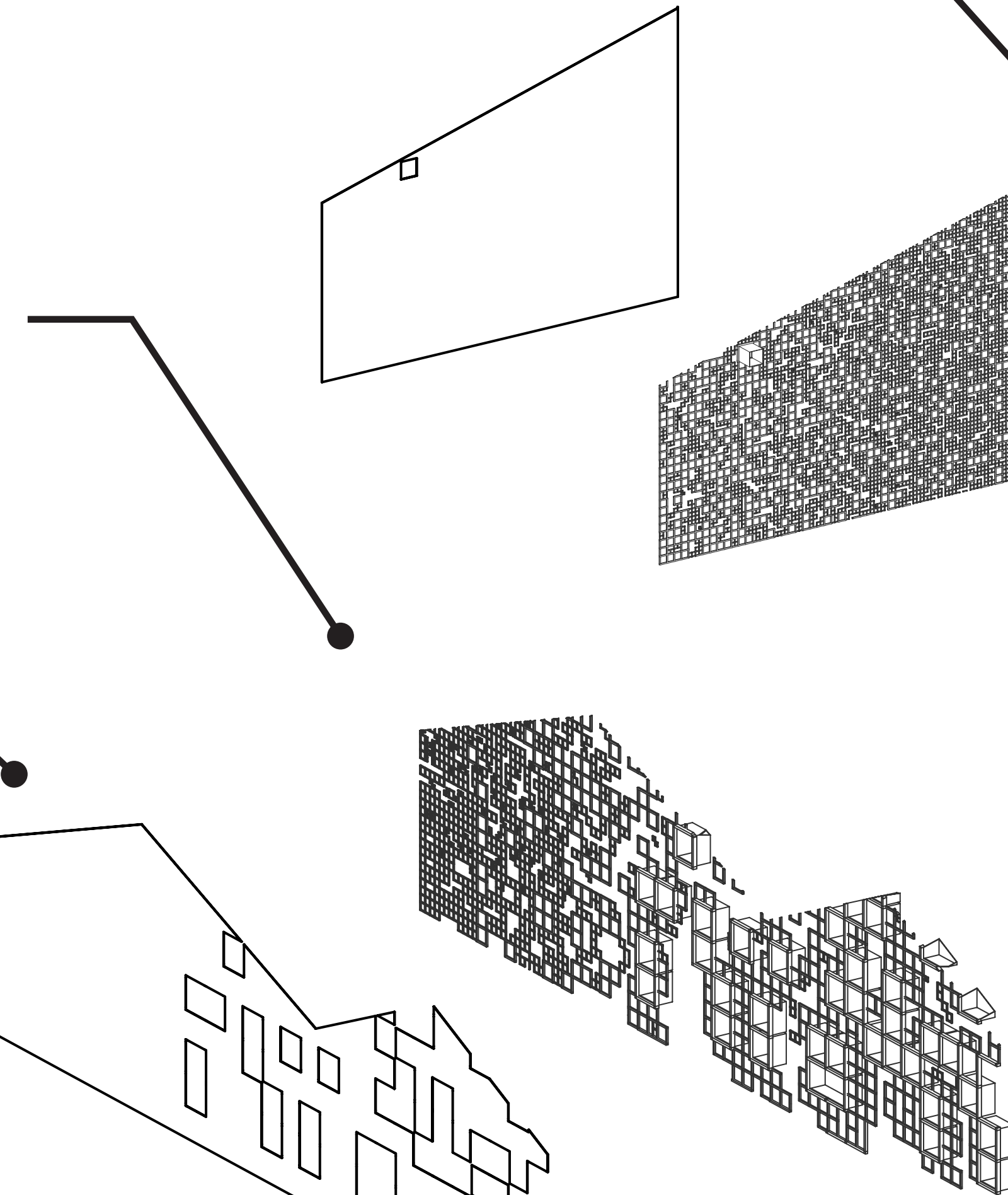

Exterior Facade Plastic Layer

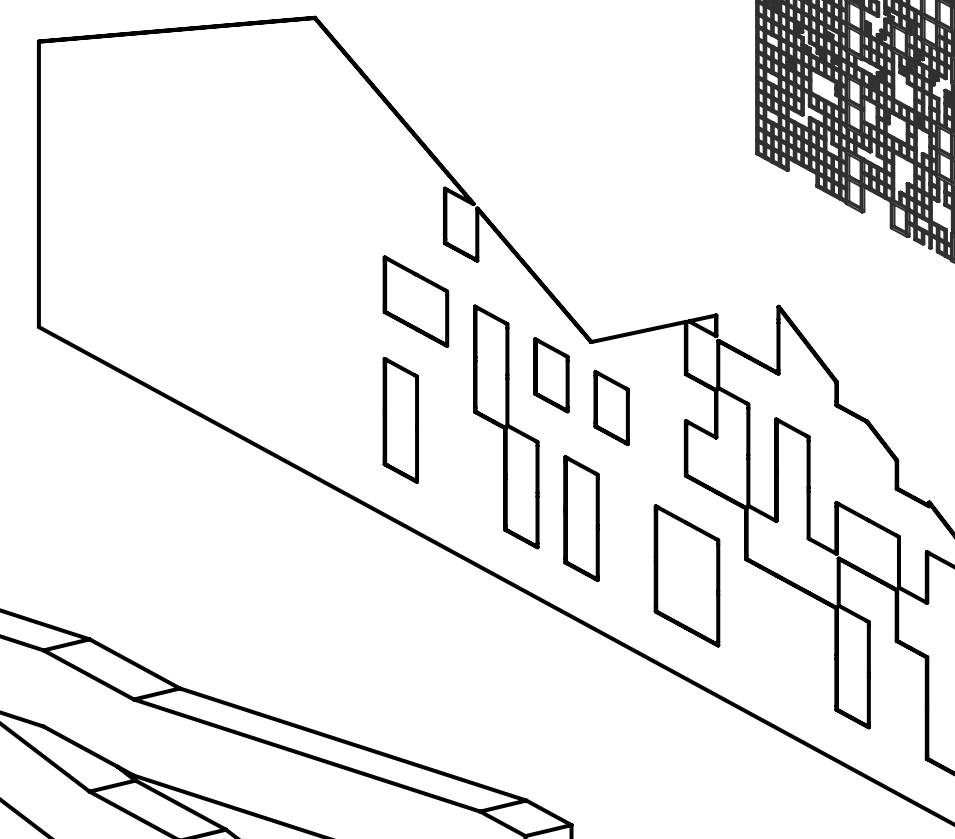

Ramp-Routing

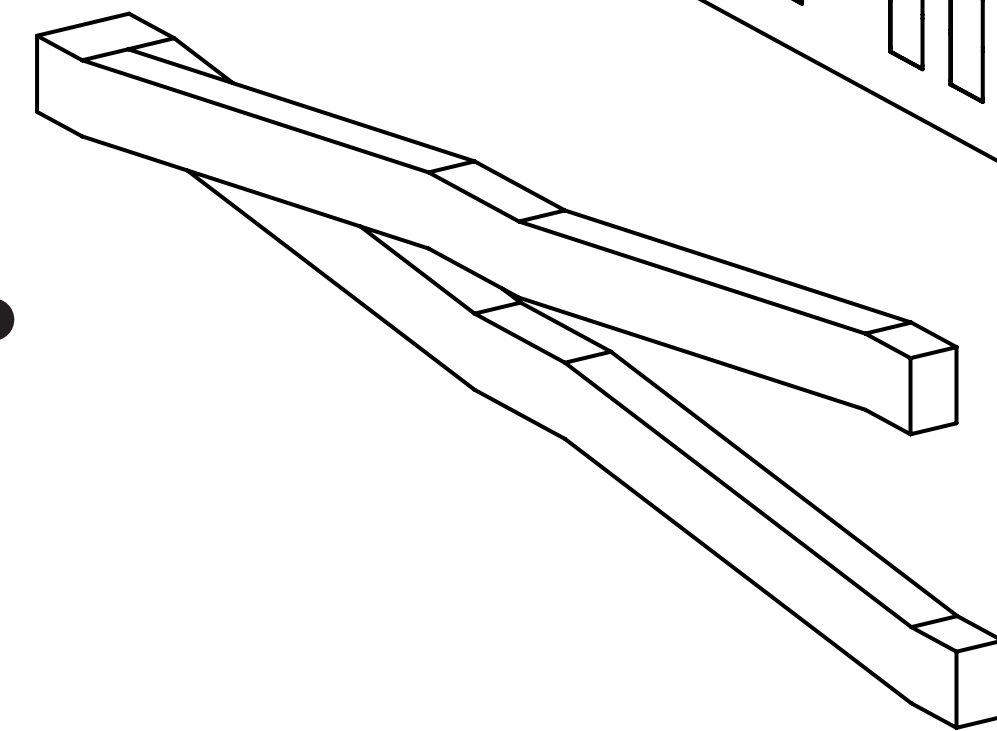

Timber columns 1000x1000mm

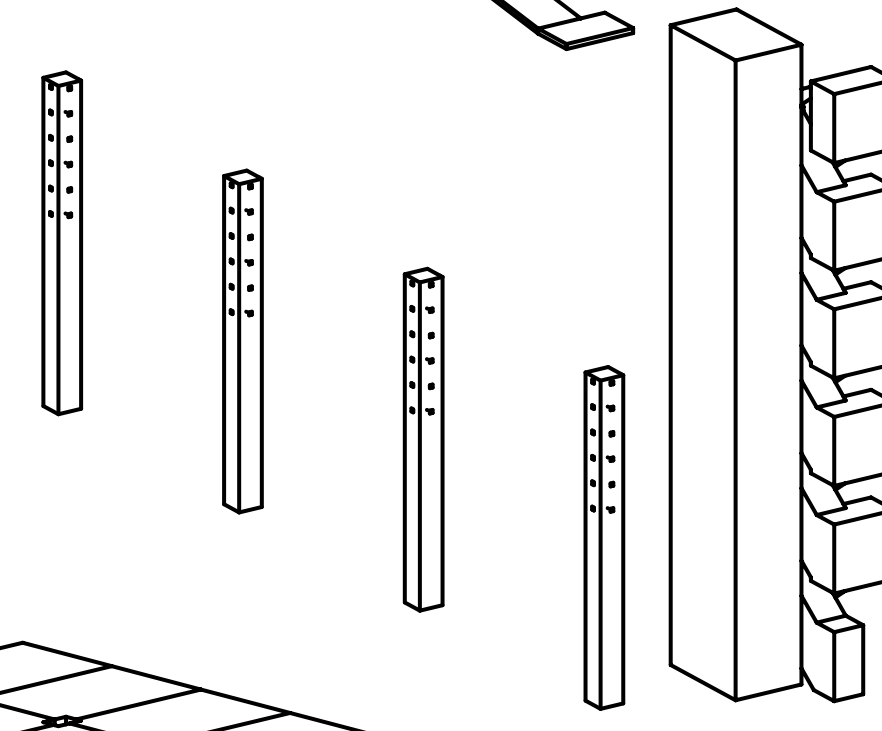

Vertical Routing

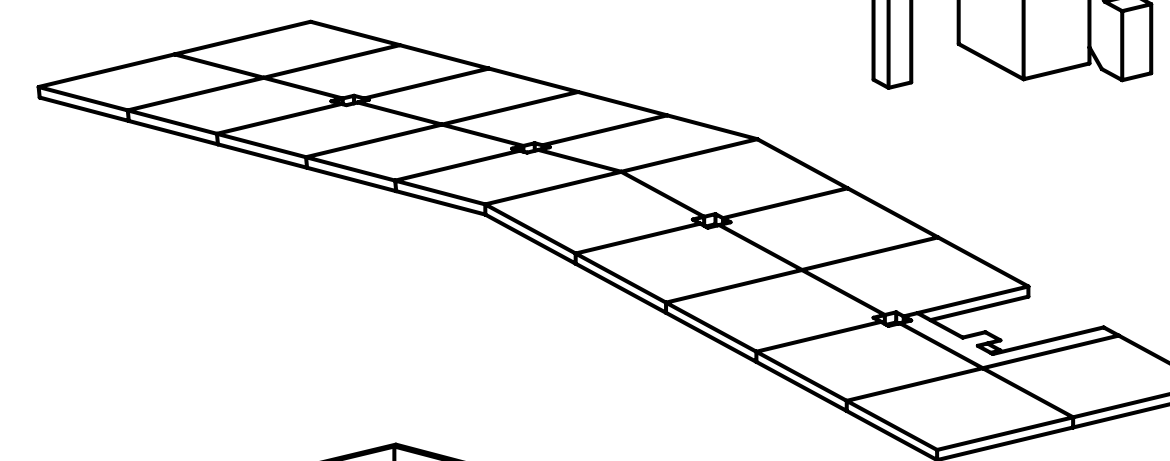

Concrete Modular Platform 6x6m

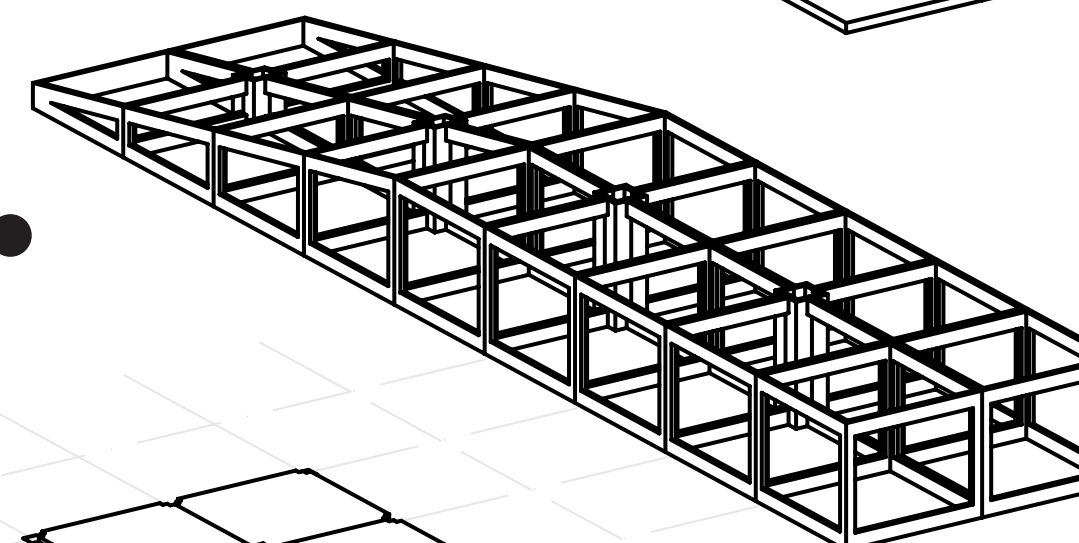

Shorting Containers

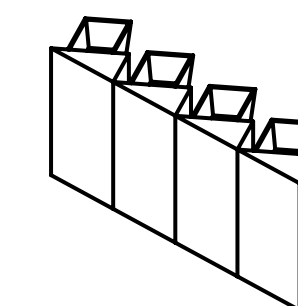

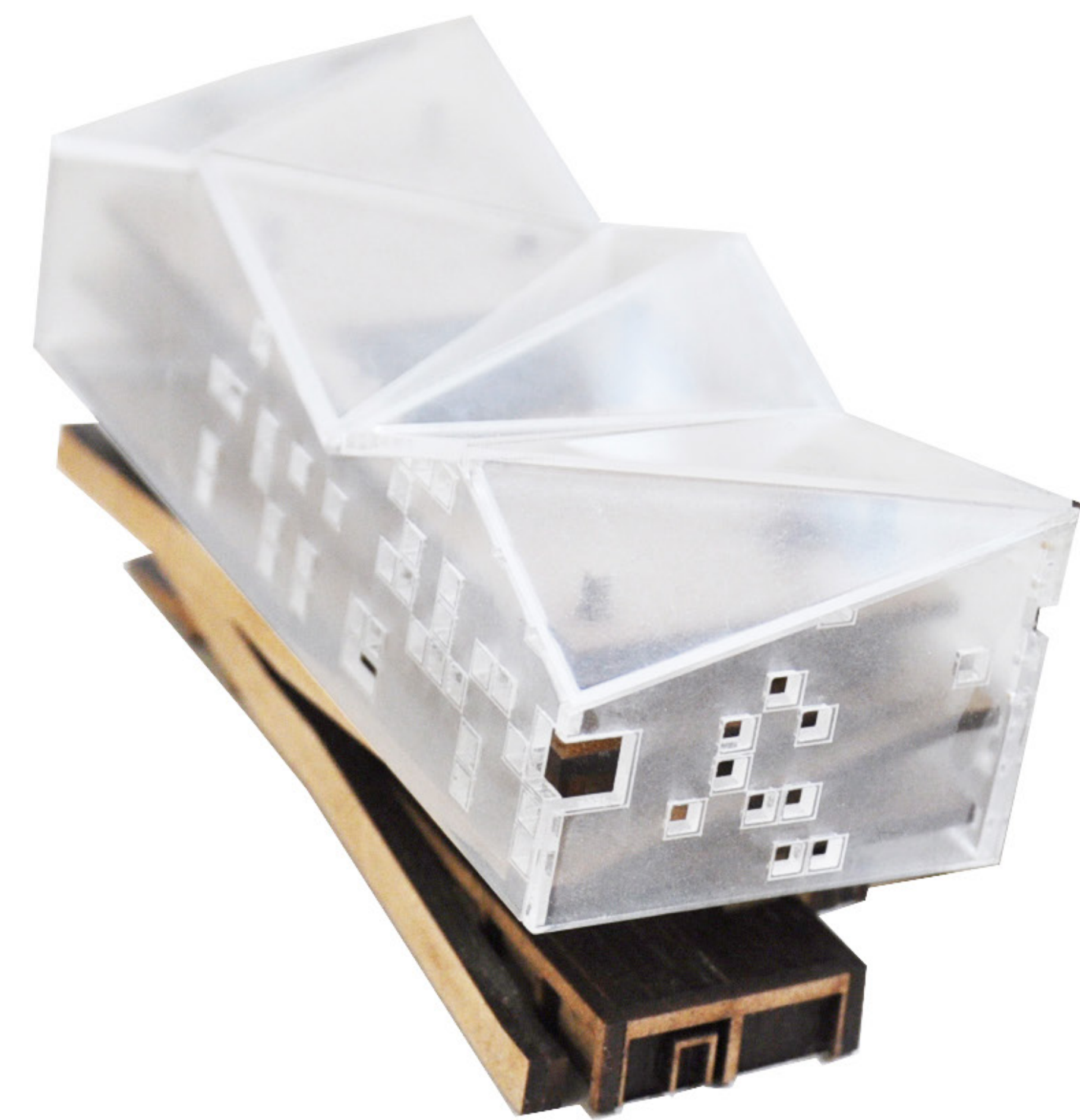
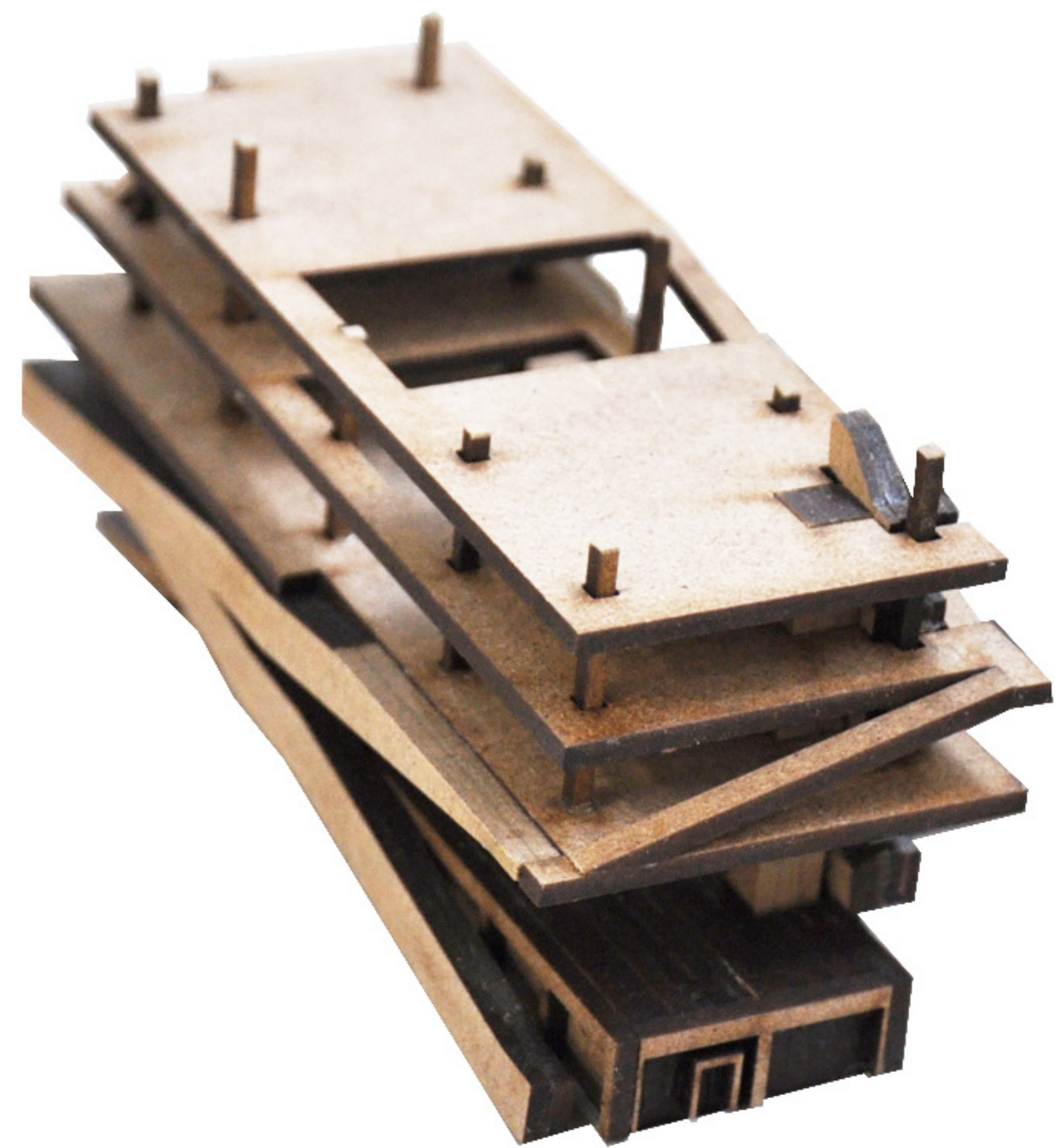

Physical Model **Scale 1:500**

















Physical Models of the Modular Component

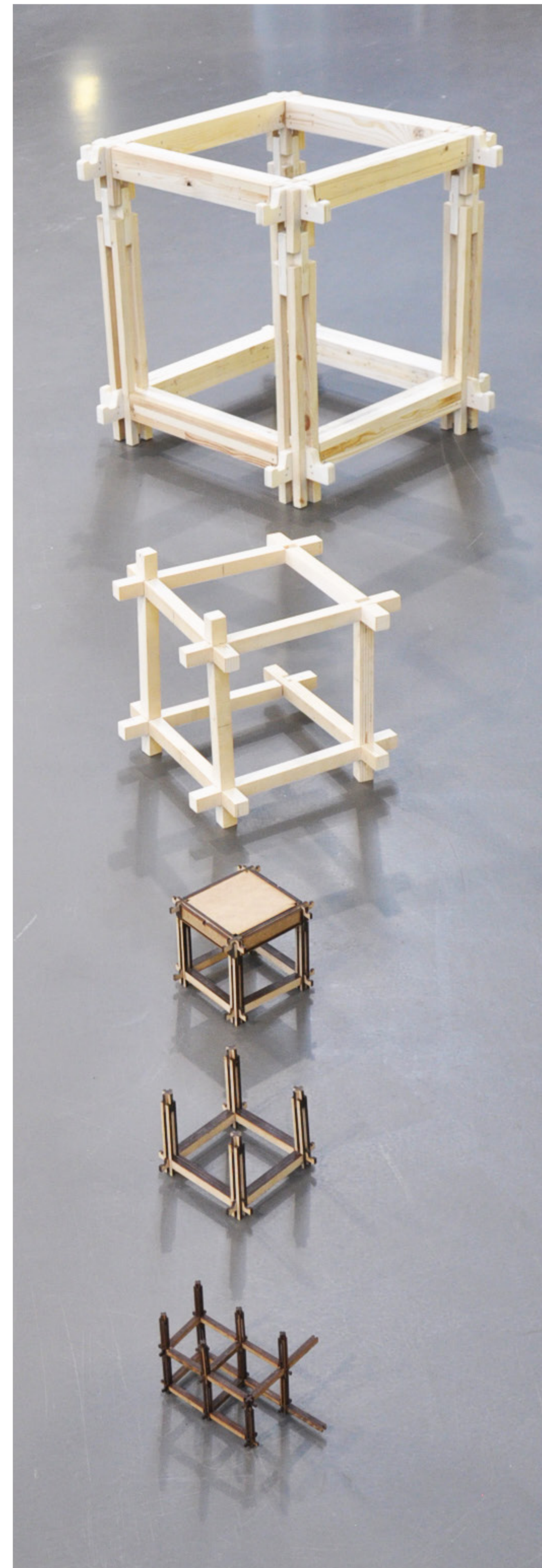



Component Development

Scale 1:10

Floor Component Construction Steps

Scale 1:10

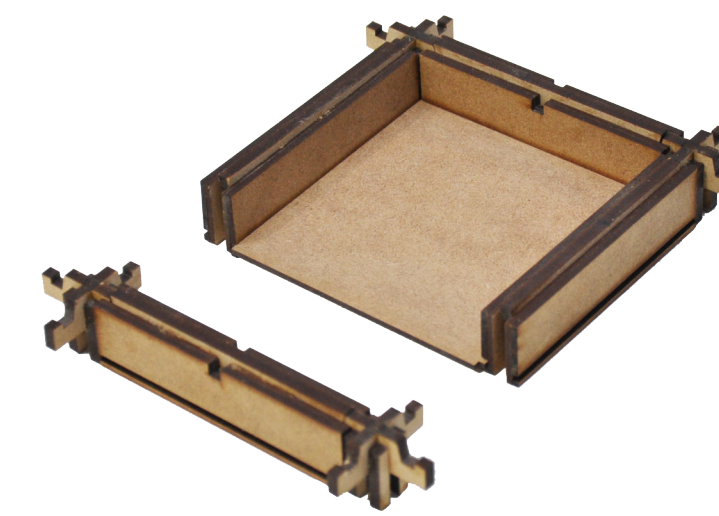
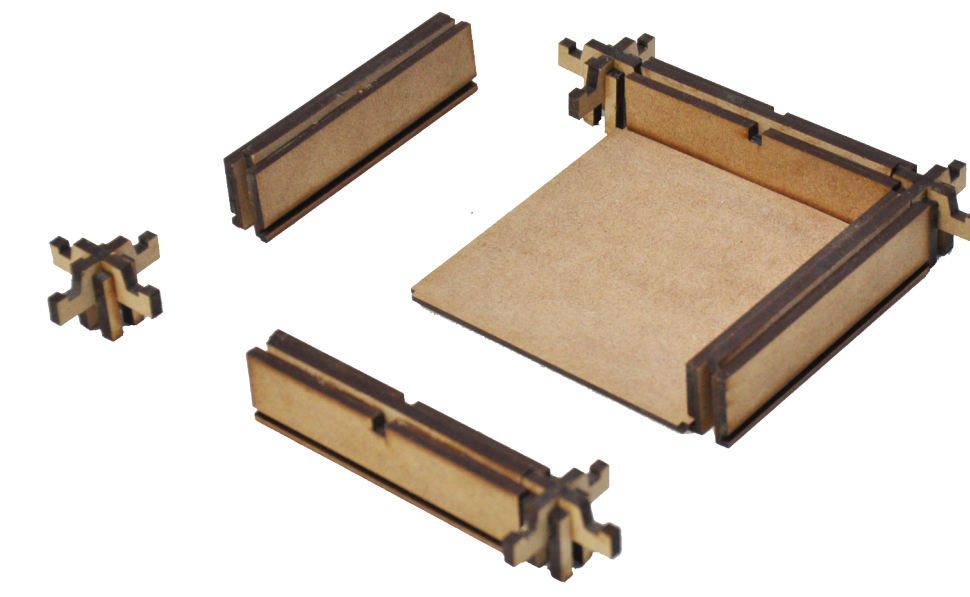
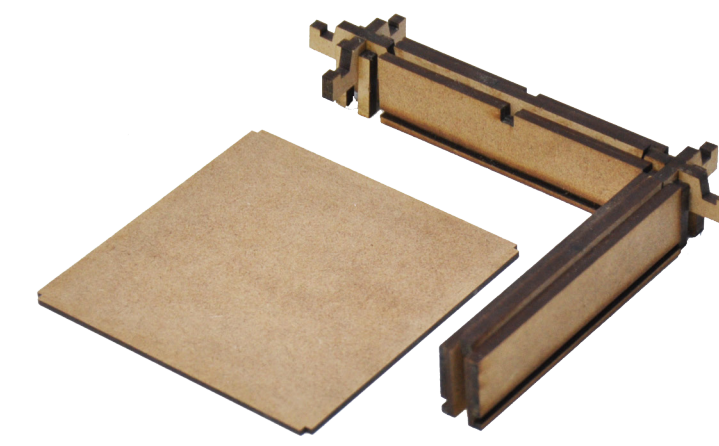



Plug-In Beam [Timber Patchwork]



Beam Elements

Beam Construction Steps

Scale 1:2







Main Modular Column Component

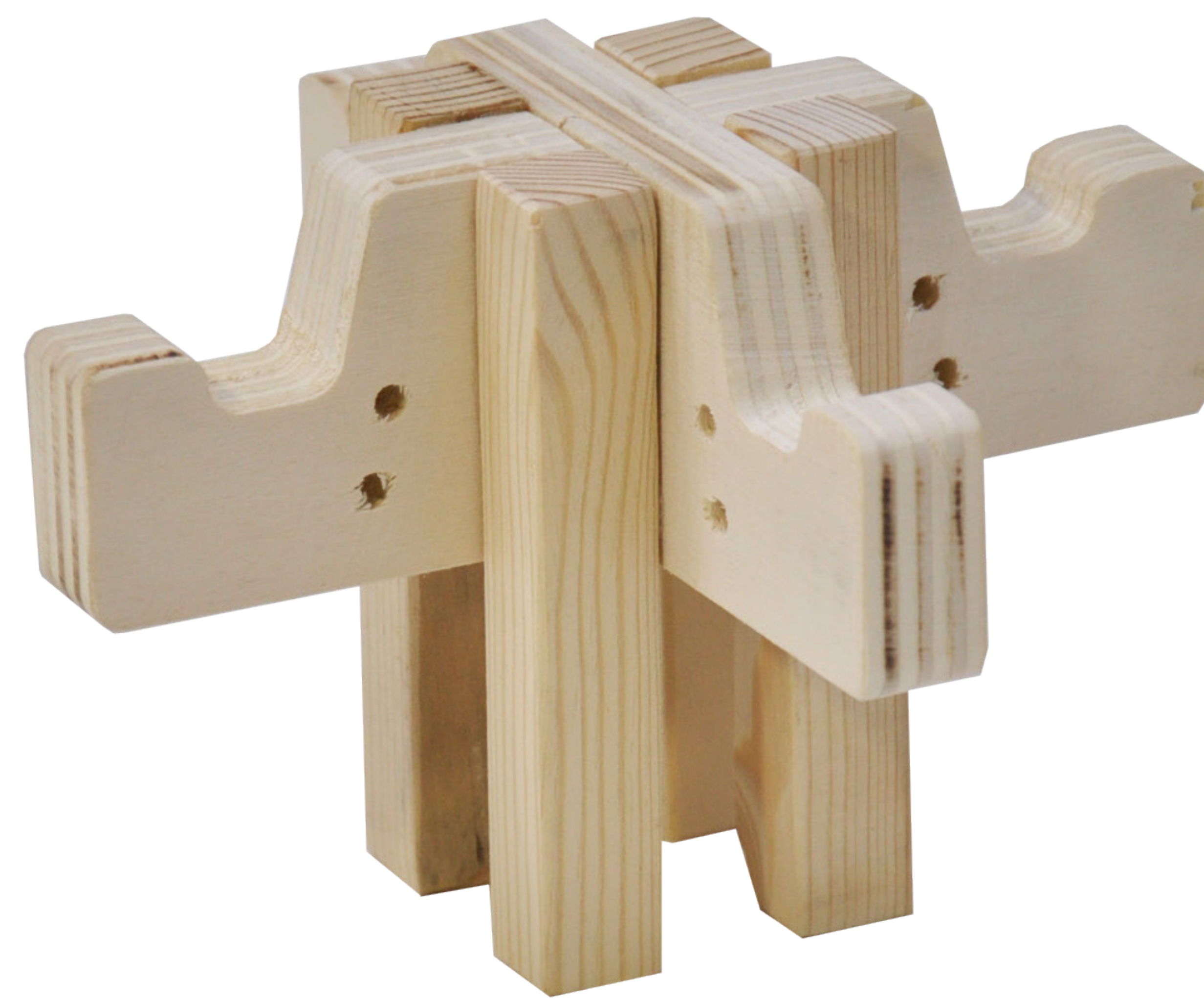

Plug-In Column Finish Component

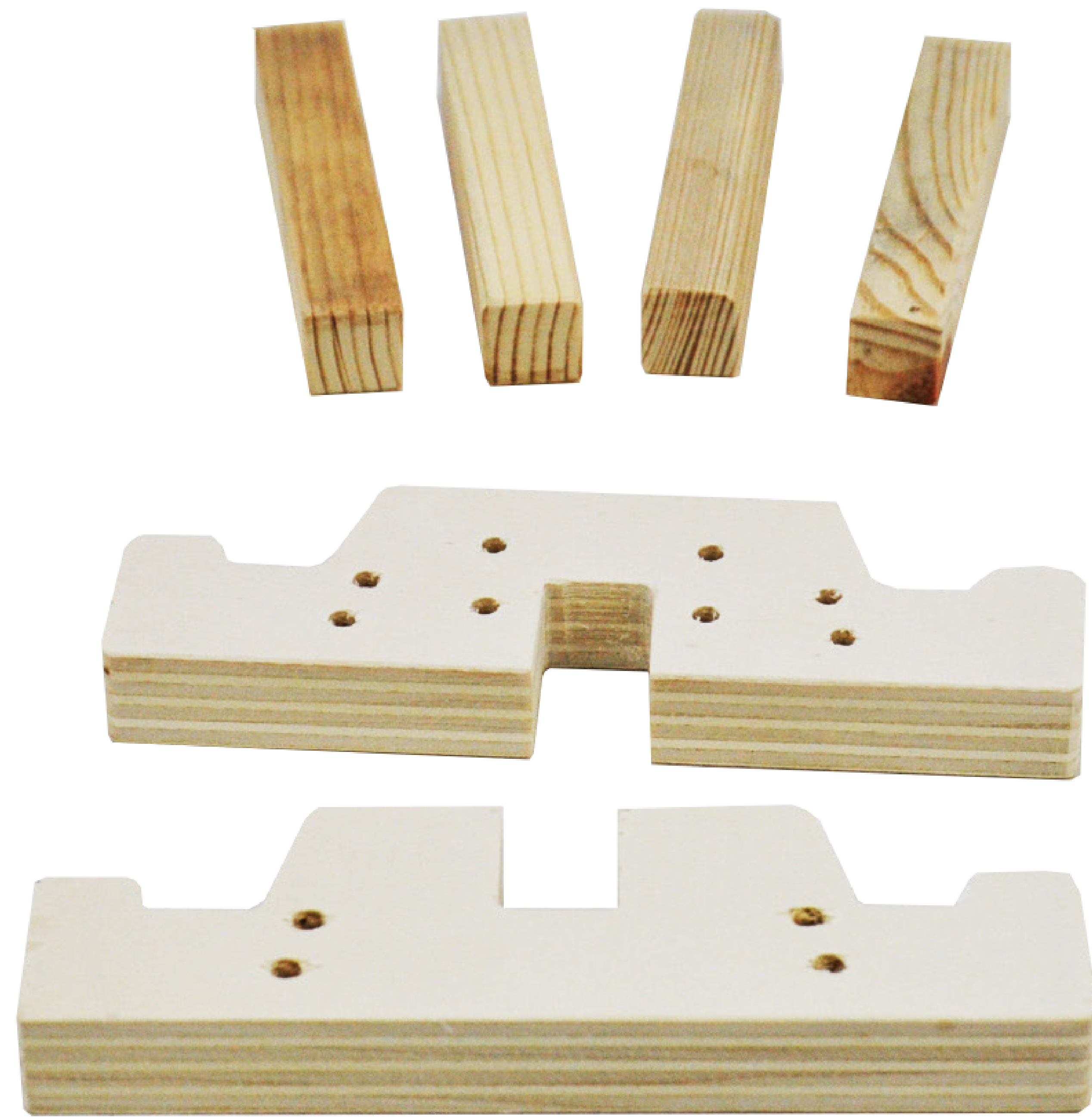

Column Finish Elements

Beam Construction Steps

Scale 1:2

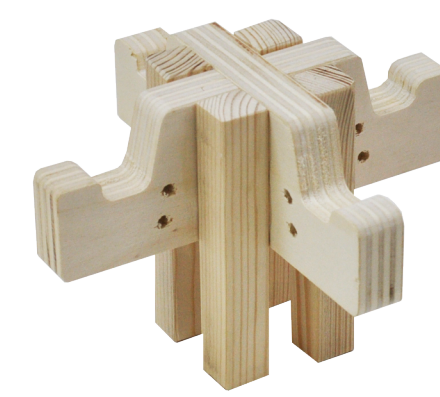
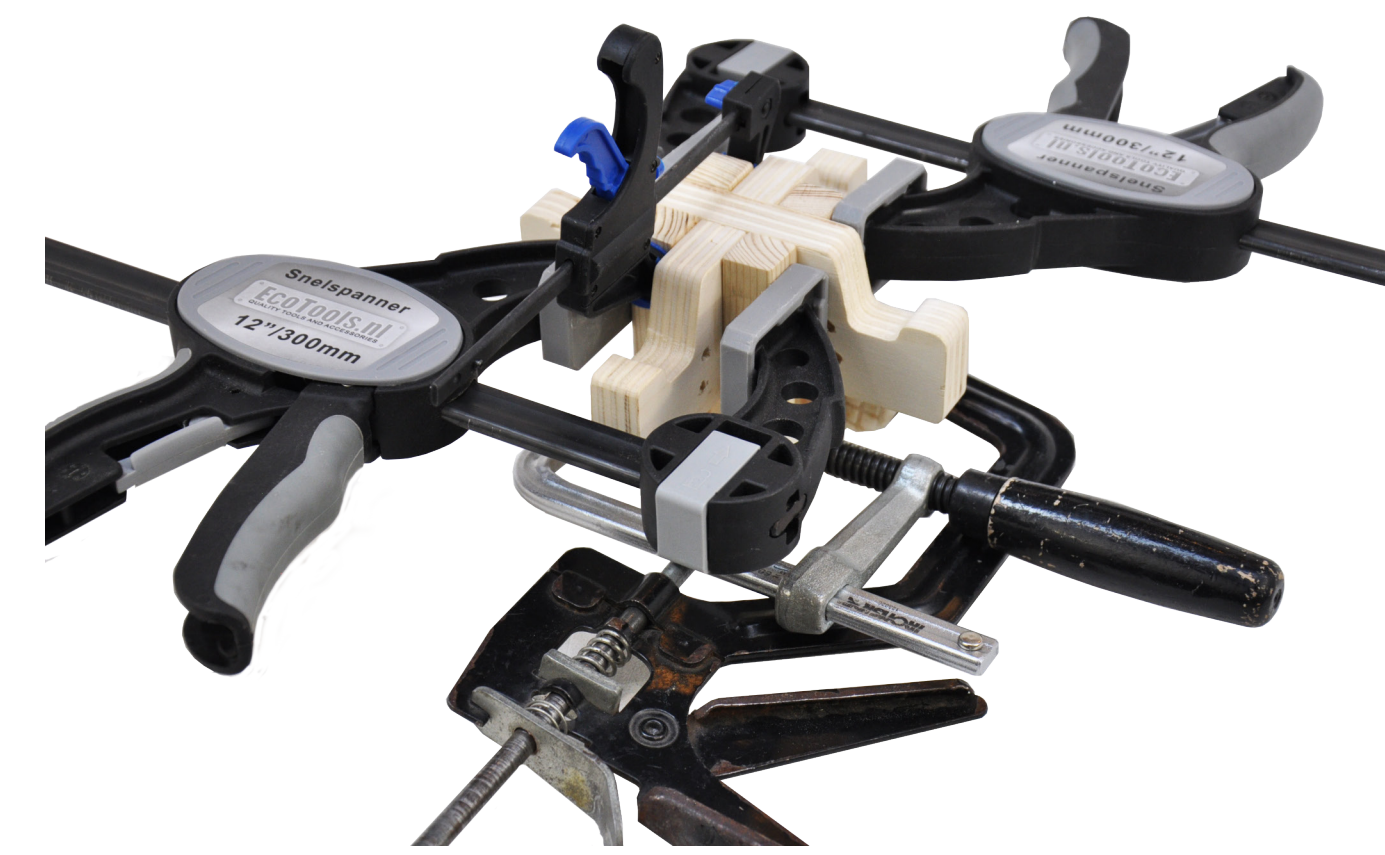
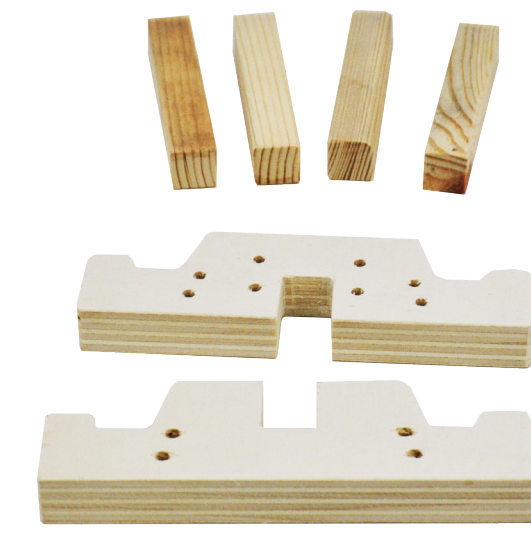

Component Development Steps

Scale 1:2

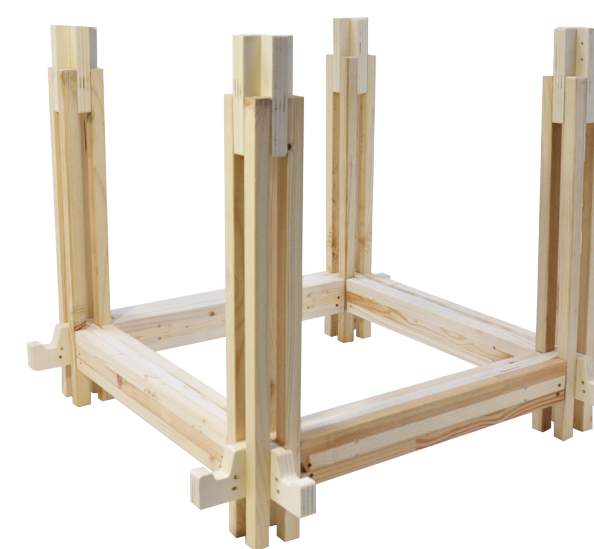
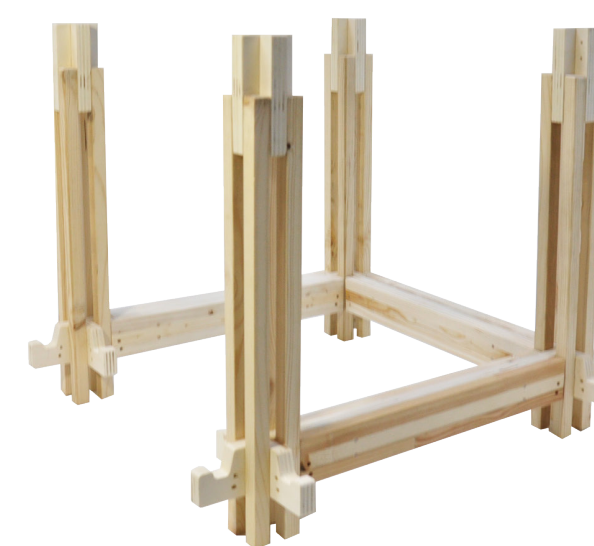
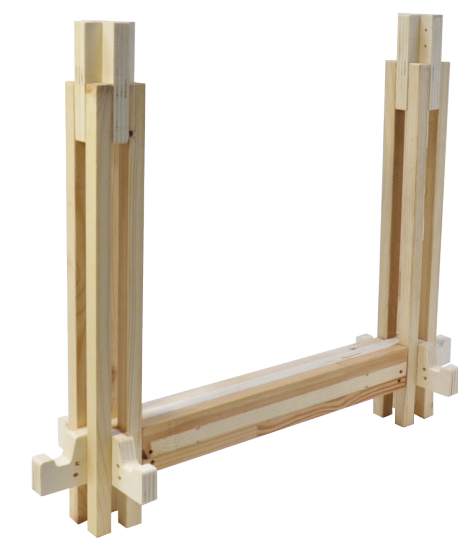



3D Printed Facade
Component from
Recycled Plastic
Bottle Caps

[PET]

Scale 1:20



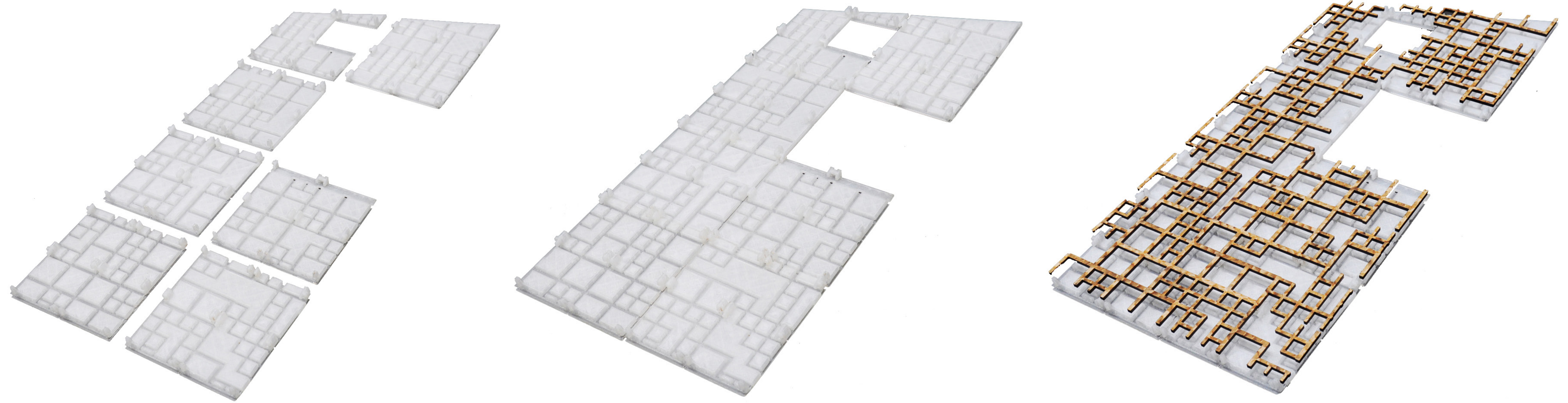

Model Facade Assemblage & Timber Framework Nesting



Physical Model Fragment

Scale 1:20



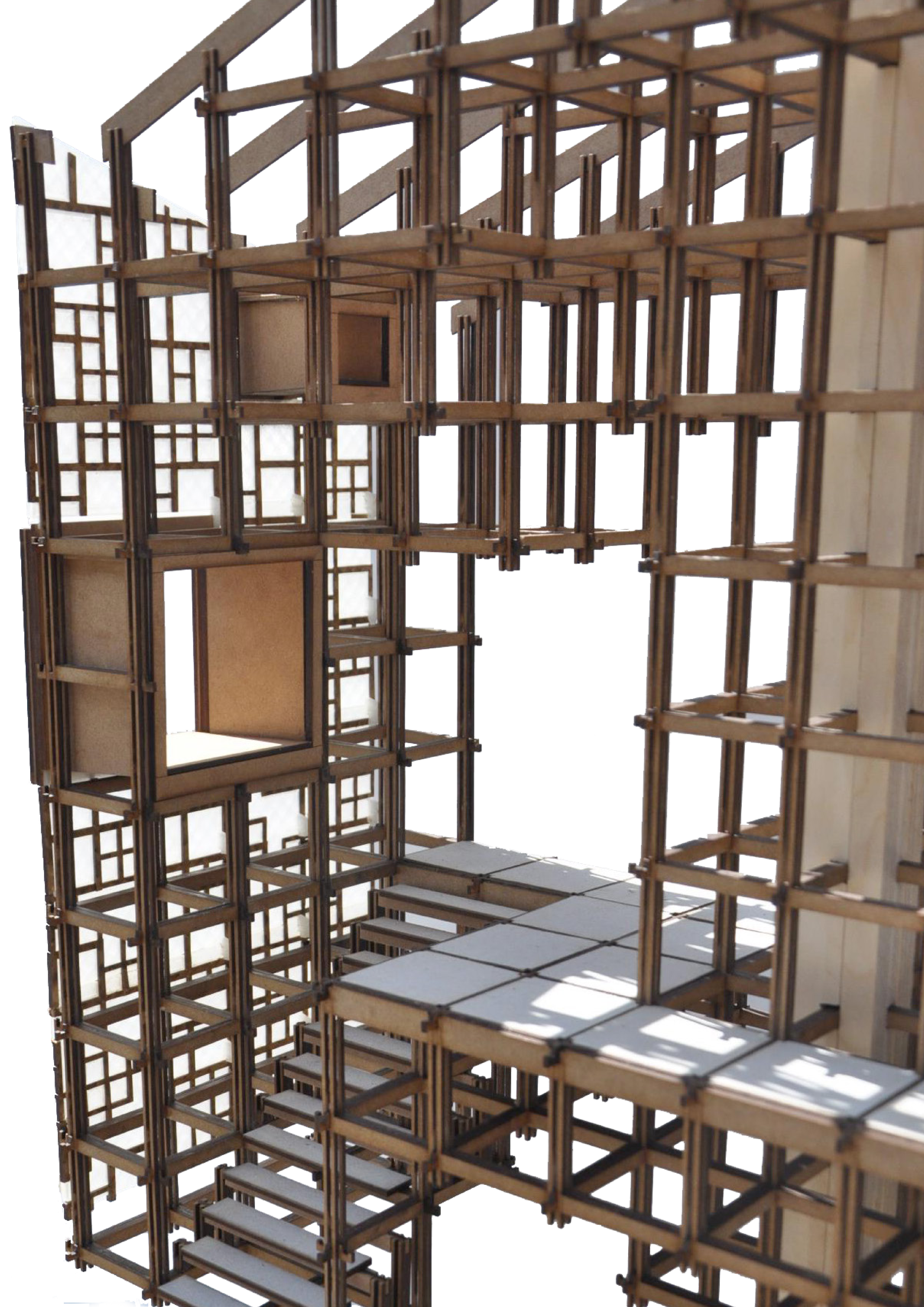







Thank You!