

227A

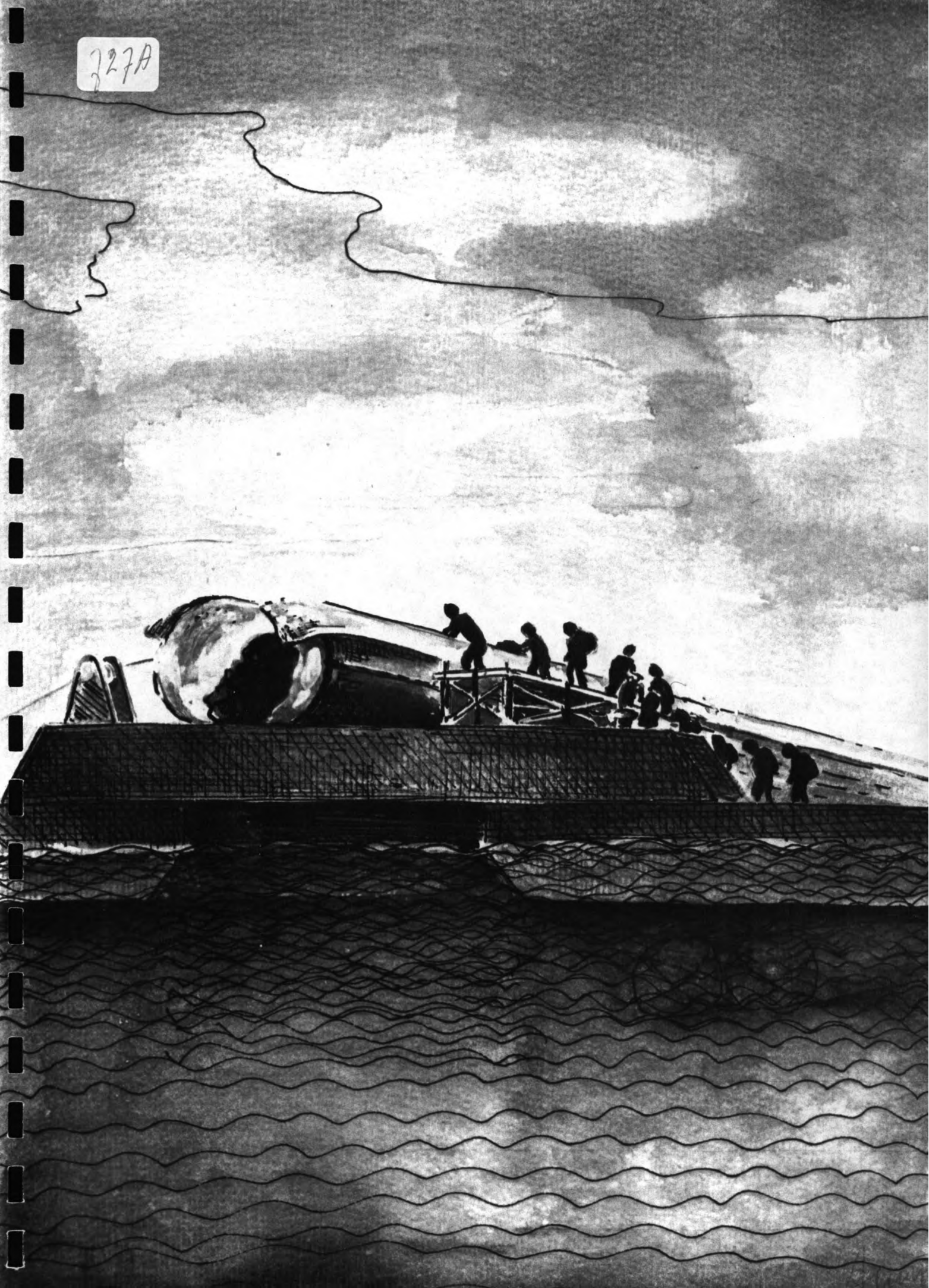

ROTTERDAM PUBLIC WORKS
Harbour Engineering
Division

STUDY ABOUT
LANDRECLAMATION

June 1986
Revised:
November 1987

CONTENT

<u>1. Problem</u>	pag. 5
<u>2. Local data</u>	
2.1 The Qiantang estuary	pag. 9
2.2 The Yangtze estuary	pag. 9
2.3 Distribution of wave heights	pag. 10
2.4 Distribution of wind speed	pag. 11
2.5 Morphology	pag. 13
2.6 Soil mechanical properties	pag. 13
2.7 Overview of available materials and prices of materials and labour	pag. 15
<u>3. Starting points</u>	pag. 17
<u>4. Planning the reclamation project</u>	
4.1 Introduction	pag. 19
4.2 Short term plan (phase one)	pag. 19
4.3 Master plan	pag. 19
<u>5. Possible designs phase one</u>	
5.1 Mechanics of the sedimentation process	pag. 21
5.2 Existing constructions	pag. 25
5.3 Possible lay-out	pag. 29
<u>6. Choice of design for phase one</u>	
6.1 Designs	pag. 35
6.2 Use of the tube-shaped geotextile filled with soil	pag. 55
6.3 Use of the pontoon	pag. 56
6.4 Method and execution	pag. 61
6.5 Costs and optimation	pag. 64
<u>7. Further approach</u>	
7.1 Further examination	pag. 69
7.2 Absent data	pag. 70
<u>8. Summary and conclusions</u>	pag. 71
Appendix 1: Calculations	pag. 77
Appendix 2: References	pag. 85



1. PROBLEM

In the Yangtze delta (Nan Hui East district) and the Qiantang delta (Cao Jing district) several reclamation projects are being prepared, the aim being to accelerate the natural sedimentation process.

In the Yangtze estuary it exists a tidal difference of 3 m (average). This estuary forms the mouth of the Yangtze Kiang River (Ch'ang Chiang) and is particularly rich in sediment (up to 3,000 mg/l).

In the Qiantang estuary it exists a tidal difference of 4 m (average), and because of the estuary's trumpet-like shape this tidal difference increases greatly the further inland it gets (8-9 m), creating one of the world's largest bores with a height of 3 m at spring tide, 1 m at neap tide, and travelling at a speed of 6 to 12 m/s. Here the water is less rich in sediment than the water in the Yangtze estuary, varying from 500 to 2000 mg/l depending on the season.

Along the east coast of the Nan Hui East district the coastline is moving seaward at a rate of 1-5 m per year and the reed-covered mud flat is silting up at a rate of 0,25 m a year. The south coast of the Nan Hui district is being eroded (the main channel of the Qiantang estuary is just before the coast at this point). At the Cao Jing district slow sedimentation occurs, the coastline has shifted some 250 meters towards the south during the last 20 years. In both cases the coastal strip where land reclamation is required lies between the HW-line and the LW-line; the shallow flat is muddy and not firm, but it can however be crossed on foot. The soil consists of a silty loam with sand deposits (non-homogeneous).

Every 2-3 years this area is swept by typhoons with wind speeds of over 30 m/s, causing higher water levels and very high waves. Up to now the banks and dikes in the region have been built up of a clay core with stone pitching, sometimes with grouting. (In the recent past large-scale poldering schemes have been carried out along the coast of both estuaries). Because stones and sand have to be transported from great distances, the construction of these banks and dikes is very costly.

Alternative reclamation structures must be sought, with as little import of foreign machines as possible. The materials, machines and labour already available locally must be used whenever possible.

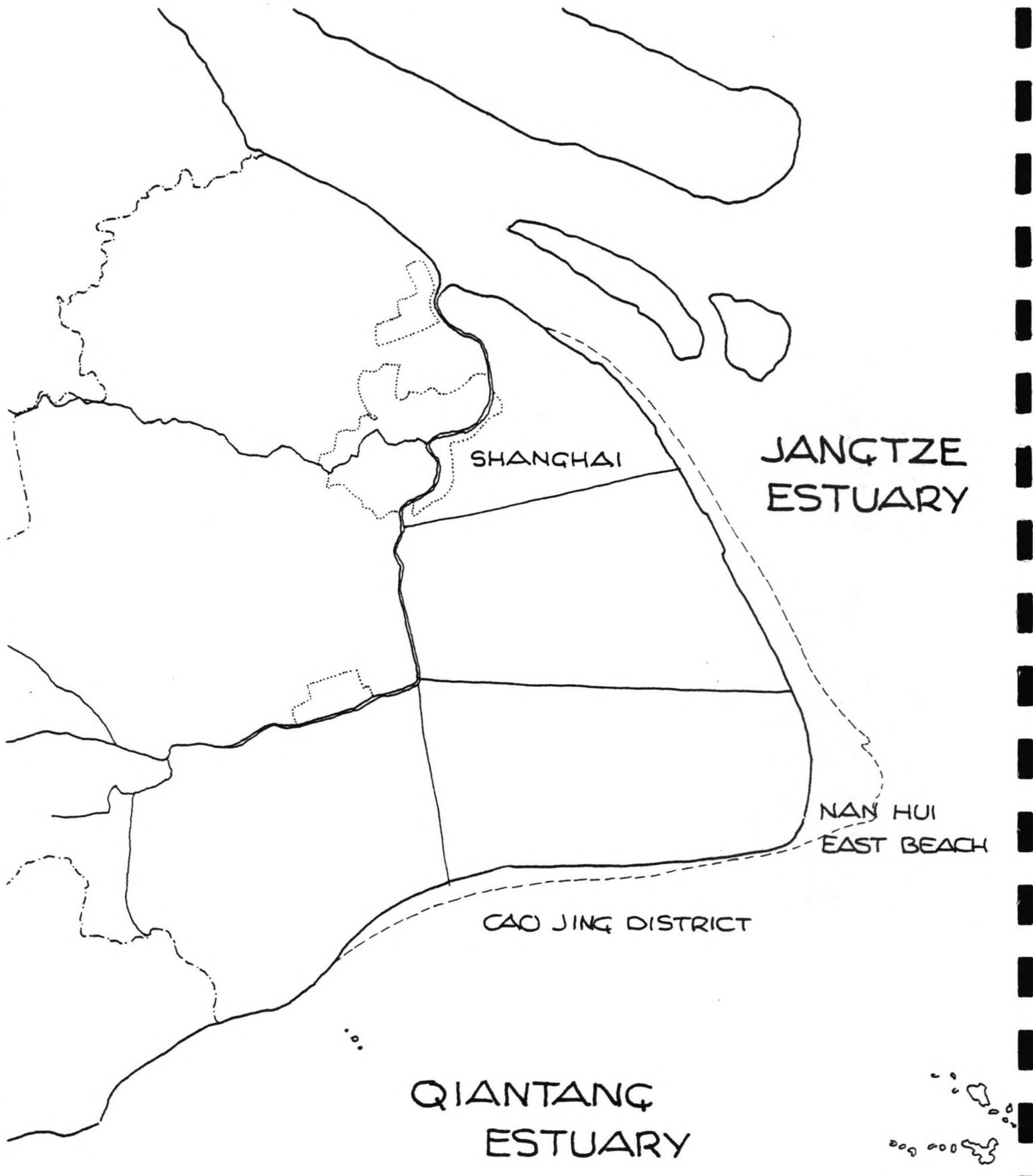

SHANGHAI

JANGTZE
ESTUARY

NAN HUI
EAST BEACH

CAO JING DISTRICT

QIANTANG
ESTUARY

The object of this report is to prepare a rough plan for the approach of studies and experiments on land reclamation. This includes the following:

1. optimization of the ratio reclaimed area to total length of dikes;
2. techniques to stimulate accretion;
3. minimizing costs.

2. LOCAL DATA

Of the Cao Jing district and the Nan Hui East district the following data are available.

2.1 The Qiantang estuary (Ch'ien T'ang Chiang) location: the Cao Jing district

average tidal range: 4.10 m MHWL 3.80
MLWL -0.30
tidal current located in channel along coast: 2 m/s
maximum tidal range: 6.30 m HHWL 5.39
LLWL -0.88
tidal current located in channel along coast: 4 m/s

flood season: June, July, August
at high tide (spring) at low tide (spring)
tidal volume: $36,6 \cdot 10^9$ m³ $36,7 \cdot 10^9$ m³
sediment yield: $51 \cdot 10^6$ ton $62 \cdot 10^6$ ton
average sediment concentration: 2,000 mg/l

dry season: January, February
at high tide at low tide (spring)
tidal volume: $33,7 \cdot 10^9$ m³ $32,4 \cdot 10^9$ m³
sediment yield: $82,2 \cdot 10^6$ ton $73,3 \cdot 10^6$ ton
average sediment concentration: 1,500 mg/l

at high tide (neap) at low tide (neap)
tidal volume: $21,9 \cdot 10^9$ m³ $21 \cdot 10^9$ m³
sediment yield: $37,7 \cdot 10^6$ ton $27 \cdot 10^6$ ton
average sediment concentration: 1,000 mg/l

Qiantang river
average run-off: 920 m³/s (annual discharge $29 \cdot 10^9$ m³);
average sediment concentration: 196 mg/l (annual $4,8 \cdot 10^6$ ton);
catchment area: $41,7 \cdot 10^3$ km²

2.2 The Yangtze estuary (Ch'ang Chiang) Location: Nan Hui East district

average tidal range: 3.90 m MHWL: 3.80
MLWL: -0.10
tidal current located in channel along coast: 2 m/s
maximum tidal range: 5.80 m HHWL: 5.68
LLWL: -0.10
tidal current located in channel along coast: 3 m/s

flood season: June, July, August
at high tide (spring)
tidal volume: $5,3 \cdot 10^9$ m³
at high tide (neap)
tidal volume: $1,6 \cdot 10^9$ m³
average sediment concentration: 2,000 mg/l
river discharge: 80,500 m³/s

dry season: January, February
 at high tide (spring)
 tidal volume: $3,9 \cdot 10^9$ m³
 at high tide (neap)
 tidal volume: $1,3 \cdot 10^9$ m³
 average sediment concentration: 2,000 mg/l
 river discharge: 4,000 m³/s

Yangtze Kiang river

average run-off river: 28,900 m³/s (annual $911 \cdot 10^9$ m³)
 average sediment concentration: 720 mg/l (annual $468 \cdot 10^6$ ton)
 suspended load $d_{50} = 15 \mu\text{m}$
 bed load $d_{50} = 50 \mu\text{m}$
 catchment area 1,830,000 km²

2.3

Distribution of wave heights

Fig. 2.3 shows a graph of the distribution of wave heights and periods at a waterdepth of approx. 20 m at cape Nan Hui. The elevation of the watersurface around its mean level is considered to be a Gaussian process (normally distributed). Resulting wave heights H (distance between crest and lowest level) follow a Rayleigh distribution, if caused by one single windfield. The long-term wave heights caused by different wave fields from different directions mostly follow a Weibull distribution, it can be interpreted from measurements (see Fig. 2.3) (if $k = 1$: exponential distribution).

$$\text{Weibull: } P(\underline{x} \leq x) = 1 - e^{-\left[\frac{x-a}{u}\right]^k}$$

The extreme wave heights again follow a Weibull distribution with other parameters.

Using this information a prediction can be done about the chance of extreme wave heights occurring at Cape Nan Hui: these are probably also, apart from shoaling and breaking effects, determining the extreme wave heights at Cao Jing and Nan Hui East Beach; if necessary the complete wave spectrum at Cape Nan Hui can be estimated from measurements, and it can be transformed to fit the Cao Jing district and the Nan Hui East Beach so that the wave climate at both areas can be predicted.

2.3

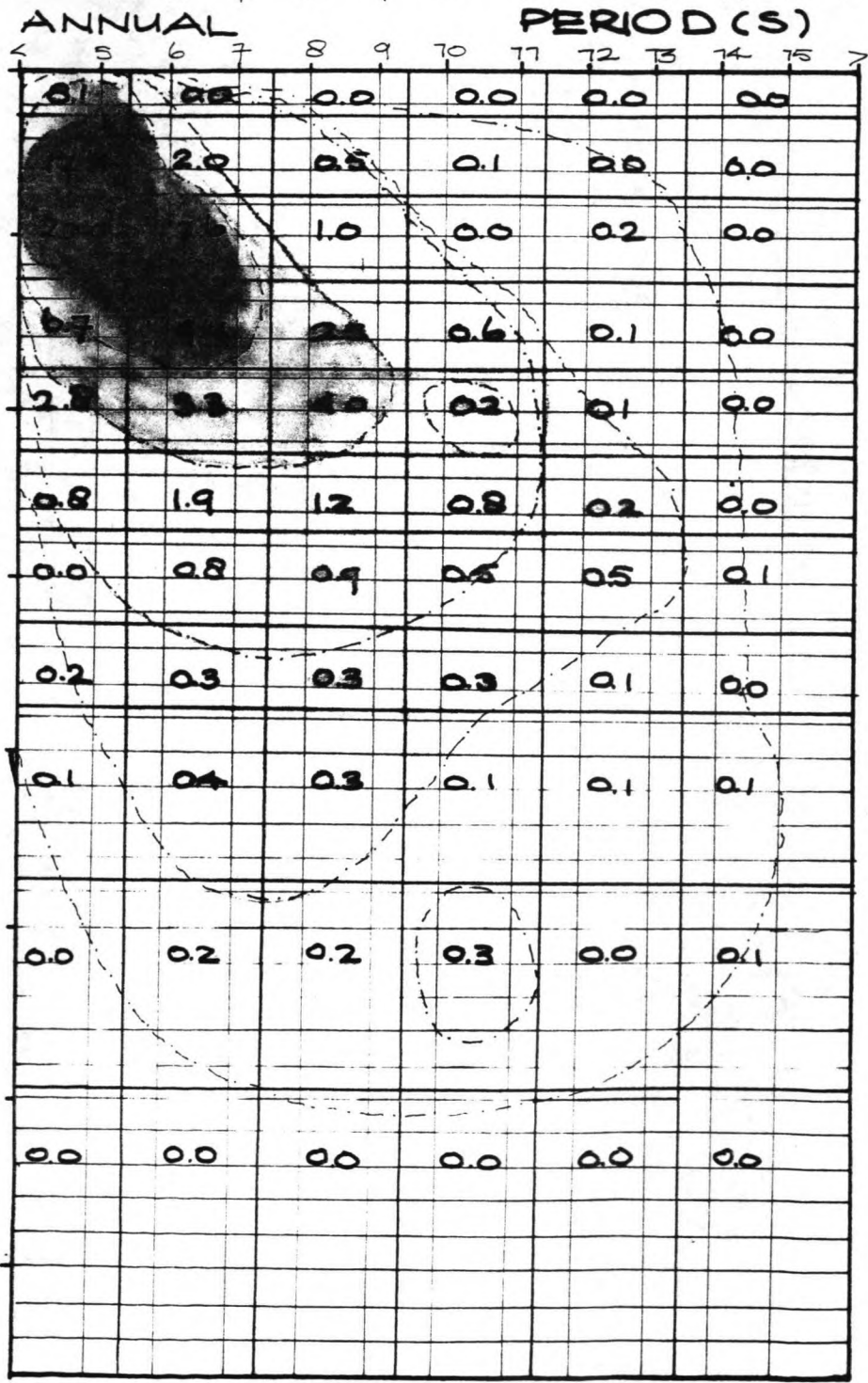
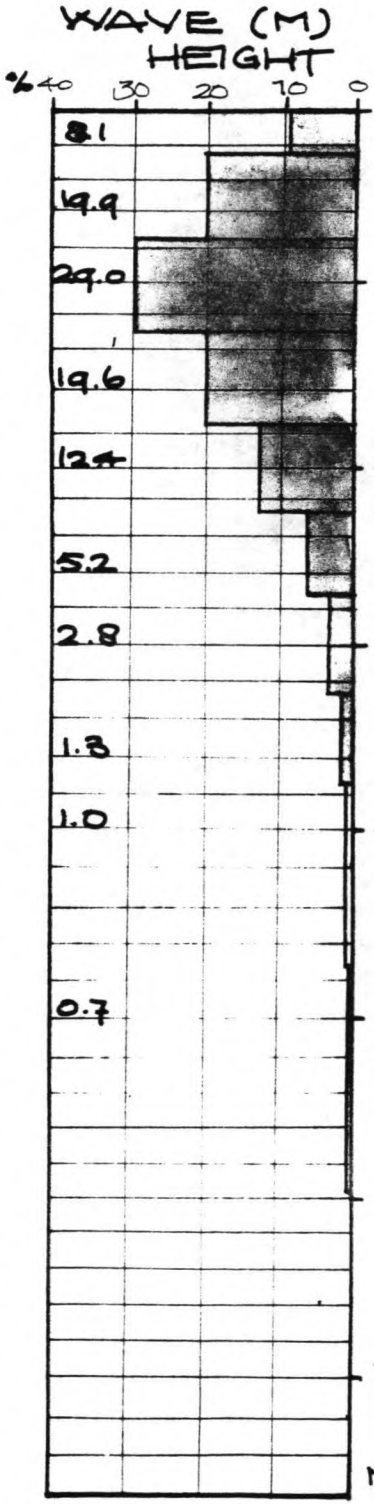
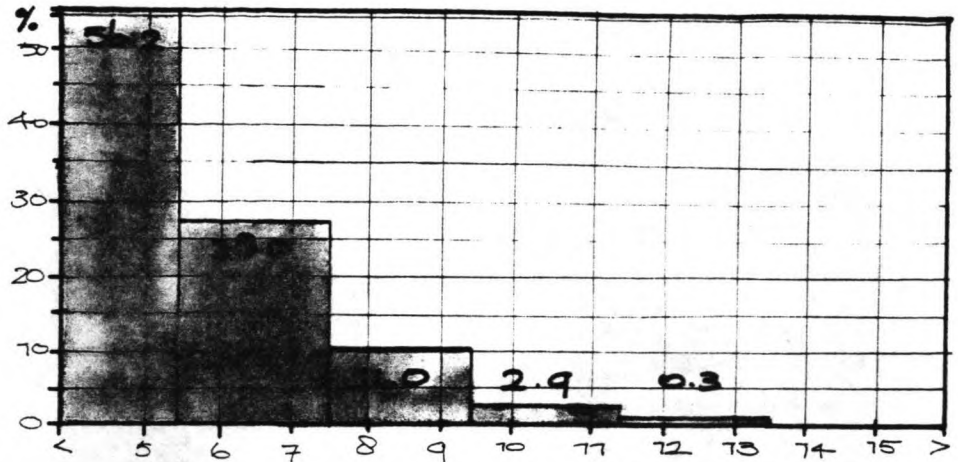

2.4

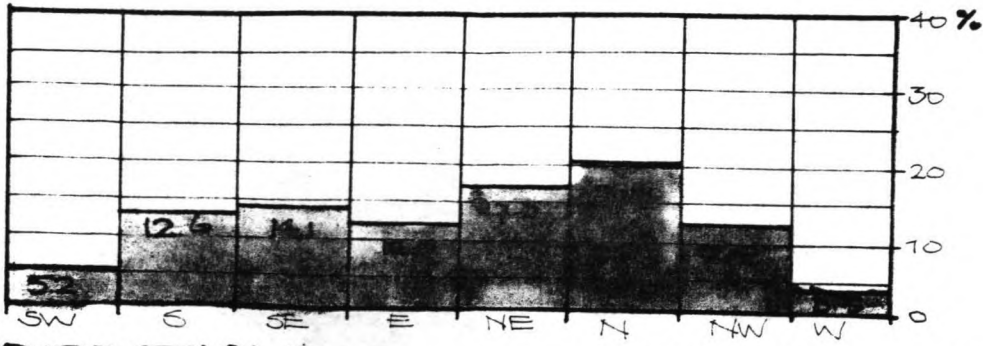

DIRECTION ANNUAL

WINDSPEED 0 10 20 30 40%

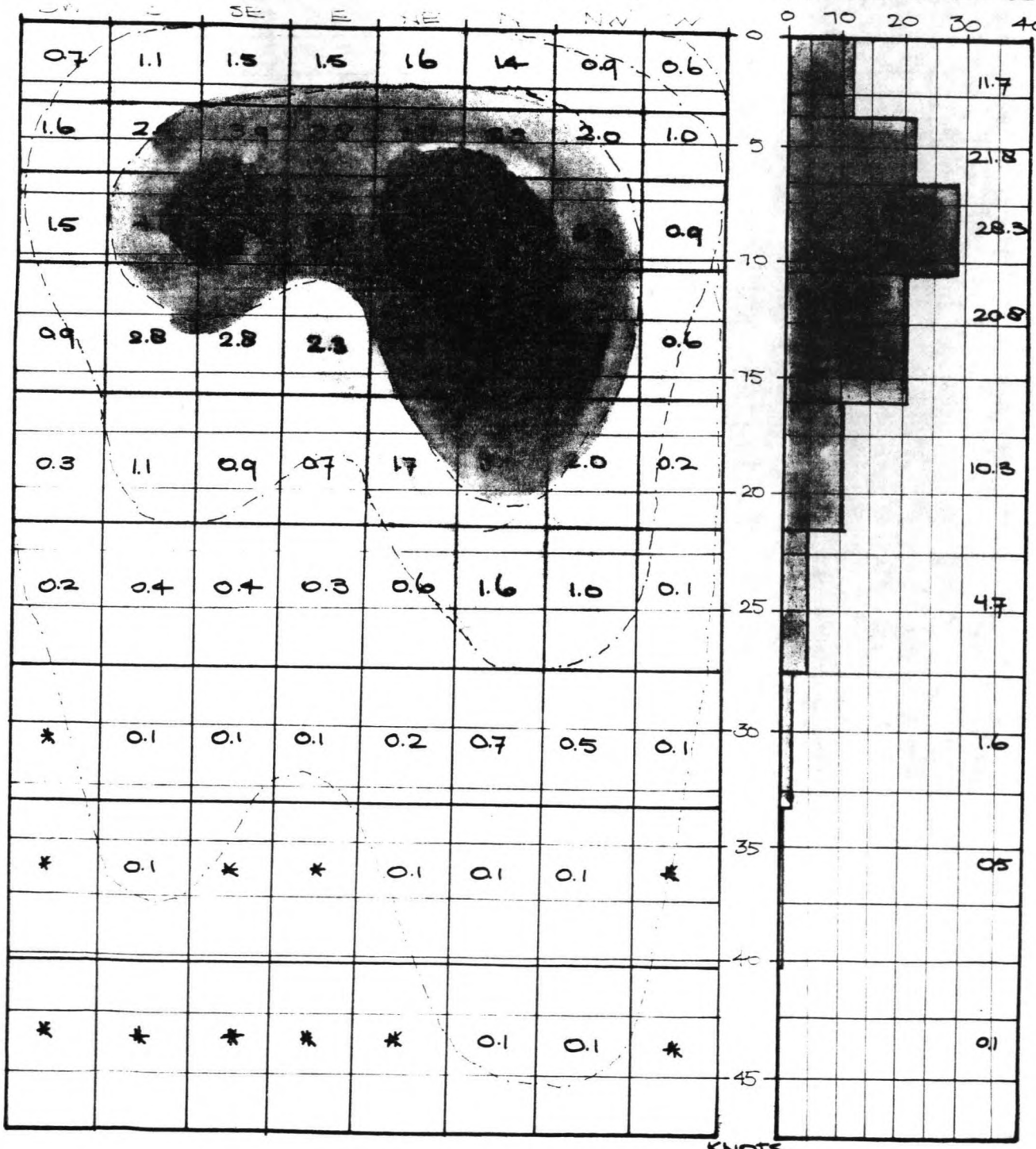

KNOTS

	SW	S	SE	E	NE	N	NW	W
0-5	0.7	1.1	1.5	1.5	1.6	1.4	0.9	0.6
5-10	1.6	2.0	2.8	2.8	2.8	3.0	1.0	0.9
10-15	0.3	1.1	0.9	0.7	1.7	2.0	0.2	0.6
15-20	0.2	0.4	0.4	0.3	0.6	1.6	1.0	0.1
20-25	*	0.1	0.1	0.1	0.2	0.7	0.5	0.1
25-30	*	0.1	*	*	0.1	0.1	0.1	*
30-35	*	*	*	*	*	0.1	0.1	*
35-40								
40-45								

WINDSPEED (KNOTS)	FREQUENCY (%)
0-5	11.7
5-10	21.8
10-15	28.3
15-20	20.8
20-25	10.3
25-30	4.7
30-35	1.6
35-40	0.5
40-45	0.1

2.4 Distribution of wind speed

Fig. 2.4 shows a graph of the wind speed (averaged over one hour) from different directions.

The wind speed is mostly considered to be Weibull distributed (this distribution often fits observations best).

The fetch length can be measured for different angles of approach, if duration and direction of windfields are known, wind set-up can be predicted at Nan Hui East Beach and the Cao Jing district (together with the wave spectrum).

The influence of typhoon conditions gives a discontinuity in the distribution (which cannot be clearly seen in Fig. 2.4, as this is a global interpretation of some data). The wind data (and wave data) at typhoon areas follow two different distributions: a Weibull distribution for "moderate" (normal) conditions and some distribution for extreme (typhoon) conditions.

A later study will include a profound study of a probabilistic approach to the extreme conditions causing high waterlevels, wave heights, currents etc.

In the North Pacific typhoons occur an average of 22 times a year, 1 or 2 of which each year sweep the area round Shanghai. Several of these typhoons cause extremely high water levels and wind speeds of over 30 m/s. It is impossible to make any forecast in this respect; but allowance should be made for the fact that one of these typhoons could disturb the land reclamation project (approx. once in the 3 to 10 years). The typhoons occur largely in July, August, September.

Fig. 2.4 distribution of wind speed at Cape Nan Hui Zui
(122,3° E 30,5° N)

U = wind speed averaged over an hour at 10 m above the seasurface

上海市 海岸线变迁示意图

Sketch Map on the Change of Coastline along Shanghai

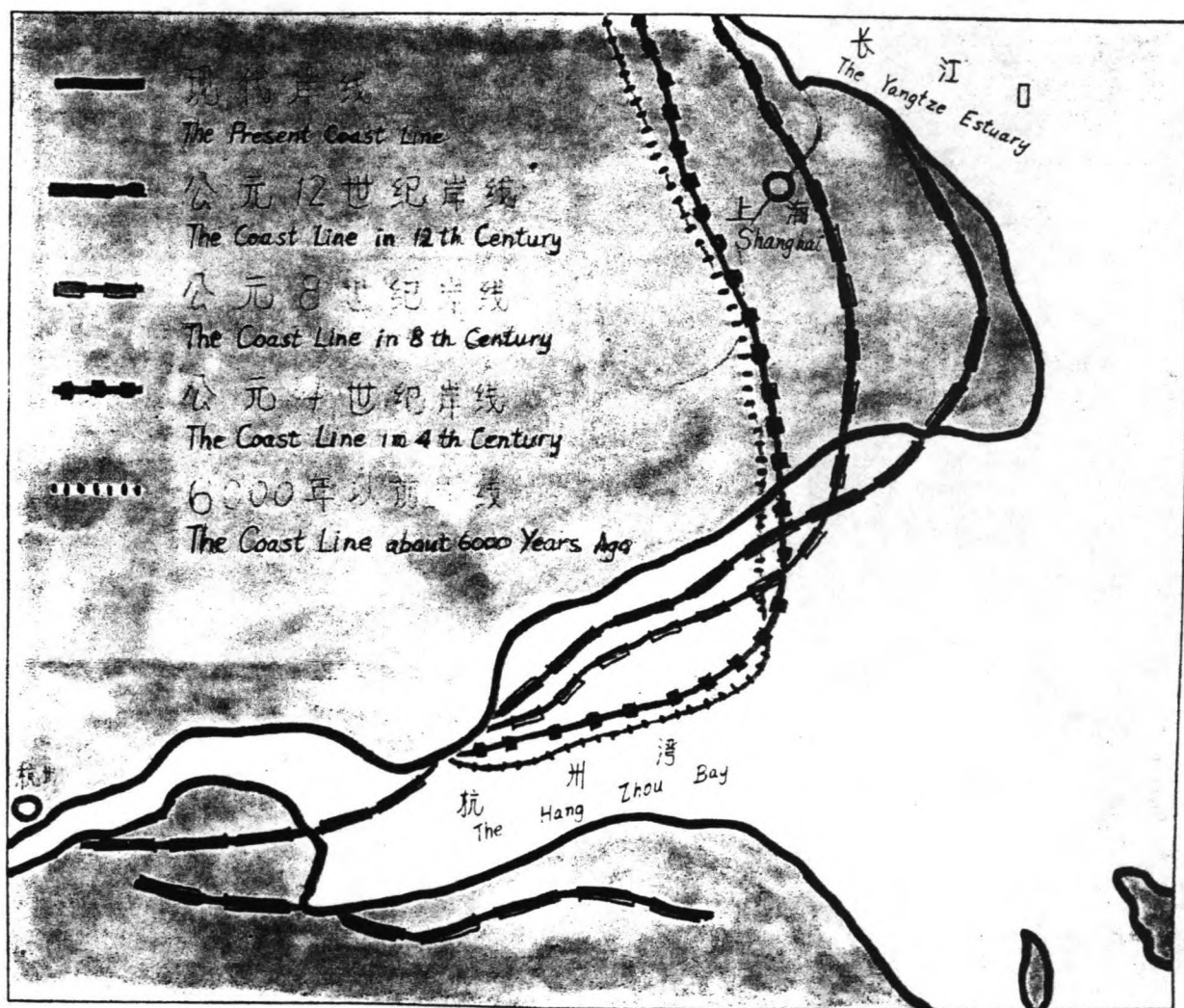

上海市水利局 S.B.W.C.

2.5

Morphology

(see also Fig. 2.5)

- In the Cao Jing district (the mud bank off the coast) the d50 (average grain size) of the soil particles varies from 30 μm at the low water line till 100 μm at the high water line; a silty loam.
The gradient is 1:200 to 1:500 on the shallow mud flat to 1:150 below the LW-line.
- The composition of the mud bank on the East side of Nan Hui varies between d50 = 40 μm at the LW-line and d50 = 80 μm at the HW-line; here too the soil is a silty loam.
The gradient in this area is considerably less, from 1:1,000 on the mud flat to 1:2,000 below the LW-line.
- Depth contours run parallel to the coast (they can be seen in more detail on the overview charts). The Nan Hui mud flat is clearly expanding eastwards; the natural sedimentation here is appr. 1/4 m per year. The south of the mud flat is eroding, caused by the current in the northern channel of the estuary mouth, which runs close to the coast at this point. The mud flat of the Cao Jing district is now more or less stable, during the last 20 years it has moved seawards.
The sediments of both rivers are of fluvial origin. The sediment in the water off the coast can accumulate greatly (up to 3,000 mg/l) due to the influences of the tide and waves in the estuaries. Newly sedimented particles can be easily churned up again by the wave movement and the currents.

2.6

Soil mechanical properties

A sample has been analysed by the soil mechanics laboratory of Rotterdam Public Works with the following results:

a. test on shear-stresses	1	2	3	average
τ_{max} :	13.9	14.2	10.7	12.9 (KPa)
τ_{rest} :	5.4	4.4	4.7	4.7 (KPa)
b. volumetric mass	1.876	1.787	1.752	1.805 (10^3 kg/m ³)
c. moisture content	-	-	-	33.28% (compared to dry matter)
d. elastic limit				36%
plastic limit				29%
plasticity index				7%

For analysis of grain distribution, see Fig. 2.6

GEMEENTEWERKEN ROTTERDAM
AFD. I-02 GEOTECHNIEK

KORRELVERDELINGSDIAGRAM
ISO 565
MINERALE FRACHTIE
NEN 2560

WERK Shanghai

BORING

MERK	DIEPTE IN m	GRIND > 2 mm %	ZAND 0.063-2 mm %	SLIB < 0.016 mm %	LUTUM < 0.002 mm %	HUMUS %	Ca CO ₃ %	U-cijfer	GRONDSOORT	d ₅₀ mm
		0.00	3.14	31.27	12.64	1.17	6.98	352.8	KLEI, V.UITERST F.ZAND	0,921

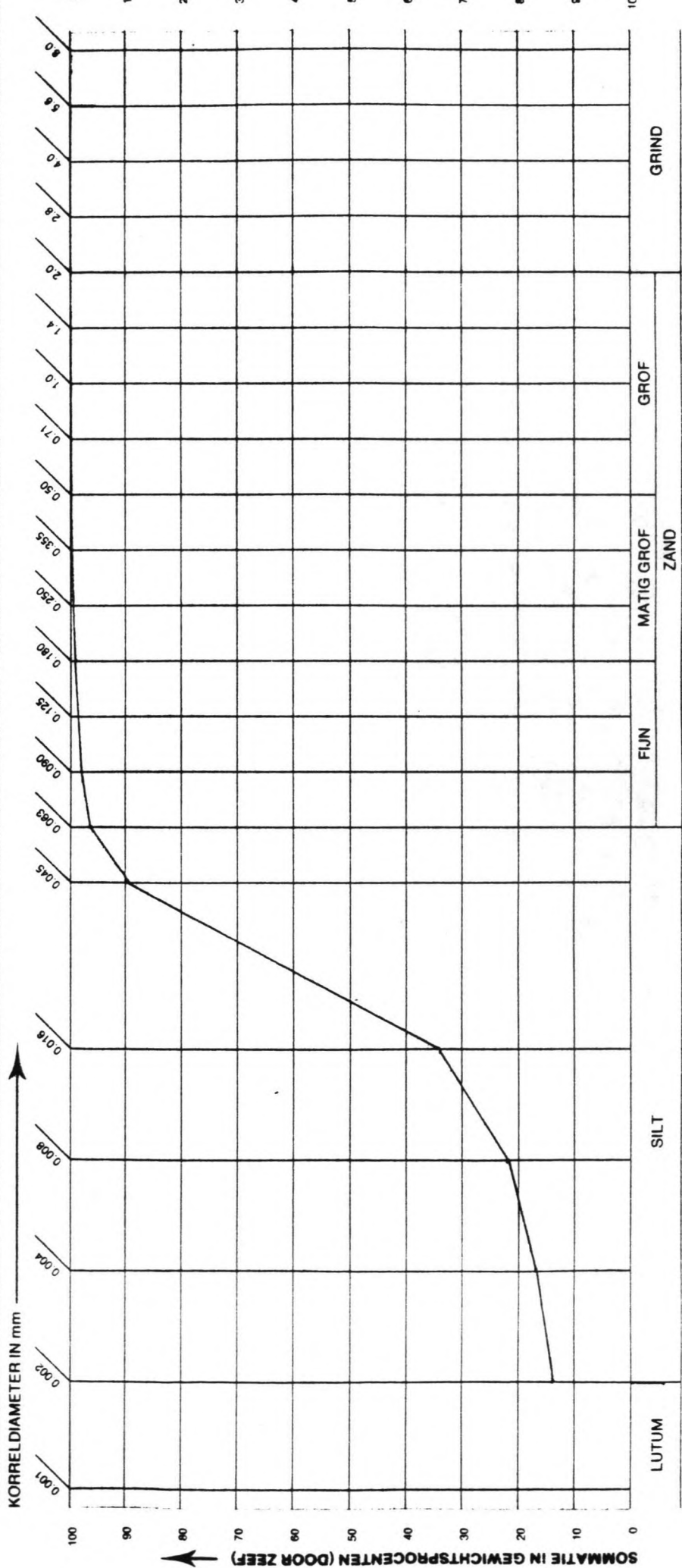

2.7 Overview of available materials and prices of materials and labour

	Nan Hui	Cao Jing
clay $\rho = 1,600 - 1,800$ kg/m ³ price*:	1.50	1.50 y/ton
sand $\rho = 1,700 - 2,000$ kg/m ³ price*:	35.1	30.0 y/ton
rubble $\rho = 2,650$ kg/m ³ price*:	20.7	17.7 y/ton
geotextiles, fascine mattresses price*:	8.75	8.75 y/m ²
labour costs :	1.50	1.50 y/manhour

Bamboo is also available in several diameters (price unknown), also fagots and reeds (price unknown).

* prices are including transport to construction site.



3. STARTING POINTS

The recommendations in this report are based on the following starting points:

firstly:

the object of the construction is first and foremost to accelerate accretion and hence the land reclamation process, the emphasis lying on the application of relatively as little construction as possible.

secondly:

it could be possible to contribute to the stabilisation of the channel systems in both estuaries: the approach route over the Yangtze estuary to Shanghai and the approach route through the Hangzhou-Wan to Hangchow.

thirdly:

when designing possible constructions allowance should be made as much as possible for the fact that local materials, forms of construction and labour should be used wherever possible. In view of the unpredictable character of the typhoons and lack of firmness of the soil, the construction must be flexible and as far as possible suitable for further expansion. In addition the construction must be able to withstand flooding. The constructions intended to stimulate accretion need only last about 5 years.

7



4. PLANNING THE RECLAMATION PROJECT

4.1 Introduction

When planning a step-by-step land reclamation project it is important to be clear about what the final situation should or could be. This will make it easier to gradually adapt the intervening and plan the appearance of the landscape with a view to achieving the desired end-result.

Two plans will be outlined, starting with the existing situation and the points mentioned in section 3.

1. A short-term plan to be executed in 5-10 years;
2. a long-term plan spreading over several decades.

For the Cao Jing district the latter would also represent the final situation for the northern side of the Qiantang delta. For the Nan Hui East district this is less clear, because as long as the upper course of the Yangtze river has not been regulated, the supply of silt will continue and the coastal strip will continue to grow.

4.2 Short-term plan (phase one)

This phase comprises the reclamation of the mud flat to the south of Cao Jing and the mud flat to the east of Nan Hui.

Basis is the plan developed by the SBWC, with the suggestion that the proposed area be extended to cover the whole mud flat area (see Fig. 4.2) because then the movement of current will be better guided by the shape of the coastline. The natural streamlines of the water must be gradually led away from the coastal strip and not be directly blocked by any construction. By using right angles in an ebb/flow estuary unfavourable eddies are caused and the construction is undermined (particularly, as here, with soil which is subject to erosion). What is more, the land reclamation along the coast can be gradually expanded seawards. Gradually a new "balanced current" can be established and less erosion will occur around the construction (this too in connection with further expansion).

4.3 Master plan

The object of the plan is to extend the reclamation area as far as possible thus creating a coastline which guides the main channels of the Qiantang estuary and the Yangtze estuary.

This has a dual objective:

1. to facilitate land reclamation (sedimentation outside the main channels will increase because of decreasing current);
2. to facilitate shipping (sedimentation inside the main channel will decrease because of the concentration of current(s) in this channel).

4.3.1

Construction

1. The project is started on a small scale with the proposed land reclamation. These reclamation works can possibly be gradually extended from the coast into the water.
2. In following stages the project must be tackled on a larger scale (see Fig. 4.3). The object is to stabilize the coastline, by constructing large dams from the mainland to fixed points in the sea.
Construction can be done in phases, starting at the bed so that the current pattern of the estuary can gradually adapt to a new (stable) situation.
Concentration of the ebb/flow currents leads to the fact that the channel requires less maintenance (sedimentation becomes less) and the location of the channel is stabilised.
Calculations must show whether eddies might develop between the long training dams. Large scale eddy-developing gives rise to navigation problems and considerable erosion between the dams.
3. Connecting the island of Chongming Dao to the mainland and in so doing closing off the northern branch of the Yangtze estuary. For this dam the same aspects apply.

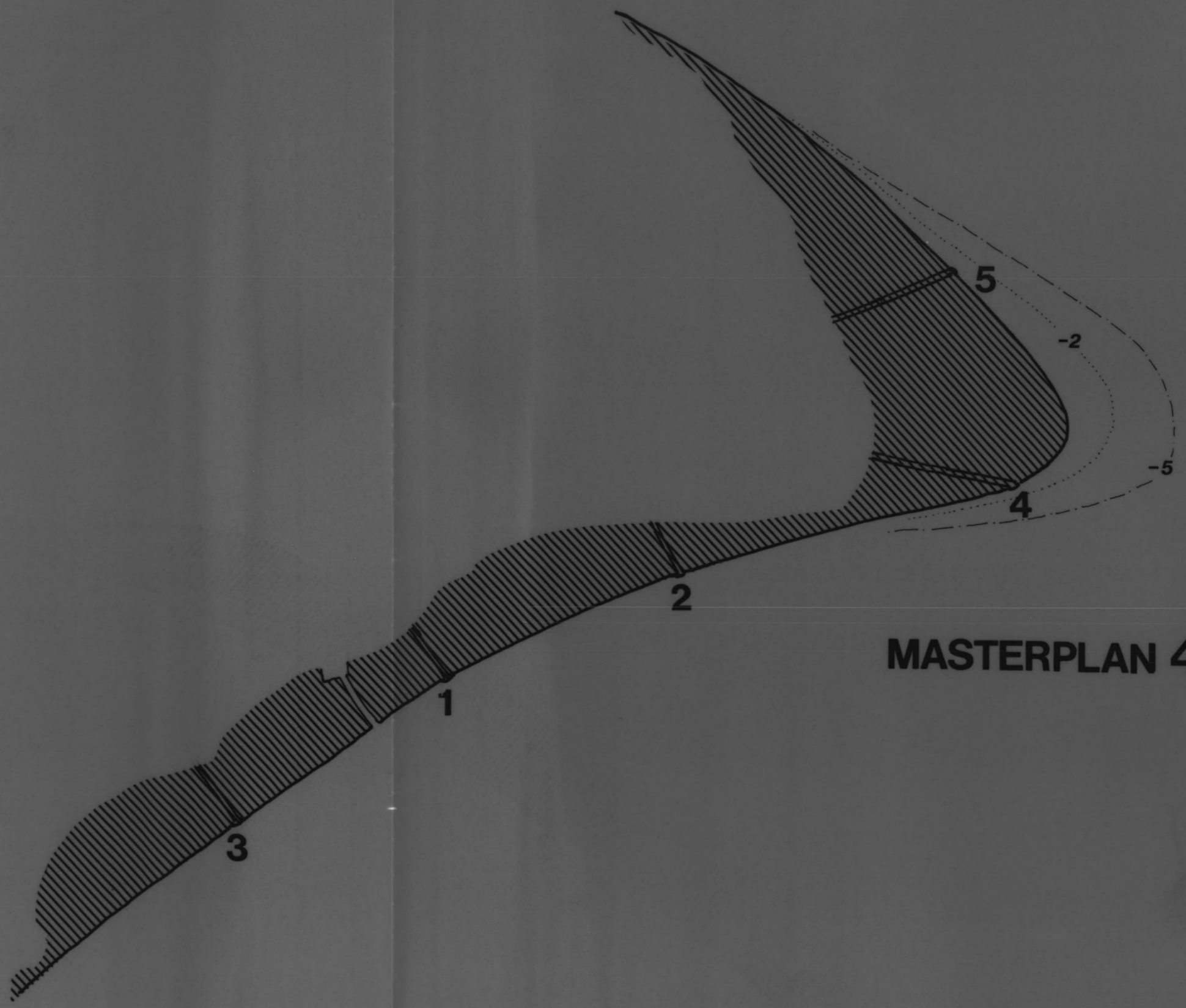

MASTERPLAN 4.3

MASTERPLAN 4.3

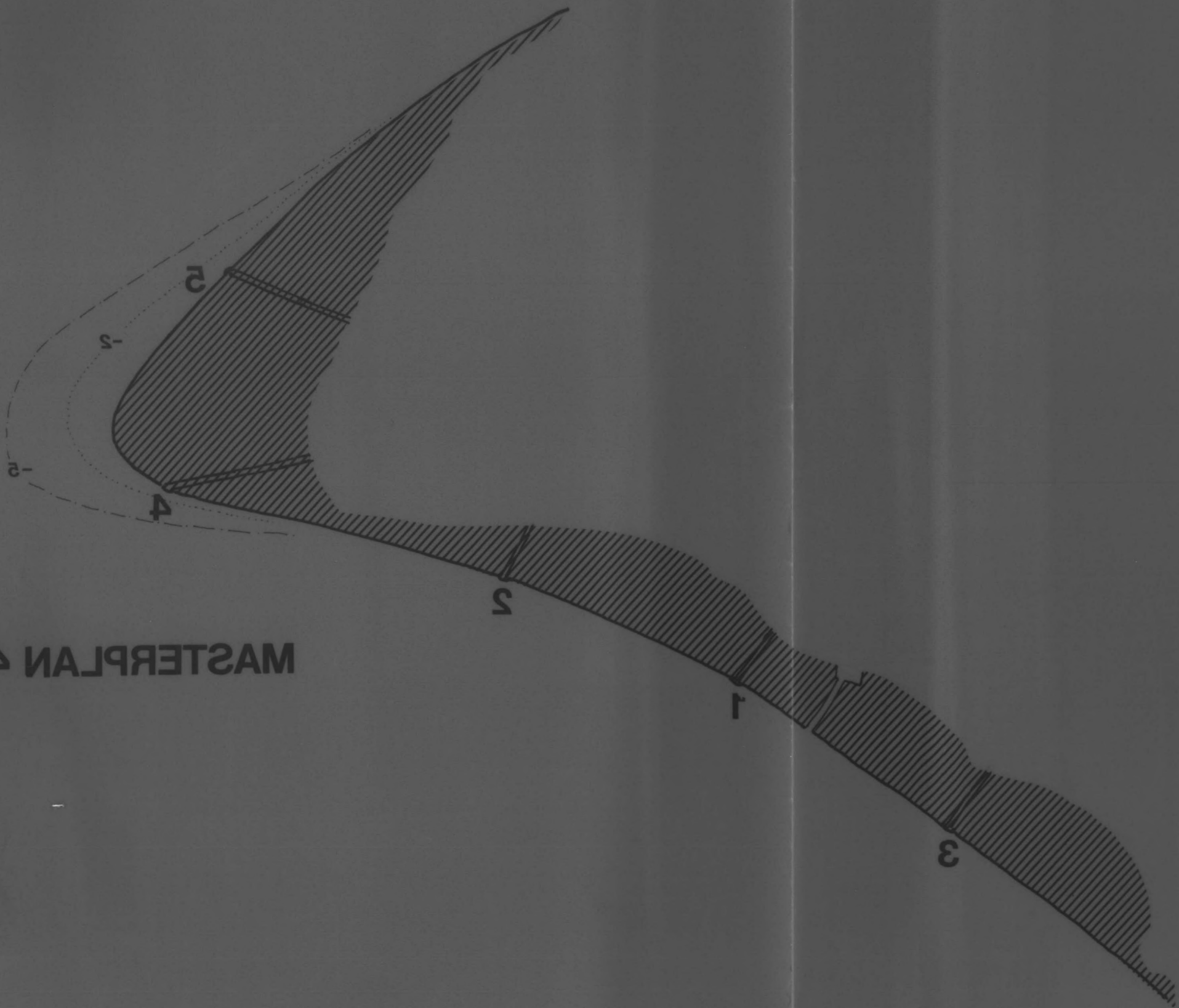

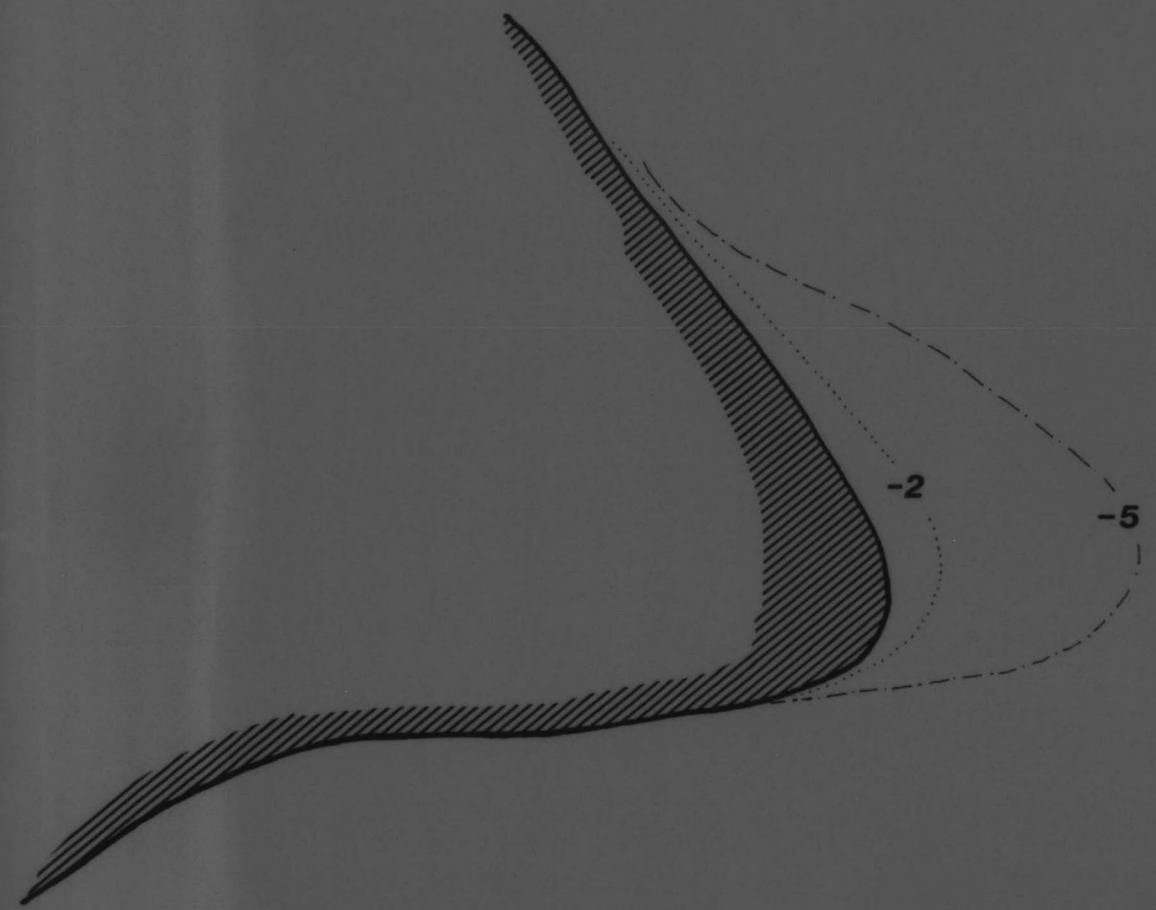

PHASE ONE 4.2

PHASE ONE 4.2

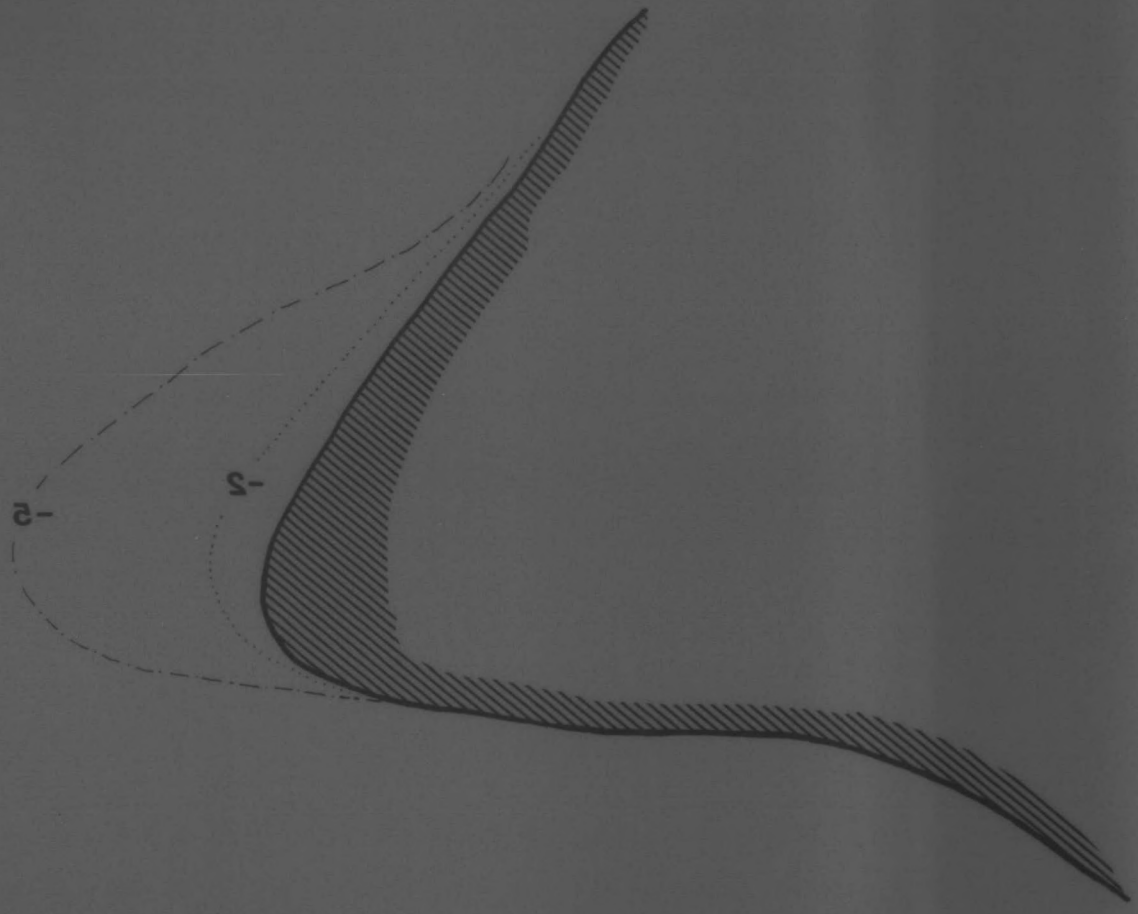

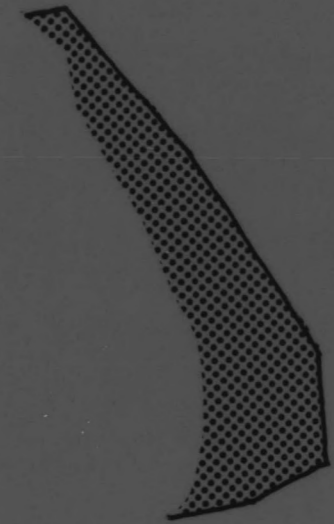
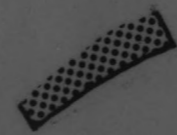

PROPOSED AREA 4.1

PROPOSED AREA 4.1

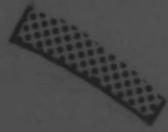
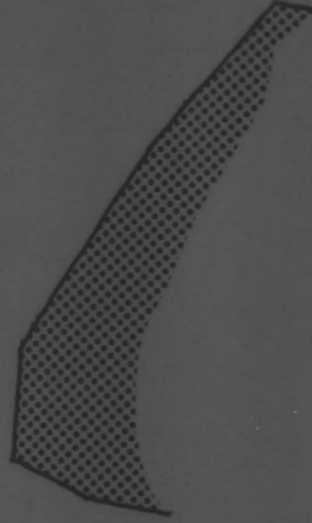

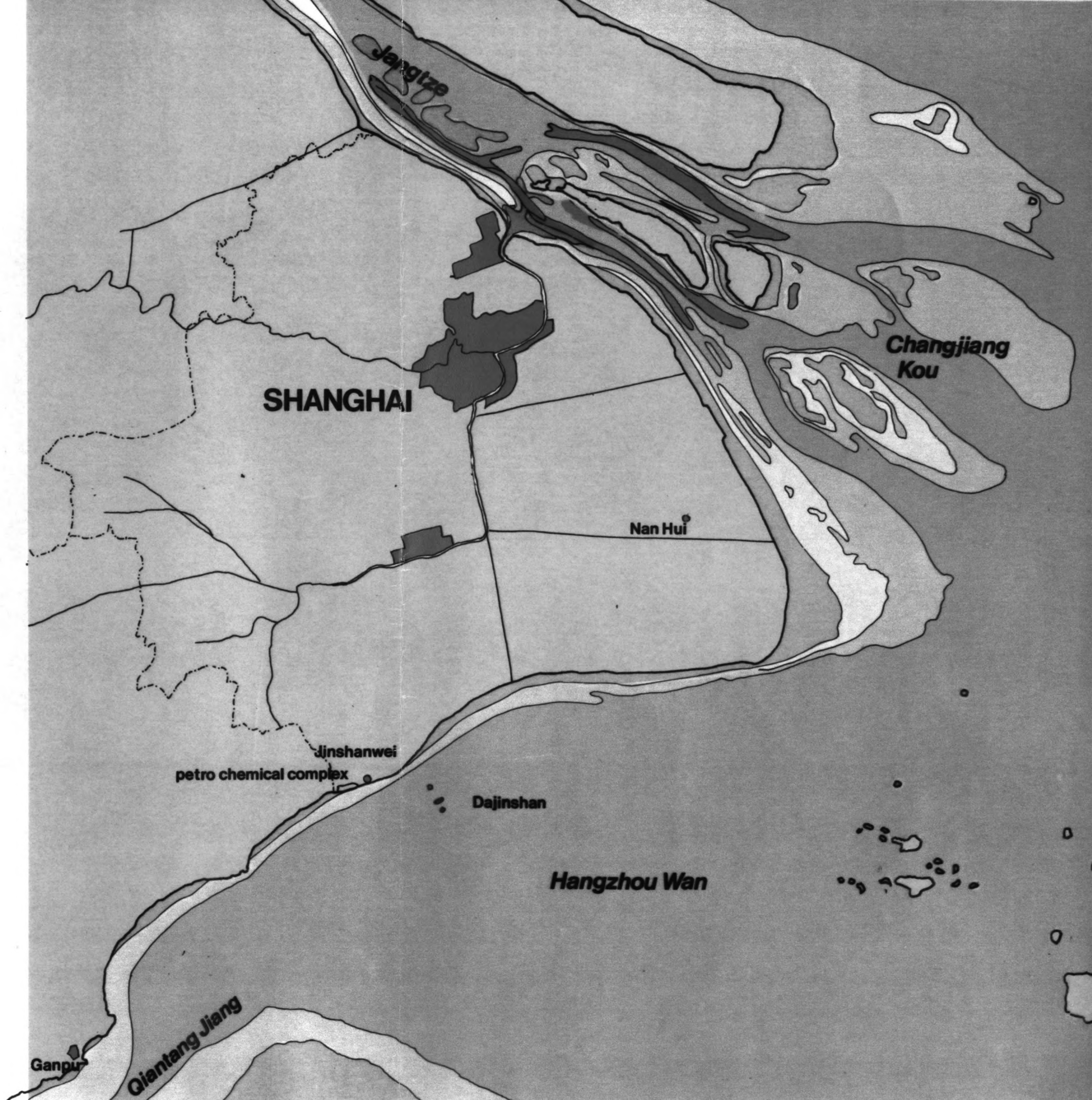

SHANGHAI

Jiangtze

Changjiang Kou

Nan Hui

Jinshanwei
petro chemical complex

Dajinshan

Hangzhou Wan

Ganpu

Qiantang Jiang

5. POSSIBLE DESIGNS, PHASE ONE

5.1 Mechanics of the sedimentation process

The movement of a water-sediment mixture - in two dimensions - is governed by the following expression:

$$\frac{\partial c}{\partial t} + u \frac{\partial c}{\partial x} + w \frac{\partial c}{\partial z} = W \frac{\partial c}{\partial z} + \frac{\partial}{\partial z} (\epsilon_z \frac{\partial c}{\partial z}) \dots \dots \dots (1)$$

- x = horizontal co-ordinate
- z = vertical co-ordinate
- u = horizontal water velocity
- w = vertical water velocity
- W = fall velocity of particles in water
- c_{x,t} = sediment concentration
- ε_z = turbulent viscosity coefficient approximated by:

$$\epsilon_z = \kappa u_* z^1 \left[\frac{h - z^1}{h} \right] \dots \dots \dots (2)$$

- κ = Von Kàrmàn coefficient = 0.4
- z¹ = elevation above bottom (bottom : z¹ = 0) (3)
- u_{*} = shear velocity = $\sqrt{\frac{\tau_B}{\rho}}$

τ_B = bottom shear stress

$$\tau_B = \tau_c \left(1 + \frac{1}{2} \left[\frac{\xi \hat{u}_b}{u} \right]^2 \right) \dots \dots \dots (4)$$

τ_c = constant shear stress caused by current = $\frac{\rho g \bar{u}^2}{C^2}$ (5)

ρ = mass density of fluid

$$\xi = \text{collection of parameters} = \frac{C \sqrt{f_w}}{\sqrt{2g}} \dots \dots \dots (6)$$

f_w = dimensionless friction parameters

u = current velocity averaged over the flow cross-section

C = Chézy friction factor = $18 \log \left[\frac{12h}{r} \right] \dots \dots \dots (7)$

r = roughness of the bed

$$\hat{u}_b = \text{maximum particle velocity due to wave action} \approx \frac{\omega H}{2\pi} \dots \dots (8)$$

$$\omega = \text{wave frequency} = \frac{2\pi}{T} \dots \dots \dots (9)$$

$$k = \text{wave number} = \frac{2\pi}{L} \dots \dots \dots (10)$$

- h = water depth
- H = wave height

Sedimentation implies that the total amount of sediment being transported ($\bar{u} h c$) decreases in x-direction.

As the vertical water velocity (w) is mostly very small, and if $\frac{\partial c}{\partial t}$

— is taken out of consideration (externally imposed)

then $u \frac{\partial c}{\partial x}$ must be negative if sedimentation is to occur, the

entrainment must be negative:

$$W \frac{\partial c}{\partial z} + \frac{\partial}{\partial z} (\epsilon_z \frac{\partial c}{\partial z}) < 0 \dots \dots \dots (11)$$

So in order to increase sedimentation, there are 2 ways:

1. to increase W , the particle fall velocity, ($\frac{\partial c}{\partial z}$ is always negative) (the downward gravity forces);
2. to decrease ϵ_z (the turbulent forces).

Ad 1: ways of increasing W :

- W can be increased by creating bigger (heavier) particles by flocculation (chemical or electrical).

Ad 2: ways of decreasing ϵ_z

- the decrease of \bar{u} (the horizontal water velocity) by obstructing the longshore current (trying to avoid eddies);
- the increase of C (the Chézy value) by increase of the bottom-depth or decrease of the bottom-roughness;
- the decrease of H (the wave height) by obstructing the waves to reach the reclamation zone.

Most effect is expected from reducing the current velocity and the wave action. Constructions that serve this purpose are discussed in the next paragraphs.

促淤工程结构示意图

Sketch Diagram on the Structures of Dikes and Groins used for stimulating the Accretion of Beaches

编织袋装土丁坝剖面图

Cross Section of Groin with Soil-Fills Geotextile Bags

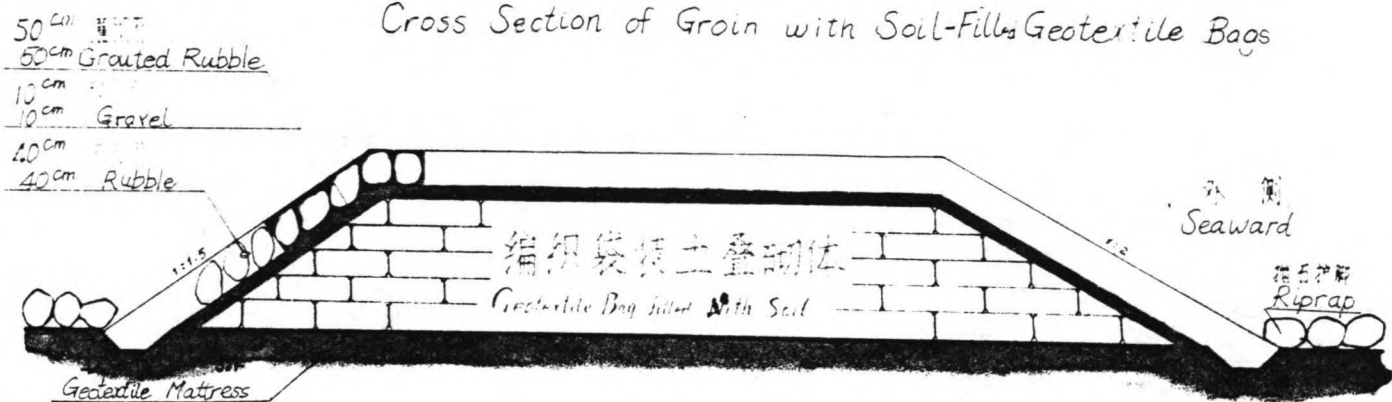

堆石体顺坝剖面图

Cross Section of Rock-Filled Longitudinal Dike

型式 I

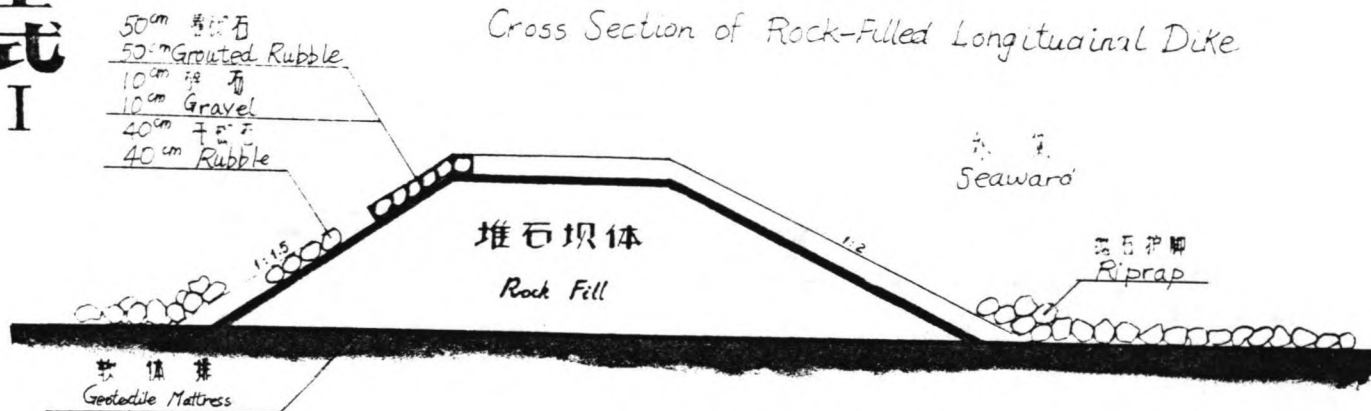

上海市水利局 S.B.W.C.

型式 II

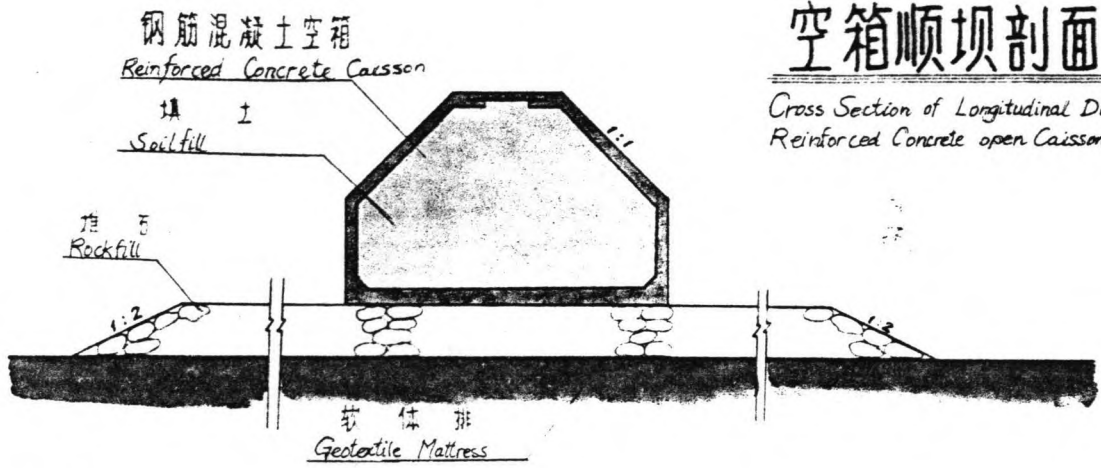

钢筋混凝土空箱顺坝剖面图

Cross Section of Longitudinal Dike with Reinforced Concrete open Caisson

型式 III

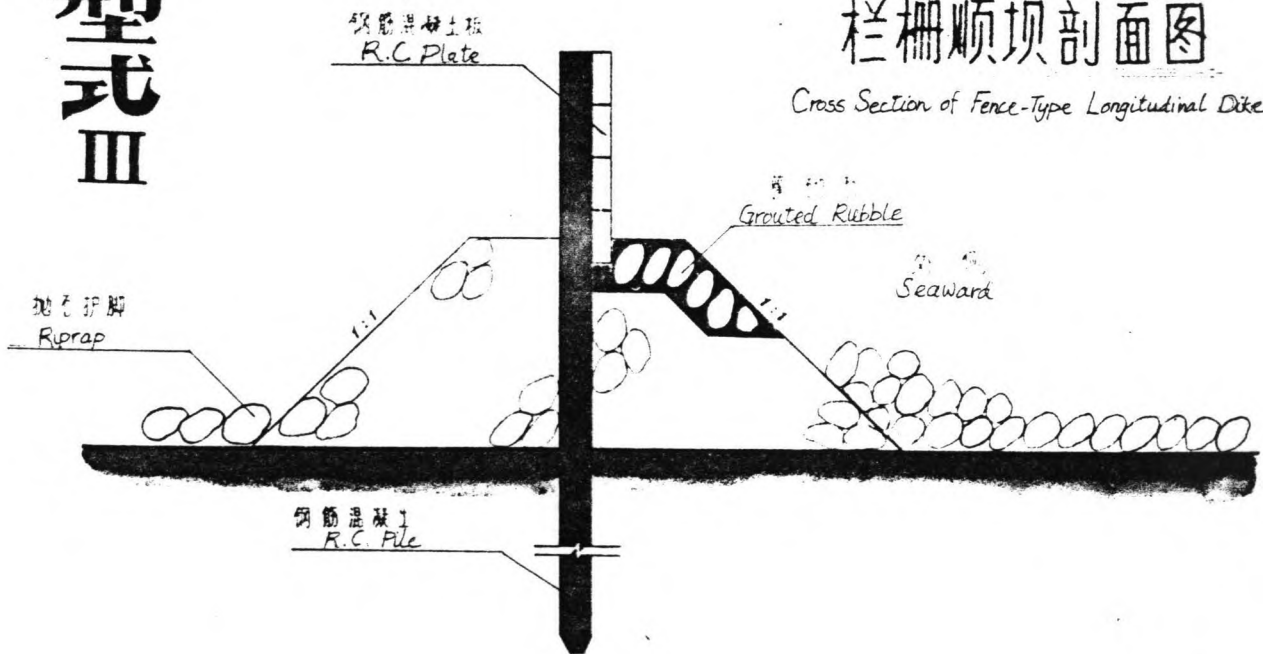

栅栏顺坝剖面图

Cross Section of Fence-Type Longitudinal Dike

上海市水利局 S.B.W.C

5.2-1.3

5.2 Existing constructions

Many land reclamation projects have been carried out in the world. The Dutch, for example, have been reclaiming land from the sea for centuries. Large poldering projects have also been completed in China and are still under construction or in preparation.

5.2.1 Works in China, see Fig. 5.2.1.1, 5.2.1.2 and 5.2.1.3

In the vicinity of Shanghai there are recent examples of reclamation: poldering of the island of Changxing Dao and parts of both banks of the Qiantang estuary between Hangzhou and Haining (within reach of the bore).

The construction method is as follows:

1. Digging canal and building dikes at planned location

The material used for building is clay dug in situ. At the same time that the canal is dug the dike is built using the canal material to fill the dike. Completion of the dike should occur during neap tide.

2. Strengthening of the dike

The outer and inner slopes of the dike are protected with large amounts of stones. The dike can only withstand smaller waves and water levels of 1 or 2 m during construction, for this reason the dike should be protected with rip rap as soon as possible.

3. Protection of the slopes by masonry works

In order to withstand impacts of larger waves and high waterlevels, the outer slope is finished with masonry. The base of the dike is protected by stone deposits (masonry works cannot be executed under the LW-line).

Normally this is enough to protect the land behind. Sometimes, however, a channel approaches the dike and extra measures have to be taken.

4. Construction of groins, spur dikes and caissons

Groins are constructed at the MHW-line built up of a clay core with stone revetment. This acts as a current block but also accelerates sedimentation in front of the dike. If a channel tends to scour the dike, the above mentioned constructions are not enough. In that case a caisson is placed 6-8 m below the LW-line and a protruding bow dike or spur dike is built onto it to protect the base of the polder dike:

- the caisson protects the spur dike,
- the spur dike protects the polder dike
- and the polder dike protects the hinterland.

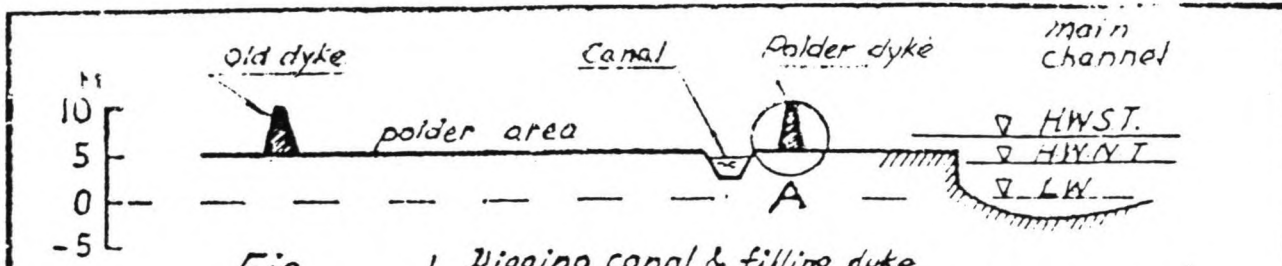

Fig. 1 Digging canal & filling dyke

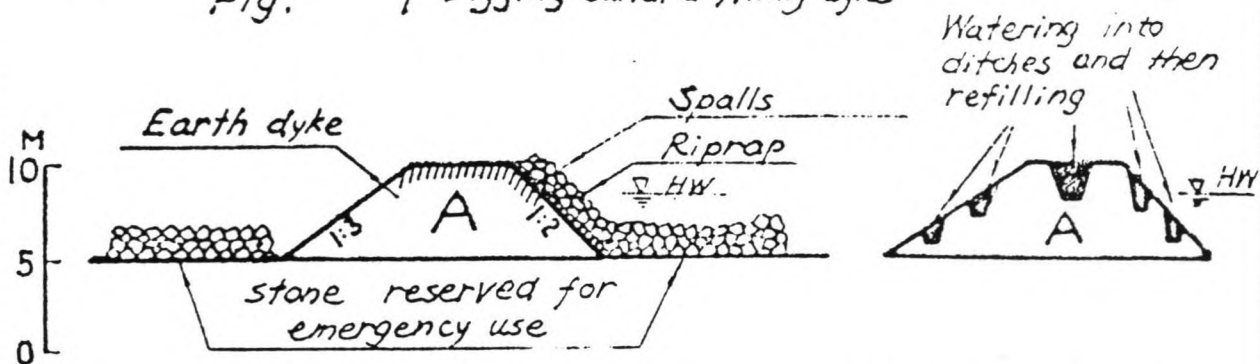

Fig. 2 Riprap protection & leakage prevention measures

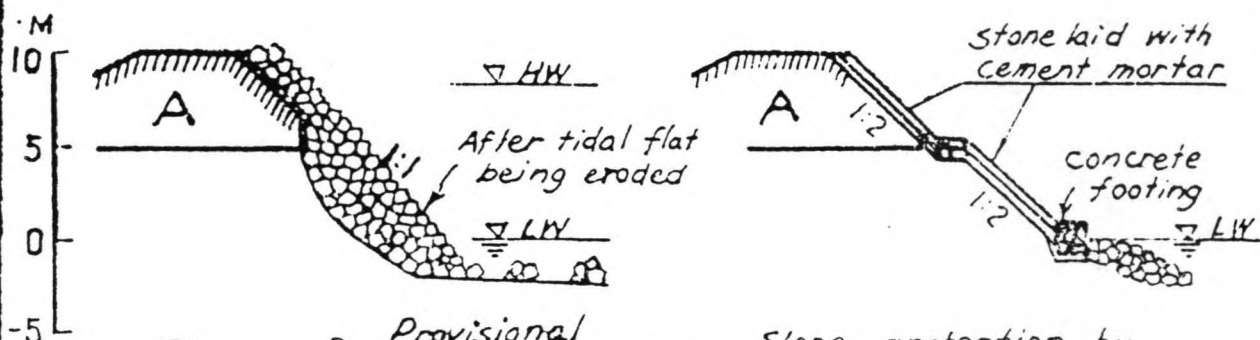

Fig. 3 Provisional riprap protection

Slope protection by masonry works

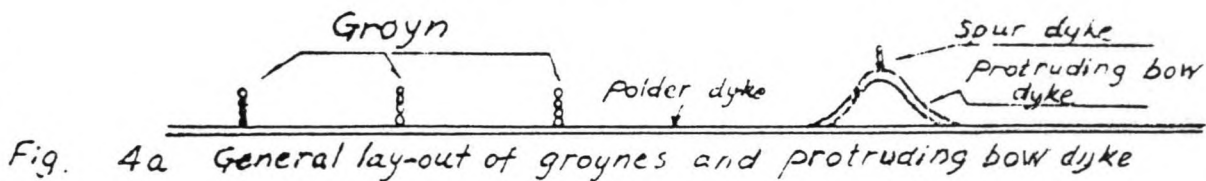

Fig. 4a General lay-out of groynes and protruding bow dyke

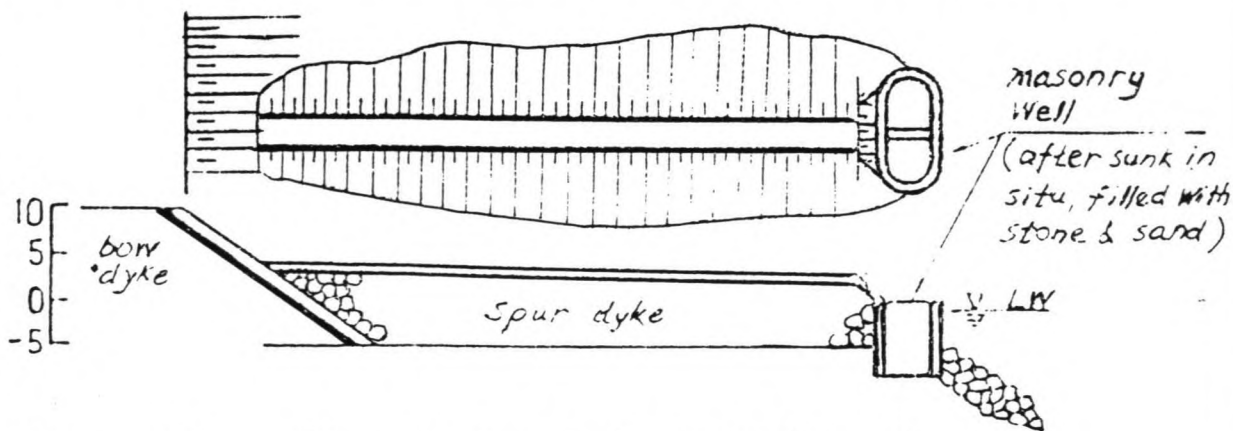

Fig. 4b Plan & longitudinal section of spur dyke

This method of construction can also be used at reclamation of land in the Cao Jin district and Nan Hui East district. But there are some objections:

- huge quantities of clay and stones are needed for these constructions, which have to be brought from far away, thus making the construction expensive;
- the above mentioned dikes are built above the LW-line; it is almost impossible at or below the LW-line, because the work would have to be carried out in the water and there is a danger that the newly deposited clay would be washed away by the waves and the current;
- 10,000 to 100,000 people are involved in the construction of these dikes. The mud flats of Cao Jin and Nan Hui are not easily traversable, which makes work difficult (especially on the LW-edge of the mud flat). This means that work either has to be done from the coast (first training walls) or prefabricated components (which may possibly be made at the HW-line) have to be transported over water.

In Fig. 5.2.1.2 and 5.2.1.3 constructions are shown designed by SBWC. They fit in a plan to reduce the construction costs and to accelerate the construction process.

5.2.2

Works in The Netherlands, see Figure 5.2.2

Many land reclamation projects have been carried out down the centuries in The Netherlands: the Zuiderzee works, poldering of the Haarlemmermeer, Lauwerszee etc. An example of recent, smaller-scale land reclamation are the works on the Frisian and Groningen shoals. The following construction method is used:

1. Construction of "rijzen dam"

Double rows of piles are constructed, the area between them is filled with fagots. These small dams form fields of 400 x 400 m. The sideslopes are protected with a cover of straw, fagots and small wooden piles (as can be seen in picture 5.2.2).

2. Digging trenches and ditches

The next step is to drain the sedimentation fields by digging trenches, cross-ditches and main ditches. The catching of silt particles in these trenches and ditches is considerable, they should be kept at the right depth (0.25 m) and width (0.60 m). The fagotting breaks the waves and a network of trenches causes calm current velocities, thus optimal sedimentation of particles occurs.

This construction can also be used in China, but it has certain disadvantages for the districts in question:

- if the average tide is higher than 1.4 m above the natural ground level, rows of wooden piles filled with fagots can no longer be applied; they have to be substituted by solid dikes;
- if the wave activity is rough and current speeds along the coast are great, the above mentioned construction will not be robust enough to withstand these forces. Hence a more solid reclamation construction must be used.

LAND RECLAMATION SYSTEM

$0.40 + HW$

5.2-2.1

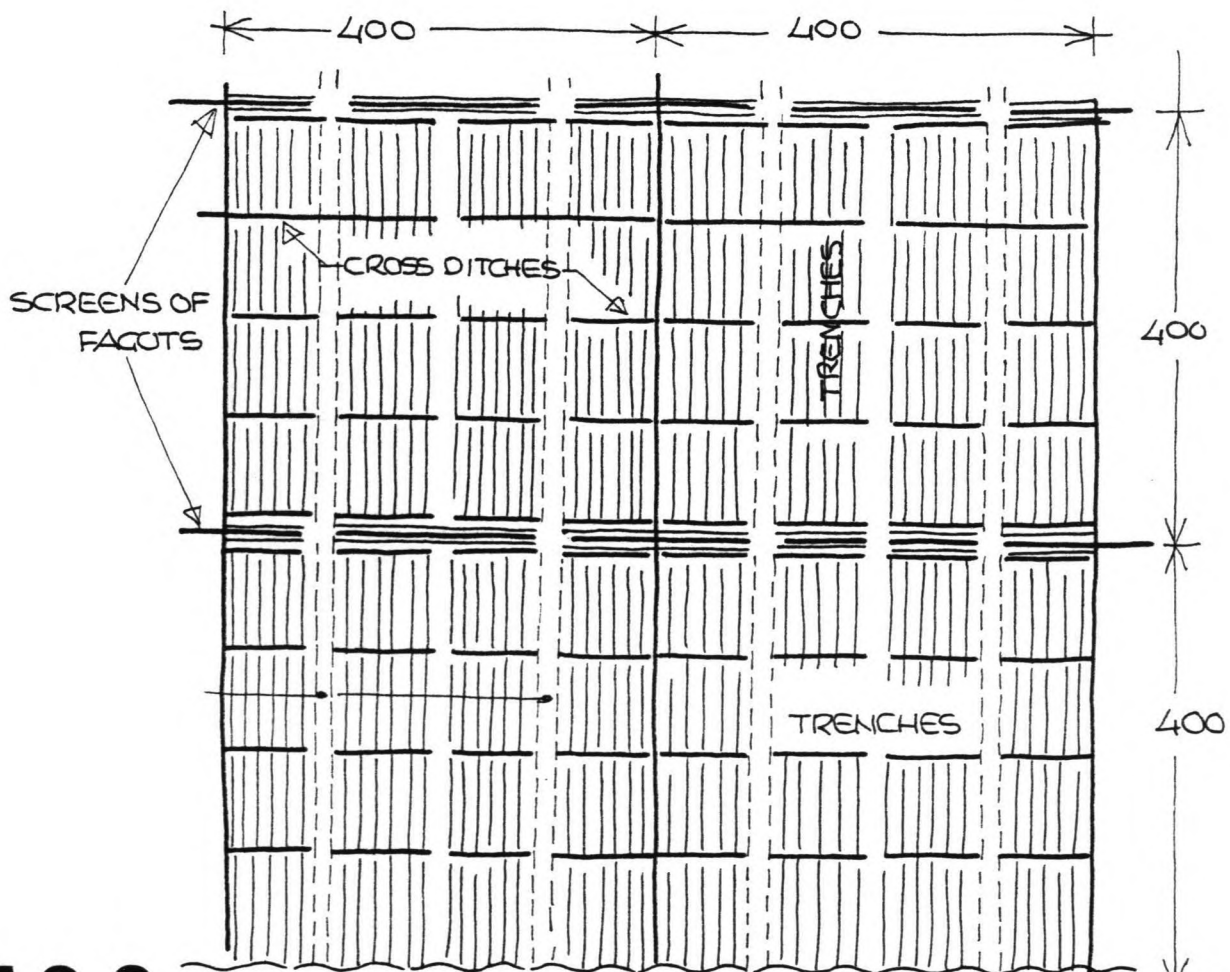
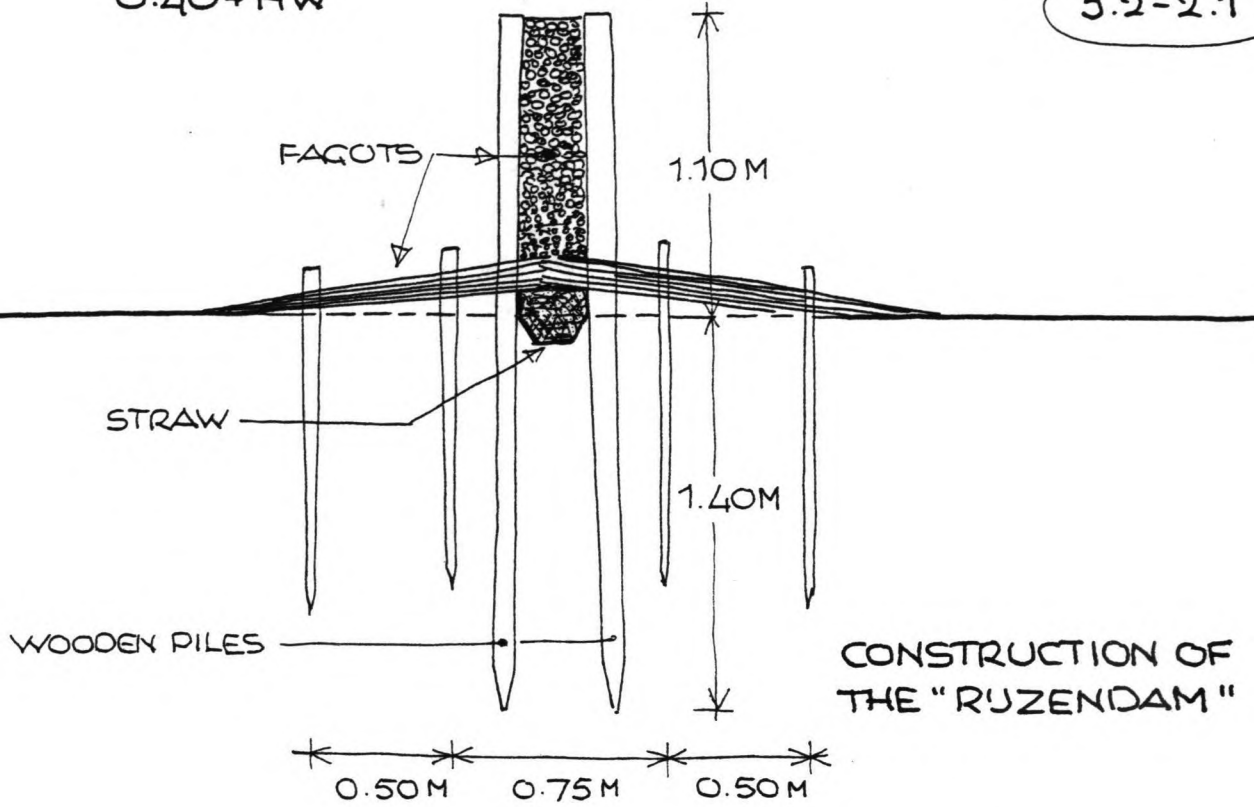

5.2-2

TOP VIEW

5.2-2.2

5.3

Possible layout

For the proposed area Nan Hui East Beach and the Cao Jing district there are a number of alternative possibilities to reclaim land. These are the following in order of increasing complexity of construction, cost and speed of sedimentation.

1. to leave the areas in their natural state (the effectivity of other possible constructions should be compared with this 0-alternative)
2. the planting of vegetation (to increase siltation)
3. the use of small-scale current-reducing constructions such as current screens and rows of piles.
4. the Schleswig-Holstein method
small dikes form fields of 400 x 400 m, within these fields there is a network of trenches and ditches.
5. cross-dams (perpendicular to the coastline)
6. longitudinal dams (parallel to the coastline), or a combination of longitudinal and cross-dams.
7. to build an embankment above high water level and reclaim the land inside
(the area inside can also be filled up with dredged material).
8. the construction of "strong points" in the sea.
Dikes or dams can be built to form a connection to the land, or between the strong points to form a dam along the coast.

Many different materials and structures/construction methods are conceivable:

- small dikes of clay
- rows of wooden piles
- current screens fabricated of geotextile and floats
- soil-filled geotextile systems
- rubble mound dams and dikes
- caissons
- rubble mound constructions reinforced by piles of sheet piles.

The object of all these constructions and measures is to reduce current speeds and wave activity in the area under reclamation (see also par. 5.1). In this way the horizontal transport of the particles is hampered creating a peaceful environment for sedimentation, the natural sedimentation process is accelerated.

Below follows an overview of the various alternatives mentioned with their specific advantages and disadvantages. Later a choice will be made from the most promising solutions with a more detailed breakdown of execution, cost and effectiveness.

5.3-1.1

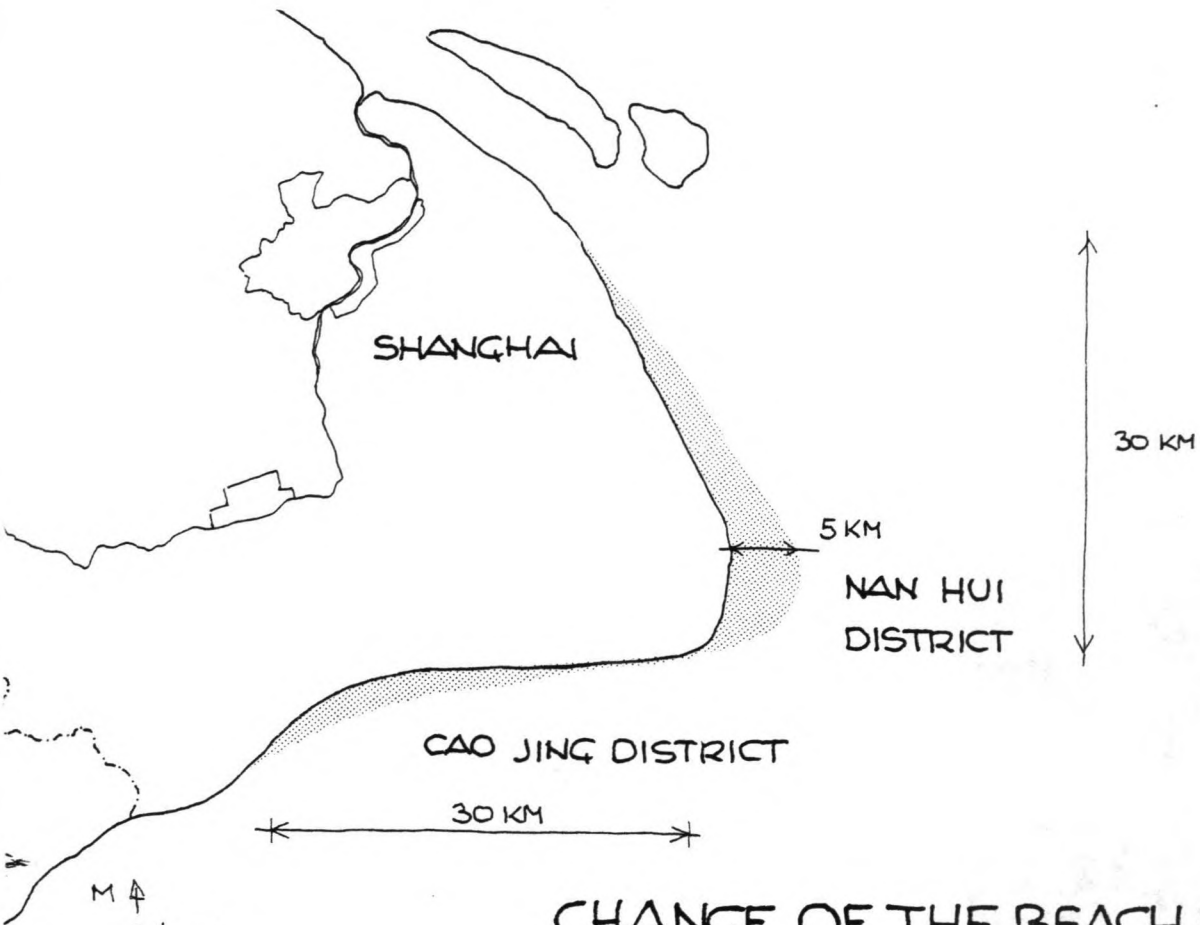

CHANGE OF THE BEACH PROFILE

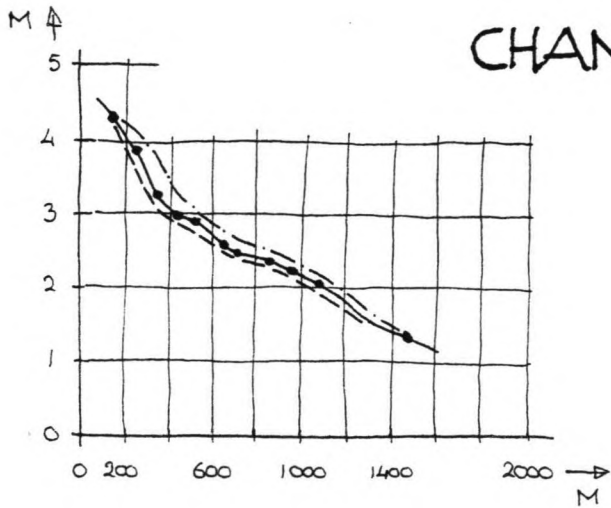

- MEASUREMENT IN 1984
- - - EXPECTED LEVEL WITH VEGETATION
- · - · - EXPECTED LEVEL WITHOUT VEGETATION

5.3-1.2

CAO JING DISTRICT

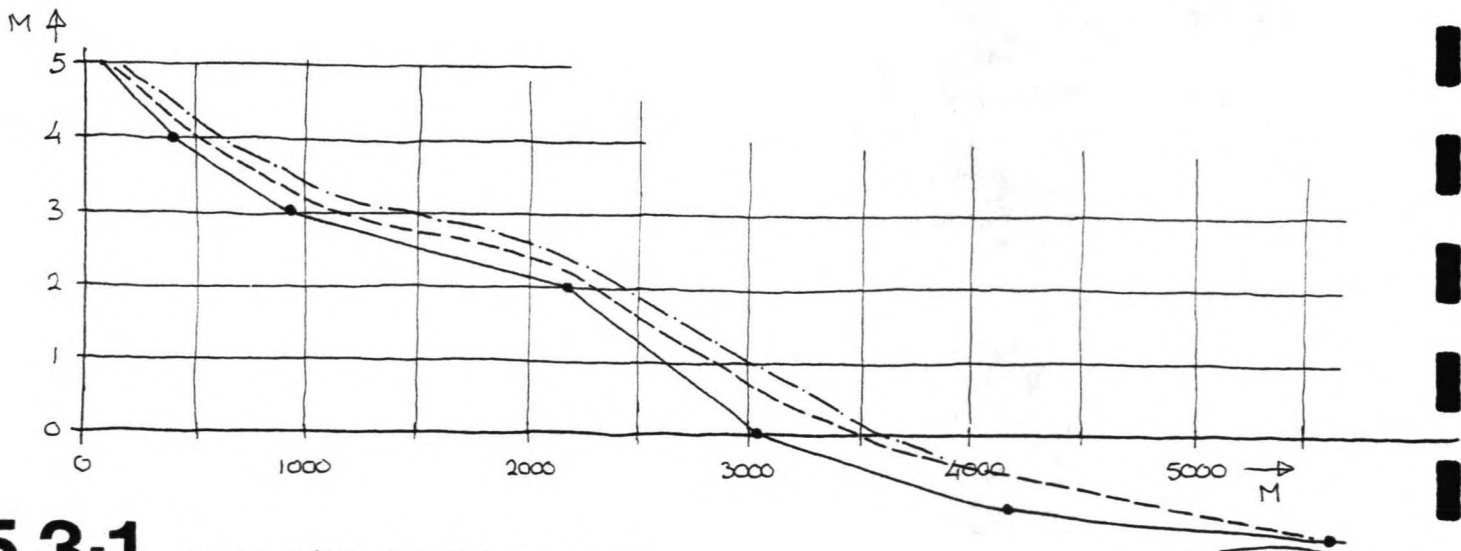

5.3-1 NAN HUI EAST BEACH

5.3-1.3

5.3.1 The 0-alternative

Location
(see Fig. 5.3.1.1)

The location is the one already suggested in par. 4.2, viz. the mud flat to the east of Nan Hui and the mud flat to the south of Cao Jing.

The limit of the reclamation area is the 0-line (the LW-line) so that these mud flats are completely exposed at low tide and completely under water at high tide.

The Cao Jing district covers: ~ 50 km²

The Nan Hui district covers : ~ 130 km²

Effect
(see Fig. 5.3.1.2 and 5.3.1.3)

In both cases the mud flat can be kept in its present form; increased erosion occurs in typhoon conditions, but under normal conditions almost no erosion will take place on the Cao Jing mud flat and siltation at the rate of appr. 0.25 m per year will occur on the Nan Hui mud flat.

5.3-2.1

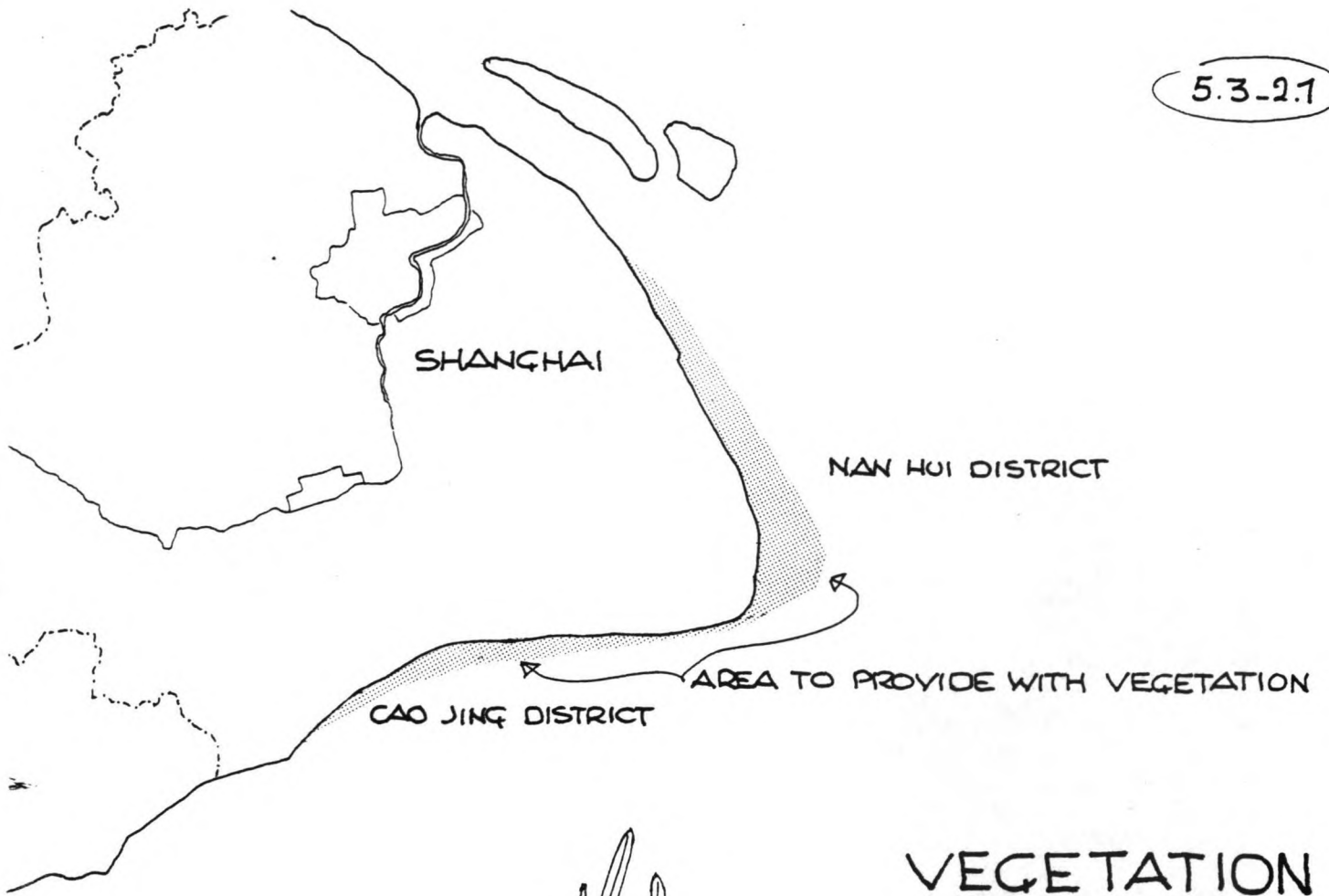

VEGETATION

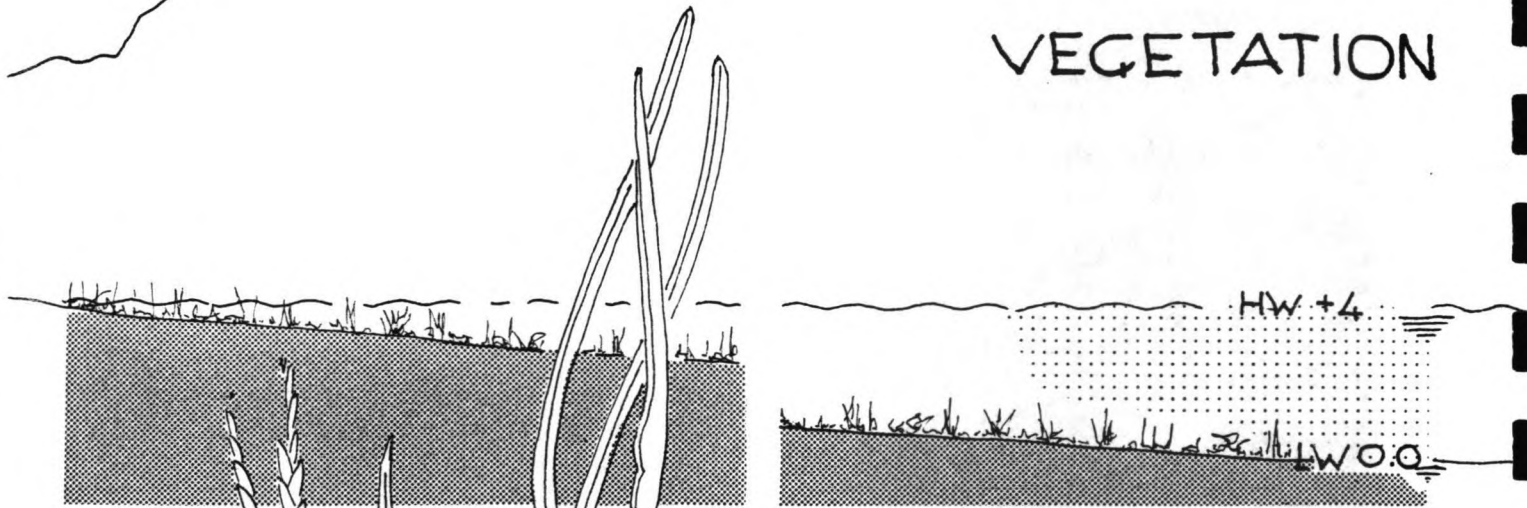

5.3-2.2

5.3-2

5.3.2

Vegetation

Location (see Fig. 5.3.2.1)

The planting of vegetation (reeds) can be started from the coast outwards (on the Nan Hui mud flat there is considerable reed growth already) up to a level of 1-1.50 m below HW-line. If the natural ground level drops further below the HW-line, another form of vegetation can be used; seaweeds can even be planted below the LW-line. After several years the ground level will have risen and the planting of vegetation can be continued out into the sea.

Construction and effect

(see Fig. 5.3.2.1 and 5.3.2.2)

The plant roots trap the deposited particles and the current is reduced between the plants. As a result the mixture of water and sediment that is carried in on each tide settles among the plants. Under typhoon conditions the vegetation and hence the process of sedimentation can be extensively damaged, so that some of it will have to be replanted.

Advantages and disadvantages

- advantages : - vegetation is cheap to plant and easy to maintain;
- the planting of vegetation improves the soil.
- disadvantages: - vegetation cannot be planted where there are fast-moving currents;
- if there is extensive damage, the whole project may have to be restarted;
- vegetation affords little protection of the hinterland against high waves and high water levels;
- it will take several decades for the land to have risen sufficiently for crops to be grown on it.

Conclusion

The use of vegetation to increase sedimentation is recommended in combination with one of the constructions mentioned below (par. 5.3.3 - 5.3.8).

Vegetation alone will not increase siltation, because the tidal current along and over the mud flat is too great. The vegetation would only survive in a strip close to the coast.

Costs : low, depending on the type of vegetation used.

Effectiveness: Cao Jing district: siltation* 0-0.25 m/year;
Nan Hui district: siltation* 0.25-0.50 m/year.

Maintenance : Each year the state of the vegetation must be checked and replanting carried out where necessary. Repairs will have to be carried out after a typhoon.

* Only in combination with current-resistant constructions.

5.3-3.1

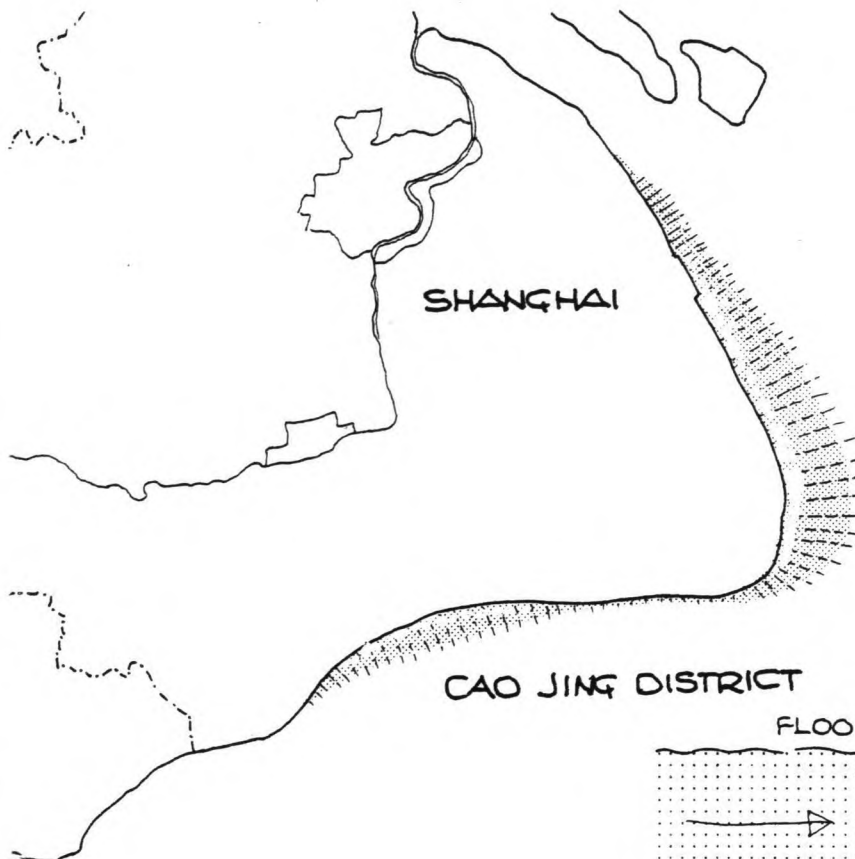

CONSTRUCTION REDUCING CURRENTS

NAN HUI DISTRICT

CAO JING DISTRICT

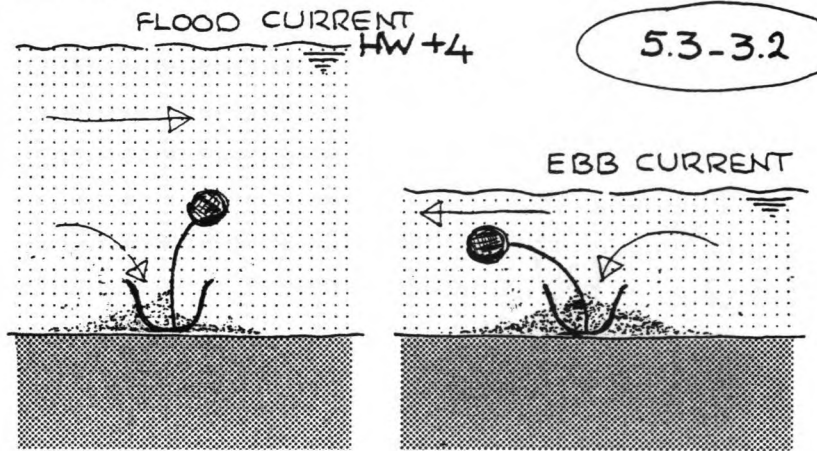

5.3-3.2

CROSS SECTION CURRENT SCREENS

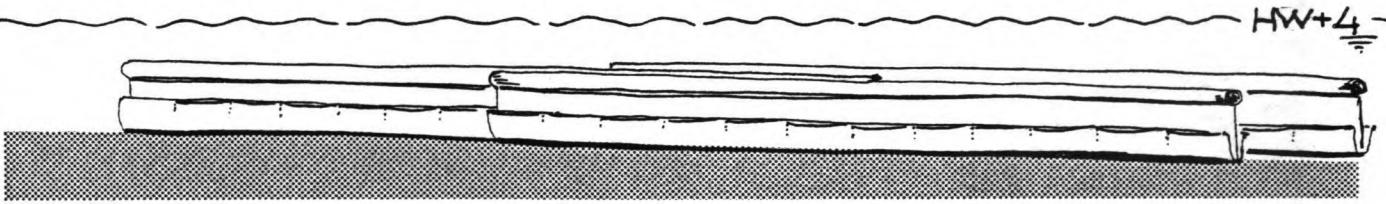

CURRENT SCREENS

5.3-3.3

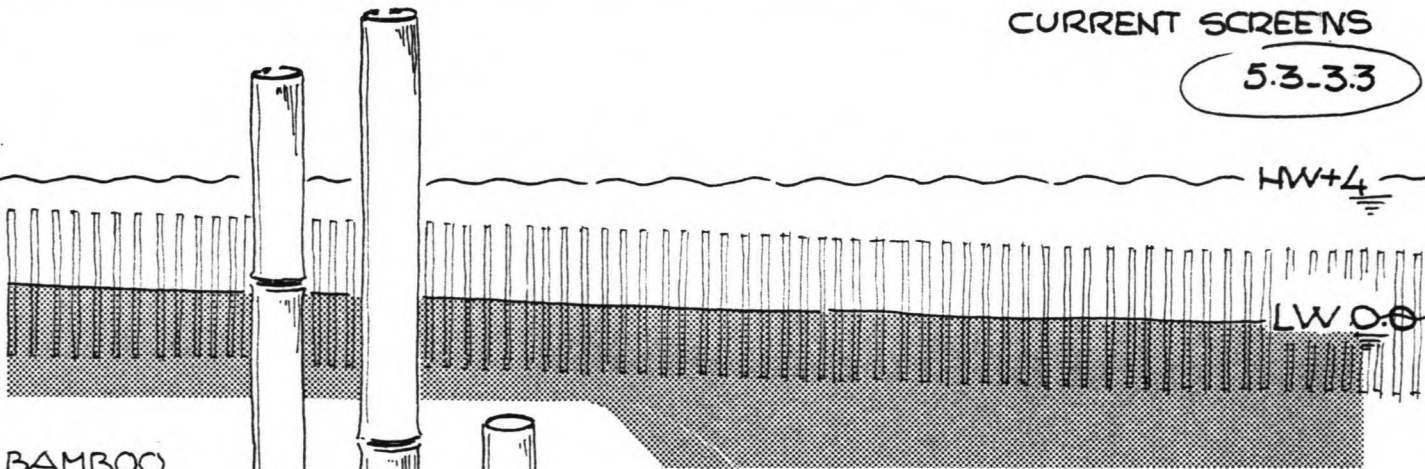

BAMBOO

5.3-3

ROW OF PILES

5.3-3.4

SCHLESWIG-HOLSTEIN METHOD

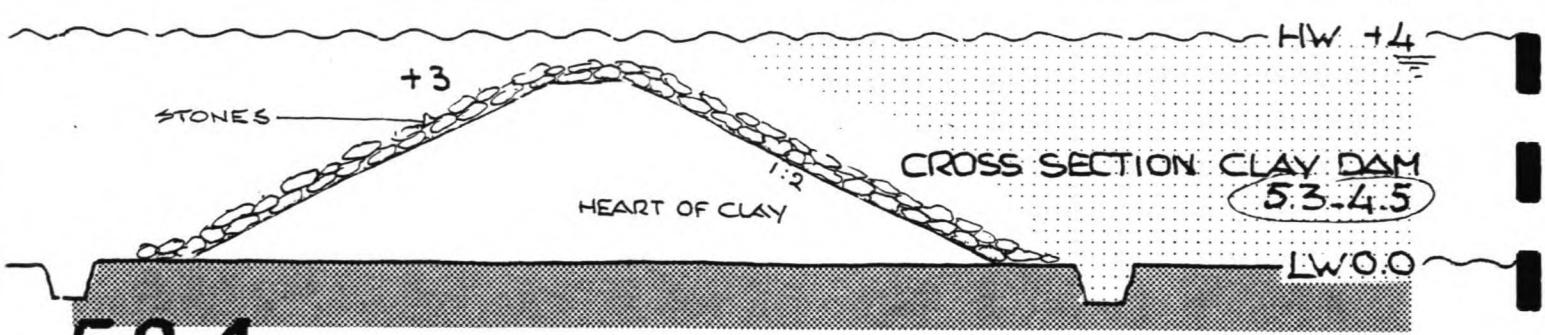
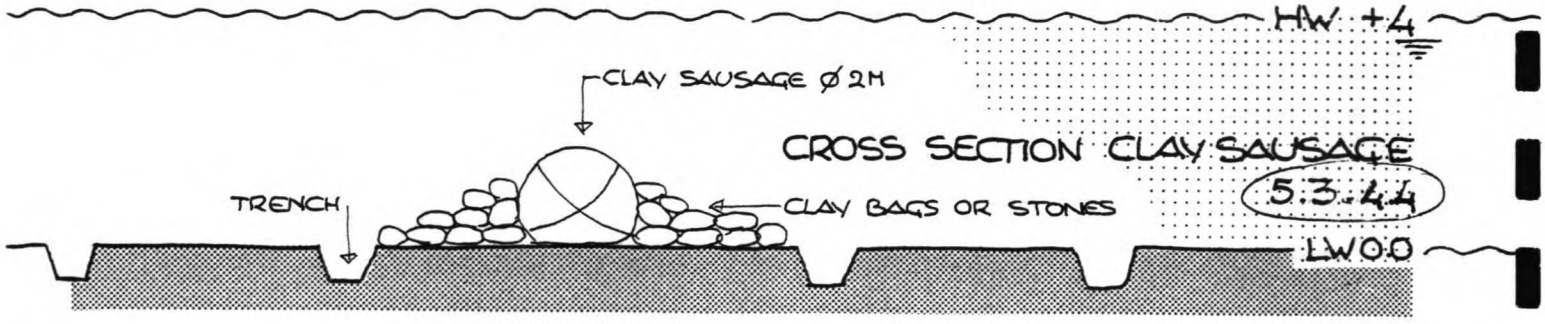
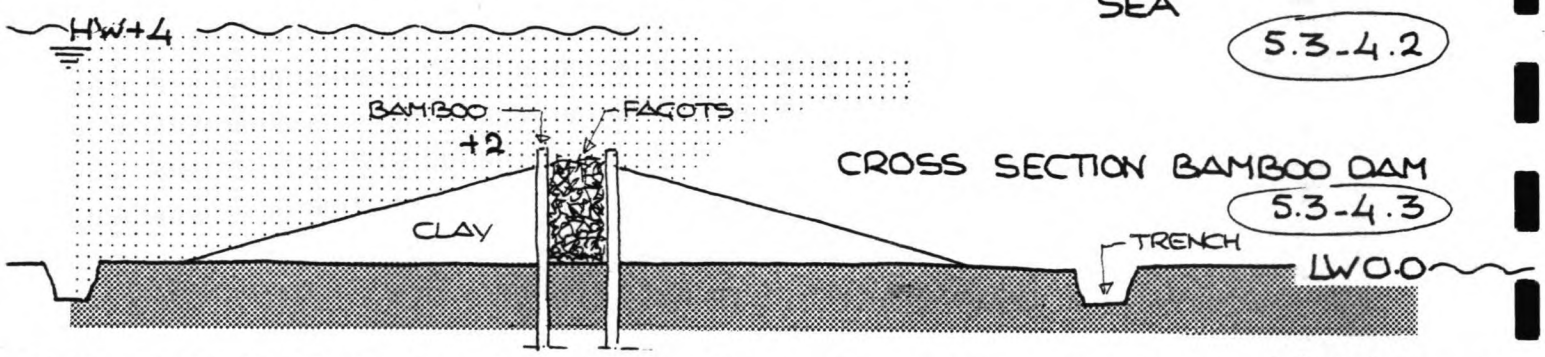
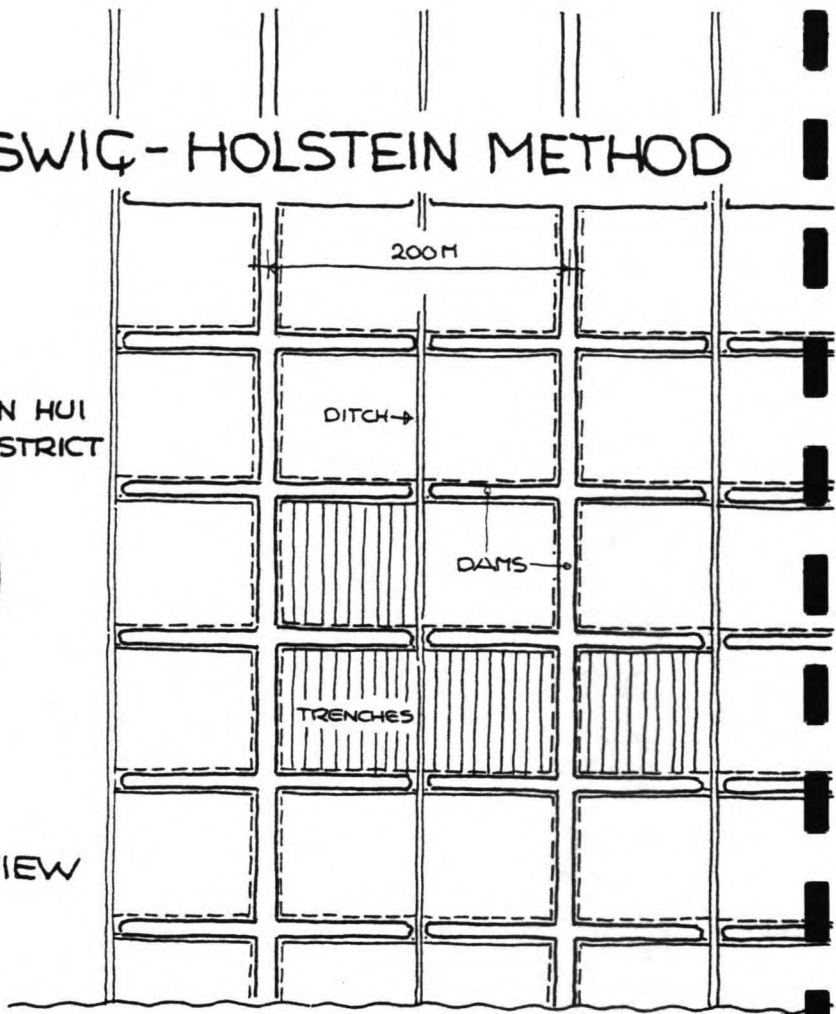
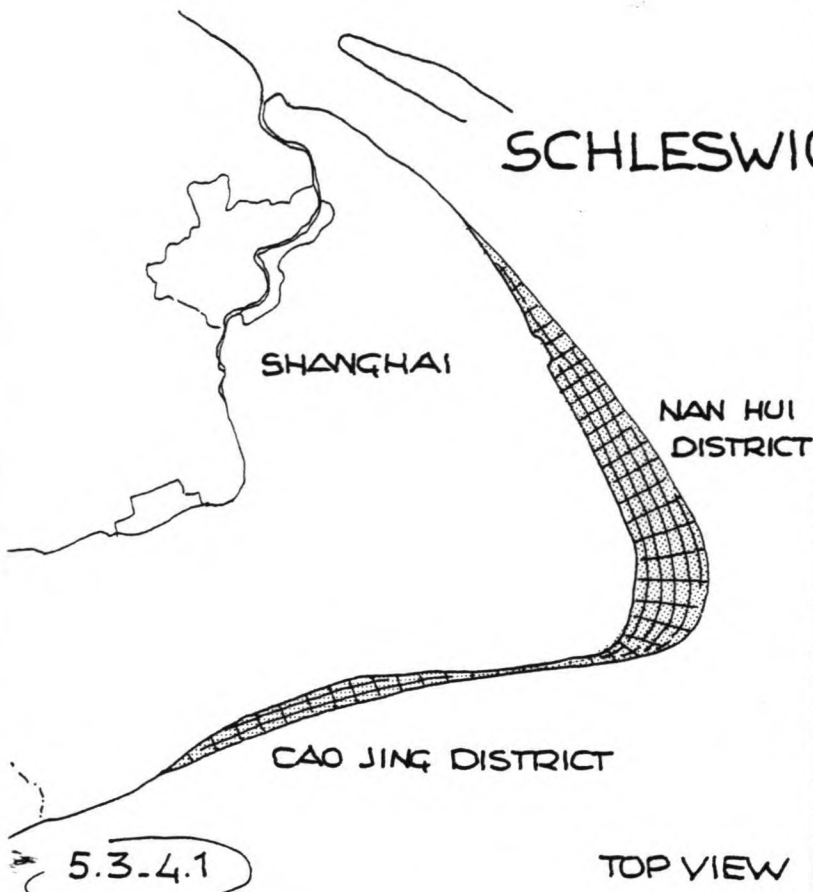

5.3.4 The Schleswig-Holstein method

Location

(see Fig. 5.3.4.1)

The district is divided into lots of 400 x 400 m beginning along the coastline. These lots are bounded by small dikes/dams (see Fig. 5.3.4.2). Within these lots a network of trenches and ditches is constructed. Once the first strip along the coast has been done the next strip can be constructed and in this way the reclamation area is gradually extended seawards.

Construction and effect

The effect is described in par. 5.2.2. The construction of the dikes can be done in different ways (see Fig. 5.3.4.2). From the 3+ line fagottings can no longer be used. More robust constructions, such as earth dams or tube-shaped geotextiles filled with soil must be used. The latter variant is to be preferred, because there is no danger that the dike core will soften and slide under wave and current impacts.

Advantages and disadvantages

- Advantages : - the sedimentation process is much increased compared with the zero-option;
- the construction can gradually be extended out from the coast, so that construction and reclamation can be spread over several years.
- Disadvantages : - relatively a large number of running meters of dam is needed per unit of reclaimed land;
- a great deal of maintenance is required, the trenches and ditches must be deepened every 6 months;
- a great deal of construction has to be performed on the lower part of the mud flat, where the available working time is short, and the bearing capacity is low.

Conclusions

The Schleswig-Holstein method is not recommended for land reclamation, because it is relatively expensive per m² of surface area due to the great difference in tides.

However, it can be used when performed on a wider grid (see par. 7.5)

- Costs : relatively high due to the dense network of dams.
- Effectiveness : siltation of appr. 0.5 m/year (provided sufficiently maintained) in the Cao Jing district and about 1 m in the Nan Hui East district.
- Maintenance : trenches and ditches must be deepened every half year and the dikes raised (extended) every year. Additional maintenance is required after typhoons.

5.3-5.1

CROSS-DAMS

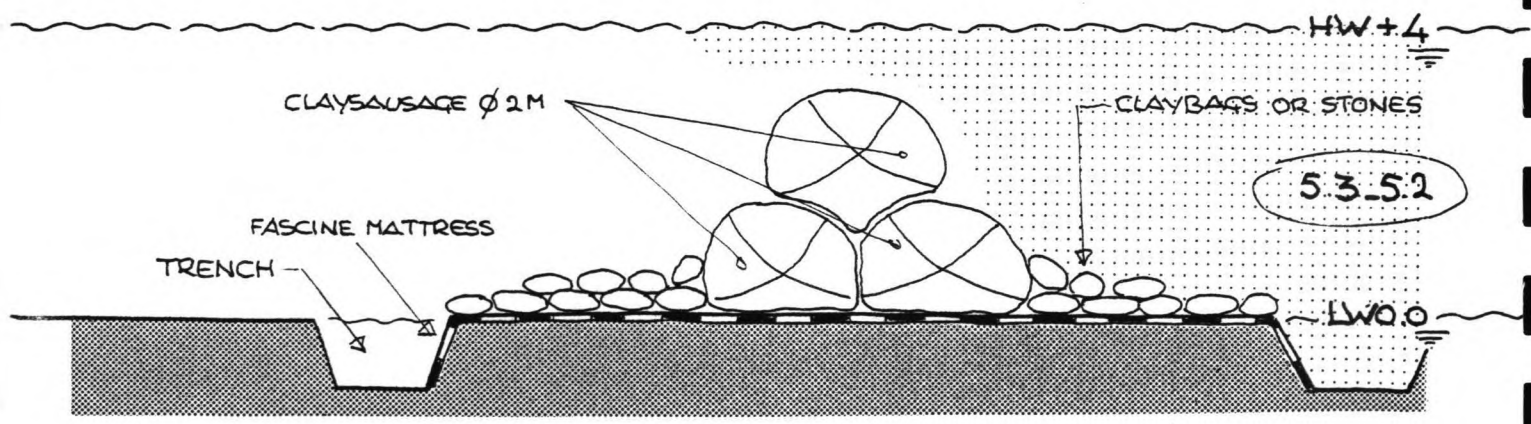
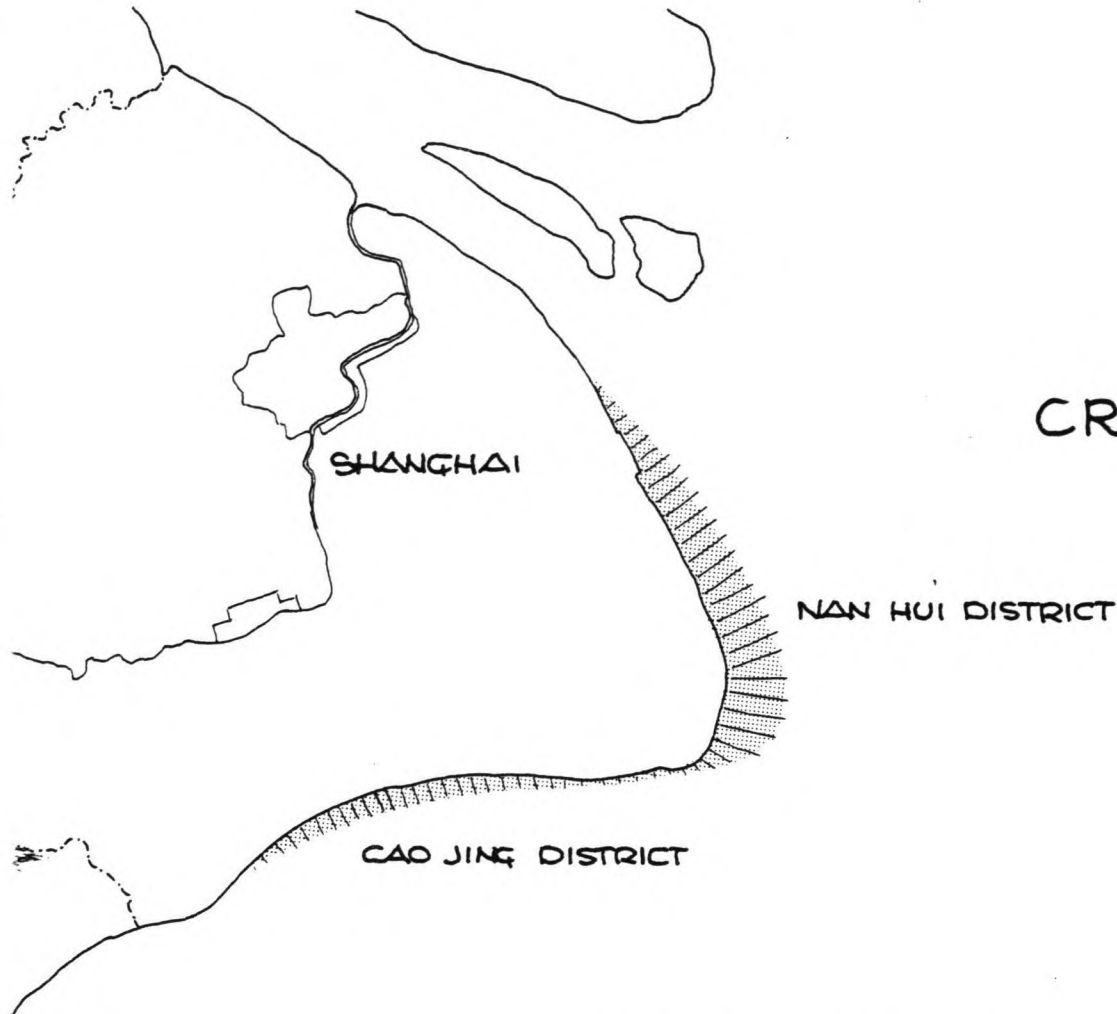

CROSS SECTION DAM OF CLAY SAUSAGES

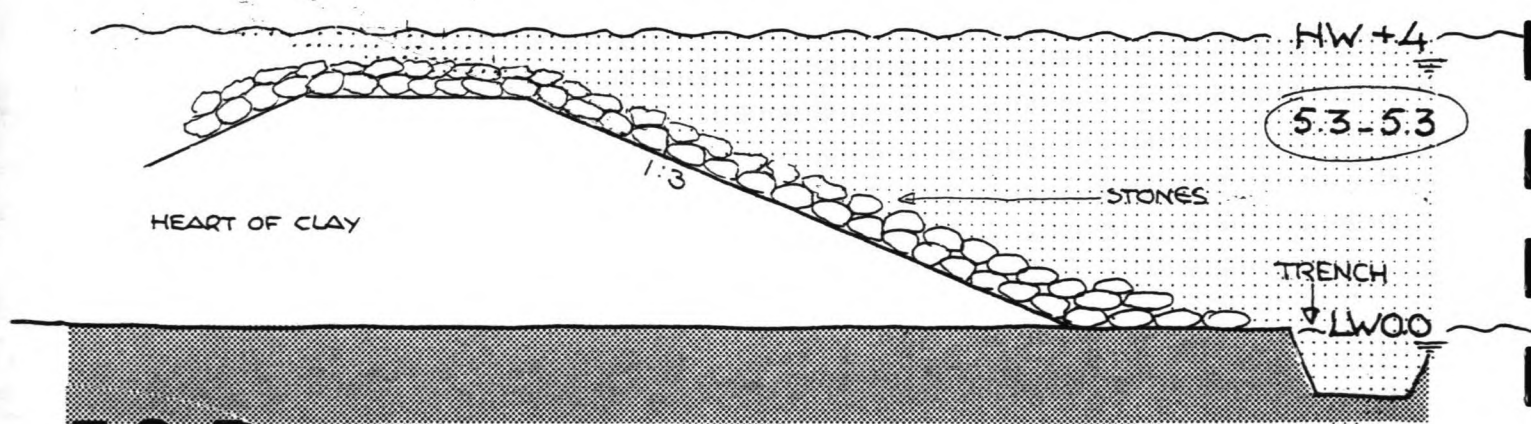

5.3-5

CROSS SECTION CLAYDAM COVERED WITH STONES

5.3.5 Cross-dams (perpendicular to the coastline)

Location

(see Fig. 5.3.5.1)

The dams are built out from the coast. The distance between the dams depends on their length and must be optimized (the distance/length ratio should be appr. 1 : 1).

Construction and effect

The dams divert the longshore current away from the coastal zone and thus stimulate sedimentation. By extending the dams to beyond the breakwater zone, particles caught up by the surf are trapped between the dams. Each tide brings new water rich in sediment and the particles settle and are trapped. It is important to create a gentle movement of current by constructing trenches and ditches between the dams.

For the construction of the dams see Fig. 5.3.5.2 - 5.3.5.3. Here too a soil-filled geotextile should preferably be used to build up the dam, so that there is no danger of the dike failing due to sliding or softening under wave impacts. Under typhoon conditions there is increased wave action, higher water levels and faster currents. On the dikes particularly the end of the dam facing the sea can be damaged (the facing can be washed away or dislodged, core units can be dislodged) but the majority will remain intact.

Advantages and disadvantages

- Advantages : - the sediment process is considerably accelerated;
- the project can gradually be extended seawards so that the current pattern has the time to adjust (its effectiveness can be manipulated according to requirements by adjusting dike heights and the distance between the dams).
- Disadvantages : - erosion pits are formed on the seaward side of the dams (the longitudinal current concentrates itself around these points). Heavy facing will have to be applied at these points.
- the effectiveness of the construction is limited, because the wave action in the sections still causes significant movement of water.

Conclusion

This variant, where the dam core is built up of soil-filled geotextile (so-called clay sausages) is a promising method and should be worked out further to optimize points such as the most effective ratio between dam height, dam distance and rate of sedimentation.

- Costs : are relatively low (needs optimizing).
Effectiveness : a siltation of approximately 0.75 m is expected.
Maintenance : digging out ditches and trenches each year to keep them at the required depth and replacement of dislodged or torn clay sausages.

5.3-6.1

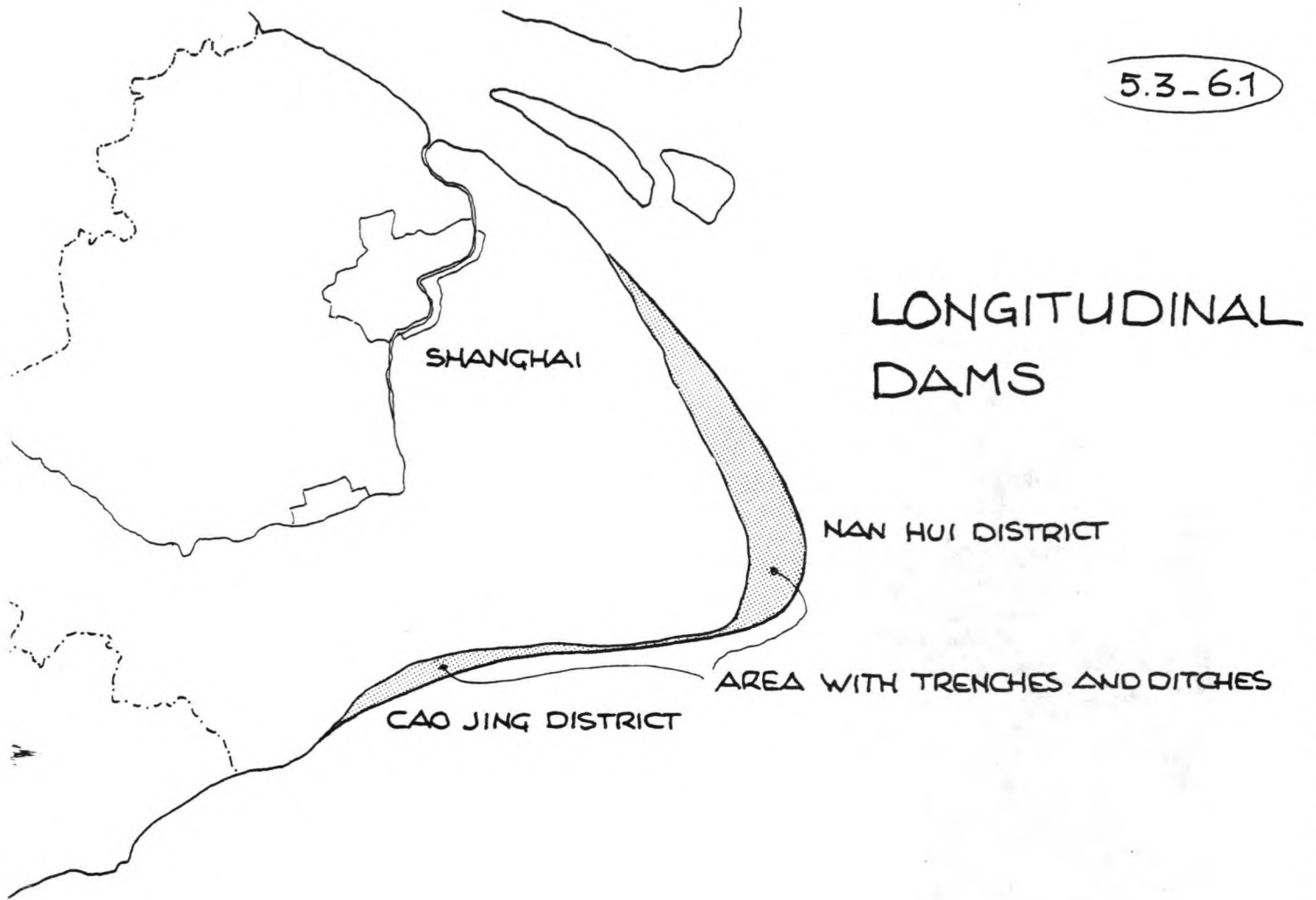

LONGITUDINAL DAMS

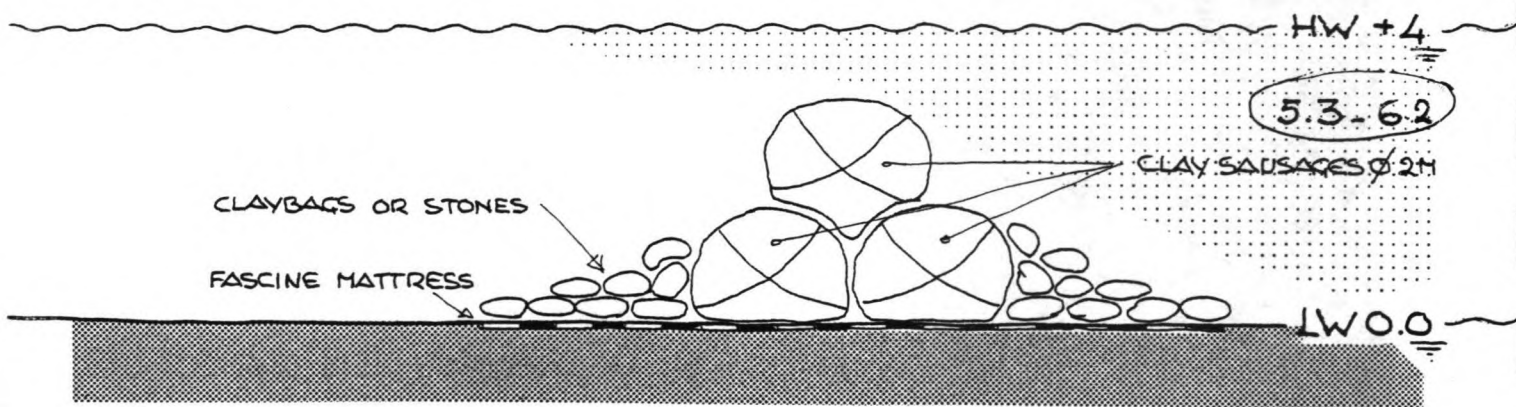

5.3-6.2

CROSS SECTION DAM OF CLAY SAUSAGES

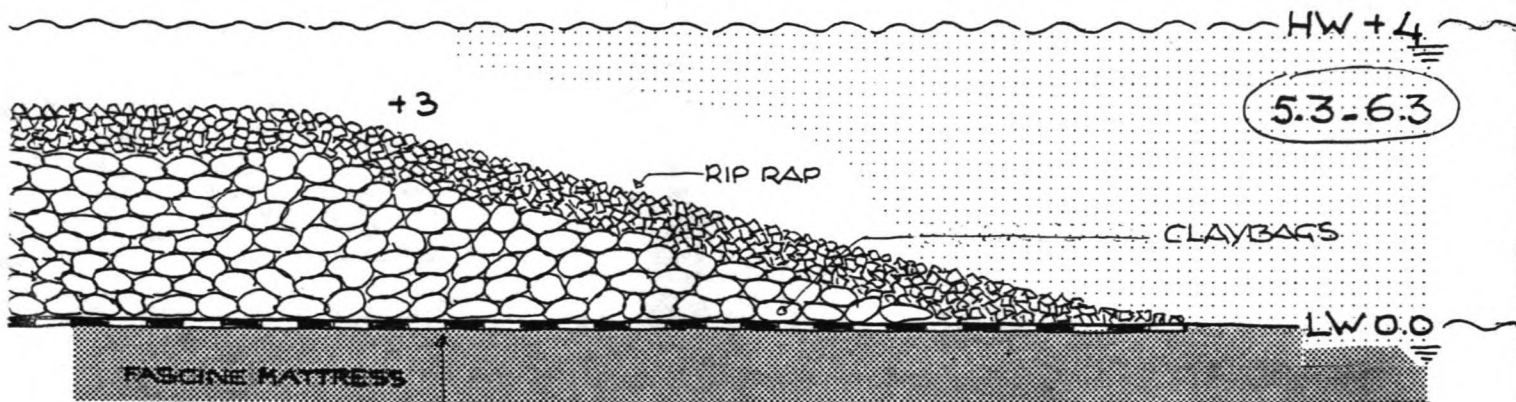

5.3-6.3

5.3-6

CROSS SECTION DAM OF STONE AND CLAY

5.3.6 Longitudinal dams (parallel to the coastline)

Location

(see Fig. 5.3.6.1)

The dam will follow the present 0-line (which is the LW-line) of the coast. The area behind the dam, between the land and the dam, forms a kind of basin where sedimentation can take place.

Construction and effect

The dam protects the basin behind against wave action and currents. As the tide comes in new water rich in sediment enters the basin through openings in the dam and the sediment subsequently settles. As the tide goes out the water passes out through the openings again. This process is repeated each cycle. There is little movement of water inside the basin. When the water levels are very high (typhoons, spring tide) the dam will flood, but this hardly affects the rate at which the sediment settles. (When the water level drops the process starts working again.)

Fig. 5.3.6.2 shows the possible structure of the dams. Once again the dam core should preferably be made of soil-filled geotextiles (see remarks above in this respect).

Under typhoon conditions the whole length of the dam will be subject to marine wave impacts, so that the construction of the dam facing must be calculated accordingly.

Advantages and disadvantages

Advantages : - maximum sedimentation occurs: up to 1.5 m in the first year;
- the present coastline is then protected by a foredike, which considerably reduces the danger of flooding.

Disadvantages : - it is not easy to construct a dam at the LW-line by hand. All the materials will have to be transported to the construction site and lowered into position, which requires special materials and a special method of construction, which in turn increases the cost of the project;
- the dam has to be faced over its whole length (the facing is very expensive).

Conclusion

If a solution can be found to the practical problems of construction of a longitudinal dam and the facing of the same, this solution is certainly one to be recommended.

- Costs : are relatively low (optimization is required of the ratio between dam height and siltation).
- Effectiveness : maximum siltation will be possible on both the Cao Jing and Nan Hui mud flats: 1.50 m per year (depending to a certain extent on dam height and the size of the flow opening).
- Maintenance : after typhoons, storms etc. the facing may have to be strengthened and repaired.

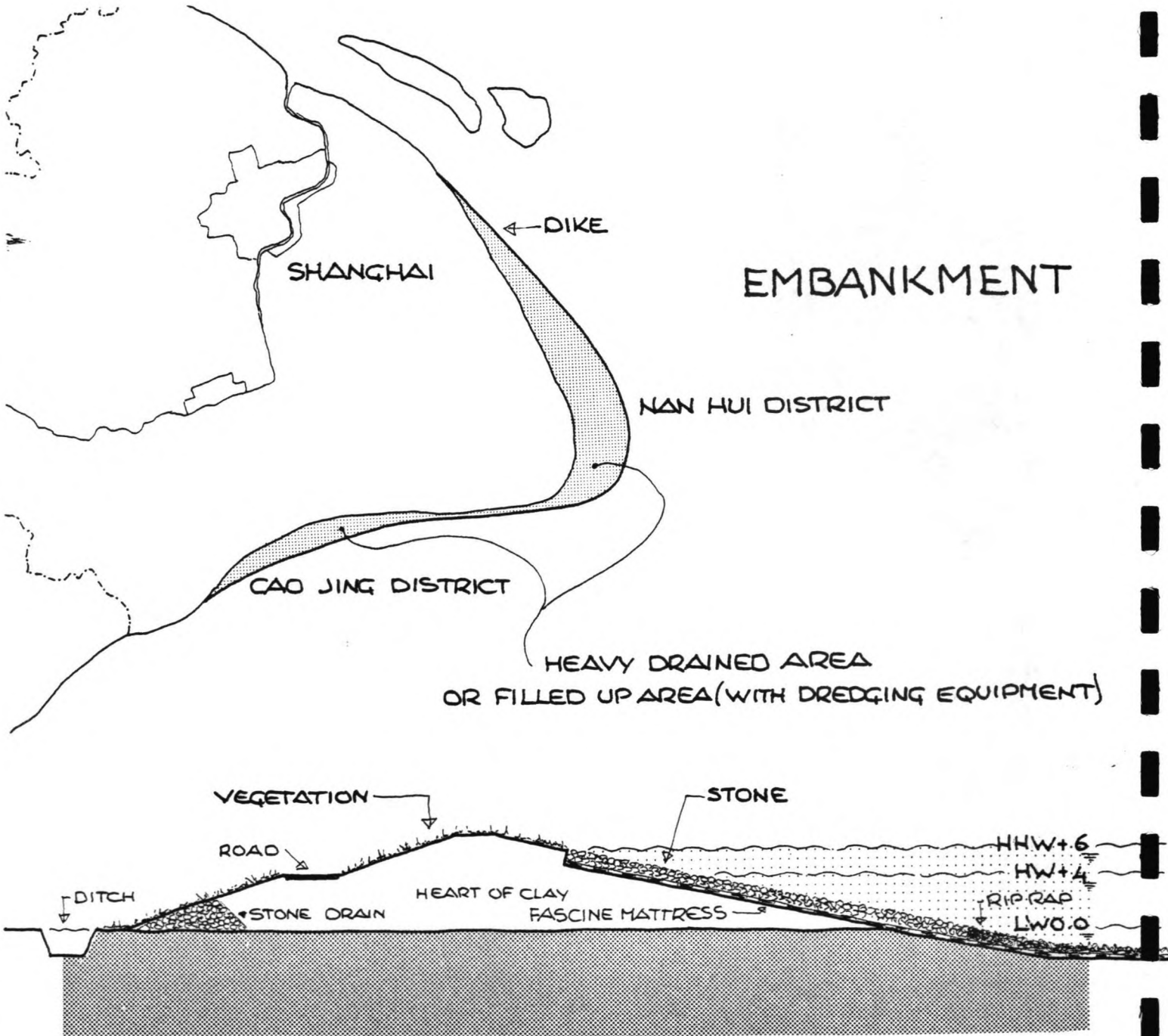

CROSS SECTION DIKE

5.3-7.2

5.3-7

5.3.7 Construction of a littoral embankment

Location

(see Fig. 5.3.7.1)

An embankment can be built wherever desired, as long as the coastline more or less follows the natural course of the depth-contours. However, the greater the depth at which the dike is planned, the higher the construction, the greater the wave impacts and currents and the more expensive it will be. The polder area inside the dike (whether or not soil-filled) must be well drained by pumping.

Construction and effect

Fig. 5.3.7.2 shows a possible cross-section.

The dike must be built up in layers, beginning with stone or clay bag deposits and filling up step by step between the deposits, in layers, followed by the facing: stone rubble from HHWL to LWL (under this a layer of grit/rock waster and two layers of stone). The dike base is protected by rubble: the clay core above HHWL can be covered with grass.

The dike must be able to withstand extreme weather conditions:

- high winds plus high water (flood);
- typhoons (high water levels and high waves);
- there may be no wave overtopping.

This dike forms a primary embankment and the land behind it can be quickly prepared for use.

If required, the level of the natural ground level in the polder can be raised by filling it up with soil, using dredge material. The dike construction can be less heavy because the filling acts as a support.

Advantages and disadvantages

- Advantages : - the land can be reclaimed immediately after the dike has been constructed;
- the hinterland is protected by this second dike.
- Disadvantage : - the cost of such a project is very high; it is much higher than the cost of construction of the other solutions discussed above;
- no use is made of the natural tendency to siltation.

Conclusion

An embankment can be constructed but it is very expensive and for this reason is not recommended.

- Costs : very high, higher than those of other solutions already mentioned.
- Effectiveness : very high; the new land (once it has been drained etc.) can be reclaimed for use immediately.
- Maintenance : a dike guard must be appointed, the area must be drained against salt intrusion, seepage, rain, etc.

5.3-8.1

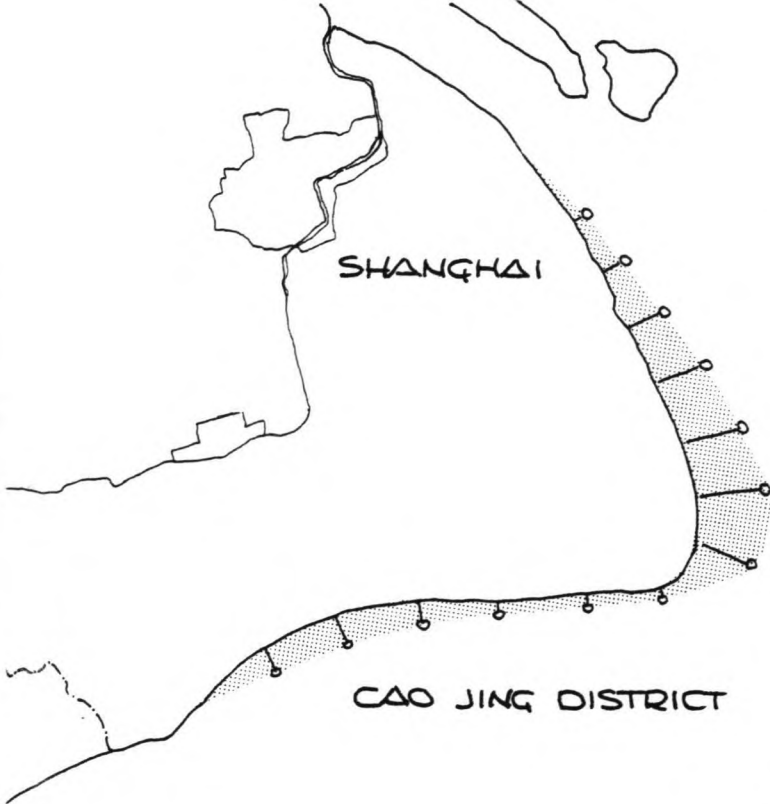

CONSTRUCTING STRONG POINTS IN THE SEA

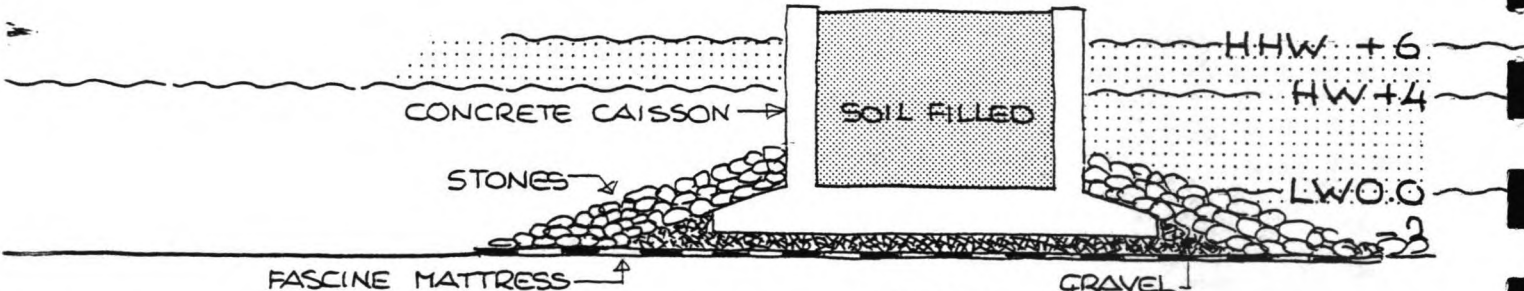

CROSS SECTION

5.3-8.2

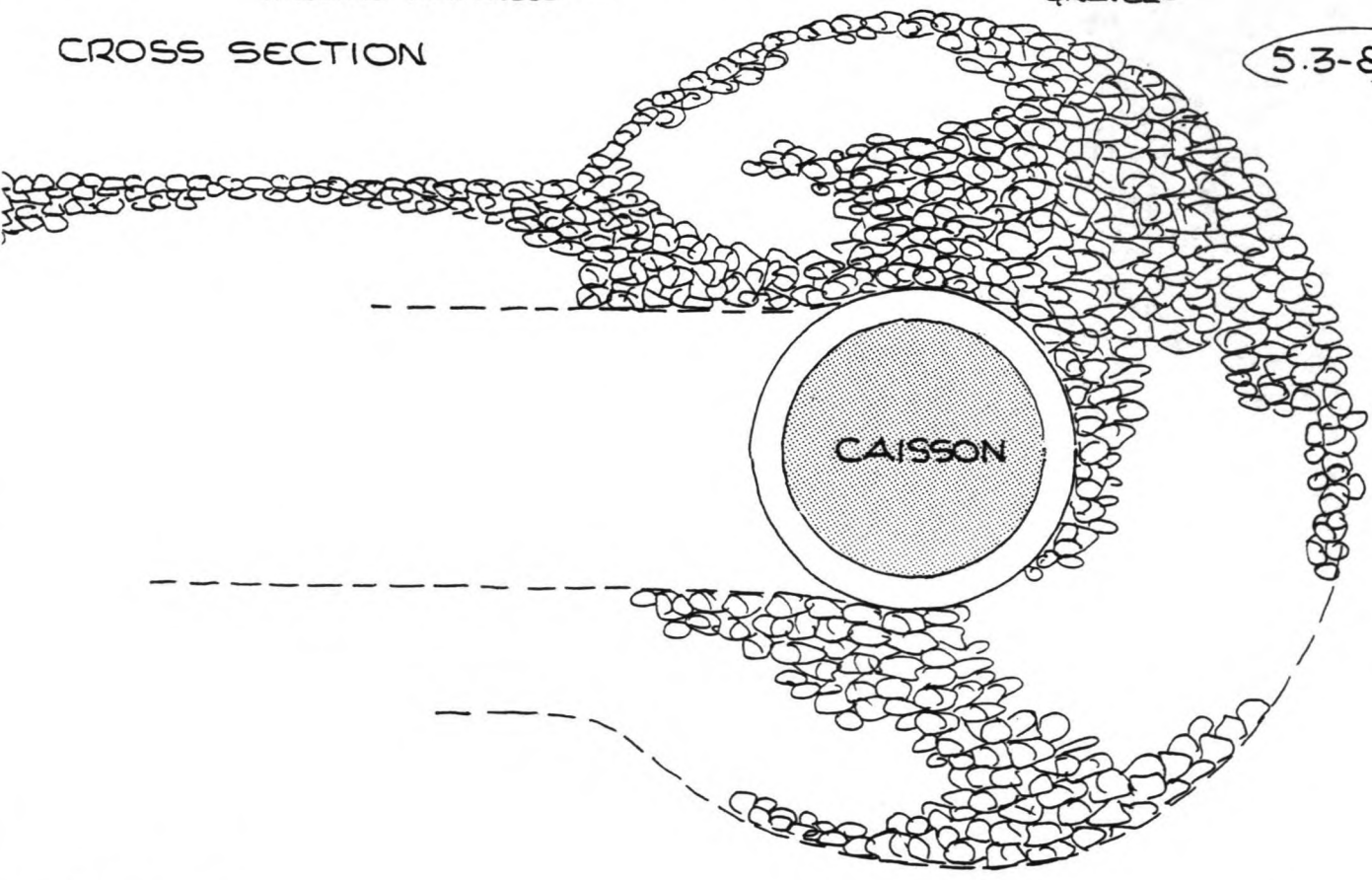

TOP VIEW

5.3-8.3

5.3.8 Construction of strong points in the sea

Location

(see Fig. 5.3.8.1)

First of all a number of strong points, or bastions, are built in the sea, which are later connected to the coast by cross-dams (perpendicular to the coastline) or possibly longitudinal dams (parallel to the coastline).

Construction and effect

Fig. 5.3.8.2 and 5.3.8.3 shows the construction of strong points. These points must be able to withstand extreme conditions (HHWL, typhoons, high winds).

After the points have been connected to the land or to each other they act as littoral dams respectively longitudinal dams/dikes.

Advantage and disadvantages

- Advantage : - the way the dams are anchored in the strong points means that the dams themselves can be constructed lighter, thus increasing their effectiveness.
- Disadvantages : - this construction is very expensive, lying with respect to price between the construction of dams along the coast and the construction of a polder dike;
- these fixed points are subject to heavy attack by waves and currents resulting in erosion with pits.

Conclusion

Such a construction is not recommended because the same effectiveness (rate of accretion) can be achieved with smaller and consequently less expensive constructions.

- Costs : very high.
- Effectiveness : see par. 5.3.5 and 5.3.6.
- Maintenance : the strong points, once constructed, do not require a lot of maintenance. The erosion around the points must be regularly checked.



6. CHOICE OF DESIGN FOR PHASE ONE

In the previous section several land reclamation constructions have been discussed. The most viable alternatives will now be worked out in greater detail. When arriving at a choice the following points have to be taken into consideration:

- optimization of costs of construction in relation to speed of accretion;
- flexible construction, with regard to possibility of extension in a later stage, and with regard to displacements by typhoon conditions, are preferable above fixed, rigid constructions;
- the lifetime of the construction must be at least 5 years.

After carefully comparing the various alternatives against these criteria and the starting points mentioned in section 3, the following methods were considered to be the most promising:

1. the construction of dams perpendicular to the coastline consisting of rows of tube-shaped, soil-filled geotextiles (proposal 1);
2. the construction of dams parallel to the coastline consisting of a core of tube-shaped, soil-filled geotextiles faced with bags of soil (if necessary with stones) against waves and currents (proposal 2).

PROPOSED SOLUTION I

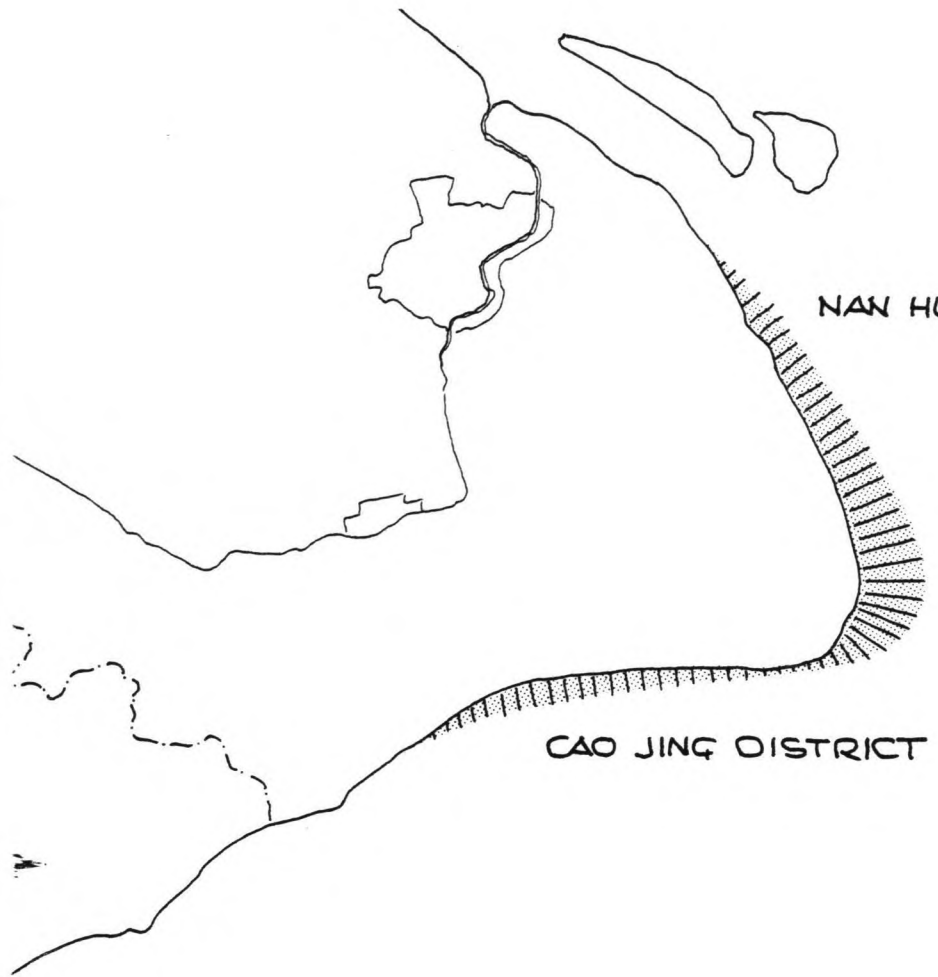

NAN HUI DISTRICT

CROSS-DAMS ⊥ COASTLINE

CAO JING DISTRICT

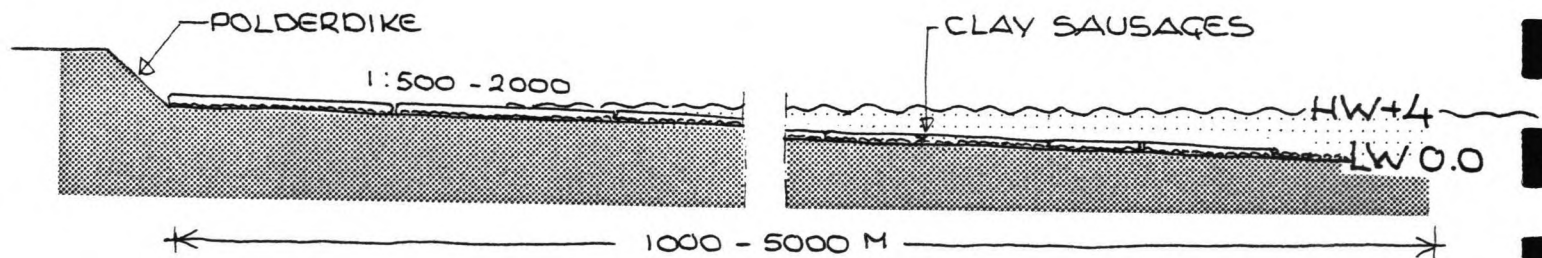

POLDERDIKE

1:500 - 2000

CLAY SAUSAGES

HW+4

LW 0.0

1000 - 5000 M

CROSS SECTION

6.1-1.2

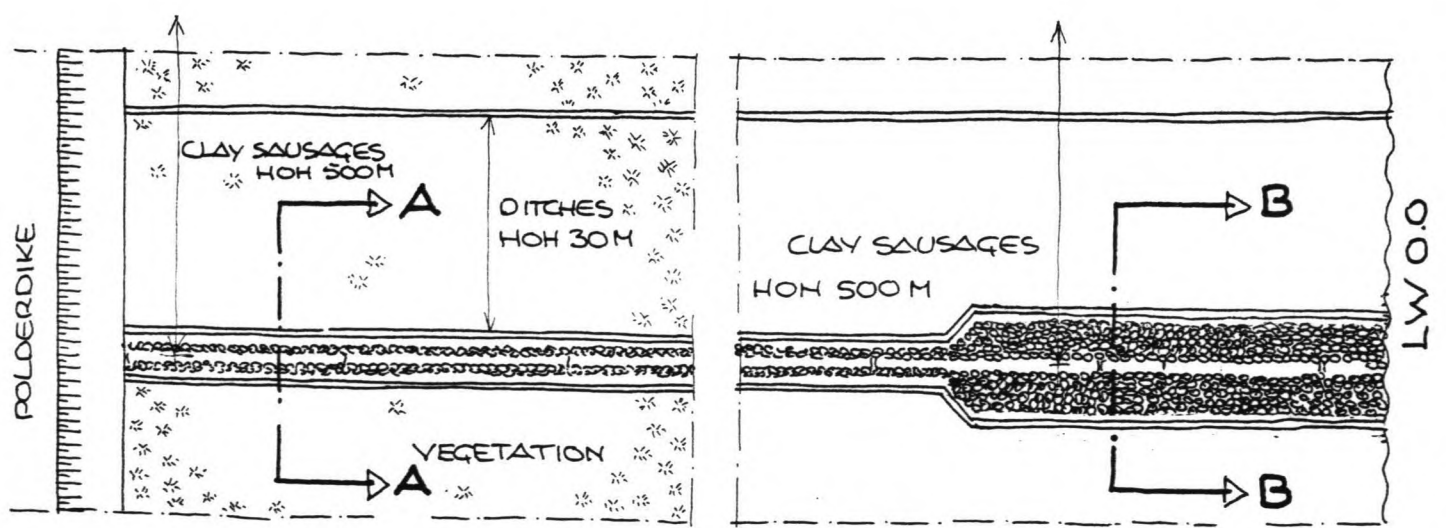

POLDERDIKE

CLAY SAUSAGES
HOH 500M

A

DITCHES
HOH 30M

VEGETATION

A

CLAY SAUSAGES
HOH 500 M

B

LW 0.0

B

6.1-1

TOP VIEW

6.1-1.3

PROPOSED SOLUTION I

NAN HUI DISTRICT

CROSS-DAMS
⊥ COASTLINE

CROSS SECTIONS

CAO JING DISTRICT

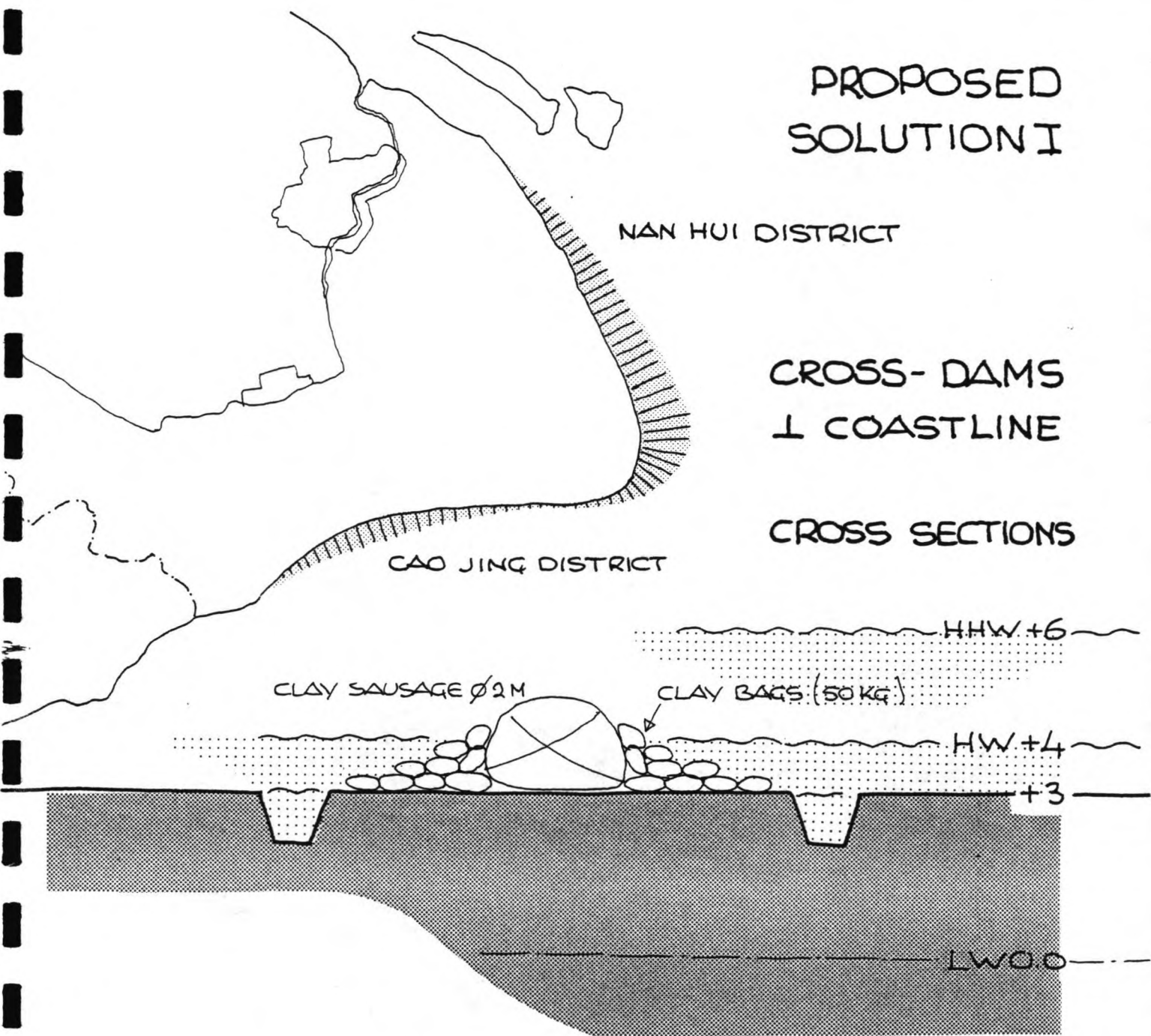

CROSS SECTION A-A

6.1-2.2

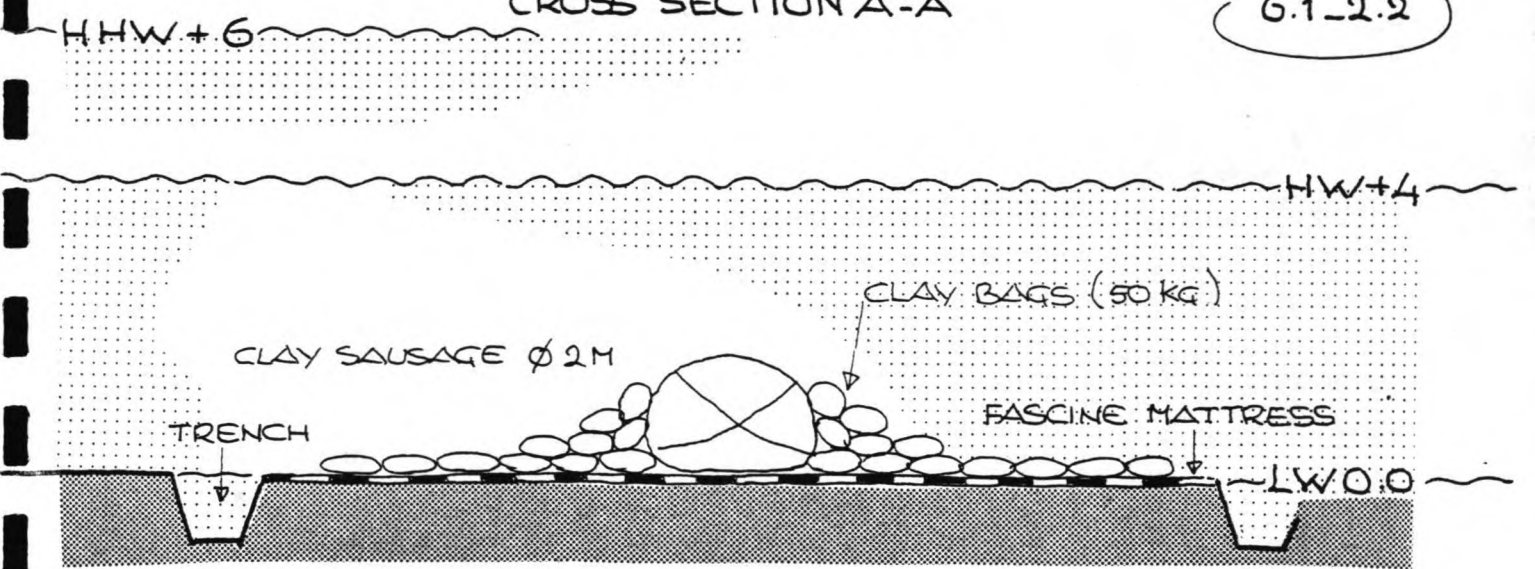

CROSS SECTION B-B

6.1-2.3

6.1-2

6.1 Designs

6.1.1 Design of proposal 1

(see Fig. 6.1.1 and 6.1.2)

Proposal 1 emphasizes the construction of cross-dams perpendicular to the coastline.

Location

A chain of clay sausages is constructed to form a dam. The first sausages are laid by the coast (HW-line) then gradually working seawards (LW-line). The dam has the same height overall, being approximately 2 m. This means that the wave impacts on the dam are less and only the head of the dam need to be reinforced with a fascine mattress and clay bags weighing 50 kg (or soil bags). The project can also be carried out in phases; half or part of the sausages are first laid in position, so that siltation begins to increase and at a later stage the remainder or more sausages are added to the chain. In this way it is possible to regulate the progress of siltation and the costs. Another study will have to be conducted to optimize the various aspects.

Cross-sections, design

The core of the dams (see section A-A) is made up of tube-shaped, soil-filled geotextiles, so-called clay sausages. The advantage of these sausages is that they work together as a whole under the influence of currents and waves. The stability of the sausages and hence of the dam is much greater than when loose clay or clay bags are used (see appendix I): The clay is "reinforced" by the geotextile membrane.

At the heads of the dams (see section B-B) there is a fascine mattress 8 x 100 m, to prevent the sub-soil from being washed away and to counter the formation of erosion pits immediately in front of the construction. The clay bags are also sewn together in units of 1,500 kg and are used to reinforce the dam head. The area between the dams must contain a network of trenches and ditches to promote the best possible flow pattern.

Effectiveness

With a construction like this an average siltation is expected of 0.75 m/year (this is half the siltation that would be achieved if a basin were to be constructed). This figure will have to be verified in a further study.

6.1.2

Design of proposal 2

(see Fig. 6.1.3 and 6.1.4)

Proposal 2 emphasis the construction of longitudinal dams parallel to the coastline.

Location

Tubes filled with soil are stacked in piles of three, one on top of the other two along the LW-line around the coast, thus making a chain of tubes, which form the dam. The height of the dam is about +3.60 m (3.60 m above the LW-line). When the tide comes in the water flows over the dam filling the basin behind. Every few hundred meters in the dam itself the top tube is left off creating a throughflow opening with a threshold which allows the water to flow into the basin as the tide comes in and flow out again as the tide goes out (see appendix I-3).

(See section BB.) The sludge can settle in the water that remains in the basin where there is little movement, forming a layer of sedimentation. This layer is fed with new sedimentation with each new tidal movement.

This project can also be carried out in phases; first the construction of the threshold of 1 or 2 "sausages" along the coastline, which is later raised by a tube over its length (but with throughflow openings). Once the hinterland has been sufficiently raised (after 3-4 years) the dike can be raised still further and reinforced to serve as an embankment.

Cross-sections, design

The core of the dam is made up of 3 tube-shaped, soil-filled geotextile clay sausages. By juxtaposing the sausages the effect of the whole core is increased (see section B-B).

The dam must be reinforced with clay bags against wave impacts and currents. These clay bags are sewn together forming units of 1,500 kg. These units also protect the throughflow openings (see section A-A) against scouring.

Above the +2.00 m (2 m above LW) the sausage itself receives the wave impacts. It is expected that the geotextile material can withstand these.

A fascine mattress must be laid under the whole of the dam to prevent the subsoil from being washed away. At the throughflow openings the fascine mattress must be broadened to prevent the formation of erosion pits close to the construction. The area in the basin can be planted with reeds and seaweed to accelerate siltation.

Effectiveness

With a design like the one described above, an average siltation of 1.50 m is expected the first year. This decreases gradually; the mass of water that is forced into the basin with each incoming tide decreases as the basin gradually becomes shallower (no sedimentation occurs above the HW-line).

PROPOSED SOLUTION II

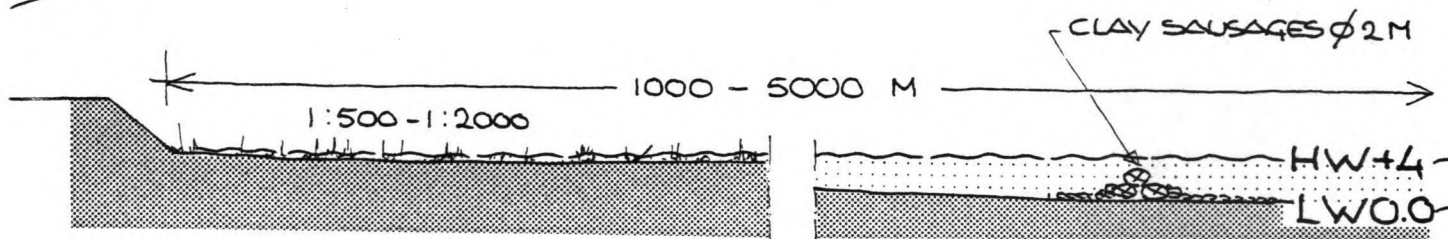

CROSS SECTION

6.1-3.2

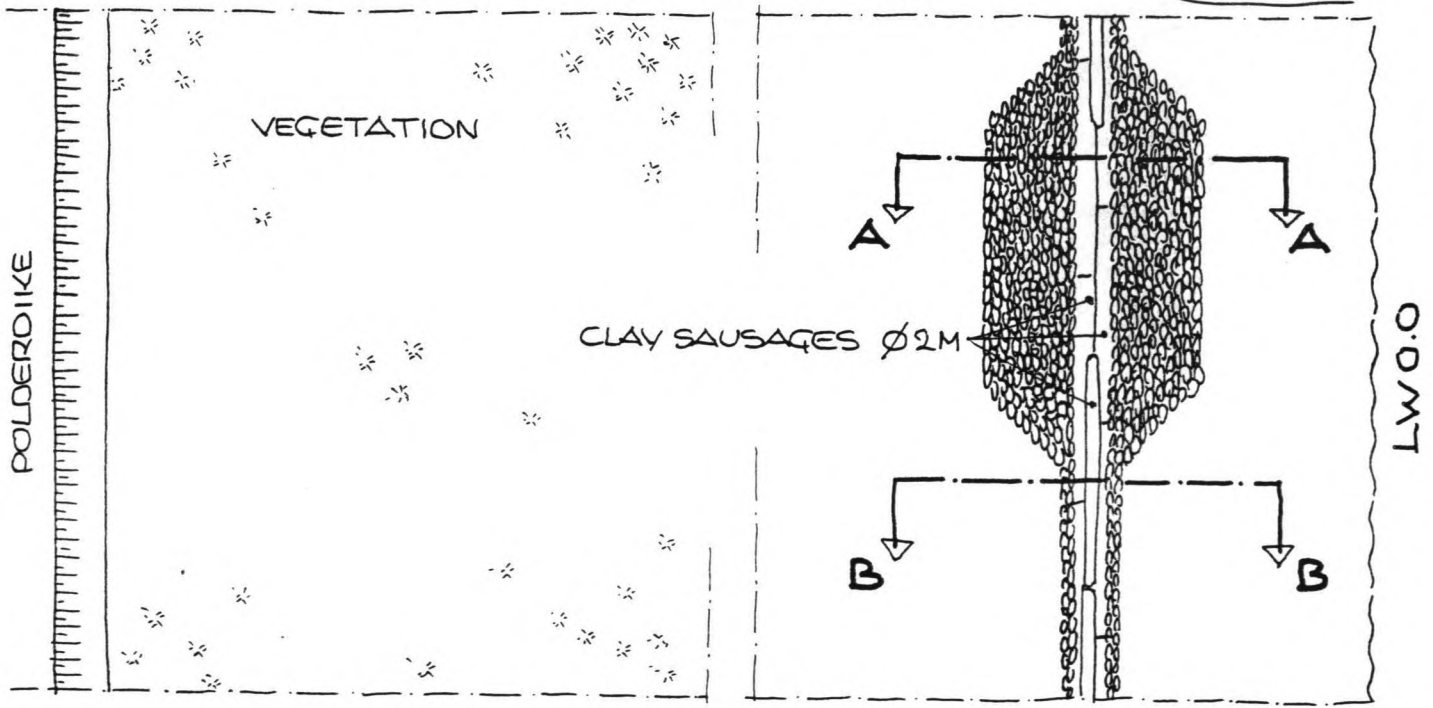

6.1-3

TOP VIEW

6.1-3.3

PROPOSED SOLUTION II

NAN HUI DISTRICT

LONGITUDINAL DAMS

CROSS SECTIONS

AREA WITH TRENCHES AND DITCHES

CAO JING DISTRICT

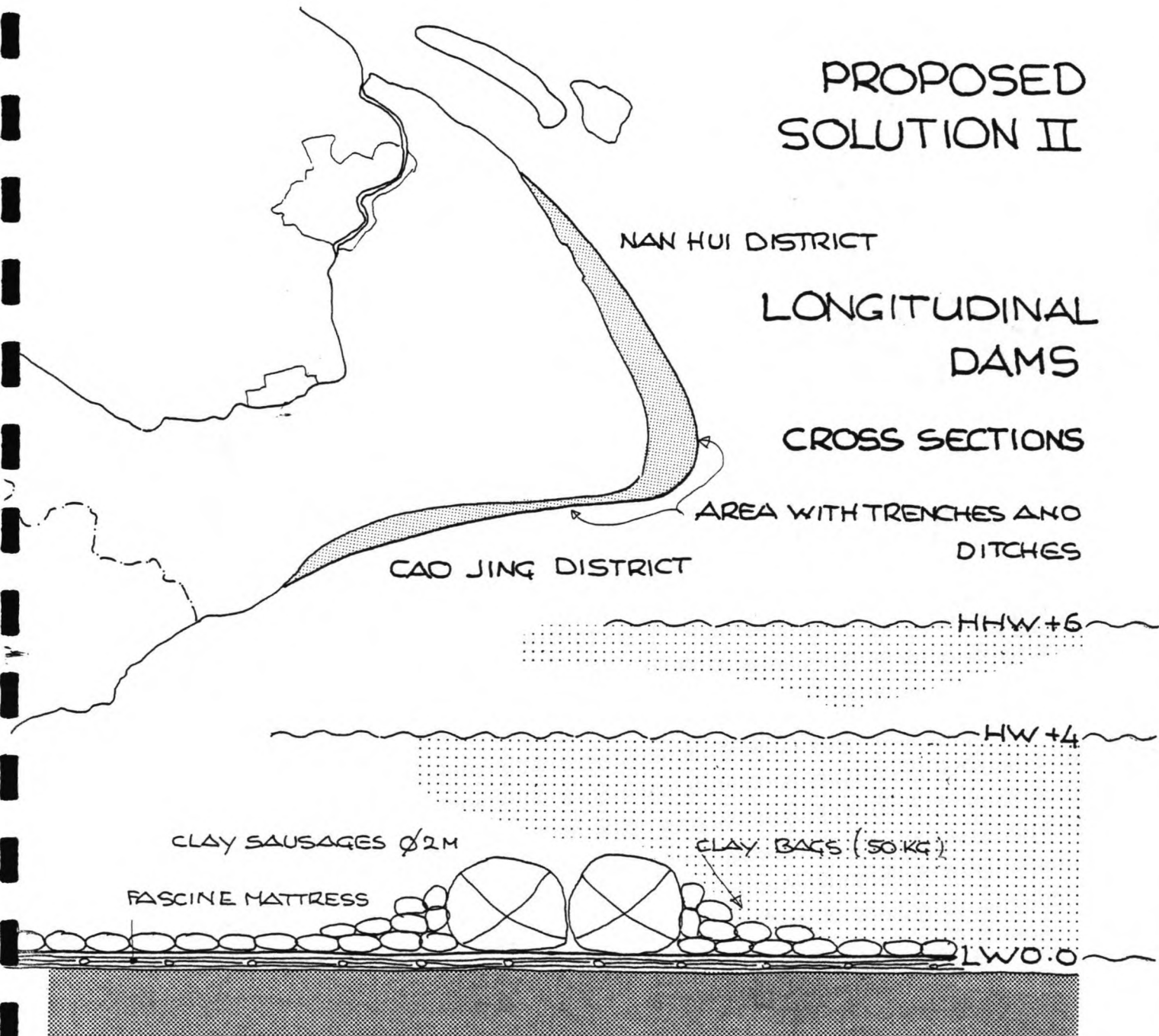

CLAY SAUSAGES $\varnothing 2M$

CLAY BAGS (50KG)

FASCINE MATTRESS

HHW+6

HW+4

LW0.0

CROSS SECTION A-A

6.1-4.2

HHW+6

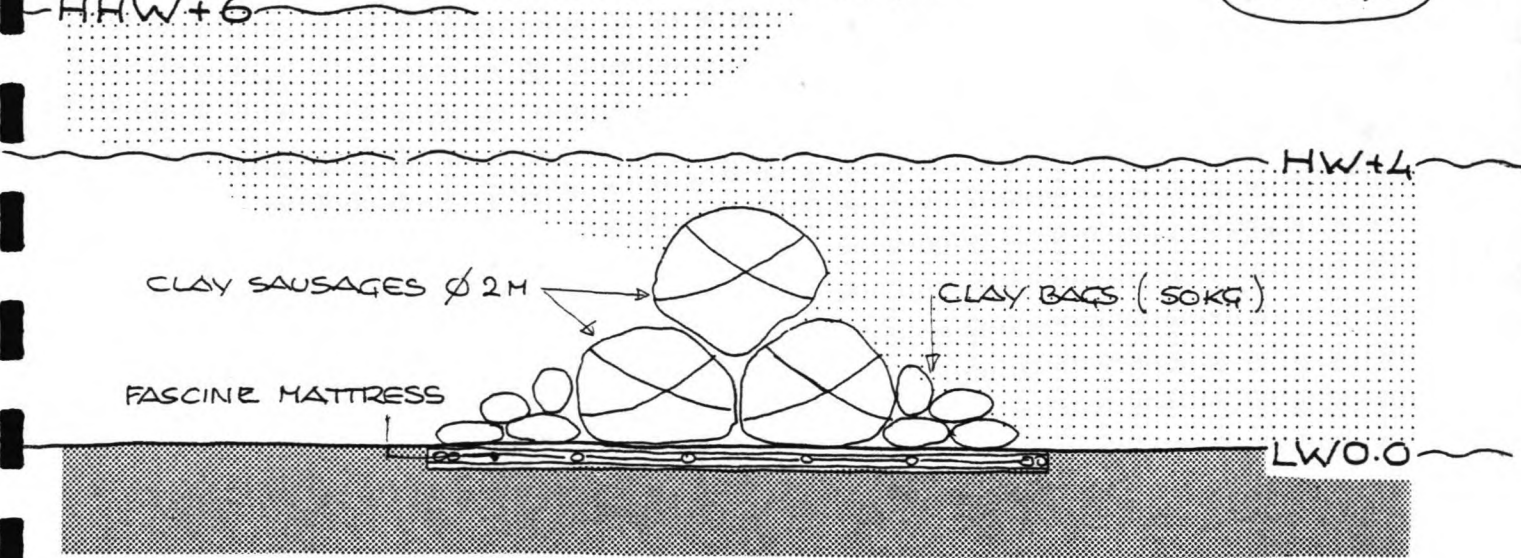

CLAY SAUSAGES $\varnothing 2M$

CLAY BAGS (50KG)

FASCINE MATTRESS

HW+4

LW0.0

CROSS SECTION B-B

6.1-4.3

6.1-4



Shore protection project from the Beaufort Sea coast in Canada (Tuktoyaktuk).



Coast protection project from Klemskerke, Belgium.

fig. 6.2.1

6.2

The use of tube shaped geotextiles filled with soil

Soil-filled geotextile tubes have been applied more or less successfully at different locations (see Fig. 6.2.1). In all earlier applications a sand-fill was used because this material can, mixed with water, be pumped into the geotextile mechanically. The sand settles in the back of the tube, the water runs out through the meshes in the textile. In case of clay or other materials with small grain sizes this method can't be applied, the size of the meshes won't allow the water to run out of the tube, small particles will block the openings. At the mud flat of Cao Jing and Nan Hui East the average grainsize varies from 20 μm to 100 μm , the smaller particles determine the maximum size of the openings, which in this case was recommended to be 35 μm . Here the tube must be filled by hand or in a mechanical way.

However there is no particular reason that clay or silt cannot be applied for filling the geotextiles using a dry method. The recommended built-up of the tube surrounding the fill is an outer layer of coarse-woven textile and a membrane with $O_{90} = 35 \mu\text{m}$ inside (the membrane itself is not strong enough to keep the tube together while dropping it on its foundation).

The tube itself, once filled and placed in position, usually remains in excellent shape. It withstands waves and currents (literature mentions no tube failures by wave impacts, large displacements etc.). Below the waterline most tubes fail in 3 à 4 years by tears in the geotextile caused by debris, boats and wood etc. Once a hole has come into existence the tube starts losing material and this process gets more severe in time (by waves, tidal changes). Most dangerous for the tube is vandalism, holes originating from knife-cuts, stones etc. A special tube coating has been developed to protect the geotextile from these dangers. This coating, applied one time only, can last for 2 à 3 years. So tube-failure is not due to displacements by waves or currents, but to local failure by holes and tears. For right functioning of the tube, regular checking is necessary and repairs should be performed.

At the Cao Jing mud-flat and the Nan Hui East mud-flat these tubes will suit well:

- . the lifetime of the structure will be 3 or 4 years.
- . at both sites there is little chance at vandalism or impacts of boats etc. Debris do not occur at the Yangtze estuary and the Qiantang estuary, only small sized particles (probably even coating will not be necessary).
- . dismantling of the tubes is very easy: cutting the seam (the geotextile might be recycled to form new tubes).
- . the tubes can be used single or in groups and many different lay-outs can be formed, cross-dams and longitudinal dams, all with the same basic unit and work-method.

6.3

The use of the pontoon

A rough design for a vessel to built, transport and drop the tubes into position below the water surface has been developed by RPW (see Fig. 6.3.1).

The catamaran type craft is constructed of two pontoons and fitted with a mould for filling the tubes. The tubes can be dropped by tumbling the mould.

Carrying-capacity	: 400 tons
(Own) weight	: 165 tons
Light draught	: 0,5 m
Loaded draught	: 0,9 m

The purpose of this pontoon is transport a tube from the construction site to its location at sea and drop it (see Fig. 6.4.2). Its function can be devided over various stages.

Stage 1: to bear the tube during filling the geotextile inside the mould and tying it up

For this purpose a working platform can be slided to the mould so that people can walk at the mould for filling-activities.

Stage 2: to transport the finished tube at its location

For this purpose the pontoon has to move through shallow water affected by waves and tides. A push boat pushes the pontoon in position (for transport the high tide has to be awaited).

Stage 3: to drop the tube in place

For this purpose the idea was developed to tumble the tube into the water (using the same mechanism as split-barks with tumbling their load into position). To stabilize the movements of the pontoon while dropping the tube this tumbling or launching device is best placed in the middle of the pontoon. Because of the enormous weight that is displaced while dropping, a launching-device at one side at the pontoon was rejected (danger of capsizing, touching the bottom because of wild side-movements or hitting an allready laid tube and tearing it).

The mould with the tube is placed slighty excentrical from its support, so that gravity causes a down-ward movement of mould with tube if the devise is unlocked. While falling down, the tube leaves the mould, afterwards the (now very light) mould can be transported upward by winches and locked into position to contain a new tube.

- Minimal waterdepth required for functioning at sea:

2 m during transport and dropping of one single tube,

3 m if the tube has to be placed next tot an allready laid tube or on top of two allready placed tubes.

(This is only valid for "normal" weather conditions and mild wave action.)

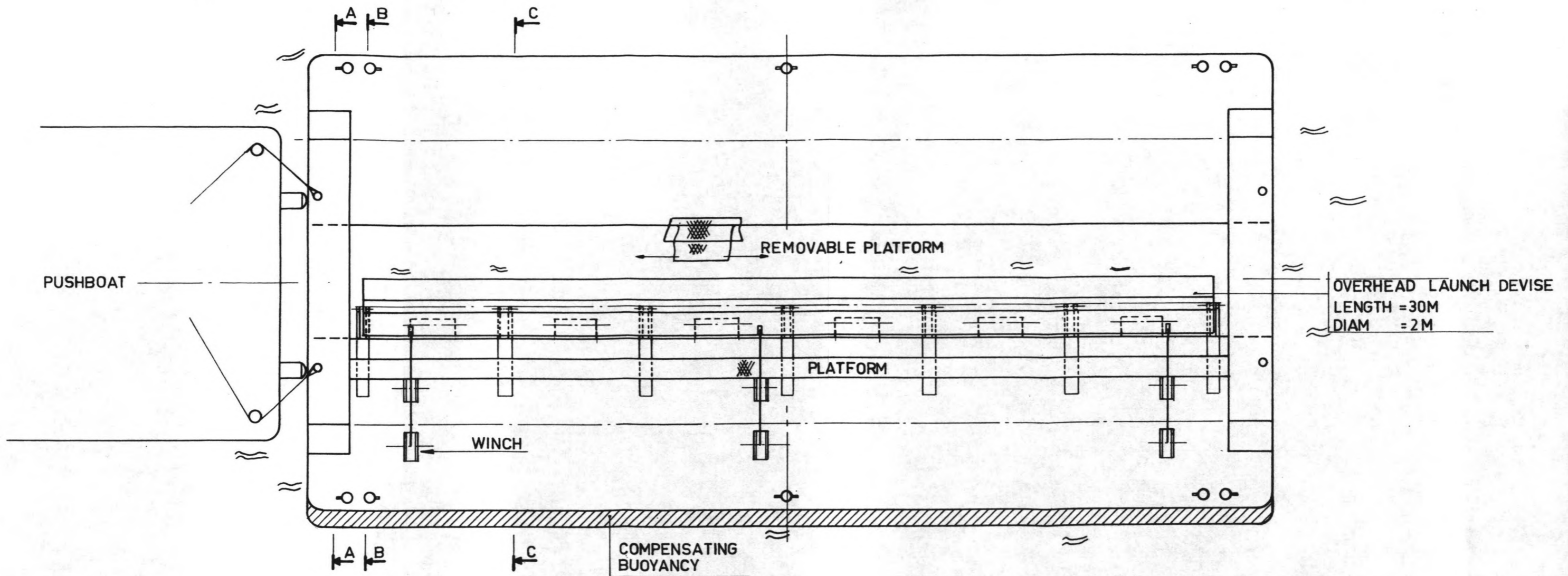

SECTION B-B

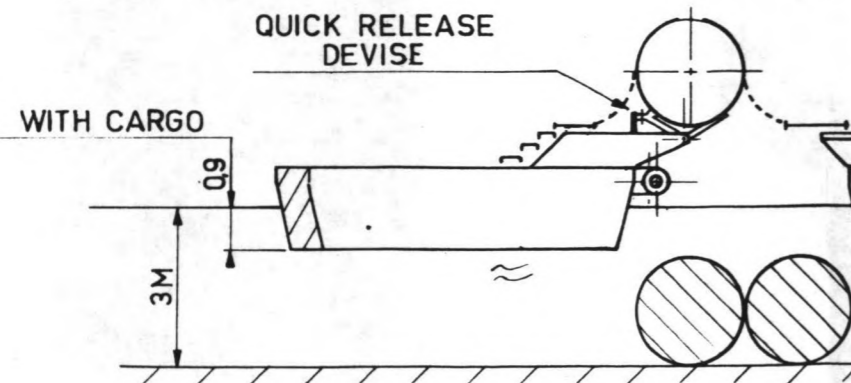

SECTION A-A

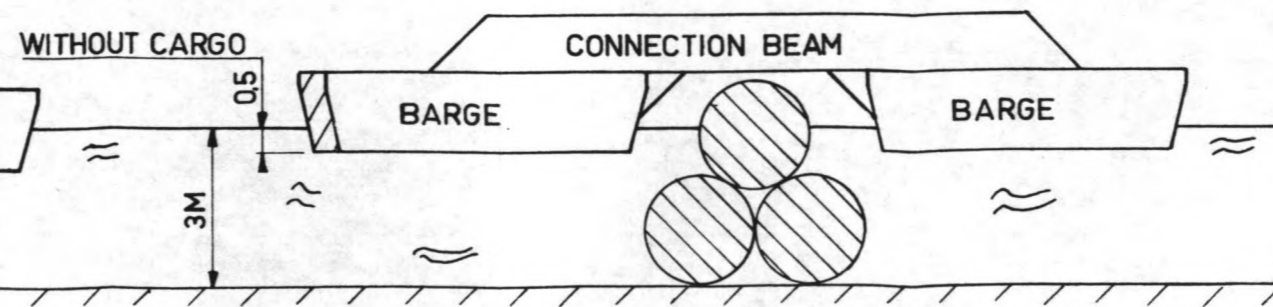

SECTION C-C

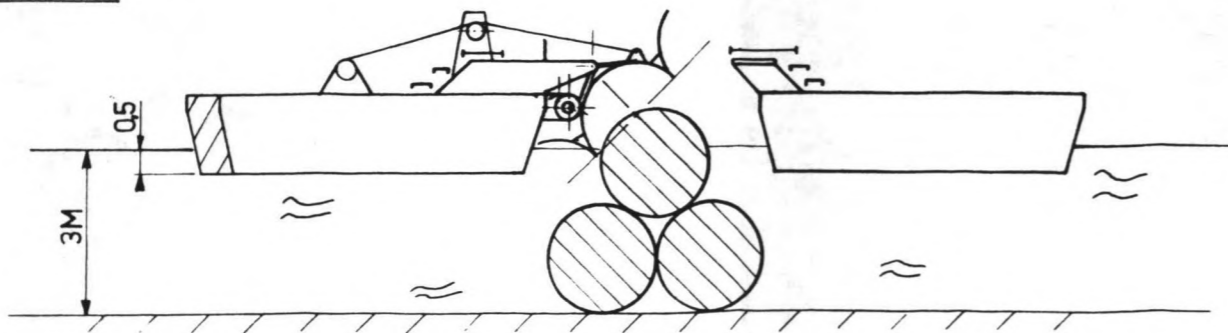

g	
f	
e	
d	
c	
b	
a	
wijzigingen	

gemeentewerken rotterdam

PROPOSAL LAUNCHING					I8	ingenieursbureau staal- en werktuigbouw	
					afd. :		
					bestek :		
					schaal :	1:100	
					datum :	13-6-86	
getekend <i>J.v.B.</i>	gecontr.	gezien	afd. chef	formaat A2			

- Some experiences have to be gained dropping the tubes, concerning the exact position of the pontoon in relation to the required position of the tube after dropping, the pontoon will move slightly sideways while dropping.
- The tubes can be filled during low tide and transported and dropped during high tide (the mudflat is then covered with water so no excavation activities can be performed during high tide).

METHOD OF FABRICATION OF THE TUBESHAPED GEOTEXTILE

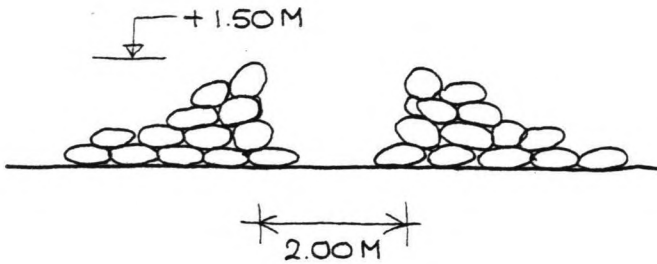

MODELLING A MOULD FROM CLAY BAGS



PLACING THE GEOTEXTILE



FILLING THE GEOTEXTILE WITH SOIL



TYING UP THE SAUSAGE

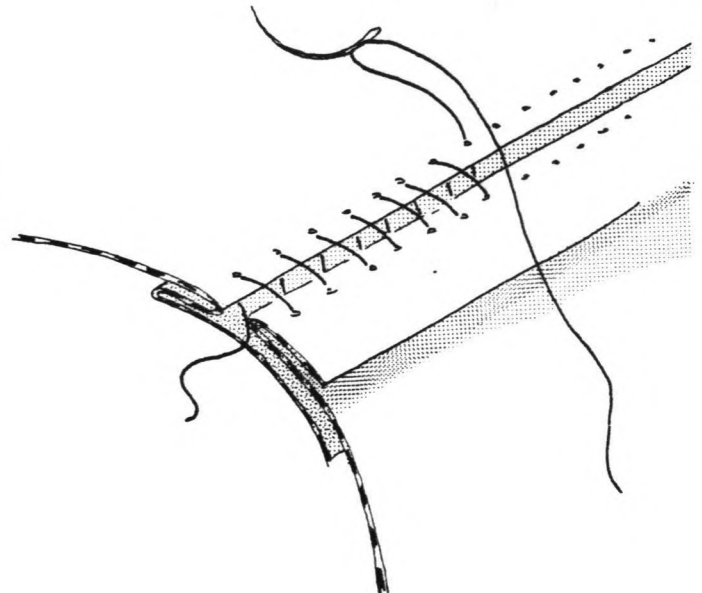

6.4 Method and execution

The filling and closing process of the soil filled geotextile tubes, and the transport from the place where they have been filled to the construction site, requires further explanation. A difference can be made between:

1. making_the_sausages "on dry land"

This can be done from the coastline to a level of 2 m above the LW-line (at a lower level there is not enough time between two tidal periods to work efficiently);

2. fabricating the sausages at the coastline and then transporting them to the construction site by pontoon, and lowering them into position.

6.4.1 Method for proposal 1 (cross-dams)

The clay sausages are first constructed on dry land, starting from the coast, as follows (see Fig. 6.2.1).

Step 1: modelling a mould made of clay bags in which the sausage is later filled.

Step 2: the geotextile is laid in the mould by hand.

Step 3: the geotextile is filled with soil and compacted. The soil from the excavation of the trenches and ditches is used.

Step 4: tying up the sausages by hand by making eyes in both flaps and sewing them together.

The sausages are made on the spot using simple aids (the filling is done with baskets). The clay bags are also filled and sewn up by hand. The soil used to fill the bags and sausages originates from the excavation of the ditches and trenches and possibly channels to facilitate the supply of material.

This process can be continued up to a level of +2.00 m (2 m above the LW-line)

After this it is necessary to position the sausages with the help of a pontoon and then lower them into position.

The method used is as follows (see Fig. 6.2.2):

Step 1: excavation of a construction harbour and canal at a suitable point near the HW-line. The soil that is excavated can later be used to fill the geotextiles.

Step 2: filling the sausage on the pontoon (in the construction harbour). A mould is erected on the pontoon (see Fig. 6.2.3) into which the geotextile is placed and then filled with soil by hand. The sausage is then closed.

COASTLINE (POLDERDIKE)

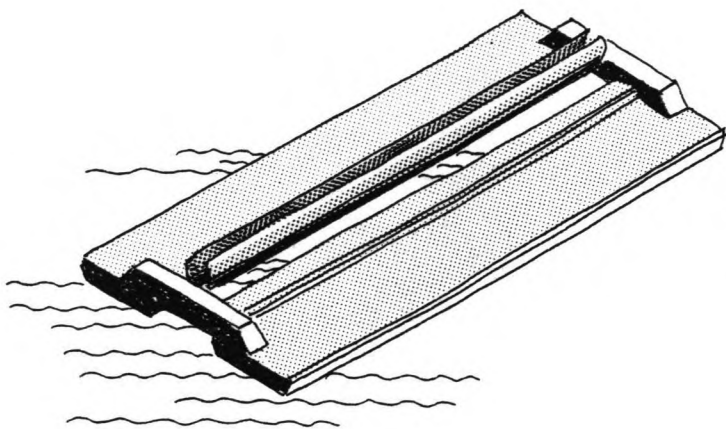

FIRST PHASE
FILLING OF
CLAY SAUSAGES
IN THE DRY

SMALL CANAL

DUMPING OF
NEW CLAY SAUSAGE

+ 2

LW 0.0

PONTOON

TOP VIEW

6.4-2

Step 3: transport to the actual dam site: a push boat pushes the pontoon from the construction harbour out to sea to the correct site.

Step 4: lowering the sausage into position. An overhead launch device on the pontoon is used to ensure that the sausage falls directly from the mould into the correct position. The pontoon then returns to the construction site.

This cycle is then repeated.

The sausages measure \emptyset 2 x 30 m and weigh appr. 150 tons per sausage.

Experiments on the best way to transport and unload the sausages must be carried out first. Experience must be gained with the material and the equipment before work starts on the dam.

When constructing the damheads, a fascine mattress is lowered into position and anchored with clay bags for ballast ready to take the sausage. Once the sausage has been dropped the fascine mattress is filled up with clay bags to complete the reinforcement of the dam heads (the clay bags can be dropped from the pontoon).

6.4.2

Method for proposal 2 (longitudinal dams)

Because the dam has to be built at the LW-line, it is not possible to work on dry land. The method used is the one described in par. 6.2.1

The order of construction is as follows:

- Step 1: lowering the fascine mattress and anchoring by clay or soil bags.
- Step 2: unloading the first sausage (as described in par. 6.2.1).
- Step 3: the second sausage is laid next to the firstone (this can only be done at HW, because the minimum water depth must be 3 m).
- Step 4: positioning the top sausage, again only at high water.
- Step 5: lowering clay bags to complete the reinforcement of the dam.

The pontoon (Fig. 6.2.3) can be used for different dam constructions.

The "sausage" method can also be used for the construction of large seam dams (master plan par. 4.3). These sausages from flexible units which are extremely stable, because of their weight, consequently they are extremely suitable for use when building on ground that is not very firm using materials such as clay and loamy silt.

6.5 Cost and optimization

It must be clear that these aspects of the plan are not easy to determine because there is no practical experience with the use of handfilled geotextiles containing silt. More over the speed of siltation is, even with known concentration of sediment and current velocities, one of the most uncertain aspects of civil engineering. Only a rough estimation can be calculated and that only if concentration and movement of the sediments are known. In this report only a global figure is given, this is not checked by calculations and yet based on what reasonably could be expected. Besides there is a large number of unknown or uncertain data like typhoon conditions, actual water levels, current velocities, wave action and soil conditions like bearing capacity, in situ shearstress and normal stresses, density of the material, speed of consolidation of just-settled material etc. A more profound study of sediment transport and concentration will be done in the near future, some experiments and also a probablistic approach of extreme conditions (wave heights, water levels) so that the approach of the optimization problem can be more grounded with figures and results of experiments.

6.5.1 Cost

1. Cost of one meter of soil-filled geotextile tube:

coarse textile + membrane:	7.50 y/m ²
freight rates etc.:	<u>1.25 y/m²</u>
price of geotextile in situ:	8.75 y/m ²

(approximately)

price of tube (7 m ² /m')	61.00 y/m'
placing of 3,14 m ² soil into tube	9.00 y/m' (6 manhours *)
transport of 3,14 m ² soil to site	18.00 y/m' (12 manhours *)
tying up 1 m of textile	0.75 y/m' (1/2 manhour *)
this yields	<u>88.75 y/m' tube</u>
	=====

*the exact rate of labour is not known, this gives an estimation

2. cost of application of special pontoon for laying tubes:

value ~ 625,000 yuan (estimated)	
depreciation, interest + maintenance (0,4%)	2,500 y/week
fuel + wages	<u>1,250 y/week</u>
	3,750 y/week
per week 300 m' tube (10 droppings) yields	<u>15 y/m' tube</u>
	=====

3. cost of 1 m of a clay-dike (see Fig. 5.3.5.3):

placing of 13 m ³ of clay	40.00 y/m'
placing of 3,5 m ³ stones (8,4 tons)	<u>142.00 y/m'</u>
yields	<u>182.00 y/m'</u>
	=====

6.5.2

Optimization

An exact optimization process supported by the necessary theoretical background and practical experience cannot be performed, therefore a discription of the way the reclamation project is best handled is given (see Fig. 6.5.2):

first phase:

the construction of small reclamation fields of 500 x 500 m

Initially, the tubes are constructed in lines of 16 or 17 every 500 m, forming groins from the coastline to some 500 m onto the mud flat (this is valid for the Cao Jing district as well as the Nan Hui East beach).

One field can be used as a test field to performe measurements. This way the development of the siltationprocess can be studied, lay-out and heights of the dams can be adapted to the desired rate of siltation.

second phase:

the extension of the fields in seaward direction

Now larger fields can be used fields of 1,000 * 1,000 m, another 16 or 17 tubes are constructed every 1,000 m forming groins of some 1,000 m into the mud flat. The former fields of 500 x 500 can be "closed of" by a line of tubes in longitudinal direction if examination of the first fields learns that sedimentation is accelerated by this measure.

SEQUENCE OF EXECUTION

6.5-1

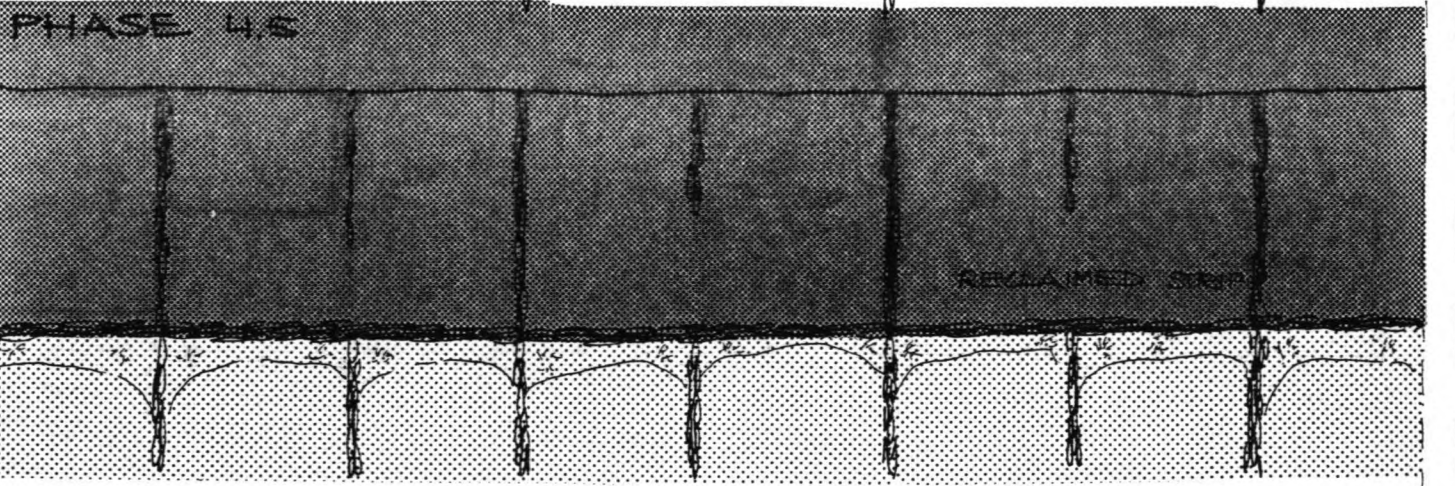
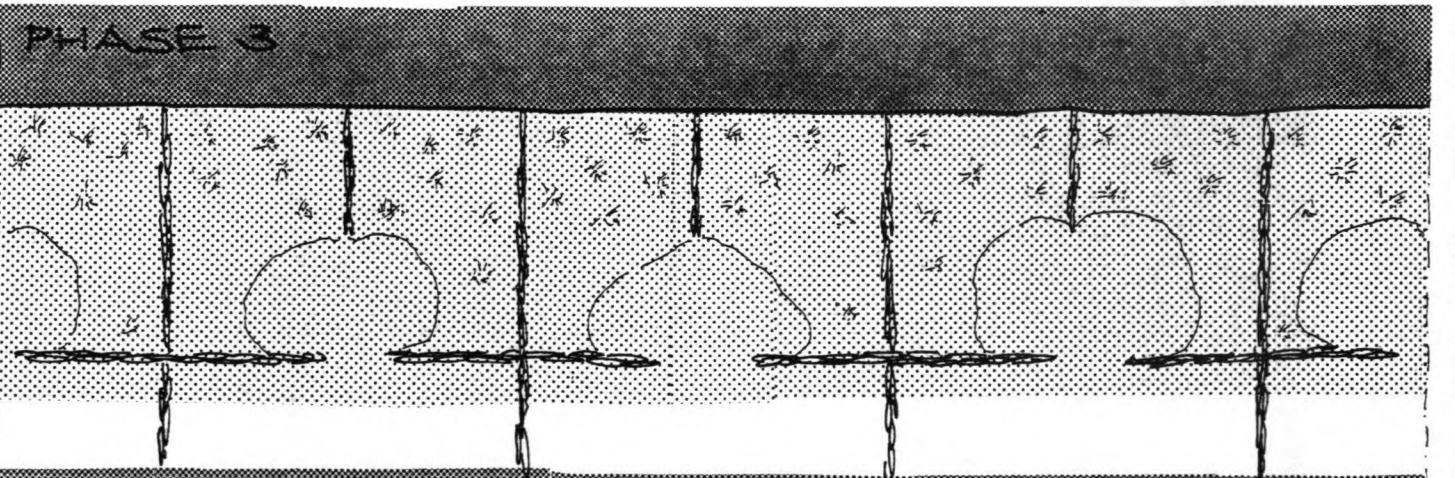
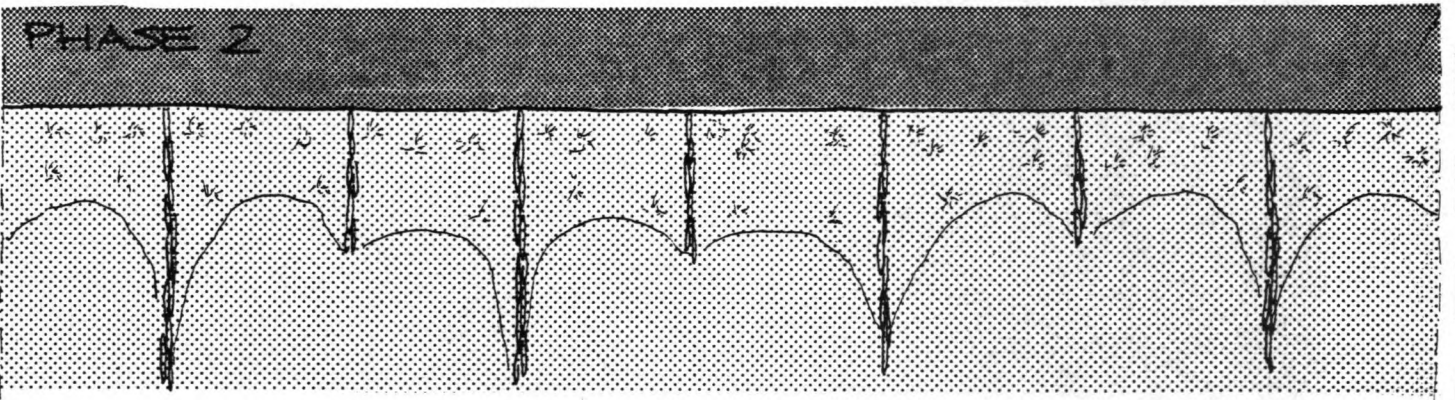
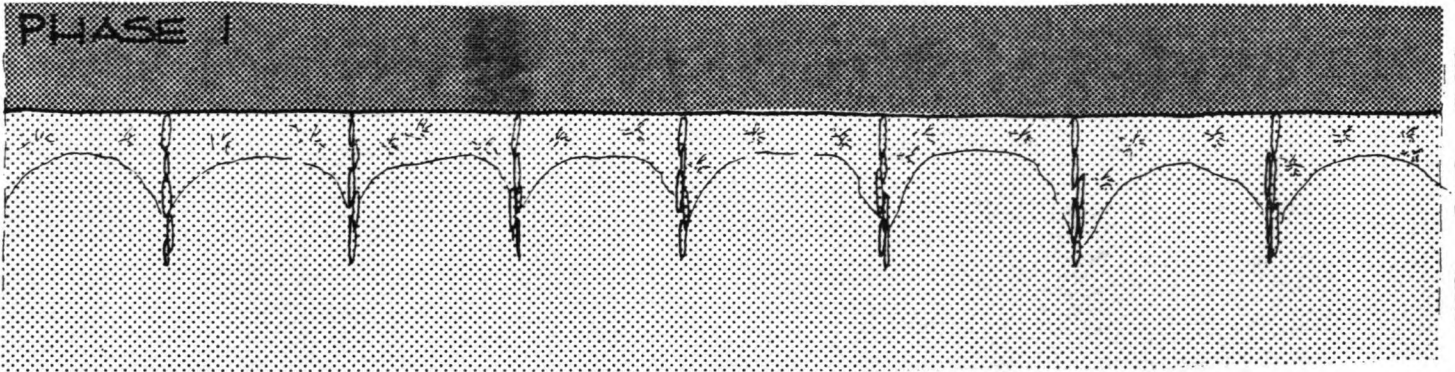

The siltation process can continually be watched, and if necessary extra tubes can be placed to improve sedimentation. In this phase of construction experience has been gained, and proper predictions about an optimization of tubes-to-be-laid to the rate of siltation can be made.

third phase:

further extension of the reclamation area

The lay-out of the construction is now adapted to earlier experiences with the test fields. The strip near to the coastline can be planted with crops that last in salted soil.

fourth phase:

closing of the first strip of reclaimed land

Longitudinal dams are constructed to fence off the area from direct influence of the sea, the existing cross-dams are heightened. If the bottom has raised sufficiently, the longitudinal dam that closes off the strip must be strengthened to form a polder dike that protects the new reclaimed land from the sea. This land then can be cultivated and built upon.

fifth phase:

continuation

The extension of the reclaiming area into the sea by repeating the principle mentioned above.

This way an optimal lay-out develops while constructing the dams and dikes. Also the construction itself is smoothly progressing in seaward direction so that the natural streampattern can adapt to the new situation.

Advantages of the use of tube shaped geotextiles for constructing dams comprise: these units are flexible and yet very suitable for withstanding wave impacts and floodings, easily placed on subsoils with bad bearing capacities, at more the lay-out can be adapted to alternative circumstances during moment of construction. The costs of tubes are lower than the costs of traditional constructions.

4



7. FURTHER APPROACH

Before going on in a next stage with exact lay-out and start of construction, some preparing examinations have to be performed, concerning tests at tube shaped geotextiles filled with silt (behaviour of the tubes in waves and currents, the optimum filling-degree etc.) but also further studies of sediment concentrations at Nan Hui East and at the Cao Jing district, and transport rates through both estuaries.

7.1 Further examination

This consists of some major research to be done:

1. Testing of a tube in situ

It is necessary to do a pilot test in situ on suggested locations. Preliminary: R.P.W. will perform some small scale tests on a tube filled with silty loam or clay, concerning:

- settlement and dislocation of the tube under various forces;
- behaviour of the tube under wave impacts and currents;
- behaviour of the material inside the tube: the forming of bubbles, the loss of material through the geotextile and the density of the material during its lifetime;
- behaviour of the subsoil: failure by sliding or squeezing erosion and wash-out beneath the tube.

2. Estimation of the rate of sedimentation for various lay-outs of constructions. This has to include following studies:

- determination of the stream pattern in the Qiantang-estuary and the Yangtze estuary, using a model for tidal estuaries;
- determination of the transport rates in the Qiantang-estuary and the Yangtze estuary;
- estimation of expected sedimentation at the Cao Jing district and the Nan Hui East beach.

3. A probabilistic computation of the appearance of extreme conditions, this study has to include following:

- the distribution of waterlevels and the predicted water level at storm or typhoon conditions;
- the distribution of maximum wave heights at both mud flats;
- the distribution of maximum tidal currents, and combinations of aspects mentioned above.

In this way a prediction can be done for the survival of the tube under severe conditions.

4. An optimization of the ratio total length of dams and dikes to the rate of sedimentation.

A more grounded study can be performed as the properties of the tube and the composition and properties of the sediment-water mixture have been investigated.

7.2

Absent data

For further calculations and studies, more vital data are necessary.

Absent data:

1. General data:

- a nautical map of the Hangzhou-Wan including depth-contours at intervals of metres or decimetres.

2. Hydraulic data:

- discharge rates of the Yangtze river and the Qiantang river and a distribution of discharges over the year;
- a distribution of the water level of the Qiantang river at Hangchow or Ganpu; and a distribution of the water level of the Yangtze river at Nan Tong or Wusong (measures of levels during the whole year);
- current velocities at the mud flat of Nan Hui and the mud flat of Cao Jing and through the main channels of the Qiantang estuary and the Yangtze estuary (if possible even a tidal calculation of these areas).

3. Sediment properties:

- concentrations measured at some evident points, at Hangchow and Wusong, in the main channels of both estuaries, and at both mud flats;
- the fall velocity of the particles in salt water;
- the rate of siltation in undisturbed water;
- the rate of consolidation of the settled material.

4. Soil mechanical properties:

- the bearing capacity of the soil, this means in situ measurements; soundings at some evident points on both mud flats, tests on in situ taken samples of shear stresses and normal stresses etc.;
- the composition of the subsoil: an overview of the different downward layers the soil exists of;
- the settlement of the natural groundlevel per year, due to subterranean activity.

Furthermore data about waves, winds and weather (precipitation etc.) are also necessary, and information on the tides in both estuaries and rivers.

8. SUMMARY AND CONCLUSIONS

8.1 In the forlying report a contemplation is given about the methods to accelerate land reclamation at the lowest possible costs, along the coastline at the south and at the south-west of Shanghai (Peoples Republic of China, Nan Hui East Beach and the Cao Jing district, see Fig. 1.1). The area is situated between the Yangtze and the Qiantang estuary. The coastal strip at the south-west of Shanghai has, predominantly under the influence of sediment discharge caused by the Yangtze-river, moved seawards during the last 60 centuries, at the same time the southcoast has moved landward.

8.2 Within this contemplation the local data as described in chapter 2 have been taken into account. Determining for the possible solutions are the following facts:

- an average tidal range of 4 m
MLW: 0.0 m, MHW +4.0 m;
- the occurance of typhoons, in this area 2 à 3 times a year, of which one every 3 to 10 years with extreme high water levels and wave heights (ca. 10 m at deep water);
- large discharges of very fine sand and silt:
Yangtze: annually 470 mln. ton, Qiantang: 5 mln. ton.
The average grainsize of the sedimented material is 45 µm.

8.3 The performance of land reclamation works can be presented according to two systems:

1. a small scale system -----

Here a reclamation construction is extended gradually from the coastline into the sea. All measurements are meant to reduce the currents and if possible wave action by which siltation will accelerate.

Figures "phase one" and "prosposed area" outline proposals in which the coastline has been extended some 2 to 5 km seaward.

2. a large scale system -----

Outlined in Figure "masterplan" is how a number of 5 dams can be built perpendicular to the coast with a length of 6/7 km to 15 km, in a period of ca. 5 years. The length of the dams is chosen in such a way that the currents and the formation of channels are leaded in the right direction nautically and hydraulically.

Inside the area of ca. 1,200 km² created this way a lot of sand and slit is expected to settle. By extending the small scale system from the coastline into the sea as pointed out above, sedimentation is further accelerated and the reclamation is fixed.

8.4

With regard to a large scale plan a further study is necessary, at more it should fit in plans concerning regulation of the lower courses of both rivers. Many years will possibly be involved in this plan so that reclamation works must be started with small scale extension of the coast. In this way the necessary experience can be gained. In paragraph 5.2 a number of methods is described and judged as they have been applied along the coastal shoals in Western Europe but also in China and the Third World.

In paragraph 5.3 alternative possibilities for the proposed areas are described:

- the planting of salt-enduring vegetation (Fig. 5.3.2);
- the placing of rows of piles or geotextile screens to reduce current velocities (Fig. 5.3.3);
- the Schleswig-Holstein method existing of small dams forming fields of 400 * 400 m in which silt is caught (Fig. 5.3.4);
- dams below HW perpendicular to the coastline (Fig. 5.3.5);
- dams parallel to the coastline (Fig. 5.3.6), below MHW-level;
- construction of an embankment along the beach with a height above storm level. The polder inside this dike is pumped dry and drained by pumping or it can be filled with dredged material, also natural sedimentation can occur via openings in the construction (Fig. 5.3.7);
- finally a discription is given of the construction of dams perpendicular to the coast with a height above storm level, protected by strong points at their seaward end (Fig. 5.3.8).

8.5

The intention has been to make a choice for such an approach that land is reclaimed working with and by nature and gradually extending from the coast. Only this way the richness of sediments in the water streaming along the area is transposed into fertile land with an optimal use of the available manpower.

According to this vision following of the forgoing resolutions must be dropped:

- dams with fagots;
- current screens;
- rows of piles.

These will show not to be able to withstand the attack of waves and currents under typhoon conditions.

This leaves the different types of clay dams laid in various patterns. Cheapest of these are stone-faced dams like they have been built in China already, resulting in good experiences. The costs of these dams with a height of 2 m are estimated at 180 yuan per running metre. A promising construction may be the tube-shaped geotextile filled with local soil having a diameter of about 2 m. The price of this construction would be about 90 yuan per running metre. Using these tube-units it is possible to built dams of various heights.

Due to the difference in prices solutions which comprise the use of geotextile "sausages" are worked out more in detail.

8.6 Starting-point is the use of local "dry" soil originating from above the level of 2 m above low water. This soil is very convenient as a fill for geotextile tubes built up out of 325 gr. woven fabrics with an inlay of non-woven filter cloth. Some experiments will be done by RPW on the Dutch beach to get a first impression of the feasibility of a construction like this. Dams are built according to the system designed in Fig. 6.1.1, 6.1.2, 6.1.3 and 6.1.4. Above the level of 2 m plus LW sufficient time is available between the high tides to fill the tubes in situ using manpower.

Below the mentioned level time is too short to work in the dry. Proposed is to fill the tubes in a cylindrical mould attached to a vessel of the catamaran-type. The mould has to be filled on a level above the 2+ line. During high tide the catamaran floats to an indicated location, makes anchorage and dumps the sausage by tumbling the mould.

8.7 It is suggested to start constructing dams perpendicular to the coastline referring to resolution I. (Fig. 6.1.1 and 6.1.2). The choice of the distance between the dams is difficult to compute. At the moment RPW-engineers are starting a calculation scheme. As for now it is suggested to start constructing groins every 500 m in lines of 16 tubes. One "field" of 500 m can be used as a testing field to perform experiments and measurements. This way the development of the siltation process can be studied and the lay-out + heights of the dams can be adapted to the optimal rate of sedimentation. The sequence of further execution of construction is outlined in Fig. 6.5.2.

8.8 It is thought that working and studying in the way mentioned above an optimal and relatively cheap resolution can be obtained. This refers to a way of constructing that is often used in hydraulic and coastal engineering: calculating, experimenting and constructing in a continuous dialogue with waves and currents, finding solutions to force the sea backwards and to reclaim land.

1



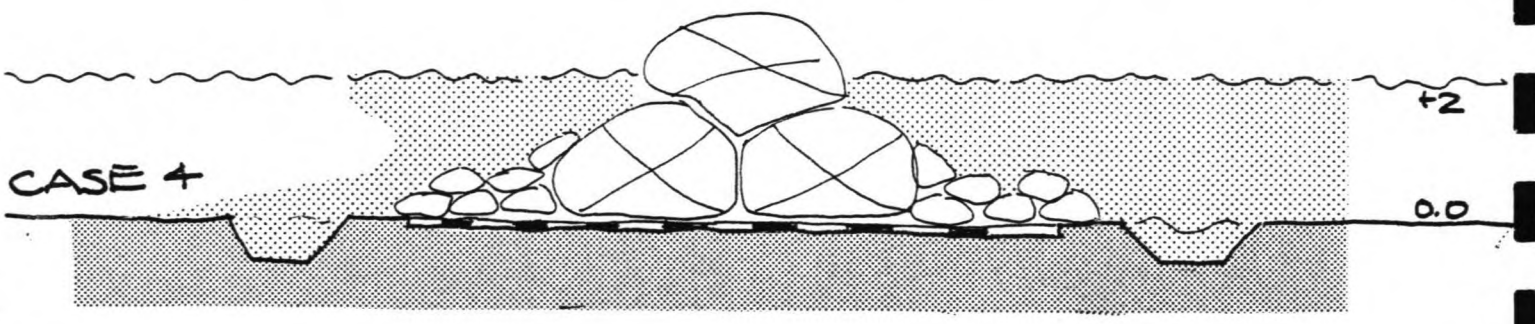
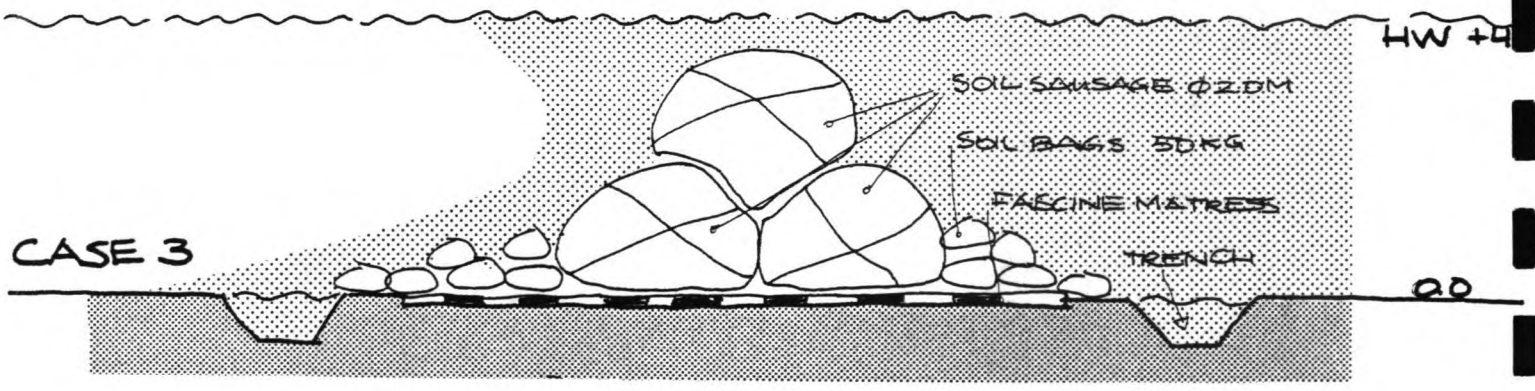
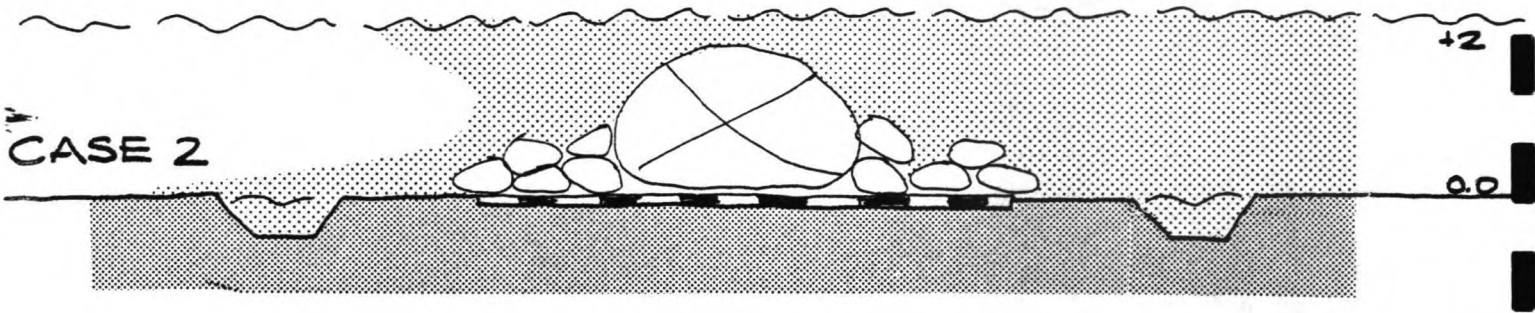
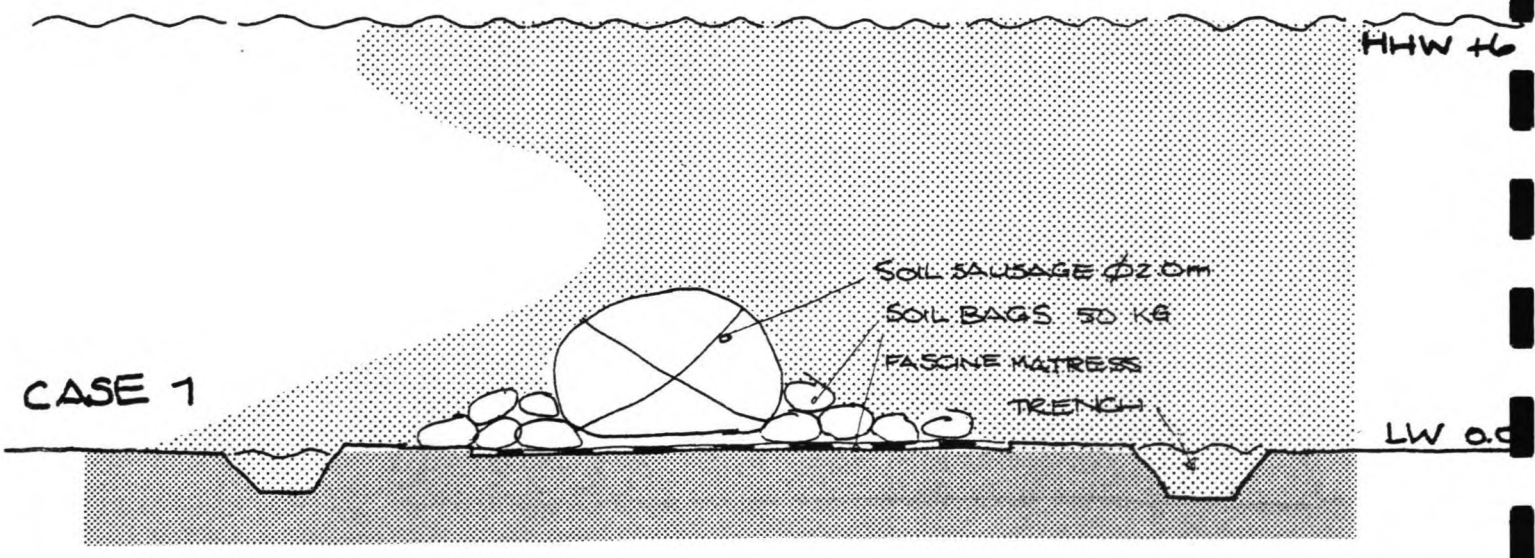

APPENDIX 1

CALCULATIONS

1. STABILITY OF REVETMENTS

General:

given: H_o (wave height deep water)
T (wave period)
d (waterdepth)

$$L = L_o \tanh kh \frac{2\pi d}{L} \quad (\text{wave length, } L_o = \frac{gT^2}{2\pi})$$

$$\xi = \frac{\tan \alpha}{\sqrt{\frac{H_o}{L}}} \quad (\text{breakertype, } \alpha = \text{slope of beach})$$

(if $\xi < 0,4$: spilling breaker)

$$u = \frac{H}{2} \frac{gT}{L} \frac{\cos h \left(\frac{2\pi}{L} \frac{z+d}{L} \right)}{\cos h \left(\frac{2\pi d}{L} \right)} \cos (\omega t - kx)$$

(horizontal orbital velocity)

Hudson:

$$W \geq \frac{\rho_s H^3}{k_\Delta \frac{(\rho_s - 1)^3}{\rho_w} \cot \alpha} \quad (\text{weight of unit in kg})$$

ρ_s = density of stone in kg/m³

ρ_w = density of seawater in kg/m³

α = angle of slope (maximum: $\cot \alpha = 1.5$)

k_Δ = damage coefficient (~ 10 for soilbags and ~ 10 for stones if some displacement can be allowed)

$$\gamma = \frac{H_b}{d} \quad (\text{breaker coefficient, } H_b = \text{breaking wave height})$$

$$W \geq 0,05 V^6 \quad (\text{weight of unit in kg})$$

case 1 (see Fig. I 1.1)

$H_o = 6$ m (maximum)

T = 7 s

d = 6 m (extreme)

then: $L_o = 80$ m
 $L_e = 60$ m
 Cao Jing $\tan \alpha = 1/150$, $\xi = 0.01$
 Nan Hui $\tan \alpha = 1/1,000$, $\xi = 0.002$
 spilling breaker $\rightarrow \gamma = 0.78 (= \frac{H_b}{d})$
 $H_b = 4.7$ m

The wave does not affect tube directly, it will pass over the tube (dynamic pressures are not included in the calculation, this will be done in a later study):

$$W \geq \frac{1,800 \times (4.7)^3}{5 (0.8)^3 \cdot 1.5} = 48,700 \text{ kg (tube, } \rho = 1,800)$$

if tube would not exist:

$$u_z = -4 \text{ (top tube)} \sim 2.8 * \frac{\cos h(2\pi \cdot \frac{2}{1.2})}{1.2} = \frac{2.8 * 1.02}{1.2} = 2.35 \text{ m/s}$$

then $W \geq 0,05 V^6 = 9,6$ kg (maximum)

Conclusion: the tube as a unit will not be moved by this wave (W = 150 ton), a detailed response study must prove which displacements and internal deformations occur under loadings. The soil bags that ballast a possible fascine mattress, will be moved by the waves (some damages).

case 2 (see Fig. I 1.2)

$H_o = 6$ m (extreme)
 $T = 7$ s
 $d = 2$ m
 $\gamma = 0.78$ $H_b = 1.6$ m

now the wave does affect the tube directly

$$W \geq \frac{2,650 * 1.6^3}{10(1.65)^3 \cot 1/2} = 121 \text{ kg (stones, } \rho = 2,650)$$

$$W \geq \frac{1,600 * 1.6^3}{10(0,6)^3 \cot 1/2} = 1,500 \text{ kg (soilbags, } \rho = 1,600)$$

Conclusion: unit of 120 kg must be used to protect a clay dam against waves, or bags of soil, tied together (in units of 30 pieces).
 The tube is not moved by the waves (W = 150 ton).

case 3 (see Fig. I 1.3)

$H_o = 6$ m
 $T = 7$ s
 $d = 4$ m
 $\gamma = 0.78$ $H_b = 3.2$ m

the wave affects the tube:

$$W \geq \frac{1,600 * (3.2)^3}{5 * (0.6)^3 \cot 1} = 25,000 \text{ kg (tube, } \rho = 1,600, W = 150 \text{ ton)}$$

($K_\Delta = 5$ for the tube and slope $\sim 1:1$)

Conclusion: the tube will not be moved by the waves (as long as the geotextile is not damaged).

case 4 (see Fig. I 1.4)

The calculation and resolution are similar to those of case 2.

A more detailed loading response study must be performed in order to determine the exact dimensions of possible tube units. These calculations predict that the proposed tube, having a diameter of 2.0 m, will be sufficient to withstand wave action.

CASE 1

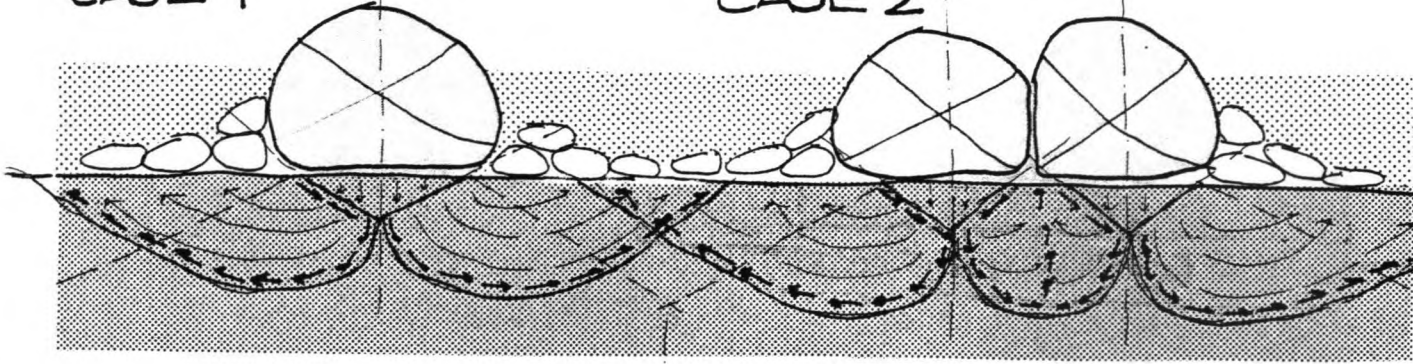

CASE 2

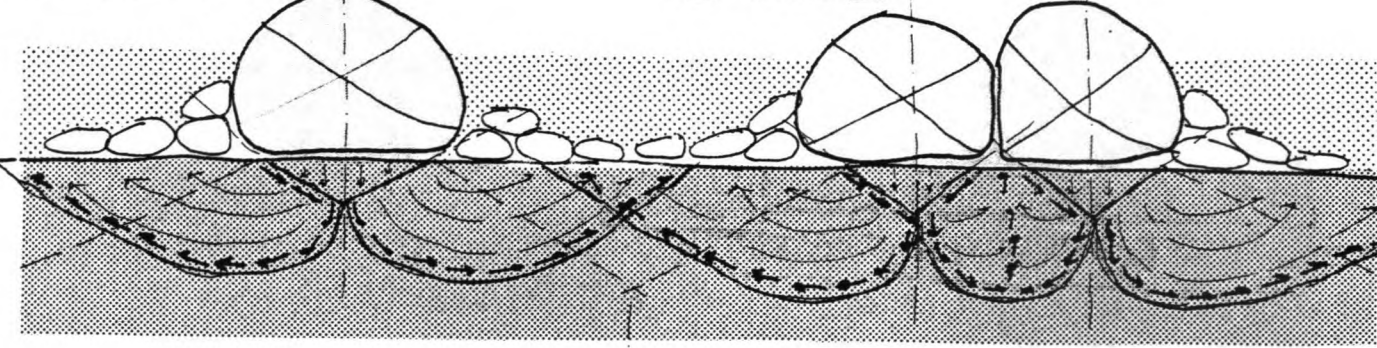

CASE 3

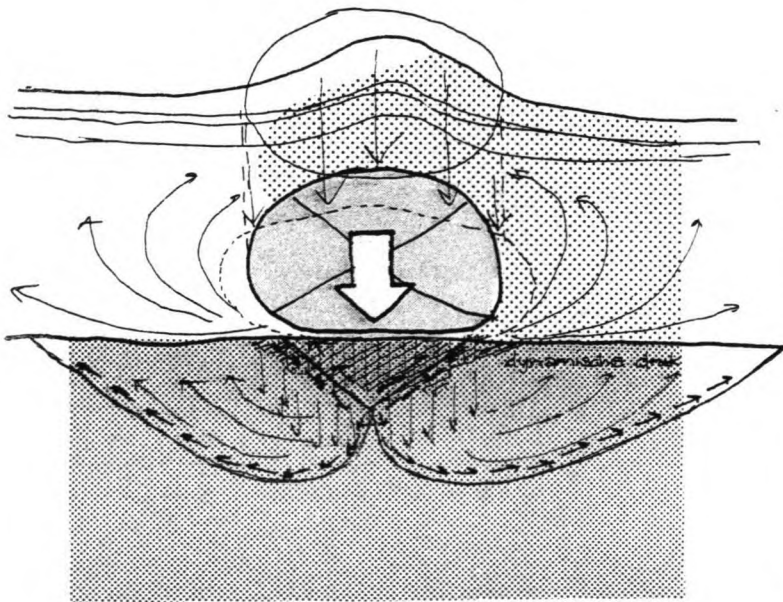
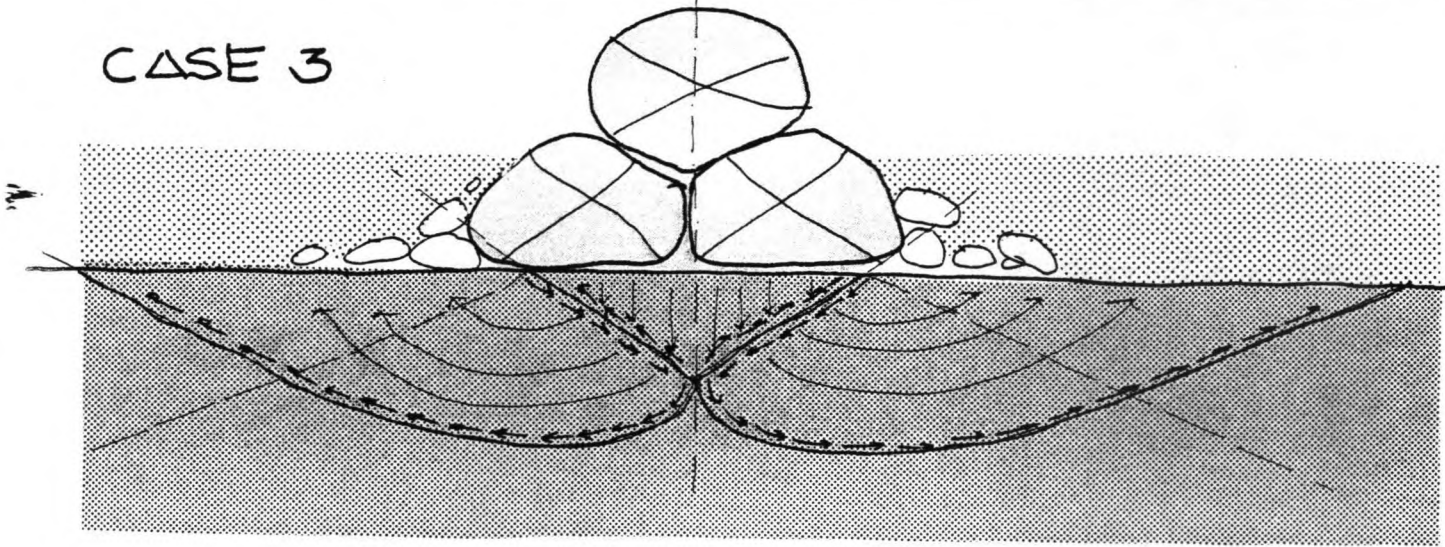

SQUEEZING

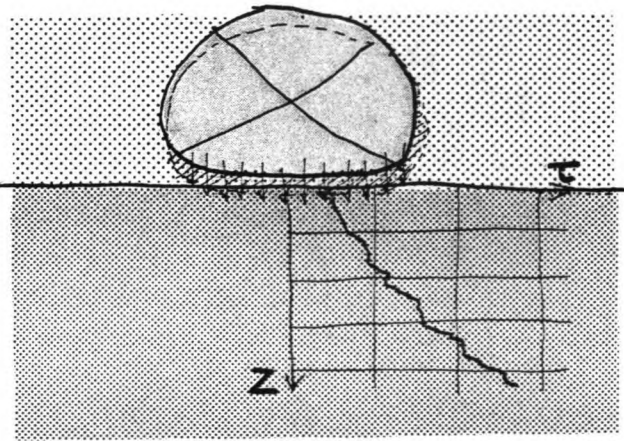

2.

STABILITY OF THE SUBSOIL

<u>case 1</u> (see <u>Fig. I 2.1</u>)	$\tau_{min} = 6.5$ kPa
<u>case 2</u> (see <u>Fig. I 2.2</u>)	$\tau_{min} = 6.5$ kPa
<u>case 3</u> (see <u>Fig. I 2.3</u>)	$\tau_{min} = 9.7$ kPa

The figures given concern the minimum undrained shearstress needed theoretically to bear the tubes.

- N.B.:
- The foundation is flexible through which local collapse at the edges of the base of the tube can occur in the very weak upper layers of the subsoil.
 - In this way "squeezing" can also occur. Some displacements will develop (see Fig. I 2.4).
 - It is very likely that some time-dependant settlement of the tube and the subsoil will occur.
 - The undrained shearstress has no constant value and usually increases from very low values at the top of the subsoil to higher values deep down (see Fig. I 2.5).

Conclusion: the tube will settle for some dm (20-50 cm) into its foundation, the most dangerous moment, referring to stability, is the moment the tubes are "dropped" into the subsoil, after that the stiffness of the subsoil will increase because of the weight of the load from the tubes.

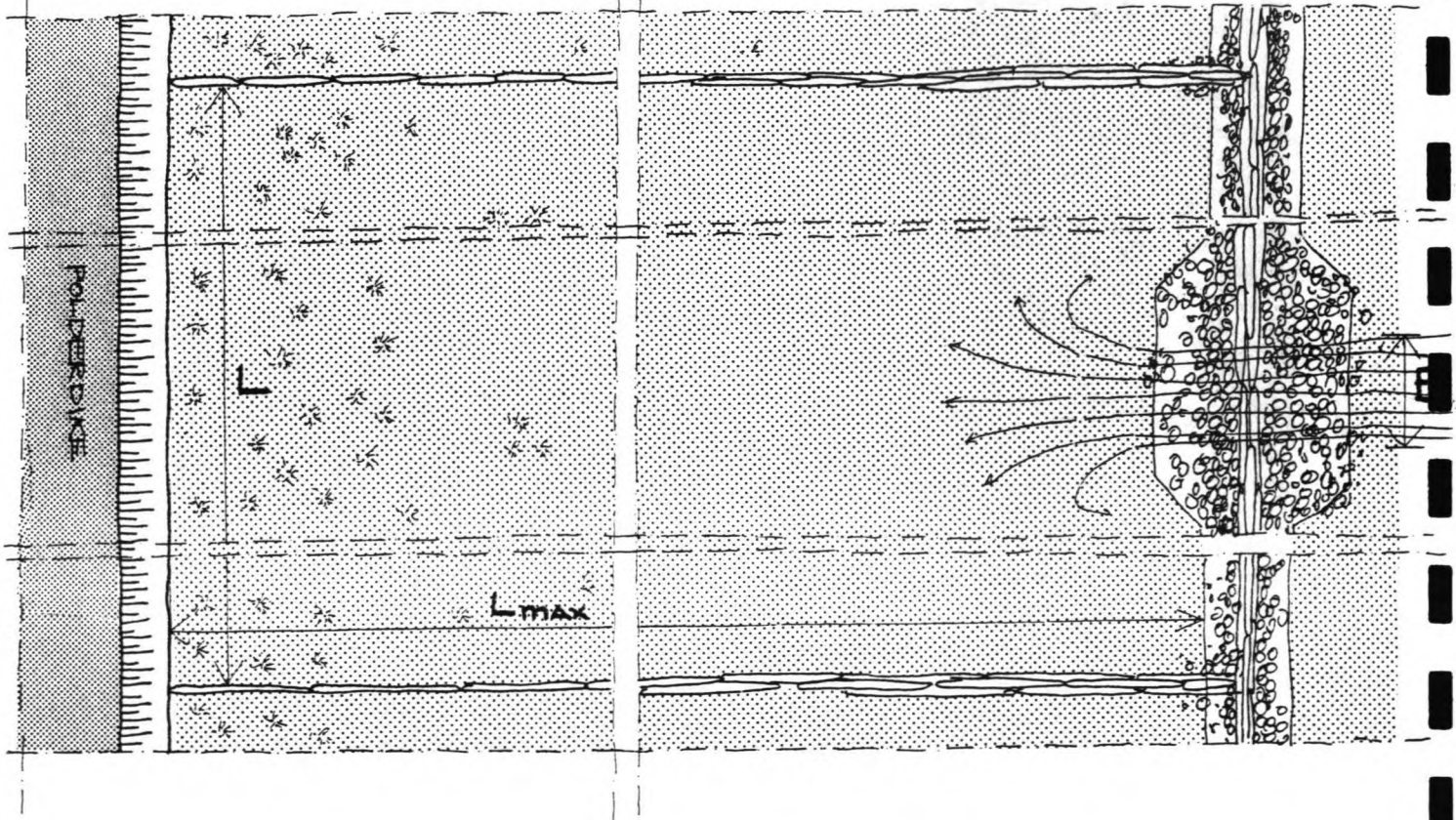
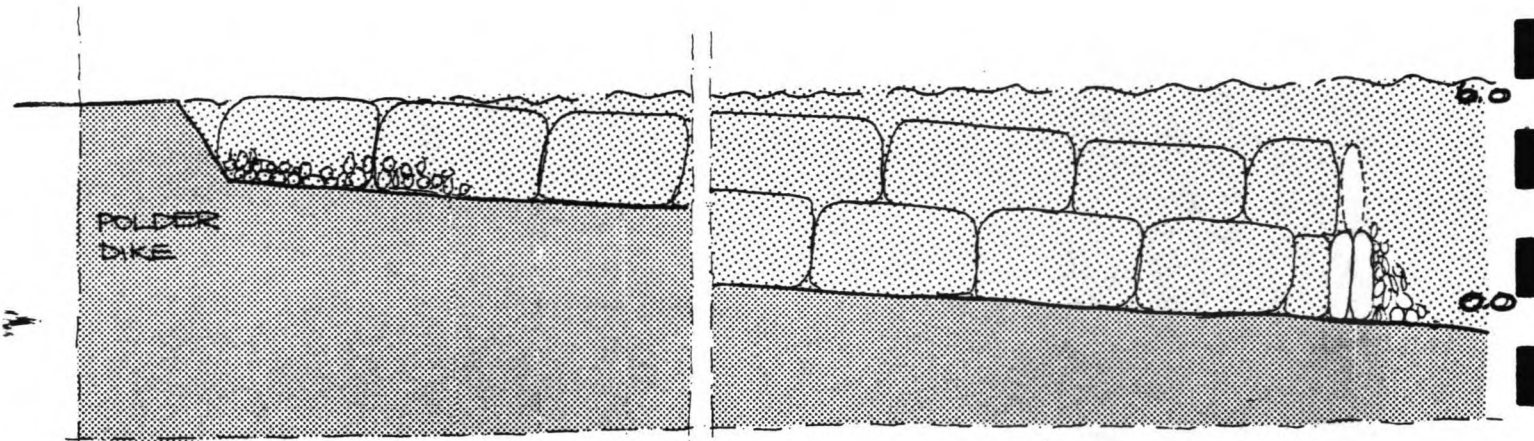
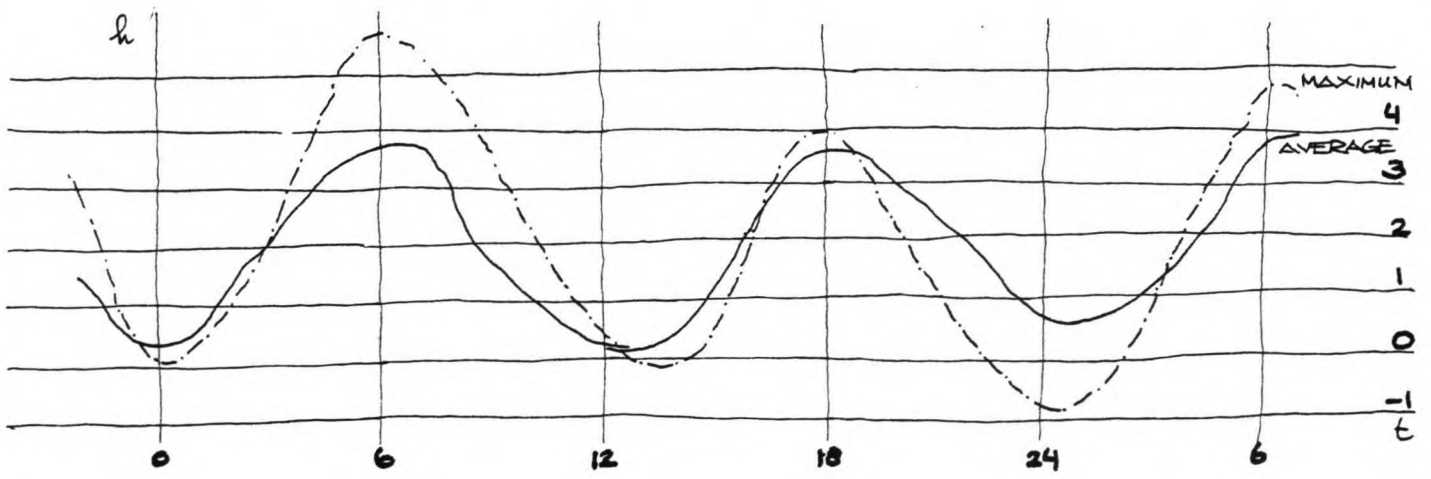

3. WIDTH OF THE STREAM-OPENING

A revetment is formed by soilbags of 50 kg each, this means that $V_{max} = 3$ m/s (max. velocity in the opening).

Maximum fall or rise of the seawater level : 1.2 m/hour
thus $\Delta h_{max} = 0.33 * 10^{-3}$ m/s.

The stream opening starts discharging water into the basin, when the water level has reached + 2 m LW, it keeps on functioning untill the level has risen up to + 4 m LW, after that the water runs over the higher tubes and the stream is no longer entirely concentrating in the opening (see fig. I 3.1). While functioning, the current velocity through the opening must not be allowed to exceed 3 m/s (if not, the bags are moved and the subsoil starts being eroded).

At Cao Jing: $L_{max} = 2,000$ m
openings every 500 m: $\Delta L = 500$ m

$$Q_{in} = L_{max} * \Delta L * \Delta h_{max} = 2,000 * 500 * 0,33 \cdot 10^{-3} \text{ m}^3/\text{s} = 330 \text{ m}^3/\text{s}$$

$$B_{min} = \frac{Q_{in}}{V_{max} * h} = \frac{330}{3 * 2} = 55 \text{ m (per 2,000 m)}$$

an opening of 2 tubes must be created every 500 m.

At Nan Hui East: $L_{max} = 5,000$ m
openings every 500 m: 5 tubes opening
openings every 200 m: 2 tubes opening.

(see Fig. I 3.2)

A.



APPENDIX II

REFERENCES

1. anonymous, Shore Protection Manual, vol. I, II, III, fourth ed. 1984, department of the army corps of engineers
U.S. Army Coastal Research Center
2. anonymous, U.S. Navy Marine climatic atlas of the world, vol. II, revised 1977, Naval Oceanography and Meteorology
3. anonymous, Admiralty Time Tables, vol. 3, 1986
hydrographer of the Navy
4. anonymous, Ch'ang Chiang pilot, third edition 1954
5. anonymous, China Sea pilot, vol. III, fourth edition 1982
6. anonymous, Flexible sandfilled tubes for Coast protection, Longard Corporation, Fredericksbourg Denmark
7. anonymous, papers of Ship Research Institute, March 1970
Ship Research Institute Japan
8. J.M. Armstrong, C.L. Kureth, Observations on the longard tube as a coastal erosion protective structure
Coastal Zone Laboratory, University of Michigan
9. E.W. Bijker, W.W. Massie e.o., Coastal Engineering, vol. II, Harbour and Beach Problems, revised fall 1980,
Coastal Engineering group, Delft University of Technology
10. ir. G.P. Bourignon, Civil Engineering in development countries, masonry works and slope protection, 1978
department of Civil Engineering, Delft University of Technology (in Dutch)
11. ir. G.P. Bourignon, Civil Engineering in development countries, embankments in Deltas, 1982
department of Civil Engineering, Delft University of Technology (in Dutch)
12. R.E. Flick, B.W. Waldorf, performance documentation of the longard tube at Del Mar, California 1980-1983, 1983
Center for Coastal Studies, Scripps Institution of Oceanography, La Jolla
13. Al Gutman, Low-cost protection in Massachusetts, 1979
Coastal Structures 1979, Shoreline protection
M.I.T. Sea Grant Programm, Office for Sea Grant, U.S. department of Commerce

14. Chen Jiyu e.a., Development of the Chanjiang Estuary and its subaqueous Delta
Institute of Estuarine and Coastal Research, East Normal University, Shanghai China
15. Chen Jiyu, Yun Caixing, Xu Haigen, Model of development of the Chang Jiang estuary during the last 2,000 years
Institute of Estuarine and Coastal Research, East Normal University, Shanghai, China
16. ir. J. v.d. Kley, H.J. Zuidweg, Polders and Dikes, 1969
Delft University of Technology (in Dutch)
17. Shen Huan Ting, Zhu Huifang, Mao Zhi-Chang, Circulation of the Chang Jiang estuary and its effect on the transport of suspended sediment. Institute of Estuarine and Coastal Research, East Normal University, Shanghai, China
18. dr. ir. P.A. Vermeer, ing. R.J. Termaat, the stability of dikes and fillings on weak subsoils, 1986
"Land en Water Nu", nr. 26, 1986
19. J.P. Welsh, R.M. Koener, Innovative uses of synthetic fabrics in coastal constructions, 1979
Coastal Structures 1979, coastal construction
20. Dai Zeheng, Reclaiming against Qiantang Bore, 1982,
Hangzhou

