

Data requirements for Traffic Control on a Macroscopic Level

Victor L. Knoop, Delft University of Technology, v.l.knoop@tudelft.nl

Hans van Lint, Delft University of Technology, j.w.c.vanlint@tudelft.nl

Serge P. Hoogendoorn, Delft University of Technology, s.p.hoogendoorn@tudelft.nl

Abstract:

With current techniques, traffic monitoring and control is a data intensive process. Network control on a higher level, using high level variables, can make this process less data demanding. The macroscopic fundamental diagram relates accumulation, i.e. the number of vehicles in an area, to the network performance, but only holds for situations with homogeneous congestion. This paper shows that subnetwork accumulation and the variation thereof are also good precursors of the network performance. With this result, traffic control can be performed with less data, namely only the accumulation of the subnetworks rather than all speeds and densities for the whole network.

Keywords: Macroscopic Fundamental Diagram, Subnetworks, Inhomogeneous congestion

1 Introduction

Whereas research into (and application of) freeway traffic control in the previous century predominantly focussed on local applications (e.g. ramp metering), in the 21st century the focus of both researchers and practitioners is firmly on the coordination of traffic control over corridors (see e.g. Kotsialos et al. (1997); Papamichail et al. (2010)) or even larger mixed motorway-urban networks, as for instance presented by Van den Berg et al. (2004). Network control in urban networks have been around already somewhat longer, e.g. (Lowrie, 1982; Robertson and Bretherton, 1991; Dinopoulou et al., 2006), but hybrid and hierarchical control of mixed networks is one of the biggest challenges in the coming years.

As alternative approach to centralised or fully communicating traffic control systems, one can introduce multi-level control. This limits the amount of information needed. The control on the lower level can be detailed with detailed information. However, the control the higher level, only aggregate information of the lower level is used and decentralized control architectures on the basis of escalation and coordination are used. As long as traffic conditions are mild and local controllers do their work sufficiently, no coordination is required. As soon as this is the case, local controllers escalate “control” to a control agent on a higher level (e.g. a corridor or subnetwork), which in turn answers with instructions based on the traffic conditions on that level.

The information needs in this case may be much lighter than in a centralized model. Theoretically, the information needs may be even very light. The macroscopic fundamental diagram (MFD) or network fundamental diagram as purported by Daganzo (2007) and Geroliminis and Daganzo (2008) summarizes the state of an entire traffic network into just two (in principle measurable) quantities: the accumulation and production of a traffic network. In case a area –

which might be a network under control or a subnetwork thereof – reaches a critical accumulation, a (sub)network level control agent may communicate this to its neighboring agents, which in that case could instruct their lower level agents to adapt their controllers such as to minimise the inflow into this (sub)network which operates at its limits. Unfortunately, the quantities in the macroscopic fundamental diagram are not easily acquired, since these would necessitate a dense network of sensors on all links in a network. Moreover, the two-state representation may not tell the entire story. Recent work by Cassidy et al. (2011) suggests that only in case networks are evenly loaded, the macroscopic fundamental diagram provides an informative measure for the state in such a network.

In this paper we explore how alternative but still “light” information may be utilised to estimate the state in an entire traffic network. This information includes the standard deviation of vehicle accumulation and incorporates intrinsically the spatial distribution of congestion in a (sub) network. We do so by simulating a network and analysing whether the accumulation of subnetworks is an explanatory variable for the network performance.

The next section gives an overview of the recent developments in the macroscopic fundamental diagram. Then, section 3 gives the details of the experiment setup. Section 4 discusses the traffic situation for the considered situation. In section 5 it is analysed what can be derived from aggregated subnetwork information. Section 6 concludes the question on the information needs, and also gives an outlook on the further work on this topic.

2 Literature overview of Macroscopic Fundamental Diagrams

In the past five years the concept of a macroscopic fundamental diagram (MFD) has been developed. Concepts were already proposed by Godfrey (1969), but only when Daganzo (2007) reintroduced the concept, more studies started. An overview of the most important ones are given in 1.

The best-known studies are the ones by Geroliminis and Daganzo (2008) and Daganzo (2007). Geroliminis and Daganzo (2008) show the relationship between the number of completed trips and the performance function which is defined as a weighted average of the flow on all links. This means that the network performance can be used as a good approximation of the utility of the users for the network, i.e., it is related to their estimated travel time. Furthermore, after some theoretical work, Geroliminis and Daganzo (2008) were the first to show that MFDs work in practice. With pioneering work using data from the Yokohama metropolitan area, an MFD was constructed with showed a crisp relationship between the network performance and the accumulation.

Also, theoretical insights have been gained over the past years. Daganzo and Geroliminis (2008) have shown that rather than to find the shape of the MFD in practice or by simulation, one can theoretically predict its shape. This gives a tool to calculate the best performance of the network, which then can be compared with the actual network performance.

One of the requirements for the crisp relationship is that the congestion should be homogeneous over the network. Buisson and Lavier (2009) were the first to test how the MFDs would change if the congestion is not homogeneously distributed over the network. They showed a reasonably good MFD for the French town Toulouse in normal conditions. However, one day there were strikes of truck drivers, driving slowly on the motorways, leading to traffic jams. The researchers concluded that that leads to a serious deviation from the MFD for normal conditions. The inhomogeneous conditions were recreated by Ji et al. (2010) in a

Table 1: Overview of the papers discussing the macroscopic fundamental diagram

Paper	data	network	insight
Daganzo (2007)	theory	none	Overcrowded networks lead to a performance degradation – the start of the MFD
Geroliminis and Daganzo (2008)	real	Yokohama	MFDs work in practices, and there is a relation between the completed trips and the performance
Daganzo and Geroliminis (2008)	data & simulation	Yokohama & San Francisco	The shape of MFDs can be theoretically explained
Buisson and Lavier (2009)	real	urban + urban motorway	There is scatter on the FD if the detectors are not ideally located or if there is inhomogeneous congestion
Ji et al. (2010)	simulation	urban + motorway	Hybrid networks give a scattered MFD; inhomogeneous congestion reduces flow, and should therefore be considered in network control
Cassidy et al. (2011)	real	3 km motorway	MFDs on motorways only hold if stretch is completely congested or not; otherwise, there are points within the diagram
Mazloumian et al. (2010)	simulation	urban grid – periodic boundary	spatial variability of density is important in deriving the performance
Geroliminis and Ji (2011)	real	Yokohama	Spatial variability of density is important in deriving the performance
Wu et al. (2011)	real	900m arterial	There is an arterial fundamental diagram, influenced by traffic light settings
Daganzo et al. (2011)	simulated	grid	Equilibrium states in a network are either free flow, or heavily congested. Rerouting increases the critical density for the congested states considerably.
Gayah and Daganzo (2011)	simulated	grid/bin	Hysteresis loops exist in MFDs due to a quicker recovery of the uncongested parts; this is reduced with rerouting.

traffic simulation of a urban motorway with several on-ramps (several kilometers). They found that inhomogeneous congestion leads to a reduction of flow. Moreover, they advised on the control strategy to be followed, using ramp metering to create homogeneous traffic states. Cassidy et al. (2011) studied the MFD for a motorway road stretch. They conclude, based on real data, that the MFD only holds in case the whole stretch is either congested or in free flow. In case there is a mix of these conditions on the studied stretch the performance is lower than the performance which would be predicted by the MFD.

The effect of variability is further discussed by Mazloumian et al. (2010) and Geroliminis and Ji (2011). Contrary to Ji et al. (2010), both papers focus on urban networks. First, Mazloumian et al. (2010) show with simulation that the variance of density over different locations (spatial variance) of density (or accumulation) is an important aspect to determine the total network performance. So not only too many vehicles in the network in total, but also if they are located at some shorter jams at parts of the networks. The reasoning they provide is that “an inhomogeneity in the spatial distribution of car density increases the probability of spillover, which substantially decreases the network flow.” This finding from simulation and reasoning is confirmed by an empirical analysis by Geroliminis and Ji (2011), using the data from the Yokohama metropolitan area.

A final theoretical explanation for the phenomenon of the influence of the spatial variance of

the accumulation is given by Daganzo et al. (2011). He shows that turning at intersections is the key reason for the drop in performance with unevenly spread congestion. Gayah and Daganzo (2011) then use this information by adding dynamics to the MFD. If congestion solves, it will not solve instantaneous over all locations. Rather, it will solve completely from one side of the queue. Therefore, reducing congestion will increase the spatial variance of the accumulation and thus (relatively) decrease the performance. This means that the performance for a system of dissolving traffic jams is under the equilibrium state, thus under the MFD. This way, there are hysteresis loops in the MFD, as also noted by Ji et al. (2010). Note that these loops are an effect by themselves and are different from for instance the capacity drop (Hall and Agyemang-Duah, 1991; Cassidy and Bertini, 1999).

3 Experiment setup

This section describes the traffic simulation used for this research. The section first describes what will be simulated in terms of network and demands. Then, section 3.2 describes the model used for this simulation. Section 3.3 describes the output of the simulator that is used later in the paper.

3.1 Experimental settings

In the paper an urban network is simulated, since this is the main area where MFDs have been tested. We follow Geroliminis and Ji (2011) and choose a Manhattan network with periodic boundary conditions. This means that the nodes are located at a regular grid, for which we choose a 20x20 size. Then, one-way links connect these nodes. The direction of the links changes from block to block, i.e. if at $x = 2$ the traffic is allowed to drive in the positive y direction, at $x = 1$ and at $x = 3$ there are one-way roads for traffic to drive in the negative y direction. We assume 2 lanes per link, a 1 km block length, a triangular fundamental diagram with a free speed of 60 km/h, a capacity of 1500 veh/h/lane and a jam density of 150 veh/km/lane.

Furthermore, periodic boundary conditions are used, meaning that a link will not end at the edge of the network. Instead, it will continue over the edge at the other side of the network. An example of such a network is given in figure 1. Traffic can continue in a direct link from node 13 to node 1 or from node 5 to node 8. This way, all nodes have two incoming and two outgoing links and network boundaries have no effect

The destinations are randomly chosen from all points in the network. In the network, there are 19 nodes chosen as destination nodes. There are no origin nodes. Instead, at the beginning of the simulation, traffic is put on the links. Vehicles are assigned to a destination, and for this distribution is equal over all destinations.

When the cars have reached their destination, they will not leave the network, but instead they are assigned a new destination. We use a macroscopic model (see section 3.2), hence we can split the flow of arriving traffic equally over the 18 other destinations. The number of cars in the network is hence constant. This number will be a parameter setting for the simulations, but throughout one simulation, it is constant. The demand level is expressed as the density on all links at the start of the simulation, as fraction of the critical density. Figure 2a shows the network used under initial conditions.

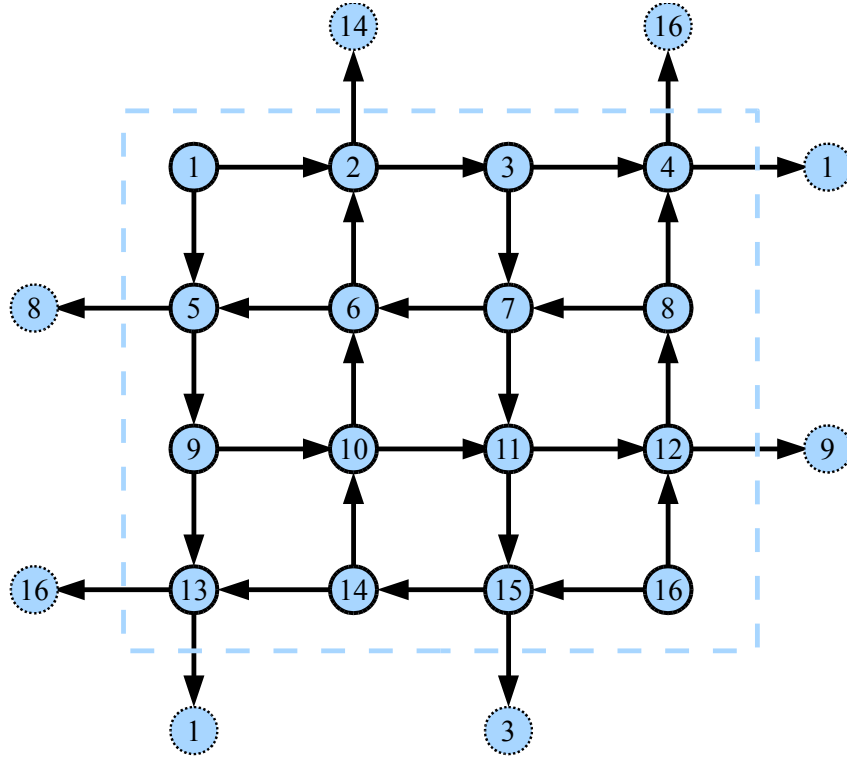

Figure 1: Illustration of a 4x4 grid network with periodic boundary conditions

3.2 Traffic flow simulation

This section describes the traffic flow model. The variables used in this section and further in the paper are listed in table 2. For the traffic flow modelling we use a first order traffic model. Links are split into cells with a length of 250 meters (i.e., 4 cells per link). We use the continuum LWR-model proposed by Lighthill and Whitham (1955) and Richards (1956) that we solve with a Godunov scheme (Godunov, 1959). Lebacque (1996) showed how this is used for traffic flows, yielding a deterministic continuum traffic flow simulation model. The flux from one node to the next is basically restricted by either the demand from the upstream node (free flow) or by the supply from the downstream node (congestion):

$$\phi_{c,c+1} = \min \{D_c, S_{c+1}\}; \quad (1)$$

At a node r we have inlinks, denoted by i which lead the traffic towards node r and outlinks, denoted by j which lead the traffic away from r . At each node r , the demand D to each of the outlinks of the nodes is calculated, and all demand to one link from all inlinks is added. This is compared with the supply S of the cell in the outlink. In case this is insufficient, a factor, α , is calculated which show which part of the demand can continue.

$$\alpha_r = \underset{[j \text{ leading away from } r]}{\operatorname{argmin}} \left\{ \frac{S_j}{D_j} \right\} \quad (2)$$

This is the model developed by Jin and Zhang (2003). They propose that all demands towards the node are multiplied with the factor α , which gives the flow over the node.

This node model is slightly adapted for the case at hand here. Also the node itself can restrict the capacity. In our case, there are two links with a capacity of 3000 veh/h as inlinks

Table 2: The variables used

Symbol	meaning
r	Node
c	Cell in the discretised traffic flow simulation
L_c	Length of the road in cell c
q_c	Flow in cell c
k_c	Density in cell c
ϕ_{ij}	Flux from link i to link <i>outlink</i>
S	The supply of cell c
D	The demand from cell c
i	The links towards node r
j	The links from node r
C	The capacity of node r in veh/unit time
α	The fraction of traffic that can flow according to the supply and demand
β	The fraction of traffic that can flow according to the demand and the node capacity
γ	The fraction of the demand that can flow over node r
X	An area
N_X	Accumulation of vehicles in area X
P_X	Production in area X
σ	Standard deviation

and two links with a capacity of 3000 veh/h as outlinks. Since there are crossing flows, it is not possible to have a flow of 3000 veh/h in one direction *and* a flow of 3000 veh/h in the other direction. To overcome this problem, we introduce a node capacity (see also for instance Tampre et al. (2011)). The node capacity is the maximum of the capacities of the outgoing links. This means that in our network, at maximum 3000 veh/h can travel over a node. Again, the fraction of the traffic which can continue over node r is calculated, indicated by β :

$$\beta_r = \frac{C_r}{\sum_{\forall i \text{ to } r} D_i} \quad (3)$$

The demand factor γ is now the minimum of the demand factor calculated by the nodes and the demand factor due to the supply:

$$\gamma = \min \{ \alpha_r, \beta_r, 1 \} \quad (4)$$

Similar to Jin and Zhang (2003), we take this as multiplicative factor for all demands to get to the flux ϕ_{ij} , i.e. the number of cars from one cell to the next over the node:

$$\phi_{ij} = \gamma D_{ij} \quad (5)$$

The route choice is static, and determined based on distance to the destination. Traffic will take the shortest route towards the destination. For intersections where both directions will give the same path length towards a destination, the split of traffic to that direction is 50-50.

3.3 Variables

In this paper, several traffic flow variables will be used. In this section we will explain them and show the way to calculate them

Standard traffic flow variables are flow, q , being the vehicle distance covered in a unit of time, and density, k , the number of vehicles per unit road length. The network is divided into

cells, which we denote by c , which have a length L_c . Flow and density in cells are denoted by q_c and k_c .

Furthermore, the accumulation N in an area X is the weighted average density:

$$N_X = \sum_{c \in X} \frac{k_c * L_c}{L_c} \quad (6)$$

Similarly, the production P in an area X is the weighted average flow:

$$P_X = \sum_{c \in X} \frac{q_c * L_c}{L_c} \quad (7)$$

Since the cell length are the same for all links in the network, the accumulation and production are average densities and flows. Recall that there is a strong relationship between the production and the number of completed trips, as shown by Geroliminis and Daganzo (2008).

The 20x20 (street) block network is split up into subnetworks. If the paper mentions a n -block network, this means that there are subnetworks which all consist of $n \times n$ nodes. For instance, the network can be split up into $10 \times 10 = 100$ subnetworks of 2×2 nodes. Each of these subnetworks is referred to as a 2-block network, meaning the subnetwork has 2 street blocks in each dimension.

This paper also studies the variations in densities and accumulations. The standard deviation of the cell density is found by considering all cell densities for one moment in time, and calculate the standard deviation of these numbers. Similarly, the standard deviation of the subnetwork accumulation can be calculated. To this end, the accumulation in all subnetworks is calculated for one moment in time. The standard deviation of this list of numbers is the standard deviation of subnetwork accumulation. Note that this does *not* involve the internal distribution of the densities within one subnetwork and only the subnetwork accumulations are required. Therefore, the calculation of the standard deviation of the subnetwork accumulation requires much less data than the calculation of the standard deviation of the densities, which requires all cell densities.

4 Simulation outcomes

This section describes the evolution of traffic over the time. First, the traffic flow phenomena are qualitatively described, then in section 4.2 the performance and variation are quantified.

4.1 Traffic flow phenomena

This section first describes the traffic flow over time. Figure 2 shows the outcomes of the simulation, in snapshots of the density and speed over time. At the start of the simulation (see figure 2a), traffic is evenly distributed over all links, since this was the initial situation as it was regulated externally. The destinations of the network are indicated by the vertical lines.

When the traffic starts to run, various distributed bottlenecks become active. This is shown in figure 2b. After some time (figure 2d-f), traffic problems concentrate more and more around one location. The number of vehicles in the rest of the network reduces, ensuring free flow conditions there. This complete evolution can be found in figure 2a-f. The network has periodic

2nd International Workshop on Traffic Data Collection & its Standardisation

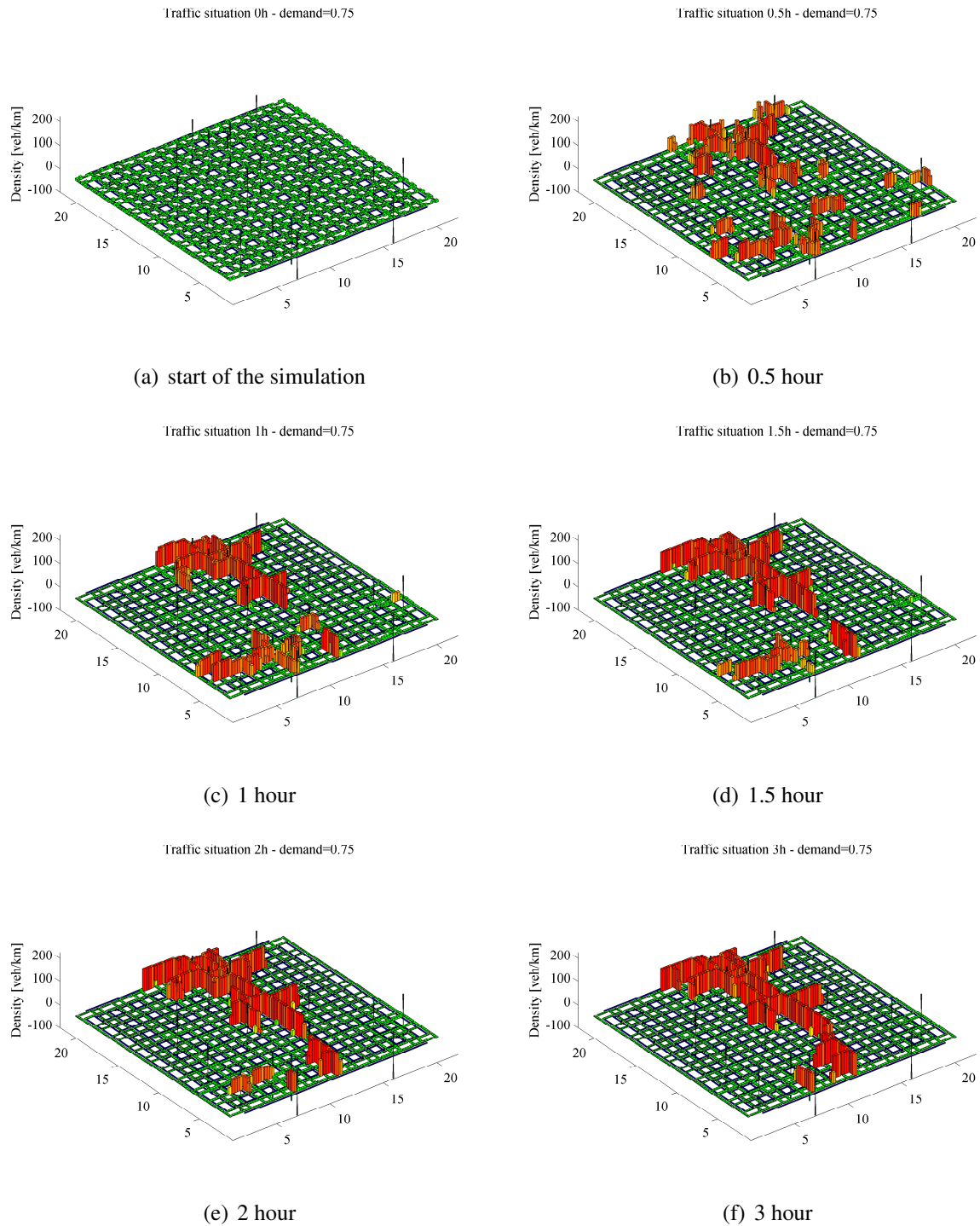

Figure 2: Evolution of the densities (bar heights) and speeds (colours) in the network

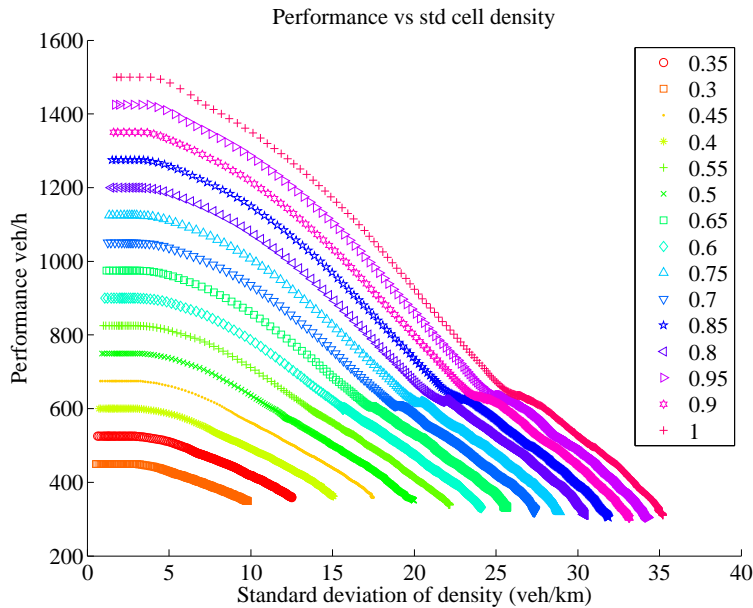

Figure 3: The network performance as function of the variation in density for different network loads

boundary conditions, which means that the network edges do not have any effect. Any deviations from a symmetry are due to random effects and thus to the location of the destinations, since the traffic simulation is deterministic.

At the end, the situation seems to have stabilised. From 2.5 to 3 hours (figure 2e-f) there have been little change, and the changes in the traffic state get smaller and smaller: an equilibrium has formed. Now, the number of vehicles passing the most restricting bottleneck equals the number of vehicles arriving at the end of the queue.

4.2 Influence of variation in density

Most articles describing macroscopic fundamental diagrams emphasize that the relationship is only valid as long as traffic states are similar for all links in the network (e.g. Geroliminis and Daganzo (2008)). This requirement of homogeneous distributed congestion clearly does not hold for our situation (see figure 2f). Furthermore, a standard macroscopic fundamental diagram would relate the network performance to the network accumulation, being the number of vehicles in the network. In this case, however, the number of vehicles in the network is constant: vehicles cannot drive out of the network and at the destination they are simply given another destination. The accumulation is thus fixed, but there are various values for the performance, depending on the congestion, hence the macroscopic fundamental diagram would result in a vertical line.

Instead of linking the performance to the accumulation, we link it to the variation of the densities in the network. This relation is shown graphically in figure 3. The figure shows the network performance versus the standard deviation of density (over cells, see section 3.3). Different lines relate to different network demands. Within one demand line, there is an evolution of the traffic state. Initially, the traffic is equally distributed over all links, and the standard deviation of the density is zero. Gradually, the system moves towards an equilibrium state with

more variation and a lower network performance. This change is expressed by each of the decreasing lines in figure 3.

It is a natural phenomenon of traffic that once traffic gets denser, it gets congested and the performance reduces. In this case, congestion started at several locations. Thereby, the number of congested cells increases, and the density in the other cells decreases, which means that there is less traffic in the other cells, and the performance reduces. Also, the cell densities differ more and the standard deviation of the cell densities increases. This explains the decreasing lines in figure 3.

As long as there is no congestion, the more cars are in the network, the higher the performance. Therefore, the higher the demand level – with no variation, at the initial traffic state – the higher the traffic performance. Let us consider the traffic situation for demand level 1, i.e., the initial state where all links have a critical density as initial density. Whenever there is the slightest variation of density, there must be congestion, since no cell has reserve space without moving to a congested state. That means that for the slightest increase of density variation, there will be directly a performance reduction.

5 Estimation variation in density by variation in accumulation

As section 4 suggests, the network performance can be expressed as a function of the variation of density over the cells. Although this theoretically an interesting insight, it will not relax the requirements for the amount of data. On the contrary: to get the spatial variation of the densities, a large amount of data is required. To overcome this problem, we analyse in this paper the possibilities to come to the same results with less data. In particular, we continue the line of the macroscopic fundamental diagrams, and analyse whether a variation of accumulation in a subnetwork can be used as explanatory variable for the network performance. This is described in section 5.1. Section 5.2 describes the influence of the size of the subnetworks.

5.1 Influence of variation in accumulation

We divide the network into subnetworks with each 4 street blocks. This means we split the network into 5x5 subnetworks. For all of these subnetworks we determine the accumulation. These 25 numbers have a standard deviation, which we relate to the network performance. This is shown in figure 4, which has more or less the same shape as figure 3. A higher load leads to a higher performance, and a higher spatial distribution of traffic leads to a lower performance. This means that also the variation in subnetwork accumulation can be used to predict the network performance.

Two elements are noteworthy. First, there is a part where the network performance is constant, whereas the variation is increasing. This is related to the network dynamics and will be discussed in section 5.3.

Secondly, the final output is at more or less the same level, irrespective of the demand. This could imply that the network performance in the end, when equilibrium is reached, is mainly determined by the bottlenecks in the network and is insensitive to the accumulation. The distribution of the traffic itself over the network is an endogenous process and is not determined by the demand levels. This is subject for further research.

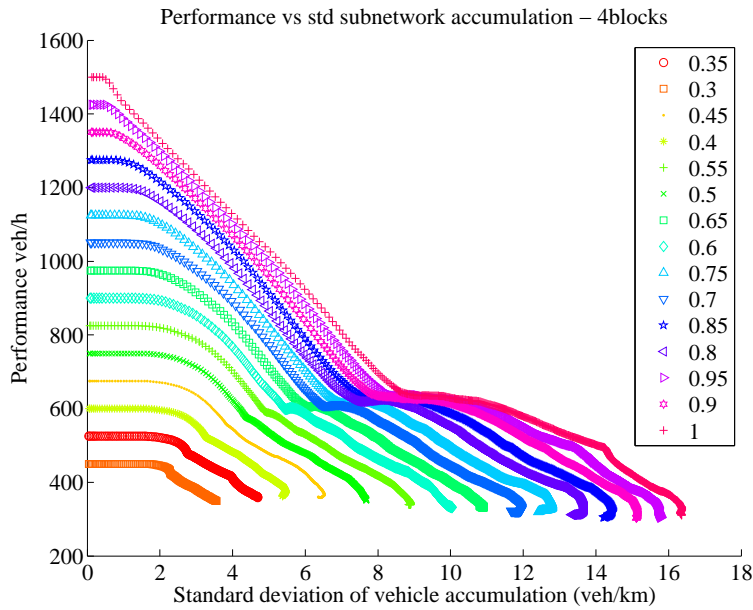

Figure 4: The network performance as function of the variation in density for different network loads

5.2 Sensitivity analysis of the block size

This section describes what the effect is of the block sizes. First of all, figure 5 shows the relationship between the variation in accumulation and performance for other subnetwork sizes, being 2 or 10 street blocks per subnetwork. Figure 5 shows the influence of the block size. Note that the horizontal axes are not the same, but the vertical axes are. These vertical axes show the network performance and that is the same irrespective of the subnetwork size, because it is a network result.

It can be estimated how the variation in accumulation depends on the subnetwork size. Statistics tells that the standard deviation of a mean of independent samples is the standard deviation of the samples divided by the square root of the number of samples in the mean. In each block, there are 2 links, and in each link, there are 4 cells. If we have an n -block subnetwork, there are $n \times n$ blocks in this this subnetwork. Hence we expect for the standard deviation (σ) of the accumulation in this $n \times n$ blocks in case of independent drawings:

$$\sigma_N (n\text{-block network}) = \frac{\sigma_c}{\sqrt{N \text{r of cells in } n \times n \text{ blocks}}} = \frac{\sigma_c}{\sqrt{2 * 4 * n * n}} = \sqrt{2}/4 \frac{\sigma_c}{n} \quad (8)$$

Figure 6 shows the relation between the variation in cell density and the variation in subnetwork accumulation for subnetworks of 2 and 10 blocks. These relationships are mainly linear. However, the ratio between variation in density and variation in accumulation is not well described by equation 8. In fact, the standard deviation in the accumulation is higher than predicted by the equation, meaning that the cell densities are not independent. This can be explained by the fact that the cells are aligned in links, and congestion is building up along these links.

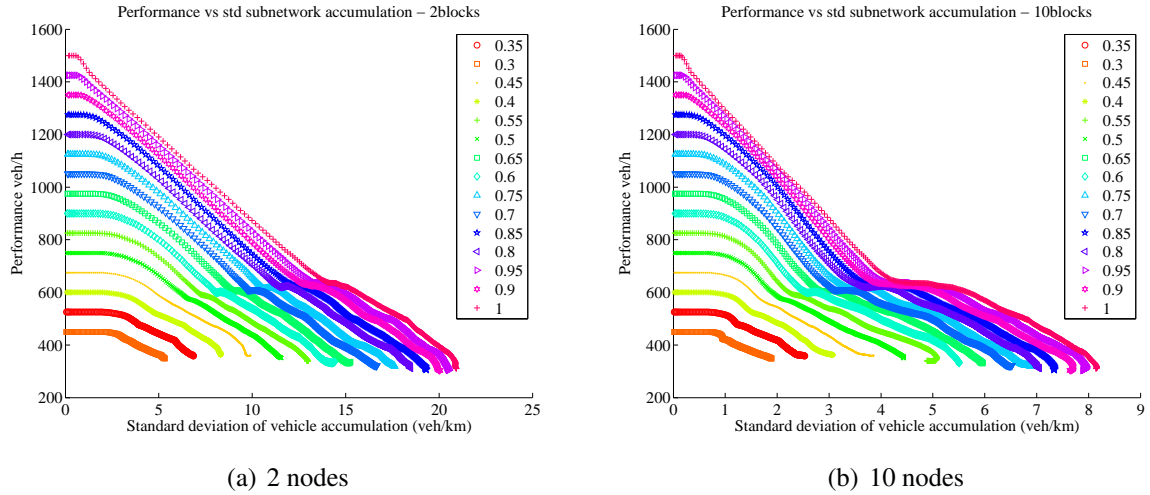

Figure 5: The network performance as function of the variation in density for different network loads for different subnetwork sizes

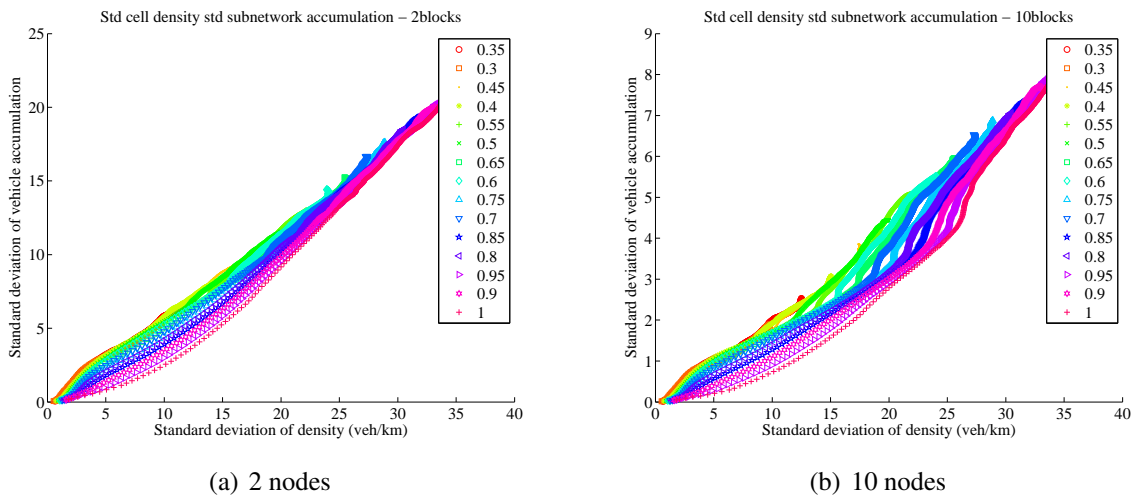

Figure 6: The relationship between the full spatial density variation and the variation in accumulation in the subnetworks

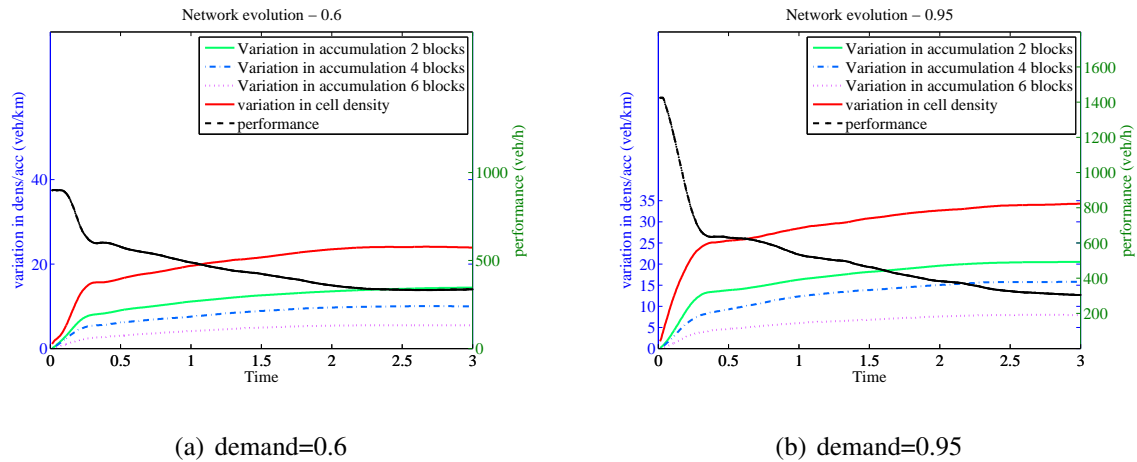

Figure 7: The evolution of the network performance as well as the variation of the densities and the accumulation in the subnetworks over time

5.3 Distribution of traffic over the subnetworks

This section analyses the dynamics of the network. What became apparent from figure 2 is that congestion concentrates around nuclei. We now analyse the time component of the network loading. Let us therefore consider figure 7. It shows that the network performance reduces when the the variation in cell density increases. It also shows a sharp decrease during the first 20-30 minutes of the simulation, a warm-up period, and then the traffic state evolves less quickly. Figure 4 shows that the performance could stay more or less constant (around 600 veh/h), whereas the the standard deviation of accumulation increases. This phenomenon is stronger for higher demand levels, and for larger subnetwork sizes (see figure 5). This can also be found in figure 7. After the initial sharp decrease of the network performance, the network performance remains at around 600 veh/h for approximately 30 minutes before it reduces further. In the mean time, the variation increases. This can be explained as follows. Congestion builds up at various locations. At 20 minutes, congestion has set in at various places. In the 30 minutes of interest here, the congestion moves from the various bottlenecks in the network to the one area with the strongest bottleneck.

Since the total congestion remains more or less the same, the network performance remains more or less stable. However, when looking at the distribution of congestion over the network, this varies. In particular, the traffic state with various distributed bottlenecks, where the accumulation in the subnetworks is approximately the same, changes to a traffic state where most congestion is localised in one or a few neighbouring subnetworks. Therefore, in this period, the standard deviation of the accumulation increases considerably.

6 Conclusions and outlook

This paper presents the conclusions of a simulation study in order to reveal if traffic performance can be described based on less data. In general, this is possible. We established a macroscopic relationship between accumulation, variation of accumulation in subnetworks and network performance, which also holds in traffic states with inhomogeneous congestion.

A network can be split in several subnetworks. The total accumulation in the network and the standard deviation of the accumulation of the subnetworks are a good precursor for the network performance. The higher the variation, the lower the performance is. This reduces considerably the amount of data needed, since not all links have to be measured, but instead only the average density in the subnetworks has to be determined.

Now this relationship has been shown, it can be studied how the subnetwork accumulation can be determined. For sure, it can be measured by cameras counting the number of inflowing and outflowing vehicles. However, simpler approaches are also possible. For instance, an estimation by a few loops could be sufficient. Which accuracy can be obtained by which amount of data (number of loops, spatial distribution; penetration grade of floating cars) is subject for further research.

Also from the perspective of traffic flow theory, several new questions are raised. The variations discussed here concern the evolution of a network from an initial, prescribed, situation to a more equilibrium state. For this setup, we found that a higher demand would lead to a higher variation of the cell densities (and subnetwork accumulations), but the end performance is similar for all demand levels. It is interesting to study how this equilibrium state depends on the network, the location of the destinations, the OD matrix and the demand. Also the simulation properties, as for instance the node modeling will be studied in this respect.

The study shows that the traffic performance decreases when traffic is clustered. Therefore, to keep up the performance, it is required to distribute the traffic over the network. This can be done by traffic control. For instance, it is planned to study the effect of routing and other network control measures, like traffic metering. For instance, the effect of a more distributed route choice, users are also considering routes which lead to a small detour, will be studied. Also, the effect of dynamic routing, for instance by advice, on the network performance will be studied. In the follow-up of this research project, we will study whether the network performance can be improved by giving route advice based on subnetwork accumulation.

Acknowledgement This research was sponsored by the project *SI4MS*, Sensor Intelligence for Mobility Systems, and by the foundation Next Generation Infrastructures in the project *JAMS*, Joint Approach for Multi-level Simulation.

References

- C. Buisson and C. Lavier. Exploring the impact of the homogeneity of traffic measurements on the existence of the macroscopic fundamental diagram. *Transportation Research Records, Journal of the Transportation Research Board*, 2009.
- Michael J. Cassidy and Robert L. Bertini. Some traffic features at freeway bottlenecks. *Transportation Research Part B: Methodological*, 33(1):25 – 42, 1999. ISSN 0191-2615.
- M.J Cassidy, K. Jang, and C.F. Daganzo. Macroscopic fundamental diagram for freeway networks: Theory and observation. In *Proceedings of the 90th Annual Meeting of the Transportation Research Board*, 2011.
- C.F. Daganzo. Urban gridlock: Macroscopic modeling and mitigation approaches. *Transportation Research Part B: Methodological*, 41(1):49–62, 2007.
- C.F. Daganzo and N. Geroliminis. An analytical approximation for the macroscopic fundamental diagram of urban traffic. *Transportation Research Part B: Methodological*, 42(9):771 – 781, 2008.
- C.F. Daganzo, V.V. Gayah, and E.J. Gonzales. Macroscopic relations of urban traffic variables: Bi-

- furcations, multivaluedness and instability. *Transportation Research Part B: Methodological*, 45(1): 278–288, 2011.
- V. Dinopoulou, Diakaki C., and Papageorgiou M. Applications of the urban traffic control strategy. *European Journal of Operational Research*, 175(3):1652 – 1665, 2006.
- V. Gayah and C.F. Daganzo. Clockwise hysteresis loops in the macroscopic fundamental diagram: An effect of network instability. *Transportation Research Part B*, 2011.
- N. Geroliminis and C. F. Daganzo. Existence of urban-scale macroscopic fundamental diagrams: Some experimental findings. *Transportation Research Part B: Methodological*, 42(9):759–770, 2008.
- N. Geroliminis and Y. Ji. Spatial and temporal analysis of congestion in urban transportation networks. In *Proceedings of 90th Annual Meeting of the Transportation Research Board*, 2011.
- J. Godfrey. The mechanism of a road network. *Traffic Engineering and Control*, 11(7):323–327, 1969.
- S. K. Godunov. A difference scheme for numerical computation of discontinuous solutions of equations of fluid dynamics. *Math. Sb.*, 47:271 – 290, 1959.
- F. L. Hall and K. Agyemang-Duah. Freeway Capacity Drop and the Definition of Capacity. *Transportation Research Record: Journal of the Transportation Research Board No.1320*, pages 91–98, 1991.
- Y. Ji, W. Daamen, S. Hoogendoorn, S. Hoogendoorn-Lanser, and X. Qian. Macroscopic fundamental diagram: investigating its shape using simulation data. *Transportation Research Record, Journal of the Transportation Research Board*, 2161:42–48., 2010.
- W. L. Jin and H. M. Zhang. On the distribution schemes for determining flows through a merge. *Transportation Research Part B: Methodological*, 37(6):521–540, 2003.
- A. Kotsialos, M. Papageorgiou, H. Haj-Salem, S. Manfrendi, J. Van Schuppen, J. Taylor, and M. Westerman. Co-ordinated Control Strategies. Technical report, DACCORD – Development and Application of Co-ordinated Control of Corridors, 1997.
- J. P. Lebacque. The Godunov Scheme and What it Means for First Order Traffic Flow Models. In *Proceedings of the 13th International Symposium on Transportation and Traffic Theory*, 1996.
- M. J. Lighthill and G. B. Whitham. On Kinematic Waves. II. A Theory of Traffic Flow on Long Crowded Roads,. *Proceedings of the Royal Society of London. Series A, Mathematical and Physical Sciences*, 229(1178):317 – 345, 1955.
- P. R. Lowrie. SCATS: The Sydney co-ordinated adaptive traffic system. Principles, methodology, algorithms. In *Proceedings of the IEE international conference on road traffic signalling*, page pp. 67–70, London, UK, 1982.
- A. Mazloumian, N. Geroliminis, and D. Helbing. The spatial variability of vehicle densities as determinant of urban network capacity. *Philosophical Transactions of the Royal Society A*, 368:4627–4647, 2010.
- I. Papamichail, M. Papageorgiou, V. Vong, and J. Gaffney. Heuristic ramp-metering coordination strategy implemented at monash freeway, australia. *Transportation Research Record: Journal of the Transportation Research Board*, 2178:10–20, 2010.
- P. I. Richards. Shock waves on the highway. *Operations Research* 4, 4:42 – 51, 1956.
- D.I. Robertson and R.D. Bretherton. Optimizing networks of traffic signals in real time-the SCOOT method. *IEEE Transactions on Vehicular Technology*, 40(1):11 – 15, 1991.
- C.M.J. Tampre, R. Corthout, D. Cattrysse, and L.H. Immers. A generic class of first order node models for dynamic macroscopic simulation of traffic flows. *Transportation Research Part B*, 45:289–309, 2011.
- M. Van den Berg, B. De Schutter, A. Hegyi, and Hellendoorn J. Model predictive control for mixed urban and freeway networks. In *Proceedings of the 83rd Annual Meeting of the Transportation Research Board*, 2004.
- X. Wu, H.X. Liu, and N. Geroliminis. An empirical analysis on the arterial fundamental diagram. *Transportation Research Part B: Methodological*, 45(1):255 – 266, 2011.