

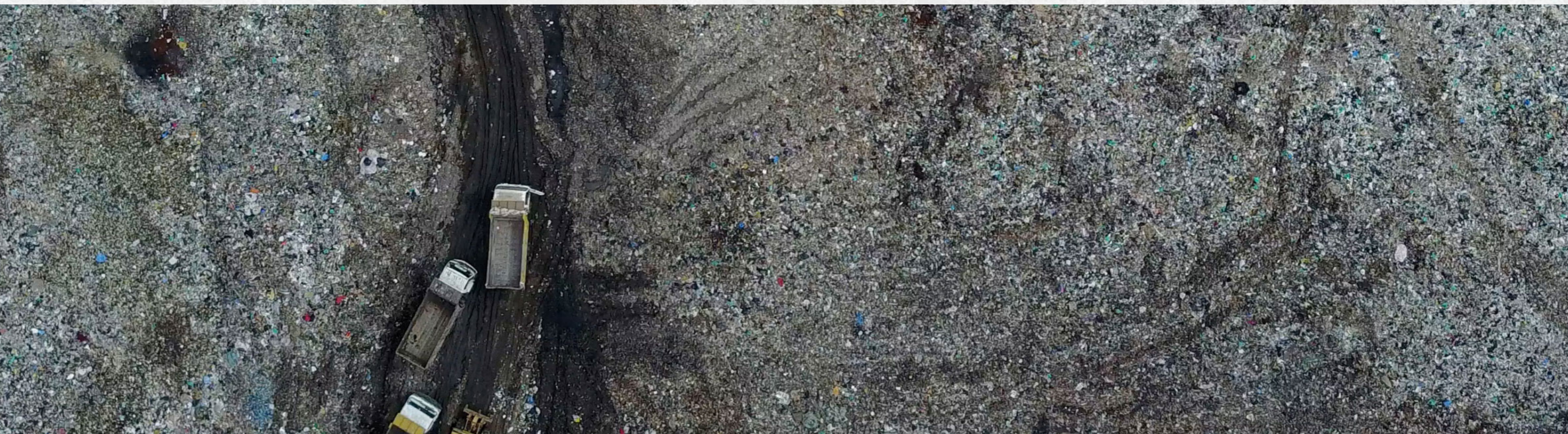

One of the biggest **challenges** facing **climate change** and **poverty**,
is **indifference**.





CIRCULAR
COMMUNITIES
FOR HOUSING

Rushabh Chheda
aE Graduation Studio 19
Mo Smit | Engbert Van Der Zaag | David Peck
P5 Presentation
10.07.2018

BANDUNG

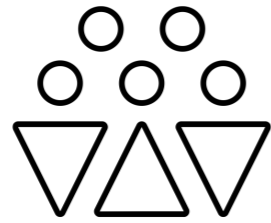

2.4 Million

4.35 Million



Expanding Urban Population



Rural Migration

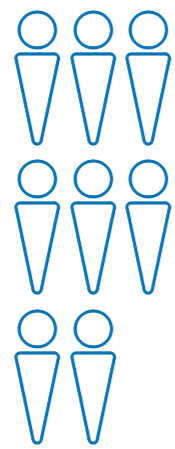

14,283  /km²



25,888  /km²

2010 | 2050

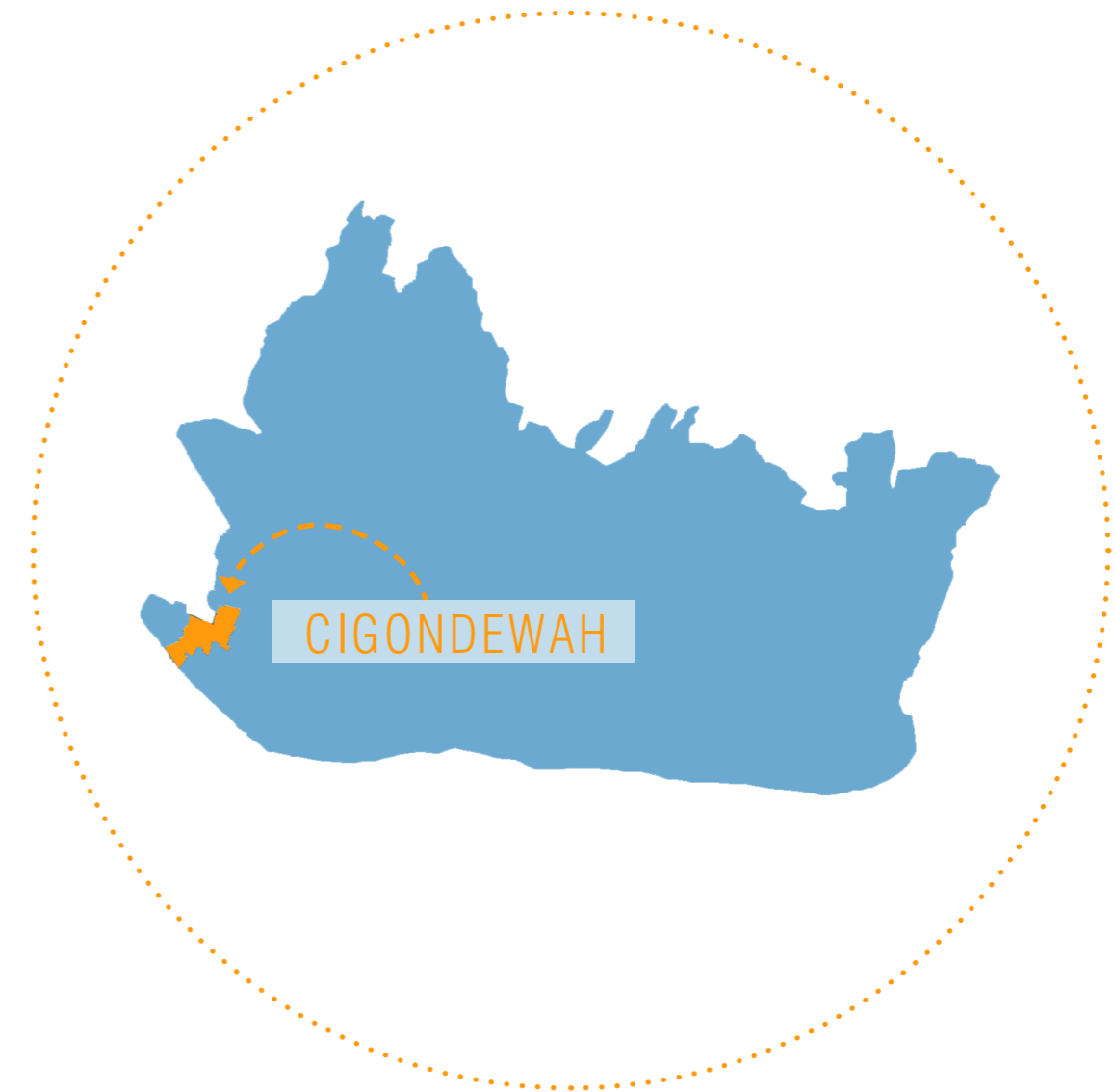

SOURCE : FASION VILLAGE - MO SMIT

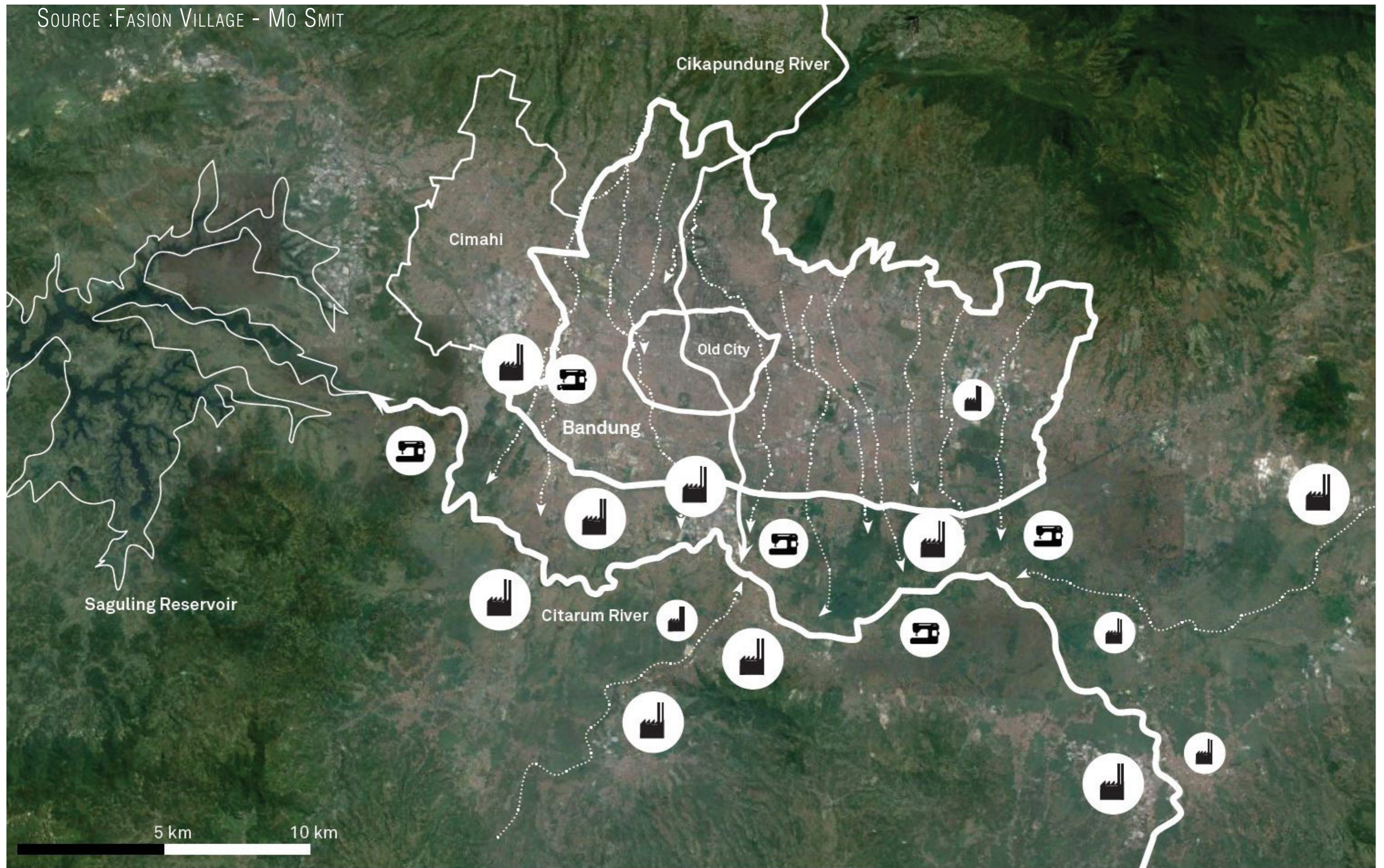

PERI-URBAN DEVELOPMENTS



PT KAHATEX

KAMPUNGS

SITE LOCATION

CIGONDEWAH | PT KAHATEX

RW02



8.1 HA

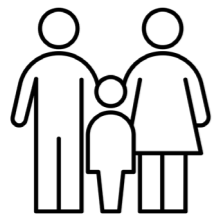

1200
PEOPLE



40%
MIGRANTS

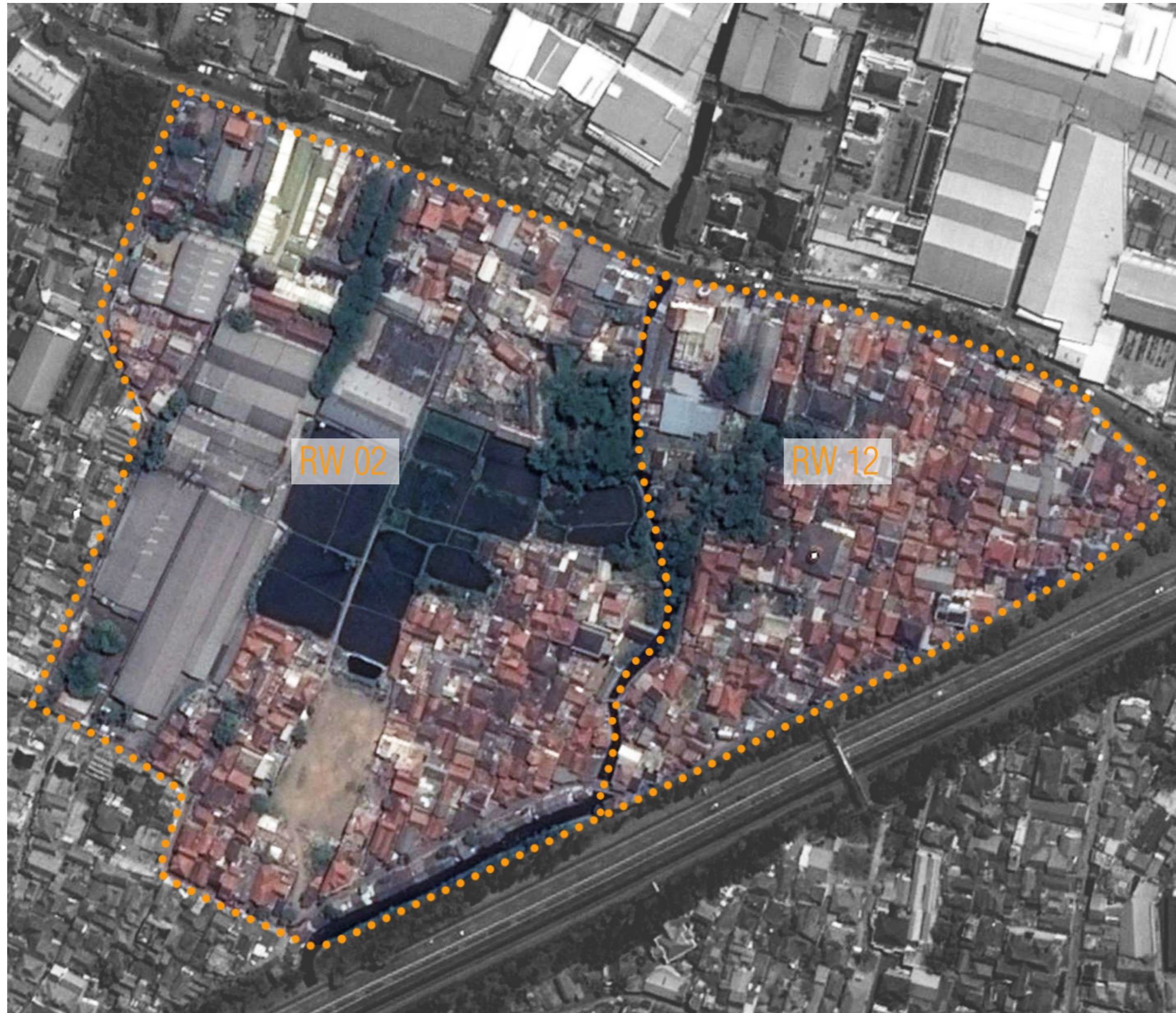

RW12



3.9 HA

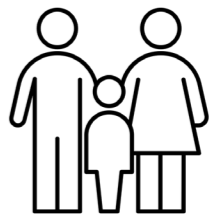

1600
PEOPLE



50%
MIGRANTS

SITE LOCATION

CIGONDEWAH | KAMPUNGS



SOURCE : FASHION VILLAGE - MO SMIT



PROBLEM STATEMENT

HOUSING | WASTE MANAGEMENT

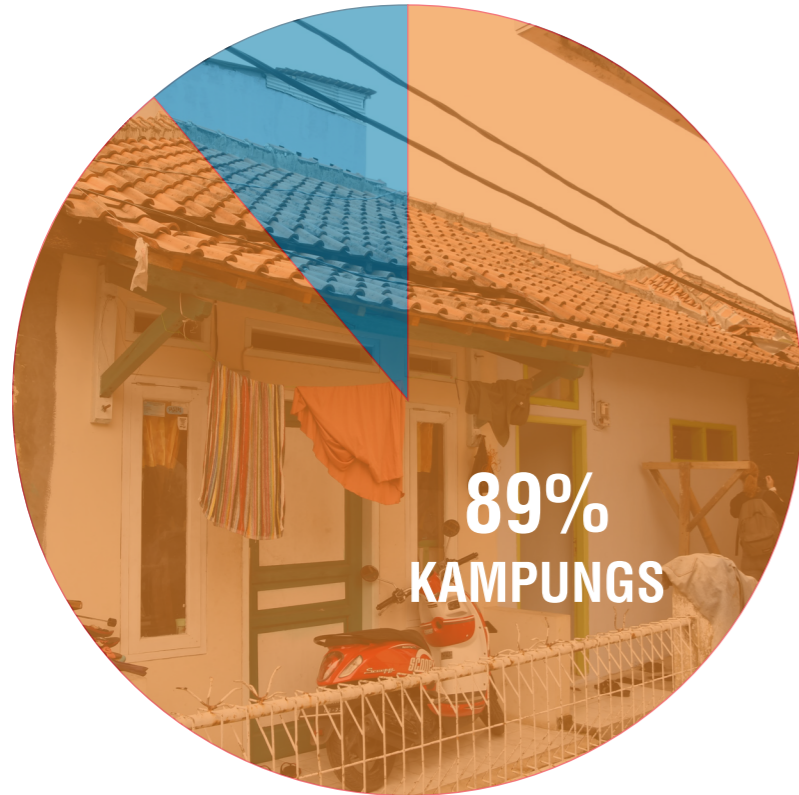

CITY HOUSING STOCK



MONTHLY HOUSEHOLD INCOME

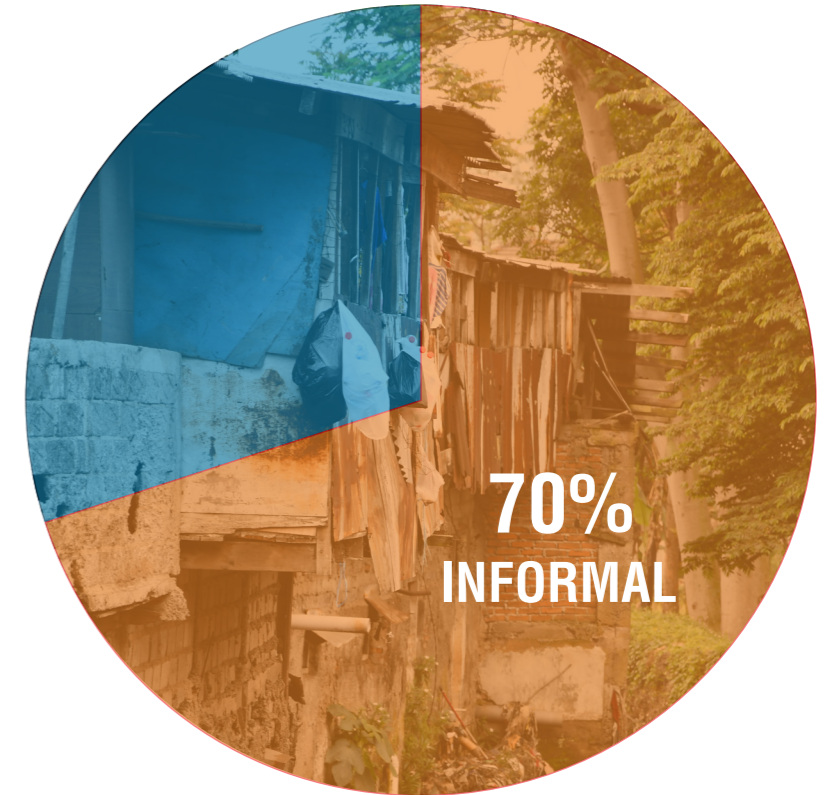

FORMAL | INFORMAL BUILDING INDUSTRY

BANDUNG

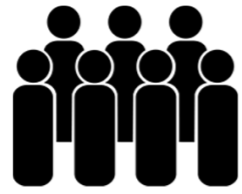

RAPIDLY GROWING
POPULATION



HOUSING SHORTAGE
+11.5 MILLION

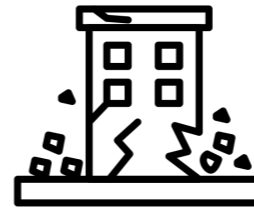

POOR QUALITY
CONSTRUCTIONS

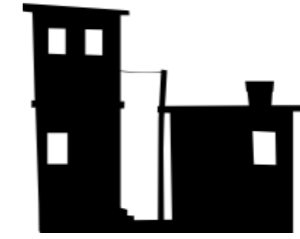

MAXIMUM G+1
STRUCTURES



Government Insufficiency



Horizontal Sprawl
Poor Living Conditions



Low-income

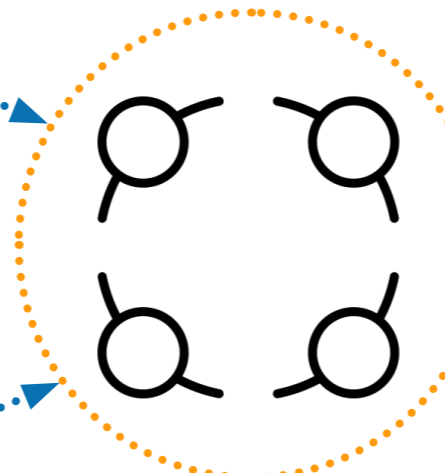

Self-Build Housing

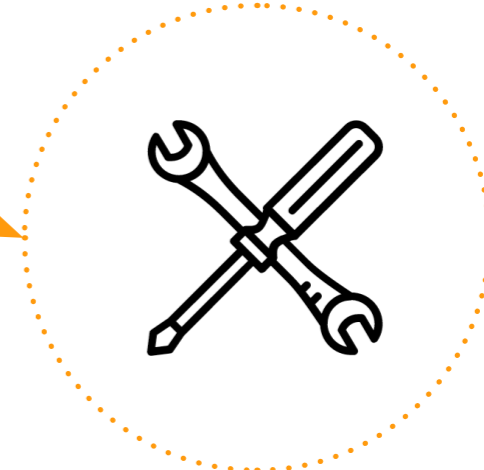

Low Technical Skills

HOUSING





FUTURE PROJECTION
TOTAL M.S.W.

WASTE MANAGEMENT

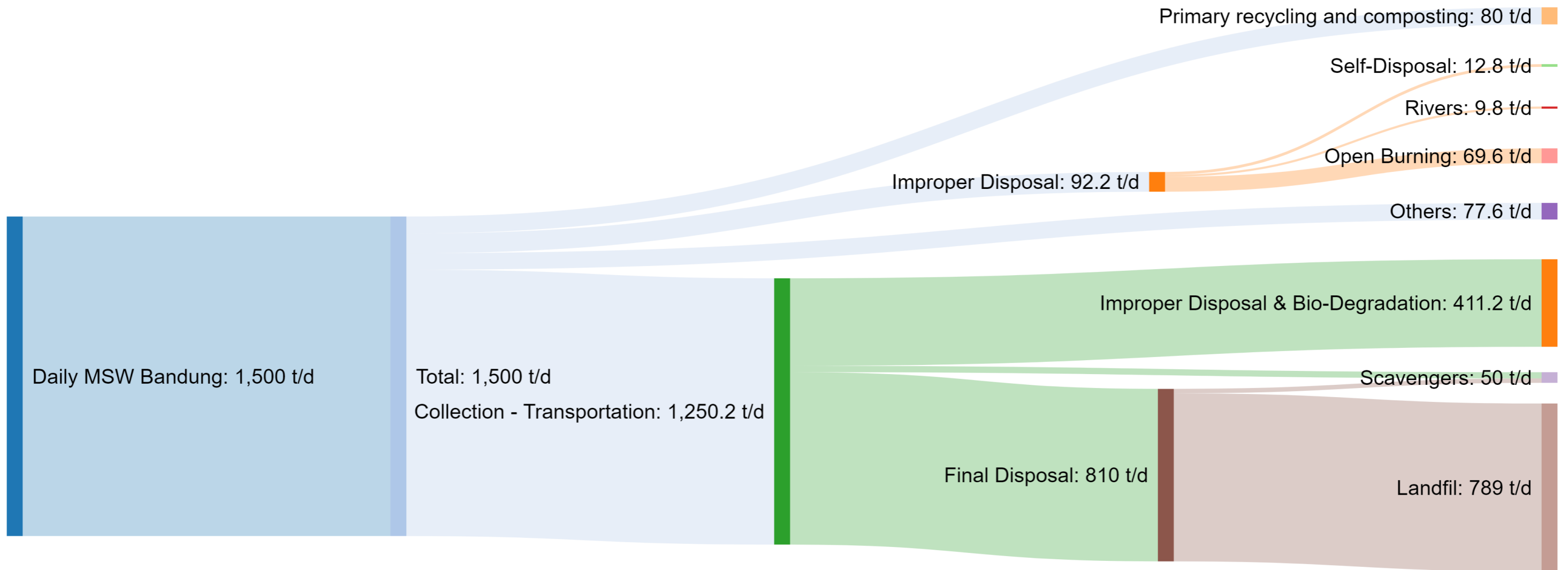

DISPOSAL OF MUNICIPAL SOLID WASTE

WASTE MANAGEMENT

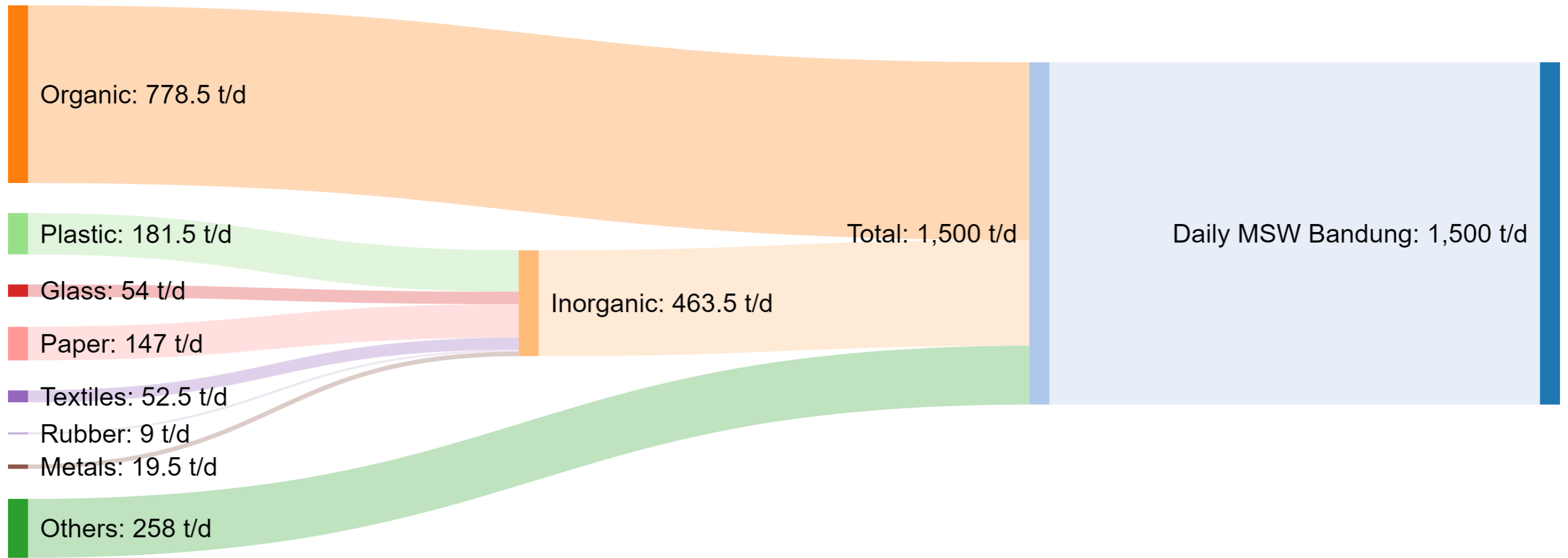

COMPOSITION OF
MUNICIPAL SOLID WASTE

WASTE MANAGEMENT



LEUWIGAJAH LANDFILL

WASTE COLLECTOR





**PLASTIC DEALER
WAREHOUSE**

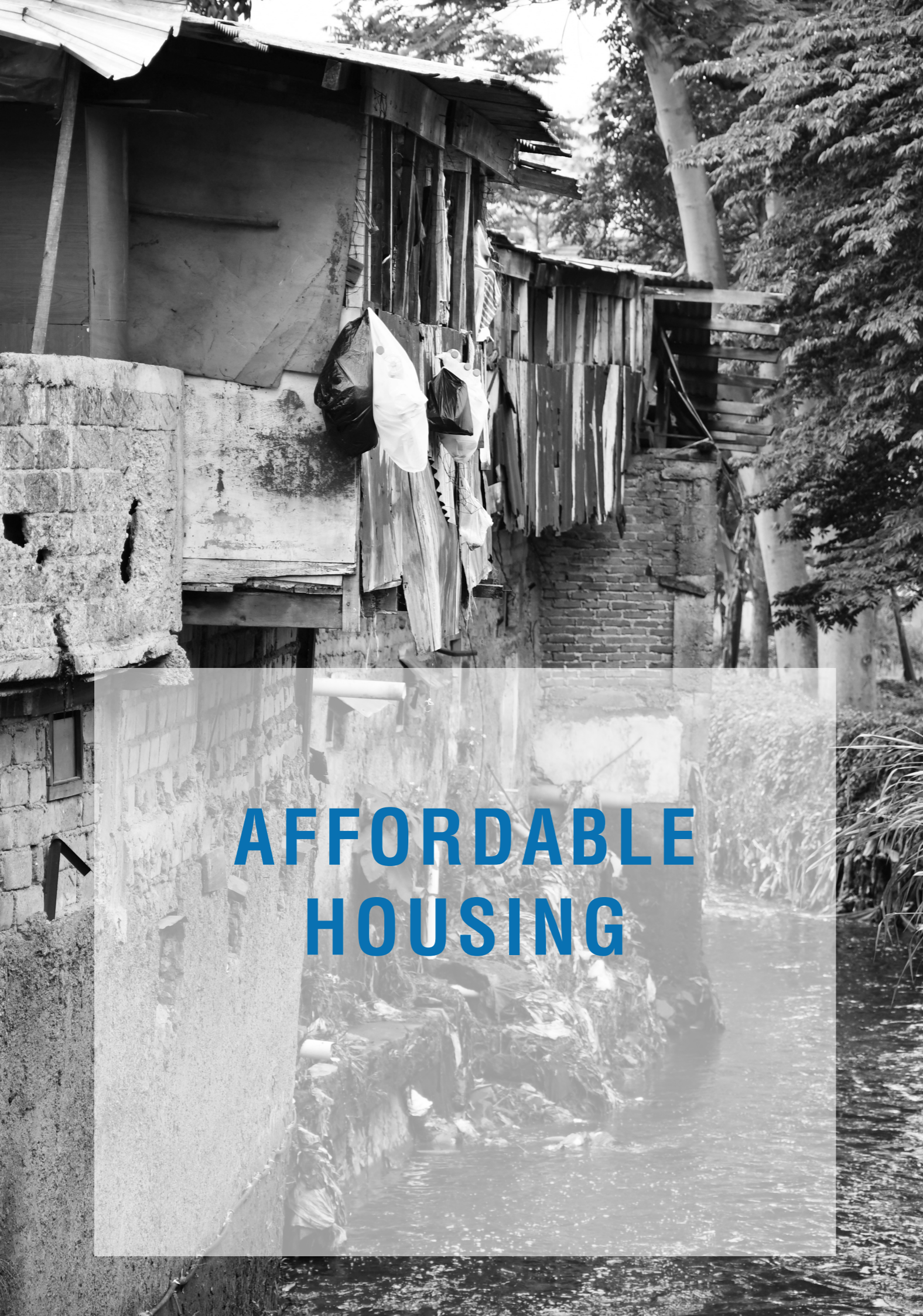

AFFORDABLE HOUSING



WASTE PLASTIC

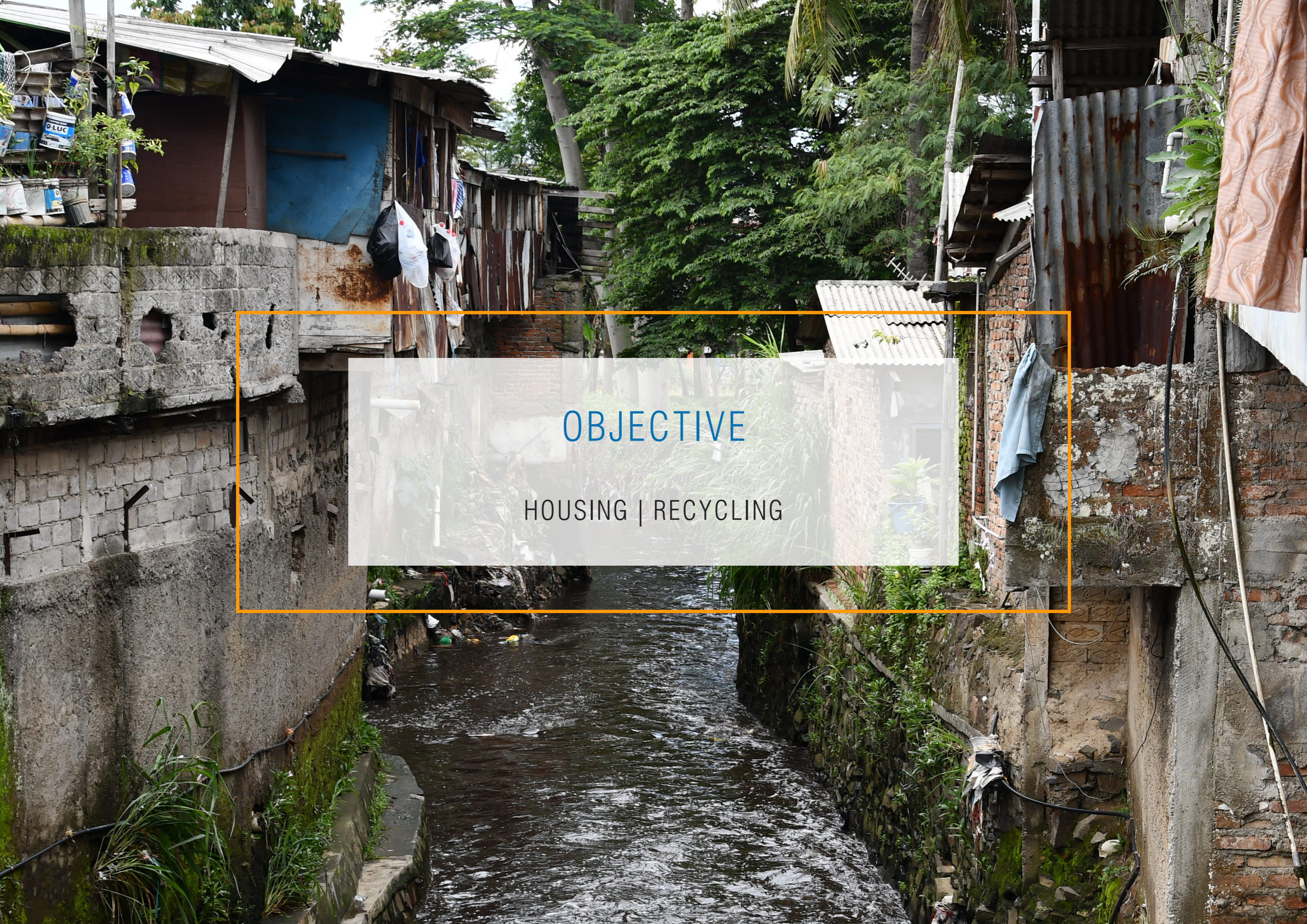

OBJECTIVE

HOUSING | RECYCLING

WHY?



PLASTIC POLLUTION

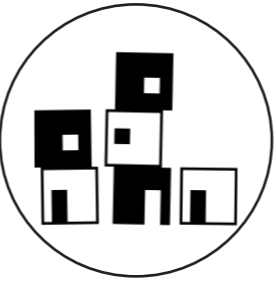

POOR QUALITY CONSTRUCTIONS



AFFORDABLE HOUSING SHORTAGE

How?

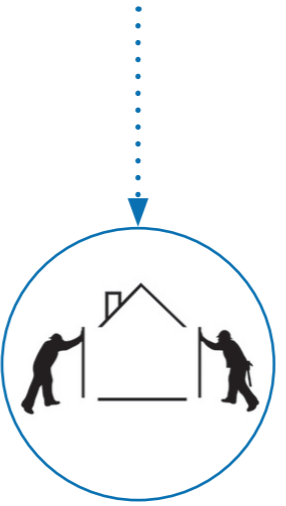

PREFAB CONSTRUCTION MATERIAL FROM WASTE



EASY CONSTRUCTION TECHNIQUE

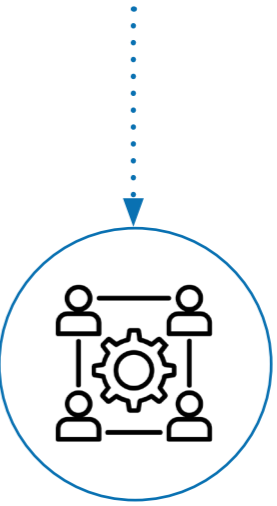

COLLABORATION OF THE INFORMAL SYSTEMS

WHAT?



ECOLOGICAL SUSTAINABILITY



VERTICAL DENSIFICATION STRUCTURAL STABILITY

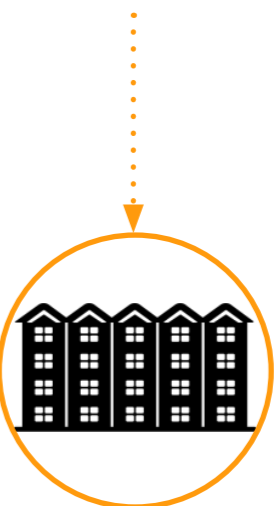

AFFORDABLE HOUSING

DESIGN QUESTION

How do we solve the affordable housing crisis in the **Kampungs** of Indonesia using a 'Decentral' **Circular Economy** system?

WHAT?



ECOLOGICAL
SUSTAINABILITY



VERTICAL DENSIFICATION
STRUCTURAL STABILITY



AFFORDABLE
HOUSING

STRATEGY

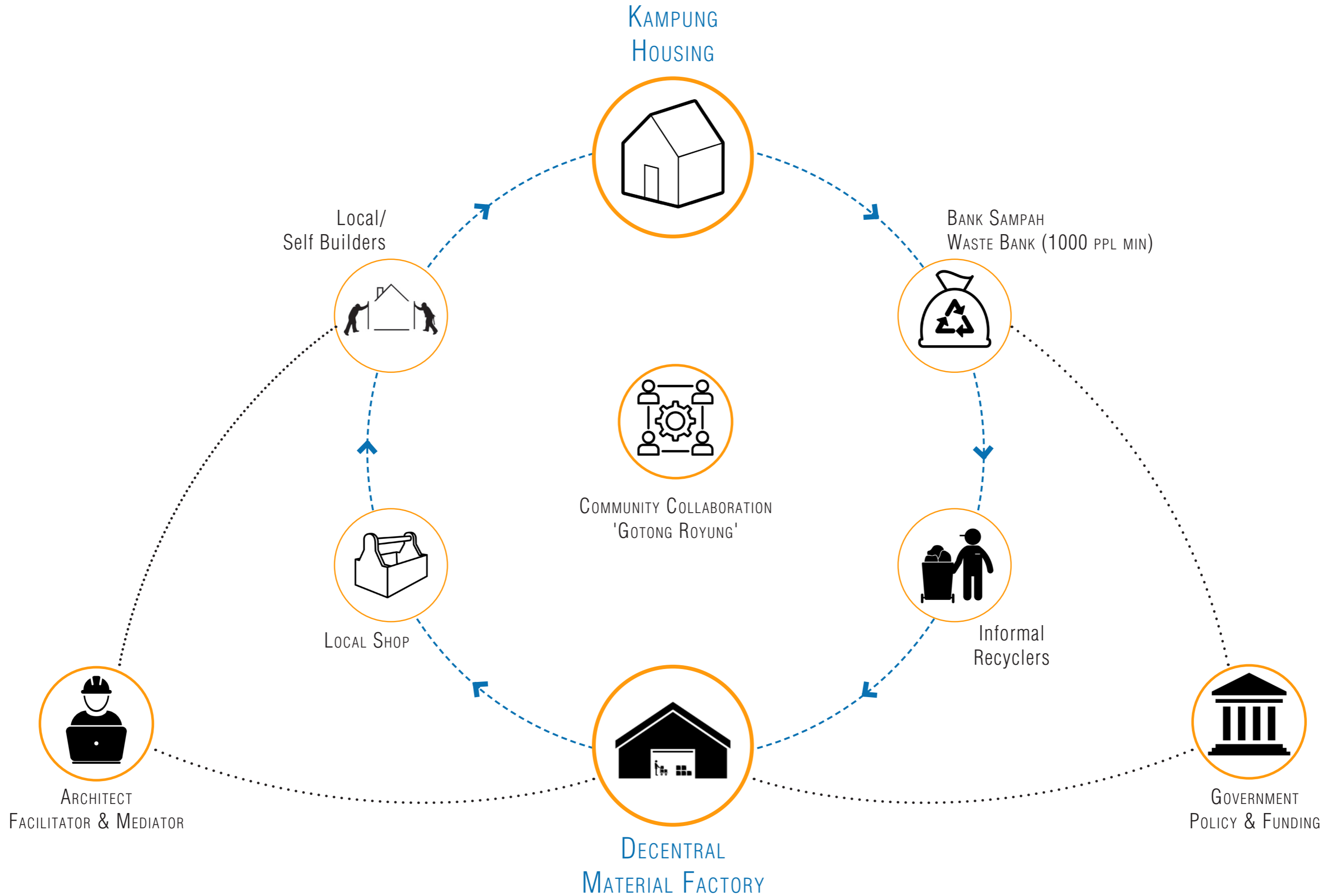

The image shows a large, dense pile of white plastic bags, likely containing waste or recyclables, stacked on top of each other. In the bottom left corner, there are stacks of flattened cardboard boxes. A semi-transparent white rectangular box with an orange border is centered over the plastic bags, containing the text 'RESEARCH' and 'METHODOLOGY | TYPOLOGY | RESULTS'.

RESEARCH

METHODOLOGY | TYPOLOGY | RESULTS

LEGO
BASED DESIGN

PLASTIC
WASTE

HOUSING
PROVISION



GROUND
STRUCTURE



EARTHQUAKE
RESISTANT



U.V.
PROTECTION



FIRE
RESISTANT

BOGOTA, COLOMBIA

CONCEPTOS PLASTICOS

LEGO
BASED DESIGN

SAND
+ POLYMER RESIN

HOUSING
PROVISION



GROUND + 2
STRUCTURE



EARTHQUAKE
RESISTANT



THERMAL & U.V.
PROTECTION



FIRE
RESISTANT

WEIBRIDGE, U.K.

POLYCARE - M.A.S.



PROTECTION
DURABILITY



AFFORDABLE

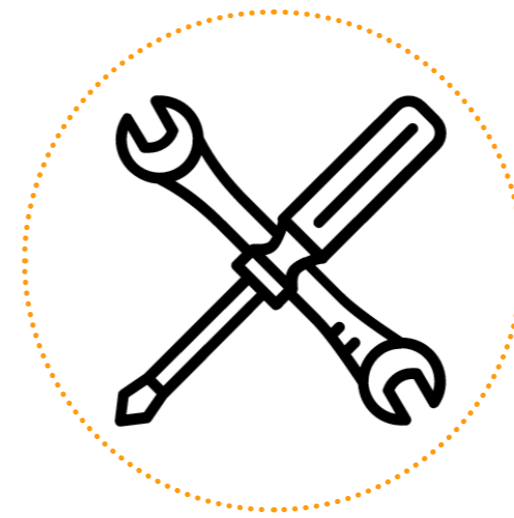

LOW-MAINTAINENCE
EASY TO USE

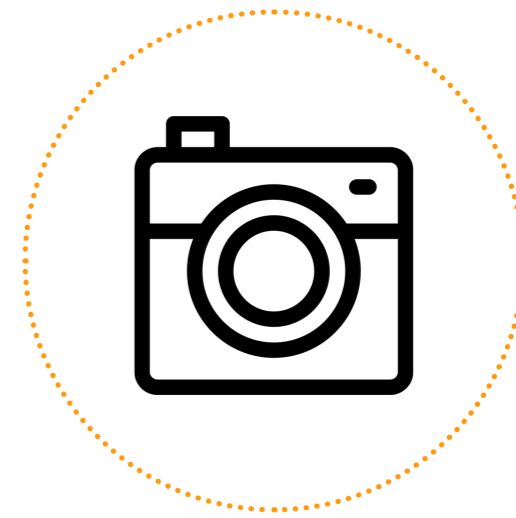

AESTHETIC
APPEAL

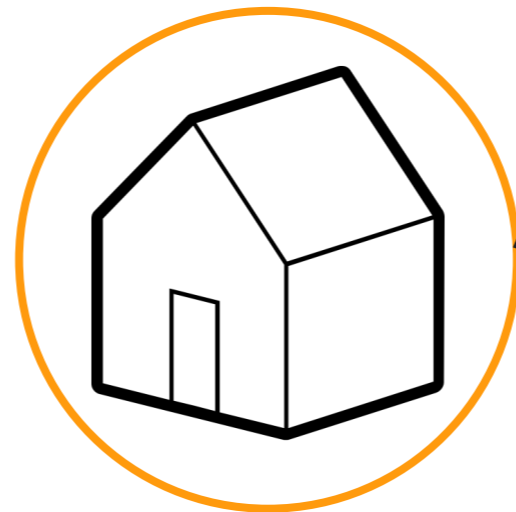

PROTOTYPE
HOUSING

DESIGN
PROGRAM

REQUIREMENTS

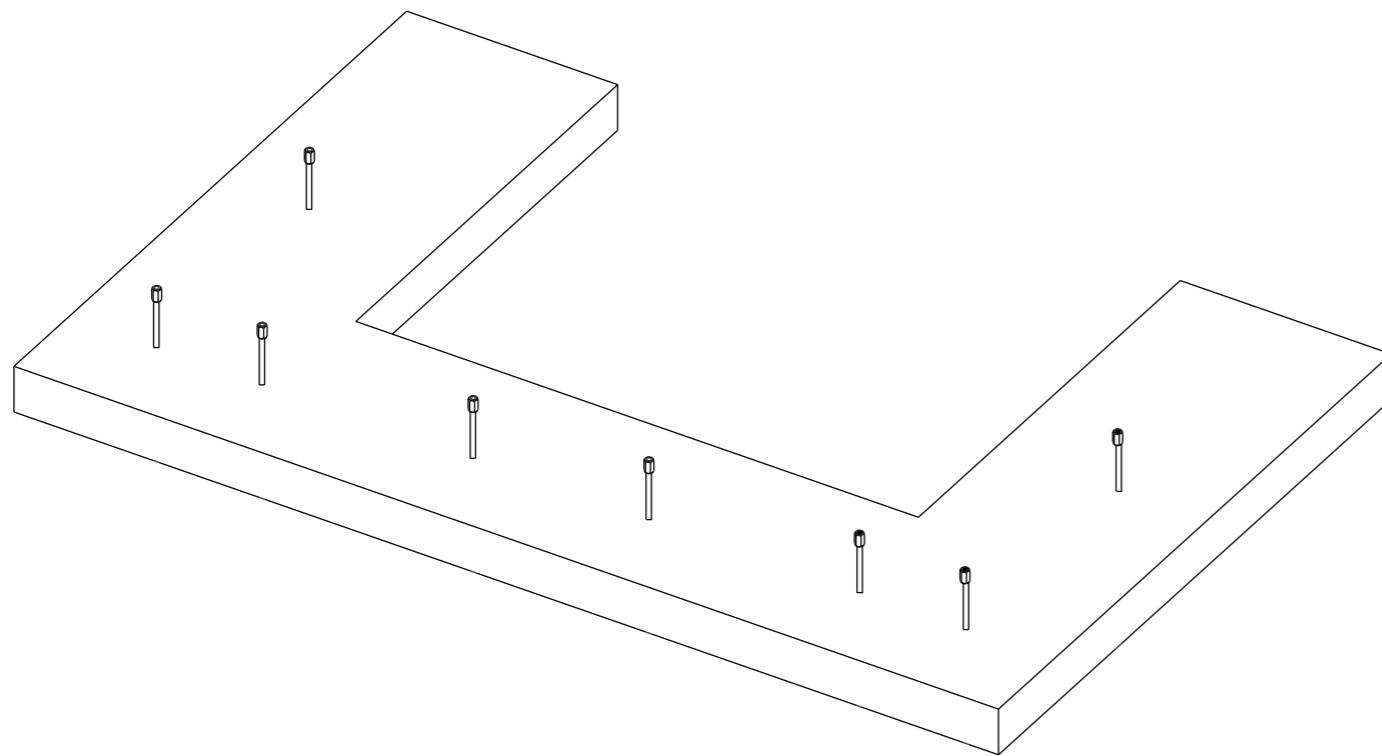

CONSTRUCTION

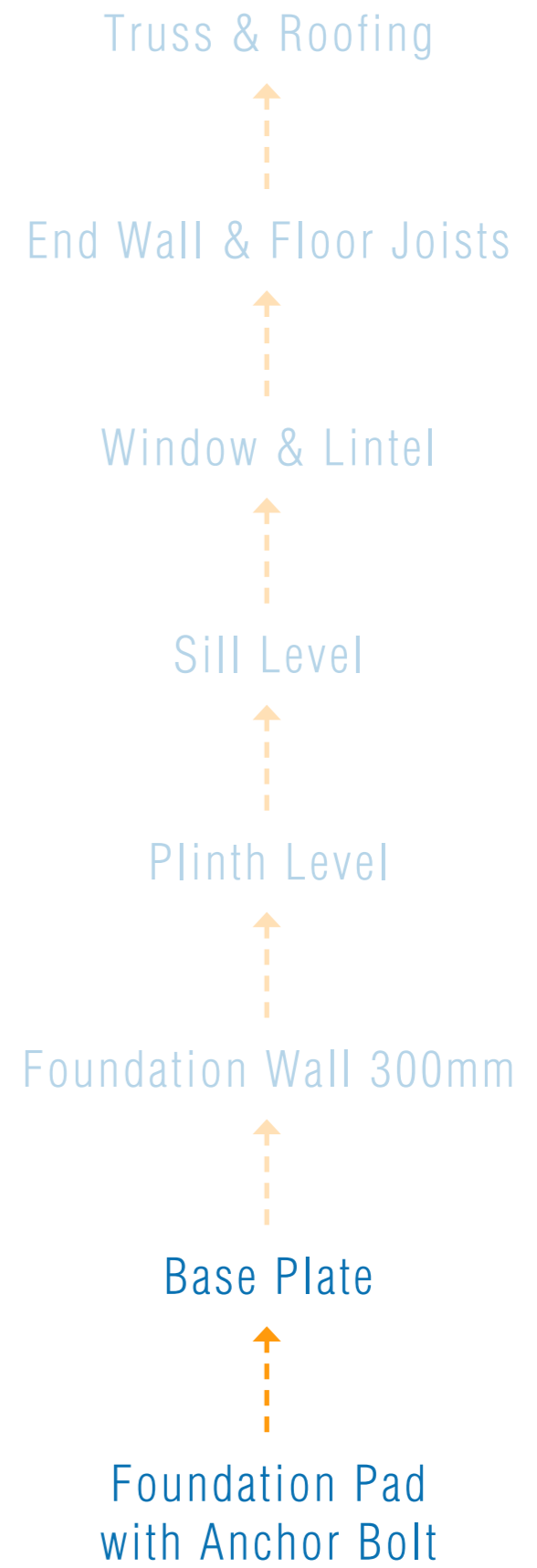
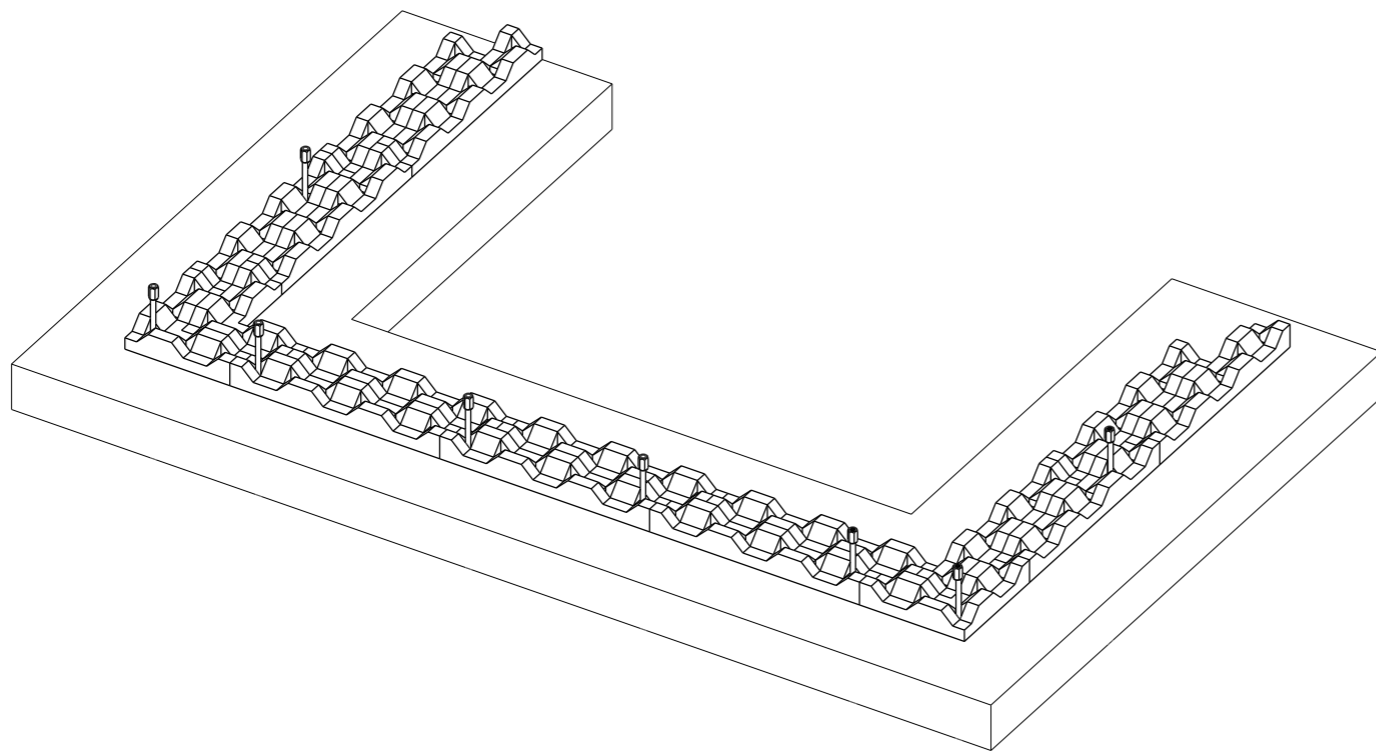

CONSTRUCTION

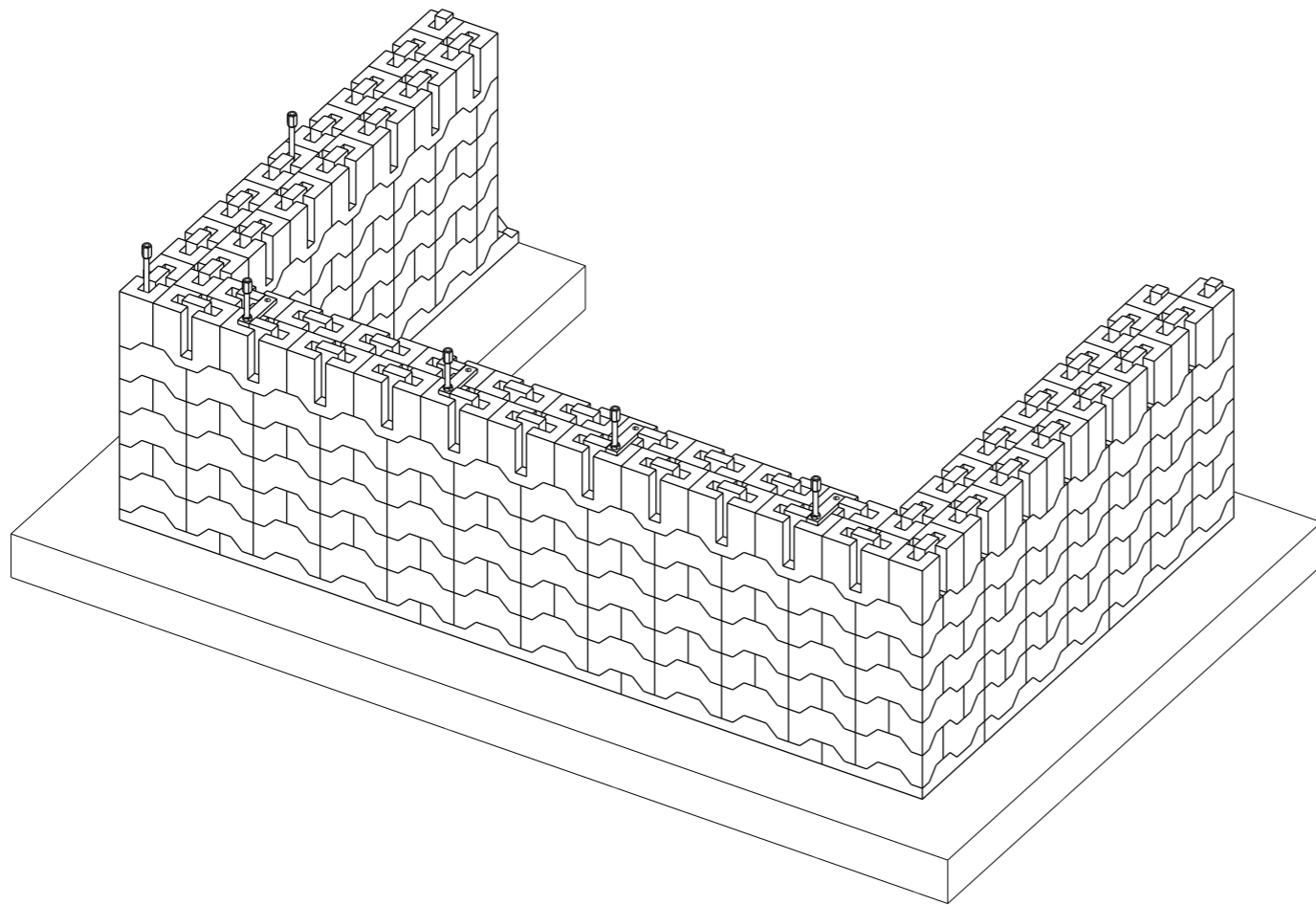

CONSTRUCTION

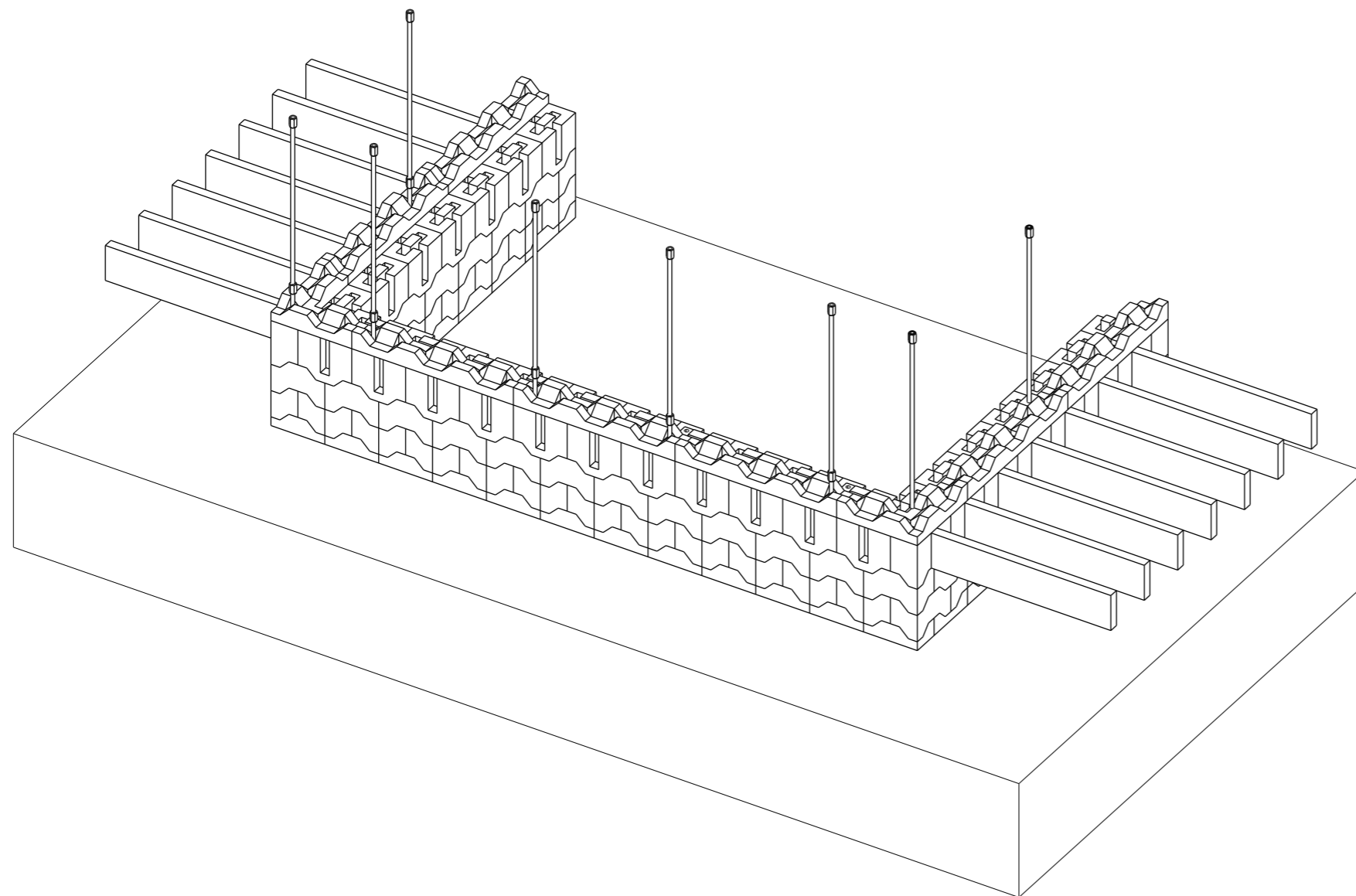

CONSTRUCTION

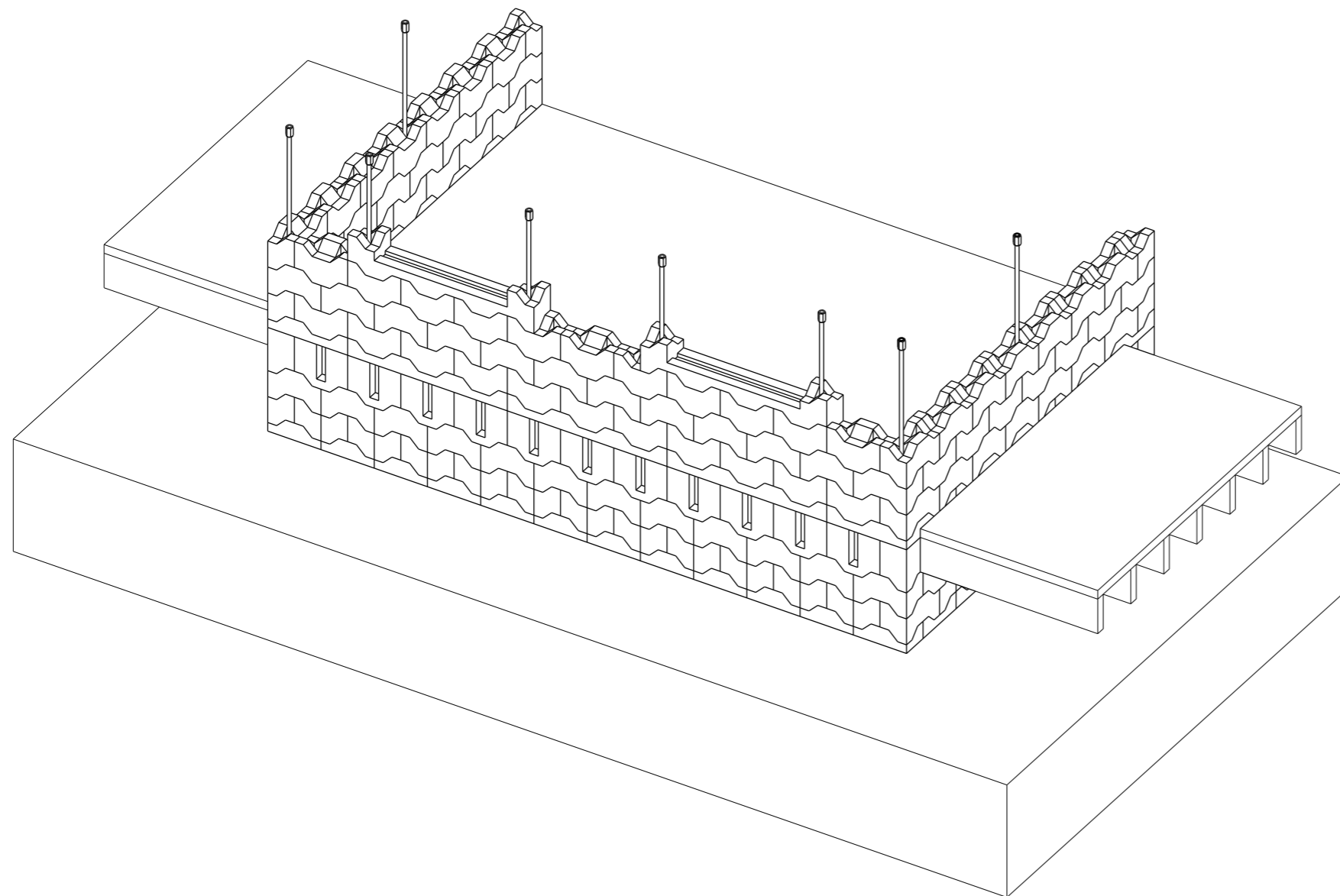

CONSTRUCTION

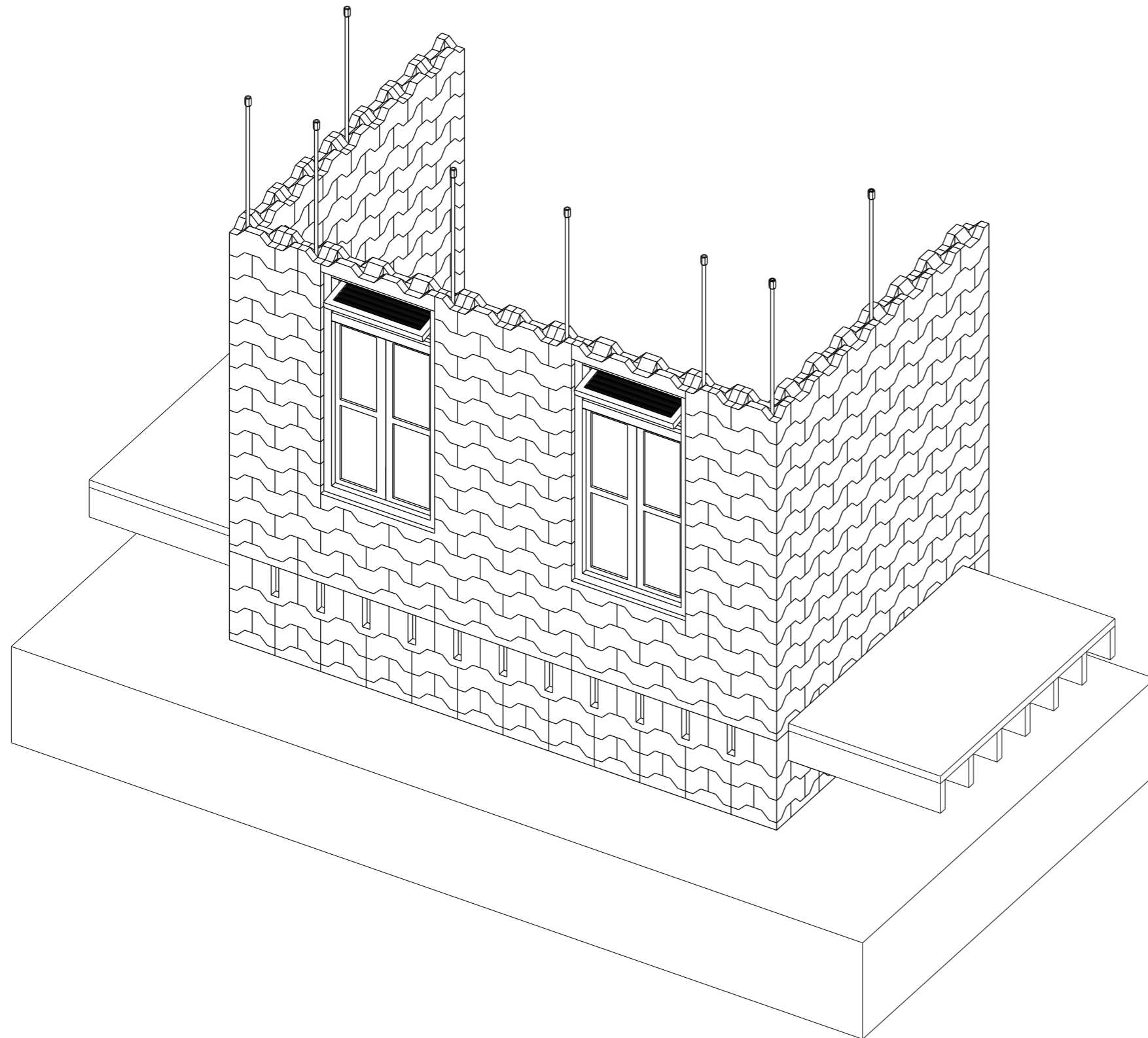

CONSTRUCTION

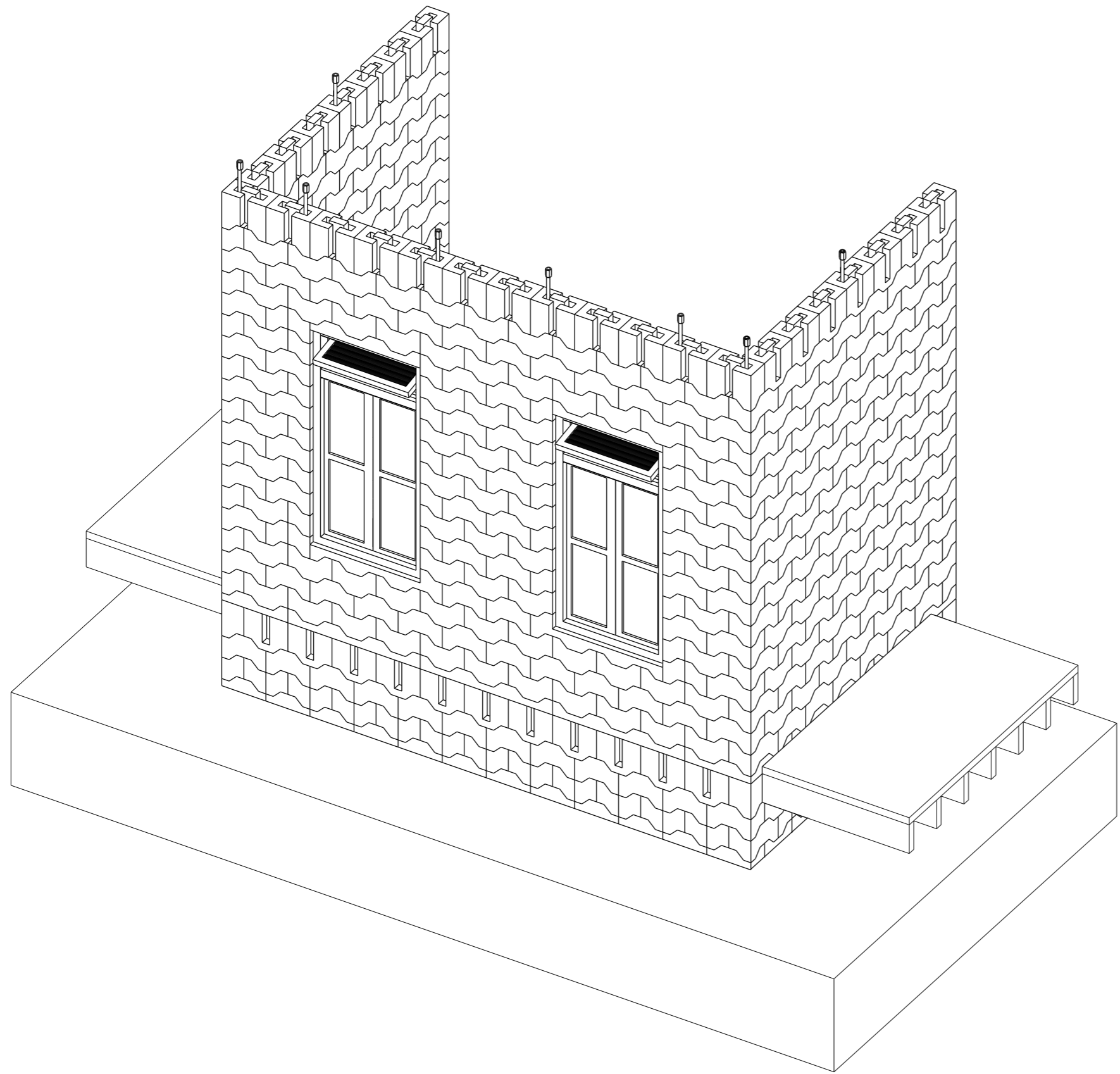

CONSTRUCTION

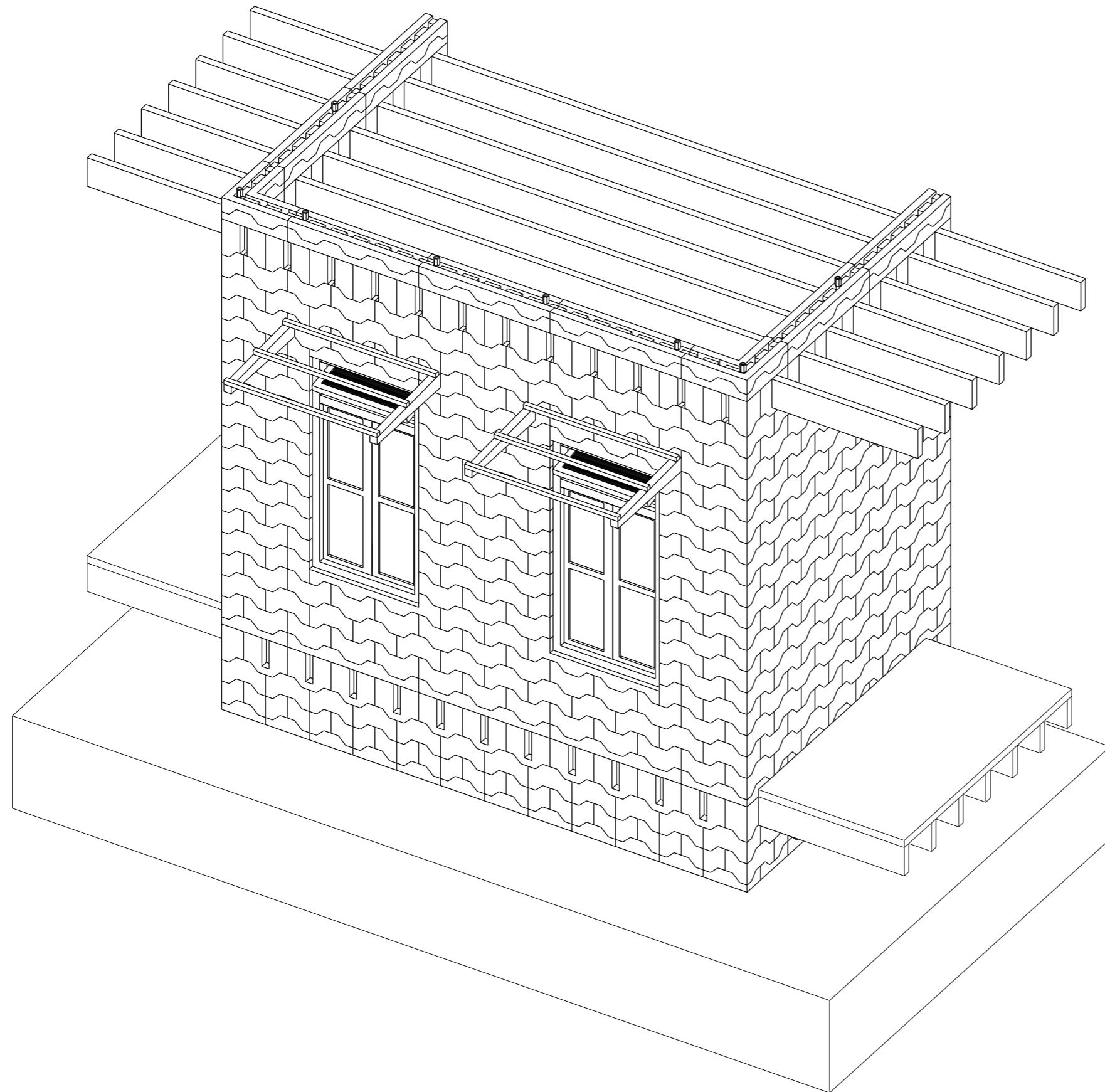

CONSTRUCTION

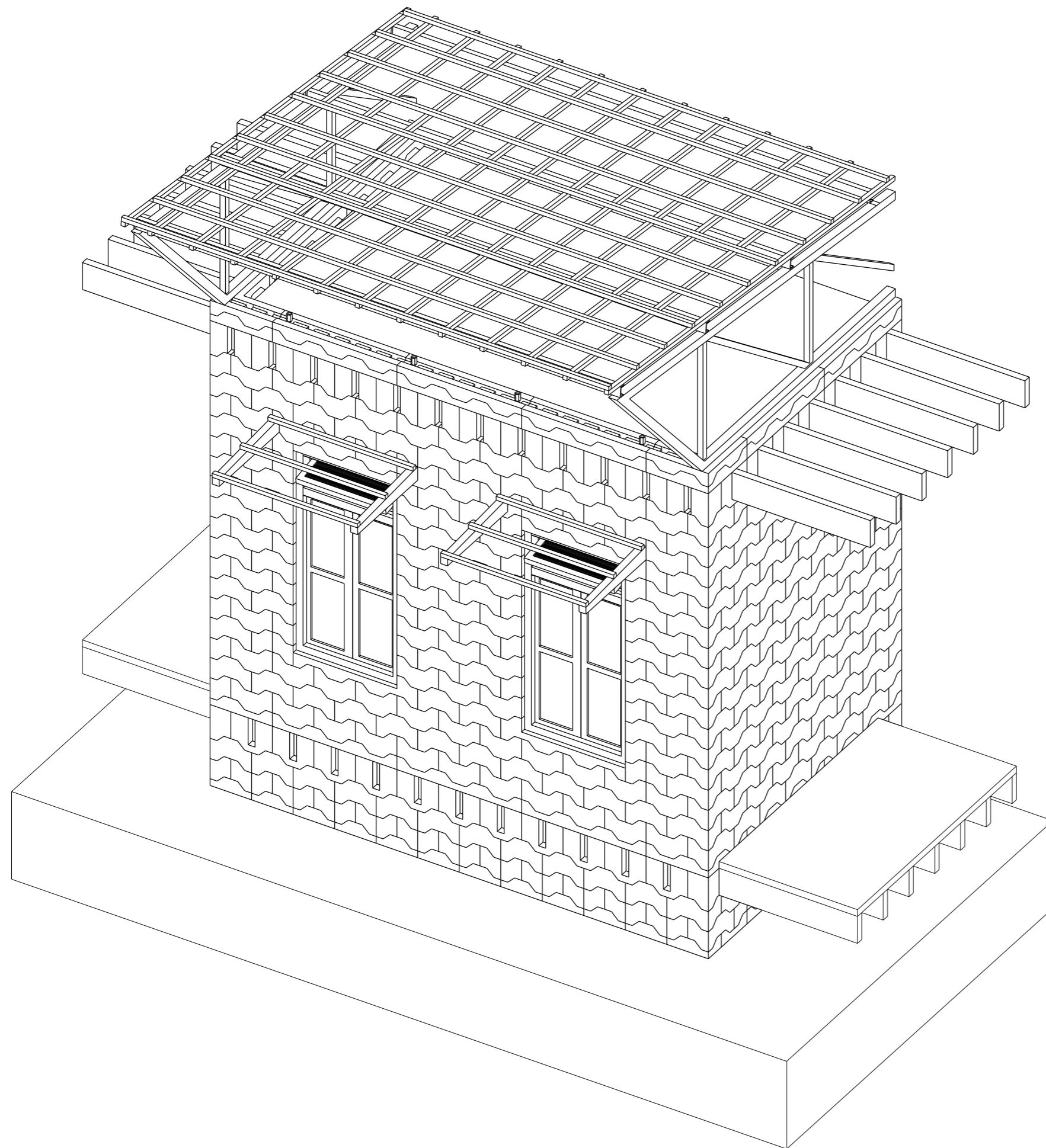

- Truss & Roofing
- ↑
- End Wall & Floor Joists
- ↑
- Window & Lintel
- ↑
- Sill Level
- ↑
- Plinth Level
- ↑
- Foundation Wall 300mm
- ↑
- Base Plate
- ↑
- Foundation Pad with Anchor Bolt

CONSTRUCTION



FRONT PORCH



BALCONY



COURTYARD

SOCIAL SPACES

HOUSING MODULE

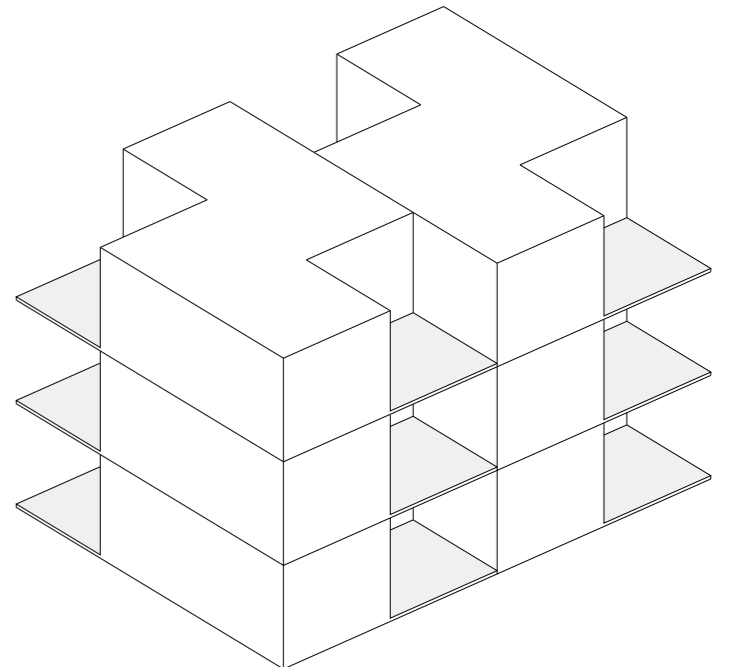
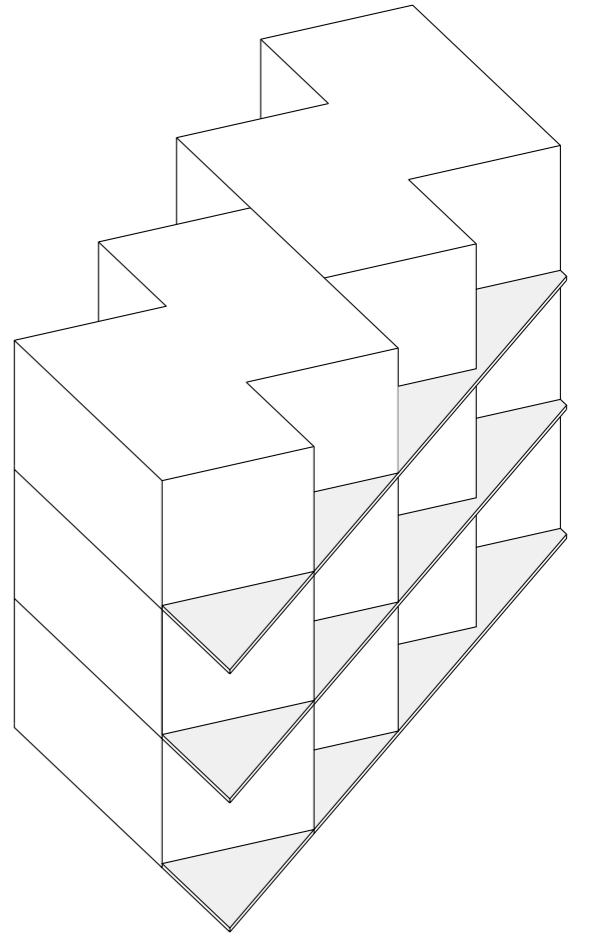
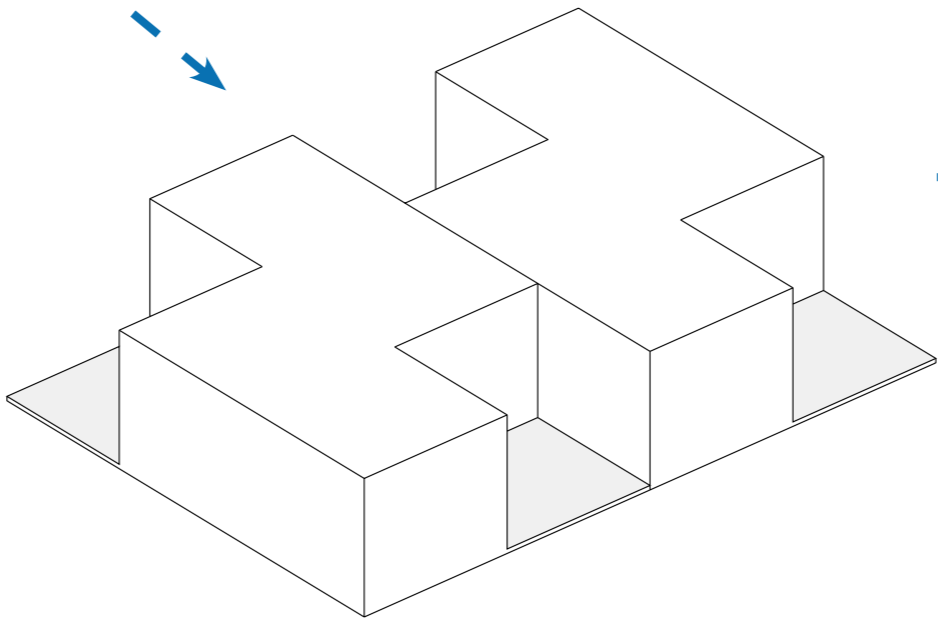
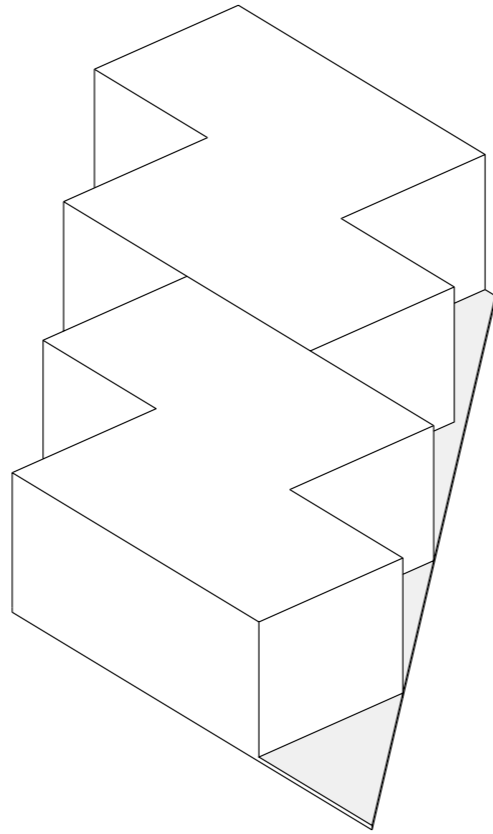
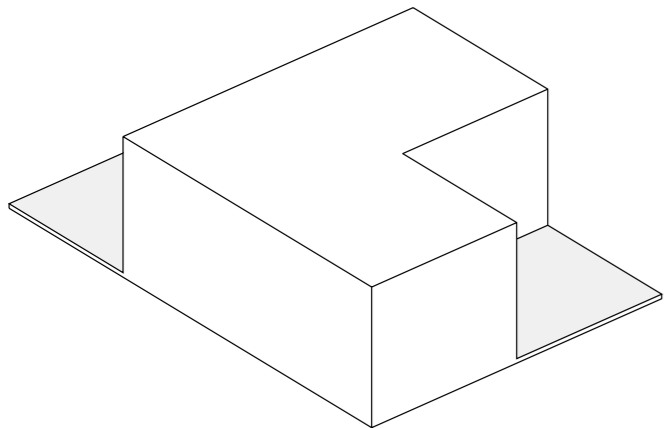
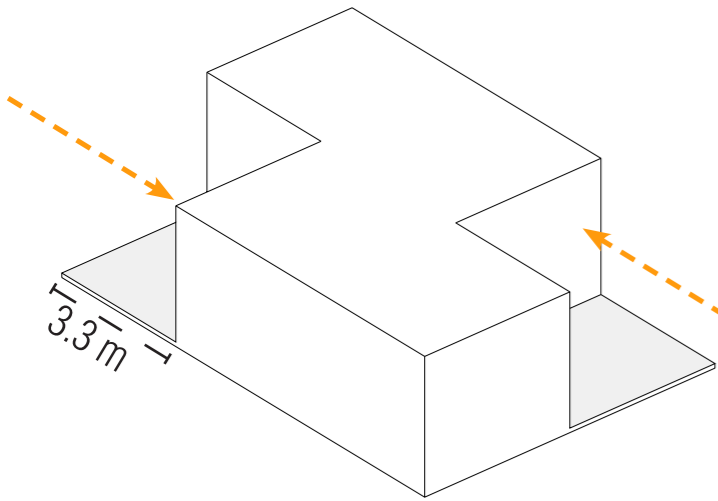
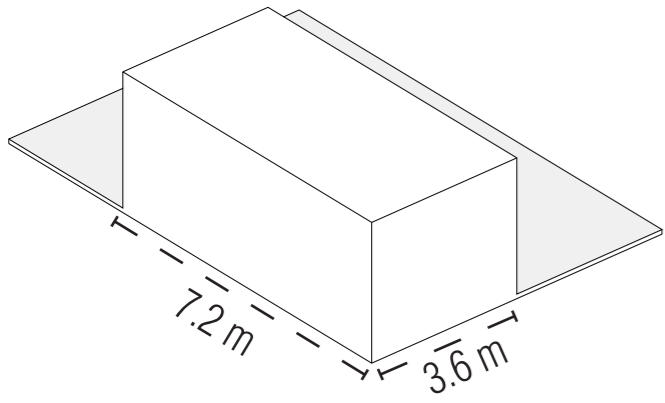

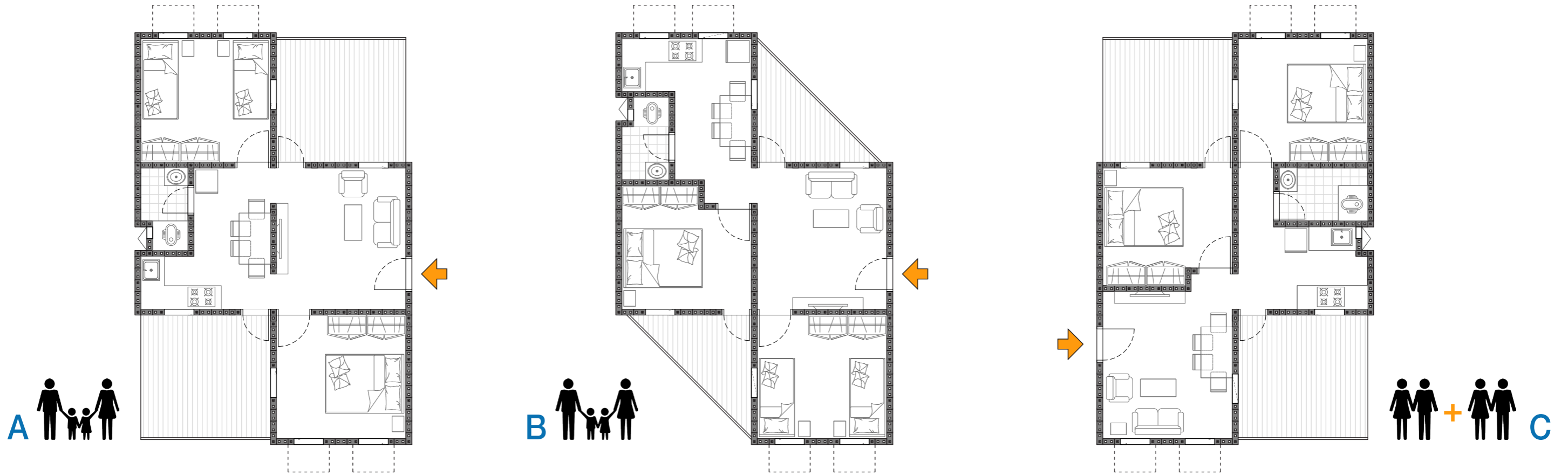

7 x FAMILY UNITS

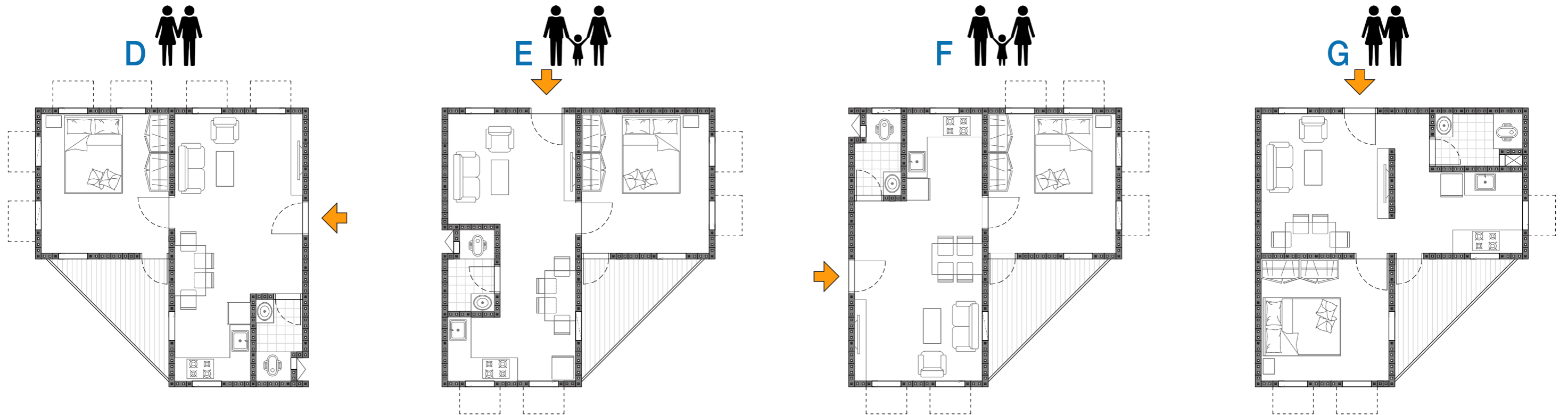

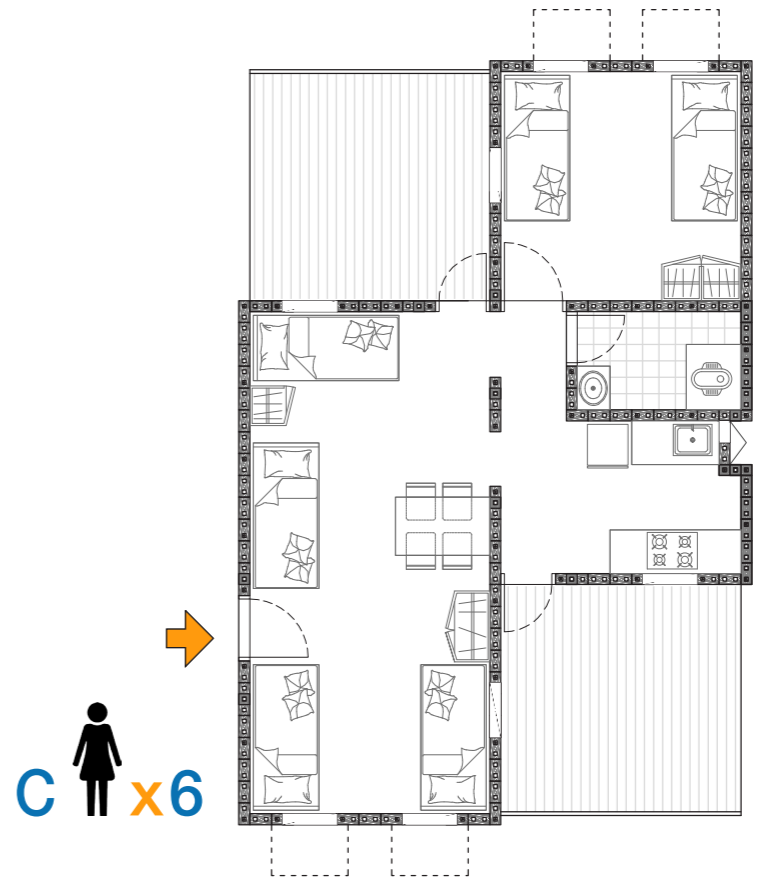
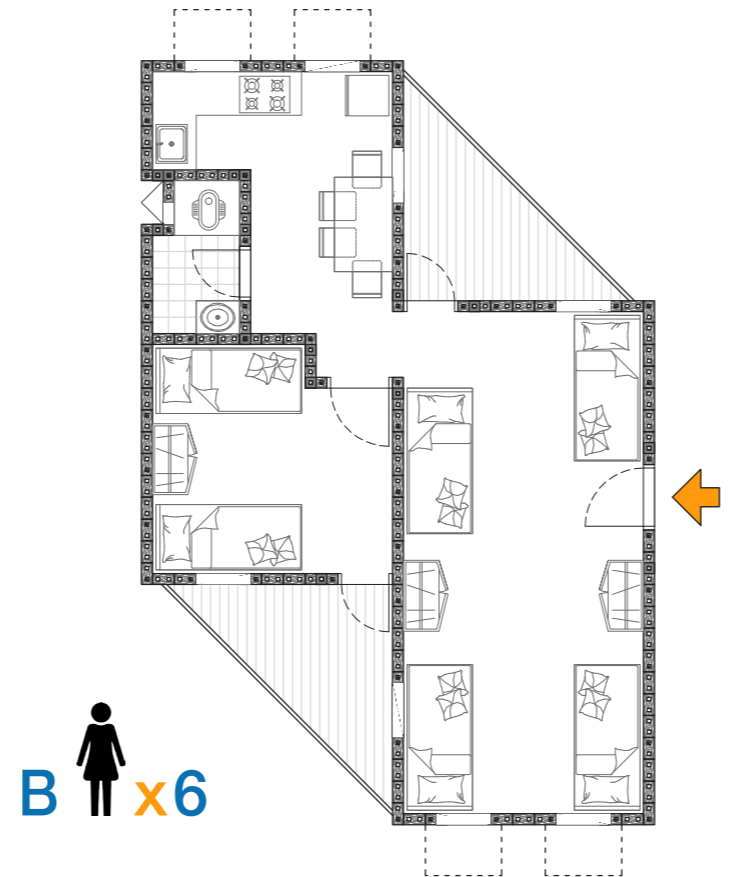

7 x RENTAL UNITS

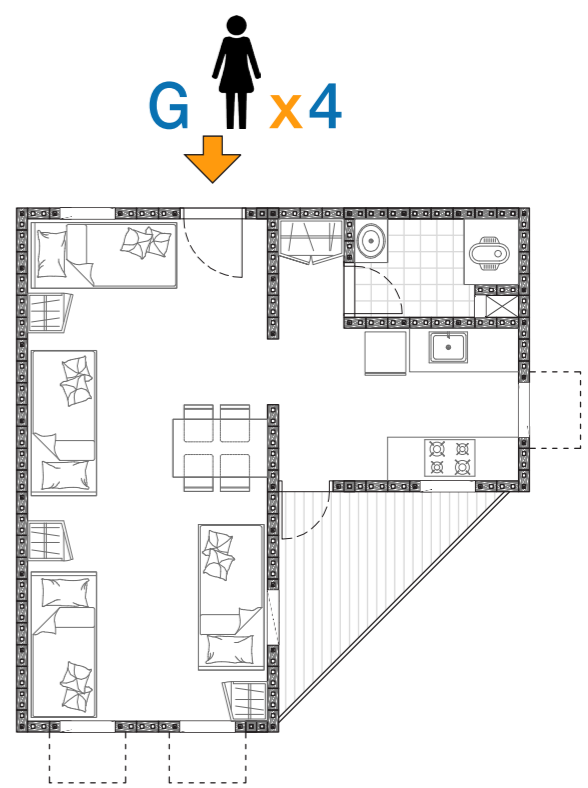
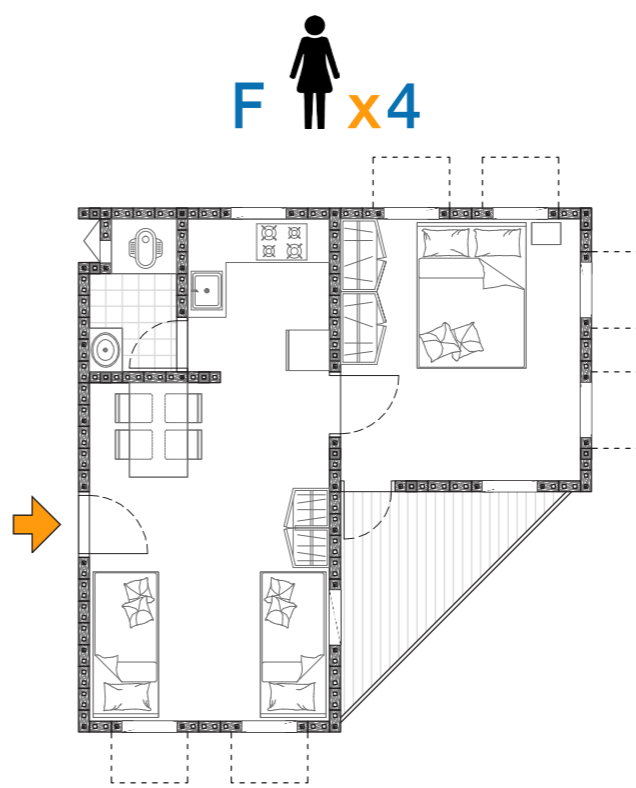
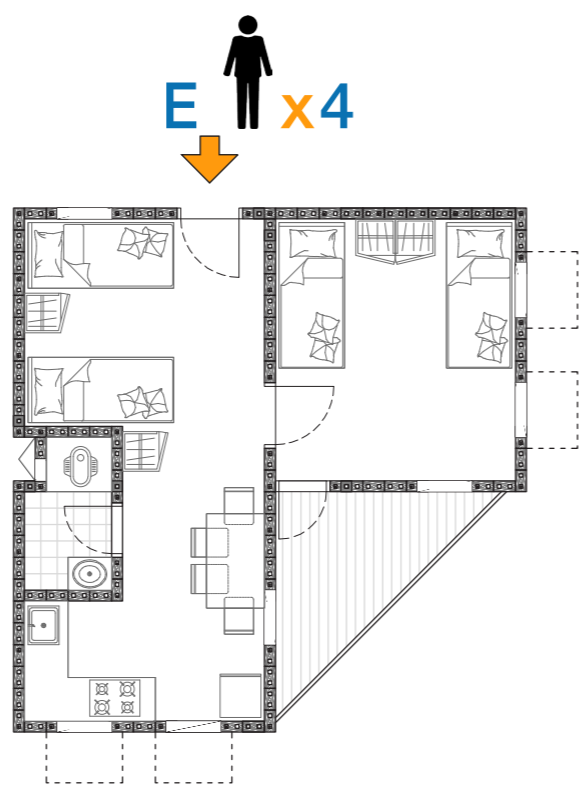
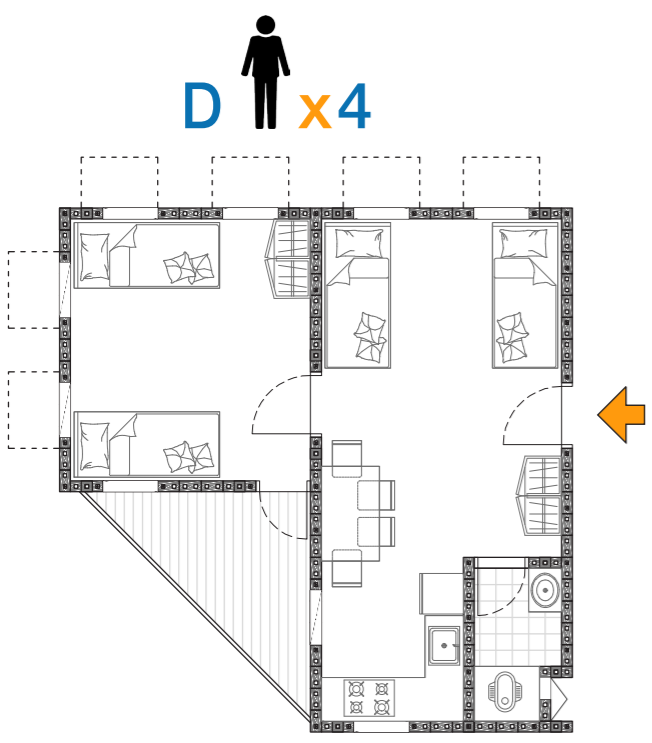

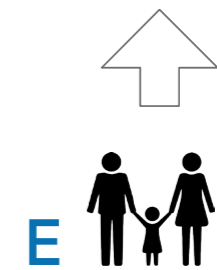
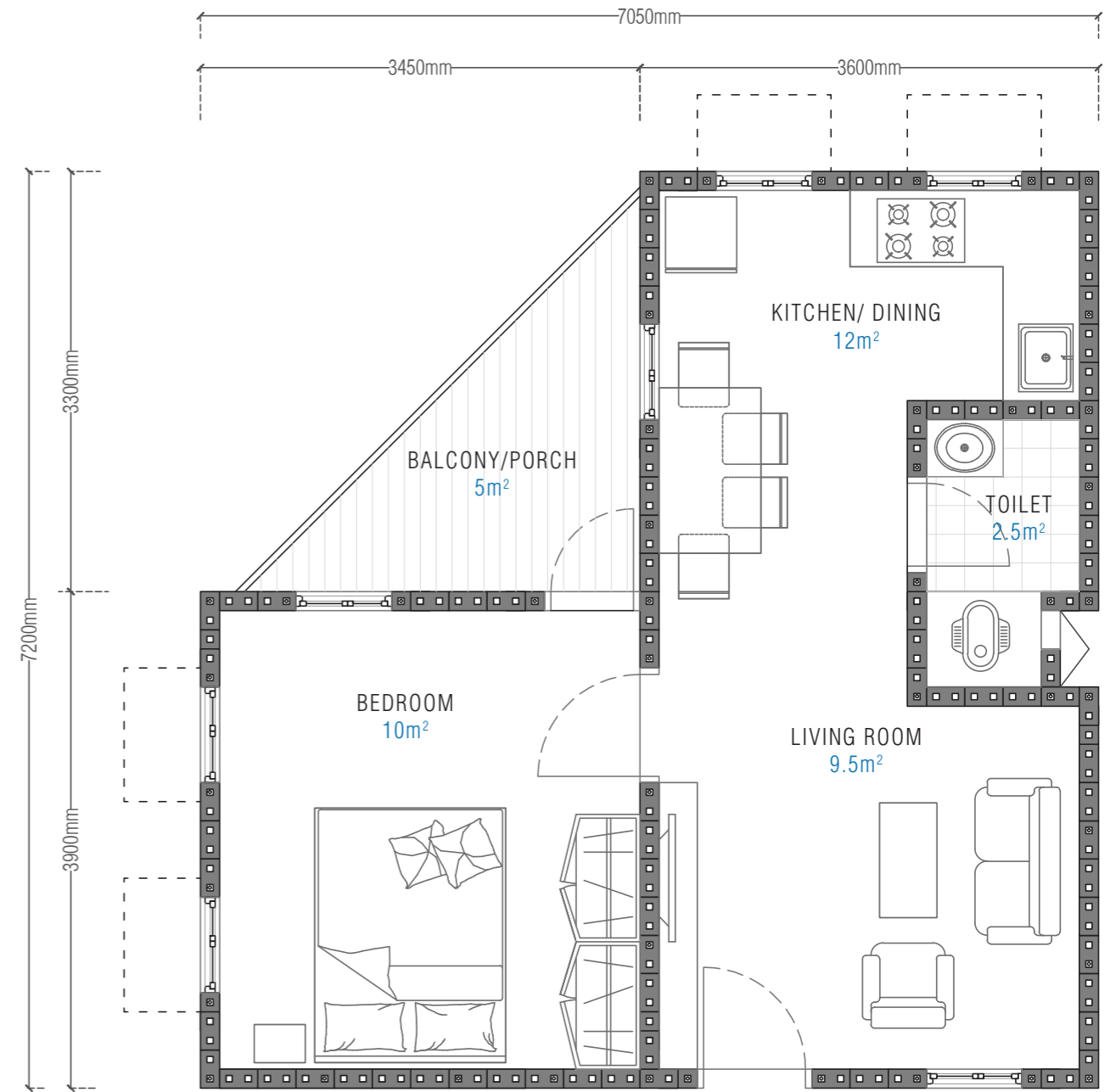
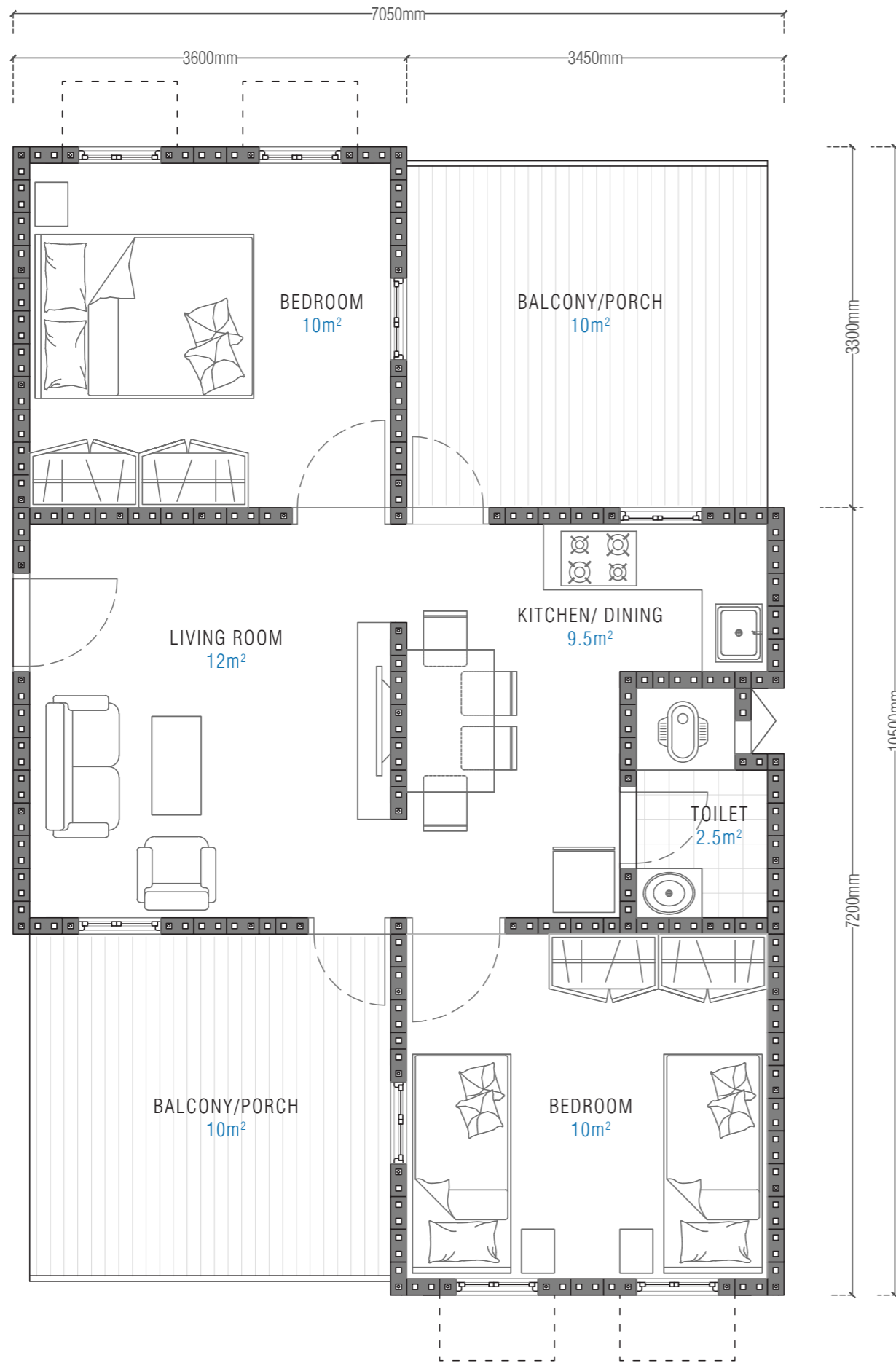
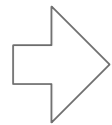

FAMILY UNITS A & E

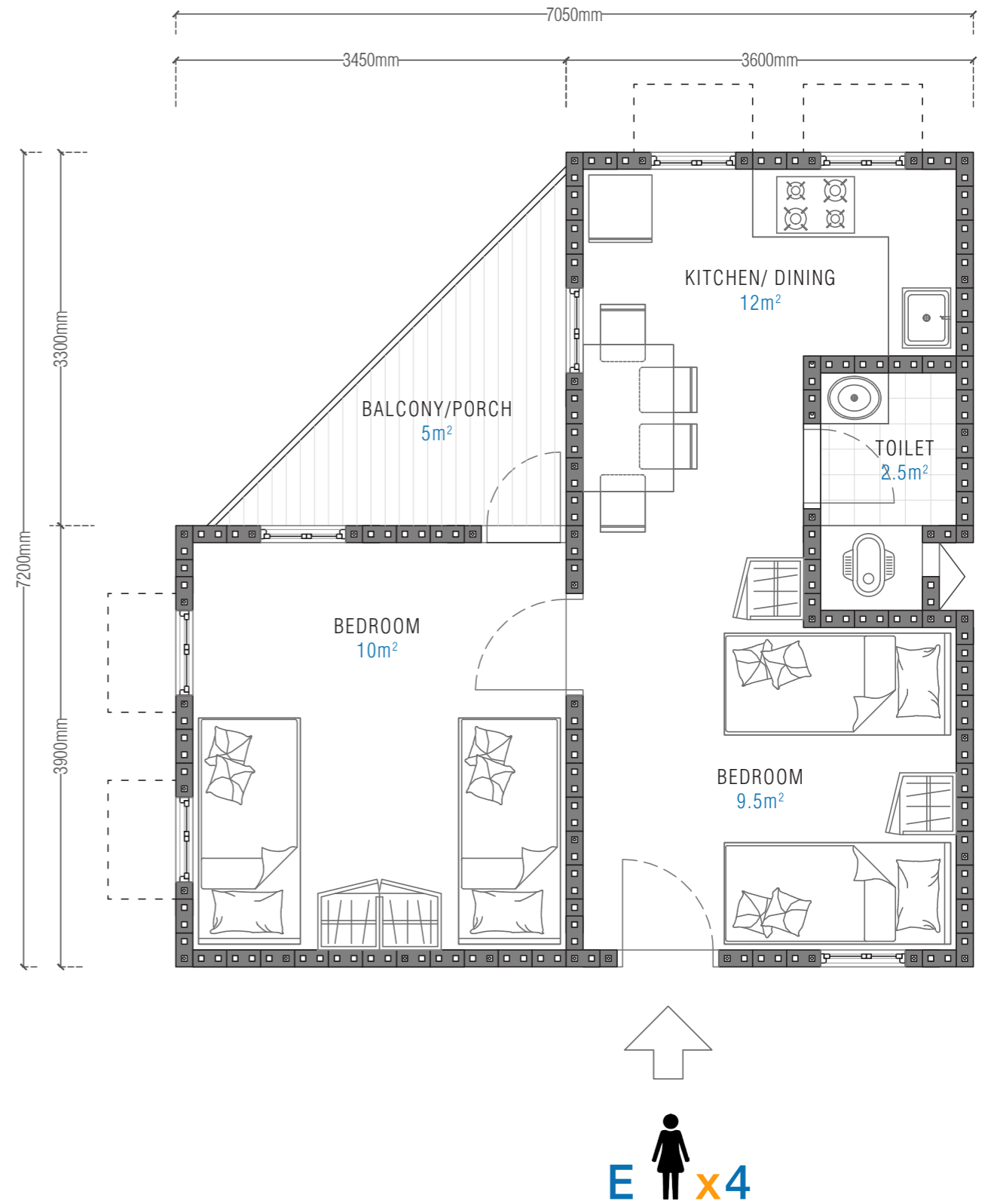
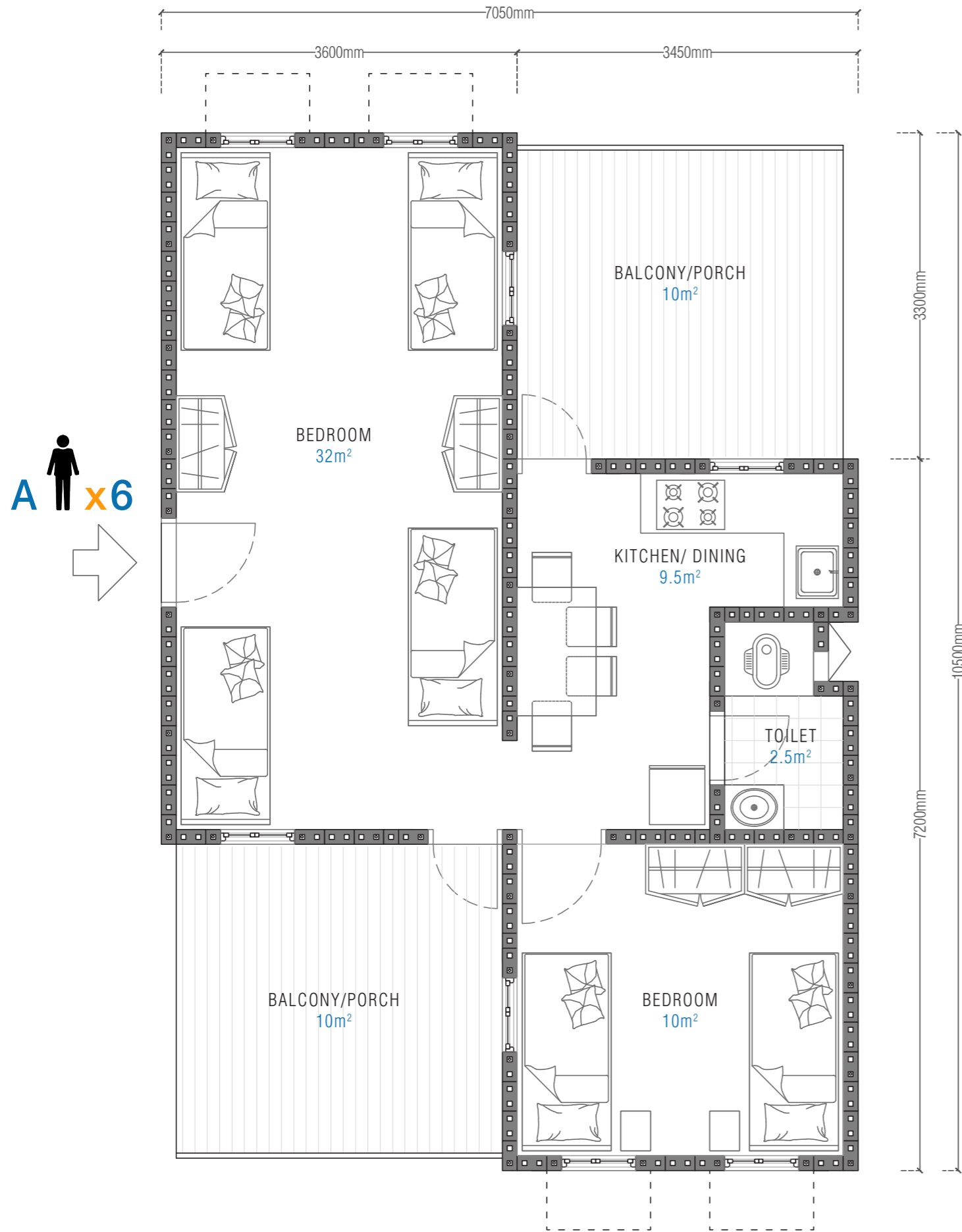

RENTAL UNITS A & E

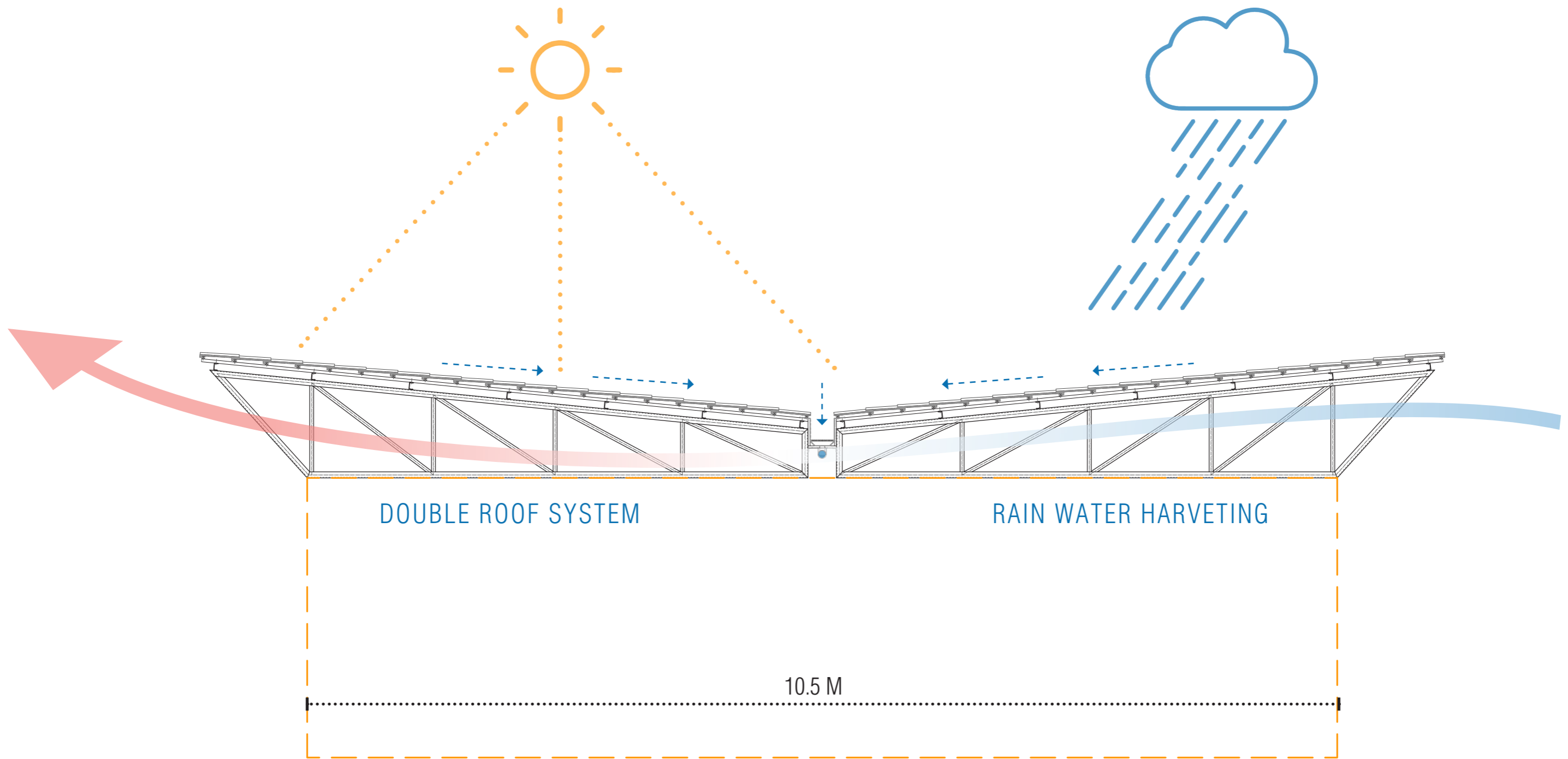

21° - 30°c
AVERAGE TEMPERATURE

7 MONTHS
WET SEASON

ROOFING TYPOLOGY

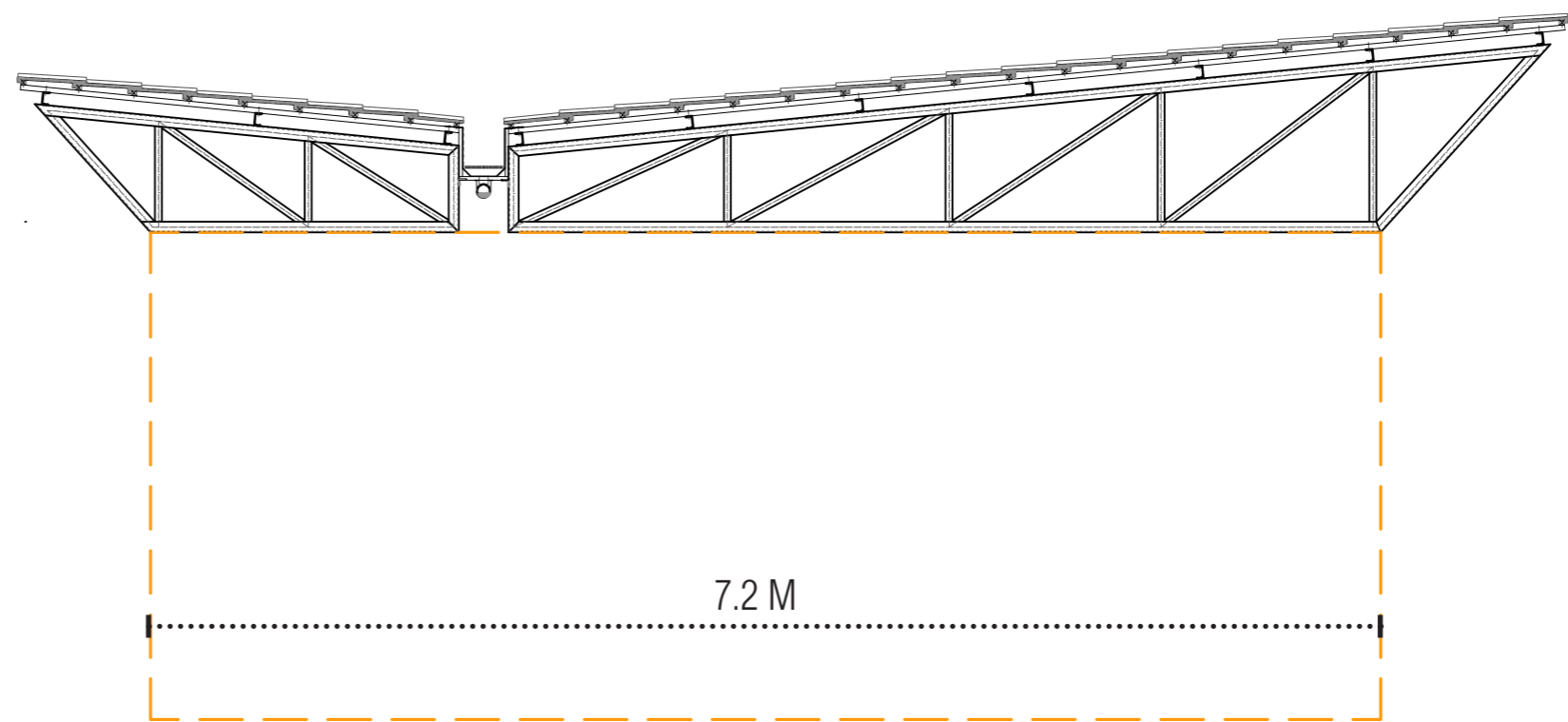

ROOFING TYPOLOGY

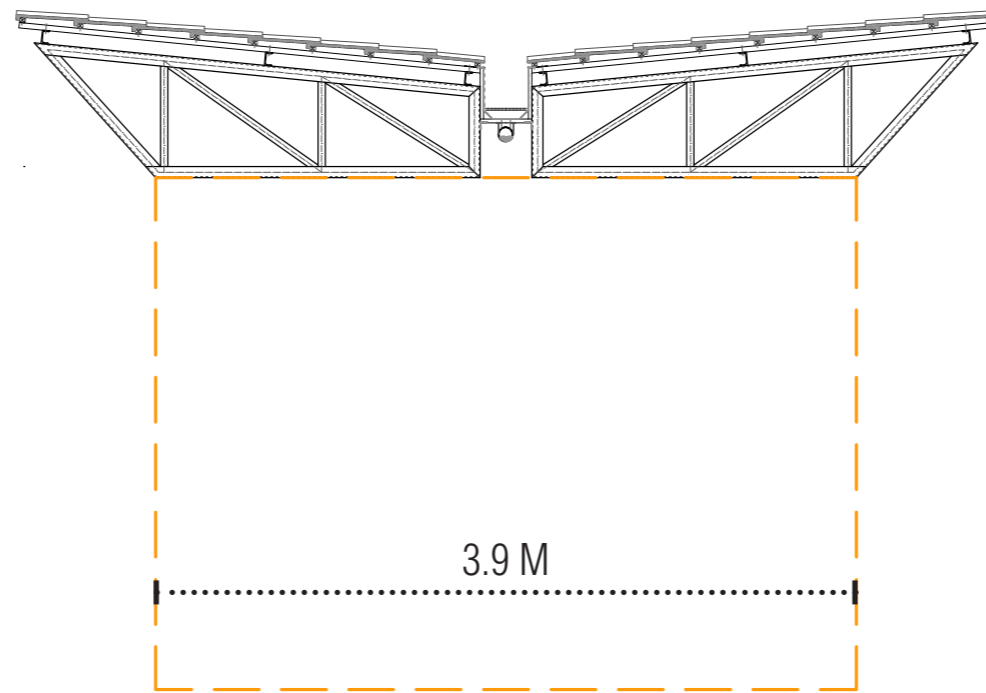

ROOFING TYPOLOGY

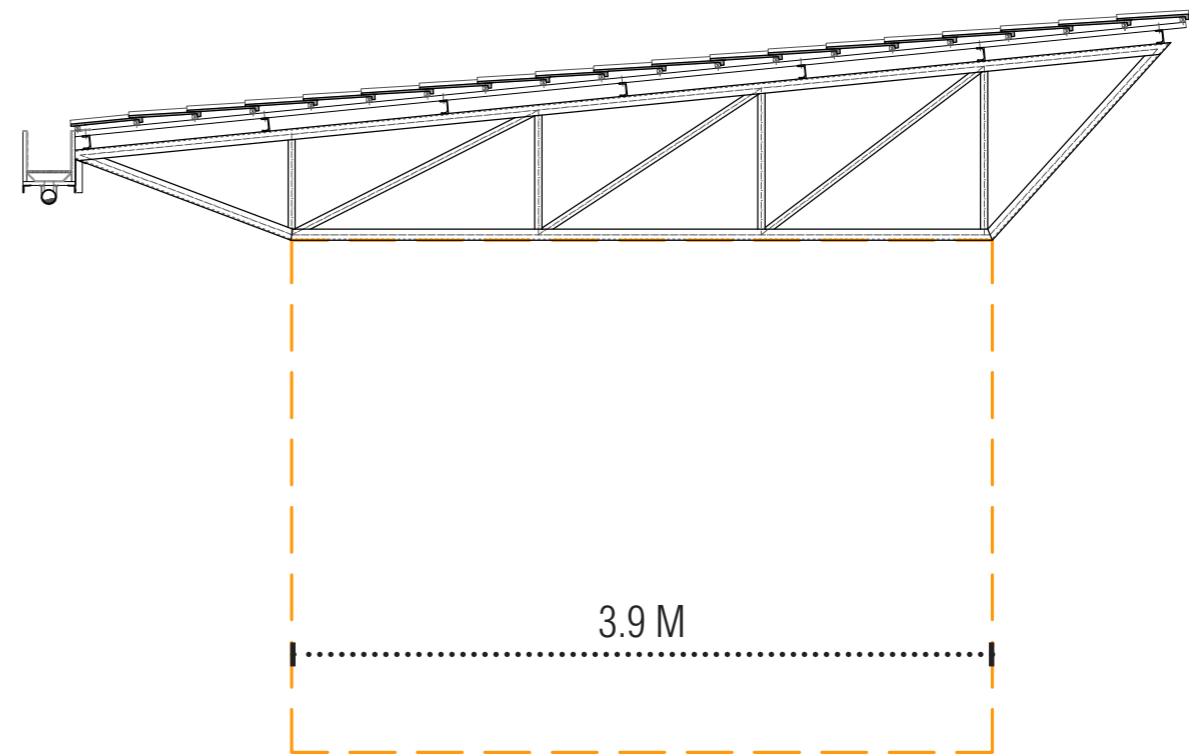

ROOFING TYPOLOGY

An architectural model of a housing complex, viewed from an elevated perspective. The complex consists of several interconnected, multi-story brick buildings with white, gabled roofs. The buildings are arranged around a central courtyard. The courtyard features a small tree in a circular planter, a person sitting on a bench, and other figures for scale. The model is set on a light-colored wooden base. A large orange rectangular frame is overlaid on the central part of the model, containing the text 'HOUSING DESIGN'.

HOUSING DESIGN



SITE LOCATION

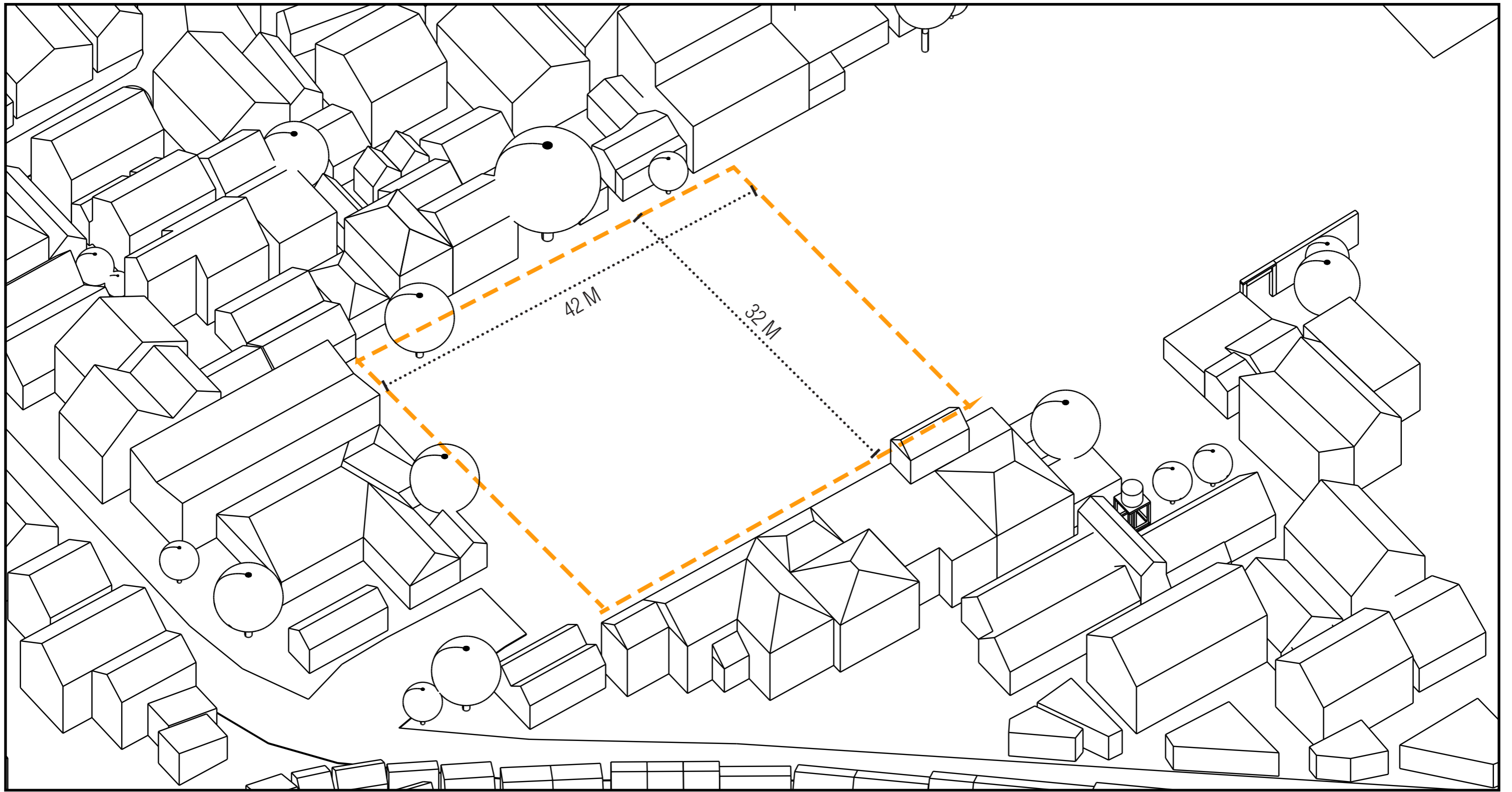

SITE LOCATION



SITE LOCATION

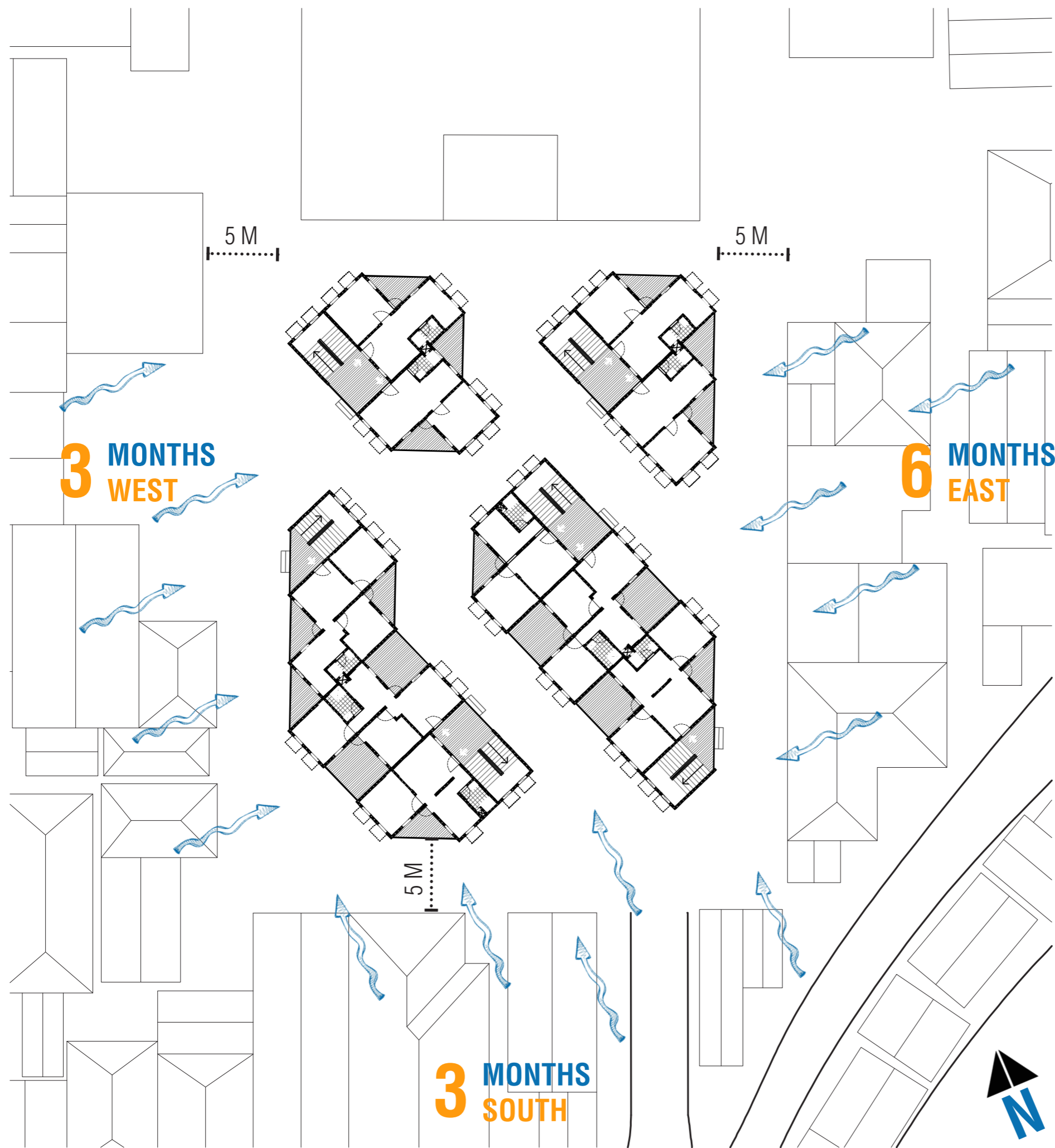

DESIGN STRATEGIES

Cross Ventilation



Breaking the Edge



Vehicular Traffic



Landscape Barrier



Public Zones



Flood Protection



Percolation Pit

GROUND FLOOR PLAN

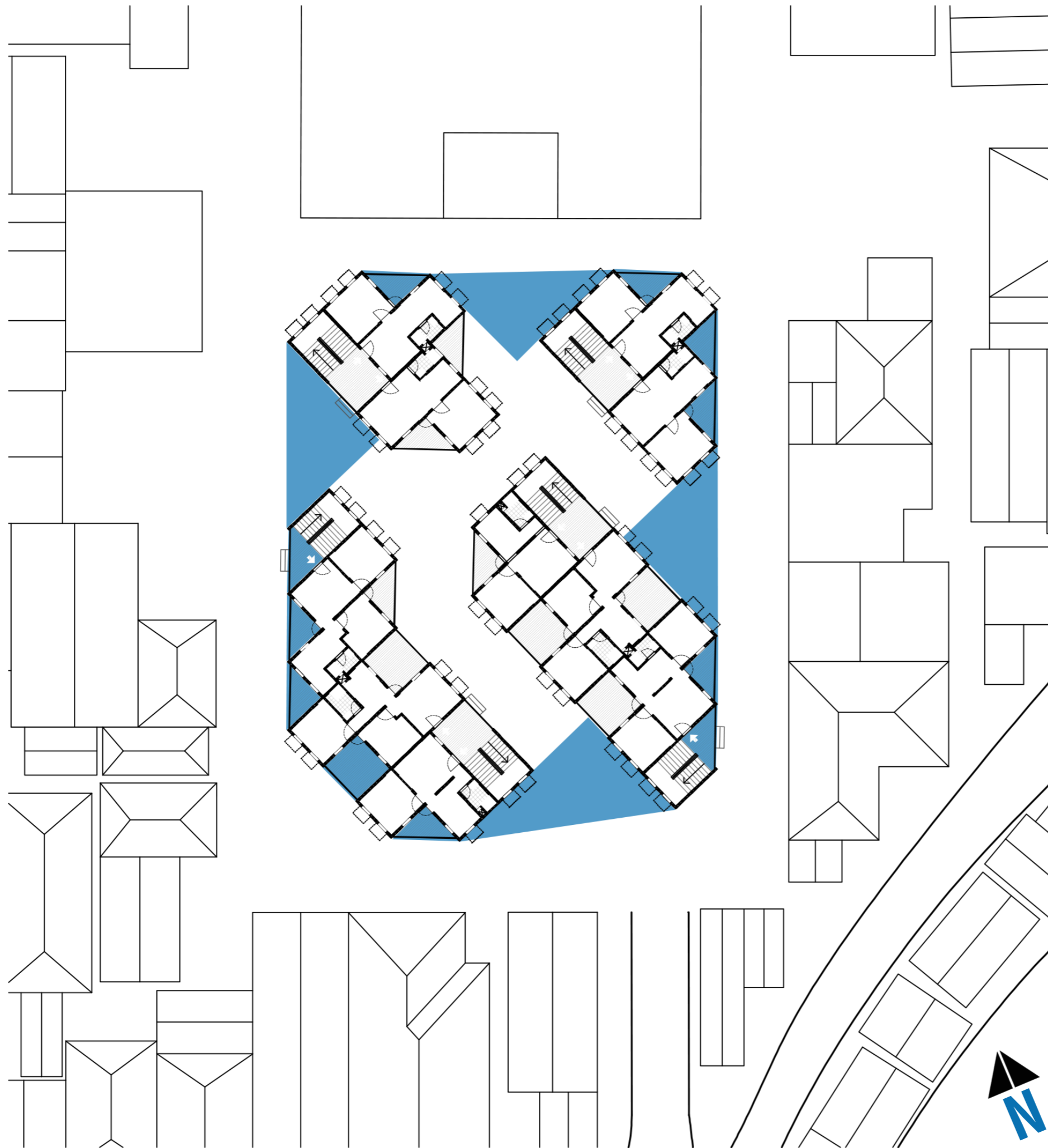

DESIGN STRATEGIES

Cross Ventilation



Breaking the Edge



Vehicular Traffic



Landscape Barrier



Public Zones



Flood Protection



Percolation Pit

GROUND FLOOR PLAN

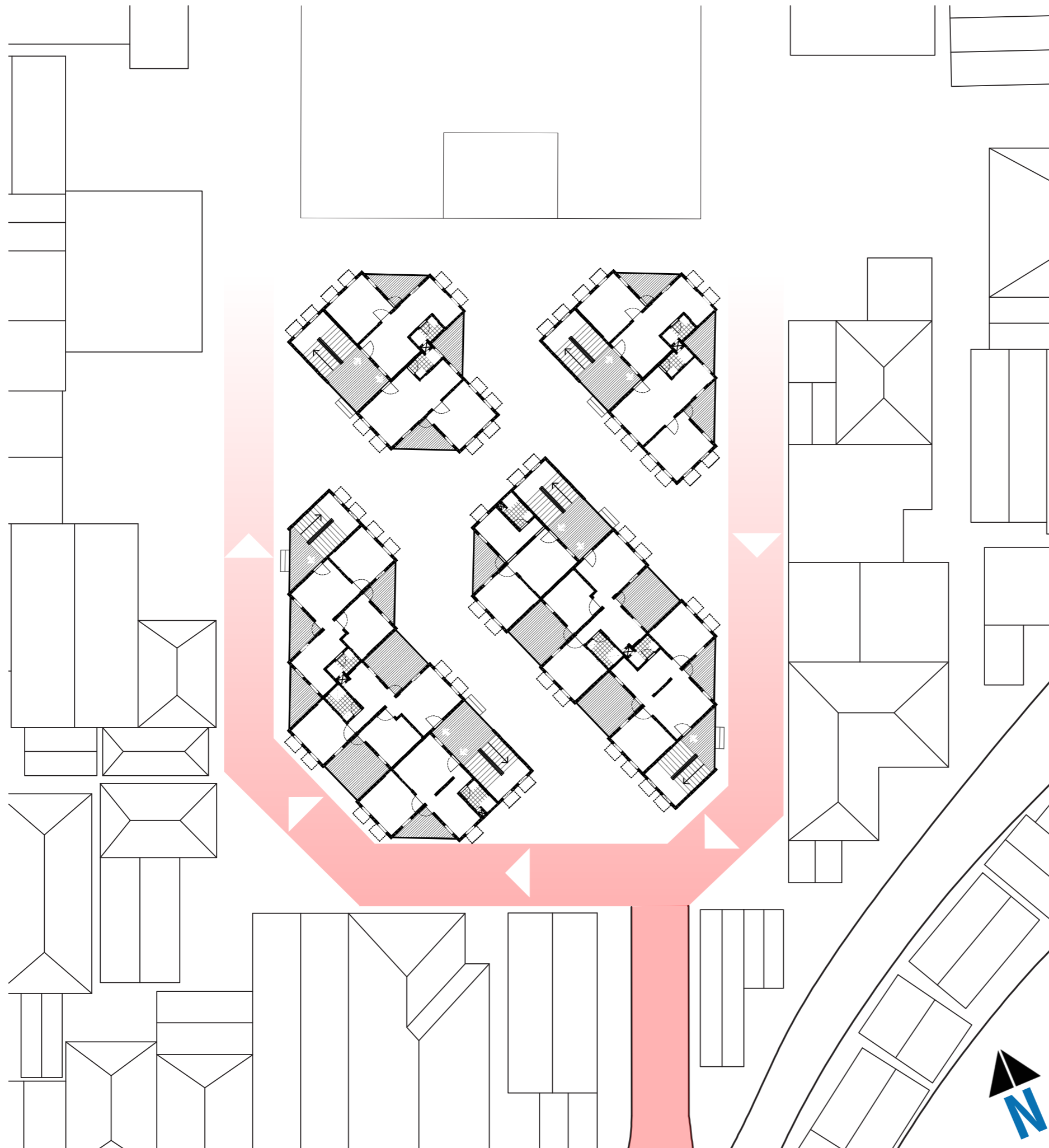

DESIGN STRATEGIES

Cross Ventilation



Breaking the Edge



Vehicular Traffic



Landscape Barrier



Public Zones



Flood Protection



Percolation Pit

GROUND FLOOR PLAN

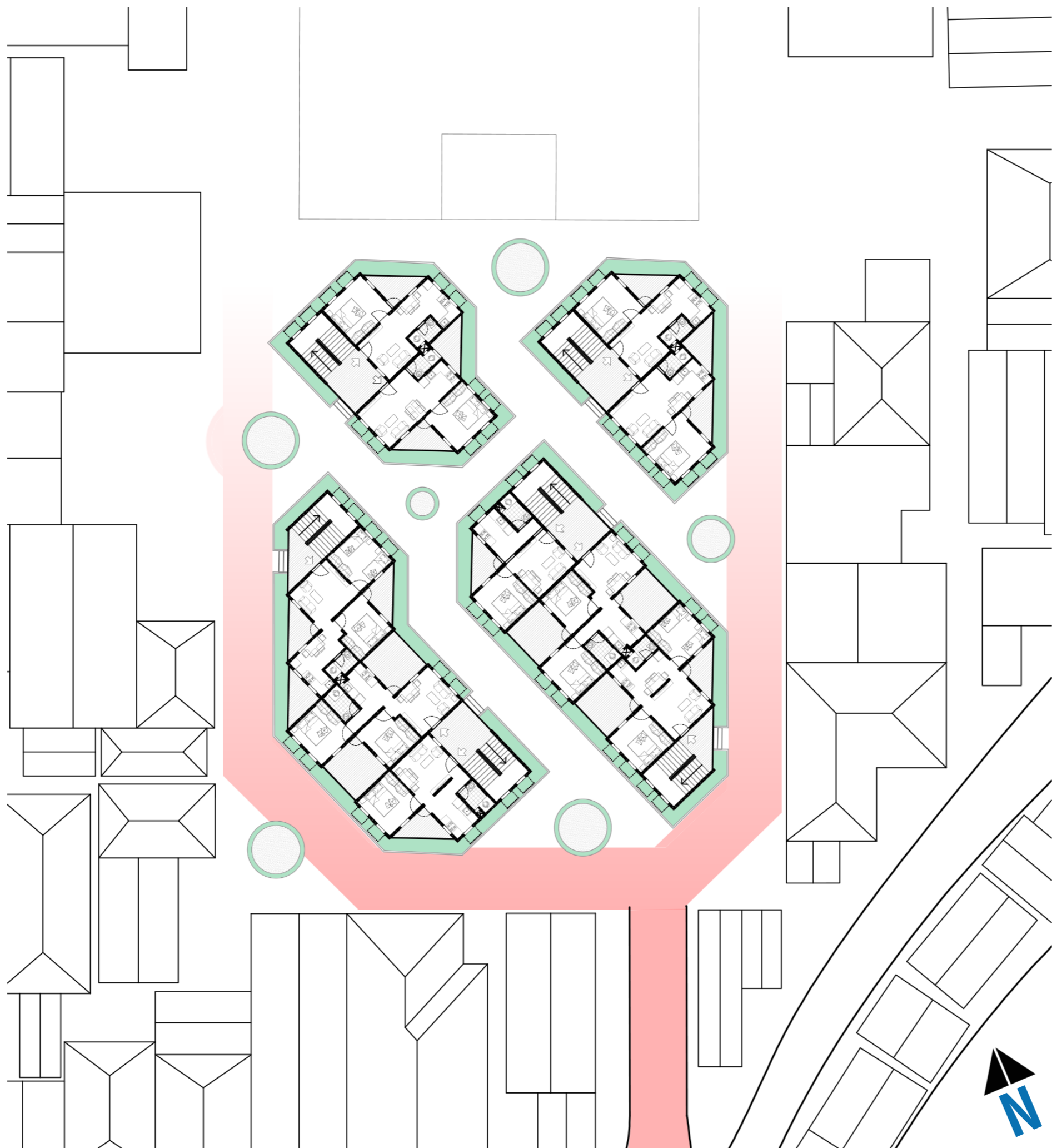

DESIGN STRATEGIES

Cross Ventilation



Breaking the Edge



Vehicular Traffic



Landscape Barrier



Public Zones



Flood Protection



Percolation Pit

GROUND FLOOR PLAN

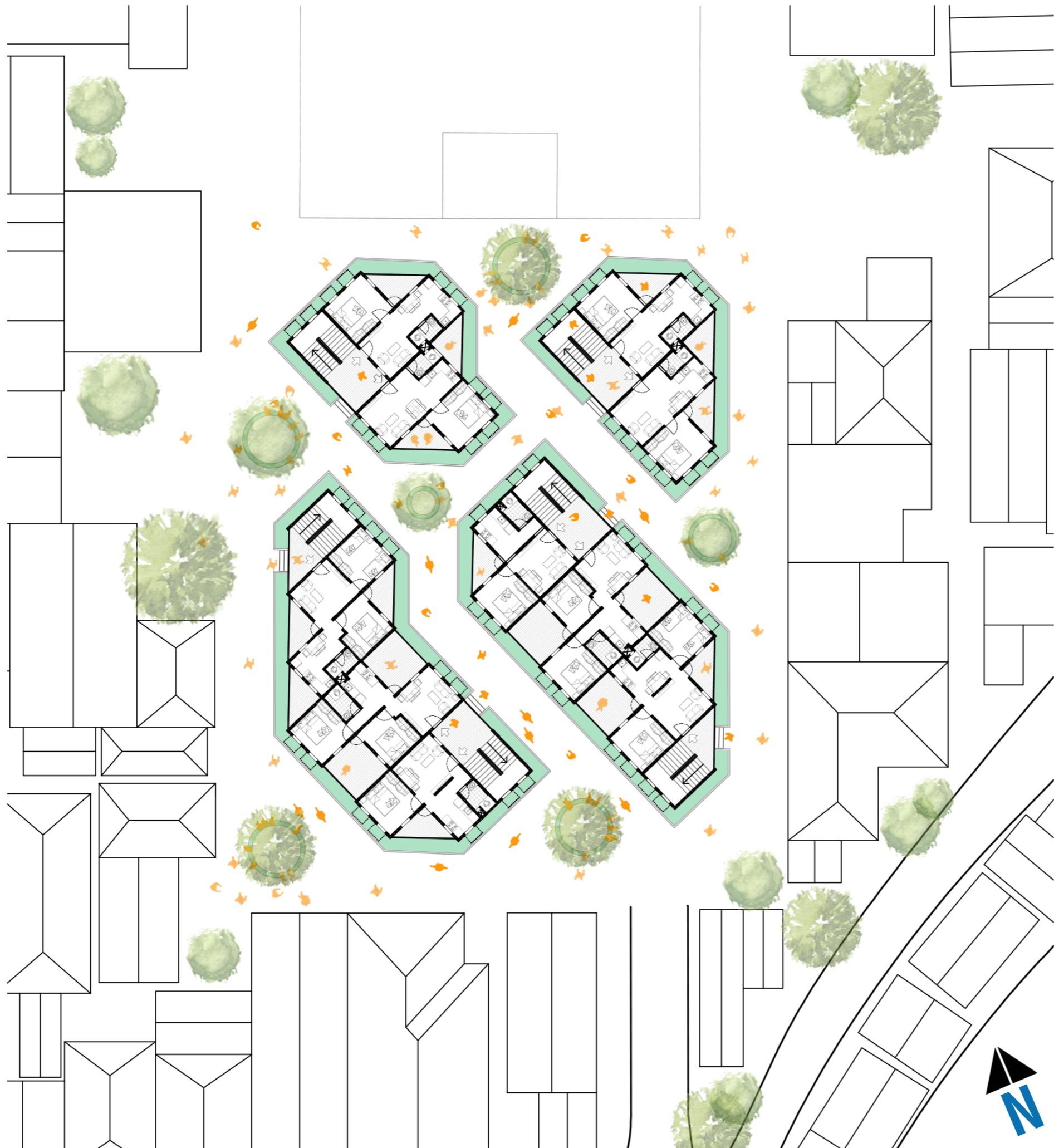

DESIGN STRATEGIES

Cross Ventilation



Breaking the Edge



Vehicular Traffic



Landscape Barrier



Public Zones



Flood Protection



Percolation Pit

GROUND FLOOR PLAN

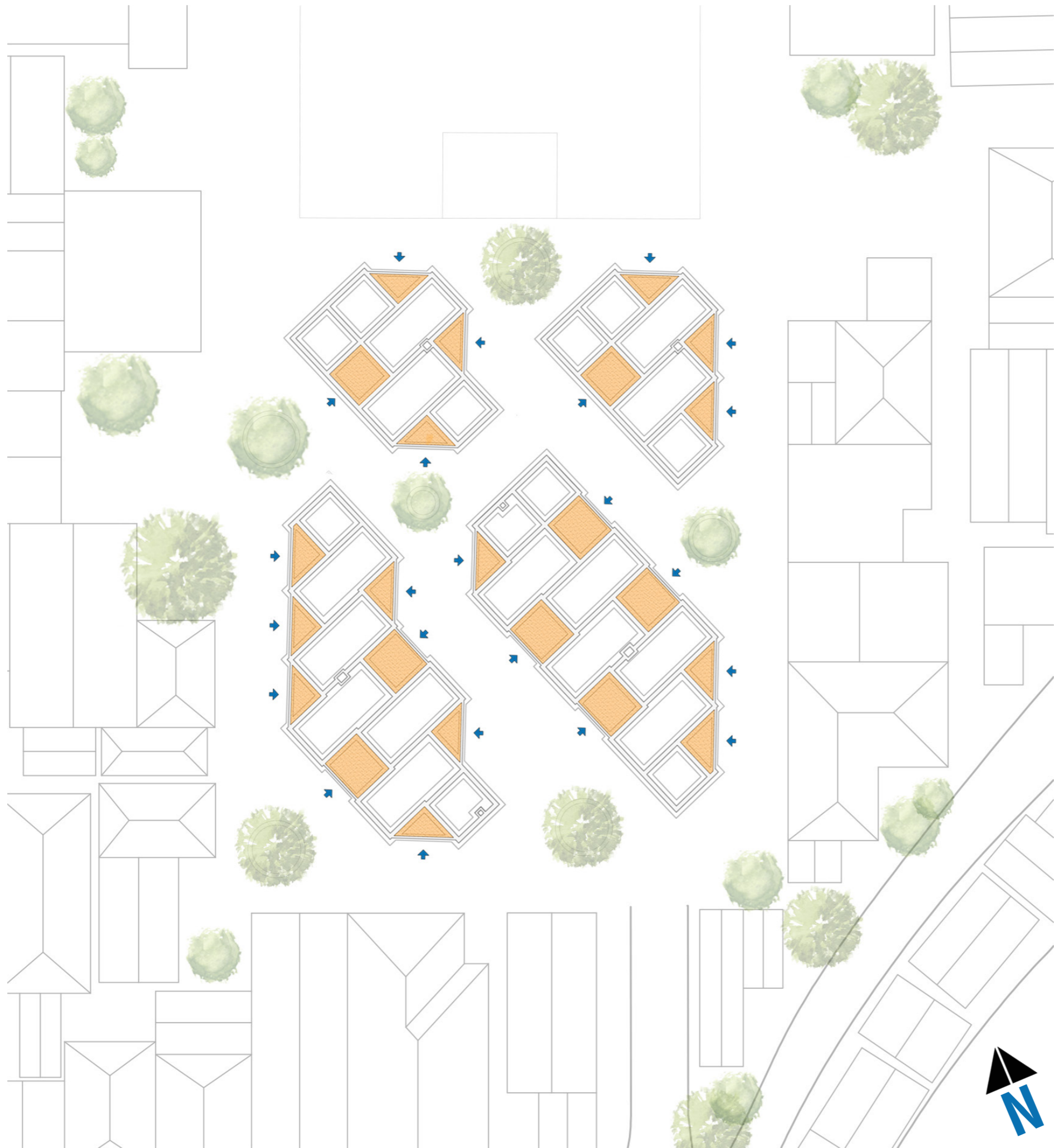

DESIGN STRATEGIES

Cross Ventilation



Breaking the Edge



Vehicular Traffic



Landscape Barrier



Public Zones



Flood Protection



Percolation Pit

FOUNDATION PLAN

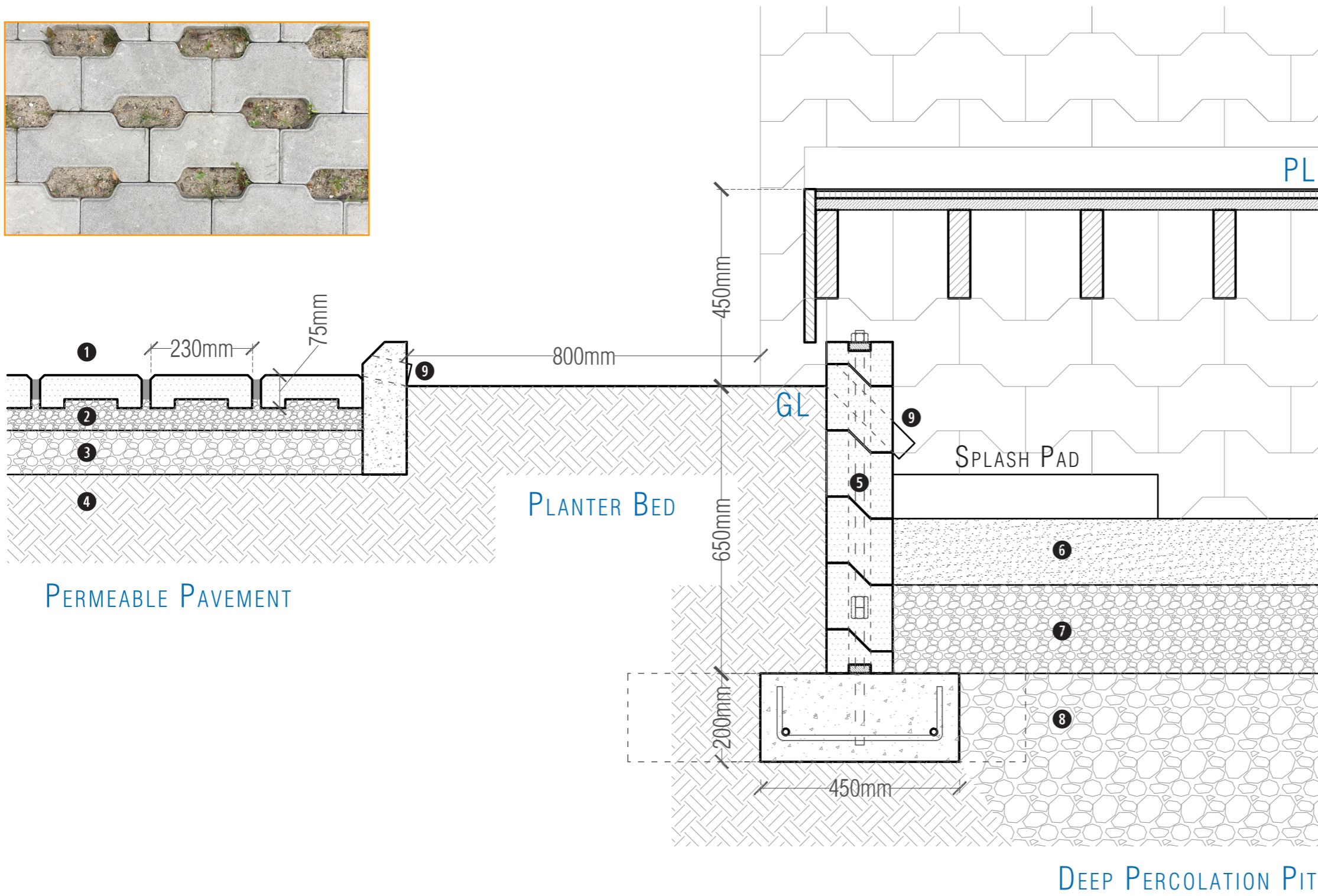

- ① Poly-Block Permeable Paver
- ② Crushed Brick 6-9mm x 50mm thk
- ③ Gravel 20-25mm x 100mm thk
- ④ Rammed Earth
- ⑤ 150mm thk PolyBlock Wall
- ⑥ Coarse Sand 150mm thk
- ⑦ Crushed Brick 6-9mm x 150mm thk
- ⑧ Gravel 20-25mm x 250mm thk
- ⑨ Drain Pipe

WATER PERCOLATION

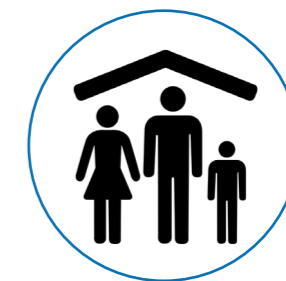

FAMILY HOUSING
30 PPL X 2 FLOORS
TOTAL = **60** PEOPLE

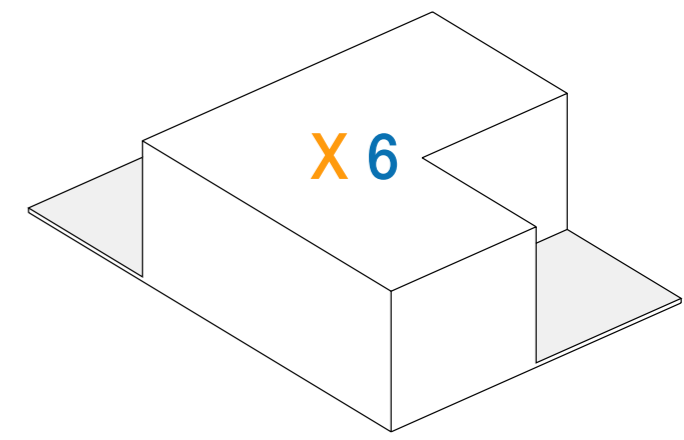
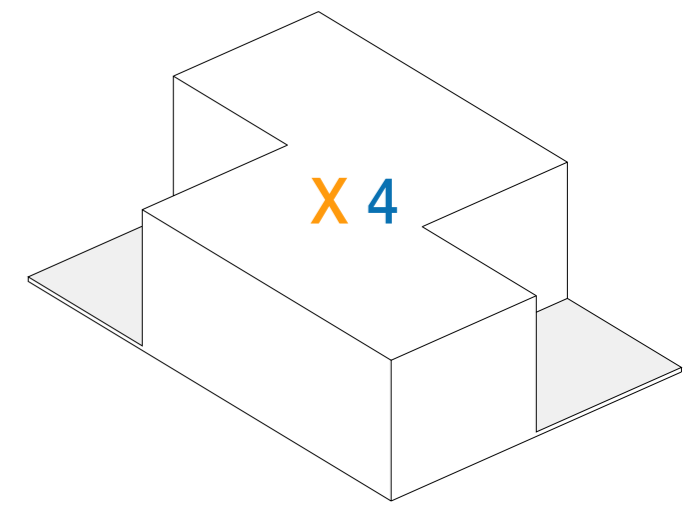
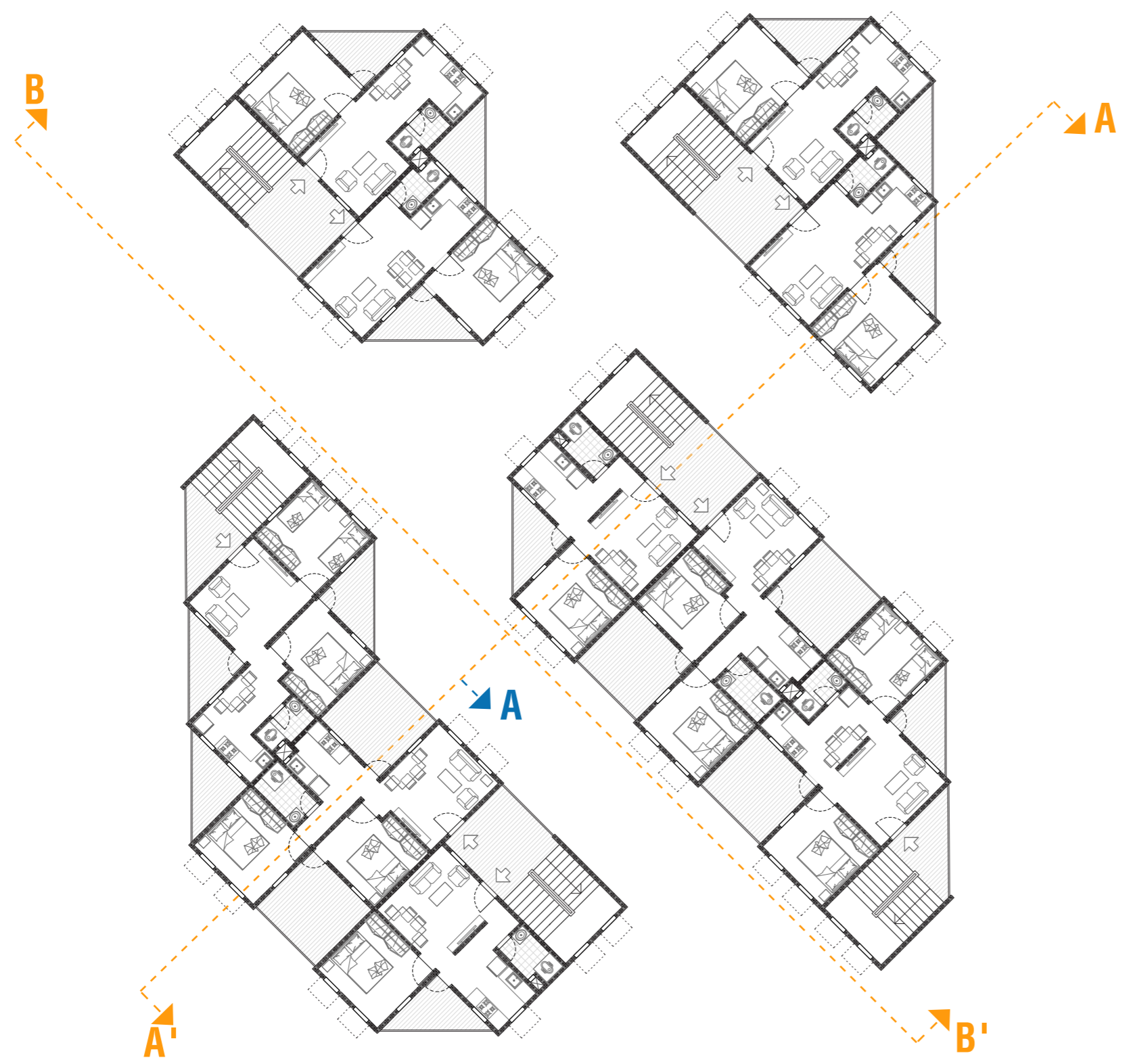

FIRST FLOOR PLAN



WORKER HOUSING

TOTAL = 48 PEOPLE

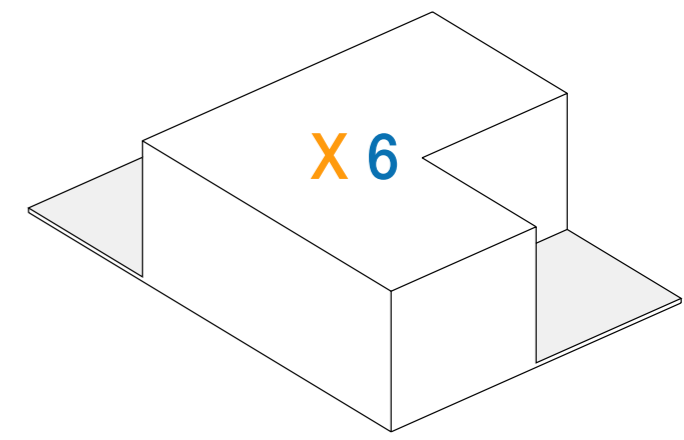
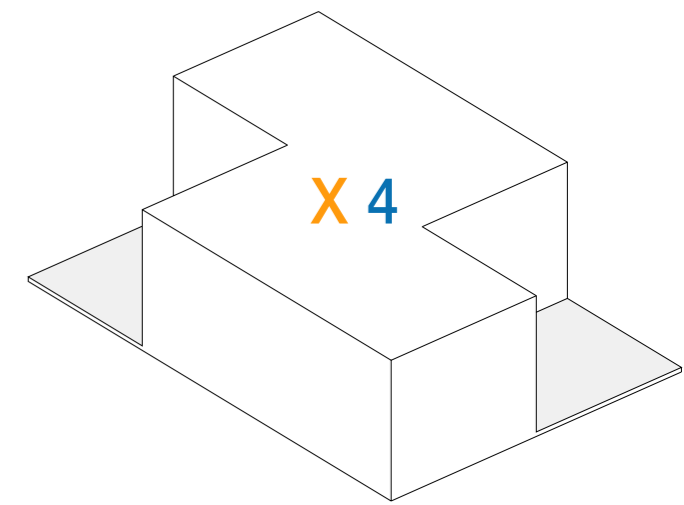
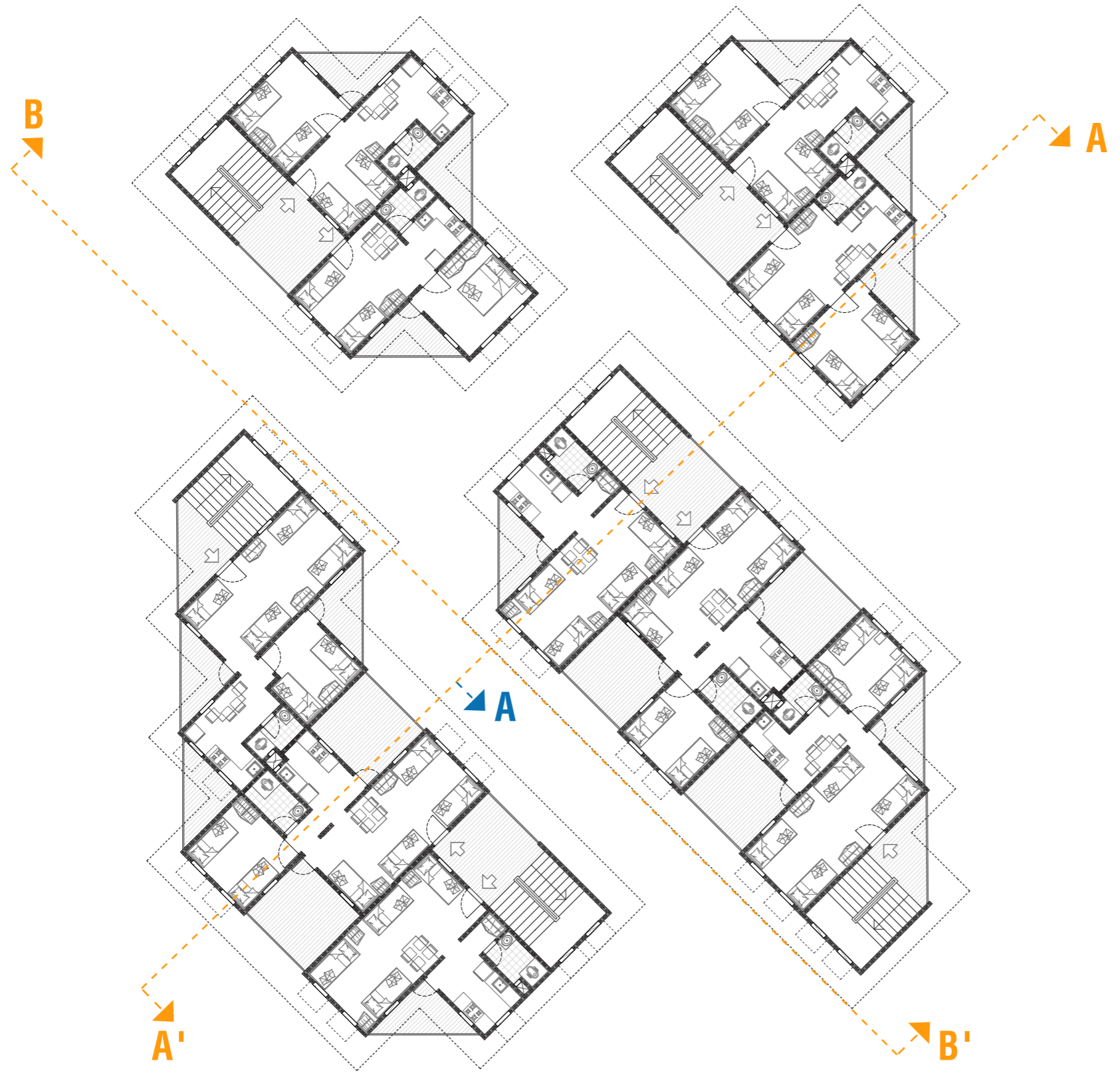

SECOND FLOOR PLAN

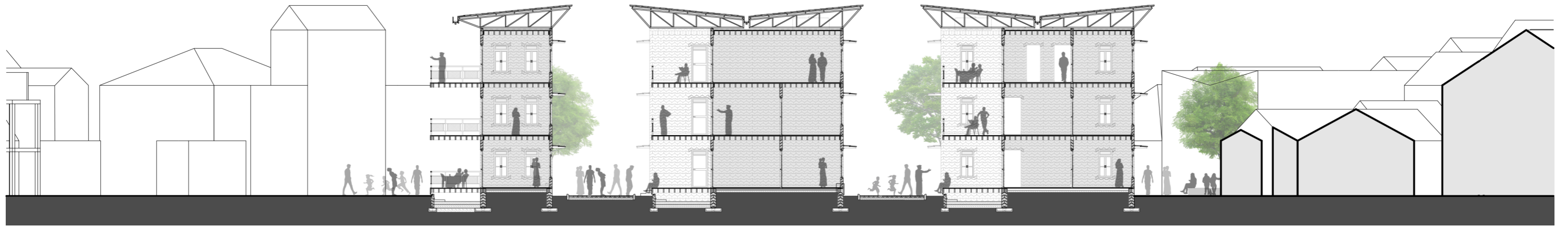

SECTION AA'



SECTION BB'



ROOF PLAN

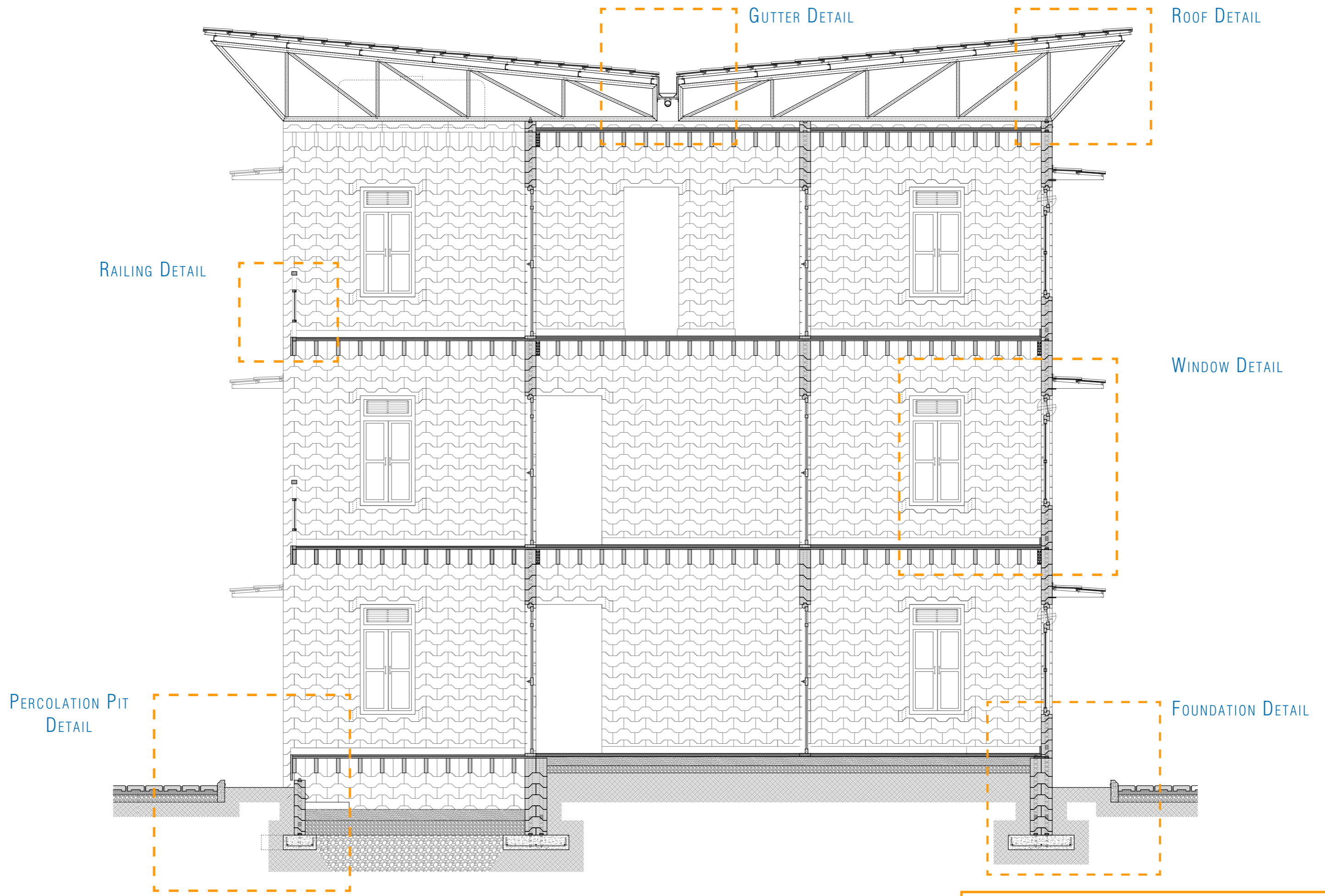

GUTTER DETAIL

ROOF DETAIL

RAILING DETAIL

WINDOW DETAIL

PERCOLATION PIT
DETAIL

FOUNDATION DETAIL

DETAIL SECTION-AA'

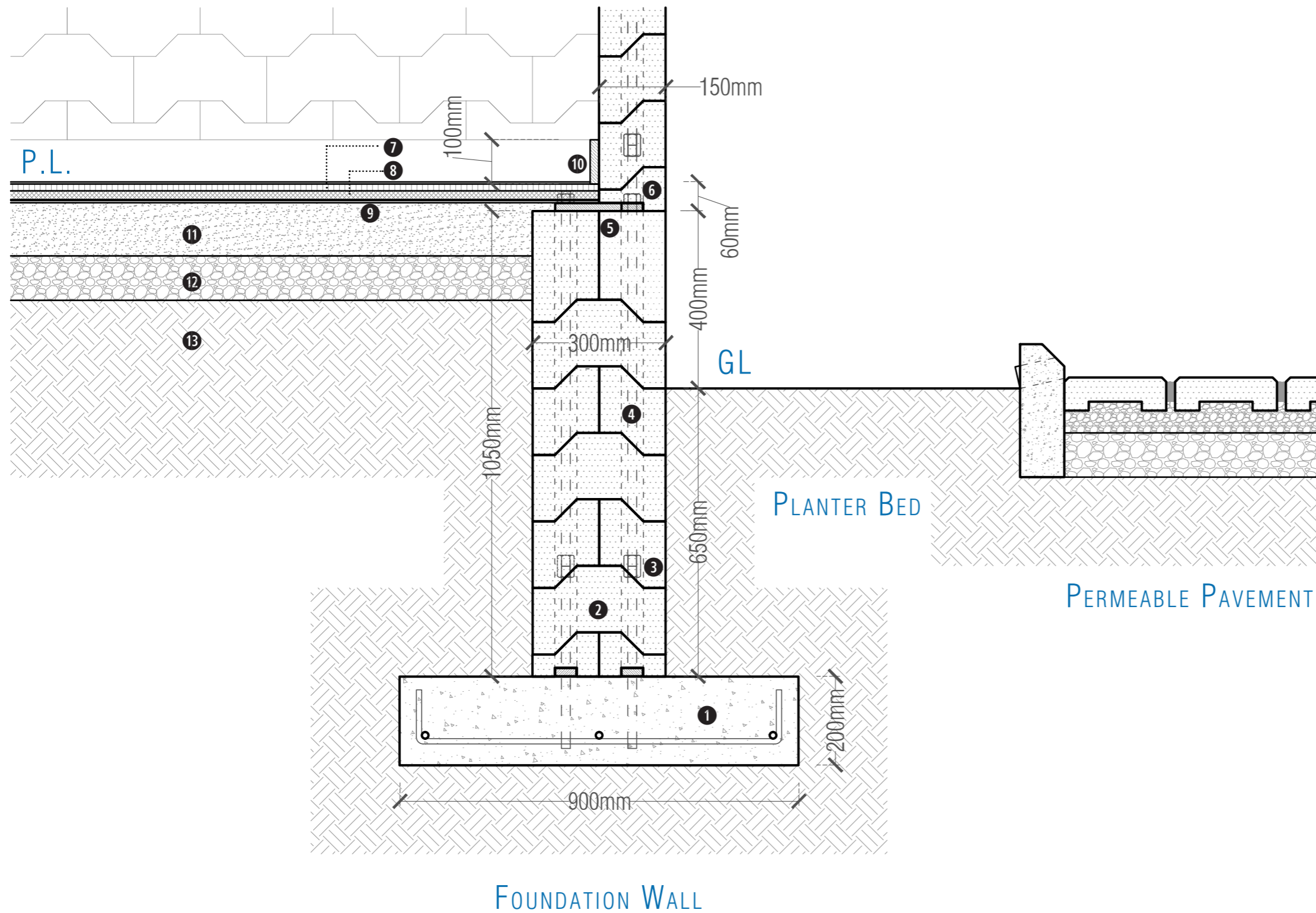

- ① R.C.C. Foundation Pad
- ② 300mm thk PolyBlock Foundation Wall
- ③ S.S. Extension Nut
- ④ M20 Threaded Rod x 950mm
- ⑤ S.S. Plate 200mm x 20mm
- ⑥ M20 S.S. Nut
- ⑦ 15mm Flattened Bamboo Flooring
- ⑧ 20mm Recycled Felt Sound Proofing
- ⑨ Water Proofind Membrane
- ⑩ 25thk Bamboo Side Board
- ⑪ P.C.C. Floor
- ⑫ Coarse Gravel
- ⑬ Rammed Earth

FOUNDATION DETAIL

ELEVATION

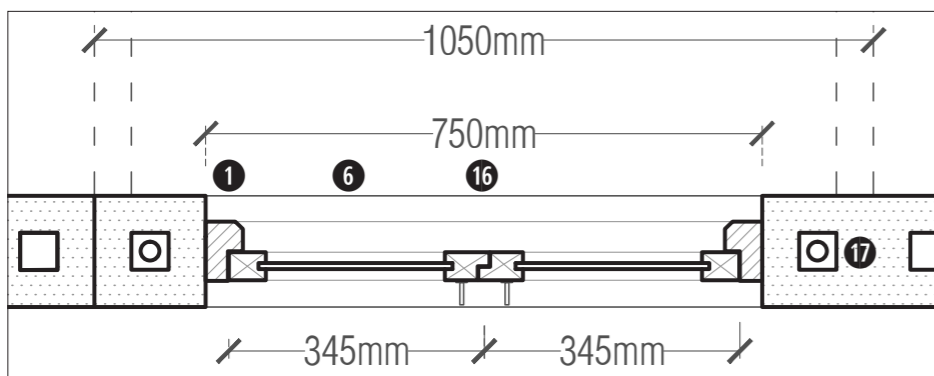
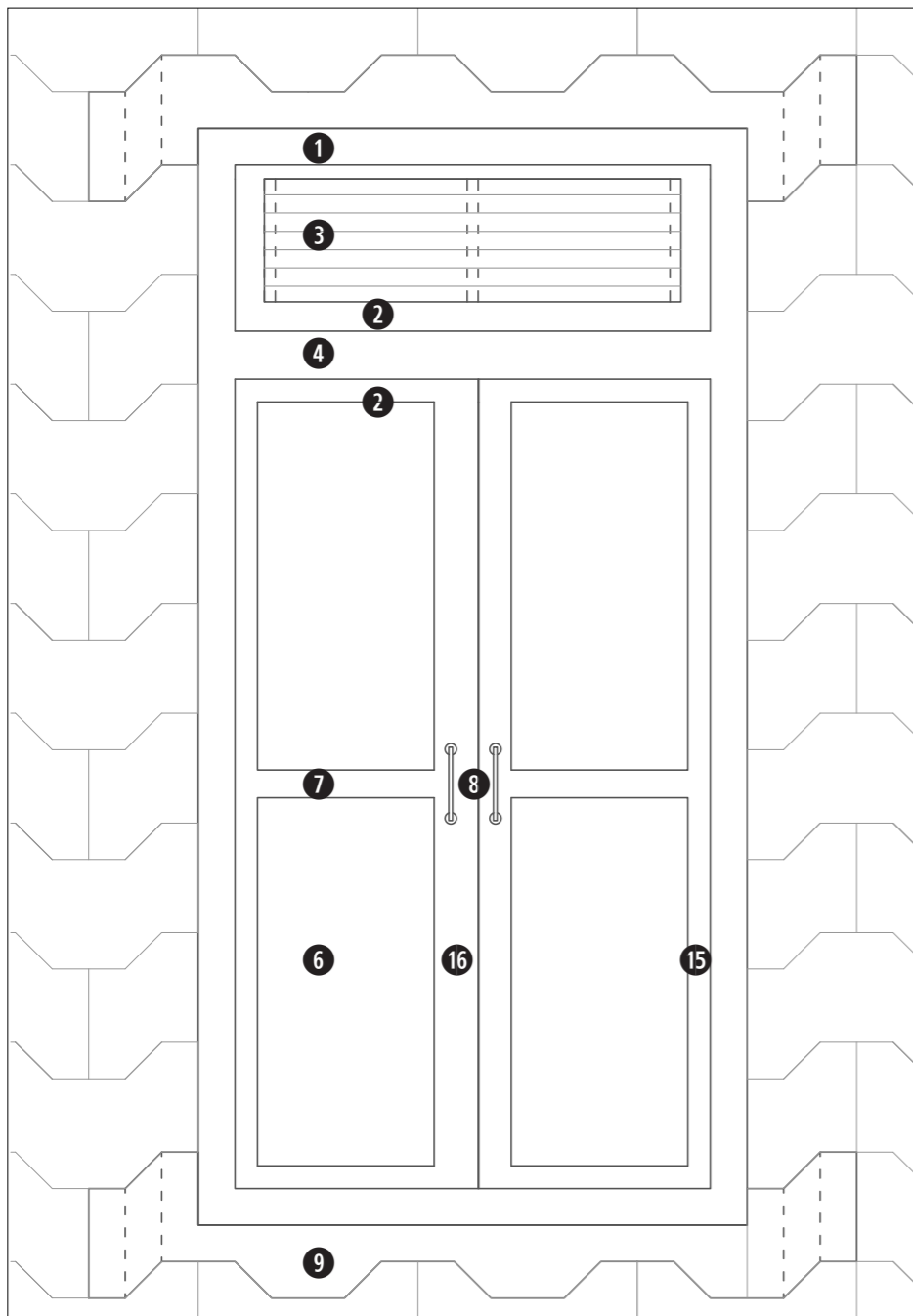

PLAN

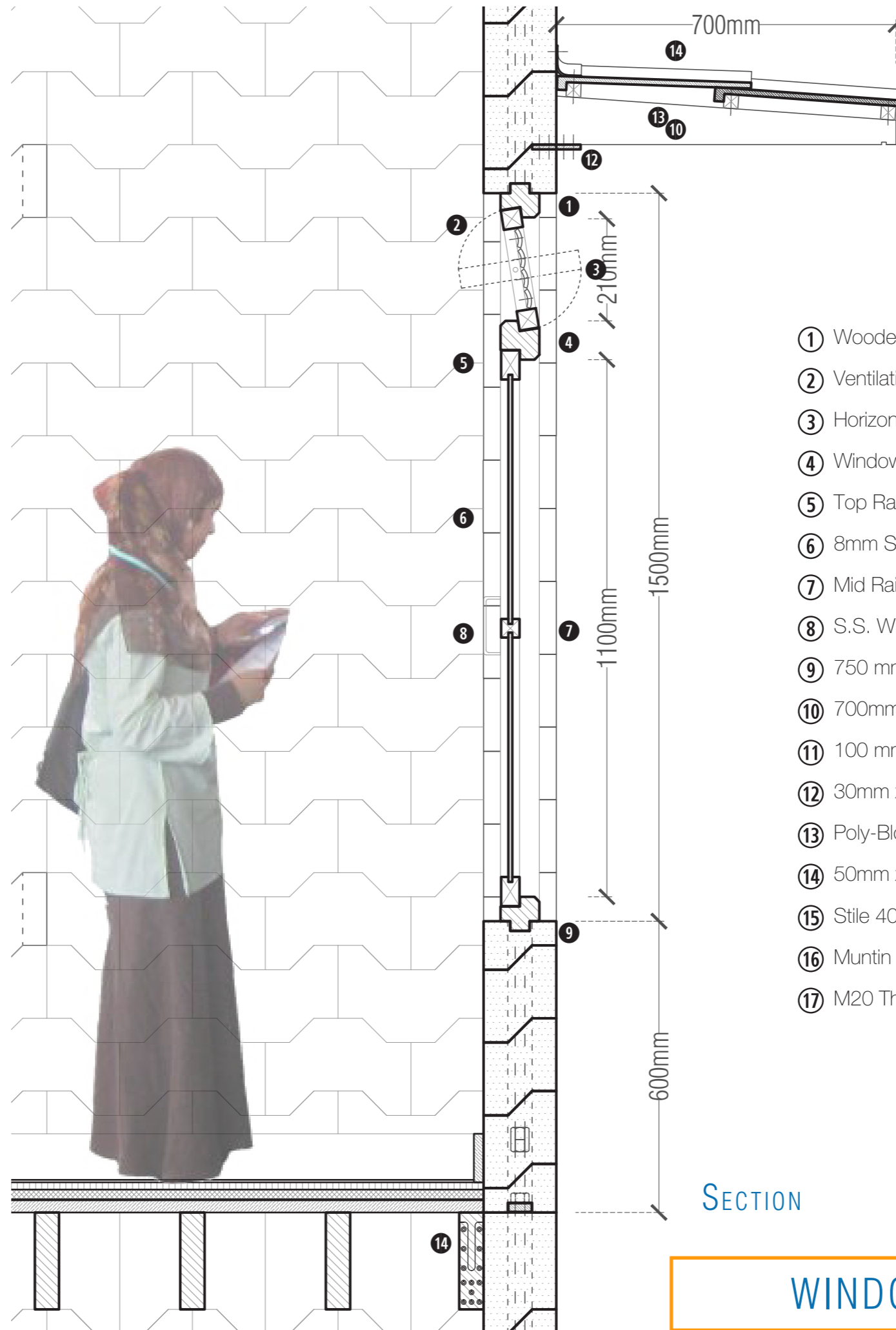

- ① Wooden Jamb 80mm x 50mm
- ② Ventilation Window Frame 40mm x 40mm
- ③ Horizontal Bamboo Slats
- ④ Window Mid Jamb 80mm x 80mm
- ⑤ Top Rail 40mm x 60mm
- ⑥ 8mm Single Glazing
- ⑦ Mid Rail 40mm x 40mm
- ⑧ S.S. Window Handle
- ⑨ 750 mm Wide Sill & Lintel Block
- ⑩ 700mm x 100 mm Wooden Support
- ⑪ 100 mm x 20 mm S.S. Plate
- ⑫ 30mm x 30mm Battens @ 325mm c/c
- ⑬ Poly-Block Roof Tiles
- ⑭ 50mm x 200mm Floor Joists @300 c/c
- ⑮ Stile 40mm x 60mm
- ⑯ Muntin 60mm x 40mm
- ⑰ M20 Threaded Rod x 950mm

SECTION

WINDOW DETAIL

- ① Poly-Block Roof Tiles
- ② 30mm x 30mm Battens @ 325mm c/c
- ③ 30mm x 30mm Runner @ 300mm c/c
- ④ Steel Purlin 40mm x 75mm @1000mm c/c
- ⑤ Steel L-Angle Truss 60mm x 60mm @ 3600mm c/c
- ⑥ Steel L-Angle Web Bracing 40mm x 40mm
- ⑦ M20 S.S. Nut
- ⑧ 20mm Recycled Felt Sound Proofing
- ⑨ Water Proofing Membrane
- ⑩ 25mm thk Plywood Subfloor
- ⑪ 50mm x 200mm Floor Joists @300 c/c
- ⑫ 240 mm x 340mm Gutter
- ⑬ Aluminum Flashing
- ⑭ 80 mm PVC Drain Pipe

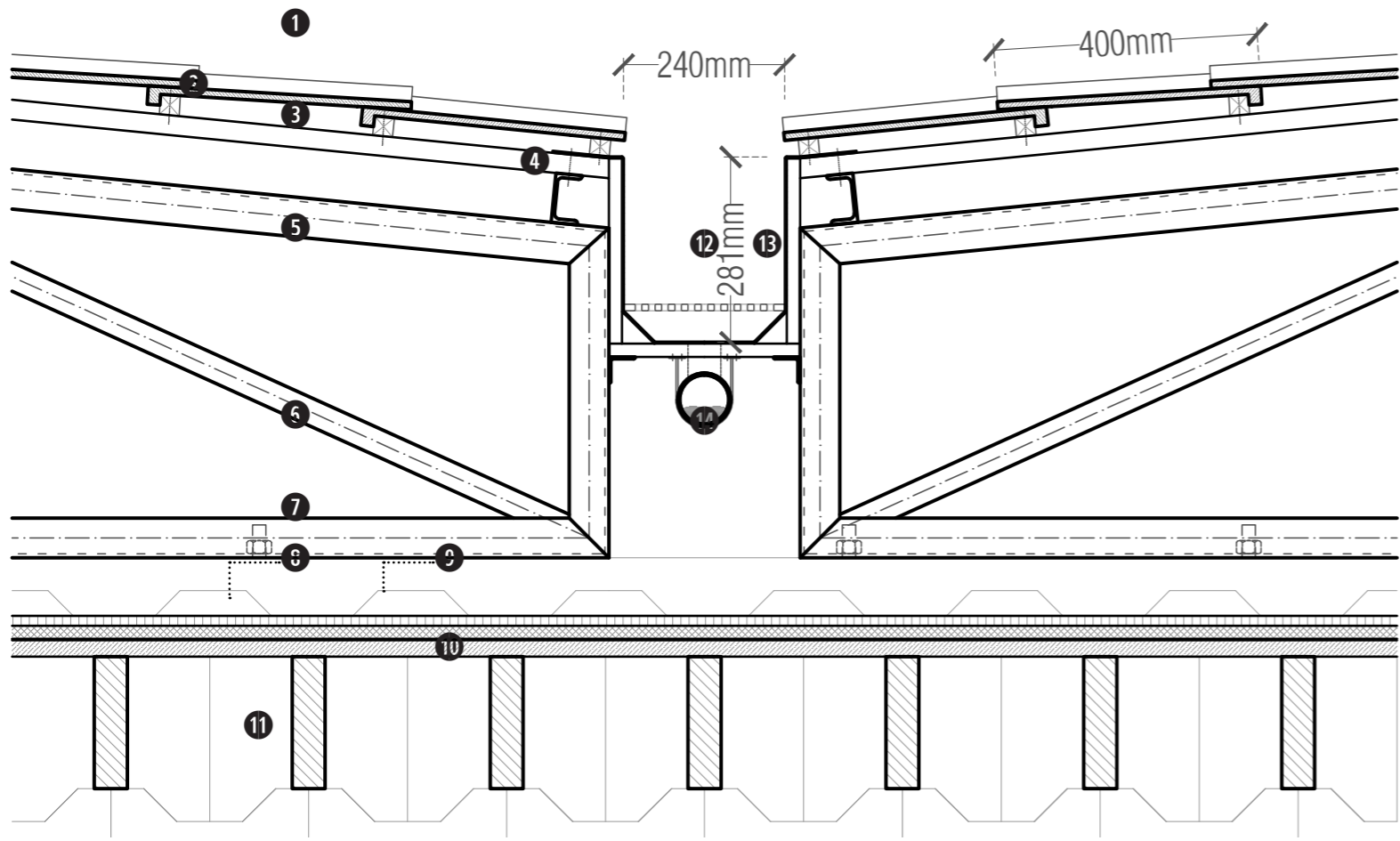

GUTTER DETAIL

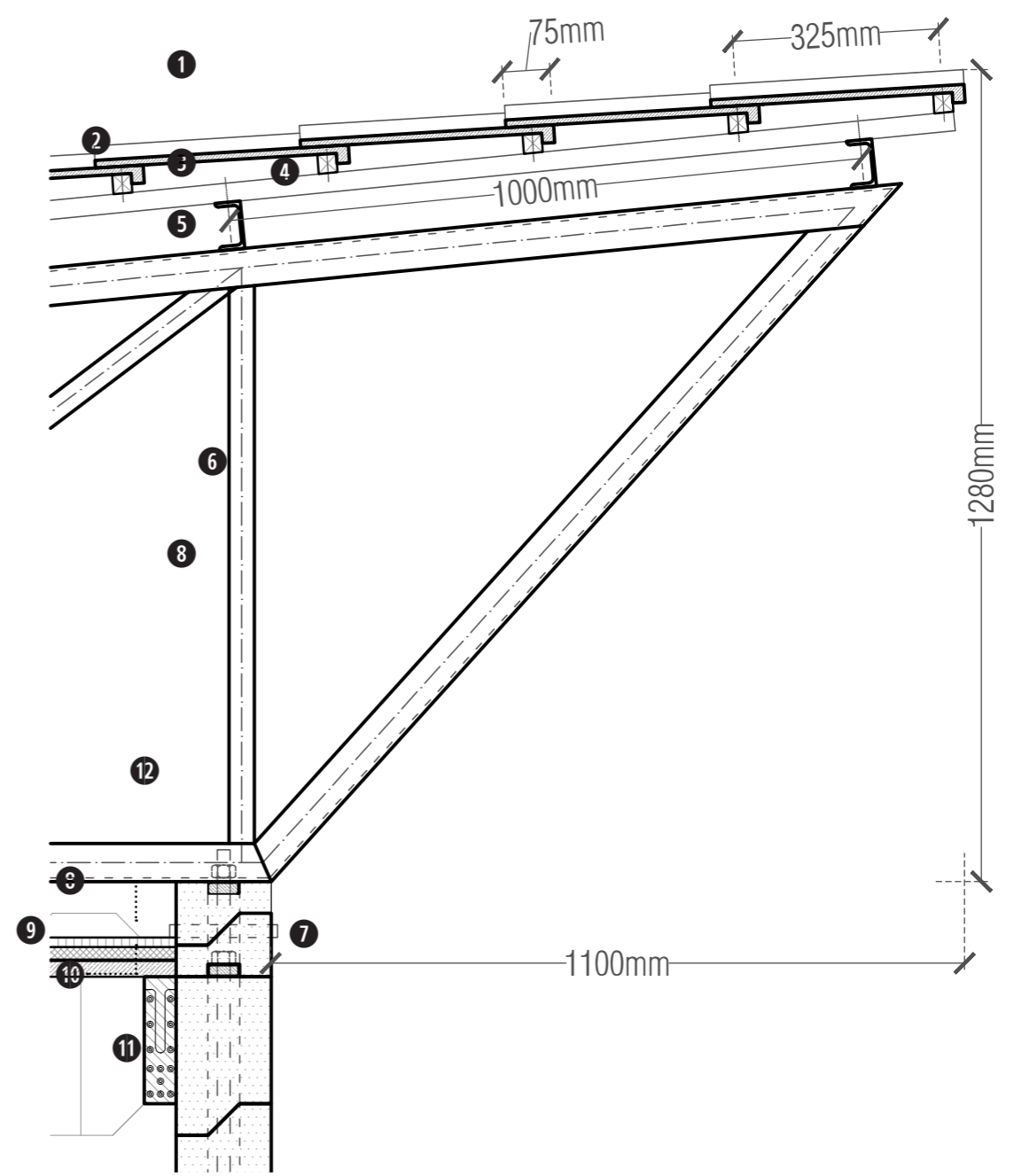

ROOF EDGE DETAIL

ROOF & GUTTER DETAIL

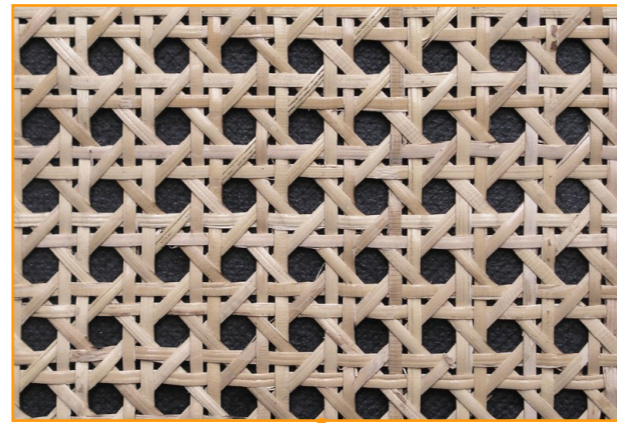

- ① Wooden Handrail 70mm x 50mm
- ② Wooden Ballusters 50mm x 50mm
- ③ Wooden Mid Rail 50mm x 30mm
- ④ Woven Bamboo Mat
- ⑤ Wooden Cleat
- ⑥ 25mm thk Facia Board
- ⑦ 15mm Flattened Bamboo Flooring
- ⑧ 25mm thk Plywood Subfloor
- ⑨ 50mm x 200mm Joist @300 c/c

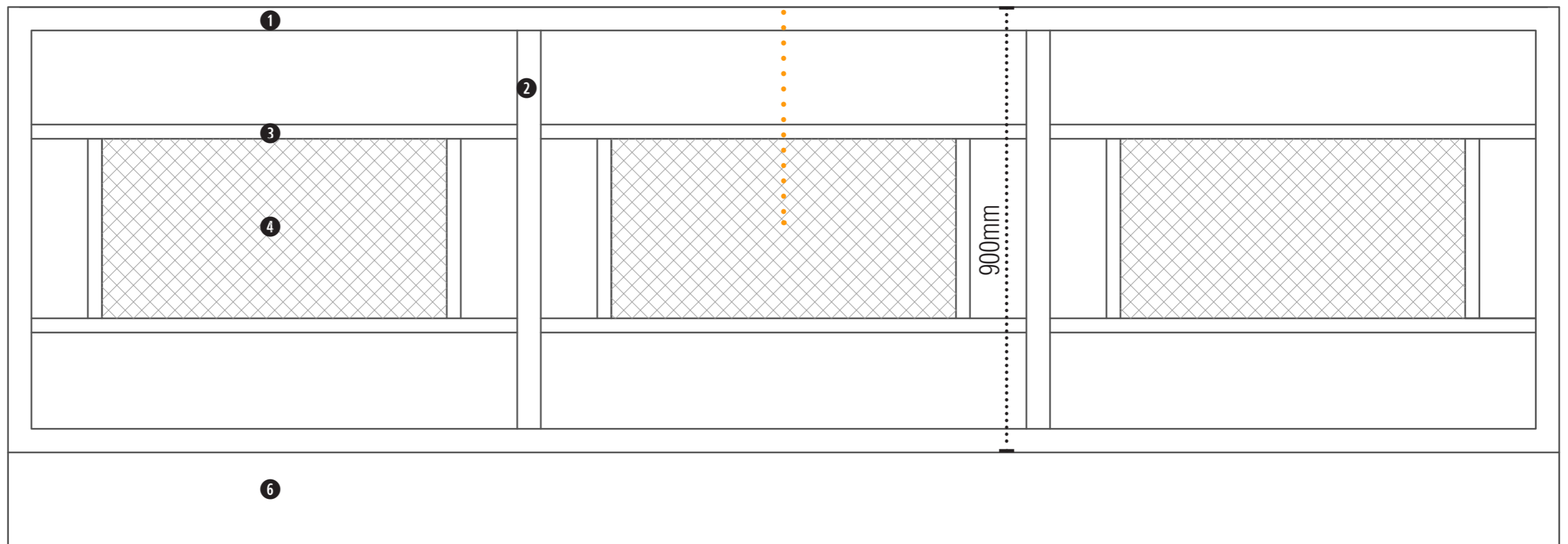
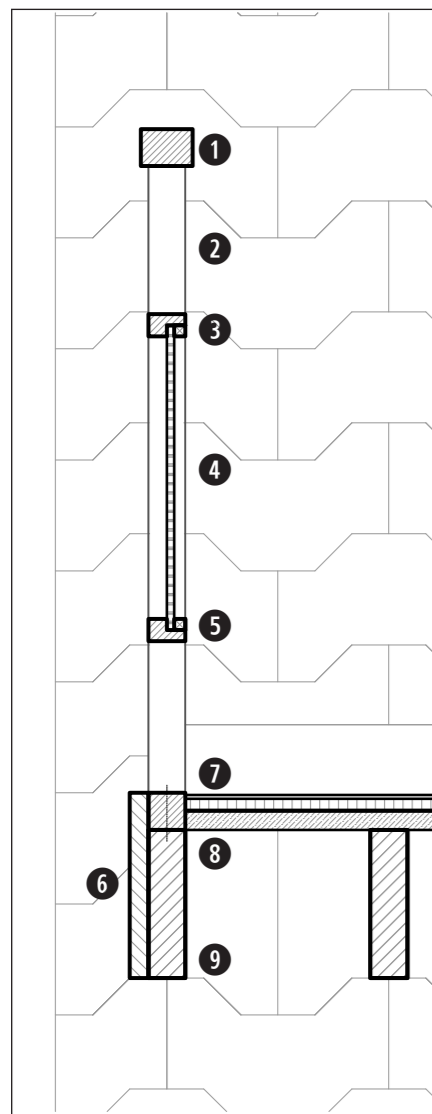

RAILING DETAIL















SUSTAINABLE DEVELOPMENT GOALS

1 NO POVERTY

3 GOOD HEALTH AND WELL-BEING

8 DECENT WORK AND ECONOMIC GROWTH

9 INDUSTRY, INNOVATION AND INFRASTRUCTURE

11 SUSTAINABLE CITIES AND COMMUNITIES

12 RESPONSIBLE CONSUMPTION AND PRODUCTION

13 CLIMATE ACTION

14 LIFE BELOW WATER

15 LIFE ON LAND

17 PARTNERSHIPS FOR THE GOALS

BROADER GOALS



PROTOTYPE TESTING

RESEARCH FUNDING

BUSINESS DEVELOPMENT

MANUFACTURER



YES!





PROTOTYPE TESTING

Science
Centre Delft



RESEARCH FUNDING

**CHANGE
MAKER
CHALLENGE**

BUSINESS DEVELOPMENT

YES!

MANUFACTURER

PROMOLDING
CREATING | POLYMER | SOLUTIONS

06.2018

NATIONAL GEOGRAPHIC

PLANET OR PLASTIC?

*18 billion pounds
of plastic ends up
in the ocean each
year. And that's
just the tip of
the iceberg.*

As of 2015, more than **6.9 billion tons** of plastic waste has been generated. Around **9%** of that was **recycled**, 12% was incinerated, and **79%** accumulated in **landfills** or **leaked** into the environment."

- Planet or Plastic?, National Geographic



THANK YOU

STRATEGY

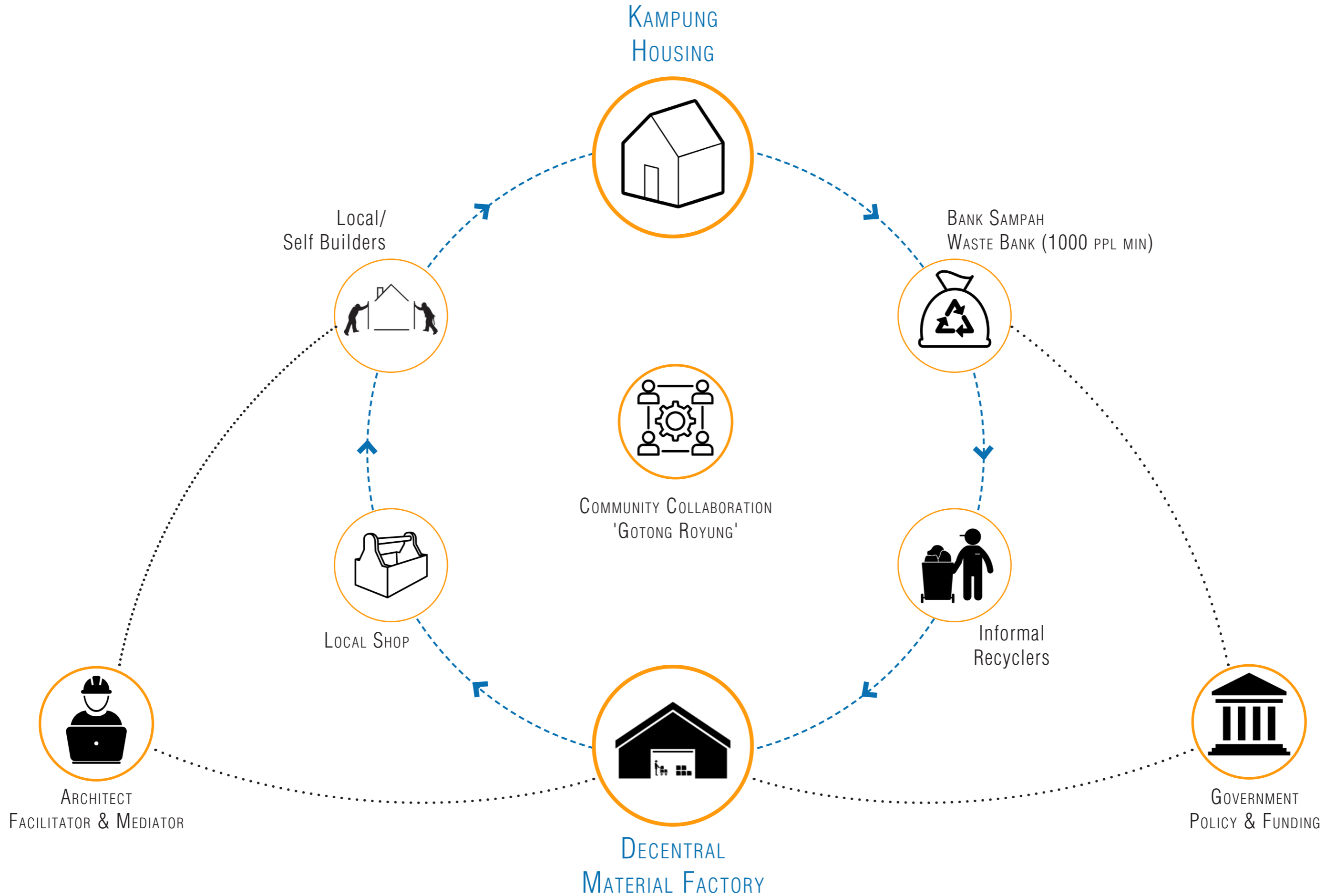

SMART SLUMS : KRILL ARCHITECTS

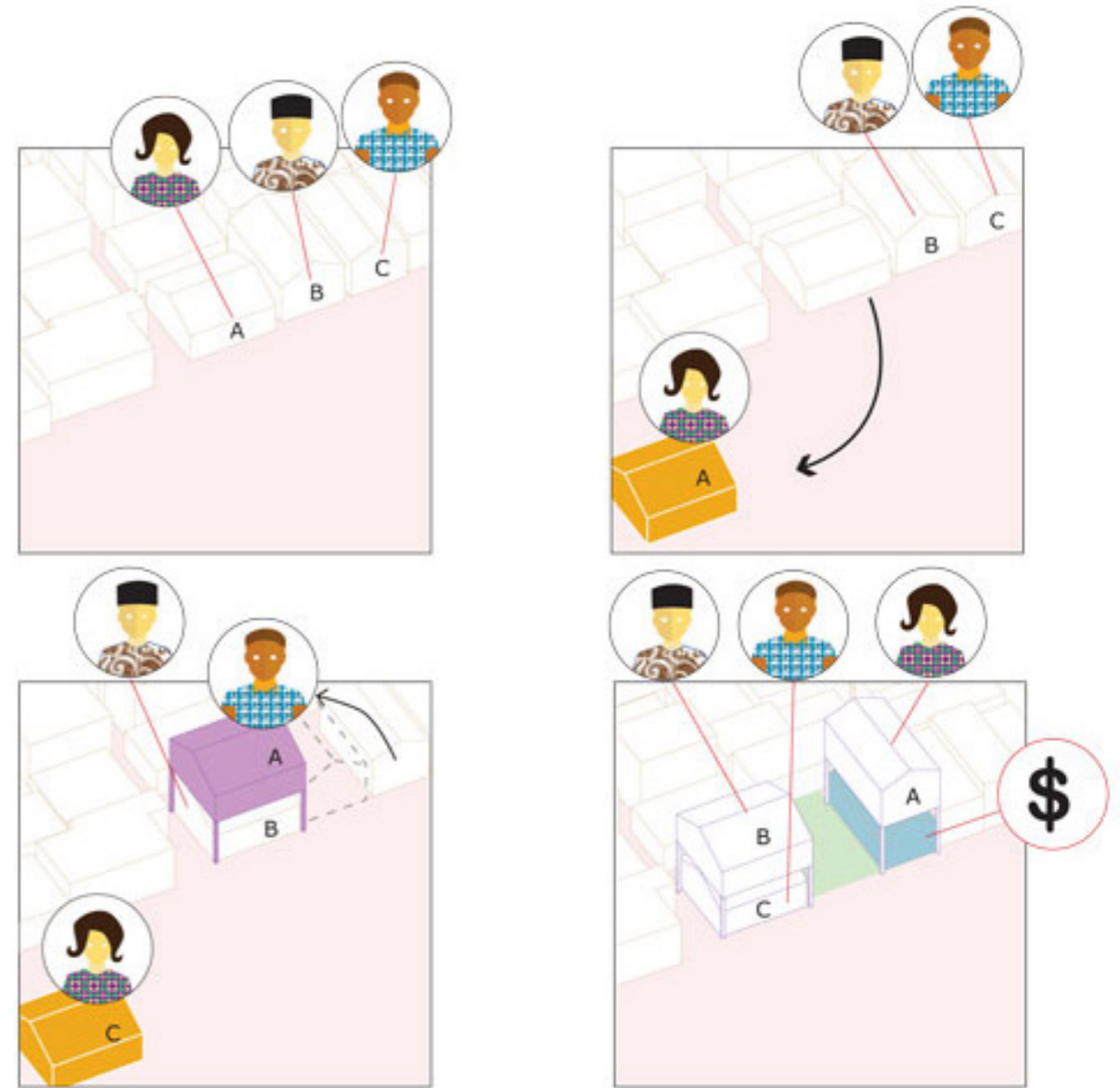
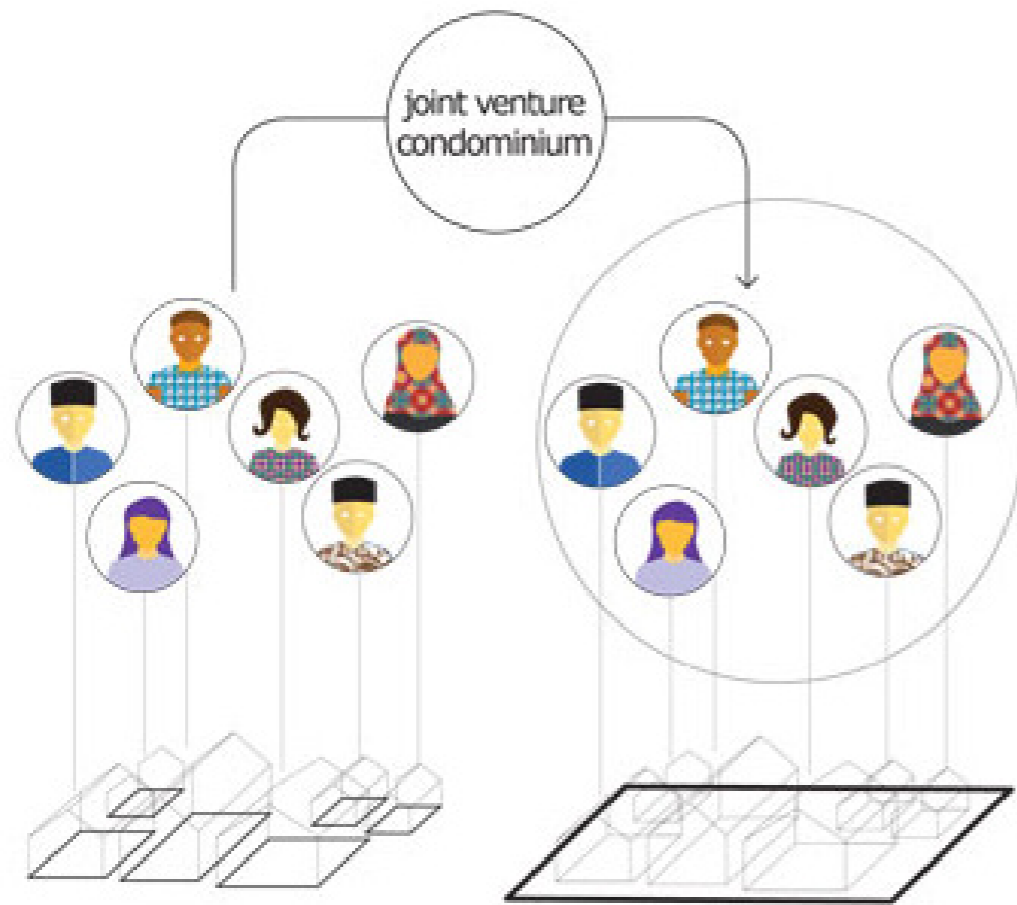

COMMUNITY DRIVEN DEVELOPMENT

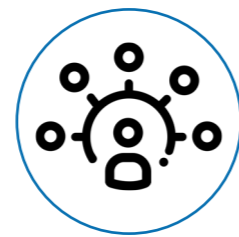

CO-DESIGN SYSTEM



HIGHER DENSITY



OPEN SPACE



RENTAL INCOME

CASE STUDY : URBAN RENEWAL







WASTE COMPOSITION

TYPE OF WASTE	CIGONDEWAH RW02 & RW12 (2010)		BANDUNG (2010)	
	%	*Tonnes/ Week	%	Tonnes/ Week
Organic	51.90	6.30	51.90	5,450
Inorganic	30.90	3.78	30.90	3,245
Plastic	10.7	1.35	12.10	1,272
Glass	2.3	0.28	3.60	380
Paper	8.4	1.05	9.80	1,030
Textile	8.0	0.98	3.50	368
Rubber	0.5	0.01	0.60	63
Metals	1.0	0.13	1.30	136
Others	17.20	2.1	17.20	1,806
Weekly Total (Tonnes)	100.0	12.25	100.0	10,500

CALCULATIONS : *DAILY WASTE IN CIGONDEWAH(2010) = (TOTAL CITY MSW/ TOTAL CITY POPULATION) x POPULATION IN CIGONDEWAH
= (1500/2.4MIL) x 2800 = 0.000625 x 2800 = 1.75 TONNES/DAY