

FRAMING PROTEST

Architecture & Public Building Graduation Studio Ground
Things and Representation: Strasbourg

student: Ada Jaśkowiec

tutors: Filip Geerts, Sien van Dam, Mauro Parravicini



RESEARCH





Anti-GCO protest at
Place de la Republique,
30th Sep 2017



EXPRESSION OF IDEAS THROUGH SPATIAL APPROPRIATION

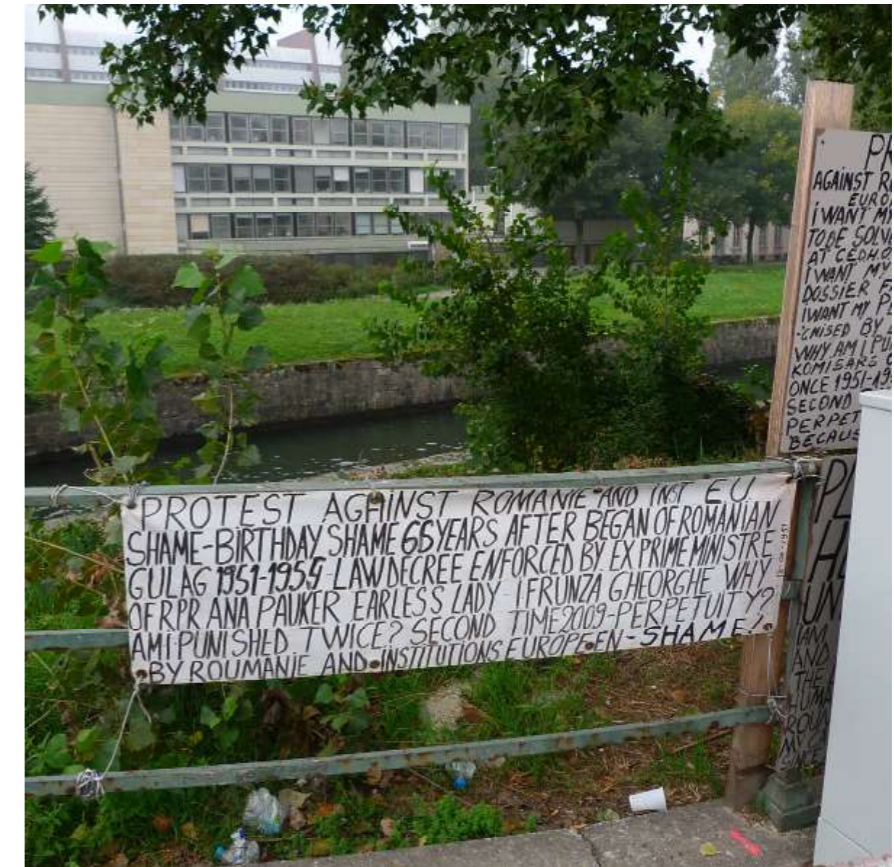

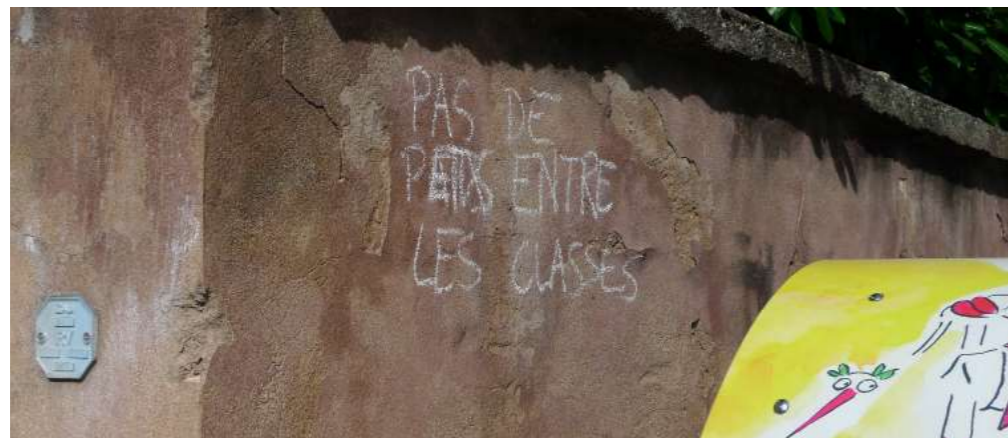

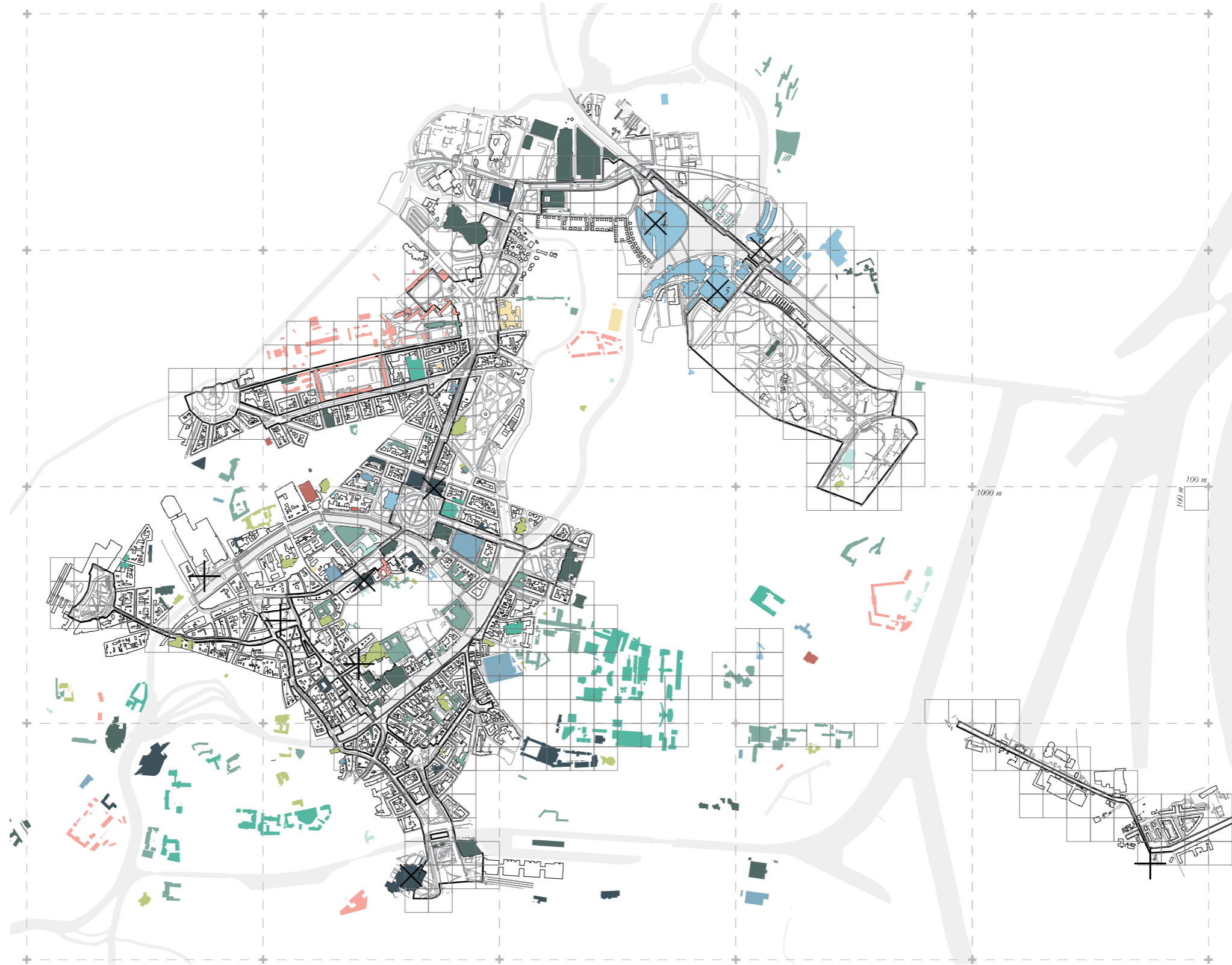

NETWORK OF PROTEST

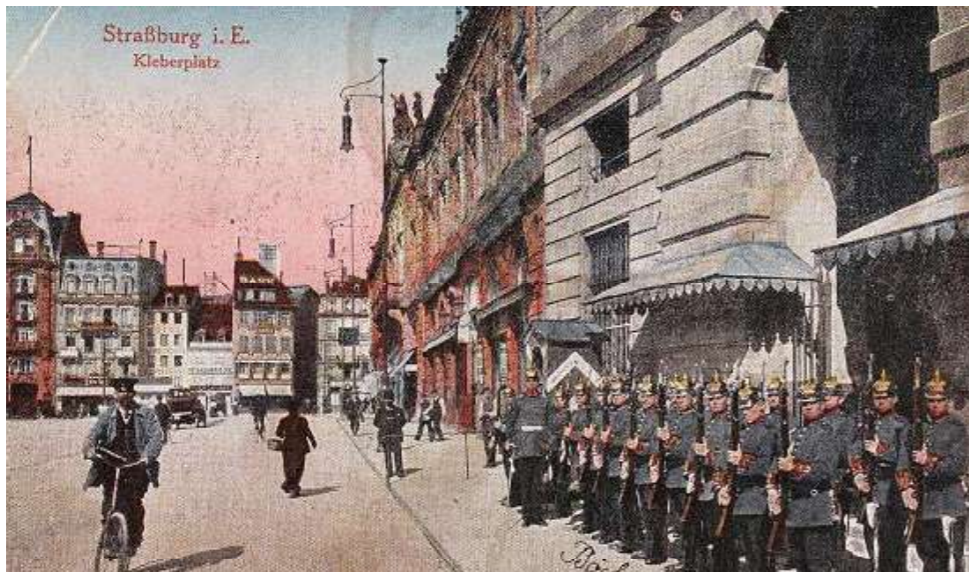

Relations between main squares and their capacities

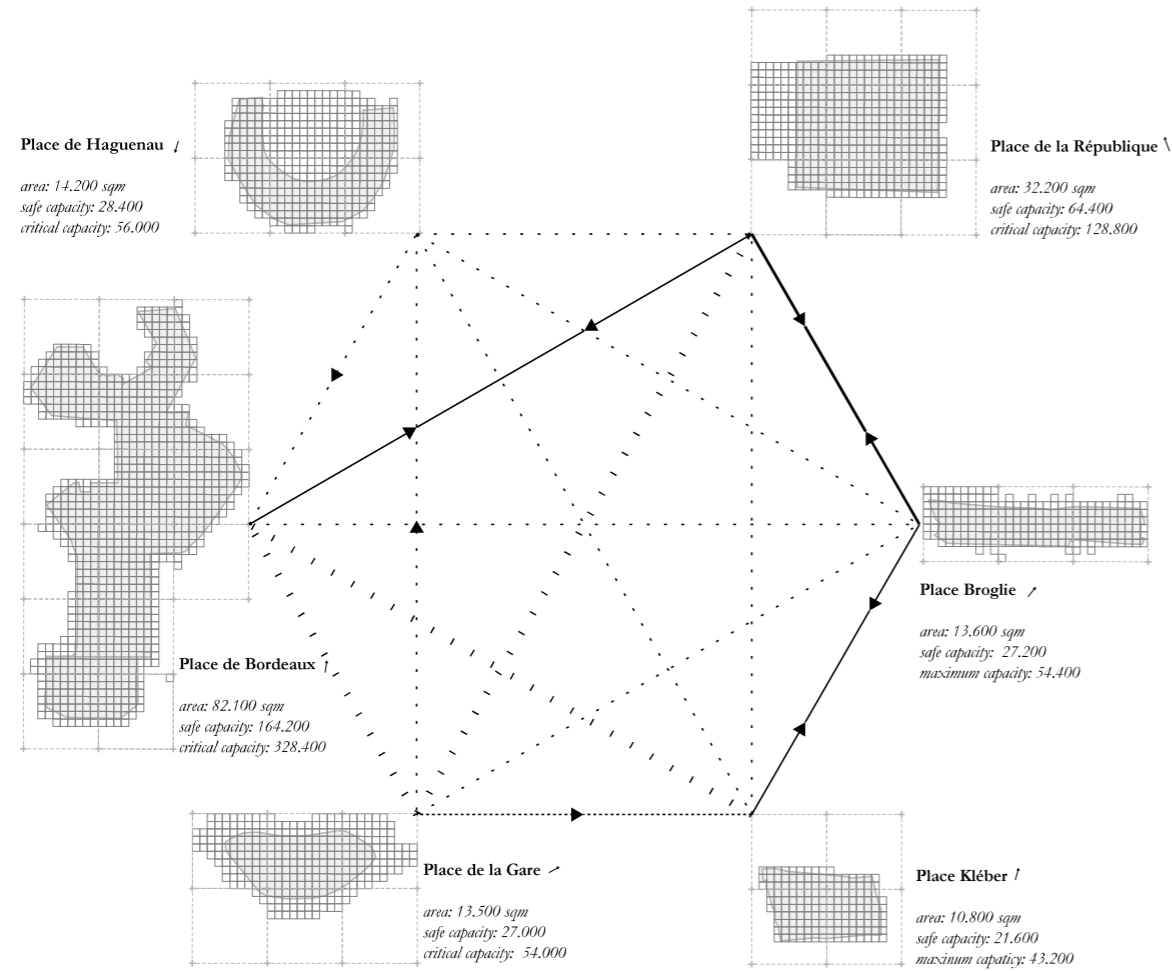

CAPACITY FOR PROTEST

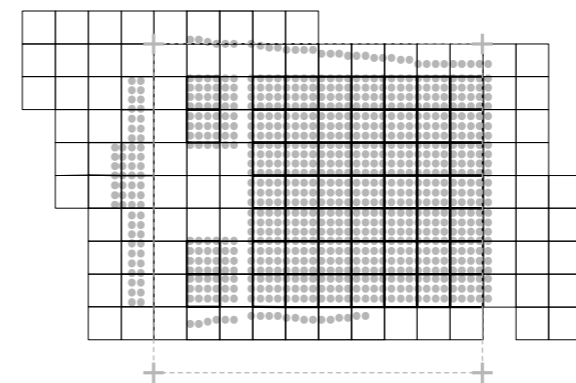
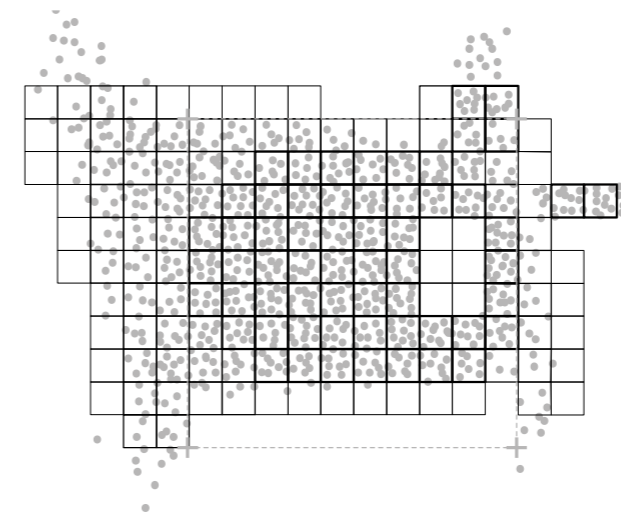
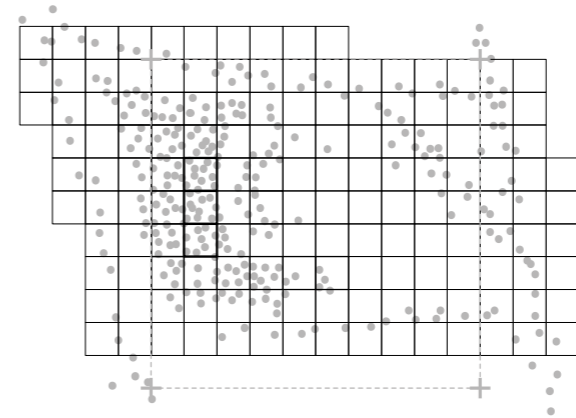
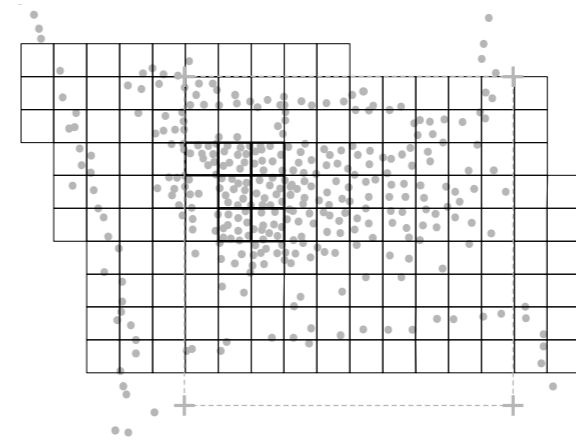

Left
Relations between main squares and their capacities

Right
Crowd shapes at Place Kléber during various gatherings

- Below 100 people / 100 sqm (safe)
- 100-300 people / 100 sqm (dense walking)
- 300+ people / 100 sqm (dense standing)

Left top
Anti-Erdogan manifestation, 10 October 2015

Right top
Anti-GCO manifestation, 30 September 2017

Left bottom
Nazi assembly, 1944

Right bottom
Je Suis Charlie, 11 January 2015

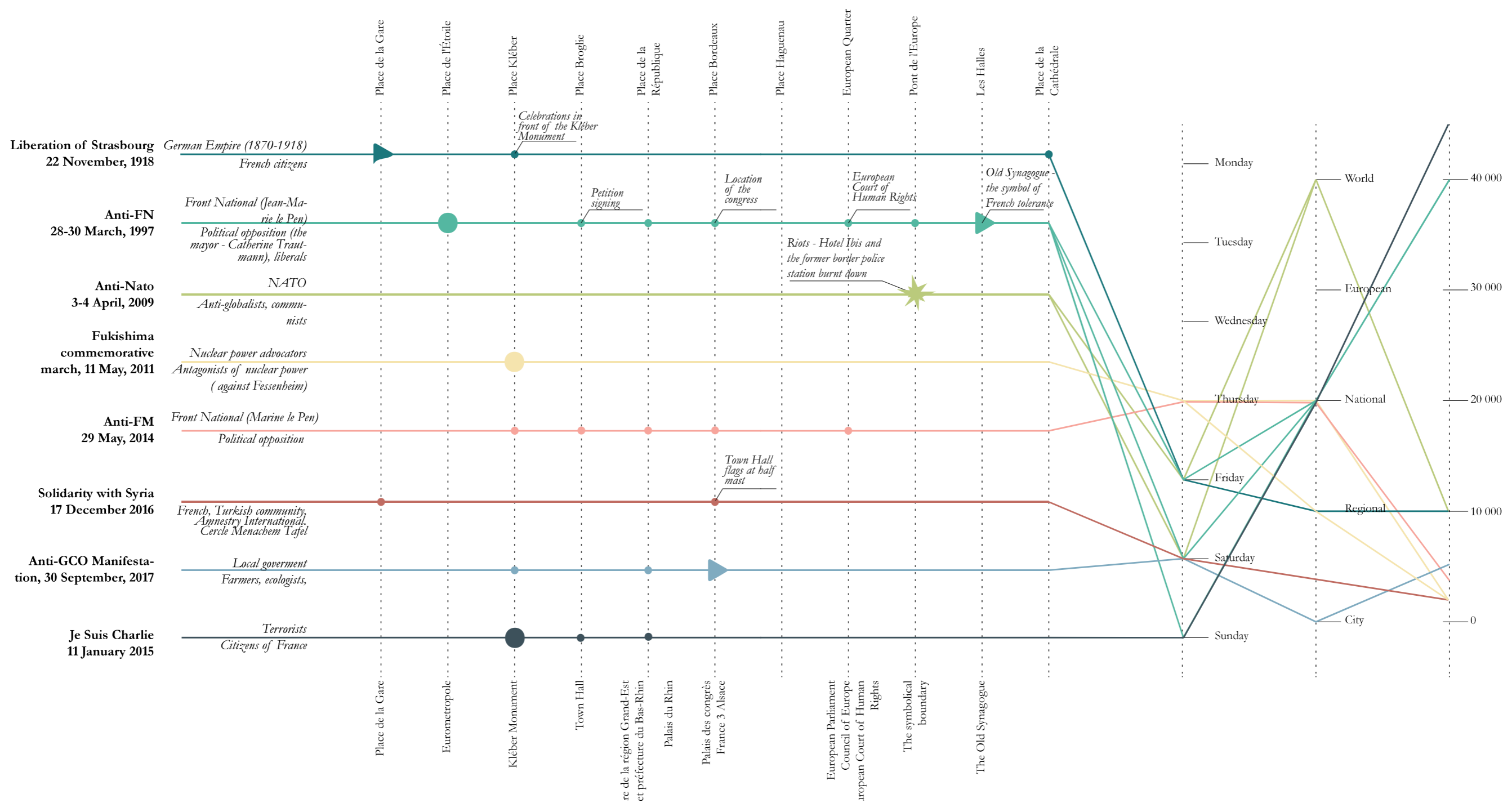

PROTEST SEQUENCING

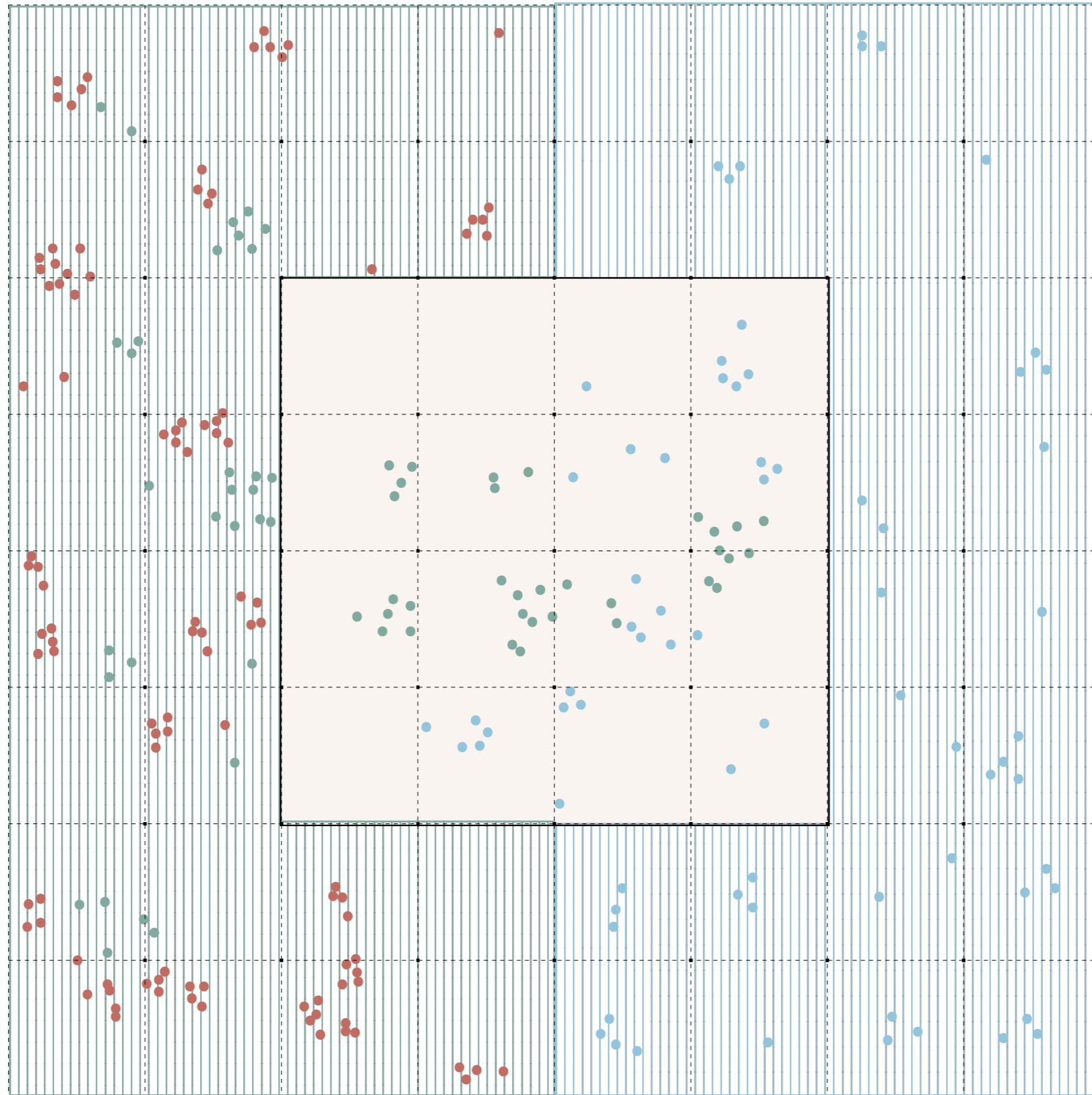

HABERMAS

SPACE AS A 'CONTAINER OR ACTIVITY'

SPACE AS 'SOCIALLY PRODUCED'

- Private interest
- ||||| Institutional interest
- ||||| Public interest
- Private people with access to public life
- Private people with restricted access to public life
- Representatives of the state
- Flexible borders
- Regular borders
- Strong borders

PUBLIC SPACE - MEDIATORY ZONE BETWEEN STATE AND SOCIETY

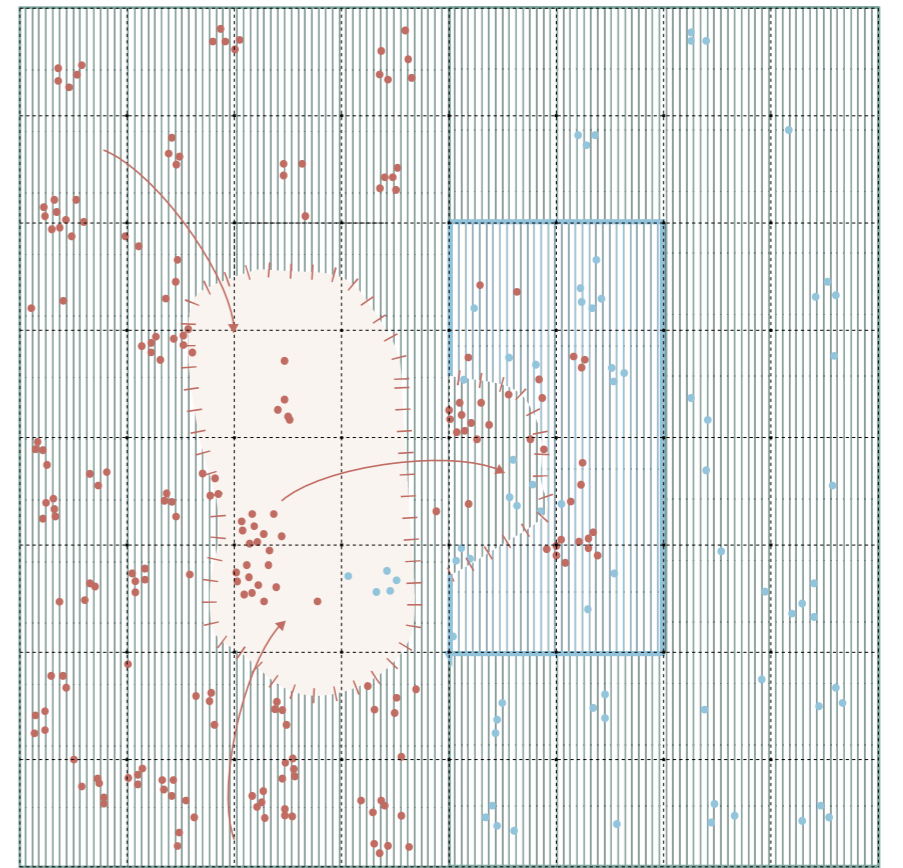
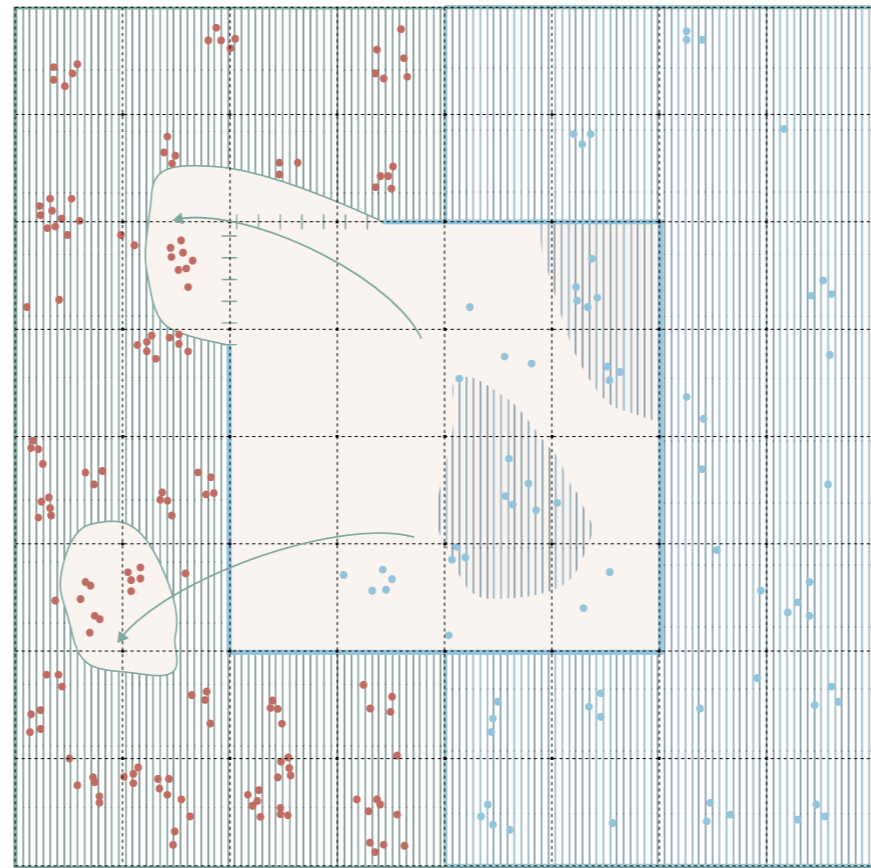
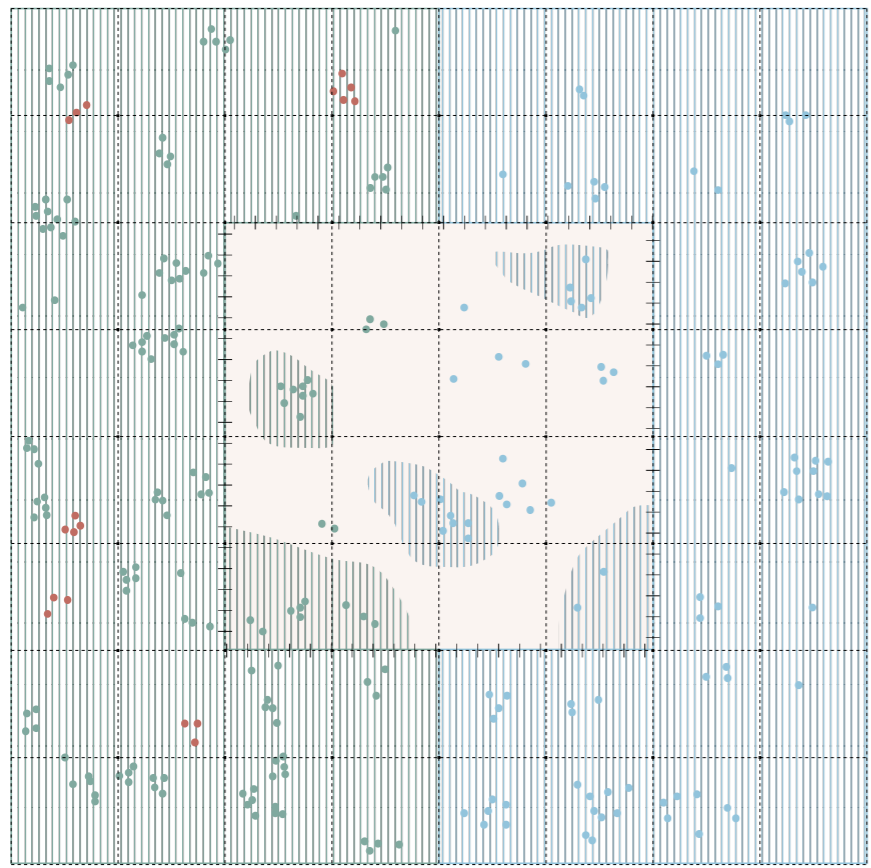
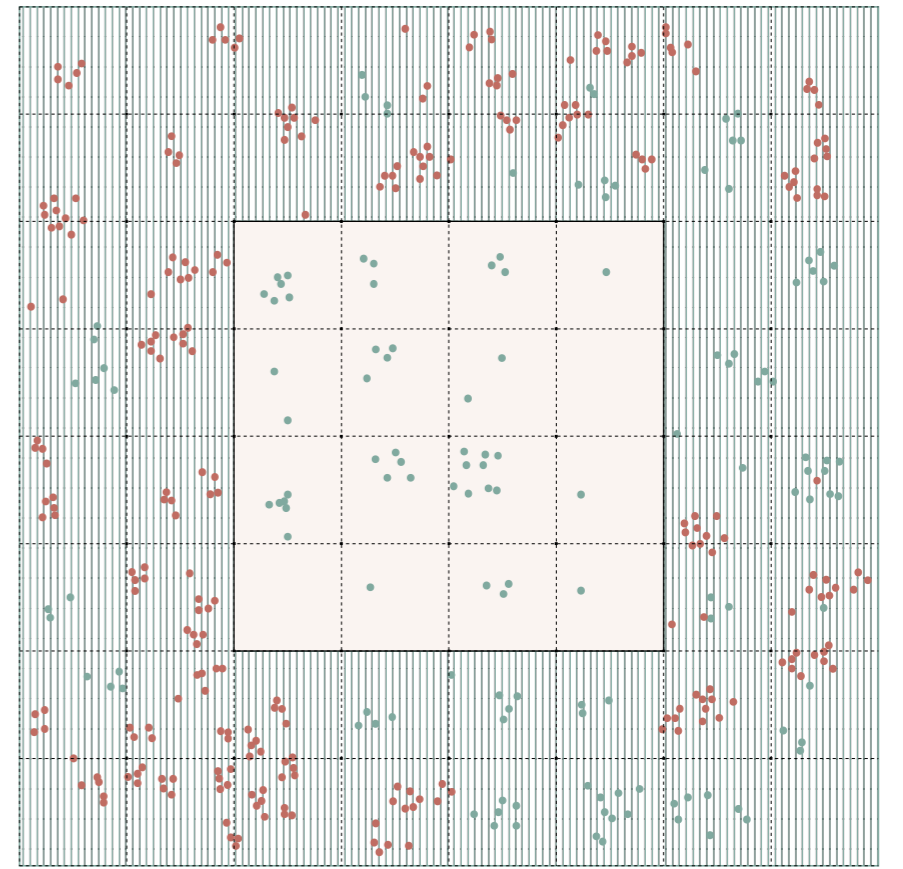
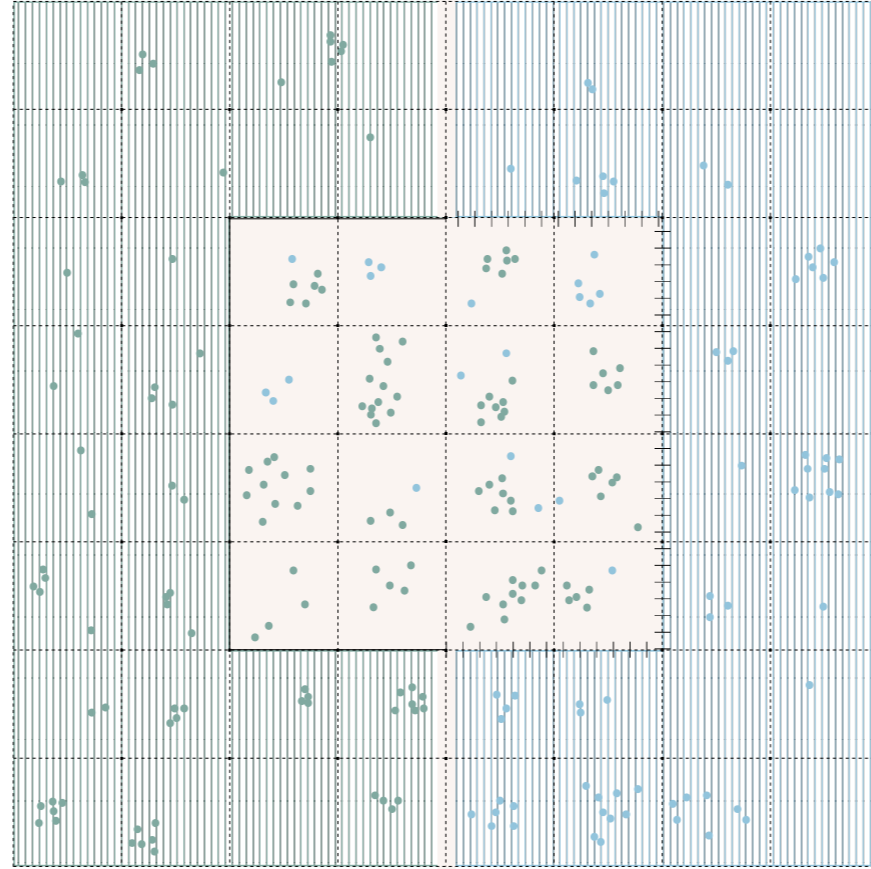
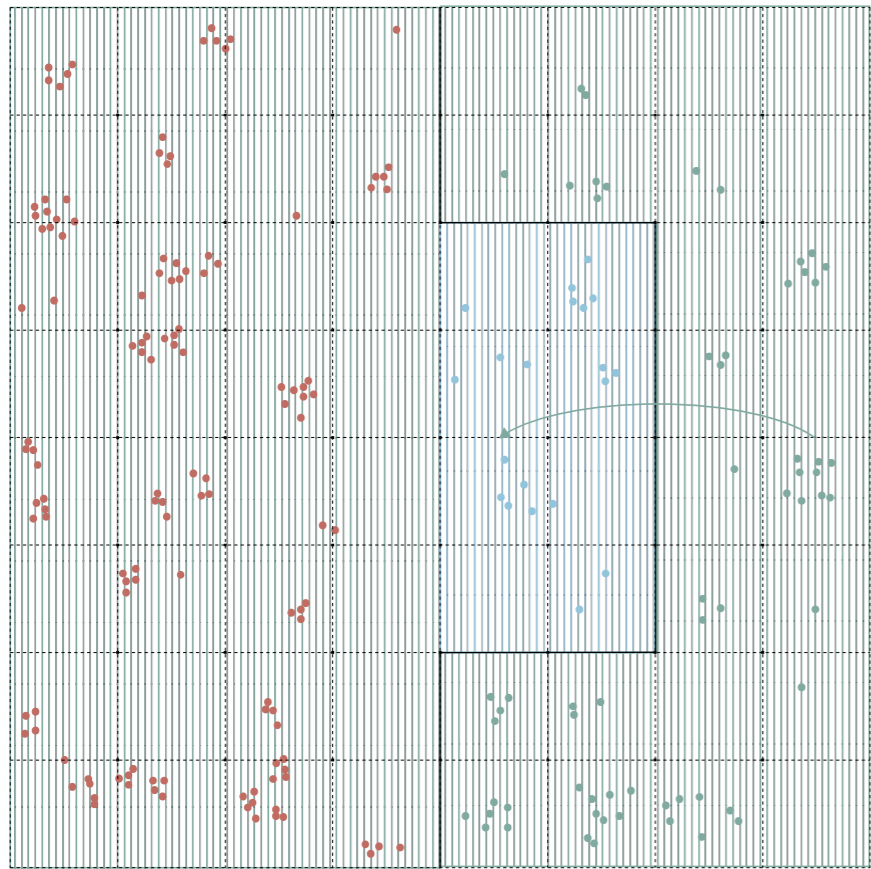



VALIDITY OF THE TOPIC

Facing the opportunity of digital participation, does the crowd still have power?

VALIDITY OF THE TOPIC

**Facing the opportunity of digital participation,
does the crowd still have power?**

McLuhan - Primacy of the visual

Debord - "a spectacle is a social relation among
people, mediated by images"

IMPORTANCE OF A BODY AND SENSORY COGNITION

Lefebvre - “the whole of (social) space proceeds from the body”

Hannah Arendt - power needs spaces of appearance, understood as public spaces arising out of actions (praxis) and speeches (lexis) of individuals, sustained due to the plurality of agents.

RESEARCH QUESTION

How architectural means help to maintain the contestative power of the crowd in the light of growing social disconnection?

How to frame the experience of being in the crowd in order to make it powerful and immersive?

IT IS NOT GIVEN TO EVERY MAN TO TAKE A BATH OF
MULTITUDE; ENJOYING A CROWD IS AN ART; AND
ONLY HE CAN RELISH A DEBAUCH OF VITALITY AT THE
EXPENSE OF THE HUMAN SPECIES, ON WHOM, IN HIS
CRADLE, A FAIRY HAS BESTOWED THE LOVE OF MASKS
AND MASQUERADING, THE HATE OF HOME, AND THE
PASSION FOR ROAMING.

Baudelaire, Ch., Crowds

SPECULATION

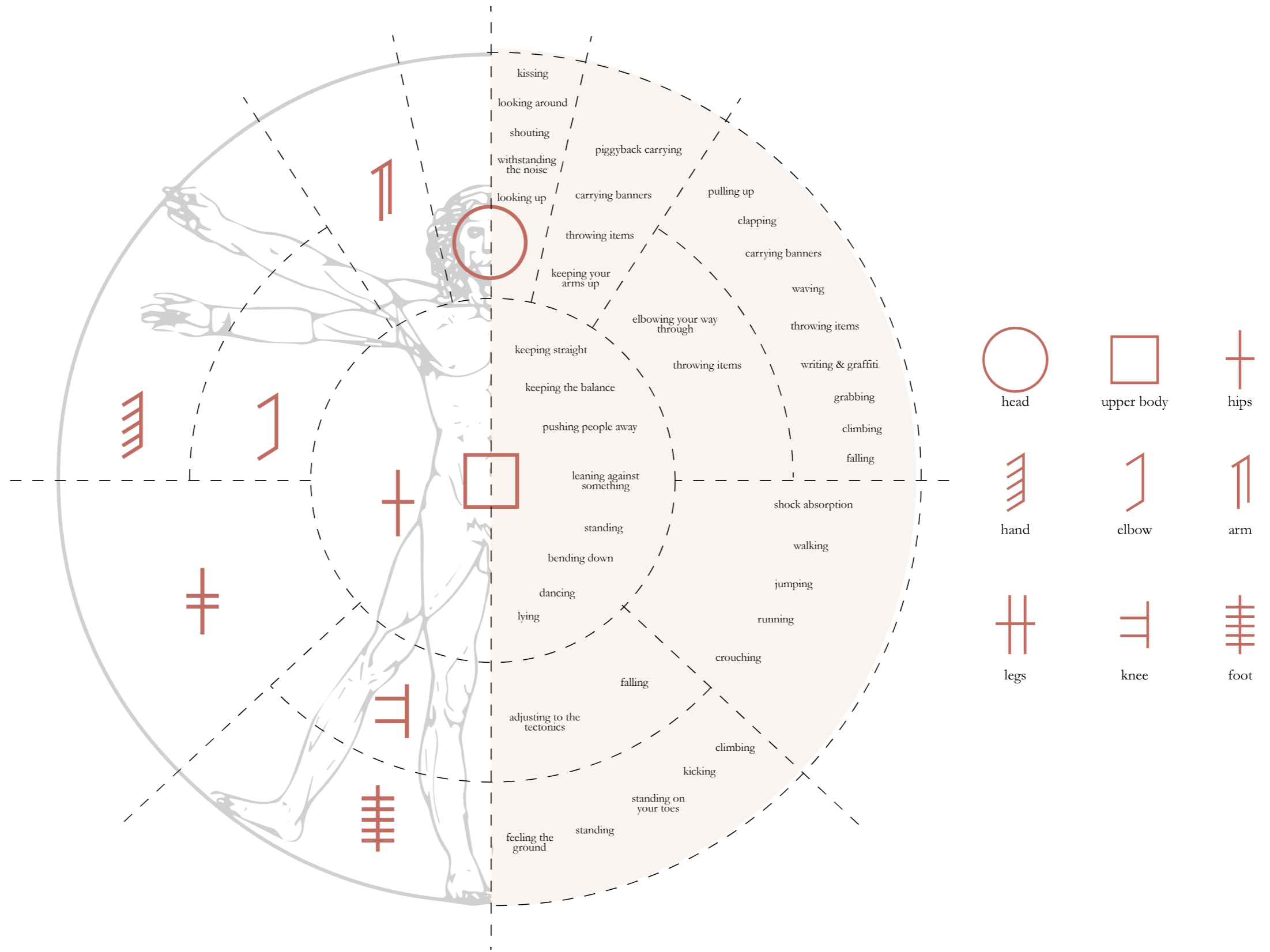

BODY IN PROTEST



CROWD AS
WORDSWORTHIAN SUBLIME

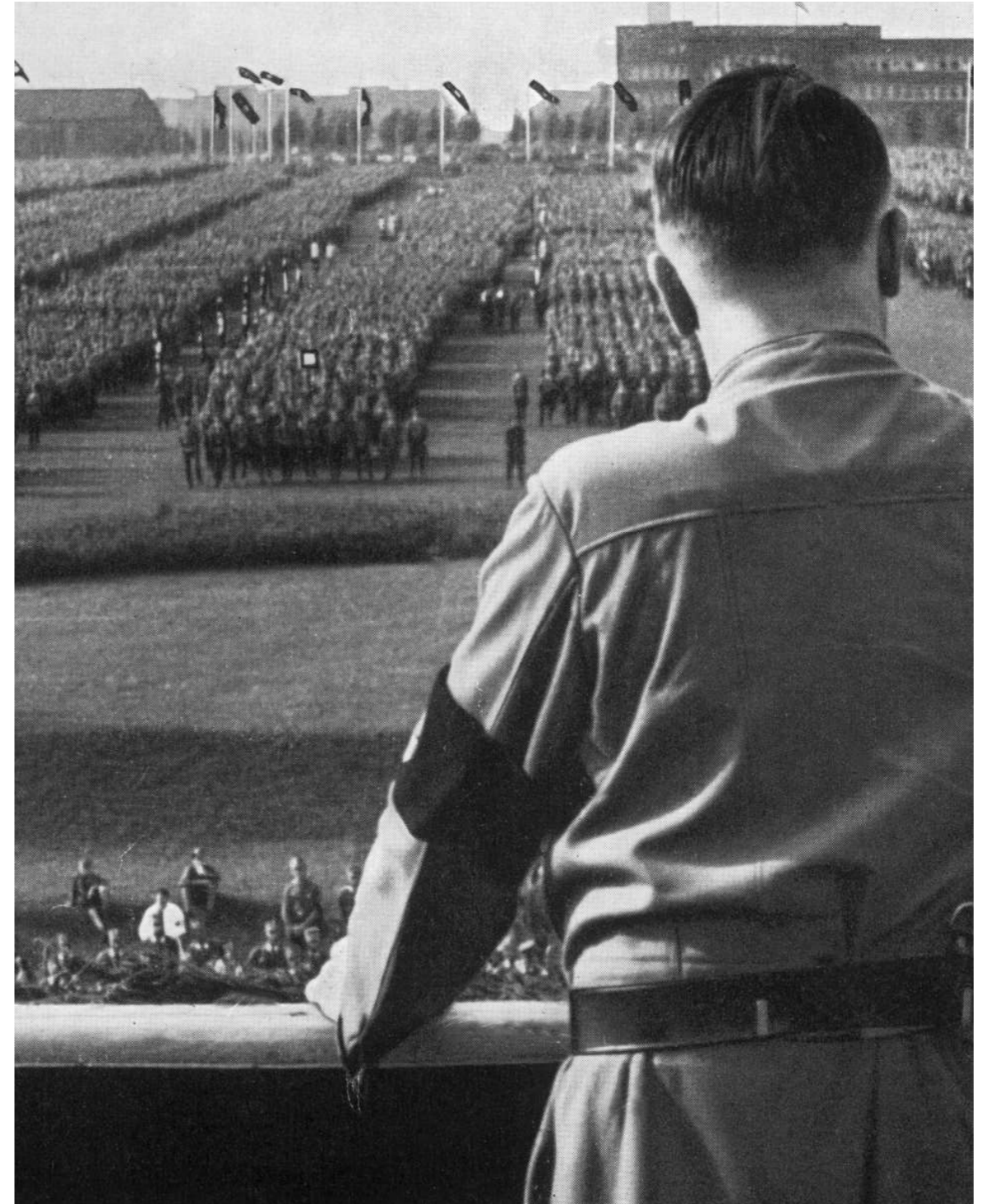

Caspar David Friedrich -
"Wanderer Above the Sea of
Fog", 1818

Hitler overlooking his troops,
[https://www.timesofisrael.com/
hitler-quote-makes-it-into-](https://www.timesofisrael.com/hitler-quote-makes-it-into-)



IMMERSIVE DEPICTIONS
OF A CROWD



< Gustav Klutssis, Everyone Vote, 1930

^ Catalan independence supporters protesting in Barcelona, 2017, <https://www.independent.co.uk/news/world/europe/catalonia-independence-referendum-catalan-police-storm->

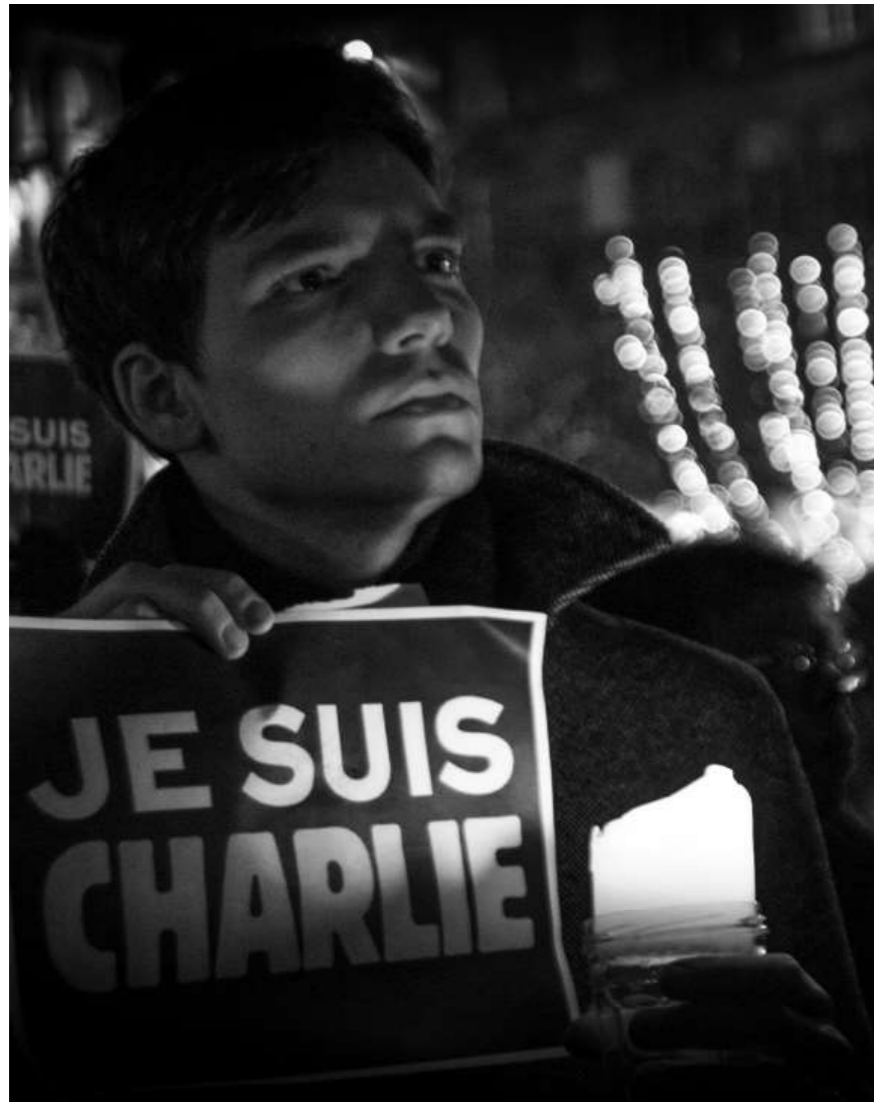

IMMERSIVE VS. SUBLIME DURING
JE SUIS CHARLIE IN STRASBOURG

< Individual perception of protest
during Je suis Charlie in Strasbourg,
[https://commons.wikimedia.org/wiki/
File:Je_suis_Charlie_Strasbourg_7_
janvier_2015.jpg](https://commons.wikimedia.org/wiki/File:Je_suis_Charlie_Strasbourg_7_janvier_2015.jpg)
^ Panoramic view of Je suis Charlie in
Strasbourg,

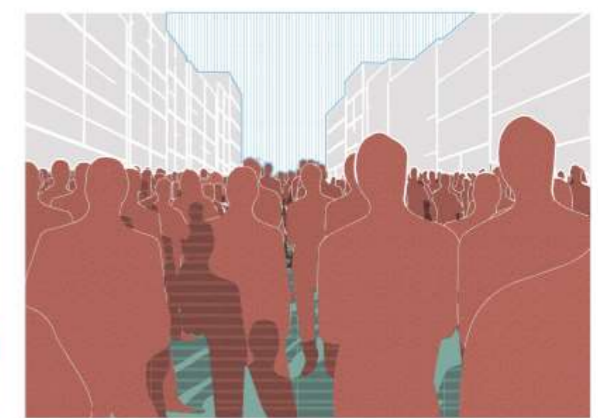
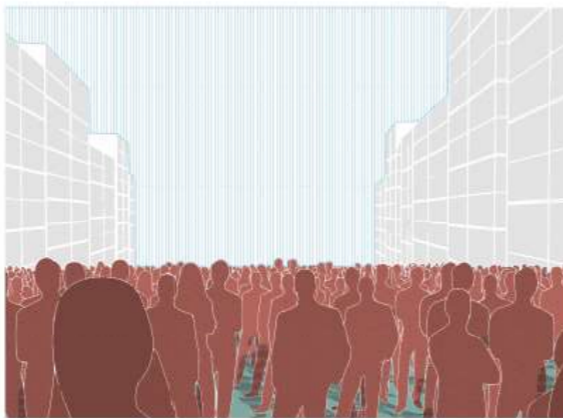
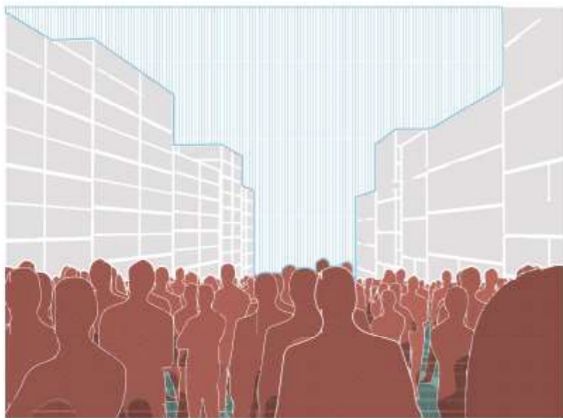
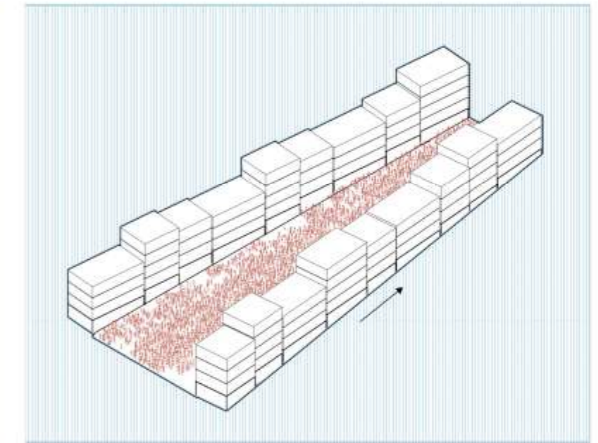
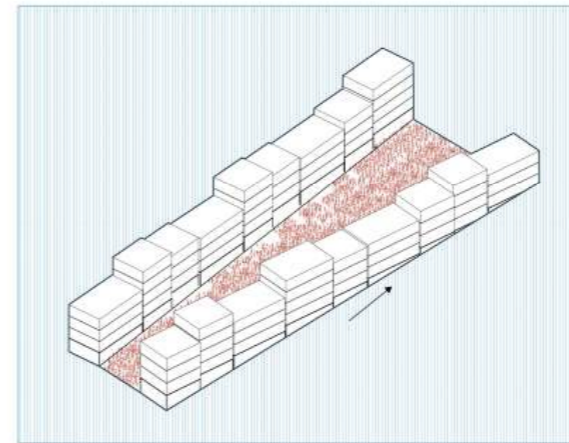
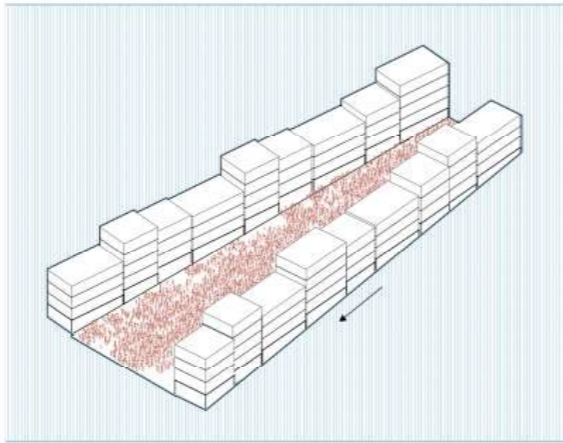
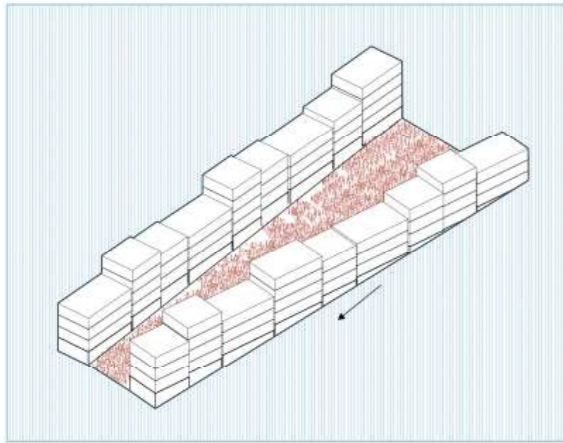
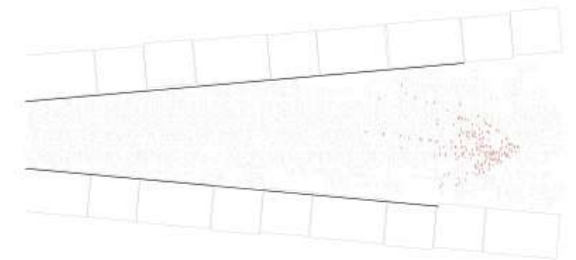
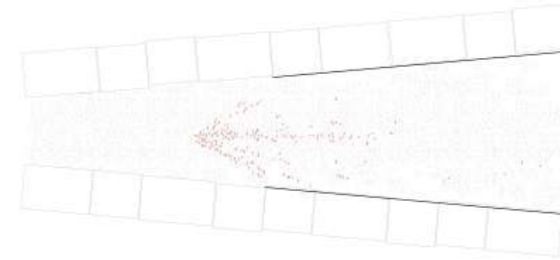
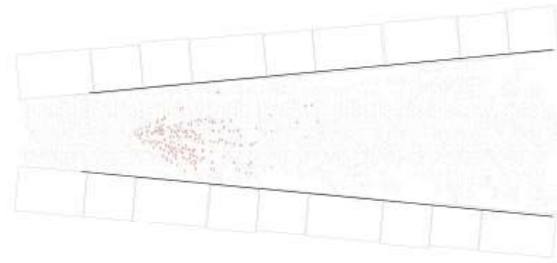
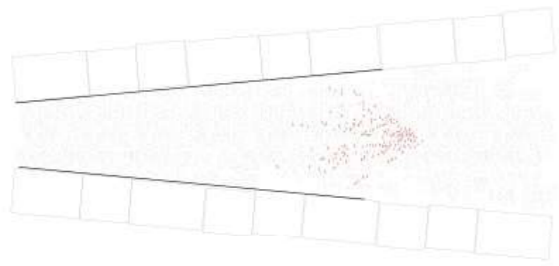

SEEING THE CROWD



City of Shadows - Alexey Titarenko



The Théâtre du Gymnase - Adolph Menzel

MOVING VS STATIONARY CROWD

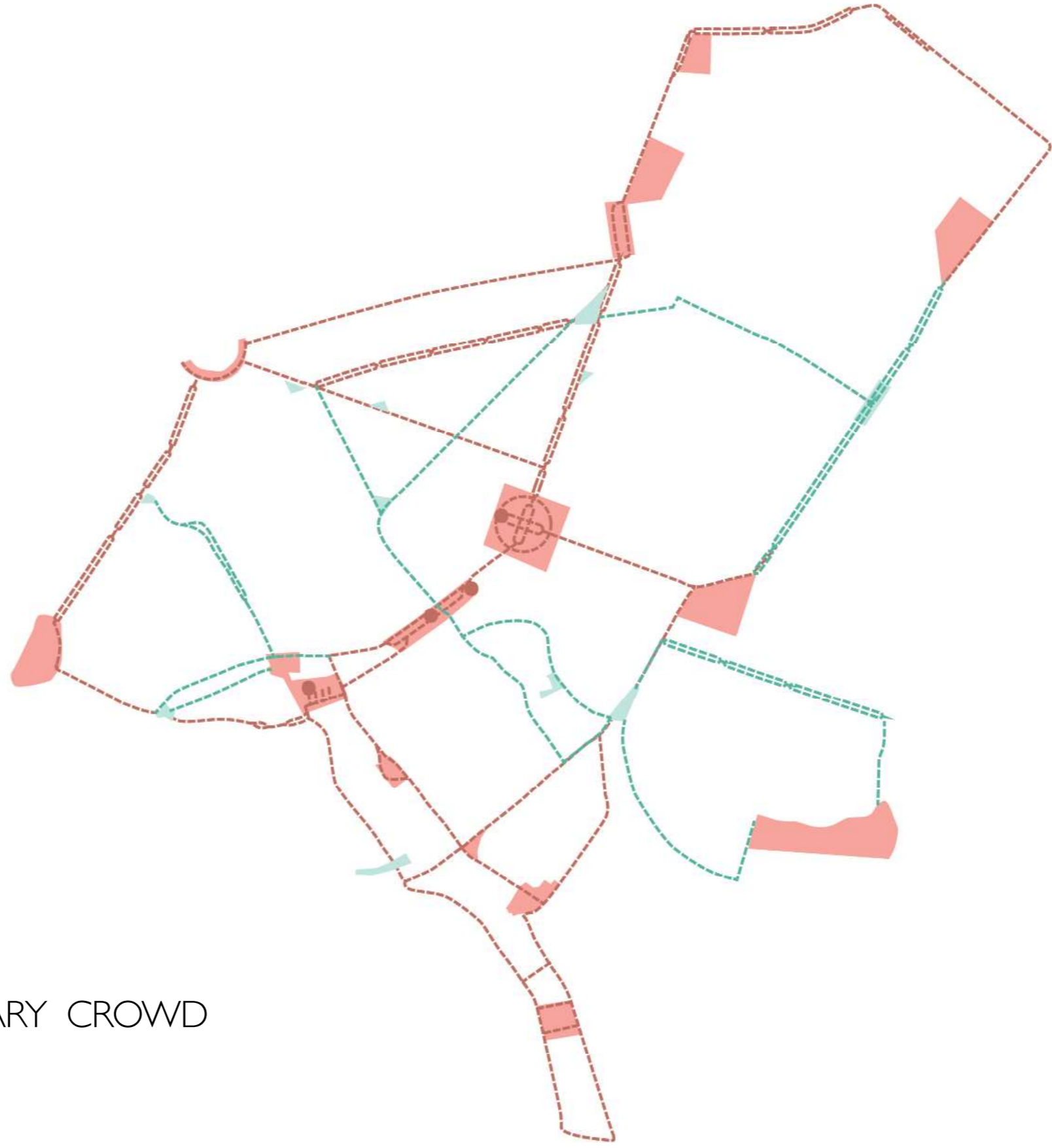

MOVING VS STATIONARY CROWD

DESIGN

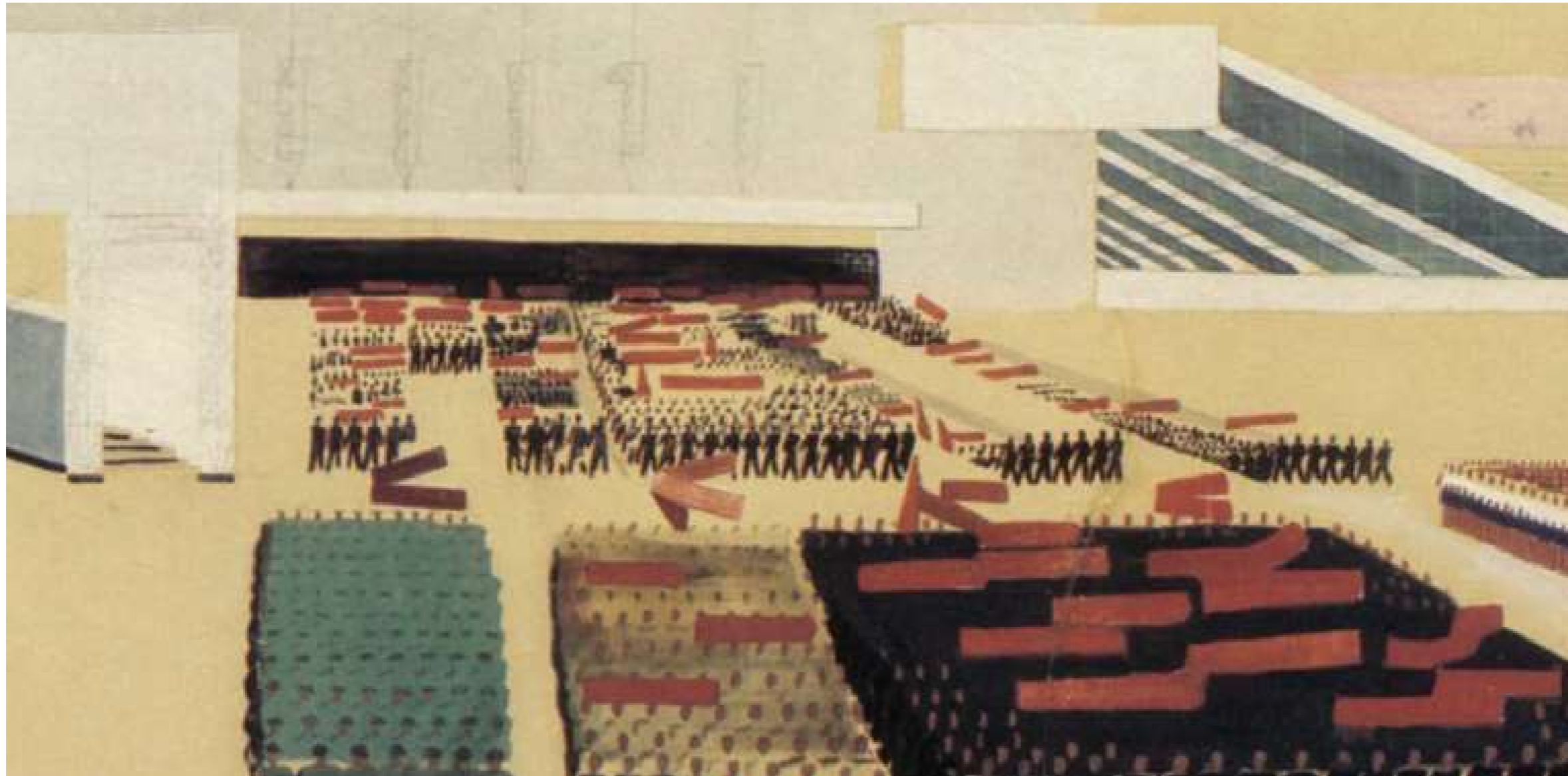

POSITIONING TOWARDS ARCHITECTURAL PRECEDENTS

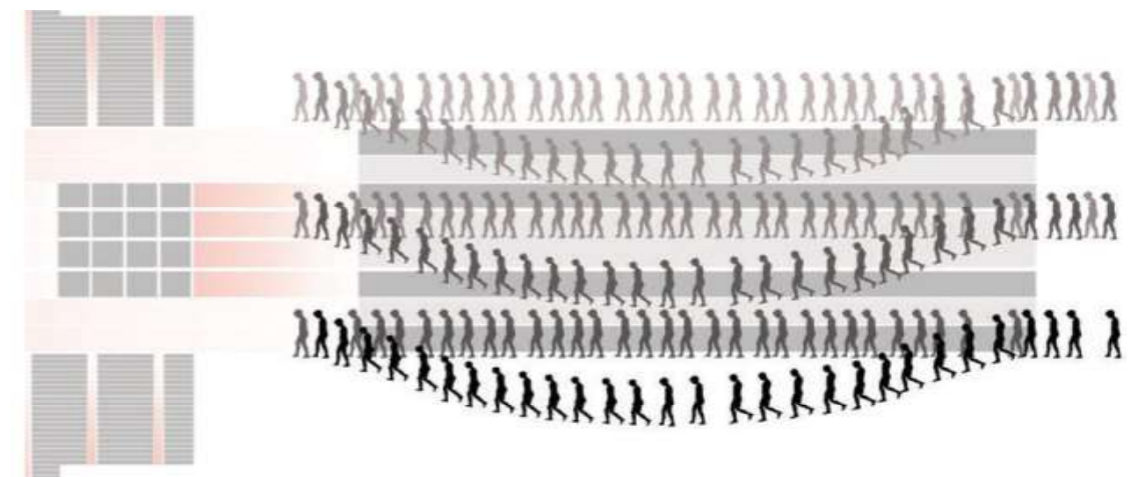

Phase I of the Palace of Soviets Competition in Moscow in 1931 by an avant-garde Soviet group – Union of Architects and Planners (ARU)



POSITIONING TOWARDS ARCHITECTURAL PRECEDENTS

Haussmannian Paris

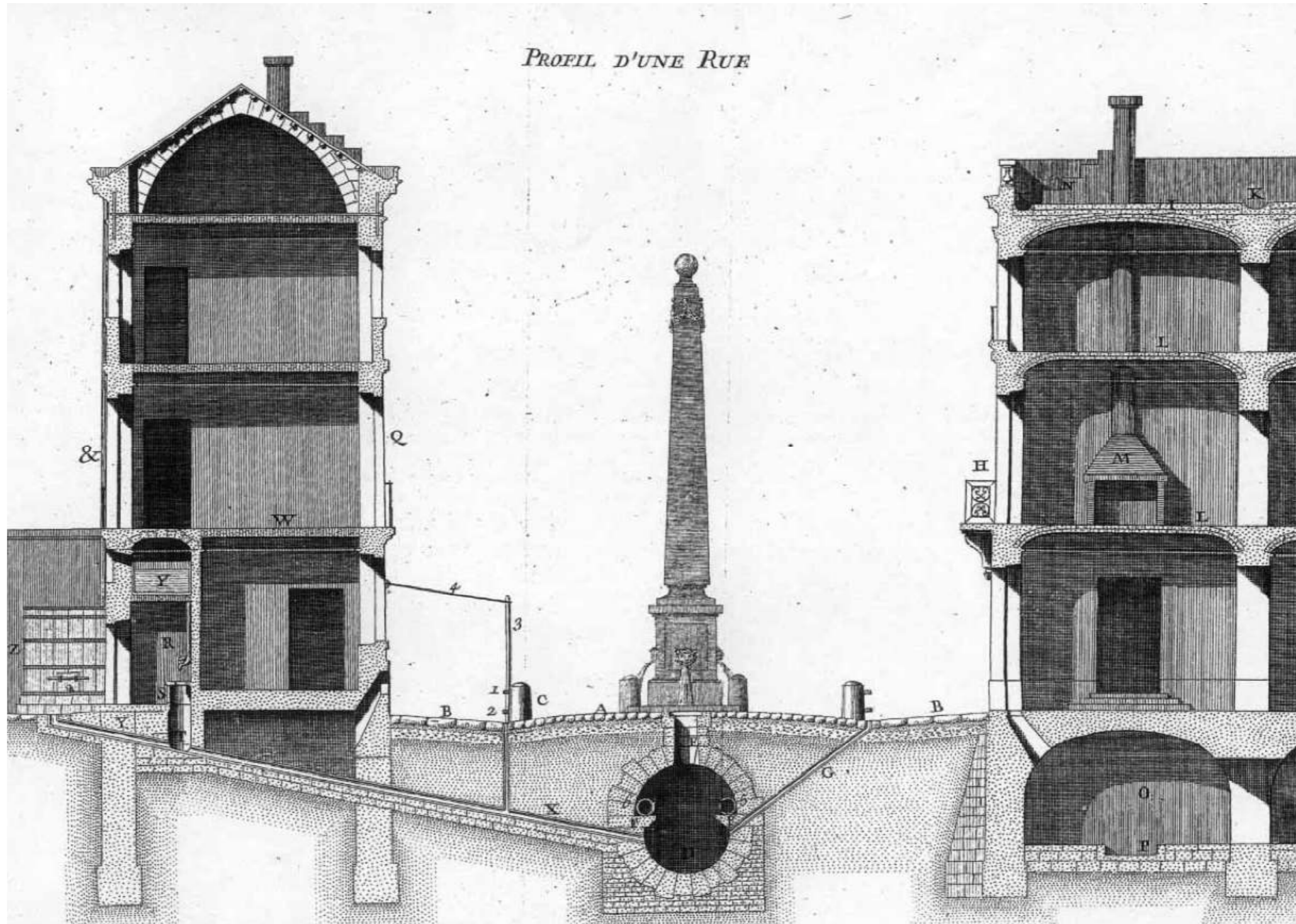

Pierre Patte
Section of a street

SECTION OF THE STREET AS A DESIGN TOOL

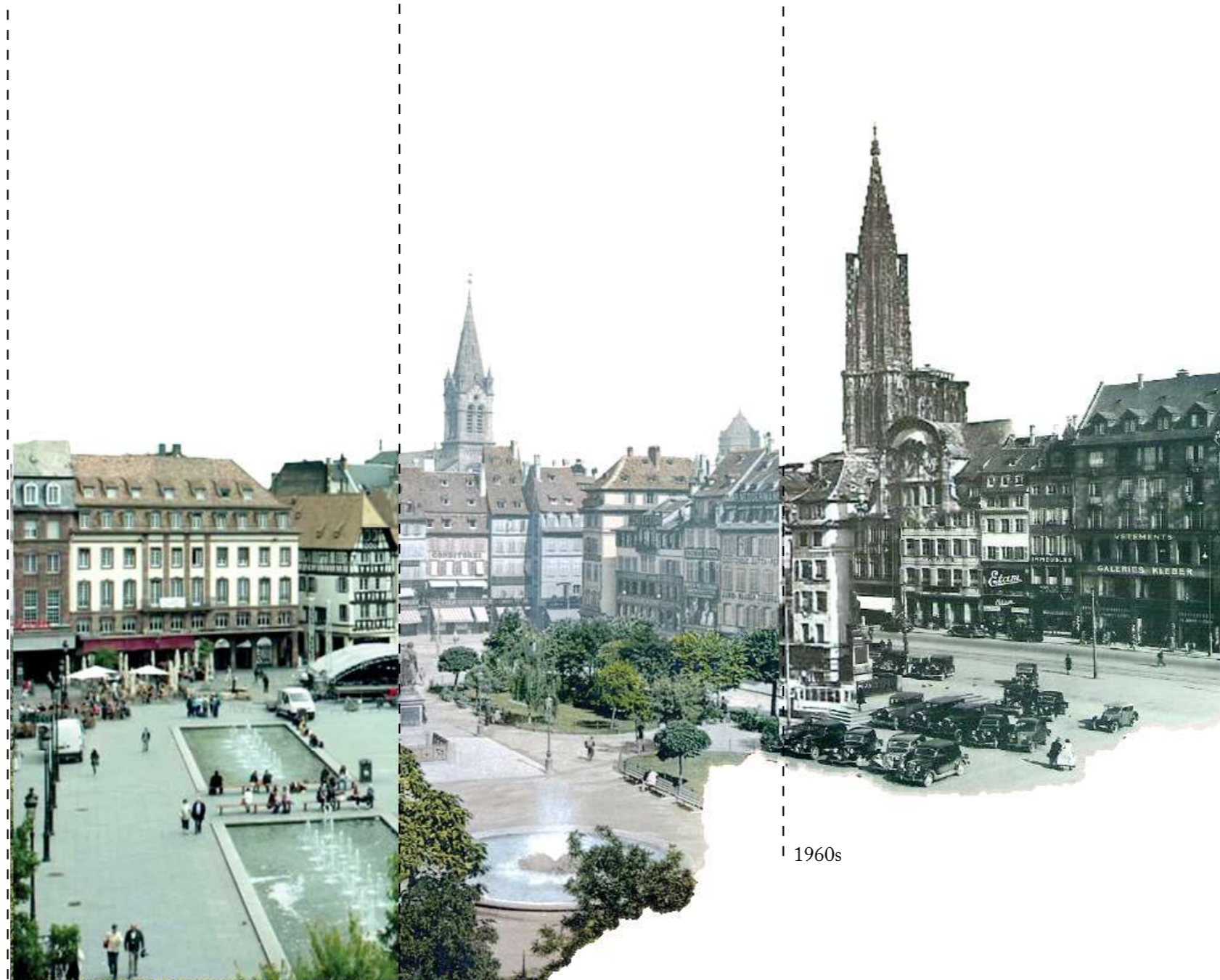

2017

1900

1960s

PUBLIC SPACE TRANSFORMATIONS

AIMS OF THE PROJECT

EXPRESSION OF THE DEMOCRATIC
ACCESS TO PUBLIC SPACES AND
CIVIC COMMONS UNDERSTOOD
AS A BASIC HUMAN RIGHT IN
A DEMOCRATIC EUROPEAN
COUNTRY

AIMS OF THE PROJECT

EXPRESSION OF THE DEMOCRATIC
ACCESS TO PUBLIC SPACES AND
CIVIC COMMONS UNDERSTOOD
AS A BASIC HUMAN RIGHT IN
A DEMOCRATIC EUROPEAN
COUNTRY

CREATION OF PROTEST
INFRASTRUCTURE

AIMS OF THE PROJECT

AIMS OF THE PROJECT

EXPRESSION OF THE DEMOCRATIC
ACCESS TO PUBLIC SPACES AND
CIVIC COMMONS UNDERSTOOD
AS A BASIC HUMAN RIGHT IN
A DEMOCRATIC EUROPEAN
COUNTRY

CREATION OF PROTEST
INFRASTRUCTURE

DEVELOPMENT OF SPATIAL
MEASURES ENHANCING THE
FEELING OF THE CROWD

AIMS OF THE PROJECT

EXPRESSION OF THE DEMOCRATIC
ACCESS TO PUBLIC SPACES AND
CIVIC COMMONS UNDERSTOOD
AS A BASIC HUMAN RIGHT IN
A DEMOCRATIC EUROPEAN
COUNTRY

CREATION OF PROTEST
INFRASTRUCTURE

DEVELOPMENT OF SPATIAL
MEASURES ENHANCING THE
FEELING OF THE CROWD

INTRODUCTION OF TOPOGRAPHY,
DEPTH AND THICKNESS INTO THE
DESIGN





European Quarter

Local TV

European TV

road to Germany

Prefecture

University library

University campus

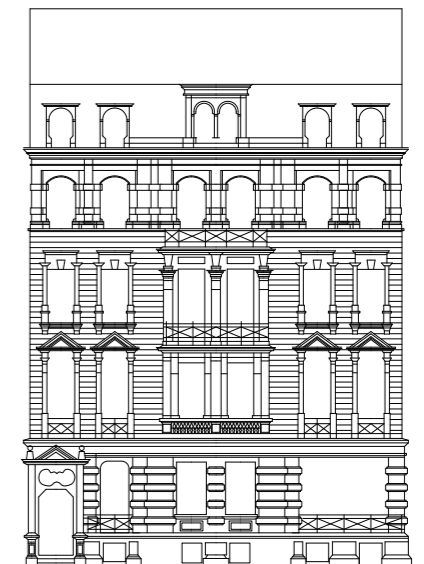

ALLEE DE LA ROBERTSAU

GEZI REPUBLIC
June 2013

30 m

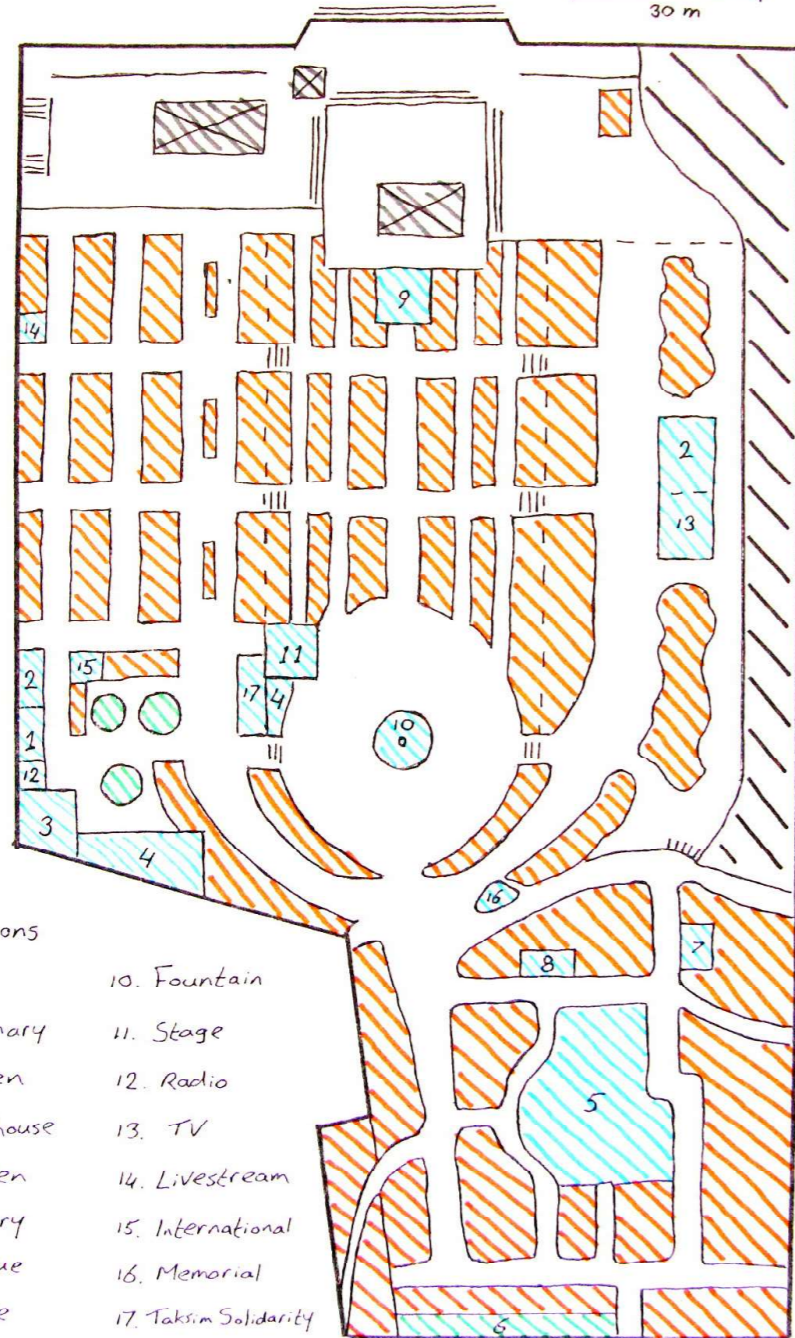

- | | |
|--------------|-----------------------|
| 1 Commons | 10. Fountain |
| 2. Café | 11. Stage |
| 3. Infirmary | 12. Radio |
| 4. Kitchen | 13. TV |
| 5. Warehouse | 14. Livestream |
| 6. Garden | 15. International |
| 7. Library | 16. Memorial |
| 8. Mosque | 17. Taksim Solidarity |
| 9. Castle | |

- commons
- café
- infirmary
- kitchen
- warehouse
- garden
- library
- mosque
- castle
- fountain
- stage
- radio
- TV livestream
- international
- memorial

GEZI REPUBLIC -
FUNCTIONAL ANALYSIS

GEZI REPUBLIC
June 2013

30 m

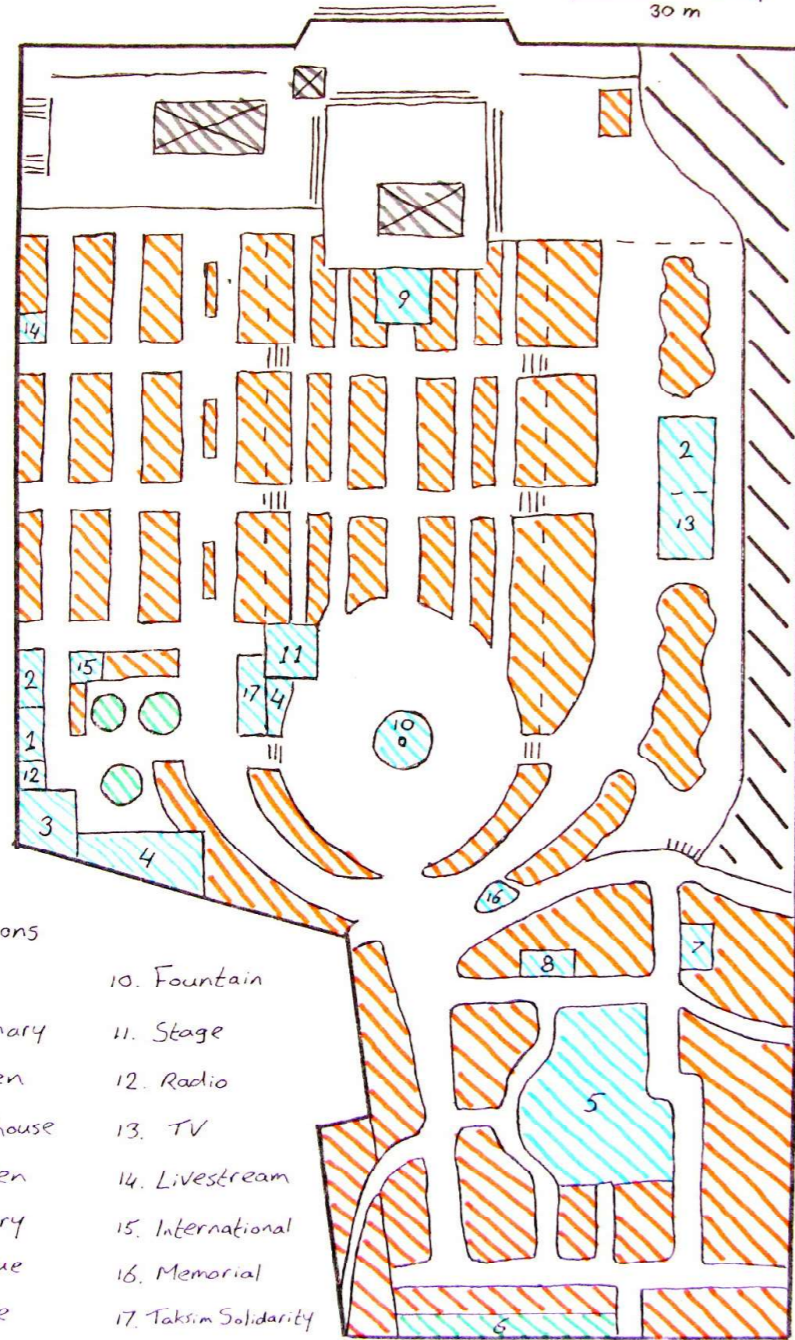

- | | |
|--------------|-----------------------|
| 1 Commons | 10. Fountain |
| 2. Café | 11. Stage |
| 3. Infirmary | 12. Radio |
| 4. Kitchen | 13. TV |
| 5. Warehouse | 14. Livestream |
| 6. Garden | 15. International |
| 7. Library | 16. Memorial |
| 8. Mosque | 17. Taksim Solidarity |
| 9. Castle | |

GEZI REPUBLIC -
FUNCTIONAL ANALYSIS



warehouse

library

café



commons

café

infirmary

kitchen

garden

mosque

memorial



fountain

stage

radio

TV

livestream

international

memorial

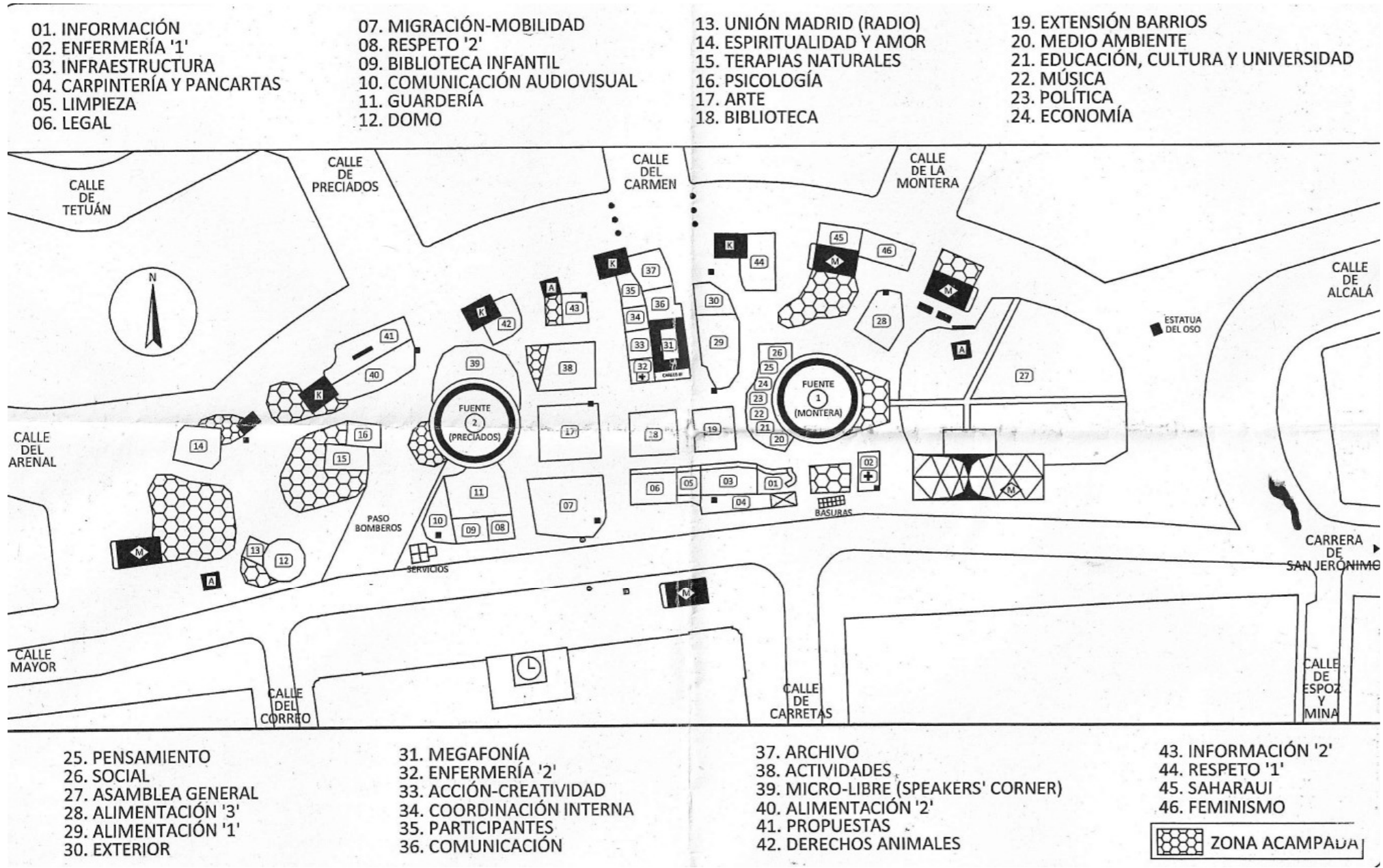

- information
- infirmary
- carpentry and posters
- library
- kindergarden
- audiovisual
- communication
- art
- gathering spaces
- conversation spaces
- stage
- food
- commons

ACAMPADA SOL - FUNCTIONAL ANALYSIS

- 01. INFORMACIÓN
- 02. ENFERMERÍA '1'
- 03. INFRAESTRUCTURA
- 04. CARPINTERÍA Y PANCARTAS
- 05. LIMPIEZA
- 06. LEGAL

- 07. MIGRACIÓN-MOBILIDAD
- 08. RESPETO '2'
- 09. BIBLIOTECA INFANTIL
- 10. COMUNICACIÓN AUDIOVISUAL
- 11. GUARDERÍA
- 12. DOMO

- 13. UNIÓN MADRID (RADIO)
- 14. ESPIRITUALIDAD Y AMOR
- 15. TERAPIAS NATURALES
- 16. PSICOLOGÍA
- 17. ARTE
- 18. BIBLIOTECA

- 19. EXTENSIÓN BARRIOS
- 20. MEDIO AMBIENTE
- 21. EDUCACIÓN, CULTURA Y UNIVERSIDAD
- 22. MÚSICA
- 23. POLÍTICA
- 24. ECONOMÍA

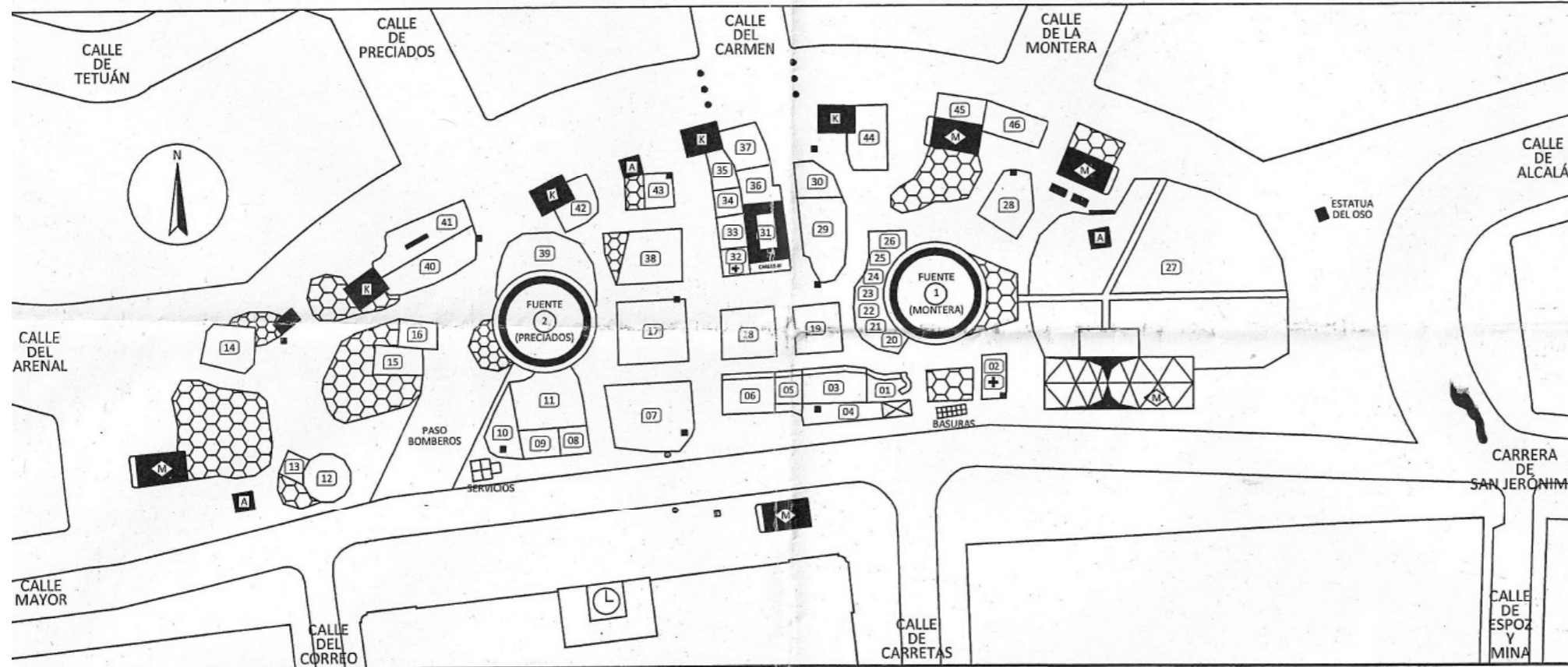

- 25. PENSAMIENTO
- 26. SOCIAL
- 27. ASAMBLEA GENERAL
- 28. ALIMENTACIÓN '3'
- 29. ALIMENTACIÓN '1'
- 30. EXTERIOR

- 31. MEGAFONÍA
- 32. ENFERMERÍA '2'
- 33. ACCIÓN-CREATIVIDAD
- 34. COORDINACIÓN INTERNA
- 35. PARTICIPANTES
- 36. COMUNICACIÓN

- 37. ARCHIVO
- 38. ACTIVIDADES
- 39. MICRO-LIBRE (SPEAKERS' CORNER)
- 40. ALIMENTACIÓN '2'
- 41. PROPUESTAS
- 42. DERECHOS ANIMALES

- 43. INFORMACIÓN '2'
- 44. RESPETO '1'
- 45. SAHARAUI
- 46. FEMINISMO

 ZONA ACAMPADA

ACAMPADA SOL - FUNCTIONAL ANALYSIS



carpentry and posters

library

art



infirmary

kindergarden

gathering spaces

conversation spaces

commons and food



information

audiovisual
communication

stage



CREATE
create and display

atelier spaces, workshops, printing houses,
exhibition spaces, museum



CONGREGATE
meet and discuss

sports fields, courtyards, gyms, discussion
clubs, cafes, galleries, restaurants



COMMUNICATE
see and be seen

radio, TV, media facilities, monuments,
characteristic points, loggias

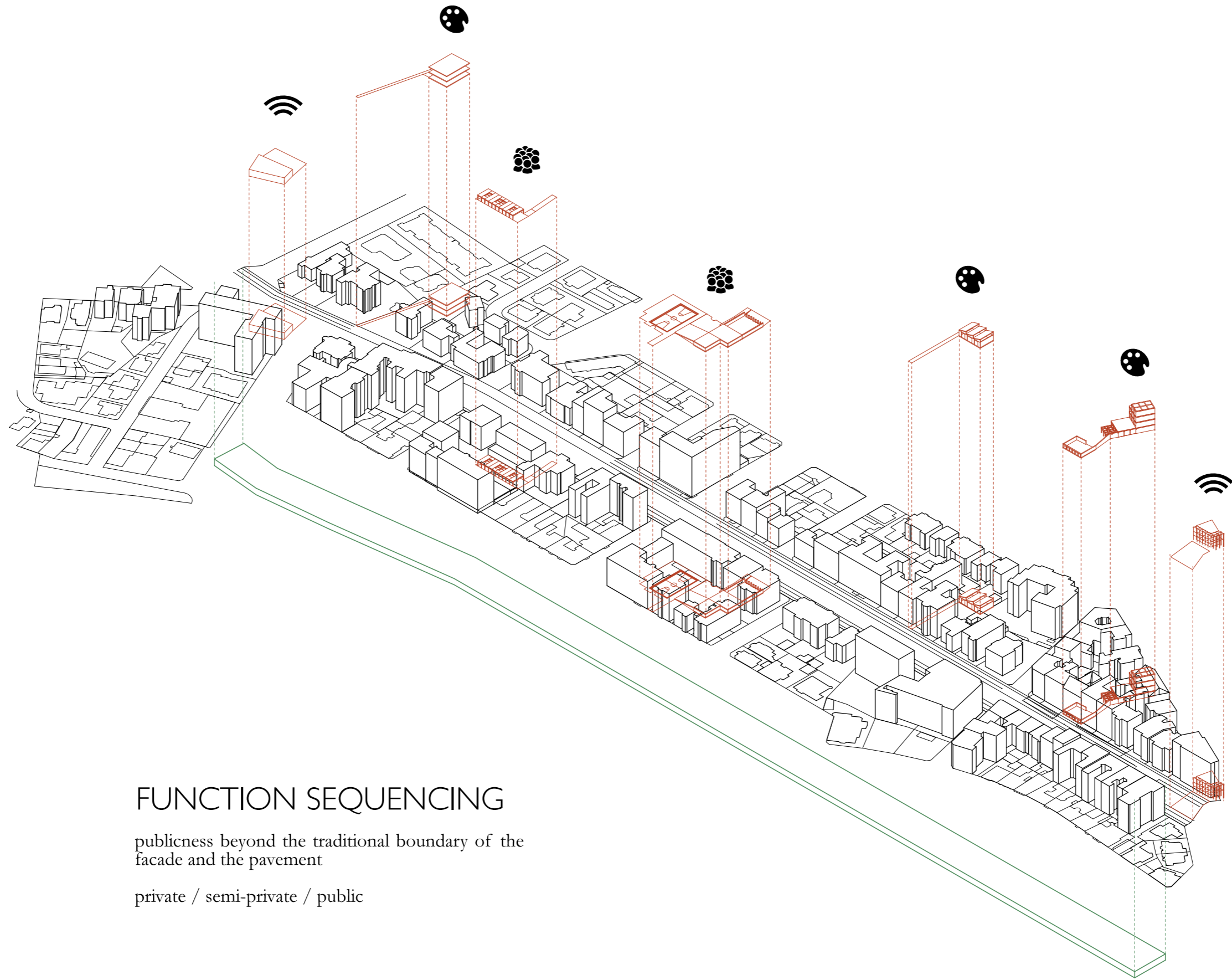

FUNCTION SEQUENCING

publicness beyond the traditional boundary of the facade and the pavement

private / semi-private / public

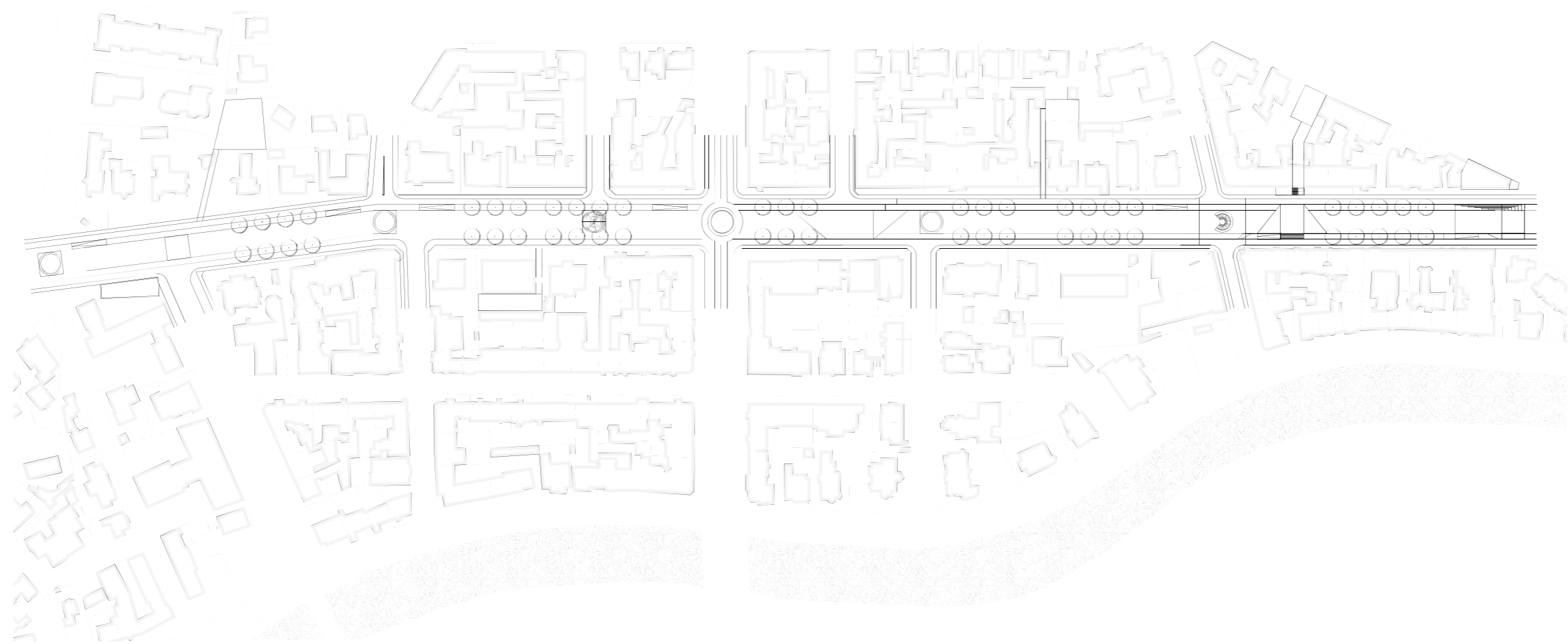

PROTEST INFRASTRUCTURE

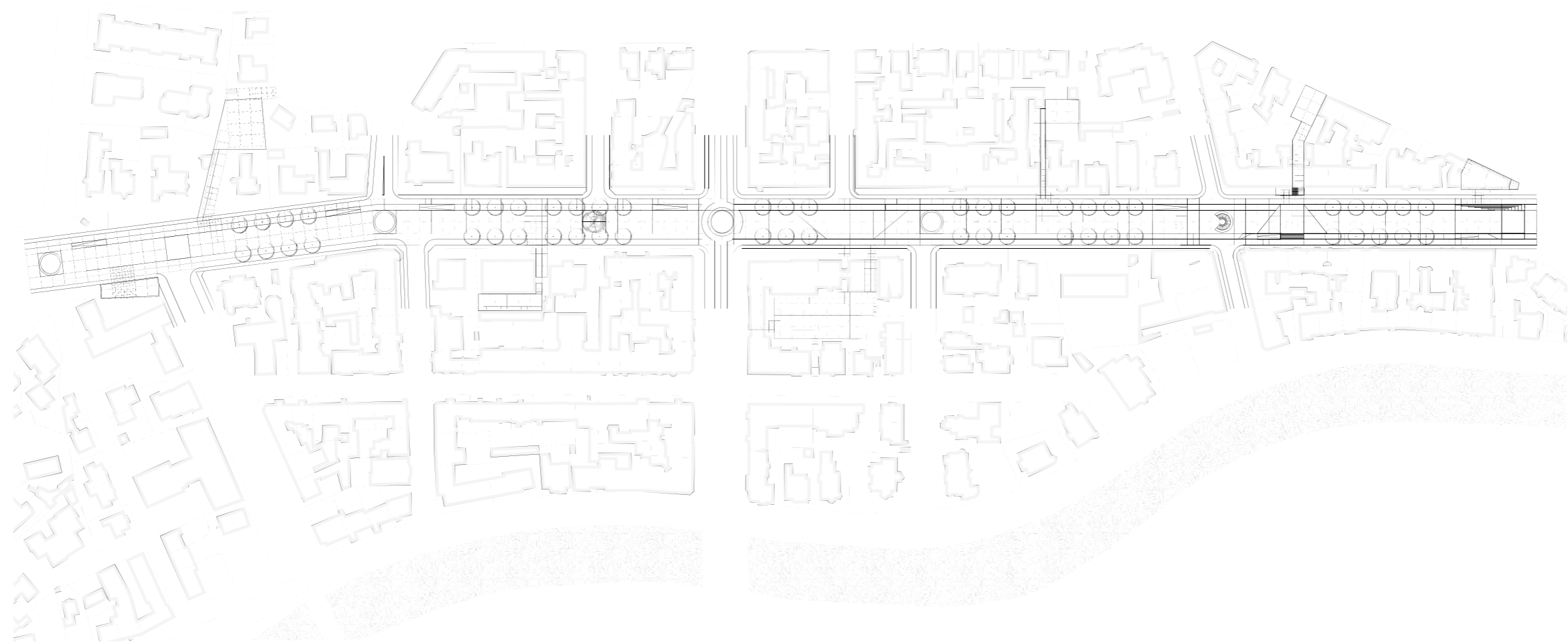

PROTEST INFRASTRUCTURE

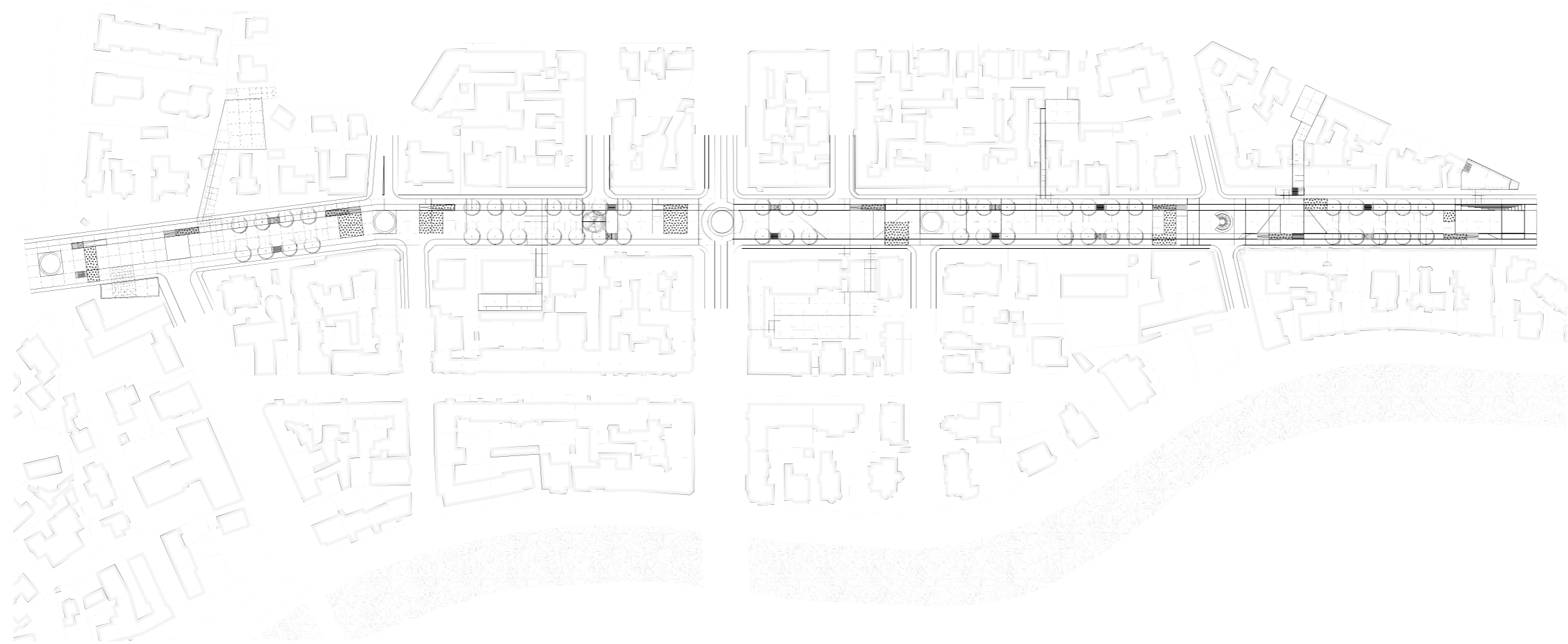

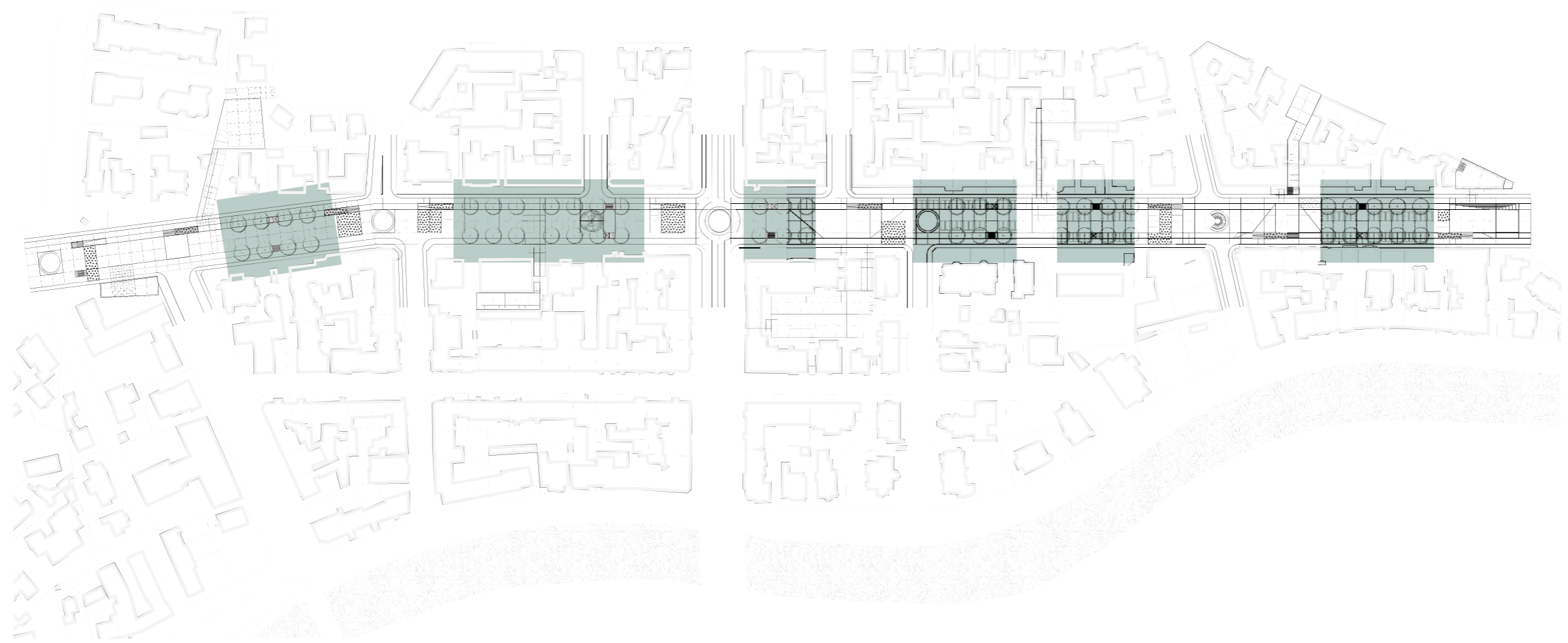

REGULAR MODULES

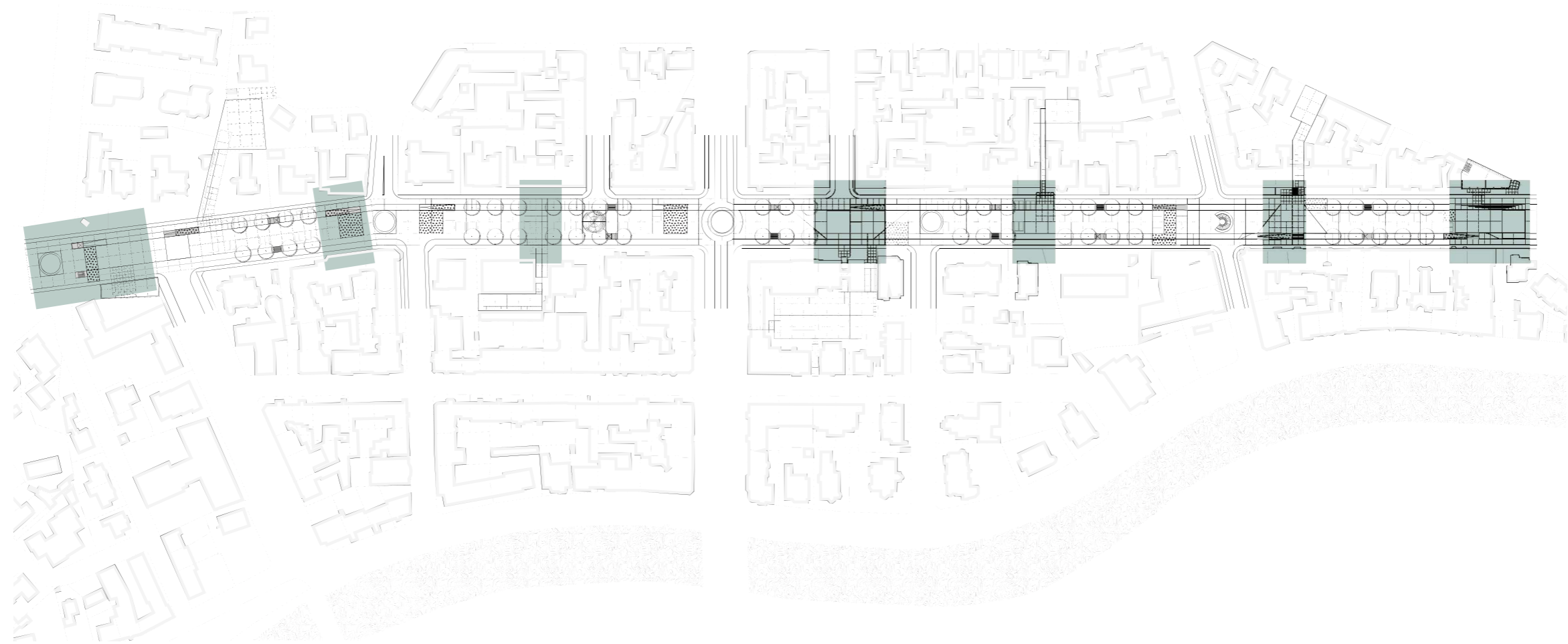

EXCEPTIONS

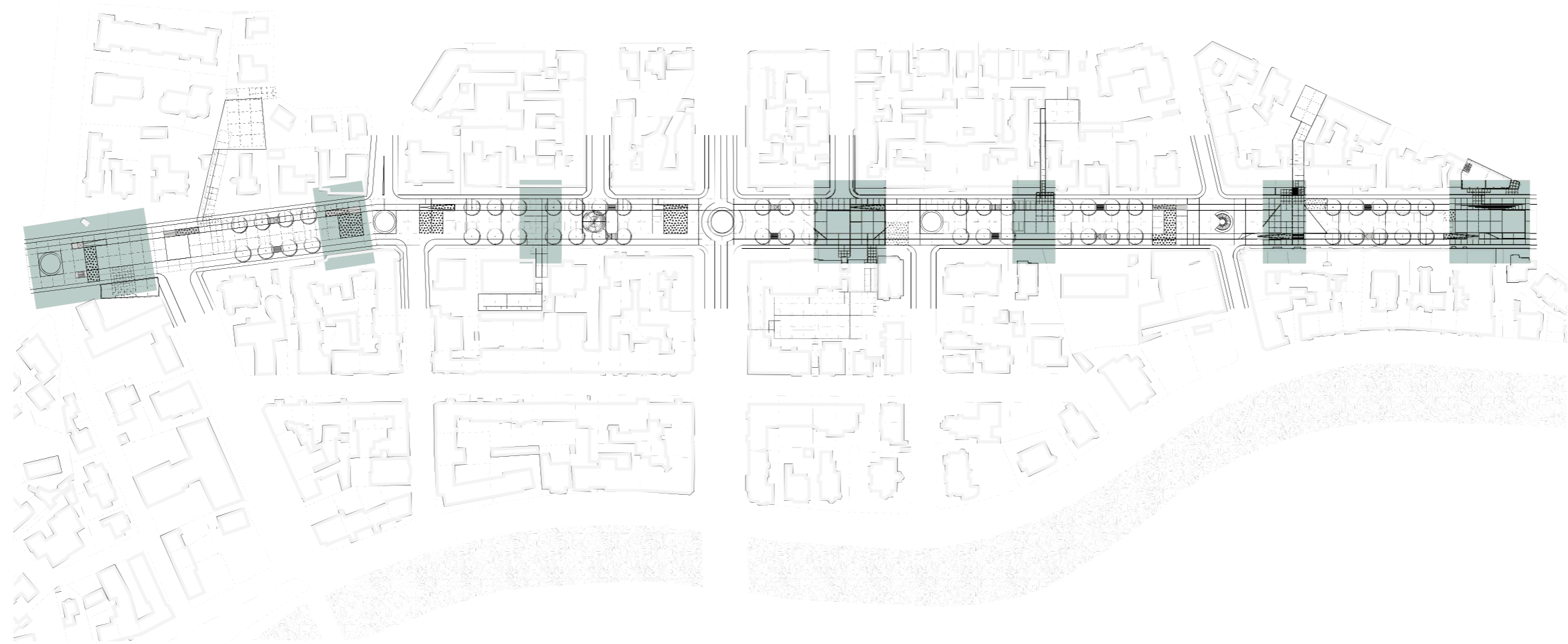
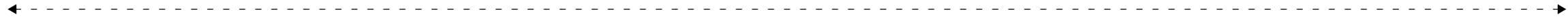

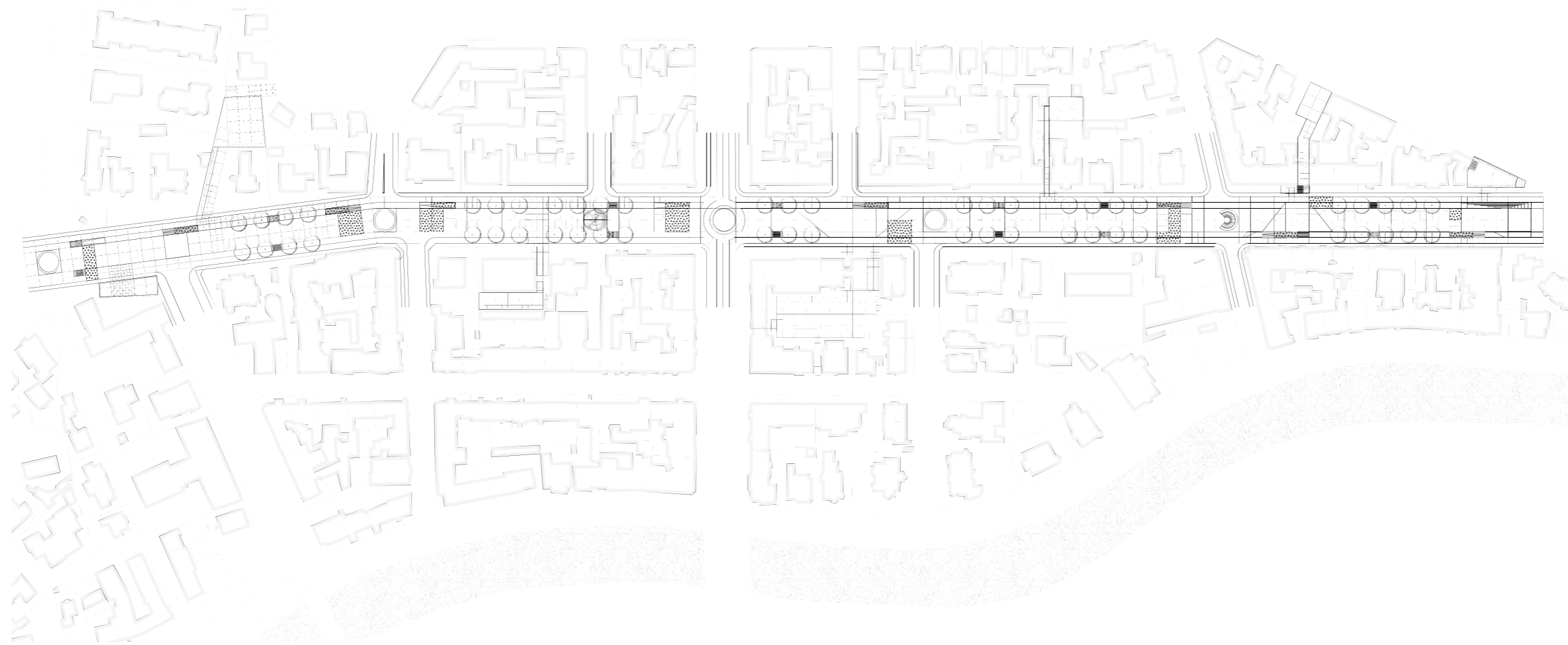
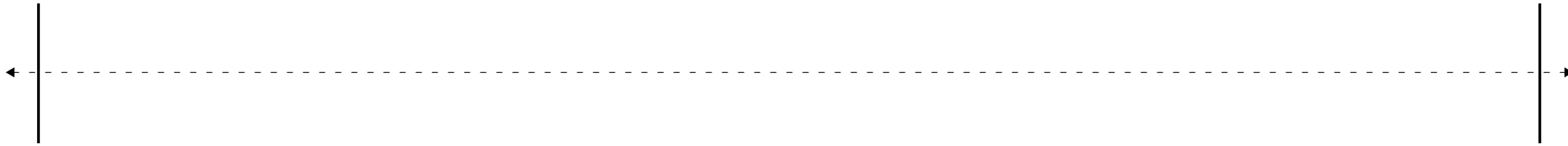

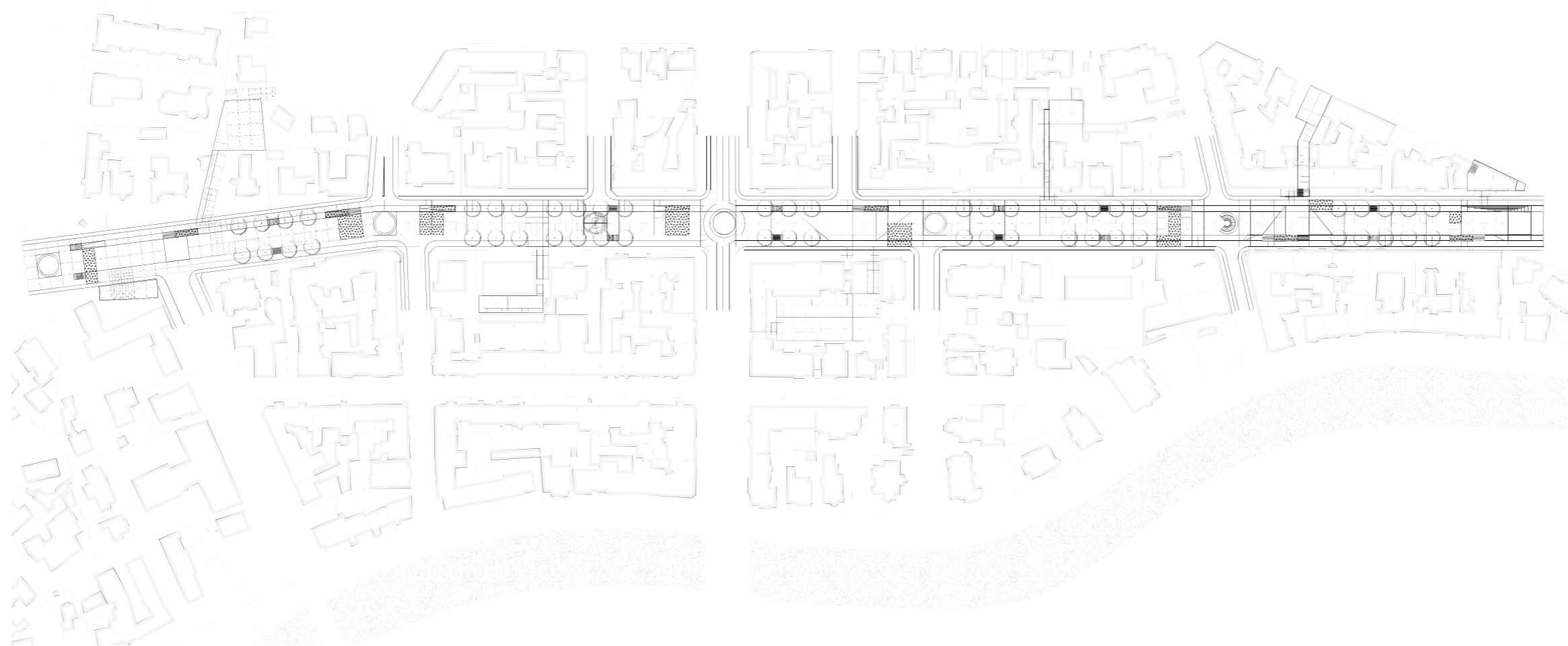
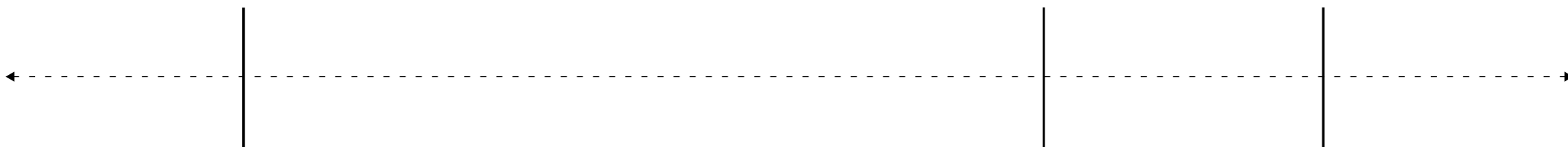

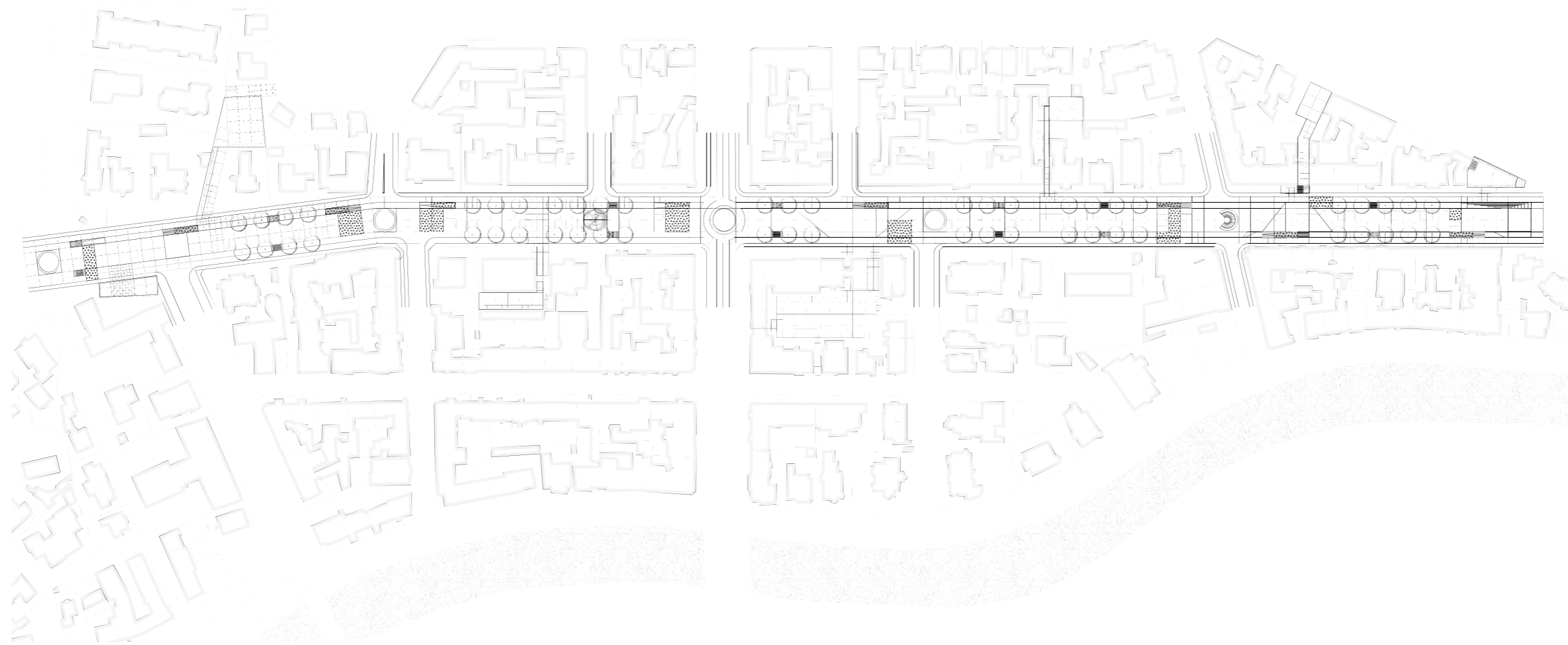
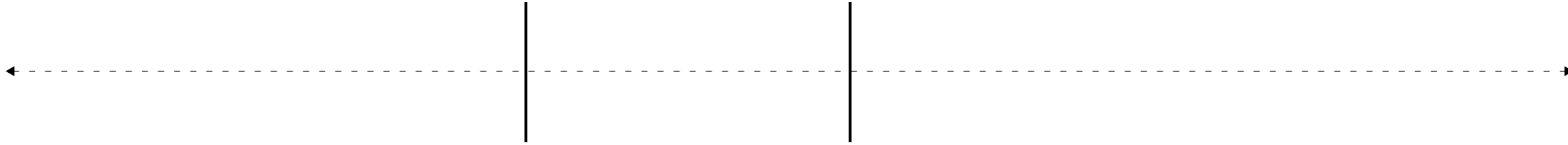

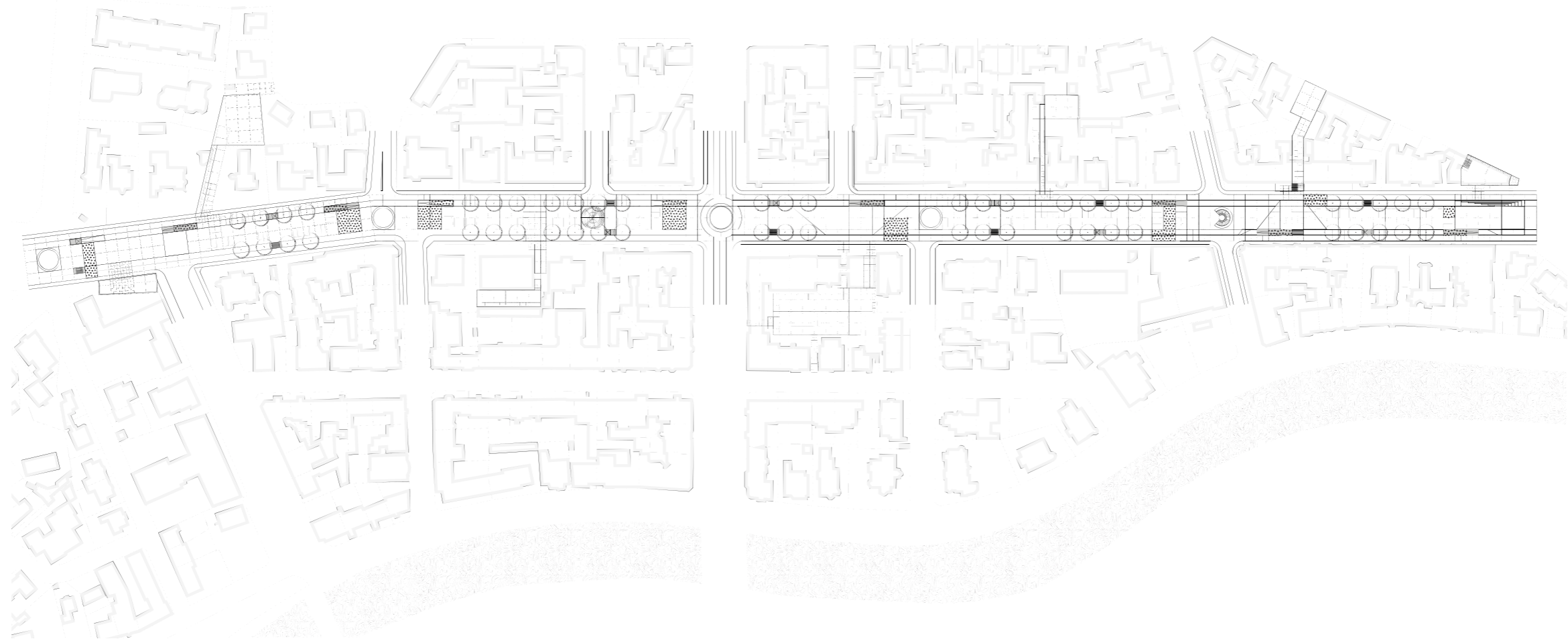
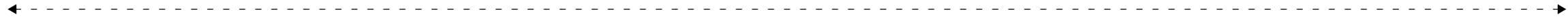
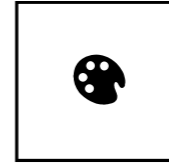
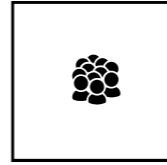

existing: school



addition: adjustment
of the sport field for
gatherings (storages),
space of meditation,
flexible leisure space

existing: residential



addition: warehouse,
art school's ateliers,
exhibition space, café

existing: residential &
retail



addition: TV studio,
conference rooms,
stage

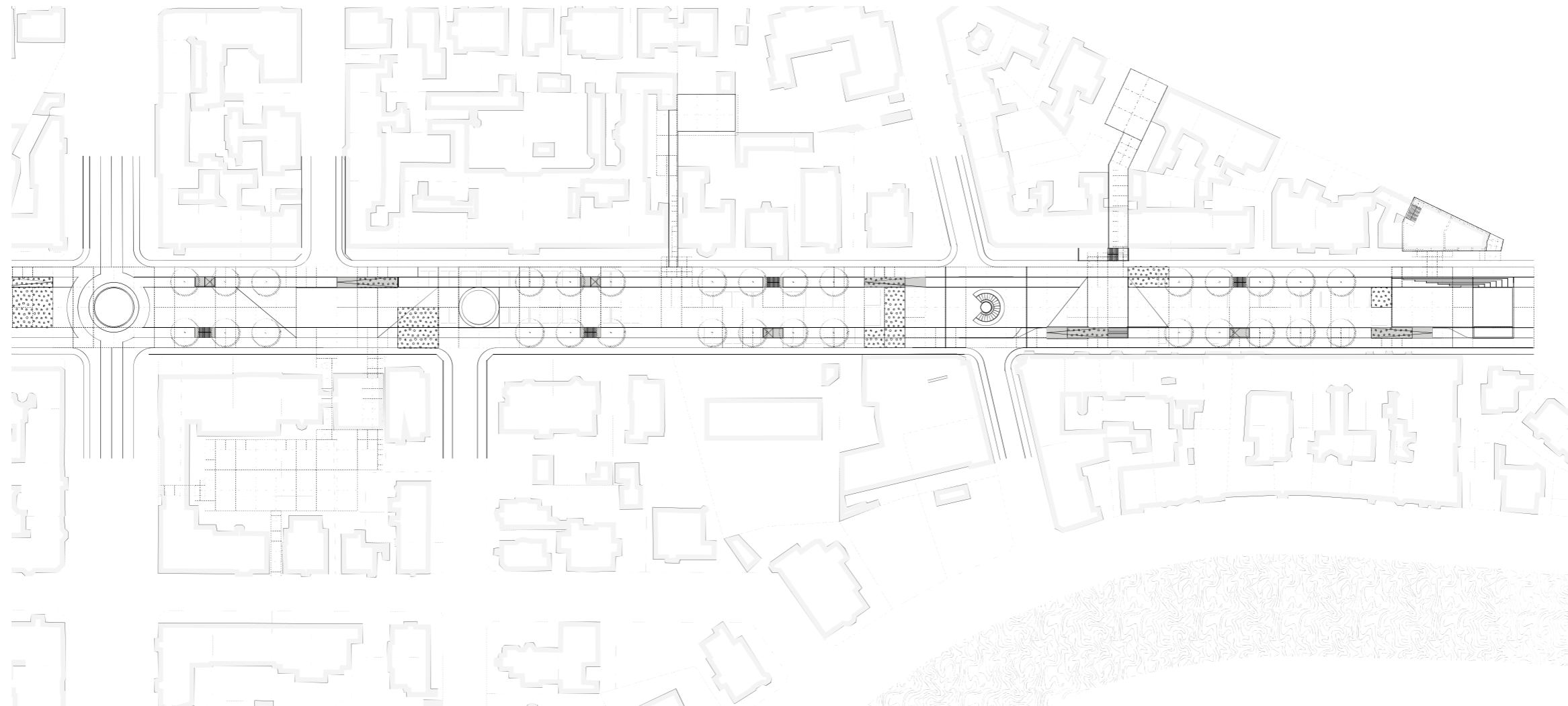

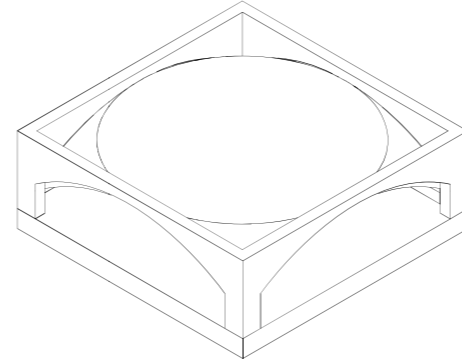
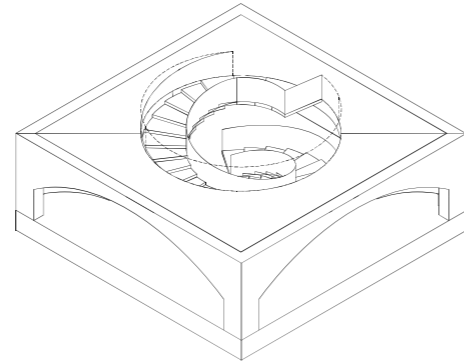
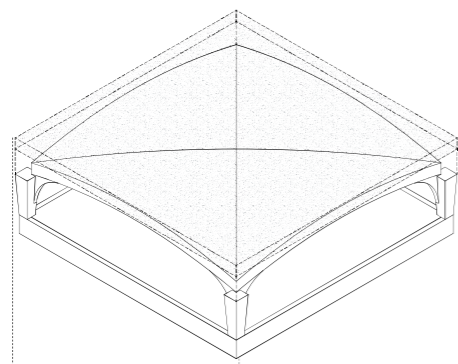

[13X13]

a module indicating zones beneath road crossings; crucial zone for underground orientation; exceptions, special functions;

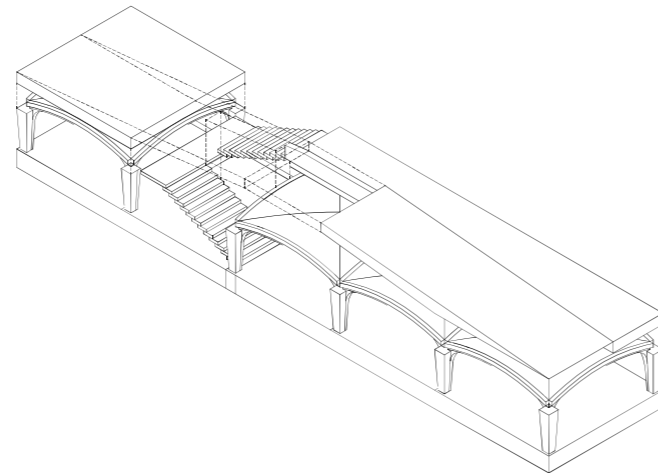
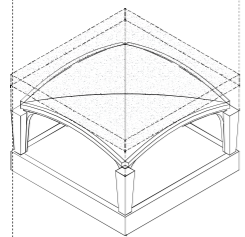

[6,5X6,5]

basic module; regular parking module

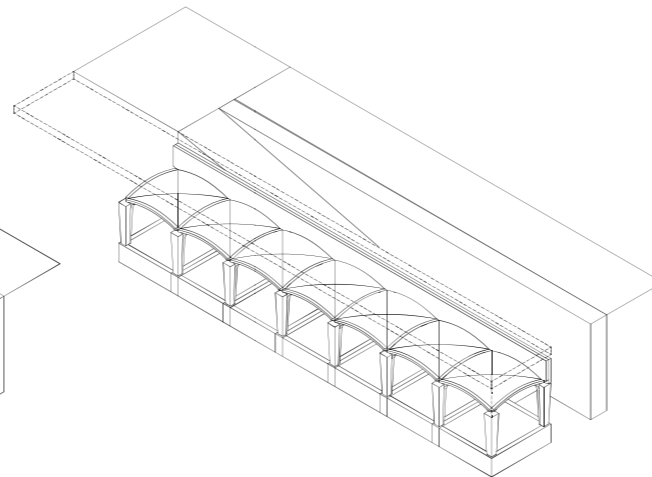
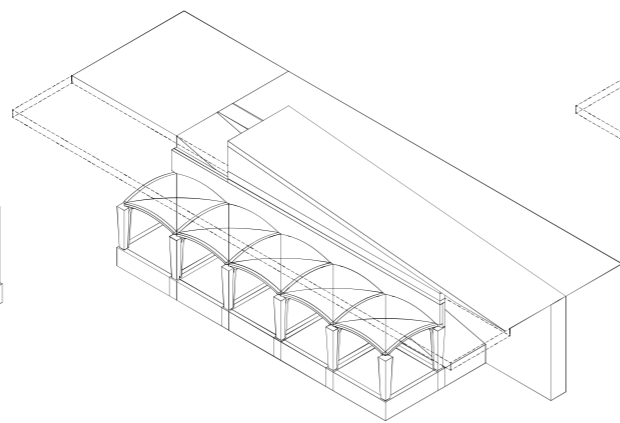
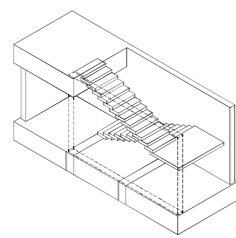
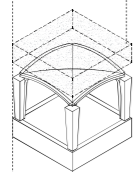

[3,25X3,25]

a module indicating exceptions, niches, links to other buildings, due to smaller vault thickness - more space for vegetation above

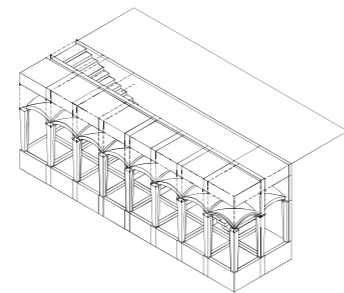
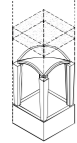

[1,63X1,63]

a transition module indicating the vicinity of a connection to another building or another zone, segregating and dividing people into smaller streams

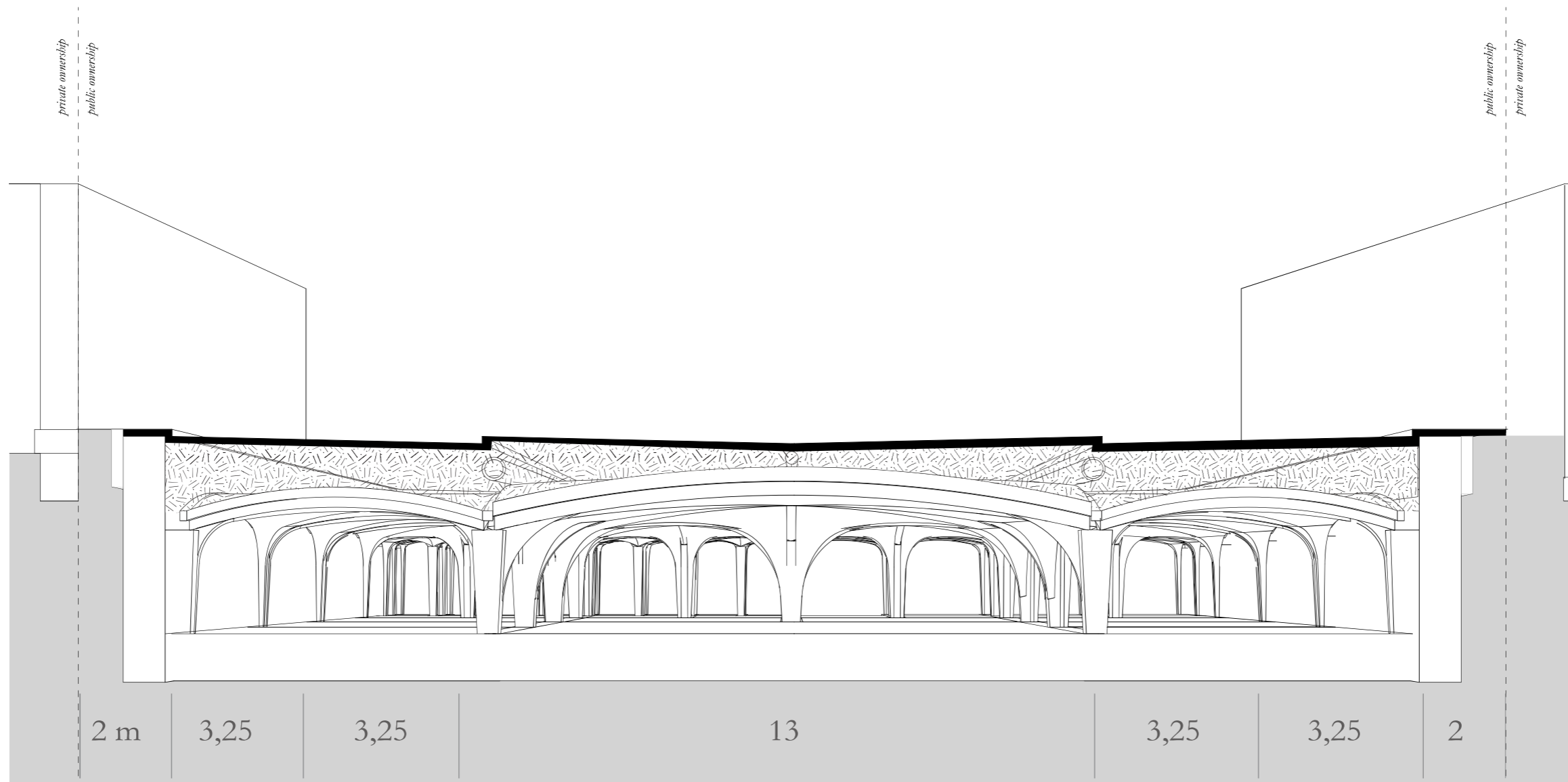

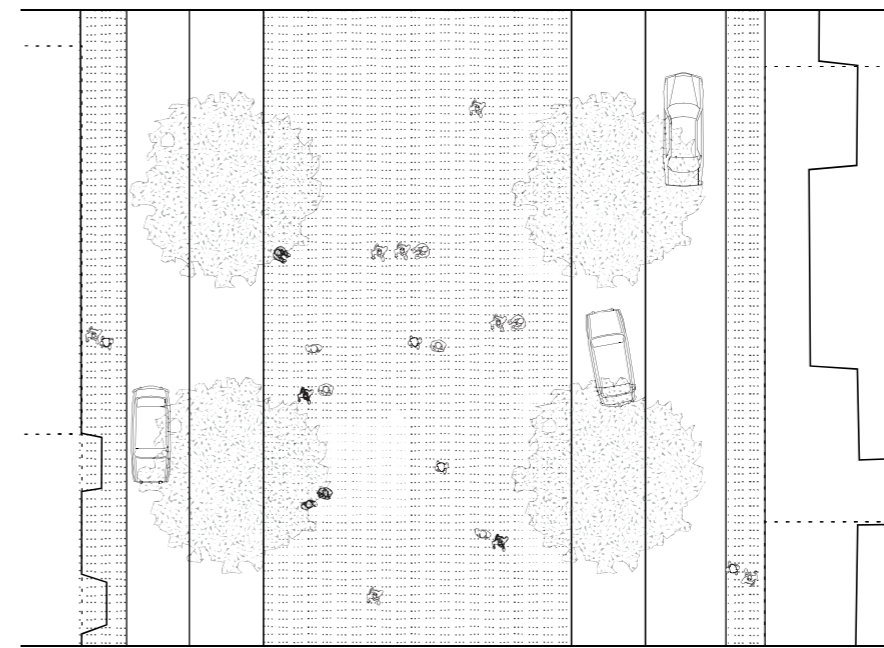
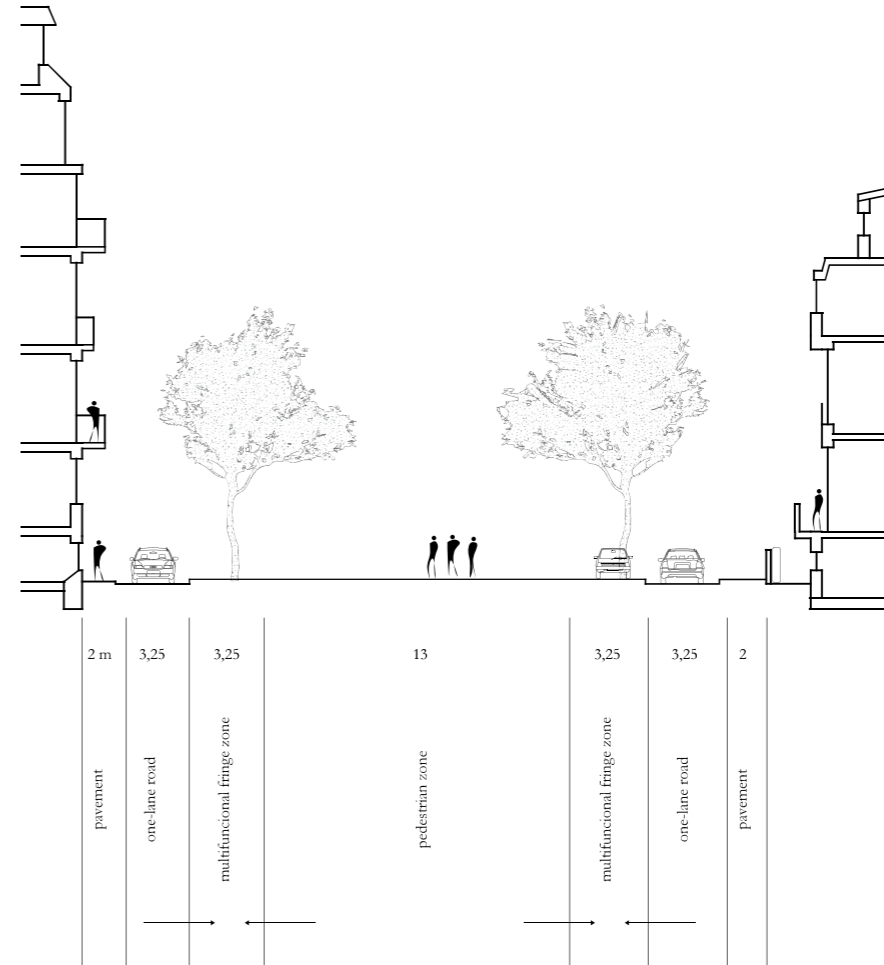
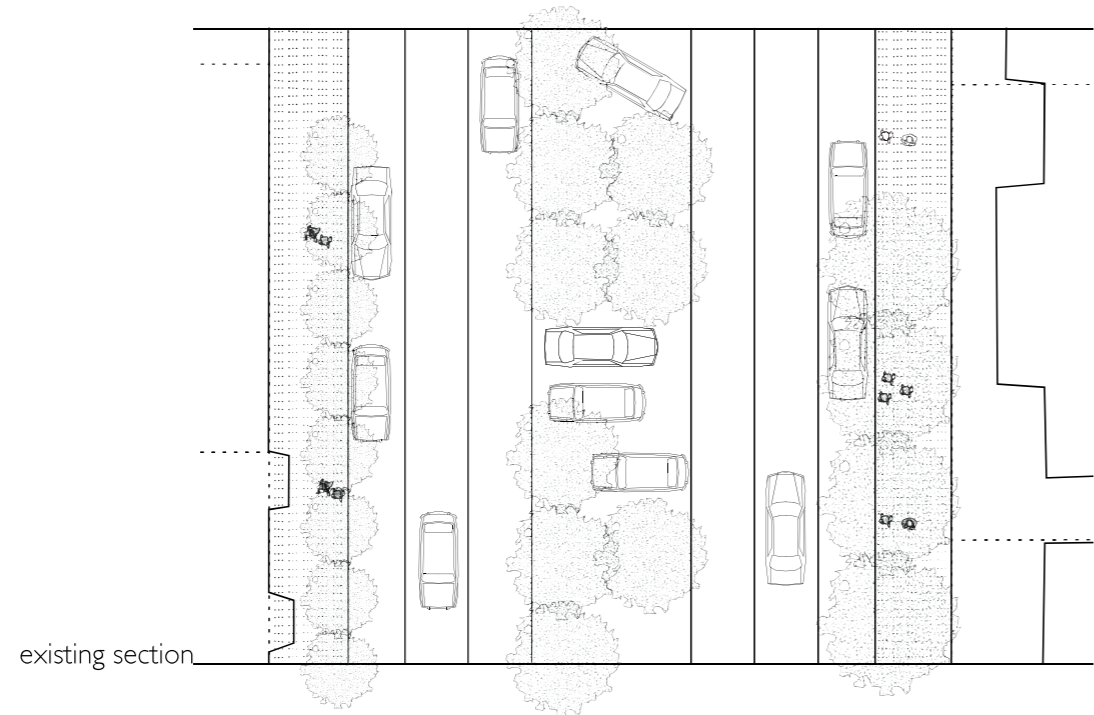
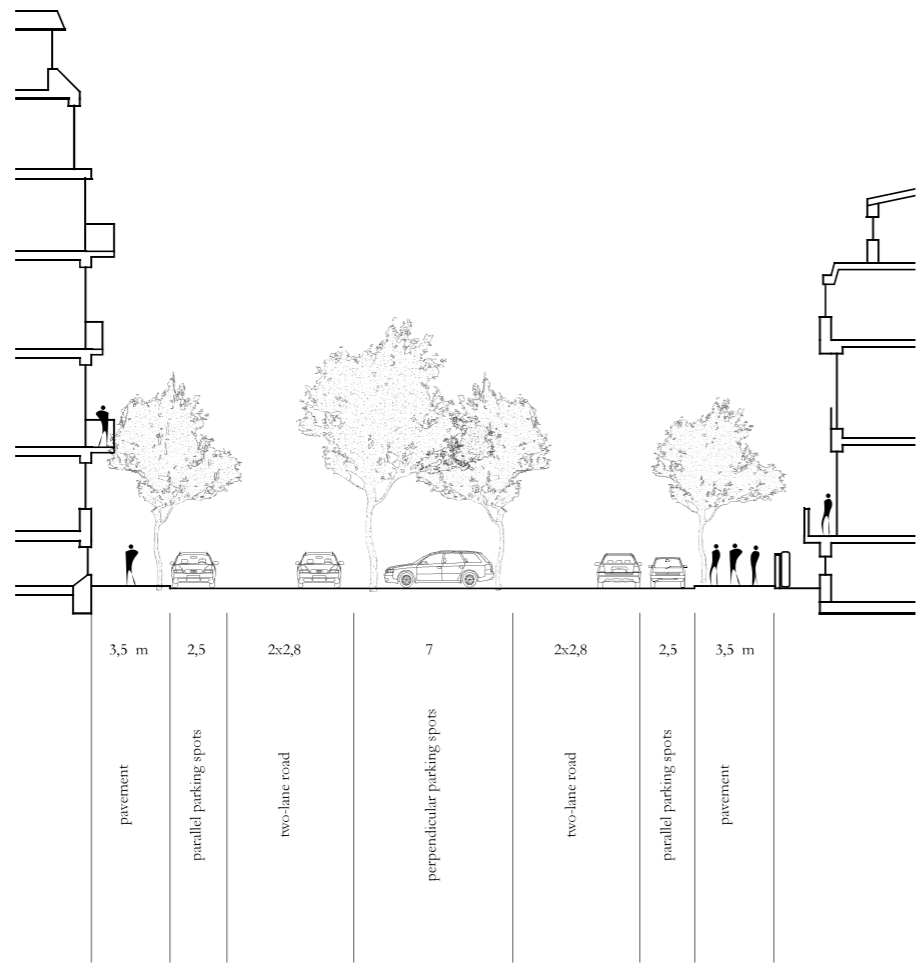



CREATE
create and display

atelier spaces, workshops, printing houses, exhibition spaces, museum

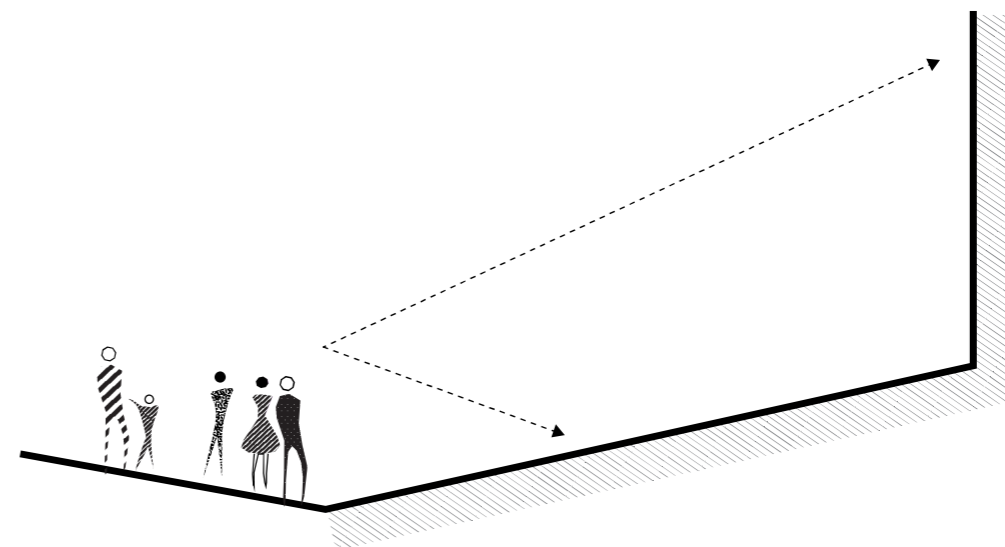

CONGREGATE
meet and discuss

sports fields, courtyards, gyms, discussion clubs, cafes, galleries, restaurants

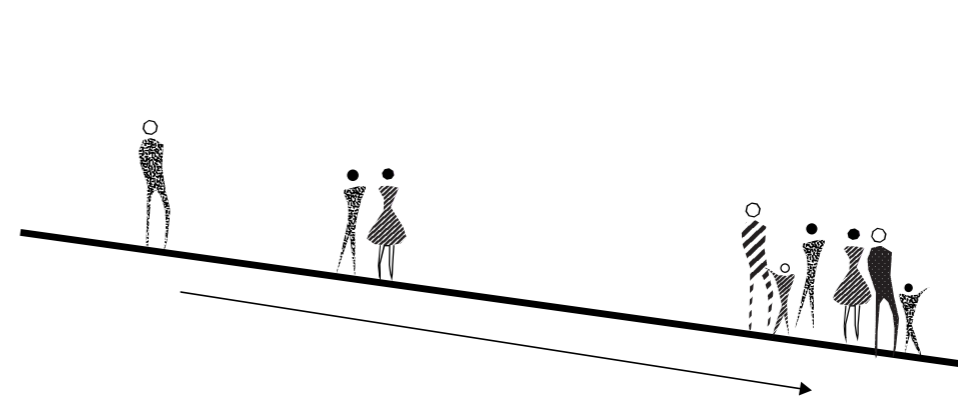

COMMUNICATE
see and be seen

radio, TV, media facilities, monuments, characteristic points, loggias

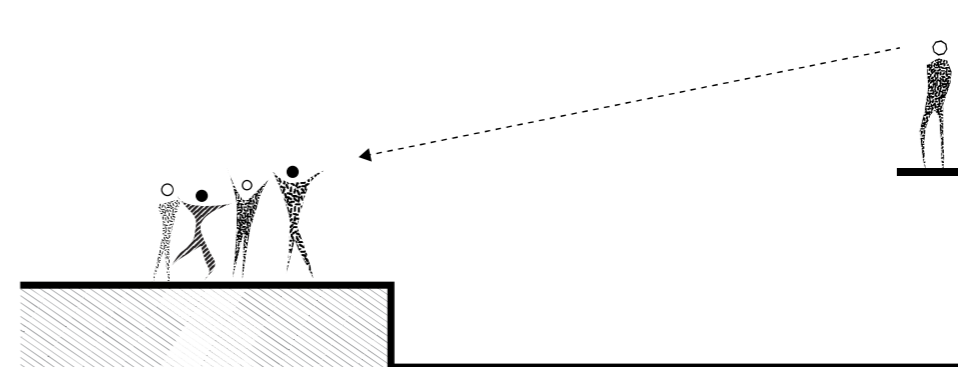

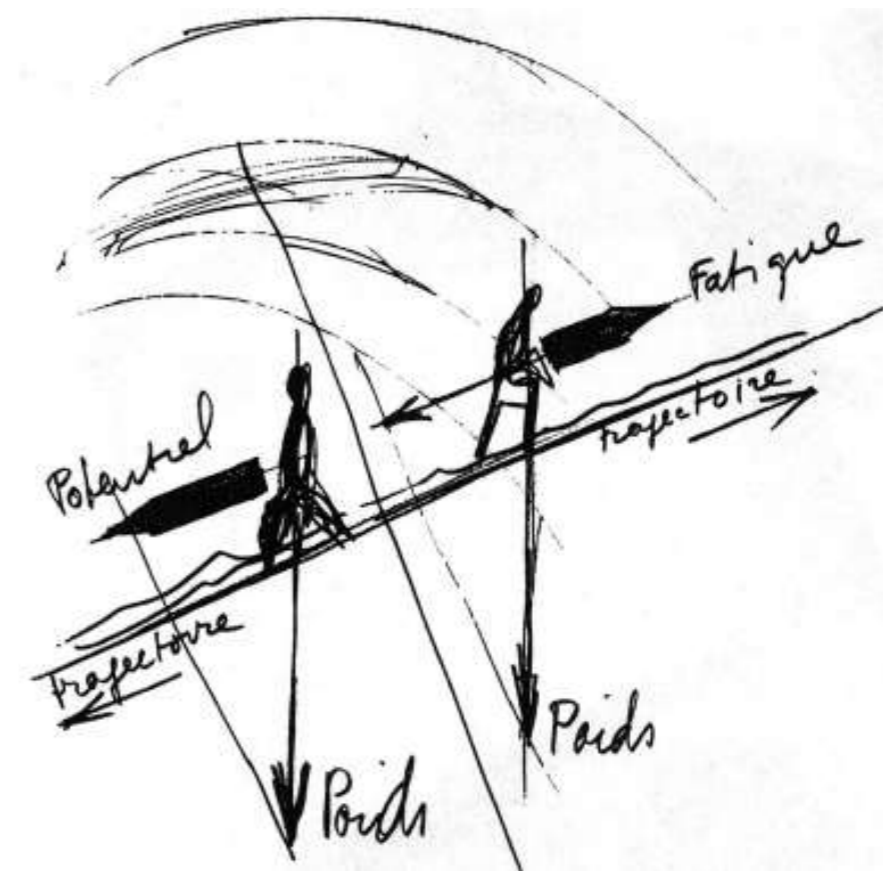
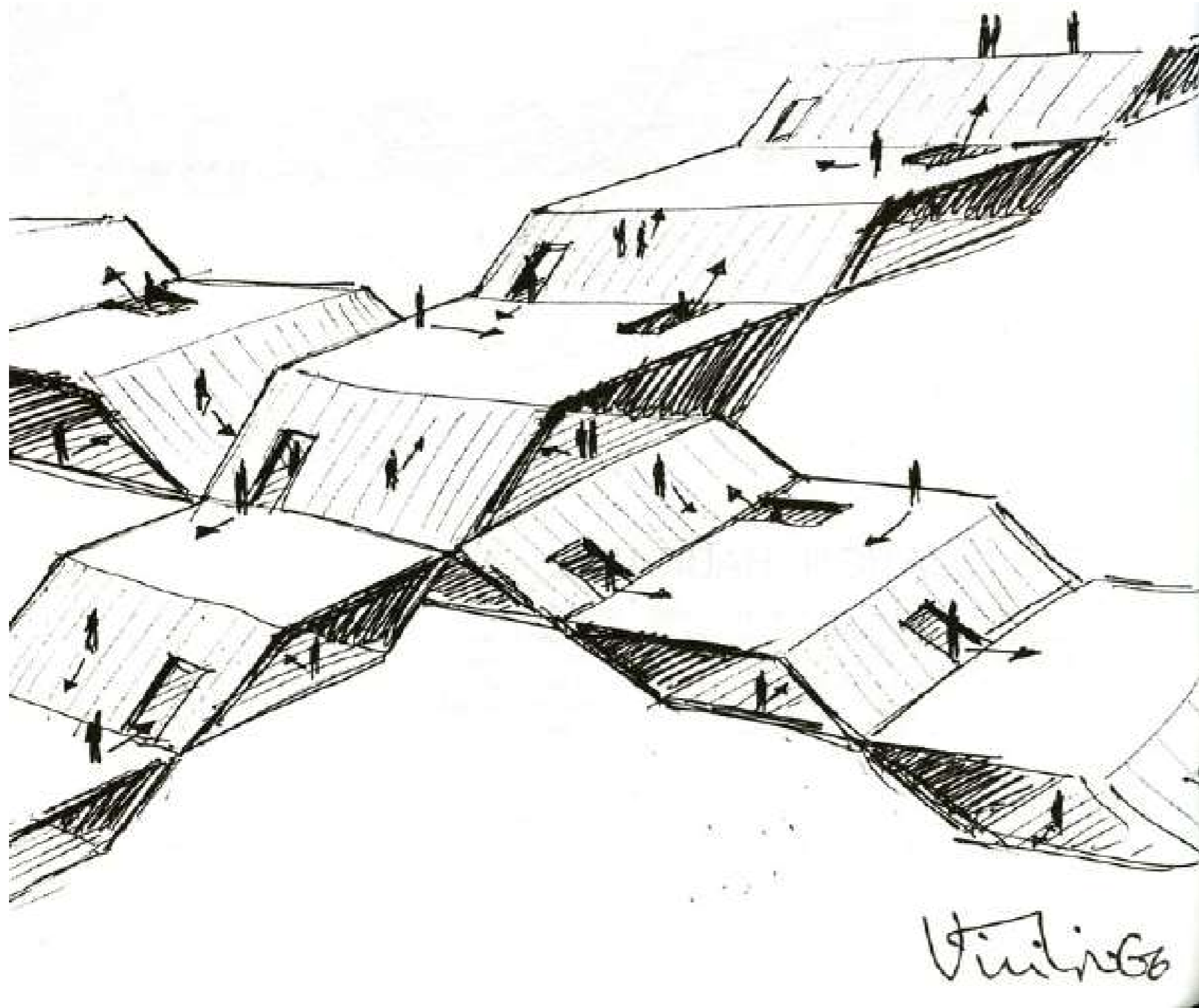

Paul Virilio
The Oblique Function



PLOT 1: OBSERVATION

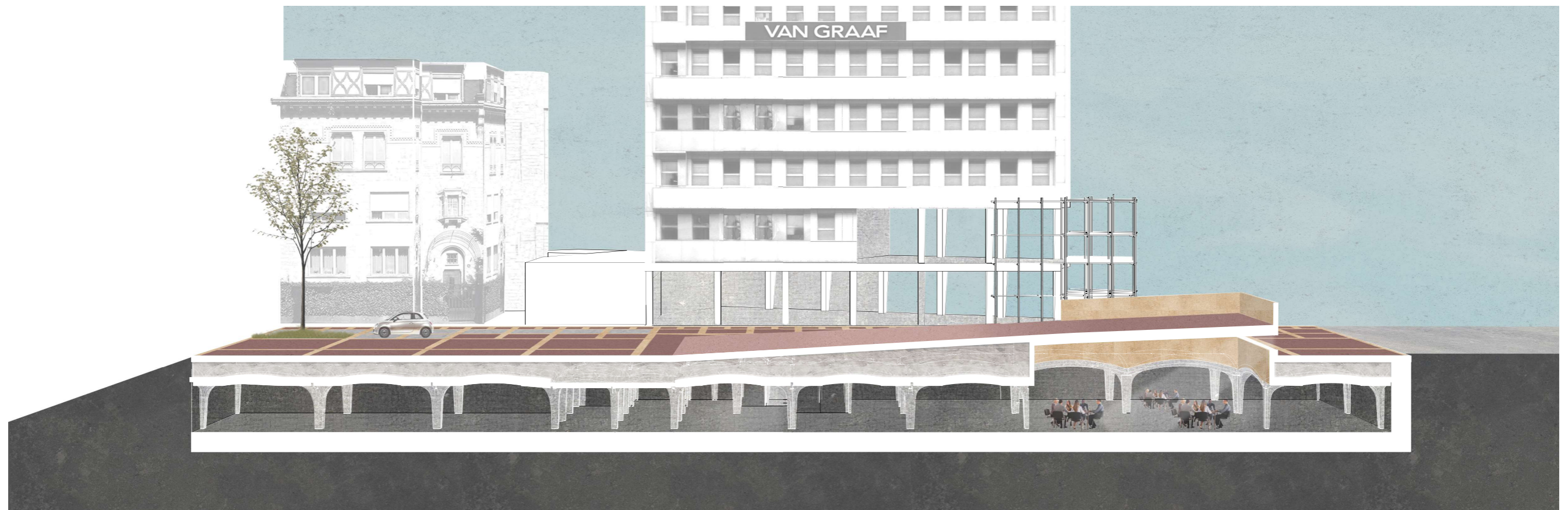
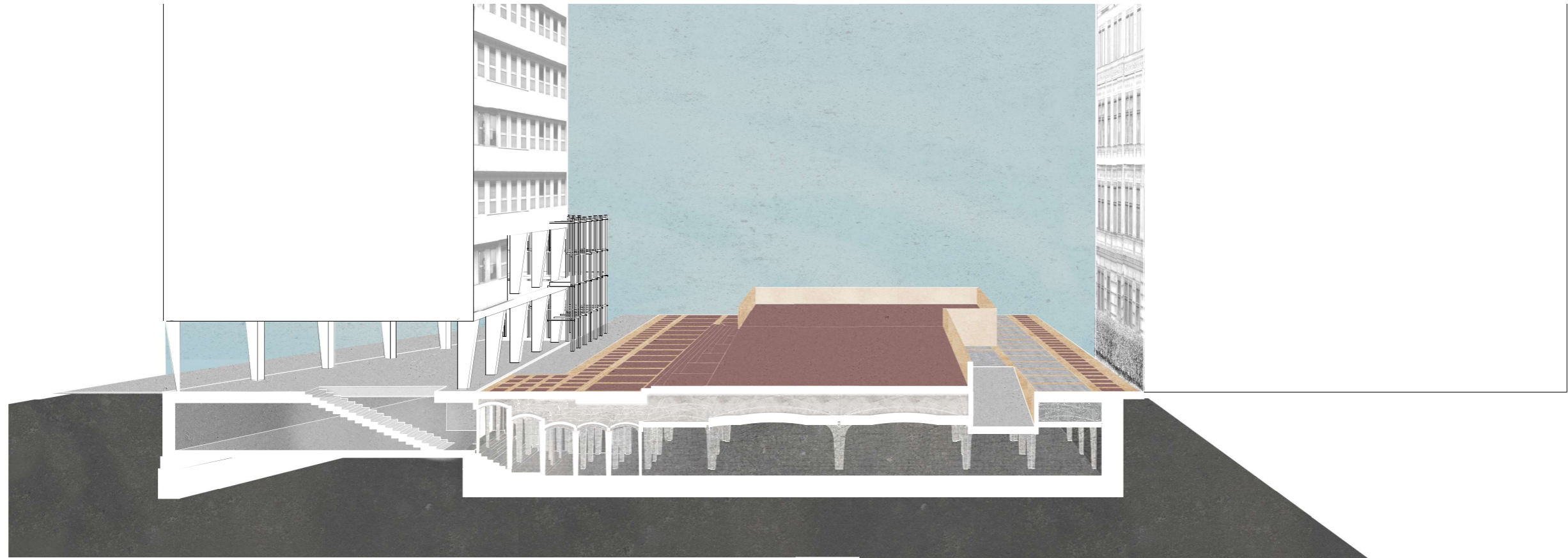

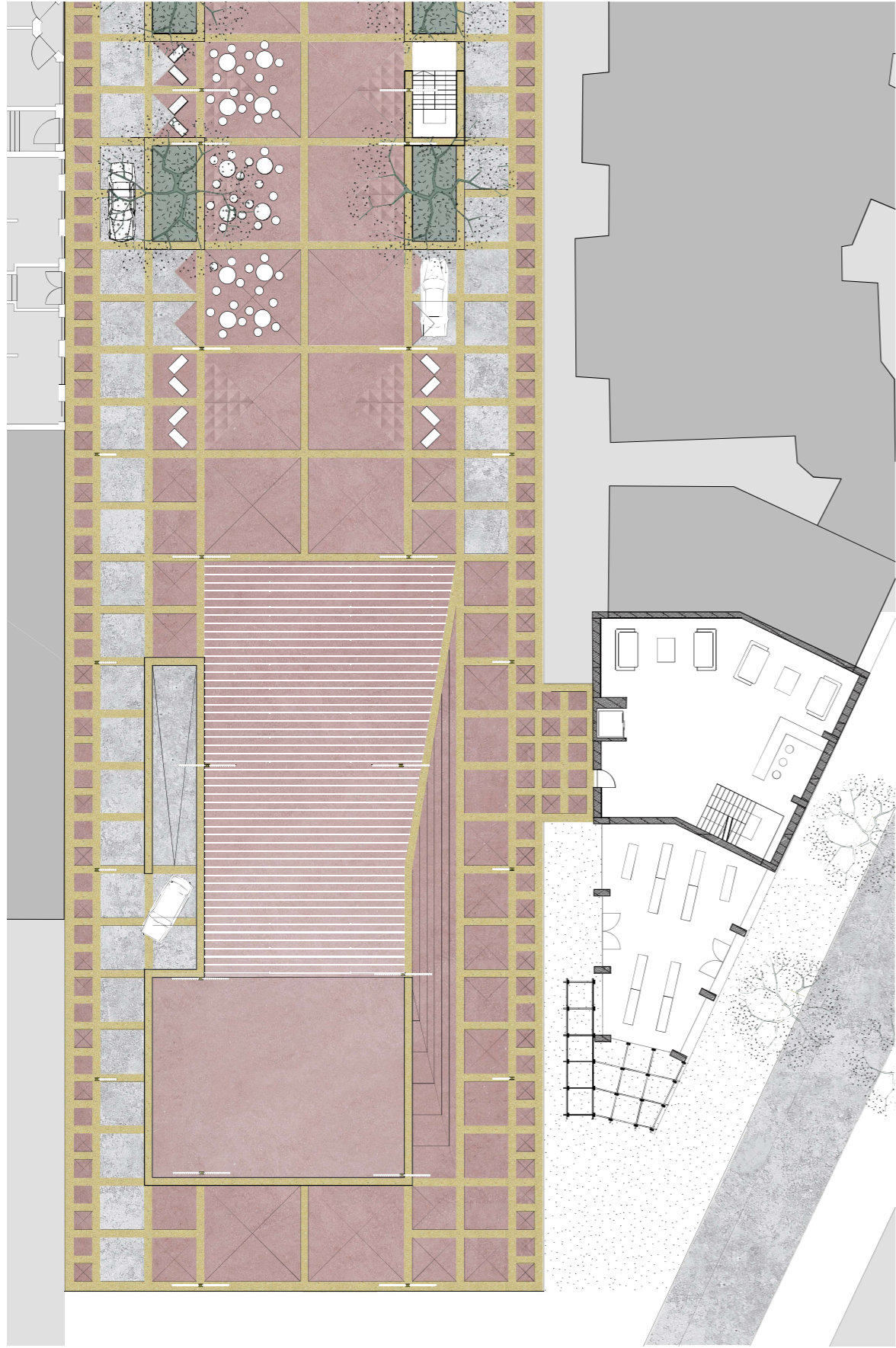



PLOT 2: CREATION

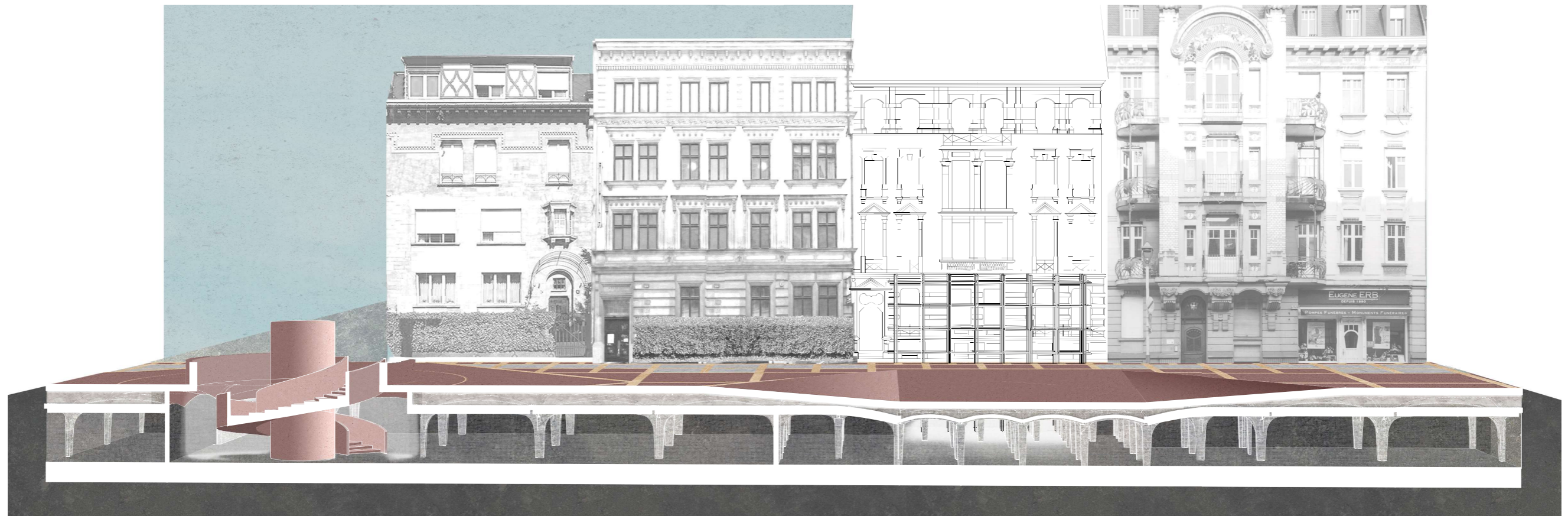
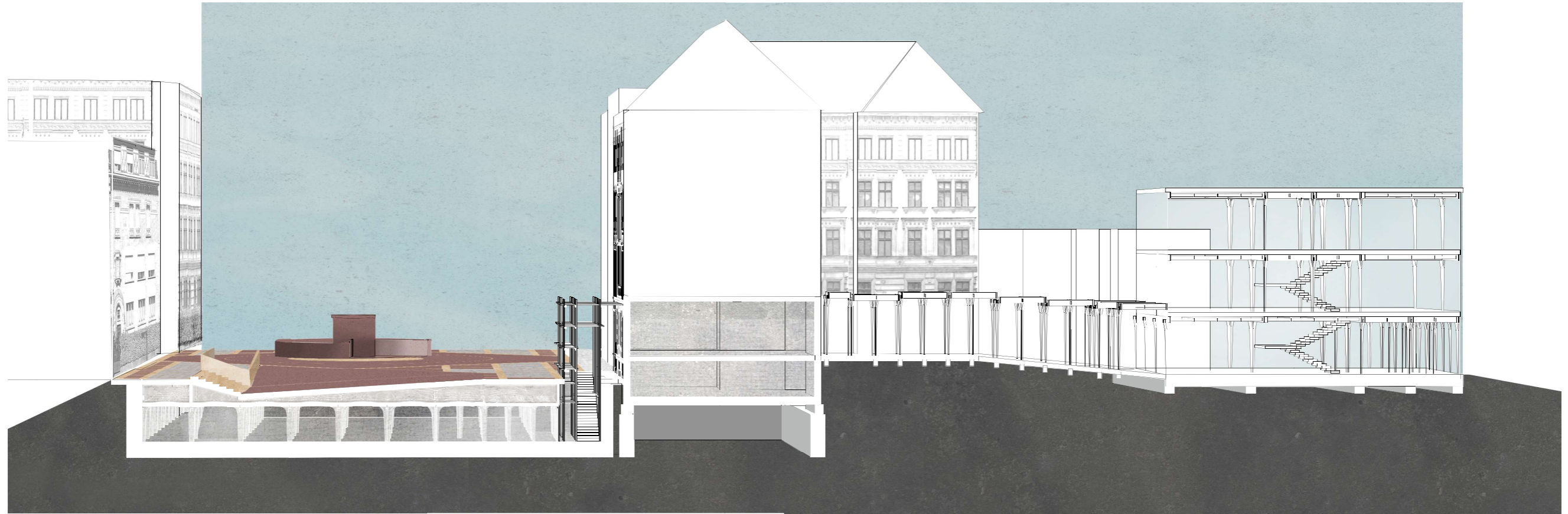

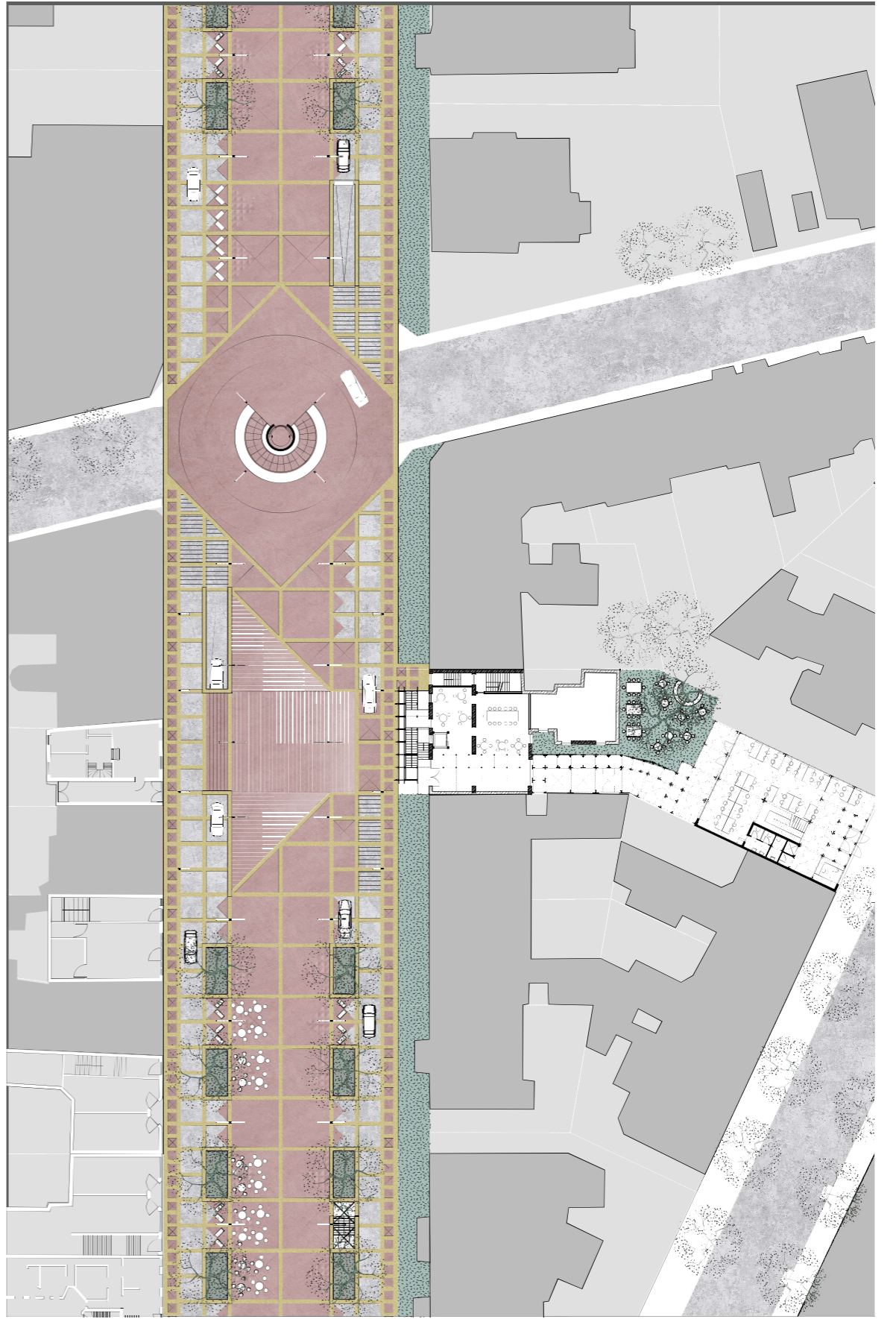
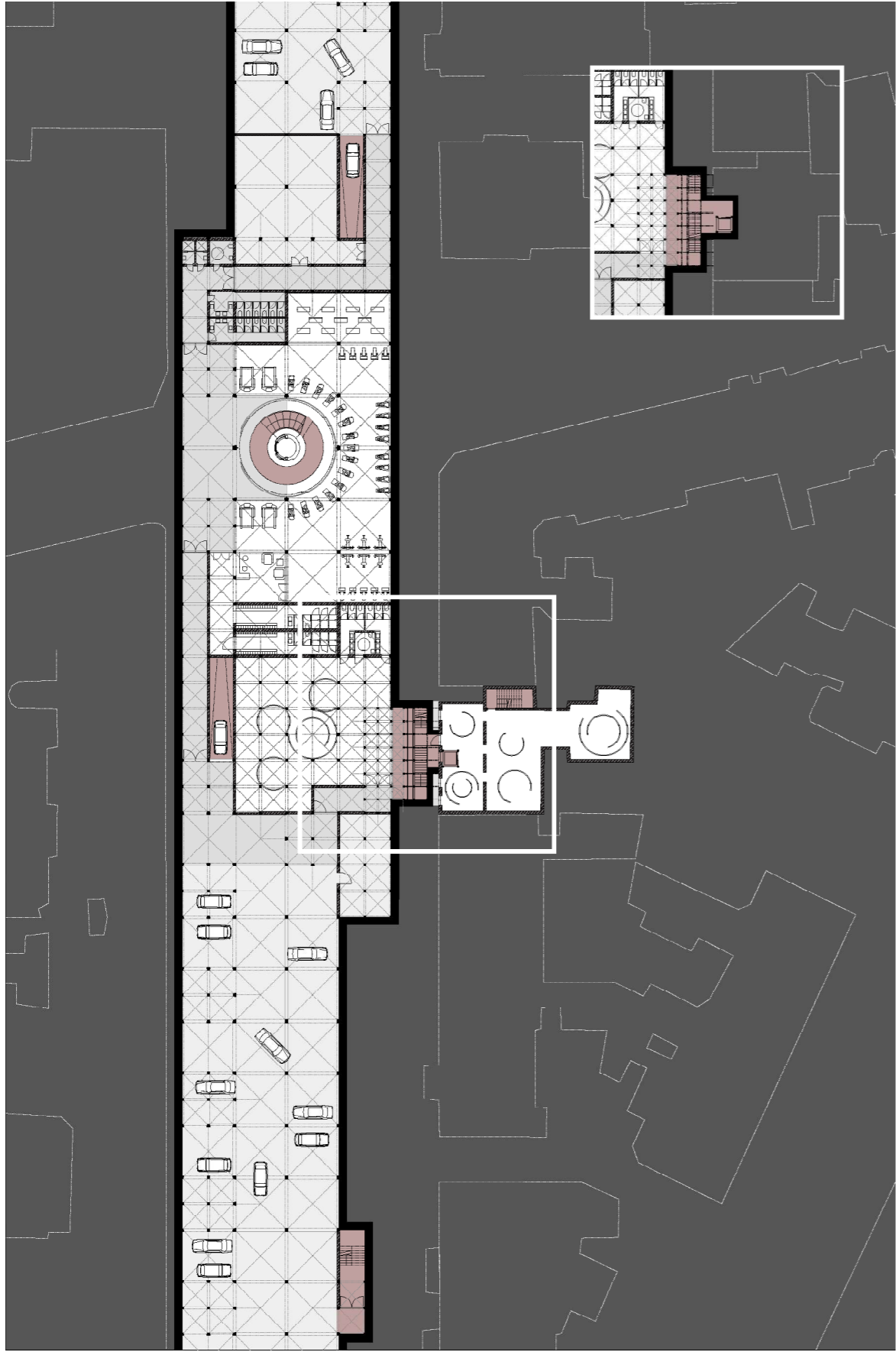

PLOT 3: GATHERING

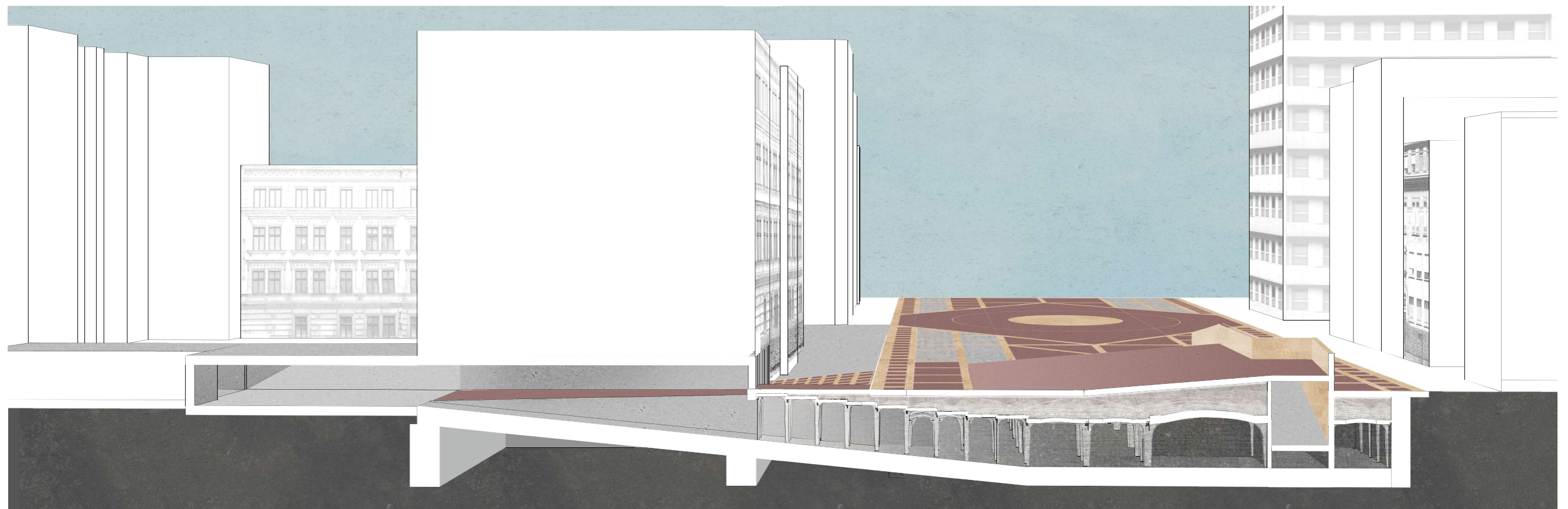

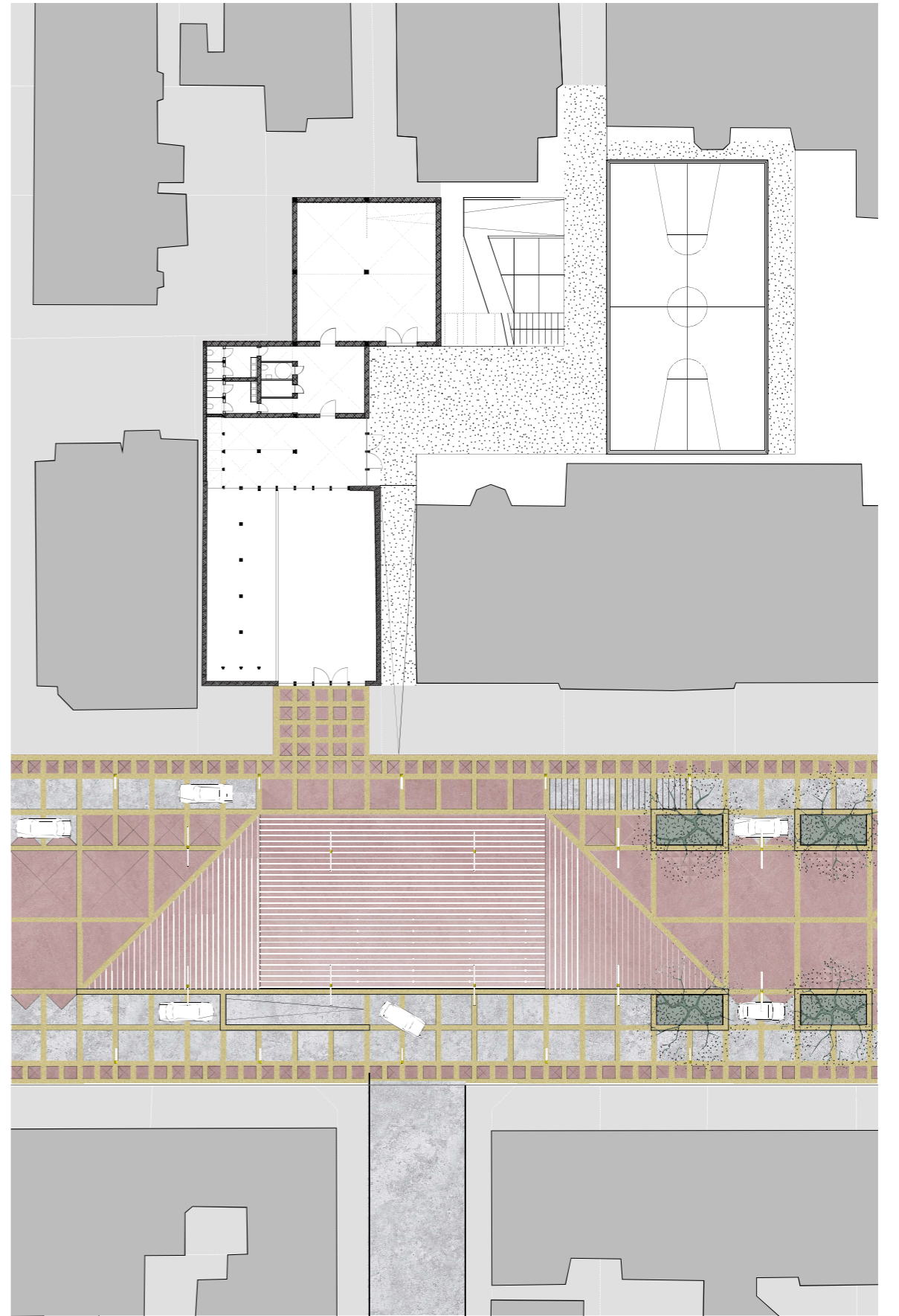
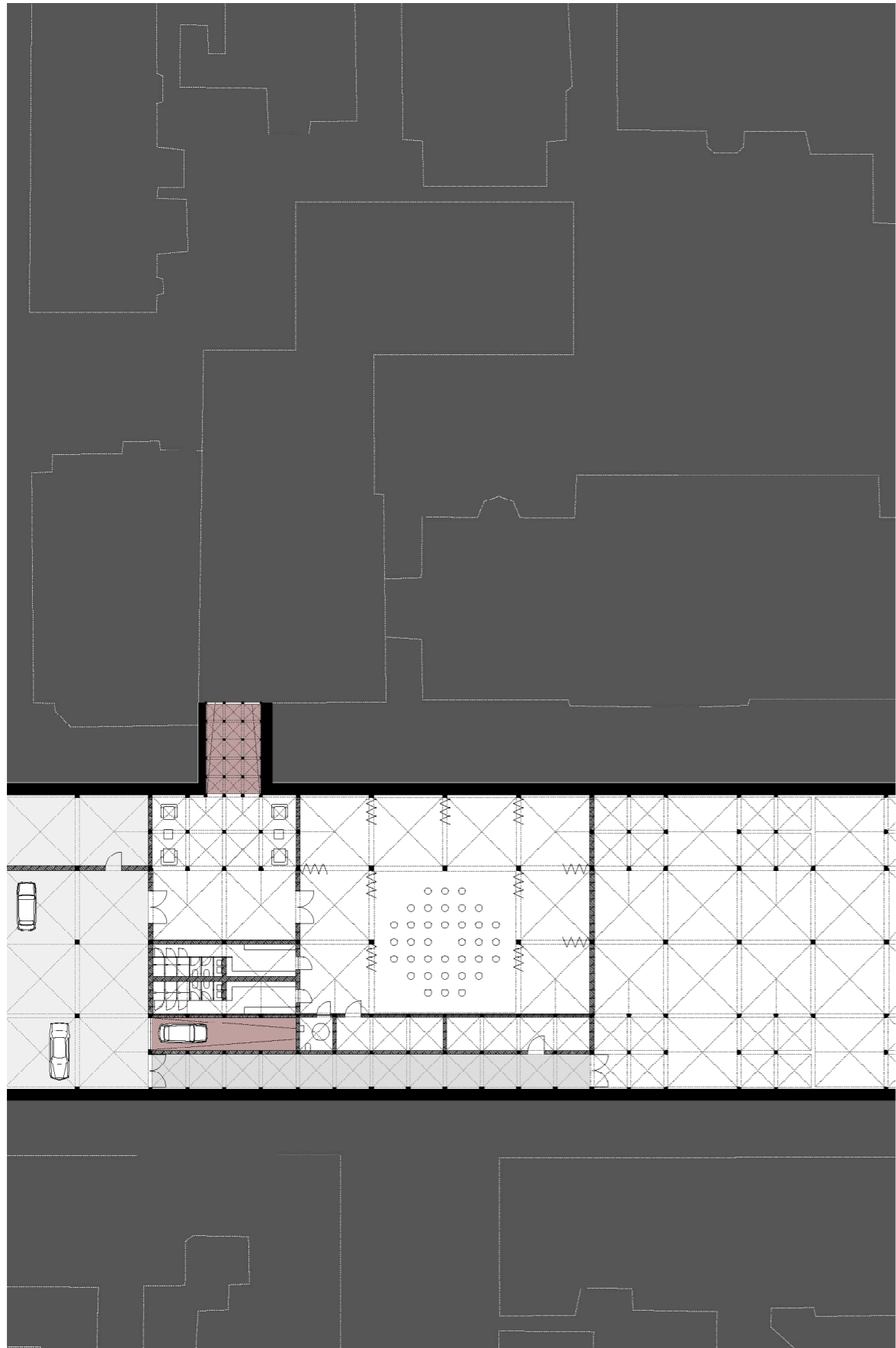

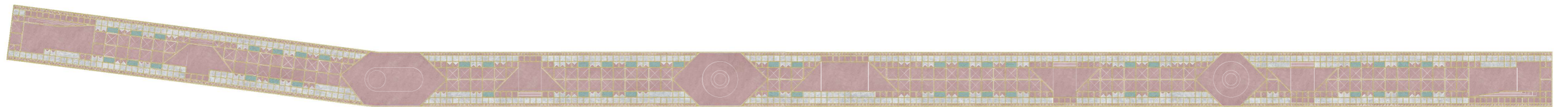

THE STREET



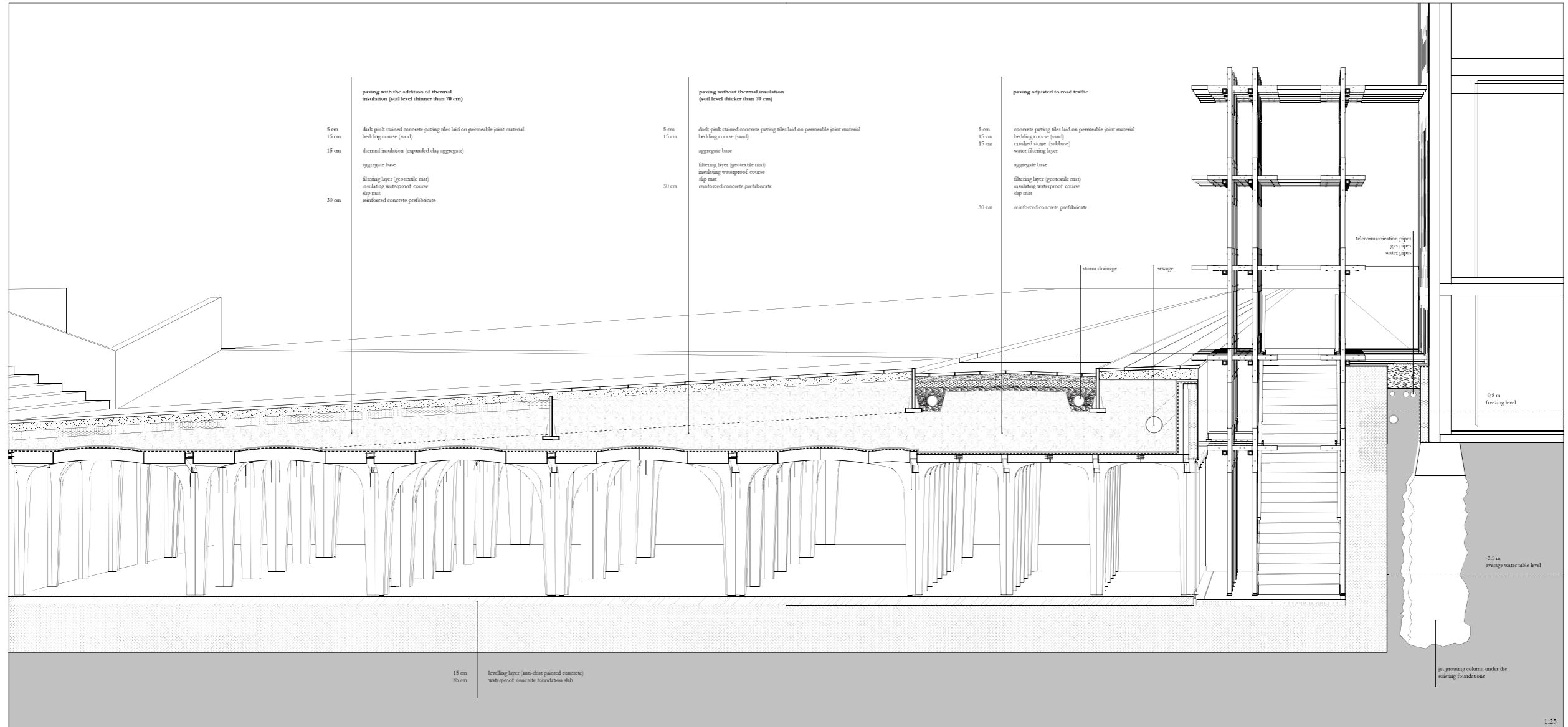

STREET SECTION

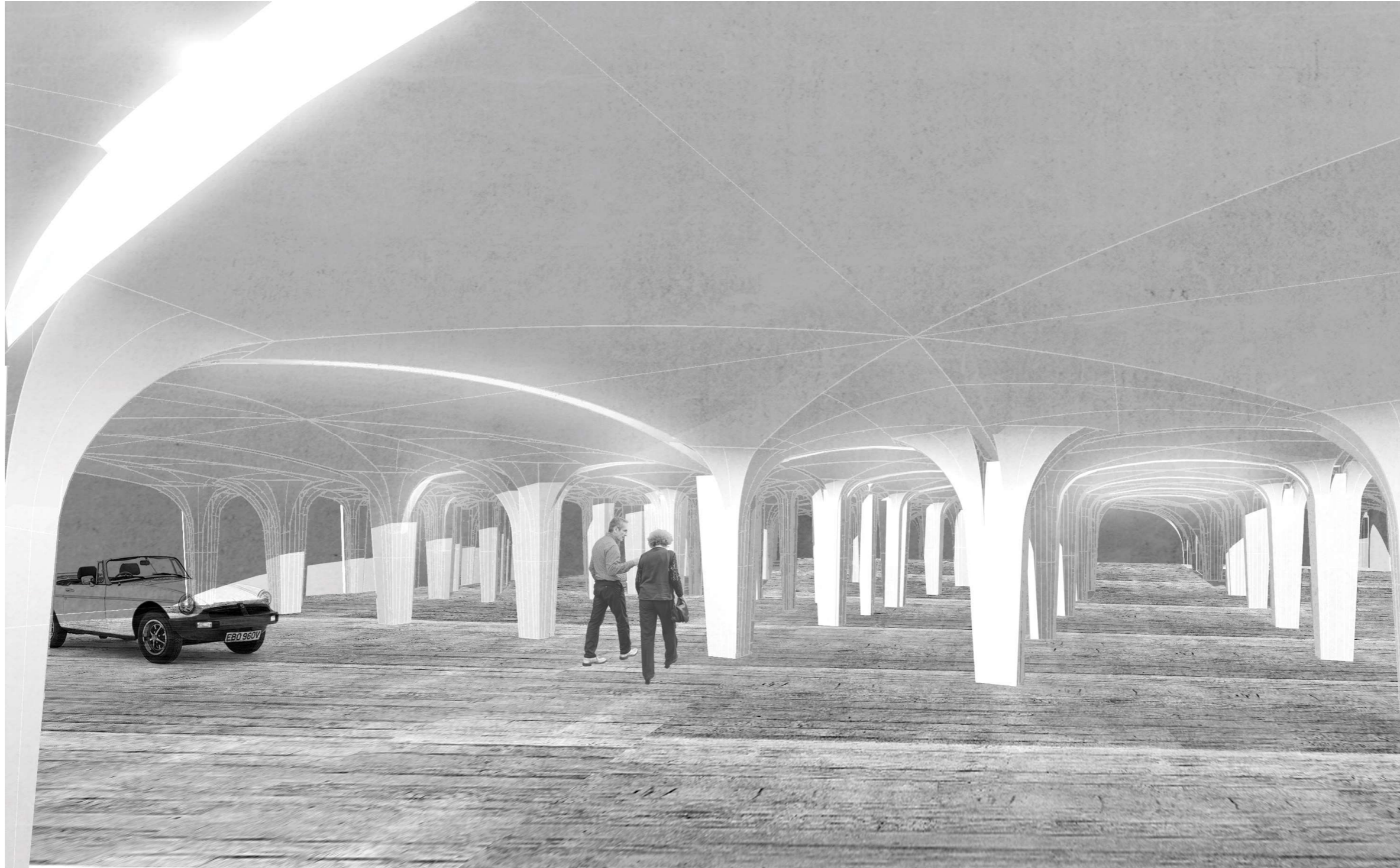

STRUCTURE

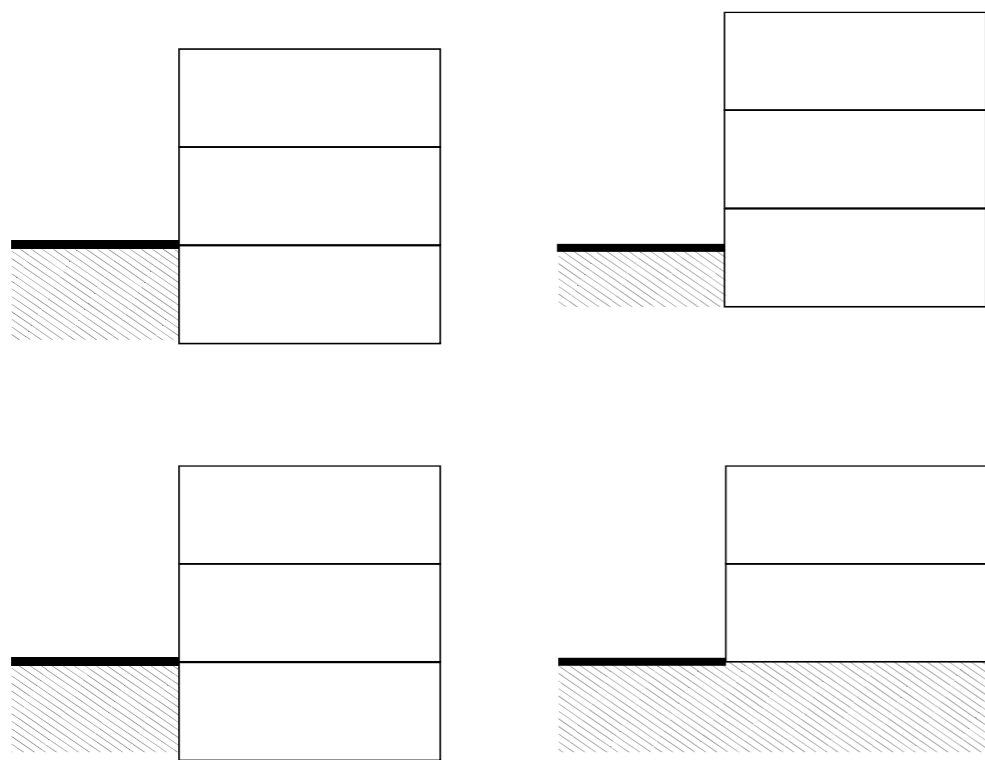

in section

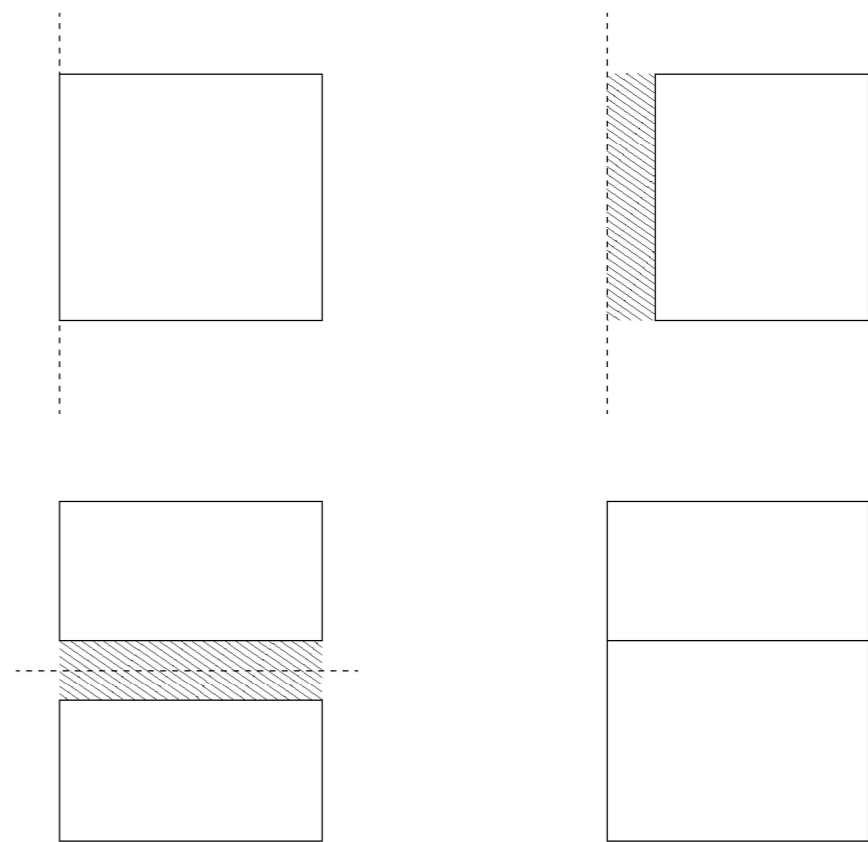

in plan

IRREGULARITIES OF THE CONTEXT

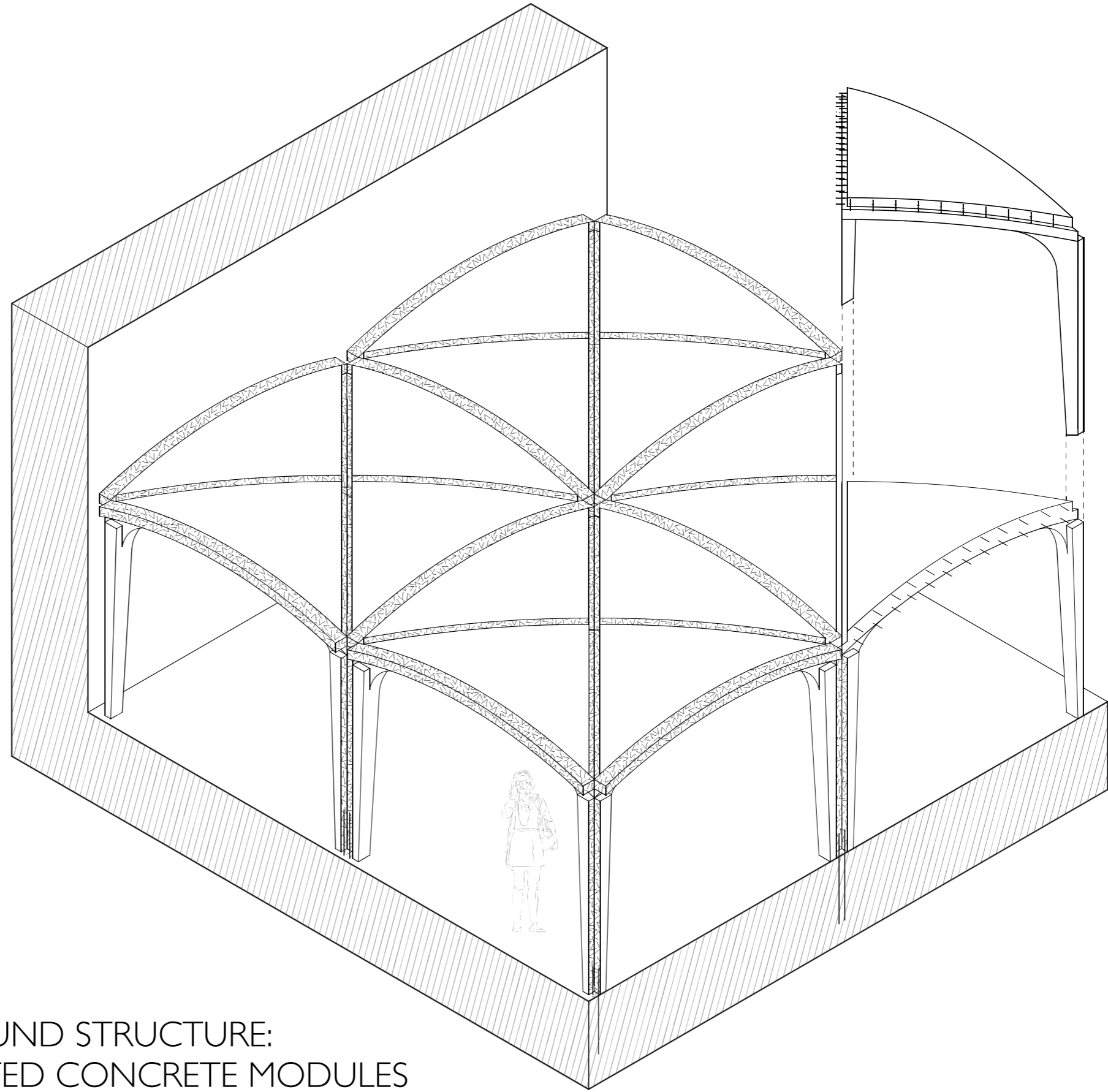

UNDERGROUND STRUCTURE:
PREFABRICATED CONCRETE MODULES

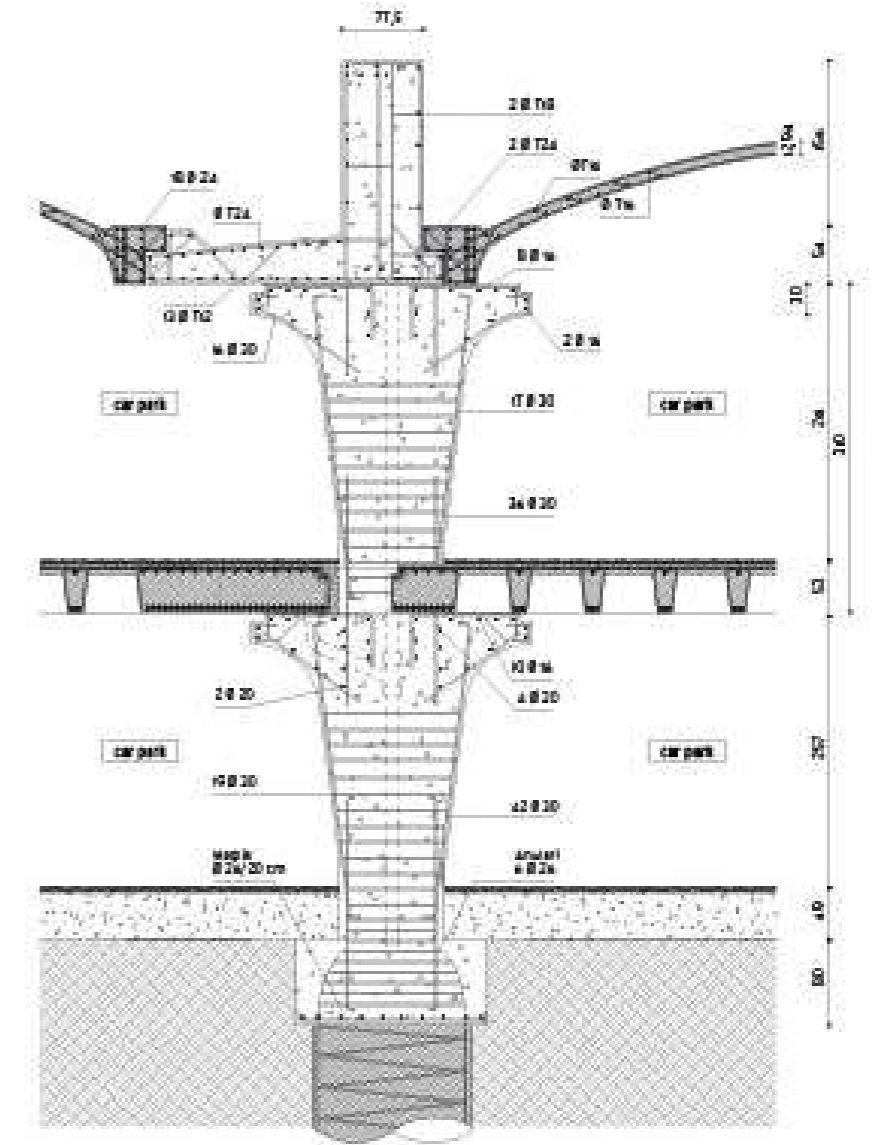

Luigi Moretti
 Parcheggio sotterraneo di Villa
 Borghese

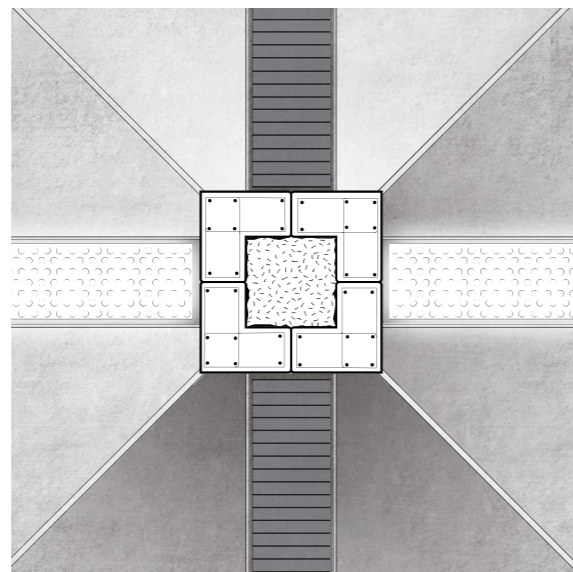
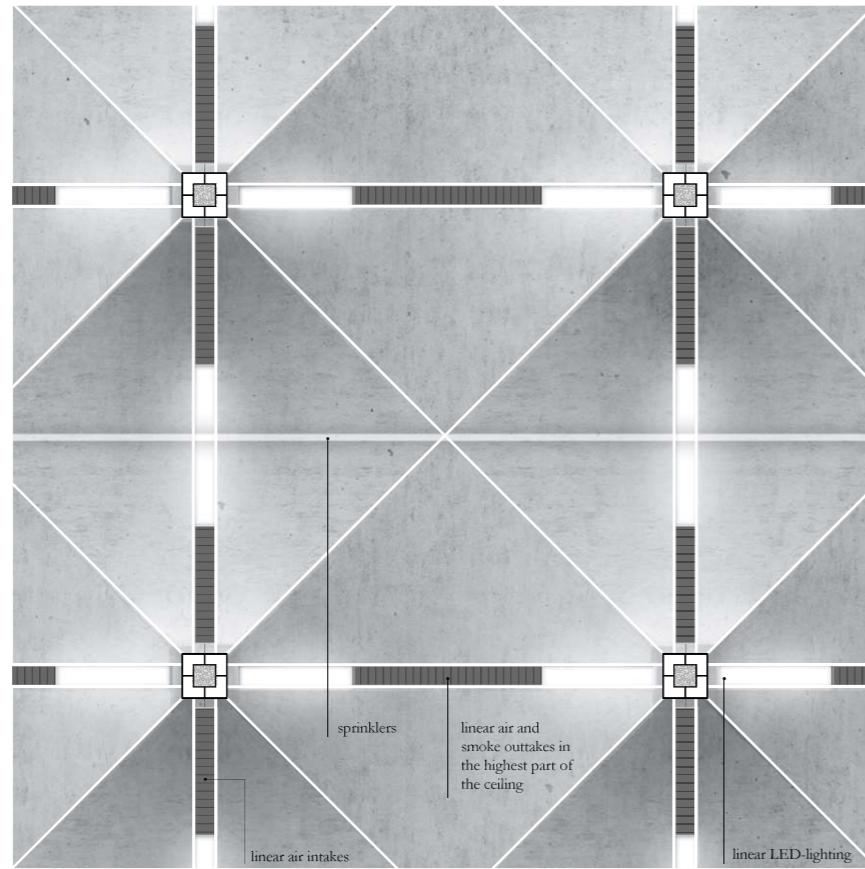

UNDERGROUND PREFAB CONCRETE MODULES

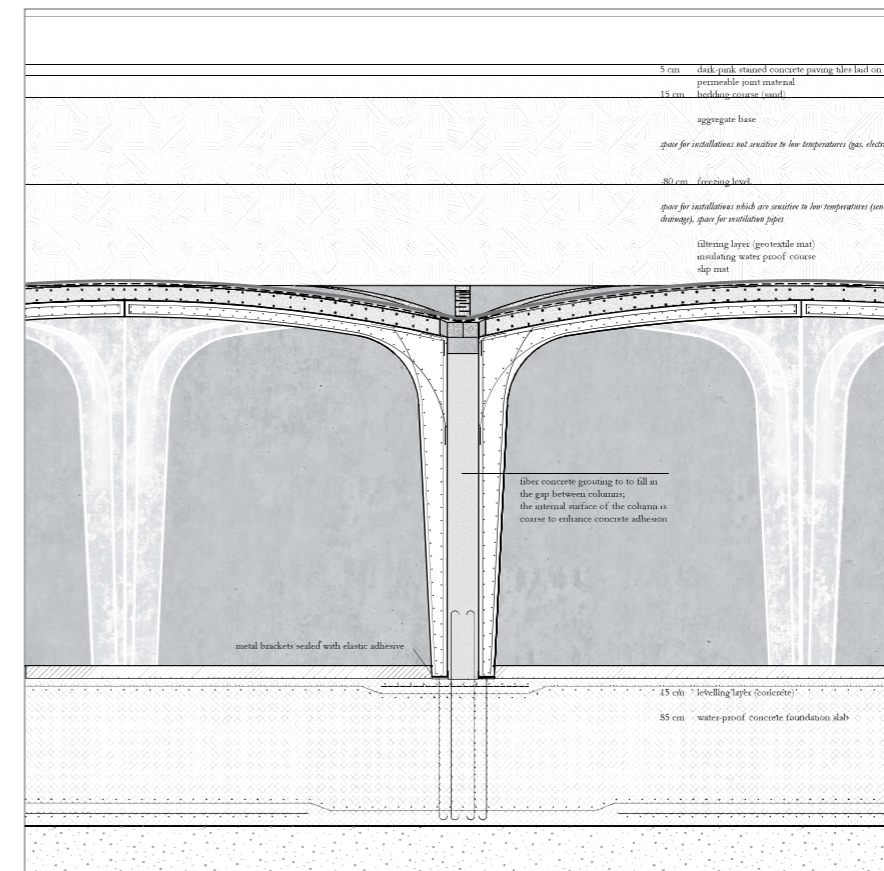
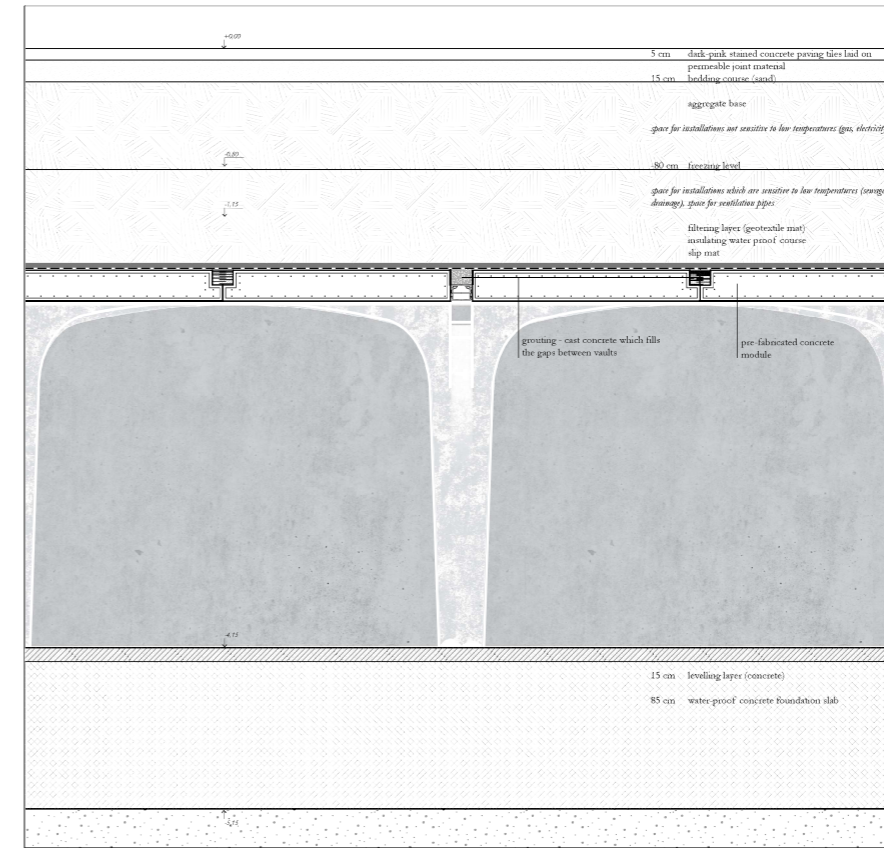

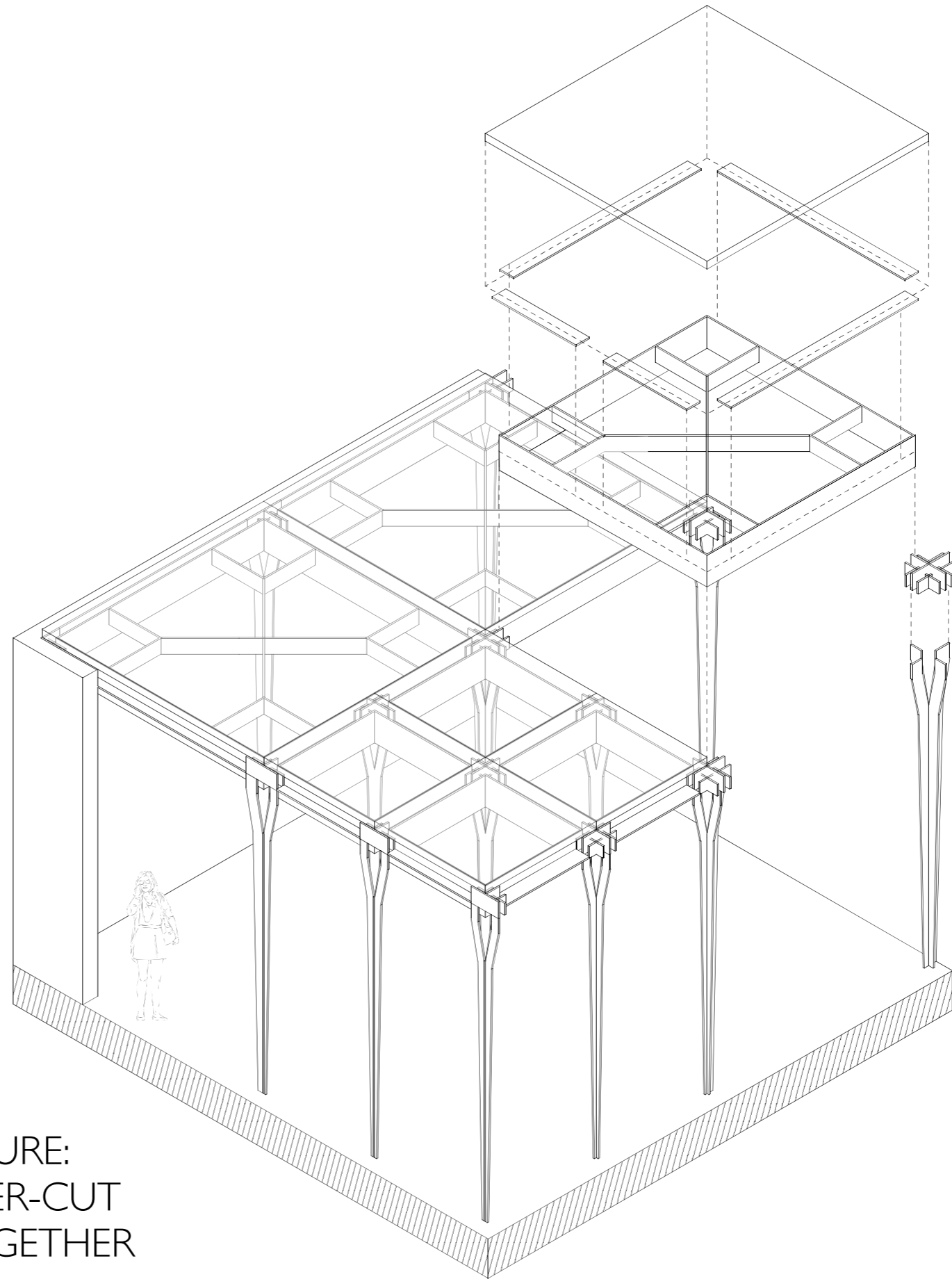

ABOVE GROUND STRUCTURE:
COLUMNS MADE OF LASER-CUT
STEEL PLATES WELDED TOGETHER



cast iron

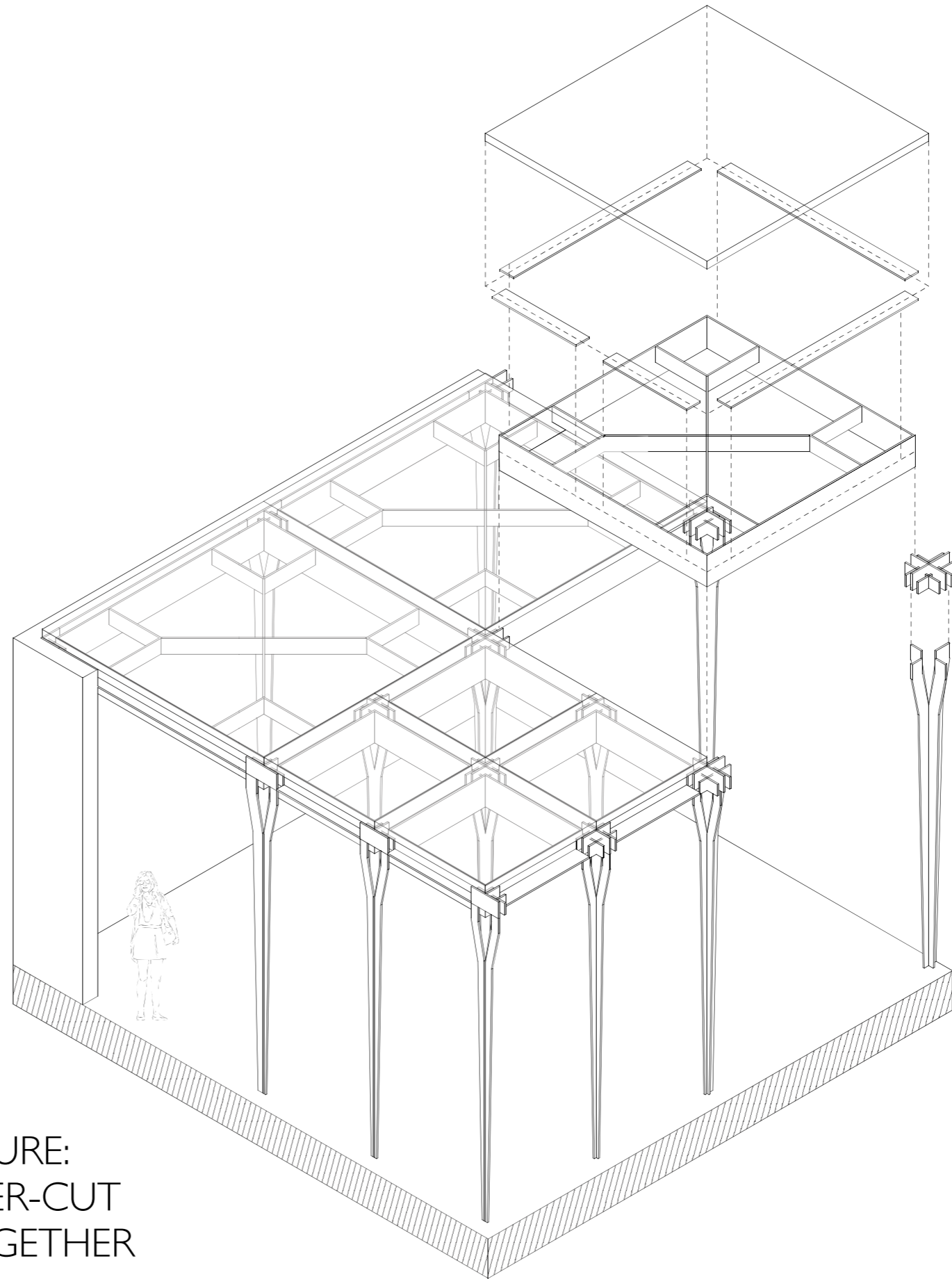

ABOVE GROUND STRUCTURE:
COLUMNS MADE OF LASER-CUT
STEEL PLATES WELDED TOGETHER



Rotterdam bus shelters by Maxwan

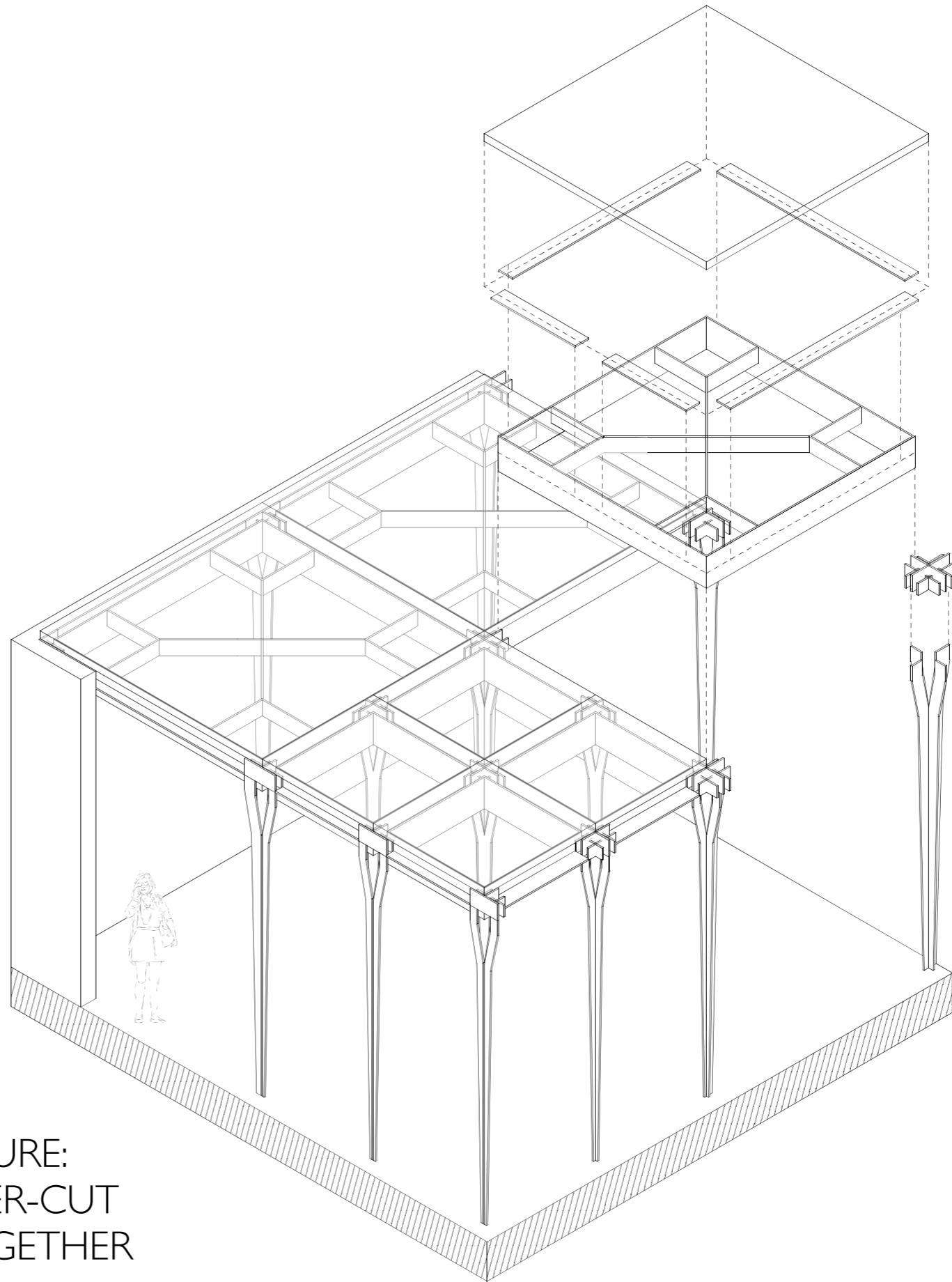

ABOVE GROUND STRUCTURE:
COLUMNS MADE OF LASER-CUT
STEEL PLATES WELDED TOGETHER

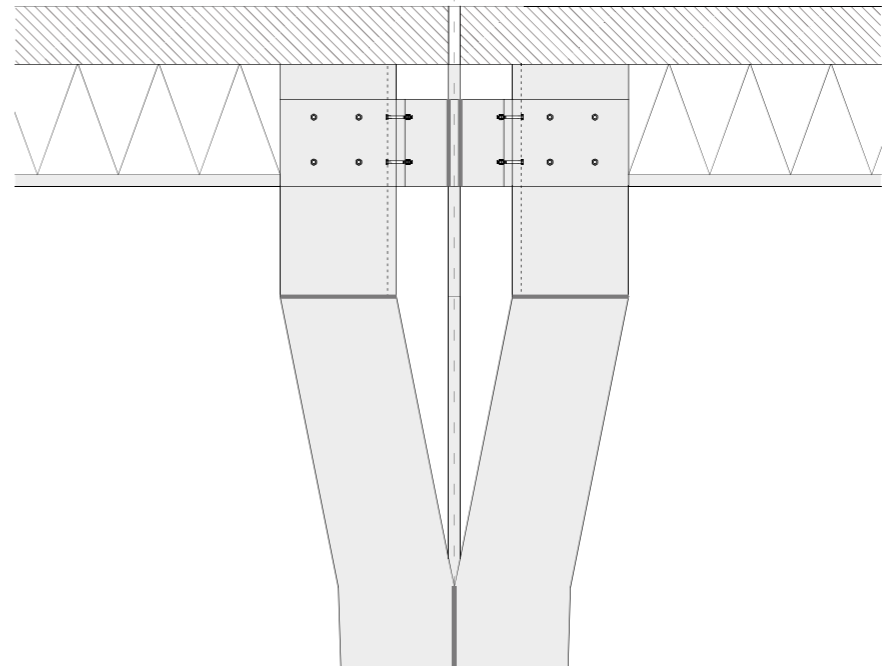
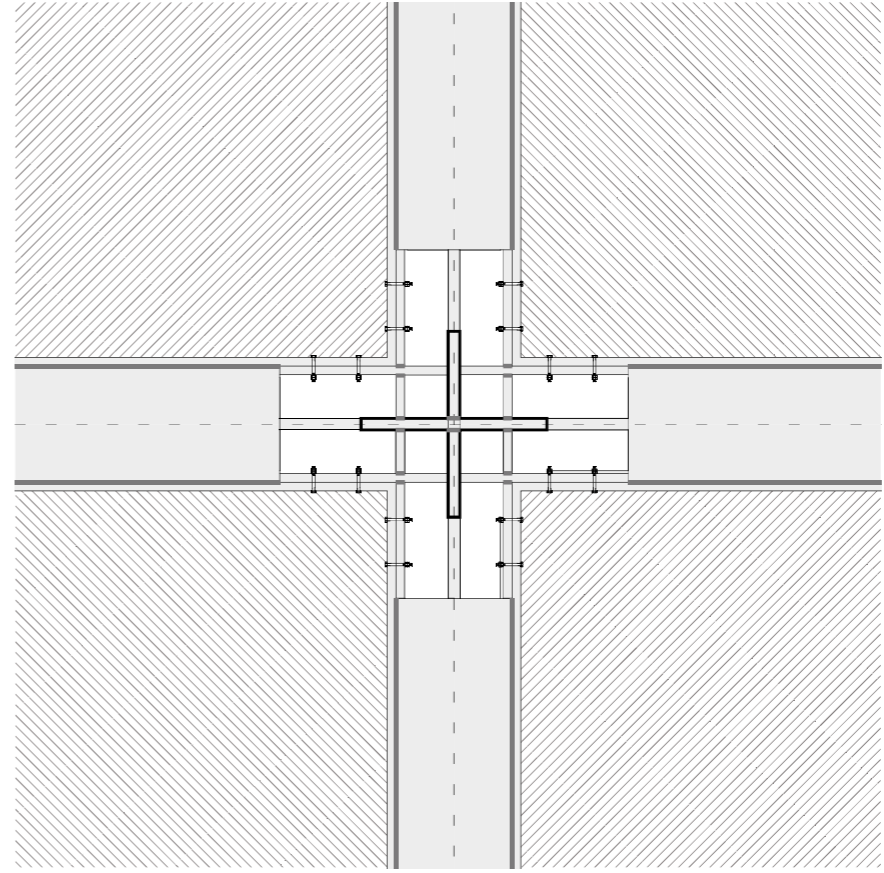
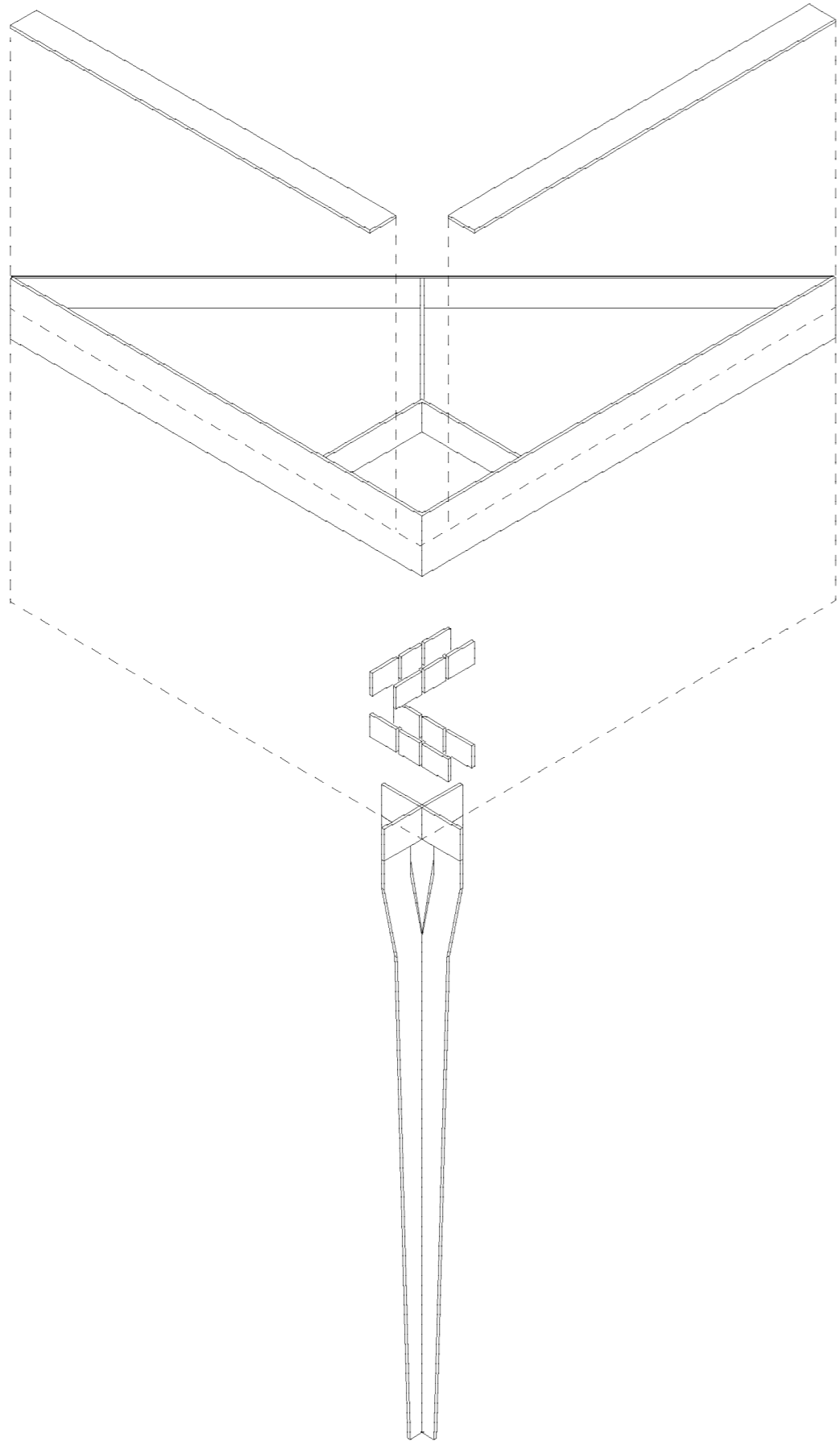

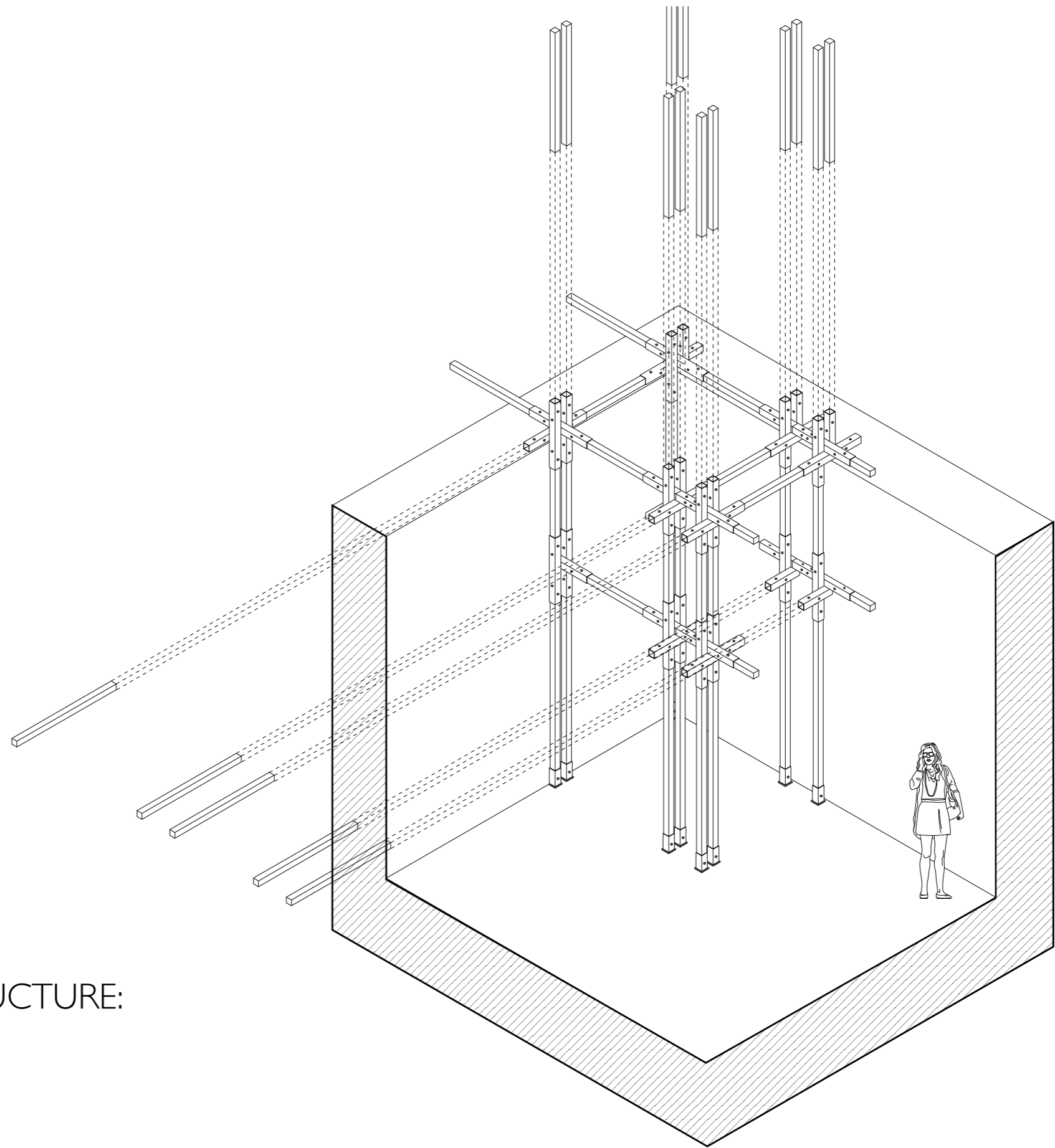

INTERMEDIARY STRUCTURE:
STEEL TUBES



Sou Fujimoto, Serpentine Pavillion

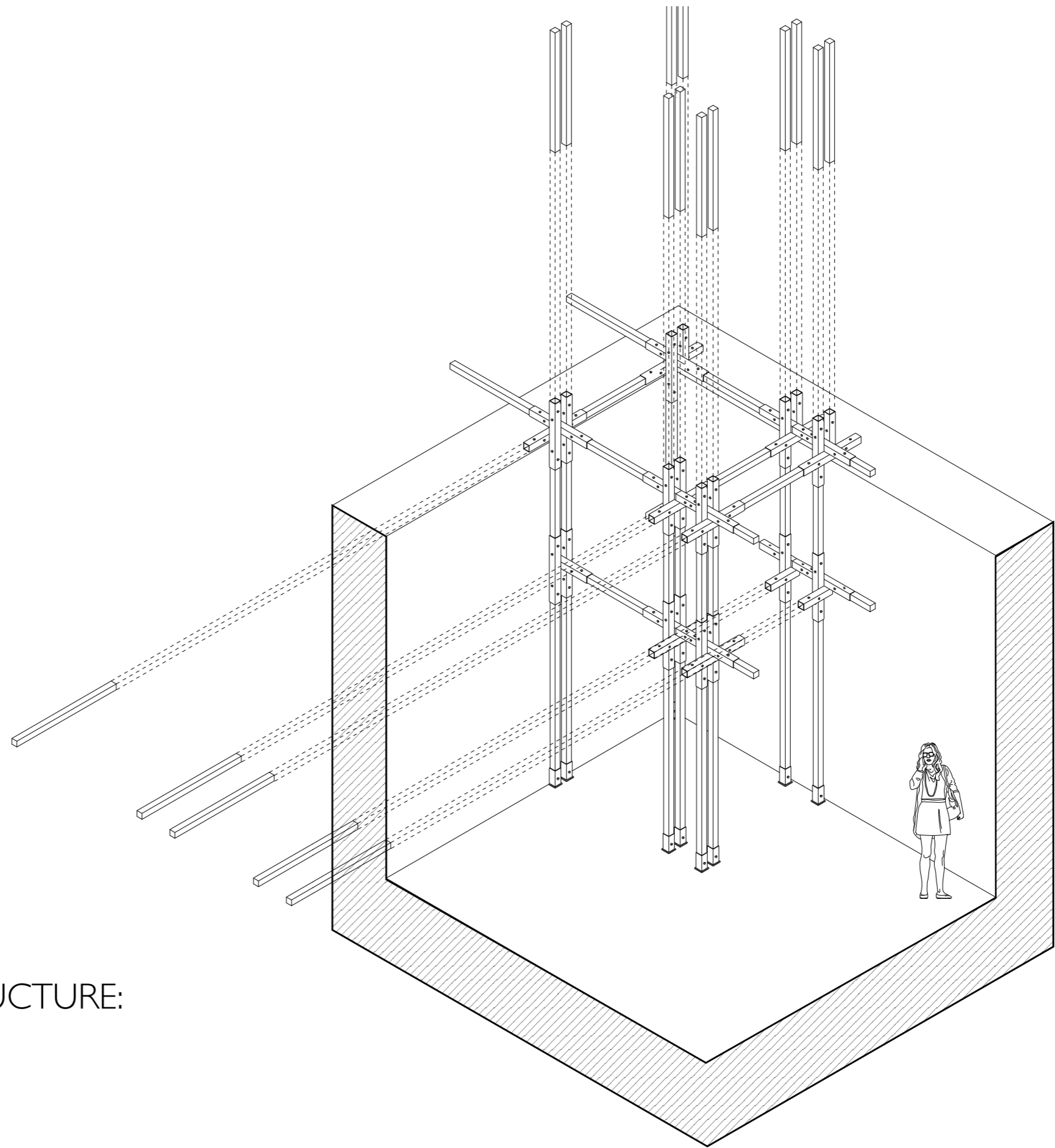

INTERMEDIARY STRUCTURE:
STEEL TUBES

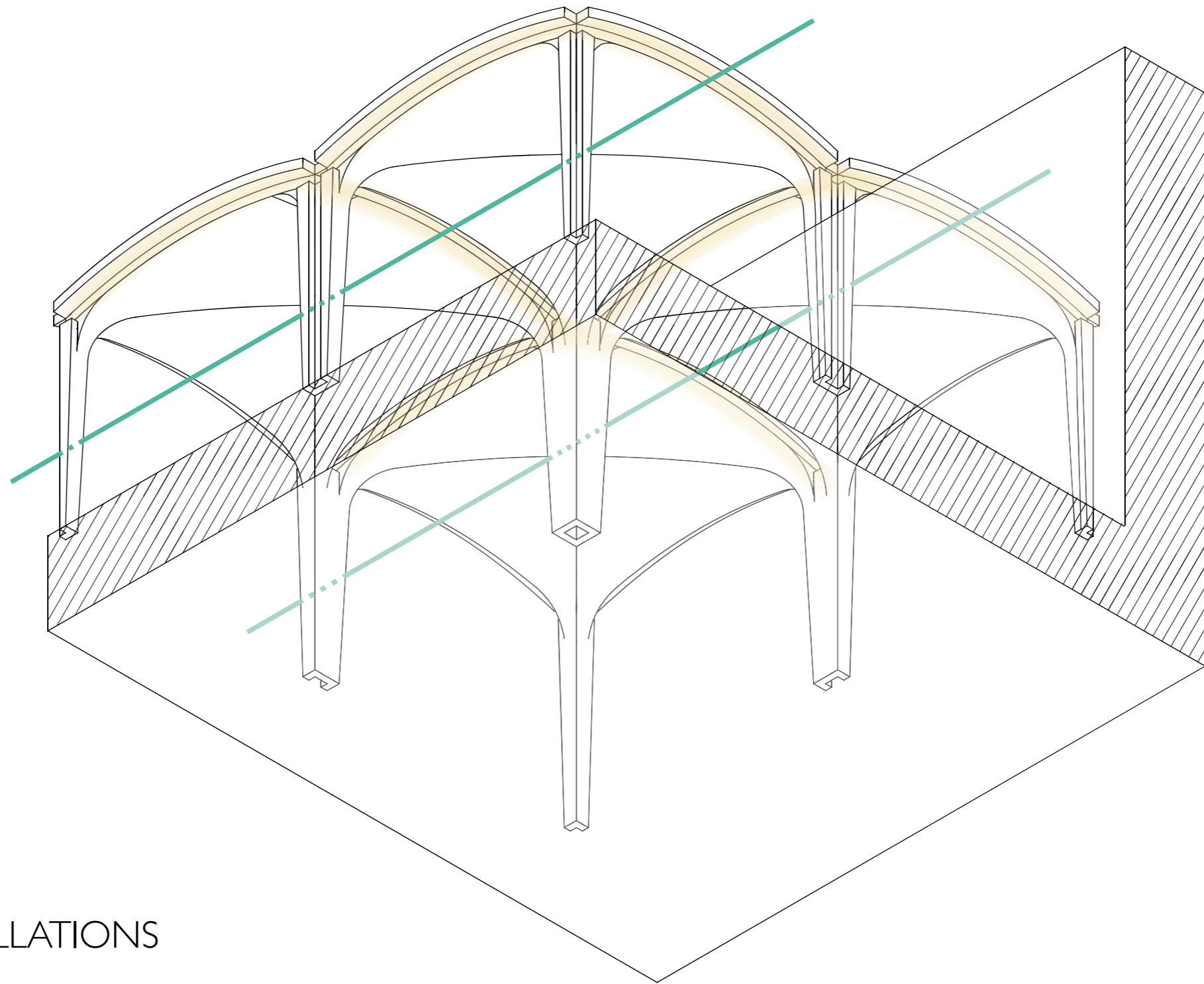

INSTALLATIONS

- electricity ducts
- sprinklers

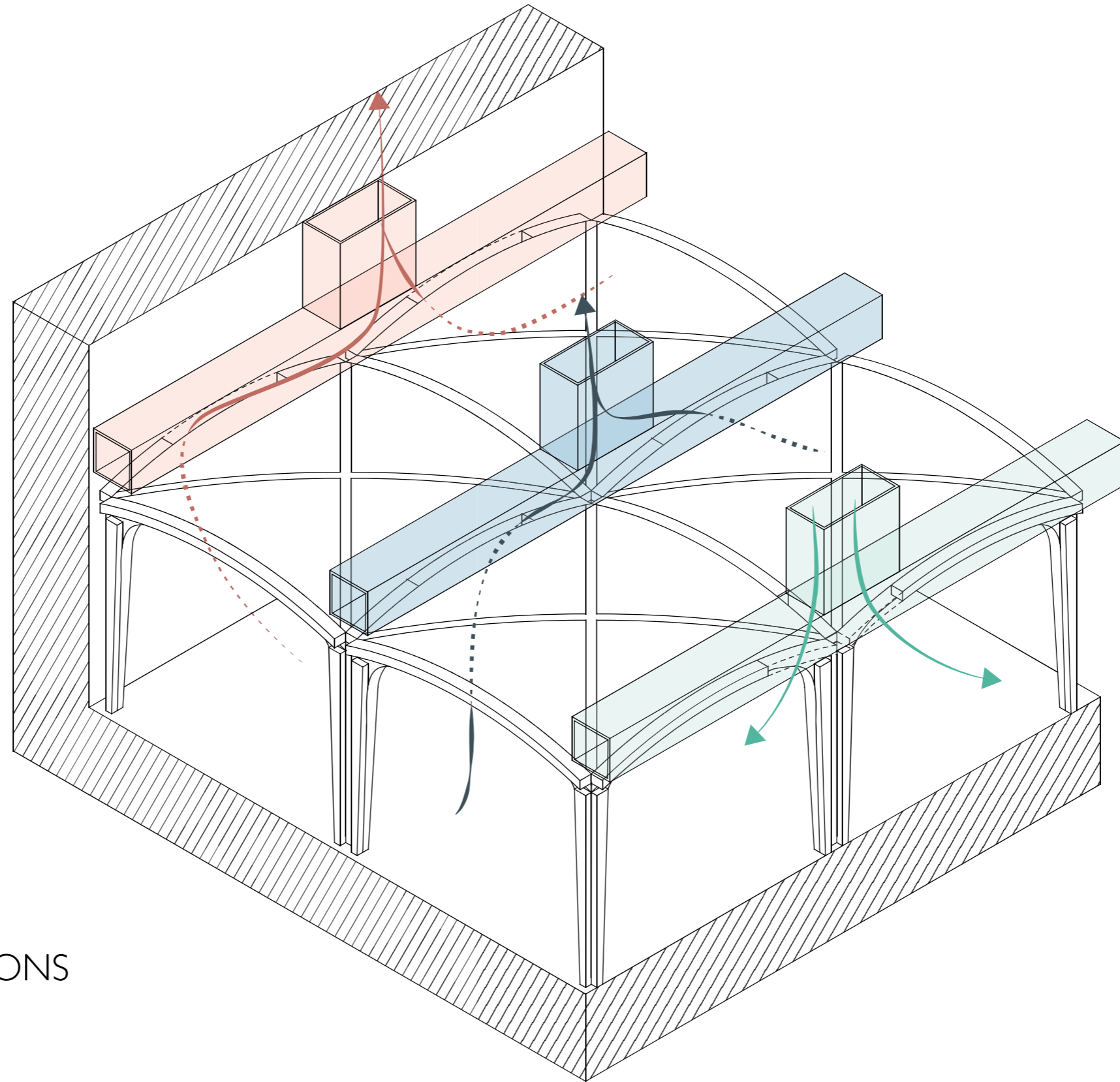

INSTALLATIONS

- air intake
- air extraction
- smoke extraction

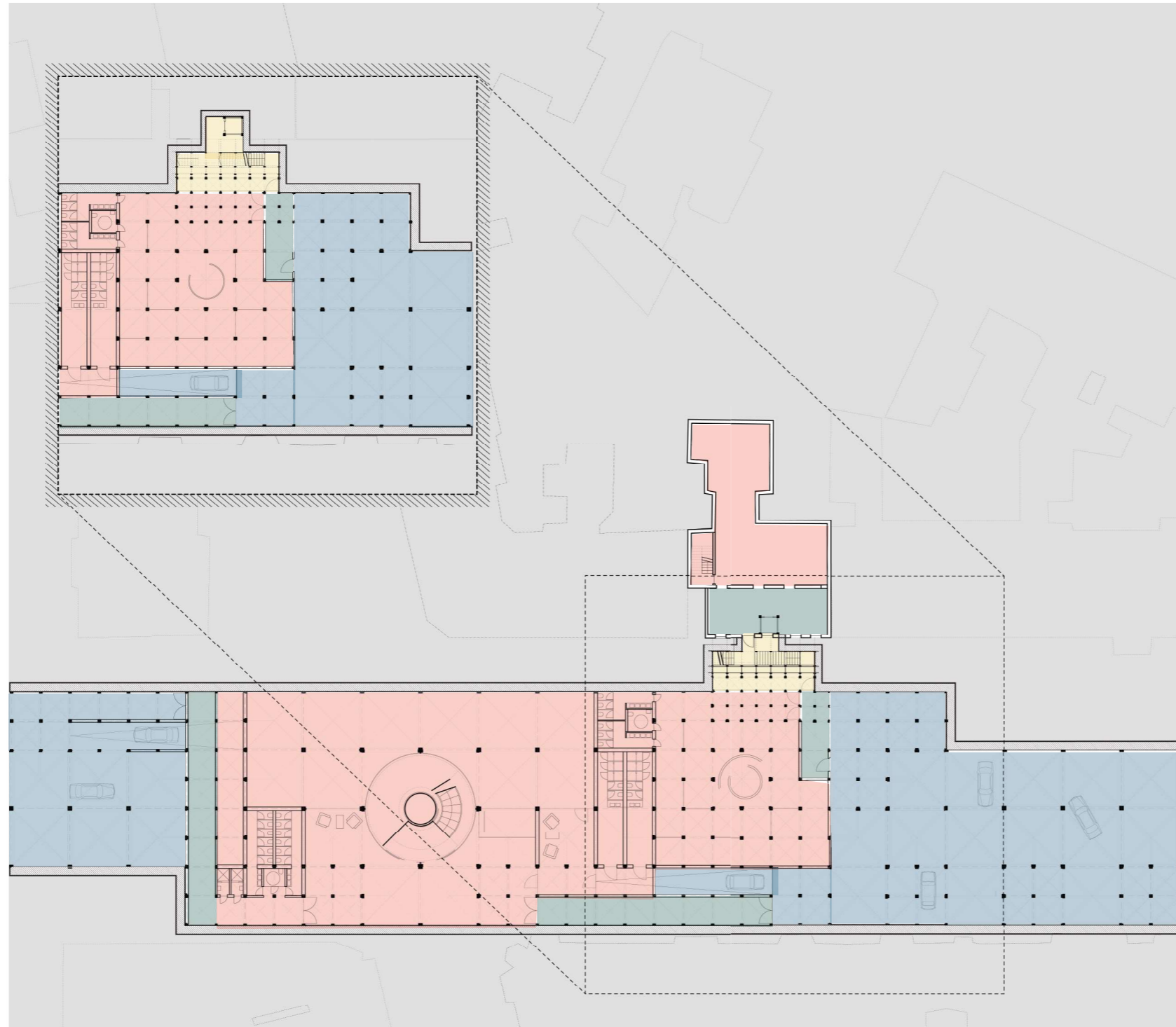

- external
- parking
- warm (permanent stay rooms)
- intermediary zones

THERMAL ZONES

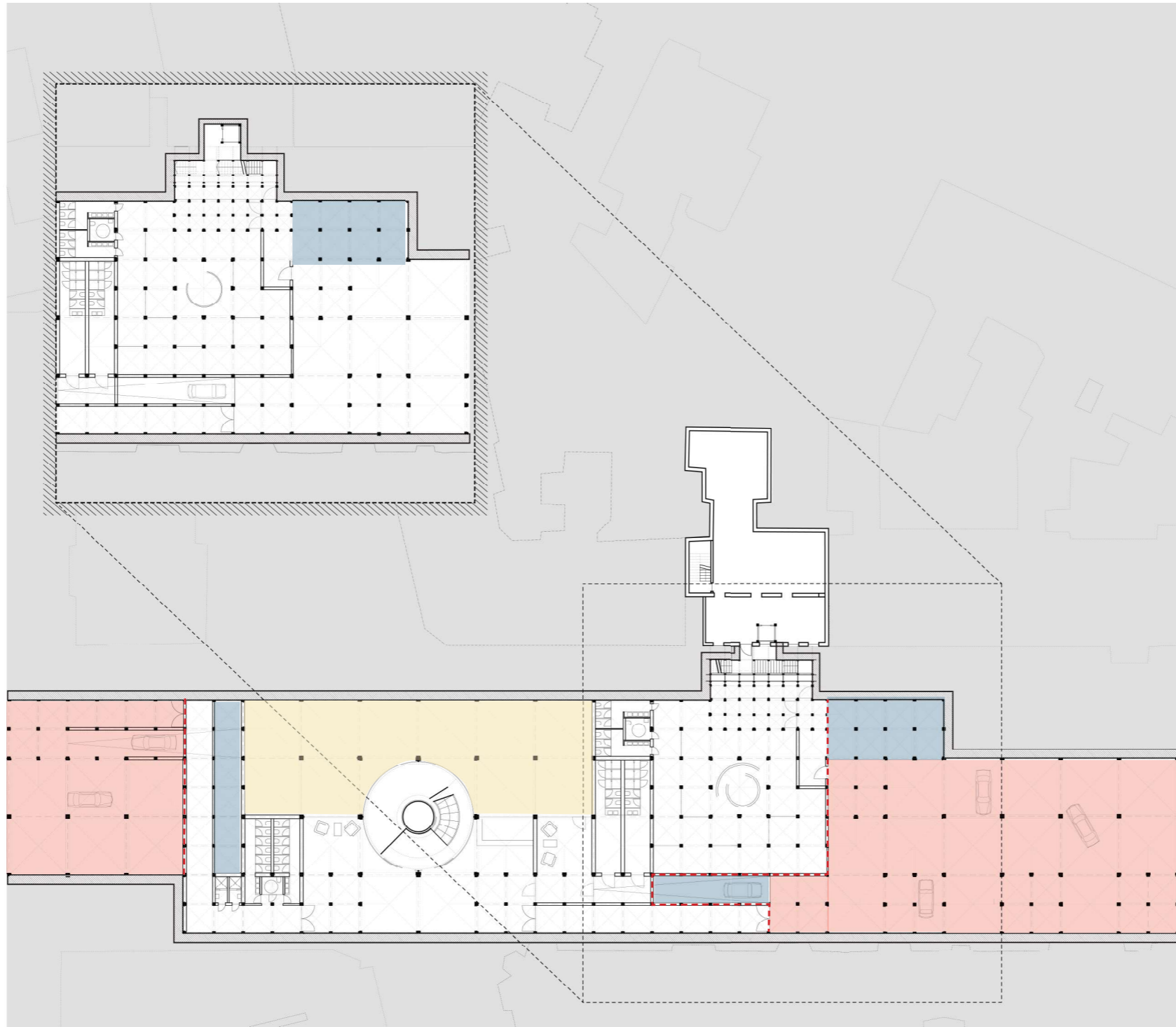

- technical rooms
- ▭ fire-proof walls
- fire extractions system + sprinklers
- zones with higher ventilation requirements (5xV/h)

VENTILATION

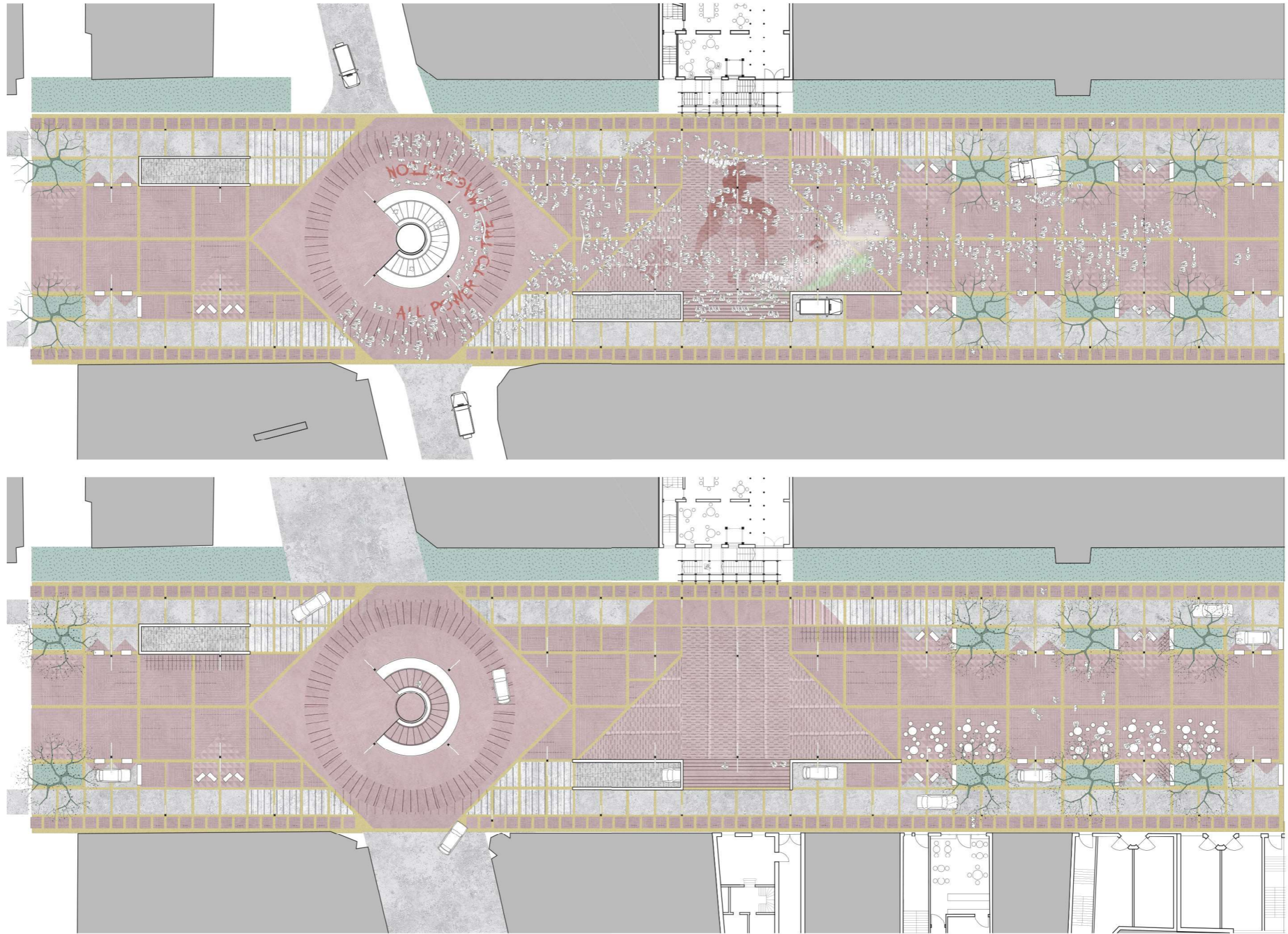

SPATIAL APPROPRIATION









