

'Gezinnen op straat'

Accommodating modern families in Amsterdam

Table of Content

	Introduction	4			
1	Families		3	Location	
	<i>Families in the city</i>	8		<i>Introduction</i>	94
	<i>Target groups</i>	12		<i>History</i>	102
	<i>Neighbourhood</i>	15		<i>Municipality plans</i>	103
	<i>Building block</i>	16		<i>Demography</i>	104
	<i>House</i>	19		<i>Morphology</i>	105
	<i>Playing</i>	22		<i>Existing situation</i>	106
	<i>Design brief 1.0</i>	26		<i>Noise</i>	109
2	Case studies			<i>Infrastructure</i>	112
	<i>Introduction</i>	30		<i>Facilities</i>	116
	<i>Meeting with Laurens Boodt</i>	32		<i>Range of action</i>	120
	<i>Habitat 67</i>	34		<i>Design brief 3.0</i>	122
	<i>Dan Leckie Way</i>	42			
	<i>Kolenkithuis</i>	52		Bibliography	124
	<i>Wisselspoor</i>	62			
	<i>Babel</i>	72			
	<i>Sheltered Urbanity</i>	80			
	<i>Conclusion</i>	88			
	<i>Design brief 2.0</i>	90			

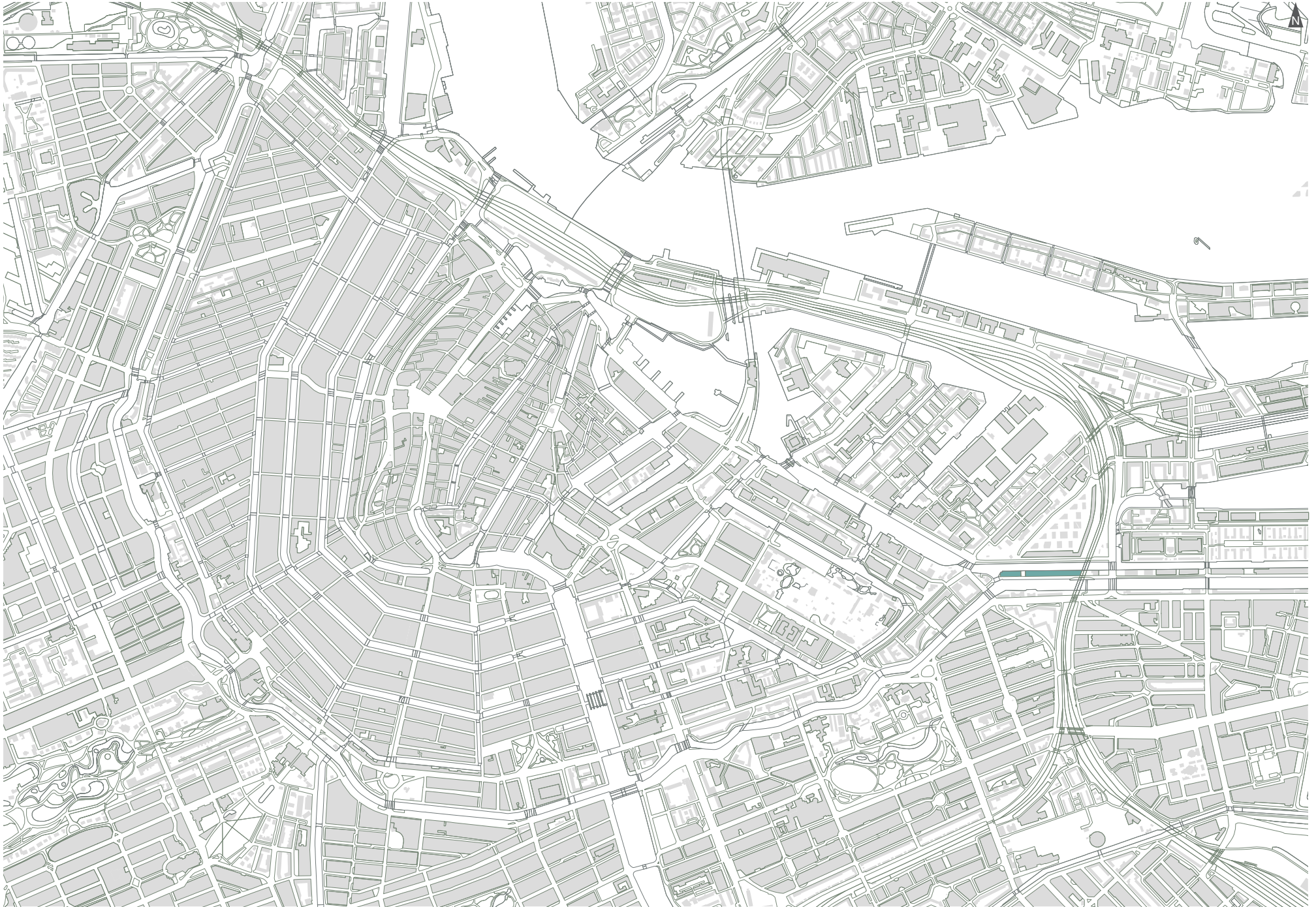

City of Amsterdam, Zeeburgerpad indicated in blue

Introduction

In the complex field of designing city living, many paths can be taken. I started the research fase by investigating a rather broad but today very relevant topic: gentrification. Gentrification is the process of renewal or rebuilding of an area in favor of attracting more affluent people, and could lead to less affluent people being displaced. This is a problem for many groups of people, one of them are families. These families are out on the street, hence the title: 'gezinnen op straat'. This is the group that I have chosen to focus on.

There is a tendency of cities to consist of much more single households and much less families than average in the Netherlands. In many of these cities, and especially in Amsterdam, more and more families are leaving the city, even though they wanted to stay. One main issue is the shortage in affordable housing, a problem gentrification strongly contributes to. All of the reasons for leaving and wanting to stay will be investigated in this research. The amount of families leaving could come to a level where it becomes problematic, as families form the backbone of a city. The importance of families for the city will be explained further in this research as well. Together this forms the main argument for the choice of target groups.

The specific target groups I chose to design for can together be called 'contemporary' or 'modern' families. More precisely the groups of *single parent-*, *co-parent-* and *patchwork families* belong to them. They differ from traditional, two-parent families in various ways. Mainly lower income and lack of a social safety net are problems single parent families have to deal with. It makes them specifically more vulnerable for the negative effects of gentrification. The latter two types of modern families can especially have complicated household compositions, generally also changing between weekend and weekday. These distinctions from more traditional families are important and will be discussed more broadly.

All of the wishes and needs of families will be researched, from urban scale to the size of the dwelling. Many of these needs are directly applicable to modern families as well. If necessary, the wishes and needs will be made more specific, and some will be added. First, this will be done by literature studies, who themselves are often based on interviews with and observations of families and children. Later on, six elaborate case studies will be presented, all researched on the same scale levels. From this conclusions will be made on what requirements a neighbourhood, building complex and dwelling ideally has. Integrating every wish however is an impossible job, mainly because affordability would become a problem. This is why a few main goals will be chosen from this to serve as starting points for the design.

To settle the three target groups, the location of Zeeburgerpad is chosen. One of the issues of this location is the train track that runs right next to it. Some special attention will be paid to this in the topic on *noise*. After this, an analysis of the location is presented. Special attention will be paid to the municipality plans for the Eastern part of the Zeeburgerpad. The wishes and needs of the target groups will be projected on the location, to understand what the strengths, weaknesses, opportunities and threats are. Combined with the starting points from the research, they form the base of the design project.

Research questions This document is used to answer the following research questions:

Which architectural and urban conditions help contemporary families, like single parent-, co-parent- and patchwork families, to live comfortably in the centre of Amsterdam?

- What are the reasons of families for leaving or staying in the inner city of Amsterdam?
- How can housing and the built environment provide space for children safely growing up?
- What are the specific design tasks in providing dwelling for contemporary families?

Families

Families in the City

Families are leaving Amsterdam, it is a headline that can be read quite often nowadays. The number of families leaving the city for another, usually cheaper location continues to grow bigger each year. This trend is a signal for the liveability in our cities, and should be taken seriously. This chapter will provide detailed information on the following themes: Figures and facts; Reasons for leaving the city; Reasons for staying in the city; Reasons for fostering families in the city.



"Families with young children are leaving Amsterdam" (source: Het Parool)



"Young families leave city more often for cheaper suburbs, especially in Amsterdam" (source: De Volkskrant)

Figures and Facts Compared to the average in the whole of the Netherlands, Amsterdam already has much a much lower percentage of households with children. This is shown in the figures on the right.

The average in the Netherlands is 29%, while Amsterdam only has 20% households with children. The amount of single person households in Amsterdam is much higher than the average in the Netherlands. This results in a much lower average household size: 1,81 (Amsterdam) versus 2,17 (Netherlands). Naturally, this leads to a bigger pressure on the housing market, as the same amount of people need a larger number of houses.

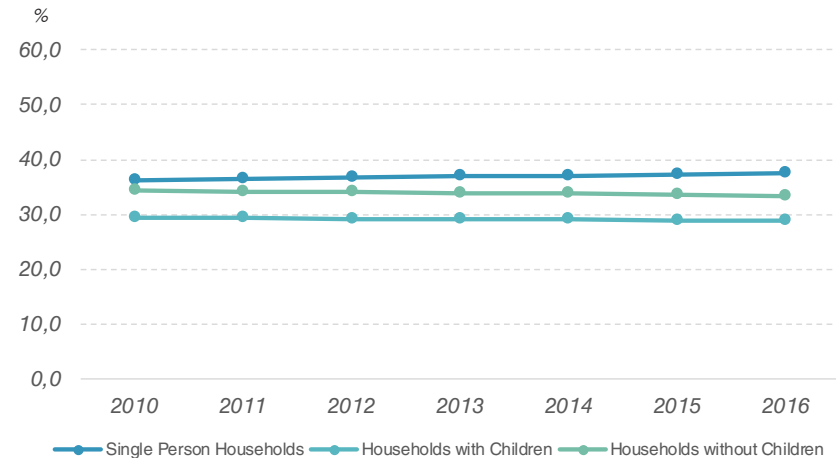

Households in the Netherlands (data source: CBS)

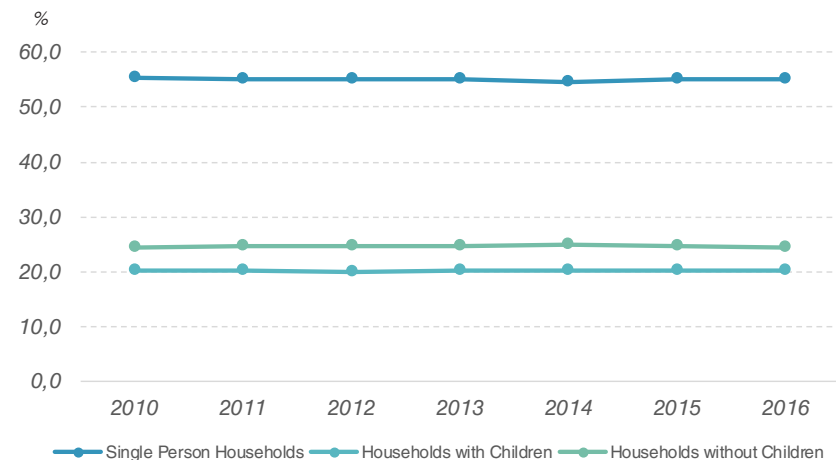

Households in Amsterdam (data source: CBS)

While looking at the graphics on the left, it looks as if the composition of citizens is a very stable one. Only when zooming in, as is done in the graphic below, one will see the decrease in households with children from 2014 and on.

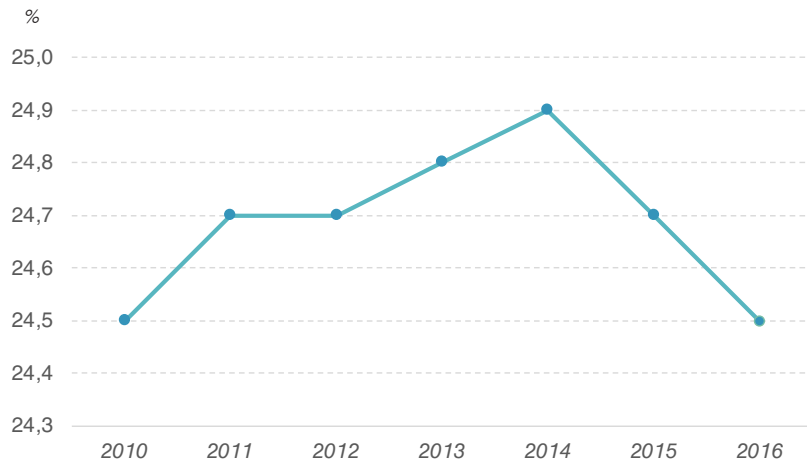

Households with children in Amsterdam (data source: CBS)

The trend of families leaving the city can also be seen in the figure on the right, showing growth started in 2012 and has already doubled in percentage in 2015. This is especially the case for young families, of which 40% leaves Amsterdam before the eldest has reached the age of four years. It is a problem also occurring in the three other big cities of the Netherlands: Rotterdam, The Hague and Utrecht, which is shown in the other illustration. Amsterdam however does stand out in a negative way.

In the documentary 'City for Sale' (VPRO Tegenlicht, November 5th 2017) they state that in the past year, primary school applications have decreased by 10%. This is a very big number, and corresponds to the fact that especially *young* families move out of the city. The moments they choose for moving are very much related to milestones in children's development, such as entering primary school (Keesom, 2013, p.14). There is also a relation between the arrival of a second child and moving.

This however still leaves the question: What are their reasons for moving?

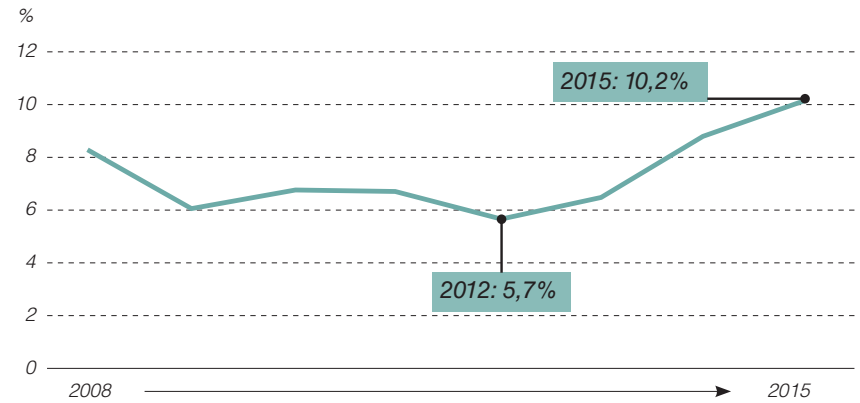

Share of young families in Amsterdam moving out to other towns (source: Het Parool, data source: CBS)

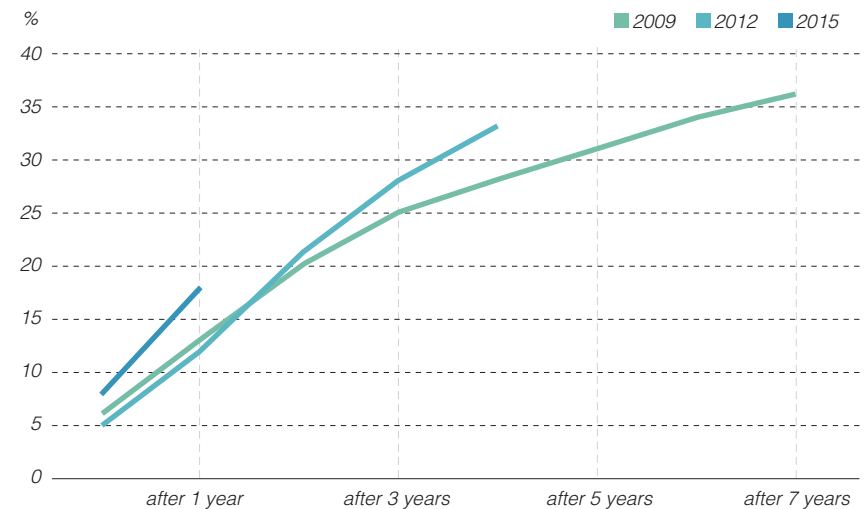

Couples moving out of one of the four big cities (Amsterdam, Rotterdam, The Hague, Utrecht) to another town, after the birth of their first child (source: De Volkskrant, data source: CBS)

Reasons for leaving the city Clearly the reasons for leaving the city must relate to the presence of children. The needs and wishes of children, and especially their safety, is of a very high value for parents. Usually parents come across many problems in their living environment that do not fit the children's needs. In search for a new and more suitable dwelling in the city of Amsterdam they very often find that there is no such thing available, at least not for a reasonable price.

In their research report of 2010 'Het gezin in de stad' (The Family in the City) Heren 5 Architects have stated that 73% of all the families living in Amsterdam are unhappy with their current living conditions and want to move. Also 73% of these families with a wish to move want to stay in Amsterdam.

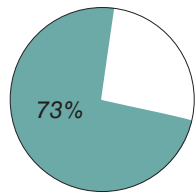

- 73% of all families in Amsterdam are unhappy with their current living conditions and want to move.

- 73% of these families with a wish to move want to stay in Amsterdam.

The reasons they give for families leaving the city of Amsterdam are the following:

- Small dwellings
- High costs
- No or limited outdoor spaces
- Heavy traffic
- Lack of safety

The problem with small dwellings is an important reason for young families to move. It was already stated that they often leave at milestones such as going to school or a second child's arrival. A similar milestone is the point where children reach the age of needing a room for themselves. Houses often only have two bedrooms, one for the parents and one for the children. This makes a two-bedroom house unsuitable for many families.

When looking for a larger house they will often come across problems of affordability. The map on the right shows how prices vary in Amsterdam,

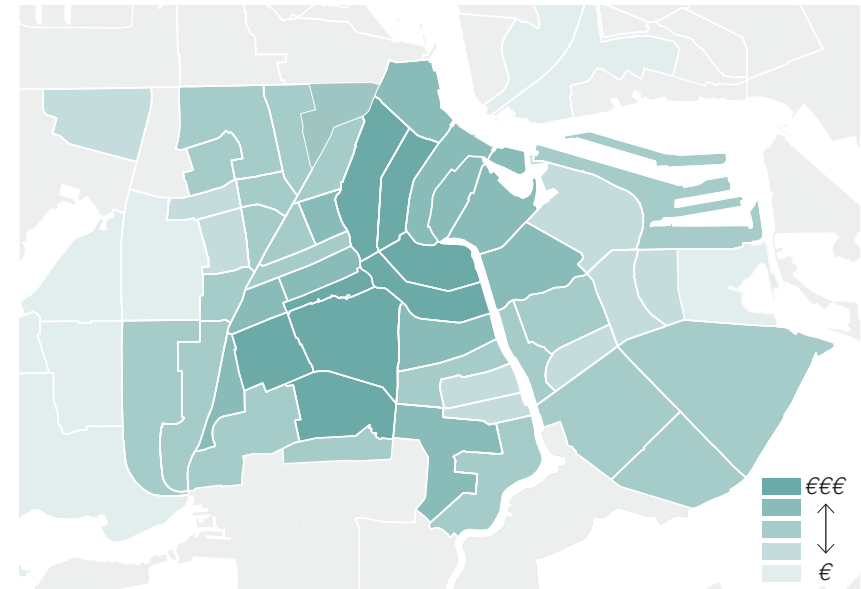

Housing values in Amsterdam, 2015 (data source: maps.amsterdam.nl)

but are clearly higher in the centre as well as in Oud-Zuid and along the IJ river. Compared to the Netherlands, prices are 37% higher in Amsterdam, as an average Dutch dwelling costs €216,000, while in Amsterdam the average is €290,000 in 2017 (cbs).

According to Karsten and Felder (2016, p. 67-68) the problems with outdoor space (both in general and more specific playgrounds) are, among others: too busy, too small sidewalk; not enough green and trees; no fence along the water; not enough fun play equipment; no goals (to play football); not enough shadow or shelter in case of rain; dirty streets; broken street furniture.

The problems with traffic are of course mainly about the danger of cars, but also about irresponsible cyclists, lack of traffic lights and not enough space to walk or cycle. This relates to the lack of safety too. Other safety problems are alcoholics, teenagers loitering on the streets and not enough 'eyes on the street', a term introduced by Jane Jacobs (1961, p. 35).

Reasons for staying in the city There are many advantages that come along with moving out of the city. Yet, for some families this is not enough. Mainly those whom also work in the city describe this as an important reason to stay. Furthermore, social reasons such as not living close to friends anymore are seen as paramount. Others do not want to miss the vast amount of facilities and cultural activities nearby.

In the book 'De nieuwe generatie stadskinderen' by Lia Karsten and Naomi Felder (2016) they talk about functional, social and symbolic connections that families create with the place they live. Functional connections are those of work and facilities. Social connections are of course about families and friends. By symbolic connections they mean a strong feeling of identification with the city, of being a real 'city person', of wanting to distinguish oneself from the 'common', suburban family.

However, not every family has the same balance of connections. They seem to be related to income and social status. Karsten and Felder divide the families into three groups: Social minima (sociale minima), social climbers (sociale stijger) and the upperclass (welgestelden). Only the upperclass seem to feel a real symbolic connections to the city. This may relate to the fact that they have consciously chosen to live on a certain location, while social minima are often placed (in a social rental house) without real choice. They often do not feel connected to their neighbourhood. Social climbers have mixed stories. Many of them live in social rental housing as well, however, they are often more actively involved in their neighbourhood. Some of them have negotiated about their social rental dwelling as well.

Functional connections are the most important reason for social minima to live in the city, as they often walk everywhere (2016, p.38). Almost none of the social minima had a paid job, thus work close by was not important to them. For social climbers and the wealthy work is very important, as well as facilities such as daycare close by.

The social connections in the neighbourhood seem to be most apparent in the upperclass. They know many of their neighbours, and find it important to have both 'people like us' and some diversity. This diversity is found to be important for every group. In general, friends and other families are more important than own family. In the research of Karsten

and Felder this is also the case for social minima, though other literature might suggest different (2016, p. 40).

The family type I am most interested in is the group of social climbers. The upperclass does not have so much trouble in finding a house for reasons of affordability, and thus need less special attention. The social minima are not very interested in investing time in social connections in the neighbourhood, which I do see as important for my design. The main reasons of social climbers for staying in the city are:

- Functional connections: work, daycare and other facilities nearby
- Social connections: friends and likeminded people nearby, but a diverse mix of people as well.

Reasons for fostering families in the city The question one will ask now is: Why would you want to keep families in the city? There are actually many good reasons for this, as is explained by Jolanda Keesom (2013, p.15). Families provide for a very large part of the economy in a city. Because of them, facilities such as sports, swimming pools, schools, creches and so on are profitable. Having these facilities create many jobs within the city, which can be very attractive for other groups to move to the city as well. Furthermore, families tend to have very close social networks, because parents meet so often at school, sports clubs, playgrounds and many other places. By this, and because they are much more often at home than other citizens, they provide for a higher level of social security within the city. To top this off, they are the ones who care for the city. Instead of ignoring problems, they will raise the alarm. For example, if a traffic light stops working, if streets are dirty, or too dangerous to cross, they care. Every other citizen can benefit from families in the city.

To sum it up, families are important because of:

- Use of facilities
 - Job creation
 - Close social networks
 - Often at home and in the city
 - Care for the city
- } Social security

Target Groups

Within the broader scope of families I would like to focus on more specific target groups. As they differ from the traditional two parent family, a new name is given to them: 'modern families'. They usually arise after a divorce, though passing away or deliberate choice of single parenthood is possible as well. In the 'NOS Journaal' of December 18th, they state that in 20 years the number of divorced parents has increased from 400.000 to 600.000. This is a trend likely to continue. Thus, it seems logical to pay more attention to these non-traditional families.

Single parent family



Co-parent family

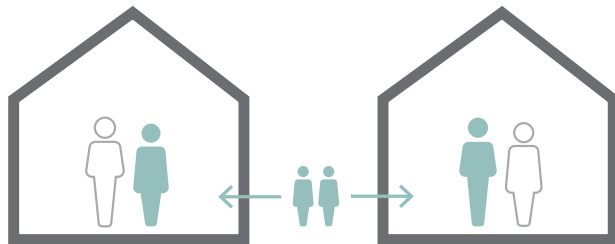

Patchwork family

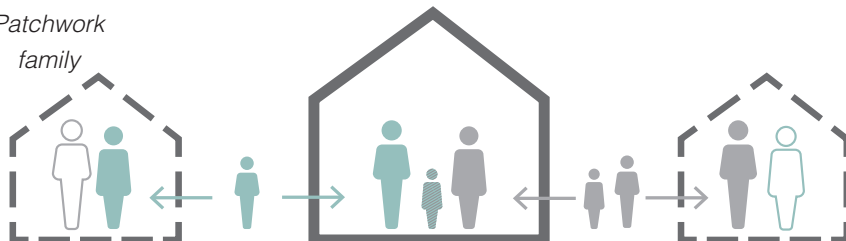

Modern families and their composition

More specifically they can be categorised in three groups: single parent families, co-parent families and patchwork families. Each of these groups have both similarities and differences. These will be explained and discussed in this chapter. The illustration on the left explains a first main characteristic of these families.

This characteristic is the composition of the family that is specific to each group. It is about where the children live, which may change between weekend and weekdays, or even every day. To illustrate this process, the image on the right called 'The changing composition of modern families throughout the week' is created. This compositional change results in difficulties in efficiency of square meters of the dwelling. This is mainly due to empty rooms on specific days and/or the struggle of finding enough (private) rooms for each child. It is clear that the price of each square meter dwelling in Amsterdam does not allow for much inefficiency.

Household composition 2016

Single parent family	8,6 %	35% of all families is a single parent family
Double parent family	16,0 %	

Household disposable income 2016

Single parent family	26.900 €	The income of a single parent family is 53% of a double parent family
Double parent family	50.500 €	

Households in Amsterdam (data source: Jaarboek Amsterdam, OIS)

Please note that the definition of single parent family used in this scheme applies on both single parent and co-parent family without a step-parent. In the illustrations above one can find information on the single parent family compared to a traditional double parent family (or as the source originally calls them: couple with under-age children). The number of single parent family households is rather large, 35% of all the families in Amsterdam belongs to this group. Their income is almost half the size of a double parent family. This creates extra difficulties in finding proper housing, usually also under some time pressure in case of divorce.

In general, single parent families are a more vulnerable group due to a significant lower income and often a need for extra social support. Co-parent families can have difficulties of efficiency as children's rooms will be empty for half of the week. Patchwork families also can have a hard time finding the right home, this is especially related to the large number of persons in their household.

Single parent family The definition of this type of modern family is a family in which one parent and at least one under-aged child are living together (CBS). The child lives with this parent more or less full-time. This differentiates it from the co-parent family. In statistic research data such as from CBS, this distinction can not be made. Thus, sometimes data is presented applying both on single parent families and co-parent families without a steph-parent present. This is as well the case for the radar chart on the right. Families without partner tend to have more need for practical services (such as a day-care). They also feel more need to be part of a group or cluster, as they miss a social security net that is more self-evident when having a partner. Providing for these practical services and a cluster or community can be essential in designing for this group.

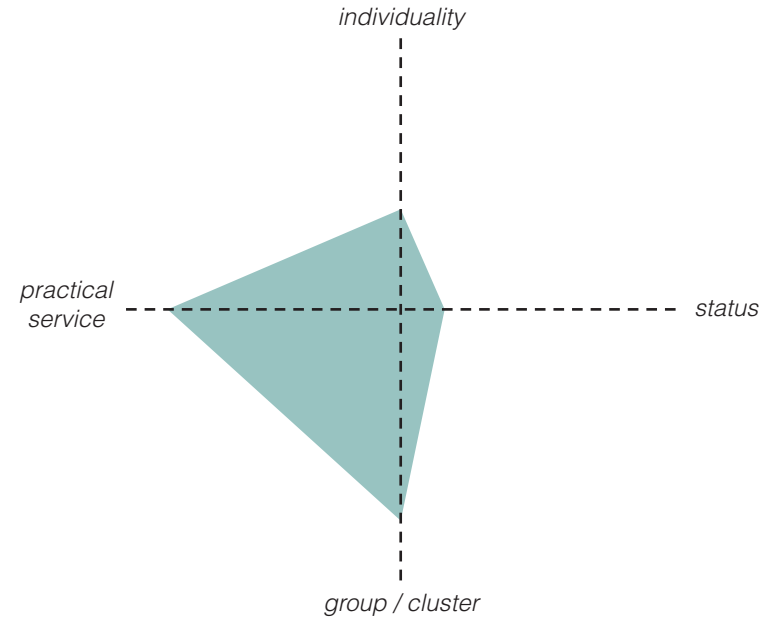

Needs of a single parent family (data source: Kummeling, (2011))

	Monday	Tuesday	Wednesday	Thursday	Friday	Saturday	Sunday
Single parent family							
Co-parent family							
Patchwork family							

The changing composition of modern families throughout the week

Co-parent family The co-parent family is defined by the equality of having the children at home and at the other parent (more on: *coparents.com*). This can be every other week, half of each week or any other division. A co-parent family may include a step-parent, but does not necessarily. It can be seen as being in-between the single parent - and patchwork family. In case of having only one parent at home, their needs may be very similar to those presented in the radar chart for single parent families. The main difference is to be found in the possibility of flexibility in the house, as a children's bedroom will be unused half of the time.

Patchwork family The need for flexibility is even more evident in the case of the patchwork family. This family is one that may consist of two combined families, possibly with addition of children from the new couple. Their composition may change from day to day, as children will stay over all at once, or more or less equally divided: anything is possible. Usually the amount of children may grow to a much larger number than in traditional families. To provide personal space for every single one can be a difficult and perhaps impossible task, however, also quite a desirable one. Research has shown that especially older children want to have a place to be able to withdraw themselves to (Levitt, 2010, p.7).

Distinctions To design especially for these modern families, it is important to know the differences with traditional ones. In the descriptions written above certain specificities have been highlighted indeed. In general, families with one parent need practical services nearby as well as the existence of a group or community. Families with a often changing composition need more flexibility in their dwelling, to make more efficient use of each expensive square meter.

As was mentioned in the very beginning of this chapter, all of the target groups are usually related to a situation of divorce. This specific occasion of divorce has led to the existence of a special service: the parents house.

Parents house The specific group, of families *in* divorce, is a target group that can possibly be served as well. When a couple (in this case, with children) has decided on divorce, usually one of the two will move out of the house. The search for a new home is a very difficult one, as money is usually tight and the waiting list for social rental is around 14

Parent House

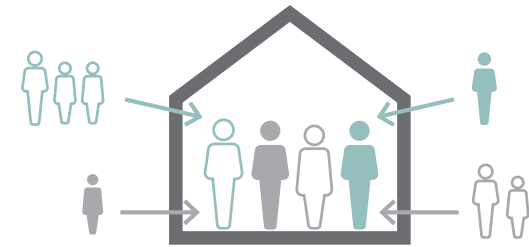

Parent house

years right now (*City for Sale*, 2017). There are already two initiatives in Amsterdam to help those people out, with the so called 'ParentsHouse'. This is a rental house, usually furnished, and meant for short stay, up to a maximum of one year. It works quite similar to a student house, as inhabitants will share kitchen, living room and bathroom. Each inhabitant will have a bedroom of his own, and there are separate bedrooms for visiting children as well. These bedrooms are shared among the house. This principle of sharing facilities can be interesting for other target groups as well and will be addressed later on. What is important when analyzing the possibility of having such a parent house, is the nearness of families. The other two in Amsterdam are both located in areas with a lot of families, and are meant for those families as well. This is because one of the main goals is to have both parents near their children after a divorce.

Budget An important issue for all of the target groups is the exorbitant pricing in Amsterdam. On average, dwellings in the stronghold region of Amsterdam cost about € 5.000 / m² (a number based on prices from *amsterdam.maps.nl*). By taking both consultation with Theo and the average income of an Amsterdam inhabitant into account, the following numbers come out:

	Housing price	Dwelling area
Single income	€ 250.000	50 m ²
Double income	€ 470.000	94 m ²

Of course there are many options inbetween, which is why these numbers will be used as borders to move inbetween. Rental housing is also possible, however this will not change the dwelling area. While price is important, it is also essential to remember that two-bedrooms apartments will not solve the issue, so the minimum size might be different.

Neighbourhood

Though touched upon in the previous topics, this chapter will now continue very specifically into the topic of wishes and needs of families. These wishes and needs will usually apply on families in general, and sometimes will be made more specific for this research, by relating it to modern families and families in the city. To divide this topic in a comprehensive manner, a division in scale levels is applied. The base for this is the so-called 'range of action'.

Range of action This notion reasons from the expanding range in which a child growing up will move. Though numbers differ depending on the parent, the following are applied, based on several studies (Bleeker and Mulderij, 1978; Felder and Karsten, 2016; Keesom, 2013; Meijer and Stobbe, 2016):

- 0 - 4 years, 30 m
- 4 - 8 years, 150 m
- 8 - 12 years, 500 m

These ranges relate to several scale levels. 30m will mainly be in and around the house; 150m is more or less similar to a street or building block; 500m is about the neighbourhood scale. These scale levels will each be employed, starting with the neighbourhood.

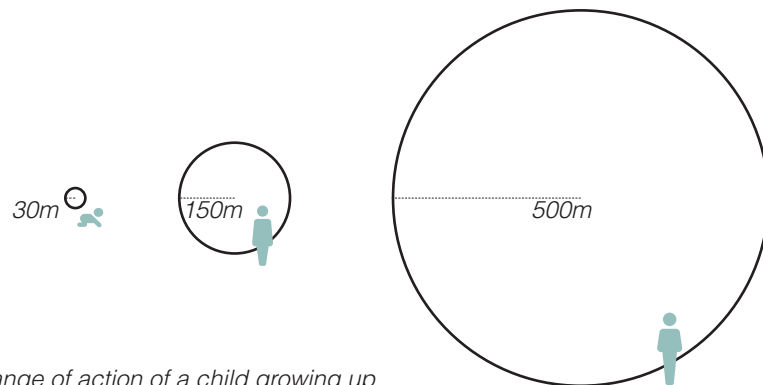

Range of action of a child growing up

In 'reasons for staying in the city' it is already mentioned that proximity of work, friends, cultural activities and other facilities are important to families. When both working and living in Amsterdam, mainly the proximity of public transport and bicycle roads will be of interest. In case of working outside the city, quick access to the highway is an advantage.

Facilities and shops An interest of any citizen is the proximity to certain facilities. Mainly supermarkets and other common shops are important, as they will often have to be visited. Especially for low income groups having these within walking distance is important, as they usually will not own a car or even a bike (Felder and Karsten, 2016, p. 38).

Education and daycare Research has shown that parents will often pay attention to the presence of (primary) schools and daycares nearby (Keesom, 2013, p. 22). Nearby in this case means preferably within a 500m reach, so that children may walk to school. Especially single parents and more wealthy families make use of daycare facilities (Van Gessel-Dabekausen, 2002, p.10-11).

Playground For 8-12 year old children, places to play football, meet friends and so on are to be found on the neighbourhood scale, within the 500m range as well. However, large or dangerous roads may make even the closest areas unreachable for a child on its own. This should be reviewed when judging the playgrounds that are present.

When choosing a suitable location all of the above named factors should be taken into account.



Facilities that families need in a neighbourhood

Building block

This scale belongs to the 150m range, usually a street or building block and some area around it. For children in the age between 4 and 8 years, this is their main territory.

Other families The very first thing that is needed on this scale level, is other kids, thus other families. Both parents and children benefit from this (Keesom, 2013, p. 12, 22). For children it is of course nice to have friends living close by to play with (Bleeker and Mulderij, 1978, p.93-94). Parents are happy with this as well, as they can have social interaction with the other parents. This creates closer social networks and social safety, which in turn is good for the neighbourhood (Karsten, 2003).

Ground for playing For these young children between 4-8 years old to be able to play outside, there are a few essential conditions. One of them is safety, mainly protection from cars and deep water (Bleeker and Mulderij, 1980, p.112-113). A broad sidewalk can be functional already, this is actually the place where children play most. To make it even more appealing, there needs to be some provocation to play. This needs not to be much: a pole, a wall or a fence, some grass, sand, water and so on will do (Keesom, 2013, p.139). A collective playground with some play equipment is also a possibility. There are many possibilities and there is much more to say about this too. Thus, how to deal with this in more detail will be explained in the topic on 'playing' later on.

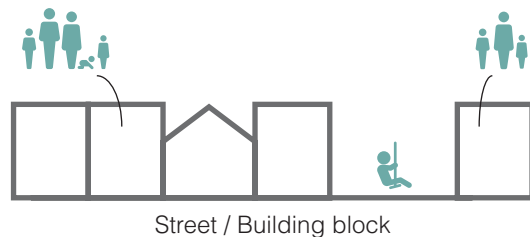

Other families and a playground nearby are essentials on the scale of the street / building block

Parking A very different yet also important issue is the one of parking. To be able to safely play, some distance between housing and cars is essential. However, being able to park next to the house is a luxury many people would like to have. Yet, in this specific case of families, a safe environment for the children is more important than fast car access. However, there are possibilities in combining both of these factors. By having a roofed parking lot, a playground can be both on top of this and next to the front doors. The illustrations underneath explain this.



Car at the front door or playing at the front door?



Both playing and the car nearby

Another important thing is the amount of parking lots that is needed. The location of the Zeeburgerpad is a B-location. For this the following rules apply (Gemeente Amsterdam, 2017, p.26):

- For dwellings of 30 - 60 m² the minimum is 0,3 P/dwelling
- For dwellings > 60 m² the minimum is 0,6 P/dwelling
- For social rental and mid-price rental, there is no minimum
- The minimum can be lowered 20% by adding shared cars. One shared car replaces 4 regular cars.

Because affordability is a big issue for families, the minimum norm will be used in the design. The shared car option is also interesting, especially for single parent families.

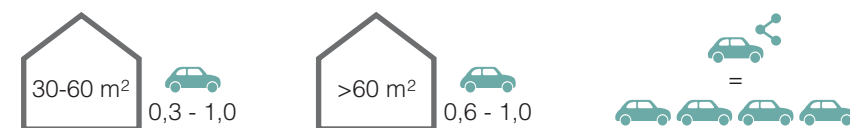

Parking norms B-location Amsterdam

From first door to front door Another issue which especially can be problematic for children, is the zone between main entrance and the actual front door. This issue arises when designing stacked dwellings instead of traditional housing. The distance that is created between actual outdoor and house may be too large, so parents will not let their children go outside by themselves. Because of this, children living higher than the third floor have much less friends and will discover many things much later in life. (Bleeker and Mulderij, 1978, p.78 and 111) They thus recommend to not have families living higher than the second floor level. Other than that, the gallery should overlook the playground. Some galleries however are wide enough to play on as well. Other than distance, the amount of 'obstacles' to take on the route can be quite difficult for children. Heavy doors, dark hallways, buttons just out of reach, just assume the role of child and you will be able to design much child friendlier environments. One idea of the broad gallery is already named as a possible solution. Another solution could be to create the playing area within the building system itself. This results in a route from front door to playground much shorter than the one to the first door and thus with less obstacles.

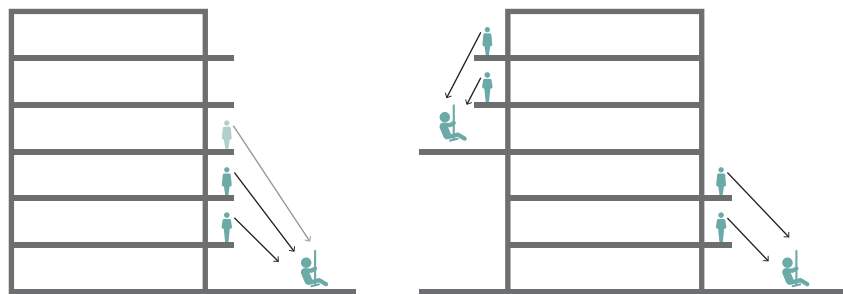

Solving the problem of supervision above the third floor by creating a playground / broad gallery on a higher level

Entrance core Another important theme that relates to both affordability and social security is the amount of dwellings connected to an entrance. In The housing design handbook by David Levitt (2010, p.74) this topic is dealt with. Limiting the number of dwellings to a maximum of 20-25 per shared entrance is desirable, to maintain a socially safe environment. A single controlled entrance is also eligible. In case of the addition of a lift, 15-25 dwellings per core is manageable for affordable rent, 10 is the

absolute minimum. A lift seems very useful as families will have buggies and heavy groceries to carry up. Up to six floors one lift is sufficient, above that an extra lift is required. This is related to the thought that in case of lift failure, six floor is the highest you can expect people to climb. Concluding from this, around 20 dwellings per entrance core is favourable, for it being both safe and affordable.

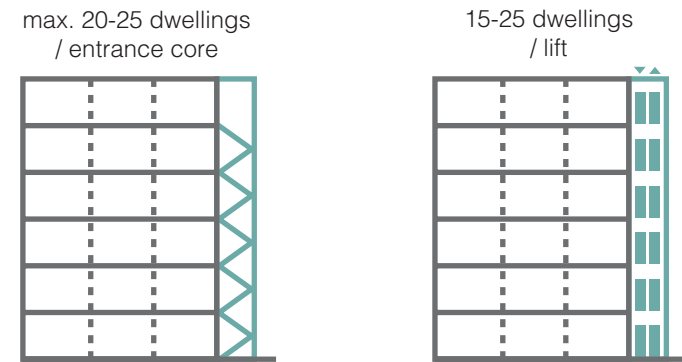

Having around 20-25 dwellings / entrance core with lift is both socially safe and affordable

Facilities According to Levitt (2010, p. 111) a typical scheme of more than 100 new homes the shared external facilities should include:

- Play areas, including space for informal games such as football, and for children of all ages
- Dedicated areas for dogs

Indoor facilities should include:

- Storage for bulky items, such as bicycles
- Provision for a creche
- Youth clubs
- Meeting rooms
- A multi-purpose hall

To have both youth clubs, meeting rooms and a multi-purpose hall seems to create a rather expensive situation. Especially in the case of

Amsterdam, where proper housing is already unaffordable, one has to consider very precisely which (essential) facilities you want to offer. It is also important to investigate which facilities might already be near. Other than that, the specificities of (modern) families will help choosing.



A multitude of facilities is needed when over a 100 new homes are built

Other than the already named facilities, it might be interesting to share other, more unusual facilities as well. This is a concept known from co-housing projects. In these co-housing projects the following shared facilities are more or less common (lvcw.nl; cohousing.org.uk):

- Large kitchen
- Living room
- Laundry facilities
- Bicycle storage
- Meeting room
- Workshop
- Guest rooms

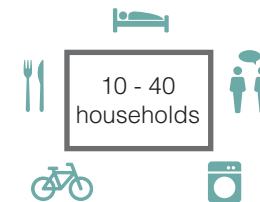

Co-housing facilities per 10-40 households: bicycle storage, shared kitchen, shared guestroom, meeting room, laundry facilities

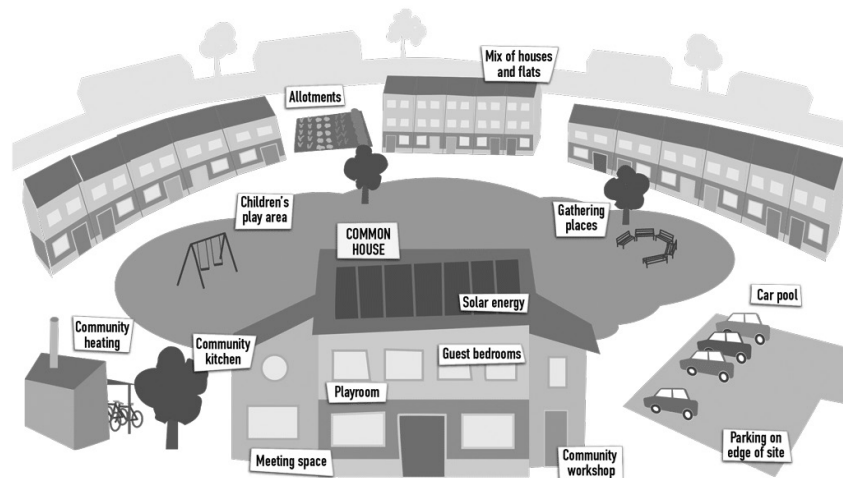

Common co-housing project (source: cohousing.org.uk)

House

In the text 'Reasons for leaving the city' a number of issues related to the house are mentioned:

- Small dwellings
- High costs
- No or limited outdoor spaces

The problems of cost and outdoor space also relates very much to the scale of the street or building block. Collective outdoor playgrounds and efficient entrance systems belong to these topics and are mentioned before. To improve however these things on the dwelling scale, another view is needed.

Adaptability The problem of small dwellings and yet high costs is a difficult one. To do the best possible job here, is to make very efficient yet flexible or adaptable dwellings (Keesom, 2013, p. 51).). This adaptability is especially important to co-parent - and patchwork families.

To implement this adaptability in the design, many options are possible, and can be combined as well.

- Clear spans between party walls
- Annex room
- Seperate kitchen and living room
- Oversized hallway
- Rather many small rooms than a large one
- Fine-grained facade design
- Different options for plan arrangement
- Spaces of multifunctional sizes

Clear spans Clear spans is both a case of affordability and adaptability. Smaller frontages creates the possibility of higher densities and thus reduces costs per dwelling (Levitt, 2010, p. 191). However, one should

not reduce frontage size too much, as narrower and deeper houses tend to need more circulation space, which in turn is inefficient. 5m is the minimum to be able to divide a double bedroom into two single ones. To take this 5m as a minimum for designing a family house seems legit.

Annex room The annex room, a closeable space next to the living, can provide many possibilities for flexible use (Keesom, 2013, p. 56). It could be a place to play, to study, it might even be turned into a guest room. According to Levitt it is important to have such an extra living space in case of lack of a real garden anyway, as a place for teenagers to hang out (2010, p. 71).

Seperate kitchen and living room To have or be able to separate the kitchen and dining room from the living room can be very useful for families. For example, children can stay and play in the living room, while guests are in the kitchen, without bothering each other. Similar to this, the kitchen table can be a place to work or study, while at the same time the living room is used to watch tv. Other reasons for wanting a seperate kitchen anyway are smells of cooking, a mess on the counter and other things that one might want to hide from guests (Keesom, 2013, p. 51).

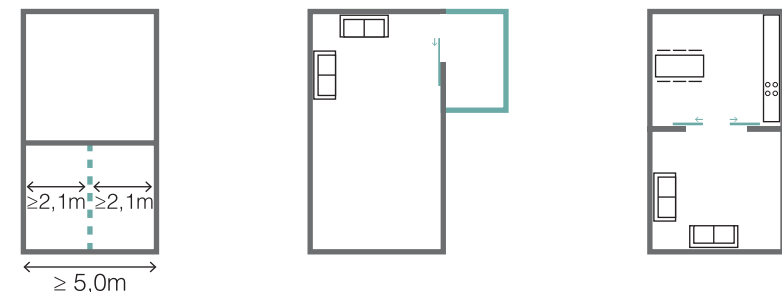

Clear spans, annex room and seperate kitchen and living room

Oversized hallway Another possibility in creating adaptability in a dwelling is an oversized hallway. This facilitates flexibility in both activity and use (Keesom, 2013, p. 53). For example playing, storage, studying, room for pets, drying clothes, welcoming guests, and so on.

Many rooms Though one might be tempted to design rather a few large, spacious rooms than multiple small ones, for families this is not

helpful. Especially when children reach the age of teenager, they want to have their own room (Levitt, 2010, p. 71). Thus designing multiple rooms, or at least the possibility to create extra rooms, is useful for families (Keesom, 2013, p. 24).

Fine-grained facade To be able to make to rooms out of one, the facade openings are critical. This is why it could be useful to create a fine-grained facade design (Keesom, 2013, p. 106). This means rather small and multiple windows, to make the splitting of a room into two habitable rooms possible.

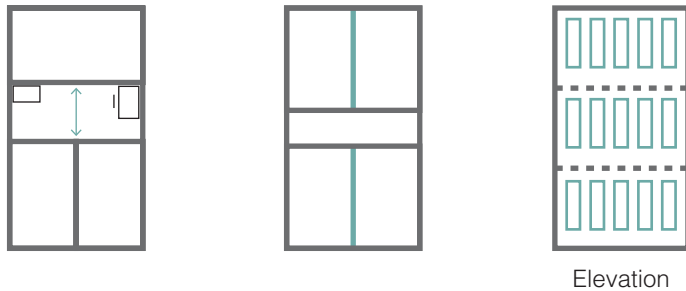

Oversized hallway, many rooms and a fine-grained facade

Plan arrangement The second last option to create adaptability that will be mentioned here are different options for plan arrangement. This is especially meant for house owners. It is common practice to sell houses before they are even finished. This creates possibilities for buyers to have a say in the design. The architect could propose a few, say 2 or 3 options, for the plan arrangement. Buyers may choose their favourite one. This provides adaptability beforehand.



Adaptability in plan arrangement

Multifunctional spaces One way of creating adaptability in plan arrangement is by making rooms of such sizes that they can take in different functions. For example, a room of 3x4m can be a parent bedroom, bedroom for two children and a kitchen with dining table (Keesom, 2013, p. 100). However, it is still important to keep positioning of shafts in mind when applying this approach.

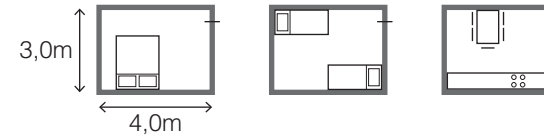

Multifunctional spaces

The options named above are all interesting to implement in the design for modern families. As mentioned before, especially co-parent - and patchwork families can benefit from this flexibility. For them, especially rooms that can double function as a bedroom are interesting.

Outdoor space The other issue families in the city have is the lack of proper outdoor space. Even though private open space is no longer sacred anymore for families in the city (Keesom, 2013, p. 24), it is still highly valued. Yet, it does have to fulfil a few goals in order to be as useful as possible. Levitt provides for information on what goals outdoor space should meet (2010, p. 97).

- To design gardens and balconies as extensions of the main living space, addressing both privacy and sunlight
- To design for a large variety of functions, being:
 - o Small-children's play
 - o Drying laundry
 - o Sitting out
 - o Growing things
 - o Keeping pets (cats, dogs etc)
- Top up the limited amount of private space by shared space for groups of residents.

He explains that a private outdoor space should at least have enough space for the whole family to sit and eat outside. This equals a minimum of 4m² private outdoor space for 2 persons, and 1m² extra for each

additional person (Levitt, 2010, p. 98). This is similar to the Dutch 'Bouwbesluit', which sets a minimum of 4m² and also a minimum depth of 1,5m. For family housing a minimum outdoor space for 4 persons, which is 6m² can be set.

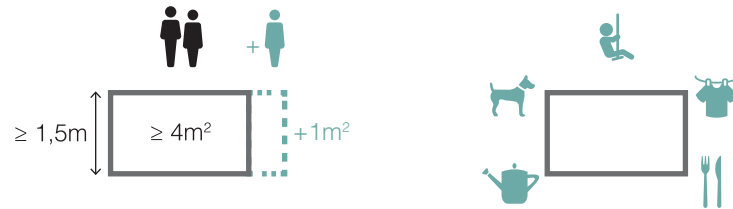

Size and function of private outdoor space

Storage As a final specific need for families, storage has to be mentioned. Families in general tend to have plenty of stuff. Some of this is (bulky) items they do not need for a while or they need it just for outside. For example a cradle, pram, ice skates, bbq, frying pan, bicycles. These items would preferably be put away in a storage space outdoors (Keesom, 2013, p. 35). It would be of use similar to a shed common in traditional Dutch 'row housing'. Other than these, many smaller items need a place to be stored as well within the dwelling. Think of toys, clothes, (electronic) devices, drying rack for clothes, shoes and coats and so on. A traditional solution to this is for example the en suite door with closets next to it. In modern housing however there is usually no reserved space at all for storage. When designing for families, it is useful to think about providing specific places for storage beforehand.

Playing

This topic of playing fits all the scale levels mentioned before and is already mentioned multiple times, but a more thorough understanding is needed and very interesting as well.

The book 'Kinderen buiten spel' (Bleeker and Mulderij, 1978) has provided for a way to get into the skin of children. By joining groups of children of different ages on their routes in the neighbourhood, they are able to show how children act and think, and make it possible to do this yourself again as well. This book however is focussed on outdoor playing, while currently many children spend more and more time indoors. Karsten and Felder (2016) have researched the topic of children and playing in contemporary times. By combining insights taken from both of these books, along with other sources, this chapter should provide many inspiration to design for the needs of children and their play.

Experienced space One of the most interesting notions from Bleeker and Mulderij is the notion of 'experienced space' (1978, p.69). By this they mean that space becomes memorizable for a child, if he or she has experienced something there. For example, they memorize a spot because they caught this big fish, or their ball was taken by that angry man. What is interesting about this as well, is the importance of multiple senses in this experience. This is a notion popularized by Juhani Pallasmaa, in his book 'The eyes of the skin' (1994). Contemporary times are usually very focussed on the eye, while Pallasmaa insists that it is important to design for a multi-sensory experience. The previously named examples are clearly multi-sensory, as - other than the obvious eyes - they also include sound (hearing the shouting, angry man) and touch (feeling the big, slippery fish).

Children also experience spaces much more with their whole body. It is not hard to notice that they are usually moving around much more than adults. Especially when seeing a family on a trip, one might notice children running around them in circles or pulling at them to show

something. They are much more curious and less prejudiced on how one should behave. For example in a staircase, they might rather just take the very small stroke on the other side of the railing, balancing and climbing their way upstairs. It is clear that children experience spaces in different ways from adults.

Imagination Another difference with adults is a more vivid imagination. The younger children are, the more they can seem to be in their own imaginative world. This is as well part of the way they experience space. Young children don't need much incentives to play, some sand, a simple concrete block, or just some pine cones on the ground can already evoke a game of playing 'store'. Similar, a simple pole can invite to stand on, jump over or cycle around with your bicycle. It is such things that need to be implemented in the environment of a child's house. However, the older children get, the more incentives they need to start playing. For them, some goals to play football are more interesting. Yet they as well can see possibilities for play all around. They might be looking for some adventure, which for example a deserted building site can offer. When designing specific locations for children to play, a playground, it is important to leave something for the imagination of a child (Bleeker and Mulderij; Karsten and Felder). If all possible games are fixed, such as a wigwam area, children will soon get bored and a playground will be deserted. On the bigger scale of a neighbourhood, it is important to have a variety of materials. Repetitive streets of unidentifiable concrete flats will not trigger a child to go outside and explore the neighbourhood.

Safety As adults tend to walk into a straight line towards their goal, children find paths just offroad. This can be dangerous in situations near water or roads, and often results in stressed out parents. Having water nearby their house is often seen as a disadvantage by parents. Children are attracted to the water, and might fall in. The book of Bleeker and Mulderij does provide a possible solution for this (1978, p. 113-114). By creating a more innocent stream of water on the plot, the attention is drawn from the more dangerous, deep water. Other dangers that nature can offer are often plants, such as nettles.

It is not just that parents want their children to be safe, children themselves need this as well. They discover the world slowly, always at a distance close enough to return to the safe haven of the home. This distance is one that changes over time. A young child will stay very

close, under mothers gaze. There is a problem related to this when living in an apartment building. Because parents want to keep an eye on their children, the distance between house and playing area can only be so much. This is mentioned before in 'from first door to front door'. The older children get, the further they go. This also has to do with their ability to remember spaces and routes, to be mentally able to know the way back home. This ability of wayfinding improves as they get older. It can also be made more easy when certain landmarks are positioned along the route (Lingwood, 2014).

Development It is true that children are playing less often outside than before (Bouw and Karsten, 2004). According to Karsten and Felder, parents have somehow gotten it into their heads that children have to be watched all of the time. This is a trend that has already started many years ago, narrowing down the radius of action of the child. Because parents will not always have time to escort their children to a playground, they stay home more often. There is however still a large variety in the amount of time different children spend outside. In general however, the older children get, the less time they play outside. In the research of Karsten and Felder on children in Rotterdam and Amsterdam, 21% plays outside only 0-1 times a week, a same 21% plays outside very often, 7 times a week or more, 32% plays outside for 2-3 times a week and 26% 4-6 times a week.

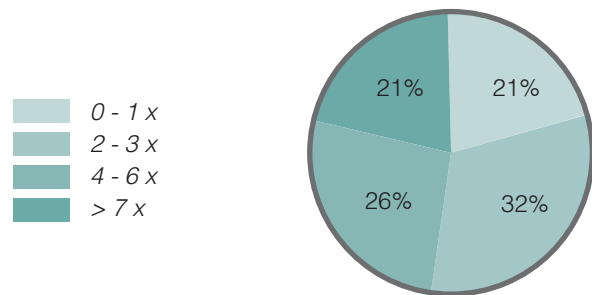

Number of times a week children go outside to play (data source: Karsten and Felder, 2016, p. 85)

Yet almost all children do like playing outside (Snel, 2013), and there are many advantages for their development. They get to know their own boundaries in strength and speed; they learn how to handle with dangerous situations; they will learn to act more social and deal with

disagreements, all without their parents help or gaze (2016, p. 80). They also become more creative, as playing outside often asks for some imagination and creativity. Children like this, it is already said before that playgrounds with very fixed activities become boring soon. Another point of attention is the problem of an increase in overweight. Other than bad nutrition, this is also a problem related to a lack of physical exercise (Karsten and Felder, 2016). As playing outdoors is often related to running and other movements, this could tackle the problem.

Locations Many possible locations to play outside have already been mentioned before in this booklet. They can be found on any scale level, however the importance of them differs among age of the child. Other than scale level, a division in formal and informal play area can be made. (Karsten, Kuiper, and Reubsæet, 2001) Informal space is space not especially meant for playing, such as sidewalks, squares and the alike. It is also applicable to indications of playing, such as the before mentioned pole, or a tree trunk or playful pavement (Meijer and Stobbe, 2016, p.7). Formal play areas are those especially designed for playing, such as playgrounds with play equipment, or a football field. We'll now discuss the possible locations on scale level, age appropriateness and whether it is formal or informal.

Starting with the smallest scale, a private balcony or garden, an informal place. This is mainly relevant for children until the age of 4. The place becomes too boring for them after that, mainly because there are no other children (Karsten and Felder, 2016, p. 92). The next step is usually the side walk, an informal place as well. If it is wide enough and other children are there as well, this is a perfect place to play. Parents are happy to let their children play here as well, as it is close enough to watch them. Some dwellings are located around a courtyard. This can be an even better place to play, as it is larger than a side walk, and more safe from traffic. A courtyard is usually informal, unless it is especially designed for children as well. For both the side walk and the courtyard, playing is usually up to the imagination of a child. As discussed before, this is not a problem, it might even be an advantage. On the largest scale, the one of the neighbourhood, one can usually find some playgrounds, which are of course formal play areas. For a few children this might be close by enough to go there on their own, others will be accompanied by their parents. A rather similar thing can be the schoolyard.

Children will stay there after school to play, while parents sit down on a bench and chat with each other.

The importance of informal play areas is quiet clear, as often the formal playgrounds can not be find close enough to home. However, the importance of formal playgrounds is also stressed by Karsten (2002). Such playgrounds often function as a meeting point for children. There is also much more certainty in knowing other children will be there, which is important, as children like to play together.

Age Though children are creative enough to come up with plays by themselves, it is still interesting to know what age group is interested in what kind of plays. Research has been done on this by the TNS Nipo research company and Jantje Beton (Snel, 2013). They use two age ranges, 6-8 and 9-12 years old. The youngest children are not researched, possibly because it is not possible to have them fill in a survey, which was their way of investigating. There is also simply less to investigate about these young children. They have a much smaller range of action to actually go places and they play more by themselves, so playgrounds as a meeting place are less important (Meijer and Stobbe, 2016, p.12). Also they don't need much indication to play because of their very vivid imagination. However, a playground for them can be combined in a playground for slightly older children. According to Meijer and Stobbe (2016) this could consist of:

- a low slide
- small house to play in
- play with sand and water
- other elements in the form of a boat, train, airplane.

The outcomes of the research of Snel are very useful for the other age ranges. Underneath the preferred location for play are indicated, along with a number inbetween 1-10 (10 is highest preference).

	6-8 year	9-12 year
1	<i>On the schoolyard</i> 7,9	<i>A lawn</i> 7,4
2	<i>Playground watched by adults</i> 7,9	<i>On the schoolyard</i> 7,2
3	<i>Small playground with equipment</i> 7,8	<i>Nature/forest</i> 7,0
4	<i>Nature/forest</i> 7,5	<i>A park</i> 6,7
5	<i>A lawn</i> 7,4	<i>Sidewalk close to home</i> 6,5
6	<i>Sidewalk close to home</i> 7,2	<i>Small playground with eq.</i> 6,3

The schoolyard scores high for both of the age groups, possibly because of the number of friends that will always be there. The younger children seem to prefer the more enclosed areas to play, with some play equipment. These can also be named formal play areas. The older children like the more open spaces, with no specific wish for equipments there. These are more informal play areas.

Continuing on this, the survey asked what kind of play the children liked to do most. This gave the following numbers.

	6-8 year	9-12 year
1	<i>Cycling</i> 8,3	<i>Cycling</i> 8,3
2	<i>Made up games</i> 8,1	<i>Made up games</i> 7,2
3	<i>Climbing</i> 8,0	<i>Climbing</i> 7,0
4	<i>Swinging</i> 7,9	<i>Skating</i> 6,9
5	<i>Building shanties</i> 7,8	<i>Playing football</i> 6,8
6	<i>Hide and seek</i> 7,8	<i>Building shanties</i> 6,6

The age difference on this topic is invisible in the first three plays. Cycling is the big winner for the 9-12 years. Making up your own games is, as expected, very popular at both age groups. These two are also the plays that most neighbourhoods have suitable space for (Snel, 2013, p.19).

A lot of children however still find many places rather boring, according to the research. Almost 50% thought that the sidewalks and squares were boring, and 35% thought this of the schoolyard. To make playing more fun, they want to have more exciting places to play. Also less dog poo, more age-specific equipment and more squares and lawns are on their wish list. Unfortunately, 'exciting' is not really defined, but a more natural environment could possibly answer to this.

Continuing on this age-specificness, there are some more things to be said. There are reasons why it is important to be careful by *not* being too age specific. Especially in areas of all newly built housing, ages of children will be comparable. This means that children will also grow out of certain playgrounds around the same time (Levitt, 2010, p.112). To prevent spaces from being unused, they should be flexible, by providing for multiple target groups. This however creates the possibility of a different problem. Especially younger children do not dare to play in vicinity of older children (Keesom, 2013, p. 138). Concluding from this it

might be best to provide for several, multi-deployable outdoor spaces. Such a place might be more inviting to a specific age group, but can be used for others as well, perhaps with a small modification.

Learning from all of this there are some things to conclude for the design of play areas:

- Both formal and informal play areas are needed

Formal play areas are:

- Playground with play equipment (0-12)
- Sports field, for example for football, basketball, skating (>8)

Informal play areas can be:

- Sidewalk
- Courtyard
- Lawn
- Square
- Street
- Any other safe place

Informal play areas may give indications to play by having:

- Poles, (concrete) blocks etc.
- Natural elements, such as sand, water, a tree trunk, hills etc.
- Playful pavement
-

Children from:

- 0-4 mainly need informal play area.
- 4-8 are interested in both formal and informal play areas
- 8-12 prefer informal play areas over formal ones.

- The schoolyard is a play area that is important to all school-going children.

Design brief 1.0

This design brief is based on the outcomes of the research presented before, and thus represents the conclusions that can be taken from the research.

± 100 dwellings

- 50 - 100 m²
- 3 bedrooms minimum
- apartments and maisonnettes
- adaptability in floorplan
- outdoor space of >6m²

± 30% of the houses at minimum possible size (with 3 bedrooms)

15-25 dwellings per entrance core (with lift)

Parking

- ± 60 parking lots (N = 0,6)
- ± 5 shared cars (1 shared car = 4 cars)

Play areas for each age group

- 0 - 4 years
 - + *informal play area right next to the house*
 - + *formal play area with play equipment*
 - + *safety from water and cars*
- 4 - 8 years
 - + *informal play area within view of the house*
 - + *formal play area with play equipment*
- 8 - 12 years
 - + *informal play area that is exciting*
 - + *formal play area for ball games*
 - + *within safe walking distance (±500m)*

Collective functions

- Laundry facilities
- Bicycle storage
- Guest rooms

Additional functions (unless already provided for in the area close by)

- Daycare
- Area dedicated to dogs
- Mixed-purpose room (meeting room, youth club)

Case studies

Introduction

For the research on family housing in the city six case studies have been selected. Through these case studies we intend to find design solutions and typical/common features in family housing design.

Each of the selected projects will introduce different elements that are of interest for this target group. All of the studies combined should provide a thorough and diverse overall impression of family housing design. The tools that are extracted from this, can be used in the design of our own project.

We have divided the analysis in five main topics, which will be explained further on.

Neighbourhood For the neighbourhood research we have focussed on the perception of a child. For this the so called 'range of action' is employed. This reasons from the expanding range in which a child growing up will move. Though numbers differ depending on the parent, the following are applied, based on several studies (Karsten, 2016; Keesom, 2013; Meijer and Stobbe, 2016):

- 0-4 years, 30 m
- 4-8 years, 150 m
- 8-12 years, 500 m

Within these ranges we have indicated several facilities, based on families' needs. These are:

-  Sport facility
-  Playground
-  Supermarket
-  Creche
-  Primary school

Interaction The topic of interaction is interpreted as a very broad one. The importance of interaction for parents living in the city is explained by Lia Karsten (2003): "In addition, unplanned socialising in public places with neighbours, friends and colleagues and their children was very positively valued. The many informal networks contributed to a feeling of social safety (...)"

Interaction will most likely happen on places where people pass each other. Furthermore, interaction can be enhanced by making such places more pleasant. For example, a covered, warm space is more attractive to stand and chat for a minute. We have indicated multiple possible places of interaction, being:

- Horizontal and vertical circulation
- Parking and storage
- Collective spaces
- Private outdoor spaces (visual connection)

Within these places one may identify both formal and informal meeting spots (Meijer and Stobbe, 2016, p. 7). Formal meeting places are especially designed for this purpose, they can for example be found in collective courtyards. Informal meeting places could be broad stoops, car free streets and so on. They provide space for bumping into each other, but are usually not especially designed to facilitate.

To clarify this more we use icons to indicate the level of interaction. This ranges from mere visual contact, to both visual and audible contact, to passing each other and finally, the actual meeting.

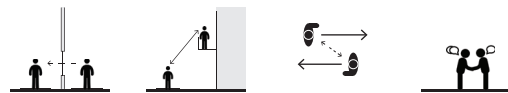

Identity Research has shown that the possibility of recognition/identification of your own home is important to people (A Pattern Language, p. 212). Especially in flats or appartement buildings this can be rather difficult.

To recognize ones own house might be more easy when the different types of housing are visible in the facade. This relates to the stacking scheme of a building. In case of stacking we are interested in the positioning of exceptions in dwelling types. This is most likely to happen on the corners and endings of each building block.

In addition, a research on wayfinding has shown that landmarks are very helpful for children to remember routes (Lingwood, 2014). This indicates that a recognisable dwelling block will help children to find their way back home.

Dwelling In this chapter the different dwellings will be analyzed on the following topics:

- Dwelling type
- Dwelling size and price
- Number of habitable rooms
- Outdoor space
- Storage
- Zoning

To calculate the dwelling price, €5000/m² is used. This is representable for Amsterdam city centre prices. In consult with Theo Kupers we have defined an affordable dwelling for families at approximately 100m². The number of habitable rooms is especially important in relation the the possible amount of bedrooms. This enables families to grow (and shrink) over time.

Storage is an important topic for families as they tend to have a lot of stuff, for example a pram, many toys, bicycles and so on. Having both outdoor and indoor storage would be ideal (Keesom, 2013, p. 35).

Zoning is about the division between more private and representative rooms. This might be important because families will simultaneously have people visiting and children playing and making a mess of the house. By dividing these activities in seperate zones, similar to the traditional family house with ground floor and upper floors, dwellings can function more properly (Keesom, 2013, p. 62).

Radar chart Radar charts are used as a tool for comparing the different dwelling types and buildings in a more quantifiable way.

In case of the building we divide the total area of parking, storage, collective space and circulation space by the total number of dwellings, to find an average area per dwelling. By comparing the different case study buildings to each other we hope to find a more general outcome.

On dwelling level we will compare the dwelling area, number of habitable rooms, outdoor space area and storage area. This might lead to a frame of reference for common sizes and numbers. It is however important to judge each dwelling seperately to find the applicability for the more specific target groups.

Meeting with Laurens Boodt

December 21th 2017

De Rotterdamse toren van Babel The meeting with Laurens Boodt and his colleague Giel Leunissen was about his project for the Open Oproep Gezinsappartementen ('Open Call Family Apartments') (Klep, 2017), De Rotterdamse toren van Babel (the Rotterdam tower of Babel). This project won this competition and Boodt and Giel Leunissen are finishing the design for the construction of the building.

He explained that the tower of Babel and the typical Dutch (row) houses are combined to create concept where the sidewalk (stoep) is a connecting route around the building. The complex consists out of twenty-four different dwelling types. The sidewalk is spiralling to the top from two starting points and it can be used as collective space for the whole building. In the core there is an elevator and a hallway that connects the two sides of the sidewalk. A gate closes the entrance of the complex after which people can enter the sidewalk. Visitors need to ring for the residents to let them through the gate and into the building complex.

Regarding the cars and bicycles there is space on the ground floor at the back of the building. Especially for families there is a special place to store cargo bikes (bakfietsen). To make efficient parking possible they are making a car elevator, however another option for parking the cars could be in combination with the neighbour buildings (if families don't want to use the car elevator). This is appointed as a possible buffer.

The collective space of the sidewalk directly connected to the dwelling provides less privacy than the residents might want to have. Boodt explains that they changed the design of the sidewalk after the competition. In the new design a private garden (2 meter) serves as a barrier between the collective sidewalk (1,2 meter) and the dwelling. This private garden can be opened or closed with different fence options on wheels. Another way to establish the use of the collective sidewalk is by creating some playground elements and benches. Boodt describes how they added swings at the collective space, where the sidewalk meets the

inner corridor. The collective space is a mean to encourage the residents to meet each other and for the children a space to play and explore. He repeatedly names this sense of community as an important factor in the design.

To provide for enough privacy in the dwelling, bedrooms are always located on the upper floor of each maisonette. The more representative spaces are thus always located next to the collective sidewalk.

The children, and the size of children, were also taken into account while designing the balustrade, doors and windows. In the doors there is a window, through which the children can see their house.

On the discussion about identity of the dwelling within the building, they explained that this was less evident in the final design of the building. Mainly because the different window types were too expensive and the identity of the whole building was more important. Also the influence of the residents was named as an extra reason, because the residents will probably express their identity by placing flowerpots or play equipment for their children.

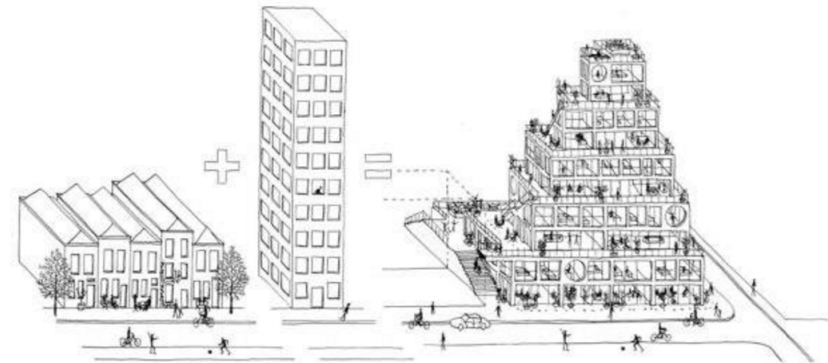

Design concept



Visualization

Habitat 67

Architect	Moshe Safdie
Location	Montreal, Canada
Year of completion	1967
No. of dwellings	158
Plot size	40.500 m ²

Habitat 67 is an experimental urban residential complex made for the Expo in 1967. This high rise apartment building is a pioneer in the combination of two housing typologies - the urban garden residence and the modular high-rise apartment building. The building consists out of 354 concrete units, that are stacked in a pyramidal like structure.

Habitat 67



Overview illustration



Habitat 67

Neighbourhood

Montreal



Parc de Dieppe



1:6000 | Neighbourhood facilities

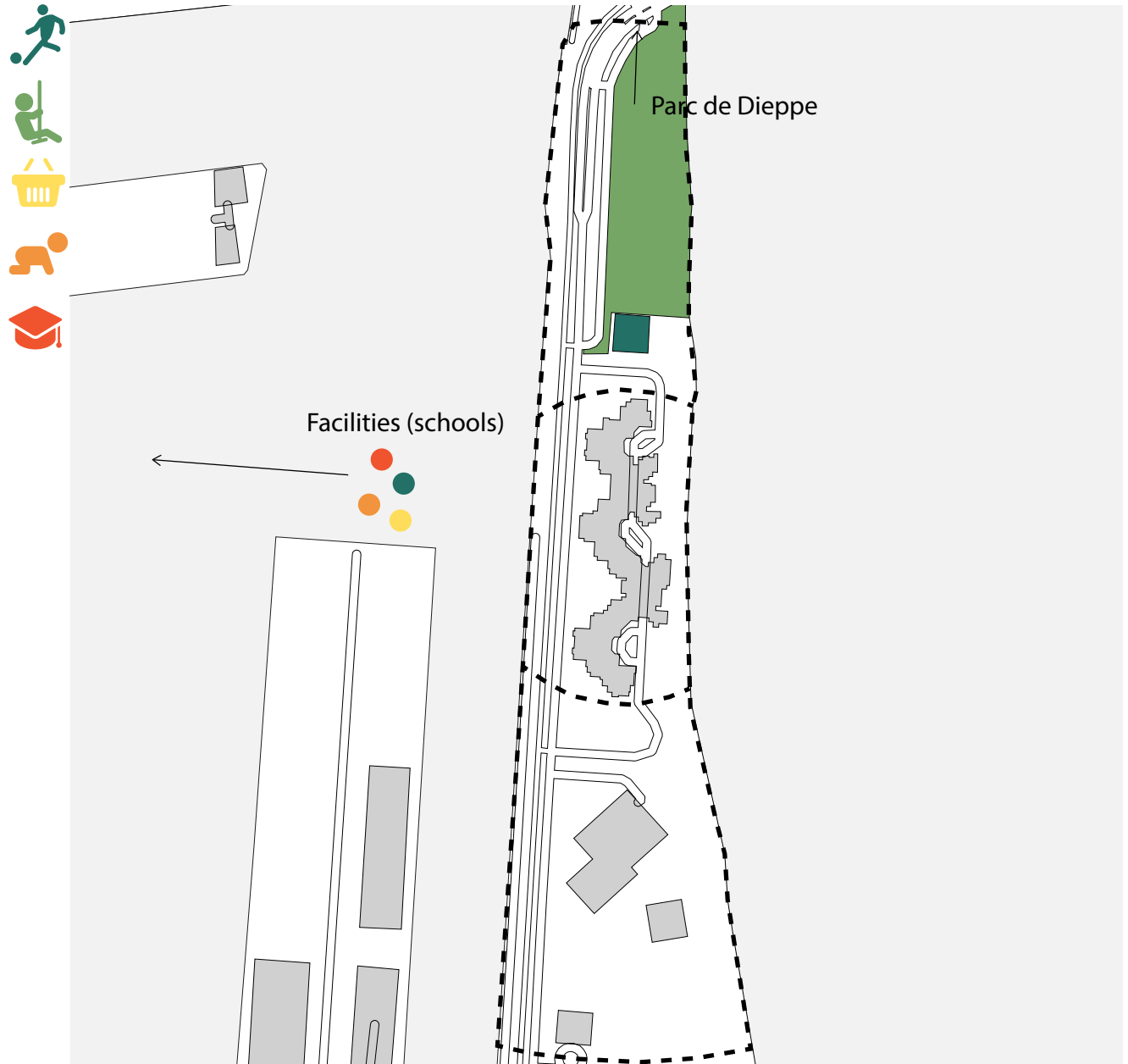

Habitat 67

Interaction

Parking and storage

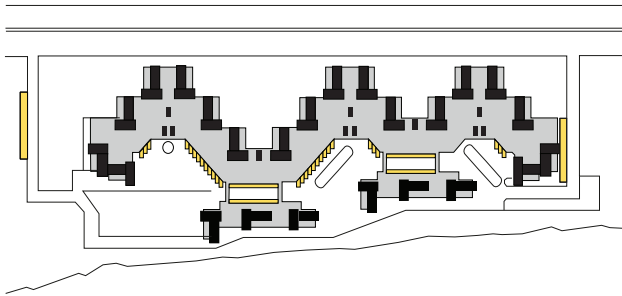

Circulation

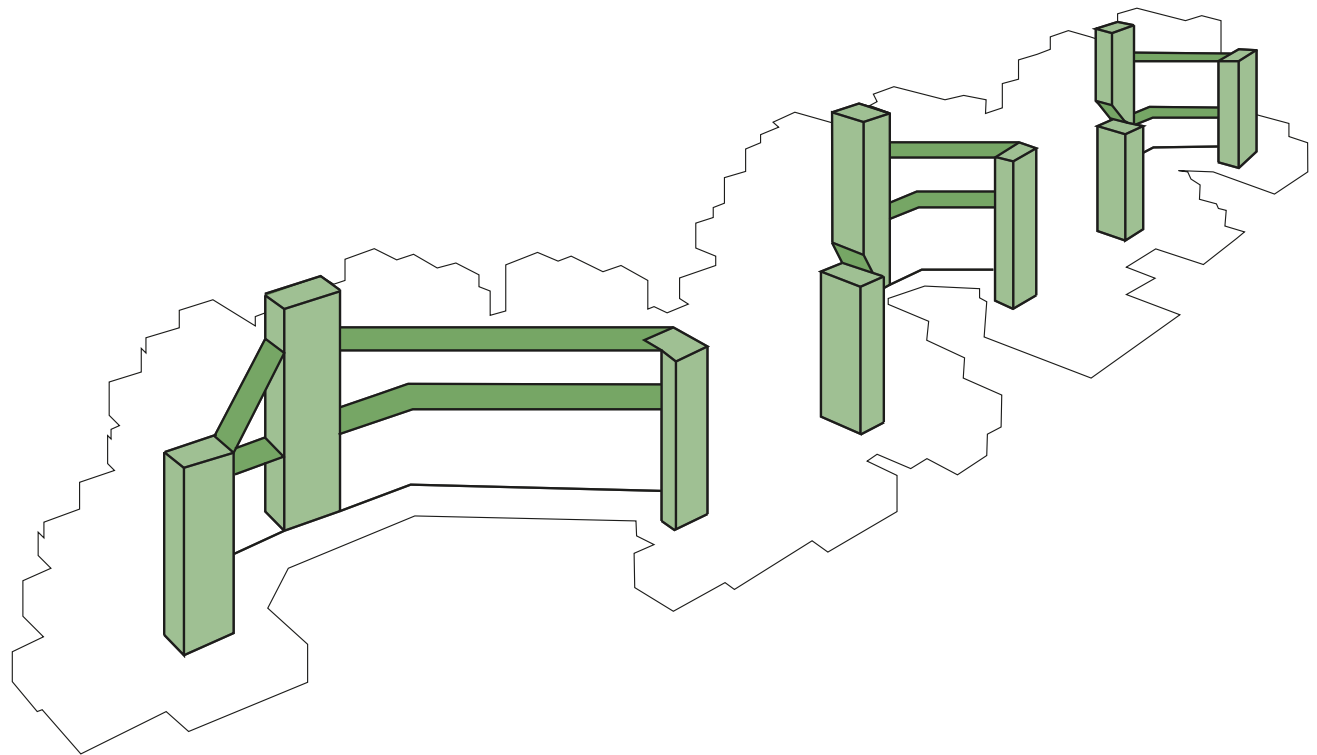

Parking



Habitat 67

Interaction

Collective outdoor space

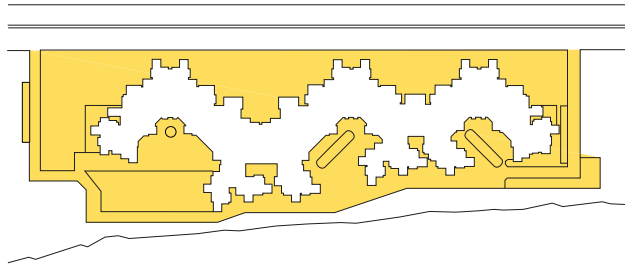

Informal meeting space

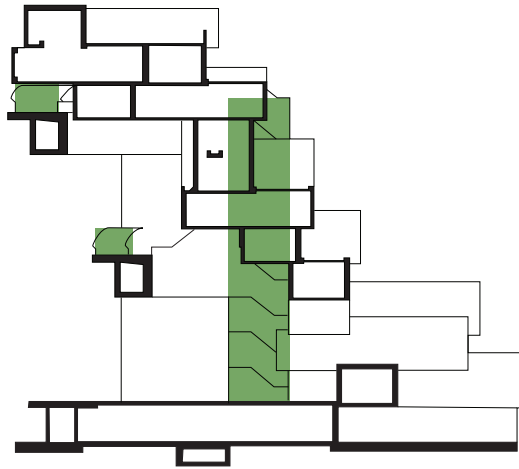

Private outdoor space

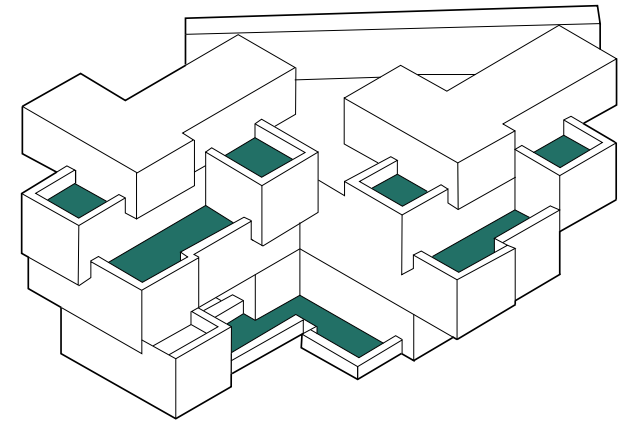
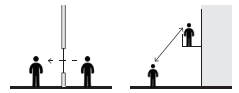

Outdoor space



Gallery



Garden terrace



Habitat 67

Identification



The building function can't be anything else then housing, because of the odd configuration. This configuration makes the building very unique and recognizable. The dwellings itself on the other hand are less recognizable within the stacking structure.

Stacking scheme

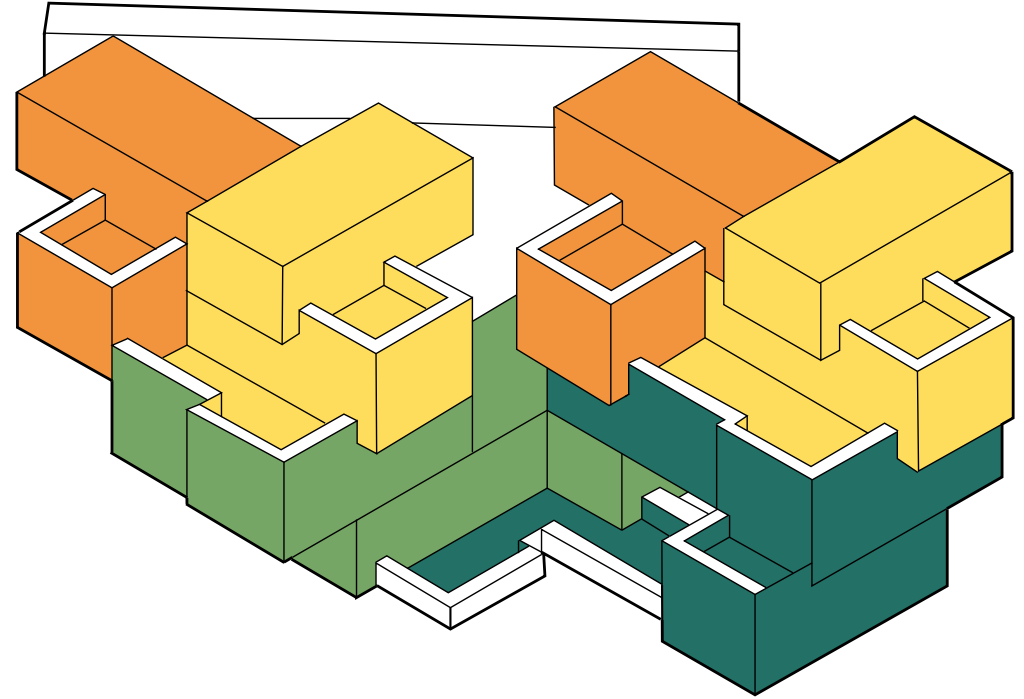

Facade



- Legend:
- Type A
 - Type B
 - Type C
 - Type D

Habitat 67

Information

Level: 10th and 11th floor
 Dwelling type: A
 Dwelling size: 110 m²
 No. of habitable rooms: 3
 Storage size: 3,5 m²
 Outdoor space: 18 m²

Floor plan, level 1

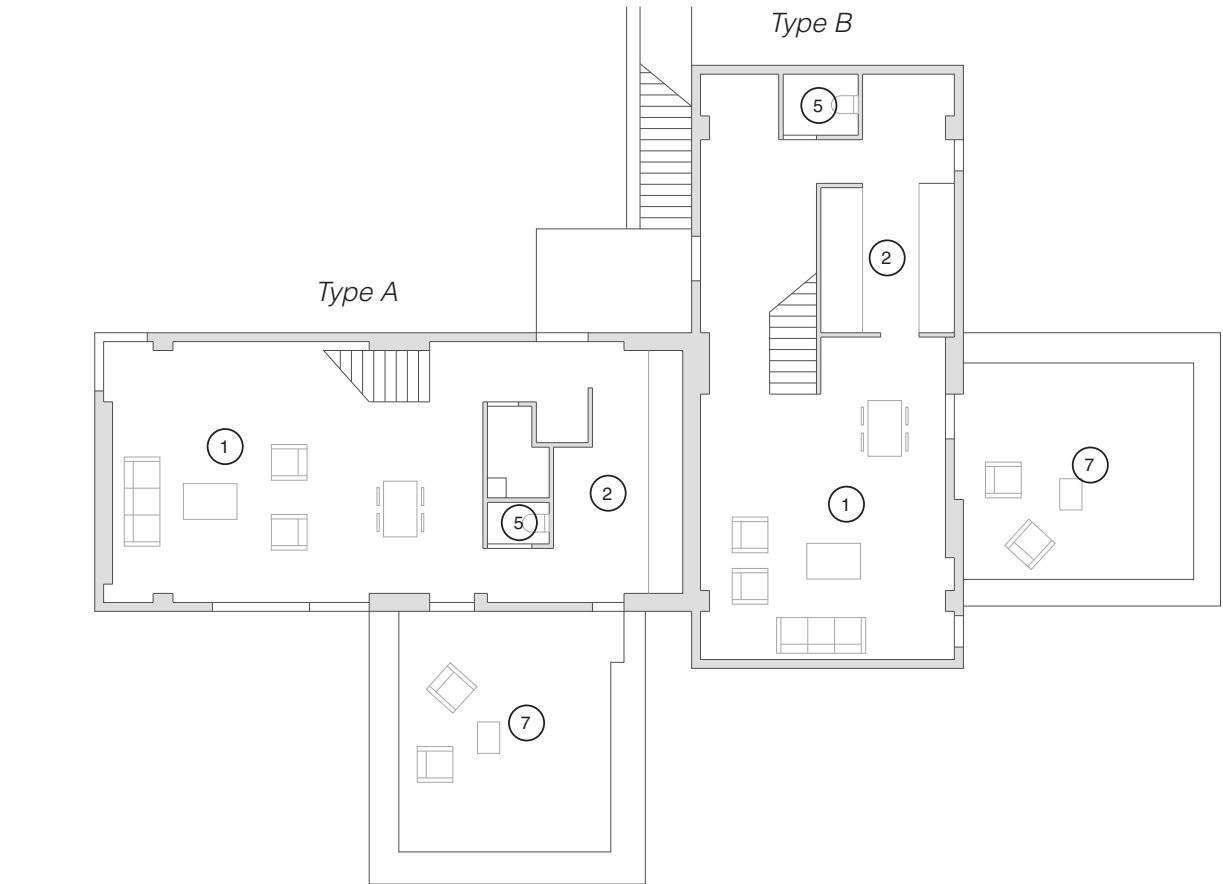
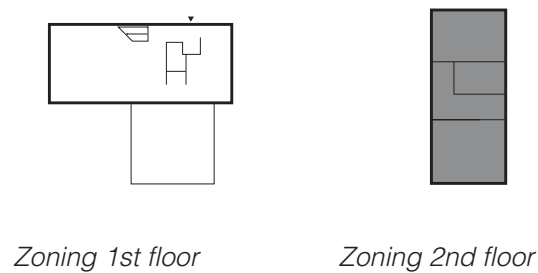
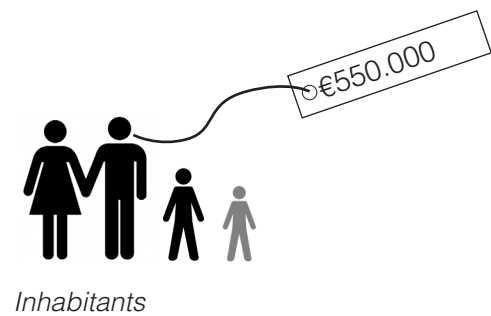
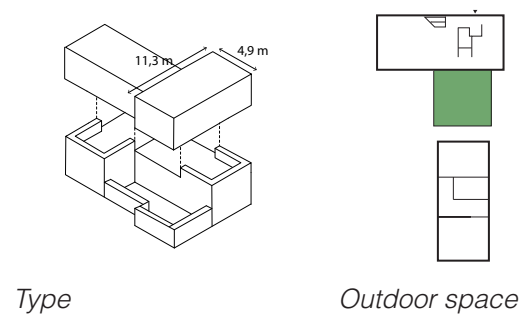

- Legend:
- 1. Living
 - 2. Kitchen
 - 3. Study
 - 4. Bedroom
 - 5. Bathroom
 - 6. Storage
 - 7. Terrace



Habitat 67

Dwelling

Information

Level:	10th and 11th
Dwelling type:	B
Dwelling size:	110 m ²
No. of habitable rooms:	3
Storage size:	3,5 m ²
Outdoor space:	54 m ²

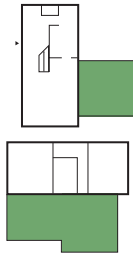
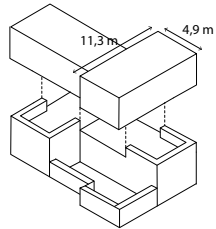

Type

Outdoor-space

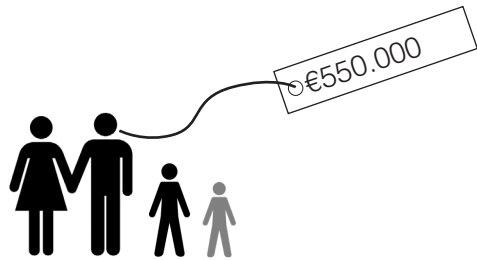

Inhabitants

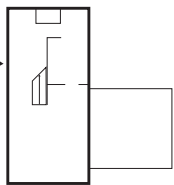

Zoning 1st floor

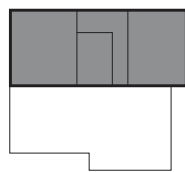

Zoning 2nd floor

Floor plan, level 2

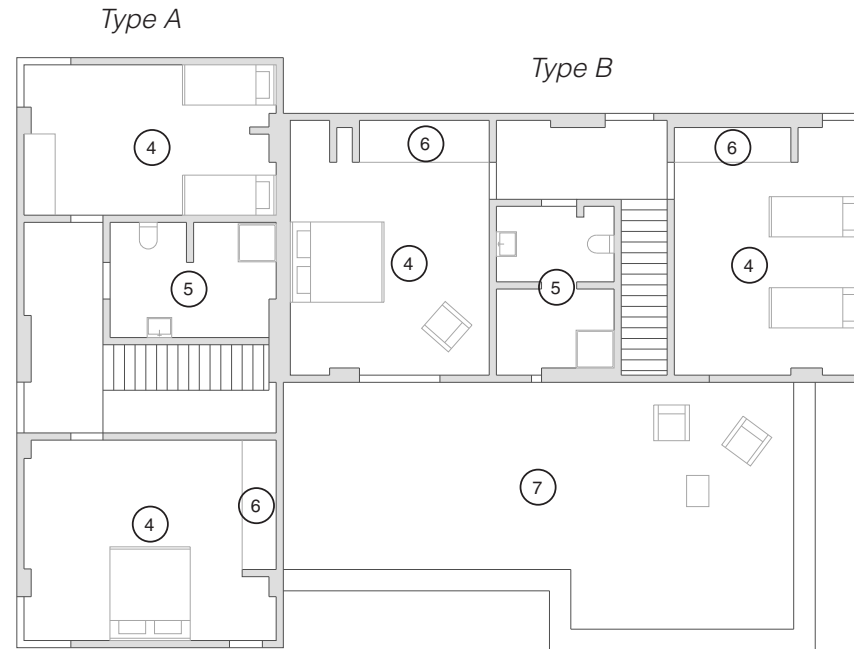

Legend:

- 1. Living
- 2. Kitchen
- 3. Study
- 4. Bedroom
- 5. Bathroom
- 6. Storage
- 7. Terrace



Habitat 67

Radar chart

Building

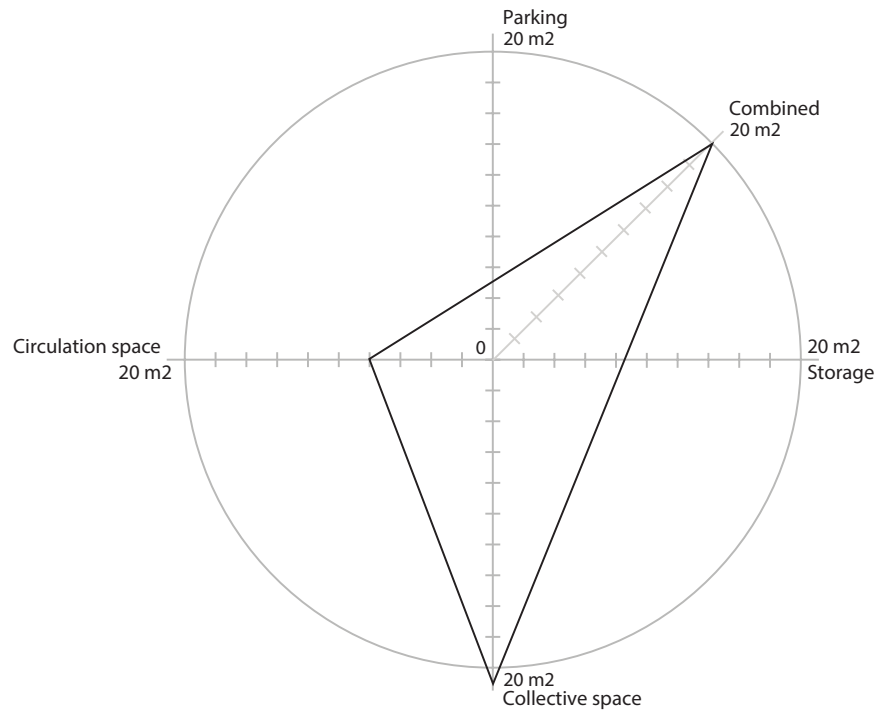

Dwelling

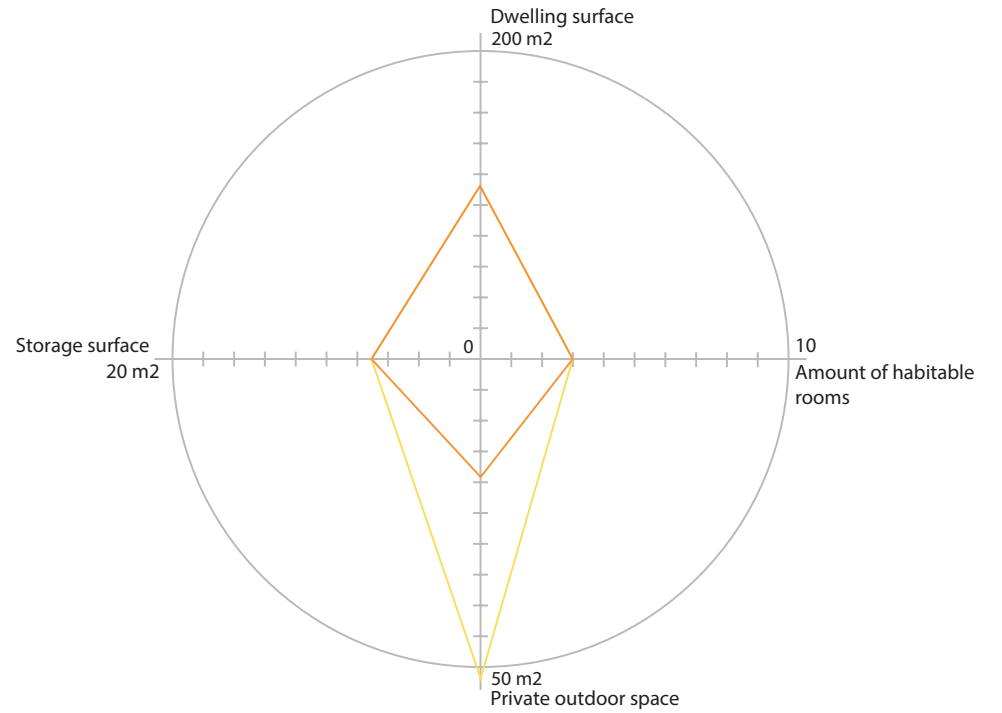

Legend:

■ Type A

■ Type B

Dan Leckie Way

Architect	KPMB Architects
Location	Toronto, USA
Year of completion	2012
No. of dwellings	total 427
Plot size	45.498 m ²

This project was developed by Context for the Toronto Community Housing corporation (TCHC) to fill a need for family-centred affordable rental housing in the downtown west. The building exists of a 41-storey tower and a 10-storey courtyard building.

Three and four bedroom units are designed around a minimal internal access corridors to maximizes play/study space within the family units.

Axo building complex

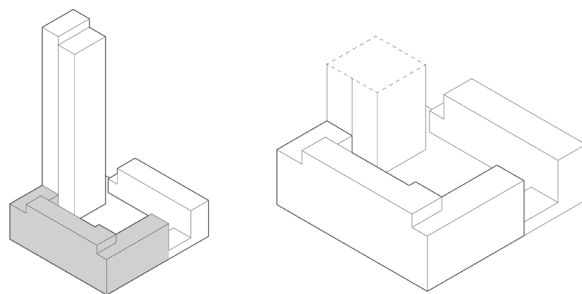

Overview illustration



Source: KPMB

Canoe Landing Park



Yoga in the Park



1:6000 | Neighbourhood facilities



Parking and storage

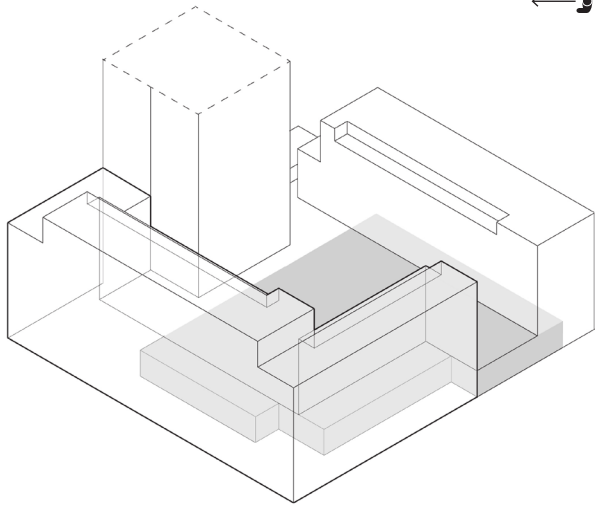

Circulation

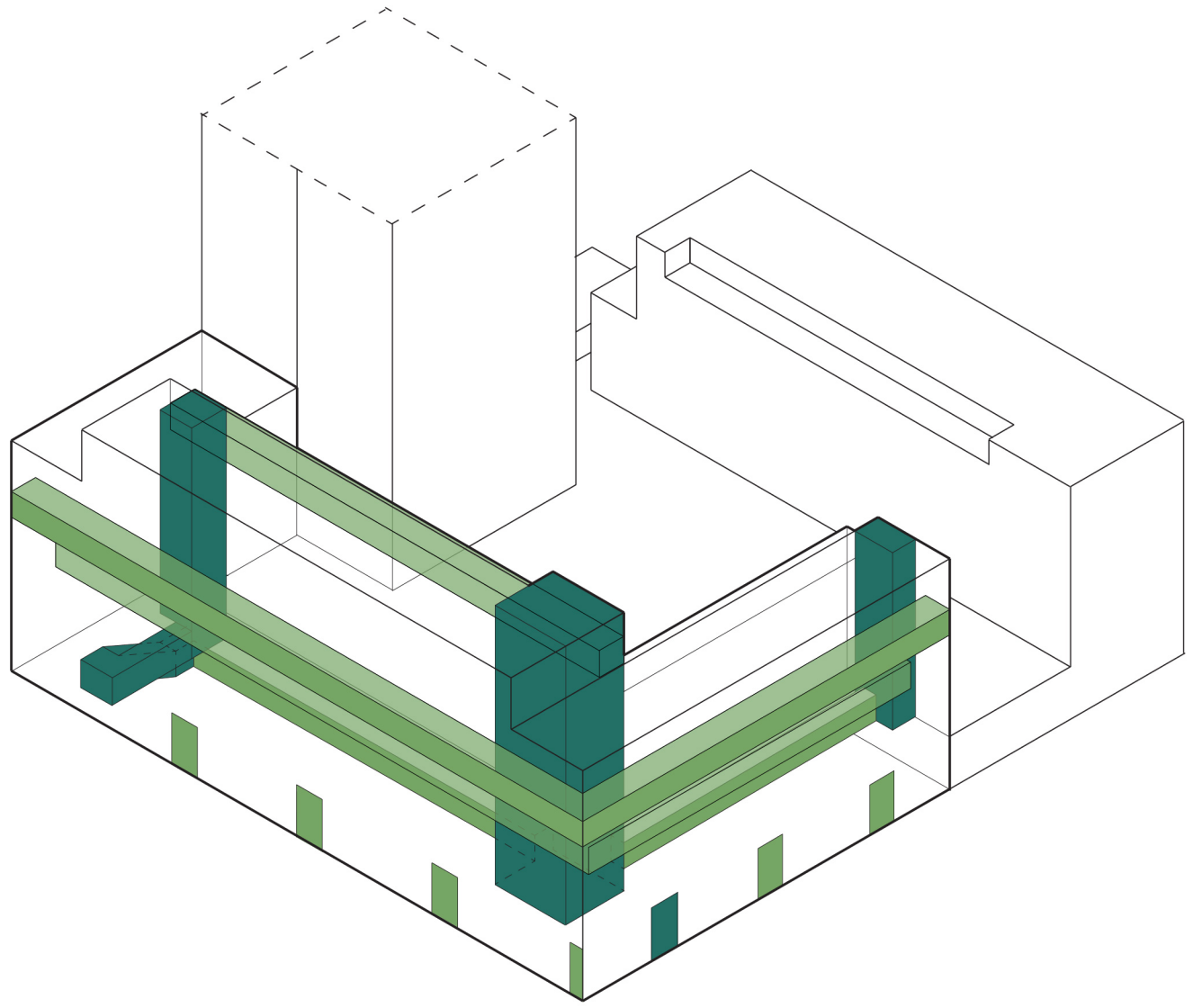

Parking garage entrance



Source: Google maps

Dan Leckie Way

Interaction

Formal meeting space

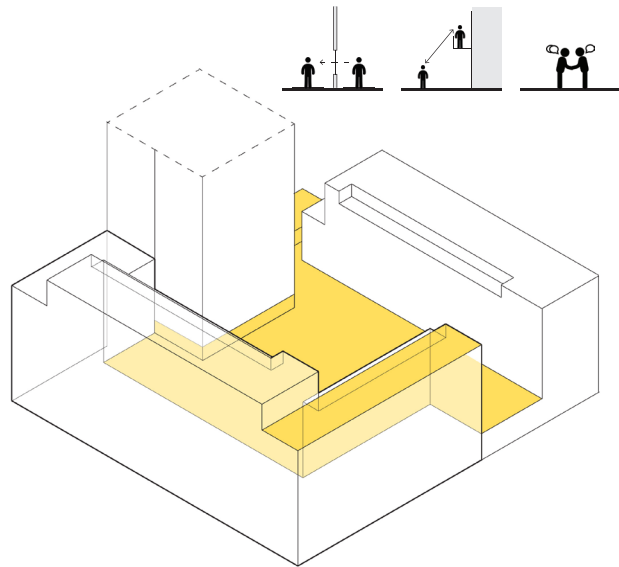

Informal meeting space

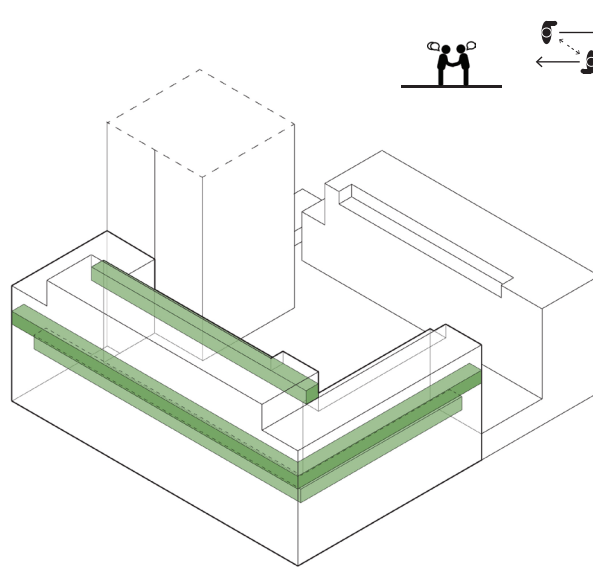

Private outdoor space

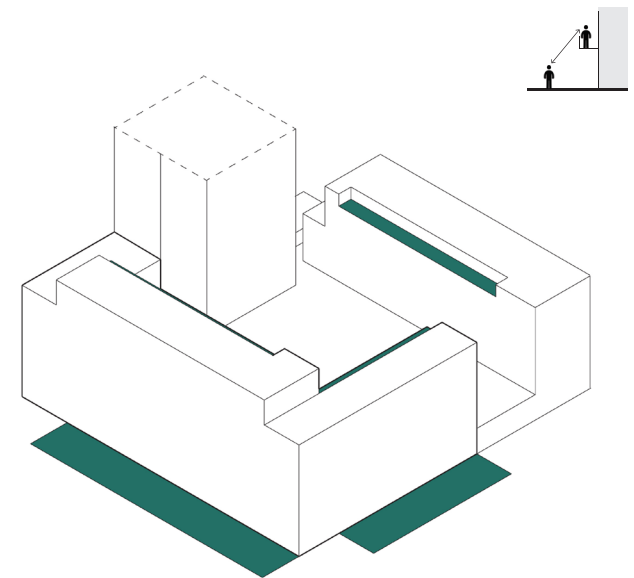

3rd level rooftop courtyard



Corridor



Front garden



Dan Leckie Way

Identification

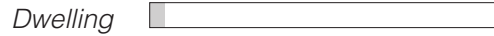

The function of the of the building is not de-
tectible, it might as well be an office. When
looking to the surroundings of the building itself
doesn't really stand out. Most of the complexes
are composed with courtyards combined with
high-rises. Because of the monotonous facade
(suitable for an office building) the separate
dwelling units are not locatable.

Facade



Stacking scheme

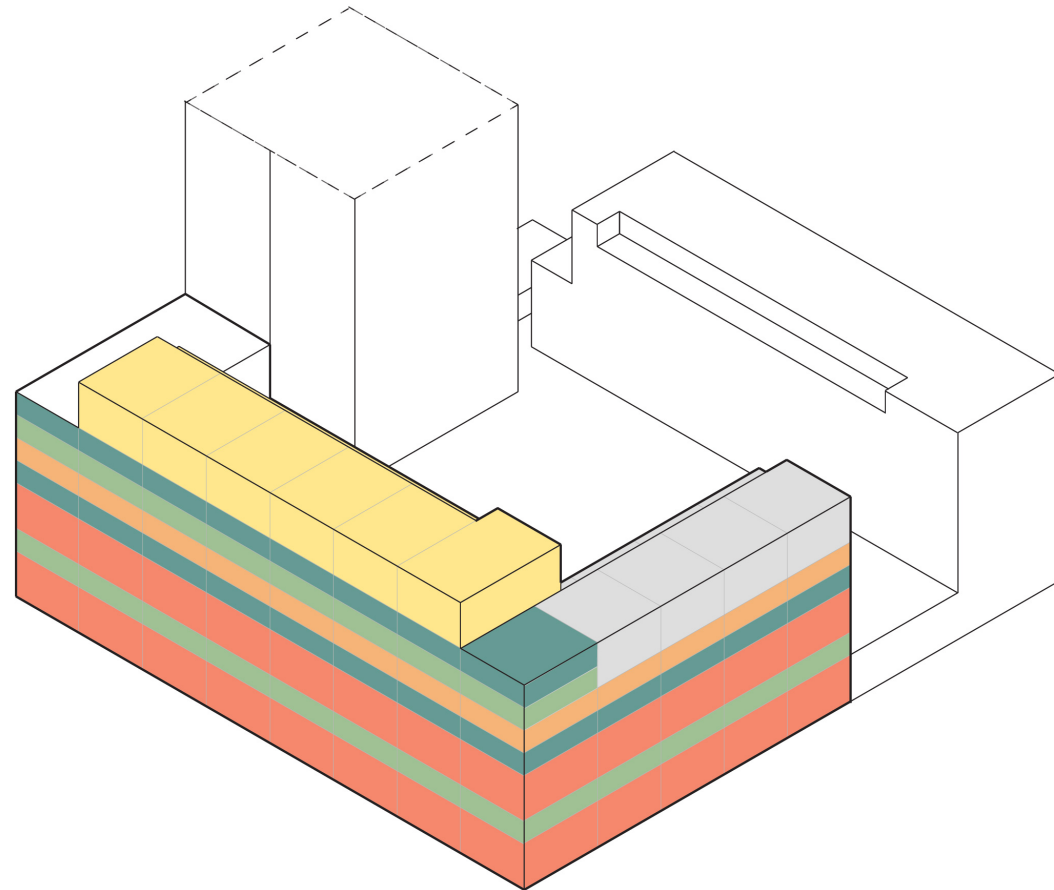

Legend:

- Type A
- Type B
- Type C
- Type D
- Type E
- Type F

Dan Leckie Way

Dwelling

Information

Level:	1 & 2
Dwelling type:	A - red
Dwelling size:	120m ²
No. of habitable rooms:	4
Storage size:	9,5 m ² ; 9 m ² outside
Outdoor space:	38,5 m ²

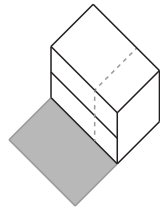
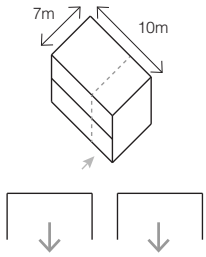

Type

Outdoor space

€600.000



Inhabitants

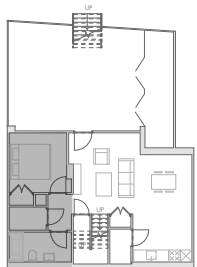

Zoning 1st floor



Zoning 2nd floor

Floor plan

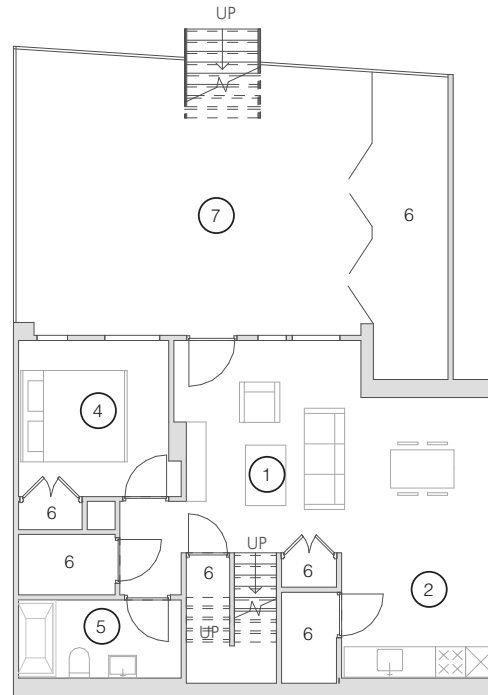

1st floor

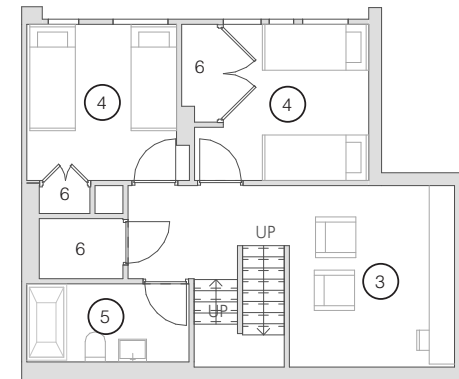

2nd floor

- Legend:
- 1. Living
 - 2. Kitchen
 - 3. Flexible space
 - 4. Bedroom
 - 5. Bathroom
 - 6. Storage
 - 7. Terrace



Dan Leckie Way

Dwelling

Information

Level: 6th & 7th
 Dwelling type: C - dark green
 Dwelling size: 150m²
 No. of habitable rooms: 5
 Storage size: 10,5 m²
 Outdoor space: -

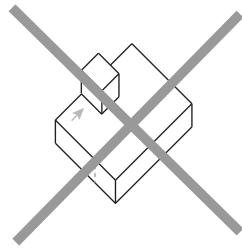
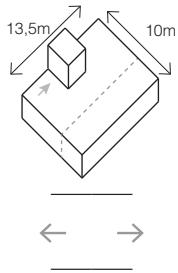

Type

Outdoor space

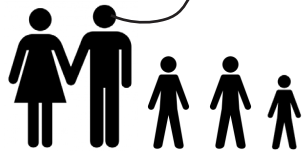

Inhabitants

€700.000

Floor plan

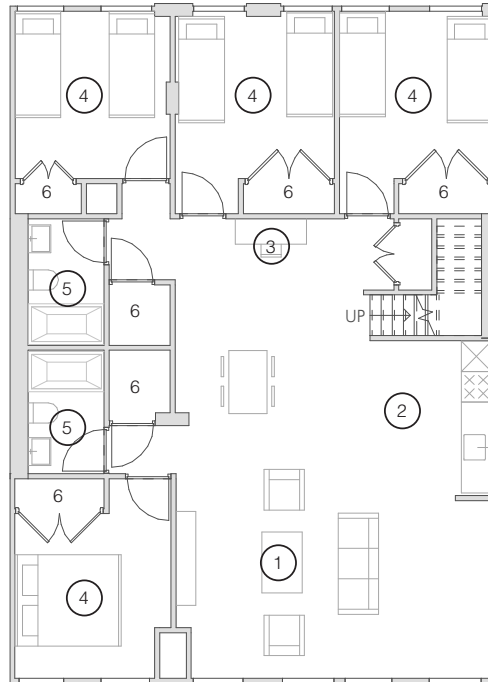

1st floor

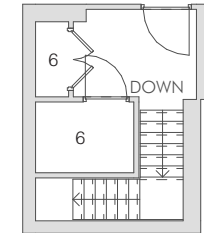

2nd floor

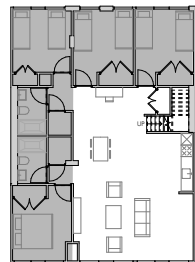

Zoning 1st floor



Zoning 2nd floor

Legend:

- 1. Living
- 2. Kitchen
- 3. Flexible space
- 4. Bedroom
- 5. Bathroom
- 6. Storage
- 7. Terrace



Dan Leckie Way

Dwelling

Information

Level: 7th
 Dwelling type: D - orange
 Dwelling size: 120 m²
 No. of habitable rooms: 4
 Storage size: 14,5 m²
 Outdoor space: -

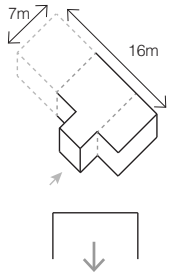

Type

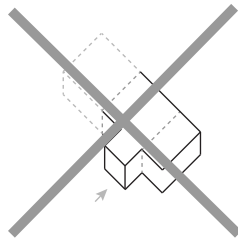

Outdoor space

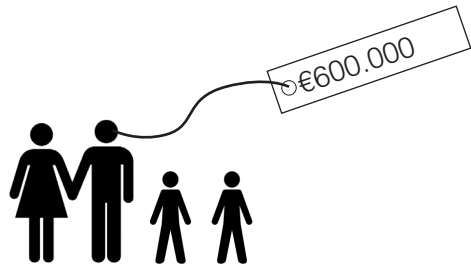

Inhabitants

Floor plan

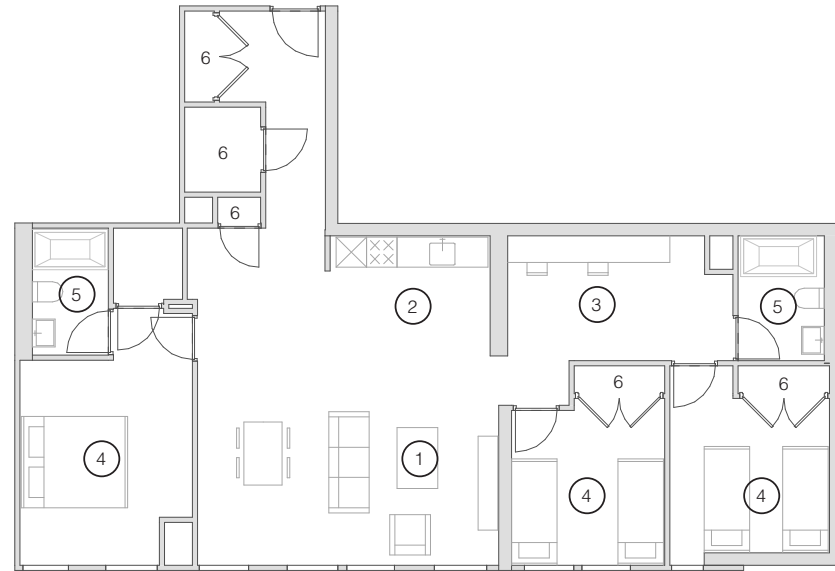

1st floor

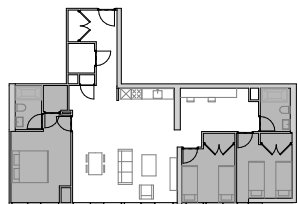

Zoning 1st floor

- Legend:
- 1. Living
 - 2. Kitchen
 - 3. Flexible space
 - 4. Bedroom
 - 5. Bathroom
 - 6. Storage
 - 7. Terrace



Dan Leckie Way

Dwelling

Information

Level: 7th, 8th & 9th
 Dwelling type: E - grey
 Dwelling size: 150m²
 No. of habitable rooms: 5
 Storage size: 10,7 m²
 Outdoor space: 20 m²

Floor plan

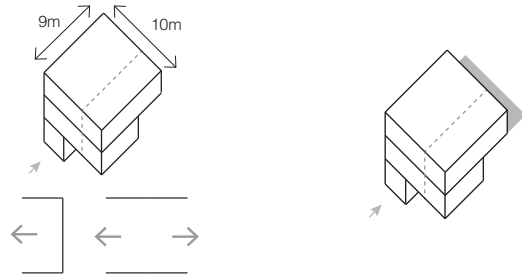

Type

Outdoor space

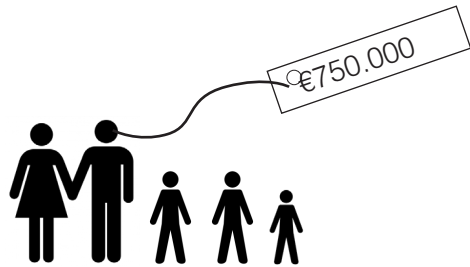

Inhabitants

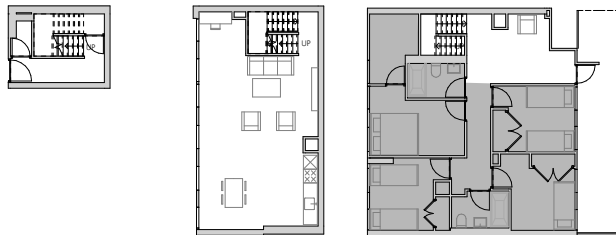

1st floor

2nd floor

Zoning 3rd floor

Legend:

- 1. Living
- 2. Kitchen
- 3. Flexible space
- 4. Bedroom
- 5. Bathroom
- 6. Storage
- 7. Terrace

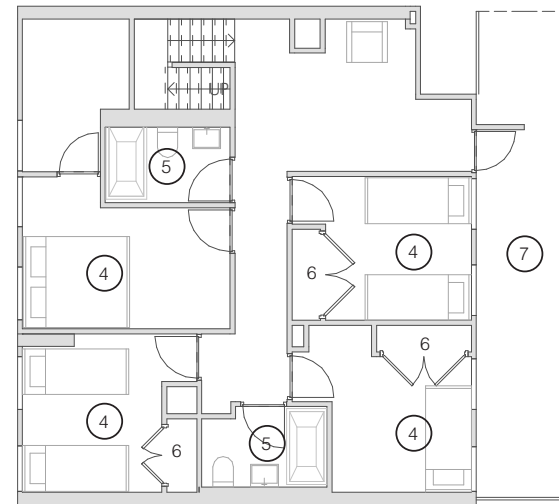

3th floor

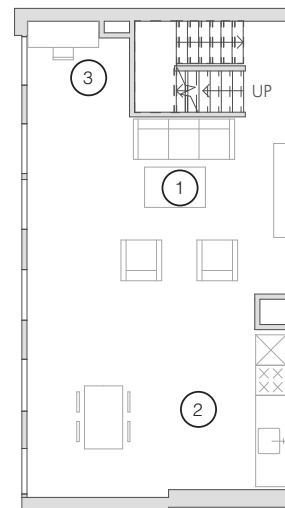

2nd floor

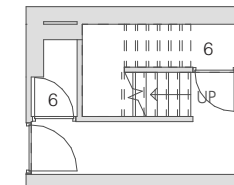

1th floor



Dan Leckie Way

Radar chart

Building

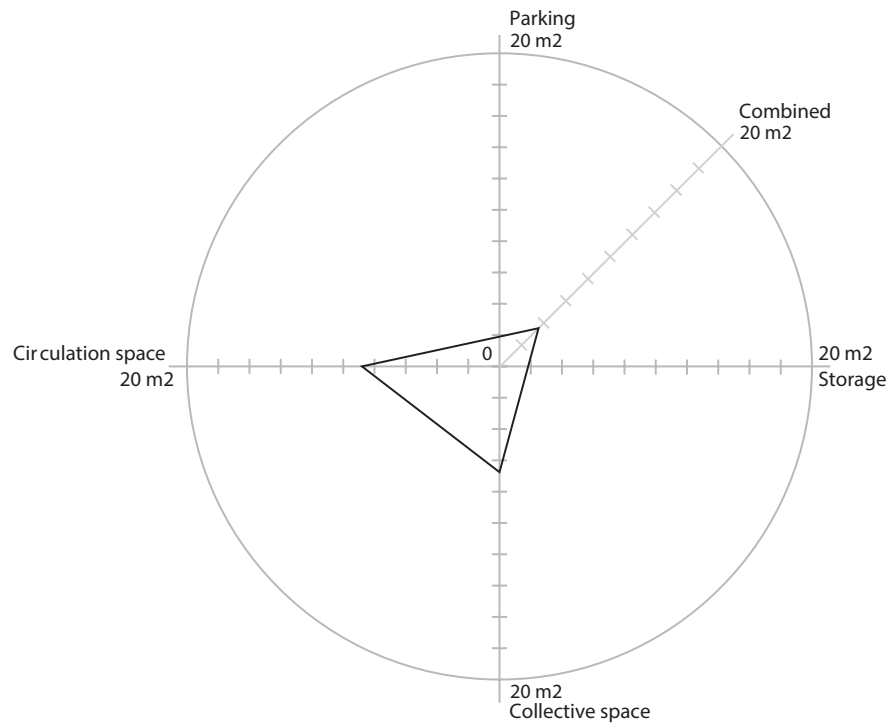

Dwelling

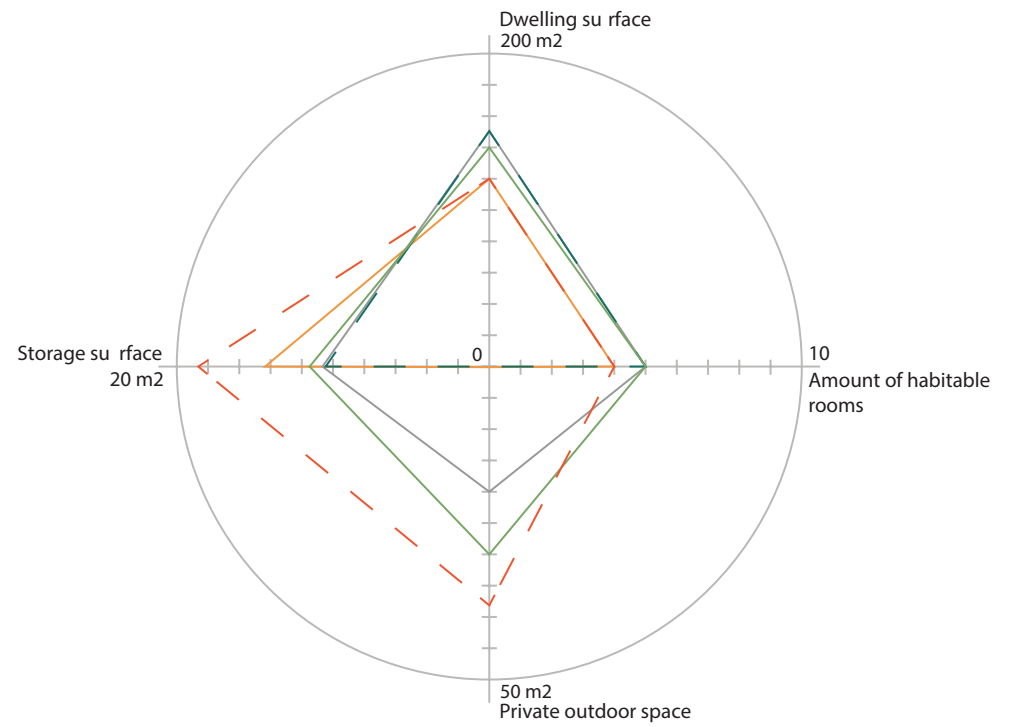

Legend:

- Type A
- Type B
- Type C
- Type D
- Type E

Kolenkithuis

Architect	Heren 5
Location	Amsterdam, Netherlands
Year of completion	2017
No. of dwellings	37
Plot size	3628 m ²

The Kolenkithuis is a design based on the research towards the ideal family apartment that Heren 5 has done. The design takes several findings into account, such as many rooms, spacious entrances, annexes to the living room and a good organization between private rooms and rooms where you receive family and friends. (source: heren5.eu)

Street view



Source: heren5.eu

Overview illustration



Source: heren5.eu

Soccer field



Playground



1:6000 | Neighbourhood facilities



Parking and storage

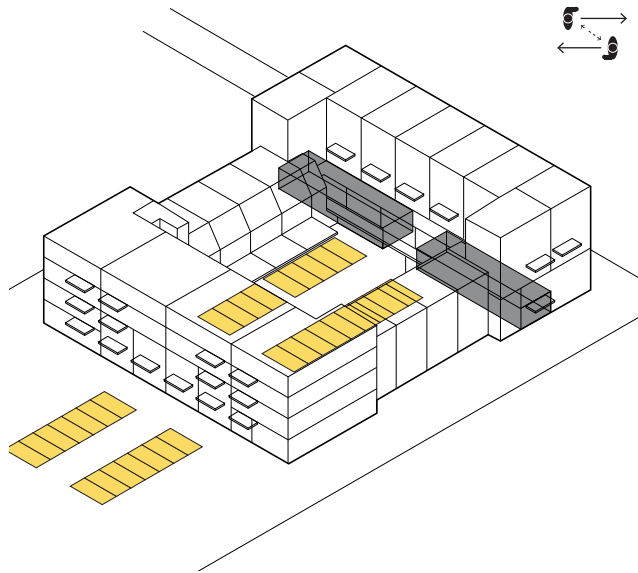

Titel illustratie

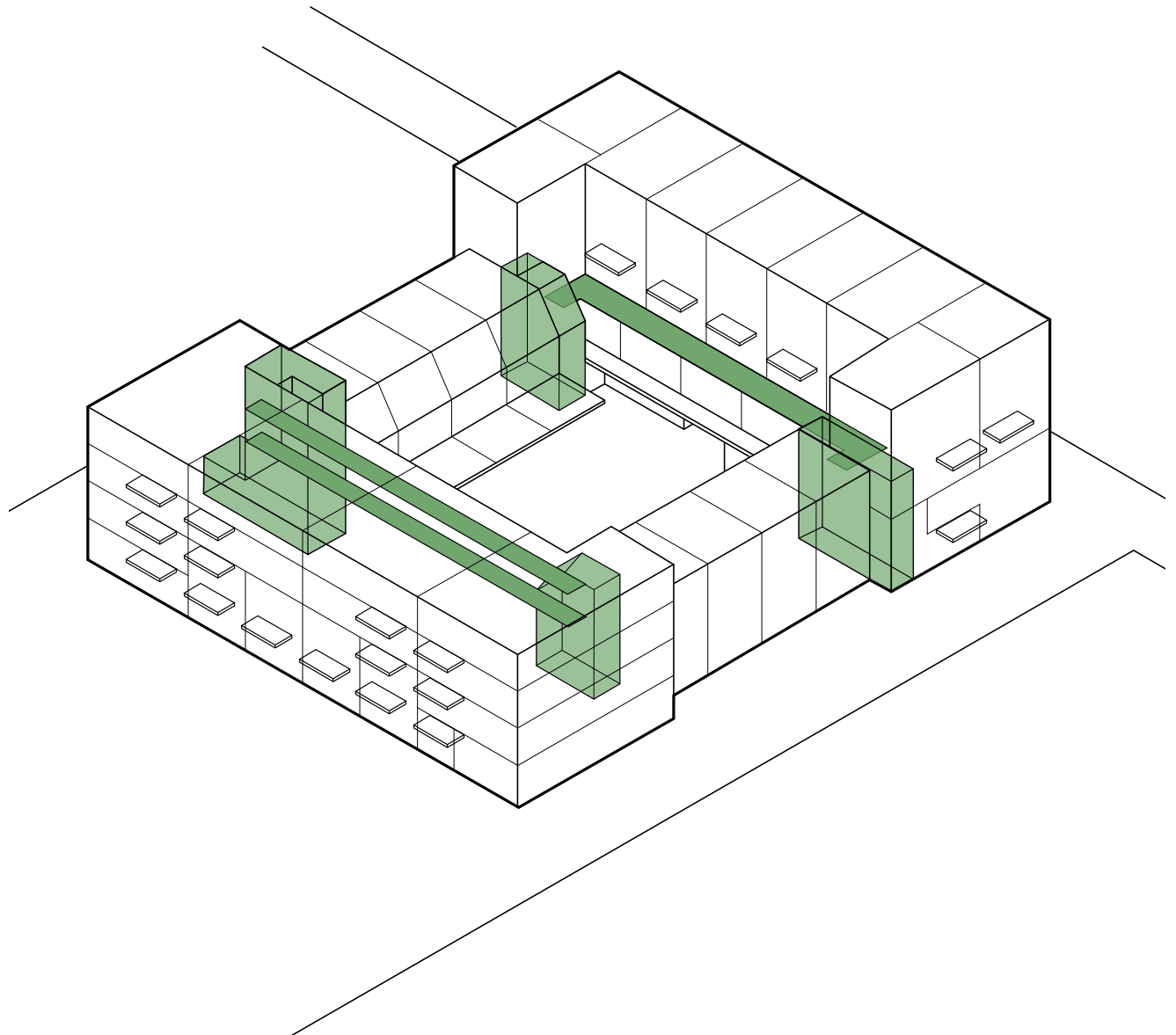

Parking in the collective courtyard



Kolenkithuis

Interaction

Formal meeting space

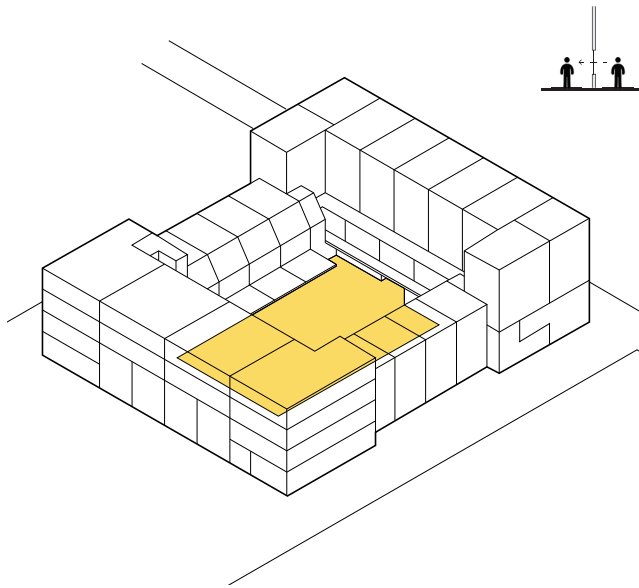

Informal meeting space

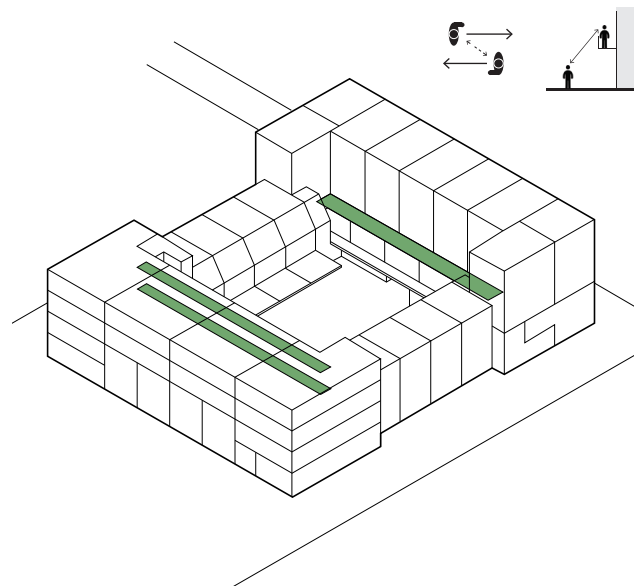

Private outdoor space

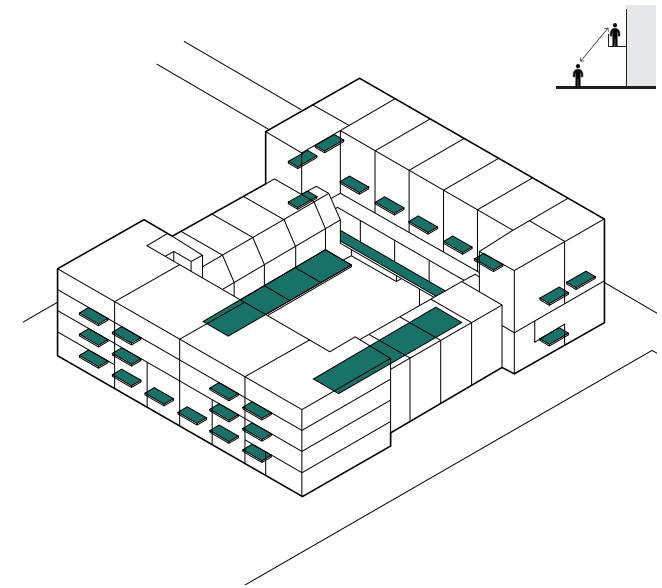

Collective courtyard



Gallery



Balconies



Identification

Function 

Building 

Dwelling 

The function of the building is very visible, mainly because of the balconies and front doors on the ground floor. The identity of the building itself is less clear, as it does not distinguish itself much from its surroundings in material or color. Each separate dwelling can be distinguished because of the different patterns in the brickwork and the balconies.



Facade



Stacking scheme



Legend:

-  Type A
-  Type B
-  Type C
-  Type D

Kolenkithuis

Dwelling

Information

Level:	Ground Floor, 1st, 2nd floor
Dwelling type:	A
Dwelling size:	180 m ²
No. of habitable rooms:	7
Storage size:	10 m ²
Outdoor space:	20 m ²

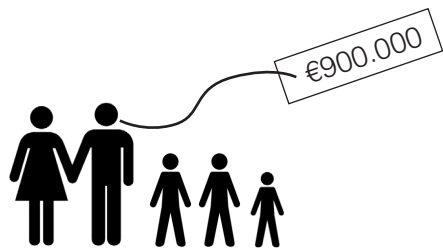
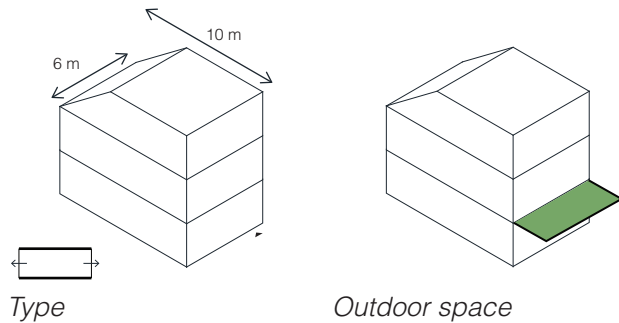

Inhabitants



Zoning 1st floor Zoning 2nd floor Zoning 3th floor

Floor plans

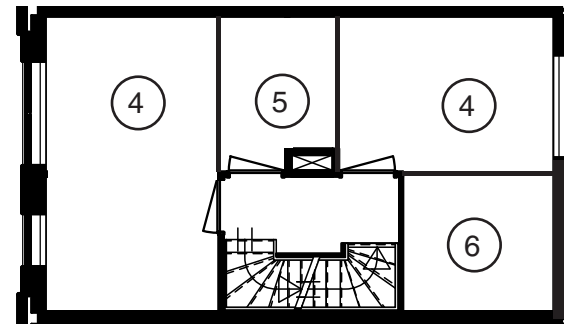

Second Floor

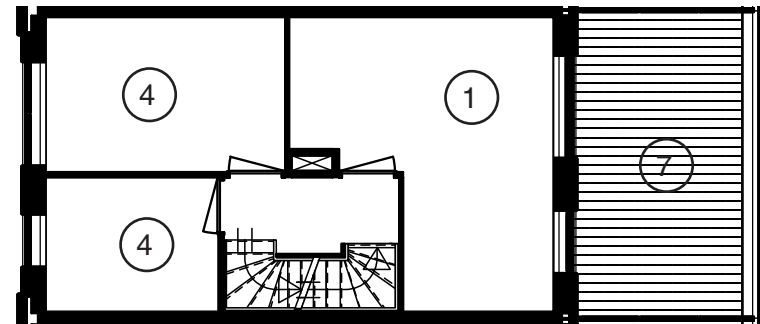

First Floor

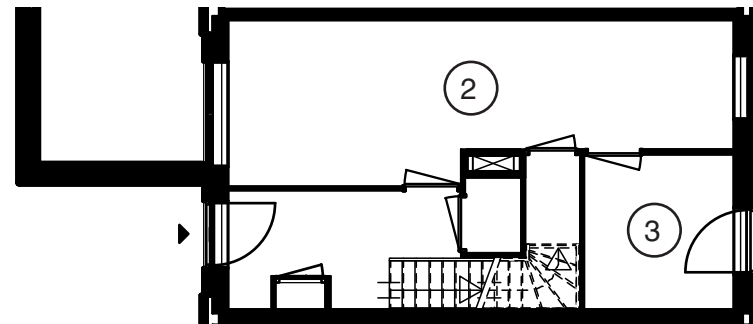

Ground Floor

Legend:

1. Living
2. Kitchen
3. Flexible space
4. Bedroom
5. Bathroom
6. Storage
7. Terrace



Kolenkithuis

Dwelling

Information

Level:	3th floor
Dwelling type:	B
Dwelling size:	142 m ²
No. of habitable rooms:	4
Storage size:	4,5 m ²
Outdoor space:	7 m ²

Floor plan

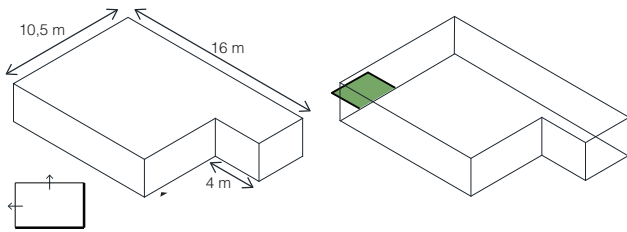

Type

Outdoor space

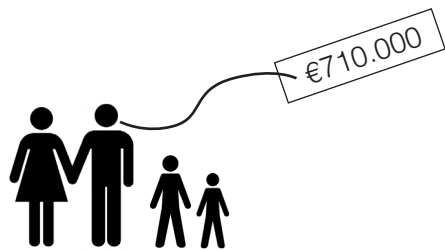

Inhabitants

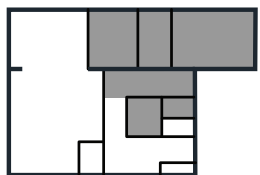
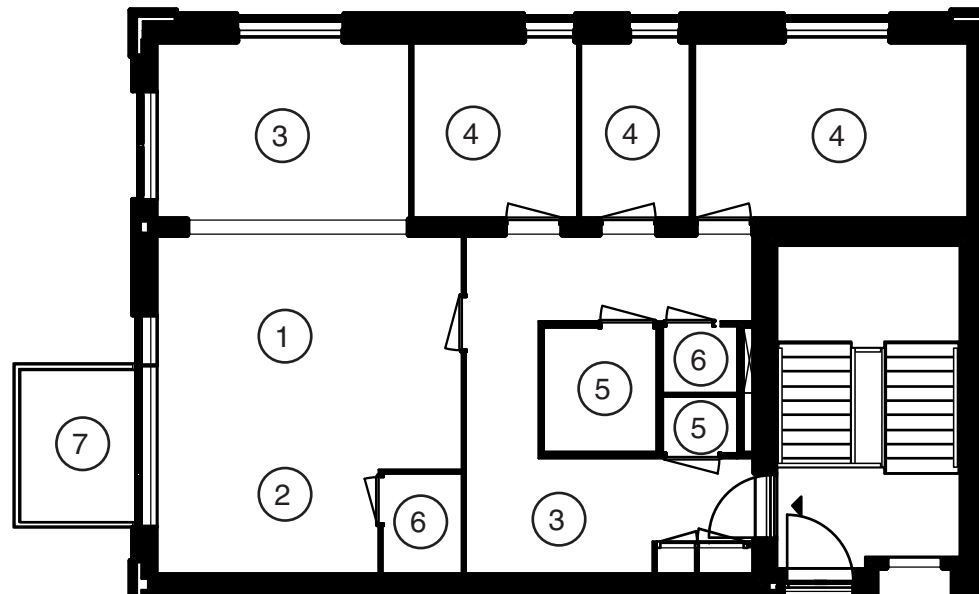

Zoning 3th floor

- Legend:
- 1. Living
 - 2. Kitchen
 - 3. Flexible space
 - 4. Bedroom
 - 5. Bathroom
 - 6. Storage
 - 7. Terrace



Kolenkithuis

Dwelling

Information

Level:	3th floor
Dwelling type:	C
Dwelling size:	150 m ²
No. of habitable rooms:	4
Storage size:	7 m ²
Outdoor space:	7 m ²

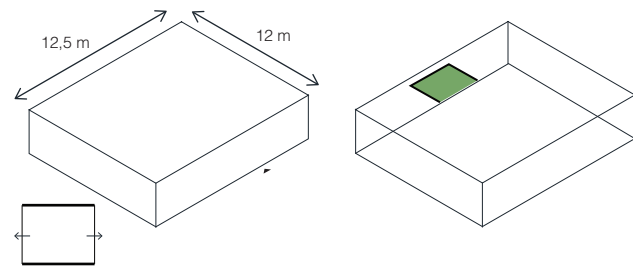

Type

Outdoor space

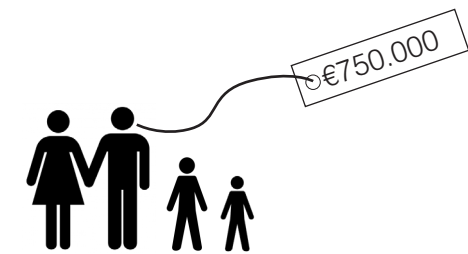

Inhabitants

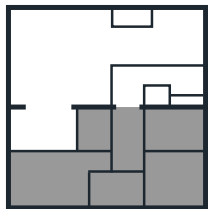

Zoning 1st floor

Floor plan

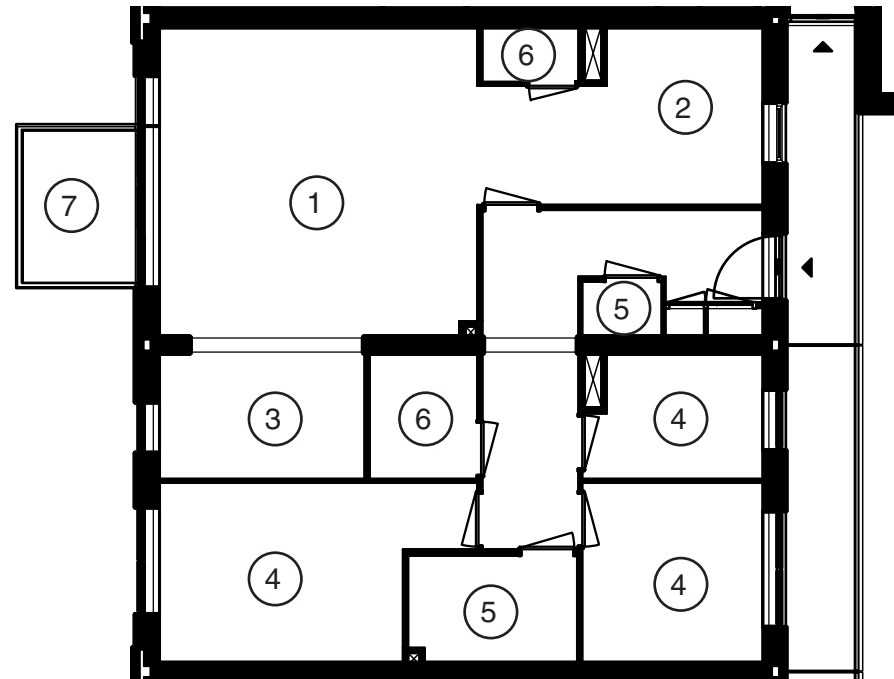

- Legend:
- 1. Living
 - 2. Kitchen
 - 3. Flexible space
 - 4. Bedroom
 - 5. Bathroom
 - 6. Storage
 - 7. Terrace



Kolenkithuis

Dwelling

Information

Level:	Ground Floor, 1st floor
Dwelling type:	D
Dwelling size:	156 m ²
No. of habitable rooms:	6
Storage size:	3,5 m ²
Outdoor space:	7 m ²

Floor plans

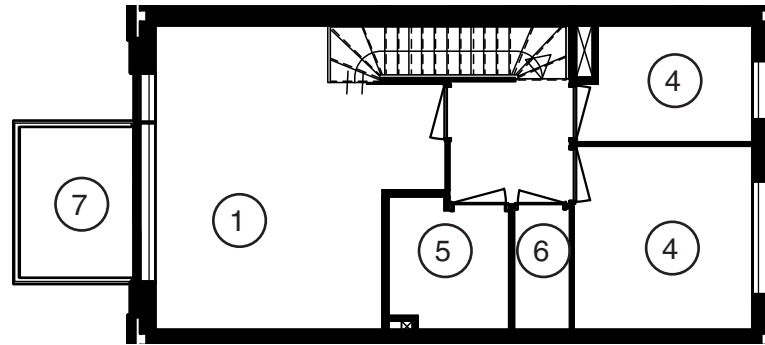
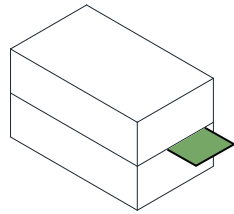
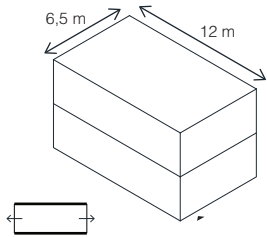

First Floor

Type

Outdoor space

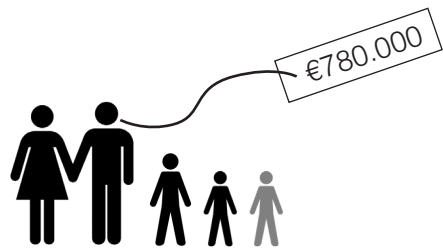

Inhabitants

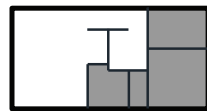
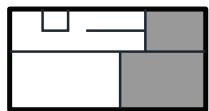

Zoning 1st floor

Zoning 2nd floor

- Legend:
- 1. Living
 - 2. Kitchen
 - 3. Flexible space
 - 4. Bedroom
 - 5. Bathroom
 - 6. Storage
 - 7. Terrace

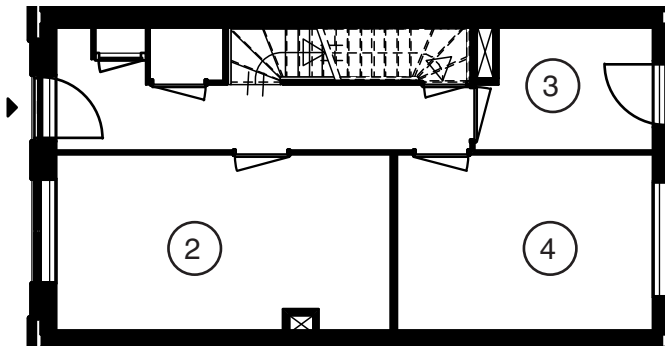

Ground Floor



Building

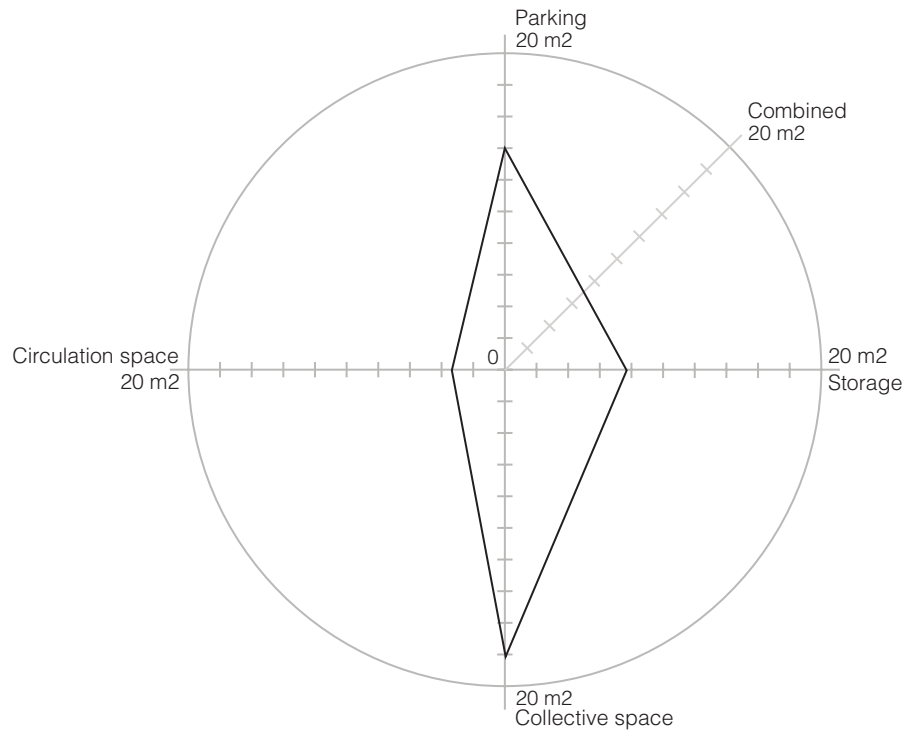

Dwelling

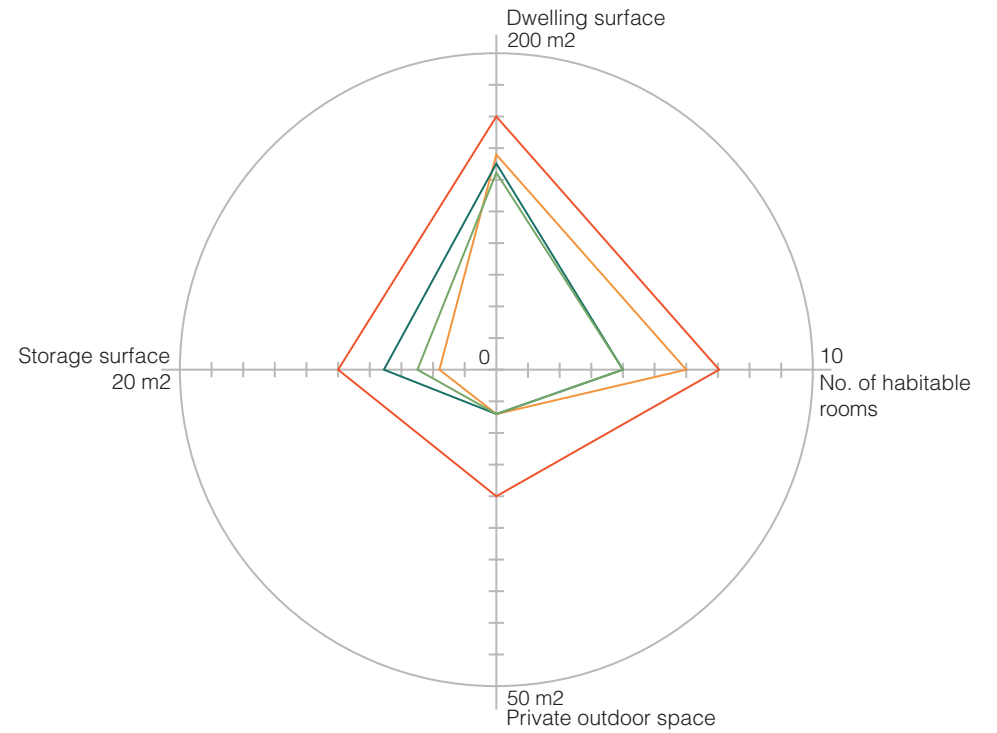

Legend:

- Type A
- Type B
- Type C
- Type D

Babel

Titel illustratie/tekst

Architect	Laurens Boodt
Location	Rotterdam, Netherlands
Year of completion	Not Build
No. of dwellings	22
Plot size	? m ²

The 'Rotterdam Tower of Babel' is design with a street that runs along tower, all the way to the top. This street contexts the several spaces and dwellings. The plan consists out of 22 family-dwellings from 70 till 160 square meters, a elevator, parking garage, community square on the first floor, indoor garden and the possibility of a roof terrace.

Axo building complex

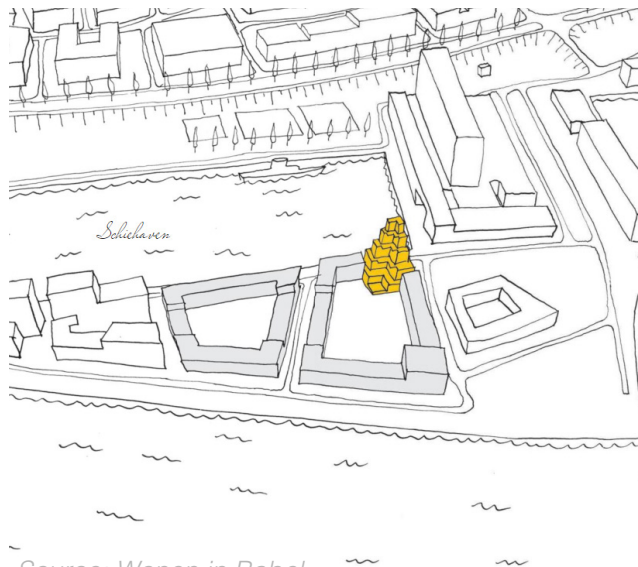

Source: *Wonen in Babel*

Overview illustration



Source: *Laurens Boodt*

Playground



Source: Google maps

Sport & game



Source: Google maps

1:6000 | Neighbourhood facilities

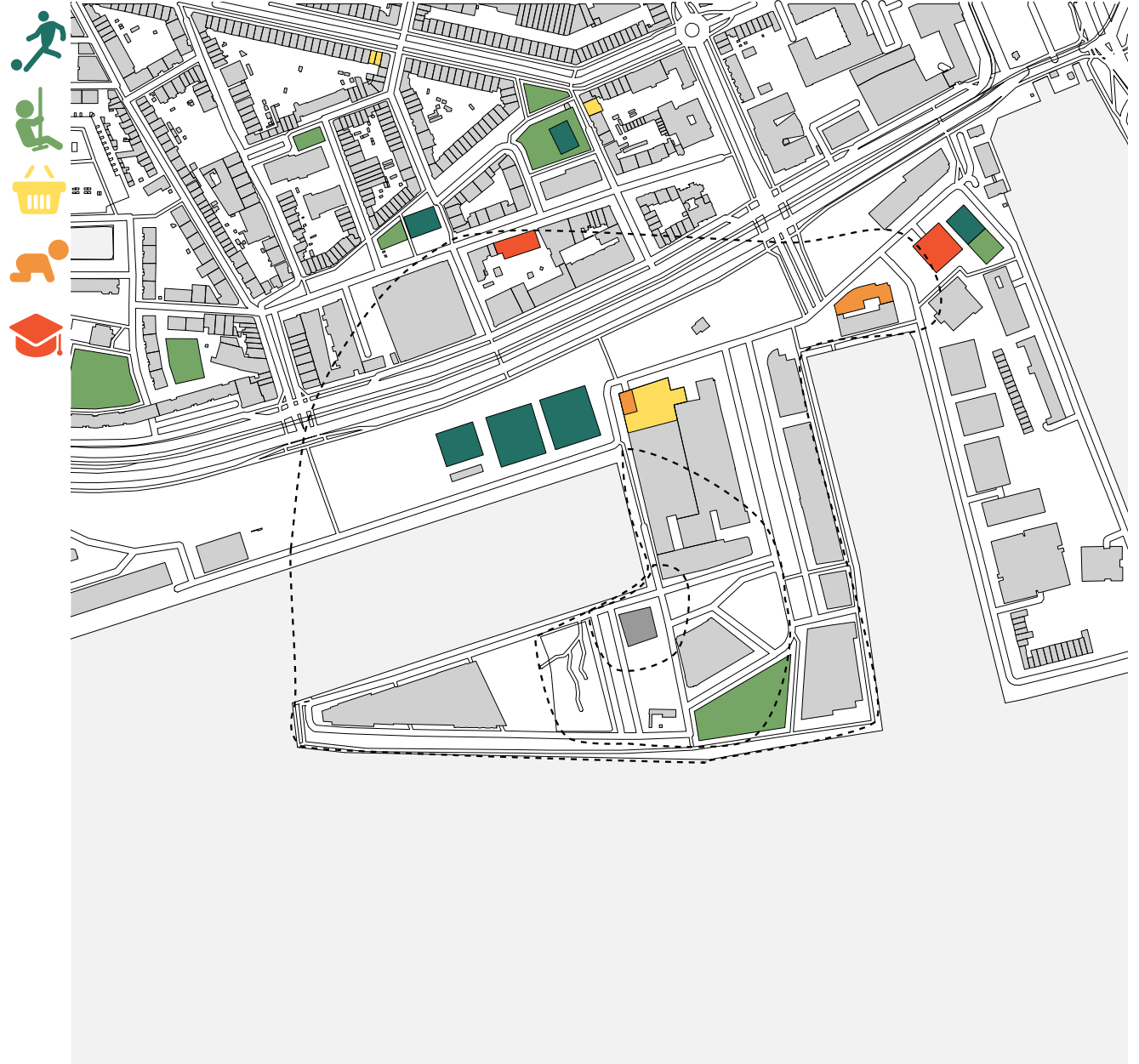

Babel

Interaction

Parking and storage

Circulation

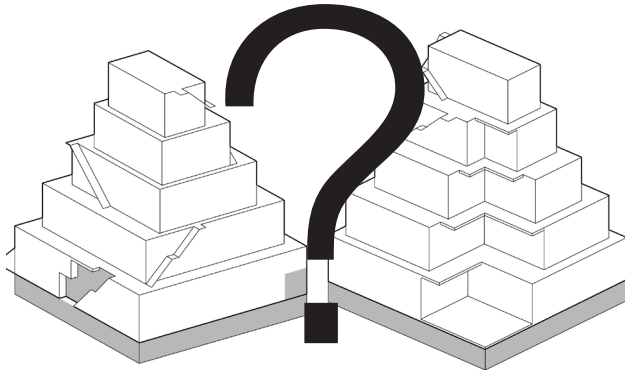

Front side

Back side

Parking garage

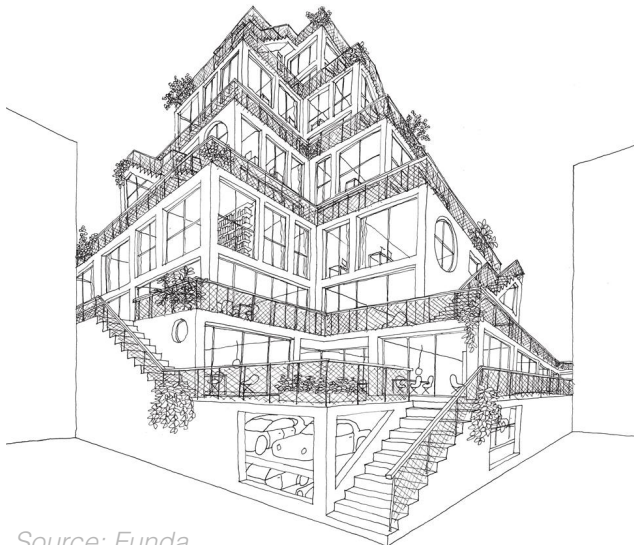

Source: Funda

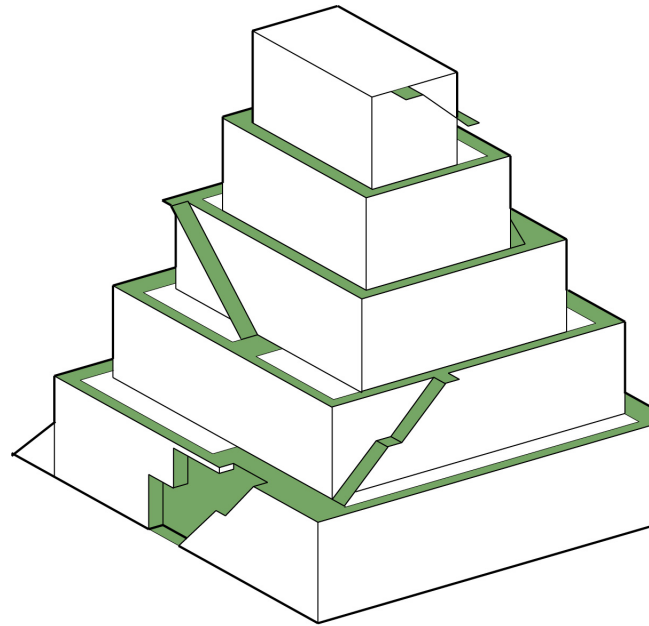

Front side

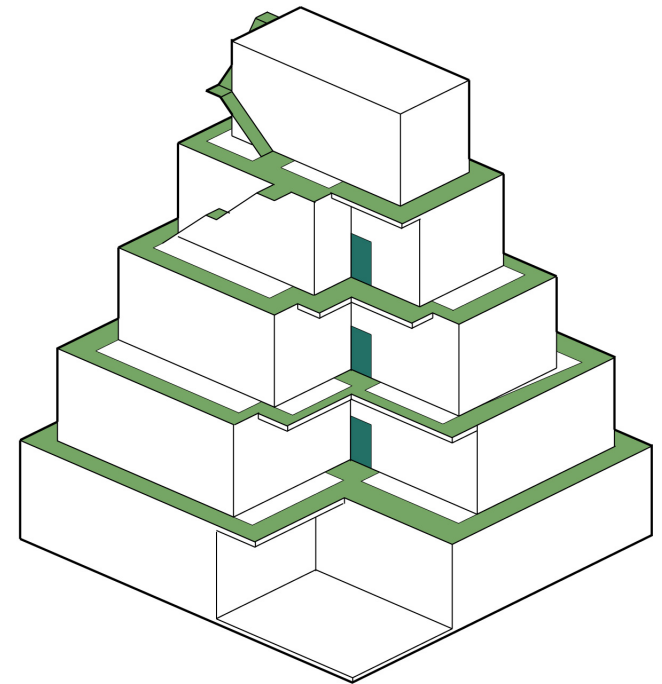

Back side

Babel

Interaction

Formal meeting space

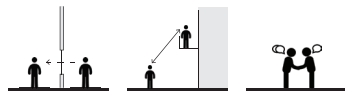

Informal meeting space

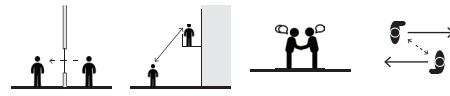

Private outdoor space

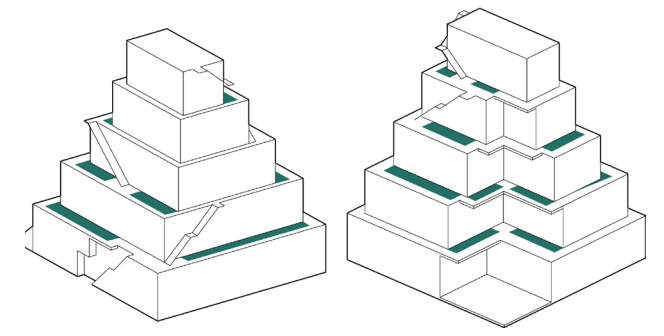
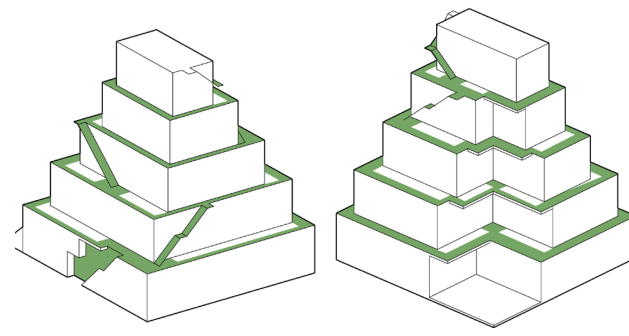
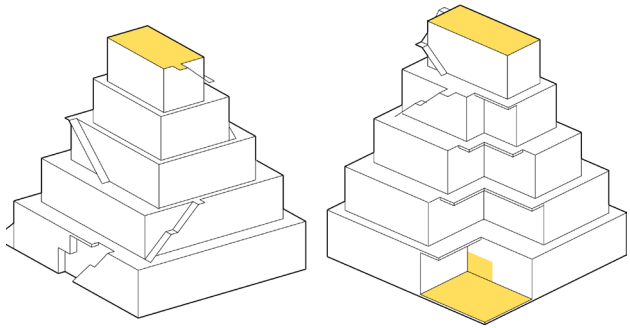
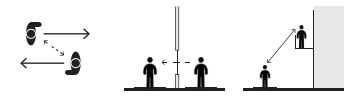

Communal Play area

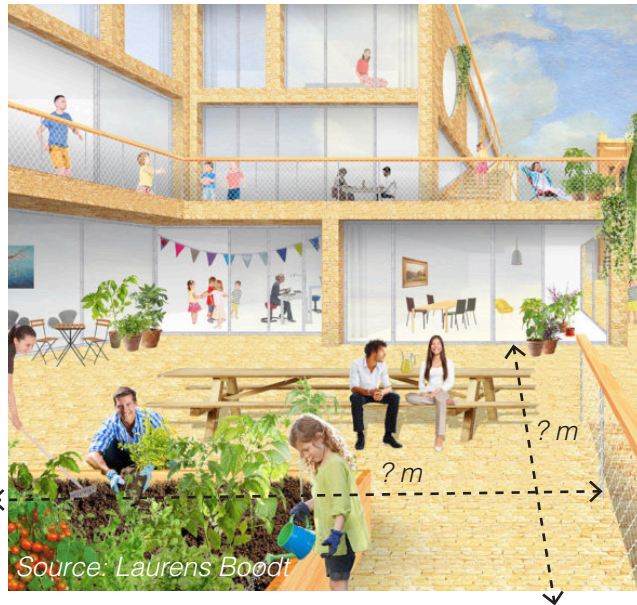

Gallery (Street in the sky)

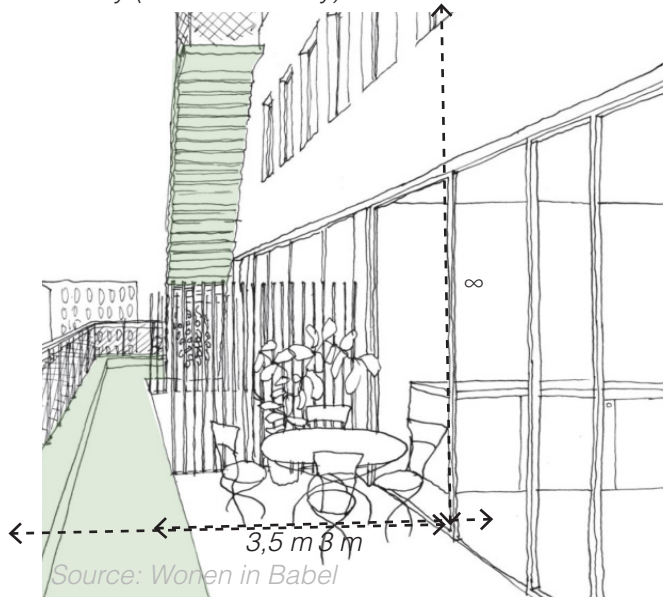

Front garden

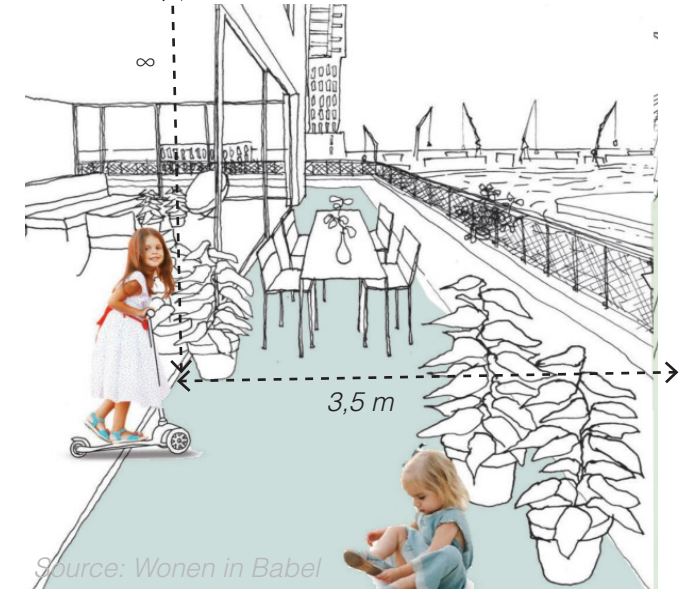

Babel

Identity

Identification



The building function could be something else then housing, but residence is the most likely function to be housed. Due to its characterizing shape and height the building would stand-out in its surrounding. Making the building easy to be found. The individual dwellings aren't distinguished, but they are to tell apart by level.

Stacking scheme

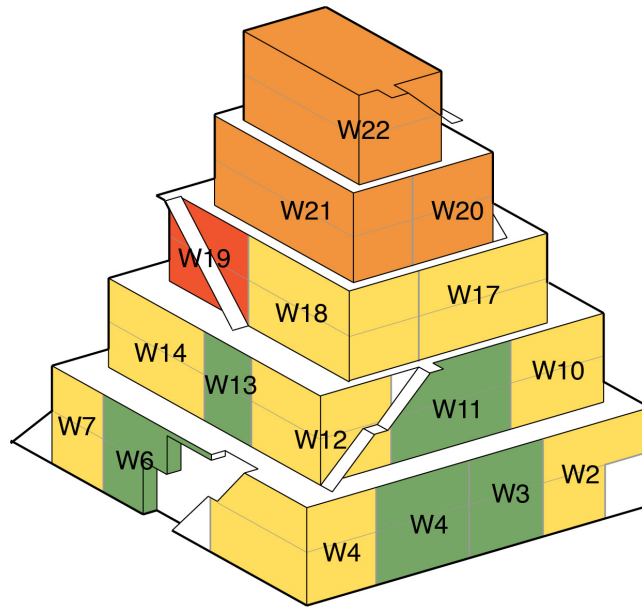

Front side

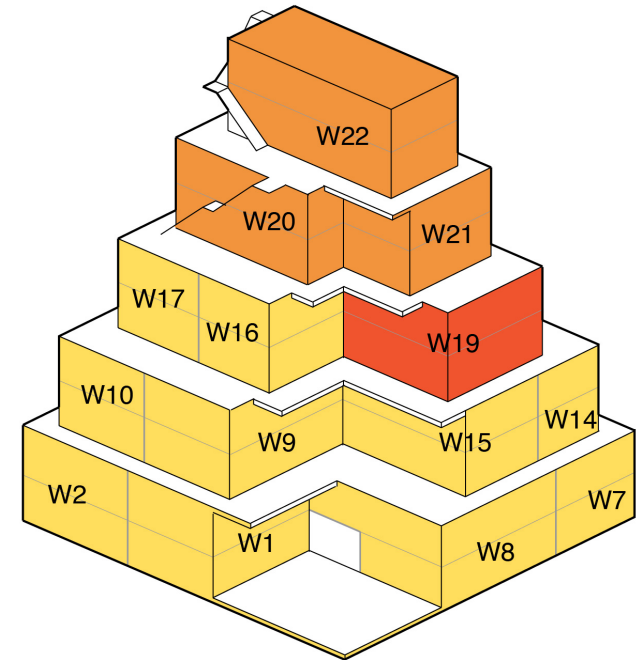

Back side

Facade



Legend:

- Type A
- Type B
- Type C
- Type D

Information

Level:	4th & 5th floor
Dwelling type:	W16 - Type A
Dwelling size:	90m ²
No. of habitable rooms:	4
Storage size:	2m ²
Outdoor space:	19,5m ²

Floor plan

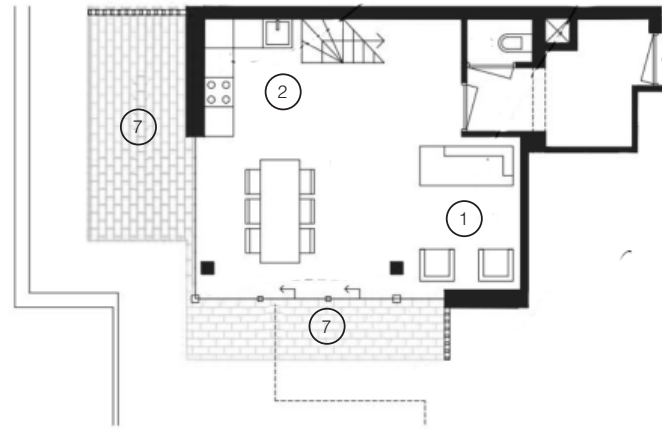
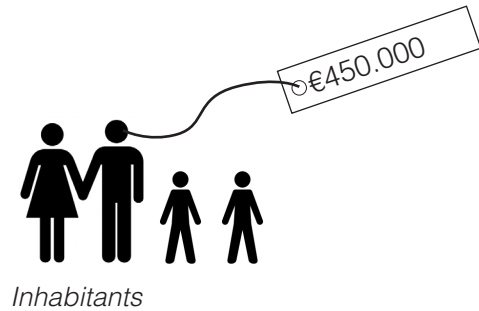
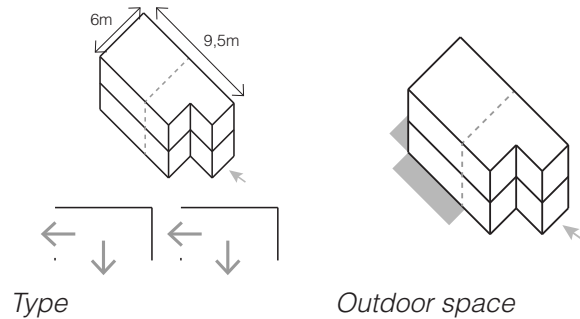

1th floor



2nd floor



Zoning 1st floor

Zoning 2nd floor

- Legend:
1. Living
 2. Kitchen
 3. Flexible space
 4. Bedroom
 5. Bathroom
 6. Storage
 7. Terrace



Babel

Dwelling

Information

Level: 4th & 5th floor
 Dwelling type: W19 - Type C
 Dwelling size: 130m²
 No. of habitable rooms: 4
 Storage size: 5,25m²
 Outdoor space: 21,5m²

Floor plan

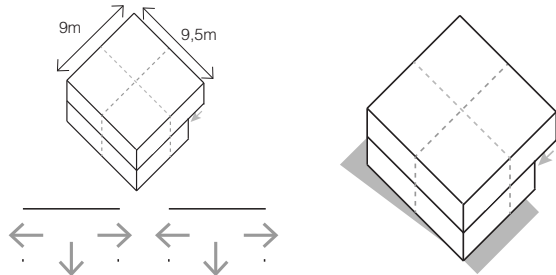

Type

Outdoor space

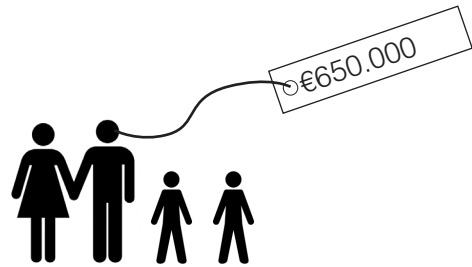

Inhabitants

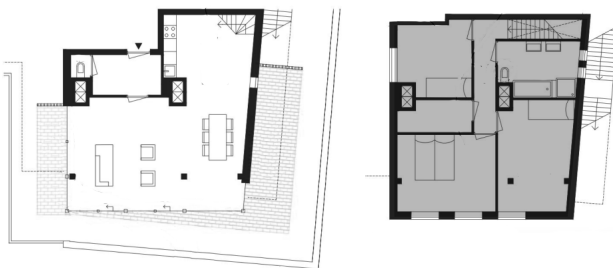

Zoning 1st floor

Zoning 2nd floor

- Legend:
1. Living
 2. Kitchen
 3. Flexible space
 4. Bedroom
 5. Bathroom
 6. Storage
 7. Terrace

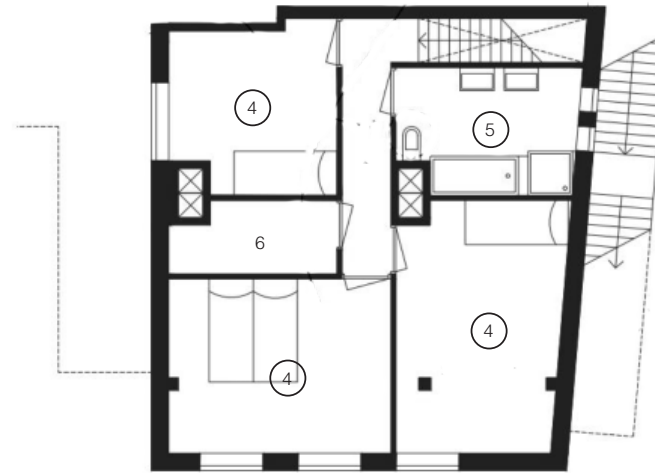

2nd floor

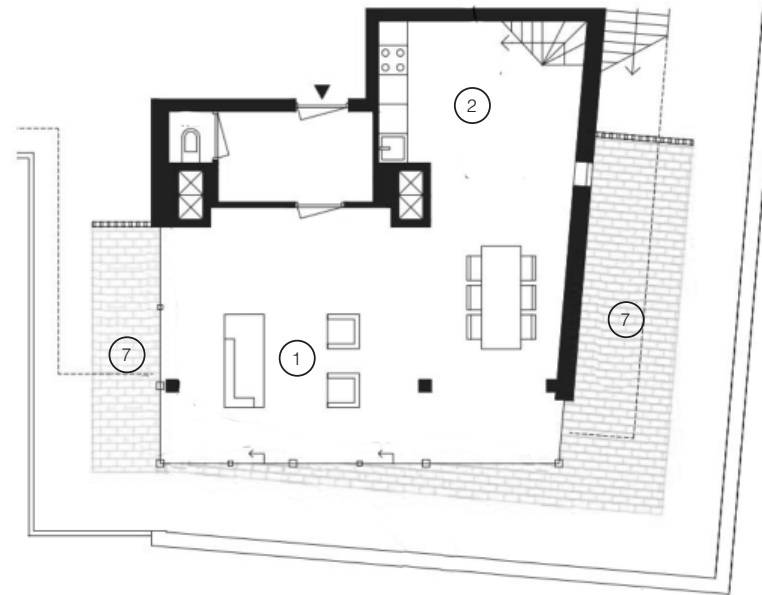

1th floor



Information

Level:	6th & 7th floor
Dwelling type:	W20 - Type B
Dwelling size:	115m ²
No. of habitable rooms:	4
Storage size:	4,25m ²
Outdoor space:	13m ²

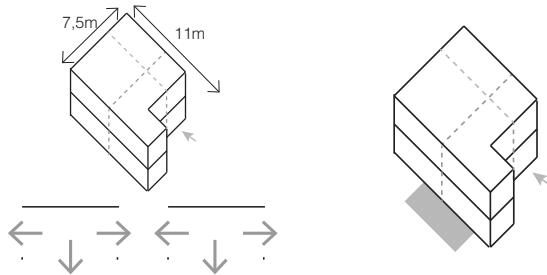

Type

Outdoor space

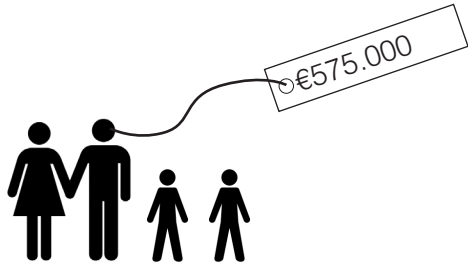

Inhabitants

Floor plan

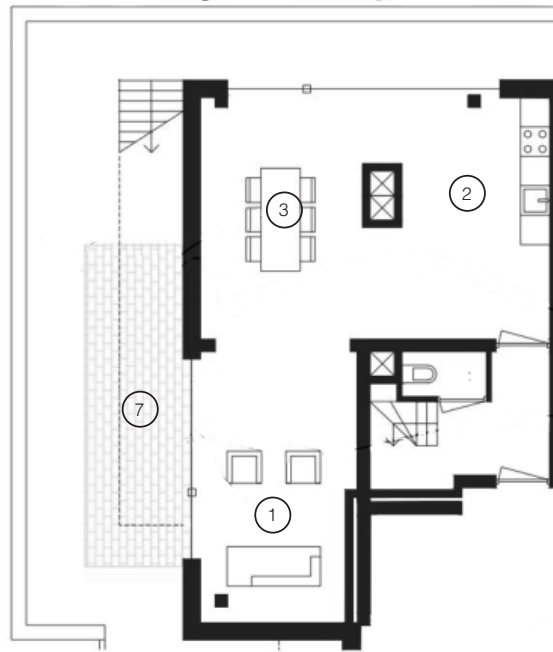

1th floor

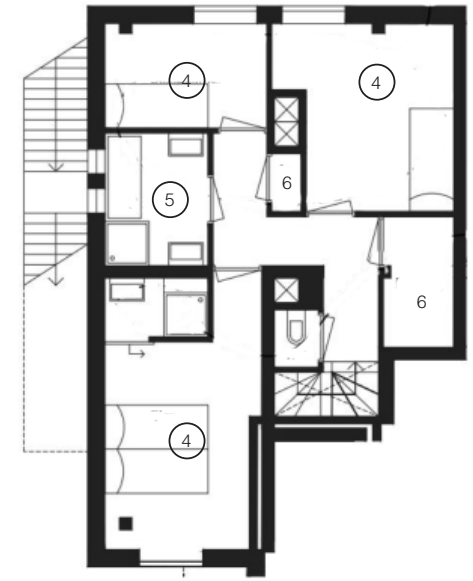

2nd floor



Zoning 1st floor

Zoning 2nd floor

- Legend:
- 1. Living
 - 2. Kitchen
 - 3. Flexible space
 - 4. Bedroom
 - 5. Bathroom
 - 6. Storage
 - 7. Terrace



Information

Level:	2nd & 3th floor
Dwelling type:	W11 - Type D
Dwelling size:	100m ²
No. of habitable rooms:	4
Storage size:	1m ²
Outdoor space:	19,5m ²

Floor plan

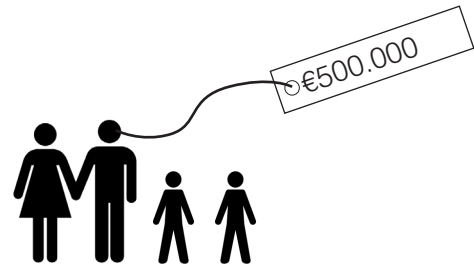
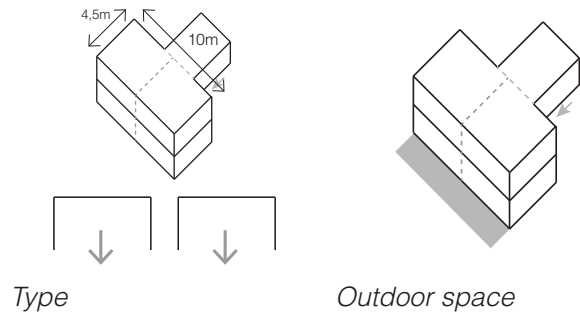

Inhabitants

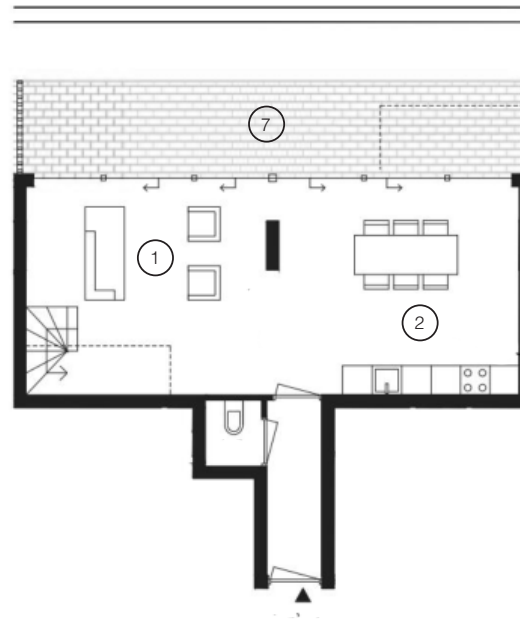

1th floor



2nd floor

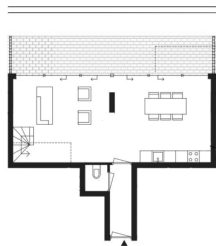

Zoning 1st floor



Zoning 2nd floor

Legend:

1. Living
2. Kitchen
3. Flexible space
4. Bedroom
5. Bathroom
6. Storage
7. Terrace



Babel

Radar chart

Building

Dwelling

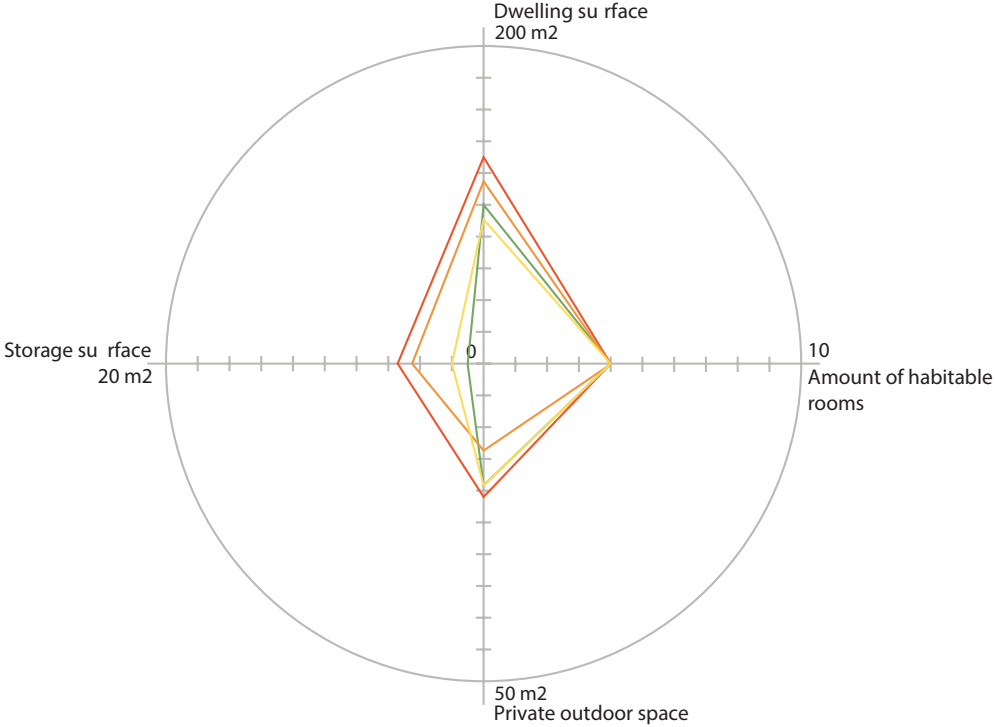
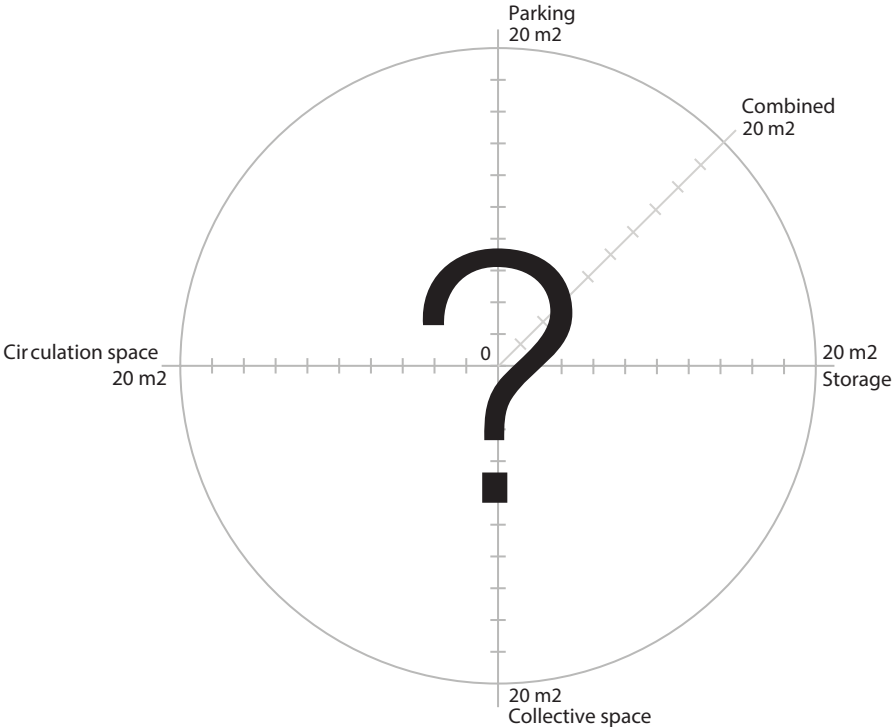

- Legend:
- Type A
 - Type B
 - Type C
 - Type D

Wisselspoor

Architect	HCVA
Location	Leuven, Belgium
Year of completion	-
No. of dwellings	46
Plot size	m ²

Wisselspoor from Happel Cornelisse Verhoeven Architecten won 2nd prize in the competition on a plot near 'Blauwputplein'. It is especially designed for families, and thus very child friendly. A collective square is designed as a playground and the galleries are so wide that they can double serve as more private front 'gardens' as well. Within the house the large entrance hall can double serve as a room for playing and storage.

Overview illustration



Source: hcva.nl

Street view



Source: hcva.nl

Playground



Source: google.nl/maps

Primary school



Source: google.nl/maps

1:6000 | Neighbourhood facilities

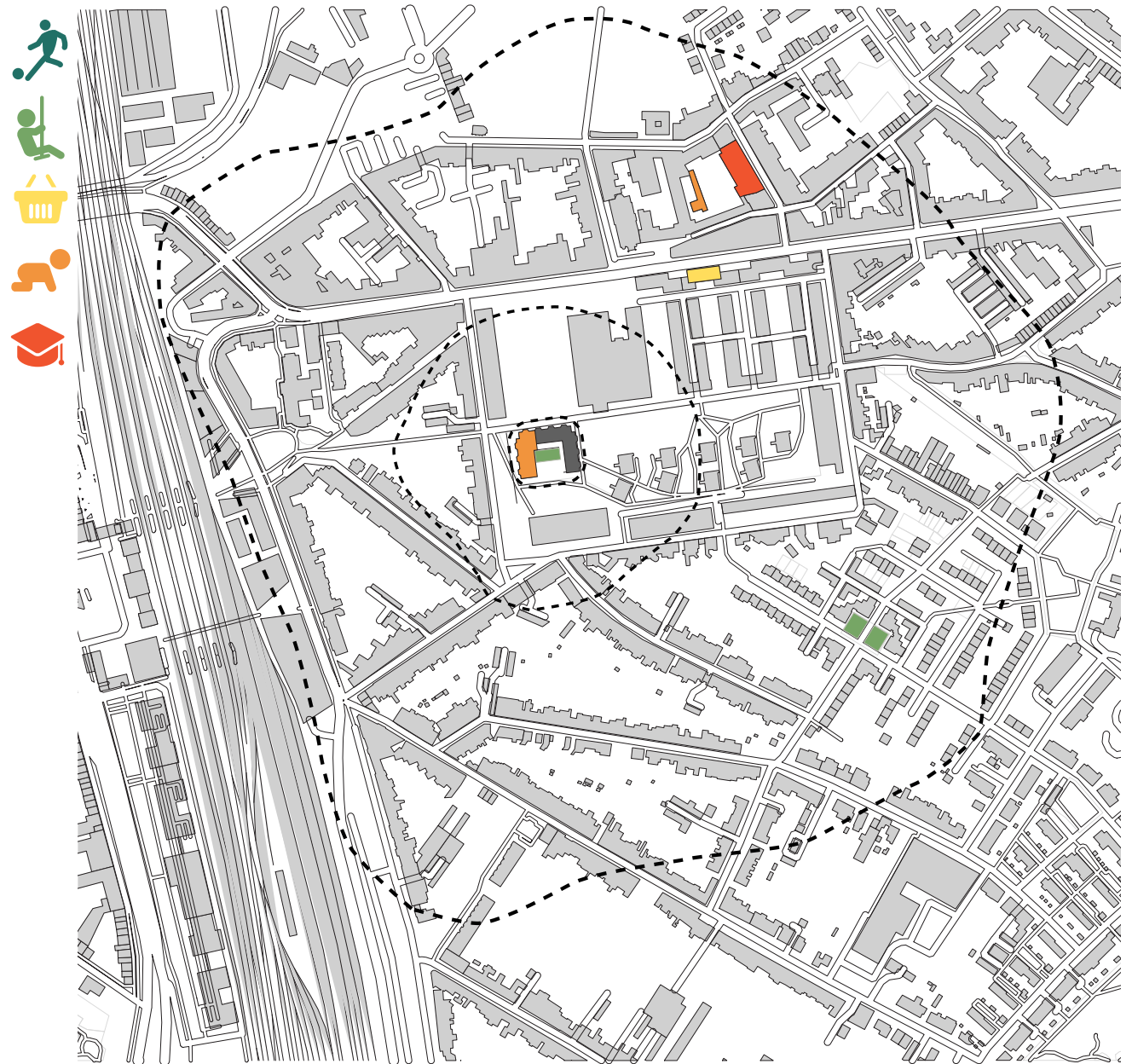

Parking

Circulation

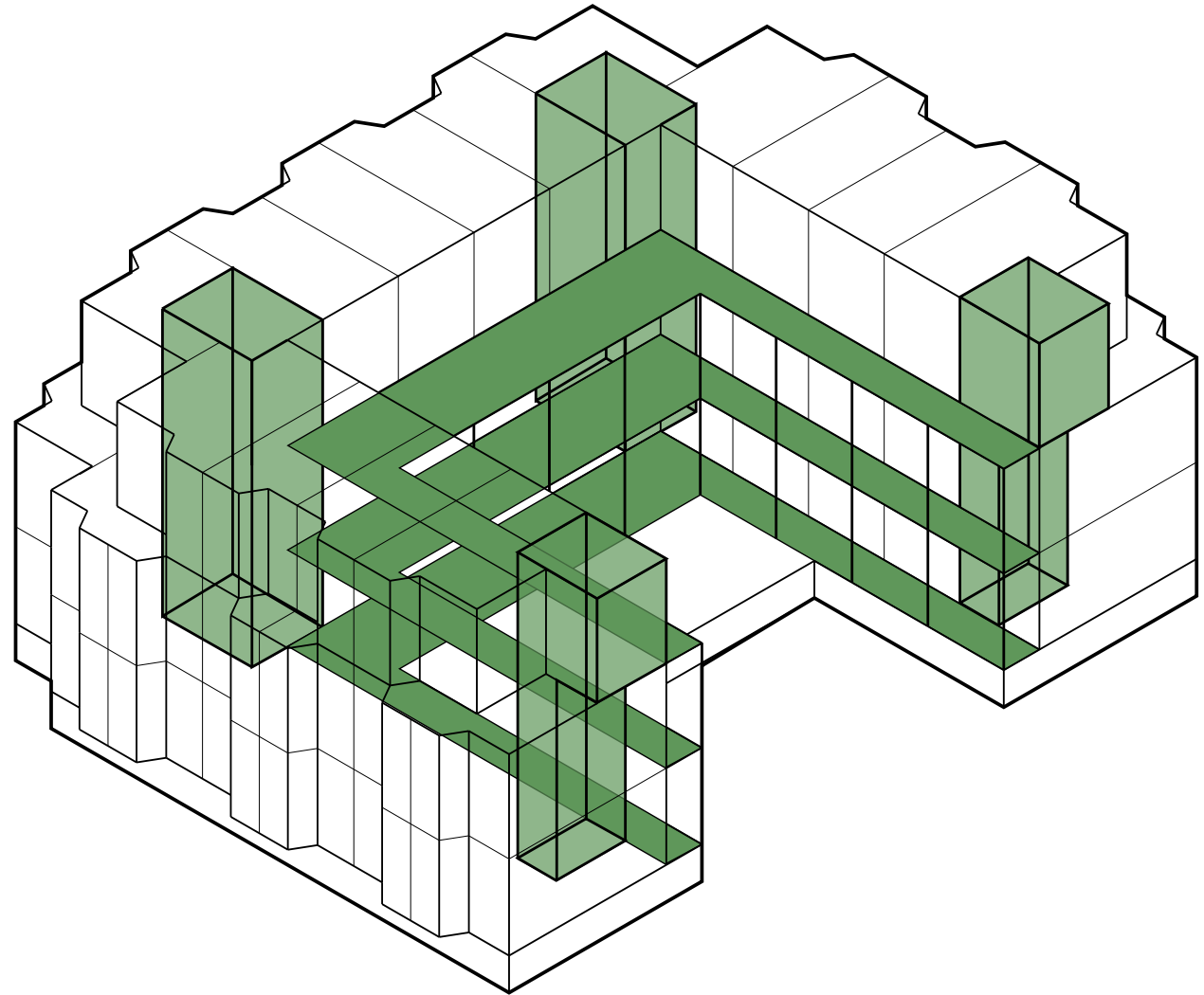
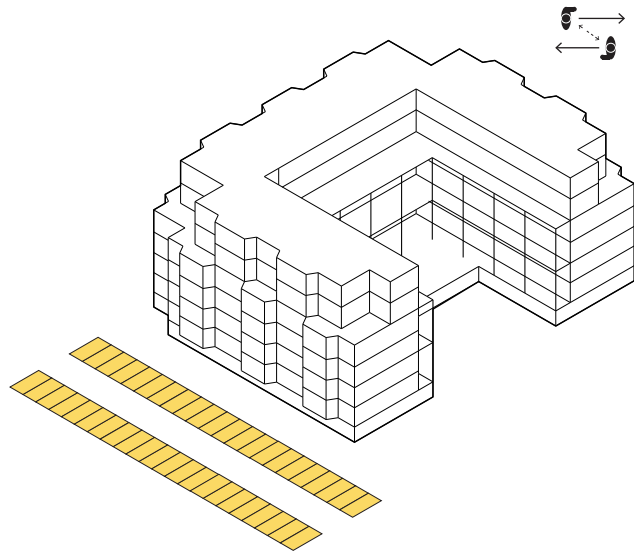

Parking

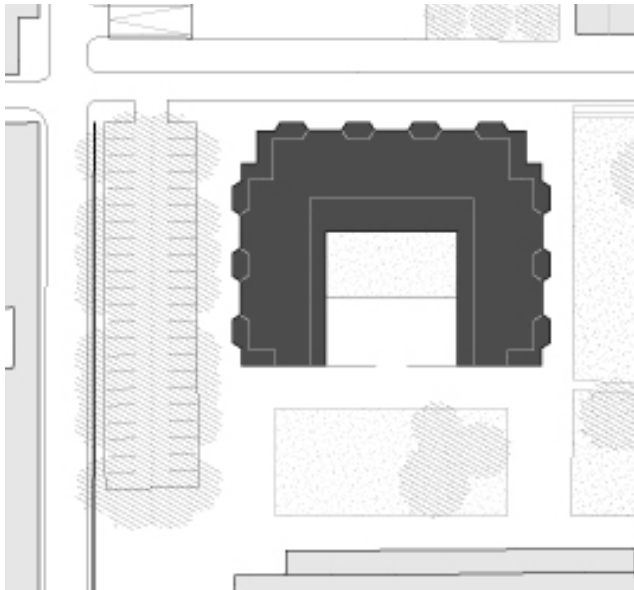

Wisselspoor

Interaction

Formal meeting space

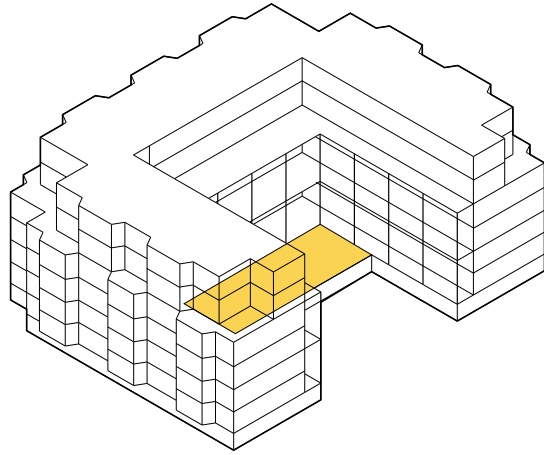
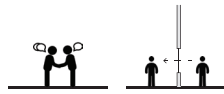

Informal meeting space

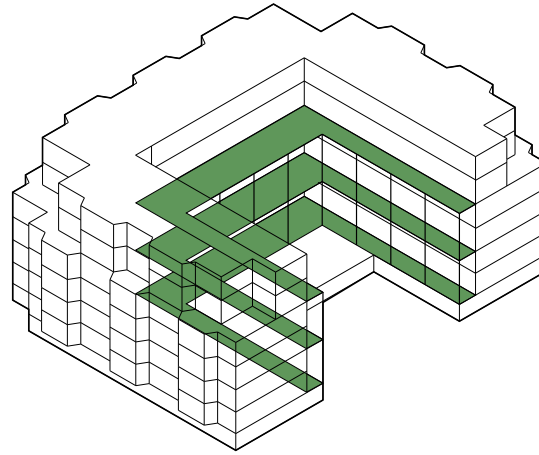
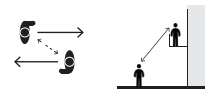

Private outdoor space

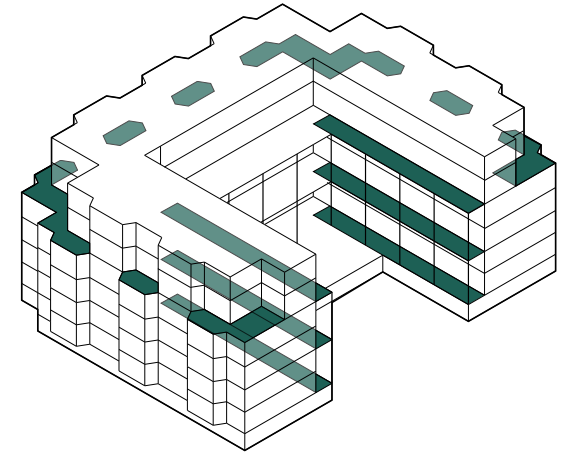
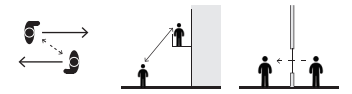

Collective courtyard/playground



Gallery doubles as semi-private front garden



Semi-private outdoor space on gallery



Identification



The function of the building is very clear when looking in the courtyard. Yet from the other side, because of public functions in the plinth, this is less clear. The building has a clear identity, because of the bay windows on the one side and large galleries on the other. To distinguish ones own house is more difficult, because of repetitiveness in the facade.

Facade



Stacking scheme

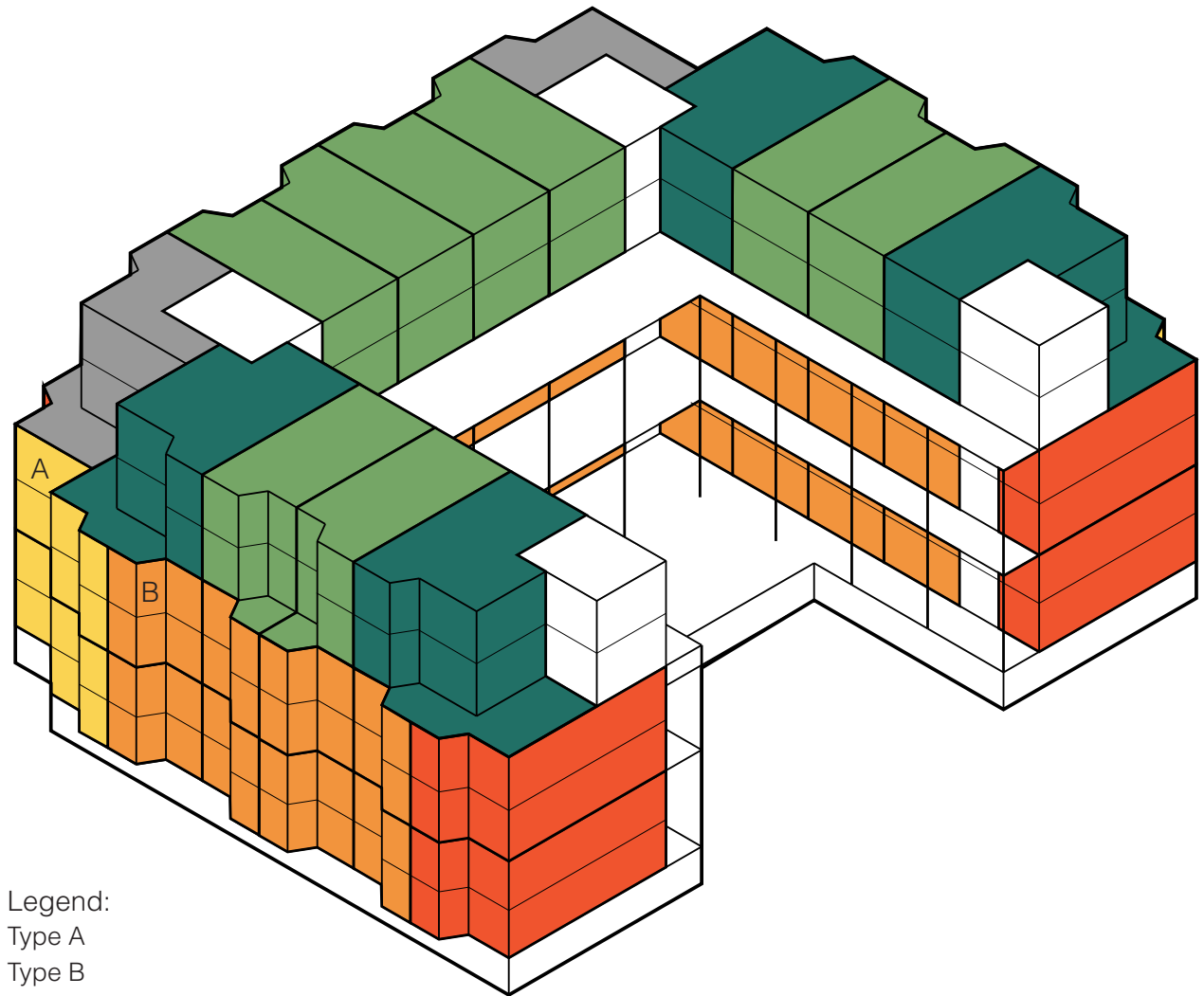

Legend:

- Type A
- Type B
- Type C
- Type D
- Type E

Information

Level:	1st floor
Dwelling type:	A
Dwelling size:	90 m ²
No. of habitable rooms:	4
Storage size:	4,5 m ²
Outdoor space:	0 m ²

Floor plans

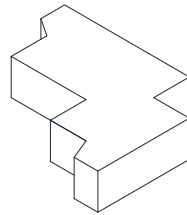
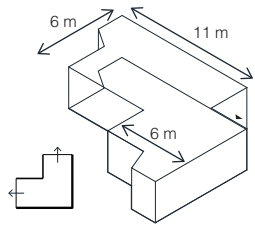

Type

Outdoor space

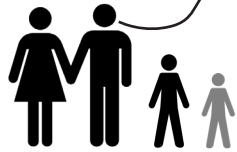

€450.000

Inhabitants

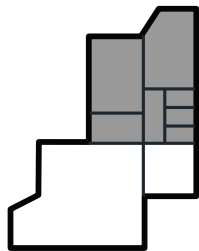

Zoning 1st floor

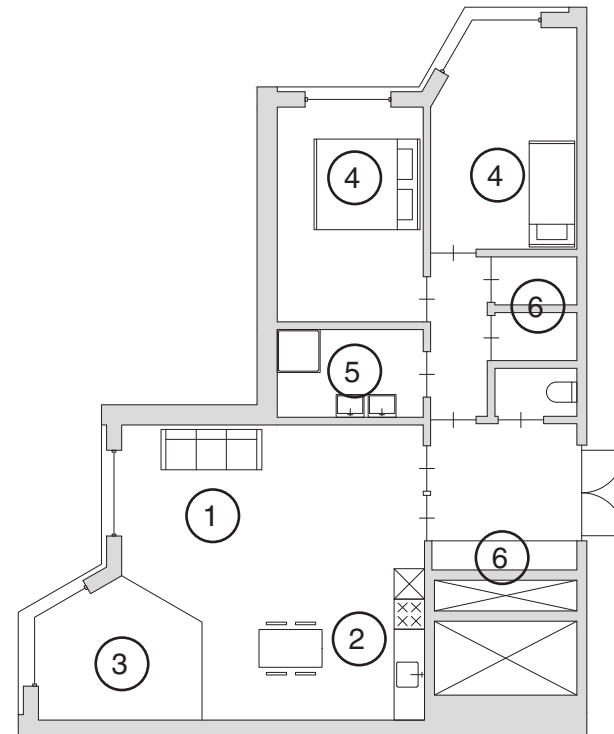

- Legend:
1. Living
 2. Kitchen
 3. Flexible space
 4. Bedroom
 5. Bathroom
 6. Storage
 7. Terrace



Wisselspoor

Dwelling

Information

Level:	1st, 2nd floor
Dwelling type:	B
Dwelling size:	151 m ²
No. of habitable rooms:	8
Storage size:	6 m ²
Outdoor space:	11 m ²

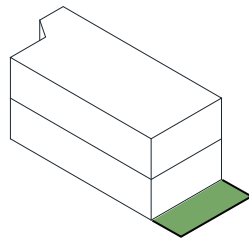
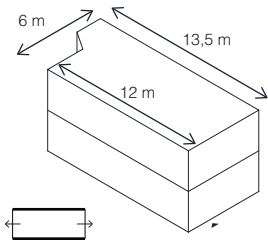

Type

Outdoor space

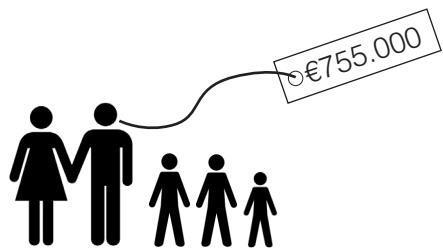

Inhabitants

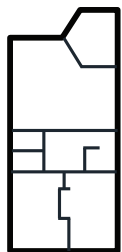

Zoning 1st floor

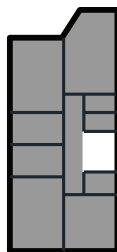

Zoning 2nd floor

Floor plans

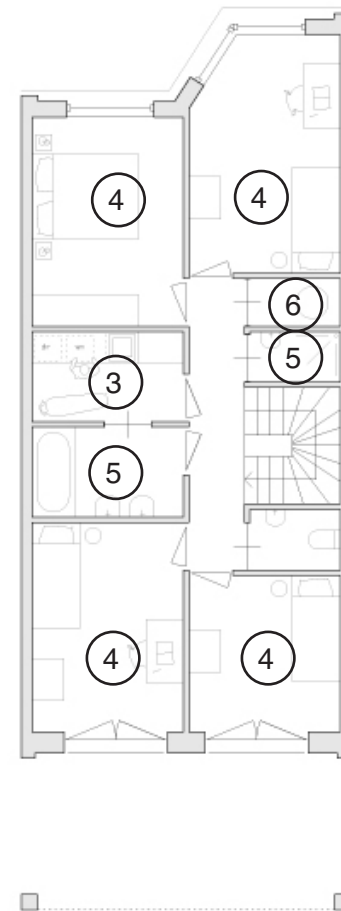

- Legend:
- 1. Living
 - 2. Kitchen
 - 3. Flexible space
 - 4. Bedroom
 - 5. Bathroom
 - 6. Storage
 - 7. Terrace



Building

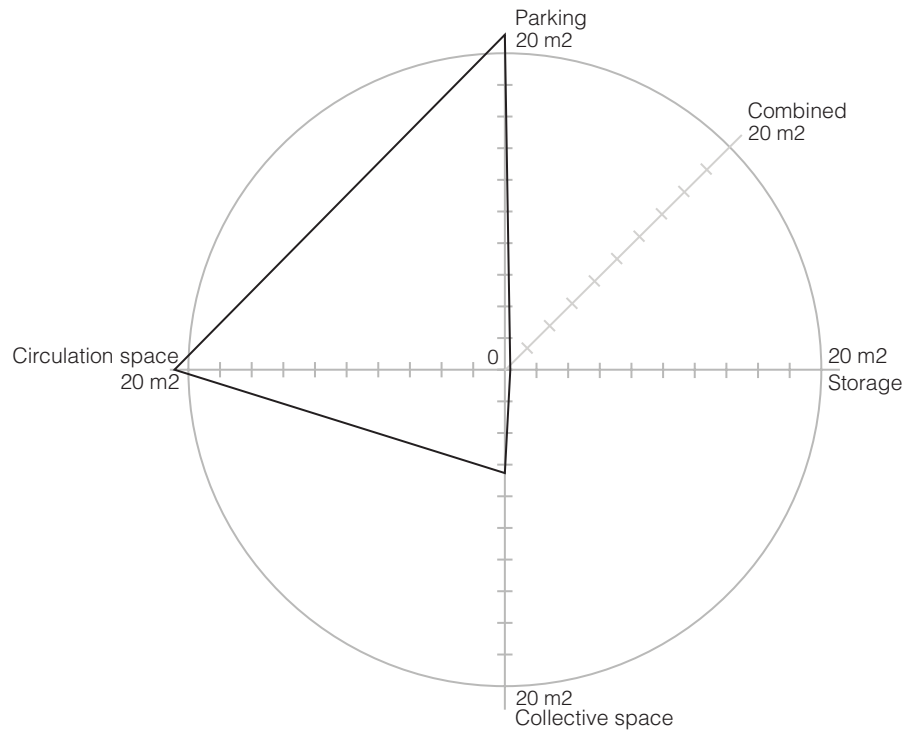

Dwelling

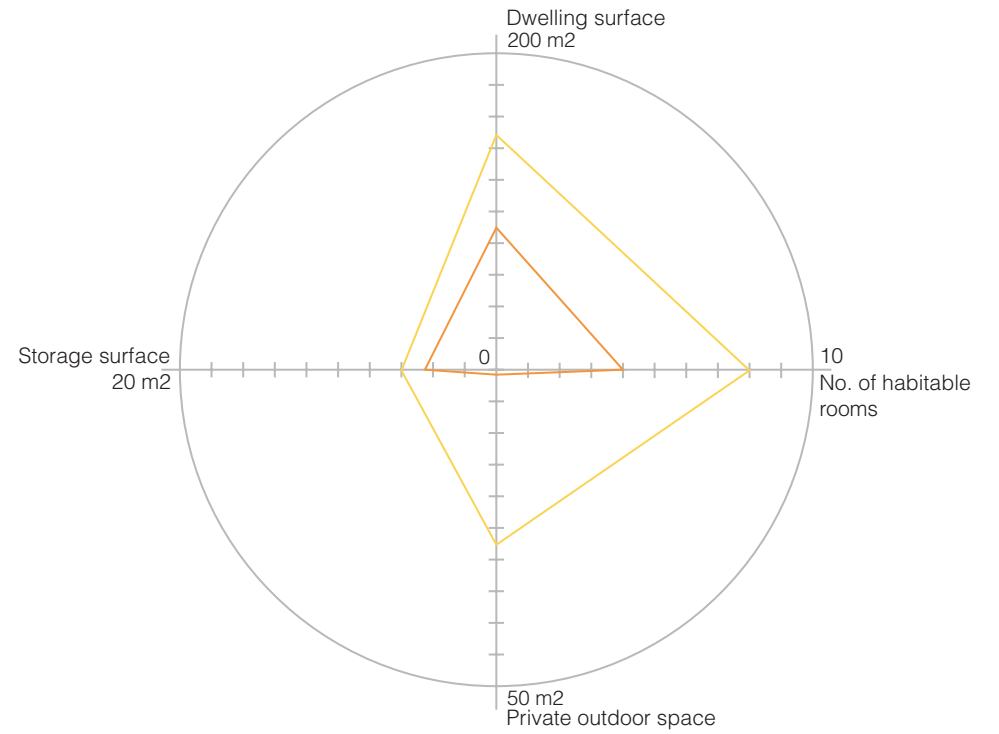

Legend:
■ Type A
■ Type B

Sheltered Urbanity

Architect	Roel Kusters
Location	Amsterdam, Netherlands
Year of completion	Graduation project 2017
No. of dwellings	54
Plot size	3000 m ²

This graduation project has been designed for families living in the city of Amsterdam on top of an already existing parkinggarage. In consists out of apartments with adaptable configurations for changing families. There is a good access to collective outdoor space, which creates a living environment that provides space and shelter for children.

Overview

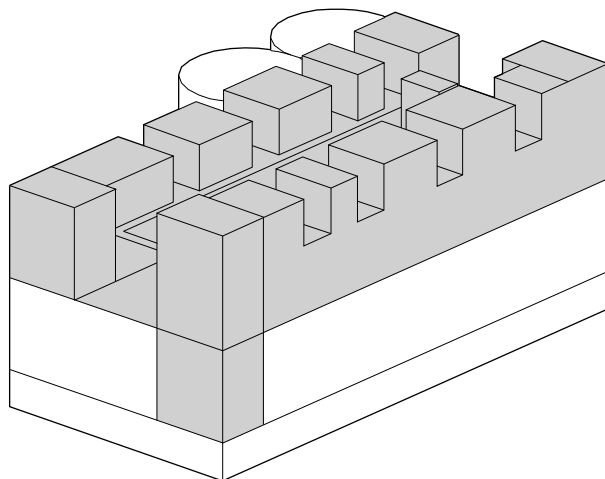

Overview illustration



Source: P5 Roel Kusters

Square in front of the building



Source: P5 Roel Kosters

Playground



Source: google.maps.nl

1:6000 | Neighbourhood facilities



Sheltered Urbanity

Interaction

Parking and storage

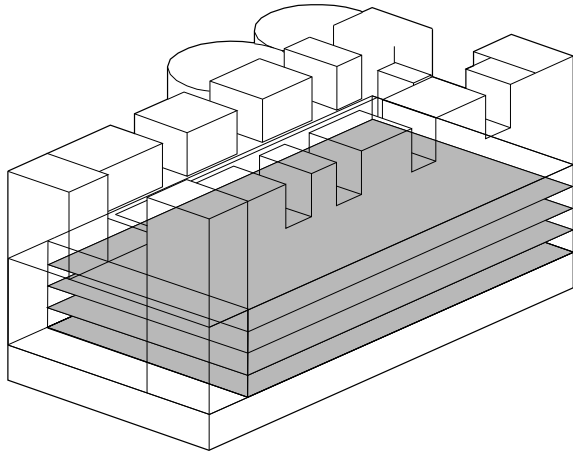

Circulation

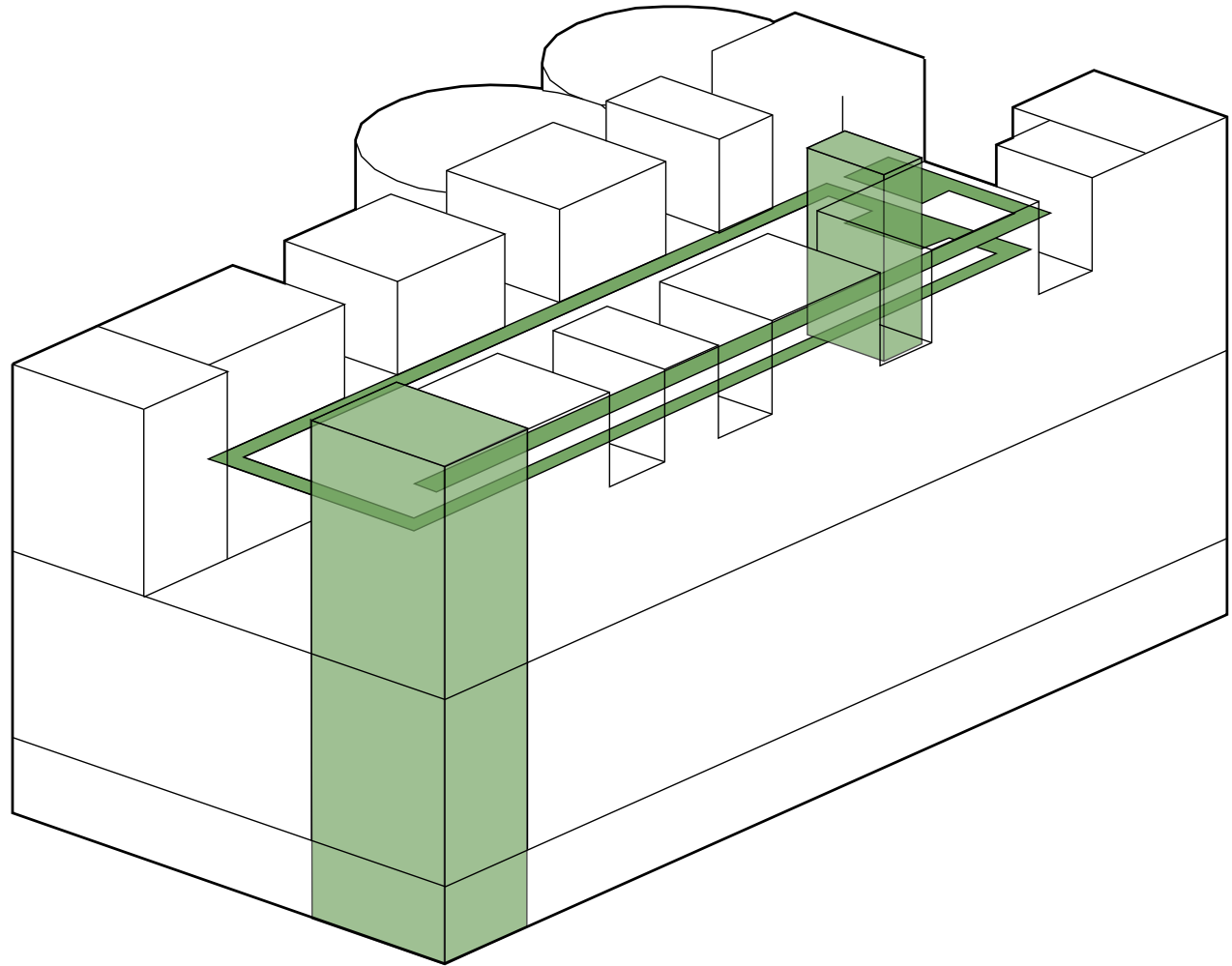

Parking



Source: amsterdamheefthet.nl

Sheltered Urbanity

Interaction

Formal meeting space

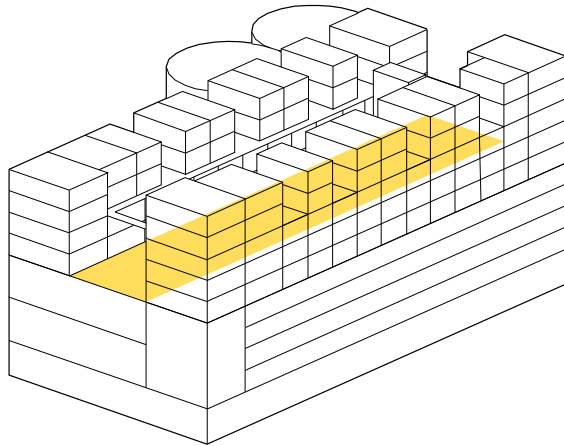
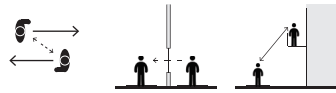

Informal meeting space

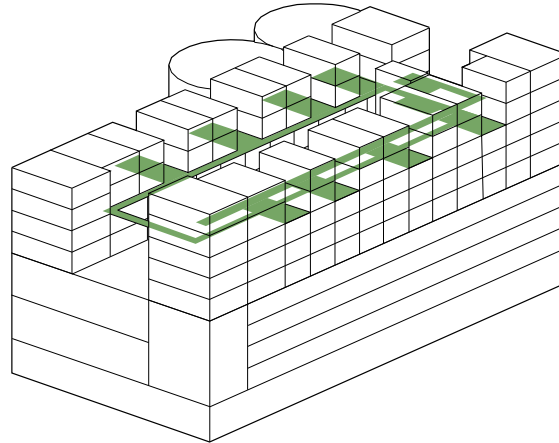
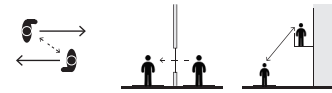

Private outdoor space

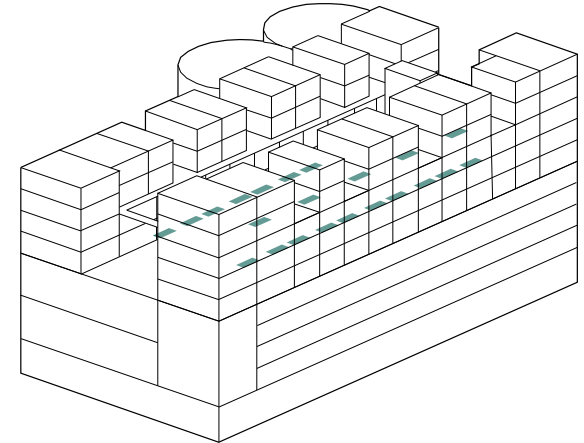
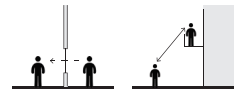

Outdoor space

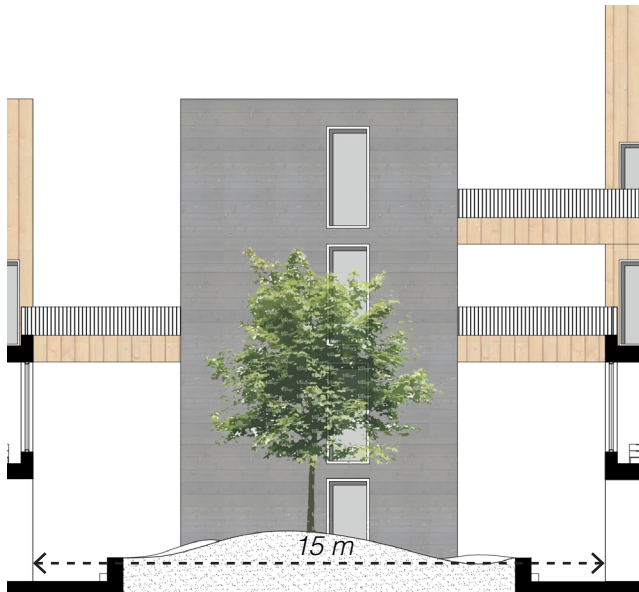

Source: P4 Roel Kusters

Gallery

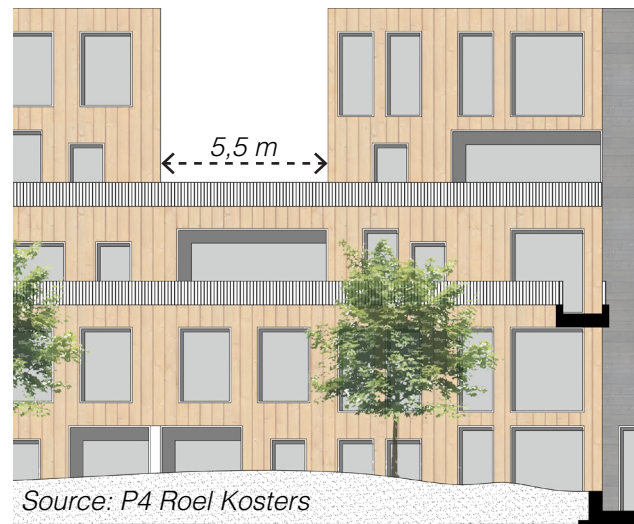

Source: P4 Roel Kusters

Covered terrace

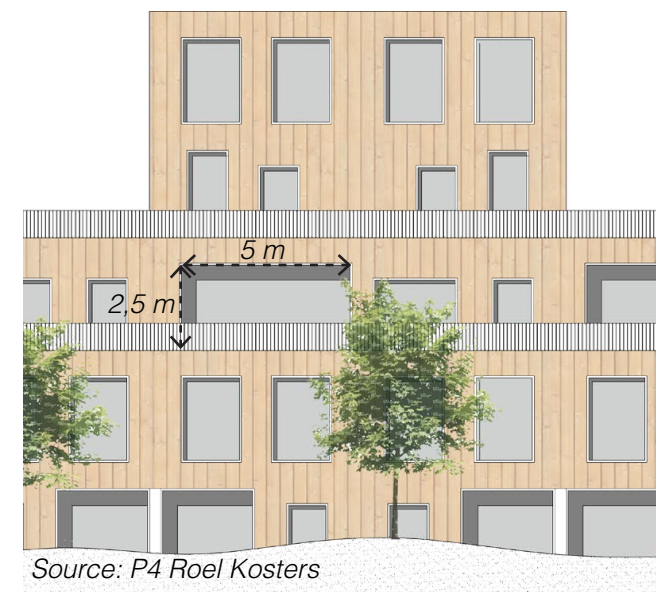

Source: P4 Roel Kusters

Identification



The two functions (parking and living) of the building are well divided with the materialisation and form of the building. The combination of these two functions makes the building very recognizable in the context. The different dwellings in the building are difficult to recognize from the street, but from the courtyard the individual dwellings are better evident.

Facade



Source: P4 Roel Kosters

Stacking scheme

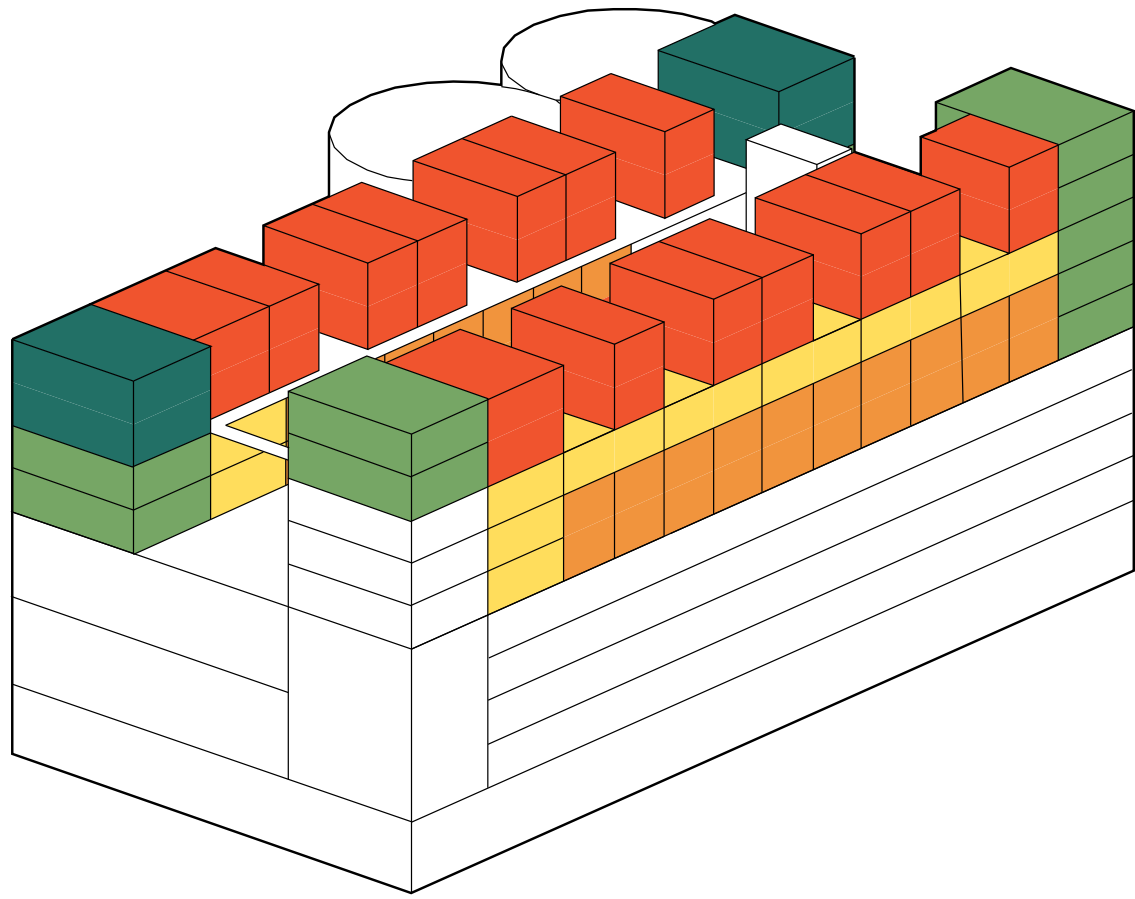

- Legend:
- Type A
 - Type B
 - Type C
 - Type D
 - Type E

Sheltered Urbanity

Information

Level:	0 and +1
Dwelling type:	B
Dwelling size:	125 m ²
No. of habitable rooms:	6
Storage size:	3,5 m ²
Outdoor space:	2,5 m ²

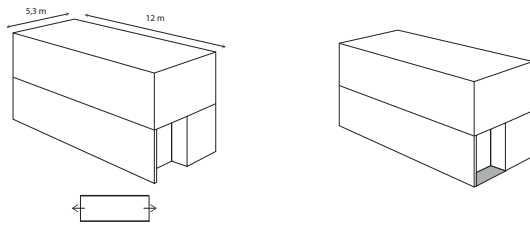

Type

Outdoor space

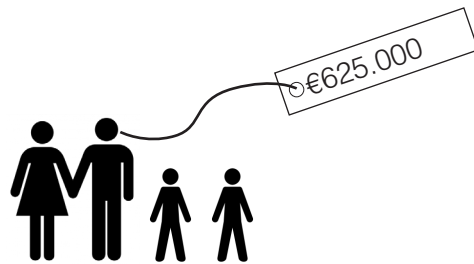

Inhabitants

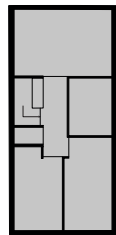
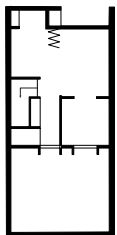

Zoning 1st floor

Zoning 2nd floor

Floor plan

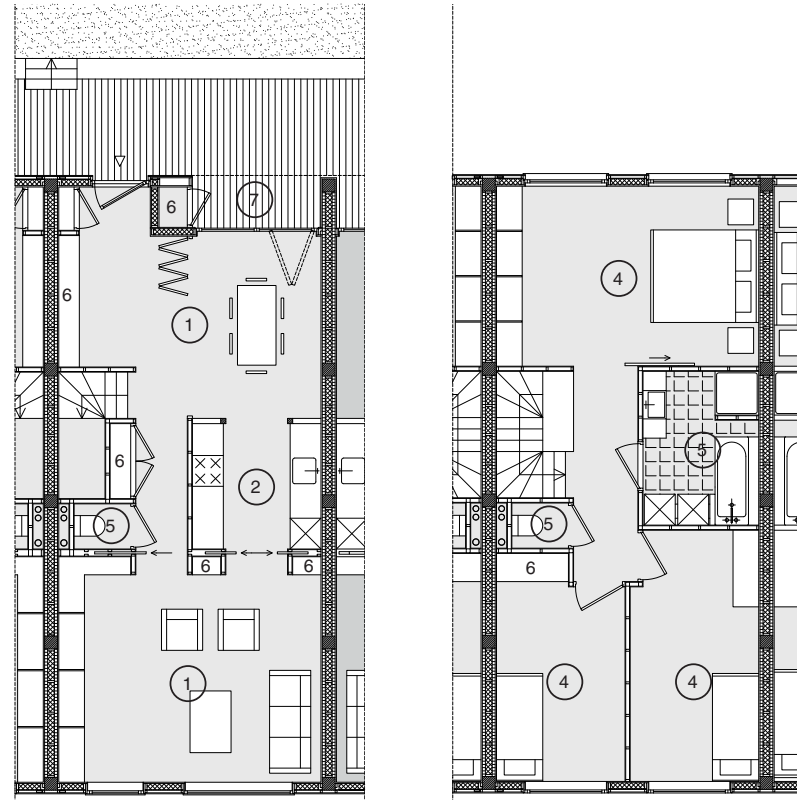

- Legend:
- 1. Living
 - 2. Kitchen
 - 3. Flexible space
 - 4. Bedroom
 - 5. Bathroom
 - 6. Storage
 - 7. Terrace



Sheltered Urbanity

Dwelling

Information

Level: 0
 Dwelling type: D
 Dwelling size: 91,5 m²
 No. of habitable rooms: 3
 Storage size: 2,5 m²
 Outdoor space: -

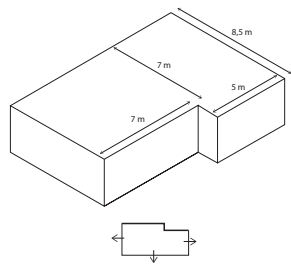

Type

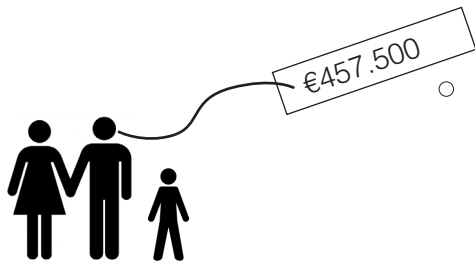

Inhabitants

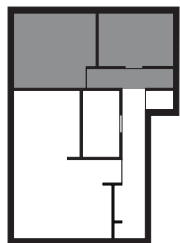

Zoning 1st floor

Floor plan

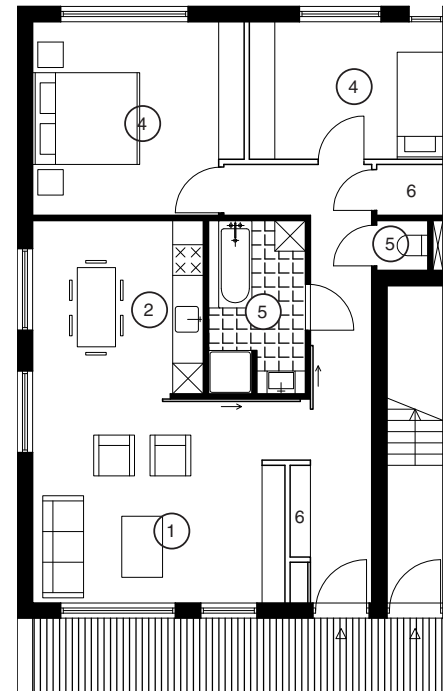

Source: P4 Roel Kosters

Legend:

- 1. Living
- 2. Kitchen
- 3. Flexible space
- 4. Bedroom
- 5. Bathroom
- 6. Storage
- 7. Terrace



Sheltered Urbanity

Radar chart

Building

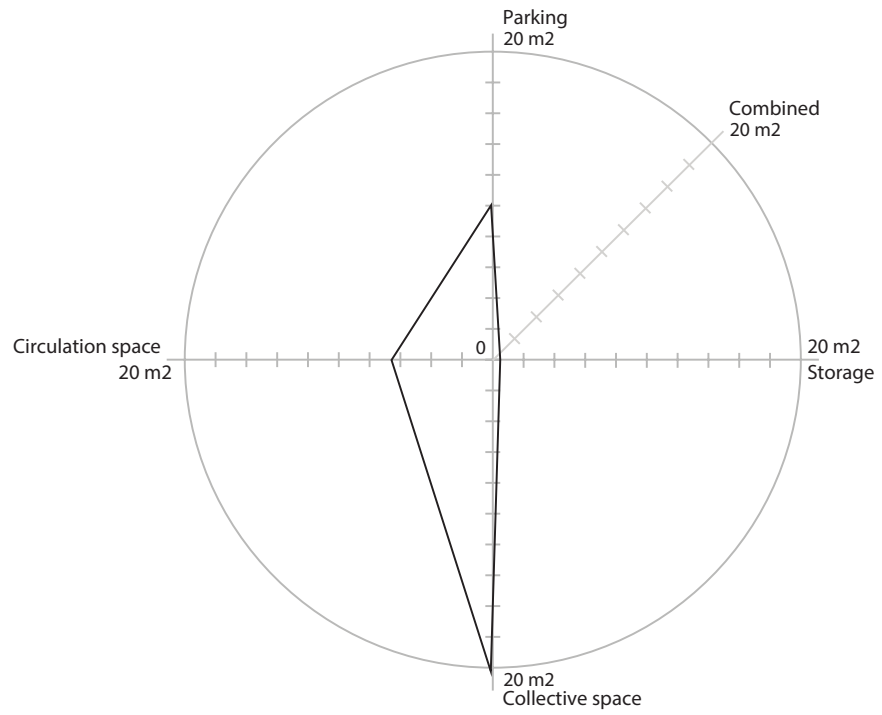

Dwelling

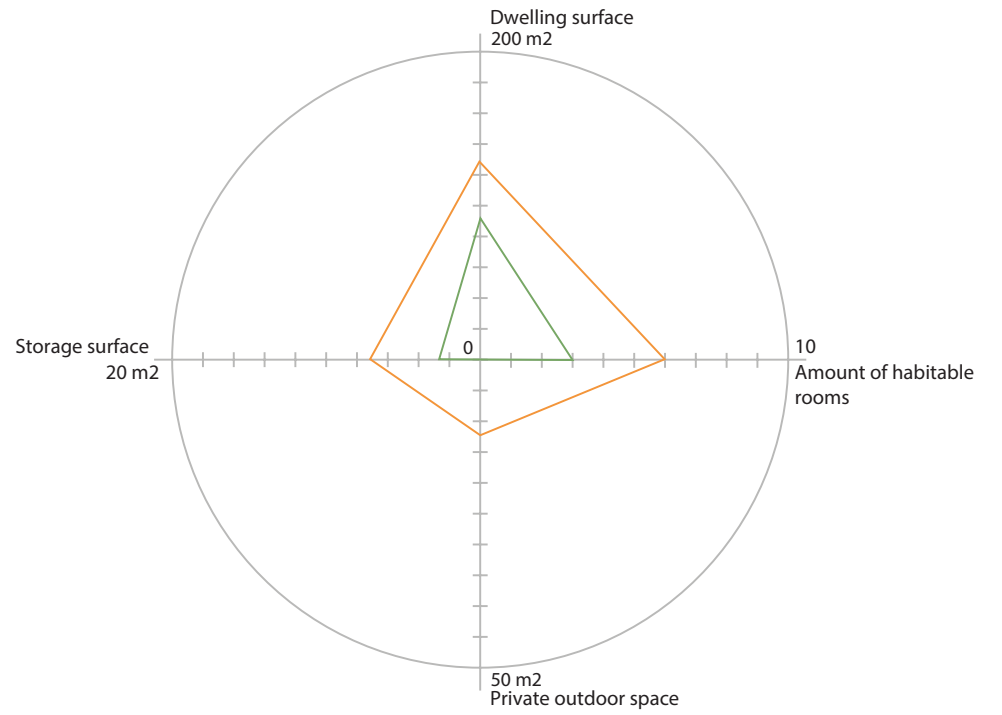

Legend:

■ Type B

■ Type D

Conclusions

Neighbourhood On the neighbourhood scale especially schools and daycare facilities tend to be quite near to the dwellings. This might indicate that parents search for this quality in a home. Playgrounds and sport facilities were usually located further away, but within the 500m range. Older children can make use of these facilities. Large shops on the other hand were not often situated within the 500m range.

Very often a playground for young children was located within the dwelling complex itself. This is not surprising, as the range of a 0-4 year old is around 30m.



Interaction In most of the projects a collective place within the building is provided. The circulation spaces however also tend to have multiple functions: entrance area, place for interaction and space for children to play. In Kolenkithuis, Wisselspoor building and Dan Leckie way the galleries had a broader width than usual, respectively 1,80m and the two latter ones 3m wide. In Babel the stairway spiralling upwards provides for a continuous playing area for children.

The collective and private outdoor areas in the already existing projects are usually strongly separated. In the new and unbuild projects, they flow over into each other or are somehow combined. This seems to be a new development or trend in family housing.

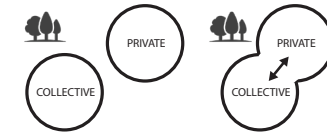
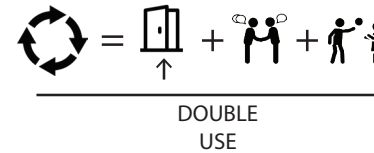

Identity Except for the Dan Leckie Way project, all of the buildings were easily recognizable as being a dwelling project. This was usually due to balconies, galleries and front doors. In the case of identity of the project, as well all except for Dan Leckie way scored rather high, in the sense that they can be recognized as a separate entity in the urban context. In the introduction it is explained how this can be profitable for children's wayfinding.

On the scale of separate houses within the building complex, identity was mostly not very present. In the Kolenkithuis they did apply this, by changing the brick pattern for each other house.

The stacking schemes generally showed exceptions on endings and corners, but this was not always visible in the facade.

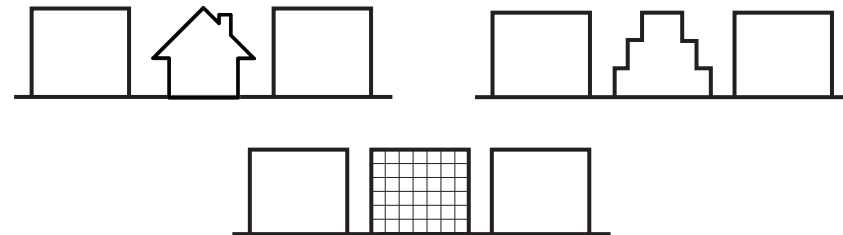

Dwelling Even though the dwellings differ largely, there are some commonalities. Almost all of the dwellings were too large, in the sense that it would be too expensive to build in the city centre of Amsterdam. The dwelling usually showed a clear division in private and representative areas. This is similar to typical two level family housing.

The average size in outdoor space (not taking into account the Habitat building) is 13m². This is rather large, as in The Housing Design Handbook it is indicated that the minimum useful outdoor space size for 2 persons is 4m², adding 1m² for each extra person (2010, p.98). This would create a minimum of 5-6m² for the average dwelling we have analyzed. However, outdoor space is pinpointed very often as being important to families. Thus, it makes sense that these sizes stand out.

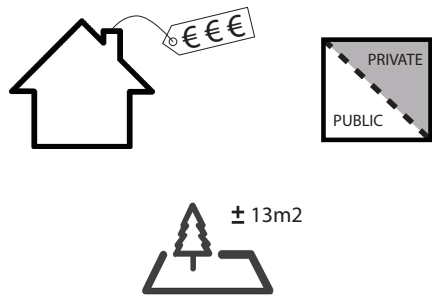

Radar chart To compare the different building blocks to each other turned out to be rather hard. They are very different from each other, also because some of them are not necessarily meant for families. To conclude solid data from this radar chart is not possible. It turned out that it is hard to define exactly the borders of each type of space. This is already visible in the combined data of parking and storage. Also, In the particular case of Wisselspoor, the amount of circulation space is very high compared to the others. This is because the circulation space double functions as 'private' outdoor space. Babel uses a similar principal, but because of insufficient information we could not measure the sizes of this building.

For the dwelling chart the results are more promising. If we leave out the results that have extreme values, some plausible averages become visible. The Habitat 67 complex for example had very large outdoor spaces, which will probably be impossible to integrate in a design for Amsterdam. The larger numbers of habitable rooms can be assigned to some of the very large dwellings from the Kolenkithuis. The big storage space came from one particular dwelling type with a garden shed. The average dwelling size is around 130m², which is too large for affordable housing in Amsterdam. It is however interesting to know the average numbers that belong to this: 4,6 habitable rooms; 15m² outdoor space; 9m² storage. If we would translate this to a dwelling of 100m², an affordable size for families, this would result in 3,5 habitable rooms; 11,5m² outdoor space and 7m² of storage.

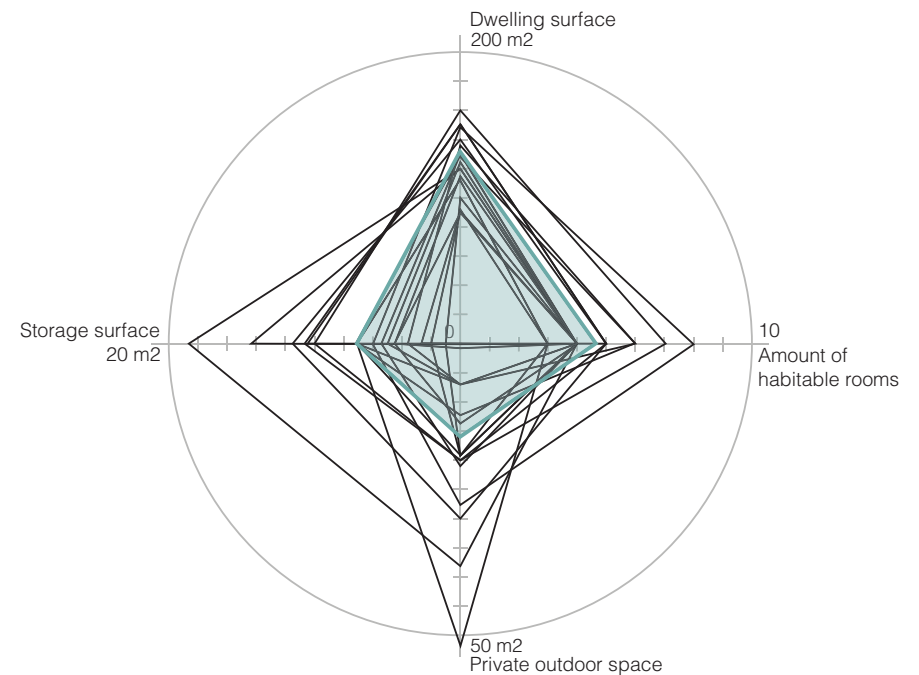
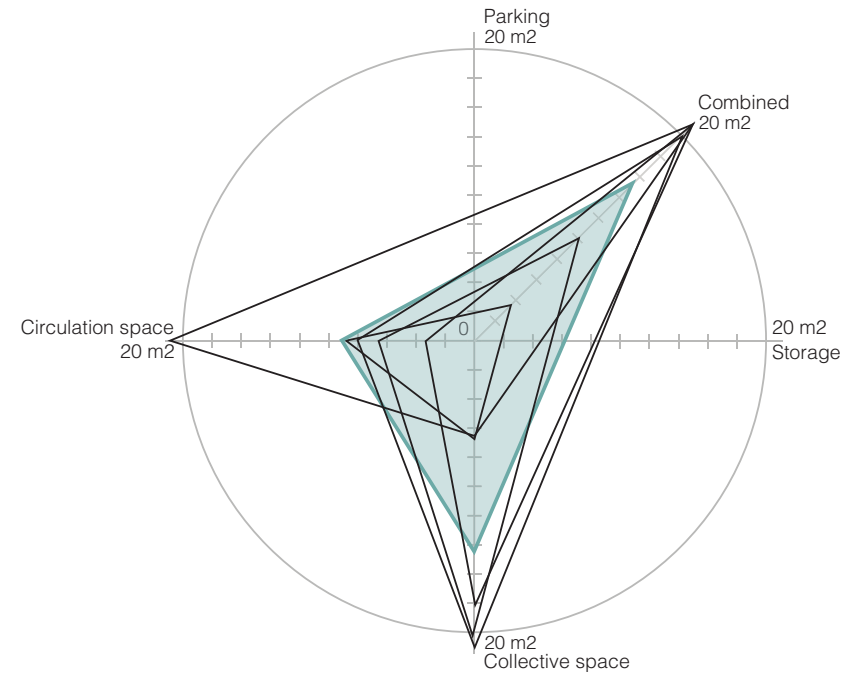

Design brief 2.0

This design brief is an updated version of the one presented after the family research. This updated brief includes the conclusions that are taken from the case studies, shown in blue.

± 100 dwellings

- 50 - 100 m²
- 3 bedrooms minimum
- apartments and maisonnettes
- adaptability in floorplan
- outdoor space of >6m²
- storage space of ±7m

± 30% of the houses at minimum possible size (with 3 bedrooms)

Building complex that

- has a clear identity in itself
- is clearly identifiable as housing

Circulation area broad enough (±3m) to facilitate

- meetings between neighbours
- playing of children

15-25 dwellings per entrance core (with lift)

Parking

- ± 60 parking lots (N = 0,6)
- ± 5 shared cars (1 shared car = 4 cars)

Play areas for each age group

- 0 - 4 years
 - + *informal play area right next to the house*
 - + *formal play area with play equipment*
 - + *safety from water and cars*
- 4 - 8 years
 - + *informal play area within view of the house*
 - + *formal play area with play equipment*
- 8 - 12 years
 - + *informal play area that is exciting*
 - + *formal play area for ball games*
 - + *within safe walking distance (±500m)*

Collective functions

- Laundry facilities
- Bicycle storage
- Guest rooms

Additional functions (unless already provided for in the area close by)

- Daycare
- Area dedicated to dogs
- Mixed-purpose room (meeting room, youth club)

Location

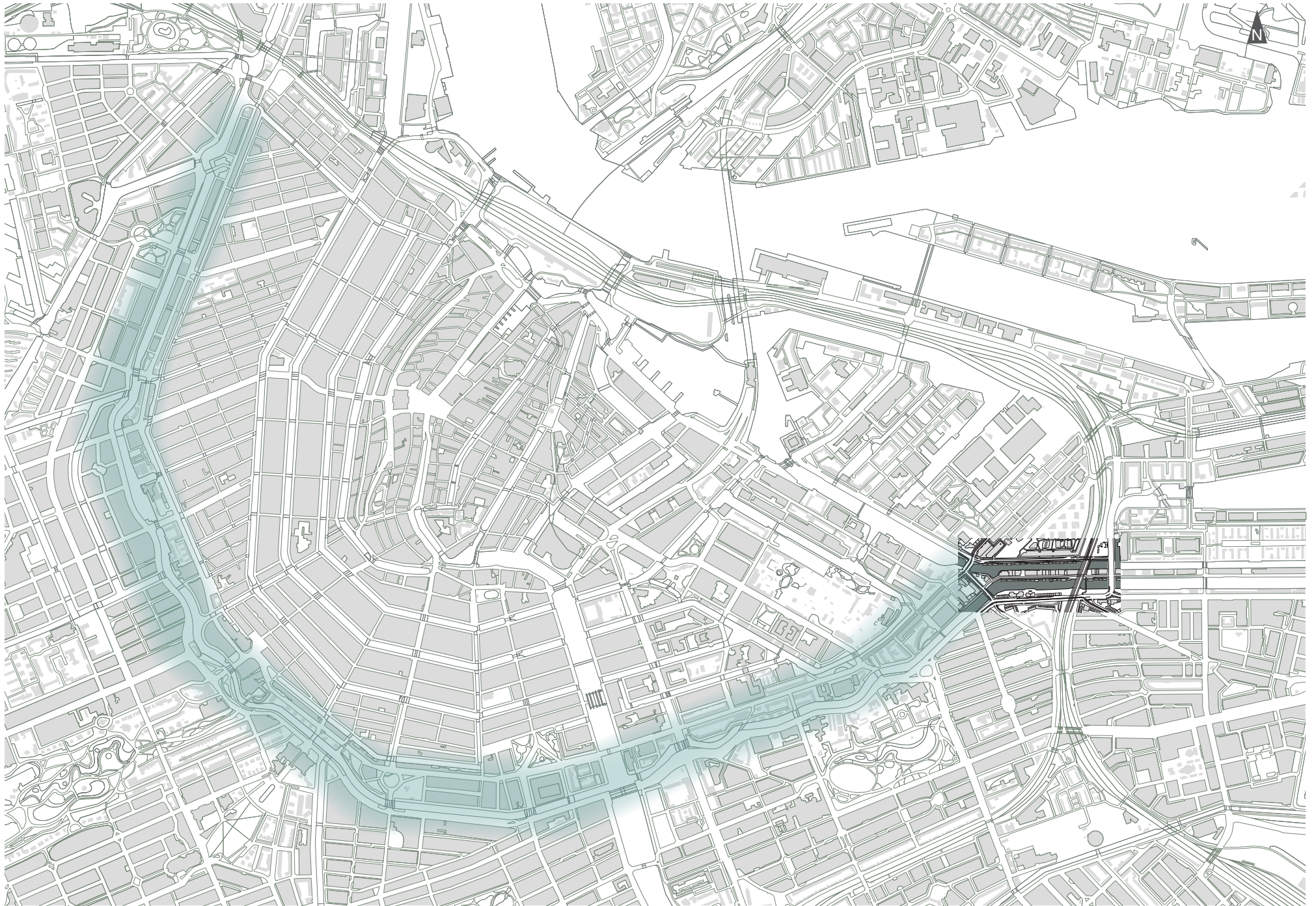

Stronghold Amsterdam, chosen location | 1:20.000

Introduction

The chosen location lays at the very East end of the former stronghold area of Amsterdam, as indicated on the map. It is the Western part of a very long street called the Zeeburgerpad. It can almost be seen as an island, only connected to other land by bridges. The beginning of this chapter will show a range of photos to understand the general look and feel of the area. The whole Zeeburgerpad has a rather industrial character and is filled with large stores, garages and offices. Its surroundings are quiet different. The part on history, municipality plans, demography, morphology and the existing situation will explain more on this subject. In the existing situation the presence of the train track is shown, and the topics on noise and infrastructure will explain more about this. In the area around the location, many dwellings, shops and facilities are located. This chapter wil look into all the present facilities around the Zeeburgerpad that are interesting for families. By applying the range of action on this as well, possibilities for childrens moving around will become visible.

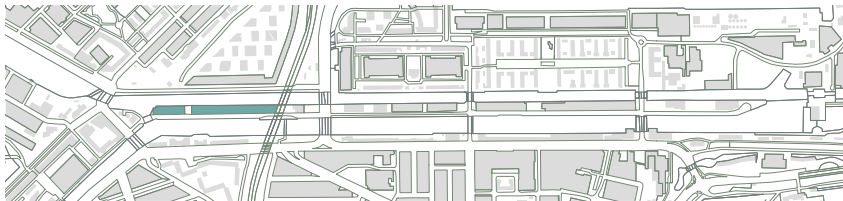

The location is the West end of the very long and narrow Zeeburgerpad

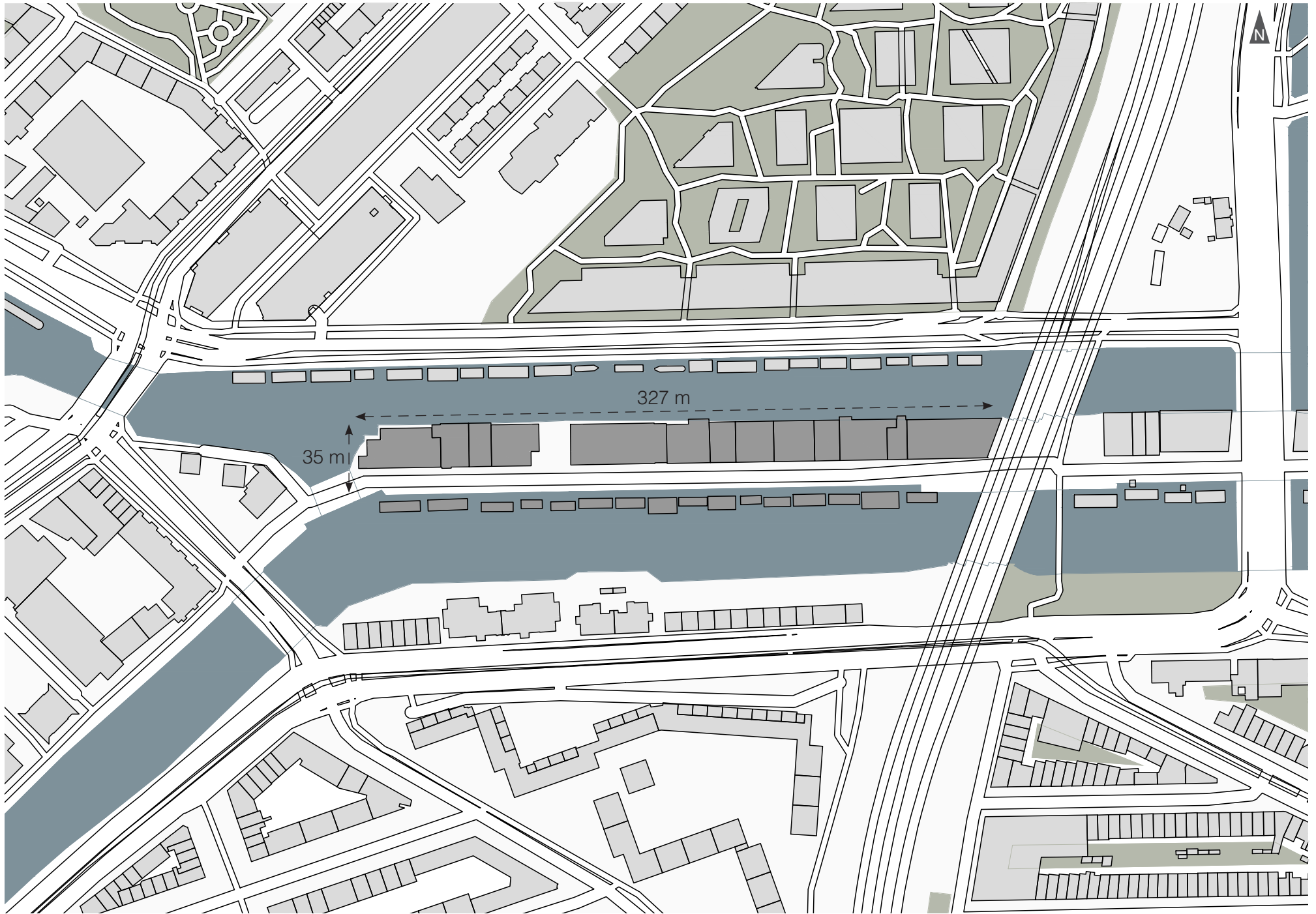



Photographic route | 1:2500 (Source: google maps)



Street views Cruquiuskade



Street overviews



Street views Zeeburgerpad



Details Zeeburgerpad

History

The Zeeburgerpad is a relative young street, as it originates from 1875. In 1874 the characteristic mill was built. After that the a dike was added in the middle of the Nieuwe Vaart, splitting it into the Lozingskanaal and the Nieuwe Vaart. It took some time before real development on the dike took place. In the 20th century the area develops as an industrial one, mainly by shipping companies. From 1925 till 1944 the Eastern end of the road was occupied by the Zeeburgerdorp, a small, secluded village, meant for 'asocial' individuals. Eventually it got closed down and demolished by order of the Germans in 1944. At around 1950 the area is filled with many different industrial functions, and it becomes a popular location for houseboats. However, eventually the area decayed, which can clearly be seen on the images on the coming pages.

Source: socialhistory.org



Postcard Zeeburgerpad (Source: beeldbank.amsterdam.nl)

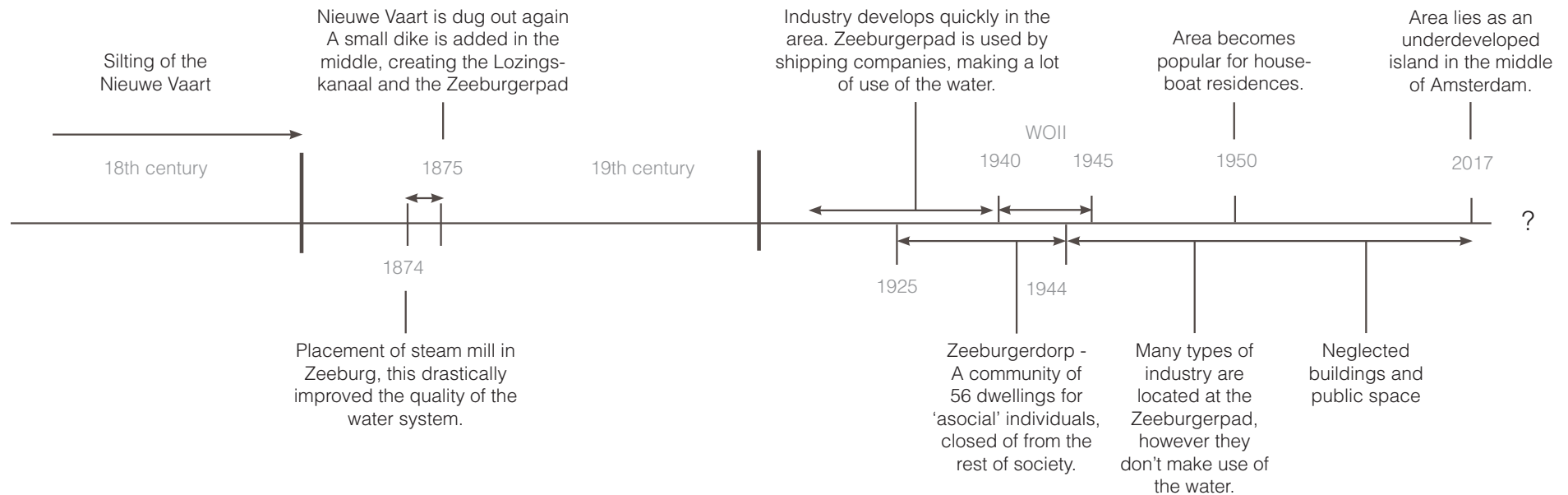

Historical development Zeeburgerpad (Source: [Marilyne de Wit](http://Marilyne.deWit))

Municipality Plans

Note: These are plans for the other part of the Zeeburgerpad

The Amsterdam municipality has released plans for a large part of the Zeeburgerpad in the end of 2011. These plans however exactly exclude the part chosen as my design location. However, it is interesting to investigate the rules and ambitions that have been made by the municipality.

Ambition The Zeeburgerpad is a very small and elongated plot with mainly deprecated buildings with a business function. Because of successful transformations of locations nearby, the Zeeburgerpad is also transforming. There is a wish to create a more mixed environment of living and working (preferably 75% living, 25% working). The unique form and village-like character of the plot is very characteristic and should be amplified. A dual aspect to both waterfronts is also eligible. By using a mix in building typologies, the site can be made more interesting as well. To evoke these qualities, a set of rules and accompanying map (Dutch: 'spelregelkaart') are put together. The map is shown underneath.

Source: Ambitie Zeeburgerpad, gemeente Amsterdam

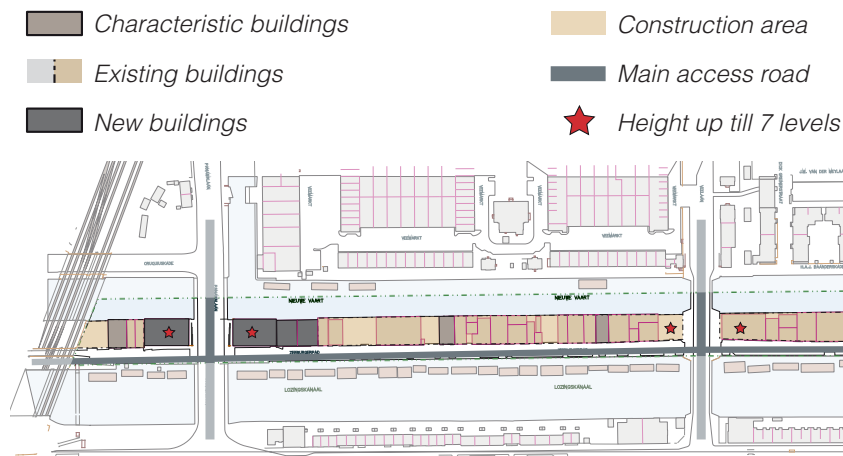

'Spelregelkaart Zeeburgerpad 11-11-2011' (Source: Amsterdam Government)

Rules Along with the map, a document with the rules is given. From this I have selected those who are applicable to dwellings.

Heads of the lot: Slightly higher buildings with a minimum of 6 layers, and a maximum of 7 levels and 25m.

Lots inbetween: A maximum of 5 layers, with a maximum height of 18m. Minimum building height of 2 layers and 8m. Preferably a mix of building heights. A maximum length of 30 meters facade. After this, an indentation of at least 3m is obligatory.

Roofs: Slanted roofs may have a maximum inclination of 25%. Slightly slanted roofs fit the industrial character of the plot, while very slanted ones do not.

Storage and Carport: Storages and carports have to be implemented in the main volume. Fragmentation of buildings is to be prevented by this.

Piers: For each building lot, a pier might be placed, with a maximum of 5m in length and 1,5m in depth. Because of the water flow it is not allowed to place poles in the water.

Source: Spelregels Zeeburgerpad, gemeente Amsterdam

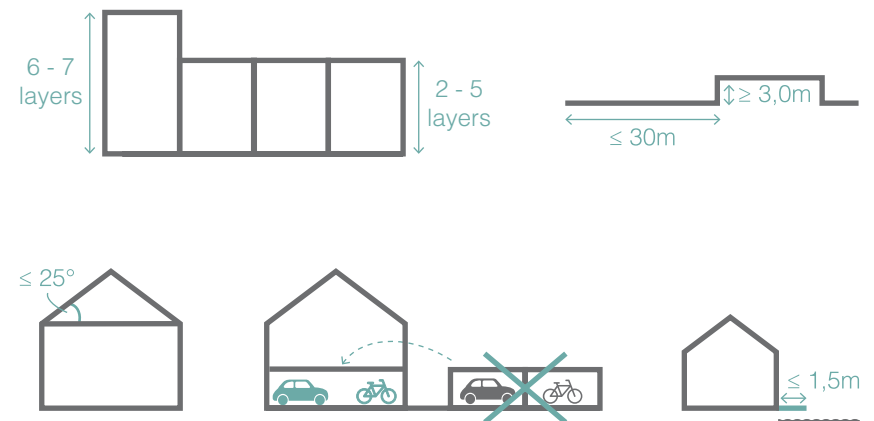

Rules for building on the Zeeburgerpad (Source: Amsterdam Government)

Demography

The Zeeburgerpad belongs to the neighbourhood of 'Het Funen', as can be seen on the map on the left. This area on the North is especially designed for families, and has a percentage of 34% families. This is very high compared to the average of 20% in Amsterdam. On the east in the Entrepot-Noordwest the average is also relatively high, 28%. The Kazernebuurt in the South West has 18% of families, this is however the second highest percentage of households with children of the whole stronghold area. The exact numbers of families can be viewed in the chart underneath.

	Married, with children	Unmarried, with children	Single parent family	Total amount of families	Total amount of households	Percentage of families
Kazernebuurt	31	25	49	105	577	18%
Czaar Peterbuurt	81	51	100	232	1418	16%
Het Funen	115	67	32	214	622	34%
Dapperbuurt Noord	201	81	204	486	2507	19%
Entrepot-Noordwest	82	33	111	226	806	28%
Indische buurt Noord	186	86	141	413	2269	18%

Family households around the Zeeburgerpad (Data source: OIS Amsterdam)

One can notice rather large differences in neighbourhoods with many two-parent or many single parent families. Especially Het Funen has many traditional families. In general, we can conclude that there will be enough families present for new families to have enough like-minded people. Of course, by designing the entire Zeeburgerpad especially for families this would be possible anyway. Possibly a parents house could also function. This however should be researched further.

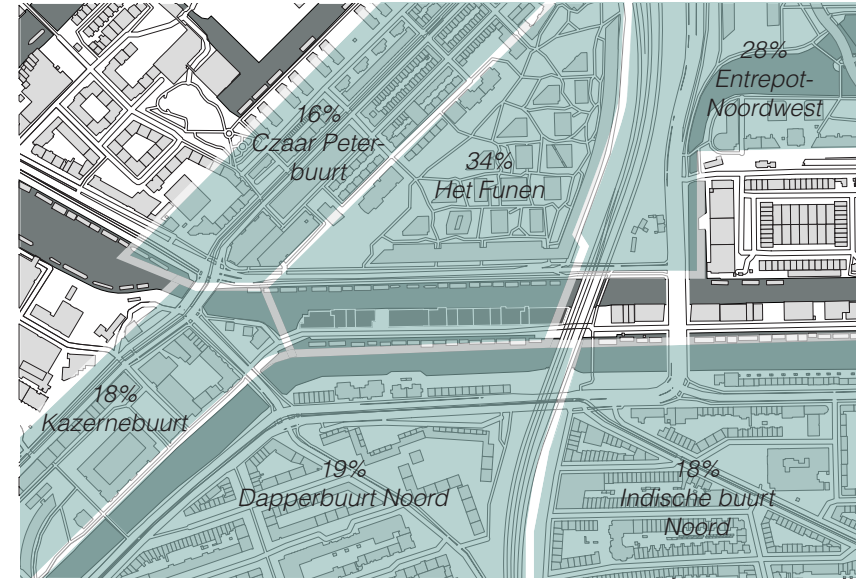

Family households around the Zeeburgerpad (Data source: OIS Amsterdam)

Morphology

Heading Text

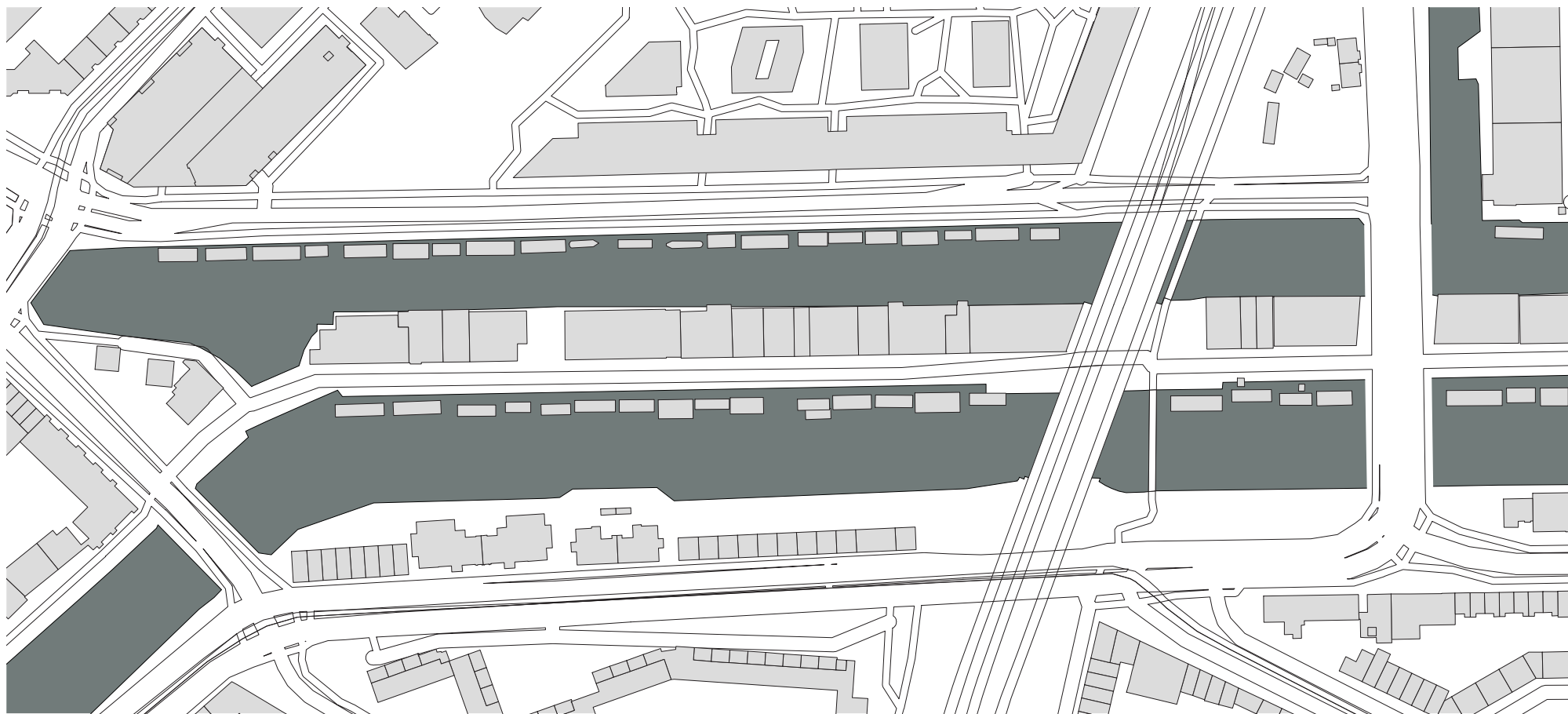

Existing situation

Functions In the current situation the location is filled with a large variety of functions. The southern edge is filled with boathouses. On the left corner a restaurant is located. Next to this as well as more to the right there are small plots with dwellings on it. Other than that the functions differ from actual stores to business companies. The stores are mainly related to the building industry, such as wood, plumbing and others.

Value assesment The photographs on the previous pages already show signs of bad maintenance, such as graffiti and messy backs. Two buildings seem to be uninhabited, one is our for rent. Also, none of the buildings are of specific cultural or historic value. Even more so, the area is designated by the 'Welstand' as 'special', meaning that a design for this area has to add quality its surroundings and have qualities in itself. This is usually because the area is important for the image of the city itself. The current state of the location does not answer this expectations. In this sense, there are no objections to demolishing the existing buildings.

However, some of the buildings contain dwellings, which can become a delicate issue. At least two of the three dwellings are owner-occupied,

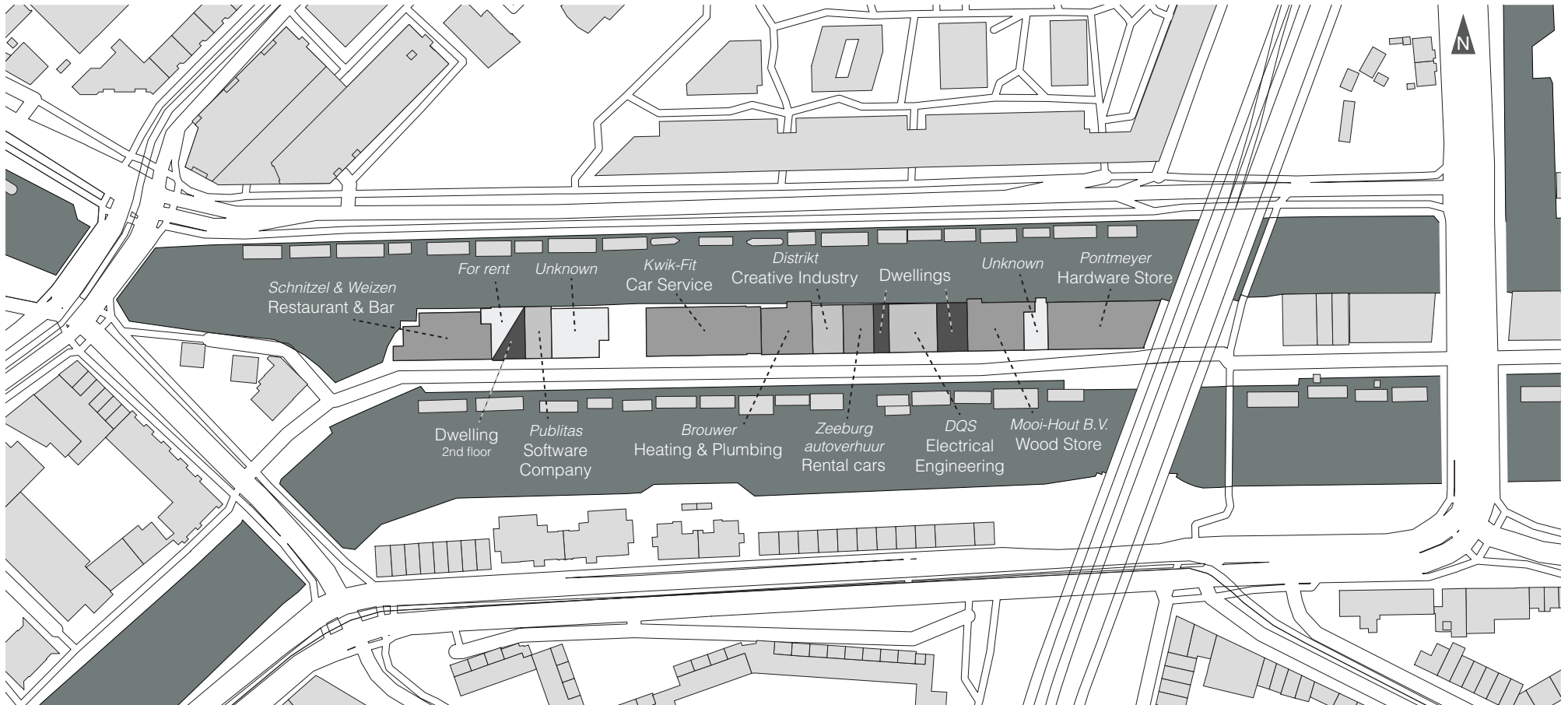

which means they will have to be bought out. The other buildings are all presumably rental, but not owned by the government. This is something to be dealt with from the start of the project.

As explained in the chapter 'Governmental plans', there are no specific plans for the chosen location, but there are for the very similar Eastern part of the Zeeburgerpad. It seems common sense to continue at least some of these ideas and create a coherent island.

Building heights The buildings on the chosen location are much lower compared to its surroundings. Almost all of the buildings are between 3-6 layers, while the location generally has 1 or 2. It thus is very acceptable to create higher buildings on the plot then the current situation offers.

This is also what the government has suggested for the Eastern part of the Zeeburgerpad. It is also in line with the idea of densification. The boat houses however should be kept in mind, as they are generally only one level high.

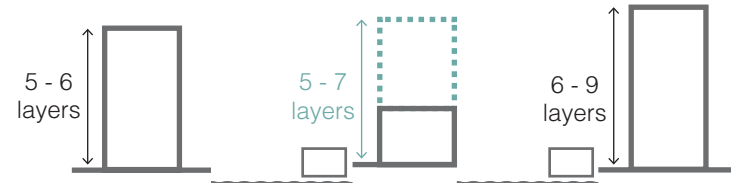

Surrounding heights of the Zeeburgerpad

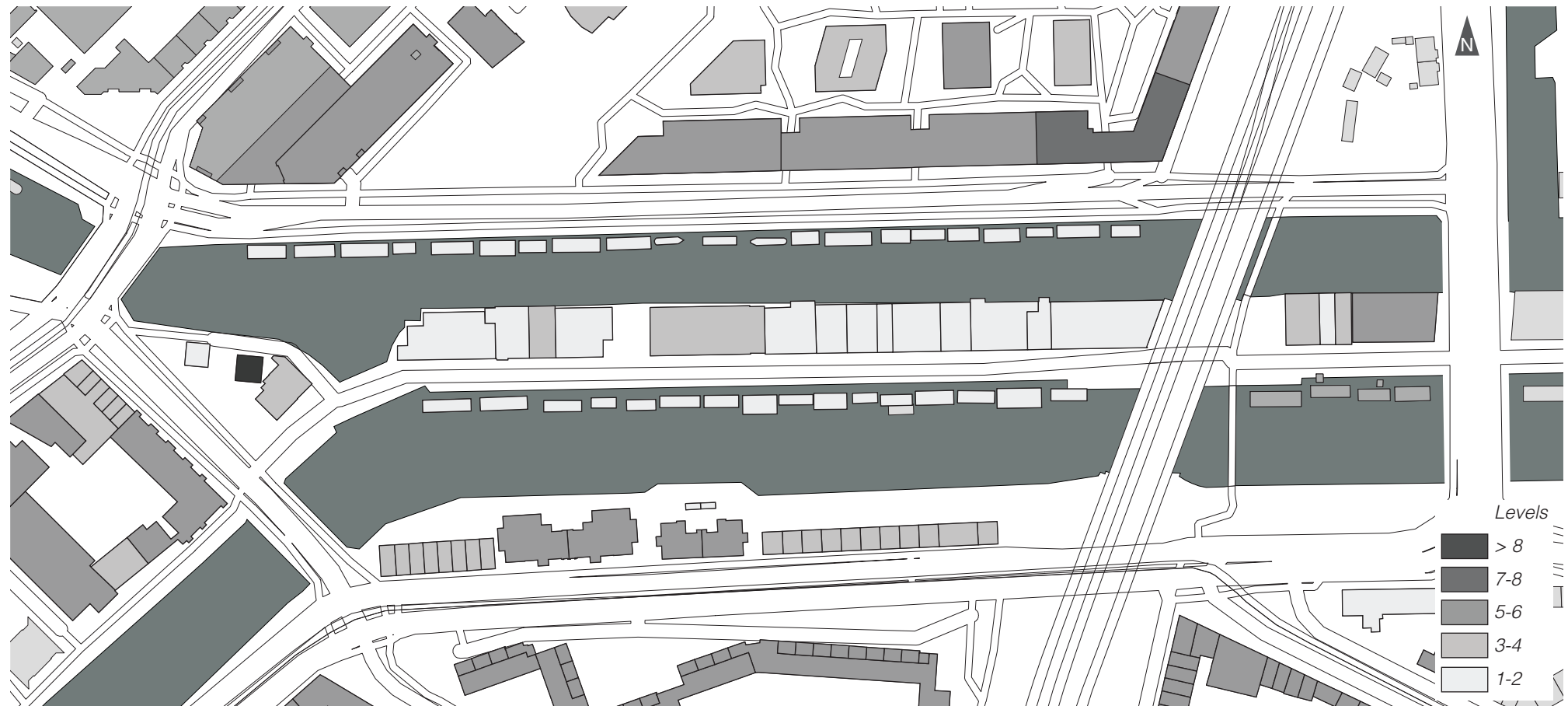

Noise The train track between Amsterdam Central Station and Amsterdam Muiderpoort passes right next to the location, causing a lot of noise. As the illustration underneath shows, the sound pollution is higher on the chosen location, compared to surrounding areas. This is presumably due to two reasons: the higher buildings in the surroundings block the sound and thus reduce the number of decibels; the water seems to carry the sound further than land. As the train track carries along between the height of about 3,5-8 m, the dwellings near the train track should probably surpass this height in order to reduce the noise for the dwellings behind.

Regulations In the 'Wet Geluidhinder' (Noise Act) the maximum sound level that is acceptable is set. The preferred maximum value ('voorkeursgrenswaarde') is set at 55 dB. Looking at the map underneath, this is currently not achievable for the area closest to the railway, thus design solutions have to be deployed. The following chapter will explore this topic.

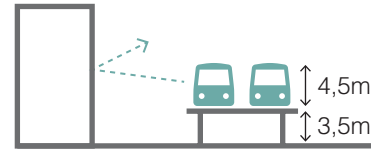

Dwellings along the train track block (part of) the noise

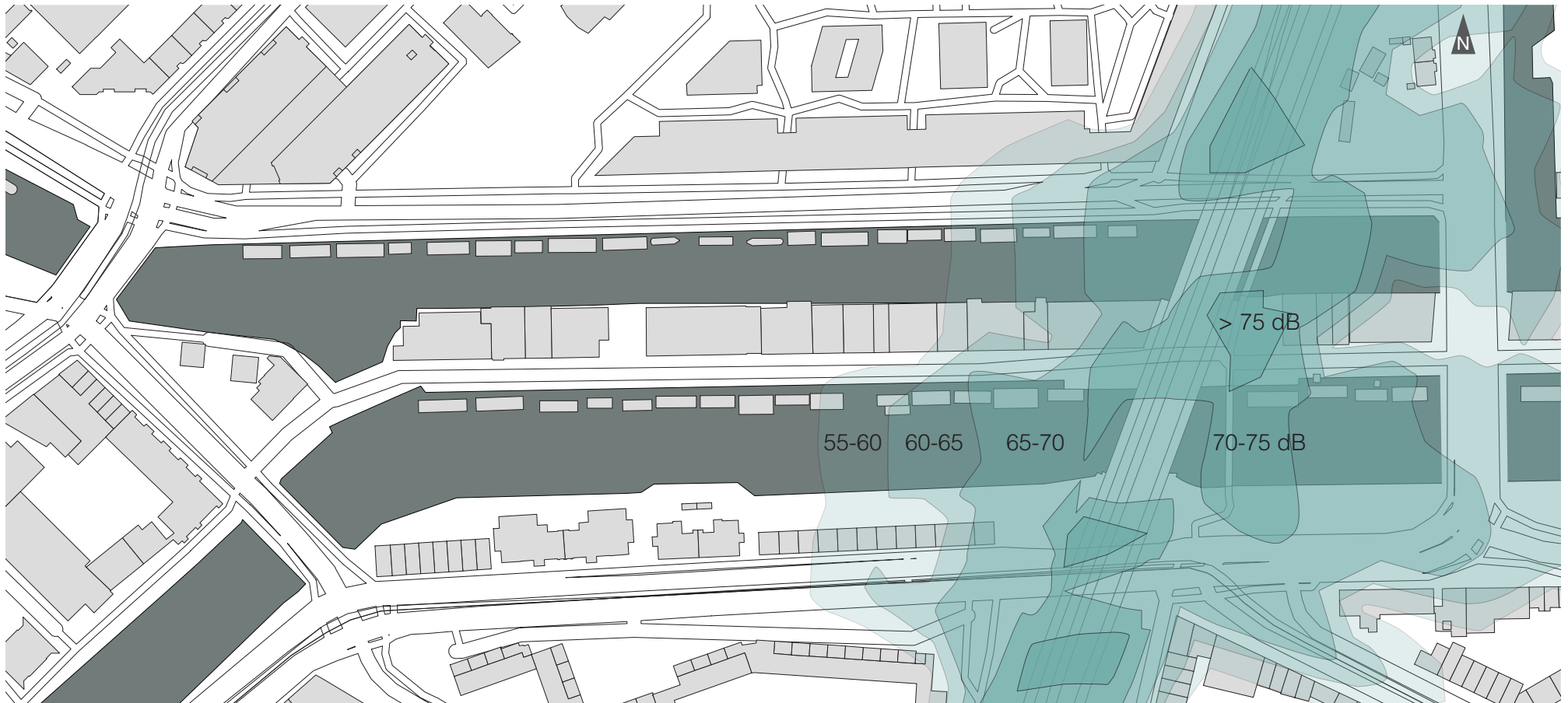

Noise

To reduce the noise levels caused by the train track there are some design solutions that can be researched. First however, it is important to understand how sound works and what the current regulations are.

There are a few notions important for understanding sound or noise and how to deal with it. As a first, sound is calculated in decibels (dB). In general, the number of dB reduces by 3dB when the distance is doubled (Rijkswaterstaat, 2010, p.3). For example, you have measured 56dB at a distance of 50 meters from the train track. When standing at 100 meters, the sound level will be $56 - 3 = 53\text{dB}$.

Secondly, sound movement acts different depending on the temperature, wind, and type of ground. As temperature and wind can be different at any time, it is hard to take into account. For type of ground the following applies: water and hard ground (such as asphalt) carries sound much further than soft soil such as grass (Geluidsvoortplanting, n.d.).



Water and hard surfaces 'carry' sound much further than soft surfaces

Regulations The Dutch 'Wet geluidhinder' (Noise act) is meant to protect citizens against too much noise. The act uses two values, a lower limit or preferred maximum value ('voorkeursgrenswaarde') and an upper limit or maximum permissible value ('maximaal toelaatbare grenswaarde'). The preferred maximum value is the number that should be applied, however in some exceptional cases this may be increased at a maximum of the upper limit. For this specific design case we are interested in the values of dwellings located in the area of a train track, they are shown underneath.

	Preferred maximum value	Maximum permissible value
Dwellings	55 dB	68 dB

The numbers are taken from the 'Besluit geluidhinder' (artikel 4.9 and 4.10). The Amsterdam government though decided to only increase the preferred maximum value by a maximum of 3dB. This sets the maximum permissible value at 58dB (Gemeente Amsterdam, 2016, p.10).

The Dutch Bouwbesluit (a law on building regulations) has set specific targets for the amount of dB that a facade needs to be able to reduce. This number is set at 20dB for dwelling facades adjacent to habitable spaces (artikel 3.2). However, if one uses a higher value than the preferred maximum (55dB), another rule applies. The facade should protect at a number of the used maximum value minus 33dB ('Besluit geluidhinder', artikel 4.9). For example, if the used number is 61dB, the calculation is $61 - 33 = 28\text{dB}$.

There is one exception, a situation in which one does not have to review the noise levels at all. This is the case if a building has a 'deaf' facade ('dode gevel'). This is a construction which has two specific rules:

- No openable elements and with a certain level of sound reduction qualities
- Only openable elements by exception, and only if they are not adjacent to sound sensitive spaces.

The Amsterdam government however does only allow (of course, with a few exceptions) such a deaf facade, if also a 'quiet side' ('stille zijde') is provided. A quiet side can not have noise levels higher than the preferred maximum. It is especially meant to be able to have bedrooms on this side, so one may sleep with windows opened.

Design solutions The noise act has set an order in which solutions against noise may be addressed. The first option is always to find solutions for the source of the noise. This would in this case be the train and the train track, which is out of the architect's and even the government's league.

The second option would be to resolve the issue in the zone between sound source and building. There are a couple of options for this, provided by the Amsterdam municipality in their publication 'Amsterdams geluidbeleid' (2016, p. 7).

These options are:

- placing a noise barrier (10-20 dB)
- placing none-noise sensitive buildings (such as offices) between dwelling and source
- enlarging the distance between dwelling and source (3 dB when the distance is doubled)
- using curtain walls (10-20 dB) or a 'coulissenscherm' (8-16 dB)

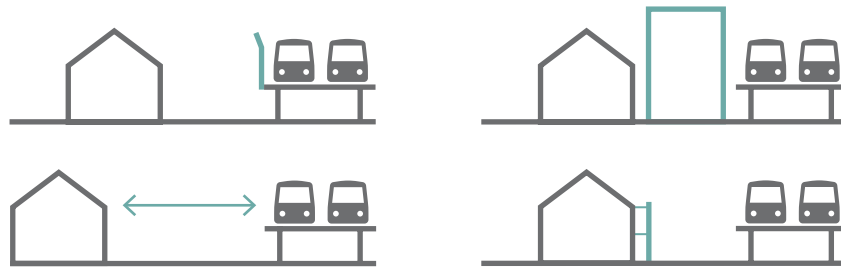

Four possibilities to reduce noise in the zone between source and dwelling

The final option is to solve the problem in the dwelling complex itself, by for example:

- facade insulation
- deaf facade
- different plan arrangement

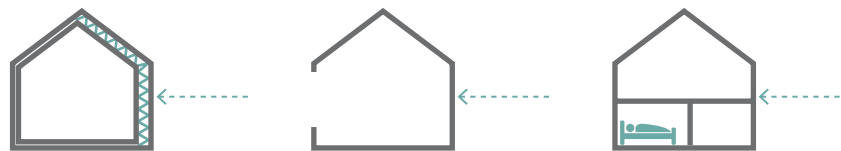

Three options in reducing noise in the dwelling or building complex itself

Case studies In order to gain ideas on the implementation of the previously named tools, a few case studies have been analysed on this topic. All of them are about blocking the sound by having a higher building and adding certain layers, for example the before mentioned curtain wall, 'coulissenscherm' or thick insulation. The higher building will function as a wall to block the sound for the buildings behind.

Sporenboog, Funen, Amsterdam (ArchitectenCie) For this project the noise was measured at 79dB, and was reduced by 48dB in the facade. The building functions as a noise barrier in itself for the buildings behind.

- The facade is made out of hsb (a timber frame) with double plasterboards
- The cavity has a minimum width of 200mm, and the ceilings have sound insulating material
- By combining a noise barrier (in the facade, -22dB), broad cavity and thick facade a noise reduction of 48dBa is achieved.

Woningen langs het spoor, Vathorst, Amersfoort (agNOVA) In order to create a more peaceful back, this project as well serves as a noise barrier for the area behind.

- The dwellings backs are closed and placed directly next to the train track
- To insulate the dwellings against vibrations, their foundation is extra heavy and has rubber mats underneath.



Two ways of dealing with noise, left: Funen, right: Vathorst

Solution The specific case of the Zeeburgerpad makes it more difficult to implement a design solution. The main reason for this is the narrow shape accompanied by two sides of water. Because of the narrow size, blocking the sound by placing a building in parallel to the train track won't be as effective as it is in the Funenpark case. The water next to it will carry the noise further and around the building, onto the land of the Zeeburgerpad (see illustration on the right). Dwellings placed close to the borders of the land will thus still receive too high levels of noise. This principal is shown in the illustration on the right.

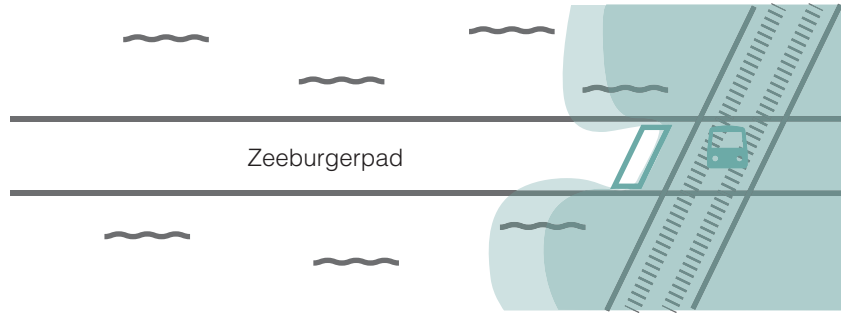

Water will carry the noise around the building and onto the land

The best solution in this case can be found in placing a sound barrier next to the train track. This can effectively block the noise, possibly for other surrounding dwellings as well.



Using a sound barrier next to the train track will reduce the noise

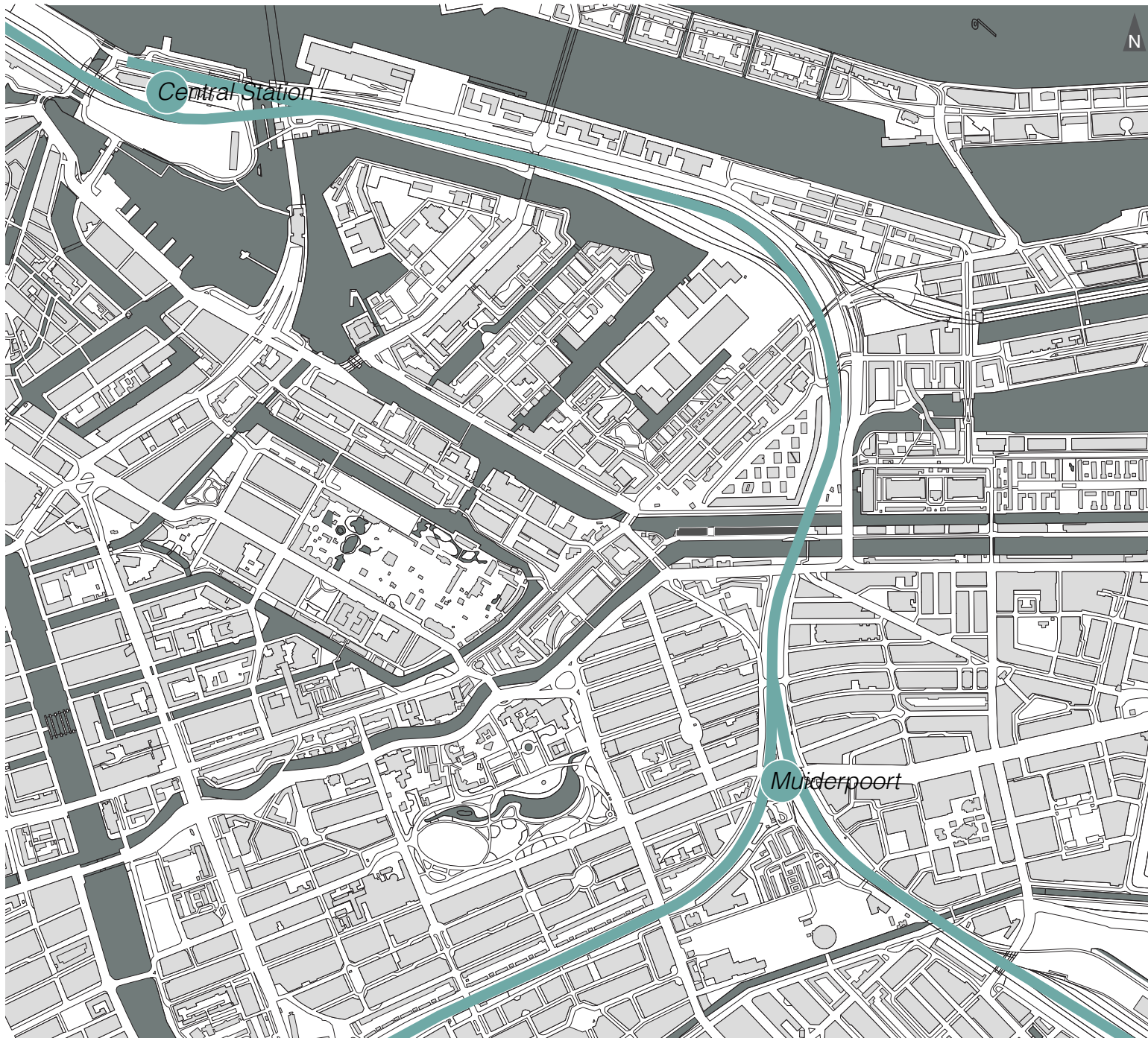

Infrastructure

Train There are two train stations quite nearby: Central Station and Muiderpoort. When commuting to work by public transport this can be a big advantage.

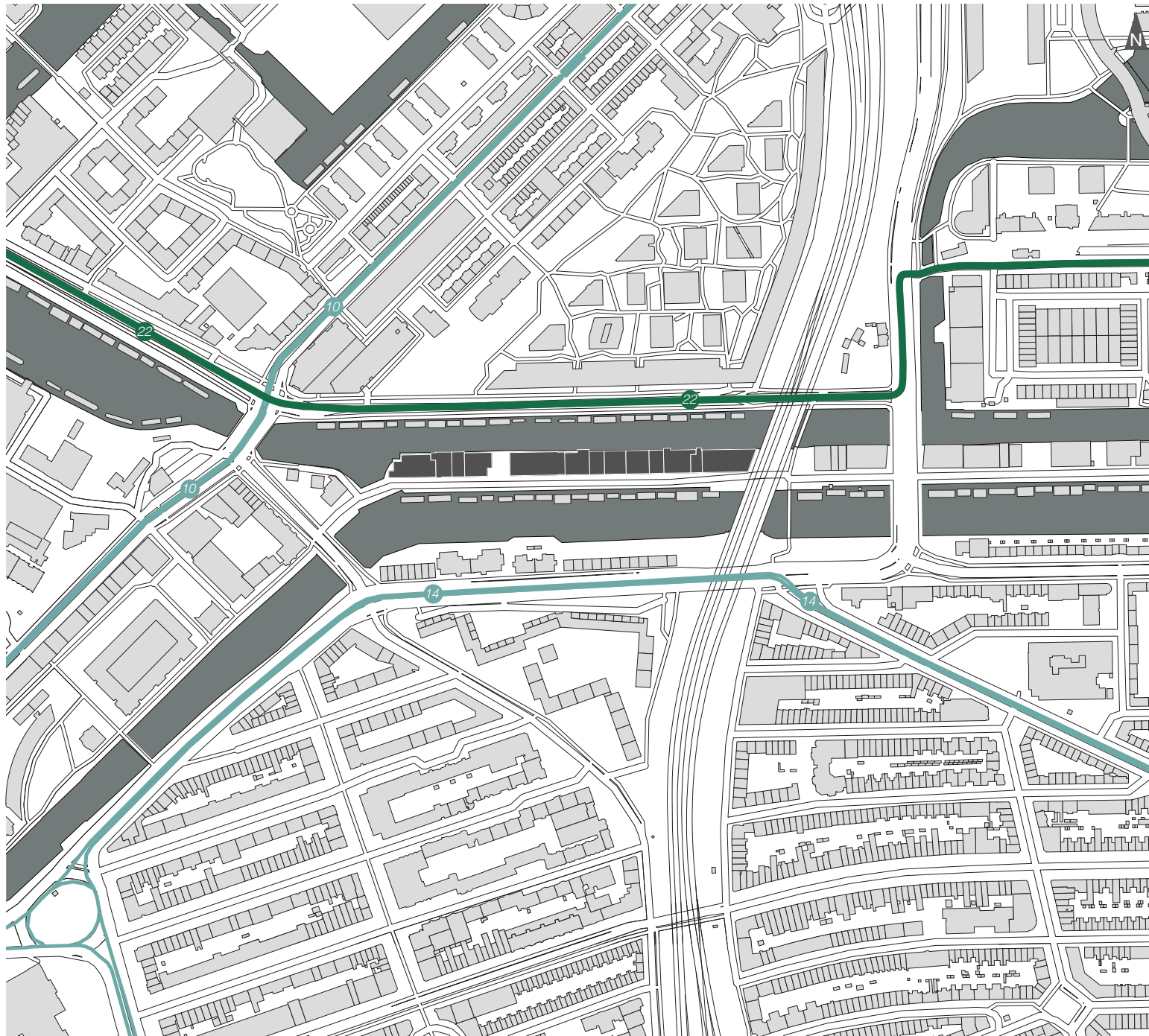

Tram and Bus Also tram and bus stations are located very close by, even two different tram lines.

- Tram
- Bus

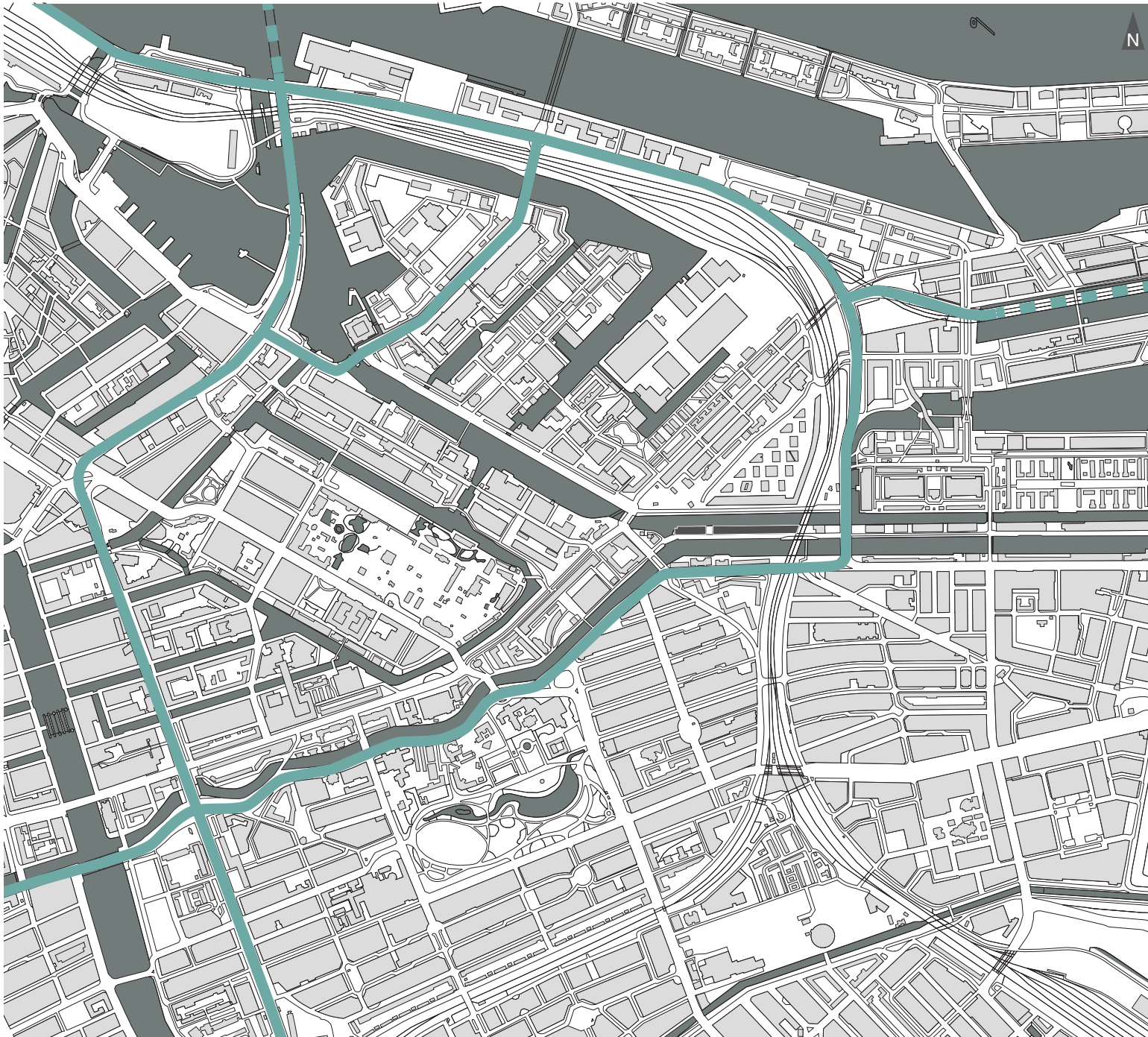

Car The location is directly located next to the main roads around the city center of Amsterdam. It is also just a kilometer away from the Piet Hein Tunnel. This is an advantage in the sense of fast commuting, yet a disadvantage for childrens' safety.

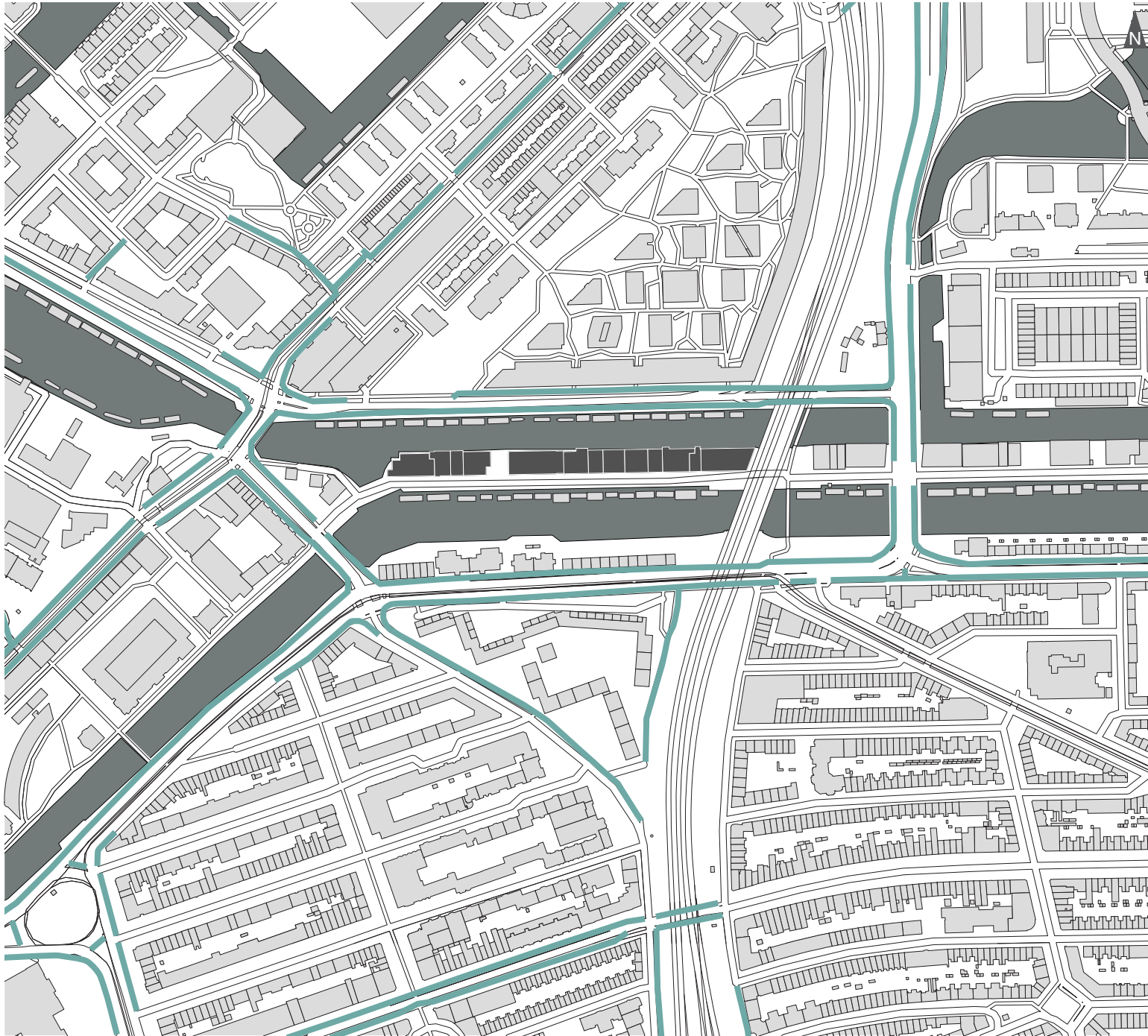



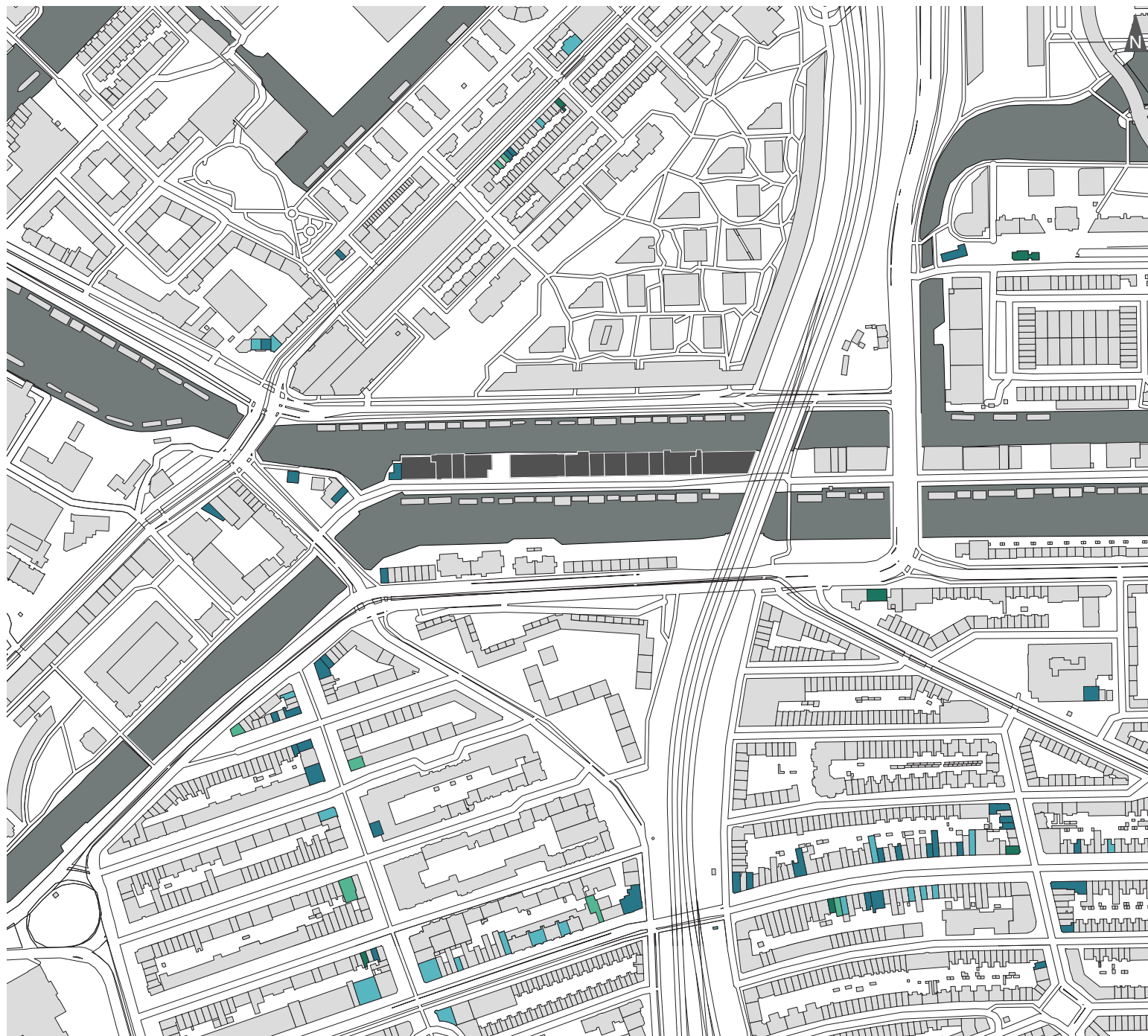

Bicycle Proper bicycle paths are very important for both parents (commuting to work) and children (safe route to school). As the surrounding roads are all rather big, the bicycle paths shown are all separated from the car road. However, because of the large roads, there are many crossings dangerous or difficult for children.

Facilities

Hospitality and Catering Services (Horeca) To have places to eat and drink nearby is seen as an advantage, especially of course if these places are 'kidsproof' as well. In the map some streets can clearly be identified as main roads for these functions.



-  Cafe
-  Fastfood
-  Lunchroom
-  Restaurant

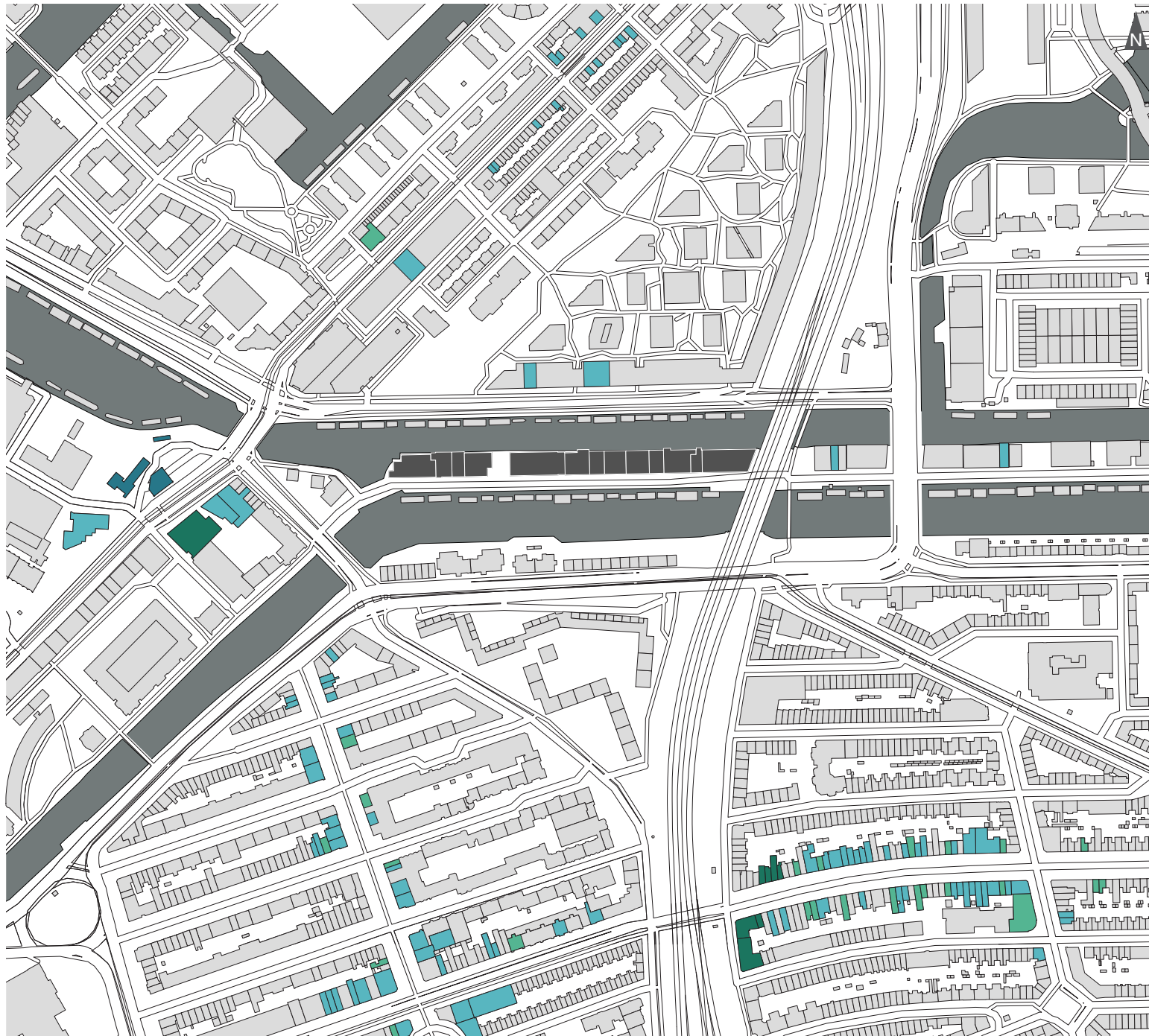

Shops To have shops nearby, especially within walking distance, is very favourable (especially for social minima). Both the gas station and a big supermarket are very close by. Other than that, the same main streets as for restaurants and alike can be distinguished.

- Gas station
- Other stores
- Food stores
- Supermarket

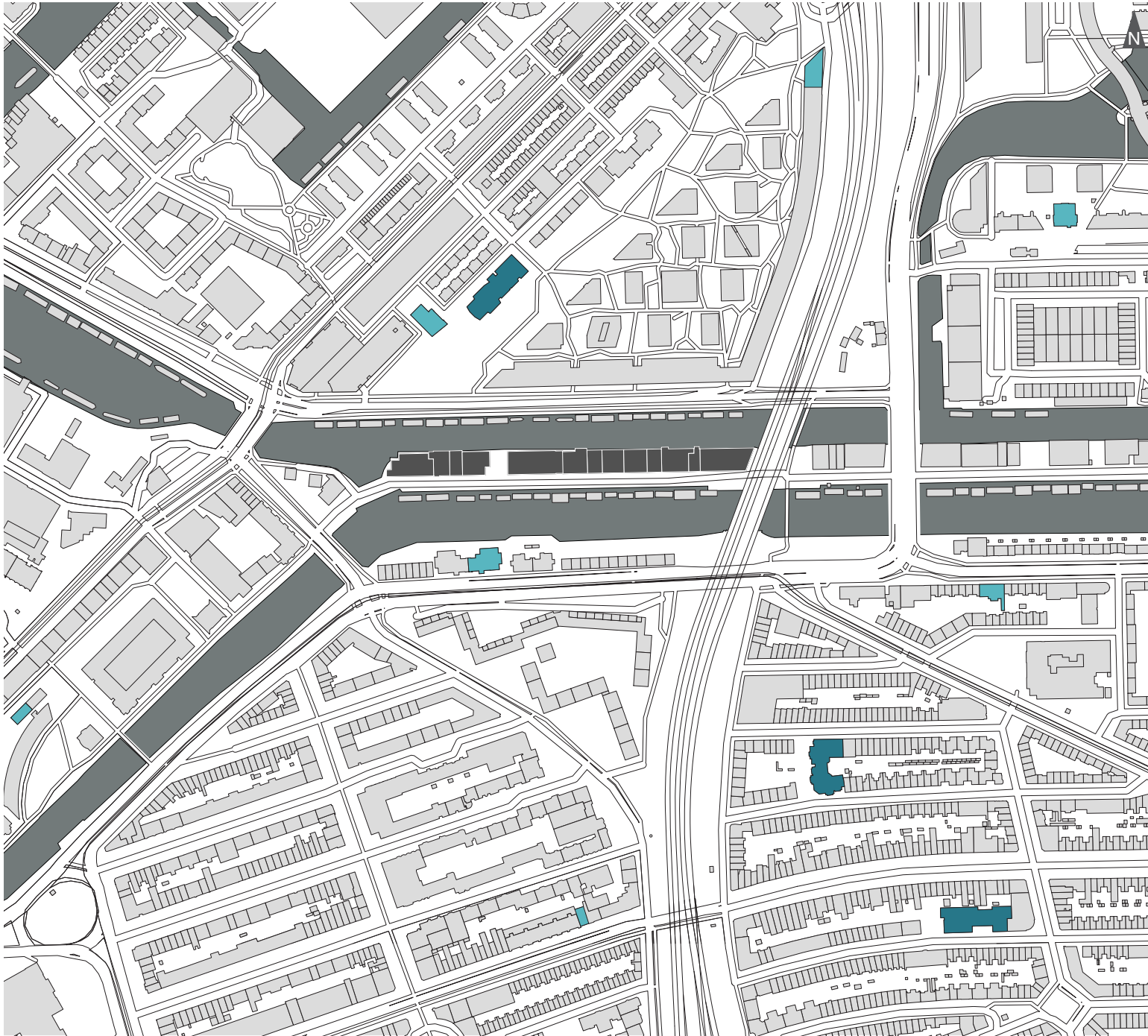

Education and daycare

Within the target group of families it is important to have facilities such as a creche and primary school nearby. Primary schools are preferably within a reach of 500m, so that children might walk to school. Though there are schools within that reach, the route to them is possibly not safe enough.

- Primary School
- Daycare

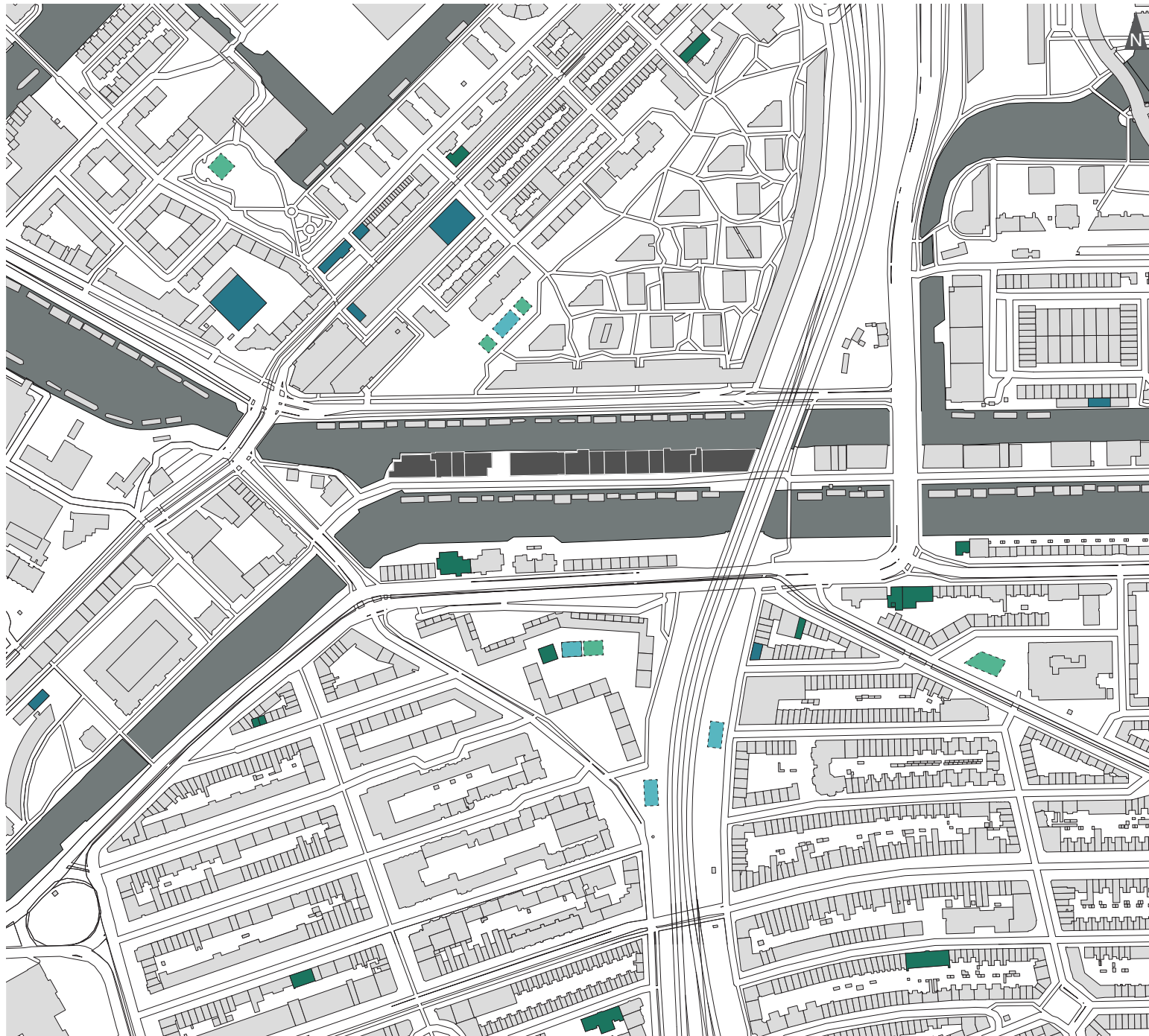

Leisure and activities
 After school there is of course time to play sports or do other activities. For the young-children playgrounds within walking distance of a few hundred meters are important. The older ones are more interested in informal games or outdoor sports, which is possible at locations with a basketball or a football field.

- Indoor sports
- Outdoor sports
- Playground
- Activities Centre

Range of action



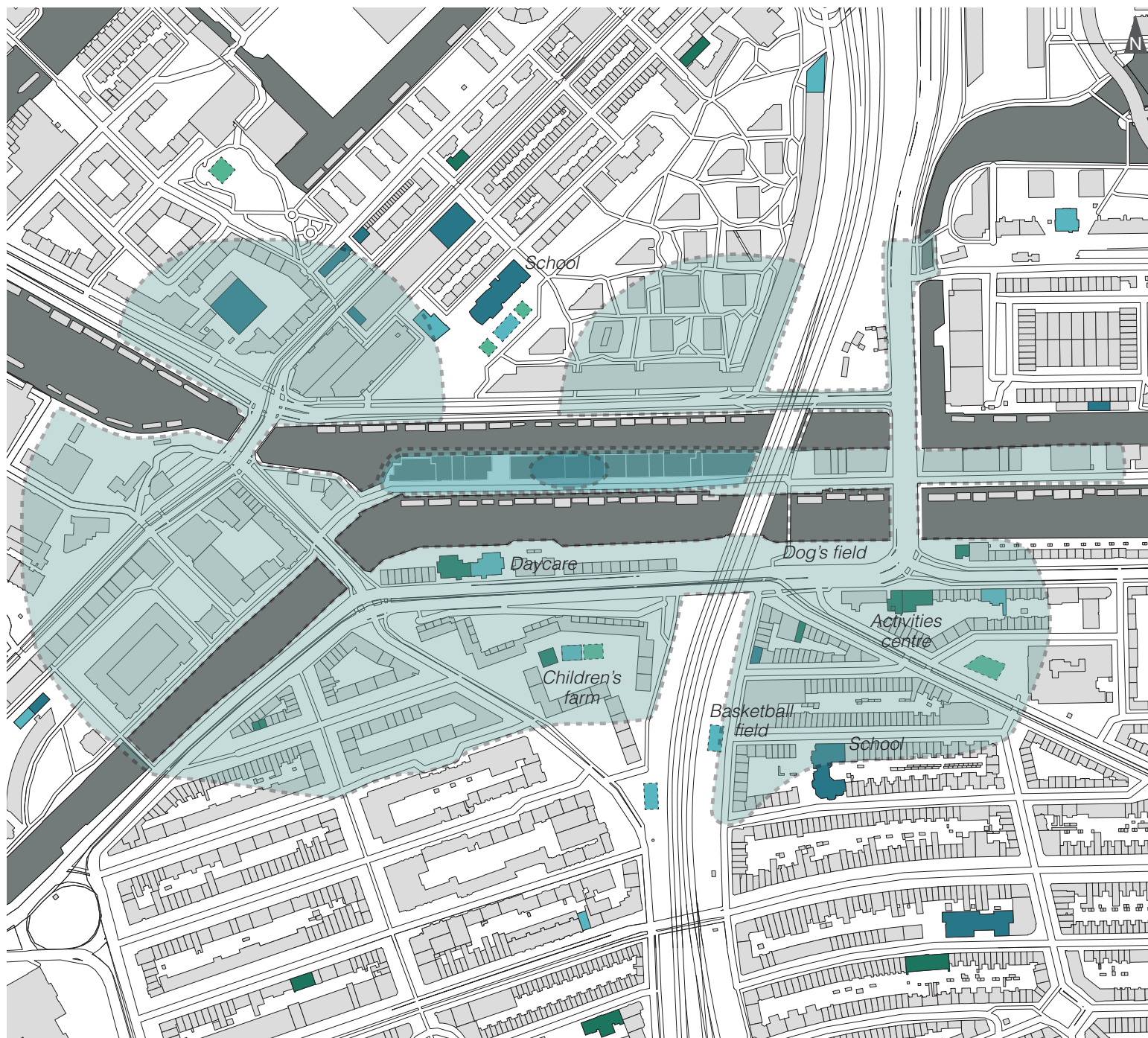

When applying the range of action of a child on the Zeeburgerpad location, it is clear that the water reduces this range very much. There is one school with 500m walking distance, even though the other one is closer by in a straight line. The Funenpark is also theoretically not completely within reach.

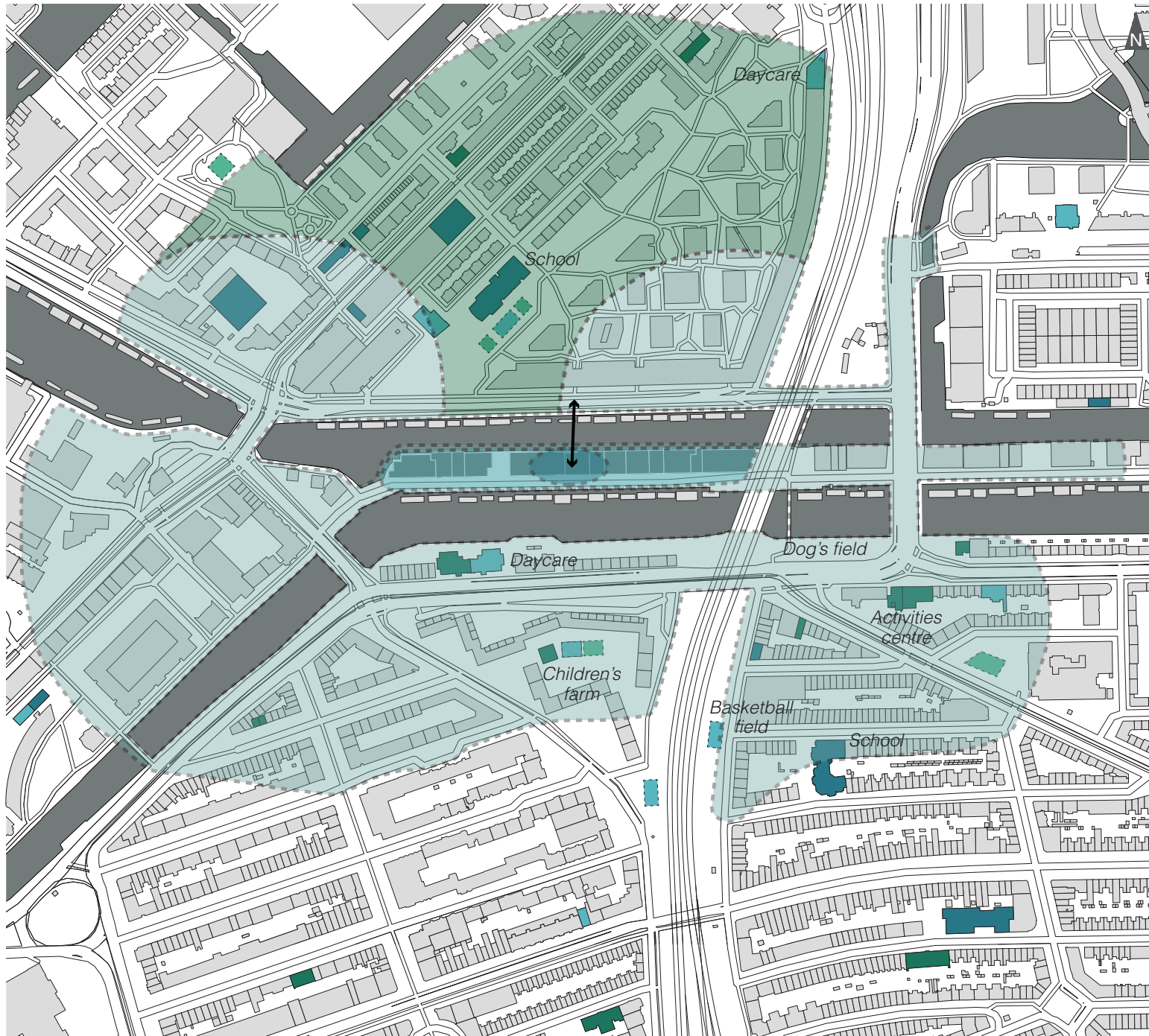

Range of action applied on map with education, daycare, leisure and activities



Extension It might add lot of value to the plot if a small bridge is added between the Cruquiuskade and the Zeeburgerpad. By doing so, a relatively safe connection is made to the Funenpark and the school next to it. The biggest border on this route will be to cross the Cruquiuskade. This is however a less big street compared to all the other ones around.

	0 - 4 years	30 m
	4 - 8 years	150 m
	8 - 12 years	500 m
	Possible extension	

Range of action extended, applied on map with education, daycare, leisure and activities

Design brief 3.0

This is the final design brief, also taking into account what has been learned from the location analysis. The added items, compared to the 2.0 version, are indicated in blue.

± 100 dwellings

- 50 - 100 m²
- 3 bedrooms minimum
- apartments and maisonnettes
- adaptability in floorplan
- outdoor space of >6m²
- storage space of ±7m

± 30% of the houses at minimum possible size (with 3 bedrooms)

Building complex that

- has a clear identity in itself
- is clearly identifiable as housing
- relates to the existing Eastern part of the Zeeburgerpad, by:
 - + building in North-South orientation
 - + building between 2 and 7 layers

Circulation area broad enough (±3m) to facilitate

- meetings between neighbours
- playing of children

15-25 dwellings per entrance core (with lift)

Parking *integrated in the building complex*

- ± 60 parking lots (N = 0,6)
- ± 5 shared cars (1 shared car = 4 cars)

Play areas for each age group

- 0 - 4 years
 - + *informal play area right next to the house*
 - + *formal play area with play equipment*
 - + *safety from water and cars*
- 4 - 8 years
 - + *informal play area within view of the house*
 - + *formal play area with play equipment*
- 8 - 12 years
 - + *informal play area that is exciting*
 - + *formal play area for ball games*
 - + *within safe walking distance (±500m)*

Collective functions

- Laundry facilities
- Bicycle storage
- Guest rooms

Additional functions (unless already provided for in the area close by)

- ~~Daycare~~
- ~~Area dedicated to dogs~~
- Mixed-purpose room (meeting room, ~~youth club~~)

A bridge to connect to the Funenpark

A sound barrier to reduce the noise from the train track

Bibliography

Books

- Bleeker, H., Mulderij, K. (1978). *Kinderen buiten spel; op zoek naar een vriendelijke woonomgeving voor kinderen*. Amsterdam: Boom.
- Keesom, J. (2013). *Nestelen in de stad; appartementen voor gezinnen*. Amsterdam: BNA
- Jacobs, J. (1961). *The Death and Life of Great American Cities*. New York: Vintage books
- Levitt, D. (2010). *The Housing Design Handbook; A guide to good practice*. Oxford: Routledge
- Karsten, L., Felder, N. (2016), *De nieuwe generatie stadskinderen; ruimte maken voor opgroei*. Rotterdam: nai010 uitgevers.
- Karsten, L., Kuiper, E., & Reubsat, H. (2001). *Van de straat?: de relatie jeugd en openbare ruimte verkend*. Assen: Uitgeverij Van Gorcum.
- Pallasmaa, J. (2005). *The Eyes of the Skin*. Chichester: Wiley.
- Woonlab 010. (2017). *Eengezinsappartement; Een gesprek tussen stadmakers. Gestapeld wonen voor gezinnen in de stad?*. Rotterdam: Veenman+

Publications

- Gemeente Amsterdam. (2016). *Amsterdams Geluidbeleid, Hogere waarde Wet geluidhinder*. retrieved from: <https://www.amsterdam.nl/bestuur-organisatie/organisatie/ruimte-economie/ruimte-duurzaamheid/geluidbeleid/>
- Gemeente Amsterdam. (2017). *Nota parkeernormen auto*. retrieved from: https://issuu.com/gemeenteamsterdam/docs/nota_parkeernormen_auto?e=19262377/56381024
- Karsten, L. (2003). *Family gentrifiers: Challenging the city as a place simultaneously to build a career and to raise children*. *Urban Studies*, 40(12), 2573-2584
- Meijer, A., and Stobbe, A. (2016). *Buitengewoon spelen: Speelruimteplan, beleidsplan, Leidschendam-Voorburg 2016-2025*. Almere: Speelplan bv.
- Kummeling, E. (Ed.) (2011). *Gezin in Den Haag, Kansenboek stedelijke gezinnen: van kans naar realisatie*. DSO Gemeente Den Haag, afdeling wonen. retrieved from: <https://kummeling.files.wordpress.com/2013/08/visie-stedelijke-gezinnen-27102011.pdf>
- Lingwood, et all. (2014). *The development of wayfinding abilities in children: Learning routes with and without landmarks*. *Journal of Environmental Psychology*, 41 (March 2015) 74-80.
- OIS Amsterdam. (2016). *Amsterdam in cijfers, jaarboek 2016*
- Rijkswaterstaat. (2010). *Geluid luistert nauw: informatie over bestrijding van wegverkeerslawaa*. retrieved from: <https://www.rijksoverheid.nl/binaries/rijksoverheid/documenten/brochures/2010/04/01/geluid-luistert-nauw-informatie-over-bestrijding-van-wegverkeerslawaa/geluid-luistert-nauw.pdf>
- Van Gessel-Dabekausen, G. (2002). *Oppas populair: opvang kinderen*, Index 8 (September 2002), 10-11

Websites

- atlasleefomgeving.nl
- beeldbank.amsterdam.nl
- bouwbesluitonline.nl
- cohousing.org.uk
- coparents.com
- gezinindestad.nl
- lvcw.nl
- maps.amsterdam.nl
- ois.amsterdam.nl
- opendata.cbs.nl
- parool.nl
- volkskrant.nl
- wetten.overheid.nl

Other

- 'City for Sale' of VPRO Tegenlicht (November 5th, 2017)
- 'NOS Journaal' (December 18th, 2017)