

into the climate
*Bioclimatic principles in vernacular architecture.
Lessons from four different climate zones.*

BIOCLIMATIC PRINCIPLES IN VERNACULAR ARCHITECTURE.

LESSONS FROM HOT-HUMID, HOT-DRY, CONTINENTAL AND COLD CLIMATES.

Wioletta Sarara

Faculty of Architecture & the Built Environment, Delft University of Technology
Julianalaan 134, 2628BL Delft

ABSTRACT

For centuries people have been using bioclimatic principles to achieve an optimal thermal comfort in their dwellings. Building with nature could bring high effectiveness without additional mechanical supplements. Nowadays, there are the artificial systems that lead the design and on which people depend so deeply. This paper will claim that re-inventing and developing bioclimatic principles from the past can improve contemporary architecture. The present research provides information about bioclimatic principles used in traditional dwellings in four different climate zones, which will be compared: hot-humid, hot-dry, continental and cold. From each climate the features were chosen that shape the building and serve thermal comfort. Additionally, existing examples of dwellings in relation to the bigger context of a farm, village or city are included. To conclude, a final matrix compares climatic principles between all researched climate zones, presenting common elements appearing in more than one climate.

KEYWORDS: *bioclimatic principles, responsive architecture, passive design, vernacular architecture*

I. INTRODUCTION

1.1. Background

Looking at the traditional architecture in different areas in the world, it can be seen that climate has got an important position in building design and a huge impact on the decisions made by locals. For centuries craftsmen looked for solutions to improve thermal comfort of their dwellings and take as much as possible from materials that the environment and climate can provide.

The first dwellers of mankind were already creating protection from rain and cold wind while facing the sun to gain as much heat as possible. One of the perfect examples of ancient passive design is the Anasazi cliff dwellings at Mesa Verde, Colorado, where dwellings are hidden inside the cliff's horizontal aperture protecting it from wind and precipitation, while still gaining heat and sunlight during winter and keeping the homes cool in summer. A longer tradition of building with climatic principles can be found in the Middle East, where it is excessively hot and dry. Inhabitants decided to build their structures compactly, next to each other, to reduce solar access, hence heat gain by thermal mass. At the same time, through thousands of years, people developed wind-catchers to enhance ventilation and capture the breeze. These were supported by the inner courtyards which allowed people to inhabit such hazardous arid areas.

Each and every region developed their own ways of approaching the local climate in architecture – utilizing its opportunities and dealing with constraints. The climate-responsive design can be very effective with smart but simple techniques and with little impact on the environment. Studying traditional dwellings can not only allow architects to re-examine their ways of

designing, give a new light for building possibilities, so important in contemporary architecture but also re-invent those old methods and principles in a new style.

1.2. Problems and objectives

For centuries anonymous ‘popular’ architecture was given a lower value, comparing to ‘representative’ architecture appreciated the critics throughout history. The latter one, usually built on a commission of aristocrats and church, attempt, with its aesthetics, to impress the observer and show the power, which overcame the importance of the environment and local climate (Coch, 1998). This architecture is the base knowledge of education till these days. On the other hand, ‘popular’ architecture, often forgotten in official circles, meet the needs of community, protecting them from local weather conditions and providing a comfort of living. Limitations of the local climate, surrounding materials and technical resources impose ways of building with close relationship to the environment and take advantage of climatic conditions. (Coch, 1998)

Nowadays, globalization became not only an advantage for architecture but also a problem. No matter where the dwelling is located, whether in Africa, Asia or Europe, the design methods and used materials became similar. Looking at the building it is not only hard to define in which climate zone it is built but what is more important, they are not suitable for the local climate, requiring compensation from high-tech solutions, which provide an even bigger impact on the environment and health of their inhabitants. ‘Unrealistic faith in artificial systems leads to designs which disregard the climate and turn out buildings that are both physiologically and psychologically inhospitable’ (Coch, 1998).

In the middle of 20th century people started to be aware on the effects of technological innovations on the environment. In 1960’s for the first time the term of ‘bioclimatic design’ appeared in scientific society which involved ‘the development of theoretical principles for ensuring favorable microclimatic conditions for human comfort by means of architectural and spatial elements’ (Bondars, 2013). Nevertheless, it is the global energy crisis in 1973, which made it clear that the changes also in architectural design should be made. People finally realize the dreadful environmental conditions of the planet and look for approaches being in balance with the laws of nature and its resources. The huge impact of building construction and its use on the environment, led experts to rethink ‘current construction processes and techniques in favor of new sustainable approaches that are able to use natural resources in a renewable manner and apply the bioclimatic features available in the specific area’ (Achenza & Giovagnorio, 2014). Countries started to implement in their law more restrict regulations on energy efficient of the buildings. Meanwhile, architects and engineers attempted to research and design buildings where ‘internal microclimate would mainly depend on a proper spatial layout and appropriate use of the building materials, not only on mechanical heating, ventilation and air conditioning systems’ (Bondars, 2013).

As mentioned previously, vernacular architecture was built with bioclimatic principles, which makes it a perfect example to analyze and rethink climatic laws hidden in traditional building designs – from North Scandinavian turf houses to tropical light-weight constructions. The optimal indoor thermal comfort and health of inhabitants was achieved by simple techniques and principles, which took advantage of local climate conditions and had been developed through the centuries. Undoubtedly, most of the methods used in the past cannot be any more directly transferred to the contemporary architecture, because it has evolved, and they do not meet today’s standards. However, the bioclimatic principles can be used not only as a lesson and inspiration but as a real tool to incorporate passive design solutions of the past with present architecture, developing new, simple low-tech solutions for buildings and bring back the positive relationship with the environment. The rediscovery of best time-tested passive strategies could bring new, better and healthier possibilities of building in architecture, set new standards of thermal comfort and introduce new architectural trends.

1.3. Research question

The problems and possibilities mentioned above prompt me to formulate the statement: Bioclimatic principles in vernacular architecture. Lessons from hot-humid, hot-dry, continental and cold climates.

Bioclimatic principles in design are not so common anymore. For this reason, I would like to re-introduce this knowledge and as a part of the research, collect climatic rules learned from vernacular architecture in four different climate zones and present their advantages and possibilities. As a result, the paper creates a bioclimatic guide for architects, showing all similarities and differences between dwellings in various zones. Every climate is unique and requires diverse techniques of building. However, the ideas already have been or could also be transferred to other regions.

1.4. Methodology

For the research I have chosen four climate zones: hot-humid - Indonesia, hot-dry – Middle East, continental Central-East Europe, cold – Iceland. The selection was made by the huge variation of the climate conditions and distinctiveness, and peculiarity of the vernacular architecture in those regions. The research is based on analysis of climatic principles in each area separately and ending up with the comparison table of the building elements, which were created for bioclimatic reasons, in the climate zones researched.

II. BIOCLIMATIC AND VERNACULAR ARCHITECTURE

2.1. Bioclimatic architecture

The term ‘bioclimatology’ was already used in 1930’s, e.g. in *Bioklimatische Beiblätter* of the *Meteorologische Zeitschrift*. Nevertheless, the idea of ‘bioclimatic architecture’ was for the first time introduced in 1953 by Victor Olgyay in the paper *Bioclimatic approach to architecture* and developed in his later book from 1963 *Design with Climate: Bioclimatic Approach to Architectural Regionalism*. The author not only combined the knowledge from physiology through climatology to building physics but also presented the importance of relations between them. According to Olgyay, bioclimatic architecture creates an attitude where the architecture is created for human beings, who are exposed for the climate and creates a filter, not a barrier, between inhabitant and nature. (Szokolay, 1998) “The essence of bioclimatic design is to create a favorable microclimate both inside the building and outdoors through application of architectural techniques” (Bondars, 2013). There is an interlocking relationship between climatology, biology, technology and architecture. Climatic data of the region leads to biological evaluation of the human needs, which solutions are found in technology, creating an architecture. Each design should be evaluated according to those four fields. (Olgyay, 2015)

Olgyay also created a bioclimatic chart which limits the comfort zone for humans in the moderate climatic zones, taking into account four weather conditions: effects of air movement on vapor pressure and moisture on high temperatures, relation of winds and high temperature, and relation of radiation and drybulb temperature. (Olgyay, 2015) Later with time, more scholars become interested in the bioclimatic design. B. Givoni in 1969 and S. Szokolay in 1986 worked on principles determining comfort zones based on the monthly climatic data with use of psychrometric chart. (Bondars, 2013) “All those studies created an important basis for development of climatic-appropriate and environmentally-balanced architectural design” (Bondars, 2013).

2.2. Introduction of four different climates

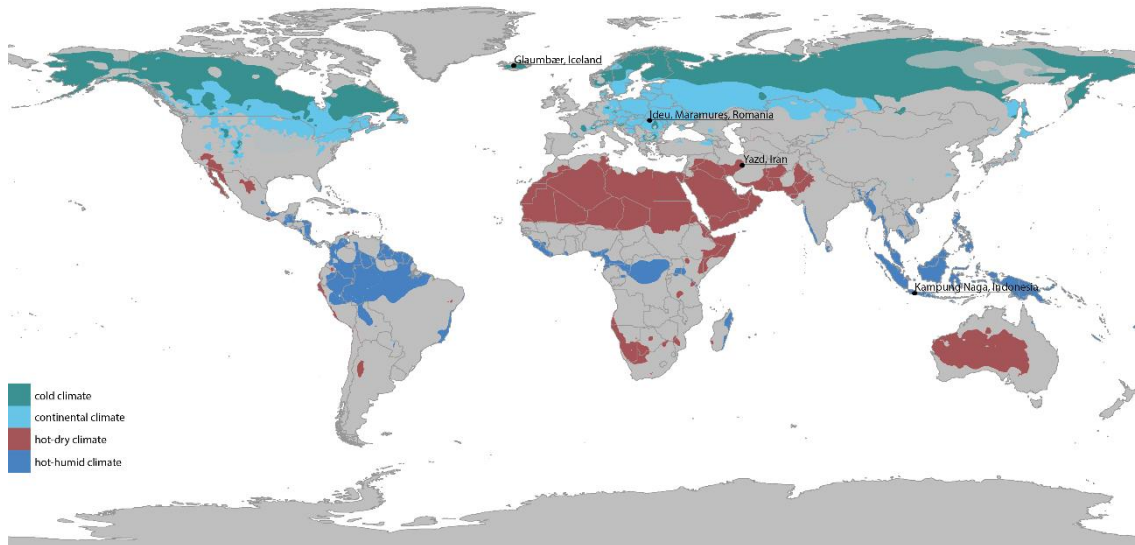

Figure 1. Four climate zones: cold, continental, hot-dry, hot-humid.

2.2.1. Cold climate

Iceland has one of the most hazardous climates – a cold climate. The temperature varies significantly in a day as well as within the year. During warm period the average temperature is around 10-13°C, while during winter rarely exceeds 0°C (Einarsson, 1984). In the northern parts of Iceland and the highlands the temperature can even drop to -30°C. The closer to the North Pole, the longer the days in the summer and the shorter the days in winter. Precipitation in Iceland is significantly greater than in more continental areas like Scandinavia. Also, the strength of prevailing east wind is more bothersome in coastal regions. The snowfall can even last even for five months – from December to April.

2.2.2. Continental climate

In contrast to polar and tropical zones, Europe is located in a temperate zone which distinguishes not two, but four seasons. Central and East Europe is situated far enough from the seas and ocean to experience very hot summers – above 25°C – and cold, snowy winters – below 0°C.

2.2.3. Hot-dry climate

In a hot-dry climate there are many disadvantages making this climate hard to adapt to – burning sun, excessive heat, hot summers and significantly colder winters, high fluctuations of the temperature differences between day and night, especially during summer. However, the biggest problem of this climate is scarcity of precipitation and absence of humidity. Lack of moist air leads to limited vegetation and a low-density population. The precipitation is less than one-third of the global average and evaporation goes faster than anywhere else in the world. Additionally, the air is polluted by dust and sand.

2.2.4. Hot-humid climate

In hot-humid climates the variation of the daily and annual temperatures is very small: it varies around 25-30°C. There are only two seasons: wet and dry, the first with very high precipitation and the second with very intensive solar radiation. The last causes the biggest problems in daily life. It is important to avoid direct and reflective sun radiation, and create natural air ventilation which is a dominant comfort factor in this climate. (Coch, 2014)

III. COLD CLIMATE

Northern Scandinavian architecture – Iceland

Wind and rainfall in northern parts of Scandinavia – the Scottish islands, Faroe Islands and Iceland – can be more severe than heavy snowfalls. As the later provides additional insulation for the dwellings, to be protected from first one, people built structures turning them back or sideways to the wind.

3.1. Materials

In the far north the availability of the wood has always been scarce. Settlers built using local stone, turf and reclaimed wood. The construction is not dug into the ground, but covered with it – at least along two longer sidewalls. The roof also contains turf as an insulating material. Timber, usually reclaimed from shipwrecks or from the trades, is used for simple structures.

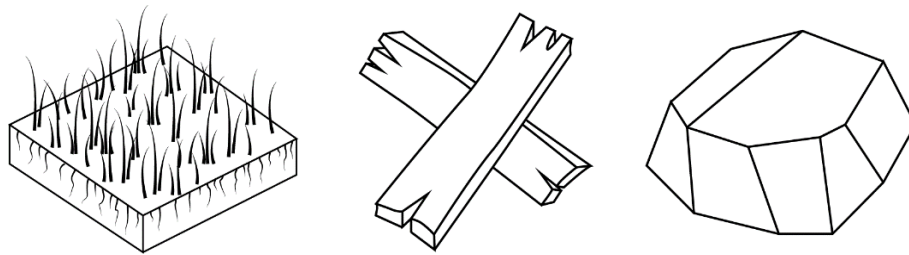

Figure 2. Construction materials used in Scandinavia. Images by author.

3.2. Turf bricks

The most interesting material in Scandinavian houses are turf bricks. They are cut from mineral-based marshland in different shapes, from cuboid to diamond shape. The most popular one is brick shaped *strengur*, cut for about 5-10 cm thick and 1 m long. Turf is the main element in building a house. It can be used in-between the stone walls, creating a thick layered wall itself or as a top part of a roof cover. Moreover, turf has good insulation properties. Nevertheless, due to degradation of the root system, in the north turf has to be replaced every 50-70 years. (UNESCO, 2011)

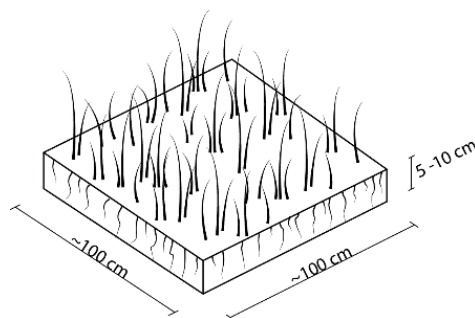

Figure 3. Turf brick. Image by author.

3.3. Wall insulation

There is a variety in the building methods of sidewalls – sometimes they are built only from stone, sometimes with the addition of some turf. However, the most popular one is the turf sidewall composed from double skin walls made from stones and turf and filled in between with soil. The thickness of the wall varies from half a meter to three meters and can be slightly narrower with the height. (Donnelly, 1992)

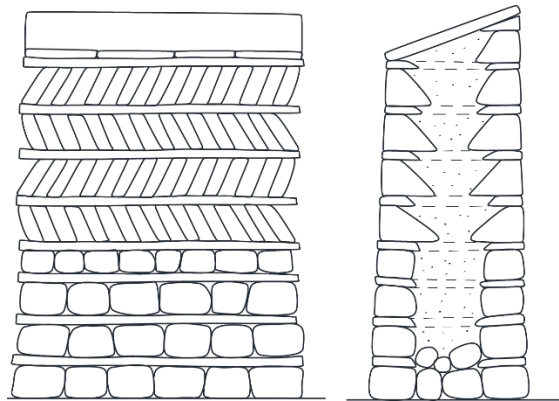

Figure 4. Turf wall construction. Images by author.

3.4. Roof structure and insulation

One of the most interesting parts of the construction in Scandinavian houses is a low-pitched turf roof, which during winters conserves snow for better insulation. The base of the roof is from wood boards on which several layers of birch bark are placed. Bark has high water- and soil-resistant properties, which prevents the roof from leaking for about 30-50 years. On top of the bark, craftsmen placed two layers of turf. The first one was placed with the grass down to protect bark from acid humus and at the same time have a drainage function. The second one was placed upwards, creating a green roof. (Donnelly, 1992)

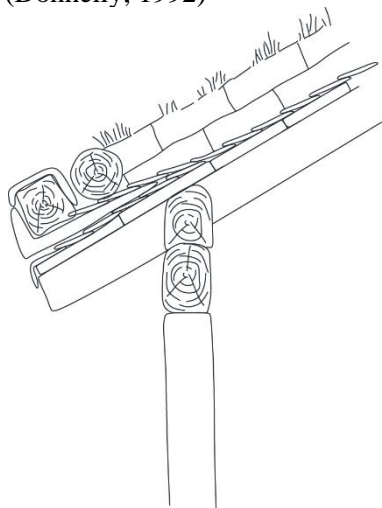

Figure 5. Turf roof construction. Image by author.

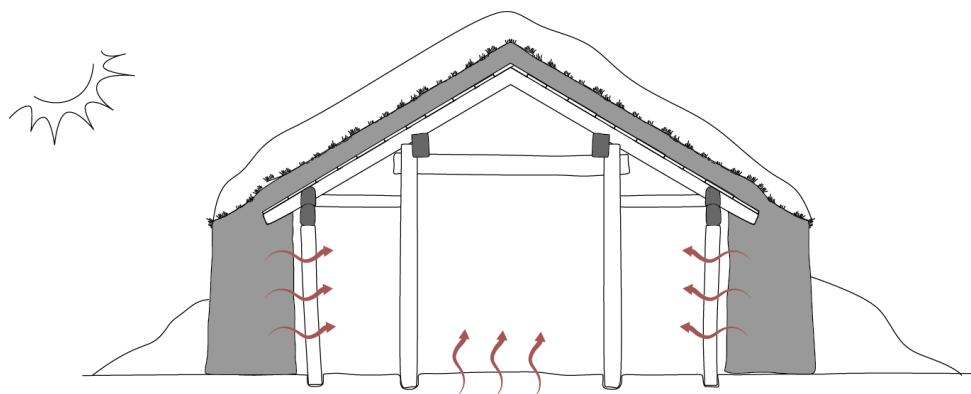

Figure 6. Gain of the heat from the earth with additional insulation from snow during winter. Image by author.

3.5. Construction

Slates were used as underlayment for the roof structure. The roof rafters either lied only on the ridge poles backed by the walls or supported by one or two poles. The structure was covered with turf, in a similar way to the south of Scandinavia, and was little bit extended further than the walls (Donnelly, 1992). Depending on the wealth and house purpose, walls and floors of interiors either could be exposed to turf walls and dirt floors (kitchen, storage), or covered with timber planks (such as with the main space, the baðstofa). (UNESCO, 2011)

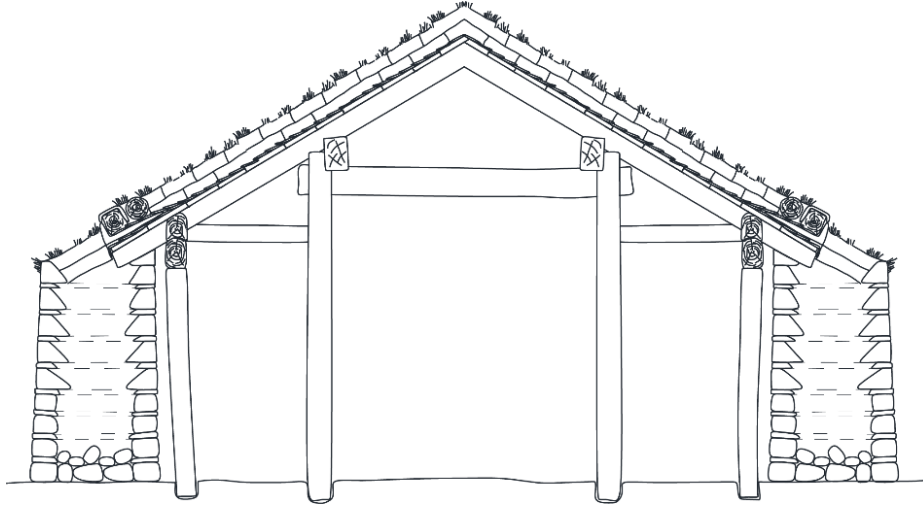

Figure 7. Turf house - section. Image by author.

3.6. Heat gain

For climatic reasons most of the houses' main façade faced south and the apertures were situated only in the south façade. Moreover, this façade – created from timber planks – was painted in dark colors to increase passive solar energy gain (Pressman, 1995). In summer, people were working outside, to heat the interior the house depended solely on the sun. During winters, when there was almost no sunlight, the heat was gained also from heat radiated from the inhabitants' body. For this reason, during winter season occupants were staying and working close together in one space. (Hoof & Dijken, 2008) If the house had more than one room, the one farthest from the entrance was meant for working and sleeping to protect inhabitants from the cold outside. It is important to mention that this caused a lack of ventilation, so the air quality was poor.

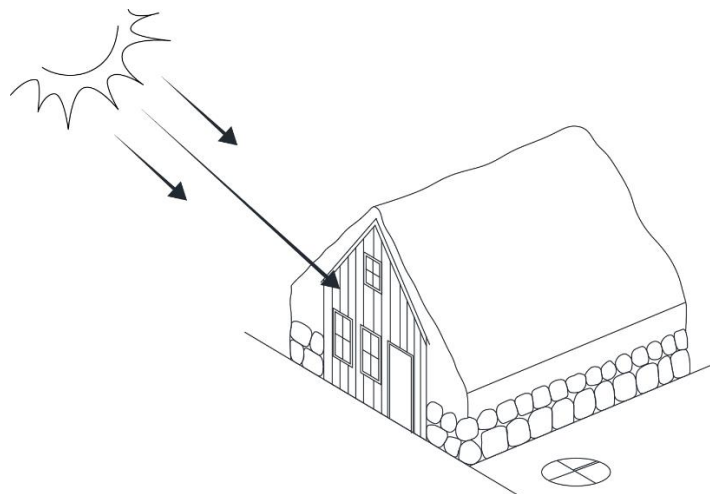

Figure 8. Gaining heat from the sun. Image by author.

3.7. Wind protection

During winters the wind-facing walls of the building caused heat losses by conductive heat flow through the structure and increasing infiltration rates. One of the most effective ways to prevent heat loss is to ‘minimalize the pressure differential between opposing sides, rather than (...) minimalize the velocity of air movements’ (Watson, 1983). One of the ways to accomplish this was by positioning the smallest facade towards the windward side while the openings were located on the side with the minimum pressure. Moreover, the rounded corners of the building reduced pressure, creating less resistant for the wind and keeping a low-pressure level (Watson, 1983).

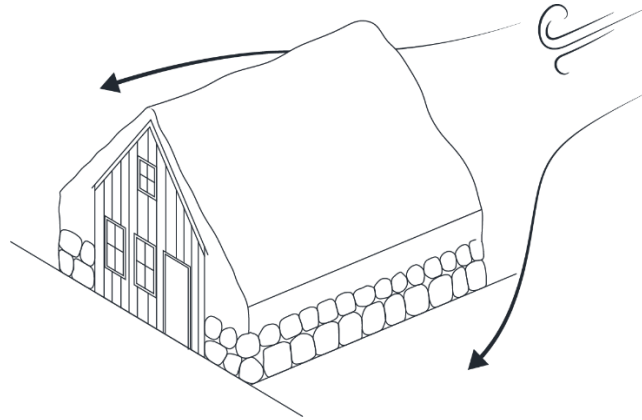

Figure 9. House orientated with prevailing wind direction. Image by author.

The other more effective way to cope with winds is to come into line with its flow and avoid air dam effect. To achieve this a house had its sloped roof positioned towards the wind, which guided and directed wind. The windowless roof which starts low near to the ground can smoothly lead the wind to the other side. (Watson, 1983) This type of protection not only solved the problem of Icelandic east winds, but also allowed houses to be oriented with their front façade in a southerly direction to gain heat from the sun. Turf roofs based on thick walls were already very low. People even frequently extended those walls, creating one slope from the top of the roof till the ground. Sometimes they also covered the back wall with a turf wall and soil, creating small hills with the only recognizable entrance from the south side.

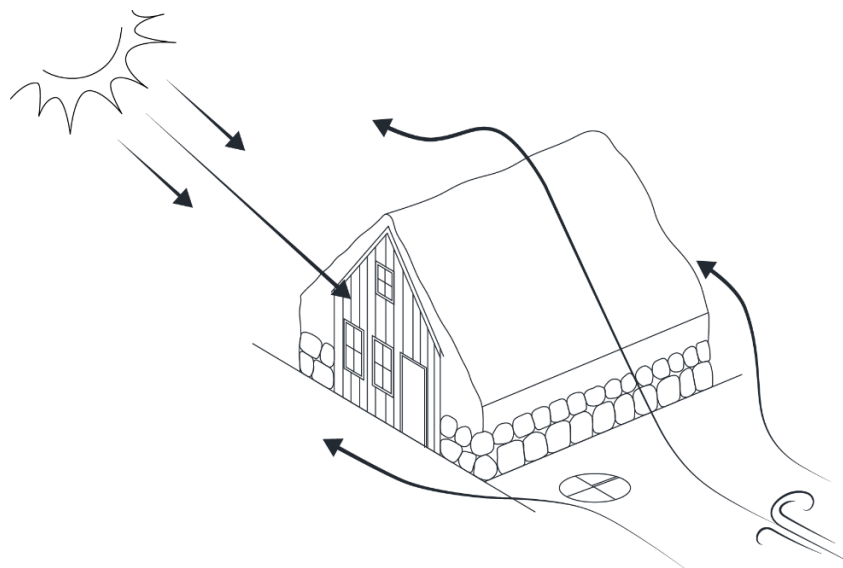

Figure 10. Orientation of the house according to sun and wind directions. Image by author.

3.8. Development of the farm house

Most of the houses were one floor high. However, if a group of buildings was formed to create a farm, houses might have second floor and the lower floor was then occupied by cattle, while the upper was used by humans. In this way the heat from cattle warmed up the floor of the first floor. The Icelandic farms were usually compact, to avoid heat loss, arranged in lines facing south. (Pressman, 1995)

The type of dwellings that transformed to different forms in Iceland are farms. The turf farm houses were developed from the long-house brought by Nordic settlers. In time, small buildings were added at the ends of the long-house and the main structure itself became longer and longer. All the facades of the buildings faced south to gain heat. Nevertheless, passing from building to building in the cold led to a passage-farmhouse type in the 14th century, where a group of small buildings with clear functions were connected by a covered central passage. The Baðstofa was the most important house used for both sleeping and working. It was located at the end of the passage and higher than other buildings to increase heating efficiency. In the 17th century the form developed to the gabled-farm. The entrance building of the passage-farmhouse was reoriented to the yard and additional farm buildings were reintegrated into the main building. However, each of them was still under its own roof. (UNESCO, 2011) Because of the reorientation of the main building, a lot of old buildings faced east instead of south.

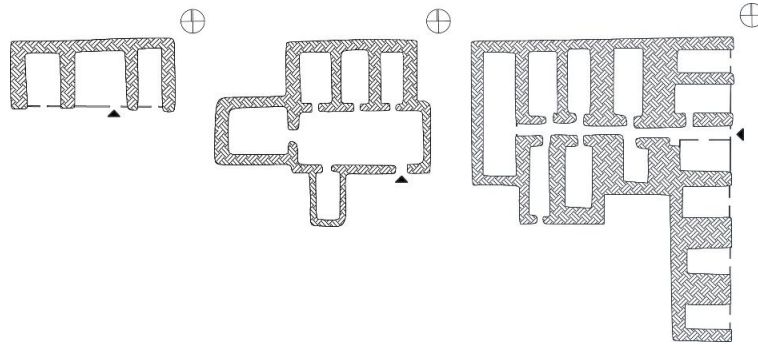

Figure 11. Theoretical farm development – long-house, passage-farmhouse, gabled-farm. Images by author.



Figure 12. Facade of gabled-farm – Glaumbær in Skagafjörður, Iceland. Images by author.

- Glaumbær farm, Iceland
1. entrance
 2. guest room
 3. kitchen
 4. pantry
 5. guest room
 6. baðstofa - sleeping area
 7. baðstofa - working area
 8. baðstofa - sleeping area
 9. separate entrance
 10. pantry
 11. dairy
 12. living room
 - 13, 14. storage
 15. smithy
 16. fuel storage

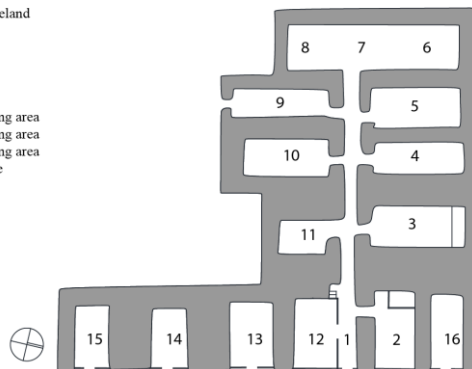

Figure 13. Plan of Glaumbær in Skagafjörður, Iceland Image by author. Based on image from: <http://naturalhomes.org/timeline/glaumbaer.htm>

3.9. Conclusions – cold climate

- Materials: turf, re-used wood, stones
- Construction: lightweight – re-used wood
- Wall: turf brick and stones
- Roof: bark, turf bricks
- Floor: soil and stones/ timber planks
- Insulation: thermal mass from turf – 1m for walls, 20cm for roof and snow
- Heat gain: through south, black façade and windows/ human heat radiation
- Wind protection: come into line with its flow and avoid air dam effect – sloped roof facing wind direction
- Buffer zones: against cold – long narrow corridor
- Urban layout: houses facing south, usually spread around, sometimes creating inner courtyards surrounded by buildings, farms are compact into one building

IV. CONTINENTAL CLIMATE

Continental architecture – Central and East Europe

Central Europe is half way between North Pole and the equator, and far enough inside the continent to experience hot summers and cold winters. The climatic conditions change significantly during the year, which requires both heating and cooling systems. This need led, in continental architecture, to the combination of northern building characteristics (compact structure, insulated walls, sloped roofs) and southern ones (protection from the sun by significant overhangs). The type of material depended on the location and available sources – stone, clay, wood, thatch and their combination. Nevertheless, climatic principles remained the same everywhere.

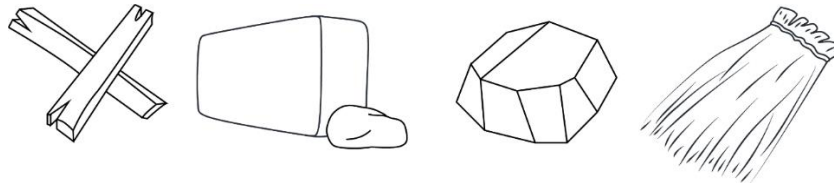

Figure 14. Construction materials used in continental climate. Images by author.

4.1. Orientation

As for every climate, including a continental one, the sun is one of the main determinants for the orientation of the building. If the prevailing winds were not strong, the house's longer façade faced south. Otherwise, either house faced the wind with its shorter façade, or was built in the shape of "L", or windbreakers in the form of vegetation were used. (Dabija, 2012) Also surrounding farm buildings created and faced the inner courtyard, protecting it from wind and snow.

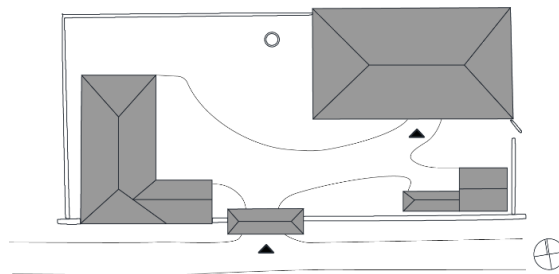

Figure 15. Plan of the farm in Iedu, Romania. Image by author.

4.2. Insulation

Traditional continental buildings are compact in its form to reduce heat losses to a minimum – usually one or two stories high, built rectangularly. An “L” shape plan of the structures was rare and functioned mainly as a protection for the front courtyard from prevailing winds. Low temperatures urged that thermal comfort needed to be achieved by proper wall structure. Mainly the wall construction depended on the local sources. Wood, clay or frame construction wattle-and-daub walls provided good insulation for this climate (Dabija, 2012). Wood, with its higher insulation effectiveness preserves heat better, and was more often used in the north. Stone, however, does not insulate well but is thermally stabilizing; for this reason, it was more often used in the south to keep the inside cool.

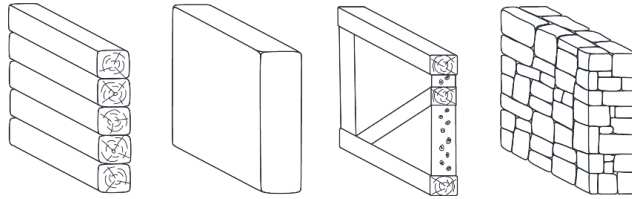

Figure 16. Four kinds of wall construction - log, clay, half-timber frame with wattle and daub, stone. Images by author.

In contrast, houses were often either built on stone foundations or raised from the ground on the stone basement creating an additional thermal buffer zone between the ground and the actual floor while keeping heat collected in buffer from emerging outside. Moreover, thanks to this design, it was protected during summer from floods but mainly during the winter from snowdrifts.

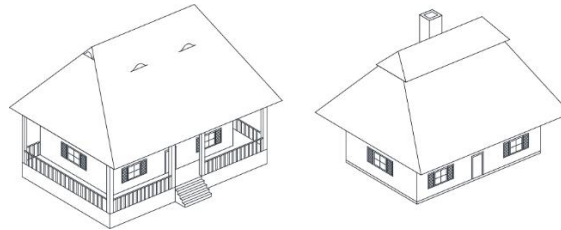

Figure 17. Typical houses of continental climate - Central Europe and Eastern Europe. Images by author.

4.5. Heating / cooling

The heating system was provided by the hearth and kitchen stove located in the center of the house or in the living room where inhabitants spent most of their day and slept. Sometimes there was more than one fireplace.

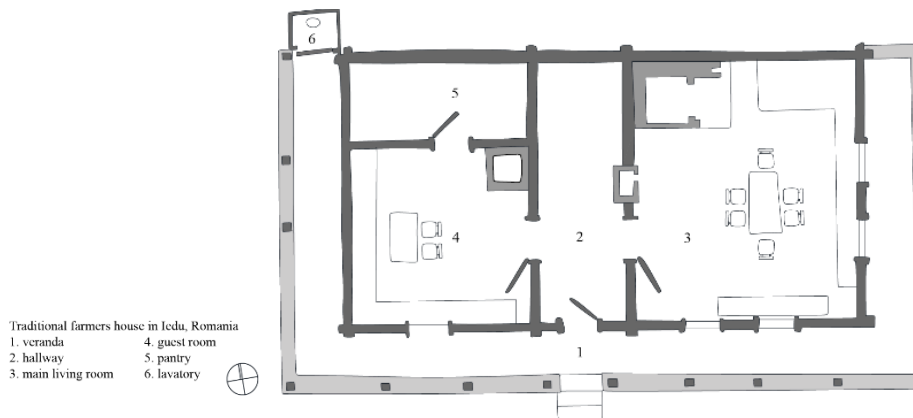

Figure 18. Plan of the farmers house in Iedu, Romania. Image by author. Based on the archive image of the building from: <https://relevec.uauim.ro/m177/>

In Central Europe – from East Poland to Romania – where the climate was less severe during winters, the heat and smoke from fireplaces went directly from clay fireplaces to the rooftop where it was creating a huge buffer zone between the cold outside and the warmth inside. Then they were exhaled through small openings in the roof.

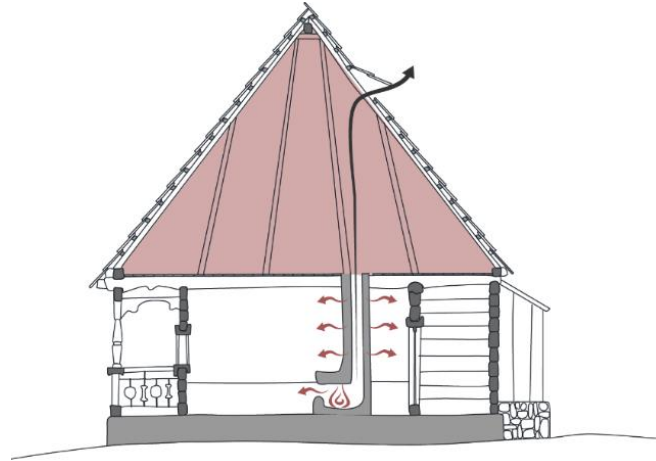

Figure 19. Heating in Central European house in Iedu, Romania. Image by author.

In contrast, more inside the continent, where summers were hot and winters harsh, people used chimneys. They were not only meant for exhaling the fumes but also as a heat gain and ventilation. When the fire was burning the exhausts were pushed out through the chimney. However, when there was no fire, the chimney was behaving like wind-catchers, without a top part to catch the wind – by creating under-pressure – to avoid huge air movement inside it. A supplementary top part of the roof was separated from the rest creating a “black roof” as additional space for gaining heat, which heated up the top part of the chimney. During winter the heat was transferred through the chimney to the inside of the house, while during summer, when there was no wind, it created a Venturi under-pressure effect by sucking out the hot air through the chimney. (AD7EB, 2013)

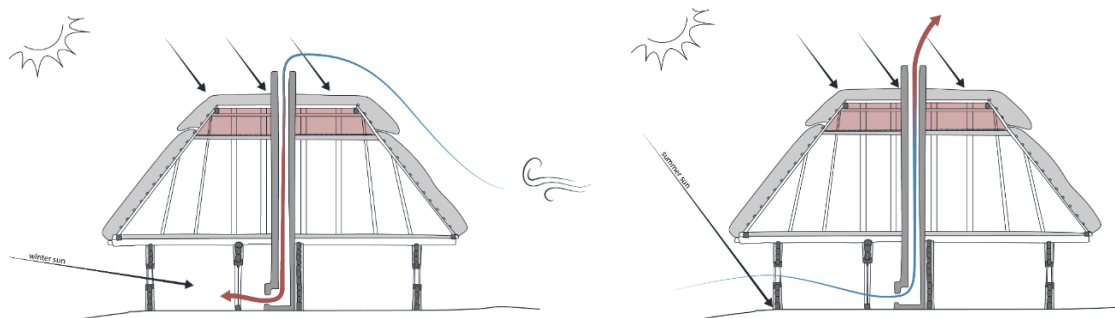

Figure 20. Additional heating and cooling system through chimney in Eastern Europe - example of Eastern Ukrainian house in Folk Museum in Pyrohiv, Ukraine. Image by author.

4.3. Buffer zones

As the winters are harsh, the summer’s heat can also be bothersome. For this reason, even in a continental climate there are the adaptation of porches, verandas and overhangs to protect the inside from direct sunlight during summer time. Verandas can be found in areas of the old Austrian Empire – from present day South-West Poland to Romania, while moving deeper inside the continent, towards Russia, more compact forms of buildings with overhangs can be seen. Open verandas were located along the south or sometimes north façade. The southern one was designed in the way to shade the interior from the sun during summer but heat it up in winter. Moreover, verandas act like a buffer zone for wind and cold. (Dabija, 2012)

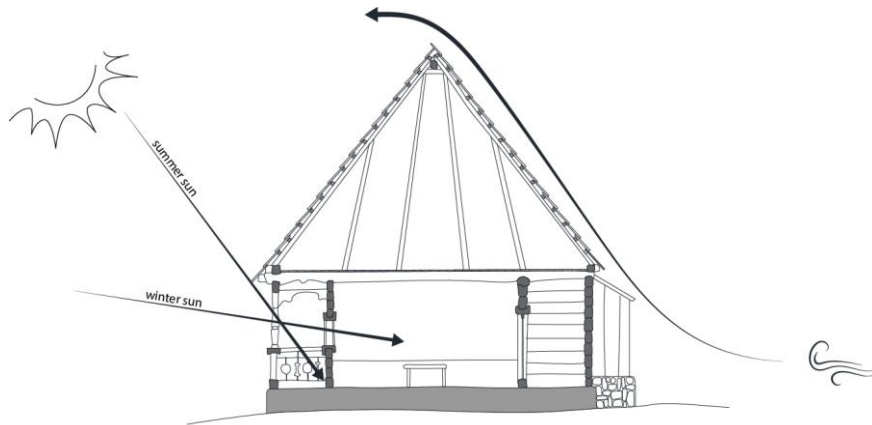

Figure 21. Sun heating / protection in example house with veranda in Iedu, Romania. Image by author.

Sometimes, porches and verandas were integrated in the cubic shape of the house and protected by one, two or even three walls, or glazed allowing either open ventilation or additional thermal buffer space. Occasionally, the open gallery around the first floor could be found in two-story houses. It did not only give the shadow for the ground floor but also protected the thermal comfort on the first floor which was mainly heated from the ground floor by stack effect and convection through floor.

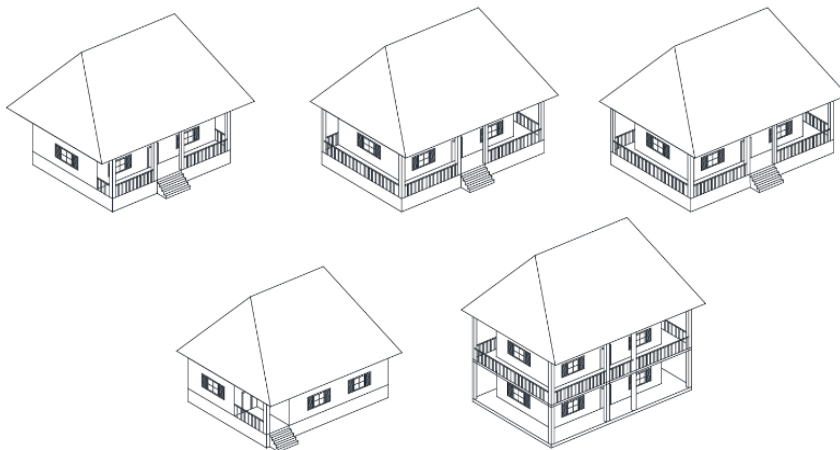

Figure 22. Variations of verandas layout in Central Europe. Images by author.

Most of the houses have got an additional buffer zone between inside and outside of the house in the form of hallway or small antechamber. This prevents cold air to enter to heated living room while opening the main doors, especially during winter.

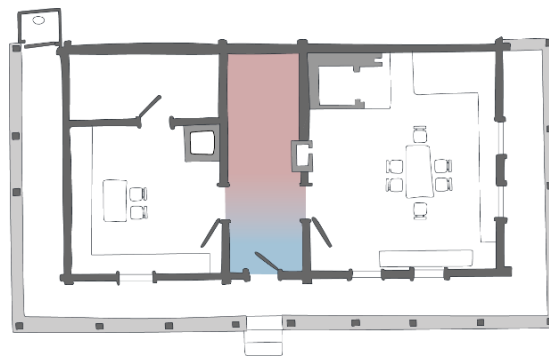

Figure 23. Buffer zone of the hallway between inside and outside.

4.4. Openings and protection of the north façade

The number of windows was low to reduce heat loss. Moreover, most of them faced south to gain heat and sunlight, while the north façade was windowless, where the pantries were located. Sometimes additional storages were also added to this façade from the outside, with extended roof, protecting from wind. The windows had a developed system of double glazing providing an airtight seal. The inner sashes opened inwards while outer ones outside, providing better insulation during wind. Additionally, where the weather conditions were more severe, exterior shutters were provided. (Dabija, 2012)

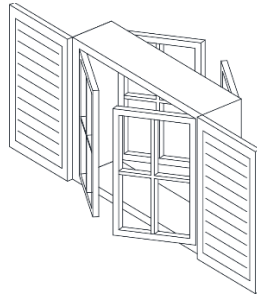

Figure 24. Window system in continental climate. Image by author.

4.6. Rain/snow protection

Protection from precipitation was achieved by a sloped roof. The angle increased in areas where the rain and snowfall were more common. The material depended also on the angle, usually thatch or wood. The space under the roof was not used for living but as a buffer zone protecting from cold and wind. Most popular was a hip roof protecting the attic from four sides and overcoming gable roof with only two-sided roof. (Dabija, 2012)

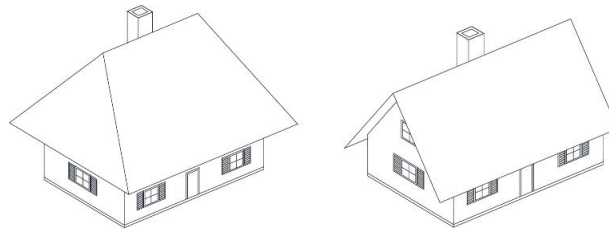

Figure 25. Hip roof and gable roof.

4.7. Roof transformations

Over time, when the attic started to be used for living roofs like gable and its transformations, the gambrel and jerkinhead roof became more popular. A gambrel roof is a symmetrical two-sided roof with two slopes on each side, leaving the lower part for living while upper as a buffer. Jerkinhead roof is a conversion where the ends were cut out, creating two smaller roofs on each side, protecting ends of the ridge from wind and again leaving the top part for heat gain.

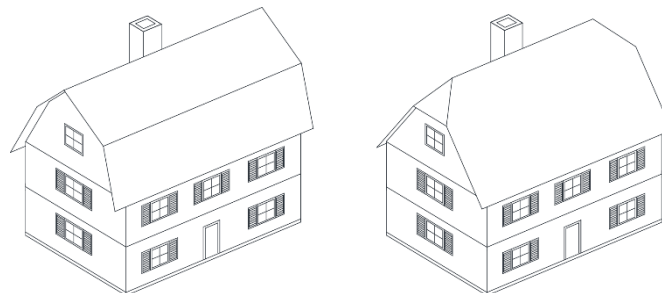

Figure 26. Gambrel roof and jerkinhead roof.

4.8. Climatic principles in urban vernacular architecture

In the denser urban development, it was almost impossible to build a free-standing house. To keep them cool and warm, houses were usually narrow and deep, standing in a row. During winter the house was protected from outside conditions by side walls shared with neighbors, which worked like insulation and kept heat inside the house. On the other hand, dwellings had openings in the front to the street and in the back to the courtyard. Moreover, every house or at least every floor was owned by one person. Thanks to them, summer cooling was achieved by cross ventilation.

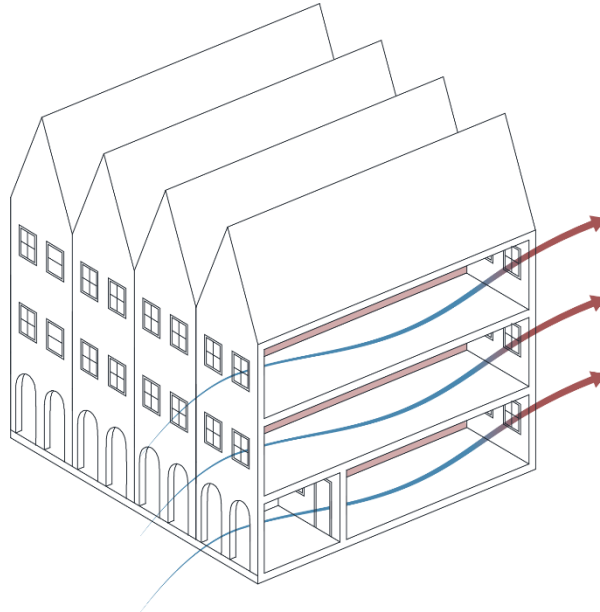

Figure 27. House typology in urban context in continental climate. Image by author.

4.9. Conclusions – continental climate

- Materials: wood, clay, stones, thatch
- Construction: log houses/ timber framed/ clay
- Roof: timber/ thatch
- Floor: soil/ timber planks
- Insulation: wood/ clay/ additional double-window system
- Heat gain: during winter: through south façade and windows, human heat radiation, hearth
- Cooling: through openings and chimney
- Protection form ground: houses lifted from the ground on stone foundations or with a stone basement protected from floods and snow
- Wind protection: come into line with its flow and avoid air dam effect – sloped roof facing wind direction, verandas as a intermediate zone
- Rain/snow protection: steep roofs
- Buffer zones: against cold – corridor, roof, against heat – veranda and significant overhangs
- Urban layout: village: houses usually facing south, farm buildings surrounding the courtyard, town: narrow, two-three floor, row houses with openings on both sides

V. HOT-DRY CLIMATE

Desert architecture – Middle East

In hot-dry climates, where the difference in temperatures between day and night is significant, the main challenge is to delay the heat as much as possible from entering the house until night time. In this climate the urban tissue is compact, with regular forms attached to each other, oriented optimally for the climatic reasons. Buildings are made from high thermal capacity materials such as clay in the form of adobe bricks or thick mud walls. They have flat or dome-shaped roof with wind-catchers on the top, as well as courtyard in the middle, creating a microclimate. The densely built cities create shade in narrow passages and for surrounding buildings. Sharing most of the external walls also decreases the amount of sun radiation on them. Moreover, the houses are introverted. In most cases there are no openings to the outside apart from entry doors. Sometimes only small openings can be found at the top of the wall to exhaust hot air from the inside but prevent sand, dust and bright light from getting inside. In contrast, there is a plethora of windows to the inner courtyard, which has more a favorable environment than outside. For those reasons cross-ventilation is hard to achieve in a hot-dry climate. In order to solve this problem, inhabitants invented wind-catchers – badgirs, as ventilating shafts at the top of the structures, which implemented with internal courtyards and natural elements, like vegetation and water. On those two elements: wind-catchers and courtyards I will focus in this chapter. This way of passive cooling was used not only in dwellings but also mosques and water cisterns. (Fouzanmehr, 2017)

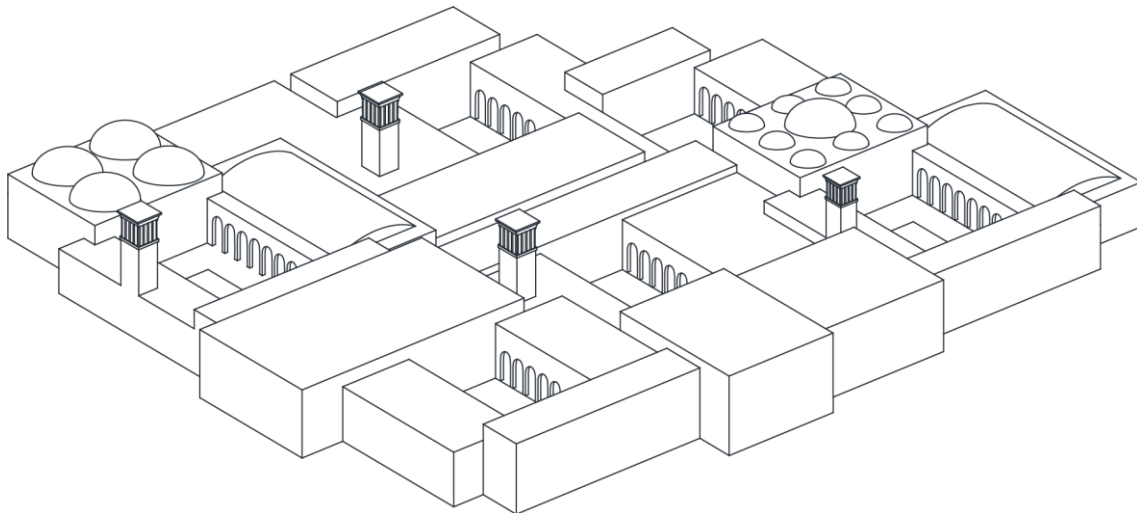

Figure 28. Dense urban development in Middle East. Image by author.

5.1. Courtyards

The main purpose of courtyards is to enhance humidity by creating a microclimate. It can be done by landscaping, adding greenery and water to it. The typical example is when hot-dry air gets through the courtyard passing the fountain, being moistened and cooled down before entering the rooms. Moreover, the layout of spaces around the courtyard also depends on the cardinal directions and seasons.

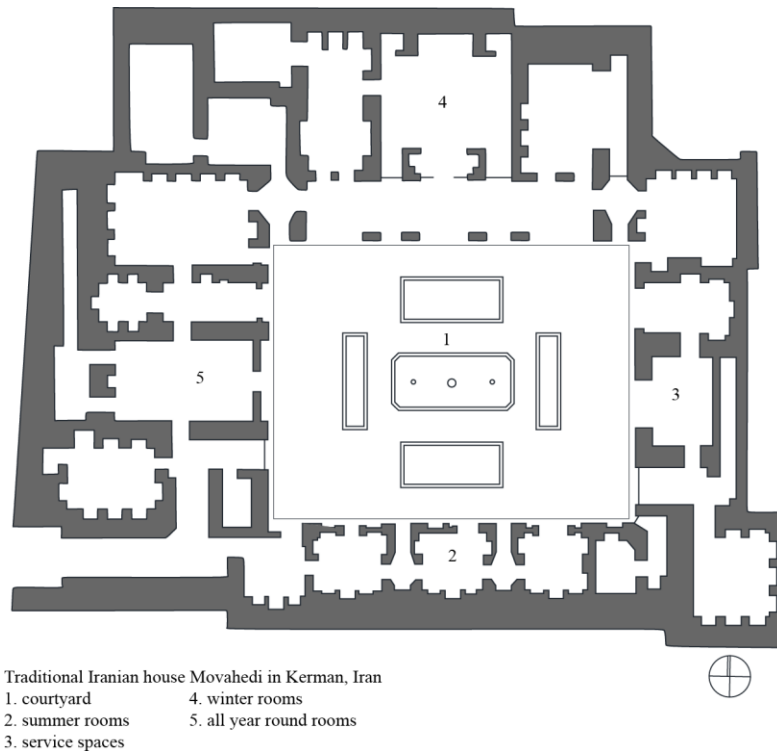

Figure 29. Decision of room orientations depending on the location relative to the courtyard in Movahedi house in Kerman, Iran. Image by author. Based on the research paper (Soflaei et al., 2016).

5.1.1. Orientation and dimensions of courtyards

The orientation of the courtyard and room layout is one of the critical aspects for the microclimate performance. Most of the houses in Iran are formed along the north-south axis or slightly angled to it, depending on the prevailing wind direction. Courtyards mostly have a rectangular shape, where on an east-west axis the length is slightly longer than the width. The average height is six meters. However, the height of the façades changes depending on the façade – the western and eastern façades are usually higher to provide more shade to the courtyard during sunrise and sunset. (Soflaei, et al., 2016)

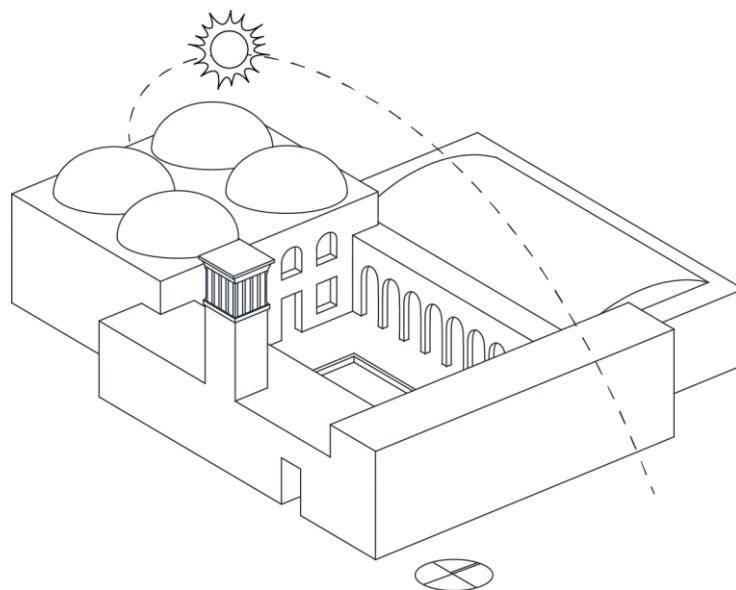

Figure 30. Orientation of the house in hot-dry climate according to cardinal directions. Images by author.

5.1.2. Water and soil in the courtyards

Natural elements in the courtyards are not only a composition but create a microclimate throughout the day. Pools, which are in the center of the courtyard, are shallow to heat up faster and increase evaporation to not only add humidity but also create convective air flows around the house. Soil, in contrast, acts as thermal mass and contributes to night ventilation. Additional native vegetation can provide shade and decrease sun radiation on the floors and facades of the courtyards. (Soflaei, et al., 2016)

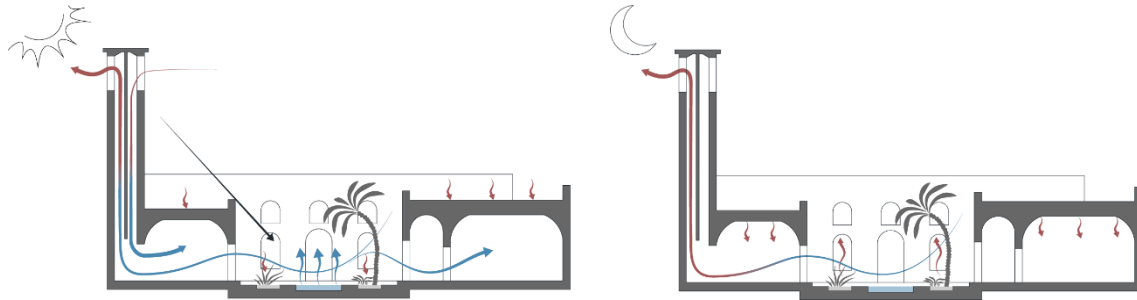

Figure 31. Heating and cooling by adding natural elements – vegetation and water. Images by author.

5.1.3. Climate and space layout

Different seasons force inhabitants to divide the house into for at least two parts – summer and winter – and move according to seasons. Orientation and position of the courtyard can maximize the use of living spaces throughout the year. On the northern part of the courtyard, which faces south, spaces are located that take advantage from of the sun's radiation during cold seasons. The courtyard façade works as thermal mass – it absorbs solar radiation during the day and radiate the heat during the night. (Soflaei, et al., 2016) In order to avoid overheating some buildings have a double façade – a closed or semi-open space between courtyard and actual living spaces, which works as thermal insulation and keeps the indoor temperature constant throughout the day (Alfata, et.al., 2017). For this reason, spaces located in the north and west are mostly the biggest in the whole house.

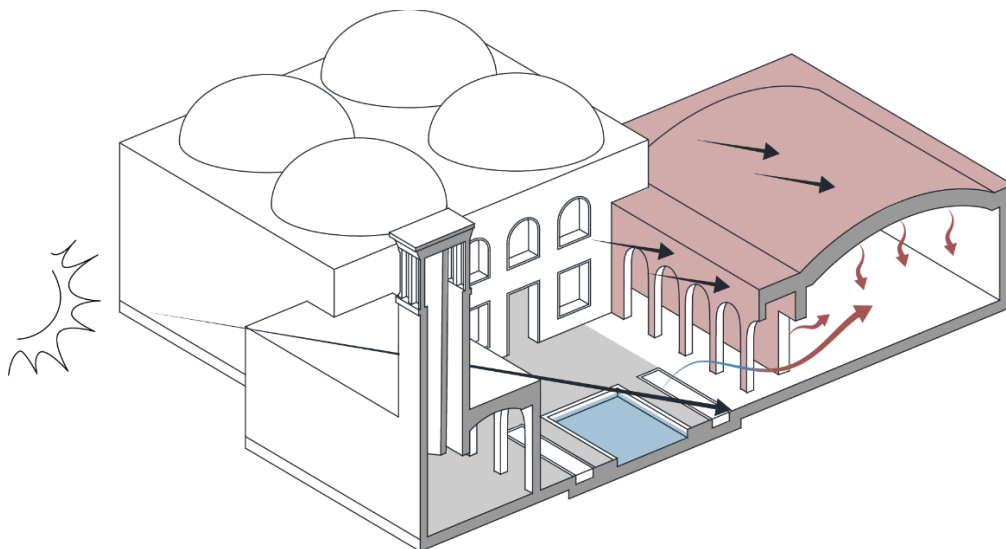

Figure 32. North part of the house heated during winter. Image by author.

The opposite situation is for southern spaces, with a northern façade – solar radiation is minimal and airflow maximal – perfect for passive cooling and natural ventilation in the summer season. Additionally, most windcatchers are situated over this part of the building. Service spaces are located in the eastern part of the courtyard, receiving the unfavorable western sun and being a buffer for heat, which at the same time occupies the small areas of the house. Both eastern and western facades have openable windows – usually closed during summer and winter when the temperature difference between inside and outside are significant, while opened during spring and autumn when thermal mass is heated. (Soflaei, et al., 2016)

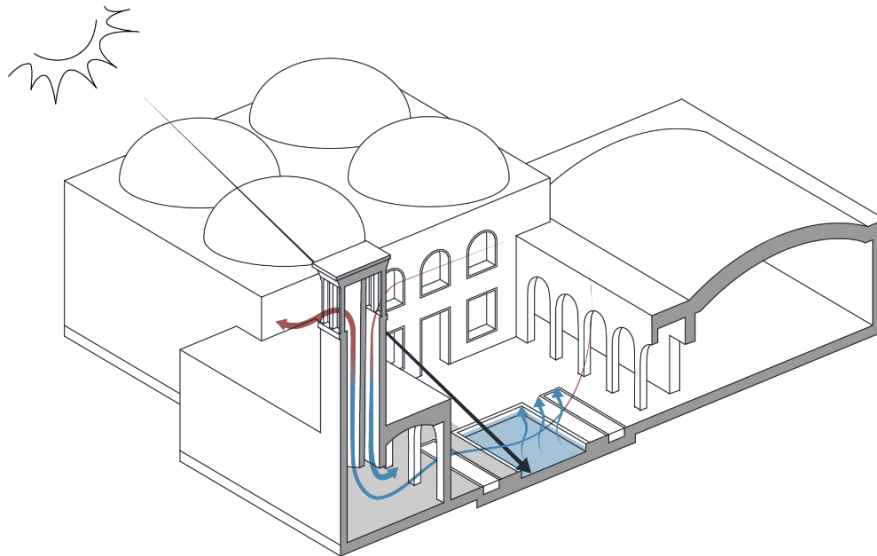

Figure 33. Cooling systems in summer rooms. Image by author.

5.2. Wind-catchers

Wind-catchers are ventilating shafts open towards the most prevailing winds. They have different forms and sizes. They can have openings on one side or on several to all of them. Badgirs – as the wind-catchers are called in Middle East – are mainly made of clay painted in bright colors with a timber skeleton and division inside the shafts. Additionally, the mud-bricks and clay are often mixed with straw to increase coarseness of walls and decrease the absorption of the sunrays. As the wind moves faster in the upper parts of the atmosphere, the badgirs are three to five meters tall. One sided wind-catchers are always oriented towards the predominant wind, while in places where the direction of the wind is changeable during the year, there are multi-sided badgirs. All of them can work as an outlet or inlet of the air. Wind-catchers are mostly related to the summer room facing the inner courtyard. (Fouzanmehr, 2017)

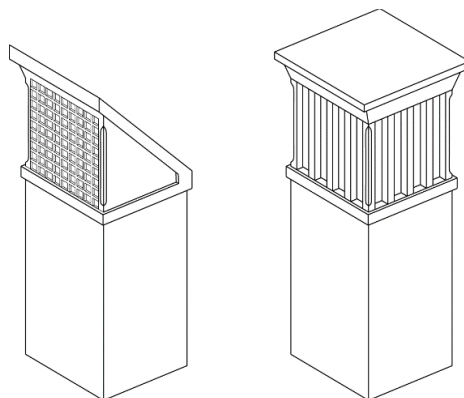

Figure 34. One-sided and four-sided wind-catchers. Images by author.

5.2.1. Functioning

Wind-catchers work on the pressure difference. Their efficiency relies on the time of the day, temperature and wind conditions. There are three ways how the badgir works. When there is no wind during the night the tower is still heated after the day and draws up the air from the house, pulling into the fresh air through openings on the ground floor. The less effective way is when there is wind during the day or night. The wind-catcher heats the surrounded air and it is blown into the house cooling enough passing through the stack. During the days without wind the air is sucked inside because of the pressure difference. The hot air from outside gets inside the wind-catcher, which lost the heat during the previous night and cools down the air, which becomes denser and drops down to the house and get out through openings. Efficiency depends on the 'air temperature, intensity of solar radiation, wind direction and velocity.'(Fouzanmehr, 2017)

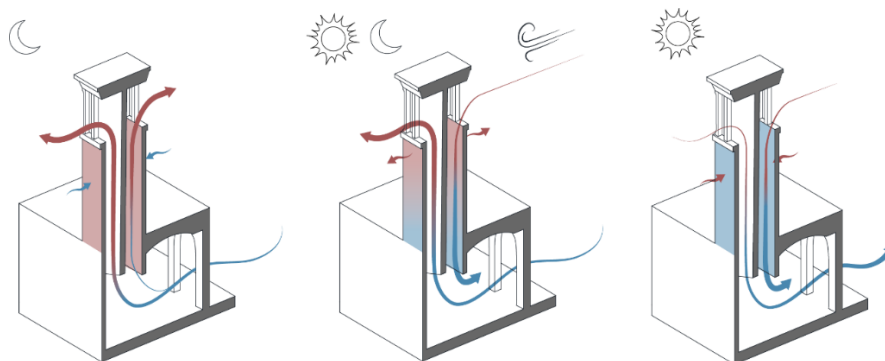

Figure 35. Four-sided wind-catcher - three ways of functioning. Images by author.

5.2.2. Disadvantages

Badgirs are one of the best solutions for natural ventilation in hot-dry countries. However, even they have got some disadvantages. People are not able to control the supply of the wind. Also, four-sided windcatchers are less effective than one sided and their design is not aerodynamical. Moreover, there is no protection from the noise, dust or insects and the only possibility of closing is by shutters, which are not so popular in badgirs. Bahaori (1994) claims that, if the badgirs had dampers and moist surfaces, they would perform better. (Fouzanmehr, 2017)

5.2.3. Wind-catchers in other climates

Wind-catchers can also be found in the south, which is counted as hot-humid climate. Their way of functioning is the same. However, because of less amount of wind they are wider and smaller. Additionally, there is at least one windcatcher in each room. (Fouzanmehr, 2017)

5.3. Conclusions – hot-dry climate

- Materials: clay, adobe brick, mud, wood
- Construction: clay/adobe brick/ timber frame
- Roof: clay/adobe brick/ timber frame
- Insulation: high thermal capacity clay walls
- Heat gain: during winter: through south façade – thermal mass
- Cooling: through wind-catchers, north façade shaded from sun, convective air flows thanks to moisturized air from the pond
- Sun protection: higher east and west facades, shading, dimensions of courtyard, arcades, dome roofs, dense urban layout
- Buffer zones: against heat – arcades
- Urban layout: compact, sharing most of the external walls attached to each other, narrow passages

VI. HOT-HUMID CLIMATE

Sundanese architecture – West Java, Indonesia

Nowadays, a plethora of islands between Pacific and Indian Ocean is called Indonesia. Nevertheless, it has not always been one country. More than 350 different tribes with their own language and culture inhabit Indonesia, bringing the variety in their designs. Nevertheless, climatic principles remain the same in every island. (Waterson, 1990)

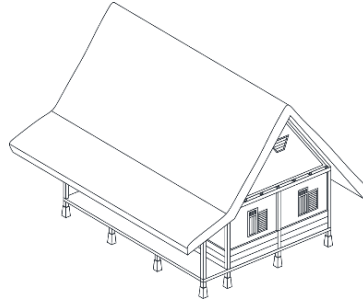

Figure 36 Traditional Sundanese house. Image by author.

6.1. Materials

Traditional houses of Indonesia are created from a light-weight construction, built from highly degradable materials. Basic building materials are wood for frame construction and woven bamboo panels for walls, while the floor could be either from timber planks or from split bamboo. The roof is thatch – the frame made from wood or bamboo, the bottom layer made from palm leaves as additional water insulation and upper part is from layered palm fibers called ijuk.

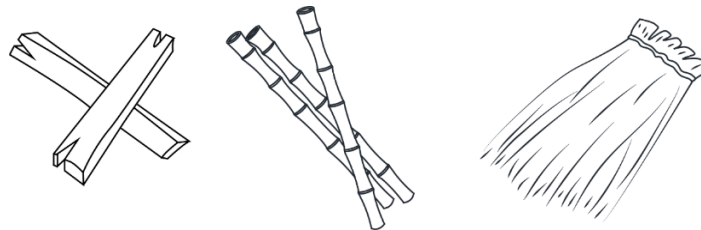

Figure 37. Locally used materials in Indonesia, Image by author.

6.2. Lower, middle and upper world

The origins of plie standing, saddle rooftop houses started thousands of years ago. Archaeologists discovered that the typical “Indonesia-houses” were already engraved on the Dong Son bronze drums dating back between 600 and 400 BC. The structure arose from the local people’s beliefs of division of the world into three elements: *handap*, *tengah* and *ambu luhur*, which means under, middle and upper world. In the similar way the house was divided: part under the house was meant for animals, middle part for humans and the roof for the ancestors. Nevertheless, apart from beliefs such a construction had a more technical and bioclimatic explanation.

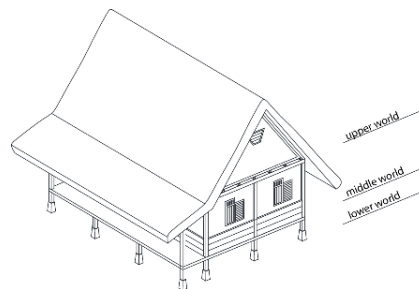
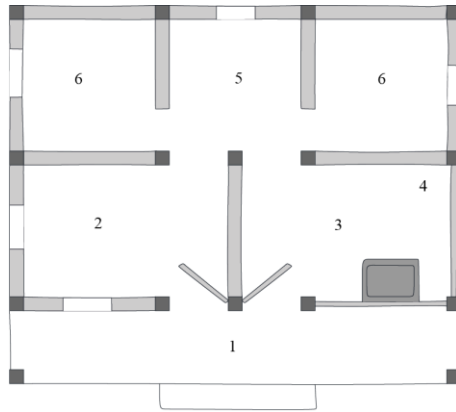

Figure 38. Vertical division of the house according to believes. Image by author.



Traditional Sundanese house, Kampung Naga, Indonesia
 1. veranda 4. rice storage
 2. man territory 5. family room
 3. kitchen 6. bedroom

Figure 39. Horizontal division of the house between man and woman - Sundanese house, Kampung Naga, Indonesia. Image by author. Based on study trip.

6.3. Lifting the house

The *imah panggung*, which is a typical Sundanese house, was lifted 40-60 cm from the ground. The space under the house had three technical functions. First of all, it was minimalizing the footprint of the house and allowing water to be absorbed on a larger scale, decreasing the risk of floods and if there were any, house was protected. Secondly, the elevation provided natural floor ventilation – air flowed from hot surrounding under the house where it was cooled and flowed into the rooms through split bamboo floors. Finally, it was used as a storage for wood and life stock. (Maknun, et al., 2016)

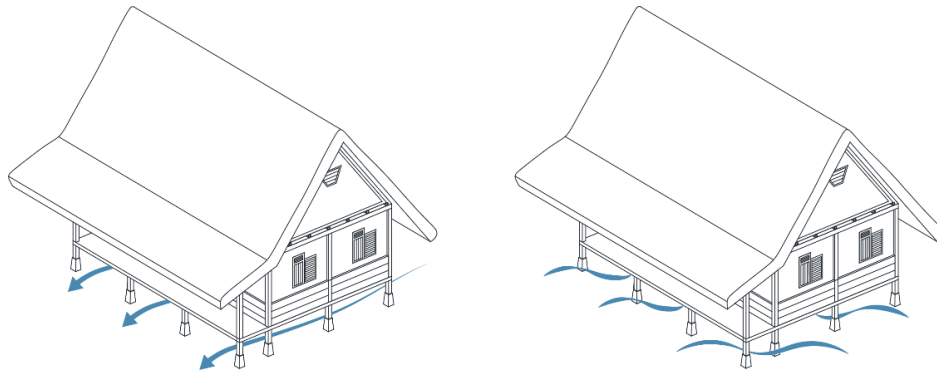

Figure 40. Ventilation and protection from flood by lifting the house. Image by author.

Timber construction poles did not stand directly on the ground but on cubic shaped rocks as pedestals, protecting the construction from dampness and weather conditions. Rock foundations were 45-60 cm high and were usually dug half in the ground for stability. (Maknun, et al., 2016)

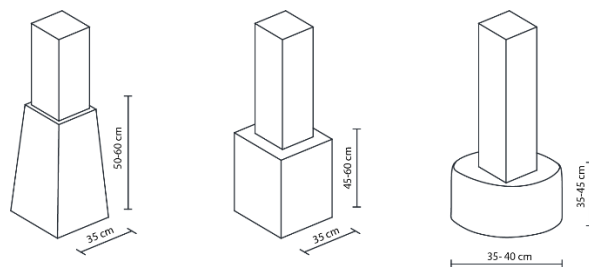

Figure 41. Different types of foundation. Image by author.

6.4. Earthquake resistance

Indonesia is situated in between the connections of several tectonic plates and as a result earthquake occur very often, especially in West Java. For this reason, traditional buildings were earthquake resistant and this part was included in local wisdom of building houses. Houses were built as a simple, lightweight construction. The whole structure was framed with timber joints, separated from the ground by stone foundations. (Maknun, et al., 2016)

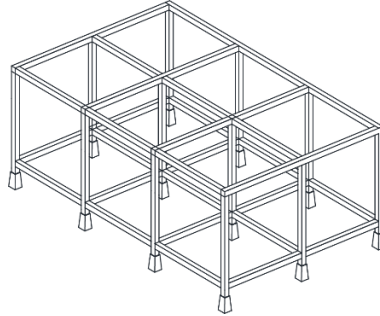

Figure 42. Frame construction of traditional Indonesian houses. Image by author.

6.5. Ventilation

Natural ventilation occurs when the air flow is caused by natural factors such as pressure, thermal forces or meteorological phenomenon. In a hot-humid climate, thermal comfort can be achieved only with constantly moving air, as there is almost no temperature difference. Moreover, the preferable structures are lightweight to not absorb heat during the day and cool down quickly during the night. (Watson, 1983)

For ventilating reasons traditional houses have large apertures usually occupying whole the wall face, covered with permeable materials or onlookers such as lattices or blinds, through which the wind can get across, but sunrays cannot. Lifted floors are created from porous material like split bamboo which allows cool air to flow from under the floor to the inside. Nevertheless, as the openness and permeability of the buildings allows air circulation, it also causes problems of privacy and lack of sound insulation. (Coch, 1998)

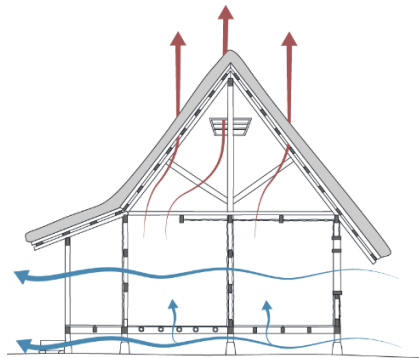

Figure 43. Permeable construction materials allow air to flow through - Sundanese house, Kampung Naga, Indonesia. Image by author.

6.6. Sun reflection

In order to not absorb the heat and reflect the sun beams walls are often painted white with limestone paint. However, the paint covers the holes in permeable materials like waved bamboo. This requires more windows and opening over them. The brightness of the natural light when looking from inside can also cause dizziness. For this reason, people sometimes cover openings with dark meshes, while to reflect the light that got through, they paint ceilings white. (Coch, 1998)

6.7. Protection from sun or rain

In South-East Asia one of the most striking elements, compared to European style, is ‘enormous predominance of roof over wall’ (Waterson, 1990). It is the most important part of the construction in a hot-humid climate. It not only protects inhabitants and construction from sun and rain but is also light and permeable allowing air to get through and not storing the heat. Usually it is extended far from the border walls of the house to give shade to the half-private spaces outside - like verandas or the surrounding of the house, where every day chores happen. Moreover, it is typical in a humid climate to have steep roof to drain faster after heavy rain. Division into overlapping roofs also allows air circulation and avoids overheating. Sometimes also the passages or meeting spaces are shaded by the roofs to create a more bearable microclimate. (Coch, 1998)

In Sundanese houses the most typical roof is the gable roof with its extension in the front for shade protection of a veranda. It has got huge overhangs, even on the sides of the roof. There are no chimneys in traditional buildings. Smoke from the kitchen goes directly through opening in the ceiling to the attic, at the same time preserving the construction from dampness. The triangle gable walls of the roof are not fully attached to any part of the construction leaving huge line openings around them allowing hot air and smoke to be expelled. Also, the roof's crossed gable end is designed to prevent water from easily seeping into the ceiling.

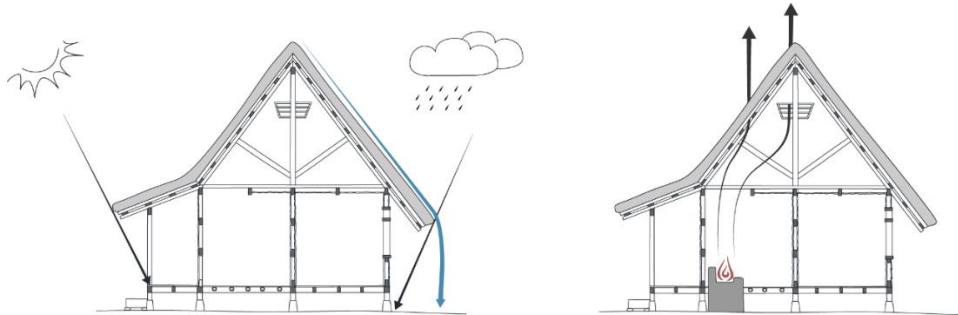

Figure 44. Sun and rain protection and smoke exhaust - Sundanese house, Kampung Naga, Indonesia. Images by author.

6.8. Urban plan

All traditional Sundanese kampungs are created from 3 elements: settlement, fields and forests, where burial grounds are scattered around. Location of a village is always near a spring and/or river. The settlement consists of more than a dozen houses, meeting hall, yards and community open spaces, a rice storage barn, livestock and poultry pens, a communal vegetable garden, rice fields, ponds, and physical amenities surrounding them that are related to settlers needs. (Salura, 2015)

For ventilation, the best layout of the neighboring buildings is to be spread around to avoid the movement of air being interrupted or blocked by another building. Nevertheless, nowadays the growth of population even in traditional kampungs requires typologies to be as dense as possible (Watson, 1983). In such urban plans huge overhangs of the roofs almost overlap each other, leaving the passages cool throughout the day.

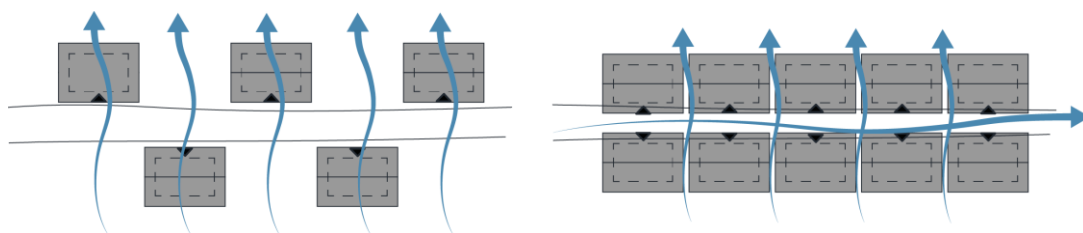

Figure 45. Comparison of two urban layouts - spread and dense one. Images by author.

There is no specific orientation of the houses with a gabled roof. However, all of them are aligned with each other. In Kampung Tonggoh the roof ridge is perpendicular to the slope and north, while in Kampung Naga, it is parallel to both – slope and north direction. Walkways in the villages are usually covered with stones so that the road will not be washed away by rainfall.

The water source is either from the springs or from the wells. While lavatories are either located on the fields, in the small streams or above ponds – being at the end of the communal water purification system.

6.9. Conclusions – hot-humid climate

- Materials: bamboo, wood, stone, thatch
- Construction: lightweight: timber framed
- Wall: timber planks or waved bamboo
- Roof: thatch from palm leaves and ijuk on timber or bamboo frame
- Floor: split bamboo or timber planks
- Protection from ground: houses lifted on cubic shaped rocks 40-60 cm allowing for air flow and protecting from floods
- Cooling: lightweight, permeable materials allowing air to get through
- Sun protection: significant overhangs of the roof
- Buffer zones: against heat – veranda
- Urban layout: spread around: allowing air to get through between the buildings/ compact: shaded passages by the roofs of the houses which keep them cool

VII. CONCLUSIONS

From the research and matrix of the climatic principles in four different climate zones, it can be seen that the elements providing thermal comfort are overlapping. Some of them have got the same, different or even contrary function.







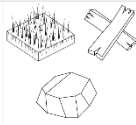

	materials	house plan	urban plan
cold	 turf bricks / re-used wood / stone	 very compact - keeping heat in one room	 houses with a huge distance between each other, if near then forming inner courtyards - protection from snow and wind
continental	 wood / clay / stone / thatch	 compact - keeping heat in one room	 creating inner courtyard - protecting from hazardous weather
hot-dry	 clay / wood	 dense - protection from the thermal mass heat, courtyard - inner microclimate	 dense - protection from the thermal mass heat
hot-humid	 wood / bamboo / thatch	 lightweight - permeable and breathable to keep cool	 spread - letting air pass through, dense - passages shaded from sun

Table 1. Matrix of climatic principles in different climate zones – part 1. Table by author. (Full quality table can be found in attachment).

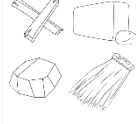
	climatic principles						
	heating	cooling	vertical ventilation system	insulation	sun protection	precipitation protection	protection from the ground
cold	 solar radiation and thermal mass	no cooling	no vertical ventilation systems	 soil - thermal mass, snow - insulation	no sun protection	 low roof: preserving snow for insulation, water resistant birch bark layer	no protection from the ground
continental	 solar radiation and hearth	 openings and by shading	 in Europe: through chimney, convective cooling, stack effect	 wood - insulation, clay - thermal mass	 during summer: significant overhangs, verandas	 steep roof	 house built on the high basement - snow and flood protection
hot-dry	 only during winter: thermal mass	 only during summer: shading, wind-catcher, pool in the yards	 wind-catcher: wind driven ventilation, stack effect	 clay and mud - thermal mass	 morning and evening shade by higher buildings on east and west	no precipitation	no protection from the ground
hot-humid	no heating	 permeable materials, shading	 small openings in the roof: Venturi effect	no insulation	 significant overhangs on all sides	 steep roof	 house lifted on poles - flood protection

Table 2. Matrix of climatic principles in different climate zones – part 2. Table by author. (Full quality table can be found in attachment).

	orientation		buffer zones	
	sun	wind	against heat	against cold
cold	 facing sun	 sloped roof positioned towards east wind	no buffer against heat	 long corridor
continental	 facing sun	 windless back wall and sloped roof towards wind	 veranda	 corridor
hot-dry	 northern part of house with southern facade facing sun	 orientation of house does not depend on wind - only wind catcher is oriented	 arcades	no buffer against cold
hot-humid	 orientation depends only on protection from morning and evening sun	 house facing the wind to allow it to flow through permeable structure	 veranda	no buffer against cold

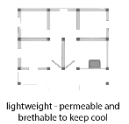
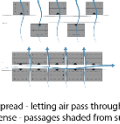
Table 3. Matrix of climatic principles in different climate zones – part 3. Table by author. (Full quality table can be found in attachment).

Courtyards in cold climates were created from group of buildings surrounding the inner yard, protecting it from hazardous winds and creating a milder microclimate. In hot-dry climates, though, the courtyard was meant to create a shadow, moisturizing the air and evoking the cooler breeze. Later examples of a humid climate can also bring examples of narrow and deep courtyards to achieve a cold air well with cool ground floor.

Wind-catchers are mostly known in hot-dry climates where their advanced structure brings the air flow to the building. Nevertheless, in the more humid regions of Middle East the wind-catcher developed in size and height to adjust to local conditions. In a continental climate, though, dwellers add an additional “black roof” to evoke the same effect in their fireplace chimney.

Verandas are popular in most of the countries as a perfect protection from the sun. Nevertheless, in a hot-dry and continental climate they were more enclosed and used as a buffer zone – in arid regions from hot air and in cold from frosty winds.

Lifting the house was popular in hot-humid as well as continental climate. As in the first underbuilding area was open and the dwelling took advantage from cool air under the floor, the second one’s space was enclosed, isolating the floor from the ground and maintaining a neutral temperature.

Moreover, in many places traditional bioclimatic elements evolved to the mixture of them within or in-between the climates. Double roofs or walls are typical feature for tropical areas of South-East Asia, which instead of ventilating the house, insulates inhabitants from the hot exterior. The inner part of the structure is from adobe as in arid climates while the outer part takes its roots from tropical thatched roofs protecting from sun and rain inner part. (Coch, 1998)

Nowadays, modern architecture should, more than ever, look back to the possibilities which the nature can give. Architecture is not only identified as a cause of many climate related problems but as well can be a solution for them. One of the examples is a transition to low carbon economy without reducing the energy consumption of the building (Olgyay, 2015). Thanks to bioclimatic design and taking the advantages from the nature this become possible. Modern architecture can not only create original solutions but mainly benefit from the historical time-proofed vernacular examples by reintroducing old principles in new expression of architecture.

Today, architects should not design with local climate but with the climate that alter and with all the problems connected with it. The climate limits are shifting because of the climate change and old solutions not suitable any more in one regions can be a perfect answer to the problems of the other. It can be implied and mix with the local architecture creating new bioclimatic designs suitable for nowadays conditions.

Nevertheless, still many architects cover their facades with glass without enough sunlight in the inner core or use air conditioning in their cubic designs claiming their sustainability. Climatic information is overlooked creating neither bioclimatic nor comfortable architecture. According to Olgyay, in bioclimatic design, architecture is created for human beings, who are exposed for the climate and creates a filter, not a barrier, between inhabitant and nature (Szokolay, 1998). For centuries vernacular architecture in all climatic zones presented such an approach and modern architecture, even with its all technical innovations, should not forget and learn from the traditional and timeless bioclimatic designs.

REFERENCES:

1. A'zami, A. (2005). *Badgir in traditional Iranian architecture*. International Conference "Passive and Low Energy Cooling for the Build Environment", May 2005, Santorini, Greece
2. Achenza, M. Giovagnorio, I. (2014). *Environment sustainability in vernacular architecture*. In: Versus: Heritage for Tomorrow. Vernacular Knowledge for Sustainable Architecture. Firenze: Firenze University Press.
3. AD7EB. (October 23, 2013). *Design for Human Comfort and Resilience: A Ukrainian Hut Strategy*. Retrieved from <https://ad7eb.wordpress.com/2013/10/24/design-for-human-comfort-and-resilience-a-ukrainian-hut-strategies2/>
4. Alfata, M., Kubota, T., Wibowo, A. (2017). *The effects of veranda spaces on indoor thermal environments in Dutch colonial buildings in Bandung, Indonesia*. Edinburgh: PLEA 2017 Edinburgh.
5. Bondras, E. (2013). *Implementing Bioclimatic Design in Sustainable Architecture Practice*. (pp.84-87) In Architecture and Urban Planning 2013/7.
6. Coch, H. (1998). *Bioclimatism in vernacular architecture*. (pp. 67-87). In Renewable and Sustainable Energy Reviews. No.2 Pergamon. Elsevier Science Ltd
7. Dabija, A-M. (2012). *Influence of Environmental Agents in Architecture. Traditional and Innovation. Romania: A Case Study*. Switzerland: Trans Tech Publications.
8. Darmayanti, T. E. (2016). *The Ancestral Heritage: Sundanese Traditional Houses Of Kampung Naga, West Java, Indonesia*. MATEC Web of Conferences 66, 00108. EDP Science.
9. Donnelly, M. C. (1992). *Architecture in the Scandinavian Countries*. Cambridge, Massachusetts, London, England: The MIT Press. Pages 220-228
10. Einarsson, M. A. (1984). *Climate of Iceland*. Elsevier. Pages: 673-693
11. Fouzanmehr, A. (2017). *Thermal Comfort in Hot Dry Climates: Traditional Dwellings in Iran*. Routledge Research in Architecture.
12. Hoof, J., Dijken, F. (2008). *The historical turf farms of Iceland: Architecture, building technology and the interior environment*. Building and Environment (nr 83)
13. Keshtkaran, P. (2011). *Harmonization between climate and architecture in vernacular heritage: a case study in Yazd, Iran*. 2011 International Conference on Green Buildings and Sustainable Cities.
14. Maknun, J., Busono, T., Nuryanto. (2016) *Disaster-friendly Sundanese Traditional Building Construction*. IOP Conference series: Materials Science and Engineering 128.
15. Olgyay, V. (2015). *Design with Climate. Bioclimatic Approach to Architectural Regionalism*. Princeton and Oxford: Princeton University Press.
16. Pamungks, G. (2013). *Kampung Naga, Indonesia*. In Vale, B., Vale, R. (Ed.), *Living within a fair share ecological footprint*. (pp.215-223). New York: Routledge. Pages 216-222
17. Pressman, N. (1995). *Northern Cityscape Linking Design to Climate*. Yellowknife, Canada: Winter Cities Association.
18. Salura, P. (2015). *Sundanese Architecture*. Bandung: PT Remaja Rosdakarya
19. Soflaei F., Shokouhian, M., Shemirani, S. (21 February 2016). *Traditional Iranian courtyards as microclimate modifiers by considering orientation, dimensions, and proportions*. Frontiers of Architectural Research (2016, nr.5), pp. 225-238
20. Szokolay, S. V. (1998). *Bioclimatic Architecture and Solar Energy*. (pp.111-131) In Advances in Bioclimatology 5. Human Bioclimatology. Australia: Springer.
21. UNESCO. (February 07, 2011). *The Turf House Tradition*: Retrieved from: <http://whc.unesco.org/en/tentativelists/5589/>

22. Waterson, R. (1990). *The Living Houses. An Anthropology of Architecture in South-East Asia*. Singapore: TUTTLE Publishing.
23. Watson, D. (1983). *Climatic Design Energy-efficient Building Principles and Practices*. New York, USA: McGraw-Hill, Inc.

APPENDIX:

1. Traditional case studies in four climate zones.

1.1. Icelandic turf farm - Glaumbær in Skagafjörður, Iceland



Figure 46. Glaumbær in Skagafjörður – front east façade. (Retrieved from: <http://naturalhomes.org/timeline/glaumbaer.htm>)



Figure 47. South façade. (Retrieved from: <http://www.nationalgeographic.com.au>)

Glaumbær is a perfect example of transformed gabled-farm. The farmhouse is one of the oldest one in Iceland and first parts of it were built about 874 AC. Probably the farm was firstly a row of buildings facing south. After some time, another row in front was added. This led to a passage-farmhouse with main, covered passage in the middle and houses with separate functions connected to it on both sides. The last room at the end of the corridor was baðstofa. This was also the warmest part of the house. In 18th century after transformation of front buildings, it took a form of gabled-farm creating a turned, comparing to original front, façade combined from couple of structures, which reminds first transformations of long-houses and dwellings without farm.



Figure 48. Glaumbaer from the sky. (Retrieved from: <http://janisland.blogspot.nl/>)

The Glaumbær farm's old part is composed from entrance (1), which lead to a passage were on both sides can be found: firstly kitchen (3) and dairy (11), further the pantries (4 and 10) and then guest room (5) and separate entrance (9). At the end of the corridor was baðstofa (6,7,8) – both sleeping and working space - divided into 3 parts. This rooms were prepared for 11 people to sleep. In 18th century new buildings with separate functions were added in the front of the plan. The biggest building is the redefined entrance with living room (12). On the other side of the entrance is second guest house. To get to the rest of the buildings inhabitants needed to get out of the house – smithy (15), storerooms (13 and 14) and fuel store (16). It is not known, however, one of the side buildings of the passage should be in the past lavatory. Indoor toilets and bathrooms appeared in turf houses in 14th century when the passage was mainly introduced for letting people to get to these places while being indoors (Donnelly, 1992).

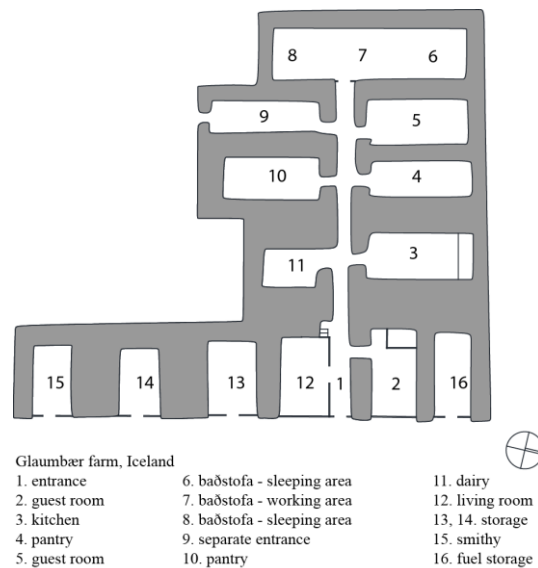

Figure 49. Plan of Glaumbær in Skagafjörður. Image by author.

For the water people usually went to the creek. However, it is interesting to mention that sometimes people were channeled the local creeks into their houses. Þverá farm in Laxárdalur is an existing example. People not only got an easier access to water especially during winter but also a cool storage. (UNESCO, 2011)

Most of the rooms had unfinished walls and floor exposing turf and stones. Only the baðstofa was covered with timber planks as the room where people spend most of their time. After redefining entrance, also the main entrance building was covered with timber.



Figure 50. Baðstofa, storage and kitchen. (Retrieved from <http://naturalhomes.org/timeline/glaumbaer.htm>)

1.2. Continental dwellings - Dimitrie Gusti National Village Museum, Romania



Figure 51. Dimitrie Gusti National Village Museum, Romania (Retrieved from: <http://muzeul-satului.ro/>)

The vernacular architecture from all parts of Romania was brought together and reassembled in village-museum in Bucharest. It contains more than 250 authentic peasant farms and houses structures, dated back to 17th century.



Figure 52. Traditional Romanian buildings with low stone foundation and verandas. (Retrieved from: <http://muzeul-satului.ro/>)

In the museum there can be found plethora of compact houses made from clay, logs or mixture. Hipped roofs with significant overhangs protect indoors from the sunlight. They are made either from thatch or wood and steepness depend on the region from where they are. Houses are lifted on stone foundations at least 30 cm from the ground. However, a great deal of them are raised above 70 cm or higher if their origins are from the Carpathian region, where the stairs lead to porches or verandas. Most of the houses have got verandas along one or two sides or even around whole house to protect not only from heat but also from cold.



Figure 53. Carpathian houses on high foundations. (Retrieved from: <http://muzeul-satului.ro/>)

The windows are small and most of them have additional shutters. Traditional houses have a middle hallway as an entrance zone dividing the building into two – living room and guest room, and sometimes pantry. The living room was meant for all family activities from cooking, through working to sleeping. The ceilings of the houses are low to concentrate the heat. The buildings are warmed up by fireplaces located in the hallway or living room which was one or double sided.

Some of the houses have got a timber extension on the side or back of the house or, if they are lifted enough, used the basement as storage. Additional buildings of the farms either continue the development usually creating plan of “L” shape with a building on the opposite side closing the courtyard or are freestanding located aside of the house creating an enclosed courtyard in the middle. In this way farmers were not only framing their space but also protecting it from wind and snow.



Figure 54. Examples of farm developments around the inner courtyard. (Retrieved from: <http://muzeul-satului.ro/>)

1.3. City of wind-catchers – Yazd, Iran



Figure 55. Yazd's high density urban plan. (Retrieved from: <https://www.timeshighereducation.com>)

Yazd is known as the desert capital, because it is surrounded by it. However, Yazd is also called the city of wind-catchers, where more than three-fourth of those structures are built on dwellings, while the rest on public buildings, making them a major landmark of the city. Nevertheless, it is not the only climatic solution which was adapted by the city. (Keshtkaran, 2011)



Figure 56. Wind-catchers of Yazd. (Retrieved from: <http://www.molon.de>)

The urban plan of Yazd reminds one of a dense mass – buildings are dense, sharing most of the walls with each other, providing the maximum protection from the Sun. Most of the sidewalks are narrow, between high walls and design in east-west direction to provide greatest amount of shadow. If the protection is not enough they are roofed and called sabat (Keshtkaran, 2011).



Figure 57. Narrow shaded passages in Yazd. (Retrieved from: http://www.panoramio.com/user/4082241?with_photo_id=55969042)

The main construction materials are mud and adobe bricks. Everything in Yazd is constructed from them. Adobe and mud are not only easily available in the desert but also most resistant to climatic conditions protecting inhabitants from sun and heating up during nights. However, lack of wood forced people to create arched or domed shaped roofs. Nevertheless, dome shaped roof is not only constantly exposed for the wind which cools them down but also reduce the area of sun radiation. Moreover, light colors are used to paint the facades to reflect the sun. Nowadays, people use plaster, raw clay and hay to create additional insulation. (Keshtkaran, 2011)

As in all hot-arid cities, Yazd houses have central courtyard protecting dwellers from the harsh environment. Nevertheless, different seasons force inhabitants to divide the house into for at least two parts – summer and winter – and move according to seasons. Summer spaces were on the south from the courtyard and were provided with shade, wind-catcher and usually basement, sometimes filled with water, to cool the floor from the bottom. On the other hand, northern part of the house was heated by Sun during winter. Courtyards in Yazd were often built deep – 3-4 meters below the house level, increasing shade and humidity, and keeping it cool. Sometimes in this way another underground level was created. (Keshtkaran, 2011)



Figure 58. Courtyard in Yazd. In front higher west or east facade with openable shutters and windows. On the sides arcades providing shade and heat buffer. (Retrieved from: http://www.panoramio.com/user/4082241?with_photo_id=55969042)

In Yazd wind-catchers are open on all four sides because there is no prevailing wind. They are covered with a cob color to reflect the sun rays. As the average moisture there is low – around 30 percent, the air passes through the courtyards where there is moisture from fountains. Also, sometimes people attach wet mats or thorns to moisten the air more. The highest wind-catcher in the world is located exactly in Yazd in Dowlat-Abad Garden and is 33 meters. (A'zami, 2005)



Figure 59. Highest wind-catcher in the world in Dowlat-Abad Garden. (Retrieved from: http://www.panoramio.com/user/4082241?with_photo_id=55969042)

1.4. Sundanese traditional village – Kampung Naga, Indonesia



Figure 60. Kampung Naga. (Photo by author)

Kampung Naga is one of the survived traditional villages of Sundanese culture. The culture exists for more than 15 centuries and Kampung Naga is one of the example village, which strongly believes in the ancestors' knowledge and traditions. However, in 1956, during the rebellion, all written manuscripts and the whole village was burnt down. Nevertheless, the people from Kampung Naga decided to rebuild their village with their oral tradition and memory of identity. (Darmayanti, 2016)



Figure 61. Kampung Naga. In front water purification fish ponds. (Photo by author.)

Kampung Naga is occupied by 101 families on 100 ha of land. In 2016 there were 113 buildings including additional sacred house, mosque and gathering building (Darmayanti, 2016). The

traditional houses are 30 to 60 m² big, are lifted from the ground to 40cm or higher above and standing on man-made the stage-shaped rock foundations. The main building materials are wood and bamboo. First one is used for the framework construction, while the second one to for the walls and ceiling. Timber planks cover almost all floors apart from the kitchen which is made from split bamboo. Woven walls are finished with lime and their vitality is from 10 to 15 years. Roof frame is made from bamboo or timber and covered with palm leaves attached by bamboo cross pieces and last for about 15 years. All elements of the building are easy to replace if needed. In September 2009 the village experienced earthquake of the 7.3 Richter scale. However, because of the flexibility of the timber construction and pillars resting on stone foundations the houses were left untouched. (Pamungks, 2013)

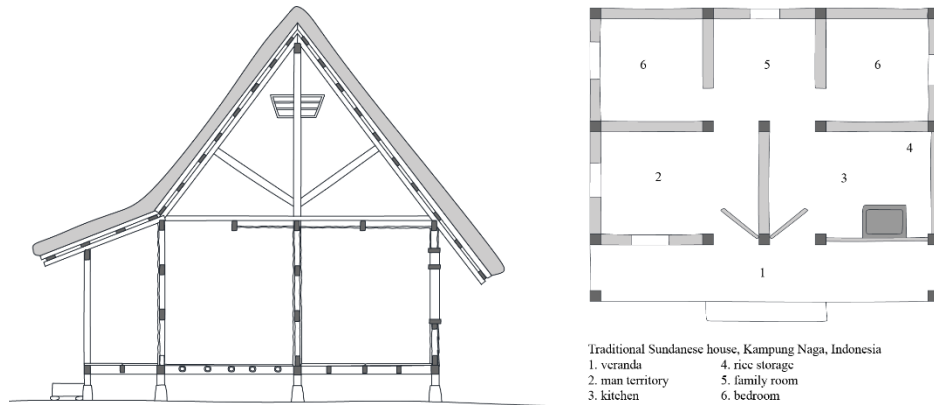

Figure 62. Section and plan of example house in Kampung Naga. (Image by author.)

Before 1956 houses had only one pair of doors as the only opening of the house. However, after rebuilt. Every house has two doors – for men and women - facing either south or north and windows. Behind the woman’s door there is the kitchen. Under the house people keep chickens. Bamboo floor in the kitchen allows food to drop through and feed chickens. Cut wood for the hearth is stacked outside next to the wall, under the roof. The cooking stove is standing on separate stone foundations. Most of the houses have got veranda in front to work there and have access to daily light. (Pamungks, 2013)

The window system in kampung Naga is developed into 2 elements: vertical lattice shutters opening to inside and full shutters opening to outside. It allows to control ventilation as well as sun brightness. There is no glass in the system.



Figure 63. Window system in Kampung Naga. (Photo by author.)

The village is an example of a low-footprint community. In the boundaries villagers can find enough amount of water food and wood. It is located in the valley next to the river surrounded by the fish ponds and vegetable fields, while rice field terraces are grown on the slopes. The food waste, which is rich in nutrients, flows back to the ponds as a fish food. (Pamungks, 2013) The village has a huge water purification system. The water from the river gets into the rice fields where the first step of purification occurs. Secondly, the water flows to the fish ponds and is cleaned by them. This water is used for bathing and washing. Then it returns to the system where it is purified by fish and where are the toilets are. On the last step the water gets back to the river. There was an attempt to use the natural filter to purify the water to be drinkable. The test results were positive. However, inhabitants did not trust this water and still took it from the spring. In the village the portable water is taken from the spring and people do not use electricity.



Figure 64. Main courtyard of the village dedicated for drying the rice in harvest season. (Image by author.)



Figure 65. Water purification pond and platform for cleaning. (Image by author.)

Population growth started to cause problems. As the villagers did not want to expand the village to the rice fields, this led to higher densification of the houses inside the settlement. Also, the number of residences was limited to a defined amount of people. If this number is exceeded, people are asked to leave the village until someone dies. Mainly those people moved just beyond the borders of Kampung Naga and created a similar version of the village to that of their home one, but with some modern materials and use of electricity. (Pamungks, 2013)



Figure 66. Narrow passages shaded by significant overhangs provide cooling in Kampung Naga. (Images by author.)