



into the climate

---

*improving living conditions in informal  
settlements in tropical countries*

why

---

*bioclimatic architecture before and now*

*informal settlements*

*location: Cigondewah, Indonesia*

how

---

*3 steps of comfort living:*

*1. shaping the architecture*

*2. reconnecting with nature*

*3. use of natural materials*

what

---

*way of living*

*typologies*

*future development*



why

---

# shaping architecture

*bioclimatic design  
and connection with nature*

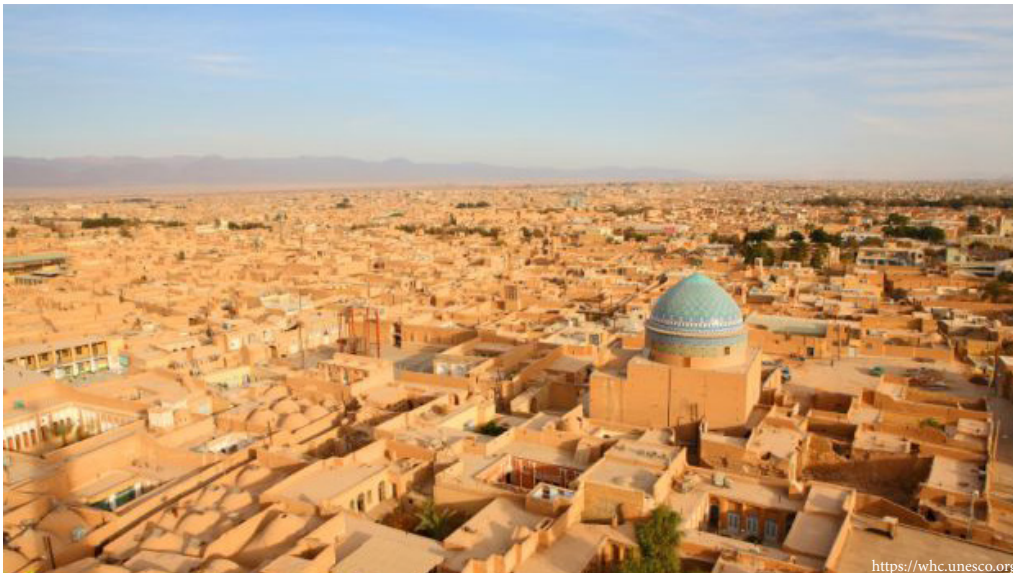

bioclimatic design in the past

*taking what nature has to offer,*

*natural materials*

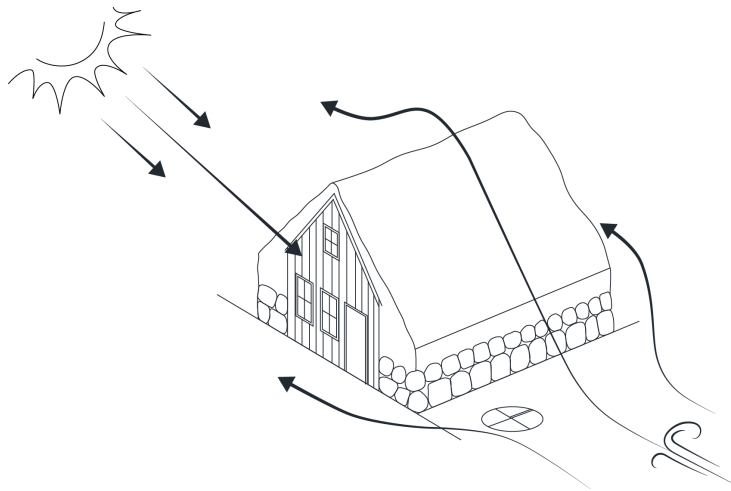

*cold climate*

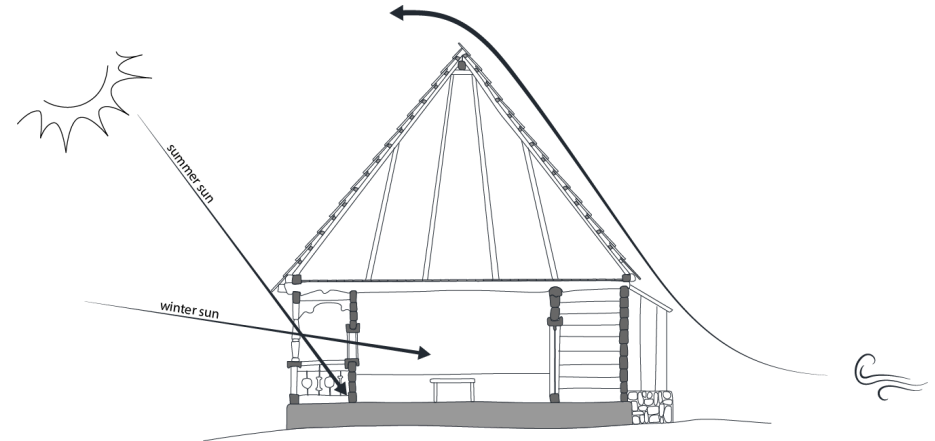

*continental climate*

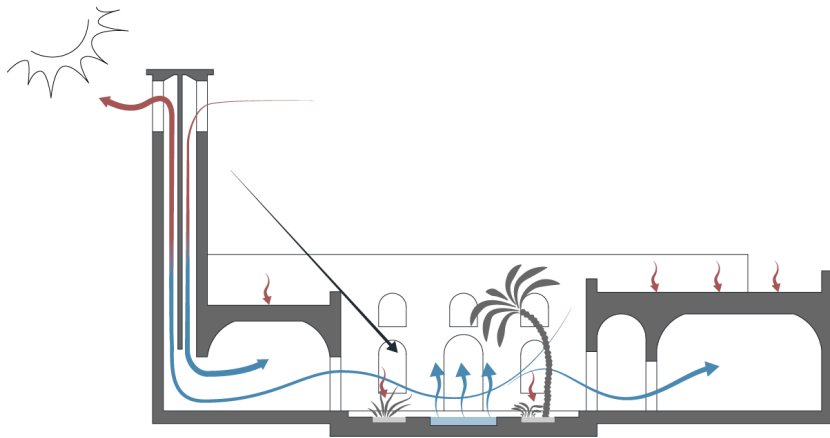

*hot-dry climate*

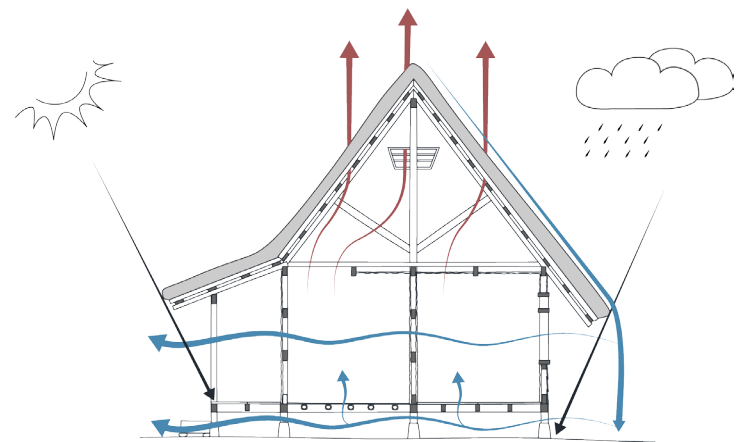

*hot-humid climate*

dominant materials nowadays

*+ comfort of living is supported  
by mechanical appliances*

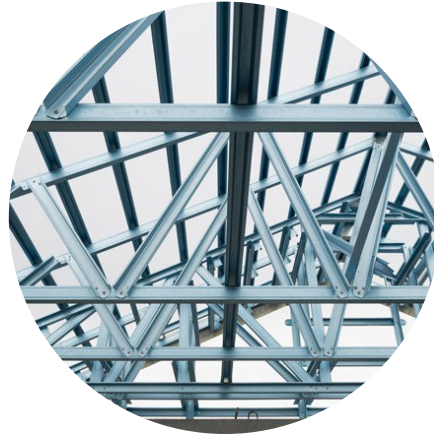

informal settlements  
*bioclimatic problem of developing countries in  
hot-dry and tropical regions*

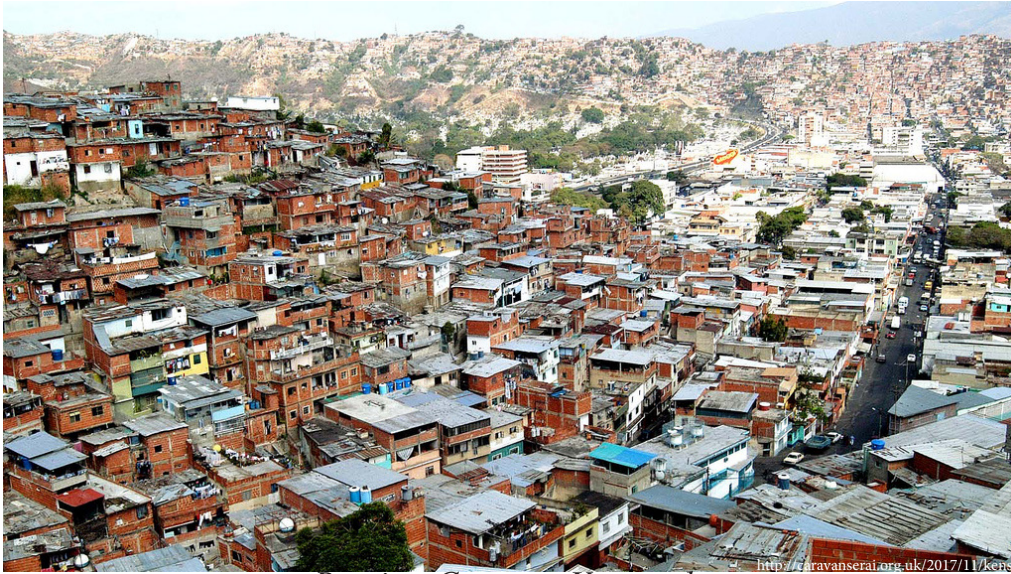

*Barrios, Caracas, Venezuela*



*Informal settlement, Mumbai, India*



*Kampung in centre of Bandung, Indonesia*



*Cabucu, Sao Paulo, Brazil*

kampungs around Indonesia

*not appropriate materials,  
overheating, lack of ventilation*



# location

*Indonesia, Bandung, Cigondewah*

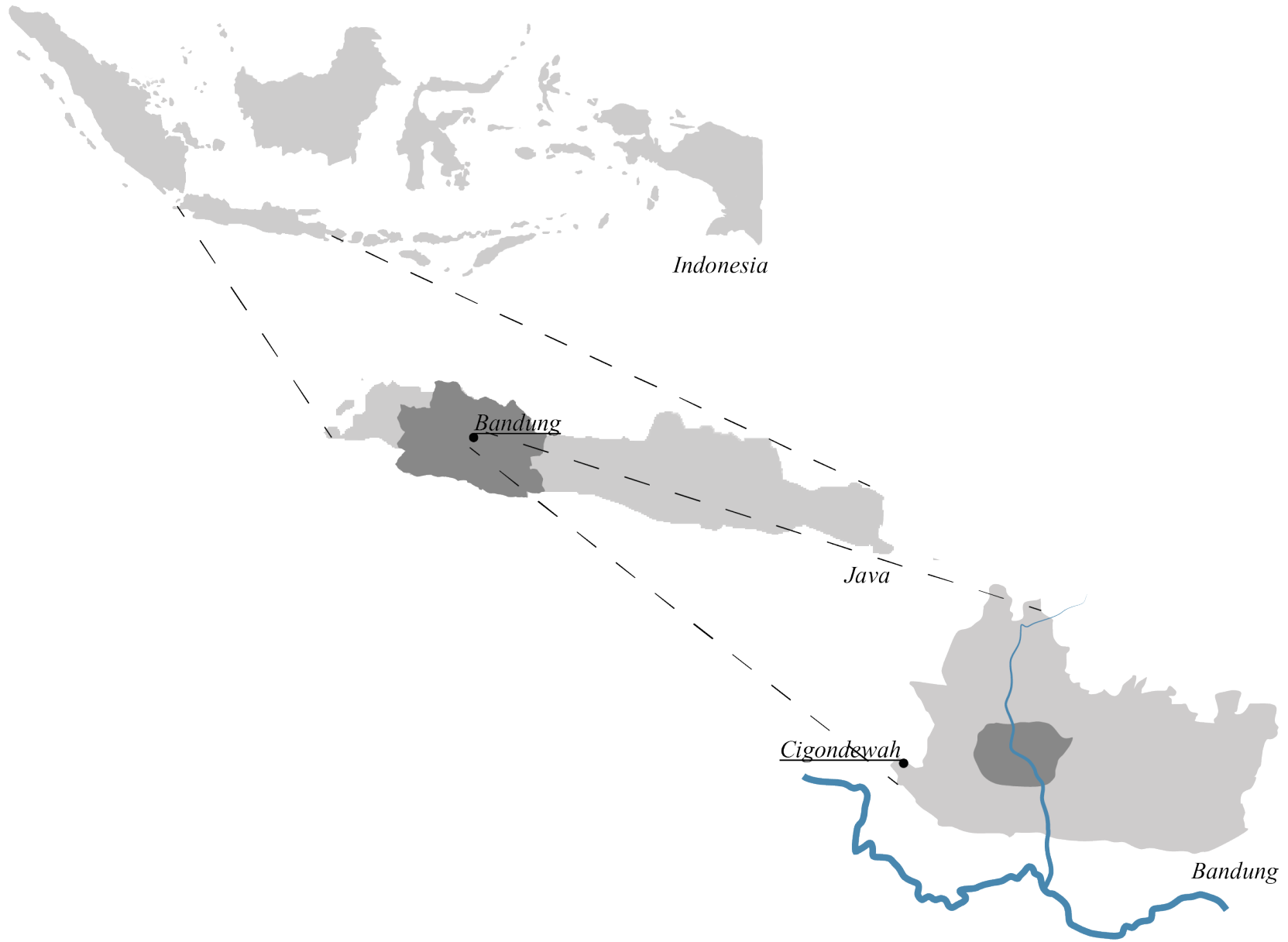

## location

*Cigondewah - kampungs RW2 and RW12*

### *CIGONDEWAH*

- *two industrial kampungs*
- *rapid change of landscape from village to peri-urban*
- *inflow of migrant workers*
- *local families built extensions or new houses for rent on off-the-grid land*
- *40-50% of inhabitants are migrant workers*



*Indonesia, Bandung, Cigondewah*

unsuitable building materials

*new constructions became unsafe,  
cheap, waste building material*



lack of healthy living conditions

*small renting rooms,*

*no ventilation, overheating, dampness*



lack of infrastructure

*no access to clean water*

*and open sewage system*



The background image shows a flooded area with rice plants in the foreground. In the middle ground, there are several buildings, some of which appear to be in poor condition or under construction. One building has a blue wall and a balcony with a wooden railing. Another building has a green wall. The sky is overcast and grey. The overall scene suggests a rural or semi-rural area that is prone to flooding.

problems

---

- *lack of healthy living conditions*
- *unsuitable building materials for the climate*
- *lack of centralized infrastructure*

how

---

location of the project  
*last green area*



*Picture taken by Mo Smit*



- *densifying area with bioclimatic dwellings for migrant workers and families*
- *keeping it as green as possible - taking advantages of what nature has to offer for internal and external community*



3 steps to improve living conditions

- 1. shaping the building with climate*
- 2. creating a low-tech, tectonic design from natural materials*
- 3. living with sybosis with nature - closed circulation of water and organic matter*

step 1: shaping the design

---

*research on bioclimatic principles*

## arquitectura vegetariana

“ ... construction in concrete as conceived in the third world produces cavernous spaces: a cave has a stone floor, stone walls and a stone roof. **We do not come from caves, we are dwellers, we come from the trees and we are men of the treetops, even if we do now live in caves.** Current architecture follows an exaggerated and unhealthy regimen. It is totally carnivorous. The state of nature demands that we come back to a more balanced, more vegetarian state ... “

*Simon Velez*

# vernacular principles

*tropical climate*

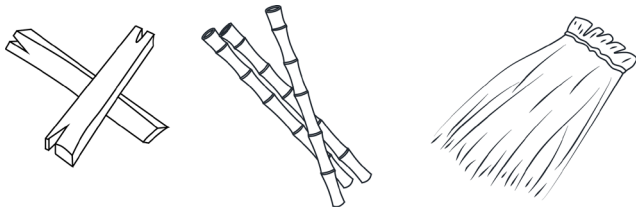

- *made from natural materials*
- *house lifted from the ground*

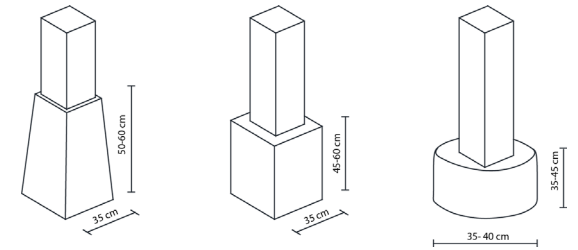

- *skeleton construction earthquake resistant*

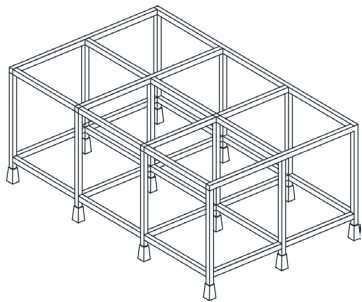

- *permeable structure allows for airflow*

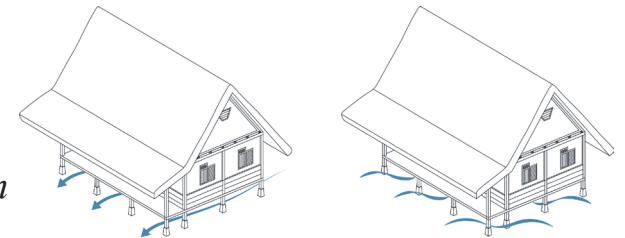

- *huge overhangs protect house from sunlight and rain*

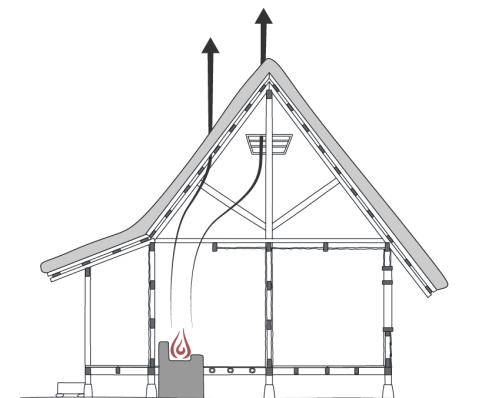
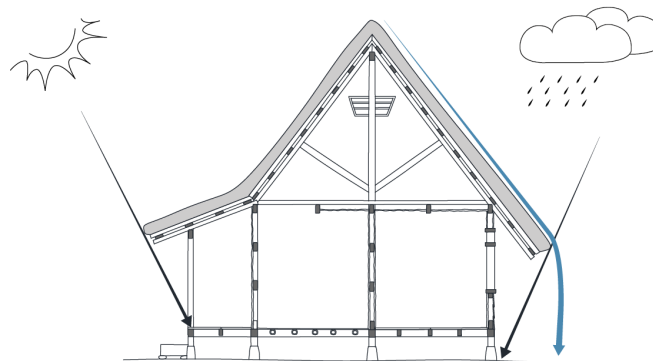
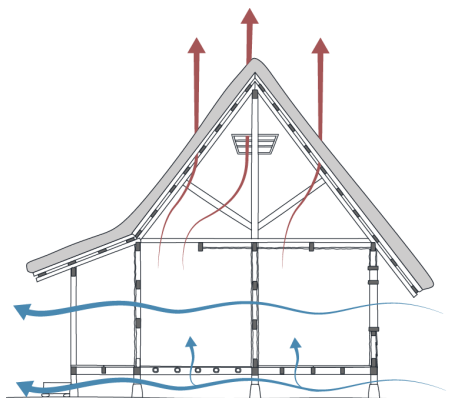

vernacular settlements

*dense, row house typology,  
separate buildings*



*Kampung Naga*

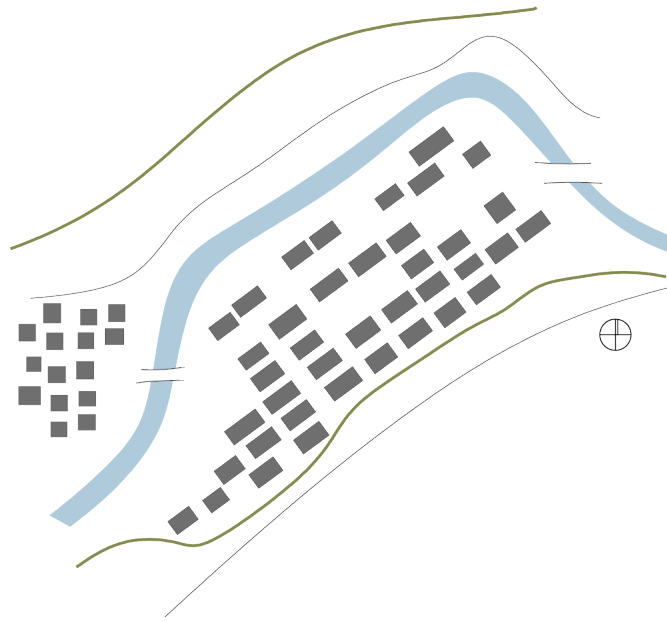

*Outer Baduy Kampung*



*Kampung Tonggoh*

Kampung Naga  
*example of bioclimatic architecture*



Kampung Naga  
*ventilation passages around the buildings*

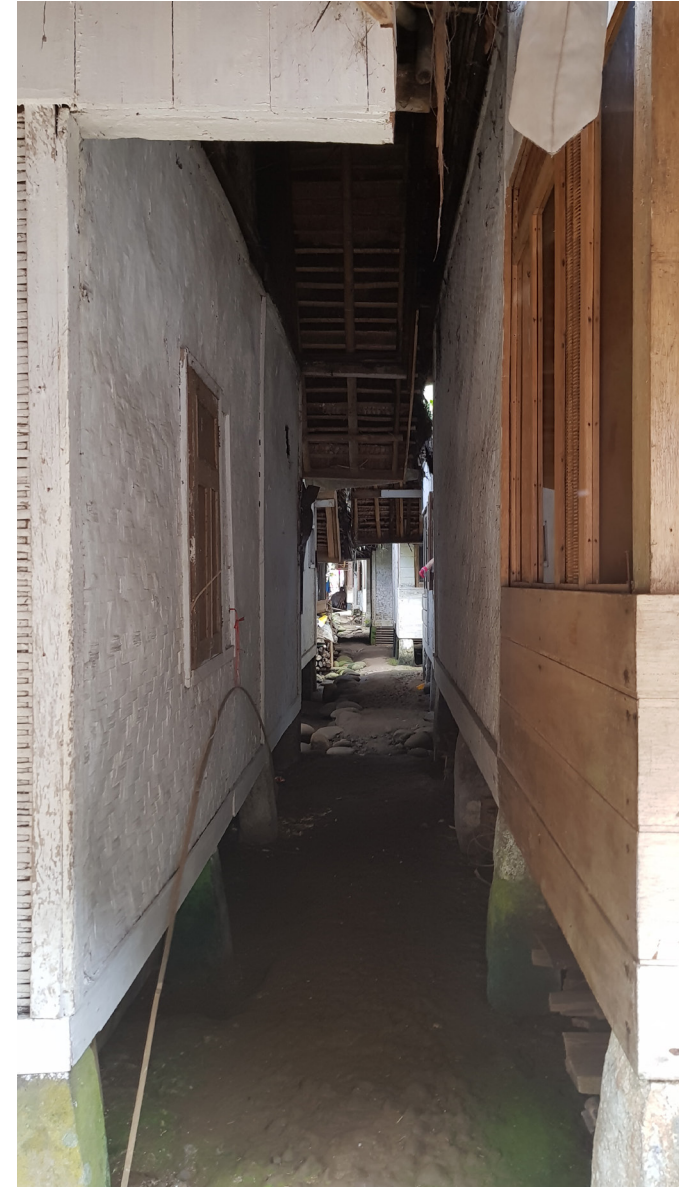

# Kampung Naga

*different housing levels  
prevents from flooding*



# Kampung Naga

---

*foundations*



Kampung Naga  
*different permability of openings*



Kampung Naga  
*roof construction*



- *houses need to facilitate more infrastructure*
  - *more people per m<sup>2</sup>*
  - *multi-story houses,*
- *need for sound insulation*
- *rotation of inhabitants,  
no closed communities*

step 1: shaping the design

---

*implementing bioclimatic principles*

climate data  
sun, wind and rain

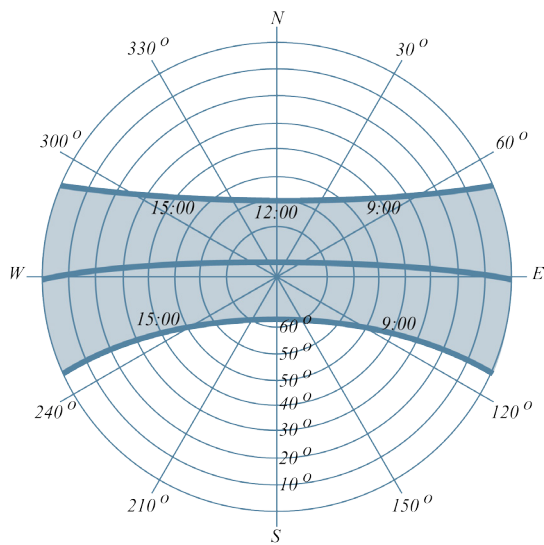

Sun path diagram for Bandung

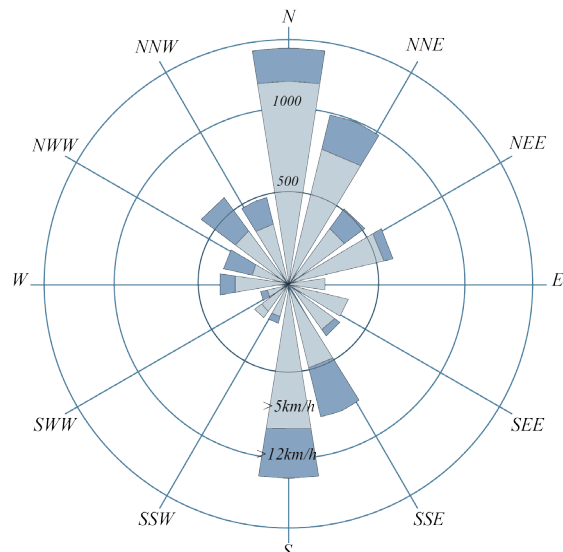

Wind rose for Cigondewah

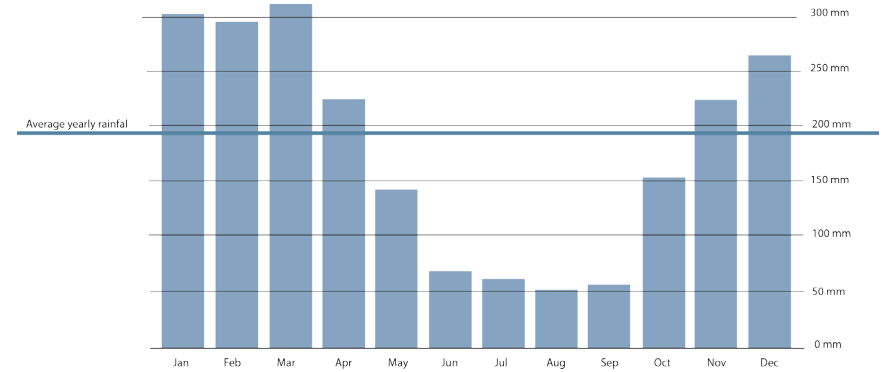

Rainfall in Bandung  
yearly rainfall around 2 300 l/m<sup>2</sup>

design guidelines  
*wind analysis - courtyard and row houses*

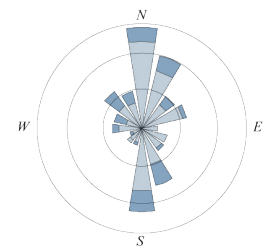
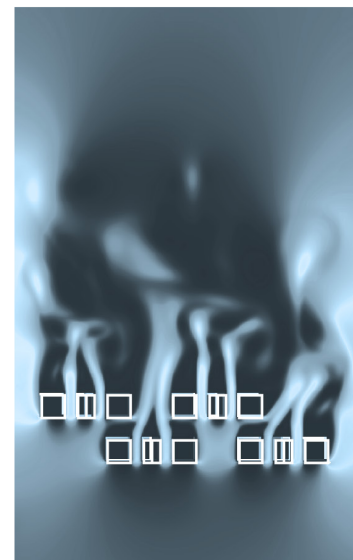
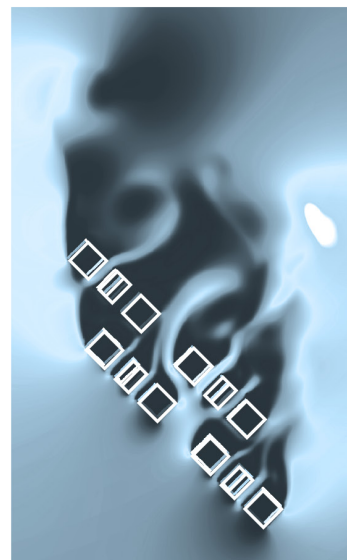
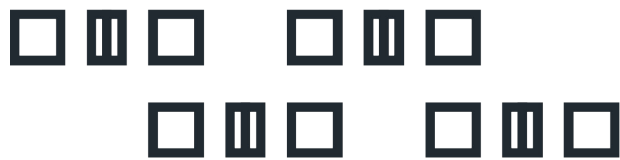
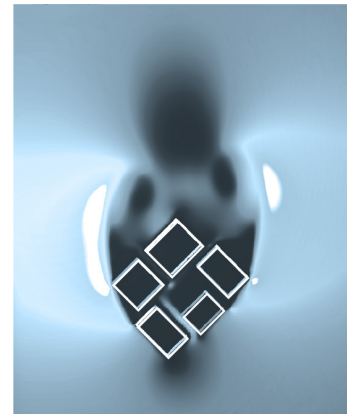
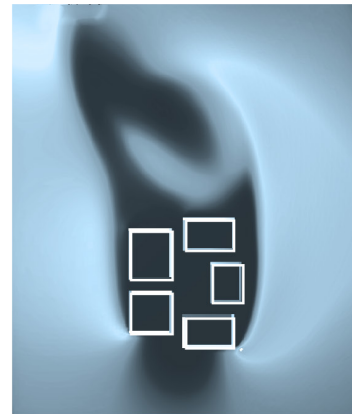

Windrose for Cigondewah

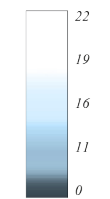

Velocity (m/s)

design guidelines  
row houses and ventilation

vernacular  
urban plans

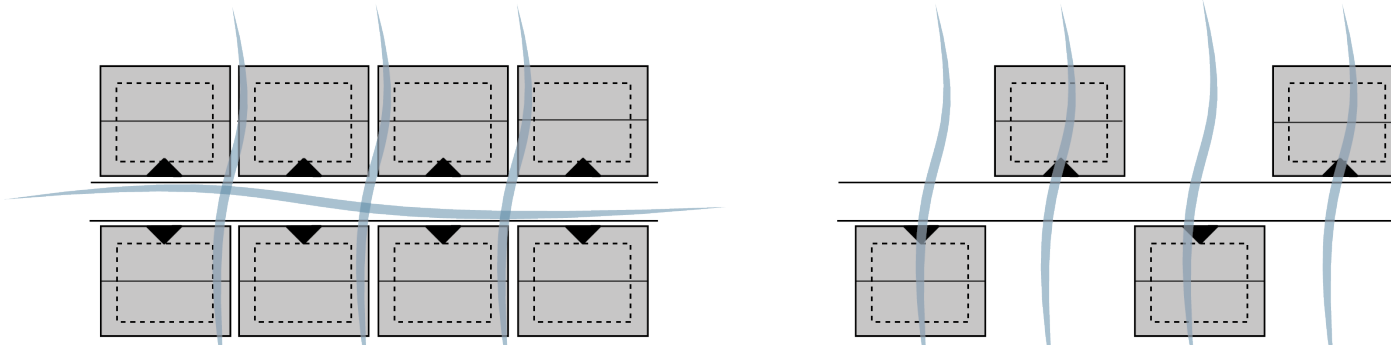

new design

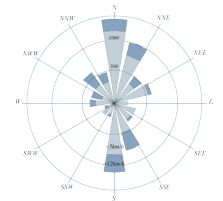
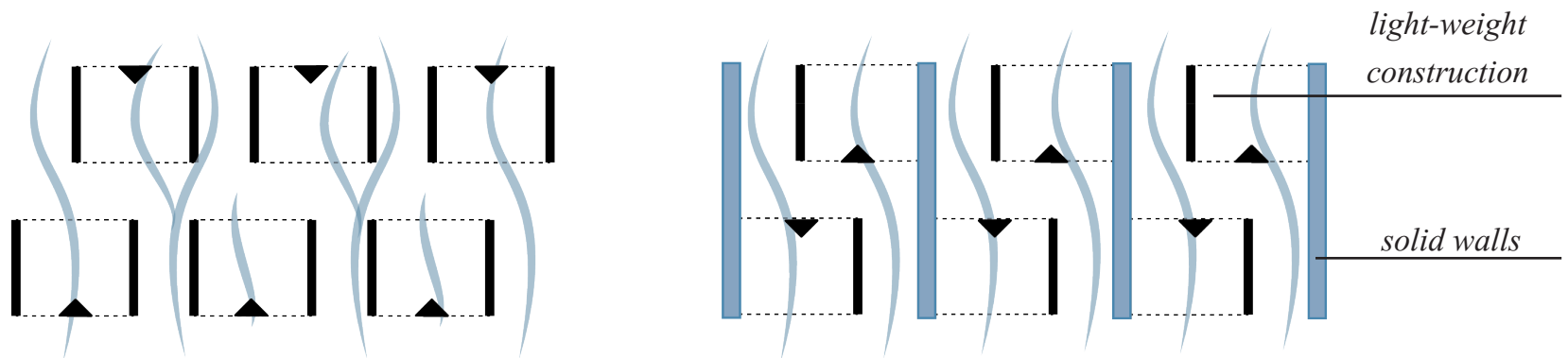

## design guidelines

*lifting the building from the ground -  
ventilation and preventing flooding*

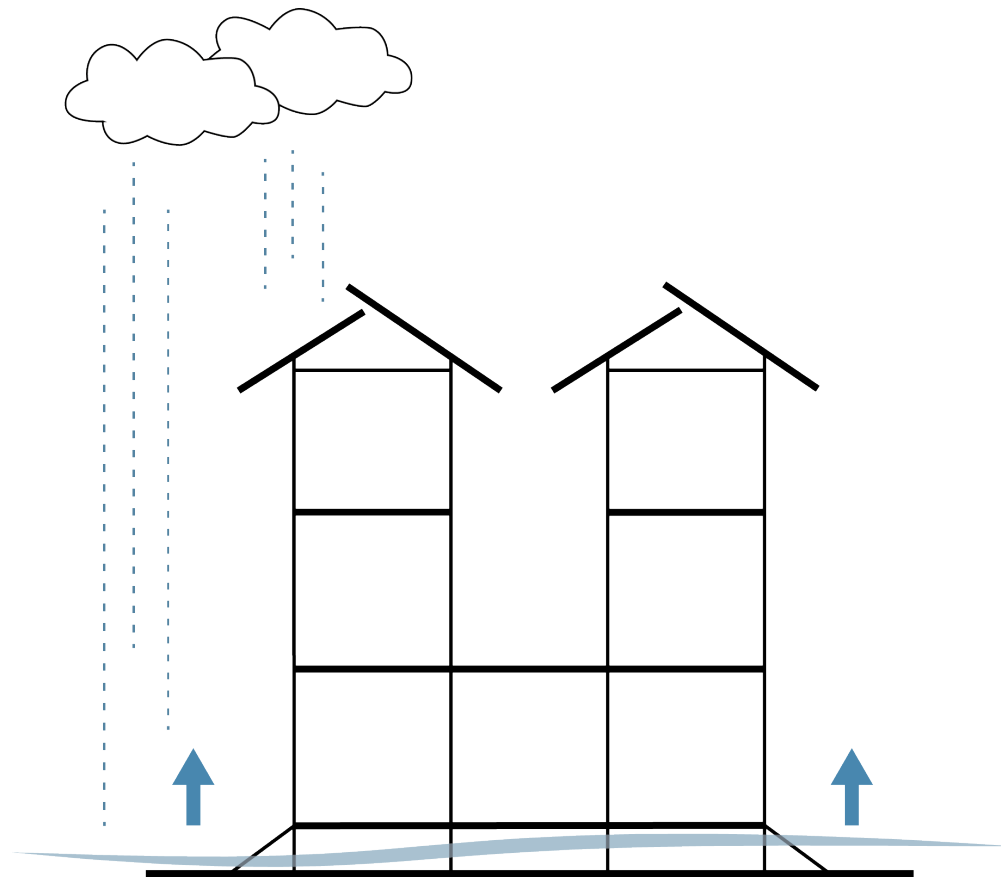

design guidelines

*extension of the facades*

*sunlight protection*

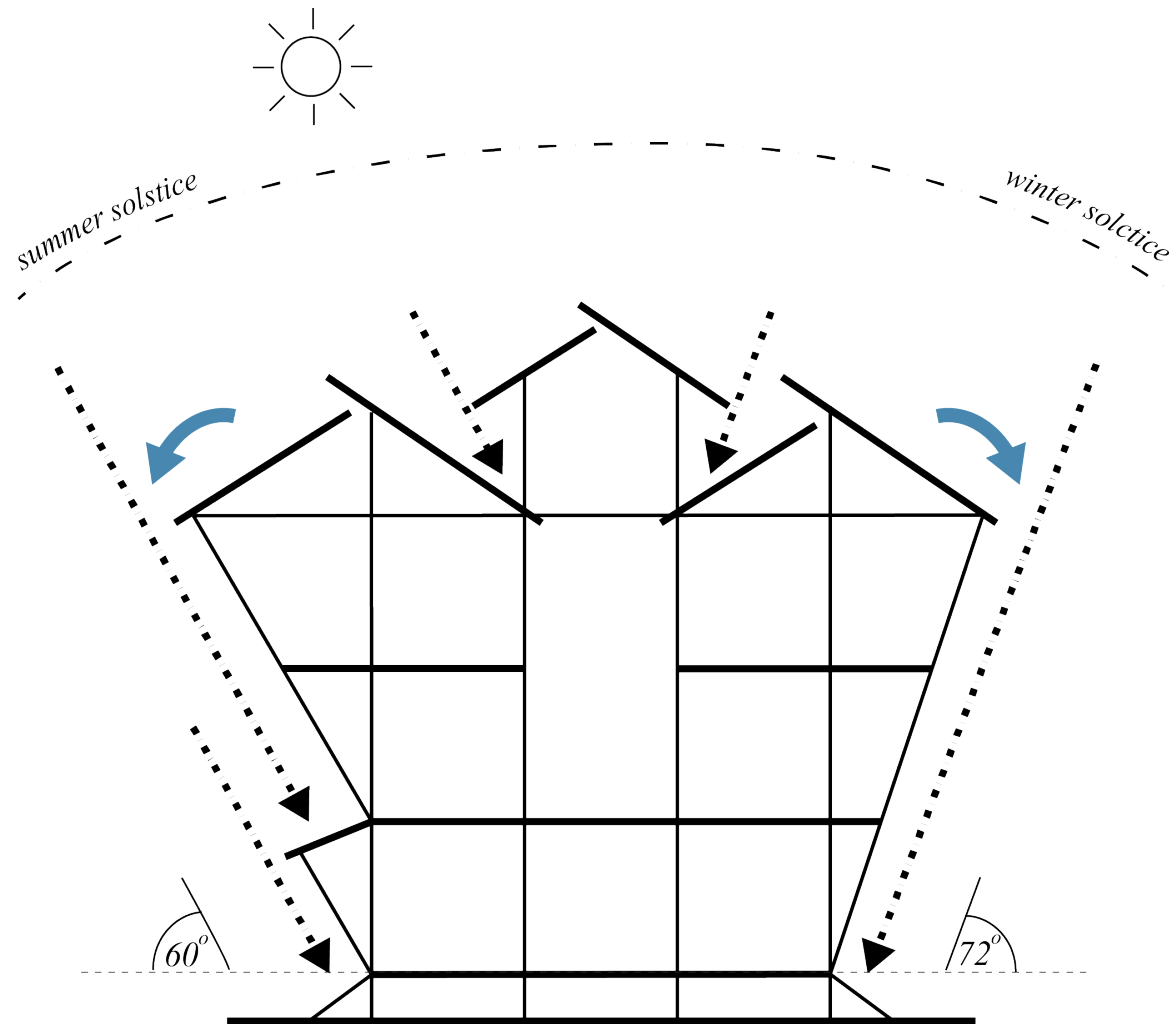

design guidelines

*butterfly roof - harvesting rain water  
and vertical ventilation*

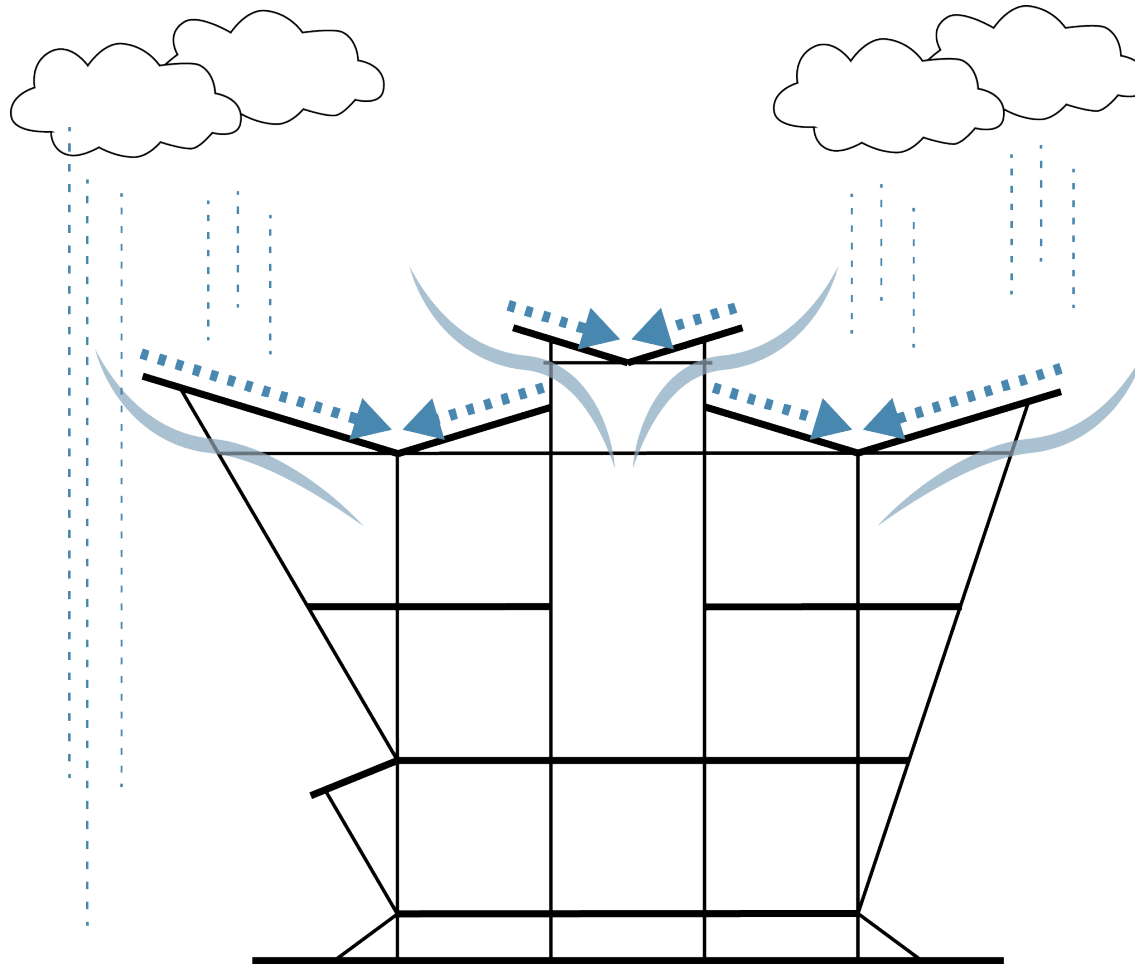

## design guidelines

### *innovative rammed earth brick wall*

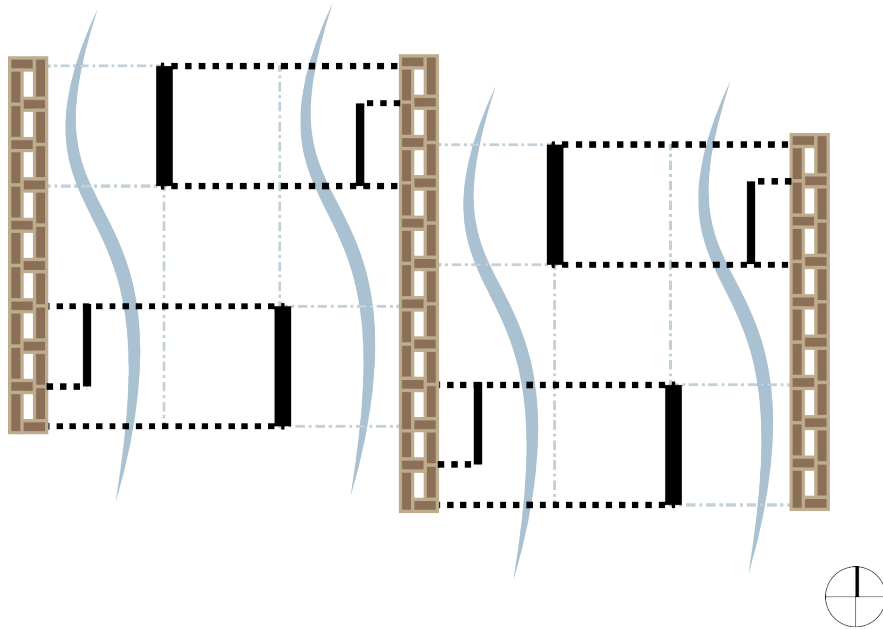

*advantages of rammed earth brick wall:*

- 1. shared wall with two buildings*
- 2. hiding space for all installations allowing the structure to be fully open*
- 3. directing the wind through the building*
- 4. keeping the humidity inside the building on the level of 55%*
- 5. sound insulation and fire wall*

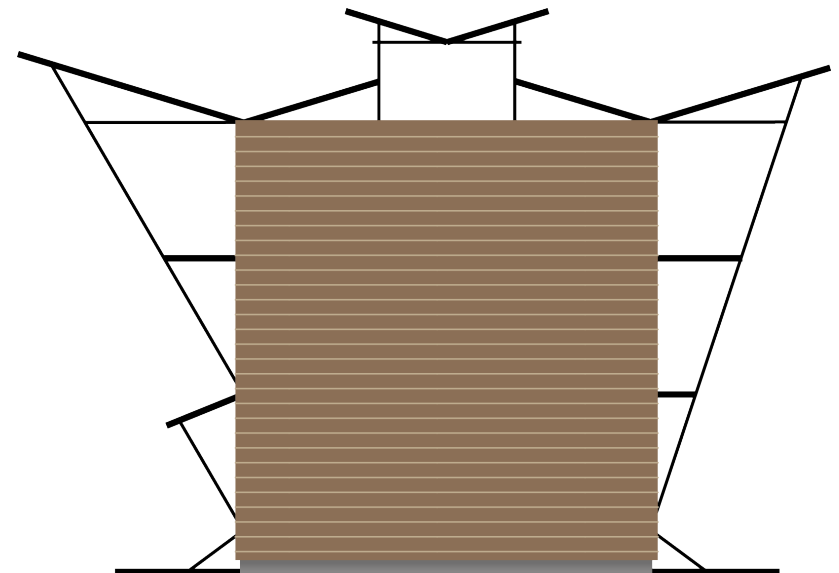

proposed shape  
*bioclimatic architecture*

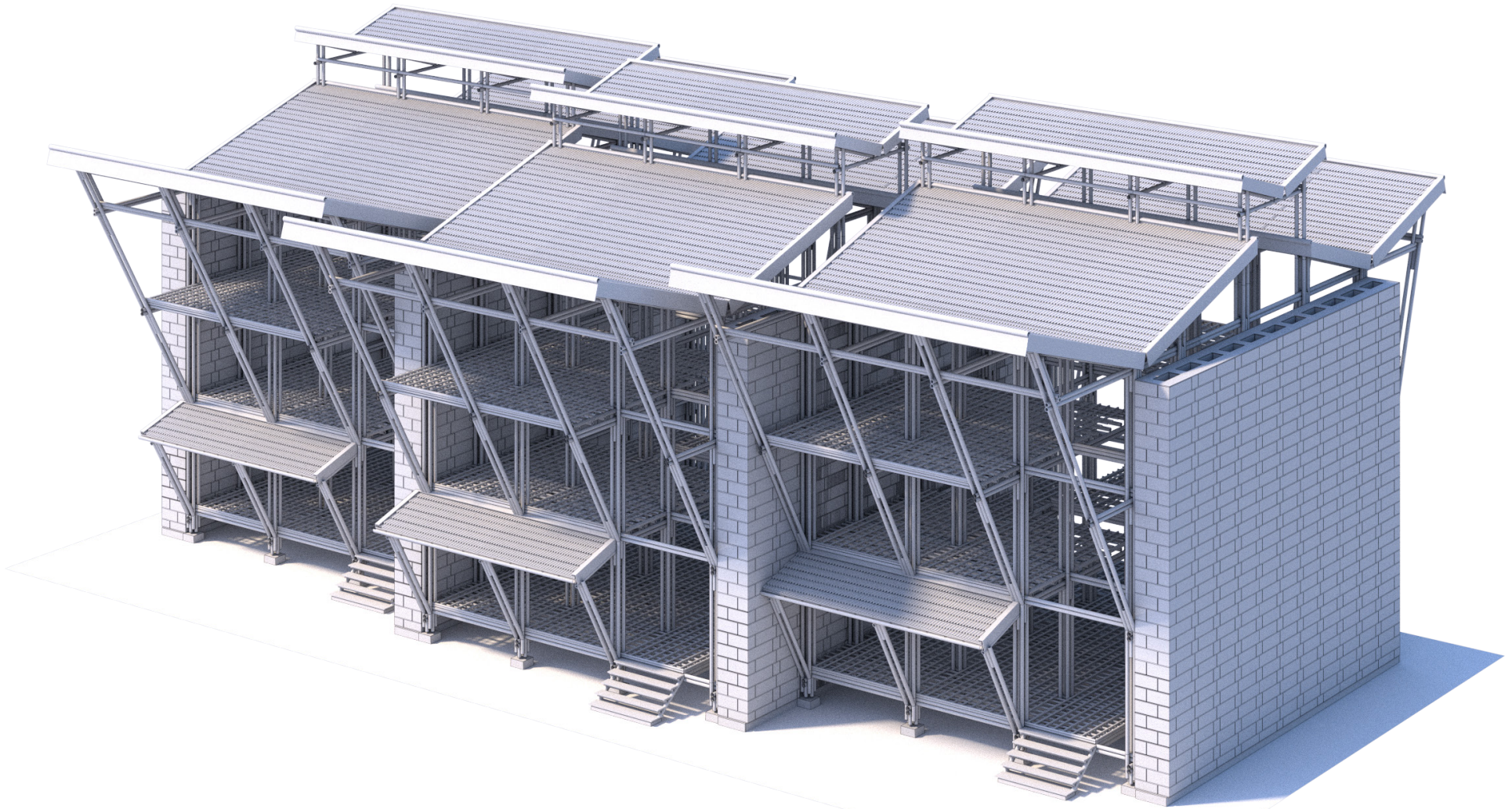

step 2: re-naturalizing surrounding  
living with symbiosis with nature

---

*research*

vernacular settlements  
*connection with the nature*



*Kampung Naga*

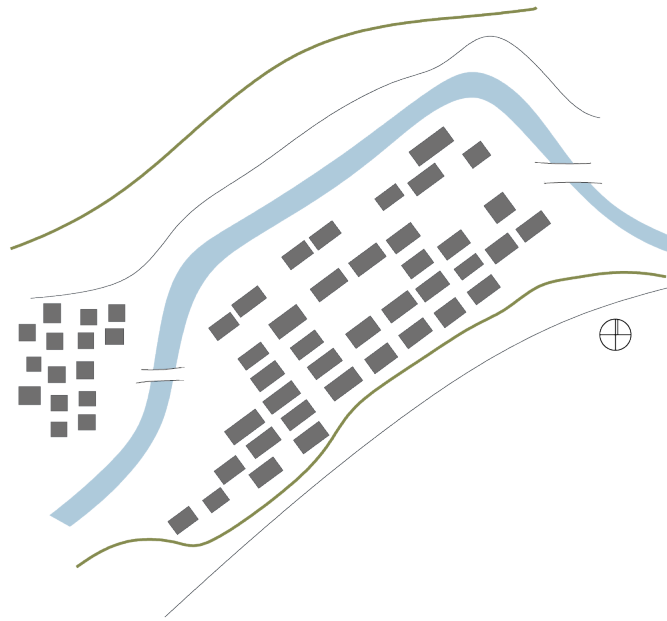

*Outer Baduy Kampung*



*Kampung Tonggoh*

# Kampung Naga

*water purification system*



living in symbiosis with nature  
circulation of water and natural matter

Density of RW2 kampung - 193 p./ha  
Predicted amount of people living in 1,2 ha - 210 p.

- water circulation
- natural matter circulation
- additional profits

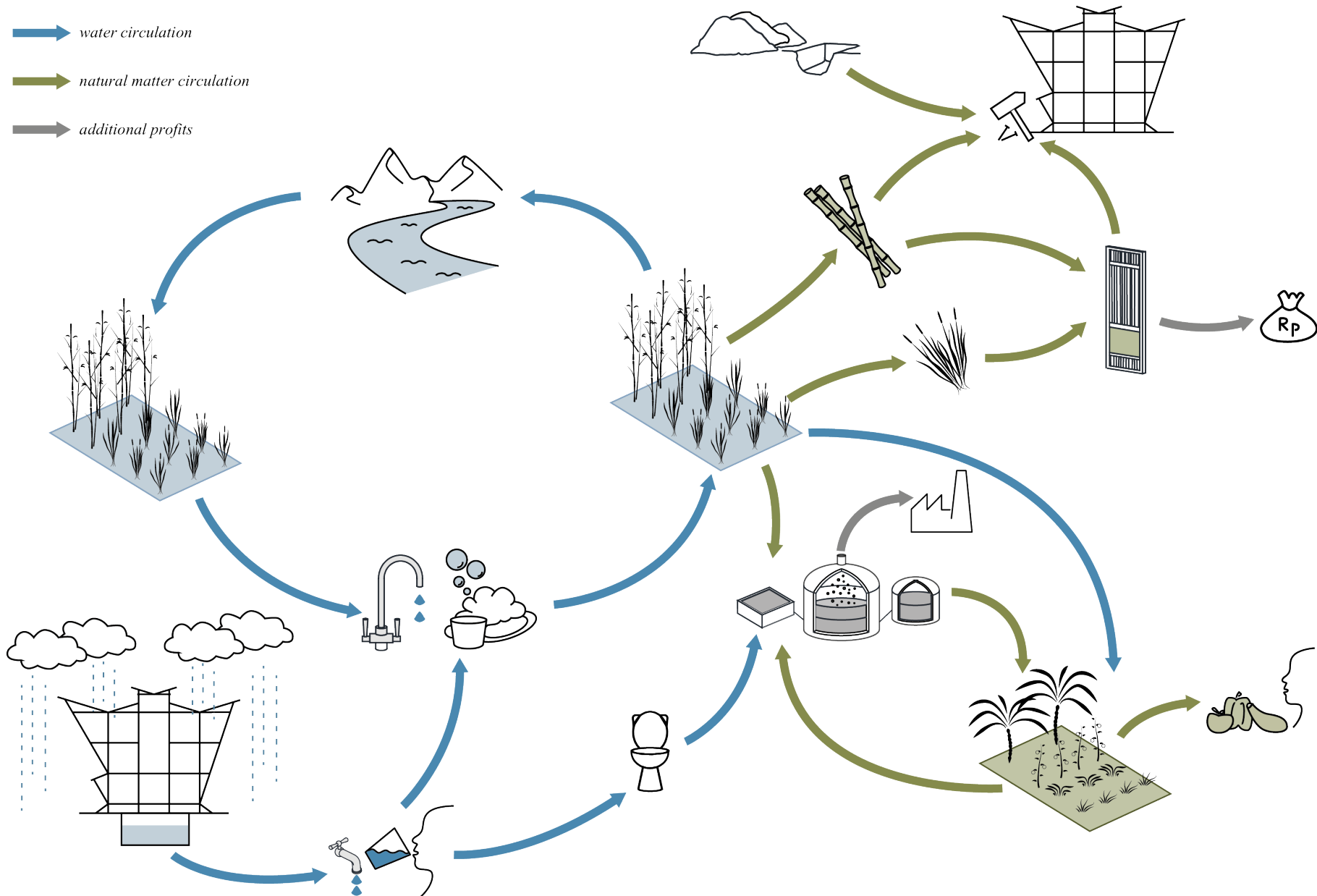

living in symbiosis with nature

*circulation of water and natural matter*

→ water circulation

→ natural matter circulation

→ additional profits

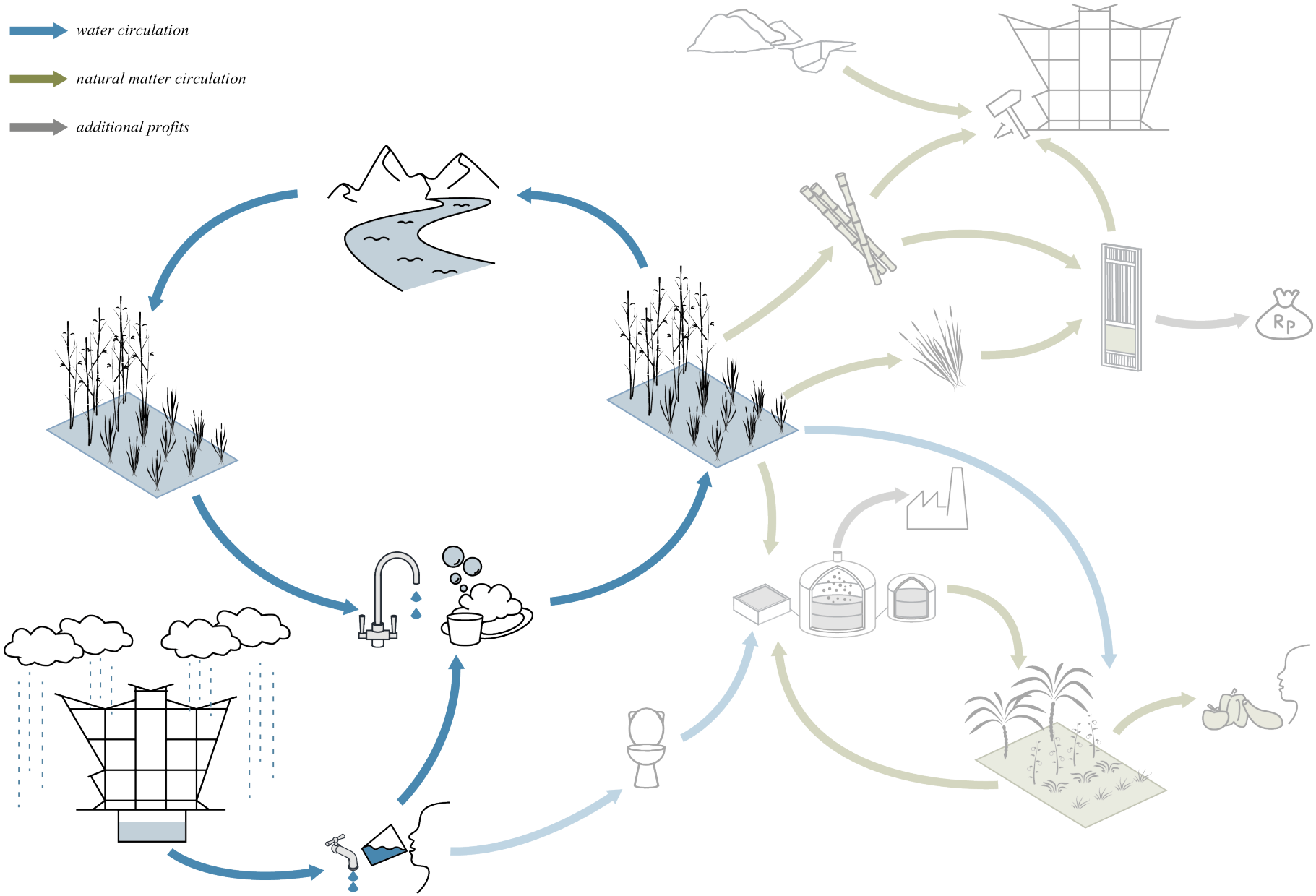

self - sufficient in water  
 water flow diagram

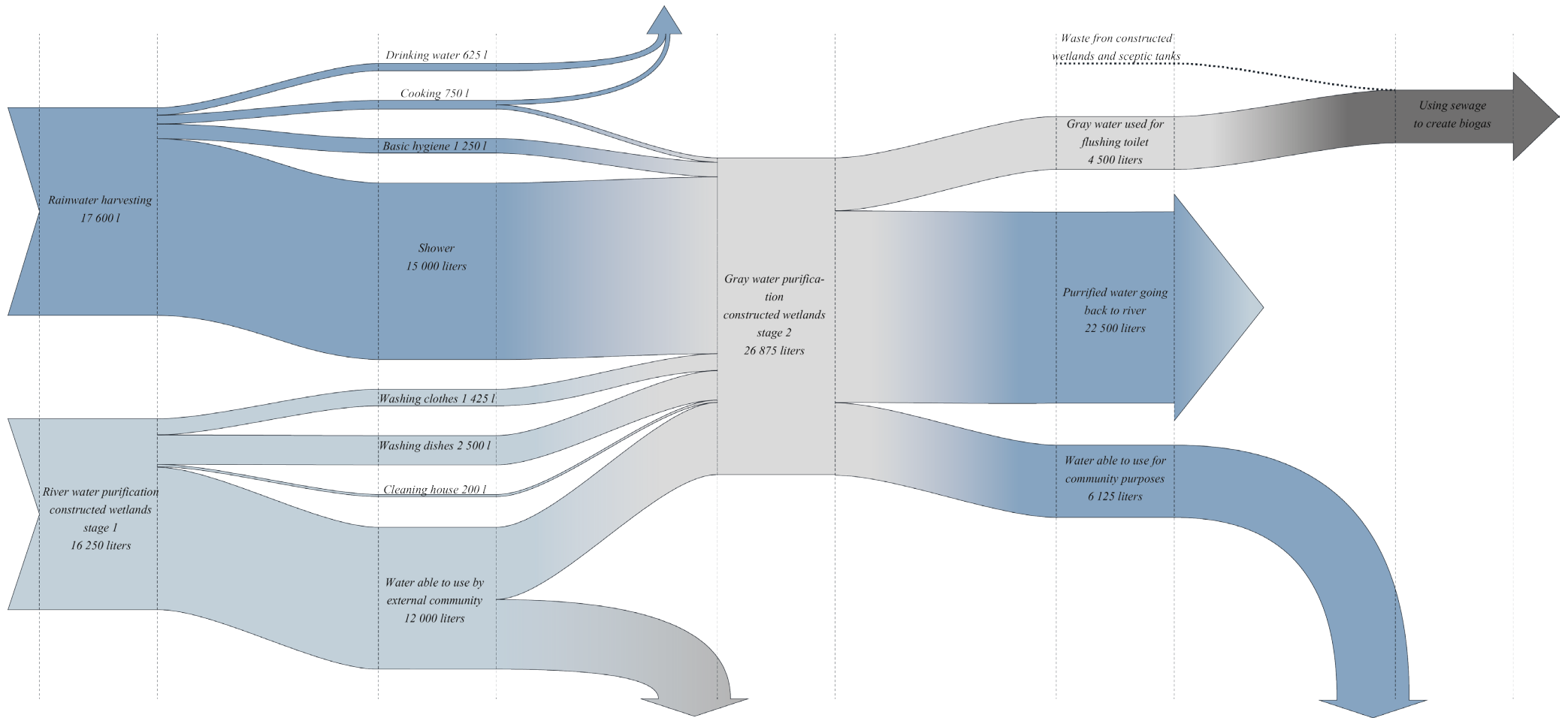

Diagram is made for 210 people living in the community + additional water for the external community

living in symbiosis with nature

*circulation of water and natural matter*

→ water circulation

→ natural matter circulation

→ additional profits

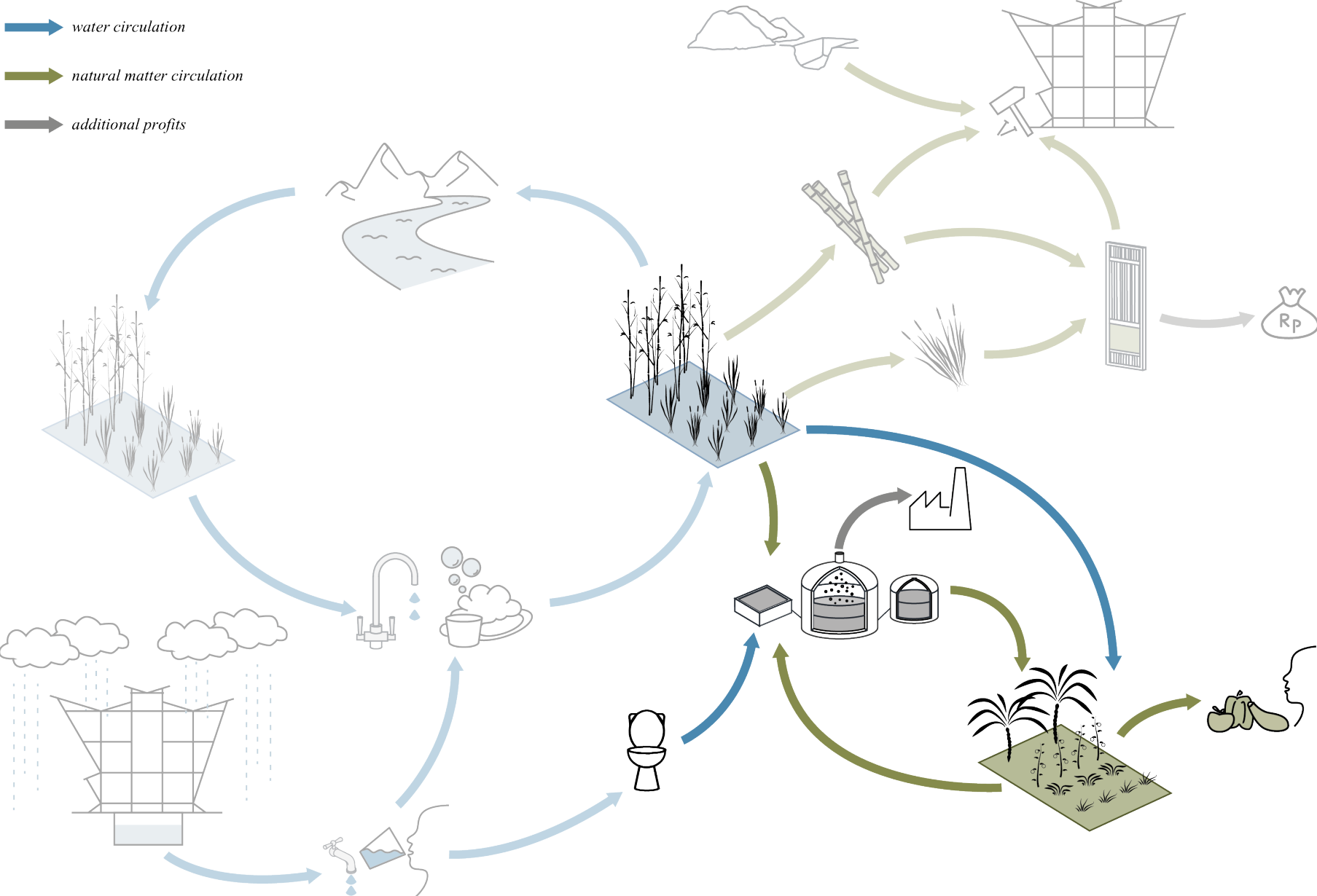

living in symbiosis with nature

*circulation of water and natural matter*

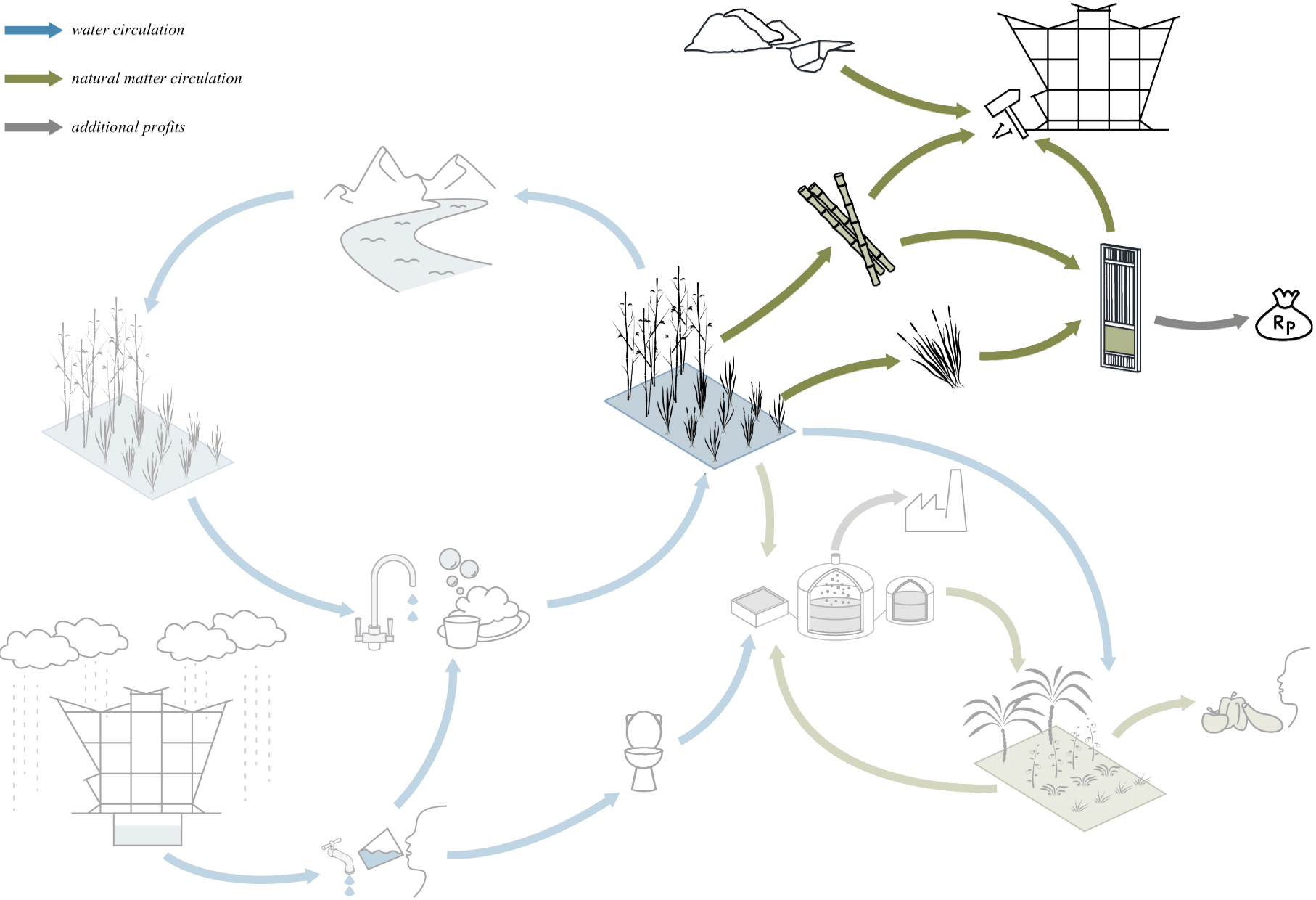

step 2: re-naturalizing surrounding

living with symbiosis with nature

---

*implementation*

urban plan development  
*existing situation*



urban plan development

1. *constructed wetlands*  
for river water purification

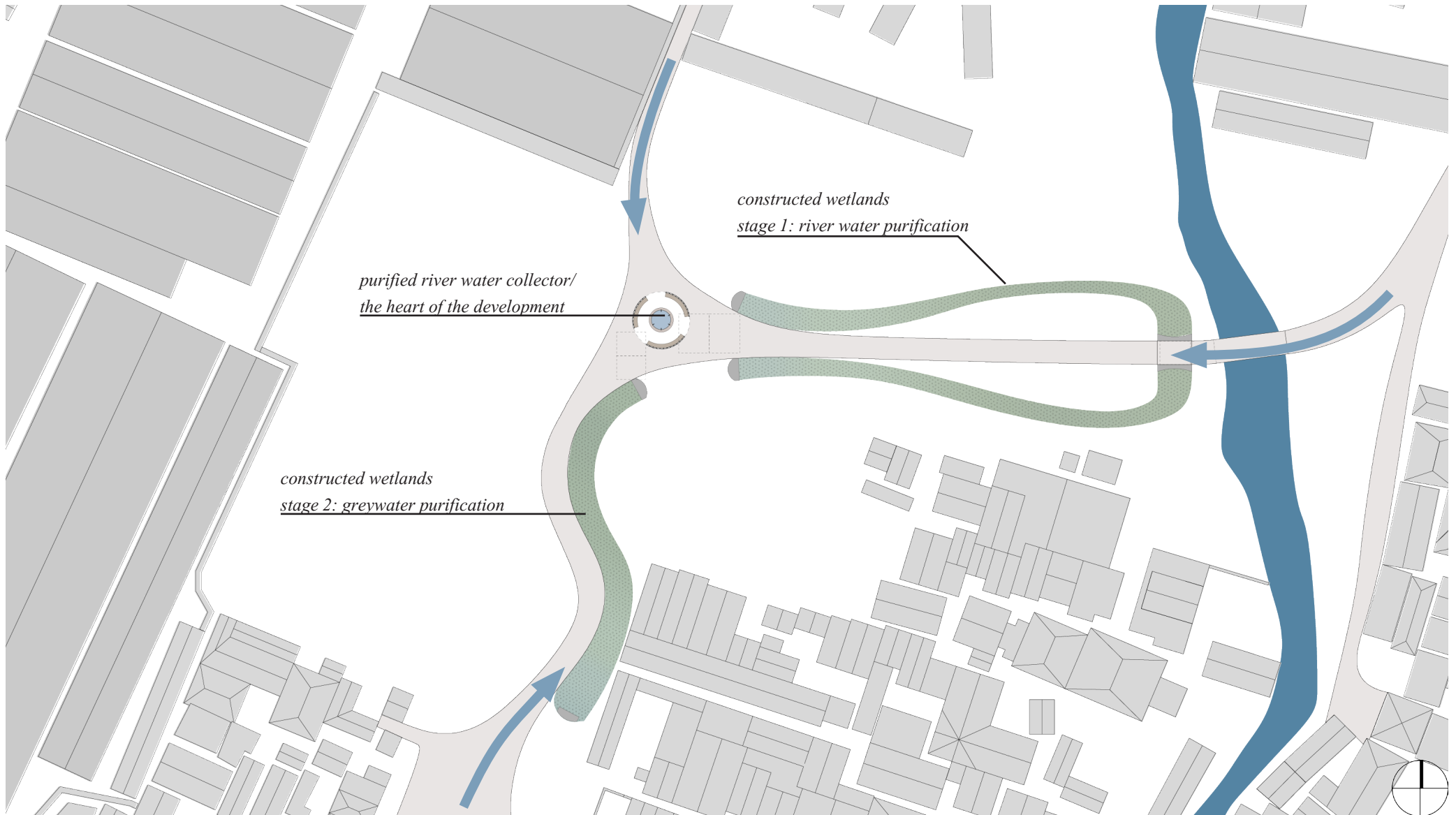

urban plan development  
*2. re-naturalizing the landscape /  
stormwater canals preventing flooding*

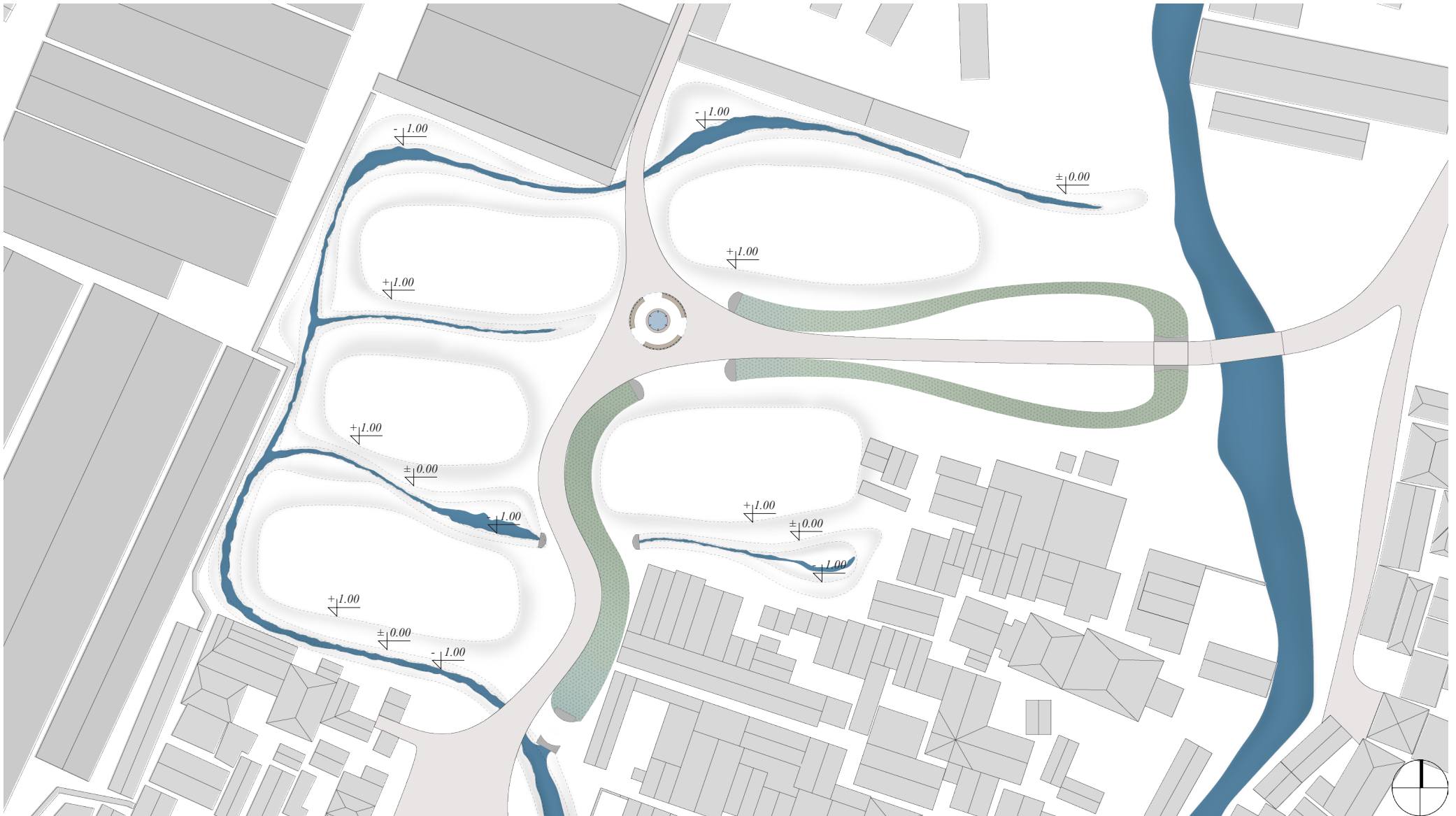

urban plan development

3. stormwater canals /  
protection from flooding



urban plan development

4. common spaces

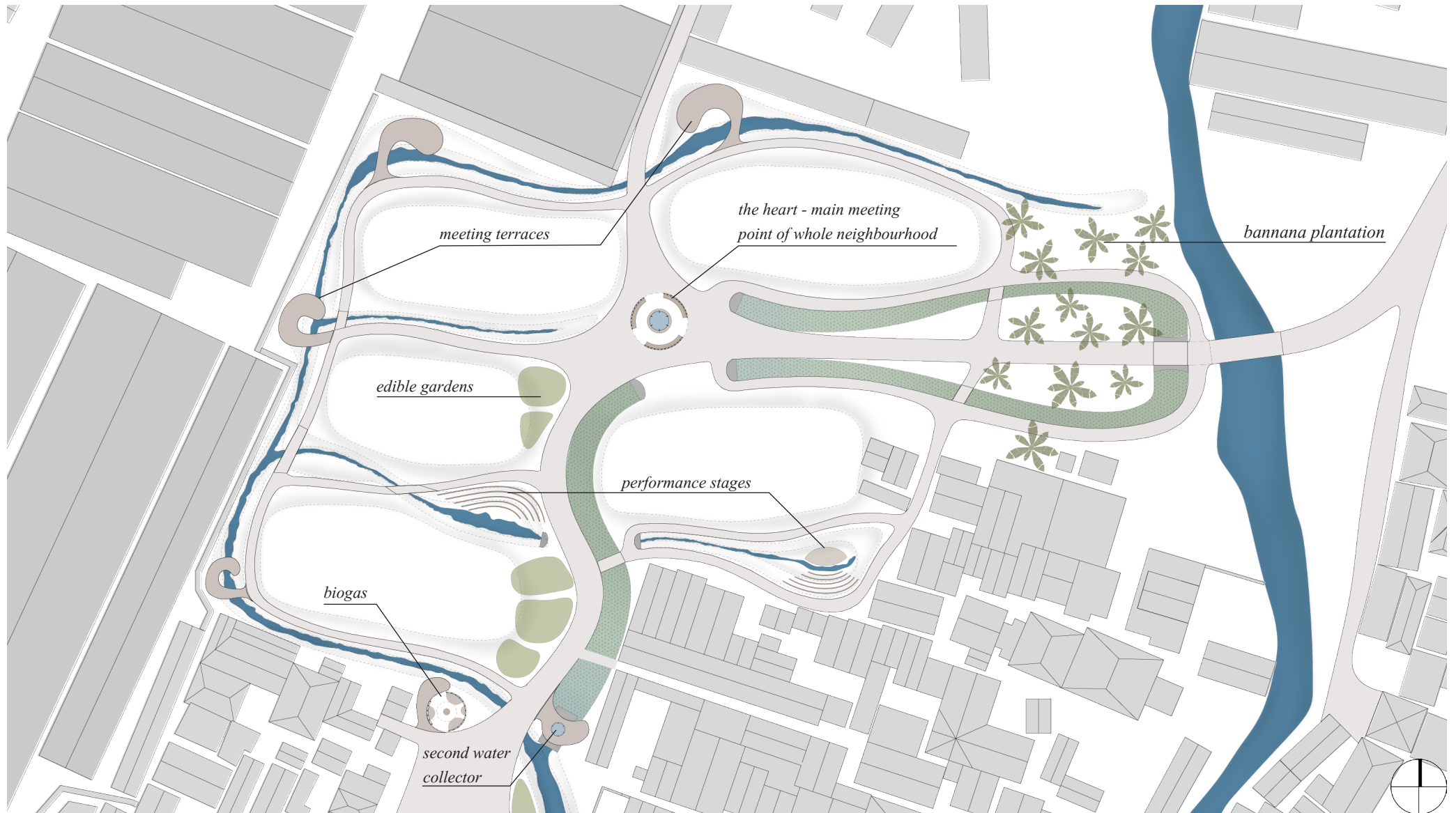

urban plan development

5. housing development

*Density of RW2 kampung - 193 p./ha*

*Density of new design area - 196 p./ha*

*Amount of people living in design area - 236 p.*



sustainable solutions in house

---

*self-sufficient in energy and water*

sustainable solutions

*rain water harvesting  
and storm water management*

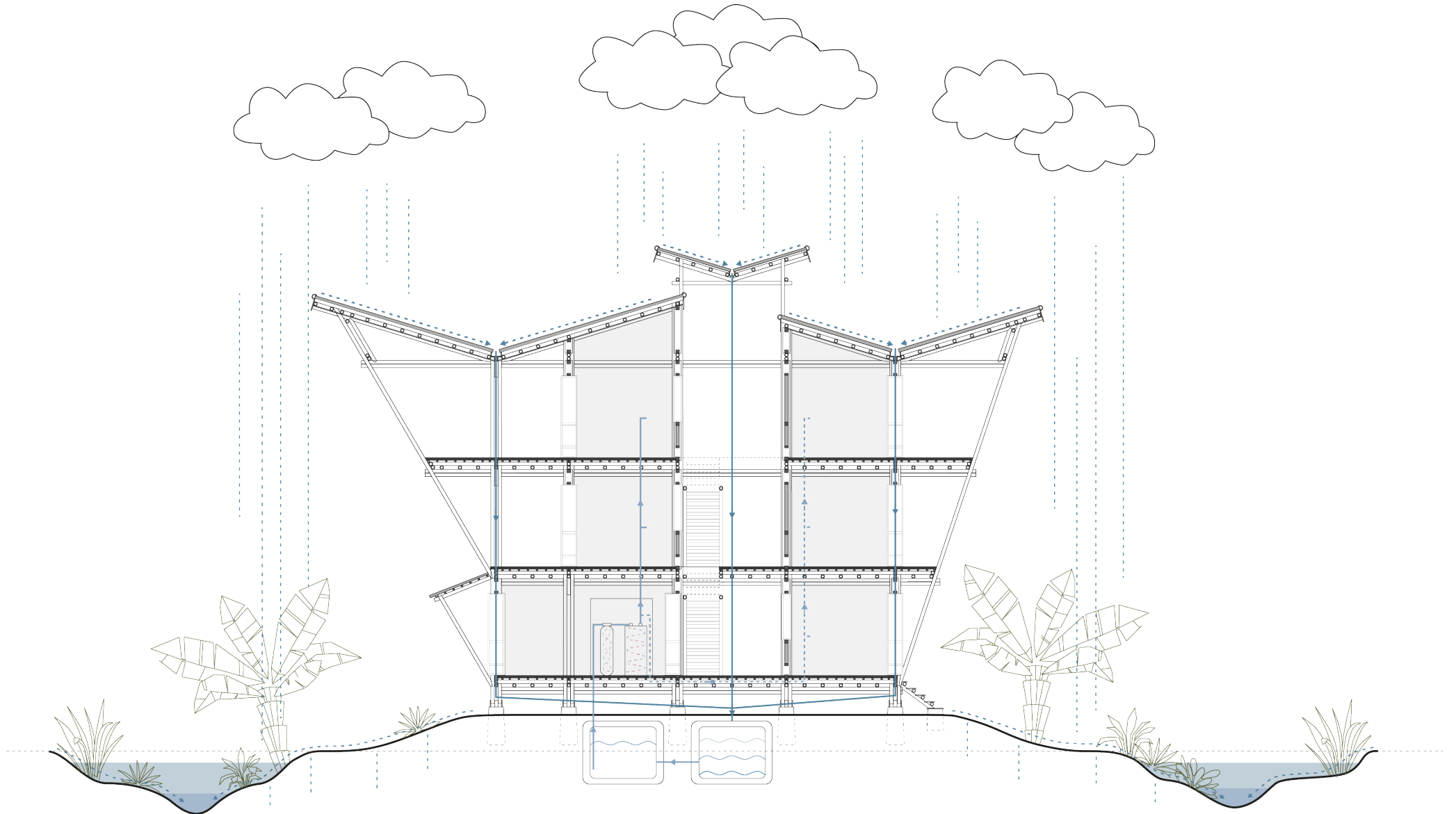

step 3: low-tech, tectonic structure

---

*natural building elements*

living in symbiosis with nature

*circulation of water and natural matter*

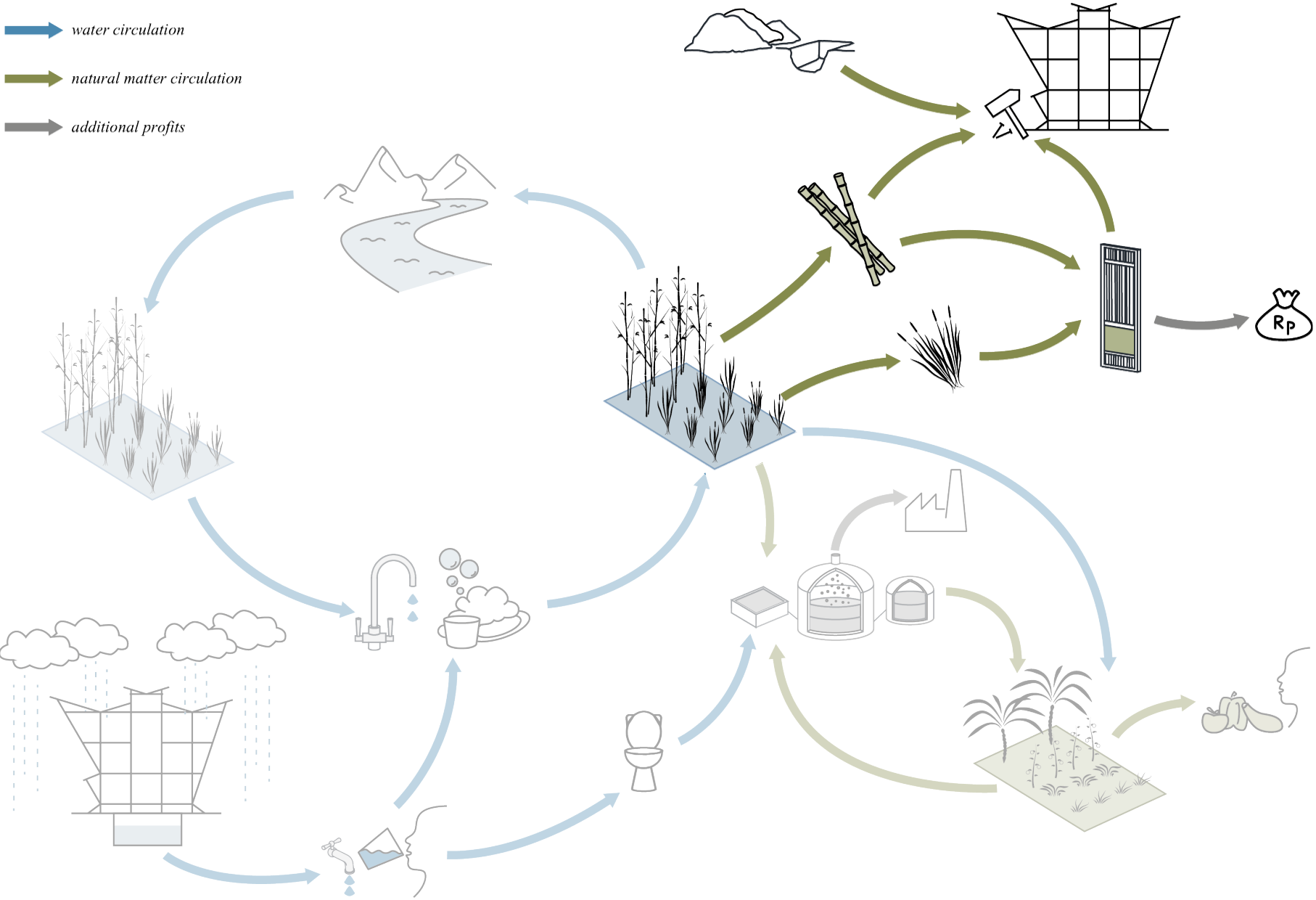

taking from the nature  
*natural building materials*  
*available on the site*

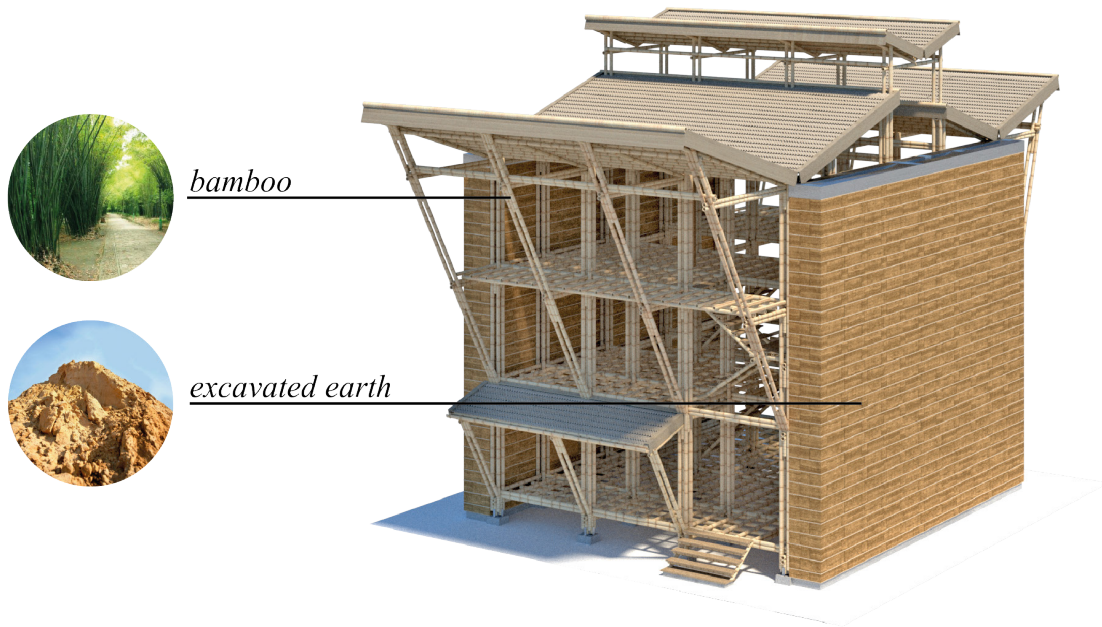

*bamboo*



*excavated earth*



*bamboo*



*excavated earth*



*re-used timber*



*common reed*



*yute*

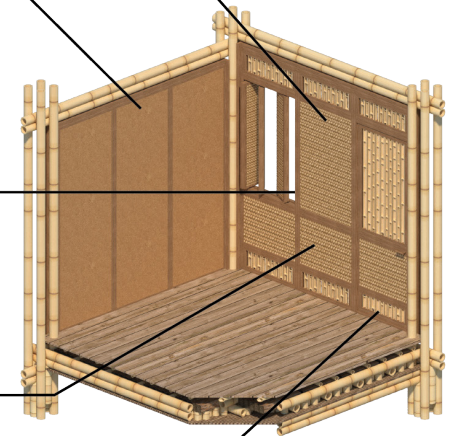

bamboo connection  
*connection of main construction*

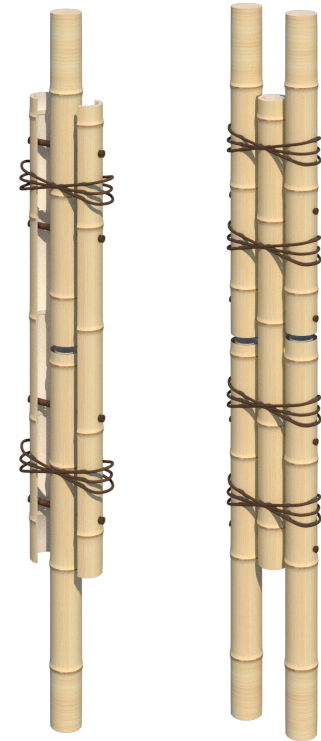
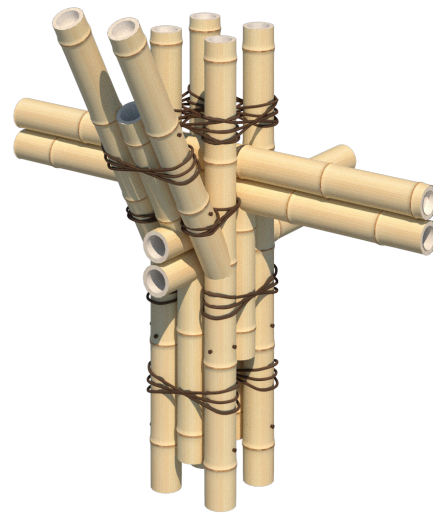
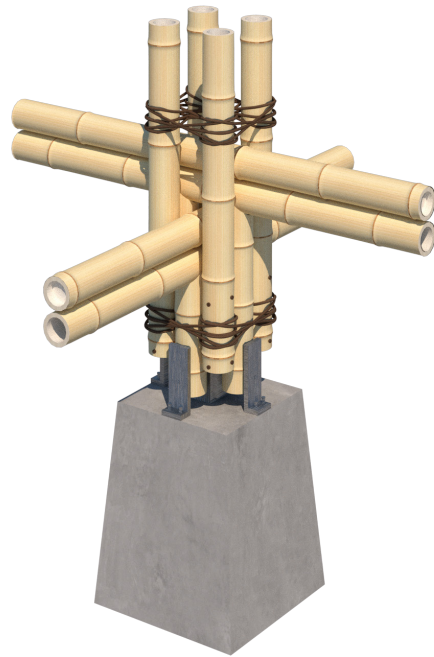
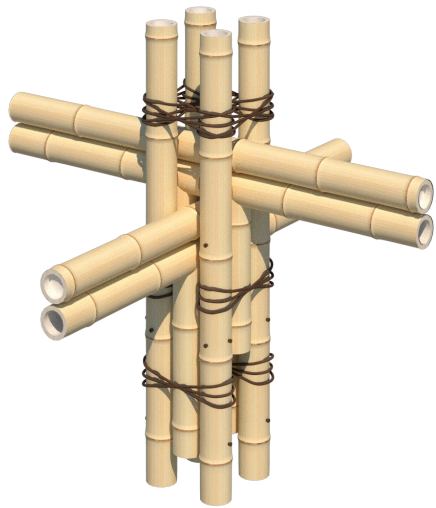
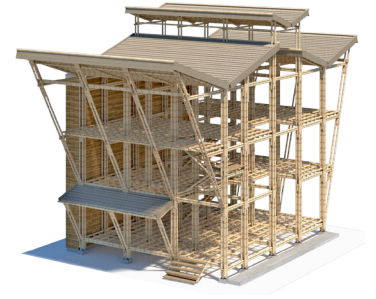

prefabricated panels  
*inserting method*

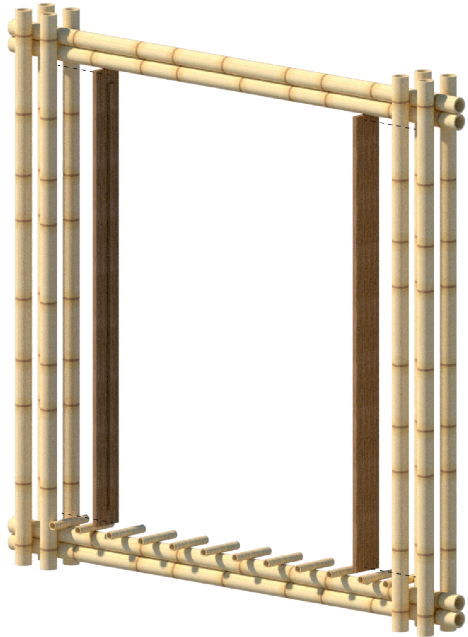

*step 1*  
*adding side, leveling-up, L*  
*shape hardwood profiles to*  
*the constructions*

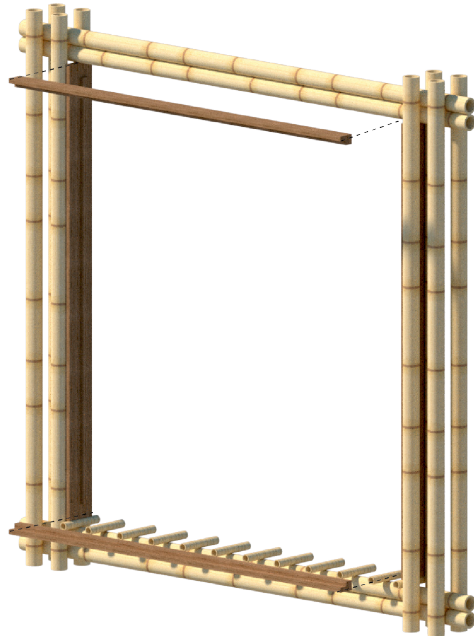

*step 2*  
*adding top and bottom,*  
*leveling-up, L shape*  
*hardwood profiles to the*  
*constructions*

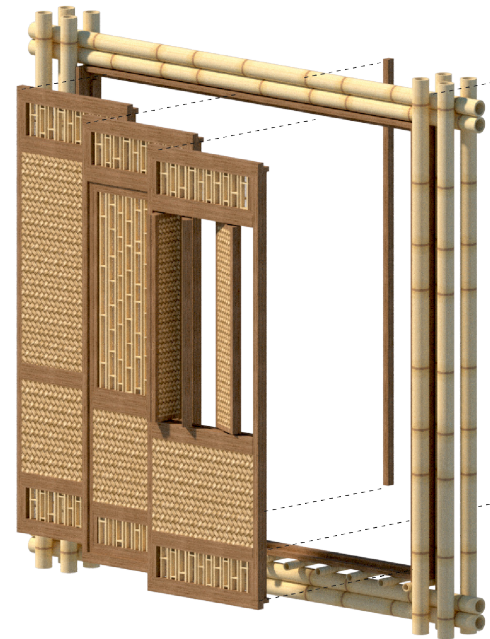

*step 3*  
*inserting prefabricated*  
*panels to the hardwood frame*  
*securing them from the back*  
*with hardwood planks*

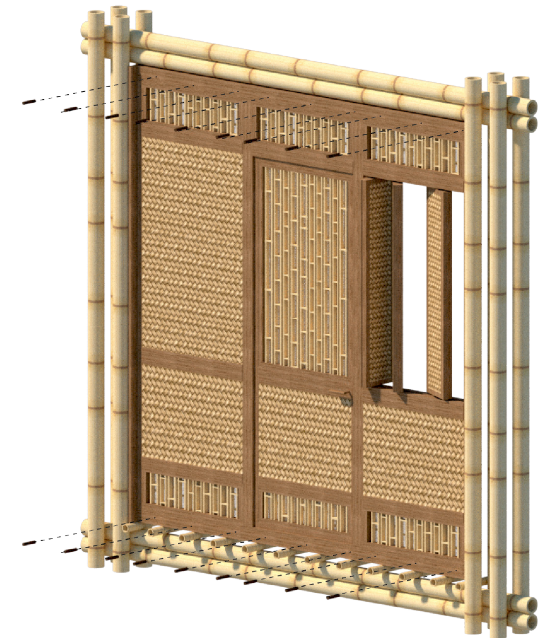

*step 4*  
*securing the panels to the*  
*frame at the top and bottom*  
*by the hardwood pins*

# prefabricated panels

*types*



*pannels installed parallel to the wind*



*pannels installed perpendicular to the wind*

tectonic structure

*low-tech, bioclimatic,  
available on site, affordable*



what

---





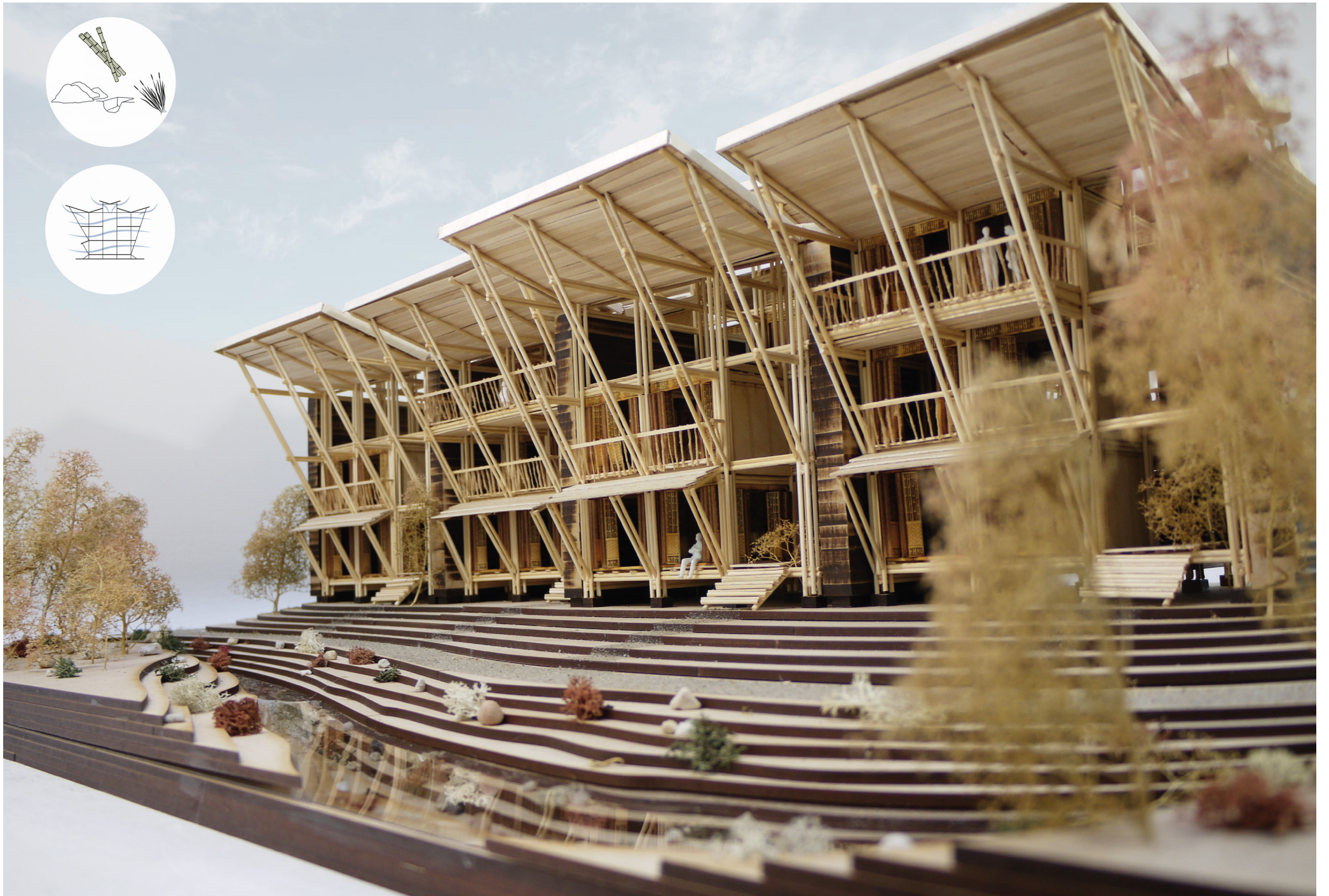

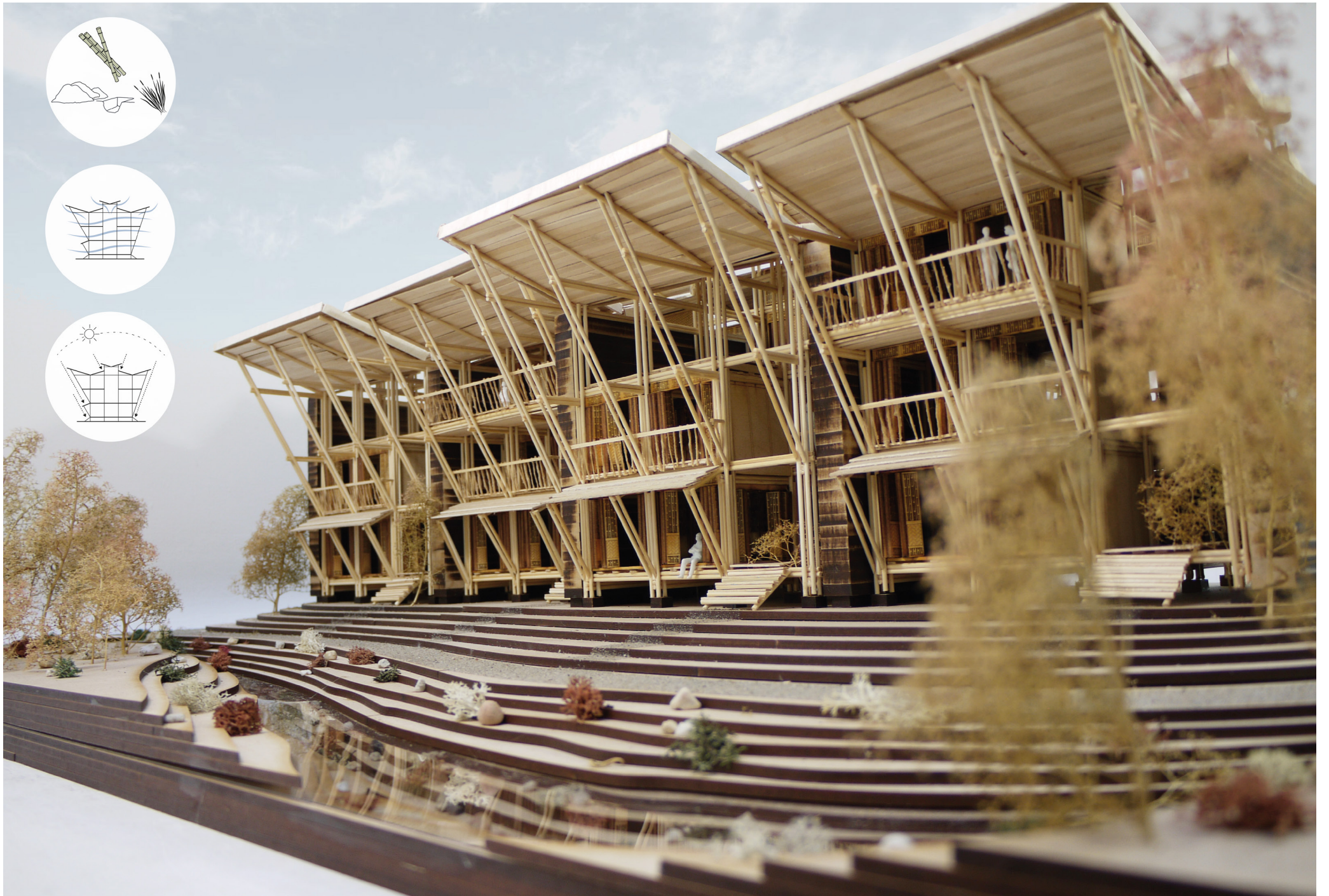



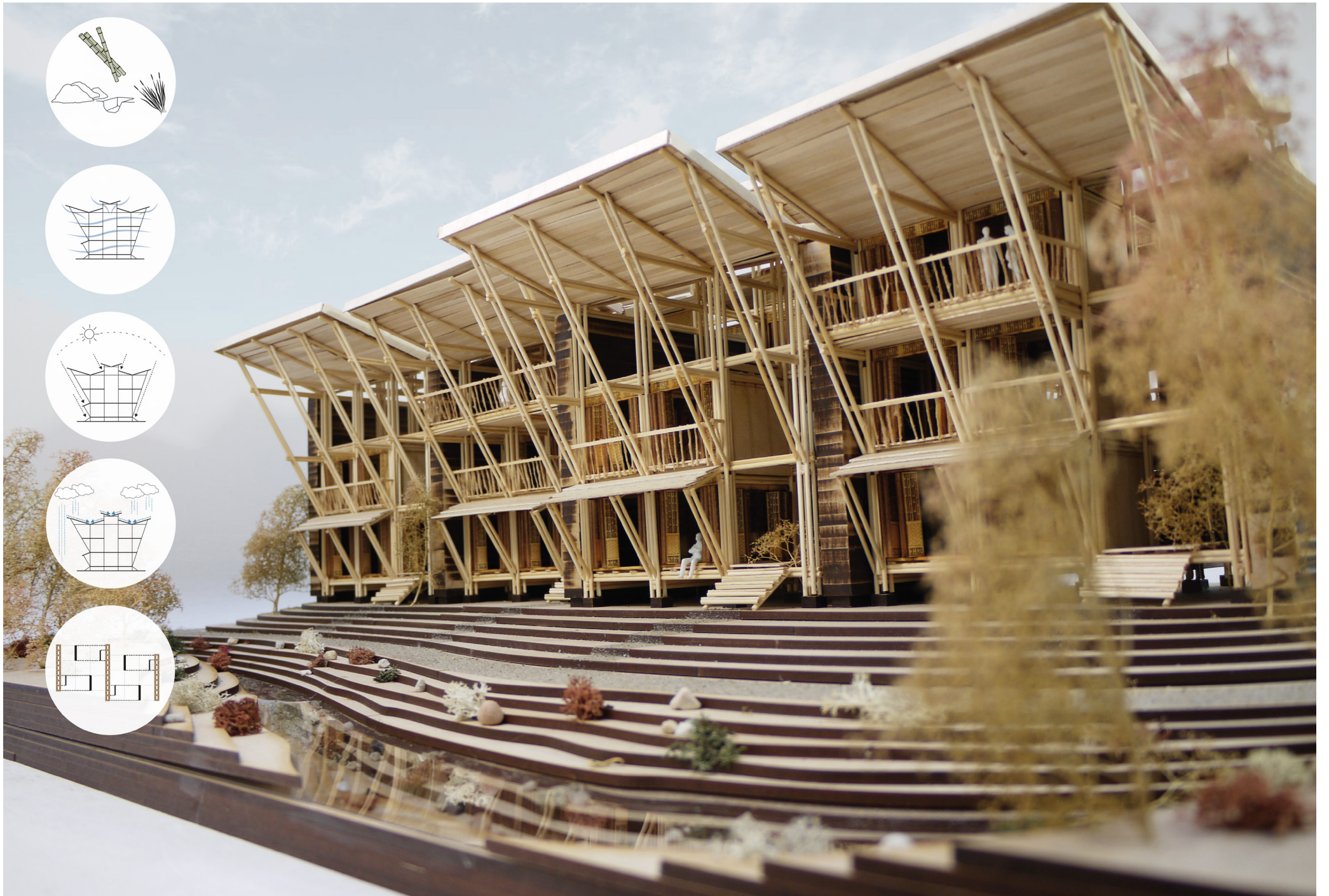

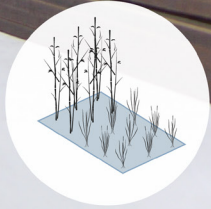
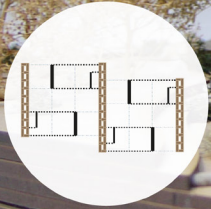
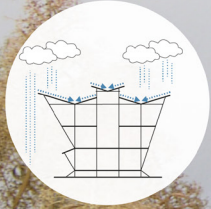
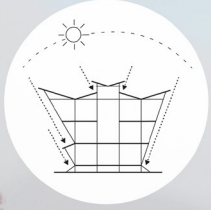

# design guidelines

*variety of zones in one building*

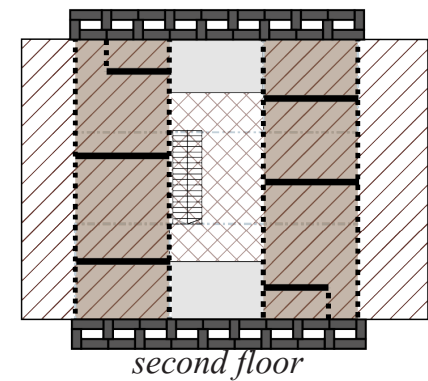
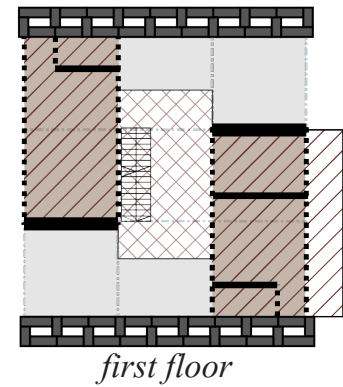
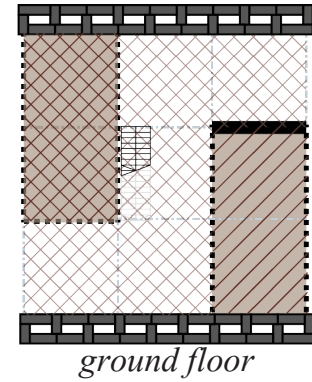
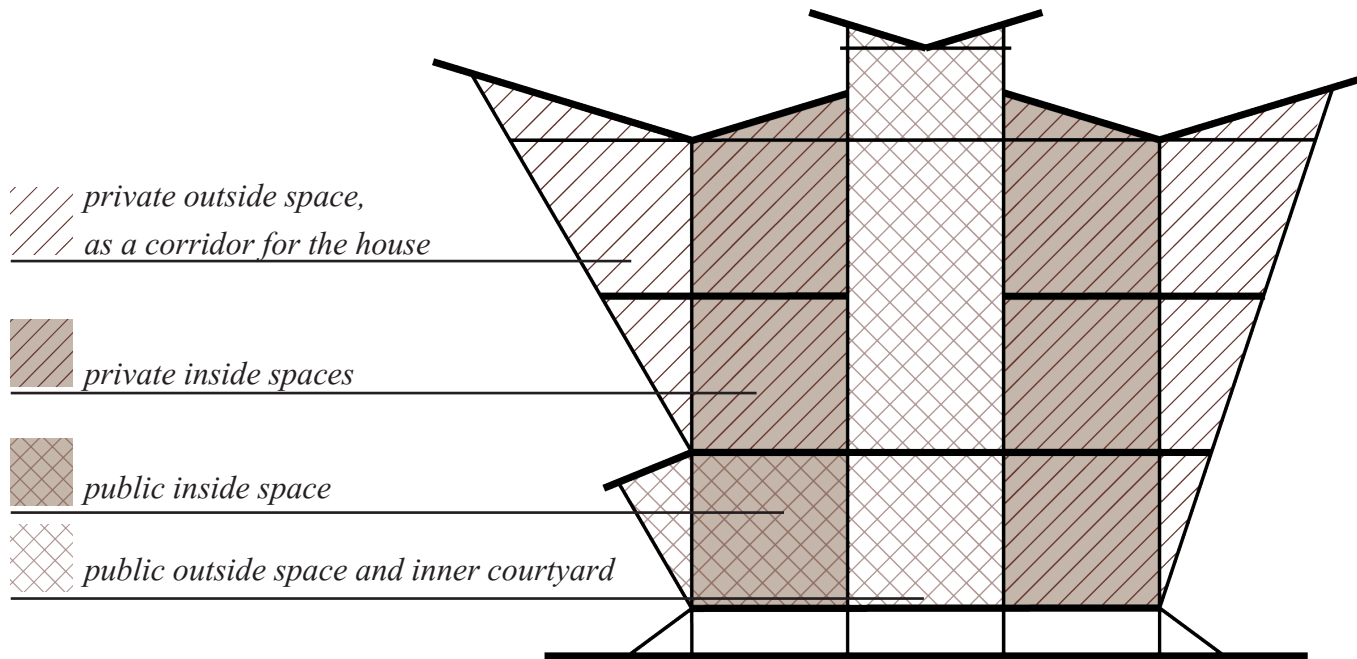

design guidelines  
*variety of zones in one building*

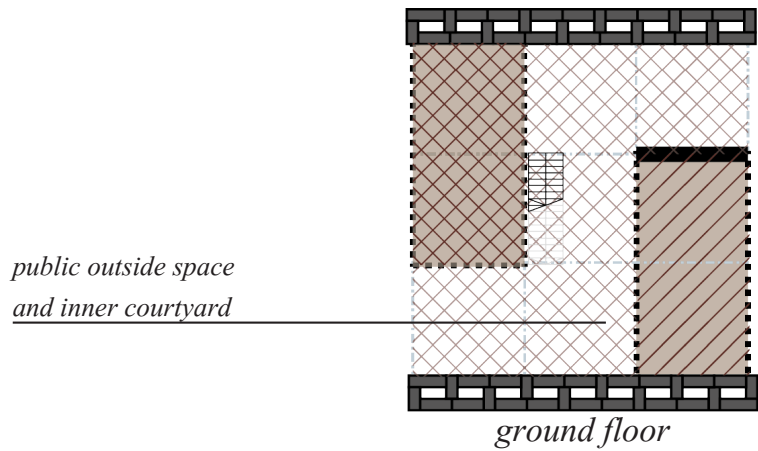
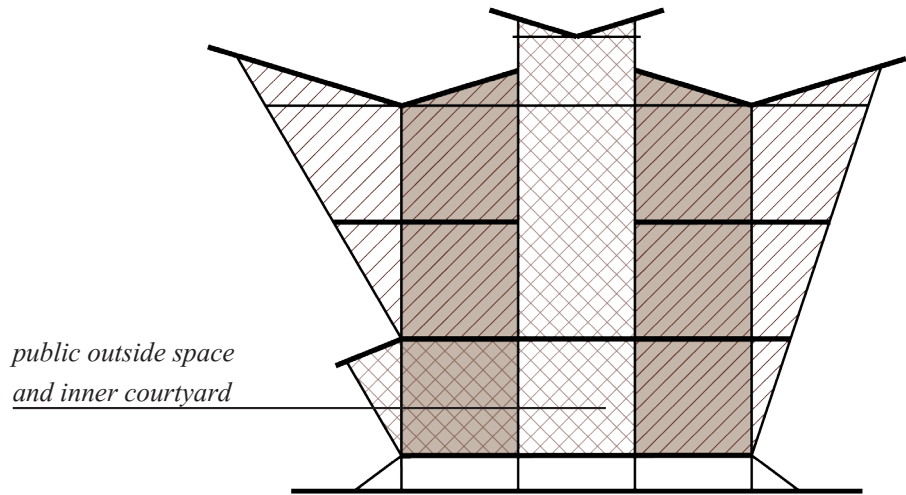

design guidelines  
*variety of zones in one building*

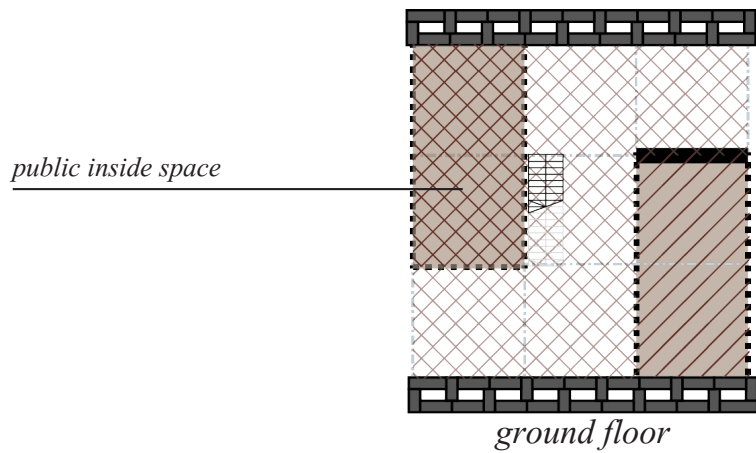
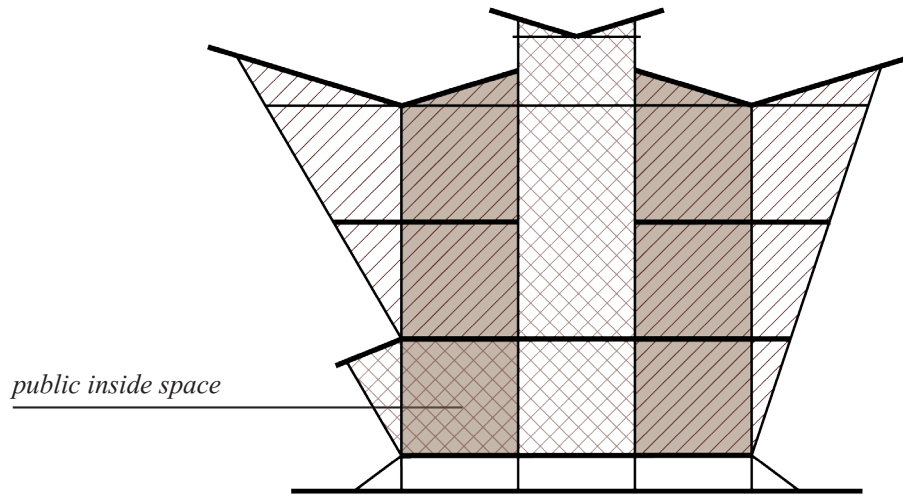

design guidelines  
*variety of zones in one building*

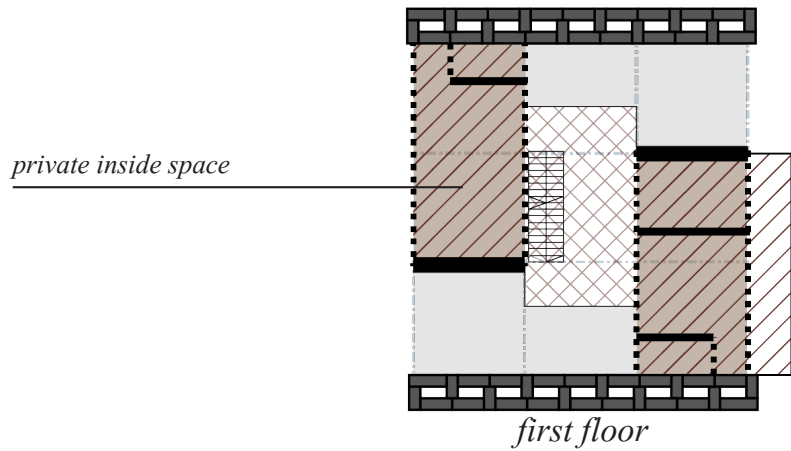
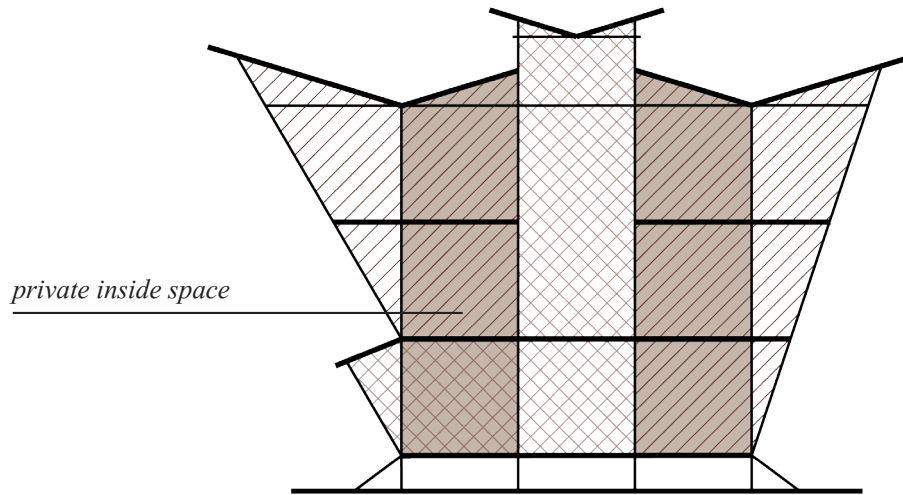

design guidelines

*variety of zones in one building*

*private outside space,  
as a corridor for the house*

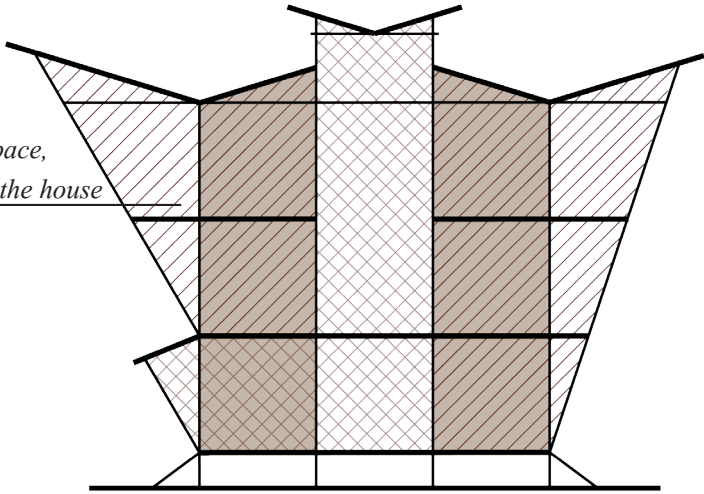

*private outside space,  
as a corridor for the house*

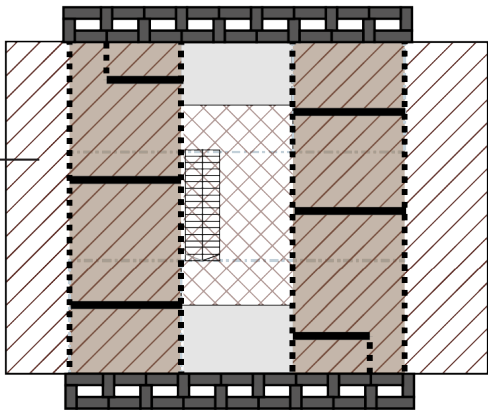

*first floor*



# design guidelines

## *incrementality*

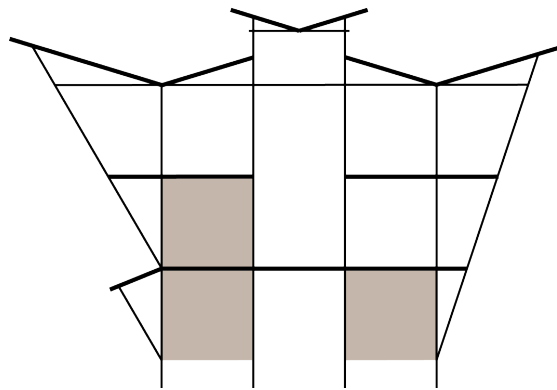

*stage 1:*  
*1 workshop*  
*1 family house*  
*1 flat for rent*

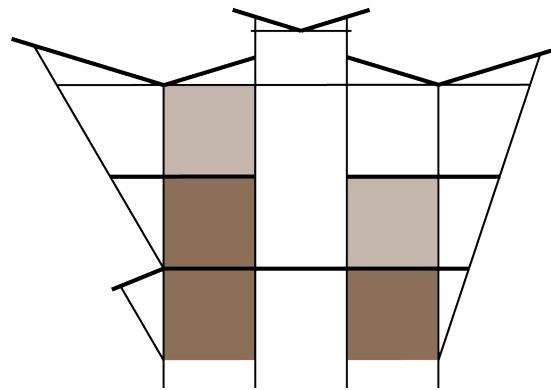

*stage 2:*  
*1 workshop*  
*1 extended family house*  
*2 flats for rent*

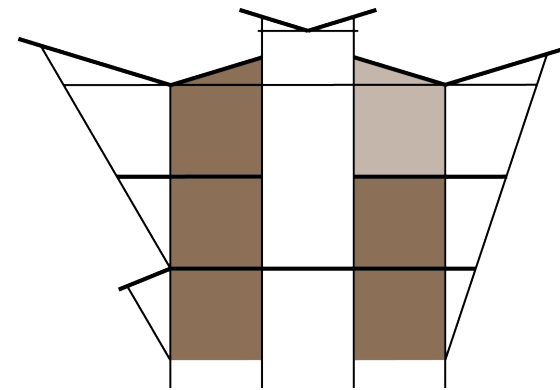

*stage 3:*  
*1 workshop*  
*1 extended family house*  
*3 flats for rent*

*construction fulfilled gradually with the prefabricated infill pannels*



typologies

---

*different possibilities to inhabitate the structure*

design guidelines  
*the grid and its varieties*

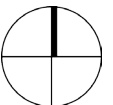
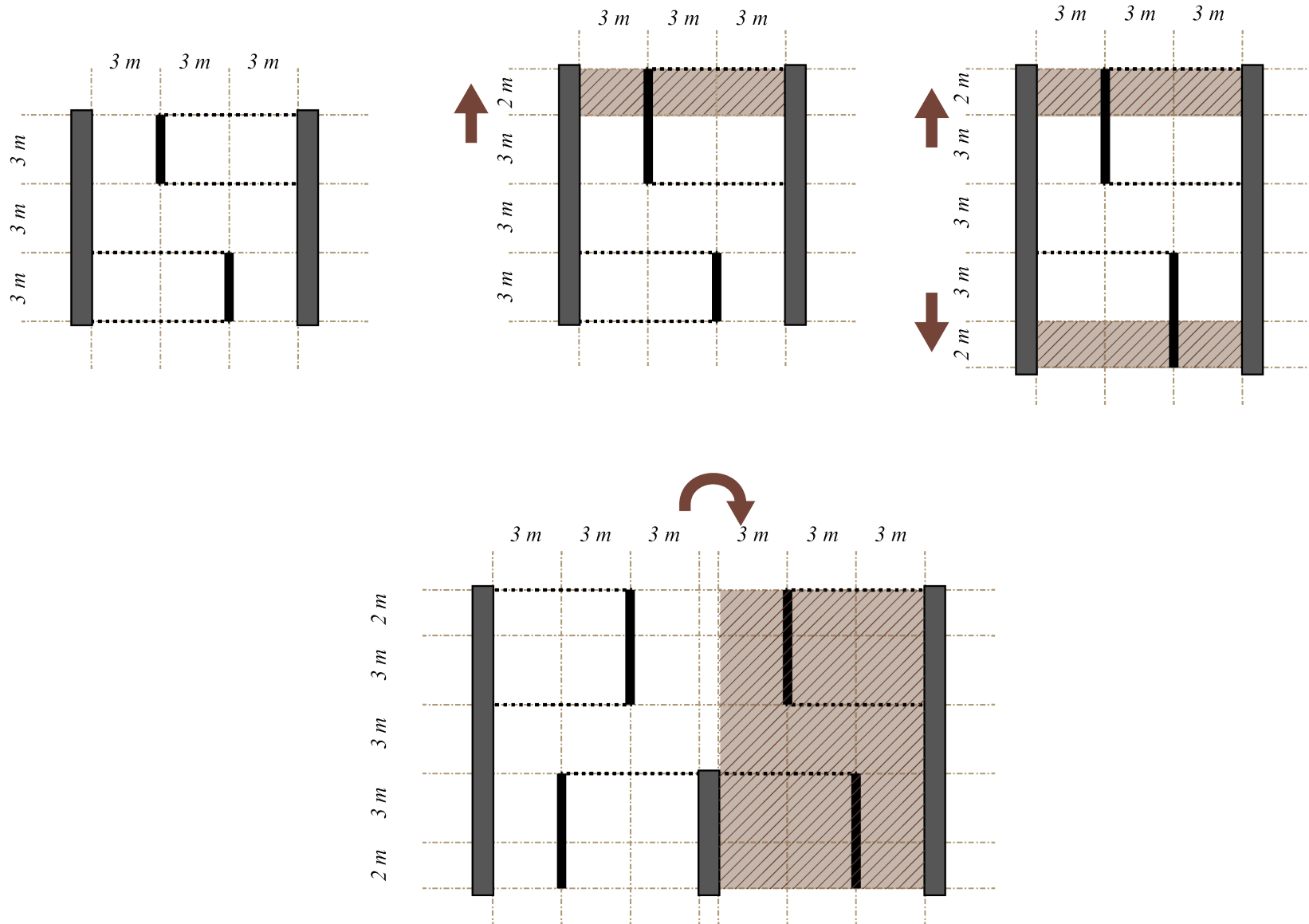

# typologies

*from worker rooms to family houses*

*Large:  
16 rooms for rent  
14m x 19m*

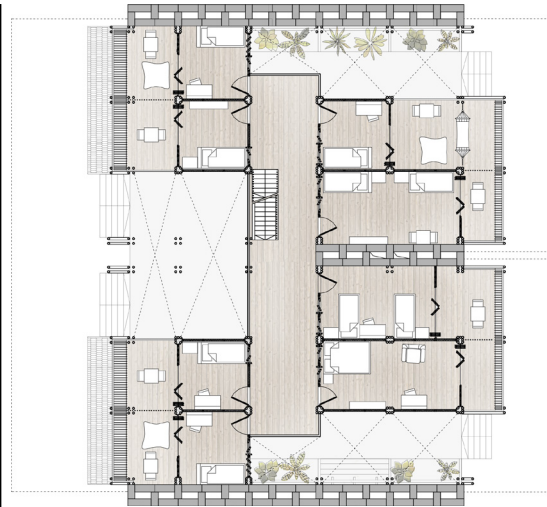

*Medium:  
2 family houses  
13m x 9m*

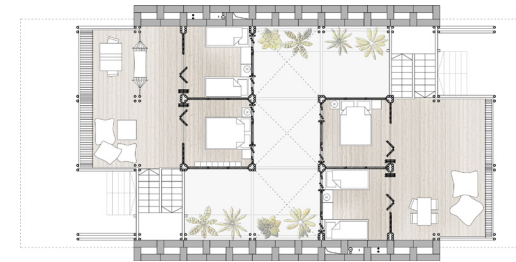
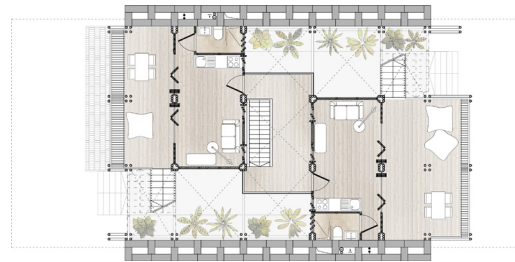
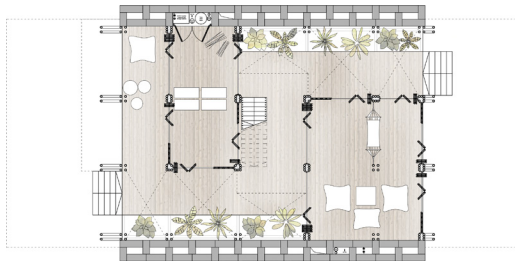

*Small:  
5 flats for rent  
9m x 9m*

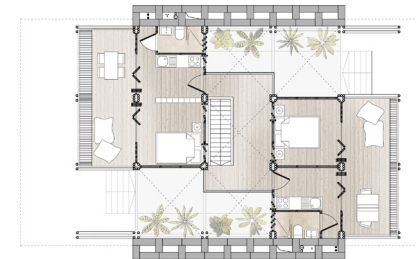
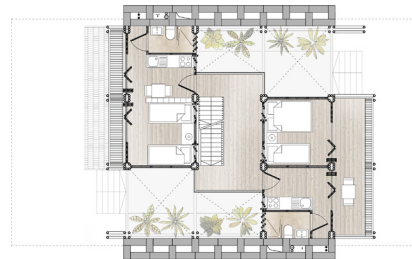
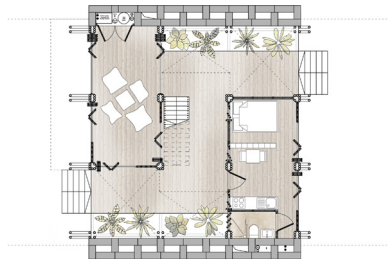

*ground floor*

*first floor*

*second floor*

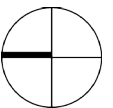



each person has different needs

*ground floor*

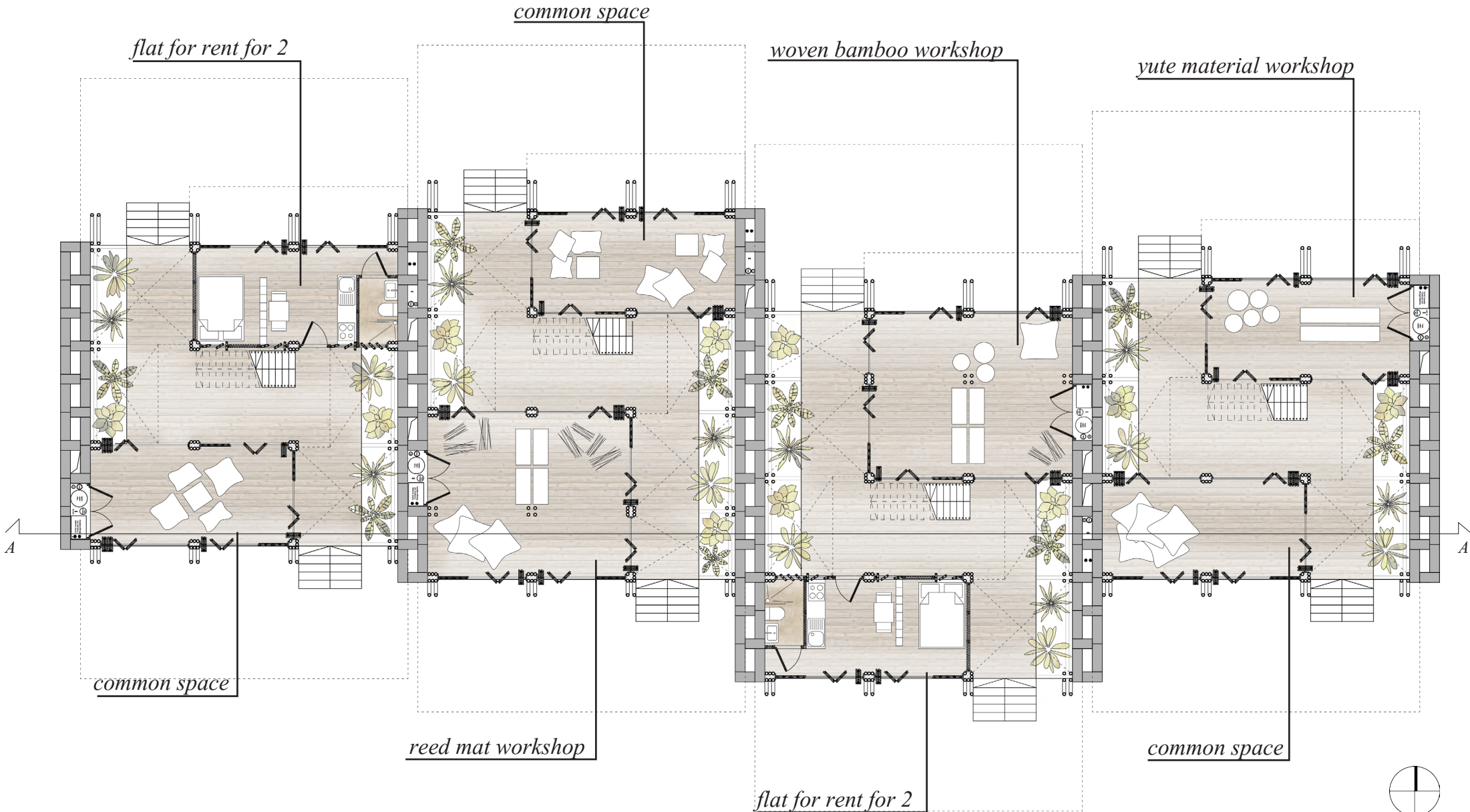

different ways of typology development

*first floor*

*flat for rent for 2*

*flat for rent for 2*

*family house 1<sup>st</sup> floor*

*flat for rent for 2*

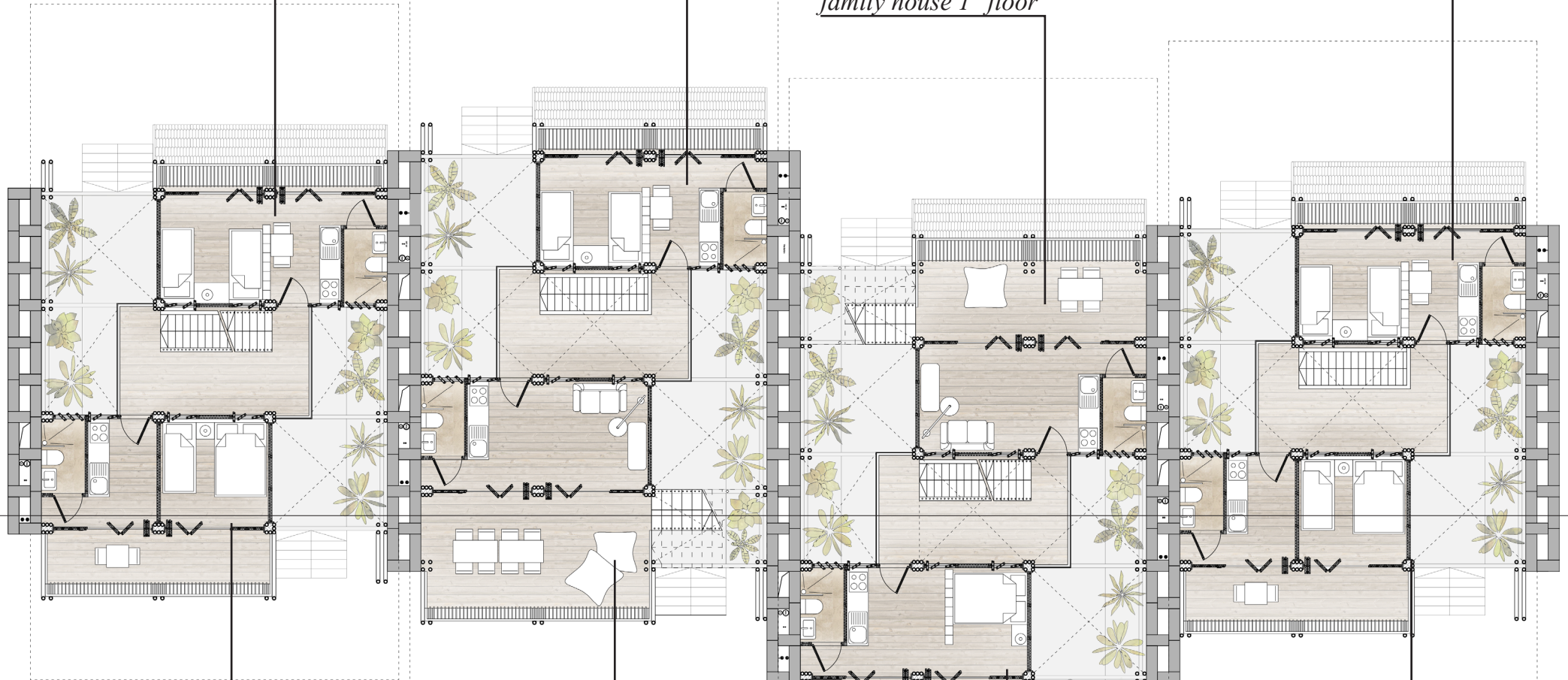

*flat for rent for 2+1*

*family house 1<sup>st</sup> floor*

*flat for rent for 2*

*flat for rent for 2+1*



different ways of typology development  
*second floor*

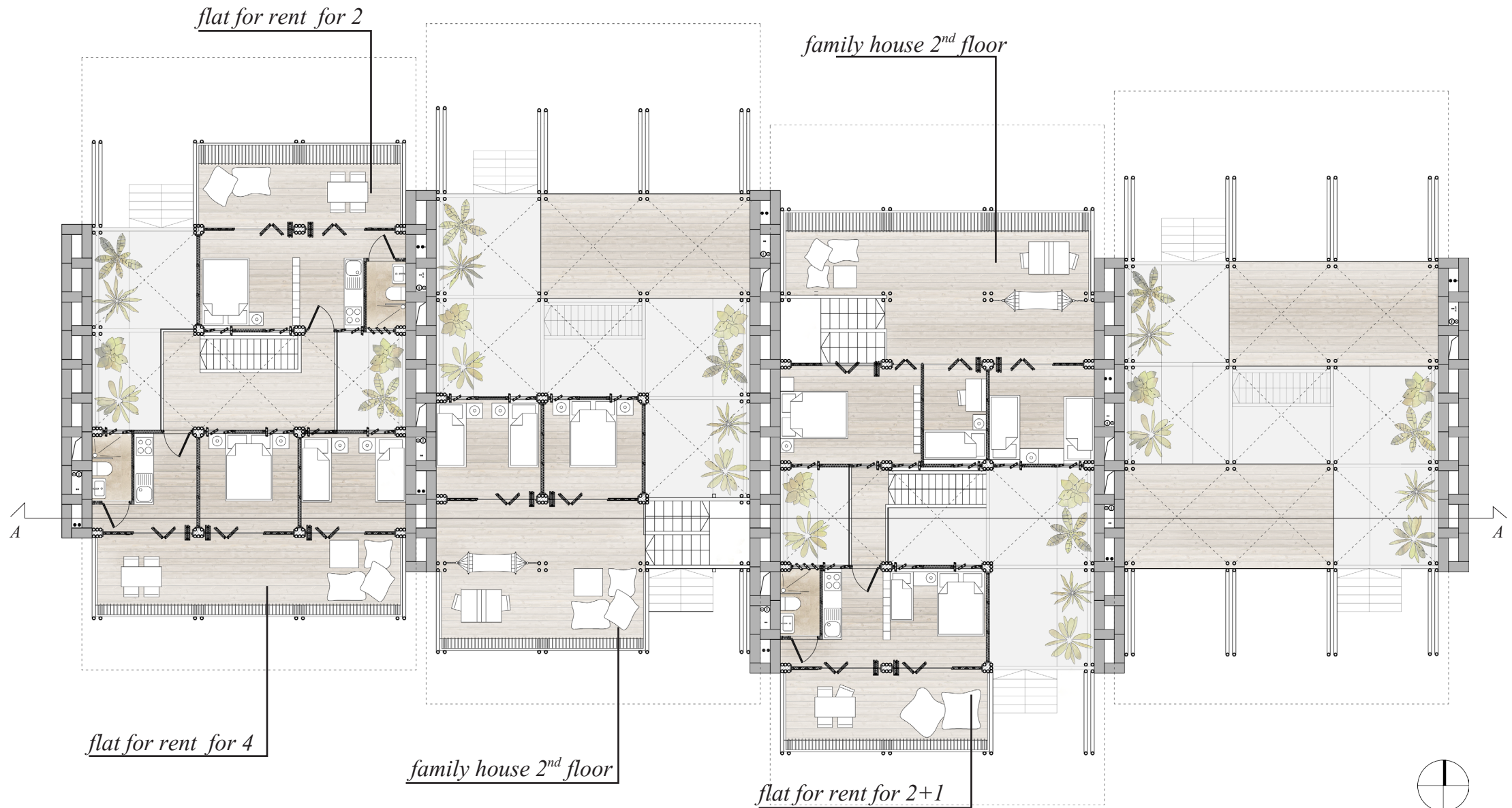

one family and three worker's flats

section B-B



organization and future development

---

# organization of the site

## *housing co-operative*

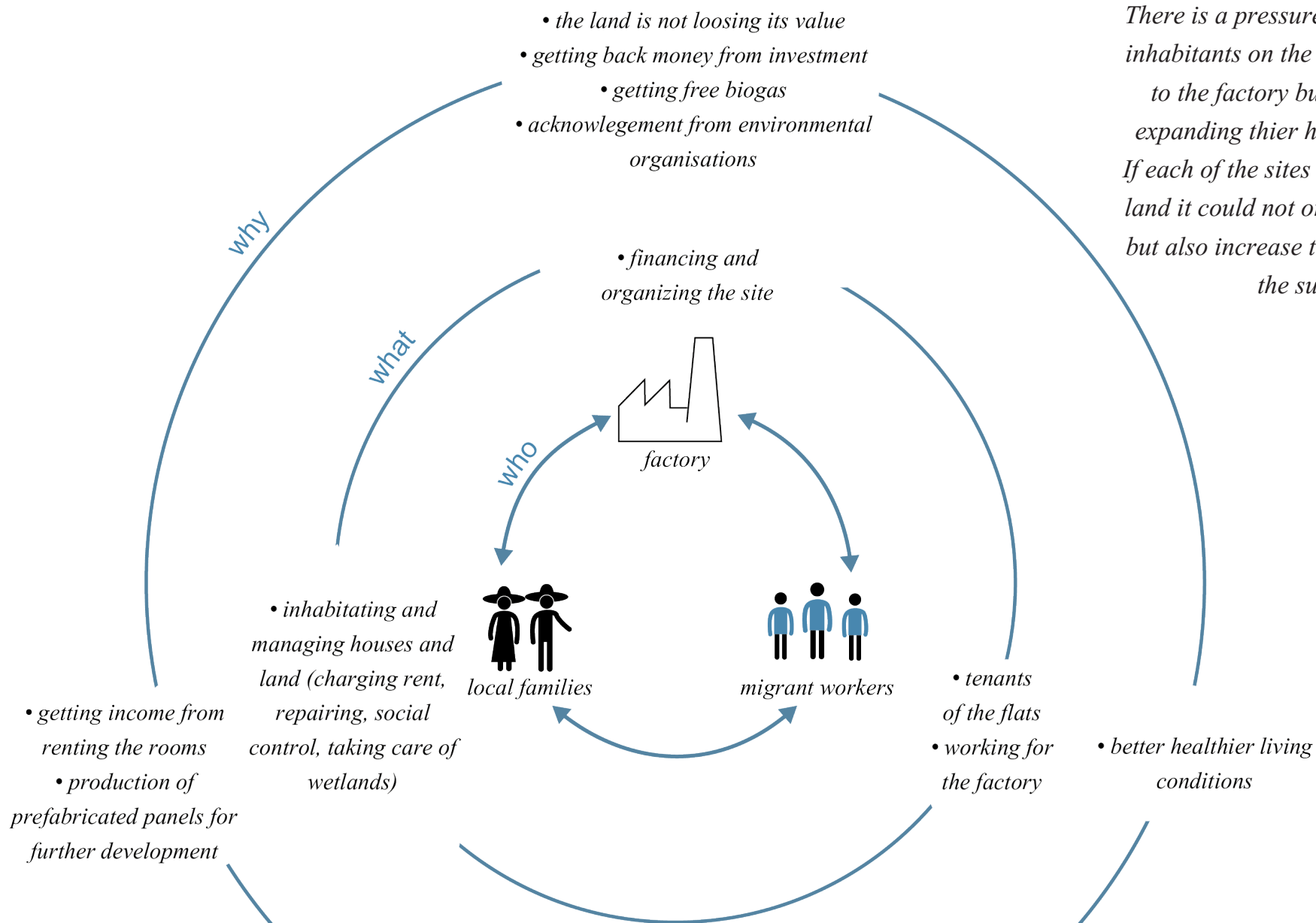

inhabitants interventions  
*spreading the idea to shape and built with  
natural built with natural materials*



summary

---



Thank you for your attention



appendix

---

sequence of local interventions

*timeline*

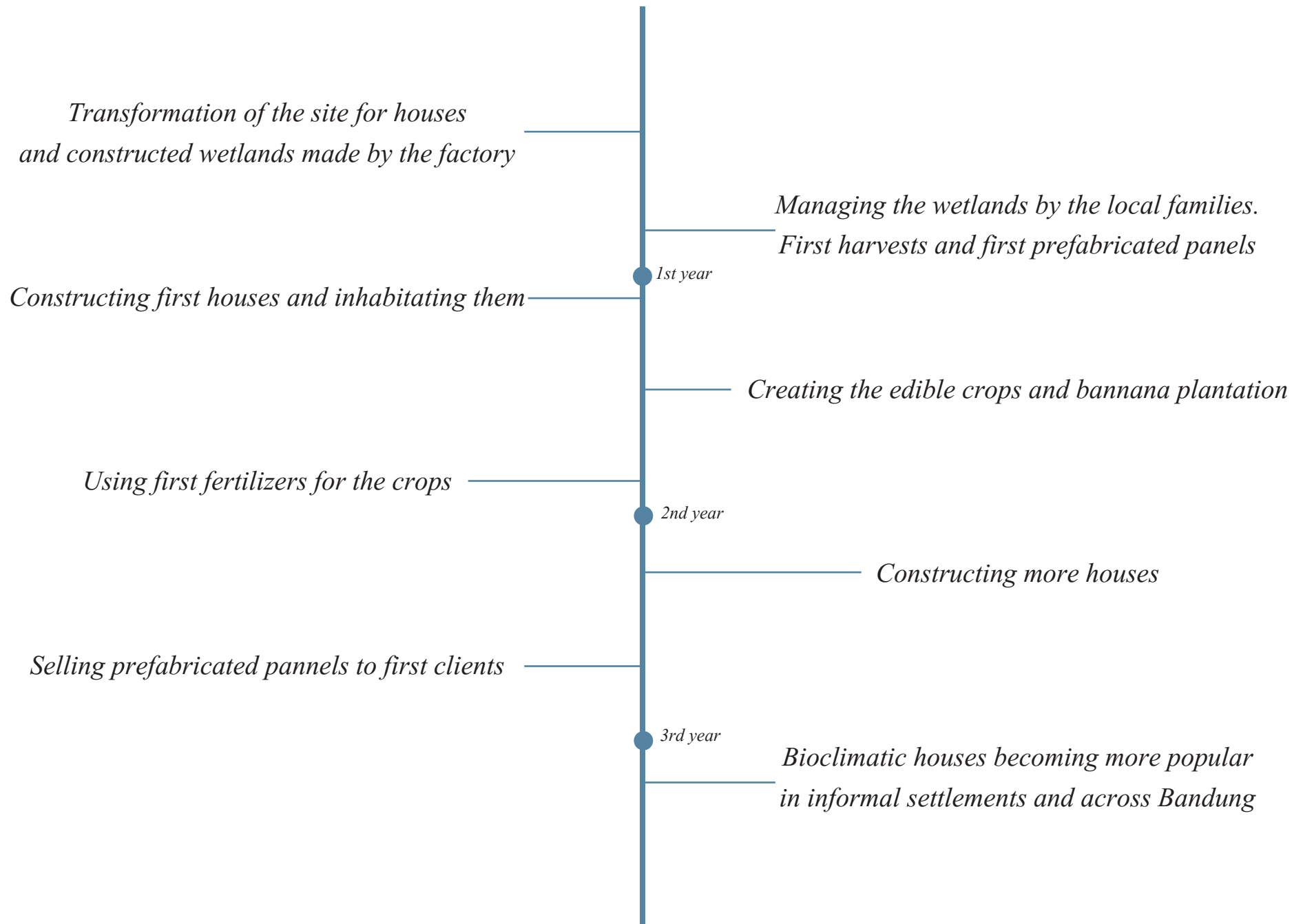

urban plan development  
*5. housing development - stage 1*



urban plan development  
*5. housing development - stage 2*



urban plan development  
*5. housing development - stage 3*



urban plan development  
*5. housing development - stage 4*



relationship with surrounding buildings

*wall problem,*

*changing the direction*



What kind of benefits does the circular water approach bring for urban landscape and the existing community?

*benefits for existing community*  
*- clear, free, unlimited sources of the water*

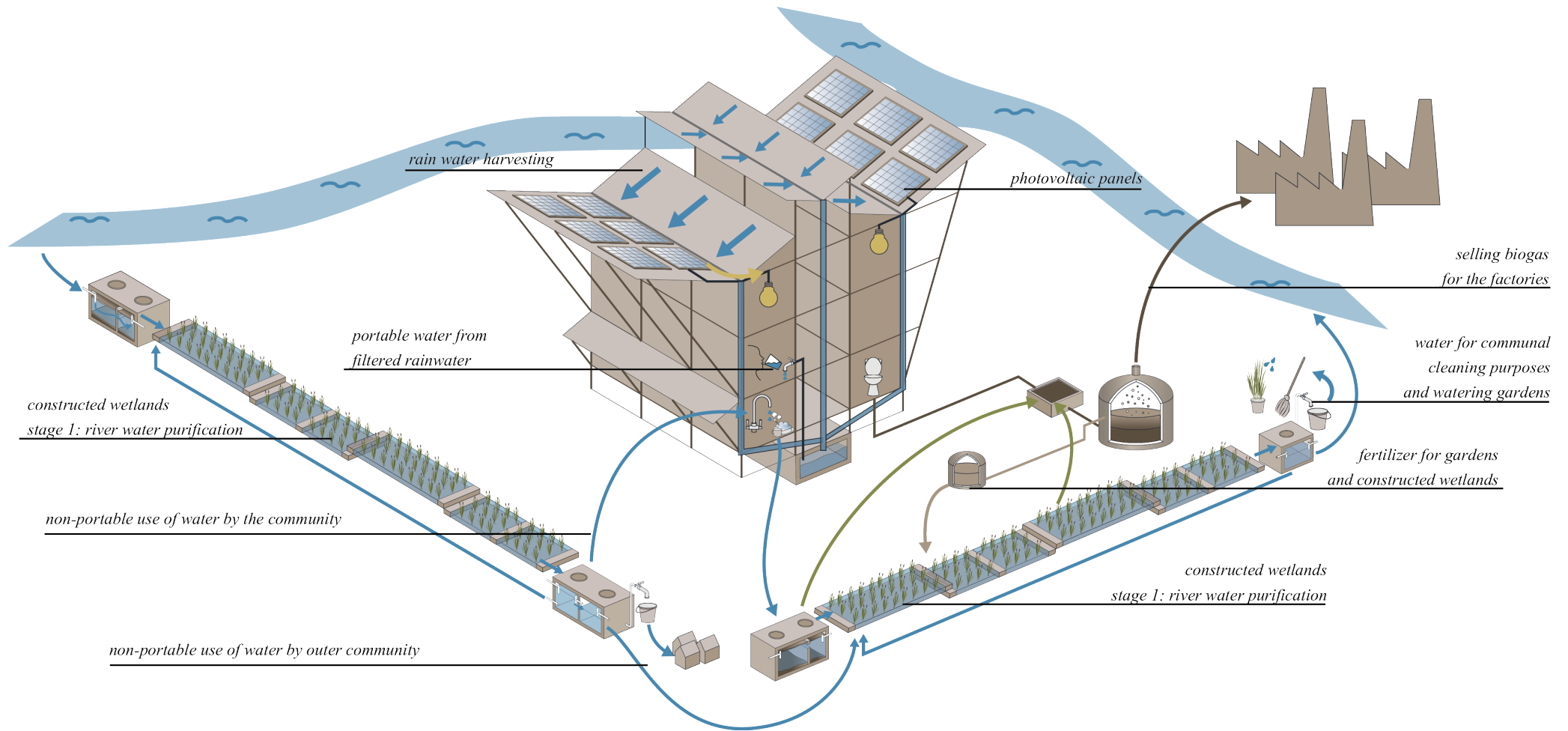

How does the proposal prevent informal development within the open parts of the urban plan?

*re-naturalization of the area - wetlands, stormwater canals preventing flooding  
elements of circulation - without disturbance of the system balance*

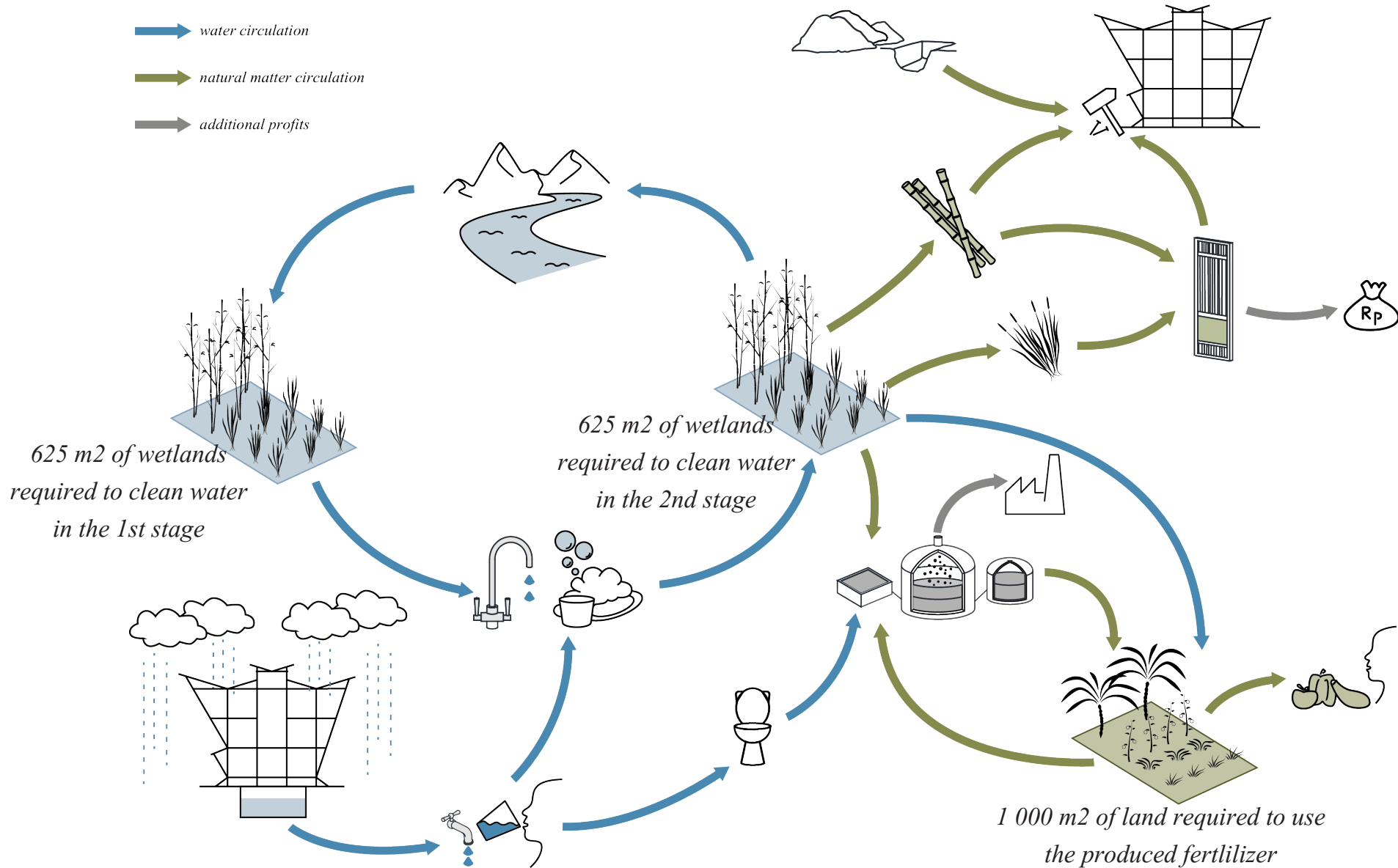

each person has different needs  
*north facade*



different ways of typology development  
*west facade*



different ways of typology development

*inner facade*



different ways of typology development  
*south facade*





floor structure  
*double sound insulation*

---

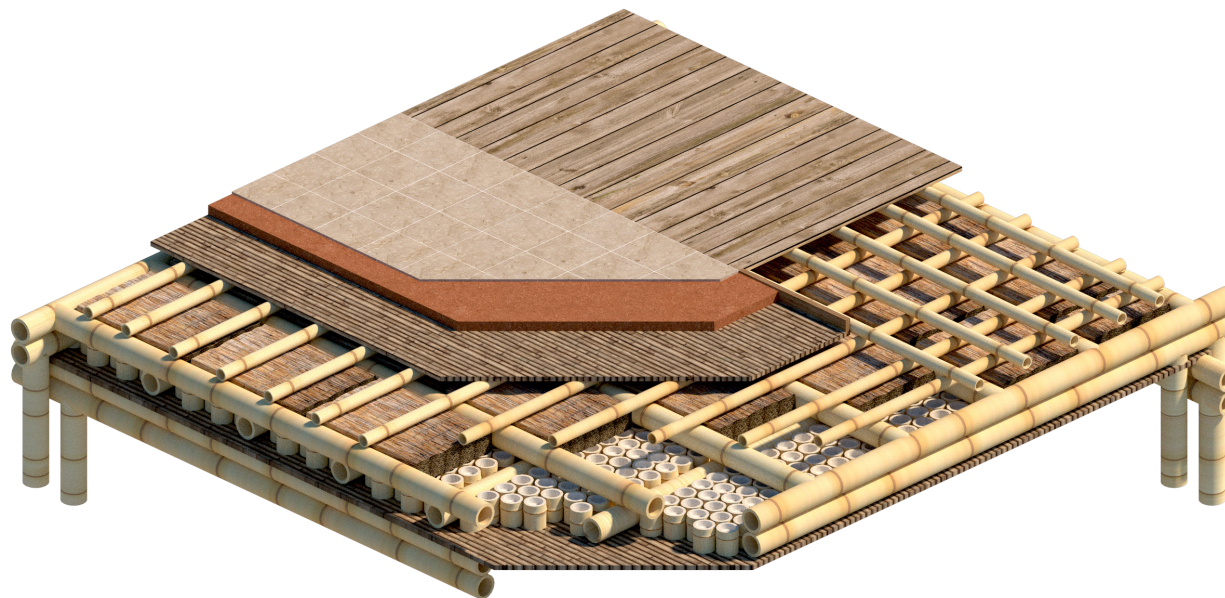

construction sequence  
*foundations*

---

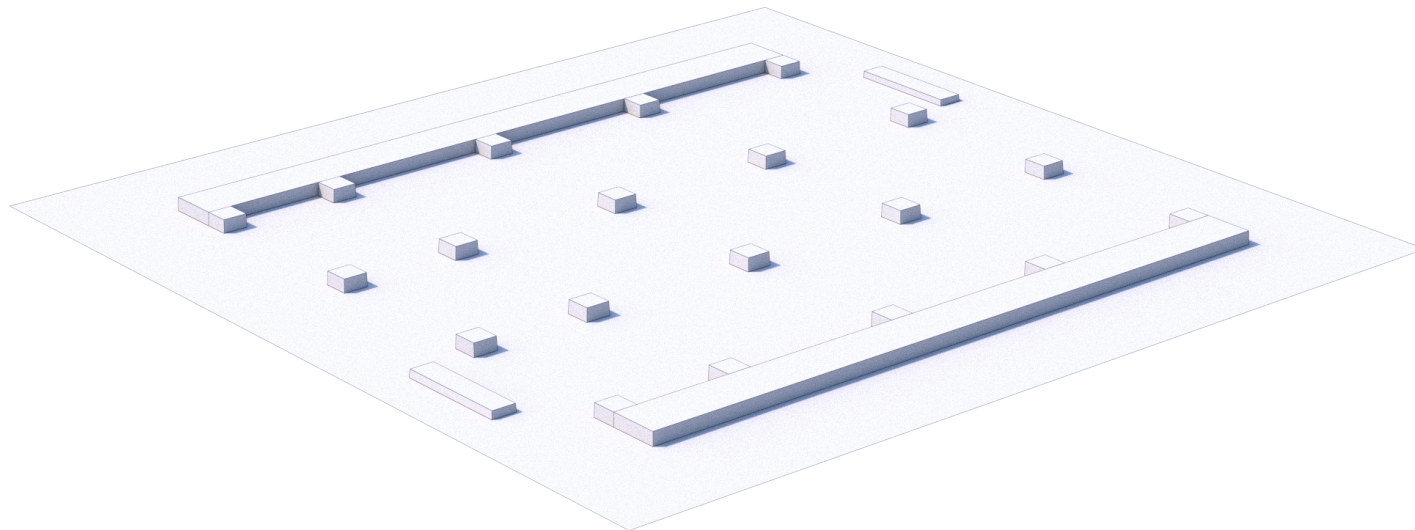

construction sequence  
*connection with the foundations*

---

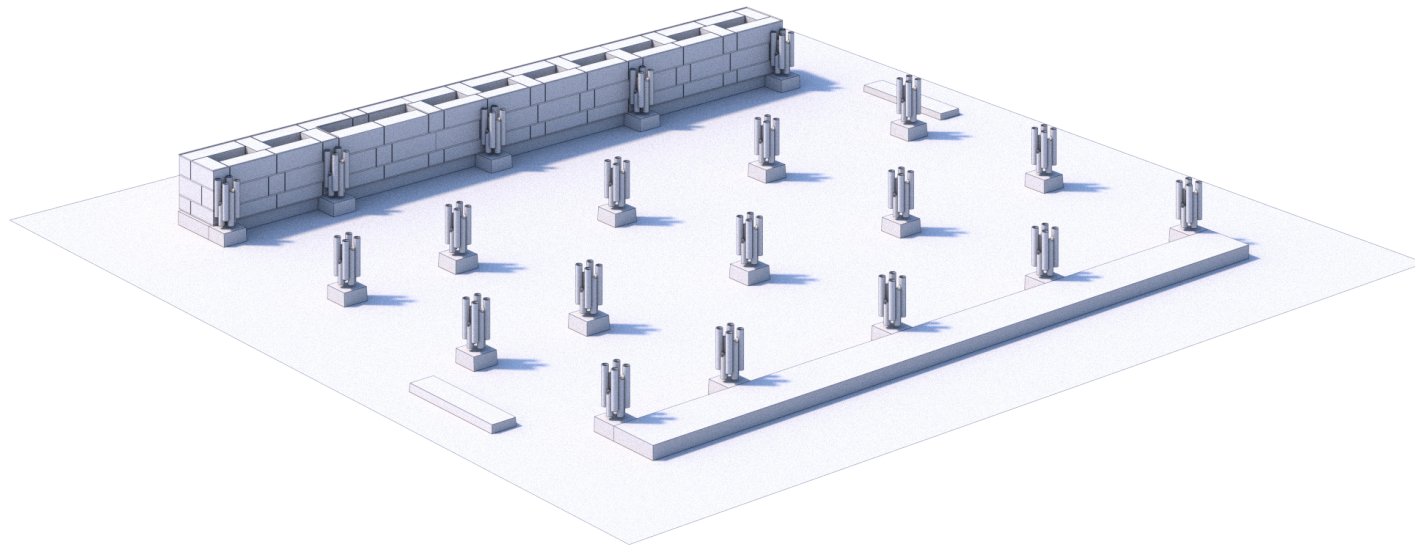

construction sequence  
*first horizontal construction beams*

---

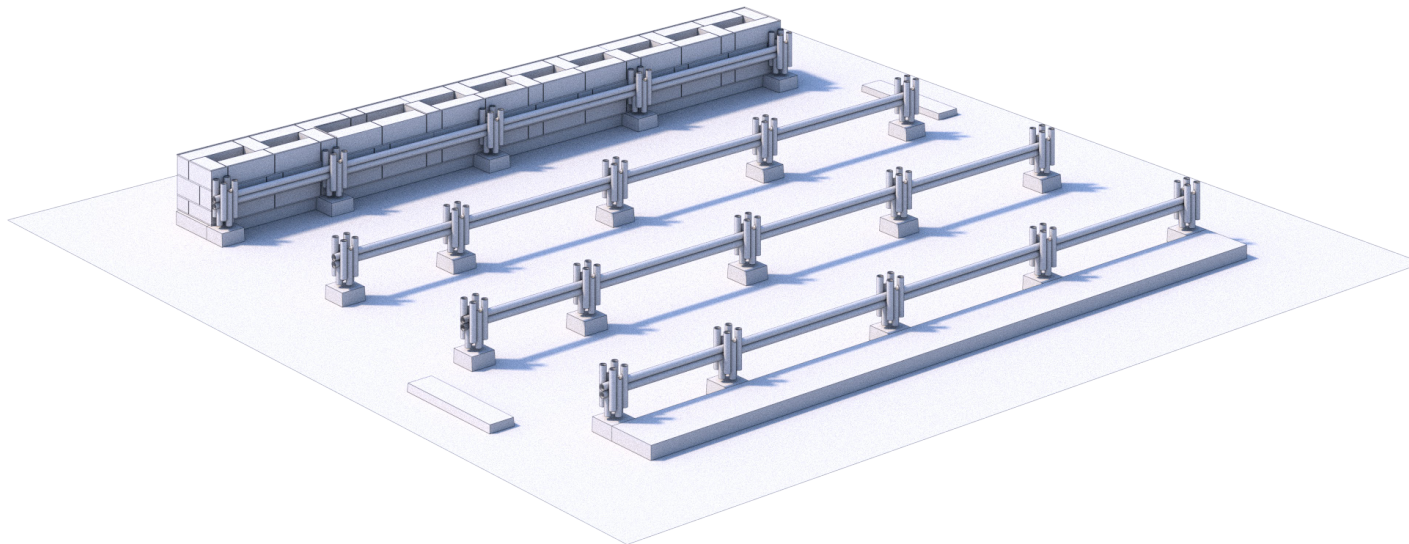

construction sequence  
*secondary construction horizontal beams*

---

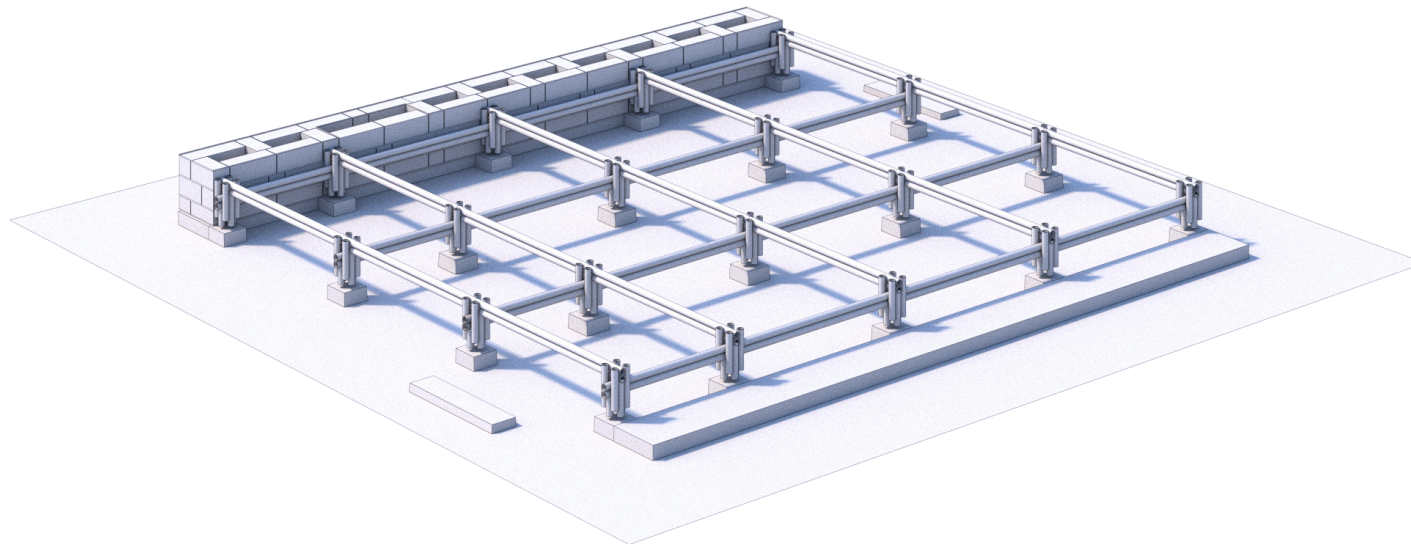

construction sequence  
*secondary construction*

---

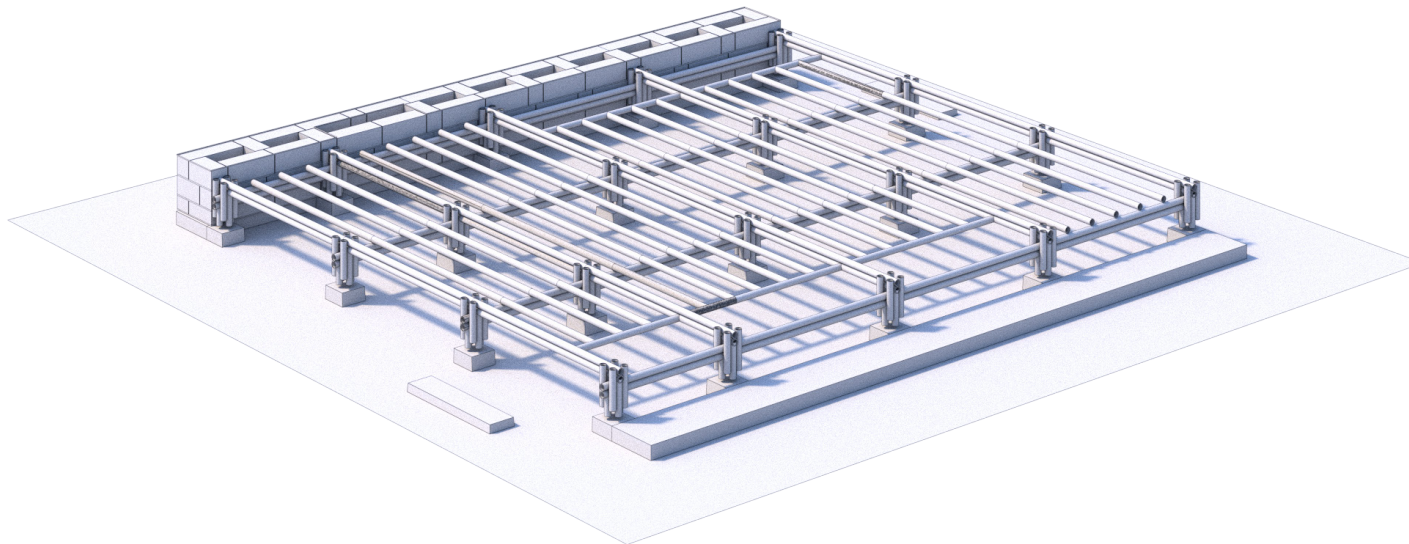

construction sequence  
*secondary construction*

---

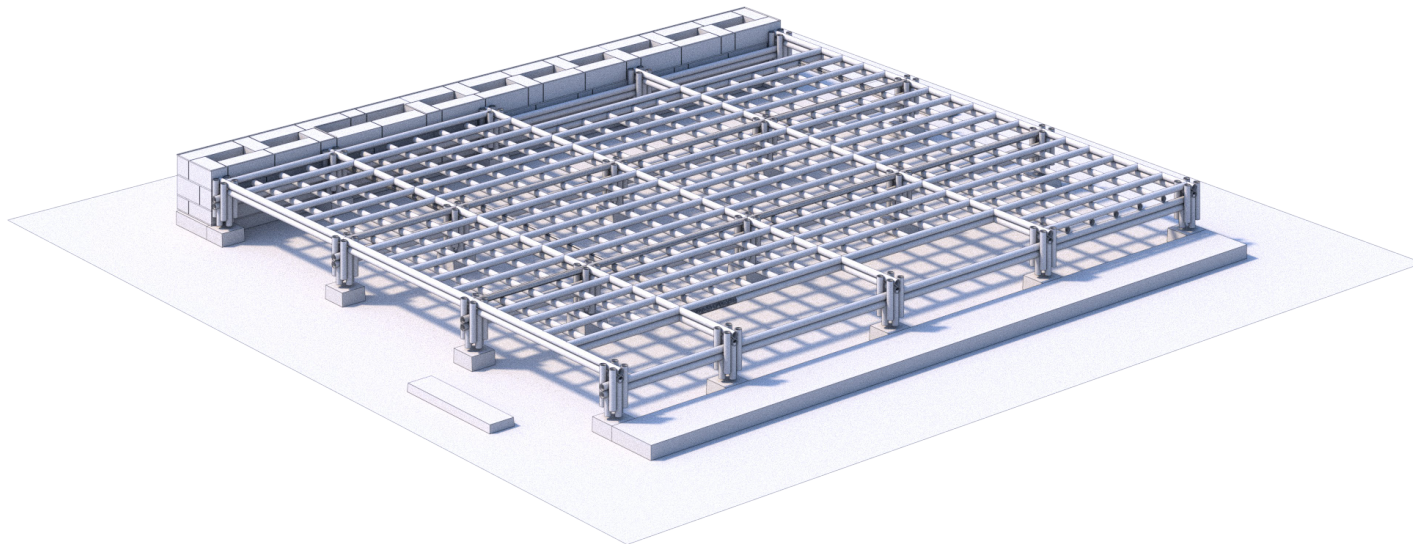

construction sequence

---

*secondary construction*

construction sequence  
*columns*

---

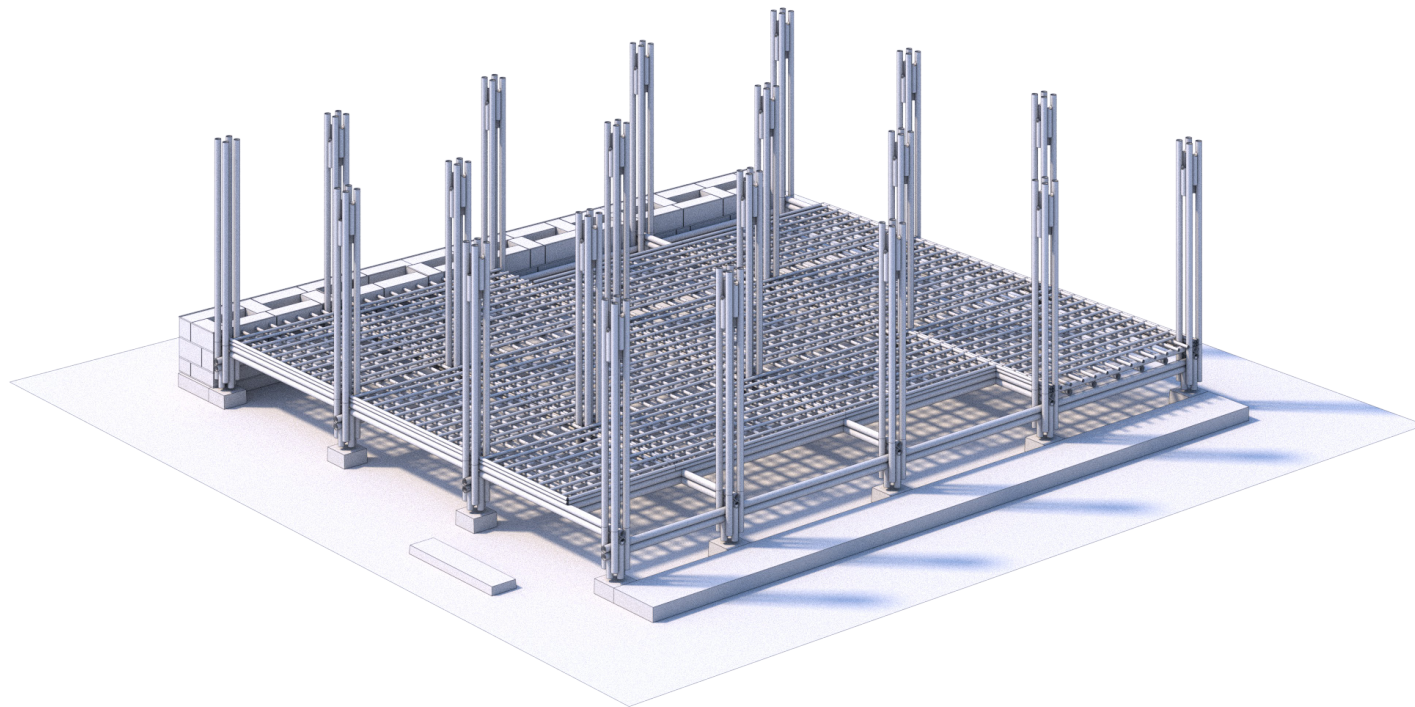

construction sequence  
*rammed earth wall*

---

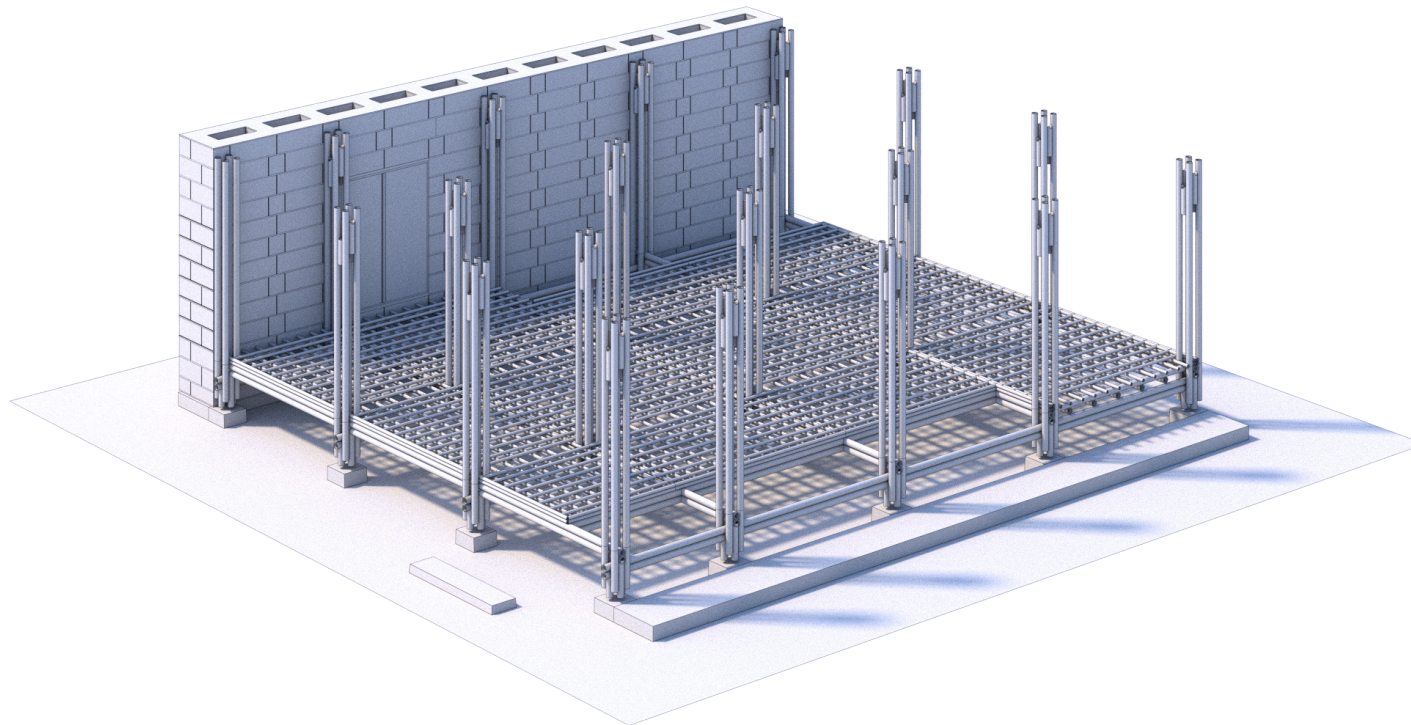

construction sequence  
*floor*

---

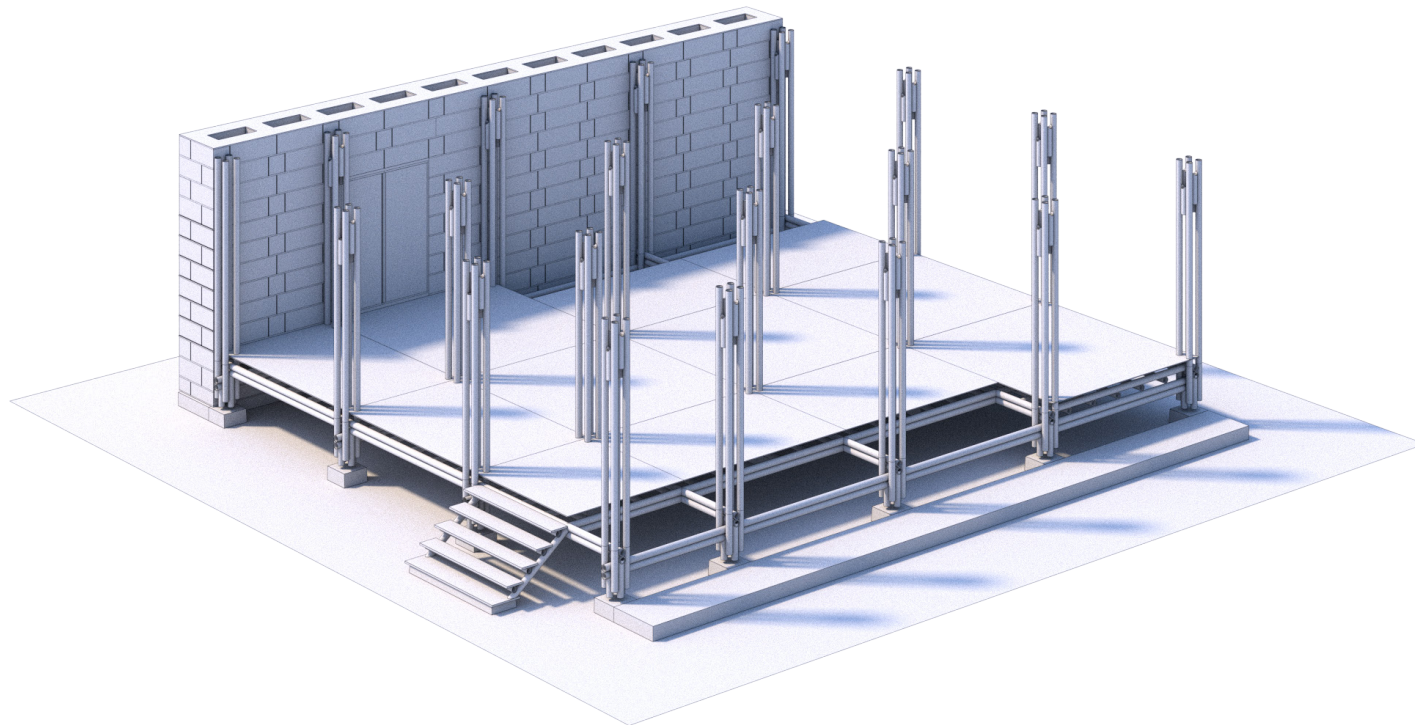

construction sequence  
*construction beams*

---

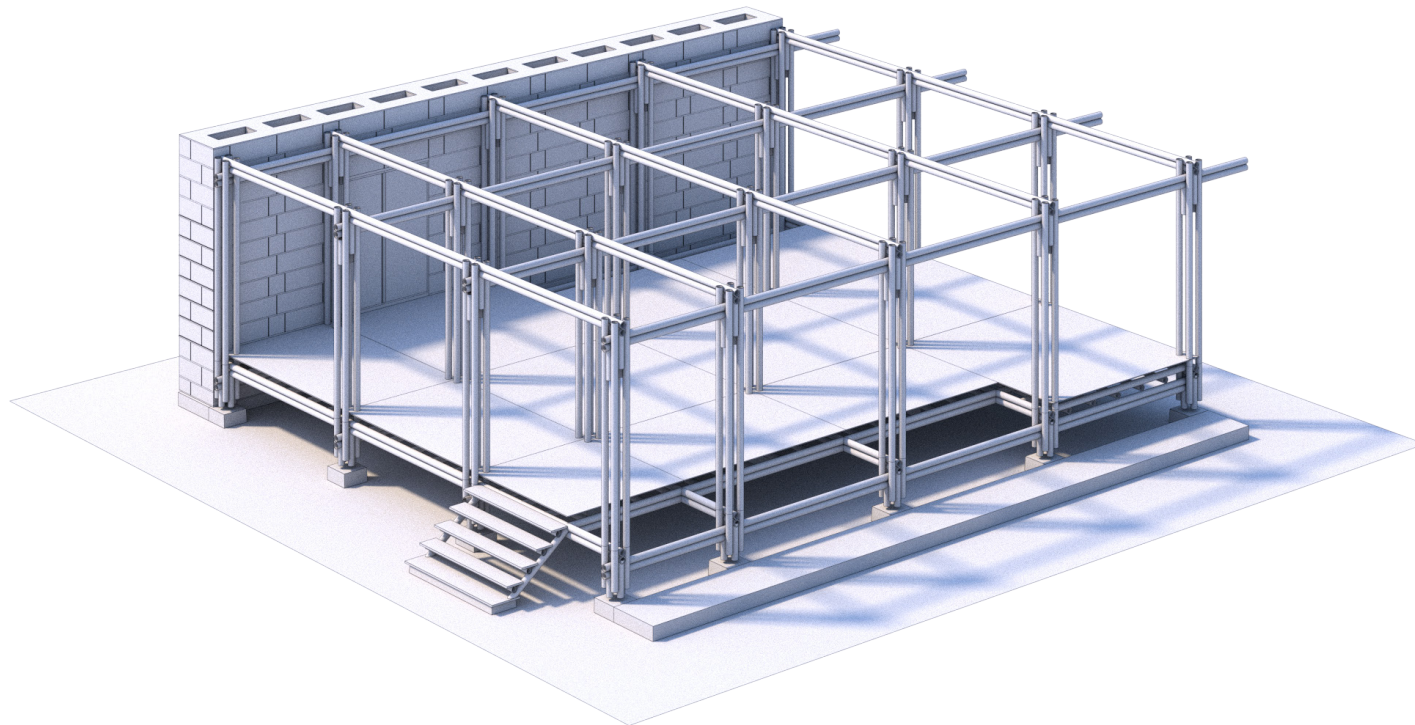

construction sequence

---

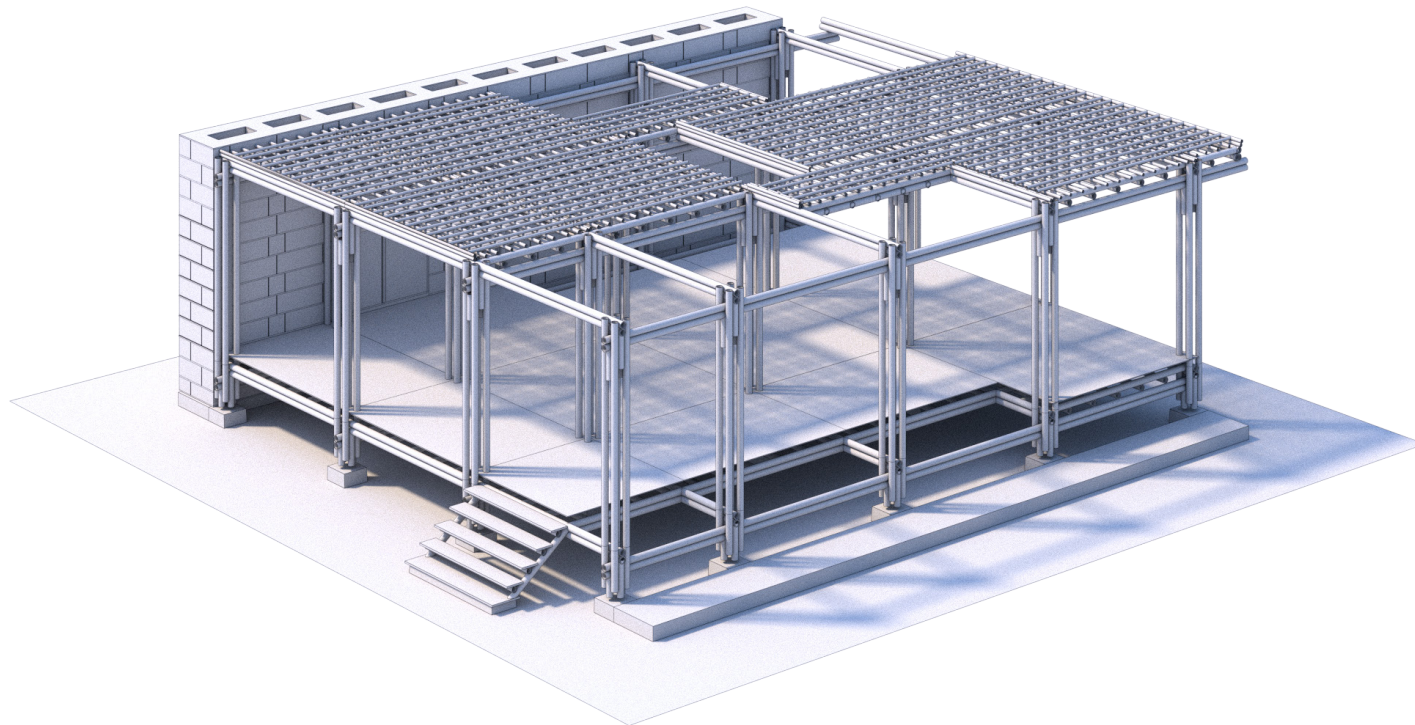

construction sequence  
*vertical poles*

---

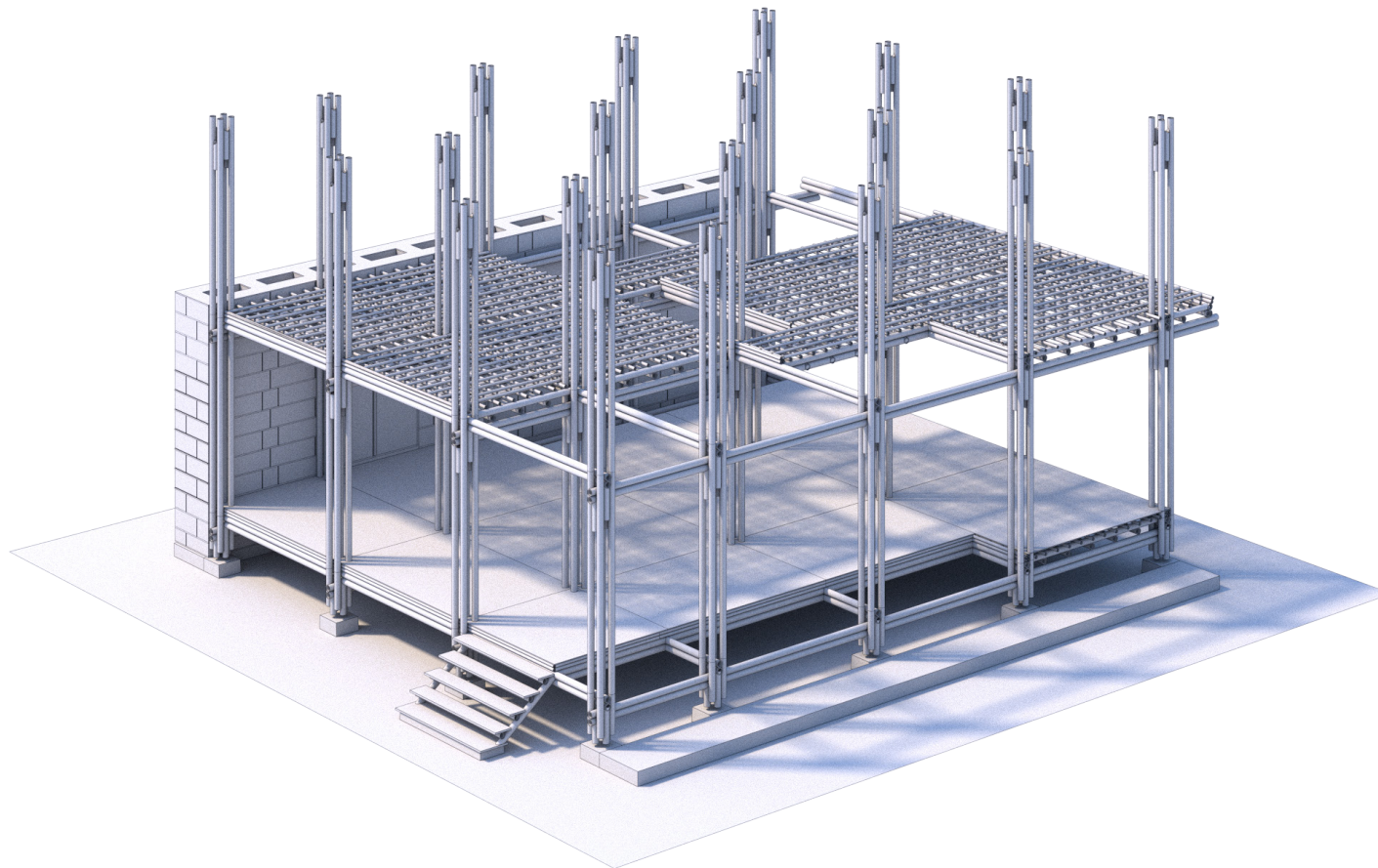

construction sequence  
*rammed earth wall*

---

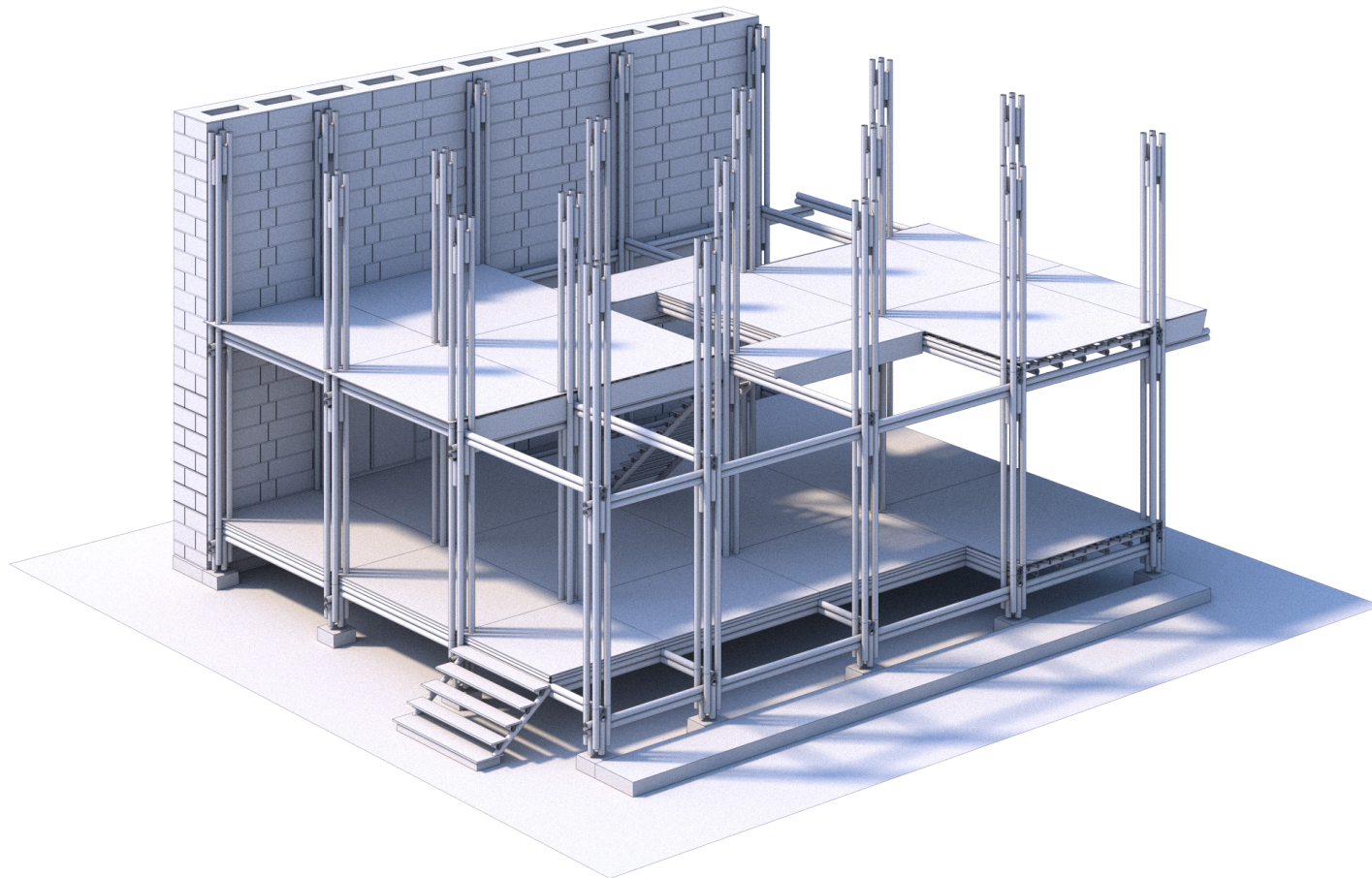

# construction sequence

## *beam construction*

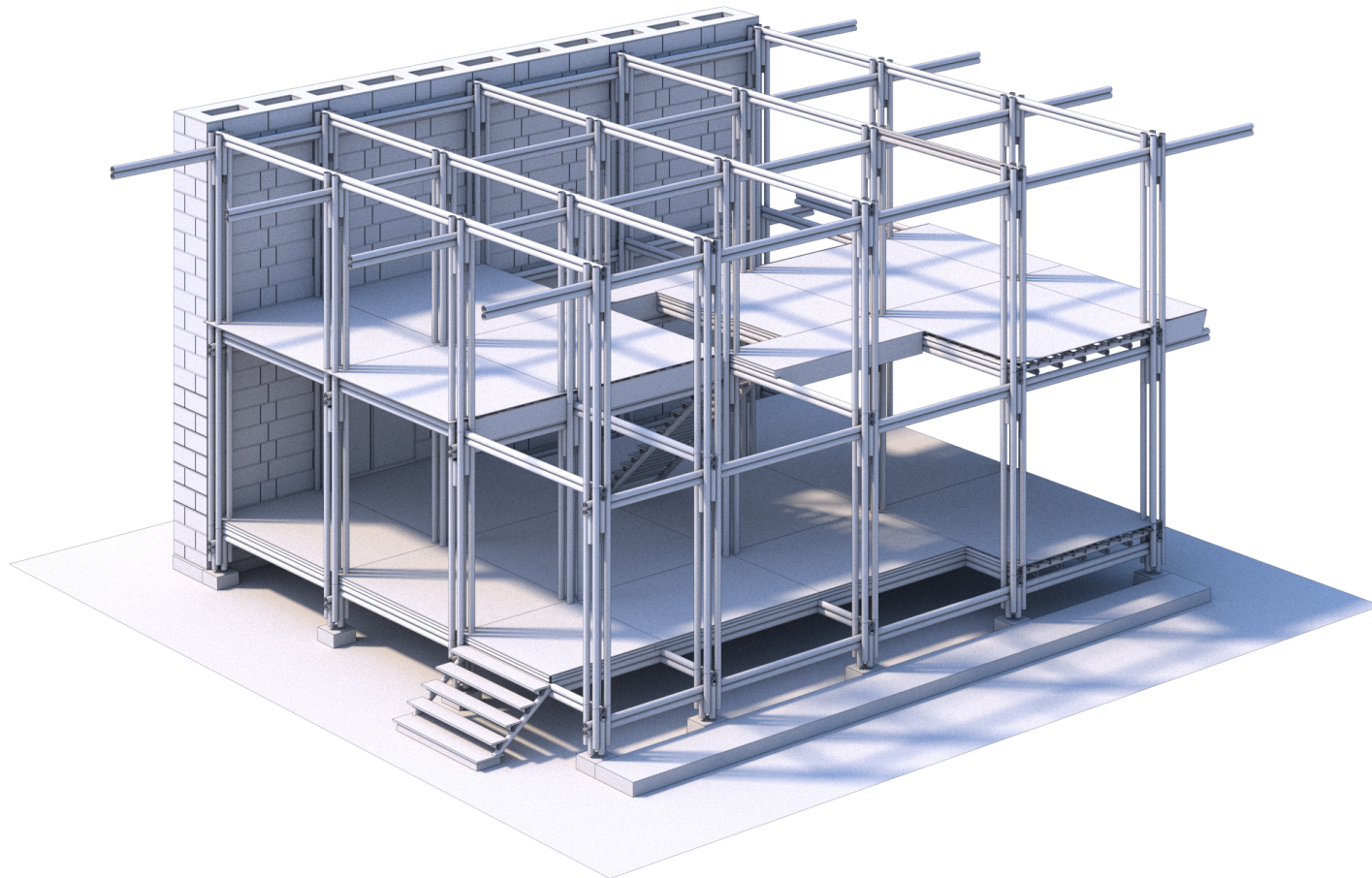

construction sequence  
*secondary construction*

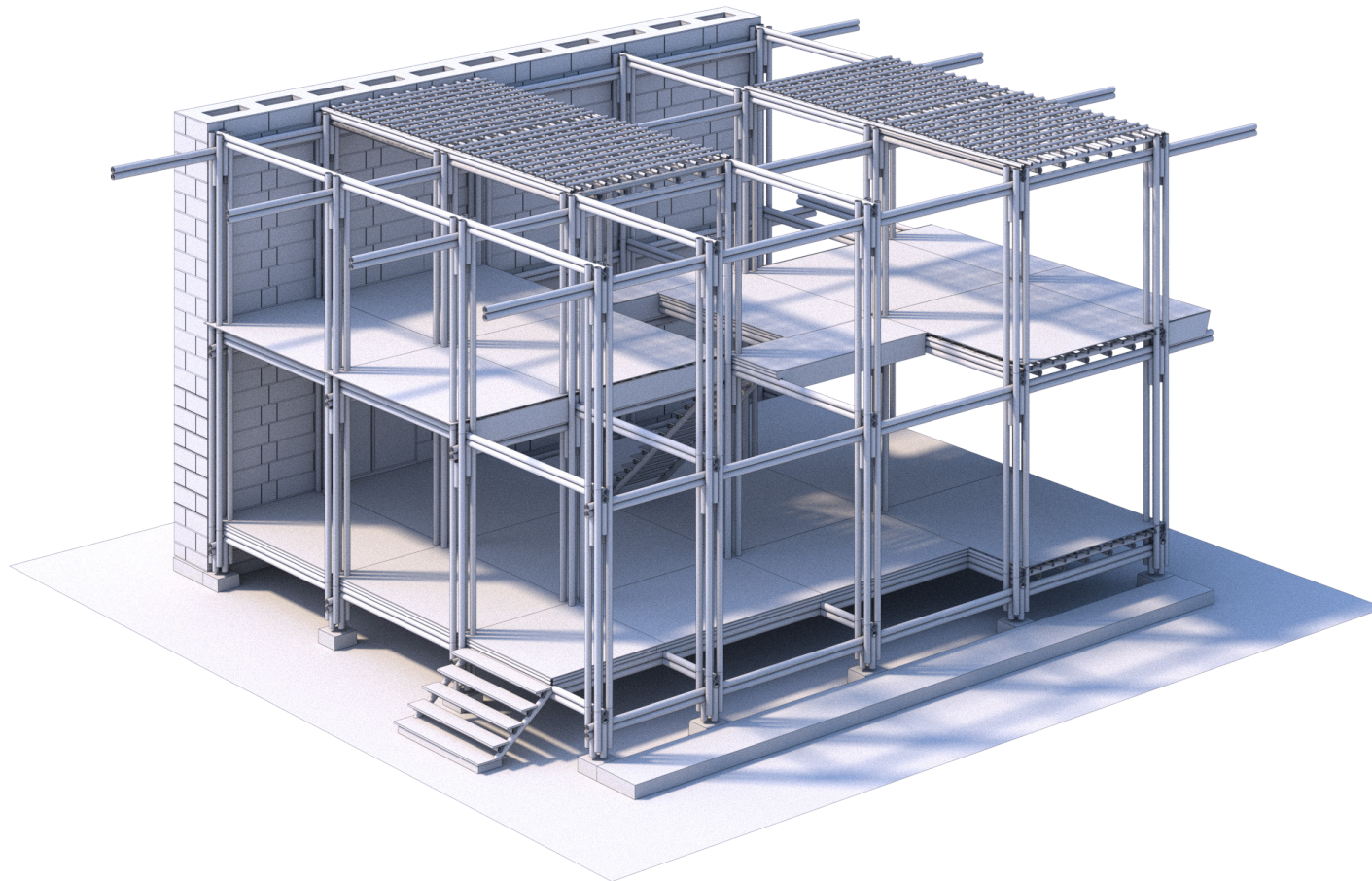

construction sequence

---

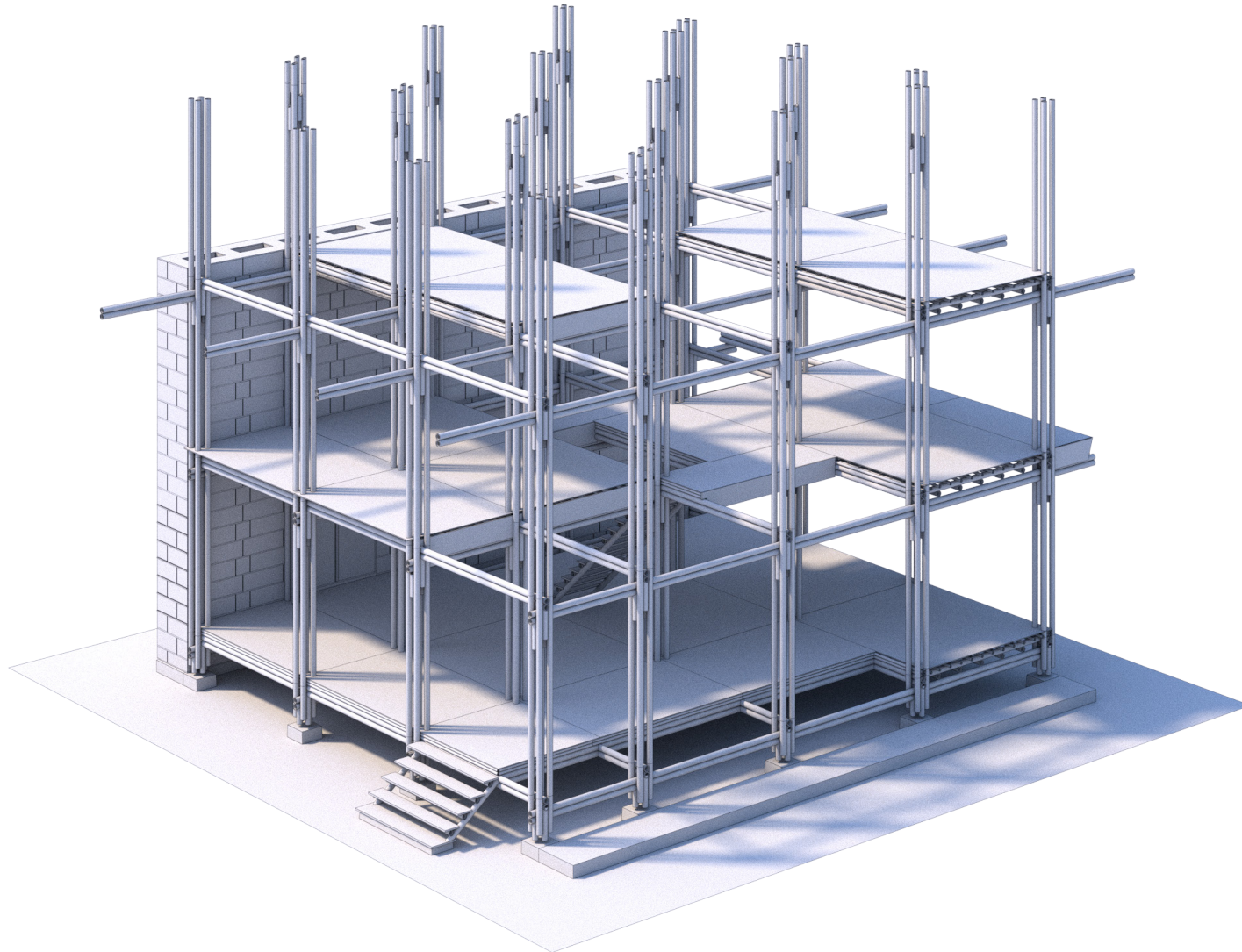

construction sequence

---

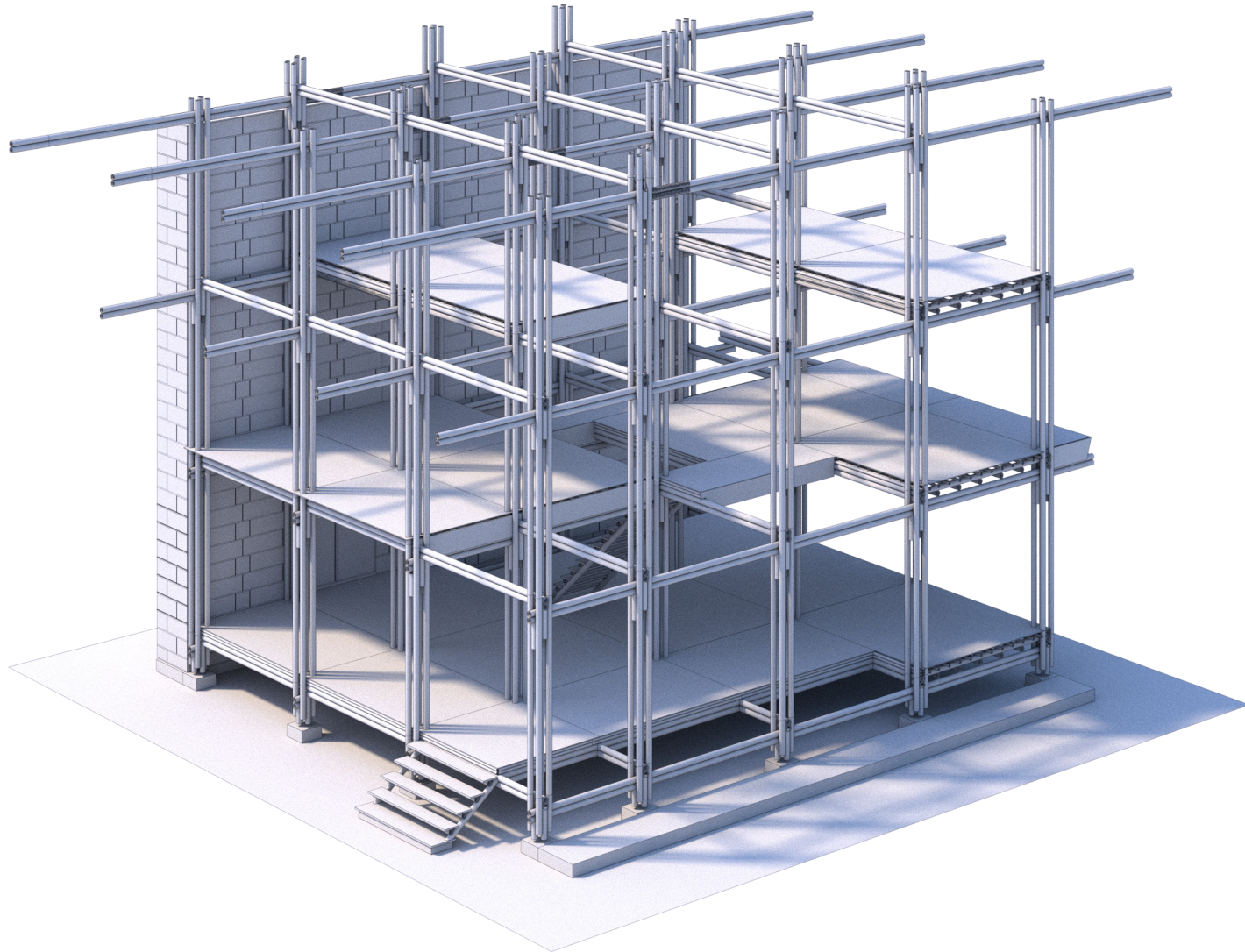

construction sequence

---

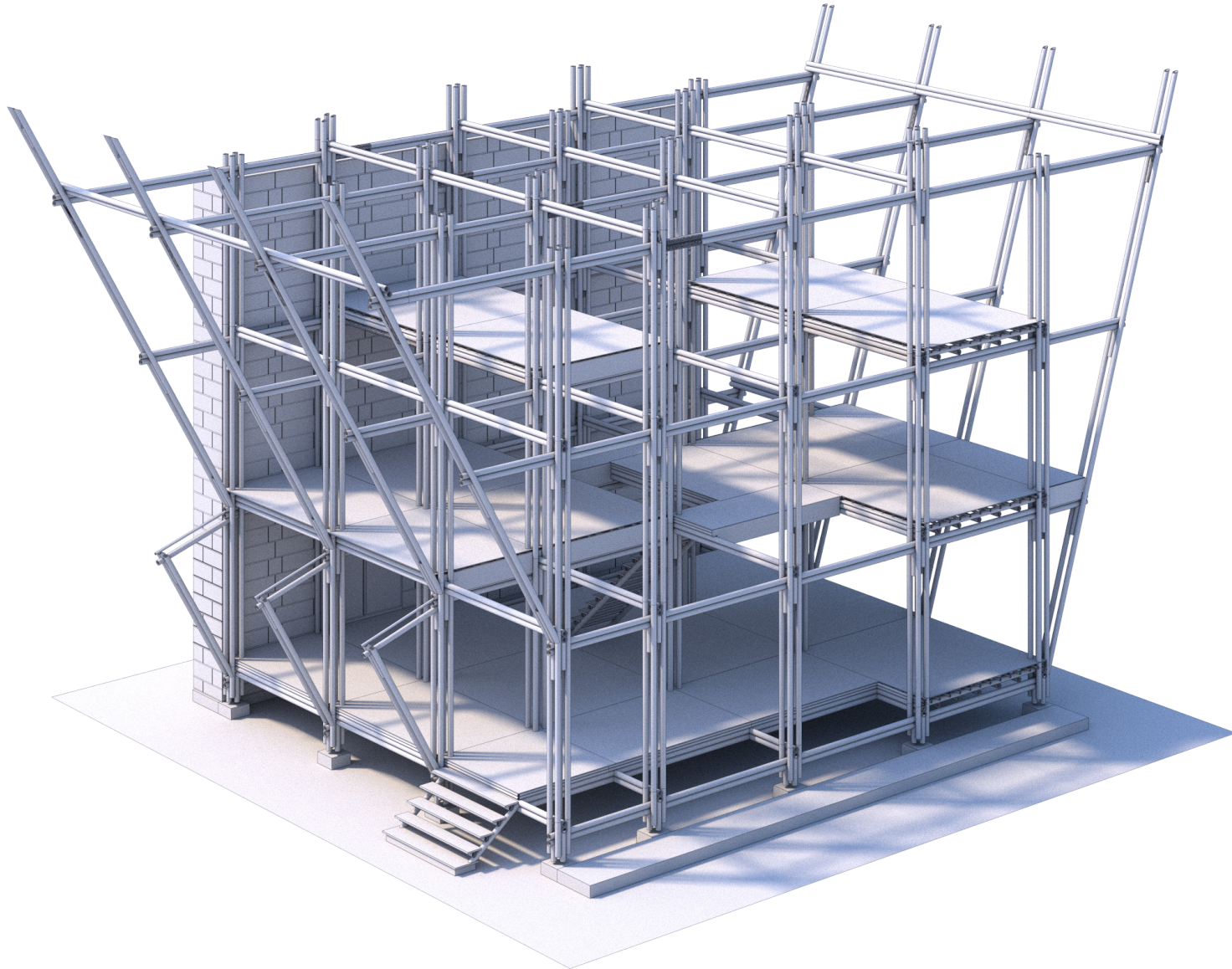

construction sequence

---

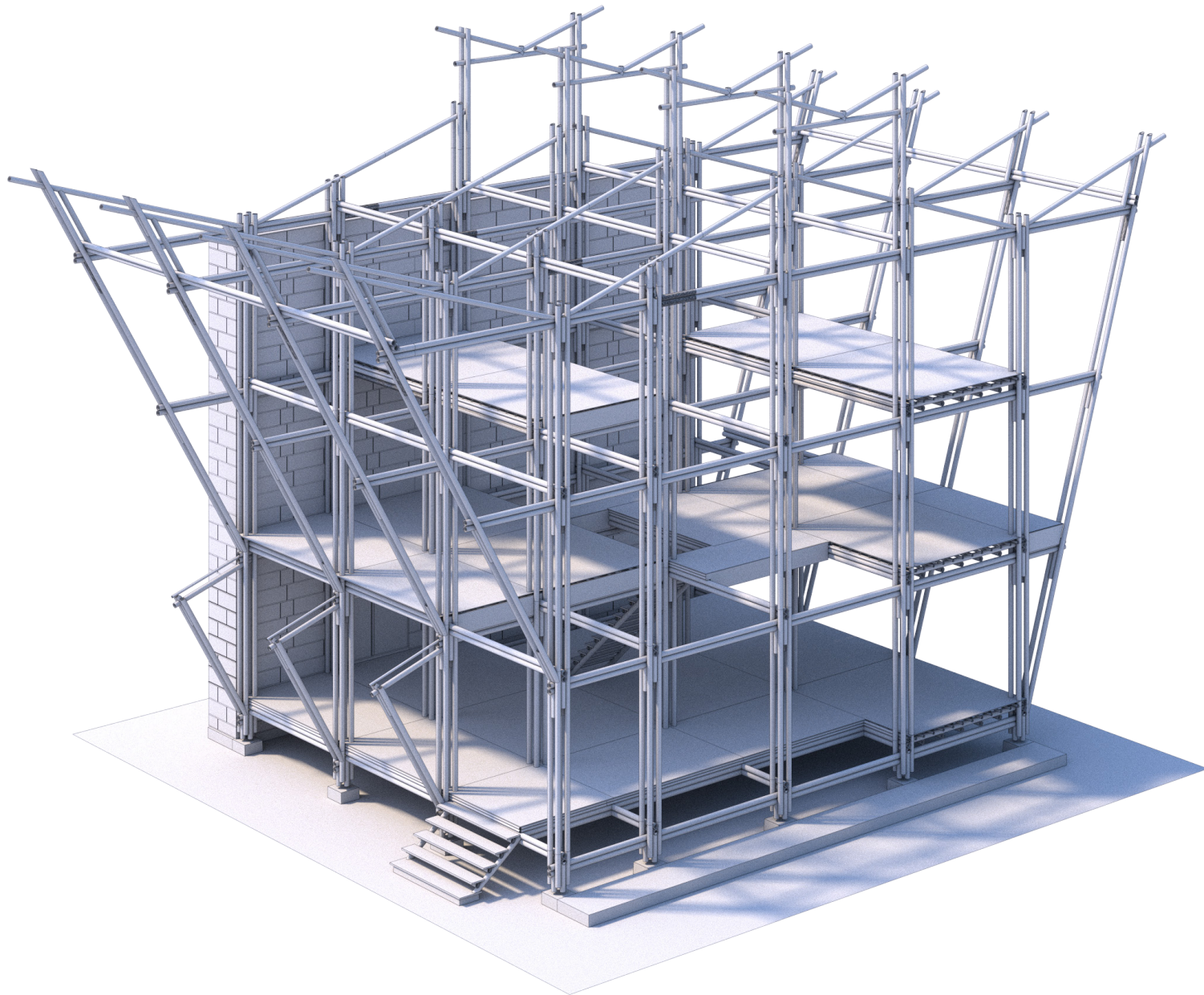

construction sequence

---

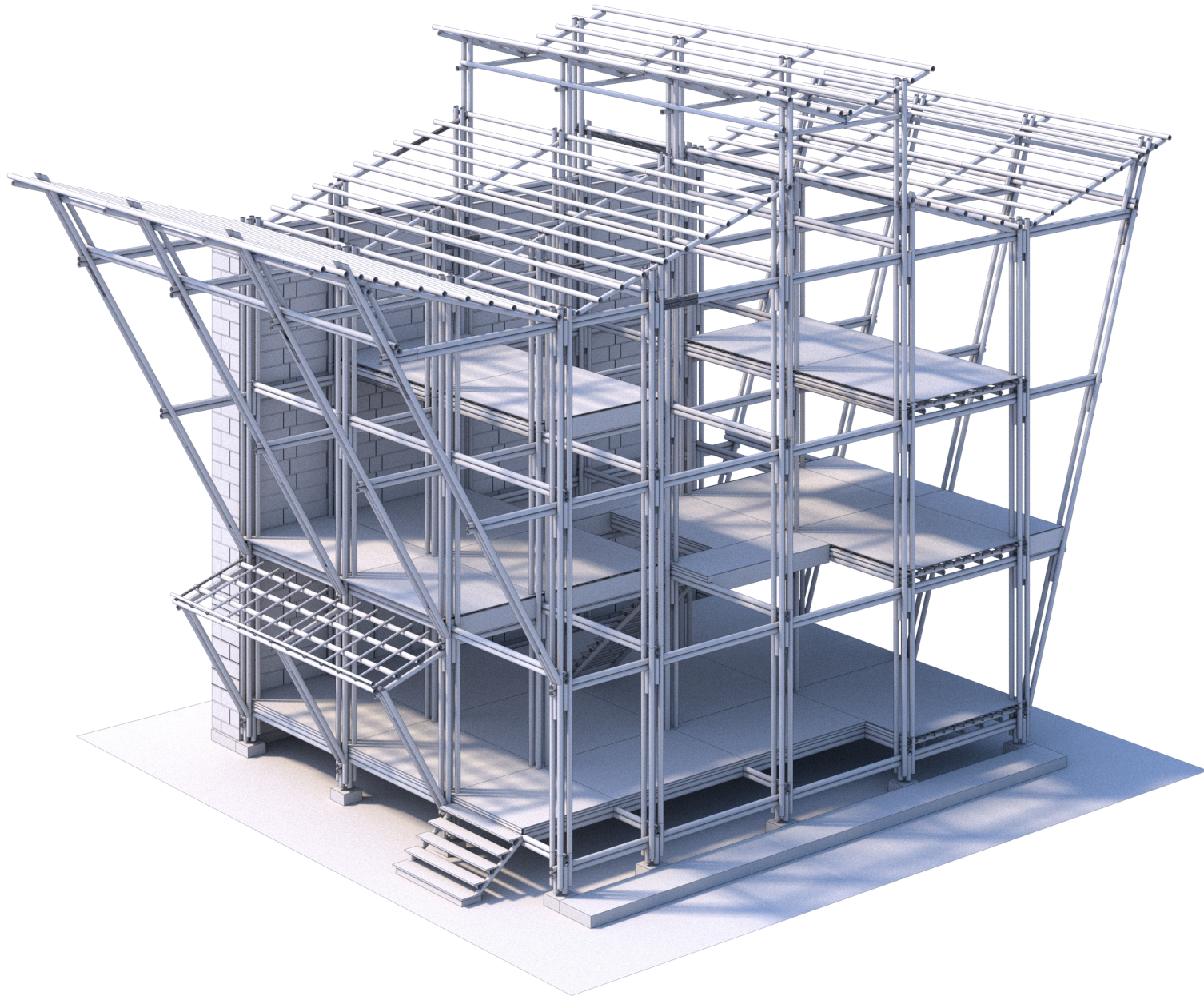

construction sequence

---

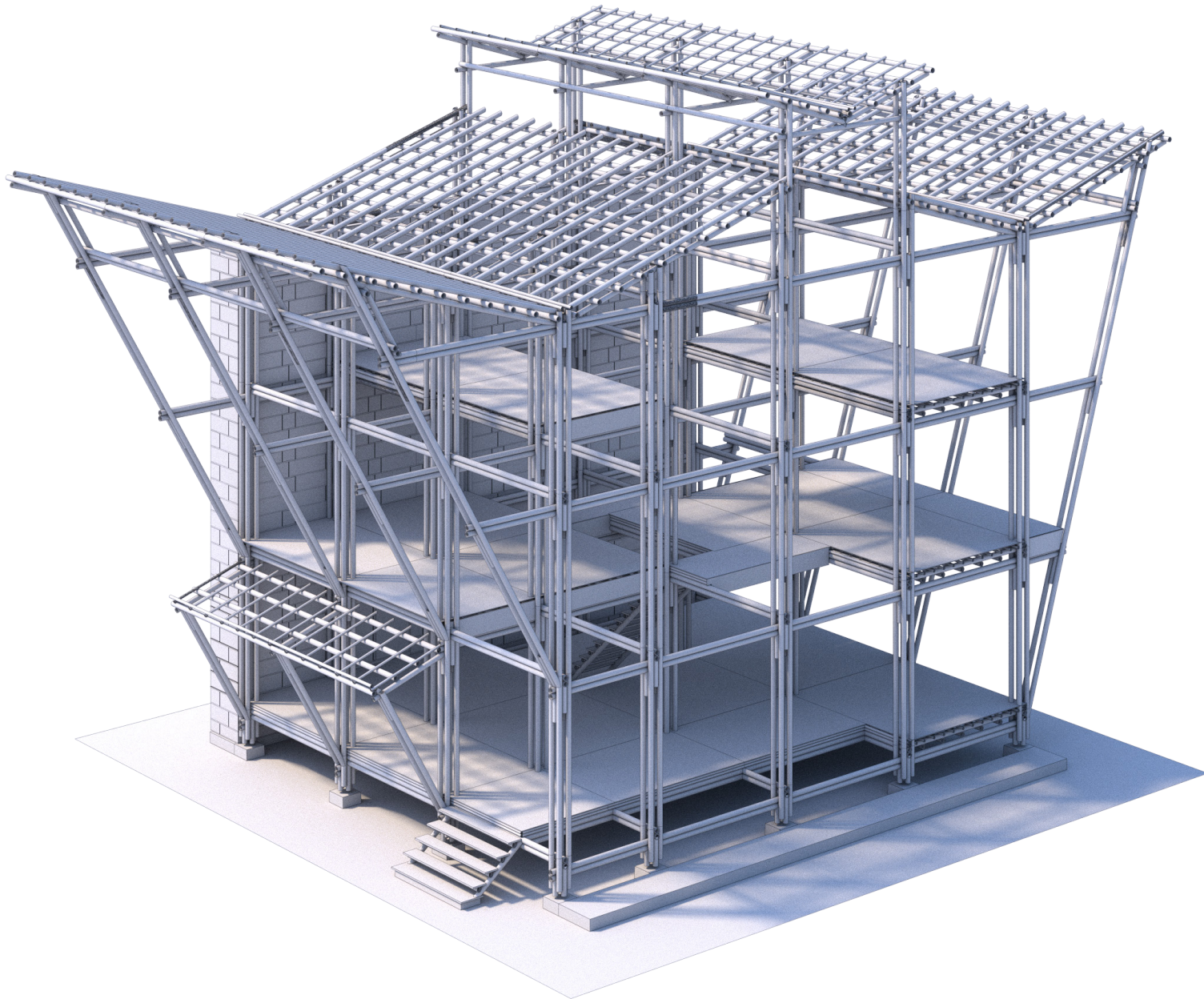

construction sequence

---

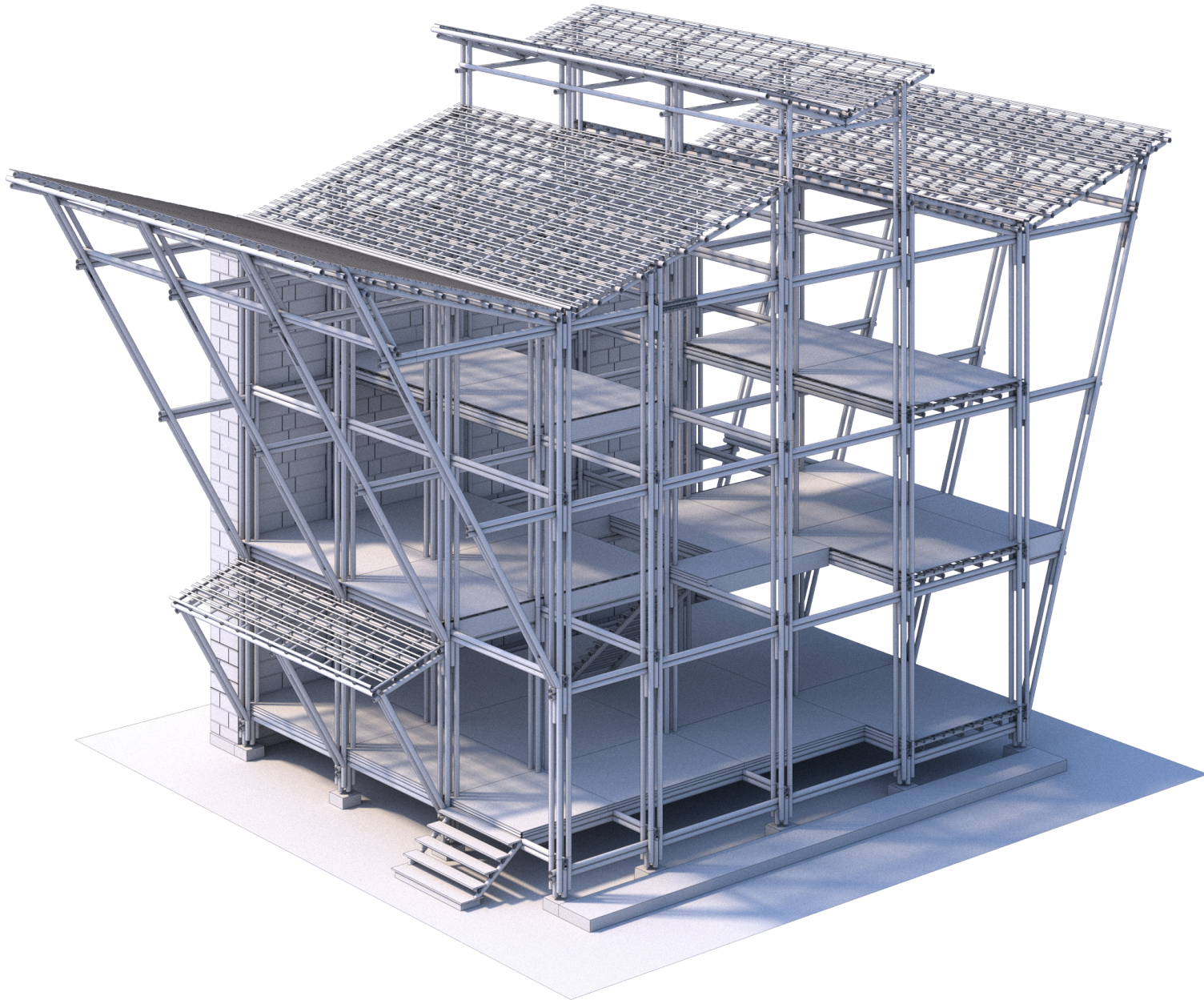

construction sequence

---

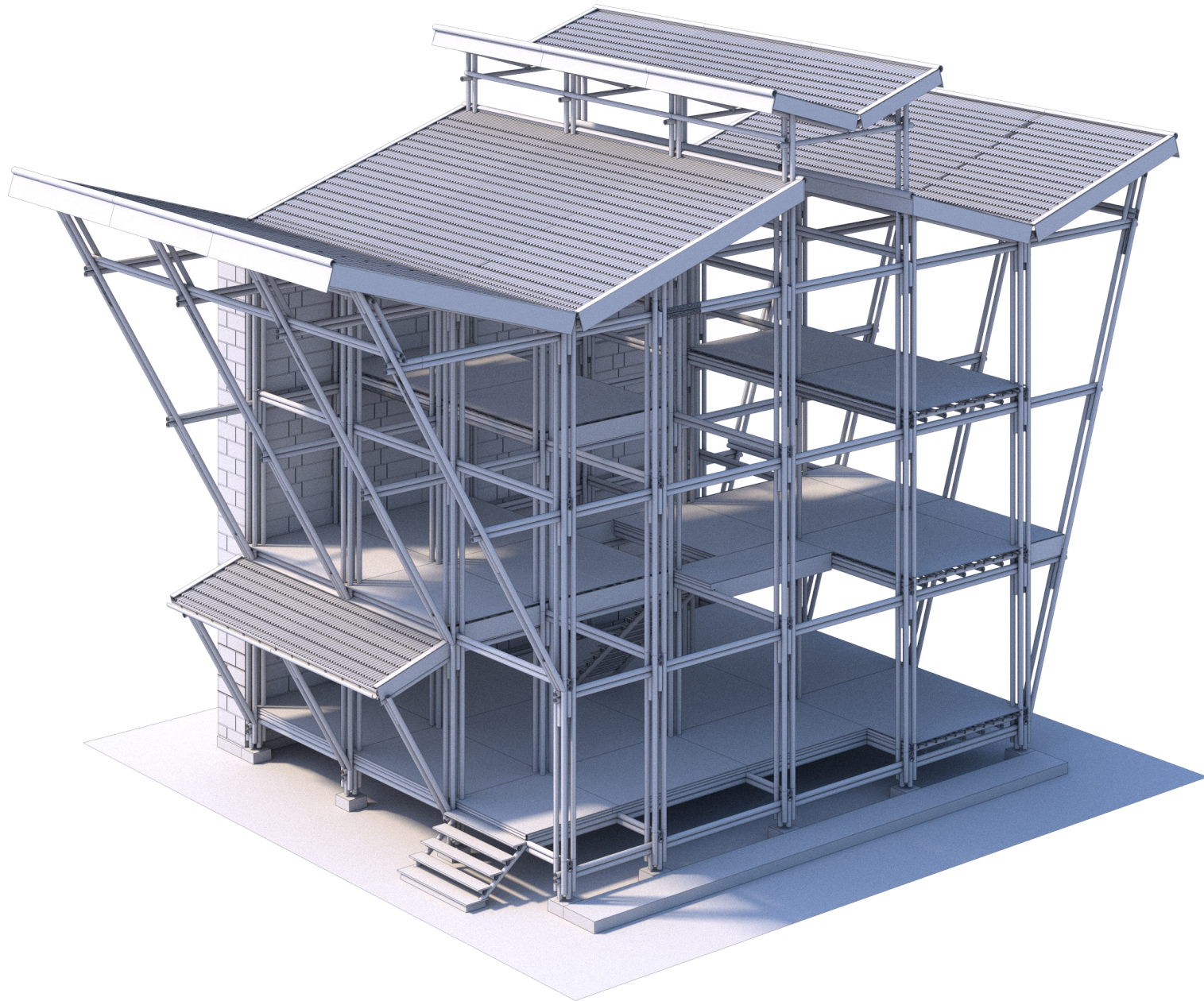

construction sequence

---

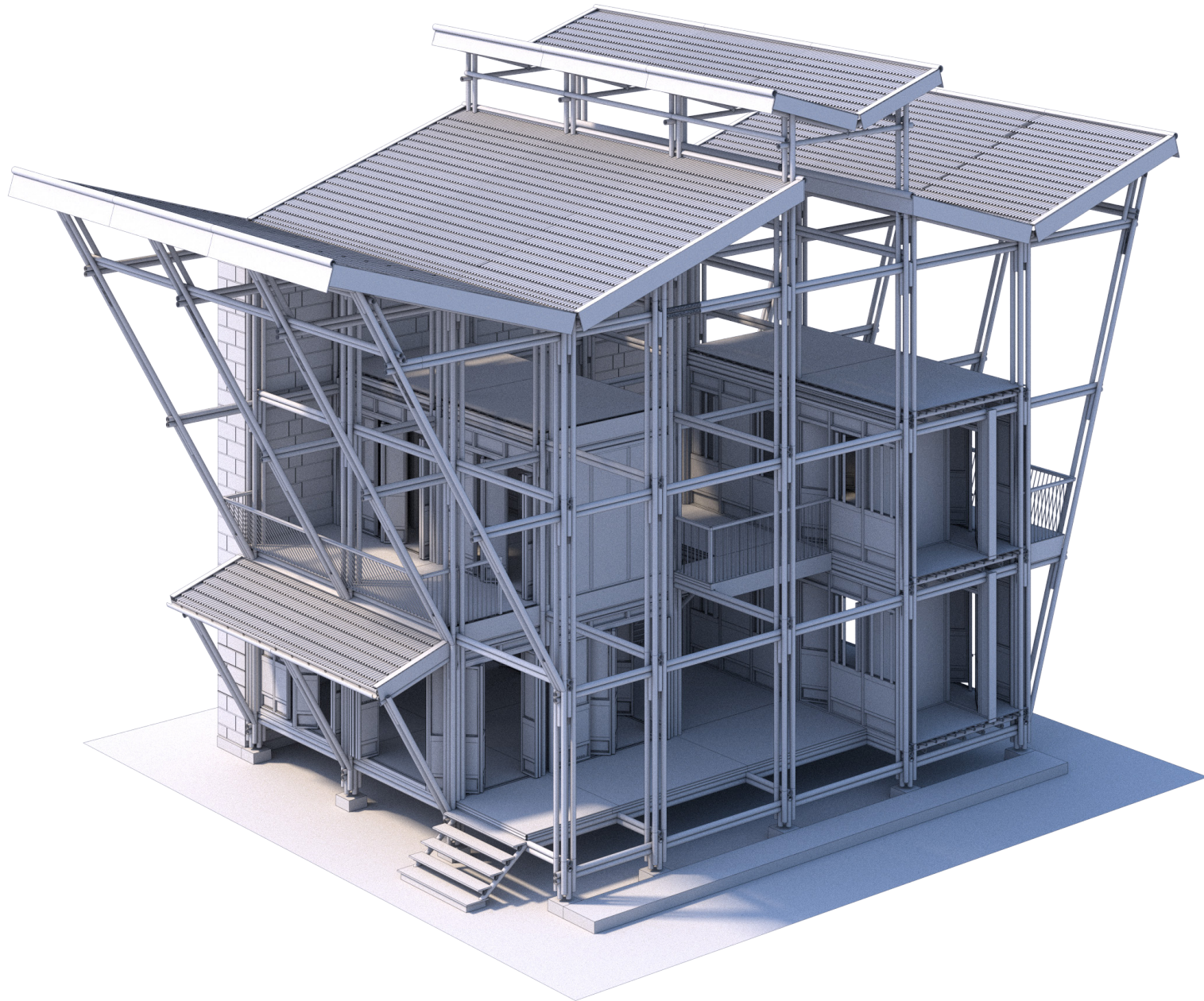

construction sequence

---

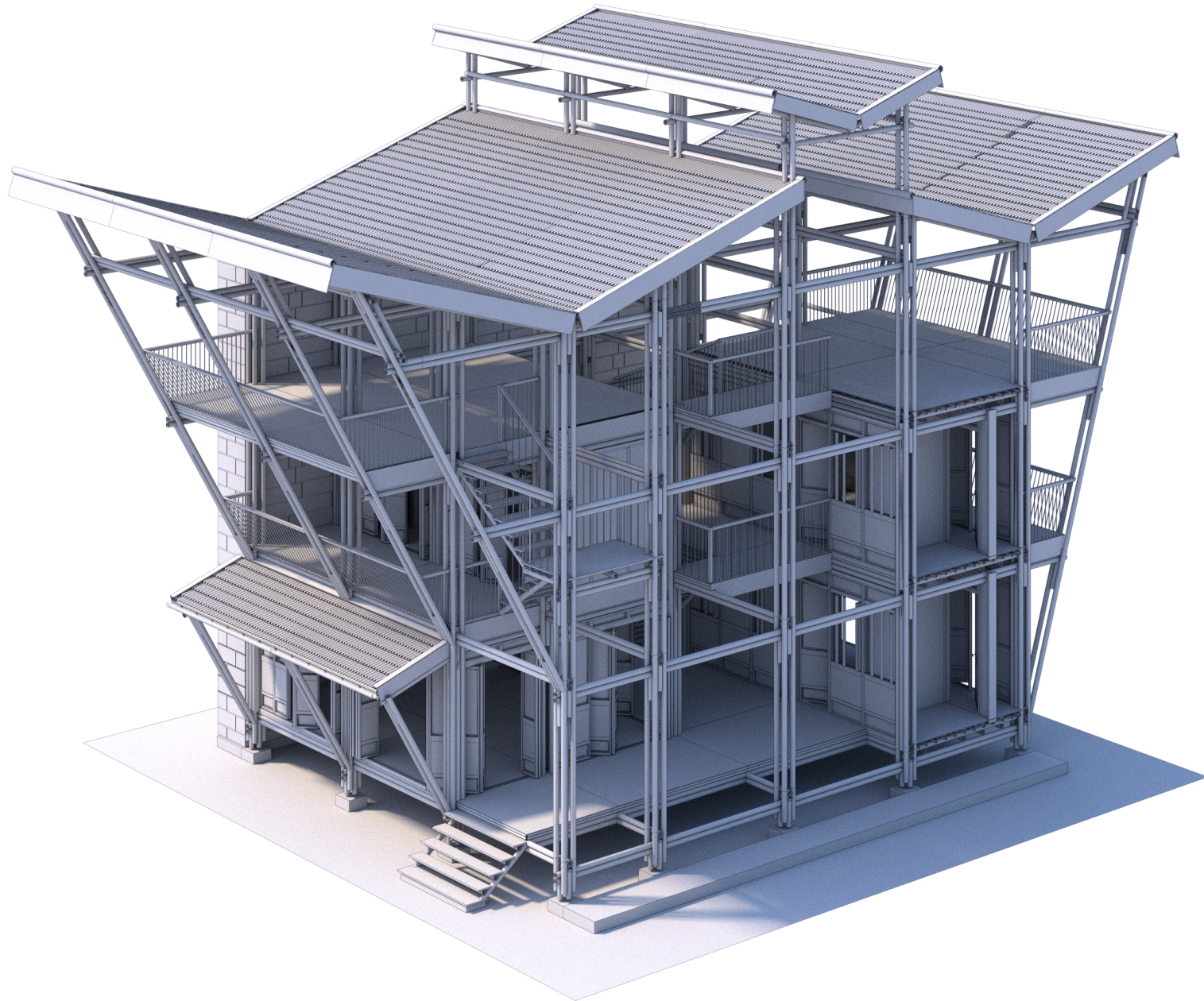

construction sequence

---

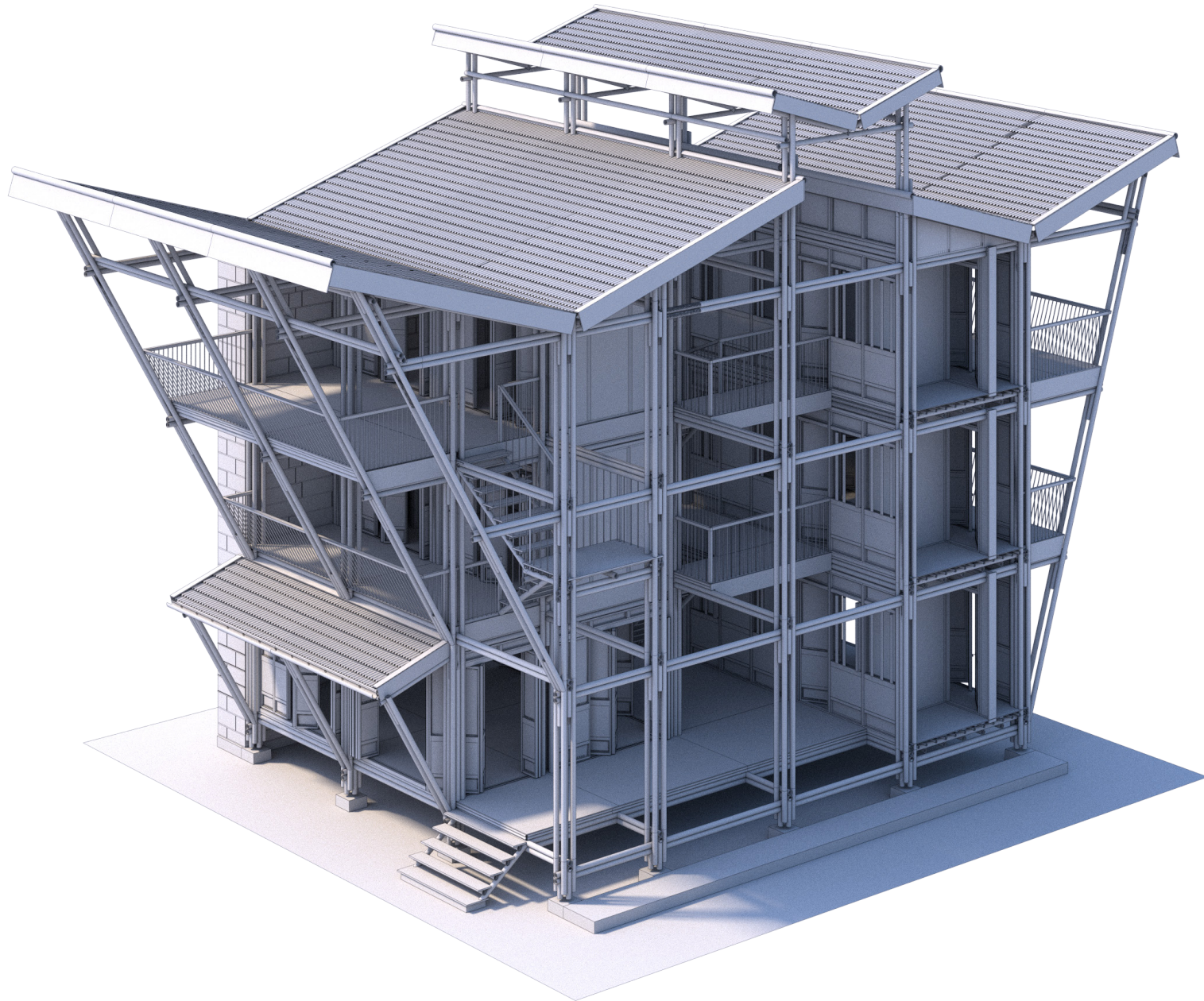

construction sequence

---

