

# Green Freighter Systems

Ronald Slingerland\* and Sijmen Zandstra†

Technical University of Delft, Faculty of Aerospace Engineering, Delft, 2629 HS The Netherlands

Dieter Scholz‡ and Kolja Seeckt§

Hamburg University of Applied Sciences, Department of Automotive and Aeronautical Engineering, Hamburg, 20099, Germany

**This paper presents the systems architecture of the Green Freighter, a new pilotless freighter aircraft. As no passengers or pilots will fly aboard this freighter aircraft, it is expected that many systems, particularly the environmental control system, could be modified or removed completely. Thus, the options for the new systems architecture will be elaborated on, followed by a description of the environmental control system model. Then the design of the new environmental, temperature and pressure control system variants, under consideration for operation in the cabin or in special containers only, will be explained. This is followed by a trade-off based on economic performance, which shows that the removal of various passenger and pilot-related cabin systems and the newly designed freight-dedicated environmental control system will allow operators of the Green Freighter to reduce direct operating costs by roughly 3.5%, while reducing environmental impact. Economically speaking, this means that operators of the Green Freighter can save up to \$5.3 million per aircraft per year, depending on operator strategy.**

## Nomenclature

$m$	kg	Mass	$t$	m	Thickness
$p$	MPa	Pressure	$T$	K	Temperature
$P$	kW	Power	$\sigma$	MPa	Stress
$R$	m	Radius			
$ACM$	=	Air Cycle Machine	$ISA$	=	International Standard Atmosphere
$APU$	=	Auxiliary Power Unit	$NO_x$	=	Nitrogen Oxides
$BWB$	=	Blended Wing Body	$PCS$	=	Pressure Control System
$CAC$	=	Cabin Air Compressor	$RATK$	=	Revenue per Available Tonne-Kilometer
$DOC$	=	Direct Operating Cost	$ROI$	=	Return on Investment
$ECS$	=	Environmental Control System	$TCS$	=	Temperature Control System
$ELC$	=	Electric Load Compressor	$TLAR$	=	Top Level Aircraft Requirement

## I. Introduction

In this global civil society, a huge amount of goods have to be transported around the world. Air transport is becoming ever more important, as companies like FedEx, UPS and DHL are offering competitive transport prices by operating fleets of old converted passenger aircraft.

Due to the quickly expanding air freight market, the demand for old aircraft currently exceeds supply. Furthermore, night-time flight and noise restrictions, rising fuel prices and the coming emission-related taxes are limiting the operability of these aircraft. In this sense, new modern freighters, like the A380F, offer the operators more flexibility and reduced fuel and emission costs. However, these modern freighters are primarily designed for passenger transport, meaning that the different set of requirements imposed by freight and freight operators is not fully met.

---

\* Assistant Professor, Chair of Design of Aircraft and Rotorcraft, AIAA Member.

† MSc. Student, Chair of Design of Aircraft and Rotorcraft, E-mail: s.j.zandstra@student.tudelft.nl.

‡ Professor, E-mail: info@profscholz.de

§ Assistant Researcher, E-mail: Seeckt@fzt.haw-hamburg.de

Therefore the Green Freighter project was started, in which a truly dedicated long-range zero-pilot freighter aircraft will be designed for the year 2025. It is envisioned that a significant reduction in direct operating costs can be accomplished with respect to the reference aircraft, the B777F, by focusing on the following solutions:

### A. Unconventional Configurations

Within the green freighter project, a lot of attention will be paid to unconventional aircraft configurations, as they provide new opportunities for the freight transport system, as well as higher operating efficiencies, lower fuel consumption and reduced noise production. One of these configurations is the blended-wing-body (BWB) design shown in Fig. 1.

To design and optimize unconventional aircraft configurations, the tool PrADO (Preliminary Aircraft Design and Optimization), developed by the Institute of Aircraft Design and Lightweight Structures (IFL) at the Technical University of Braunschweig, Germany, is used. With this tool various conventional and unconventional aircraft configurations can be compared, so that the optimal green freighter configuration can be determined.

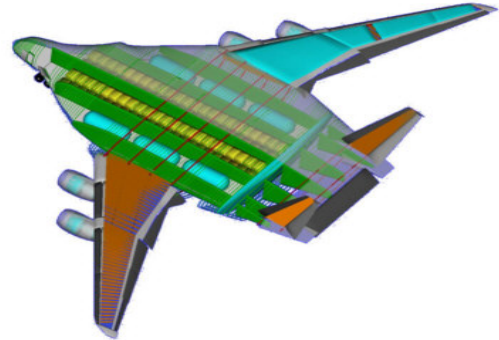

Figure 1. Blended-wing-body Configuration.

### B. Utilization of Alternative Fuels

As oil is becoming scarcer and hence more expensive, alternative fuels are being considered for the Green Freighter. These fuels, or the resources used to create them, should not only be non-depletable and (more) environmentally friendly, their utilization should also result in (more) economic operation in the long run. Currently, two options are listed for investigation: Liquid hydrogen and synthetic fuels.

### C. Reducing Crew (including zero-pilot operation)

A major cost factor for aircraft operators is crew cost. It is therefore evident that serious gains can be achieved with the so-called zero-pilot operation. Autopilot systems are progressively becoming more sophisticated and it is expected that soon they will be advanced enough to fly a commercial aircraft from point A to point B, with only minor human intervention needed. Furthermore, certification is less strict for freighters than for passenger aircraft. Therefore, it is envisioned that many of the safety related issues regarding zero-pilot operation no longer apply. Human supervision of the aircraft is still advised, however this could be done from a ground control station, possibly integrated with aircraft traffic management as is known today.

## II. Green Freighter Systems

When zero-pilot operation becomes a success many systems become superfluous. Some examples of systems that can be omitted from the Green Freighter are the human-pilot interface (flight-deck), the galleys, the water-waste system (including toilets, taps and reservoirs) and all windows (including the cockpit windows).

Other systems cannot be removed completely, but might change significantly once optimized for the pilotless Green Freighter. The most important system under consideration in this respect is the environmental control system (ECS), because it consumes a large amount of power, while being costly and maintenance intensive. As it appears uneconomical to remove it completely, a number of new ECS strategies have been defined.

1. A freight dedicated ECS, which allows for temperature and pressure control aboard the aircraft, similar to conventional ECS, but with a wider temperature bandwidth.
2. A temperature control system (TCS), which allows for temperature control only. This implies that pressure-sensitive goods cannot be transported. It is expected that this system will operate much more efficiently and that a reduction of cabin pressure will result in a lighter cabin structural design.
3. A pressure control system (PCS) has been defined. This implies that temperature-sensitive goods cannot be transported. However, large system size and power consumption reductions can be expected for this system, as many components can be omitted and the requirements on the system are relaxed.

It might be possible to transport goods that require some form of environmental control in special containers. This way it is envisaged that the system variants can be made significantly smaller and more efficient, as they only have to supply conditioned air to freight that requires it. Furthermore, the hull does not need to be pressurized and can thus be made lighter, which seems to provide a special benefit for a blended-wing-body (BWB) design with its non-cylindrical fuselage, which is by no means optimal for carrying pressure or hoop stresses.

Applying a systematic approach allows us to determine all available options for the Green Freighter's ECS through the choice of offering pressure control and/or temperature control and the choice of offering controlled conditions in the whole cabin or only in special containers. This leads to the 8 design options shown in Table 1.

**Table 1. Green Freighter ECS design options.**

	Cabin ECS	Cabin TCS	Cabin PCS	Container ECS	Container TCS	Container PCS	Cabin TCS + cont PCS	Cabin PCS + cont TCS
Cabin Temperature Control	☺	☺	-	-	-	-	☺	-
Cabin Pressure Control	☺	-	☺	-	-	-	-	☺
Container Temp. Control	-	-	-	☺	☺	-	-	☺
Container Pressure Control	-	-	-	☺	-	☺	☺	-

Usually, it is enough to compare various system configurations on the basis of direct operating costs (DOC), but in this case the demand is not constant for all defined configurations. Therefore, the analysis incorporates an estimation of the market potential of the various configurations, such that the final trade-off can be made on the basis of cash flow and return on investment (ROI).

### III. Freight Market and Market Potential of the ECS Configurations

In order to estimate the lost revenue due to reduced flexibility one should have an accurate idea of the amount of goods requiring temperature, pressure and/or oxygen partial pressure control. Taking this into account, the transported goods between Sydney and the USA, Sydney and Hong Kong and Sydney and New Zealand have been categorized. Graphs, as shown in Fig. 2, are obtained for the imports and exports over the last years. Assuming that the data is representative of the rest of the world, the market potential of the various ECS configurations can be determined.

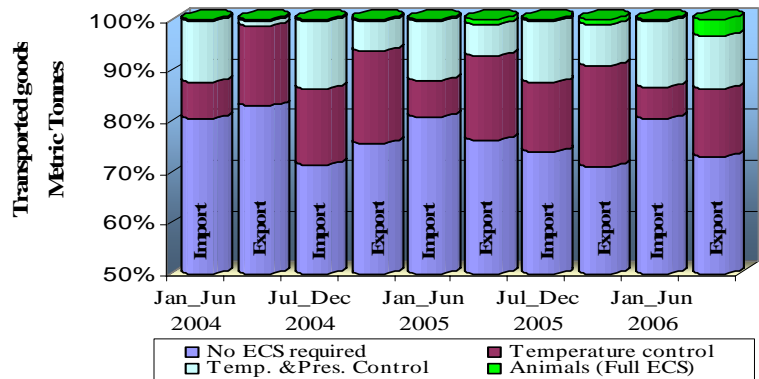

**Figure 2. Categorization of airfreight between Sydney & the USA.**

From Fig. 2 it appears that up to 30% of the goods, being imported into Sydney, require some form of air conditioning. The largest portion of 20-30% of the goods require temperature control. Furthermore, another 5-10% require temperature and pressure control and finally a small portion of up to 1-2% of the goods are live stock, requiring a sufficiently high oxygen partial pressure as well.

### IV. Environmental Control System Model

The ECS model consists of three main parts. The first part is the dynamic simulation of the cabin heat fluxes, from which the required ECS output flow state can be determined. The second part is the determination of the ECS operating cycle, such that the system can supply the required ECS output, at a given ambient air input, determined by the flight cycle. Following previous research such as presented in Ref. 12 and Ref. 18, it is concluded that a more-electric ECS layout using separate electric load compressors driving conventional pneumatic ECS packs, is superior over any other configuration.

Finally, when the power consumption and flow states at the various ECS stations have been established, a system weight estimation can be performed. This will allow us to compare the various ECS configurations on the basis of direct operating costs at a later stage. First however, the requirements have been determined.

#### A. Environmental Control System Requirements

First, it has been decided that the same cabin pressure requirements are utilized as for passenger aircraft. This means that the cabin pressure shall not be lower than 750 mbar, as defined in Ref. 3. Contrary to the temperature requirements for passengers, it is unlikely that freight requires a strict temperature range. From Ref. 5 appears that during cruise at 20,000 ft, the cargo hold is kept at a temperature of 7 °C and during hot day operation up to 37 °C.

According to other sources such as Ref. 17, it appears that the cargo hold temperature can even exceed 45 °C, even when animals are onboard. As temperatures exceeding 30 °C often lead to fatalities, it is decided that the latter temperature limit is applied for the Green Freighter.

Furthermore, it is required that the empty aircraft cabin can be heated or cooled to within the required bandwidth within half an hour from ambient temperatures between -32 °C to 46 °C during ground operation. This is similar to the requirements on passenger aircraft, as defined in Ref. 2. These temperature requirements determine the required heat flow and thus air mass flow from the ECS and TCS variants. However for the PCS, the temperature is allowed to vary freely, so the cabin airflow is not defined by the thermodynamic balance anymore. Instead the air leakage and ambient pressure variation determine the required airflow into the cabin.

## B. Cabin Heat Flows

The primary step in the design of the ECS is to determine the cabin heat flow. To this end the heat sources and sinks need to be determined and modeled. In this sense the heat losses through the cabin wall and the system waste heat play a major role aboard the freighter.

The heat flux through the cabin wall can be determined using the method presented in Ref. 5. During flight, convection is the dominant factor determining the outer wall temperature. Subsequently, the heat flux can immediately be calculated on the basis of conduction and the cabin temperature. During ground operation there is no single dominating factor determining the outer wall temperature. Therefore it has to be calculated taking into account conduction, convection and radiation. Then the heat flux through the cabin wall can be calculated for all flight phases, under all circumstances in which the Green Freighter will be operated.

The system waste heat onboard the Green Freighter will be significantly less than on a passenger aircraft, due to the absence of cabin lighting, galleys and entertainment systems. Therefore it is assumed that the total generated system heat is only half that of a passenger aircraft, which gives us an estimated 10 kW of heat generated aboard the aircraft<sup>1</sup>. Furthermore, the variation will be significantly less, as most systems onboard the Green Freighter will operate continuously, contrary to the case of the cabin entertainment systems and lighting. Therefore a variation of only 2 kW is assumed.

Subsequently a Simulink model<sup>14</sup> has been created, which allows us to dynamically simulate the heat flux that has to be provided by the cabin ECS to keep the cabin temperature within the required bandwidth. When using a container ECS however, the model becomes slightly more complicated, because the ECS output airflow, now flows into the containers first. Subsequently, the container interior is heated or cooled and a certain amount of non-recirculated air is rejected into the cabin through a pressure reducing valve to prevent pressure buildup in the cabin. This of course affects the cabin temperature and thus also the container wall temperature. Finally it is assumed that the heat is distributed evenly throughout the cabin, and that the radiation from container to container can be neglected under the assumption that the walls of air conditioned container, directly facing the walls of other air conditioned containers do not count as heat flux surface to the cabin.

Then the requirements on the ECS to heat or cool the cabin, or simply provide it with a sufficiently large airflow to keep it pressurized, have been determined. The next step is to model the ECS itself, to determine how the required output can be delivered and how much power is consumed in the process.

## C. More-Electric ECS Model

In order to evaluate the various ECS configurations, a generic more-electric ECS model has been developed. As stated, the input of the system is completely determined by the flight or ambient conditions, while the required output of the ECS can be determined using the cabin heat flow model. The generic electric ECS operates on the basis of a thermodynamic air cycle. The most common air cycles applied in the design of environmental control systems are the so-called simple cycle and bootstrap cycle. These are schematically shown in Fig. 3.

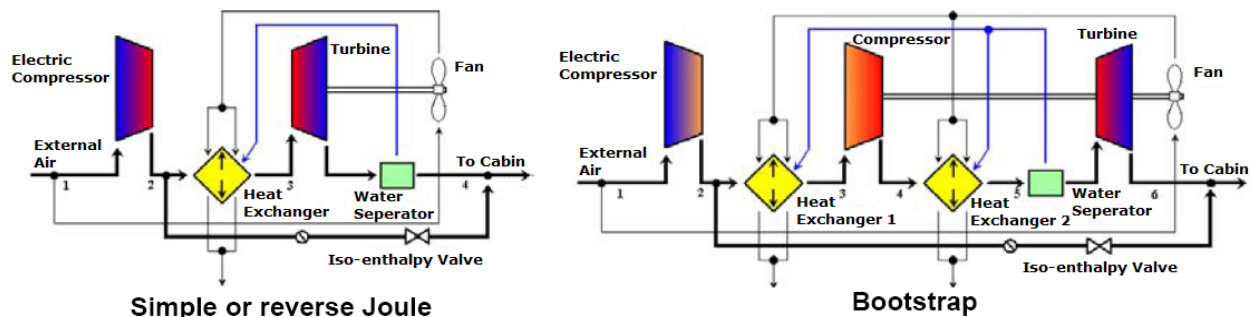

Simple	Bootstrap	
1→2	1→2	Isentropic compression in the engine (bleed air) or APU (electrically driven)
2→3	2→3	Isobaric cooling in a heat exchanger, that uses the external air as a coolant
N/A	3→4	Second isentropic compression in a specific compressor
N/A	4→5	Second isobaric cooling in a heat exchanger using external air as coolant
3→4	5→6	Isentropic expansion through a turbine

Figure 3. Schematic representation of the simple cycle and the bootstrap cycle<sup>3</sup>.

From the first station to the last we see that ambient air is sucked into one or more scoops, after which it passes through the first compressor. Then the pressurized, hot air is cooled down in the first heat exchanger. In the case of a bootstrap cycle, this process is repeated, such that a lower peak pressure is required to bring the airflow to the required state, making this process more efficient. Subsequently, the air is expanded in a turbine in both cycles to the required cabin pressure, while doing useful work.

In order to control the output temperature, a bypass channel is incorporated. The compressed air going through this channel is expanded through a pressure-reducing valve, such that the temperature of this flow remains high. By regulating this hot airflow and mixing it with the much cooler flow going through the complete cycle, the output flow temperature can be controlled.

Using the one dimensional approach, looking at these components as black boxes, allows us to calculate the state of the flow at the input and output sides of each component within the process by applying the thermodynamic relations, as defined in Ref. 3. To make a simulation possible, the general thermodynamic relations for the air cycles have been rewritten for the various ECS configurations, such that a required output can directly be translated into the required operating cycle, cooling requirements, ram air flow and system power consumption.

#### D. Estimation of the Mass of the Various ECS Configurations

In order to estimate the mass of the various ECS configurations, the ECS is split up in three main components: The air cycle machine (ACM), the heat exchangers and the electric load compressor (ELC). Furthermore, the electrically driven compressor is divided into four components: the cabin air compressor (CAC), the electric motor, the power electronics and fan. The weight of the electric motor can be estimated as soon as it is determined, which type of electric motor will be utilized.

Therefore a trade-off was executed using data from Ref. 8, from which it appeared that the most suitable electric motor is the permanent magnet synchronous motor with distributed windings. It has a high power density, a high efficiency and a high dynamic performance. Furthermore, they are relatively easy to control and reliable. In order to estimate its weight, a number of existing motors with varying power and weight have been plotted in Fig. 4<sup>8, 10, 11, 13</sup>. From this figure it appears that the weight of high speed permanent magnet electric motors depends linearly on the required power output, allowing us to determine the specific weight of the electric motor.

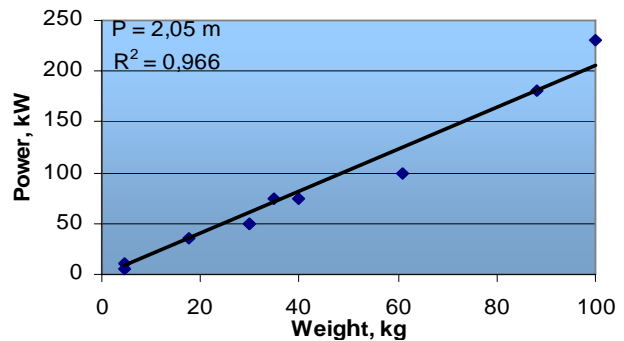

Figure 4. Weight of high speed permanent magnet motors.

The weight of the power electronics can be estimated in a similar way. From Ref. 10 appears that the current specific weight of this component is about 2 kW/kg. However, it is expected that this will rapidly increase to 4 kW/kg during the coming years. Therefore the latter is applied for the Green Freighter's ELC.

The weight of the cabin air compressor (CAC) and the cooling fan have been estimated using size and weights data of existing APUs. In order to scale appropriately it was assumed that the volume of the load compressor is directly proportional to the size of the impeller's inlet radius, which can be estimated using axial flow limits with respect to area and the critical Mach number. Furthermore, for thin-walled structures, the thickness of the walls does not change with the volume, so the mass of the load compressor should be proportional to the area. This assumption has been verified by scaling the reference load compressor to the size of a cabin air compressor of the B787, for which data was also available. It appeared to be within 5% accurate. Then the weight of the ELC can be determined.

The air cycle machine (ACM) consists of the second compressor and the turbine and is used only in the case of a bootstrap cycle ECS. The ACMs weight should be comparable to existing ACMs as the operating principle and pressure ratio range can be expected to coincide. Therefore, the ACM weight has been evaluated for various

commercial passenger aircraft. These aircraft all have one ACM per ECS pack, so that in total, two ACMs provide the total air flow. Interestingly each ACM weighs about 25 kg. The Green Freighter’s ACM is also a pneumatically operated system, meaning its turbine powers the compressor. Furthermore, its operating regime and the mass flows only change marginally, in both the case of a conventional ECS as well as in the case of a TCS. Therefore, the weight of the Green Freighter’s ACM has been assumed to be about 25 kg as well.

The performance of the heat exchangers is proportional to the temperature increase of the coolant ram air and the ram air mass flow. Therefore, the specific weight can be determined for heat exchangers on existing long-range aircraft that are operated in similar flight conditions. In this way it appeared that the specific weight of the heat exchangers varies between 2.2 kW/kg during hot day operation to 3.2 kW/kg during high altitude cruise. Thus, one can determine the mass of the heat exchangers, when the coolant mass flow and temperature differential have been calculated using the more-electric ECS model.

The total system weight is determined by the weight of the electric load compressors and the ECS packs. The latter consists of the ACM and the heat exchangers, as well as many smaller components such as additional valves, control electronics and piping. To take into account the weight of the smaller components, the ELC, ACM and heat exchanger weight is multiplied by a factor of 1.8, which has been empirically established using conventional ECS pack data. Then the total ECS weight is given by the following relations, which concludes the discussion of the ECS model.

$$m_{ECS} = 1.8 \cdot n_{ELCs} \cdot (m_{ELC} + m_{fan}) + 1.8 \cdot n_{packs} \cdot (m_{ACM} + m_{HX}) \quad (1)$$

where:  $n_{packs}$  = The number of environmental control packs aboard the aircraft  
 $n_{ELCs}$  = The number of electric load compressors aboard the aircraft

## V. Design of the Various Environmental control System Options

Using the method described above, it becomes possible to design and analyze the various Green Freighter environmental control options. In this chapter the results of the analysis of the various cabin environmental control options will be discussed.

Before continuing to analyze these systems, it should be noted that the flight cycle and the worst case heat flows must be established, such that each system will be analyzed on the same basis. In this sense an 8 block hour flight standard flight cycle has been assumed in accordance with the Green Freighter TLARs. Subsequently, the cabin heat flux model allows us to calculate the required heat flow into the cabin to keep the cabin within the desired temperature range of 7 °C – 30 °C during flight, or bring it within the temperature range of 7 °C – 30 °C within half an hour during ground operations. This is done for the six operating cases shown below in Table 2.

**Table 2. ECS design scenario inputs: ISA and worst-case (Ground operation with closed doors).**

	ISA Cruise	ISA Ground	In-flight heating	In-flight cooling	Ground heating	Ground cooling
Altitude (m)	10000	0	11000	0	0	0
Ambient Temp. $T_\infty$ (K)	228.15	293.15	213.15	323.15	241.15	319.15
Mach (-)	0.84	0	0.8	0.36	0	0
Solar radiation (W/m <sup>2</sup> )	-	342	0	-	0	1136
Wind speed (m/s)	-	6	-	-	15	0
Systems heat (kW)	10	10	8	12	8	12

With these input conditions the heat flux can be determined for the various ECS’s, giving us the required output heat flow of the environmental control system variants. Subsequently the ECS model can be applied to determine the characteristics of the various systems. This is done for each variant in the following paragraphs, while making the following trade-offs:

- Bootstrap cycle versus Simple cycle
- Electric heaters versus No electric heaters
- 2 ELCs versus 4 ELCs
- Cabin insulation versus No cabin insulation

The more-electric ECS and TCS can be operated on the basis of a simple and a bootstrap cycle. Both cycles have thus been evaluated in order to find out which of the two is more efficient. Furthermore, there is the possibility of using electrical heaters to reduce the required pressure ratio of the electric load compressor during worst-case heating. This way the compressor can be designed closer to its normal operating point, making it more efficient and reducing its size. On the other hand, the electric heaters will add to the weight and complexity of the system.

The reliability of the system requires that the system be built with redundancy. Therefore, it is assumed that one load compressor and one environmental control pack (ACM plus heat exchangers) can be allowed to fail, without having an impact on the operation of the whole system. Furthermore, it is assumed that the two ACMs will be aboard the aircraft, similar to conventional aircraft. Thus the choice of the number of electric load compressors remains unanswered. Two possibilities have been looked at. The first option is to use 2 ELCs and the second option is to use 4 ELCs. Thus in total we have eight different more-electric cabin ECS options.

Finally, in the case that the temperature of the cabin is allowed to vary freely, (hence cabin PCS and the container variants), it might be interesting to omit the cabin insulation. However, this will also affect the operating efficiency of these systems so another trade-off is done in this respect.

### A. More-Electric Cabin ECS

The first step in the preliminary design is to look at the power consumption of the system over the complete flight cycle and the worst case conditions. This is shown in Fig. 5 for the bootstrap cycle cabin ECS.

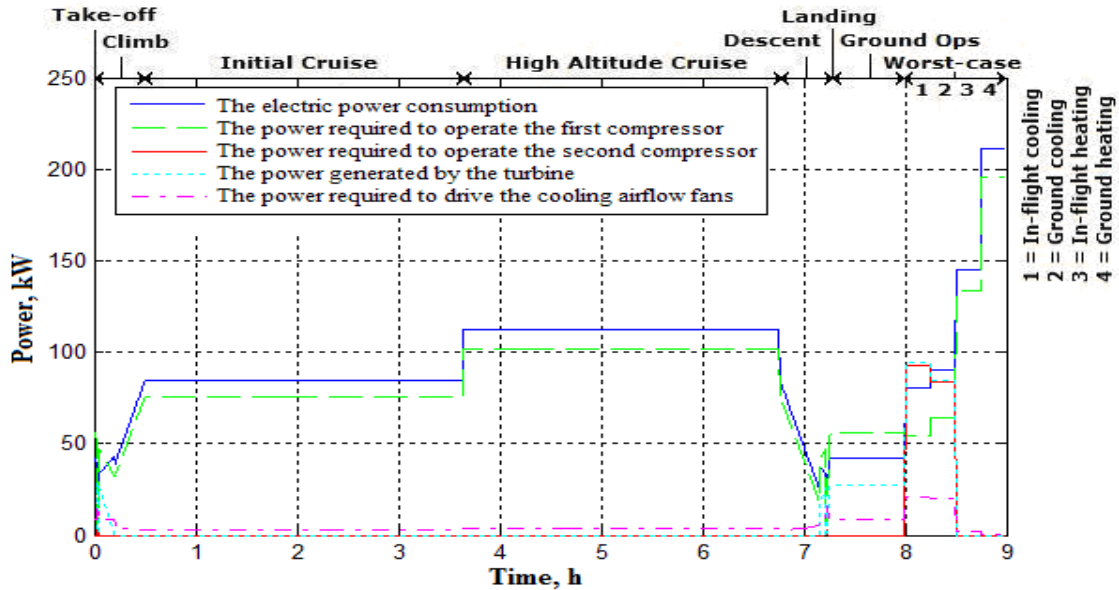

Figure 5. Power consumption of the Bootstrap ECS over the flight cycle and in worst-case conditions.

From the analysis of the more-electric cabin ECS, it appears that the bootstrap cycle is superior to the simple cycle ECS variants. The reason for this is the higher efficiency and lower pressure peaks inside the bootstrap cycle ECS. This leads to a lower system weight, even though the simple cycle has fewer components. Furthermore, it appears that the ECS variants with 4 ELCs allow for a lighter system, due to the fact that the system is less over-dimensioned for the case of a single ELC failure. Finally, it appears that the electric heaters make the more-electric cabin ECS more efficient and lighter, making it superior to the variants without additional electric heaters. The characteristics of the more-electric cabin ECS can be found in Table 3, together with the other optimized ECS variants.

### B. More-Electric Cabin TCS

It was expected that reducing the airflow output pressure to ambient pressure ( $p_\infty$ ) would reduce the required power consumption. However, analysis shows that it instead leads to an increase in power consumption. In short, the reason for this is that the airflow has to be pressurized more profoundly to obtain the required output temperature after expansion through an expansion valve.

To further clarify what physically happens, the process is plotted in an enthalpy-entropy diagram, shown in Fig. 6. In the case of a TCS the air is expanded through an expansion valve. This leads to a further increase of entropy. In the case of a normal ECS, where a certain cabin pressure ( $p_{cabin}$ ) has to be maintained, the air is cooled in the heat

exchangers, leading to a decrease of entropy (note that the total entropy of the conventional ECS does not increase, as the entropy of the cooling flow increases). Three other cases are also shown in Fig. 6. These cases have increasingly high output pressure, increasingly close to the pressure ratio where the pressurized airflow matches the required output temperature. This way the over-pressurization is reduced, leading to a more efficient system.

Using this knowledge it becomes possible to define two possible options for the more-electric TCS. The first is the so-called “free-pressure” TCS, which allows the pressure inside the cabin to vary freely. Further analysis shows that the pressure always remains high enough to transport pressure-sensitive goods, but on the other hand still allows for a reduction in fuselage structural weight. The second is the so-called “ram air heating” TCS. This variant utilizes a second ram air flow, which is heated by the pressurized airflow. Subsequently the heated and unpressurized ram air flow can be used to warm the cabin, while the pressurized airflow can be utilized to generate useful thrust.

Further analysis of these variants showed that the bootstrap variants are more efficient and lighter than the simple cycle variants and that the use of electric heaters does not increase the systems efficiency.

Furthermore, the variants with 4 ELCs appear to outperform the variants with 2 ELCs, similar to the more-electric cabin ECS variants. Finally it is noted that the free pressure TCS and the ram air heating TCS are too different to compare at this point, so both have been analyzed further.

### C. More-Electric Cabin PCS

This system consists of electric load compressors only as the temperature will not be controlled. Therefore no trade-off between different thermodynamic cycles is required. Instead a decision must be made as to whether the cabin will still be thermally insulated or not. This is expected to make a significant difference, as the weight of the insulation could be saved. On the other hand, a somewhat warmer or cooler cabin will lead to a more efficient pressurization system, which will also allow for weight savings. Therefore, both cases have been evaluated.

From the analysis it appears that the more-electric cabin PCS operates less efficiently and becomes somewhat heavier when the cabin is uninsulated. However, the reduced cabin weight more than offsets these disadvantages, making this the preferred solution. (assuming that the more extreme temperatures can be allowed in the aircraft cabin) Furthermore, it appears that the PCS with only 2 ELCs operates more efficiently and is lighter than the variants with 4 ELCs. The reason for this is that the added benefit of reduced over-dimensioning of the ELCs does not make up for the added weight of the additional components.

As the temperature of the cabin has become free, it would be interesting to know what temperatures can be encountered during operation of the Green Freighter with a more-electric cabin PCS. It appears that the cabin temperature is about -10 °C during ISA 10 km altitude cruise and up to 30 °C just after take-off and before landing. Furthermore, the cabin temperature on the ground is somewhat higher than the ambient temperature during day time. However, during worst-case cooling conditions the cabin temperature goes up to 65 °C and during worst-case heating conditions the cabin temperature goes down to -25 °C. These are quite extreme temperatures, which will seriously limit the aircraft’s market potential. In this sense it should be verified whether these temperatures can be permitted aboard a freighter aircraft if this system appears to perform better than the other environmental control system variants.

### D. Design and Analysis of the Green Freighter Container ECS Options

The first step in the design of the three more-electric container ECS options, is to determine whether a central or container mounted ECS is preferable. In this sense it appears from the analysis of the cabin PCS, that there is a certain optimum with respect to the size of electric load compressors. Therefore, it is likely that a number of electric load compressors, small enough to supply a single container only, will never be lighter than a single onboard ECS, which can be connected to the containers. Further advantages of the central container ECS over a container-fitted system would be reduced logistics problems with the special containers and probably reduced maintenance, as containers are frequently handled without care. Finally, an expensive compression system inside a container would

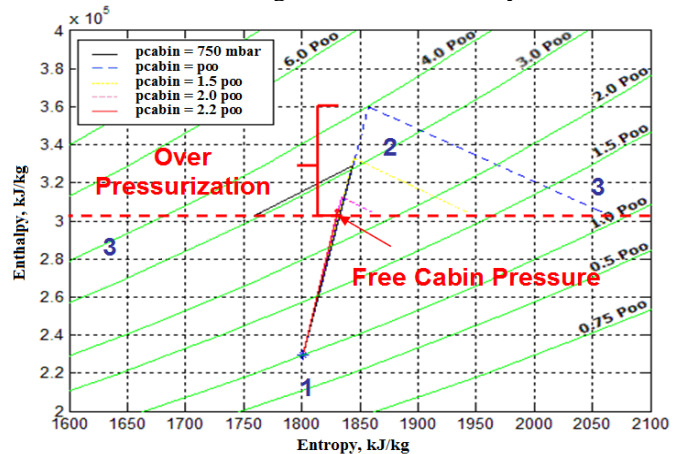

Figure 6. The effect of the TCS output pressure on the TCS cycle illustrated in an Enthalpy-Entropy diagram.

drastically increase the interest losses of containers that are not being used and on top of that they would be vulnerable to theft. Therefore, it has been decided that the onboard container ECS is the only viable option, to be considered here.

To determine the requirements of the system output of the ECS, the number and size of conditioned containers has to be determined. This is necessary because this will set the volume that needs to be heated, as well as the container surface that emits heat to the cabin. In this respect it has been decided that the container size will be similar to standard LD6 containers, such that they can also be flown on other aircraft. Subsequently the maximum number of air conditioned containers has been determined using the assumption that the available transport volume equals the maximum market share of each freight category, as defined in Section III.

With respect to the more electric container ECS it has been decided that only the goods which require a full-fledged ECS will be transported in pressurized containers in order to keep the additional container weight as low as possible. Thus the container ECS is actually a combination of an ECS and a ram air heating TCS. Using these assumptions, the number of pressurized containers can be determined to be 6 LD6 containers, and the number of insulated containers is equal to 30 LD6 containers.

For the more-electric cabin TCS, two options exist for the container TCS: the free pressure TCS and the ram air heating TCS. However, the amount of containers to transport the freight requiring a temperature controlled environment is 33 LD6 containers, i.e. more than half the aircraft's total capacity. Thus, it is expected that even if the weight increase per container is moderate, the total weight increase cannot be justified by the free pressure container TCS. Thus, only the ram air heating container TCS has been analyzed here.

For the more-electric container PCS 10% of the onboard containers need to be pressurized, which equals 6 LD6 containers. However, when there is no heating onboard the Green freighter, 40% of the goods cannot be transported. As a consequence, 16.7% of the total amount of goods transported onboard the Green Freighter will require pressurized containers, so instead 10 pressurized LD6-sized containers are required.

The operating cycle of the container ECS variants is exactly the same as the cabin versions, but with a significantly reduced mass flow. Therefore, it was quickly found that also here the bootstrap cycle was more efficient and lighter than the simple cycle for the container ECS and TCS. Furthermore, both variants (with and without electric heaters) have been considered, and again it appeared to be beneficial for the ECS, but not for the TCS. Finally, the most optimal number of ELCs for all the container ECS variants appeared to be two.

Also a trade-off between an insulated and an uninsulated cabin has been made, as it is unclear if the increased efficiency of the container ECS and TCS, due to a more temperate cabin atmosphere, justifies the additional weight of the cabin insulation. However following the analyses, the differences in power consumption, weight and ram air flow between the insulated and uninsulated cabin scenarios were inconclusive for the container ECS and TCS and did not allow for an immediate trade-off. Therefore, both options have been evaluated further. For the PCS it was again found that an uninsulated cabin is the preferred choice.

## E. Summary of the Characteristics of the Various ECS Configurations

The results of the design of the various ECS configurations have been summarized in Table 3 to give an impression of their size and power consumption, as well as the required average ram air flow and expected thrust.

**Table 3. Summary of weight and power consumption of the various ECS configurations.**

	Average Power	Max Power**	Weight	Ram Air Flow	Thrust	Insulation Weight
Cabin ECS	87.45 kW	4x 62 kW	687 kg	4.23 m <sup>3</sup> /s		-
Cabin TCS (Free Pressure)	55.52 kW	4x 42.0 kW	574 kg	3.16 m <sup>3</sup> /s		-
Cabin TCS (Ram Air Heating)	55.52 kW	4x 42.0 kW	574 kg	6.04m <sup>3</sup> /s	110 N	-
Cabin PCS	14.79 kW	2x 42 kW	119 kg	0.54 m <sup>3</sup> /s		-90 kg
Container ECS - Cabin Ins.	33.5 kW	2x 61 kW	286 kg	2.37 m <sup>3</sup> /s	46 N	-
Container ECS - No Cabin Ins.	40.2 kW	2x 82 kW	328 kg	2.84 m <sup>3</sup> /s	40 N	-90 kg
Container TCS - Cabin Ins.	21.3 kW	2x 46 kW	239 kg	2.37 m <sup>3</sup> /s	46 N	-
Container TCS - No Cabin Ins.	25.5 kW	2x 56 kW	290 kg	2.84 m <sup>3</sup> /s	40 N	-90 kg
Container PCS	0.59 kW	2x 1.5 kW	26.6 kg	0.02 m <sup>3</sup> /s		-90 kg

\*\* Electric heater power consumption included

## VI. Snowball Effects

Now that the cabin and container environmental control systems have been designed, the snowball effects have to be analyzed. This will be quite important in the final trade-off, as various system configurations promise significant weight reductions with respect to the power generation and distribution system, as well as for the fuselage and container structure. These snowball effects will be looked at briefly in the following paragraphs.

### A. Weight Reduction of the Fuselage Structure

Using the pressure vessel relations in combination with the minimal fuselage skin thickness allows us to make a first estimate of the fuselage wall thickness reduction, due to a lower cabin pressure with respect to the reference aircraft, the B777F. Obviously, the fuselage thickness cannot be reduced indefinitely, as other requirements become dominant. Therefore it has been assumed that the minimal wall thickness cannot be thinner than 1 mm, in combination with aluminum tensile buckling prevention. Then, applying an aluminum fatigue strength of 90 MPa, the average skin thickness reduction has been calculated. The results hereof are shown in Table 4.

**Table 4. Weight estimation of the (Un)pressurized cabin structure.**

	Pressure Vessel	Min. Skin Thickness	Weight Reduction
Conventional Pressurized Cabin	1.16 mm	1.80 mm	0 kg
Freely Pressurized Cabin	0.91 mm	1.39 mm	1150 kg
Unpressurized cabin	0.26 mm	1.00 mm	2243 kg

### B. Weight of the Pressurized Containers

The most important consideration in the design of pressure vessels is their shape. A good option is the cylindrical body, as bending stresses are largely prevented. However, cylindrical tanks significantly reduce the useful space per container. Therefore, it would be interesting if we could use rectangular pressurized containers, because the amount of dead space would be minimized. Unfortunately, the container wall thickness will be an order of magnitude thicker, due to the bending moments, which determine the wall thickness for a rectangular pressurized container. This difference is schematically shown in Fig. 7.

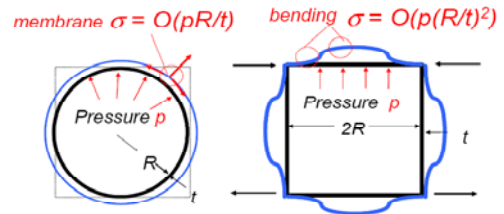
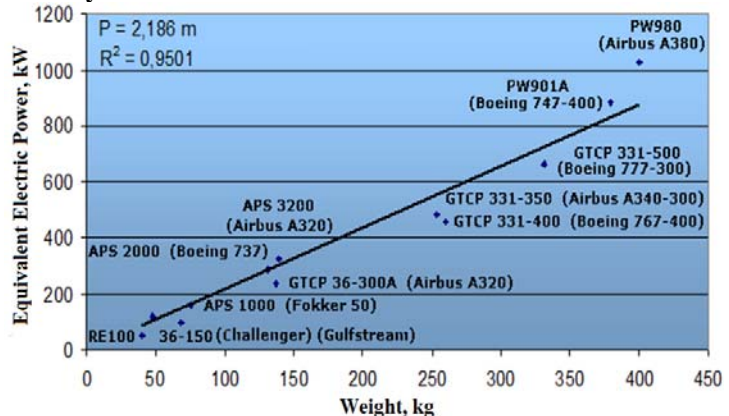

**Figure 7. Cylindrical and Non-Cylindrical Pressure Vessels<sup>9</sup>.**

As the pressure differential between the container and the cabin does not exceed 500 mbar, both a cylindrical vessel inside an LD6 container and a rectangular LD6-sized container have been designed. This led to a trade-off based on weight and useful volume, which showed that the rectangular container with stiffened walls is the preferred solution. This container weighs about 400 kg, more than twice the weight of a conventional LD6 container and roughly 15% of the useful volume is lost, due to the space required for the stiffeners and insulation.

### C. Weight of the Power Generation and Distribution System

The mass increase of the more-electric power generation and distribution system can largely be determined by determining the weight increase of the starter-generators, the power electronics and the APU to facilitate the increase in power consumption of the ECS variants. From analysis, it appears that all these subsystems can be scaled linearly with respect to existing systems, by determining their specific weight. This appears to be roughly 2 kW/kg for the starter/generators, 4 kW/kg for the power electronics and 2 kW/kg for the APU, as shown in Fig. 8. Thus, utilizing the calculated power consumption of the various ECS configurations we can determine the weight of these components.



**Figure 8. Equivalent electric power generation vs. APU weight<sup>6, 18</sup>.**

## VII. The Direct Operating Costs on System Level

Next an estimation of the direct operating costs at the system level is pursued. To this end the fuel, maintenance and ownership costs have been analyzed for the various ECS configurations, including their snowball effects. To do this accurately the DOCsys method<sup>7</sup> has been used, which is based on the Breguet range equation and takes into account the different flight phases. In this sense it is imperative to accurately define the trip distance and number of trips per year. In accordance with the analyses conducted in the previous chapters, we have taken an 8 block hour (BH) trip time as the standard trip. This means that the distance flown can be estimated to be roughly 6800 km. Furthermore, it has been assumed that the Green Freighter will make about 570 trips per year. Finally the 2007 average kerosene price of \$85.3/barrel<sup>††</sup> has been assumed.

From the first DOC trade-off, it appears that the combined ECS variants are significantly more expensive than the other variants. Therefore these options are discarded. Furthermore, it appears that the container ECS and TCS operate more economically when the cabin is insulated. For the other options no further trade-off could be made, because the market potential of the various ECS configurations is not equal.

Therefore, one needs to find a way to incorporate the effect of the reduced flexibility of the various ECS configurations. The most straightforward way to proceed is to reduce the load factors of the various Green Freighter configurations according to their market potential, as defined in Section III. However, this would not take into account any possible strategy changes of the operators, who will of course seek to obtain the highest possible load factor. Therefore, it has been chosen to multiply the reduction in market potential by a compensation factor, which has been designated the strategy compensation factor. In this sense the reduced load factor varies between 0 and 100% of the minimum defined reduction of the market potential. This allows for the determination of the bandwidths in which a certain ECS variant performs best. In Fig. 9 the DOC including the reduced load factor penalty (shown in the figure as percentages above the bars) and 95% strategy compensation has been shown for the remaining variants, for the revenue per available tonne-kilometer (RATK) of FedEx, Emirates (EK), British Airways (BA) and UPS, which is \$0.57 on average.

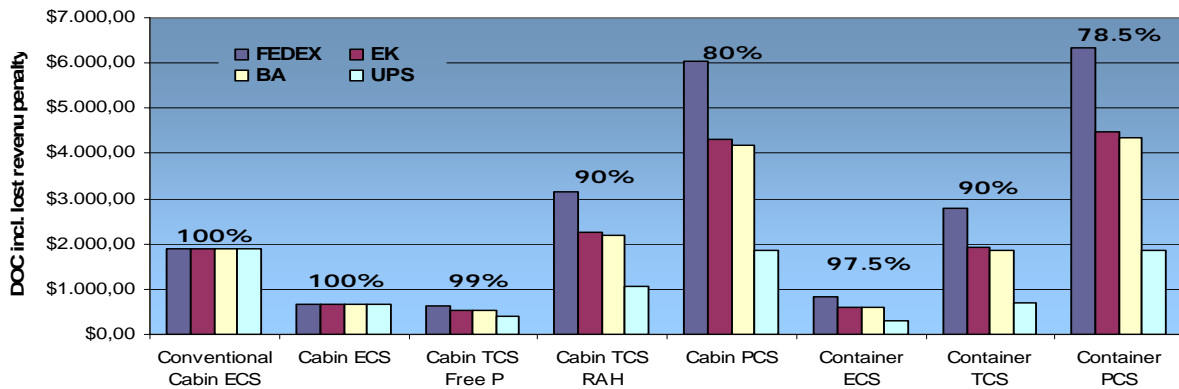

**Figure 9. DOC of the GF configurations for a 8h trip, incl. a revenue penalty according to each configuration's market potential and transport volume reductions, which in turn is compensated by 95% due to operator strategy.**

From Fig. 9, it seems that the RATK and load factor have a very big effect on the economic performance of the more exotic Green Freighter configurations. A small reduction of the load factor quickly leads to large revenue losses, which are counterproductive to the reduced operating costs.

Figure 9 also shows that if the operators succeed in applying an operations strategy that compensates up to 95% of the market potential reductions, the free pressure cabin TCS performs best. The question now however is how it performs in other scenarios; and if another Green Freighter configuration becomes superior. To answer this question the operator strategy compensation is varied. It appears that the free pressure TCS remains the preferred solution in the range of 91% to 98.5% load factor compensation due to operator strategy.

If the operators do not succeed in making an operation strategy that compensates more than 90% of the reduced market potential, the more-electric cabin ECS becomes the preferred solution. The reason for this is that in this case also animals can be transported, such that the operators can operate their aircraft with 100% market potential. Therefore, this option will remain the preferred solution over the complete range under 90% reduced market potential compensation. On the other hand, if the operator succeeds in operating the aircraft with a strategy that allows for more than 99% load factor compensation, the container TCS becomes the preferred solution.

<sup>††</sup> Source: [http://www.iata.org/whatwedo/economics/fuel\\_monitor/index.htm](http://www.iata.org/whatwedo/economics/fuel_monitor/index.htm)

In this sense it becomes possible to discard the solutions that do not become the preferred solution no matter what load factor compensation is reached. It is noted that an exception is made for the Green Freighter configuration with a container ECS, because this system's performance lies very close to the performance of the free pressure cabin TCS. Furthermore, it would become the preferred solution if no cabin pressure is allowed, such as decided for the Green Freighter BWB configuration. In this case the container ECS will become the superior choice over the entire strategy compensation range. Thus at this point the ram air heating TCS and both the cabin and container PCS can be discarded as optimal solutions for the Green Freighter.

### VIII. Economic Performance of the Green Freighter

Finally the DOC is estimated at the aircraft level, for each of the four remaining configurations. Here also the reduced costs are taken into account, due to the omitted systems, such as defined in Section II and due to zero-pilot operation, which leads to a reduction of 46% of the crew costs according to Ref.15 . Again the market potential and strategy compensation need to be taken into account, so it has been decided to look at the generated cash flow and profitability. Here we apply the average RATK of \$0.57. Furthermore, the price of the B777F is known to be approximately M\$236.25. Thus the initial investment can be calculated for the various configurations by subtracting the cost of the removed or modified systems from the B777F price. Finally, the indirect operating costs are estimated to account for 50% of the total operating costs of the reference aircraft<sup>4</sup>.

As the purchase of an aircraft is a long term investment, inflation and capital cost are taken into account. First, it appears that 3% inflation is typical in Europe. Second, with regard to the capital cost, it appears that aircraft investment interest, or discount rates are typically 12% to 20%<sup>16</sup>. The discount rate usually reflects the risk associated with an investment, so possibly the Green Freighter discount rate will be higher than for a conventional aircraft. However, the average is taken as a first estimate, so that the discount rate is 16%. Then the cumulative cash flow can be plotted for a chosen operator compensation strategy. Furthermore, the return on investment (ROI) is shown in Table 5 for 95%, 50% and 5% strategy compensation to give an impression of the economic behavior of the ECS configurations with respect to the operating strategy.

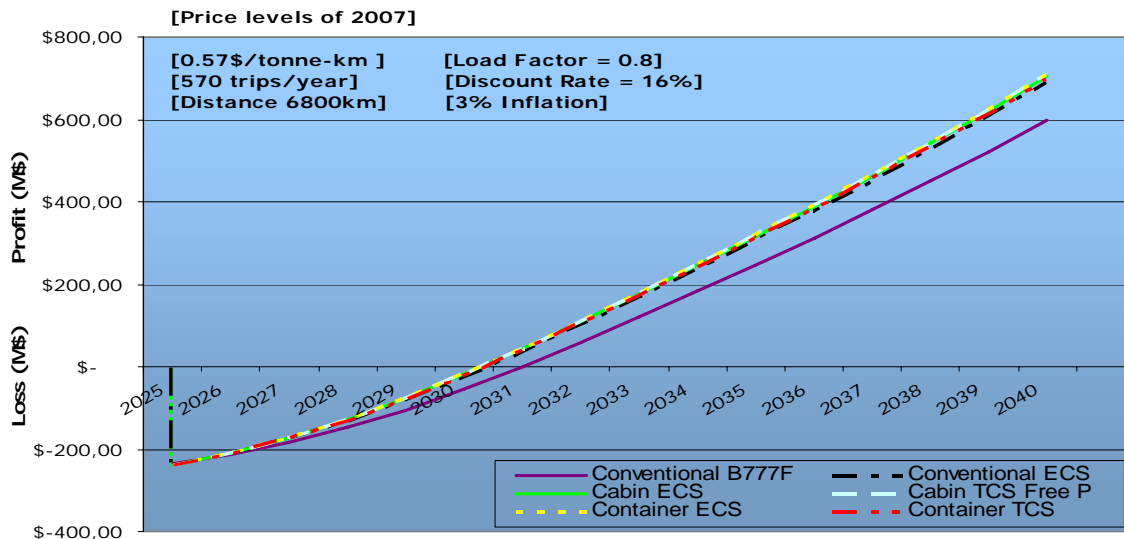

Figure 10. Cumulative cash flow of GF configurations w.r.t. the B777F incl. risk-coupled capital cost and an operator compensation strategy, compensating for 50% of the reduced market potential.

Table 5. Mean Annual ROI over the 15 year depreciation life (16% discount rate and 3% inflation).

	B777F	Bleed Air ECS	Cabin ECS	Cabin TCS	Container ECS	Container TCS
95% strategy compensation	17.92%	19.89%	20.18%	20.28%	20.27%	20.01%
50% strategy compensation	17.92%	19.89%	20.18%	19.88%	19.26%	15.97%
5% strategy compensation	17.92%	19.89%	20.18%	19.48%	18.25%	11.93%

From Fig. 10 and Table 5, it appears that the Green Freighter performs better than the conventional B777F and that the operator's strategy is decisive for which system performs optimally. Without reducing the flexibility of the freighter, the more-electric cabin ECS allows operators of the Green Freighter to increase their ROI by 2.26%, which is the equivalent of more than \$5 million per year. Furthermore, it is interesting to note that the application of the more-electric dedicated freighter ECS allows for a cost saving roughly \$650,000 per aircraft per year with respect to a conventional bleed air ECS.

Choosing the free pressure cabin TCS, allows for a further increase of the operator's ROI to 20.28%, which means a profit increase of roughly \$800,000, with respect to a Green Freighter with a conventional bleed air ECS. On the other hand, if the operators strategy can only compensate for 50% of the reduced market potential, this means a ROI decrease of 0.40%. Therefore, it is recommended that this decision be made in consultation with the operators and their view on how their strategy might compensate the reduced market potential.

## IX. Conclusion

The new Green Freighter systems architecture allows operators to reduce operating costs by more than \$5 million per year per aircraft, without losing operational flexibility. This can be achieved by omitting many passenger and pilot-related systems, using a more-electric freight dedicated cabin ECS and operating the Green Freighter without pilots. Furthermore, should operators succeed in adapting their strategy to operation with the new free pressure cabin temperature control system (TCS), freight operators could further reduce their operating costs by \$150,000 per aircraft per year.

Finally, it appears that a container ECS would be the preferred solution for the blended-wing-body design of the Green Freighter, because in this way the non-cylindrical fuselage of this aircraft configuration can be designed significantly lighter. It is estimated that this system operates only slightly less economic as the cabin TCS, over the entire range of load factors.

It can therefore be concluded that a Green Freighter, with the proposed systems architecture can significantly increase the competitiveness of freight operators and the newly developed more-electric cabin ECS, dedicated to freight, could be used on today's aircraft, allowing for cost savings up to \$650,000 per aircraft per year!

## References

### Books

- <sup>1</sup> Committee on Air Quality in Passenger Cabins of Commercial Aircraft, *The Airliner Cabin Environment and the Health of Passengers and Crew*, ISBN: 0-309-08289-7, National Academy Press, Washington D.C., USA, 2002, Chap 2
- <sup>2</sup> Mark Davies, *The Standard Handbook for Aeronautical and Astronautical Engineers*, McGraw-Hill, New York, USA, 2003
- <sup>3</sup> Paolo Astori, *Aircraft systems, version 2003*, TU Delft press, Delft, The Netherlands, 2004, Chap. 9
- <sup>4</sup> Rigas Doganis, *Flying Off Course -The economics of international airlines (3<sup>rd</sup> Edition)*, Routledge, London, England, 2002
- <sup>5</sup> SAE, *Aerothermodynamic Systems Engineering and Design*, SAE AIR1168/3, Warrendale, USA, 1990, p28-p30

### Periodicals

- <sup>6</sup> Guy Norris: *Dawn of the Auxiliary*, Flight International, Los Angeles, USA, December 1998

### Proceedings

- <sup>7</sup> D. Schmitt, (Ed.), *Bewertung von Flugzeugen*, (Workshop: DGLR Fachausschuß S2 - Luftfahrtsysteme, München, October 1998), Deutsche Gesellschaft für Luft- und Raumfahrt, Bonn, Germany, 1998. – <http://Paper.ProfScholz.de>
- <sup>8</sup> Jon Clare, et al, *Electrical Motor Drives for More Electric Aircraft*, TEOS Forum, Paris, France, June 2006
- <sup>9</sup> Matthias Witschke, Gerhard Schmitz, Thomas Scherer, *Effects on Increased Humidity in Airplane Cabins on Airplane Insulation*, AIAA Conference, Reno, USA., January 1999
- <sup>10</sup> Max Binet et al, *Electrical Power Source and Aircraft Power Networks*, TEOS Forum, Paris, France, June 2006
- <sup>11</sup> Mike Hirst et al, *The More Electrical Engine*, TEOS Forum, Paris, France, June 2006
- <sup>12</sup> Ronald Slingerland, Sijmen Zandstra, *Bleed Air versus Electric Power Off-takes from a Turbofan Gas Turbine over the Flight Cycle*, AIAA Conference, Belfast, USA, September 2007
- <sup>13</sup> Wilfried Lehle et al, *Environmental Control System and Wing Ice Protection*, TEOS Forum, Paris, France, June 2006

### Software

- <sup>14</sup> MatLab, *Matrix Laboratory*, Software Package, Version 7, The Mathworks Inc., May 2004

### Reports, Theses, and Individual Papers

- <sup>15</sup> David Fellechner, *Potential und Realisierbarkeit eines unbemannten Frachtflugzeugsystems*, Hochschule Bremen, Hamburg, Germany, September 2006
- <sup>16</sup> Karen Willcox, (MIT): *Aircraft Systems Engineering – Cost Analysis*, <http://dspace.mit.edu>, Boston, USA, September 2004

<sup>17</sup> Nathan J. Winograd, *Animals as airline cargo*, SPCA, San Francisco, USA, November 1998, p21

<sup>18</sup> Sijmen Zandstra, *The "More-Electric" Aircraft*, Aeronamic, Almelo, Holland, January 2007