

THE IMPACT OF SUSTAINABILITY IN DEVELOPERS' DECISION-MAKING PROCESS

A comparative study of urban
sustainability assessment systems

/ Table of contents



- 01 Introduction
- 02 Research Methodology
- 03 Literature Review
- 04 Empirical Review
- 05 Findings & Recommendations
- 06 Research Conclusions
- Discussion & Questions

01/ Introduction



1.1 Introduction

Sustainable Urban Redevelopment

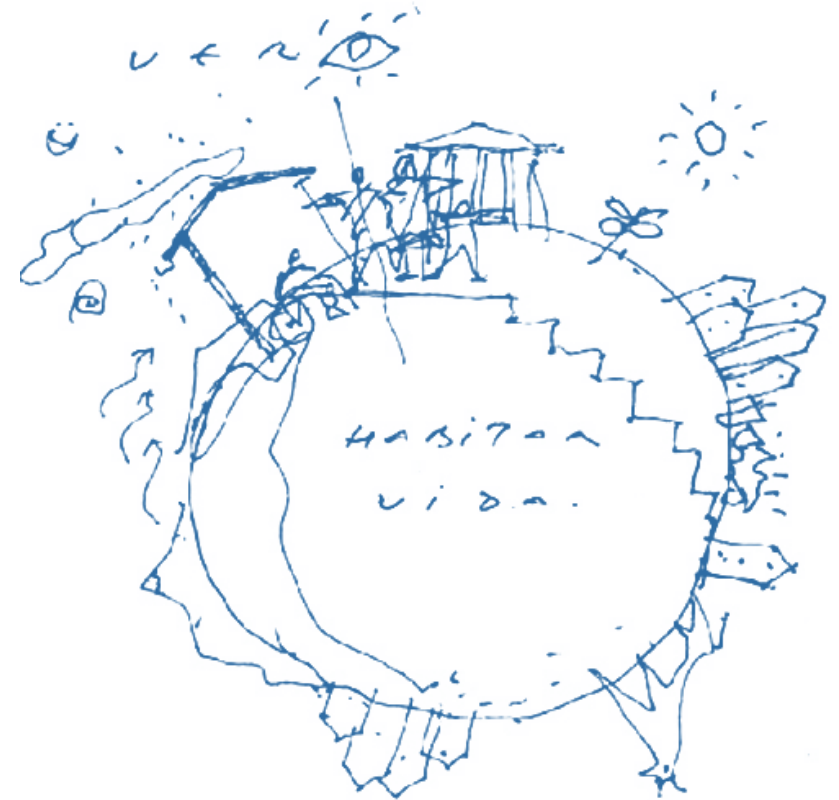

1.1 Introduction

Sustainable Urban Redevelopment

- Towards Sustainable Urban Policies
- Changing Role of Private Actors
- Value of Urban Sustainability
- Existing Assessment Tools

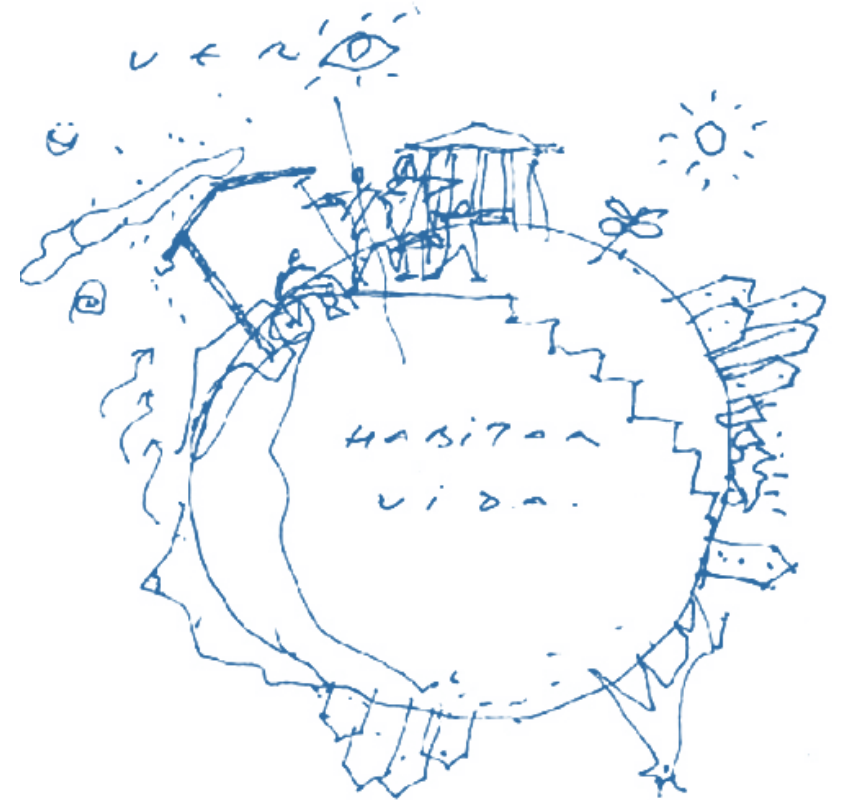

1.2 Problem Statement



As an object of study, urban redevelopment projects have been one of the main targets of policy and finance in the last couple years. That highlights the challenges of integrating and balancing sustainability targets alongside financial viability

1.2 Problem Statement



As an object of study, urban redevelopment projects have been one of the main targets of policy and finance in the last couple years. That highlights the challenges of integrating and balancing sustainability targets alongside financial viability

MRQ

How can sustainability be enhanced from a private sector perspective in urban redevelopment projects when implementing USASs ?

Developers

Market-Driven
Sustainability
Assessment Systems

Sustainable Urban
Redevelopment
Project

1.3 Research Goals



- To provide learnings based on the **motivations, implementation and added value** behind the use of USASs, for a potential improvement of BREEAM-NL Area and the practices related to it in the Dutch context
- To provide an overview of how **market-driven assessment systems** for urban sustainability can **influence the decision-making** process of developers

02/ Research Methodology

2.1 Research Questions



MRQ

How can sustainability be enhanced from a private sector perspective in urban redevelopment projects when implementing USASs ?

MRQ

Figure. 1
Research Questions Diagram. P17

2.1 Research Questions



MRQ

MRQ

How can sustainability be enhanced from a private sector perspective in urban redevelopment projects when implementing USASs ?

BiQ1

How do developers assess sustainability through USASs?

BiQ2

How developers' sustainable ambitions are embedded in their decision-making process?

Figure. 1
Research Questions Diagram. P17

2.1 Research Questions

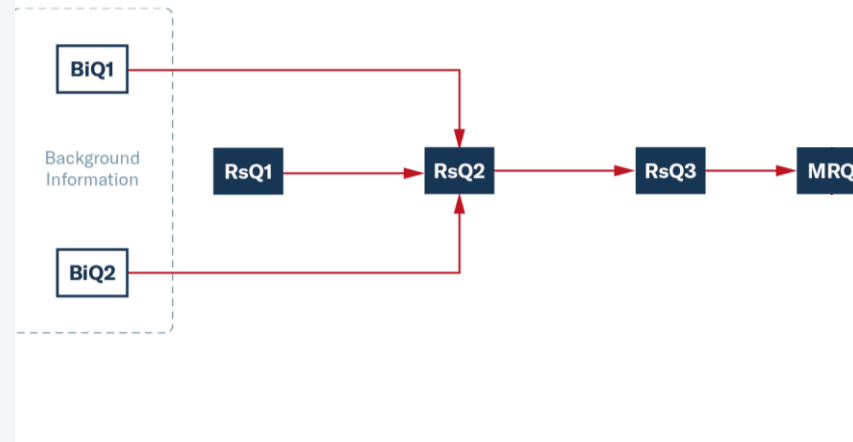

- MRQ** How can sustainability be enhanced from a private sector perspective in urban redevelopment projects when implementing USASs ?
- BiQ1** How do developers assess sustainability through USASs?
- BiQ2** How developers' sustainable ambitions are embedded in their decision-making process?
- RsQ1** Why do developers decide to implement USASs?
- RsQ2** How developers decision-making can be influenced by the implementation of USASs?
- RsQ3** To what extent the developers' implementation of USASs leads to a more sustainable urban redevelopment project?

Figure. 1
Research Questions Diagram. P17

2.2 Research Design Overview

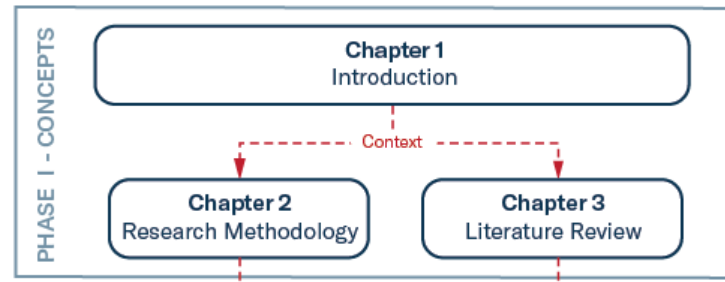

Figure. 2
Research Design. P20

2.2 Research Design Overview

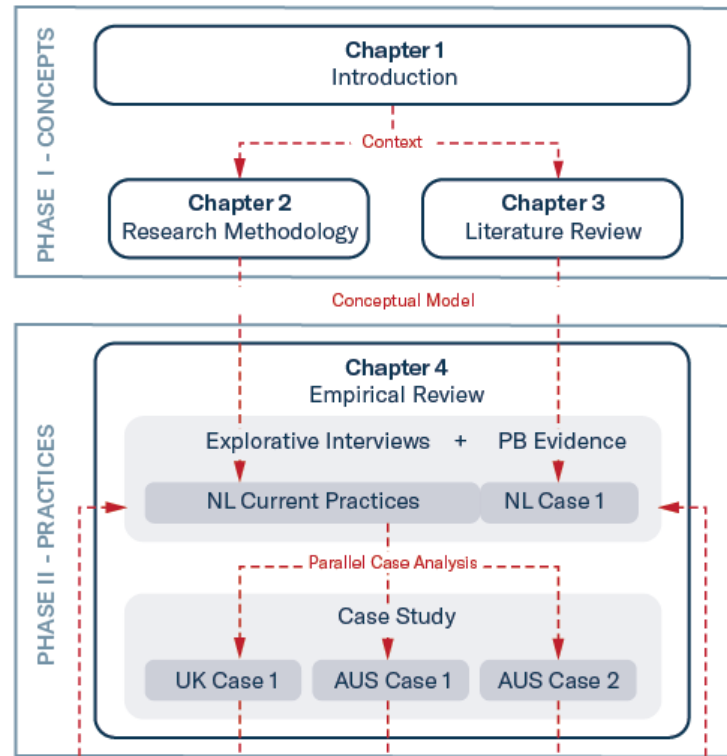

Figure. 2
Research Design. P20

2.2 Research Design Overview

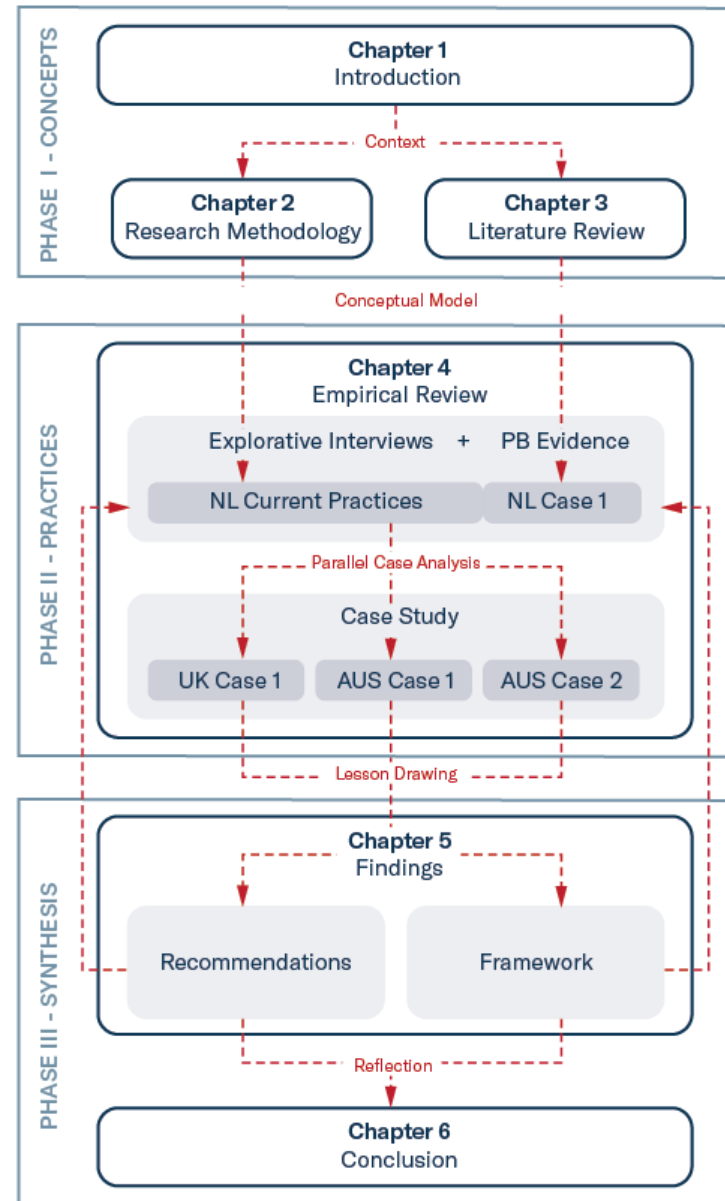

Figure. 2
Research Design. P20

03/ Literature Review

3.1

Concept Operationalization



- **Sustainability Assessment Systems**
 - The existing USASs
 - The BREEAM-NL Area framework
 - The scope of the assessment
 - The actors involved
 - The assessment process
- **Developers' Decision-Making**
 - The developers' drivers
 - The decision-making process
 - The organisational alignment in decision making
 - The role of USASs from a management perspective
 - The use BREEAM-NL Area as strategic planning
- **Implementation of USASs in Sustainable Urban Redevelopment Projects**
 - The drivers for implementing evaluative practices
 - The barriers for implementing USASs
 - The advantages of implementing USASs

3.2 Conceptual Model

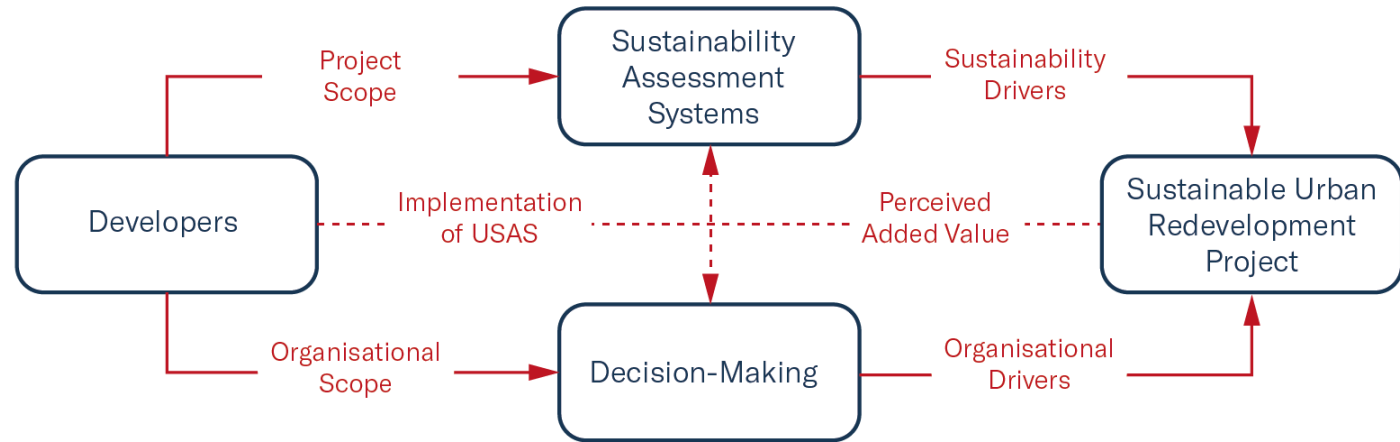

Figure. 3
Conceptual Model. P23

04/ Empirical Review



4.1

The Dutch Base Case



Dutch
Current
Practices



Wisselspoor
Redevelopment
(NL Case 1)



Wisselspoor Redevelopment. Synchroon + Gemeente Utrecht

4.2 International Case Study Analysis



Aylesbury Estate
Redevelopment
(UK Case 1)



Aylesbury Estate Redevelopment. Notting Hill Genesis + Southwark Council

Brisbane Showgrounds
Redevelopment
(AUS Case 1)



Brisbane Showgrounds Redevelopment. Lendlease + RNA

Waterloo Metro Quarter
Redevelopment
(AUS Case 2)



Waterloo Metro Quarter Redevelopment. John Holland + Mirvac + Sydney Metro

05/ Findings and Recommendations



5.1 Parallel Case Study Analysis

Sustainability
Assessment
System
Implementation

- **RsQ1: Why do developers decide to implement USASs?**

Assessment Scope

- Means to achieve long-term goals in masterplan
- High emphasis on framework utility for urban scale principles
 - Water usage, Land usage, Biodiversity, Ecology



5.1

Parallel Case Study Analysis

Sustainability
Assessment
System
Implementation



- **RsQ1: Why do developers decide to implement USASs?**

Assessment Scope

- Means to achieve long-term goals in masterplan
- High emphasis on framework utility for urban scale principles
 - Water usage, Land usage, Biodiversity, Ecology

Assessment Drivers

- Highly driven by active external demand
 - Implementation driven by a growing tendency to involve USASs as sustainable development criteria (local authorities or clients)
 - Implementation driven by the willingness to attract investors for funding and tenants for premiums
- High intrinsic motivation
 - Alignment between assessment scope and corporate strategy
 - Voluntary USAS implementation as means to achieve their organisational goals (reputation, long-term vision & competitiveness)

5.1

Parallel Case Study Analysis

Sustainability
Assessment
System
Implementation



- **RsQ1: Why do developers decide to implement USASs?**

Assessment Scope

- Means to achieve long-term goals in masterplan
- High emphasis on framework utility for urban scale principles
 - Water usage, Land usage, Biodiversity, Ecology

Assessment Drivers

- Highly driven by active external demand
 - Implementation driven by a growing tendency to involve USASs as sustainable development criteria (local authorities or clients)
 - Implementation driven by the willingness to attract investors for funding and tenants for premiums
- High intrinsic motivation
 - Alignment between assessment scope and corporate strategy
 - Voluntary USAS implementation as means to achieve their organisational goals (reputation, long-term vision & competitiveness)

Assessment Barriers

- Resource intensive process with moderate implementation cost
- Limited internal knowledge and expertise
- Challenge in terms of coordination, work scope and market knowledge



5.1 Parallel Case Study Analysis

Decision-Making

- **RsQ2:** How developers' decision-making can be influenced by the implementation of USASs?



5.1

Parallel Case Study Analysis

Decision-Making

- **RsQ2:** How developers' decision-making can be influenced by the implementation of USASs?

Organisational Scope

- Reflective Role
 - Positive perception of a limited influence on organisational scope (developers ambitions)
 - Positive influence as a catalyst to raise awareness (developers mindset and industry maturity)





5.1 Parallel Case Study Analysis

Decision-Making

- **RsQ2:** How developers' decision-making can be influenced by the implementation of USASs?

Organisational Scope

- Reflective Role
 - Positive perception of a limited influence on organisational scope (developers ambitions)
 - Positive influence as a catalyst to raise awareness (developers mindset and industry maturity)

Development Process

- Guiding Role
 - High emphasis on the assessment's guiding role based on strategic planning goals and long-term urban development approach
 - High utility as communication enabler for discussion, coordination, and advice

5.1

Parallel Case Study Analysis

Decision-Making

- **RsQ2: How developers' decision-making can be influenced by the implementation of USASs?**

Organisational Scope

- Reflective Role
 - Positive perception of a limited influence on organisational scope (developers ambitions)
 - Positive influence as a catalyst to raise awareness (developers mindset and industry maturity)

Development Process

- Guiding Role
 - High emphasis on the assessment's guiding role based on strategic planning goals and long-term urban development approach
 - High utility as communication enabler for discussion, coordination, and advice

Project Scope

- Evaluative Role
 - Positive influence on project decisions mostly relies on technical knowledge acquisition (adaptability based on multidisciplinary mindset)
 - Potential influence on the project scope and decision weighting is limited by the organisational scope (developers ambitions)





5.1 Parallel Case Study Analysis

Sustainable Urban Redevelopment

- **RsQ3:** To what extent does the developers' implementation of USASs lead to a more sustainable urban redevelopment project?

Perceived Added Value

- Experienced financial benefits vary
- High emphasis on reputational benefits
- High emphasis on competitiveness and marketing benefits
- High emphasis on internal learnings as benefits

Sustainability Driver

- Positive impact of the assessment as sustainability driver (enabler) mostly enhances process and innovation
- Can help overcoming existing barrier (knowledge-technical and organisational)

Organisational Driver

- Implementation acts as a positive incentive for developers to be more sustainable (organisational internal awareness)
- Partial alignment as means to stimulate developers' drivers for sustainable urban development (incentive)
- Implementation of the assessment can lead to strive for more sustainable urban outcomes as part of the value creation strategy (resilience, urban adaptability, community involvement, communal spaces)



5.2 International Case Studies vs. Dutch Base Case

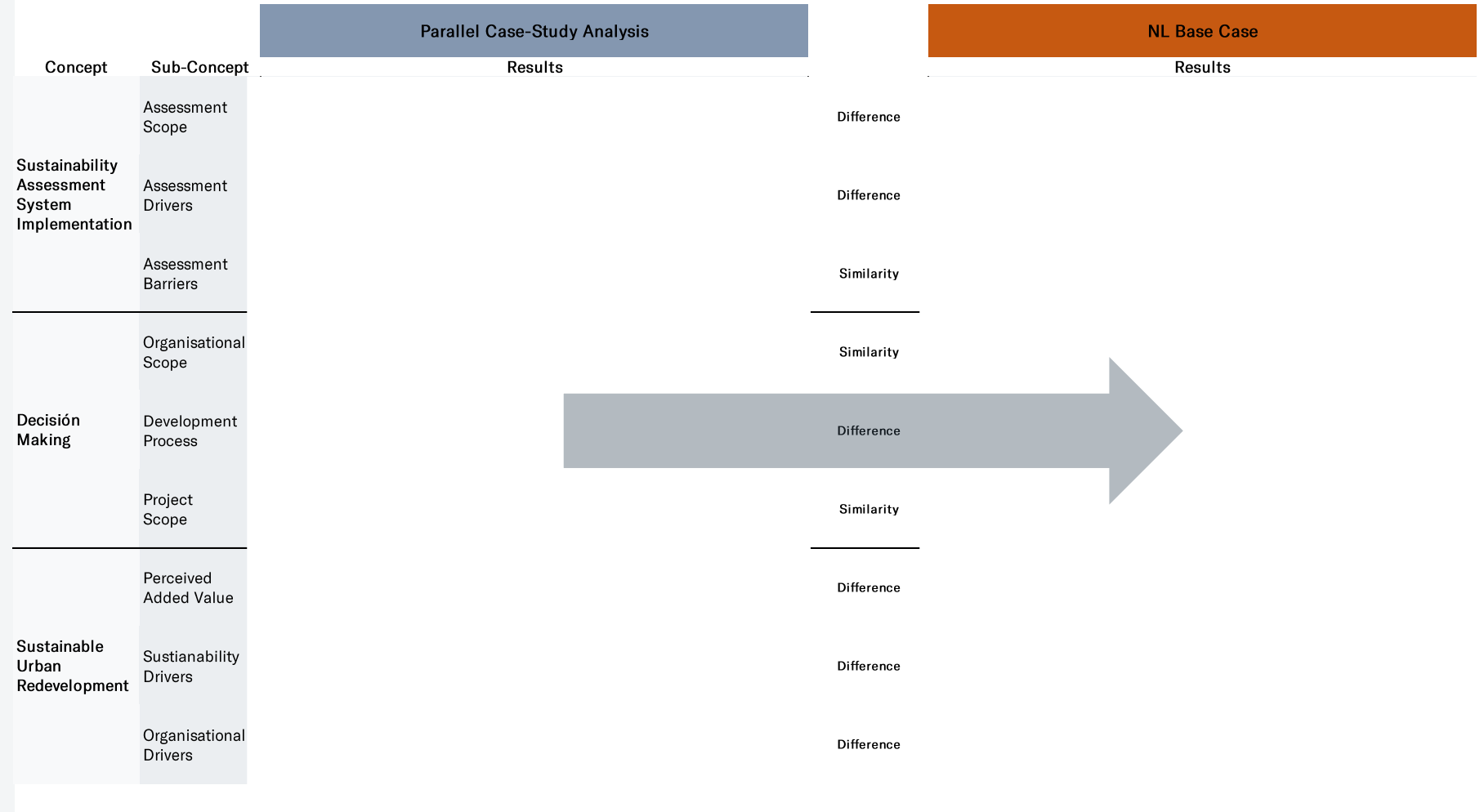



5.3 Empirical Lessons

Recommendations to DGBC

Research Goal:

to provide learnings based on the motivations, implementation and added value behind the use of USASs, for a potential improvement of BREEAM-NL Area and the practices related to it in the Dutch context

- Sustainability Assessment System Implementation

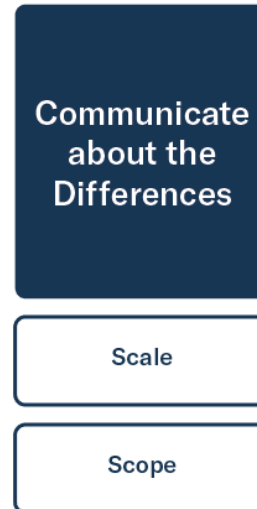

Figure. P 99

5.3 Empirical Lessons

Recommendations to DGBC

Research Goal:

to provide learnings based on the motivations, implementation and added value behind the use of USASs, for a potential improvement of BREEAM-NL Area and the practices related to it in the Dutch context

Figure. P 99

- Sustainability Assessment System Implementation

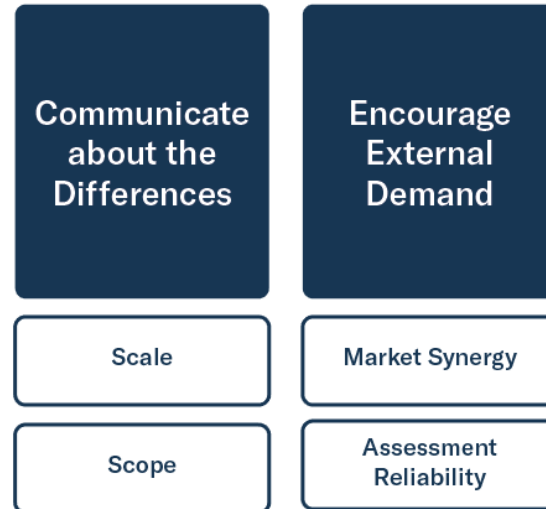



5.3 Empirical Lessons

Recommendations to DGBC

Research Goal:

to provide learnings based on the motivations, implementation and added value behind the use of USASs, for a potential improvement of BREEAM-NL Area and the practices related to it in the Dutch context

- Sustainability Assessment System Implementation

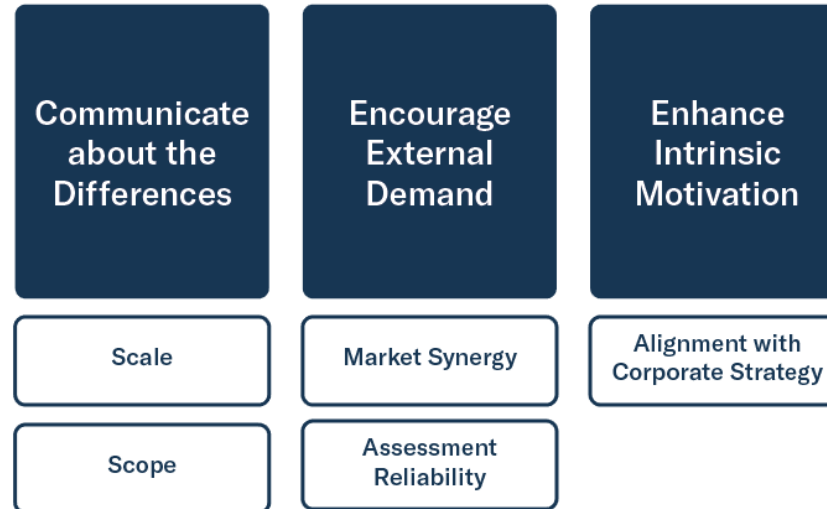

Figure. P 99



5.3 Empirical Lessons

Recommendations to DGBC

Research Goal:

to provide learnings based on the motivations, implementation and added value behind the use of USASs, for a potential improvement of BREEAM-NL Area and the practices related to it in the Dutch context

- Sustainability Assessment System Implementation

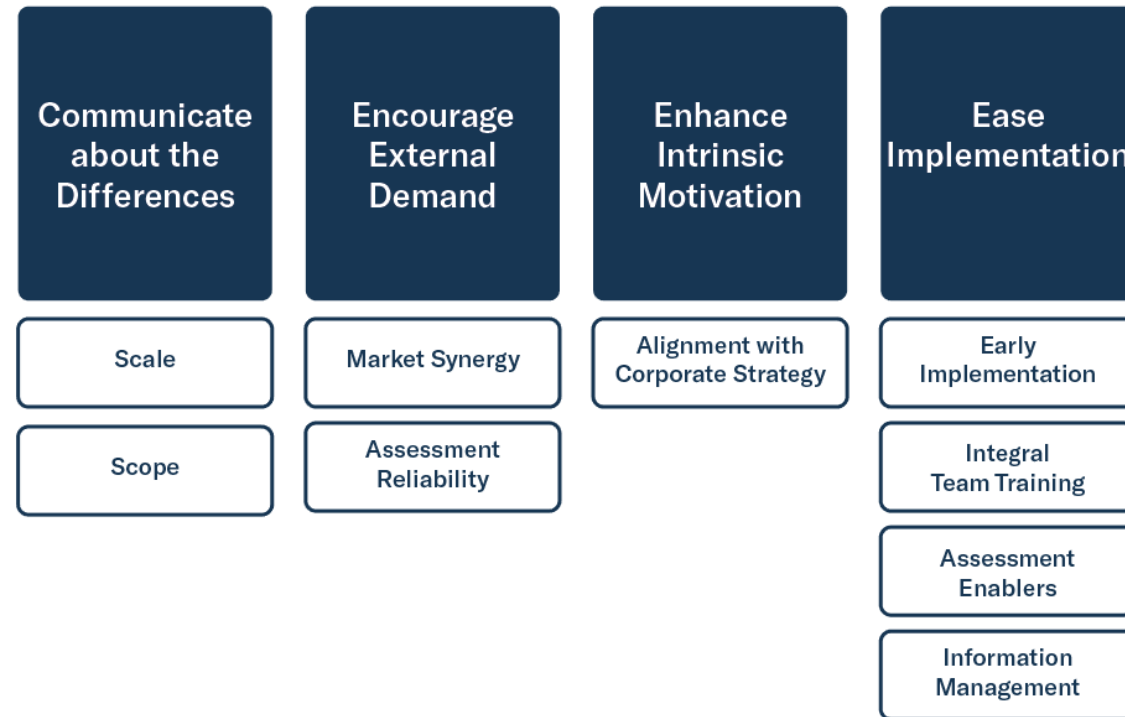

Figure. P 99



5.3 Empirical Lessons

Recommendations to DGBC

Research Goal:

to provide learnings based on the motivations, implementation and added value behind the use of USASs, for a potential improvement of BREEAM-NL Area and the practices related to it in the Dutch context

- Sustainability Assessment System Implementation

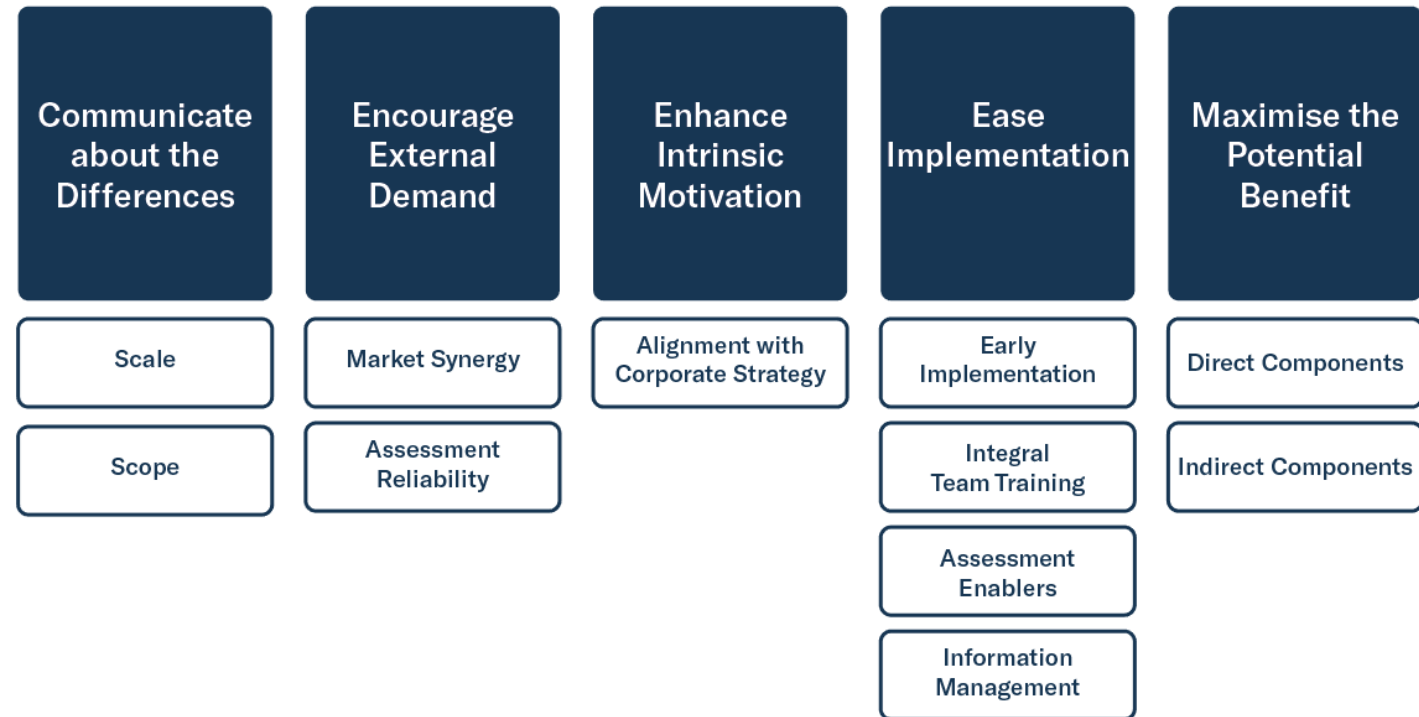

Figure. P 99



5.3 Empirical Lessons

Recommendations to DGBC

Research Goal:

to provide learnings based on the motivations, implementation and added value behind the use of USASs, for a potential improvement of BREEAM-NL Area and the practices related to it in the Dutch context

- Decision-Making & Sustainable Urban Redevelopment

**Be optimistic
about the
influence of the
reflective role**



5.3 Empirical Lessons

Recommendations to DGBC

Research Goal:

to provide learnings based on the motivations, implementation and added value behind the use of USASs, for a potential improvement of BREEAM-NL Area and the practices related to it in the Dutch context

- Decision-Making & Sustainable Urban Redevelopment

**Be optimistic
about the
influence of the
reflective role**

**Dare to reflect
on the
perception of
the guiding role**



5.3 Empirical Lessons

Recommendations to DGBC

Research Goal:

to provide learnings based on the motivations, implementation and added value behind the use of USASs, for a potential improvement of BREEAM-NL Area and the practices related to it in the Dutch context

- Decision-Making & Sustainable Urban Redevelopment

**Be optimistic
about the
influence of the
reflective role**

**Dare to reflect
on the
perception of
the guiding role**

**Acknowledge
the limitations
of the
evaluative role**

5.3 Empirical Lessons

Recommendations to DGBC

Research Goal:

to provide learnings based on the motivations, implementation and added value behind the use of USASs, for a potential improvement of BREEAM-NL Area and the practices related to it in the Dutch context



- Decision-Making & Sustainable Urban Redevelopment

Be optimistic
about the
influence of the
reflective role

Dare to reflect
on the
perception of
the guiding role

Acknowledge
the limitations
of the
evaluative role

The
chicken-egg
paradox;
strive for both



5.4 Empirical Lessons

Recommendations to Dutch Developers

Research Goal:

to communicate developers about the positive impact that implementing USASs can have on their practices

**Adapt to
Successfully
Implement**

Market benefits in
alignment with
societal goals



5.4 Empirical Lessons

Recommendations to Dutch Developers

Research Goal:

to communicate developers about the positive impact that implementing USASs can have on their practices

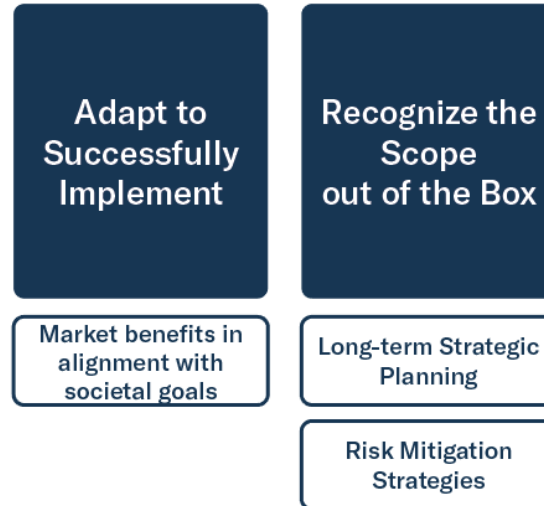



5.4 Empirical Lessons

Recommendations to Dutch Developers

Research Goal:

to communicate developers about the positive impact that implementing USASs can have on their practices

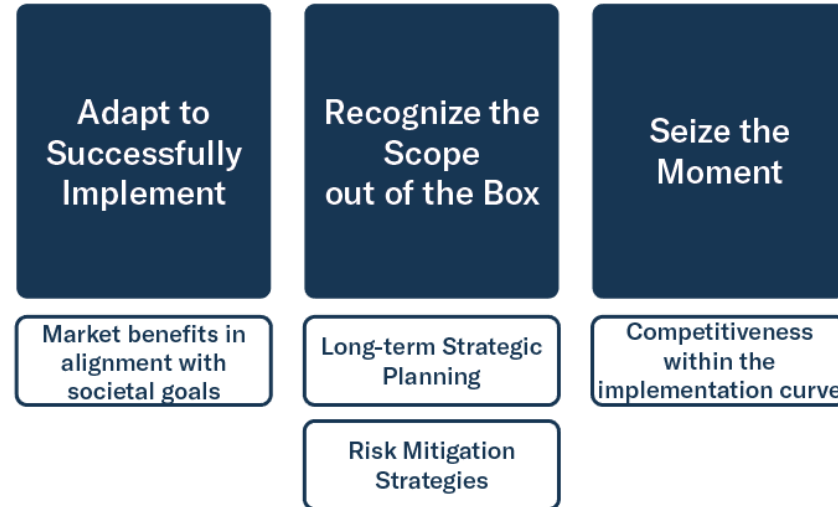



5.4 Empirical Lessons

Recommendations to Dutch Developers

Research Goal:

to communicate developers about the positive impact that implementing USASs can have on their practices



5.4 Empirical Lessons

Recommendations to Dutch Developers

Research Goal:

to communicate developers about the positive impact that implementing USASs can have on their practices

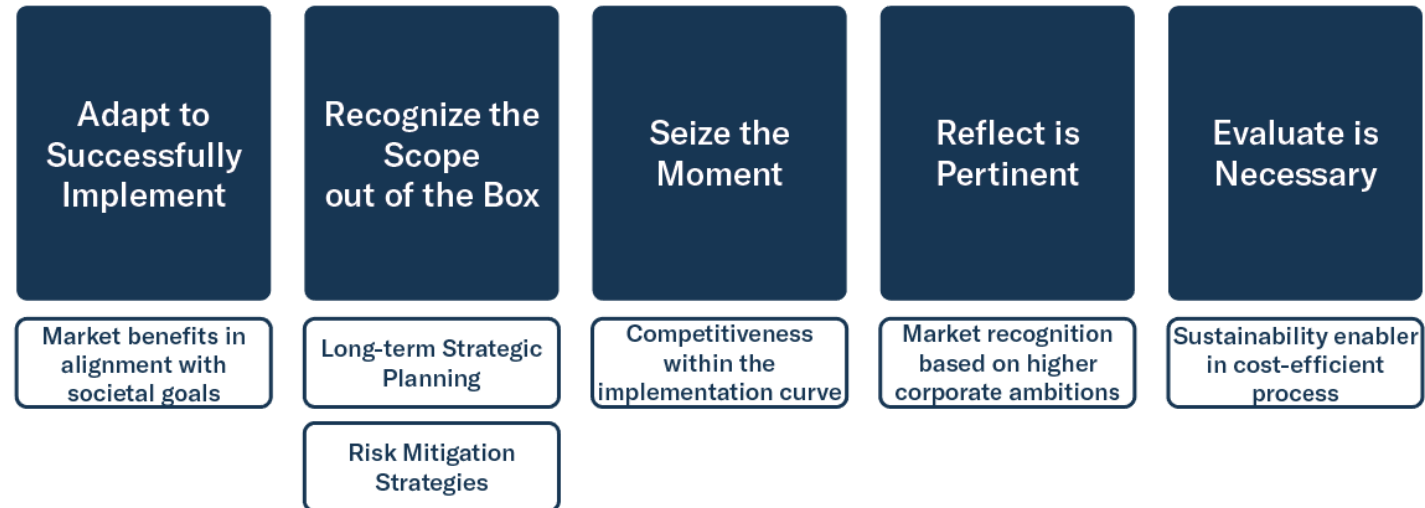

5.4 Empirical Lessons

Recommendations to Dutch Developers

Research Goal:

to communicate developers about the positive impact that implementing USASs can have on their practices

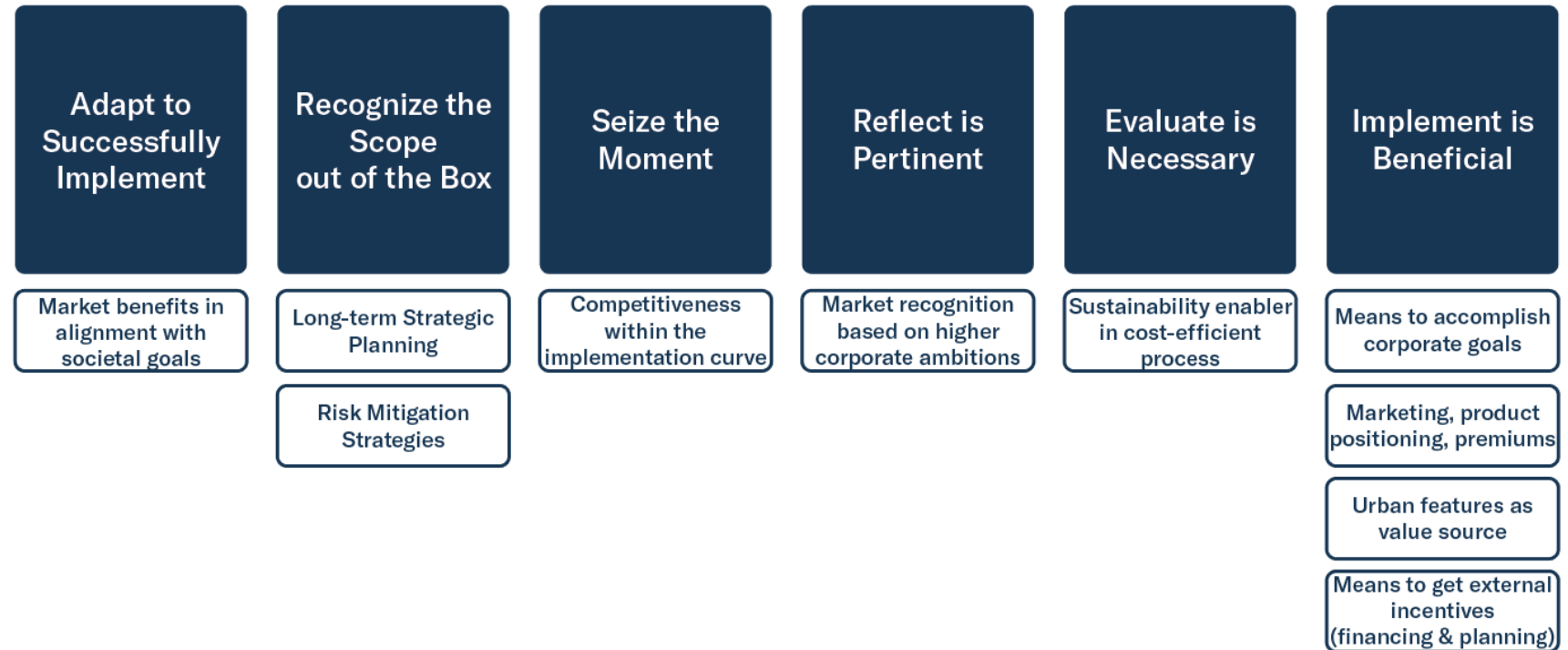



5.4 Empirical Lessons

Recommendations to Dutch Developers

Research Goal:

to communicate developers about the positive impact that implementing USASs can have on their practices

- As a means to accomplish some organisational drivers, which makes sustainability more beneficial
- As a sustainability enabler by lowering down barriers and enhancing a more efficient decision-making process
- As a means to improve the development process in terms of strategic decision-making
- As a means to raise internal awareness and enhance more sustainable decisions
- As a means to achieve external incentives in a transition towards sustainable urban policies

5.4 Empirical Lessons

Recommendations to Dutch Developers

Research Goal:
to communicate developers about the positive impact that implementing USASs can have on their practices

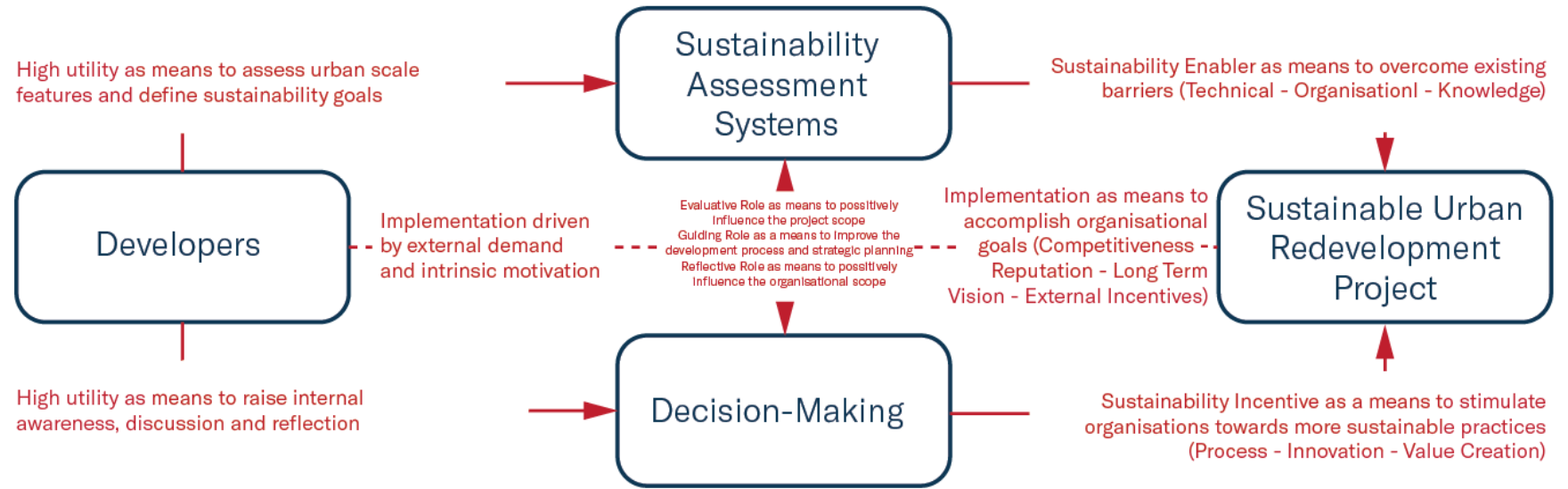

06/ Research Conclusion



6.1 Research Questions



- **MRQ:** How can sustainability be enhanced from a private sector perspective in urban redevelopment projects?

6.2 Reflection

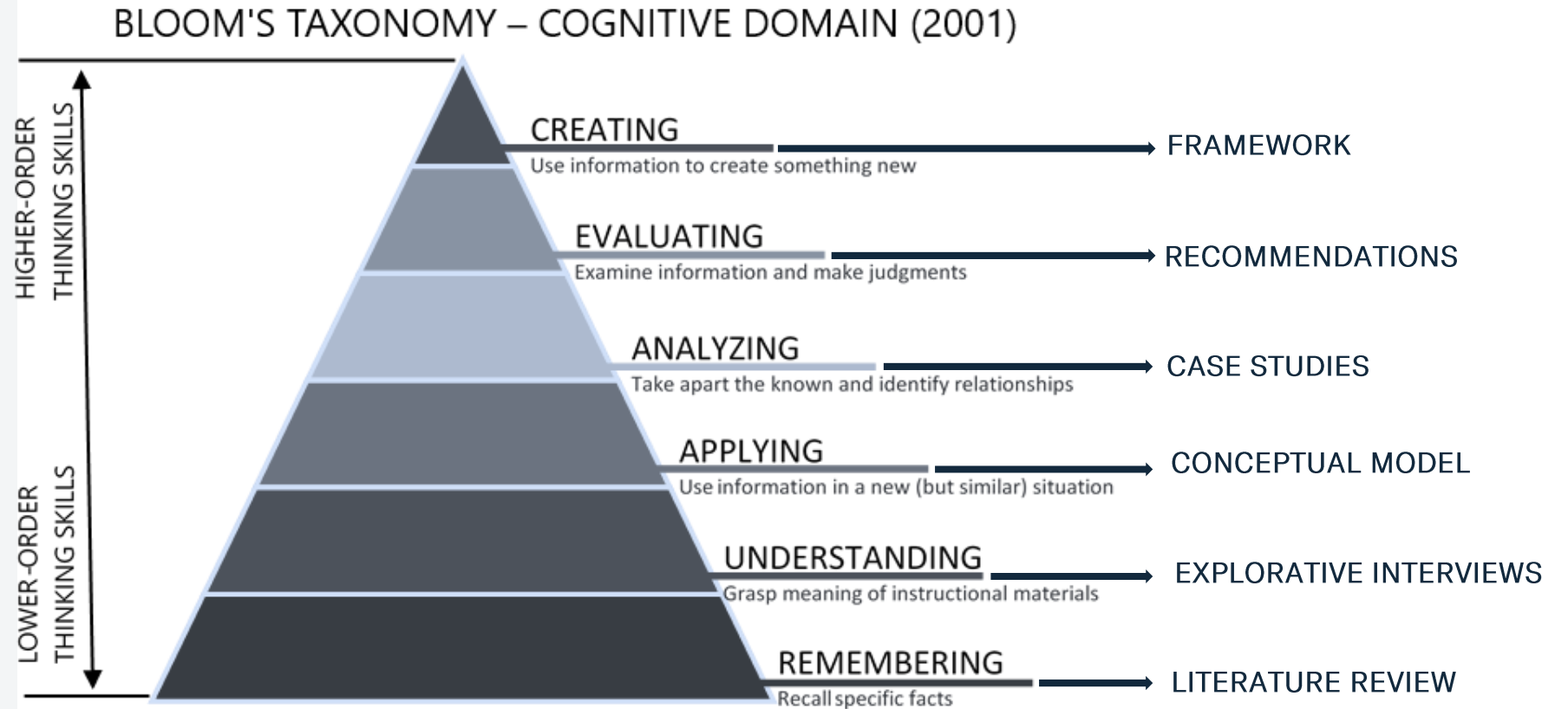

6.3 Framework for Analysis

Research Goal:

to provide an overview of how market-driven assessment systems for urban sustainability can influence the decision-making process of developers

Figure. P 103

Figure. P 101

Figure. P 105

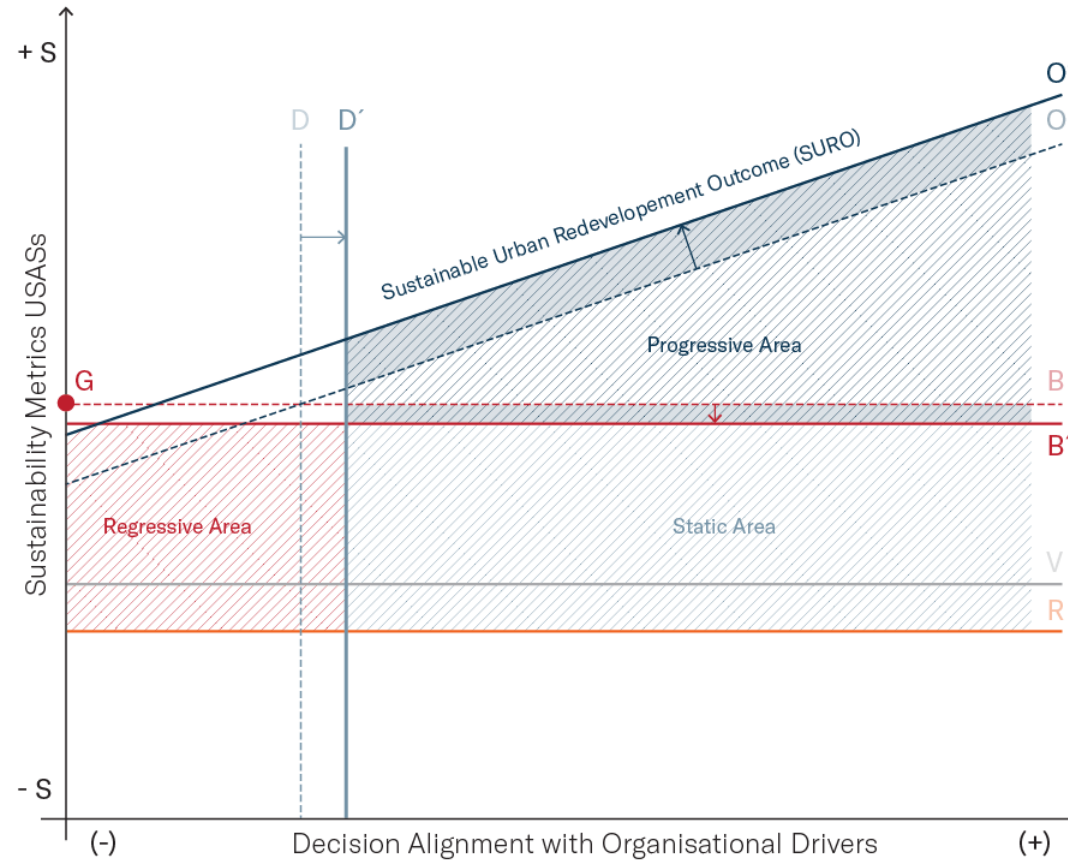

$R + V + O = \text{Sustainable Urban Redevelopment Outcome}$

- R = Regulatory Requirements
- V = Holistic Initiative
- O = Organisational Scope

- G = Sustainability Goal
- B = Barriers withholding more sustainable decisions
- D = Decision making (As weighing decision criteria)

- Regressive Decision Area
- Static Decision Area
- Progressive Decision Area

- B' = Influence of Evaluative Role (On Project Scope)
- O' = Influence of Reflective Role (On Organisational Scope)
- D' = Benefit (Added Value as Incentive)
- Progressive Area Increase

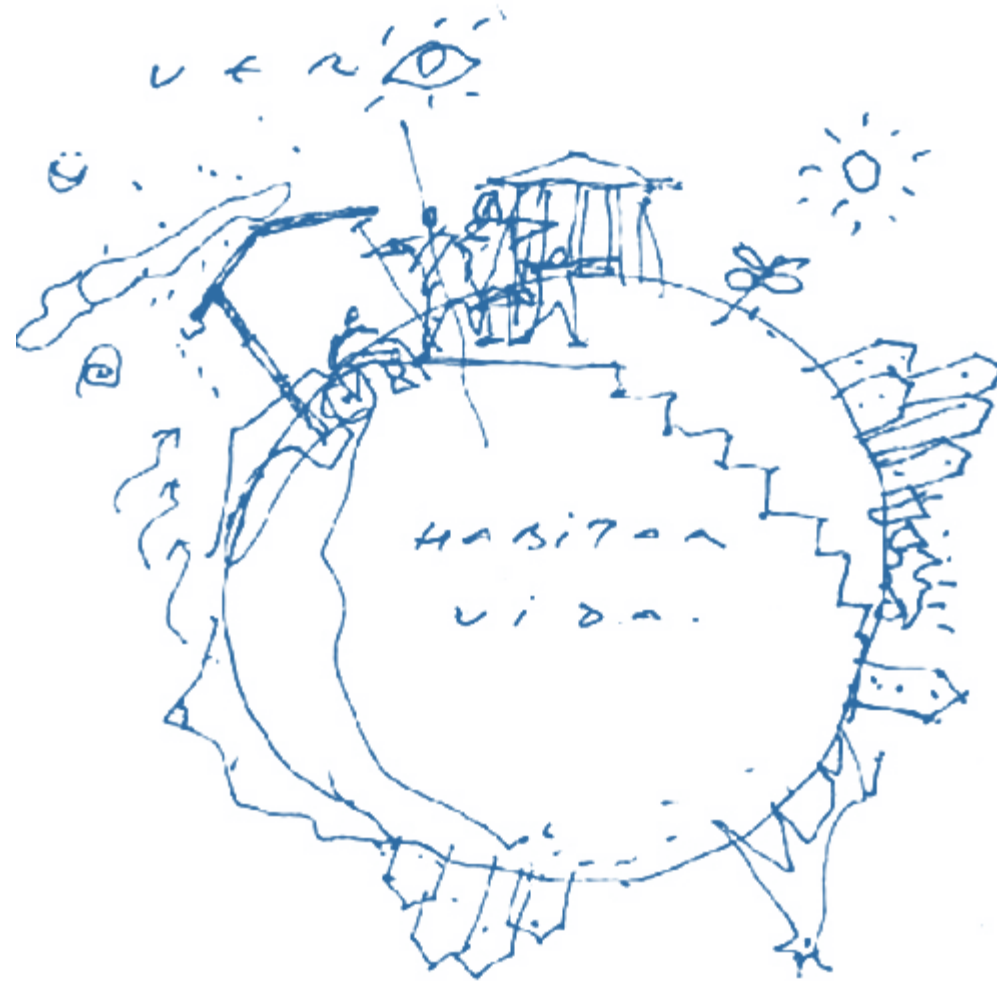

06/ References



- Abdelnour, S., Hasselbladh, H., & Kallinikos, J. (2017). Agency and Institutions in Organization Studies. *Organization Studies*, 38(12), 1775–1792. <https://doi.org/10.1177/0170840617708007>
- Adams, D., & Tiesdell, S. (2012). Shaping places: Urban planning, design and development. In *Shaping Places: Urban Planning, Design and Development*. <https://doi.org/10.4324/9780203105665>
- Appendino, F. (2018). Heritage-related Indicators for Urban Sustainable Development : A Systematic Review. *Urban Transportation & Construction*, 4(December), 1–11. <https://doi.org/10.18686/utc.v4i1.32>
- Bhandari, P. (2021). Ethical Considerations in Research | Types & Examples. <https://www.scribbr.com/methodology/research-ethics/>
- Blaikie, N., & Priest, J. (2019). Designing Social Research. *polity*.
- BRE Group. (2015). BRE Trust Review 2014. 60.
- BREEAM-NL. (2021a). Level of evidence - BREEAM-NL guideline. <https://richtlijn.breeam.nl/42-niveau-van-bewijsmateriaal-297>
- BREEAM-NL. (2021b). Projects - BREEAM-NL. <https://www.breeam.nl/projecten?tools%5B0%5D=GEBIED>
- BREEAM. (2012). BREEAM Communities. Technical Manual SD202 - 0.1:2012. 175.
- BREEAM. (2021). BREEAM Projects-Global. <https://tools.breeam.com/projects/explore/buildings.jsp?from=0§ionid=0&projectType=Communities&rating=&countryID=0&client=&description=&certBody=&certNo=&developer=&location=&buildingName=&assessor=&subschemeid=0&Submit=Search&rpp=20>
- Brundtland, G. H., & UN. (1987). Our Common Future ('The Brundtland Report'): World Commission on Environment and Development. The Top 50 Sustainability Books, 52–55. https://doi.org/10.9774/gleaf.978-1-907643-44-6_12
- Bryman, A. (2015). *Social Research Methods (4th Edition)* by Alan Bryman. Abhigyan VO - 32, 4.
- Bullen, P., & Love, P. (2011). A new future for the past: A model for adaptive reuse decision-making. *Built Environment Project and Asset Management*, 1(1), 32–44. <https://doi.org/10.1108/20441241111143768>
- Callway, R., Dixon, T., & Nikolic, D. (2019). Embedding green infrastructure evaluation in neighbourhood masterplans—does BREEAM communities change anything? *Journal of Environmental Planning and Management*, 62(14), 2478–2505. <https://doi.org/10.1080/09640568.2018.1563371>
- Capald, N., Idowu, S., Schmidpeter, R., & Brueckner, M. (2019). Responsible Business in Uncertain Times and for a Sustainable Future. In Springer Nature Switzerland AG. <http://link.springer.com/10.1007/978-3-030-11217-2>
- Cappai, F., Forgues, D., & Glaus, M. (2018). Socio-Economic Indicators for the Ex-Post Evaluation of Brownfield Rehabilitation: A Case Study. *Urban Science*, 2(4), 100. <https://doi.org/10.3390/urbansci2040100>
- Chegut, A., Eichholtz, P., & Kok, N. (2014). Supply, Demand and the Value of Green Buildings. *Urban Studies*, 51(1), 22–43. <https://doi.org/10.1177/0042098013484526>
- Chegut, A., Kok, N., & Piet, E. (2011). The Value of Green Buildings New Evidence from the United Kingdom. *Eres 2010*, July 2011, 1–43. http://immobilierdurable.eu/images/2128_uploads/Chegut_Eichholtz_Kok_green_value_in_the_uk.pdf
- Coppens, T., Van Acker, M., Machiels, T., & Compennolle, T. (2021). A real options framework for adaptive urban design. *Journal of Urban Design*, 26(6), 681–698. <https://doi.org/10.1080/13574809.2021.1927688>
- Cradock-Henry, N. A., Buelow, F., Flood, S., Blackett, P., & Wreford, A. (2019). Towards a heuristic for assessing adaptation knowledge: Impacts, implications, decisions and actions. *Environmental Research Letters*, 14(9). <https://doi.org/10.1088/1748-9326/ab370c>
- da Fonseca, L. M. C. M. (2015). ISO 14001:2015: An improved tool for sustainability. *Journal of Industrial Engineering and Management*, 8(1). <https://doi.org/10.3926/jiem.1298>
- de Magalhães, R. F., Danilevicz, Â. de M. F., & Palazzo, J. (2019). Managing trade-offs in complex scenarios: A decision-making tool for sustainability projects. *Journal of Cleaner Production*, 212, 447–460. <https://doi.org/10.1016/j.jclepro.2018.12.023>
- DGBC. (2016). Operations Manual for BREEAM-NL assessments. November, 1–30.
- DGBC. (2021). BREEAM-NL - Dutch Green Building Council. <https://www.dgbc.nl/tools/breeam-nl-6>
- Dobrovolskienė, N., Tamošiūnienė, R., Banaitis, A., Ferreira, F. A. F., Banaitienė, N., Taujanskaitė, K., & Meidutė-Kavaliauskienė, I. (2019). Developing a composite sustainability index for real estate projects using multiple criteria decision making. *Operational Research*, 19(3), 617–635. <https://doi.org/10.1007/s12351-017-0365-y>
- Dutch Green Building Council. (2018). BREEAM-NL Gebied. www.breeam.nl
- Dyllick, T., & Hockerts, K. (2002). Beyond the business case for corporate sustainability. *Business Strategy and the Environment*, 11(2), 130–141. <https://doi.org/10.1002/bse.323>
- Flyvbjerg, B. (2006). Five misunderstandings about case-study research. *Qualitative Inquiry*, 12(2), 219–245. <https://doi.org/10.1177/1077800405284363>
- Fredriksen, E. (2015). Private Developers Motivations for BREEAM Communities. *Geltner, D., Kumar, A., & Van de Minne, A. M. (2020). Riskiness of Real Estate Development: A Perspective from Urban Economics and Option Value Theory. Real Estate Economics*, 48(2), 406–445. <https://doi.org/10.1111/1540-6229.12258>
- Gherardi, S. (2019). How to conduct a practice-based study: Problems and methods, second edition. In *How to Conduct a Practice-based Study: Problems and Methods*, Second Edition. <https://doi.org/10.4337/9781788973564>
- Gluch, P., & Bosch-Sijtsema, P. (2016). Conceptualizing environmental expertise through the lens of institutional work. *Construction Management and Economics*, 34(7–8), 522–535. <https://doi.org/10.1080/01446193.2016.1177191>
- Group, B. (2021). BREEAM Communities International 2012. <https://www.bregroup.com/buzz/breeam-communities-international-2012-is-now-live/?cn-reloaded=1>
- Hawkins, D. (2006). Corporate social responsibility: balancing tomorrow's sustainability and today's profitability.
- Heurkens, E. (2012). Private Sector-led Urban Development Projects (Issue 04).
- Heurkens, E. (2019). The role of private parties in sustainable urban development. <https://www.service-studievereniging.nl/magazine/artikel/de-rol-van-private-partijen-in-duurzame-stedelijke-ontwikkeling/>
- Heurkens, E., Adams, D., & Hobma, F. (2015). Planners as market actors: The role of local planning authorities in the UK's urban regeneration practice. *Town Planning Review*, 86(6), 625–650. <https://doi.org/10.3828/tpr.2015.37>
- Heurkens, E., Hobma, F., Verheul, W. J., & Daamen, T. A. (2020). Stedelijke Financiering van gebiedstransformatie Strategieën voor het toepassen van (Issue June).

06/ References

- Jackson, C., & Orr, A. (2021). The embeddedness of sustainability in real estate investment decision-making. *Journal of European Real Estate Research*. <https://doi.org/10.1108/JERER-09-2020-0050>
- Jankalová, M., & Kurotová, J. (2020). Sustainability assessment using economic value added. *Sustainability (Switzerland)*, 12(1), 1–19. <https://doi.org/10.3390/su12010318>
- Kauko, T. (2017). Pricing and sustainability of urban real estate. Routledge.
- Kauko, T. (2019). Innovation in urban real estate: the role of sustainability. *Property Management*, 37(2), 197–214. <https://doi.org/10.1108/PM-10-2017-0056>
- Lambert, P. (2021). A Stepping Stone to Enhance Competitiveness through Sustainable Development.
- Lincoln, Y., & Guba, E. (1985). *Naturalistic Research*.
- Miles, M., & Huberman, M. (1994). *Qualitative Data Analysis An expanded Sourcebook* (p. 354).
- Morris, P. W. G., & Jamieson, A. (2005). Moving from Corporate Strategy to Project Strategy. *Project Management Journal*, 5–19.
- NEPROM. (2018). *Thuis in de toekomst*. [https://www.neprom.nl/Downloads/onderzoek-rapporten/Thuis in de toekomst.pdf](https://www.neprom.nl/Downloads/onderzoek-rapporten/Thuis%20in%20de%20toekomst.pdf)
- Newell, G., MacFarlane, J., & Walker, R. (2014). Assessing energy rating premiums in the performance of green office buildings in Australia. *Journal of Property Investment and Finance*, 32(4), 352–370. <https://doi.org/10.1108/JPIF-10-2013-0061>
- Pedro, J., Reis, A., Duarte Pinheiro, M., & Silva, C. (2019). A systematic review of the international assessment systems for urban sustainability. *IOP Conference Series: Earth and Environmental Science*, 323(1). <https://doi.org/10.1088/1755-1315/323/1/012076>
- Pickvance, C. G. (2001). Four varieties of comparative analysis. *Journal of Housing and the Built Environment*, 16(1), 7–28. <https://doi.org/10.1023/A:1011533211521>
- Planbureau voor de Leefomgeving PBL. (2012). *Grootschalige of kleinschalige verstedelijking?*
- Reed, R. (2021). *Property Development*. In *Property Development*. <https://doi.org/10.1201/9781003015307>
- Regales, C. (2017). *Stimulating Sustainable Urban Development Investments: Incentivize developers to sustainable mixed-use urban development projects*. Master thesis. February, 193. <https://drive.google.com/drive/folders/OB49WzetV9QHOQTNUZOpjenNOUKU%0Ahttps://repository.tudelft.nl/islandora/object/uuid:01245591-4663-498b-bf55-1c08845f81e5?collection=education>
- Roberts, C., & Henneberry, J. (2007). Exploring office investment decision-making in different European contexts. *Journal of Property Investment and Finance*, 25(3), 289–305. <https://doi.org/10.1108/14635780710746939>
- Rose, R. (1991). What is Lesson-Drawing? *Journal of Public Policy*, 11(1), 3–30. <https://doi.org/10.1017/S0143814X00004918>
- Schweber, L. (2013). The effect of BREEAM on clients and construction professionals. *Building Research and Information*, 41(2), 129–145. <https://doi.org/10.1080/09613218.2013.768495>
- Senge, P. et al. (2008). *The necessary revolution: How individuals and organizations are working together to create a sustainable world*. London, UK, Johan Murray Press.
- Sharifi, A., & Murayama, A. (2014). Neighborhood sustainability assessment in action: Cross-evaluation of three assessment systems and their cases from the US, the UK, and Japan. *Building and Environment*, 72, 243–258. <https://doi.org/10.1016/j.buildenv.2014.05.011>
- Shenton, A. K. (2004). Strategies for ensuring trustworthiness in qualitative research projects. *Education for Information*, 22(2), 63–75. <https://doi.org/10.3233/EFI-2004-22201>
- Simhachalam, V. (2008). BIM for BREEAM-NL assessments : An implementation strategy based on BIM Maturity. 1–113.
- Squires, G., & Heurkens, E. (2015). *Introducing international approaches to real estate development*. February.
- Squires, G., & Heurkens, E. (2016). Methods and models for international comparative approaches to real estate development. *Land Use Policy*, 50, 573–581. <https://doi.org/10.1016/j.landusepol.2015.10.005>
- Tsutsui, K. (2015). *Corporate social responsibility in a globalizing world*. Cambridge University Press.
- UN Global Compact, & RICS. (2018). *Advancing Responsible Business in Land, Construction and Real Estate Use and Investment – Making the Sustainable Development Goals a Reality*. April, 1–113.
- Urban Land Institute. (2018). *The case for open space: whe the real estate industry should invest in parks and open spaces*.
- Van der Heijden, J. (2017). *Innovation in urban climate governance*. Cambridge University Press.
- Verheul, W. J., Daamen, T., Heurkens, E., Hobma, F., & Simon van Zoest, W. (2019). *Leren van stedelijke transformaties Essay Over sturingsdilemma's en veerkracht in binnenstedelijke gebiedsontwikkeling*.
- Vieira De Castro, A., Ramírez Pacheco, G., & Neila González, F. J. (2020). Holistic approach to the sustainable commercial property business: Analysis of the main existing sustainability certifications. *International Journal of Strategic Property Management*, 24(2), 251–268. <https://doi.org/10.3846/ijspm.2020.12174>
- Warren-Myers, G. (2012). The value of sustainability in real estate: A review from a valuation perspective. *Journal of Property Investment and Finance*, 30(2), 115–144. <https://doi.org/10.1108/14635781211206887>
- Whittington, R. (2006). Completing the practice turn in strategy research. *Organization Studies*, 27(5), 613–634. <https://doi.org/10.1177/0170840606064101>
- Williams, K., & Dair, C. (2007). *in England ? Barriers Experienced Sustainable Developments*. English, 147(September 2006), 135–147.
- Willows, R., & Connell, R. (2003). Climate adaptation: Risk, uncertainty and decision-making. 41–87.
- Xiaoling, Z. (2011). Barriers to Implement Green Strategy in the Process of Developing Real Estate Projects. *The Open Waste Management Journal*, 4(1), 33–37. <https://doi.org/10.2174/1876400201104010033>
- Yin, R. K. (2018). Case study research and applications: Design and methods. In *Journal of Hospitality & Tourism Research* (Vol. 53, Issue 5). <https://doi.org/10.1177/109634809702100108>
- Yu, J. H., & Kwon, H. R. (2011). Critical success factors for urban regeneration projects in Korea. *International Journal of Project Management*, 29(7), 889–899. <https://doi.org/10.1016/j.ijproman.2010.09.001>
- Zheng, H. W., Shen, G. Q. P., Song, Y., Sun, B., & Hong, J. (2017). Neighborhood sustainability in urban renewal: An assessment framework. *Environment and Planning B: Urban Analytics and City Science*, 44(5), 903–924. <https://doi.org/10.1177/0265813516655547>





Decision-Making and Evaluative Practices



- Relationship between
Assessment process
Evaluative practices
Decision-making level

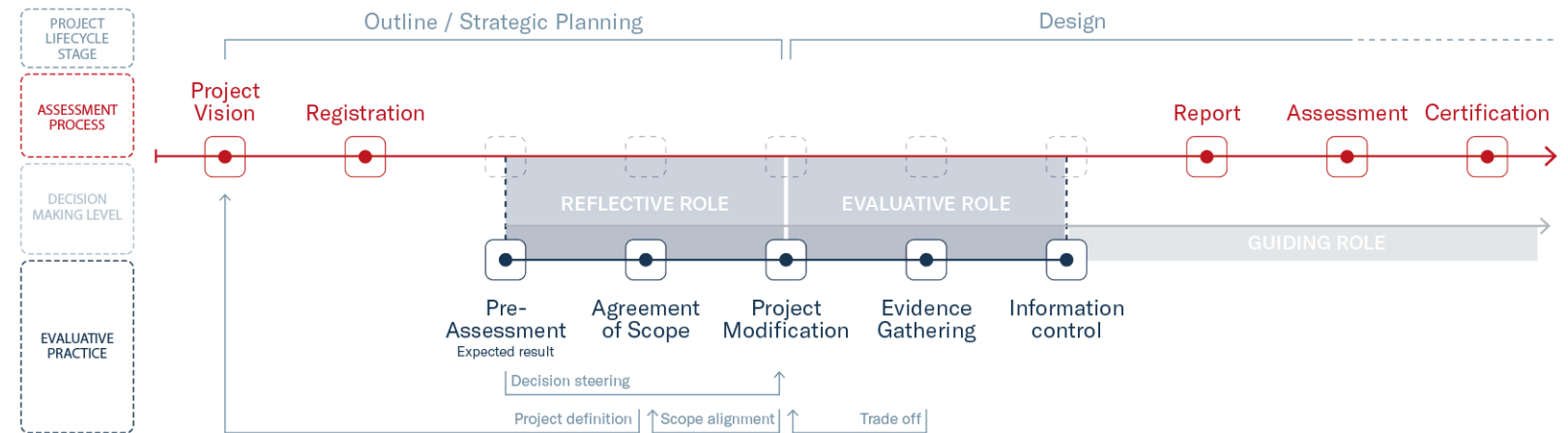

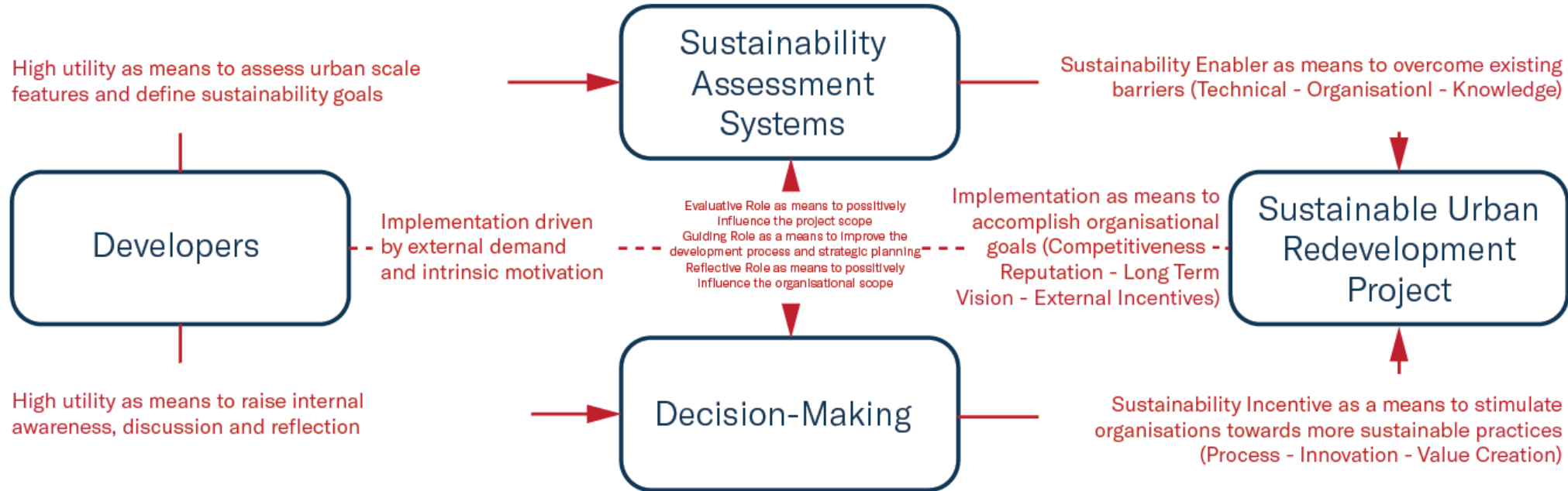

5.4 Empirical Lessons

Recommendations to Dutch Developers

Research Goal:

to communicate developers about the positive impact that implementing USASs can have on their practices

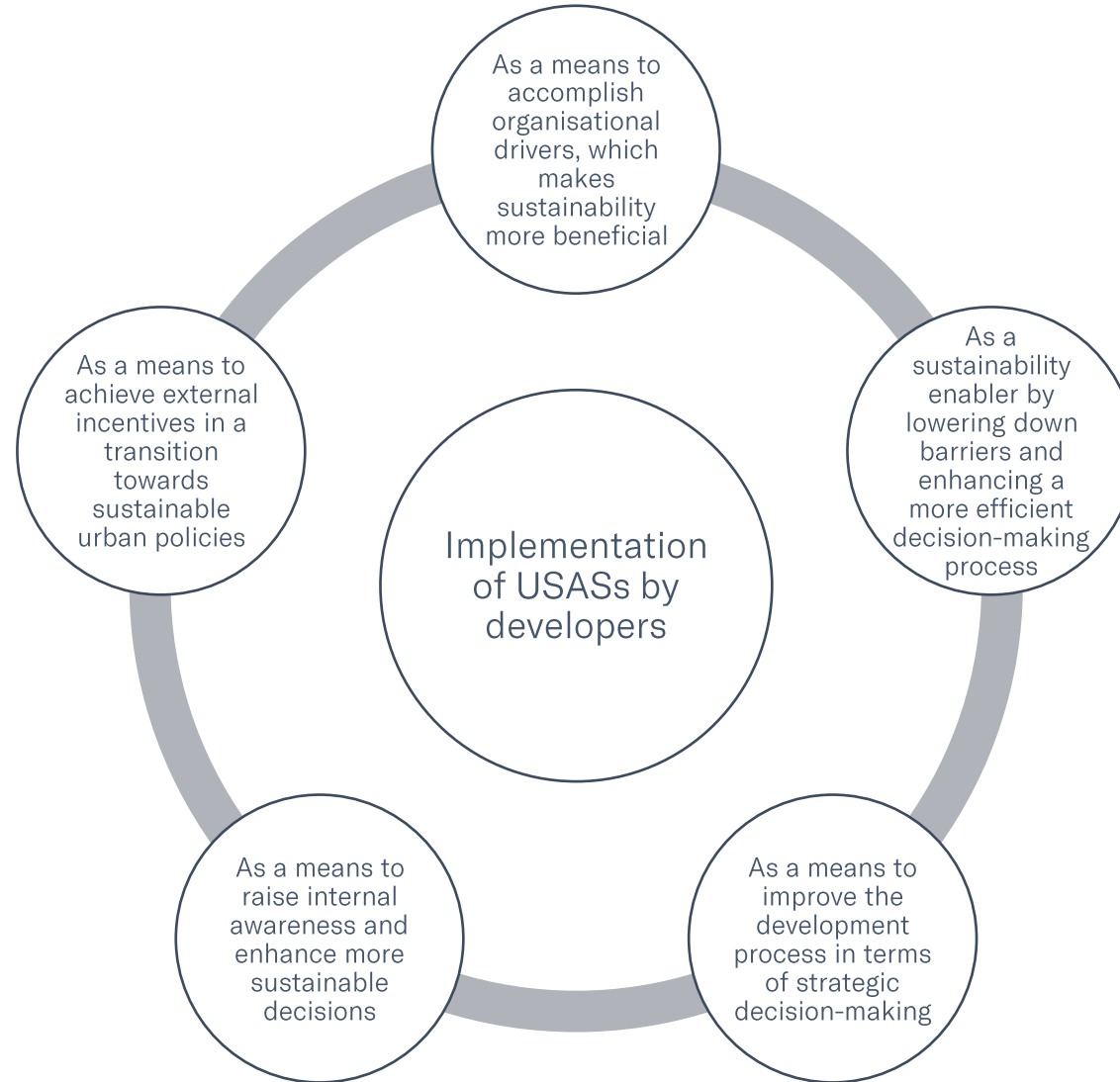

6.3 Framework for Analysis

Research Goal:

to provide an overview of how market-driven assessment systems for urban sustainability can influence the decision-making process of developers

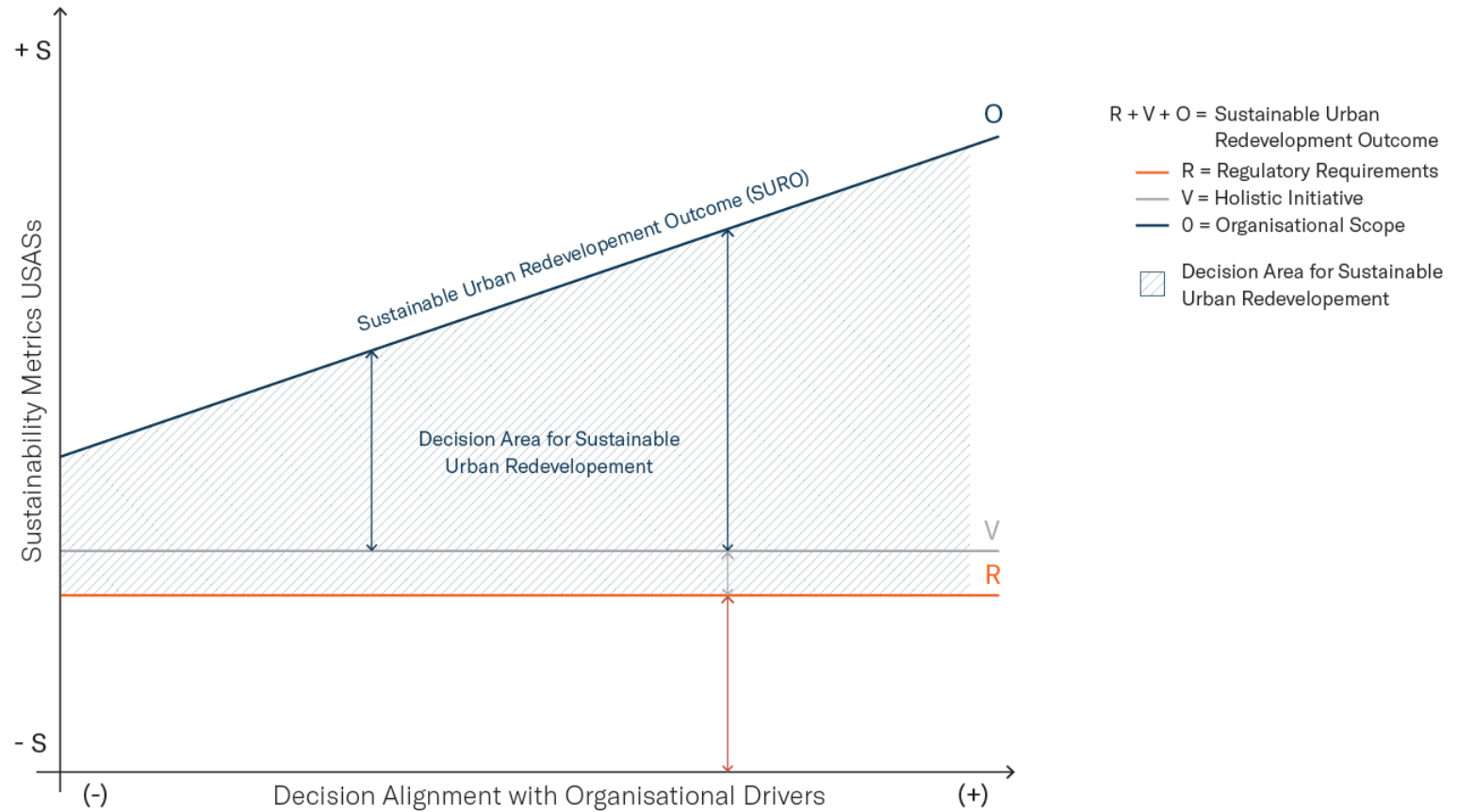

6.3 Framework for Analysis

Research Goal:

to provide an overview of how market-driven assessment systems for urban sustainability can influence the decision-making process of developers

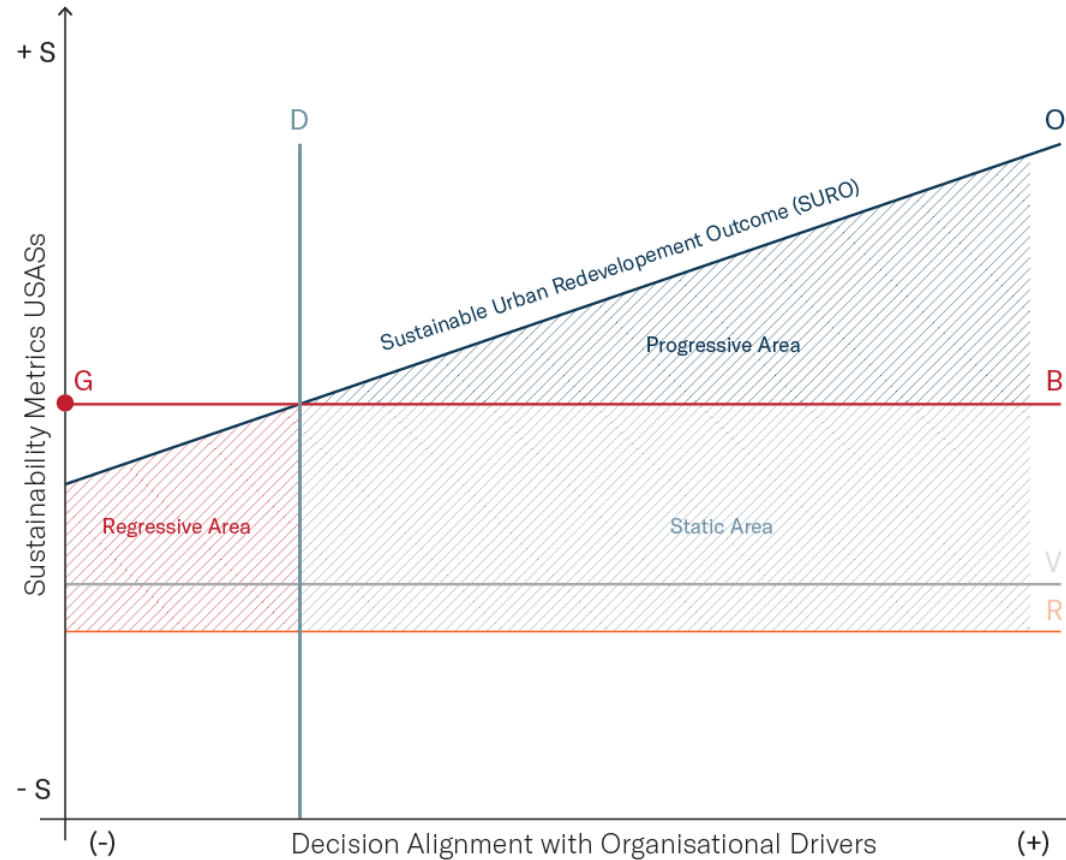

- R + V + O = Sustainable Urban Redevelopment Outcome
- R = Regulatory Requirements
- V = Holistic Initiative
- O = Organisational Scope
- G = Sustainability Goal
- B = Barriers withholding more sustainable decisions
- D = Decision making (as weighing decision criteria)
- Regressive Decision Area
- Static Decision Area
- Progressive Decision Area

6.3 Framework for Analysis

Research Goal:

to provide an overview of how market-driven assessment systems for urban sustainability can influence the decision-making process of developers

Figure. P 103

Figure. P 101

Figure. P 105

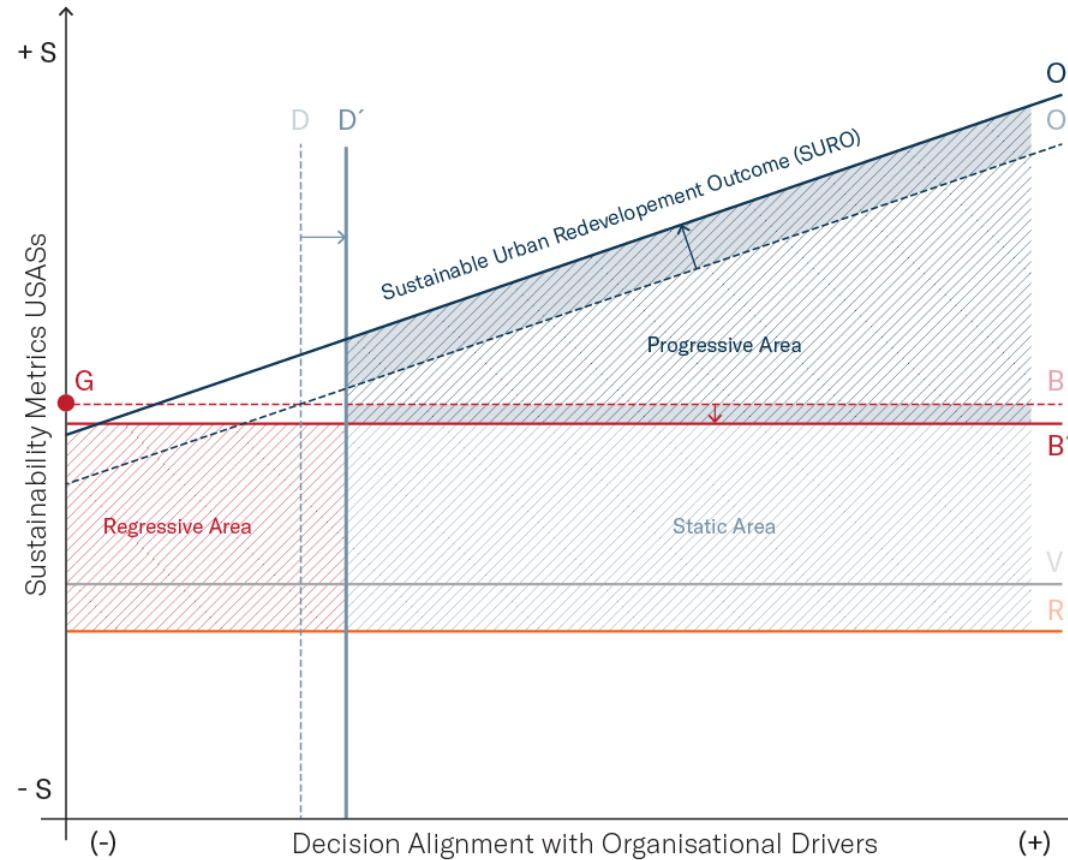

$R + V + O =$ Sustainable Urban Redevelopment Outcome

- R = Regulatory Requirements
- V = Holistic Initiative
- O = Organisational Scope

- G = Sustainability Goal
- B = Barriers withholding more sustainable decisions
- D = Decision making (As weighing decision criteria)

- Regressive Decision Area
- Static Decision Area
- Progressive Decision Area

- B' = Influence of Evaluative Role (On Project Scope)
- O' = Influence of Reflective Role (On Organisational Scope)
- D' = Benefit (Added Value as Incentive)
- Progressive Area Increase

6.3 Framework for Analysis

Research Goal:

to provide an overview of how market-driven assessment systems for urban sustainability can influence the decision-making process of developers

Figure. P 103

Figure. P 101

Figure. P 105

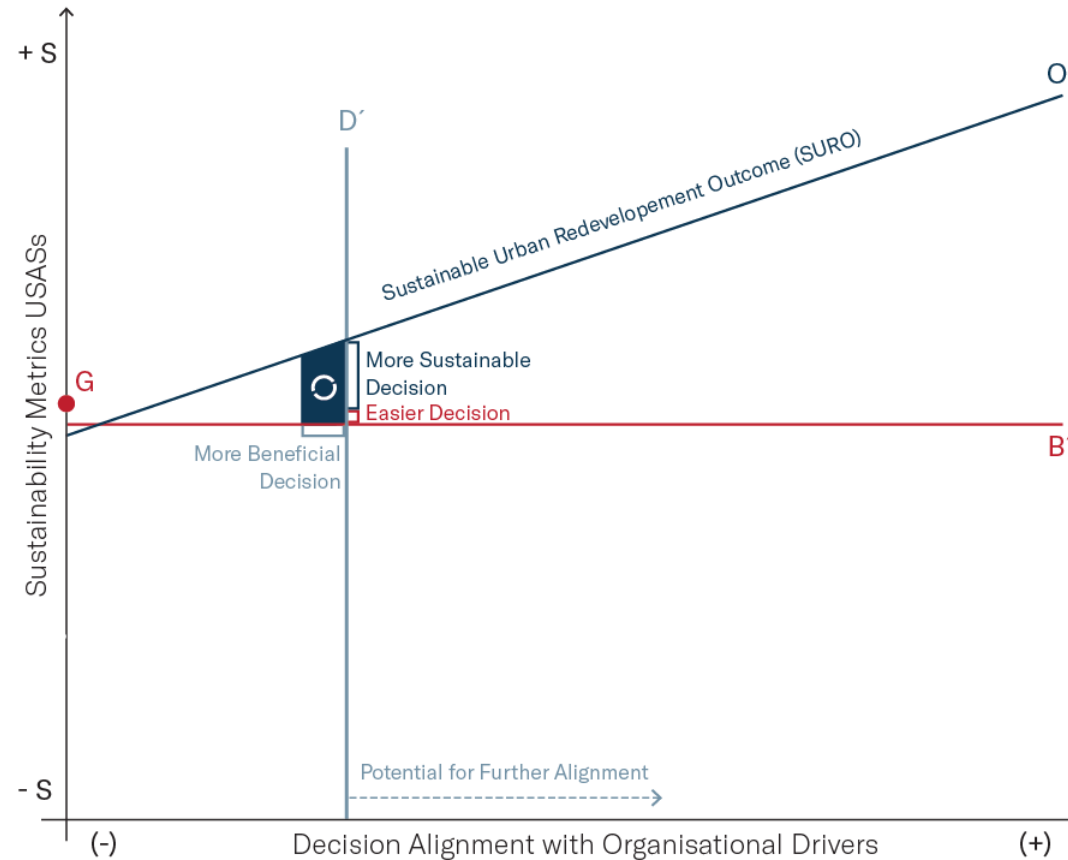

R + V + O = Sustainable Urban Redevelopment Outcome

- R = Regulatory Requirements
- V = Holistic Initiative
- O = Organisational Scope

- G = Sustainability Goal
- B = Barriers withholding more sustainable decisions
- D = Decision making (As weighing decision criteria)

- Regressive Decision Area
- Static Decision Area
- Progressive Decision Area

- B' = Influence of Evaluative Role (On Project Scope)
- O' = Influence of Reflective Role (On Organisational Scope)
- D' = Benefit (Added Value as Incentive)

- Progressive Area Increase
- Impact of USASs in Developers Decision-Making Process

4.1 Case Study Set Up

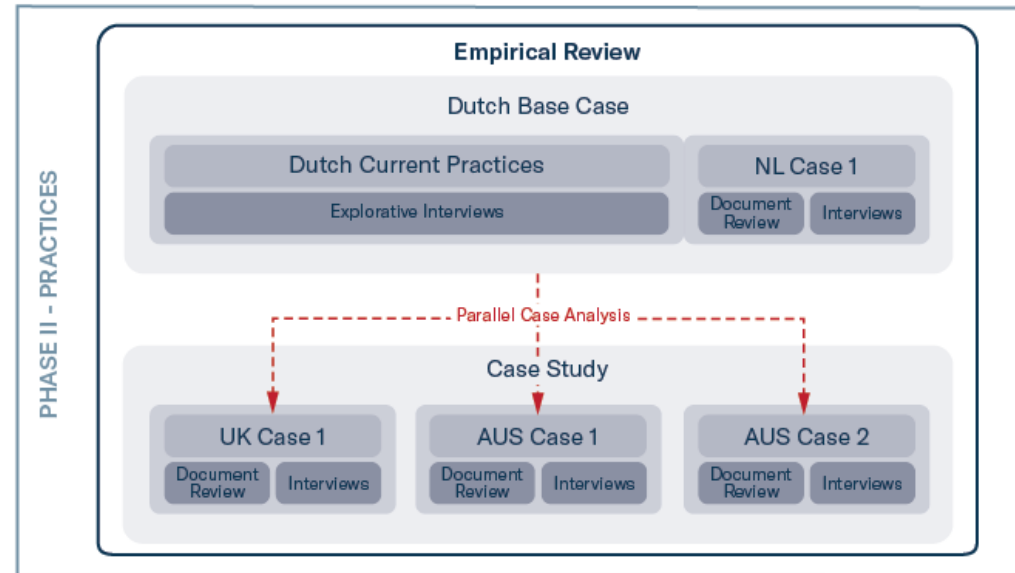

Figure. 4
Case Study Setup

1.3 Research Relevance



Social Relevance



The research could steer the private sector perspective and stimulate developers to accomplish integral sustainable redevelopment projects

Academic Relevance



The research can contribute to filling the existing gap between sustainability assessment systems and decision-making processes in urban redevelopment projects

Source:
Reed, 2021
Callway et al., 2019
Capald et al., 2019
Kauko, 2019

2.3 Techniques, Methods & Data Collection

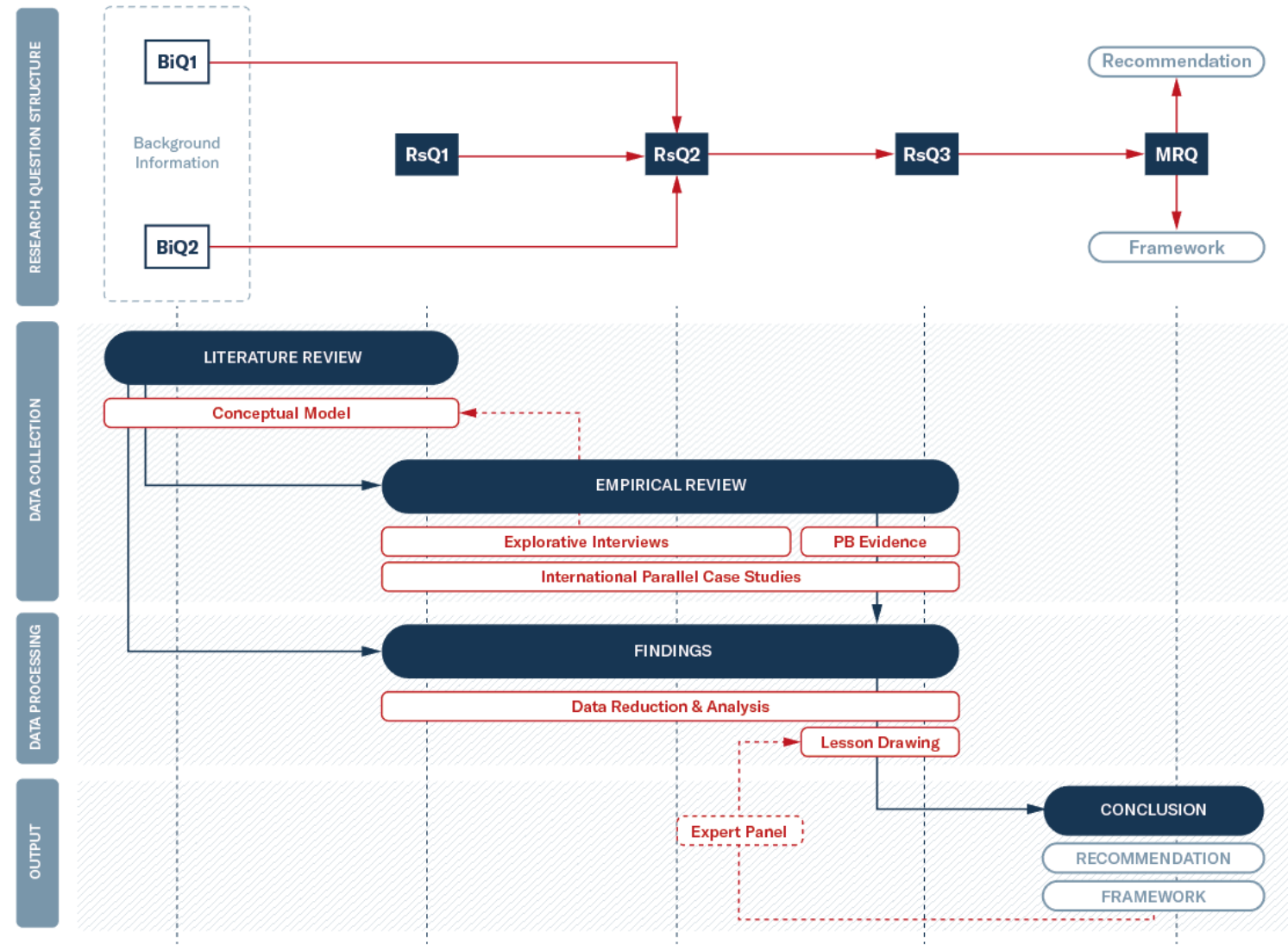
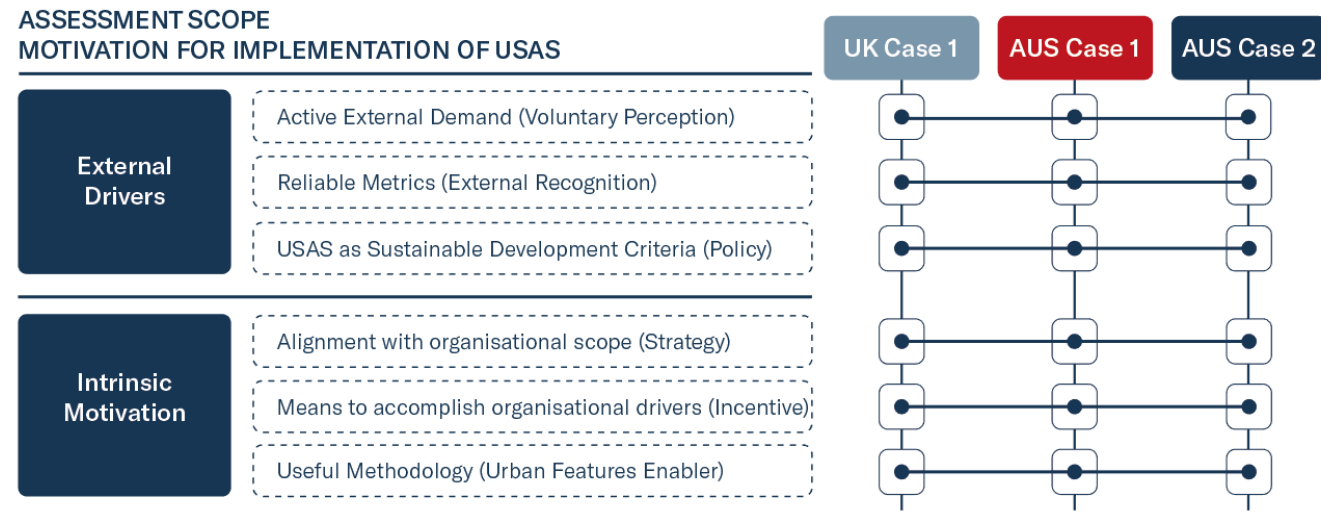

Figure. 3
Research Methods, Techniques & Data Collection



- **RsQ1:** Why do developers decide to implement USASs?





- **RsQ2:** How developers' decision-making can be influenced by the implementation of USASs?

PERCEIVED POTENTIAL INFLUENCE OF USAS ON DECISION-MAKING PROCESS





- **RsQ3:** To what extent does the developers' implementation of USASs lead to a more sustainable urban redevelopment project?

ADDED VALUE OF USAS AS SUSTAINABILITY ENABLER
(MEANS TO LOW DOWN EXISTING BARRIERS)

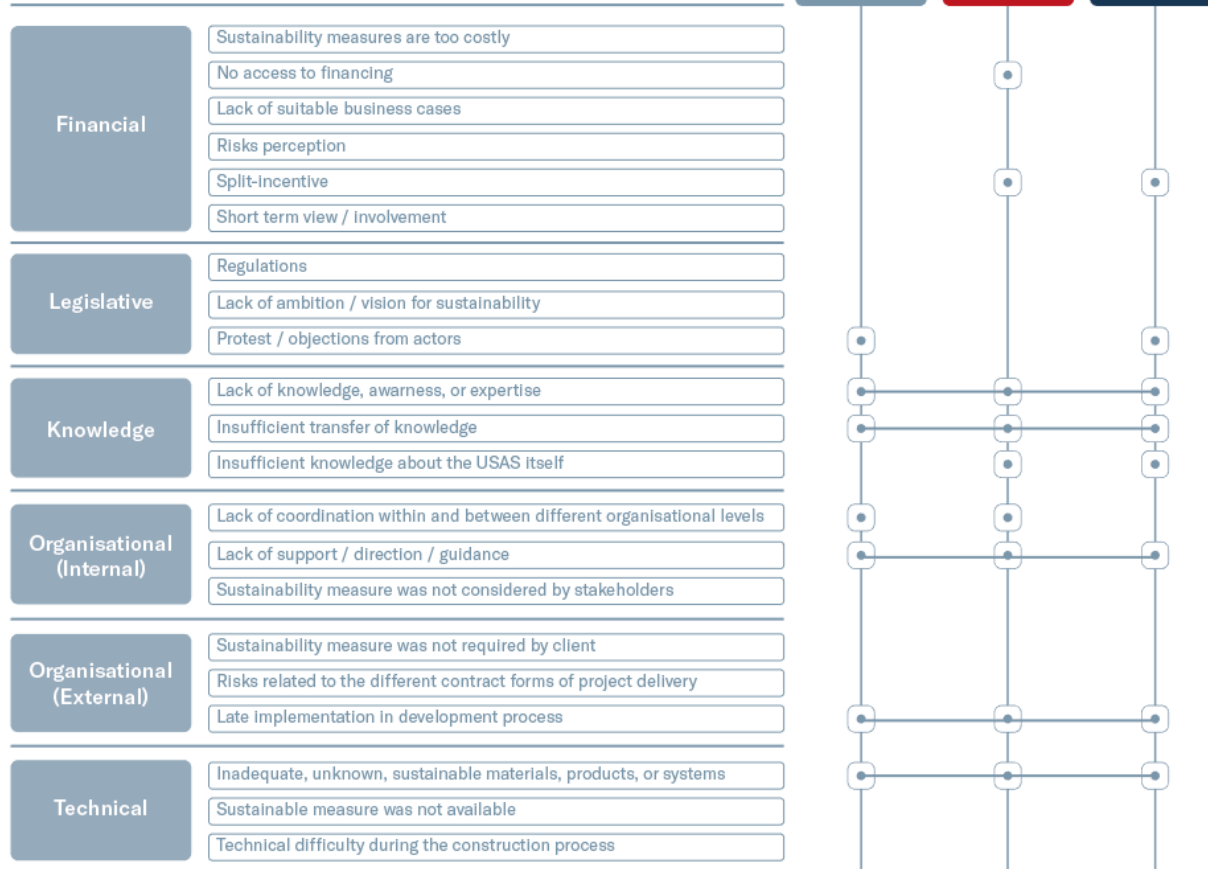



- **RsQ3:** To what extent does the developers' implementation of USAs lead to a more sustainable urban redevelopment project?

ADDED VALUE OF USAS AS MEANS TO ACCOMPLISH ORGANISATIONAL GOALS (BENEFITS)



4.1 Dutch Current Practices

Sustainability
Assessment
System
Implementation



- **RsQ1: Why do developers decide to implement USASs?**

Assessment Scope

- Developers Profile & Project Characteristics
- Reliable Metrics
- Intrinsic Ambition & Reputational Business Strategy

Assessment Drivers

- Local Authorities Procurement
- Demand from Investors / Clients / End Users
- Helpful Methodology supported by Initiatives of Process Optimisation

Assessment Barriers

- Low Demand
- Low Knowledge Transfer
- High Indirect Costs + High Workload and Time Consuming
- Low Initial Ambition + Low Internal Knowledge
- Misalignment with Technical Requirements

4.1 Dutch Current Practices

Decision-Making



- **RsQ2:** How developers' decision-making can be influenced by the implementation of USASs?



4.1 Dutch Current Practices

Sustainable Urban
Redevelopment



- **RsQ3:** To what extent does the developers' implementation of USASs lead to a more sustainable urban redevelopment project?

Perceived Added Value (Potential)**

- Access to Financing & Attract Investors and Tenants
- Procurement Eligibility & Regulation Predictability
- Marketing & Reputation
- Internal Awareness & Retrofit Corporate Strategy

Sustainability Driver

- Can potentially help overcoming existing barrier
- Positive influence is not quantifiable

Organisational Driver

- Rises Awareness and Discussion
- Catalyst for a change in mindset
- Can act as means to get incentives

4.3 International Case Study Analysis



Project	Aylesbury Estate Redevelopment	Brisbane Showgrounds Redevelopment	Waterloo Metro Quarter Redevelopment
Location	London, United Kingdom	Brisbane (QL), Australia	Sydney (NSW), Australia
Developer & Governance	Notting Hill Genesis (Housing Association) + Southwark Council (Local Authority)	Lendlease (Developer-Investor) + RNA (Not-for-profit local organisation)	Mirvac Group + John Holland Joint Venture + Sydney Metro
Scope	Regeneration of a Residential Neighbourhood	Regeneration of a Commercial Area	Regeneration of a Residential Neighbourhood
Urban Sustainability Assessment System	BREEAM-CM 2012	Green Star-CM	Green Star-CM
Assessment Status	Stage: Interim Cert. date: 26/08/2015 Score: Pass	Stage: Certified Cert. date: 14/11/2017 Score: 6 Stars 78	Registered
Scale	25 hectares 300.000 GFA (Developed by phases)	20 hectares 400.000 GFA (Developed by phases)	2 hectares 80.000 GFA (Developed by phases)
Type	On-Going Brownfield Redevelopment	On-Going Brownfield Redevelopment	On-Going Brownfield Redevelopment
Function	Mixed-Use Housing Oriented	Mixed-Use Commercial Oriented	Mixed-Use Transport Oriented
Timeframe	20 year Masterplan 4 Phases (2015-2035)	15 year Masterplan 3 Phases (2010-2025)	7* year Masterplan 3 Phases (2017-2024)
Lifecycle Stage	1 Phase to be Completed In 2023 (15%)	3 Phases Completed (90%)	1 Phase to be Completed In 2024 (20%)

Figure. 6
Case Selection Criteria



4.2

The NL Case 1 Project-Based Evidence

Scope of Project-Based Evidence

- Give a complementary insight to the Dutch current practices
- Refine the base case for lesson drawing
- Orient the findings based on developers' perspective

Complementary Perspective

- Partial misalignment between implementation and corporate strategy
- Limited organisational capabilities
- Relative high scepticism and limited evidence of influence in terms of decision-making
- Potential benefit vs Expected Benefit

Research Plan Proposal

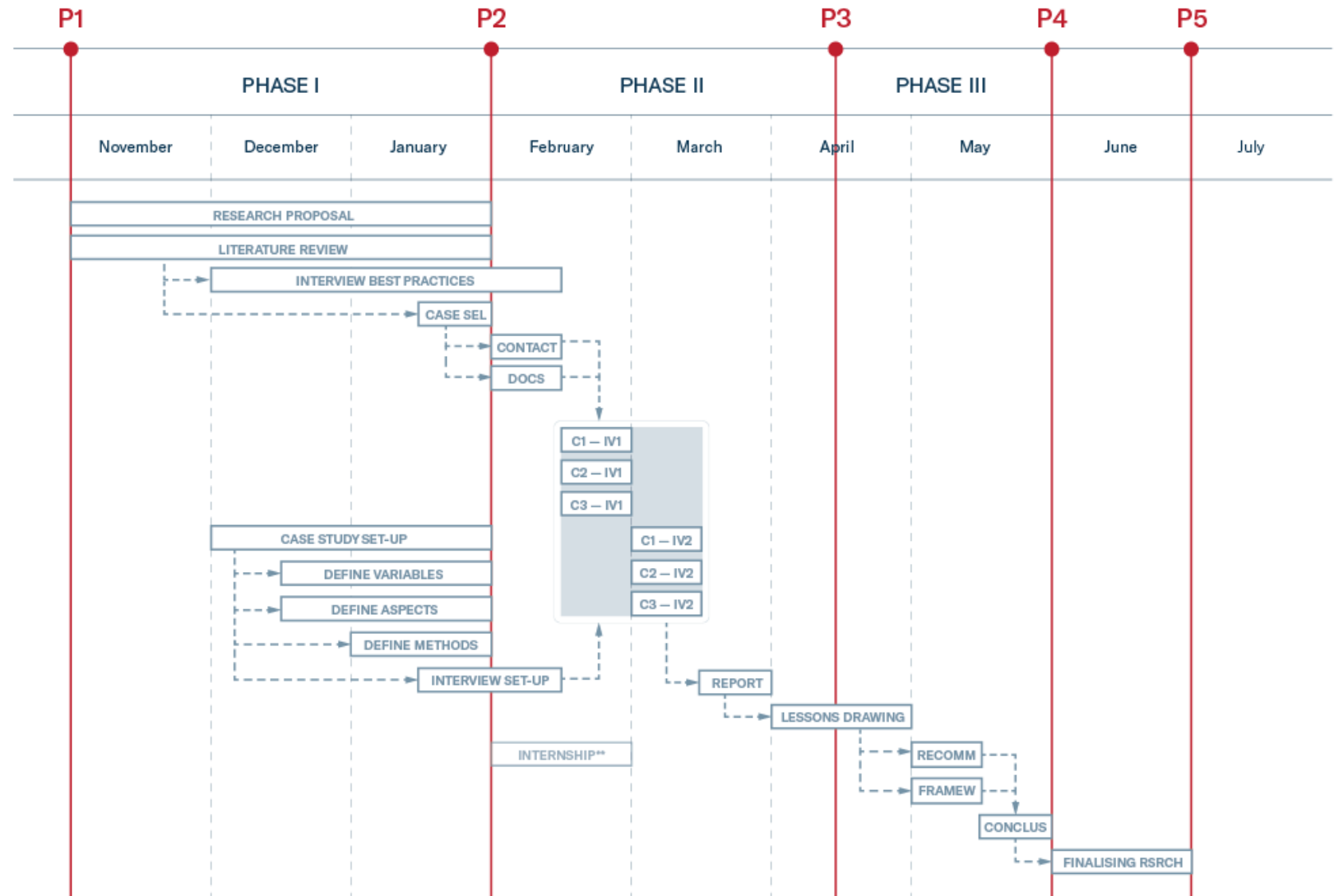
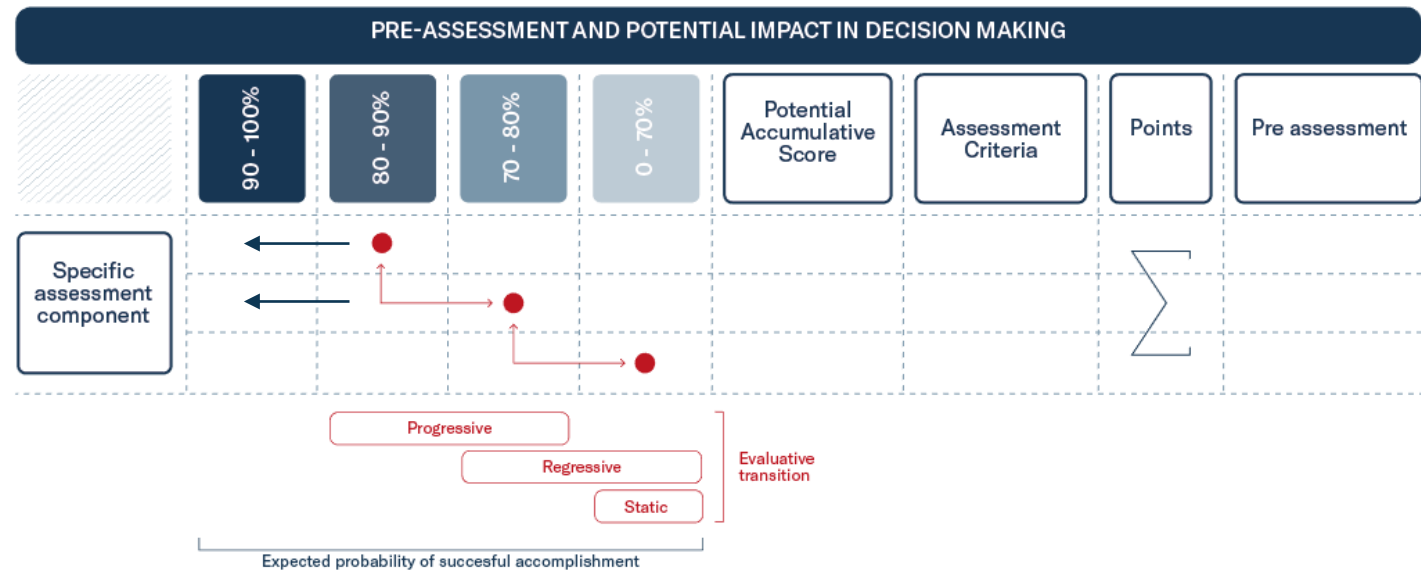

Figure. 5
Research Plan Proposal



Decision Logic and Evaluative Practices

- Practice-based framework to guide developers' decision-making regarding specific requirements for sustainable area development
- Evaluative transition as steering mechanism





Decision-Making Process

- From practice base to implementation impact

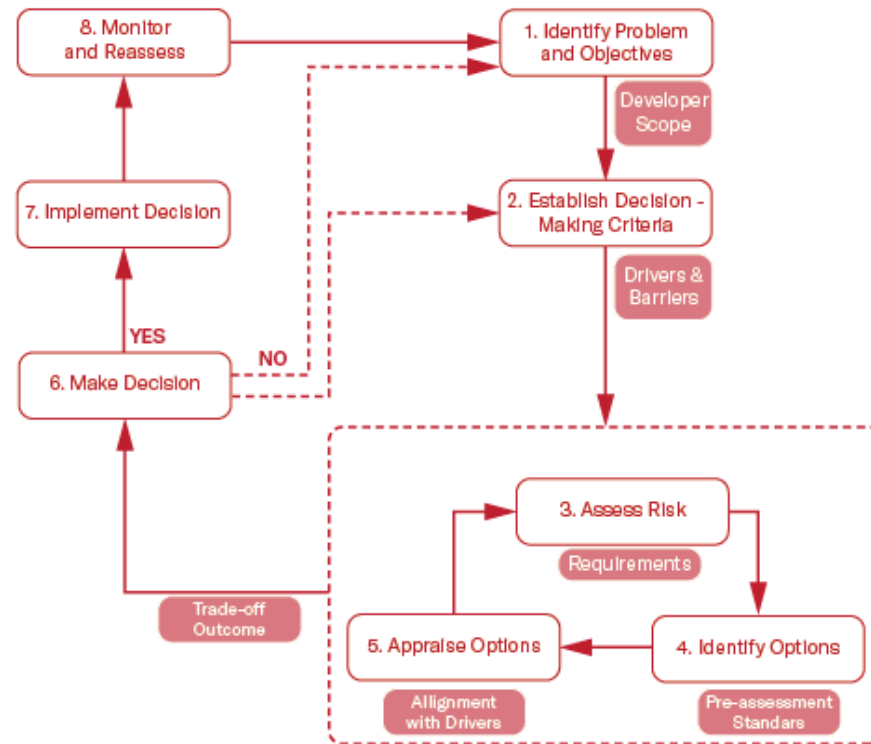

3.2 Conceptual Model

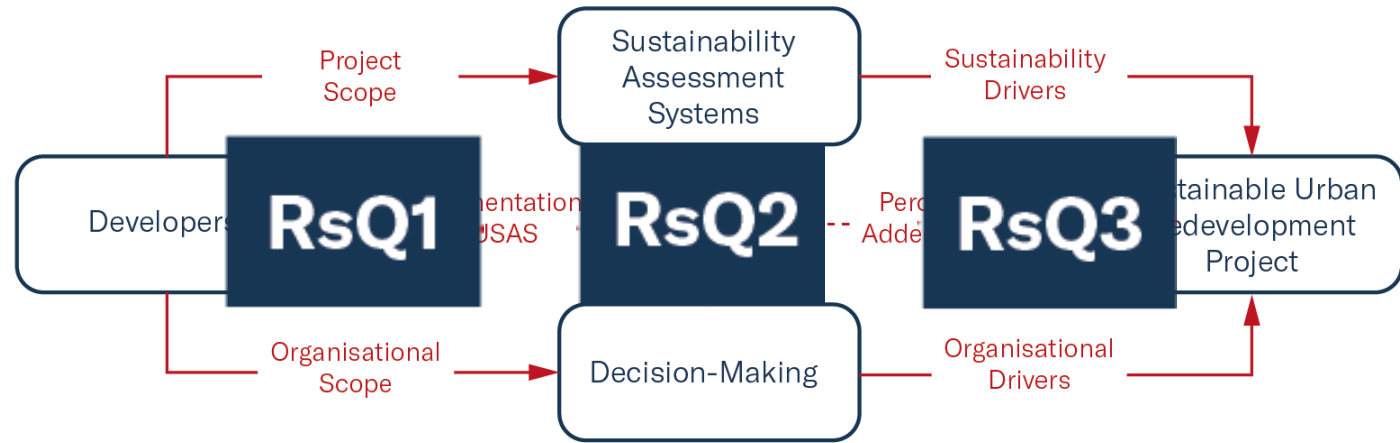

Figure. 3
Conceptual Model

5.3 Empirical Lessons

Recommendations to DGBC

Research Goal:

to provide learnings based on the motivations, implementation and added value behind the use of USASs, for a potential improvement of BREEAM-NL Area and the practices related to it in the Dutch context

Figure. P 99

- Sustainability Assessment System Implementation
 - Communicate about the differences
 - Encourage external demand
 - Enhance intrinsic motivation
 - Ease implementation
 - Emphasize on the importance of an early implementation
 - Promote an integral team training
 - Emphasize on the relevance of assessment enablers
 - Enhance more efficient information management practices
 - **Maximise the potential benefit**
 - Direct Components
 - Indirect Components





5.3 Empirical Lessons

Recommendations to DGBC

Research Goal:

to provide learnings based on the motivations, implementation and added value behind the use of USASs, for a potential improvement of BREEAM-NL Area and the practices related to it in the Dutch context

- **Decision-Making**
 - Be optimistic about the influence of the reflective role
 - Dare to reflect on the perception of the guiding role
 - Acknowledge the limitations of the evaluative role

- **Sustainable Urban Redevelopment**
 - The chicken-egg paradox; strive for both



Data Coding and Structure

Research Question	Research Sub-Question	Concept	Sub-Concept	Category	Interview Questions
MRQ How can sustainability be enhanced from a private sector perspective in urban redevelopment projects?	Before RsQ1 Why do developers decide to implement USASs?	Sustainability Assessment System Implementation	Assessment Scope		
			Assessment Drivers		
			Assessment Barriers		
	During RsQ2 How developers' decision-making can be influenced by the implementation of USASs?	Decision Making	Organisational Scope		
			Development Process		
			Project Scope		
	After RsQ3 To what extent does the developers' implementation of USASs lead to a more sustainable urban redevelopment project?	Sustainable Urban Redevelopment	Perceived Added Value		
			Sustianability Drivers		
			Organisational Drivers		



5.4 Empirical Lessons

Recommendations to Dutch Developers

Research Goal:

to communicate developers about the positive impact that implementing USASs can have on their practices

- **Adapt to successfully implement**
 - Market benefits practices in alignment with societal goals
- **Recognize the scope out of the box**
 - Long term strategic planning and Risk mitigation
- **Seize the moment**
 - Competitiveness within the implementation curve
- **Reflect is pertinent**
 - Market recognition based on higher corporate ambitions
- **Evaluate is necessary**
 - Sustainability enabler in cost-efficient process
- **Implement is beneficial**
 - Means to accomplish corporate goals
 - Marketing, product positioning, premiums
 - Urban features as value source
 - Means to get external incentives (financing & planning)

6.1 Research Questions



- **RsQ1:** Why do developers decide to implement USASs?

Figure. P 98

6.1 Research Questions



- **RsQ2:** How developers' decision-making can be influenced by the implementation of USASs?

Figure. P 101

6.1 Research Questions



- **RsQ3:** To what extent does the developers' implementation of USASs lead to a more sustainable urban redevelopment project?

Figure. P 103 &105



“You cannot make a sustainable progress without making decisions.”

Adapted from Jim Rohn