



Delft University of Technology

TECHNICAL RESEARCH PAPER

THE MERGING OF A SKATEPARK INTO A
BUILDING THROUGH THE USE OF LOCAL
INDONESIAN WOOD RESOURCES

MATTEO BIELLA

4330757

biellaram@hotmail.com

Department of Architecture
Architectural Engineering studio 13

JANUARY 6th, 2015

INDEX

1	Abstract
1	Introduction
2	Methodology

CHAPTER 1: Skateboarding & architecture

4	1.1	The relationship between skateboarding & architecture
5	1.2	The 5 skateable elements of the built environment
8	1.3	From elements to components: skatespots
9	1.4	Skateparks: disambiguation & typology definition
10	1.5	Skatepark design process
13	1.6	Further considerations in skatepark design
13	1.7	Construction materials adopted
15	1.8	The possibilities of wood in facilitating the merging

CHAPTER 2: Local Indonesian wood resources

18	2.1	Introduction
18	2.2	Plantations by-product: Pros & Cons
21	2.3	Sengon
23	2.4	Teak
25	2.5	Bamboo
27	2.6	Oil Palm Tree
30	2.7	Coconut Tree
33	2.8	Rubberwood Tree
35	2.9	Skateboard Decks

CHAPTER 3: Conclusions (consult attached Flow-scheme)

38	3.1	Flow-scheme criteria
38	3.2	Selection of resources: reasons
39	3.3	Implementation of selected resources
39	3.4	Costs speculation
40	3.5	Labor hours
41	4.1	Endnotes
42	4.2	Literature

Abstract

The skatepark is an architectural typology in constant evolution since the moment it has been introduced in the U.S. in 1976. Designers developed such a typology from a mere “fenced space filled with ramps” into a much more complex that define skateparks as urban facilitators of activities in the city.

On the other hand, from an architectural point of view, such a definition can be deepened much more. Specifically, skateparks can be merged, to some extends, into the architectural parts of a building (roof, walls, pavement) and ultimately define the building itself through a ‘total merging’ which has never been attempted before.

Such a ‘total merging’ has been objectified in a flexible and sustainable design solution located in Bandung (Indonesia) that, given the specific context, could only take place throughout the use of non-traditional local Indonesian wood resources (rubber tree, coconut tree, oil palm tree).

Common criteria such as local availability and extension of plantations have been outlined to have real data on which to base the choices in the proposed design. Other more technical criteria helped to understand structural potential or weaknesses of the woods to further identify which wood was suited best for.

A final flowscheme has been produced to show in detail the industrial and technical processes that woods undergo from raw material to elements or components in a building. From this, it can be inferred a speculation on implied costs, labor hours, sustainability level in order to grasp the effectiveness of the proposed design.

Therefore, this research paper aims to investigate how the strategic use of local Indonesian wooden resources can facilitate the construction of an hybrid building/ skatepark in Bandung (Indonesia).

Keywords: Skateboarding, Skatepark, Wood, Indonesia, Bandung, Plantation by-product, Bamboo, Coconut tree, Rubber tree, Oil palm tree,

Introduction

It is a matter of fact that people use cities in ways different to how architects and planners intended them to be used.¹

Bernard Tschumi, by affirming that *architecture is defined by the actions it witnesses as much as by the enclosure of its walls* comes in support of that statement.

In this regard, skateboarders are the perfect example of city-users that give a new meaning to the urban environment by interpreting it in a very functional way.

On the other hand, over the years, municipalities kept fighting against skateboarders because they were literally destroying the urban environment and because they were considered as a ‘dangerous species’ for other pedestrians or city-users. In order to make the city safer, skateboarders have been pushed away by providing them a specific place: the skatepark.

Initially, skateboarders appreciated this new ‘architectural typology’ as it was perceived as a new gathering spot for youngsters sharing the same passion beside being free to skate without getting fined by police (skateboarding was declared illegal in many U.S. states in the ‘80s and ‘90s).

Later on, being skateboarding a naturally evolving discipline that constantly requires new challenges, skateboarders realized that artificially built skateparks were unable to meet their needs as they were limiting their capabilities and as a result they went back to the streets (the built environment). Moreover, skateparks were commonly built in leftover or downgraded areas of the city, far away from their centers and from basic facilities such as supermarkets. This facilitated criminal activities to take place inside skateparks and forcing skateboarders to go back to the streets.

These phenomena pushed skatepark builders, architects and planners to think the design of a skatepark as an architectural challenge,² being an interactive public space with specific topological requisites and social implications.

Therefore, in the last 2 decades, skateparks have been designed more consciously, hosting other functions and

Methodology

actually becoming 'urban facilitators'.

From an architectural point of view there is still a lot to improve to make skateparks efficient urban facilitators. For instance, a skatepark can be merged on different levels into the building that usually host it and a total merging, from a thorough case studies analysis, has never been attempted yet.

The 'total merging' is a fascinating architectural challenge that this paper has undertaken in order to investigate the possibilities and limitations of local Indonesian wooden resources (see Chapter 2) as the main construction material.

The proposed design of the 'total merging' (see attached Flowscheme in Chapter 3) has been proposed in the city of Bandung (West Java, Indonesia) and for this reason the research on wooden resources has been narrowed down to only locally available wood resources. More specifically, the research focused on the so-called plantations by-product (rubber tree, coconut tree, oil palm tree) as neglected wooden resources with a great but unexplored potential since they have been started to be exploited only in the last few decades.

To achieve the 'total merging' in a sustainable and concrete way, it has been necessary to implement these plantations by-product woods instead of the more traditional Indonesian woods (i.e. teak, sengon, mahogany and other hardwoods).

Chapters 1 and 2, dealing with different topics, are detached from each other and are meant to give the necessary background knowledge on which to base the choices taken in chapter 3.

The proposed design in Chapter 3 can finally give an answer to my technical research question:

"how can the strategic use of local Indonesian wood resources be implemented to facilitate the construction of an hybrid building/skatepark in Bandung?"

Since the research paper deals with 2 distinct subjects (the merging between skateboarding and architecture in chapter 1 and local Indonesian wood resources in chapter 2) the investigation methodologies implied resulted to be different as well.

Given the specificity of the topic in chapter 1 and being the literature consequently scarce, Chapter 1 mainly focused on a thorough case studies analysis that helped to have an insightful overview on the topic. Personal considerations and experience, when considered relevant for a complete understanding of the topic, have been implemented. Sometimes research by design has been implemented in a few sub-chapters to replace the lack of information on the topic.

An external booklet of Case studies has been produced and can be consulted in order to have a broader overview / knowledge on the topic, Nevertheless Chapter 1 is self-explanatory and does not need the external booklet to be understood.

Chapter 2, dealing with more objective and quantifiable data, has been developed based on literature resources, most of which are technical research paper, books, or information readily available on-line.

Based on the previous chapter, research by design has been the key for the realization of chapter 3. Data has been assessed and evaluated in accordance with declared criteria. A Flowscheme that can be found in attachment to this research paper, has to be consulted for a thorough understanding of the conclusions drawn in Chapter 3.

Another bonus booklet, studying the implementation of discarded or broken skateboard deck in architecture, has been produced but not included in this paper as it deals with a too much narrow topic which is not considered crucial. Nevertheless, the bonus booklet extends in some points the knowledge on some topics discussed in this research paper.



Chapter 1

SKATEBOARDING AND ARCHITECTURE

1.1 The relationship between skateboarding & architecture

The relationship between skateboarding and architecture is twofold.

Firstly, skateboarding is dependent on architecture as it requires a built environment to be executed. Secondly, on the other hand skateboarding is a form of architecture criticism since it rejects any predetermined use of space and all the hierarchies that the architect has created.¹

Nonetheless it is clear that the study of such a relationship is relevant for a deeper understanding of the built environment (the city) as a social value instead of a mere set of physical objects. Furthermore, the city can be perceived from a skateboarder point of view as a set of spatial experiences,² as continuous opportunities that require a personal level of interpretation of the cityscape.

Such an **interpretation**, defined as the encoding process that takes place through the “skateboarder’s eye” looking at the city, sets the very first stage at the base of the relationship between skateboarding and architecture.

It happened originally in a spontaneous manner when the surfers were trying to replicate their moves on the waves by skating onto the concrete ground of the city: downhill or anything sloping-down terrain and emptied pools later on were interpreted as the only skateable ground.

The second stage that defines the relationship skateboarding-architecture occurs with the **reproduction** of the built environment in an artificial way.

In the early '70s, along with the rise in popularity of skateboarding as a fashion on the same wavelength of roller disco and CB radio,³ and the invention of the first tricks, skateboarders started to build customized obstacles in order to speed up their learning curve and to improve their skills.

Skateboarding here is still very dependent on the built environment but it declared itself as able to influence it instead of just interpreting it.

Skateboarding showed its leverage on the built environment as able to directly af-

fect it when in 1976, in Florida, a brand new architectural typology was established: **the skatepark**.

Followed by other 300 across the U.S. in the following years,⁴ mostly poorly constructed due to the lack of knowledge in regards to how to design and build them, skateparks were the clear architectural objectification that resulted from the previous interpretation of the cityscape and its consequential physical reproduction in an artificial way.

Thus, skateparks embody the third stage of the relationship between skateboarding and architecture.

From this moment of the history onwards, skateboarding has merged into architecture more on a physical level, demanding for clear boundaries (fences) together with the improvement of construction materials and techniques for building skateparks.

This merging occurred from that moment on different levels. Skateparks started to be built under bridges or flyovers, in leftover spaces of the cities as well as in their centres, rehabilitating old factories or self-standing as brand new facilities.

Material experimentation brought discarded marble, unused old-factory steel elements (see: **Case Studies booklet**), scrap woods from construction sites, old tiles taken off old buildings to become integral parts of very successful skateparks.

In relation to construction techniques skateparks could be built by specialized companies as well as by skateboarders themselves(X) or being sponsored by informal local association of skateboarders, municipalities or even entirely sponsored by famous sports brands as it seems to be the rule in the last decade.

The next level of merging it is possible to foresee, still unexplored and hence unattempted, would imply the total blending of a skatepark in within the building, where the roof, the load-bearing structure, the exterior and interior partitions, the foundations and so on would cooperate as a whole.

It is the aim of this research paper to analyze what are the possibilities and solutions in this regard.

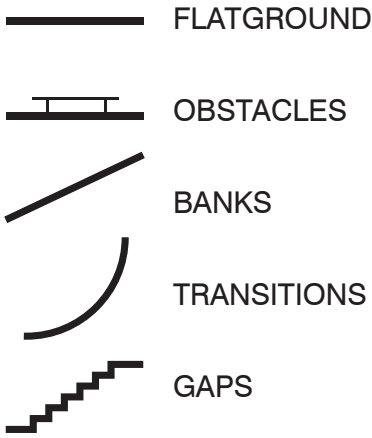

Fig. 1.2.1

(own illustration)

The 5 basic elements that are elaborated by skateboarders through the so-called "skateboarder's eye".

Fig. 1.2.2

(own illustration)

Flatground could be considered at the base of all the elements. Without its presence all the other elements would be very hard, if not impossible, to be skated.

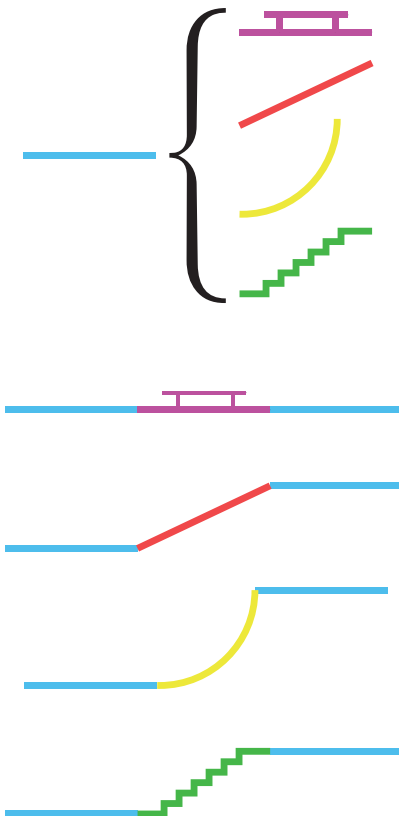

1.2 The 5 skateable elements of the built environment

Skateboarding is an evolutive discipline that has changed a lot from its early days. Peaks of activity have occurred four or so years, directly reflecting changes in technology and product development, public sentiment, facility availability, and economic climate.⁵

On the other hand, after the first few decades in which skateboarding was evolving very fast and many were the experimentation of what could be skated and how, a series of 5 skateable "elements" was to some extent set in the mind of every skateboarder.

These "elements" refer to the architectural manifestation that has been taken over by skateboarders and after a process of interpretation through the so-called "skateboarder's eye" has been given a brand new meaning to it.

The 5 elements, in an evolutive order from the most spontaneous one, are: Flatground, Obstacles, Banks, Transitions, gaps. (Fig 1.2.1)

FLATGROUND has to be considered the very fundamental element since it allows skateboarding to take place in its simplest form: freestyle.

Furthermore it works as a gluing element between the other 4 elements, like mortar between the bricks, giving the possibility to the other 4 elements to exist and as a consequence, to be skated. (Fig 1.2.2)

It can be made of Concrete, wood, metal, tiles, stones, composite material; virtually anything that is smooth enough but not slippery can be used as a safe skateable flatground.

Flatground can host a whole series of different type of obstacles.

OBSTACLES are simple objects on which to perform a trick.

Obstacles are very commonly found in the urban environment and can be nearly everything: poles, hydrants, guard-rails, traffic dividers, even cars as long as the skateboarder's eye is creative enough.

Obstacles can be skated in as many

ways as the creativity allows it, but it can be stated that there are 3 main ways. (Fig. 1.2.4)

When flatground is split in two height levels but still linked by sloping flatground it breeds a new element: the bank.

BANKS can easily be defined as sloped skateable flatground.

An average bank requires a slope of around 30° , with a maximum of 45 degrees and a minimum width of 1.2 meters⁶ to allow enough room for performing certain kind of tricks.

Banks are not a common elements in the urban environment. The skateboarder can interpret and skate them in generally 3 different ways. (Fig. 1.2.4) Banks can also be formally declined in another standing-alone element: transitions.

TRANSITIONS are defined as curved flatground skateable surface (with a constant radius).

Transitions necessitate a minimum radius of 1.8 m to be skated with ease,⁷ whereas 2.1 m is considered the optimal radius together with a height of 1.5m.⁸

Transitions are commonly called quarters as they resemble $1/4$ of a full pipe.

Transition is the hardest element to be found in the urban environment, and it is normally made out of concrete, such as in the case of dikes, pools, or any other architectural possibility or metal in the case of sculptures.

The skateboarder can interpret transitions is 3 main ways. (Fig. 1.2.4)

The last and much common element occurs from the breakage of the flatground continuity, creating in this way a gap.

GAPS are defined by two flatground elements interrupted by a non-skateable surface.

Gaps can be of any size and length and they do normally imply a split level as they force the skateboarder to ollie (jump) from the higher flatground to the lower one.

Gaps are the most common elements after flatground and obstacles and very much appreciated in the last two decades as they

define the purest form of skateboarding: street-skating.

Gaps can be skated in only 1 way. (Fig. 1.2.4)

Below a summarizing diagram representing the variables involved in the definition of every element as skateable. (Fig. 1.2.3)

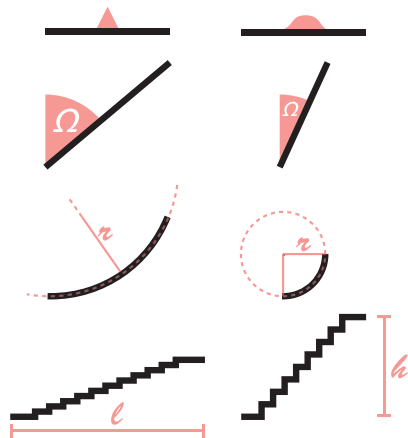

FIG. 1.2.3

(own illustration)

The skateability of the elements (excluding flatground) is dependent on a few variables.

OBSTACLES' skateability depends on their **SHAPE**

BANKS' skateability is greatly affect by the slope **ANGLE**.

TRANSITIONS are skateable depending on their **RADIUS**.

GAPS skateability is affected by the relationship between **LENGTH** and **HEIGHT**

OBSTACLES

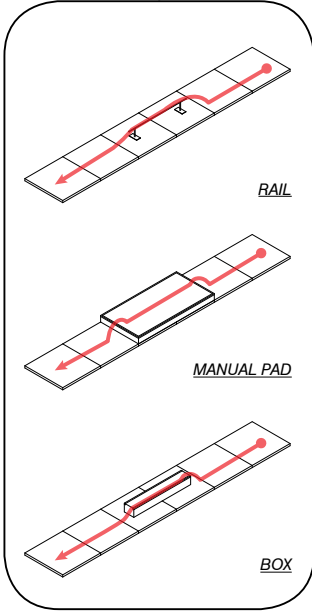
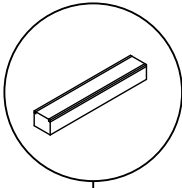

BANKS

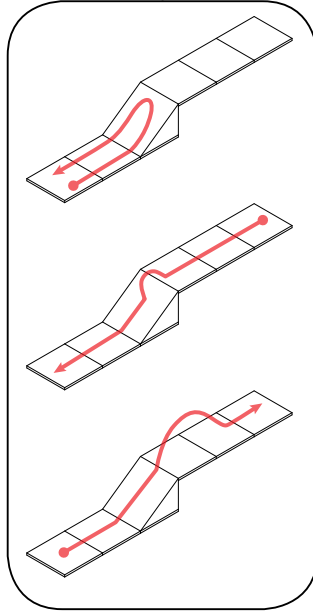
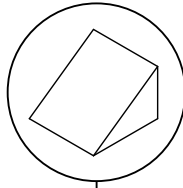

TRANSITIONS

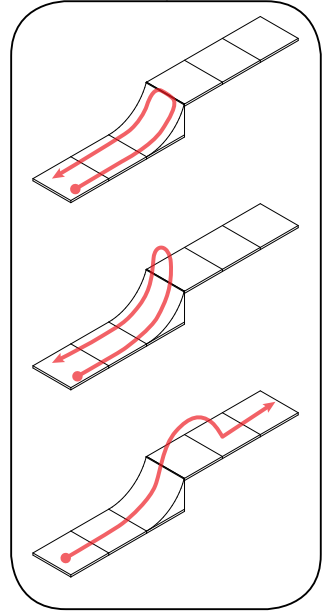
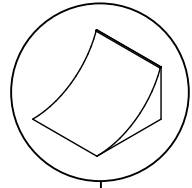

GAPS

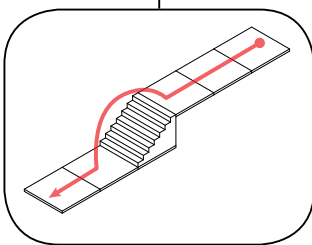
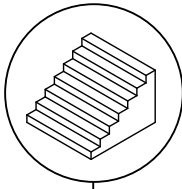

Fig. 1.2.4

(own illustration)

OBSTACLES can be **RAIL** (for mainly sliding), **MANUAL PADS** (for equilibrium tricks on 2 wheels), **BOXES** (for mainly grinding).

Tricks are performed onto the obstacles.

BANKS and **TRANSITIONS** can be skated in 3 ways.

GAPS can only be skated in 1 way.

Fig. 1.3.1

(own illustration)

GAP+OBSTACLE combination, with the help of **FLATGROUND**, creates a skateable **COMPONENT**.

If this component is found in the built environment it can be called **SKATESPOT**.

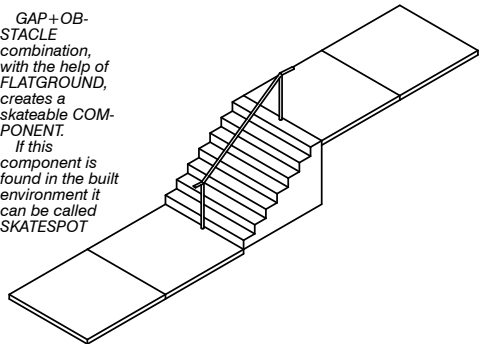

1.3 From elements to components: skatespots

The 5 basic elements are often found in the urban environment individually whereas it is way harder to encounter them in a functional combination based on the skateboarder's eye point of view.

A clear example is a staircase with a handrail. (Fig. 1.3.1) Staircases are meant to facilitate the flow of pedestrians on a sloping terrain or to connect two split levels. On the contrary, skateboarders see the element "GAP" alone or the combination of elements "GAP + OBSTACLE" and the possibility to perform different tricks accordingly.

The physical combination of "Staircase + handrail" refers to the abstract combination of the two elements "GAP + OBSTACLE" so that this last one can be referred as a skateable **COMPONENT**.

Therefore, components can be defined as the functional combination of two or more elements.

Due to the infinite possibilities of connections, components can not be cataloged in a fixed number as it was the case for the 5 elements, anyway it has been possible to identify the most common combinations patterns. (Fig 1.3.2)

In jargon, skateable components are generally referred as **SKATESPOTS**.

Skatespots are then defined as skateable components that pertains to the built environment with an original function/purpose which had nothing to do with skateboarding.

According to the last given definition, it is of paramount importance to remark that skatepots are only belonging to the spontaneous built environment and they exist only when the skateboarder's eye has been able to codify them as skateable, for this reason it is not possible to talk about skatepots inside skateparks.

In skateparks, components are artificially linked together in order to facilitate the skateboarder's learning or to challenge him. In such a context components are artificial and normally called ramps or structures.



Fig. 1.3.2

In order from left

1) Flatground is used to speed up, hitting a obstacle that can even be interpreted as a very steep bank allows the skater to jump off of it.

2) A parked car on the flatground is seen as a slideable obstacle

3) A passage in a bank is seen as a gap, on which to perform a trick

4) Vertical flatground is interpreted here as skateable, to do so a gap before the vertical flatground has to be cleared in order to land into a bank

5) The peculiar column of a bridge has the characteristics of a transition, the bridge itself is seen as a vertical flatground obstacle that can be ridden

6) Flatground merges into a transition. This is used as a ramp to perform a trick in the air without touching the obstacle

7) a typical pattern: the gap is cleared performing a trick (grind) on the obstacle "handrail"

8) another very common pattern: flatground is used to take the run-up to the gap, which is cleared by a trick (flip) performed in the air, and to land the trick.

Fig. 1.4.1

(own illustration)

Skateparks typologies based on elements presence, absence and their recurring frequency

LEGEND:

- NOT PRESENT
- HIGHLY FREQUENT
- RATHER FREQUENT
- RARE
- OPTIONAL



STREETPARK				
SKATEPLAZA				
MINIRAMP				
BOWLPARK				
ALL-ROUND P.				
STRAKERUN				

1.4 Skateparks disambiguation & typology definition

First of all a clarification: skatepark is a word with a general and confusing meaning nowadays where a message of exclusion is implicitly sent.

Although it usually refers to a shorter way to say skateboard-park, it could also be misinterpreted as a park for the practice of in-line skating.

As a matter of fact skateparks can also fit the needs of in-line skaters as well as those of BMXers, push scooter, and other less popular practitioners such as, street-boarders, snake-boarders and so on.

Secondly, the skatepark, thus meaning here an area designated and equipped for skateboarding⁹ refers to a general architectural typology whereas other terms such as streetpark, skateplaza, bowlpark can define more sharply how such a skatepark is designed, based on the presence, absence or the recurring frequency of the skateable “elements” (excluding flatground since its presence is obviously implied).

It has been possible to identify 6 skatepark typologies out of a thorough selection of case studies analysis and the diagram (Fig. 1.4.1) is graphically listing them.

Whereas the first 5 typologies are very well established, the 6th (snakerun) is an old-school one which already had little success back in the days, but it has been included in the list because it gives a richer overview on what skateparks can look like although not built anymore.

Furthermore, skateparks typologies greatly differ on the way they are skated, or on the flow they generate, for this reason a diagram (Fig. 1.4.2) has been created with the intent to juxtapose the typologies also based on the possible achievable flows.

Fig. 1.4.2

(own illustration)

Skateparks typologies differentiated according to the flow they can generate.

LEGEND:

- LINE
- START LINE
- TRICK PERFORMED
- END LINE

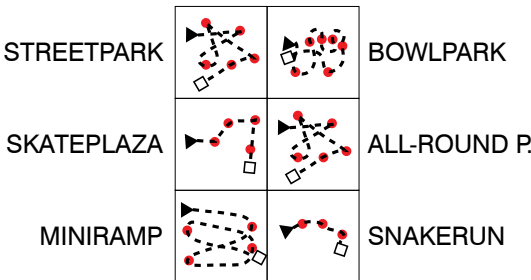

1.5 Skatepark design process

An average size for a small but complete street skate park is around 3000m²;¹⁰ unless a skating surface is at least 30mx40m it is difficult to provide enough diversity to sustain the interest of beginners, intermediate and extreme skaters.¹¹

An area of 3000m², within a rectangular perimeter of for example 40x75m, should be enough to provide more than 1 flow, differentiating in this way one for the beginners and another one for more advanced users.

The design of a skatepark therefore consists of 2 main phases interconnected between each other: a **conceptual phase** (Fig. 1.5.1) which implies zone design, flow design and rough ramp location design, and a **technical phase** (Fig. 1.5.2) where the skatepark comes together by determining the final dimensions of the components, construction materials and techniques.

During the conceptual phase the designer must consider physical factors such as sun orientation to avoid skaters having collisions and getting blinded by the sun in case of an outdoor skatepark. For this reason it is recommended a north-south orientation.¹² Another important factor relates to the rhythm of the skatepark which is ultimately defined by the distance between the ramps. The closer the obstacles the faster the park, and the more experience skaters must have to be able to use it. Obstacles placed too far apart will create too many dead spots.¹³

It is of paramount importance to avoid cross patterns because although they would maximize the usage of the available space, they are an invitation to disaster.¹⁴

Once the conceptual phase is over it has to be materialized throughout the technical phase.

First of all the ramps can be considered as artificial elements or components specifically designed in relation to each other so that their dimensions are in good proportion and will facilitate the good flow.

The number of components is not fixed

as they can amount to hundreds considering the many combination possibilities. In the diagram (Fig. 1.5.2) are shown the most common ones used in the design of skateparks.¹⁵

Anyway, the most meaningful distinction it is possible to make discerns components into: internal, lateral and independent.

Lateral components need to give to the skateboarder enough speed in order to perform tricks on internal components. For this reason they are normally made of very much sloping banks or big transitions that connect an elevated flatground (table-top) to the main flatground surface of the skatepark.

On the other hand, internal components, have the characteristic to be mostly symmetrical, in order to be skateable in 2 directions, with smaller banks or transitions and filled with obstacles of all kind.

Independent components, which self sustain the flow of skaters, are only mini-ramps and vertramps.

Furthermore components can also be divided into high-speed or slow-speed.

The intermediate and advanced areas of the skatepark can be filled with high speed components such as fun-boxes, pyramids, quarter pipes, allowing a minimum of 5m and a maximum of 10m for setting up.¹⁶

In the beginner area components can be roughly the same as those in the more experienced areas but simply scaled down and slightly modified (less sloped banks, lower quarters with bigger radius) in order to reduce speed. In this way components can be placed closer between each other.

Fig. 1.5.1 CONCEPTUAL PHASE
(own illustration)

- | | |
|--|---|
| ■ Slow speed zone | ■ High speed zone |
| ■ Medium speed zone | ■ Independent zones |

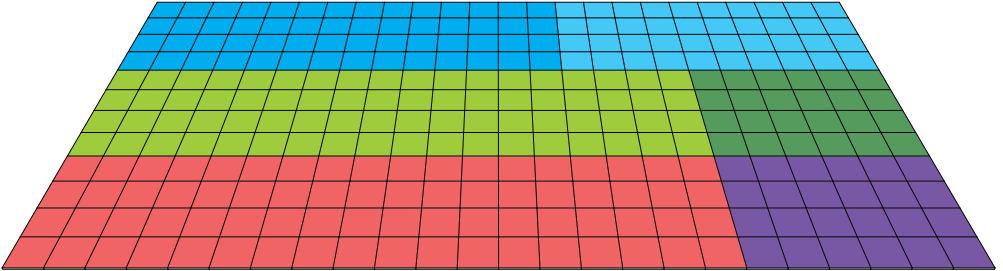

Zone design: in this example an area of 24x12 flatground tiles has been carefully zoned in order to have a fast-speed area, a medium speed one, and a low speed one, together with 2 independent areas.

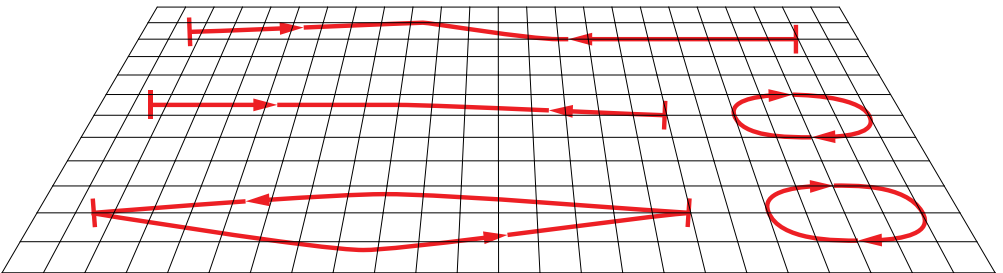

Flow design: subsequently, it has been avoided the creation of cross patterns so that skateboarders will flow from left to right in the stretched zones and in loop in the smaller zones.

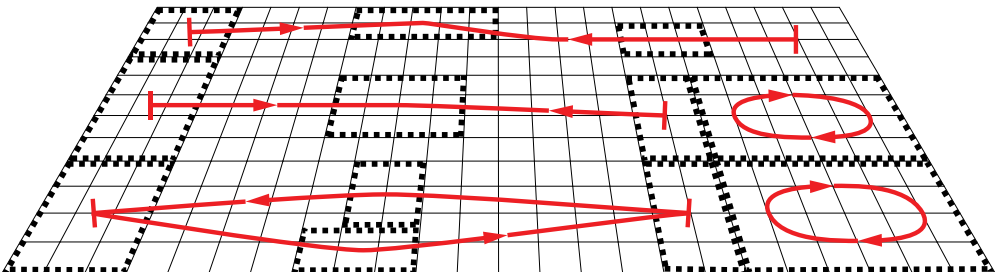

Ramp location design: every flow line will start from a lateral set of ramps, and will end in its opposite set of ramps, hitting another set of ramps on the way. The set of ramps will take form in the technical phase.

Fig. 1.5.2 TECHNICAL PHASE
(own illustration)

int Internal components
ind Independent components
lat Lateral components

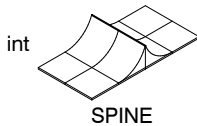
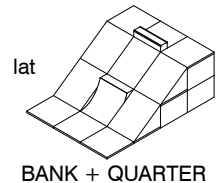
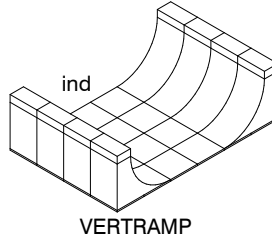
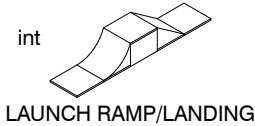
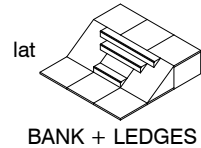
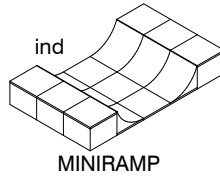
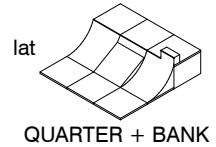
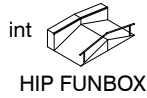
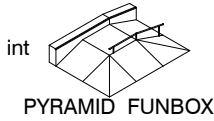

Artificial components design: Artificial components get initially defined in both materials and dimensions to be individually proportionated.

Final dimensions will be determined based on the reciprocal distance between all the components.

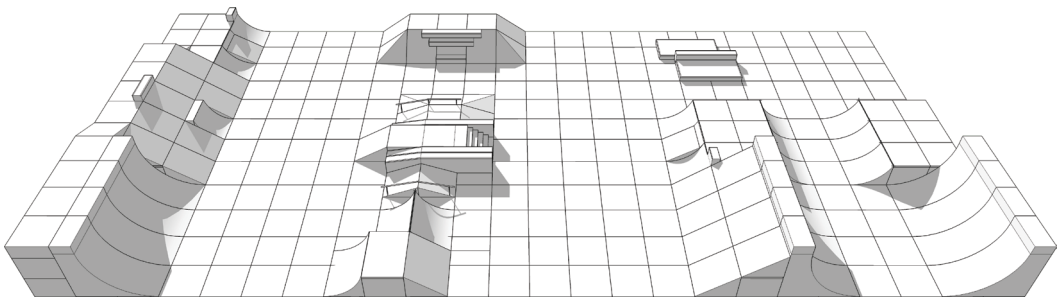

Final Skatepark: Additional connections between artificial components can be made to increase the flow of the skatepark. The miniramp has been linked to a lateral component as well the vertramp. The internal components, being all merged into each other, are also hard to distinguish as individual ones.

What is important to underline is that the surface of the skatepark is still mainly composed by flatground tiles. This is to underline the importance of Flatground as the most present element in a skatepark.

1.6 Further considerations in skatepark design

The success of a skatepark, beside its specific design is given by a whole series of other factors, from sociological to economic aspects.

Some of the most important points to be explicitly addressed in any skatepark design are given as follows:

LOCATION A skatepark acting as a facilitator where urban sport, street culture and youthful souls all meet together¹⁷ is able to highly influence its surrounding. Unfortunately skateboarding is also a noisy practice so that it has to be avoided in specific areas. As it was the case, the trinity skatepark in Milan, the only indoor skatepark of the city has been shut down due to the continuous complains of the neighbors.

OWNERSHIP There can be big differences between public and private skateparks.

Public-owned skateparks, especially in small towns, happen to be built with a tight budget, scratching on material quality and skilled-labor. As a result they do fail to work as urban facilitator since skateboarders tends to go back to the streets.

On the other hand, private skateparks, due to an entrance fee, opening-closing time and "rules", are also sometimes avoided by skateboarders.

A good solution would be to involve skateboarders themselves in both design and construction, with the help of non-lucrative association for the management of the facility.

MAINTENANCE Skateparks tend to deteriorate according to the material (see: [next sub-chapter 1.7](#)) used in construction and to whether it is indoor or outdoor. Having programmed maintenance every few years by the constructors or qualified labors is the key to keep it alive.

1.7 Construction materials adopted

In the case of the construction of an outdoor skatepark, external factors such as minimum/maximum temperatures, amount of annual precipitation, relative humidity have to be carefully addressed in the choice of the main construction material.

Concrete is considered the utmost material in skatepark construction. It is long-lasting, highly flexible as it can be cast in all kind of shapes and relatively cheap.

On the other hand it is labor-intense, it requires skilled-labor carpenters for a good qualitative final result and a great effort has to be put in the set up: the fill, the re-bars, the form-works, everything has to be well organized and on point before the casting process.¹⁸

A well polished concrete surface can be very fast while providing a nice grip, without producing too much noise

Concrete is a great material that facilitates the D.I.Y. Philosophy of building a durable skatepark, as in the case of the *Burnside skatepark* ([Fig. 1.7.1](#))

Wood (lumpers for the structure and plywood as final surface) is another popular choice in skatepark construction, most of the cases for indoor solutions.

Compared to concrete, wood is a much more expensive material but it requires less assembly time and labor cost unless curved transition or corners have to be built.¹⁹

The main advantage over concrete is that wooden ramps, being detached from the flatground, can be moved, disassembled and re-assembled somewhere else, increasing the level of flexibility of the skatepark. Furthermore, in case of bail wooden ramps will, to some extent, absorb the impact.

A well sanded wooden plywood surface gives a nice feeling of riding but it will decay in few months so that they would require constant maintenance. The problem is easily solved by applying a final layer of (costly) specific composite material, masonite or MDF.

Wood is a great material for indoor

solutions that require a certain degree of flexibility as in the case of the *die welle project* (Fig. 1.7.2) or fast built and temporary outdoor solutions as in the case of the *CONS project in Barcelona*. (Fig. 1.7.3) Another material widely used in skatepark construction is metal.

Metal (mild steel for structure and aluminum for final ramp surface) is always used as a cheaper option for outdoor skateparks due to its very good weather resistance, durability, low maintenance.

On the other hand it easily radiates heat, it can cause glares and the final skateable surface can become very slippery in a humid environment.

Furthermore it is the most noisy among the 3 material listed and the feeling of skating metal ramps is awkward and generally unpleasant.

Metal is the ideal material for building independent small and durable ramps/structures that can be assembled/disassembled to make an ever-changing skatepark as in the case of the *CONS space Berlin*. (Fig. 1.7.4)



Fig. 1.7.1

Burnside skatepark in Portland, Oregon, U.S.

The use of concrete (durable and plastic) allowed the construction of one of the best skateparks in the world, Made from skaters to skaters.

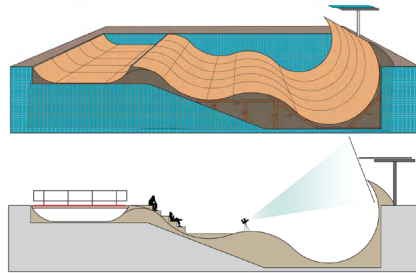

Fig. 1.7.2

Wood has been exploited in this project (not realized) to rehabilitate an empty pool without affecting its integrity.



Fig. 1.7.3

CONS project in Barcelona. Wood exploited to build flexible/movable skateboard ramps set on discarded trucks.

The temporary skatepark designed for the event has been built in a few days with wood since it is a fast and nice material when durability is not a concern. Wooden ramps have been shaped to resemble the "Converse Logo", sponsor of the event.



Fig. 1.7.4

Metal exploited in the construction of durable and movable skateable elements that can be arranged together to create more interesting skateable components.

1.8 The possibilities of wood in facilitating the merging

From the analysis of selected case studies regarding both architectural solutions that facilitate skateboarding and wooden skateparks construction, it will examine the potential of wood as a facilitator for the merging process of a skatepark into a building. After a thorough case studies analysis it has been possible to identify 5 merging possibilities. (Fig. 1.8.1)

WOODEN SKATEPARKS

Wood can be used in skatepark construction for both the load-bearing structure as well as the final surface.

In case of the main structure there are 2 common solutions: the more traditional frame-building construction (Fig. 1.8.2) or the more recent profile-building construction.²⁰ (Fig. 1.8.3)

The choice of a solution over the other is mainly dictated by economic concerns, in fact the frame-building solution is way cheaper since it implies the use of lumbers instead of highly engineered plywood and it optimizes the material usage, making frame-building ramps also lighter.

Frame-building construction is clearly exploited in the Bastard Bowl in Milan, (Fig. 1.8.4) where the main concerns were weight as well as an aesthetic and pleasant result. The 200m² bowl has been built as light as possible in order to be suspended on top of the products depot warehouse. The use of wood in general has facilitated the prefabrication of the Glue laminated elements in the factory and as a result the assembly process has been fast and precise. In this specific case it has been necessary the use of steel for creating a solid belt on which to secure the wooden construction.

The profile-building construction can on the other hand be seen in the casa Pas project. (Fig. 1.8.5)

Being uniformity as well as a sense of coherency the main concern in this project, this was the ideal construction solution for

a solid and faster assembly.

Profile-building is also normally exploited in the construction of temporary skateparks for events, as in the case of the CONS Space in Barcelona. The main need of fast and easy assembly and, in this case, also the cheaper cost of the structural plywood were easily justified for a win-win solution.

Furthermore the structural plywood planks visible on the border of the ramps can be easily painted with sponsors, graffiti, or solid colors giving the profile-building construction solution a further aesthetic meaning.

WOODEN BUILDING

The Yunnan library in China (Fig. 1.8.6) is a good example of how segments of a building, in this case roof and walls, can be merged into a single surface that resembles a new skateable component.

Although not skateable due to the lack of appropriate paneling, it could be imagined as an amazing skatespot in case it would be added.

The use of wood for a structural solution that recalls the above-mentioned frame-building construction facilitated the external surface to be flexible and smooth, while at the same time adding architectural value to the interior library.

The Yokohama port terminal, (Fig. 1.8.7) on the other hand, exploits wood only as a surface material and has been able to actually facilitate skateboarding although it was not meant to do so.

Being a long and narrow building with a strong predetermined directionality, the project blurs the distinction between architecture and landscape and allows skateboarders to see in it a perfect skatescape, since the orientation of the wooden planks used as a flatground flows in the same direction of pedestrian motion.

The roof of the port terminal is a unique wooden surface that facilitate skateboarding to happen in one direction, avoiding dangerous cross patterns. The use of concrete would have caused a dangerous multi-directionality.



Fig. 1.8.4

*Bastard bowl,
Milan*

Fig. 1.8.2

*FRAME-
BUILDING
construction
technique*



Fig. 1.8.5

*Casa Pas,
Presented in
Bordeaux,*



Fig. 1.8.3

*PROFILE-
BUILDING
Construction
technique*



LATERAL
WALLS



1

ROOF

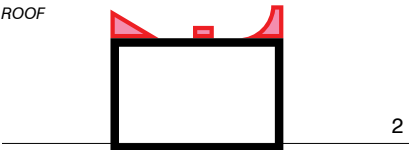

2

FLAT
GROUND



3

SUSPENDED

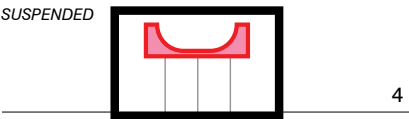

4

TOTAL
MERGING



5

Fig. 1.8.6

*Yunnan library,
China*



Fig. 1.8.7

*Yokohama port
terminal, Japan*

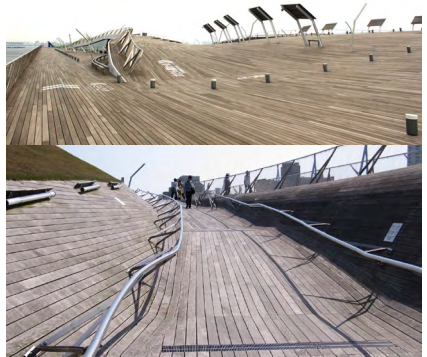

Fig. 1.8.1

(own illustration)

*The merging
of a skatepark
into architecture
can happen in 5
possible ways*



Chapter 2

LOCAL INDONESIAN WOOD RESOURCES

2.1 Introduction

This chapter is exploring what are the actual possibilities of local Indonesian wood resources as construction materials for a project in Bandung.

For this reason every wood resource has been individually studied and analyzed under 4 criteria that were considered relevant for an accurate overview in order to juxtapose their potential and weak points.

- **EXTENSION** of plantations
- **VOLUME** of available wood
- Possible **USES** of wood
- **COST / PRICE**

A distinction in regards to the local wood resources led to a separation into two main categories:

- **TRADITIONAL RESOURCES**
(Sengon, Teak, Bamboo)
- **NON-TRADITIONAL RESOURCES**
(Coconut wood, Rubber wood, Oil palm wood, Skateboard decks)

Such a distinction aims to underline the role of the emerging wood resources, also known as plantations-by-product, over the traditional ones. In this way it was also possible to add an important criteria to the analysis of the non-traditional wood resource category:

- **WASTE** material

In the end, the non-traditional wood resource “skateboard decks”, although it could look as a weird choice to be included in this paper, deserved a special attention and it has been developed a thorough analysis in a **Bonus Booklet** accompanying this research paper.

See **Fig. 2.1.1** for a graphical overview.

2.2 Plantations by-product: Pros & Cons

The most widespread plantations by-product (coconut, oil palm and rubber tree) but also many others such as cocoa, banana, pineapple can be very dangerous for the environment if not carefully planned.

The risks imply the fragmentation of habitats and ecosystems including plants and animals, loss of biodiversity, extreme land degradation and pollution due to the large quantities of pesticides and herbicides required to maintain these plantations.¹

These plantations by-product, especially the oil palm one, are also called “biological deserts” due to the lack of fruits, nuts, leaves, roots, nectar, bark, shoots, widely present in natural tropical rain-forests.

In Indonesia, forest loss for the harvesting of tropical hardwood and for converting land for agricultural crops started to become a serious concern in 1970s when industrial scale logging concession were first established. Drastic losses in the 80s and 90s left only half of the initial Indonesian tropical rain-forest.²

Specifically, according to a UN report, the establishment of oil palm plantations caused virgin tropical forest destruction from the 1990 onwards in both Indonesia and Malaysia.³

Realizing the destructive potential of Oil palm plantation, Malaysia established the RSPO (Round-table for Sustainable Palm Oil) with the aim to develop principles and criteria of a sustainable palm oil industry. In this regard, in 2006 Malaysia had also announced the Malaysian palm oil conservation fund (MPOCF). Conversely, the Brazilian government widely promoted the expansion of these kind of plantations only on degraded land.⁴

Furthermore the risks of such intensive plantations are reflected also on a sociological level with the aggravation of social conflicts, beside obvious land ownership.

Local communities face serious problems with the companies; there is a widespread feeling in the communities of being cheated by the companies or being

pushed into agreements through false promises without having a voice in decision making.⁵ Communities also fear that the labor condition would not be favorable if working for big companies.

Moreover many people depend on tropical rain-forests for food, shelter, economic needs, and continuation of cultural and spiritual traditions.⁶

On the other hand there, intense plantations by-product would bring socio-economic benefits as well, including poverty alleviation and long-term employment opportunities.

The Indonesian government, since the 1970s, started the so-called NES programs which implied the help from state-owned plantation companies to help farmers in growing oil palm. Plantations development policies were carried out in close relation with population redistribution through resettlement schemes or transmigration to stimulate the development of the outer islands of Sumatra, Kalimantan, and Papua.⁷ In such a way the Indonesian government created a lot of employment while engaging smallholders in state-led agribusinesses, but unconsciously laid down at the same time a fertile terrain fostering the destruction of great part of the tropical rain-forest.

Other more practical and positive aspects of plantations by-products relate to the tree logs as a valuable resource at the end of every rotation period, which varies according to the type of plantation.

In the past, for example, old rubber-wood trees of 30 years of age, unable to produce latex in good quantity, were simply felled and replanted with new ones. These logs were commonly destroyed at a cost⁸ or let on the plantations to rot, attracting in this way also dangerous insects such as the rhinoceros beetle (*Oryctes Rhinoceros*) that breeds in the decaying biomass and from there attacks the healthy trees.

Smallholders were not educated to foresee in felled logs a valuable resource or they were simply not willing to spend money in transportation costs for clearing them out since this is seen as an unneces-

sary extra cost.

Rubber wood, as well as coconut and oil palm woods needed applied research in order to understand its intrinsic potential and after having overcome a number of problems related to wood seasoning, preservation and the small size of the logs it developed as one of the most successful export timbers of southeast Asia.⁹

Coconut and oil palm wood, to be exploited as a wooden resource, had to overcome problems related to its nature as a monocotyledon, which makes it rather inhomogeneous along the trunk section. FAO and bilateral co-operation facilitated the applied research¹⁰ in this regard and these woods are also currently exploited in the construction industry.

INDONESIAN LOCAL WOODEN RESOURCES

TRADITIONAL NON-TRADITIONAL

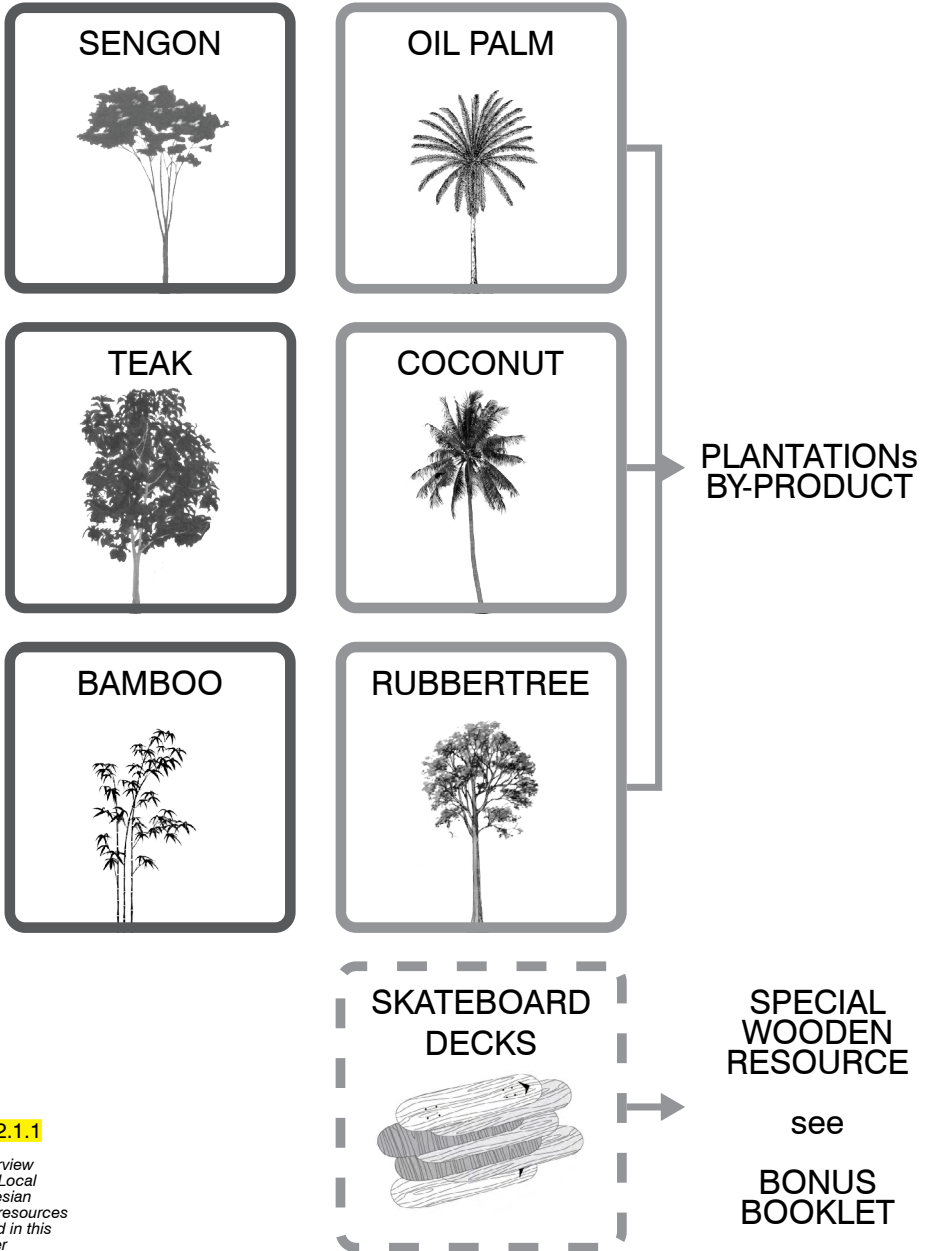

Fig. 2.1.1

Overview of the Local Indonesian wood resources studied in this chapter

SENGON



DENSITY 230 - 500 kg/m³
ROTATION 5 (intensive) 8+ (normal) years

WORLD UNKN
INDONESIA UNKN
JAVA ISL. 1.2 million Ha (2006)
W. JAVA 0.72 million Ha (60% of above)
BANDUNG 0 Ha

PLANTS x Ha 3000+ (intensive) 800(normal)
VALUE 79\$/m³

YIELD PROD. 221 million m³ (in 2005 in Ciamis)
YIELD AVER. UNKN

2.3 SENEGON

Paraserianthes falcataria is a native softwood of south-east especially cultivated in Indonesia. It is always been well appreciated by smallholders and wood-companies for its rapid growth rate, one of the fastest in the world; under favorable condition it can reach 7m height after 1 year, 16 meters after 3 years and 22 meters after 9 years.¹¹

Due to the low density of 230-500 kg/m³ sengon wood is easy to sawn, bore, glue and peel to produce quality veneers.¹²

In the last decade the demand of sengon increased dramatically, especially in 2009 its price has quadrupled,¹³ giving trouble to the Indonesian producers to supply such a heavy demand.

It has a rotation period of normally 6 to 8 years¹⁴ but it can be intensively exploited with a rotation of 5 years.

EXTENSION

Sengon is the major forest resource especially in Java island with an over 1,2 million hectares of plantations in 2005.¹⁵ From a report by the ministry of forestry and the national statistics agency, it is estimated that in West Java around 60% of sengon plantation are managed by smallholders.¹⁶

No precise data have been found on the hectares of sengon plantation in West Java region alone, but an extensive and very productive location resulted to be in Ciamis district.

VOLUME

Depending on whether the sengon plantation is managed by smallholders or a state-owned company, strategies to increase productivity and profit are more or less exploited.

Smallholders rarely intensify their plantations: as it happens in Kediri, East Java, they prefer to mix sengon trees with pineapple trees since the latter produce fruits every year, providing to them a constant income until sengon tree will be harvested

after 8 years from being planted.¹⁷ In this case there will be a density of 800 sengon trees per hectare.

On the other hand, in case of intensified plantations, a total amount of 3000 trees per hectare can be planted but 1000 trees have to be thinned at the 3rd year of age (diameter 15-20cm), further 1000 at the 4th year (diameter 20-25cm) and the remaining 1000 at their 5th year ($\varnothing > 25\text{cm}$).¹⁸

After 2 years sengon trees reached a volume capacity of 39 m³ per hectare, having a mean annual increment of 41.8 to 52.5 m³ ha⁻¹ yr⁻¹ over a lifespan of 12 years.¹⁹

Sengon timber production in Ciamis, West Java, increased dramatically from 2003 to 2006: the yield was recorded 50.399.935 m³ in 2003 and 221.584.347 m³ in 2006.²⁰

USES

It is commonly used as raw material in construction, especially for form-works

It is processed in planks, plywood, particle boards, both MDF and HDF, creating lightweight packing cases and boxes for transportation of material. Besides industrial uses it can also be used for furniture making and, curiously, disposable chopsticks.

Other uses are charcoal production and fuel wood.

COST

See table for an overview. (Fig. 2.3.1)²¹

Recently the price of sengon with a diameter of 30cm was oscillating between 800000 Indonesian rupee per m³ and 1 million if top quality. The diameter of the log is a big discriminant in the determination of the price.

Therefore, thinned logs can be bought for a fraction of that price and are always very much available.

Operator	Origin of wood	Products sold	Markets	Size requirements \varnothing DBH or dimensions	Prize paid IDR/m ³
Garat	Ciamis	Round logs to industry	MMP	\varnothing 10 – 14 cm	300 000 IDR
			Puruworejo (Central Java)	\varnothing 15 – 24 cm	350 000 IDR
				\varnothing > 25 cm	640 000 IDR
APL	Ciamis	lightweight interior panel	China	assortments: 15 x 5 x 130 cm	500 000 – 600 000 IDR
			Japan	16 x 5 x 130 cm	
			Tasikmalaya	17 x 5 x 130 cm	
	Garut	block board	Taiwan	18 x 5 x 130 cm	675 000 IDR
	Banjar	layered block board	Middle East	\varnothing 19 – 24 cm	
			India	\varnothing 25 – 29 cm	
				\varnothing > 30 cm	800 000 IDR
MMP	Ciamis	block board	Japan	assortments: 5 x 8 x 130 cm	Grade A: 750 000 IDR
			China	5 x 10 x 130 cm	Grade B: 700 000 IDR
	Tasikmalaya		Korea	5 x 12 x 130 cm	
			Taiwan	5 x 14 x 130 cm	

Where *Garat* = the intermediary/middleman operating in North Ciamis, *APL* = Albasi Prangan Lestari, Banjar, *MMP* = Makmur Maju Pallet Industry, Tasikmalaya, IDR= Indonesian currency, rupiah

Fig. 2.3.1

The prices paid for seller of P. Falcataria wood in Ciamis, West Java

TEAK



DENSITY 700 - 900 kg/m³
ROTATION 25 - 70 years

WORLD 2.25 million Ha (1995)
INDONESIA UNKN
JAVA ISL. 1+ million Ha
W. JAVA UNKN
BANDUNG 0 Ha

PLANTS x Ha 1200-1600 + thinning
VALUE 270 \$/m³ (Ø: 30cm minimum)

YIELD PROD. 0.82 million m³ (in Java)
YIELD AVER. 100 m³/Ha (after 70 years)

2.4 TEAK

Tectona Grandis is the most valuable tropical hardwood with a density of 700-900 kg/m³, widely esteemed for its aesthetic quality and for its durability. Teak, being a native tree of India, Myanmar, and Thailand, it has been managed intensively in Indonesia only after 1897 by a Dutch governmental organization.²²

The rotation period varies considerably according to the final desired product: teak for luxurious uses will have a rotation of 80 or more years whereas for uses in the construction industry the rotation can be of only 25 years.

EXTENSION

It is recorded that in 2004 there were 5.7 million hectares of teak plantations in at least 36 countries, India and Indonesia being the main contributing countries.²³

In Java the state-owned company Perum Perhutani manages 1,2 million hectares of teak plantations, including some very old naturally regenerated forests. Smallholders are normally not cultivating teak since it does not provide a constant income.

VOLUME

Teak has a low growth rate of around 10-20 m³ per hectare per year when young but it decreases to 4-8 m³ per hectare per year with age. Perum Perhutani itself declared that 470000 hectares of their plantations in Java have the best growing stock for producing timber with an average yield of 100 m³/ha after 70 years rotation.

Since the MAI (mean annual increment) gets very low, around 3 m³/ha/year, with the increase of the age, some producers even prefer to exploit this feature letting the plantation to get older so that the wood will be considered more luxurious and it will gain much more value on the market.

However, due to the very high demand of teak, shorter rotations of 20 or 30 years are becoming increasingly common, despite selling the tree with a lower value.²⁴ In Java,

Perum Perhutani's production is around 820000 m³ per year.

USES

Deriving its name from the Greek word "tekton", which means carpenter, it is clear that teak has long been considered to be the carpenter's pride and used in construction with all sort of structural purposes. Lately it is considered a luxurious wood mainly exploited in furniture making and ships.

COST

See table for an overview. (Fig. 2.4.1)²⁵

Normally teak is harvested after 25 years when the log diameter is at least 30 cm and its price is estimated to be around 270\$ per m³. The price can be much higher according to the age of the tree.

Age (year)	DBH (cm)	Price for farmer (US\$/standing tree)	Log volume after processing (m ³)	Log price to traders (US\$)
10	12 – 18	3 – 6	0.045 - 0.189	3 – 25
15	13 – 31	5 – 30	0.060 - 0.515	6 – 123
20	21 – 45	10 – 265	0.307 - 1.061	57 – 284
25	29 – 49	20 – 296	0.320 - 1.321	54 – 329

Fig. 2.4.1

The prices paid for teak depending on age and diameter at breast height (DBH)

BAMBOO



DENSITY 300 - 400 kg/m³
ROTATION 3 - 7 years (normally 5)

WORLD 36 million Ha
INDONESIA 2,08 million Ha
JAVA ISL. UNKN
W. JAVA 343604 Ha
BANDUNG 3925,9 Ha

PLANTS x Ha 665 culms
VALUE 0.4 - 1 \$ (raw) / 5 \$ (preserved)

YIELD PROD. 10 million tonnes (2005)
YIELD AVER. 5 tonnes/Ha

2.5 BAMBOO

Bamboo is a grass that is cultivated in Indonesia in a variety of 135 species: Bamboo tali (*gigantochloa apus*) and bamboo gombong (*G. pseudoarundinacea*) being the most common in Indonesia.²⁶

With a good strength-to-weight ratio and flexibility despite its medium density, it is nowadays intensively cultivated with a rotation period of no more than 5 years because bamboo older than 5 years gets harder and the inner culm wall becomes impermeable to the treatment solution.²⁷

Bamboo favors environmental conservation due to its rooting system that can effectively prevent landslides and soil erosion.

EXTENSION

Bamboo plantations amount in 36 million hectares worldwide, 24 hectares of which being in Asian countries. After India and China, Indonesia has the most extensive plantation area accounting to 2,081 million hectares in 2005. (Fig. 2.5.1)

West Java is the biggest cultivator of bamboo as it can be seen in Fig. 2.5.2.

From the "country report on bamboo resources of the year 2005" of Indonesia, the most extensive region planted with bamboo, accounting 343604 estimated hectares, is West Java.

Specifically, in Bandung district there are about 3925,9 hectares of bamboo plantations.²⁸

Curiously, Gunter Pauli affirms that with 500 m² of bamboo plantation are sufficient to harvest a house each year, so that it can be understood its intrinsic potential as a widely exploited construction material in the Indonesian context.

VOLUME

The average production per hectare of bamboo comes from the mathematical division of the whole stock of available bamboo in 2005 (around 10 million tonnes (Fig. 2.5.3) calculated considering 7,5 kg/

culm or 133 culms/tonne as an average) divided by the estimated area of 2,081 million hectares of bamboo plantations.

Therefore it is resulted an average of 5 tonnes/hectare.

Considering that every year a bamboo plantation produces 5 tonnes of bamboo, it is possible to esteem that in West Java alone there are 1718020 tonnes of available bamboo and in Bandung district 19629,5 tonnes.

USES

It can be considered one of the most versatile wood in the world. Culms in their shape of stick are used in construction for structural purposes, including scaffolding. When processed it can be laminated in boards, shredded into textiles or fibers for reinforcement. For outdoor uses it has to undergone a preservation treatment consisting in a bath of water mixed with borax and boric acid for 2 weeks.²⁹

COST

According to prof. Andry Widyowijatnoko of the ITB University in Bandung, an untreated 6m long bamboo culm could be sold on the local market for 5000 / 12000 Indonesian Rupiah (0,4 / 1 U.S. Dollars) whereas a treated one can reach the price of 60000 Rupiah (5 U.S. Dollars).

The fact that bamboo is more than two and a half times more cost-efficient for building material than wood, and more than 50 times cheaper than steel suggests that it should be considered much more in the construction industry.³⁰

Countries	1990			2000			2005		
	Naturally regenerated	Planted	Total	Naturally regenerated	Planted	Total	Naturally regenerated	Planted	Total
Bangladesh	80	10	90	76	10	86	73	10	83
China	2 789	1 087	3 856	3 235	1 634	4 869	3 354	2 090	5 444
India	7 844	2 867	10 711	7 996	2 867	10 863	8 434	2 927	11 361
Indonesia	624	1 527	2 151	690	1 414	2 104	723	1 358	2 081
Malaysia	422		422	592		592	677		677
Myanmar	951	12	963	883	12	895	847	12	859
Pakistan		9	9		14	14		20	20
Papua New Guinea	23		23	38		38	45		45
Philippines	124	3	127	153	3	156	168	4	172
Republic of Korea		8	8		6	6		6	6
Total	12 857	5 503	18 360	13 663	5 960	19 623	14 321	6 427	20 748
% of total	70	30	100	70	30	100	69	31	100

Note: Data on plantations in African and Latin American country reports are very limited and therefore not presented in the table.

Fig. 2.5.1

Characteristics of bamboo resources in Asia

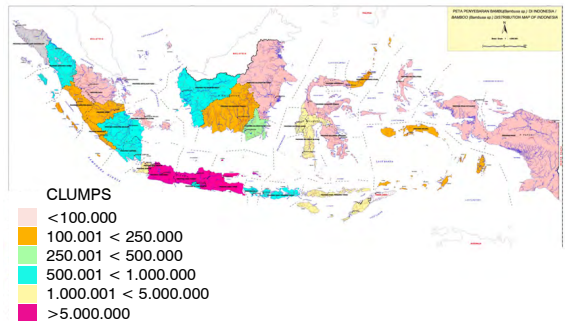

Fig. 2.5.2

Bamboo distribution map of Indonesia. Agricultural census 2003. National Statistics Agency

Country	1990			2000			2005		
	Stock (million tonnes)	Area (1 000 ha)	Average (tonnes/ha)	Stock (million tonnes)	Area (1 000 ha)	Average (tonnes/ha)	Stock (million tonnes)	Area (1 000 ha)	Average (tonnes/ha)
Bangladesh	1	90	11	1	86	12	1	83	12
China	96	3 856	25	144	4 869	30	164	5 444	30
India	115	10 711	11	117	10 863	11	122	11 361	11
Indonesia	13	2 151	6	11	2 104	5	10	2 081	5
Malaysia	7	422	17	10	592	17	11	677	17
Myanmar	18	963	19	18	895	21	18	859	21
Pakistan	0.09	9	10	0.14	14	10	0.21	20	11
Philippines	8	127	48	8	156	39	6	172	35
Total Asia	257	18 329	14	307	19 579	15	332	20 897	16
Ethiopia	21	849	25	21	849	25	21	849	25
Kenya	1	124	5	1	124	5	1	124	5
Nigeria	27	1 590	17	27	1 590	17	27	1 590	17
Uganda	3	67	37	3	67	37	3	67	37
United Republic of Tanzania	5	128	35	5	128	35	5	128	35
Total Africa	57	2 758	21	57	2 758	21	57	2 758	21
Total	314	21 087	15	364	22 337	16	389	23 455	17

Fig. 2.5.3

Growing stock of bamboo resources in Asia

OIL PALM



DENSITY 170 - 700 kg/m³
ROTATION 25 years

WORLD 16.4 million hectares
INDONESIA 7.32 million hectares (2009)
JAVA ISL. 0.03 million hectares (2009)
W. JAVA 0
BANDUNG 0

PLANTS X Ha 143
VALUE 40 - 70 \$ x m³

YIELD PROD. Unknown
YIELD AVER. Unknown

2.6 OIL PALM TREE

Elaeis guineensis, commonly known as Oil palm tree is a tropical plant from West Africa introduced in the "Bogor botanical garden", West Java, Indonesia in 1848.³¹

Being a plantation by-product, it has been intensively exploited especially in the last decade because it is more efficient than any other oil crop.

The density of the oil palm stem is generally low: the trunk has densities ranging from 170 to 700 kg/m³ depending on position along the height and cross-sectional zones.³² Generally, the density at the peripheral region is over twice the values of the central region. (Fig. 2.6.1) At any height level, the density decreased towards the center of the trunk. The mean density ranges from 485-575 kg m⁻³ (aver. 530 kg/m³) and 190-280 kg m⁻³ (aver. 235 kg/m³) at the peripheral and central regions respectively.

The rotation period for oil palm plantations is around 25 years, due both for decreased yield production and difficulties in harvesting since the oil palm tree has grown too tall, above 7 meters.³³

It is a monocotyledon as well as coconut tree, therefore it has no cambium, secondary growth, growth rings, ray cells, sapwood or heartwood, branches or knots.

EXTENSION

In 2006 Indonesia became the world's leading producer of palm oil with the biggest oil palm tree plantations area of 7,32 million hectares (2009). This number is expected to get closer to 32 million hectares (Fig. 2.6.2) in the next decades according to the plan from the "Directorate General of Plantation Production and Development" (DGPPD) of exploiting this plant since there is always an increasing demand of its oil.

Almost 85% of oil palm plantation are in south-east Asia with most of it occurring in Malaysia and Indonesia,³⁴ whereas the other 15% of the plantations are distributed in central Africa and Latin America.

Despite the first oil palm tree has been planted in Bogor, West Java, This region

has seen the exploitation of other plantations by-product, cultivating now only 0,03 hectares of oil palm tree (Fig. 2.6.3), having only in Bali a key plantation.

The growing worldwide interest in bio-diesel as an alternative to fossil fuel is expected to lead to the further expansion oil palm plantation,³⁵

VOLUME

Oil palm trees are planted on a triangular grid, keeping a distance of 9 meters from each other, achieving in this way 143 trees per hectare.

Due to the high inconsistency of the wood density along the trunk and depending on the method chosen to cut it, there could be a higher or lower sawn yield average, which is however hard to establish.

Sawn recovery can be very high if peeled with rotary cut.

In 2002, a study³⁶ showed that around 70% of the oil palm wood boards traditionally sawn in lumbers and kiln dried afterwards, had severe drying defects such as wavy deformations and internal checks, whereas the other 30%, coming from the peripheral region of the trunk and hence higher density, were free of defects. (Fig. 2.6.4) For this reason the sawn recovery rate could be around 30%.

This data is supported by the fact that in cross section, only 20% is high density wood coming from the periphery.³⁷ To increase this percentage, boards from the peripheral region having higher density but lower moisture content should be dried separately from the middle and the inner regions. This solution would rise the labor costs not knowing if it would be worthwhile due to the lack of experimentation in this direction.

To conclude, oil palm tree is not an easy wood to process because its fibers are looser, extremely wet and, if peeled, veneers tear easily too.

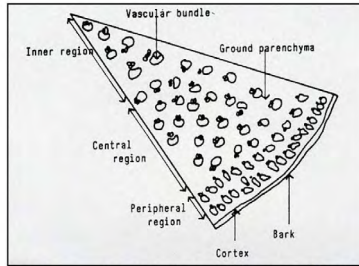
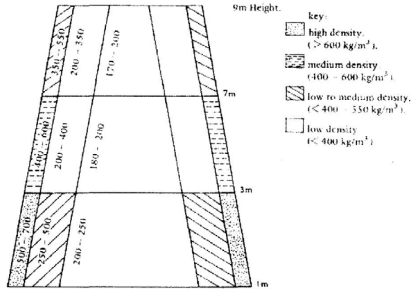

Fig. 4. Cross-section of oil palm trunk (Killmann and Lim 1985)

Fig. 2.6.1

Cross-section of oil palm trunk (Killmann and Lim 1985).



Vertical section of a 9m tall oil palm tree and corresponding densities areas.



Source: Center for Soil and Agroclimate Research and Development, Indonesia 2002

Fig. 2.6.2

Potential land extensification for oil palm plantations in Indonesia

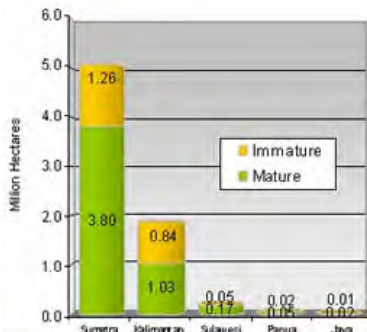

Fig. 2.6.3

Palm area growth by owner. It juxtaposes the negligible amount of oil palm plantation in Java (the smaller producing region in Indonesian) and the biggest producing region of Sumatra.

(Indonesian Palm Oil Commission (IPOC), Directorate General of estate Crops, 2009

Fig. 2.6.4

The kiln dried lumbers used in the experiment by Anon in 2002.

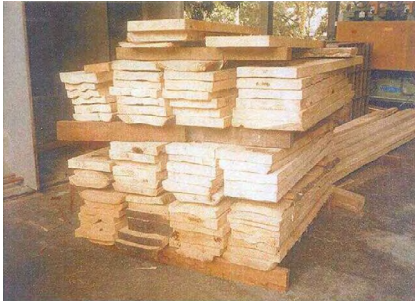

The very clear cupping effect on the board with the lowest density.

**Fig. 2.6.x**

Oil palm tree logs



COST

Raw palm wood can cost up to 10% more than timber like rubber wood while palm wood furniture can cost 10 to 30% more". The environmental and durability aspects of palm wood outweigh its slightly higher cost.³⁸

USES

Oil palm wood is used in furniture making, chair, blackboard, desks

Palm used as filler in thermoplastics and turned into fuel³⁹ and good paper can be produced with its pulp.

Generally it finds uses in construction industry as non-structural element due to its low density in shape of MDF boards.

Recently, a team of researchers developed LVL lumbers completely out of oil palm veneers undergoing a compression process (injections of stabilizer or polymer into the veneers) that turned out to dramatically improve the strength of the weak oil palm veneers but the processes involved were very expensive.⁴⁰

WASTE

Oil palm waste is a reliable resource because of its availability, continuity and capacity for renewable energy solution.⁴¹

The solid wastes may consist of empty fruit bunches (EFB), mesocarp fruit fibers (MF) and palm kernel shells (PKS), which can be turned into WPC composites, MDF, HDF, and other fiber based panels.

For each kg of palm oil roughly another 4 kg of dry biomass are produced, approximately a third of which is found in derived fruit wastes and the other two thirds is represented by trunk and frond material.⁴²

COCONUT



DENSITY 110 - 850 kg/m³
ROTATION 60 years

WORLD 12 million Ha
INDONESIA 3.81 million Ha (2012)
JAVA ISL. UNKN
W. JAVA 172700 Ha
BANDUNG 0 Ha

PLANTS x Ha 100
VALUE 50% less than other Hardwood

YIELD PROD. 65 mln m³ (1998) in Indonesia*
YIELD AVER. 100 m³/Ha

* look Fig. 2.7.x on the next page

2.7 COCONUT TREE

Cocos nucifera, mostly known as coconut palm, is considered as a tropical hardwood tree, but the lack of annual growth rings as well as the absence of rays, heartwood and branches suggest its nature as a monocotyledon which greatly differs from common hardwoods such as teak or mahogany.

Its hardwood can only be found in the periphery of the trunk just below the bark, the so-called "dermal zone" which has the highest density up to 850 kg/m³.⁴³ Consequently, the wood at the "central core" is very weak with a density of only 110 kg/m³.⁴⁴ (Fig. 2.7.1)

It is intensively planted with rotation of 60 years, in fact it can not produce coconuts anymore after this age.

The wood is particularly appreciated for its attractive grain, obtaining hence the name of "porcupine" timber,⁴⁵ and the lack of knots.

EXTENSION

In 1997 the total world area planted with coconut palms was about 12 million hectares, more than 90 percent of which was in Asia. Major coconut producers were Indonesia, the Philippines and India; in these countries 90% of the plantations are from smallholdings.

Indonesia, in the last 2 decades, did not face a significant increment of coconut plantations. In 1993, more than 3,6 million hectares were exploited, while in 2012 the hectares raised up to only 3,81 million.

Sumatra alone accounts for around one third of the total Indonesian coconut cultivation.

In west Java region there are 172.700 hectares of land officially planted with coconut trees.⁴⁶ In Bandung district coconut trees are scattered in the outskirts amounting to 707 Hectares.

Very precise data are available in regards to coconuts plantations in west Java region. (Fig. 2.7.2)

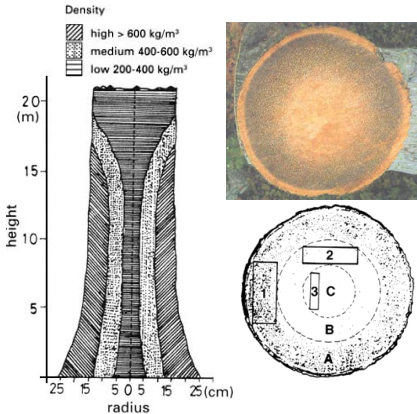

Fig. 2.7.1

Coconut palm section. Density:

A High
B Medium
C Low

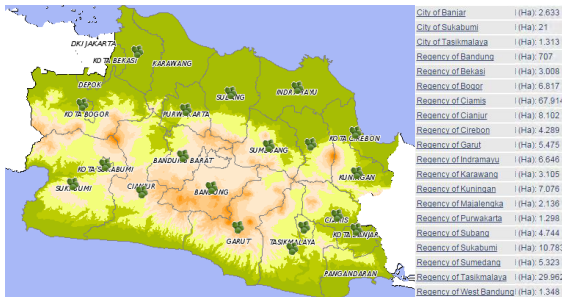

Fig. 2.7.2

West Java extension of Coconut plantations in detail for every district.

*** Fig. 2.7.x**

Yield production of coconut tree in 1998.

Source: APCC, 1998,

Country	1993 (1000 ha)	1997 (1000 ha)	1993 overmature (%) ²	1993 overmature (1000 ha)	Coconut wood ³ (1000 m ³)
Indonesia	3 636	3 760	20	727	65 400
Philippines	3 075	3 314	30	923	83 000
India	1 538	1 886	5	77	69 300
Sri Lanka	419	442	20	84	75 600
Thailand	336	377	35	118	10 600
Malaysia	310	270	60	186	16 700
Vietnam	215	200	n.a.	n.a.	n.a.
Rest Asia	64	65 ¹	n.a.	n.a.	n.a.
Asia Total	9 593	10 314	n.a.	2115	320 600
Papua New Guinea	260	260	30	78	7 000
Vanuatu	96	96	58	56	5 000
Fiji	65	54	43	28	2 500
Solomon Islands	59	59	50	30	2 700
Samoa	50	75	54	27	2 400
Rest Pacific	151	152 ¹	average 45	68	6 100
Pacific Total	681	696	n.a.	287	25 700
Tanzania	305	310 ¹	40	122	10 900
Rest Africa	141	350 ¹	n.a.	n.a.	n.a.
Africa Total	446	460¹	n.a.	n.a.	n.a.
Brazil	228	250 ¹	n.a.	n.a.	n.a.
Mexico	141	135 ¹	n.a.	n.a.	n.a.
Rest America	79	83 ¹	n.a.	n.a.	n.a.
America Total	448	476¹	n.a.	n.a.	n.a.
World	11 168	11 974		2 524	375 200

VOLUME

It is estimated that a typical Coconut farm produces 100 trees per hectare⁴⁷ and the average log volume is about 90 m3 per hectare.⁴⁸ These data can be rounded off to 100 m3 per hectare for convenience as estimated by Arancon for the Indonesian context. Unfortunately, since the tree tapers at the top and presents a wider base, it is hard to exploit it in its entirety for lumber production. (Fig. 2.7.3)

Based on a sawn timber recovery of 0,30 m3 per tree⁴⁹ it can be deduced that every hectare of coconut plantation can produce 30 m3 of finished/sawn coconut wood for construction.

Given the fact that in West Java there are 172.700 hectares of coconut tree plantations and assuming, statistically on the rotation of 60 years, that around 1,6% of the plantations are over-mature, an amount of 86350 m3 of sawn coconut wood is available in West Java alone every year.

USES

Dermal timber (high density) is used for pillars, trusses, rafting, furniture, window and door frames, floors, decking and floor joists.⁵⁰

Core timber (low density) has to be used for non-load bearing application such as interior wood paneling and ceilings.

Besides architectural related uses, coconut palms were traditionally used for production of energy via burning them or for charcoal making.

In the Maldives, coconut wood has been traditionally used for building fishing boats.⁵¹

The Fig. 2.7.4 graphically explains the usable and non-usable part of the coconut tree.

COST

Since coconut palms are planted mainly for their fruits, its wood has become lately exploited as a cheaper substitute to the ever-increasingly expensive natural rain-forest hardwoods. The wood at the dermal zone has proved to be comparable to conventional wood in terms of durability, sturdiness and versatility.⁵² It costs half or a little more than half the price of conventional wood.⁵³

Following the same trend, as stated by Ohler J.G. the price of coconut wood rafters is about 30% of the price of conventional wood used for roof structures.

The final price should come only from its harvesting process and transportation.⁵⁴

WASTE

The coconut husk, also known as coir, **Fig. 2.7.5** has become a very useful raw material in light of today's environmental and economic concerns.

A neat thing, being the only rot-resistant natural fiber, it does not break down like other fibers do,⁵⁵ for this reason it can be considered the perfect material for doormats.

Furthermore, its resistance to salt water makes it a good wooden derivative to be used in humid climates, as it is Indonesia during the monsoon season.

Finally the coirs can be formed into acoustic insulation boards in flooring or ceiling application, an easy and additive-free production method.⁵⁶

Fig. 2.7.3

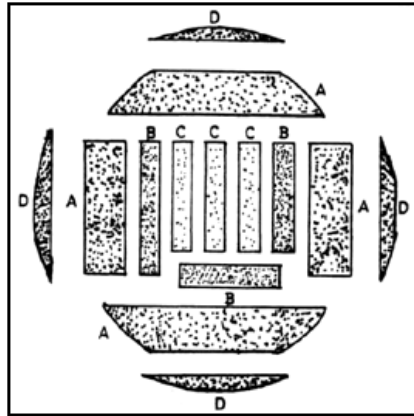

Nothing of the coconut tree is wasted. It is very hard to get lumbers of coconut wood since the dermal zone is too slim. The D elements will be processed into smaller wooden planks, such as parquet planks. C are weak lumbers to be used as raw construction material. A and B elements are low-medium density lumbers to be used in the construction industry for general purposes.

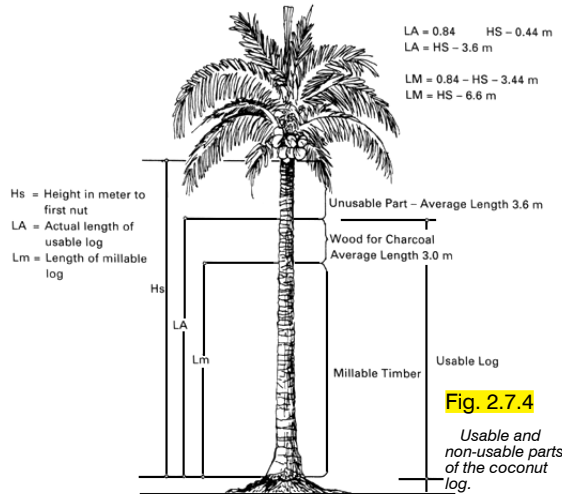

Fig. 2.7.4

Usable and non-usable parts of the coconut log.



Fig. 2.7.5

Coconut coir for acoustic insulation

RUBBER



DENSITY 435 - 626 kg/m³
ROTATION 25 - 30 years

WORLD 9.68 million Ha (1998)
INDONESIA 3.5 million Ha (1998)
JAVA ISL. UNKN
W. JAVA 55670 Ha
BANDUNG 0 Ha

PLANTS x Ha 350
VALUE 36 - 62 \$ x m³

YIELD PROD. 30 million m³ per year
YIELD AVER. 100 m³/Ha

2.8 RUBBER TREE

Hevea Brasiliensis is a tropical hardwood widely known as rubber tree. It has traditionally been much more appreciated and exploited for its product, latex, being Indonesia the second biggest producer of rubber in the world after Thailand, than for its wood. It has to be stated that due to its density of 560 – 650 kg/m³, it can not be entirely considered a hardwood.

It has a rotation period of no more than 30 years; after 25 years the latex production decreases dramatically up to the point that harvesting is not profitable anymore.

Its wood is appreciated for its light colour, especially in Japan, and for its flexibility under steam-bent. Furthermore, being a plantation by-product, the acceptance of rubber wood as a sustainable plantation-grown "environmentally friendly" timber has contributed to its universal appeal.

EXTENSION

In 1997 there were almost 10 million hectares of rubber tree plantation worldwide.

In the same year and with an overall area of more than 3.5 million hectares, Indonesia was the world's largest producer of natural rubber.⁵⁷ Nowadays, the number of hectares in Indonesia is still exactly the same discarding little fluctuation in the past 2 decades. (Fig.2.8.1)

In Indonesia, extensive plantations run by government or private companies account for only about 20% of the total area planted with rubber tree, the remaining 80% of the plantations are run by small-holders geographically dispersed in the country.⁵⁸

In West Java the state-owned Perkebunan Nusantara VIII manages half of the total amount of rubber tree plantations. These plantations are spread in 11 districts/cities all around West Java (Sukabumi, Bogor, Cianjur, Bandung District, West Bandung District, Bandung City, Garut, Tasikmalaya, Purwakarta, Subang, and Ciamis) and 2 districts in Banten Province (Lebak and Pandeglang). (Fig. 2.8.2)

Specifically, The rubber plantation areas managed by PTPN VIII is 25.536 hectares⁵⁹ whereas the total amount of hectares of rubber tree plantations in west Java is 55670, including smallholders.⁶⁰

VOLUME

It is estimated that a typical rubber tree farm produces 350 trees per hectare. The available log volume ranges from 52 m3 to 162 m2 per hectare⁶¹ so that an average of 100 m3 per hectare will be taken in consideration.

The sawn timber recovery fluctuates between 25% and 40%. Assuming an average of 32,5% sawn timber recovery it is possible to obtain 32,5 m3 of sawn rubber tree per hectare.

Given the fact that in West Java there are 55670 hectares of rubber tree plantations and assuming, statistically in a rotation period of 30 years, that 3,33% of them is surely over-mature, an amount of 60309 m3 of sawn rubber wood must be available every year in West Java.

It has to be said that due to the much lower standards in the management of plantation by smallholders, many times the wood recovery is even less than the above-mentioned 25%-40%. As an example it was calculated that in Malaysia only 18% of the rubber wood logs were suitable for sawn timber and in the end only 5% of the rubber tree wood volume available was converted into wood product.⁶²

USES

Due to lack of durability, rubber wood was rarely used as utility timber except in timber-scarce countries. Where it was abundant it was normally used for industrial brick burning, tobacco curing, or for fueling of locomotive engines.

After a number of problems had been overcome with the help of applied research, particularly in connection with wood seasoning and preservation but also related to the small size of logs, rubber wood developed as one of the most suc-

cessful export timbers of Southeast Asia.⁶³

Salleh (1984) reported 61 different products made from rubber wood. The most important uses are: furniture and furniture parts, parquet, paneling, wood-based panels (particleboard, cement and gypsum-bonded panels, medium-density fiberboard (MDF), kitchen and novelty items, sawn timber for general utility.

Rubber wood is also still used for charcoal manufacturing and wood fuel.

COSTS

Rubber wood has certain advantages over conventional timbers from the natural forest. Because it is a plantation by-product, it is available at the relatively low cost. Thus, in spite of its comparatively low recovery rate, the cost per cubic meter of rubber wood oscillates between 36 and 62 U.S. Dollars per m3.

Rubber wood is only about 30 percent of the production cost of meranti.⁶⁴

The main reasons for success are its favorable timber and woodworking properties and the relatively low cost of the raw material since rubber wood is an agricultural by-product. This factor makes the timber highly competitive in comparison to teak, mahogany and other common hardwoods.

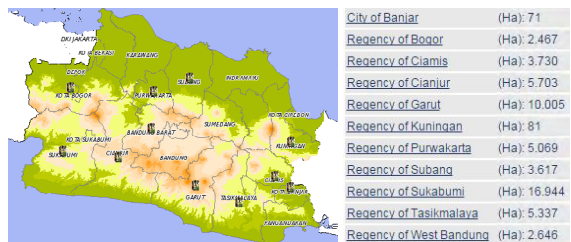

Fig. 2.8.2

Rubber wood, extension of plantations in west Java by districts

AREA OF RUBBER PLANTATION IN INDONESIA 2008-2013 (in thousand hectares)

PRODUCER	2008	2009	2010	2011	2012*	2013**
SMALLHOLDER	2,910	2,912	2,922	2,932	2,959	2,963
GOVERNMENT ESTATE	238	239	239	257	258	259
PRIVATE ESTATE	276	284	284	267	267	269
TOTAL AREA	3,424	3,435	3,445	3,456	3,482	3,492

Fig. 2.8.1

Amount of rubber tree hectares of plantations in Indonesia

SKATE-DECKS

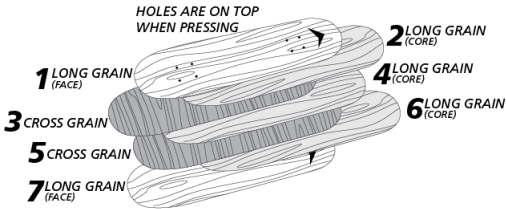

DENSITY 600 - 750 kg/m³
ROTATION depending on skater level

WORLD 6.4 million decks every year*

INDONESIA NOT AVAILABLE

JAVA ISL. NOT AVAILABLE

W. JAVA NOT AVAILABLE

BANDUNG 8240 broken/discarded x year

/// ~8240 Decks in Bandung
VALUE FREE

WEIGHT x DECK 1.2 kg

VOLUME 10 tonnes (in Bandung)

* from indiegogo.com

2.9 SKATEBOARD DECKS

Acer Saccharum (Canadian hard maple) is the preferred type of wood implemented in the realization of skateboard decks.

The high density of 700 kg/m³ is the result of the strong Canadian winters which make this wood appreciated for its strength and stiffness while allowing a certain degree of flexibility. Today's skateboard deck is an engineered, sculpted work of art.⁶⁵

ESTENSION

In shape of skateboard decks, Canadian maple is a resource that nowadays can be found anywhere in the world.

It is estimated a number of more than 6 million skateboard decks produced annually, however the distribution of this resource is highly inconsistent throughout the world, finding heavy concentration in or around big cities, such as the case of Bandung.

It has been estimated by Inong Fani professional and legendary skateboarder in Bandung, a number of around 2000 skateboarders including the nearby districts.

VOLUME

Following a simple math, it is possible to estimate the total amount of hard-rock Canadian maple as a wood resource:

2000 skateboarders in Bandung

STARTING LEVEL skaters use 1 deck / 6 month

NORMAL skaters use 1 deck / 2 month

PRO skaters use 1 deck / 1 month

STARTING LEVEL skater = 50%

NORMAL LEVEL skater = 48%

PRO LEVEL skater = 2%

(1000 x 2 decks) + (960 x 6 decks) + (40 x 12 decks)
 2000 + 5760 + 480 = **8240** decks per year

1.2kg (weight of every deck) x 8240 =

ALMOST **10 tons** of wood can be recycled

COST

The price of a normal professional skateboard deck can range between 35 to 65 U.S. dollar, according to brand, production method and location of the factory.

In Europe it is common to buy the same American branded skateboard decks for 65 - 70 Euro; the price difference has to be found in import duties.

Broken skateboard decks have no value whereas discarded but still "in shape" decks can still retain 10% of their initial value.

USES

Giving a second life to broken/discarded skateboard decks is relatively a new trend.

Many artists (Fig. 2.9.1) collect for free broken decks from skateshops and by shredding and re-gluing them in certain ways it is possible to create sculptures, furnitures, small everyday use objects. (Fig. 2.9.2)

Their use in architectural terms is highly unexplored. (see: [Bonus Booklet](#))



Fig. 2.9.1

An American artist displaying the amount of discarded skateboard decks and some shredded ones



Fig. 2.9.2

Different uses of discarded or broken skate decks

A decorative graphic consisting of a series of parallel, diagonal, light red lines that create a striped effect across the top of the text area.

Chapter 3

CONCLUSION

3.1 Flow-scheme criteria

Through *research by design* this chapter aims to finalize in a concrete and personal design solution the merging between architecture and skateboarding throughout the use of local Indonesian wood resources.

The guidelines given in the book *hierarchische reeks van bouwproducten* by Mick Eekhout have helped to structure a complete flow-scheme that illustrates all the stages that the wood resources experience from the stage of raw material to final building.

- It is divided in **3 main parts**:

Selection of Resources: The local wood resources have been selected in regard to their specific properties studied in the previous chapter and on how they could contribute in the design in a sustainable way. Some had to be discarded for not being sustainable enough, other for being too expensive while having a cheaper wooden surrogate.

Industrial processes: It has been necessary a deep study of all the industrial steps that the wood resources undergo for their transformation from raw materials into trade materials.

This gave an overview on the amount of energy used up in the industrial processes in order to have consciousness on the level of sustainability of the 'trade material'.

Assembly: The last part of the scheme explains all the subsequent steps that traded materials undergo to become functional parts in a final building. It deals with practical matters, the quantifiable side of an architectural design: amount of material, assembly time and implicitly costs. Furthermore it deals with architectural choices: the personal design solution had to be easy to build, as much flexible as possible, functional both as skatepark and building with general function.

Local construction techniques have also been addressed, so that no skilled labor is needed in the construction process.

3.2 Selection of resources: reasons

Disregarding skateboard deck as a special resource which could not fit in the flow-scheme, among the 6 local Indonesian wooden resources, 2 of them had to be culled out: teak and Oil palm.

Teak: Although it has always been considered the best wood in construction, it had to be turned down mainly due to the very high costs as raw material, the non-ready availability in the surrounding of Bandung district, and the possibility to be replaced with another structural hardwood, the rubber-wood. Furthermore teak, if coming from tropical rainforest, would have been a very unethical and unsustainable choice.

Oil palm: It had to be turned down purely for the lack of availability on Java Island. Despite being Indonesia the biggest cultivator of oil palm tree in the world with a huge amount of wood volume available, such an availability is only present on the other Indonesian Islands: Sumatra and Kalimantan. For this reason, the implementation of oil palm wood would have been unsustainable for the meaningless and unjustified transportation that would have turned such a cheap resource perhaps into an expensive one.

- The following resources have been selected:

Sengon: Being widely cultivated in West Java, it has been selected only in the shape of thinned logs with a small diameter of around 15cm, which are very cheap, always available due to the fast rotation period of sengon, and normally considered hard to sell as a waste material.

Plantations of Sengon are not so sustainable since the exploitation of such wood cleared already huge areas of tropical rainforest, but the choice to use only thinned logs otherwise used for charcoal production can be seen as sustainable as it contribute to reduce CO2 emissions.

Bamboo: It has been selected for many

positive reasons. Being locally available in Bandung district is a great contribution towards shrinking transportation costs and related pollution to the minimum. It is a very cheap resource that can be used with structural purpose while being highly flexible in the design process. Furthermore in Indonesia there is a wide knowledge on how to use bamboo in construction, so that its implementation would be a coherent choice in such a context.

Coconut wood: It has been selected for the fact that it is a plantation by-product, which refers to a sustainable wood resource and cheap hardwood, and it is widely available in West Java, so that transportation costs and related pollution would be limited.

Beside the hardwood, the waste material such as coconut coir could be easily formed into composite wooden material for acoustic insulation.

Rubbertree: Among the selected wooden resources, it is the most similar to teak in terms of structural properties so that it can entirely substitute it while being much more sustainable, being a plantation by-product widely available in West Java.

3.3 Implementation of selected resources

The proposed design sees the merging of a skatepark at the level of the roof of a building as the case studies presented in the chapter 1 show this to be the most common configuration.

Technically, to achieve the merging with only local Indonesian wooden resources, it has been necessary a separation between main structure and roof structure as it is clearly illustrated under the “building section” tab in the flowscheme. (consult: [Flow-scheme](#))

The two building sections, considered as separate entities, can be easily assembled on-site.

The flowscheme is also clearly showing how some wooden resources are co-op-

erating in achieving bigger components starting from the trade materials stage.

Bamboo culms & Sengon thinned logs co-work in the main structure: bamboo, being the structural element is designed to support the triple bamboo beam, the sengon thinned log has ornamental function of visually filling the bamboo column while keeping the 4 bamboo sticks of the structural pillar together.

Rubber wood has been implemented as the unique material in the construction of the roof structure. Starting from standard 4'x8' plywood planks, carpenters are able to cut custom shapes that will define the rafters. These will be assembled together with lumbers in achieving the truss outline (repeated 3 times for convenience, but in further development of the merging the outline of every truss could be different from each other). The final truss is assembled with other custom cross joists obtained again from standard plywood planks. The truss, constituted from rubber wood alone, assures mechanical stability. Cheap MDF panels assembled on a series of studs lay down the base for the final skateable surface which is conceived here as a Wood Plastic Composite panel realized from the waste of the coconut tree. These skateable panels have to resist natural decay from the usage by skateboarders, that is why it is necessary a WPC material.

The pavement is proposed here as made of coconut planks, as already implemented in many architectural projects. Coconut wood parquet planks are the only element easy enough to obtain from the coconut trunk. Bigger studs or lumber are impossible to get since the hardwood is only present at the slim dermal zone of the trunk.

Foundations and internal/external partitions are not addressed here as not relevant in this proposed design solution.

3.4 Costs speculation

The proposed design using waste materials and locally available woods coming

from plantations by-product dramatically reduces the overall price by a fraction of what it would be if built with traditional woods.

Utilizing hypothetically larch wood for the roof structure (the skatepark) and teak for the main structure:

Larch: \$380 m³

Teak: \$270 - 500 m³ or more

- From the Flowscheme it results that:

Roof structure uses 60% of the whole amount of wood. Rubberwood uses 55% whereas coconut wood only 5%. The 5% coconut wood, being a negligible amount will be ignored for simplicity.

Main structure uses 35% of the whole amount of wood. Bamboo uses 31% whereas sengon only 4%. The 4% sengon wood will be ignored for simplicity.

Pavement use 5%, which will be ignored for simplicity.

- Since:

The whole building is composed by

Roof structure made of Rubberwood
Main structure made of Bamboo

Rubberwood: \$ 62 m³

Bamboo: \$5 per 6m culm

- The roof structure alone would cost **6.1 times more** if made out of Larch wood.

The main structure exploits around 27 preserved bamboo culms of 6m length (cut in 3m and 5m long stick with a little bit of waste):

$$\$5 * 27 = \$135$$

If the roof structure would be made out of teak, hypothesizing 9 structural pillar of 200x200x3000mm and 3 beams of 200x300x5000mm the total amount of teak wood need would be:

$$\begin{aligned} &(9*0.12) + (3*0.3) = \\ &= 1.08 + 0.9 \\ &= \sim 2\text{m}^3 \text{ of teak} \end{aligned}$$

The main structure would cost around 540\$, considering here the lowest price for teak.

- The main structure alone would cost **4 times more** if made out of Teak wood.

By the way, a detailed attempt to calculate the precise cost has been avoided because the main point of the flowscheme is to show in an info-graphic way the complex amount of processes/stages hidden behind the final building result.

3.5 Labor hours

From the flowscheme it can be seen an attempt to quantify the amount of labor hours required in every single step during the construction of the proposed design.

This has been done in the effort to understand what phase of the construction, accordingly also to the need or not of skilled labor, will be more costly/time-consuming.

- From the flowscheme:

The main structure requires 9 hours and 45 minutes to be completed. (31% of total amount of hours used)

The roof structure needs 14 hours and 30 minutes (46% of total amount of hours used)

Further 2 hours (6.3%) are required to assemble roof structure and main structure together.

- The roof structure, requiring a lot of customized elements, deserves more time for its realization and assembly,

- As a result, the roof structure has more leverage in the whole design, both in regards to amount of wood used (60%) and labor hours (46%)

4.0 Endnotes

Introduction Endnotes

- 1 Anonymous (2011) skateboarding and architecture
- 2 Quirk, V. (2012) Why skateboarding matters to architecture

Chapter 1 Endnotes

1. Borden, I., (2001) Skateboarding Space and the City: Architecture and the body. p. 173. Berg Oxford (from Archi-ninja.com Skateboarding and architecture. 2011.)
2. Sport and recreation Victoria, The skate facility guide. 1999. p. 6
- 3 Ibid. 2
- 4 Ibid. 2
- 5 Ibid. 2, p. 5
- 6 Personal source
- 7 Ibid. 2, p. 54
- 8 Personal survey
- 9 Personal definition
- 10 Ibid. 2, p. 56
- 11 Ibid. 2, p.7
- 12 Ibid. 2, p.76
- 13 Ibid. 12
- 14 Ibid. 12
- 15 Personal selection, Research by design
- 16 Ibid. 12
- 17 Borden, I. (2014). The spaces of skateboarding. *The Architects' Journal*, 56 - 59.
- 18 Moore Doug, Cons space design, 2013
- 19 Ibid. 18
- 20 IOU Ramps, < <http://www.iou-ramps.com/> >

Chapter 2 Endnotes

- 1 N Abdullah, et al. (2013). the oil palm wastes in Malaysia. p. 76
- 2 Ellie Brown, et al. (2005). Cruel oil, how palm oil harms health, rainforest & wildlife. Washington: Center for science in the public interest. p. 8
- 3 UNEP (2011). Oil palm plantations: threats and opportunities for tropical ecosystems.
- 4 Ibid. 3, p. 6
- 5 Suseno Budidarsono et al.(2013). Oil palm plantations in Indonesia: the implications for migration, settlement/resettlement and local economic development. p. 174
- 6 Ibid. 2, p. 11
- 7 Ibid. 5, p. 174
- 8 FAO. (2001). Non-forest tree plantations. < www.fao.org >
- 9 Ibid. 8
- 10 Ibid. 8
- 11 Varis, E. (2011). Sand growth and management scenarios for *Paraserianthes falcataria* smallholder plantations in Indonesia. (Master thesis), University of Helsinki. p. 16
- 12 Ibid. 11
- 13 ITTO. (2009). Indonesia: Sengon used as alternative to raw materials from production forests. Retrieved from < www.fordaq.com >
- 14 Ibid. 11
- 15 Ibid. 11
- 16 Ibid. 11, p. 7

- 17 Ulfah Siregar et al. (2005). Economic analysis of sengon (*paraserianthes falcataria*) community forest plantation, a fast growing species in East Java, Indonesia. *ScienceDirect*. p. 1
- 18 < Sengonkepahi.blogspot.nl >
- 19 Surharlan et al.
- 20 Siregar et al. (2009).
- 21 Ibid. 18
- 22 Ibid. 18
- 23 Ibid. 19
- 24 < www.pipietasaratie.com >
- 25 Anonymous source
- 26 Personal survey
- 27 Garland, L. (2005). Vertical soak diffusion for bamboo preservation. Bali, Indonesia: Environmental bamboo foundation.
- 28 Widjaja, E. A. State of the art of Indonesia Bamboo. Bogor, Indonesia.
- 29 Ibid. 27
- 30 Lefter, C. (2012). Wood, material for inspirational design. Delft: Rotovision. p. 82
- 31 Othman Sulaiman, e. a. (2012). The potential of oil palm trunk biomass as an alternative source for compressed wood.
- 32 (Khoo et al, 1991; Killmann and Lim, 1985)
- 33 Timber tech bulletin
- 34 Ibid. 31
- 35 Ibid. 31
- 36 S C Lim , K. S. G. (2005). Characteristics and utilisation of oil palm stem.
- 37 (Killmann and LIM 1985)
- 38 William Wong, from < thestar.com.my >
- 39 N Abdullah, F. S. (2013). the oil palm wastes in Malaysia.
- 40 Wahab, R. (2008). Utilization potential of 30 year-old oil palm trunks laminated eneer lumbers for non-structural purposes. *journal of sustainable development*.
- 41 Ibid. 39
- 42 Ibid. 39
- 43 Palomar (1990)
- 44 Peter Griffe, < www.ecoport.org >
- 45 Ohler J. G., *Modern coconut Management: Palm cultivation and products*.
- 46 < <http://regionalinvestment.bkpm.go.id/> >
- 47 Romulo Arancon et al (1997). Asia pacific forestry sector outlook: focus on coconut wood. p. 3
- 48 Jensen and Killmann (1981)
- 49 Ibid. 47
- 50 < www.wikipedia.com >
- 51 < www.fao.org >
- 52 Ibid. 47, p. 11
- 53 Ibid. 52
- 54 Ibid. 51
- 55 Lefter C. (2012) Wood, material for inspirational design
- 56 Ibid. 55
- 57 Ibid. 51
- 58 Ibid. 51
- 59 < <http://www.pn8.co.id> >
- 60 < <http://regionalinvestment.bkpm.go.id/newsipid/id/commodityarea.php?ic=4&ia=3207> >
- 61 Gan et al. (1985)
- 62 Ibid. 51
- 63 Ibid. 51
- 64 Kollert and Zana (1994), from < www.fao.org >
- 65 < www.wizzley.com >

4.0 Literature

General literature in Chapter 1,2,3

- Borden, I. (2014). The spaces of skateboarding. *The Architects' Journal*, 56 - 59.
- Brown, M. (2014). The Rom, Hornchurch, becomes the first skatepark in Europe to get listed status. *The Guardian*.
- P. J. (2007). Skateboarding vs Architecture. Retrieved from < www.skynoise.net >
- Quirk, V. (2012). Why skateboarding matters to architecture. < www.archdaily.com >
- Sport and recreation Victoria (1999). *The skate facility guide*.
- Young, B. (2014). A skateboarder's guide to architecture or an Architect's guide to skateboarding. Retrieved from < www.loudpaper-mag.com >
- Anonymous (2011). Skateboarding and architecture. Retrieved from < www.archi-ninja.com >
- Various authors (2010). *Tropical plantation timbers*. Retrieved from < www.rainforestinfo.org.au >
- Eekhout, M. (1997). *POPO of ontwerpmethoden voor bouwproducten en bouwcomponenten*. Delft: Delft University Press

Bamboo

- FAO. (2005). *Global forest resources assessment 2005, Indonesia, country report on bamboo resources*. Jakarta.
- FAO. (2012). *Extent and characteristics of bamboo resource*.
- Garland, L. (2005). *Vertical soak diffusion for bamboo preservation*. Bali, Indonesia: Environmental bamboo foundation.
- International tropical timber organization (2010). *Model capacity building for efficient and sustainable utilization of bamboo resources in Indonesia*.
- Sulastiningsih, I. M. *Bamboo resources of Indonesia*. Retrieved from < www.arkn-fdp.org >
- Widjaja, E. A. *State of the art of Indonesia Bamboo*. Bogor, Indonesia.
- Wong, K. (2004). *Bamboo the amazing grass*. University of Malaya.

Coconut tree

- Ohler J. G. *Modern coconut Management: Palm cultivation and products*. Retrieved from < www.ecoport.org >
- Romulo A. (1997). *Asia pacific forestry sector outlook: focus on coconut wood*.
- Lefter, C. (2012). *Wood, material for inspirational design*. Delft: Rotovision.
- McLaren, W. (2007). *Palmwood goes architectural*.
- Nellie Oduor, J. G. *Wood characteristics and properties of Cocos nucifera (the coconut tree) grown in Kwale District*.
- Wulf Killman, D. F. (1996). *Coconut palm stem processing*. Eschborn: Protrade.

Oil palm tree

- Basiron, Y. (2007). *Palm oil production through sustainable plantations*.
- Malaysian palm oil council. (2007). *Oil palm... Tree of life*.
- Ellie Brown, M. J. (2005). *Cruel oil, how palm oil harms health, rainforest & wildlife*. Washington: Center for science in the public interest
- World Growth (2011). *The economic benefit of palm oil to Indonesia*.
- MPMA. (2011). *The Malaysian plywood industry utilizing OPT logs*.
- N Abdullah, F. S. (2013). *the oil palm wastes in Malaysia*.
- Othman Sulaiman et al. (2012). *The potential of oil palm trunk biomass as an alternative source for compressed wood*.
- S C Lim , K S Gan. (2005). *Characteristics and utilisation of oil palm stem*.
- Suseno Budidarsono, Annelies Zoomers. (2013). *Oil palm plantations in Indonesia: the implications for migration, settlement/resetlement and local economic development*.
- UNEP. (2011). *Oil palm plantations: threats and opportunities for tropical ecosystems*.
- Wahab, R. (2008). *Utilization potential of 30 year-old oil palm trunks laminated veneer lumbers for non-structural purposes*. Journal of sustainable development.

Rubber tree

- FAO. (2001). *Non-forest tree plantations*.
- Heng, C. Y. (2003). *Structural rubberwood LVL: an engineered wood product for prefabricated timber roof truss*.
- FAO. (1998). *Looking after the plantation before tapping*.

Sengon

- Sengon tree new favorite*. (2009). *The Jakarta post*. Retrieved from < www.thejakartapost.com >
- Ulfah Siregar J. et al. (2005). *Economic analysis of sengon (paraserianthes falcataria) community forest plantation, a fast growing species in East Java, Indonesia*. ScienceDirect.
- Blog. (2013). *Why should Sengon*. Retrieved from < sengonkepahiang.blogspot.nl >
- ITTO. (2009). *Indonesia: Sengon used as alternative to raw materials from production forests*. Retrieved from < www.fordaq.com >
- Varis, E. (2011). *Sand growth and management scenarios for Paraserianthes falcataria smallholder plantations in Indonesia*. (Master thesis), University of Helsinki.

Teak

- James M Roshetko et al. (2012). *Smallholder teak system on Java, Indonesia: income for families, timber for industry*.
- Larasatie, P. (2012). *Teak plantation in Indonesia*. Retrieved from < pipietlarasatie.wordpress.com >
- Pratiwi N Lust. (1994). *Teak (tectona grandis L.f.) forests in Java, Indonesia, Plantations, management and policy*.
- Siswamartana, S. (2010). *Teak forest management in Indonesia* Retrieved from < www.fao.org >
- Suhaendi, H. *Teak improvements in Indonesia*. Retrieved from < www.fao.org >