

30.8.22

16:45

CONCERTO DINAMICO



PUBLIC BUILDING

MICHAEL LANDMAN

www.concerto-dinamico.nl



Residentie
Orkest
Den Haag

Concerto Dinamico - Classical Hall

Mercuriusweg 3
2516AW Den Haag

Row 2 Seat 3

The Hague Residence Orchestra

Block B left Second floor	Row	Seat
	2	3

Ticket price
65,00 EUR
386662

Tuesday
30.08.2022
16:45

72111 A
13.11.2021 17:24:57

An ensemble of

RC Royal
TH Conservatory
The Hague

**Ticket switch
Accepted**

1. MUSIC MARVEL
2. PREMISE
3. RESEARCH
4. DESIGN

music marvel



music marvel



music marvel



1. MUSIC MARVEL
- 2. PREMISE**
3. RESEARCH
4. DESIGN

CONTEXT

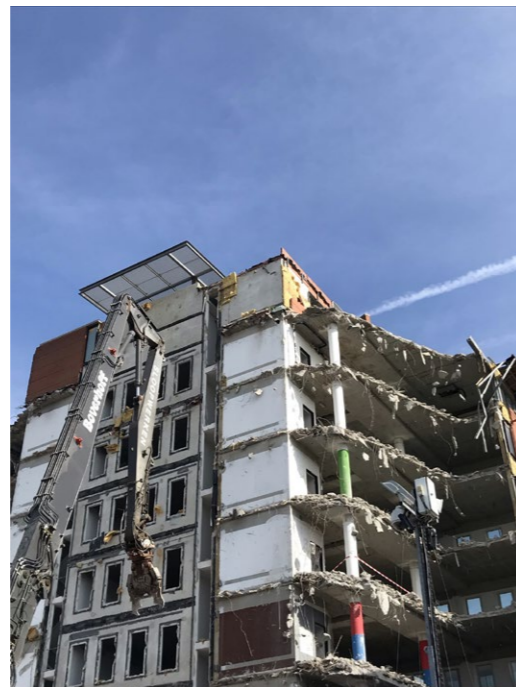

CONTEXT

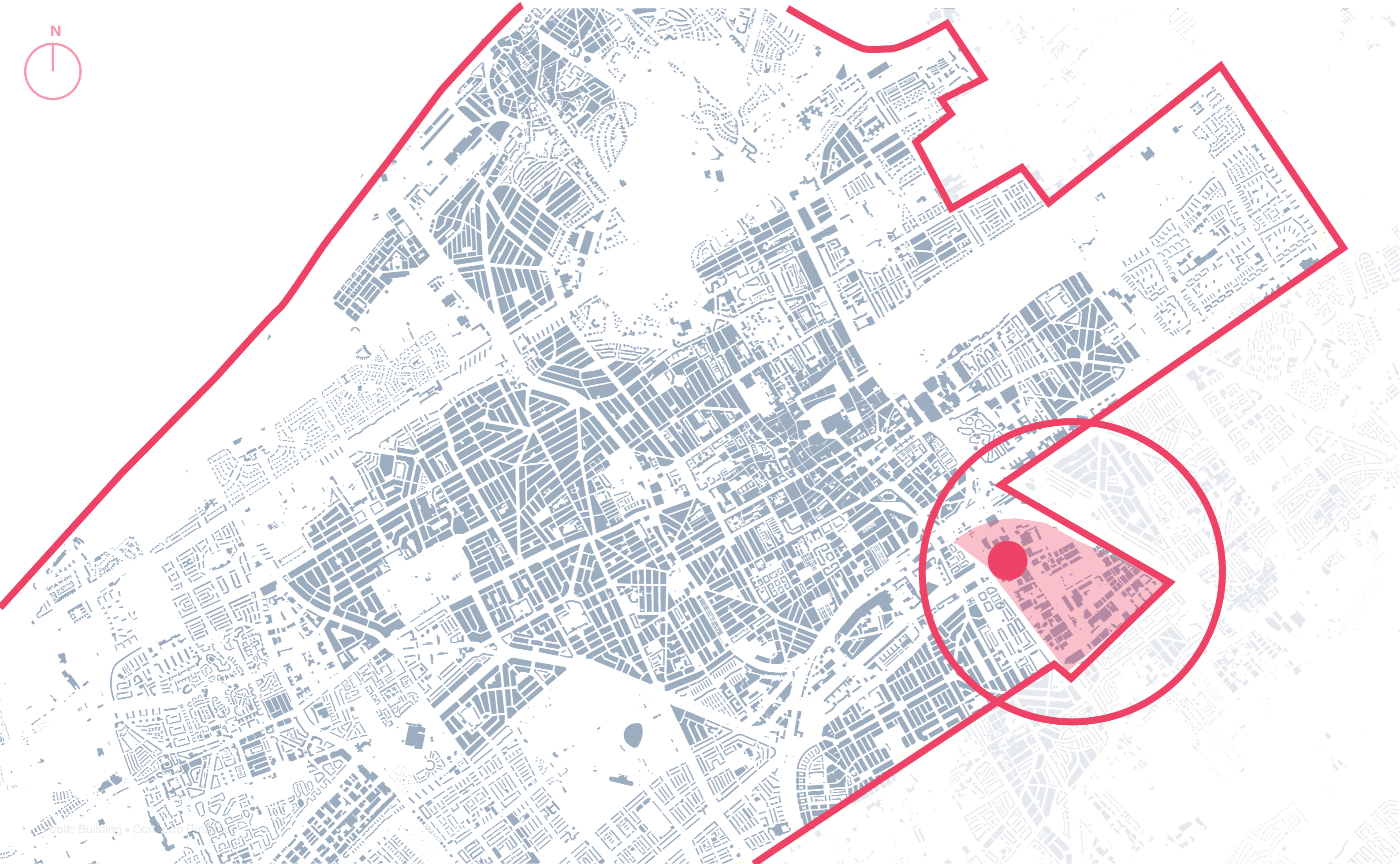
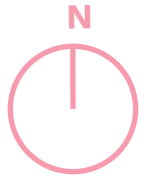

CONTEXT

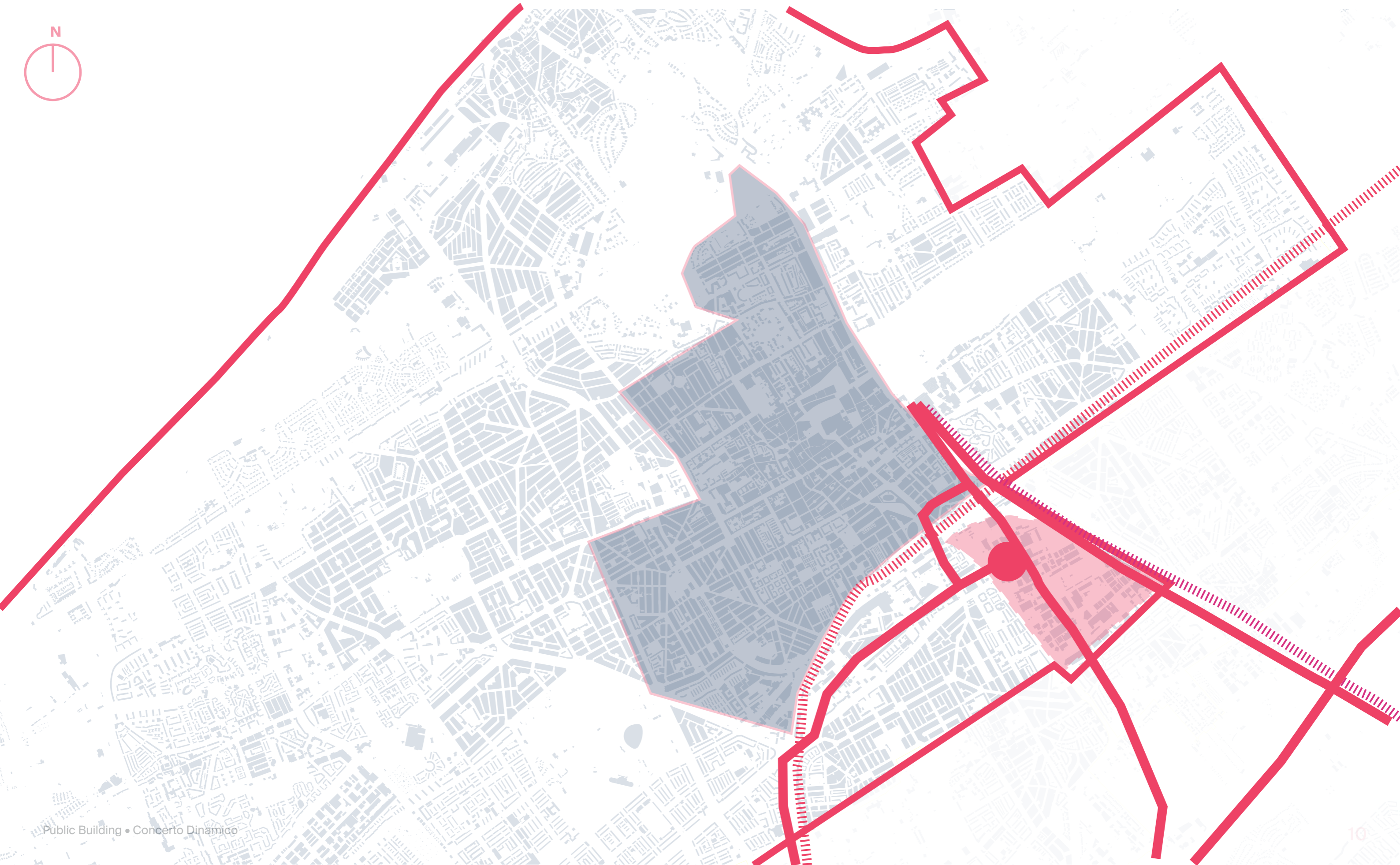
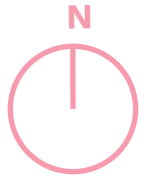

CONTEXT

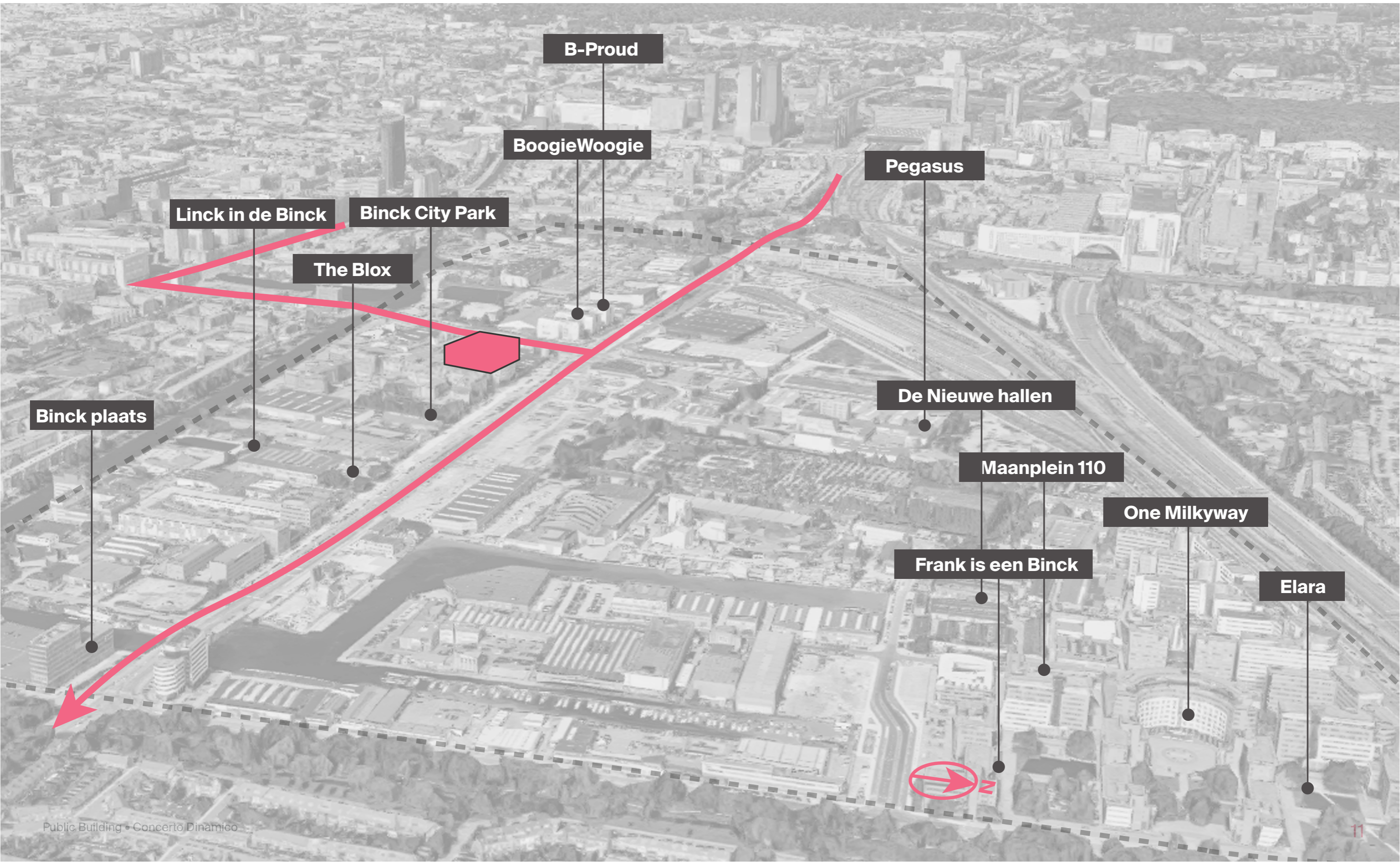

B-Proud

BoogieWoogie

Pegasus

Linck in de Binck

Binck City Park

The Blox

Binck plaats

De Nieuwe hallen

Maanplein 110

One Milkyway

Frank is een Binck

Elara

CONTEXT



Southbound Rotterdamsebaan

CONTEXT



B-Proud, OZ Architects

GOALS

City to impose a beating heart of culture in the new mixed-residential zone

Connection to provide a publicly accessible urban interior

Multiplicity to serve as multifunctional and futureproof music venue

Culture to manifest a new generation of classical music enthusiasts

CHANCES

Modern media consumption changes music-listening habits

Traditional



Contemporary



CHANCES

Increase in younger classical music listeners through music streaming

Traditional



65+

Contemporary



CHANCES

Increase of hybrid developments in the live classical music scene

Traditional



65+



Contemporary

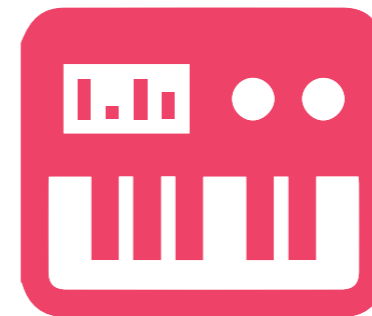

1. MUSIC MARVEL
2. PREMISE
- 3. RESEARCH**
4. DESIGN

RESEARCH QUESTION

How can **dynamic re-iteration** of concert hall designs **modernise** the audience **experience** of the live contemporary **classical music scene**?

RESEARCH SEQUENCE

RESEARCH



→ Object → Movement → Perception

DESIGN

Perception → Movement → Object →

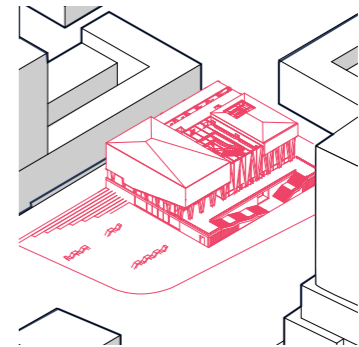

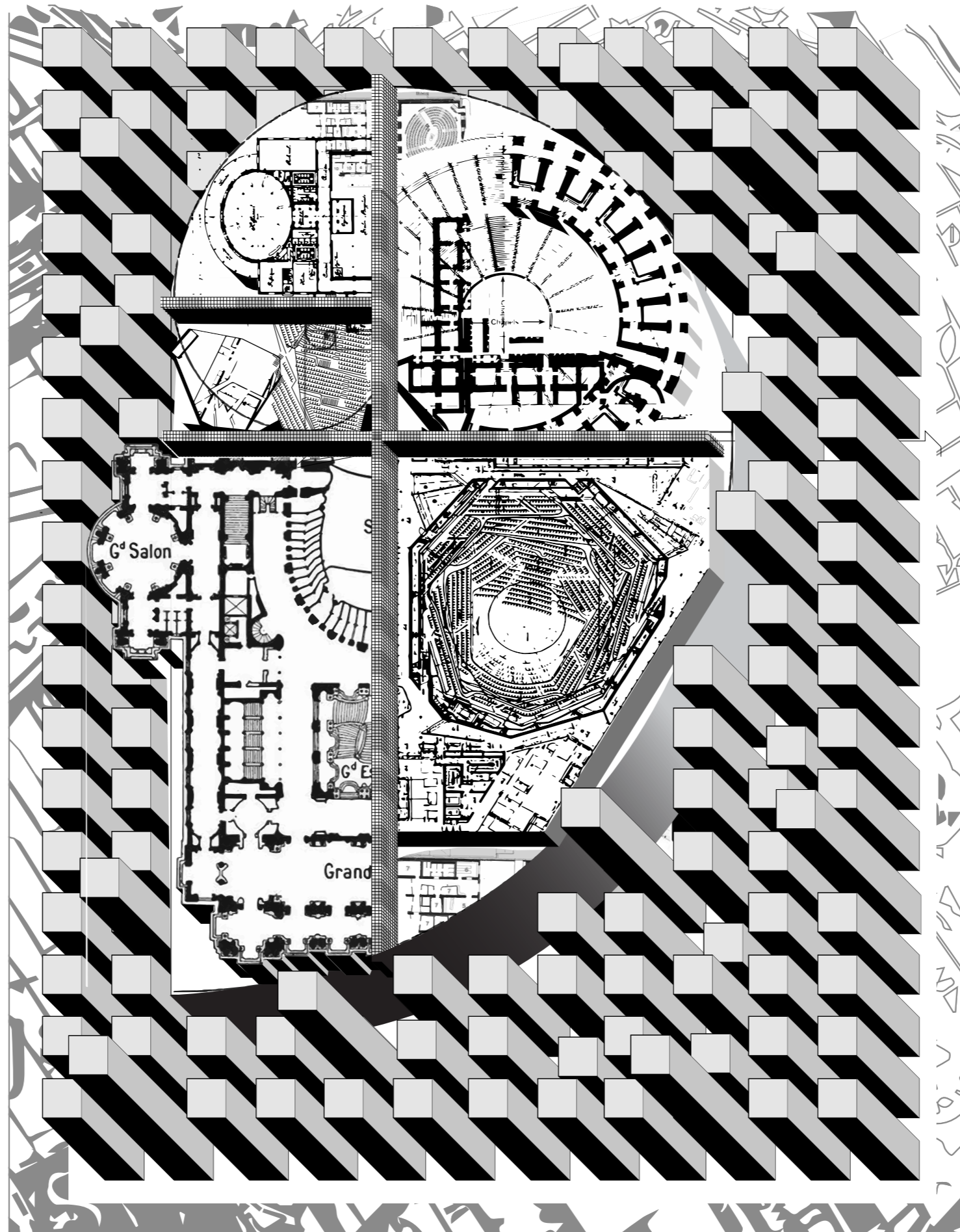

PERCEPTION



PERCEPTION



MOVEMENT

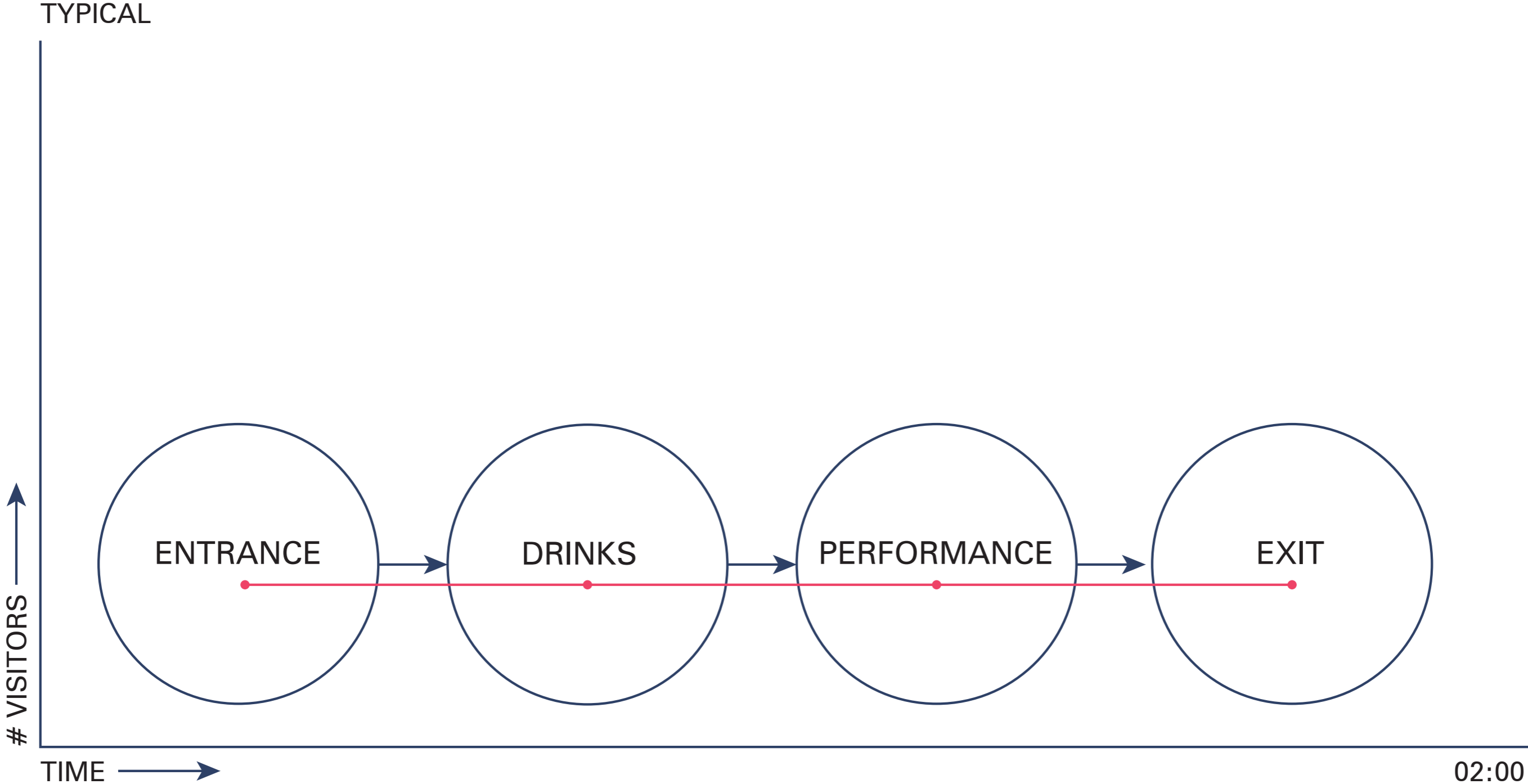

MOVEMENT

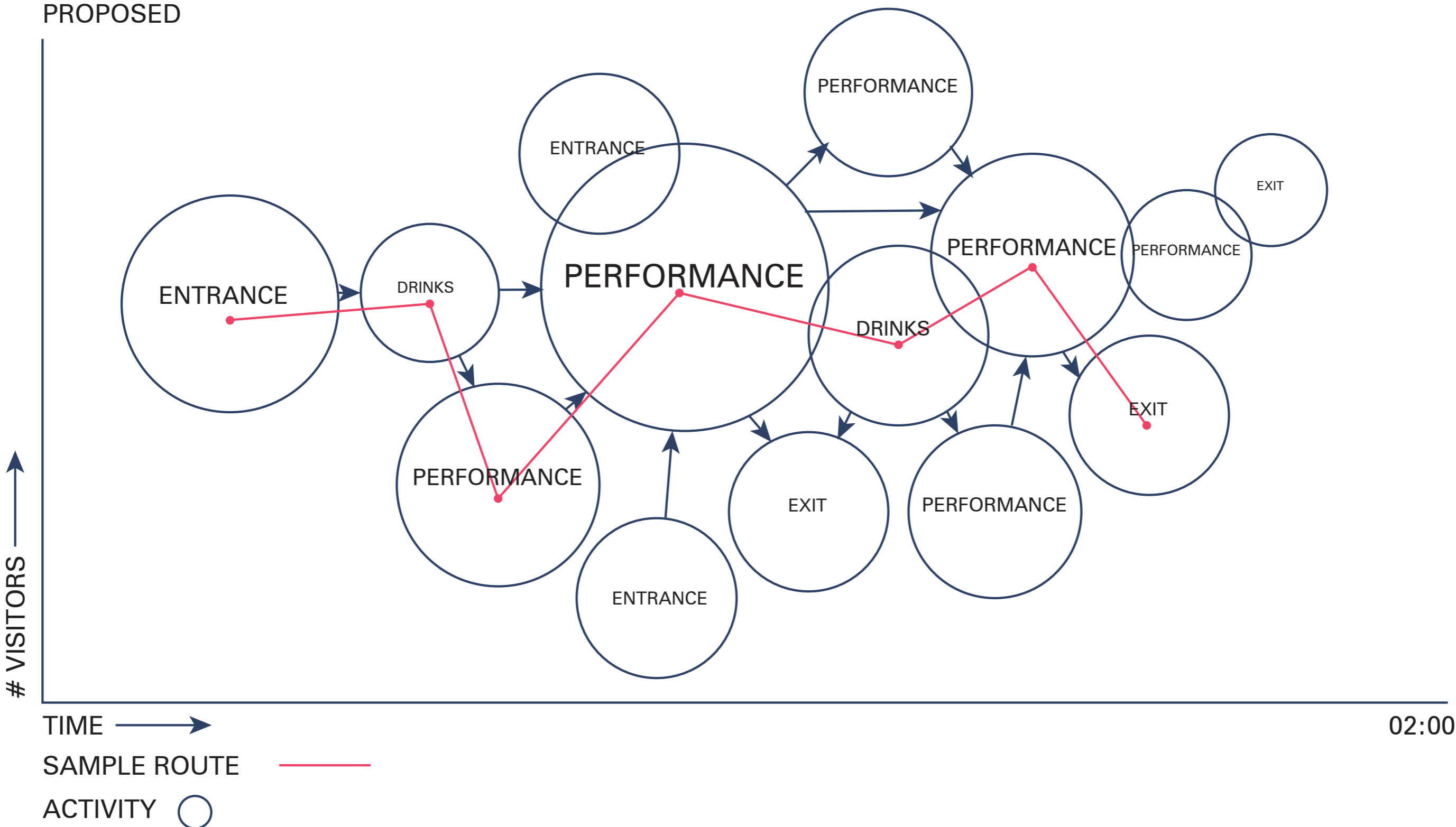

OBJECT



OBJECT



ARCHITECTURAL REFERENCE CATALOGUE

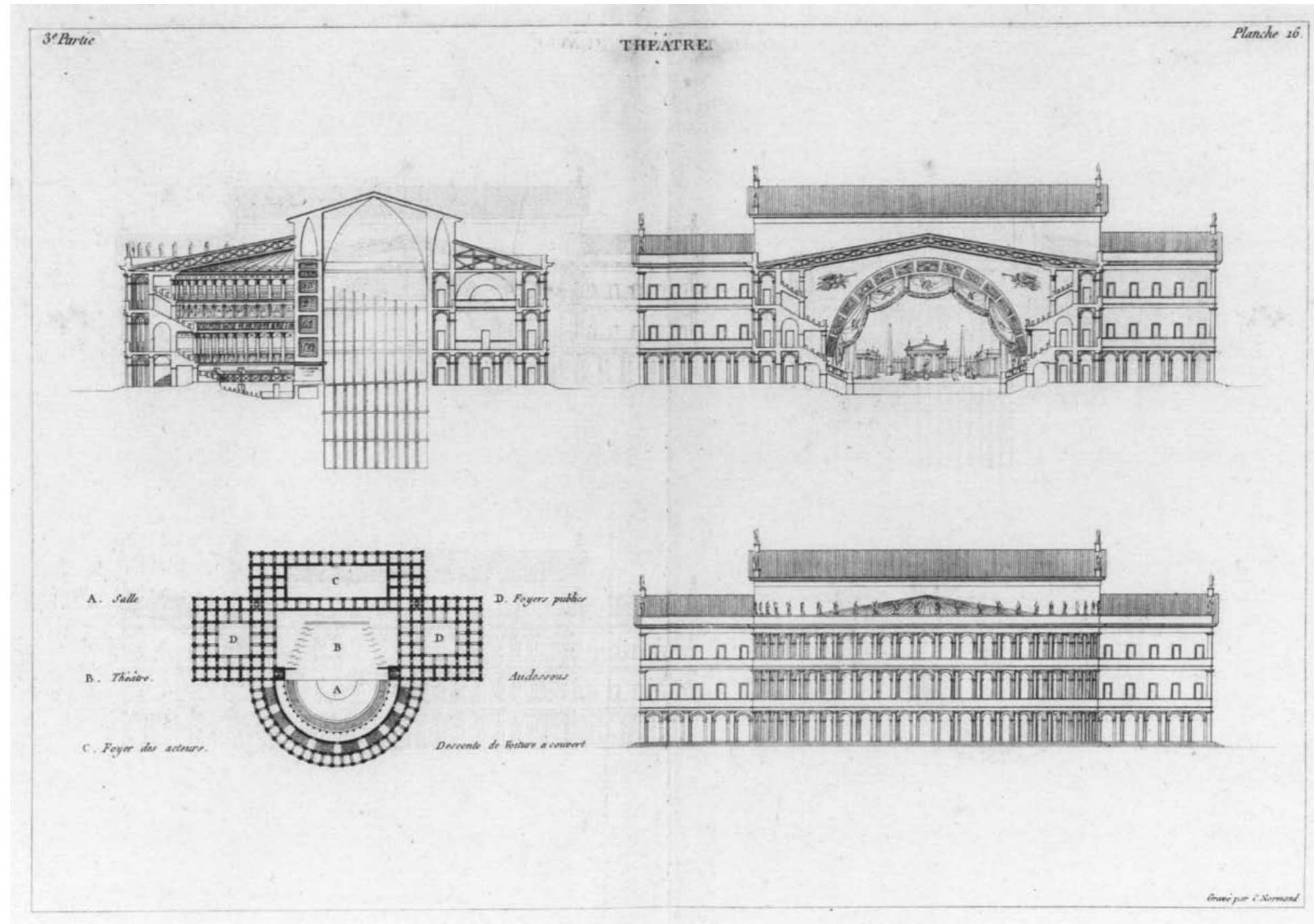

Jean-Nicholas Durand, exemple Theatre,
Précis des Leçons d'Architecture

ARCHITECTURAL REFERENCE CATALOGUE

Conclusions

Music Marvel

Teatro Oficina, Sao Paulo

Paradiso, Amsterdam

Case Conclusions

Philharmonie, Paris

Muziekgebouw aan 't IJ, Amsterdam

Public Building

Royal Festival Hall, London

Oslo Opera House, Oslo

Barbican Centre, London

Elbphilharmonie, Hamburg

music
marvel

REFERENCE CATALOGUE

Concert halls

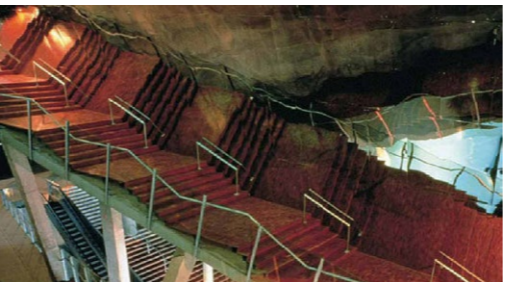
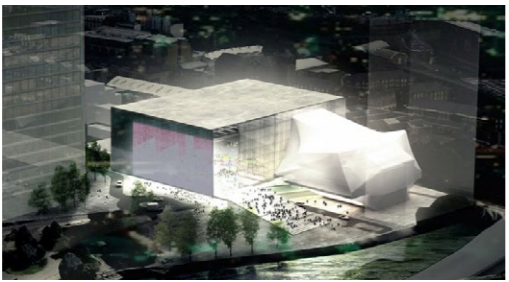
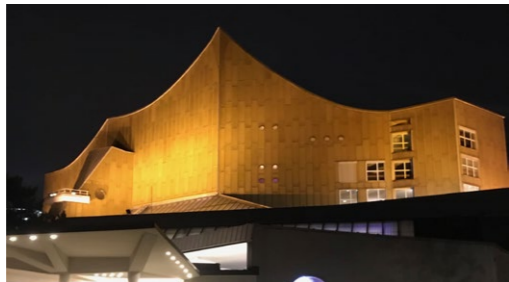
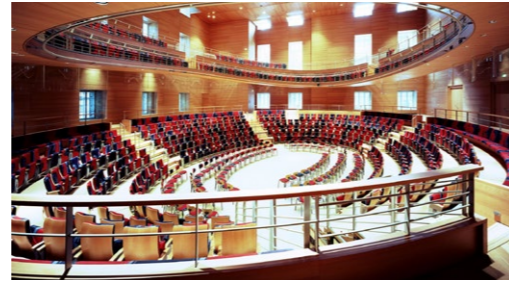

Museums,
hybrids



1. Royal Festival hall 2. Pierre Boulez Saal 3. Gdansk Shakespeare 4. Teatro Reggjo 5. Berliner Philharmonic 6. Opéra Garnier 7. Berlin Philharmonic 8. Factory arts centre 9. Mumbai city museum 10. Congrexpo 11. Neue Nationalgalerie 11. Carré d'Art 12. Eye museum 13. Neue Staatsgalerie

CATALOGUE APPLICATION

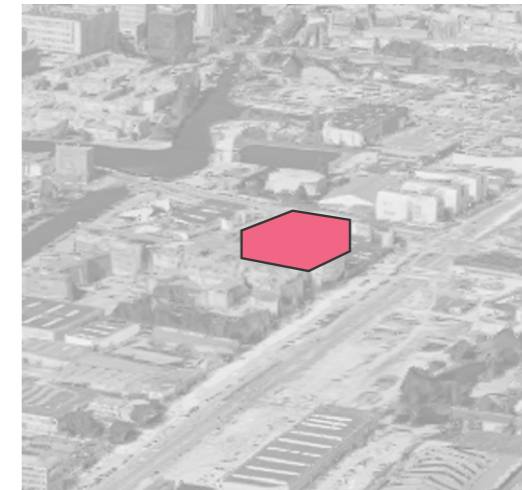
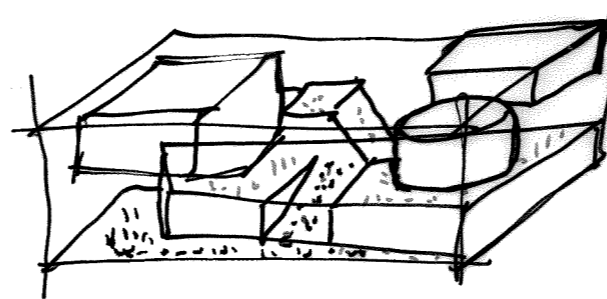
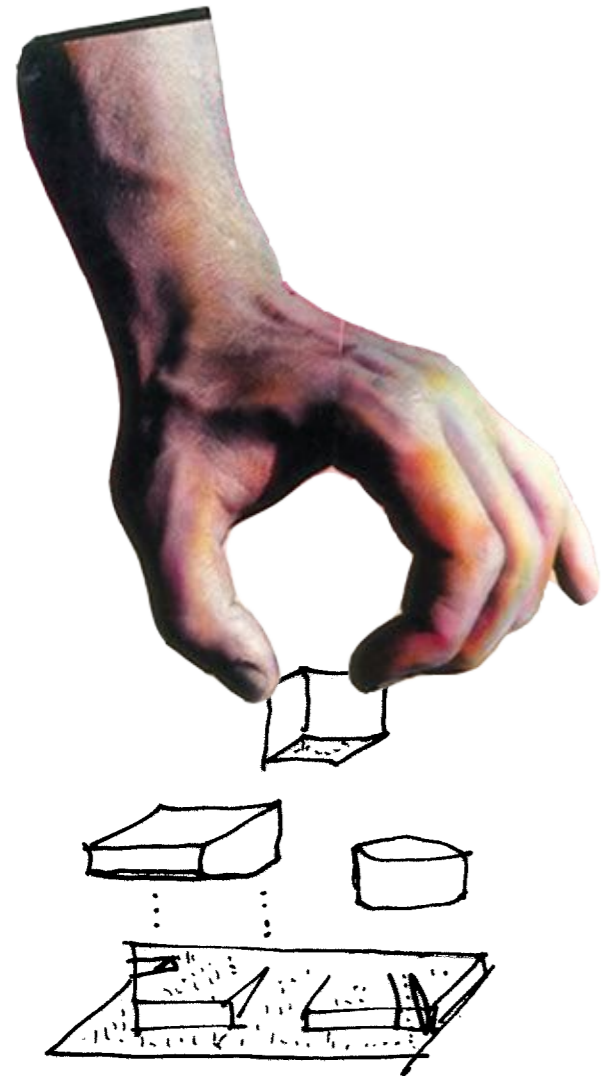

CONTEXT



CONTEXT

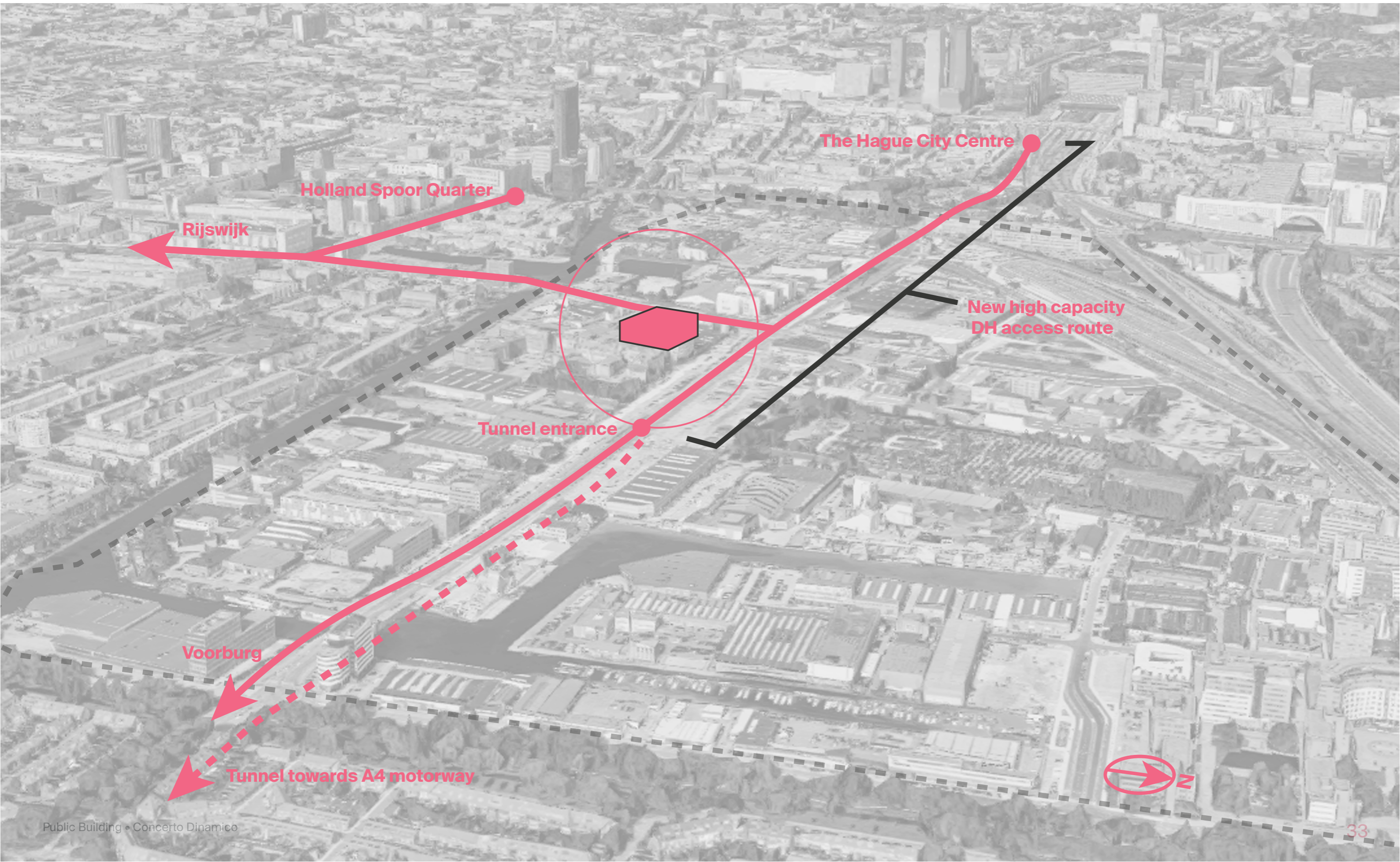

CONTEXT

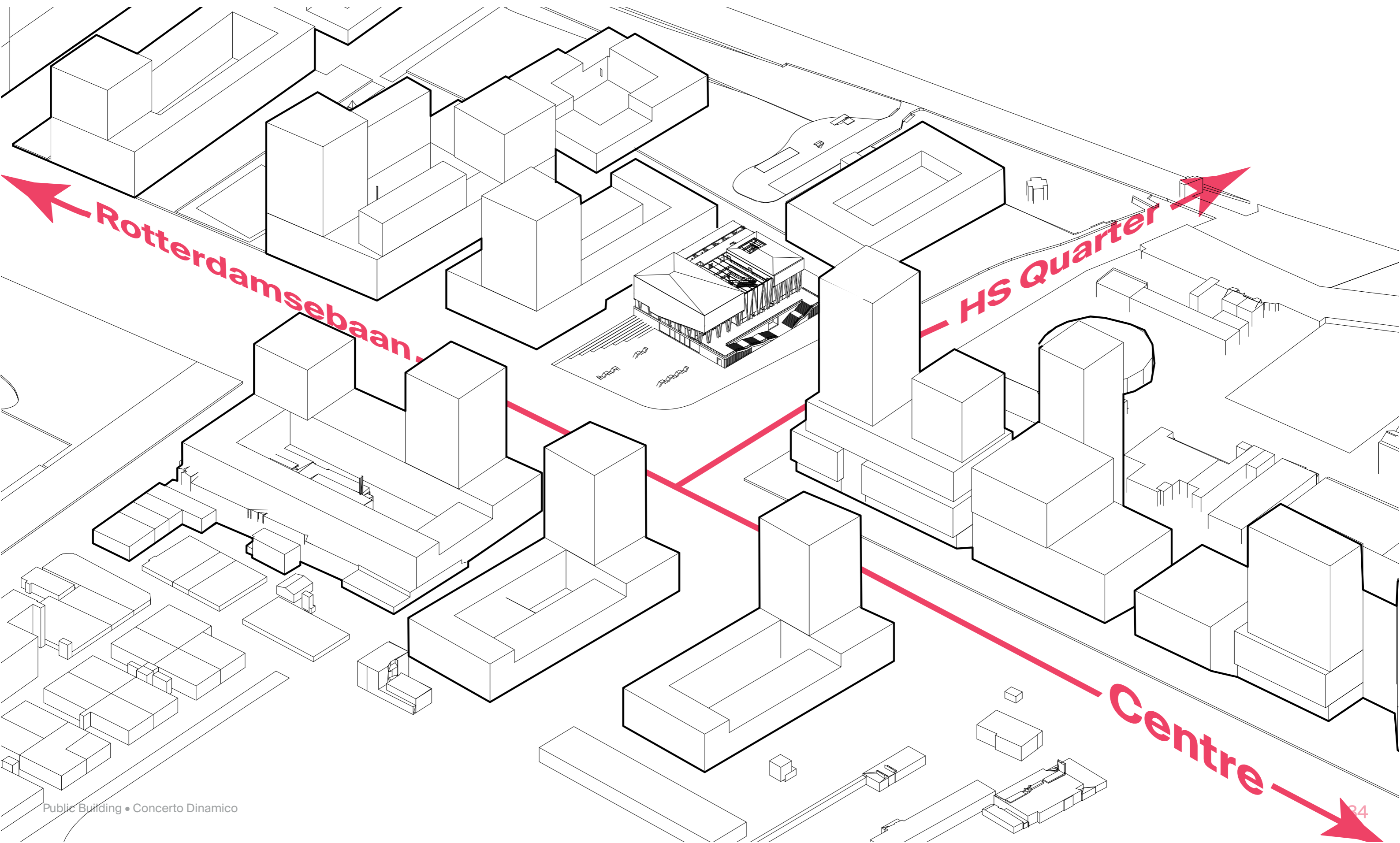

URBAN CONTEXT

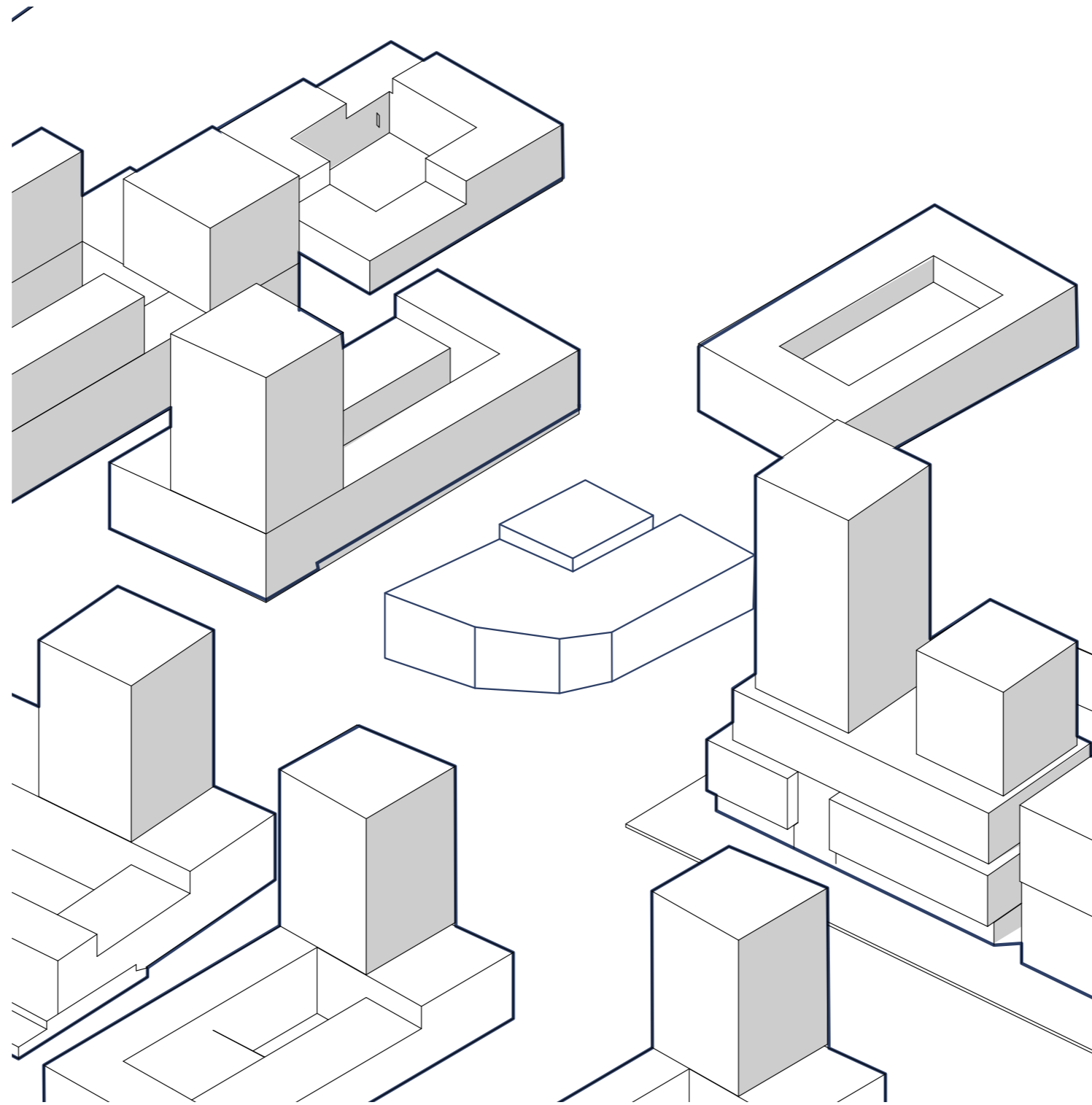

Existing situation

URBAN CONTEXT

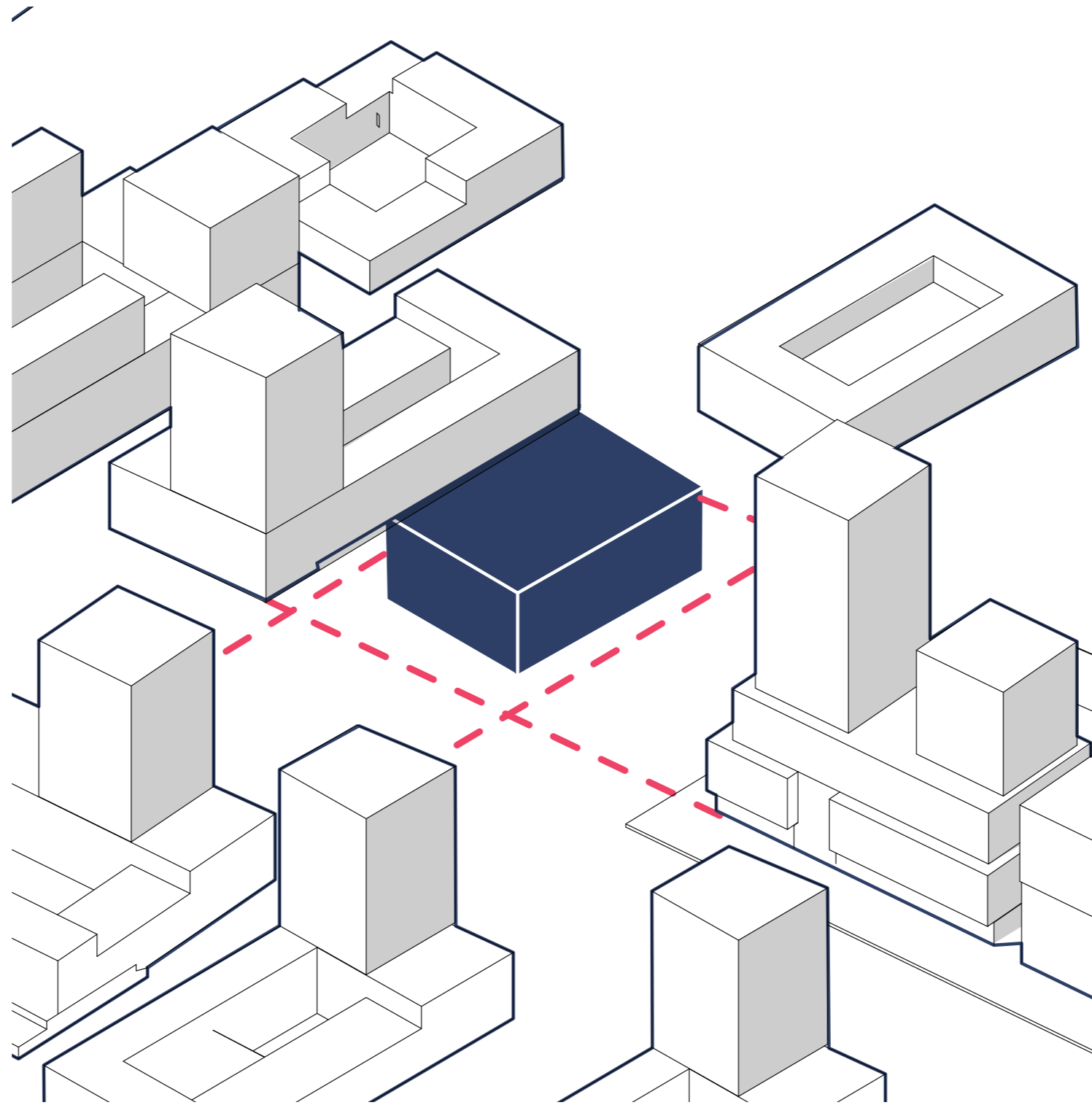

Imposing a distanced structure

URBAN CONTEXT

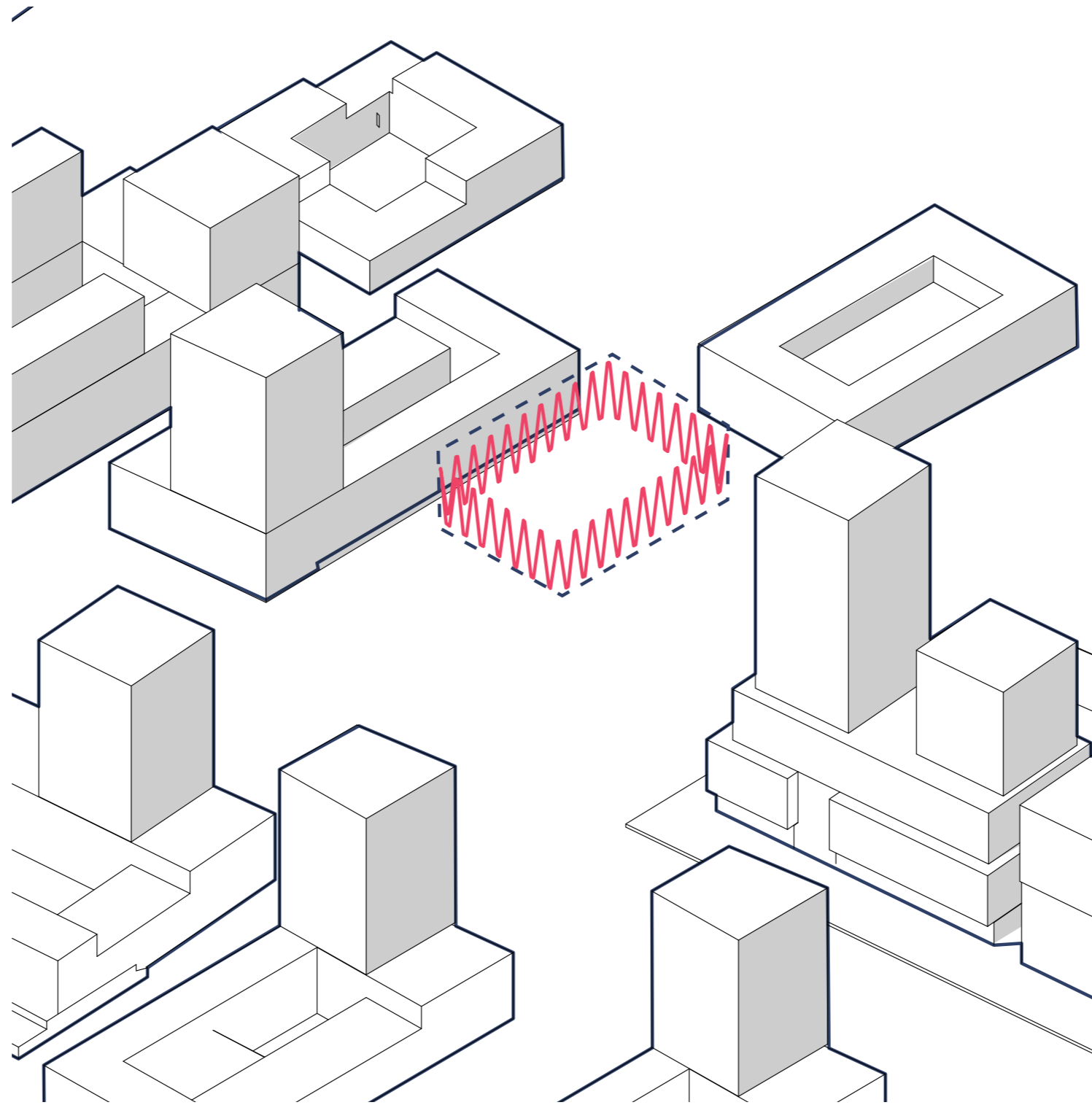

Defining a physical frame

PERCEPTION

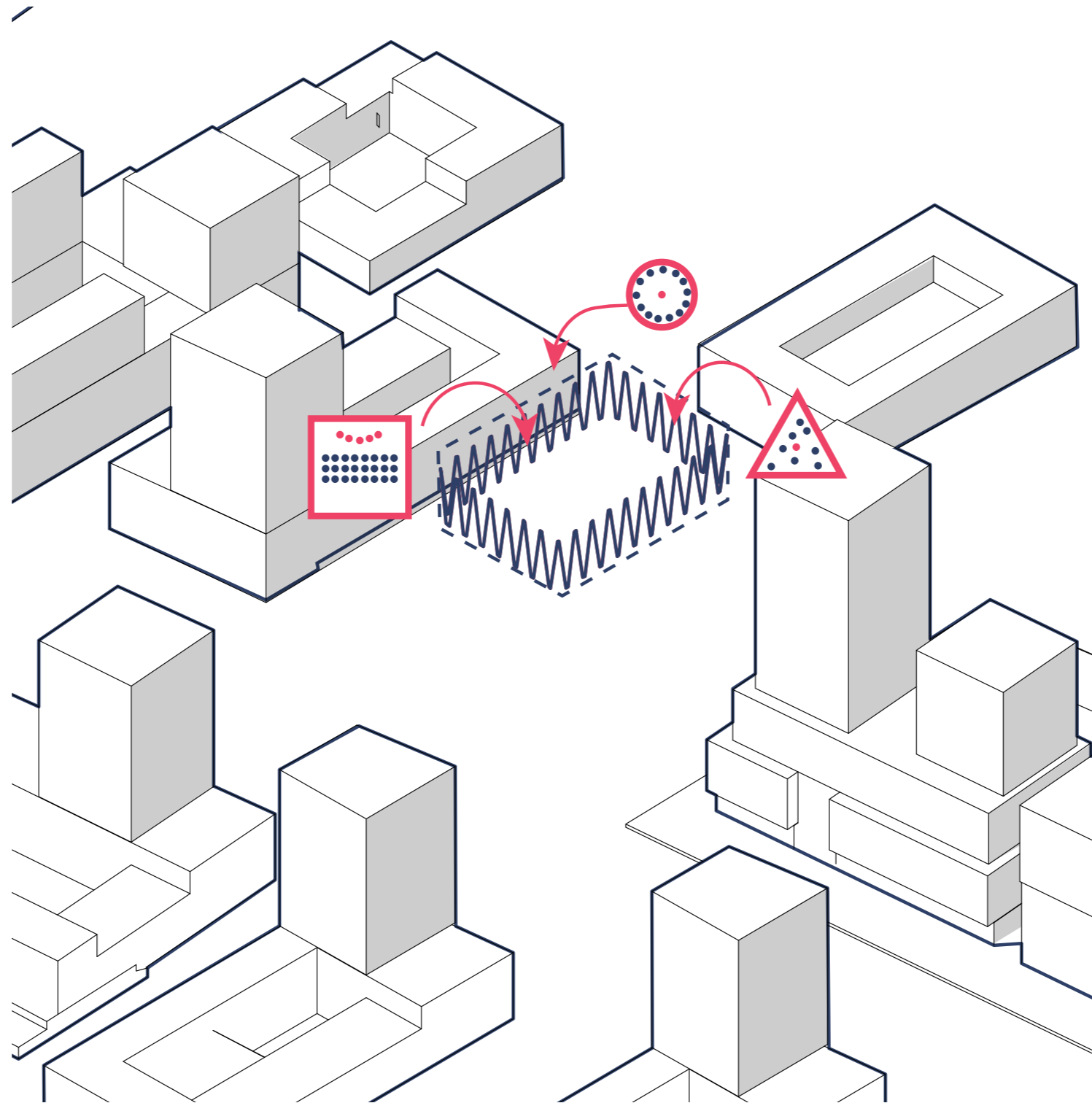

Various performer-audience relationships

OBJECT

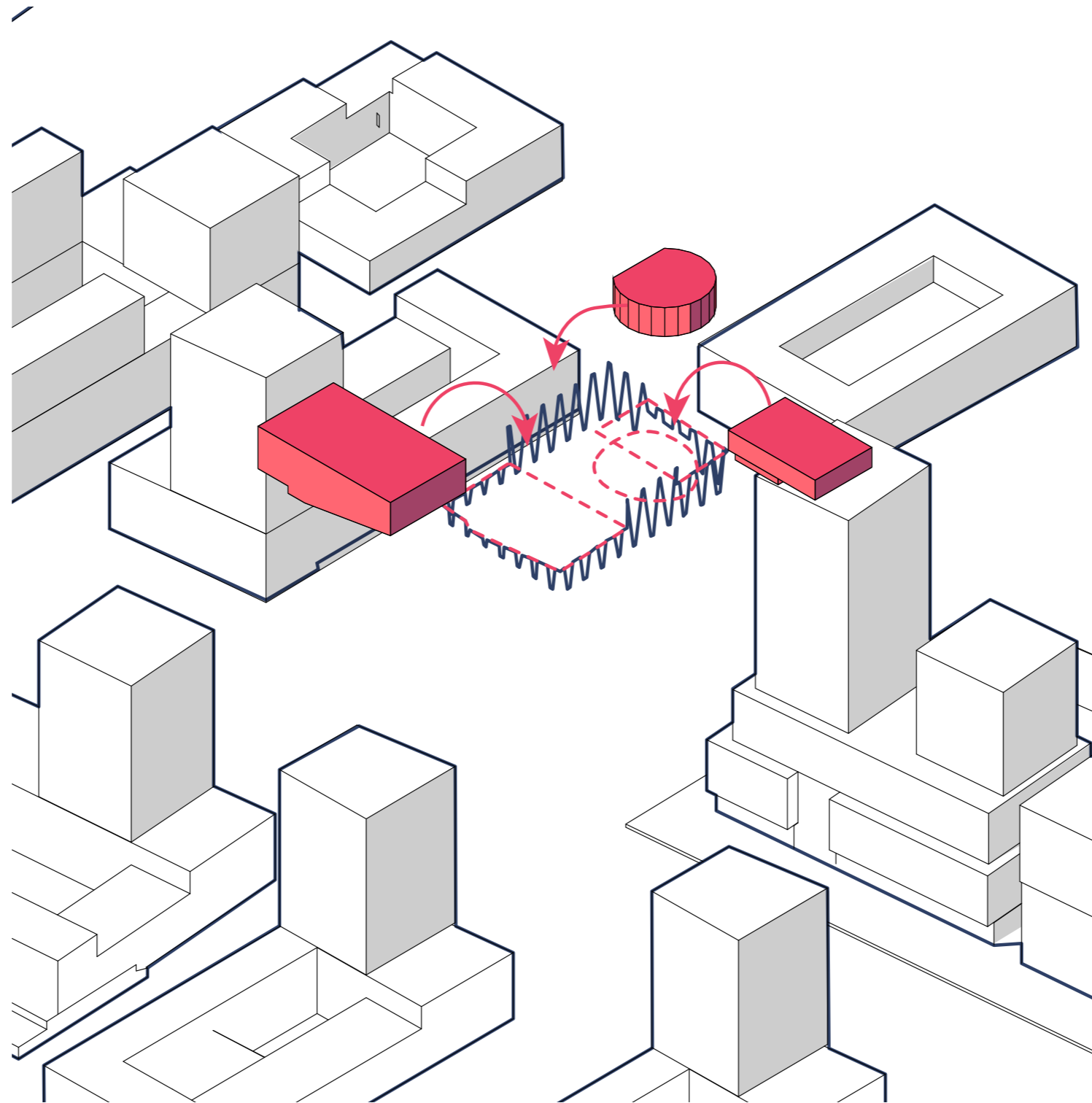

Form components using catalogue

OBJECT

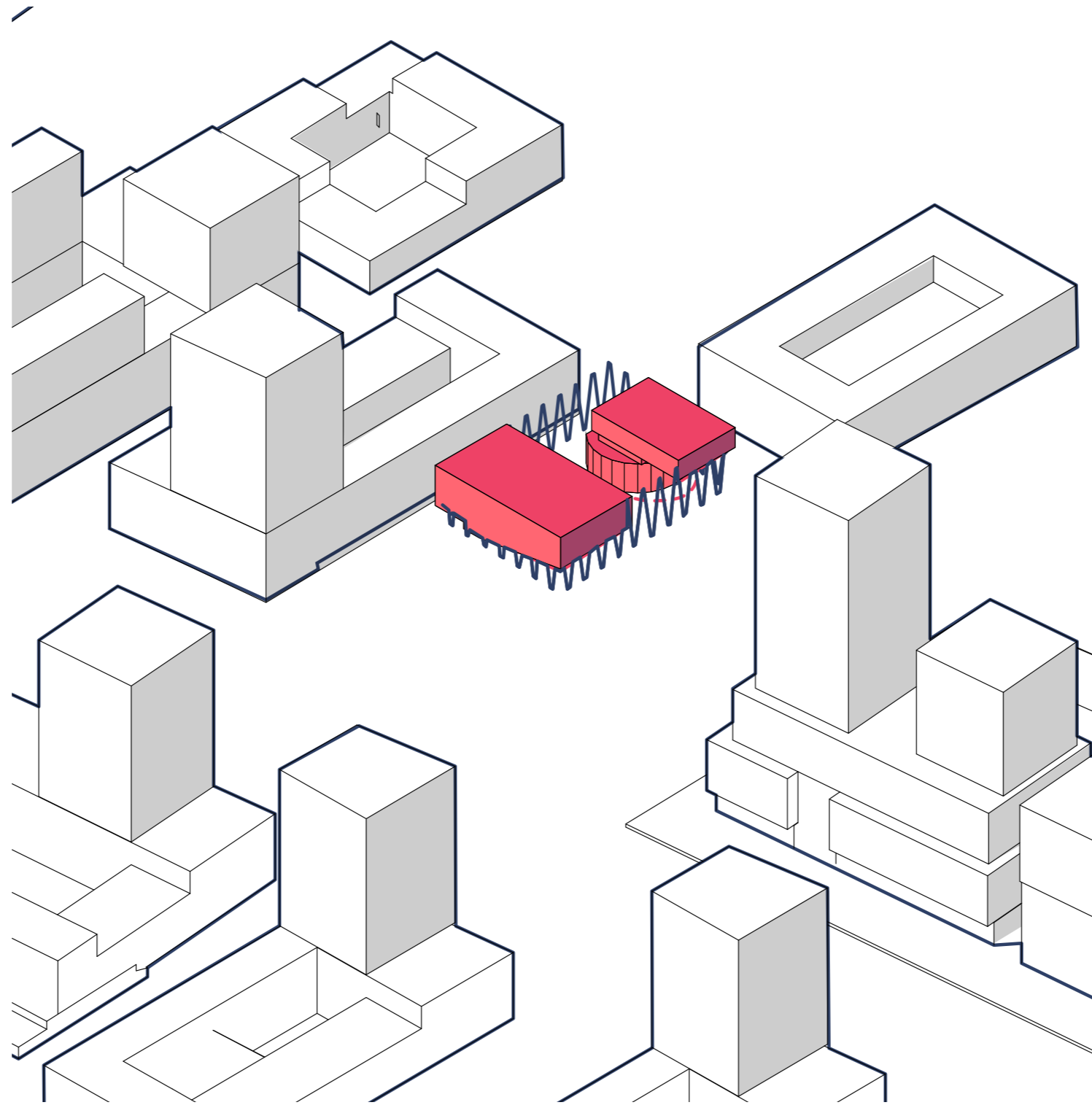

Components enter frame

OBJECT

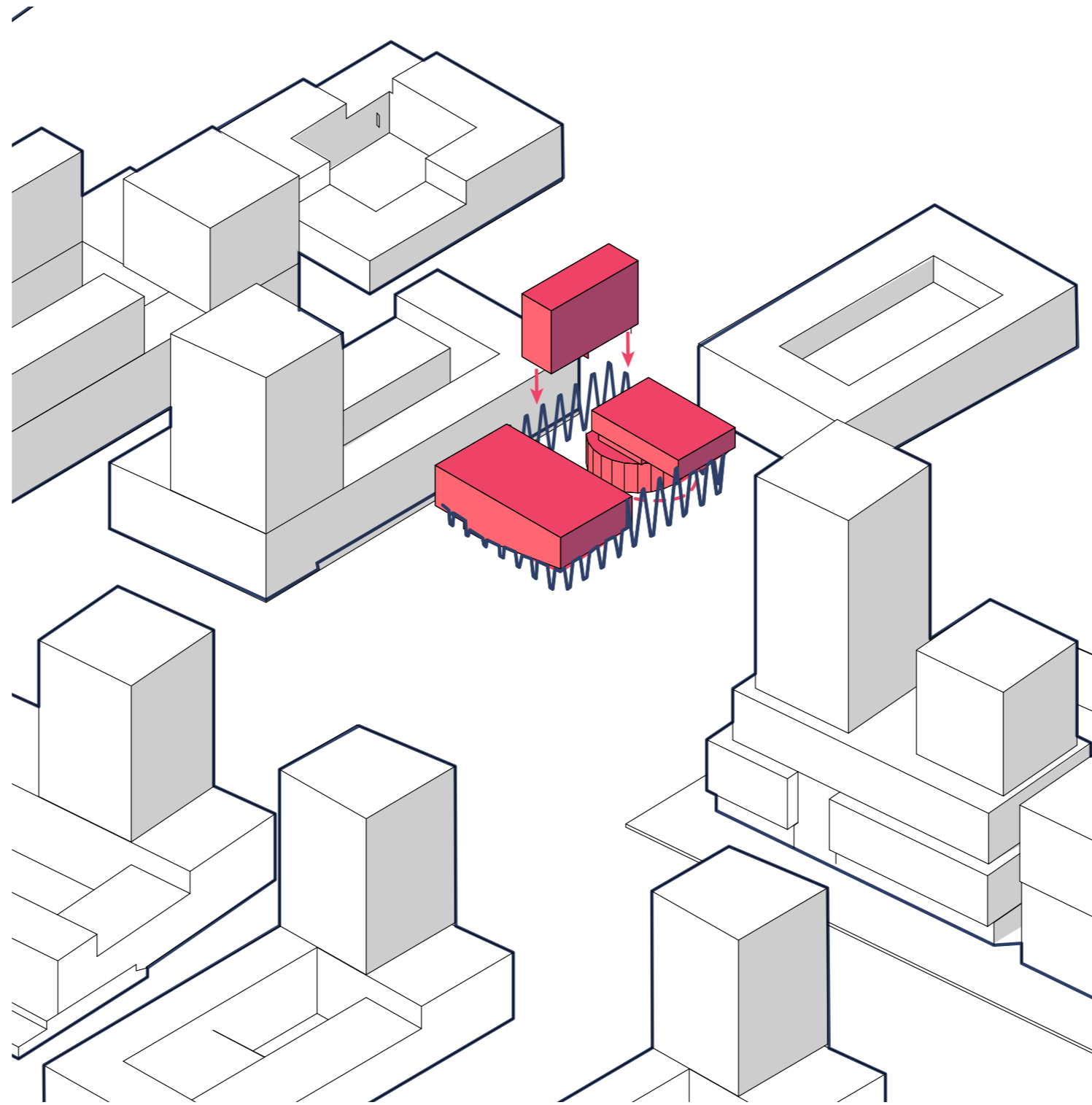

Enter backbone block in frame

OBJECT

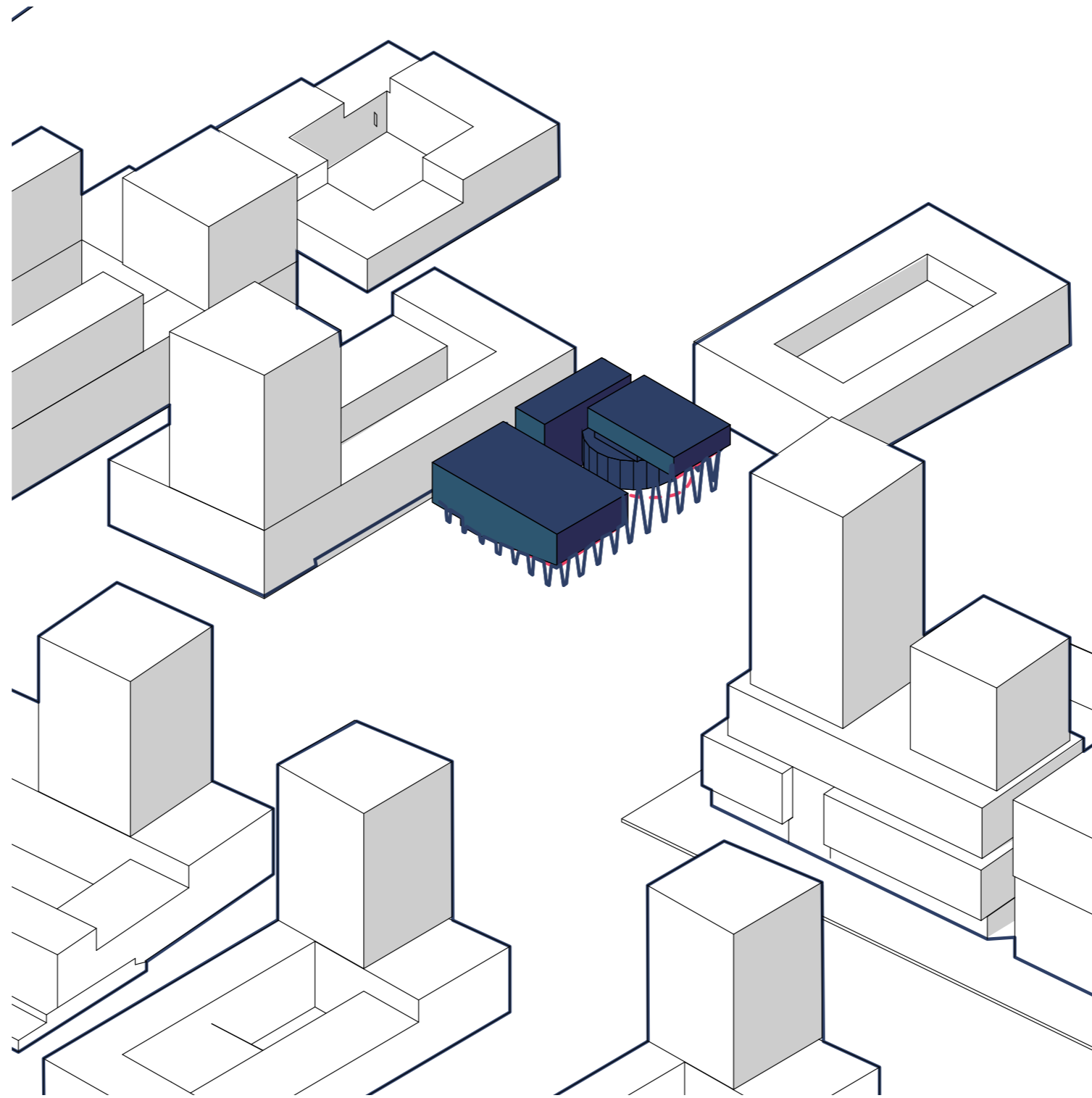

Frame filled

MOVEMENT

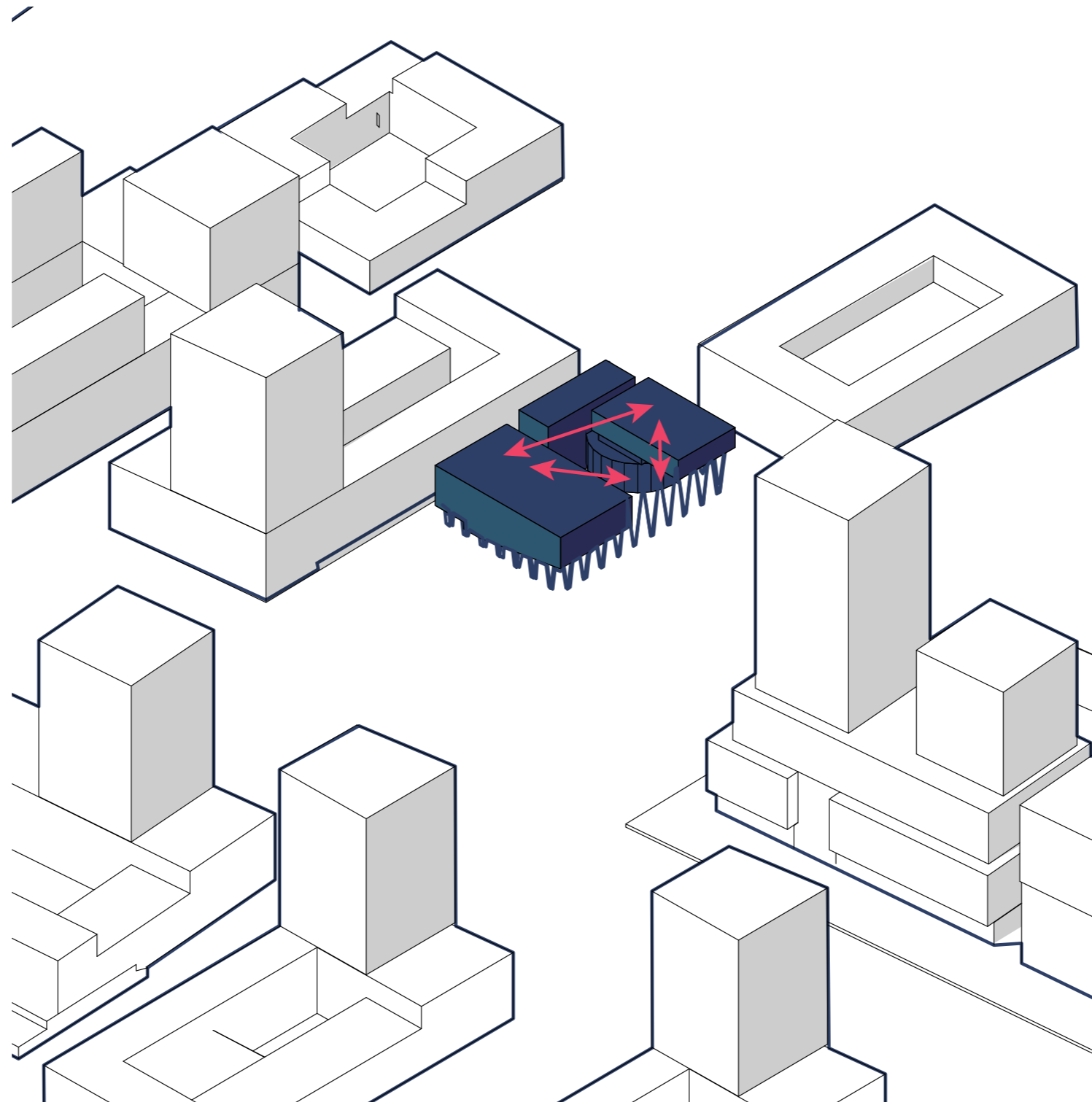

Interconnecting through routes

MOVEMENT

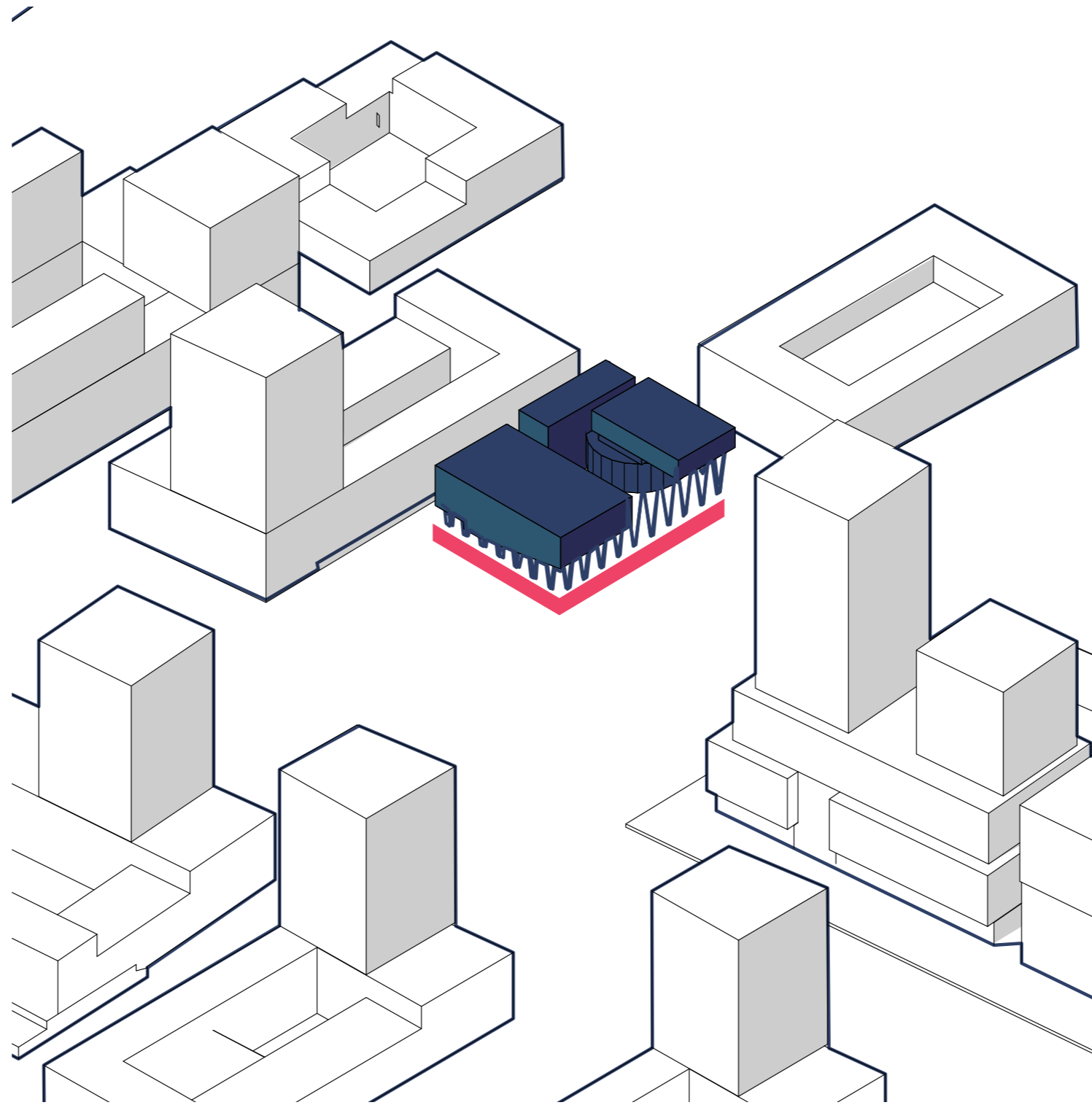

Raising objects on pedestal

MOVEMENT

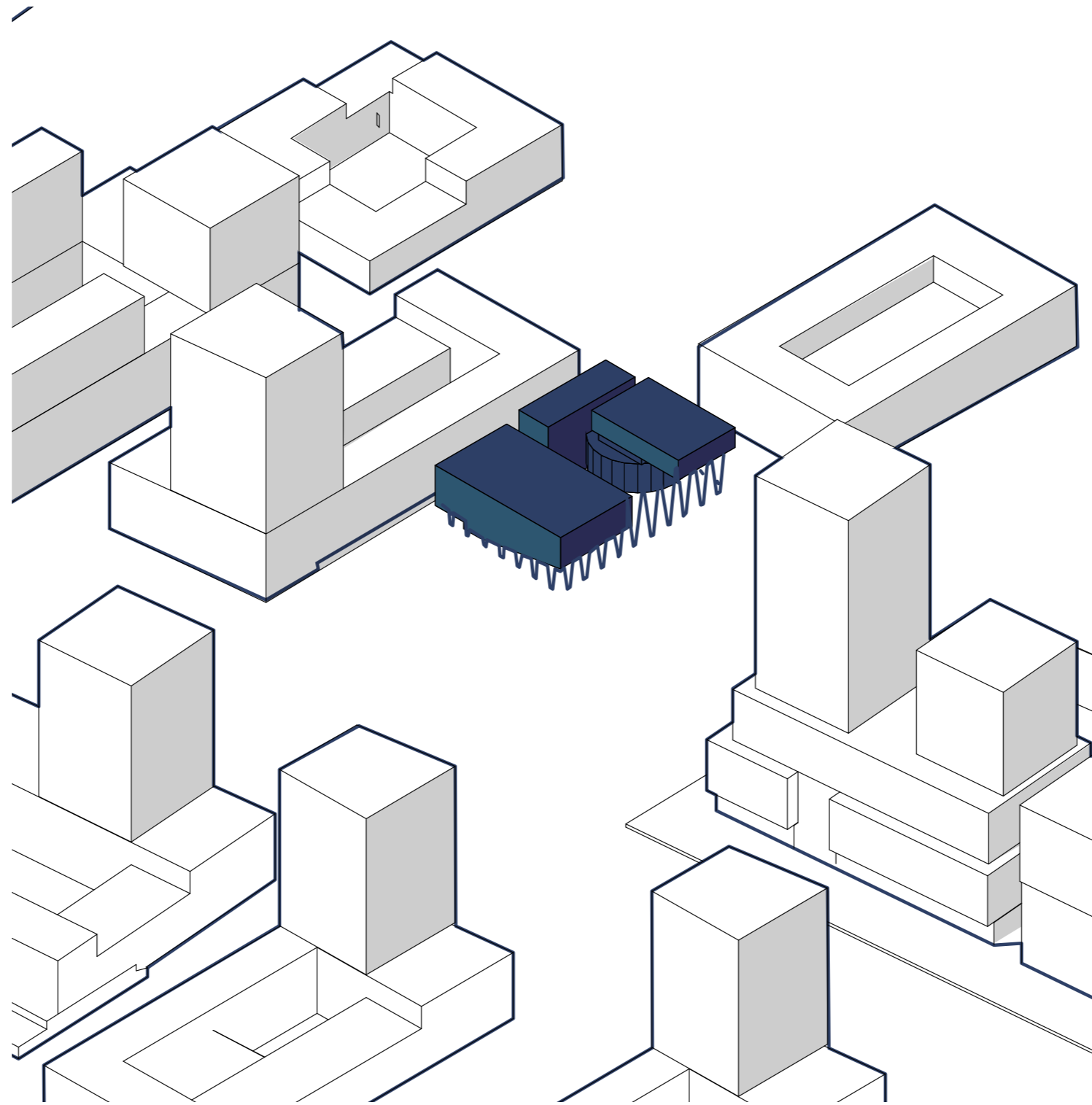

Extending pedestal as balcony

MOVEMENT

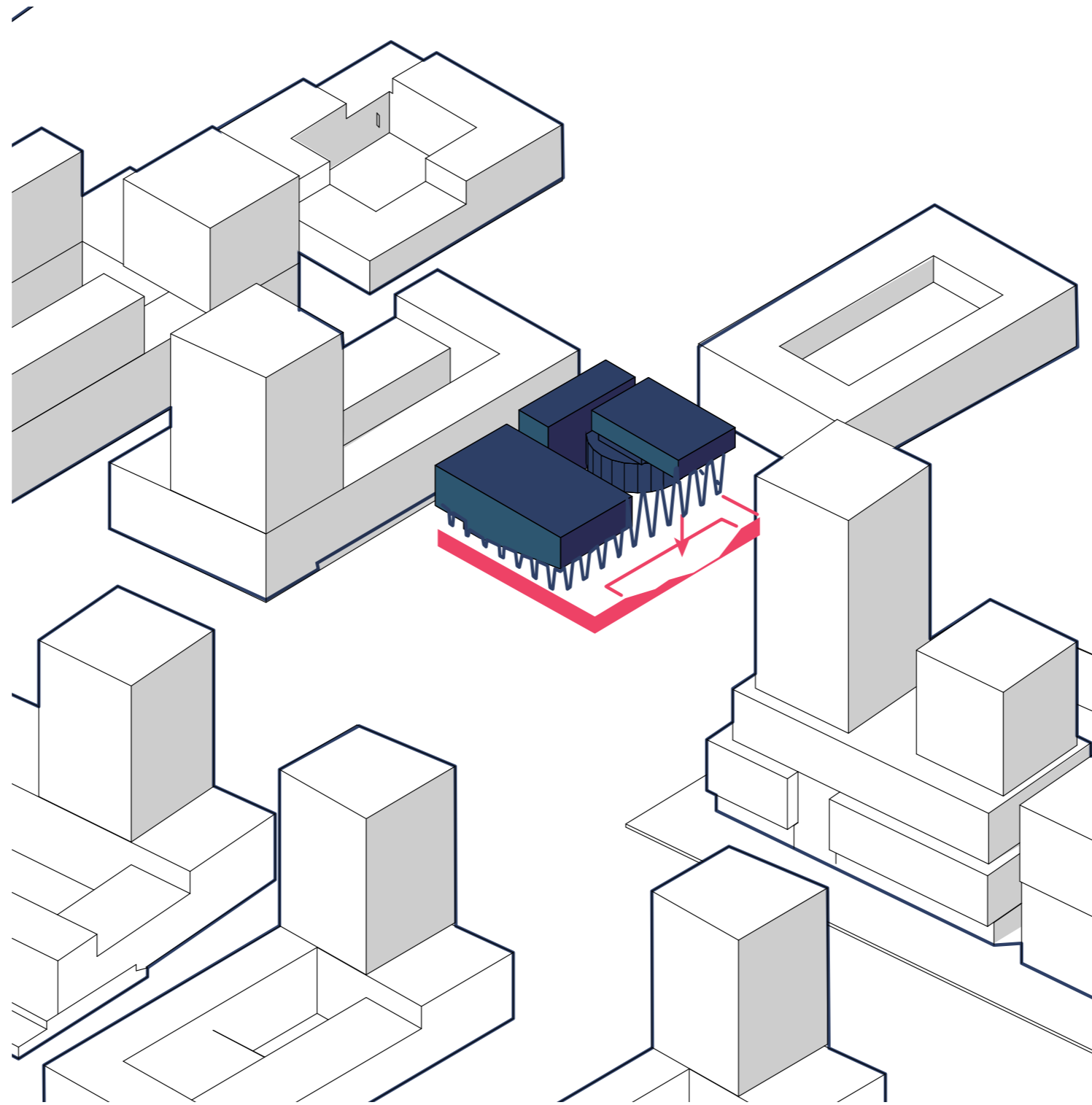

Lowering balcony to invite urban activity

MOVEMENT

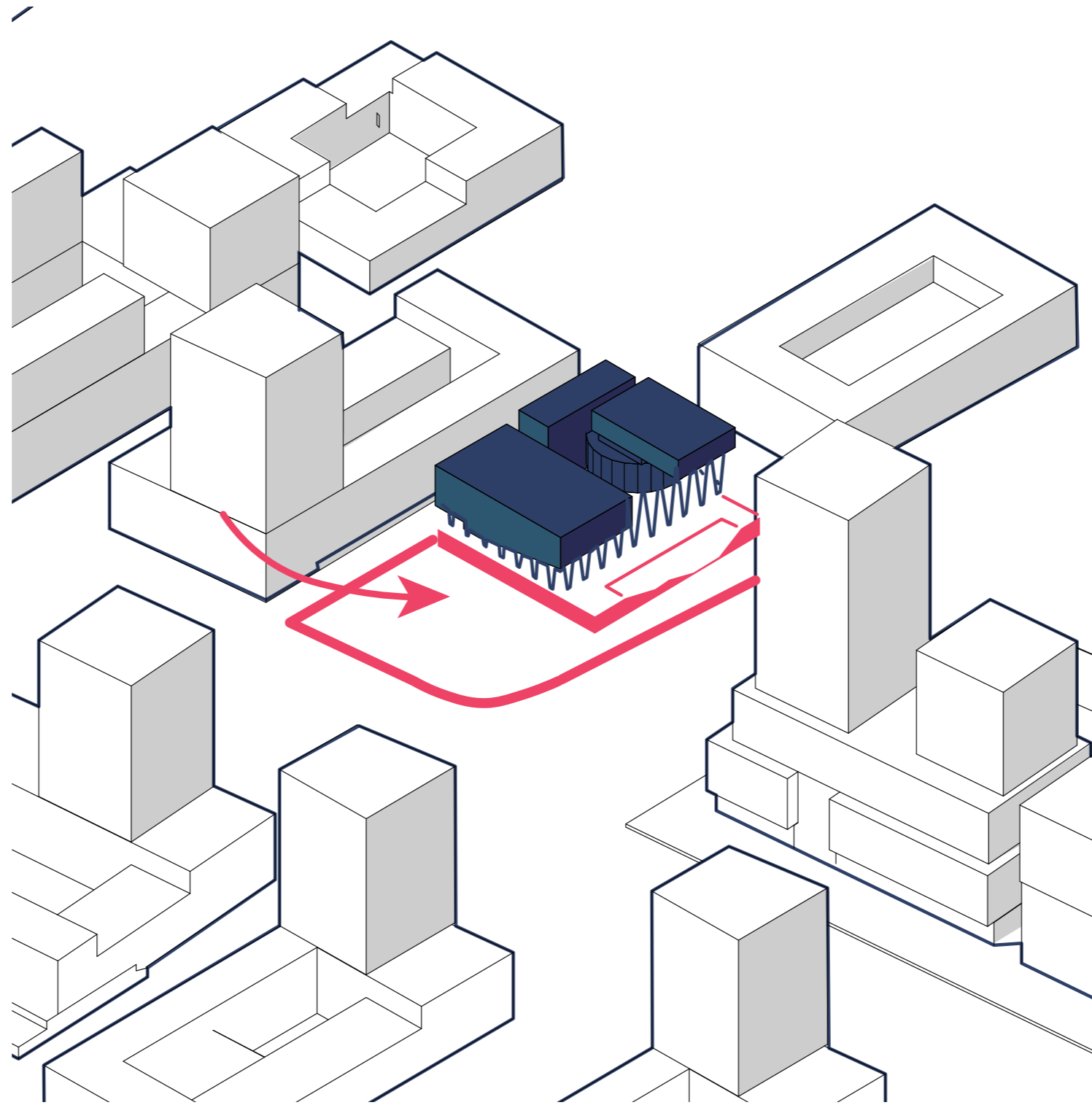

Placing structure onto lowered square to engage entrances

PRODUCT

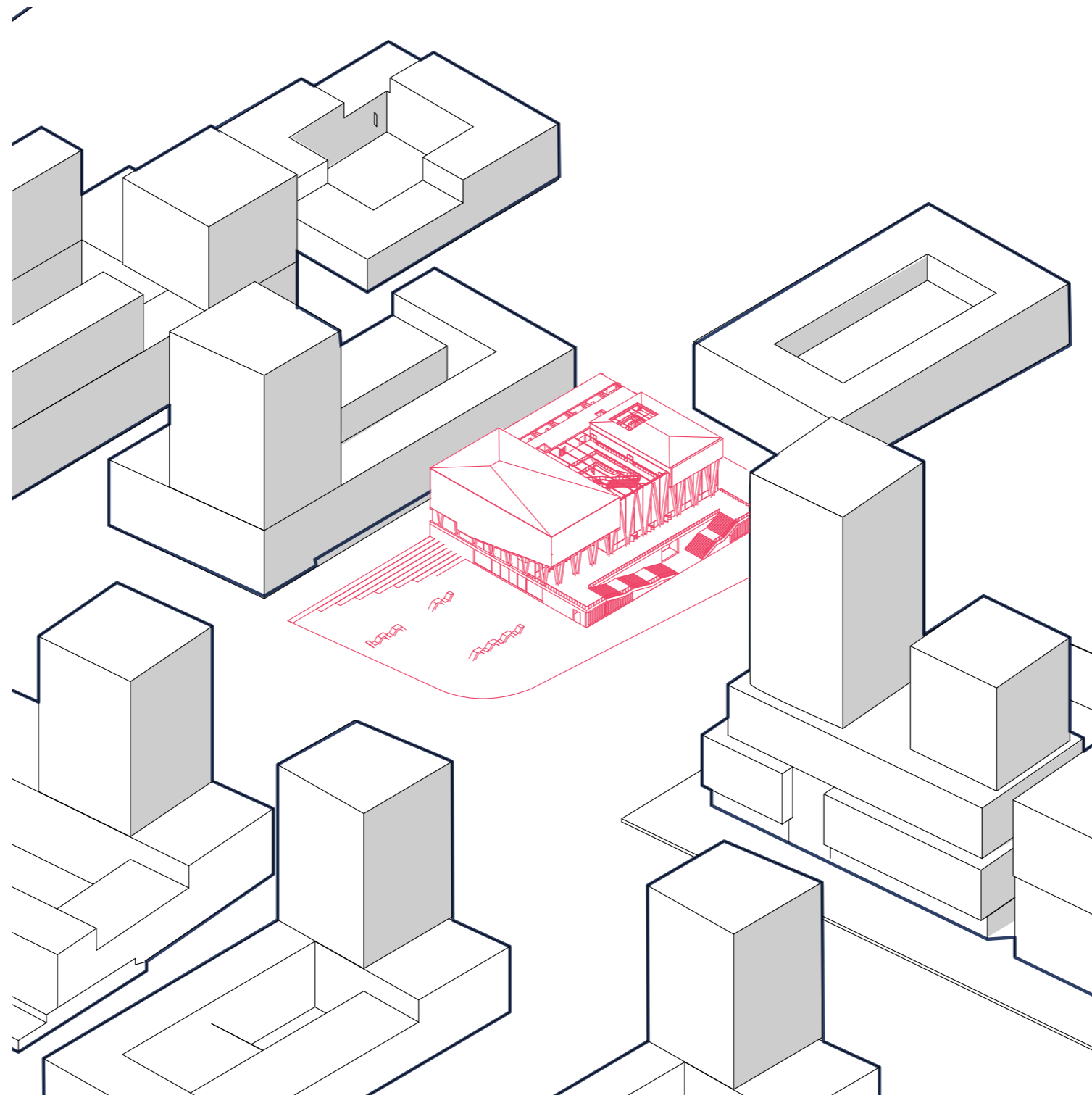

MORPHOLOGY



east-west axis

MORPHOLOGY



north-south axis

1. MUSIC MARVEL
2. PREMISE
3. RESEARCH
4. DESIGN

COMPONENTS

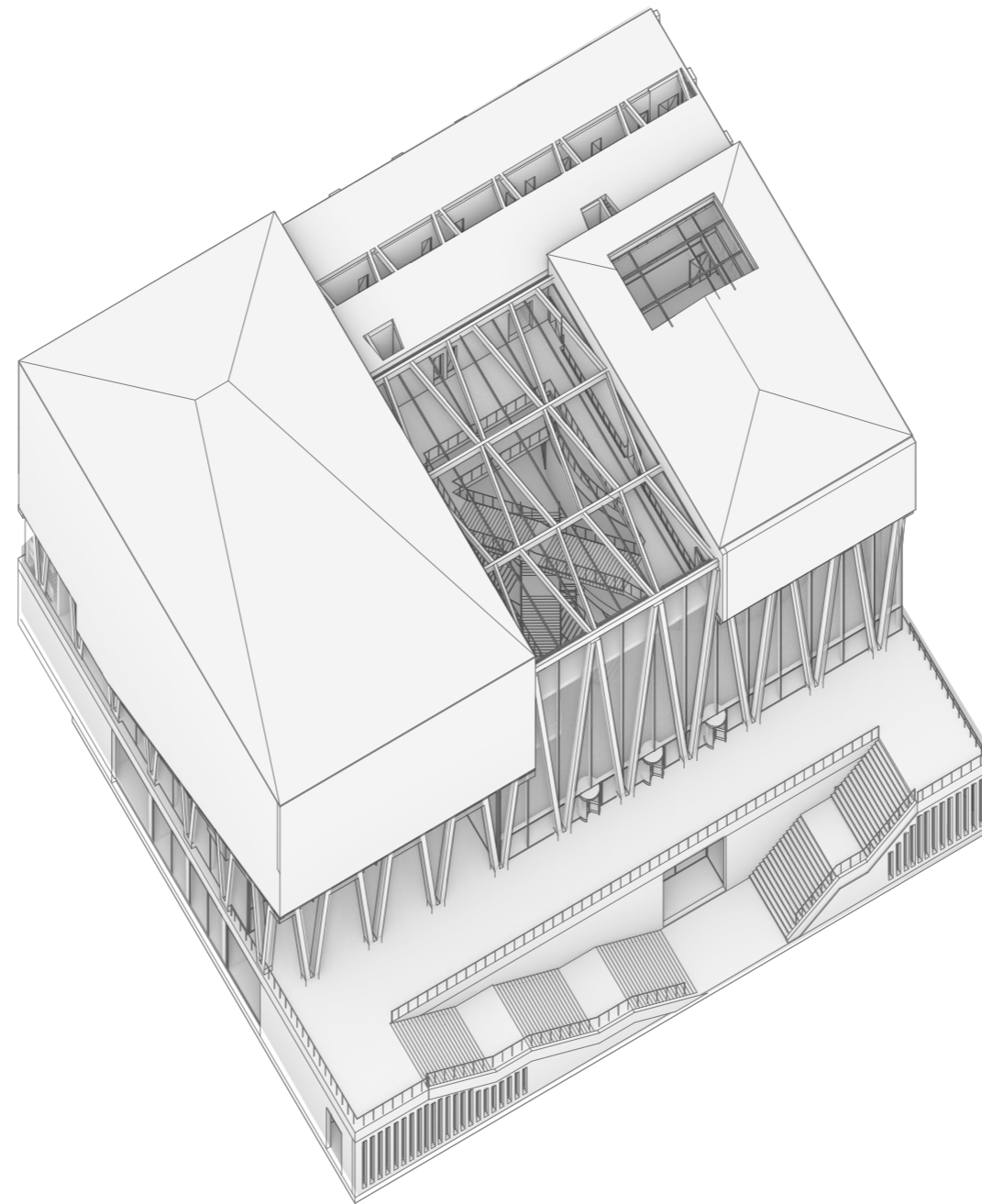

COMPONENTS

Classical Hall

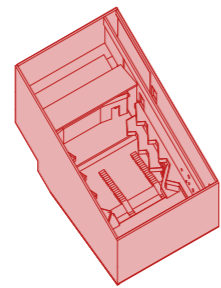

Shakespeare hall

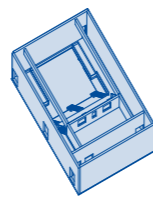

Horseshoe hall



Servant space

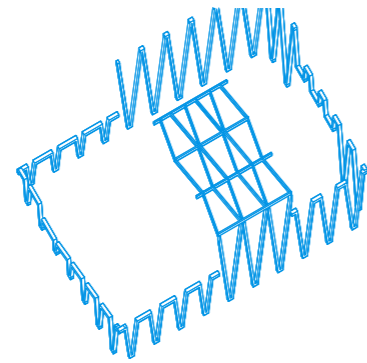
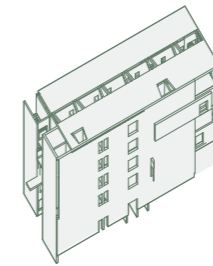

Weave



Column booths

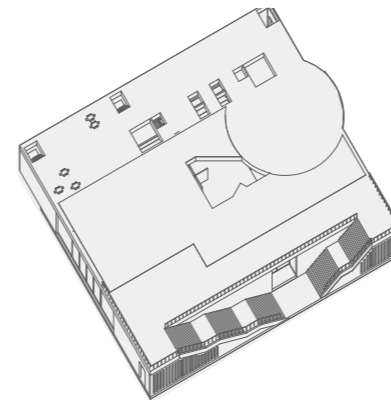

Plinth

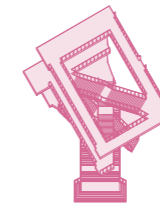

Connections



Classical Hall

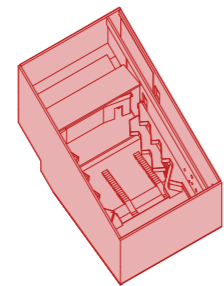

Weave

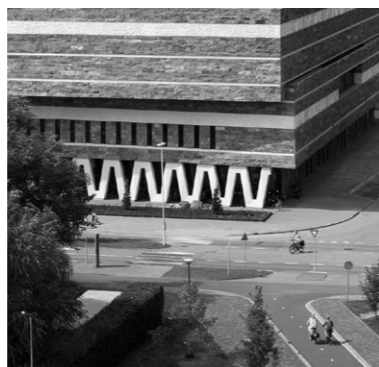

Shakespeare hall

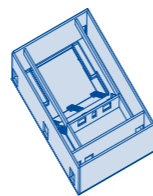

Column booths

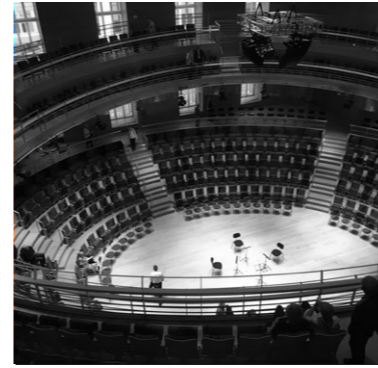

Horseshoe hall



Plinth

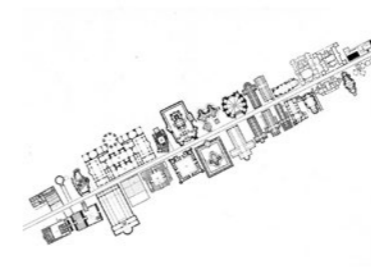
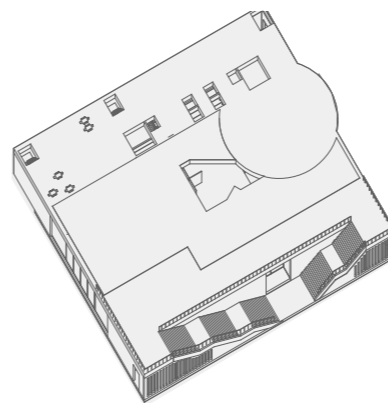

Servant space

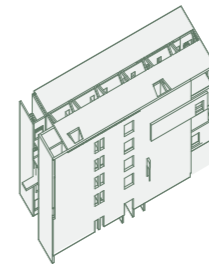

Connections

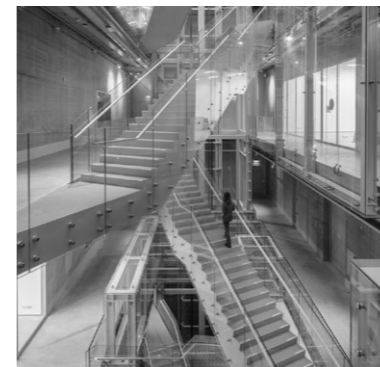

COMPONENTS

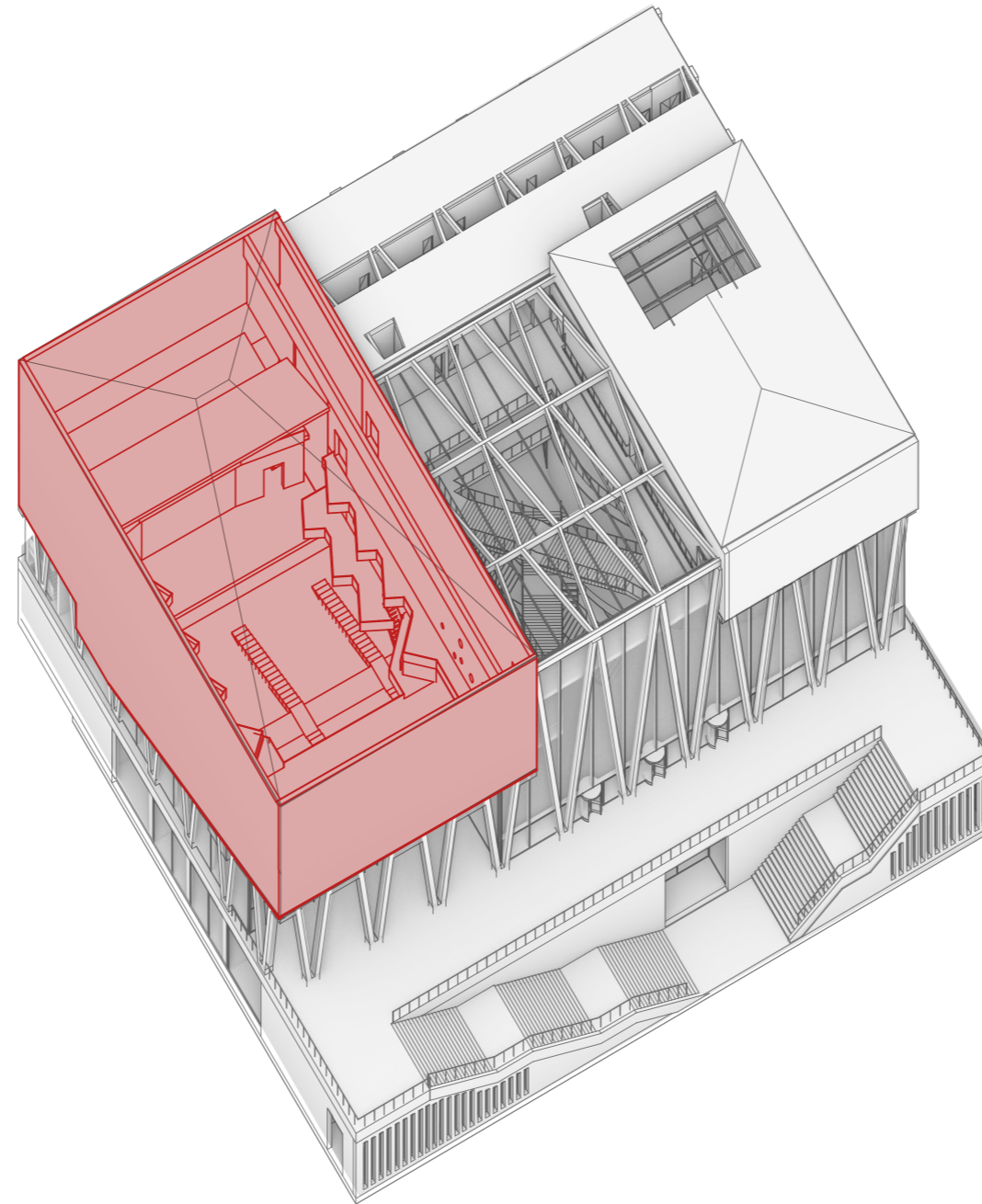

Classical Hall

COMPONENTS

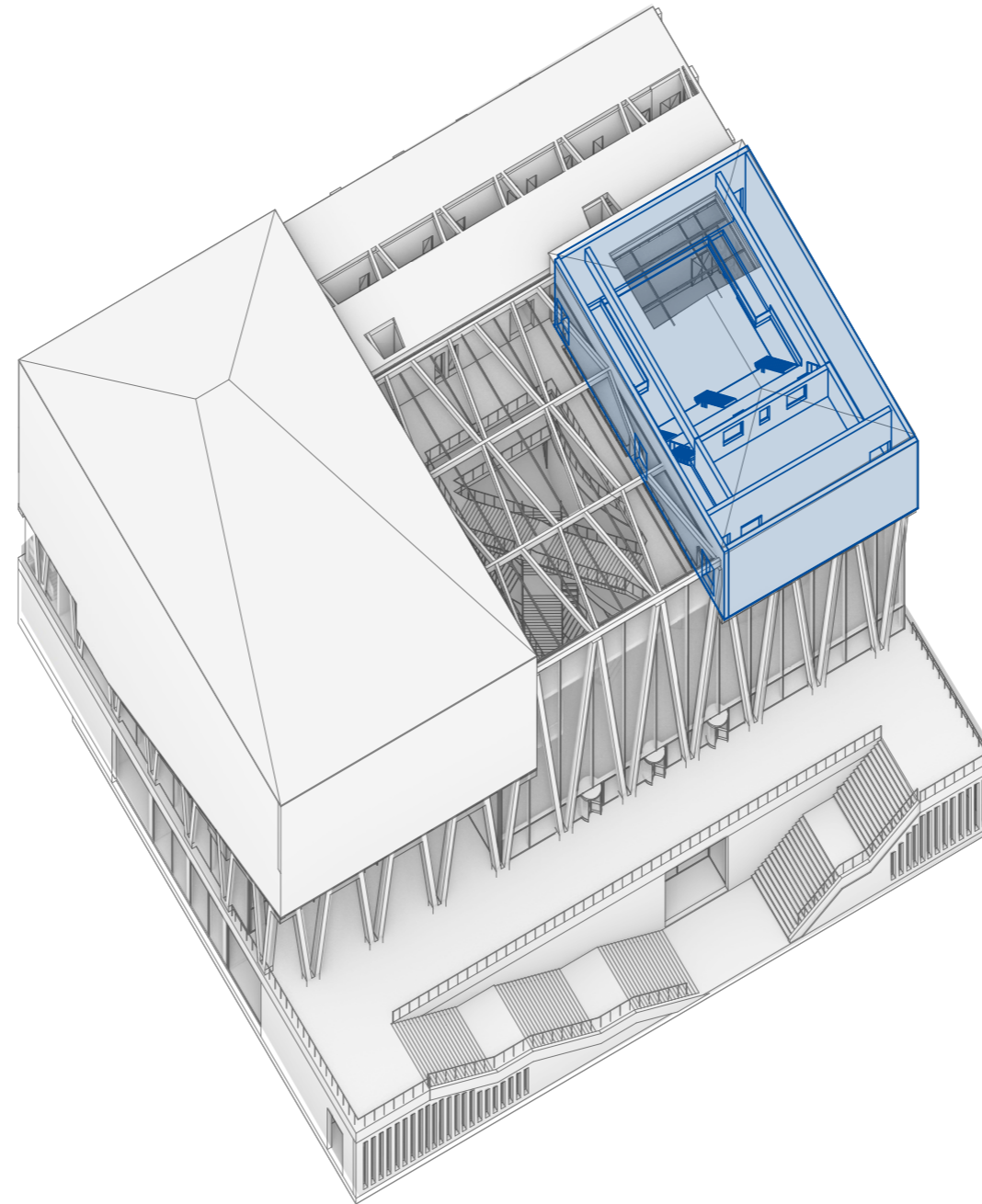

Shakespeare hall

COMPONENTS

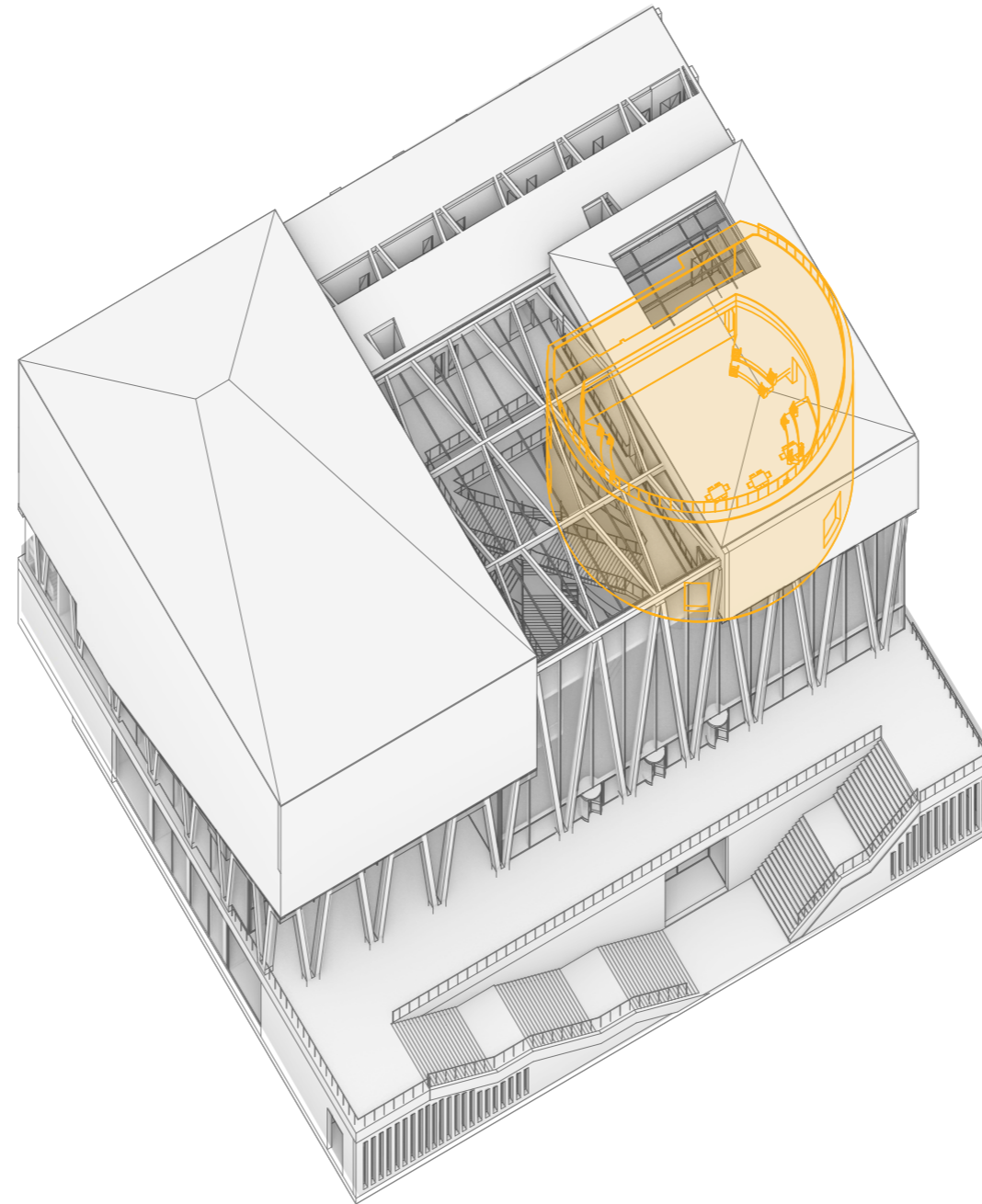

Horseshoe hall

COMPONENTS

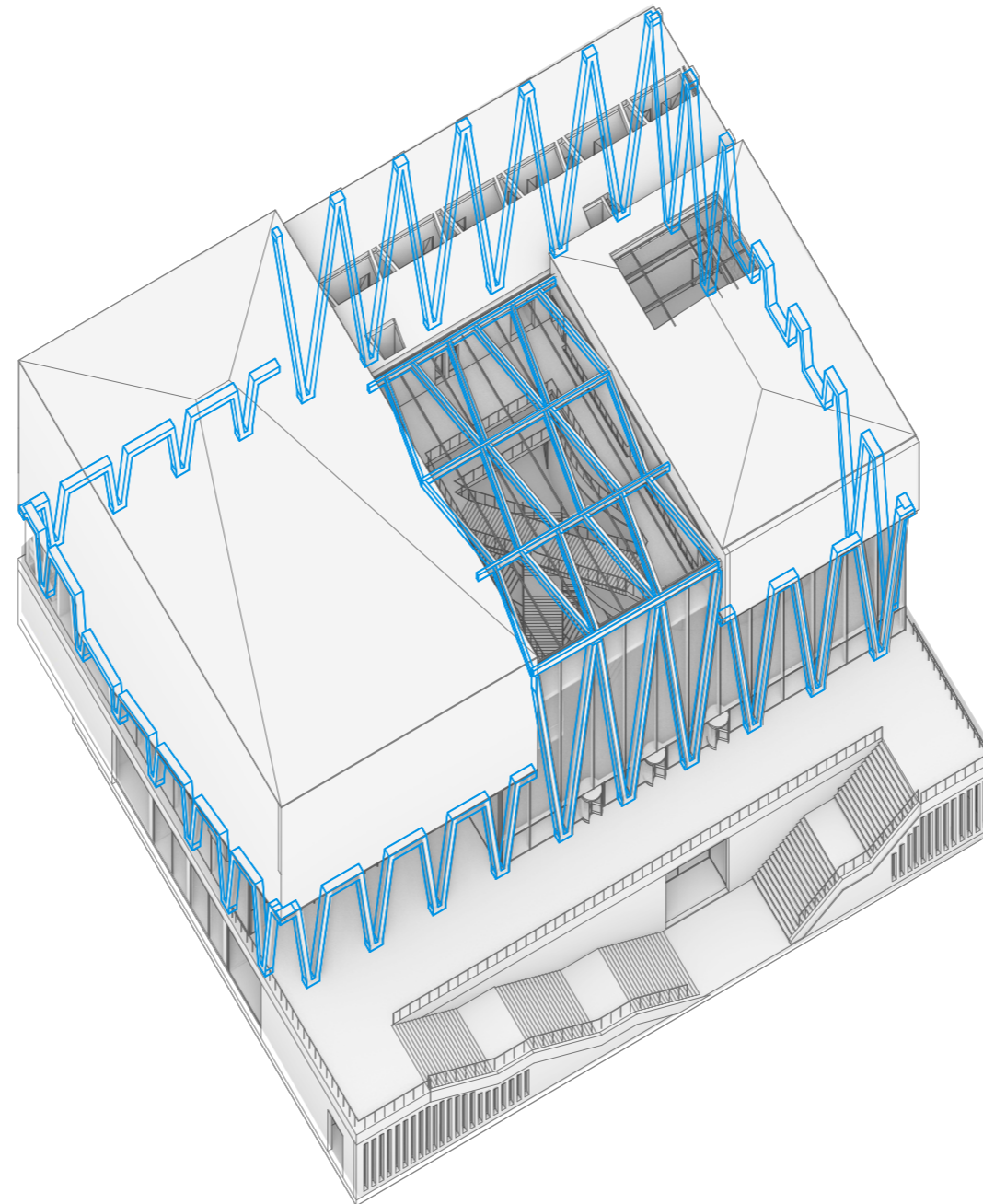

Structural weave

COMPONENTS

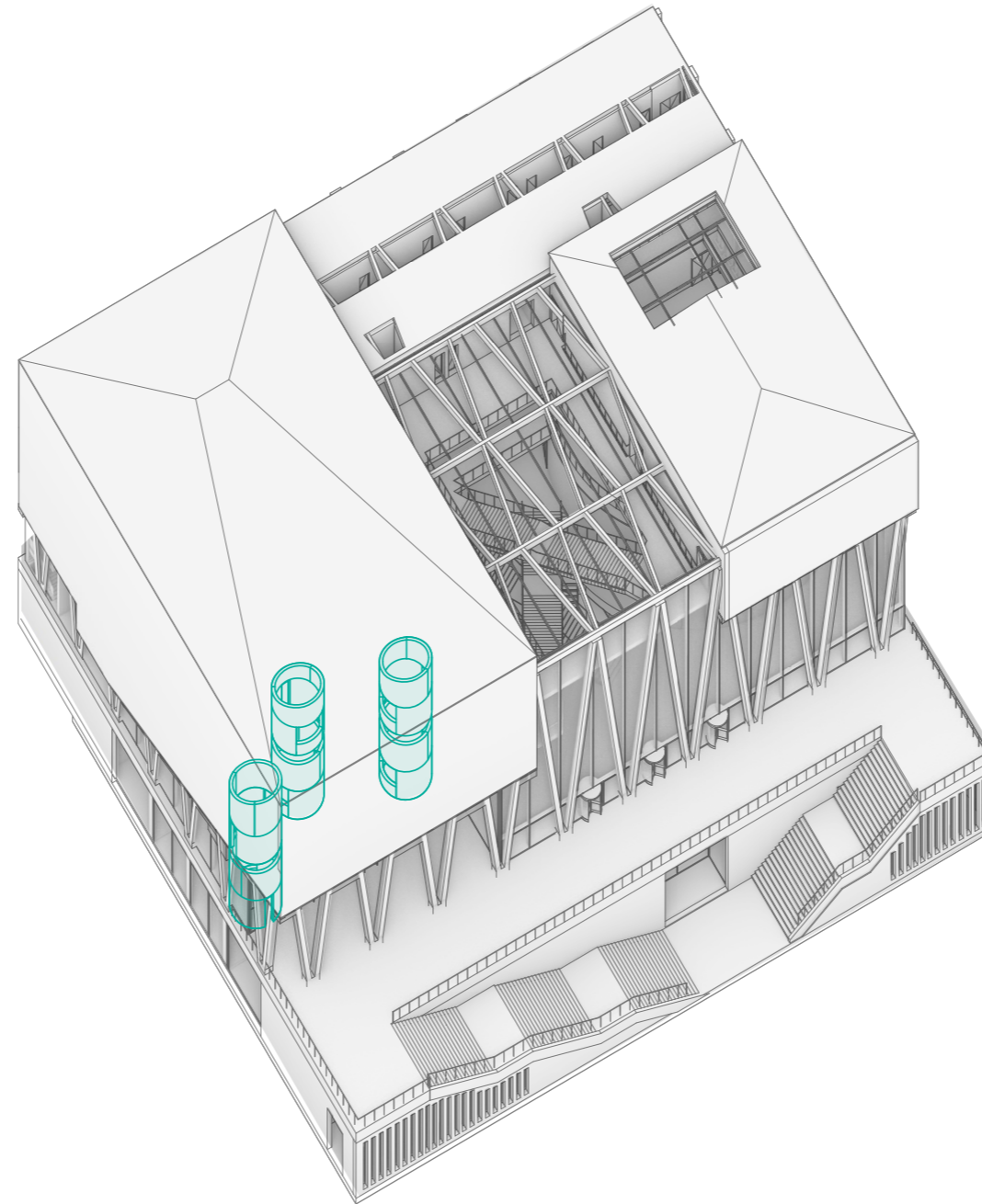

Structural ticket booths

COMPONENTS

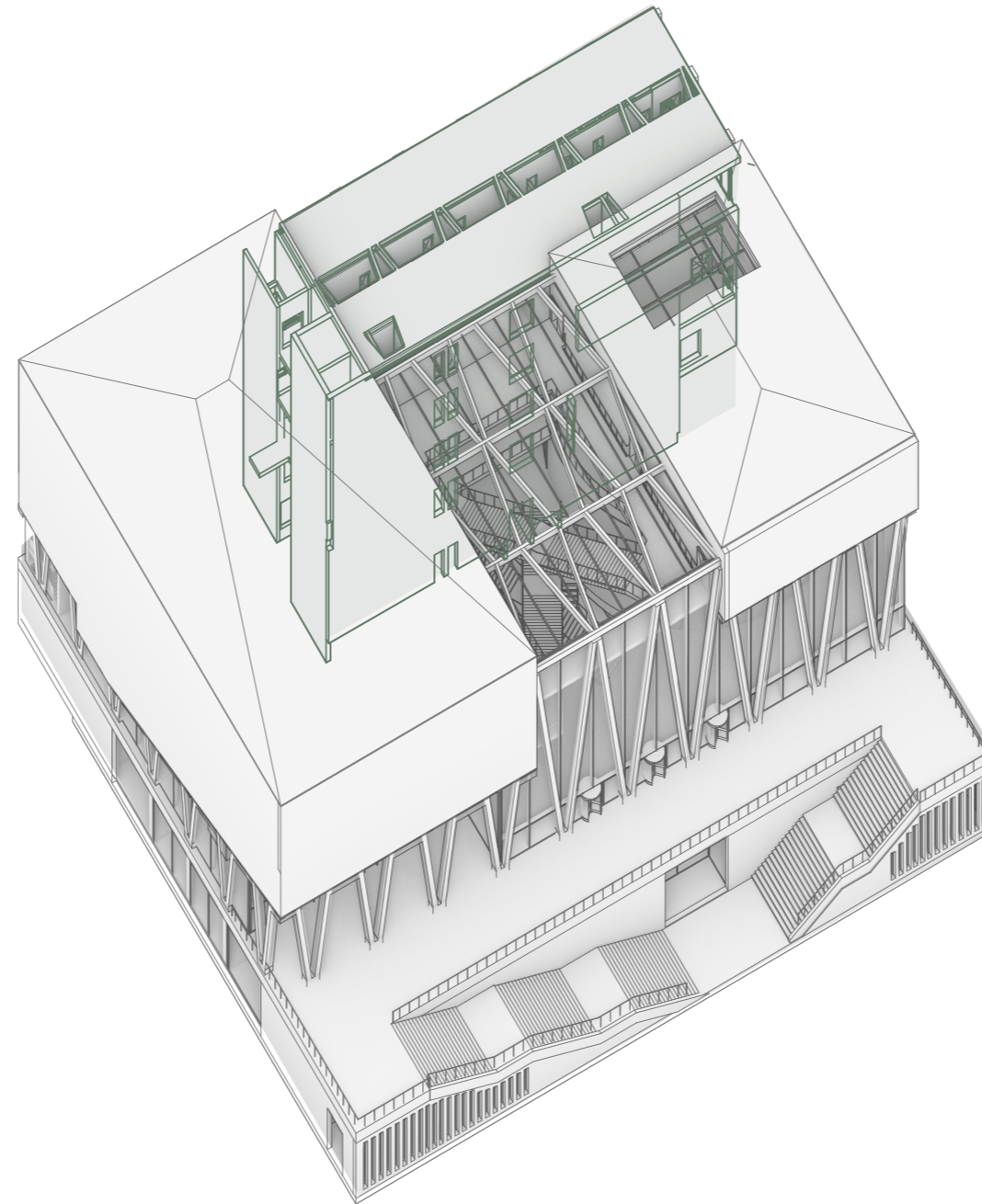

Backbone block

COMPONENTS

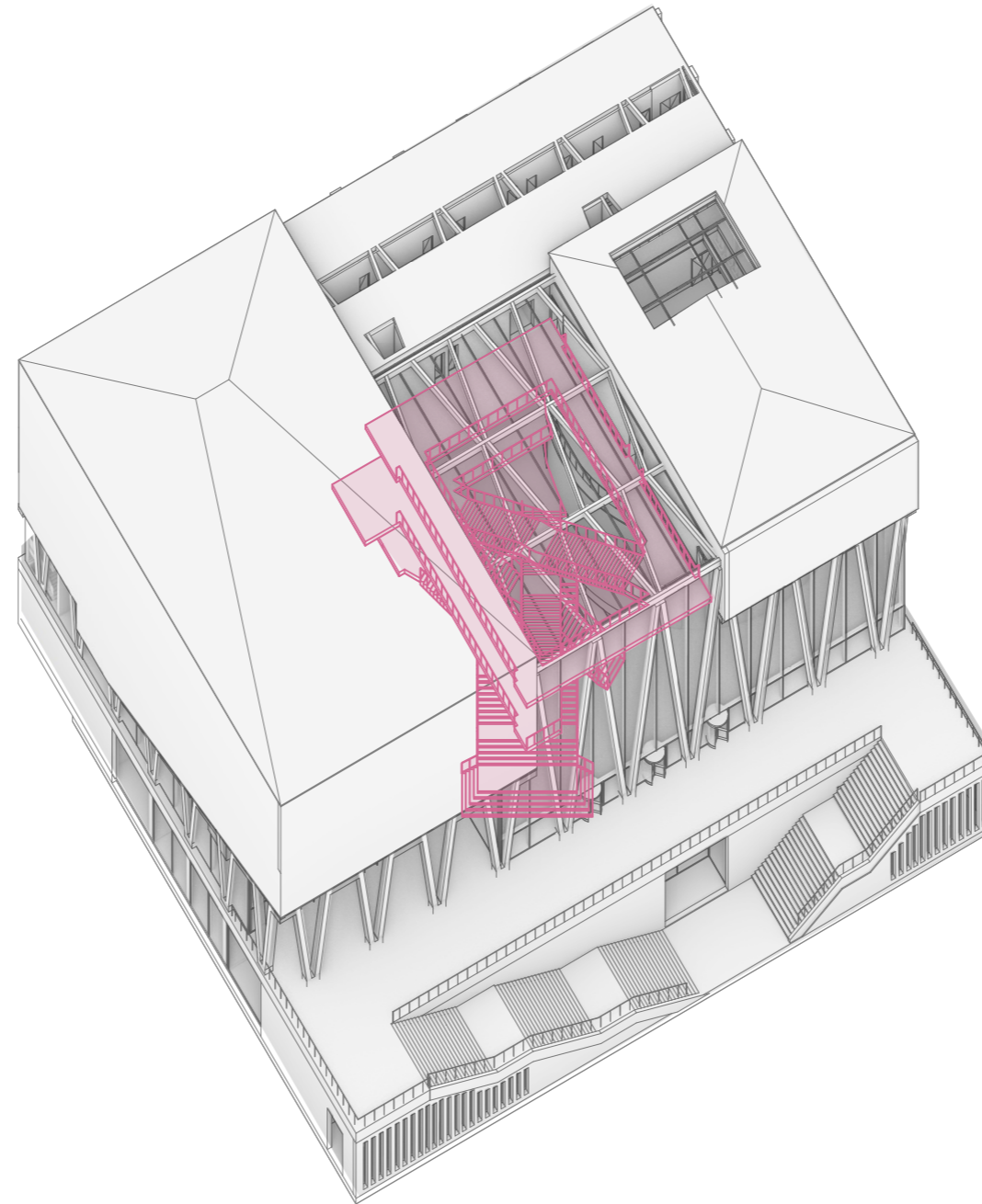

Interconnecting stairs

COMPONENTS

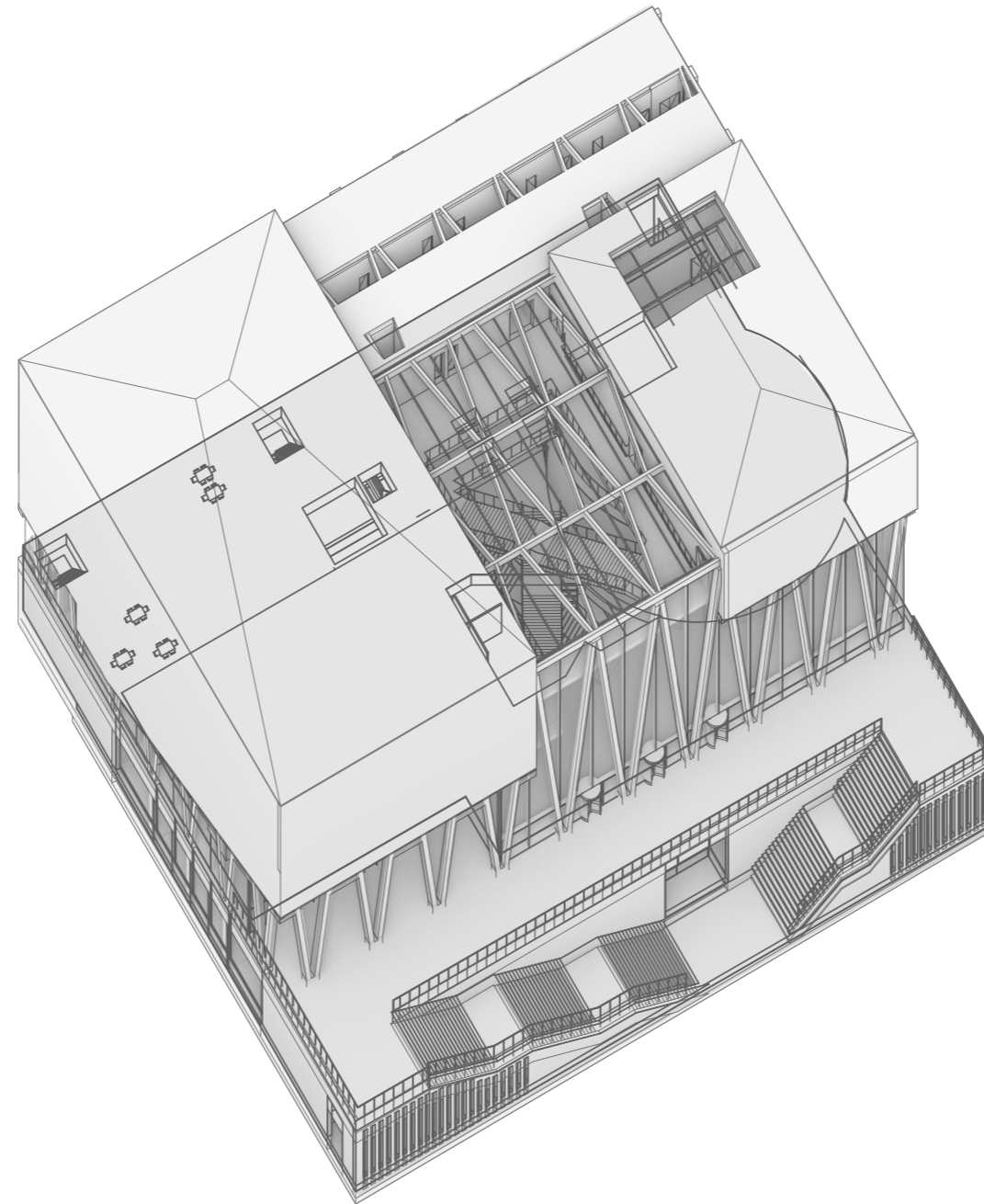

Monolith base

PROGRAM DISTRIBUTION

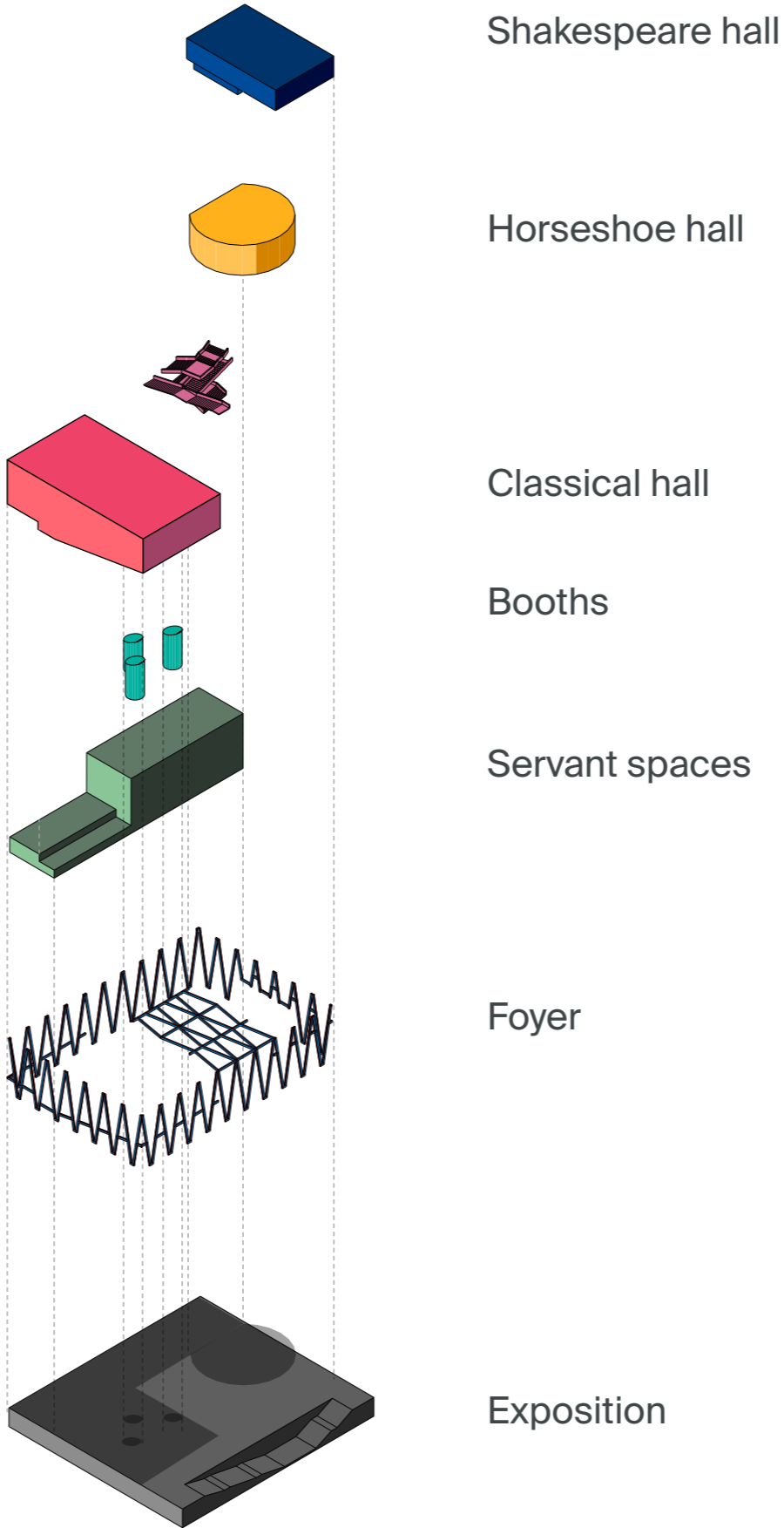

PROGRAM DISTRIBUTION

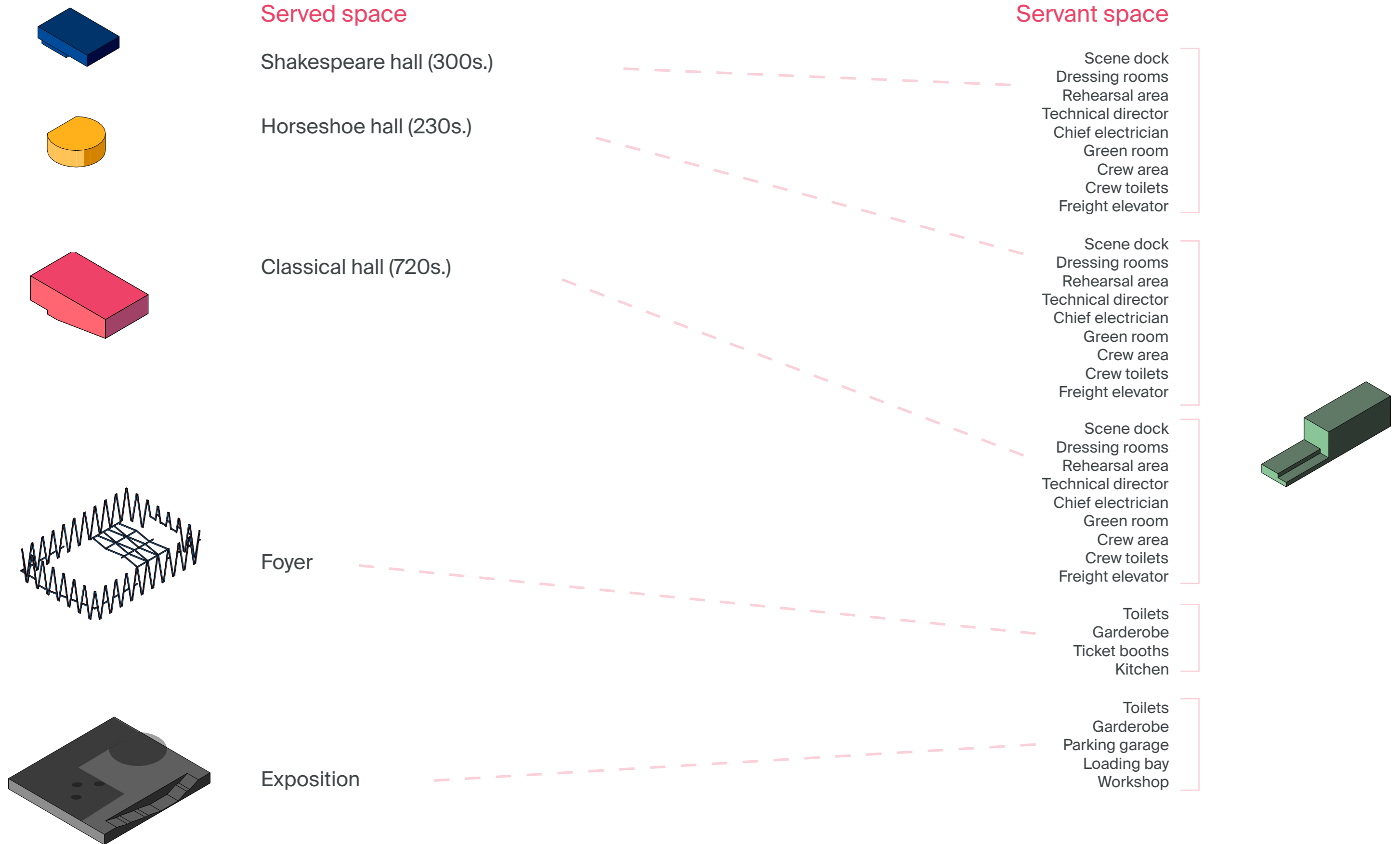

CONCEPTUAL SECTION



INTERNAL ROUTING

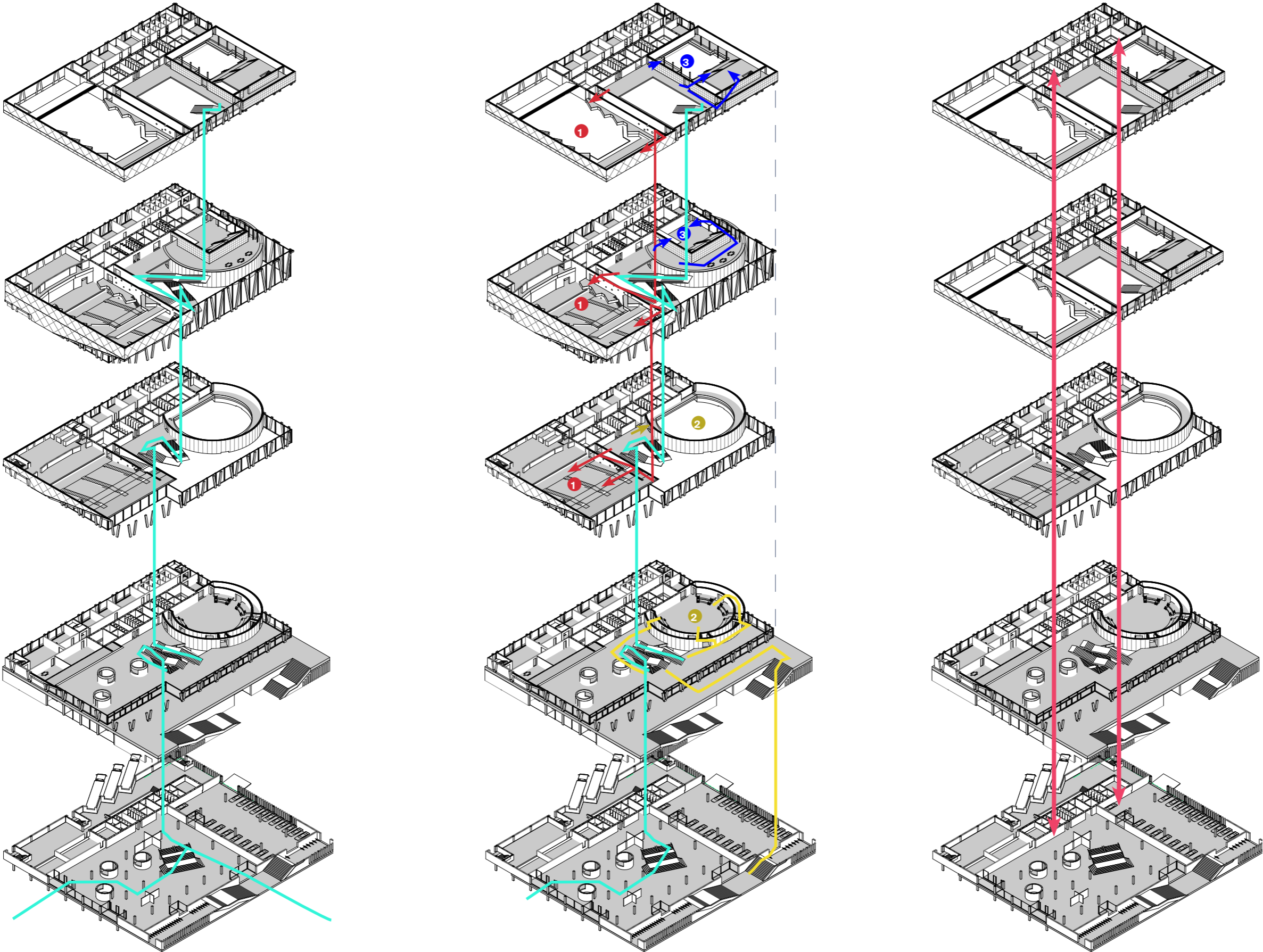

URBAN PLAN

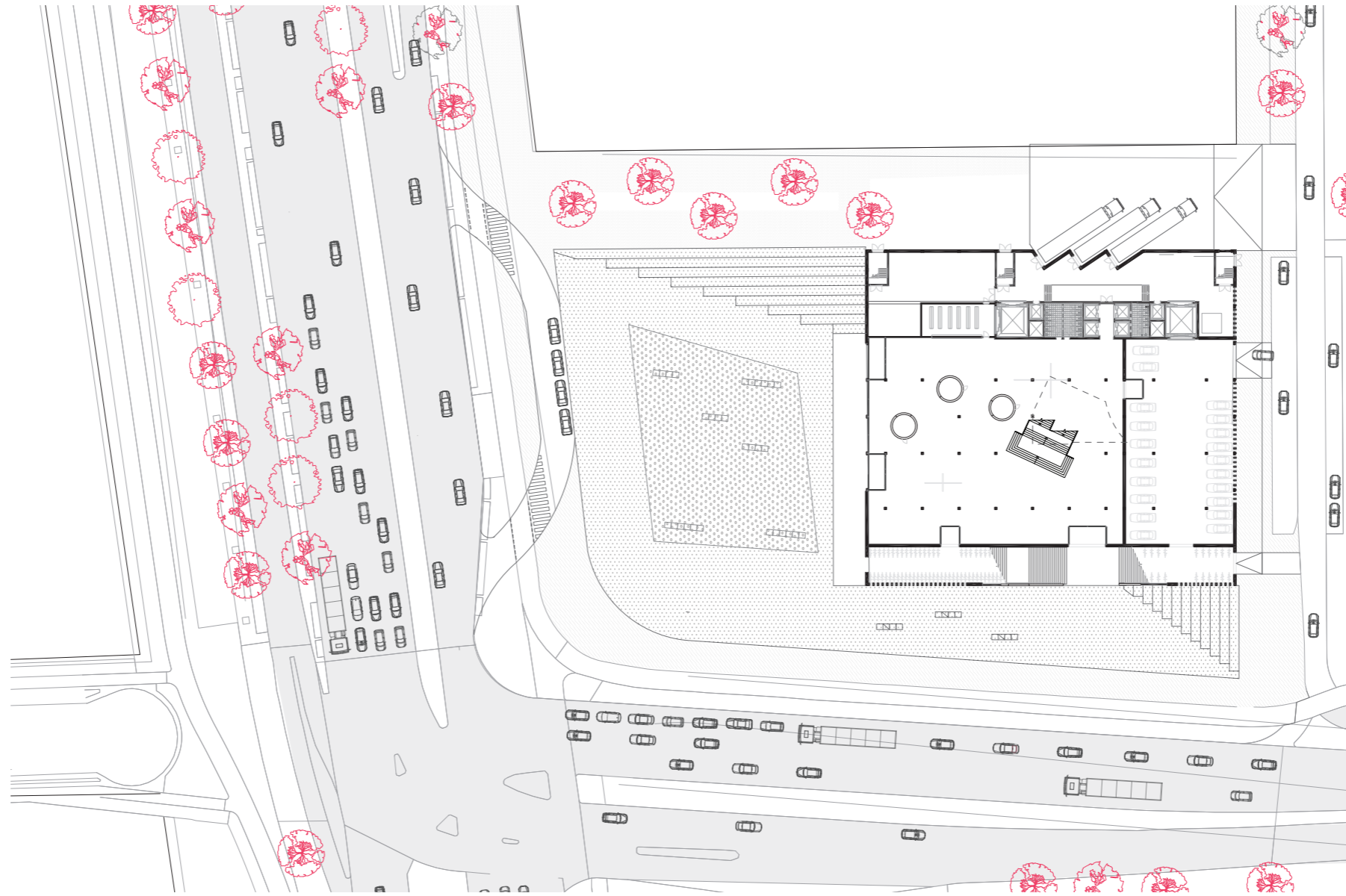
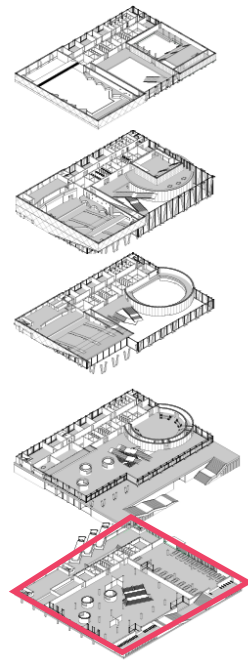

GROUND FLOOR

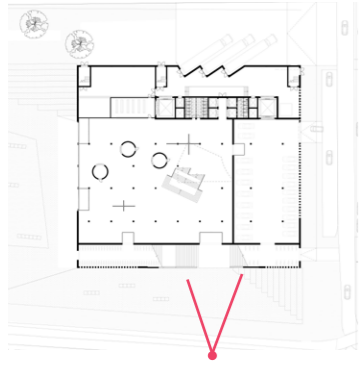

GROUND FLOOR

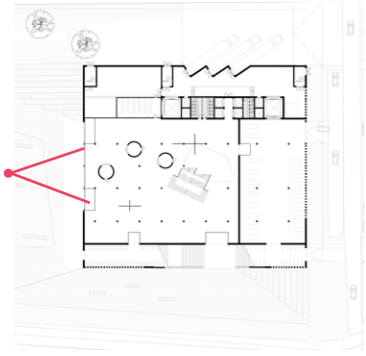

GROUND FLOOR

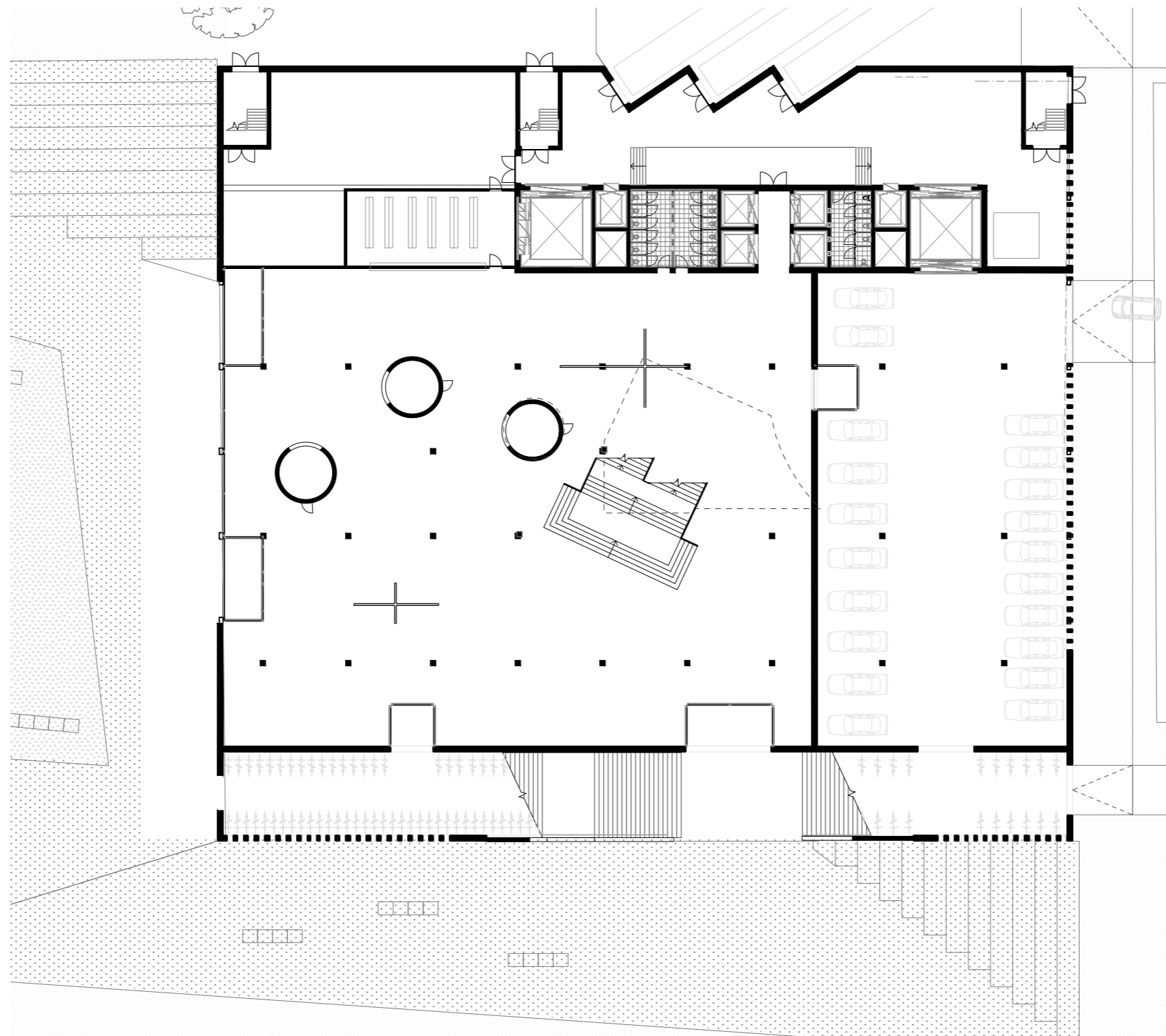
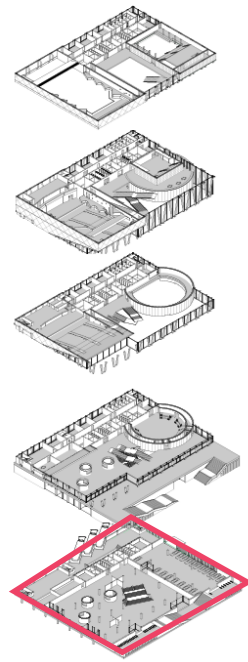

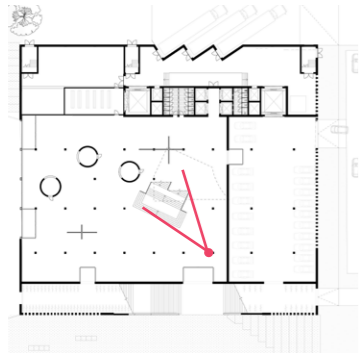

GROUND FLOOR



FIRST FLOOR

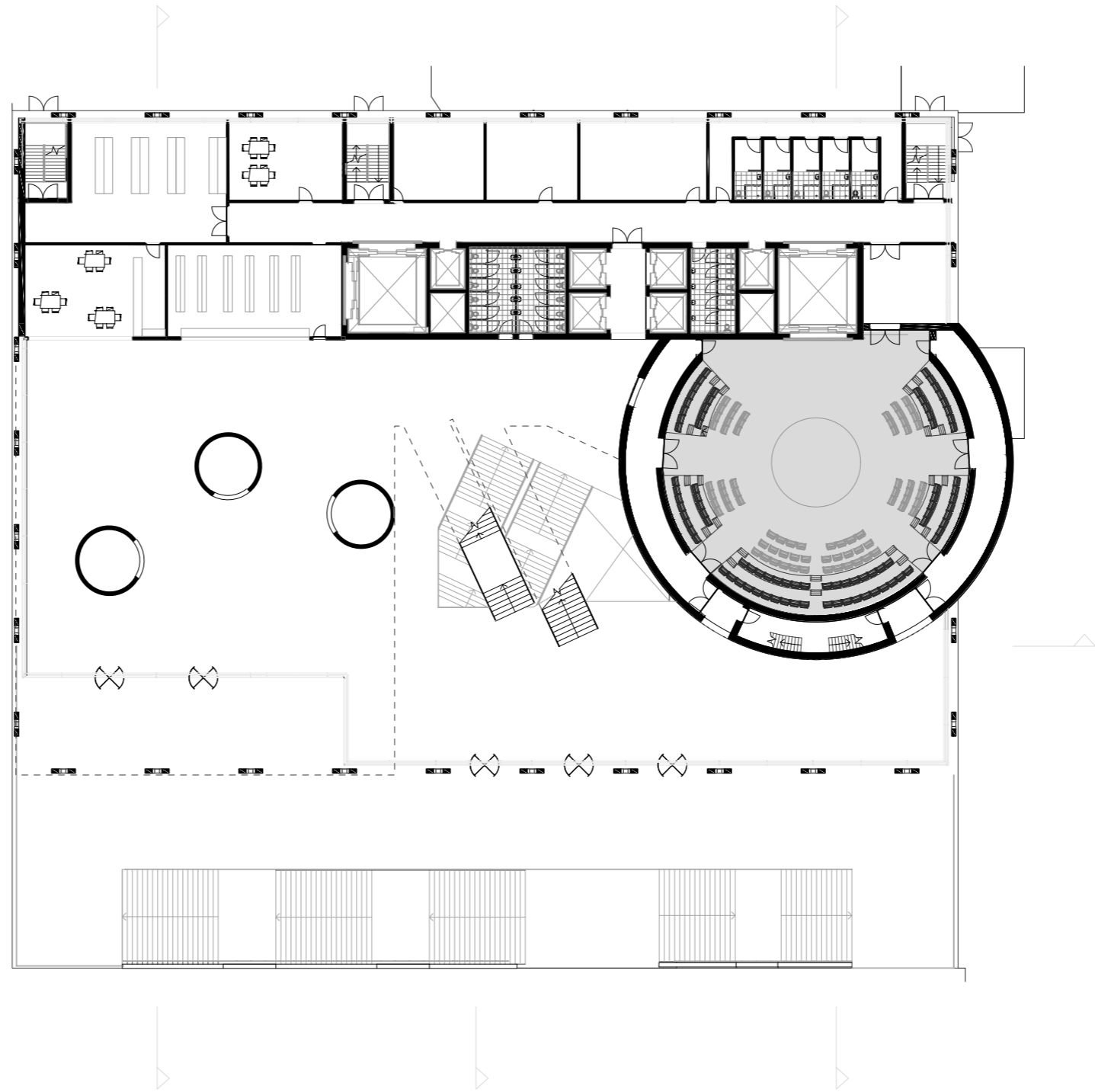
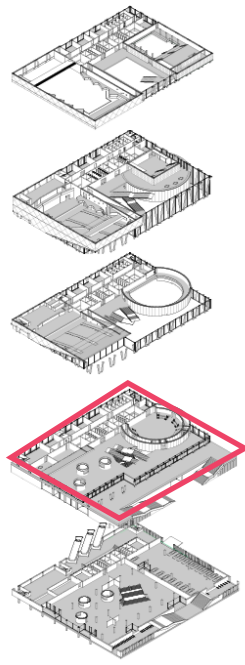

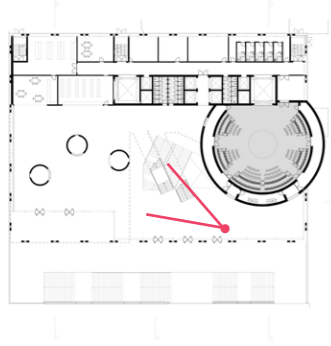

FIRST FLOOR



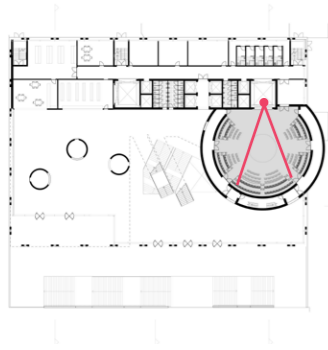

FIRST FLOOR



SECOND FLOOR

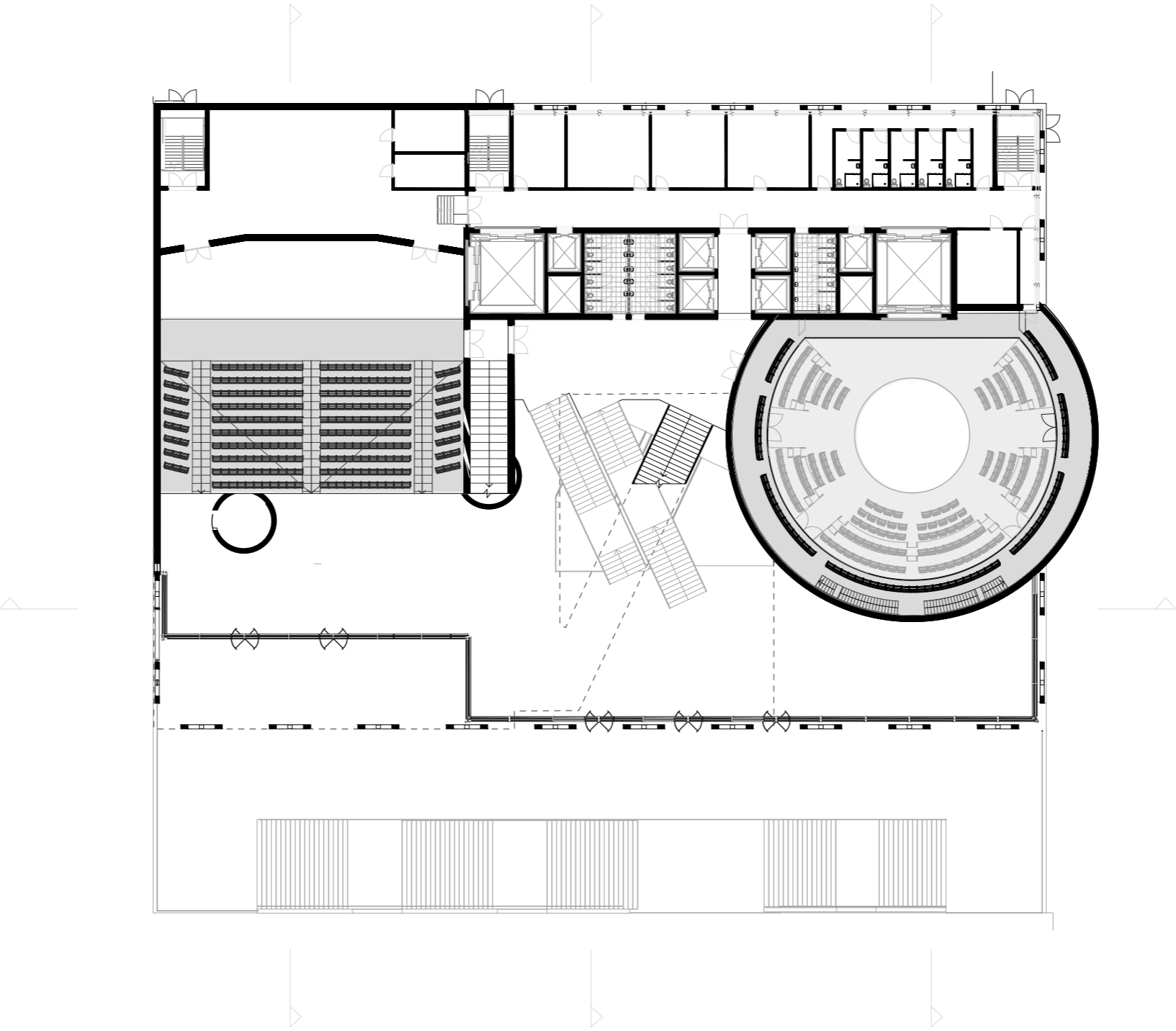
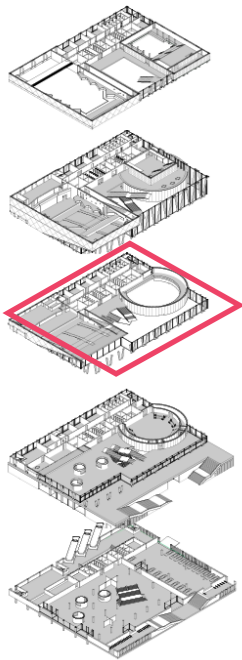

SECOND FLOOR

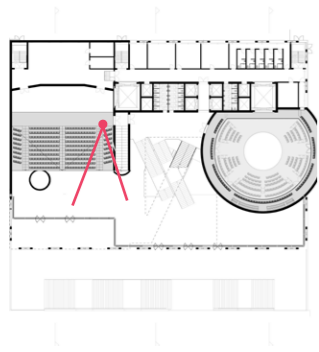

THIRD FLOOR

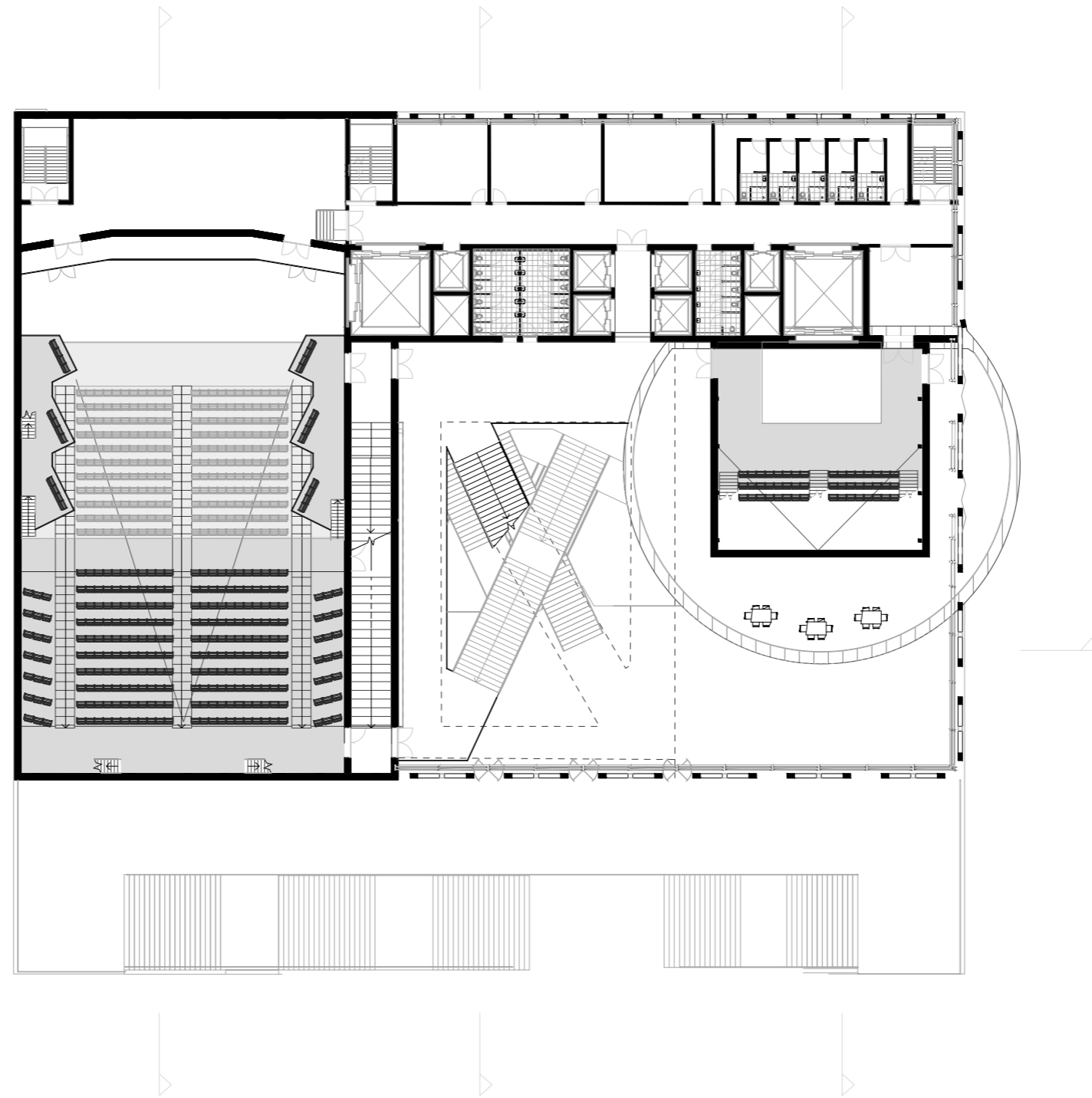
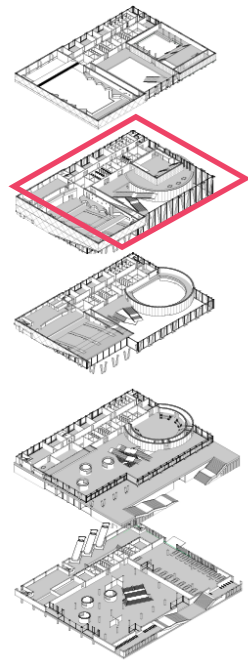

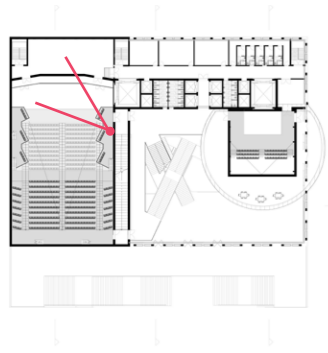

THIRD FLOOR

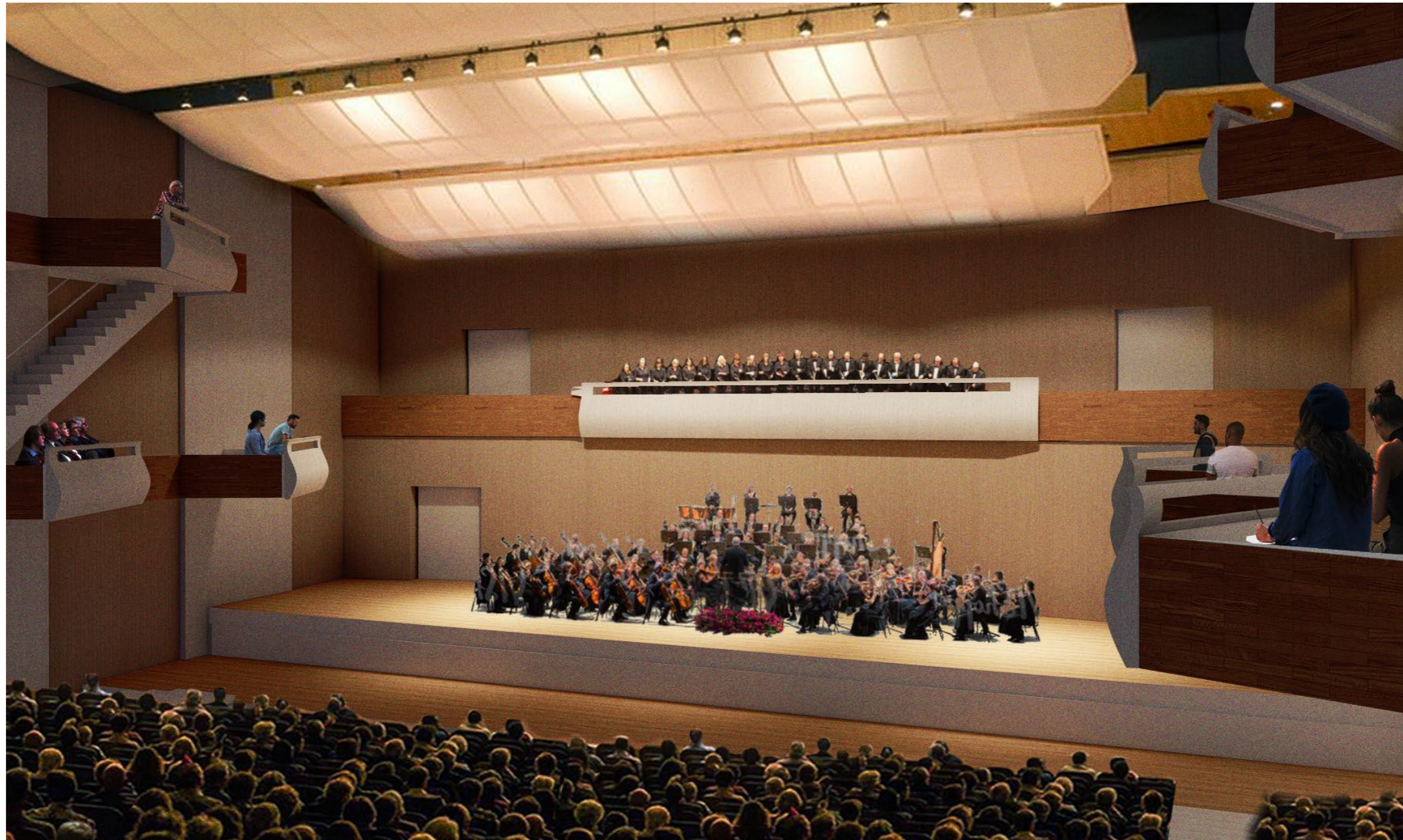

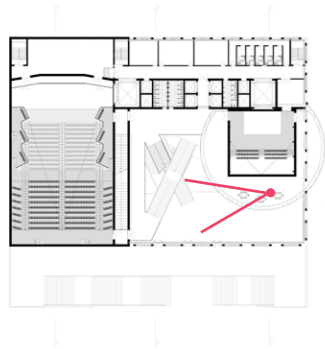

THIRD FLOOR



FOURTH FLOOR

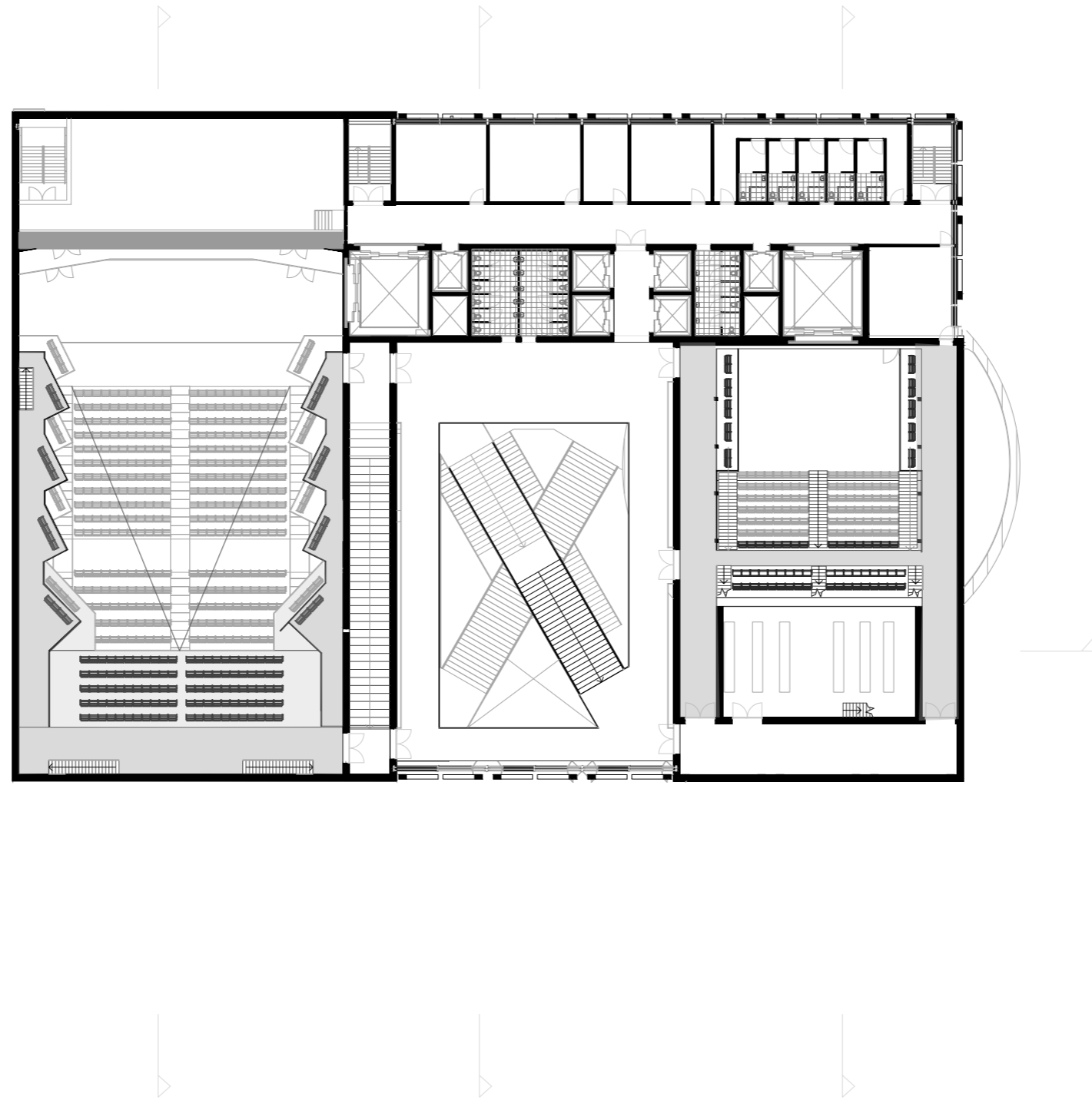
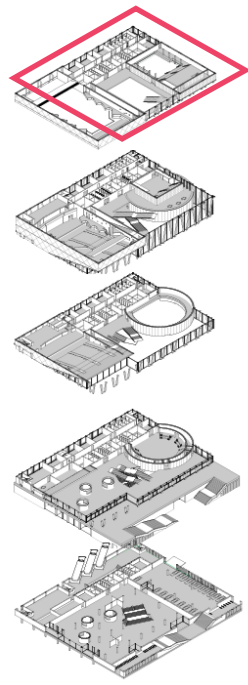

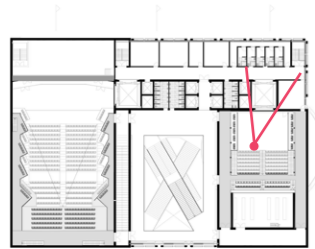

FOURTH FLOOR



AXONOMETRIC SECTION

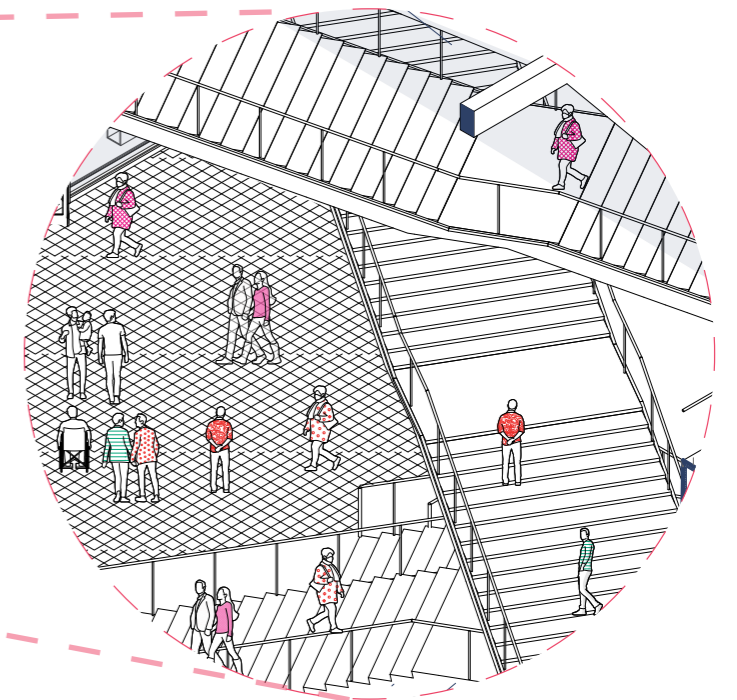
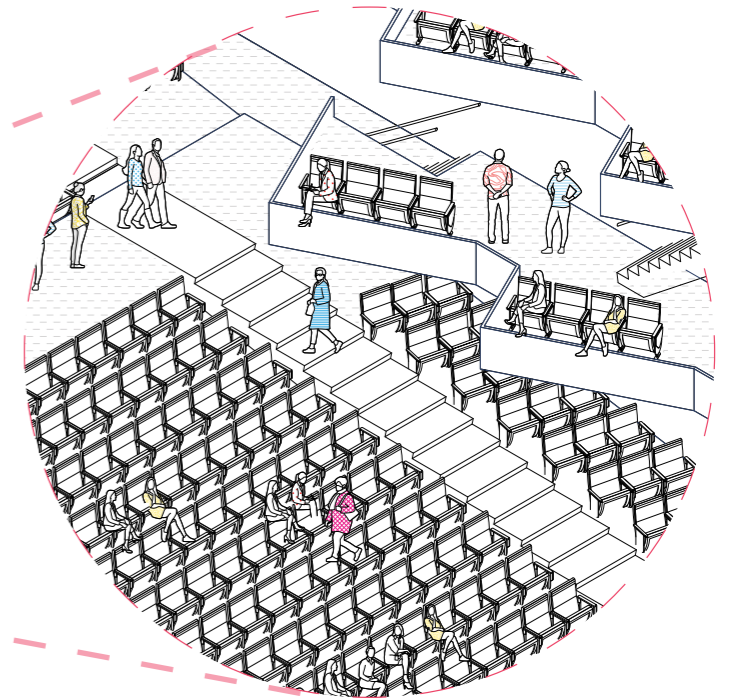
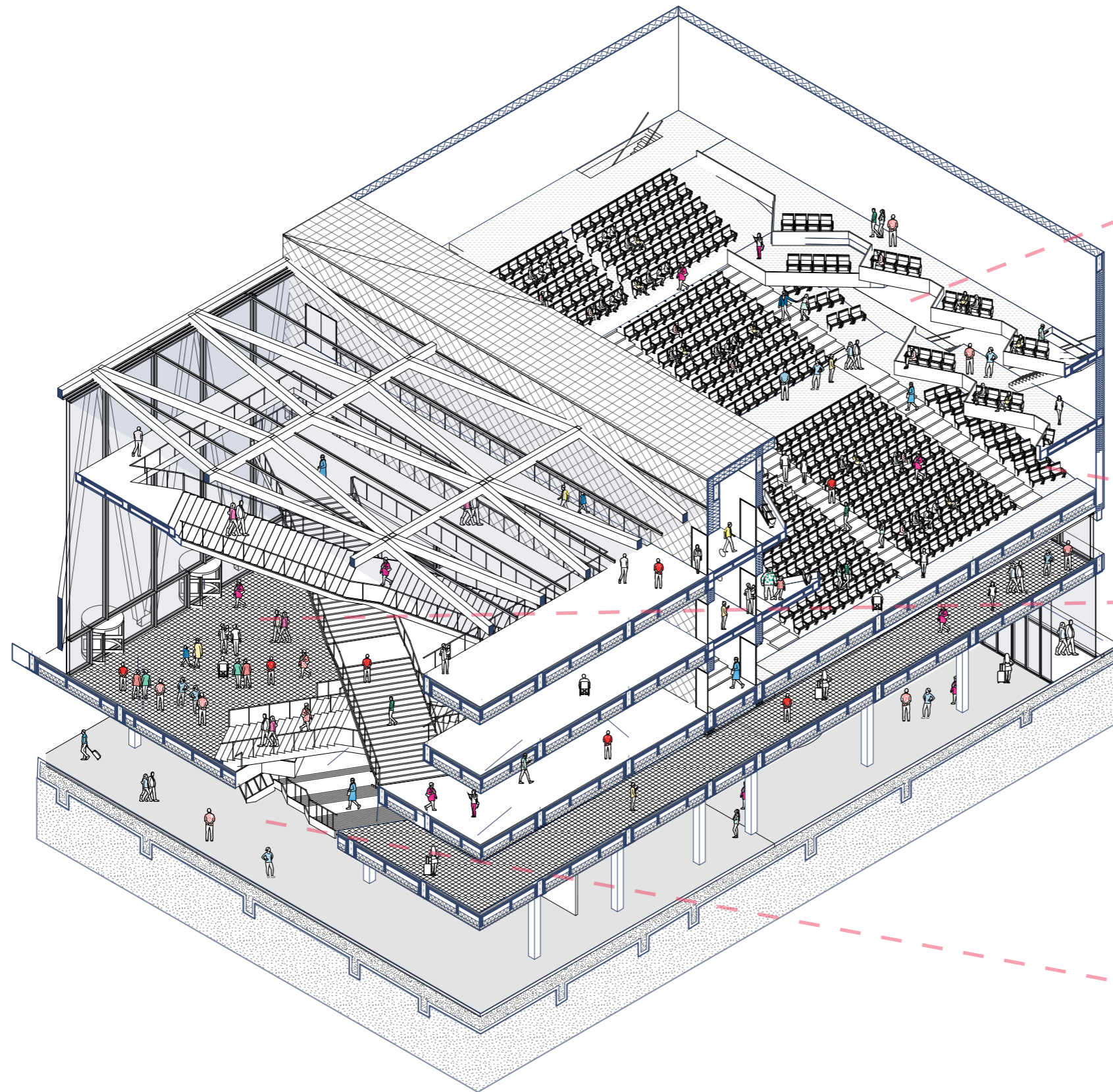
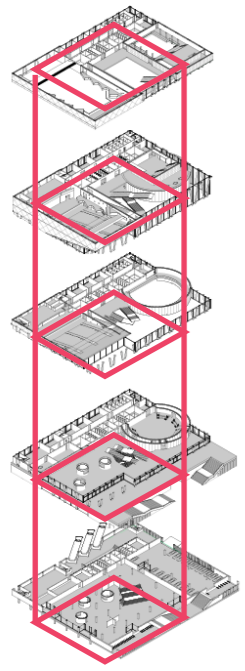

MULTIPLICITY CONCEPT

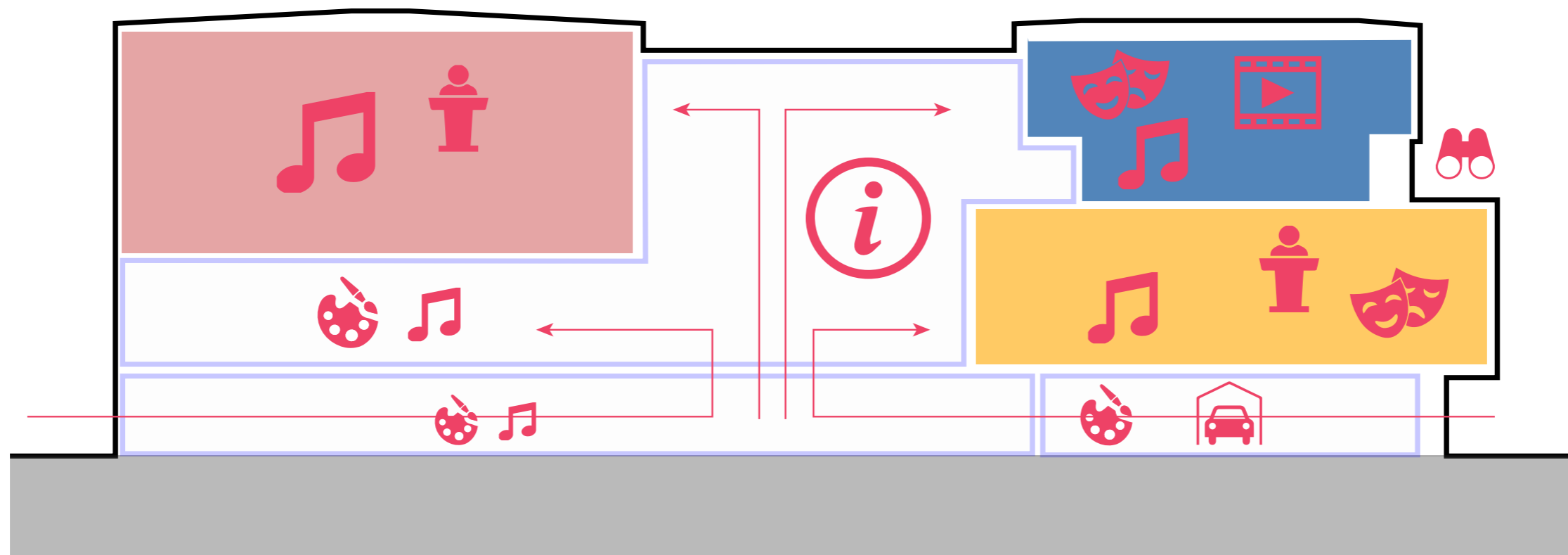
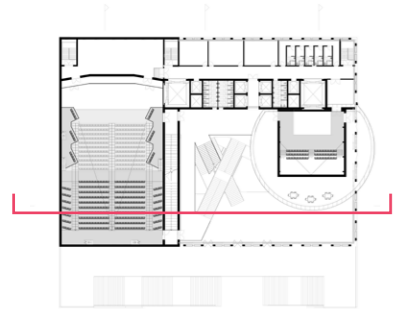

Exposition and foyer spaces allow for wide variety of uses,
halls for various performance-settings

SECTION A1

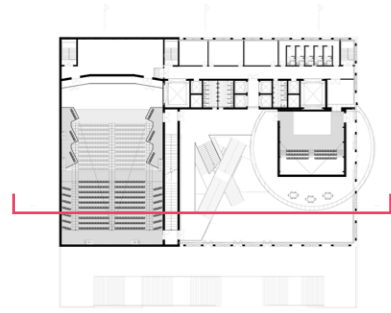

SECTION A2

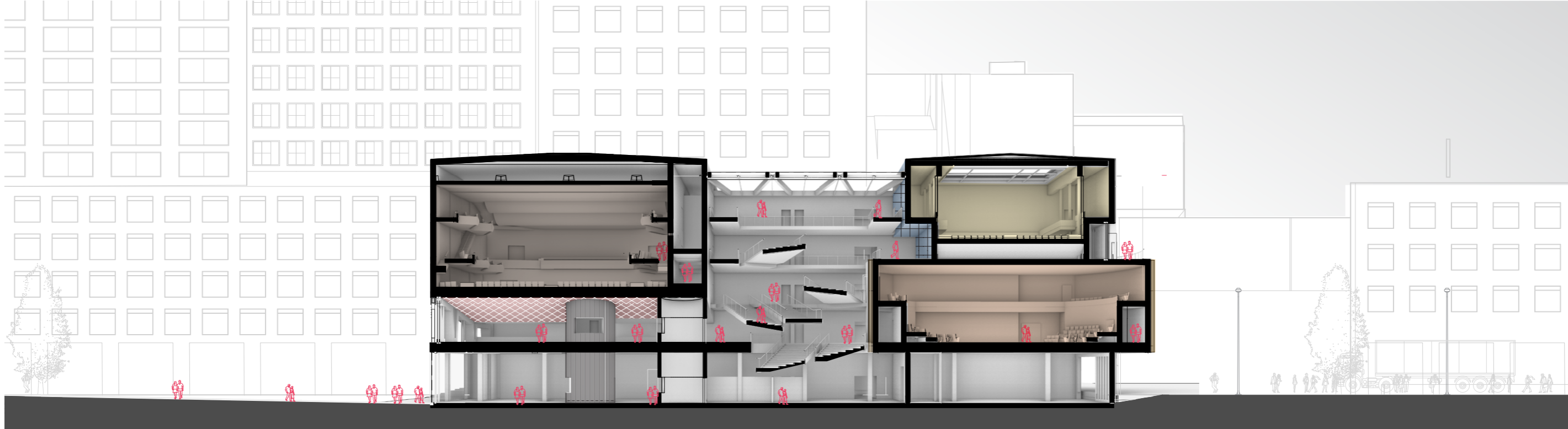
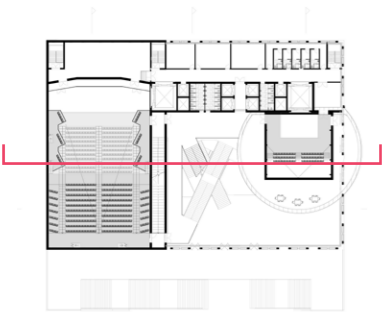

CLIMATIC CONCEPT - SUMMER

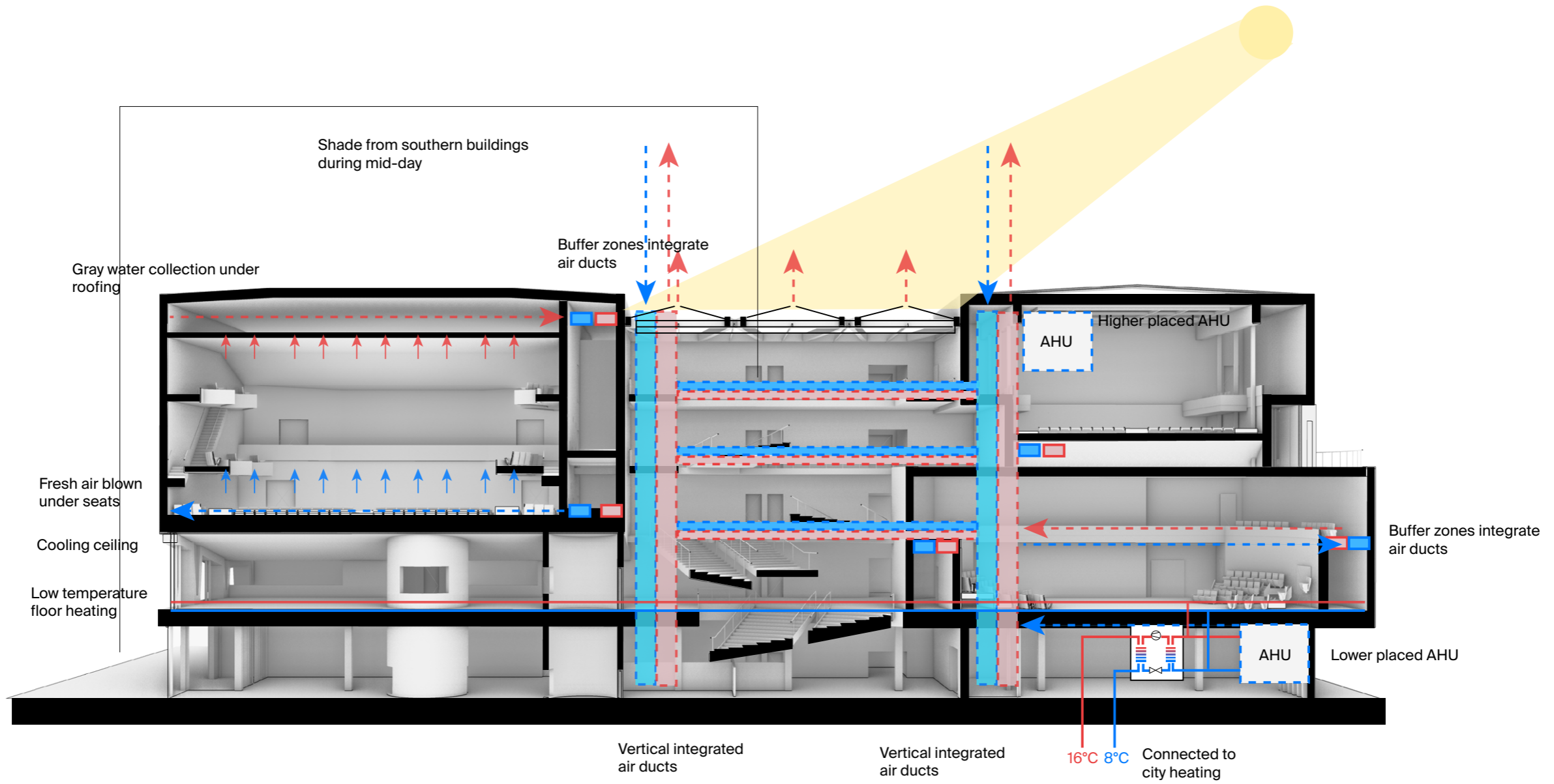
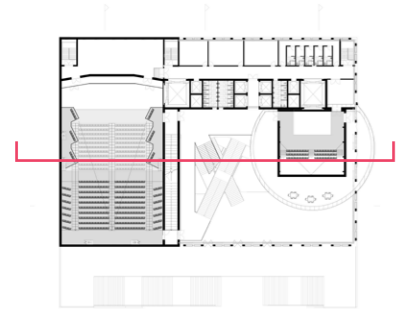

CLIMATIC CONCEPT - WINTER

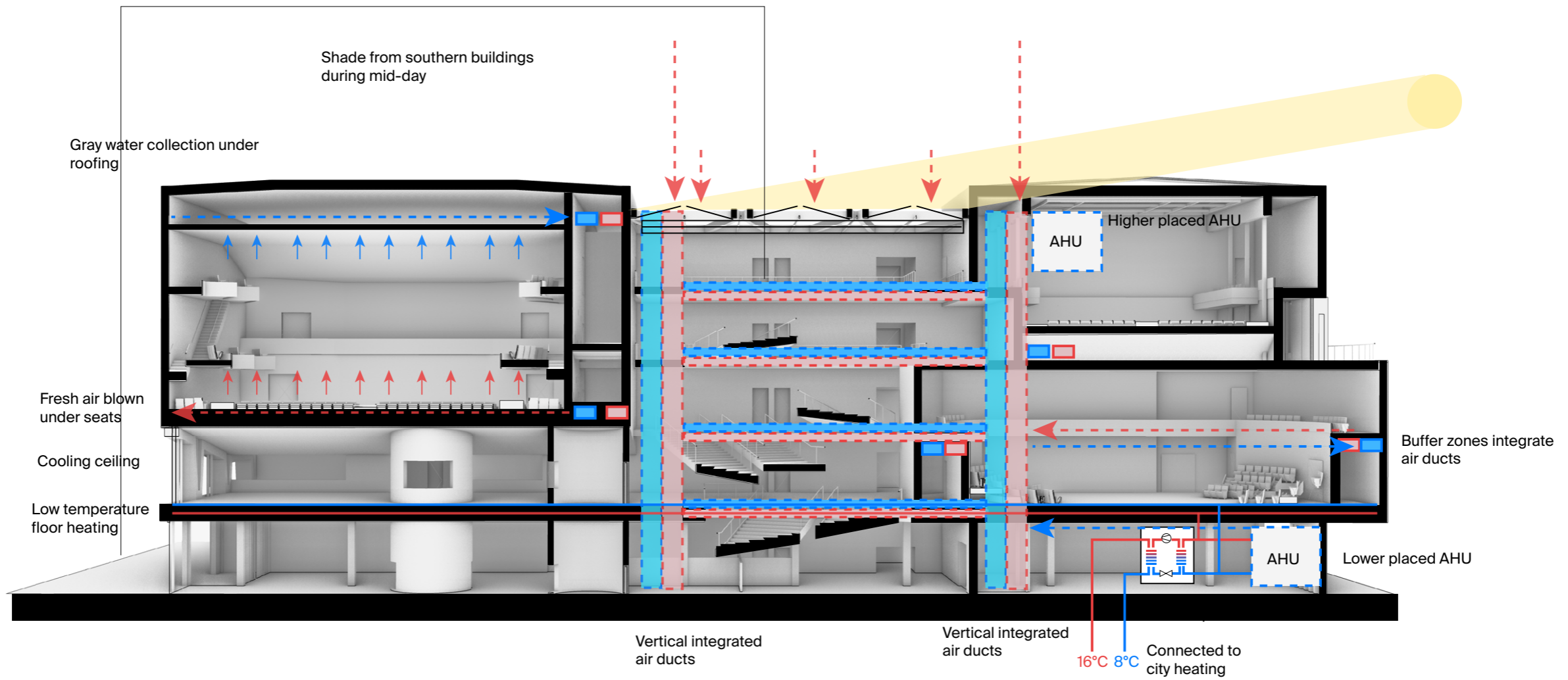
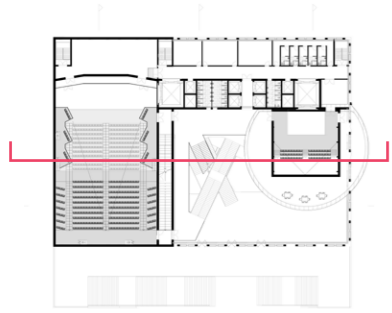

ACOUSTIC CONCEPT

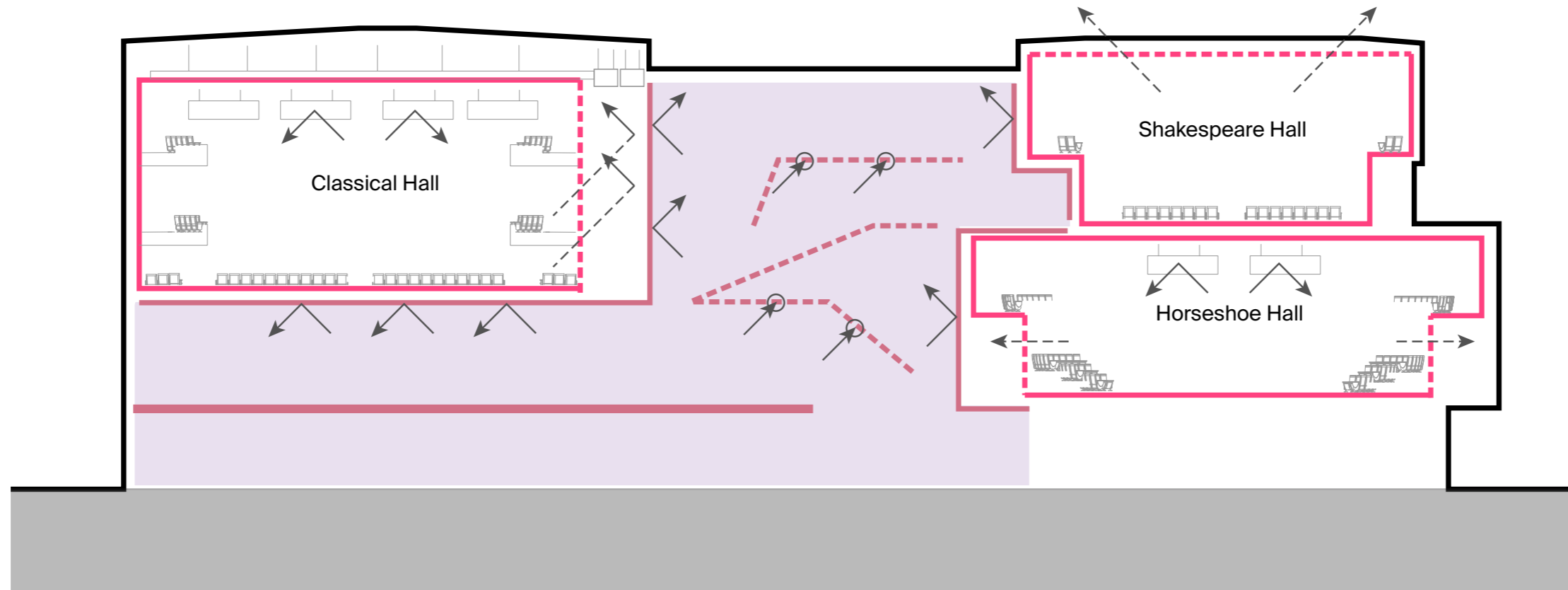
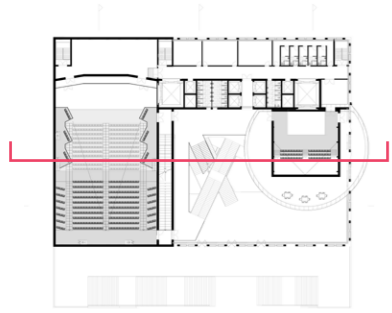

Independently sound-isolated halls through buffer zone and material variety

SECTION B2

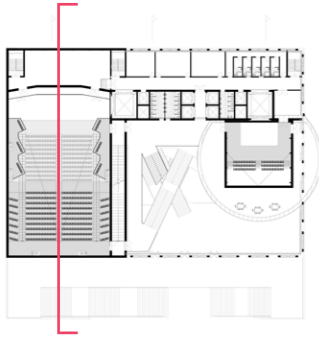

SECTION B2

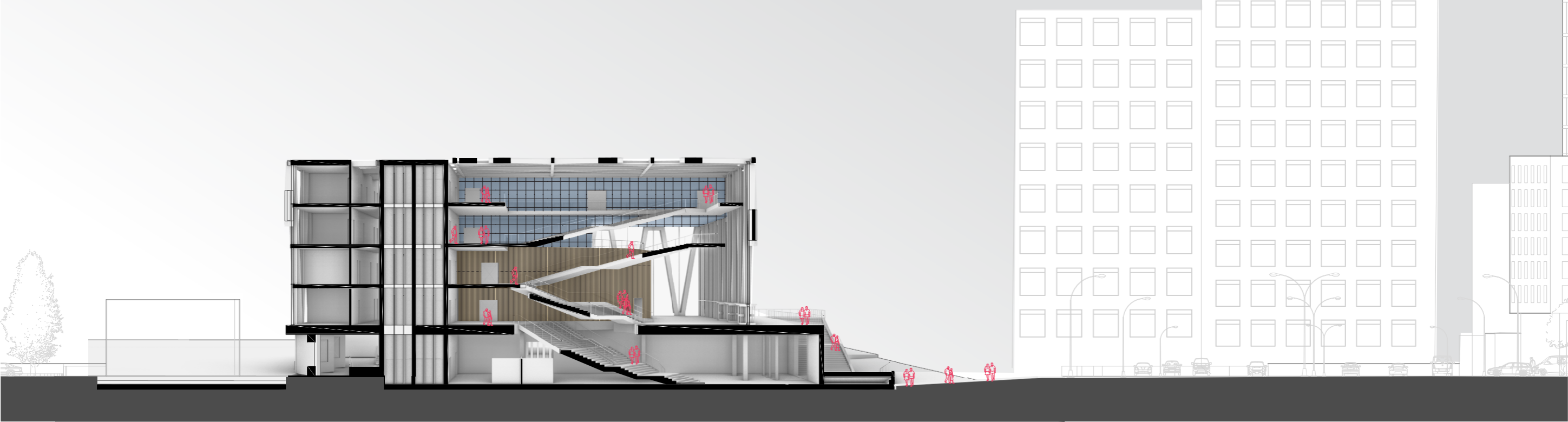
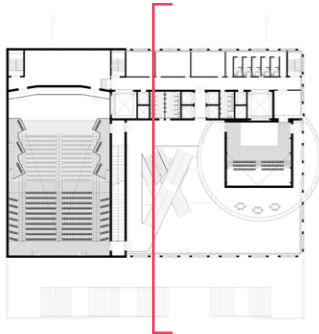

CLIMATIC CONCEPT - SUMMER

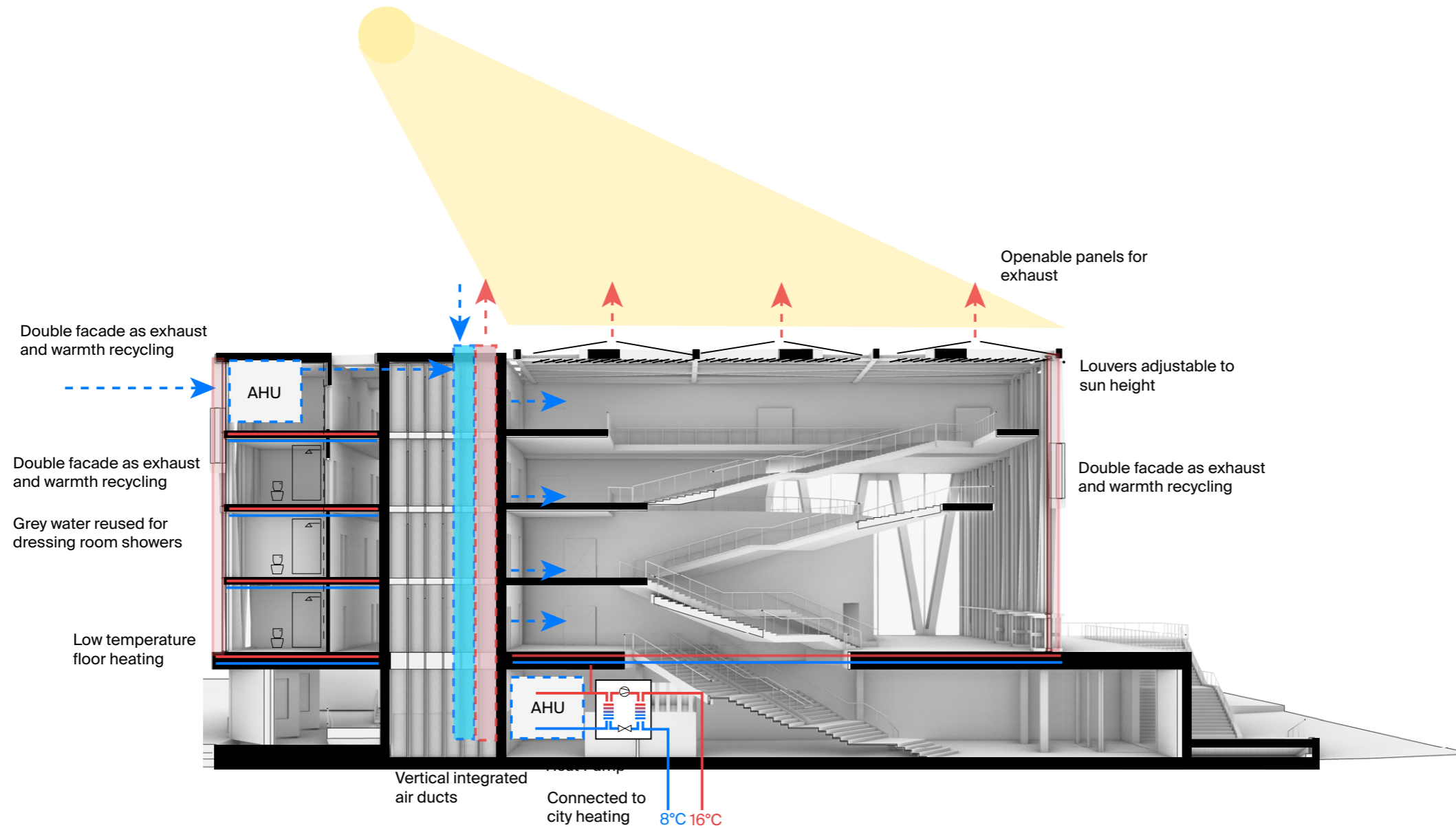
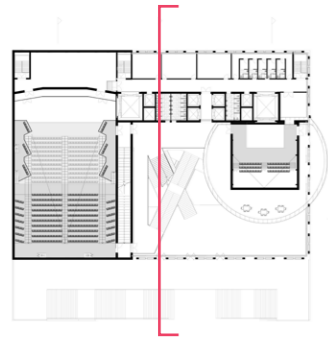

CLIMATIC CONCEPT - WINTER

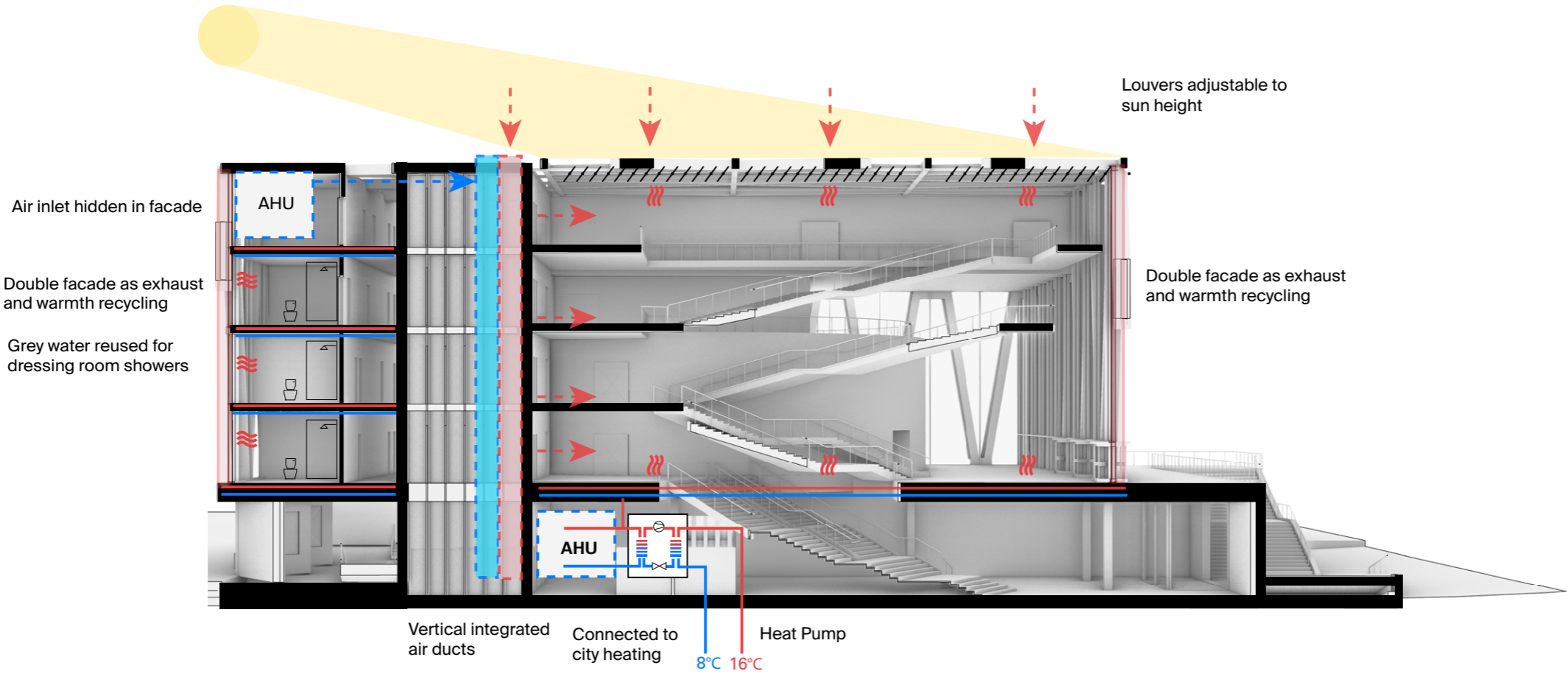
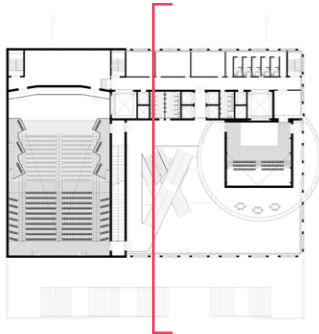

SECTION B3

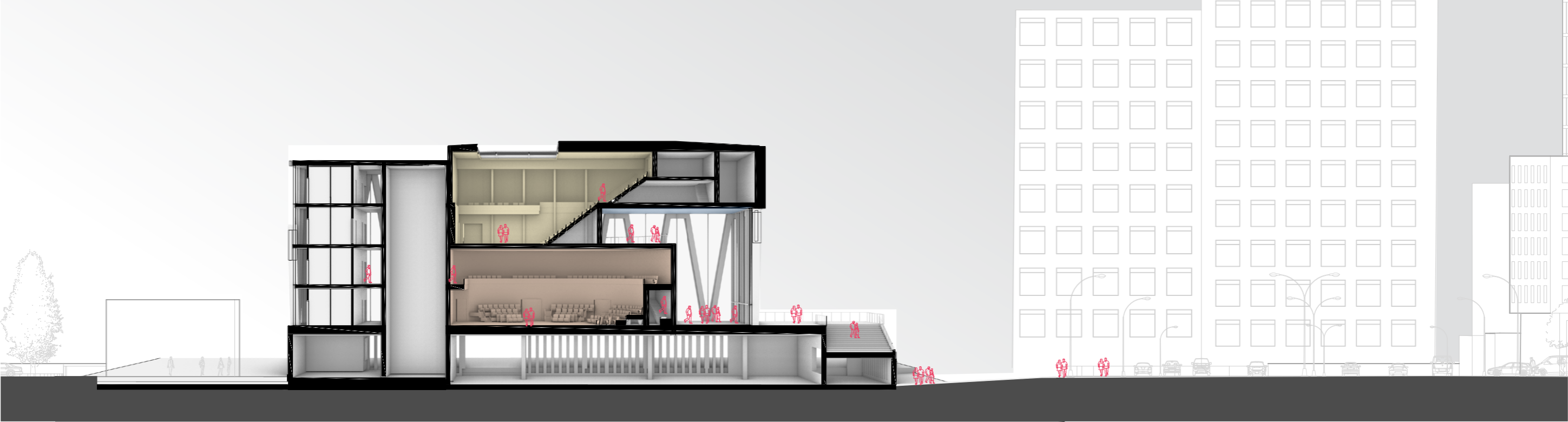
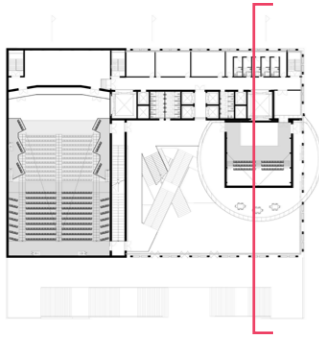

IMPRESSION EAST FACADE



ELEVATIONS

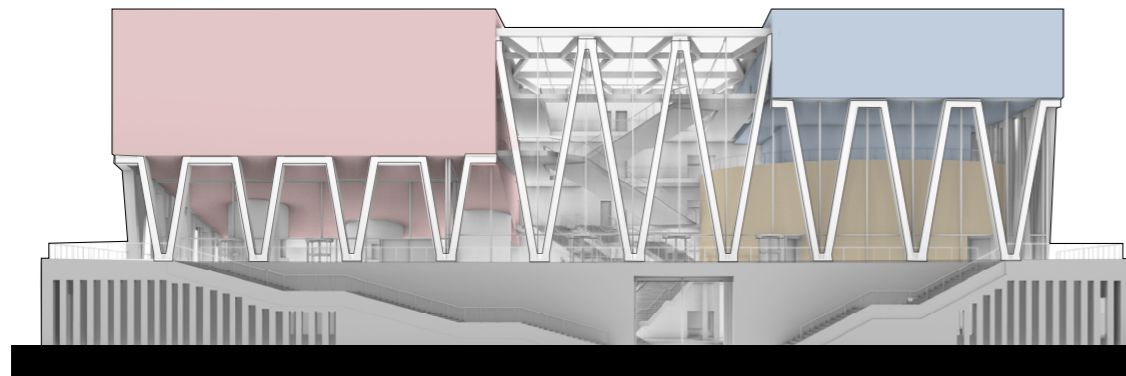

North elevation

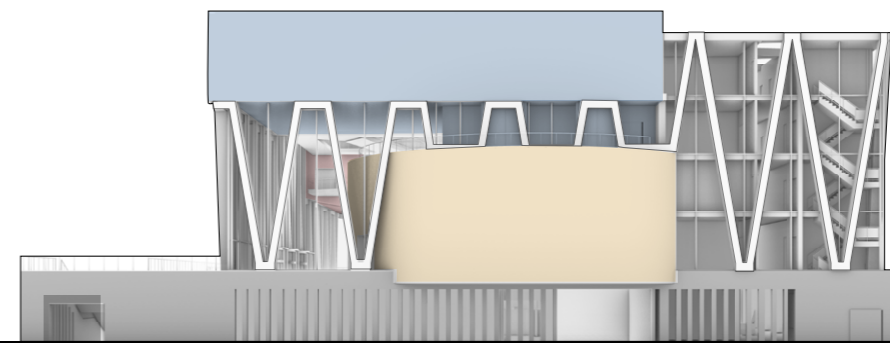

West elevation

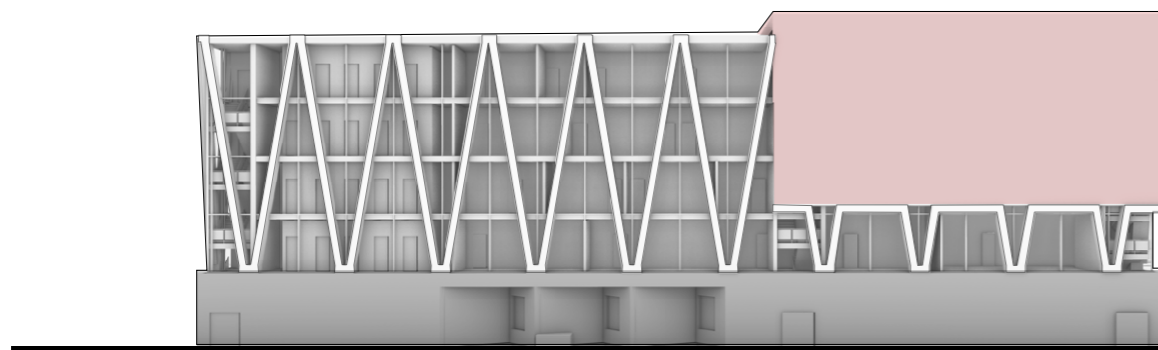

South elevation



East elevation



ELEVATIONS

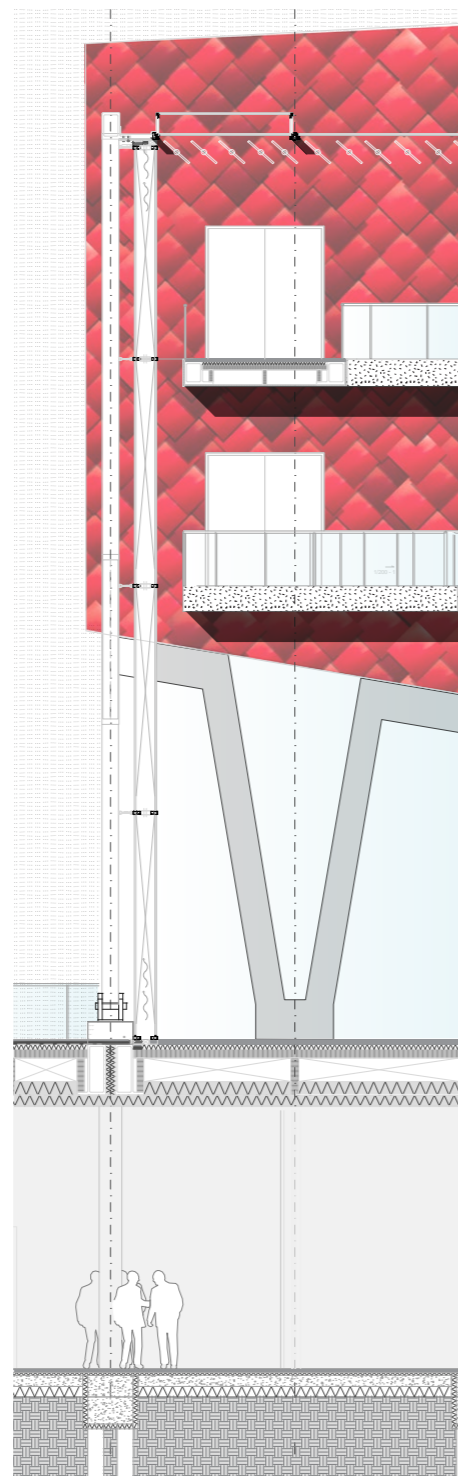

Foyer section

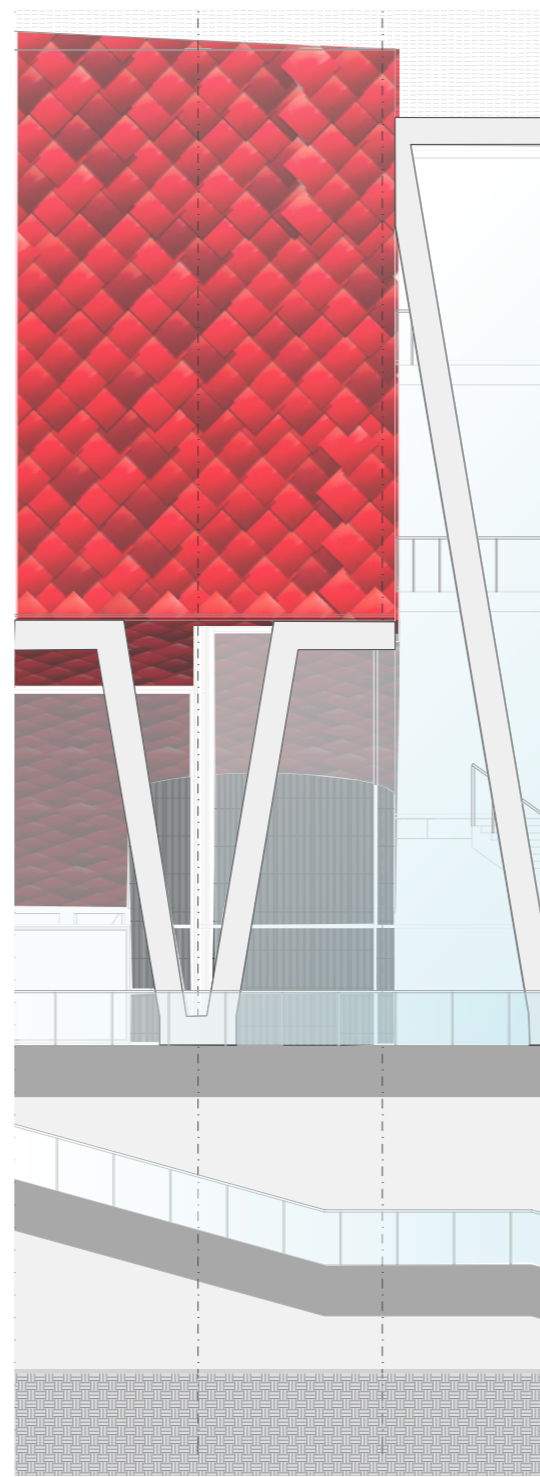

North facade

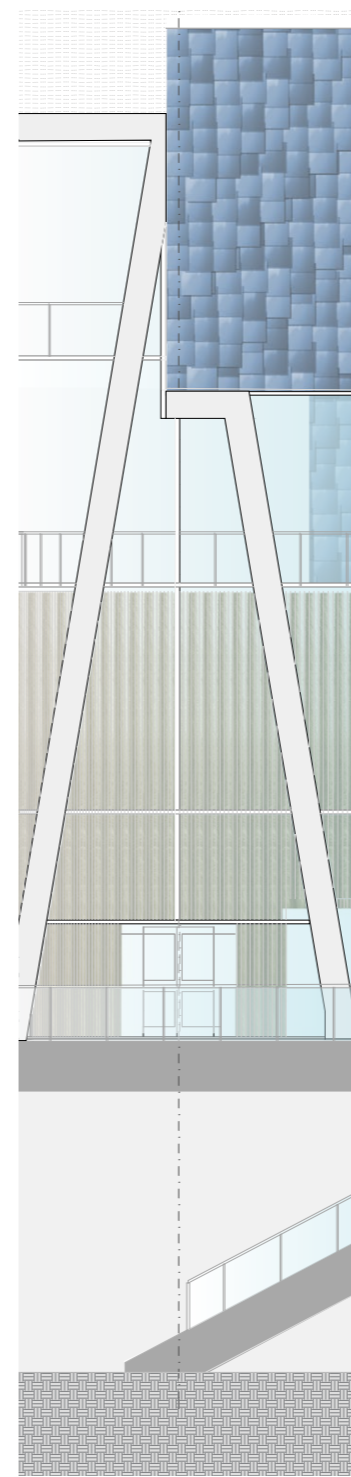

North facade

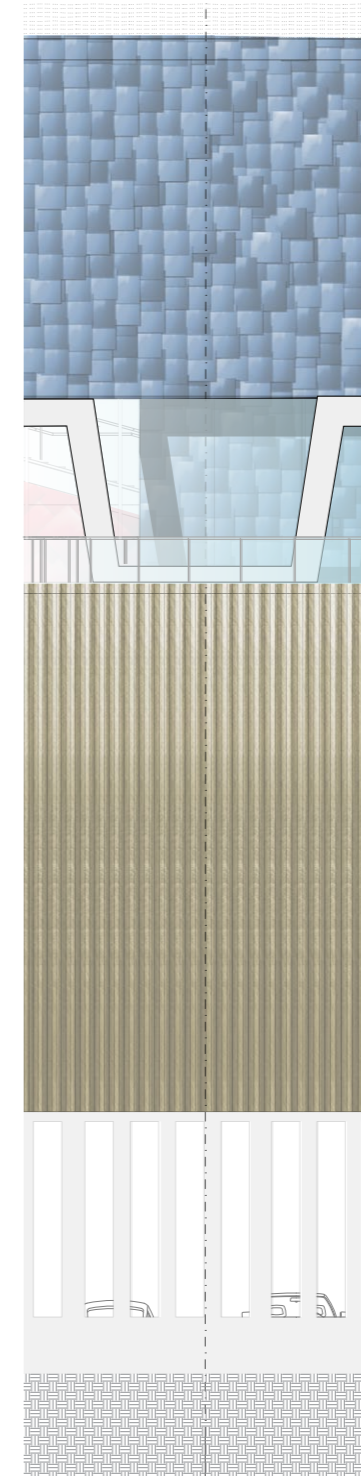

West facade

CONSTRUCTION CONCEPT

Demountable joints

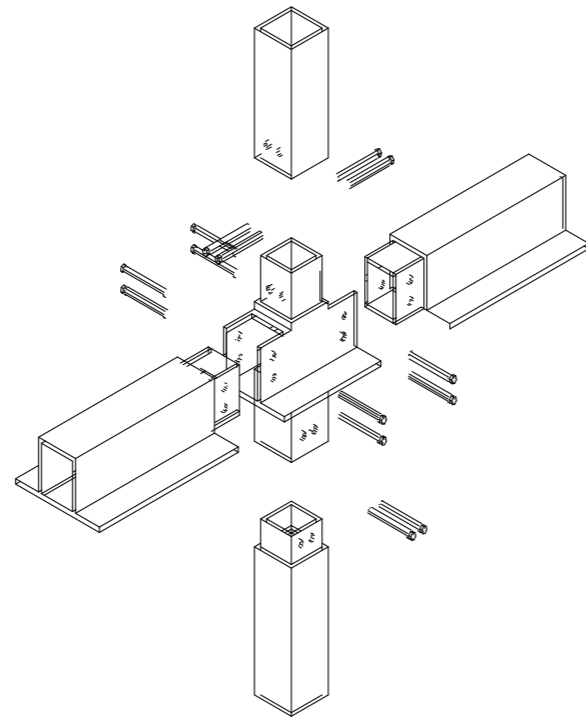

Framework for transport

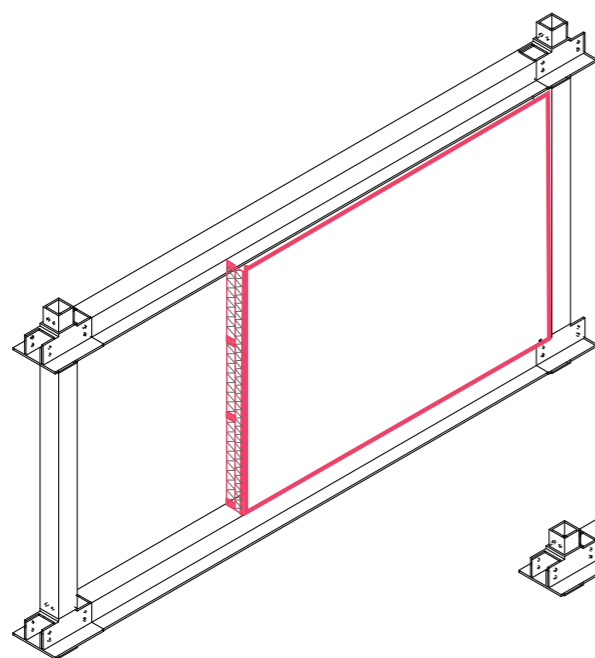
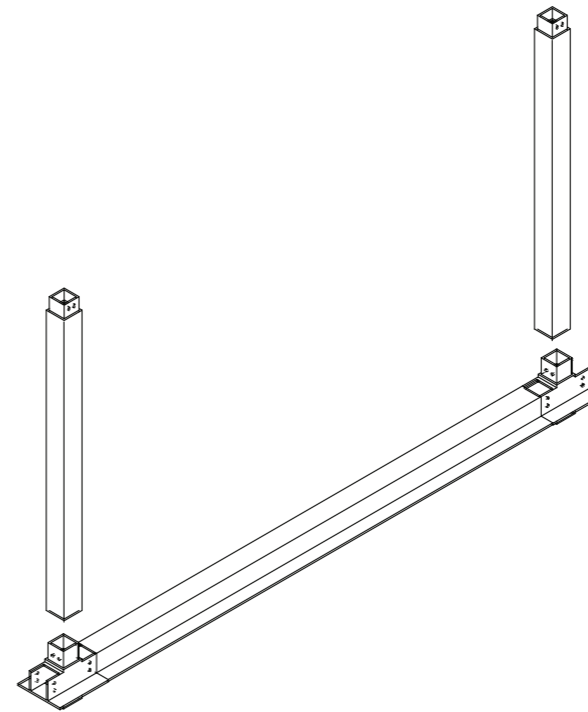

Wooden system walls

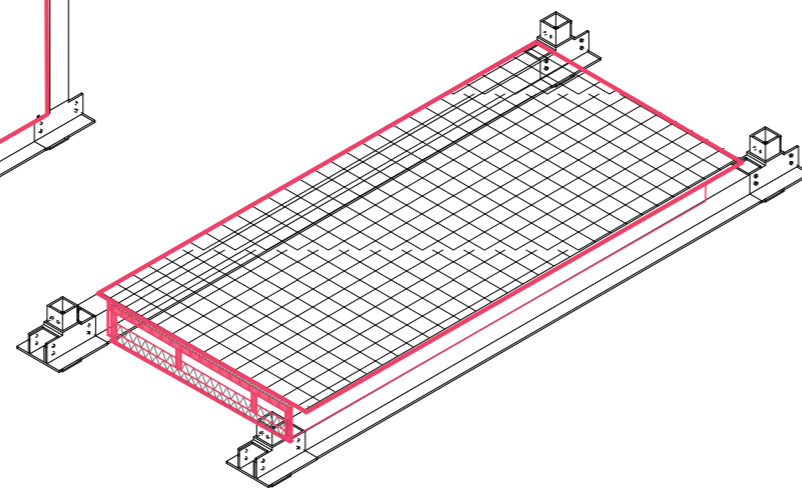

Vertically laminated lumber floor panels

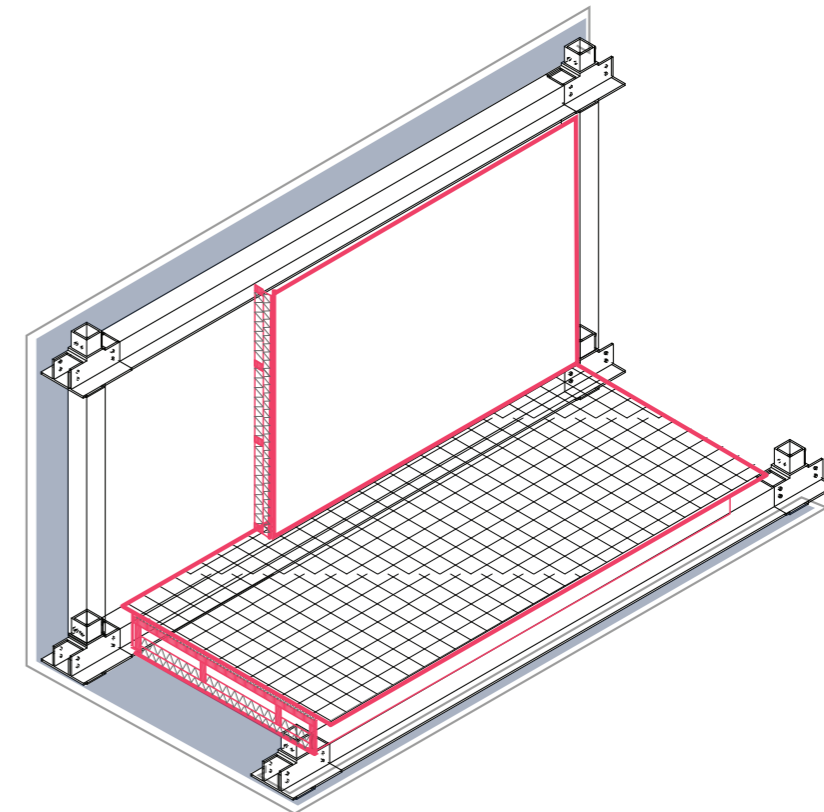

Steel cladding as hall cladding

CONSTRUCTION CONCEPT

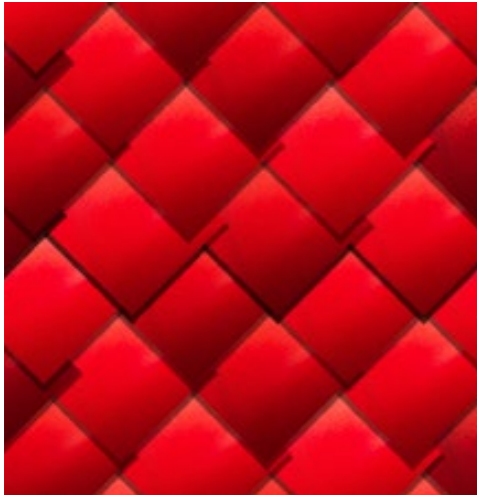

Reused car sheet metal
583 cars recycled /day in NL

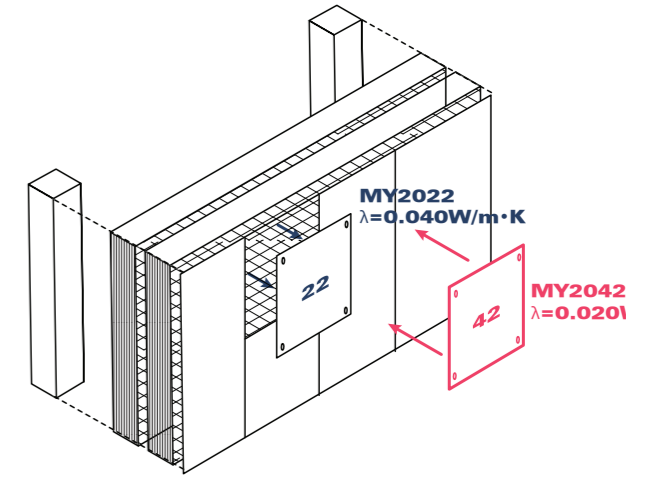
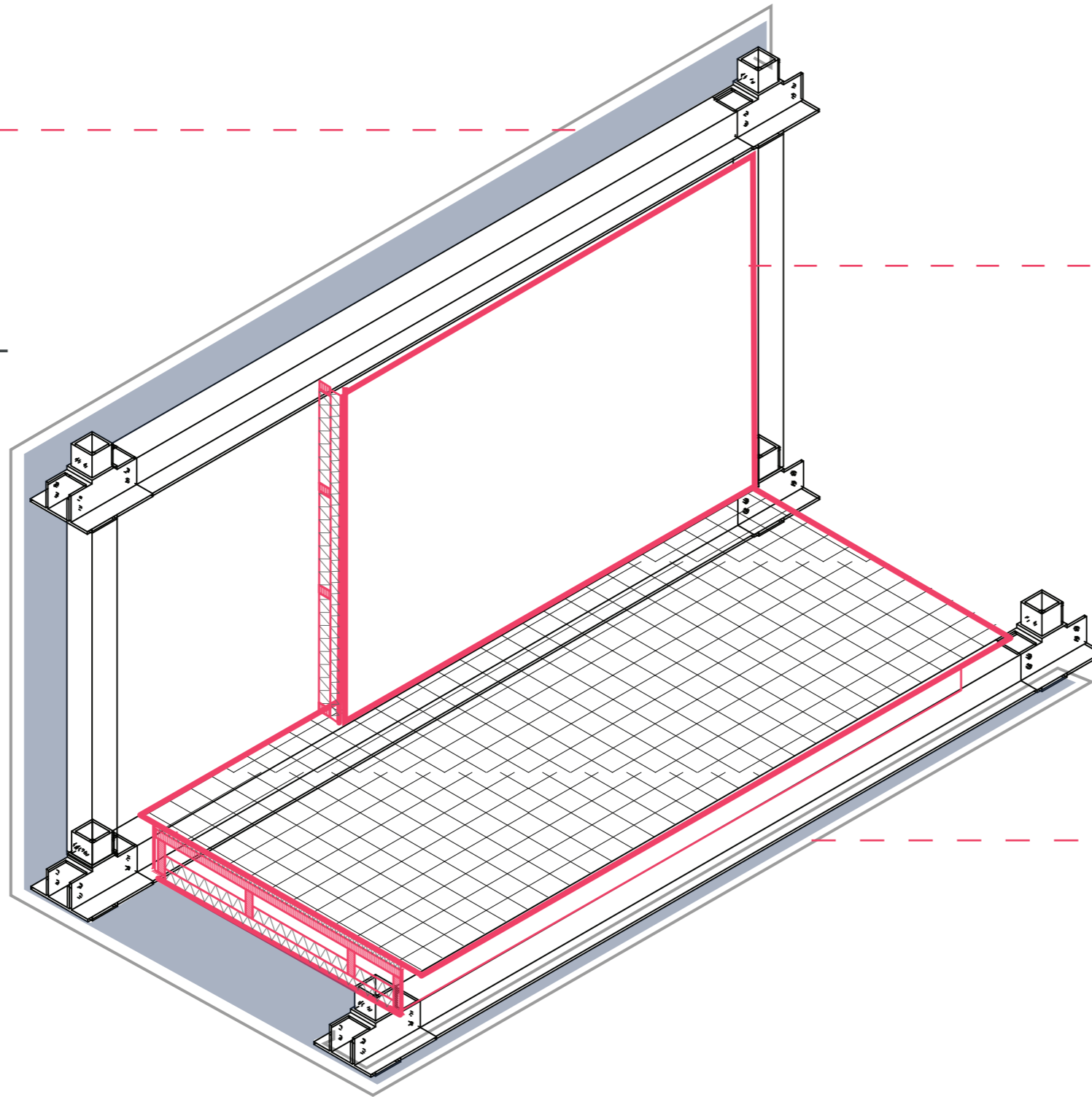

Replacable parts
Upgradable over time

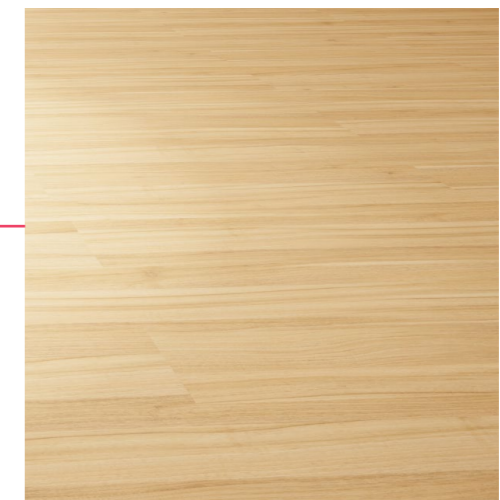

Nationally sourced wooden panels for acoustics and weight reduction

CONSTRUCTION CONCEPT

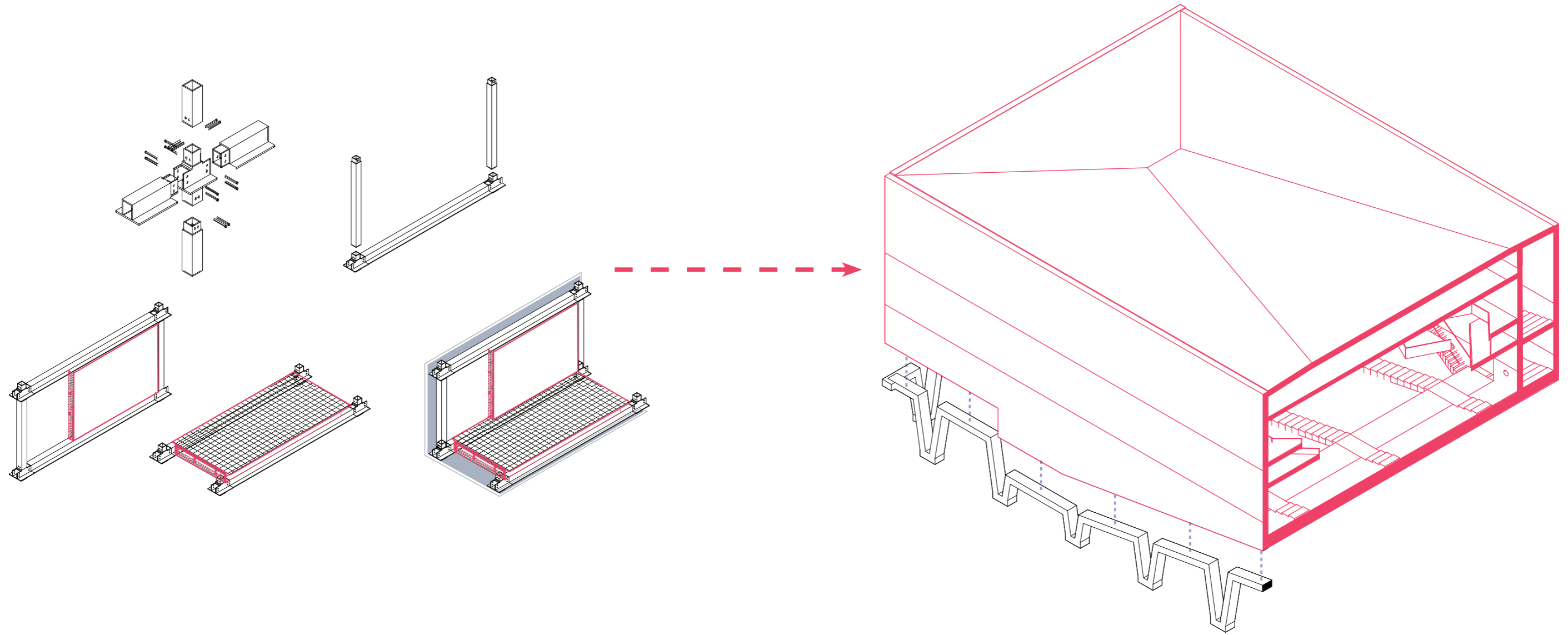

Independently constructed and placed on structure

CONSTRUCTION SEQUENCE

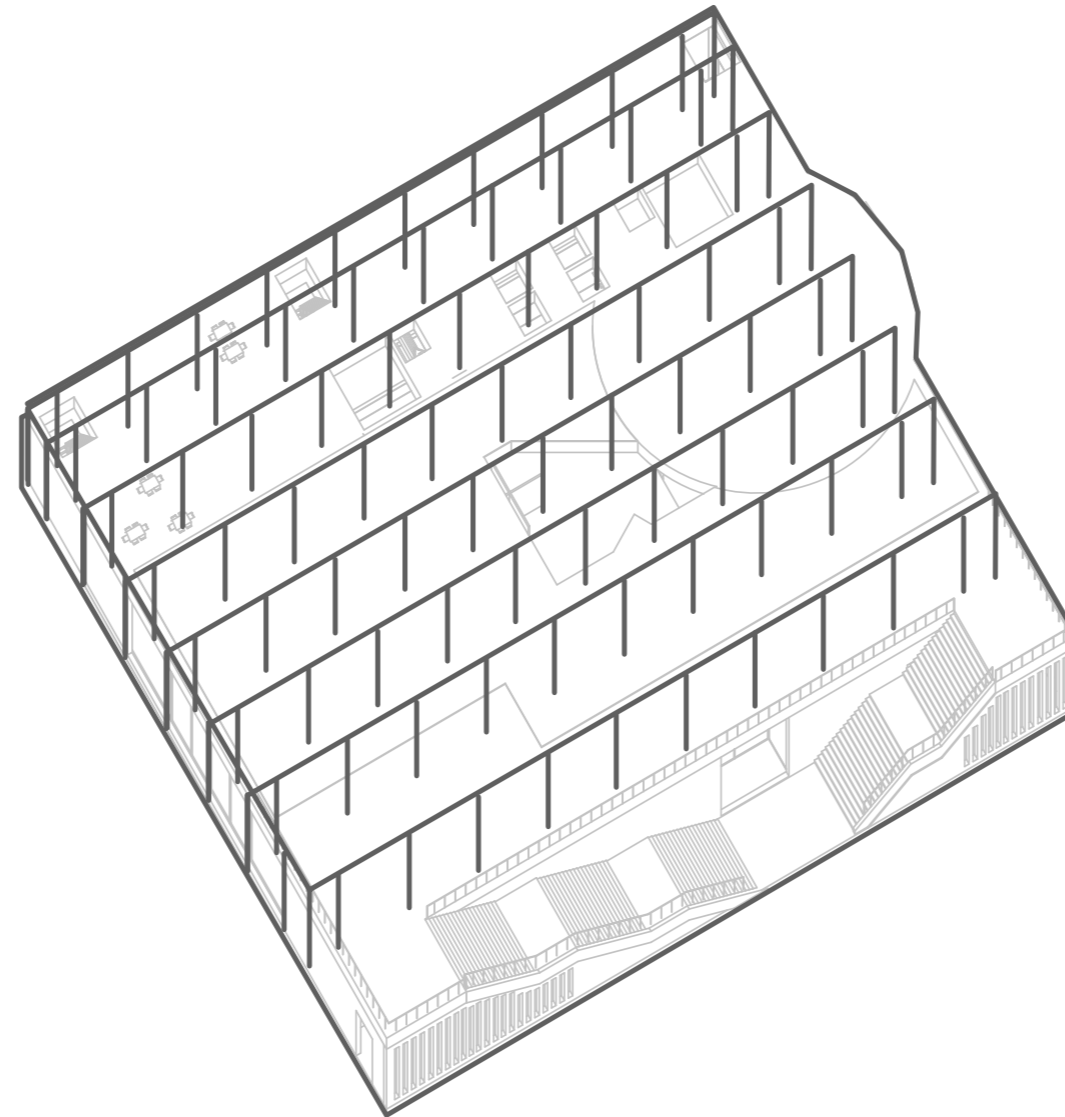

Construction of steel framed base

CONSTRUCTION SEQUENCE

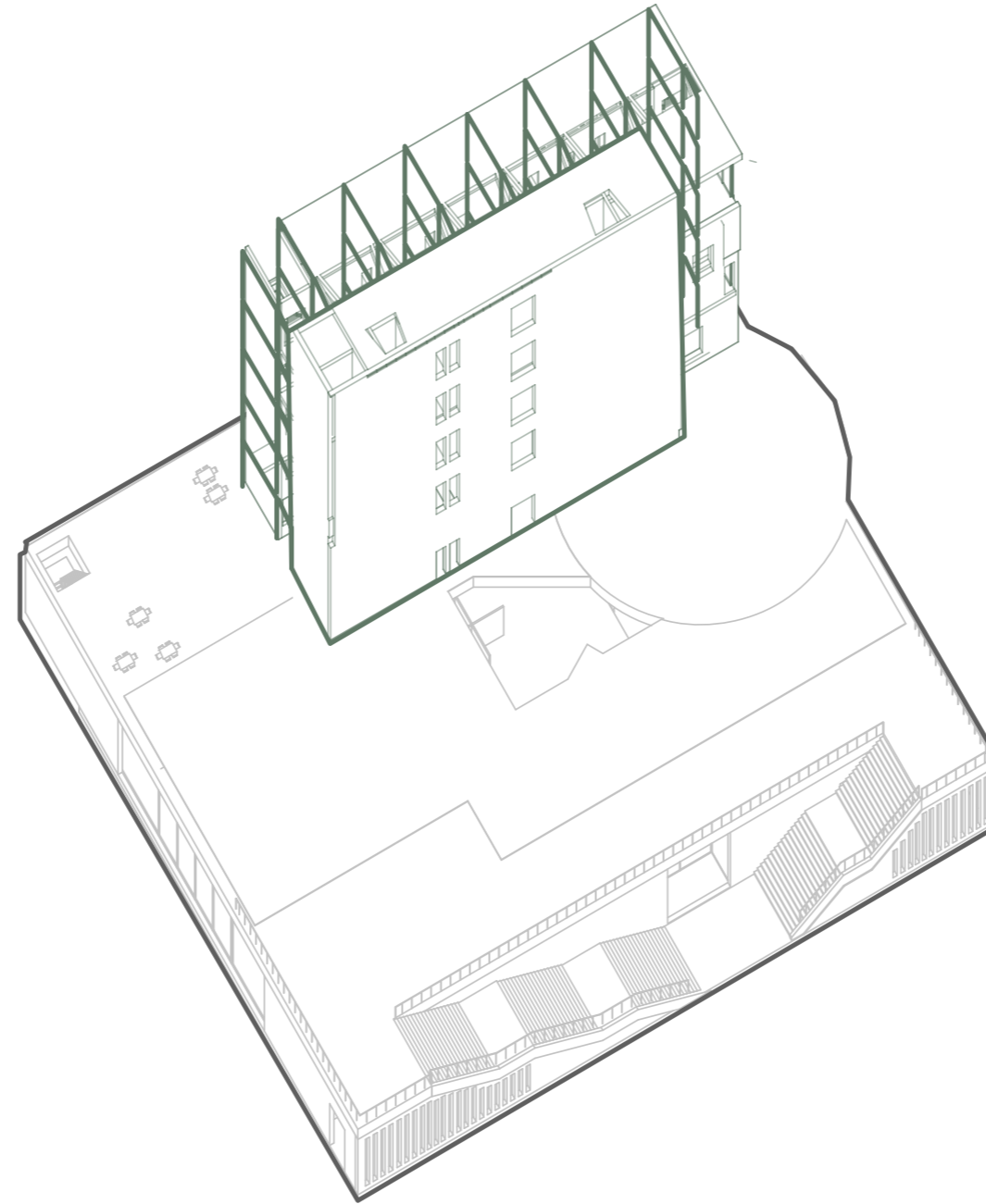

Hybrid structure backbone and shafts

CONSTRUCTION SEQUENCE

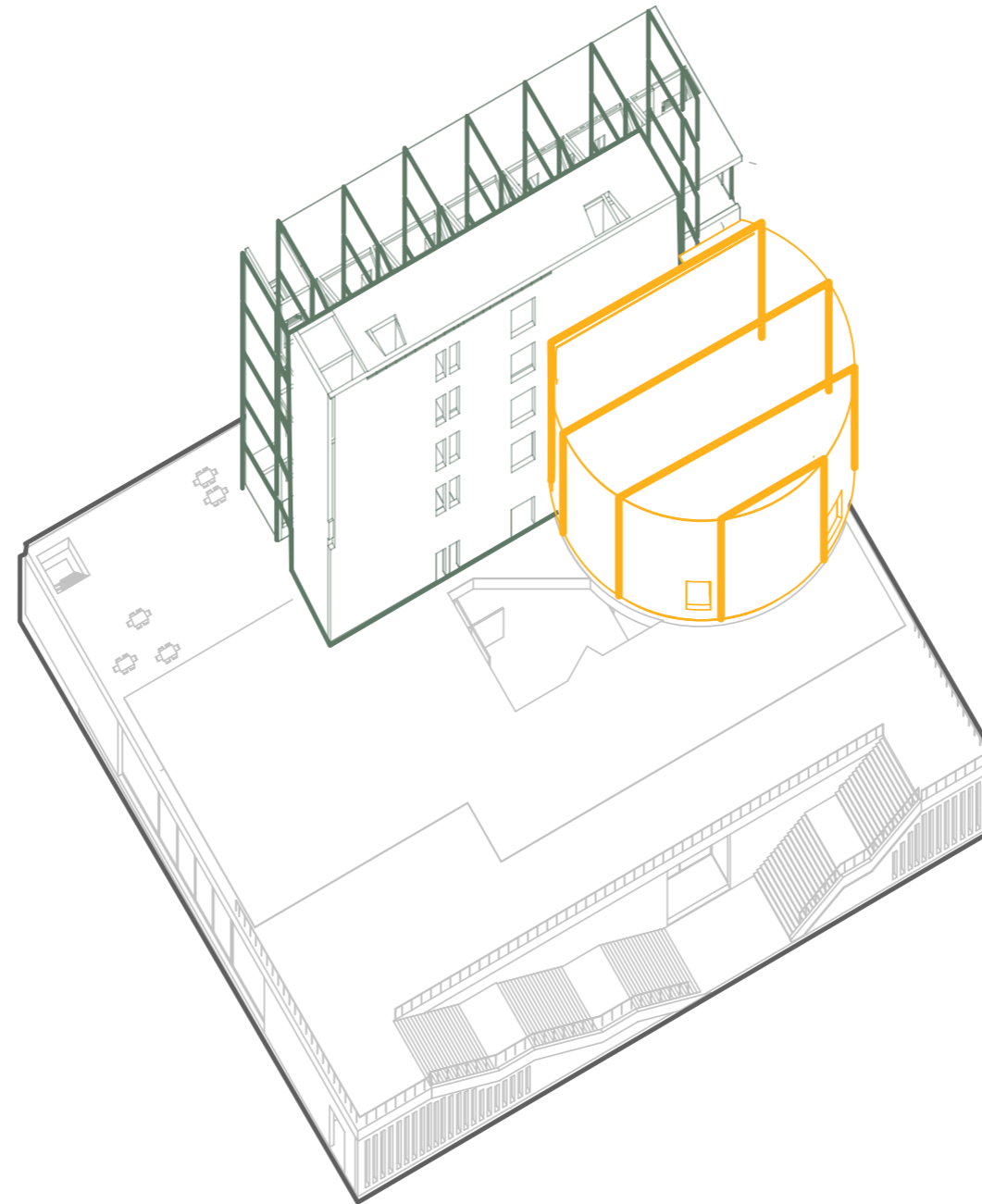

Horseshoe hall steel framework

CONSTRUCTION SEQUENCE

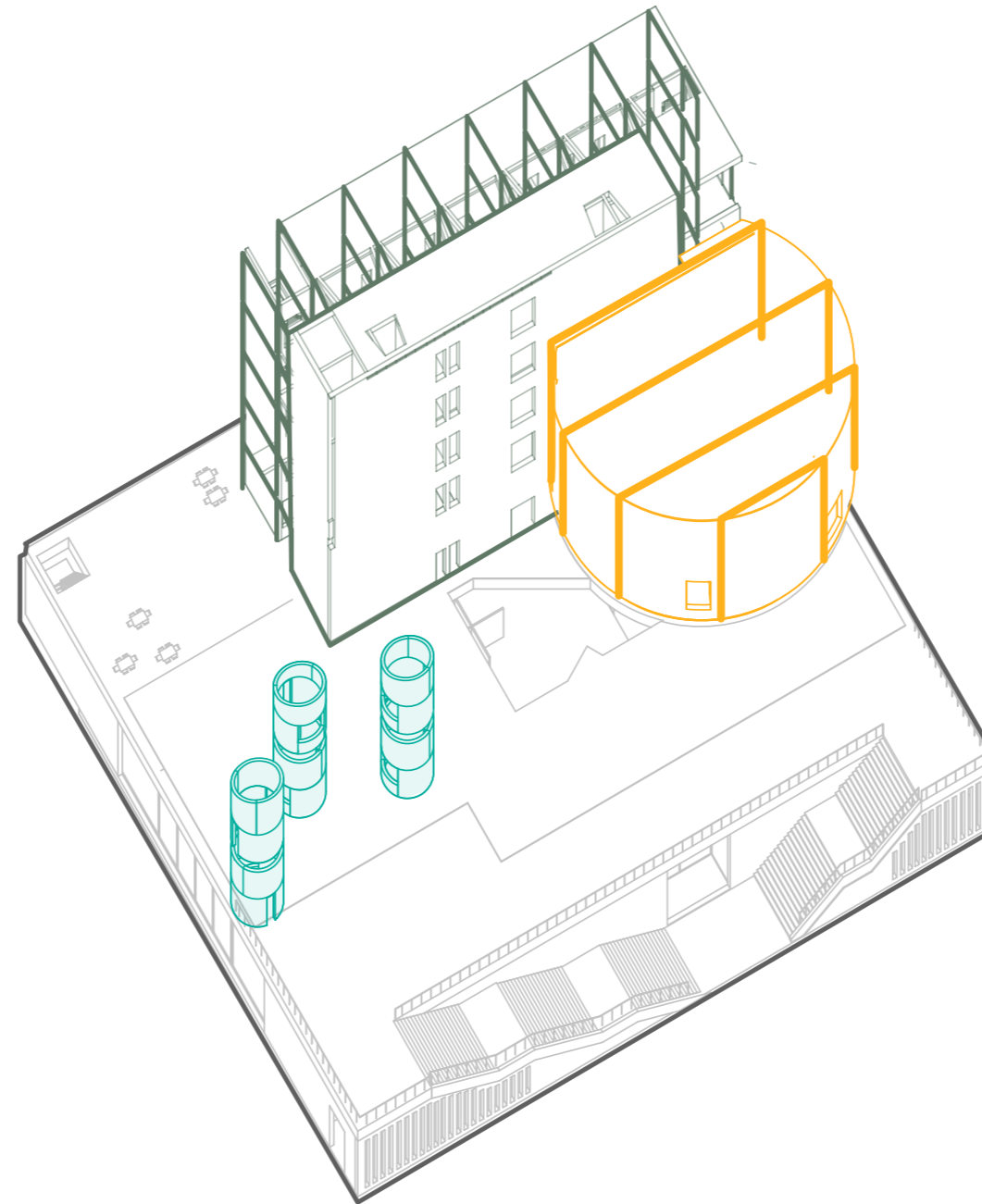

Construction of load bearing booths

CONSTRUCTION SEQUENCE

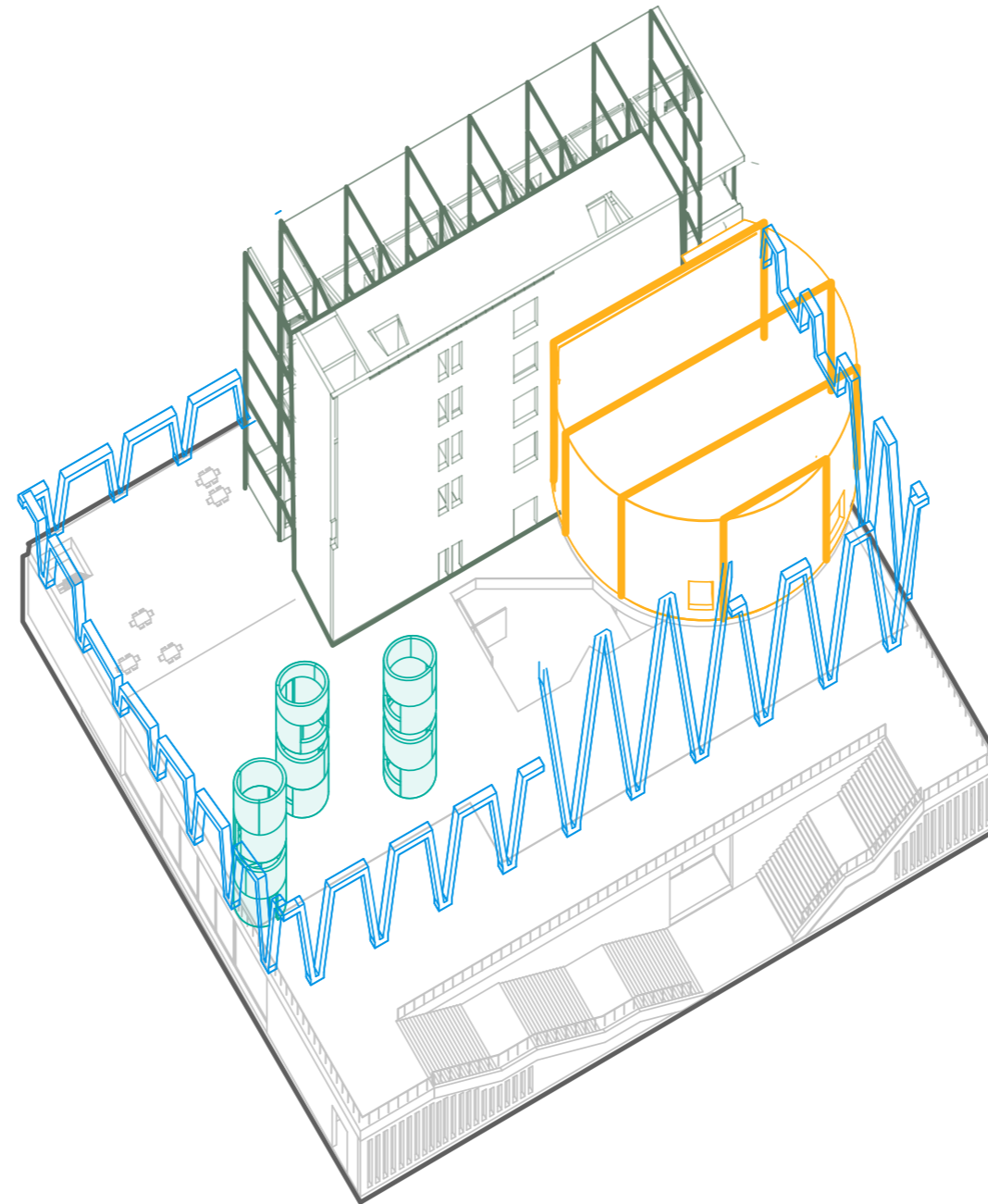

Load-bearing facade around objects

CONSTRUCTION SEQUENCE

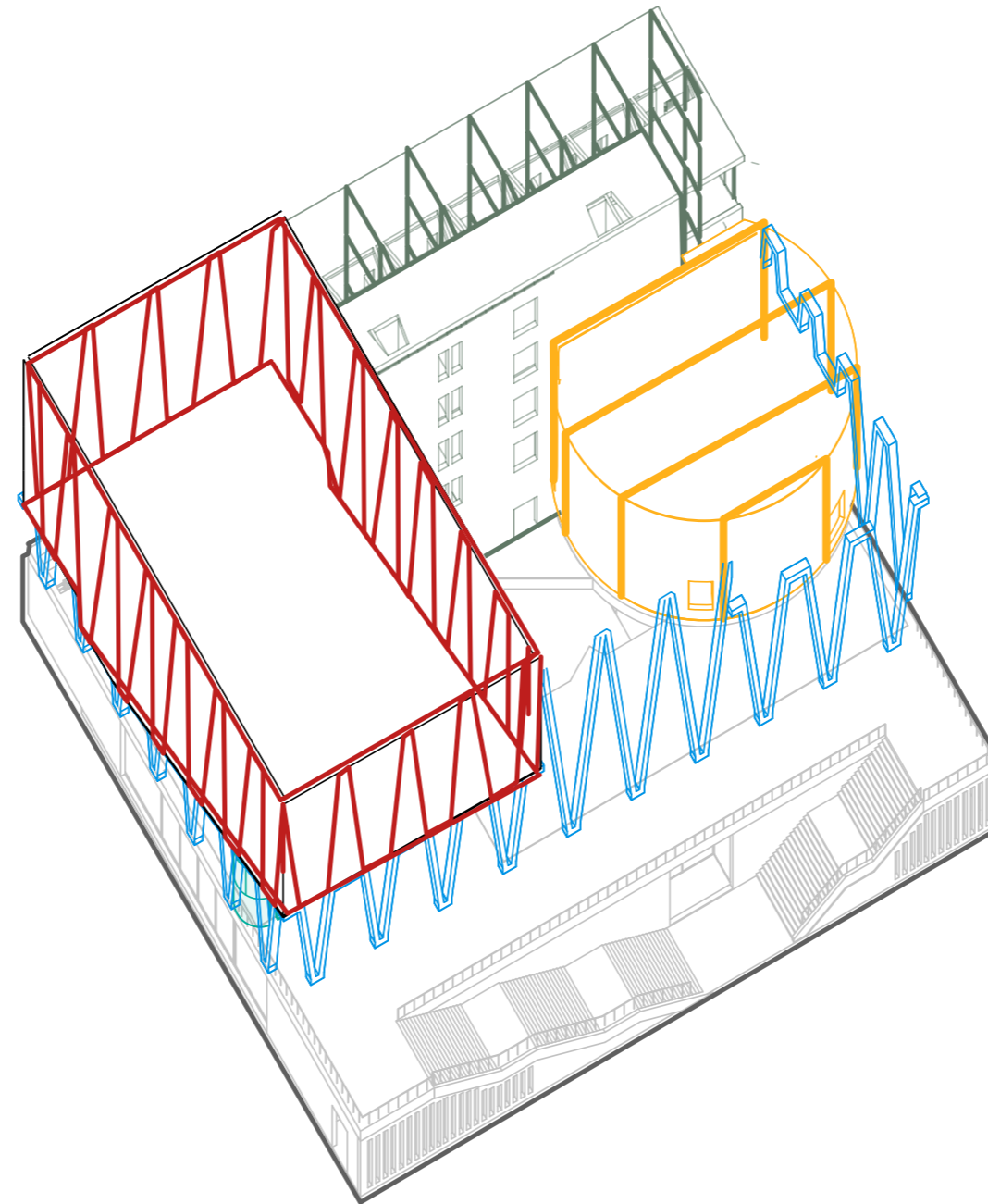

Classical hall constructed and placed on top

CONSTRUCTION SEQUENCE

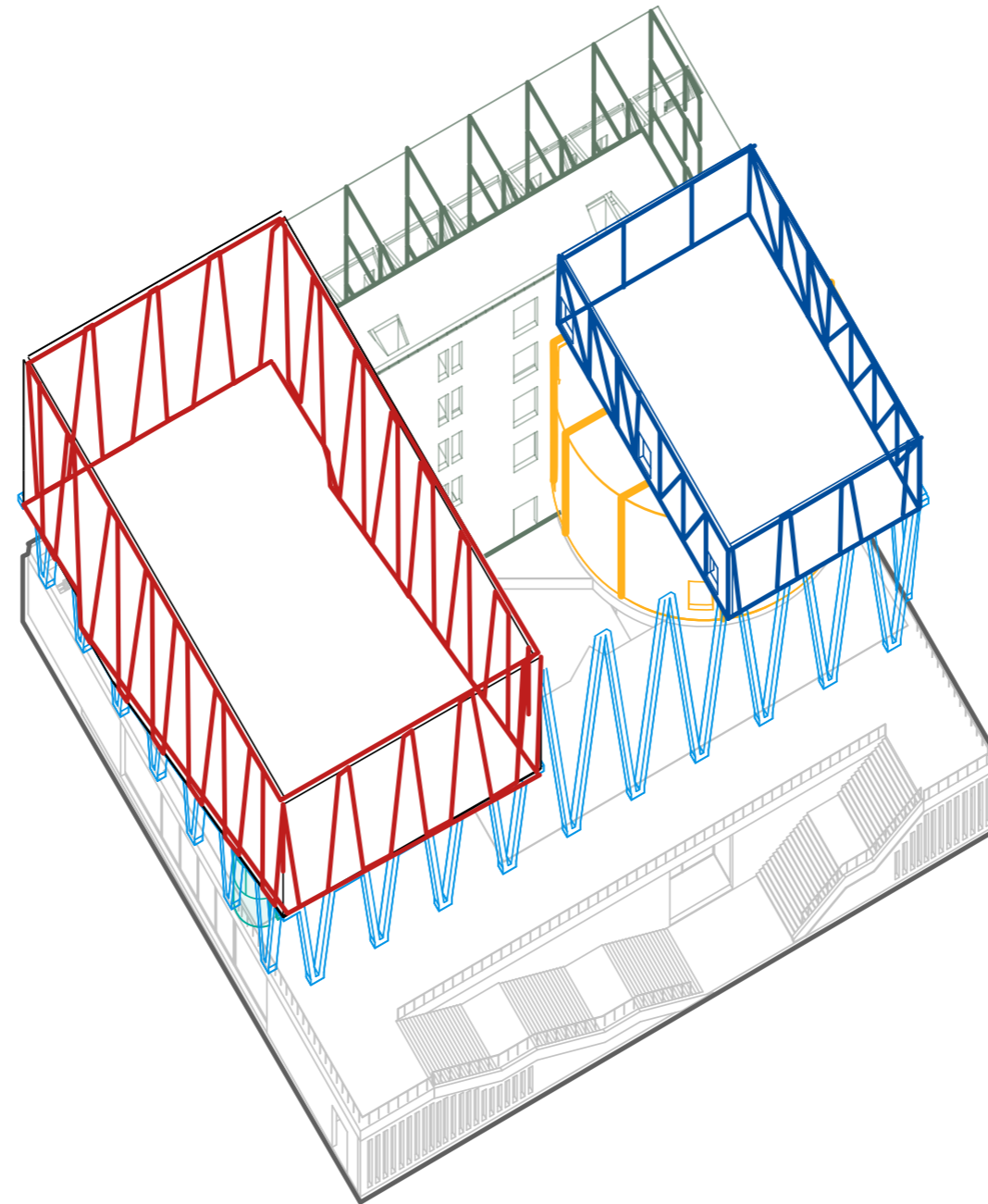

Shakespeare hall placed using trusses in walls

CONSTRUCTION SEQUENCE

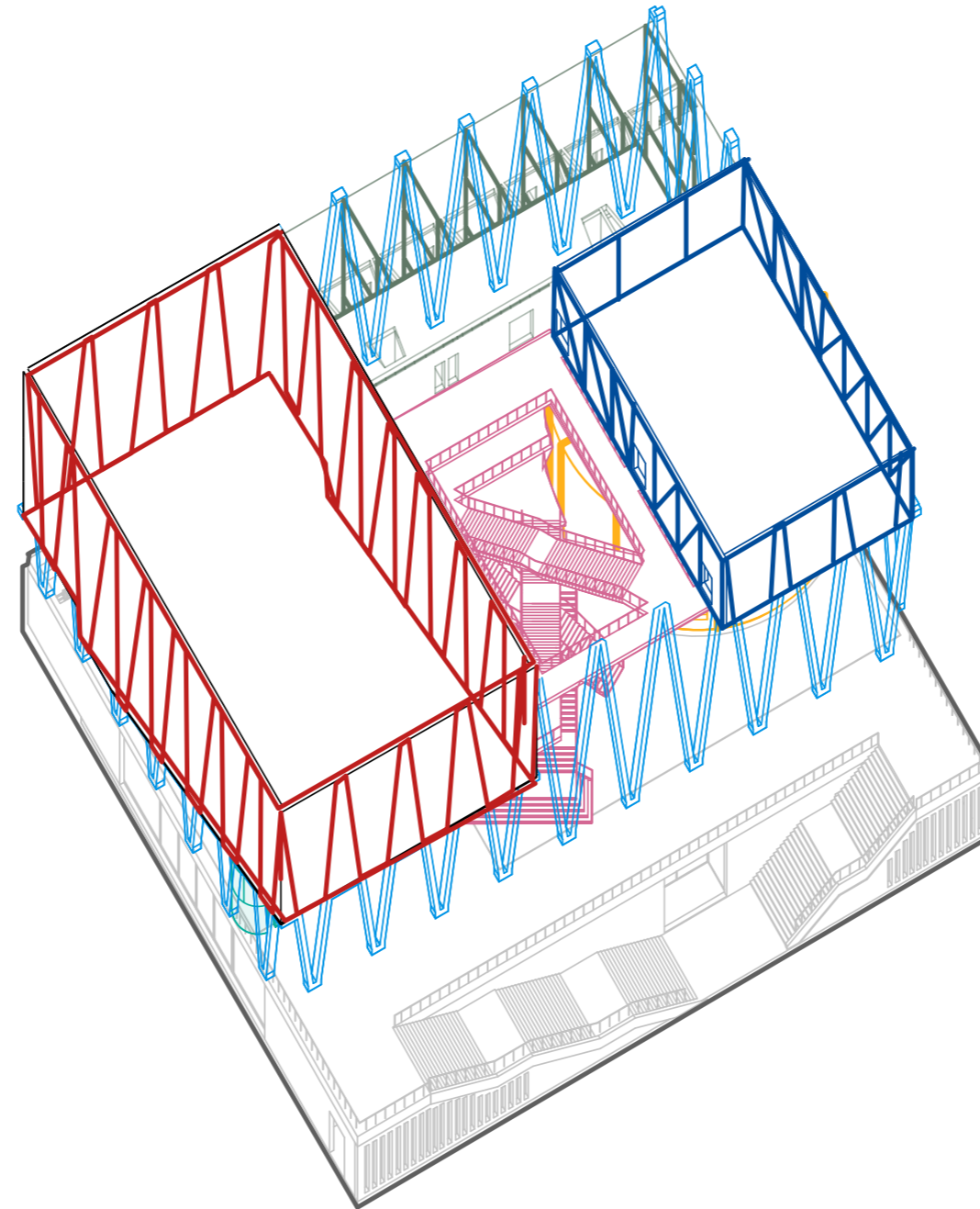

Staircases mounted in between for rigidity

STRUCTURAL CONCEPT

Facade

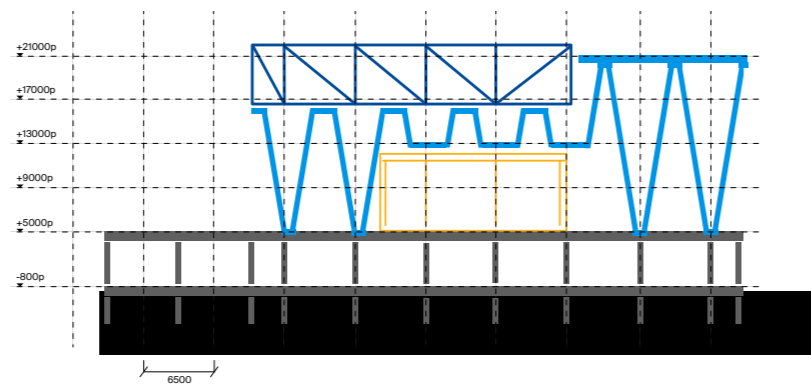
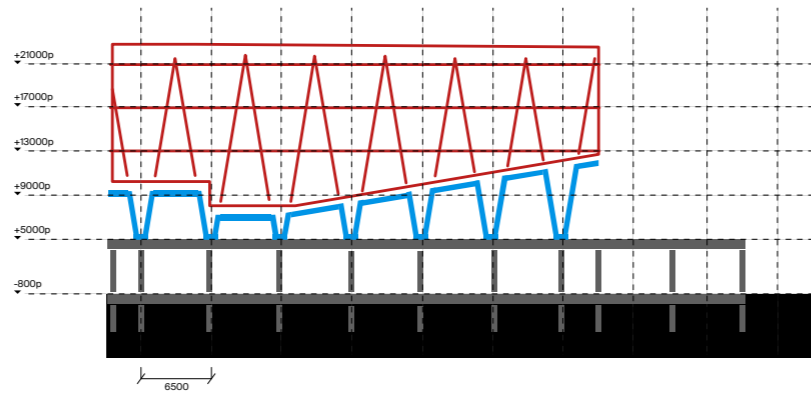
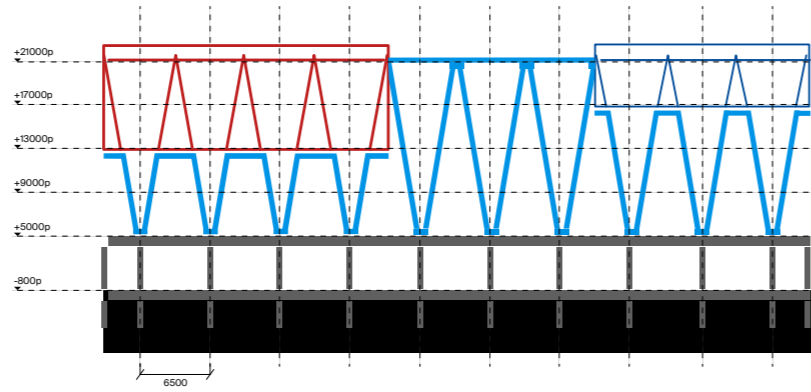

Section

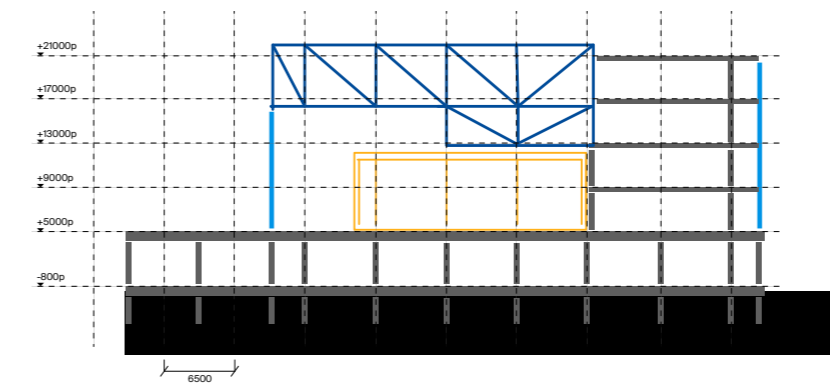
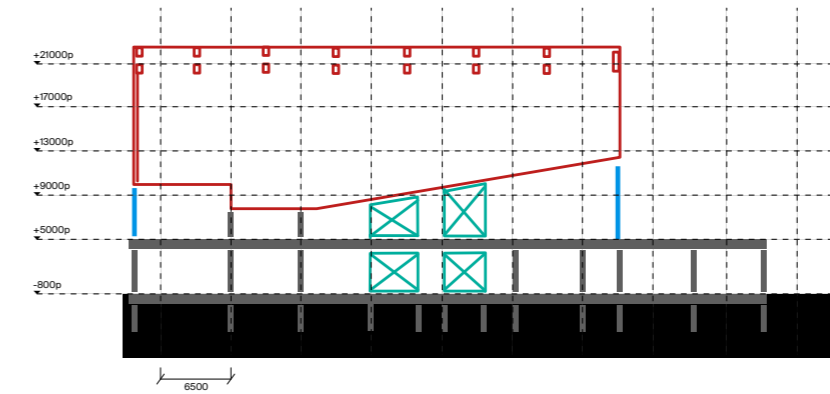
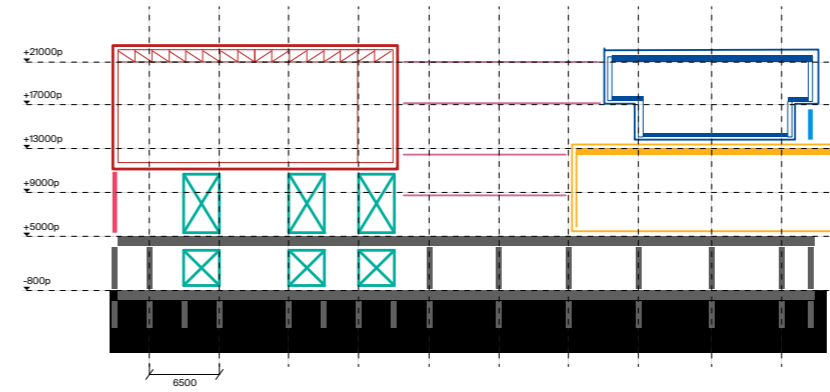

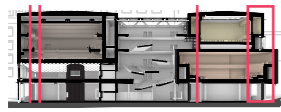

INTERIOR SECTIONS - CLASSICAL HALL

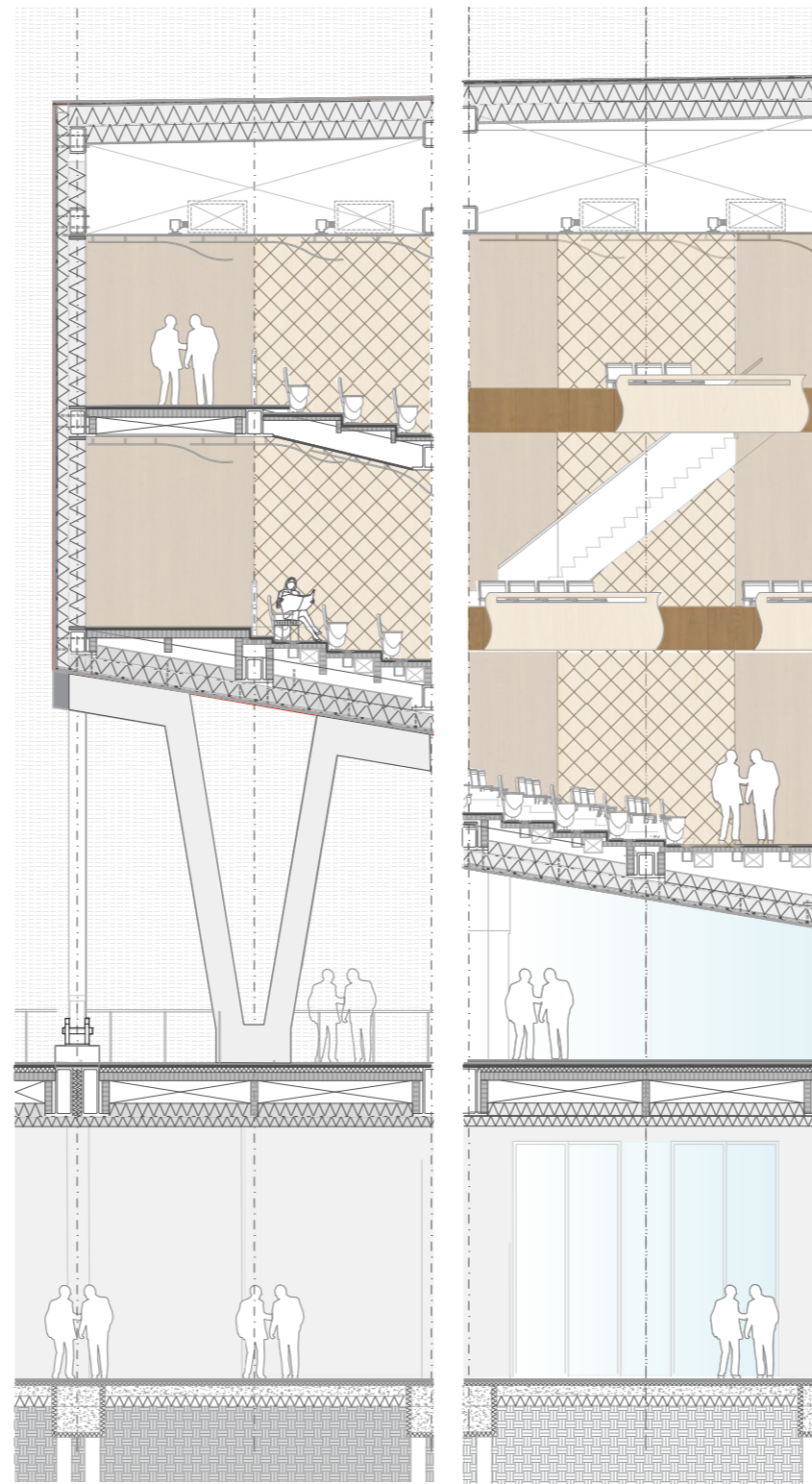

Longitudinal sections

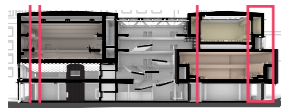

INTERIOR SECTIONS - SHAKESPEARE/HORSESHOE

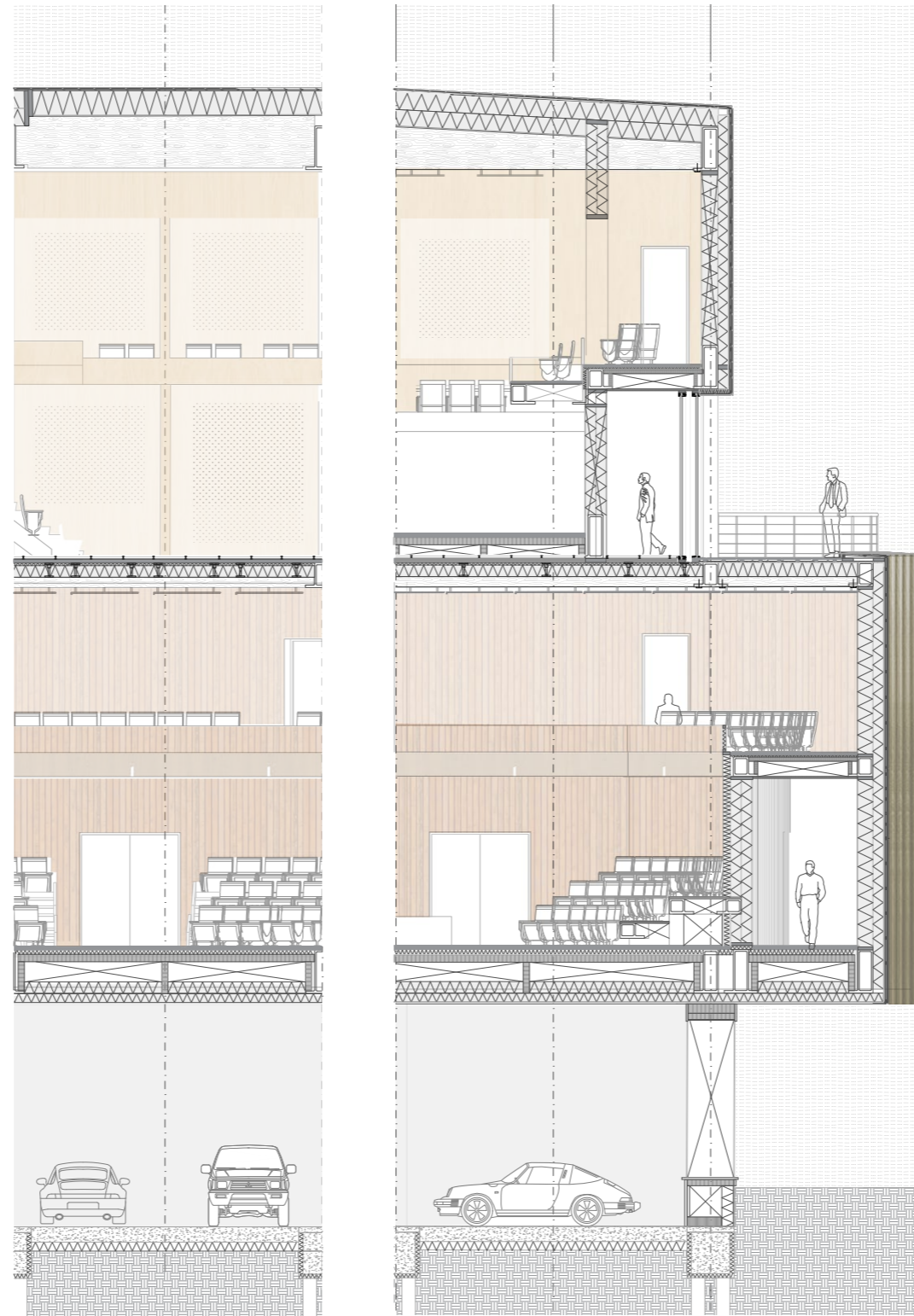

Longitudinal section

Transverse section

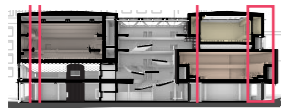

INTERIOR SECTIONS

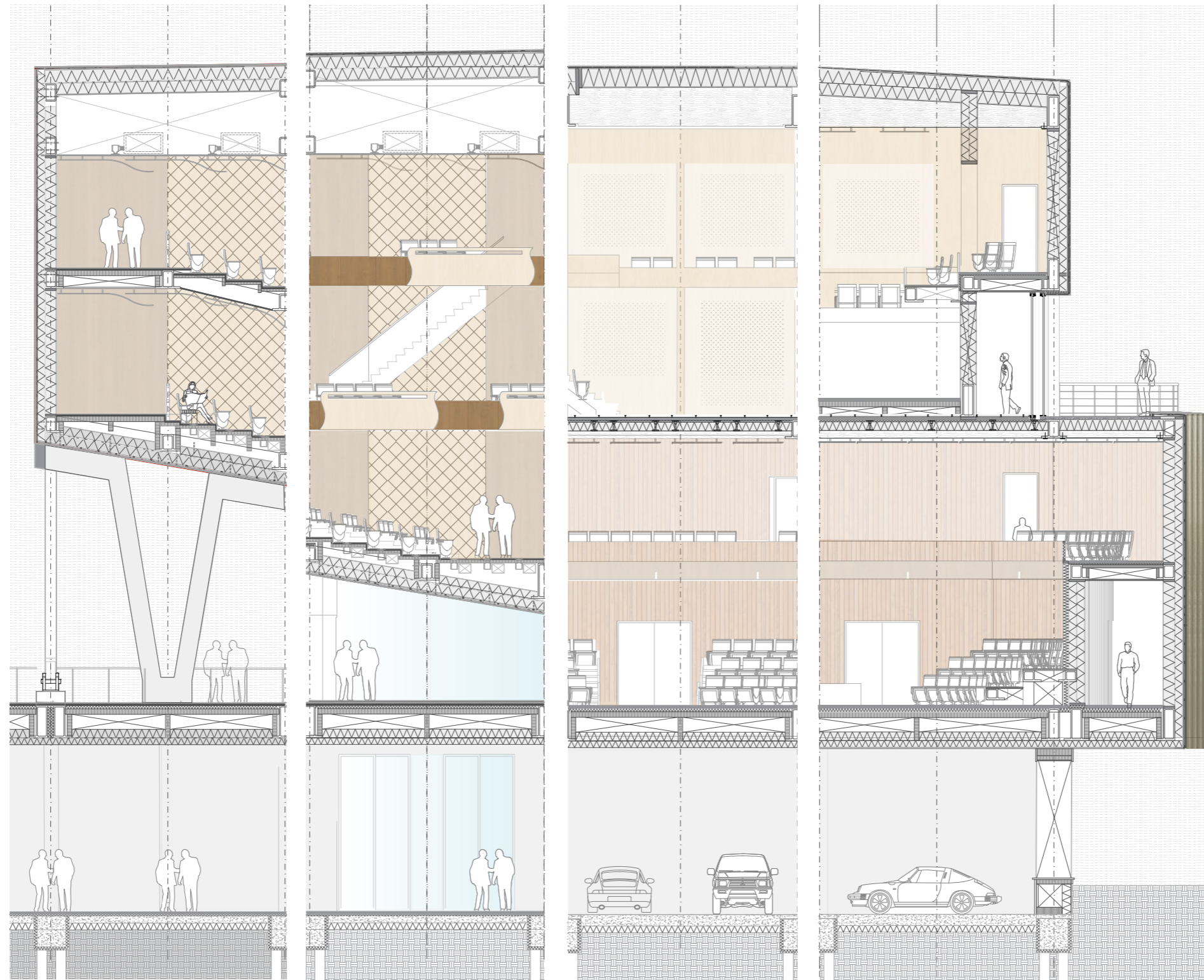

Classical hall

Shakespeare and Horseshoe hall

ELEVATIONS

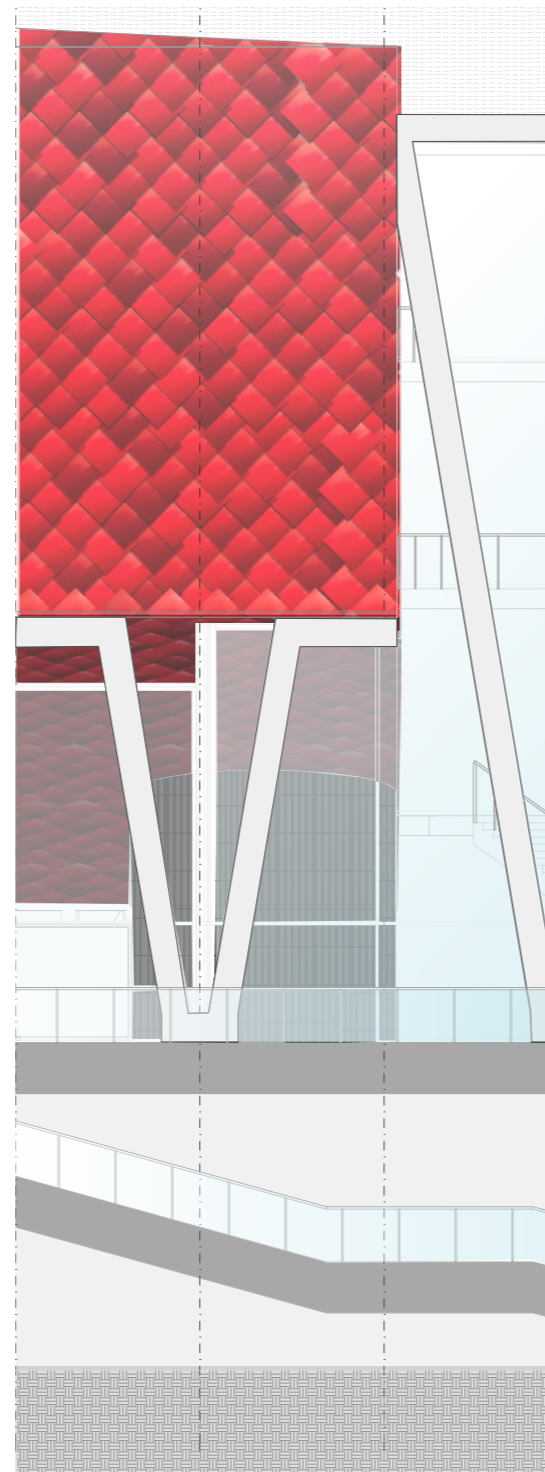

North facade

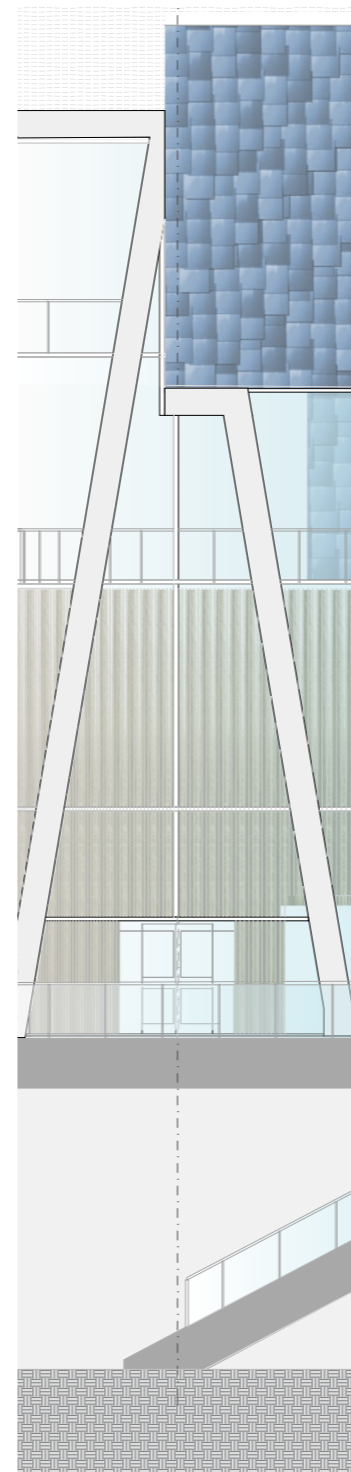

North facade

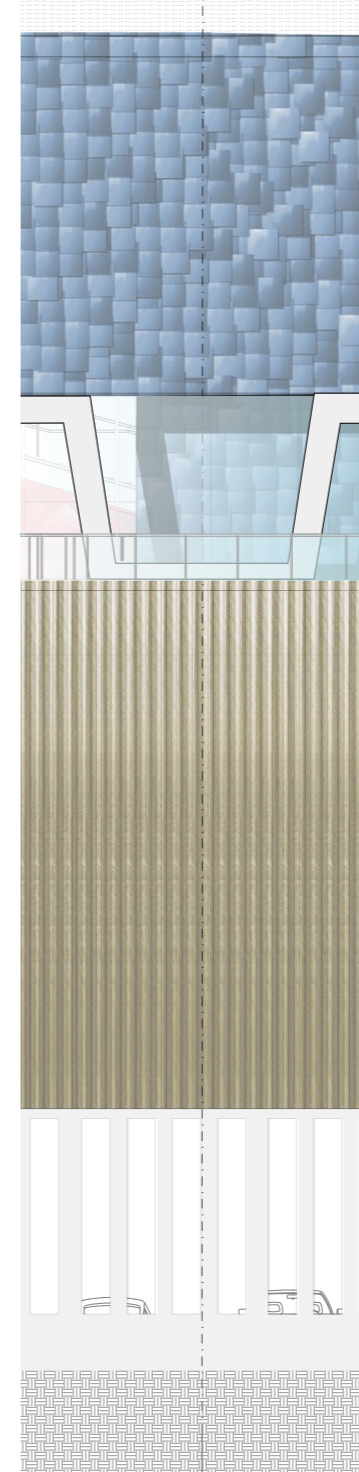

West facade





Thank you

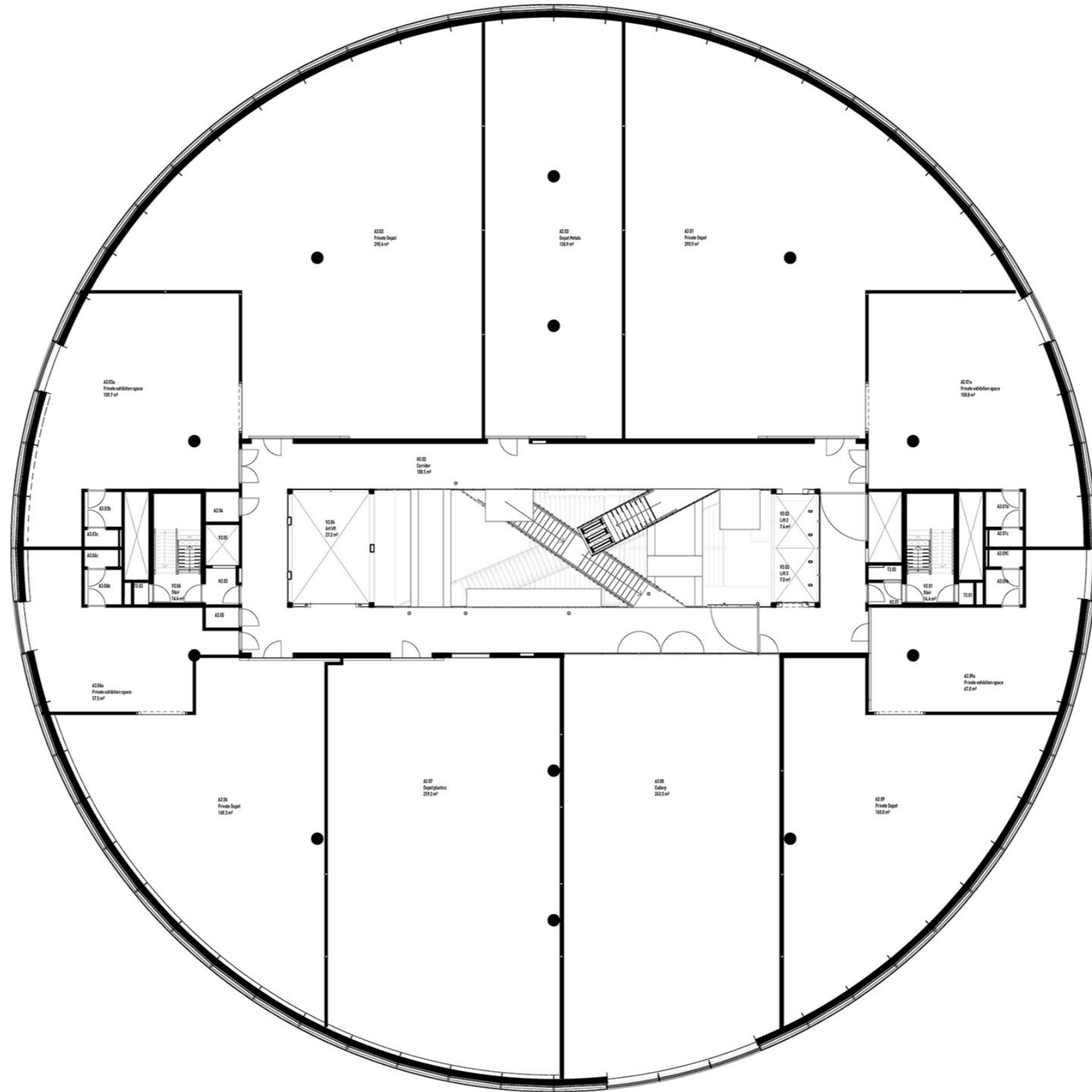







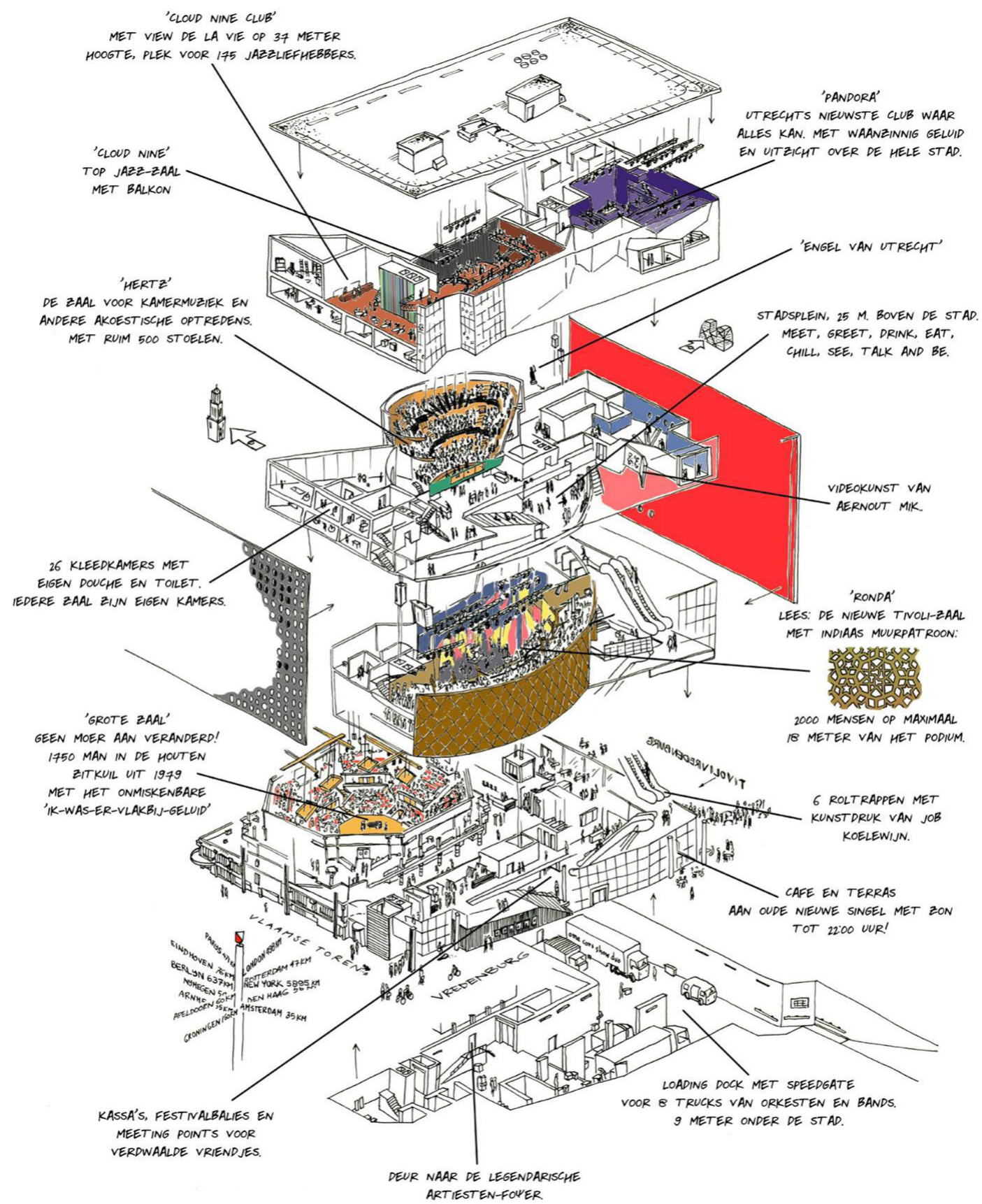

VOOR MEER DAN 7000 MUZIEKLIEFHEBBERS DOOR HERMAN HERTZBERGER, PATRICK FRANSEN, JO COENEN, THIJS ASSELBERGS & NL ARCHITECTS

2014 © FEDOR VAN ROSSUM

