



Vertical Cities Asia
Graduation & Competition

Lifetime City & Theater City

평생시 와 극장시

Laura Dinkla
TU Delft 16 april 2013

narrative

introduction location

research for masterplan

design Lifetime City

new masterplan

concept Theater City

how to build the Theater City

a day in the life of Sun Hee



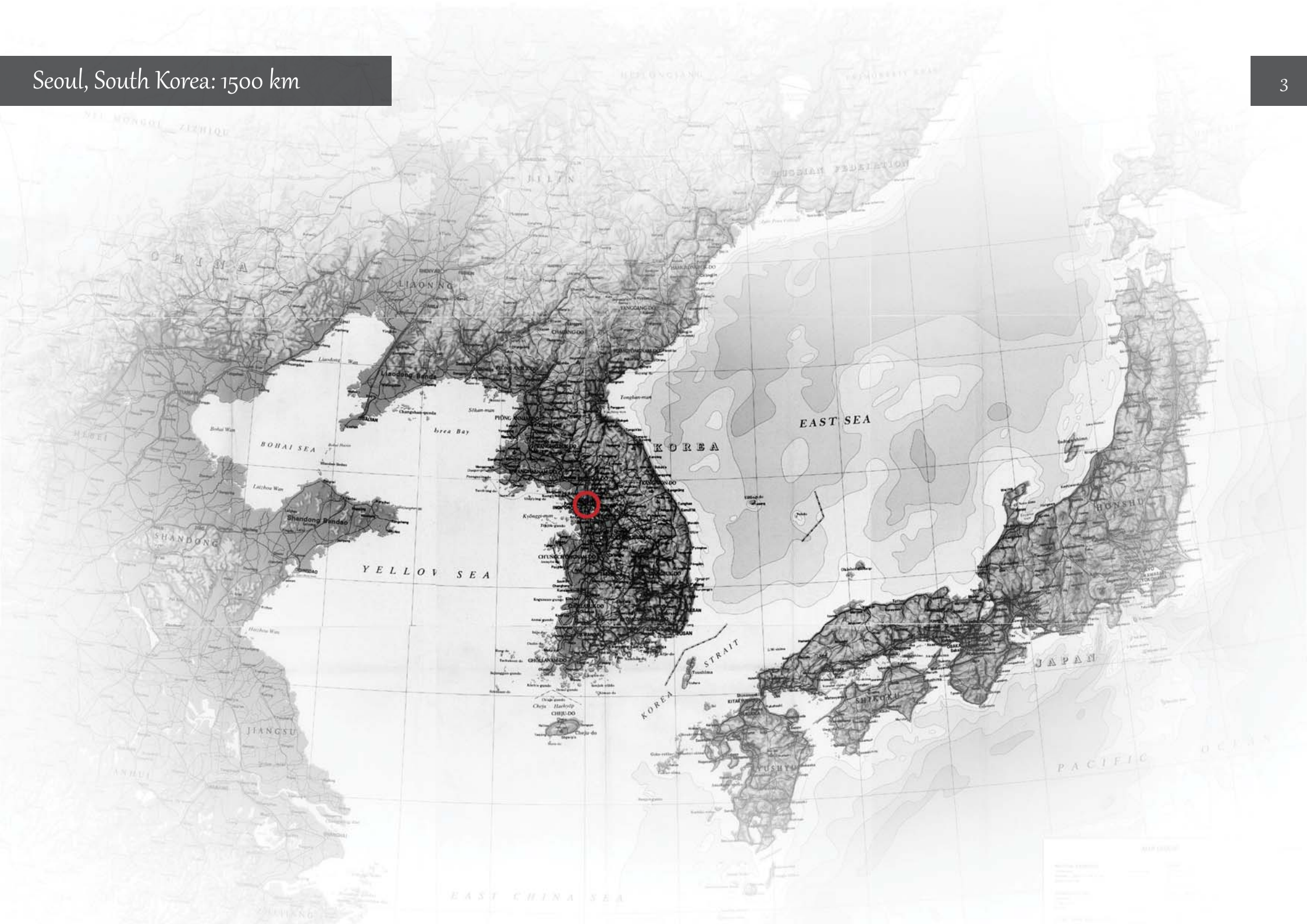

Yongsan, Seoul: 20 km





YONGSAN STATION

YONGSAN ELECTRONIC MARKET



SEOUL N TOWER

MOUNTAIN NAM

YONGSAN STATION

RIVERSIDE PARK

RIVER HAN

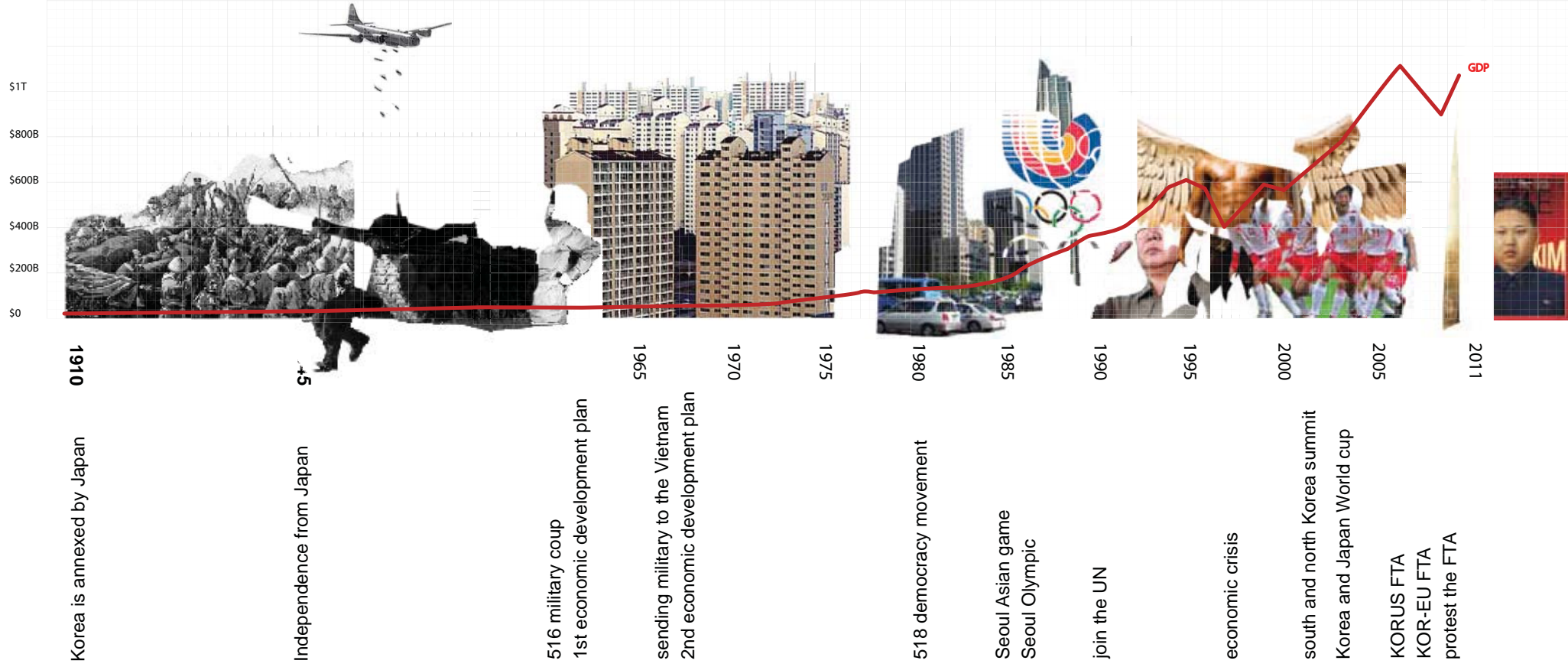

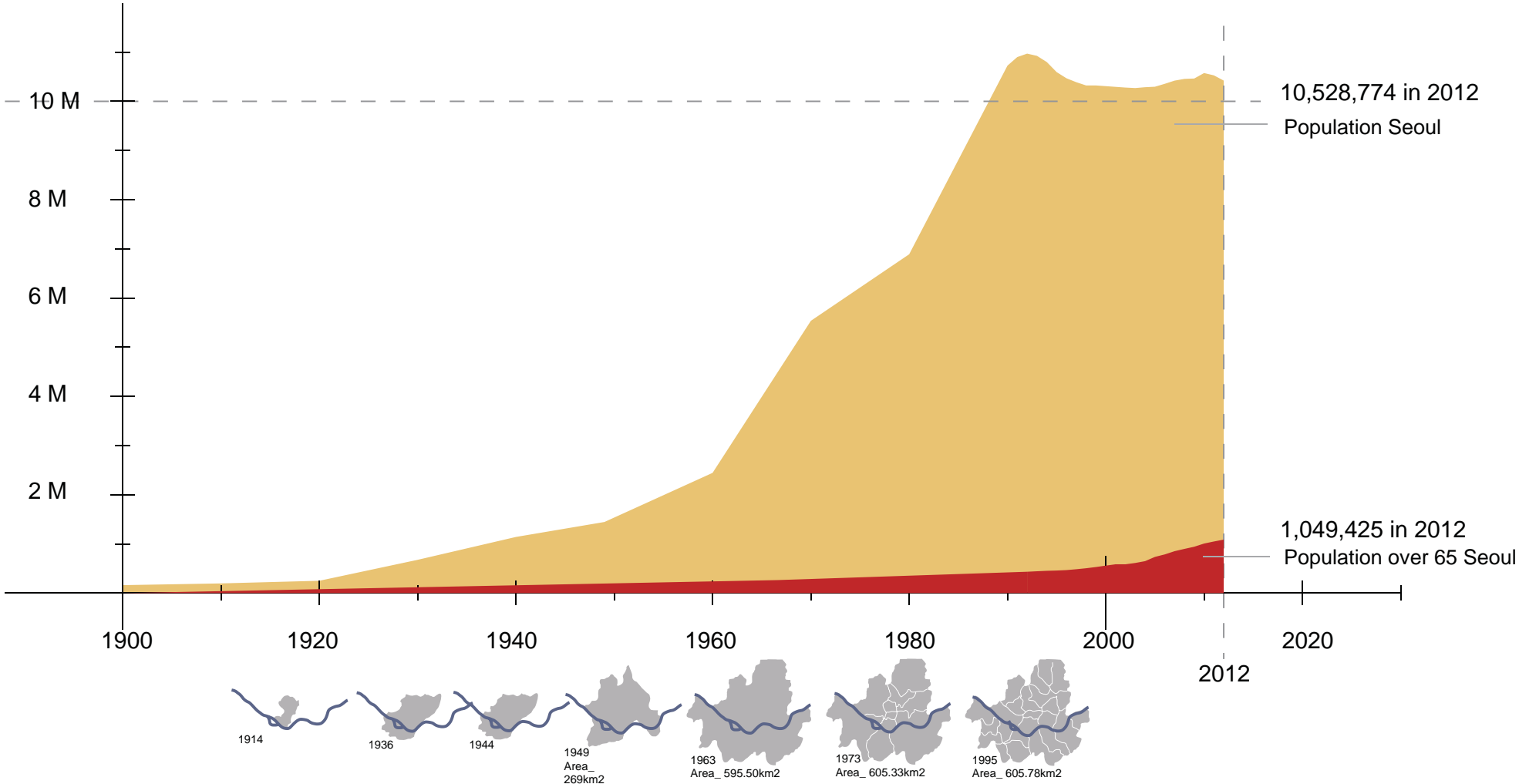

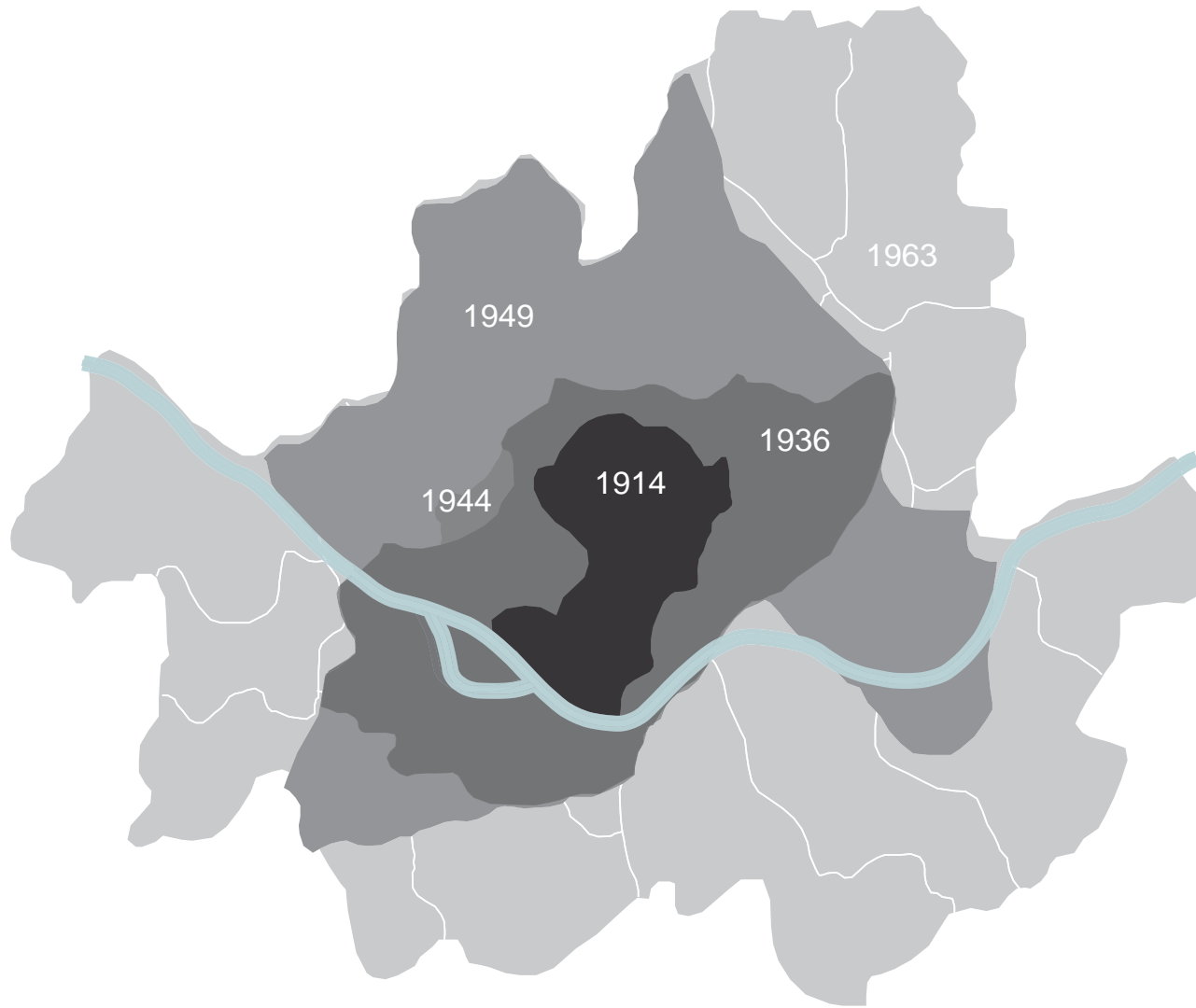

City boundaries in time

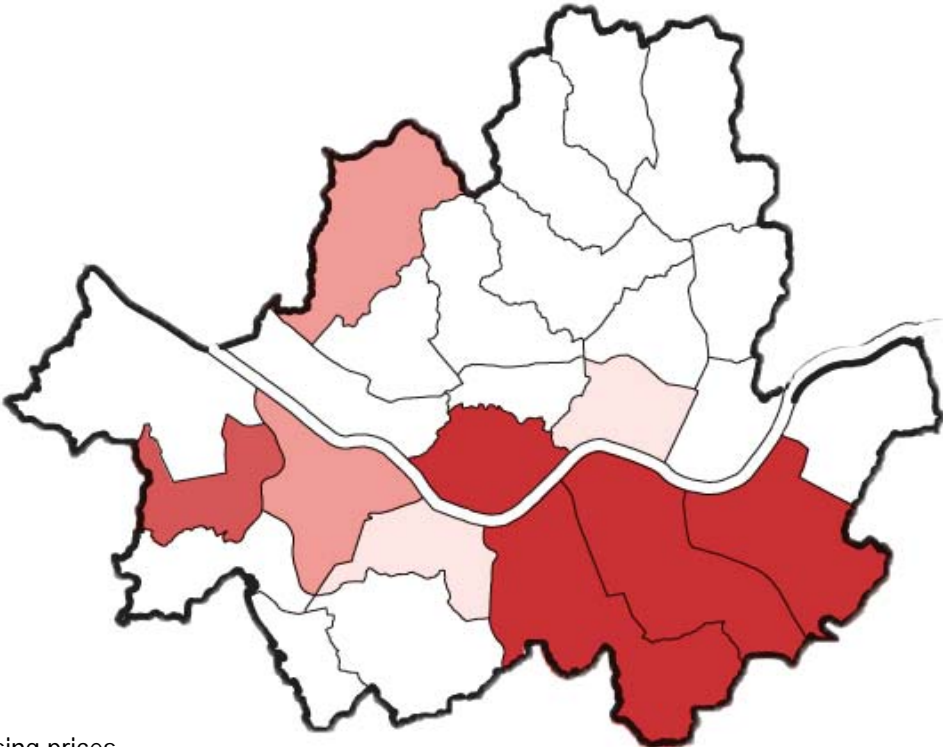

Housing prices

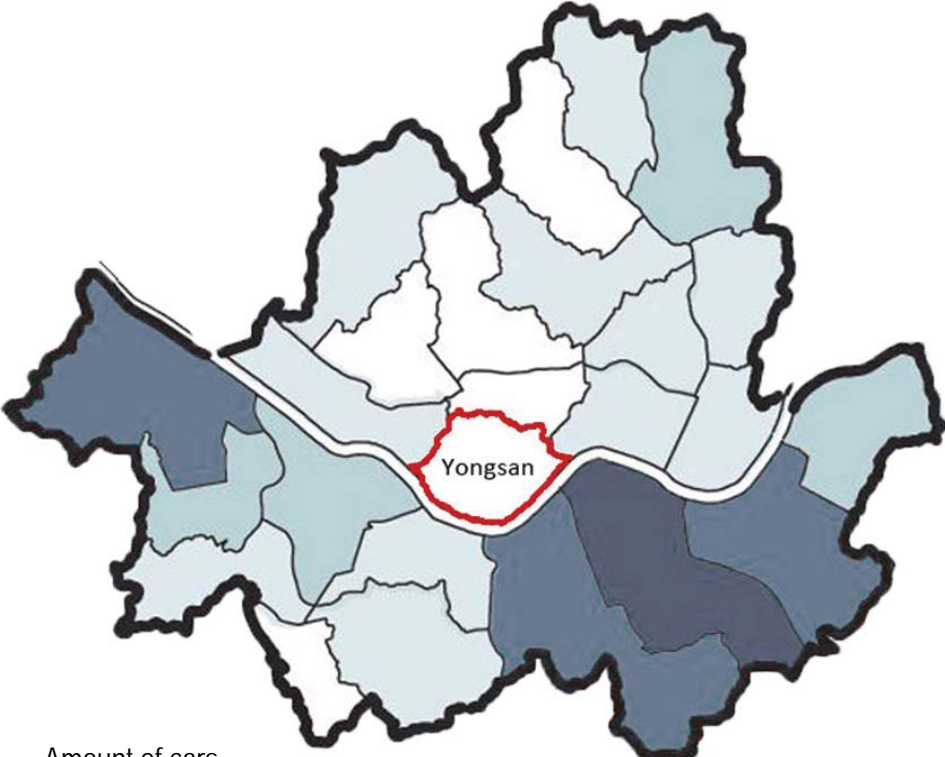

Amount of cars

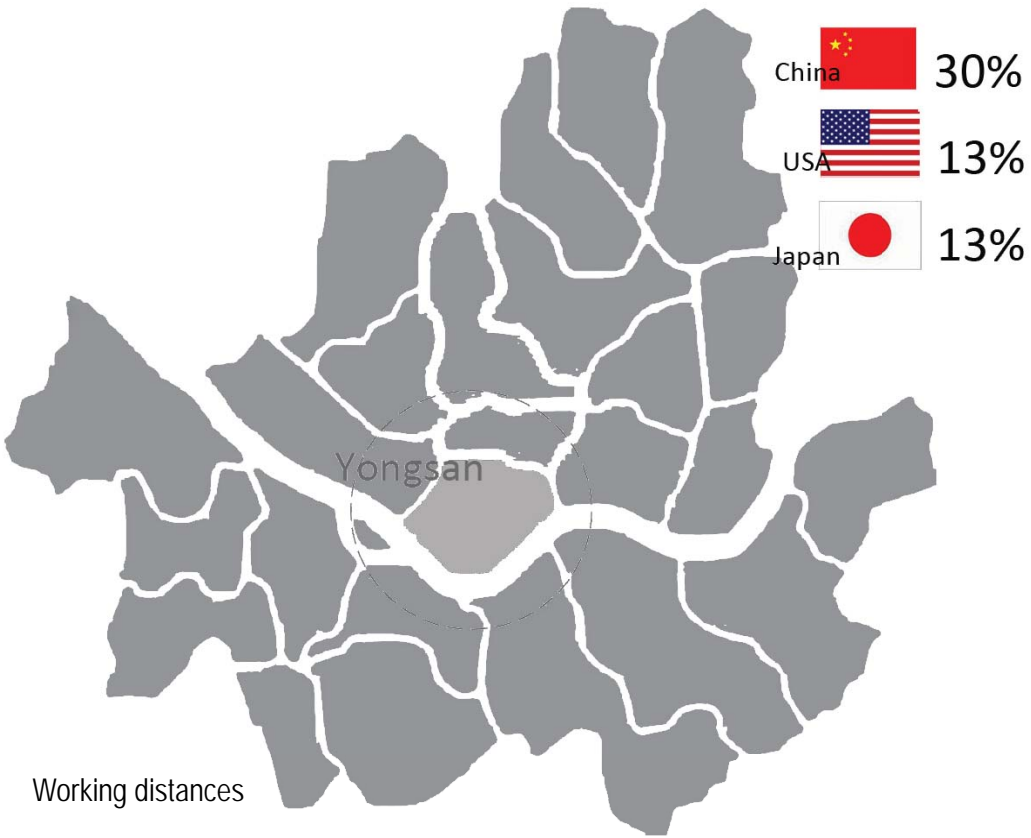
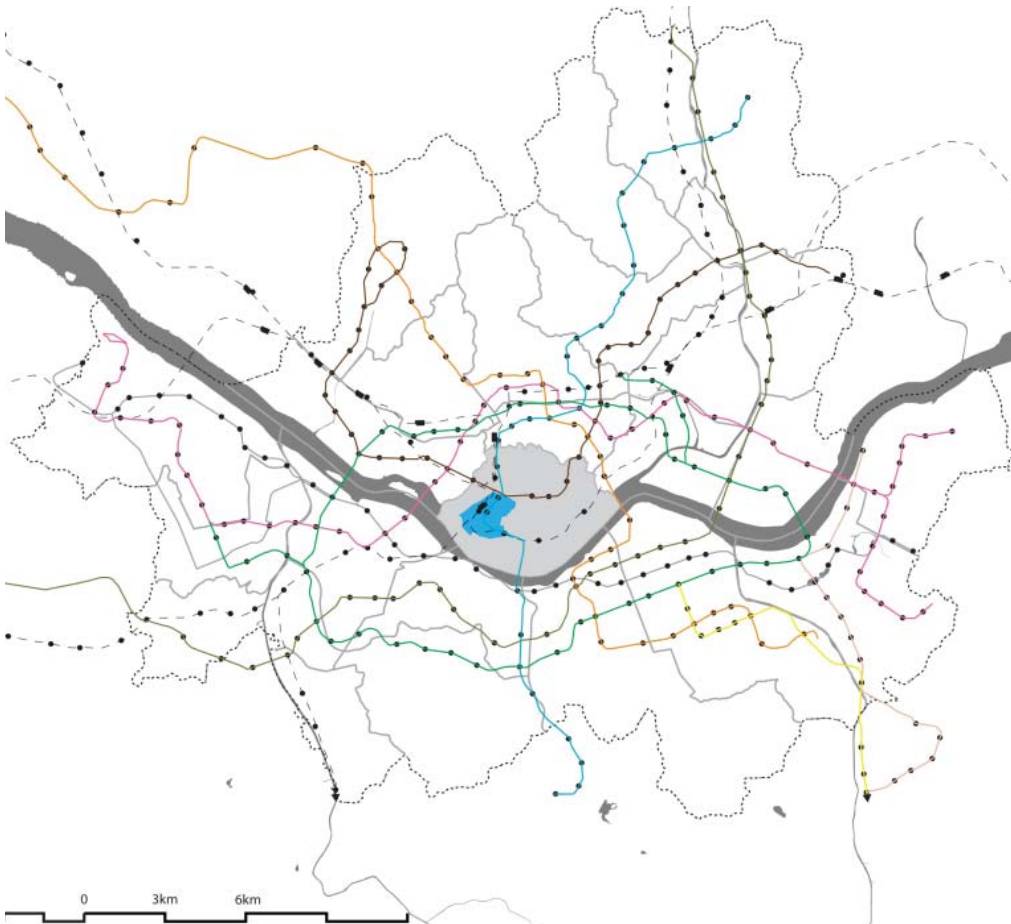

A large crowd of people, mostly men, are gathered in a public square. Many are sitting on the ground, playing board games like Go or Xiangqi. Some are standing and talking, while others are sitting on benches. The scene is busy and social.

“The objective of the competition is to seek a holistic solution or a new urban paradigm for a rapidly growing Asian city which also faces the issues of sustainability and quality of life that also adresses the increasing aging population in Asian cities.”

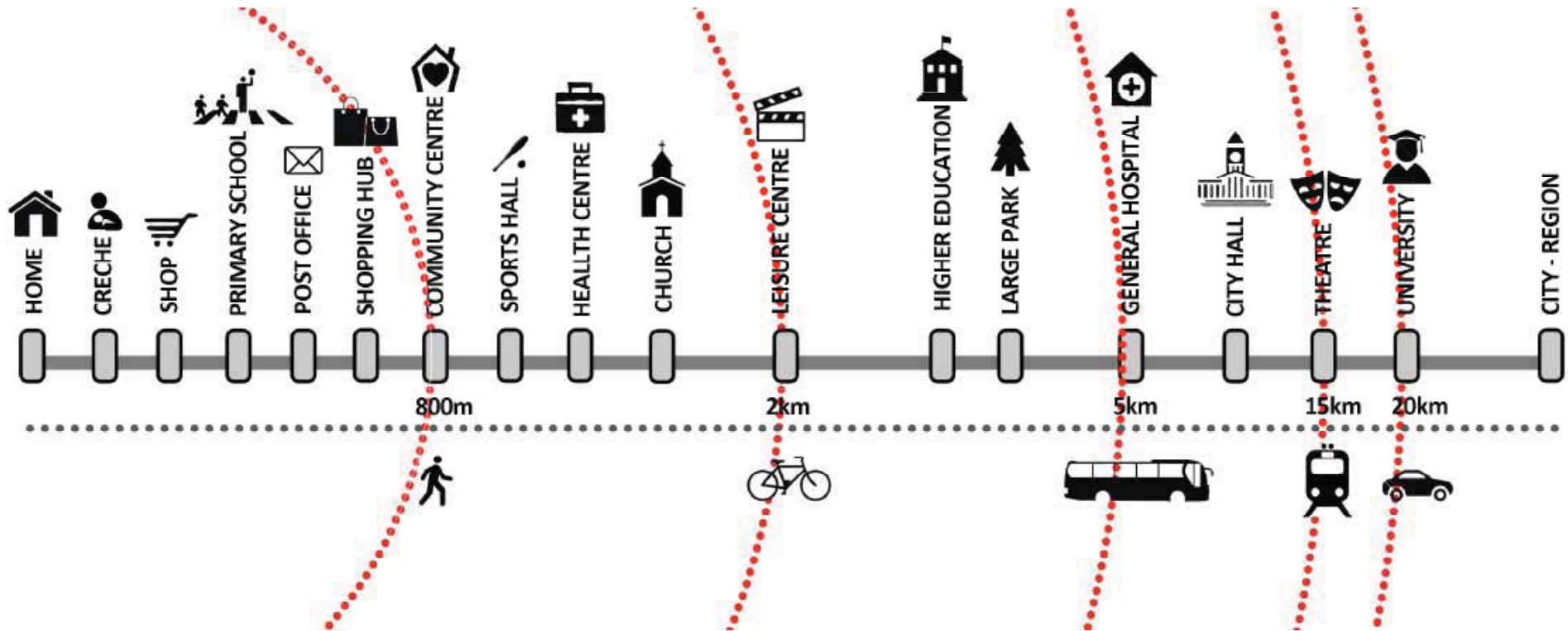



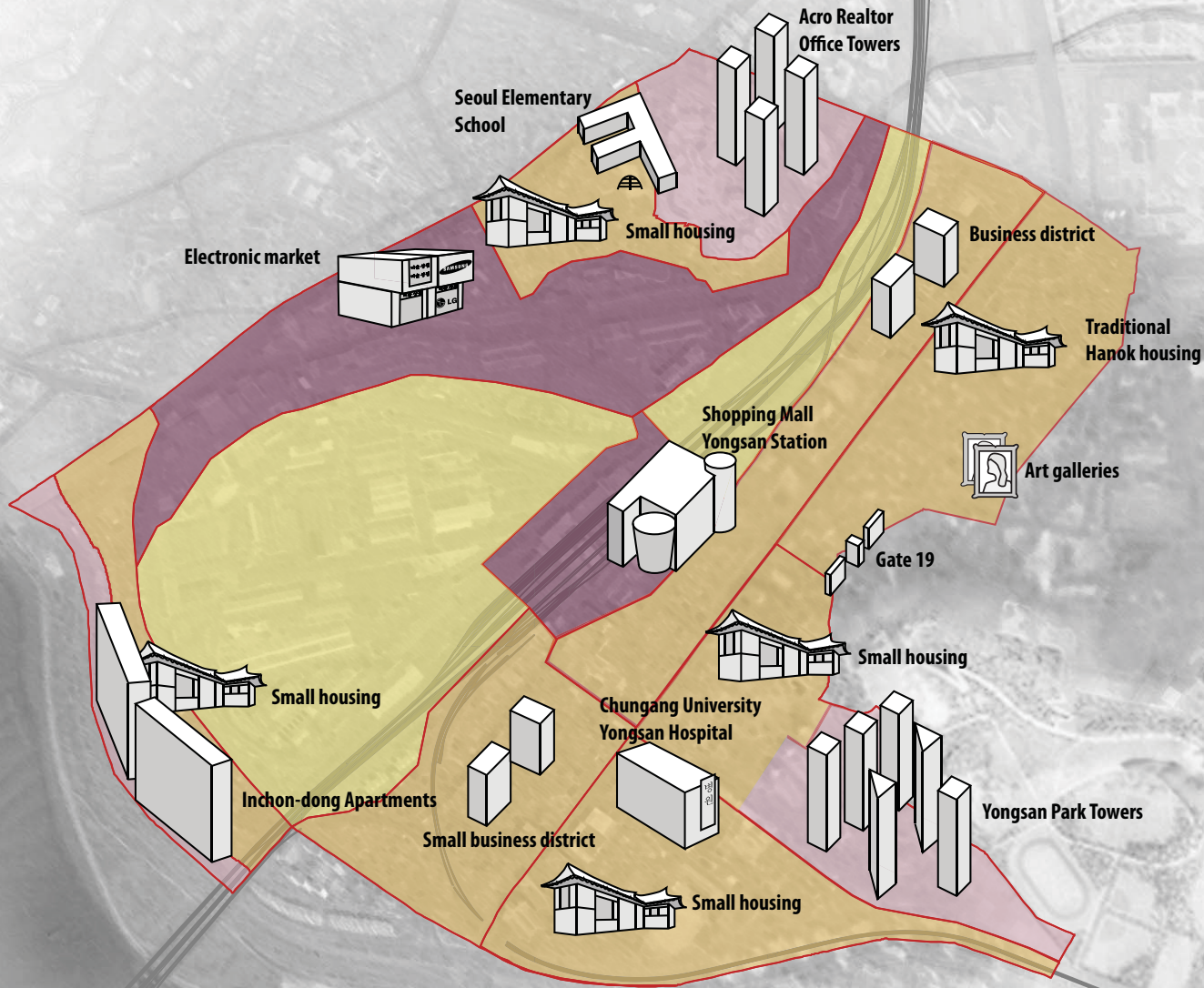

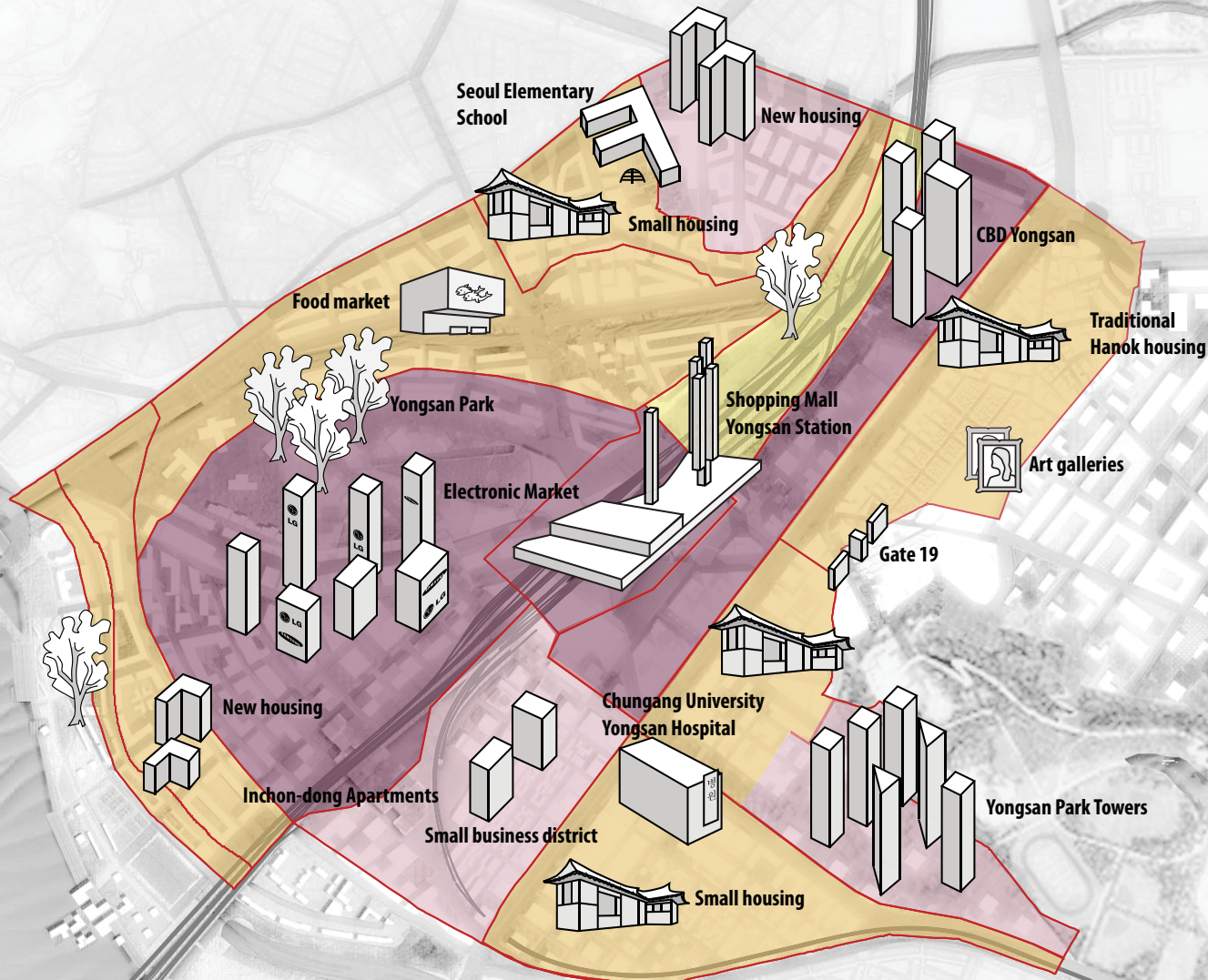



- Primary Streets
- Secondary Streets
- Neighbourhood Backbones

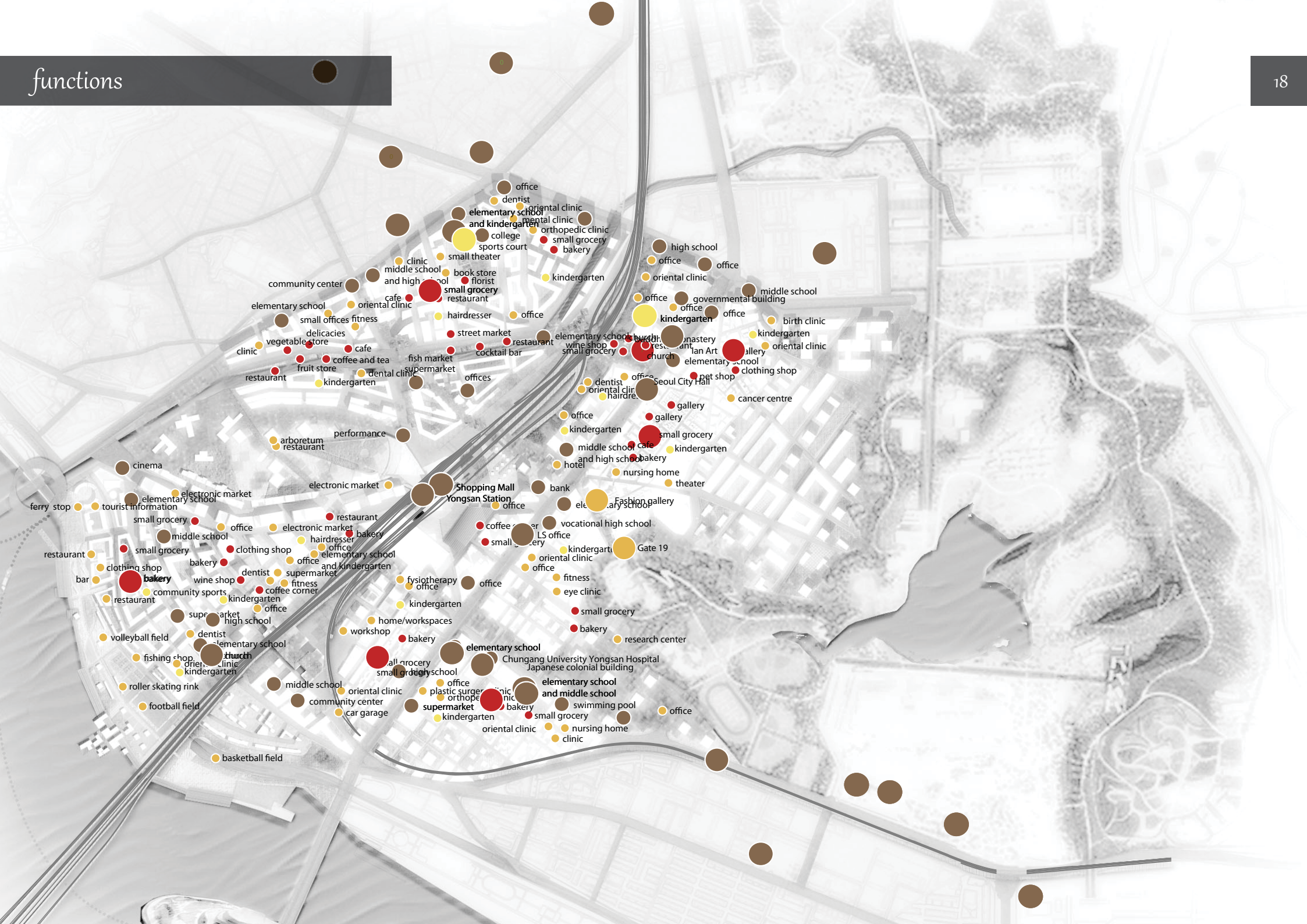

land use

GROUND LEVEL¹⁹

Legend:

- service
- commercial
- leisure
- housing
- culture
- education
- offices
- health services



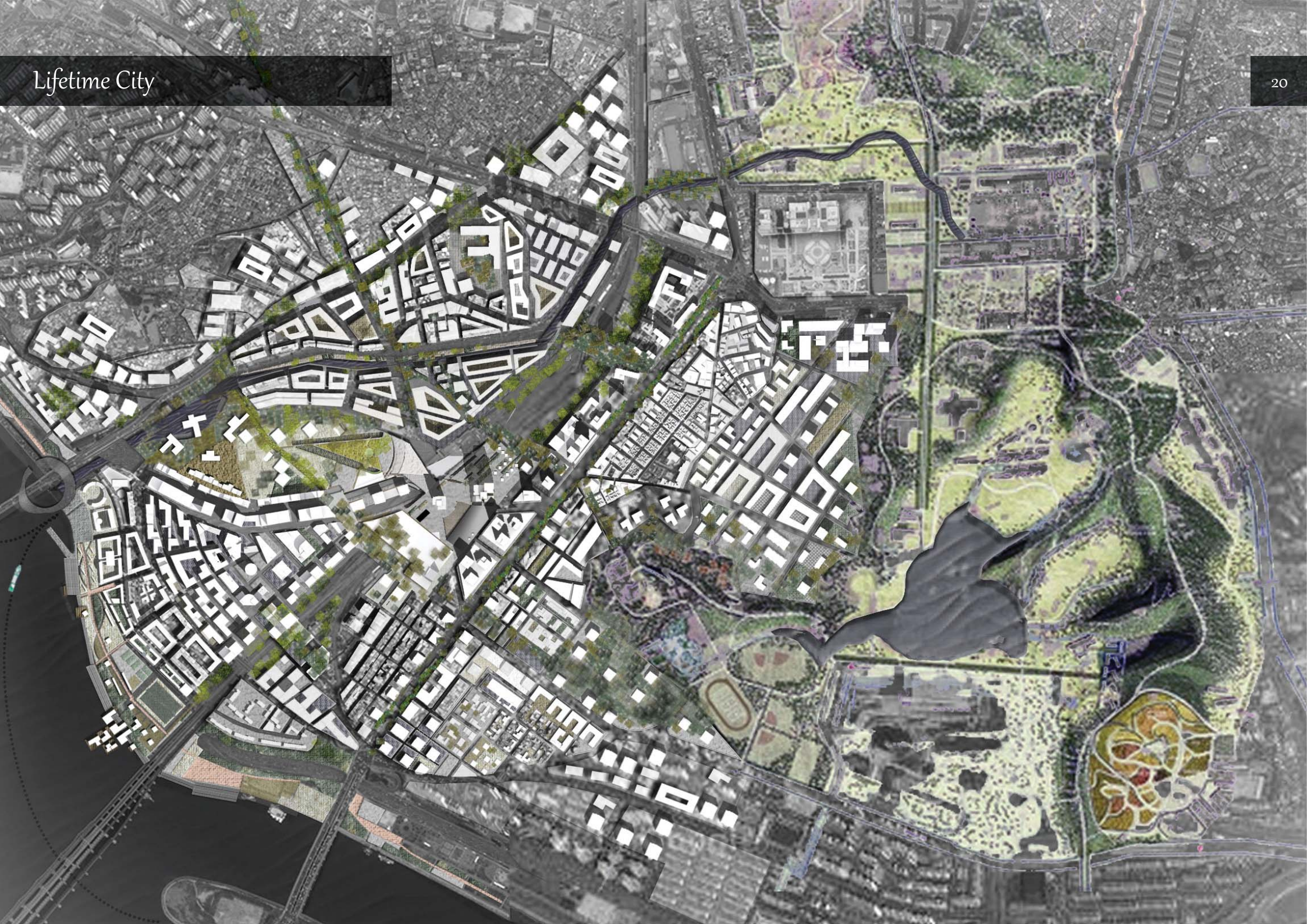

winners VCA competition



Open Ended City



The Loop



Water city

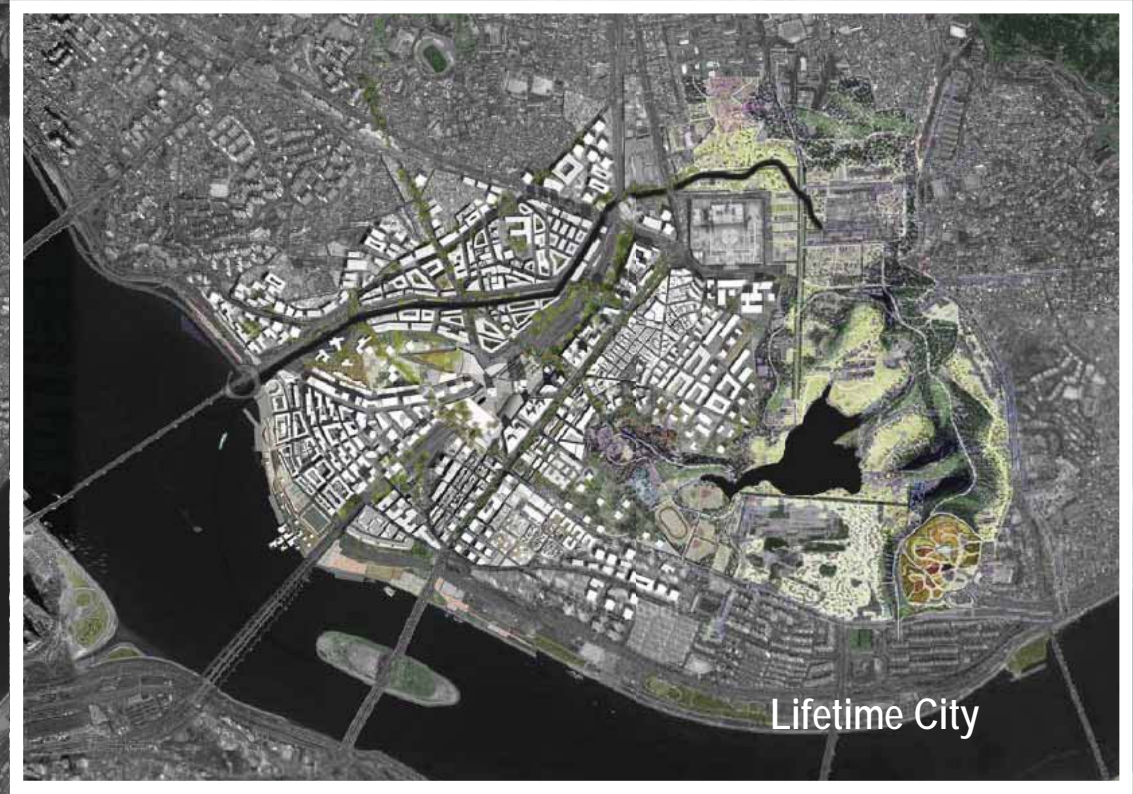

Lifetime City

chosen masterplan

Open Ended City

The Loop

Water city

Lifetime City

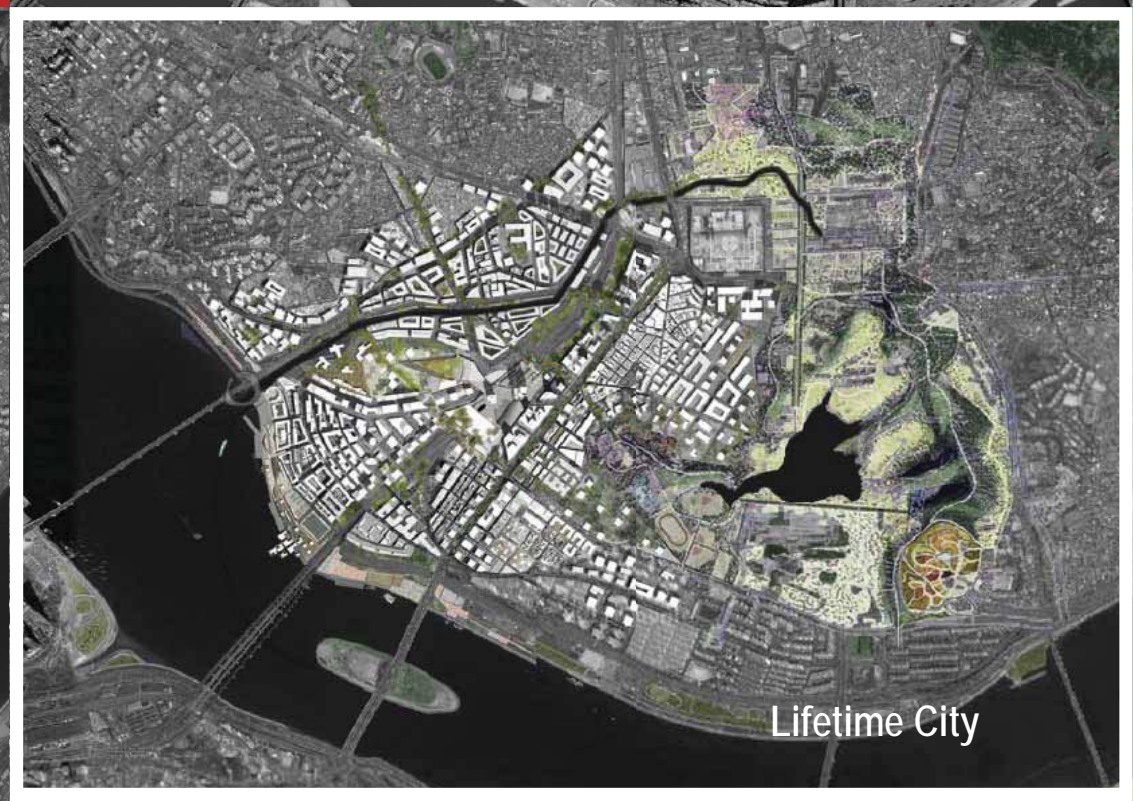
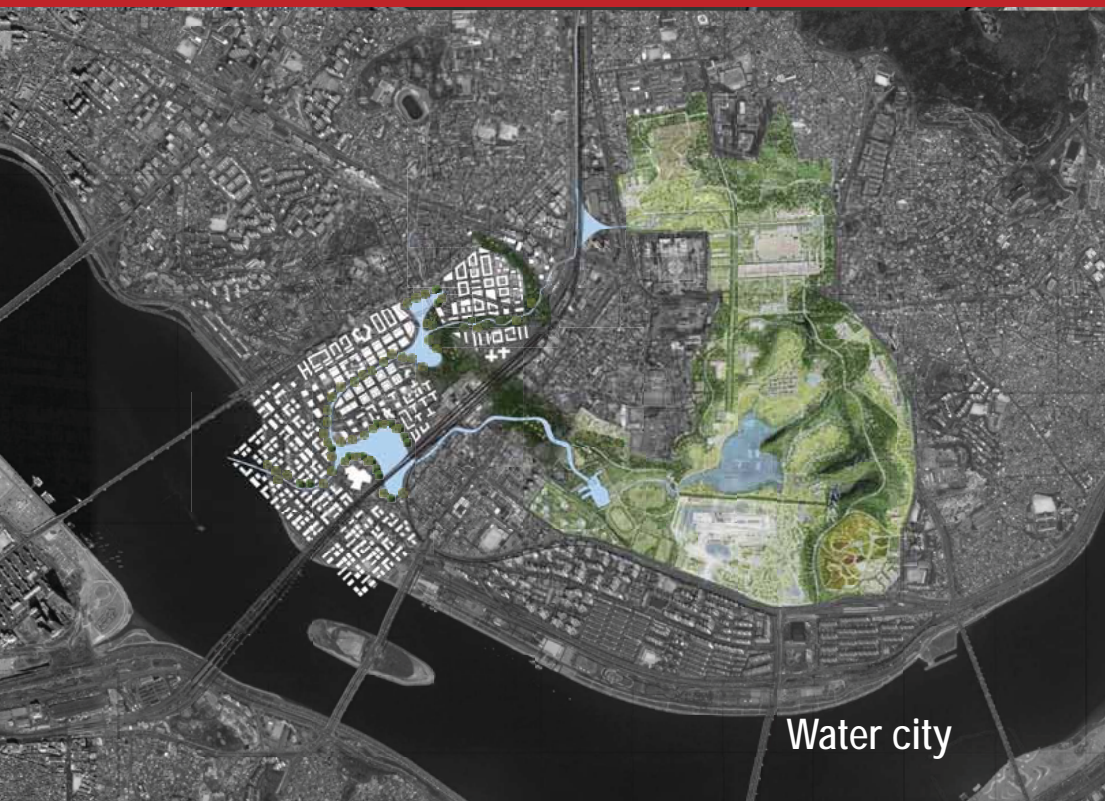



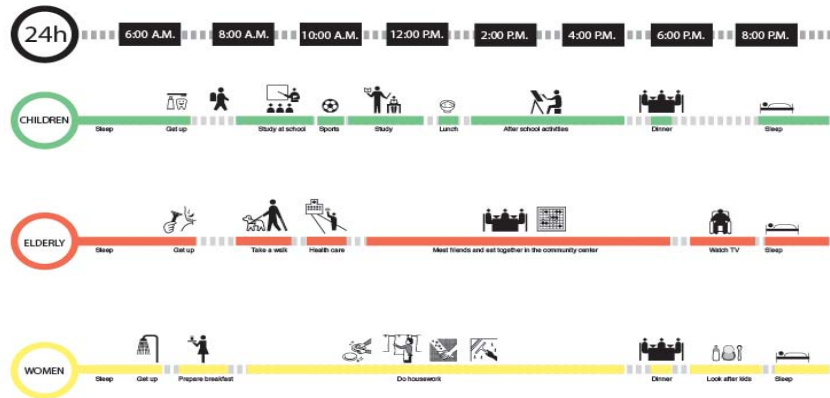

Before the Hybrid Centres

“The Hybrid centres create more opportunities for the elderly to be well integrated in society, as they are given responsibilities in providing day care services and programs for children”

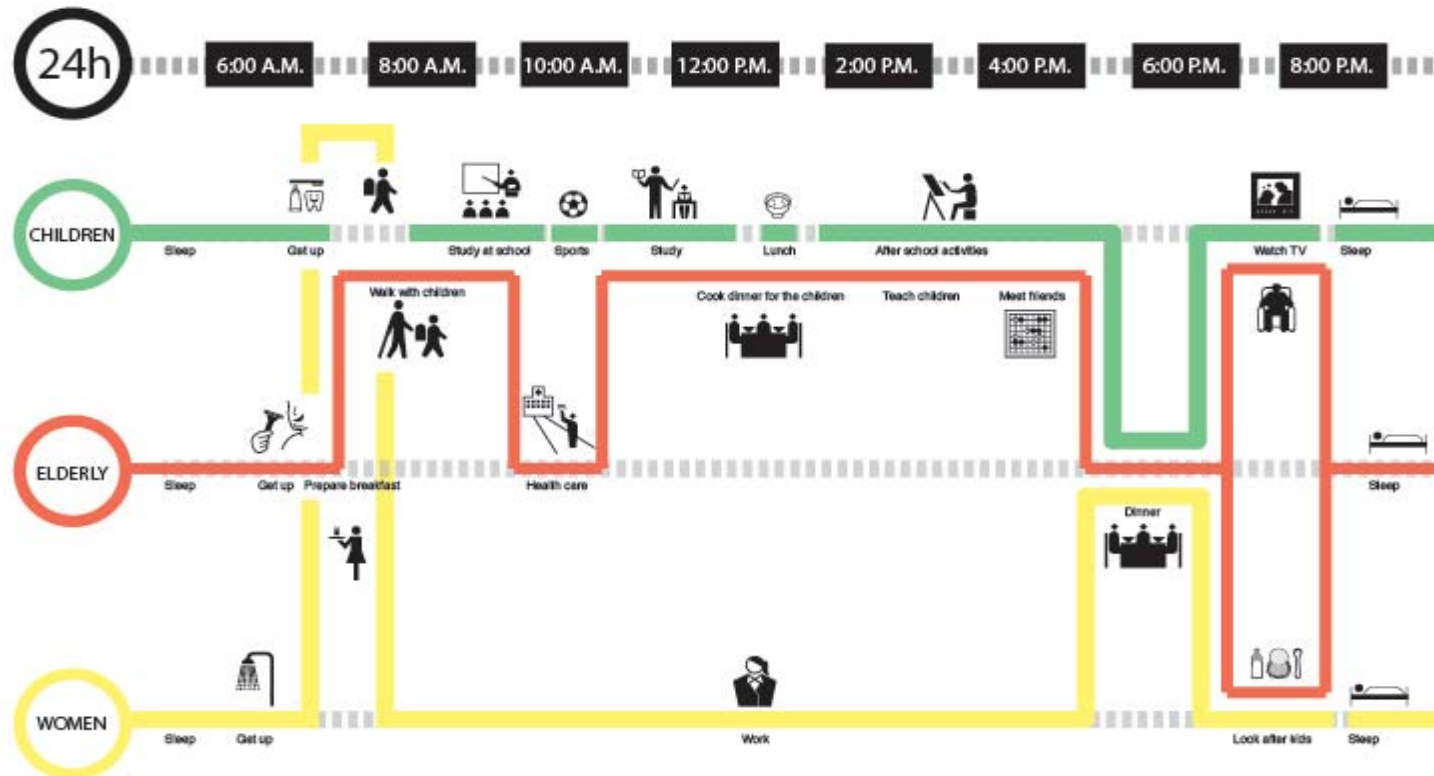

After the Hybrid Centres

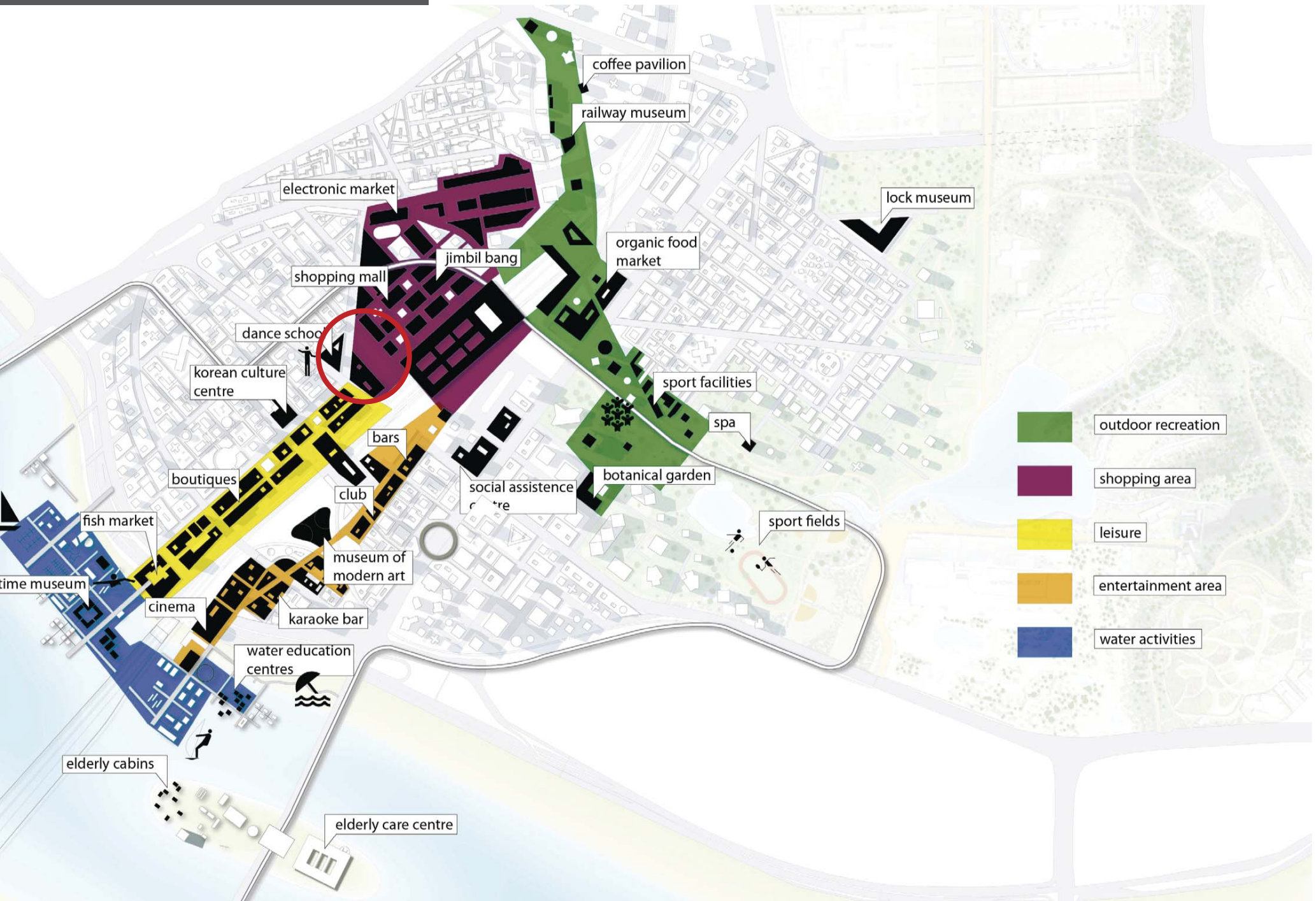

- outdoor recreation
- shopping area
- leisure
- entertainment area
- water activities



Falls are a major health problem in an aging society, which arise as a consequence of a decline in postural and balance due to muscle weakness and other risk factors (Melzer et al., 2001; Sturnieks et al., 2008). Falls, or even the fear of falling lead to a reduced quality of life (Voermans et al., 2007).

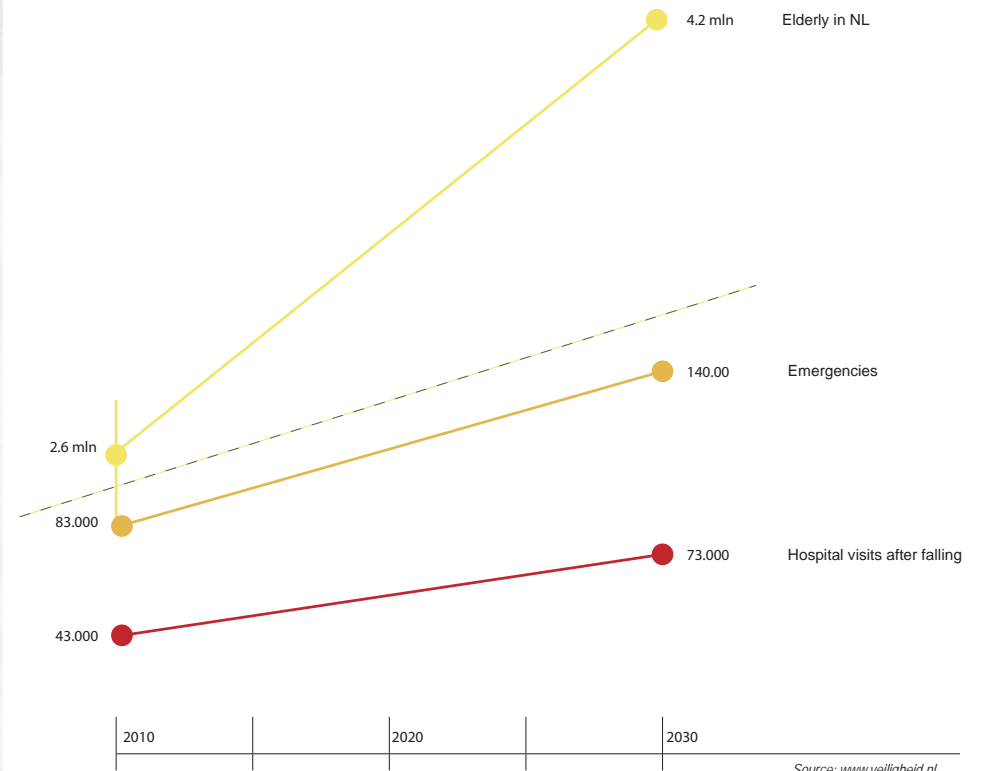
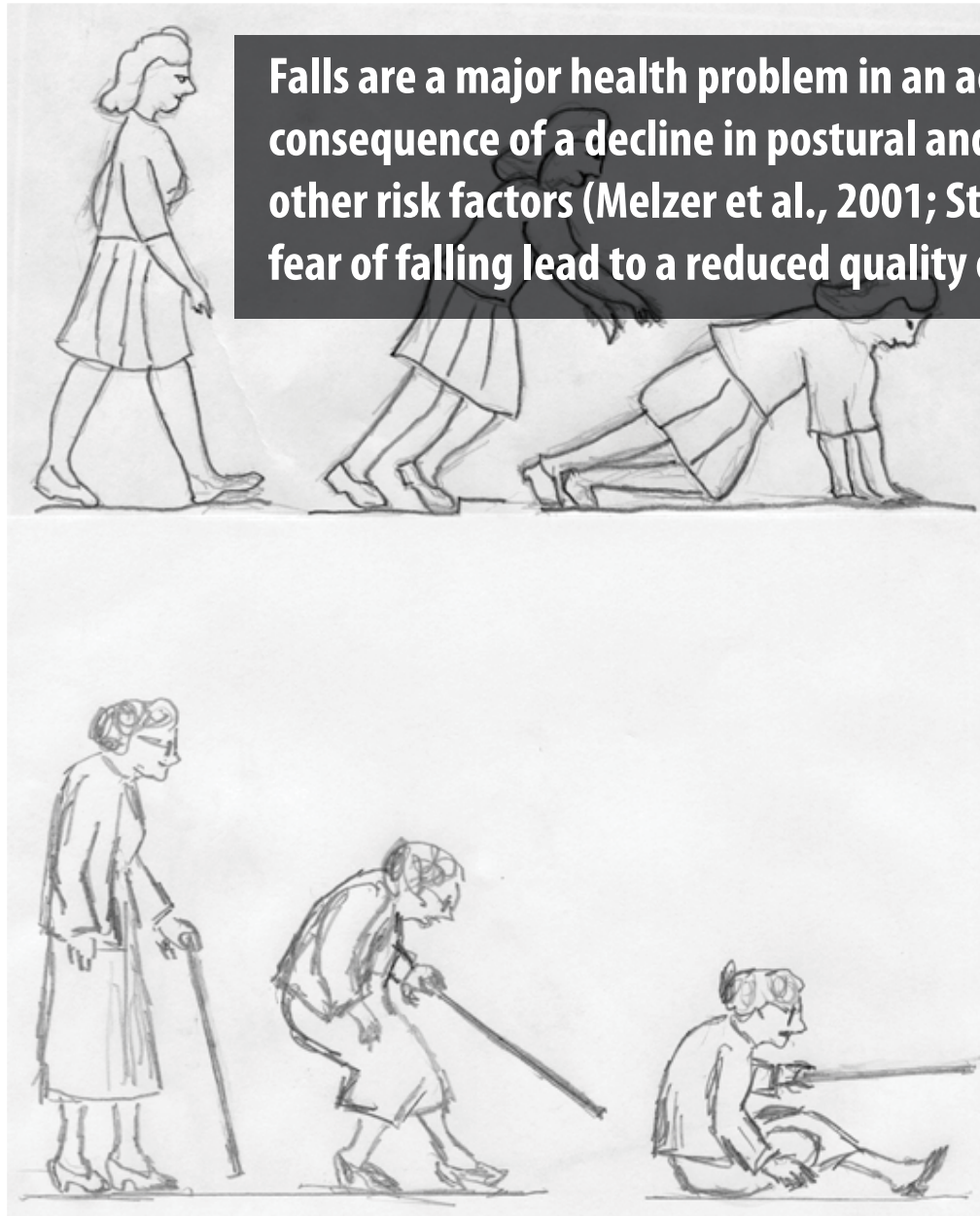

Source: www.veiligheid.nl

'... Yoga therefore is considered therapeutic. It helps you become more aware of your body's posture, alignment and patterns of movement. It makes the body more flexible and helps you relax even in the midst of a stress stricken environment.'

www.abc-of-yoga.com

Our study provides strong evidence that dance promotes a wide-range of beneficial effects that are not limited to motor behavior, posture and balance, but covers also perceptual and cognitive abilities. Therefore, dance might be an appropriate approach for enforcing and maintaining plasticity processes in elderly populations, thereby contributing to successful aging.

Superior Sensory, Motor, and Cognitive Performance in Elderly Individuals with Multi-Year Dancing Activities Jan-Christoph Kattenstroth, Izabella Kolankowska, Tobias Kalisch, and Hubert R. Dinse



STAY
YOUNG
AND GO
DANCING



School of dance:
Department of Dance Performance
Department of Dance Theory
Department of Choreography



Seoul Arts Centre

concerts - 2523 seats

recital - 354 seats

chamber music

music

opera hall - 2200 seats

yayu - experimental - 300 seats

National Theatre Seoul - 1547 seats

Arko Theatre - modern dance - 600 seats

Karma theatre - martial arts/dan - 589 seats

Jump Theatre - martial arts - 510 seats

Lotte World Art Theatre - breakdance/ballet - 466 seats

Gangbuk Dong Nanta - nanta - 386 seats

Myeong Dong Nanta - nanta - 386 seats

Hongdae Nanta - nanta - 375 seats

Sa.Choom Theatre - K-pop/modern dance - 370 seats

Chongdong Theatre - traditional arts - 344 seats

Hakchon Theatre - rock musical - 198 seats





Educatorium
500 Seats



Cordoba Congress Center
566 Seats



Dallas Theater
575 Seats



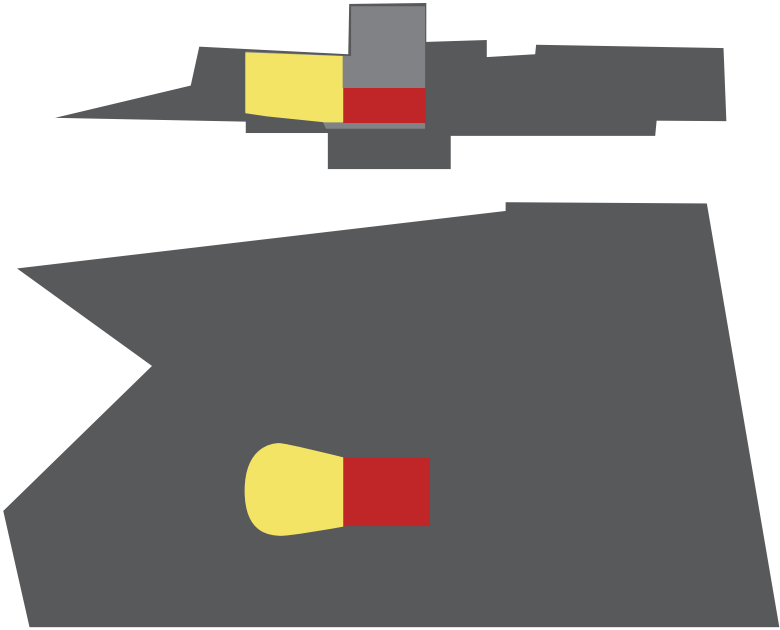

NORWEGIAN OPERA AND BALLET
1370

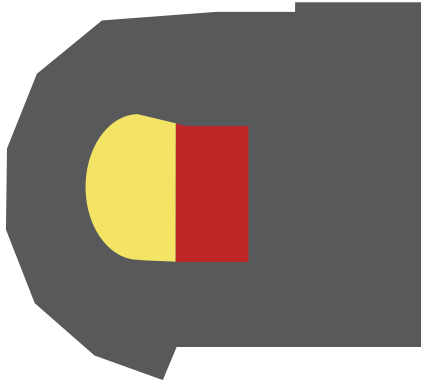

MUZIEKTHEATER AMSTERDAM
1500 SEATS

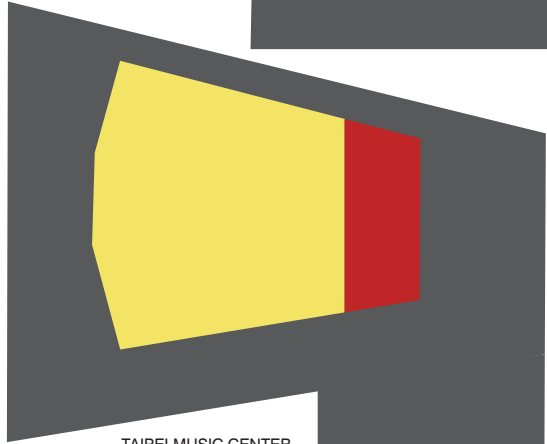
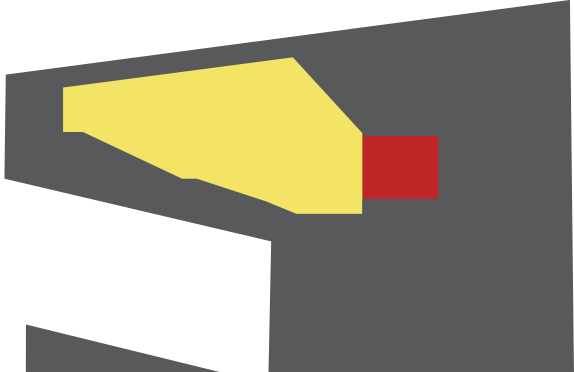

TAIPEI MUSIC CENTER
3500 SEATS 1500 STANDING

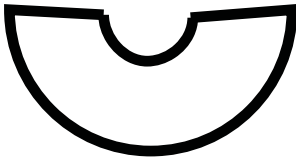
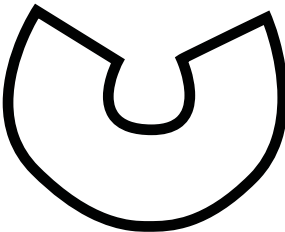

Greek/Roman

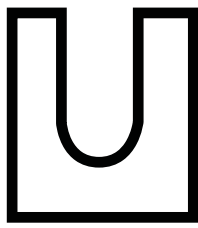
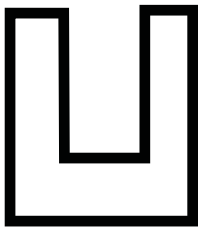
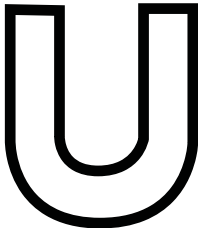

Gradins (+standing in between)

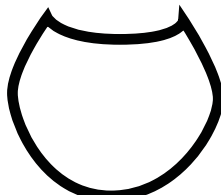
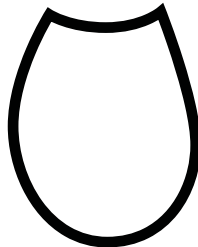

Renaissance



V shape since 1876

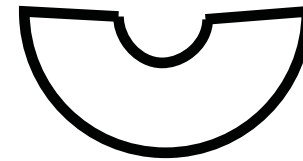
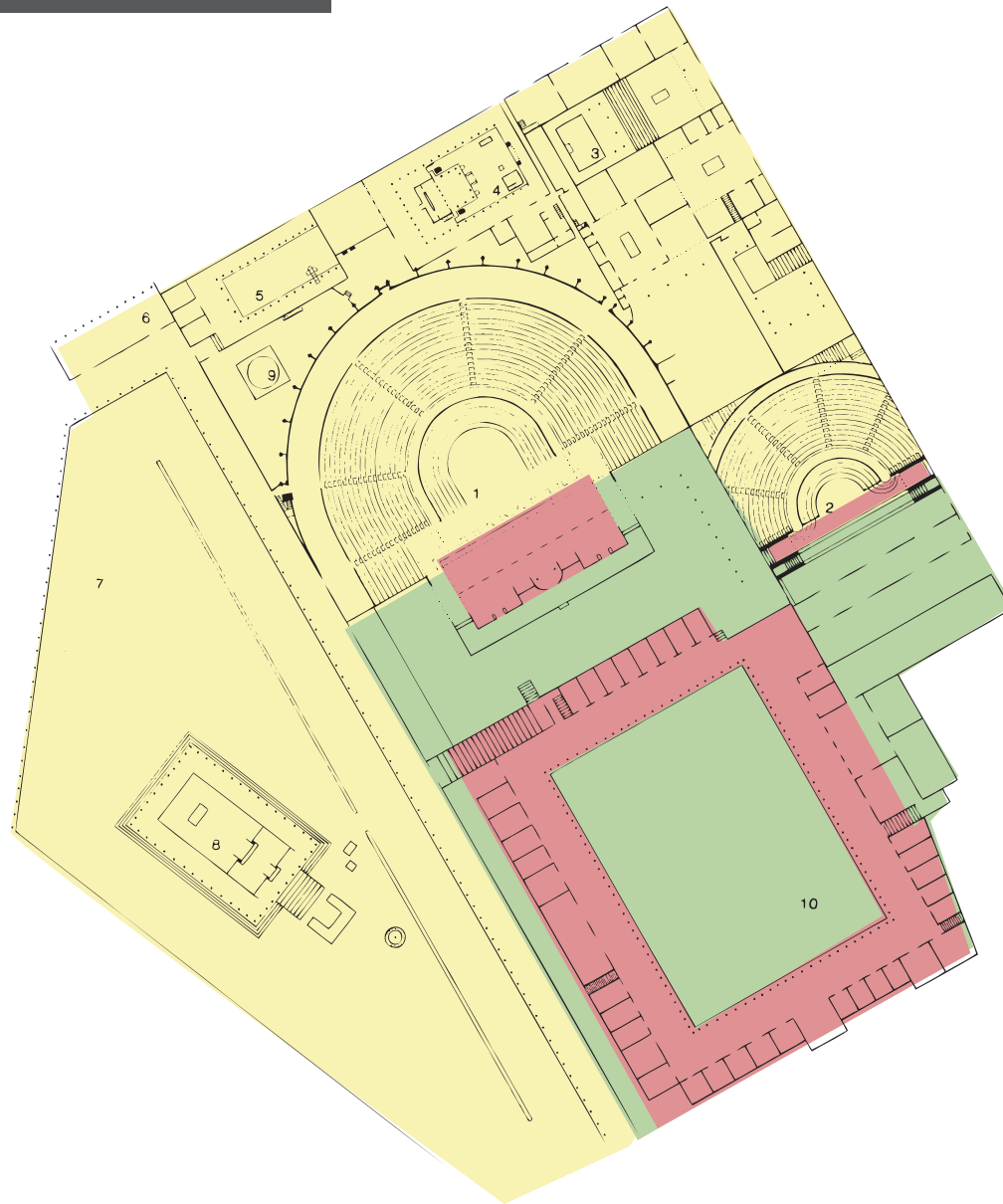

- 1 Large Theater
Original: 200 B. C.
Rebuilt: 2 B. C.
Capacity: 5000 persons
Architect: M. Artorius Primum
- 2 Small Theater
Constructed: 80 B. C.
Capacity: 1500 persons
Builders: G. Quinctius Valgus
Marcus Poraius
- 3 Temple of Zeus Milichius
- 4 Temple of Isis
- 5 Palaestra (gymnasium)
- 6 Propyleum (portico)
- 7 Forum Triangulare
- 8 Doric Temple
- 9 Tank for Saffron Water
- 10 Theater Colonnade
(gladiator barracks)

Pompeii (Italy), Quarter of the Theaters, 79 A.D.

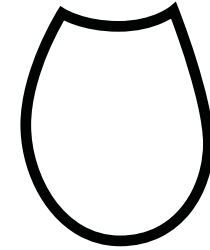

- a. main entrance
- b. public foyer
- c. main auditorium, 1600 seats
- d. small auditorium, 700 seats
- e. outdoor theater
- f. green steps
- g. entrance plaza and main entrance steps
- h. exhibition space
- i. assembly and loading area
- j. stage
- k. backstage area
- l. staff entrance / dressing room

1:1000
Plan +6m level

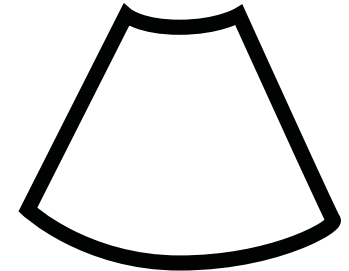
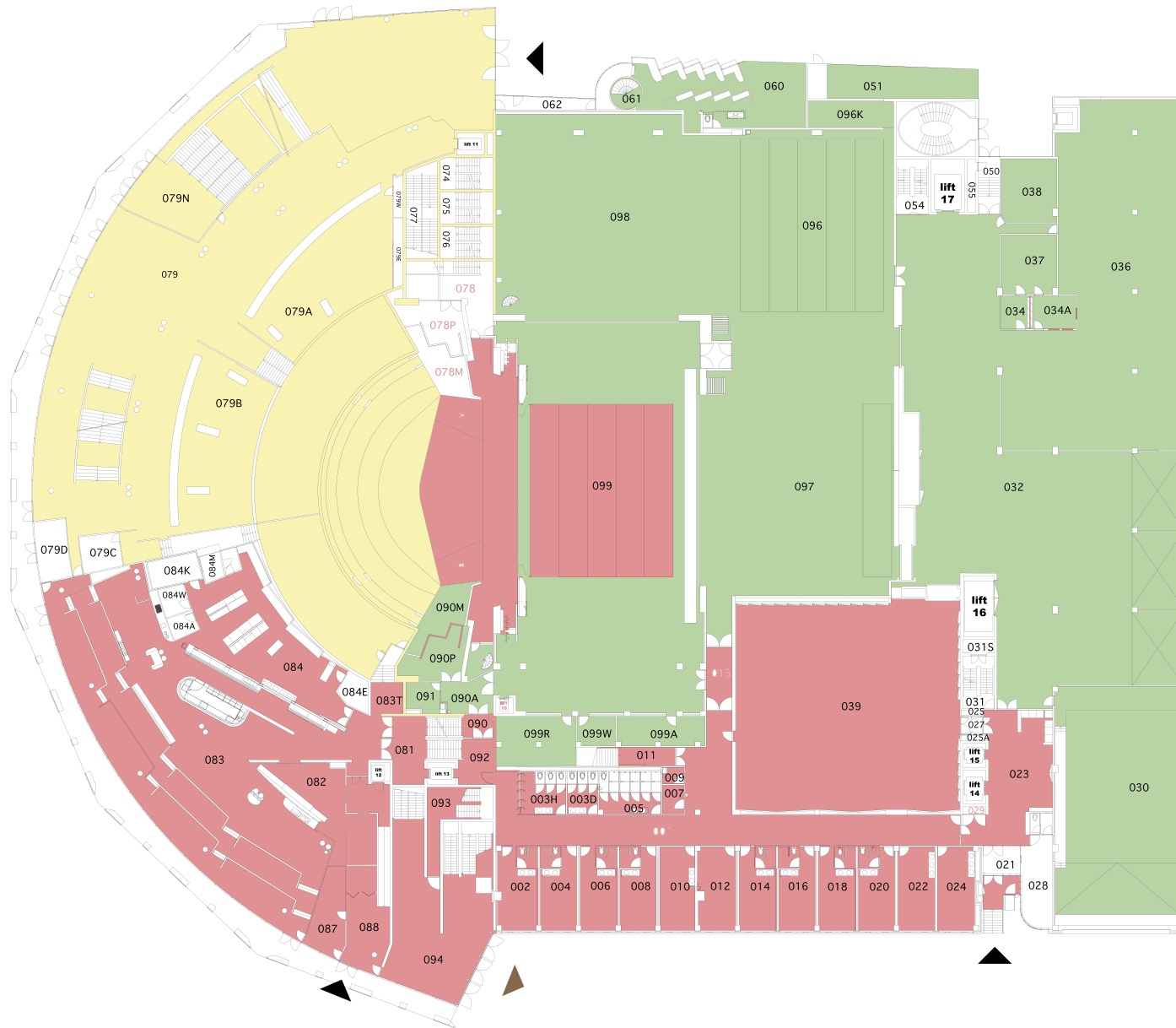

WERK
Het Muziektheater
Waterlooplein 22 Amsterdam

ONDERVERP
Begane grond

SCHAAL
1/200
GEBREUK
Karel Bodon
GEZEH

DATUM
09/07/07
GEVILDIG

DAM
&
PARTNERS
ARCHITECTEN
Schiedamschen 4, 1012 HE Amsterdam
The Netherlands
T +31 20 623 47 55
F +31 20 627 72 80
E office@dampartners.com
H www.dampartners.com
CODE







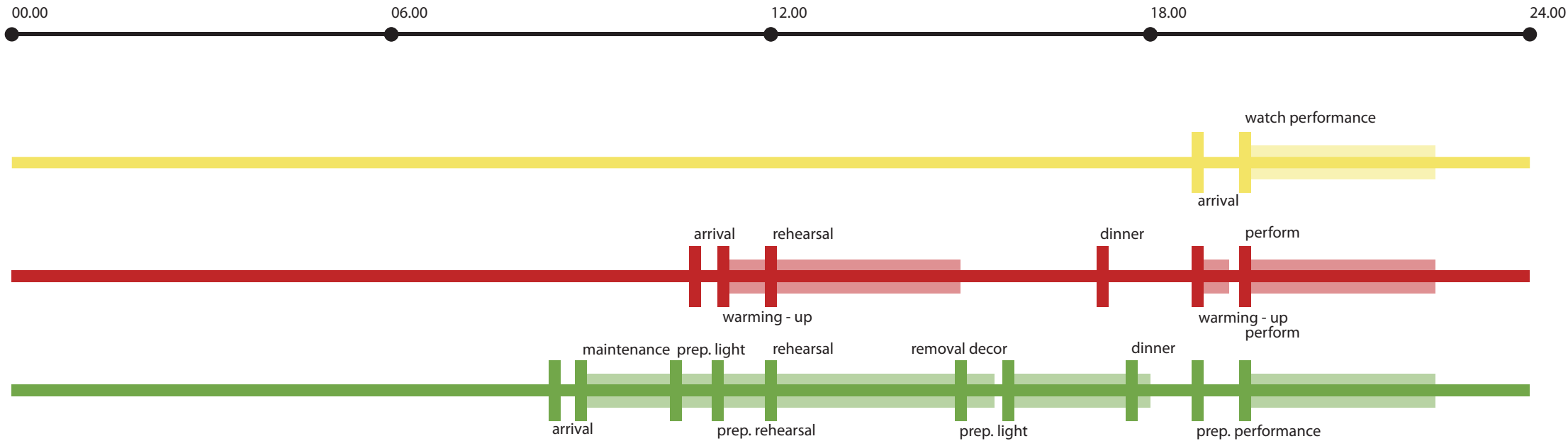

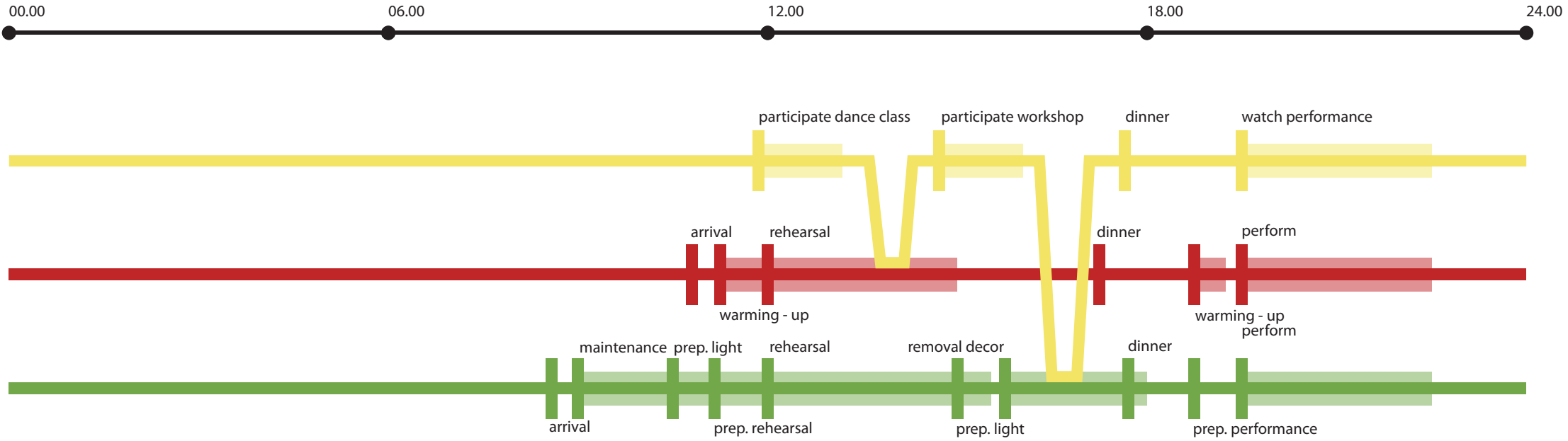

Proscenium theater

- Classical ballet productions**
- Large modern dance productions**
- Opera**
- Musicals**
- Acting**

Thrust stage

- Modern dance productions**
- Acting**
- Cabaret**

Black box/flat floor

- Modern dance productions**
- Folkloristic dance productions**
- Experimental/mixed performances**

End stage

- Music performances**
- Cabaret**

In the round stage

- Circus**
- Sports**

Traverse theaters

- Opera**
- Fashion shows**
- Music performances**

Proscenium theater

Classical ballet productions
Large modern dance productions
Opera
Musicals
Acting

Thrust stage

Modern dance productions
Acting
Cabaret

Black box/flat floor

Modern dance productions
Folkloristic dance productions
Experimental/mixed performances
Cabaret

End stage

Music performances
Cabaret

In the round stage

Circus
Sports

Traverse theaters

Opera
Fashion shows
Music performances

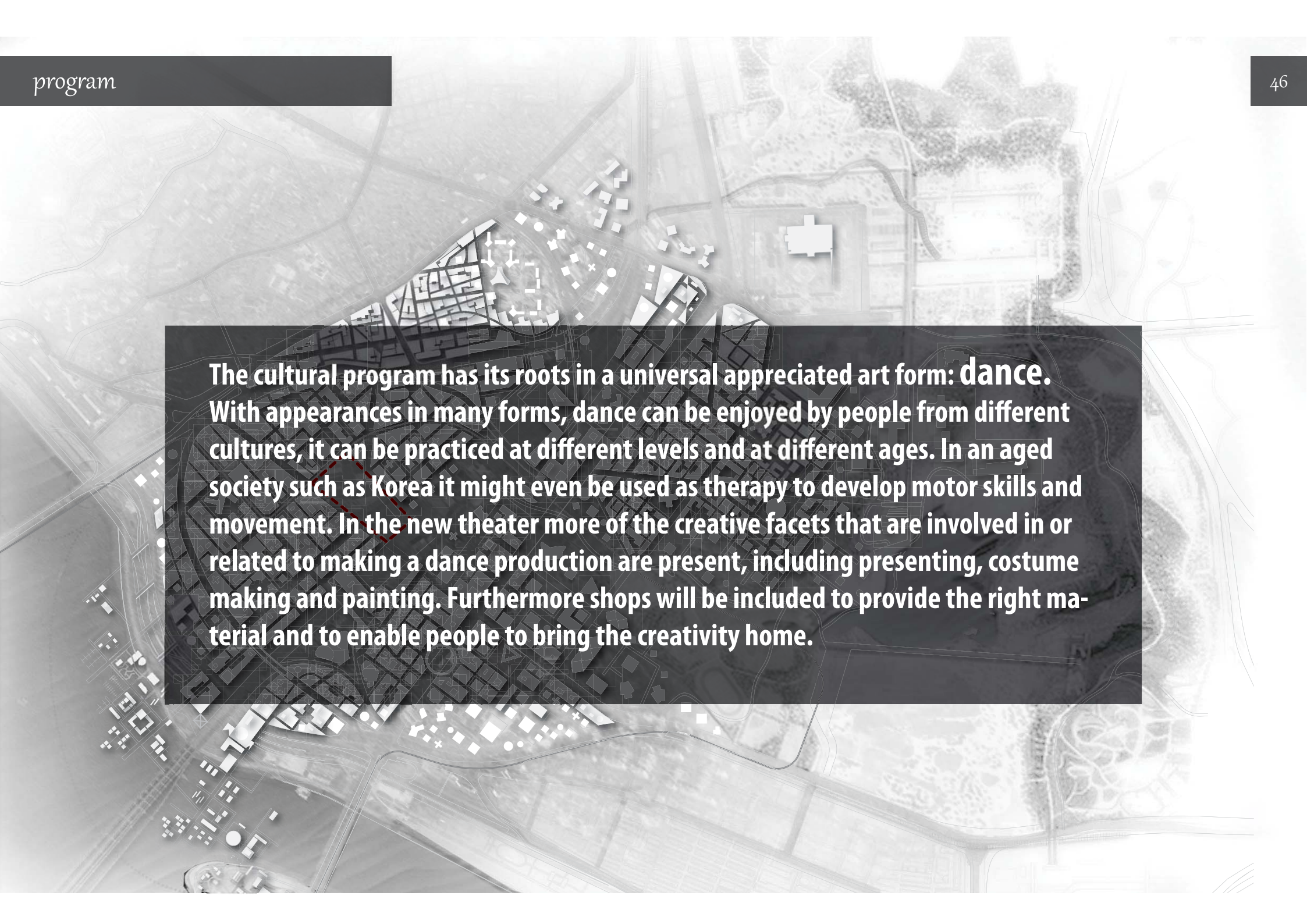
The background of the page is a grayscale aerial architectural rendering of a city. It shows a complex network of streets, building footprints, and green spaces. A prominent feature is a large, dark, semi-transparent rectangular box in the center, which contains white text. The text describes a cultural program centered on dance, highlighting its role in an aged society and the inclusion of various creative activities like theater, costume making, and painting. The overall aesthetic is clean and professional, typical of an architectural or urban planning document.

The cultural program has its roots in a universal appreciated art form: dance. With appearances in many forms, dance can be enjoyed by people from different cultures, it can be practiced at different levels and at different ages. In an aged society such as Korea it might even be used as therapy to develop motor skills and movement. In the new theater more of the creative facets that are involved in or related to making a dance production are present, including presenting, costume making and painting. Furthermore shops will be included to provide the right material and to enable people to bring the creativity home.

The ambition of the Yongsan theatre is to bring people together. It takes the ancient Greek Agora as its precedent, a place for social interaction, for sharing ideas and for recreation. Literally Agora also means 'gathering place'. It is a truly public domain that is open to everyone. The new theater in the heart of Yongsan attracts people from around the neighbourhood, but also people from outside Yongsan, that come by the adjacent station, or by car. The building attracts visitors from all ages. Both young and old people find activities they can join, or they can learn from each other. Also amateurs get the chance to learn from professionals, by watching, talking and acting. People can share their ideas and explore their talents. Routes and program cross each other in one building so that interaction is almost inevitable. Also passersby are welcome in and around the building. While passing they can interact with the building and its visitors. They will be aware of the fact that they pass the new theater, it will become a reference point in the city. Already its location is unique and therefore a reference point. The amount of people and its facilities make it a real urban element in the city. When it has become a well known point, it is easy to say '...let's meet at the theater'.



Numbers

Location size: 34310 m²

Total built square meters: 76860 m²

Plot size: 3492 m²

Square meters built within plot: 36560 m²



























Main connection (12m)

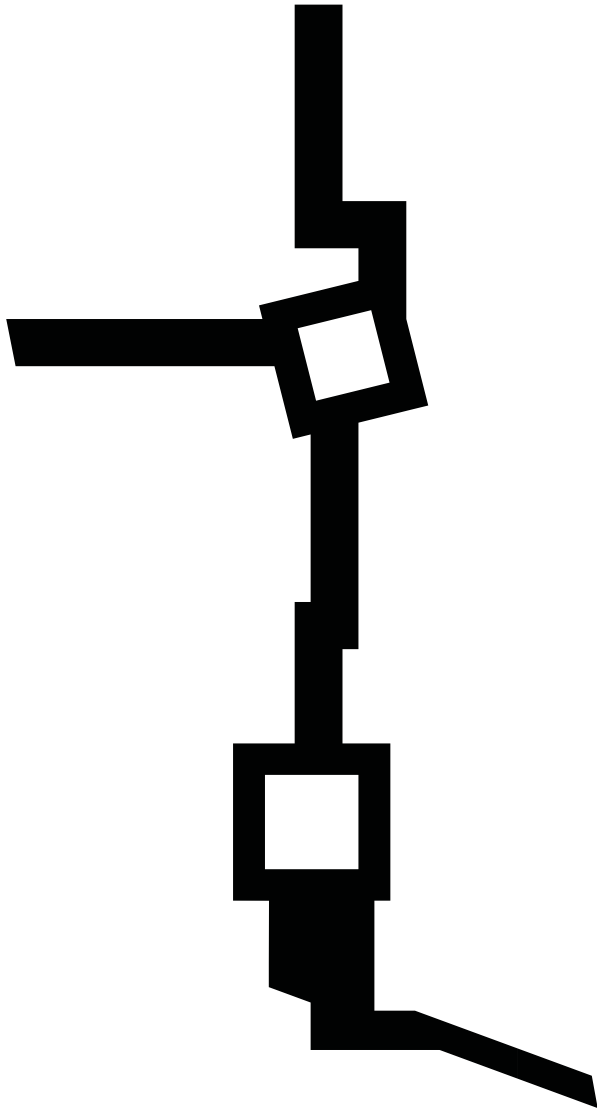

Secondary breaks (6m)

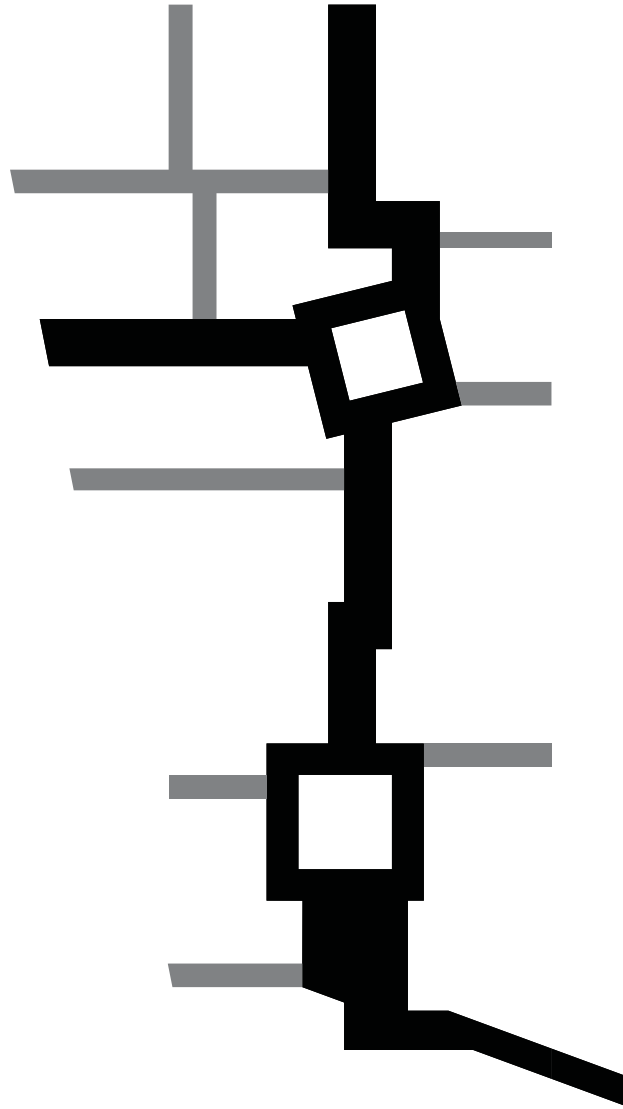

Tertiary breaks (3m)

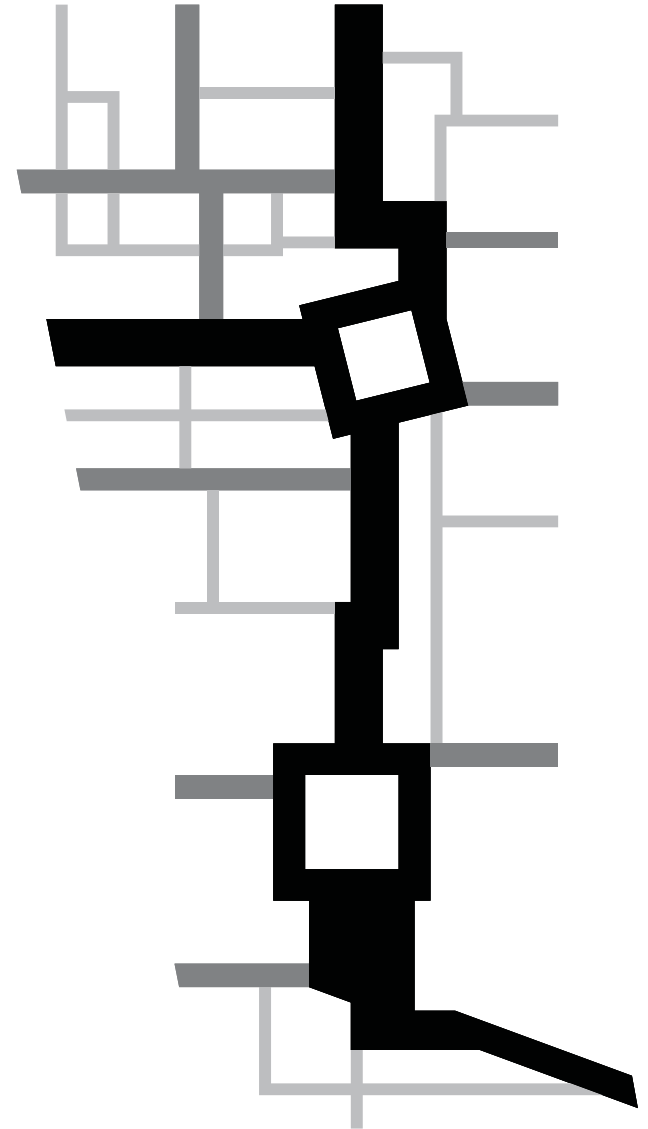

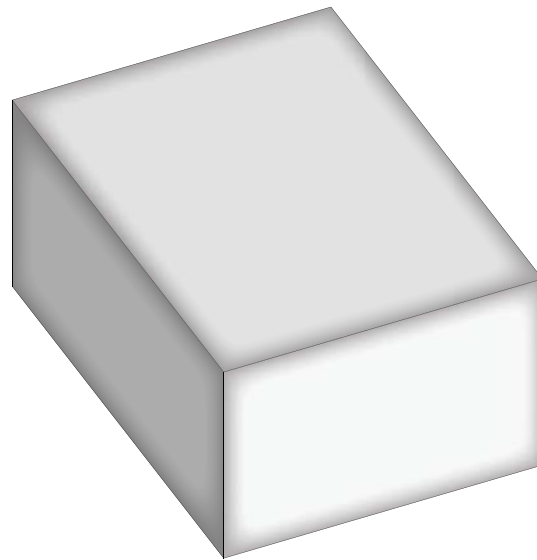

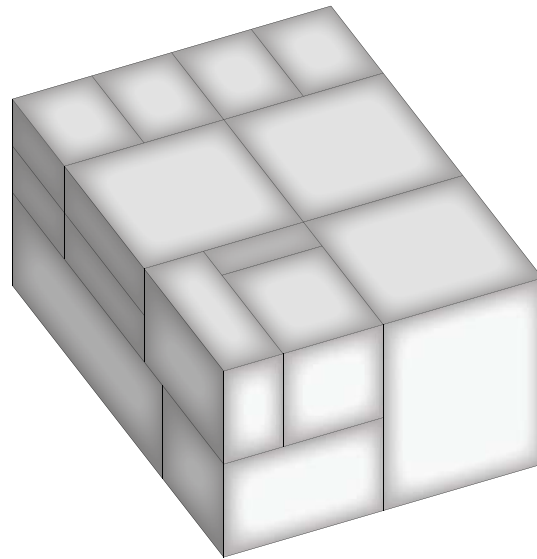

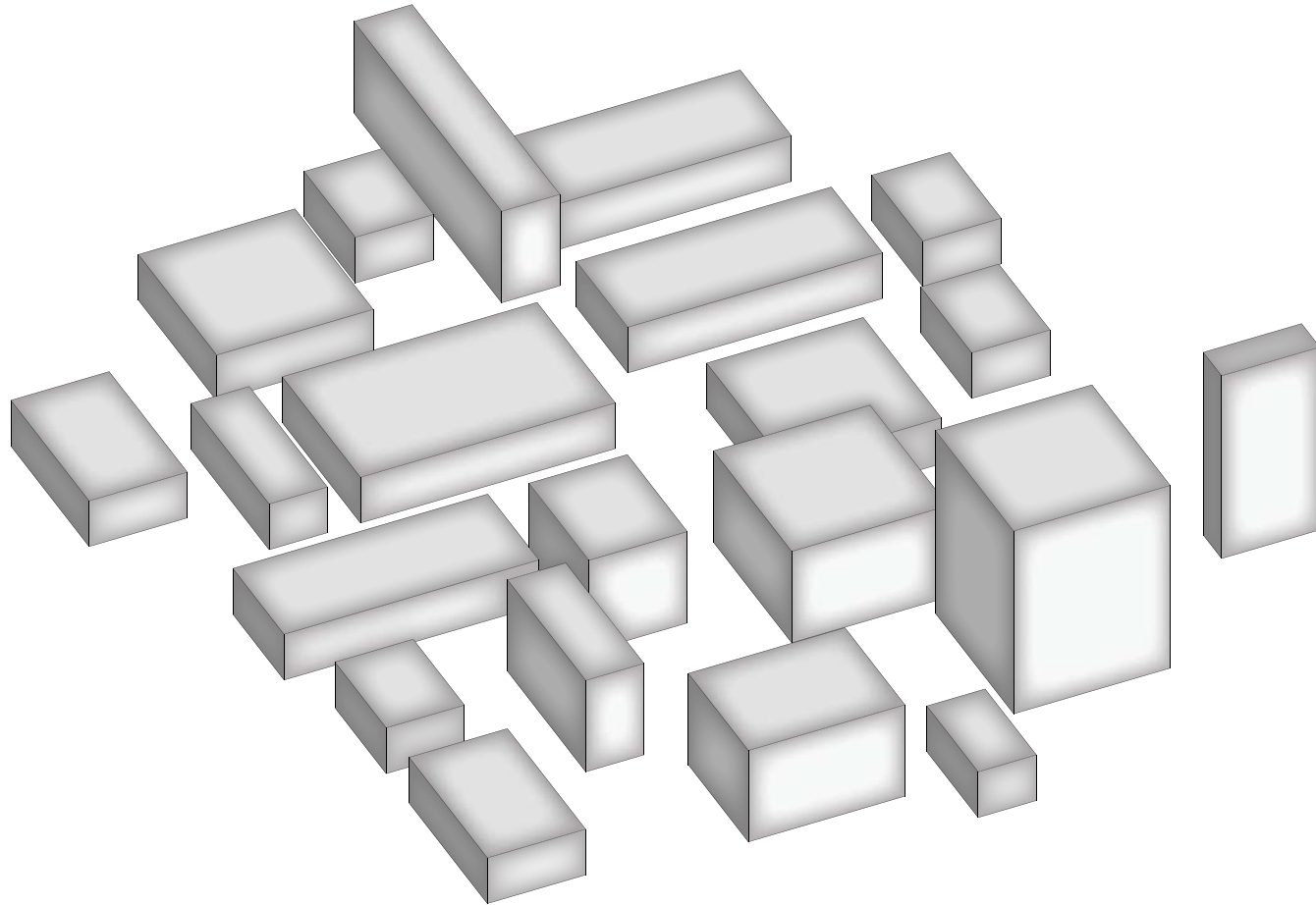

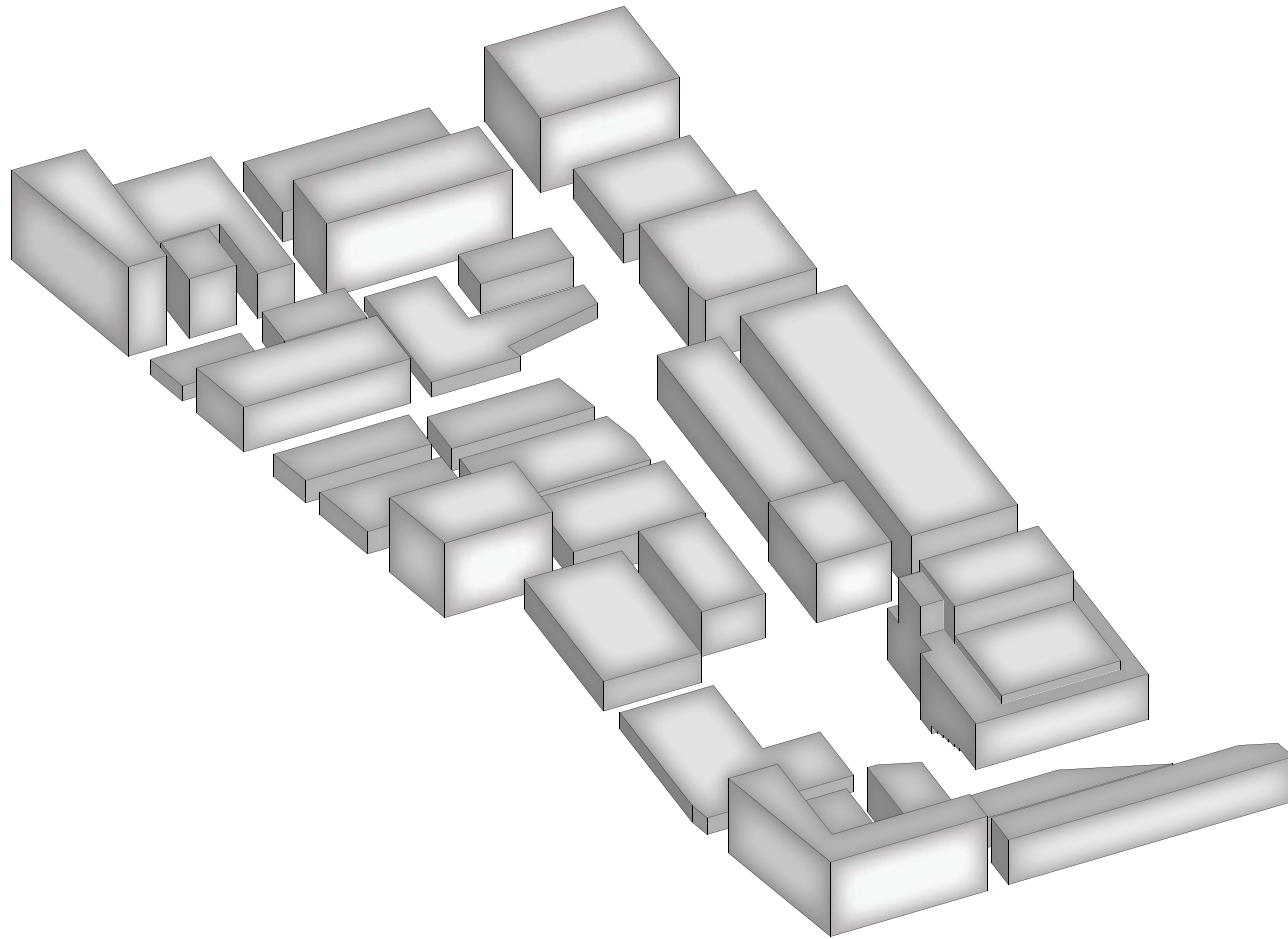

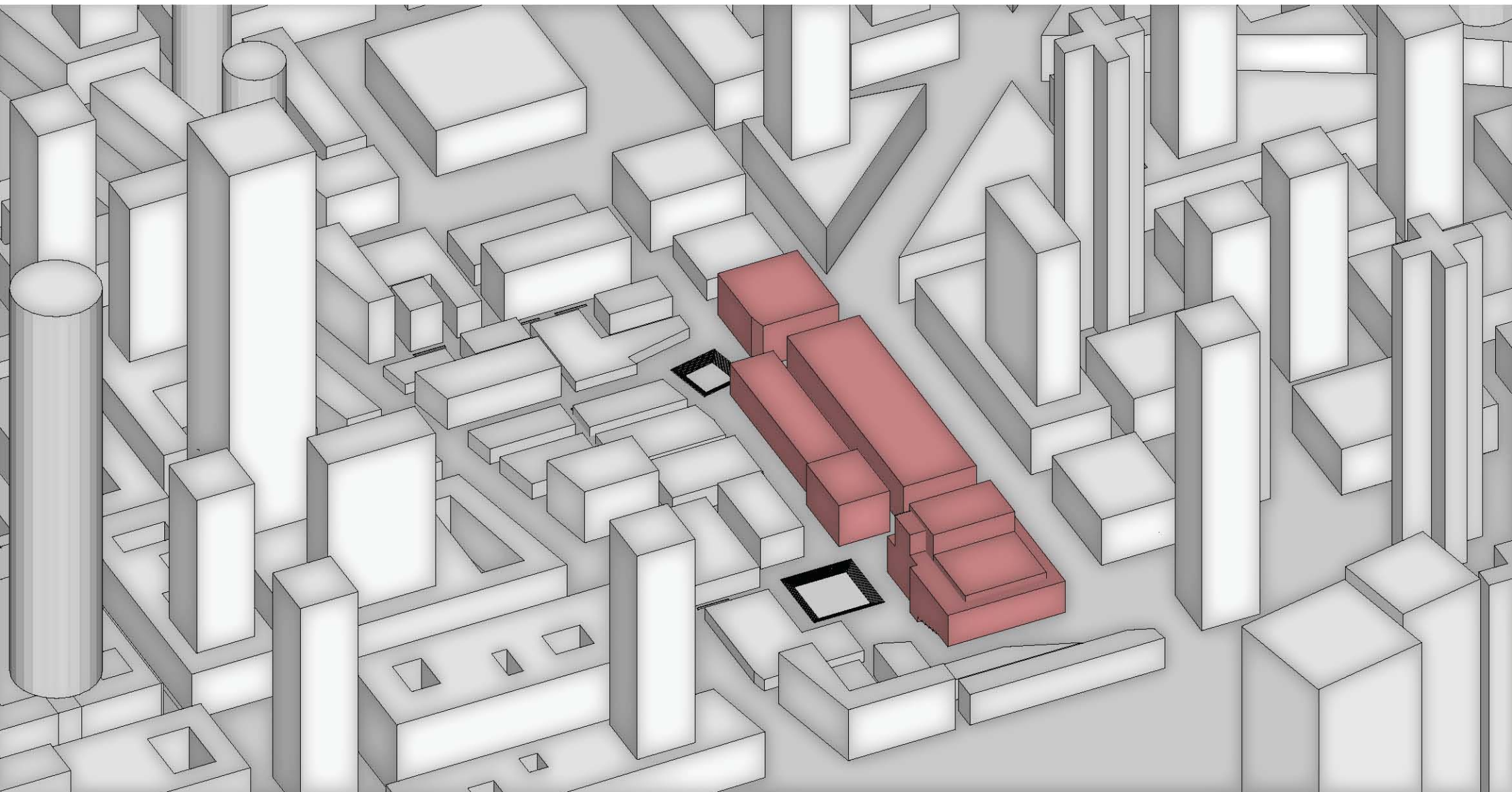

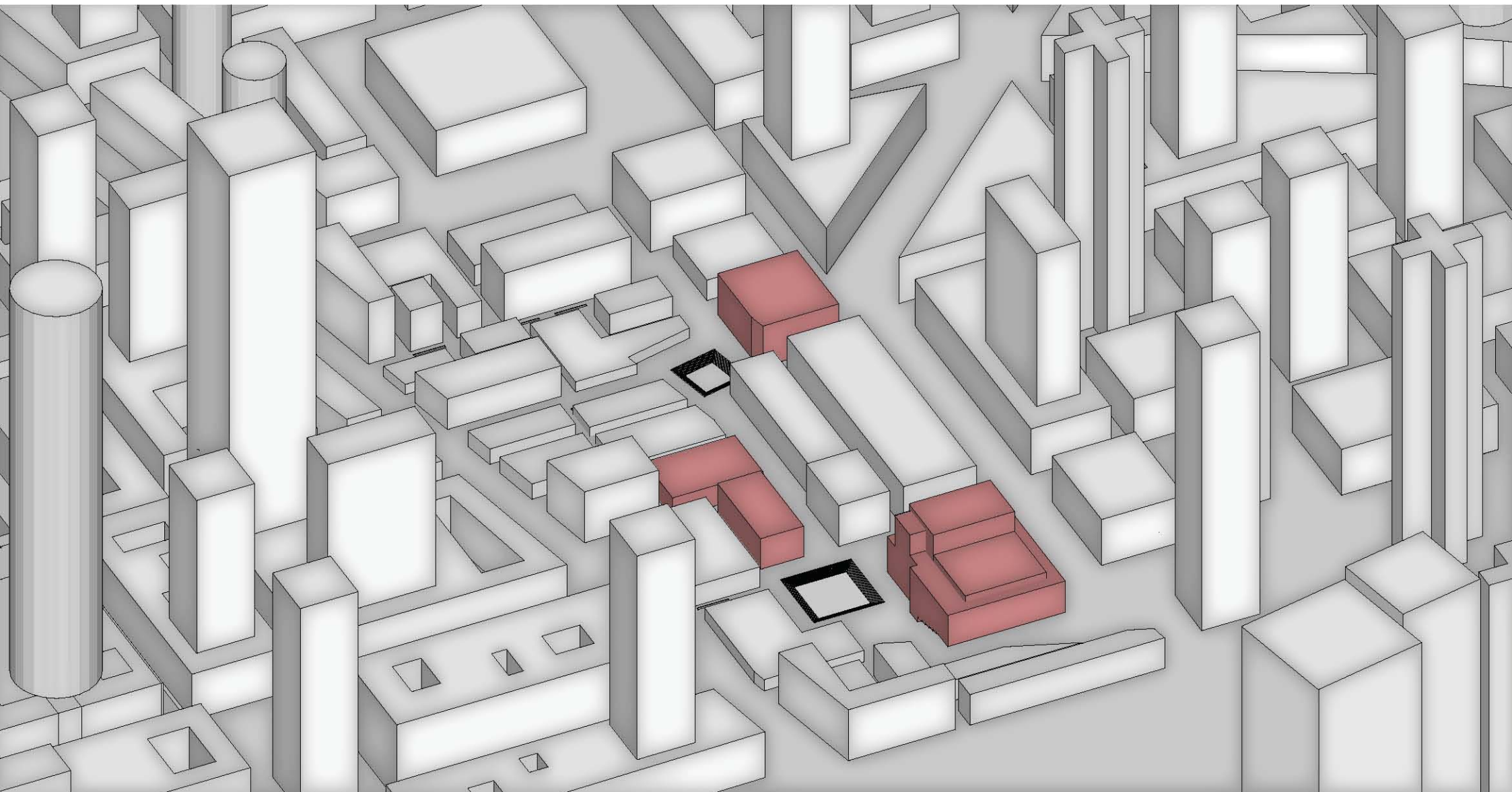

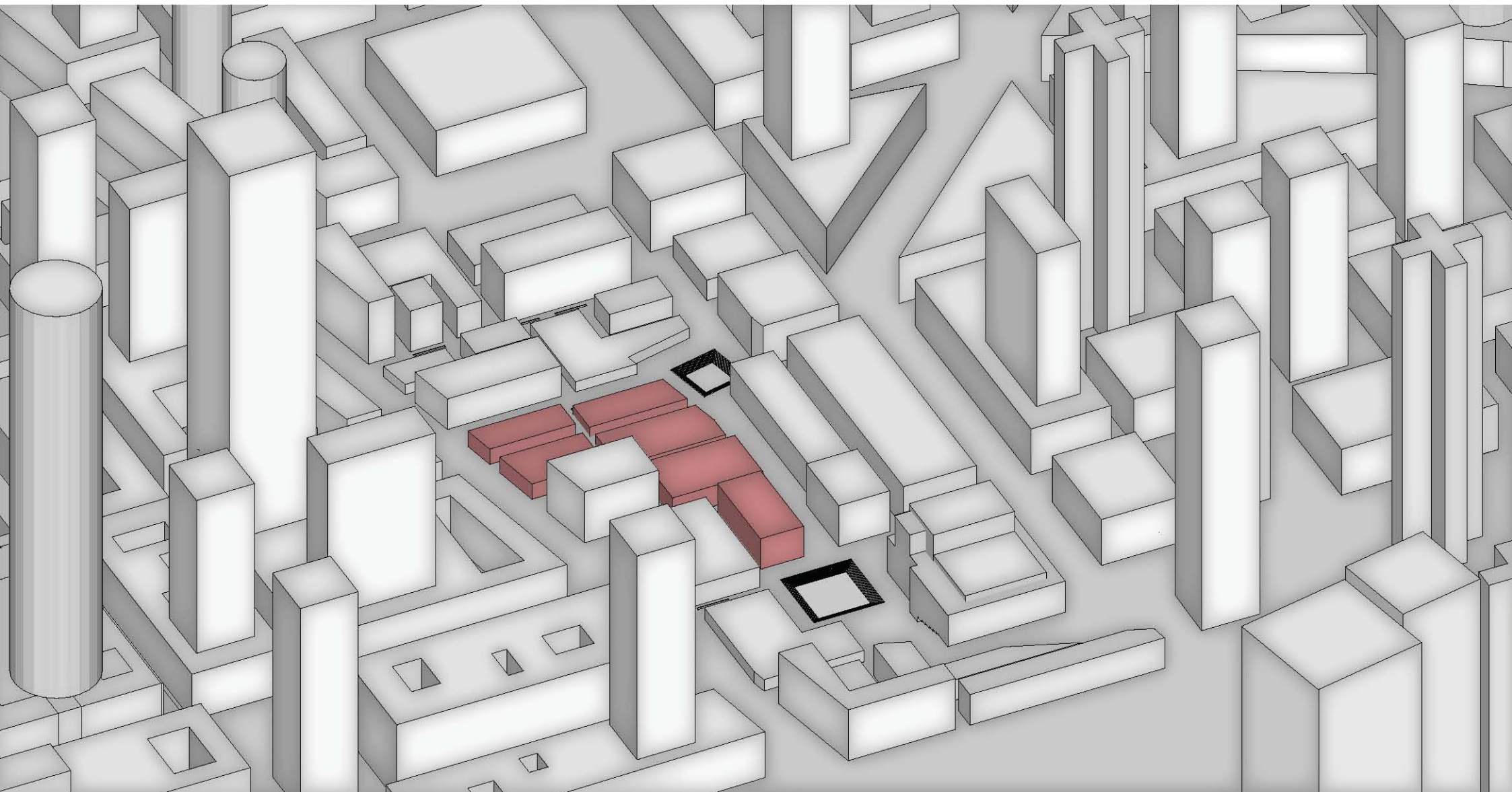

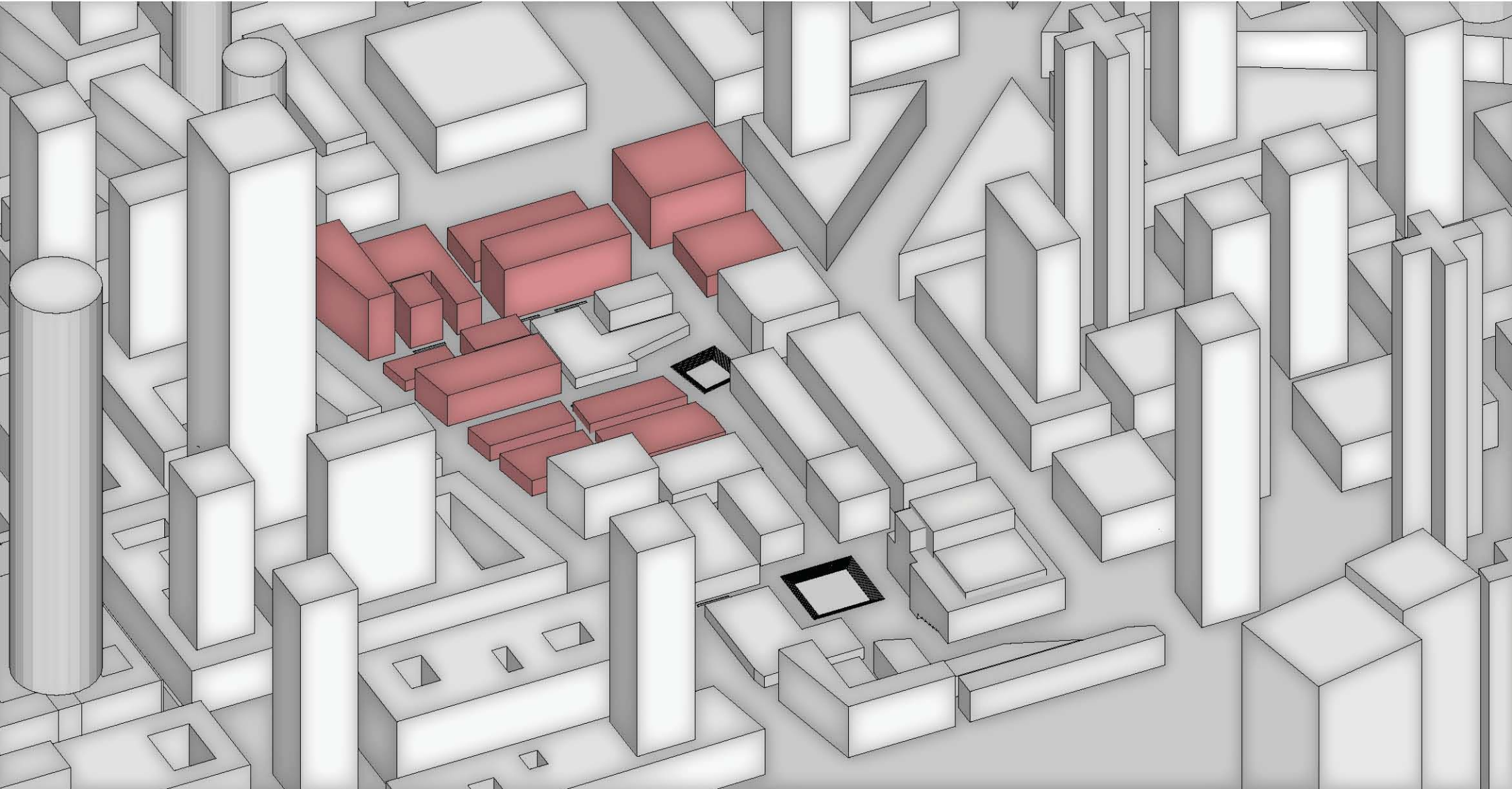

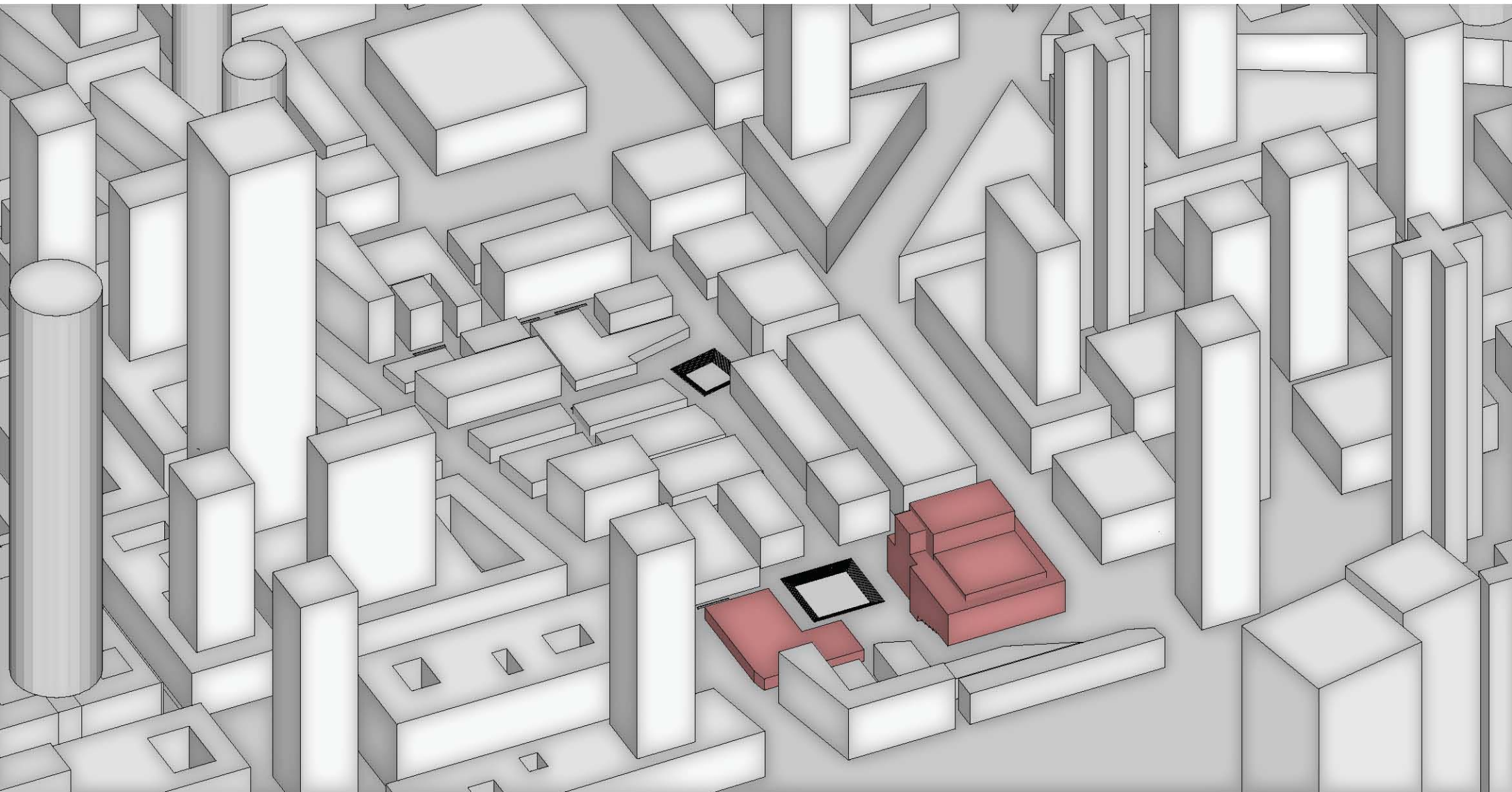

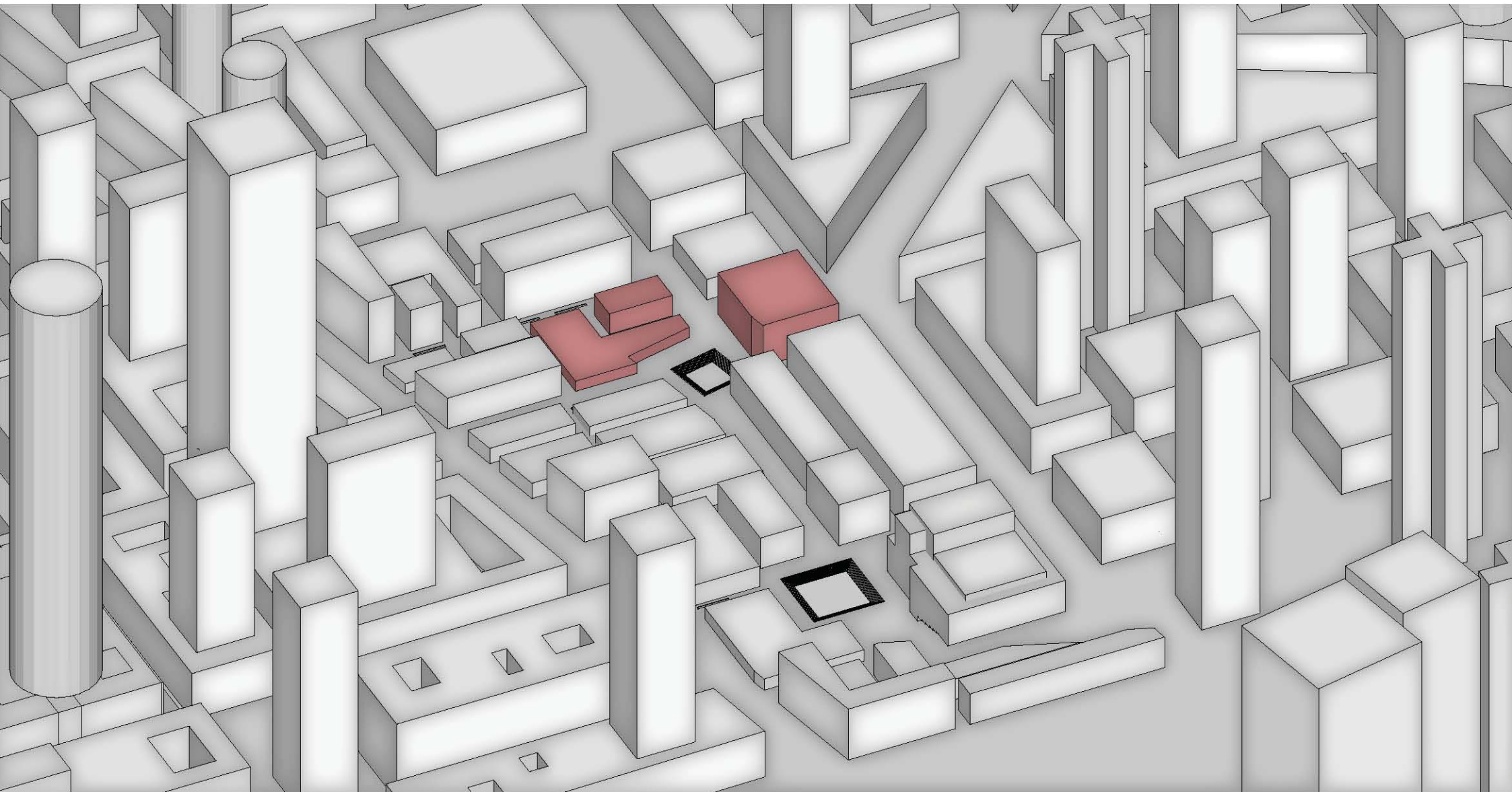

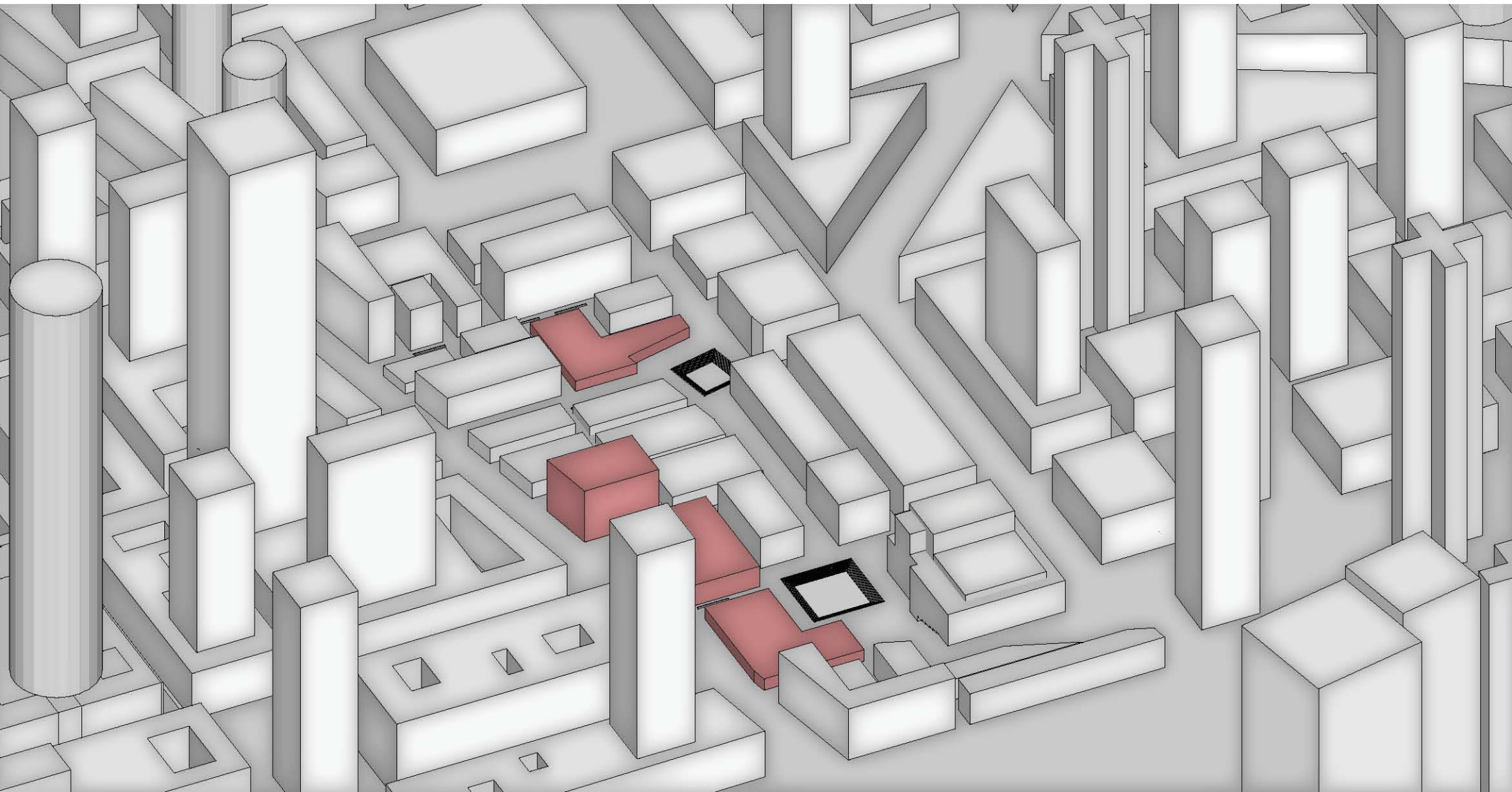

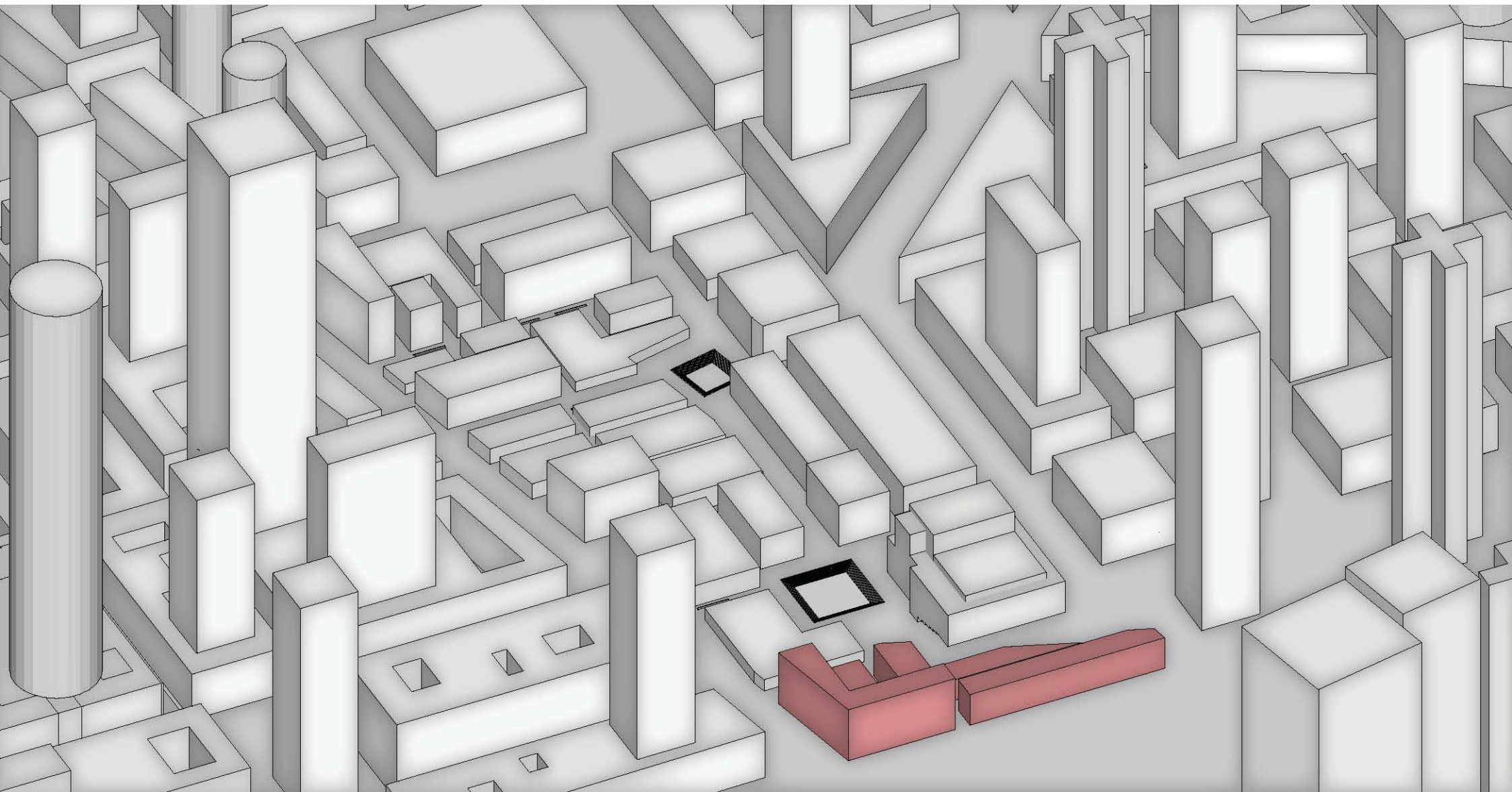

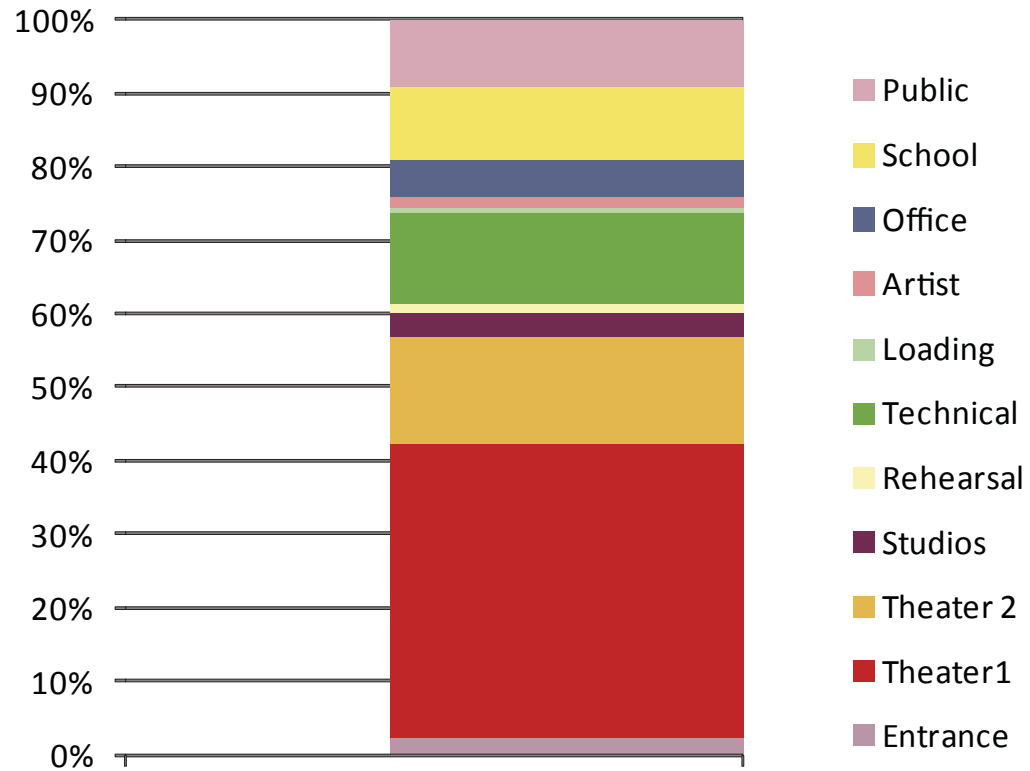

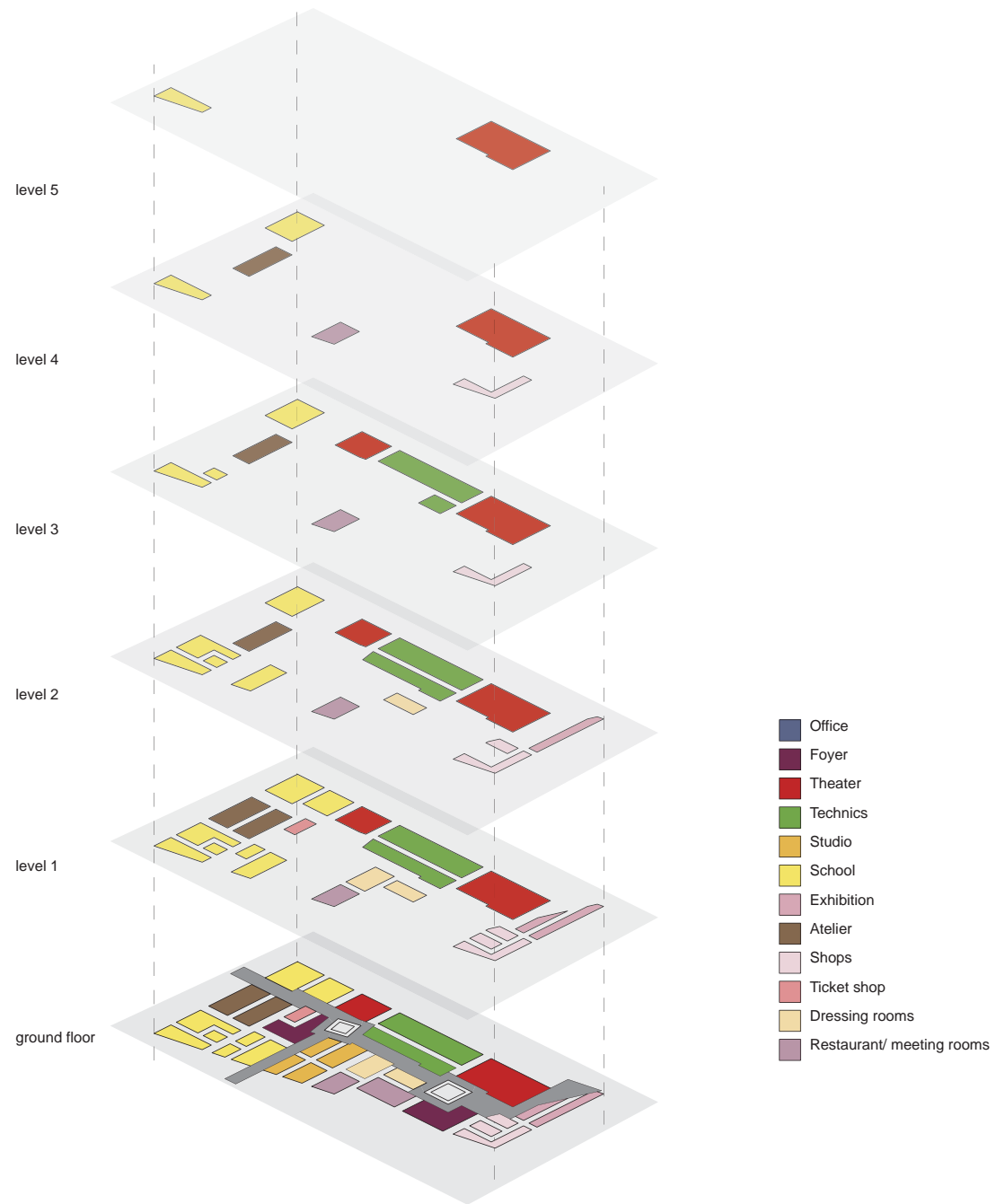

March

June

September

December

10.00



13.00



16.00



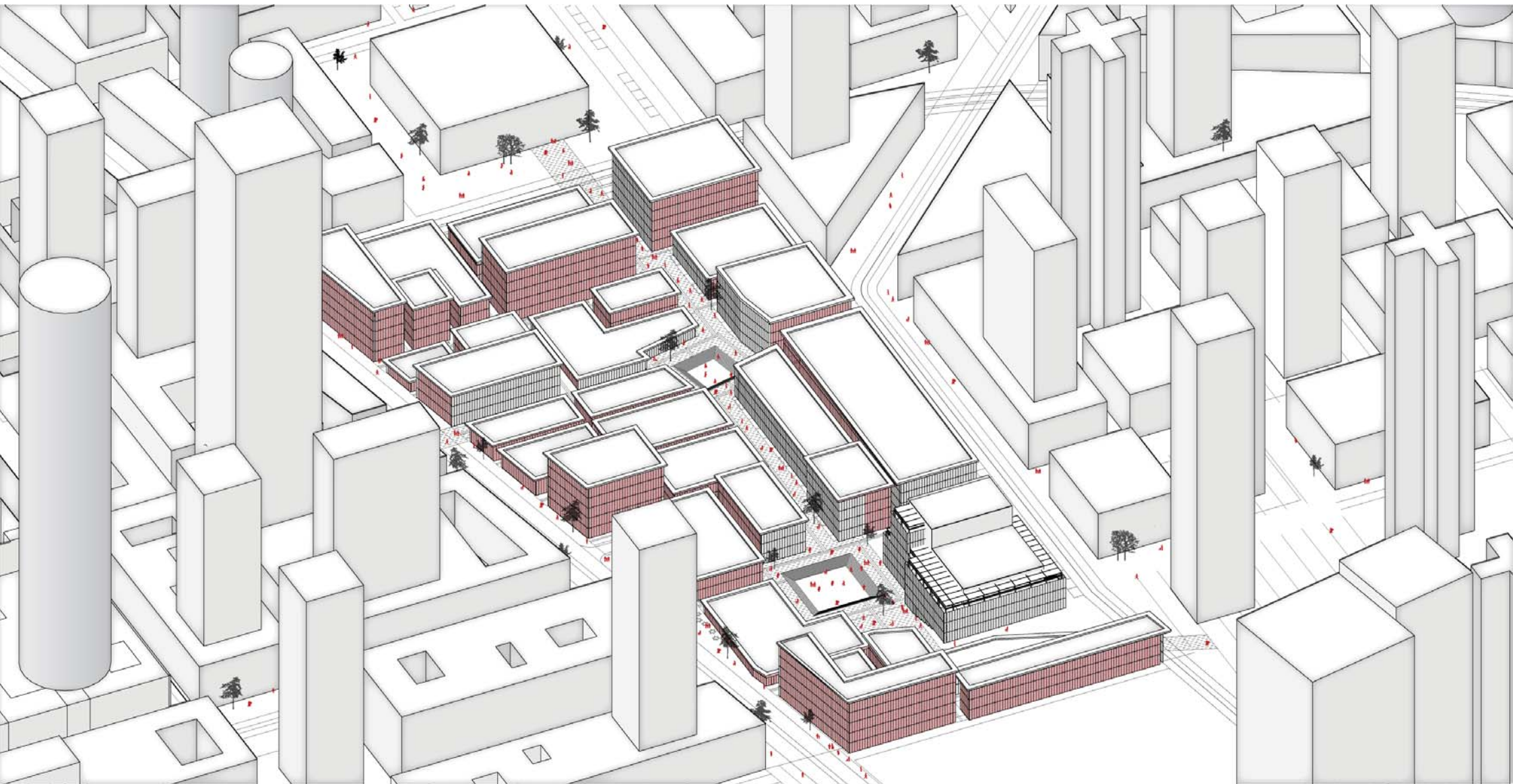

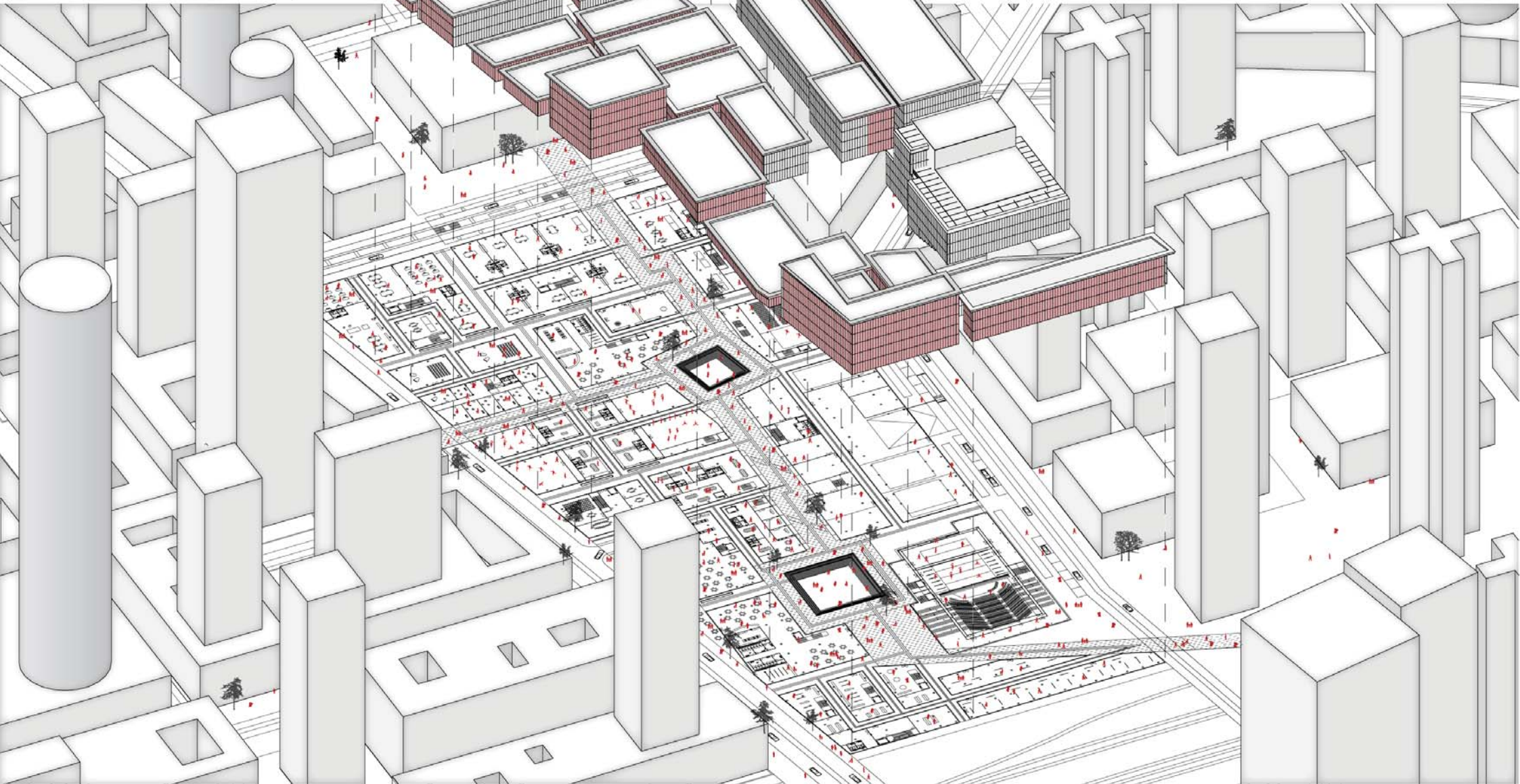

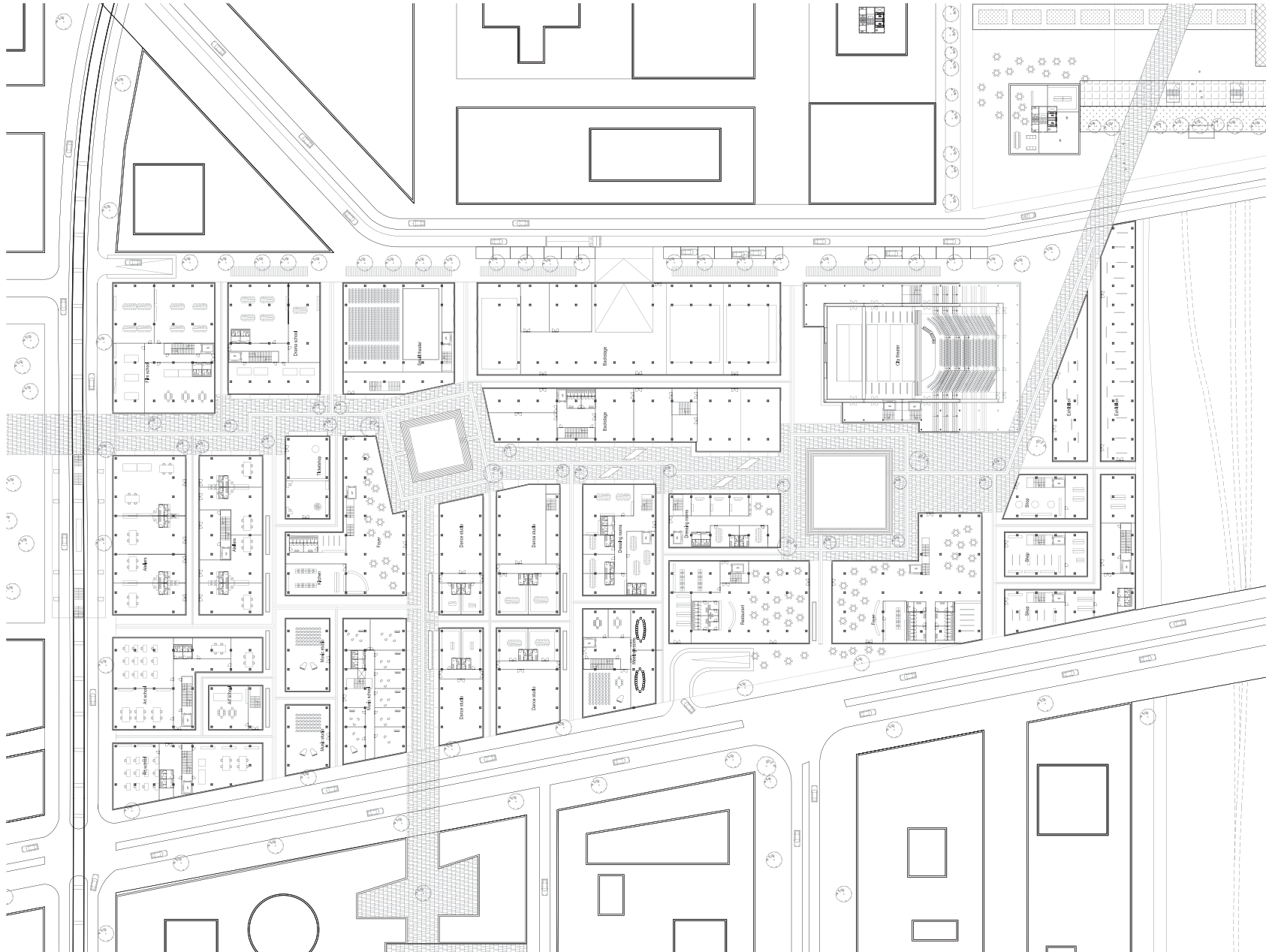

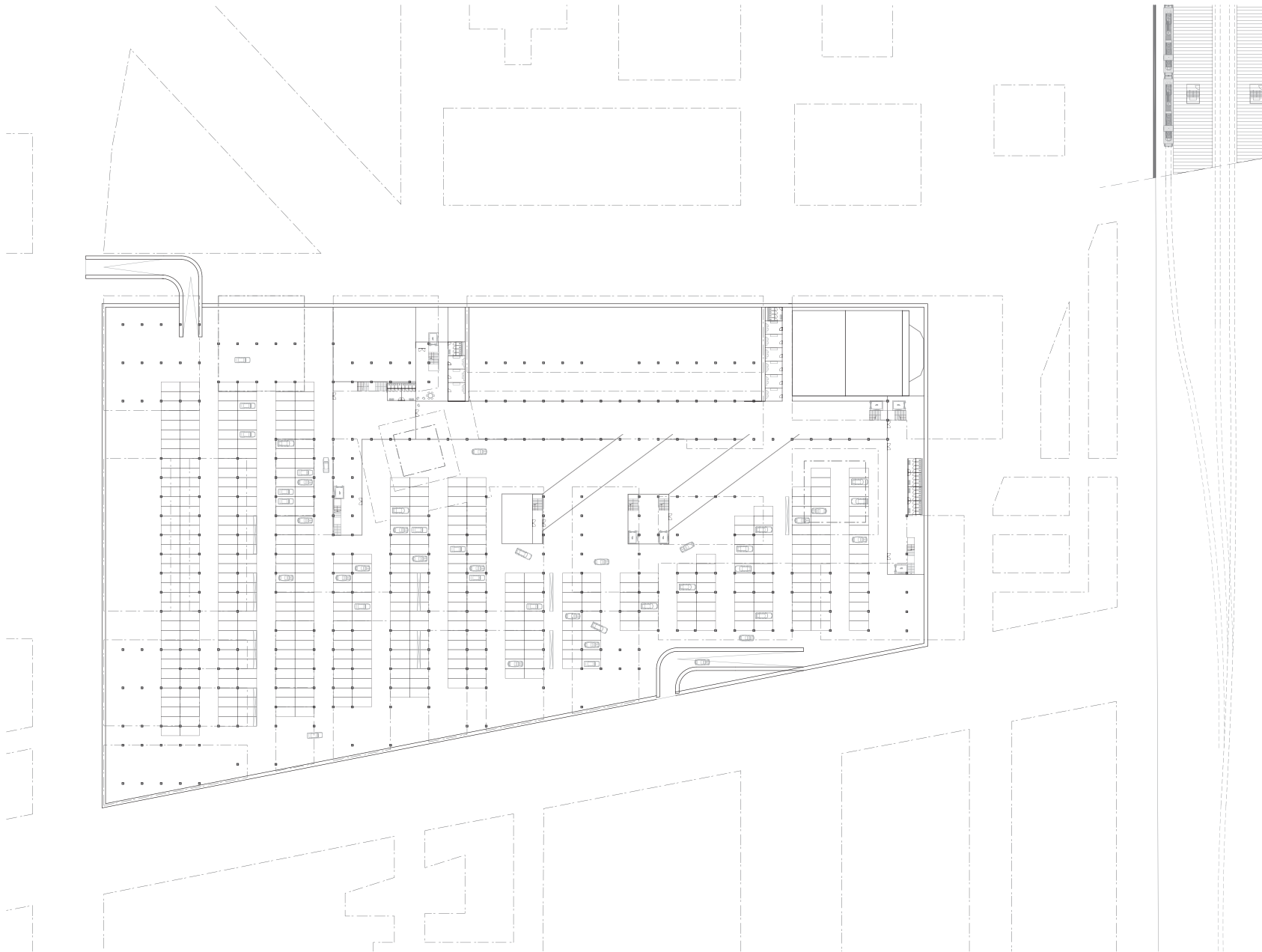

main entrances and public transport

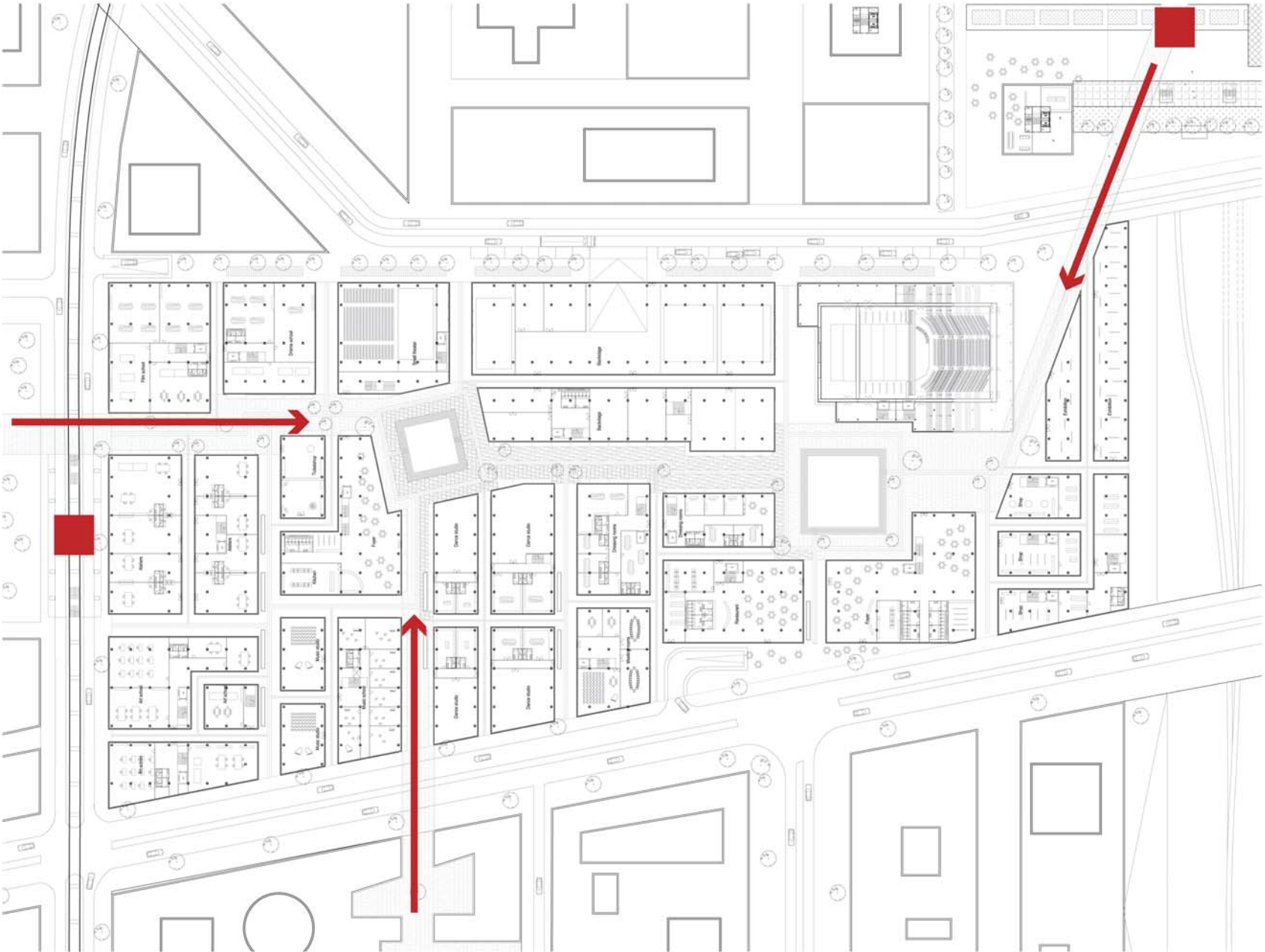

Thacker City
Incheon - Seoul - South Korea
1200 (Floorplan 0)

PH Graduation Laura Dinkla
Vertical Cities Asia
Delft University of Technology



parking entrances



Thessaloniki
Region - South Korea
1200 (Project 0)

PH Graduation Laura Dinkla
Interior Cities Asia
Delft University of Technology



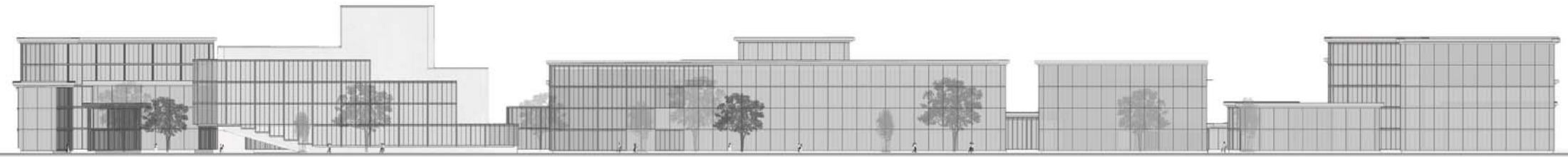

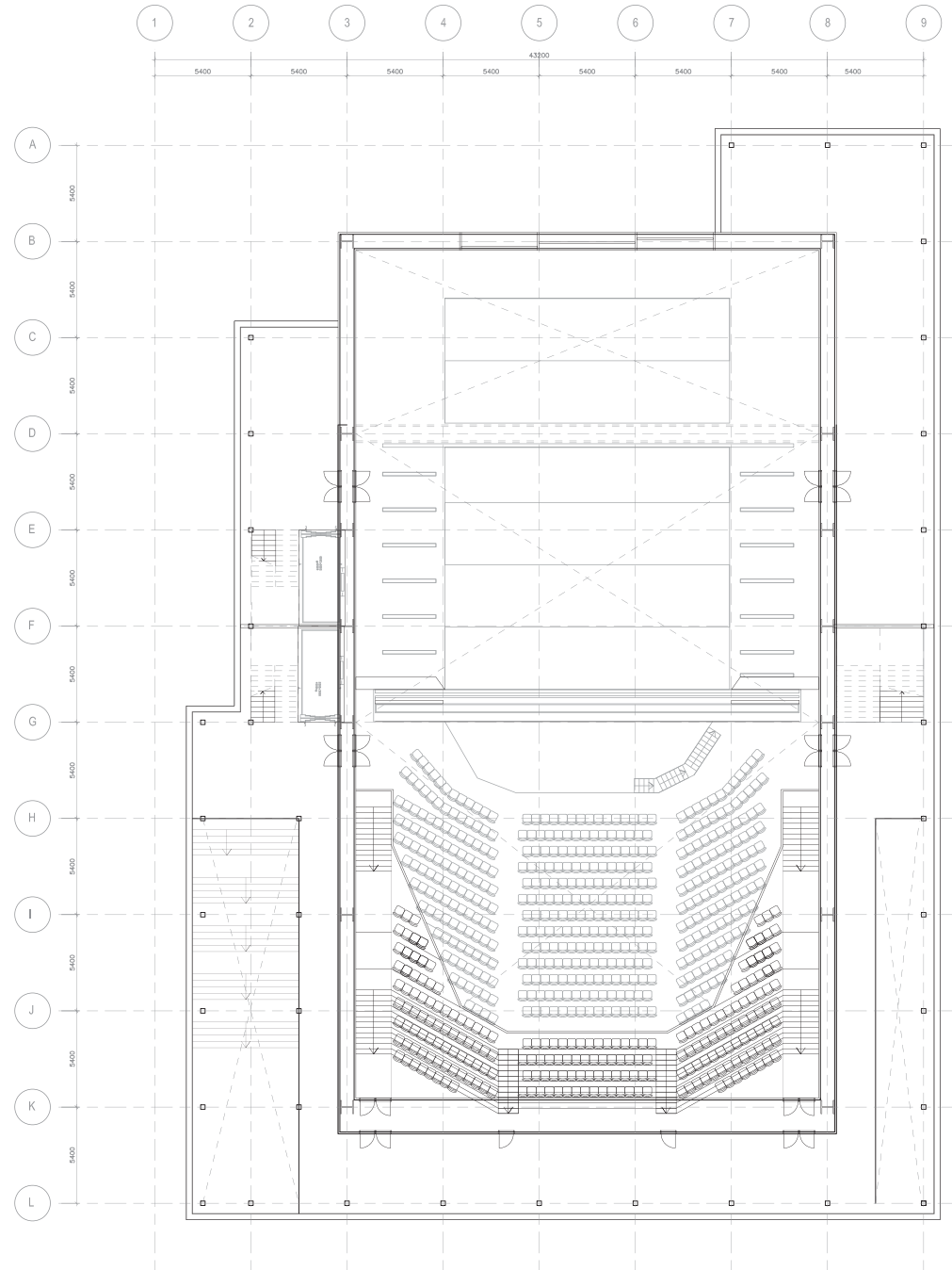
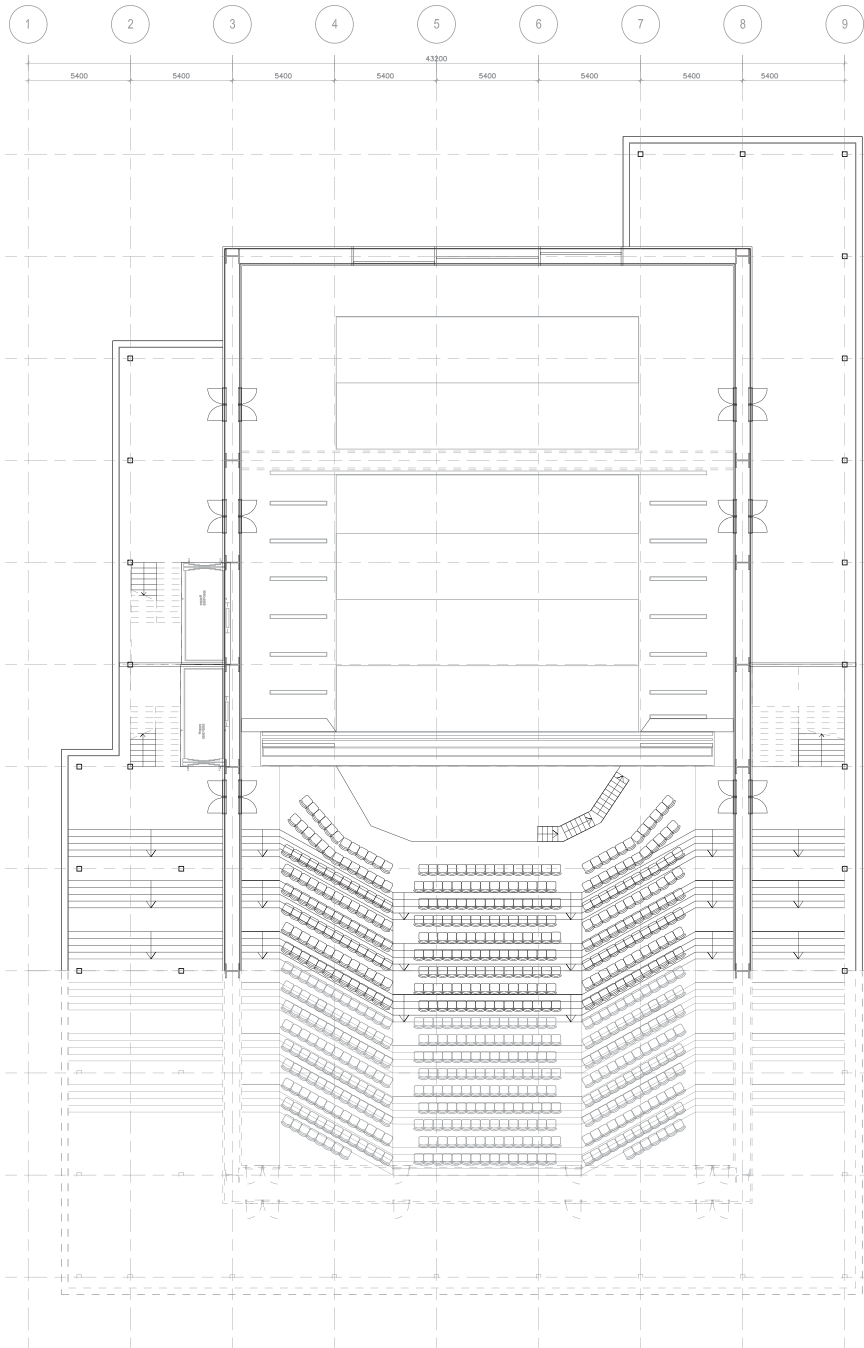

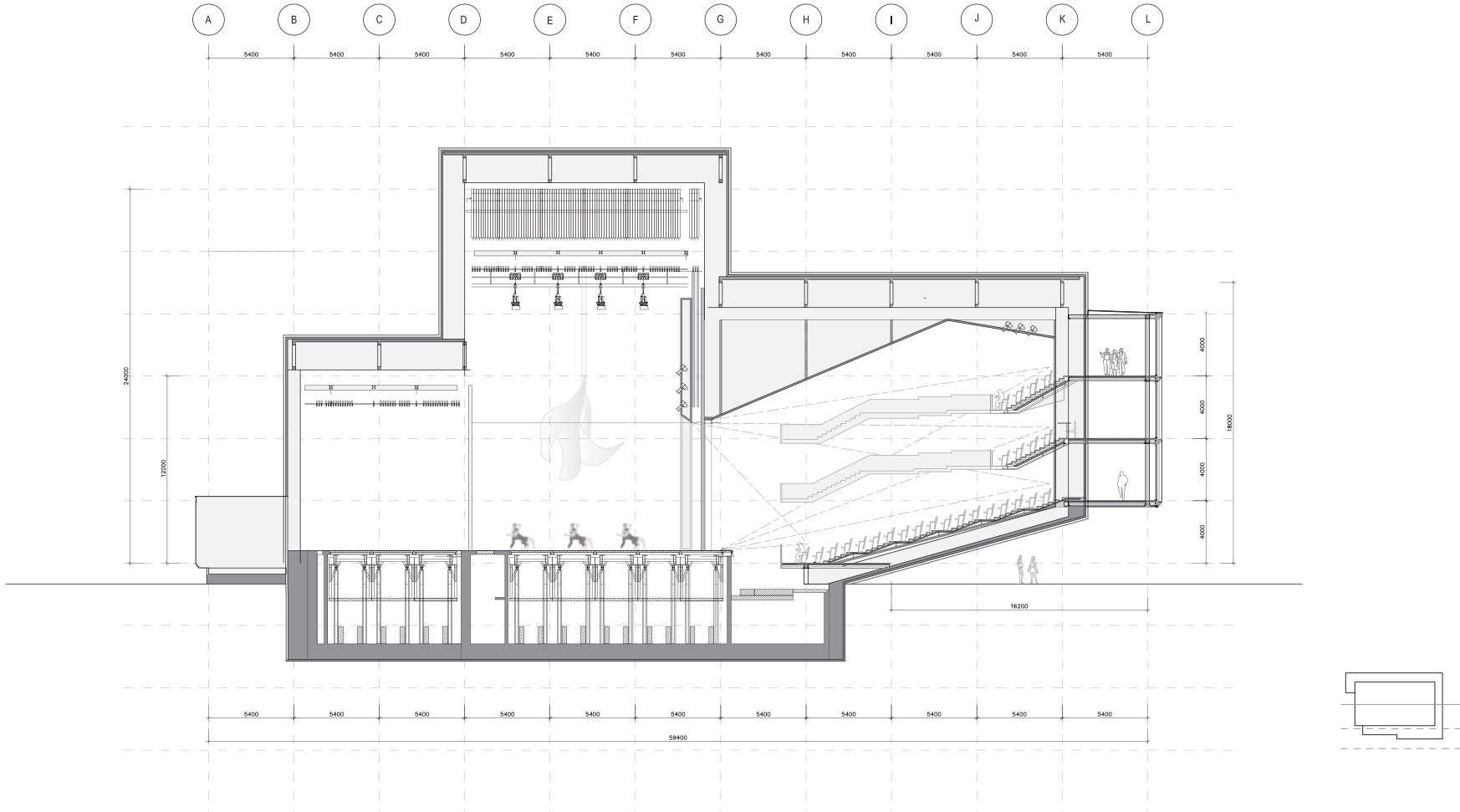

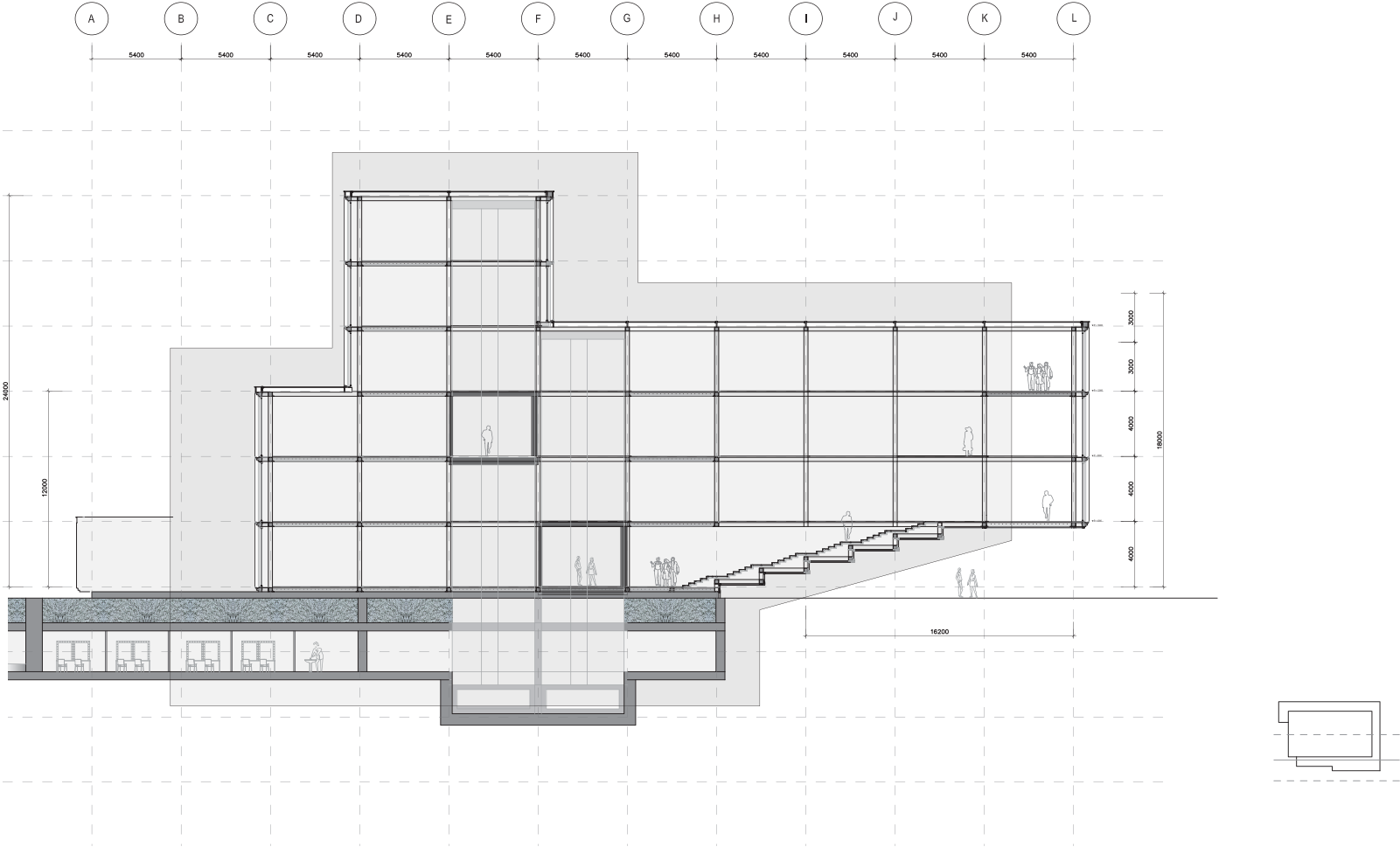

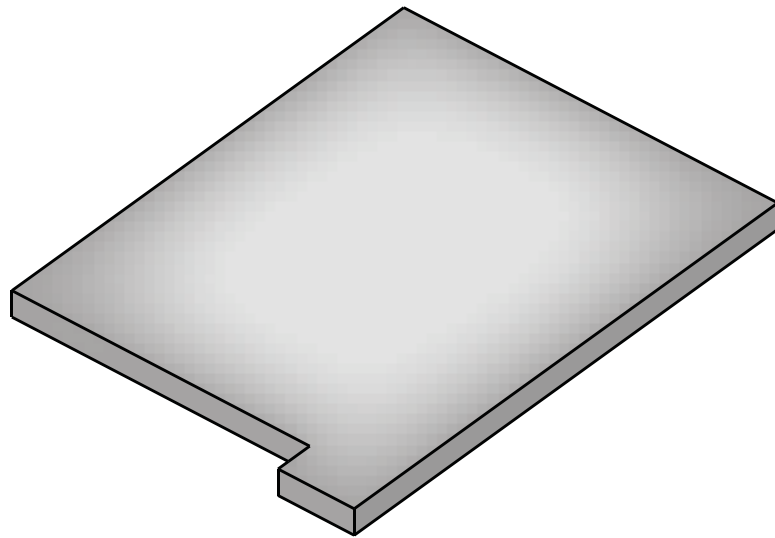

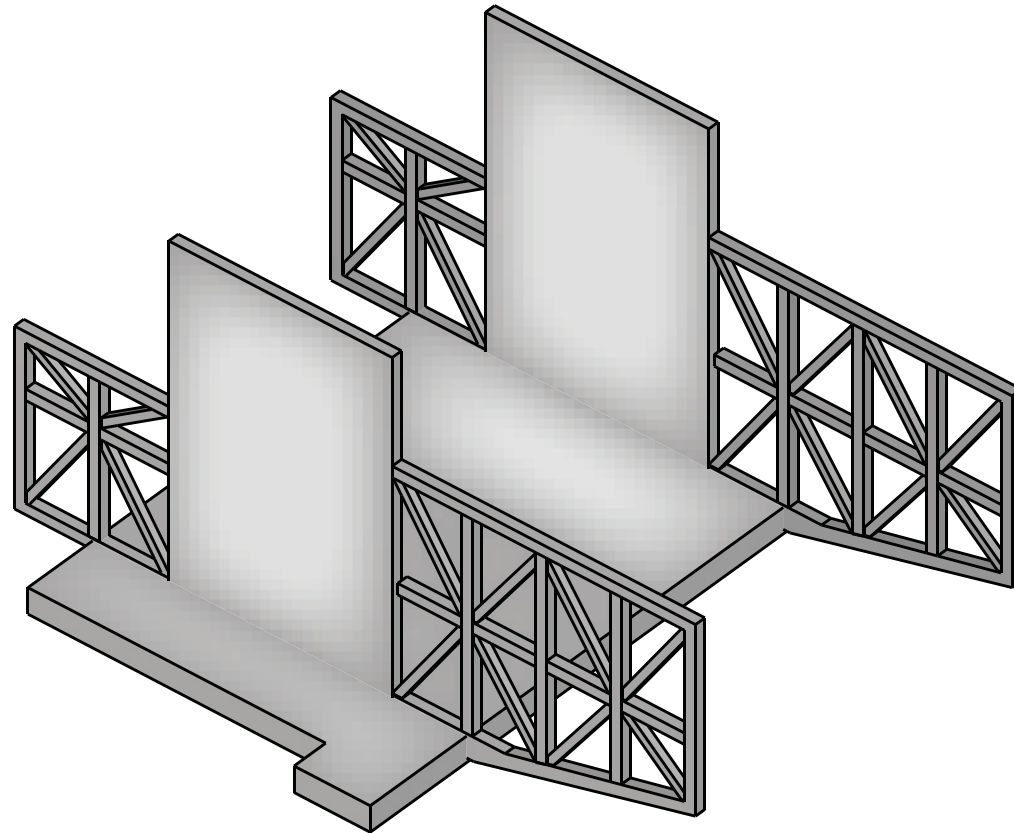

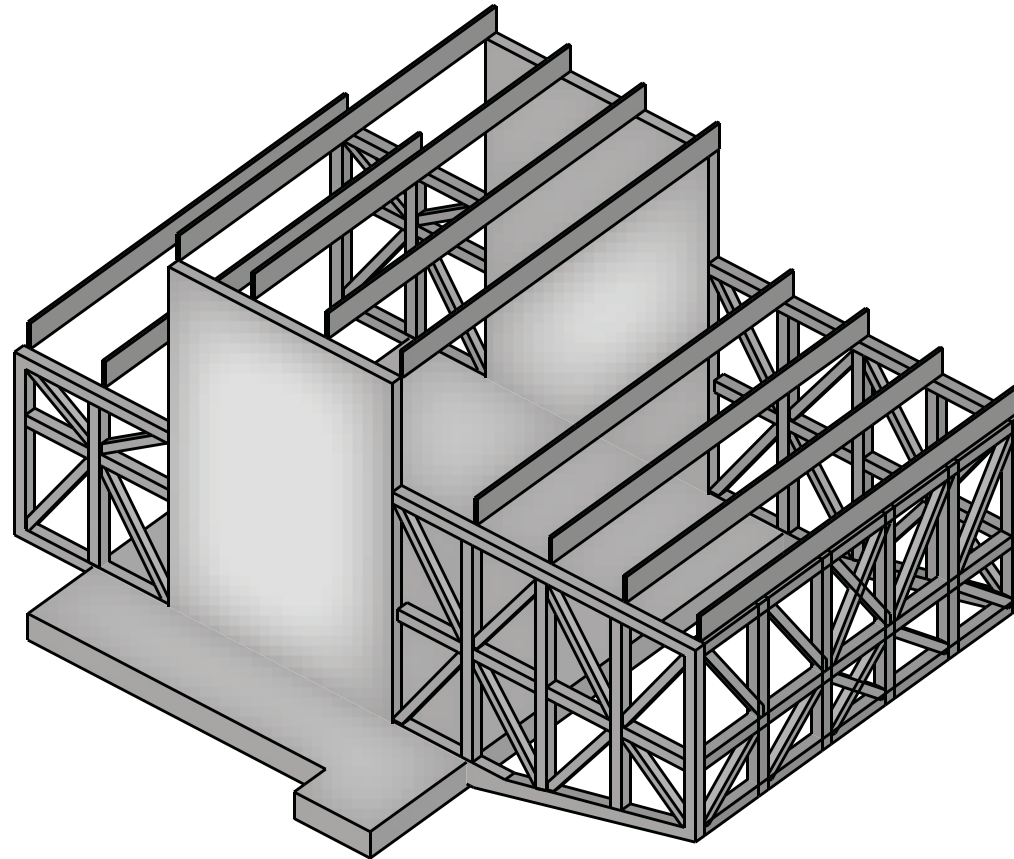

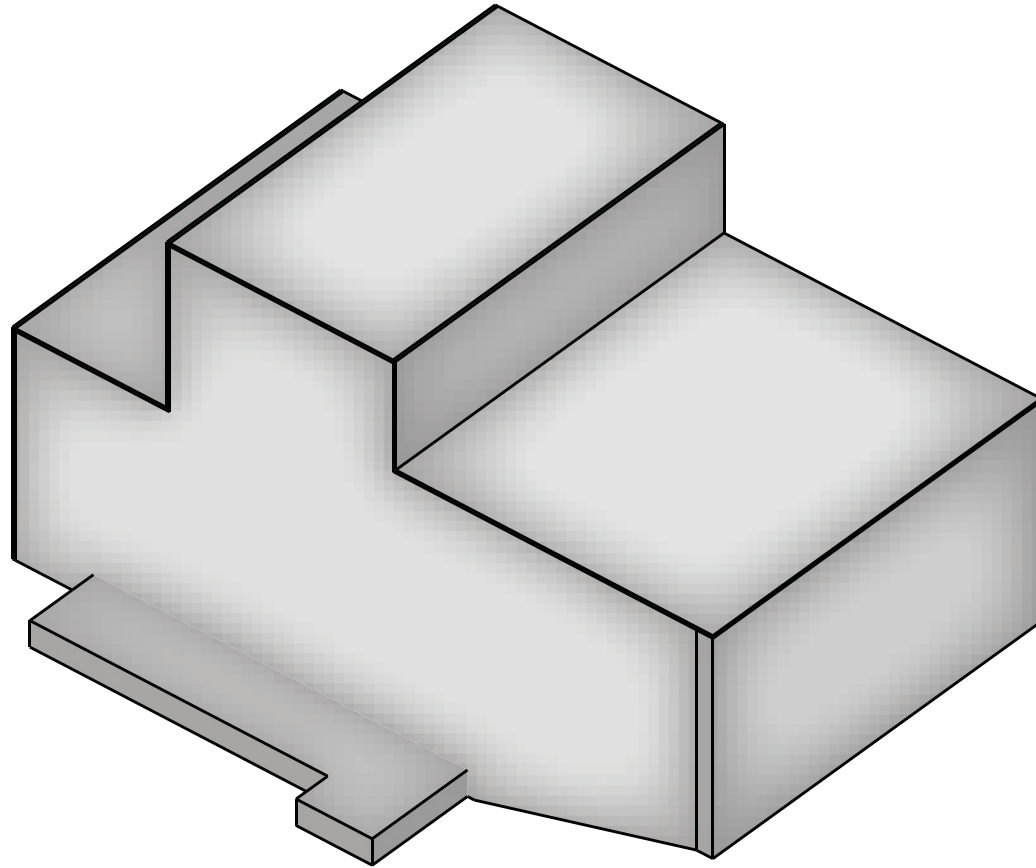

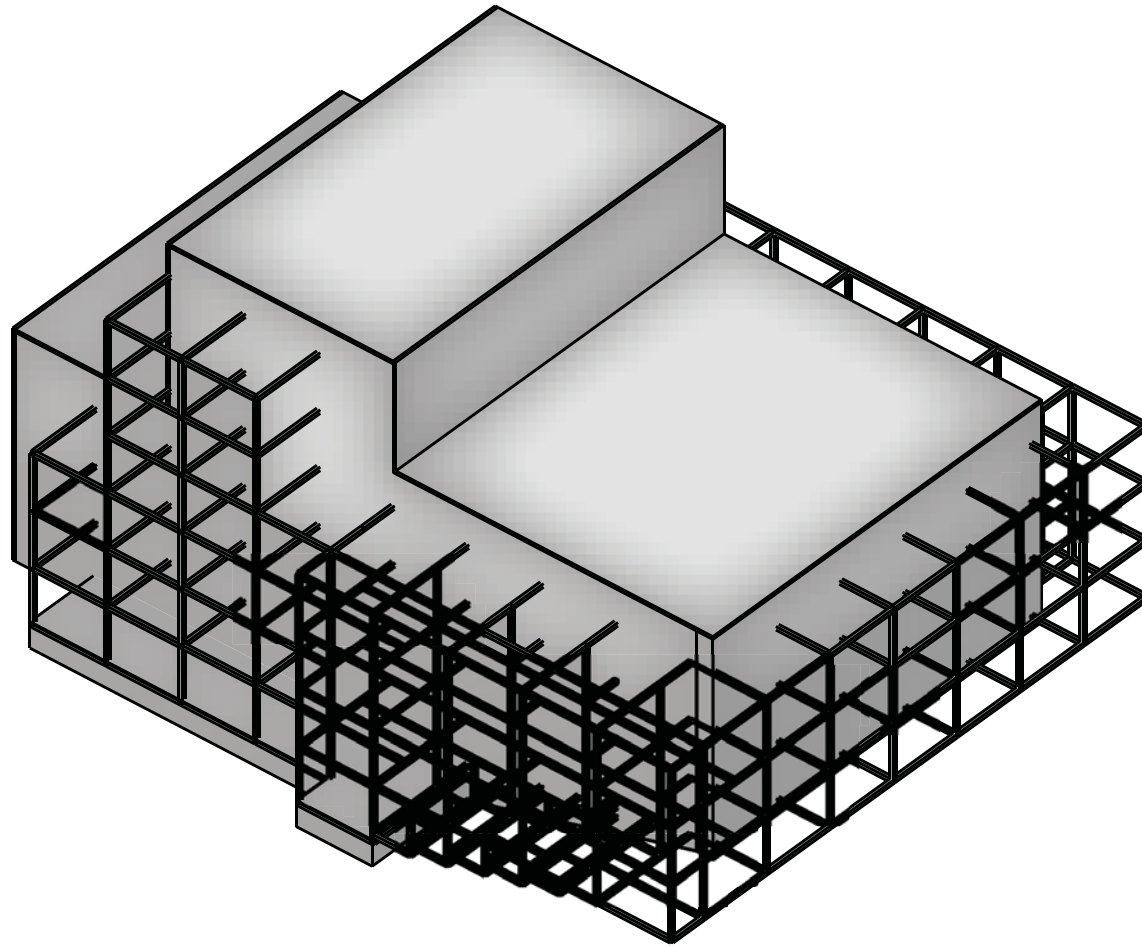

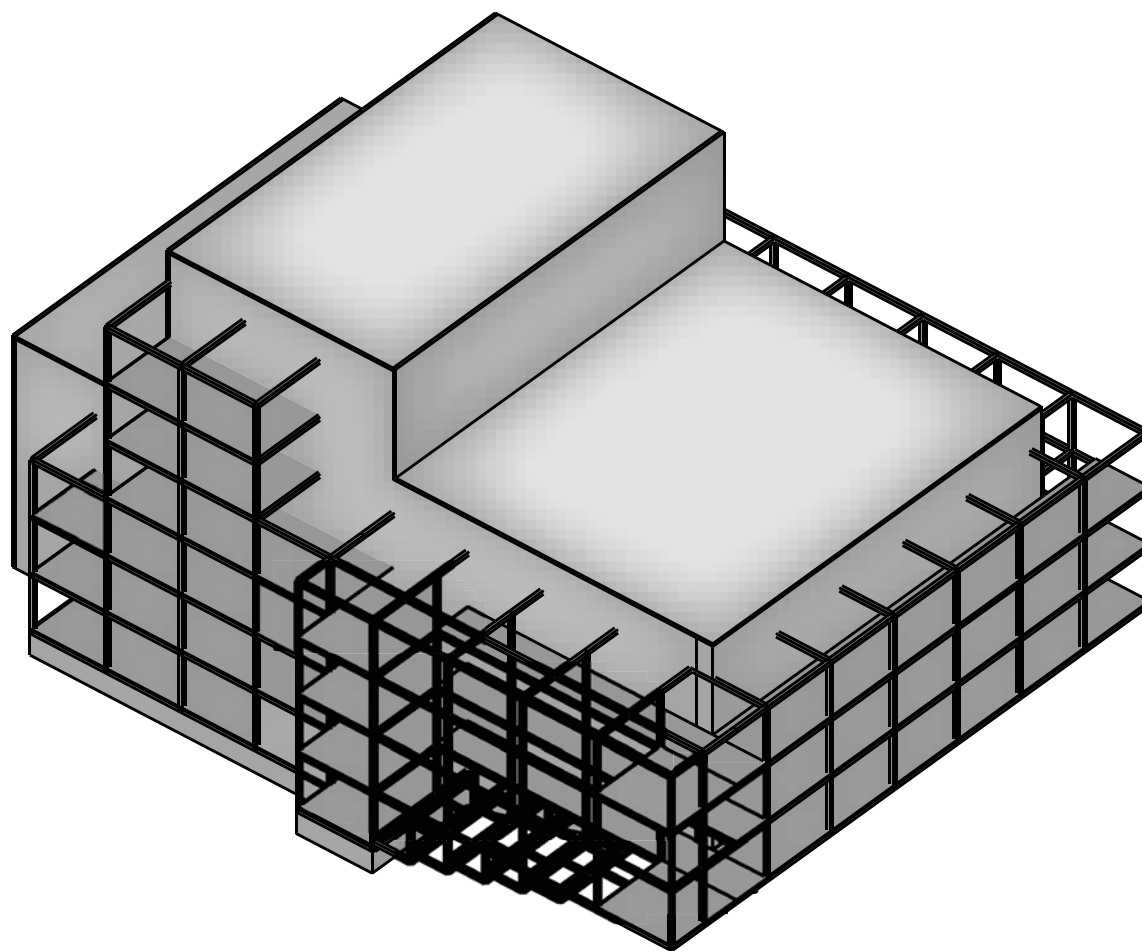

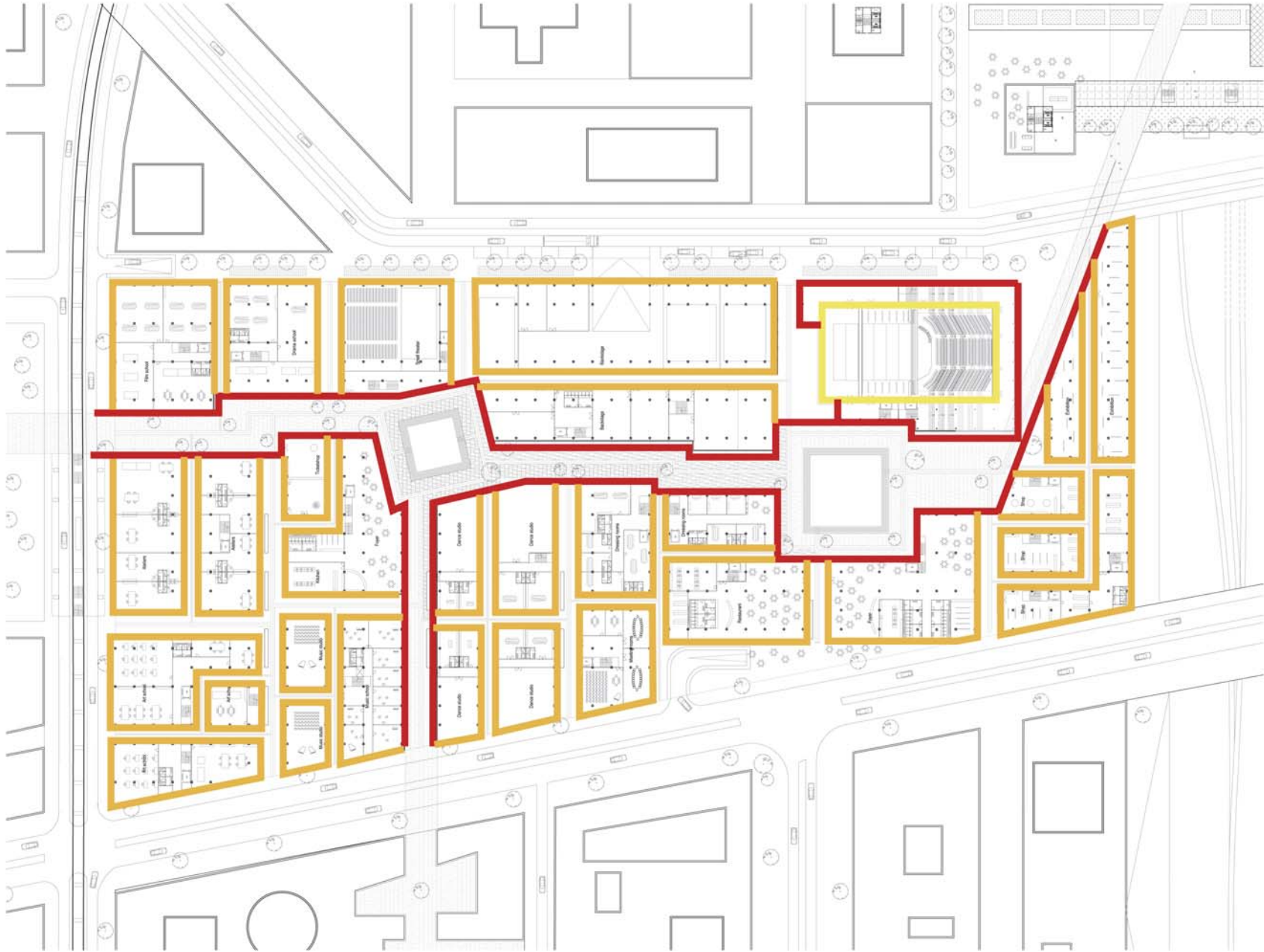

Thacker City
Program: School, South Korea
1200 Floorplan ©
PH Graduation Laura Dirks
Visual Cities Asia
Delft University of Technology



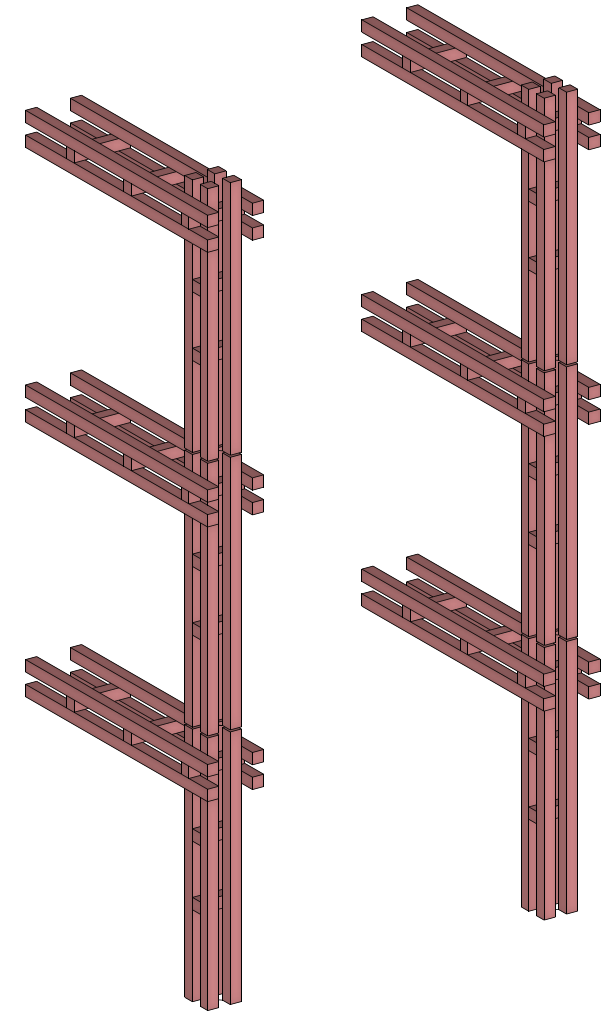

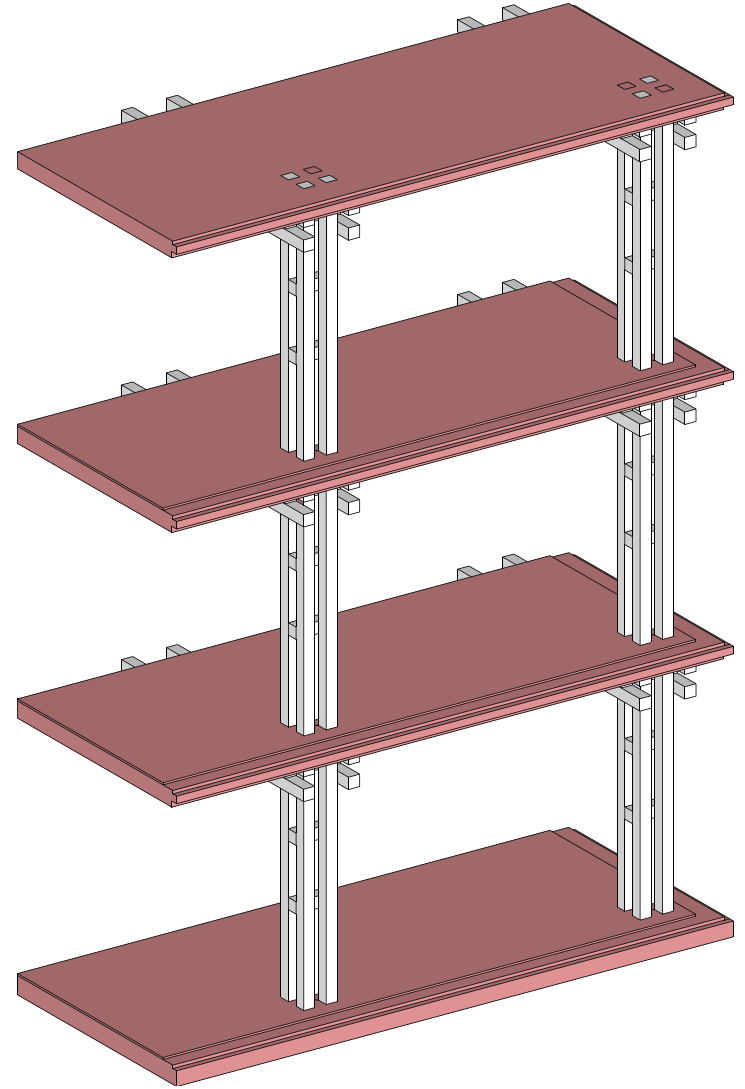

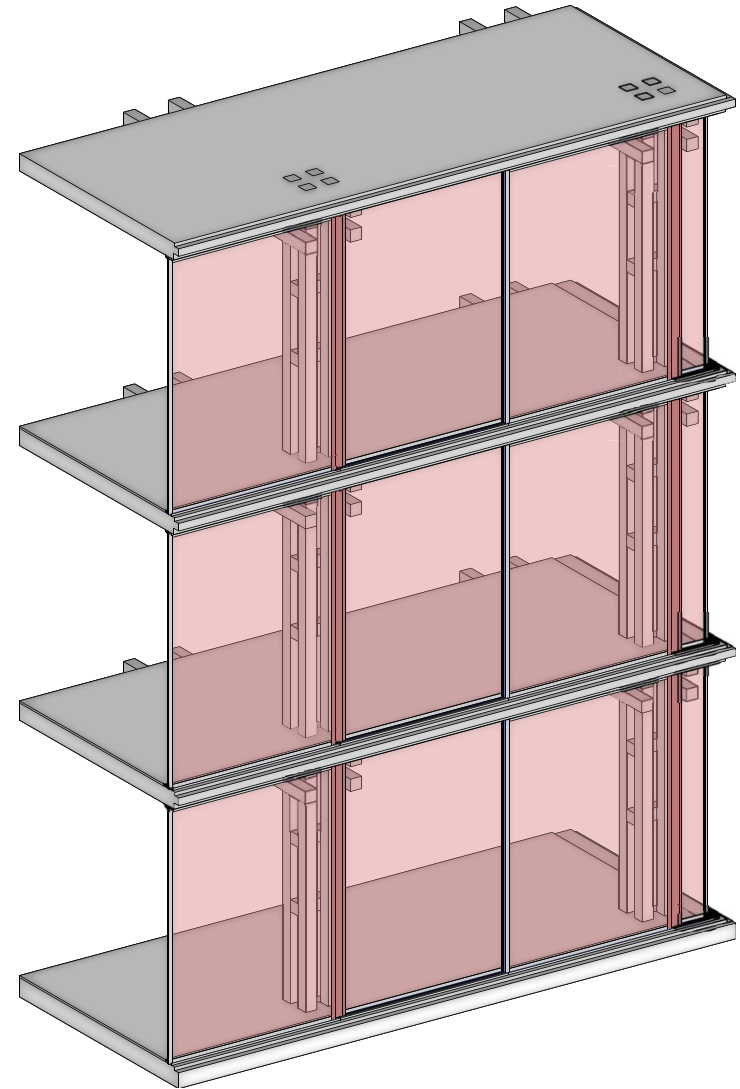

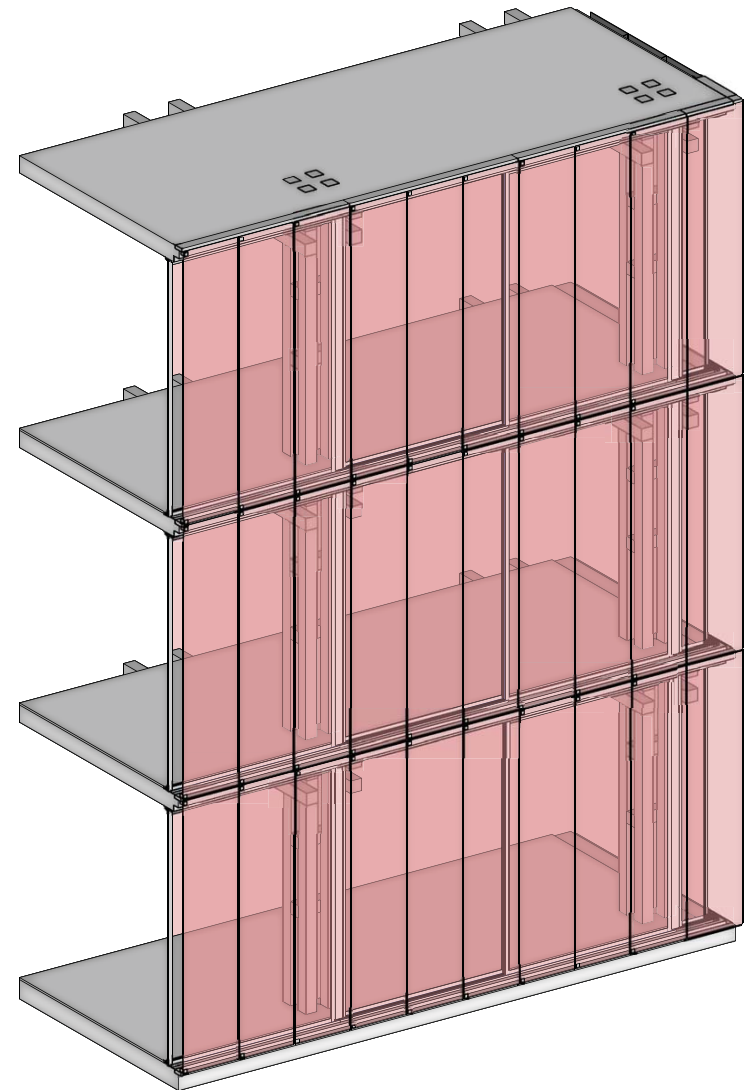

mirror effect

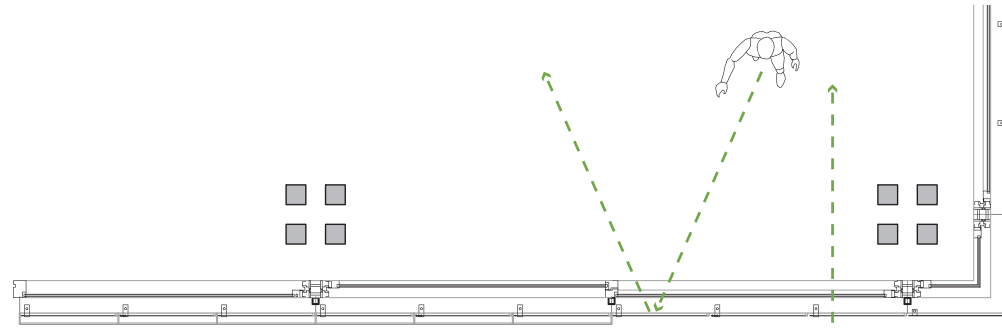

Closed one sided mirror panel

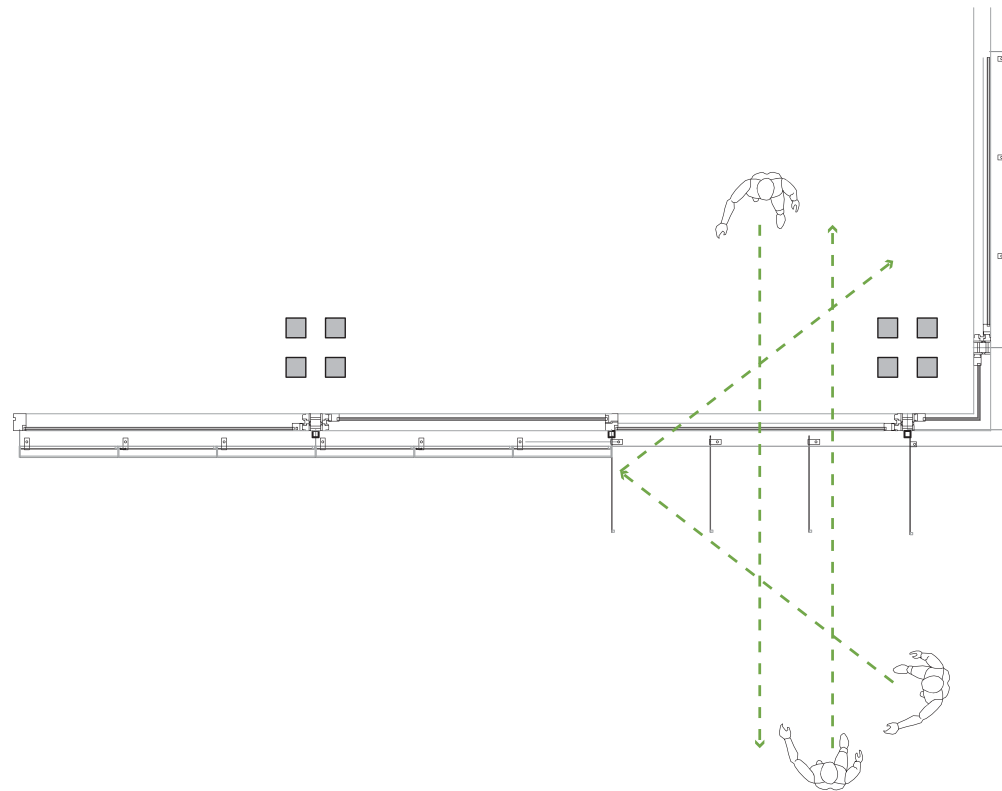

Closed one sided mirror panel

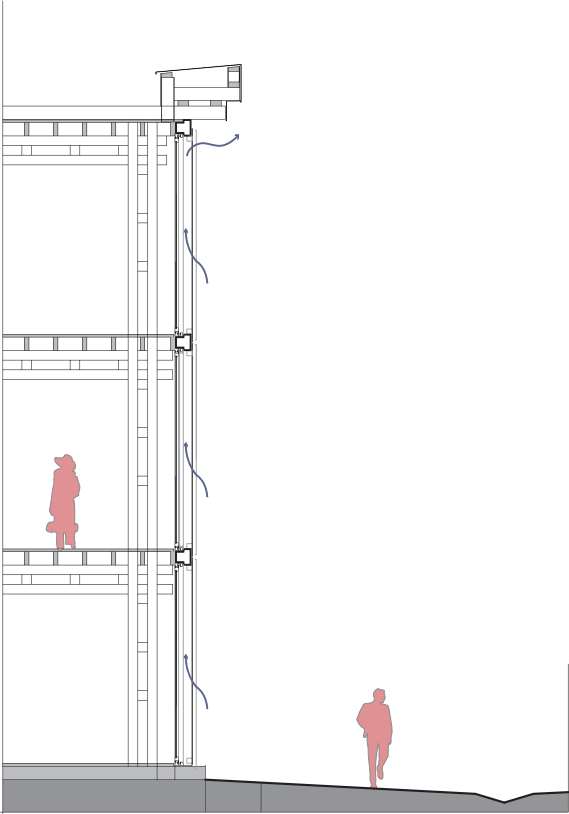

Closed window

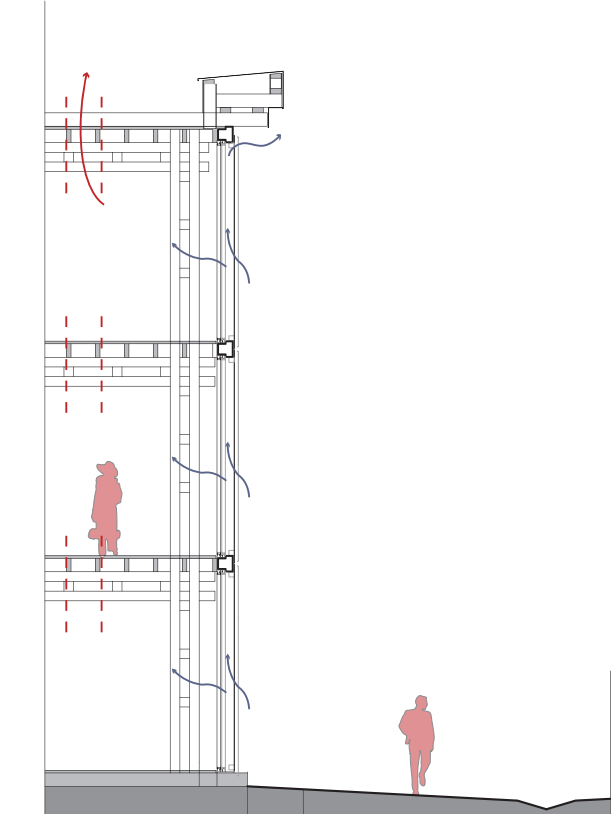

Open window

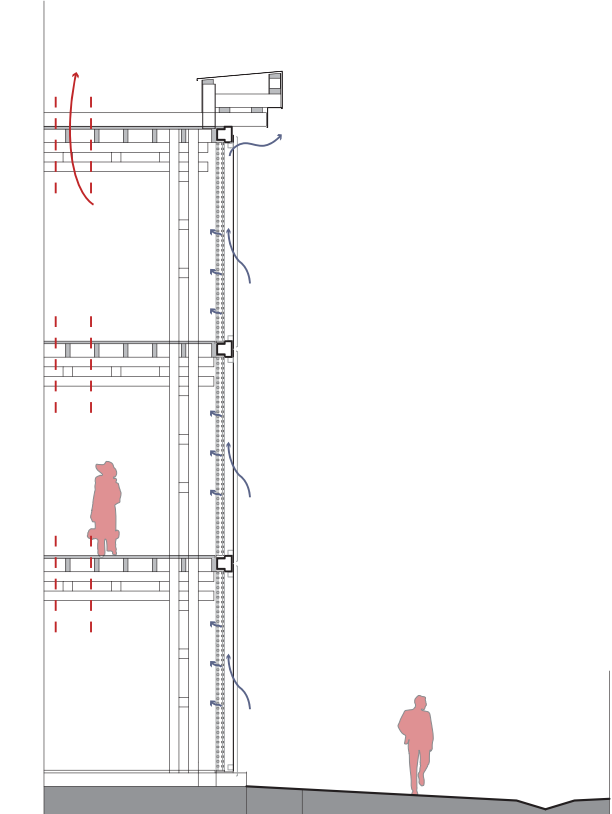

Open ventilation

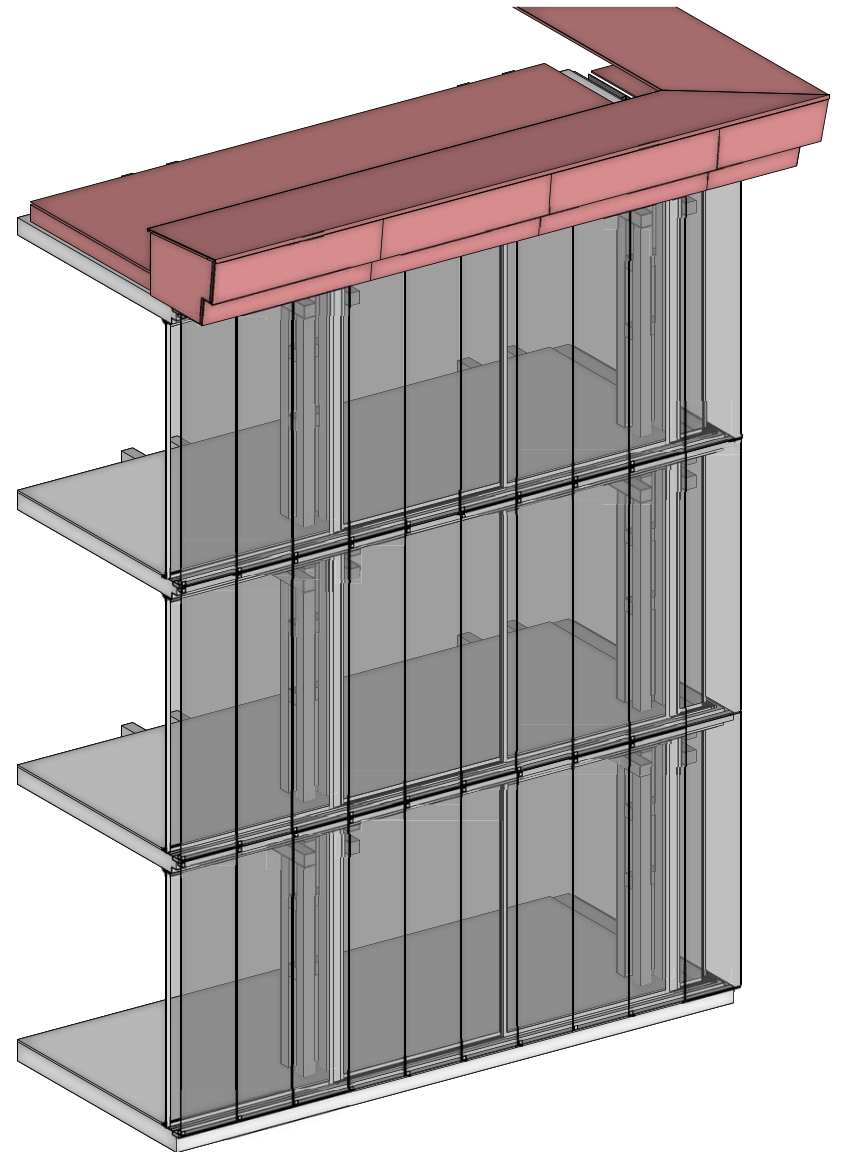

woven layer semi transparant



Des Moines Public library

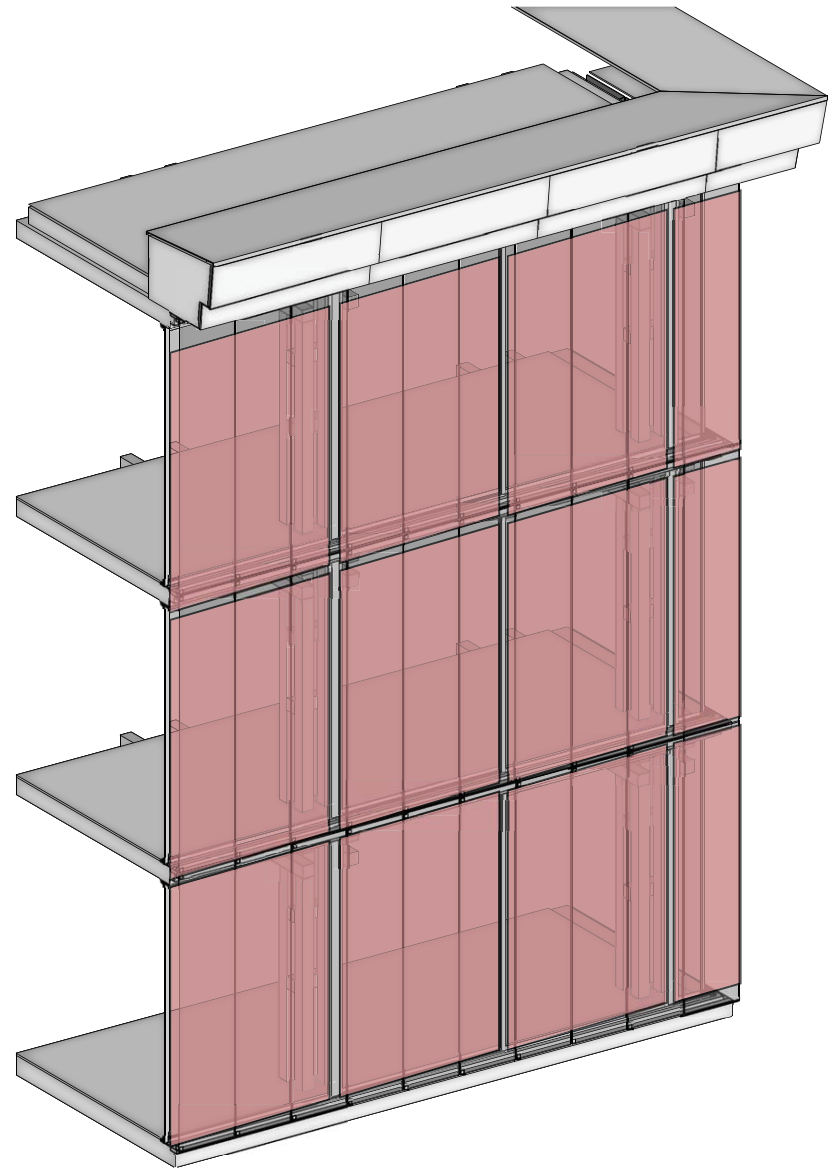



Digital facade medialab Prado



Eye Amsterdam



resulting image

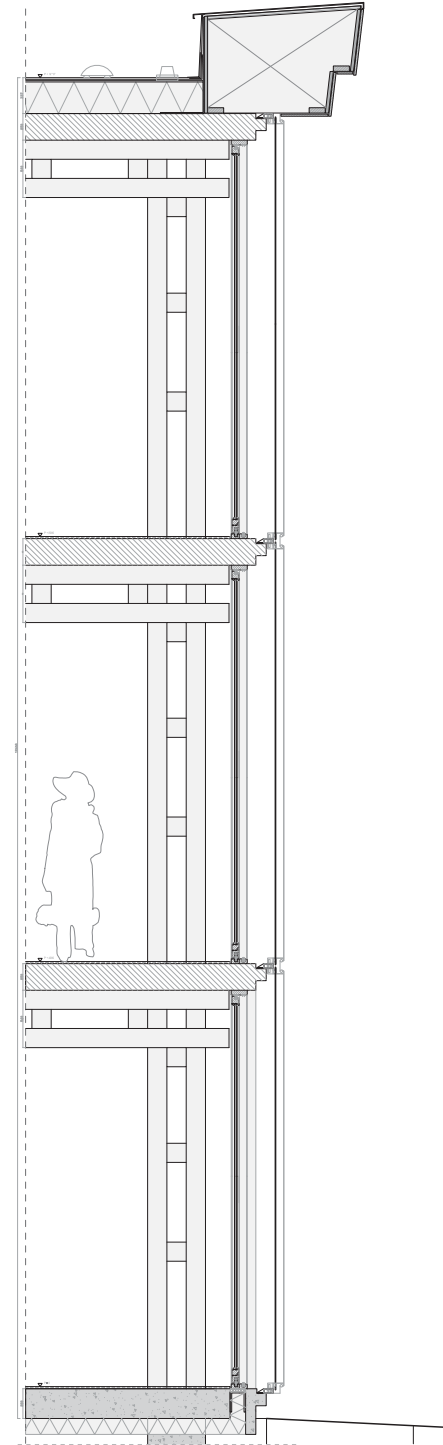

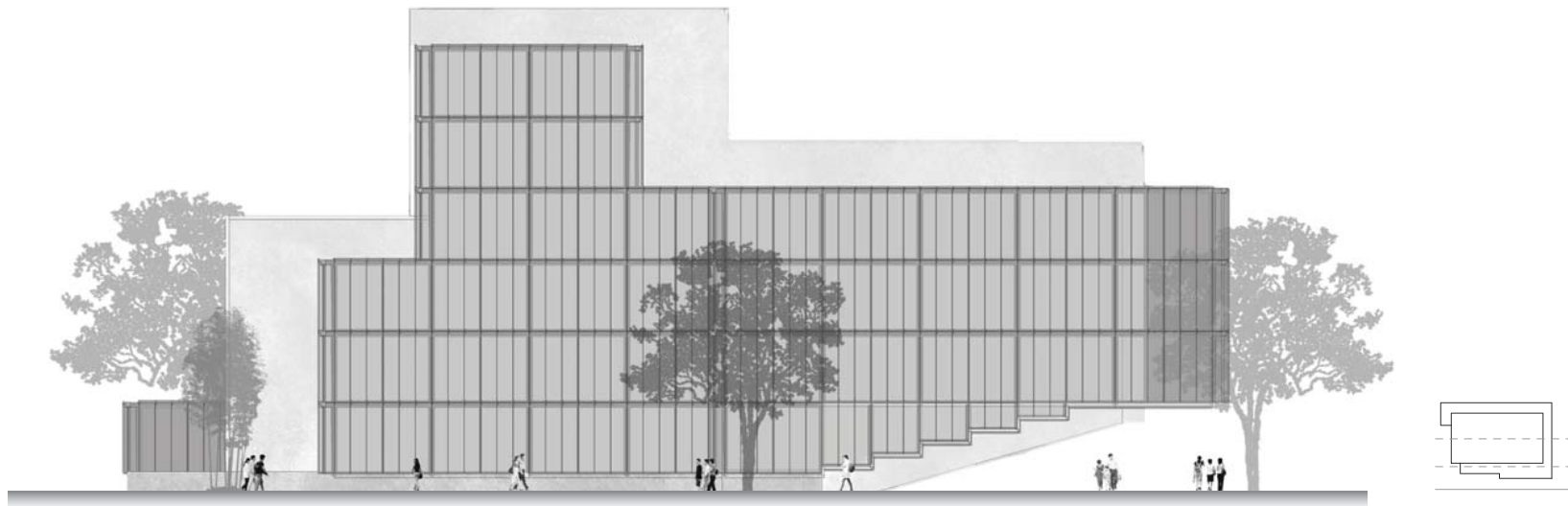



Digital facade medialab Prado



Un studio Galleria Department Seoul



Digital facade medialab Prado



Un studio Galleria Department Seoul

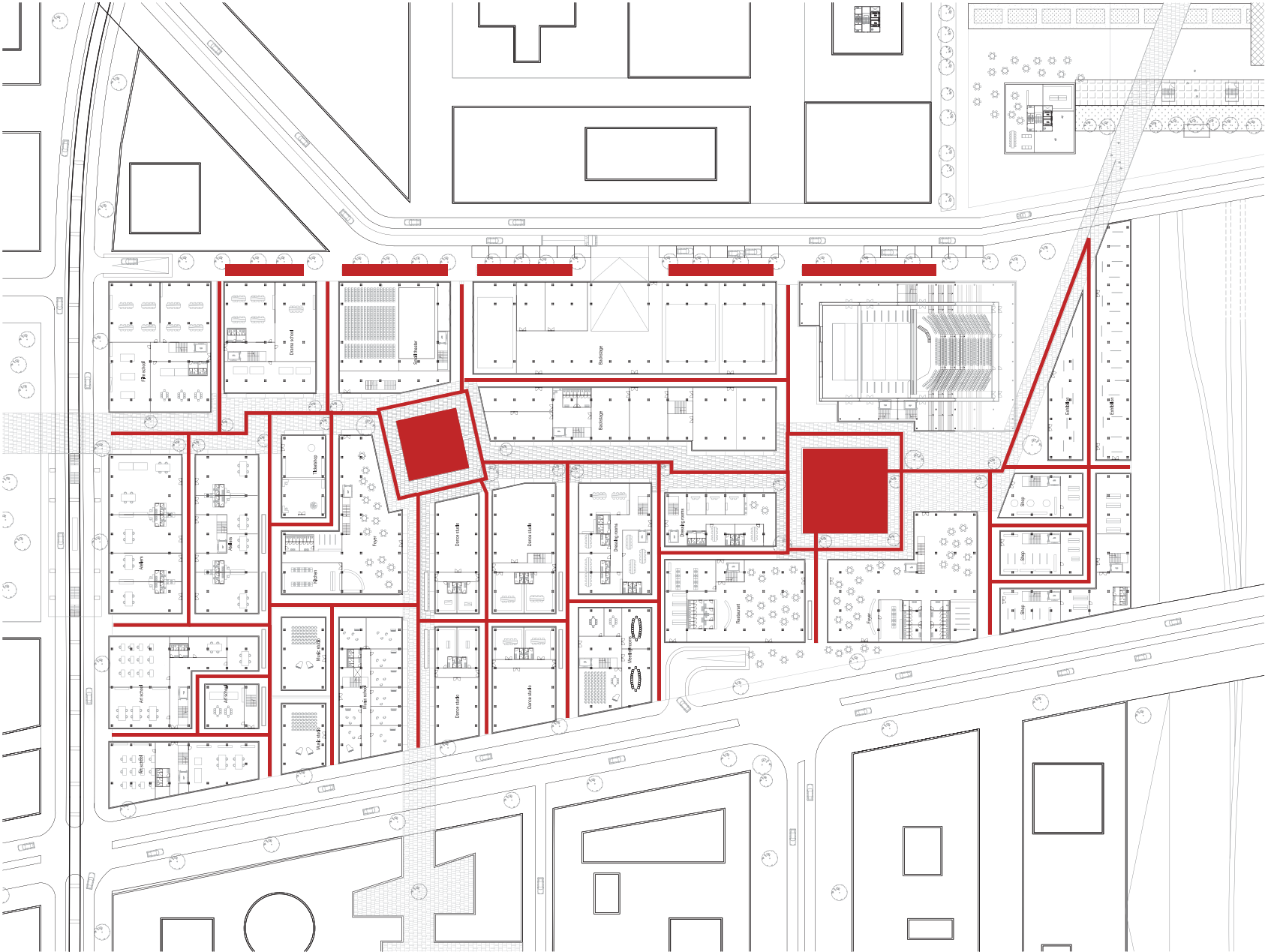

Thrustor City
Thrustor City - South Korea
1,500 (approx.)
P4 Evaluation Lara Deika
Lara Deika - South Korea
Dell University of Technology



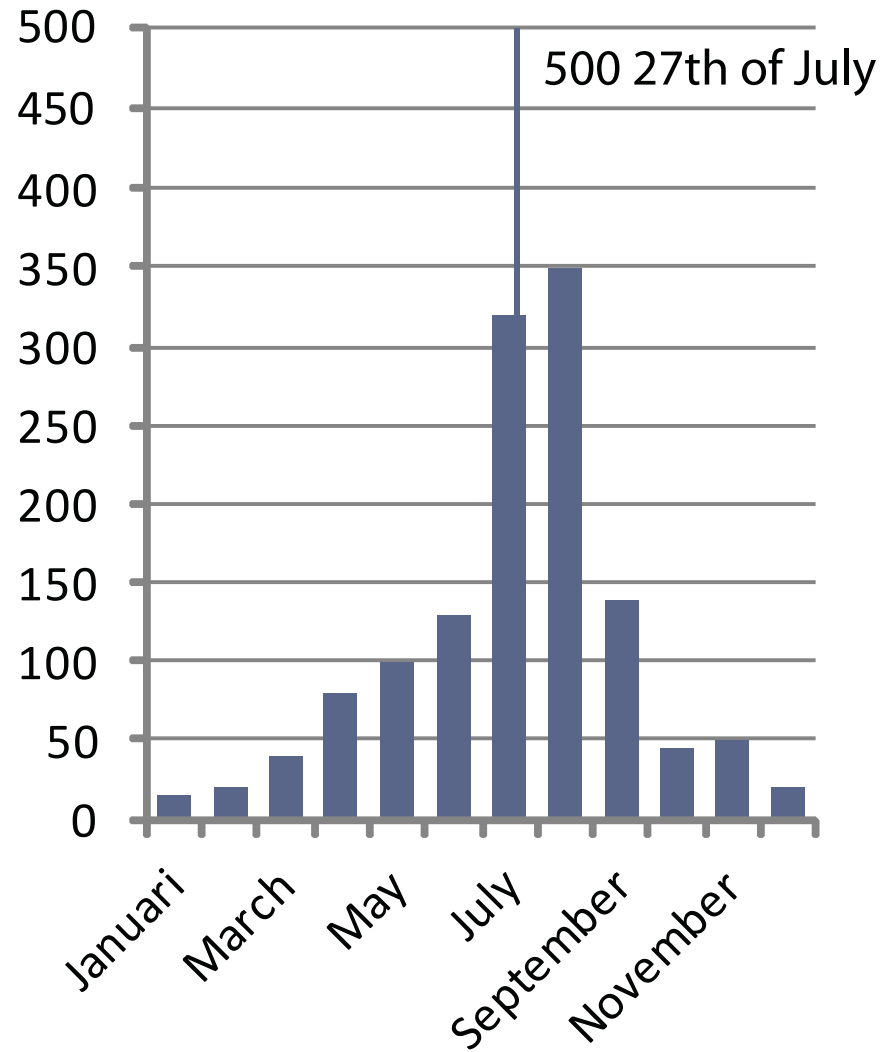

Rainfall Seoul

■ mm
precipitation

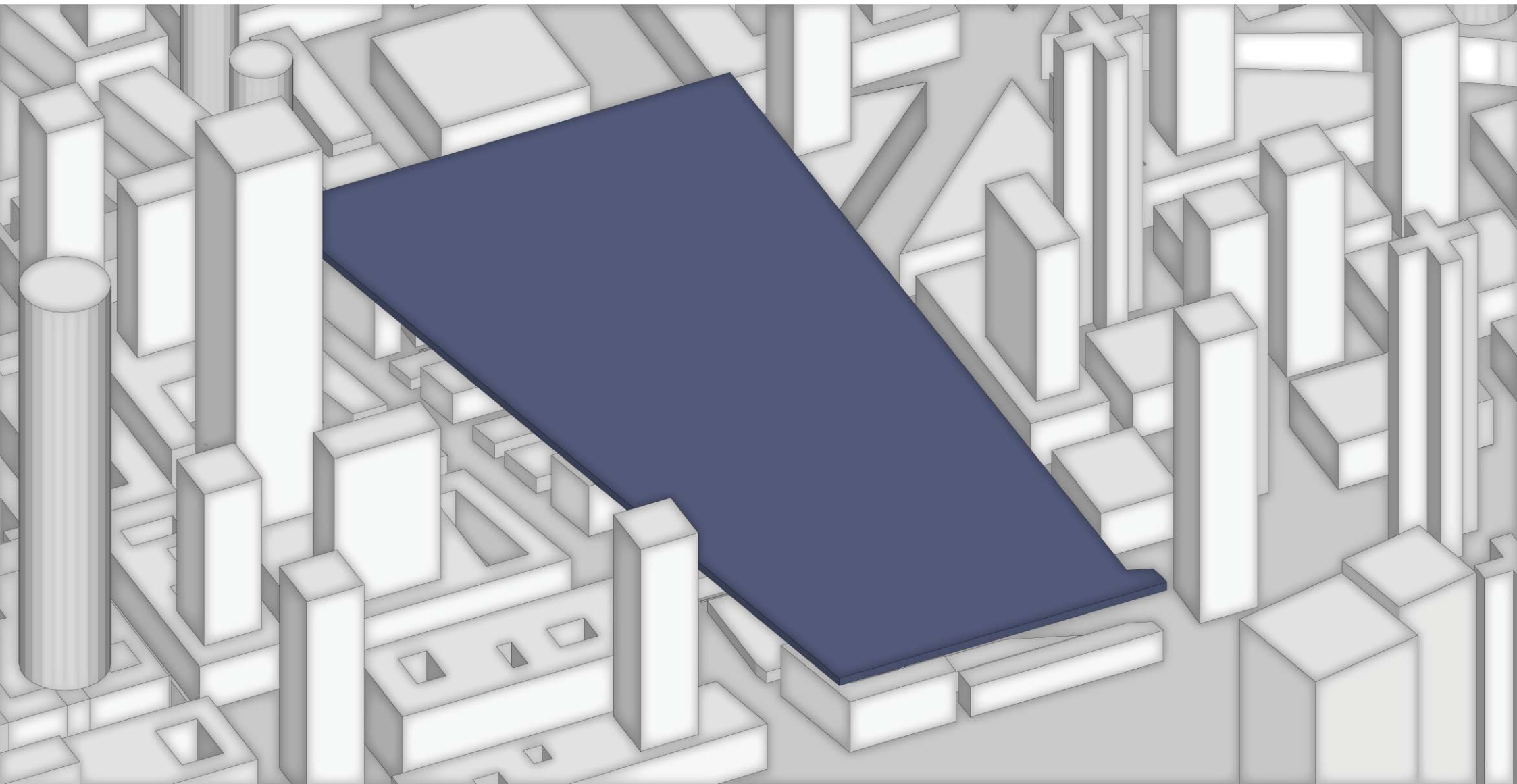

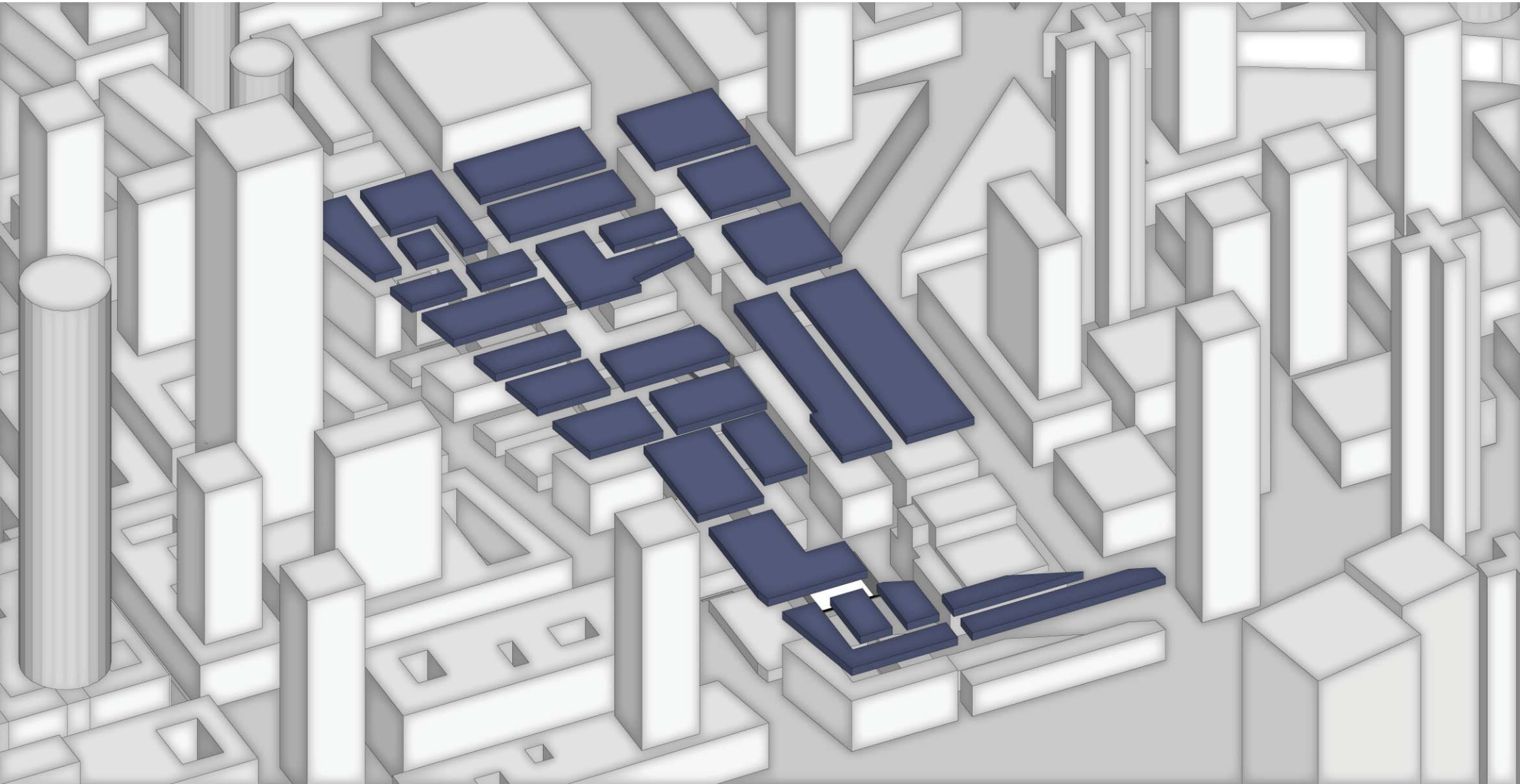

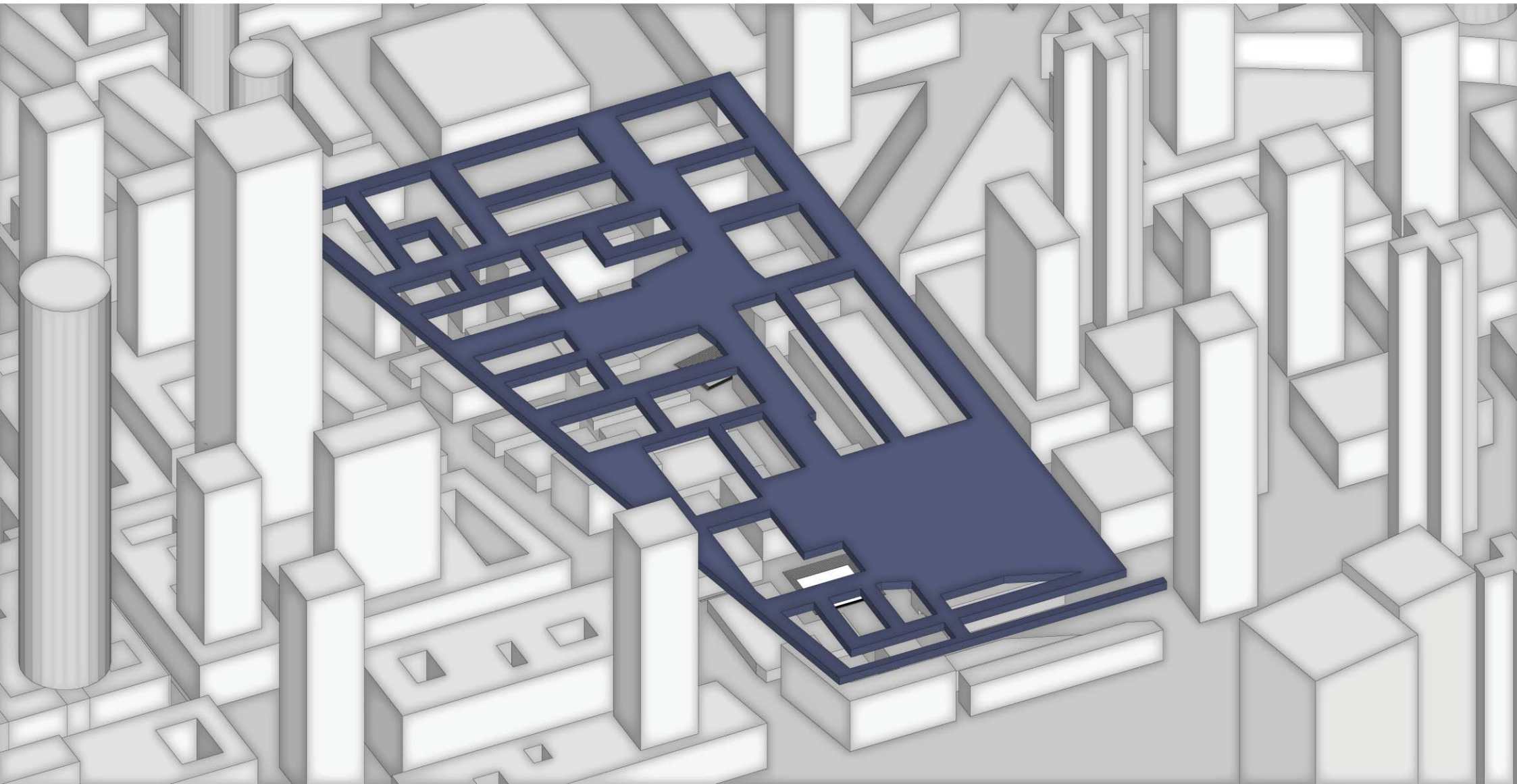

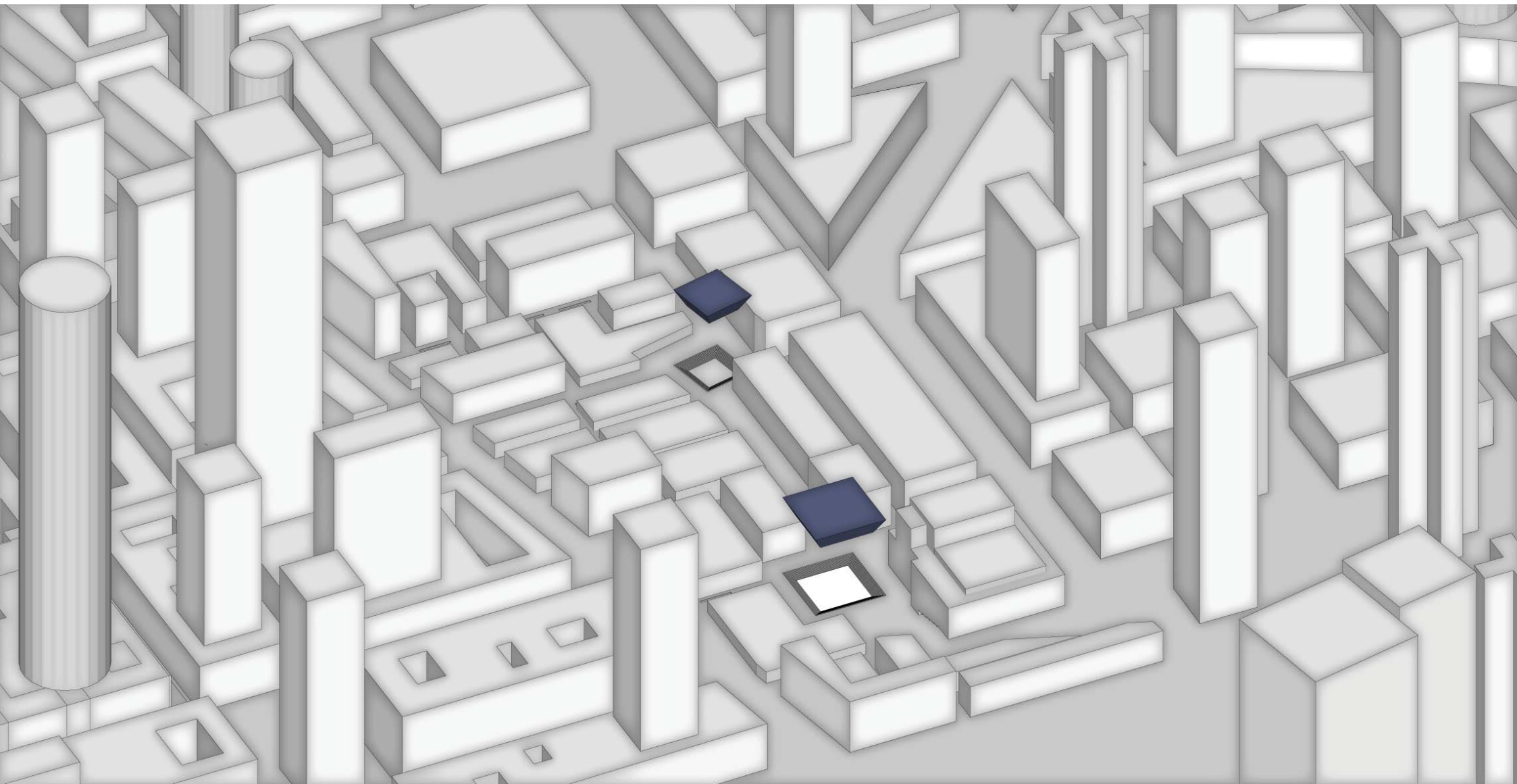





Watersquare 17th century

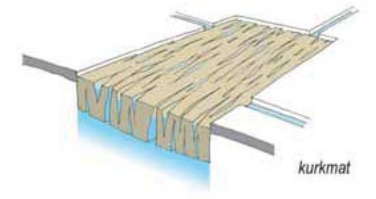
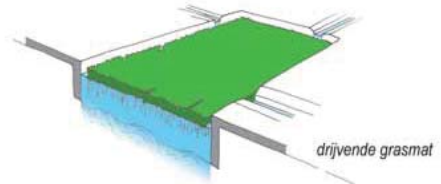
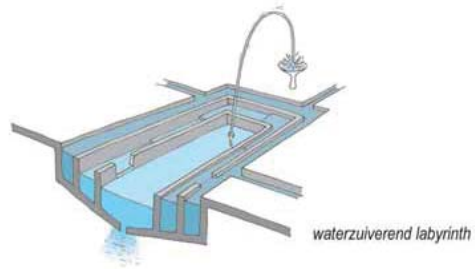
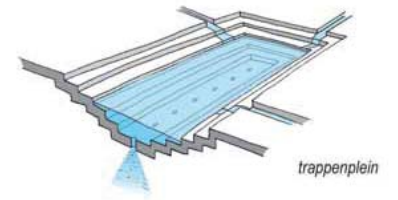
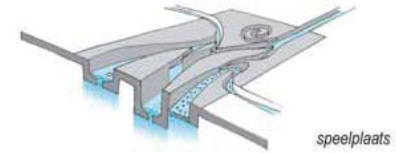
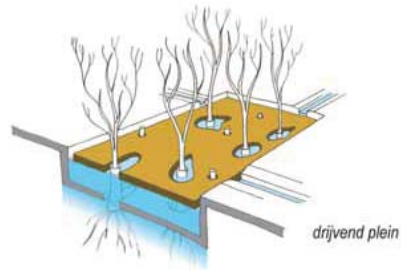

Waterplein Rotterdam research Layout



Museumpark Rotterdam



Belastingkantor Apeldoorn







Vertical Cities Asia
Graduation & Competition

Lifetime City & Theater City

평생시 와 극장시

Laura Dinkla
TU Delft 16 april 2013