



# Circular Economy of Mechanical Recycled Post-Consumer PP

ir. Emma P.A. van Bruggen

Delft University of Technology



# Circular economy of mechanical recycled post-consumer PP

By

**ir. Emma P.A. van Bruggen**

in partial fulfilment of the requirements for the degree of

**Master of Science**

in Materials Science and Engineering

at the Delft University of Technology,

Supervisor:	Prof. dr. P.C. Rem	TU Delft
Thesis committee:	Prof. dr. T.J. Dingemans	TU Delft
	Dr. ir. M. Janssen	TU Delft
	Dr.ir. R. Wever	TU Delft



Telephone: +31 642992768

Email: [vanbruggen.emma@gmail.com](mailto:vanbruggen.emma@gmail.com)

# Acknowledgement

Without support of many colleagues, family and friends, it would have not been possible to finish this thesis. Therefore, I would like to thank all members of the Technical University of Delft (TU Delft), Transylvania University of Braşov , Univeristy of Ghent (UGhent), Hordijk, Hermion and SITA and family and friends who were involved.

A special thanks goes to Prof. dr. P. Rem ,Prof. dr. T.J. Dingemans, Dr. ir. M. Janssen and Dr.ir. R. Wever (TU Delft) for their excellent guidance and opportunities they gave me during my study.

In addition, a special thanks goes out to Alexandra Ioana Rusănescu (Transylvania University of Braşov, Romania), for the collaboration during the three months of practical work of this thesis. Together we executed the steps outlined in the proposal, which was prepared by me three months before she joined. The practical work is performed together and adjustments of the proposal are done in agreement. Together, we processed all results into graphs. The first draft version of the introduction and experimental description (excluding section 4.1 and section 4.3) of this study are written by Alexandra. These drafts were reviewed, adjusted and expended by me. The description of the scope of the study, literature study and analysis of the results, layout and finalization of this thesis are done by me. Alexandra will hand in a modified version of this thesis in agreement, as fulfillment of her requirements for her thesis. Her thesis will include a more elaborated FTIR analysis, supported by her supervisor Prof. Dr. Ch. S.C. Paţachia.

Additionally, I also would like to thank Prof. dr. ing. K. Ragaert, M. Moerman and M. Erkoç (UGent) helping us in the lab with compounding, injection molding, melt flow index test and sharing their experience. Also thanks to dr.ir. A.C. Riemslog (TU Delft) who helped us getting used to the software for the Mechanical tests. Also many thanks to the employees of the department Resources and Recycling of the faculty civil engineering of the TU Delft for their help during cleaning, shredding, FTIR-scans and their help in general.

Furthermore, I would like to acknowledge dr.ir. E. Liebers (Hordijk), for providing information about their material use and offering their materials for free. Also thanks to R. Driesen (Hermion) for having allowed us to use their equipment during one of the steps of the preparation of the samples.

I also would like to thank ir. drs. M. Nieuwesteeg (NVC); J. Vandehoek (Umincorp); K. van de Stadt (KIDV); N. Fraunholcz (Recycling Avenue) and Prof. dr. S. J. Picken (TU Delft) for inspiring discussion on specific topics.

Finally I would like to thank my parents, sisters and friends for their support and keeping me motivated upon finishing my thesis.

*Ir.Emma P.A. van Bruggen*

*Delft, June2015*

# Abstract

**Background:** The growth of the global population in combination with technological development results in the need to improve the living conditions. This led to a significant and unsustainable increase in production of products. The unstable increase is especially the case for plastics, which have an annual worldwide production of over 288 million tons, that grows exponentially. Sustainable solutions and a circular economy are required to limit the unsustainable increased demand on natural resources. Solutions to this unsustainable situation include: the use of bio-based polymers, increased use of flexible packaging or improved recycling; either chemical or mechanical.

**Objective:** This study focuses on the possibility to create a circular economy of plastics by applying mechanical recycling. Mechanical recycling is a promising solution, especially with the new separation technology that is currently in development. The current separation technology of mechanical recycling separates plastic by type, but does not take any further separation criteria into account. This results in a mixed waste stream of many different grades, which cannot be used in a circular economy. However, the separation technology currently being developed can separate plastic on flake level. In addition to accurate density separation on flake level, the technology is able to separate flakes based on wall thickness and color. Separation based on wall thickness enables the possibility to separate based on manufacturing type. This study investigates whether this new separation technology can realize a circular economy for mechanical recycled post-consumer plastic.

**Methods:** The study is performed on post-consumer polypropylene (PP) from the packaging industry, as this industry counts for majority of plastics production. PP is one of the key plastic types used in packaging and its popularity is expected to increase, as transparent PP already replaces poly(ethylene terephthalate) (PET) in many applications. PP is a thermoplastic semi-crystalline polymer which properties are strongly correlated to its molecular parameters. Tacticity, crystallinity, molecular weight and copolymerization impact the properties of PP. The optical, mechanical and rheological properties of further categorized pure post-consumer PP (based on manufacturing type and color) are studied, as these properties give insight in their possibility to address the market needs.

**Results:** A first separation based on blow mold, thermoformed and injection mold leads to recycled material streams with well defined rheological and mechanical properties. The melt flow indices (MFI) of the categorized mechanical recycled waste streams address the needs of plastic manufacturers. Additionally, the thermoformed and blow mold waste streams show a ductile fracture behavior. However, the injection mold grade shows a brittle fracture mechanism. Categorization based on manufacturing type is correlated with a slight color separation. Further categorization of injection mold into a white and transparent grade leads to mechanical recycled materials streams with even better defined optical, rheological and mechanical properties. However, the injection mold white grade has become brittle, probably related to its low molecular weight. Modifications, such as the addition of virgin grade, might be required to meet the needs of the manufacturing industry.

**Conclusion:** Both results show that more defined categorization of recycled post-consumer can realize a circular economy of post-consumer PP. However, regulations for standardization are required to enable the appropriate use of PP in the food packaging industry and to prevent change in product characteristics over time (e.g. yellowing) things like yellowing.

By regulating standards to create a circular economy for mechanical recycled post-consumer plastics, manufacturers have to take their responsibility in recyclability, rather than minimizing the mass of packaging waste.

# Table of Contents

<b>1. Introduction .....</b>	<b>1</b>
1.1. <i>Plastic Production</i> .....	1
1.2. <i>Trends in Europe</i> .....	2
<b>2. Scope of the Study .....</b>	<b>5</b>
2.1. <i>Scope of this Study</i> .....	5
2.2. <i>Objective</i> .....	6
2.3. <i>Structure of this Study</i> .....	8
<b>3. Literature Study .....</b>	<b>9</b>
3.1. <i>Polypropylene in General</i> .....	9
3.2. <i>Impact of Recycling</i> .....	30
3.3. <i>Financial Aspects of Mechanical Recycled Post-Consumer Polypropylene</i> .....	37
<b>4. Experimental Part .....</b>	<b>41</b>
4.1. <i>Overall Study Method</i> .....	41
4.2. <i>Materials</i> .....	42
4.3. <i>Measured Properties</i> .....	45
4.1. <i>Testing Equipments</i> .....	50
4.2. <i>Sample Preparation</i> .....	52
<b>5. Results and Discussion .....</b>	<b>62</b>
5.1. <i>Limitations</i> .....	62
5.2. <i>Categorization method</i> .....	63
5.3. <i>Reference method</i> .....	72
<b>6. Conclusion.....</b>	<b>97</b>
6.1. <i>Secondary Research Questions</i> .....	97
6.2. <i>Primary Research Question</i> .....	99
<b>7. Recommendations .....</b>	<b>100</b>
7.1. <i>Related to the Results</i> .....	100
7.2. <i>Feasibility in Practice</i> .....	103
<b>8. List of Symbols .....</b>	<b>106</b>
8.1. <i>General Abbreviations</i> .....	106
8.2. <i>Abbreviations of Equations</i> .....	106

<b>9. Bibliography .....</b>	<b>108</b>
<b>10. Appendices .....</b>	<b>A</b>
10.1. <i>Material Datasheets .....</i>	<i>B</i>
10.2. <i>Post-Consumer Products Selected for this Study .....</i>	<i>H</i>
10.3. <i>Cut Offs and Removala from Post-Consumer Products of Reference Method .....</i>	<i>J</i>
10.4. <i>Equipment .....</i>	<i>L</i>
10.5. <i>Extensive Tables of Characteristic Absorption Bands for Functional Groups in IR Spectrum[129] .....</i>	<i>N</i>

# List of Figures

Figure 1: Human development index over ecological footprint[2]	1
Figure 2: World/European plastics production 1950-2012 [5]	2
Figure 3 Factors that influence the market of bio-based polymers[9]	3
Figure 4 European plastics demand by segment and resin type 2012[5]	5
Figure 5: Schematic representation of inter correlations between properties and parameters of polymers [26]	9
Figure 6: schematic representation of composition of the overall polymer [29]	10
Figure 7: Structural form of polypropylene [30]	10
Figure 8 Tacticity of polypropylene [32]	10
Figure 9: Example of narrow and broad molar mass distribution [35]	12
Figure 10: Schematic representation of an entanglement[40]	13
Figure 11: Schematic representation of molecular structures of PP Homopolymer (PP-H); PP Random Copolymer (PP-R); PP Heterophasic Copolymer (PP-B).[43]	13
Figure 12: Resonance stabilization after oxidation BHT [47]	15
Figure 13: Reaction of peroxides with phenoxyl radical of the BHT stabilization resonance [47]	15
Figure 14: Structure of sodium benzoate [57]	17
Figure 15: Electromagnetic spectrum [74]	21
Figure 16: Proposed schematic, monotectic phase diagram of the binary system i-PP/clarifier (1,3:2,4-bis(3,4-dimethyldibenzylidene)sorbitol (DMDBS)). Four regimes are indicated and their structures are sketched and represented with actual micrographs. [80]	23
Figure 17: nucleation of regular, heterogeneous nucleated and clarified PP[81]	24
Figure 18: example of sorbitol based clarifier: 1,3:2,4-bis(3,4-dimethylbenzylidene)[83]	24
Figure 19 Typical plot of the tensile strength as a function of the MW (here: M=number-average MW)[86]	26
Figure 20: schematic representation of Dependence of shear viscosity on molecular weight[88]	27
Figure 21: Impact of molecular weight distribution on viscosity behavior. [89]	27
Figure 22: Impact of different parameters on viscosity behavior. [89]	28
Figure 23: schematic representation of relaxation modulus over temperature. Optimal temperature ranges of different manufacturing processes.[94]	29
Figure 24: Schematic representation of bimodal MWD (LMW=low MW, HWM= high MW)[96]	30
Figure 25 Schematic representation of thermal degradation process of PP [107]	32
Figure 26 Schematic representation of thermal degradation process of PE [107]	32
Figure 27 Schematic representation of oxidation process of polypropylene[108]	33
Figure 28 Schematic representation of oxidation process of polyethylene and polypropylene [47]	33
Figure 29: Difference between conjugated and not conjugated systems. [112]	35
Figure 30: Over-oxidation of BHT resulting in a conjugated system that appears yellow[47]	35
Figure 31: Used anti-oxidants and process stabilizers in example of Figure 32[113]	35
Figure 32: Example of discoloration after repeated extrusion of PP including different anti-oxidants and process stabilizers as given in Figure 31[113]	36
Figure 33: Polyolefin prices in Central Europe between beginning of June (week 23) of 2014 and end of May (week 22) of 2015. [122]	39
Figure 34: Crude oil prices between beginning of June (week 23) of 2014 and end of May (week 22) of 2015 [123] The Oil price of North Sea Brent and The West Texas Intermediate (WTI) are given.	39
Figure 35: Prices of recycled PP granules between beginning of June 2013 and end of May 2015 [124]	40
Figure 36 categorization method	41
Figure 37 Reference method	42
Figure 38: Collection of post-consumer PP from conveyor belt	43
Figure 39: Schematic representation of a typical tensile response of a ductile plastic (stress-strain curve). [33]	45



Figure 40: General correlation between polymer viscosity and MFI [127]	46
Figure 41: Schematic representation of stretching and bending vibrations	47
Figure 42: IR spectra of 1) atactic, b) syndiotactic and c) isotactic PP[34]	48
Figure 43 Structural forms of repeating units of a) Polyethylene; b) Polypropylene; c) Polystyrene; d) Polyvinyl Chloride and e) Polyethylene terephthalate.	49
Figure 44 molecular structure of polybutene[130]	49
Figure 45: Infra red spectra of Rutile[132]	50
Figure 46: First step of cleaning: examples of product before washing (left) and after washing (right)	54
Figure 47: Fraction of PP blow mold flakes	55
Figure 48: Mixer of type HOBART A200	56
Figure 49: Second step of cleaning: Cleaned PP blow mold flakes (left), filtered impurities (right))	56
Figure 50: The shape and dimensions of the samples (mm)[33]	61
Figure 51: optical properties of flakes, granules and injection molded sample of PP at different stages of categorization method	63
Figure 52: optical properties of flakes, granules and injection molded sample of PP injection mold grades from specific products: a) Jumbo salads excluding labels; b) Jumbo salads including labels; c) Huzaren salads excluding prints; d) Huzaren salads including prints; e) Milbona desserts excluding labels; f) Milbona desserts including labels (granules missing).	72
Figure 53: optical properties of flakes, granules and injection molded sample of PP thermoformed and blow mold grades from specific products: a) Bami boxes; b) vegetable boxes; c) Persil bottles.	73
Figure 54: optical properties of flakes, granules and injection molded sample of PP virgin injection mold grade before and after extrusion	74
Figure 55: optical properties of flakes, granules and injection molded sample of PP virgin injection mold grade before and after extrusion	74
Figure 56: Diffraction patten of a highly amorphous structure (left) and a highly crystalline structure (right) [136]	100
Figure 57: Schematic representation of a general DSC plot[137]	101
Figure 58: schematic representation of analysis of spherulite structure by polarized light[138]	101
Figure 59: Schematic representation of GPC working principle [139]	102
Figure 60: Panatone color matching system for colored PP plastic.[141]	103

# List of Tables

Table 1: Commercial UV stabilizers[47]	16
Table 2: Interaction between different anti-oxidants and UV-stabilizer of PP. AO= anti-oxidants; UVA=UV absorber. [47]	19
Table 3: overview of properties of PP	19
Table 4: Comparison of three types of PP based on rigidity, abuse resistance and transparency[36]	20
Table 5: Crystalline and amorphous densities for polyethylene and polypropylene	22
Table 6 Degree of transparency [75]	22
Table 7: Virgin materials used in this study	43
Table 8: Post-consumer products for the reference method	44
Table 9: Frequencies of important IR stretching vibration[129]	47
Table 10: Sampling time of MFI tests: categorization method	51
Table 11: Sampling time of MFI tests: reference method	51
Table 12: Characteristic signs of products depending on the manufacturing process	53
Table 13: mass fraction of labels in parts of products containing labels	55
Table 14 Temperature profiles for compounding process: categorization method	58
Table 15 Temperature profiles for compounding process: reference method	59
Table 16: Temperature profile during injection molding. Temperature profile given from inlet to outlet and subsequently the mold temperature	60
Table 17: Holding pressure of during injection molding of each sample: categorization method	60
Table 18: Holding pressure of during injection molding of each sample: reference method	60
Table 19: Selected injection mold post-consumer products	H
Table 20: Selected thermoformed post-consumer products	H
Table 21: Selected blow mold post-consumer products	H
Table 22: The fractions of the injection mold post-consumer products related to the reference method	J
Table 23: The fractions of the thermoformed post-consumer products related to the reference method.	K
Table 24: The fractions of the blow mold post-consumer products related to the reference method	K

# List of Graphs

Graph 1: Fraction of injection mold productions in comparison to thermoformed and blow mold products in preselected conventional post-consumer PP stream (4kg)	52
Graph 2: Ultimate tensile strength of all grades of categorization method, averages and standard deviation are given	64
Graph 3: Strength at break of all grades of categorization method, averages and standard deviation are given	64
Graph 4: Strain at break of all grades of categorization method, averages and standard deviation are given	65
Graph 5: Melt flow index of all grades of categorization method, averages and standard deviation are given	66
Graph 6: FTIR spectra of five samples of conventional sorted PP + non-PP plastics	68
Graph 7: FTIR spectra of five samples of conventional sorted PP - non-PP plastics	68
Graph 8: FTIR spectra of five samples of blow mold products	69
Graph 9: FTIR spectra of five samples of injection mold products	69
Graph 10: FTIR spectra of five samples of thermoformed products	70
Graph 11: FTIR spectra of five samples of white injection mold products	70
Graph 12: FTIR spectra of five samples of transparent injection mold products	71
Graph 13: Ultimate tensile strength of all injection mold grades from specific products, averages and standard deviation are given	75
Graph 14: Tensile Strength at break of all injection mold grades from specific products, averages and standard deviation are given	75
Graph 15: Strain at break of all injection mold grades from specific products, averages and standard deviation are given	76
Graph 16: Ultimate tensile strength of all thermoformed and blow mold grades from specific products, averages and standard deviation are given	78
Graph 17: Tensile strength at break of all thermoformed and blow mold grades from specific products, averages and standard deviation are given	78
Graph 18: Strain at break of all thermoformed and blow mold grades from specific products, averages and standard deviation are given	79
Graph 19: Ultimate tensile strength of one injection mold and one thermoformed grade and their mixture, averages and standard deviation are given	80
Graph 20: Tensile strength at break of one injection mold and one thermoformed grade and their mixture, averages and standard deviation are given	81
Graph 21: Strain at break of one injection mold and one thermoformed grade and their mixture, averages and standard deviation are given	81
Graph 22: Melt flow index of all injection mold grades from specific products, averages and standard deviation are given	82
Graph 23: Melt flow index of all thermoformed and blow mold grades from specific products, averages and standard deviation are given. NOTE: another scale is used than for the other graphs of melt flow index	83
Graph 24: Melt flow index of one injection mold and one thermoformed grade and their mixture, averages and standard deviation are given	83
Graph 25: FTIR spectra of five samples of injection mold 100% homopolymer	85
Graph 26: FTIR spectra of five samples of injection mold virgin grade Jumbo salads	85
Graph 27: FTIR spectra of five samples of injection mold Jumbo salads	86
Graph 28: FTIR spectra of five samples of injection mold Jumbo salads including labels	86
Graph 29 FTIR spectra of five samples of Jumbo labels, printed side	86
Graph 30: FTIR spectra of five samples of Jumbo labels, unprinted side	87
Graph 31: FTIR spectra of five samples of injection mold virgin grade Huzaren salads	88
Graph 32: FTIR spectra of five samples of injection mold Huzaren salads	88

Graph 33: FTIR spectra of five samples of injection mold Huzaren salads including printing inks	89
Graph 34: FTIR spectra of five samples of injection mold virgin grade Milbona Desserts	89
Graph 35: FTIR spectra of five samples of injection mold Milbona desserts	90
Graph 36: FTIR spectra of five samples of injection mold milbona desserts including in mold labels	90
Graph 37: FTIR spectra of five samples of injection mold virgin grade Milbona Desserts, after extrusion	91
Graph 38: FTIR spectra of five samples of Milbona labels, printed side	91
Graph 39: FTIR spectra of five samples of Milbona labels, unprinted side	92
Graph 40: FTIR spectra of five samples of thermoformed grade Bami and vegetable boxes (white random copolymer)	92
Graph 41: spectra of five samples of thermoformed grade Bami and vegetable boxes (white random copolymer), after extrusion	93
Graph 42: spectra of five samples of thermoformed grade Bami and vegetable boxes (blue random copolymer), after extrusion	93
Graph 43: FTIR spectra of five samples of thermoformed Bami boxes	94
Graph 44: FTIR spectra of five samples of thermoformed vegetable boxes	94
Graph 45 FTIR spectra of five samples of mixture: injection mold + thermoformed grade	95
Graph 46: FTIR spectra of five samples of blow mold Persil bottle	95

# 1. Introduction

The growth of the global population in combination with a continuous technological development is correlated with the need to improve the living conditions. This led to a significant increase in the development and production of products that meet the demands for increased comfort. This latter resulted in a large footprint for people living in developed countries, as is illustrated in Figure 1. A footprint is a measure of the demand on nature, land and water, to produce the resources and the required area to absorb the waste produced. [1] It is expressed in the hectares, as the area of the earth which is needed by a population. Nowadays, we already need more than one planet to provide the resources and to absorb our waste. The additional growth in human development index of people from developing countries will result in a world that is unsustainable. The development of circular economies is therefore necessary to limit the footprint per person. This study will focus on possible ways to create a circular economy for plastic materials.

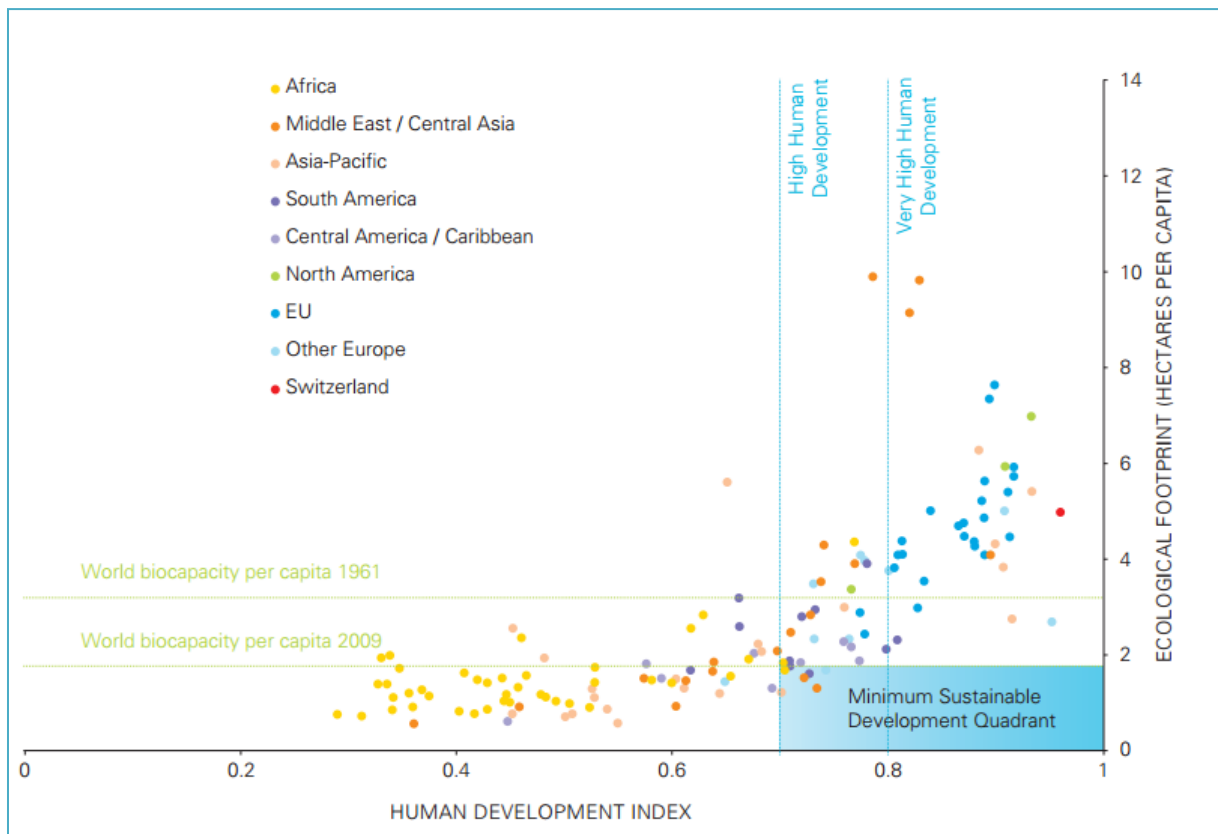

Figure 1: Human development index over ecological footprint[2]

## 1.1. Plastic Production

The use of plastics is enormous, 288 million tons worldwide in 2012, and still grows exponentially every year. Reason being the multiple advantages of plastics: easy manufacturing; low density; flexible design and the fact that properties of each application can easily be tailored. [3] The latter means that plastics provide the possibility to adapt to the characteristics required. [4] Another major advantage is the relatively low cost of plastics. Less than 10% of the total costs of plastic products are related to the material costs. [3]

However, the production of plastic products is causing a worldwide challenge: the treatment of post-consumer products. At European level (in 2011) the amount of produced plastic products was estimated at 47 million tons, of which 25 million tons ended up as post-consumer plastic waste. The demand for plastic materials is increasing enormously as is illustrated in Figure 2. The latter shows the ever increasing need for a solution of the treatment [4].

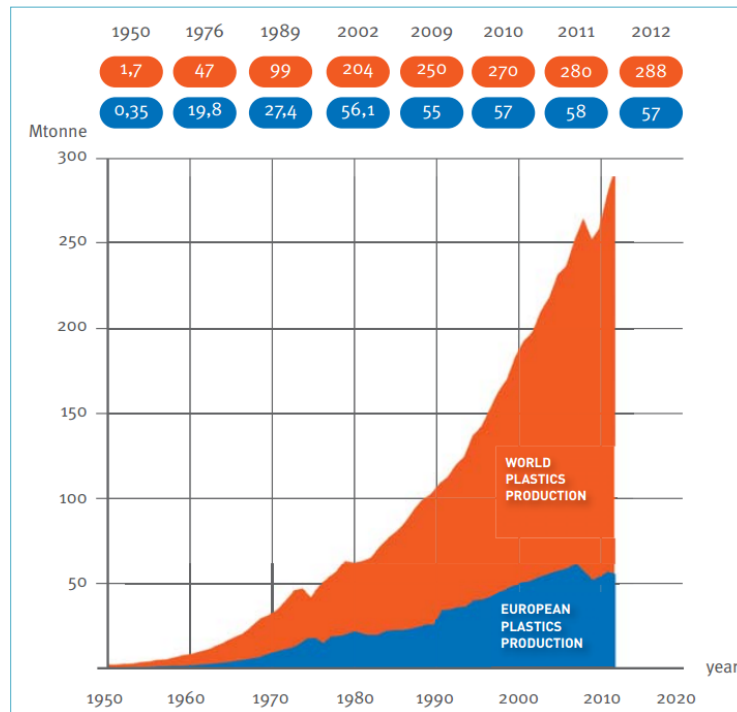

Figure 2: World/European plastics production 1950-2012 [5]

## 1.2. Trends in Europe

As the production of plastic products correlates with its footprint, not only treatment of post-consumer plastic waste, but also the production of plastic products is a key area of focus. For the majority of plastics, raw materials are derived from fossil fuels. About 4% of all petroleum used is annually converted into over 250 million tons of plastics [3], of which packaging represents about 40% [5]. The natural resources were able to provide the required quantities for the production of plastics in recent decades, but the shortage of resources is growing rapidly. This issue, in combination with the challenge around the treatment of plastic waste, emphasizes the need to find alternatives that meet current needs. This is in accordance with the concept to create a more sustainable environment that: *“meets the needs of the present without compromising the ability of future generations to meet their own needs”*. [6]

Creating a more sustainable environment, in the context of plastic materials, means that both the environmental impact as the depletion of natural resources must be managed. This can be done by a change in the way the plastic products are manufactured and treated by the society. In Europe there are several trends towards a solution that can manage these two factors. The three main solutions will be explained in more detail.

### 1.2.1. Bio-based Materials

One of the feasible alternatives to traditional polymers production is the replacement of raw material of polymers manufacturing with a renewable raw material: *bio-based polymers*. They provide a sustainable solution, as they are made of renewable agricultural raw materials such as starch corn or soy protein. [7] Also, food sources such as algae can be used for manufacturing. [8] Compared to their petroleum counterparts, biopolymers are relatively new to the market, but a more promising approach to

sustainable plastics in the future. Fossil fuel consumption and CO<sub>2</sub> emissions will decrease by an increased use of bio-based polymers. Other important factors that influence replacement of current plastics by more sustainable plastics include price, fit for use in all applications and laws and regulations. An overview of all factors is presented in Figure 3. [7]

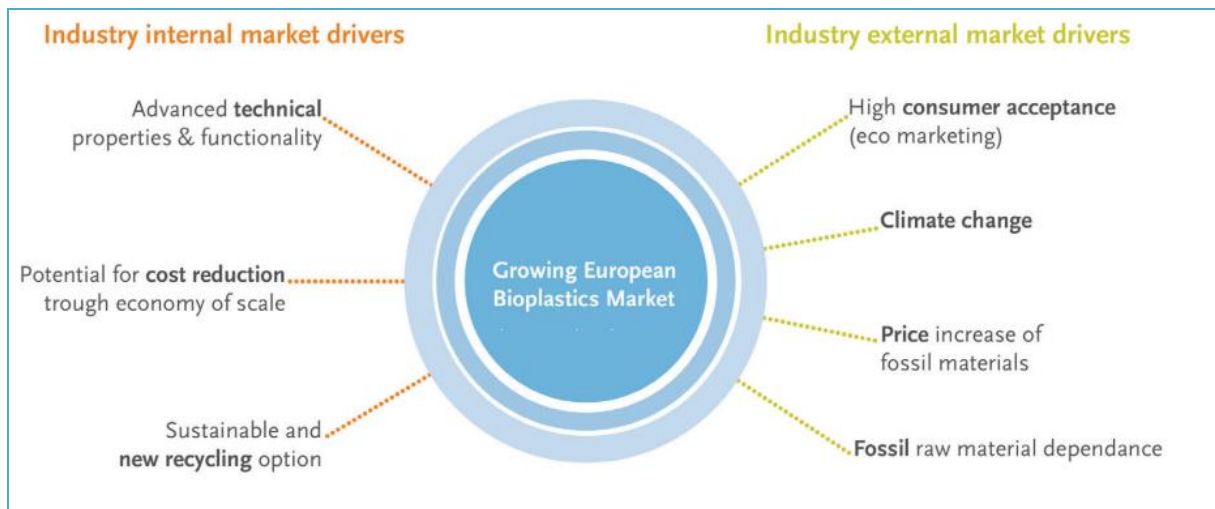

Figure 3 Factors that influence the market of bio-based polymers[9]

### 1.2.2. Flexible Packaging

Another trend in Europe is the increased production of flexible packaging. The basic idea of this concept is the design of lighter-weight packaging by reducing the wall thickness significantly. Flexible packaging decreases the total need for materials, as the materials are used more efficiently. This trend will reduce the quantity of raw materials required, which is also in close correlation with the factors. Currently, 40% of the plastic packaging sector consists flexible packaging. This percentage is low and growth is desired to make it a sustainable solution. [10]

### 1.2.3. Recycling

Most known in Europe is the tendency to move towards a "recycling society". Recycling directly leads to a decreased demand for new materials. Additionally it results in the possibility to create a circular economy. Furthermore, it leads to a direct reduction in energy consumption by the manufacturing process and the emission of greenhouse gases. However, the current situation of recycling is not in line with the requirements as formulated by the manufacturing market. The recycled material cannot be returned back into the same production process due to significant changed properties after recycling and a circular economy is not possible. New developments and concepts of recycling are required, to develop material that meets the needs of the market. Current technologies and new developments will be discussed in more detail.

#### ***Current Recycling Process***

The current recycling process starts with the collection of plastic. The main method of recycling of plastics is mechanical recycling. However, the recycling rate is low and an increased growth is required. [5]

After collection, the plastic is sorted based on its polymer type. The current technology used for this separation is near infrared (NIR). NIR separates plastic per type, where after the material can undergo chemical or mechanical recycling.

### Chemical Recycling

Chemical recycling involves depolymerization of polymer chains into oligomers or monomers. These materials can be used in the petrochemical industry and for the reproduction of new polymers. Chemical recycling can therefore close the material loop, however, the large amounts of energies are needed. Therefore new catalytic technologies are in development which will reduce the energy consumption and increase the conversion rate. [11][12]

### Mechanical Recycling

NIR separation is able to separate per plastic type, but does not take any further separation criteria into account. This results in a mixed waste stream of many different grades with mixed properties which do not meet the requirements of the origination manufacturers. For this reason, extra treatments are required to modify the properties. For example PP needs to undergo a peroxide treatment in order to obtain chain scission and therewith modify the flow behavior of the material. However, this treatment only results in the formation of injection mold grade PP. This means that the plastics cannot be used for the same purposes as their origin. Additionally, NIR system is not able to recognize the type of plastic of black properties, as all light is absorbed. Therefore new technologies are developed to improve the market value of recycled plastics.

### ***New Mechanical Recycling Technology***

This new technology is able to separate post-consumer plastic in better and more specific categories as compared to the conventional sorting technology. Magnetic density separation (MDS) is a technology, developed by the Technical University of Delft and used since 2007. It is a technology that can separate plastics on flake level. Shredded plastic flakes run through a magnetic liquid and pass a magnet that sorts the polymers into categories of different densities. These densities can be recovered separately and even further sorted. The technologies are still in development, but ultimately, the technique will be able to separate the flakes based on wall thickness[13] and color.



## 2. Scope of the Study

The application of flexible packaging, bio-based polymers and recycling of plastic products will all result in a decreased footprint. This study will specially focus on the possibility to create a circular economy of plastics by mechanical recycling. The reason to specifically focus on mechanical recycling is based on the fact that the flexible packaging leads to a decrease in material demand, but does not close the material loop. Additionally bio-based polymers are not necessarily also bio-degradable which makes an end-of-use treatment still needed. Finally Mechanical recycling is preferred over chemical recycling since the eco-costs of mechanical recycling are lower as compared to chemical recycling. This is mainly caused by the higher energy consumption of chemical recycling. This study will therefore focus on the possibility to create a circular economy for plastics by mechanical recycling, using new separation opportunities of the new recycling technology

### 2.1. Scope of this Study

There exist many types of plastics which properties and diversities depend on their final application. The main applications are packaging, building & construction, automotive and electrical & electronic industries (Figure 4). This study will focus on the packaging industry since it is the industry where the plastics have the shortest life time in combination with the largest demand.

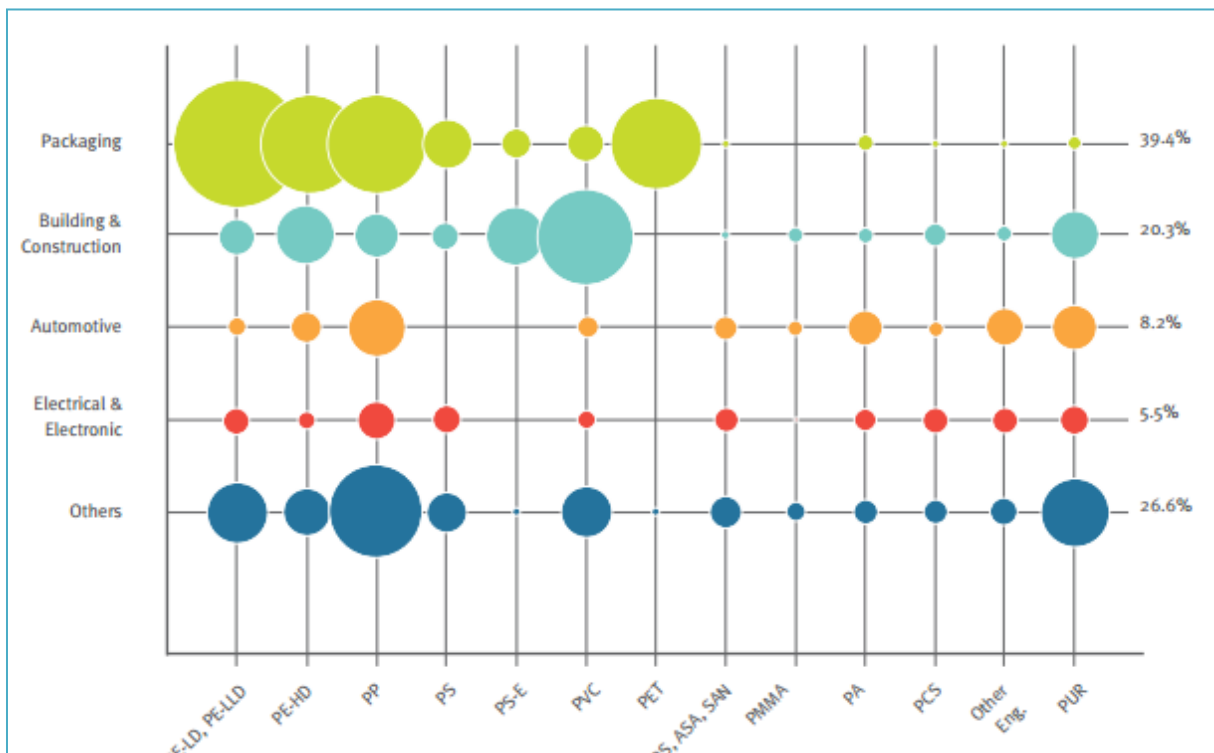

Figure 4 European plastics demand by segment and resin type 2012[5]

#### 2.1.1. Focus on Polypropylene

The scope will further narrowed by focusing on the polypropylene (PP) fraction of the packaging industry, which besides polyethylene terephthalate (PET) and polyethylene (PE), is one of the major types used in the packaging industry. The final choice for PP is partly based due to the fact that the demand for transparent plastics is increasing in the EU. The advantage of transparent plastic is that people can look through it without touching the food. This cuts down the damaging of food[14]. Transparent packages

also enhance the sales of the packaged products. Clear PET is widely available and commonly used grade. High density polyethylene (HDPE) is not available in transparent form and in this study will therefore not focus on this type. However, transparent PP is currently developed and is known as clarified PP. Clarified PP is already widely used in the packaging sector [15]. PP is even replacing PET in several products. [16] The advantage of clear PP compared to PET is the lower density, among  $0.90 \text{ g/cm}^2$  compared to  $1.35 \text{ g/cm}^2$ . This helps reduce overall packaging weight and therewith minimize waste production and cuts fuel usage during shipping [17]. Clarifying of PP also speeds the cycles and increases the stiffness[16]. All these properties results in a lower carbon footprint during production and the supply chain compared to PET[18]. In addition, PP has an exceptionally good price/ performance ratio [19] and makes PP a serious competitor of PET. The Freedonia Group of the US predicts that the demand of PP will outpace the overall container resins demand growth through 2016 [20].

Furthermore, recycling PET is already a quite stable process [21] and it is the largest plastic material recycled in Europe [22]. The reasons for this are the drop-off collection programs and the easy recognition and selection of the PET bottle by conventional sorting machines. The PET recycling is also promoted by framework agreements: 23-28% recycled PET needs to be used for the production of new PET bottles [23]. Because of the possible replacement of PET by clear PP and its general significant commercial interest, there is a need to study the recycling possibilities of PP. The strategy for recycling is a very important factor for the environmental policy of the plastic industry. [24]

### **2.1.2. Focus on Separation Opportunities**

This study will focus on opportunities of the new mechanical recycling technology. As explained in section 1.2.3, this technology will be able to separate the flakes based on wall thickness and color. Color is a very important property for designers of packages. The color of a plastic package interacts with the end-user. Assumed is the existence of a color-property relation. For example bleach is commonly packed in yellow colored packaging, which requires specific properties of the plastic used. The risk of leakage of this product is assumed to be significantly lower as compared to package of non-toxic food. This study will focus on transparent and white PP. Transparent, as there is a high interest for transparent packaging. White PP is highlighted related to its market value, as white material can still be transferred into all colors, which is not the case for an already colored material. The separation based on color makes it also possible to separate flakes including (inmold) labels from the pure flakes. Separation based on wall thickness will lead to the ability to separate based on manufacturing type (blow mold/ thermoformed and injection mold) as studied of B. Hu [13].

## **2.2. Objective**

---

The above mentioned separation possibilities can lead to a major change in the total market construction and recycling possibilities of plastic waste. Plastics are expected to be used in the same quality products as their origin and will thereby contribute to circular economy. However, the quality of the final more specified categories and the marketability of these categories are unknown. Optical, rheological and mechanical properties are important factors that give an insight in possibility of the of the mechanical recycled grade to address the needs of the market: Rheological properties are related to the processing conditions; mechanical properties are related to allowed external loads in applications; optical properties are important for the designers of plastic products, as it determines the product aesthetics. Understanding the impact of specific sorting of post-consumer PP on its optical, mechanical and rheological properties is therefore the objective of this study. These three properties are the major properties that determine the final feasibility of a circular economy by mechanical recycling. To achieve this objective, this study will provide answers to the following primary and secondary research questions.

### 2.2.1. Primary Research Question

Can mechanical recycling realize a circular economy of post-consumer PP?

### 2.2.2. Secondary Research Questions

The secondary research questions are related to the two methods used in this study. The first method, the categorization method, is performed to analyze the feasibility of a circular economy of mechanical recycled post-consumer PP. The analysis is based on the impact of further categorization on the optical, mechanical and rheological properties. The second method, the reference method, is used to get an insight in the impact of different parameters on the optical, mechanical and rheological properties. The parameters studied are degradation during a complete life cycle of PP, degradation during extrusion, the impact of a different service life, impact of labels and printing inks; impact of mixing two different grades of PP. The first three parameters are studied to get an insight in the impact of different stages in a life cycle of the plastic on the product and gives insight on which stage requires most attention to prevent degradation. The impact of in mold labels and printing inks are tested, because separation based on color can be used to separate the labeled/ printed flakes from the pure flakes. Finally, understanding the impact of mixing different grades is of interest because compounding of grades after categorization might be required.

Details on the categorization and the reference method are explained in section 4.1.

#### ***Categorization Method***

- What is the impact of removing non-PP impurities on the optical, mechanical and rheological properties of recycled post-consumer PP?
- Do the optical, mechanical and rheological properties of recycled post-consumer PP better address the market needs after separation based on the manufacturing process of the product?
- Do the optical, mechanical and rheological properties of recycled post-consumer PP better address the market needs after separation based on color?

#### ***Reference Method***

- What is the negative impact of degradation during processing, service life and subsequent mechanical recycling on the optical, mechanical and rheological properties of recycled pure post-consumer products?
- What is the impact of extrusion in relation to the total impact of degradation of post-consumer plastic on the optical, mechanical and rheological properties of virgin materials?
- What is the impact of a different service life on the optical, mechanical and rheological properties of recycled pure post-consumer products?
- What is the impact of in mold labels on the optical, mechanical and rheological properties of recycled pure post-consumer products?
- What is the impact of printing inks on the optical, mechanical and rheological properties of recycled pure post-consumer products?
- What is the impact of mixing a virgin injection mold grade with a virgin thermoform grade on the optical, mechanical and rheological properties of the blend?

### **2.3. Structure of this Study**

---

This study will start with a literature study, describing the inter-correlation between molecular parameters, optical, mechanical and rheological properties of PP. Followed by a short description of the difference between different processing grades and the theoretical impact of degradation. Chapter 4 will explain the general methodology used for this study, including an overview of the materials used. Chapter 4 also contains a detailed description of experiments used in this study. The results are presented and discussed in chapter 5. The answer to the primary research question is presented in chapter 6. Finally, chapter 7 contains recommendations for further studies.

## 3. Literature Study

A review of the literature provides a better understanding of the properties of recycled post-consumer PP. The literature study is divided in three sections, starting with a general description of PP, including existing inter-correlation between molecular parameters and macroscopic properties. Properties taken into consideration are mechanical, rheological and optical properties, as mentioned in the scope of this study. The second part describes the impact of recycling on these properties. Finally, the financial aspects are discussed.

### 3.1. Polypropylene in General

PP, a synthetic polymer, is popular and widely used because of its good overall performance/cost ratio and the fact that its properties can easily be tailored. Tailoring is required to optimize the properties and its process ability for each application. The molecular structure greatly impacts the mechanical, rheological, optical and processing properties. These parameters are inter-correlated as schematically presented in Figure 5. [25] This chapter will discuss each of these parameters separately.

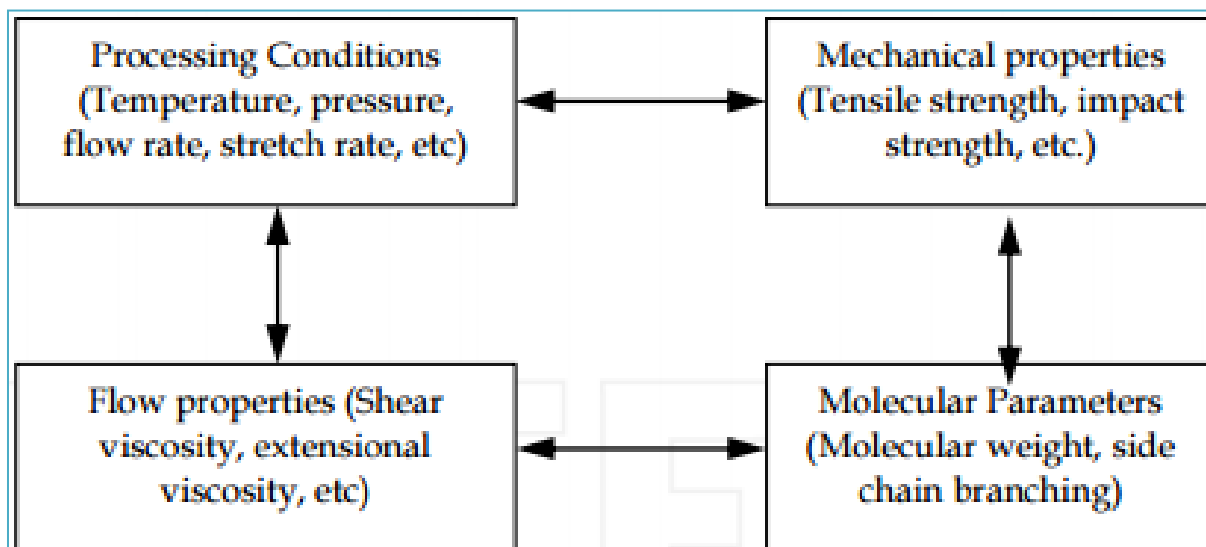

Figure 5: Schematic representation of inter correlations between properties and parameters of polymers [26]

#### 3.1.1. Molecular Parameters

A polymer is composed of long polymer chain with a repeating molecular unit. These chains fold together and form order regions, referred as lamellae. Subsequently these lamellae form a spherical structure called spherulites. The folded, crystalline, regions in a spherulite are separated by amorphous regions. A plastic consists of spherulites that impinge on each other. The composition of the overall structure is schematically represented in Figure 6. [27] The repeating unit of PP is an important parameter. The molecular structure repeating unit of PP, given in Figure 7, has a chiral carbon and the polymer can therefore be categorized based on tacticity. Tacticity highly influences the properties of PP and is therefore discussed in this section. Additionally, modifications of the crystallinity, molecular weight (MW), copolymerization and/or the addition of additives can be used to tailor the properties of PP [28]. The impact of tailoring these properties will be described in more detail

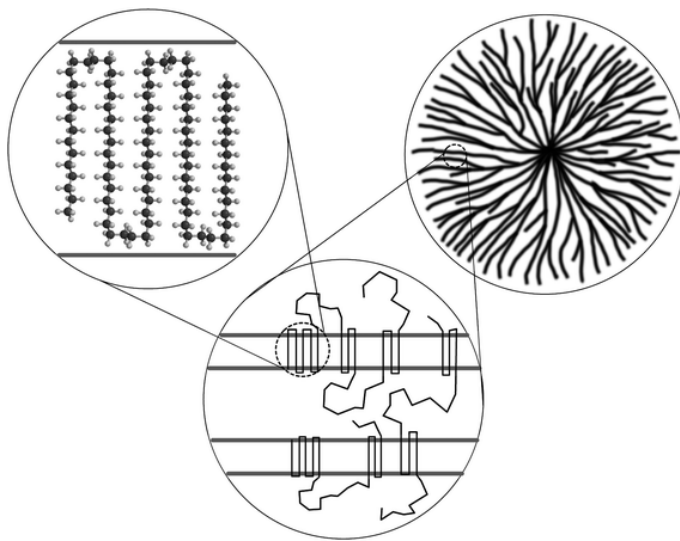

Figure 6: schematic representation of composition of the overall polymer [29]

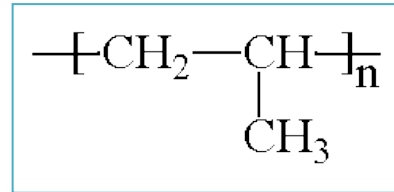

Figure 7: Structural form of polypropylene [30]

### Tacticity

The term tacticity is used to describe the way pendant methyl groups are all located at the backbone of polypropylene. The relative position of this group can have significant impacts on the physical properties of the polymer as it influences the final structure (Figure 6). Polypropylene has three different categories: Isotactic, syndiotactic and atactic. The categories are based on the position of the methyl group. [31]

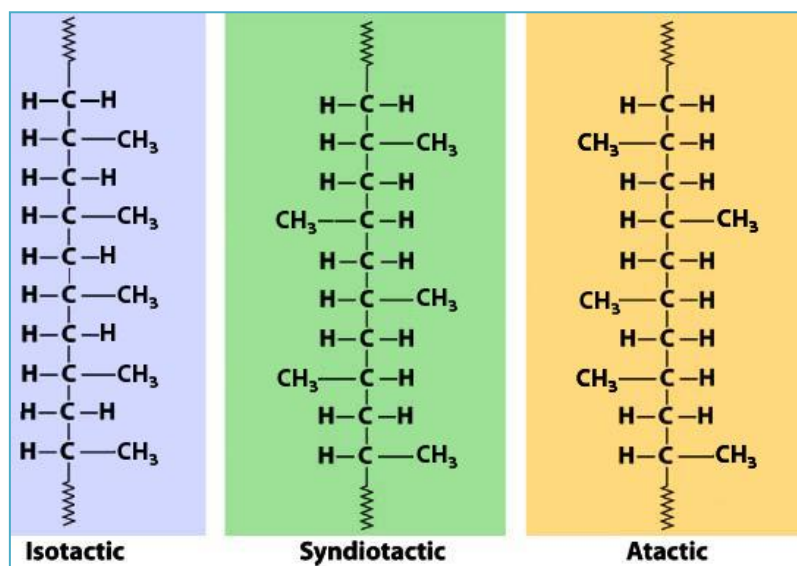

Figure 8 Tacticity of polypropylene [32]

### Crystalline Structure

Polypropylene is a semi-crystalline polymer, in co-existence of amorphous and crystalline regions. The degree of crystallinity and the microscopic structure of the crystalline regions affect the macroscopic properties of PP. The crystallinity is correlated to the tacticity and molecular weight.

Additionally, the average size of the spherulites partly determines the final properties of PP. The average size of spherulites is determined by a combination of nucleation rate and growth. The spherulites grow after nucleation, until they impinge with one another. The optimal mechanical properties are obtained at very small spherulite size.

Finally, also polymorphism plays a role in the determination of the properties of PP. Polymorphism is the ability of PP to exist in more than one crystal phases. During crystallization, different crystal phases are formed simultaneously. The two main phases for Isotactic PP are the  $\alpha$ - and  $\beta$ - phases. The  $\alpha$ - phase is the primary form and is in a stable equilibrium. Phase  $\alpha$ - is formed under normal processing conditions. The  $\beta$ - phase is metastable and is formed at higher cooling rates and by the addition of specific nucleation agents. [33]

### **Molecular Weight**

In addition to tacticity, MW and molecular weight distribution (MWD) largely determine the mechanical and rheological properties of polypropylene. Understanding the relation between MW and these properties requires knowledge of the length of the polymer chains. MW is often related to the molar mass of the repeating monomers and the number of these monomers connected in the chain. All synthetic polymers are polydisperse, which means that the polymer exists of a distribution of chain lengths. The MW is therefore described as an average. There are different ways of defining the average weight. The three mostly used methods are: number average, weight average and higher average molecular weights. These will be discussed prior to explaining the general impact of increased MW.

#### Molar Mass Averages

The number-average molar mass is equal to the sum of the products of the molar mass of each fraction multiplied by the mole fraction. The weight molar mass is equal to the sum of the products of the molar mass of each fraction multiplied by its weight fraction. Their equations are given in Equation 1 and Equation 2.

$$\overline{M}_n = \sum X_i M_i = \frac{\sum N_i M_i}{\sum N_i} \quad \text{Equation 1[34]}$$

$$\overline{M}_w = \sum w_i M_i = \frac{\sum N_i M_i^2}{\sum N_i M_i} \quad \text{Equation 2[34]}$$

where

$\overline{M}_n$  = Number – average molecular weight

$\overline{M}_w$  = Weight – average molecular weight

$X_i$  = mole fractions of molecules of molar mass  $M_i$

$N_i$  = Number of molecules of molar mass  $M_i$

$w_i$  = the weight fraction: the mass of molecules of molar mass  $M_i$  divided by the total mass of all the molecules present

The higher molar mass is defined as

$$\overline{M}_z = \sum X_i M_i = \frac{\sum N_i M_i^3}{\sum N_i M_i^2} \quad \text{Equation 3[34]}$$

The relative values of these averages determine the final properties of PP. A commonly used definition is the polydispersity index (PDI) of the polymer. It is often used as a measure of the breadth of the molar mass distribution. [34] The polydispersity is defined as

$$PDI = \frac{\overline{M}_w}{\overline{M}_n} \quad \text{Equation 4[34]}$$

An example of a narrow and broad molar mass distribution is given in Figure 9 and illustrates the possible mass distributions in relation with the averages.

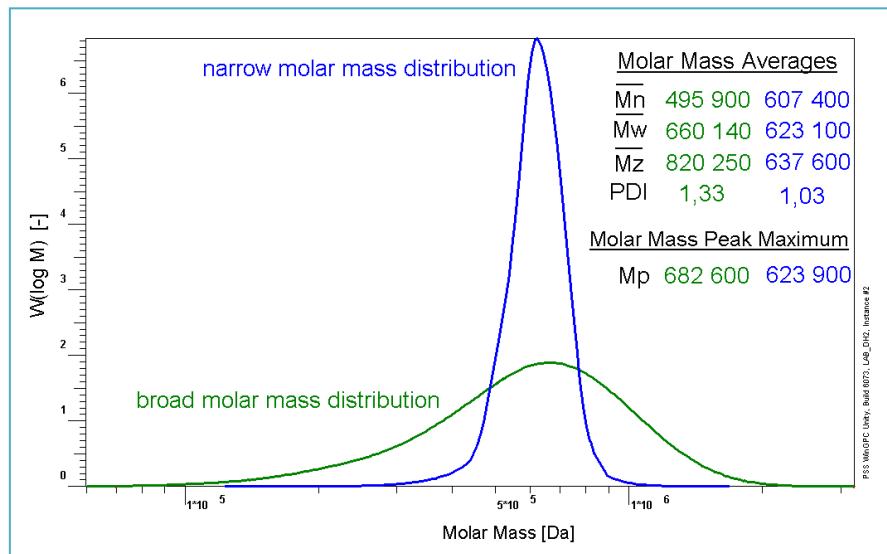

Figure 9: Example of narrow and broad molar mass distribution [35]

Another way to express the average chain size is as the degree of polymerization (DP). DP represents the average numbers of monomers in a chain and can be calculated by

$$DP = \frac{\overline{M}_n}{m} \quad \text{Equation 5[27]}$$

where

$m = \text{weight of repeating monomer}$

### Influences of Molar Mass

Many properties of polymers are affected by the chain lengths of the polymer and its distribution. A broad MWD is advantageous for its rheological behavior during processing. [36] A narrow MWD can be advantageous in fiber and molding applications, since the chains with more uniform MW, since its response to internal and external stresses is more uniform. This results in less warpage. [37]

The properties are mainly influenced due to the existence of entanglements, which constrains the movements of the individual chain by its neighboring polymer chains. Figure 10 illustrates such an entanglement between neighboring polymer chains. The impact of entanglements becomes significant from the so called critical molecular weight for entanglement. [38]. Entanglements constrain the polymer chains to flow in the melt, which influences the rheological properties. The entanglements also influence the mechanical properties: entanglements must take place to obtain a material that is strong enough to carry load. [31] The melting temperature increases with molecular weight as well.

MW also influences the crystallinity and subsequently impacts the properties. Smaller spherulite sizes are obtained with an increase in molecular weight. [33] However, the degree isotacticity has a greater impact on the crystallization than the MW. But as soon the tacticity remains constant, the molecular weight is the main factor that influences the degree of crystallinity.[39]



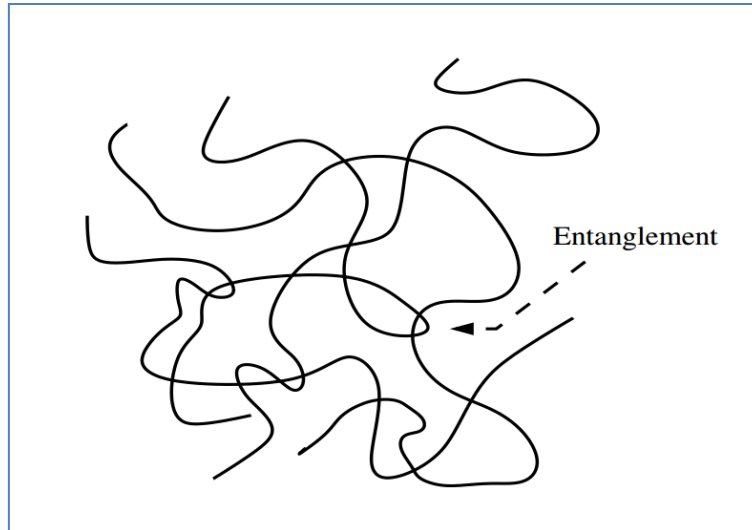

Figure 10: Schematic representation of an entanglement[40]

### Copolymerization

The three basic types of PP are homopolymers, heterophasic copolymers and random copolymer. Homopolymers consists purely of PP. Heterophasic copolymers are commonly manufactured in a two-reactor system. The PP homopolymer of the first reaction is conveyed to a second one, which contains a high concentration of ethylene. The ethylene (4-15%) with residual PP monomers will copolymerize to an ethylene-propylene rubber (EPR). This rubber disperses finely as a second phase in the homopolymer matrix. PP random copolymer is obtained by copolymerization of propylene with olefins, such as ethylene or 1-butene in the first reactor. The amount of olefins added is usually one-to-seven percent. The comonomers are randomly distributed into the long propylene sequences and cause a decrease in crystallization ability of homo-propylene sequences. [41][42] An schematic overview of the three different structures is given in Figure 11.

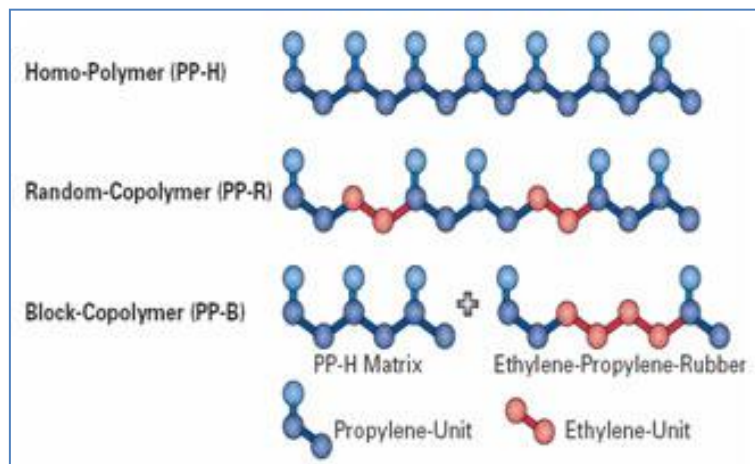

Figure 11: Schematic representation of molecular structures of PP Homopolymer (PP-H); PP Random Copolymer (PP-R); PP Heterophasic Copolymer (PP-B).[43]

Another method to modify properties of PP is the incorporation of long chain branches. The branches can be introduced into linear polypropylene by a post-reactor process. The chain branches increased the melt strength which is required for manufacturing processes such as thermoforming and extrusion, as will be explained in section 3.1.6. [44]

## **Additives**

Plastics are hardly viable without additives. There exist more than 1.000 additives, which improve processing possibilities, durability of the product and can tailor the final properties of the material. Additives are added to the polymers and, due to their high molar volume, dissolve in the amorphous regions of the semi-crystalline structure. To be effective, additives need to be able to survive the processing and the end use. [45]

### Types of Additives

The main groups of additives including their maximum amount encounter in wt% are processing aids, anti-oxidants, UV stabilizers, pigments, nucleation agents, impact modifiers, fillers, fire retardants and polymer bound additives. Different types of additives can be used in a combined manner, to increase the durability of the material. [45]

### *Processing aids*

The ease with which a polymer can be processed depends on its melt viscosity, resistance to heat and oxidation. The use of process aids as additives can improve these characteristics. For example these additives can form a film around colored particles that improve their dispersion possibility. Process aids can also improve the adhesion between particles and therewith increase their melt rate. Another option is the use of lubricants, which reduce the viscosity by creating a film between the polymer melt and the mould. [45]

### *Anti-oxidants*

During processing, free radicals, that generate a lot of reactions, are formed. These reactions results in a decreased molecular weight, crosslinking and loss of mechanical properties. Energy in the form of heat or shear cause the escape of hydrogen from the polymer chain. A polymer radical is formed and can react with oxygen. A peroxy radical will be formed and can remove another hydrogen from the polymer chain. This process will continue and the polymer will become brittle. Isotactic polypropylene is especially sensitive to oxygen and ozone The existence of anti-oxidants can stop the auto-oxidation and prevents the degradation.[46] [45]

The working mechanism of anti-oxidants can differ per type. Primary anti-oxidants are radical scavengers and slow down the reaction mechanism. Anti-oxidants of this type are mainly phenol and amine derivatives. A common used phenolic antioxidant is butylated hydroxytoluene (BHT). [47] BHT acts as an inhibitor and reacts with radicals in the polymer and thereby forms a radical by itself. The BHT radical is much less reactive due to resonance stabilization (Figure 12) and slows down the reaction rate of propagation. One of the resonance structures can combine with peroxy radicals (Figure 13) and breaks the auto-oxidation cycle. BHT is therefore seen as a radical scavenger. [48]

Secondary anti-oxidants consist of phosphates and hindered phenols, with lower molecular weight as compared to the primary anti-oxidants. Secondary anti-oxidants are usually added to decrease the color formation and to provide process stability during extrusion, granulating and molding processes. Phosphate anti-oxidants generally have a lower molecular weight, as compared to the phenolic ones, but their performance is better. [49]

The level of anti-oxidants is related to the processing temperature. The anti-oxidant can migrate from the plastic. The determination of the antioxidant level after recycling can give information about the quality of plastic. [49]

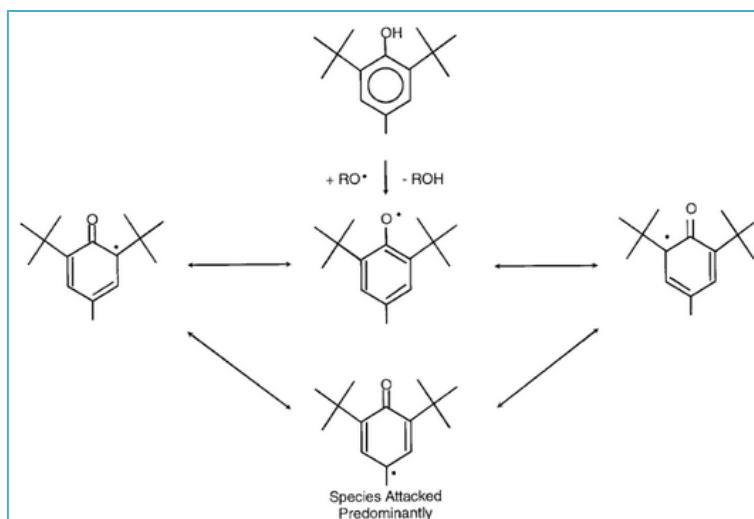

Figure 12: Resonance stabilization after oxidation BHT [47]

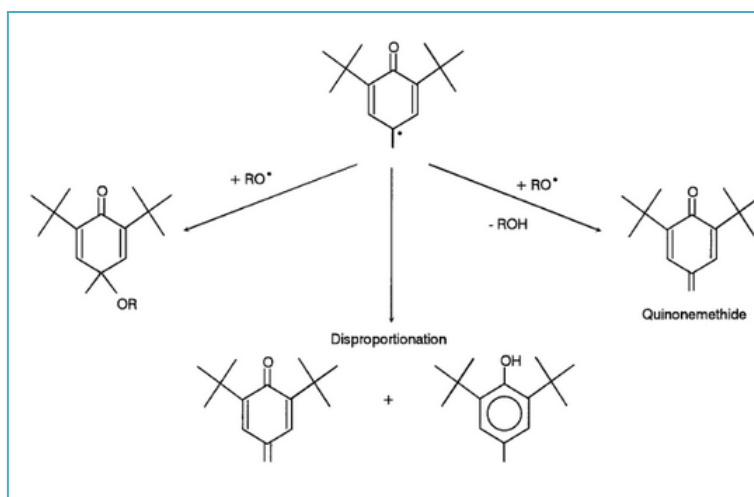

Figure 13: Reaction of peroxides with phenoxyl radical of the BHT stabilization resonance [47]

### UV stabilizers



Energy from UV light of short wavelength can result in photo degradation and the presence of reactive metals such as catalyst residues can trigger the degradation process and makes PP sensitive to UV-light. [50] PP is sensitive to certain wavelengths with a maximum sensitivity at the wavelengths of 290-300, 330 and 370 nm. [51] The energy from the UV light results in the formation of free radicals and the polymer would degrade without UV stabilizers. A main group of UV stabilizers are UV absorbers which can be used to prevent degradation. Absorbers compete with the polymer chain to absorb UV radiation. They change the UV radiation into heat or infrared radiation that is dissipated through the polymer. UV absorbers have low costs, but may be useful for short-term exposure only. The most effective and commonly use UV absorber is carbon black. Carbon black can also act as effective hydroperoxide decomposer. Because it can decompose the hydroperoxides formed during degradation (section 3.2.1) into non-radical products. However, only black colored products can be obtained.

Rutile, white pigment of titanium oxide, is another UV-stabilizer, which is effective in the range of 300-400nm, but not very useful below a wavelength of 315. Hydroxy- benzophenone and hydroxyl-phenylbenzotriazole, two other UV stabilizers, are suitable for transparent materials but cannot be used in products with a thickness smaller than 100 $\mu$ m.

Another group of UV stabilizers are the Hindered Amine Light Stabilizers (HALS). HALS are also effective at the long term. They trap the free radicals of a plastic and thereby limit the photo degradation process. There is a wide range of different structure of HALS product commercially available. HALS are especially effective in polyolefins, which includes PP. In practice, HALS stabilizers are often combined with other UV absorbers. [52]

An overview of commercially available UV stabilizers is given in Table 1.

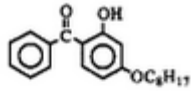
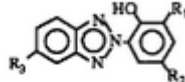
Table 1: Commercial UV stabilizers[47]

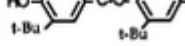
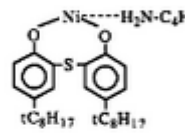
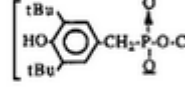
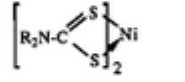
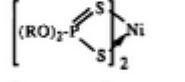
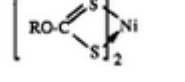
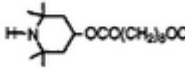
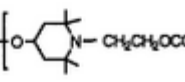
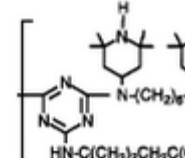
Antioxidant	Commercial or Common Name
<b>UV Absorbers</b>	
	Cyasorb UV531 Chimasorb 81
 $R_1=R_2= tBu, R_3=Cl$	Tinuvin 327
 $R_1=tBu, R_2=CH_3, R_3=Cl$	Tinuvin 326
 $R_1=H, R_2= CH_3, R_3=H$	Tinuvin P
	Tinuvin 120
<b>Nickel Complexes</b>	
	Cyasorb UV1084 Chimasorb N-705
	Irgastab 2002
	Nickel dialkyl- dithiocarbamate (NiDRC)
	Nickel dialkyl- dithiophosphate (NiDRP)
	Nickel dialkyl- xanthate (NiRX)
<b>Hindered Amines</b>	
	Tinuvin 770
	Tinuvin 622
	Chimasorb 944 35

### *Pigments*

A pigment is a material that has a selective wavelength absorption that can be added to a relatively neutral or colorless material. The material suspends and causes the coloring of polypropylene. [53] Most common pigment is white (rutile), which will be discussed in more detail in section 0. Other most common pigments are brown, grey and orange which are based on various iron oxides and hydrates. Inorganic green pigments are usually based on chromium (III) oxide. The pigments can influence the anti-oxidation reaction in either a positive or negative way.

Pigments are in general added to the polymer in a concentrated form, called masterbatch.

### *Nucleation agents*

Homogeneous nucleation of the polymer by supercooling rarely takes place under real processing conditions. Nucleation rate already increases by chain alignment during processing, which causes orientation-induced crystallization. However, nucleation can be further enhanced by the adding nucleation agents that cause heterogeneous nucleation. Nucleation agents provide surface areas for the polymer to nucleate on. They enhance the nucleation rate which results in faster solidification and thereby results in shorter processing cycles. Nucleation agents have a significant influence on the solid-state structure and therewith on the final properties of the material, such as stiffness, ductility, clarity and transparency. The use of nucleation agents can, under certain conditions, specifically create one of the crystal polymorphism phases of isotactic PP, which were described in section 3.1.1 [54] [55]

In general, nucleation agents are inorganic materials with a small average particle size. Nucleation agents normally require a high melting temperature to remain solid in the molten phase of the polymer during processing. Chemical derivatives of benzoic acid are the most effective nucleation agents for PP. The most widely used one is sodium benzoate, which structure is given in Figure 14. Sodium benzoate cannot be used in combinations with red pigments, as that would make it orange. Other commonly used nucleating agents are naturally occurring minerals such as kaolin and talc. Nucleation agents are normally not used to stiffen PP random copolymer. [56]

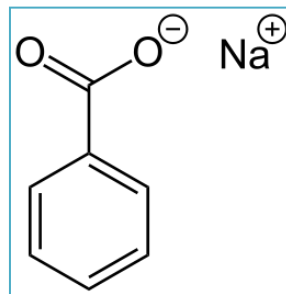

Figure 14: Structure of sodium benzoate [57]

### *Impact modifiers*

One of the most used methods to modify the toughness of PP is the incorporation of rubber-like materials. The rubbers are finely dispersed in the PP matrix and joined in a network, have a high mobility and flexibility. Therefore impact modified PP can bear higher loads and it will return into its original position after removal of an external load. The impact of the particles on the final impact strength of PP depends on their ligament length, which is the distance between particles. There exists a brittle to tough transition at the critical ligament length. The critical ligament length is determined by the polymer matrix and lies between 0,1 and 1 $\mu$ m for PP. In general Ethylene Propylene Diene Monomer (EPDM), Ethylene Propylene Rubber (EPR), Ethylene-octene rubber (EOR) and Ethylene Butylene Rubber (EBR) are used as impact modifiers for PP, which rubbers are miscible with PP.[33]

Normally, impact modified PP is opaque or translucent since it is composed of two distinct phases and cannot be transparent. However, Impact modification of transparent PP is possible, by adding rubber like material such as styrene-butadiene-styrene (SEBS) to improve the impact strength without having an impact on the transparency. [58][59] [60]

#### *Fillers*

The initial purpose of the use of fillers was cost reduction. However, nowadays fillers are also used for its functional role. Combination of fillers with PP results in new materials with specific properties such as increased stiffness or improved dimension stability. The most commonly used fillers for PP are talc, calcium carbonate and glass fibers. [61] Not only the filler content, but also the size and shape of the filler have a significant impact on the properties. [62]

The main part of filled PP is used in automotive and domestic appliances. However, new markets are developed and of interest for talc filled PP is food packaging. Especially thermoformed packaging, including microwaveable products, are of interest. [63][64][65]

#### *Fire retardants*

Polypropylene by itself burns rapidly with a relatively smoke-free flame and has a high flammability. Flame retardants interfere with the combustion process during heating; pyrolysis; ignition or flame spread stages by a chemical or physical mechanism. Flame retardants can be applied as additive, but can also be incorporated in the polymer chain itself during production of PP. The first flame retardants additives consisted of a halogen compound, which are nowadays forbidden by the law. [66] Fire retardants are mostly used in the textile, automotive and home furnishing industry products, where they need to comply with the safety requirements.[67] Fire retardants will therefore not be discussed in more detail, as the focus of this study is the food packaging industry.

#### *Polymer bound additives*

Additives can have a poor adhesion with the polymer and can leach out. Polymer bound additives can be used to stabilize the dispersion of other additives or fillers. In general, they are melt-miscible with the polymer matrix. Migration of additives is of special interest in the food packaging, since these migrating substances can cause undesirable flavors or even leads to toxicity. Migration is facilitated when food packages are heated in a for example a microwave. Polymer bound additives can therefore extensively be found in microwave products. [68]

#### Interactions Between Additives

There exist many synergistic and antagonistic interactions between the different additives for PP. Antagonistic means that the overall impact that is less than the sum of the individual impacts. It leads to a reduced effectiveness of both additives and must therefore be avoided. The interactions between the different anti-oxidants and UV-stabilizers are summarized in Table 2. Another example is mineral additives, which can reduce the antioxidant effectiveness by absorbing them on their surface. The minerals are therefore sometimes coated to minimize the absorption. [47]

### **3.1.2. Overview of General Characteristics of Polypropylene**

An overview of properties and parameters of commercial available PP are listed in Table 3. The top four listed parameters are explained in more detail, as they are the key parameters discussed in this study. Additionally, the density is explained shortly, as the technology, on which this study is based, initially separates on density. At least more attention is paid to the melting and glass transition temperature as these are important properties for the use in application and use of temperature profiles during processing. Finally, the applications of the three different types of PP are described to get an insight in the impact of the PP structure on the properties.

Table 2: Interaction between different anti-oxidants and UV-stabilizer of PP. AO= anti-oxidants; UVA=UV absorber. [47]

Synergistic	Antagonistic
phenolic AO + phosphites	HALS + thioesters
phenolic AO + dialkyldithiocarbamates	HALS + acidic carbon black
UV absorbers + phenolic AO	HALS + some phenolic AO
phenolic AO + Kemamine™ AS990	silica + erucamide
sulphur containing AO + carbon black	talc/silica + processing aids
UVA + HALS	Irganox™ 1010 + DHT-4A
UVA + nickel dithiocarbamates	zinc stearate + erucamide
phenolic AO + zinc thiolate	calcium stearate + UVA

### Properties of Polypropylene

Table 3: overview of properties of PP

What	value
<b>Tacticity (section 3.1.2)</b>	97% isotactic + 3% atactic
<b>Degree of crystallinity(section 3.1.2)</b>	Up to 50%
<b>Molecular weight(section 3.1.2)</b>	220.000-700.000 g/mol
<b>Density(section 3.1.2)</b>	0,85 g/mol – 0,95 g/mol
<b>Glass transition temperature(section 3.1.2)</b>	0°C
<b>Melting temperature(section 3.1.2)</b>	165°C
<b>Modulus of Elasticity[27]</b>	1,14-1,55 GPa
<b>Ultimate Tensile Strength[27]</b>	31,0-41,4 MPa
<b>Yield strength[27]</b>	31,0-37,2
<b>Elongation at break[27]</b>	1-6 mm/mm
<b>Fracture toughness[27]</b>	3,0-4,5 MPa $\sqrt{m}$
<b>Expansion [27]</b>	146-180 *10 <sup>6</sup> (°C) <sup>-1</sup>
<b>Thermal conductivity[27]</b>	0,12 W/m-K
<b>Specific heat[27]</b>	1925 J/kg-K
<b>Electrical resistivity[27]</b>	> 10 <sup>14</sup> Ω-m
<b>Transparency (section 3.1.3)</b>	Opaque

#### Tacticity

Commercial grades contain around 97% of the isotactic variant, together with 3% of atactic and virtually none of the syndiotactic variant. [36] Tacticity became less important over time, as an excellent catalyst which results in high isotacticity is developed. [31] The impact of tacticity and stereo impact on the properties of PP will therefore no longer be taken into account for this study.

### Degree of Crystallinity

The degree of crystallinity is mainly determined by tacticity. Due to its regular chain structure, isotactic PP has a high tendency to crystallize, resulting in a semi-crystalline structure. A 50% degree of crystallinity can be approached by isotactic PP. [31]

### Molecular Weight

Polymers of interest in the plastic industry have molecular weights that range between 10.000 to several million g/mol, since polymers with a weight up to 100g/mol exists as liquids at room temperature. [38]. The critical molecular weight of entanglements is in the order of 7.000 g/mol for isotactic PP[69].The weight-average molecular weight of PP generally ranges from 220.000 to 700.000 g/mol.[70] Commercial grades of polypropylene are produced by polymerization using high performance heterogeneous Ziegler-Natta catalyst systems.[71] These resins usually have a broad MWD. [36]

### Density

The density of PP depends on many factors, including the degree of copolymerization, addition of additives and the degree of crystallization. Amorphous regions in PP have a density of 0,85 g/ cm<sup>3</sup>, while the crystalline regions have a density of 0,95 g/cm<sup>3</sup>. Isotactic PP with 50% of crystallinity therefore has a density of around 0,90 g/cm<sup>3</sup>.

### Glass Transition and Melting Temperature

During melting of PP, its structure changes from an ordered and aligned solid stage to a viscous and highly random liquid structure. Melting of a polymer takes place over a range of temperatures ( $T_m$ ). The exact range depends on several factors, such as the degree of crystallinity, the existence of impurities, the rate of heating and etcetera. Before the PP melts upon heating, it first overcomes the glass transition temperature ( $T_g$ ). The material undergoes a transformation from a rigid solid to a rubbery material, based on the increased free movements of the chains in the amorphous regions. Both temperatures are important parameters that determine their processing conditions and final applications. The  $T_g$  and  $T_m$  for isotactic PP are 0°C and 165°C respectively. [72] Both characteristic temperatures are affected by molecular weight due to entanglements, degree of crystallinity and copolymerization and can therefore vary from grade to grade.

### **Applications**

All three types of PP (homopolymers, heterophasic copolymers and random copolymers) are widely used in the packaging industry. The use of each polymer in the different applications depends on their rigidity, abuse resistance (impact strength) and transparency. Heterophasic copolymers are normally used in fridge/freezer packaging. Random copolymers are in general used in highly transparent PP. Homopolymers are more commonly used for the rigid packages.

**Table 4: Comparison of three types of PP based on rigidity, abuse resistance and transparency[36]**

1. Highest 2. Intermediate 3. Lowest	Rigidity	Abuse Resistance	Transparency
<b>Homopolymers</b>	1	3	2
<b>Heterophasic copolymers</b>	2	1	3
<b>Random copolymers</b>	3	2	1



### 3.1.3. Optical properties

Color is an important aesthetic property of packaging. This section will first of all give a general description of the optical properties, after which additives to obtain transparent and white PP (focus of this study) will be discussed in more detail.

#### *In general*

The optical properties of a material are related to its response by an exposure to electromagnetic radiation and, in particular, to visible light. The overall electromagnetic spectrum is illustrated in Figure 15. The visible light lies within a narrow region (400-700nm) of the spectrum and the color is related to its specific wavelength. When light proceeds at the surface of a plastic product, part of the light will be transmitted through the medium, absorbed and/or reflected. The fraction of each phenomenon determines its optical characteristics. Only a small fraction of materials has a bandgap in between and will appear as colored by itself. [73] Plastics are therefore generally colored by pigments (section 3.1.1).

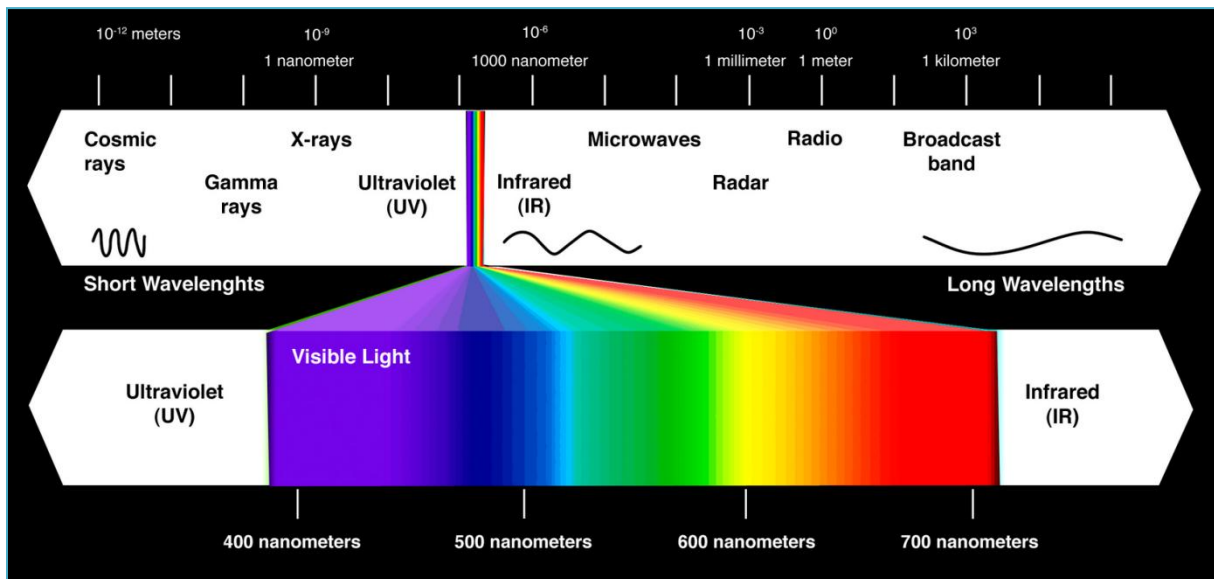

Figure 15: Electromagnetic spectrum [74]

Plastics that transmit light with only limited absorption and reflection are transparent. Their transparency is related to the scattering/reflection and is therefore directly related to its structure: the existence of amorphous and crystalline regions including the size of the spherulites.

#### Crystalline Structure

Most scattering occurs in the crystalline regions, when the spherulites size are in the order of magnitude (or larger than) than the wave length of visible light. [70] Generally, plastics that are transparent in their natural, unpigmented form are amorphous.

Scattering also occurs at the surfaces of the amorphous and crystalline regions. This is caused by a difference in refractive index of both regions and, even though this is only a slight fraction, the number of amorphous-crystalline interface can make the impact significant. The refractive index depends on the crystallinity and therewith on the density which changes with a change in crystallinity. As an example, the density of amorphous and crystalline regions of PE and PP are given in Table 5. There is a smaller difference in density between the two regions of PP compared to PE. PP therefore has a higher level of transparency. The last column of the table shows the level of transparency, which is based on general categorization as listed in Table 6.

**Table 5: Crystalline and amorphous densities for polyethylene and polypropylene**

Polymer	Crystalline density (g/cm <sup>3</sup> )	Amorphous density (g/cm <sup>3</sup> )	Optical properties
<b>Polyethylene</b>	1,00	0,88	Opaque
<b>Polypropylene</b>	0,95	0,85	Translucent

**Table 6 Degree of transparency [75]**

Level of transparency	Visible light transmission	description
<b>Opaque</b>	0%	Material does not transmit any visible light
<b>Translucent</b>	≥0%, < 70%	Material transmits a little light, in a diffuse way
<b>Transparent</b>	≥70%, < 85%	Material transmits enough light to see through it
<b>Optical Quality</b>	≥ 85%	Material transmits light almost perfectly. Images transmitted through it are clear and not distorted.

PP can also become transparent as the size of the spherulites reach a size that is smaller than the minimum wavelength of visible light. The optical properties of isotactic PP can therefore be controlled by the number of nuclei and the size of the spherulites. [76]

#### Molecular Weight

Larger molecules, with more side groups, generally have more light absorption due to the vibrational modes of side groups. [77]

#### Copolymerization

The copolymerization materials grafted to the PP polymer chain must have a closely matched refractive index to obtain good optical performance. Copolymers therefore contain ethylene or 1-butene groups. The crystallinity decreases and copolymers will therefore have an improved clarity as compared to homopolymers. This type of PP is therefore often used as ‘see-through’ freezer storage containers. [78]

#### Other

As last addition to crystal/amorphous and crystal/crystal interfaces also polymer/ air interface causes refraction. The impact of the polymer/air interface is related to the smoothness of the surface of the polymer and its impact increases with an increase in roughness.

#### ***Additives for Transparent Polypropylene***

The transparency of PP can be further improved by the addition of nucleation agents, besides to the possibility of copolymerization. Nucleation agents can modify the size of the spherulites. They provide surface area for the polymer to nucleate on and enhance the nucleation rate, as explained in section 3.1.1. Nucleation agents has been widely investigated and developed due to their advantages [76]. However, most commercial available heterogeneous nucleation agents, like talc, do indeed increase the nucleus density, but do not increase transparency significantly.

There exists a subgroup of nucleation agents, known as clarifiers, which significantly improve optical properties. [16] These clarifiers can improve transparency with a factor 2 to 6[79]. The disadvantage of clarifiers, as compared to normal nucleation agents, is the fact that the improved optical property is at the expense of other properties, such as thermal stability and stiffness. In addition, clarifiers are more costly than standard nucleates and require a higher content. However, addition of clarifiers does enhance the crystallization speeds of PP, which results in shorter cycle times and a reduction in processing

costs.[19][16] The use of clarifiers has strongly influenced the growth and use of PP in the packaging industry[16]

### Working Principle

Clarifiers are melt-sensitive, dissolve in the melt during compounding and do not need to be dispersed mechanically like heterogeneous nucleation agent, which are melt-insensitive. The dissolving behavior depends on the phase diagram of the binary system of the polymer and clarifier. As an example, a proposed phase diagram by Kristiansen et al for an isotactic PP/clarifier blend is given in Figure 16.

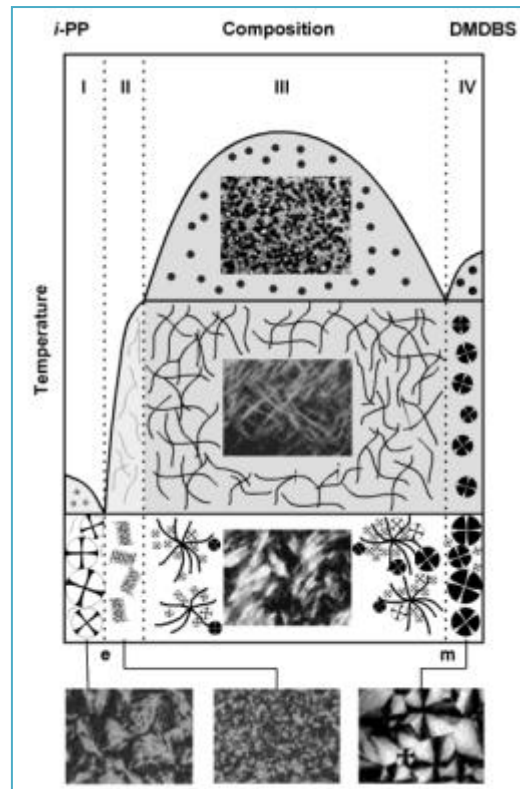

**Figure 16: Proposed schematic, monotectic phase diagram of the binary system i-PP/clarifier (1,3:2,4-bis(3,4-dimethyldibenzylidene)sorbitol (DMDBS)). Four regimes are indicated and their structures are sketched and represented with actual micrographs. [80]**

The region of use is regime II, where the PP and clarifier form a homogeneous liquid that exceeds the so called 'lower liquidus' temperature. The content of the clarifier is typically 0.2-0.3% (for regular nucleation agents this is: 0.1-0.15%)[16]. In contrary to the working principle of this regime, phase separation will occur in the other regimes, which leads to light scattering and therefore to a decrease of transparency.

Upon cooling, the clarifier crystallizes prior to the PP, without phase separation [80]. The clarifiers crystallize into fine needles or form a fibrous network by self-assembling, which occurs due to hydrogen-bonding during cooling process. The crystallized clarifier provides a tremendous surface that can act as nucleation site for the polymer. The latter results in a high density of nucleates and an increase in the peak crystallization temperature. As a consequence many more crystals grow in the same space, the spherulites become smaller in size, smaller than the wavelength of visible light. This leads to a substantial decrease in scattering of the visible light and therewith in an improved transparency. The working principle is illustrated in Figure 17, where clarified PP is compared to regular PP and nucleated PP. [79] [76]

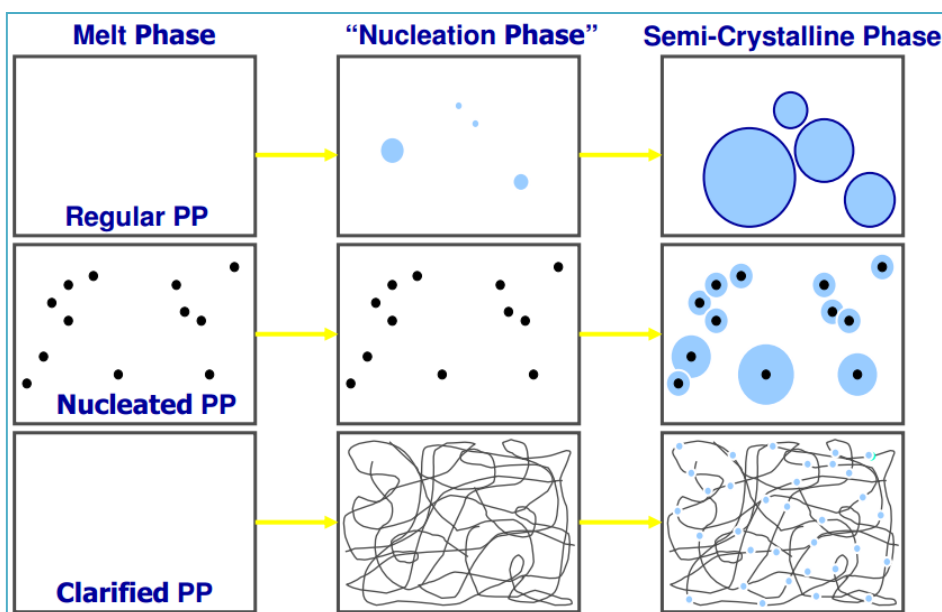

Figure 17: nucleation of regular, heterogeneous nucleated and clarified PP[81]

### Main Group of Clarifiers

The main group of clarifiers consists of sorbitol derivatives. The sorbitol-derivatives are widely employed in the industry of injection-molding products, which is the largest market for PP [82]. Milliken Chemical is the pioneer in this field and is already offering three generations of di-benzylidene sorbitol. The first generation, 1,3:2,4-di-benzylidene sorbitol (DBS, Millad 3905), could not be used at high temperatures which limited its suitability for injection molding. The second generation, known as 1,3:2,4-di-p-methylbenzylidene sorbitol (MDBS, Millad 3940), could be processed at slightly higher temperatures and provided enhanced transparency. The third generation, 1,3:2,4-bis(3,4-dimethylbenzylidene) sorbitol (DMDBS, Millad 3988) (Figure 18), had an even more enhanced thermal stability that allowed it to be used in different types of processing with a range of melt flows [79] [80] [16] However, thermal decomposition, sublimation and/ or blooming are still unwanted problems that may appear during processing.[54]

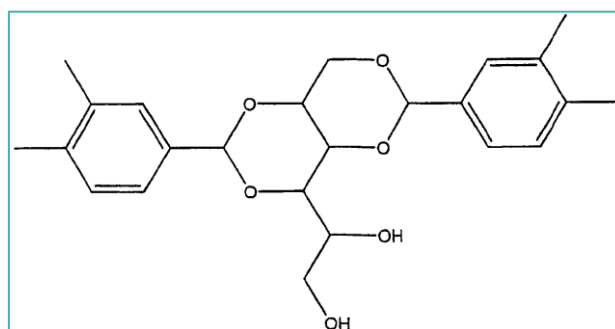

Figure 18: example of sorbitol based clarifier: 1,3:2,4-bis(3,4-dimethylbenzylidene)[83]

A second manufacturer of sorbitol-based clarifiers is Ciba Specialty Chemicals, which made its first generation sorbitol-based clarifier in 1998 (Irgaclear D). Followed by Irgaclear DM and the recently launched Irgaclear DM-LO. The first generation is still used for applications like CD boxes where less clarity can be tolerated. The second generation is currently used in, among other things, food packaging and high clarity housewares. The third generation is still tested in injection molded household containers and is expected to aim for food-packaging use as well. The haze value of a 1-mm thick PP homopolymer, including DM-LO, varies between 10-15%. [16]

Amfine Chemical is a third manufacturer of clarifier, which claims that their clarifier ADK NA-21 at 0.15% use level provides clarity that is equal to or better than DMDBS of Milliken Chemical. However, NA-21 is difficult to disperse in high-flow PP grades, which limits its use for thermoforming and blow molding[16]

Other clarifiers are: 1,3:2,4-bis(p-ethylbenzylidene)sorbitol, known as NC-4 is from Mitsui Chemicals [80] and AD-800P from Chrostiki; [84]

### ***Additives for White Polypropylene***

There exist a wide range of pigments that can improve the opacity of PP. In contrast to clarifiers, pigments used to whiten PP are insoluble. One of the categories is non-hiding white pigments, which are commonly referred to as fillers. Use of these fillers results in products with relatively low refractive index, however the fillers only play a minor role in providing opacity. In addition, these fillers reduce the possibilities for further filling of the PP since it already consists of a high content of second phase material. Examples of commonly used non-hiding white pigments are: calcium carbonate, barium sulphate, talc,.

In contrast to non-hiding pigments, hiding white pigments provide high refractive indexes and result in products with a high opacity. The most commonly used hiding white pigment is titanium dioxide. Its extensive use is due to its excellent durability and non-toxicity in addition to its excellent light scattering capacity. It is manufactured in two polymorphic forms: rutile and anatase. Rutile is the most commercially used form, due to its better weathering properties compared to anatase. However, anatase is used when a distinct blue-whiteness is desired, obtained from the absorbance of the blue-violet region of visible light by anatase. This color is especially preferred in plastics with an inherent yellowish color. Other minor commercially produced white hiding pigments are: zinc oxide; zinc sulphide; lithopone (mixture of ZnS and BaSO<sub>4</sub>) and antimony oxide. [45]

### **3.1.4. Mechanical Properties**

#### ***Crystalline Structure***

The mechanical properties are highly influenced by the size of the spherulites. A significant increased stiffness and impact strength are the result of a decrease in size of the spherulites. [33]

Furthermore, the mechanical properties of PP are related to polymorphism. A PP with a dominant  $\beta$ -phase shows a lower elastic modulus and yield strength, a higher strain at break and impact strength as compared to a PP with a dominant  $\alpha$ -phase. [33]

Finally the degree of crystallinity also plays a role. An increased crystallinity generally has an increased Young's modulus, increased tensile strength, decreased elongation at break and initially decreases in impact strength as a result. [33]

#### ***Molecular Weight***

The mechanical properties are related to the molecular weight, based on the possibility of entanglements. PP with a low MW will therefore be brittle. The strength and elongation of polymers with a MW above the critical MW increase towards a limiting value. Above a certain MW, polymers become even such entangled that it shows a rubber-like behavior. [85]Chain ends can act as imperfections which affect the strain properties, however this impact is negligible at high MW. [31]

Due to the significant influence of MW on the mechanical properties, there is large interest in understanding the exact correlation between the mechanical properties and the molecular weight. Therefore different empirical equations are formulated to be able to study the relation theoretically. Equation 6 gives an empirical equation as proposed by Flory already in 1945. [31]

$$P = P_{\infty} - A/MW$$

Equation 6 [31]

where

$$P = \text{mechanical property}$$

$$P_{\infty} = \text{Constant: limited value of property}$$

$$A = \text{Constant}$$

$$MW = \text{Molecular weight}$$

The values of the constants  $P_{\infty}$  and  $A$  depend on the chosen mechanical property  $P$ . The equation can be used for ultimate tensile strength and strain at yield. However, no satisfactory relation was obtained for tensile strength at break and elongation at break by T. Ogawa [31]. As an example, a schematic representation for the curve of the tensile strength ( $S$ ) is given in Figure 19.

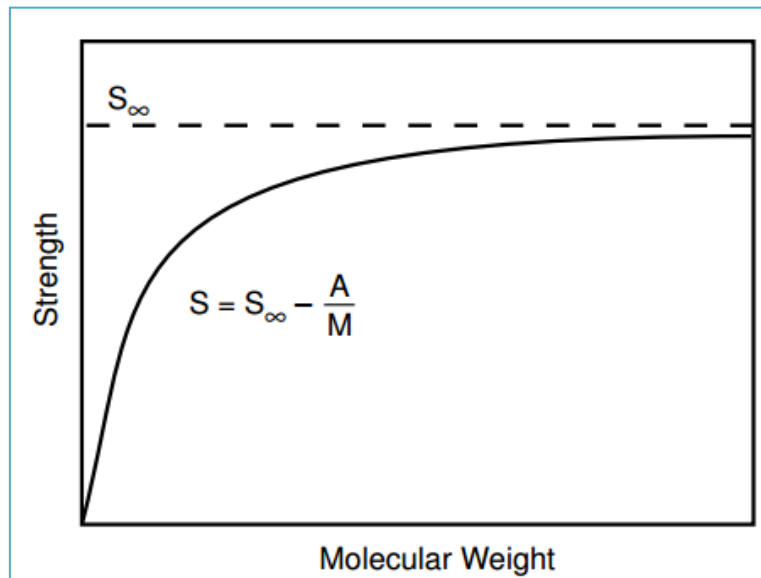

Figure 19 Typical plot of the tensile strength as a function of the MW (here:  $M$ =number-average MW)[86]

### **Copolymerization**

Copolymerization reduces the crystallinity, which leads to an excellent balance of stiffness and toughness.[41] Copolymers have a better impact strength at lower temperatures as compared to homopolymers. However, this is at the expense of its stiffness and ultimate tensile strength. [78] Additionally, long chain branches PP that undergo strain hardening tend to undergo rather ductile than brittle deformation. [87]

### **3.1.5. Rheological Properties**

#### **Crystalline structure**

An increased degree of crystallization causes an increased softening temperature. The melt viscosity throughout the whole processing procedure will therewith be increased[26]

#### **Molecular Weight**

The impact of molecular weight on the rheological properties is influenced by the existence of entanglements. Entanglements cause reduction in the mobility of PP molecules. [26] There is a direct

proportional relation between the viscosity and MW below the critical MW (Equation 7), while there is a power law relation at higher MW (Equation 8). This behavior is schematically represented in Figure 20.

$$\eta_0 = K * MW \tag{Equation 7[38]}$$

$$\eta_0 = K * MW^{3.4} \tag{Equation 8[38]}$$

where

$\eta_0 =$  Zero shear viscosity

$MW =$  Molecular weight

$K =$  constant

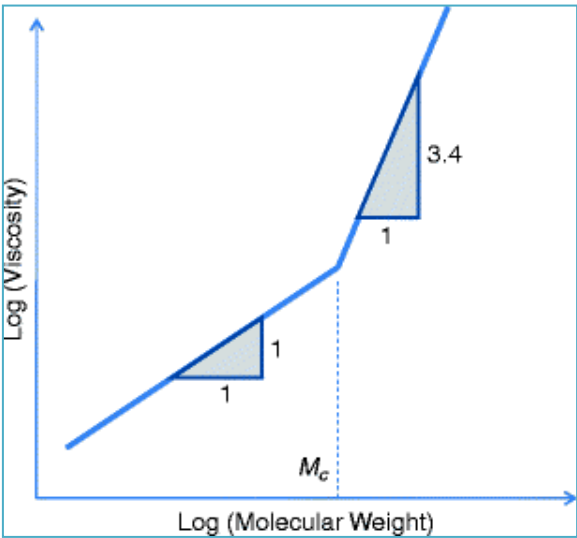

Figure 20: schematic representation of Dependence of shear viscosity on molecular weight[88]

The MWD also largely determines the rheological properties. Generally, broadening of the MWD was found to increase the non-Newtonian behavior of the material and more shear thinning is noticeable. This influence is schematically represented in Figure 21

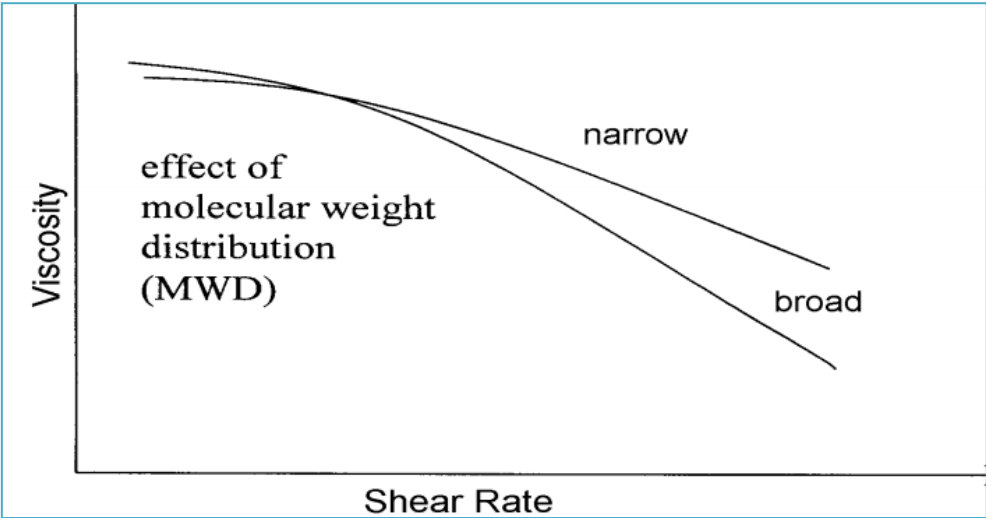

Figure 21: Impact of molecular weight distribution on viscosity behavior. [89]

### **Copolymerization**

The rheological properties are strongly dependent on the molecular architecture and therefore also on the grafted groups on the backbone after copolymerization. Viscosity of PP in general decreases after copolymerization. [26]

### **Additives**

Additives that are added in small quantities do not bring significant impact on the flow behavior of PP melt. [26] However process aids, such as lubricants, have an impact on the PP melt flow. Lubricants reduce the viscosity by creating a film between the polymer melt and the mould. [45][26]

### **Thermal Energy**

The rheological properties are hardly related to the thermal energy, which makes the molecules mobile by an increase in free volume and the ease in which they can pass each other. The viscosity is expected to increase with processing temperature for isotactic PP, since the free volume increases with temperature. The PP molecules can occupy more space, which makes it easier to pass each other [26]

All the impacts are summarized and schematically represented in Figure 22.

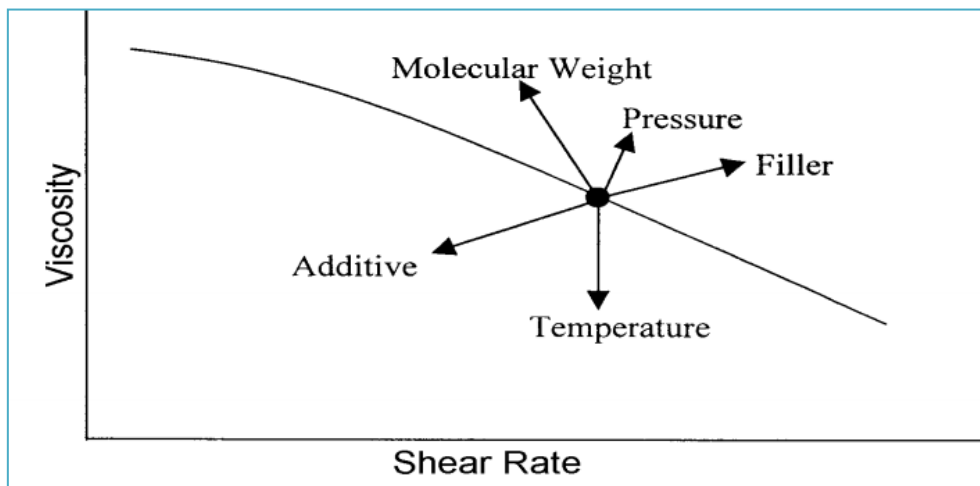

Figure 22: Impact of different parameters on viscosity behavior. [89]

### **3.1.6. Manufacturing Process**

The processing of PP can be performed in different ways. The most common used ones are extrusion, thermoforming, blow molding and injection molding. These four methods are described in this chapter. Secondly characteristic parameters and manufacturing settings related to these methods are discussed

#### **Main Manufacturing Processes**

##### Extrusion

During extrusion PP is converted from solid into the liquid state where after it is forced through a die that shapes it into a specified cross-section, such as thin sheets. [70]

##### Thermoforming

In thermoforming, a thin extruded sheet of PP is heated to certain desired temperature where after it is formed into a mold. The forming can be done with vacuum, pressure, a mechanically operated plug or any combinations of these. [90]



### Injection Molding

By the process of injection molding products are formed by forcing molten plastic material under pressure into a mold where it is cooled and subsequently released. With this process intricate plastic parts with excellent dimensional accuracy can be produced.[91] Its process predominates in the manufacturing of packaging such as food storage containers and water bottles. [92]

### Blow Molding

Blow molding is used to produce hollow objects from PP. The basic process of blow model consists of two fundamental parts. In the first part a parison, or perform, of hot plastic is formed. It has in general a tubular shape which is expanded in the second part. The parison is press against the mold cavities by pressure which is held until the PP is cooled. [93]

### **Characteristic Parameters**

#### Melt Flow Index

The melt flow index (MFI) is a common used property of high interest in the manufacturing industry. The MFI is a good indicator of the flow of PP at a fixed temperature and load. PP with a MFI less than 2 g/10min is generally suitable for extrusion and blow molding, since they have a high melt strength. [70] High melt strength grades are also suitable for thermoforming, which MFI is slightly higher[90] MFIs between 8-35 g/ 10 min are suitable for injection molding of thin-walled packaging. [70]

#### Temperatures of Manufacturing

The visco-elastic behavior of the PP determines the processing temperature which differs for each manufacturing type. An important measurement of the visco-elastic behavior is the visco-elastic modulus. It is measurement of a time-dependent stress at a certain strain level, which is maintained constant. It can fully determine the visco- elastic behavior of PP by incorporating the influence of temperature. [27] The change in visco-elastic modulus over temperature of PP is schematically represented in Figure 23. The plateau between the  $T_g$  and  $T_m$  is called the rubbery plateau and its length is determined by the amount of entanglements and thus by the MW. The height of the plateau depends on the degree of crystallinity and will increase with an increased degree. The lower plateau (dotted line) corresponds to a low degree of crystallinity and the upper line to a high degree of crystallinity.

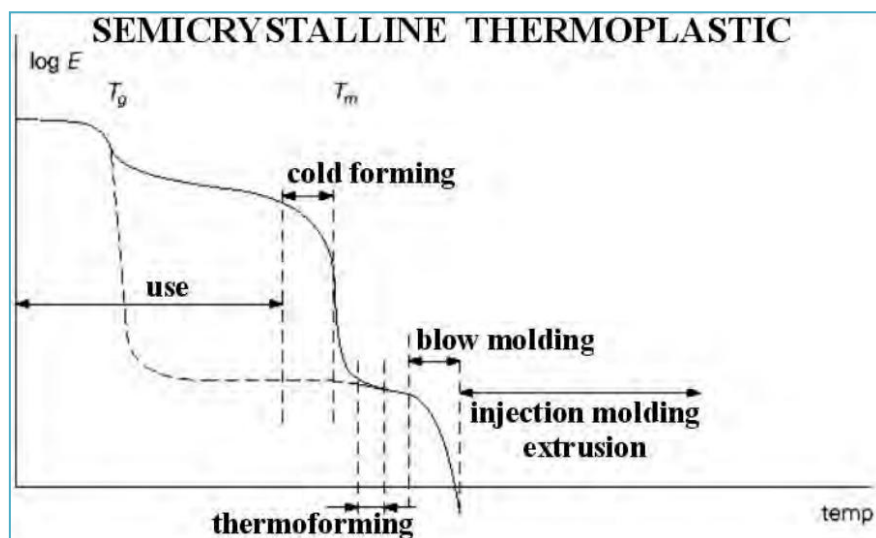

Figure 23: schematic representation of relaxation modulus over temperature. Optimal temperature rages of different manufacturing processes.[94]

### Molecular Weight Distribution

Commercial PP is produced by Ziegler-Natta usually results in a narrow MWD as was mentioned in a previous section (section 3.1.2). This narrow MWD has a low melt strength and poor processing characteristics in flow-dominated processes: extrusion, thermoforming and blow mold. In order to make PP suitable to these processes, modifications are needed to enhance the strain hardening behavior. Polymers that undergo strain hardening tend to undergo rather ductile than brittle deformation. A broad molecular weight distribution, bimodal system, can already achieve a high melt strength (Figure 24). However, the most efficient method to achieve this is by the addition of long chain branches, as they cause many sites for entanglements[95]

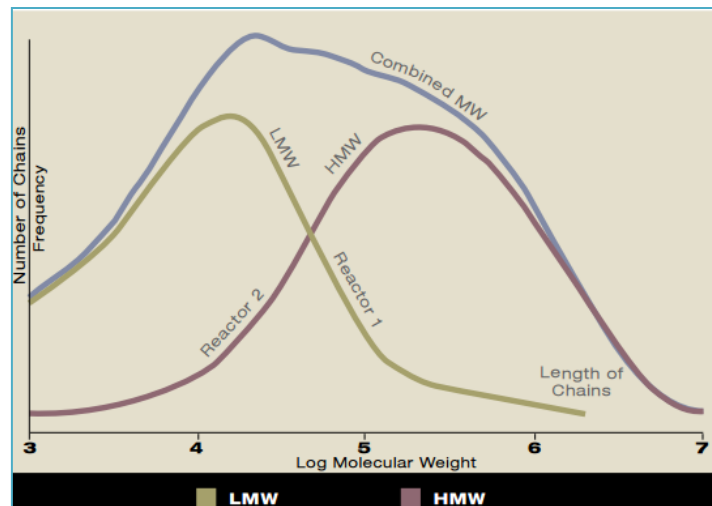

Figure 24: Schematic representation of bimodal MWD (LMW=low MW, HWM= high MW)[96]

## 3.2. Impact of Recycling

### 3.2.1. General Description of Degradation during the Life Cycle

The total life cycle of recycled post-consumer PP consist of three phases: processing, service life and mechanical recycling. During each step, PP is subjected to degradation. Processing results in thermo-mechanical degradation and the service life may induce physical and chemical changes in the polymeric structure due to exposure to certain environmental conditions. Additionally, subsequent mechanical recycling may results in further degradation due to enhanced sensitivity. [97] The degradation during these three steps will be discussed in more detail.

#### ***Degradation during Processing***

The temperature and shear employed for processing of PP causes thermo-mechanical and thermo-oxidation degradation. The degradation can shift the molecular weight distribution (MWD) curve away from its original position. Degradation can result in chain scission where the curve shifts towards the lower molecular weight side. It can also result in crosslinking which has the opposite impact. The number of chain scissions that occurs depends on the chemical structure, and so its degradation mechanism, and the processing conditions. The chain scission is random at low molecular weight and selective at high molecular weight. [98] The high molecular mass tails tend to undergo more chain scission and the extent of degradation in these grades is therefore higher. The content of low molar mass molecules therewith increases and therefore the crystallization as well. However, also the content of non-crystallizable defective chains increases and hinders the crystallization process. Both processes are in competition and changes the crystallization process as compared to virgin PP. Even a small degree of degradation has an enormous impact on the macroscopic properties. [99][100] [24]

### ***Degradation during Service Life***

The degradation during the service life of the PP product is dependent on the environmental conditions to which PP is exposed. Factors that influence the degradation are: temperature, air, humidity or other chemical environment, radiation, biological and microbial attack, mechanical stress, and etcetera. Degradations processes that can occur are thermo-oxidation, photo-oxidation and weathering. However, the fraction of degradation caused during its service life is assumed to be relatively small. This assumption is based on the relative short life time of packaging products and the fact that thermo-mechanical degradation (during processing) more affects the structure compared to thermo-oxidative degradation. [97]

Especially for food-packaging also the interactions between the food and packaging can play a role. These interactions can be divided in three main categories: migration, sorption and permeation. Migration is the transfer of components from the packaging into the food. Sorption is the controversy of migration and permeation is the transfer of components through the packaging in either direction. Migration has become a major factor in the regulations including safety and quality of packaged food. Additives or degradation products of low MW [101] can diffuse to the surface and migrate into the food. The degree of migration seems to be determined by parameters such as power of the microwave, material thickness, chemical nature of components in the PP, food stimulants, and etcetera. The rate of migration is also influenced by properties of PP such as density, crystallinity, combination of additives and glass transition temperature. The migration of components from the packaging material into the food is characterized by diffusion and the rate of migration is therefore not related to its concentration. It is only dependent on the temperature in addition to the thermodynamic properties such as polarity and solubility of the migrant in the PP and food stimulant. [102] The migration of additives from the packaging waste into the food will result in a loss of additives and the requirement to add the additives again to the plastic in recycling process.

Additional to migration, also sorption can play a role. Volatile flavors from the food are absorbed by the package. The extent absorption is influenced by the flavor molecules, external conditions such as pressure and by properties of PP such as degree of crystallinity and chain stiffness. [103] However, these volatile flavors are most probably removed during the extrusion by a degassing step and their impact on the final properties of recycled post-consumer PP is assumed to be negligible.

Additionally also biotic degradation can have an impact on the properties of recycled post-consumer PP. Biotic degradation is the degradation by the activity of microorganisms that grow on the plastic. The growth and impact of these microorganisms depends on the type of polymer and the environmental conditions such as humidity, weather and pollutants from the atmosphere. The chain scission reactions, producing low molecular products with oxygenated groups, increase the sensitivity for biotic degradation. [104]

### ***Degradation during Mechanical Recycling***

Prior degradation process increases the sensitivity of PP for further chain scission, possibly caused by the hydroperoxides formed during earlier steps. This means that in addition to the choice of processing conditions also further addition of additives such as stabilizers can influence further degradation of the material during subsequent mechanical recycling. [97]

Additionally, incomplete sorting results in the inclusion of second-phase particles which significantly influence the final properties of the recycled PP. Reprocessing helps to homogenize the blend which improves the mechanical properties of the recycled PP, in competition with the degradation processes.

### Thermo-Mechanical and Thermo-Oxidation Degradation

The two main types of degradation are thermo-mechanical and thermo-oxidation degradation. These two types will be discussed in more detail for PP. PP preferably degrades by chain scission due to the presence of a hydrogen linked to a tertiary carbon in the backbone chain. The methyl groups attached to the isotactic PP backbone are easily oxidized and degrades more drastically as compared to atactic and syndiotactic PP with similar molecular weights.[26] [105]

Additionally, the degradation mechanism of PE will be discussed, as it might be included in the copolymer chain and does not result in chain scission, but in crosslinking. The degradation mechanism of polybutene is not included, as it is expected to show the same degradation mechanism as for PP. [106]

### Thermo-Mechanical Degradation

#### Polypropylene

The thermal degradation of PP results in chain scission, which process including the most abundant degradation products is schematically represented in Figure 25. The primary pathway is A. Secondary radical degradation reaction results in products such as pentane (24.3%), 2-methyl-1-pentene (15.4%), and 2,4-dimethyl-1-heptene (18.9%) following pathway A. [107]

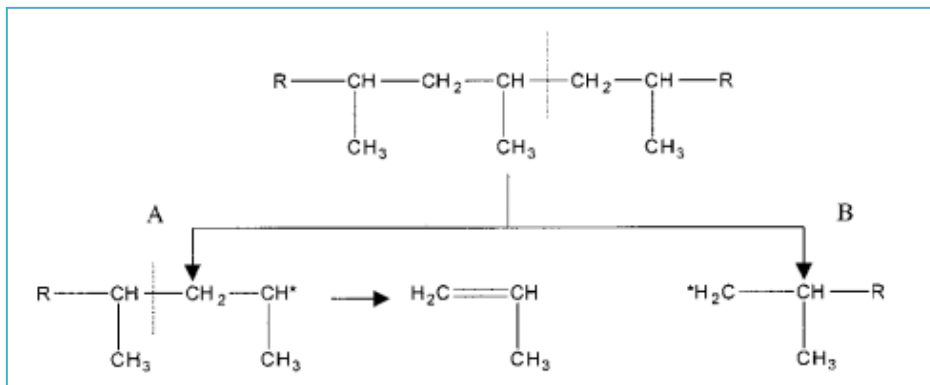

Figure 25 Schematic representation of thermal degradation process of PP [107]

#### Polyethylene

The degradation mechanism of PE is much more complex than that of PP. Its degradation process is schematically represented in Figure 26. First of all large amount of hydrocarbon are formed which breaks down in mainly propene and 1-hexene (pathway A and B respectively). Although random chain scission is the primary pathway for degradation of PE, chain branching and crosslinking can occur simultaneously. [107]

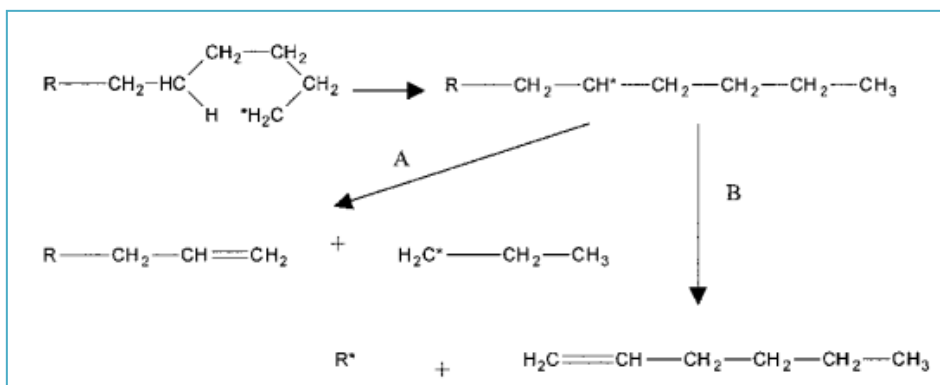

Figure 26 Schematic representation of thermal degradation process of PE [107]

## Thermo-Oxidative Degradation

### Polypropylene

The thermo-oxidation degradation process of polypropylene starts with an initiation step, where a radical ( $R^\bullet$ ) is formed. This radical reacts with oxygen resulting in propagation of the reaction mechanism by the formation of a new radical simultaneously with chain scission. The products of the chain scission include COH, C=O, COR, COOR and COOH. The oxidation process is schematically represented in Figure 27.

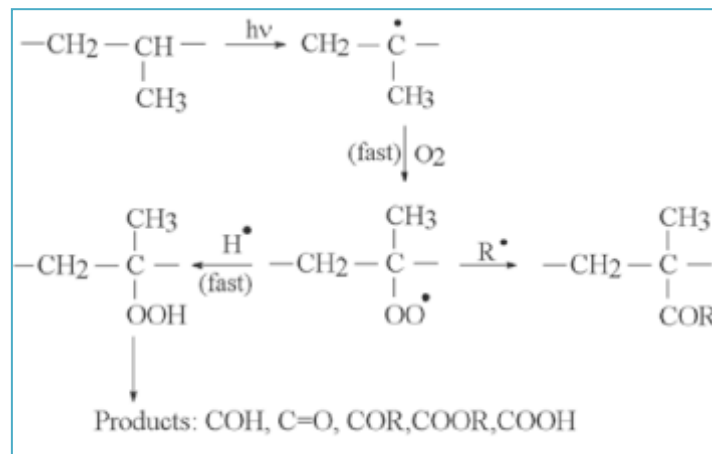

Figure 27 Schematic representation of oxidation process of polypropylene[108]

### Polyethylene

The oxidation process of PE results in preferably in crosslinking, which process is schematically represented and compared to PP in Figure 28

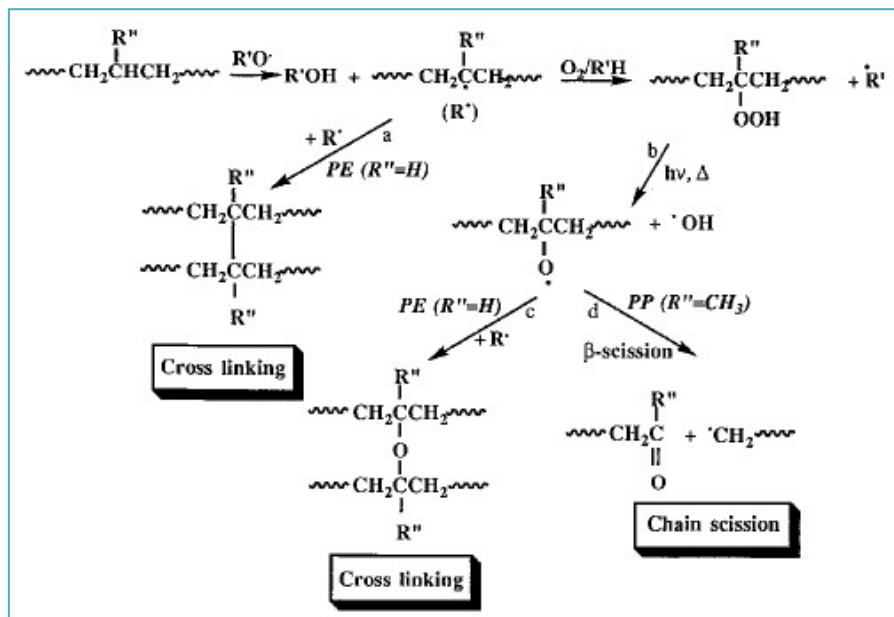

Figure 28 Schematic representation of oxidation process of polyethylene and polypropylene [47]

### 3.2.2. Impact of Incomplete Sorting and Washing

The recyclability of materials is not only influenced by the degradation but depends also on the techniques for sorting. Blends of different polymers are immiscible and a mixture of different types of plastic would result in a heterogeneous mixture with poor qualities. The compatibility of two types of polymers depends on their difference chemical nature and can be determined by the Gibbs free energy. The Gibbs free energy of the mixture must be lower than the summation of the Gibbs free energy of the

separated polymers (A and B). This is also known as the Gibbs free energy of mixing and is given in the equation:

$$\Delta G_{mix} = G_{AB} - (G_A + G_B) \leq 0 \quad \text{Equation 9 [34]}$$

where

$$\begin{aligned} \Delta G_{mix} &= \text{Gibbs free energy of mixing} \\ G_{AB} &= \text{Gibbs free energy of polymer blend} \\ G_A &= \text{Gibbs free energy of polymer A} \\ G_B &= \text{Gibbs free energy of polymer B} \end{aligned}$$

This can also be written as:

$$\Delta G_{mix} = \Delta H_{mix} - T\Delta S_{mix} \leq 0 \quad \text{Equation 10 [34]}$$

where

$$\begin{aligned} \Delta H_{mix} &= \text{Enthalpy or heat of mixing} \\ T &= \text{Temperature of mixing} \\ \Delta S_{mix} &= \text{Entropy of mixing} \end{aligned}$$

Polymers do have long polymer chains which cause only a small impact on the entropy after mixing and will even vanish by an increased molar mass, while the enthalpy of mixing is always positive. This will result in a two heterogeneous phases in the blend. Additionally the other types of polymers have other melting points as compared to PP and will possibly not melt and distribute evenly over the melt (melting temperature of PET is around 265°C[27]). This results in large and even more critical second phase regions. Sorting of polymers of different types is therefore necessary.

Also impurities such as food residues and paper, in mold labels and printing inks can result in (burned) second phase particles, following the Gibbs equation. This makes washing an important step of the recycling.

### 3.2.3. Expected Impact on Optical, Mechanical and Rheological properties

#### **Optical Properties**

Recycling induces changes in the structure of polypropylene resulting in yellowing, gloss and transparency reduction. This is a result of the formation of the degradation products [109] the yellowing of aromatic amines (such as in UV stabilizers), over-oxidation of phenolic anti-oxidants[110][111].

The coloring after recycling of PP is a result of the existence complex molecules with multiple bonds that are conjugated. Multiple bonds are conjugated if electrons can move freely over the bond, which is the case by alternating double and single bonds (Figure 29). The ground states and excited states of the electrons of conjugated molecules are closer in energy than for not -conjugated systems. Therefore a lower energy light (absorption) is needed to excite electrons in conjugated systems. Less highly conjugated systems will generally appear as yellow and more highly conjugated systems can even appear as more red or orange. [112]

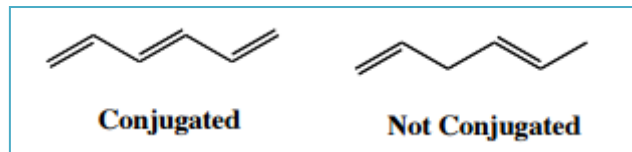

Figure 29: Difference between conjugated and not conjugated systems. [112]

Complete exhaustion of the phenolic molecules results in a conjugated system and therewith appears yellow. As an example, the over-oxidation of the radical BHT (Figure 12) is represented in Figure 30.

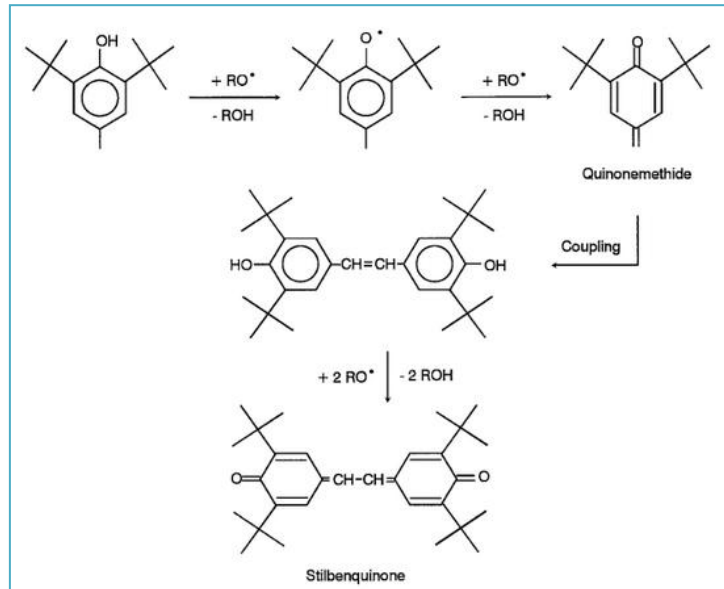

Figure 30: Over-oxidation of BHT resulting in a conjugated system that appears yellow[47]

An example of discoloration of PP including different anti-oxidants and process stabilizers is given in Figure 32. The anti-oxidants and stabilizers used in this example are illustrated in Figure 31. [113]

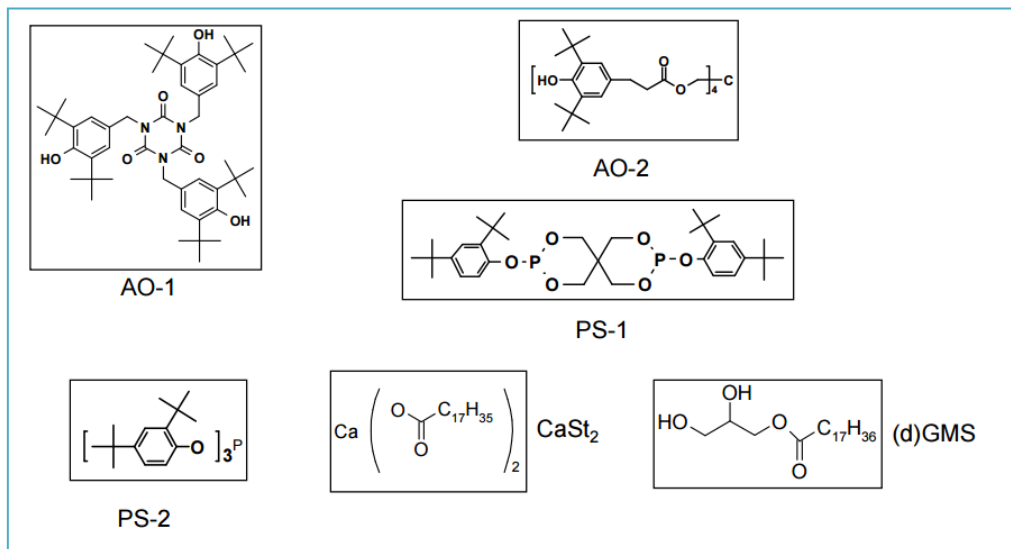

Figure 31: Used anti-oxidants and process stabilizers in example of Figure 32[113]

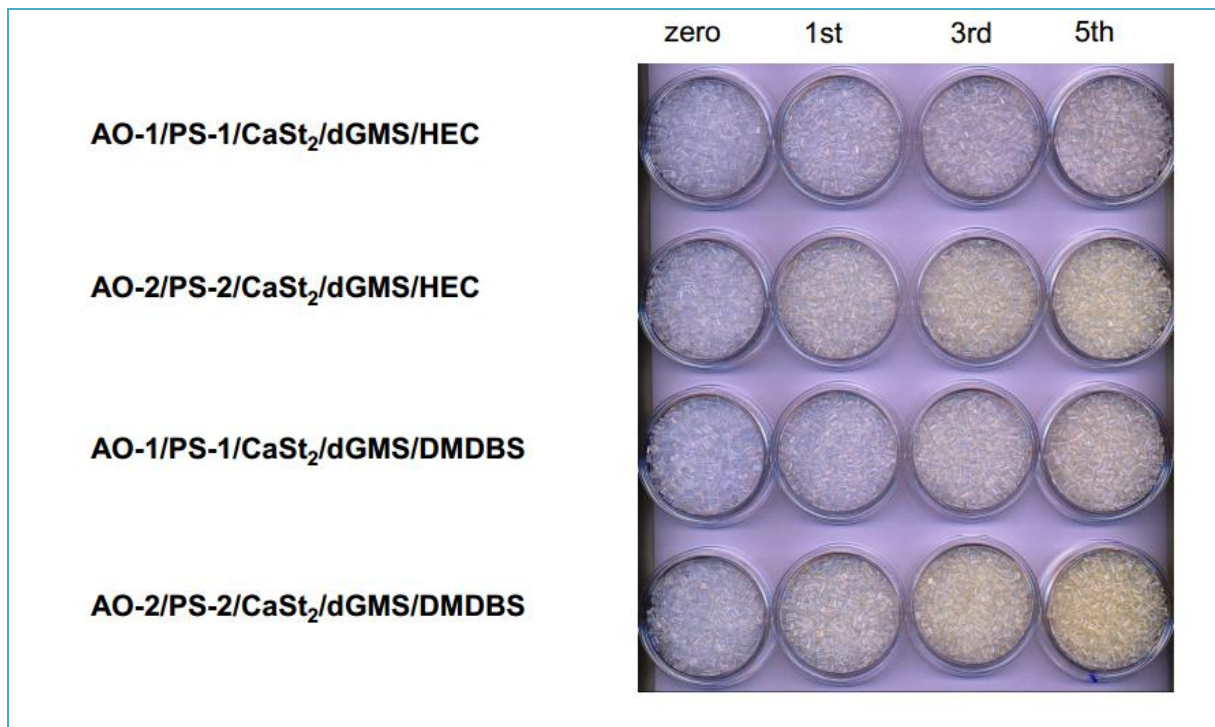

Figure 32: Example of discoloration after repeated extrusion of PP including different anti-oxidants and process stabilizers as given in Figure 31[113]

Additionally, a reduction in transparency can also be a result of interaction of the different additives during processing [101] and the inclusion of second phase particles which results in high refraction.

A loss of pigments is not expected, as pigments are phase-separated which migration rate is too slow.[114]

The presence of titanium dioxide (white pigment) in combination with over-oxidized phenols can result in pinking. [110] A treatment of titanium dioxide, with for example silica or alumina, can protect the mineral from reacting with the phenolic anti-oxidants which causes the discoloration. [45] However, the titanium dioxide also has a masking impact as it has a very high refractive index. [115]

Additionally, a mixture of polymers can decrease the concentration of additives such as nucleation agent/clarifiers, which will lose their impact on the optical properties.

Finally, a mixture of PP of all results in a mixture of pigments. A mixture of colors results in a grayish to black mechanical recycled PP grade, as all light will be absorbed (section 3.1.3)

### ***Mechanical Properties***

#### Impact of Non-PP plastics

Dispersed second phase particles in the PP matrix results in a heterogeneous system. These heterogeneities induce stress concentration by applying an external load. The development local stresses influence the deformation and fracture mechanism. The magnitude of these stress concentration depend on the miscibility and average size of the second phase particles. The miscibility depends on the interfacial adhesion between the both phases. The average size of the dispersed phase is related the average size also depends on the viscosity ratio of both phases and thus on the shear rate and temperature of mixing. Additionally, it is for a major part determined by the interfacial tension as well. The interfacial tension is therefore seen as a parameter that has a dominant impact on the final properties. A high interfacial tension, which is the case for immiscible plastics, prevents the stress transfer between the matrix and the dispersed phase and results in poor mechanical properties. [33]



### Impact of Mixture of all Types of PP

The mixture of all types of PP results in a very broad MWD and mixtures of copolymerization types, which impact cannot be predicted.

### Impact of Degradation

Degradation of PP results in chain scission of the polymer. These reactions embrittle the material, which means that they break at a lower strain. [116]

### ***Rheological Properties***

#### Impact of Non-PP impurities

Other polymer types or impurities with a higher melting temperature than the processing temperature of PP stay solid in the molten phase. The rheological properties of the two-phase system depends on the size, size distribution and shape of the second phase particles. However, the viscosity can be predicted by the equation of Einstein, where the unmolten impurities in the molten PP matrix are seen as a dilute dispersion of small hard spheres.[117] The impact can be compared to the impact of fillers which impact was illustrated in Figure 22.

$$\eta_{PP+imp} = \eta_{PP} (1 + 2.5\phi_{imp}) \quad \text{Equation 11[117]}$$

where

$\eta_{PP}$  = Viscosity of PP including impurities

$\eta_{PP}$  = Viscosity of PP excluding impurities

$\phi_{imp}$  = Volume fraction of impurities

#### Impact of Mixture of all Types of PP

The zero shear rate viscosity of an ideal binary liquid mixture can be predicted by the Arrhenius equation (Equation 12). This equation suggests dominance by low viscous material.

$$\ln(\eta_{12}) = x_1 \ln(\eta_1) + x_2 \ln(\eta_2) \quad \text{Equation 12[118]}$$

where

$\eta_{12}, \eta_1, \eta_2$  = zero shear viscosity of: blend, phase 1 and phase 2 respectively

$x_1, x_2$  = Mole fraction of phase 1 and 2 respectively

Additionally to the value of viscosity, the shear sensitivity is changed. A broad MWD shows a higher shear thinning impact as compared to a narrow MWD, as was illustrated in Figure 21.

### Impact of Degradation

Degradation lowers the polymer melt viscosity, since the molecular weight in general decreases upon recycling which increases the flow ability of the material. [119]

## **3.3. Financial Aspects of Mechanical Recycled Post-Consumer Polypropylene**

The value of recycled plastics increases when there are more various ways to use the plastics in new products [21]. This chapter will first describe the current application sector of recycled plastic. Secondly the impact of regulations in Europe which intend to promote the recycling of plastic is described. Thereafter the price dependence on price of virgin PP and finally a short conclusion on the financial feasibility of the new technology will be given.

### 3.3.1. Current Applications of Recycled Polypropylene

Recycled PP grades consist of a mixture of products made by all the different manufacturing processes. The flow behavior is not characteristic for a specific manufacturing process. PP therefore requires a peroxide treatment in order to obtain chain scission and therewith modify the flow behavior of the material. [119] The MFI increases by chain scission and the recycled PP grade can only be used for the manufacturing of injection mold grade products. Typical applications are clothing and industrial fibers, compost bins, transport crates and gardening apparatus such as furniture and plant pots.

### 3.3.2. Impact of Packaging Tax

The Netherlands actively tries to prevent waste and promote recycling through its Nation Waste Management Plan. The plan covers the period 2009-2015 and looking ahead up to 2021. This management included a carbon-based packaging tax to increase the recycling rate of plastic packaging. The tax was introduced in 2008, after 8 months simplified, to make planning payments easier and to facilitate a wider compliance, and replaced by a contribution to the Packaging Waste Fund. The fund (and initial tax) promote waste reduction and at the same time financially supports the recycling.[120] The manufacturers and importers became responsible for a minimum use of packaging and for the collection and recycling of the waste.[121] The rates that are applied are related to the mass of the plastic packaging produced by a manufacturer. For plastic is this rate equal to 0,3876 €/kg, which is next to unspecified waste, by far the highest rate (glass on the second place with a rate equal to 0,0595€/kg). The costs are correlated to the costs for collection and processing and to acquire the guarantee from recycling companies that they will recycle the plastic waste. The rate of a package consisting of multiple layers of different materials is calculated based on its fraction.

The packaging waste rates indeed promote waste production by the rates based on mass, but they do not promote the recyclability, especially in the case of plastic packaging. The rate does not promote the use of plastics that are advantageous for recycling. The rate is the same for very pure materials as well as for multilayer plastic packaging of different types, packages including in-mold labels or printing inks. There are also no regulations for standard use of color pigments or other additives and antagonistic interactions will occur. All these factors can have an influence on the final market value of recycled post-consumer plastic.

### 3.3.3. Price Correlation to Virgin Plastic

The price of virgin granules is correlated to the price of the crude oil as is shown in Figure 33 and Figure 34. Additionally Figure 33 also shows a difference in prices for different grades of PP. Abbreviations are assumed to be: PPH= PP homopolymer; PPC= PP heterophasic copolymer; PPR= PP random copolymer. However, there is one price for recycled PP granules (Figure 35, since it is a mixture of all types of PP. The influence of the crude oil price and virgin plastic is slightly noticeable: a peak in price is noticeable in June 2014 and a drop of the price is seen in February 2014. The difference between the price of virgin and recycled price is on average in the order of 0,40€/kg, except during the unstable situation in February 2014. This difference is in the same order as the tax rate.

The increased use of biopolymers can make the price of plastic less dependent on the oil prices. Additionally a further categorization of post-consumer PP will result in distinguishable recycled grades. Both facts can make the price of recycled post-consumer PP more dependent on the final properties.

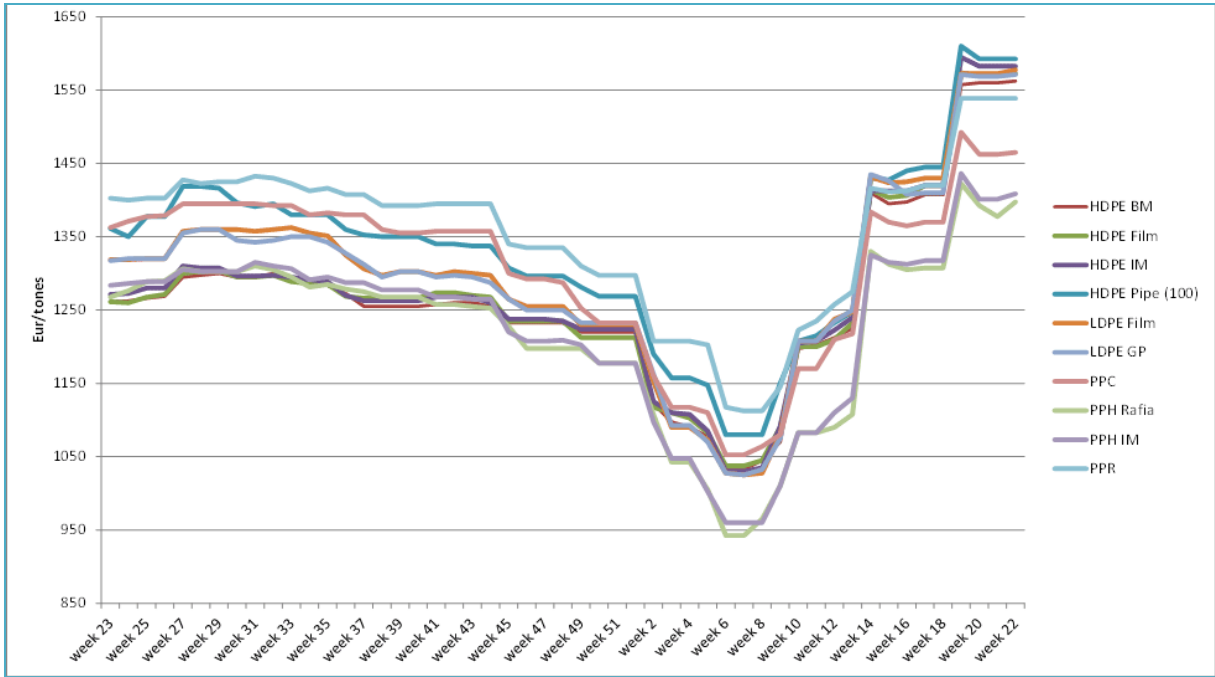

Figure 33: Polyolefin prices in Central Europe between beginning of June (week 23) of 2014 and end of May (week 22) of 2015. [122]

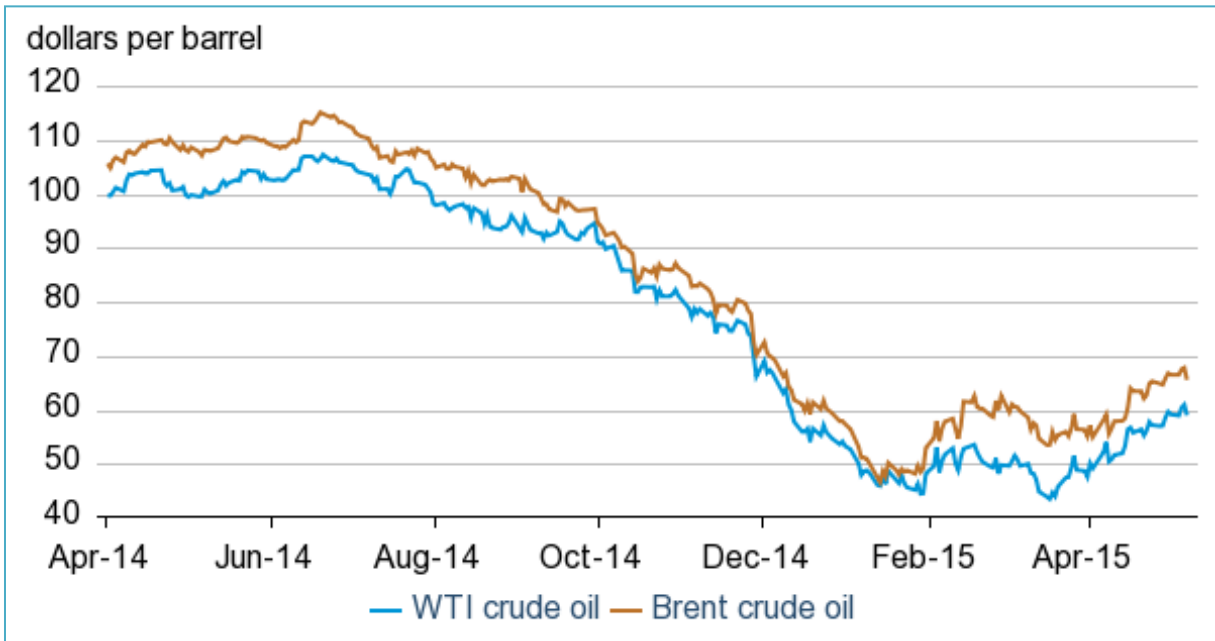

Figure 34: Crude oil prices between beginning of June (week 23) of 2014 and end of May (week 22) of 2015 [123] The Oil price of North Sea Brent and The West Texas Intermediate (WTI) are given.

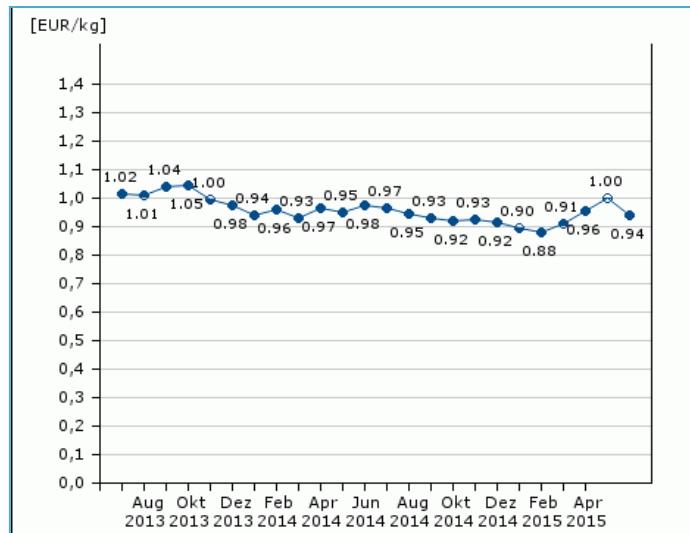

Figure 35: Prices of recycled PP granules between beginning of June 2013 and end of May 2015 [124]

### 3.3.4. Financial Feasibility of Circular Economy of Mechanical Recycling

A circular economy is financial feasible as it positively impact the economics of recycling in two ways. Firstly, due to increased efficiency in recycling, overall recycling costs might be lower. Secondly, a the new technology closes the gap between the value of recycled grade and virgin grade, which allows increased re-use of material.

## 4. Experimental Part

### 4.1. Overall Study Method

To fulfill the objective, the study is divided in two parts: the categorization method and the reference method. Both methods are discussed in this document.

#### 4.1.1. Categorization Method

The categorization method is applied to study the impact of each categorization step on the compared properties.

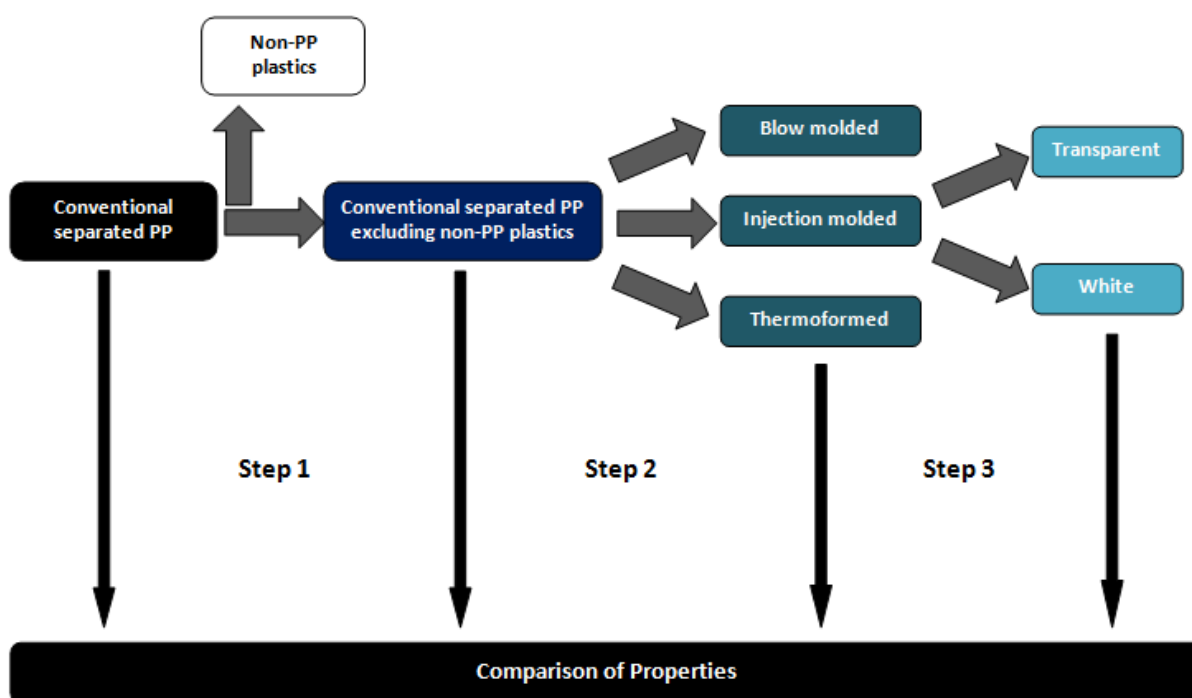

Figure 36 categorization method

#### **Step 1**

Conventional separated PP is further separated by removing Non-PP plastics. This step is performed to prevent the negative impact of non-PP plastics and contaminants on the analysis of the impact of following categorization steps.

#### **Step 2**

The conventional sorted post-consumer PP stream, excluding non-PP plastics, was further separated based on their manufacturing process. Extruded films were already removed in the first step, as no characteristic signs can be found on films. These products were therefore already removed after the first step. Therefore, the remaining major categories are blow mold, injection mold and thermoformed and were selected. This separation step is related to the new developed separation technology, based on wall thickness.

#### **Step 3**

The final step involves separation based on color. The colors that contribute to the highest fraction of post-consumer PP (white and transparent) were selected and analyzed.

### 4.1.2. Reference Method

The reference method (Figure 37) is applied to study the impact of different parameters on the degradation during processing, service life and subsequent mechanical recycling.

First of all, virgin grades will be analyzed. The virgin grades are related to products that are selectively picked out the conventional post-consumer PP stream, for mechanical recycling. This includes the mixture of different injection mold grades. The properties of the mechanical recycled grades are compared to the virgin grades. Additionally, the impact of extrusion is measured for two virgin grades, to get an insight in the impact of different stages in the life cycle on the properties. Pure plastic parts and parts containing in-mold labels/ printing inks are analyzed separately to analyze their impact on the properties, as mentioned in the scope of this study. Finally, a mixture of an injection mold and thermoformed grade is analyzed, as compounding of grades after categorization might be required.

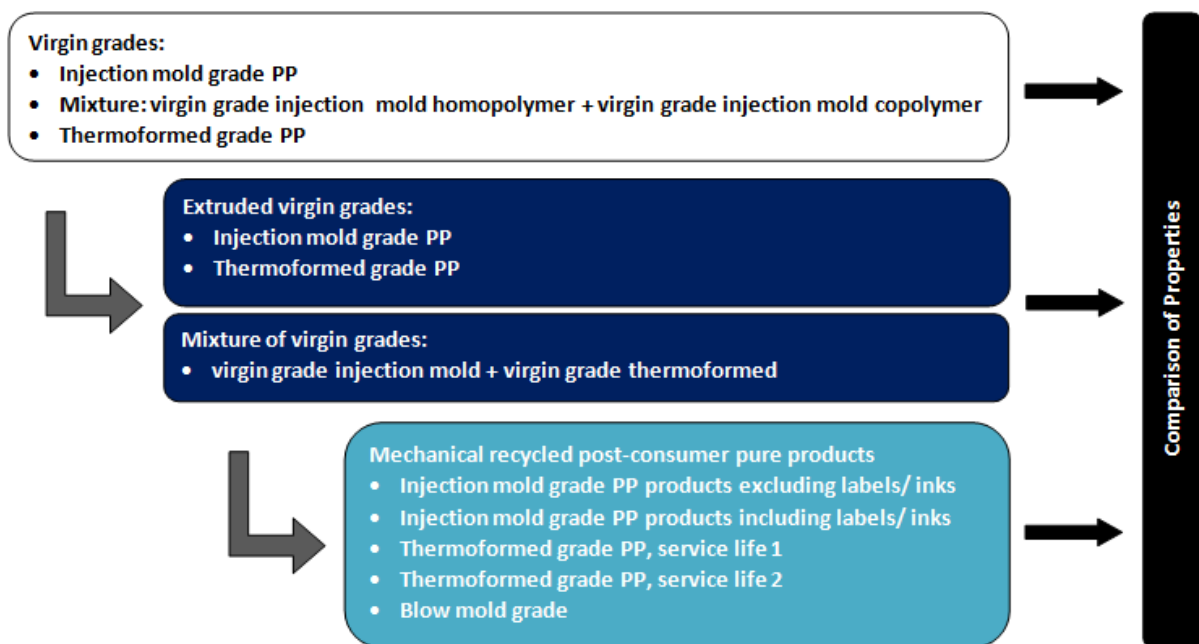

Figure 37 Reference method

The reference method is used to get an insight in the level of impact of different parameters on the optical, mechanical and rheological properties: degradation during a complete life cycle of PP; degradation during extrusion; the impact of a different service life; impact of labels and printing inks; impact of mixing two different grades of PP. The first three parameters are studied to get an insight in the impact of different stages in a life cycle of the plastic on the product.

## 4.2. Materials

The materials selected for this study are categorized according to the two methods used for this study: The categorization method and reference method respectively.

### 4.2.1. Categorization Method

Conventional sorted post-consumer PP was provided by SITA Suez Environment Company, Rotterdam, The Netherlands, whose main activity is the collection and separation of household plastic waste generated by individual households or businesses. The household plastic waste is separated in the major categories of polymeric materials: PP, HDPE, PET, low density polyethylene (LDPE) and mixed. The separation is done using the NIR technology. After sorting by NIR, the material streams are inspected manually and left non-plastic plastics and films are removed from the stream. In total 32 kg of post-

consumer PP was randomly collected by catching an average stream from the conveyer belt (Figure 38), representing the amount of materials needed for the categorization method of the study.

Further purification and separation of the categorized streams will be discussed in section 4.1.



Figure 38: Collection of post-consumer PP from conveyor belt

#### 4.2.2. Reference Method

The materials used for the reference method consists of known virgin materials and materials coming from post-consumer products made out of these virgin materials. Virgin grades of PP were supplied HORDIJK, Amsterdam, The Netherlands, whose business is the manufacturing of food packaging from polymeric materials. They supplied material of injection mold grade and thermoformed grade. Also a master batch white was supplied, which was used in some of the injection mold products. A list of the virgin materials used in this study is given in Table 7, including their material code, manufacturing process and related appendix.

There are two types of random copolymer used in the study, as both materials are randomly used in the manufacturing of the related products.

Table 7: Virgin materials used in this study

Name	Code	Manufacturing process	Appendix
Homopolymer	HJ 325MO	Injection mold	10.1.1
Heterophasic Copolymer	BH 345MO		10.1.2
Homopolymer	4042	thermoforming	10.1.3
Random copolymer (white)	PPR211		10.1.4
Random copolymer (blue)	unknown		x
Masterbatch	Tosaf White	-	-

#### *Injection Mold Grade*

Three different injection mold products were selected which contained various compositions of homopolymer, heterophasic copolymer and masterbatch. The virgin grades as well as the grades from the

pure mechanical recycled post-consumer products were analyzed. To get an insight in the impact of copolymer content in a mixture with homopolymer, the virgin grade of 100% homopolymer was analyzed as well. Additionally, the impact of extrusion on the properties of one composition of homopolymer/copolymer was measured as well. The grade for extrusion is arbitrary selected.

### ***Thermoformed Grade***

Two different thermoformed products containing the same composition of homopolymer and random copolymer, were selected. The two products differed in service life, as they contain another type of food: fatty and aqueous. Additionally, the package containing the fatty food is in general heated in the microwave before consumption of the food.

The grades from the pure products were compared to a virgin grade, as well as to the extruded virgin grades. There are two extruded grades, as there are two random copolymers, which are randomly used in the manufacturing of the related products.

### ***Mixture: Injection mold + Thermoformed***

A virgin injection mold grade with a thermoformed grade is mixed in the extruder, for the mixture. The impact of extrusion on the properties of both selected grades is already analyzed. Therefore these grades were selected again.

### ***Blow Mold Grade***

Additionally, a blow mold product is collected for the reference method. However, the virgin grade of this product was not available during this study. This product can therefore only be used as reference of the mixed blow mold grade, obtained from the categorization method.

An overview of all selected material for the reference method, including composition, is given in Table 8. The virgin grades were supplied by HORDIJK and the post-consumer products were collected manually from the conveyor belt of the conventional sorted PP stream at SITA Suez Environment. Images of the products can be found in appendix 10.2.

**Table 8: Post-consumer products for the reference method**

Manufacturing process	Product name	Composition virgin grade(%wt)
<b>Injection Mold</b>	-	100% Homopol.
	Jumbo Salads	80% Homopol.+20% Copol.
	Huzaren Salads	97%[80%Homo+20%Copo]+3% Materbatch
	Milbona Dessert	50% Homopol.+ 50% Copol.
<b>Thermoformed</b>	-	Extruded 50% Homopol.+ 50% Copol
	Bami Boxes	70%Homopol.+30% Random Copol. (white)
	Vegetables Boxes	70%Homopol.+30% Random Copol. (white)
	-	Extruded 70%Homopol.+30% Random Copol.(white)
<b>Injection mold + thermoformed</b>	-	Extruded 70%Homopol.+30% Random Copol.(blue)
	-	Extruded (injection 50% Homopol.+ 50% Copol.) + (thermo: 70%Homopol.+30% Random Copol.(white)
<b>Blow Mold</b>	Persil Bottles	-



### 4.3. Measured Properties

Optical, rheological and mechanical properties are important factors that give an insight in possibility to address the needs of the market, as explained in the scope of this study. This study focused on specific properties that fall within these overall group of properties. The selected properties are explained in this section. Additionally, the composition of the samples will be measured as it can give an insight in the molecular parameters of the samples: chain scission reactions, existence of other polymers and/ or additives.

#### 4.3.1. Optical Properties

The optical property will be inspected by human eye, as the first indication of the degradation can be observed by visual analyzing. Yellowing, gloss and transparency reduction are may caused by the formation of degradation products. [109] This study will focus on the yellowing, as it can be observed by eye. Additional, the overall impact and correlation with color will be shortly discussed

#### 4.3.2. Mechanical Properties

Two standard testing methods to test the mechanical properties are the are impact test and tensile test. This study will focus only on the tensile test. The total stress- strain diagrams obtained from the tensile test gives more information as compared to the impact strength. In addition the strain at break is the property of most interest in industry.

The values from the tensile test which will be compared are: the ultimate tensile strength, strength at break and strain at break. The tensile strength is the maximum stress that the polymer can withstand while being stretched before breaking. The strength and strain at break are the two values measured at the moment of rupture. The latter two give insight in the ductility of a material that increases with an increase in stain at break. [125] A schematic representation of the response of a typical ductile plastic is given in Figure 39. The molecular images illustrate the fracture mechanism at molecular scale. A polymer undergoes direct molecular disentanglement and exhibits a brittle fracture mechanism, if it cannot deform elastically. [33]

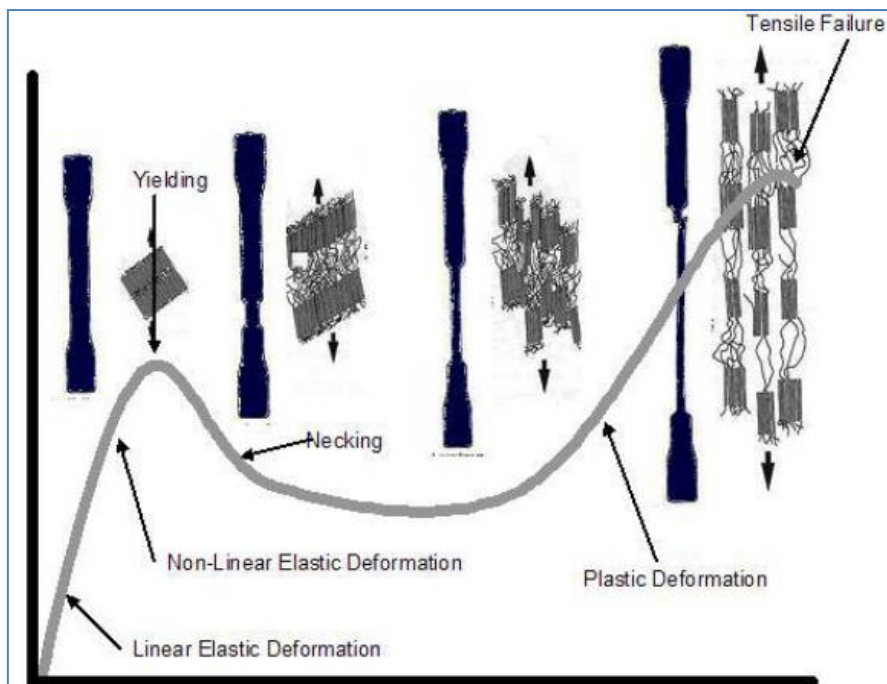

Figure 39: Schematic representation of a typical tensile response of a ductile plastic (stress-strain curve). [33]

### 4.3.3. Rheological Properties

The rheological properties are in general presented by viscosity measurements. Viscosity measurements give the total overview of flow behavior of a polymer over temperature and shear. A more standard and less- time consuming method is the melt flow index (MFI), which is more common used in practice and is a property that is of high interest in industry. The MFI is a good indicator of the flow of PP at a fixed temperature and load, but it is not a fundamental polymer property. It can be seen as a single-point measurement of the viscosity at a fixed temperature and pressure/ shear stress. Figure 40 shows the general relation between viscosity and MFI. The MFI itself gives information about the process ability and quality of the grade. It is commonly used to compare different grades with each other. [126]

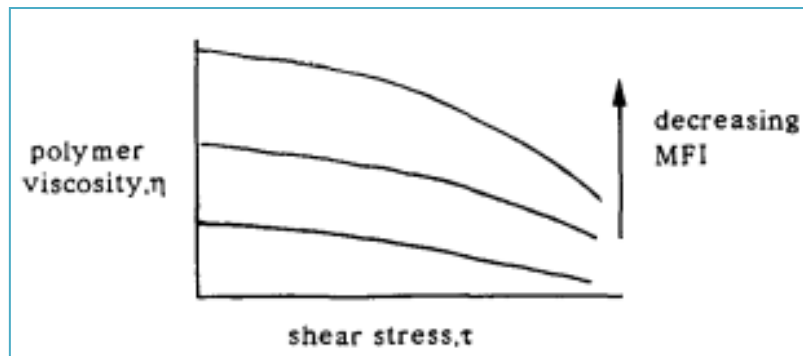

Figure 40: General correlation between polymer viscosity and MFI [127]

The MFI can give information about the quality of the grade, since it is collated with the MW. The MFI is inversely proportional to MW as shown by the empirical model of Bremner and Rudin [128]:

$$MFI = \frac{1}{G * \overline{M}_w^x} \quad \text{Equation 13 [128]}$$

where

*MFI = melt flow index*

*G = constant: ranges from  $2 * 10^{-20}$  to  $1 * 10^{-24}$*

*$\overline{M}_w$  = weight average molecular weight*

*x = constant: range from 3.9 to 4.6*

The correlation between viscosity and MFI follows from the combination of Equation 13 and Equation 8, assuming a MW higher than the critical entanglement MW.

$$MFI \propto \frac{1}{\overline{M}_w^x} \propto \frac{1}{\eta^{3.4}} \approx \frac{1}{\eta} \quad \text{Equation 14}$$

### 4.3.4. Composition

The most suitable and sensible analysis for assessing polymer degradation is Fourier Transform InfraRed (FTIR) spectroscopy [109]. FTIR makes use of infrared radiation that has the right range of frequencies that correspond to the frequencies of stretching and bending vibrations (Figure 41) of the molecules. Diatomic molecules undergo stretching vibrations only, because they have no bond angles. While the molecules that contain three or more atoms show more complex vibrations.

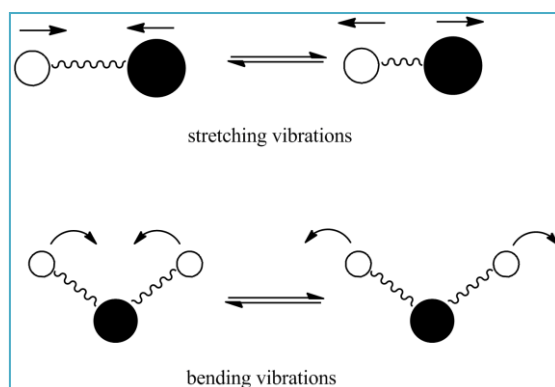



Figure 41: Schematic representation of stretching and bending vibrations

A molecule absorbs the radiation if the frequency of the radiation exactly matches with the frequency of the vibration. Each absorption will form a peak in the IR spectrum. By analyzing these, the existence of different bond and thus different molecules in the material can be determined.

The IR spectra can be divided in two areas: left hand from 4000 to 1400  $\text{cm}^{-1}$  and the right hand from 1400-600  $\text{cm}^{-1}$ . The left hand side is called the functional group region and can be used to determine the existence of functional groups. The right hand side the finger print region, which spectrum is characteristic for the compound as a whole. In this way, two molecules containing the same functional groups can be distinguished.

Stretching a bond requires more energy than bending a bond. The stretching absorption peaks will therefore be found in the left-hand of the spectrum, whereas the absorption peaks of the bending vibration can in general be found in the right hand side. The stretching frequencies of most important compounds are given in Table 9. An extensive list of characteristic functional group vibrations is given in Appendix 10.5. The exact position depends on the total structure and impact of neighboring molecules. The frequencies are therefore given as ranges instead of exact points. The strength of the bond also depends on the degree of hybridization. A C-H bond is stronger when the carbon is  $\text{sp}$  hybridized ( $\approx 2900\text{cm}^{-1}$ ) than when it is  $\text{sp}^2$  hybridized ( $\approx 3100\text{cm}^{-1}$ ), which is in turn stronger as a  $\text{sp}^3$  hybridized ( $\approx 3300\text{cm}^{-1}$ ) carbon.

Table 9: Frequencies of important IR stretching vibration[129]

Type of bond	Wavenumber ( $\text{cm}^{-1}$ )	Intensity
$\text{C}\equiv\text{N}$	2260–2220	medium
$\text{C}\equiv\text{C}$	2260–2100	medium to weak
$\text{C}=\text{C}$	1680–1600	medium
$\text{C}=\text{N}$	1650–1550	medium
	$\sim 1600$ and $\sim 1500\text{--}1430$	strong to weak
$\text{C}=\text{O}$	1780–1650	strong
$\text{C}-\text{O}$	1250–1050	strong
$\text{C}-\text{N}$	1230–1020	medium
$\text{O}-\text{H}$ (alcohol)	3650–3200	strong, broad
$\text{O}-\text{H}$ (carboxylic acid)	3300–2500	strong, very broad
$\text{N}-\text{H}$	3500–3300	medium, broad
$\text{C}-\text{H}$	3300–2700	medium

### ***Tacticity of Polypropylene***

All PP used in this study are assumed to consist for the major part out of isotactic PP. The tacticity of PP is therefore not taken into account as explained in section 3.1.2. This assumption can be confirmed by FTIR analysis.

The tacticity of polypropylene can be analyzed by the absorption spectra as well. The absorptions at 970 and 1460 $\text{cm}^{-1}$  are characteristic for PP, but independent on the tacticity. However, the absorptions at 840, 1000 and 1170 $\text{cm}^{-1}$  are characteristic for isotactic PP and the absorption at 870 $\text{cm}^{-1}$  is characteristic for syndiotactic PP (Figure 42). [34]

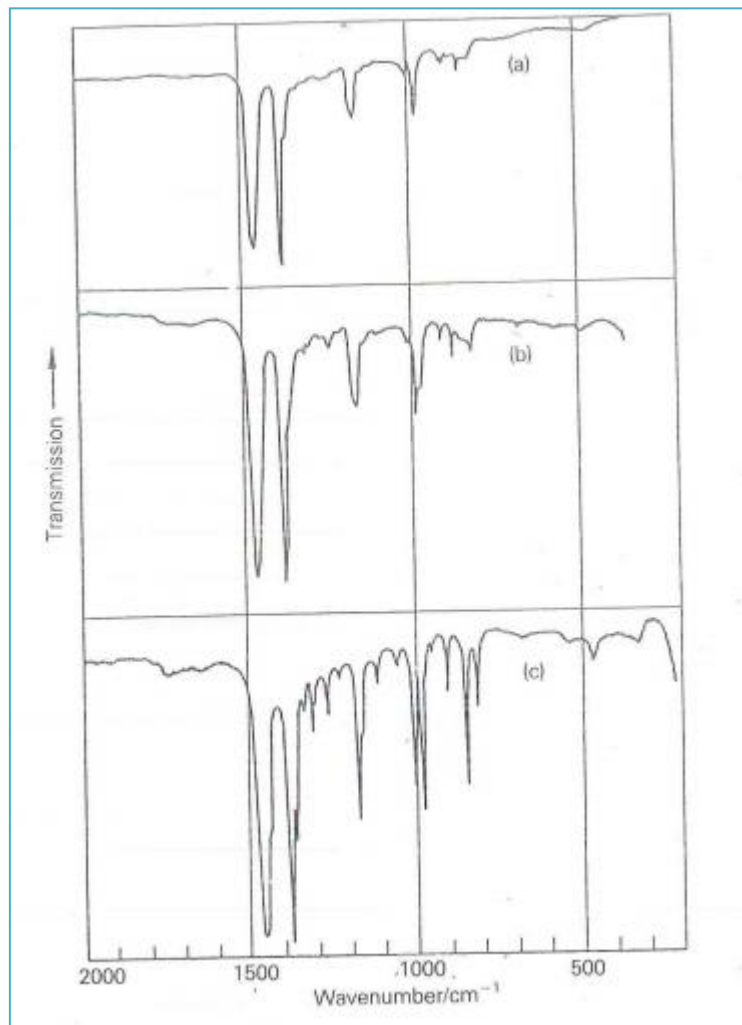

Figure 42: IR spectra of 1) atactic, b) syndiotactic and c) isotactic PP[34]

### ***Other Polymers***

To be able to determine the existence of other polymers in the material, the structural forms of the repeating units of most common plastic types are given in Figure 43. The absorption peak that can be expected from the different bonds can be obtained from 10.5.

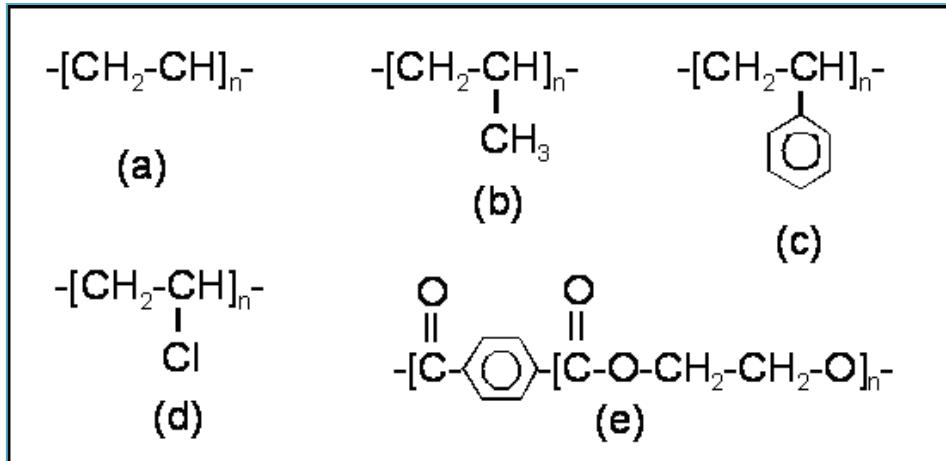

Figure 43 Structural forms of repeating units of a) Polyethylene; b) Polypropylene; c) Polystyrene; d) Polyvinyl Chloride and e) Polyethylene terephthalate.

Already is known that PP copolymers exist of additional other types of molecules in the polymer chain. The two common used structures are ethylene (Figure 43a) and 1-butene (Figure 44).

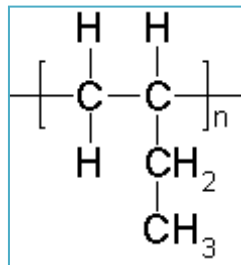

Figure 44 molecular structure of polybutene[130]

### Degradation Products

The PP chain undergoes chain scission and oxidative reactions during degradation processes as was shown in Figure 25 and Figure 27. The degradation products of thermo-mechanical degradation contain C=C bonds. Absorbance in the region 1680-1620 cm<sup>-1</sup> and at 908 cm<sup>-1</sup> indicates the existence of methylene and vinyl groups.

The degradation products of thermo-oxidative degradation contain C=O and O-H bonds. The absorbance in the region of 3650-3200 cm<sup>-1</sup> and 1850-1630 cm<sup>-1</sup> indicated the presence of the carbonyl (C=O stretching) and hydroxyl groups (O-H stretching) respectively.[131][109]

The degradation can be quantified by the calculation of the carbonyl index (CI) which is the ratio of the absorbance of the carbonyl group and the absorbance of a specific band for PP (Equation 15). However, the value calculated by this equation may give a wrong conclusion, since C=O might be released when chain scission occurs and other degradation products will be formed (Figure 28). [109] The analysis of degradation by FTIR therefore needs to be done in combination with mechanical and rheological properties.

$$CI = \frac{A_{\text{carbonyl}}}{A_{PP}} \quad \text{Equation 15 [109]}$$

where

$CI = \text{carbonyl index}$

$A_{\text{carbonyl}} = \text{intensity of absorbance at frequency related to}$

*C = O bond in degradation product of PP*

*A<sub>PP</sub> = Intensity of absorbance at frequency related to C – C bond in PP*

### **Additives**

Additives are rarely noticeable in the FTIR spectra as the content is very small. However, this is not the case of white pigments, as it absorbs a lot of light. The additive analysis will therefore only focus on the existence of rutile, which spectra is given in Figure 45. This spectrum is specific for organic materials, which in general show absorption peaks in the region of shorter wavelengths.

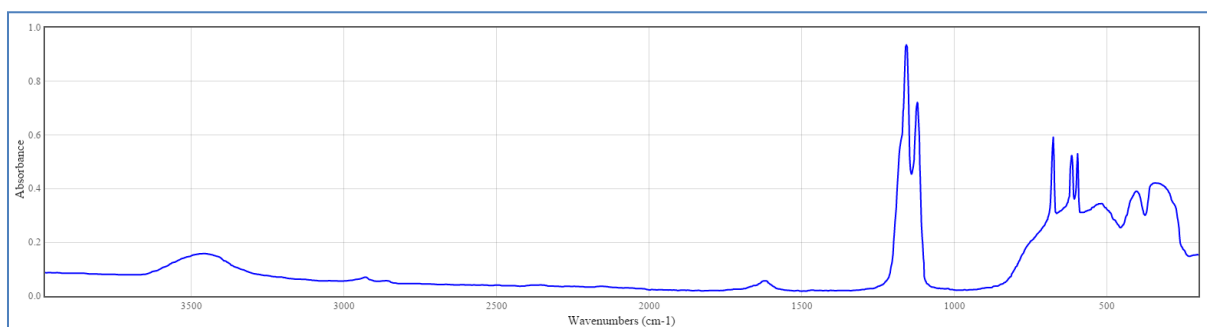

Figure 45: Infra red spectra of Rutile[132]

## **4.1. Testing Equipments**

### **4.1.1. Optical Properties: Visual Optics**

There is no equipment needed for the analysis of the optical properties, as the analysis will be done by human eye.

### **4.1.2. Mechanical Properties: Tensile Test**

The ZWICK Z010 equipment is used to perform the tensile test, at room temperature. A loadcell of 10kN is used, since a load is optimal, when 7.5% to 92.5% of the load is used during the test. The ZWICK Z010 was provided with the processing software 'test Xpert II'. The tests were performed at a crosshead speed of 50 mm/min according the ISO 527 standards. The initial gauge distance between the clamps was set to 98.55 mm, based on the length of the sample. The nominal strain and the standard force were obtained from the software. This data is used in the graphs of this study. The graphs represent the average and standard deviation of each grade, based on ten measurements (chapter 0)

### **4.1.3. Rheological Properties: MFI**

The MFI measurements were performed using the ZWICK Roell 4100 equipment. The determinations were conducted in compliance with applicable standards, ie ISO 1133. According this standard, the temperature was set to 230°C. The plastic was heated for 4 minutes to assure the melting of granules before the load of 2,16 kg was applied. The sampling times of each grade was determined during the experiments. The time varies to ensure accuracy of measurements, as the measurements needs to be done between to marked positions of the load. The time intervals are therefore determined based on the flow ability of the grade. The sampling time for each grade is given in Table 10 and Table 11.

The mass of each sample, obtained from the MFI testing equipment, was measured using an analytical balance of type PRECISA XR205SM-DR, with an accuracy of  $\pm 1$  mg. The average and standard deviation of each grade are calculated based on five measurements

Table 10: Sampling time of MFI tests: categorization method

Sample name	Sampling time (s)
Conventional sorted PP+ Non-PP plastics	60
Conventional sorted PP- Non-PP plastics	60
Blow Mold	180
Injection Mold	10
Thermoformed	60
Injection White	10
Injection transparent	10

Table 11: Sampling time of MFI tests: reference method

Manufacturing type	Sample	Sampling time (s)
Injection mold	100% Homopolymer	10
	80% Homopol.+20%Copol.	10
	Jumbo Salads pure product	10
	Jumbo Salads product including Labels	10
	97% [80% Homopol.+20% Copol.] + 3% White	10
	Huzaren Salads pure product	10
	Huzaren Salads product including labels	10
	50%Homopol+50% Copol.	10
	Extruded 50%Homopol+50% Copol.	10
	Milbona Dessert pure product	10
	Milbona Dessert product including Labels	10
	Thermoformed	70% Homopol.+30%Random pol. white
70% Homopol. + 30% Random pol. white extruded		120
70% Homopol. + 30%Random pol. blue extruded		120
Bami Boxes		120
Vegetables Boxes		120
Mixture injection mold + thermoformed grade	50% injection [50% Homo.+50% Copol.] + 50% thermoformed [70 %Homo. + 30% Rand. White]	60
Blow mold	Persil Bottles	180

#### 4.1.4. Composition: FTIR

The FTIR tests were performed, using PERKIN ELMER Spectrum 100 equipment. Spectra of each sample were obtained between 600 and 4000  $\text{cm}^{-1}$  with a resolution of 4  $\text{cm}^{-1}$ . Each recorded spectra represents average of five successive scans. Analysis of five samples of each grade was performed. The overflow part of the injection mold samples for mechanical tests were used during this analysis.

## 4.2. Sample Preparation

The sample preparation consists of: Separation, size reduction and cleaning, homogenizing and finally injection molding. These steps were set up especially for this study, to obtain pure and clean material grades. The steps will be described in this section.

### 4.2.1. Separation

#### *Categorization Method*

The first step in sample preparation is the purchasing of the right categories which were described in section 4.1.1. Non-PP plastics and impurities such as: other types of plastic sorted incorrectly, alumina and other metals, attached impurities such as caps and film and labels. Also materials inserted inside packaging by consumers were removed. And finally flower pots were removed as well, as these products are made out of recycled PP and therefore already consist of impurities. Only the products including a characteristic sign of PP were selected to guarantee the purity of the post-consumer PP stream. Extruded films were, due to the lack of a sign, not selected. The average distribution of the different fractions in a general conventional sorted PP stream excluding non-PP plastics is represented in Graph 1. This can only be used as indication, since the measurements are done based on 4 kg of conventional sorted PP excluding non-PP plastics only.

**Graph 1: Fraction of injection mold productions in comparison to thermoformed and blow mold products in preselected conventional post-consumer PP stream (4kg)**

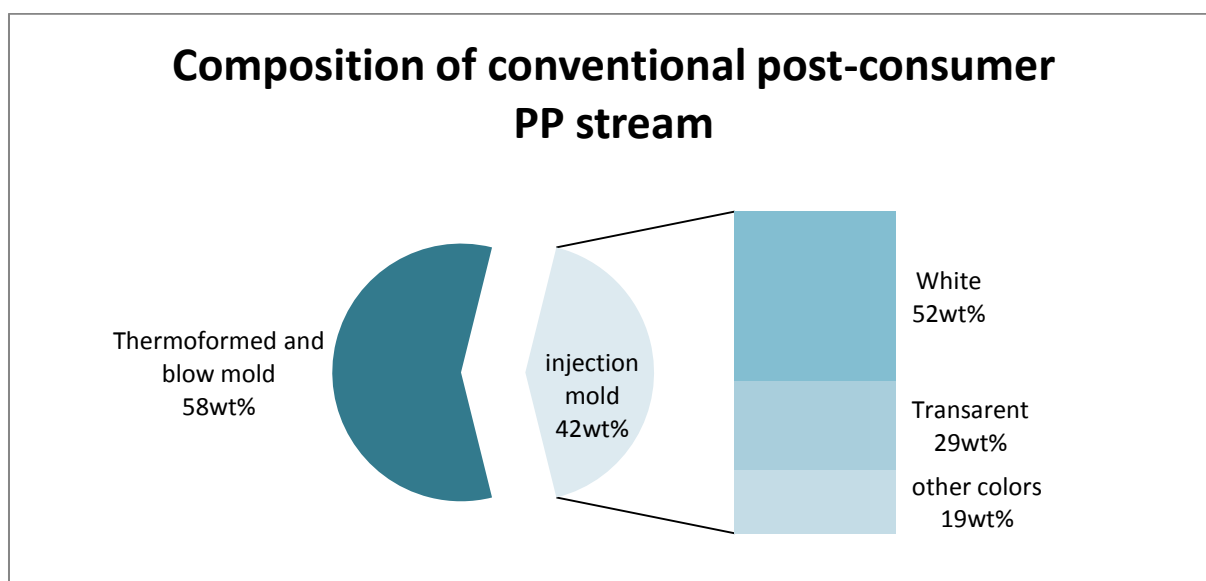

Four kg of conventional sorted PP + and – non-PP plastics were selected to get a more average and representative mixture. Two kg was selected for all the other fractions. This amount was needed to make enough test samples, taking unavoidable material losses during the following stages into account. What still needs to be taken into account is the unavoidable existence of variation in the composition of the post-consumer waste. The composition depends on the collection system which differs per region. The season also influence the type of packaging: for example in the summer there are more packaging related to barbeques and in the winter there are more packaging for Christmas gifts and cards. [133]

The separation of blow mold, injection mold and thermoformed fractions were selected based on specific characterizations. The characterizations were recognized based on experience and will be explained for each category and finally illustrated in Table 12.



### Blow Mold Grade

Blow mold products are manufactured by a process that blows the product in to a specific shape, determined by the mold, by blowing air through a single hole. Plastics bottles are a good example of blow mold products. The products are also characterized by a weld line in, especially recognizable at the bottom of the products.



### Injection Mold Grade

The injection mold are characterized by an injection point and remaining fingerprints on the place where the product ejected from the mold. Injection mold products are in general more complex as compared to thermoformed and blow mold process. The complex structure also results in products with a high stiffness.

### Thermoformed Grade

In general, the products of this category are characterized by a non-complex structures and a relatively low wall thickness. The products therefore show a high flexibility. Also fingerprints could be recognized, origination from the ejection.

**Table 12: Characteristic signs of products depending on the manufacturing process**

<i>Injection mold</i>	<i>Blow mold</i>	<i>Thermoformed</i>
		
<b>Injection point</b> <b>Complex structures</b>	Hollow product Weld line	No injection point Non complex structures

The white and transparent injection mold products were subsequently selected after the separation based on manufacturing processes.

### ***Reference Method***

The post-consumer products were selected directly selectively picked from the conveyor belt of SITA Suez Environment

#### **4.2.2. Cleaning, Drying and Size Reduction**

This part of the sample preparation was intended to remove residues of any kind from the product surfaces, as they will lead to poor mechanical and changed rheological properties, explained in section 3.2.

The cleaning of the products was achieved in two stages. The first stage involved cleaning of the products as a whole. Followed by cutting off specific parts of the products, in the case of the reference method. Where after each category of products (parts), including the ones of the categorization method, were shredded into small flakes. Thereafter a second washing stage was performed. This second washing was done to even further remove impurities such as paper from paper labels, small particles of aluminum foil,

and etcetera. This washing stage was also followed a second size reduction to make the flakes small enough to be fed through the extruder.

### ***First Step of Cleaning***

A general household washing machine of type INDESIT WIA 121 was used for the first cleaning step, as proposed by the company HERMION, which has experience in washing plastic waste stream. The standard washing program of the machine (number one) was used at a temperature of 90°C. about 55 ml of liquid detergent for color clothes of the brand Persil was used. The detergent for color was specifically chosen, since it does not contain the peroxide that breaks down the polymer chains as is the case in detergent especially for white clothes. The program was stopped after 50 minutes, before the centrifuging step and the plastics were taken out after drainage. The washing program was the most optimal program according to cleaning efficiently and time. The program setting were determined during the experiments.

In average 0,7 kg of plastic post-consumer product could be washed per cycle. The plastic was washed within a jute bag to prevent the ingress of small pieces of plastic to the water exhaust system of washing machine. The efficiency of the cleaning is illustrated in Figure 46.

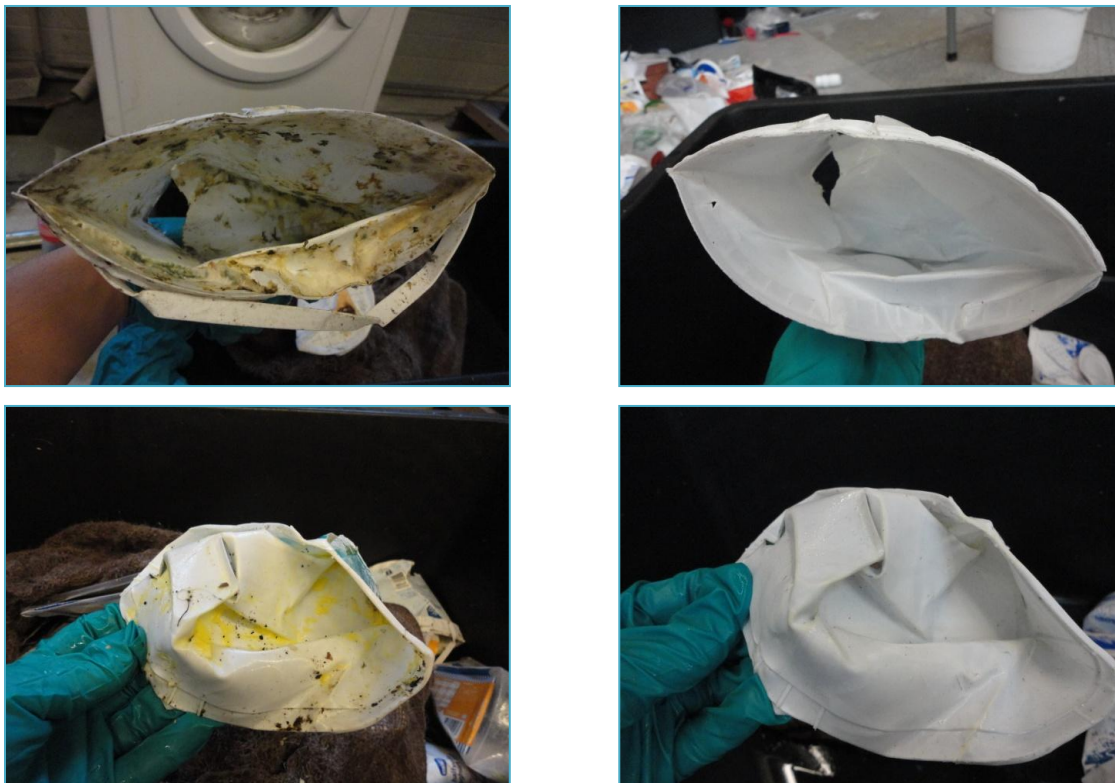

**Figure 46: First step of cleaning: examples of product before washing (left) and after washing (right)**

The products were spread out inside the lab and dried overnight at room temperature.

### ***Cutting***

The cutting step was only performed to a part of the products of the reference method. The cutting was done manually and provided the possibility to study the impact of in mold labels and printing inks on the injection mold products. Therefore the fractions of post-consumer products including and excluding labels or printing inks were separately analyzed. The fraction of label in the products parts containing the labels are calculated and given in Table 13. The average mass fraction is based on the measurement of ten product parts.

Table 13: mass fraction of labels in parts of products containing labels

Product	Mass label (g)	Average mass fraction (wt%)
Jumbo salads	0,55	14,2
Milbona Desserts	0,60	38,96

In the same stage, aluminum residues from especially the Milbona desserts were removed as well. In addition, the glued films were cut off from the thermoformed products to prevent their impact on the measured properties. The tops and labels were removed from the blow mold products. The cut offs and removals are presented in appendix 10.3

### ***First Size Reduction***

All the (parts of) post-consumer from both methods were subjected to a shredding process. The shredder including a sieve with a mesh diameter of 10 mm was used for the first shredding. This size was chosen based on the counteracting requirements of cleaning efficiently and losses during subsequent steps. A larger size would result in a less effective cleaning, while a smaller size would increase the losses during subsequent steps. Especially in the spinner as will be explained. This resulted in the size, which resulted in a huge volume reduction. As example the flakes of the blow mold fraction are presented in Figure 47.



Figure 47: Fraction of PP blow mold flakes

### ***Second Step of Cleaning***

The second step of cleaning was applied to remove the remaining impurities and contaminants. The cleaning step is much effective at flake level as compared to products level, since all surface are better in contact with the cleaning liquid. An industrial mixer of type HOBART A200 for this step (Figure 48)



Figure 48: Mixer of type HOBART A200

Each washing cycle contained 1 kg of plastic flakes, 4 liters of water at 80°C and 30 ml of detergent (brand *NEUTRAL*) which contains Sodium Laureth Sulfate. This detergent is chosen, based on experience by a recycling company in Romania (ROM WASTE) The detergent is obtained from natural compounds, is inexpensive, has a high cleaning power, an antimicrobial character and does not contain carcinogenic or mutagenic compounds. Additionally, the detergent is safe to clean food grade packages, which is required for a circular economy. The flakes were washed in de mixer at a rotation speed of 107rpm for 10 minutes. After mixing, an additional 10 L of water was added to the mixture, which facilitated the float-sink separation. PP floats on water while impurities, such as paper and fine aluminum particle. The impurities were removed by a sieve with a mesh size of 2 mm (Figure 49). Non-PP plastics that sunk in the mixer, where were taken back to the batch of flakes in the case of conventional sorted PP including non-PP plastics. After the removal of the impurities, the flakes were rinsed by water at 80°C temperature. Subsequently, the flakes were dried overnight in the lab.



Figure 49: Second step of cleaning: Cleaned PP blow mold flakes (left), filtered impurities (right)

### ***Spinning***

This stage involved the use of an industrial spinner to remove the last minuscule residues of impurities. The operation was performed in the company HERMION BV, Waalwijk, The Netherlands. Hermion BV designs, builds and implements customized plastic waste washing technologies. The flakes were wetted before passing through the spinner. The spinner consists of rotating paddles that strike the wet material with great kinetic energy. And airflow dries the plastic and leads it to the outlet, while water, contaminants and particles smaller than 2 mm pass through the sieve and are removed. The spinner has a power of 22kW and rotated with 3000rpm.

### ***Drying***

To prevent negative impact of moisture in the subsequent steps (especially homogenizing and injection molding), the flakes were dried in an oven (MEMMERT ULE800) at 60°C for 22h, including ventilation (setting: 6)

### ***Second Size Eeduction***

The dried flakes were shredded into smaller sizes using the same shedder as in the first size reduction step. This time a smaller sieve, with a mesh size of 6 mm was used. The size reduction was done to obtain a better inlet stream in the extruder, used for homogenizing. The flakes are taken by the screw of the extruder and a small size of flakes was required. The smaller size also increased the homogeneity of the pre-mix of flakes.

The flakes were used to analyze the optical properties.

### **4.2.3. Homogenizing**

The homogenizing step was carried out by a extruder to obtain granules with a more or less homogeneous composition. Additionally to homogeneity, the conversion into granules makes injection molding possible, as granules can be directly fed to the inlet of the injection molding equipment. The flakes converted to granules in a co-rotating twin screw extruder, ZSK 18 MEGAlab from Coperion, which datasheet can be found in Appendix **Error! Reference source not found.**. The extruder consists of two degassing steps, which are important for the removal of volatile substances, such as gas from printing inks[134]. The rotation speed and temperature settings for each sample are given in Table 14. The torque was maintained at around 40%. The temperature profiles were based on the MFI of the materials, as explained in further detail below, while the rotation speed and torque were set to obtain a constant thickness of around 2( $\pm$ 0,3) mm of the extruded thread. The size was related to the maximum granule size of 3,5mm that could be taken by the inlet zone of the injection molding machine. The thickness of the thread was measured by an automatic laser sensor KEYENCE LASER SENSOR Intelligent-G, after the thread was led through a cooled water bath at room temperature, dried by pressed are and drawn by two rotating wheels. The thread was, after the automatic measurement, directly fed into a granulator of BRABENDER.

The granules were used to analyze the optical and rheological properties.

### ***Temperature Profiles***

Extrusion has a negative impact on the final properties due to degradation processes as explained in section 3.2. There are multiple processing conditions influence the level of degradation, such as the temperature profile, deformation rate and residence time.[135] The two latter two are related to the rotation speed and pressure, but also intercorrelate with the temperature profile. The impact of processing conditions on the level of degradation is quite complex and the settings are therefore based on standards. The temperature and rotation speed were chosen as variable settings. The temperature profile is related to the viscosity of the material, and was needed to vary to adjust the throughput and therewith the thickness of the thread. High viscous PP (low MFI) requires lower temperatures than low viscous (high MFI) PP. A higher rotation speed was chosen at higher temperatures, to decrease the residence time and therewith limit the negative impact of higher temperatures on the degradation processes.

### Categorization Method

A compounding temperature profile with a maximum temperature of 230°C is commonly used for post-consumer mixed PP, based on advice provided by several recycling companies and experienced employees of the UGent. A rising temperature profile up to 230°C was therefore set for the samples containing conventional sorted PP, including and excluding non-PP plastics. The temperature itself in a co-rotating extruder has only a small impact, since no dead zones exist in this type of extruder. A more or less linear rise of temperature can therefore be used. The inlet temperature must stay low, to prevent constipation of the inlet by semi-molten material. The other temperature profiles were based on the relative assumed MFIs. Injection mold grade are assumed to have a higher MFI as compared to a mixture and are processed at a lower temperature, while thermoformed and blow mold products are assumed to have a lower MFI and are processed at a higher temperature. A blow mold grade in generally even has a lower MFI as compared to blow mold. These assumptions were based on section 3.1.6. The temperature profiles of the categorization method are listed in Table 14

**Table 14 Temperature profiles for compounding process: categorization method**

Sample	T <sub>1</sub> (°C)	T <sub>2</sub> (°C)	T <sub>3</sub> (°C)	T <sub>4</sub> (°C)	T <sub>5</sub> (°C)	T <sub>6</sub> (°C)	T <sub>7</sub> (°C)	T <sub>8</sub> (°C)	T <sub>9</sub> (°C)	Rotation speed (rpm)
<b>Conventional sorted PP+ Non-PP plastics</b>	155	170	180	190	200	205	210	220	230	150
<b>Conventional sorted PP- Non-PP plastics</b>										
<b>Blow Mold</b>	155	170	180	190	200	210	220	230	240	150
<b>Injection Mold</b>	155	170	180	185	190	195	200	205	210	120
<b>Thermoformed</b>	155	170	180	190	200	210	220	230	240	150
<b>Injection White</b>										
<b>Injection transparent</b>	155	170	180	185	190	195	200	205	210	120

### Reference method

The temperature profiles of the post-consumer products of the reference products were set as the temperate profiles of the materials of the categorization method, except for the injection mold products. The MFIs of the injection mold products, as given by their datasheets, were assumed to be relatively high, as the MFI of injection grade polymers normally ranges between 8-35 g/10min (section 3.1.6). The temperature profile was therefore set to a lower temperature range (Table 15).

**Table 15 Temperature profiles for compounding process: reference method**

Sample	T <sub>1</sub> (°C)	T <sub>2</sub> (°C)	T <sub>3</sub> (°C)	T <sub>4</sub> (°C)	T <sub>5</sub> (°C)	T <sub>6</sub> (°C)	T <sub>7</sub> (°C)	T <sub>8</sub> (°C)	T <sub>9</sub> (°C)	Rotation speed (rpm)
<b>Jumbo salads</b>										
<b>Huzaren salads</b>										
<b>Milbona desserts</b>	155	170	170	175	175	180	180	185	190	120
<b>Extruded injection mold grade</b>										
<b>Bami boxes</b>										
<b>Vegetable boxes</b>										
<b>Extruded thermoformed mold grade</b>	155	170	180	190	200	210	220	230	240	150
<b>Mixture injection mold + thermoformed grade</b>										
<b>Persil bottle</b>										

#### 4.2.4. Injection Molding

The samples for mechanical testing were prepared in the horizontal injection molding machine of type BOY 22S. The temperature profiles, including mold temperature, were held constant for all materials (Table 16) and only the holding pressure was varied. The temperature profile was held constant to limit the impact of processing conditions of the injection molding on the final properties. Cooling rate is held constant in this way, which is an important parameter in the determination of the final properties. [33] The temperature profile has no influence on the residence time, since settings of the injection molding equipment is based on volumes, in contrary to the extruder. A change in holding pressure was needed to address complete filling of the mold, in case of low MFI materials, and to prevent overflow, in the case of high MFI materials. The holding pressure for each material is given in Table 17 and Table 18, for the categorization and reference method respectively. The holding pressure was determined partly based on the MFI assumptions and partly on the direct analysis of the samples by eye during the sample preparation. The mass of the samples were also weighted and were held constant at  $7 \pm 0,2$  g as a quality check. A complete overview of the settings during injection molding is given in the complete set-up data as shown in Appendix 10.4.

Table 16: Temperature profile during injection molding. Temperature profile given from inlet to outlet and subsequently the mold temperature

T <sub>1</sub> (°C)	T <sub>2</sub> (°C)	T <sub>3</sub> (°C)	T <sub>4</sub> (°C)	T <sub>5</sub> (°C)	T <sub>MOLD</sub> (°C)
180	195	200	210	210	30

Table 17: Holding pressure of during injection molding of each sample: categorization method

Sample	Holding pressure (%)
Conventional sorted PP-Non-PP plastics	15
Conventional sorted PP+Non-PP plastics	15
Blow Mold	50
Injection Mold	15
Thermoformed	30
Injection White	15
Injection Transparent	15

Table 18: Holding pressure of during injection molding of each sample: reference method

Manufacturing type	Sample	Holding pressure (%)
Injection mold	100% Homopolymer	15
	80% Homopol.+20%Copol.	15
	Jumbo Salads pure product	15
	Jumbo Salads product including Labels	15
	97% [80% Homopol.+20% Copol.] + 3% White	15
	Huzaren Salads pure product	15
	Huzaren Salads product including labels	15
	50%Homopol+50% Copol.	15
	Extruded 50%Homopol+50% Copol.	15
	Milbona Dessert pure product	15
	Milbona Dessert product including Labels	15
	Thermoformed	70% Homopol.+30%Random pol. white
70% Homopol. + 30% Random pol. white extruded		40
70% Homopol. + 30%Random pol. blue extruded		40
Bami Boxes		40
Vegetables Boxes		40
Mixture injection mold + thermoformed grade	50% injection [50% Homo.+50% Copol.] + 50% thermoformed [70 %Homo. + 30% Rand. White]	15
Blow mold	Persil Bottles	50



The test samples obtained by injection molding were dogbone-shaped tensile bars, which dimensions are given in Figure 50.

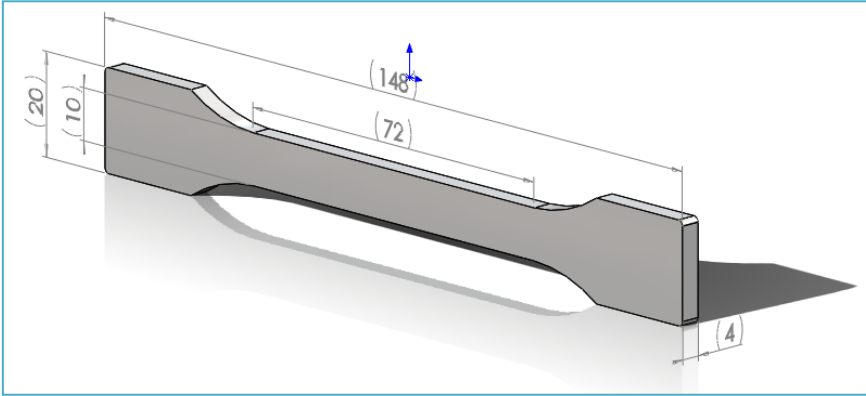

Figure 50: The shape and dimensions of the samples (mm)[33]

# 5. Results and Discussion

This chapter includes the discussion of the results. The discussion will be done based on the two methods: Categorization method and reference method. First of all the limitations, that needs to be taken into consideration for the discussion ,are given.

## 5.1. Limitations

---

The overall limitations and limitations per method are summarized:

### ***Overall Limitations***

- Impact of tacticity is neglected
- Limited analysis: only basic analysis of optical, mechanical and rheological

### ***Limitations Categorization Method***

- The separation in this study is done manually. However, technology will not have a 100% efficiently.
- The waste stream of films is not taken into account
- Categorization of colors is only provided for injection mold grade.
- Only white and transparent products are taken into account in the categorization of colors
- No distinction between transparency of the transparent/ translucent products is made

### ***Limitations Reference Method***

- Only one range of injection mold grades and one thermoformed grade is analyzed
- Detailed information about grades is unknown (MW, long chain branching, additives)
- Impact of in mold label and printing inks only analyzed for one/ two grades
- Type of ink on labels and printing inks is not taken into account
- Only the impact of mixing two grades of PP is taken into account

## 5.2. Categorization method

### 5.2.1. Optical Properties

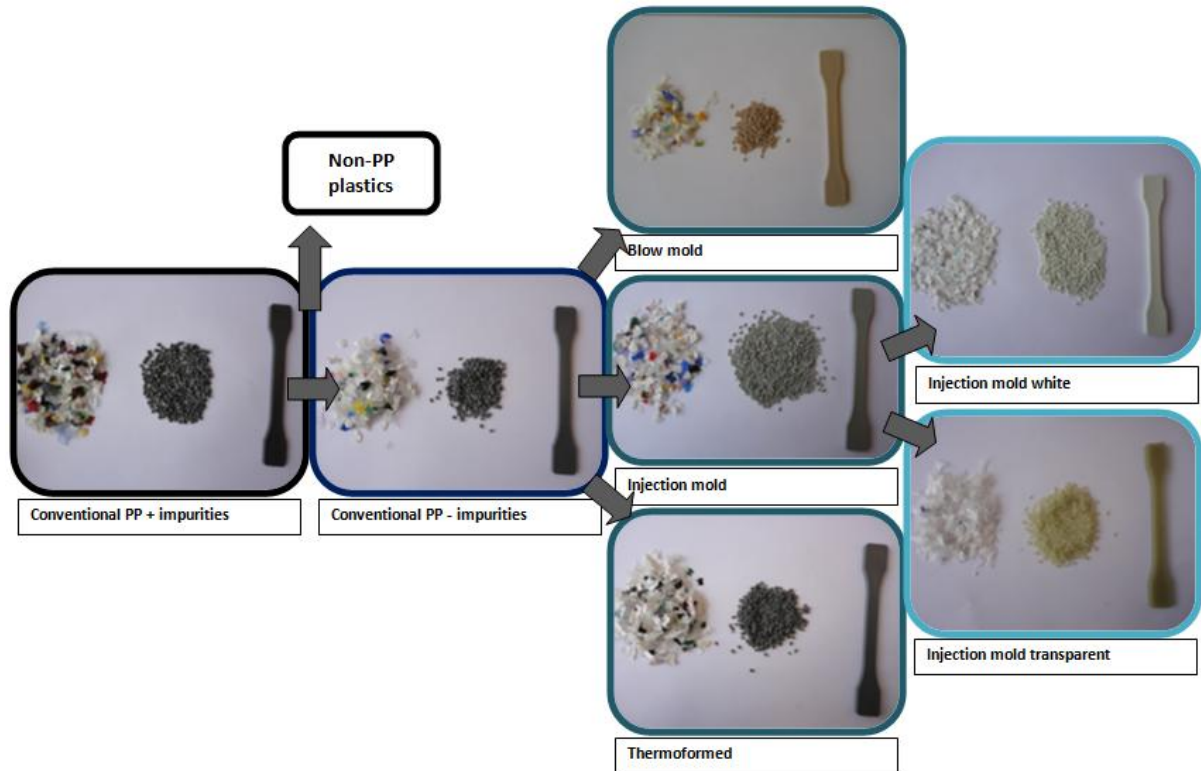

Figure 51: optical properties of flakes, granules and injection molded sample of PP at different stages of categorization method

The impact of each step in further categorization of post-consumer PP on the visual optical properties is given in Figure 51. The color of conventional sorted PP including non-PP plastics is dark grey to black, as was expected based on the mixture of all pigments (section 3.2.3). The color becomes lighter upon the removal of non-PP plastics. This might be caused by the fact that black plastics cannot be identified by NIR, as they absorb all the light. The PP used in this study were separated by the NIR technique

The second step of categorization (blow mold, injection mold and thermoformed) shows a inter correlation with color separation. There are no black flakes (and thus products) observed in the blow mold stream and the mechanical recycled post-consumer grade results in a beige color after homogenizing in the extruder. The injection mold products consisted of a diversity of colors, but mainly transparent and white (Graph 1). This resulted in a light grey color. The thermoformed products consisted mainly of white, transparent and for a minor part of black colored products. This small fraction of black colored products already results in a very dark material after homogenizing in the extruder.

The further selection white and transparent products only from the injection mold waste stream results in a bit bluish white and a yellowed transparent grade. The first observation can be related to a high content of butter cups in this waste stream, including a lot of blue printing inks. The yellowing of the transparent grade shows over-oxidations of anti-oxidants has occurred, which was expected after reprocessing. However, the white grade does not show yellowing, while a same extend of over-oxidation of anti-oxidants is assumed. The non-yellowing character might be masked by the white pigment (section 3.2.3).

### 5.2.2. Mechanical Properties

Graph 2: Ultimate tensile strength of all grades of categorization method, averages and standard deviation are given

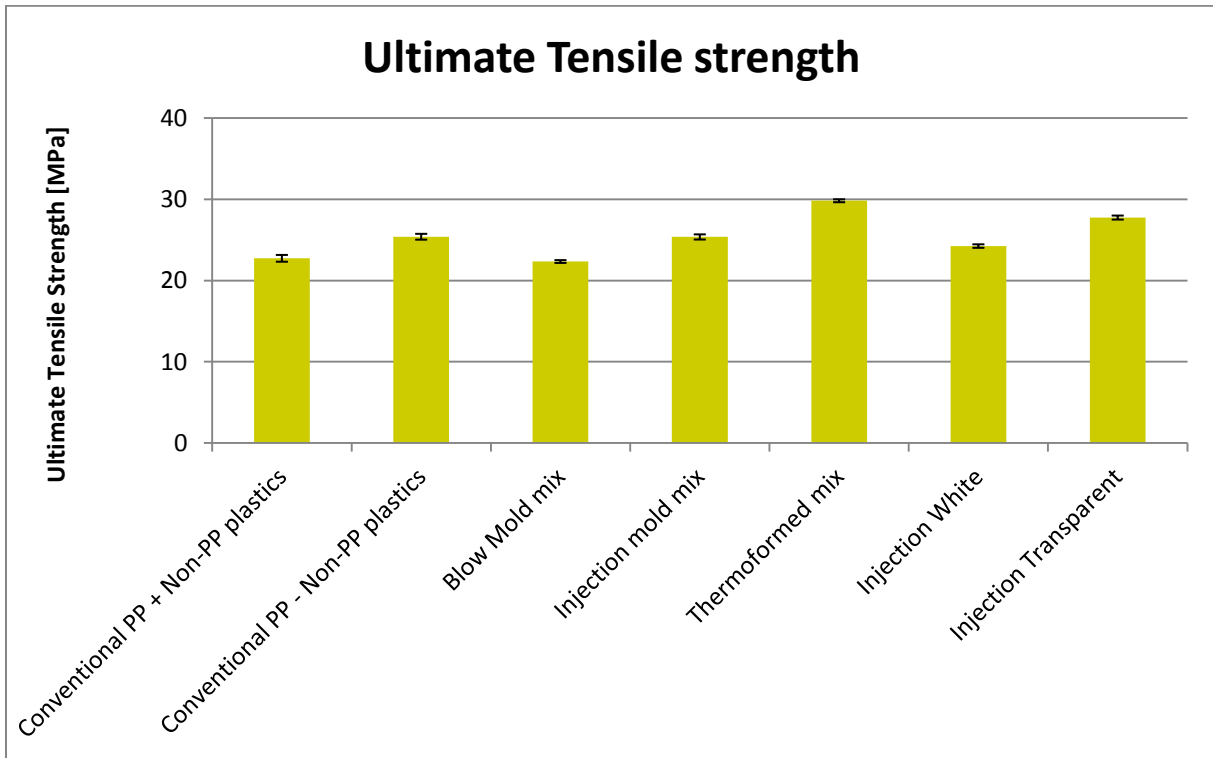

Graph 3: Strength at break of all grades of categorization method, averages and standard deviation are given

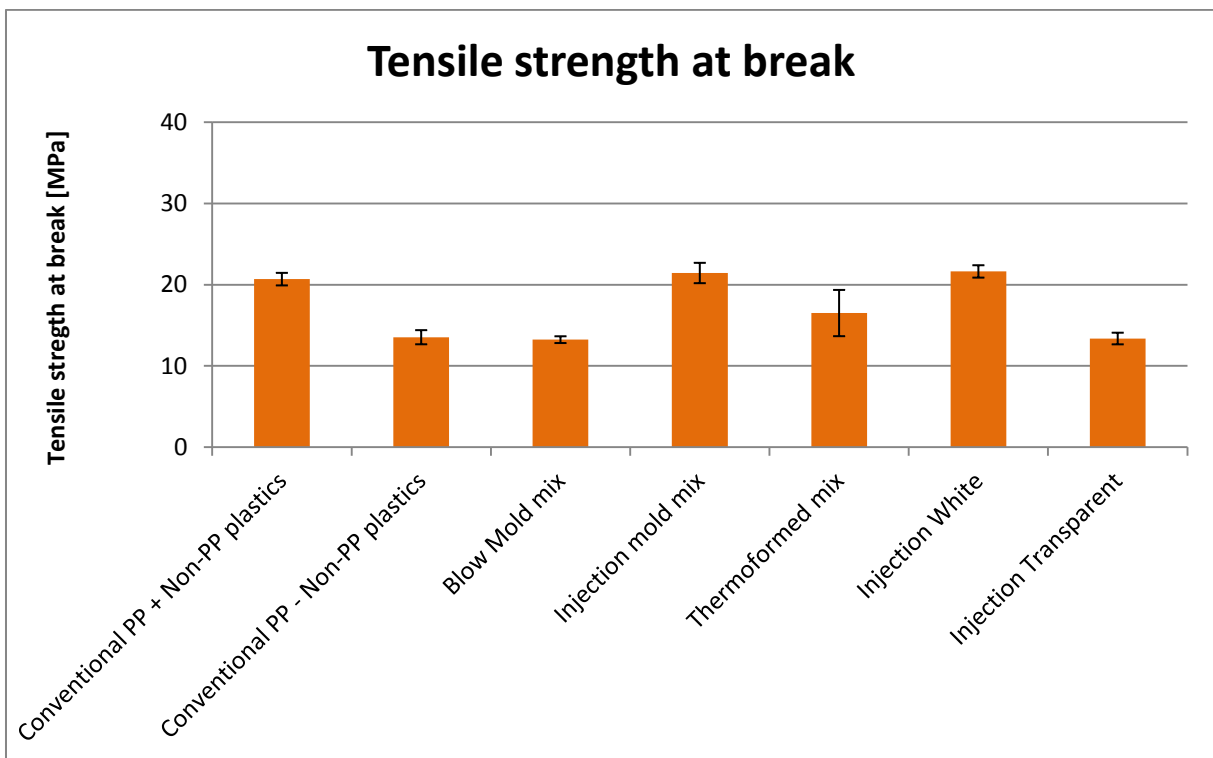

Graph 4: Strain at break of all grades of categorization method, averages and standard deviation are given

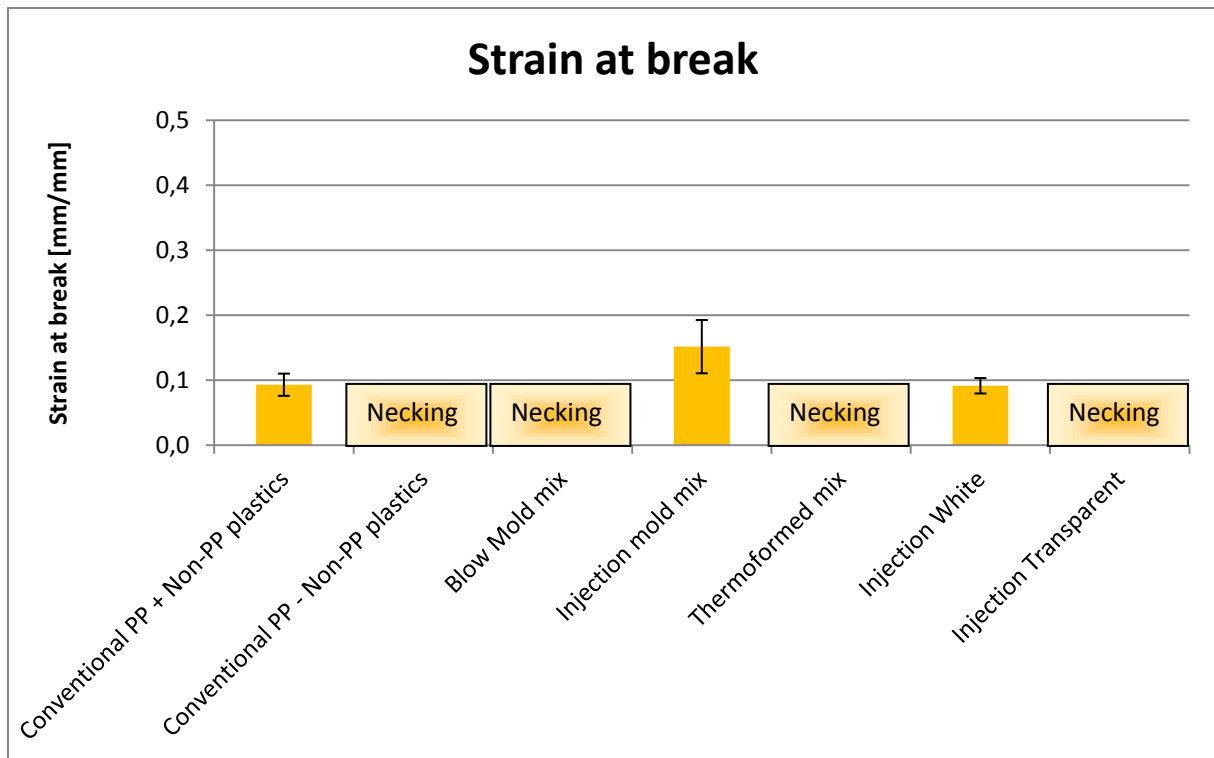

The ultimate tensile strength ranges between 22 and 30 MPa, which is lower as compared to virgin grade, which ultimate tensile strength ranges between 31 and 31.4 MPa (section 3.1.2). The difference is most probably a result of chains scission which results in a lower MW and thereby results in a lower ultimate tensile strength, as was illustrated in Figure 19.

Additionally, the ultimate tensile strength of conventional sorted PP + non-PP plastics is lower as compared to the one – non-PP plastics. Non-PP plastics can be seen as voids as a high interfacial tension and phase separation is expected as explained by Equation 9. The non-PP plastics do not transfer the external load and the ultimate tensile strength is therefore lower, as discussed in section 3.2.3.

The ultimate tensile strength of the conventional sorted PP -non-PP plastics is in between the strengths of the more categorized mixtures. This means that further categorization does not result in an increased ultimate tensile strength. This means that further categorization is intercorrelated with molecular parameters.

However, it is difficult to determine the dominant parameters. To point out the impact of some parameters: 1) an increased molecular weight results in an increased ultimate tensile strength 2) Long chain branches and copolymers reduce the crystallinity and therewith reduces the ultimate tensile strength. 3) PE branches undergo crosslinking during degradation that leads to an increased MW. 4) Clarifiers or other nucleation agents increase the crystallinity and therewith the ultimate tensile strength. Since the exact compositions of the different mixtures are unknown, no further conclusion can be drawn from the results of the ultimate tensile strength.

Based on the results of the tensile strength at break and strain at break it can be said that the mechanical recycled grades originating from: conventional sorted PP including non-PP plastics, injection mold mixed PP and white injection mold mixed PP show a brittle behavior. These grades have a relative high tensile strength and low strain at break. The strain at break (0.9 to 1.5 mm/mm) is significantly smaller than the values of commercially used PP, given in Table 3. The brittle behavior of conventional sorted PP including

non-PP plastics is caused by the fact that the non-PP plastic can be seen as voids and no transfer of the external load is possible (section 3.2.3).

The brittle behavior of the mechanical recycled white injection mold grade can be related to a reduction in MW that approaches the critical MW for entanglements. Entanglements must take place to obtain a material that is strong enough to carry the load, as explained in section 3.1.1.

However, transparent injection mold mixed PP sample show ductile fracture mechanism. This might be related to a higher copolymer content, including ethylene, as it results in a higher transparency (Table 4). Degradation of ethylene results in crosslinking and might compete with chains scission reactions of PP, as discussed in section 3.2.1. It cannot be a result of clarifiers, since it act as a nucleation agent and increases the crystallinity, which would result in a more brittle character. This observation results in the conclusion that the higher ultimate tensile strength of the transparent compared to the white injection mold grade is not related to the increased crystallinity by the addition of clarifiers.

The mixed injection mold mechanical recycled grade (including transparent and white PP) shows a brittle fracture mechanism. The low MW content in the mixture is most probably too high and negatively influences the possibility to form entanglements by the higher MW fractions, such as the ones coming from transparent PP. However, the conventional PP excluding non-PP plastics shows a ductile behavior. This means, that the impact low MW content can be compensated by the entanglements density in the blow mold and thermoformed grade. The blow mold and thermoformed grade show a ductile behavior and are therefore expected to have a high entanglement density, as a high melt strength during processing is required. The high entanglement density is related to a high MW and probably the incorporation of long chain branches (3.1.4). Rheological properties

Graph 5: Melt flow index of all grades of categorization method, averages and standard deviation are given

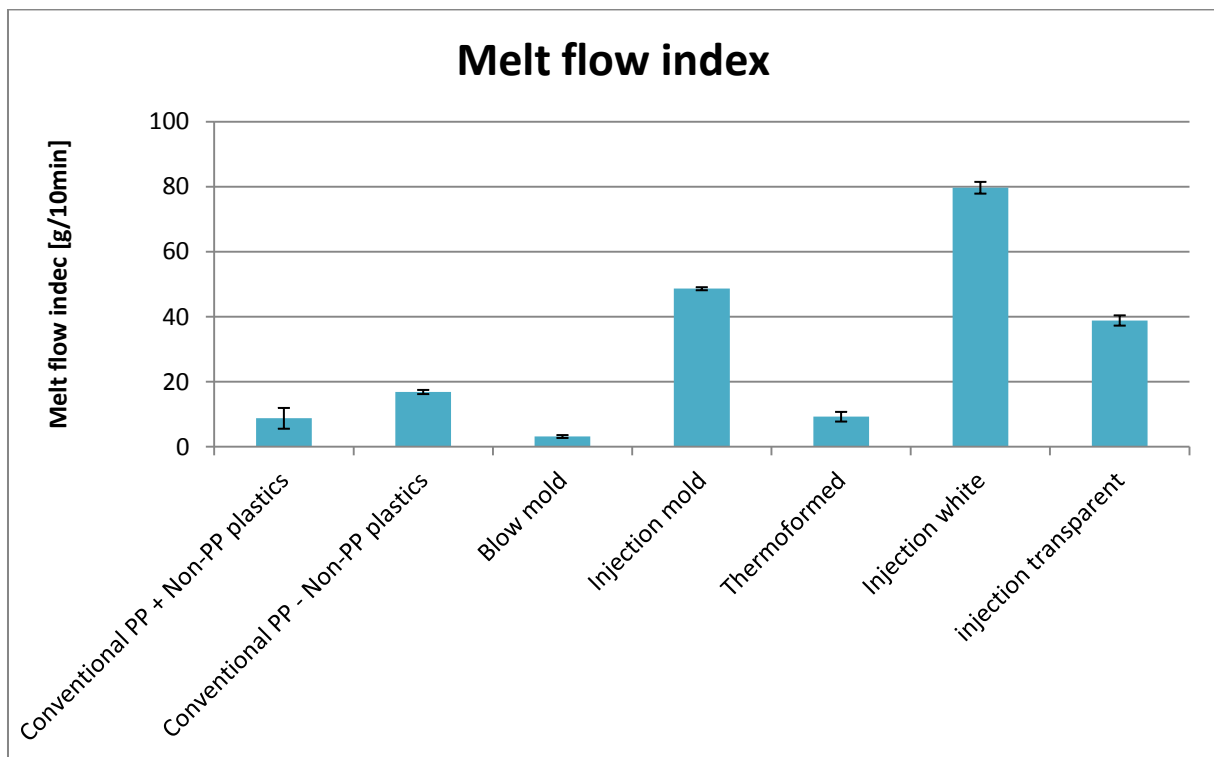

Conventional sorted PP excluding non-PP plastics has a higher MFI than conventional sorted PP + non-PP plastics. Non-PP plastics with a higher melting temperature than PP are incorporated as second phase particles. The impact of second phase particles on the MFI can be predicted by Equation 11. Since MFI is inversely correlated with the viscosity as shown by Equation 14, Equation 11 can be rewritten as:

$$\frac{1}{\text{MFI}} = \frac{1}{\text{MFI}} (1 + 2.5\varphi_{imp})$$

$$\text{MFI} = \frac{\text{MFI}}{(1 + 2.5\varphi_{imp})}$$

Equation 16

This shows that the increase in MFI upon removal of non-PP plastics is in line with the theory. The grade including non-PP plastics is also shows a larger confidence interval. This is related to the fact that the grade is less homogeneous, since the second phase particles are immiscible and do not distribute evenly

The categorization based on manufacturing type results in MFIs that are in line with ranges required by the different processes, discussed in section 3.1.6.

Additionally, the results show a higher MFI of the white injection mold grade than the transparent injection mold grade. A higher copolymer content, as expected for the transparent grade based on Table 4, would result in a higher MFI. This is not the case. Probably crosslinking of the ethylene fraction during degradation leads to an increased MFI. Additionally, pigments of the white grade can be seen second phase particles which results in a decreased MFI, based on Equation 16. The MFI of the mixed injection mold grade, containing transparent and white, is more similar to the white grade. This was also the case for the mechanical properties.

### 5.2.3. Composition

Graph 6: FTIR spectra of five samples of conventional sorted PP + non-PP plastics

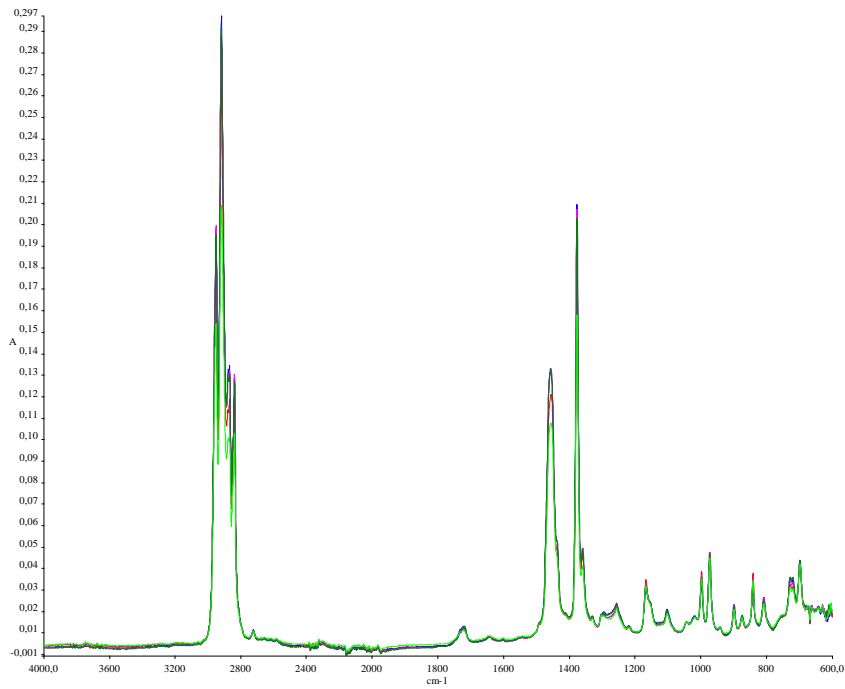

Graph 7: FTIR spectra of five samples of conventional sorted PP - non-PP plastics

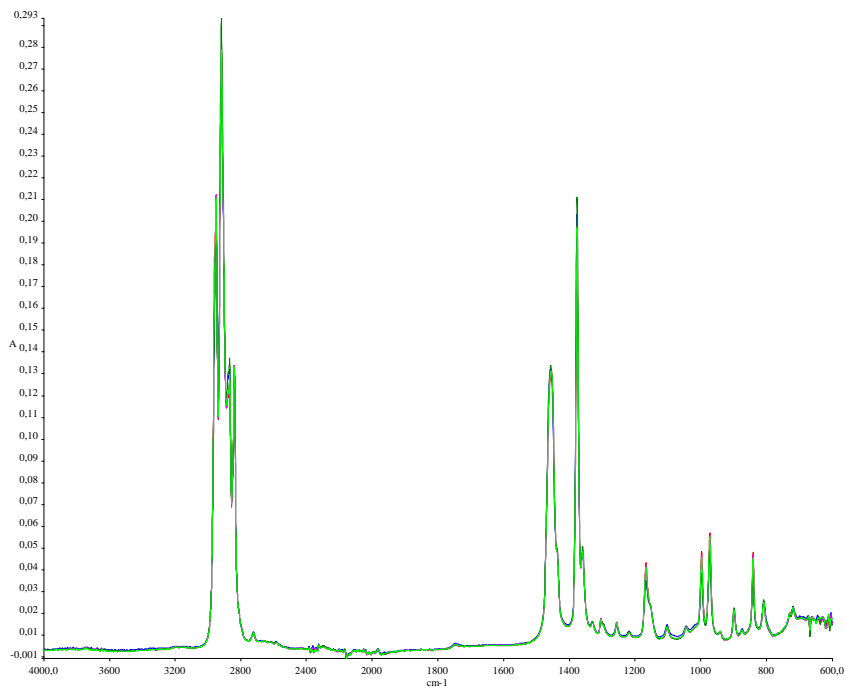



Graph 8: FTIR spectra of five samples of blow mold products

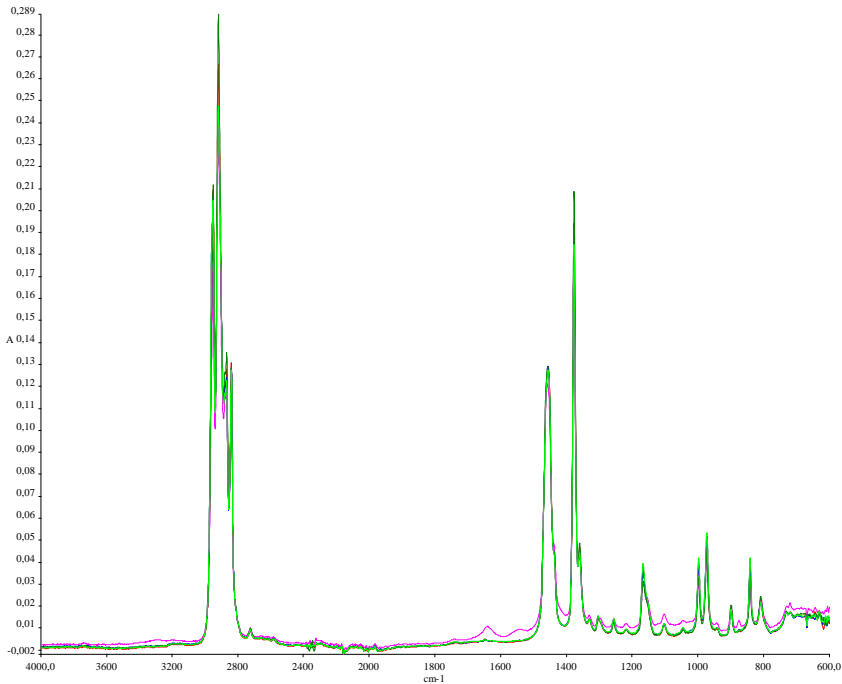

Graph 9: FTIR spectra of five samples of injection mold products

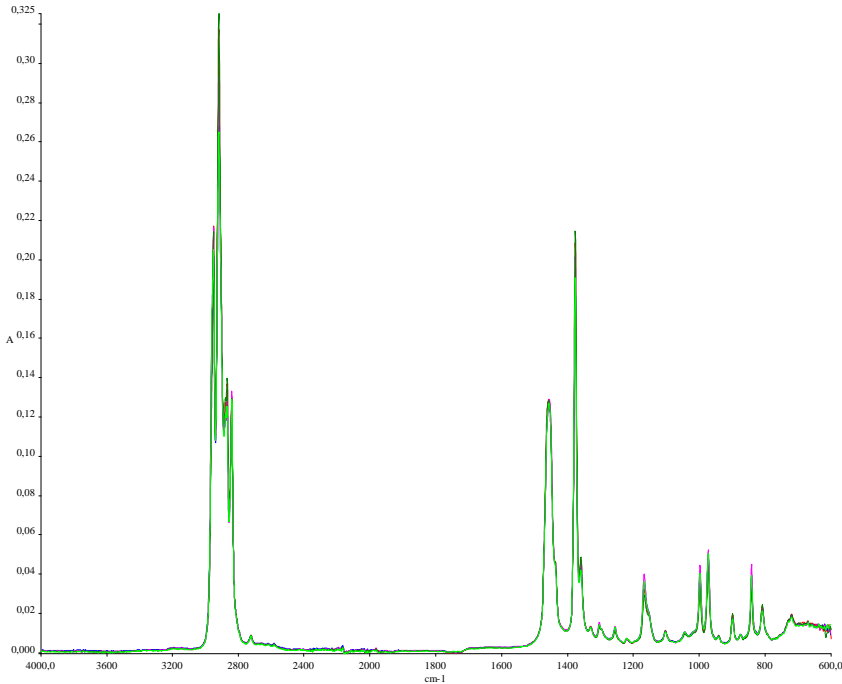

Graph 10: FTIR spectra of five samples of thermoformed products

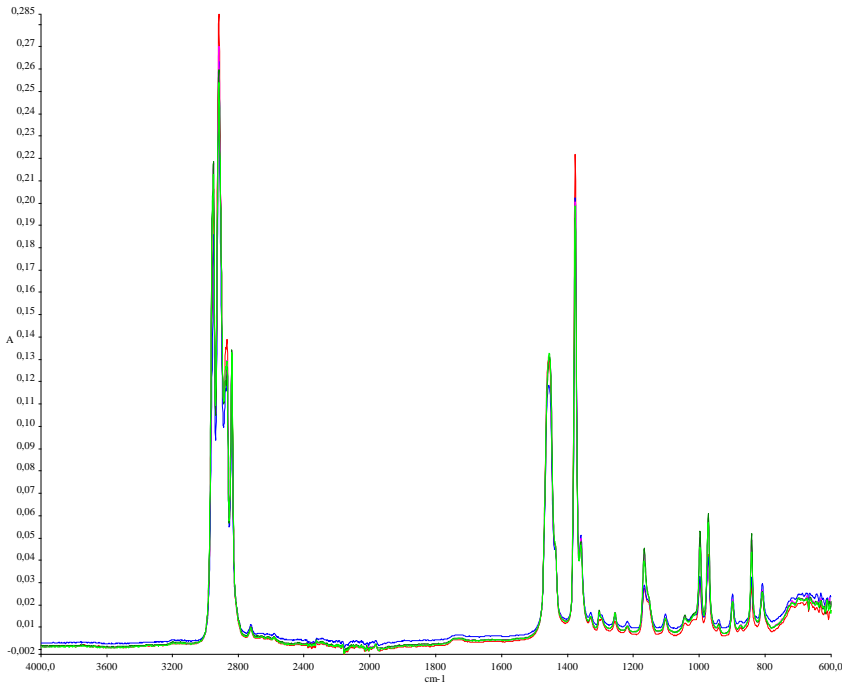

Graph 11: FTIR spectra of five samples of white injection mold products

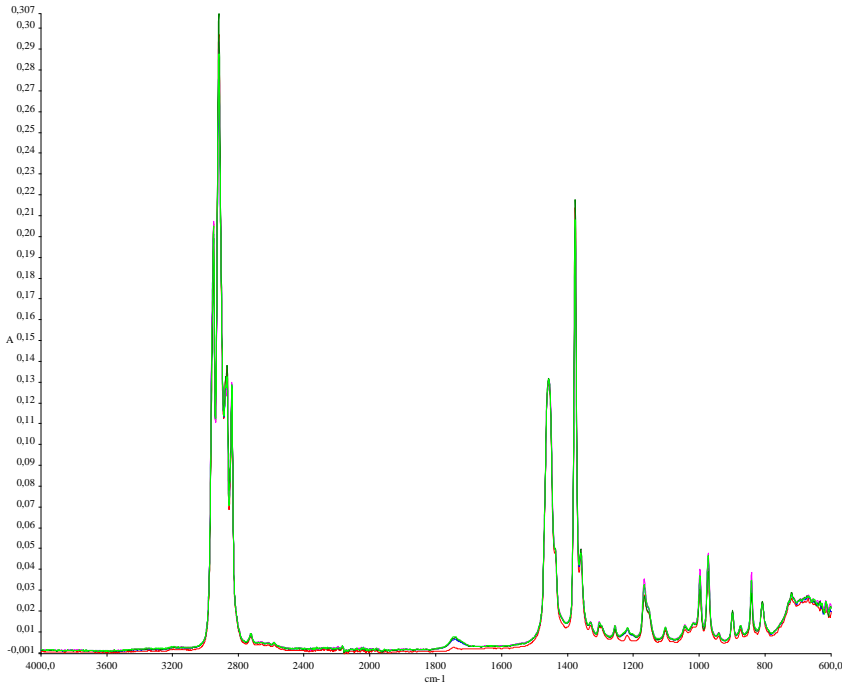

Graph 12: FTIR spectra of five samples of transparent injection mold products

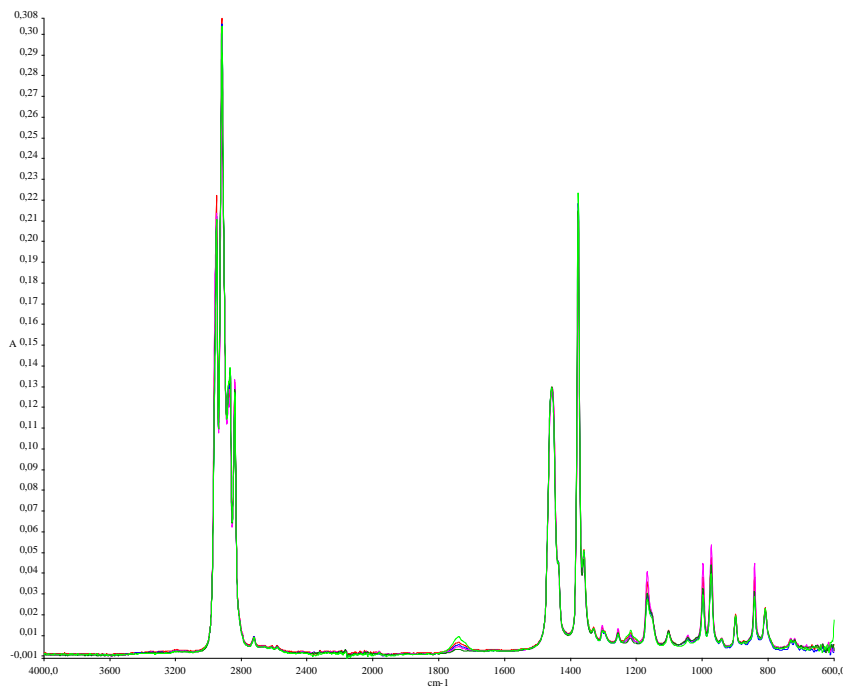

The results of the FTIR analysis show constant values for each grade, as the spectra of the five measurement of each grade show a high overlap. This means that the material has become very homogeneous by the sample preparation. Additionally, the results are in line with the assumption that the impact of tacticity could be neglected as the majority was assumed to be isotactic. The FTIR spectra show that the PP grades used in this study are indeed isotactic, as the spectra correspond to Figure 42c.

Other types of plastics are not recognized in spectra of conventional sorted PP + non-PP plastics. This is most probably caused by the fact that overflow parts of the injection molded mechanical test samples were taken. The detection of large second phase particles is thereby unexpected.

The intense peaks at the low frequency region, except in the case of transparent injection mold grade, probably indicate the existence of inorganic pigments

Additionally, no significant peaks for degradation are observed. This means that no significant degradation is noticeable by FTIR analysis, no significant degradation has occurred and/or detectable degradation products are released by chain scission (section 4.3.4)

## 5.3. Reference method

### 5.3.1. Optical Properties

#### *Injection Mold Products*

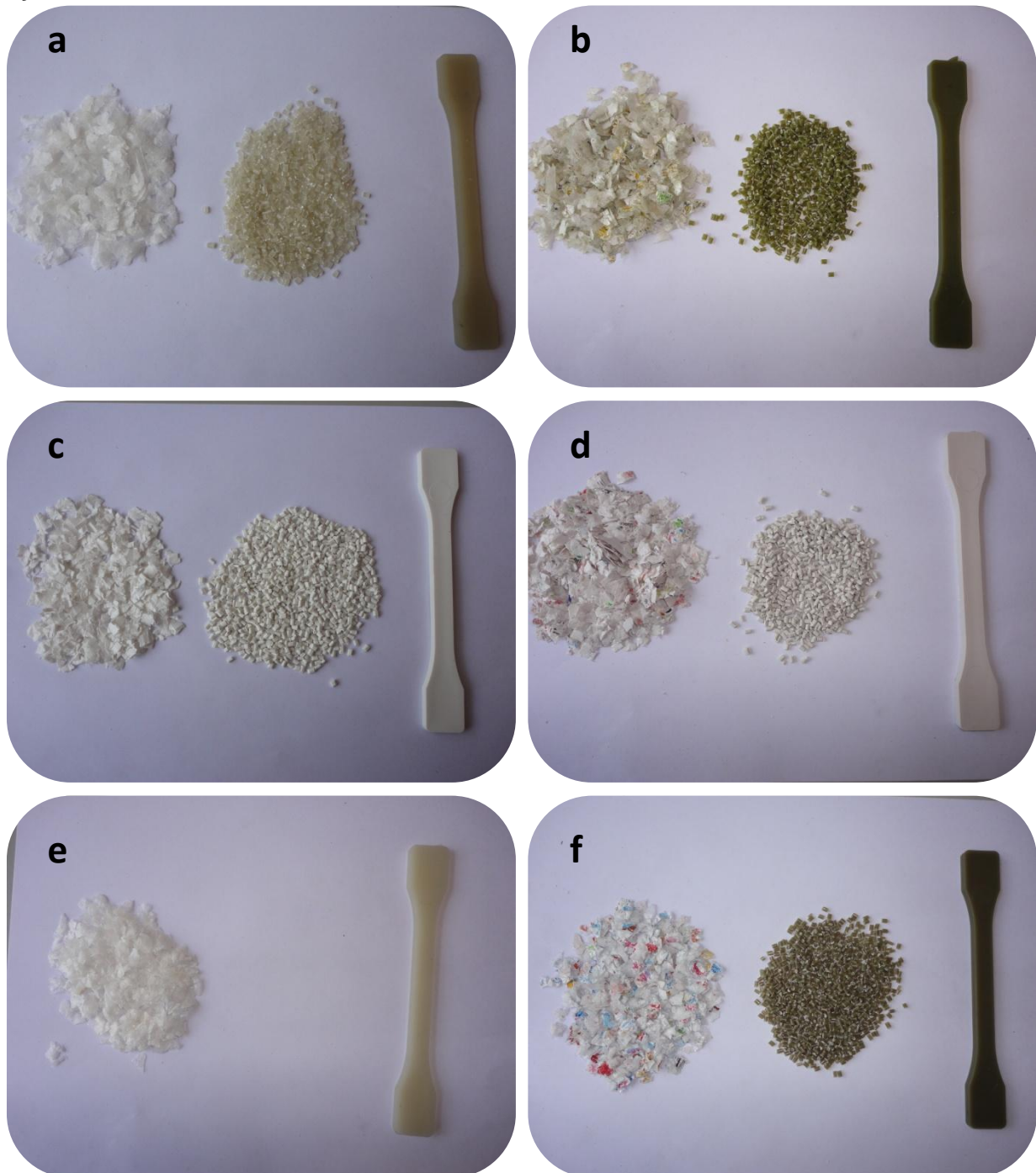

Figure 52: optical properties of flakes, granules and injection molded sample of PP injection mold grades from specific products: a) Jumbo salads excluding labels; b) Jumbo salads including labels; c) Huzaren salads excluding prints; d) Huzaren salads including prints; e) Milbona desserts excluding labels; f) Milbona desserts including labels (granules missing).

The visual optical properties of the injection mold grade pure post-consumer products including and excluding labels or printing inks are given in Figure 52. The results show yellowing of the transparent

grades, while the white grade does not show significant yellowing. This is in line with the results of the categorization method, where this observation was linked to the masking impact of the white pigment.

Additionally, the results show that the in-mold labels in the Jumbo salads and the Milbona dessert packages have a significant impact on the visual optical properties. However, this impact on the visual optical properties is not observed in the case of the Huzaren salads, which includes printing inks salad packages. The insignificant impact of printing inks can be a result of a low initial content or degassing of printing inks during extrusion (section 4.2.3). It might also be related to the masking impact of the white pigment.

### ***Thermoformed and Blow Mold Products***



**Figure 53: optical properties of flakes, granules and injection molded sample of PP thermoformed and blow mold grades from specific products: a) Bami boxes; b) vegetable boxes; c) Persil bottles.**

Figure 53 shows significant yellowing for all transparent thermoform and blow mold post-consumer products. This is in line with the previous results in this study and is probably caused by over-oxidation of anti-oxidants (section 3.2.3).

**Impact of Extrusion on Injection Mold and Thermoformed Grade**



Figure 54: optical properties of flakes, granules and injection molded sample of PP virgin injection mold grade before and after extrusion



Figure 55: optical properties of flakes, granules and injection molded sample of PP virgin injection mold grade before and after extrusion

Figure 55 illustrates that yellowing is not observed after the extrusion of virgin grade PP. This is in contrast to the impact of extrusion on the visual properties of post-consumer transparent PP flakes. This is probably caused by the increased sensitivity to degradation of post-consumer products (section 3.2.1),

which increases the change of over-oxidation of remaining anti-oxidants. Additionally, the results show that the service life has a significant impact on the visual optical properties. This in contrast with the findings discussed in the literature study, which assumed only a small impact by service life (section 3.2.1).

**5.3.2. Mechanical Properties**

**Injection Mold Products**

Graph 13: Ultimate tensile strength of all injection mold grades from specific products, averages and standard deviation are given

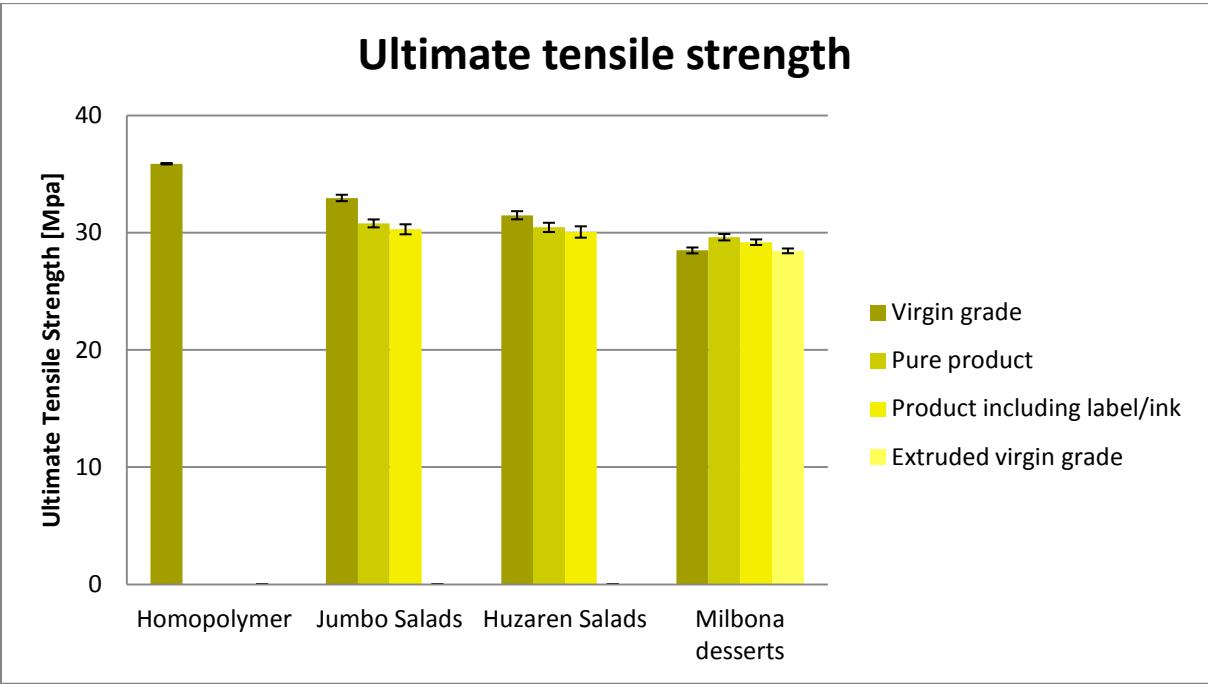

Graph 14: Tensile Strength at break of all injection mold grades from specific products, averages and standard deviation are given

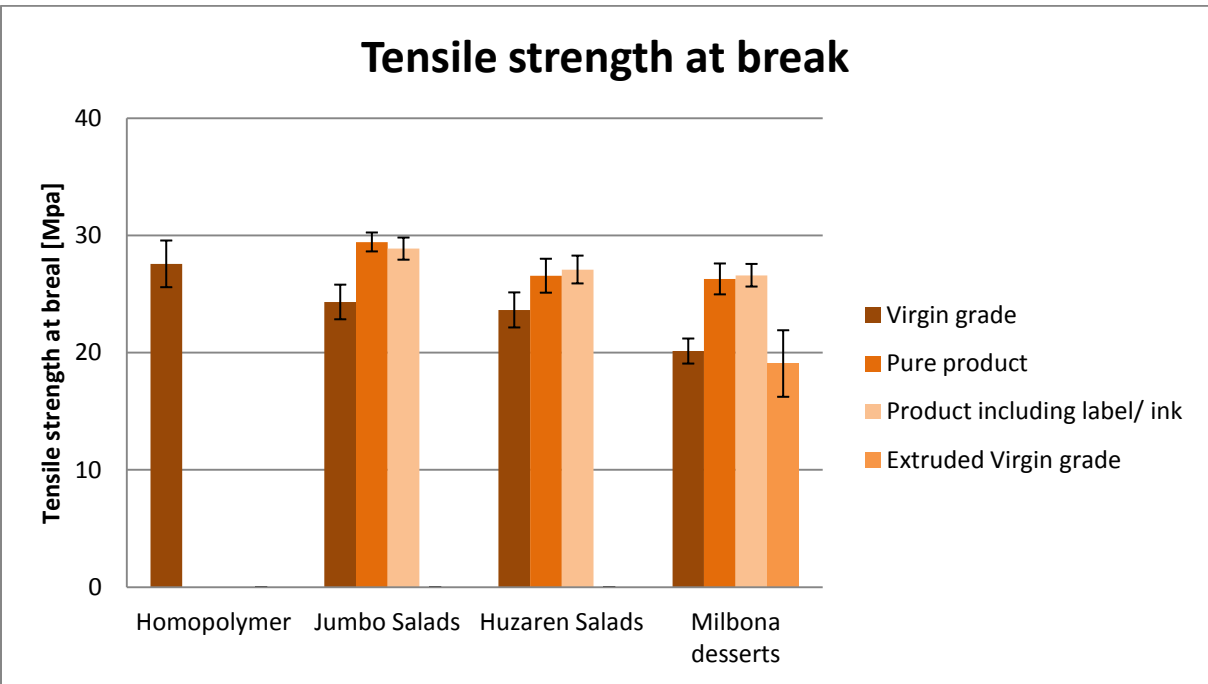

Graph 15: Strain at break of all injection mold grades from specific products, averages and standard deviation are given

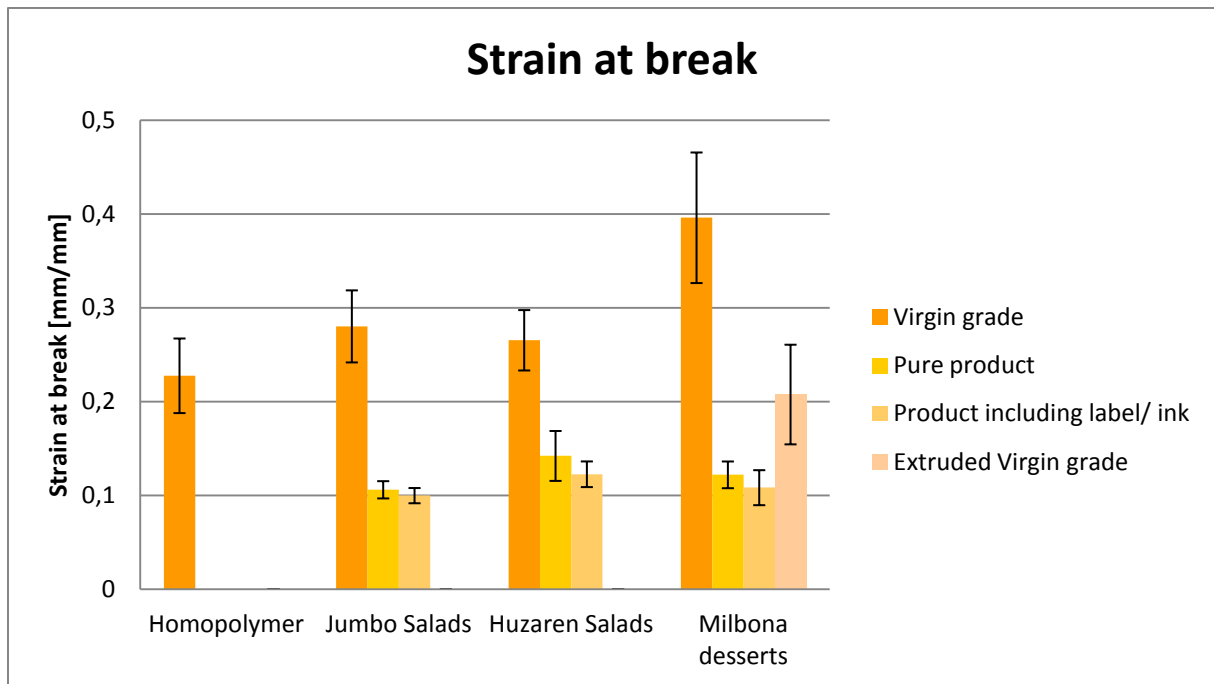

The ultimate tensile strength ranges between 29 and 31 MPa for the recycled post-consumer injection mold products. This strength is lower than the strength of its virgin grade, which ranges between 28 and 32 MPa. The difference is most probably a result of chains scission which results in a lower MW and thereby results in a lower ultimate tensile strength, as was illustrated in Figure 19.

The ultimate tensile strength of the virgin grade decreases with an increase in copolymer content (Table 8). This is most probably due to the decreased crystallinity as a result of the incorporation of copolymers. A decreased degree of crystallinity is expected to result in a decreased ultimate tensile strength, as was discussed in section 3.1.4.

The ultimate tensile strength is decreased during the life cycle of the jumbo salads and Huzaren salads. However, the strength is increased in the case of the Milbona desserts. This confirms the reasoning of the positive impact of PE crosslinking on the ultimate tensile strength as discussed by the analysis of the ultimate tensile strength of the categorization method.

The addition of 3% masterbatch (difference between material from Jumbo and Huzaren salads packages (Table 8)) has a small but significant negative impact on the ultimate tensile strength. This can be explained by the fact that the masterbatch can be seen as impurities and therefore as voids, that do not transfer the external load. However, the negative impact vanishes after a life cycle of the product. This might be a result of the possible nucleating impact of the pigments.

Extrusion of the virgin grade of the Milbona dessert packages has no significant impact on the ultimate tensile strength. However, there is a significant difference noticeable between the ultimate tensile strength of virgin and mechanical recycled PP of the Milbona desserts packages. This means that the impact of service life is significant, which is in contrast with the findings of the literature study, discussed in section 3.2.1.

The inclusion of labels has no significant impact on the ultimate tensile strength, while a higher MW is expected, since the labels are made by an extrusion process, as discussed in section 3.1.6. However, the labels contain a high contamination content, as will be discussed in after the FTIR analysis, which counteract on the positive impact.



The inclusion of printing inks also has no significant impact on the ultimate tensile strength. The initial content is either very low or ink is (partly) degassed during extrusion.

The strain at break ranges between 0,11 and 0,14 mm/mm for the recycled post-consumer injection mold products. This strain at break is significant lower than the strain at break of its virgin grade, which ranges between 0,27 and 0,40 mm/mm. All the grades are embrittled significantly after a life cycle. The difference is most probably a result of chains scission which results in a lower MW and thereby results in a decreased entanglement density. Most probably the MW even approaches the critical MW for the formation of entanglements. Even a small change in MW will result directly in a large change in ductility. The crosslinking of ethylene fractions in the polymers are not able to compensate the chain scission reactions, or butene instead of ethylene is included in this copolymer, which does not form crosslinks during degradation (section 3.2.1)

The ductility of the virgin materials increases with an increased copolymer. An increased ductility is in line with expectations, discussed in section 3.1.4

White pigments have a small, but significant positive impact on the strain at break after degradation. This means that a larger absorbance of anti-oxidants by the pigments has no significant impact. Probably the migration of anti-oxidants play a bigger role (difference in food in packages) and/or the pigments are modified by surface modifications which makes the absorbance impact by the white pigment negligible, as was explained in section 3.2.1.).

Extrusion of the virgin grade, used in the packages of Milbona desserts show a significant impact on the brittleness of the material. However, the impact of service life is again not very small, as assumed by findings in the literature study (section 3.2.1.).

The inclusion of labels has no significant impact on the ductility, while a higher entanglement density is expected, since the labels are made by an extrusion process, as discussed in section 3.1.6. However, the labels contain a high contamination content, as will be discussed in after the FTIR analysis, which counteract on the positive impact.

The inclusion of printing inks also has no significant impact on the strain at break. The initial content is either very low or ink is (partly) degassed during extrusion.

**Thermoformed and Blow Mold Products**

Graph 16: Ultimate tensile strength of all thermoformed and blow mold grades from specific products, averages and standard deviation are given

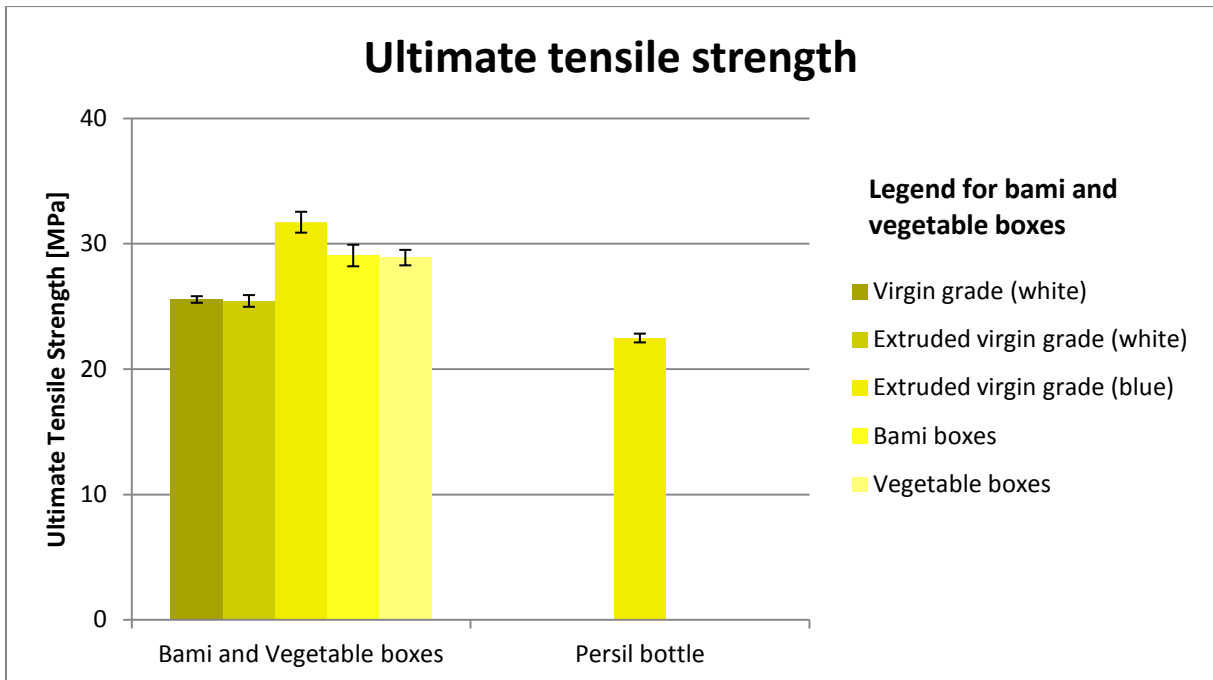

Graph 17: Tensile strength at break of all thermoformed and blow mold grades from specific products, averages and standard deviation are given

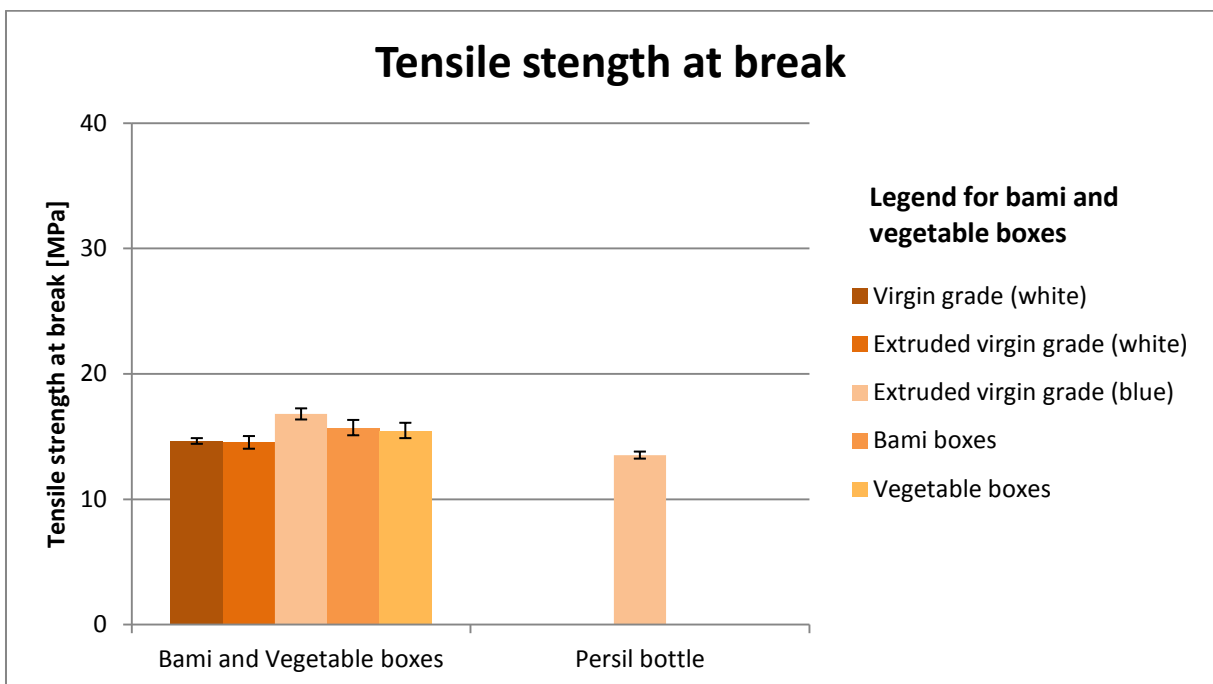

Graph 18: Strain at break of all thermoformed and blow mold grades from specific products, averages and standard deviation are given

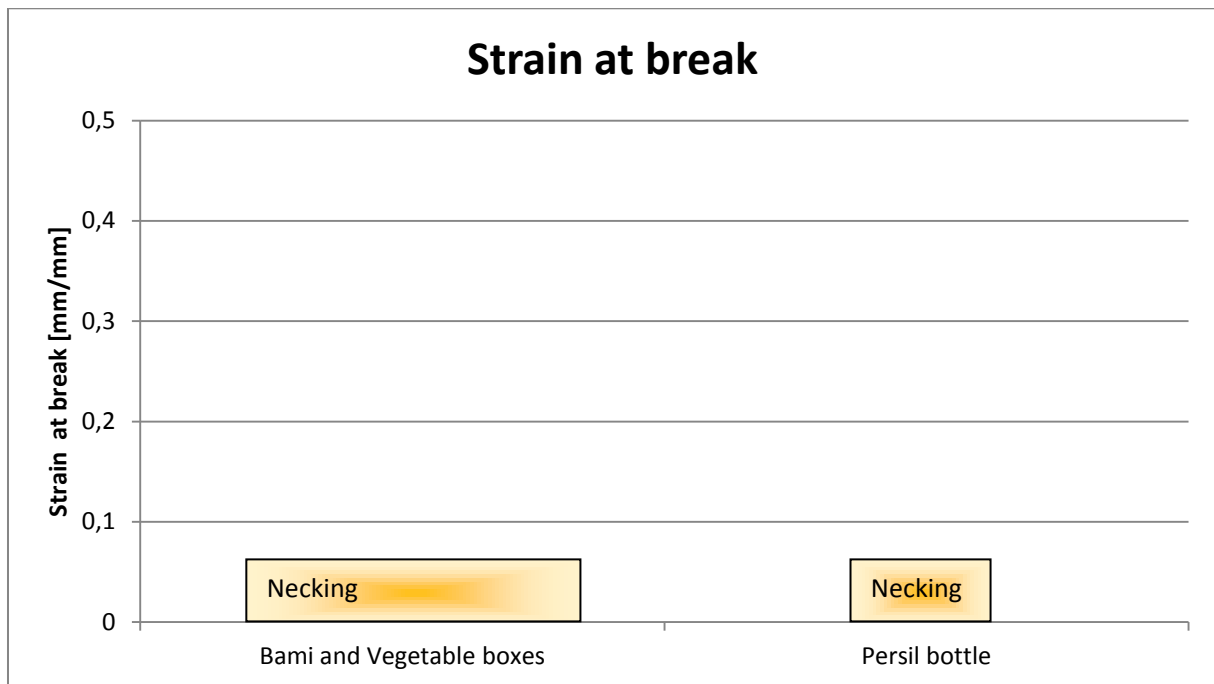

#### Thermoformed Products

The ultimate tensile strength of the recycled post-consumer products is in the order of 29 MPa while the ultimate tensile strength of the two extruded virgin grades (two different types of random copolymers, as explained in section 4.2.2) ranges between 25 and 32 MPa. The grades are assumed to be randomly used a 50wt% content of each grade in the post-consumer products is assumed. A strength of 29MPa for the post-consumer products lies exactly between the two values of the virgin grade and no significant impact of complete life cycle on the ultimate tensile strength is observed. Additionally, extrusion has no significant impact on the ultimate tensile strength. Finally there is no difference observed between the two packages with different service life: microwave and fatty food, in the case of bami boxes, in comparison to aqueous food, in the case of vegetable boxes (section 4.2.2).

Additionally, all thermoformed samples show a ductile fracture mechanism, and no significant difference in ductility is observed. All these observations lead to the reasoning that the MW is significant higher as the critical MW for entanglements and/or long chain branches are included. A slight decrease of the high MW has no significant impact on ultimate tensile strength, as illustrated in Figure 19. Therefore the impact of extrusion and service life cannot be observed.

#### Blow mold Products

The recycled post-consumer blow mold products show a smaller ultimate tensile strength as compared to the thermoformed grade. Additionally, it shows a ductile fracture mechanism. This complies with the results of the categorization method.

**Mixture Injection Mold with Thermoformed grade**

Graph 19: Ultimate tensile strength of one injection mold and one thermoformed grade and their mixture, averages and standard deviation are given

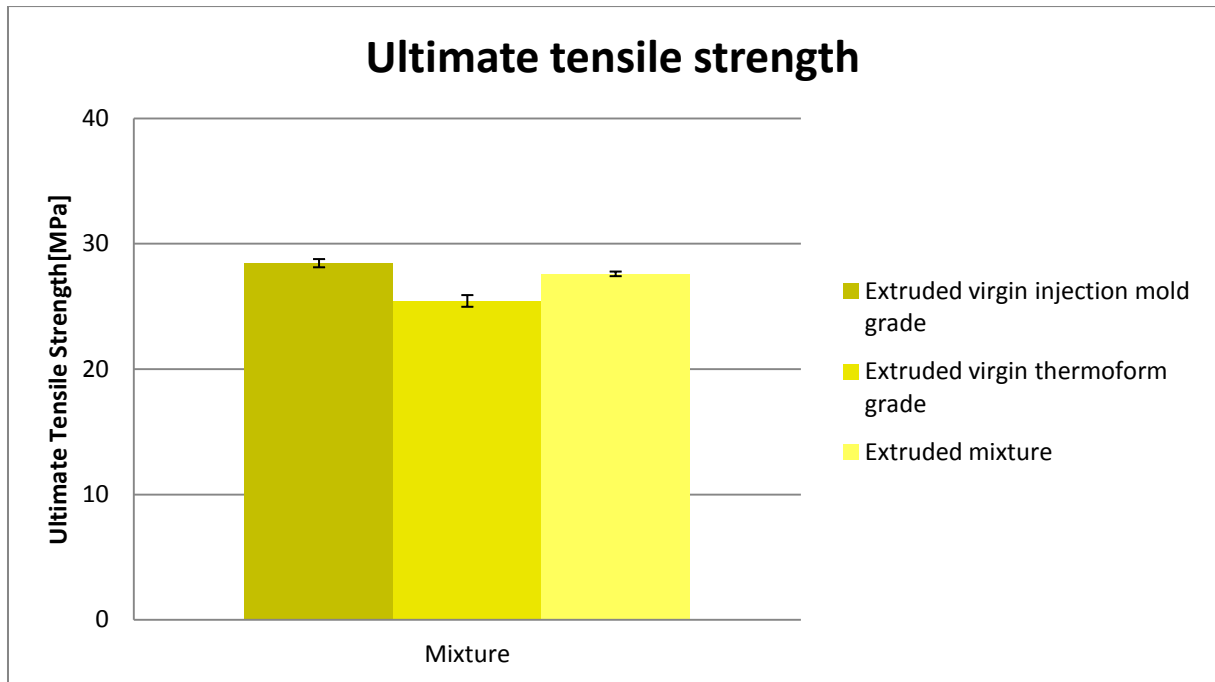

Graph 20: Tensile strength at break of one injection mold and one thermoformed grade and their mixture, averages and standard deviation are given

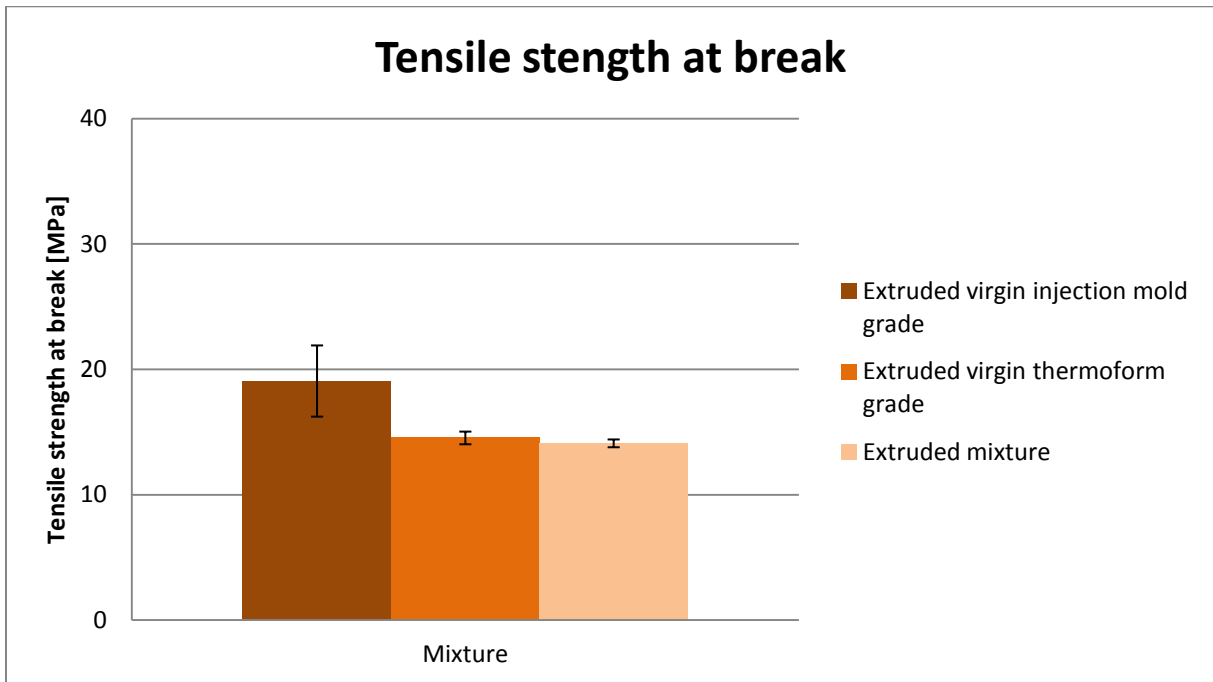

Graph 21: Strain at break of one injection mold and one thermoformed grade and their mixture, averages and standard deviation are given

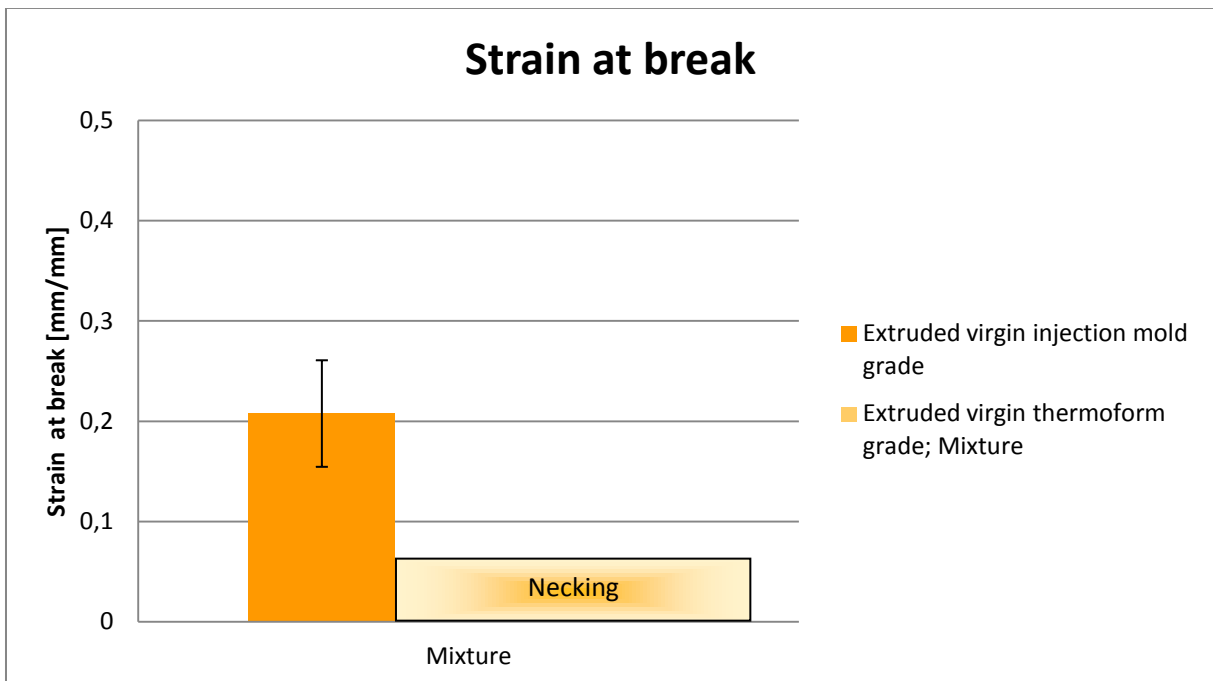

The ultimate tensile strength of the mixture of an injection and thermoformed grade is dominantly determined by the thermoformed grade in this case. This is most probably related to a MW of the injection mold grade which approaches the critical MW of entanglement (as explained earlier in this chapter), in combination with a very high MW of the thermoformed grade. An average MW, based on these two grades, will result in a larger than average ultimate tensile strength, as expected based on Figure 19. The ultimate tensile strength of the mixture is therefore slightly, but significant, closer to the strength of the pure thermoformed grade than the pure injection mold grade.

Additionally, thermoformed grade provides enough entanglement such that the total mixture shows a ductile fracture mechanism. This might be related to the existence of long chain branches, which provides a large amount of entanglement possibilities as explained in section 3.1.4.

### 5.3.3. Rheological Properties

#### **Injection Mold Products**

Graph 22: Melt flow index of all injection mold grades from specific products, averages and standard deviation are given

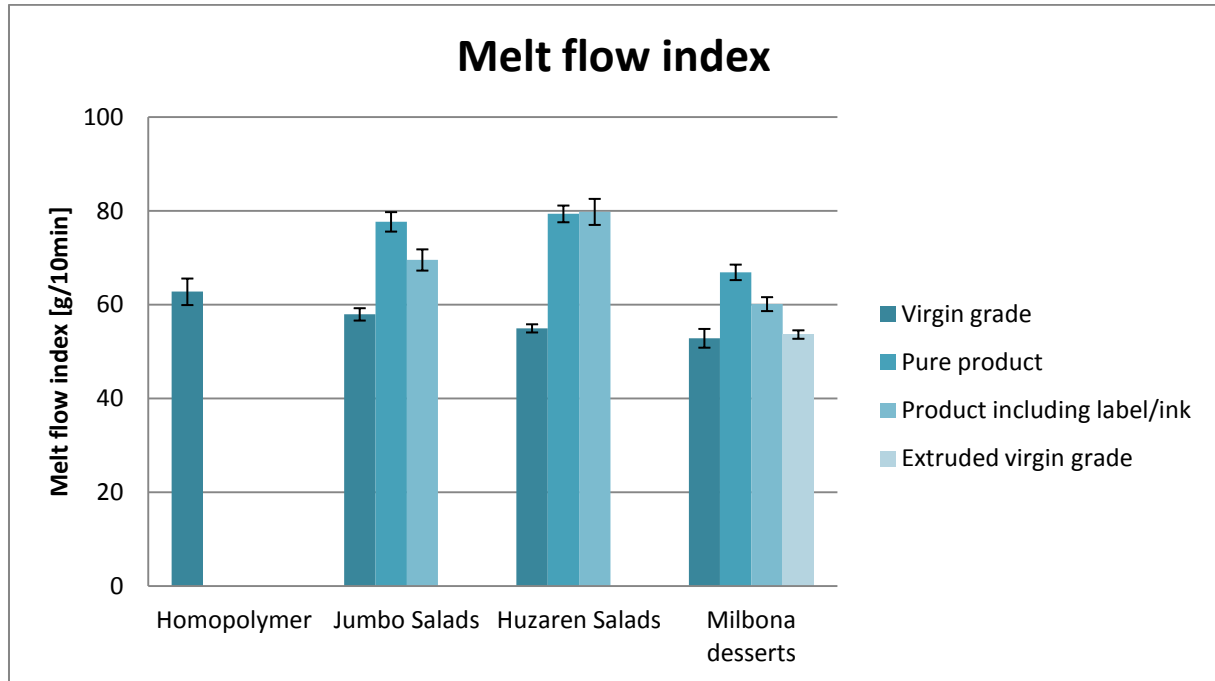

The increase in copolymer content in the virgin grade results in a decreased MFI. This is not in line with the finding in the literature study (section 3.1.5). However, the MFI of the copolymer grade is lower than the MFI of homopolymer, as given by their datasheets, and a decreased MFI after increased copolymer content is expected following Equation 12.

The MFI is increased during the life cycle of the packages of jumbo salads, Huzaren salads and Milbona desserts. However, the decrease in MFI of Milbona desserts is less significant. This confirms again the reasoning of the positive impact of PE crosslinking on the ultimate tensile strength as discussed by the analysis of the ultimate tensile strength of the categorization method. The copolymer grade therefore most probably contains ethylene rather than butane.

Extrusion of the virgin grade, used in Milbona dessert packages, has no significant impact on the MFI. This means that the MW is not changed or crosslinking of the PE counteracts the chain scission of PP. The results also show that the impact during service life is significant.

The MFI after the addition of white pigments is slightly, but significant decreased. The decrease can be calculated using Equation 16, as the pigments can be seen as second phase particles. The calculation is based on the addition of 3% masterbatch, which contains on average 70% pigment:

$$\begin{aligned}
 \text{MFI}_{\text{Huzaren}} &= \frac{\text{MFI}_{\text{Jumbo}}}{(1 + 2.5 * \varphi_{\text{imp}})} \\
 &= \frac{58}{(1 + 2.5 * 0.03 * 0.70)} = 55 \text{ g/10min}
 \end{aligned}$$

The calculated decrease is exactly in line with the results.

The incorporation of labels in the recycled post-consumer PP grades of Jumbo and Milbona results in a significant decreased MFI, while no significant difference was observed in the mechanical properties. This can be caused the expected high MFI of the label, as they are made by an extrusion process in addition to the higher dependence of MFI on MW (Figure 20).

The incorporation of printing inks has no significant impact on the MFI. The initial content is either very low or ink is (partly) degassed during extrusion.

### **Thermoformed and Blow Mold Products**

**Graph 23: Melt flow index of all thermoformed and blow mold grades from specific products, averages and standard deviation are given. NOTE: another scale is used than for the other graphs of melt flow index**

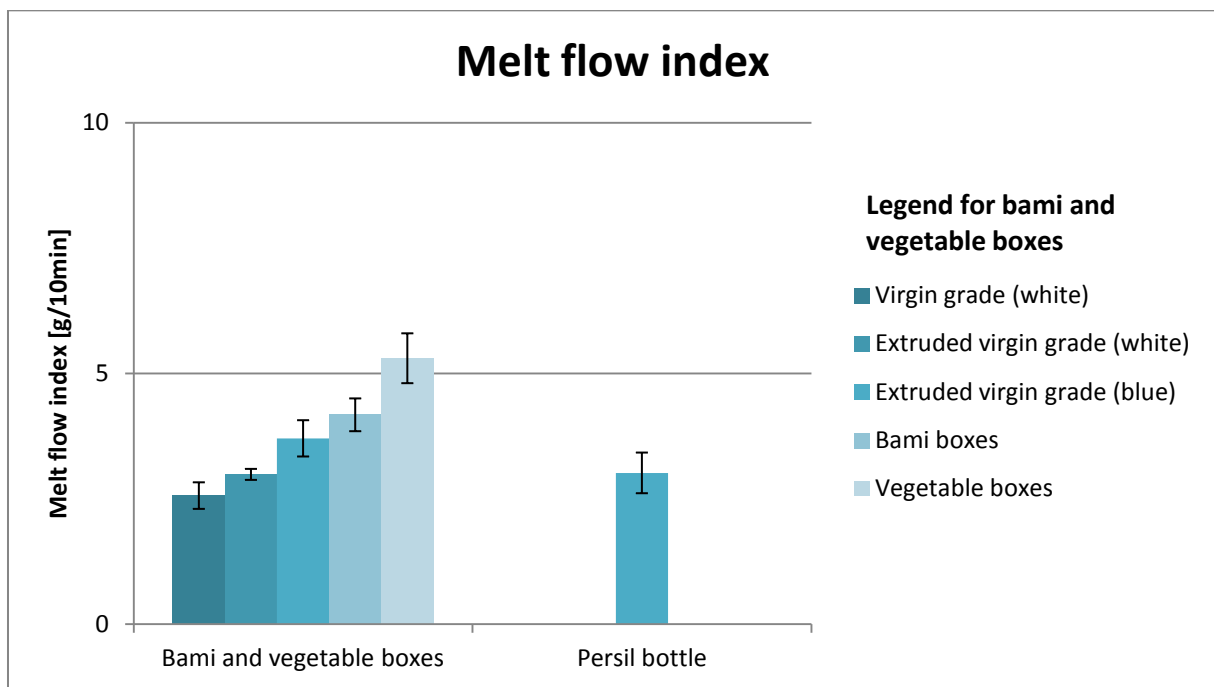

### Thermoformed Products

The MFI increased significantly during service life, when compared to the average MFI of both randomly used grades. However, the service life had no significant impact on the mechanical properties. This is caused by the higher sensitivity of rheological properties (Figure 20) on the MW as compared the mechanical properties.

The post-consumer recycled material coming from the bami and vegetable boxes show a difference in MFI, while containing the same composition of virgin grade, as was assumed in section 4.2.2. Migration of anti-oxidants is expected to be different, as both packages contain another type of food and microwave is only used in the case of bami boxes. The migration of anti-oxidants would lead to a higher sensitivity to degradation. Depending on the PE content, a higher sensitivity might results in a decreased MFI, as crosslinking will occur.

### Blow mold Products

MFI of blow mold product is lower compared to thermoformed products which comply with results of specific sorting method.

### **Mixture Injection Mold with Thermoformed grade**

**Graph 24: Melt flow index of one injection mold and one thermoformed grade and their mixture, averages and standard deviation are given**

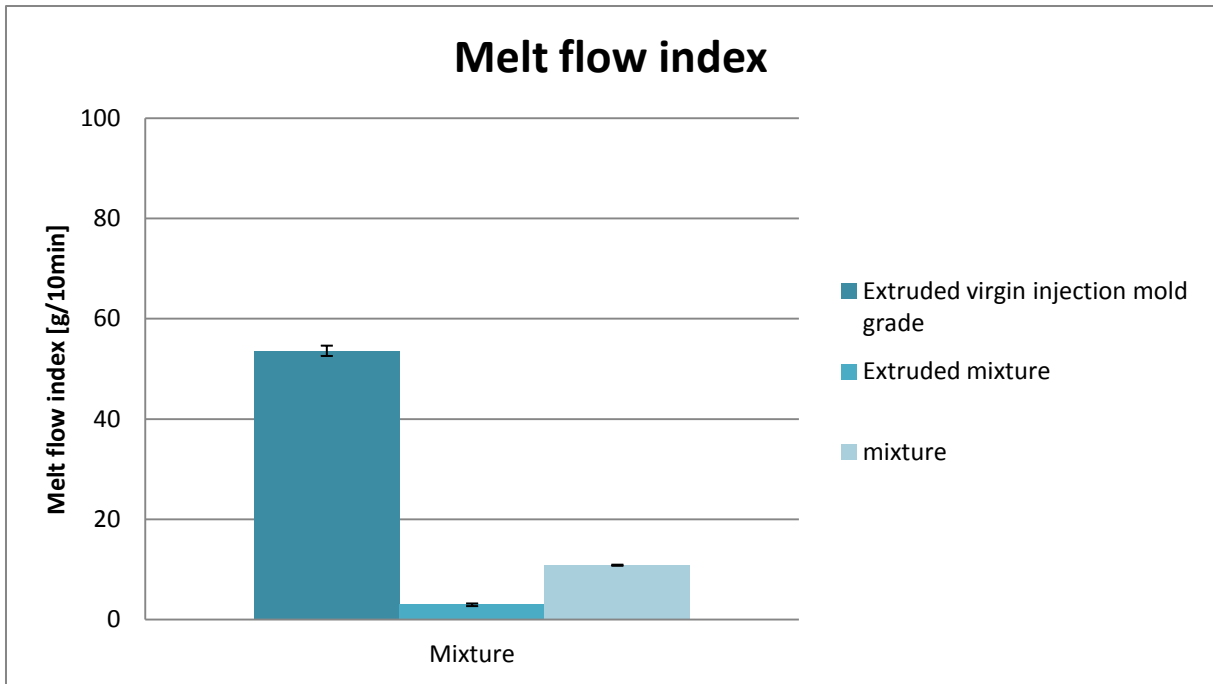

Theoretically a dominant impact on viscosity by the low viscous (high MFI) grade is expected following the Arrhenius equation (Equation 12). However, this is not the case. This might be caused by the fact that this equation is valid for zero shear rate viscosity, while higher shear rates are applied during MFI measurements. Probably the incorporation of long chain branches results in strain hardening by a significant increased entanglement density. Only a small fraction of chain branches already has a significant impact on the entanglement density, and therewith on the MFI. This means that the thermoformed grade most probably contains long chain branches, which dominantly determines the MFI.



### 5.3.4. Composition

#### *Injection Mold Products*

##### 100% Homopolymer

Graph 25: FTIR spectra of five samples of injection mold 100% homopolymer

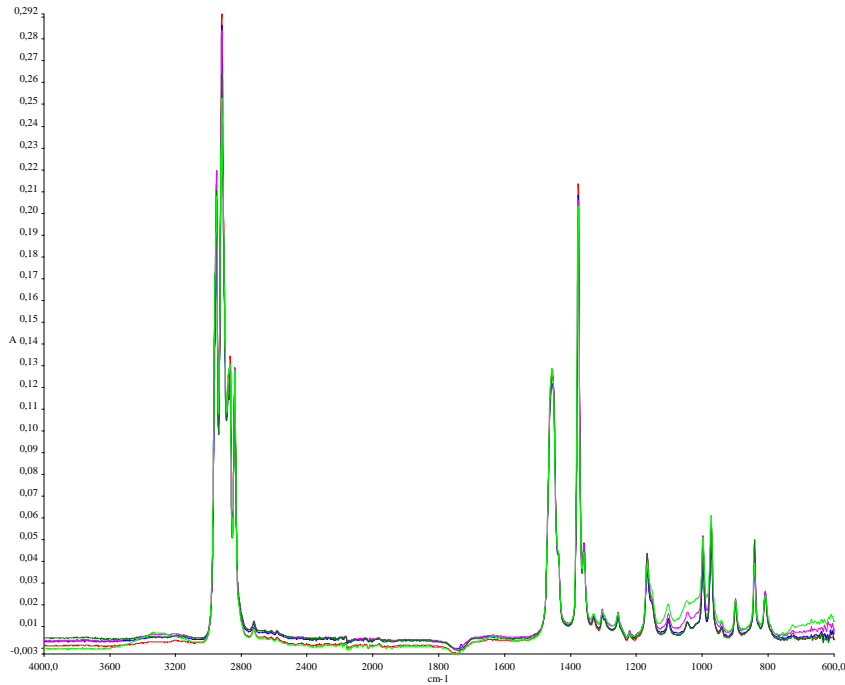

##### Jumbo Salads

Graph 26: FTIR spectra of five samples of injection mold virgin grade Jumbo salads

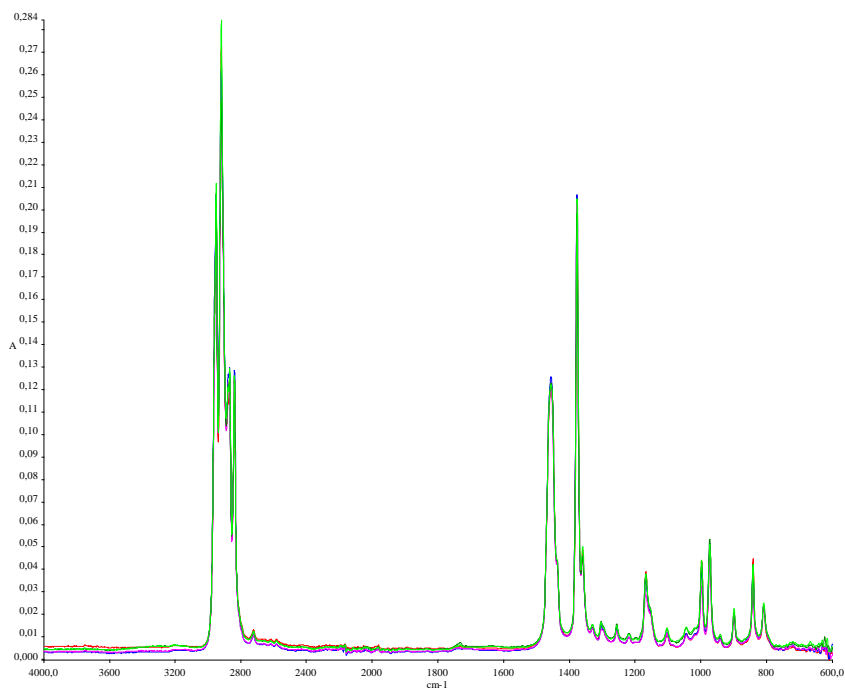

Graph 27: FTIR spectra of five samples of injection mold Jumbo salads

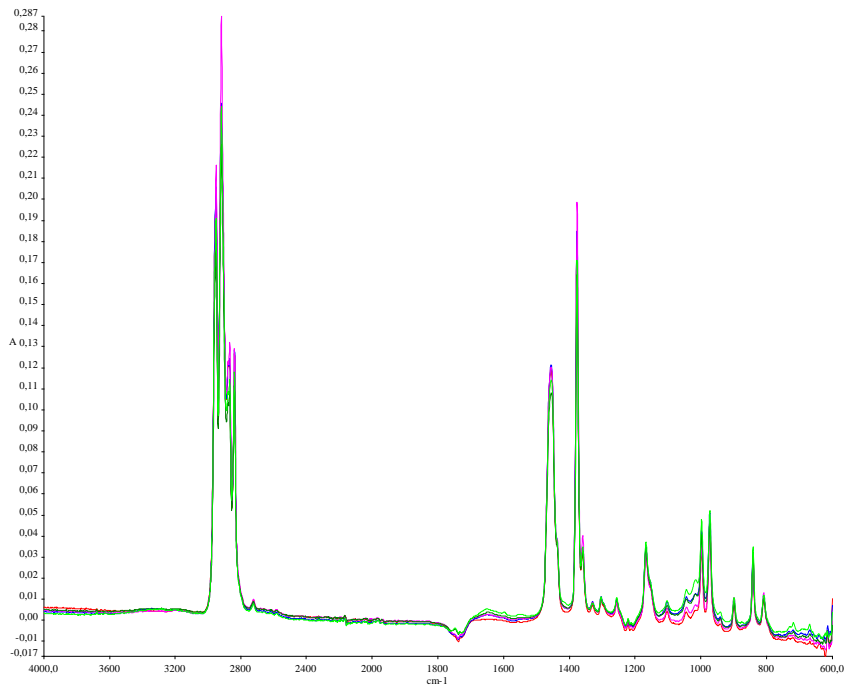

Graph 28: FTIR spectra of five samples of injection mold Jumbo salads including labels

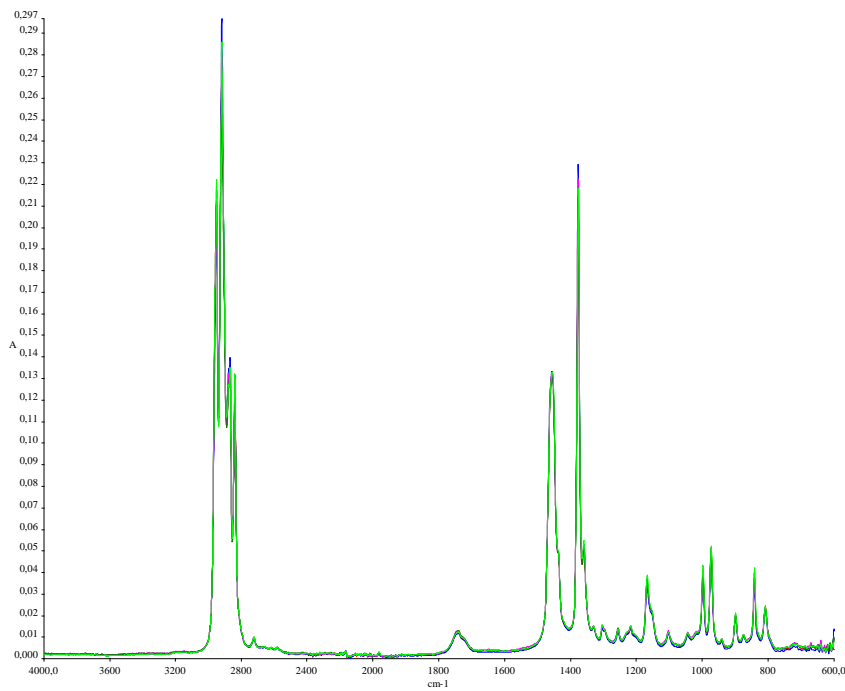

Graph 29 FTIR spectra of five samples of Jumbo labels, printed side

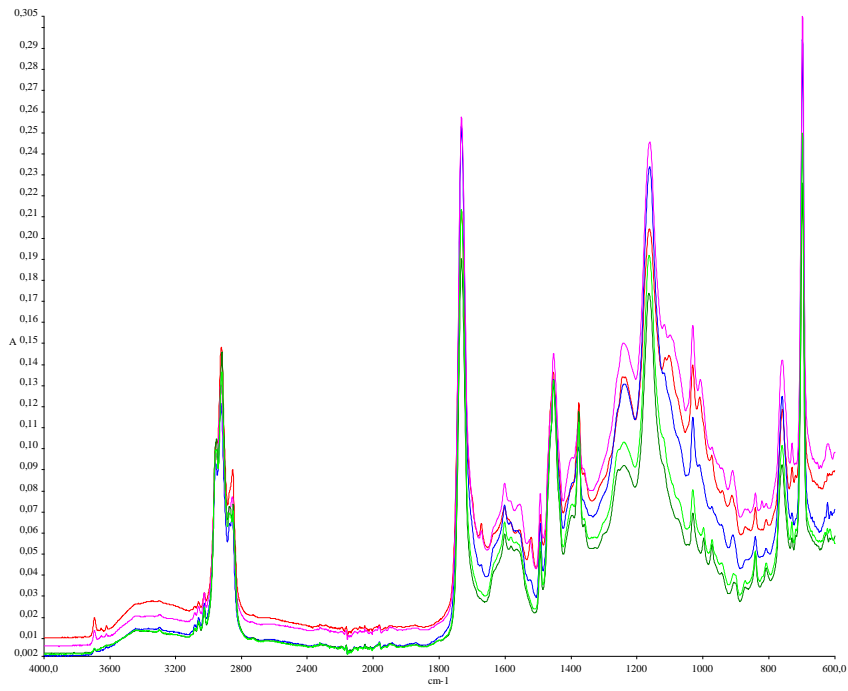

Graph 30: FTIR spectra of five samples of Jumbo labels, unprinted side

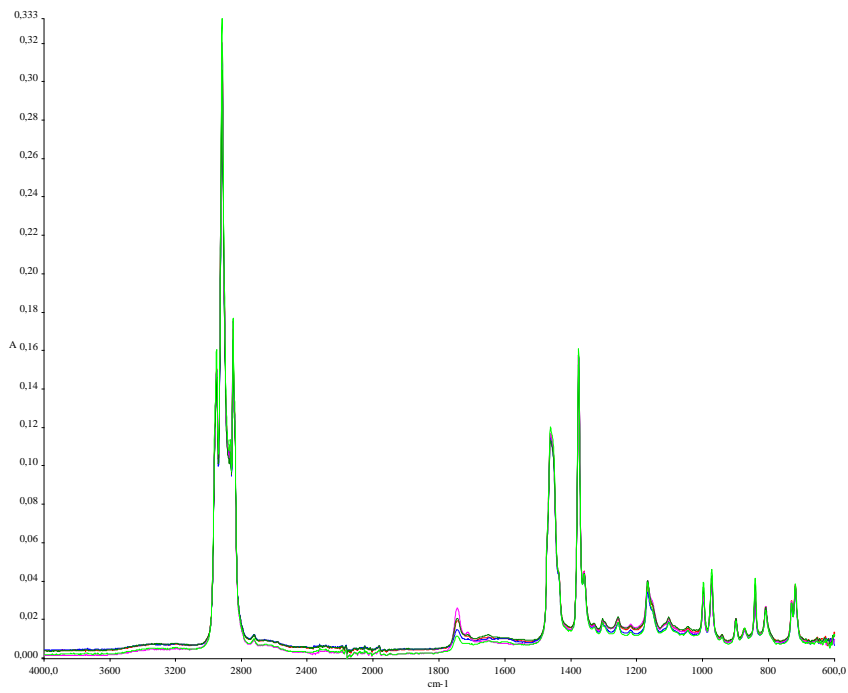

## Huzaren Salads

Graph 31: FTIR spectra of five samples of injection mold virgin grade Huzaren salads

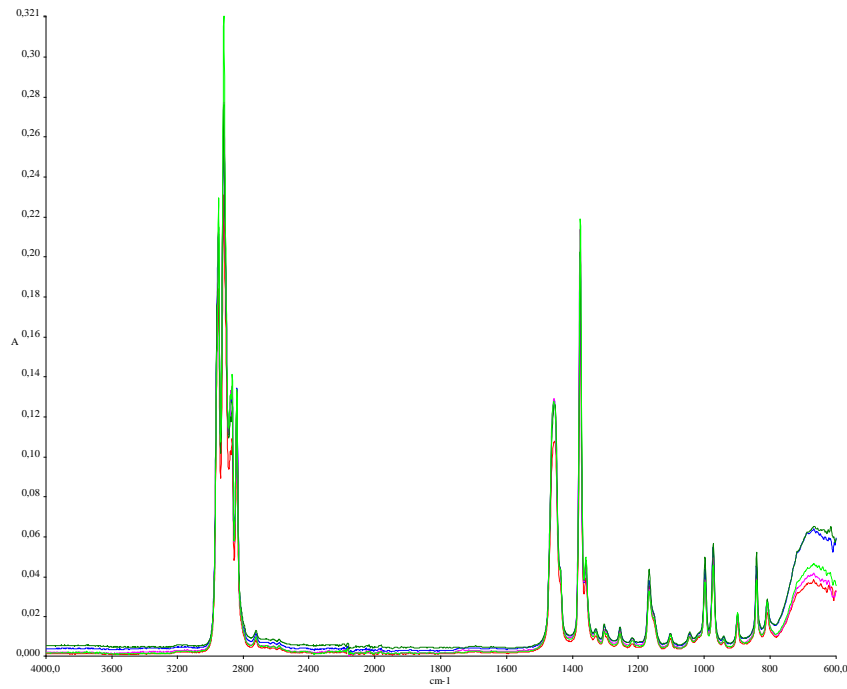

Graph 32: FTIR spectra of five samples of injection mold Huzaren salads

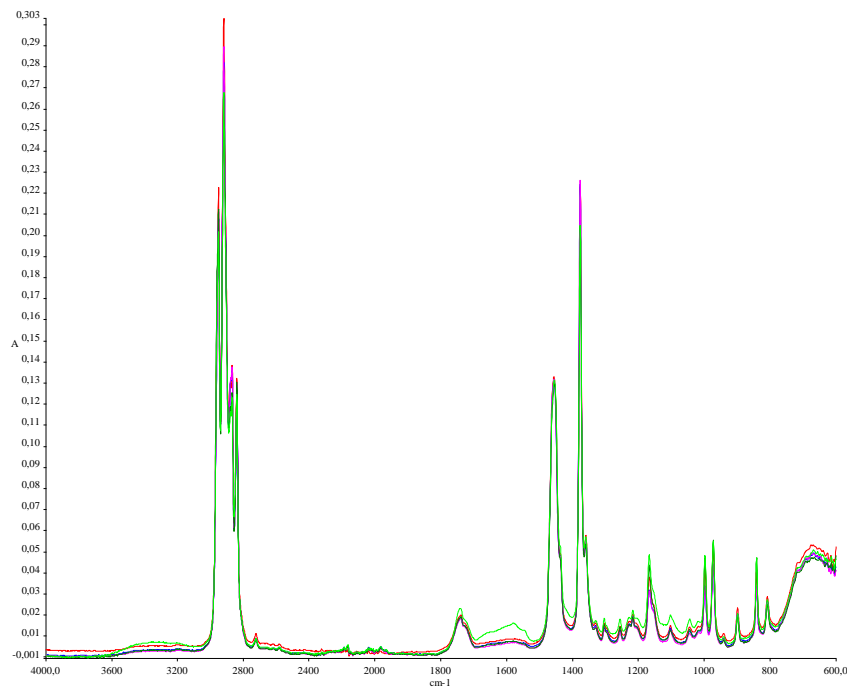

Graph 33: FTIR spectra of five samples of injection mold Huzaren salads including printing inks

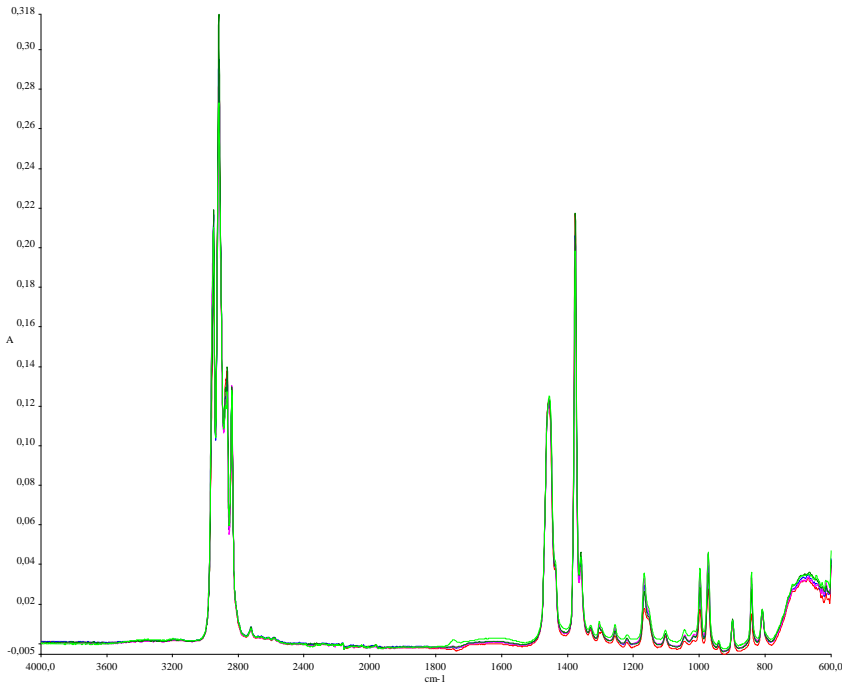

Milbona Desserts

Graph 34: FTIR spectra of five samples of injection mold virgin grade Milbona Desserts

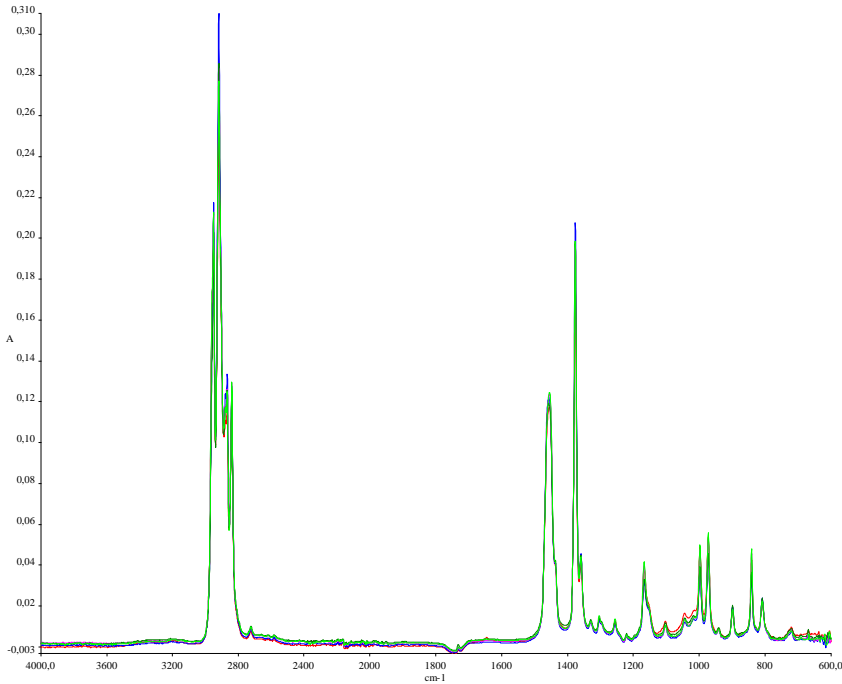

Graph 35: FTIR spectra of five samples of injection mold Milbona desserts

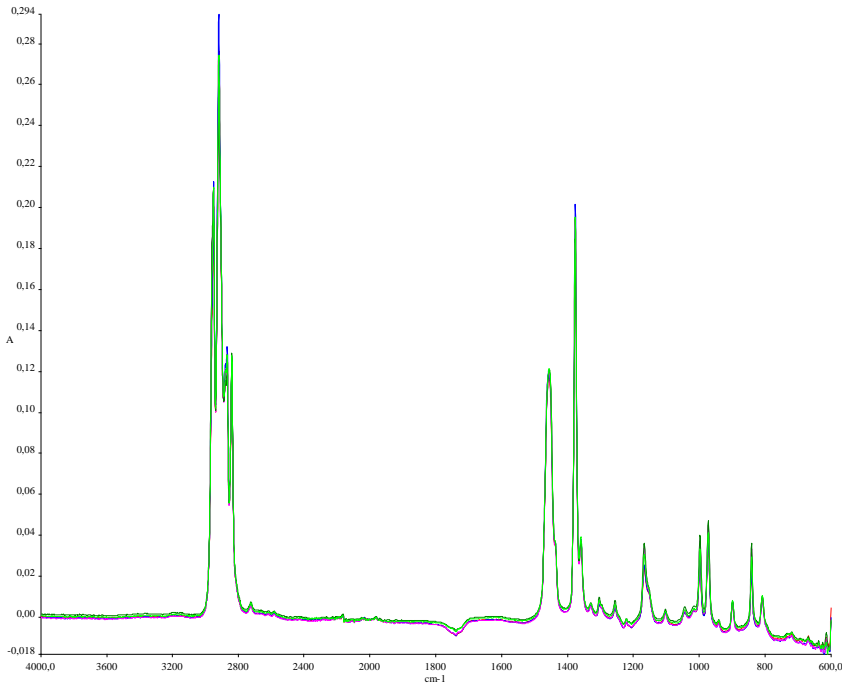

Graph 36: FTIR spectra of five samples of injection mold milbona desserts including in mold labels

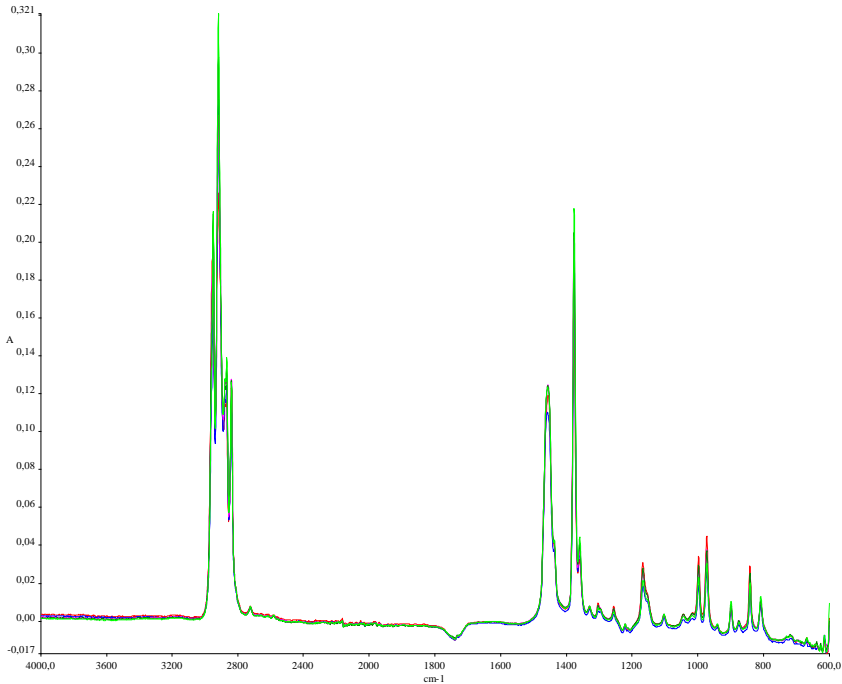

Graph 37: FTIR spectra of five samples of injection mold virgin grade Milbona Desserts, after extrusion

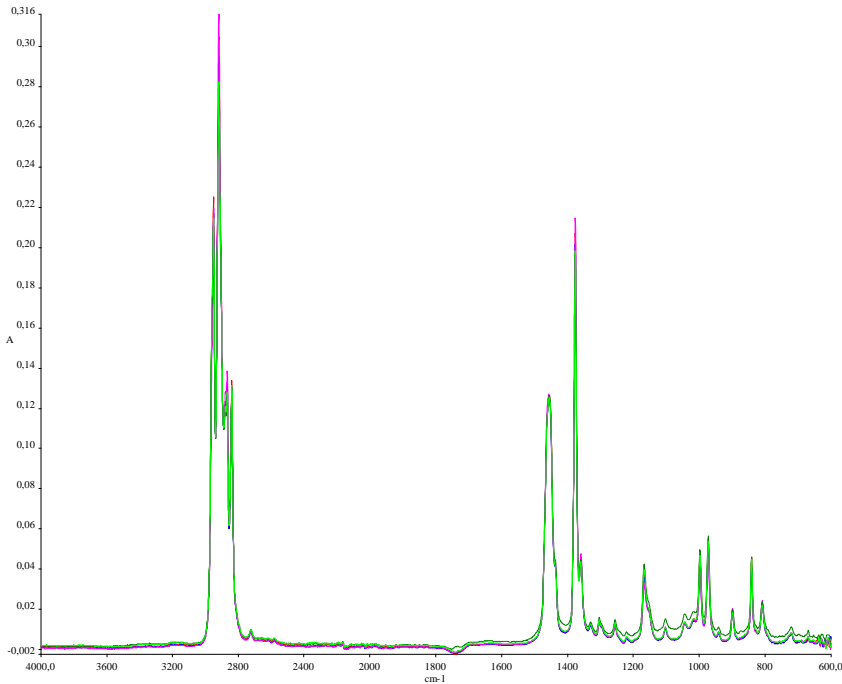

Graph 38: FTIR spectra of five samples of Milbona labels, printed side

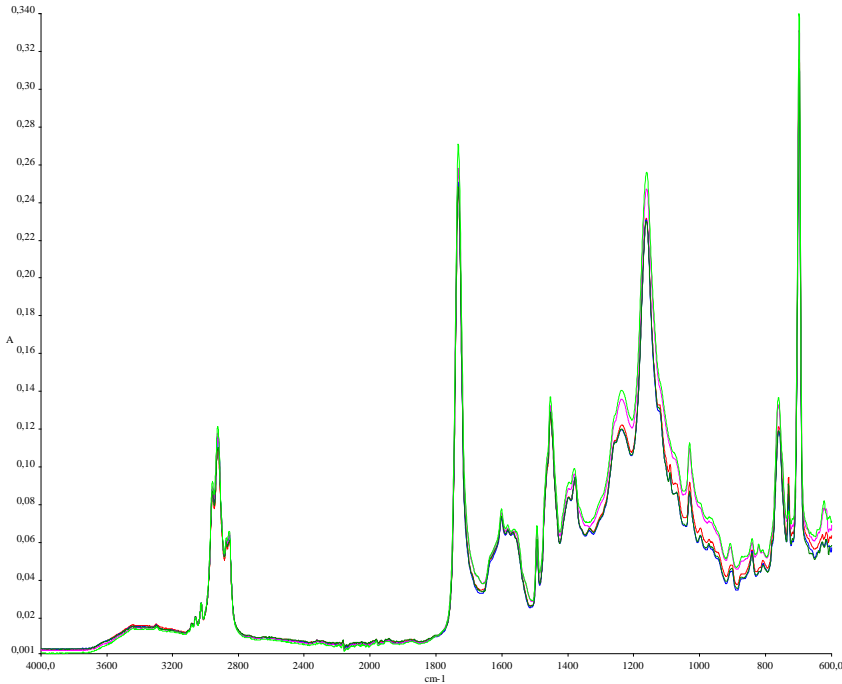

Graph 39: FTIR spectra of five samples of Milbona labels, unprinted side

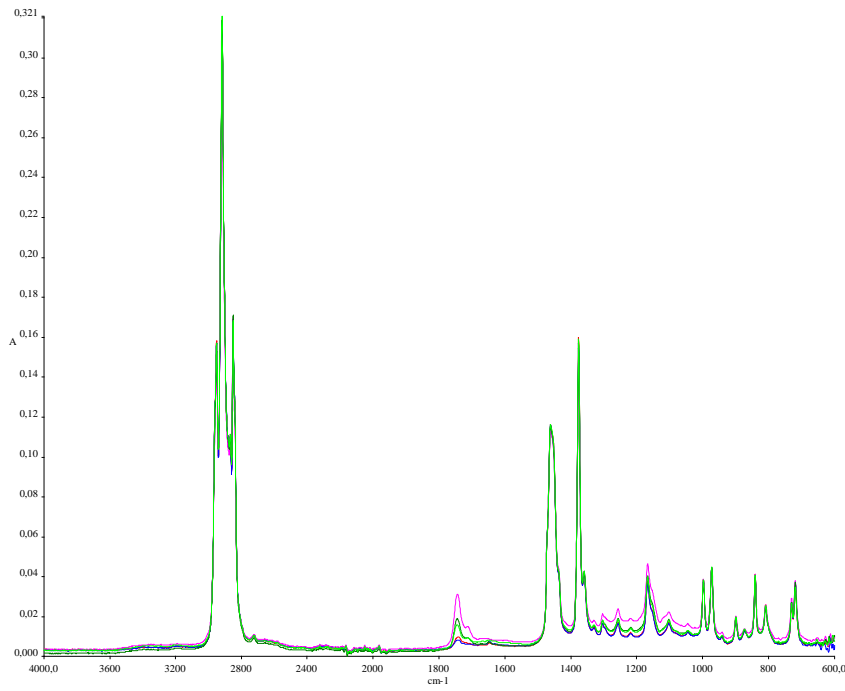

### ***Thermoformed Products***

#### **Bami and Vegetable Boxes**

Graph 40: FTIR spectra of five samples of thermoformed grade Bami and vegetable boxes (white random copolymer)

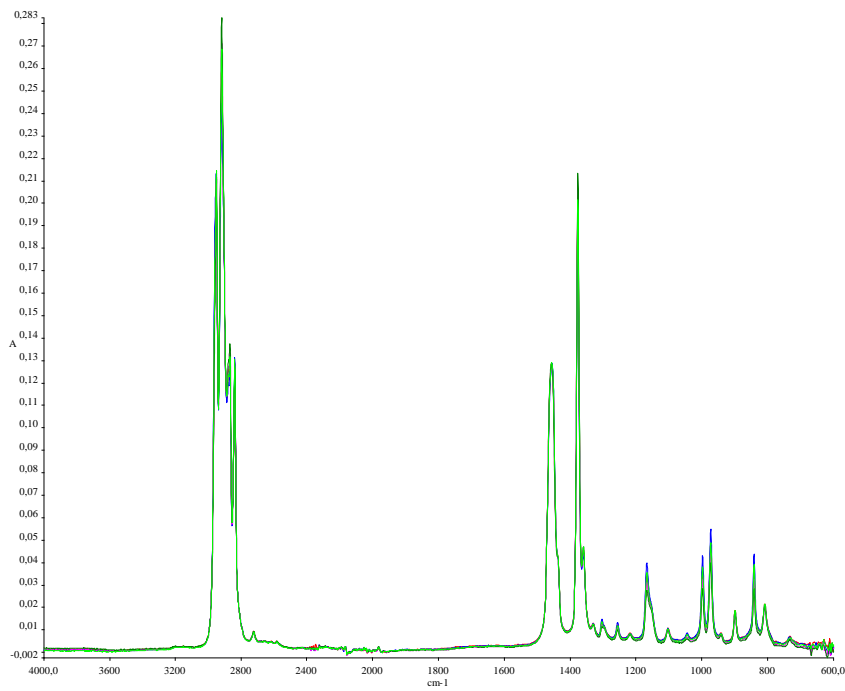



**Graph 41: spectra of five samples of thermoformed grade Bami and vegetable boxes (white random copolymer), after extrusion**

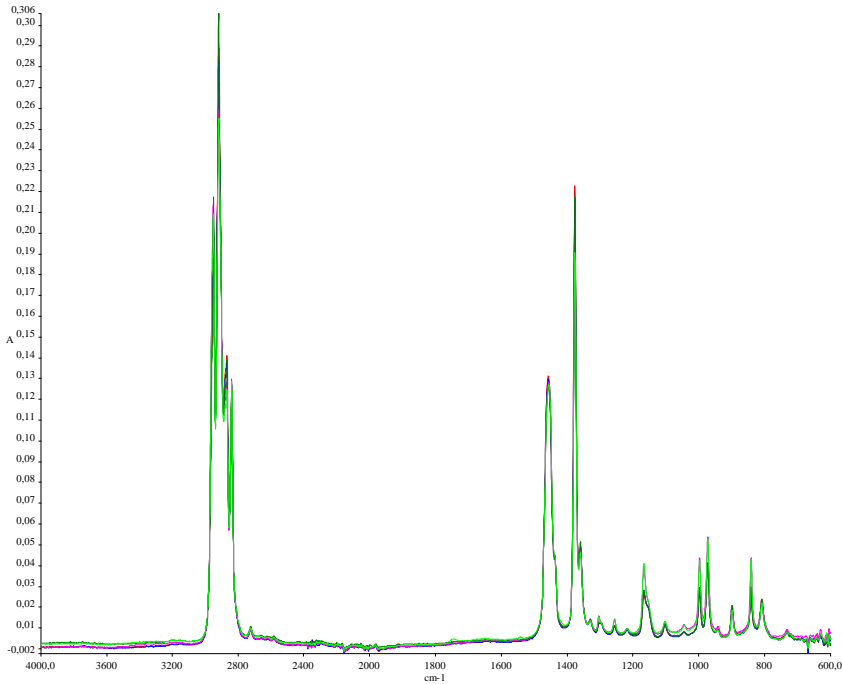

**Graph 42: spectra of five samples of thermoformed grade Bami and vegetable boxes (blue random copolymer), after extrusion**

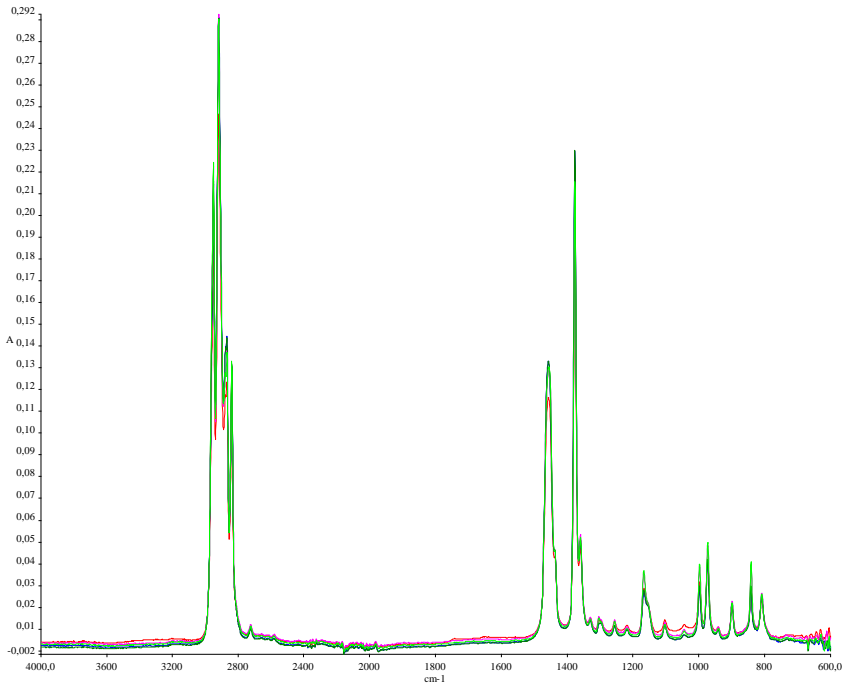

Graph 43: FTIR spectra of five samples of thermoformed Bami boxes

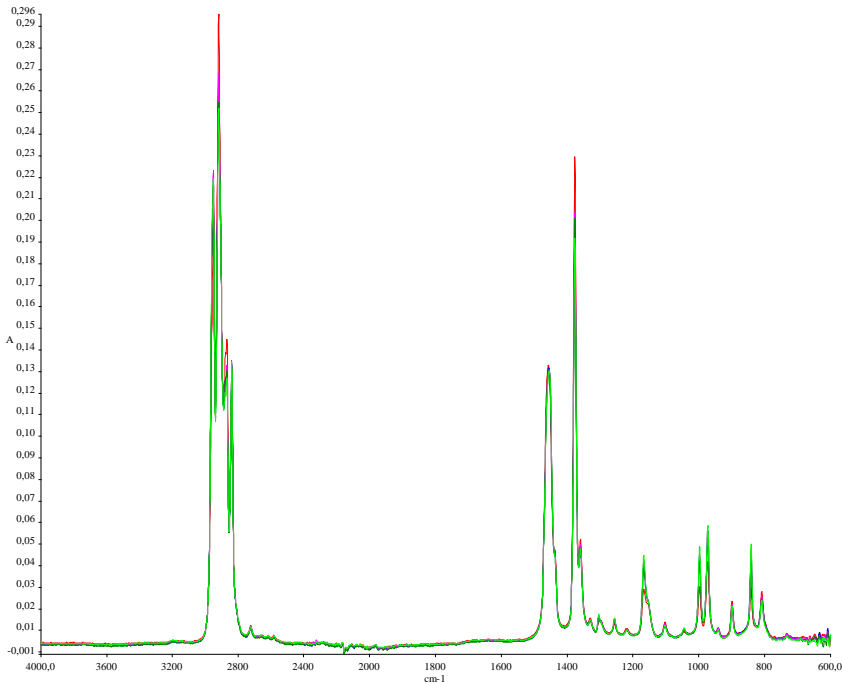

Graph 44: FTIR spectra of five samples of thermoformed vegetable boxes

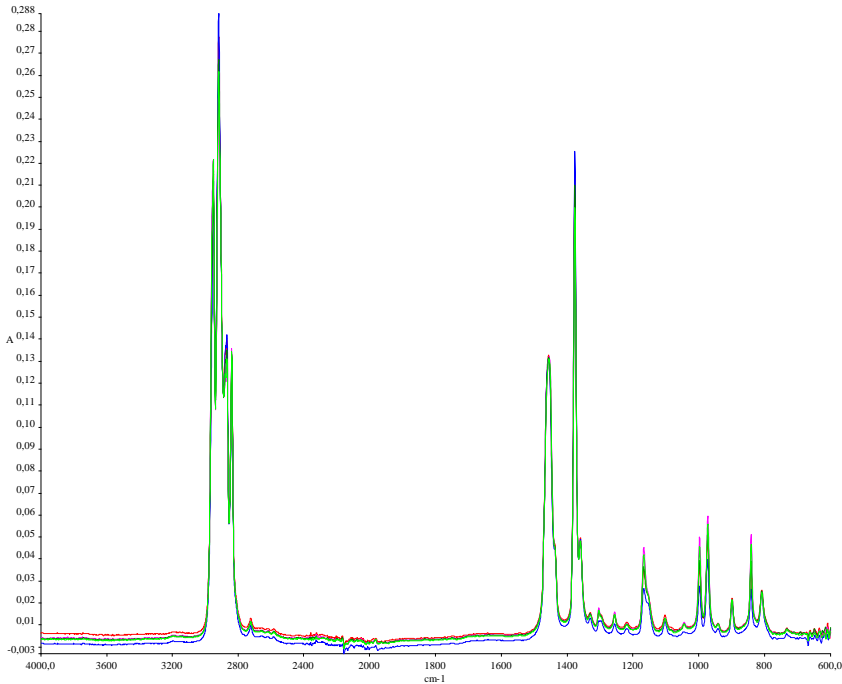

### **Mixture: Injection Mold with Thermoformed grade**

**Graph 45 FTIR spectra of five samples of mixture: injection mold + thermoformed grade**

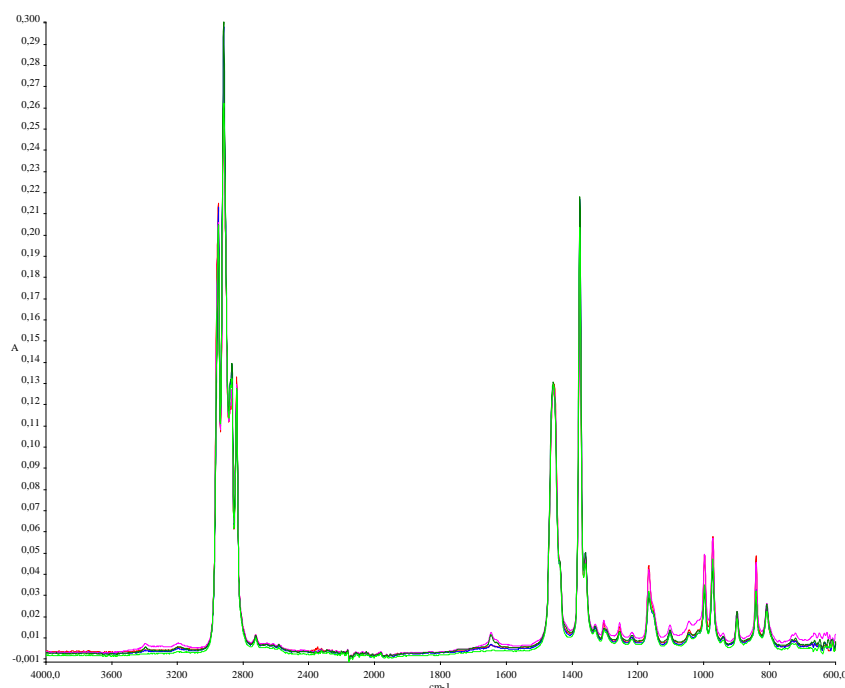

### **Blow Mold Product**

#### Persil Bottle

**Graph 46: FTIR spectra of five samples of blow mold Persil bottle**

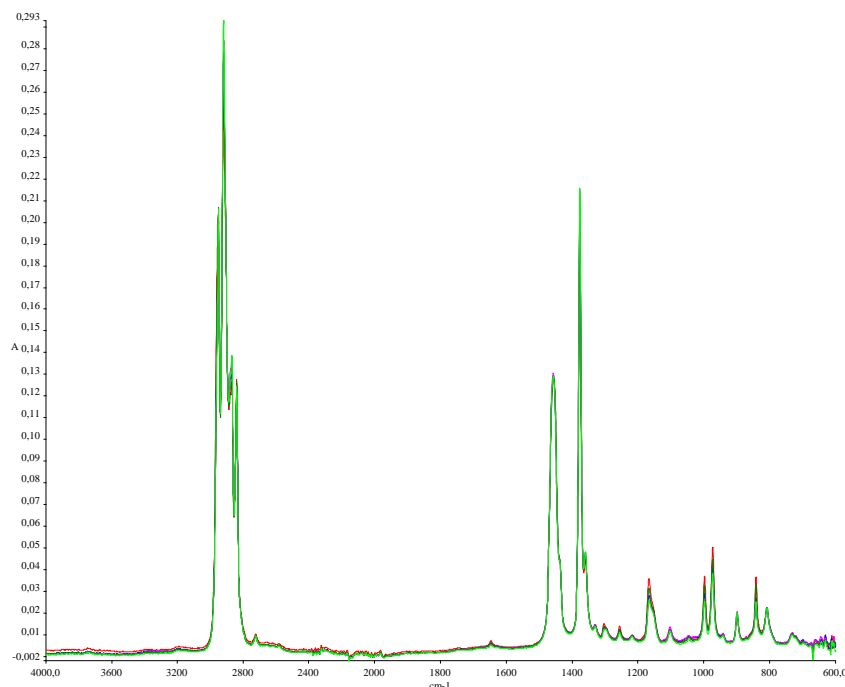

The results of the FTIR analysis show constant values for each grade, as the spectra of the five measurement of each grade show a high overlap. This means that the material has become very homogeneous by the sample preparation. Additionally, the results are in line with the assumption that the impact of tacticity could be neglected as the majority was assumed to be isotactic. The FTIR spectra show that the PP grades used in this study are indeed isotactic, as the spectra correspond to Figure 42c.

The intense peaks at the low frequency region, in the case of the Huzaren salads indicate the existence of inorganic pigments. Additionally, significant and major absorption at the low frequency regions are noticeable in the spectra of the printed side of both Jumbo and Milbona labels. This is correlated to the high content of organic compounds. This is in line with the discussion of peaks in this region of grades from the categorization method.

The peak at around  $1380\text{cm}^{-1}$  is relatively low in the case of both labels. This might be related to a higher PE content.

Additionally, also no significant peaks for degradation are observed. This means that no significant degradation is noticeable by FTIR analysis, no significant degradation has occurred and/or detectable degradation products are released by chain scission (section 4.3.4)

## 6. Conclusion

The study will be concluded by giving answers to the secondary and subsequently to the primary research question.

### 6.1. Secondary Research Questions

---

#### 6.1.1. Categorization Method

***What is the impact of removing non-PP plastics on the optical, mechanical and rheological properties of recycled post-consumer PP?***

Removal of non-PP plastics has a positive impact on the visual optical properties of conventional sorted PP as the color becomes light and can be colored more easily. This is mainly due to the fact that incorrectly recognized plastic types are originating from black products which cannot be inspected by the NIR. However, this impact is assumed not to be observed with the new technology as the separation is based on density instead of NIR.

Removal of non-PP plastics has a positive impact on the mechanical properties, as it results in a change from a ductile to a brittle fracture behavior.

Removal of non-PP plastics has a positive impact on the rheological properties, as it results in increased MFI and thereby decreases the cycle time during manufacturing.

***Do the optical, mechanical and rheological properties of recycled post-consumer PP better address the market needs after separation based on the manufacturing process of the product?***

Separation based on manufacturing process has a positive impact on the optical properties, as a correlation between manufacturing type and color of the material is observed. Blow mold mixed PP results in light colored granules, which can easily be colored and increases the range of applications in which the grade can be used.

Separation based on manufacturing process has a positive impact on the mechanical properties, as a correlation between manufacturing type and ductility of the material is observed. The separation provides a differentiation between brittle and ductile PP grades. However, the injection mold grade might be too brittle and might therefore not address the market needs as good as virgin PP.

Separation based on manufacturing process has a positive impact on the rheological properties, as a correlation between manufacturing type and MFI of the material is observed. The separation provides a good division of MFI, which final ranges comply with the market needs

***Do the optical, mechanical and rheological properties of recycled post-consumer PP better address the market needs after separation based on color?***

Separation based on color has a positive impact on the optical properties, as it results in better defined colors. However, the transparent grade is somewhat yellow and the white grade somewhat bluish. The optical quality of both grades is therefore lower than the quality of virgin grades and separation based on color therefore only partially meets the market needs.

Separation based on color has a positive impact on the mechanical properties, as a correlation between color and ductility of the material is observed. A better defined ductility is required, as different applications need different levels of ductility.

Separation based on color has a positive impact on the rheological properties, as a correlation between color and MFI of the material is observed. It is advantageous for manufacturers as the MFI of recycled post-consumer PP is more in line with the MFI of the virgin grade, as the same manufacturing settings can be used.

### 6.1.2. Reference Method

#### ***What is the negative impact of degradation during processing, service life and subsequent mechanical recycling on the optical, mechanical and rheological properties of recycled pure post-consumer products?***

The negative impact of degradation during processing, service life and subsequent mechanical recycling is significant for injection mold grades, as their MW is close to the critical MW of entanglements. The degradation results in reduced optical properties, since transparent grades show yellowing and white grades become a bit colored. Additionally, degradation results a significant decreased ductility and increased MFI. The first degraded optical and mechanical properties are negative, as the way they addresses the market needs is inferior to the virgin grade. The rheological change is positive, as time cycles of the manufacturing process will decrease.

The negative impact of degradation during processing, service life and subsequent mechanical recycling on the optical properties is significant. The degradation results in reduced optical properties, as yellowing occurs. However, no significant change in ductility or MFI is observed for thermoformed grades, because their MW is significantly higher than the critical MW of entanglements and/or because it might incorporate long chain branches which results in a high entanglement density.. The change in optical properties is negative, as the way it addresses the market needs is inferior to the virgin grade. The impact on mechanical and rheological properties is neutral, as no changes are observed.

#### ***What is the impact of extrusion in relation to the total impact of degradation of post-consumer plastic on the optical, mechanical and rheological properties of virgin materials?***

Extrusion of injection mold grades has no significant impact on the optical properties. However, extrusion significantly decreases the ductility and increases the MFI. The changes in mechanical and rheological properties are probably related to their MW, which approaches to the critical MW of entanglements.

The service life of the product significantly impacts the optical properties, mainly due to the inclusion of printing inks and labels. The other way in which the service life of products impacts the optical properties is by increasing its sensitivity for yellowing of transparent grades during subsequent extrusion. In addition, the service life increases the embrittlement of the material and significantly increases the MFI. Both are probably related to an increased sensitivity for degradation during subsequent extrusion, due to its service life. This means that the impact of extrusion is related to the service life and its significance of impact depends on its service life of the injection mold grade.

Extrusion of thermoformed grades has no significant impact on the optical, mechanical or rheological properties, as no difference is observed as compared to the virgin grade. This is probably related to their MW, which is significantly higher than the critical MW of entanglements and/or because the grade might incorporate long chain branches which results in a high entanglement density.

The service life of the product significantly impacts the optical properties, due to its increased sensitivity for yellowing of transparent grades during subsequent extrusion. However, the service life has no significant impact on the mechanical and rheological properties, as their MW most likely remains significantly higher than the critical MW of entanglements and/or because the grade might incorporate long chain branches which results in a high entanglement. The impact of extrusion is only significant for the optical properties and depends on the service life of the grade.

***What is the impact of a different service life on the optical, mechanical and rheological properties of recycled pure post-consumer products?***

A different service life of a transparent thermoformed grade has no significant impact on the optical properties as no difference is observed due to dominant yellowing. However, a significant difference in mechanical and rheological properties is observed.

***What is the impact of in mold labels on the optical, mechanical and rheological properties of recycled pure post-consumer products?***

The inclusion of in mold labels in a transparent/opaque injection mold grade has a significant impact on the optical properties, as it highly influences the coloring of the final grade. The latter is caused by the inks that are incorporated in the in mold labels. The inclusion of the in mold labels has no significant impact on the mechanical properties. However, inclusion of the in mold labels significantly decreases MFI. This is related to the larger dependence of rheological properties on the MW as compared to the mechanical properties. The inclusion of in mold labels most likely increases the density of entanglements, as it is an extruded PP film.

***What is the impact of printing inks on the optical, mechanical and rheological properties of recycled pure post-consumer products?***

The inclusion of printing inks in a white injection mold grade has a minor significant impact on the optical properties, as it highly influences the coloring of the final grade. However, the impact is only minor as printing inks are most likely degassed during extrusion or because the impact is masked by the white pigments. The inclusion of the printing inks has no significant impact on the mechanical and rheological properties. This is probably due to the very low printing inks content.

***What is the impact of mixing a virgin injection mold grade with a virgin thermoform grade on the optical, mechanical and rheological properties of the blend?***

Mixing a virgin opaque injection mold grade with a virgin opaque thermoformed grade has no significant impact on the optical properties. However, it significantly impacts the mechanical and rheological properties. Both are mainly determined by the thermoformed grade. The dominance is most likely caused by the significant influence of long chain branches that are incorporated in the thermoformed grade. This addition of a thermoformed grade to an injection mold grade therefore results in an increased entanglement density, which increases the ductility and decreases the MFI significantly.

## **6.2. Primary Research Question**

---

***Can mechanical recycling realize a circular economy of post-consumer PP?***

The results of this study show that a circular economy of mechanical recycled post-consumer PP becomes more realistic when the levels of categorization increase. More defined grades can be obtained and better address the market needs. Having more defined grades is an important step into the right direction to create a circular economy. However, removal of non-PP plastics, categorization based on manufacturing type and color is not sufficient to fully realize a circular economy of post-consumer PP. Extra categorization steps and/or standardizations are required to realize a circular economy by mechanical recycling. These extra modifications on technology and regulations will be discussed in more detail in the recommendations.

## 7. Recommendations

The conclusions of this study result in recommendations of two different categories. Firstly, recommendations to perform additional research on the basis of the results, to be able to differentiate between different parameters that cause changes in optical, rheological and mechanical properties for mechanical recycled post-consumer PP as compared to virgin grades. Proposed subsequent analysis of the crystallinity, molecular weight, copolymerization and additives are explained.

Secondly, recommendations that focuses on the feasibility of the use of the new technology in practice. It discusses the additional studies that can be performed and explains proposals for amendments in European recycling regulations.

### 7.1. Related to the Results

The impact of the parameters (crystallinity, molecular weight, copolymerization and the additives) are explained in the literature study. However, the separated impact by each parameter was not analyzed. The further categorization of the PP waste stream results in better defined properties. However, the underlying reason is unknown as the categories might still contain a mixture of different types of PP. It is therefore interesting to do extra analyses of the main parameters that influence the properties of PP.

#### 7.1.1. Crystallinity

The crystallinity of PP is influenced by many factors such as: MW, polymer structure (copolymerization and incorporation of long chain branches) and nucleation agent additives. This study gave no insight in the impact of further categorization on the crystalline structure of PP. In order to understand the impact of further categorization on the properties, it is interesting to analyze the degree of crystallinity.

X-ray diffraction is the primary method to analyze the crystallinity of a polymer. Unoriented, amorphous, structures show defused bands over all diffraction angles, while highly oriented, crystalline, structure show sharp bands at characteristic diffraction angles. The difference between a X-ray diffraction pattern of a highly amorphous and highly crystalline polymer is schematically illustrated in Figure 56. The degree of crystallinity can be determined based on the intensities of the lines in the pattern.

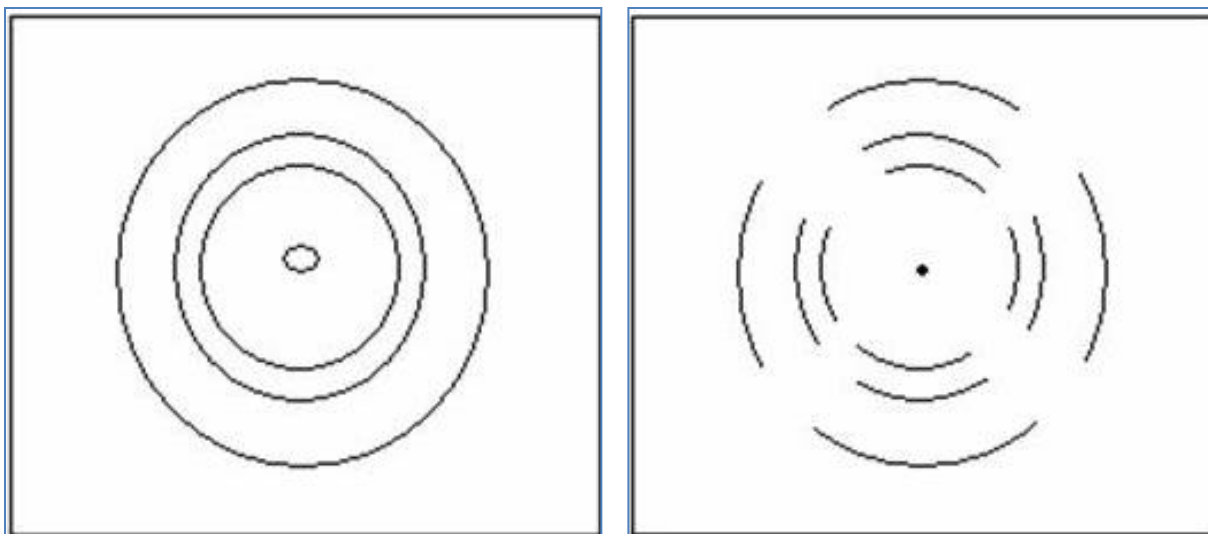

Figure 56: Diffraction patter of a highly amorphous structure (left) and a highly crystalline structure (right) [136]



Differential scanning calorimetry (DSC) is a standard equipment, used to determine the degree of crystallinity in a polymer. A DSC allows to explore the thermal behavior of PP, which is related to its degree of crystallinity. An example of a DSC plot is given in Figure 57. PP that is complete amorphous shows a large increase in heat flow at the  $T_g$  while it does not show a dip or peak at the crystallization temperature ( $T_c$ ) or  $T_m$ , while a 100% crystalline PP shows no change at  $T_g$ , and a large dip and peak at the  $T_c$  and  $T_m$  respectively. Based on the areas under the peak, the degree of crystallinity can be determined.

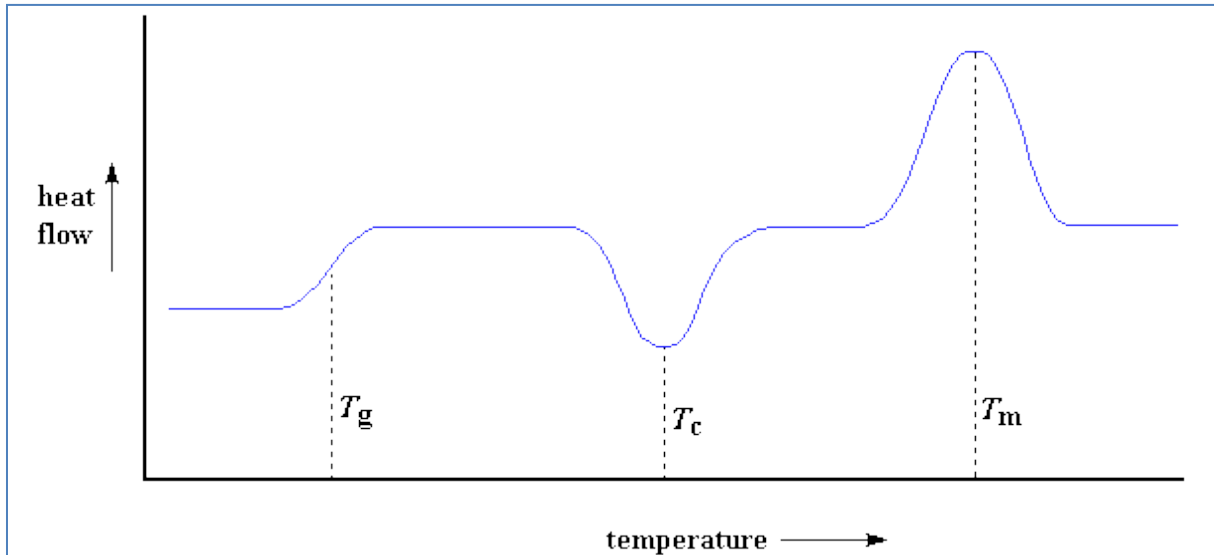

Figure 57: Schematic representation of a general DSC plot[137]

A third analysis technique makes use of polarized light. This analysis can be used to get an insight in the spherulite structure. The size of the spherulites also has a significant impact on the properties and its analysis can therefore be useful. This method is schematically represented in Figure 58

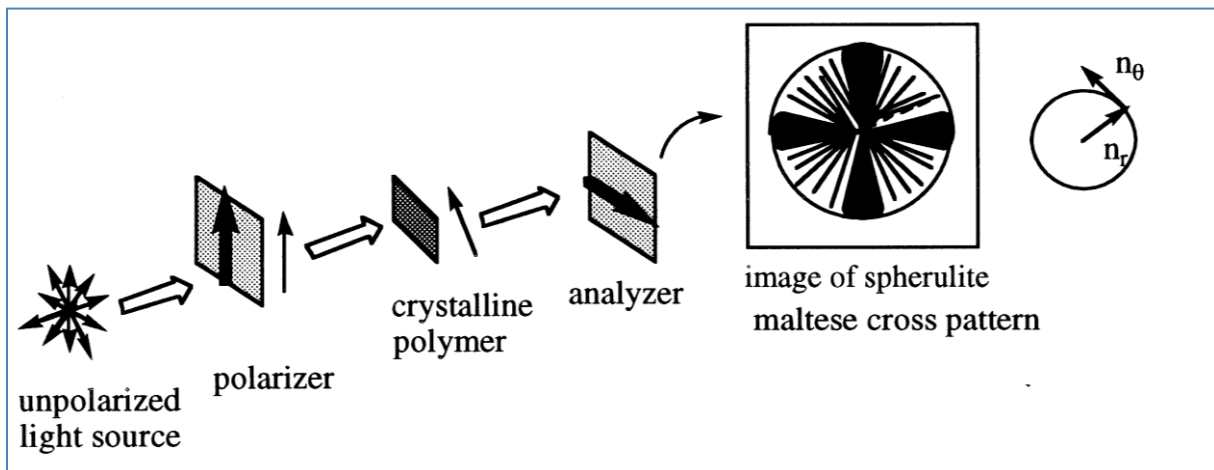

Figure 58: schematic representation of analysis of spherulite structure by polarized light[138]

### 7.1.2. Molecular Weight

The MW of PP decreases upon chain scission during degradation. The content of short chains, and thus the MWD, in mechanical recycled post-consumer PP grades is unknown. Additionally it is interesting to understand the impact of crosslinking of PE during degradation. However, to understand the impact of degradation on the MW, it is interesting to know the MWD.

Gel permeation chromatography (GPC) is a primary method to analyze the MWD. GPC involves the permeation of dissolved PP through a column. The column contains different pore size, which causes a different residence time for large (long chain) and small (short chain) molecules. The large size molecules have a shorter residence time than smaller molecules, as they do not penetrate each pore. This principle is schematically represented in Figure 59. The largest molecules are therefore detected first and the smallest molecules as last. The MWD can be determined from the detection.

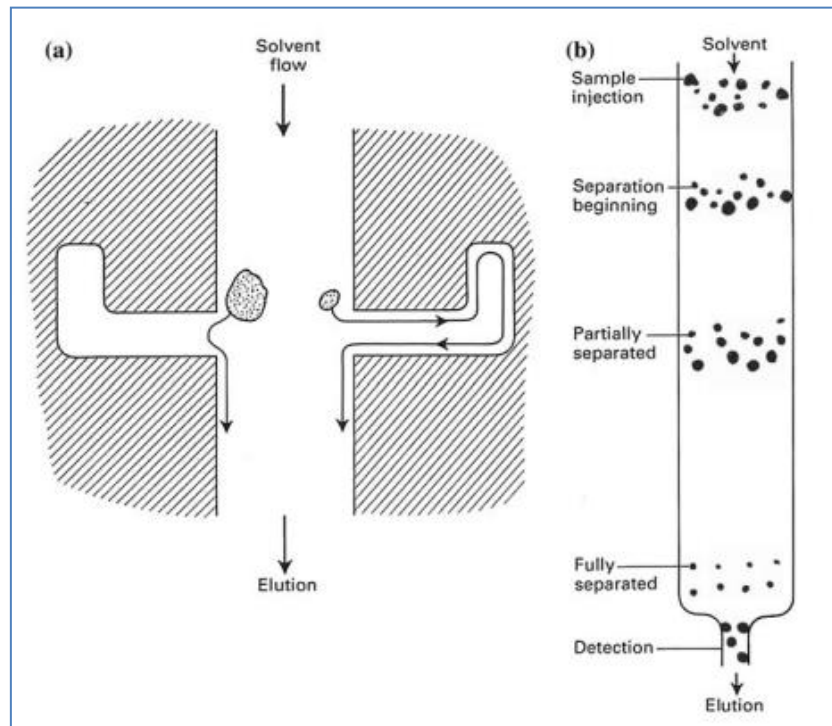

Figure 59: Schematic representation of GPC working principle [139]

In addition to chain scission reaction, degradation can result in crosslinking in the case of copolymers. Sol-gel analysis can be used to determine the crosslinking content. If the structure becomes highly crosslinked, the molecule becomes insoluble. The soluble fraction is extracted with a boiling solvent and in this way insoluble fraction can be measured. Subsequently analytical models can be used to determine the content of crosslinking. [140]

### 7.1.3. Copolymerization

The intermolecular interactions, free volume and entanglement densities are determined by the type of copolymerization. They highly impact the properties of PP and therefore it is interesting to analyse the existence of for example PE blocks in the polymer chain. The DSC analysis, which can be used to analyze the crystallinity, can also be used to determine the content of other types of plastics, such as PE, incorporated in the polymer chain by copolymerization. PE has another  $T_g$ ,  $T_c$  and  $T_m$ . The PE content can be calculated based on the intensities of the different peak in the DSC plot.

### 7.1.4. Additives

There exist more than 1.000 additives, which can have synergistic and antagonistic interactions. Additionally, different additives have a different efficiency. It would be interesting to know the existence of specific (over-oxidized) additives, fillers or pigments to analyze their impact on the properties. However, the analysis of additives is a challenge: additives range from organic to totally inorganic materials; additives are seldom pure and traces of curing agents or oligomers can complicate the analysis. The content of additives also play an important role, very low contents of additives are difficult to isolate.

The physical and chemical properties of PP determine how the additives can be isolated for analysis. Isolation techniques are solvent extraction, high temperature distillation, ashing and chromatography. The additives can be analyzed by infra-red, which is most powerful, UV, nuclear magnetic resonance (NMR), mass spectroscopy and X-ray diffraction. The choice for an isolation and analysis technique must be based on the additives of consideration. [45]

## 7.2. Feasibility in Practice

---

### 7.2.1. Technological Aspects

#### *Further Analysis of Properties*

##### Optical Properties

Only the visual properties are analyzed in this study. White PP consists of a wide range of standard types of white. The Pantone Color Matching System is largely a standardized color reproduction system, which has a specific system for PP colored plastics. In this way the color can be determined with higher accuracy.



Figure 60: Pantone color matching system for colored PP plastic.[141]

However, the system cannot be used for the analysis of transparent PP. One of the major methods to determine the transparency is by analysis of the haze of the material. Haze is in general correlated to transparency, or 'see-through'. The fraction light that is diffracted above an angle of  $2.5^\circ$  contributes to haze. Haze is percentage of light that is diffusely scattered compared to the total light transmitted. The material becomes translucent when the value of haze exceeds 30%. [142]

##### Mechanical Properties

This study only focused on the ultimate tensile strength and the strength and strain at break. Additionally, the elastic modulus and yield strength are also important properties, which are standard provided on the datasheet of plastics. The measurement of these properties require an accurate extension meter during measurements and another cross head speed as is used for the measurements of the other properties. [33]

An additional and important standard test is the impact test. The impact tests measures the energy that is absorbed by the material during fracture. The result of this analysis is standard provided at the datasheet of the polymer. It is important to determine the suitability of the material in a product application. [33]

### Rheological Properties

This study only focused on MFI measurements, which is a good indicator of the viscous character of PP. However, it is not a fundamental polymer property and the complete visco-elastic behavior of PP can be analyzed by dynamic mechanical analysis. The flow of the polymer is characterized and information about the elastic, viscous and plastic behavior of the material can be obtained. The viscosity and modulus changes over temperature and shear rate can be analyzed. A distinguish can be made between PP grades that show strain hardening, strain softening or a Newtonian behavior. The melt strength, that addresses the suitability to a manufacturing type, can be determined based on measurements of the modulus. [33]

### ***Further Studies into Feasibility of New Technology***

#### Impact of further Categorization

This study was done on a limited amount of categories. The impact of further categorization based on more colors and color separation of the different manufacturing types of products are recommended to analyze. The further analyzes will give a broader overview of the impacts of further categorizations. Some of the categorization steps might not lead to a more defined grade, while others do.

#### Efficiently of Separation

The separation and purification of the different categorization grades were done manually in this study. However, in practice the technology never has an efficiency of 100%. Additionally, there is an overlap in wall thickness for the different manufacturing types. [13] It is therefore recommended to analyze the impact of impurities from other categories on the properties.

#### Impact of Categorization on Properties of Other Types of Plastics

This study focused on the impact of categorization on the properties of mechanical recycled post-consumer PP. However, the impact will not be the same for other types of plastic, due to their difference in chemical nature. For example, PE undergoes crosslinking reactions during degradation, while PP undergoes chain scission. Additional, additives and impurities might have another impact, due to difference in miscibility and melt behavior. It is therefore recommended to apply this study on other major types of plastics.

#### Use of Low Quality Grades

This study showed poor mechanical properties of the mechanical recycled post-consumer injection mold white PP grade. This grade may not address the needs of the market. Mixing with virgin grade PP can be a method to use these 'left overs'. It is therefore recommended to study the impact of mixing virgin grade with specific categories of the recycled waste stream.

Another solution to improve the mechanical properties is by the incorporation of impact modifiers. Many studies already analyzed the impact of the addition of commercial available additives. Also compounding might be a solution. An extra literature study is therefore recommended. [33]

Additionally, a solution must be found for mixture of colors that do not fall in defined ranges. Extra pigments can be added to modify the color. However, only darker colors can be obtained by this method. Also a solution for yellowing of the transparent grades must be found. The right choice of additives can already be advantageous, as was illustrated in section 3.2.3. The addition of extra additives can also prevent over-oxidation and thereby decreases the level of yellowing.

A solution to compensate potential yellowing of white grades is the addition of brighteners. Brighteners absorb UV light and re-emit most absorbed energy as light in the blue region. Brighteners shift the shade of yellowish material towards blue, which increases the whiteness, observed by the human eye. [143]

### 7.2.2. Regulations

Technologies alone are not enough. Also changes in food grade regulations and increasing manufacturers' responsibility are required to create a circular economy of mechanical recycled plastics.

#### ***Food Grade***

Article 4 of *The Commission regulation (EC) No 282 [144]* sets out conditions for the use of recycled post-consumer plastic in food packages. Only plastics originating from food packaging can be used in food packaging again, as this plastic does contain food approved additives only. However, the new technology is not able to recognize the difference between food and non-food packages. It is therefore of interest to set out other conditions for the use of recycled post-consumer plastics in food packages. For example, transparent plastic is very popular in the food packaging industry. However, the transparent recycled plastics cannot be used in food packages, as not all transparent plastic is food approved. It would be interesting to regulate all transparent plastics to be food-grade, as the technology is able to separate based on color. Additionally, for example, specific color/ manufacturing type combinations can be used for packages of more toxic-materials.

#### ***Manufacturer Responsibility***

Manufacturers and importers in the Netherlands are already made responsible to minimize the use of packaging and to collect and recycle plastic waste. However, the prices they have to pay for plastic waste are related to its total weight, rather than the recyclability of the grade. To create a circular economy for plastics by mechanical recycling, it is recommended to further regulate the development, use and recycling of plastics based on the results of further studies. For example certain anti-oxidants and process stabilizers cause less yellowing than others and their use should therefore be promoted. Another possibility is to develop a technology that extracts anti-oxidants. However, regulating the use of certain additives seems to be a more cost-effective solution. It would be relevant to study the impact of different additives and their efficiency for use in recycling, and create standards for grades and additives.

By regulating standards to form a circular economy for mechanical recycled post-consumer plastics, manufacturers will have to take their responsibility in recyclability specifically, rather than minimizing the mass packaging waste.

## 8. List of Symbols

### 8.1. General Abbreviations

---

BHT	Butylated hydroxytoluene
CI	Carbonyl index
DP	Degree of polymerization
DSC	Differential scanning calorimetry
FTIR	Fourier Transform Infrared
GPC	Gel permeation chromatography
HALS	Hindered Amine Light Stabilizers (
HDPE	High-density polyethylene
LDPE	Low-density polyethylene
PDI	Polydispersity index
PE	Polyethylene
PET	poly(ethylene terephthalate)
PP	Polypropylene
MFI	Melt Flow Index
MW	Molecular Weight
MWD	Molecular Weight Distribution
NIR	Near infrared
RPM	rotations per minute
WTI	West Texas Intermediate
Wt%	Weight percentage
$T_c$	Crystallization temperature
$T_g$	Glass transition temperature
$T_m$	Melting temperature

### 8.2. Abbreviations of Equations

---

#### 8.2.1. Roman Letters

$A$	<i>Constant</i>
$A_{\text{carbonyl}}$	<i>Intensity of absorbance at frequency related to C = O bond in degradation product of PP</i>
$A_{\text{PP}}$	<i>Intensity of absorbance at frequency related to C – C bond in PP</i>
$K$	<i>Constant</i>
$G$	<i>Constant: ranges from <math>2 * 10^{-20}</math> to <math>1 * 10^{-24}</math></i>
$\Delta G_{\text{mix}}$	<i>Gibbs free energy of mixing</i>

$G_{AB}$	<i>Gibbs free energy of polymer blend</i>
$G_A$	<i>Gibbs free energy of polymer A</i>
$G_B$	<i>Gibbs free energy of polymer B</i>
$\Delta H_{mix}$	<i>Enthalpy or heat of mixing</i>
$m$	<i>Weight of repeating monomer</i>
$\overline{M}_n$	<i>Number – average molecular weight</i>
$\overline{M}_w$	<i>Weight – average molecular weight</i>
$N_i$	<i>Number of molecules of molar mass <math>M_i</math></i>
$P$	<i>Mechanical property</i>
$P_\infty$	<i>Constant: limited value of property</i>
$\Delta S_{mix}$	<i>Entropy of mixing</i>
$T$	<i>Temperature of mixing</i>
$w_i$	<i>Weight fraction: the mass of molecules of molar mass <math>M_i</math> divided by the total mass of all the molecules present</i>
$x$	<i>Constant: range from 3.9 to 4.6</i>
$X_i$	<i>Mole fractions of molecules of molar mass <math>M_i</math></i>
$x_1, x_2$	<i>Mole fraction of phase 1 and 2 respectively</i>

### 8.2.2. Greek Letters

$\eta_0$	<i>Zero shear viscosity</i>
$\eta_{12}, \eta_1, \eta_2$	<i>Zero shear viscosity of: blend, phase 1 and phase 2 respectively</i>
$\eta_{PP}$	<i>Viscosity of PP including impurities</i>
$\eta_{PP}$	<i>Viscosity of PP excluding impurities</i>
$\varphi_{imp}$	<i>Volume fraction of impurities</i>

## 9. Bibliography

- [1] “Ecological Footprints.” [Online]. Available: <http://www.gdrc.org/sustdev/concepts/06-footprints.html>. [Accessed: 16-Jun-2015].
- [2] J. Hering, “Many paths to a common goal : water in context,” no. 01. Eawag, 2013.
- [3] T. a Cooper, *4 - Developments in plastic materials and recycling systems for packaging food, beverages and other fast-moving consumer goods*. Woodhead Publishing Limited, 2013, pp. 58–107.
- [4] V. W. Y. Tam, *Handbook of Recycling*. Elsevier Inc., 2014, pp. 285–295.
- [5] PlasticsEurope, “Plastics – the Facts 2013 An analysis of European latest plastics production , demand and waste data,” 2013.
- [6] World Commission on Environment and Development, “Our Common Future,” 1987.
- [7] Plastice, “Biopolymers and Bioplastics.” National Insitute of Chemistry, Ljubljana.
- [8] T. a. Hottle, M. M. Bilec, and A. E. Landis, “Sustainability assessments of bio-based polymers,” *Polym. Degrad. Stab.*, vol. 98, no. 9, pp. 1898–1907, 2013.
- [9] European Bioplastics, “Driving the evolution of plastics,” pp. 1 – 12, 2012.
- [10] “Resource Efficiency starts with prevetnion.” Flexible packaging Europe, pp. 1–2, 2015.
- [11] D. S. Achilias, C. Roupakias, P. Megalokononimos, a. a. Lappas, and V. Antonakou, “Chemical recycling of plastic wastes made from polyethylene (LDPE and HDPE) and polypropylene (PP),” *J. Hazard. Mater.*, vol. 149, pp. 536–542, 2007.
- [12] K. Hamad, M. Kaseem, and F. Deri, “Recycling of waste from polymer materials: An overview of the recent works,” *Polym. Degrad. Stab.*, vol. 98, no. 12, pp. 2801–2812, 2013.
- [13] B. Hu, “Magnetic density separation of polyolefin wastes,” TU Delft, 2014.
- [14] “Let’s talk plastics.” [Online]. Available: <http://www.letstalkplastics.com/about-plastics>. [Accessed: 02-Feb-2015].
- [15] “Plastemart,” 2006. [Online]. Available: [http://www.plastemart.com/upload/Literature/clarified\\_Polystyrene.asp](http://www.plastemart.com/upload/Literature/clarified_Polystyrene.asp). [Accessed: 02-Feb-2015].
- [16] L. M. Sherman, “New Clarifiers & Nucleators: They Make Polypropylene Run Clearer and Faster,” *Plastics Technology*, 2002. [Online]. Available: <http://www.ptonline.com/articles/new-clarifiers-nucleators-they-make-polypropylene-run-clearer-and-faster>. [Accessed: 02-Feb-2015].



- [17] MPW-Staff, "Thermoforming primer: The secret to clear PP packaging," 2010. [Online]. Available: <http://www.plasticstoday.com/articles/thermoforming-primer-secret-clear-pp-packaging>. [Accessed: 02-Feb-2015].
- [18] "New Clear Thinking On Polypropylene Benefits," *Canadian Packaging*. [Online]. Available: <http://www.canadianpackaging.com/sustainability/new-clear-thinking-on-polypropylene-benefits-2337/>. [Accessed: 02-Feb-2015].
- [19] A. Menyhárd, M. Gahleitner, J. Varga, K. Bernreitner, P. Jääskeläinen, H. Øysæd, and B. Pukánszky, "The influence of nucleus density on optical properties in nucleated isotactic polypropylene," *Eur. Polym. J.*, vol. 45, no. 11, pp. 3138–3148, Nov. 2009.
- [20] The Freedonia Group, "Polypropylene: the next gen plastic," 2014. [Online]. Available: <http://www.packagingnews.com.au/news/polypropylene-the-next-gen-plastic>. [Accessed: 02-Feb-2015].
- [21] Plastic Zero, "Carbon Black Plastic: Challenges and ideas for environmentally friendly alternatives." City of Copenhagen, 2014.
- [22] P. Europe, "Petcore Europe: More than 60 billion PET bottles recycled 2012!," 2013. [Online]. Available: <http://www.plasticsrecyclers.eu/news/petcore-europe-more-60-billion-pet-bottles-recycled-2012>. [Accessed: 20-Feb-2015].
- [23] Milieu Centraal, "Meldpunt verpakkingen." [Online]. Available: <http://meldpuntverpakkingen.nl/meldpunt-verpakkingen/veel-gestelde-vragen/919/welke-grens-zit-er-aan-het-gehalte-gerecycled-materiaal-van-verpakkingen.html>. [Accessed: 29-Feb-2015].
- [24] F. De Santis and R. Pantani, "Optical properties of polypropylene upon recycling," *Sci. World J.*, vol. 2013, Jan. 2013.
- [25] L. Incarnato, P. Scarfato, G. Gorrasi, V. Vittoria, and D. Acierno, "Structural modifications induced by recycling of polypropylene," *Polym. Eng. Sci.*, vol. 39, no. 9, pp. 1661–1666, 1999.
- [26] Z. M. Ariff, A. Ariffin, S. S. Jikan, N. Azura, and A. Rahim, "Rheological Behaviour of Polypropylene Through Extrusion and Capillary Rheometry." InTech, 2012.
- [27] W. D. (Jr. . Callister, *Materials Science and Engineering an Introduction*, Seventh. John Wiley & Sons Inc, 2007.
- [28] H. Granlund, E. Andreassen, E. T. B. Skjønsvjell, K. Høydalsvik, A. Diaz, and D. W. Breiby, "Measuring and simulating morphology gradients in injection-molded talc-reinforced isotactic polypropylene," *J. Polym. Sci. Part B Polym. Phys.*, vol. 52, no. 17, pp. 1157–1167, Sep. 2014.
- [29] S. T. Milner, "Polymer crystal-melt interfaces and nucleation in polyethylene," pp. 2909–2917, 2010.
- [30] The Macrogalleria, "Polypropylene." [Online]. Available: <http://www.pslc.ws/macrog/pp.htm>. [Accessed: 05-Feb-2015].
- [31] T. Ogawa, "Effects of molecular weight on mechanical properties of polypropylene," *J. Appl. Polym. Sci.*, vol. 44, pp. 1869–1871, 1992.

- [32] “Steinwall.” [Online]. Available: <http://steinwall.com/pages/Polypropylene/>. [Accessed: 12-May-2015].
- [33] E. van Bruggen, “Dominant Role of a Functionalized Compatibilizer in the Compatibilization of a Polypropylene/ Poly(ethylene terephthalate) Blend,” TU Delft, 2014.
- [34] R. J. Young and P. A. Lovell, *Introduction to polymers*, Second. Cheltenham: Chaoman & Hall, 2000, pp. 1–424.
- [35] PSS, “Molar mass determination.” [Online]. Available: <http://www.pss-polymer.com/solutions/molar-mass-determination/>. [Accessed: 06-Jun-2015].
- [36] NPCS Board of Consultants & Engineers, *Disposable Products Manufacturing Handbook*. Niir Project Consultancy Services, 2014, pp. 1–528.
- [37] Equistar, “Polyolefin Flow Characteristics: More than Just Melt Index or Melt Flow Rate.” pp. 1–3.
- [38] L. J. Fetters, D. J. Lohse, S. T. Milner, and W. W. Graessley, “Packing length influence in linear polymer melts on the entanglement, critical, and reptation molecular weights,” *Macromolecules*, vol. 32, pp. 6847–6851, 1999.
- [39] I. Amer, “Molecular weight effect on crystallization of polypropylene,” University of Stellenbosch, 2011.
- [40] R. Janssen, “Deformation and Failure in Semi-Crystalline Polymer Systems,” 2002.
- [41] B. Wang, Z. Chen, J. Kang, F. Yang, J. Chen, Y. Cao, and M. Xiang, “Influence of melt structure on the crystallization behavior and polymorphic composition of polypropylene random copolymer,” *Thermochim. Acta*, vol. 604, pp. 67–76, 2015.
- [42] R. a. García, B. Coto, M. T. Expósito, I. Suarez, A. Fernández-Fernández, and S. Caveda, “Molecular characterization of polypropylene heterophasic copolymers by fractionation techniques,” *Macromol. Res.*, vol. 19, no. 8, pp. 778–788, 2011.
- [43] “General properties of Polypropylene,” *Sangir*. [Online]. Available: [http://www.sangir.in/pro\\_pp\\_pipes.html](http://www.sangir.in/pro_pp_pipes.html). [Accessed: 16-Jun-2015].
- [44] C. He, S. Costeux, P. Wood-Adams, and J. M. Dealy, “Molecular structure of high melt strength polypropylene and its application to polymer design,” *Polymer (Guildf)*, vol. 44, pp. 7181–7188, 2003.
- [45] Geoffrey Pritchard, *Plastics Additives: An A-Z Reference*. Surrey: Chapman & Hall, 1998.
- [46] A. M. Wims, S. J. Swarin, and A. Chemzstry, “Determination of Antioxidants in Polypropylene,” vol. 19, pp. 1243–1256, 1975.
- [47] A. Eltayef, “Polyethylene (Stabilization and Compounding),” *Linked-in*, 2015. [Online]. Available: <https://www.linkedin.com/pulse/polyethylene-stabilization-compounding-ahmed-elstayef>. [Accessed: 28-May-2015].
- [48] DFG, “2,6-Di- tert -butyl- p -cresol (BHT),” *MAK-Collection Part 1 MAK value Doc.*, vol. 23, pp. 157–215, 2007.

- [49] Equistar, “Additives: Antioxidants.” Lyondell Chemical Company, pp. 1–2.
- [50] J. Karger-Kocsis, *Polypropylene: An A-Z reference*. Springer Science & Business Media, 2012, pp. 1–966.
- [51] M. Tolinski, *Additives for Polyolefins: Getting the Most out of Polypropylene, Polyethylene and TPO*. William Andrew, 2015, pp. 1–240.
- [52] K. Gerard, “Craftech,” 2014. [Online]. Available: <http://info.craftechind.com/blog/bid/383570/The-Top-3-Plastic-Additives-for-UV-Stabilization>. [Accessed: 16-May-2015].
- [53] Wikipedia, “Pigment,” 2015. [Online]. Available: <http://en.wikipedia.org/wiki/Pigment>. [Accessed: 28-Jan-2015].
- [54] M. Blomenhofer, S. Ganzleben, D. Hanft, H. Schmidt, M. Kristiansen, P. Smith, K. Stoll, D. Ma, and K. Hoffmann, “‘ Designer ’ Nucleating Agents for Polypropylene,” *Macromolecules*, vol. 38, pp. 3688–3695, 2005.
- [55] M. Stumpf, a. Sporrer, H.-W. Schmidt, and V. Altstadt, “Influence of supramolecular additives on foam morphology of injection-molded i-PP,” *J. Cell. Plast.*, vol. 47, pp. 519–534, 2011.
- [56] Equistar, “Additives: Nucleating and Clarifying Agents.” Lyondell, pp. 1–3.
- [57] Wikipedia, “Sodium benzoate.” [Online]. Available: [http://en.wikipedia.org/wiki/Sodium\\_benzoate](http://en.wikipedia.org/wiki/Sodium_benzoate). [Accessed: 18-May-2015].
- [58] lyondellbasell, “Random Copolymer Polypropylene.” [Online]. Available: <http://www.lyondellbasell.com/Products/ByMarket/PlasticsAndRubber/RandomCopolymerPolypropylene/>. [Accessed: 05-Feb-2015].
- [59] Network Polymers, “Random Copolymer Polypropylene.” [Online]. Available: <http://www.networkpolymers.com/RandomCopolymerPolypropylene>. [Accessed: 05-Feb-2015].
- [60] C. Grein, M. Gahleitner, and K. Bernreitner, “Mechanical and optical effects of elastomer interaction in polypropylene modification: Ethylene-propylene rubber, poly-(ethylene-co-octene) and styrene-butadiene elastomers,” *Express Polym. Lett.*, vol. 6, no. 9, pp. 688–696, 2012.
- [61] B. Pukánszky, *Fillers for polypropylene*. Springer Netherlands, 1999, pp. 240–246.
- [62] W. C. J. Zuiderduin, C. Westzaan, J. Huétink, and R. J. Gaymans, “Toughening of polypropylene with calcium carbonate particles,” *Polymer (Guildf)*, vol. 44, pp. 261–275, 2002.
- [63] MondolMinerals, “Talc in Plastics.” Mondo Minerals.
- [64] “Talc Reinforced Polypropylene,” *Washington Penn Plastic*. [Online]. Available: <http://washingtonpennplastic.com/products/mineral-fillers/talc-filled/>. [Accessed: 18-May-2015].

- [65] S. Kant, U. Doctor, J. Kumar, and G. Pundir, "Study of talc filled polypropylene-A concept for improving mechanical properties of polypropylene," *Int. J. Res. Eng. Technol.*, vol. 2, pp. 411–415, 2013.
- [66] S. Zhang and a. R. Horrocks, "A review of flame retardant polypropylene fibres," *Prog. Polym. Sci.*, vol. 28, pp. 1517–1538, 2003.
- [67] F. Rault, S. Giraud, F. Salaün, and X. Almeras, "Development of a Halogen Free Flame Retardant Masterbatch for Polypropylene Fibers," *Polymers (Basel)*, vol. 7, pp. 220–234, 2015.
- [68] M. Alin, Jonas ; Hakkarainen, "Type of polypropylene material significantly influences the migration of antioxidants from polymer packaging to food simulants during microwave heating," *J. Appl. Polym. Sci.*, vol. 118, no. 2, pp. 1084–1093, 2010.
- [69] A. K. Ghosal, *Crystallization of Isotactic Poly(propylenes) with Enhanced Melt Strength*. ProQuest, 2008, pp. 1–269.
- [70] C. Maier and T. Calafut, *Polypropylene: The Definitive User's Guide and Databook*. Taylor & Francis, 2008.
- [71] P. B. Vyas, S. Kaur, H. R. Patil, and V. K. Gupta, "Synthesis of polypropylene with varied microstructure and molecular weights characteristics using supported titanium catalyst system," *J. Polym. Res.*, vol. 18, pp. 235–239, 2011.
- [72] L. A. Utracki, *Commercial Polymer Blends*. Springer Science & Business Media, 2013, pp. 1–658.
- [73] W. D. Callister and D. G. Rethwisch, "Optical Properties," in *Materials Science and Engineering: An Introduction*, 2009, pp. 307–356.
- [74] Fundamental Research Lab, "Workshop electromagnetic and radiation spaces." [Online]. Available: [http://fundamental.art.pl/WORKSHOP\\_ERS.html](http://fundamental.art.pl/WORKSHOP_ERS.html). [Accessed: 28-Jan-2015].
- [75] F. P. Bos, F. Veer, and A. Heidweiller, "Using plastics in the design of joints in transparent structures," *Int. Symp. Appl. Archit. Glas. 2006*, p. 12, 2006.
- [76] K. M. Bernland, "Nucleating and Clarifying Polymers presented by," ETH Zurich, 2010.
- [77] "Chapter 4- Polymer Structures." [Online]. Available: [https://nanohub.org/resources/5548/download/ch04\\_polymers.pdf](https://nanohub.org/resources/5548/download/ch04_polymers.pdf).
- [78] Equistar, "Introduction to Polypropylene." Lyondell Chemical Company, pp. 1–3.
- [79] M. Tenma, N. Mieda, S. Takamatsu, and M. Yamaguchi, "Structure and Properties for Transparent Polypropylene Containing Sorbitol-Based Clarifier," pp. 41–47, 2007.
- [80] M. Kristiansen, M. Werner, T. Tervoort, P. Smith, C.- Zu, M. Blomenhofer, and H. Schmidt, "The Binary System Isotactic Polypropylene / Bis ( 3 , 4-dimethylbenzylidene ) sorbitol : Phase Behavior , Nucleation , and Optical Properties," *Macromolecules*, vol. 36, no. 14, pp. 5150–5156, 2003.

- [81] D. Lukaszewski and T. Hauck, “New Horizons in Clarification and Nucleation of Polyolefins,” 2007.
- [82] M. Tenma and M. Yamaguchi, “Structure and properties of injection-molded polypropylene with sorbitol-based clarifier,” *Polym. Eng. Sci.*, vol. 47, no. 9, pp. 1441–1446, Sep. 2007.
- [83] J. K. D. L. Jiannong Xu, Xiaodong Edward Zhao, Jiang Li, “Blends of polyolefin additive compositions and articles,” EP 1883675 B1, 2005.
- [84] Chrostiki, “New products.” [Online]. Available: <http://www.chrostiki.gr/whatsnew/whatsnew.htm>. [Accessed: 05-Feb-2015].
- [85] J. G. Drobny, *Handbook of Thermoplastic Elastomers*, 2nd ed. Elsevier, 2014.
- [86] “Polymer Molecular Weight,” Indian Academy of Sciences, pp. 43–56.
- [87] R. S. Hoy and M. O. Robbins, “Strain Hardening of Polymer Glasses: Effect of Entanglement Density, Temperature, and Rate,” vol. 44, pp. 3487–3500, 2006.
- [88] D. A. Dillard, “Part D,” in *Physical Properties of Adhesives*, Springer Berlin Heidelberg, 2011, pp. 391–414.
- [89] J. Vlachopoulos and D. Strutt, “The Role of Rheology in Polymer Extrusion.” McMaster University, Hamilton, Ontario, Canada.
- [90] H. C. Lau, S. N. Bhattacharya, and G. J. Field, “Melt strength of polypropylene: Its relevance to thermoforming,” *Polym. Eng. Sci.*, vol. 38, no. 11, pp. 1915–1923, 1998.
- [91] “Injection Moulding.” Reliance Industries Limited, pp. 1–20.
- [92] K. Harutun, *Handbook of Polypropylene and Polypropylene Composites, Revised and Expanded*, 2nd ed. CRC Press, 2003.
- [93] “Blow Moulding.” Reliance Industries Limited, pp. 1–12.
- [94] R. P. Koster, “Designing & Manufacturing with Plastics.” TU Delft, 2014.
- [95] a. D. Gotsis, B. L. F. Zeevenhoven, and C. Tsenoglou, “Effect of long branches on the rheology of polypropylene,” *J. Rheol. (N. Y. N. Y.)*, vol. 48, p. 895, 2004.
- [96] Total, “Bimodal Molecular Weight Polyethylene for Blow Molding.” Total Petrochemicals, Houston, Texas.
- [97] F. Vilaplana and S. Karlsson, “Quality concepts for the improved use of recycled polymeric materials: A review,” *Macromol. Mater. Eng.*, vol. 293, pp. 274–297, 2008.
- [98] S. V. Canevarolo, “Chain scission distribution function for polypropylene degradation during multiple extrusions,” *Polym. Degrad. Stab.*, vol. 70, no. 1, pp. 71–76, 2000.
- [99] H. Hinsken, S. Moss, J.-R. Pauquet, and H. Zweifel, “Degradation of polyolefins during melt processing,” *Polym. Degrad. Stab.*, vol. 34, no. March 1990, pp. 279–293, 1991.

- [100] J. Majumdar, F. Cser, M. C. Jollands, and R. a. Shanks, "Thermal properties of polypropylene post-consumer waste (PP PCW)," *J. Therm. Anal. Calorim.*, vol. 78, no. 3, pp. 849–863, 2004.
- [101] R. C. Portnoy, *Medical Plastics: Degradation Resistance and Failure Analysis*. Cambridge University Press, 1999.
- [102] R. Cai, "Effect of Microwave Heating on The Migration of Additives From PS , PP and PET Container Into Food Simulants," Rochester Institute of Technology, 2013.
- [103] M. G. Sajilata, K. Savitha, R. S. Singhal, and V. R. Kanetkar, "Scalping of flavors in packaged foods," *Compr. Rev. Food Sci. Food Saf.*, vol. 6, pp. 17–35, 2007.
- [104] L. Montagna, M. D. C. Forte, and R. Santana, "Induced Degradation of Polypropylene with an Organic Pro-Degradant Additive," *Mater. Sci. Eng.*, vol. 3, no. 2, pp. 123–131, 2013.
- [105] T. M. Madkour and A. Soldera, "Tacticity induced molecular microstructure dependence of the configurational properties of metallocene-synthesized polypropylenes," *Eur. Polym. J.*, vol. 37, pp. 1105–1113, 2001.
- [106] M. Ezrin, "Trends in Failure of Synthetic Polymers." University of Connecticut, 2014.
- [107] J. D. Peterson, S. Vyazovkin, and C. a. Wight, "Kinetics of the thermal and thermo-oxidative degradation of polystyrene, polyethylene and poly(propylene)," *Macromol. Chem. Phys.*, vol. 202, pp. 775–784, 2001.
- [108] N. Sellin and J. S. D. C. Campos, "Surface composition analysis of PP films treated by corona discharge," *Mater. Res.*, vol. 6, no. 2, pp. 163–166, 2003.
- [109] A. Molldovan, R. Buican, S. Patachia, and M. H. Tieran, "Characterization of polyolefins wastes by FTIR spectroscopy," *Bull. Transilv. Univ. Brasov*, vol. 5, no. 2, 2012.
- [110] "Yellowing and Picking of white PE/PP," *Ampacet*. [Online]. Available: <http://www.ampacet.com/faqs/yellowing-and-pinking-white-pe-pp/>. [Accessed: 28-May-2015].
- [111] M. Gahleitner, J. Wolfschwenger, and J. Fiebig, "Sterilization effect on polypropylene: technology and polymer type effect," in *9th Europlace Conference*, 2003.
- [112] "A Brief Discussion on Color." [Online]. Available: <https://people.chem.umass.edu/samal/269/color.pdf>.
- [113] J. Yu, T. Finnegan, and R. Maier, "Organic Pigments in Polypropylene," 2012.
- [114] J. C. J. Bart, *Polymer Additive Analytics: Industrial Practice and Case Studies*. Firenze University Press, 2006.
- [115] "The Essential Chemical Industry online," 2013. [Online]. Available: <http://www.essentialchemicalindustry.org/chemicals/titanium-dioxide.html>. [Accessed: 17-Jun-2015].
- [116] J. Jose, a. Nag, and G. B. Nando, "Environmental ageing studies of impact modified waste polypropylene," *Iran. Polym. J.*, vol. 23, pp. 619–636, 2014.

- [117] K. Toda and H. Furuse, "Extension of Einstein's viscosity equation to that for concentrated dispersions of solutes and particles.," *J. Biosci. Bioeng.*, vol. 102, no. 6, pp. 524–528, 2006.
- [118] Y. Song, P. M. Mathias, D. Tremblay, and C.-C. Chen, "Liquid Viscosity Model for Polymer Solutions and Mixtures," *Ind. Eng. Chem. Res.*, vol. 42, pp. 2415–2422, 2003.
- [119] C. Tzoganakis, J. Vlachopoulos, a E. Hamielec, and D. M. Shinozaki, "Effect of molecular weight distribution on the rheological and mechanical properties of polypropylene," *Polym. Eng. Sci.*, vol. 29, no. 6, pp. 390–396, 1989.
- [120] European Commission, "Waste Prevention Best Practice Factsheets - Carbon Tax on Packaging (Netherlands)," no. June 2009, p. 1, 2009.
- [121] "afvalfonds," 2015. [Online]. Available: <http://www.afvalfondsverpakkingen.nl/>. [Accessed: 16-Jun-2015].
- [122] "Plasticker," 2015. [Online]. Available: [http://plasticker.de/preise/preise\\_ecebd\\_en.php](http://plasticker.de/preise/preise_ecebd_en.php). [Accessed: 16-Jun-2015].
- [123] eia, "Short-Term Energy Outlook Market Prices and Uncertainty Report," no. June. p. 11, 2015.
- [124] "Plasticker." [Online]. Available: [http://plasticker.de/preise/preise\\_monat\\_single.php](http://plasticker.de/preise/preise_monat_single.php). [Accessed: 16-Jun-2015].
- [125] J. Jansen, "Understanding the Consequence of Ductile-to-Brittle Transitions in a Plastics Materials Failure," *Antec*, pp. 736–742, 2008.
- [126] a. Dutta, "On viscosity - melt flow index relationship," *Rheol. Acta*, vol. 23, pp. 565–569, 1984.
- [127] T. Bremner, D. G. Cook, and a. Rudin, "Further Comments on the Relations between Melt Flow Index Values and Molecular Weight Distributions of Commercial Plastics," *J Appl Polym Sci*, vol. 43, no. 1990, p. 1773, 1991.
- [128] K. C. Seavey, Y. a. Liu, N. P. Khare, T. Bremner, and C.-C. Chen, "Quantifying Relationships among the Molecular Weight Distribution, Non-Newtonian Shear Viscosity, and Melt Index for Linear Polymers," *Ind. Eng. Chem. Res.*, vol. 42, no. 1, pp. 5354–5362, 2003.
- [129] P. Y. Bruice, *Organic Chemistry*, Fifth. Pearson Education, 2007.
- [130] E. Francis, "Nomenclature," 2003. [Online]. Available: <http://dl.clackamas.edu/ch106-02/nomencla1.htm>. [Accessed: 28-May-2015].
- [131] C. L. de Carvalho, A. F. Silveira, and D. D. S. Rosa, "A study of the controlled degradation of polypropylene containing pro-oxidant agents.," *Springerplus*, vol. 2, p. 623, 2013.
- [132] National Institute of Standards and Technology, "Titanium calcium (rutile)," 2011. [Online]. Available: <http://webbook.nist.gov/cgi/cbook.cgi?ID=B6004653&Mask=80>. [Accessed: 16-Jun-2015].
- [133] E. U. Thoden van Velzen, "Technisch haalbare sorteer- rendementen." Wageningen UR Food & Biobased Research, 2014.

- [134] C. 06.2013, “Extrusion & Degassing.” Starlinger, 2013.
- [135] H. M. Da Costa, V. D. Ramos, and M. C. G. Rocha, “Rheological properties of polypropylene during multiple extrusion,” *Polym. Test.*, vol. 24, pp. 86–93, 2005.
- [136] R. R. Hegde, M. G. Kamath, and A. Dahiya, “Polymer Crystallinity.” [Online]. Available: [http://web.utk.edu/~mse/Textiles/Polymer Crystallinity.htm](http://web.utk.edu/~mse/Textiles/Polymer%20Crystallinity.htm). [Accessed: 16-Jun-2015].
- [137] H.-U. Z. Berlin, “Differential scanning calorimetry investigation of polymers,” *HUMBOLDT-UNIVERSITÄT ZU BERLIN*. pp. 1–17, 2011.
- [138] “Characterization of Polymer Spherulites Using Polarized Optical Microscopy.” [Online]. Available: <http://memo.cgu.edu.tw/gwo-mei/%E5%8C%96%E6%9D%90HTM/%E5%AF%A6%E9%A9%97%E5%85%AD%E7%90%83%E6%99%B6%E6%88%90%E9%95%B7%E9%80%9F%E7%8E%87%E5%AF%A6%E9%A9%97.html>. [Accessed: 16-Jun-2015].
- [139] W.-F. Su, “Principles of Polymer Design and Synthesis,” *Extracts*, p. 19, 2013.
- [140] A. Shyichuk and I. Shyichuk, “Macromolecule crosslinking and scission yield determination from sol-gel analysis using a log-log scale method,” *Macromol. Chem. Phys.*, vol. 203, pp. 401–404, 2002.
- [141] “Pantone.” [Online]. Available: <http://www.pantone.com/pages/products/product.aspx?pid=1501&ca=5>. [Accessed: 16-Jun-2015].
- [142] R. H. French, J. M. Rodriguez-Parada, M. K. Yang, R. a. Derryberry, M. F. Lemon, M. J. Brown, C. R. Haeger, S. L. Samuels, E. C. Romano, and R. E. Richardson, “Optical properties of materials for concentrator photovoltaic systems,” *2009 34th IEEE Photovolt. Spec. Conf.*, pp. 000394–000399, Jun. 2009.
- [143] “Optical brighteners,” *Ciba Specialty Chemicals*, vol. 183. Schwarzwaldallee, p. 798, 1999.
- [144] “COMMISSION REGULATION (EC) No 282/2008,” *Official Journal of the European Union*, no. 282. pp. 9–18, 2008.



# 10. Appendices

## 10.1. Material Datasheets

### 10.1.1. Homopolymer Injection Mold

# Polypropylene HJ325MO

#### Description

**HJ325MO** is a polypropylene homopolymer intended for injection moulding. Its very high melt flow makes it especially suitable for thin-wall packaging and products with long flow length. It is designed for high-speed injection moulding and contains nucleating and antistatic additives. The additives are optimized to provide reduced tendency for mould plate-out.

This polymer is a CR (controlled rheology) grade with narrow molecular weight distribution giving low warpage. Components moulded from this grade show good ejectability and combine good stiffness with good transparency and gloss, good antistatic properties and good impact strength at ambient temperatures.

#### Applications

Thin wall containers  
Square containers

Rectangular and flat products, like lids and trays  
Caps and closures

#### Special features

Good stiffness  
Good impact strength

Shows excellent antistatic performance  
Improved gloss and excellent transparency

#### Physical Properties

Property	Typical Value <small>Data should not be used for specification work</small>	Test Method
Density	910 kg/m <sup>3</sup>	ISO 1183
Melt Flow Rate (230 °C/2,16 kg)	50 g/10min	ISO 1133
Tensile Modulus (1 mm/min)	1.650 MPa	ISO 527-2
Tensile Strain at Yield (50 mm/min)	9 %	ISO 527-2
Tensile Stress at Yield (50 mm/min)	35 MPa	ISO 527-2
Heat Deflection Temperature (0,45 N/mm <sup>2</sup> ) <sup>1</sup>	103 °C	ISO 75-2
Charpy Impact Strength, notched (23 °C)	2 kJ/m <sup>2</sup>	ISO 179/1eA
Hardness, Rockwell (R-scale)	101	ISO 2039-2

<sup>1</sup> Measured on injection moulded specimens acc. to ISO 1873-2

#### Processing Techniques

HJ325MO is easy to process with standard injection moulding machines.

Following parameters should be used as guidelines:

Melt temperature	210 - 250 °C	
Holding pressure	200 - 500 bar	Minimum to avoid sink marks.
Mould temperature	10 - 30 °C	
Injection speed	High	

Borealis AG | Wagramerstrasse 17-19 | 1220 Vienna | Austria  
Telephone +43 1 224 00 0 | Fax +43 1 22 400 333  
FN 269858a | CCC Commercial Court of Vienna | Website [www.borealisgroup.com](http://www.borealisgroup.com)



## 10.1.2. Copolymer Injection Mold



# Polypropylene BH345MO

Polypropylene Heterophasic Copolymer for Injection Moulding

### Description

**BH345MO** is a high melt flow heterophasic copolymer (block copolymer) with high impact strength and stiffness. **BH345MO** has additive formulation containing antistatic and nucleating agents allowing fast cycle time even on products with high flow length/narrow wall thickness ratios.

Products moulded from **BH345MO** shows good ejectability and combine very good low temperature, impact strength with good stiffness, good gloss, good antistatic- and excellent organoleptic properties.

### Applications

**BH345MO** is specially designed for fast production of thin wall food packaging containers requiring good low temperature impact properties.

Main application areas are:

- Thin wall containers, pails.
- Frozen food packaging.
- Closures.
- Housewares
- Technical parts

### Physical Properties\*\*

		Typical Value*	Unit	Test Method
Density		904	kg/m <sup>3</sup>	ISO 1183
Melt Flow Rate	(230°C/2.16kg)	45	g/10 min	ISO 1133
Tensile Stress at Yield	(50 mm/min)	26	MPa	ISO 527-2
Tensile Strain at Yield	(50 mm/min)	5	%	ISO 527-2
Tensile Modulus	(1 mm/min)	1400	MPa	ISO 527-2
Charpy Impact Strength, notched	(+23°C)	6.5	kJ/m <sup>2</sup>	ISO 179/1eA
Charpy Impact Strength, notched	(-20°C)	4.0	kJ/m <sup>2</sup>	ISO 179/1eA
Hardness, Rockwell		89	R-scale	ISO 2039-2
Heat Deflection Temperature	(0.45 N/mm <sup>2</sup> )	95	°C	ISO 75-2
Instrumented Falling Weight				
Total Penetration Energy	(0°C)	30	J	ISO 6603-2
Total Penetration Energy	(-20°C)	22	J	ISO 6603-2

\* Data should not be used for specification work

\*\* Mechanical properties determined on injection moulded specimens acc. to ISO 1873-2 (97), based on 7 days conditioning time.

**Borealis A/S**  
Parallevej 16  
DK-2800 Kongens Lyngby (Denmark)  
Telephone: +45 45 96 80 00  
Fax : +45 45 96 81 23  
www.borealisgroup.com



### 10.1.3. Homopolymer Thermoformed



## Polypropylene PPH 4042

Technical data sheet  
Polypropylene – Homopolymer  
Produced in Europe

#### Description

Polypropylene PPH 4042 is a nucleated homopolymer with a Melt Flow Index of 3 g/10min.

Polypropylene PPH 4042 has been developed for extrusion-thermoforming, providing improved rigidity and impact resistance combined with high clarity, reduced cycle times and good antistatic properties.

Polypropylene PPH 4042 is suitable for the injection moulding of technical and household items.

#### Characteristics

	Method	Unit	Typical Value
<b>Rheological properties</b>			
Melt Flow Index 230°C/2.16 kg	ISO 1133	g/10 min	3
<b>Mechanical properties</b>			
Tensile Strength at Yield	ISO 527-2	MPa	35
Elongation at Yield	ISO 527-2	%	9
Tensile modulus	ISO 527-2	MPa	1650
Flexural modulus	ISO 178	MPa	1550
Izod Impact Strength (notched) at 23°C	ISO 180	kJ/m <sup>2</sup>	5.5
Charpy Impact Strength (notched) at 23°C	ISO 179	kJ/m <sup>2</sup>	6.5
Hardness Rockwell - R-scale	ISO 2039-2		93
<b>Thermal properties</b>			
Melting Point	ISO 3146	°C	165
Vicat Softening Point	ISO 306	°C	
50N-50°C per hour			90
10N-50°C per hour			153
Heat Deflection Temperature	ISO 752	°C	
1.80 MPa - 120°C per hour			57
0.45 MPa - 120°C per hour			105
<b>Other physical properties</b>			
Density	ISO 1183	g/cm <sup>3</sup>	0.905
Bulk Density	ISO 1183	g/cm <sup>3</sup>	0.525

#### Handling and storage

Please refer to the safety data sheet (SDS) for handling and storage information. It is advisable to convert the product within one year after delivery provided storage conditions are used as given in the SDS of our product. SDS may be obtained from the website: <http://www.totalrefiningchemicals.com>

Information contained in this publication is true and accurate at the time of publication and to the best of our knowledge. The nominal values stated herein are obtained using laboratory test specimens. Before using one of the products mentioned herein, customers and other users should take all care in determining the suitability of such product for the intended use. Unless specifically indicated, the products mentioned herein are not suitable for applications in the pharmaceutical or medical sector. The Companies within Total Petrochemicals do not accept any liability whatsoever arising from the use of this information or the use, application or processing of any product described herein. No information contained in this publication can be considered as a suggestion to infringe patents. The Companies disclaim any liability that may be claimed for infringement or alleged infringement of patents.



Refining & Chemicals

Total Research & Technology Feluy  
IP & Regulatory Affairs Department  
Regulatory Affairs  
Tel. : +32 (0)64 51 41 04  
Fax.: +32 (0)64 51 41 49  
petrochemicals.felr-regaffairs@total.com

Feluy, 08/05/2013

Ref PPH- 04042-C35046  
DB 2012-3

**POLYPROPYLENE PPH 4042 grade as produced in Europe**

TOTAL PETROCHEMICALS Polypropylene			
Grade:	PPH 4042		
Type:	Homopolymer		
CAS RN:	9003-07-0		
DISCLOSED INGREDIENTS	Unit	Max. Residual Quantity	CAS RN
<b>Processing aid With SML</b>			
N,N- Bis(2-hydroxyethyl) alkyl (C8-C18) amine	ppm	20	PM ref 39090
<b>Additives With SML</b>			
Lithium Benzoate	ppm	650	553-54-8
<b>Dual Additives</b>			
Glycerol monostearate 90%	ppm	2600	31566-31-1

**SML : Specific Migration Limit**

This information is given for the sole purpose of checking the Polypropylene PPH 4042 intended for food packaging applications and specifically the additives which are subject to a Specific Migration Limit in food contact regulations and/or the additives which are listed with restriction in the food regulations 89/107/EC and 88/388/EC.

This disclosure is valid for a period of eighteen months starting from the above-written date and replaces any earlier disclosure which should be considered as null and void. Upon the expiration of this disclosure, we can issue a new one at your request.

Total Research & Technology Feluy

C. RAIMOND  
Regulatory Affairs

F. WYLIN  
Regulatory Affairs, Manager

Issued by an electronic system

1/1

Total Research & Technology Feluy  
Zone Industrielle Feluy C - B-7181 Senefte - Belgique.  
Tel.: +32 (0)64 51 41 11  
Fax.: +32 (0)64 54 08 45  
E-mail: research-feluy@total.com

#### 10.1.4. Random Copolymer Thermoformed (white grade)



PLASTICS

Overakkerstraat 90-92  
4834XN BREDA  
E-mail : info@tcrplastics.eu

PO Box 4617  
4803EP BREDA  
internet: www.tcrplastics.eu

Tel : +31 (0) 76 763 01 76  
Fax : +31 (0) 76 763 01 19

---

## TRACOLEN® PPR211

POLYPROPYLENE RANDOM COPOLYMER

---

**Tracolen® PPR211** is a random copolymer and has been developed for Thermoforming and Blow moulding applications. The material exhibits good transparency and contact clarity, High Stiffness and High Heat distortion temperature.

**Process:** Blow moulding, Sheets, Thermoforming

**Applications include:**

- Blow moulded containers
- Thermoformed containers

---

### Physical properties Tracolen® PPR211

---

Property	Units	Typical value	Test method
Density	g/cm <sup>3</sup>	0.900	ISO 1183
Melt Mass-flow rate (230 °C/2.16 kg)	g/10min	2	ISO 1133
Flexural Modulus	Mpa	1100	ISO 178
Charpy Notched Izod impact strength (23 °C)	kJ/m <sup>2</sup> kJ/m <sup>2</sup>	18 4	ISO 179
Heat Deflection Temp. 66 psi (0.45MPa), Unannealed	°C	86	ISO 75-2/B

---

Technical information contained herein is furnished without charge or obligation, and is given and accepted at recipient's sole risk. Because conditions of use may vary and are beyond our control, TCR Plastics makes no representation about, and is not responsible or liable for the accuracy or reliability of data, nor for toxicological effects or Industrial Hygiene requirements associated with particular uses of any product described herein. Nothing contained in this document shall be considered a recommendation for any use that may infringe patent rights, or an endorsement of any particular material, equipment, service, or other item not supplied by TCR Plastics. The "Properties" and "Applications" listed in this document are not specifications. They are provided as information only and in no way modify, amend, enlarge, or create any specification or warranty, and ALL WARRANTIES, EXPRESS OR IMPLIED, INCLUDING WITHOUT LIMITATION THE WARRANTIES OF MERCHANTABILITY AND FITNESS FOR A PARTICULAR PURPOSE, ARE EXCLUDED.



PLASTICS

Overakkerstraat 90-92  
4834XN BREDA  
E-mail : info@tcrplastics.eu

PO Box 4617  
4803EP BREDA  
internet: www.tcrplastics.eu

Tel : +31 (0) 76 763 01 76  
Fax : +31 (0) 76 763 01 19

---

## TRACOLEN® PPR212

POLYPROPYLENE RANDOM COPOLYMER

---

Tracolen® PPR212 is a random copolymer and has been developed for extrusion applications. The material exhibits high transparency, excellent mechanical properties and good processing.

**Process:** Blown film, Extrusion.

**Applications include:**

- Shrink film
- Specialty film / multilayer components
- Thermoforming
- Extrusion

---

### Physical properties Tracolen® PPR212

Property	Units	Typical value	Test method
Density	g/cm <sup>3</sup>	0.900	ISO 1183
Melt Mass-flow rate (230 °C/2.16 kg)	g/10min	2	ISO 1133
Flexural Modulus	Mpa	900	ISO 178
Charpy Notched Izod impact strength (23 °C)	kJ/m <sup>2</sup>	18	ISO 179

---

Technical information contained herein is furnished without charge or obligation, and is given and accepted at recipient's sole risk. Because conditions of use may vary and are beyond our control, TCR Plastics makes no representation about, and is not responsible or liable for the accuracy or reliability of data, nor for toxicological effects or Industrial Hygiene requirements associated with particular uses of any product described herein. Nothing contained in this document shall be considered a recommendation for any use that may infringe patent rights, or an endorsement of any particular material, equipment, service, or other item not supplied by TCR Plastics. The "Properties" and "Applications" listed in this document are not specifications. They are provided as information only and in no way modify, amend, enlarge, or create any specification or warranty, and ALL WARRANTIES, EXPRESS OR IMPLIED, INCLUDING WITHOUT LIMITATION THE WARRANTIES OF MERCHANTABILITY AND FITNESS FOR A PARTICULAR PURPOSE, ARE EXCLUDED.

## 10.2. Post-Consumer Products Selected for this Study

Table 19: Selected injection mold post-consumer products

Injection mold	
Jumbo salad boxes	
Huzaren salad boxes	
Milbona dessert boxes	

Table 20: Selected thermoformed post-consumer products



Thermoformed	
Bami –microwave boxes	
Vegetable boxes	

Table 21: Selected blow mold post-consumer products



Blow mold

Persil bottle



### 10.3. Cut Offs and Removala from Post-Consumer Products of Reference Method

Table 22: The fractions of the injection mold post-consumer products related to the reference method

Product name	Product	Fraction of material itself	Labels fraction	Contaminant fraction
Jumbo Salades				
Huzaren Salades				
Milbona Dessert				

Table 23: The fractions of the thermoformed post-consumer products related to the reference method.







Product name	Product	Fraction of material itself	Contaminant fraction
<b>Vegetable Boxes</b> (≈Bami boxes)			

Table 24: The fractions of the blow mold post-consumer products related to the reference method

Product name	Product	Fraction of material itself	Contaminant fraction
<b>Persil Bottles</b>			

## 10.4. Equipment

### 10.4.1. Extruder

#### ZSK 18 MEGAlab laboratory extruder

The ZSK 18 MEGAlab laboratory extruder possesses the successful genes of the ZSK MEGAcoumpounder technology and was developed especially for processing of smallest batch sizes. The reliable scale-up to larger ZSK extruders make it the ideal compounding system for formulation development and basic scientific research.



ZSK 18 MEGAlab laboratory extruder

#### Special features

Throughput rates up to 40 kg/h
Small batches of 200 g
Fast plug&play installation and start-up
Reliable, low-noise drive concept
Modular structure with exchangeable 4D barrels and all standard screw elements
Simple operation by PLC controller and touch screen
Simple handling and quick product changes using quick release connections
Compact design – mobile base frame with integrated motor and extruder control system, water cooling and vacuum unit
Reliable scale-up by ZSK MEGAcoumpounder features

#### Technical data

Centerline distance [mm]	15
$D_0/D_1$	1.55
Screw outer diameter $D_3$ [mm]	18
Channel depth [mm]	3.2
Barrel length [mm]	72
Centerline height [mm]	1,100
Nm/shaft [Nm]	38
Power density $Md/a^3$ [Nm/cm <sup>3</sup> ]	11.3
Max. output factor [rpm]	1,200
Motor power [kW]	11.7
Heating power / barrel [W]	800
Main dimensions (L x W x H) [mm]	1,660 x 600 x 1,850

### 10.4.2. BOY 22S Dipronic Set-Up Data Sheets

102224

Mass A.  mm

B61W   
B60W

B11W   
B14W   
B10W   
B111W   
B7W   
B64W

1 2 3 4

1 2 3 4 5 6

°C

B40W	120
B41W	150
B51W	56
B53W	56
B54W	22
B502W	24

210 200 195 180 °C

Hot runner: 210 °C  
Cooling water: 30 °C

N85T N84T N83T N81T

**BOY 22S**  
*dipronic*  
Set-up Data Sheet

Customer		
Article		
Mould		
No. of cavities		
Cycle time	sec.	
Shots per hour	l/h	
Material		
Pre-drying	° F	h
Colour	%	
Shot weight	oz	
Material input	lb/h	
Net partial weight	oz	
Machine no.		
Responsible		

BOY dipronic

## 10.5. Extensive Tables of Characteristic Absorption Bands for Functional Groups in IR Spectrum[129]

Characteristic Infrared Group Frequencies (S = strong, M = medium, W = weak). (Courtesy of N.B. Colthup, Stamford Research Laboratories, American Cyanamid Company, and the editor of the *Journal of the Optical Society*.) Overtone bands are marked  $2\nu$ .

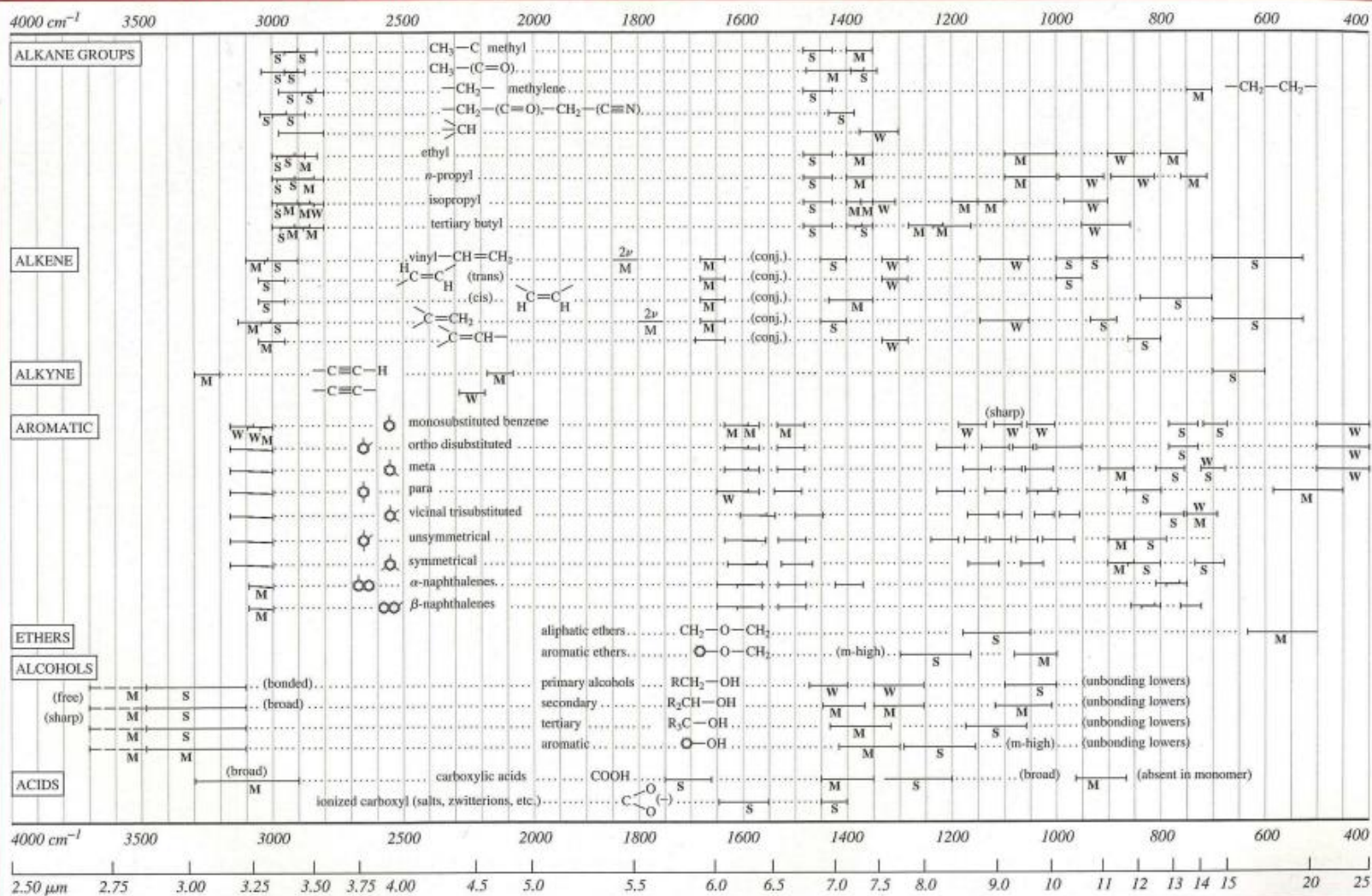

Characteristic Infrared Group Frequencies (continued)

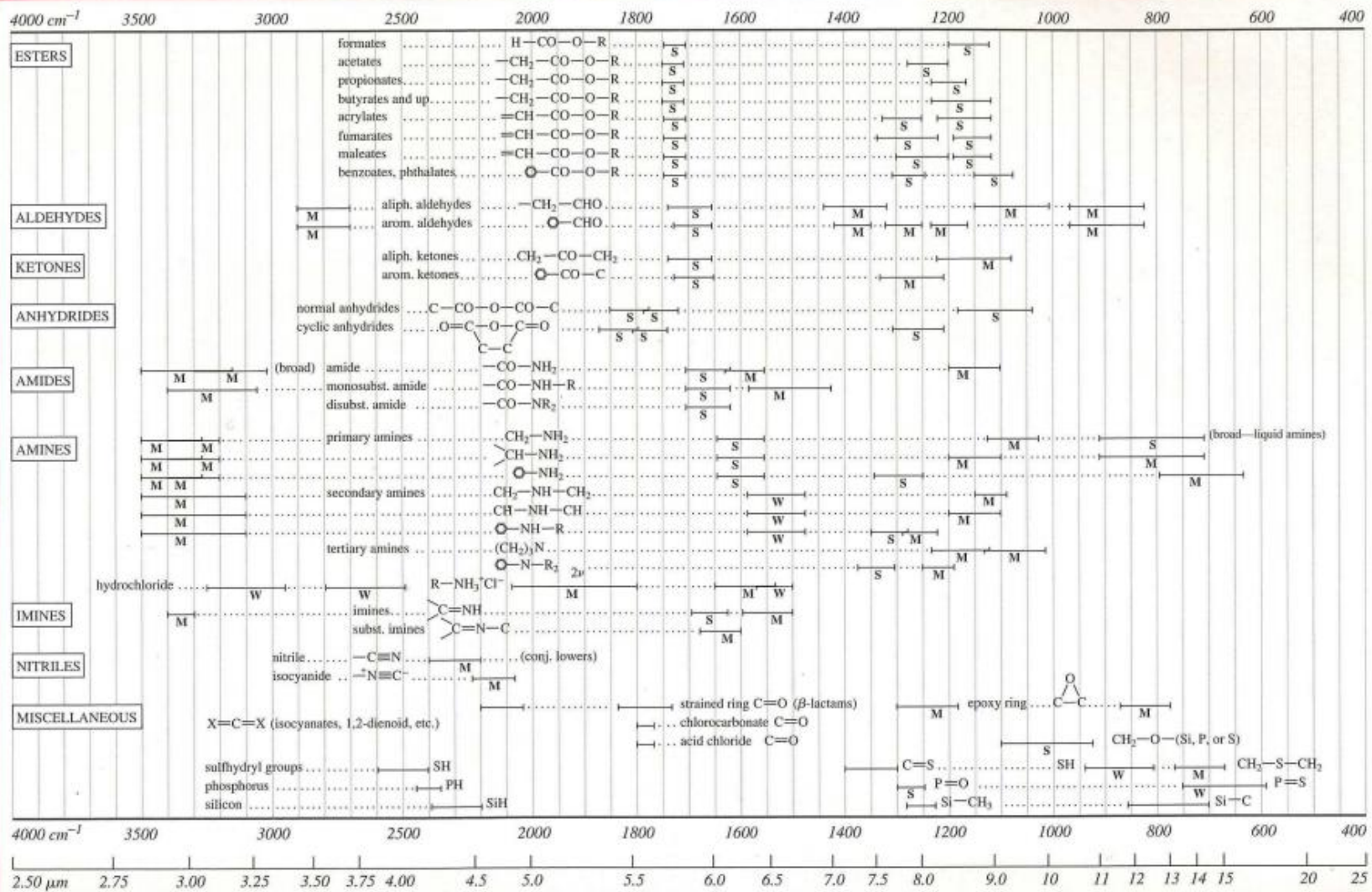

Characteristic Infrared Group Frequencies (continued)

