

Phase 00 - Present situation

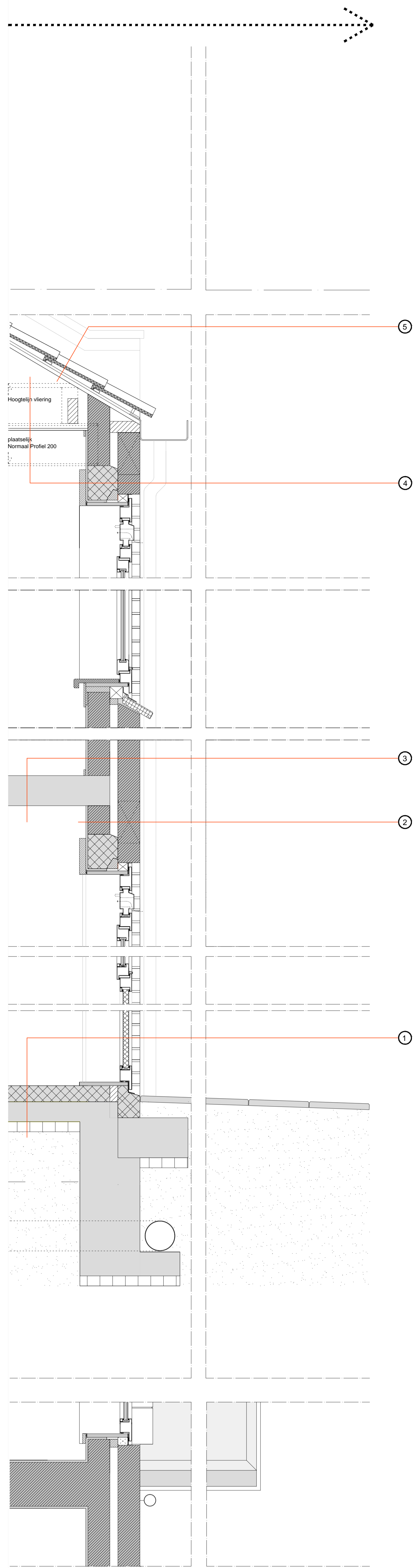

Details present 1:10

Phase 01 - Second skin

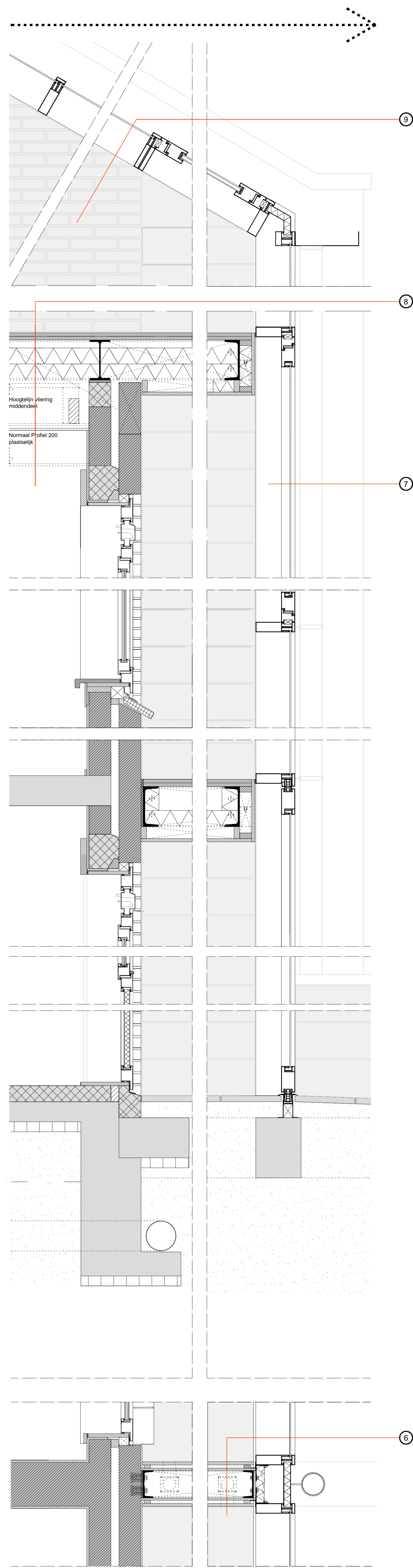

Details phase 01 1:10

Phase 02 - Inbuilt

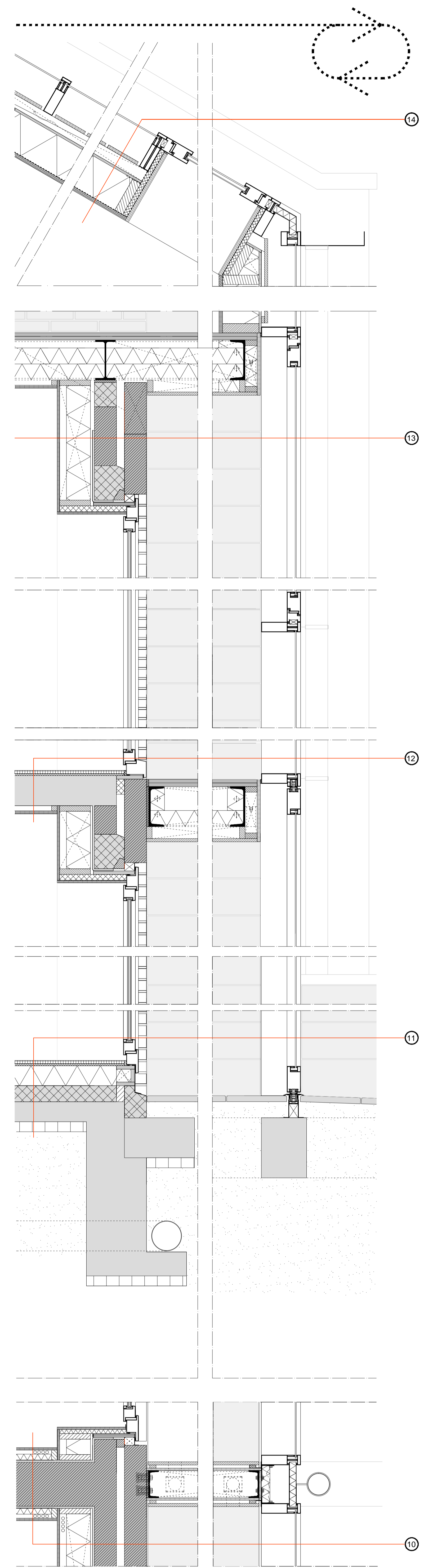

Details phase 02 1:10

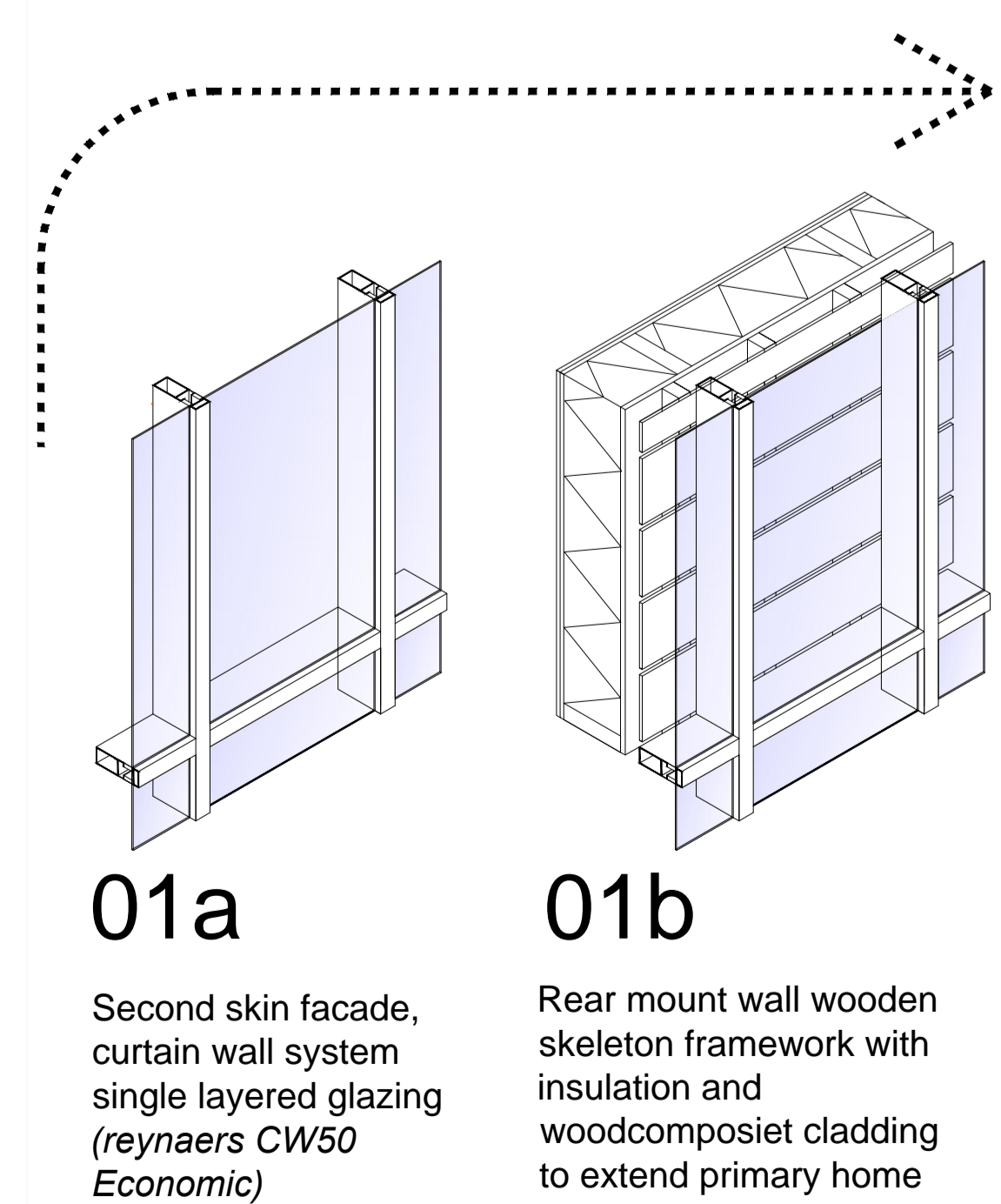

01a

Second skin facade, curtain wall system single layered glazing (reynaers CW50 Economic)

01b

Rear mount wall wooden skeleton framework with insulation and woodcomposit cladding to extend primary home

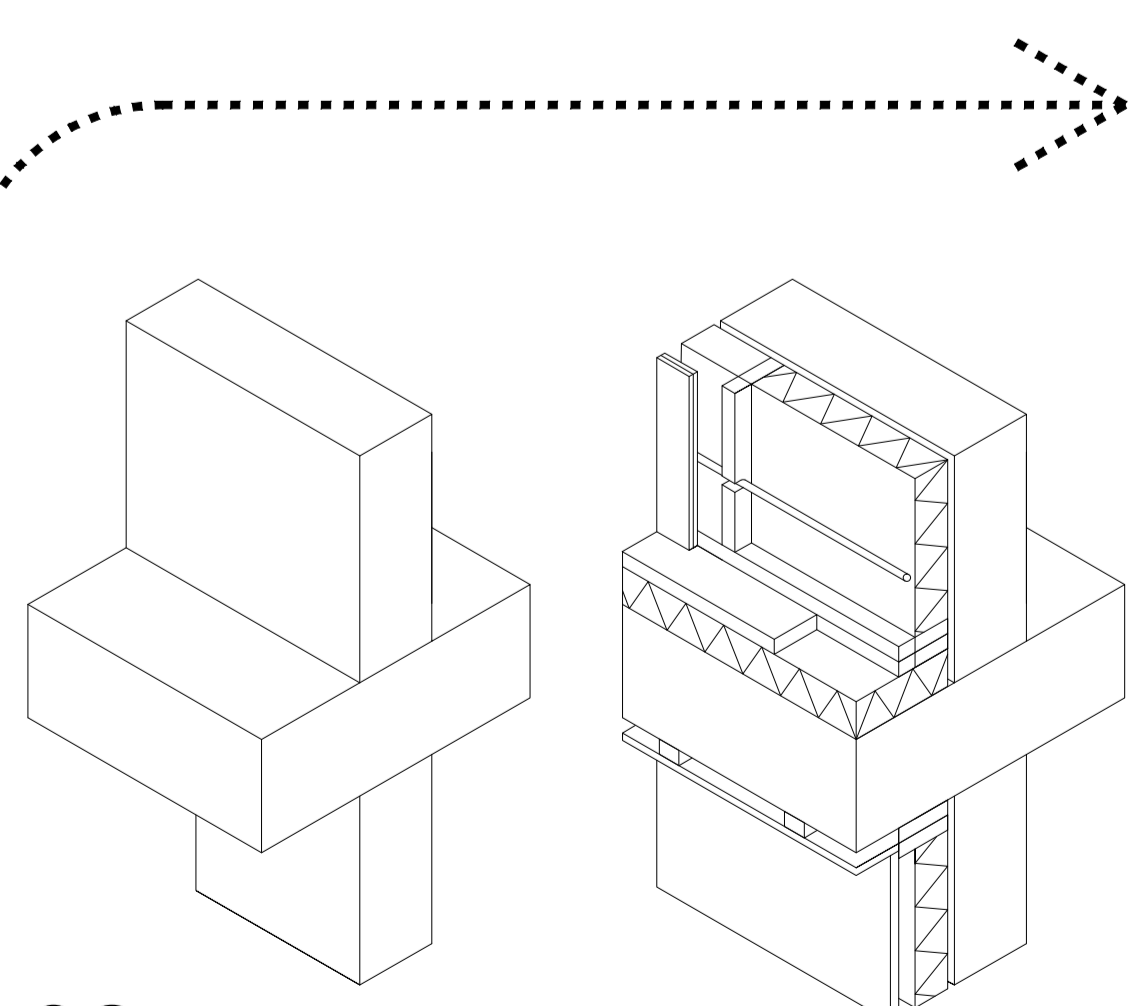

02a

Existing hull, traditional building techniques, combination of stacking and forming building methods, mesanry and concrete in situ

02b

Rear mount walls, hightened floors and lowered ceilings in different thicknesses en insulation type (Aerogel based or PIR) with cavities for pipework

Axonometries principles building technique

⑥	ROOF Existing		
	Roof tile (VH pan blauwgrijs)	12 mm	
	Batten (Panlat)	12 mm	
	Batten (Tengel)	18 mm	
	Roof partition (Dakbeschoot)	18 mm	
	Purlins (gordingen) 80x180	80 mm	
④	FACADE Existing		
	Stucco (Stucwerk)	110 mm	
	Masonry (metselwerk)	110 mm	
	Cavity (luchtsponw)	40 mm	
	Masonry (metselwerk)	110 mm	
③	FLOOR 02 Existing		
	Partition layer (Vloerbeschoot (vliering))	18 mm	
	Beams (vliering) 180x80	180 mm	
	Beams 120x80	(120) mm	
	Plaster on reed (Stuc op riet)	20 mm	
	Normaalprofiel 200 (plaatselijk)	200 mm	
②	FLOOR 01 Existing		
	Reinforced concrete in situ	150 mm	
①	FLOOR 00 BESTAAND		
	Concrete finishing layer	80 mm	
	Reinforced concrete in situ	150 mm	
	Working layer (Werklaag)		
	Soil improvement sand		

⑧	ROOF phase 01		
	Self load bearing aluminium curtain wall system (Reynaers cw50 eco)	190 mm	
	Single layered safety glass	6 mm	
⑦	FACADE phase 01		
	Self load bearing aluminium curtain wall system (Reynaers cw50 eco)	190 mm	
	Single layered safety glass	6 mm	
⑧	FLOOR 02 phase 01		
	Prefab floor addition		
	Steel framework combination	2x 200 mm	
	Finishing layer	16 mm	
	Insulation PUR	200 mm	
	Damp-proof membrane layer (On top of existing floor)		
⑥	SEPERATION WALL phase 1		
	Wood composit panelling	16 mm	
	Battens	16 mm	
	HPL plate (Volkernplaat)	10 mm	
	Steel frame composite wall	160 mm	

⑭	ROOF Phase 02		
	Vliesgevel (phase 01)		
	Solid wood composit panelling	16 mm	
	Battens	50 mm	
	HPL plate (Volkernplaat)	10 mm	
	Insulation PIR	180 mm	
	Damp-proof membrane layer		
	Gipsplaat	12.5 mm	
⑬	FACADE INBUILT Phase 02		
	Existing facade	180 mm	
	Timber frame wall	140 mm	
	Styles and battens	140 mm	
	Insulation PIR	140 mm	
	Damp-proof membrane layer		
	Gypsum	12.5 mm	
⑫	FLOOR 01 INBUILT Phase 02		
	Floating screed floor	16 mm	
	Resilient layer	10 mm	
	Existing floor concrete in situ	200 mm	
	Battens	38 mm	
	Gypsum	12.5 mm	
⑪	FLOOR 00 INBUILT Phase 02		
	Floating screed floor	16 mm	
	Resilient layer	10 mm	
	Insulation PIR	80 mm	
	Existing concrete floor in situ	200 mm	