

7 PROJECTS



## THE INFRASTRUCTURE

Crossing the city the infrastructure engages the built environment in a process of regeneration.

Tired of the life in the city the inhabitants get offered a chance to experience a different way of living. Liberated from the economic constraints production becomes a natural outcome of every living body, unproductivity and laziness cease to exist. Life is a constant stream of activities and labour.

Going against its formal definition the wall loses its divisive property and becomes a unifying tool, bringing together housing blocks, schools, office spaces.

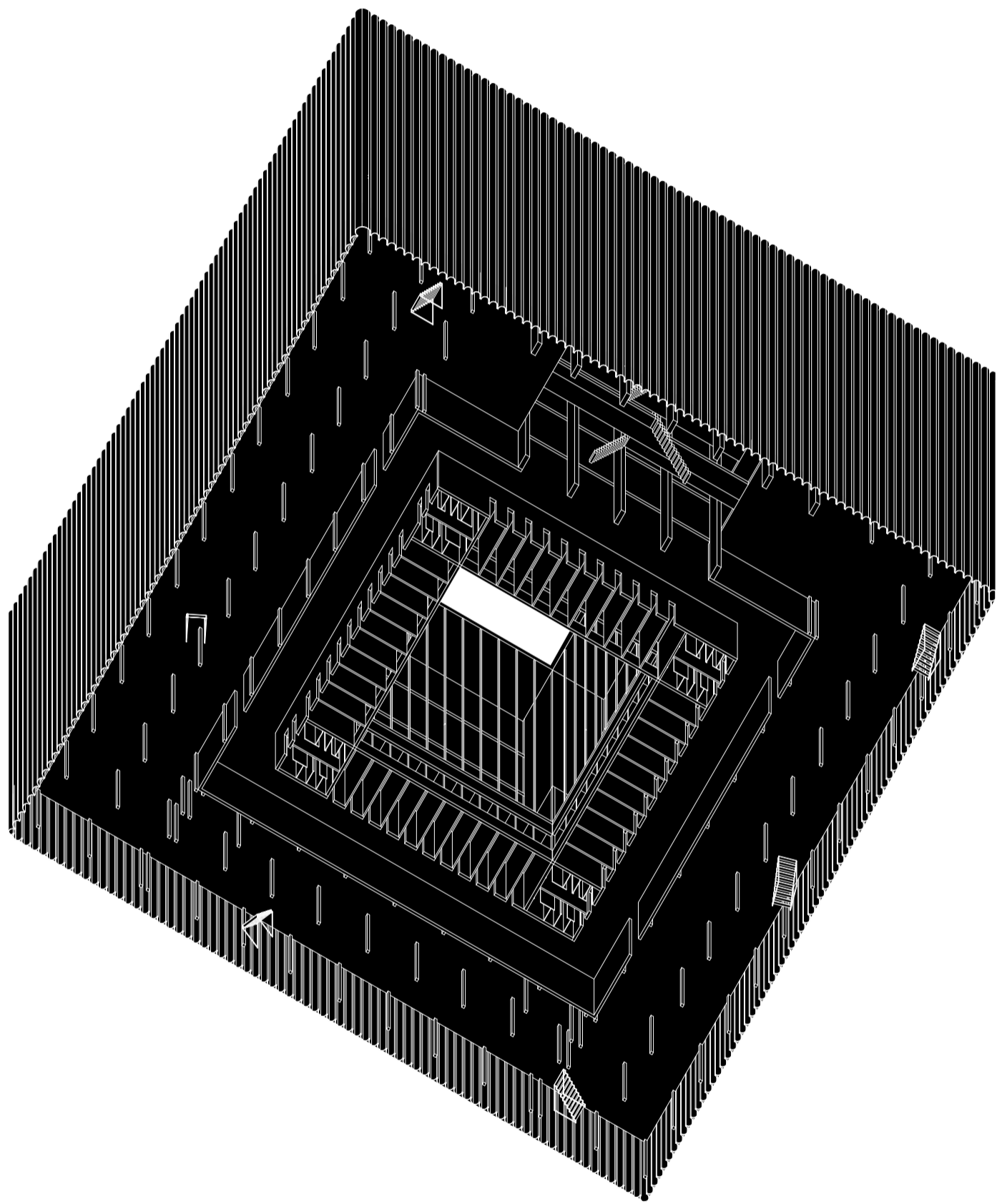

## THE TEMPORARY ARCHIVE

After many ages of stacking pieces after pieces in useless towers of objects the man finally looks back, and finds himself submerged by the amount of information he collected. Finally aware, he walks away to find a new place where to start again, but eventually he realises that everything accumulates and he cannot escape the loop of production. He conceives, then, a space where it is still possible to get lost, to discover without the necessity of classification. In there he stores his knowledge illogically, every piece to be found again and again for no specific reason, in an endless loop. The man wonders, and he becomes wiser. Other men join him, they store their memories, he comes across things he would have never imagined.

The books stacked in illogical sequences slowly travel on conveyor belts, they descend, from top to bottom, eventually reaching the incinerator. Readers continuously move them, they bring them up, they accelerate their journey to the underground, they bring them up again, they stop, they read, they wonder. It is an endless practice, readers stay for days, or weeks. At the end of the day they eventually reach the ground floor and overwhelmed they take a rest in the individual cabins.

Sometimes the archive burns, the incinerator ejecting smoke in the clouds as a signal, but the readers don't try to stop the fire, eventually they stand to watch, and they finally feel liberated.

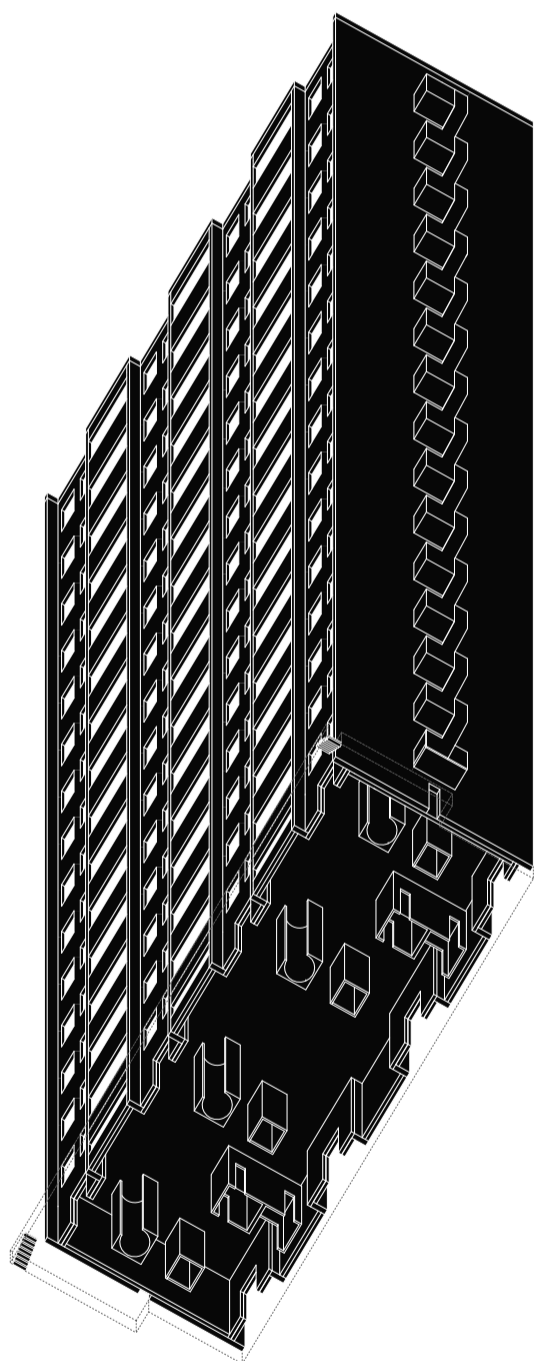
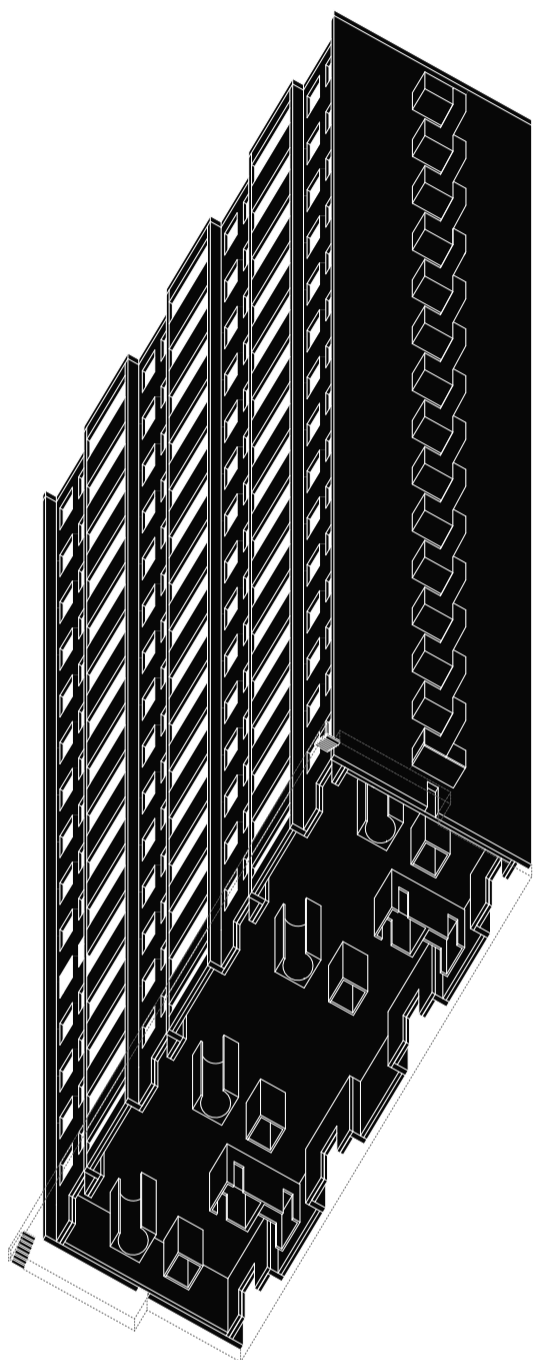

## PERFORMANCE ROOMS

Devoted to the liberation of the performative powers of every human being, the rooms stand as isolated containers. No fee is imposed to attend the show, no requirements to perform. The performers share their experience through many forms: the rooms host concerts, plays, conferences and lectures. The rooms are like pumps that propagate intensity in the polluted sky above the city, the three gigantic boxes are connected by suspended bridges. In the bridges screens cover the walls, the performances are recorded and projected there, sometimes the Performers would stop to watch, gathering around some scattered chairs.

A soft light pervade the space, filtered by the movable curtains. The Performers climb the infinite stairs like a continuous flow, getting lost in the labyrinth of rooms, then finding the way again. They climb as they would climb the Tower of Babel, they're elevated from the ground, their minds like empty fields waiting for inspiration. The artist is between them, but it is no different under the same light of neons.

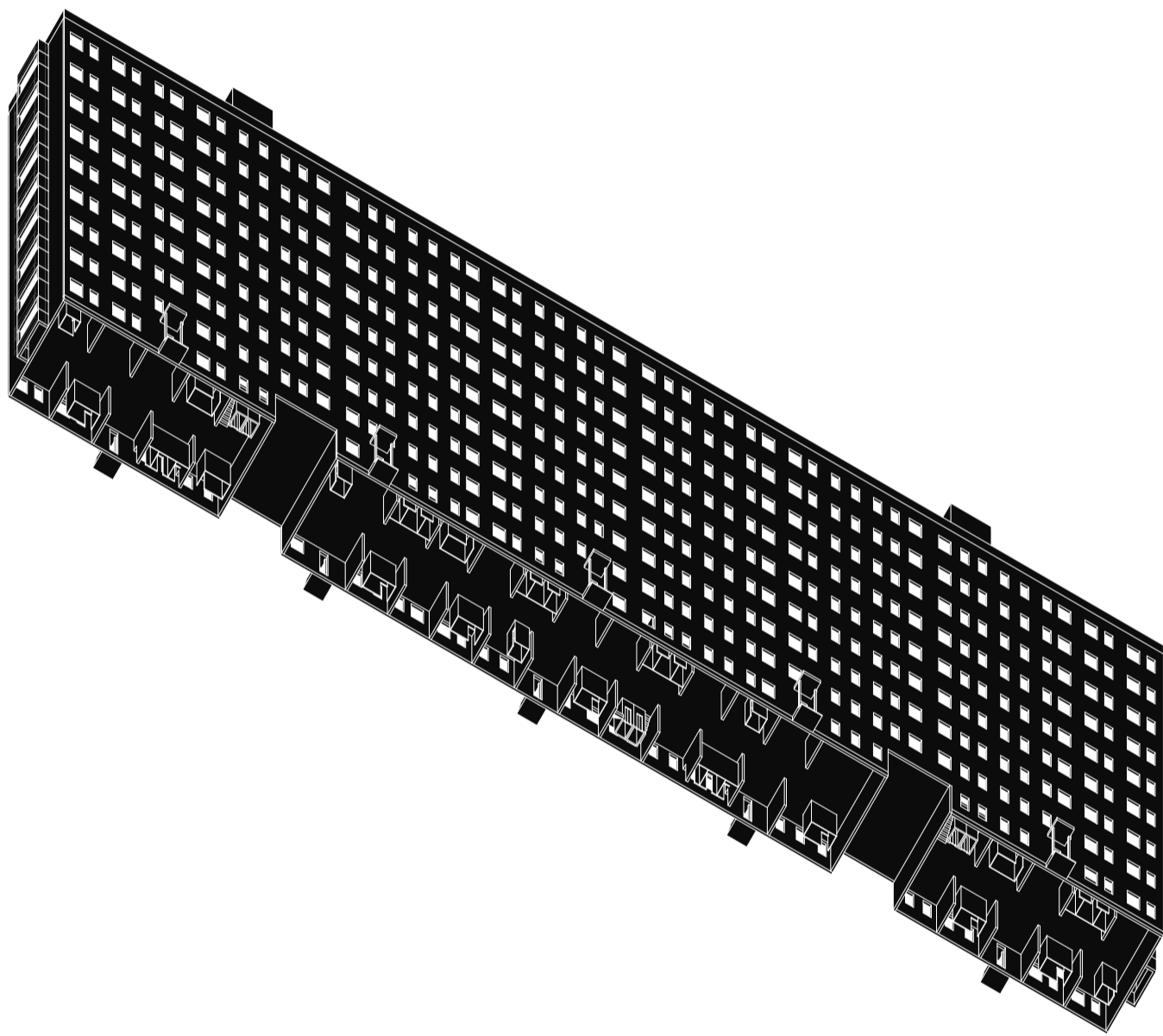

## HOUSING FOR ALL PEOPLE

No division, no compartmentalisation, no private property, no specification. The society deprived of its main hierarchical system, the household. In a land where there is no need to own or to delimit, the house becomes the ultimate collective space, where everyone finally comes together and perform the act of living. Some tell stories, some cook, some read, some talk. The space is finally freed from any specialisation, it coordinates its movements with those of its users. There are no constraints, the space is always different and yet always the same. Only one thing stands still, providing the ultimate place of solitude, where in the deepest silence, the Inhabitants dream about the days to come.

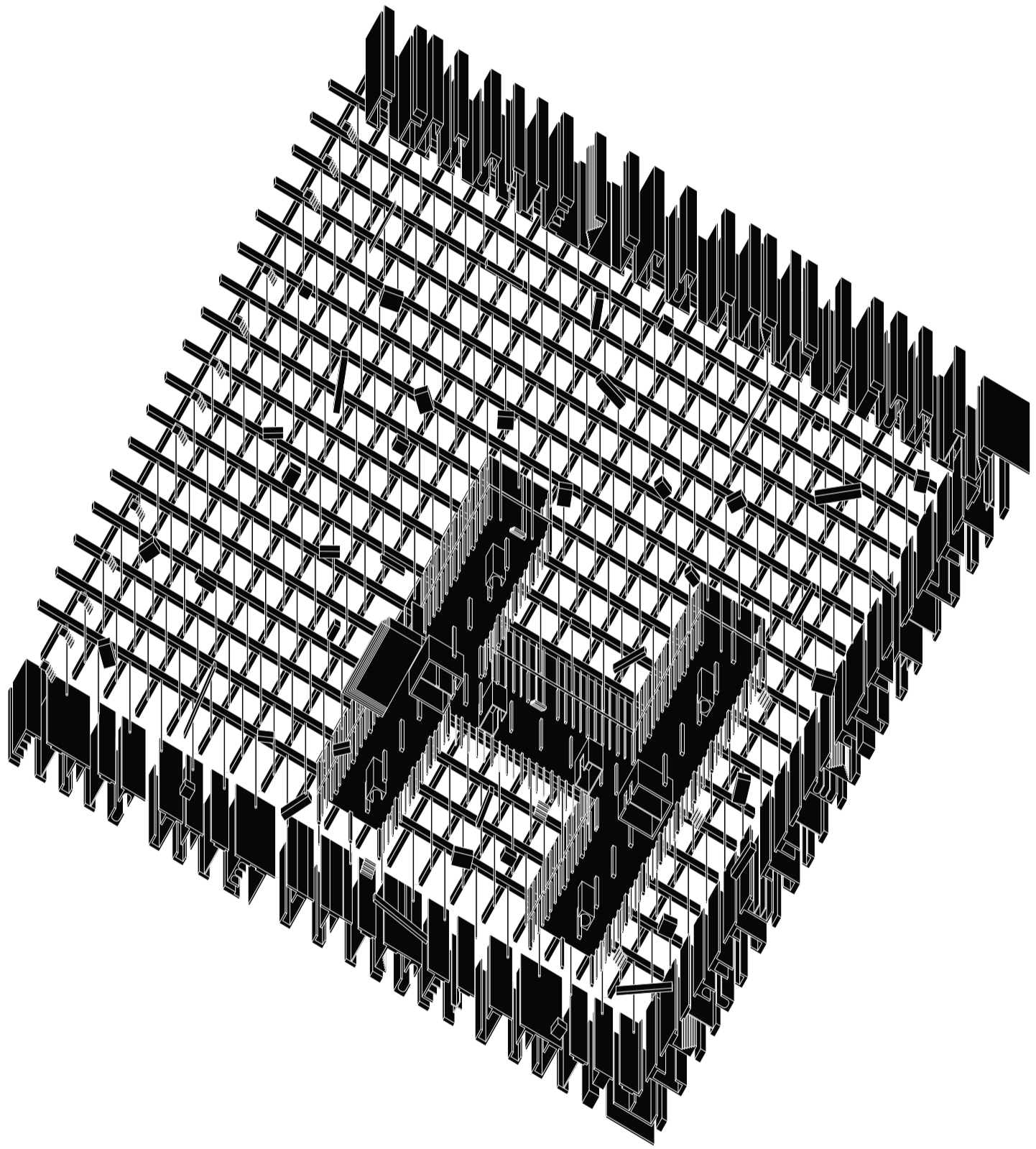

## ART ATELIER

The false academy is not an academy. Coherently to the idea that every body is expressive, art acquires a diverse connotation. Liberated from the need to be valued, every form of expression becomes valuable. Liberated from the label of being an artist the artist just inhabits the academy, becoming a resident, the resident becoming an artist.

A sequence of rooms along the perimeter functions as buffer between inside and outside. In the endless sequence of rooms, niches and doors that bring in the hall or nowhere the entrance is concealed. The visitors go in and out the rooms inevitably getting lost in admiring golden sculptures, paintings and gypsum human bodies. When finally reaching an entrance the endless field of doors receives the visitor and transports him(her) in a parallel dimension, where walls in perpetual motion continuously reconfigure passages and spaces.

Inside the artists move the art objects around, aimlessly trying to fix the exhibition layout. Eventually they give up and let their work flow in all directions, wandering alongside the visitor to find it back. Everyday artists replace objects, there is no fixed collection, tags are white rectangles, pedestals turn into plug-in stations and chairs are scattered around without order. The replaced objects are brought in a procession to the market, but no sadness walks with the artists, the procession is a festive occasion, when they reach the black towers the iron bells start ringing. Inhabitants descend in the market square to take the objects, they will use the gypsum, the canvases, the gold again and again in a endless loop of production and reproduction.

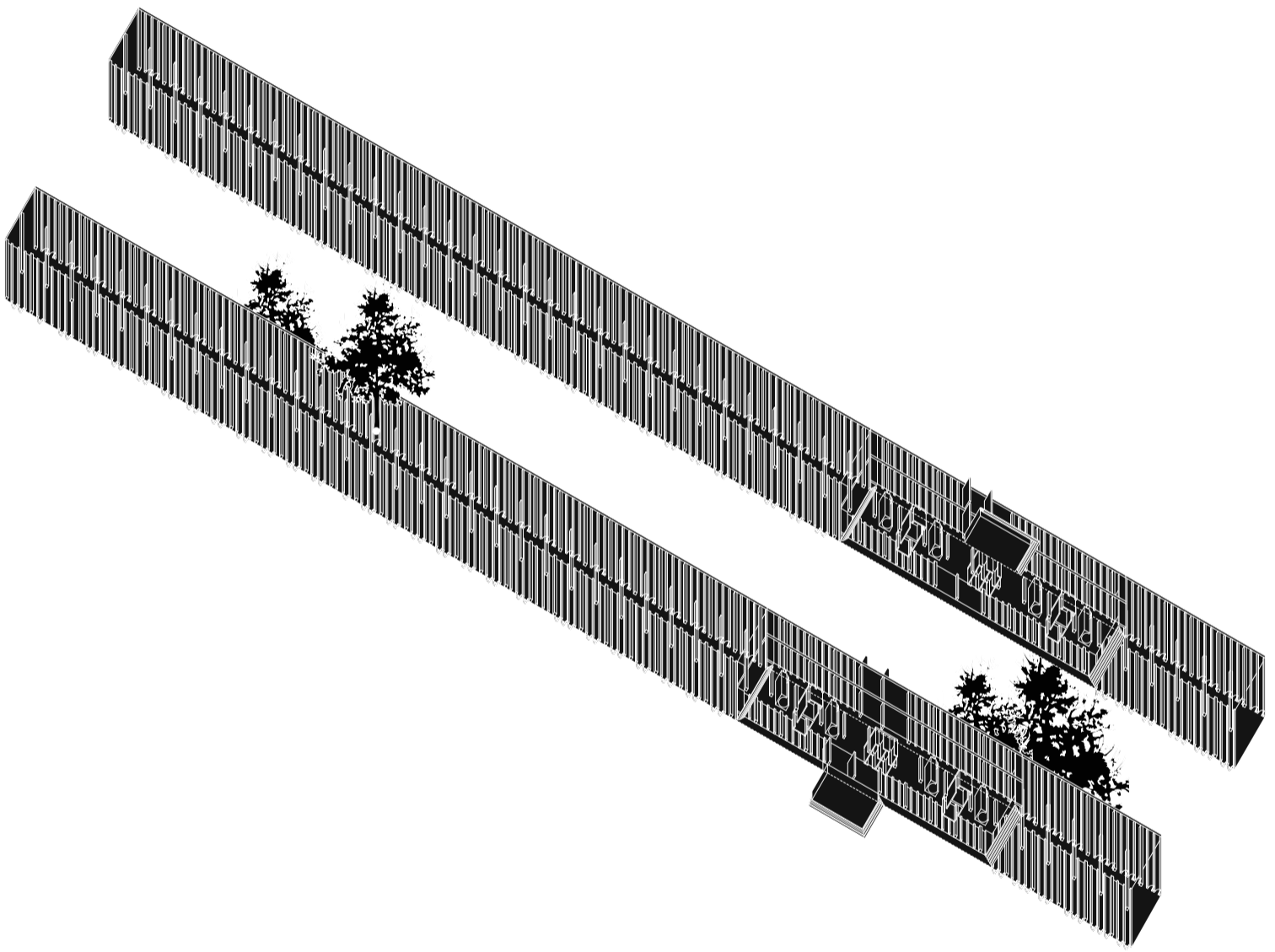

## LABORATORY + MARKET

Covering meters and meters of ground and overlapping with building and bridges the market appears as a land of forgotten debris. Citizens wander between the mountains of objects that grow skyward in the mirror of a natural landscape. All of them wear specific glasses that allow them to spot materials and their state. They wander and often stop to pick up pieces, storing them in the chariot they carry behind. Some of them climb the mountains, producing a metallic sound of broken pieces and waterfalls. Meanwhile in the laboratory the work never stop, citizens are busy with continuous experimentation, they run around the machines like ants building an anthill. The laboratory extends in two wings, directly opening to the market. Almost in the middle, a safe zone is created, here citizens come to sit, but they don't stop working, they compile forms and write reports discussing about their findings. At night the laboratory is open, often citizens would climb off their beds and like sleepwalkers they would reach the machines, struck with a midnight idea that needs to be experimented.

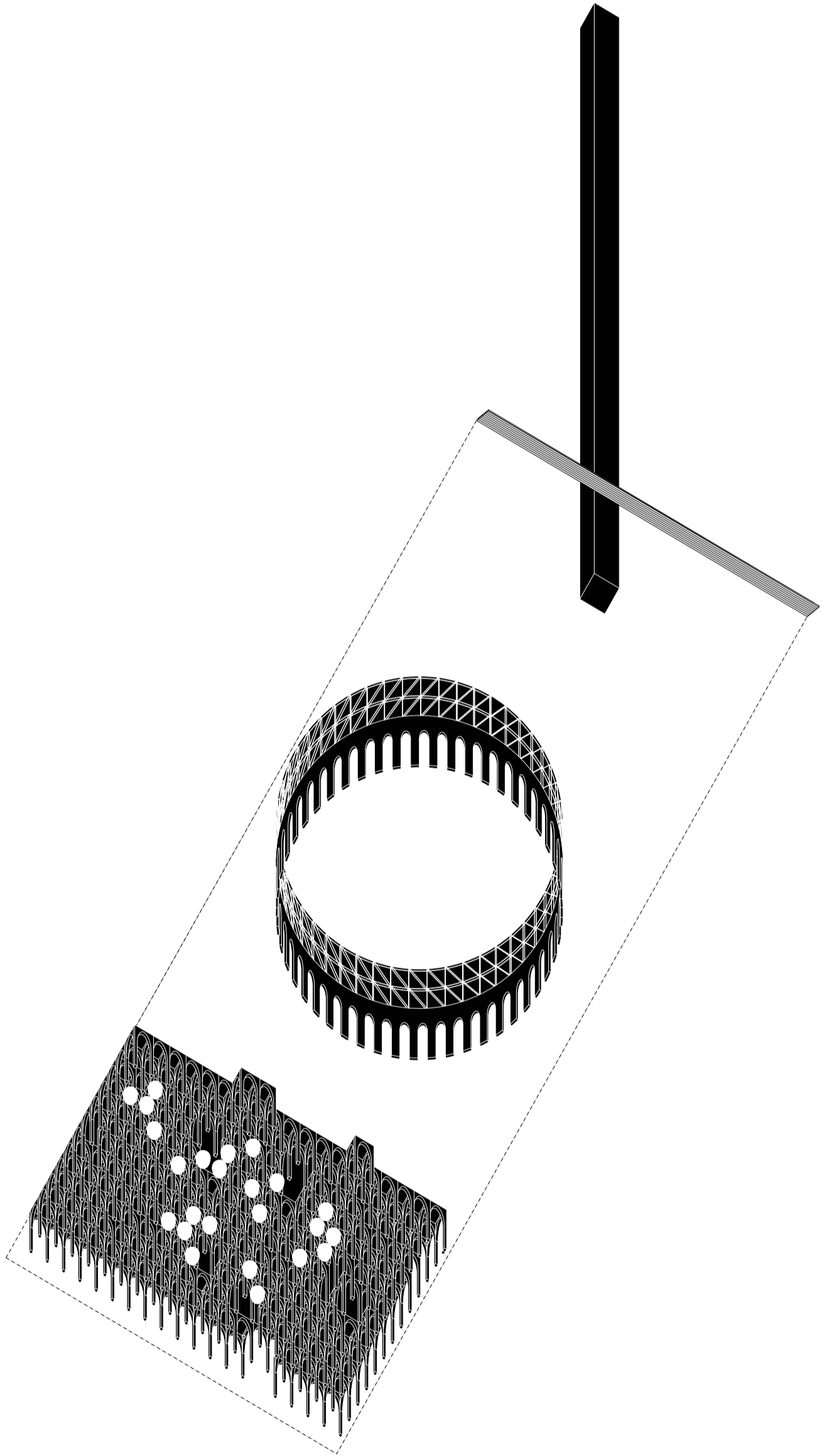

## SOCIAL CLUB

Before everything was created was a concrete plinth, the foundation for something to come. The plinth was two hundred meters long and around fifty meters large. Like an island adrift in the sea it stood still, waiting. One day on the plinth a steel structure was installed, geometric and cold, based on modules of two meters. Only one column stood different, as large as the modules it was cave inside and covered with stairs, outside screens, broadcasting all the news coming from the world. Politic, finance, war, science, biology, philosophy, art. Like the Traiano Column it stood immanent, telling a story about the future.

The Wonderers often stopped to watch, firstly just from the car, creating infinite cues, then the parking came, so they left the car and stood there at the feet of the immense monster, in silence. Always after having been to the Column the Wonderers felt the need to talk about what they had seen, they strived to share and confront themselves, overwhelmed by the amount of information, extremely exciting or terrifying. Unable to find a space large enough to contain them all, they decided to build their own. Excavating the concrete in the middle of the plinth they created a rudimental amphitheatre, high steps on the sides and a large platform in the centre. The Wonderers talked and discussed for days and years. Always, after gathering, they felt the need to retire in silence and reflect on what had been said. But there was no place quite as that.

One day, on the left side of the plinth, opposite to the column, they built the Cathedral, using the steel structure as the main structure they excavated the concrete creating an infinite amount of rounded holes in the ground, like primitive huts, in a forest of columns. There they stood to take decisions, each one alone but aware of the presence of others. The Wonderers would shake hands descending the stairs, promising to come back the following day. There were decisions to be taken, they had to build parks, archives, rooms, and bridges.

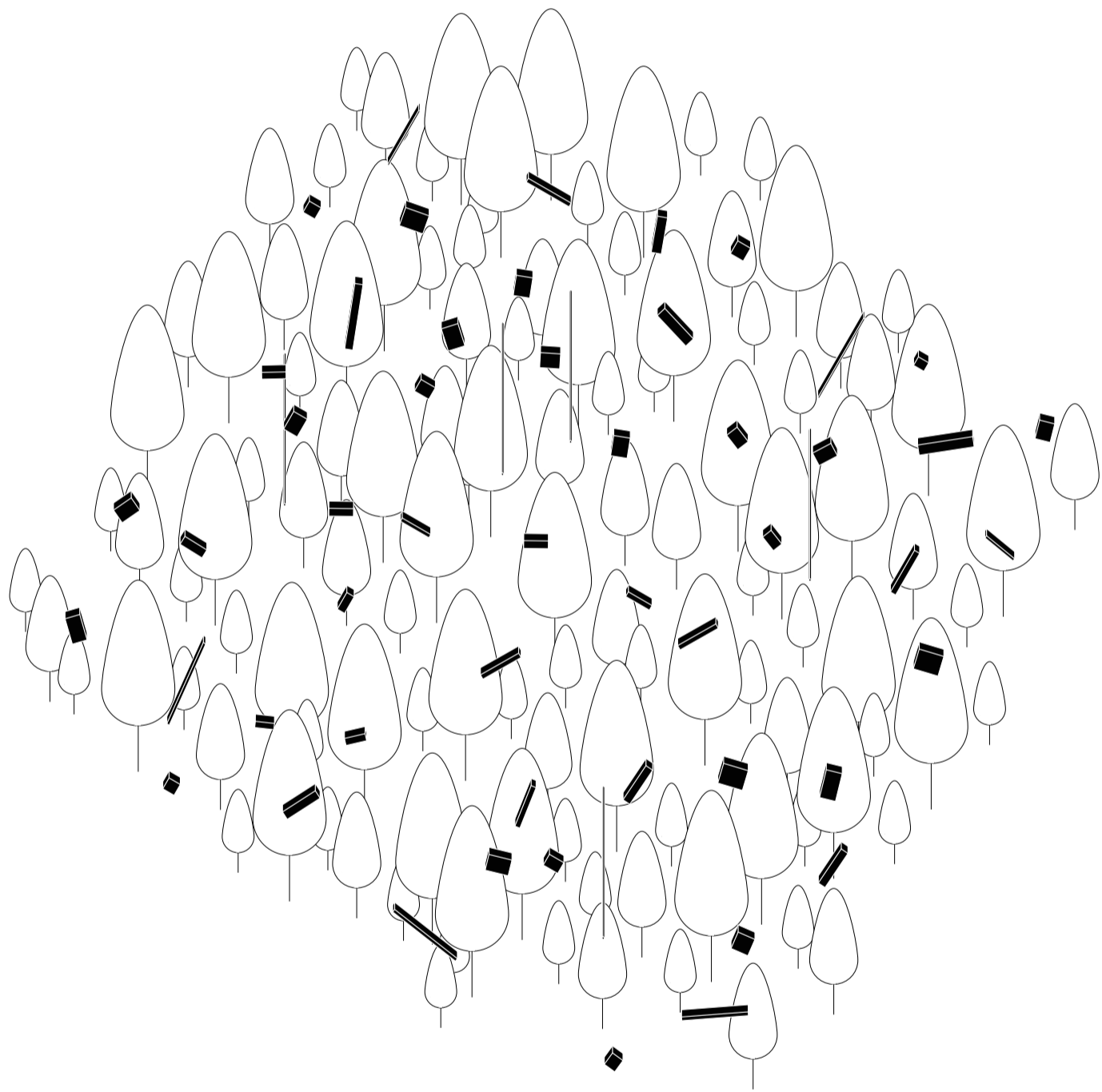

## WINTER GARDEN

Apparently untouched lays on the ground an infinite field of vegetation. Massive aeration conducts maintain the temperature at the ideal level for the field ecosystem. Along the paths incandescent tubes warm the surrounding air in the colder days. Like classical statues, hidden in the grass, are the remains of the existing utilitarian structures, silent witnesses of their transformation. At a closer look, the existing ruins are punctuated with white obelisks, plugs that allow ubiquitous connections. Wifi signal materialises into the cables of the irrigation system that descends from the suspended bridges. An old man plant crops in a corner on the notes of Dimitri Shostakovich Jazz Suite No. 2.

