

DESIGN OF AN UNMANNED AERIAL VEHICLE LOADING SYSTEM

FOR HUMANITARIAN AID OPERATIONS

Max Weetzel

Master thesis

Integrated product design

Delft University of Technology

March 2020



VANBERLO

Part of **Accenture Industry X.0**



REACHING PEOPLE ANYWHERE

▶ TABLE OF CONTENTS

<i>EXECUTIVE SUMMARY</i>	4	<i>DESIGN DIRECTION</i>	42
<i>UAV LOADING SOLUTION</i>	5	<i>CONCEPT DIRECTION</i>	44
<i>INTRODUCTION</i>	6	<i>CONCEPTS</i>	45
<i>CONTEXT</i>	8	<i>EMBODIMENT</i>	50
<i>ASSIGNMENT</i>	9	<i>LOADING CART</i>	52
<i>ANALYSIS METHOD</i>	10	<i>ALIGNMENT SYSTEM</i>	56
<i>EXPERTS & ADVISORS</i>	11	<i>CONFIGURATION CREATION STATION</i>	60
<i>UNDERSTANDING HUMANITARIAN AID OPERATIONS</i>	14	<i>OVERALL PROCESS</i>	62
<i>KEY PERFORMANCE INDICATORS</i>	19	<i>VALIDATION</i>	64
<i>CONSTRUCTING THE FORWARD OPERATING BASE</i>	20	<i>PROTOTYPING</i>	66
<i>UNDERSTANDING THE WINGS FOR AID CONCEPT</i>	22	<i>USER TEST</i>	68
<i>ELEMENTS OF THE FOB</i>	24	<i>VALIDATION CONCLUSION</i>	74
<i>STATISTICS OF AN EFFICIENT FOB</i>	26	<i>CONCLUSIONS</i>	76
<i>PROJECT DIRECTION</i>	28	<i>RECOMMENDATIONS</i>	79
<i>DECONSTRUCTING THE LOADING OPERATION</i>	30	<i>REFLECTION</i>	81
<i>CURRENT LOADING OPERATION OBSERVATIONS</i>	32	<i>ACKNOWLEDGEMENTS</i>	82
<i>DESIGN BRIEF</i>	36	<i>REFERENCES</i>	84
<i>IDEATION</i>	40	<i>APPENDICES</i>	86



Figure 1 : Test platform for performing drop tests

▶ EXECUTIVE SUMMARY

HUMANITARIAN AID

In the aftermath of a disaster, Humanitarian Aid Organizations (HAO) must operate in highly uncertain and complex contexts in order to provide the lifesaving aid to the people in need. However, the systems currently available to them are limiting the aid logistics. Affordable options are not well suited for the devastated environment and the ones that are, come with a high cost.

It is estimated a record number of 168 million people will need humanitarian aid in 2020 (Dyer, 2019). This concerns about 1 out of 45 people on earth. (Dyer, 2019). And these number are expected to keep rising (Dyer, 2019).

The novel Wings For Aid concept could drastically improve this. However, although there are already first prototype systems, the initial operation must still take shape. This overall operation is a crucial part in tying all its components together in an efficient and viable system. The more the overall operation, the processes and products within are optimized, the more lives can be saved faster, with lower costs and lower risks.

ANALYSIS

In this project, based on the identified Key Performance Indicators of current HAO's, a potential future vision of the WFA and Forward Operating Base (FOB) operation was created. After this, statistics were found for a future operation, as well as a future context to design within, through modelling the operation. This showed its viability to be promising. The WFA concept can deliver high amounts of cargo directly to the people in need, for competing cost with the currently used systems.

In 2020, nearly 168 million people over 53 countries will need humanitarian assistance and protection

DESIGN DIRECTION

Although many elements of the complex WFA FOB operation need to be elaborated upon, the project continued by focusing on the Unmanned Aerial Vehicle (UAV) loading process. This is a crucial step in the operation in order to deliver the correct aid to the correct locations. Furthermore, it is the most WFA specific step within the FOB operation and offered many design opportunities and relevance within the overall WFA system development.

Through observations of the current loading process used during tests, several design opportunities were identified for the creation of a novel system. Altogether, the research led to the following design brief:

Create a loading system for the FOB with low risk and low operational costs

PROPOSED SOLUTION

The proposed system provides a novel solution to load the WFA UAV in the required cargo box configuration. It consists of both the required functional product systems as well as the integrated process.

This solution is expected to fit the overall FOB operation very well, as it fits in the required throughput time, can be used in harsh conditions and is highly versatile. The system reduces the risks of incorrect UAV loading, which could have devastating effects. Furthermore, its simplistic, yet optimized construction minimizes the system, maintenance and transport costs. Finally, the foolproof usage allows only two minimally trained local workers to perform this process with minimal errors, highly reducing the operational costs.

In order to validate the proposal, several prototypes were created, followed by a user test to evaluate the product usability. This confirmed the functioning of the system and its intended use, proving it to be a promising solution.

UAV LOADING SOLUTION

FOR HUMANITARIAN AID OPERATIONS

- » LOW OPERATIONAL COSTS
- » MINIMIZES SIGNIFICANT RISKS
- » SUITED FOR FUTURE OPERATIONS



*BOX CONFIGURATION
CREATION STATION*

Prepare trolley with cargo boxes of specific content



LOADING TROLLEY

Transport cargo boxes towards UAV over any terrain

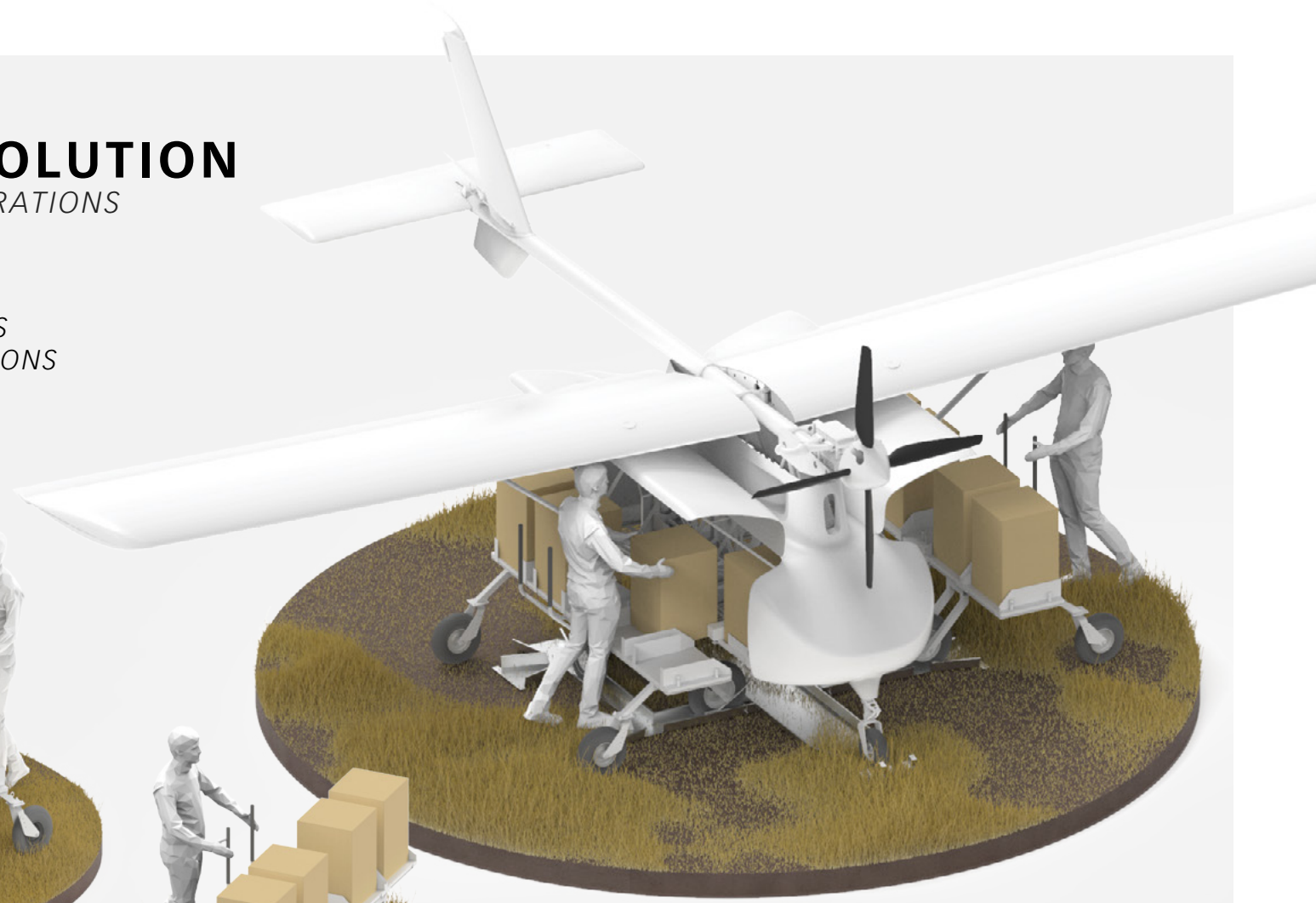

UAV ALIGNMENT SYSTEM

Aligns loading cart to load the cargo boxes into the UAV, without any lifting.

▶ INTRODUCTION

HAITI 2010

On Tuesday January 12th 2010, Haiti was hit by an earthquake of magnitude 7.0, just 17km southwest of its capital Port-au-Prince (Government of Haiti, 2010). Around 1,5 million people were directly affected, leaving 316.000 dead or missing and 300.000 injured (Government of Haiti, 2010).

Directly after the disaster, the survivors were in urgent need of water, food and medicine (Goyet, Sarmiento, & Grünwald, 2011). The problem, however, was getting all this relief aid to the actual people in need, as Haiti's infrastructure was destroyed. Using the main port was not possible anymore and the damaged small airport could not cope with all flights arriving (Goyet, Sarmiento, & Grünwald, 2011). And even when it arrived, the cargo was still only at one spot. Lack of transport and fuel made further distribution to the victims difficult (Goyet, Sarmiento, & Grünwald, 2011) and failing power systems hindered all communication efforts (Richard Pallardy, 2010). Transportation by truck was problematic due to the many damaged or obstructed roads, and plunder risks from the desperate people in need (Goyet, Sarmiento, & Grünwald, 2011).

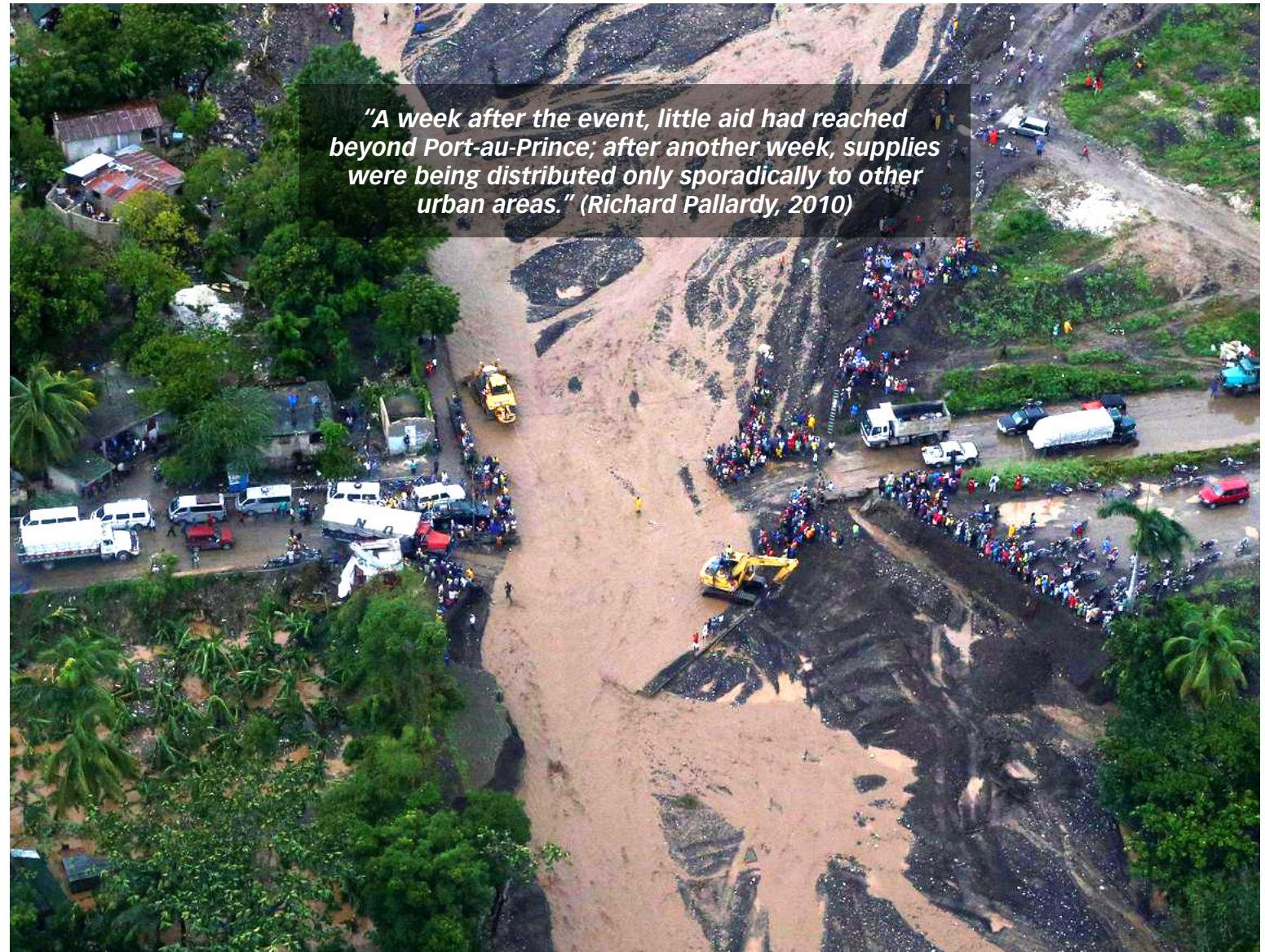

"A week after the event, little aid had reached beyond Port-au-Prince; after another week, supplies were being distributed only sporadically to other urban areas." (Richard Pallardy, 2010)

Figure 2 : Haitiens are cut off by a broken bridge (Reuters, 2016)

► INTRODUCTION

A NOVEL SOLUTION

Wings For Aid is a young consortium solving this problem. Their goal is to create a system able to deliver goods across 'the last mile', making it possible to provide the aid directly where it is needed.

The concept is to create temporary airfield(s), called a forward operating base (FOB), just outside the affected area, from which a swarm of Unmanned Aerial Vehicles (UAVs) fly to the locations in need, unhindered by the ground conditions. Without landing, the aid is dropped in cost-effective and sustainable cargo boxes. After the cargo arrives safely on the ground, relief workers distribute the goods to the people in need.



Figure 3 : Wings For Aid concept sketch (VanBerlo, 2019)

► CONTEXT

WINGS FOR AID

The main client of the project is Wings For Aid; a consortium with the ambition to set a new standard of simplicity in humanitarian aid logistics. This collaboration of industry, universities and humanitarian organizations provides all the necessities to develop the optimal solution to the difficult 'last mile' of relief operations.

After several years of initial research and development, major milestones were achieved from 2018 onwards.

WFA has already gone through many cargo box iterations followed by a pilot in the Dominican Republic in 2018. Their first manned aircraft prototype was realized only several months ago. Now, the first unmanned prototype is almost completed. This will allow for the first demonstrations and pilots in the nearby future.

www.wingsforaid.org

VANBERLO

The project was executed at VanBerlo. It is the head of design within the consortium and support the development of the UAV (cargo bay) design and overall operations. VanBerlo is a renowned design studio with about 100 multidisciplinary experts, and has worked on numerous of projects in the areas of design engineering, UX, digital transformation, strategic design and more.

www.vanberloagency.com

PROJECT CONTRIBUTION

The project is currently focused on the development of the UAV prototypes and the cargo boxes. First proofs of concept have been created to show the feasibility and test the desirability of the core concept.

However, these two products cannot provide a viable relief operation on their own. In order to do this, a complete operation must be set up around it. This must be tailored to the correct context and be equipped with the correct processes and products. Only through this, the full potential of this innovative delivery UAV can be utilized. The more efficient this operation becomes, the more lives can be saved, faster and cheaper.

In this project a desirable future operation is identified and analyzed. This overview provided a starting point to find key aspects to prioritize. Through this, an opportunity was found in the UAV loading operation, resulting in a validated loading system concept for initial operations.

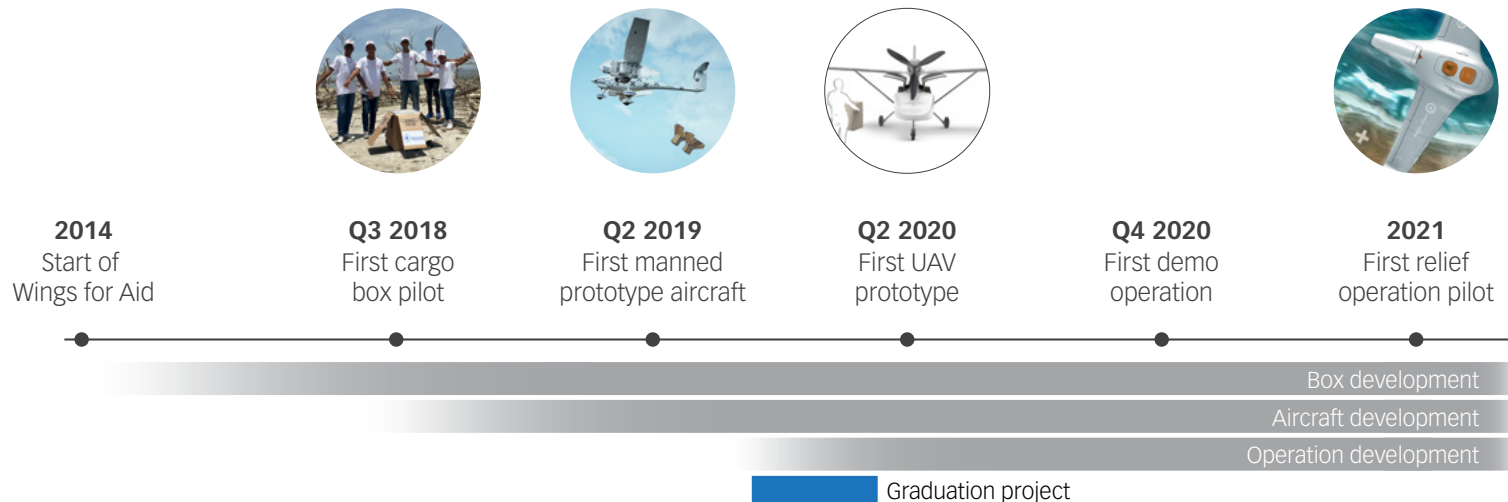

Figure 4 : Timeline of Wings For Aid developments

► ASSIGNMENT

DESIGN BRIEF

The original project brief was formulated as:

Design of an Unmanned Aerial Vehicle product ecosystem for humanitarian aid operations

This concerned a broad subject in which the overall humanitarian systems and the Wings For Aid eco system were analysed. Afterwards, in order to converge to a more concrete design brief with an integrated product design aim, the UAV loading process within this whole operation was focussed on, as explained in chapter 'Design Direction'. This allowed for design implementations on a product level. The design should be usable for the upcoming UAV. The initial project brief led to the following design brief:

Create a loading system for the FOB with low risk and low operational costs

The full initial design brief can be found in Appendix A.

SCOPE

The project is focussed on the so-called forward operating base (FOB), the main part of the WFA operation, and its product ecosystem within it. The goal is to define this context and identify a design engineering opportunity for this future context. Within this opportunity a solution can be created. This provides a futureproof direction and an initial (sub)solution ready for iteration and integration within the company's process.

Humanitarian aid operation can provide relief in all kinds of situations. The three main distinctions are based on; the cause (natural or man-made), the abruptness (slow or sudden onset) and the scale. The scope of this project was large scale sudden onset natural disasters, such as earthquakes or cyclones.

The systems currently already tackled within the consortium are out of the design synthesis scope. This includes the UAV and its cargo bay design and the technical box design, except for the relevant interfaces with related systems and non technical changes, such as graphics.



Figure 5 : Overview of questions throughout the different scope of the project

► ANALYSIS METHOD

DOUBLE VISION IN PRODUCT

During the analysis phase of the project, the Vision in Product (ViP) framework was used. This is a context-driven and interaction-centered approach to design for future possibilities, not just to solve present-day problems. It starts by deconstructing the status quo, then a new desired context is created, for which fitting interactions and products can be designed.

This project follows the ViP process twice. First to create the future forward operating base within the context of the WFA concept, through deconstructing present-day relief operations. This then determined the focus of the second ViP process, which was used to deconstruct the current WFA prototype loading interactions, in order to create a novel loading system for the envisioned WFA operation.

Figure 6 provides a schematic overview of this process.

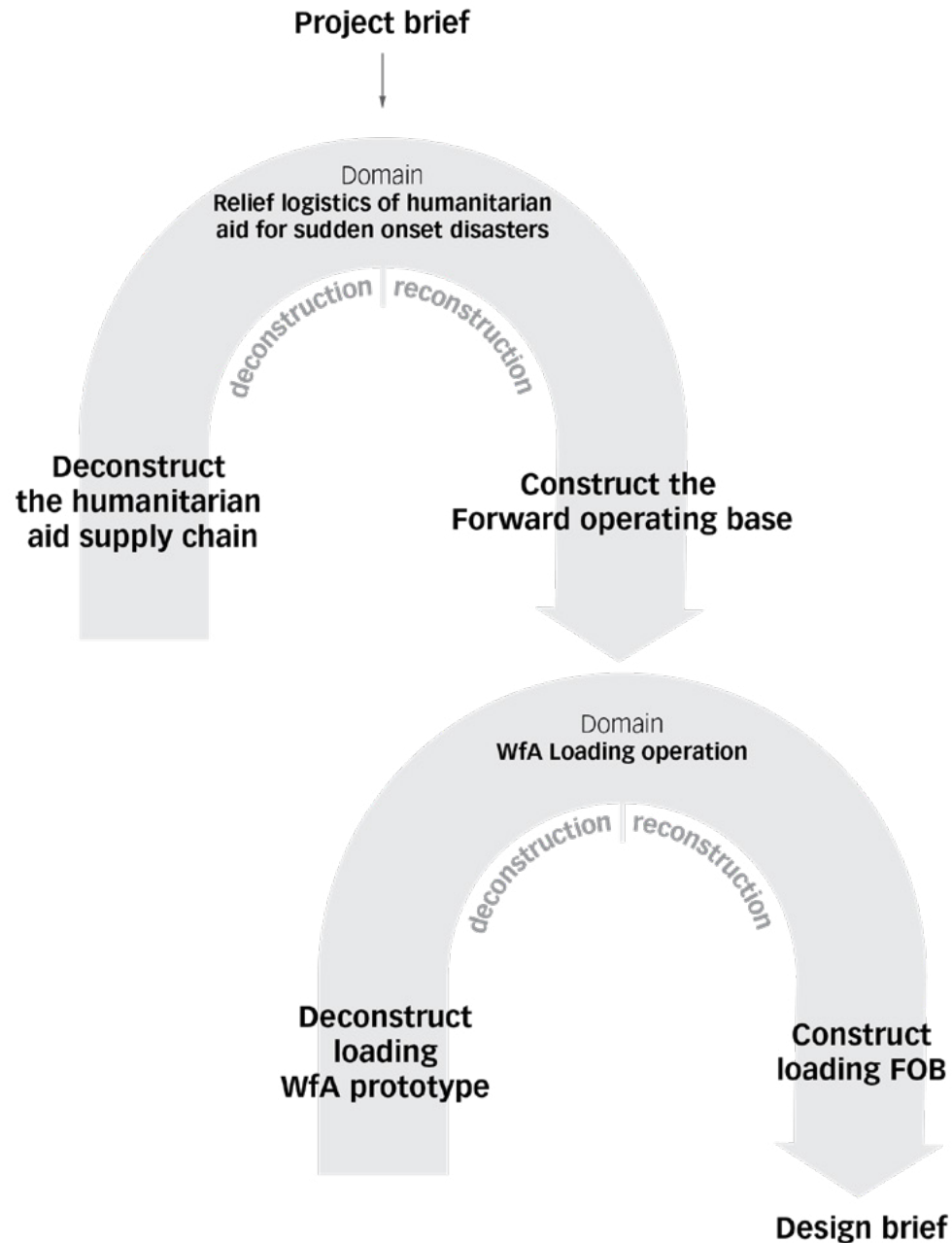

Figure 6 : Overview of project process

▶ EXPERTS & ADVISORS



Erik Tempelman
TU Delft Chair



Henk Crone
TU Delft Mentor



Roeland Reitsema
VanBerlo Coach



Eric van Dorst
VanBerlo / WFA Coach



Alexis Roseillier
Wings For Aid Lead engineer



Barry Koperberg
Wings For Aid general manager



Eelko Brouwer
Red Cross relief operations



Arie Slagter
Remote aerial operations



Taco Schuur
Mechanical engineering



Bas Bruining
User focus

DECONSTRUCTING THE STATUS QUO

In this chapter the status quo of humanitarian aid operations (HAO) is analyzed. First it must be understood what a humanitarian aid operation (HAO) is and how it functions. Then the supply chain systems, and the reported interaction with the operation itself are deconstructed. All the found insights led to the identification of several key performance indicators. These KPI's provide the main target for the future WFA system and support the assessment of future directions and concept.



Figure 7 : A tree blocks the Red Cross from progressing (Brouwer, 2016)

▶ UNDERSTANDING HUMANITARIAN AID OPERATIONS

STRUCTURE

In the aftermath of a disaster, humanitarian aid operations are initiated to provide the life saving aid to the victims. This is done through a cooperation between many different organizations, from NGO's to governments.

A humanitarian aid operation (HAO) is structured by different clusters of organisations focussing on one aspect. The main clusters are relief, logistics and health.

The focus of this project lies within the logistics cluster as this is the facilitating party to make sure the relief arrives at the right locations on the right time. What is needed where and when, is determined by the other clusters.

PHASES

In the aftermath of a disaster, the relevant needs change over time. Although every disaster is different, there are several overall phases established. An overview is presented in Figure 8. The project focus is on the first two, most demanding, phases.

1. Search and rescue

The initial phase is always search and rescue; finding survivors and providing them with medical services has the highest priority and can last from hours to days (Crutchfield, 2013) (Goyet, Sarmiento, & Grünewald, 2011).

2. Emergency relief

Simultaneously, the emergency relief is started. This concerns the identification of needs and providing victims with critical support, such as nourishment, shelter and medical services (Crutchfield, 2013) (Goyet et al., 2011). The emergency relief phase ends when the basic needs for survival are no longer a daily struggle (Crutchfield, 2013). This could take weeks to months, depending on the initial situation of the country and the magnitude of the disaster. In the case of Haiti this even took almost a full year (Crutchfield, 2013).

3. Early recovery

During this phase the people have regained proper shelter and a stable supply of their basic needs. Now they can slowly start rebuilding their lives, taking up weeks up to months (Earthquake in Haiti, sd)

4. Long term recovery

Once people have slowly started picking up their lives again, this final phase will start. Temporary shelters will be replaced by permanent structures and people can start working on improving their lives again on a social, financial and educational level (Crutchfield, 2013).

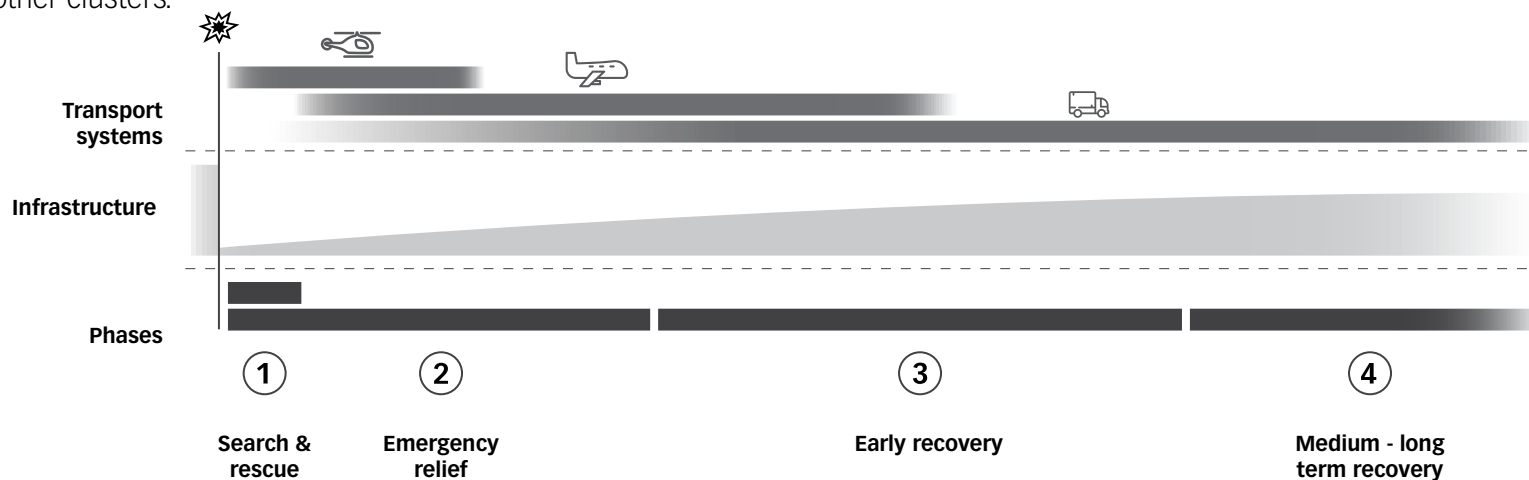

Figure 8 : Overview of phases within a humanitarian aid operation

▶ UNDERSTANDING HUMANITARIAN AID OPERATIONS

CONTEXT

Disasters disrupt every aspect of the society. Therefore, relief operations for sudden onset disasters are always highly volatile and unpredictable, especially in the initial two phases.

In the aftermath of a disaster, the infrastructure is often severely crippled due to unusable airport and roads, but also communication and power are vulnerable (Goyet, Sarmiento, & Grünewald, 2011). Furthermore, resources, such as food, water and fuel quickly run low. Over time, as the infrastructure is restored, the relief operation becomes more stable.

These times of chaos leave the often already politically instable countries highly prone to corruption (Willitts-King & Harvey, 2005). Also, social structures are amplified, with people either driven to extreme solidarity, but also to extreme self-preservation through violence and plunder (Goyet, Sarmiento, & Grünewald, 2011)

Several past disasters were analysed in order to try to grasp the situation. See Appendix C.



Figure 9 : Rescue workers searching for survivors after earthquake

► STATUS QUO SUPPLY CHAIN

TRANSPORT SYSTEMS

Currently, there are already several systems used to deliver goods to disaster struck areas, each with their own advantages and disadvantages. Commonly used are Hercules C-130 cargo planes, Bell Huey helicopters and large trucks. Next to a desktop study, expert discussions supported this research.

Hercules C-130 cargo plane

The Hercules C-130 is a widely used cargo plane, commonly used by the military to transport heavy loads reliably. Fully loaded, it can haul almost 20 tons (C-130 Hercules, 2018) and can even perform air drops of the same weight for an aerial supply mission. The C-130H costs € 12.719 per flight hour (Mark Thompson, 2013), which results as about €1,20/ton/km. Its main limitation are the required 1,5km long airstrip to land on (C-130J Specifications and Performance, sd) or the large secured area and costly parachutes for an airdrop (Chris Klimek, 2016). These parameters make it unsuitable to deliver goods directly to where it is needed, requiring additional transport onwards.

Bell Huey helicopter

On the contrary, helicopters are highly versatile as they can land and take off vertically. This maximizes the possible locations it is able to deliver goods. Per trip it is able to haul up to 1750kg (Uh-1H Huey, sd). Unfortunately, it must be operated by skilled pilots, resulting in high costs of € 12.374 per flight hour (Mark Thompson, 2013) and €25,79/ton/km. Therefore, other options are always considered first.

V-22 Osprey VTOL

A combination of the capacity and range of the C-130 with the versatility of the Bell Huey, is the VTOL concept. This is an airplane able to tilt its rotors and land vertically, able to carry 9000kg and cruise efficiently at 510km/h (V-22 Osprey Aircraft, sd). However, the reliability of this concept is low. The only operational craft is the V-22 Osprey and caused many controversies on its low reliability and high maintenance (Mark Thompson, 2007). This results in an average €66.730 per flight hour (Mark Thompson, 2013) (Mike Nudelman, Jeremy Bender, 2016) and €13,73/ton/km.

Truck

Using trucks for last mile delivery, is the most cost effective method. In normal conditions trucks can transport 10 tons of cargo, for the minimal cost of €0,063/ton/km (Levinson, 2011). However, trucks and their related costs are highly susceptible to ground conditions, such as damaged roads, fuel scarcity and raids. This highly impairs their employability during the first phases of relief operations.

Conclusion

All aerial systems used during a HAO have a military origin and are designed for a wide range of applications. The lack of specificity for HAO makes them less than ideal.

An ideal system can at least compete with the versatility of a helicopter and the capacity and costs of the Hercules C-130.

The low price of trucks keeps the desirability to use them whenever possible and in later phases of the HAO when infrastructures are rebuilt.

DISTRIBUTION

The distribution centers are the border between the HAO and the victims. As this is the final link in the chain, it determines what the previous steps should accommodate.

Through an expert interview with Eelko Brouwer (Red cross) and a desktop study the following insights were found.

The distribution centers serve a high number of victims over a large area with 10-100 tons per delivery. This makes crowd control an important aspect of distribution, due to the high amount of valuable aid stored for multiple days on site. Consequently, the distribution center must be highly coordinated and secured, requiring a large team. The distribution is difficult to plan ahead as the arrival of the actual goods is often insecure, making the operation harder to manage.

It was also found that locals are often integrated into the system as they offer readily available support. This can be simple labor, security or crowd management and can include a compensation. If needed, they receive a brief training for extended jobs. This could benefit for both parties.

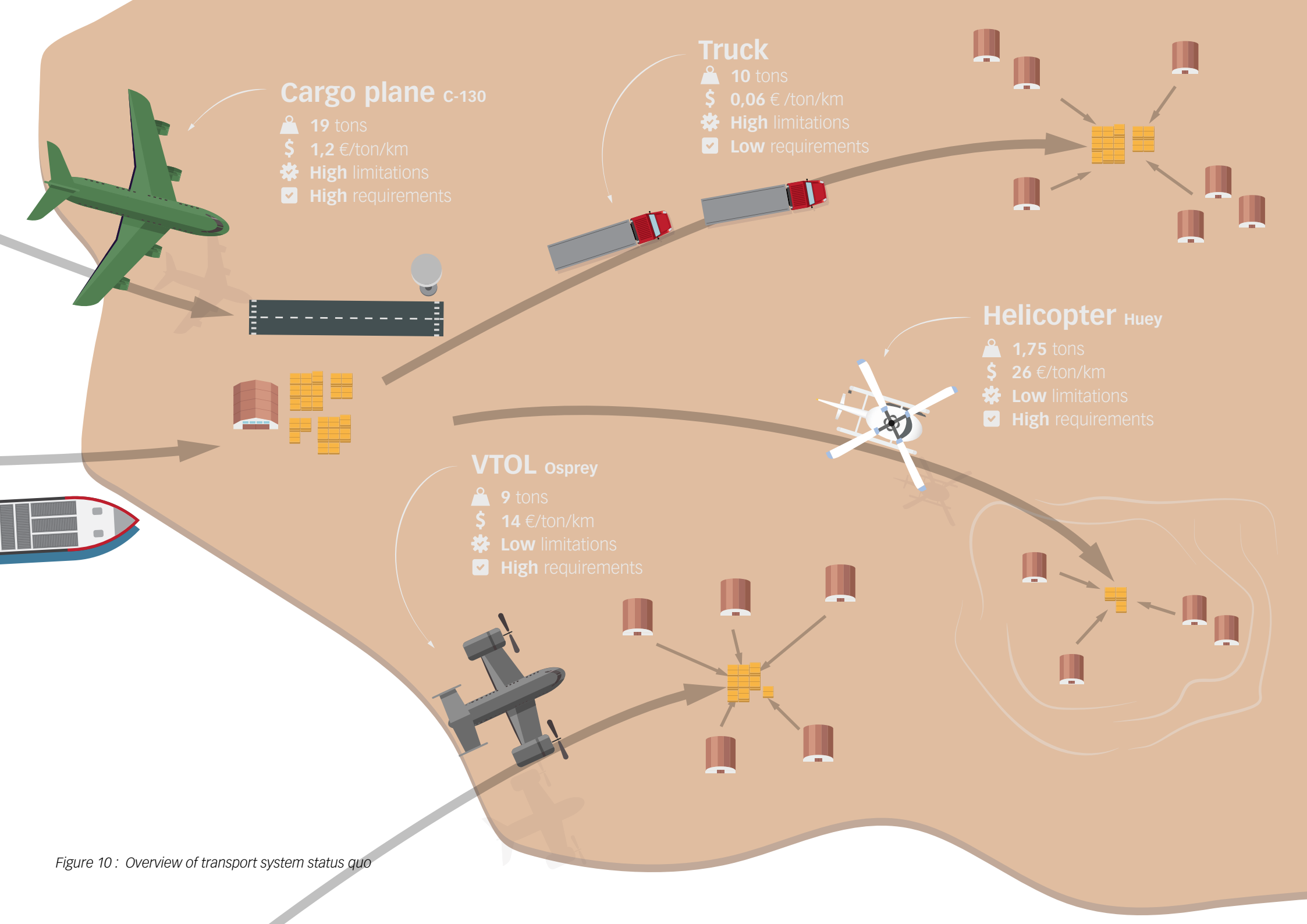

Figure 10 : Overview of transport system status quo

▶ OPERATION INTERACTIONS

The operations of the status quo can be seen as the interactions with the transport products, matching the interaction layer of the ViP method. Performance evaluations for HAO are very important as NGO's must be able to justify activities and funding to stakeholders. By analyzing the evaluation and process reports of HAO's and academic studies overall operational insights were found.

“Humanitarian supply chains tend to be **unstable, prone to political and military influence, and inefficient due to lack of joint planning and inter-organisational collaboration**. They deal with **inadequate logistics infrastructure, along with shifting origins of and/or destinations for relief supplies** without warning.

McLachlin et al., 2009

“In most disaster situations, the **management of incoming supplies is one of the major bottlenecks** in the humanitarian system.

Goyet et al., 2011

“Many humanitarian supply chains have a **short and unstable** existence with an **inadequate link between emergency aid and longer-term development aid**.

Oloruntoba and Gray 2006

“The goal of humanitarian supply chain is to be able to **respond to multiple interventions, as quickly as possible and within a short time frame**

Wassenhove, 2006

“**Irregularity in terms of size, timings, and locations** is a characteristic feature of demand patterns for relief items.

Chandraprakaikul, 2010

“Important for the success of the process is the **integration of key stakeholders** throughout the entire process as well as the **simplicity and userfriendliness**.

Chandraprakaikul, 2010

▶ KEY PERFORMANCE INDICATORS

Based on the deconstruction of the status quo in the previous chapters, Key Performance Indicators (KPI's) can be determined.

These KPI's lay the foundation of a novel system within the HAO. Furthermore, they can be used to aid in the assessment of further directions and concepts.



CAPACITY

- The possible amount of cargo delivered per day.
- Should be more than the 20 ton capacity of the Hercules C-130 cargo plane.



VERSATILITY

- Minimal size of area required to deliver cargo
- Maximum diversity of cargo possible to be transported.
- Maximum time span the operation stays competitive.



RELIABILITY

- Minimal difference between expected and realised deliveries, in terms of content, quantity and timing.
- Minimal dependency on external factors, such as power, communication and infrastructure.



FLEXIBILITY

- Minimal time needed to adopt to changes in what is needed where and when.



DEPLOY SPEED

- Minimal duration between turn out and first delivery of relief.
- Should be within one week.



COSTS

- Minimal costs of operation in €/ton/km
- Should at least compete with the €1,20 /ton/km of the Hercules C-130



USER FRIENDLINESS

- Minimal investment needed to fit within WFA development phase.
- Should fit the positive brand image of WFA.

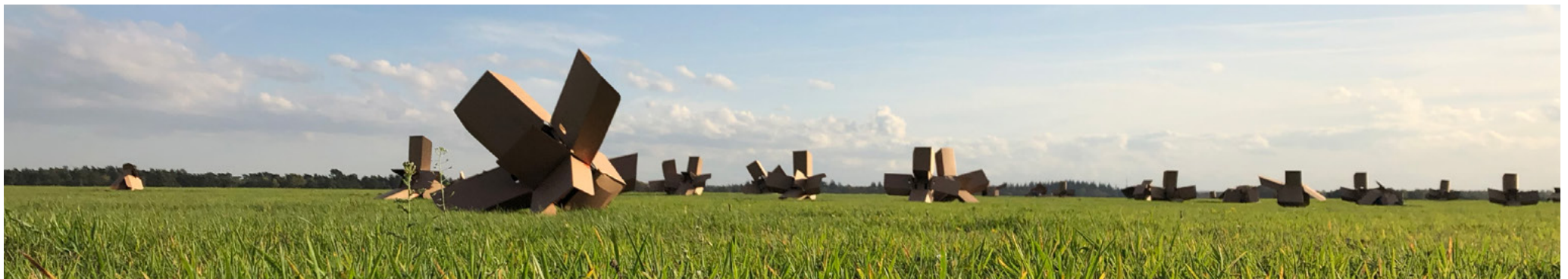

Figure 12 : Dropped boxes on a test day (Wings For Aid, 2019)

CONSTRUCTING THE FORWARD OPERATING BASE

Now the status quo is deconstructed, and its takeaways formulated in KPI's, the new context of the Wings For Aid system within a humanitarian operation can be created.

To construct the WFA forward operating base (FOB), first the overall Wings For Aid concept must be understood and how it influences the FOB. Then the main elements of the FOB are constructed.

After all the elements of the FOB are known, the FOB statistics can be quantified in a model. This allows for the creation of a feasible and viable operation model and presents the relation and influences between parameters. This can then be used to identify potential design opportunities.

Confidential Appendix O presents potential research questions found throughout the process.

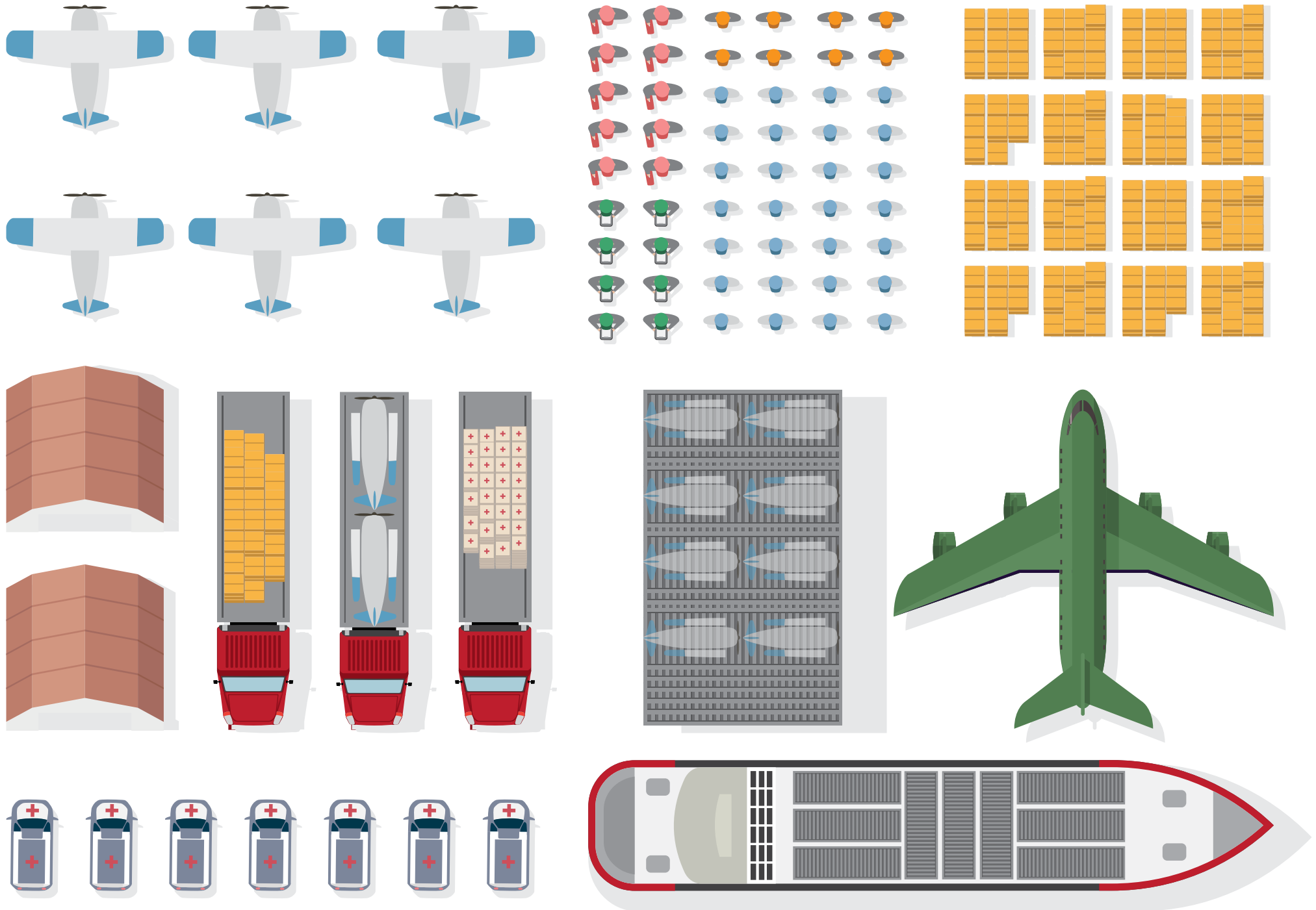

Figure 13 : Collection of the elements used to create the FOB

► UNDERSTANDING THE WINGS FOR AID CONCEPT

THE CONCEPT

Normally the Wings For Aid (WFA) systems are stored in one or several locations around the world. When a disaster occurs, the WFA systems are transported and a temporary base outside of the disaster area is set up, this is called the Forward Operating Base (FOB).

From the FOB, a swarm of Unmanned Aerial Vehicles (UAVs) will take off carrying cargo towards one or multiple drop zones.

This allows for transport of the cargo without being affected by the situations on the ground, directly to the ones in need.

Therefore, its strength lays in the rapid deployment and providing aid during the initial phases after the disaster.

The WFA operation can stay unhindered from most difficulties of a normal relief mission, as the FOB can be strategically placed on almost any location from which the affected area can be reached. Although still placed in an affected area, the separate base allows it to be independent. It must however be able to operate in remote places in rough environments.

The UAVs are designed specifically for the operation. They could be able to carry almost 200kg of cargo over a range of about 500km (Roseillier, 2019). In order to achieve this, these are no small aircrafts, featuring a wingspan of around 10m (Roseillier, 2019).

To drop the cargo safely without landing, a custom cargo box is being developed. These cargo boxes can contain up to 20kg of diverse cargo and slow down the descent to ensure a safe landing (Roseillier, 2019).

The cargo is dropped on the designated drop zones. As the dropping accuracy is high, the drop zones can be kept small, thereby increasing the versatility of its placement (Roseillier, 2019). The cargo can then be distributed to victims or used in facilities, such as hospitals or camps.

To validate the use of the WFA system, it was implemented in the 2019 Cyclone Idai disaster, see Appendix C.

INFLUENCE OF WFA SYSTEM ON THE FOB

The FOB is influenced by the storage and drop zone related processes. In order to create a FOB which fits in the overall system, these influences were identified. Expert interviews and discussions with additional desktop research were performed to identify insights and visualise this in a system infographic, see Figure 15.

The most important aspect is the required transport of all the FOB elements. Therefore, all systems should be optimized for this. This results in minimal overall weight and volume. As well as optimal dimensions for standardized shipping containers, such as pallets, 20ft container used on trucks and ships and the ULDs used for air freight. This creates a demand for systems which can be disassembled and reassembled quickly and reliably.

Concerning the personnel, transport time and costs can be saved by only needing a minimum of WFA specialists and sourcing additional workforce locally. **This creates a desire for systems requiring only minimal training, so local workforce can easily be implemented.** As this is currently done in the distribution centers.

The system should be flexible in where the cargo can be dropped by the UAVs. This could be large or small distributions zone in which relief workers manage the dropped cargo and distribute it among the victims. Next to this, facilities such as hospital, camps, construction sites, could require deliveries as well. All these locations will require different interactions and potential cargo. Small drop zones with infrequent drops have a larger need for scheduling and notification of drops, compared to large drop zones with continuous drops. As the location, required content and timing could quickly shift, **the FOB should be able to load UAVs with specific configurations of cargo in order to deliver the correct cargo using the optimal flightpath.**



Figure 14 : Potential context of the WFA operation

WINGS FOR AID OPERATION OVERVIEW

UAV & FOB STORAGE

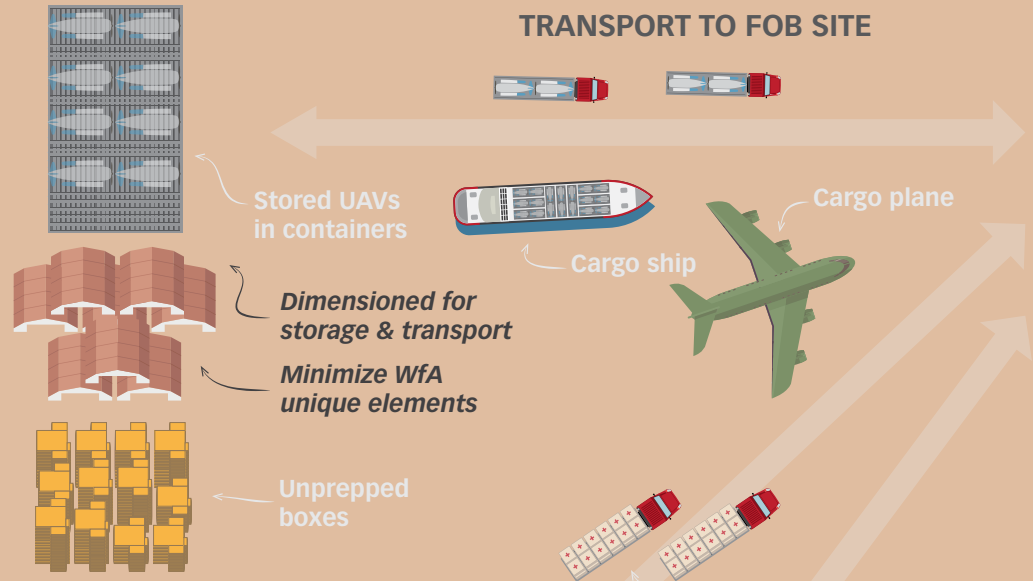

TRANSPORT TO FOB SITE

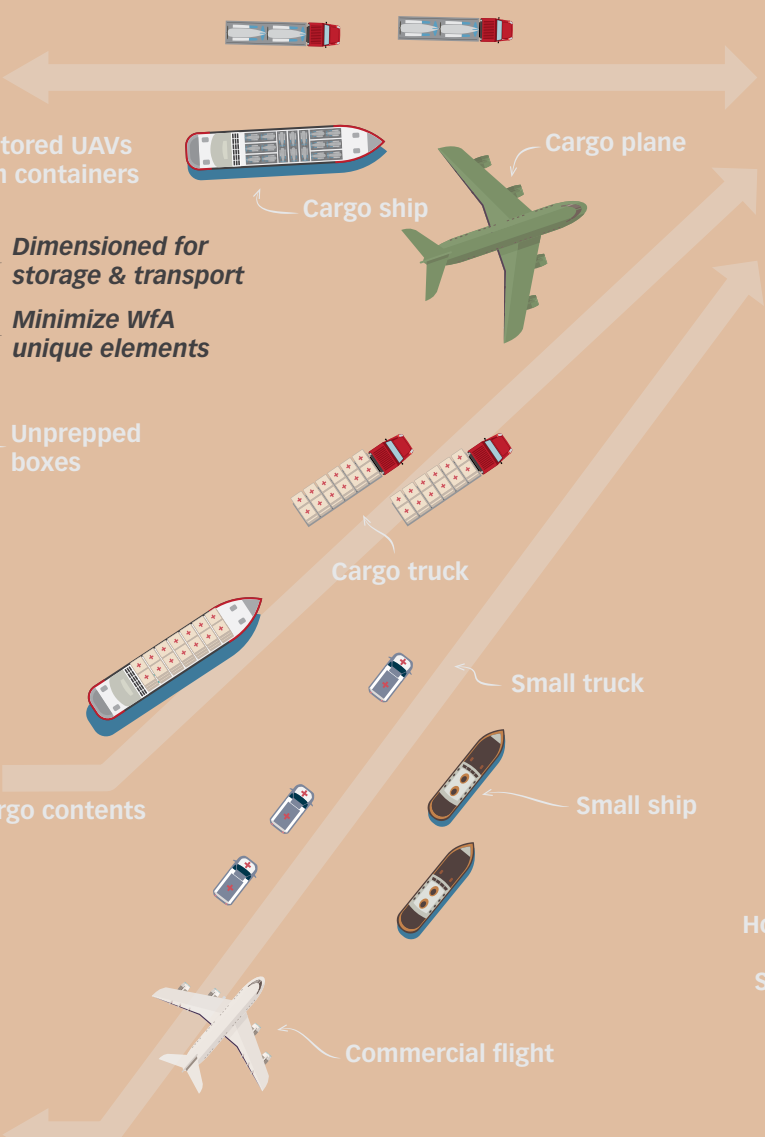

CARGO STORAGE

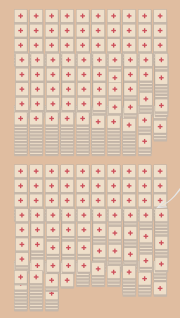

PERSONNEL

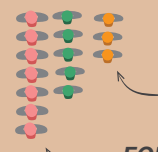

Minimize number of personnel needed to save costs of housing.

FOB operation must be easy and reliable to allow maximum use of (trained) local workers

FORWARD OPERATING BASE

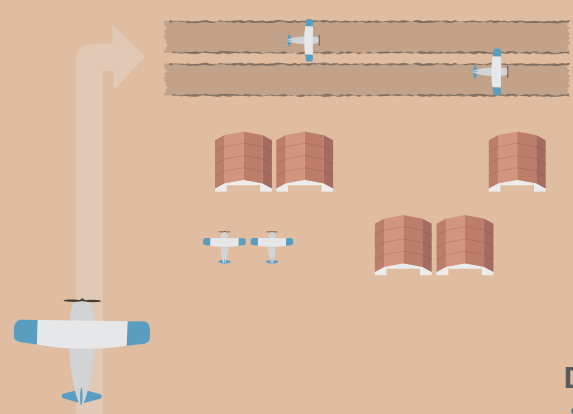

LARGE PLANNED DISTRIBUTION CENTER

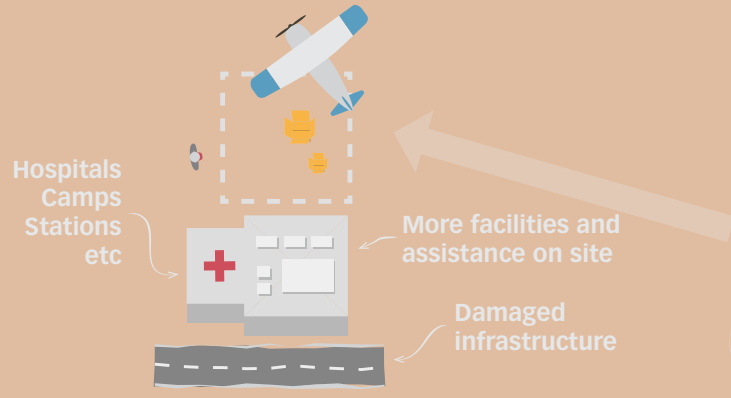
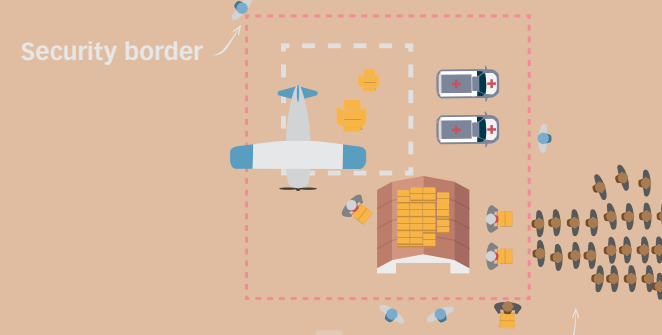

FACILITY DROPZONE

Harsh terrain

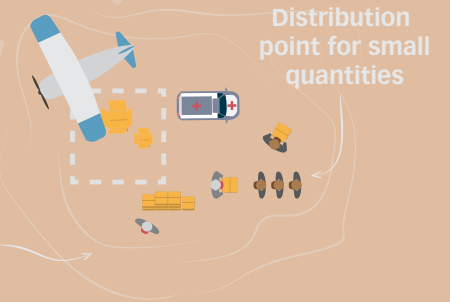

SMALL IMPROVISED DISTRIBUTION SITE

Figure 15: overview of the WfA operation including the FOB influences

► ELEMENTS OF THE FOB

OPERATIONS

To be able to transport large amounts of cargo over time, a swarm technique is used with many smaller UAVs. Therefore, the operations at the FOB should be optimized for throughput using an assembly line style of working, in which the UAV is moved by hand between stations. See Figure 16 for an overview. This overview was created through expert discussions and desktop research. See Appendix P and Appendix Q for the transcripts.

Landing

After returning to the FOB, each UAV goes into a holding pattern until a pilot is available to manually land it.

Through flight check

After landing, the UAV is visually and digitally checked to determine if any repairs or (scheduled) maintenance is needed. Scheduled maintenance is determined by the set maintenance schedule of each part. (Slagter, 2019).

Maintenance

If there is anything out of order, the UAV is brought to the maintenance station (Slagter, 2019). To spread out this station's workload, careful planning, a maintenance stagger and failure prediction could be implemented.

Loading

Once the UAVs are all checked up, they can be loaded with the appropriate cargo. First, the required cargo boxes need to be prepared by packing the cardboard boxes with the correct cargo. After, they are weighed and logged in the digital system. Based on these, a set of 'missions' is created, including a flightpath and a matching cargo configuration per UAV. The required boxes are then collected accordingly and loaded into the UAV. Finally, the matching flight path is uploaded.

Fueling

After loading, the UAV is fueled with the required amount, based on the flight path and weight of the cargo (Slagter, 2019). This station must abide to fuel safety regulations which includes specifics on locations, equipment and usage.

Preflight check

Before taking off, a pre-flight check might be needed. However, ideally this check should not be necessary if everything is done correctly and checked during the individual steps already. The UAV is then ready for a manually controlled take-off to deliver the cargo.

PERSONNEL

Categories

There are 3 categories considered, the high wage specialists (operations manager, pilots), the medium wage specialists (technicians, instructors, inspectors etc) and the minimally trained low wage personnel. As mentioned before, ideally the majority of work is done by cost effective minimally trained locals, as these do not require significant transportation to the FOB and have lower wages. Furthermore, this strategy could support the local community by providing paid work.

User friendly systems

To allow locals, the systems must be optimized for user friendliness, intuitiveness and be foolproof to minimize risks. If done correctly, the locals will only require a brief training upfront and minimal supervision during their work.

Facilities

Finally, the FOB must be equipped with housing and nourishment facilities to accommodate everyone in the remote area.

LOGISTICS

This mostly concerns the supply of the relief cargo to be delivered by the WFA system. But also, the logistics of the prepared cargo boxes, spare parts, fuel and all the personnel facilities. These required logistics influence the optimal FOB location.

It is key to deliver the first aid as soon as possible, yet be able to continue for months. Therefore, it should first deliver all the standard basic goods for every operation. Then, once stable, continuously improve the general parts of the base, such as improved station shelter and housing. The WFA specific system should be designed to be usable in any phase to only need to deliver this once.

The FOB must obtain information about *INTEL*

new delivery demands and feedback on the delivered cargo. However, it should also collect information for internal and external purposes, such status of deliveries, stock, maintenance reports etc. By gathering this information, future operations can be improved. This mostly digital system must be kept as independent as possible to minimize its liability on the operation.

FORWARD OPERATING BASE OVERVIEW

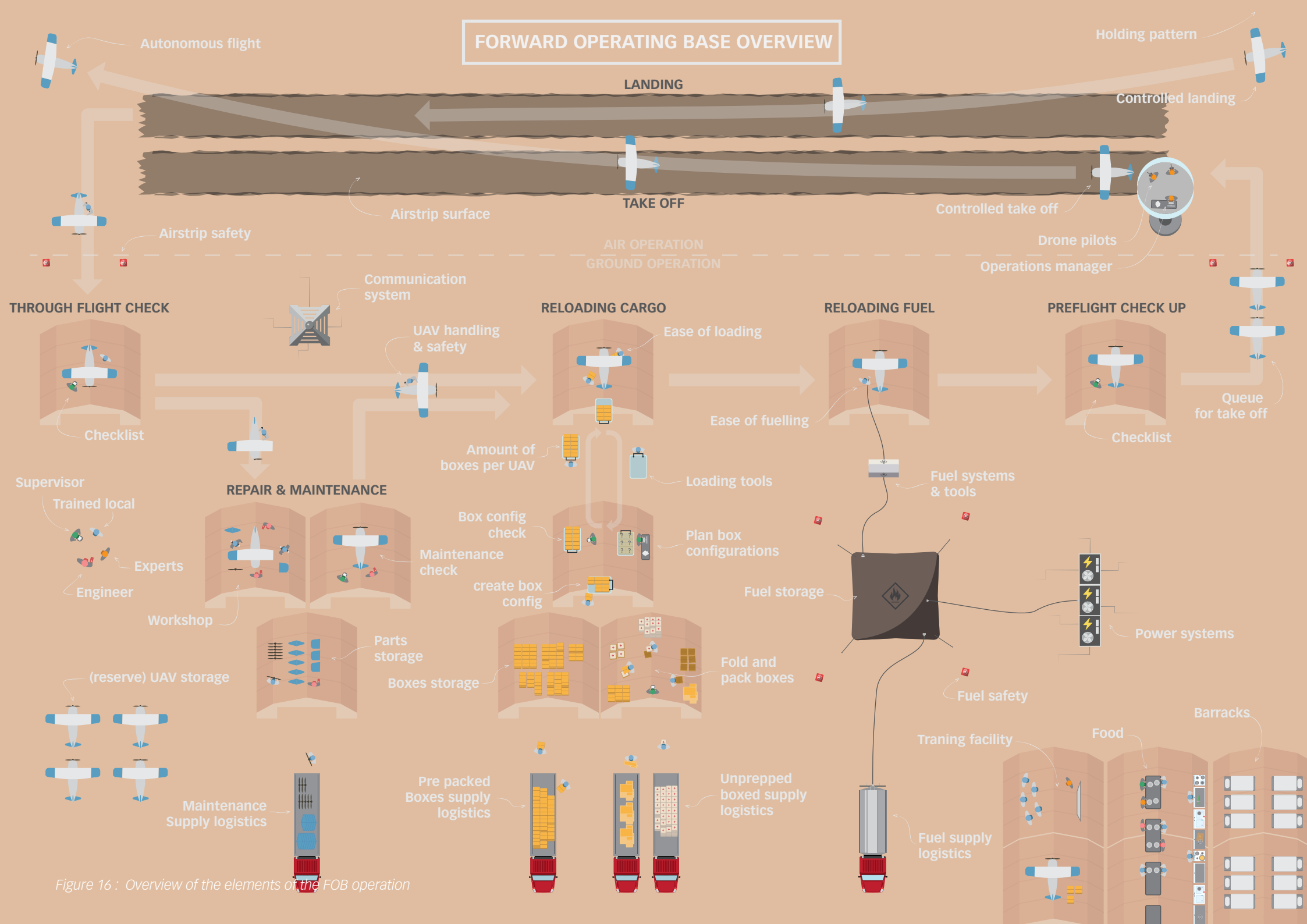

Figure 16 : Overview of the elements of the FOB operation

► STATISTICS OF AN EFFICIENT FOB

By integrating all the static elements of the previous chapter and applying the external influences and KPI's, the statistics for a FOB concept can be created. This validated the four hypotheses below.

A calculation model was created in an iterative way, as results led to discussions and new questions. The KPI's were used as guidelines for decisions. The model focuses on the FOB in a running state, with the operations and personnel as main aspects. This excludes the transport costs to the FOB. These statistics provide a vision for the future FOB and design opportunities to reach this goal. The main resulting statistics can be found in Figure 17.

The model itself, as well as the reasoning behind the main statistics can be found in Confidential Appendix M & Appendix N.

1. THE WFA FOB CAN COMPETE WITH THE STATUS QUO TRANSPORT SYSTEMS.

With the ability to transport 46 tons per day, for an estimated price only slightly higher as the C-130 (Confidential Appendix M), the WFA system offers the same versatility as a helicopter for a significantly lower price (€28,64 /ton/km). **It can also compete with the costs and capacity of a Hercules C-130** (1,33 /ton/km and 20tons resp.).

2. THE REQUIRED UAV THROUGHPUT WILL CREATE A SIGNIFICANT BOTTLENECK.

Based on the model, the standard throughput of 5 min/UAV was found. Yet in order to deal with irregularities, such as maintenance and breaks a higher pace should be possible. Therefore, a throughput of 4 min/UAV should be achievable. The additional minute of margin allows for an average of 12min of break or 3 additional UAVs taking off every hour. The required throughput is less demanding as expected. **It is considered most operations should be able to perform the required tasks after optimization,** without the need of parallel stations.

3. A SWARM OF LARGER UAVS IS PREFERRED OVER MANY SMALL UAVS.

A swarm of larger UAVs is more efficient. The current limiting factor is the maximum wingspan of 8m, set by the SORA regulations (Appendix I). Through expert discussions, it was deemed at least 8 boxes per UAV will be feasible for this, however if possible, a slight increase to 10-12 boxes per UAV could be beneficial.

4. PERSONNEL IS THE LARGEST COST FACTOR OF A RUNNING OPERATION.

Even when minimally trained personnel are used when considered possible, the personnel costs still make up for 39% of the running operation costs (with the UAV and station costs based on depreciation). However, fuel is also expected to make up for a large part (30%)

▶ DAILY STATISTICS

 **5 Min**
per UAV

 **24** h/day

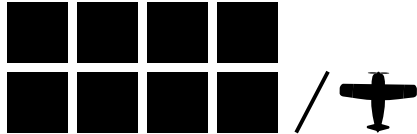
8 Boxes
per UAV

46
TONS

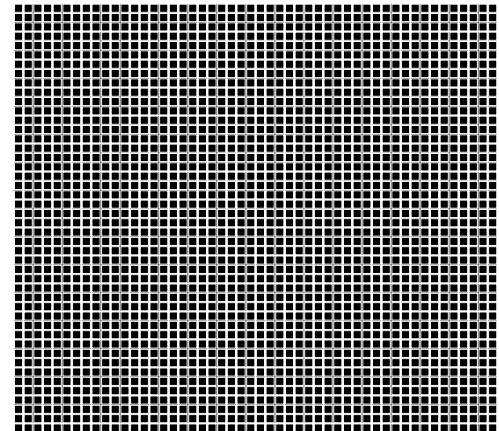
2300 Boxes

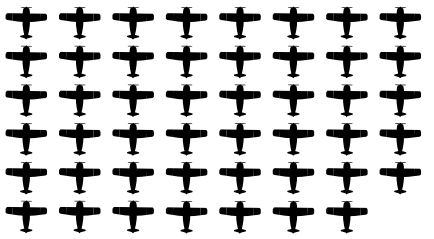
47 UAVs

↻ 500km ↻ 150km/h

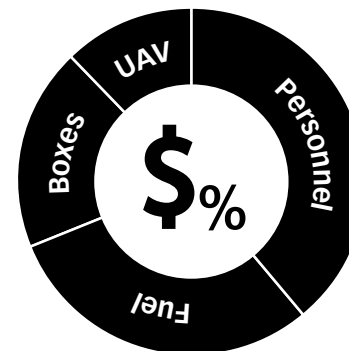
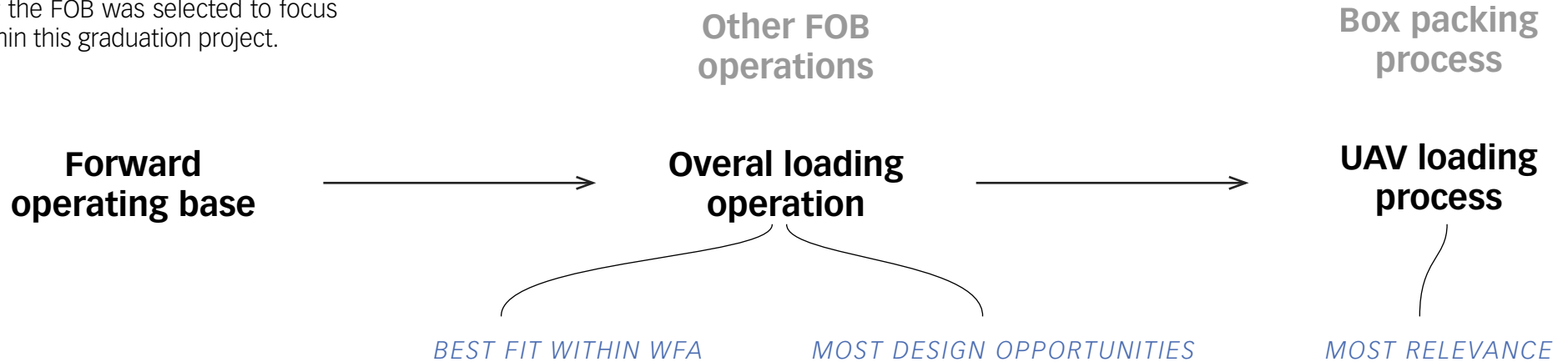

Figure 17 : The resulting main statistics for a future FOB

▶ PROJECT DIRECTION

In the previous chapter, the overall FOB is constructed. As the goal of the project is to optimize this operation through product development, a single part of the FOB was selected to focus on within this graduation project.



As mentioned in chapter 'context', WFA has recently been testing the first manned aircraft prototype and is currently developing the first unmanned aircraft. This upcoming UAV is expected to already be suitable for first operations demonstrations and initial pilots. The most relevant operation to perform these initial validations is the loading operation, as this is directly related to the currently existing components, the box and UAV. The others; check, maintain and fuel operations are more independent and only start playing a significant role during extended pilots at remote locations.

The loading operation is the most WFA specific operation, providing the least amount of existing knowledge on this process. The other sub-operations, such as refueling, and maintenance are already familiar processes within many different kinds of operations. Although they still must be carefully optimized for the FOB, it does allow for more existing knowledge and resources and is therefore a less demanding aspect.

The current loading operation can be divided into two parts, see Figure 18; (1) packing and logging of the box and (2) collecting the required boxes and loading into the UAV.

The focus will be on the 2nd phase, as the 1st part is mostly out of scope of this project due to its focus on the box design. Furthermore, this preparation process could easily be sped up by adding more workers and is more independent from the UAV throughput. The 2nd part is limited by the UAV interactions in which more workers will not increase the process speed.

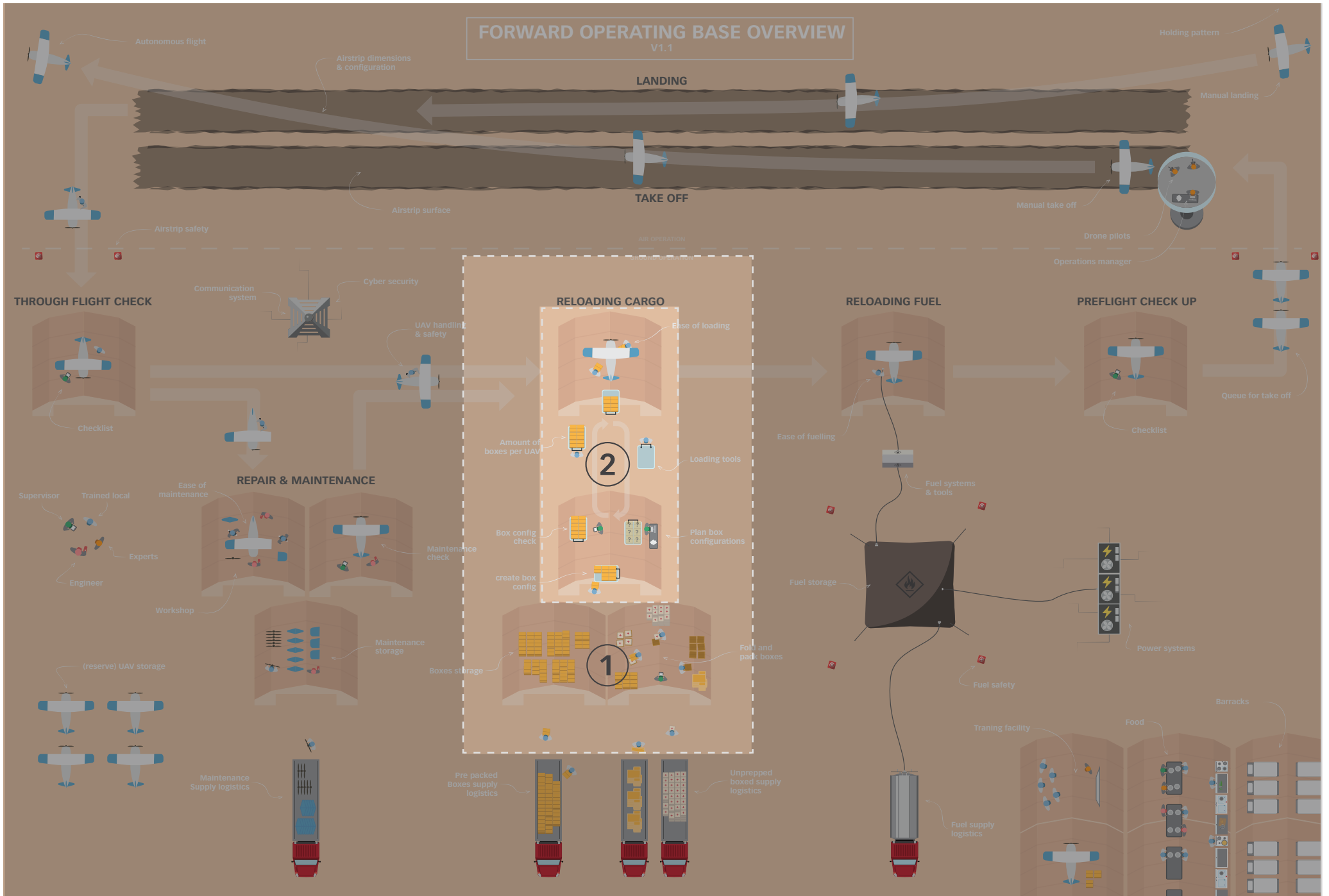

Figure 18 : Indication of the selected project focus within the FOB.

DECONSTRUCTING THE LOADING OPERATION

The existence of the current manned aircraft prototype allowed for a deconstruction in the newly set WFA loading domain. This was done through observations and questionnaires in order to create a new desired context and a final design brief for the rest of this graduation project.



Figure 19 : Demonstration of the Wings For Aid system (Wings For Aid, 2019)

▶ CURRENT LOADING OPERATION OBSERVATIONS

SETUP

To analyze the current loading operation, the following research question was defined:

How does the current loading operation limit its implementation into the envisioned FOB?

This was done through observations and questionnaires to find the duration, workload and risks within the UAV loading process. The process as currently performed during tests is presented in Figure 21. This process was repeated 10 times.

Duration

The duration was analyzed to discover what steps are limiting the fit of the operation within the desired maximum 4min/UAV throughput.

This was timed using a stopwatch and logged on a observation sheet. See Confidential Appendix J for the sheet and results.

Workload

However, to put the recorded time into perspective, the workload was also recorded. If the overall workload is very low, it can be considered that

the achieved time could potentially be improved. Both too high and too low workloads over extended periods of time tend to result in lower performance and higher error rates, due to exhaustion and boredom respectively (Casner & Gore, 2010).

the workload recorded by using the renowned NASA Task Load Index (TLX) questionnaire (see Appendix D). Although other methods of workload assessment were considered, the (raw) NASA TLX was deemed most appropriate as it is widely used, multidimensional, yet quick and easy to understand (Casner & Gore, 2010).

Risks

To determine the risks, errors and uncertainty in the process, video recordings and interviews were used.

① Preparing boxes on the cart



② Bring cart to UAV



③ Load boxes into UAV cargo bay



⑦ Fill in inspection checklist

Figure 20 : Collage of captures images during observation

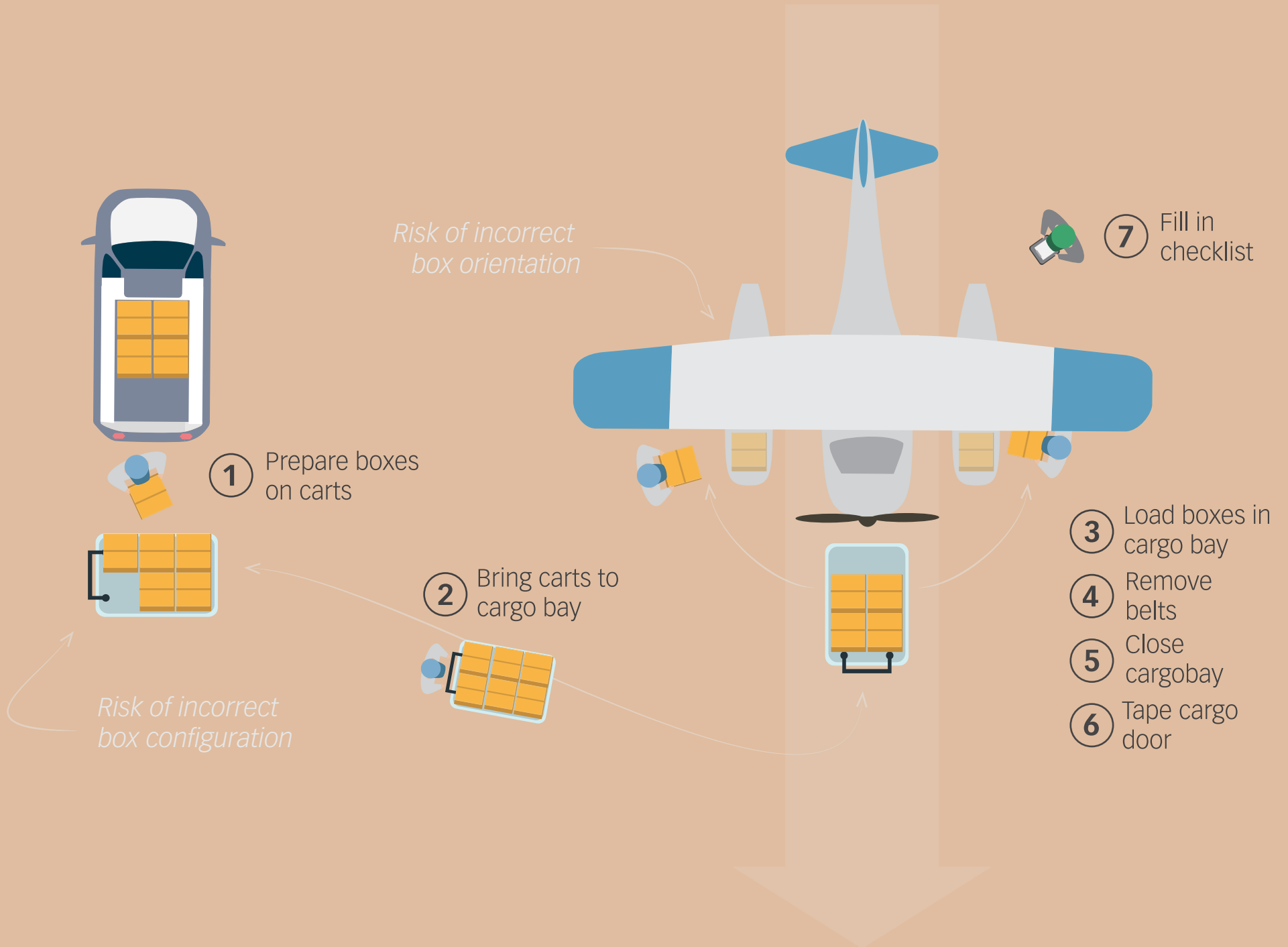

Figure 21 : Overview of the observed loading operation

▶ CURRENT LOADING OPERATION OBSERVATIONS

RESULTS

The results of the duration, the mental and physical workload are presented in Figure 24. Raw data can be found in Appendix J.

Several aspects were kept in mind when analyzing the results:

All the tasks were performed by highly educated people who had (at least some) prior understanding about the system. Next, the cargo boxes used in this test were loaded with 10kg instead of the maximum 20kg, as needed for the drop tests being performed.

Furthermore, as the aircraft has a cargo bay on each side, 2 people could work in parallel (as indicated in Figure 24), speeding up the process.

Finally, all boxes were loaded with identical cargo, removing the need to create complex non-uniform box configurations.

These factors are considered to increase the workload in a future scenario when working with minimally trained personnel and a diversity of up to 20kg cargo boxes. Therefore, the baseline 'average' workload was lowered as indicated in Figure 24.

RISKS

The main observed execution error risk is the loading of the boxes in the incorrect orientation during step 3. The box should be loaded into the UAV in one specific way in order to drop successfully, see Figure 22. As the box is square and looks similar on all side, it can easily be loaded with the incorrect side forwards, see Figure 20 & 21. If done incorrectly the airbrakes of the box will not open and plummet down, destroying the cargo and creating a major risk for the people beneath.

Another risk is the incorrect creation of the box configuration. When the boxes are collected (Step 1), there is no confirmation if the process is done correctly. If a UAV takes off with an incorrect configuration of boxes, the wrong cargo ends up at wrong drop zone, as it does not match the instruction the UAV is given.

Currently both risks are covered by an inspection at the end to check if everything is done correctly. However, **a foolproof system could prevents these risks directly at the source, instead of inspecting and correcting afterwards.** Thereby saving time and a costly inspector.

CONCLUSION

The current loading operation could fit into the desired 4min/ UAV throughput. The recorded average of 4:32 is only just outside this requirement and the fastest time was only 3:25. However, this was during ideal condition on a paved surface.

The participants were highly skilled and still indicated high mental loads due to uncertainties and made (minor) mistakes. **This shows that it is a complex task , requiring constant focus, and mistakes are easily made.** There is a need for a intuitive and foolproof system which guides users through the process and removes the need for inspections to prevent errors.

The peaks in the physical workload were due to the carrying of the boxes and the required suboptimal postures. **The recorded physical workload was considered unsustainable over longer periods of time** as would be the case at the FOB, due to the weight difference of the box. A solution should be found to minimize this physical workload. This minimizes errors and costs and maximizes the possible work shifts and worker satisfaction.

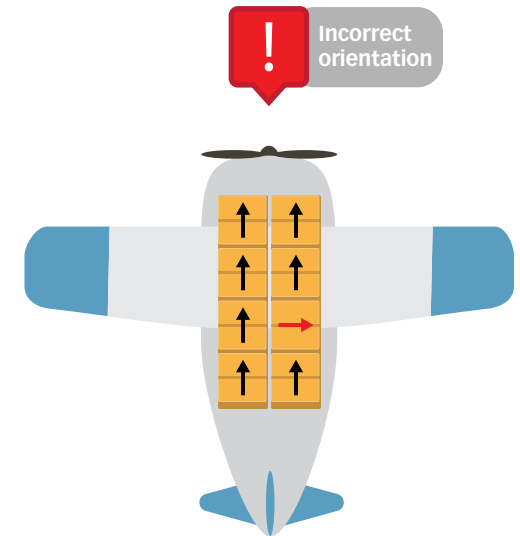

Figure 22 : Incorrect orientation in the UAV

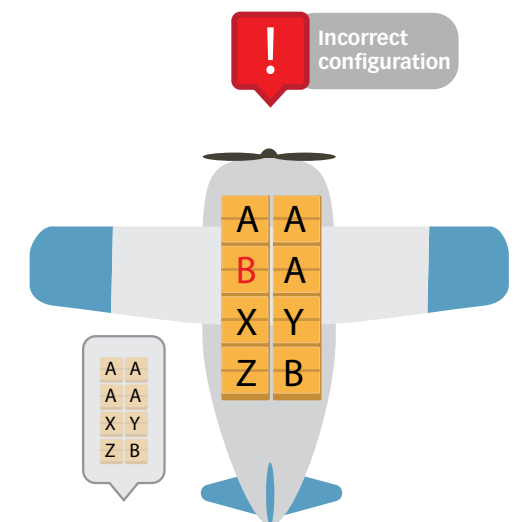

Figure 23 : Incorrect configuration in the UAV

CURRENT LOADING OPERATION
DURATION & WORKLOAD

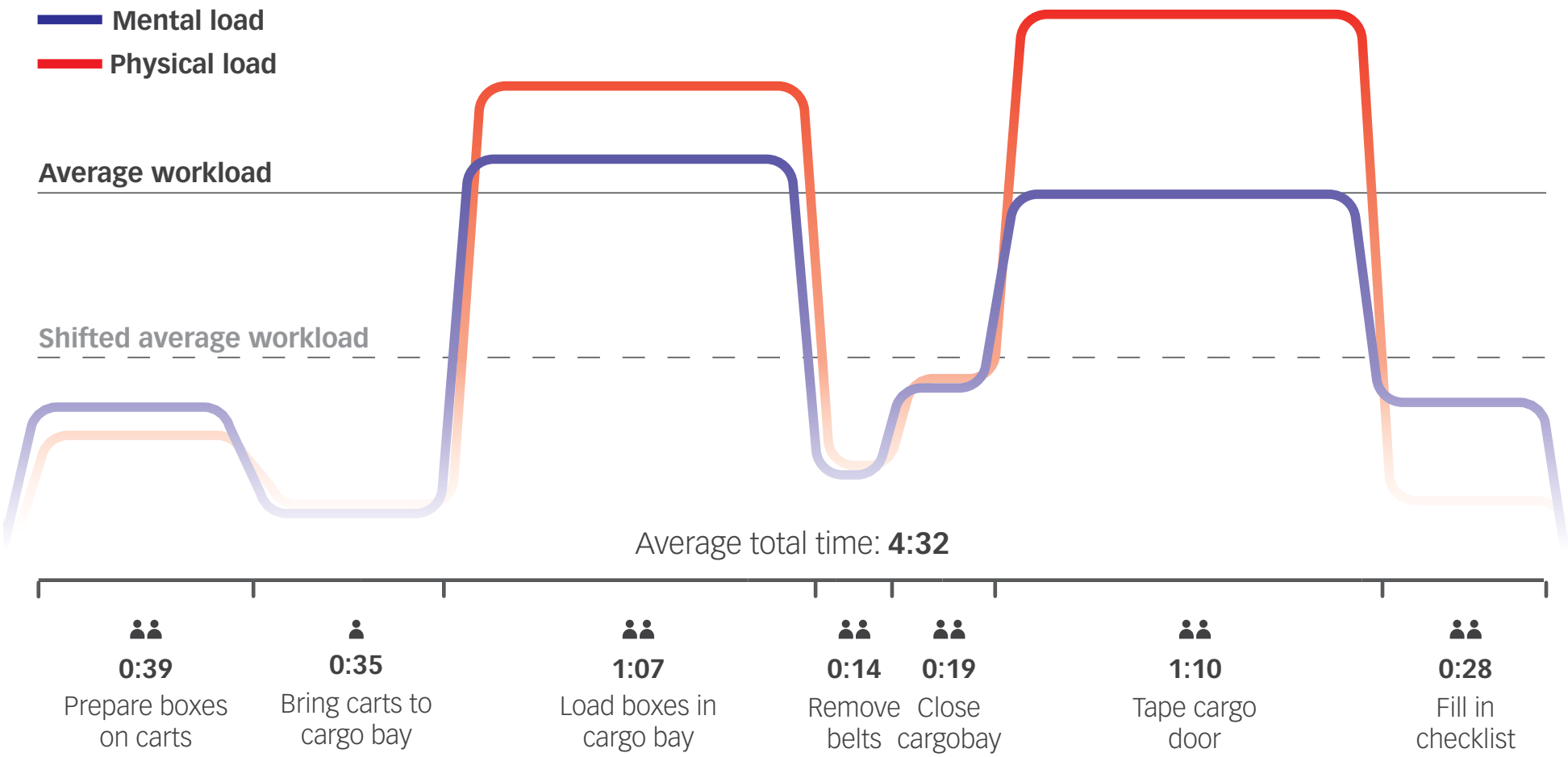

Figure 24 : The duration and workload during the observed UAV loading process

► DESIGN BRIEF

As presented in the previous chapter, the current loading operation is limited by its ergonomics, due to the excessive mental and physical workload as well as the errors made in the process. In order to create a suitable solution for the future WFA operation, the following design brief was defined.

From prepared boxes and a non-uniform configuration to a fully loaded UAV
See Figure 25

- » Load within 4 min
- » Usable in harsh environments
- » Long & short term viability
- » Versatile in operation

“

Create a **loading system** for the **FOB** with **low risk and low operational costs**

- » Minimal human error
- » Reliable systems
- » Minimal box configuration & orientation errors

- » Allow minimally trained workers
- » Low system costs
- » Low quantity of personnel
- » Low transport costs

Throughout the project new requirements and wishes were set and recorded in a list of requirements. The listings in this living document also served as a way to evaluate concepts and ideas. It was constructed using Pugh's checklist (Roozenburg & Eekels, 2016) to take into account all aspects of the design's life cycle. The full list of requirements can be found in Appendix E.

► DESIGN CHALLENGE

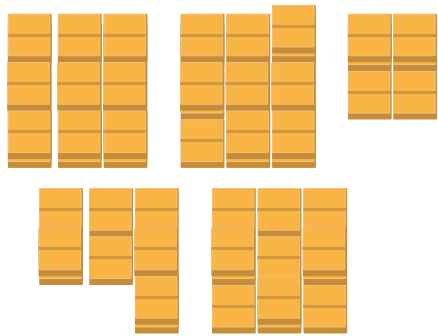

+

A	A
A	A
X	Y
Z	B

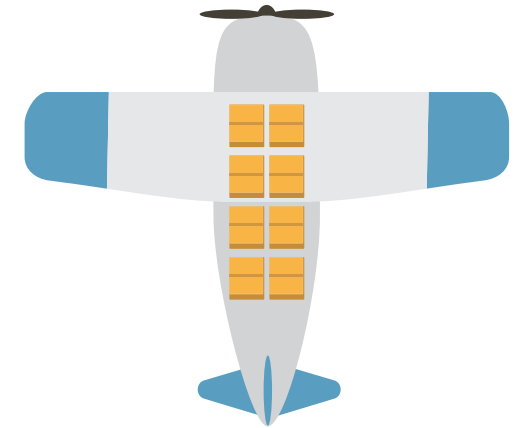

PREPARED BOXES

- Diverse contents
- 20 kg
- Correctly packed
- Registered
- Labeled

CONFIGURATION

- Non uniform
- 2 x 4 boxes

LOADED UAV

- Suitable for the upcoming UAV
- < 4 min / UAV
- Without errors

DEVELOPMENT

Starting from the defined project brief, ideas and concepts were developed in an iterative and hands-on way. This chapter is concluded by the chosen concept direction.



Figure 26 : Hands on process of interating on potential cart setups

► IDEATION

In order to create fitting solutions for the design challenge, the loading system is split up in two main functions and subsequent sub-functions. Solutions for each function were developed, captured in a morphological chart and ordered. Figure 36 presents the final overview. A design direction was created by combining the highest rated solutions. See Figure 30 for an overview of the development process.

The two main functions of the loading system are:

1. Create and maintain a correct configuration and orientation of boxes
2. Transport and load the boxes into the UAV

The focus was put on the second, as this is the core of the operation and should be usable for the client first.

CREATIVE SESSION

In order to gain fresh ideas, an ideation session was organized together with VanBerlo employees and interns. After a warmup and introduction of the project and context, the main task during the session was brain sketching subsolutions, whereafter integrated solutions were presented and discussed.

The brainstorming tasks were divided into the mentioned two main functions.

ANALOGIES

One of the methods used to generate ideas was by using analogies. By looking at different existing industries, analogies can be made with the design problem at hand to find inspiration in existing systems. A full overview of all the analogies can be found in Appendix F.



40 Figure 27 : Ideation session sketches

Figure 28 : Ideation session presentations

Figure 29 : Collage of different inspirations and analogies

DEVELOPMENT PROCESS

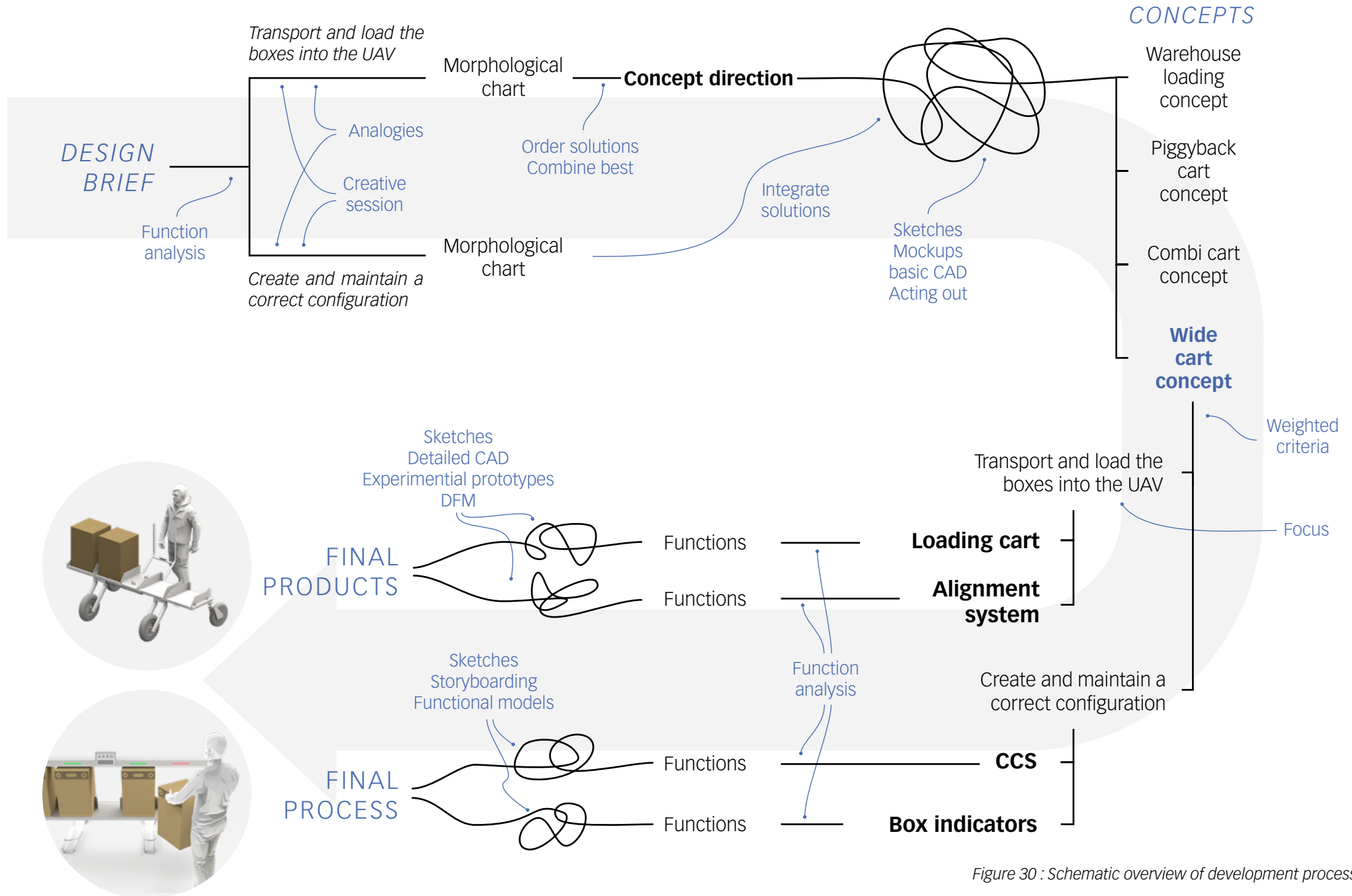

Figure 30 : Schematic overview of development process 41

DESIGN DIRECTION

In order to narrow down the initial direction of the loading system, a principal solution was created by combining solutions per function based on the 'transporting and loading the boxes into the UAV' morphological chart. This was done to quickly narrow down the general direction for further elaboration and iteration. The concept and chosen sub solution are presented in Figure 35.

The argumentation of the main selected morphological chart solutions was presented to and discussed with the client for validation. The reasoning behind each main function is described on page 44.

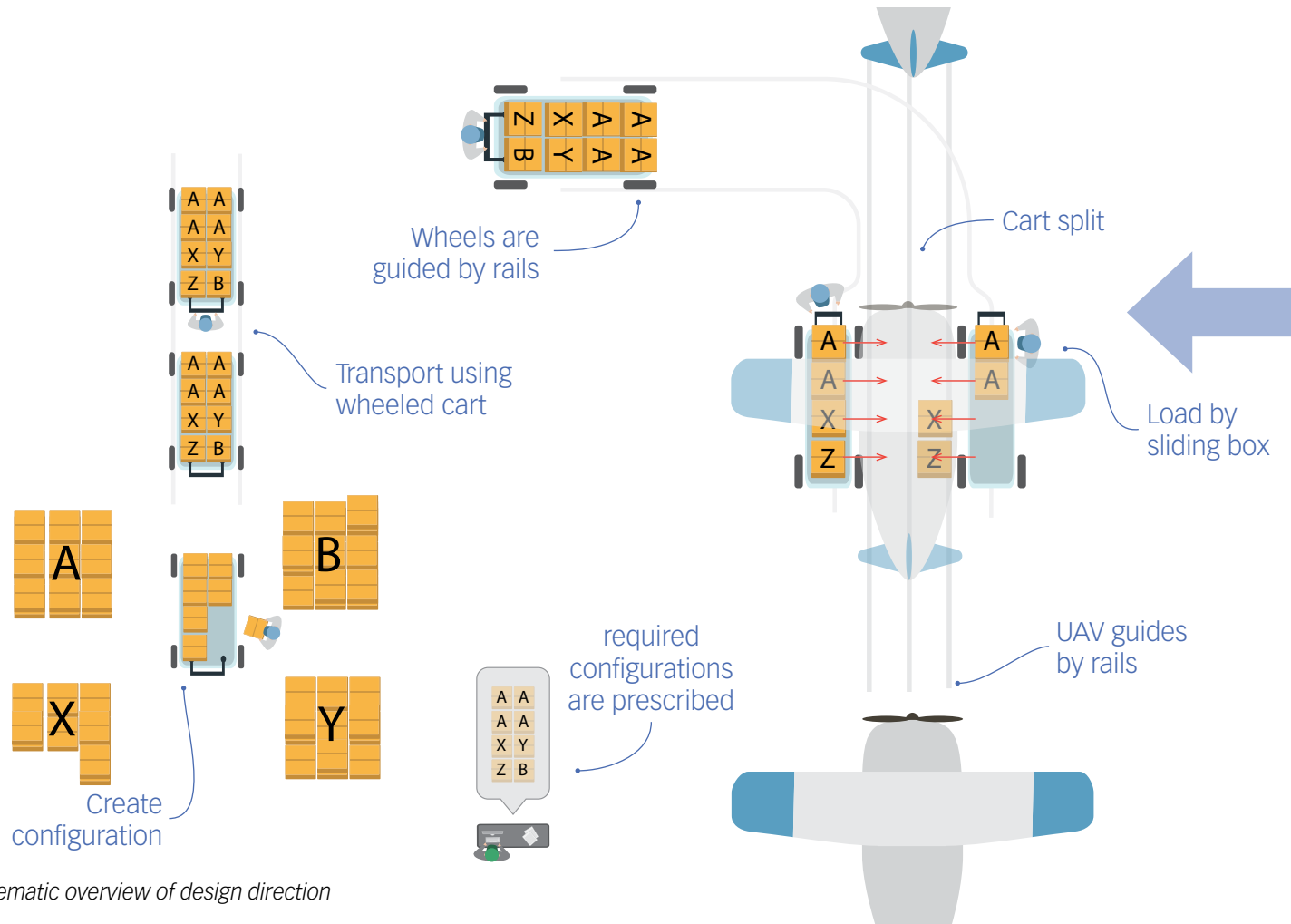

Figure 35 : Schematic overview of design direction

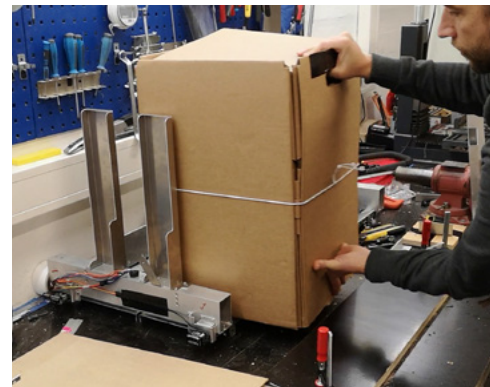
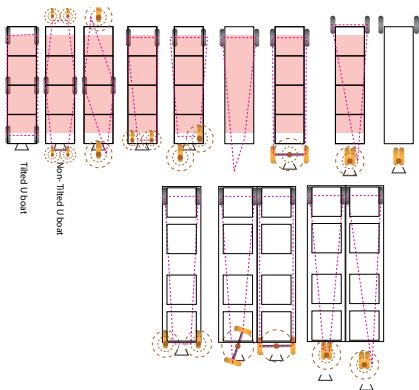

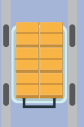

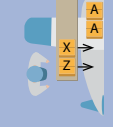



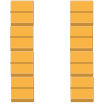
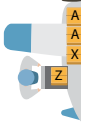



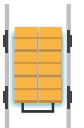
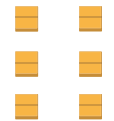
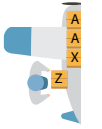
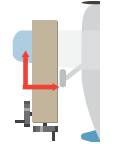

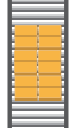
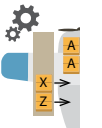

Figure 32 : Wheel configuration iteration

Figure 33 : Testing sliding box into cargo bay

Figure 34 : First cart prototype loaded with sand

► MORPHOLOGICAL CHART

① TRANSPORT AND LOAD BOXES INTO UAV

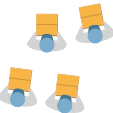
TRANSPORT BOXES	TRANSPORT PER ...	LOAD BOX INTO UAV	ALIGN WITH UAV	TRANSPORT ACTUATION	AVOID UAV WHEEL
 Wheel and rails	 Configuration	 Slide in by hand	 Guide rails	 Optional powered	 Switch direction
 Wheels	 UAV side	 Load with tool	 system - UAV Interface	 Manual	 Perpendicular
 Rails	 Single box	 Lift in by hand	 Adjustment dials	 Powered	 'click in'
 Conveyer		 Mechatronic system	 Improve surface		
 by hand					

② CREATE AND MAINTAIN CORRECT BOX CONFIG





COLLECT BOXES	PREVENT CONFIG ERROR	PREVENT ORIENTATION ERROR
 Order picking	 Sensors in prep system	 Sensors in prep system
 Creation station	 Scan all at once	 Graphic indicators
 Dispenser system	 Sensors in UAV	 Sensors in UAV
	 Scan each box	 Scan all at once
 Graphic indicators		 Shape lock

Figure 36 : Morphological chart of overall system

► CONCEPT DIRECTION

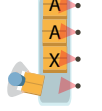
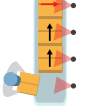
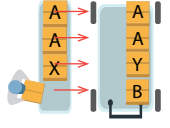
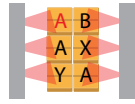
LOADING METHOD

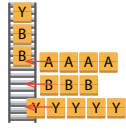
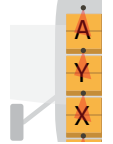
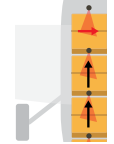
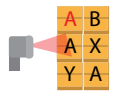
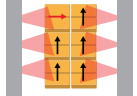
As seen during the observations of the current design, the ergonomics of loading the cargo boxes into the UAV can be greatly improved. Several ideas were generated as shown in the morphological chart (Figure 36). Loading by sliding the boxes was deemed optimal as it significantly improves the ergonomics of the task.

As humans can more easily adapt to (small) differences in the task, such as non-perfect alignment, a manual element in the operation is preferred over complex electromechanical systems. Sliding the boxes from a preconfigured system also offers locking of the orientation and configuration of the boxes beforehand, which minimizes the risk or errors.



44 Figure 37 : Testing sliding box into cargo bay

TRANSPORT METHOD

As the orientation and configuration can be correctly maintained during loading, the transport of the boxes can be done in the required configurations. The chosen transport system is a combination of a wheeled cart and a rail cart. Wheels provide the full flexibility of movement and therefore offer the versatility for every operation. Rails create an optimal surface in the rough terrain, reducing the effort needed to move the cart. However, rails are not as flexible and versatile in operation. By using rails which accommodate normal wheels, the carts keep their versatility, while rails can be placed over time to optimize their movement.

TRANSPORT ACTUATION

The transport systems can either be powered or operated manually. It was deemed optimal to create a system which allows to be powered, but is always useable manually. This modularity provides redundancy, optimization over time and customization per operation. The focus within the project will be the manual base system, while allowing for powered systems to be added later.

ALIGNMENT SYSTEM

In order for the boxes to be pushed into the UAV, the loading cart must be aligned with the UAV. The uneven terrain makes this especially difficult. Furthermore, the UAV should also be protected from the cart to not get damaged by reckless use.

Two general directions are possible; the cart has an integrated system to ensure a correct alignment to the UAV, or an external system which makes sure both the position of the UAV and the loading cart are guided and fixed.

The second is preferred as it simplifies the design over the multitude of carts. Furthermore, if the alignment must be (slightly) changed, an external system only needs to be dialed in once, instead of all the carts individually.

A system similar to the transport rails mentioned before would provide an optimal solution. By placing both the UAV and the loading cart on rails, their positions can be accurately guided.

One of the biggest challenges for the alignment system was to avoid the protruding wheels and the wing struts of the UAV in a simple way, see Figure 38.

CONCEPT ELABORATION

After setting up the general direction for the loading system, the concept was elaborated upon using the other functions of the morphological chart.

Many system concepts and variants were generated throughout this process and iterated upon. This was an iterative process using system sketches to ideate and discuss. After which, digital and physical models, were used in order to validate technical feasibility. Acting out was used to evaluate use and determine the durations.

Next, the 4 main system concepts are presented in schematic process storyboards. Based on these, a final system concept was chosen to elaborate upon.



Figure 38 : Protruding wheel and wing strut

▶ CONCEPT 1. WAREHOUSE LOADING

In this concept the UAV's are loaded directly in the box warehouse from 2 sides. Configurations are created on a special table providing instructions. Once correct, the platforms can be pushed towards the UAV to slide in the boxes. The tables are then moved away to make room for the UAV wheel.

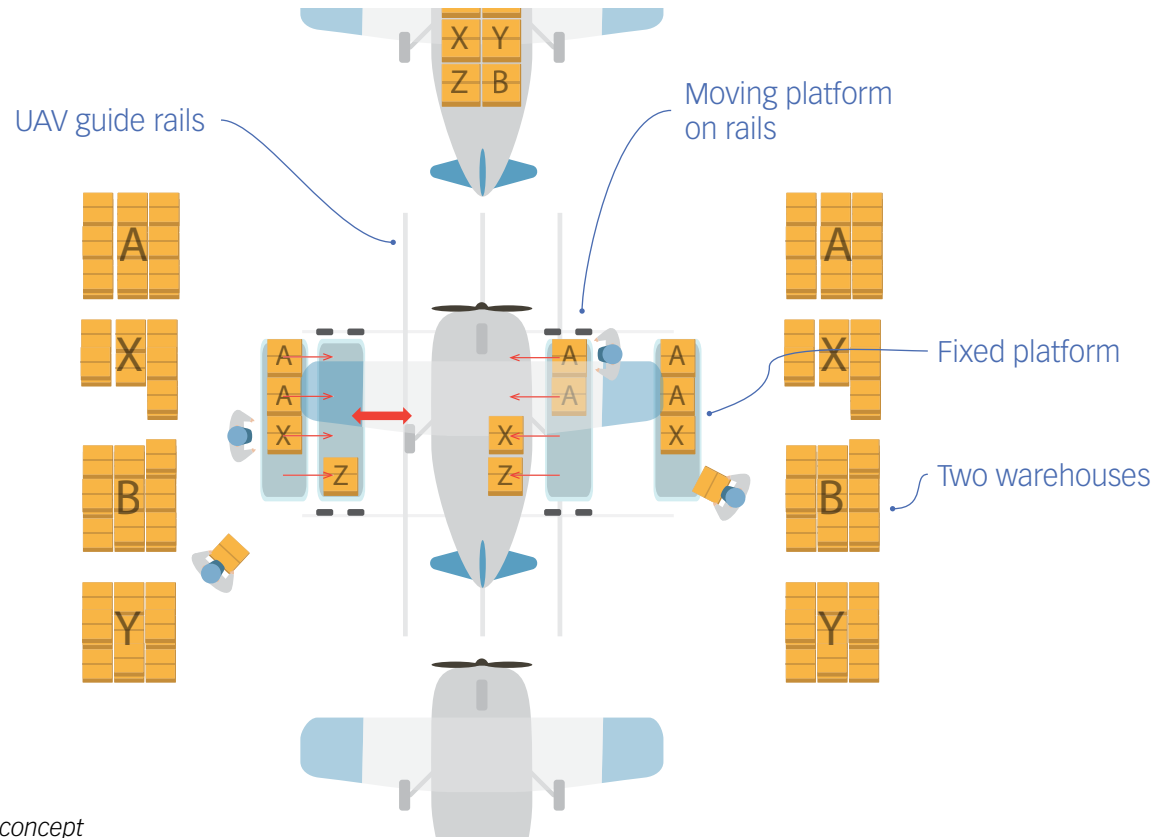

Figure 42 : Initial sketch of concept

Create config
Load UAV ⌚ 2:15

- + Dedicated alignment system
- + Integrated config station
- + Fastest complete loading process (config creation + loading)
- + Low complexity, just 2 carts

- 2 warehouses must be maintained logistically
- Boxes must be transported across UAV path
- Cannot prepare configs beforehand, no buffer
- Large space needed around loading ops, not versatile within operation

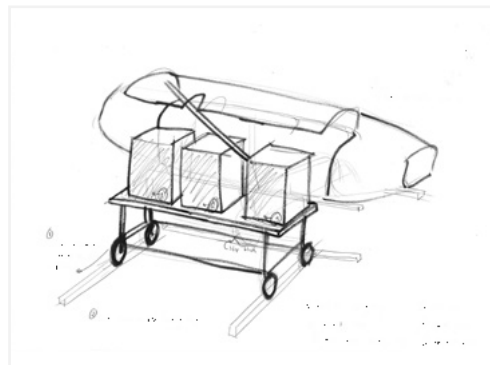

Figure 39 : Initial sketch of concept

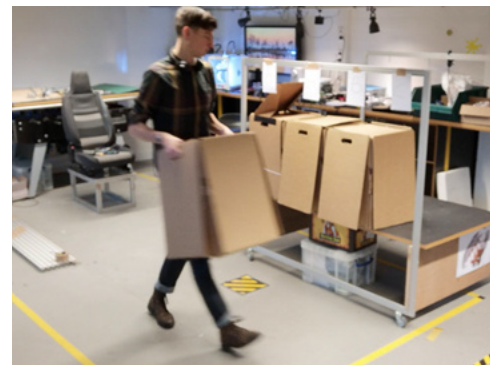

Figure 40 : Acting out the configuration creation



Figure 41 : Ideation of different rail systems

▶ CONCEPT 2. PIGGYBACK

This concept is based on a simple cart which is loaded with the correct boxes through order picking in a warehouse. It is then transported and driven onto a platform allowing a perpendicular movement. First the platform is split to both sides of the UAV path, then the UAV is placed in between. Finally the platform is pushed against the UAV and boxes slid in.

Create config ⚙️ ⏱️ 1:45
Load UAV ⚙️ ⏱️ 2:00

- + Simple carts, complexity in a single alignment system
- + Configs can be prepared beforehand
- + Nothing crosses the UAV path
- + Order picking system can handle both highly complex configurations as uniform configs
- Cart does not work without alignment system
- Complex alignment system
- Cart movement per 8 boxes is very hard manually
- Order picking can be less well guided

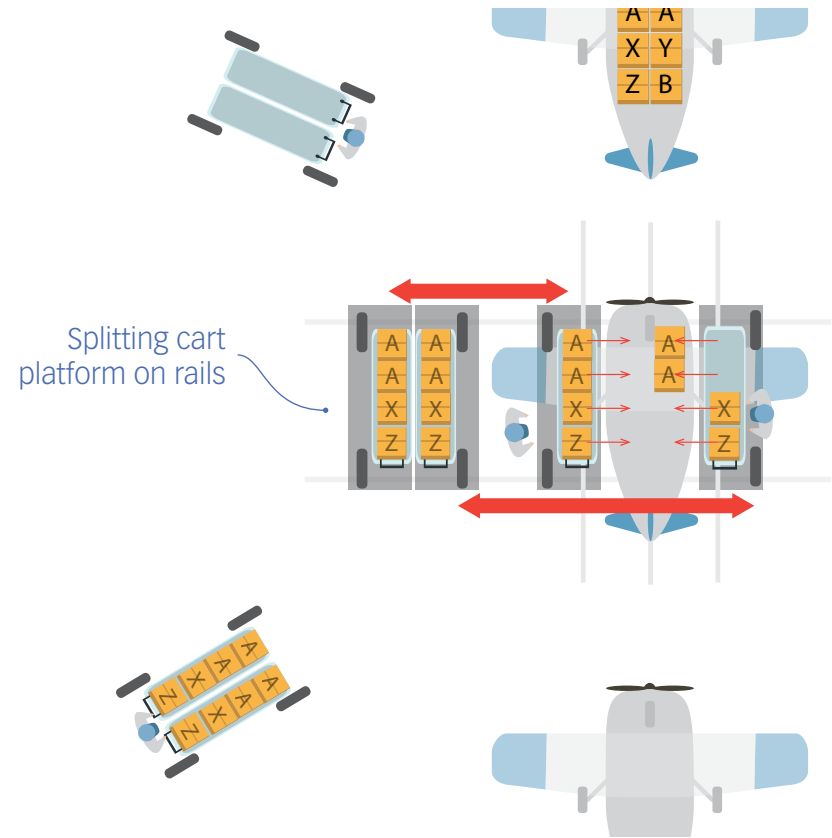
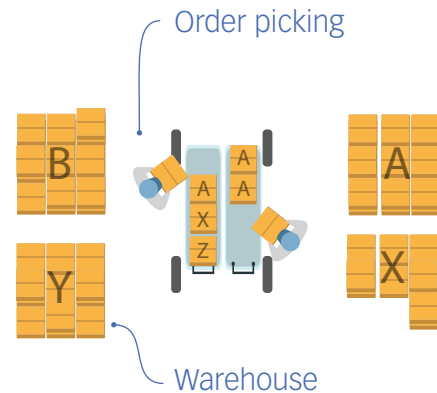

Figure 43 : Schematic overview of concept 2

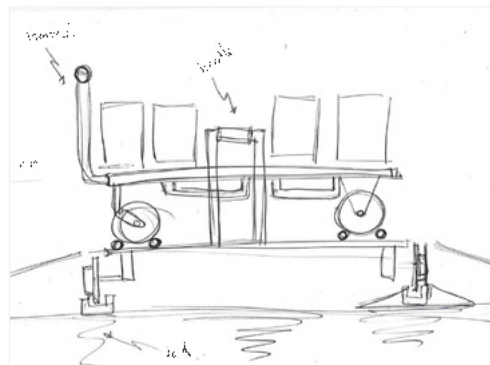

Figure 44 : Rough sketch of concept

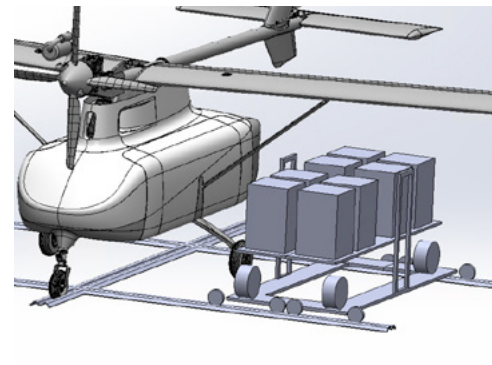

Figure 45 : CAD mockup of concept



Figure 46 : Acting out the loading sequence

▶ CONCEPT 3. COMBI CART

In this concept the configurations are created similar to concept 1, with a sensed platform. The boxes are however then first loaded on a cart per set of 4. The carts are then moved to each side of the UAV, where they use an additional set of smaller wheels on rails to move perpendicular towards the UAV, whereafter the boxes can be slid in. The carts use an ackermann steering system, see Figure 50 similar to military loading carts to provide optimal handling.

Create config		⌚ 0:52
Load UAV		⌚ 2:15

- + Per 4 or per 8 boxes transport
- + Cart can be prepared before hand
- + Optimal cart handling
- + Config creation can have a direct link to packing ops
- + Config creation system can closely guide box configuration and orientation
- Cart must cross UAV path
- Carts are more complex as they have a perpendicular movement system integrated
- There is a specific left and right version of the cart

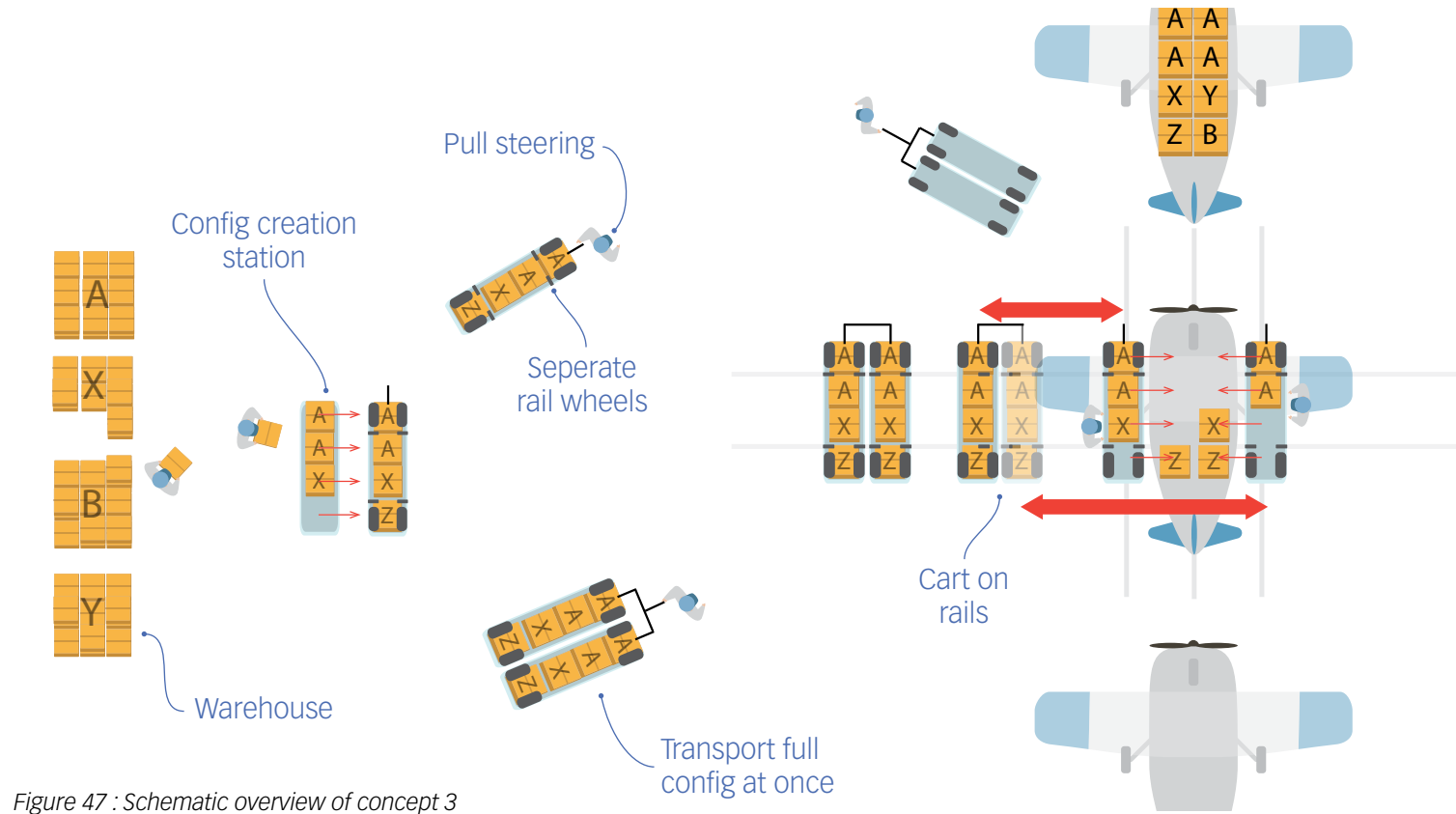

Figure 47 : Schematic overview of concept 3

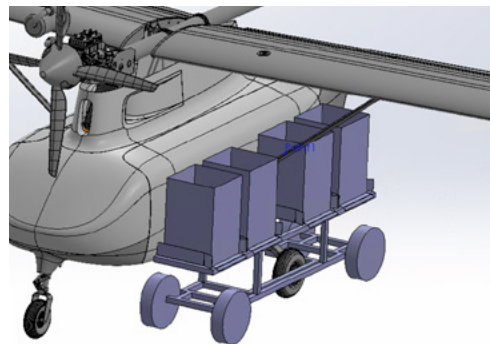

Figure 48 : CAD mockup of concept



Figure 49 : Cart prototype of concept



Figure 50 : Ackermann steering inspiration

▶ CONCEPT 4. WIDE CART

This concept removes the need for a separate system to avoid the UAV wheels, by switching the movement direction and make it possible to approach the UAV from the sides. The alignment system is only a simple guide and stopblock.

The box configurations are created similar to 1 and 3, by using a sensed platform.

Create config		⌚ 0:52
Load UAV	 	⌚ 1:52

- + Fastest loading speed
- + Does not need any complex systems for alignment
- + Simple and universal cart
- + Cart can be prepared before hand
- + Config creation system can closely guide box configuration and orientation
- + Works without alignment system as well
- + Config creation can have a direct link to packing ops
- Less optimal cart handling
- Cart must cross UAV path

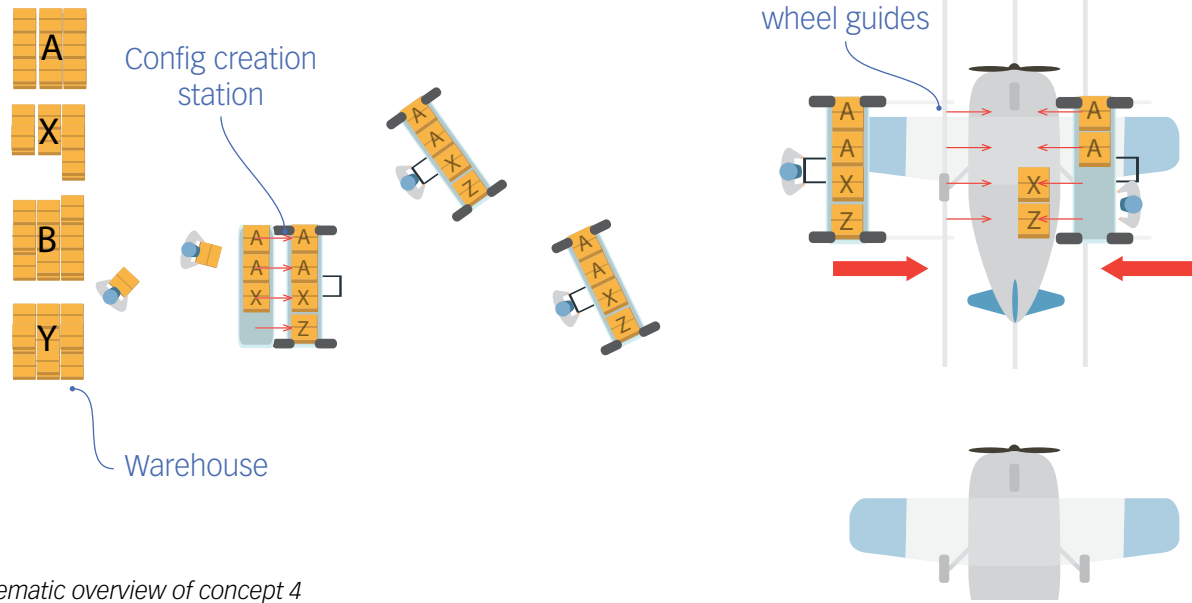

Figure 51 : Schematic overview of concept 4

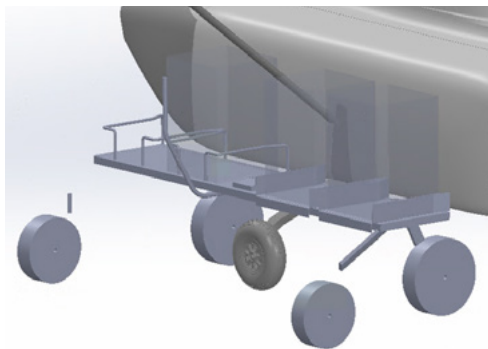

Figure 52 : CAD mockup of concept



Figure 53 : Cart prototype of concept

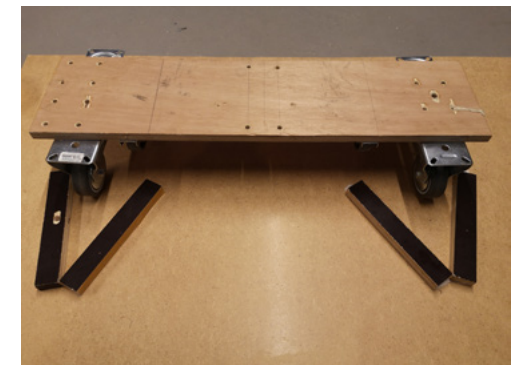
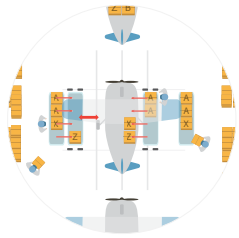

Figure 54 : Ideation of alignment system

▶ CONCEPT DECISION

The final concept was chosen using the weighted criteria method based on the relevant subcategories of the main drivers. the detailed scoring can be found in Appendix G.



1- WAREHOUSE LOADING

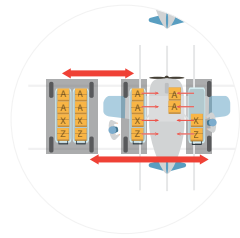
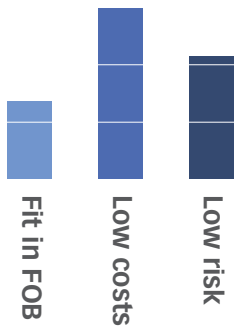

2- PIGGYBACK

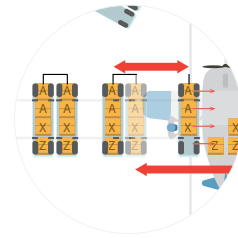
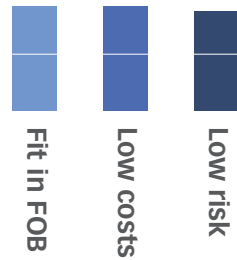

3 - COMBI CART

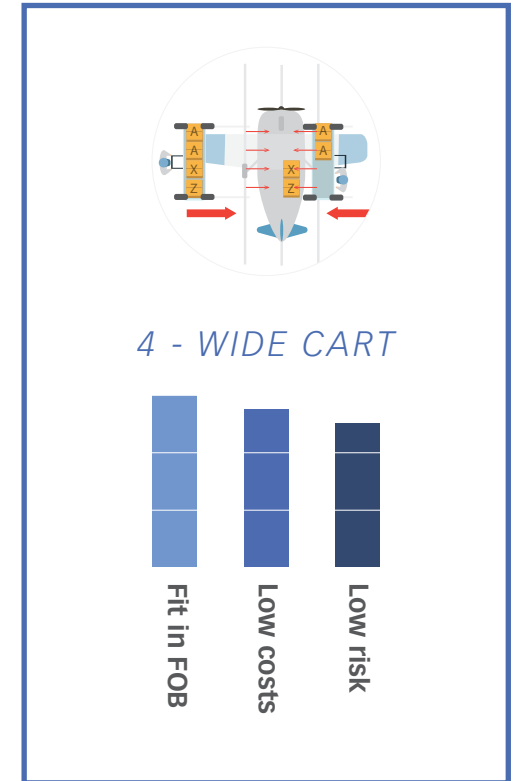
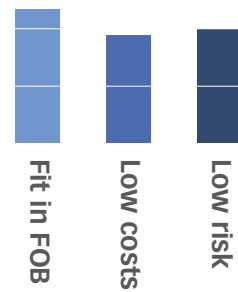

4 - WIDE CART

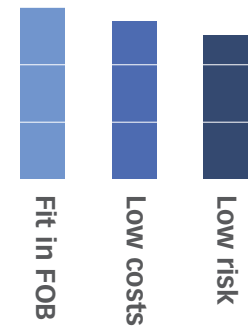

The wide cart can offer an optimal solution, as it removes the need for complex systems, while still providing a fast and ergonomic loading process. Due to its versatility, it does not hinder the planning of the layout of the operation. Although it was first thought the handling of a wide cart to be below par, the functional prototypes showed this to exceed expectation, negating its largest counterargument.

EMBODIMENT

After the selection of the wide cart concept, it was elaborated upon.

The embodiment was done based on the two main elements:

1. Create and maintain a correct configuration and orientation of boxes and the overall process
2. Transport and load the boxes into the UAV

Just as for the ideation, the focus for the embodiment was put on the second part. This part requires higher level physical prototypes in order to effectively validate the ergonomics and usage of the system.

On the contrary, creating and maintaining correct orientations and configurations can rely more on visual mockups in order to be validated.

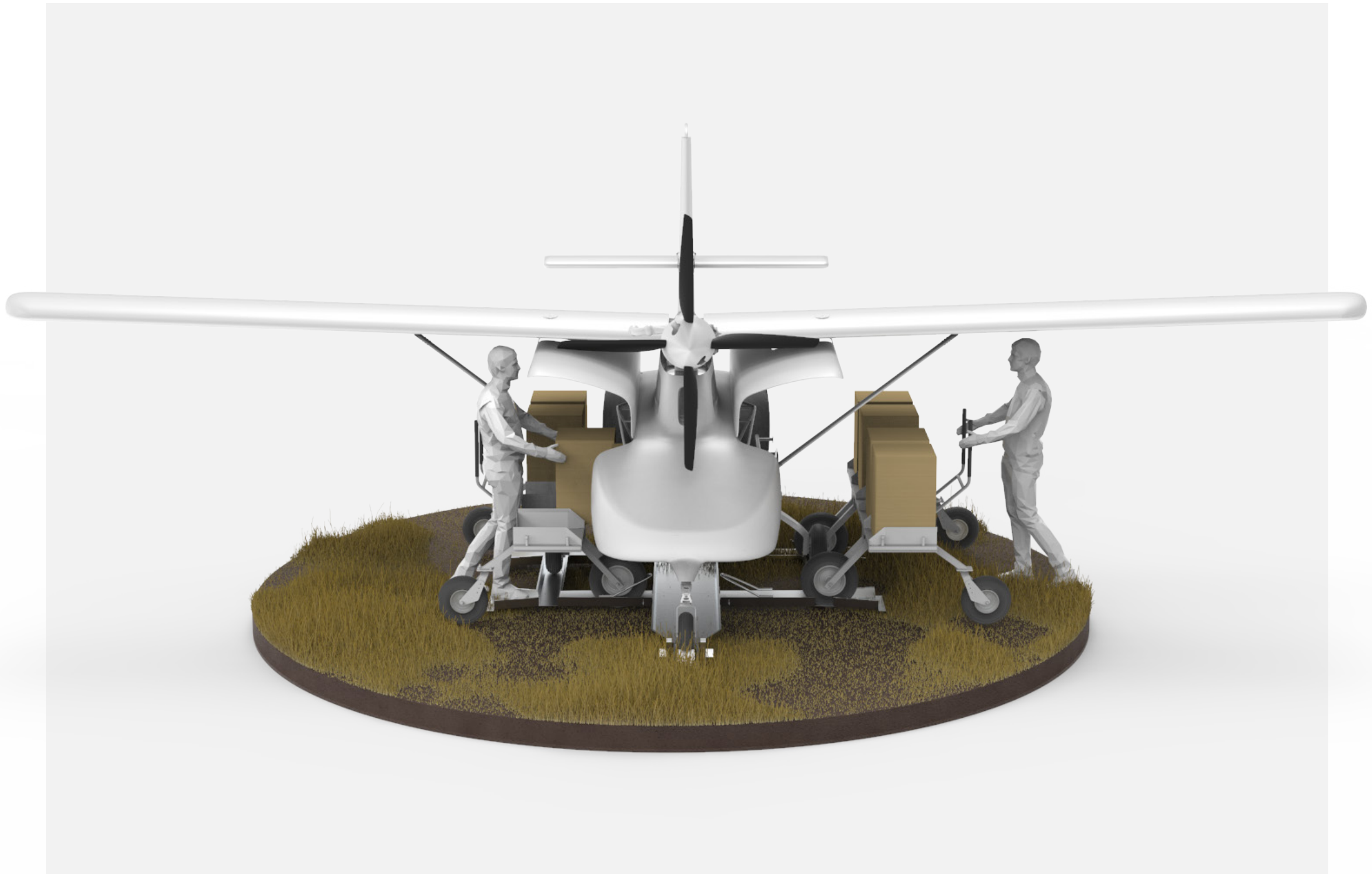

Figure 55 : Visualisation of final UAV loading process

▶ LOADING CART

DESIGN DRIVERS

To design a suitable loading cart, requirements derived from the main drivers were set up. The full list of requirements can be found in Appendix E.

FIT IN FOB

- » Easy transport and storage
- » Versatility
- » Minimal training required

LOW RISK

- » Stable and easy movement on unpaved terrain, such as grass or soil

LOW COST

- » Low and easy maintenance
- » Low system costs

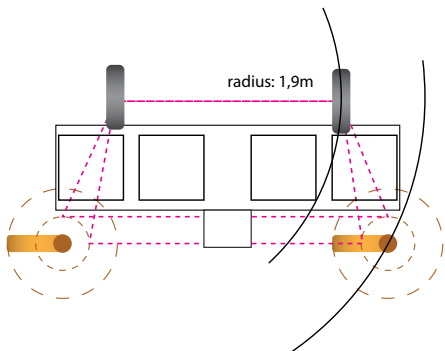

STABILITY

In order to create a stable cart, the center of gravity should always be kept within the ground plane at all times. A stable cart is realized when the center of gravity can project a 18° cone within the ground plane, see Figure 57 (Kyer, 2019). Full scale tests validated this, but just barely. Expectedly, a rough terrain was not taken into account. Therefore, the minimum wheelbase (when the cart is in reverse) was increased to 730mm. The maximum wheelbase is 1030mm.

Furthermore, an extended wheelbase makes it easier to overcome obstacles as the center of gravity is further away from the wheel, increasing the moment arm.

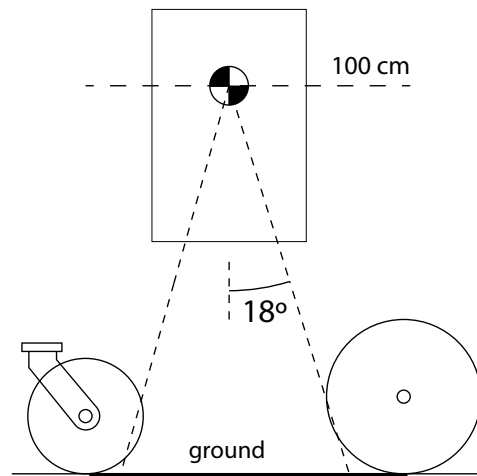

WHEEL CONFIGURATION

Different wheel setups were tested during the ideation phase, as shown in Figure 31. Based on this, it was chosen to use a set of fixed and a set of swivel wheels. The main benefit of this is the simplicity and freedom in implementation and they are off the shelf parts which function independently. This allows easy disassembly, low cost and easy maintenance.

The larger the wheel, the less effort it takes to overcome obstacles. 400mm wheelbarrow anti-puncture wheels were chosen for the fixed wheels. These wider and softer wheels sink less deep while the rounded wheel surface makes it easier to turn on soft terrain. A meeting with Blicke wheels validated this selection and offered the supply for the prototype.

For the swivel wheels a larger wheel also influences the stability, as a larger wheel decreases the ground plane further when the cart is reversed. It also increased the swivel radius which hinders movement in tight spaces. Therefore, a 340 mm wheel was selected. For a swivel wheel, a longer lead angle (see Figure 59) greatly reduces the effort needed to swivel

around. This was confirmed by testing a modified swivel wheel (see Figure 58) and implemented.

In order to make the loading cart easier to turn the front wheels are placed closer together. This lowers the torque required to rotate and decreases the turning radius. The rear wheels are kept to the edge of the cart, so the operator is not hindered by them when pushing the boxes into the UAV. See Figure 56.

The offset between the front and rear wheels allows the cart to be stacked against each other, minimizing the overall storage footprint.

More details on wheel selection considering configuration and ergonomics can be found in Appendix H.





Modular system
Independent parts to cater different UAV's or operations



Optimizes for transport
8 bolt disassembly
Parts are stackable and fit on a EURO 1 pallet

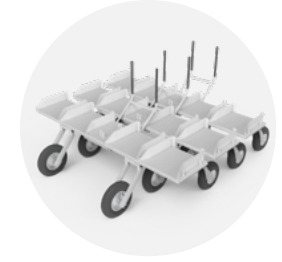

Stacking carts
Off set wheels allow space saving storage

Offset handlebars
Reduces turning force
Fit for global P5 to P95



Towing hooks
Allows the cart to be pulled by a vehicle



Folding box guides
Reduces storage space and damage to parts



Large anti puncture wheels
Reliable on any terrain

Narrowed wheel base
For easier turning

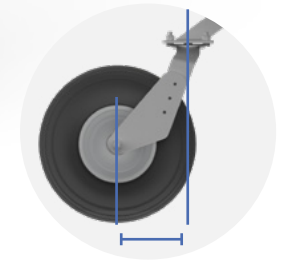

Increased lead angle
Reduces turning force on unpaved terrain

Figure 59 : Overview of loading cart features

▶ LOADING CART

HANDLES

Pushing is most effective and ergonomic when the force can be exerted at elbow height. (Song, Young 2013) For the handles to be used by 90% of global population, the gripping height must be between 916mm (P5 global elbow height) and 1206mm (P95 global elbow height) (Appendix H). A wider grip up to 46cm (CCOHS, 2020) allows to exert more twisting force needed to turn the cart, yet the handlebars cannot be in front of the boxes hindering the loading. Therefore, the handles are placed just between the inner boxes. By extending the handles further backwards, the turning arm is increased, optimizing handling.

BOX GUIDES

As the boxes only need to move on and off one side of the cart, the box guide rails stop the box at the rear. Yet, the inner middle of the box is kept free of obstruction to allow the user to place his hands, making it easier to slide.

The guide rails hold the boxes tight enough to prevent any rotation of the boxes and prevent changes in box orientation. Yet, a slight margin of 10 mm is kept around the box to allow the user to manually overcome slight alignment issues. Several different spacings were tested and 42cm was found optimal. The chamfered front makes it easier to align the boxes when loading onto the loading cart.

LOADED MOVEMENT

As two operations will never be the same, versatility in operation planning and layout is highly important to allow optimal fit for every kind of scenario. By allowing the cart to be transported while loaded, a larger distance between the box warehouse and the UAV loading process is possible, providing more freedom in layout planning.

Next to the movement by hand, the carts can also be linked together to create a train of loaded carts behind a (small) car. This allows transport over a greater distance by a single operator with ease.

The (un)loaded cart also just fits into a maneuverable smaller transport truck with a 2,3m internal width.

TRANSPORT

When transporting the loading cart without boxes, only eight bolts need to be undone in order for the cart to be taken apart and folded up. It can then be stacked on top of each other. The small feet to prevent damage to the box guides.

The complete package then fits on the preferred transport methods; on a standard euro pallet and in the lower holds of a cargo plane. This standardises transport logistics.

Folded up, it can even fit in the back of a larger car or pickup, to allow easy transport around the FOB.

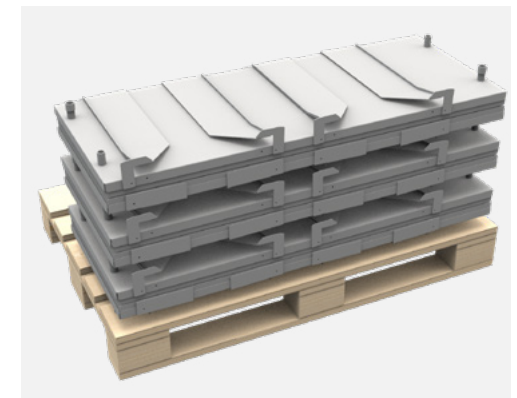

54 Figure 60 : Initial testing of wide cart prototype

Figure 61 : Mockup of folding box guides

Figure 62 : Initial testing of towing feature

Figure 63 : Transport of loading cart parts

▶ LOADING CART

MODULARITY

As the cart can be taken apart in several parts, it serves the basis of a modular system for multiple UAV models. When different UAV models are used for different operations, only parts of the cart need to be interchanged.

For example, to load new UAVs with a different number of boxes, only the main plate needs to be changed to match the correct box number and spacing. The wheels and handles can be kept the same. For different heights of cargo bays the cart can be slightly raised using spacers between the wheel brackets and the main plate up to a certain point.

As the upcoming UAV model was created with the lowest feasible cargo bay, the current height can be used as the minimum.

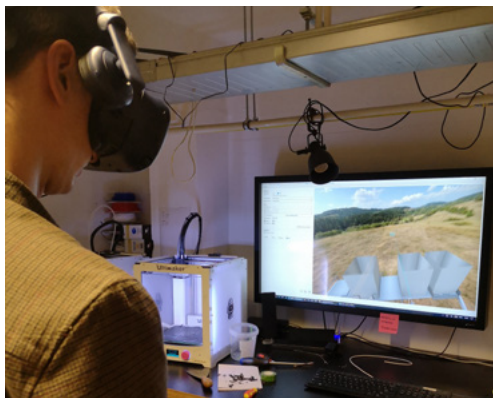

Figure 64 : VR validation of handles and view

MANUFACTURING

The frame is constructed out of lightweight aluminium tubing. Other parts are made out of aluminium sheet metal. Only the handlebars are constructed out of steel as FEA analysis showed aluminium was not strong enough. All parts use standard sizes and thicknesses and require no investment to be manufactured.

The aluminium tubing is welded and all sheet metal is riveted. By using these same construction techniques and materials as used for the UAV cargo bay, no extra skills or tools are needed to maintain the carts at the remote FOB. To protect the loading cart from the environment all parts are powdercoated.

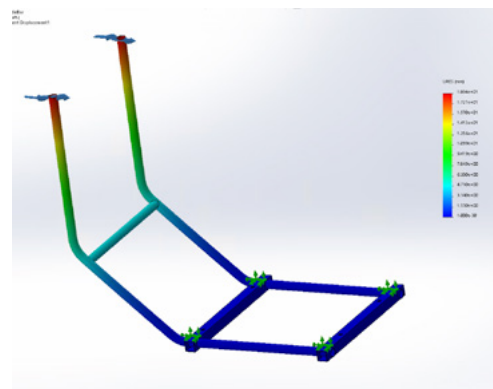
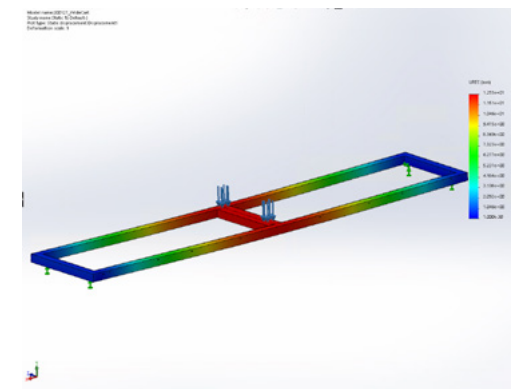
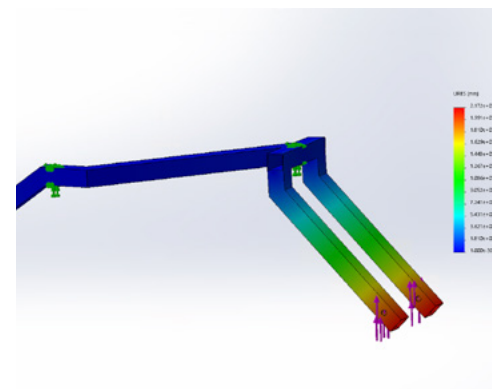

Figure 65 : Collage of FEA validation of parts

The used wheels are standard sizes and can easily be sourced from a supplier such as Blicke wheels. Unfortunately, the extended lead swivel wheel bracket was not found through a supplier. Therefore a customized off the shelf bracket was used to achieve the same result.

The total weight of the loading cart is only 45 kg and can support twice its maximum loading capacity. Total cost price per prototype cart is estimated at $\pm 1650,-$, based on references. This includes manufacturing, powder coating and assembly. Unfortunately, the exact quote from a manufacturer was not received in time for this report.



▶ ALIGNMENT SYSTEM

DESIGN DRIVERS

For the alignment system several requirements derived from the main drivers were set up. The full list of requirements can be found in Appendix E.

FIT IN FOB

- » Easy transport and storage
- » Quick and easy setup
- » Minimal training required

LOW RISK

- » Provides accurate and repeatable alignment

LOW COST

- » Low and easy maintenance
- » Low system costs

ALIGNMENT

The alignment system guides both the loading cart and the UAV to ensure the boxes can be slid into the UAV with ease. It should be a 'first time right' setup to remove any fiddling and ensure the UAV cannot get damages by pushing the loading cart too far.

As mentioned in chapter 'Design direction', the external rail system provides several advantages. As it is an external system, it allows the loading carts to be as simple as possible. It is also redundant, as the loading can still be done without it.

There are several tolerances in the system to create a satisfactory alignment as shown. These were found using the box sliding test setup shown in Figure 37.



X

The edge of the cart can be up to 8cm away from the hull of the cargo bay.

Alignment system provides adjustable stops

Y

UAV only has 13mm space on sides of boxes

Cart box guides allow 20mm movement for alignment during loading

Z

Cart should be higher than cargo bay bottom. It can be up to 6cm too high.

Alignment system provides adjustment system

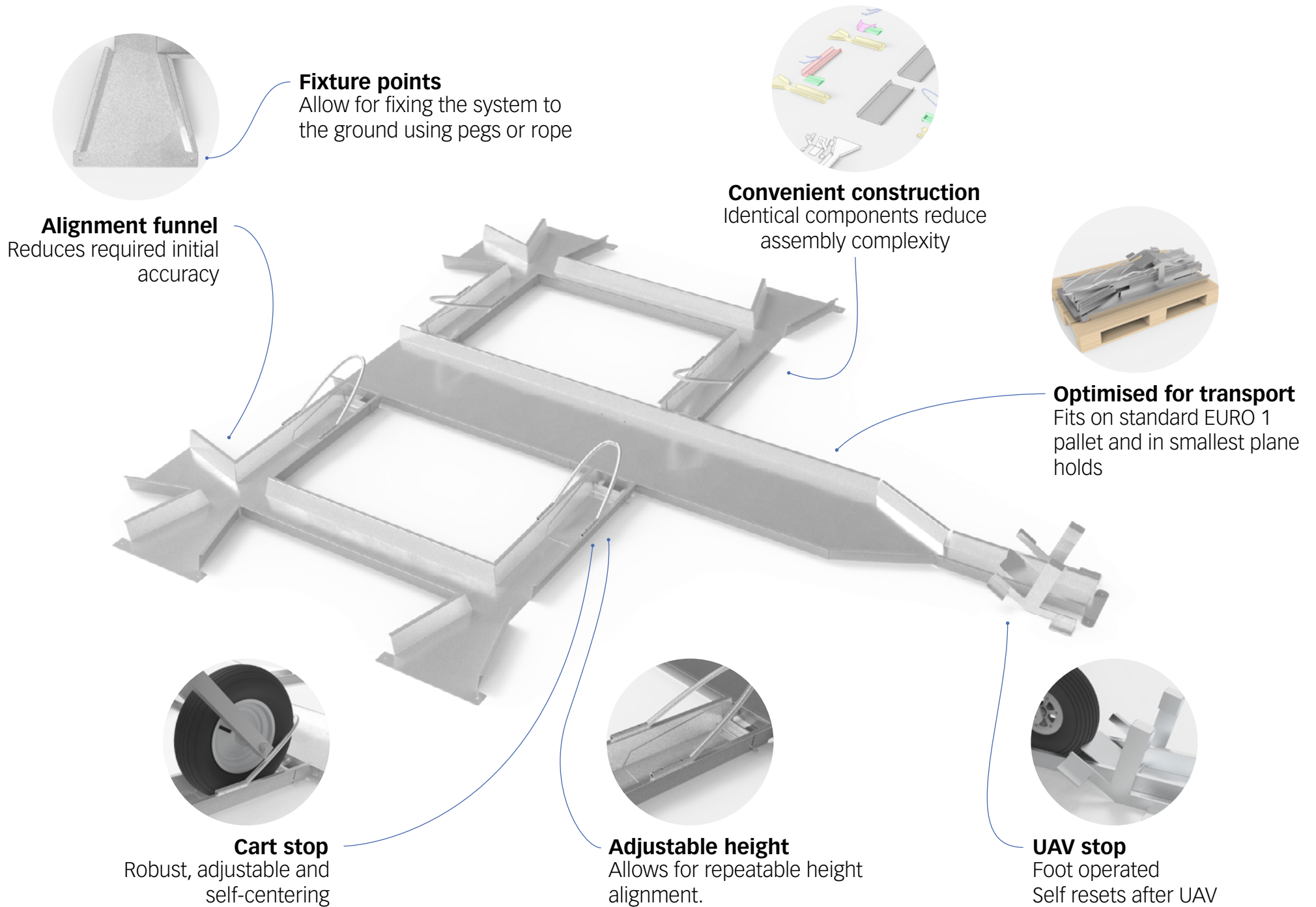

Figure 66 : Overview of alignment system features

► ALIGNMENT SYSTEM

PROTOTYPING

The functioning of the concept was validated using the cart prototype with tapered stop blocks. This proved easy and effective. See Figure 67.

To find the width and height of the rails, small tests were done by creating basic guides with different dimensions and rolling the loading cart wheel into it.

During ideation tests were done using V-groove rails, which self-center the round wheel. However, the found required tolerances did not have to be this tight, simple non centering U-rails were adequate.



58 Figure 67 : Alignment system prototype

TRANSPORT

As for all the Wings For Aid specific necessities, the alignment system must be transported to the FOB location.

As mentioned for the loading cart, standardised containers are used for logistics. The complete alignment system uses identical bolted connections and can be easily disassembled.

As all the parts do not exceed 800x1200mm, all parts fit onto a standard EURO 1 pallet and into the lower hold of cargo planes. Furthermore, as all the side edges are slightly tapered outwards and universal dimensions are used, the parts can be stacked into each other. As the heaviest part only weighs 8,9Kg, each part is easily lifted and hauled manually.

Assembly is simplified by creating as many identical parts as possible, as seen in Figure 68. This also improves ease of maintenance and spare part logistics.

MANUFACTURING

The alignment system construction was inspired by drive plates for motorcycles. They were also used during the user test. These are made to carry adequate weight, yet are lightweight.

All the main parts are designed to be produced by folding sheet metal the parts meant to stop the cart are made from bent tubing. Both these common processes reduce costs and prevent tooling costs. Costs are also reduced by using identical parts, as shown in Figure 68. To protect it from the environment, all parts are galvanised.

The total weight is just under 70kg, yet could be reduced by creating cutouts in the bottom surface.

Costs of sheet metal is €392,- (24tailorsteel, 2020), bent tubing; €98,- (Vanderhoorn, 2020) and galvanising is expected to be around €100,- (Coating.nl, 2020). Total expected costs are 590,- .

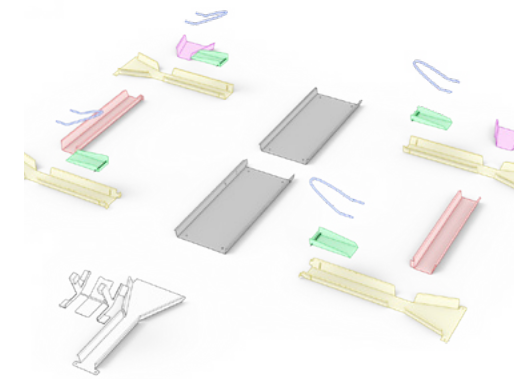

Figure 68 : Highlighted identical components

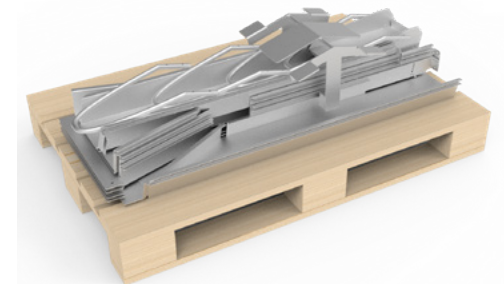

Figure 69 : Alignment system part on a pallet



Figure 70 : Motorbike drive plate inspiration



Figure 71 : Visual of loading cart in use

► CONFIGURATION CREATION STATION

INTRODUCTION

The Config Creation Station (CCS) is the first step in the process. This system concept was chosen within the concept decision, based on its speed and its ability to guide the operators effectively. See Figure 75 for an overview of the system.

At the CCS, the operators receive instructions on what configurations to make. These instructions are based on the required planned missions to deliver what, where and when. In order to create a foolproof system, the operators are guided by a digital system checking for mistakes. As mentioned in chapter 'Current loading observations', the two main errors to prevent are orientation and configuration errors.

Several drivers were set up to create a low error operation;

- » Internationally understandable
- » Only intervenes when a mistake is made
- » Is woven into the process instead of an additional step
- » Detects errors as early in the process as possible

BOX ID SYSTEM

During the packing operation of the boxes beforehand, the boxes are loaded with the needed cargo, weighed and registered. A label is then printed and will have the required information labeled on it, such as content (variant), weight and center of gravity, needed to ensure a balanced configuration with the correct aid. The label is then stuck on a specific spot on the box's lid.

It was initially deemed the label would incorporate digital data using RFID, however QR could be a viable solution as well. The CCS can make use of both technologies. It is advised to start using the system as simple as possible, by using just printed information for initial tests. Thereafter integrating the digital error checking later on.

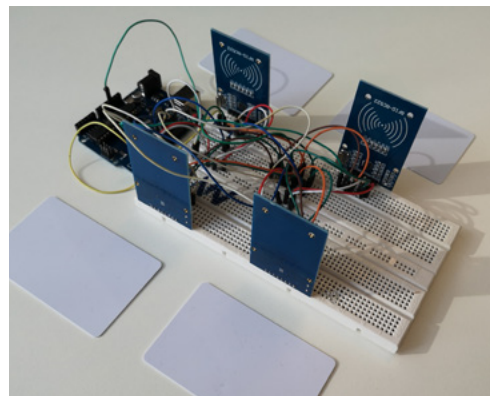

Figure 72 : Functional model of RIFD verification

PROCESS

On the CCS, the to-be created configuration is shown on the middle display. It was first thought to make several displays per box, however a single display centralized the info and only requires a single glance to read.

The patterns displayed on the CCS indicate in which orientation the boxes must be placed. The orientation differs if the configuration is for the left or right side of the UAV. This allows the user to know how to place the box.

Once a box is placed, the specific label position allows it to be scanned by one of the two readers. The operator receives feedback if the box position is correct. After all boxes are done and the loading cart is lined up against the CCS, the boxes are pushed onto



Figure 73 : Ideation of indication system

the loading cart. This also triggers the CCS to send the configuration info to the loading cart. The specific loading number and side are then displayed on the E-ink display of the loading cart.

PATTERNS

Initially it was thought to place different colors on the sides of the box to communicate the orientation, however this is not easily printed on the brown cardboard box and can be more difficult to distinguish in different light conditions. Therefore, monochrome patterns are used, the high contrast makes them stand out easily and only require black ink to be printed. Initial tests showed participants understood it and could use it to orient the box correctly.



Figure 74 : Ideation of orientation patterns

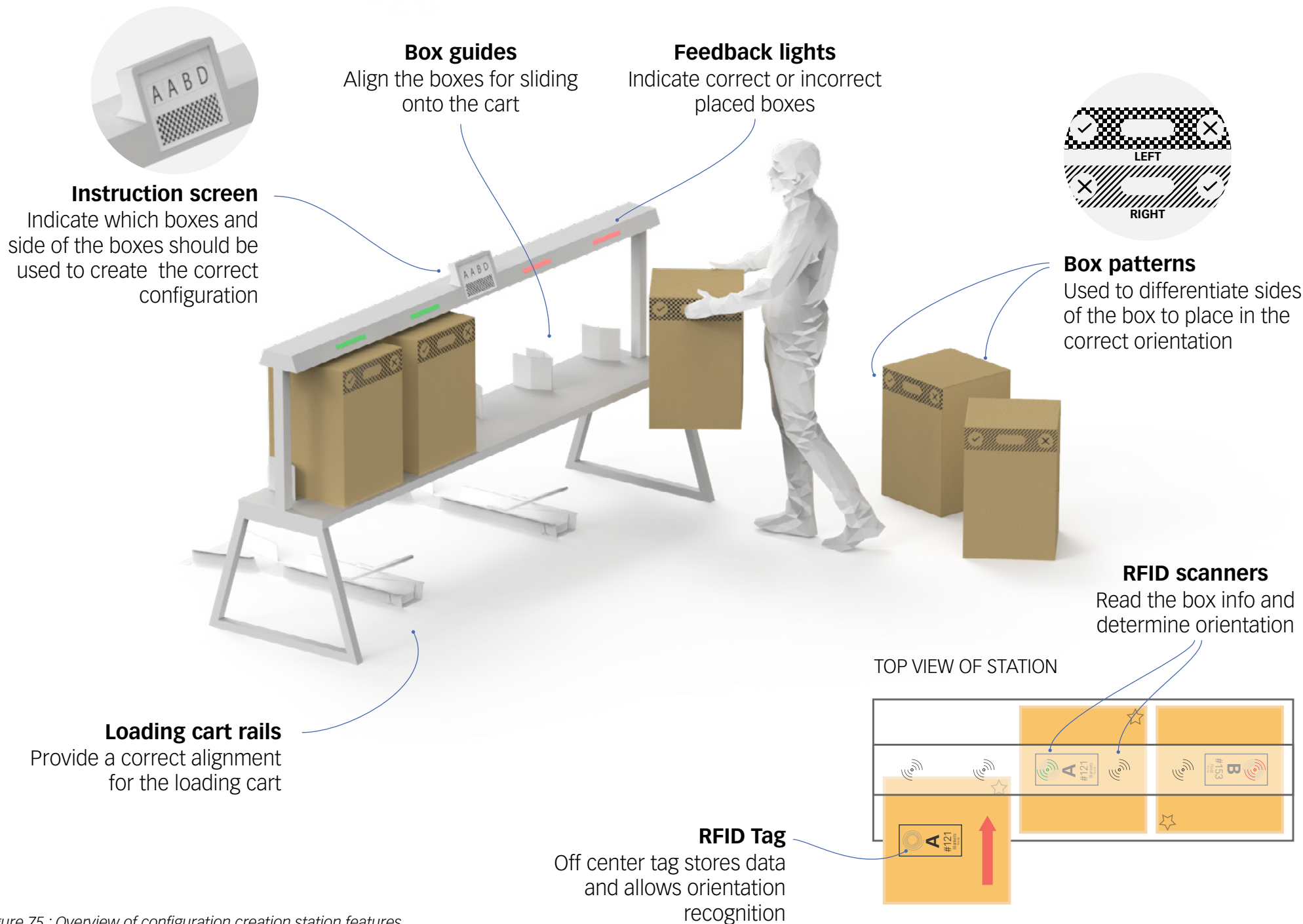
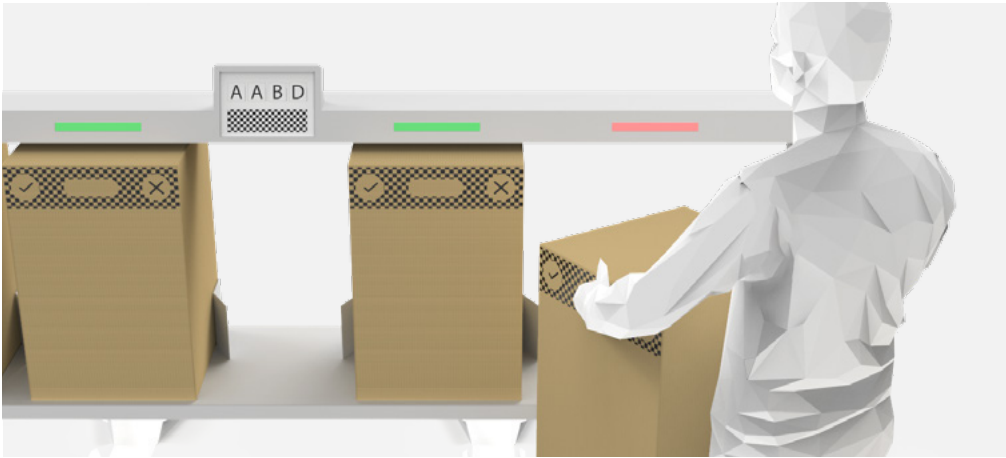

Figure 75 : Overview of configuration creation station features

▶ OVERALL PROCESS - CREATE CONFIG



① Central screen indicates which boxes are needed. Patterns indicated correct orientation



② Loading cart is lined up with CSS

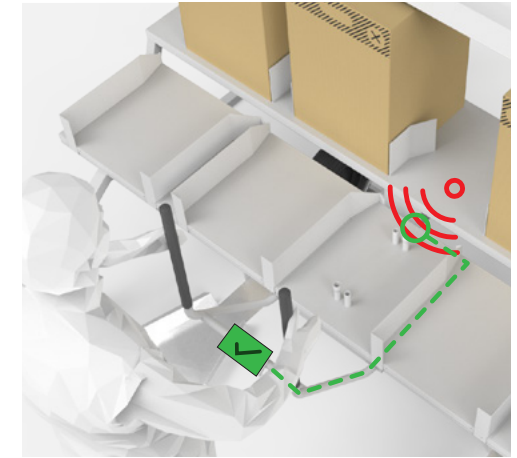

③ CSS transfers box data to loading cart and provides feedback



④ Boxes are slid on the loading cart



⑤ The loaded cart(s) are moved towards the UAV

▶ OVERALL PROCESS - UAV LOADING



- ⑥ Loading cart display indicates which side to load. Cart is driven into the alignment rails.



- ⑦ Boxes are slid into the UAV. Patterns inside the UAV allow verification of correct orientation

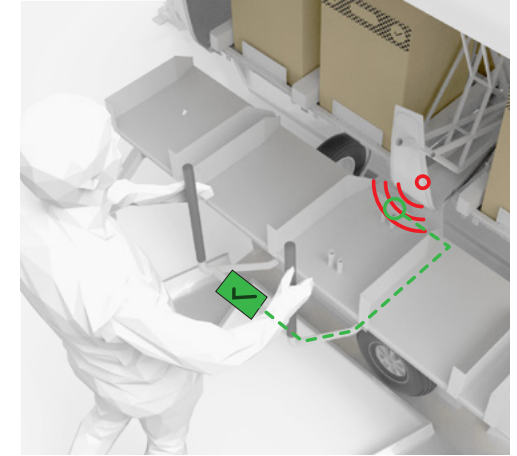

- ⑧ Loading cart sends box data to UAV and provides feedback to operator

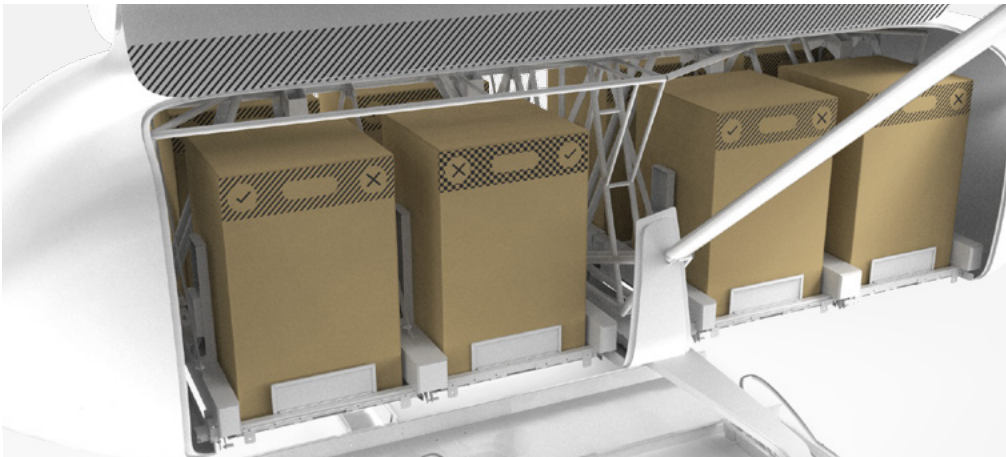

- ⑨ All boxes are loaded



- ⑩ Cargo door is closed. visual ports display any incorrectly oriented boxes for final check

VALIDATION

The overall functioning system and process was validated through a product usability evaluation. For this, several prototypes were created. A loading scenario was acted out in order to test the functioning of the loading process using the new concept



Figure 76 : Product usability evaluation in the rain

▶ PROTOTYPING

To validate the overall product system, a user test was set up focussed on product usability evaluation. As this is heavily dependent on the physical interaction between system and users, several functional prototypes were needed.

A production delay cancelled the use of the actual UAV cargo bay components in the test. However, this did enable the use of a single mockup for both the CCS and the UAV.

The focus of the prototyping was put on the loading cart, as this will be needed first in future and could be used directly when the UAV is finished.

For the alignment system, only one side was created. To represent the screens on the config creation station, two rotating indicators were created to change the configuration and orientation to be created.

Although several manufacturers were contacted to outsource the production, it was decided to do most of the work in house. This was faster and cheaper and allowed to gain more prototyping skills.



Cutting parts

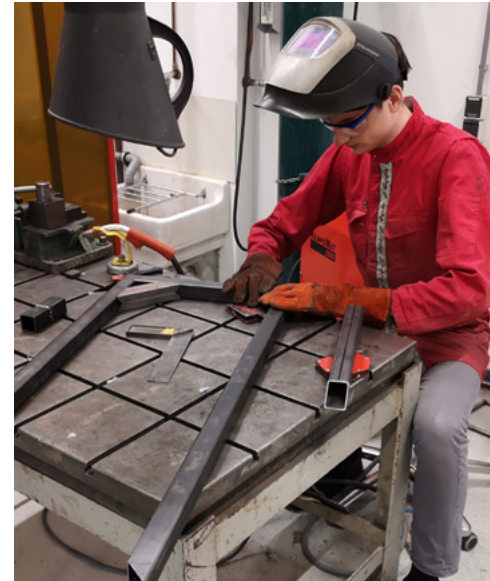

Aligning parts



MIG welding parts



Bending handlebars



Layout of components

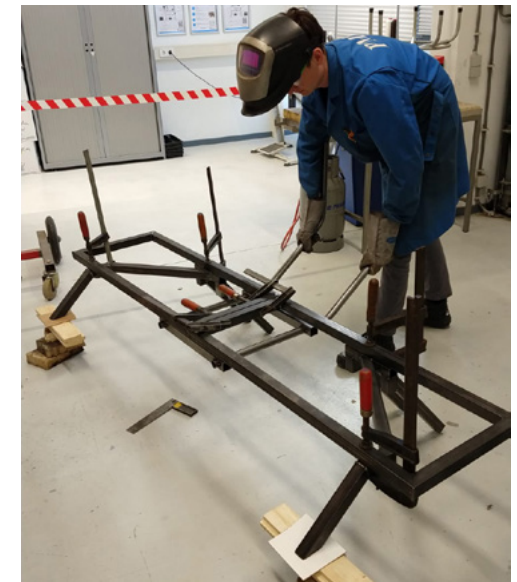

Verifying cart is level



Bending top sheet

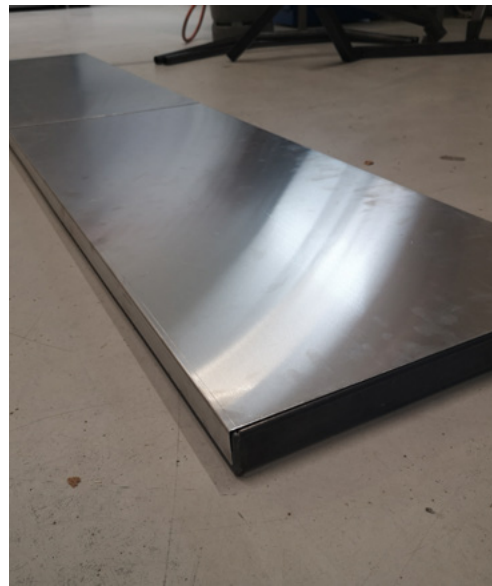

Mounting top sheet



Lining up the wheel axles



Ordered sheet metal parts



Mounting box guides

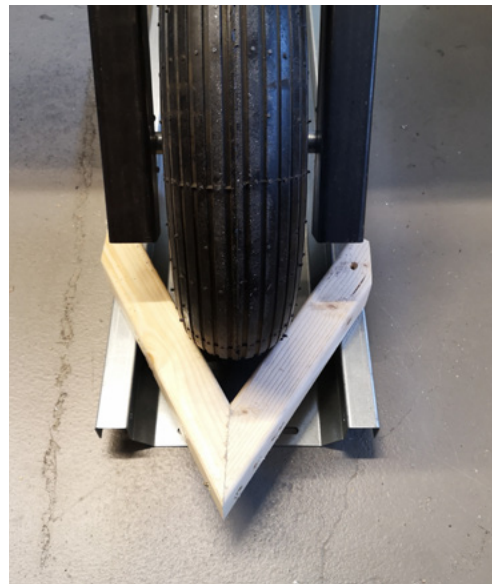

Prototype loading cart stop



Prototype CCS instructions



Box orientation indicators

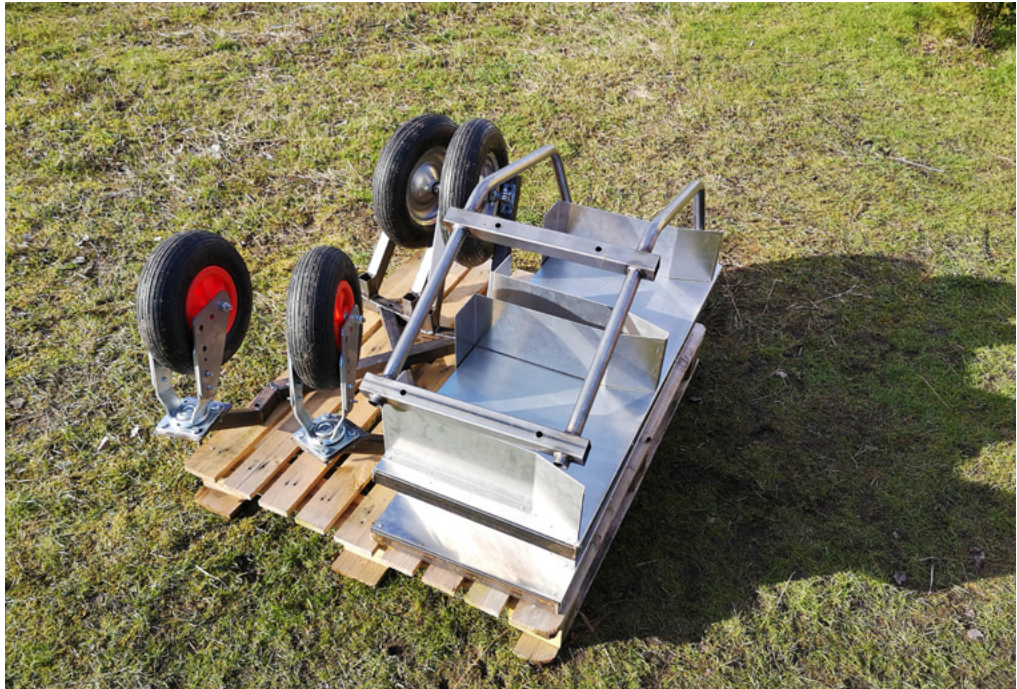
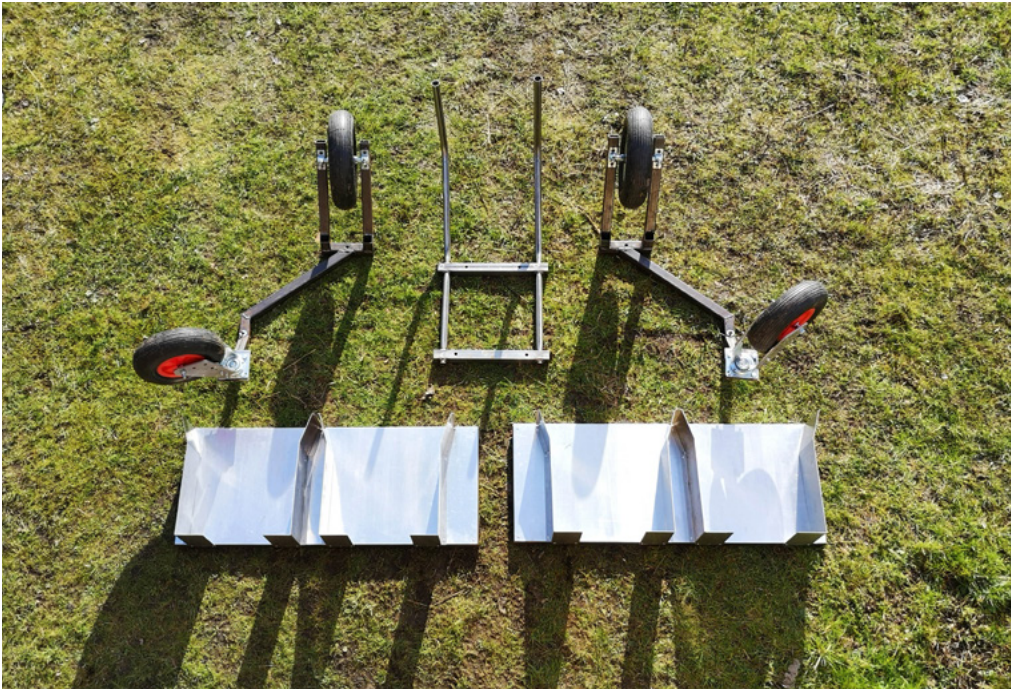
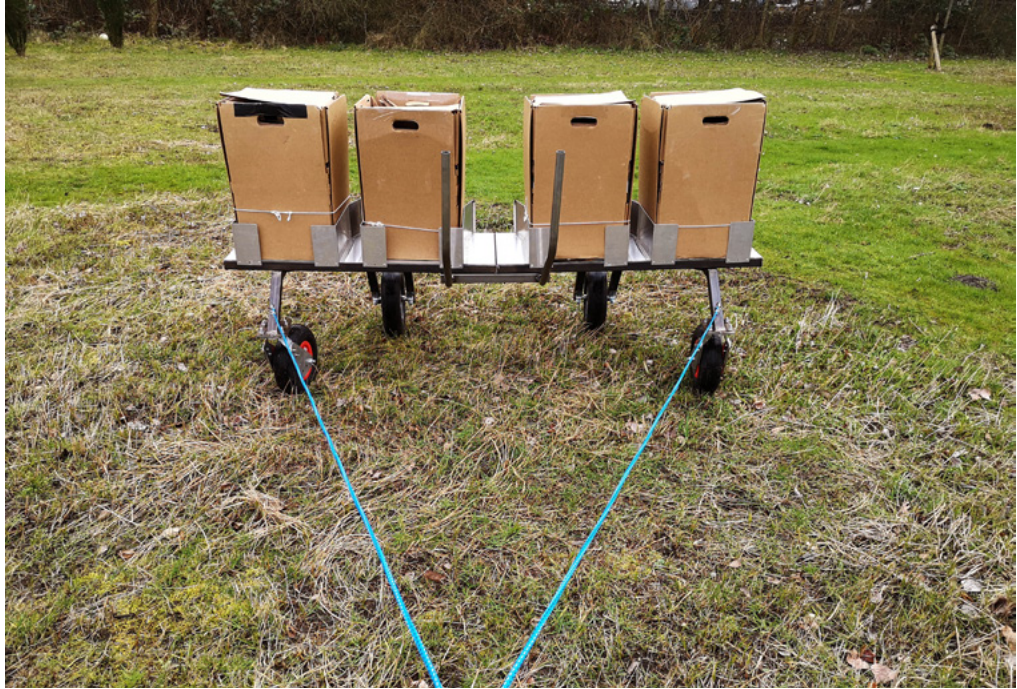

Figure 77 : Collage of loading cart prototype features



Figure 78 : Prototype setup of loading system for user evaluation

▶ USER TEST

SETUP

A product usability evaluation was conducted with the following research questions;

- » How does the usage compare to the intended use?
- » How intuitive is the process?
- » What is the influence of the separate parts?
- » How does the system compare to the status quo?

In order to answer these questions, the prototypes were used to simulate a loading operation. To simulate the correct environment, it was performed outdoors on a grass field. The overall process can be seen in Figure 79.

The participants were two male energy measuring systems installers. They had limited to no prior experience with industrial design or the project itself.

To gain qualitative data, the time, errors and the NASA Task Load Index questionnaire were recorded, providing insights on the performance and effort. Observations and brief semi-structured interviews provided qualitative data. All tasks were recorded on video.

1. Create box configuration



2. Align & load cart



3. Transport boxes



4. Align & load UAV



HOW DOES THE USAGE COMPARE TO THE INTENDED USE?

Overall the systems were used as intended; the loading cart operation and movement, the creation of correct box configurations and the alignment system usage.

It was intended to slide the boxes from one part of the system to another. However, the sliding friction was significantly increased due to the rain and the MDF and cardboard materials. Furthermore, the height difference between the loading cart and CCS/UAV was too little, resulting in the box catching the surface edges. This led the participants needing to briefly lift the boxes over the gap, increasing effort.

It was intended to push the boxes from the CCS onto the loading cart, however it was preferred to pull the boxes onto the loading cart. This was mainly due to the lack of brakes on the loading cart and the sliding issues.

“A brake would be convenient, now pulling the boxes is easier”
Participant 1

Figure 79 : Loading process as performed during product usability evaluation

▶ USER TEST

HOW INTUITIVE IS THE PRODUCT SYSTEM?

The participants were asked to carry out the operation after only receiving a general description of their task and goal, without details. All steps were immediately clear, except for the orientation indication as participants were misled by the emoticons. However, after only hinting at the orientation indicator on the CCS, it became immediately clear.

The duration of the full process (with one loading cart) quickly dropped from 4:57 to 1:11, see Figure 80. Error rate also dropped after initial sequence, only during the creation of the configuration several errors were made, see Figure 81.

“The cart moves easier than I thought and it is all terrain”

Participant 2

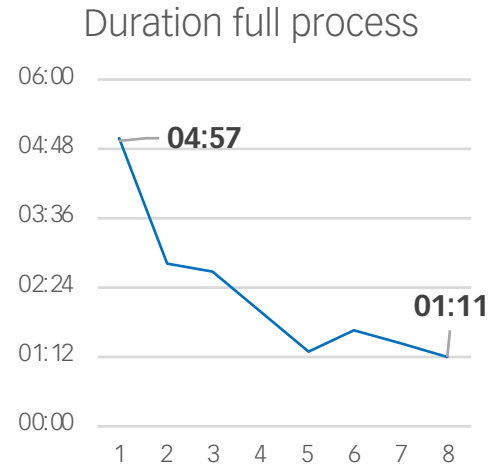

Figure 80 : Durations of loading process

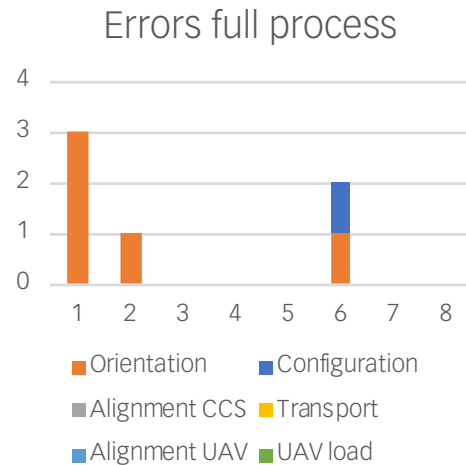

Figure 81 : Errors made during loading process

WHAT IS THE INFLUENCE OF THE SEPARATE PARTS?

Box indicators

The box indicators were crucial for understanding how to create to correct configuration of boxes. Without them, one participant indicated a significant increase in mental demand and an unnoticed error was directly made.

As mentioned the emoticons were misleading, as they only serve a purpose later on in the process.

However even with the indicators in place, errors were made. To have a completely error free operation, a (digital) confirmation system should be implemented, as included in the concept.

“Please keep the pattern on the boxes, it makes it a lot easier”

Alignment system

Although the participants indicated an improved performance after removing the alignment system (16,3 and 11,8 resp.), they only made errors without the system, mostly bumping into the ‘UAV’.

As expected, without the alignment system the loading cart was lower than the ‘UAV’, making sliding not possible without lifting the box first.

“The rails prevents me from bumping into the UAV”

▶ USER TEST

HOW DOES THE SYSTEM COMPARE TO THE STATUS QUO?

Lifting vs sliding

This is one of the main differences in the process compared to the status quo. Unfortunately, as mentioned, the sliding method did not work as well as it did before. The boxes still had to be lifted slightly, increasing the effort needed. The operators mentioned a preference for the lifting. Yet, the quantitative data showed no significant difference for the duration or task load questionnaire between the two methods.

However, the boxes were handled a lot rougher as they are almost thrown. This can have a devastating impact on the contents and functioning of the box, increasing risk and cost.

Therefore, sliding is the preferred method from the operation point of view.

When the sliding does work as intended, which was proven to work before, the required effort will reduce. See Figure 84. It is expected sliding will then also be clearly preferred by the operators.

SLIDING



Figure 82 : Loading by sliding during user test



LIFTING



Figure 83 : Loading by lifting during user test



SLIDING UAV CARGO BAY



Figure 84 : Loading by sliding using UAV cargo bays



▶ USER TEST

HOW DOES THE SYSTEM COMPARE TO THE STATUS QUO?

Overall

The user test only involved one loading cart, while the final process requires two loading carts per UAV, one for each side. Nevertheless, using the recorded times, the final process can be generated, see Appendix L.

The time from prepared boxes until they are loaded into the UAV, was reduced from 2:21 to 1:44, as well as reducing the overall mental workload. See Figure 85. However, it must be taken into account, this excludes potential necessary steps as removing the belts around the boxes, closing the cargobay and moving the UAV.

In the new process there is still a peak in the physical workload, however it must be taken into account this process used 20kg boxes. Furthermore, while transporting the boxes, twice the distance was covered over rough terrain in the same time. See Figure 85 for a comparison.



STATUS QUO



PROPOSED DESIGN

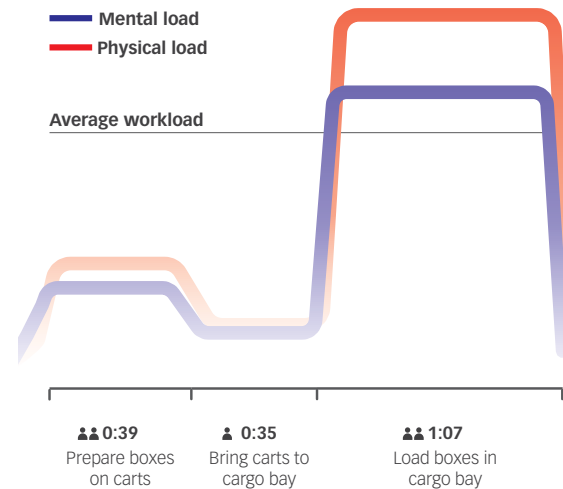

Total time: **2:21**

Familiar and educated
10kg
6
No
Yes

Operators
 Box weight
 # of boxes
 Specific configuration
 Specific orientation

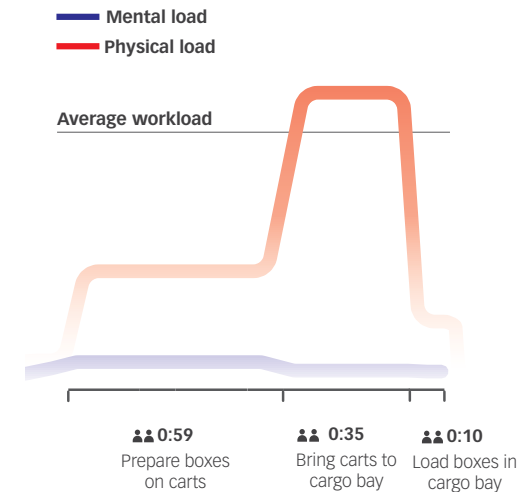

Total time: **1:44**

No prior knowledge
20kg
8
Yes
Yes

Figure 85 : Comparison between status quo and proposed design

► VALIDATION CONCLUSION

To validate the final design proposal, it is evaluated based on the created design brief and the (sub) drivers:

Create a loading system for the FOB with low risk and low operational costs

FIT IN THE FOB

Load within 4 min

The user validation showed the UAV loading operation will only take 1:44 min. Although This does depend on the distance between the CCS and the UAV. Furthermore, some minor additional steps might be necessary. Nevertheless, it can be concluded this operation should be able to fit into the envisioned 4min throughput. If cut down enough it could be performed by a single operator. Otherwise, any spare time can be spent on supporting the adjacent box packing process.

Usability in harsh conditions

Although it is not yet fully clear what the conditions will be during operation, the system has proven to function on rough terrain. Several features allow movement and alignment on unpaved and uneven terrain. An additional feature should be implemented to protect the boxes on the loading carts from the rain during transport. If conditions become more extreme, the loading system is not expected to become the limiting factor.

Long & short term viability

The simplicity and modularity of the system makes it both quickly deployable to provide functionality at the start, as well as to adapt to changes during the operation to stay viable over time. Furthermore, the configuration verification of the CCS supports both inexperienced operators at first, yet also minimizes intervening in the process of experienced operators.

Versatility in operation

The modularity allows the system to fit different UAV models. The different loaded transport options allow both small and large distances between the warehouse and the UAV loading site, simplifying site planning when space is limited.

LOW RISK

Minimal human error

Even without the configuration verification system, the minimally trained participants only made minimal errors after their first try of the user study. The low mental demand indicated the little effort needed to achieve this. However, it was only tested using a simulated scenario without the actual UAV. Testing during a larger operation with the UAV is expected to pose new opportunities for error.

Reliable systems

By creating minimalistic functional systems and the use of familiar materials and construction, the capability of the system is more predictable. Still, in order to validate this, higher level alpha prototypes are required which resemble the proposed design.

LOW OPERATIONAL COSTS

Low quantity minimally trained (local) workers

The more intuitive process including verification removed uncertainty and lowers mental demand. It was shown to be possible to implement minimally trained workers, without increasing risks. However, more studies with more than two participants are needed to verify this.

Low system costs

By creating minimalistic functional systems, the use of familiar materials and construction production costs are minimized. Two initial loading cart prototypes and an alignment system will cost around €3800,-. The CCS must be developed further to validate this.

Low transport costs

The UAV loading system can be easily disassembled and fit into the expected transport systems as used for the other systems. Further optimization can be done to reduce weight and transport volume. The CCS must be developed further in order to validate this.



Figure 86 : Product usability evaluation

CONCLUSIONS

The following chapter concludes the project, after which recommendations are presented for the continuation of the project.

Finally, the report is concluded with a reflection and acknowledgements on the the project.

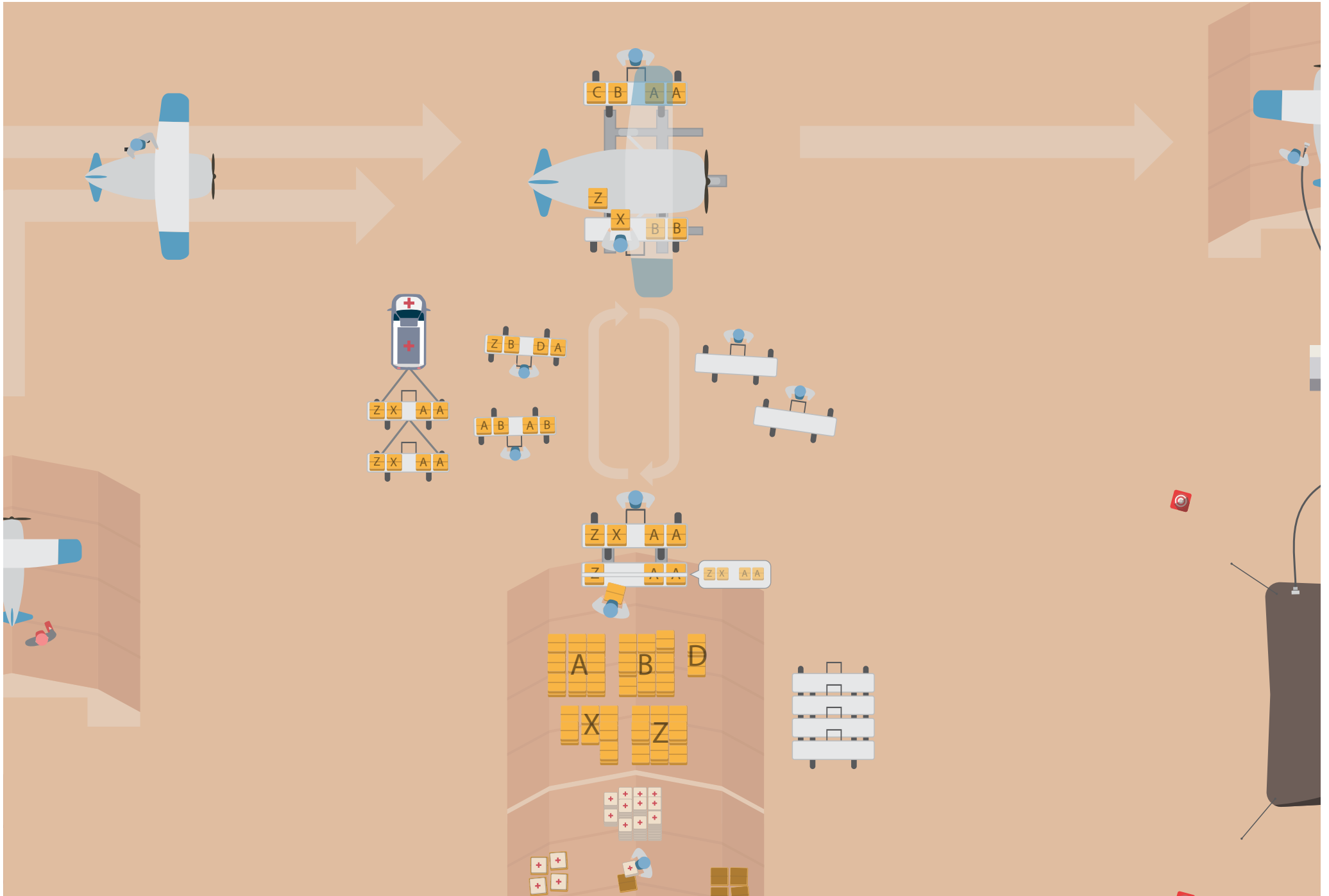

Figure 87 : Schematic overview of proposed design implemented into WFA operation with

► CONCLUSION

In the aftermath of a disaster, Humanitarian Aid Operations must operate in highly uncertain and complex contexts in order to provide the lifesaving aid to the people in need. The systems currently were found to not integrate well in these scenarios and to be suboptimal.

The novel Wings For Aid (WFA) concept could drastically improve this. However, although there are already first prototype systems, the initial operation must still take shape. This overall operation is a crucial part in tying all its components together in an efficient and viable system. The more the overall operation, the processes and products within are optimized, the more lives can be saved faster, with lower costs and lower risks.

Based on the identified Key Performance Indicators of current HAO's, a potential future vision of the WFA and Forward Operating Base (FOB) operation was created. By modelling the FOB operation, statistics were found for a future operation, as well as a future context to design within. This showed its viability to be promising. It can deliver high amounts of cargo directly to the people in need, for competing cost with the currently used systems.

Although many elements of the complex WFA FOB operation need to be elaborated upon, the project continued by focusing on the UAV loading process. This is a crucial step in the operation in order to deliver the correct aid to the correct locations. Furthermore, it is the most WFA specific step within the FOB operation and offered many design opportunities and relevance within the overall WFA system development.

Through observations of the current loading process used during tests, several design opportunities were identified for the creation of a novel system. Altogether, the research led to the following design brief:

“Create a loading system for the FOB with low risk and low operational costs”

The proposed system provides a novel solution to load the WFA UAV in the required cargo box configuration. This solution fits the overall FOB operation very well, as it fits in the required throughput time, can be used in harsh conditions and is highly versatile. The system reduces the risks of incorrect UAV loading, which could have devastating effects. Furthermore, its simplistic, yet optimized construction

minimizes the system, maintenance and transport costs. Finally, the foolproof usage allows only two minimally trained local workers to perform this process with minimal errors, highly reducing the operational costs.

In order to validate the proposal, several prototypes were created, followed by a user test to evaluate the product usability. This confirmed the functioning of the system and its intended use, proving it to be a highly promising solution.

However, the main limitation of the project is the fact that the operation it has been designed for, is currently only hypothetical. Therefore, it was strived for to create a realistic future scenario and create a highly flexible system, based on independent elements, to adapt to changes. A small change could potentially have a large impact on the (sub)operations and the requirements within them.

Nevertheless, the resulting system can already be (partially) implemented into the current phase of the project, during upcoming demonstrations and pilot tests. This direct application allows for early insights for further development.

► RECOMMENDATIONS

The project, user and expert evaluations resulted in recommendations for the continuation of the loading system.

GENERAL

- » Gain more insights on the requirements for contexts such as warzones or slow onset disasters, which were excluded in the scope of this project.
- » Obtain more detailed insights in how Humanitarian Aid Organizations could integrate the WFA system into their operations, to further specify needs and drivers.
- » Keep further developing the operation and the possible scenarios to evaluate the integration of the proposed system.
- » Further develop the proposed system based on the two main functions; (1) create and maintain a correct box configuration and (2) transport and load the boxes into the UAV. Focus on the second function first as this is the core of the concept. Continue by integrating parts of the first function, through

the box patterns and indicators to allow verification of orientation during tests. Only then continue on the CCS system to create the configuration, as this mostly adds value in more developed future operations.

- » More elaborate evaluations methods by setting up extended tests including a higher number of participants and in different environments. Include updated alpha prototypes and the upcoming UAV to perform two-sided loading operations. This will provide significant insights in the functioning and additional errors possibilities of the system.

LOADING CART

- » Protect boxes from rain. A roof is not recommended as it hinders user movement during loading. An optional tarp could be a potential solution.
- » Remove folding guides, create fixed guides which allow stacking. The folding guides only beneficial during the short period of setting up the system. The expected improved reliability of fixed guides outweighs this benefit.
- » Create bend on the front of the cart to reduce the box catching the edge
- » Improve wheel brackets space claim during transport
- » Find better source for the custom swivel wheels
- » Add an orientation indicator on the cart to allow verification without the CCS during initial tests
- » Create box locks to prevent the boxes from falling off. This is found to be possible with boxes loaded with a very height center of gravity during sudden stops
- » Add a deadman's brake to prevent cart from rolling away when not in use
- » Test the towing feature with multiple carts
- » Experiment on a new sliding surface to reduce weight and lower the wet surface from the rain, potentially affecting the cardboard boxes.
- » Test horizontal handlebars as users mentioned this to be potentially beneficial.

► RECOMMENDATIONS

PROCESS

- » Remove the checkmarks / smileys. Integrate visuals which only makes sense later in the process to remove initial confusion. For example, a line of the box aligns with a line next to the port in the UAV.
- » Experiment with different orientation patterns and placement on the box.
- » Place the instructions and feedback system of the CCS on the bottom of the CCS. The user test indicated this could be a more intuitive placement.
- » Improve intuitiveness of hand placement during sliding boxes. Experiment on a possible loading tool to improve sliding task.
- » Develop and integrate a system to transfer data of the box and flight information to the UAV.
- » Further develop feature to reduce the risk of placing a loading cart on the incorrect side of the UAV.
- » Further develop the box packing operation and connect it the UAV loading operation, to integrate the box identification system and warehouse storage into the complete process.
- » Investigate the possibility to remove the need for belt around the boxes. These normally keep the airbrakes of the box together to ease the handling and loading.



Figure 88 : Product usability evaluation

► REFLECTION

ASSIGNMENT

One of the most compelling aspects of the project was its potential impact. The outcomes of the project could potentially be directly implemented and benefit the further developments of the WFA system. I looked forward to being able to use my knowledge to support such a good cause.

ANALYSIS

The assignment I started out with to identify and analyze the ground operations was broader than expected and involved many different levels of complexity. As the WFA system only existed out of an aircraft test platform, all the elements concerning the operation and upcoming UAV around it were still mostly unknown. Within every layer of the operation, new elements and insights were discovered and the scope kept growing.

Combined with a rough personal period, and being out of my comfort zone, the analysis phase was a struggle. However, through all the project support I received, I was able to get back on track. Nevertheless, I have learned a great deal on all the aspects of humanitarian and remote operations, from planning to people, to systems. As well as how to try to fit all these pieces together in a strategic way.

EMBODIMENT

Although I was held back at first by the size of the project to start prototyping on a full scale, this then provided insights directly. This hands-on approach allowed me to think with my hands and validate ideas quickly and showed my expertise within this. Nevertheless, it also pushed me to grow in this area. Improving my approach on how to create minimal viable prototypes to find the insights I needed. Furthermore, I gained more knowledge on how to design for cost effective production in low volumes, such as tube bending, sheet metal and welding. Although the outcome might appear as a simple cart and some gutters, I strongly believe that this is exactly what the hands-on developments led to; simplify the design and strengthen functionality.

PARTNERS

The possibility to execute this project within VanBerlo and the direct connection to the stakeholders allowed me to keep short lines of communication and adopt and adjust alongside the fast moving WFA project. This resulted in the proposed system to be usable for the parallel developed UAV, as well as insights which were integrated into the UAV design. Yet, this graduation project was still kept separate from the main developments.

OVERALL

Looking back, it was an intense and great project and I am satisfied with the result. I believe this result has a lot of potential and provides a validated future proof foundation to build upon. Its potential to be integrated into upcoming tests allows for early iteration to grow within the WFA project. I am curious to see if and how it will grow!



► ACKNOWLEDGEMENTS

I would like to thank the following people for supporting me and getting the most out of this project.

Henk

Thank you for your dedication and honesty throughout the project. Your guidance kept me sharp and your experience and network lifted to project to another level.

Erik

Your wisdom did not only provide perspective within the project, but also helped protect me from myself.

Eric

Thank you for making this project possible and because of your guidance from the WFA perspective, maximizing the potential impact of the result.

Roeland

Your guidance and readiness to directly help out have been amazing. And being able to continue on the WFA project with you have been both very insightful and very fun.

Barry

Thank you for making this project possible and providing me with all the possibilities and your network

Alexis

Thank you for all your help throughout the project and all the WFA engineering discussions

Mom

Thank you for all the loving support, I could not have pulled through without you.

Taco Schuur

Thanks for all your down to earth advice, your sarcastic jokes and great modelling help.

My housemates

Thank you for taking my mind off the project, all the support and great food.

Taco Sieben

Thanks for all the fun and joining me discover the world of welding to make the result possible. A Je to!

▶ REFERENCES

- » Air Services Australia. (n.d.). Runway Selection. Retrieved from Air Services Australia: http://www.airservicesaustralia.com/wp-content/uploads/12-139FAC_NCIS-Runway-selection_P2.pdf
- » Amadeo, K. (2019, June 25). Haiti Earthquake Facts, Its Damage, and Effects on the Economy. Retrieved from The Balance: <https://www.thebalance.com/haiti-earthquake-facts-damage-effects-on-economy-3305660>
- » ARBO. (n.d.). Arboportaal. Retrieved from Regels voor werktijden: <https://www.arboportaal.nl/onderwerpen/regels-voor-werktijden>
- » Black, R., & Blaum, R. (2018). Even Heavier Weather. London: Energy & Climate intelligence unit.
- » Brouwer, E. (2019, September 27). Humanitarian aid operation and integration of WFA. (M. Weetzel, Interviewer)
- » Bunk, Y., Faber, M., Jong, D. d., Lodder, L., Loo, L. M., Mollema, M., . . . Vertonghen, L. (2016). DSE - Wings For Aid. TU Delft.
- » C-130 Hercules. (2018, June 20). Retrieved from U.S. Air Force: <https://www.af.mil/About-Us/Fact-Sheets/Display/Article/1555054/c-130-hercules/>
- » C-130J Specifications and Performance. (n.d.). Retrieved from global security: <https://www.globalsecurity.org/military/systems/aircraft/c-130j-specs.htm>
- » Casner, S., & Gore, B. (2010). Measuring and Evaluating Workload: A Primer. Moffet Field: NASA.
- » CCOHS. (2020, 03 14). Pushing & Pulling - Handcarts. Retrieved from CCOHS: <https://www.ccohs.ca/oshanswers/ergonomics/push2.html>
- » Chandraprakasul, W. (2010). HUMANITARIAN SUPPLY CHAIN MANAGEMENT: LITERATURE REVIEW AND FUTURE RESEARCH.
- » Chitagu, T., Schemm, P., & O'Grady, S. (2019). 'It was too late': Hundreds are dead as rescue efforts stall in Mozambique and Zimbabwe. Washington Post.
- » Chris Klimek. (2016, March 9). An Aerial Food Drop Over Syria Missed Its Target, and That's No Surprise Read more at <https://www.airspacemag.com/daily-planet/anatomy-high-altitude-air-drop-180958361/#181p3h0rXuMytalm.99>. Retrieved from Airspace magazine: <https://www.airspacemag.com/daily-planet/anatomy-high-altitude-air-drop-180958361/>
- » Chutel, L., & Wolfe, D. (2019). Satellite images show Mozambique's Beira city before and after Cyclone Idai. Quartz Africa.
- » Crutchfield, M. (2013). Phases of Disaster Recovery: Emergency Response for the Long Term. Reliefweb.
- » Csereklyei, Z., & Stern, D. I. (2018). Flying more efficiently: Joint impacts of fuel prices, capital costs and fleet size on airline fleet fuel economy. Centre for Climate Economics & Policy .
- » Darcor. (2001). The Ergonomics of Manual Material Handling: Pushing and pulling tasks. Ontario: Darcor.
- » Defense Media Activity. (2010, Januari 20). Maritime Force Serves as Cornerstone of Relief Operations in Haiti. Retrieved from America's Navy: https://www.navy.mil/submit/display.asp?story_id=50696
- » Department for International Development. (2019, March 20). UK to provide extra £12 million in UK aid for survivors of Cyclone Idai. Retrieved from Gov.uk: <https://www.gov.uk/government/news/uk-to-provide-extra-12-million-in-uk-aid-for-survivors-of-cyclone-idai>
- » Dyer, C. (2019, 12 4). 168 million people worldwide will need emergency aid of some kind in 2020 due to climate change and wars, the UN warns. Retrieved from Daily mail: <https://www.dailymail.co.uk/news/article-7754273/UN-launches-29-bn-emergency-funding-appeal.html>
- » Earthquake in Haiti. (n.d.). Retrieved from Nations Online: https://www.nationsonline.org/oneworld/Haiti_earthquake.htm
- » Government of Haiti. (2010). Action plan for national recovery and development of Haiti. Port-au-Prince.
- » Goyet, C. d., Sarmiento, J. P., & Grünewald, F. (2011). Health response to the earthquake in Haiti. Washington DC: Pan American Health Organisation.
- » Johnston, J. (2019, Januari 11). Haiti by the Numbers. Retrieved from CEPR: <http://cepr.net/blogs/haiti-relief-and-reconstruction-watch/haiti-by-the-numbers>
- » Kim, J.-C., & Chung, K. (2017). Emerging risk forecast system using associative index mining analysis. Cluster Computing.
- » Kyer, M.-A. (2019, 11 10). Calculating the Stability of Your Equipment. Retrieved from Vention: <https://vention.io/blogs/calculating-the-stability-of-your-equipment-89>
- » Levinson, D. (2011). Operating Costs for Trucks.
- » Mark Thompson. (2007, September 26). V-22 Osprey: A Flying Shame. Retrieved from Time: <http://content.time.com/time/magazine/article/0,9171,1666282,00.html>

▶ REFERENCES

- » Mark Thompson. (2013, April 2). Costly flight hours. Retrieved from Time: <http://nation.time.com/2013/04/02/costly-flight-hours/>
- » Melkert, J. (2019, Oktober 30). Interview on the WFA graduation project. (M. Weetzel, Interviewer)
- » Mike Nudelman, Jeremy Bender. (2016, March 3). Business Insider. Retrieved from This chart shows the incredible cost of operating the US Air Force's most expensive planes: <https://www.businessinsider.com/air-force-plane-cost-per-flight-hour-chart-2016-3?international=true&r=US&IR=T>
- » Murfin, T. (2018). UAV Report: Growth trends & opportunities for 2019. GPS World.
- » OCHA. (2019). MOZAMBIQUE: Cyclone Idai & Floods: Situation Report No. 12. OCHA.
- » Richard Pallardy. (2010, Januari 15). 2010 Haiti earthquake. Retrieved from Britannica: <https://www.britannica.com/event/2010-Haiti-earthquake>
- » Ritchie, H., & Roser, M. (2019). Natural Disasters. Retrieved from Our World in Data: <https://ourworldindata.org/natural-disasters>
- » Roseillier, A. (2019, September). Project brief meetings. (M. Weetzel, Interviewer)
- » SEI industries. (n.d.). SEI industries. Retrieved from Custom pump systems: <https://www.sei-ind.com/products/litre-hosen-cpd/>
- » Slagter, A. (2019, September 27). Interview on operation organisation and desing of FOB. (M. Weetzel, Interviewer)
- » Sphere Association. (2018). The Sphere Handbook. Geneva: Sphere.
- » Song, Young. (2013). Ergonomic Optimization of the Handle Height and Distance for the Two-Vertical Type Handles of the 4-Wheel Cart. Journal of the Korea Safety Management and Science. 15.
- » Thompson, B. (2019, April 8). Unit Load Device ULD Air Container Specifications. Retrieved from IncoDocs: <https://incodocs.com/blog/unit-load-device-uld-air-container-specifications/>
- » Uh-1H Huey. (n.d.). Retrieved from Heli Air Sweden: <https://www.heliairsweden.com/en/uh-1h-huey>
- » Unicef. (2019). Cyclone Idai and Kenneth. Retrieved from Unicef: <https://www.unicef.org/mozambique/en/cyclone-idai-and-kenneth>
- » V-22 Osprey Aircraft. (n.d.). Retrieved from Air Force Technology: <https://www.airforce-technology.com/projects/osprey/>
- » Willitts-King, B., & Harvey, P. (2005). Managing the risks of corruption in humanitarian relief operations. Overseas Development Institute.
- » Worksafe. (2010). ERGONOMICS GUIDELINES FOR MANUAL HANDLING. WorksafeNB.
- » World Food Programme. (2019). Overview. Retrieved from WFP: <https://www.wfp.org/overview>
- » World Food Programme. (n.d.). Logistics Cluster. Retrieved from World Food Programme: <https://www.wfp.org/logistics-cluster>
- » Yeow, J., Ng, P. K., Tan, K. &, & Lim, W. (2014). Effects of Stress, Repetition, Fatigue and Work Environment on Human Error in Manufacturing Industries. Journal of Applied Sciences, 14

APPENDICES

▶ APPENDIX A – ORIGINAL DESIGN BRIEF

DESIGN
FOR OUR
future

IDE Master Graduation

Project team, Procedural checks and personal Project brief

This document contains the agreements made between student and supervisory team about the student's IDE Master Graduation Project. This document can also include the involvement of an external organisation, however, it does not cover any legal employment relationship that the student and the client (might) agree upon. Next to that, this document facilitates the required procedural checks. In this document:

- The student defines the team, what he/she is going to do/deliver and how that will come about.
- SSC E&SA (Shared Service Center, Education & Student Affairs) reports on the student's registration and study progress.
- IDE's Board of Examiners confirms if the student is allowed to start the Graduation Project.

! USE ADOBE ADOBE READER TO OPEN, EDIT AND SAVE THIS DOCUMENT
Download again and reopen in case you tried other software, such as Preview (Mac) or a webbrowser.

STUDENT DATA & MASTER PROGRAMME

Save this form according to the format "IDE Master Graduation Project Brief_familyname_firstname_studentnumber_dd-mm-yyyy". Complete all blue parts of the form and include the approved Project Brief in your Graduation Report as Appendix 1!

<p>family name <u>Weetzel</u></p> <p>initials <u>M.J.</u> given name <u>Max</u></p> <p>student number <u>4511093</u></p> <p>street & no. <u>Brahmslaan 103</u></p> <p>zipcode & city <u>2625BT Delft</u></p> <p>country <u>Netherlands</u></p> <p>phone <u>+31645379909</u></p> <p>email <u>m.j.weetzel@student.tudelft.nl</u></p>	<p>Your master programme (only select the options that apply to you):</p> <p>IDE master(s): <input checked="" type="radio"/> IPD <input type="radio"/> DFI <input type="radio"/> SPD</p> <p>2nd non-IDE master: _____</p> <p>individual programme: _____ (give date of approval)</p> <p>honours programme: <input type="radio"/> Honours Programme Master</p> <p>specialisation / annotation: <input type="radio"/> Medisign</p> <p><input type="radio"/> Tech. in Sustainable Design</p> <p><input type="radio"/> Entrepreneurship</p>
--	--

SUPERVISORY TEAM **

Fill in the required data for the supervisory team members. Please check the instructions on the right!

<p>** chair <u>Erik Tempelman</u> dept. / section: <u>DE / AM</u></p> <p>** mentor <u>Henk Crone</u> dept. / section: <u>DE / AM</u></p> <p>2nd mentor <u>Roeland Reitsema</u></p> <p>organisation: <u>VanBerlo</u></p> <p>city: <u>Den Haag</u> country: <u>Netherlands</u></p> <p>comments (optional): Erik for the combination between Aerospace eng and IPD, as well as his knowledge on materials and manufacturing. Henk for the very good general coaching experience I have with him and his expertise in project management</p>	<p>Chair should request the IDE Board of Examiners for approval of a non-IDE mentor, including a motivation letter and c.v.</p> <p>! Second mentor only applies in case the assignment is hosted by an external organisation.</p> <p>! Ensure a heterogeneous team. In case you wish to include two team members from the same section, please explain why.</p>
---	---

Procedural Checks - IDE Master Graduation

APPROVAL PROJECT BRIEF

This form is to be filled out by the student.

chair Erik Tempelman date 26-09-19 signature

CHECK STUDY PROGRESS

This form is to be filled out by the student. It is used to check the progress of the student's graduation project. The student should fill in the form and submit it to the IDE Board of Examiners.

Master electives no. of EC accumulated in total _____ EC YES NO

If which, taking the conditional requirements into account, can be part of the exam programme _____ EC YES NO

List of electives obtained before the third semester without approval of the Bot

name _____ date _____ signature _____

FORMAL APPROVAL GRADUATION PROJECT

This form is to be filled out by the student. It is used to check the progress of the student's graduation project. The student should fill in the form and submit it to the IDE Board of Examiners.

Does the project fit within the MSc-programme of the student (taking into account, if described, the activities done next to the obligatory MSc specific courses)? YES APPROVED NOT APPROVED

Is the level of the project challenging enough for a MSc (DF) graduating student? YES APPROVED NOT APPROVED

Is the project expected to be done within 100 working days/20 weeks? YES APPROVED NOT APPROVED

Does the composition of the supervisory team comply with the regulations and fit the assignment? YES APPROVED NOT APPROVED

comments

name _____ date _____ signature _____

© TU Delft E&SA Department of Product Innovation & Supervision, 2018-01 v3.0 Page 2 of 7

name & name M. Weetzel Student number 4511093

Title of Project Design of a UAV product ecosystem for human-robotic operators

Designing the future unmanned airplane for humanitarian aid delivery project title

Please state the title of your graduation project (above) and the start date and end date (below). Keep the title compact and simple. Do not use abbreviations. The remainder of this document allows you to define and clarify your graduation project.

start date 09 - 09 - 2019 end date 24 - 02 - 2019

INTRODUCTION **

Please describe, the context of your project, and address the main stakeholders (interests) within this context in a concise yet complete manner. Who are involved, what do they value and how do they currently operate within the given context? What are the main opportunities and limitations you are currently aware of (cultural- and social norms, resources (time, money,...), technology, ...).

During natural or man-made disasters, transport and communication infrastructures are often deficient and geographical conditions can be harsh, making delivering humanitarian aid to everyone in need is a very difficult task. Airdrops are capable of reaching the most area and providing aid directly where it is needed. However this operation is expensive due to the logistics and the materials such as parachutes. Unmanned Aerial Vehicles (UAV's) combined with cheaper cargo boxes can reduce these costs significantly.

Wings for Aid is a young consortium solving this problem. Their goal is to create a system able to deliver goods across 'the last mile', making it possible to provide the aid directly where it is needed. At this stage they have shown the initial feasibility through a proof of concept. This is comprised of a manned plane fitted with a custom delivery system capable of dropping custom cheap and sustainable cargo boxes (see the image on the following page) These boxes can supply the needed aid e.g. food, medicines or blankets. Their next step will be to modify this plane by converting it to autonomous and integrating the delivery system in the fuselage.

Within the consortium, VanBerlo is the lead design partner. VanBerlo is an all-round design agency supporting companies with expertise covering the full design cycle. VanBerlo is currently responsible for the design of the delivery system/plane and the ground operations.

space available for images / figures on next page

introduction (continued): space for images



image / figure 1: Initial sketch for delivery UAV by VanBerlo



image / figure 2: Current proof of concept prototype using a manned airplane

PROBLEM DEFINITION **

Limit and define the scope and solution space of your project to one that is manageable within one Master Graduation Project of 30 EC (= 20 full time weeks or 100 working days) and clearly indicate what issue(s) should be addressed in this project.

Currently Wings for Aid is focused on getting the cargo box system and the delivery plane off the ground to show and test the possibilities. However, the ground operation in which the UAV will be used, is not fully defined yet. During testing it showed that several aspects like reloading, refueling, preparing the boxes and the safety checks offer opportunities for improvement. For example, loading the boxes is currently a task that can only be done by expert personnel to make sure it is done correctly. This step could be optimized to make its operation predictable even when minimal trained workers are used.

In the final operation, there will be many more elements to the operation, such as; maintenance, material and parts storage, housing for the workers etc. Also operations on the drop zone side, such as marking the area and keeping it safe. Optimizing all these steps can result in a simpler, cheaper and faster operation.

Within the scope of this graduation, only the Forward Operating Base, the base from which the planes departure, will be examined. Specifically the steps involving the UAV, such as; maintenance, the reloading of the correct boxes, refueling and checking that all this is done correctly. These are also the elements that could influence the UAV design itself and can provide insights for the future UAV design.

ASSIGNMENT **

State in 2 or 3 sentences what you are going to research, design, create and / or generate, that will solve (part of) the issue(s) pointed out in "problem definition". Then illustrate this assignment by indicating what kind of solution you expect and / or aim to deliver, for instance: a product, a product-service combination, a strategy illustrated through product or product-service combination ideas, ... In case of a Specialisation and/or Annotation, make sure the assignment reflects this/these.

Defining the ground operations of an UAV for humanitarian aid delivery and optimization on a product level.

The first step will be to get a better general overview of the Forward Operating Base operation as a whole and the steps within this. This will give insights in how many planes are needed, the throughput and where the bottlenecks are. Then, a focus will be put on the main activity; the restocking of the plane. This includes, reloading (the correct) cargo boxes, refueling and making sure this is done correctly. This will be analyzed on the aspects of the people, the logistics, the legal and safety aspects. This will be done through literature, observational research and expert meetings. This analysis will then provide insights and scenarios, through which the operation could be improved.

The most relevant and interesting solution will be chosen and receive a focus to detail it further from a product engineering perspective and validated through prototypes. This converging phase is important for me as this is where my strength lays and some learning opportunities. This is expected to involve CAD modeling, potentially some electronics as well as building prototypes to test and validate the design. Possible examples of this are box handling / loading system, the box logistics tracking system or the refueling system.

Afterwards the design will be evaluated with the involved stakeholders of the project.

PLANNING AND APPROACH **

Include a Gantt Chart (replace the example below - more examples can be found in Manual 2) that shows the different phases of your project, deliverables you have in mind, meetings, and how you plan to spend your time. Please note that all activities should fit within the given net time of 30 EC = 20 full time weeks or 100 working days, and your planning should include a kick-off meeting, mid-term meeting, green light meeting and graduation ceremony. Illustrate your Gantt Chart by, for instance, explaining your approach, and please indicate periods of part-time activities and/or periods of not spending time on your graduation project, if any, for instance because of holidays or parallel activities.

start date 9 - 9 - 2019 end date 24 - 2 - 2019

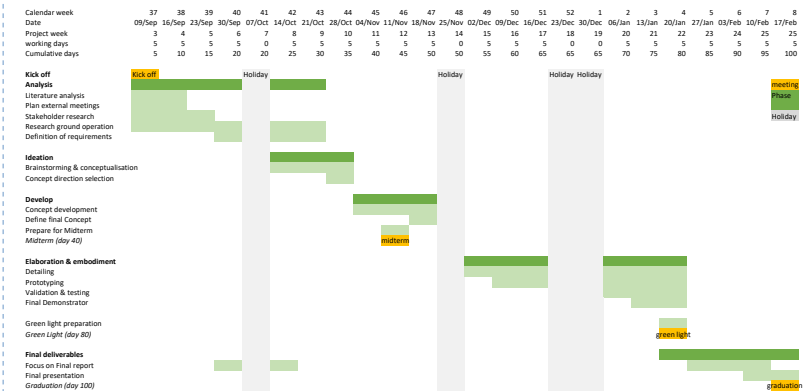

Analysis: This phase will lay the foundation for the project through research. Specific topics can be seen in the gantt chart. These elements should provide me with knowledge and key insights to form requirements for the project.
 Ideation: In this phase the requirements will be used for generating possible solutions to (sub)problems / opportunities. It will also make a start on how these solution could be combined and integrated.
 Develop: After the chosen direction is found, this phase will further detail the concept How are all the requirements integrated? This will be done through visualizations, storyboarding and expert discussions. At the end, I want to have a clear validated visualization of the improvement concept within the operation.
 Elaborate & Embodiment: Here the concept is refined and details are defined. It is expected this will involve CAD modeling. These details are expected to be validated through physical and VR prototypes. Possibly, a final prototype or demonstrator is created.
 Potential risks: 1) As the research phase is quite divergent, it is a risk to get lost in this. To converge afterwards and be able to go into detailing an prototyping, a close watch must be kept on the process. For me this is always a difficult element, but the time line and coach supervision will help with this. This could also mean that the research is not fully rounded to make sure enough time is kept for elaboration.
 2) During the research phase, external party discussion will add a lot, however this could be difficult to schedule within this phase. This could result in delayed or lack of information and therefore extended research phase.
 I expect my holiday during week 41 offers more time for externals without delaying my progress.

Holidays: I planned multiple full weeks of holiday in order to be able to visit my girlfriend who moved to the UK.

MOTIVATION AND PERSONAL AMBITIONS

Explain why you set up this project, what competences you want to prove and learn. For example: acquired competences from your MSc programme, the elective semester, extra-curricular activities (etc.) and point out the competences you have yet developed. Optionally, describe which personal learning ambitions you explicitly want to address in this project, on top of the learning objectives of the Graduation Project, such as: in depth knowledge a on specific subject, broadening your competences or experimenting with a specific tool and/or methodology, Stick to no more than five ambitions.

The first reason I chose this project is that it helps me get more experience and prove my competence in my focus areas of industrial design; design engineering, prototyping and systems architecture design. I find it very interesting to work on technical projects that integrate other engineering directions, in this case aerospace engineering. It supports gaining a more holistic view on engineering and growth as an (system) integrator.

However, I did not just want to only focus on the aforementioned. I want to use this graduation project as an opportunity to gain more experience on holistic and strategic design, compared to my more detailed focus.

The project also interest me as the consortium is still very young and it is still in its startup phase. I personally like startup environments and would like to gain more knowledge and experience in strategically designing a system that supports the growth of the startup.

Finally, by working together with the design agency VanBerlo, I can learn a lot from the available expertise within the company. And as the project is based within a consortium, many companies and contact are expected to be able to advise on different parts of project. Together creating a breeding-ground to accelerate the learning process.

FINAL COMMENTS

In case your project brief needs final comments, please add any information you think is relevant.

▶ APPENDIX B – PROCESS OF FOB OVERVIEW

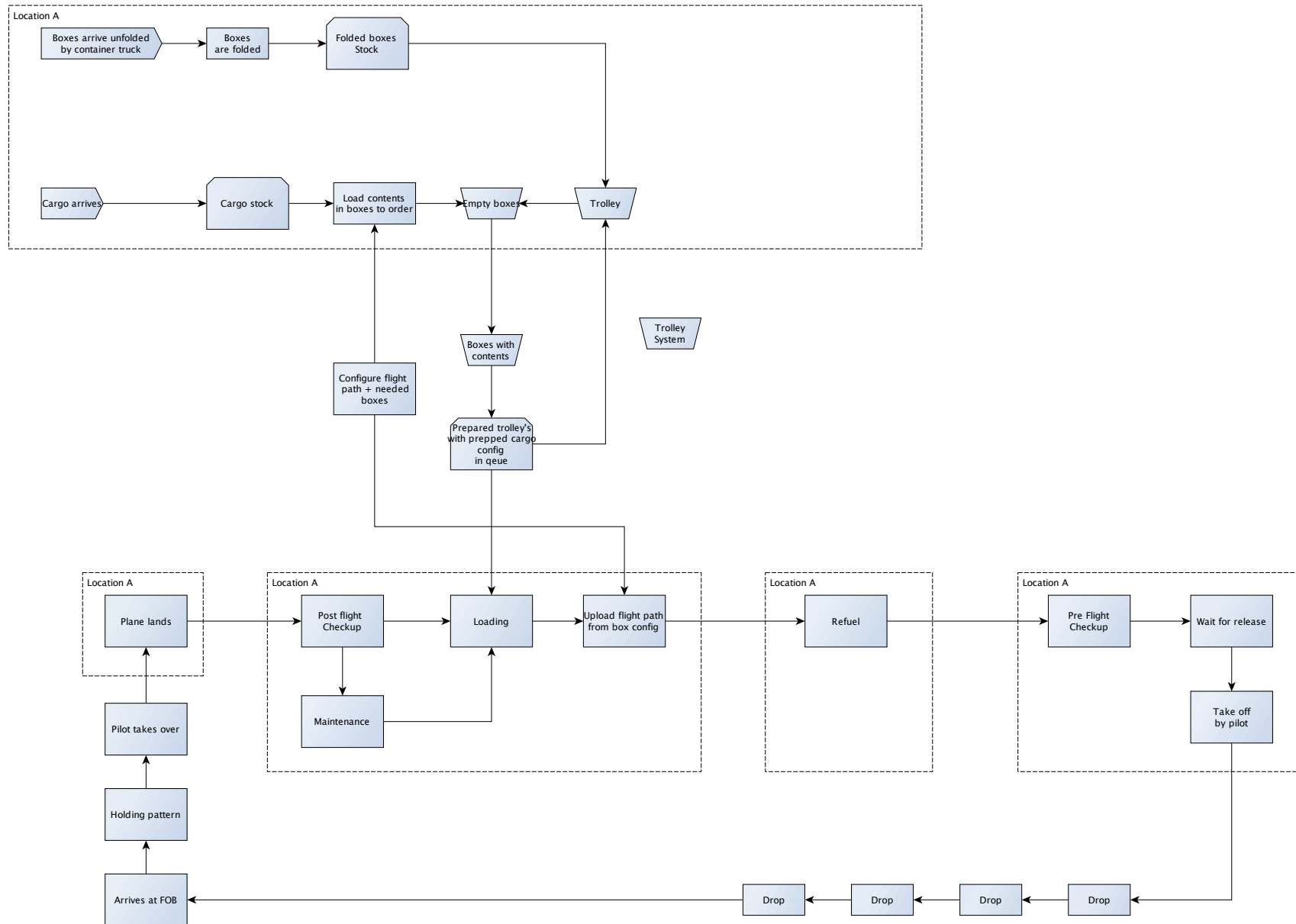

▶ APPENDIX C – CYCLONE IDAI SCENARIO STATISTICS

- » 14-16 march 2019
- » 1000+ deaths
- » 2500+ injured
- » Winds up to 230km/h
- » Massive flood
- » Power cuts
- » 400.000 people displaced & 75.000 in dire need of assistance
- » Infrastructure destroyed / blocked by flood and landslides
- » 711,000 ha of near harvest crops destroyed

Local officials established 187 evacuation camps while churches and schools were utilised as makeshift shelters

Aid has been slow to reach affected villagers due to collapsed infrastructure, although the military has been handing out small packets of cooking oil, maize meal and beans.

Beira airport suffered damage and was closed, but was not completely destroyed. Beira airport did not flood as it is located on higher grounds. The port of Beira was also intact and allowed for ships to harbor for supply of goods.

Beira and Chimoio airports were fully operational again on 23th of march (after 6 days). However, as it only

suffered minor damaged, such as the tower and lighting, it could still be used as a WFA FOB beforehand.

Beira airport only has one airstrip, therefore it could also be required for other logistic purposes. Another usable airport would be Chimoio. Or if possible an area around to Beira airport is used, as this should at least provide a longer space needed for the UAV airstrip.

Many roads are destroyed by the rain and the landslides. Leaving many people cut off from aid.

One month after the cyclone cut off communities are still found:

Oxfam found 2000 people in need of aid even a month after the cyclone and 4000 more were expected to still be cut off. It can be considered that just after the cyclone a lot more people were in hard to reach areas.

With an average of only 33 people per km², Mozambique has a low population density. Beira has a population of around 500.000 people.

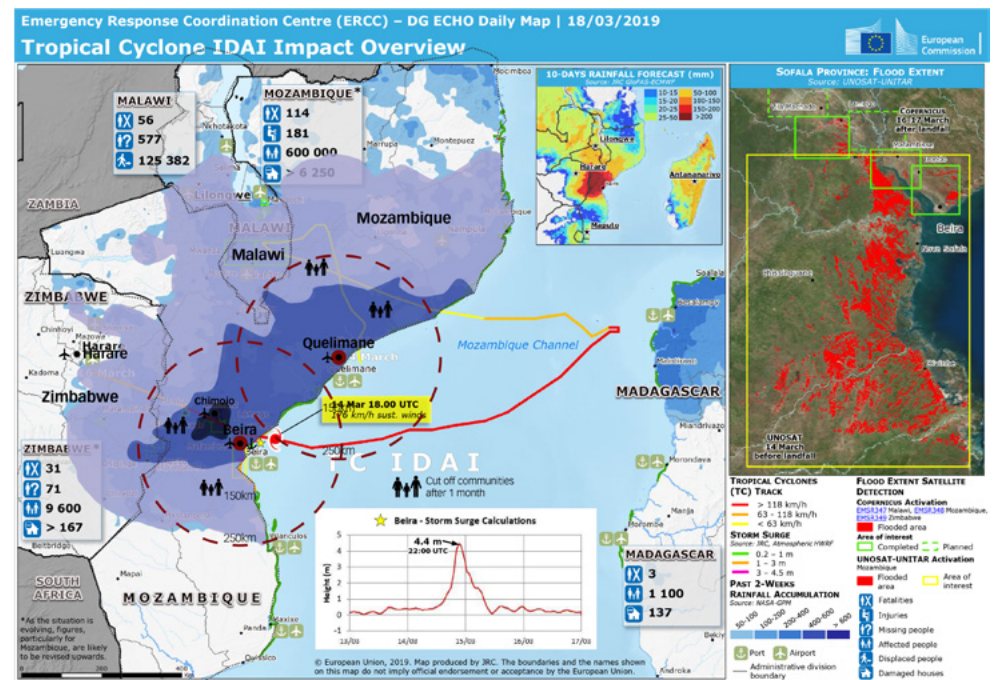

Figure 89 : Schematic of WFA system range in cyclone Idai scenario

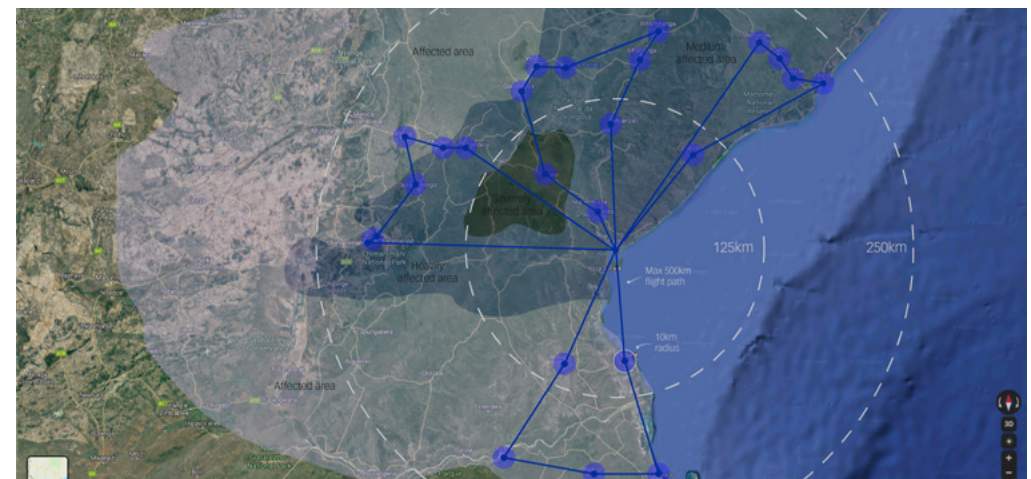

Figure 90 : Possible flight path of WFA UAV from the Beira airport in Idai scenario

▶ APPENDIX D – NASA TASK LOAD INDEX

The original Nasa Task load index on the left, as used during the observations of the status quo loading operation. The translated version as used during the final user evaluation.

Figure 8.6

NASA Task Load Index

Hart and Staveland's NASA Task Load Index (TLX) method assesses work load on five 7-point scales. Increments of high, medium and low estimates for each point result in 21 gradations on the scales.

Name	Task	Date
Mental Demand	How mentally demanding was the task?	
Physical Demand	How physically demanding was the task?	
Temporal Demand	How hurried or rushed was the pace of the task?	
Performance	How successful were you in accomplishing what you were asked to do?	
Effort	How hard did you have to work to accomplish your level of performance?	
Frustration	How insecure, discouraged, irritated, stressed, and annoyed were you?	

NASA Task Load Index

Naam	Taak	Tijd
Mentale vereiste	Hoe mentaal veeleisend was de taak?	
Fysieke vereiste	Hoe fysiek veeleisend was de taak?	
Druk	Hoe gehaast of gestressed verliep de taak?	
Prestatie	Hoe succesvol heb je de taak uit kunnen voeren?	
Moeite	Hoeveel moeite moest je doen om dit niveau van prestatie te behalen?	
Frustratie	Hoe onzeker, ongemotiveerd, geïrriteerd, gestressed en geërgerd was je?	

▶ APPENDIX F – ANALOGIES / INSPIRATION



Towing principal



Towing system



Rail system



Rail system



Rail system



External powered actuation



Swivel wheel for unpaved terrain



Ergonomic handles



Wheel configuration



Wheel configuration

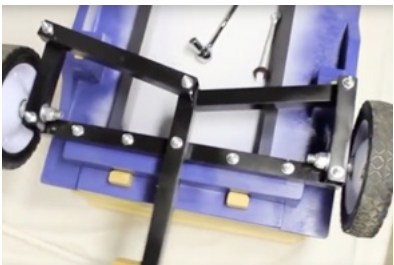

Steering system



Wheel config + powered system



Wheel config + height alignment

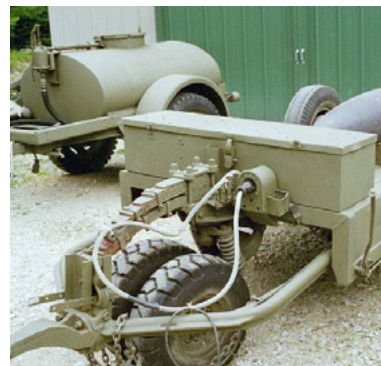

Wheel configuration / steering



Wheel configuration / steering

▶ APPENDIX G – WEIGHTED CRITERIA CONCEPT DECISION

		Concept 1	Concept 2	Concept 3	Concept 4
	Weight	Warehouse loading	Piggyback	Combi	Wide cart loading
Fit within FOB		26	36	43	47
Long & short term operation	2	7	7	8	10
Versatility in operation	2	3	7	9	9
Link with packing operation	1	6	8	9	9
Low risk		55	40	52	57
Minimal human error	3	9	7	9	10
Ergonomic	1	8	5	9	7
Reliable systems	2	10	7	8	10
Low operational costs		67	48	56	64
System costs	2	10	7	8	9
Quantity of personnel	2	10	8	8	8
Process speed	3	9	6	8	10
		148	124	151	168

▶ APPENDIX H – CART ERGONOMICS RESEARCH

WHEEL CONFIGURATION

- » Large diameter soft wheels are best for rough terrain
- » Used sealed maintenance free bearings
- » The longer the swivel lead the less force is needed to align the wheel, but the caster can hold less weight.
- » Double wheel casters reduces turning forces to a minimum
- » Hand holds should be on the swivel wheel side to reduce turning and twisting force
- » Compliant wheel material reduces force to overcome uneven surfaces. They also reduce noise and vibration.
- » The larger the wheel diameter the less force is needed to overcome uneven surfaces (this is one of the most important factors)
- » A dead mans brake is advised on the cart as is could 'run away' on sloped surfaces

- » Pushing is preferred over pulling. It is safer, more ergonomic, more force can be applied and allows view on path.

HANDLES

- » For handles fixed to the cart's surface, the handles should not be more than 46 cm apart. Wider separations increase the load on smaller shoulder muscles
- » Handles should be thick enough to grip easily - 2.5 cm to 3.8 cm
- » Fixed handles mounted in the horizontal direction should have a minimum length of 20 cm
- » Fixed horizontal handles should be at a height between 91 cm and 112 cm above the floor
- » Ideally, handles should be on elbow height for optimal ergonomics
- » Elbow height for global P5 to P95 is 916-1206mm

(Worksafe, 2010), (Darcor, 2001)
(DINED, 2017)

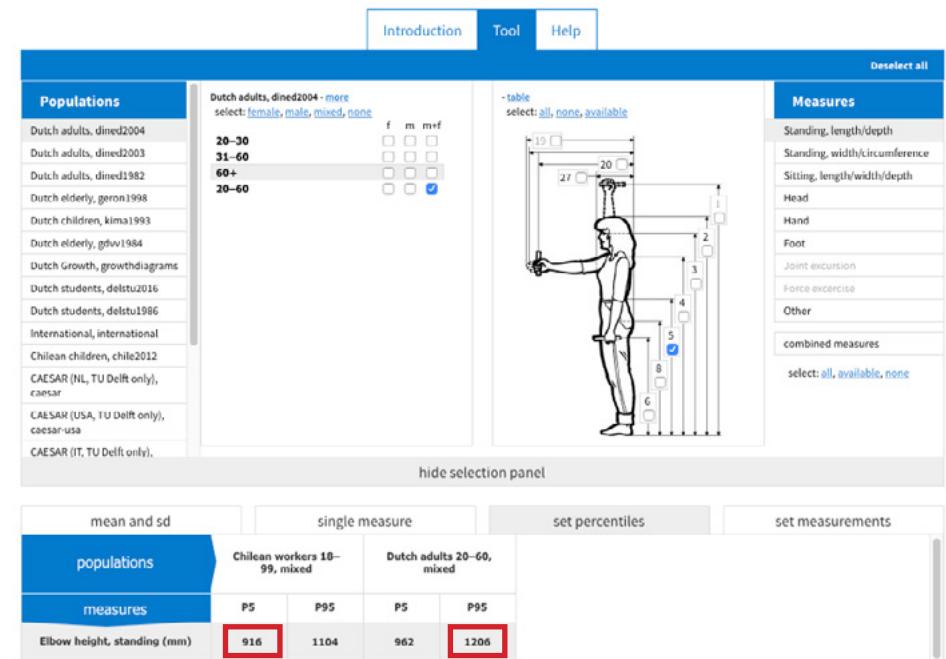

Figure 91 : Minimal and maximal elbow height globally (DINED, 2017)

▶ APPENDIX I – SORA REGULATIONS

SORA (Specific Operation Risk Assessment) is a methodology to guide whether or not the UAS operation can be conducted in a safe manner. It comprises of the risk of a fatal incident when the operation is no longer under control, due to ground and air collisions. These risks are assessed on factors such as the wingspan of the UAV, the population density, the airspace class and the flight altitude. For this project, the assessment provides limitations to the wingspan of the UAV, limiting its cargo capacity.

energy limit. With a 3m wingspan, the MQ-9 reaper drone has an MTOW of only 5kg. Even when considering this is designed for high speeds, carrying a cargo box of 20kg will be unfeasible. Furthermore, certain mitigations can be implemented to reduce the risk level, such as parachutes or strategic flight path planning. To conclude, in terms of UAV wingspan dependent regulations, everything feasible below an 8m wingspan will be assessed in the same way and 8m is the maximum wingspan.

The wingspan and population density mostly determine the ground risk. The population density is uncontrollable as it depends on where the operation is executed. The max wingspan categories are 1m, 3m, 8m, >8m. This shows that a 4m UAV is categorized the same way as a 7m UAV. When looking at the consequences of these categories, it becomes clear that >8m wingspan creates a too large risk and fall outside of the SORA altogether. As this would make regulations significantly more difficult, the max wingspan of the UAV should be 8m. In order to go one category lower (3m) the UAV can only weigh roughly 100-150kg including cargo (assuming a cruise speed of 120-150km/h) in order to stay within the corresponding kinetic

The full SORA regulations can be found here: <http://jarus-rpas.org/content/jar-doc-06-sora-package>

Intrinsic UAS Ground Risk Class				
Max UAS characteristics dimension	1 m / approx. 3ft	3 m / approx. 10ft	8 m / approx. 25ft	>8 m / approx. 25ft
Typical kinetic energy expected	< 700 J (approx. 529 Ft Lb)	< 34 KJ (approx. 25000 Ft Lb)	< 1084 KJ (approx. 800000 Ft Lb)	> 1084 KJ (approx. 800000 Ft Lb)
Operational scenarios				
VLOS/BVLOS over controlled ground area	1	2	3	4
VLOS in sparsely populated environment	2	3	4	5
BVLOS in sparsely populated environment	3	4	5	6
VLOS in populated environment	4	5	6	8
BVLOS in populated environment	5	6	8	10
VLOS over gathering of people	7			
BVLOS over gathering of people	8			

Table 2 – Intrinsic Ground Risk Classes (GRC) Determination

Figure 92 : Ground risk indication table from the SORA regulation

► APPENDIX K – COSTS PRICE ESTIMATION LOADING CART

Manufacturing		#	Piece	Total	Source
Production parts total				€ 750,00	Expert estimat
	Box guides	8		€ 103,60	Tailorsteel
	Top plate	2		€ 112,00	Tailorsteel
	swivel wheel extension	4		€ 53,00	Tailorsteel
	Top frames	2		-	
	Handlebars	1		-	
	Wheelmounts	2		-	
Powdercoating				€ 300,00	Coating.nl
Assembly of system				€ 250,00	Expert estimat
Purchase parts				€ 186,30	
Front wheels 400mm	400mm TARROX	2	€ 30,00	€ 60,00	Hornbach
Swivel brackets	260mm swivel wheel	2	€ 14,30	€ 28,60	Wielenzaak.r
Swivel wheels 340mm	340mm TARROX	2	€ 16,00	€ 32,00	Hornbach
Axles	20mm TARROX	4	€ 3,48	€ 13,90	Hornbach
handlebar grips	30x400mm	2	€ 8,90	€ 17,80	Fitness-seller
Axle shaft collar	20mm	8	€ 2,38	€ 19,00	Hornbach
Rivets				€ 10,00	
M10 bolts				€ 5,00	
Total costs per cart prototype				€ 1.672,60	

▶ APPENDIX L – FINAL LOADING PROCESS

