

# I solemnly pledge to public space

dualities in contemporary public space developments;  
polycentralisation, collectivity, digitalisation and urban identities

applied in brussels' leopold quarter  
and the european project.

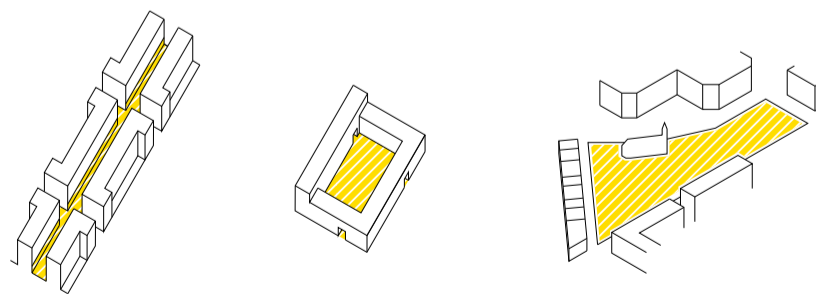

L DANIEL SWAKMAN

## preface

### PREFACE

This thesis roughly concerns public space; its theorisations, its urban perception, its issues of identity and property, and finally its crafting and design.

It is a means of exploring a personal fascination with the public domain. It can be seen as a pivot point in the functioning of the city, a place where the actors of the urban condition meet, move, interact and effectively live out the city. This thesis therefore has a research component which deals with the contemporary phenomena in public space. Namely its developments of mobility and digitalisation.

In a more real and practical sense, the thesis has a real component: the analysis, treatment, strategy and design of an actual urban situation.

A conclusive statement would be that this thesis is the final product of a 1,5 year graduation project in the combined field of architecture+urbanism. This has been a conscious combination.

### READING GUIDE

The thesis is divided in five parts: the introduction, initiating the reader in the topic of this research and outlining the problem definition, aim and methodology for the development of the research into

a strategy and design. The second chapter, "Changing urban public space", gives an overview of the first part of the theoretical background. It is actually a reworking of a paper written earlier on in the research, now fitted into the larger scope of this thesis. The third chapter "Celebrating Europe" discusses the second part of the theory; the location-specific themes that have been researched and analysed. In the fourth chapter "Embedded publicness" the observations from both previous chapters are combined into the elaboration of the urban strategy for the case study location. The fifth chapter "A European Forum" deals with the elaboration of the physical design for one of the strategic projects.

As a newspaper, this thesis has different levels

This thesis roughly concerns public space; its theorisations, its urban perception, its issues of identity and property, and finally its crafting and design.

of reading; there is the 'headhunting' (Dutch: koppensnellen) and visual browsing, which should give the reader an overview of the content and understand the line of reasoning from the images and diagrams. The second layer is the underlined parts of the texts. They allow for a more textual elaboration (in keywords)

of the images and headlines. When one dives into the texts themselves, the total content is revealed, and elaborated on. This way, both quick readers and people who are interested further are served.

### COLOPHON

architecture+urbanism graduation thesis  
L Daniel Swakman

12 april 2011

tutors (architecture): S. Lee, T. Avermaete

tutors (urbanism): W. Hermans, S. Read

tutor (building technology): E. van der Zaag

Faculty of Architecture, Delft University of Technology

All content made by  
(unless stated otherwise)  
L Daniel Swakman

Typeface design  
Europa, London, UK  
[www.europaeuropa.co.uk](http://www.europaeuropa.co.uk)

# contents

preface	2
01 introduction	5
01.01 topic	5
01.02 problem definition	6
01.03 research question	6
01.05 case location	7
02 changing urban public space	9
02.01 introduction	9
02.02 theoretical background	10
02.02.01 non-places	
02.02.02 despatialised city	
02.02.03 personalised portability	
02.03 the effects	11
02.03.01 decentralisation	
02.03.02 augmented reality	
02.03.03 urban identity	
02.03.04 collectivisation	
02.04 conclusions	14
03 celebrating europe	15
03.01 introduction	15
03.02 historical developments	15
03.03 development into the EU quarter	19
03.04 network analysis of Brussels	19
03.06 a grid pattern vs the object city	21
03.07 a european capital and symbiosis	21
03.08 public space atmosphere	23
03.09 conclusion	23
04 urban strategy	25
04.01 problem summary	25
04.02 proposal	26
04.03 from flatness to a polycentric network	26
04.04 project 1 urban boulevards	28
04.05 project 2 recaptured blocks	29
04.06 project 3 european forum	28
06 reflection/recommendations	31
bibliography	33
appendices	35





Mulberry street in Little Italy,  
New York, around 1900



Patchwork  
Metropolis, Willem  
Jan Neutelings



street scene in front of  
New York's Grand Central  
Station, 2008



map of light pollution in  
Europe around urban cores



# 01 introduction

## TOPIC

The contemporary city is a place of constant change and development. A simple but eloquent statistic is the world's urban population in relation to the rural. From 2007 onwards, more people have been living in urban areas than on the countryside [Figure x]. The Industrial Revolution allowed people to move with automated means, and incorporate distant locations into their daily patterns; the Digital Revolution allowed people to communicate and work on these distant locations. The traditional image of public space in a pre-industrialised society [Figure x] has been replaced by a space dominated by infrastructure and communication [Figure x].

This pattern has been a driving force in the globalisation of cities throughout the planet. This connectivity of metropolises gave way for a new type of culture, rather different than that of the local culture. Like the emergence of a city as a centrality between a landscape of small villages, the global city is a centrality between large cities throughout the planet. And likewise, a global culture of connectivity emerges in those places of a city that are embedded in larger networks.

The particularly fascinating aspect of this above mentioned shift from the city as a regional centrality towards its being a node in a network of increasing size, is the perception of the urban space by the city dweller. A direct result of the availability of faster means of transportation – like the car, train, metro, airplane and so forth – is a shift in perception of the city around you. Instead of experiencing the city from space to space, from one street to the next and on to the city's square, we now have a set of fragmented glimpses of the urban public space. Because we step

into the car and drive onto the highway, or whether we emerge from a metro entrance in a vibrant part of town – no longer are we able to understand the city by its sequence of spaces. On top of that, a completely new type of space needed to be designed: that space dominated by infrastructure. Metro stations, airport lounges, highways and their environments – all examples of a space typology that emerged right along

“the traditional image of public space in a pre-industrialised society has been replaced by a space dominated by infrastructure and communication”

with the technologies they derive from: non-places.

This thesis discusses the effect of an urban space that is not only significant as a local place, but embedded in an increasingly larger set of networks. An eloquent example of such an increasing density of

networks and layers in a part of the city, and thereby an increasing complexity, is the situation of the capital of the European Union. Ever since the emergence of European collaboration treaties like the ECSC and the EEC in the 1950s [note], the issue has emerged of how such an international (if not global) political institution should manifest itself. The first aspect of it is the notion of a capital: the European officially lists three: Brussels, Luxembourg and Strasbourg. In these cities, the seven institutional bodies of the European Union are housed, the majority of which are located in Brussels. At present date, four of the seven European governing bodies are located in the Leopold Quarter in Brussels, occupying almost a million square meters in this centrally located part of the city.

The relationship of the city of Brussels with the European Union as its inhabitant can be said to be highly problematic. Since the arrival of the EU in the 1960s, the Leopold quarter was transformed by half a century of uncontrolled office expansion into an administrative ghetto: the European Quarter (Gall,

2004). The integration of the new office functions with its context was absent, since there had never been a vision of how this office development should relate to the context it was set in.

This outlines the main problem the European Quarter has to deal with: an expanding but decentralised European Union government, housed in a monumental former residential area of a culturally very defined city, lacking a clear identity or even a direction of architectonic expression.

This introduction to the topic of this thesis already shows the [dual/twofold] character of the theoretical background: the first part being the observations of the changes our public space is undergoing as a result of increasing mobility and communication, and the second part being the discussion of the case study of the European Union, and its role in the city of Brussels. The paragraph ‘case study location’, further on in this introduction, will show the considerations for choosing the European project.

## PROBLEM DEFINITION

The globalising tendency of urban spaces puts the city under pressure: an emerging and increasing confrontation of multiple identities and networks. No longer is the city home to people living and working within its borders, making it their place; but the city's public space has had to deal with its being a host to external visitors and corresponding identities.

These newcomers in the city's space are not mere incidents; they leave their distinct trace. The city's space is now a shared domain.

One of the main tangible components is a new type of space as a result of the physical scale of transportation interventions: the train stations and airport lounges that facilitate modern global mobility. How can the city cope with this increasing pressure on public space?



EU occupancy of the Leopold Quarter in Brussels

#### RESEARCH QUESTION

In order to get started with the exploration of the themes that are addressed here, this thesis firstly gives an overview of theories about public space of the twentieth century city. This should provide a theoretical background answering to the first research question: what are the main contemporary developments in the city's public space?

The aim here is to obtain a clearly interpretable set of themes that are apparent points of conflict or duality in public space today. Pointing out these themes in real situations will provide an elaboration.

In a more practical framework, the case of the European Union in Brussels has its own story. As stated before, it is an imminent example of a globalising public domain, and functions thus as a logical consecutive step. In this case it is important to treat the following

question: what exactly is the manifestation of the European Union in Brussels today, and what are the historical developments leading up to it? This involves the treating of the physical housing of the global identity of Europe in the local context of the city

“an expanding but decentralised European Union government, housed in a monumental former residential area of a culturally very defined city, lacking a clear identity or even a direction of architectonic expression”

of Brussels. Here, the aim is to get a clear overview of the situation, in order to outline the main problems. This will then provide the framework for the urban strategy and the design of the public space.

#### CASE LOCATION

Along with the exploration into the changing values of contemporary public space, came the need to actually observe and test these assertions in a case study location. To be able to work with the themes that were adopted in the theory, the location would logically be located in an area that has grown up with the technological advances of which we speak; a modern city. A number of urban areas started to emerge; mostly dealing with infrastructure in the city, a meeting point of cultures or activities, and a certain

sensitivity with regard to historical buildings and the modern.

This overview shows six location where such phenomena are present, if not native to their existence. An important observation in this case was, that

the presence of (heavy) infrastructure is a key factor – apparently this brings about a typical sense of place, inherent to the contemporary complex city. Reasons for this will be further explored in [Chapter 2].

“In the general sense, this thesis talks about the public realm of the post-modern technological city. In the particular sense, one location was chosen where the public domain is a very real topic of debate: the European Quarter in Brussels.”



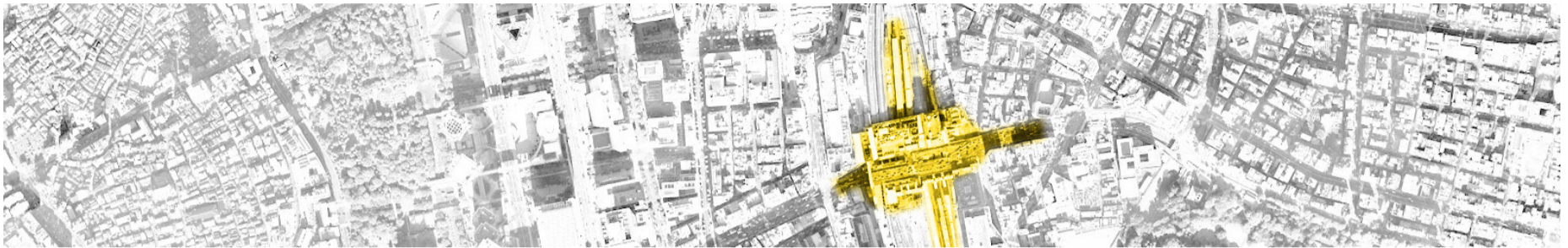

Shinjuku Station Tokyo  
*3.64 million passengers per day*

Being the largest station in Tokyo, processing an estimated 3.46 million passengers each day, Shinjuku Station forms one of the main hubs of Tokyo. Though its sheers size and density of program, the

node becomes almost like a machine facilitating the existence of a polynuclear megalopolis.



Dam Square Amsterdam  
*functionless monument since 1665*

Originated as one of the central spaces of the old town of Amsterdam, the Dam Square and the Royal Palace on it still perform a major function in the city. Although the palace used to function as a true point of interaction between the municipality and the citizens

(through the 'Burgerzaal'), now its uses are mainly ceremonial and touristic. The infrastructure beside it is one of the main arteries of the inner city, and being expanded with a metro tunnel.

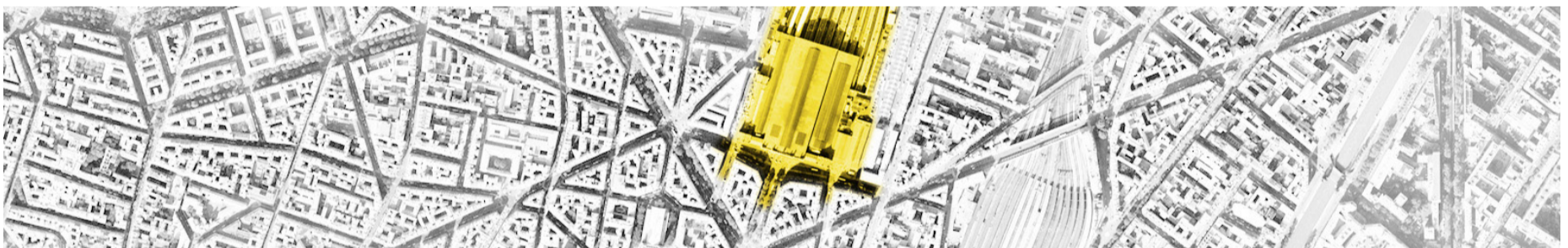

Gare du Nord Paris  
*0.5 million passengers per day*

The European equivalent of an infrastructural hub. The paradox of Paris as the absolute centre of France and internationally as a major hub of train connections, all the train lines terminate at one of

the 6 major stations on the edge of the city. Here, the connection between the enormous amount of interurban traffic and the status quo of the urban place is felt.

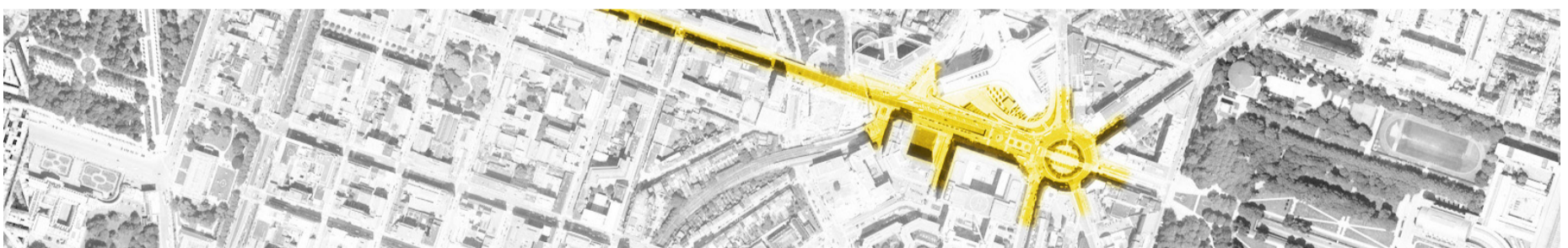

European Quarter Brussels  
*150.000 'European' residents*

At the emergence of the post-war European collaboration Communities (EEC, ECSC, later EU), this former residential quarter rapidly transformed into a business district. As a sudden wedge in the continuity of the urban fabric, the uncontrolled

office expansion took over the area, and obliterated all residential function. Now the area is faced with exclusion from the city, and the constant influx of 150.000 European commuters each day.





Forum Les Halles Paris  
*failed metro station and underground shopping mall*

Historically relevant as a vibrant marketplace, the Forum Les Halles was transformed along the line of thought of post-war Brutalism, and houses a metro station and an underground shopping mall underneath a garden landscape. Since long characterised as a failed

urban space, the whole world seems to be calling for its redesign. A challenge of an urban centrality faced with heavy infrastructure and programmatic densification.



Plaça de la Catalunya Barcelona  
*the grid meets the old town and doesn't like it*

A remnant space of the square grid extension plan by Ildefons Cerdà in 1859, the Plaça de la Catalunya is one of the infrastructural centralities for the inner city traffic. Both faced by the difficulty of facilitating heavy infrastructure with urban pedestrian space, as

well as the morphological and cultural meeting of two parts of the city (old and new), the square is a space constant development.

#### LOCATION CHOICE

A clear characterisation of place shows from the above discussed places. Perhaps the most important aspect is the convergence of infrastructure – be it car roads, metro stations or train lines – with a cultural-historical relevance, and often a demand for programmatic density as a central place in a city. With the exception of Tokyo, all locations are Western European, reflecting a certain position in urban development. Also important in this sense, is the approach of consciously designing public places. This is a feature rather present in European developments when compared to developing countries, and perhaps also even more than in North America. One of the most striking place conditions is the

presence of the European institutions in Brussels. With a rapid growth within 50 years, a true office district has emerged, unplanned. This resulted in the extrapolation of the public space into a deserted area between office blocks. Combined with the need for large scale infrastructure for facilitate the influx of its workers, this location was chosen as a test case to improve the condition of the public space.

In the following chapters we will expand on the project. Starting with a theoretical framework, outlining the contemporary developments of public space in [Chapter 2]. After that, the condition of the EU in Brussels will be discussed. Following these two

parts, the proposed strategy for improvement of the area will be described. Then a further elaboration on the intervention in the form of a physical design for the public space will be presented.



## 02 changing urban public space



City of London by night, from above

### 02.01 INTRODUCTION

The perception of the form of the contemporary city has changed drastically in the 20th century. In pre-industrialised society, an individual's habitat used to be defined by reach (on foot) and spatial continuity. An urban dweller would perceive the urban fabric as a contiguous environment in which they move, where one space is followed by another, and thereby establishing their mutual relation. Ever since the Industrial Revolution allowed people to incorporate distant locations into their daily patterns, this traditional relation between urban spaces is no longer omnipresent.

According to Manuel Castells (1996), the traditional concentric organisation of towns around the church and market square and encapsulated by fortification walls (Arendt, 1958), has transformed into a 'network society'. In this theory, one of the main properties of the spatial structure of public spaces is its body of communication. As Castells defines it, "a network society is a society whose social structure is made of networks powered by microelectronics-based infrastructure and communication technologies" (Castells, 2004). In other words, no longer is the principal carrier of society real-time personal interaction between persons and between person and space, but it has advanced into relying on advancing technological infrastructure for its functioning.

This communication infrastructure has become an embedded property of the contemporary global city. This is evident for example in the organisation of the global financial and trading market, which has become fully electronic and fully international (Sassen, 2002).

On a spatial level, urban decentring is taking place as a result of the described mobility patterns. This leads to the production and consumption of 'empirical non-places': spaces of circulation, consumption and communication (Augé, 1995). Hajer & Reijndorp talk about the effect of the emergence of non-places; they consider society as an archipelago of enclaves, a stage where people develop a personalised set of spaces in which they choose to either encounter or avoid (Hajer & Reijndorp, 2002) - a kind of selective urban experience. There is a fundamental difference to the pattern of the city when it is considered as a collection of places with specific identity, as opposed to a continuous spatial fabric. In the latter, the act of travelling functions as the glue in this organisation.

Taking these notions into account, two principal factors can be discerned that have influenced the emergence of this spatially disjoint organisation. The first is mobility of people to move themselves from place to place, effective through public and private transport; the second is the communication networks that have been set up to facilitate this mobility, like

(mobile) phone systems and the internet.

In order to get a grip on the previously discussed shifts in perception, it is important to first look at the reasons why this has come to be. In other words, to answer the question: Why is public space of the metropolitan city undergoing such rapid change? In three parts, the concept of changing contemporary public space will be treated. In order to refrain from remaining too abstract or general, a deliberate choice is made to treat some more concrete theories in the first section. Here, Augé's description of non-places is juxtaposed with concrete empirical research on digital technologies in public space.

If these changes are recognised and to some extent defined, the question arises: How to design for a new perception of public space, no longer local and contiguous? This will be explored in the next section. Here, four principal characteristics are presented that can be used.

This crystallisation of the rather broad theories is a way of making the transition into design. This literature review will form the basis for developing statements for a design location, and thus provide a solid argument for decisions from the design point of view. During the further stage of the project new topics will arise that will require further exploration of certain aspects, as should always happen in a

fruitful design process. However, this paper forms the basis for a grip on the topic.

## 02.02 THEORETICAL BACKGROUND

Theorisations on the changing mobility in the urban environment are manifold. Something that Castells, Augé, Sassen, Roberts and many others all deal with however, is the fact that public space is faced with new factors: speed, mobility, migration, the global, internationality etc. It is dangerous to argue the superiority of the changes of this time when compared to the magnitude of historical revolutionary events that were also reason for great developments (i.e. the expansion of the Roman Empire); one runs the risk of denying the latter's profundness. Something that can be said however, is that the rate of contemporary changes is unprecedented. Especially developments in the ICT field are within a timeframe of less than 30 years.

Consequently, it is relevant to consider the cultural framework in which these theories take place. Most of the discourse on the change in public space as a result of recent development discussed here, is talking about – and is conducted by players from – public space in western developed society. It is true though, that this is often the place which is on the cusp of new developments, and can be said to be an 'early adapter' of new technologies and trends.

### Non-places

In the introduction to the second edition of his book 'Non-places', Marc Augé (1995) poses a triple decentring that is taking place in the urban fabric of developed countries: Firstly, cities nowadays are defined by their capacity to facilitate urban flows, in other words the import and export of people, products, images and messages. Secondly, in the individual's dwelling the tv and computer have replaced the hearth as the centre of the household. Thirdly, an individual is living in multiple visual, musical or intellectual environments that are independent of their physical environment through portable devices, thus becoming decentred from themselves on a specific place.

Augé theorises these developments by defining the emergence of empirical non-places: spaces of circulation, consumption and communication. He describes characteristic areas like airport lounges, shopping malls, station areas and highways – the majority of our contemporary physical public domain. The principal problem with these spaces is that they are not designed or aimed for dwelling of man, but processing people's activities, like shopping

nonphysical reality, but rather a generic character that disconnects space from its rooting on a specific location – it can be reproduced anywhere.

In the second place there emerges a new need for security. The arms of global communication reach out to a multitude of places and poses new questions to privacy borders and restrictions. It also relates to the cocooning effect that modern media have on public



global culture of airport lounges

or travelling. According to Augé, these theories are already reality, and we are 'doomed to seek beauty in non-places'.

### Despatialised city

Another theory that describes the notion of mobility in public space is that of the despatialised city. Michael Sorkin (1992) talks about the 'instant artificial adjacency' as a result of computers, credit cards and phones, leading to an ageographical city – an urbanity without a place attached to it. In this new type of city, the phone and modem render the street irrelevant and other dimensions become preeminent.

Sorkin talks about the three characteristic properties of this city; firstly, the loosening of ties to any specific place. Globalised capital, electronic communication and mass culture are the reason for this. This despatialised environment does not per se entail a

life – one can easily wall themselves off from public engagement by interaction with other environments through a phone call or a media player.

The third notion is the need for thematisation or simulation. A public space in itself needs to possess identifiable qualities in order to remain relevant in a world with increasingly closer links. In this way, a city centre – with all its spatial restrictions – can only survive by marketing its history; the only confluent value for the urban becomes the historic.

### Personalised portability

Relating to Sorkin's observations above is the use of personalised objects to relate or distantiate from one's environment. How public space is perceived nowadays cannot be seen without taking into account the influence of portable technologies, which have become a commodity in contemporary metropolitan



life. A triad of objects can be discerned at the basis of this: telephone, wallet and keys (Ito et al, 2007). These objects allow for interaction with physical space (keys), with people (either nearby and remote through phone) and with institutions (payment with bank card, personalised public transport card, etc). Also advanced digital devices like portable music player and laptop play an important part here.

A recent research by Ito, Okabe and Anderson (2007) shows the effect of personalised portable objects in public space. The study presents three ways of urban dwelling that involve the usage of portable media devices, infrastructure, the interaction with people and locations: cocooning, camping and footprinting. Cocooning involves the – deliberate or accidental – creation of a bubble of privatised space around oneself when negotiating through public domain, for instance when one is on the phone in the street, or listening to a music player and reading a book while in the metro. Camping is the creation of a small temporary encampment in public space; but this is often more because of the engagement with the surrounding public environment than isolation. An example of this is setting up a laptop in a cafe to sit and work, while enjoying the surrounding ambient sounds. Footprinting means leaving traces of a personal profile in public space, in databases of institutions.



From the point of view of the institutions it can serve commercial purposes, from the individual's point of view it is about financial benefits or (easy) access. Examples here are a public transport card, discount or saving cards at stores, or keycards to access less public spaces.

All three observations relate to what Manuel de Solà-Morales (1992) states about collective spaces: to give private spaces a public character, in order to achieve a 'true' urban experience. It juxtaposes this theory in the sense that the above mentioned examples are in a way privatising public domain (instead of collectivising private domain), but also here they redefine – and

indeed shift – the border between private and public.

## 02.02 THE EFFECTS

The aspect that has been the central focus of discussion here is the uprooting of the traditional concept of a city understood as a spaces which are only related by direct physical adjacency. As shown above, this fundamental difference in moving through public spaces is due to two reasons: physical infrastructure (public and private transport) and digital networks (phone, internet). This section presents four characteristic fields that are most relevant when considering how to design with this urban complexity.



### Decentralisation

One of the main reasons for the continuing success of the internet was its user-based development. It is the power of the a-hierarchic mass that gives it a broad basis of credibility. This is something that has emerged under the denominator of 'web 2.0'; rather than a digital elite providing information and content, it is based on the participation of virtually everyone to the provision of content in a database-like structure. This movement is an example of a democratic bottom-up structure, as opposed to a top-down

governance where everything is controlled through a hierarchy.

The same can be said about the organisation of centrality in public space. When considering the network of centralities in a city, the most flexible system is formed through the complete interconnectivity of all nodes (Salingaros, 2000). This utopian theorisation has started come to reality, in the first place in the organisation of internet, and consequently in the organisation of the financial and economical sector as a global system (Sassen,

2002). Furthermore, with the increasing physical mobility and the consideration of an archipelago of enclaves (Hajer & Reijndorp, 2002) it also starts to become relevant for the structure of public spaces. The Randstad is a good example here of a highly polycentric metropolis, where each node (city) has certain qualities and enjoys a great deal of movement in-between nodes.



### Augmented reality

One generalising observation that can be drawn from the usage of internet in contemporary society, is its multi-functionality. At the beginning of the 21st century we are only at the start of the possibilities of this non-physical mode of interaction with information and people; new technologies constantly broaden the scope of possibilities. This poses the systemic question: where does this revolution end?

Media theorists in the 1990s had the rather lucid image of 'the virtual' taking over all physical actions of man (Avermaete, 2009), since digital space is much less bound to laws - only to our imagination.

More recently, the debate in this area has started to shift; real space has proven its value and is considered to be enhanced by the information and interaction flow of virtual space. This augmented reality theory

(Manovich, 2002) poses that man occupies physical space, real space, but that its experience can be augmented by the instant access of information and interactions of the virtual domain. In that sense it is true that this virtual domain is just as 'real' as the physical world.



### Urban identity

The notion that is very much at hand in the light of cities expanding their horizons to a broader audience. Even though it is true that the question of whom the city is made for has never had an unambiguous answer, the effects of the globalisation of mainly the world economy (Sassen, 2001) suddenly make a global city to actually function by its name. This can be juxtaposed by the very fundamental notion of a place - any place, really - being made by people or inhabitants with a certain idea in mind on the usage of

this place, and its identity starts to act accordingly.

So more than ever the question of how to relate the parochial to the global is a relevant one at envisioning public space. An example of this for instance is Brussels; on the one hand it functions as a capital of a relatively modest and accessible country; on the other hand, it is the unofficial capital of Europe and houses most of the European organisations. This leads to tensions in the urban composition in the city; the rather monofunctional office park that makes the

European District is juxtaposed with the small scale friendliness of a Northern European city centre with its historic quality and vibrancy.



### Collectivisation

The last notion that deserves attention for consideration is the relation between public and private, particularly in public space. The previous section already talked about the effects of telecommunications and digital media in public space, and address the notion of publicness and interaction. Simultaneously, the increasing despatialising and

thematization that Michael Sorkin talks about also tend towards an increasing privatisation of public places. This is often the result of a market (private) governance on space management.

It will remain important to address the border between the private and public, and to consider the qualities of a collective character of frequently used

spaces; Manuel de Solà-Morales mentions this as a precondition for the true urban experience. The imminent privatisation of the current public domain (Banerjee, 2001) poses a threat to the diversity of the urban city.



LEFT

Plan of Parc de La Villette, Paris - This design for a park with folly structures placed on a regular grid illustrates designing with polycentralisation: the grid as the ultimate organisational system without hierarchy

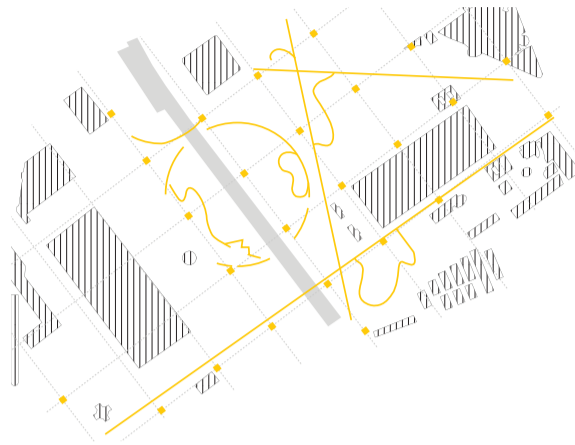

RIGHT

Polycentralisation taking place in cities: Rotterdam no more consists of one urban centre, but has a clearly marketed diversity of cores with different characters

LEFT

People using digital devices in the subway - the digital space has emerged as a secondary public space

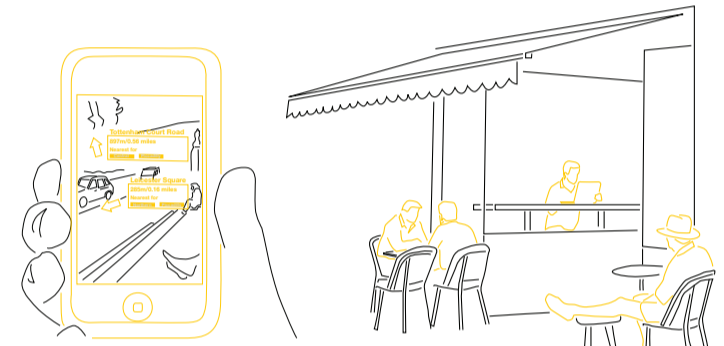

RIGHT

iPhone AR apps - 'augmented reality' apps use the camera of the phone to display the physical world, but overlay it with layers of information, thereby connecting the virtual with the physical

LEFT

International signs in local Amsterdam street - the urban space is no longer home to one identity; it has to face many different scales

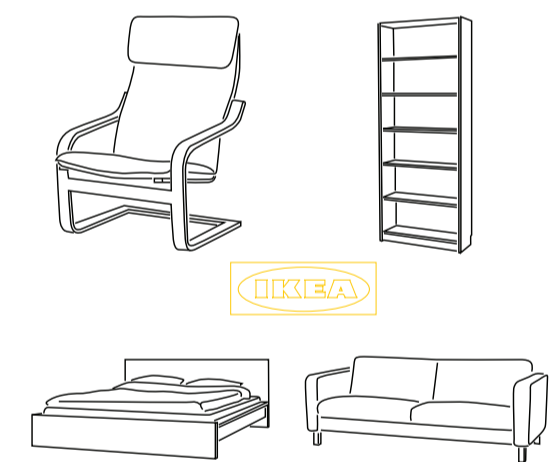
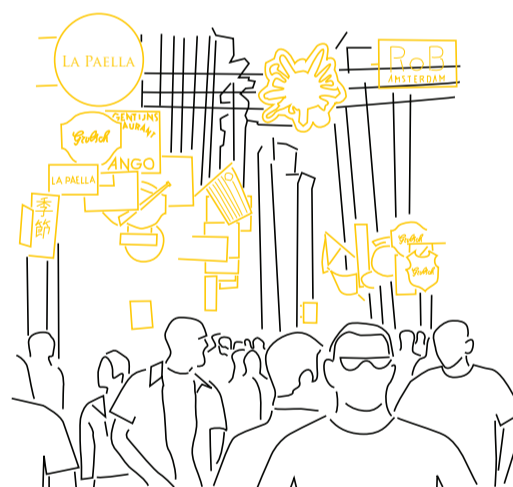

RIGHT

IKEA product catalog - as a global brand, IKEA produces a generic identity, replicated around the world and designed to emanate genericness

LEFT

store within a store - the public domain has shifting borders, when the interior of a bookstore becomes like a street in the sense that it hosts the entrance to a coffee store

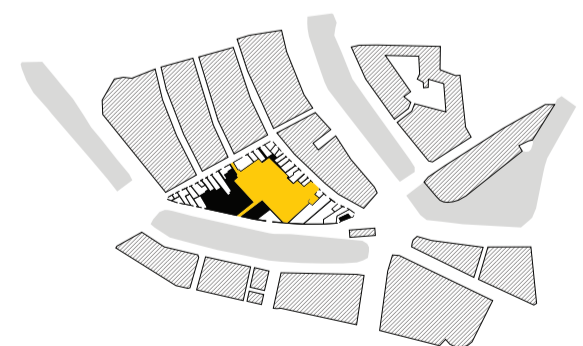

RIGHT

plan of Kalvertoren shopping centre, Amsterdam - During daytime, this essentially private interior becomes public as a street, having shops inside it



## CONCLUSIONS

This paper discussed the changed spatial perception of public spaces as a result of the digitalisation and mobilisation of contemporary western society. The emergence of a non-contiguous urban fabric can be distinguished clearly, as a societal phenomenon (Castells, 2004; Augé, 1995), as a global financial system (Sassen, 2001), or as a pattern for public space organisation (Hajer & Reijndorp, 2002).

Two theorisations that clearly describe a set of effects were discussed: Marc Augé's observations of triple decentring: a city as an interactive import-export system, the display being the central element in a home environment, and the multiplicity of environments that are inhabited by a person that are detached from the physical. Michael Sorokin relates to these statements: he poses the despatialised city as a reality. Three reasons he mentions for this are the loosening of ties to any specific place, the new need for security (or capsularisation), and the emerging thematisation or simulation.

Then this development was linked to the increasing importance of personalised portable objects, which use digital technologies to perform actions that change an individual's relation to the space around them. Three types of behaviour were observed: cocooning, camping and footprinting. The first two are more active than the last one; footprinting is rather a subconscious system that in a way tracks an individual in space. Cocooning is the more isolative act of the three; deliberately shielding oneself from interactions when one is forced to reside in a space. The most important issue with all three however, is how usage of digital interfaces shifts the boundary between publicness and capsularisation. One can start to be private in a public environment.

As a result, four central themes describe the relevant fields of discussion: decentralisation, augmented reality, urban identity and collectivisation. In a way, they are already positions on each's own gradient duality within themselves. In the gradient of top-down hierarchy versus node-based patterns, the notion decentralisation claims that

to avoid a bureaucratic structure of hierarchy and aim for a system that is connecting nodes offers much more flexibility.

Augmented reality posits somewhere between the physical and the virtual; it states that physical space is the basis for human dwelling, and the virtual ought to complement it with its dynamic qualities. It should make use of its immediacy of information, thereby relieving physical space from the necessity of function.

Urban identity is a more neutral position on the parochial vs the global; both worlds have their relevance and should be taken into account. In design terms, this means considering the small-scale local activities and patterns, as well as the relation to a globalised urban environment.

Collectivisation deals with the relation between public and private; the trend of privatisation of the public realm as a result of private ownership diminishes the unexpected and the alien, a condition of public space essential to the true urban experience. Collectivisation advocates general publicness to counteract this trend.

This discourse did not aim not to provide a solution to one specific problem; the discussed aspects already show the complexity of the problem. It rather gives an overview of the main consequences that the public domain is faced with when one considers the developments of digital technologies and physical mobility. In other words, what remains of our traditional image of public space when faced with increasing mobilisation and the digital.

## RECOMMENDATIONS

Although the complexity of the topic has become clear, there are certainly clear points that have emerged, which can connect to further research. A useful aspect is to use design to envision what truly decentralised, collective, urban, augmented space can be.

When faced with the unknown, it lies in design to provide powerful imagery to help us adapt to revolutionary developments (Drewe, 2001). The next step will be to take the four characteristics, to

project them on a design location, and to draw the image that should bridge the gap between theory and realisation.



# 03 celebrating europe

## INTRODUCTION

What are we talking about here? The European residence in Brussels can be seen as a very relevant example of globalising urban space: the confrontation of different identities - global and local, the confrontation of different infrastructural scales. In the European Quarter, these developments have taken a big flight; it is characterised by polarisation of office culture, leading to the exclusion from the area as a public domain from the city. The role and physical presence of infrastructure further increases this polarisation.

But since this is the place that has one of the most physical manifestations of the Europe, questions regarding its identity go further than just an office district (Kallas & Picqué, 2007). This chapter analyses the current situation and its developments, thereby denoting the main problems that characterise the deadlock that the area is in.

## HISTORICAL DEVELOPMENTS

The Leopold Quarter was part of an extension plan of King Leopold built between 1850 and 1880. King Leopold posed a vision for a monumental Brussels, reminiscent of Haussmann's interventions in Paris. His most important marks on the texture of the city are the Pentagon ring road around the city centre, and the monumental boulevards stretching outwards from it. On the east side of the centre, the Rue de la Loi connected to the Parc Cinquantenaire, a former military marching field ('champ de mars').

The extension of the urban fabric towards the east

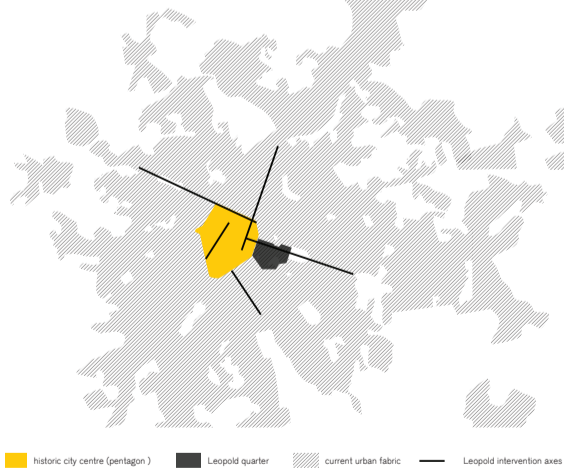

■ historic city centre (pentagon) ■ Leopold quarter ■ current urban fabric — Leopold intervention axes

was along the lines of the envisioned monumentality; an orthogonal grid pattern of streets was laid out, in which a residential neighbourhood emerged. In an attempt to prevent the outflux of higher middle class French citizens in the second half of the 19th century, this quarter was set up with a grandeur and luxury that was not found in the original city centre. This demographic shift was a result of the lingual and cultural dynamic going on in the city for centuries: the Flemish versus the Walloons. The urban fabric mostly consisted of three storey high housing, in a closed block structure with private

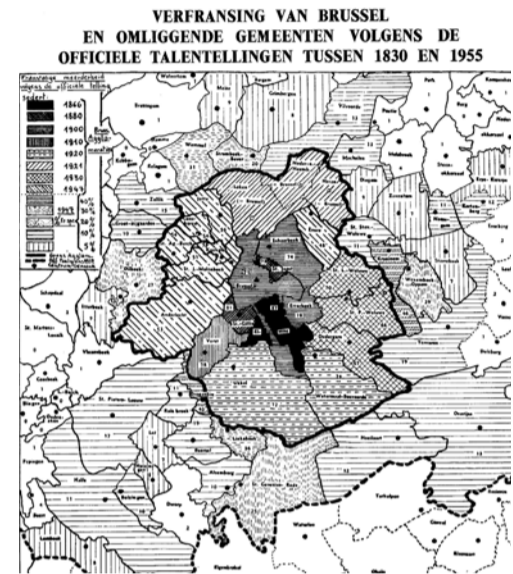

ABOVE the Leopold Quarter, 1935

BELOW Leopold Quarter, 2005

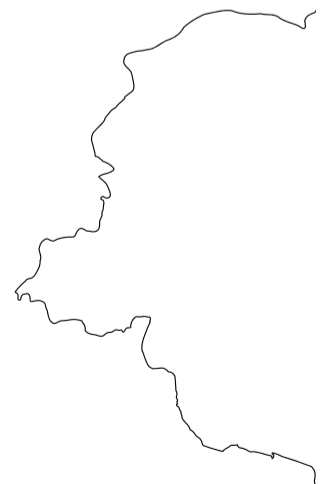
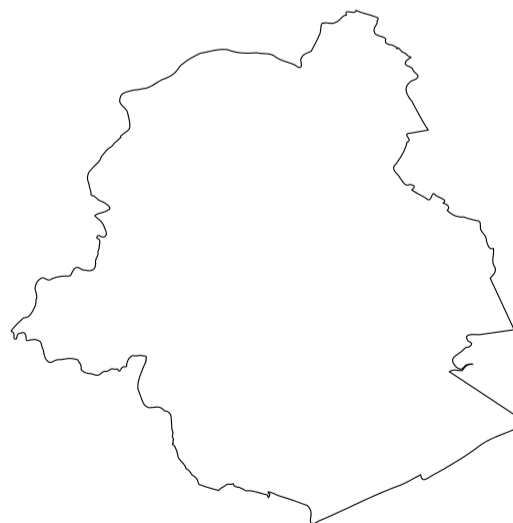
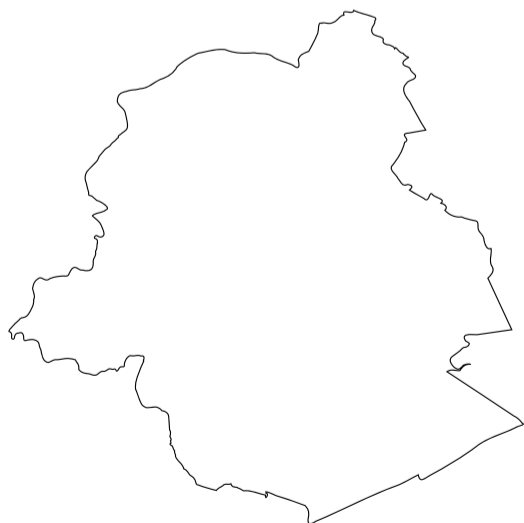
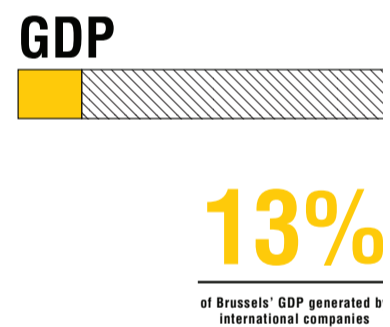
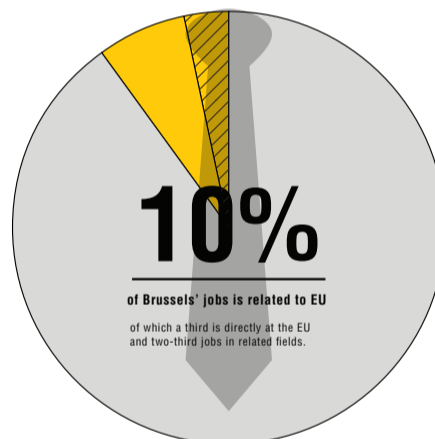
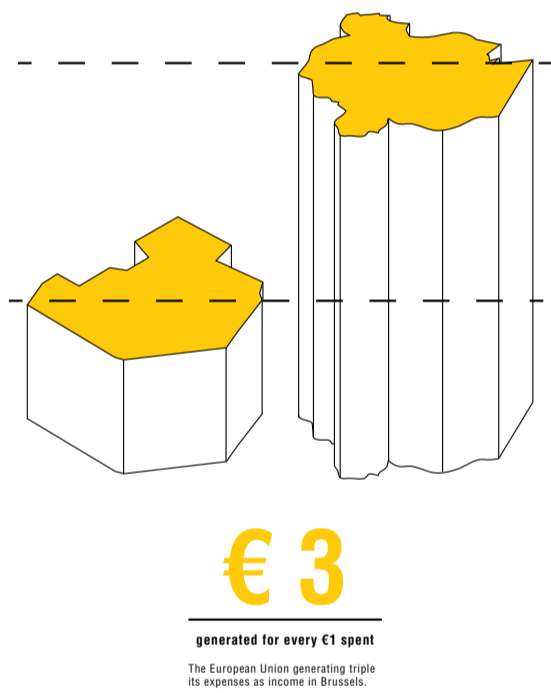
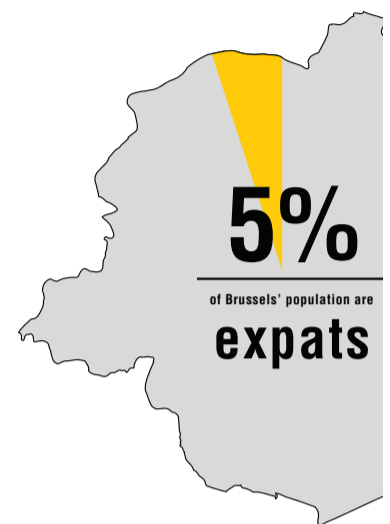
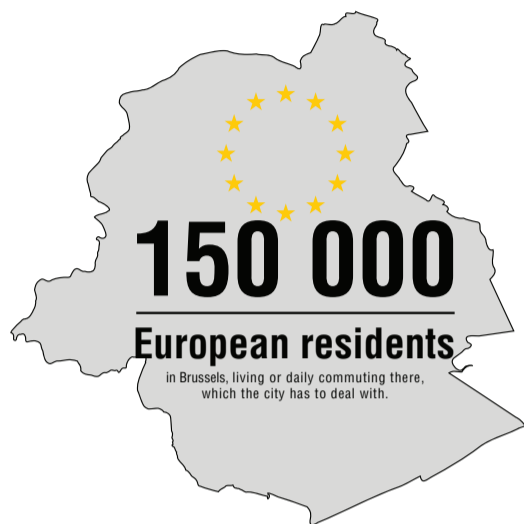



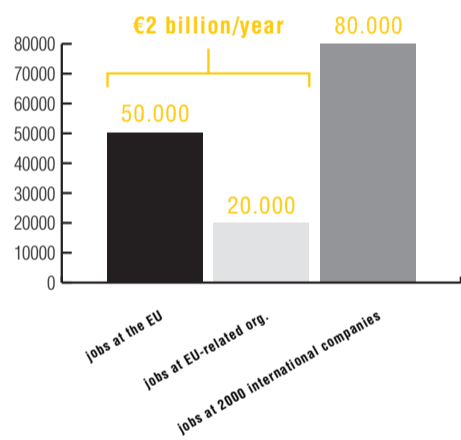
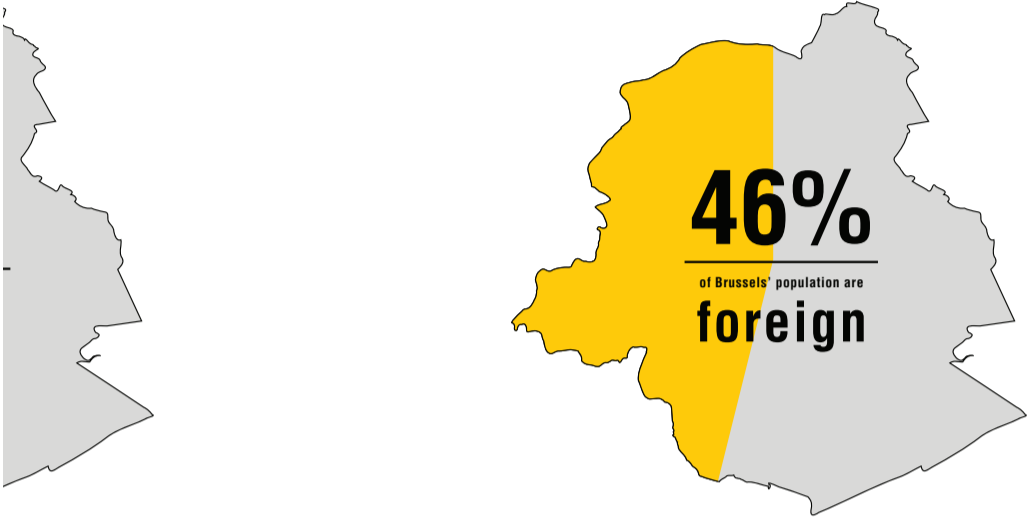

## POPULATION

## ECONOMY

## OFFICE SPACE

### EUROPE IN BRUSSELS

What does Europe in Brussels mean?

Brussels has to deal with about 150,000 'European' residents that either live in the city or daily commute there,

though 75% of the European officials work in the EUQ actually live in Brussels.

Expats make up 5% of the total Brussels population almost half (46%) of Brussels' population is foreign (non-Belgian)

Every job at one of the European organisations create two jobs in related fields, and every 1 euro spent at the EU organisation is equalled by 3 euro elsewhere in Brussels, as a result of this.

10% of the Brussels jobs is related to the EU; the EU institutions provides 50,000 jobs, another 20,000 in peripheral activity – generating 2 billion per year – and 80,000 people are employed by the 2000 international companies

13% of Brussels' GDP comes from international organisations.

The EU officially has capital in 3 cities, although Brussels houses 4 of the 7 European governing bodies

the EC currently occupies about 490.000 m<sup>2</sup> of EU office space (170k EC, 300k other, 20k facilities), and plans to expand with about 390.000 m<sup>2</sup> (230k EC, 10k other, 40k facilities) to almost 1 million m<sup>2</sup> in total, the European institutions occupy 1,75 million m<sup>2</sup> office space, which is half of the total occupied office space in Brussels, and a quarter of the total available office space

running costs of the EU are 2 billion per year



map showing Brussels and its most important road connections, in 1837

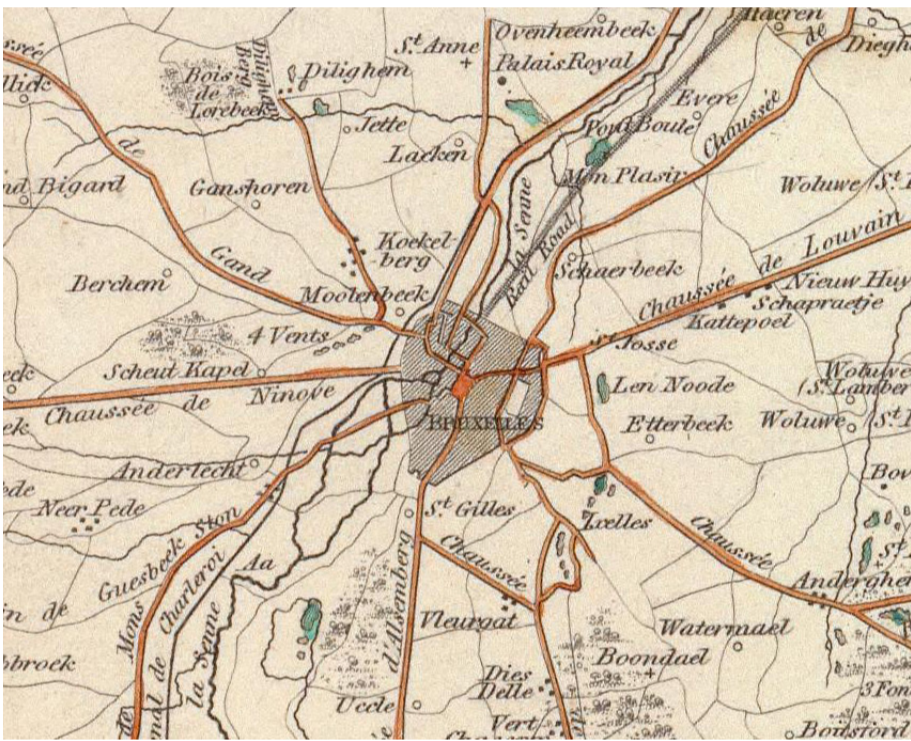

Rue de la Loi on a rainy day

juxtaposition of vernacular 'European' architecture with contemporary office buildings by the European Union





gardens in its interior. It resulted in a green residential environment, in which the Leopold Park, the Cinquantenaire Park and the Square Frere-Orban and Meeus acted as green public spaces.

#### DEVELOPMENT INTO THE EU QUARTER

In the 1950s, the post-war European Zeitgeist led to the forming of several international communities between countries in Europe. One of them was the European Coal and Steel Community, between six countries [see map] in Northwest Europe. This trading community soon formed the basis of what in 1993 officially came to be the European Union. This political body currently encompasses 27 member states, and ensures free movement of people and goods, services and capital (EU core, Europa.eu). The choice for a capital and main seat of the governing institutions has been subject to heavy debate. The democratic union between states demanded a decentralised system, which put pressure on whichever city or country would be chosen as capital.

A 'Committee of Experts' decided Brussels the most appropriate host city. Reasons for this were: it being a large and active metropolis without a congested centre or poor quality housing, a vibrant economy, a strong integration in international transport networks. next to this, as a smaller country Belgium didn't run the risk of developing a superior-nation status in relation to the other countries (Demey,

"... [Brussels] cuts across urban hierarchies since it is now very global, European, Belgian and local at the same time. This small city is constantly under heavy pressure from the continuous expansion of EU offices and activities; its population is rapidly internationalizing; and its service economy is becoming global."

Guy Beaten, 2001



2007). In short, Brussels was characterised as a neutral and smaller node in the well integrated network of northwest European metropolises.

Because of the initial debate around the issue, a provisional system was set up where the institutions would temporarily take up residence in other such 'neutral' cities like Strasbourg and Luxembourg. When Brussels was deemed as the most appropriate city, the other cities had already settles themselves in a hosting role. This is the reason the current situation is still a multi-capital organisation.

After the Belgium government assigning new office space to the east of the centre, the European Commission, the Council of Europe and part of the European Parliament took up seat in a number of newly constructed offices around the Rue Belliard. As a result of the rapid expansion of the European Union, the 1960s and 1970s showed an uncontrolled and unprecedented expansion of office space in the Leopold Quarter [see map].

This proces of unplanned commercial property development has come to be known as Brusselisation (Harding, 2001) - and the Leopold Quarter is one of the most famed examples of this phenomenon. The

direct consequence for the street level is summed up by [Photo 1]: the indigenous urban tissue, complemented by anonymous glass facades. As Guy Baeten states, "... [Brussels] cuts

across urban hierarchies since it is now very global, European, Belgian and local at the same time. This small city is constantly under heavy pressure from the

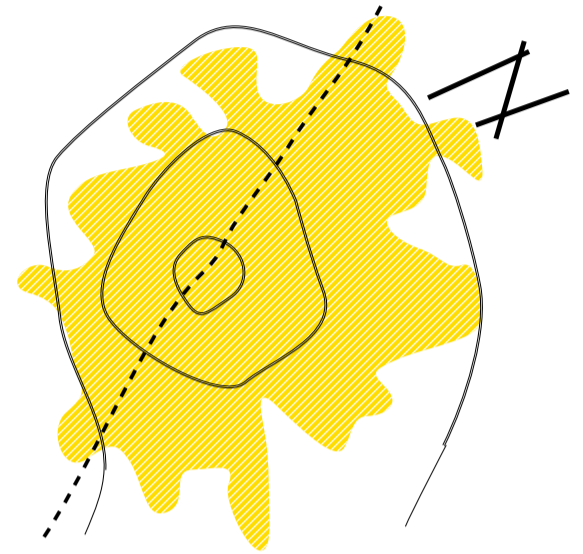

continuous expansion of EU offices and activities; its population is rapidly internationalizing; and its service economy is becoming global" (Baeten, 2001).

#### NETWORK ANALYSIS OF BRUSSELS

The presence of the European Union can be clearly discerned when regarding the infrastructural networks. On three levels of interurban infrastructure – highways, rail network and airport – its influence is significant. The diagram of Brussels' connections can be abstracted into the city's three clear ring roads (the





Europe transformed: map of reachable places per time unit

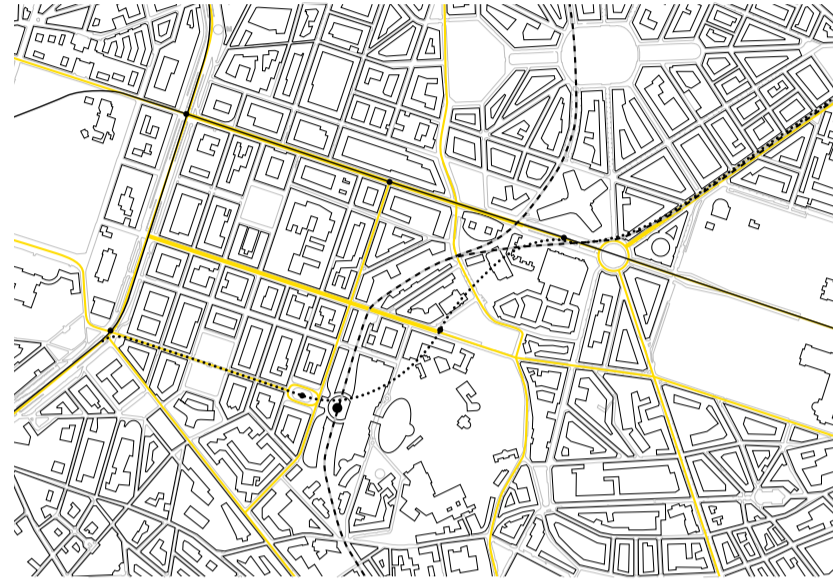
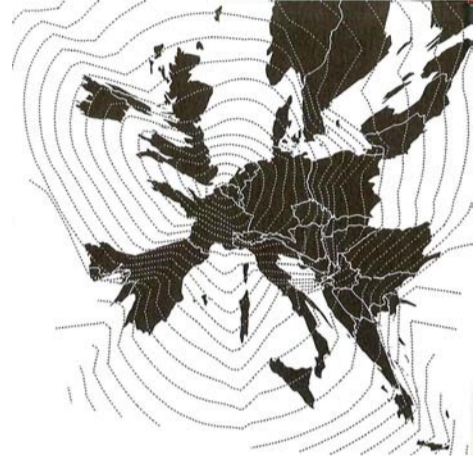

five lane single direction road through the quarter

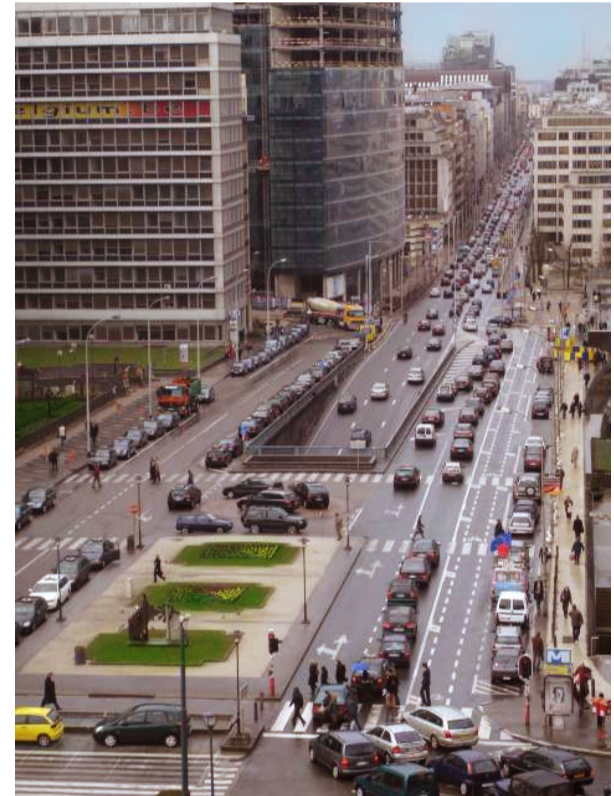

Rue de la Loi near the EU Commission  
Building with busy traffic

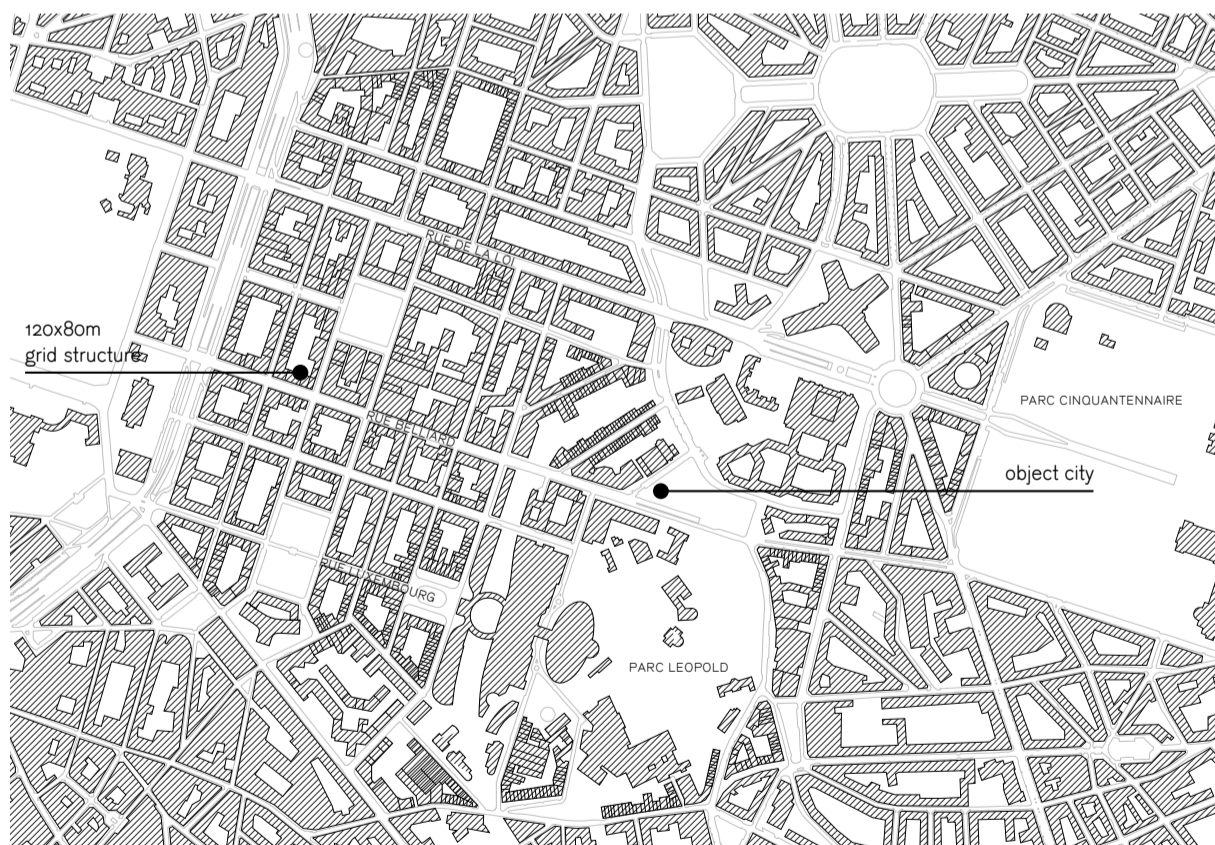



outermost one is the actual highway), the north-south rail line crossing through the centre, roughly along the line of the canal, and the airport on the northeast periphery, closely linked with highway and train.

Because of its clearly defined historic city wall, which was preserved by the transformation into a ring road by King Leopold, the city's road system is rather concentric: three layers of ring roads, with radial boulevards connecting them. These radial roads serve the in- and outflux of car traffic for the ring roads. When one regards the car intensity of the roads, it

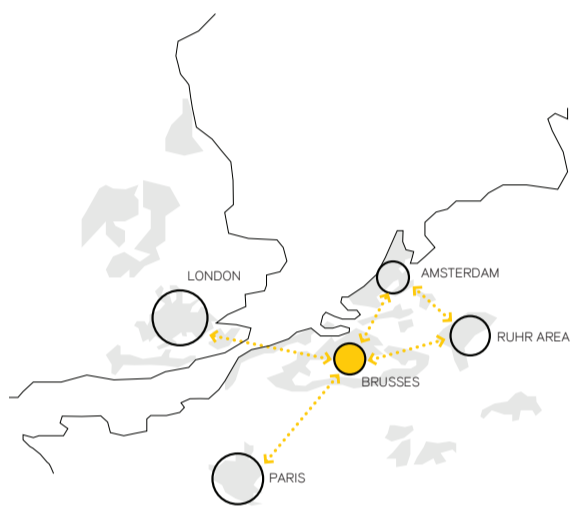

reveals the nature of the connection to the east of the

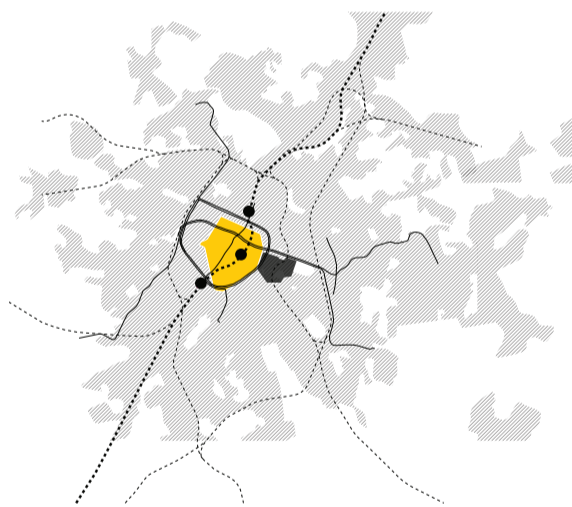

city centre – in the Leopold Quarter. Two five-lane single direction roads transverse the area. As [Photo 3] show, the perception of these roads on street level is dominated by the abundance of cars. The car intensity map shows, that these two roads together form one of the most important arteries in and out of the city: Rue Belliard and Rue de la Loi. Apart from directly linking the European Quarter to the larger infrastructure, the two roads provide an access to the highways and even to the airport for the most of inner Brussels. This also

explains the 5 lanes that form these roads.

The train connection could be considered as one of the most important networks, embedding Brussels in the Northwest European metropolitan area. With this network, the urban areas of Paris, London, the Ruhr Area and the Randstad are easily connected within 2 hours. This transforms the effective map of Europe and how it is experienced in time distance like in [Image 5].

Brussels has three large stations: Brussels North, Central and South, of which the Central station acts as an important connector for the European Quarter. It is connected by the metro lines; the train and metro map reveals the intense connection between Brussels' Central Station and the European Quarter, linking it by about 5 metro lines [Image 6].

When compared to the role of airports in the surrounding metropolitan areas, Brussels Airport proves to actually be quite local – only 10% of its traffic is transit or transfer (Brutrends, 2009). Zaventem is an airport for local traffic – a logical explanation is the large amount of EU officials flying in and out of the city. The connection of the European Quarter to the airport is effective mainly through the train connection from Gare du Luxembourg (under the EU Parliament building) in 30 minutes, and the highway, making it a 20 minute taxi drive (outside the infamous rush hour).

Summed up, the Leopold Quarter is embedded in a strong infrastructural networks. Firstly, the the road system proves to be one of the most important radial axes to the highway for the whole city. Secondly, the metro system and train station link the area to the three main international train station of the city. Lastly, the Zaventem airport can be reached through either road (20 minutes) or train connection (30 minutes).

#### A GRID PATTERN VS THE OBJECT CITY

In order to get a further grip on what actually characterises the European Quarter, its structure should be considered. The Leopold quarter, built as a three-storey residential neighbourhood [Photo x] is

known as the European Quarter because it houses the office space of the European institutions. It stretches from the pentagonal ring road to the east, until the monumental Parc Cinquantenaire and the Parc Leopold.

The area can be characterised in two distinct morphologies: an orthogonal grid structure of about 120x80 m, which was the original residential structure. Further to the east, the large office developments of the European Union break up this tissue, and form an object city in combination with undefined open spaces and the Leopold Park.

This differentiation in urban form also shows a functional distinction: the large objects are housing the main seats of the major European institutions: the European Parliament, the European Commission and European Council. In turn, the grid provides space for smaller institutions, satellite offices of the major institutions, and embassies and other companies. Connecting to the discussion of the networks in the previous paragraphs, the two major car axes - Rue Belliard and Rue de la Loi - transverse the area in east-west direction, weaving together the two different morphologies. A third axis that does this too, but has a smaller infrastructural role, is the Rue Luxembourg, to the south of the other two.

#### EUROPEAN CAPITAL AND SYMBIOSIS

In Eurostars and Eurocities, Adrian Favell characterises a triad of urban cultures present in the current Europe (Favell, 2006). He sets up three types of cities: Amsterdam as the 'cultural Eurocity' – an urban area based for a large part on its cultural heritage and subsequent tourism. Other examples of this are Paris or Rome. Then he determines the economic Eurocity: London. It distinguishes itself by it being the economic heart of an immense region. Other examples are German cities like Munchen or the Ruhr Area.

The third category is the political city: Brussels. Favell highlights a number of spin-off effects of the EU residency in the city, outlining its self-reinforcing effect as a political point of gravity.

This typification, still augmenting because of

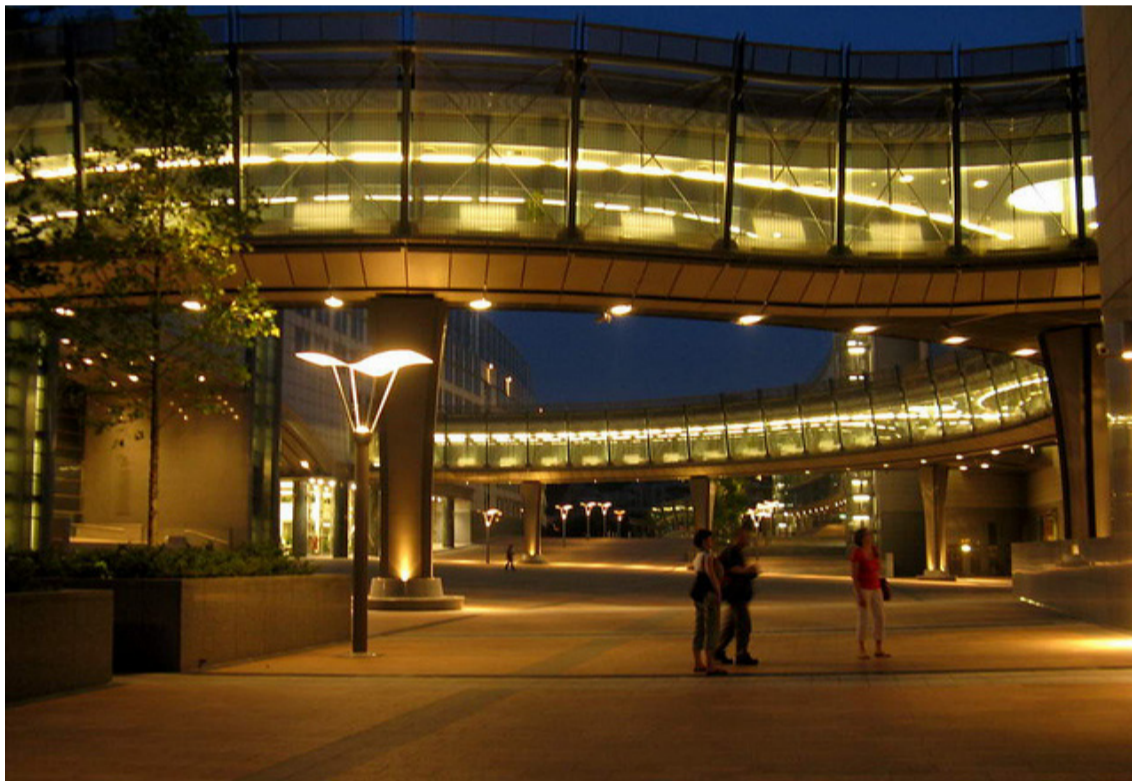
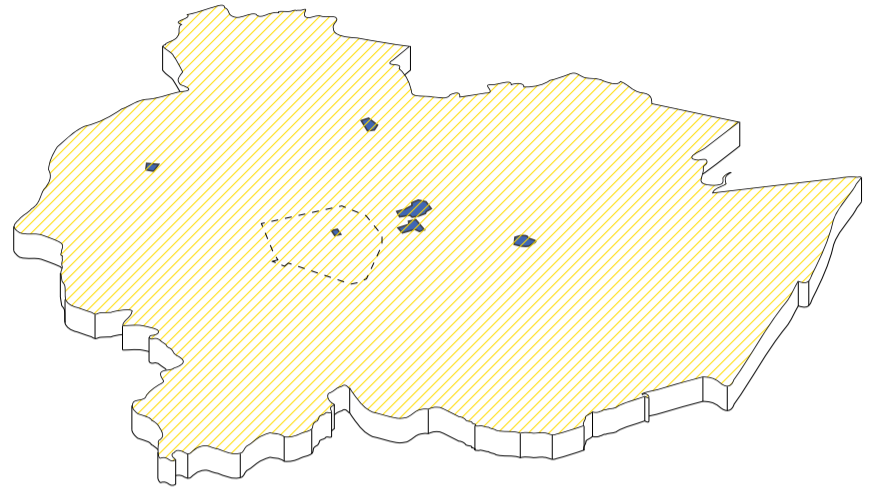
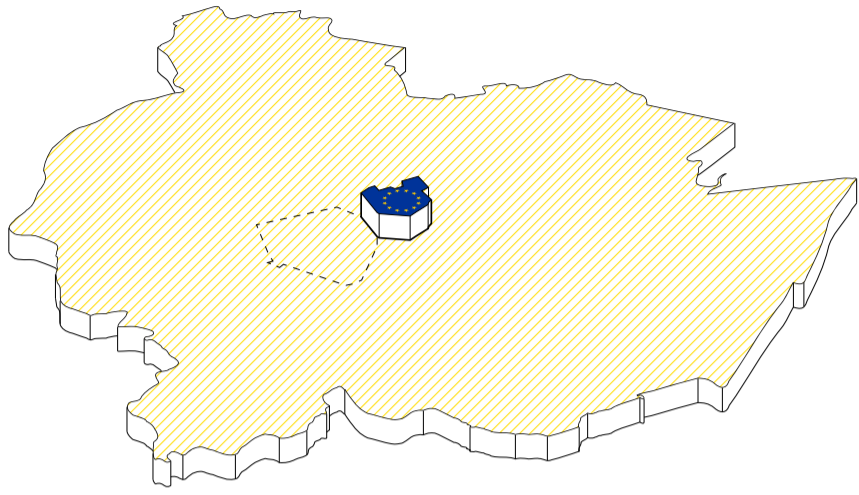

public space near the Parilament building at nighttime



proposal for new flag of Europe by OMA/Rem Koolhaas



the expanding bodies of power wielders, political institutions and lobbyists, offers not Brussels itself to have an iconic image, but also provides an opportunity for the European Union to provide an image for what an outspoken politic public space can be for the city.

In 2001, a debate was (re-)opened regarding the nature of a capital of the European Union and its physical manifestations. Apart from a lively debate and the realisation of the topic's complexity, certain characterisations regarding the space of a European capital were made. Rem Koolhaas posed the necessity for a European icon, in order to position it in the global international landscape. In this case, Brussels should house a monument for celebrating Europe. In

The emergence of a [...] polycentric capital, is not the result of an explicit policy, but rather of the particularities of the creation and formation of the EU in response to the interests of the member states.

Carola Hein, 2006

this, its identity is polyform; a combination of its 27 members. For this, his office designed a new European flag that would represent the new situation of Europe [see Image x].

Umberto Eco characterises the EU as a soft institution, lacking a power hierarchy. Relating to this network politics is his notion of a 'soft' capital. According to Eco, the EU should reinforce its position as a network of identities; one should in this case not speak about one absolute capital, but rather a hybrid and integrated system in which a network can function (Zucchinni, 2006; Prodi & Verhofstadt, 2001). This defies the notion of Brussels as an outspoken European Capital.

The notion of concentration of 'capital functions' in the European Quarter is often discussed and criticised.

Based on the current atmosphere of the area as a lifeless office district, a general critique is spreading on the current situation. In this direction, a certain decentralisation of functions is often proposed (Hein, 2006). Current policy shows this direction, explained in [Diagram x]: the introduction of a polynuclear system of housing the EU in Brussels. It would create a network throughout the city, of points with distinct European character. In this policy, the European Quarter itself is released from part of the pressure of office space.

#### PUBLIC SPACE ATMOSPHERE

The current state of the image of the Leopold Quarter is rather an absolute status quo. Among many opinion surveys amongst citizens, the Quarter is regarded as an office area, where ordinary citizen have little or no business.

As a result of the above mentioned Brusselisation in the 1960s and 1970s, a citizen initiative group was founded in 1982. The GAQ (Groupe d'Animation du Quartier Europeen) forms a non-profit counterweight to the expanding office developments and the threat of losing all spatial qualities of the public space and buildings in the area.

This image is confirmed by the image the streets give past office hours: a deserted space, closed off from interior activity by glass facades of the surrounding offices – often mimicking and reinforcing the look of emptiness [Photo x].

#### CONCLUSION

The particular topics reviewed here in this chapter - the nature and development of the residency of the EU, the historical context of the area, the integration of the area in surrounding networks, the monoculture of offices and its effect on public space, and the debate about the Leopold Quarter as a European capital - outline the principal characteristics and problems of the area.

It has become clear that the Leopold Quarter has become a lot more complex as 'just' a neighbourhood

in 'just' a city; its original fabric and function have been complemented and even replaced by a global culture - a culture that reinforces and expands itself, on the one hand creating a strong integration in

networks by the presence of infrastructure, but on the other hand creating a monocultural district. This is an effect harmful for both the identity of the European Union, as well as the city of Brussels and its inhabitants. In the European Quarter there is an opportunity for the EU to show what an outspoken public space for politics can mean for the city.

"In the European Quarter there is an opportunity for the EU to show what an outspoken public space for politics can mean for the city."

The next chapter will deal with a proposed strategy for the area. In it, a redevelopment of the public space is proposed, as a backbone for the reintegration of the Leopold Quarter with the city. By proposing a number of key urban projects, this strategy will be elaborated.





# 04 urban strategy

As elaborated in the previous chapter, the relation of the European institutions with the city of Brussels can be said to be highly problematic. There is an obvious lack of definition in terms of identity and position of the European Union in Brussels. The rapid developments of European collaborations in the last 60 years has led to an expanding but decentralised European government, housed in a generic office complex pasted over a former residential neighbourhood in a culturally very defined city.

The previous two chapters have introduced a number of themes and problem observations, regarding contemporary urban public space and the European Quarter. This chapter summarises the most relevant problems, and synthesises these into a strategy for the public space.

## PROBLEM SUMMARY

As Baeten (2001) states, these 60 years of uncontrolled office expansion without any governing strategy, is characteristic for the politically complex governmental situation – where about 5 levels of legislation are involved in planning the European Quarter. This is the first direct problem of the European Quarter: **the constant need for expansion of office space because of the expanding EU** (1).

A number of reasons can be given for the current deficits of the European Quarter – but the most important basis is the observation that becomes clear from all who discuss the quarter: the area is a ‘dead’ office district, devoid of any liveliness or urban activity.

Although the offices seem to be the stage of the dynamism of European political developments, the public space within the area explicitly lacks such activity – any activity, really. The daily highlights of urban activity could be summed up by three particular and encapsulated moments: the morning rush hour, lunchtime, and the evening rush hour. Outside these times, the streets are deserted. This describes the second main problem: **the monoculture of office functions deprives the public space of any liveliness** (2).

On the one hand a spin-off effect of this monoculture of offices, and on the other hand a historically important route for the entire centre of Brussels, is third problem characterising the area: **heavy infrastructure dominating the public spaces** (3) – most notably two five-lane single-direction roads, Rue Belliard and Rue de la Loi. Together they form one of the primary connections to the Brussels ring road and the airport. The presence of this infrastructure disconnects the public space with the human scale.

The fourth, rather more soft aspect depriving the character of the European Quarter from coming to fruition, is **the monumentality of the urban spaces through the continuity of the axes** (4). This originated in the development of the former residential area, based on a marching field in the hills with a straight road leading up to it. The open and grand character it had when occupied with high class, three-storey high residences was quite fitting – but now has its repercussions for the resulting space between the office blocks as too large

and sometimes windy. Moreover, it contrasts with the identity of the European Union as a non-hierarchical political entity. Europe as a polycentral network, unhampered by a classical power orders [more about this in the conclusion of chapter 2].

Complementary to the characteristics of the case study area in Brussels, a number of themes that were discerned in the start-up of this project, the research on changing public space. As discussed in [chapter 2], four themes about public space can be concluded as considerations or dualities that emerge in the current debate about cities, globalisation and infrastructure.

Out of these themes, urban identity, decentralisation polycentralisation and collectivisation are particularly relevant. **Urban identity** (1) in the case of the European Quarter is very literally the invasion of the EU in the 1960s into the existing residential fabric of the city. Taking over to an extent that there is almost no dwellings left in the area, a definite conflict can be observed.

**Polycentralisation** (2) refers to the layout of the contemporary urban space from infrastructural nodes or socio-cultural centralities outwards. This is happening effectively through the large in and outflux of ‘eurocrats’ in Brussels, but still lacks clear definition in the articulation of public space. Space for these nodes to grow and develop is necessary, in order to let the polycentral city function. **Collectivisation** (3) as a theme deals with the border between the private and the public domain. The urban public space explicitly is a key space in

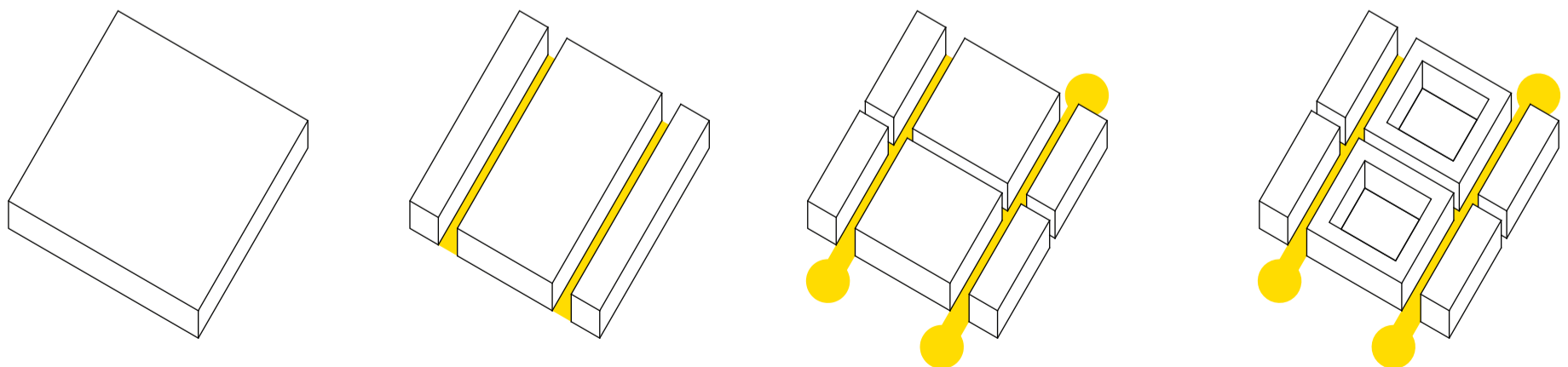

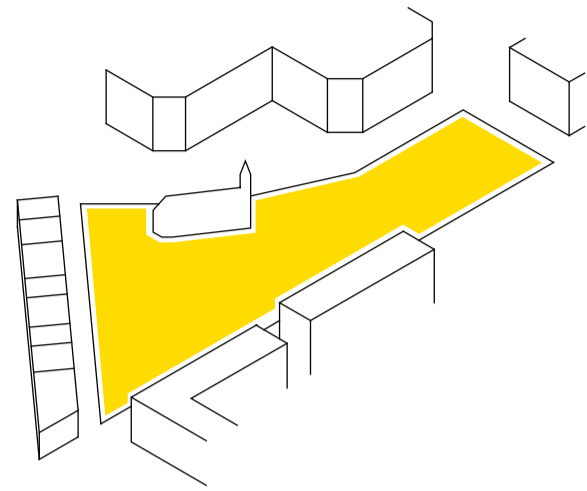
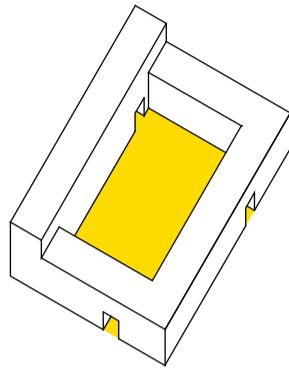
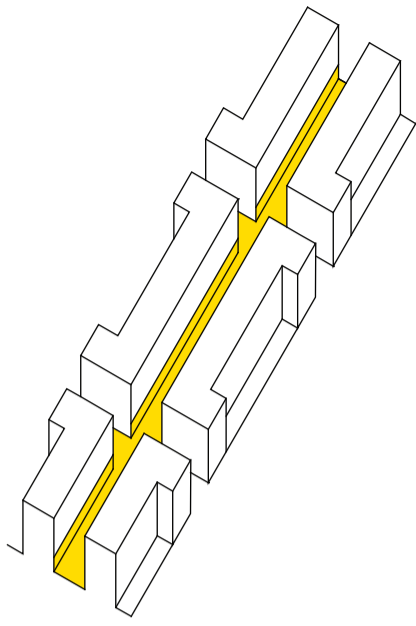

this debate; to what extent is place still public? What determines its publicness, and should this aspect always be guarded to remain present? In the European Quarter, the office monoculture has almost eradicated this existence of a collective public space, since there is hardly any confrontation of different groups in society.

So the aim of this intervention project is defined as such: to redefine the existing public space appropriate to the expression of the European Union as a political entity, addressing diversity and liveliness. An integrated, diverse, global and local, polycentral neighbourhood.

#### PROPOSAL

In order to particularly readdress the characteristics of a clean glass office district with only a

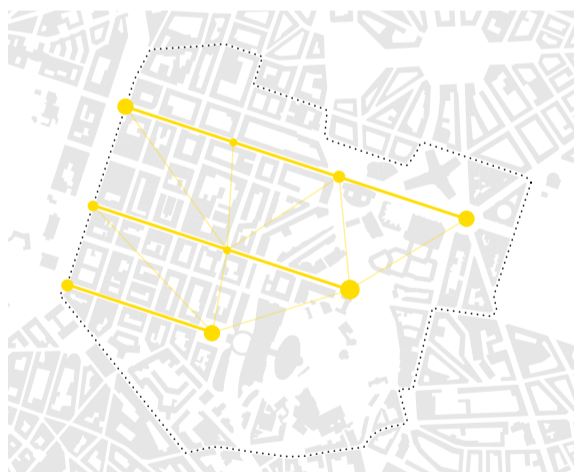

9-to-5 working inhabitation, and liminal public space that is dominated by the presence of car infrastructure, a new strategy for the public space in the area is proposed. What is needed here, is an exterior public environment that appreciates the multitude of infrastructural modes, the multitude

of identities (temporary, global, or immutably embedded in the city), and the multitude of functions that belong here. The European Quarter as a true neighbourhood of Brussels city, embedded in the urban fabric.

#### FROM FLATNESS TO A POLYCENTRAL NETWORK

This position on the atmosphere of the public space is mirrored in the **flatness** of the structure of the Leopold Quarter: a flatness in program (the office monoculture), a flatness in distinction between type of streets and a flatness in street facades and building differentiation. Levels of hierarchy are missing in the area: a continuous strip of glass facades. As a result, the emergence of centralities in the public space is lacking, mainly in the grid pattern directly to the east of the ring

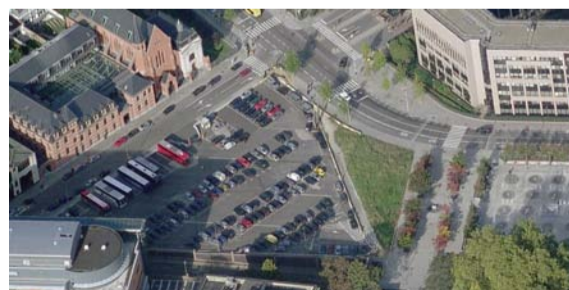

road, before the object-based morphology of the large EU buildings. A differentiation of public environments is necessary to regenerate the quarter. [footnote: For a further analysis of morphology, see Chapter x].

Diagram [x] above shows the proposed abstract zoning plan; the old situation consisted of a homogenous texture of glass office blocks with car-dominated streets inbetween them; the new situation positions a reorganisation. The first initiator of the proposed differentiation are the centralities of two important axes running through the quarter. Secondly, the locations where a potential for centralities is present on the axes are extrapolated to form anchorpoints. The start of the axes is from the ring road, an existing set of nodes in itself. The axes themselves then run into the fabric of the Leopold quarter, not as an ongoing set of glass facades, but as a rhythm of nodes, leading the urban stroller from one centre point to the next. This way, a spatial sequence will exist like it is present in the inner city [See map x] - a logical sequence of spaces.

The set of nodes in [diagram x] is based on existing centralities, like the historic Place du Luxembourg, the Schumann roundabout with its large office buildings next to it, but also the crossroads of the axes with the ring road that mark the entrance of the European Quarter. Next to this, smaller nodes are located around metro entrances and significant crossroads.

On the one hand these nodes are extrapolations of existing centralities - in some cases they are actually added. For instance at the end of the middle axis, the Rue de la Loi, a new centrality will be located, to terminate the axis itself like happens





with the other two.

The termination of the axes is at one of the three thematic squares: the political (Schumann), the nostalgic (Luxembourg), and the interactive (European Forum).

The previously addressed lack of real public space in the area and the lack of functions other than offices make up the core of the new network of public spaces. By means of an overall strategy, three type of new spaces are developed: Firstly, a pair of pedestrian-friendly boulevards where infrastructure is reorganised for public functions (1). Secondly, a set of semi-public spaces in the form of new interior of the urban blocks, being opened up and given to the city to be reused, at the same time creating an environment for residential use in the area (2). Thirdly, a forum square at the end of the Belliard axis, in between the large European buildings, providing a new centrality that addresses both the local functions (EU) as well as for the larger city inhabitants (3).

In these paragraphs, we will treat the first two intervention projects - in a relatively abstract manner - and how they relate to the overall strategy for the network of public spaces. In the next chapter, the third project will be treated more extensively.

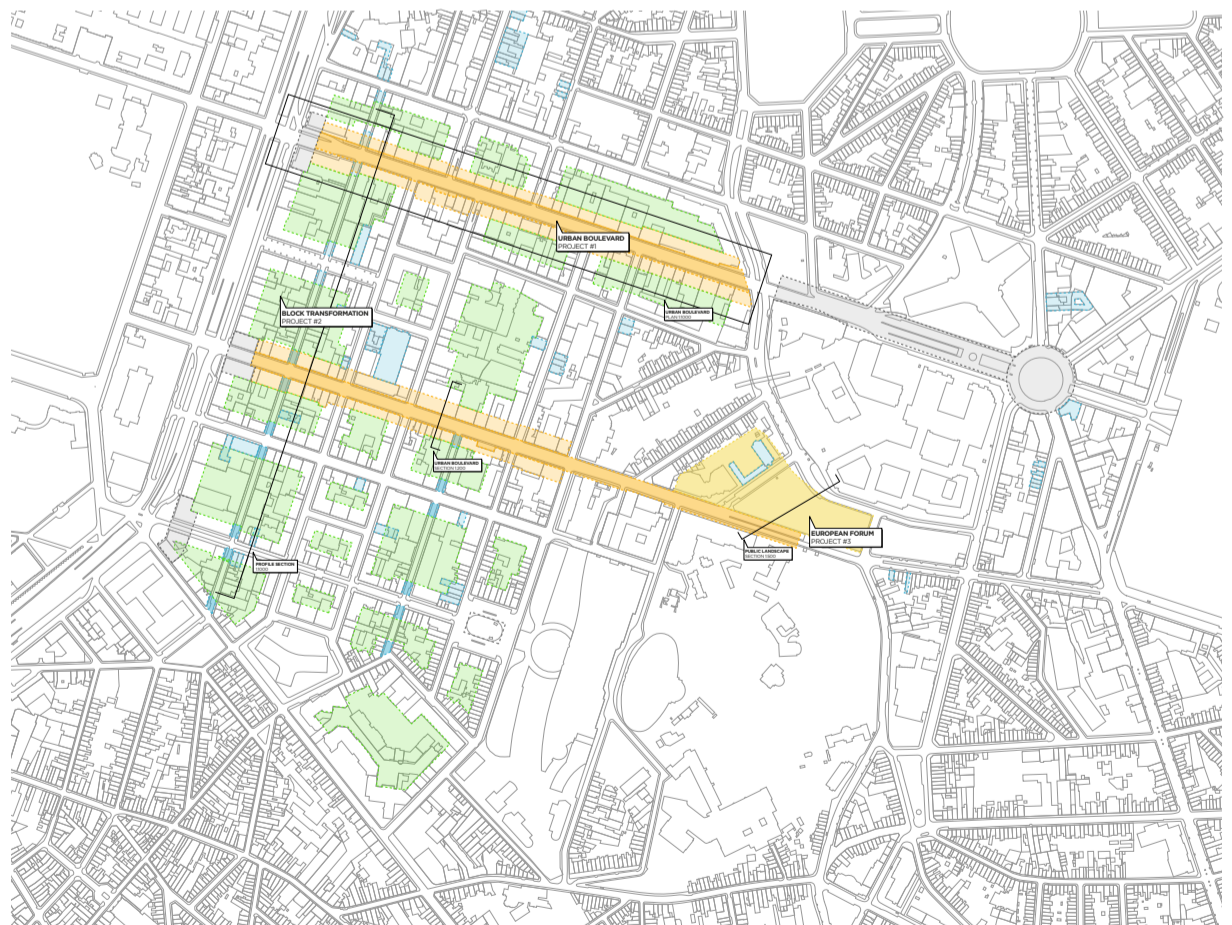



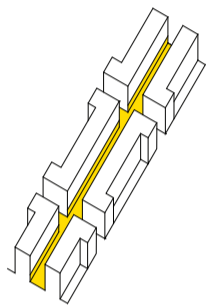
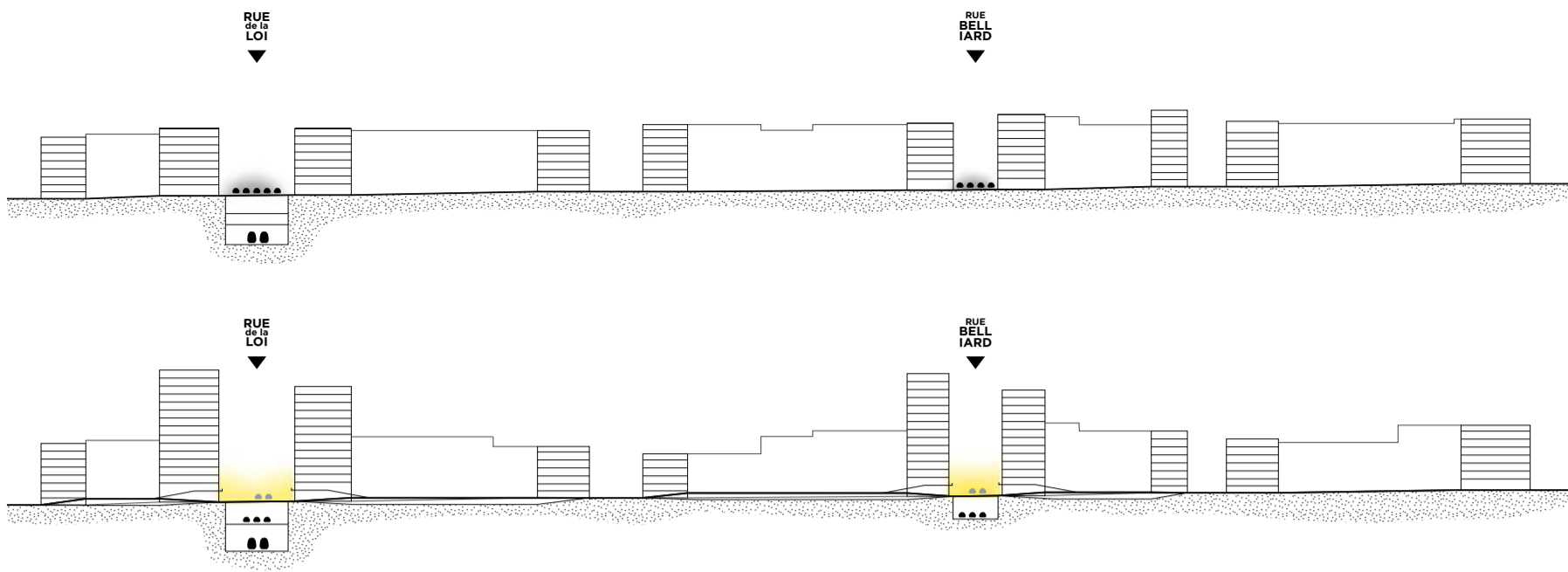

PROJECT 1 URBAN BOULEVARDS

The first project for the european quarter encompasses the redevelopment of two major axes. Currently burdened with heavy five-lane traffic arteries, the new situation proposes the separation of interurban and local traffic. This way, the street level is reopened for public life.

Together with the activation of the plinth of the buildings with public functions, the new boulevards will start to act as new centralities in the quarter.

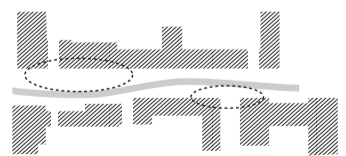
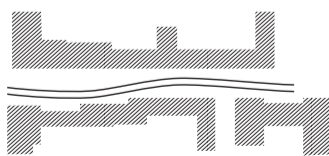
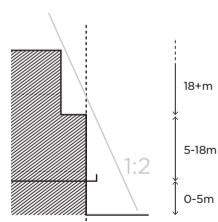
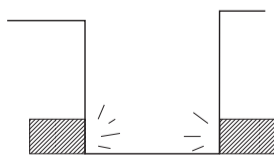
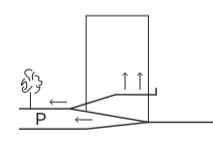
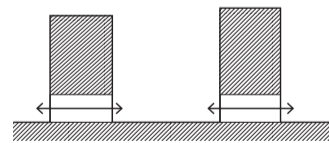
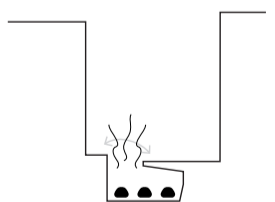
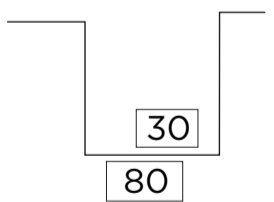
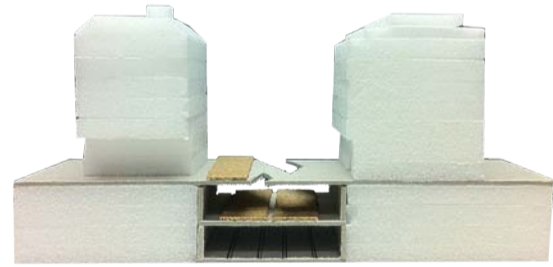
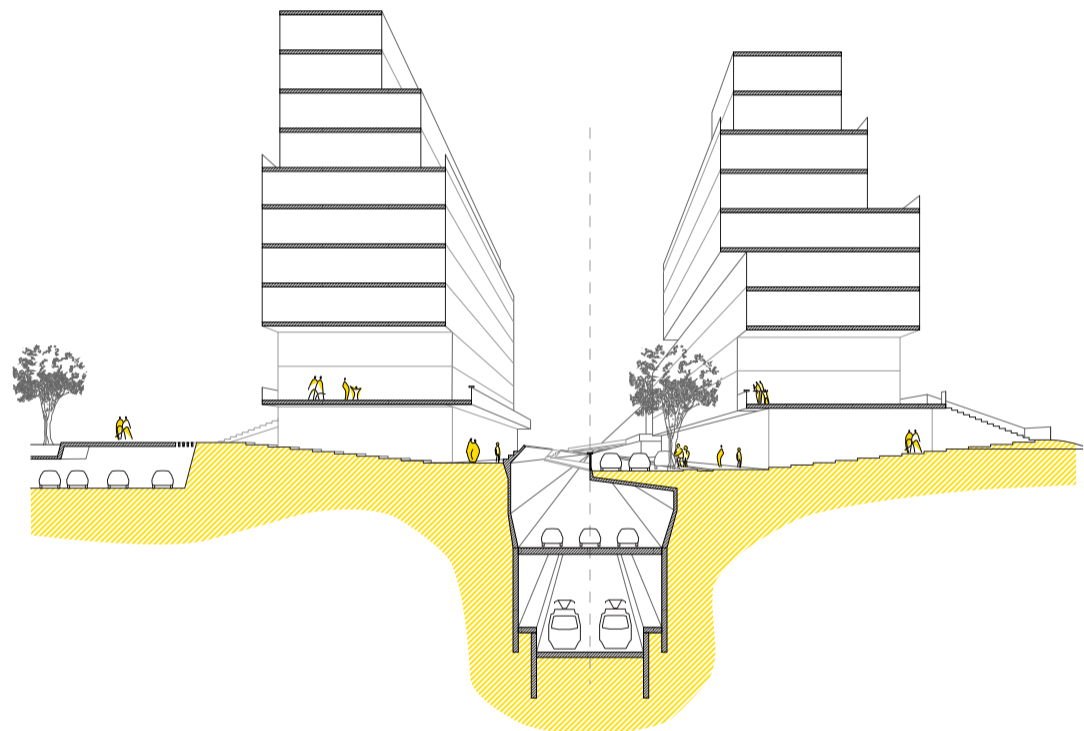



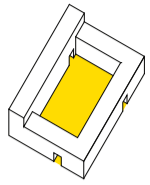

PROJECT 2 RECAPTURED BLOCKS

The transformation of the current flat and solid office blocks is the second key project. The original dimensions meant for three storey residential use have densified so that the courtyards are closed off and (partially built).

The project proposes an increase in size for the interior courtyards by combining two blocks. This will open up the space for a secluded residential atmosphere. By reorganising the volume of the block, new housing can be added to promote functional diversity in the european quarter.

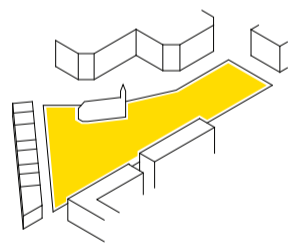
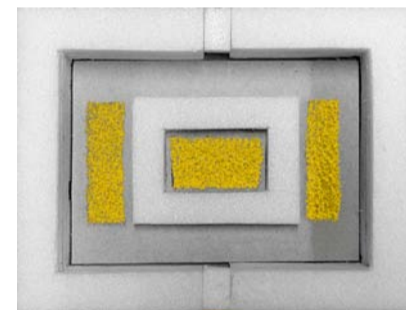
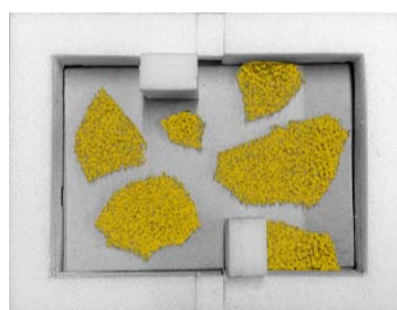
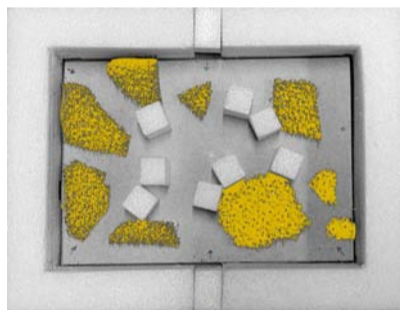
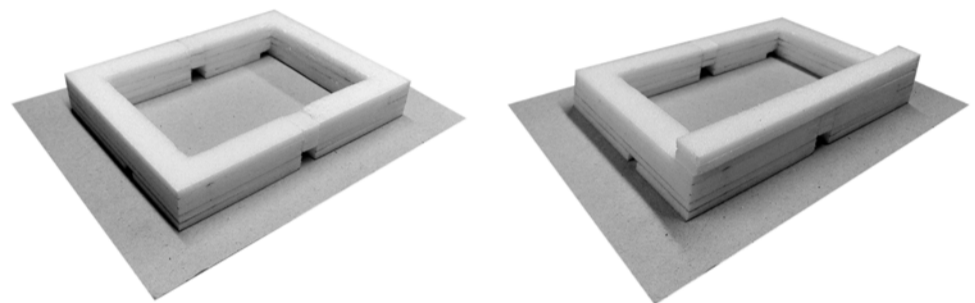
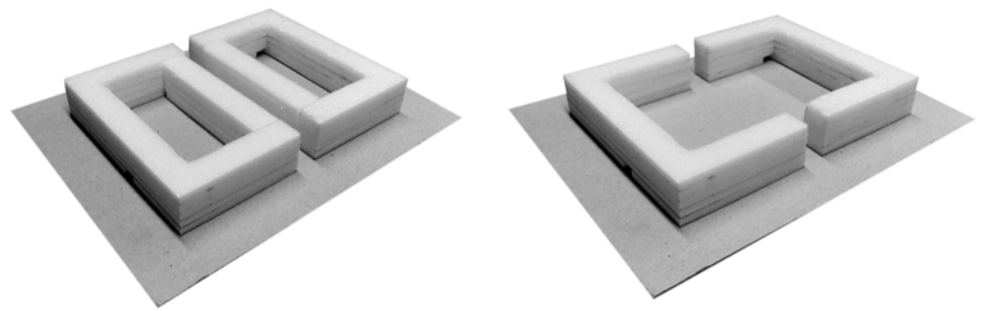

PROJECT 3 EUROPEAN FORUM

The third project for the european quarter is a new square amidst the main EU office buildings. In it, a number of functions are embedded - not only offices for the EU, but also for the city, like shopping, restaurants, a metro station and a cinema.

The european forum explores a new method of integration of functions with the public level: by folding and creasing the sloping geometry of the site, and 'stuffing' the program underneath, new spatial relations are formed that generate publicness.

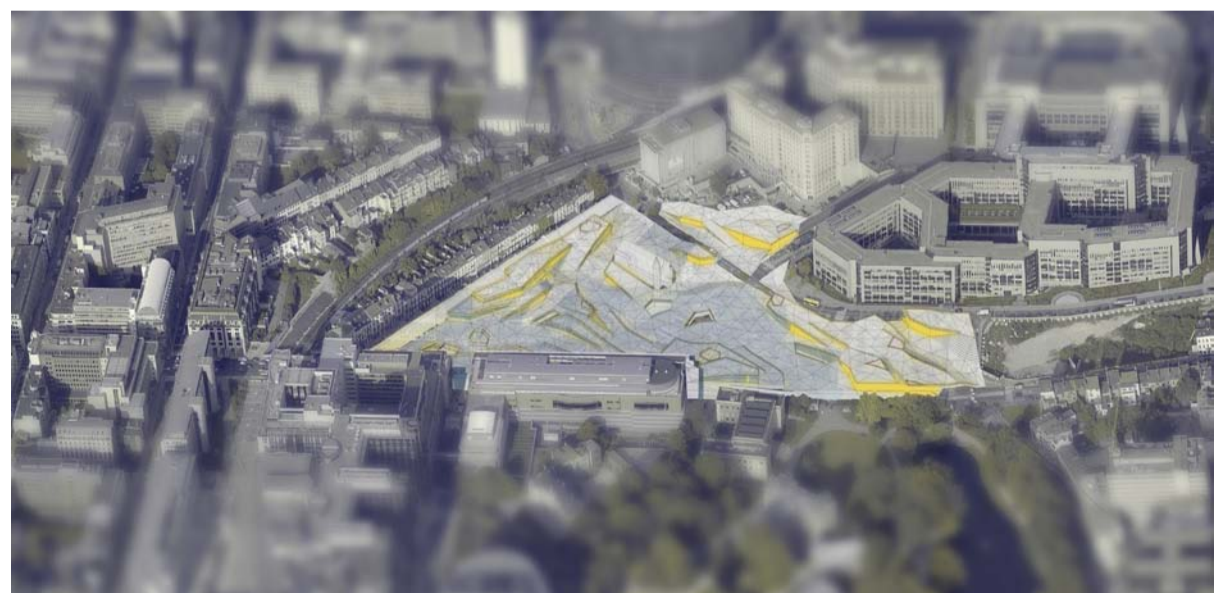

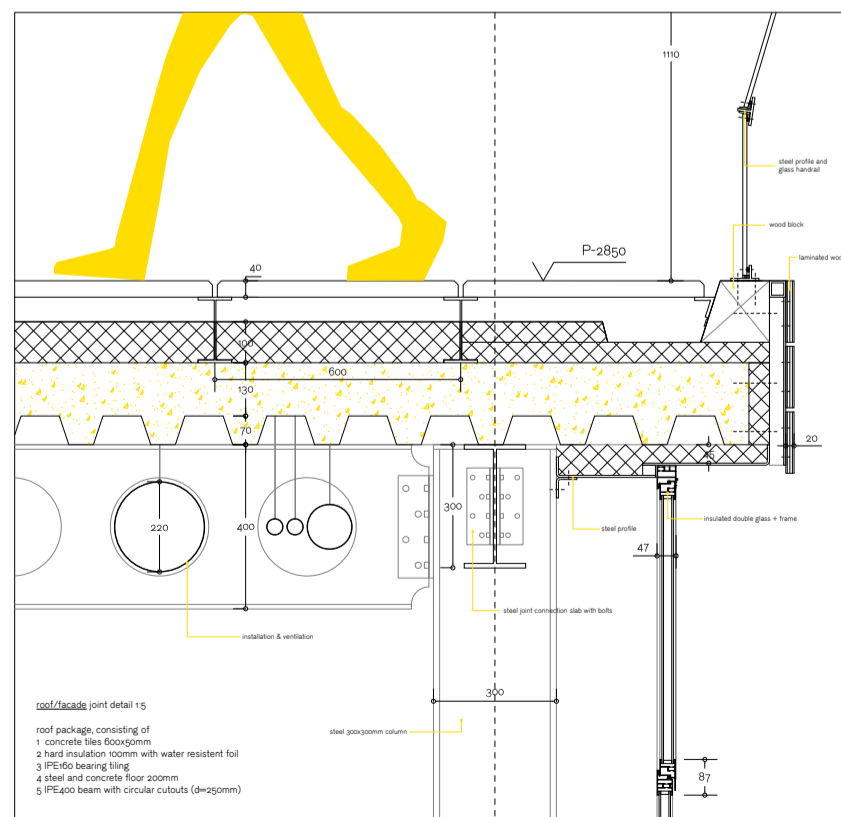
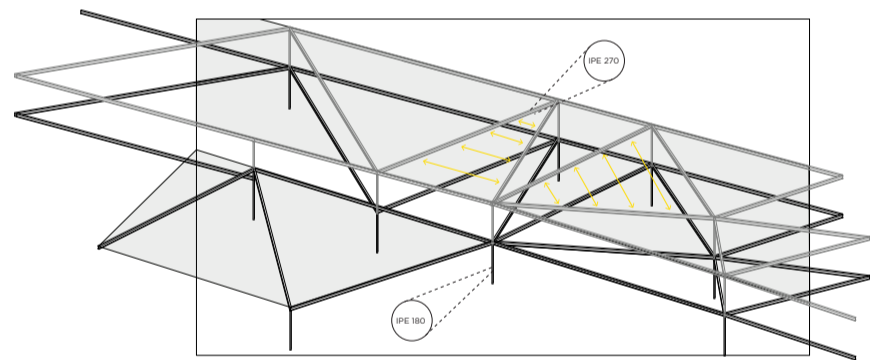
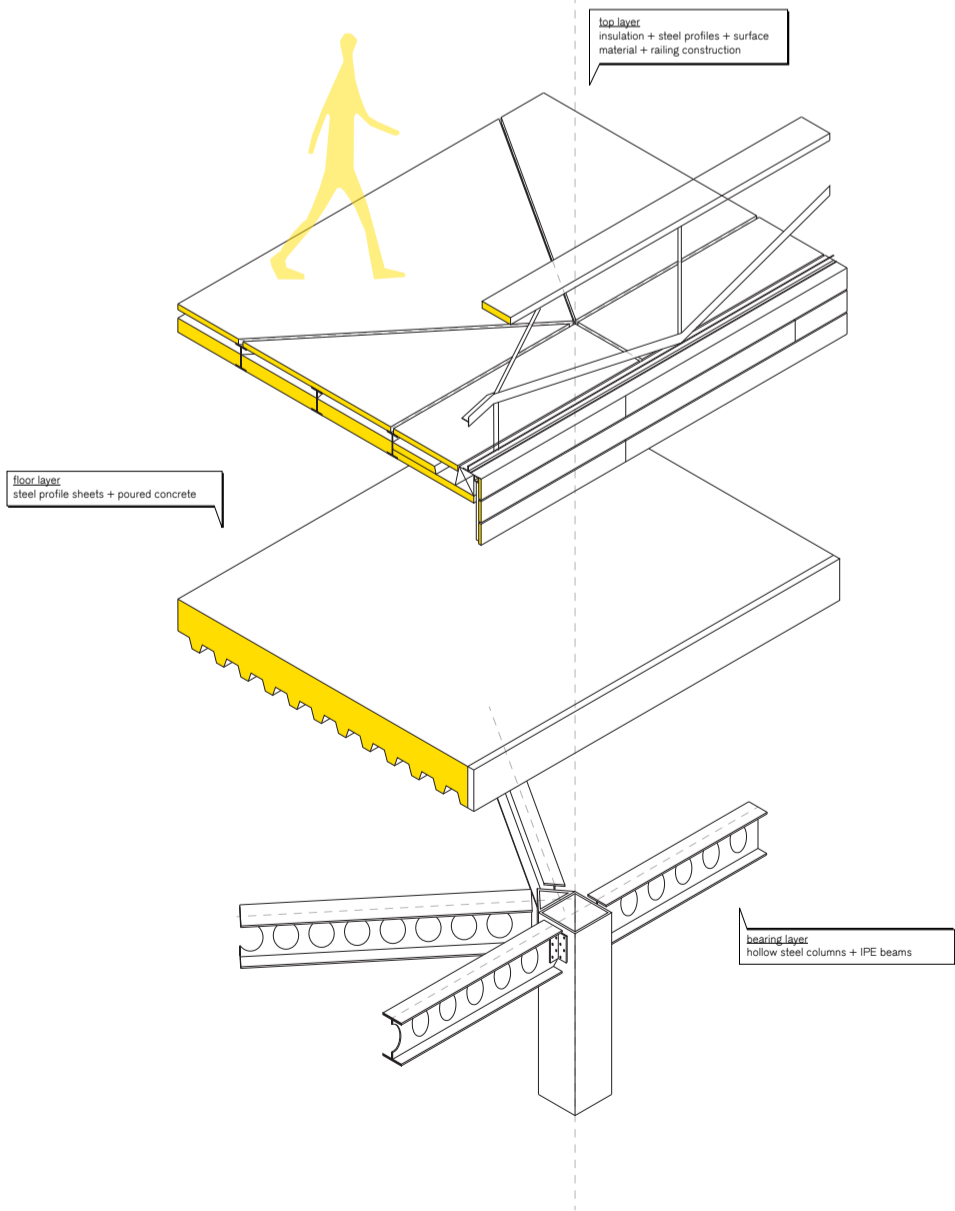
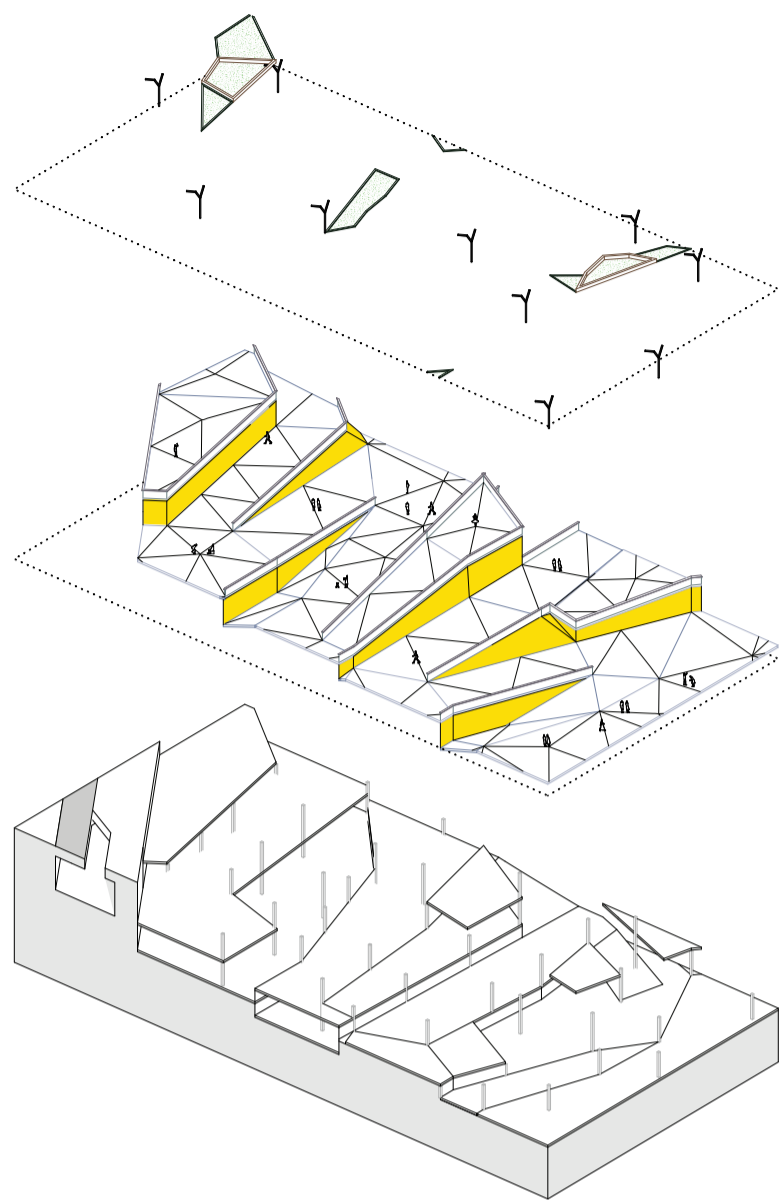
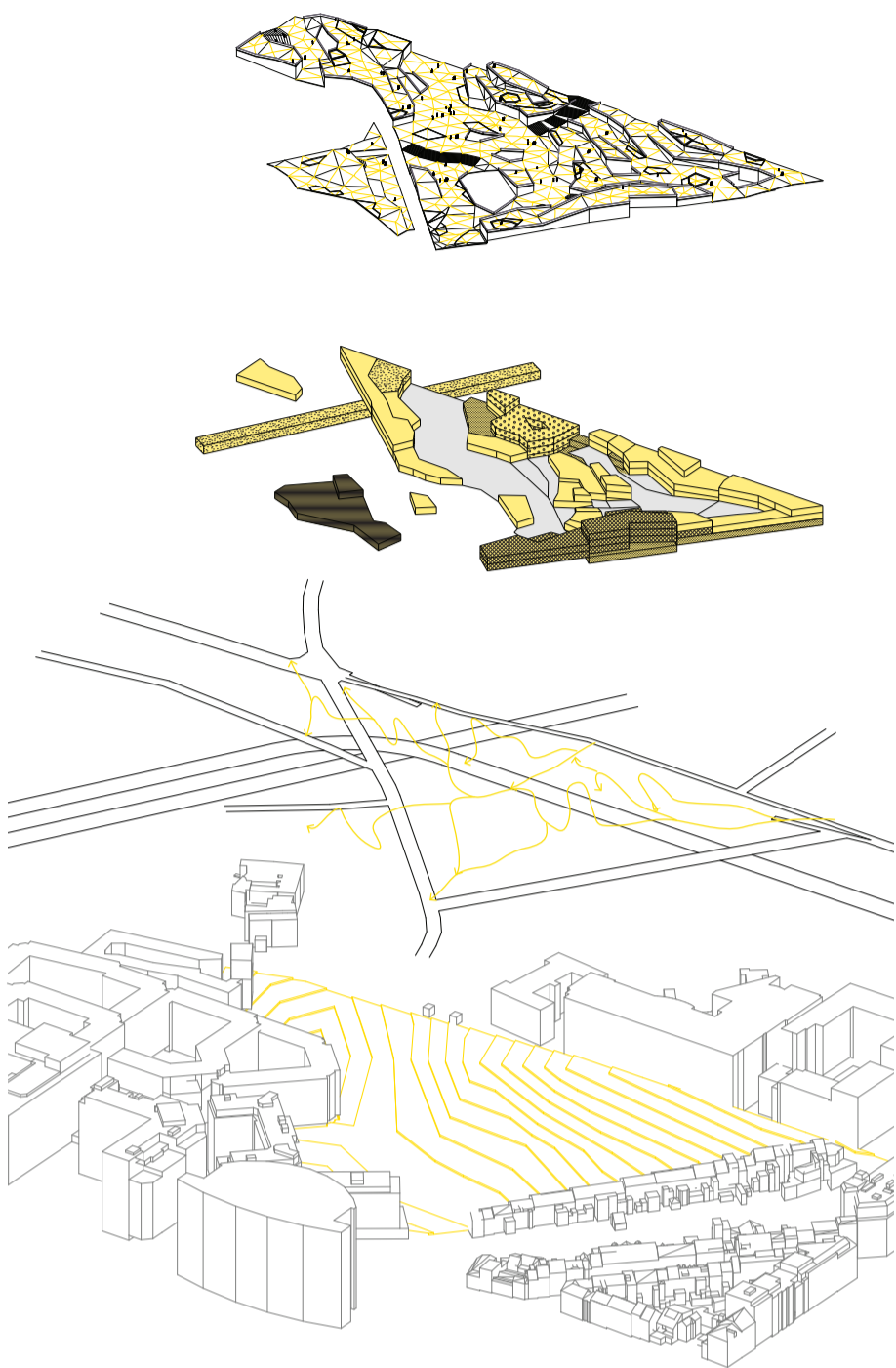



# 05 reflection/recommendations

As a project, the European Quarter in Brussels is far from finished. Questions of identity and branding as a political space make it rather different than another office district in a medium-sized European metropolis. Looking at the stakeholders and actors in the game of developing this district reveals the unique approach of the proposal as treated in this paper.

From the point of view of the European organisations, there is a very pragmatic need for office space. So far, this demand has been met by the rigorous movement that has been concluded in the previous chapter as one of the main threats for the character of the area. The point of view of the city is tangled up in multi-leveled political hierarchy and (dis)organisation, and the point of view of the few citizens of the area (and surroundings) is mainly aimed at historicising the area into its former state.

In this project, the aim has been to take the public space, almost as a design object, and approaching the situation from that point of view. On the one hand, this has its roots in the initial research topic, discussing contemporary changes in the public domain - elaborated in chapter 2. On the other hand,

the debate around the European Quarter has become more and more focused around the polarisation that has taken place towards a monoculture, as discussed in chapter 3.

One of the most direct consequences of this approach soon turned out to be the maximalisation of the public domain. Quantitatively, the current projects cause about a tripling of the amount of real public space - that is, continuously accessible and where all normal laws of the city are applicable.

One can easily raise the question about the desirability of this large amount of public space; from the point of view of safety and property, the European institutions for one might not be that eager to 'publicize' all interiors of the blocks, and spaces around their main office buildings.

However, 'maximizing public domain' seemed to benefit the value of the project, in the sense that it opened the possibility of thinking about different expressions of a public domain, in one proposal. In this sense, the strategy for a polycentral network and its hierarchy of spaces (see chapter 4) offers a point

of view to a perhaps somewhat more well-organised society, where people in general enjoy the feeling of the public condition, only really needing private space when sleeping or bathing.

This relates back to a broader interest of the author: research into the utopian condition: architectural vision where mankind puts its wildest dreams and worst nightmares.

Actually a very real proposal, this project has its utopian character in the fact that it assumes a certain desire towards a lot of pedestrian friendly outside and public spaces.

L Daniel Swakman  
april 2011



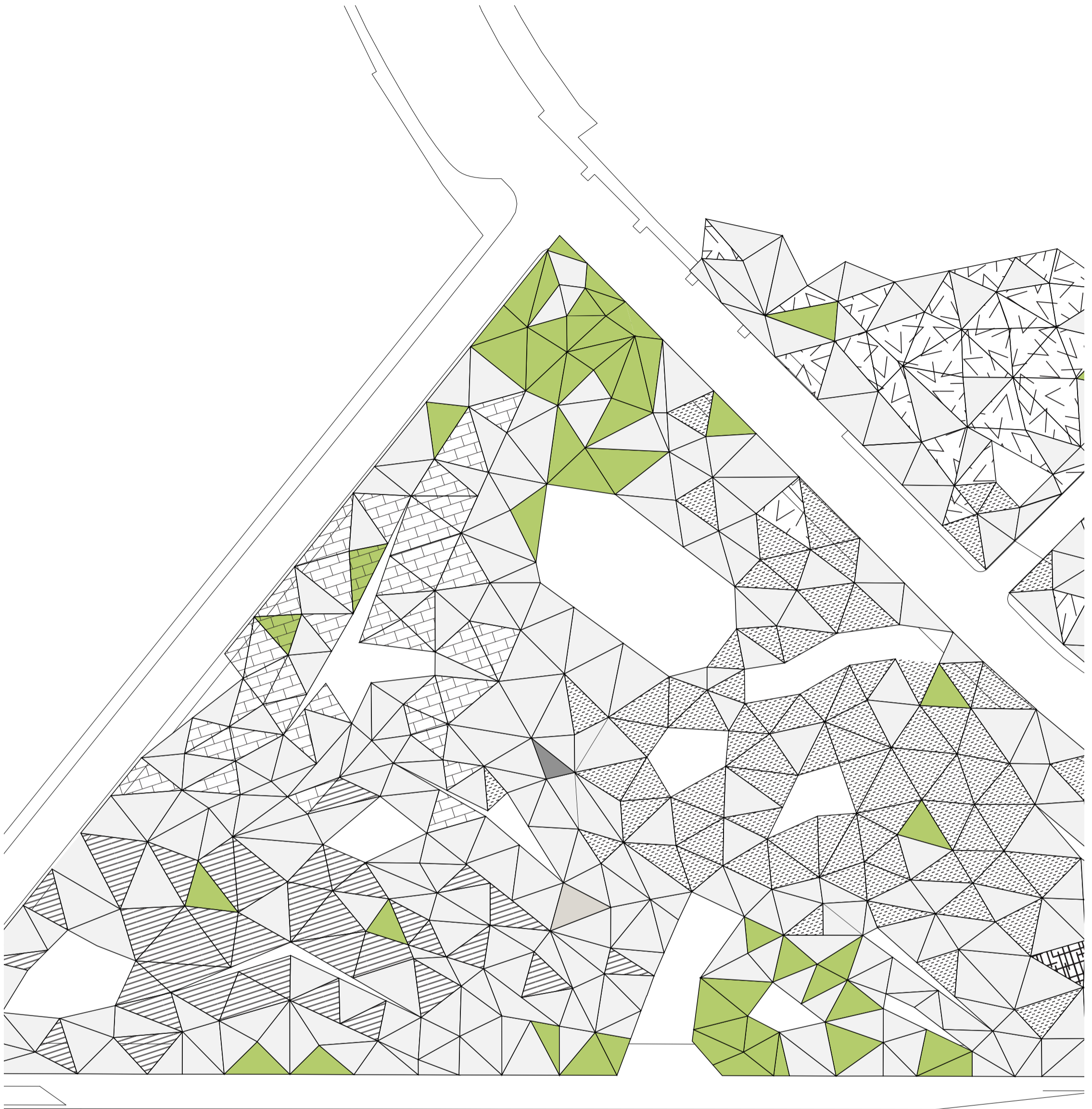



# bibliography

## BOOKS

Auge, M. - Non-places: introduction to an anthropology of supermodernity, Verso Books, 1992

Castells, M. - The Information Age: Economy, Society and Culture - Vol 1: The Rise of the Network City, Wiley-Blackwell, 1996

Foucault, M. - Discipline and Punish, Gallimard, 1975

Hajer, M. & Reijndorp, A. - In Search of New Public Domain, NAI Publishers, 2001

Orwell, G. - 1984, Secker and Warburg, 1949

Sorkin, M. - Variations on a Theme Park: The New American City and the End of Public Space, Hill & Wang, 1992

Architecture, Modernity and the Public Sphere: An Everyday Triad (Introduction in Architectural Positions) - T. Avermaete, K. Havik, H. Teerds, 2009

Non-places: an introduction to supermodernity - Marc Augé, 1995

The Reconstruction of Space and Time: Mobile Communication Practices (introduction) - Rich Ling & Scott W. Campbell, 2009

## ARTICLES

Avermaete, T. - Making things public - the multi-modal public space as a new Dutch design challenge, in Dutch Design Yearbook, NAI Publishers, 2009

Castells, M. - Informationalism, Networks and the Network Society: A Theoretical Blueprint (chapter Networks, Society and Communication Technology), in: The Network Society: A Cross-Cultural Perspective, 2004

Drewe, P. - ICT and Urban Design, a Paradigm Challenge, 2001

Foucault, M. - Of Other Spaces: Heterotopia, 1967

Jenkins, H. - Convergence Culture: Where Old and New Media Collide (excerpt), 2006

Manovich, L. - The Poetics of Augmented Space, 2004

Oosterling, H. - Intermediale Esthetiek - over het politico-esthetisch belang van het 'inter', in Itinera. Onderzoekstrajecten voor de studie van de hedendaagse kunst, Academic press, Gent 2003

Sassen, S. - Towards a Sociology of Information Technology, in Current Sociology, May 2002

Moore, C.W. (1965) - You Have to Pay for the Public Life, in Architectural Positions, SUN, 2009

de Solà-Morales, M. (1992) - Public Spaces, Collective Spaces, in Architectural Positions, SUN, 2009

## WEBSITES

Brussels, a soft capital - Zucchini  
<http://www.cafebabel.co.uk/article/18468/>

[brussels-a-soft-capital.html](#)

Brussels, Capital of Europe - Demey, T.  
<http://www.badeaux.be/Publications/Pub9/Pub9-Presentation.html>

Brusselisation - Harding  
<http://www.time.com/time/arts/article/0,8599,100115,00.html>  
<http://en.wikipedia.org/wiki/Brusselization>

The Seat of the Council of the European Union - ena  
<http://www.ena.lu/?lang=2&doc=5631>  
[http://en.wikipedia.org/wiki/Brussels\\_and\\_the\\_European\\_Union](http://en.wikipedia.org/wiki/Brussels_and_the_European_Union)

One seat for the European Parliament  
<http://www.oneseat.eu/>

What do we want to protect? - Groupe d'Animation du EUQ in Brussels (citizen group GAQ)  
<http://www.gaq.be/What-do-we-want-to-protect.html?lang=fr>







# appendices

## THEMATIC LITERATURE DIAGRAMS ICT and digital networks

1995

PAUL DREWE

"ICT and Urban Design, A Paradigm Challenge"



2002

SASKIA SASSEN

"Towards a Sociology of Information Technology"



2002

LEV MANOVICH

"The Poetics of Augmented Space"



2006

HENRY JENKINS

"Convergence Culture: Where Old and New Media Collide"

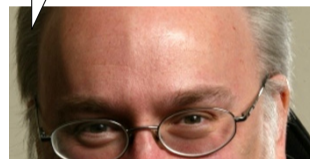

2009

LING & CAMPBELL

"The Reconstruction of Space and Time: Mobile Communication Practices"



2009

TOM AVERMAETE

"Making Things Public: the multi-modal public space as a new Dutch D..."



1965

CHARLES W. MOORE

"You Have to Pay for the Public Life"



1967

MICHEL FOUCAULT

"Of Other Spaces: Heterotopia"



1992

MANUEL DE SOLÀ-MORALES

"Public Spaces, Collective Spaces"



1995

MARC AUGÉ

"Non-places: an introduction to supermodernity"



2001

HAJER & REIJNDORP

"In Search of New Public Domain" Ch.1



- **GENERIC DWELLINGS**  
current housing is becoming more generic, less relation to their context
- **PAID PUBLIC SPACE**  
Disneyland is most important enactment of public space, but it is not free
- **EXPRESS COMPLEX FUNCTIONS**  
public space should be formed by contemporary public functions, like monuments of mobility (parkings, highways)

- **DESANCTIFICATION OF SPACE**  
time has been Enlightened and desanctified, but space still remains mystical
- **HETEROTOPIAS**  
real spaces that incorporate all sites of a culture
  1. crisis heterotopias & of deviation
  2. changing over time
  3. juxtaposing incompatibilities
  4. accumulating or letting flow time
  5. opening vs closing
  6. function in relation to remaining space, sometimes counteracting

- **PUBLIC-PRIVATE**  
balanced city and municipalisation define border clearly
- **FUNCTION OF PUBLIC SPACE**  
to give urban character to building and places that without it would be only private (to urbanise the private)
- **COLLECTIVE SPACE**  
hybrid form, not public not private - ie. public space for particular use, or private spaces acquiring collective use
- **PUBLIC PRIVATE-OBJECTS**  
elements of private objects (street facades, building lobbies) that have a public value
- **EXPERIENCE PUBLIC SPACE**  
recognising the complex character as one of experience, rather than prejudice and thus exclusion

- **URBAN DECENTRING**  
taking place in three aspects:
  1. cities measured in connectivity to infrastructure
  2. television has replaced the traditional hearth in the home
  3. individual can live in different networks that have no direct physical relation
- **EMPIRICAL NON-PLACES**  
spaces of circulation, consumption and communication
- **ANTHROPOLOGICAL PLACE**  
inscriptions of a social relationship or a collective history influence human behaviour
- **GLOBALISATION MATTERS**  
current globality produces homogenisation and exclusion, but frontiers don't have to mean compartmentalisation when properly recognised
- **VIRTUAL META-CITY**  
interconnectedness of metropolis in decision-making and economics (Paul Virilio)

- **NON-PLACES**  
problem of 'non-places' in current urban sphere: functional laid-out transit zones that lack a dwelling identity
- **CULTURAL MOBILITY**  
need for places that facilitate 'cultural mobility' - where people have new experiences and change of perspective

SEE AVERMAETE "HISTORICAL CENTRES IDE"

SEE SASSEN "KNOWLEDGE TYPES"

SEE DREWE "THREE TYPES OF NETWORKS"



# appendices

## THEMATIC LITERATURE DIAGRAMS

changing urban public space

2001  
HAJER &  
REIJNDÖRP

"In Search of New  
Public Domain" Ch.2



2001  
HAJER &  
REIJNDÖRP

"In Search of New  
Public Domain" Ch.3



2001  
HAJER &  
REIJNDÖRP

"In Search of New  
Public Domain" Ch.4



2004  
MANUEL  
CASTELLS

"Informationalism,  
Networks and the  
Network Society: A  
theoretical blueprint"



2009  
AVERMAETE  
HAVIK & TEERDS

"Architecture,  
Modernity and the  
Public Sphere: An  
Everyday Triad"

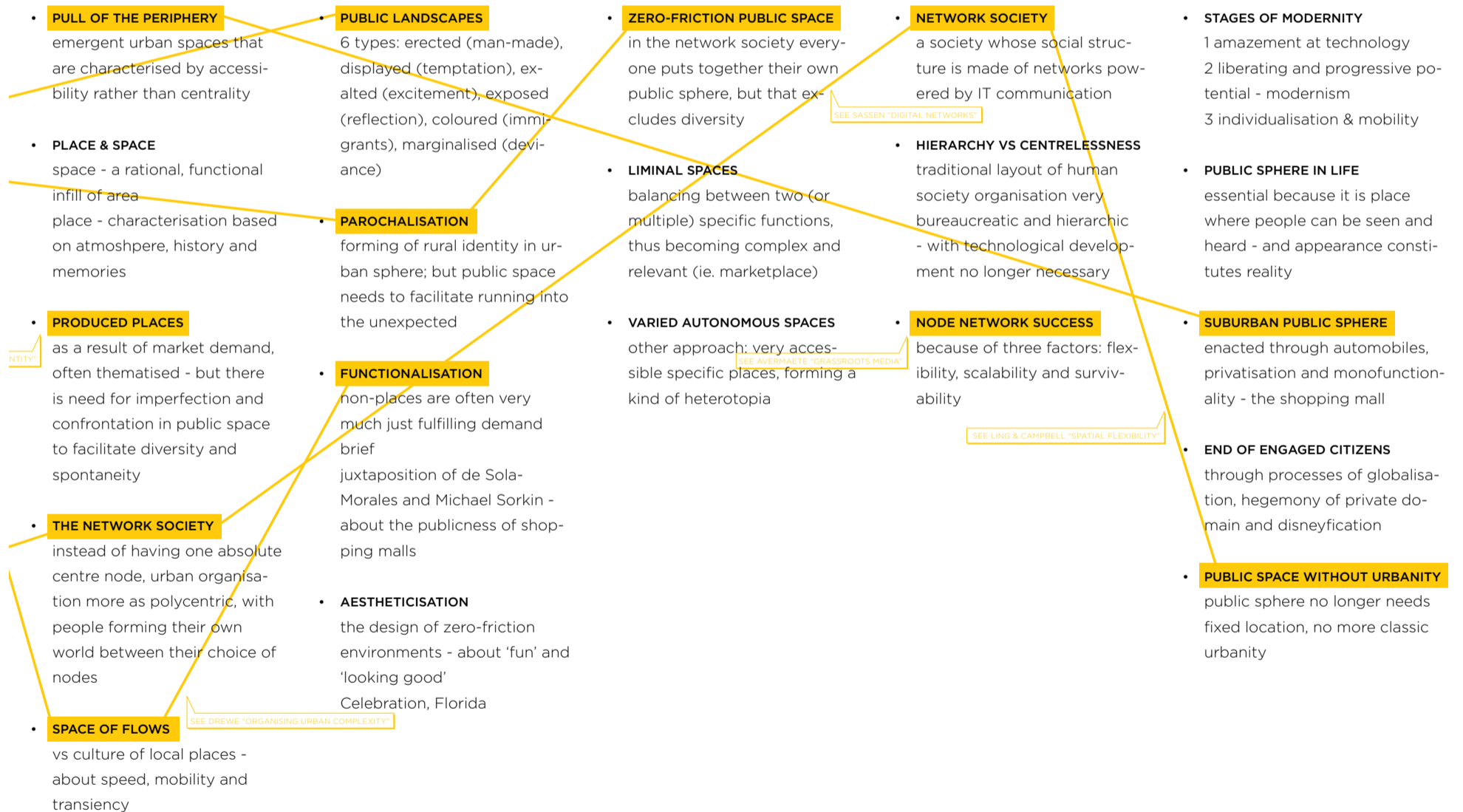

1998

JACOBS & MAIER

"European identity: construct, fact and fiction"



2001

GUY BAETEN

"The Europeanisation of Brussels and the Urbanisation of Europe"



2001

UMBERTO ECO

"The soft European capital"

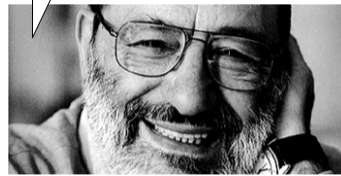

2001

REM KOOLHAAS

"The hard European capital"



2001

VERHOFSTADT & PRODI

"Brussels, capital of Europe"



- POLITICAL FORM**  
 Europe as a super-state or loose association of nation-states
- IDENTITY AS A CONSTRUCT**  
 identity is a combination of a cultural historical basis and a construction of 'what it should be'
- THREE PROJECTS FOR EUROPE**  
 Europe as an important power factor, - as a social entity for human rights and democracy, and - as a status quo of existing national states
- ECONOMICAL IDEOLOGY**  
 Europe not as a political ideology, but a unified economical field and a single market; has been the strongest so far
- CULTURAL IDEOLOGY**  
 creation of a culturally defined identity; a supranational rights system; a EU citizenship
- CAPITAL SCALES**  
 Brussels functions as capital of Belgium, reigning colony of Congo, and capital of Europe - a multi-scaled global place
- AMBIVALENT POLITICS**  
 exclusion and inclusion, polarisation and integration, poverty and prosperity - euQ not only an island, but provides jobs in tertiary sector
- ASPECTS OF GLOBALISATION**  
 global financial trade, global media, communication systems (internet), air traffic, global consumption of products, homogenisation of cultures, global migration flows, world cities, foreign trade, growing importance of international institutions
- RUES DE LA LOI & BELLIARD**  
 cutting across urban fabric, preventing integration
- BORDERLANDS**  
 flea markets, avant-garde art scenes and nightclubs
- SERVER INSTEAD OF TREE**  
 national capital's identities are like trees, establishing hierarchies; the EU capital is not national so should be more like a server in a network
- NODE IN A NETWORK**  
 organising the city as a node in a network, not longer absolute and hierarchical, but relative to other nodes
- BRUSSELS' FOYER CULTUREL**  
 Brussels as a capital shouldn't focus on 'hardware' - but 'software' makes the culture (ie. art, cinema, literature)
- EXPRESSING EU IDENTITY**  
 two ways: through communication (verbal/visual, addressing diversity), or physical manifestation (evoking symbolism)
- THE EUROPEAN PROJECT**  
 approach of treating physical symbolism most difficult in context, but most relevant (circle and path)
- DYNAMIC IDENTITY**  
 expressing a EU identity that advocates differences (stretched stars flag, member colours flag)
- EU CAPITAL NOT NATIONAL**  
 a European capital should not have to function in the same absolute and monumental way as national capitals
- CAPITAL IS REALITY**  
 in everyday practice, the EU quarter already functions - making policy and wielding power
- DECENTRALISED POWER**  
 stability does not mean the concentration of power in Brussels - it fares well with decentralisation
- NETWORKING**  
 tool to prevent Tower of Babel syndrome in addressing differences; not trying to unite all under one denominator
- EUG LACKS ...**  
 current situation of EU integration in the city is not a good example; lack of communication, lack of coherent architecture, lack of addressing citizen's wishes



# appendices

THEMATIC LITERATURE DIAGRAMS  
the European Union and Brussels

2004

WHITE, PURDY & PADMORE

"Europe, Inc."



2004

YANN GALL

"Brussel, hoofdstedelijk gewest voor 450 miljoen inwoners"



2006

ADRIAN FAVELL

"Eurostars and Eurocities"



2006

CAROLA HEIN

"The polycentric and opportunistic capital of Europe"



- **EUROPE LEADING**  
European companies play large part in economical top of the world, although not perceived as such

- **ECONOMICAL AMBITIONS**  
two strategies to benefit from Europe's potential: creating Single Market, and exploiting capacity for innovation

- **UNITY IN DIVERSITY**  
Europe's greatest characteristic and opportunity: largest amount of diversity in the world

- **BRANDING EUROPE**  
strategies for developing Europe's (economical) role: establish Single Market, develop clear vision and branding, encourage involvement in all layers

- **ALIEN INVASION**  
expanding need for office space resulted in uncontrolled building of the EU quarter, losing respect for inhabitants

- **COMPLETE DECONCENTRATION**  
completely spreading institutions throughout city(s), respecting existing tissue

- **SYMBIOTIC JOBS EMERGE**  
every job at European organisation creates two jobs in other fields (tertiary); every euro spent at EU organisation equalled by three elsewhere; 13% of Brussels GDP comes from international organisations

- **ECONOMICAL VS CULTURAL**  
two modes of European development; both are present in EU's history, mostly not at the same time

SEE SASSEN 'DIGITAL NETWORKS'

- **LOCAL & GLOBAL PEOPLE**  
European quarter 'used' by international travelling elite, while attention for deeply rooted middle-class lacks

- **GLOBAL CITIES ARE LOCAL**  
Amsterdam, London, Brussels, allowing global and mobile culture (mostly elite); but bottom-up observation shows presence of very local daily patterns

SEE HAJER & REIJNDORF 'SPACE OF FLOWS'

- **DECENTRALISED INSTITUTIONS**  
EU has capital seats in 3 cities since 1992, and agencies in 20 cities - could hamper daily work, but makes them more integrated in local culture

- **ORGANISING DECENTRALITY**  
instating a special 'decentralisation office', allowing decentral policy-making and connecting EU nodes

- **CONNECTING LOCAL AND EU**  
bring together public and private stakeholders in single place - calls for architecture not only administrative, but also symbolic

L DANIEL SWAKMAN