

The Bathyard

A Public Courtyard

P4 Presentation 22.05.2014

Marie-Lahya Simon

Sint Jacobsplaats, Rotterdam



Formality vs Informality : the limit of design

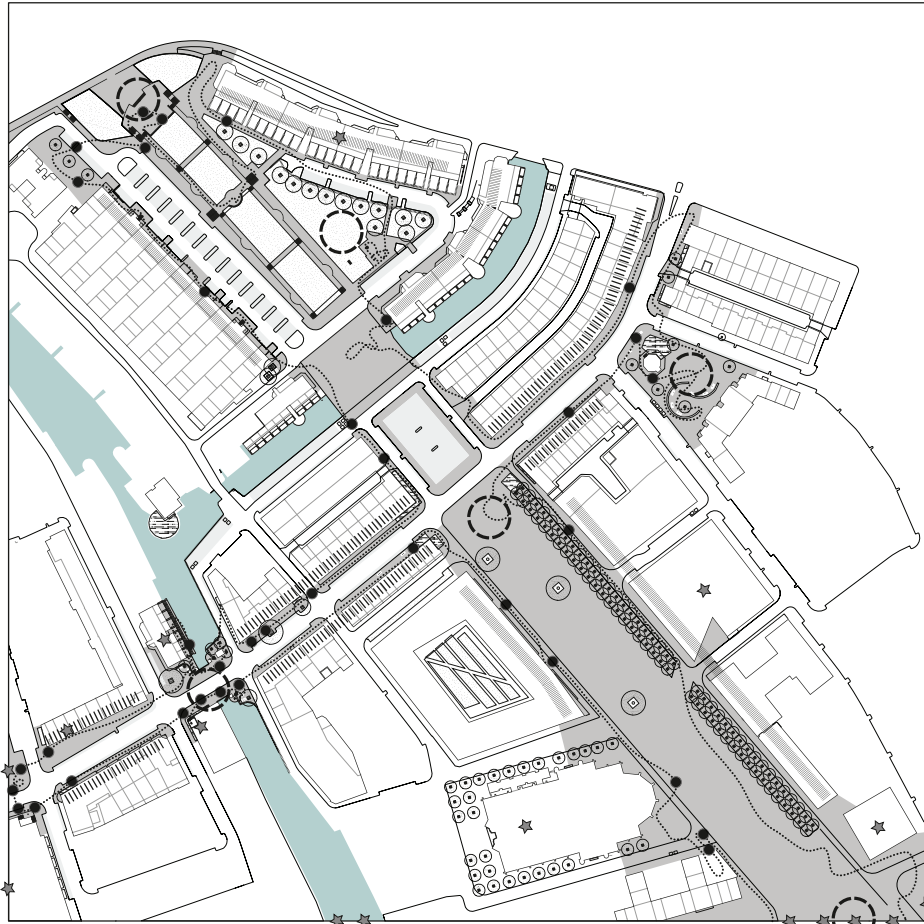

1. Reality

The Reality of the plan.
How is the public space designed ?



2. Reaction

What is our reaction upon
certain elements or situation ?

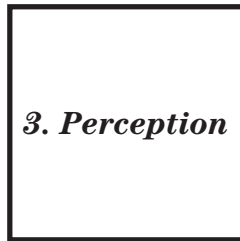

3. Perception

How do we perceive this
space ?

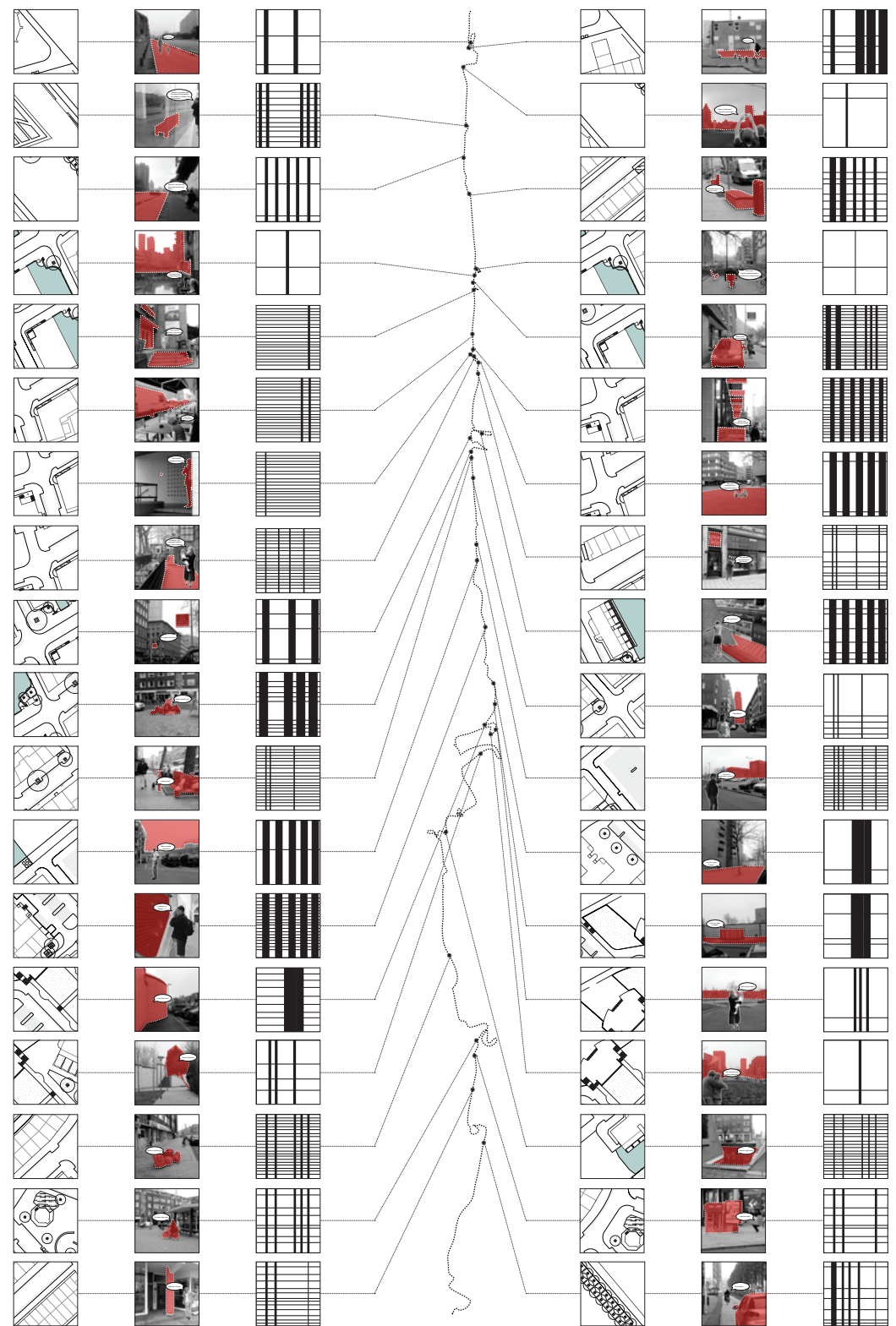

Morphology

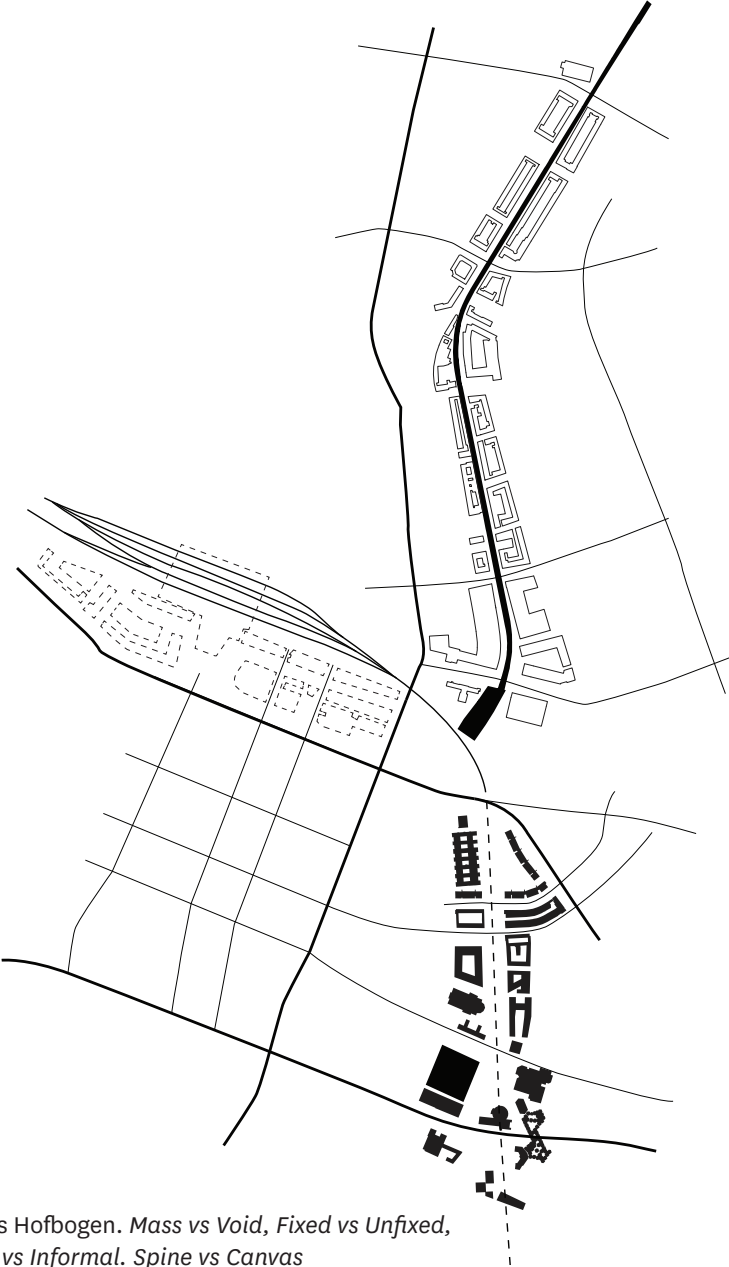

Blaak vs Hofbogen. Mass vs Void, Fixed vs Unfixed, Formal vs Informal. Spine vs Canvas

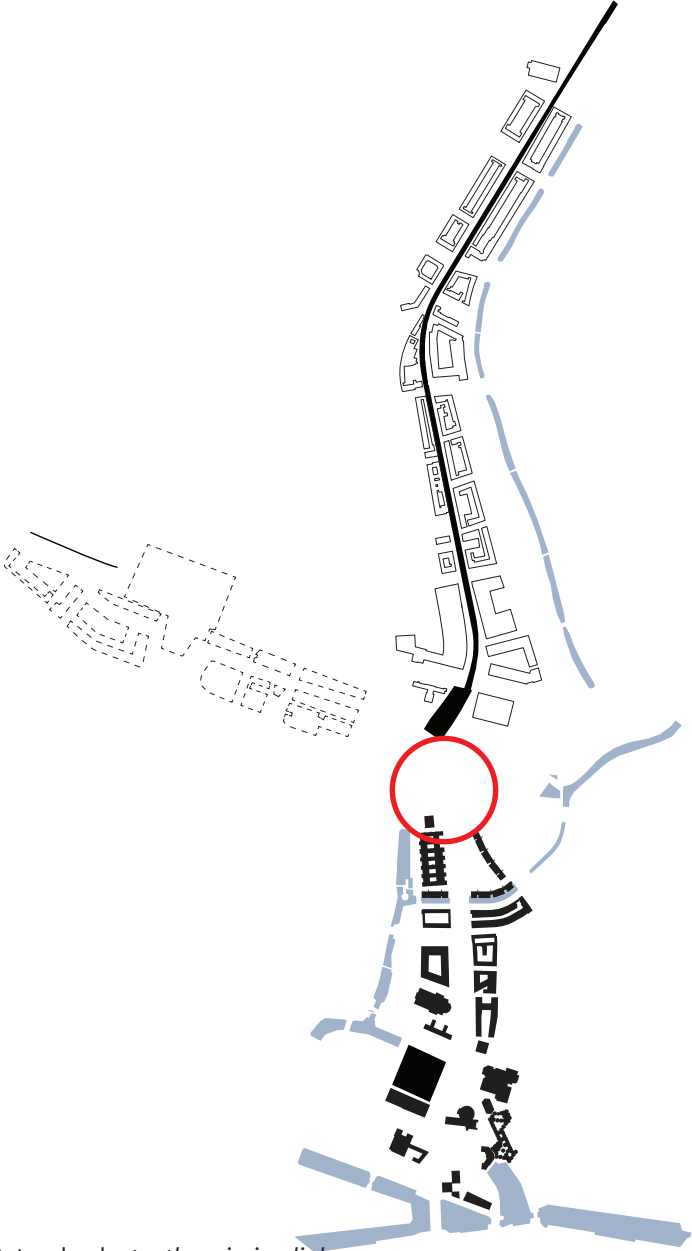

Sint Jacobsplaats, the missing link

The 3 layer Manual



network

transitions

areas

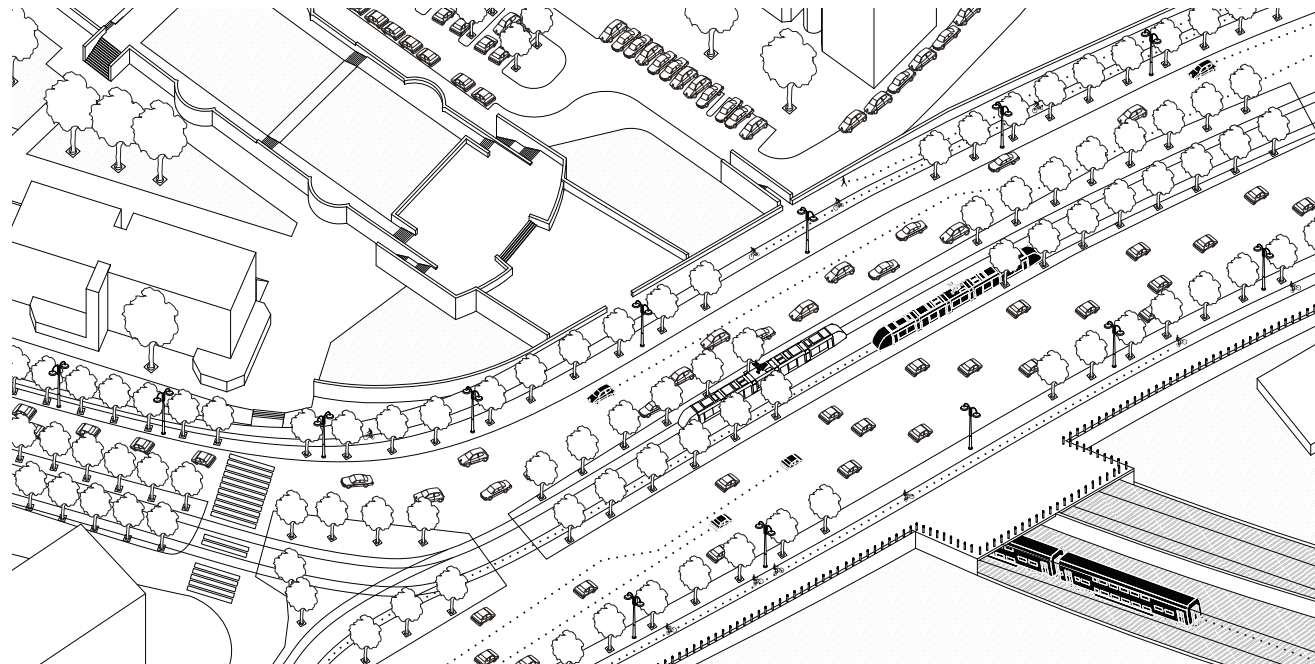
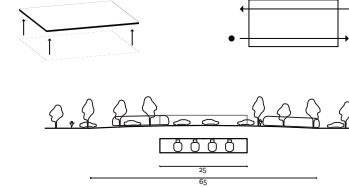
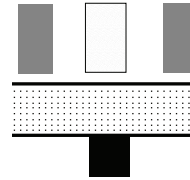
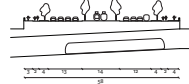
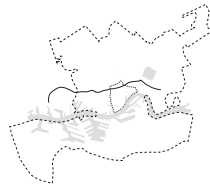

Example of the Popenburg

Rotterdam Icons, the artificial and the water



The AquaStripe



The Follies, inhabitable structures for everyone

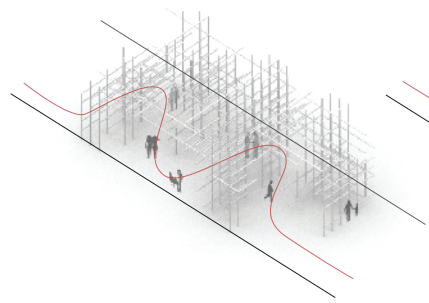

1. Maze

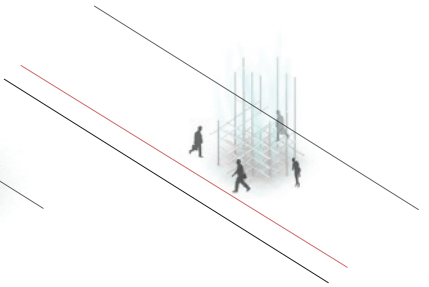

2. Fountain

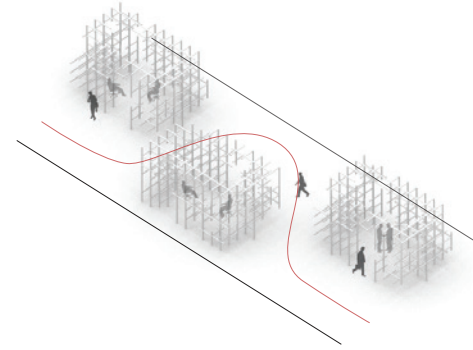

3. Offices

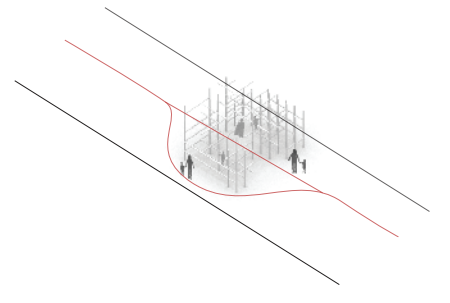

4. Playground

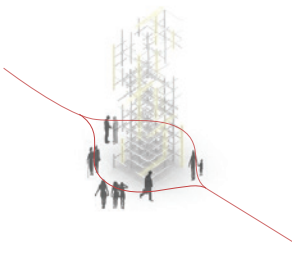

5. Lighttower

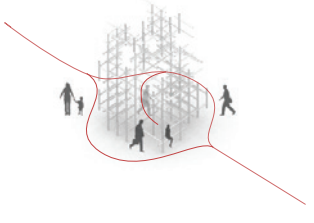

6. Sculpture

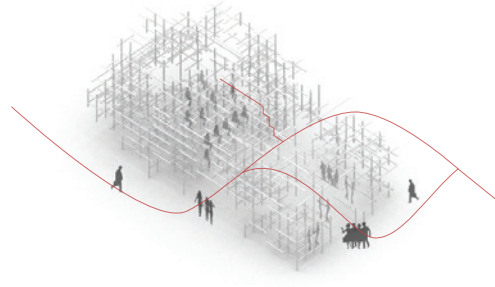

7. Stage

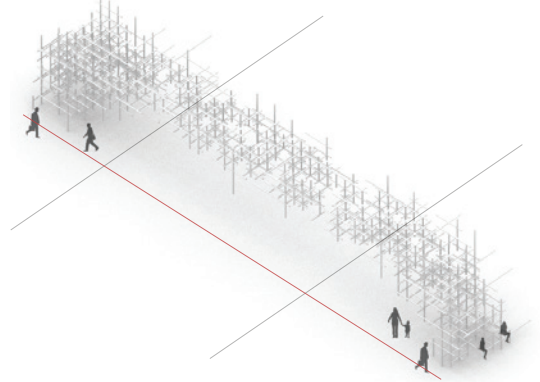

8. Gate

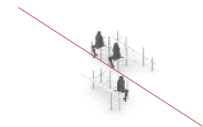

9. Benches



10. Cafe

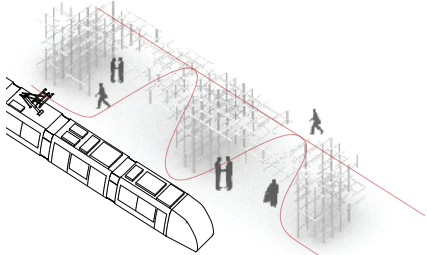

11. Busstop

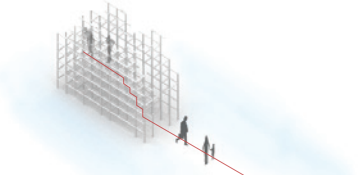

12. Stairs

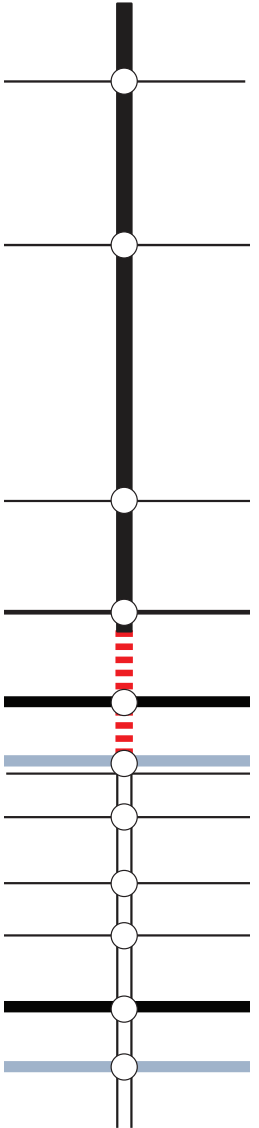

Follies. The follies are an answer to the intersections on the boulevard. They promote a shared identity on the boulevard and their aim is to create chances, and therefore to help developing the public participation and involvement within the promenade.

Catalog of Opportunities

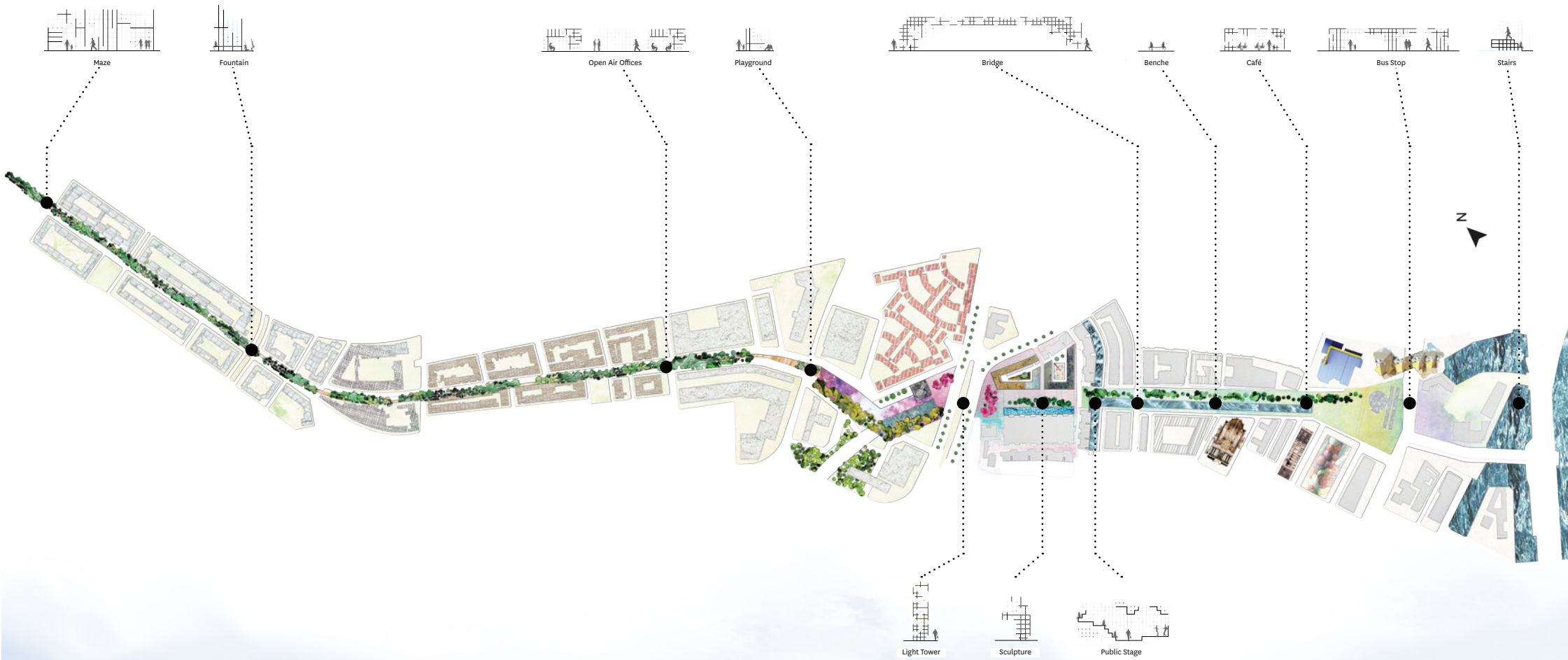

Urban promenade
Potential Program
1.2500



Catalog of Opportunities

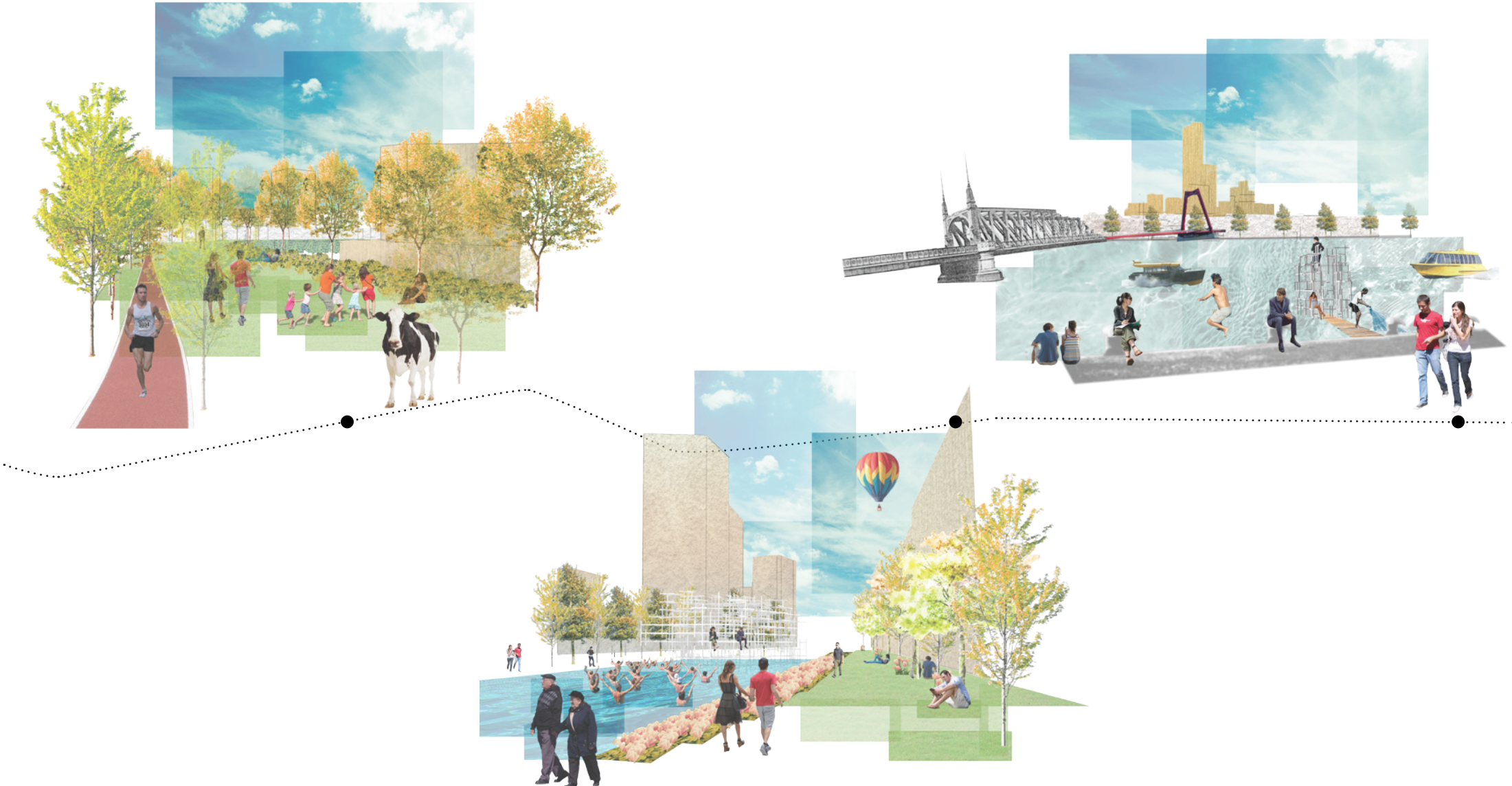

The Sint Jacobsplaats, Regaining a facade

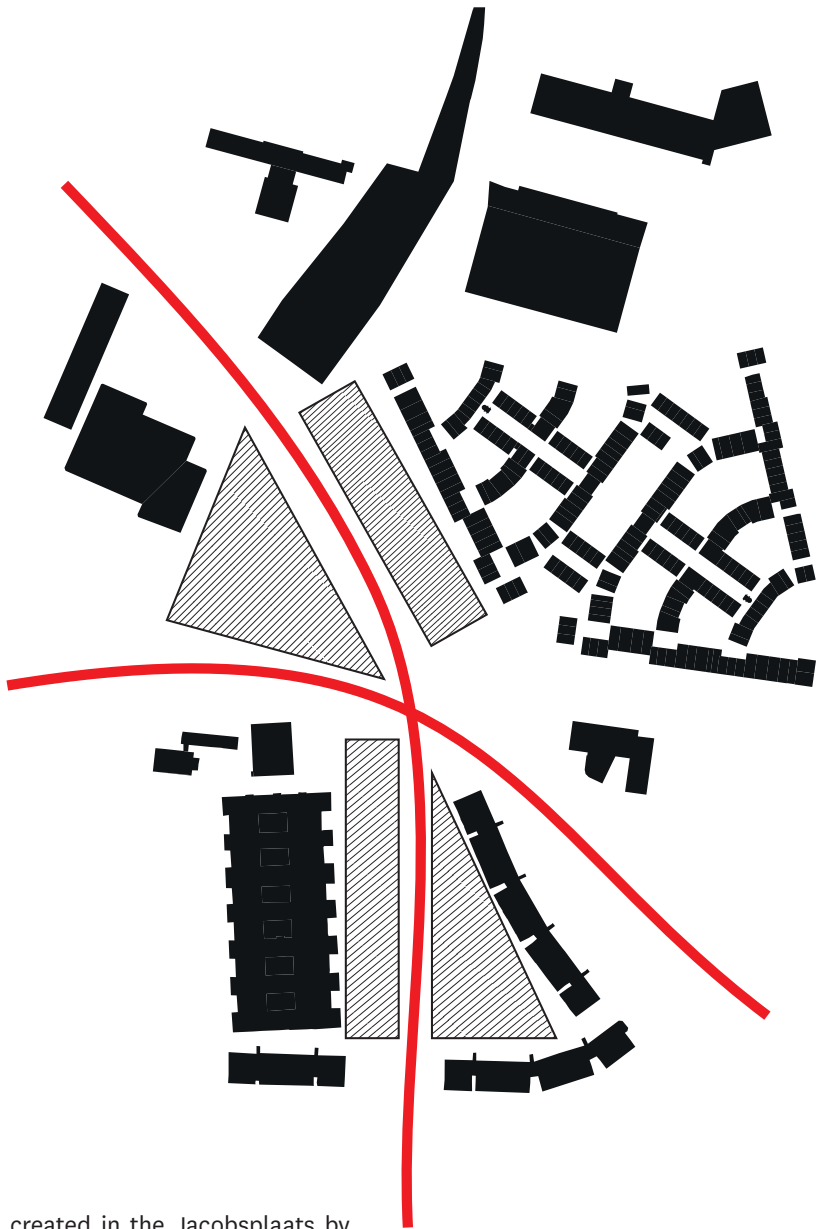

Boundaries created in the Jacobsplaats by infrastructure

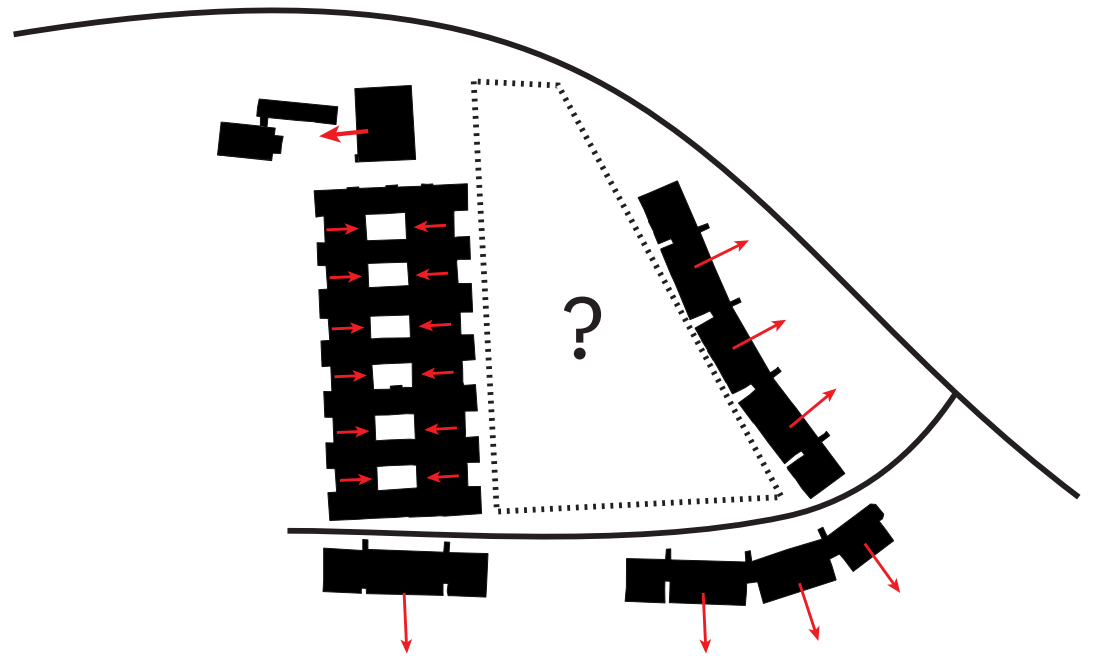

The undefined backyard, due to a clear lack of address.

The Binenrotte, the road of reinterpretations

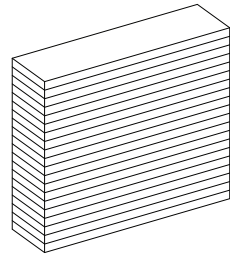

The Slab

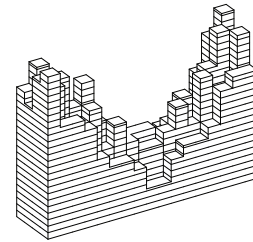

The Rotta Nova

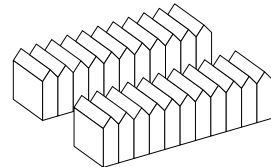

The Row houses

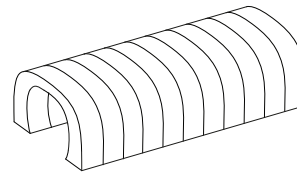

The Market Hall

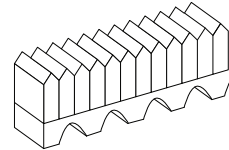

The Inhabitable Bridge

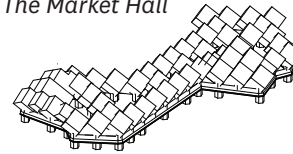

The Cubic Houses

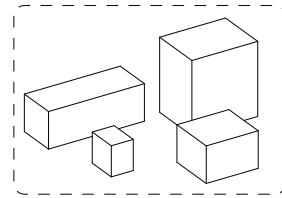

The Block Cluster

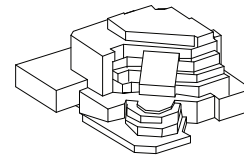

The Library

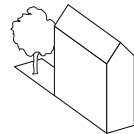

The Private house with a backyard

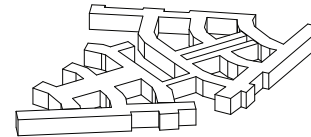

The Heliport

The Test Site : Bienenerotte

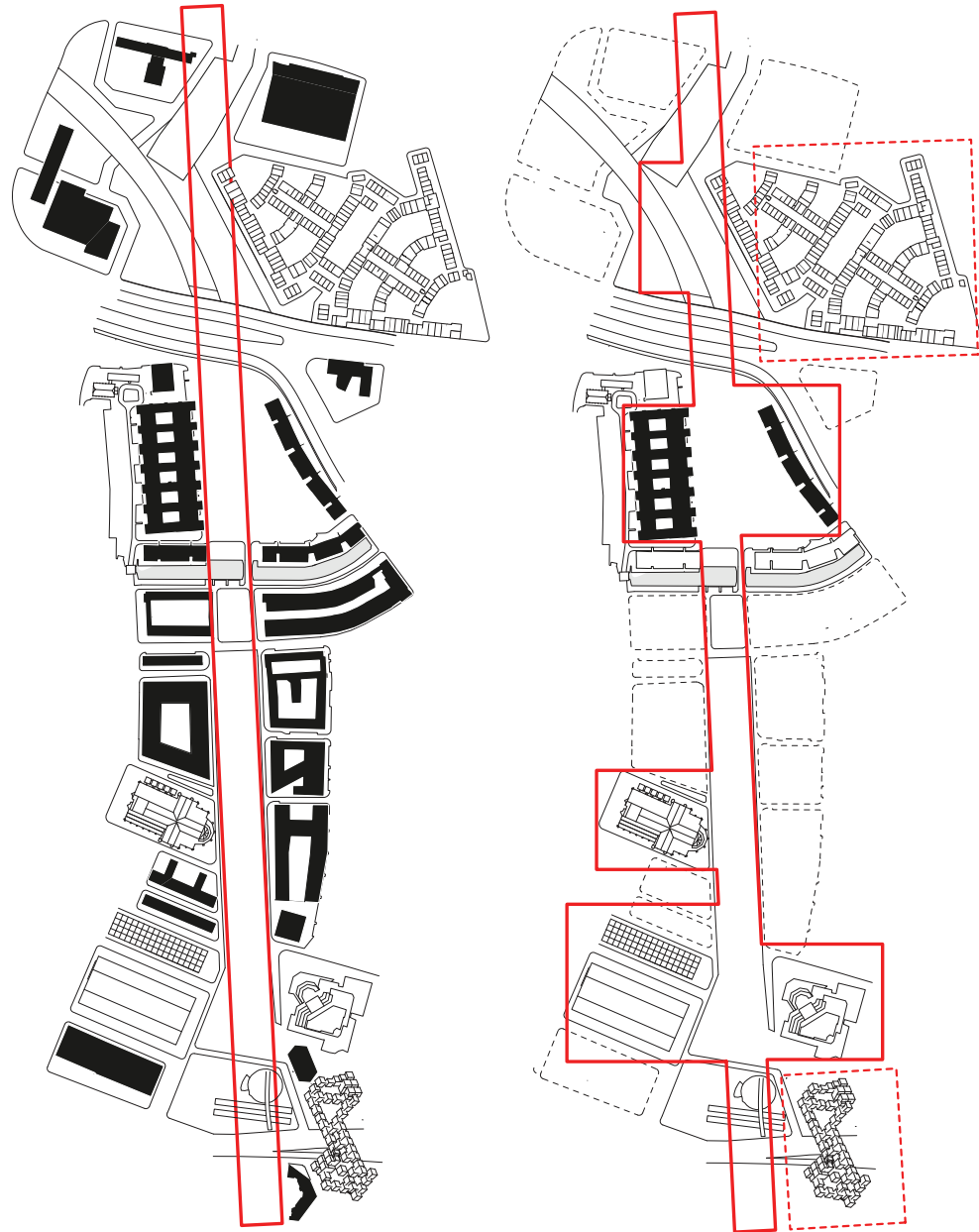

Reorientation of the facade towards the Urban Promenade

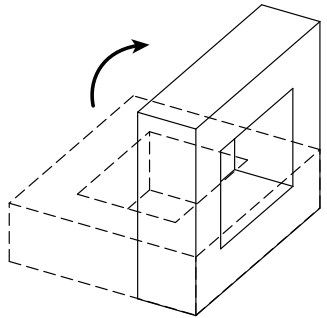
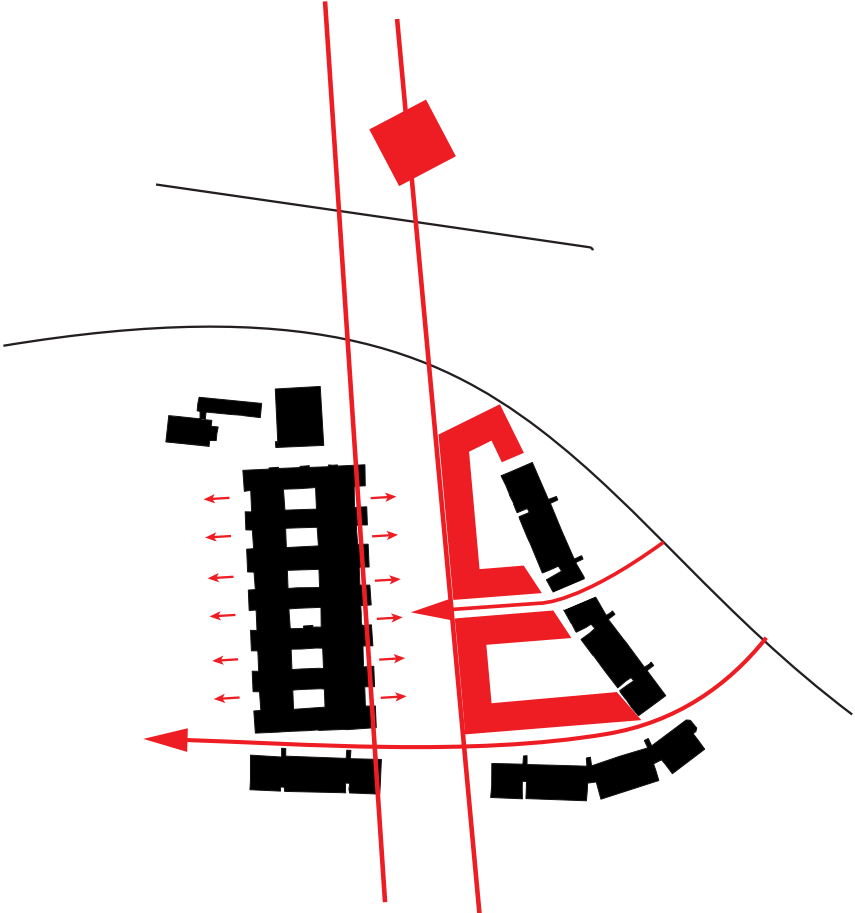

The Vertical Courtyard

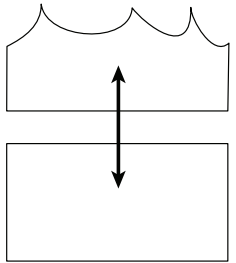

The Shared Courtyard

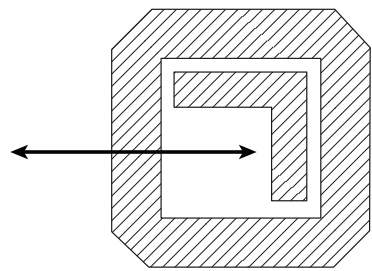

The Public Courtyard

Masterplan



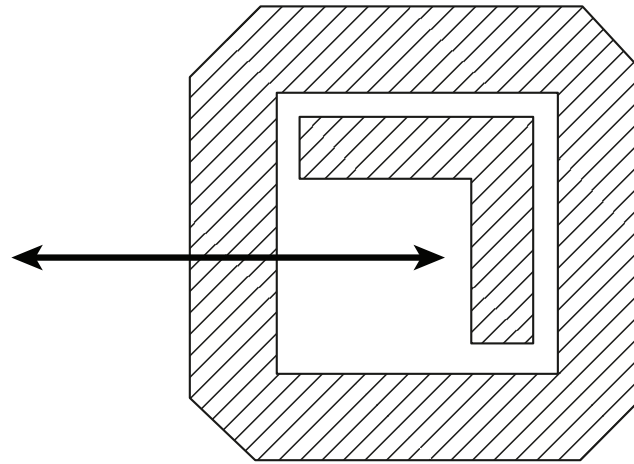

What is a Public Courtyard ?

Block with Courtyard Typologies

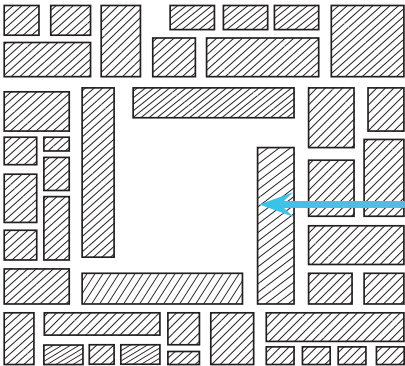

The Piazza, public square for the City

Collective

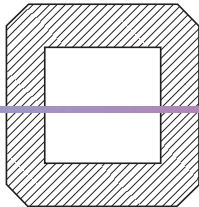

Public

Private

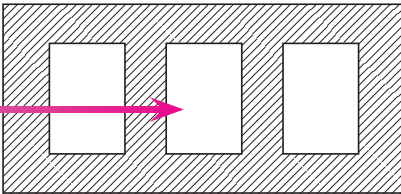

The Berlin Block, private courtyard for a portion of the Block

Contemporary interpretation of the block with courtyard

The Courtyard becomes public hosting the pools and the baths.
Using Void, ie Baths, as an extension of the courtyard through the building.

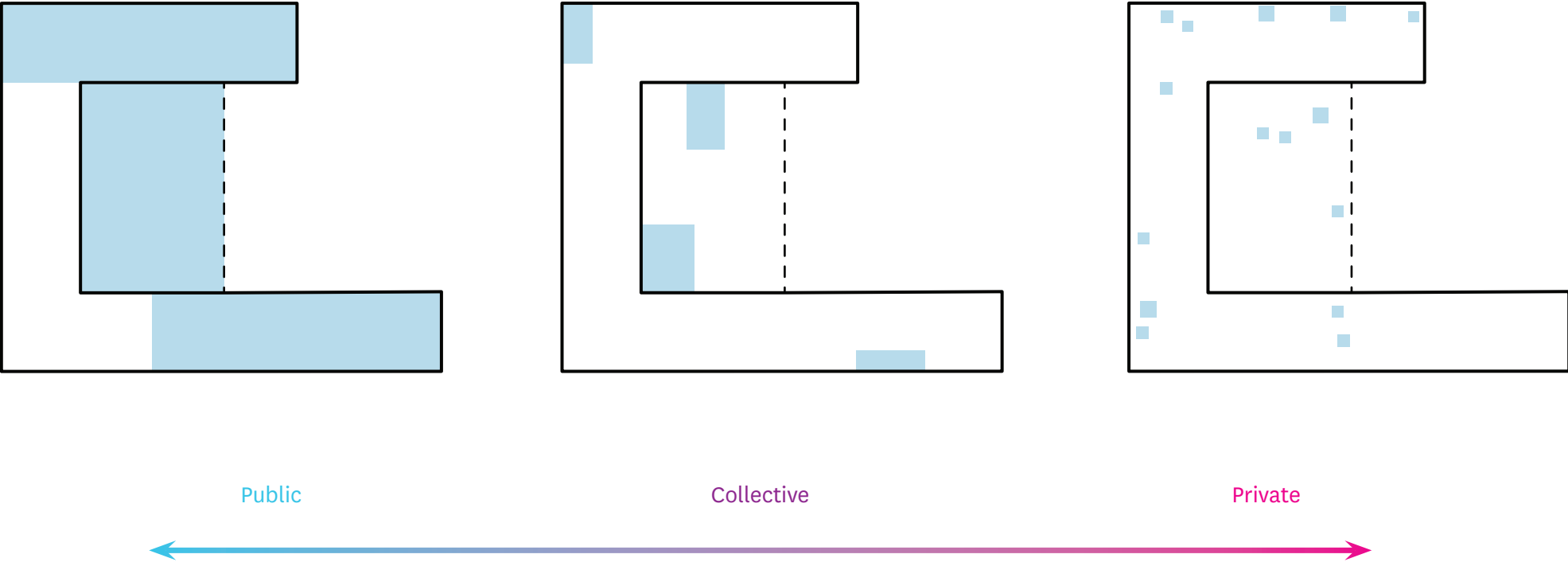

Programme

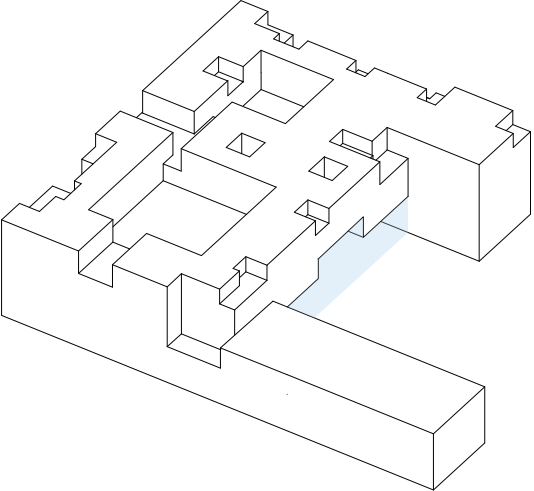

15 Maisonettes with Individual Baths

16 Appartements sharing 4 Collective Baths

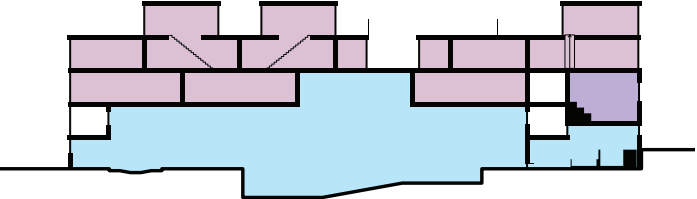

Collective entrance to Dwelling

Public Pool and Thermal Baths

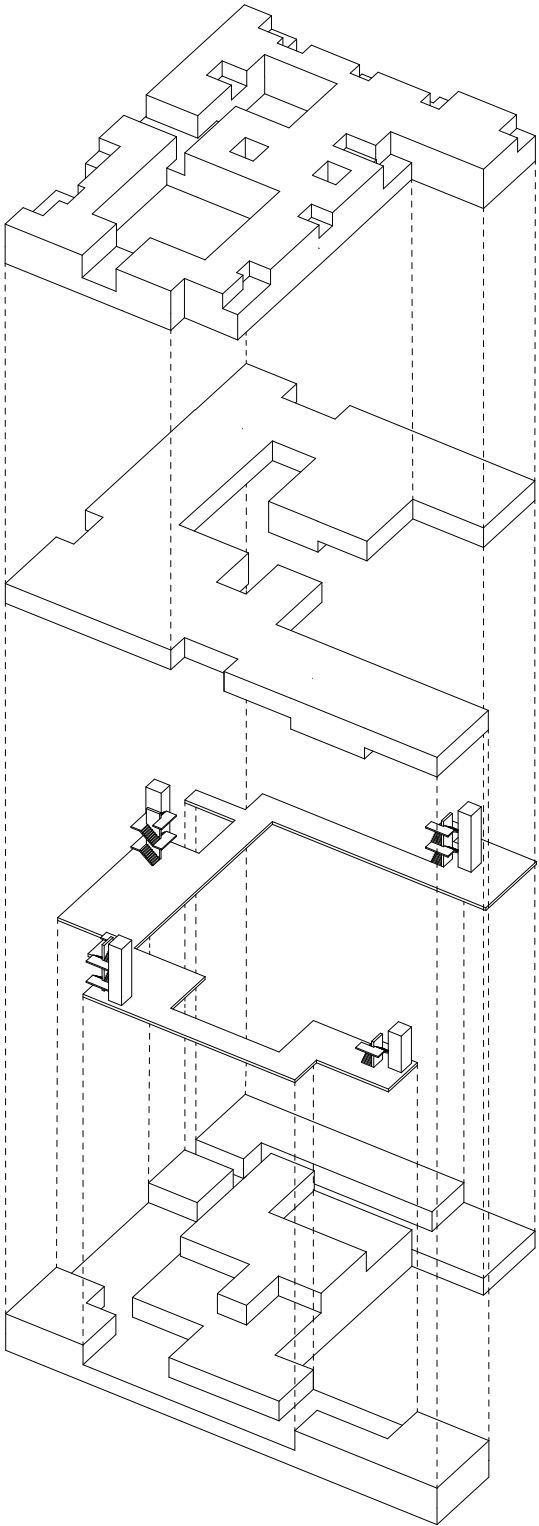

Overview

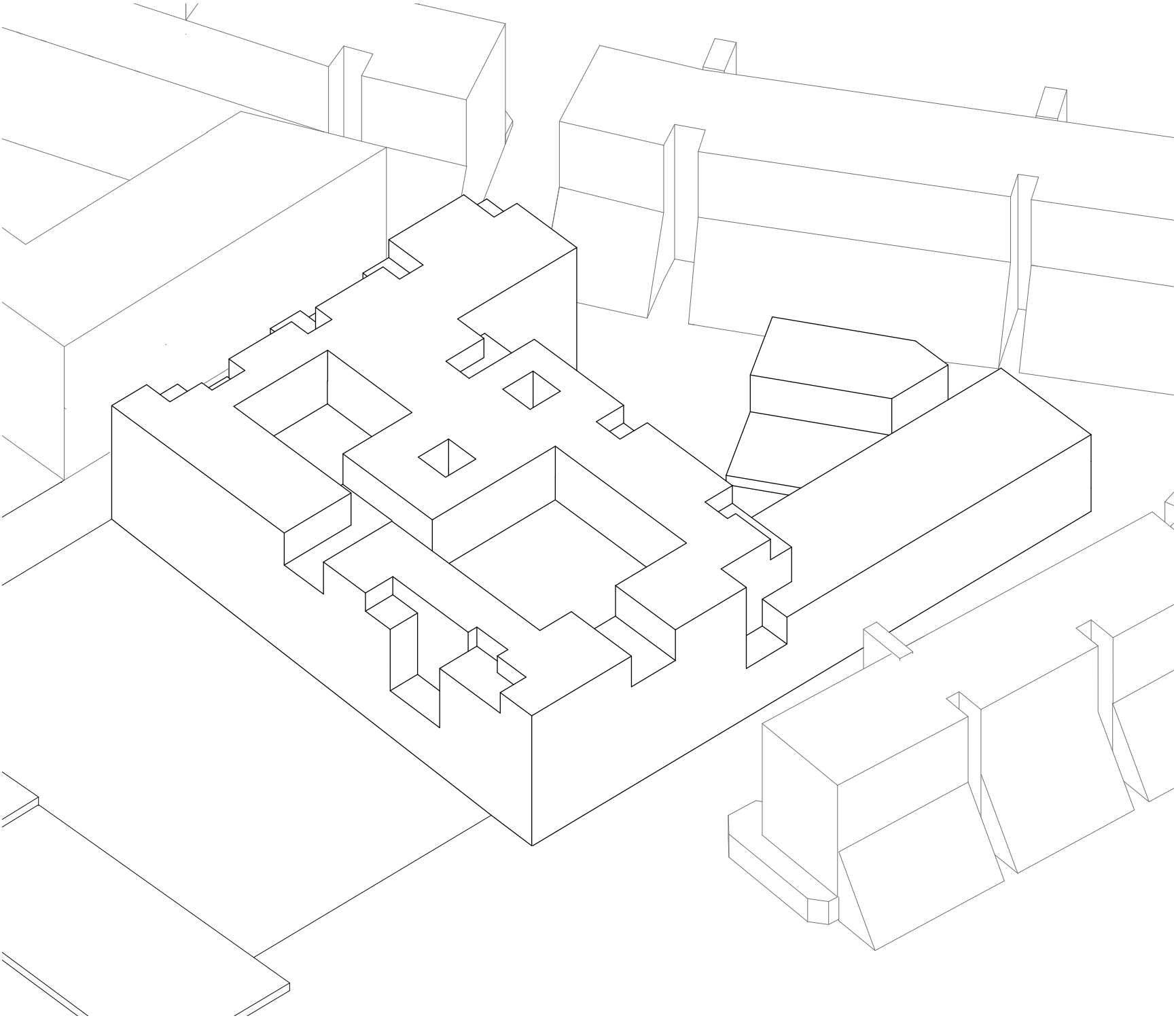

Pools and Thermal Baths

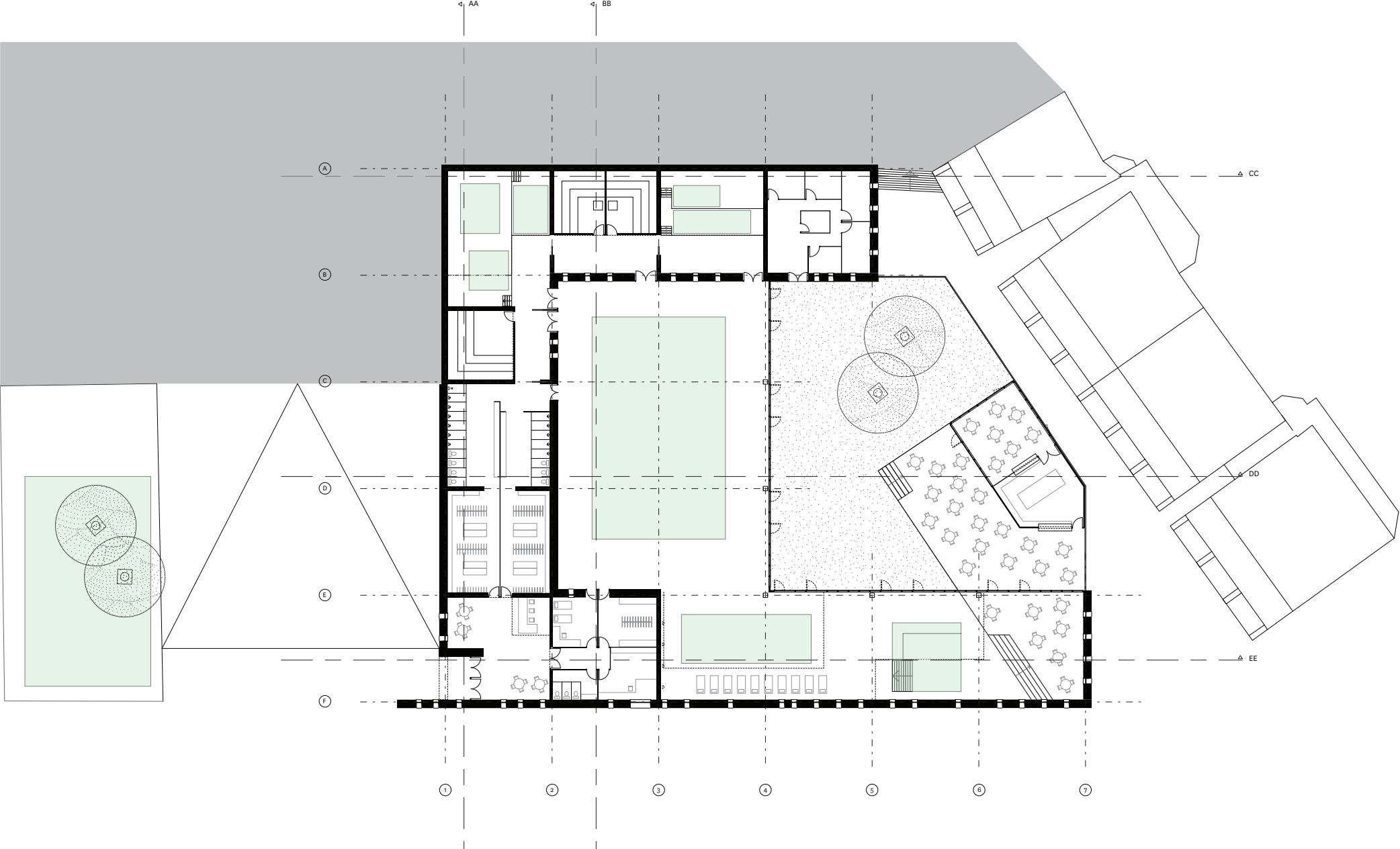

Entrance to Dwelling, the 'extended living room'

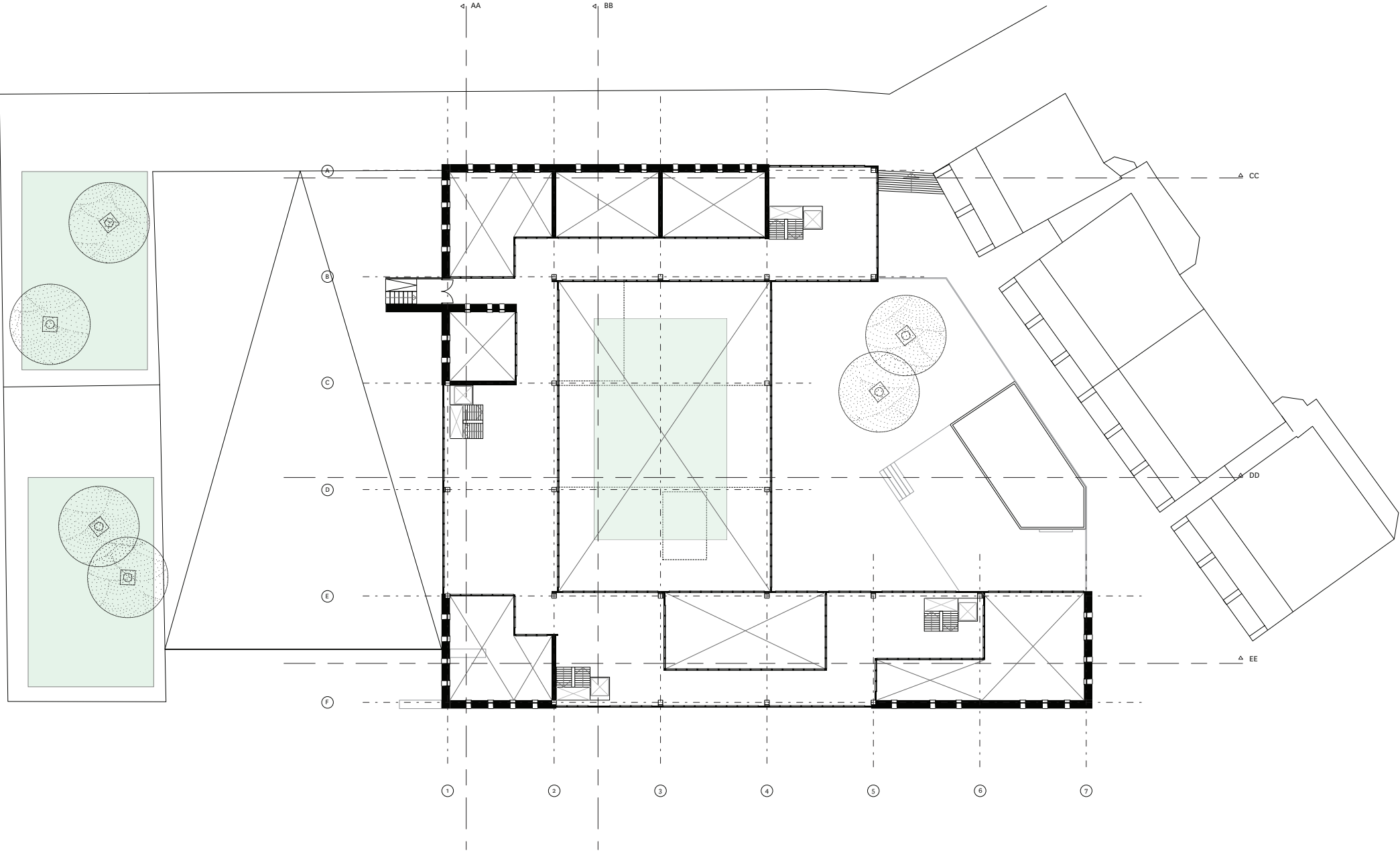

16 Apartments sharing 4 collective Baths

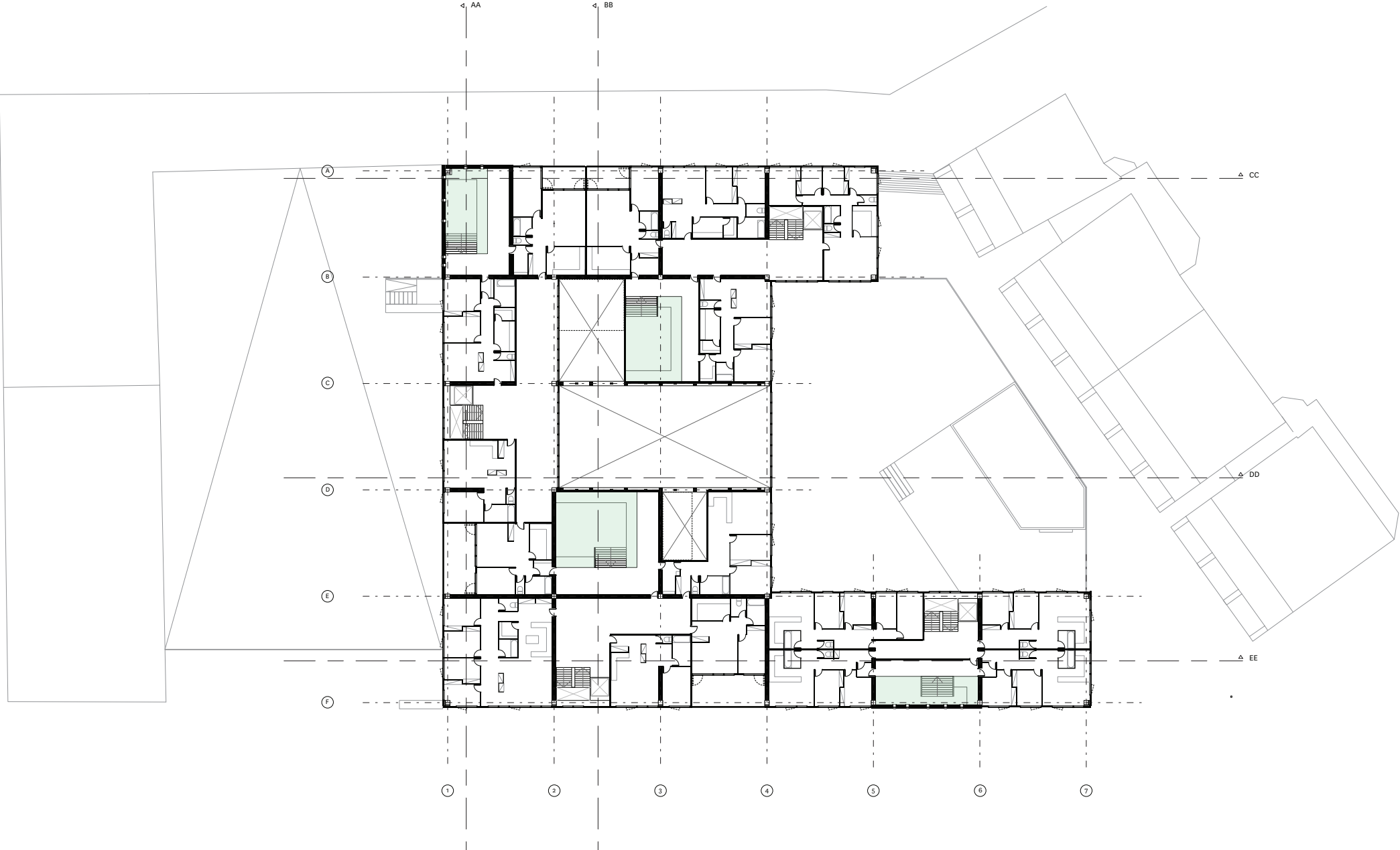

Interlocking of Baths

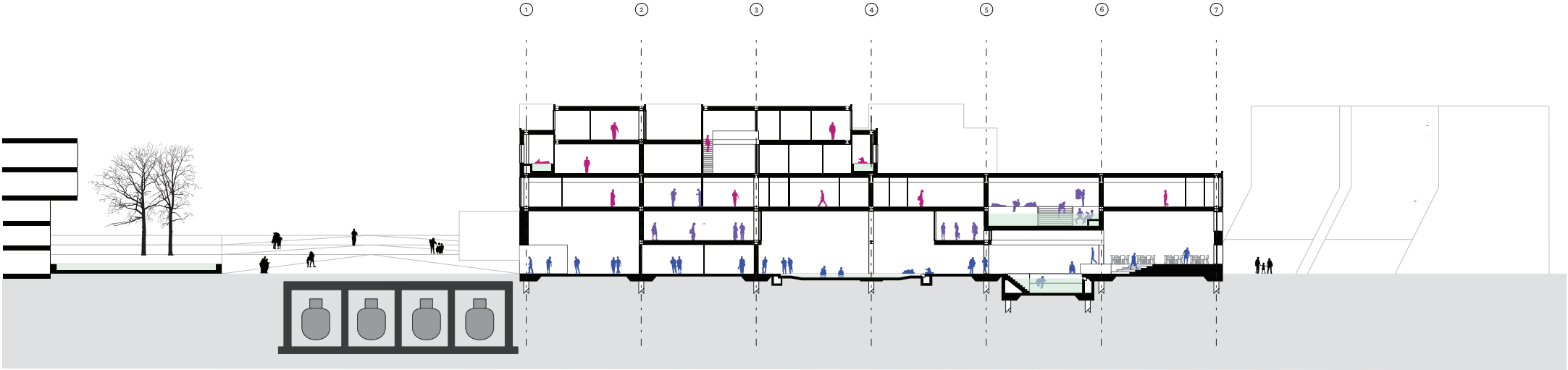
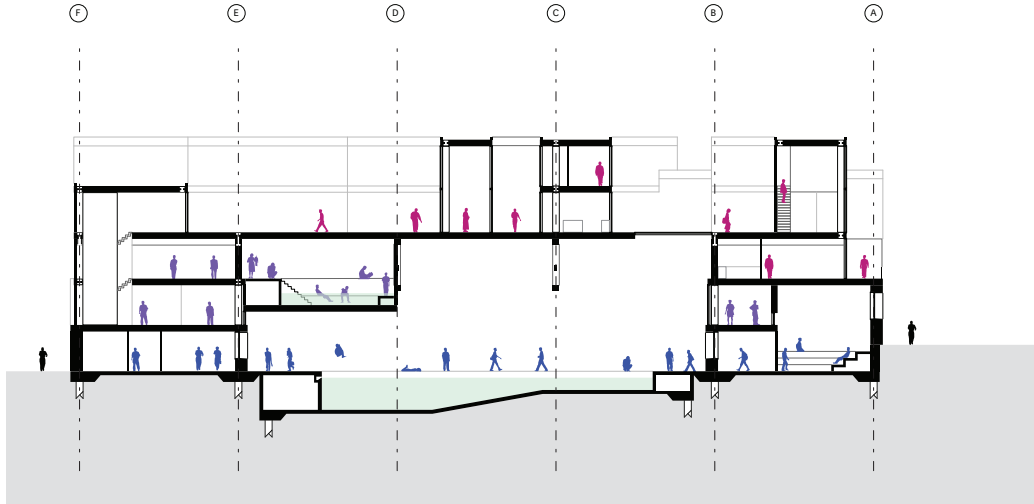

Example of an Appartement with private entrance to Bath

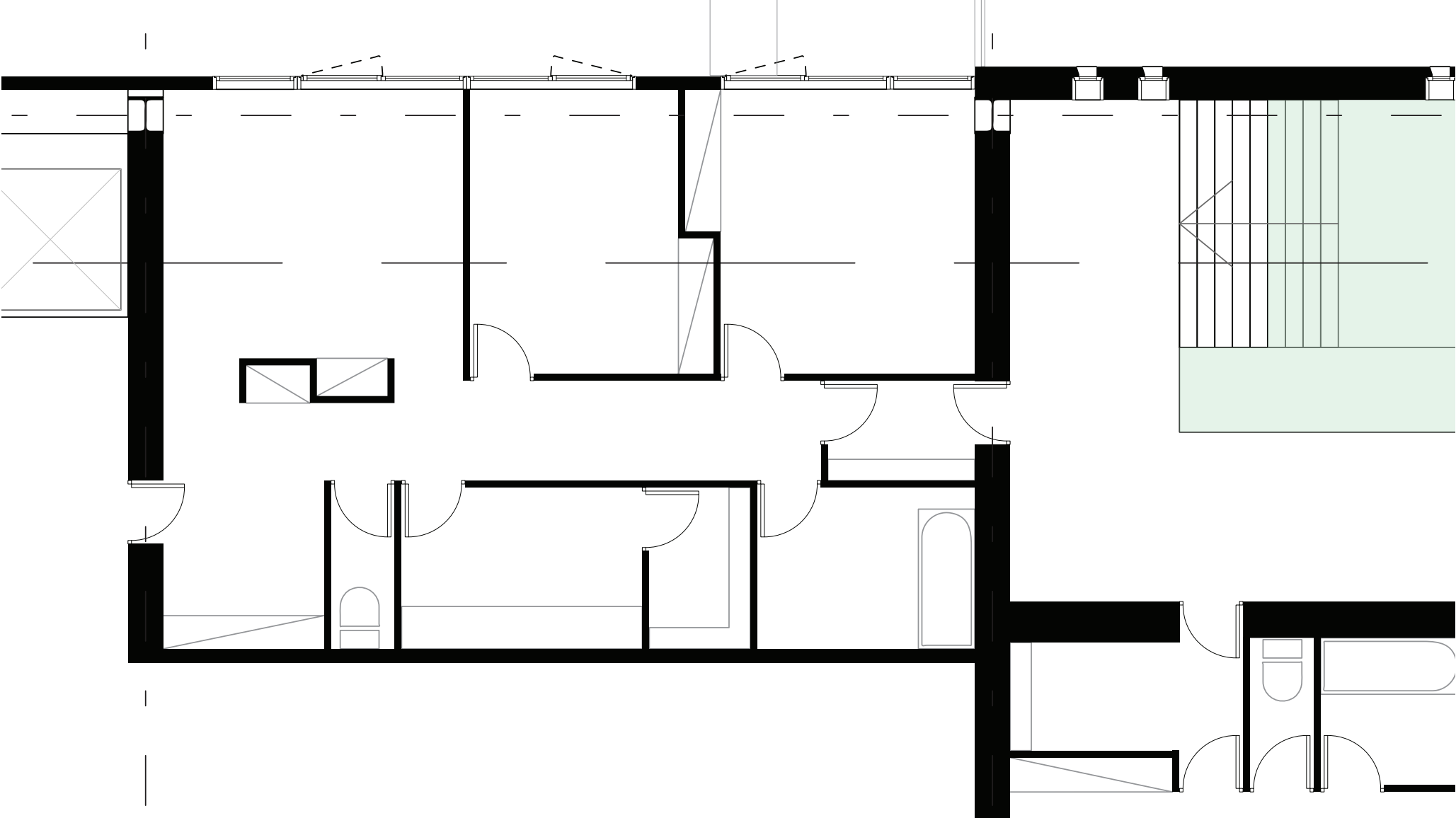

Maisonnettes with entrance through 'piazza'

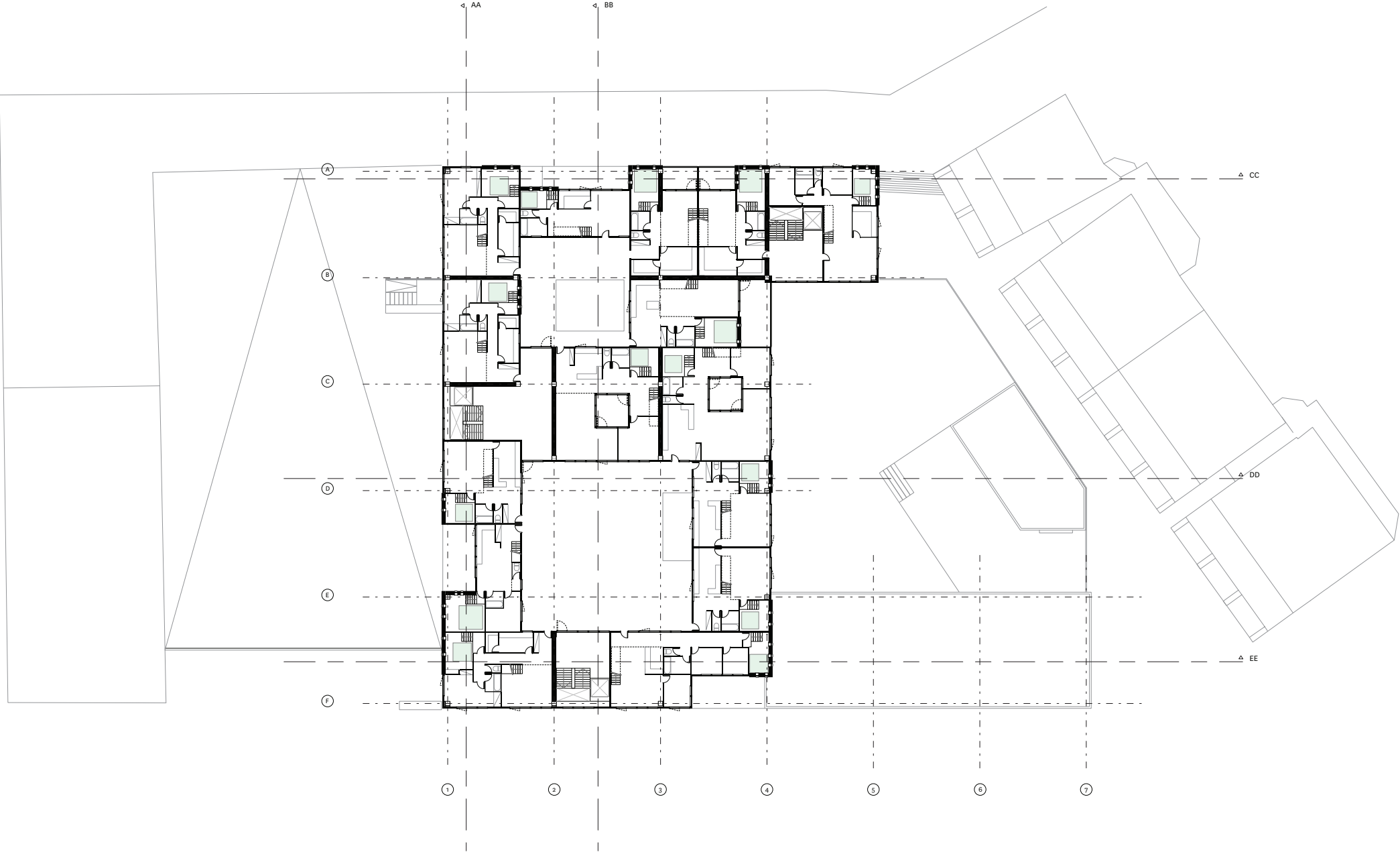

Example of Maisonnette : private bath and double height living room

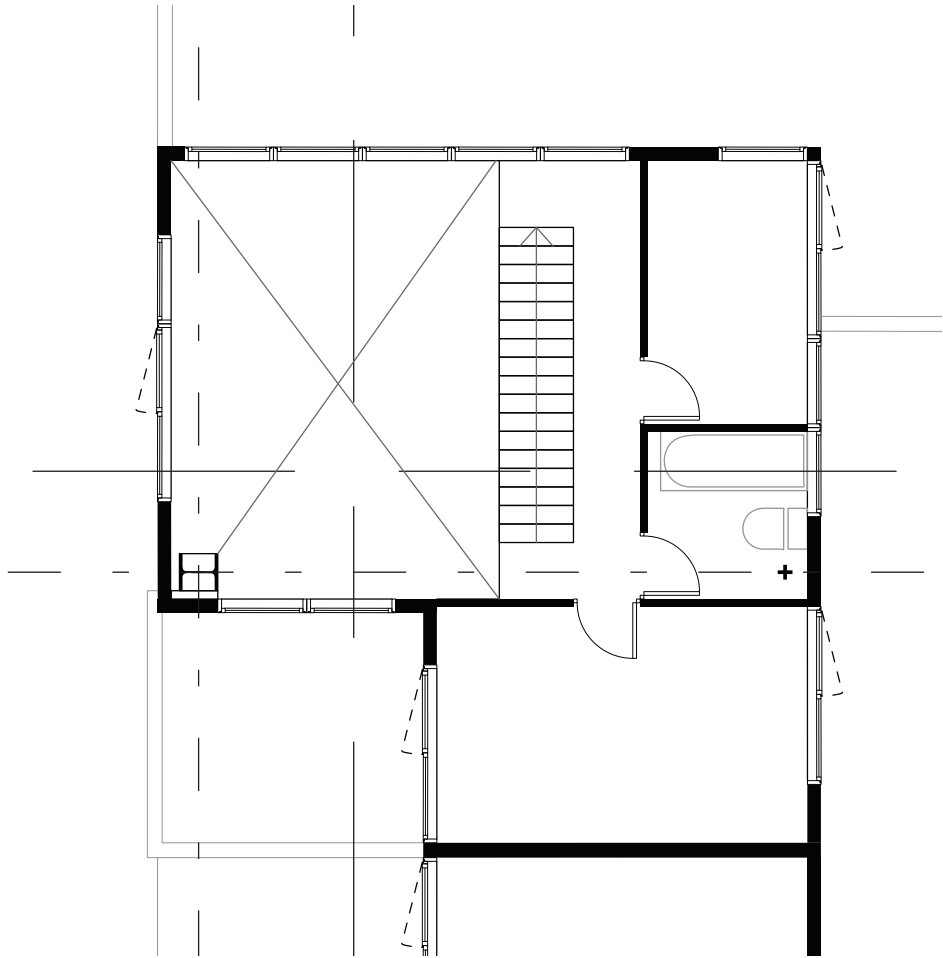
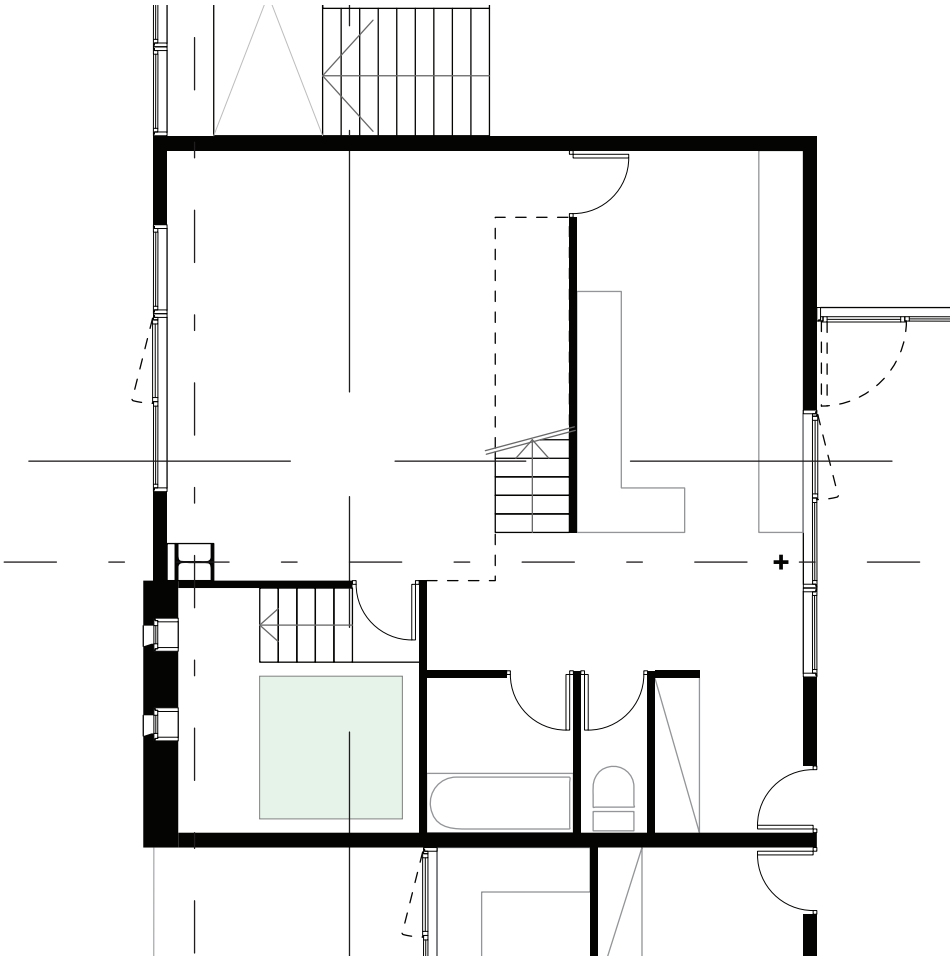

Facade



MUMOK, Museum of Modern Art in Vienna

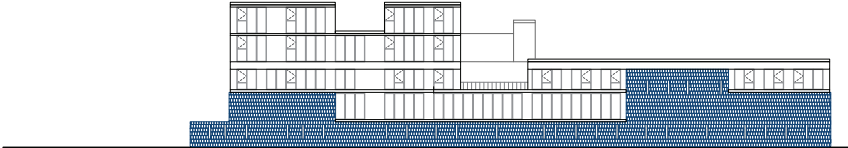
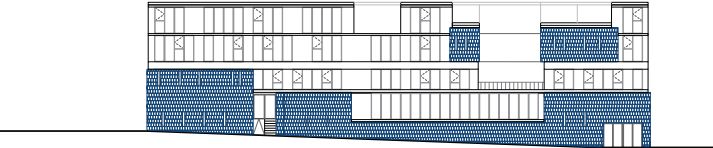
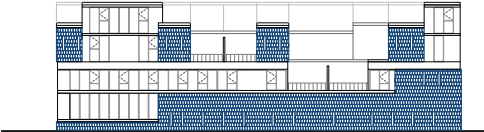
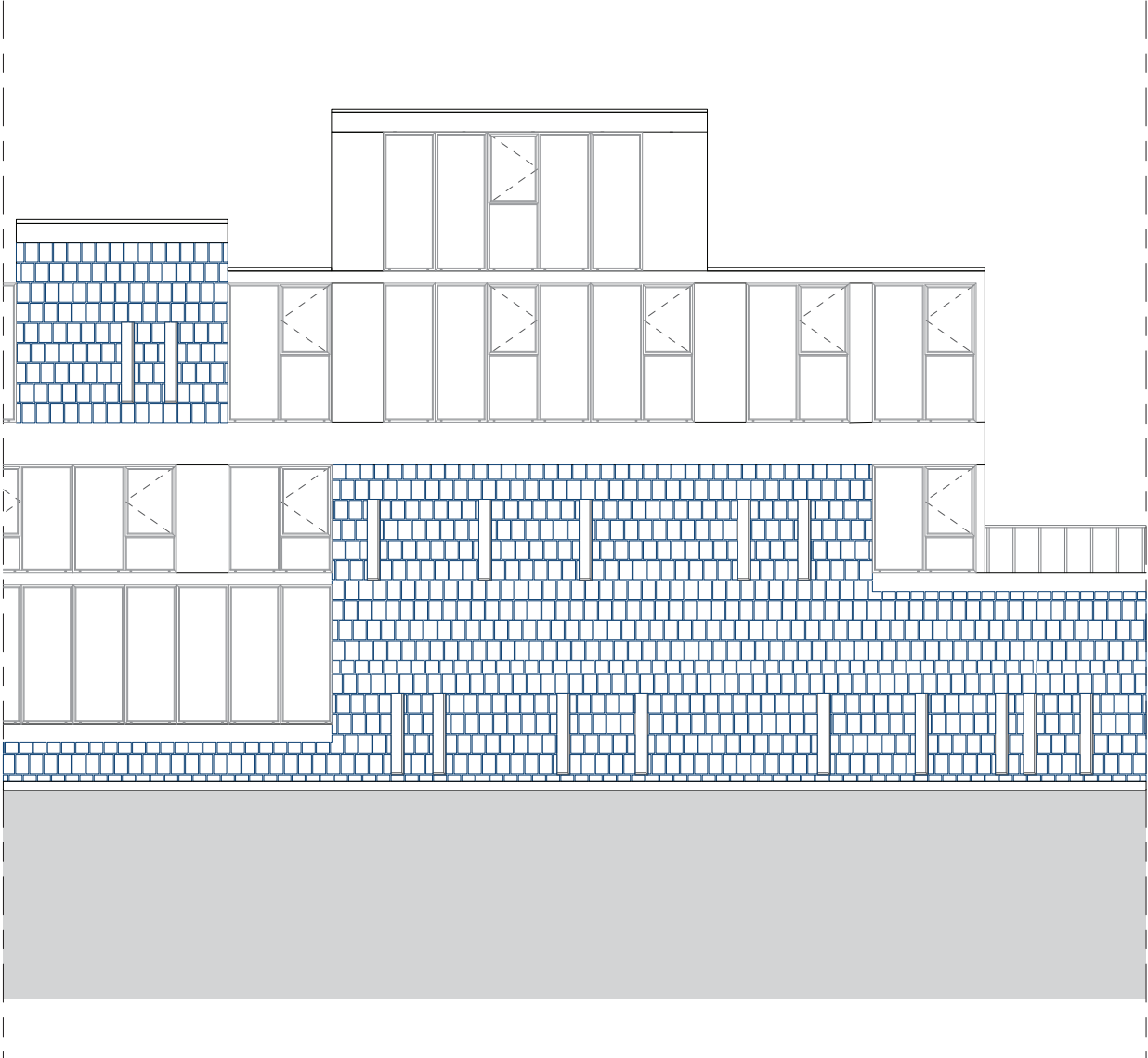

Facade



Mendiger Basalt Lava Stone



MUMOK, Museum of Modern Art in Vienna

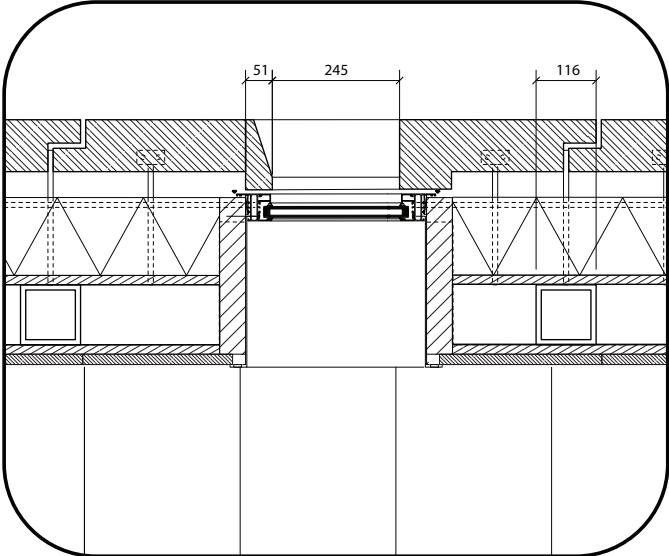
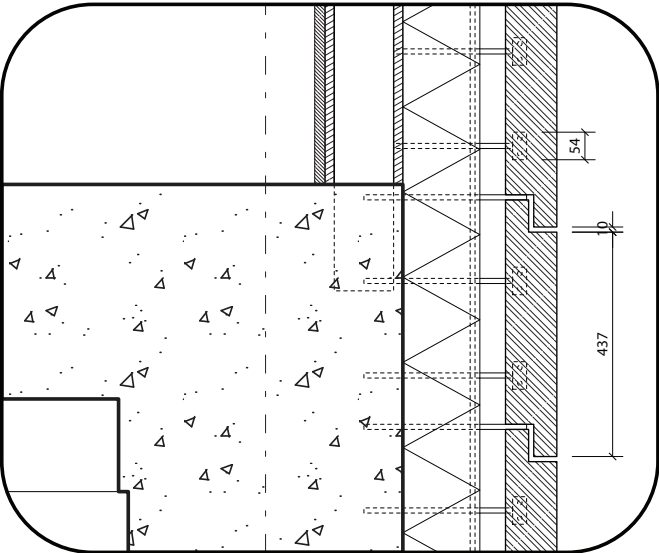

Facade



MUMOK, Museum of Modern Art in Vienna



Textured Concrete

