

Exploring the possibilities of structural cast glass in the consolidation of historic buildings



Rita Torres Guimaraes da Cunha Areias Hollebrandse

Exploring the possibilities of structural cast glass in the consolidation of historic buildings

by

Rita Torres Guimaraes da Cunha Areias Hollebrandse

in partial fulfilment of the
requirements for the degree of

Master of Science
in Building Engineering, Structural Design,
Faculty of Civil Engineering



to be defended publicly on Friday July 22, 2022

Chairman:	Prof. ir. R.. Nijse,	TU Delft
Thesis committee:	ir. C. Noteboom	TU Delft
	ir. S. Pasterkamp,	TU Delft

Acknowledgements

I would like to take this moment to express my gratitude to everyone who helped me completing my master thesis.

First I would like to thank my thesis committee for keeping up with me until the end, in particular Rob Nijse and Sander Pasterkamp. Thanks to Rob Nijse for providing me with such an inspiring topic and taking time from his pension to help me. I'm specially thankful to Sander Pasterkamp who besides sharing his expertise in mechanics and masonry also encourage me to move forward whenever I encounter problems. Further, I would like to thank Chris Noteboom, who started in the middle of the process and gave me a lot of support as daily mentor organizing the regular meetings, sharing his expertise with glass and encouraging me. I also would like to thank Lida Barou my first daily mentor for inspiring me with her research about restoration and glass and sharing her research papers with me, besides being always helpful during the process. She supported me a lot also with data about the case study, Schaesberg castle.

Besides my thesis committee some people helped me a lot during the thesis. I'm specially thankful to Francesco Messali, who shared his expertise in masonry and Diana FEA, my knowledge of it was very limited and he always managed to make some time in his busy schedule, even sometimes during the weekend. I'm also very grateful to Sandra Nunes, who helped me as a friend and giving her perspective as a teacher from the Tudelft, giving support sometimes through the night. Thank you for revising my thesis and providing very valuable feedback. A special thank goes to my friend Vicky Dudley Owen for revising my thesis and providing very valuable feedback regarding the correct English.

In evaluating the ruin of Schaesberg Castle, I would like to thank Aryan Klein, the project manager at the actual restoration who provided me valuable information about the site and state of the ruin.

On a personal level, I am very thankful to my parents, for revising the thesis and helping with feedback to finish the thesis, always believing in me and supporting me emotionally. Their perspective and expertise from the academic world was very helpful. Thank you for always being there for me. I am specially thankful to my husband for not giving up on me and always supporting me at home and with our son when I needed to be working for the deadlines. Thank you to my brother and sister for always believing in me and encouraging me to finish the thesis. And at last, I would like to thank my friends Nagihan and Marija for their friendship and motivation. Thank you to all my friends for their positive perspective.

Rita Areias,
Rotterdam, July 2022

Abstract

The search for a transparent, reusable, innovative, architecturally aesthetical, structural material that could be used as consolidation system for decayed historic buildings led to the ambition to test a topological interlocking (osteomorphic) design by using numerical calculations. In the last decennia glass has evolved to be a structural material that could be implemented in diverse structural elements. The mechanical properties of glass, in particular the high compressive strength, offer today a competitive solution that can be used for the purpose of restoration, allied to its transparency and aesthetics. The use of glass as a material is also aligned with the recommendations laid down by the international agreements for restoration. Due to its transparency it allows the ruin (Schaesberg Castle) to be perceived in its damaged state keeping the identity and at the same time being distinguishable from the original material in a subtle and immaterial way.

A literature research gave the technical background necessary related to glass, and how by choosing cast glass in the form of topological interlocking (osteomorphic) this would improve its strength and stiffness by introducing a 3d dimension and optimizing the use of compression. The case study's main purpose was to give a context for the architectural and structural design and evaluate the technical consequences of applying a topological interlocking structural assembly to replace the missing parts of the existing castle. A design was proposed based on the topological interlocking osteomorphic stability system. The design criteria obtained by the literature and case study were then combined to obtain a model to be tested using numerical calculations.

A global model in Finite Element Analysis, with Diana FEA was chosen to test the whole structural integrity and performance by looking at the stresses and the maximum capacity of the system to check if it fulfilled the strength and stability requirements and to test the influence of two types of connections between the materials.

The results suggested that the system performed well and was strong enough but are based on the assumption of a monolithic system which resulted in a less accurate outcome, unable to predict the failure mode by delamination. According to the results, this system can be implemented to replace the missing parts of a monument but a more detailed model is needed to study more accurately the local failure behaviour.

This can serve as a starting point for future research in similar situations. The study of the connections, although conceptual, can support decisions for detailed design proposals.

Contents

Acknowledgements	4
Abstract.....	6
1 Introduction	9
1.1 Objective	9
1.2 Research questions	9
1.2.1 Main research question.....	9
1.3 Methodology.....	10
1.3.1 Thesis structure	10
2 Literature study.....	12
2.1 Glass	12
2.1.1 Introduction.....	12
2.1.2 Properties	13
2.1.3 Manufacture methods- Float, Cast.....	16
2.1.4 Safety	19
2.1.5 Cast glass stability systems.....	23
2.1.6 Cast glass strength.....	26
2.1.7 Conclusion	30
2.1.8 Case study applications	32
2.2 Connections	37
2.2.1 Introduction.....	37
2.2.2 Tested glass connections related to consolidation of historic structures.....	39
2.2.3 Conclusion	45
2.3 Restoration theory.....	46
2.3.1 Introduction. Why to preserve/restore?.....	46
2.3.2 The origin of the modern restoration principles.....	46
2.3.3 How is glass used in restoration?	49
2.3.4 Conclusion	50
2.3.5 Case Study applications.....	51
3 Case study.....	58
3.1 Historic Overview.....	58
3.2 Consolidations.....	61
3.3 Analysis of the pathology.....	75
3.4 Replacement of monument interventions: design.....	76

3.6 Structural validation.....	85
4 Discussion, conclusion and recommendations.....	95
4.1 Discussion.....	95
4.2 Conclusion.....	95
4.3 Recommendations for further research	96
List of references:	98
5 Appendices.....	101
Appendix A - Structural validation masonry	101

1 Introduction

Historic buildings are part of our cultural built heritage. They figure a travel in time to our ancestries, testifying their habits, architecture and technologies, a link to the past showing the strata of different eras, defining our tangible cultural identity as society which we seek to protect and enhance for future generations to witness.

Regarding the restoration of partially collapsed historical structures, glass can be the solution, as “the state of art technology and continuous progress on glass fabrication, processing and assembly brings transparent materials to the foreground for applications of strengthening our decayed historic structures” (Barou *et al.*, 2018b). Due to its transparency it allows a ruin to be perceived in its damaged state keeping the identity and at the same time being distinguishable from the original material in a subtle and immaterial way. Those characteristics are aligned with the recommendations laid down by the international agreements (e.g. Charter of Venice, (ICOMOS, 1964)) which serve as guidelines to help preserving and restoring the built heritage.

The mechanical properties of glass, in particular the high compressive strength, offers today a competitive solution as a structural material which can be used in the consolidation practice. Consolidation protects the ruined structure from further decay reassuring its structural integrity. In here the connection of the glass and the historical material is an important aspect to consider in order to ensure the correct load transfer and enhance the historical structure.

1.1 Objective

This thesis intends to research the latest technologies regarding structural cast glass by analysing different types of structures and looking at the main philosophical principles on restoration. With this the aim is to find out an innovative, harmonious, compatible, and reversible structural design solution for this particular context, the restoration of a collapsed ruin (Schaesberg castle), applying it as a consolidation alternative to the current interventions. This can be used as a design methodology for similar situations. To ensure the new structure contributes to the integrity of the whole structure by enhancing its fragile structural behaviour, the way the existing and new material connect plays here an important role.

1.2 Research questions

A main research question will be the drive of this thesis research. The sub-questions are formulated to guide the research towards the objective and be able to answer the main research question. The sub-questions are thus answered along the thesis chapters.

1.2.1 Main research question

In what ways can we replace the missing parts of a monument using structural (cast) glass?

Sub-questions:

1. What are the main properties of glass?

2. How is structural cast glass used as load bearing material?
3. What are the main connection types of structural glass elements in general and in relation to historic building material?
4. What is the current restoration philosophy and how can this be implemented in restoration practice?
5. How are the main design principles derived from the literature review applied into a design?
6. Is the topological interlocking (osteomorphic), cast glass assembly strong enough to ensure the consolidation of a monument?
7. What is the influence of the different connection types (fixed and hinge) on the structural performance?

1.3 Methodology

A literature research was performed to acquire a broad knowledge of glass, possibilities and limitations when designing with glass as a structural material with a focus on cast glass, dealing with the restoration of historic buildings and how to connect different (historic) materials with glass. This literature research gave the technical background necessary to define the starting points and boundary limits of the design of a structural cast intervention on an existing decayed historic building. The literature research was followed by a case study. A collection of information, onsite visit and interview with the project manager Aryan Klein gave enough information to perform an analysis of the pathology. Its main purpose was to give a context for the architectural and structural design and the technical consequences of applying a topological interlocking structural assembly to replace the missing parts of the existing castle. A design was proposed based on the topological interlocking osteomorphic stability system. This design was subsequently tested with a global model in a Finite Element Analysis, with Diana FEA to check if it fulfilled the strength and stability requirements and to test the influence of choosing between two types of connections between the materials. A global model was chosen to study the system as a whole and to validate the topological interlocking osteomorphic as structural method for this situation.

1.3.1 Thesis structure

The thesis is divided in four parts. Part 1 is the introduction. Each consecutive part seeks to give a conclusive summary and input to the next part. The research sub-questions will be answered along the thesis:

Part 2: Literature study

By researching the literature and analysing different case studies, design principles and boundary conditions can be formed to come to a design. The literature study on restoration should give some restrictions and guidelines for the architectural concept. The part on glass will give some concepts and boundaries for the structural design. The connections research will focus on some tests already done in order to have some basic ground for design.

Chapter 2.1: Structural glass- Background information about glass, properties, manufacturing methods, types of glass, safety. Cast glass research on stability principles and strength. Overview of projects made with the last technologies in glass.

Chapter 2.2: Connections- A general research is performed on connecting glass to glass and glass to other (hard) materials related to historic buildings

Chapter 2.3: Restoration theory- Researches the principles and practice of building conservation and how glass can be used as a conservation material providing some reference projects. Overview of projects of historical materials restored with glass.

Part 3: Case Study

Chapter 3.1: Case study assessment- The monument Schaesberg castle is analysed by an historical overview, on site assessment, data research and analysis of the pathology. A case study assessment should provide enough information for the initial architectural and engineering concepts by studying its context and history.

Chapter 3.2: Case study consolidations assessment- An overview is made about the current and past consolidations.

Chapter 3.3: Analysis of the pathology- The Castle is analysed regarding the decay and consolidations done. An assessment is done regarding the needs of the decayed structure in order to consolidate and to integrate with the principles of restoration.

Chapter 3.4: Replacement of monument interventions- Based on the previous research, a design proposal is made having in consideration the principles and design requirements of the literature review. The proposal is displayed and integrated into the current decayed site.

Chapter 3.5: Structural validation- Two finite element models are analysed in Diana FEA and compared and validated with hand calculations.

Part 4: Concluding summary

Chapter 4: Discussion, conclusion and recommendations- Discusses the results of the models in relation to the research done and the chosen design for the glass consolidation and what is the influence of the connections on the assembly. The main research question is answered by a concluding summary related to the research done. Acknowledging the limitations of the current study, recommendations and suggestions for future research are presented.

2 Literature study

2.1 Glass

2.1.1 Introduction

Glass is a very special material, it's strong and it's fragile at the same time. These antagonistic features didn't, however, prevent its use and becoming very popular, being even one of the oldest man-made materials. It was, nonetheless, very expensive to manufacture and considered until short a luxury material, only available for the richest. In architecture, its application as a building material is already very old. In the ruins of Pompeii, the ancient city close to Naples, which vanished after the eruption of the Vesuvius in Ad79 (*Pompeii - Wikipedia*, no date), fragments of glass windows were found. The architecture techniques developed though, side by side with the innovations in the manufacturing of glass (Nijse, 2003). From very small and opaque windows where both sides had to be polished, to the stained glass windows used in the gothic churches separated by small lead frames, and finally to the huge glass facades available today (to up 18 meters length). With further innovation, glass became, a very affordable material to produce in the form of windows (Soda lime float glass). Architects thought of a transparent structure, a structure that people don't see, the ultimate goal. For structural designers, a headache, they don't like structures that are unpredictable and break without giving a warning that they are about to collapse. A lot of research was done in the past 20 years and pioneers, like Rob Nijse, made the impossible possible and provided the means to use glass as a structural material. Beams, columns, floors, roofs and walls are now possible to make and glass went from an infill material, used for windows, car windshields, glasses, cooking and laboratory utensils to a main load carrying structural material. Research on the last couple of years (8 or so) pathed the way to even more amazing pieces of engineering glass, the cast glass. Although one of the first techniques of man-made glass, cast glass which was used for windows become unused after the invention of the float glass technique, (which exempted the step of post-processing, the polishing). The cast glass came to the forefront of the structural glass techniques after the building of the Crystal House (in Amsterdam) and other small projects (Atocha memorial, Optical house and Crown fountain). Cast glass became validated as a structural material and very competitive in comparison to the 'standard' float glass even surpassing the qualities by its 3d shape which provide more strength against horizontal loads (wind, earthquake), buckling and bending. Its use proved that almost no auxiliary structure is needed in order to transfer the loads and that the structure can be used in its best feature the compression loads (self-weight). By segmenting the building elements to the size of the current masonry units and even better, employing a dry interlayer, its failure mechanism (failure in tension) becomes restricted to the element (unit), preventing the spreading of cracking to its neighbours and consequently avoiding the collapse of the whole structure (Oikonomopoulou, 2019), the biggest nightmare of the structural engineers.

In this chapter first an overview is made about the main features of glass as a material, with 2.1.1 Properties. Then 2.1.2 is about the manufacture methods or main production techniques including cast glass. The chapter 2.1.3 is about safety, and how to overcome the issue of the brittleness (fragility) of glass. The chapter 2.1.4 is focused on cast glass, the stability systems by making a comparison between the already built structures and the researched. And the last chapter 2.1.5 digs into the strength of cast glass.

2.1.2 Properties

a) Definition, Composition (soda-lime, borosilicate), Mechanical properties

When we think of glass, two properties come to our mind, it's transparent and fragile (Bos, 2009). This very reason that makes glass transparent it's also the reason why glass is brittle. When forming glass out of a fusion of materials, the molten glass is cooled fast enough to avoid crystallization (quenching). By doing so, cooling it under the melting point of a crystal, instead of a solid crystal, a supercooled liquid is obtained (Shelby, 2005). In the process towards the solid glass, the liquid becomes more and more viscous and the particles become locked in a disordered state like a liquid, being prevented to return to an equilibrium, to a perfect crystal arrangement as a solid (CMOG, 2011). Glass is therefore also referred to as an amorphous isotropic solid (Shelby, 2005) (Wikipedia, no date). Unlike crystals which form an organized arrangement of particles in 2d and 3d, glass lacks the long-range order, meaning that the 3d basic molecule of glass doesn't repeat itself but instead connects to other molecules in a disorganized ring like structure in random order missing the periodicity and symmetry like crystals (Zachariassen, 1932). It is however a misconception that glass internal structure completely lacks order as it consists, just like crystals of 3d basic molecules with high degree of internal order, the short range order (Shelby, 2005). By looking at the network of soda-lime silica glass, there is an equilibrium in the basic molecule of glass, the tetrahedron (see Fig. 2) in which the atomic bonds are strongly connected forming a short range order. The negative signs on the outside in contact with other negative signs pull apart and form small gaps (ring like structures) which are responsible for the transparency of glass but also its vulnerability to crack in tension, its brittleness. The small gaps allow the photons of light to go through almost unhindered but they are not big enough to allow the visible spectrum to be absorbed, which results in being transparent (Nijssse, 2003).

Amorphous also makes glass isotropic, its properties are the same regardless of direction or orientation (Wurm, 2007).

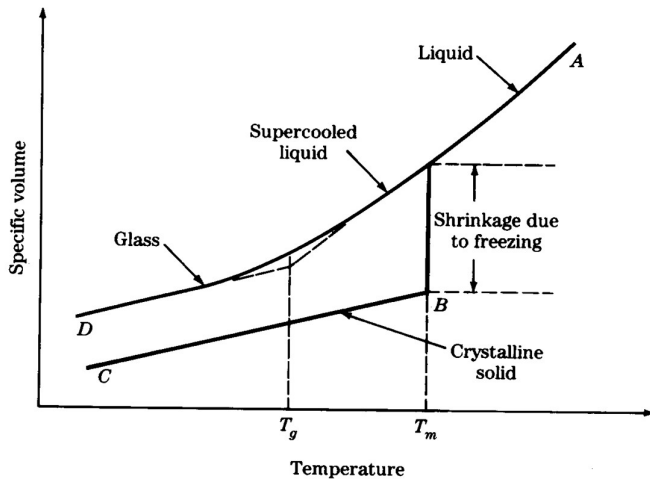

Figure 1- Phase transitions during the production of glass comparing with Crystal (Shelby, 2005)

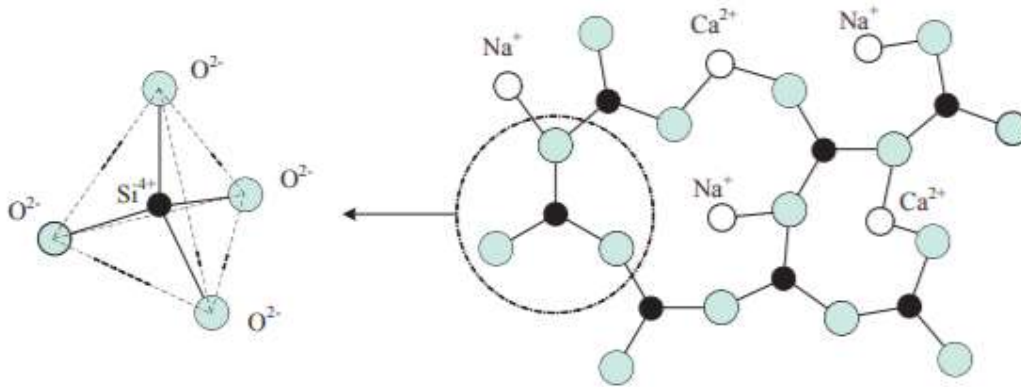

Figure 2- Schematic structure of soda lime silica glass, In 3d, the basic molecule (left), in 2d the irregular network (right) (Oikonomopoulou, 2019) based on (Louter, 2011)

		Soda lime silica glass	Borosilicate glass
Silica sand	SiO ₂	69–74%	70–87%
Lime (calcium oxide)	CaO	5–14%	–
Soda	Na ₂ O	10–16%	0–8%
Boron-oxide	B ₂ O ₃	–	7–15%
Potassium oxide	K ₂ O	–	0–8%
Magnesia	MgO	0–6%	–
Alumina	Al ₂ O ₃	0–3%	0–8%
Others		0–5%	0–8%

Table 1- From the book *Structural use of glass* (Haldimann, Luible and Overend, 2008)

	Units	Soda-lime	Borosilicate glass
Thermal resistivity	[m*°C/W]	0.909–1.11	0.769–0.909
Thermal expansion coefficient	10 ⁻⁶ /K	9.1–9.5	3.2–4
Tensile strength	MPa	30–35	22–32
Compressive strength	MPa	300–420	260–350
Young's modulus	GPa	68–72	61–64
Hardness	kg/mm ²	440–485	84–92
Cost	€/kg	1160–1370	3430–5150
Typical Chemical Composition		73% SiO ₂ 17% Na ₂ O 5% CaO 4% MgO 1% Al ₂ O ₃	80% SiO ₂ 4% Na ₂ O 13% B ₂ O ₃ 2.3% Al ₂ O ₃ 0.1% K ₂ O

Table 2- Comparison of Soda-lime to Borosilicate glass retrieved from (Oikonomopoulou, 2019)

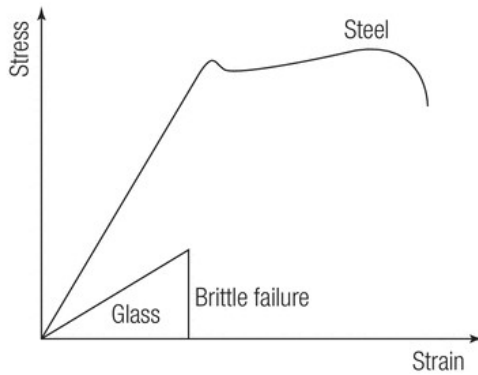

Figure 3- Stress/Strain behaviour for steel and float glass
Retrieved from (O'Reagan, 2015)

Due to its strong atomic bonds, glass has theoretically a very high compression strength. This is however, in practice, of low relevance as this theoretical strength can never be reached. As glass is not perfectly made intact and smooth, randomly distributed pre-existing microscopic imperfections (Oikonomopoulou, 2019) on the surface and defects on its microstructure, the Griffith flaws, result in peak tensile stresses when subjected to mechanical actions. Unlike other materials, glass is unable to dissipate these peak stresses through plastic deformation which results in a much lower capacity to withstand stress (Schittich *et al.*, 2007). The strength of glass is therefore not a material constant but rather depending on the degree of damage (Louter, 2011), (Wurm, 2007).

When comparing glass with other structural materials like steel, the latter is ductile, it can yield and deforms plastically. Glass behaves almost perfectly elastic until it breaks unpredictably (Fig. 3), cannot plastically deform which means it gives no warning before collapse, giving no chance for replacement before it completely loses its coherence and falls apart. That's not a good feature to have in a structural material (Nijse, 2003). Fortunately, due to the great interest in glass as a structural material, there has been a huge advance in the last twenty years and there are many ways to give glass the strength and protection it needs to be a structural material and compete with the ones on the market today. More on that in chapter 2.1.3. (Safety).

The types of glass that are mainly used in construction for structural use are Borosilicate and Soda Lime Silica glass. Both are Silica glasses which implies that Silica sand, or quartz (SiO_2) or Silicon Dioxide is the main component in the production of the glass (Table 1), or the former. Silicon Dioxide is basically sand like the one found on most of the beaches but where the impurities are filtered out, like iron for instance which brings colour (greenish-blue) in glass. In fact, all metals can add a different colour according to type. The former has to be heated to a very high temperature to become viscous, which enables glass to be shaped (essential in glass). To the former, flux and stabilizer are added, the flux to lower the melting temperature and therefore making the process cheaper and easier to make and the stabilizer, like the name suggests gives stability to the mix or provides more stable chemical reactions (CMOG, 2011). In the case of the Silica glasses the flux is soda-ash (Na_2O) or potash which was made traditionally from marine plants, burning them until they became ash (CMOG, 2011). The stabilizer is for Soda Lime Silica glass, limestone or Calcium Oxide

(CaO), a mineral which can be also be found on the beach in the form of sea shells (Nijse 2003). Borosilicate glass has Boron oxide (B₂O₃) instead of Lime which gives a high melting temperature (CMOG, 2011) making it less economical than Soda lime glass but it gives, also, a high (higher than Soda lime) thermal shock resistance making it ideal for products subjected to high temperature changes or thermal fatigue resistance. Examples are the Pirex glass we know from the kitchen utensils, but also diverse laboratory utensils. Borosilicate glass is also more resistant than Soda lime glass to alkaline solutions, hydrolytic and acids. For structural purposes Borosilicate glass can be sometimes, even more practical than Soda lime glass (the main glass used in construction), because of the low thermal expansion coefficient results in the annealing of glass being much faster (Oikonomopoulou, 2019). For the manufacturing of cast glass this feature can be very useful (see chapter 2.1.2.).

As described before, Soda lime glass is the main type of glass used in the building industry and the one type which has been used already (almost unchanged) since centuries (Nijse, 2003) It was the first man-made glass or artificial glass. With the industrial revolution and inherent progress, the production of glass in massive quantities became a reality, due to improved furnaces and the achieving of higher melting temperatures (hence much cheaper), which also had influence in the production innovations (see chapter 2.1.2) and the architecture. The use of glass for the car industry and the finetuning as a safety glass paved the way for the construction field (more on that in chapter 2.1.3), the so called heat tempered glass or safety glass. Soda lime glass, evolved to be not only the glass for windows but also with the recent technologies, research and pioneers like Rob Nijse, to be used as a structural material already being used for the main structural components, beams, columns, floors, roofs and with the most diverse shape (Nijse, 2003) The big advantage of Soda lime glass in comparison to Borosilicate, besides being much cheaper and more massively produced and available, is the higher strength (see Table 2). With this, the ultimate wish of architects to make the structure invisible is finally possible.

Borosilicate and Soda Lime glass are both used in the construction, not only because of its low melting temperatures (in comparison to other types of glass) but also by its workability making it very useful to shape into every form, or to make the structural elements as 3d elements (Oikonomopoulou, 2019).

2.1.3 Manufacture methods- Float, Cast

The float glass process, invented by Alastair Pilkington and finetuned at the end of the 60's of the XX century, revolutionised the world of glass production for windows which enable the mass production at a very cheap cost. The method was so good that almost no flaws were allowed in the process, providing a continuous process in which most industries worked 24/7. Until that moment the glass produced for windows had to be polished to achieve a better quality. With this process, the glass gets two even (polished) surfaces because of the gravity (the side in contact to the air) and by floating (the tin side). The raw materials, usually cullet (pieces of glass) are mixed together with the basic components, as described in the previous chapter, and introduced in the big furnace, the melter (see Fig. 4) which has a temperature of around 1500°C (for Soda lime glass, for Borosilicate is higher). That temperature enables the glass to quench (very hot heating) and achieve the viscosity it

needs to become a glass (see chapter 2.1.1) by avoiding the crystal phase. From the furnace to the tin bath, the inlet is at about 1000°C, the melted raw materials are poured into a bath of molten tin. As tin (a metal) is heavier, it sinks to the bottom. Molten glass and tin are immiscible, the molten glass which is poured on top of the tin surface is allowed to float, like magic (or physics) and spread outwards uniformly by a controlled temperature forming a ribbon (a thin sheet of solid glass) with two optically perfect smooth surfaces. The ribbon then follows to the annealing lehr, a very important stage (annealing) to release the residual internal stress (Wikipedia), introduced during manufacturing (quenching and then cooling), by letting it gradually cool down, which otherwise would cause cracks in glass. After that the ribbon is automatically inspected for flaws and subsequently cut in standards sizes. The thickness of the glass is dependent on the speed of rate by which the process is done from the raw materials to cutting. This process enables almost perfect windows which require almost no post process. In fact, the process became so cheap that is cheaper to put in a new window, to replace the broken, than to invest in the improvement of the quality of glass (Nijssse, 2003). That hinders also, the even further innovation in the use of glass as a structural element, as the strength and safety of glass is still an issue (more on that on the next chapter 2.1.3. Safety) and Soda lime glass (the glass for windows) is still the most available type of glass in the market and therefore cheaper to use for this purpose (structural).

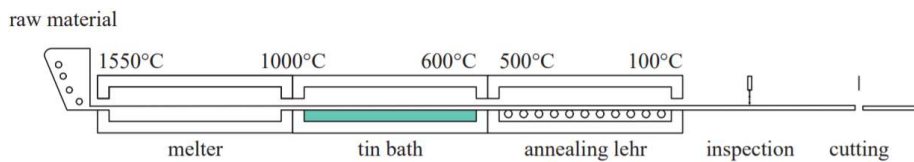

Figure 4- Float glass/annealed glass manufacture process (Oikonomopoulou, 2019) readapted from (Louter, 2011)

Cast glass process:

During the last few years, a lot of research has been made into using cast glass as a structural element with the help of the glass lab department at the TU Delft, and the experience of using cast glass as a structural element, researching by doing by the Crystal Glass house in Amsterdam (Oikonomopoulou, 2019). This made evident, firstly that cast glass can be used as a structural element (for the first time), because in the past hollow glass elements were used, but they have no structural qualities (Oikonomopoulou, 2019). Secondly, that there is a lot of room for improvement (more in the following chapters), including in the manufacturing of the elements, to make it an affordable and competitive structural material. Cast glass is one of the oldest methods of producing glass artificially (Oikonomopoulou, 2019). There are, basically, two methods of producing cast glass. The primary (hot forming or melt quenching) and secondary casting (kiln casting) (see Fig. 6). The main difference between the two, besides the initial state of glass, is the needed infrastructure for the process. In the first the molten glass is poured into a mould and is put into a furnace, and subsequently placed once again into another furnace for the annealing. In the second, the already glass (and not raw materials) is placed into a furnace (kiln) and left in the same kiln for melting and annealing. What is important to know from these methods, is that the melting scheme, time, annealing, process and quality of the final product are influenced by multiple factors (Oikonomopoulou, 2019). The second method, kiln casting

may be used for the most affordable outcome, as the employment of disposable moulds is possible, also custom made objects are easier and more affordable to make with this method. The hot pour is generally used for quality, standardized, repeatable elements with metal moulds, press metal moulds or adjustable metal moulds (see Fig. 6). 3d print is also an option, although the quality of the end product is not as good. The research made in cast glass also put in evidence that there is more investigation needed in order to become more affordable and sustainable. Affordable by improving the production process and time of manufacturing (less time spent in annealing). Sustainable by using disposable glass from used utensils in the daily life (glasses, windows and so on) which are not really being used in its full capacity. Most of the trashed glass is in fact, never re-used and just a small percentage is recycled with the most ending up in landfills. Glass can be endlessly remelted without the loss of strength, transparency, quality, and hence it is a pity it's not being used for more things, like structural materials. Telesilla Bristogianni has been studying that since some years (Bristogianni *et al.*, 2018) The kiln casting has been used in research for more custom made elements, like the interlocked cast elements. More on that in the following chapters.

What is also worth mentioning, is that, the studies carried on by the glass lab also demonstrated that there is some design criteria that can be established in relation to the manufacturing of glass. The first is in relation to the annealing time, the volume should be limited, otherwise the process takes too much time to occur. Additionally, on the annealing issue, a proposal or option is given to choose Borosilicate glass instead of Soda Lime silica glass. Due to its lower expansion coefficient and higher melting temperature results in the annealing time to be much shorter (Oikonomopoulou, 2019). Secondly, rounded shapes are preferred instead of rectangular, or sharp edges and equal mass distribution, in order to prevent the concentration of residual stresses, which can damage the glass when it reaches a certain amount due to inhomogeneous shrinkage. Towards, the purpose of transparency, these damages can also be an issue because the optical quality is affected by visible cracks. Lastly, small connectors or notches should be avoided because they act as stress concentrators (Oikonomopoulou, 2019). More on the design in the following chapters.



Figure 5- Hot pour (left), kiln-cast (right) (Oikonomopoulou, 2019)

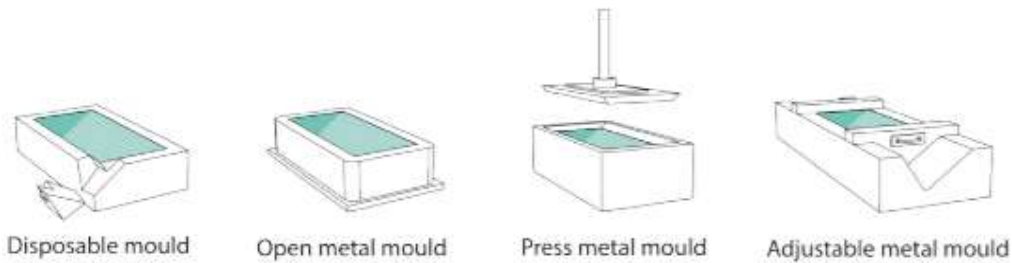

Figure 6- Types of moulds for producing cast glass (Oikonomopoulou, 2019)

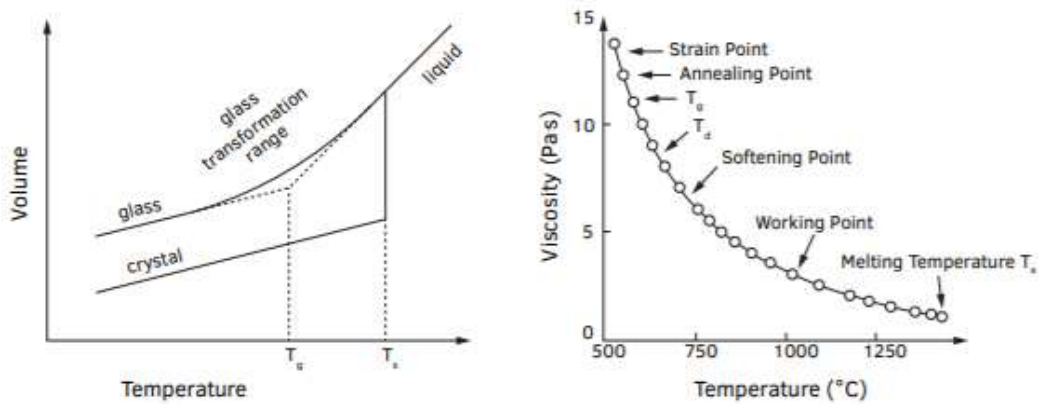

Figure 7- “Left: Schematic representation of the volume’s dependence on temperature for a glass and a crystalline material. During the cooling process from a liquid to a solid, glasses do not convert to a crystalline state. Right: Typical curve for viscosity as a function of temperature for a soda-lime-silica melt (NIST Standard No. 710). Defined viscosity points are indicated on the figure”. Source: (Oikonomopoulou, 2019) retrieved from (Shelby, 2005)

Glass process	Optical Characteristics	Main type of glass applied	Standard size [mm]	Thickness [mm]
Float	Smooth Transparent	Soda-lime	3210 x 6000 ^a	2-25
3D-printed	Layered Transparent	Soda-lime	currently up to 30 kg	currently approx. 30 mm ^b
Cast	Smooth Transparent	Soda-lime Borosilicate Lead	currently up to 20000 kg ^c	n/a

a The max. panel size is continuously stretching. At present, up to 20 m long panels have been produced.

b Based on the work of (Klein 2015)

c Weight of the Hale Telescope monolithic glass blank.

Table 3- Overview of three existing glass fabrication methods for structural elements and their current size limitations (Oikonomopoulou, 2019)

2.1.4 Safety

a) Robustness, Redundancy, Post failure residual strength, Protection, Lamination, FT/HS/CT, 2nd load path related to bricks

Annealed glass:

As previously stated, the brittleness of glass is not a good feature to have when applying it for structural purposes. All structural materials give a kind of warning before they get overload, steel is ductile (warning by deformation, on the plastic zone) and takes the tension for concrete, glass is brittle, and can only take compression (Nijssse 2003). With that, concrete, is able to give notice that is reaching its capacity and gives time to take measures before the structure collapses (Nijssse, 2003). Glass doesn't have that warning mechanism by its own, although there are many studies made about reinforcing glass with steel (Louter, 2011). That redundancy needed to make glass safe, though, can be achieved in multiple ways, by for instance, laminating three glass layers together and as the two outside layers break, the one inside is able to keep load carrying capabilities (Nijssse, 2003). Another way is to heat strengthen the glass, by introducing artificially, a compression layer (residual stress/strength) on the outside skin of a glass layer (Nijssse, 2003). That gives the glass, the quality of being able to close the tension cracks caused by flaws (mostly present on the surface) and therefore have a much higher strength than the 'simple' annealed glass. Heat strengthen method is similar to the fully tempered by heating the flat glass to around 600°C and quickly cooling (quenching), creating a compression layer which closes the cracks at the surface. The process can be seen in the diagram of Fig. 9, as the glass layer is heated to a high temperature and subsequently cooled very quickly, the outside surface cools down first and the inside core remains hot. The outside skin will then start to compress, the inside core will try to pull out, so the inside will be in tension and the outside in compression (Nijssse, 2003). The difference between heat tempered (heat strengthened) and fully tempered is in the cooling rate which results in a different strength and fracture pattern (see Fig.10, 11 and 12). In the case of fully tempered, is the cooling rate higher, meaning that the cooling is done faster (more abruptly). Chemical 'prestressing' is also an option, but due to its very expensive manufacturing costs it is mainly used for curved or odd shape elements that are not possible to make with the 'traditional' heat strengthening methods. This process is very distinct to the heat strengthening methods demanding no use of heat, the glass is laid in a bath of potassium salt. These salt particles are much bigger (30%) than the sodium particles, present in glass, are replaced by the first, in an ion exchange operation, that results in a compression profile at the surface (like for the other methods). The main distinction between these three methods besides the breakage pattern is also the case depth (see Fig. 11) which for heat strengthened and tempered is higher than chemically strengthened. What this implies, is namely that the compression layer, which protects from tension cracks is thinner or easier to break through in the case of chemical treated (strengthened) glass, leaving less space for imperfections (Haldimann, Luible and Overend, 2008) The heat tempered has also a major disadvantage in comparison to heat strengthened, although it can reach a much higher strength, if the compression layer is disrupted reaching into the tension area, the glass layer breaks into million pieces, leaving no big shards (behind) and not being able therefore to carry any load when broken. Heat tempered has a similar breaking pattern to annealed glass and chemical treated glass (see Figures 9, 10 and 11).

NiS (nickel sulphide) inclusions may be present in all types of glass but due to the nature of quenching of (fully) tempered glass which consists of a more abrupt cooling, it's more prone to expand these inclusions (Haldimann, Luible and Overend, 2008). This process moreover, involves much more energy which is stored in the glass in the form of residual strength on the surface. If somehow the NiS inclusions lead to the fracture of glass (spontaneous fracture), that results in the pane of glass shattering completely in very small pieces

translated by the same amount of energy needed to make it stronger and totally losing its load bearing capacity (Swain, 1981), (Wiki, no date).

Even better, is to add both treatments, laminating and heat strengthening, that ‘doubles’ the capabilities. The glass is in this way strong and almost risk free for injuries, as the laminating film keeps the broken pieces (shards) of glass in place and avoiding injuries. That was the conclusion by analysing the car wind shields and the effect they have on the safety of people. Besides the safety, by adding layers of heat strengthened glass results not only in a stronger structure but also, in the case of breakage retains its load bearing functions until is repaired/replaced because of the big shards remaining in place. These measures add redundancy, robustness and a possible 2nd load path in the case that the broken layer is not able to carry any more loads, leaving that function to the outer layer. Another possibility is adding sacrificial layers or protective structures to avoid breaking the load bearing structures (see Fig. 12).

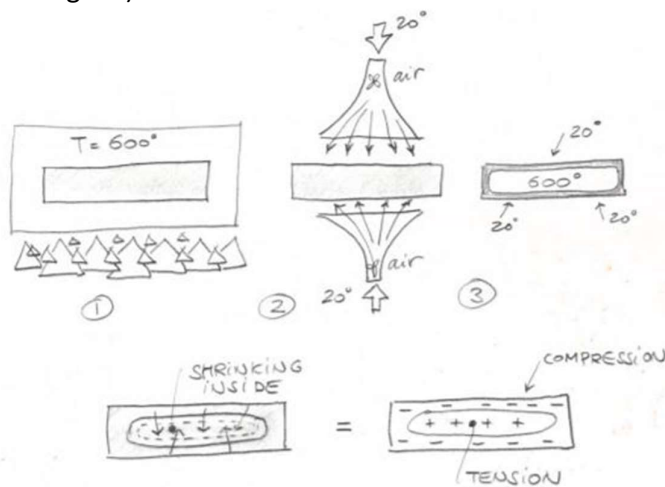

Figure 8- Process of heat strengthening (Nijse 2003)

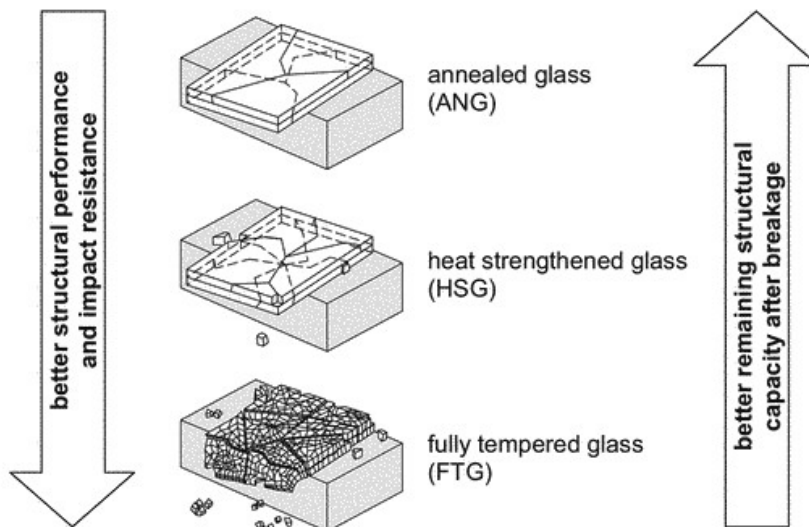

Figure 9- Overview of the breakage patterns for the different types of glass (Haldimann, Luible and Overend, 2008)

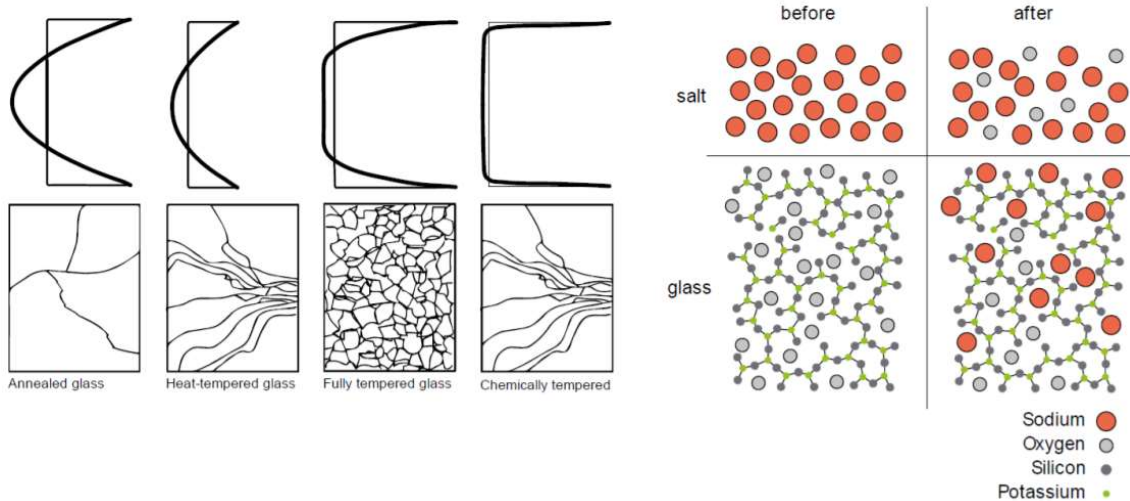

Figure 10- Comparison of the three systems of glass reinforcement, heat tempered, fully tempered and chemically tempered with annealed glass: breakage patterns (van der Velden and Nijse, 2019)





1. Type of Glass	+ / or	2. Lamination	+ / or	3. Protective elements
A. Tempered (Stronger, breaks in small pieces) or B. Heat strengthened/Annealed (weaker, breaks in large pieces)		 <ul style="list-style-type: none"> - Many glass panes are bonded together by an interlayer - If one pane breaks, the others remain intact - The broken pane does not fall down - Sacrificial layers can be added 		 <p>Architectural choices or visible elements that protect common damage (commonly due to accidental impact)</p>
 A. Tempered Glass - 4 times stronger than Annealed - Breaks in tiny pieces - no sharp edges - Collapses completely or  B. Heat strengthened / Annealed - Breaks in big pieces - Sharp fragments - Does not collapse completely		 <ul style="list-style-type: none"> - In laminated tempered glass the shards are held together, but the broken pane has no load bearing capacity left. 		
		 <ul style="list-style-type: none"> - In laminated heat strengthened or annealed glass the shards are held together, and the broken pane can still carry loads. 		

Figure 11- Overview of possible safety strategies. Retrieved from (Oikonomopoulou, 2019)

Cast glass:

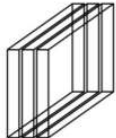
In the case of cast glass, different measures are possible for safety. Heat tempering is for now, not yet an option, as the research is not far enough (Oikonomopoulou, 2019) Interlocking cast glass can be a safety measure by increasing fracture toughness and preventing crack propagation (see Table 4). In comparison to a monolithic system where the

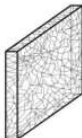
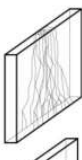
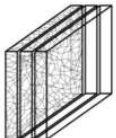
failure of one element can lead to the failure of the whole structure, the former has an inherent robustness (Oikonomopoulou, 2019). This interlocking system also works as a 2nd load path. In case of one broken element, the others can take the loads. Other measures could be protective structures like a steel plinth, not only protecting the glass to be damaged, but also transferring the loads to the foundation, like the one used on the Crystal house (Oikonomopoulou, 2019). For more information on the stability systems employing cast glass, see next chapter 2.1.5.

	SUB-STRUCTURE	ADHESIVELY BONDED	INTERLOCKING
			
ASSEMBLY TYPE	Dry-assembly	Adhesively bonded	Dry-assembly
TOLERANCES	Interlayer accommodates size deviations	Adhesive's thickness requires high precision in unit size	Interlayer compensates for size deviations
EASE OF ASSEMBLY	Easily assembled	Meticulous, intensive labour of high precision	Easily assembled
TRANSPARENCY	Compromised transparency	High transparency	High transparency
CIRCULARITY	Reversible	Non-reversible	Reversible

Table 4- Comparison of different stability systems for cast glass (Oikonomopoulou, 2019)

2.1.5 Cast glass stability systems

There are, already, some realized buildings made of structural (solid) cast glass. The only system not yet realized and validated in execution is the interlocked system. From these systems, a possible classification can be made related to the way they are assembled and stabilized (see table 4 (Oikonomopoulou, 2019))

- Substructure
- Adhesively bonded
- Interlocking

The first one, by making use of a substructure, relies upon an auxiliary structure to take and transfer the tension forces, which the glass elements are not able to, leaving them the compression (self-weight). This system also uses this normally metal structure to take care of the stability. In the case of the Optical house (Fig. 21), threaded prestressed cables are taking the horizontal loads and transferring it to a metal beam (behind on top). The glass blocks are in this way supported (hung from above) and the buckling is, to this extent, furthermore, covered. The dry interlayer was also used here instead of glue, making the

assembly and possible replacement of the glass elements easier. Additionally, construction tolerances are easier to take into account as the interlayer can accommodate those inaccuracies. The Crown fountain is another example according to the first system, in spite of, the structure being very distinct from the Optical House. A thick support structure is built behind, basically a tower in steel with wind bracings, columns and beams. This support structure transfers all the loads from the glass elements to the foundation. The glass elements are grouped in a sort of pre-assembled modules composed of 250 units each (Oikonomopoulou, 2019). From this first system, the conclusion is, that the overall transparency is compromised due to the support structure, but has however, in contrast other positive features like the reversibility, allowing possible reuse or easy replacement of the blocks, the dry interlayer takes care of the construction tolerances and thus the assembly is also easier and quicker (and cheaper).

The 2nd system, adhesively bonded, was implemented in the Atocha Memorial and the Crystal house. This system relies on the adhesive (the glue) to acquire a monolithic behaviour. The behaviour of the adhesive is therefore critical to the overall performance of the structure. The collaboration between the adhesive and glass blocks is thus of utmost importance, working for the stability and strength. Rigid adhesives are thus, necessary to accomplish this bond strength. This means acrylates or epoxies can be used. In the choice of an adhesive, also the creep behaviour has to be taken into account, as it has a big influence in the dimensional tolerances, stiffness, strength and performance over time. On both projects transparent adhesives were used to get the most transparency, additionally UV curing for both projects. In the case of Atocha memorial, borosilicate blocks were used because of the big difference of temperature in Madrid throughout the year. Borosilicate glass is also much faster to produce than Soda lime glass (see previous chapters) due to the annealing time which in the first, is much faster. This project also used the geometry (elliptical) for the overall stability while the Crystal house used buttresses to support the main wall horizontally (Oikonomopoulou *et al.*, 2018). A big disadvantage of this system for both projects is the inability of the glue to take care of the construction tolerances, resulting in a very meticulous, challenge to assemble structure, requiring very demanding logistics. Furthermore, it's irreversible and makes the replacement of a block difficult. The recycling or reuse of the glass blocks is also a problem due to the adhesive contamination (Oikonomopoulou, 2019). The use of adhesive can also trigger crack propagation, which for glass can be a big risk (of collapsing the whole structure) (Dimas, 2020).

The 3rd system, the interlocking, not yet validated in construction, has been researched already in various research studies and diverse geometries. The stability is acquired by the total weight (compression) in combination with the blocks' interlocking geometry that provide constraints against lateral movement. Instead of relying on an adhesive to transfer shear stress, shear locks can be designed where the shear transfer is needed. To prevent stress concentrations between glass elements, a transparent foil (or interlayer) is placed between the units. This dry assembled construction circumvents the use of glue and alternatively uses this interlayer (intermediate medium) which takes care, additionally, and compensates for the inevitable dimensional tolerances. This results in a structure with no or minimum auxiliary metal support, allows an easy assembly, demountability, circular use of glass by recycling and reusing. Organic shapes, with rounded geometry and equal mass distribution is favoured rather than rectangular sharp ones, to prevent the concentration of residual stresses during annealing which can occur due to inhomogeneous shrinkage. Equal cross section area throughout the unit allows it to gradually cool down uniformly. Limited

volume or mass is also preferred because of the annealing time needed and otherwise, financially unaffordable. Numerical results have shown that geometrical factors like the amplitude and element height have a significant influence on the type of mechanical failure mechanism and performance on the ultimate carrying capacity in shear. This system tackles the limitations of the previous and offers an alternative which has yet to be validated in practice.

Other conclusions can be drawn from studies like the lower bending rigidity than a monolithic system because of the blocks acting independently and not being bonded to each other and can rotate under bending which continuously diminishes the contact area in the course of loading (Dyskin, Estrin and Pasternak, 2019). In this case the shear locks also help to keep the units in place and act against delamination, at blocks interfaces, or a constraining structure, can also help in that sense. The soft interlayer between units gives extra compliance and ductility which for brittle materials such as glass is very important. This system if topological interlocked has furthermore, a high tolerance to local failure (Oikonomopoulou, 2019). In research it is proved that the percolation of 25% of the blocks is allowed until it reaches collapse (Dyskin, Estrin and Pasternak, 2019). Blocks follow a concave convex geometry which allows them to establish a self-lock whilst remaining free of stress concentrations. In plane and out of plane movement is in this way, prevented by its neighbours without the need of connectors or glue (binders) (Oikonomopoulou, 2019). Another feature of this system is, the enabling of some restricted movements of the units relative to each other. This is very important and useful in earthquake prone areas, in which the vibration energy is dissipated due to the friction between the moving surfaces avoiding cracking. The most promising form type of Lego like elements are the Osteomorphic units type A and B used in studies (see Fig. 13). By comparing them (on Table 5), these shapes offer the highest shear capacity by restraining movement in two perpendicular directions, the self-alignment capacity is very high too, by its concave, convex shapes, the equal mass distribution is effective allowing a homogeneous annealing and less probability of inhomogeneous shrinkage. The limited number of units which facilitates in the logistics, manufacturing and assembling is also another good feature. Together with the symmetry of the blocks, for type B in both directions eases the possibilities and flexibility in construction. For instance the units can be used in corners, columns or double layers. That symmetry promotes, furthermore the centric load bearing capacity avoiding excessive bending moment stresses.

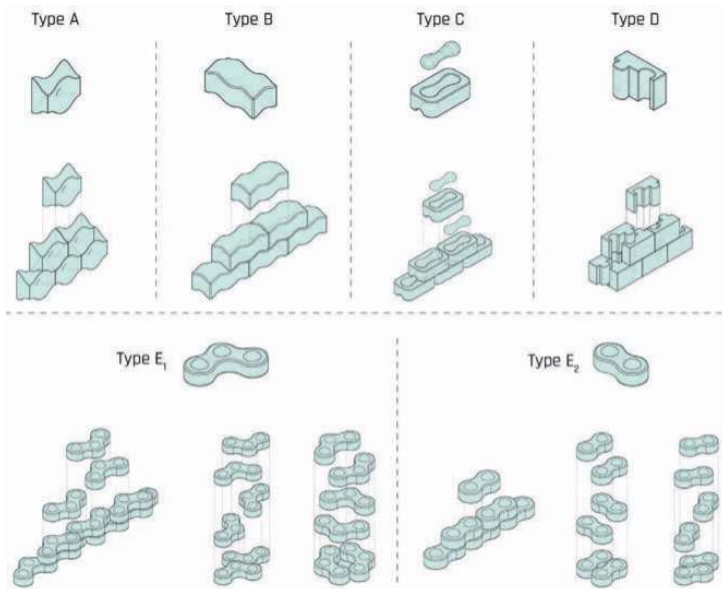

Figure 12- Comparison of different types of interlocking blocks retrieved from (Oikonomopoulou, 2019)





Block type	A	B	C	D	E
					
Interlocking mechanism	smooth curves	smooth curves	male and female blocks	sliding blocks – intense curves	semi-sphere keys for vertical stacking – ability to rotate
Shear capacity	high	high	moderate	moderate	moderate to high
Self-alignment	high	high	high	low	high
Multifunctionality	high	high	moderate	moderate	high
Equal mass distribution/ homogeneous annealing	effective	effective	risk of internal residual stresses	risk of internal residual stresses	effective
Lim. number of dif. units/Ease of assembly	high	high	moderate	moderate	high

Table 5- Comparison table of the different types of interlocking blocks researched retrieved from (Oikonomopoulou, 2019)

2.1.6 Cast glass strength

As stated before, glass is a brittle material. Its strength value, especially when considering for structural purposes, is not a standard value, it should, for that reason, be tested, in order to get more reliable values. In theory, the strength of the typical silica glass (Young's modulus is $E = 70 \text{ GPa}$; fracture surface energy $\gamma = 3 \text{ Jm}^{-2}$; equilibrium spacing of the atoms $r_0 = 0.2 \text{ nm}$) amounts 32 GPa (Oikonomopoulou, 2019) retrieved from (Shelby, 2005), see Table 6 for more information). This value is however, not relevant in practice because of the randomly distributed flaws (the Griffith flaws, see previous chapters), usually present on the surface

that open in tension. According to NEN2608 (the Eurocode meant to be which is not yet regulated), the recommended characteristic bending strength of float glass is 45 MPa (tension in bending is prevalent). As mentioned in previous chapters, the strength of glass is not only influenced by the components and recipe (raw materials) used in the manufacturing, but also the greater the surface the greater chance of inaccuracies. Most of the flaws are on the surface and the edges due to manufacturing, processing, handling and use. When the flaw starts in those areas, the rapid progression (see Fig. 14), owing to the fact, that glass cannot flow and all atoms are blocked from acting plastically and deforming (van der Velden and Nijse, 2019), the flaw grows (cracking) until the whole structure loses its coherence and breaks in many pieces. Those flaws open in tension, and compression is usually not prevalent, even though glass is very good on the 2nd. According to F. Oikonomopoulou, the value of cast glass is comparable with the recommended values by NEN2608 for annealed glass (Oikonomopoulou, 2019). There are however few studies and scarce statistical data to judge otherwise, and only a few examples are validated in building. The inherent brittleness of glass, which makes a very unreliable material, and therefore needing much more research, when comparing to other structural materials, and there are also no codes or standards, in order to make the right assumptions in real life.

Although there are not yet enough testing results, to establish statistical relations to the design strength values of cast glass and the manufacturing method is different from float (annealed) glass, meaning that the manufacturing method is less accurate by the lack of standardization and controlled methods (Oikonomopoulou, 2019) (see previous chapters), some comparison can be made in order to form some assumptions. By comparing annealed glass and cast glass, the 2nd is usually smaller in surface (by comparing cast glass units that are similar in dimension to masonry blocks) and the chance that a flaw occurs is less (inverse scale effect, (Oikonomopoulou, 2019) and (Louter, 2011)). The 3d shape, robustness of its mass (more compact) and the fact that cast glass elements can tolerate more loads (buckling, bending and horizontal loads) without breaking, give a clear advantage in comparison to float glass panels which act in 2d (slender, ratio of thickness related to surface area) and its thickness is very vulnerable to the brittleness of glass (the opening in tension of the flaws). The cast glass units take more advantage of the full potency of glass as a compression structural material. Its 3d shape can bear much more buckling and horizontal loads and can tolerate, additionally, more flaws and prevent the progressive cracking to its parents, being the failure constrained to the unit and not the whole structural wall (depending also on the structural assembly). Glued cast units behave more monolithic than interlocked dry fixed elements. For this thesis, some studies will be used and some assumptions based on the 'real' calculations, which are normally applied for 'normal' glass (float, soda lime glass). The interlocked blocks studied by Oikonomopoulou were tested and compared against numerical calculations (Oikonomopoulou, 2019). Although the study was very useful for these type of blocks, and the results give a very good representation about the shear strength and design recommendations, shear is generally not the most prevailing load and it will be hence, only briefly discussed. The results indicate that higher amplitudes are rendering, in principle more stiffness, but they are also more prone to dimensional deviations (caused by peak stresses at areas of insufficient contact) and to induce eccentricity during assembly (Oikonomopoulou, 2019). Oikonomopoulou suggests the osteomorphic interlocked block type B to prevent these setbacks. Such a shape can introduce enhanced "self-alignment properties and extra redundancy in case of failure of

individual locks of the interlocking mechanism” (Oikonomopoulou, 2019). The numerical results showed that blocks with less height have decreased shear capacity and the system’s failure mechanism is altered: a shorter brick is more vulnerable to bending failure, whereas a higher brick is more susceptible to shear failure (by the shear lock failure) (Oikonomopoulou, 2019). It was as well evidenced that an increased amplitude of the interlock is favourable as it leads to an enhanced shear capacity and decreased uplifting effects, as it was furthermore demonstrated by the out-of-plane shear experiments. Higher amplitudes also demand higher precision in the manufacturing whereas the components can reach the failure stress limit at substantially lower deformation (Oikonomopoulou, 2019).

Tests for the Crystal House without the use of an intermediary material show that blocks fail (in tension) at 20-30 MPa although being tested in compression (Oikonomopoulou *et al.*, 2014). From the tests of Bristogianni, (Bristogianni *et al.*, 2020) the recycled pure (single pane) float glass samples have an average flexural strength of 55 MPa. As a general trend, glass samples produced at lower viscosities and from purer (without contamination) cullet (pieces of glass) scored the highest values of flexural strength. It’s also worth mentioning, that in this research Poesia bricks were also tested. Those contain a slightly different formula than soda lime glass, a small amount of K_2O and B_2O_3 and higher Na_2O/CaO ratio with consequently a decreased forming temperature compared to conventional SLS (TL is approximately 980°C, 80-100°C lower than for SLS). Despite the lower E (young’s modulus) it had the highest flexural strength among all tested samples, attributed to the low brittleness. The higher molar volume (V_m) plays here a key role in the reduction of the brittleness, as a more open structure allows more deformation prior to crack initiation, namely, an increasing soda/calcia ratio as well a partial substitution of soda by potash (Bristogianni *et al.*, 2020). By comparing to literature 55MPa is at the low end of the achieved ranges, a much higher strength is expected by higher quality manufacturing and processing. Although the tests are not enough to make statistical recommendations, they provide a good estimate of structural performance of each type. The manufacturing methods, processing and recycling contribute to the low quality of the samples. It’s therefore, wise to assume as conservative results. A value of 45MPa will be used for further calculations according to the NEN2608 for annealed glass. The proposed formula for annealed glass can be also applied for cast glass (without the prestress part used for FT glass):

$$f_{m;t;u;d} = \frac{k_a * k_e * k_{mod} * k_{sp} * f_{g;k}}{\gamma_{m;A}}$$

In this formula:

k_a - factor for surface effect usually taken as 1

k_e - factor for edge quality of pane, for float glass 0,8

k_{mod} - factor depending on the load duration and reference period $k_{mod} = \left(\frac{5}{t}\right)^{\frac{1}{c}}$

k_{sp} - factor for surface structure, taken as 1 for float glass

$f_{g;k}$ - characteristic value of bending tensile strength in N/mm² : 45 N/mm²

$\gamma_{m;A}$ - material factor of glass, 1.8, in all situations, except, when wind load is normative.

Then: $\gamma_{m;A} = 1.6$.

c - is the corrosion factor, typically 16, but can be determined according to NEN 2608 Table 5

t - is the load duration in seconds

Taking the load duration as $t = 15768 * 10^5 s$ (50 years in seconds), considering the own weight as prevalent:

$$k_{\text{mod}} = \left(\frac{5}{50 * 365 * 24 * 3600} \right)^{\frac{1}{16}} = 0.29$$

$$f_{\text{mt;u;d}} = \frac{1 * 0.8 * 0.29 * 1 * 45}{1.8} = 5.8 \text{ MPa}$$

For wind loads, considering $t = 5 s$ (5 seconds):

$$k_{\text{mod}} = \left(\frac{5}{5} \right)^{\frac{1}{16}} = 1$$

$$f_{\text{mt;u;d}} = \frac{1 * 0.8 * 1 * 1 * 45}{1.6} = 22.5 \text{ MPa}$$

By comparing these results to the compression test results, no test scores less than 20 MPa (Oikonomopoulou *et al.*, 2014) and therefore, this design strength values are considered safe.

	Symbol	Units	Soda-lime	Borosilicate glass
Density	ρ	Kg/m ³	2500	2200-2500
(Knoop) Hardness	$HK_{0.1/20}$	GPa	6	4.5-6
Young's modulus	E	GPa	70	60-70
Poisson's ratio	ν	-	0.22-0.24	0.2
Thermal expansion coefficient	α_T	10 ⁻⁶ /K	9	Class 1: 3.1-4 Class 2: 4.1-5 Class 3: 5.1-6
Specific thermal capacity	c_p	J·kg ⁻¹ ·K ⁻¹	720	800

Table 6- Comparison table of the main mechanical and thermal properties of Soda Lime and Borosilicate glass according to EN572-1:2004 (Oikonomopoulou, 2019)

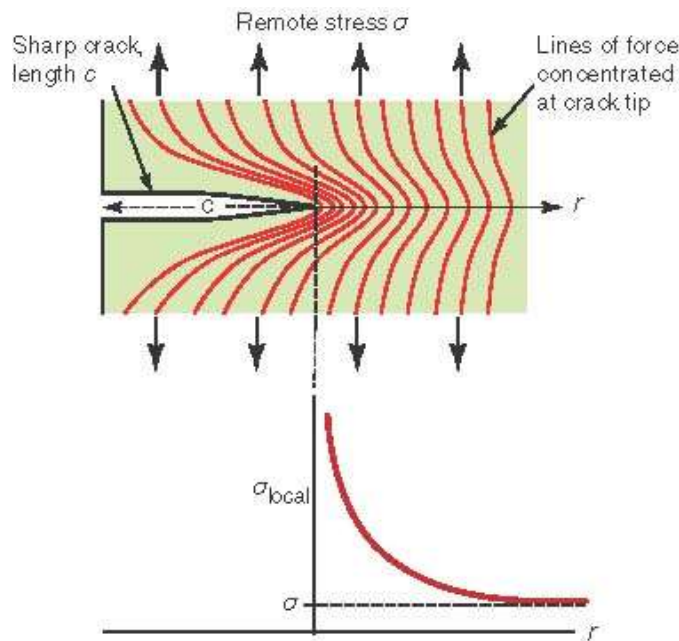

Figure 13- Local peak stresses caused by a crack (Veer, *Structural glass classes 2019*)

2.1.7 Conclusion

Summing up, glass is a very peculiar material. Ambivalent in its features, strong and fragile at the same time. Due to composition (recipe of the raw materials), manufacturing, processing and use it is very prone to flaws which are randomly mostly present in the meso-structure, the surface and edges. These vulnerabilities tend to open in tension when glass is subjected to different loads, since impact, to own weight cause buckling or bending. The crack propagation is a big issue, as glass doesn't give enough time and warning mechanism to repair or replace and avoid injuries. This is a huge problem especially in structures. Strategies are necessary to provide safety and reliability, so important to the structures. Although the composition of glass gives origin to brittleness, it also originates the transparency, a feature so well appreciated by architects. Besides being transparent, by mixing the right metals, different colours can be achieved. Due to its composition, (mostly Soda-lime silica glass) is as well very strong in compression, or else it can take its self-weight and transfer it to the foundation. Its capacity in compression is even better than competing structural materials like concrete, steel and timber. Unfortunately, the failing in tension (originated by the loads) is a big problem as glass can be considered having no resistance against it. Because of this, glass is mostly never considered as a main load carrying structural material but rather diverting the loads to other supporting main structures (usually in steel or concrete). Other materials, have warning mechanisms, steel can yield, deforms in the plastic region and is therefore able to redistribute the loads avoiding an imminent collapse like glass. Reinforced concrete relies on steel to take the tension forces and cracks are usually the first warning mechanism, providing a visual mean to be repaired or replaced. Fortunately, and due to a lot of research and pioneering work, like the one of Rob Nijssse, glass evolved to be a safe material by laminating, heat tempering or both. Glass can now be used in the main structural elements, beams, columns, floors, roofs and walls. Also techniques to transform the glass in 3d elements, like the heat bending or the cast glass bricks came to the forefront as the bright promising engineering masterpieces in glass. The second have already some validated

experience in the form of buildings like the Cristal House which showcased and evidenced first that it was possible to build with cast glass blocks, a completely transparent self-supporting wall made of glass bricks. Secondly, it put forward that by working with adhesives many issues can occur, like the almost impossibility to take care of construction tolerances, meticulous assembly is needed and the inherent high costs of the whole process, also due to lack of standardization. Replacement of the blocks is very difficult and recycling is very laborious and costly, due to the glass contamination with adhesive. A new system (interlocking) is being studied and promising in answer to the setbacks of the adhesive. This lego-like system relies on its stability by a dry-interlayer (a transparent foil) which together with the interlocking geometry transfers by shear (friction) its horizontal loads and prevents stress concentrations by glass to glass contact. The researched forms for the units base its shape in organic forms (osteomorphic) with convex and concave geometry, providing constraints to lateral movement in combination with the total weight (compression). The use of a foil circumvents the use of an adhesive, takes care of the construction tolerances and makes it much easier the assembly (also depending on the number of different types of units). Its demountability, replaceability, recyclability or circular use and reversibility are among the good features besides the high tolerance to failure, restraining the crack in the unit and not spreading to its parents.

To wrap up, some important conclusions/statements can be drawn and used in the design:

- A strength value of 22.5 MPa can be considered a conservative design strength value for design, as most test values and literature indicate values above 50 MPa and even testing without intermediate like for the Crystal Houses, compressive test, which at the end failed in tension indicated a result between 20-30 MPa. In reality a foil or soft material is used as intermediate to avoid direct contact of hard materials with glass (or glass with glass).
- Glass is weak in tension but very strong in compression. By using glass cast blocks in the form of the standard masonry, even better in a Lego-like system (interlocked, osteomorphic) failure is limited to the element and not to the whole structure. By using its own weight, optimizes the use of compression in combination with shear by the interlocks, transferring the horizontal loads and limiting the tension. Besides that the assembly is made easy and replaceable or recyclable.

2.1.8 Case study applications

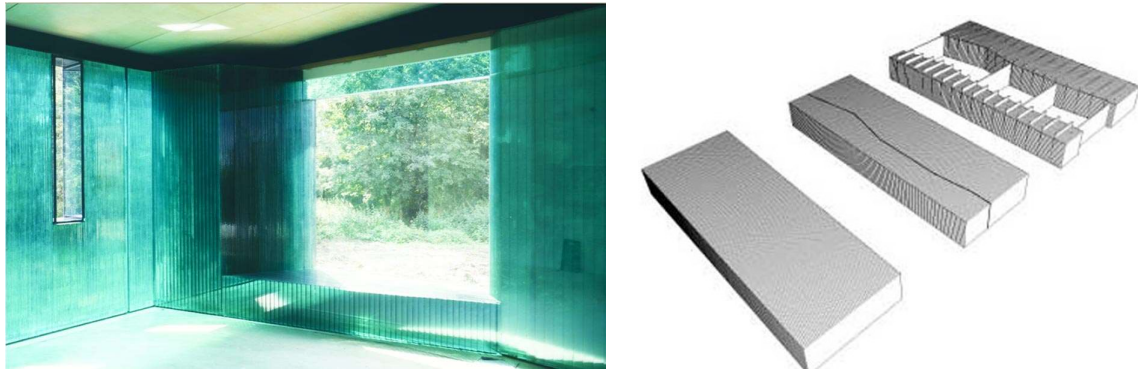

Figure 14- Temporary Laminata house (already demolished), vertical (laminated) stacked glass, Leerdam (Netherlands) retrieved from (Kruunenberg Van der Erve Architecten, 2002)



Figure 15- Left: 'Passagem de luz' (light passage), low iron staked glass, Quinta do Lago Algarve (Portugal), Danny Lane 2009 retrieved from dannylane.co.uk, right: Statue of St Michael in stacked glass in front of St Michael's Church in Zwolle (Netherlands) Herman Lamers, 2010 retrieved from Wikipedia

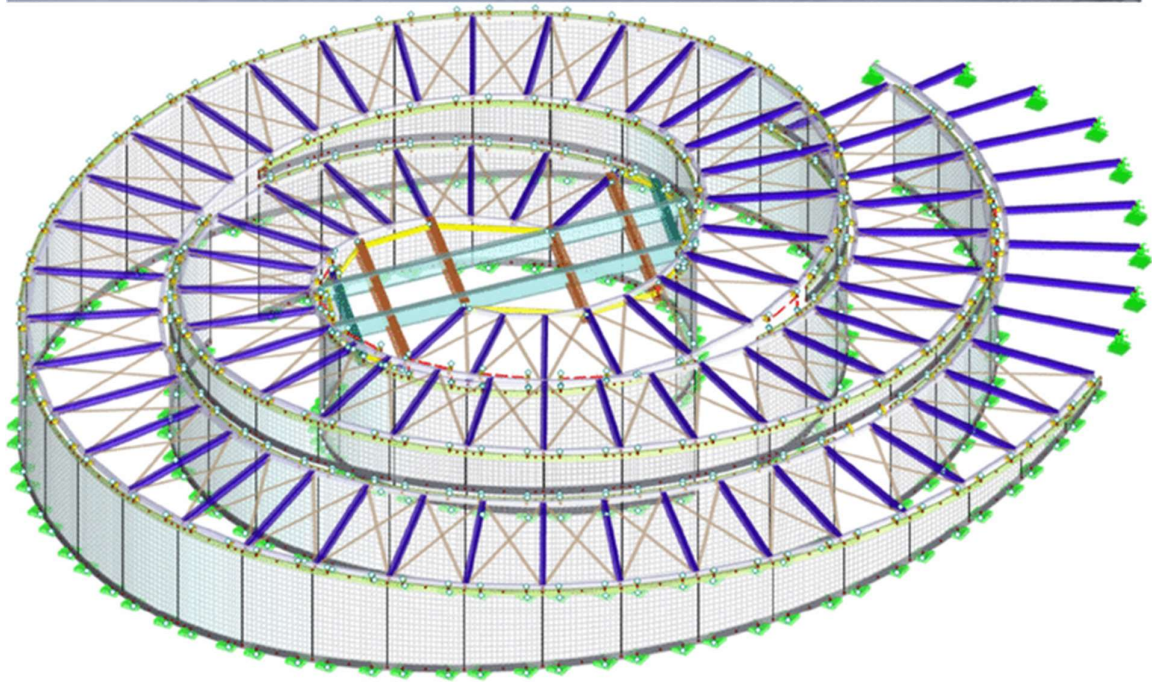

Figure 16- All glass load bearing spiral glass wall of “La maison des fondateurs” (the founders house), BIG architects and Lüchinger + Meyer structural engineers, 2018, Brassus Switzerland retrieved from (VILLIGER ET AL., 2019)



Figure 17- Above: Apple store, Foster+partners and eocengineers, 2017, Chicago, USA, below: All self-supporting glass wall, Steve Jobs pavilion Apple park, Foster+partners and eocengineers 2018, Cupertino California, USA retrieved from dezeen.com



Figure 18- The glass house Santambrogiomilano, 2010, Milan, Italy retrieved from <https://www.santambrogiomilano.com/the-glass-house>

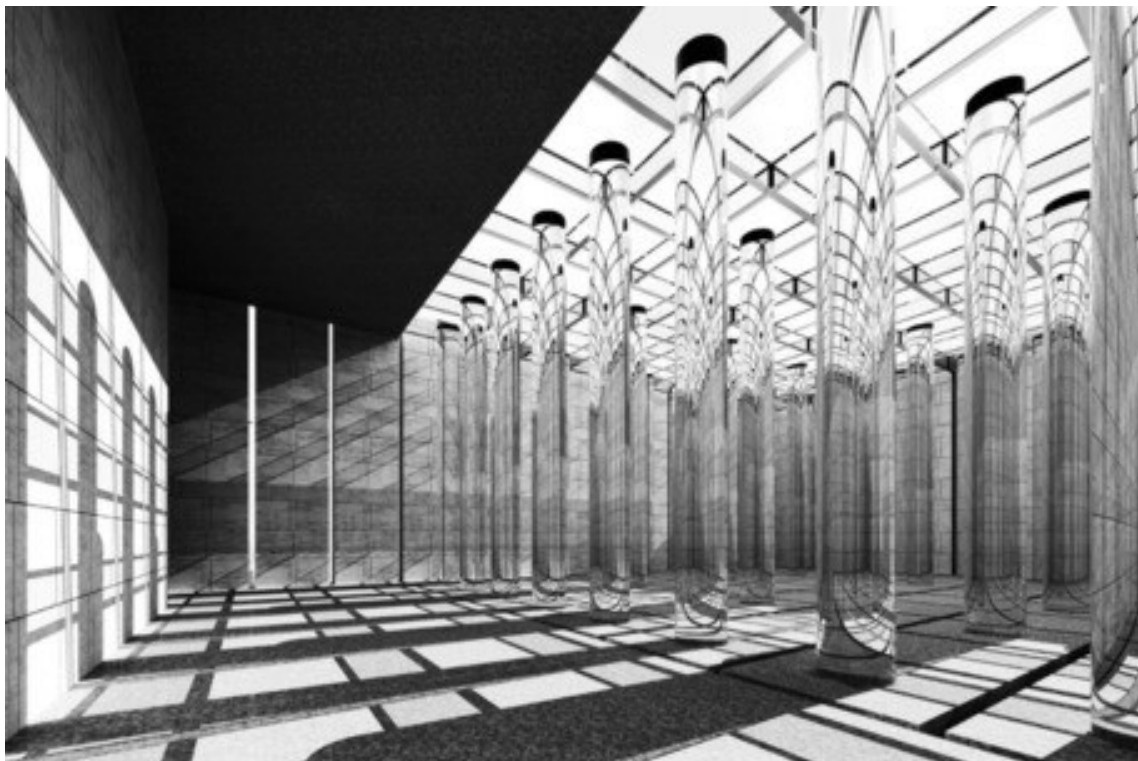

Figure 19- Unrealized glass columns project Danteum by Giuseppe Terragni and Pietro Lingeri in 1938. Source: archeyes.com.

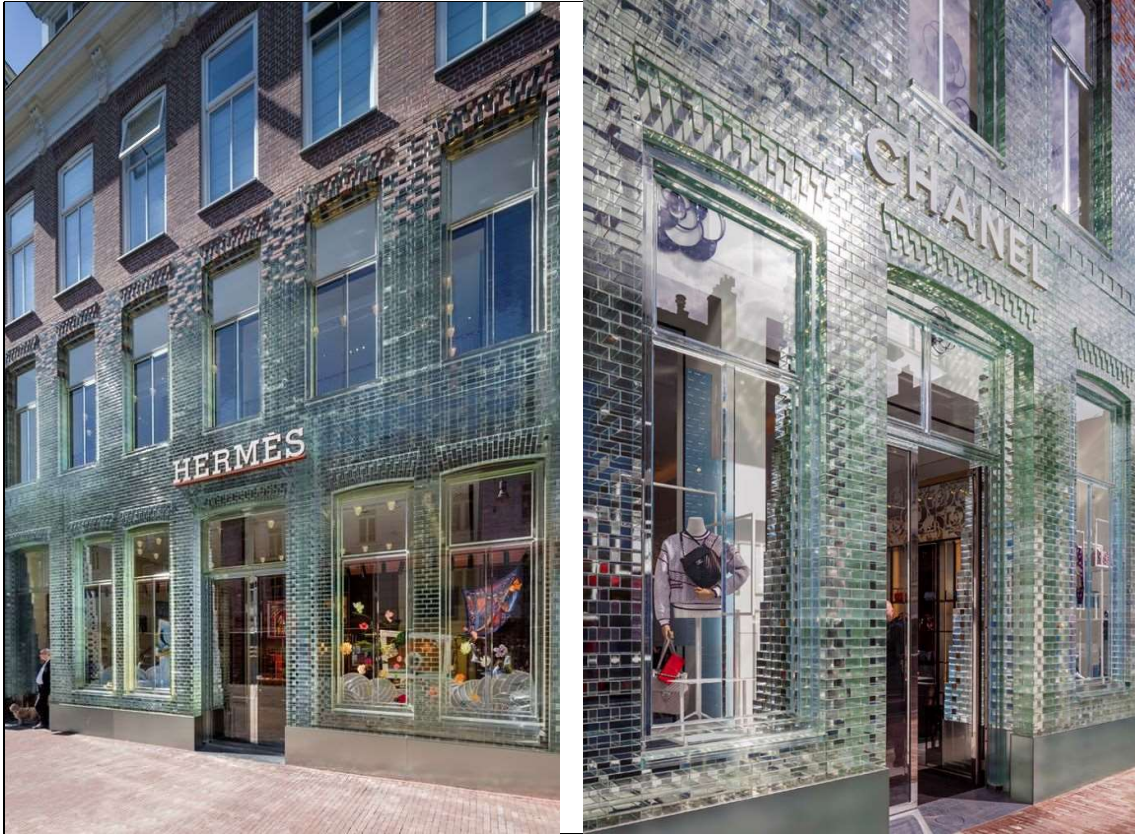

Figure 20- Crystal House made of cast glass bricks, Amsterdam, the Netherlands retrieved from (MVRDV, 2016)

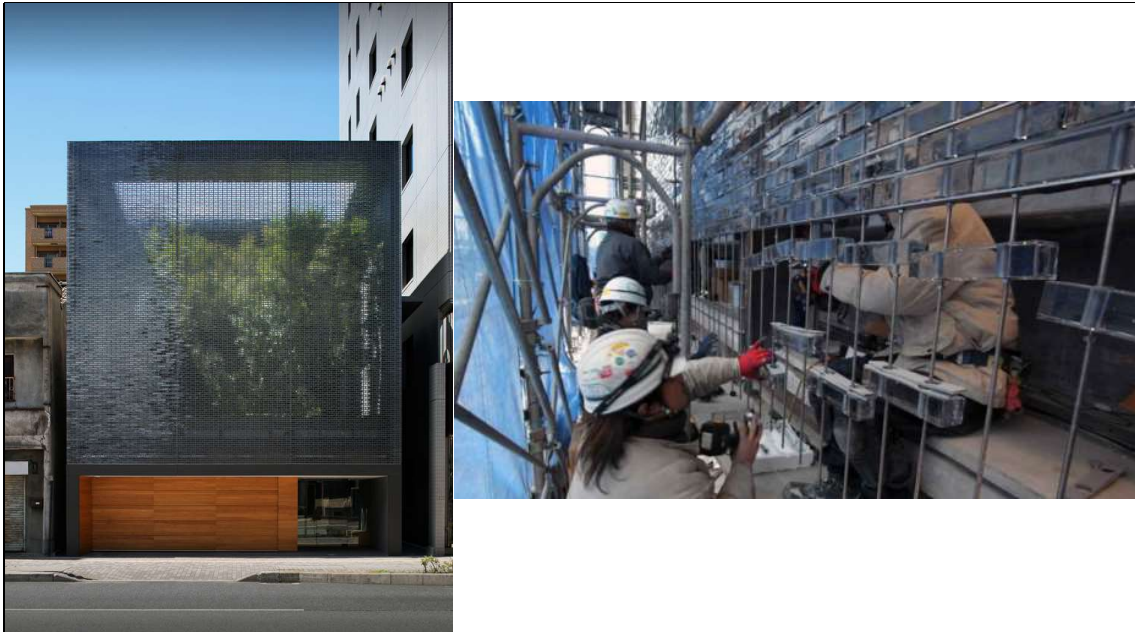

Figure 21- Optical House made of cast glass bricks, Hiroshima, Japan retrieved from (HIROSHI NAKAMURA & NAP, 2012)

2.2 Connections

2.2.1 Introduction

A chapter about connections is introduced, as connections are vital for brittle structural materials like glass. Due to the vulnerabilities of glass, to avoid tension 'issues' and to guarantee no local peak stresses are present, an homogeneous gradual transfer of forces is needed through the connection. In this regard, connections can ensure compatibility between different materials and glass, as glass can't have direct contact with hard materials and additionally to make sure the building and force tolerances/movements are possible. Different types of connections are distinguished and studied according to force transfer. Mostly, the types of connections were derived from other materials like steel (mechanical) and its use for glass was not optimized towards its fragility. Mechanical connections with use of a bore hole and through bolt are the most used type and proved to be quite problematic as peak stresses around the bore hole are an issue for glass and can progress to cracking the whole glass panel. Moreover, this type of connection is only possible if glass is heat tempered. Friction grip connection is an alternative connection to this as by pre-stressing the bolt provides a different type of force transfer and the peak stresses around the bore hole are not an issue, by spreading the forces more evenly, through friction over a much bigger area. Another possible types of connections can be very interesting for glass, as to diminishing the use of a traditional frame to the minimum, like the clamped connections, but its employment is still very restricted, as this type of connections are introduced locally and bring in a moment connection and should be well accounted for in design (Bedon and Santarsiero, 2018) as moment connections tend to attract forces and glass is vulnerable to local peak stresses. A soft plastic interlayer should be implemented to avoid also the direct contact with hard materials. It's applied generally, for balustrades. Other very interesting types of connections are the adhesive connections, very willed by the architects as the use of frame or support material is exempted or minimum. There are several options of structural adhesive connections, with a wide range of mechanical and physical features (Bedon and Santarsiero, 2018), since the most soft (silicones) to the most rigid but brittle like epoxies and acrylates. The strongest adhesives like epoxies are usually applied in a very thin layer and therefore taking few construction tolerances into account. Adhesive connections can be punctual, linear or surface like according to force transfer (Bedon and Santarsiero, 2018) and location of the connection. In general, the applications and due to transparency are UV-cured in one or two component adhesive and applied to corner beam-column or beam to beam (spliced laminations) (Bedon and Santarsiero, 2018).

In linear adhesive connections, (the most traditional) usually the force transfer is made over a long linear surface (Bedon and Santarsiero, 2018). Punctual adhesive are mostly employed to substitute bore hole connections, but as the name says are transmitted over a reduced bonded area and a high mechanical resistant adhesive is desirable (Bedon and Santarsiero, 2018). Adhesive connections have a more complex behaviour specially in long term loads as its resistance to time and creep is not very well known. They're also hence, very vulnerable to temperature, load duration, aging, load conditions, surface preparation, chemical properties of the surface, among others. Advantages of these type of connections are, for instance, the relief of drilling and bore holes, the more even mechanical transfer of forces or mechanical performance as well as their assembly. The first feature, by spreading the forces along the bonded surface, avoids the peak local stresses which are problematic, in the case of the bolted connections. The second, its production is made easier as bore holes are not

needed and the residual stress field distribution due to tempering treatment is unaltered at the connection (Bedon and Santarsiero, 2018). Moreover, due to continuous surfaces and architectural flushness its transparency and optical quality is made very good. Finally, these type of connections can improve thermal performance, thermal bridges and losses are minimized (Bedon and Santarsiero, 2018). A sub-type of adhesive connections with very promising results are the laminated connections which make use of metal inserts to extend the length and properties of glass (splice laminated). Laminating like the standard procedure by using a foil in an autoclave and the standards foils are used, EVA (Ethylene Vinyl Acetate, PVB (Poly Vinyl Butyral) and SG (Sentry glass) (Bedon and Santarsiero, 2018).

TSSA, Transparent Structural Silicon Adhesive is currently being used as a promising system, with the difference to the traditional silicon of enhanced mechanical performance (Bedon and Santarsiero, 2018) , with higher strength and stiffness capabilities. Its applicability is generally for metal-glass connections. Sentry glass adhesive is used like the general laminated (PVB) connections in the form of interlayer and it's transparent, ionomer polymer with very high stiffness (about 100 times stiffer than traditional PVB) and strength (5 times stronger). Other good features are the retaining of transparency of colour and therefore not aging or yellowing over time, it is less temperature dependent than PVB but not constant for all temperatures, higher adhesion to both faces of glass (tin and air), excellent adhesion to metals. Less good features are the quite less affordability in comparison to PVB, cannot be mixed/used with other interlayers and can be difficult to trim when cured.

In this chapter tested glass connections in relation to clay masonry will be discussed and afterwards a conclusion is going to be drawn regarding the best features and possibilities for design.

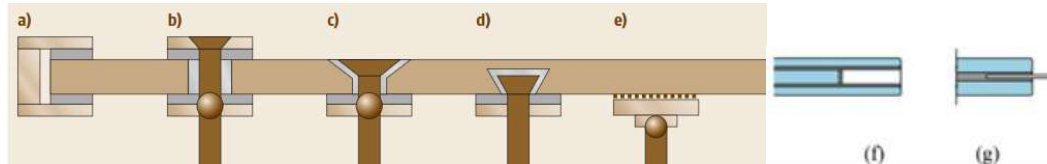

Figure 22- Connection alternatives: (a) clamped, (b) cylindrical hole, (c) conical hole, (d) undercut hole, (e) adhesive bond f) laminated connection embedded with thick insert; g) laminated connection embedded with thin insert retrieved from (Belis et al., 2019) and (Bedon and Santarsiero, 2018)

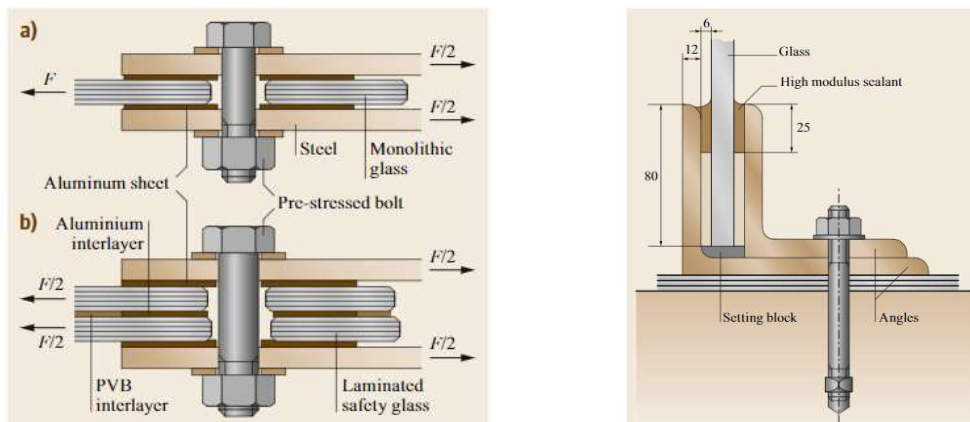

Figure 23- Left: Schematic representation of a friction grip in (a) monolithic or (b) laminated glass. Right: Clamped connection, retrieved from (Belis et al., 2019)

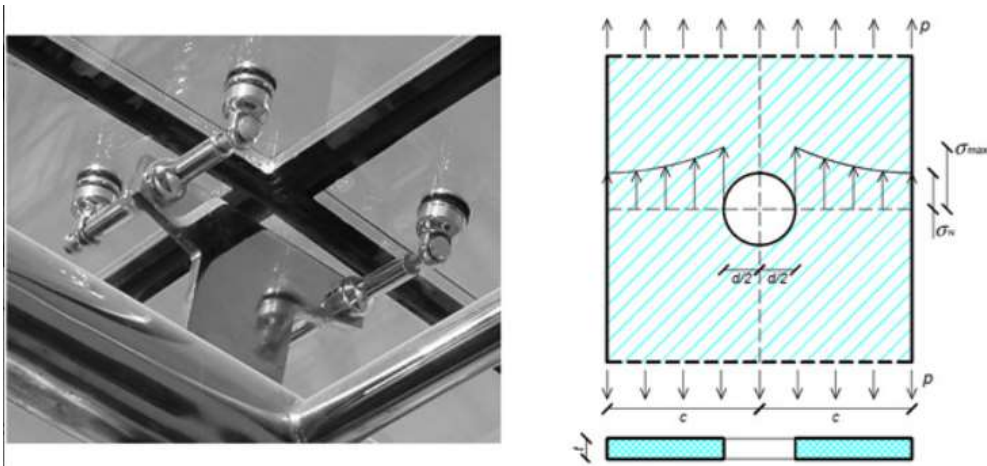

Figure 24- Example of bore hole bolted connections on the left with typical distribution of stresses near holes on the right retrieved from (Bedon and Santarsiero, 2018)

2.2.2 Tested glass connections related to consolidation of historic structures

There are not so many papers about the consolidation of historical materials in decay by a new material, especially considering when talking about glass as a structural material. In that concern, there's only a hand full of examples (see following chapter for examples). Most of structural glass, as described in previous chapter, is used in the form of 1d, 2d plate elements, embodied as beam (fin), column (fin), floor and roof (mostly laminated, heat strengthened). When talking about cast glass, its applicability is even more scarce as there are only a few examples built and not really concerning decaying structures. As the relation/connection of glass and historical materials is very important regarding this thesis, an overview is made with the papers published and afterwards a conclusion is drawn about the most important issues or principles to take into account when designing.

Firstly, a description is made with respect to the paper *"Fill-in-glass Restoration: exploring issues of compatibility for the case of Schaesberg Castle"* (Barou *et al.*, 2020), written about the same case study Schaesberg Castle and the connection of glass to (decaying) clay masonry. In this, two types of adhesive connections, mortar and glues, are tested with a construction of stacked float glass in different directions. A comparison is studied between mortars and glues by testing in shear. Furthermore, the effect of the stacked glass layout direction is researched in order to see the result of the geometry on the mechanical performance.

According to this paper the connection requirements are, in general:

- accommodate thermal/hygric tolerances
- transfer loads between the old and new
- allow for retreatability in the future
- behave as the weakest link between the old and new in order to preserve the historic fabric
- for construction tolerances and movements, a connection thickness between 5 and 30 mm is required

The mortar connection requirements are:

- Paste consistency (suitable for vertical joints)
- Low shrinkage
- Low pH to avoid alkali-silica reaction to glass

The adhesives (glues) connection requirements are:

- Flexible, semi-rigid to allow for large thicknesses
- Medium-high viscosity
- Long setting time
- Weather resistant (UV, moisture, water, salt)

Table 7 exhibits an outline of the main features of the connecting materials. *“Remix Multimortar is a dry multi-purposed cement-based mortar (Class M15), suitable for hollow glass masonries. Remix Flexible Tile Adhesive is an all-round cement-based tile adhesive with polymer additives, suitable for bonding ceramic and stone materials for indoor and outdoor use. Both of these materials have a consistency suitable for vertical joints. Three different types of glues are chosen, depending on their properties and base technology. Tec 7 is an MS Polymer-based, strong and permanently elastic adhesive, suitable for glass. Ottoseal S50 is a silicone-based sealant and Zwaluw Hybriseal 2PS is a high-quality professional sealant based on hybrid technology and suitable for bonding glass joints”*(Barou et al., 2020).

Material	Base	Shore Hardness	Young's Modulus	Compressive strength	Tensile Strength	Flexural strength
			MPa	MPa	MPa	MPa
Multimortar (Remix)	Cement	-	-	15.7-17.2	-	3.48-4.7
Flexible tile adhesive (Remix)	Cement and dispersible powder	-	-	20.8-30.4	-	4.63-6.03
Tec7 (Tec7)	MS Polymer	A60	1.72	-	2.6 (after 7 days) 2.8 (after 30 days) 3.1 (after 90 days)	-
Ottoseal S50 (Otto-Chemie)	Silicone	A16	0.5	-	1.6	-
Zwaluw Hybriseal 2PS (Den Braven)	Hybrid	A30	0.65	-	1	-

Table 7- Overview of connections material and mechanical properties (Barou et al., 2020)

Shear tests were carried out in order to evaluate the bonding strength of the above mentioned (table 7) connection alternatives and evidence the potential of this binding system. *“In total five different connecting materials are tested: two cement-based materials and three types of glues. The aim of this first experimental program is to observe the:*

- *failure mode of the joint; specifically whether it results in damage to the brick, which represents the historic material*
- *effect of the edge geometry of the glass assembly (straight compared to saw-tooth pattern)*
- *effect of different orientation of the stacked glass assembly (horizontal or vertical stacking)”*(Barou et al., 2020)

In this research the testing samples show favourable failure modes, meaning that neither the glass or the existent (clay) masonry are affected but the connection which works as the weakest link (Barou *et al.*, 2020). As result, *“the mortar and tile adhesive failed in a brittle way, whereas all adhesives (glues) exhibiting significant deformation capacity and the ductile behaviour of the joint. For the mortar and tile adhesive, failure mostly occurs by delamination of the glass, which indicates the weak adherence bond to the non-porous glass surface. Most of the adhesives (glues) show the opposite result; failure occurs either by cohesion or by delamination of the brick”* (Barou *et al.*, 2020).

Two cement-based materials and three types of glues were tested in shear with the aim to access the mechanical performance of this type of connection. Although the tested specimens are not enough to make a statistical evaluation and cannot be considered conclusive for establishing mechanical properties, a first indication is drawn of the performance of such system and can be employed as starting point for future application. According to the results some conclusions can be made:

- *“All connecting materials exhibit acceptable failure modes that do not result in damaging the historic substructure.*
- *Specimens bonded with Tec7 demonstrate the highest shear bond between glass and clay brick, as the most rigid glue. Both mortar and tile adhesive show consistently lower shear strength compared to all types of glues.*
- *The orientation of the stacked glass elements can influence the shear capacity and ductility of joints with brittle connecting materials, showing potential for cases where shear loading parallel to the stacking plane is dominant (e.g. wind load acting on a horizontally stacked glass assembly).*
- *The saw-tooth pattern as edge geometry of the glass component is favourable to mortars and tile adhesives and has negative effect on glues.*
- *The joint thickness fluctuations that occur in the interface due to the geometry of the stacked glass assembly can be better tackled using connecting materials with high stiffness (mortars, tile adhesives) rather than flexible glues.*
- *Polymer additives are crucial to the shear performance of mortar joints as they increase not only their strength, but also their adherence to the glass surface”* (Barou *et al.*, 2020).

Concerning these findings some things have to be taken into account:

- Adhesive glued connections are a very promising solution and exhibit a very good failure more with a ductile behaviour and deformation capacity and therefore a visual mean to be able to repair it on time, but maintenance and future repair are quite challenging to account for in future restoration interventions
- Mortars in contrast are quite easy to maintain, the challenging in this remain, is the poor adhesion of mortar to the glass surface. Mortars offer in general also more room to construction tolerances, as the thickness of the connection is usually bigger than in the case of glued adhesive connections. (Barou *et al.*, 2020)

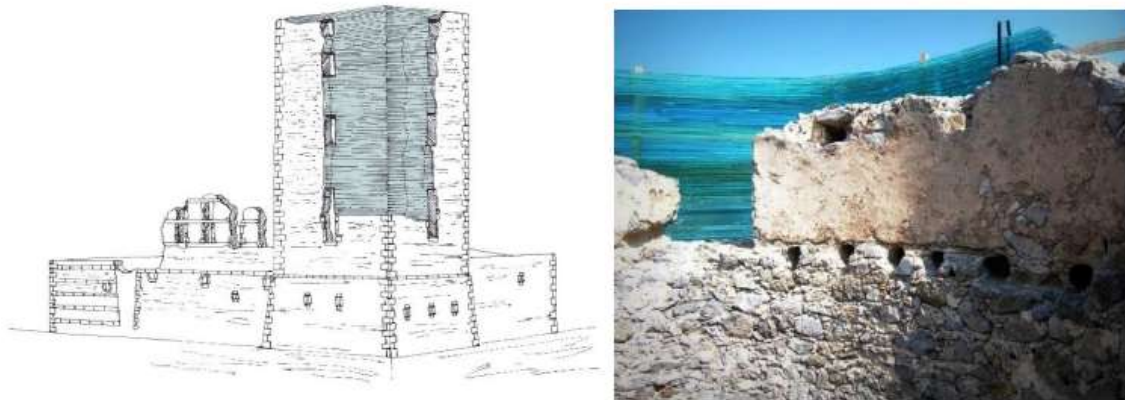

Figure 25- Left: overview of the design concept for the case-study Schaesberg Castle, right: horizontal stacked glass example used in the restoration of a historic flourmill designed by the artist C.Varotsos retrieved from (Barou et al., 2020)

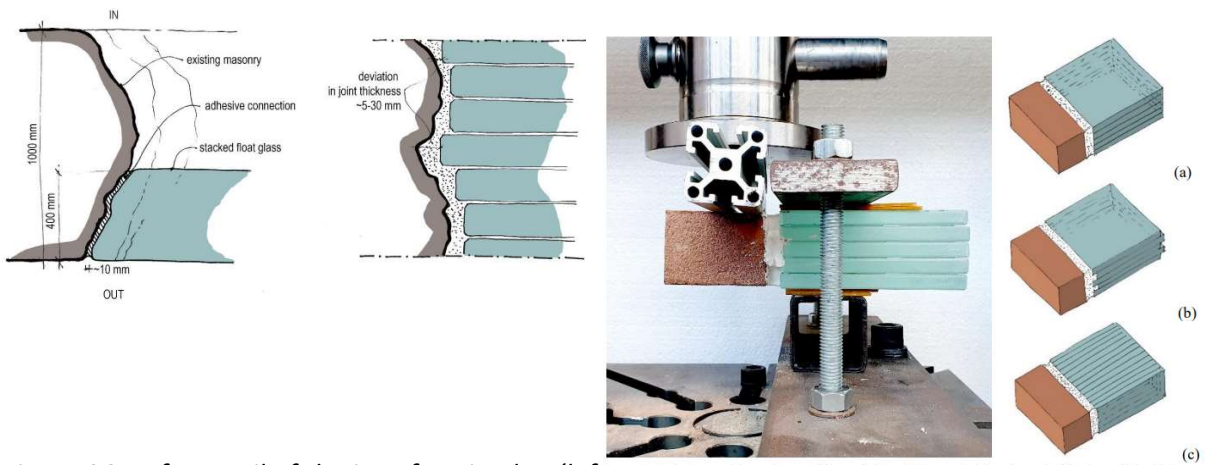

Figure 26- Left: Detail of the interface in plan (left) and section (right). On the most right: Set-up 1 in testing machine: (a) Set-up 1 (glass is stacked horizontally), (b) Set-up 2 (glass is stacked horizontally in a saw-tooth pattern), (c) Set-up 3 (glass is stacked vertically) retrieved from (Barou et al., 2020)

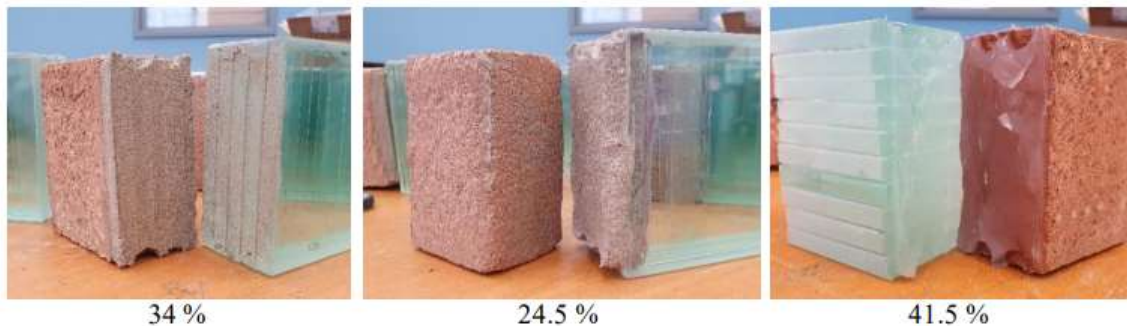

Figure 27- Left: Adhesion to glass, middle: Adhesion to brick, right: Cohesive failure retrieved from (Barou et al., 2020)

Material	Set-up	F_{max}	DI at F_{max}	Nominal shear stress τ_{max}	Prevailing failure mode
	#	N	mm	MPa	
Multimortar (Remix)	1	209.25	0.34	0.05	Adhesion to glass
	2	1146.66	1.31	0.15	Adhesion to brick, adhesion to glass, cohesion
	3 ^a	0	0	0	-
Flexible tile adhesive (Remix)	1 ^b	490.29	1.44	0.12	Adhesion to glass
	2 ^c	1683.56	3.71	0.23	Adhesion to glass, cohesion
Tec7 (Tec7)	3	1209.82	2.56	0.27	Adhesion to glass
	1	1986.43	10.99	0.47	Adhesion to brick
	2	1377.89	7.62	0.17	Adhesion to glass, cohesion
Ottoseal S50 (Otto-Chemie)	3	1963.59	11.0	0.47	Adhesion to brick
	1	527.17	13	0.36	Cohesion
	2	1172	11.11	0.14	Cohesion
Zwaluw	3	1540.33	12.30	0.37	Cohesion
	1	1603.34	15.90	0.38	Adhesion to brick
Hybriseal 2PS (Den Braven)	2	1026.87	12.90	0.13	Adhesion to glass, cohesion
	3	1706.40	16.63	0.39	Adhesion to brick, cohesion

^a specimens disintegrated during fixture to the machine

^b results from two specimens; the third is considered unreliable due to rotation of the set-up

^c results from a single specimen; the other two are considered unreliable due to rotation of the set-up

Table 8: Overview of the shear tests (Barou et al., 2020)

The second paper from 2016 focuses also on the connection of glass and historical masonry. Several possibilities are tested including Tech 7 (Ms polymer adhesive) used also in the previous, more recent research. A full scale model was tested with three different layouts of float and cast glass. The first was a hollow float glass in which the connection surface was minimal, the second a hourglass shape made of stacked vertical float glass layers, the third a cast glass imitating the shape or the standard clay masonry blocks.

The requirements of the glass addition and connection according to (Oikonomopoulou et al., 2016):

- *“being respectful to and preserving the aesthetic and historic value of the building by being minimally intrusive.*
- *ensuring reversibility by connections that do not adversely affect the original monument and can be removed without causing additional damage.*
- *structurally repairing the cracked wall and protecting it from further degradation by attaining a coherent system, with good interaction and collaboration between the original and added structure.*
- *activating warning mechanisms in case of failure to prevent the monument from further damage” by having a connection as the weakest link.*

Two types of adhesives were tested in shear, a rigid epoxy (Araldite 2013) and semi-rigid modified polymers (Tec7 Brown, Sabatack 780 and MD-MS polymer). (Oikonomopoulou et al., 2016). Tec7 was selected as the most promising connection and employed in the full scale 3 point bending full scale testing. Although the study cannot be used for statistical purposes and be used as conclusive for mechanical properties some aspects can be highlight:

- *“The glass addition is much stiffer and stronger than the (decayed) masonry. Therefore it is important that the adhesive connection is designed as the weakest link to prevent the brittle failure of the historic masonry.*

- *Float glass is considered more applicable for the glass restoration scheme as it allows for more freedom in shapes and can account for dimensional tolerances.*
- *In the case of specimens 1 and 3, cracks initiated at the mortar or the masonry due to support reactions before a visible deformation of the adhesive. Still, the adhesive connection was strong enough to hold the specimen together and elastic enough to absorb the deformations created in the masonry. Only after a considerable load increase and visible deformation did the adhesive connection fail, leading to the complete detachment of the damaged part of the masonry. In reality, such cracks may occur to the masonry and it is important that the adhesive can hold the pieces together until the cracks can be fixed. Yet the failure of the masonry at its tensile zone indicates that a new experimental set-up is needed with support reactions that simulate a wall condition in order to derive consistent results.*
- *Specimen 2 failed in the most favourable way. First, the adhesive connection gave a warning by visibly deforming before failing by adhesion to glass in a load much higher than the other two specimens. This higher load can be attributed to the absence of any cracks in the masonry as well as to the maximized connection surface between the two structures. The latter leads to a uniform transfer of stresses within the construction. In addition, by reducing the mass towards its centre, the glass intervention becomes lighter, yet stiff enough to ensure the overall stability of the component. This design seems to be the most promising for further development” (Oikonomopoulou et al., 2016).*

On the table (9) below the results are summarized:

Spec. No.	Weight of glass kg	Connection surface mm ²	F _{max} kN	DI at F _{max} mm	Failure mode
1 (float)	24.31	7560	43.0	41.3	Crack in masonry
2 (float)	38.60	13290	68.1	22.7	Failure of connection
3 (cast)	35.56	11025	44.6	18.7	Crack in mortar

Table 9: summarizing of the results of the testing and failure modes retrieved from (Oikonomopoulou et al., 2016)

2.2.3 Conclusion

Three alternative adhesive connections were tested, mortar (dry multi-purposed cement-based), tile adhesive (all-round cement-based tile adhesive with polymer additives) and glues (semi-rigid modified polymers, Tec7, Sabatack 780 and MD-MS polymer, silicone-based sealant Ottoseal S50 and Zwaluw Hybriseal 2PS a high-quality professional sealant based on hybrid technology). In both studies Tec 7 adhesive was tested and with the best results, showing deformation capacity, ductility of the connection and therefore a warning mechanism to allow repairing before collapse. Tec7 had the highest shear bond between glass and clay masonry. It was tested with different layouts and orientations with float and cast glass (in the 2nd study). Overall the results were very promising but in the second study wherein a full-scale testing was done only using Tec 7, the failure modes were different and not conclusive for statistical data and therefore more studies are needed. In the case of hourglass vertical stacked glass, the outcome was the best, owing to the maximized connection surface and the most uniform transfer of stresses within the structure (Oikonomopoulou *et al.*, 2016). The cast glass sample had lack of flexibility regarding the irregular setting of the connection, also adhesive, due to its smaller thickness is less suited to resolve construction tolerances and movements. In general adhesives are a very good solution, in specific Tec7, exhibiting a very good failure mode, ductile behaviour and deformation capacity, providing a visual mean to be able to repair it on time, but maintenance and future repair are quite challenging and also less reversible. Mortars, in contrast are easier to maintain and due to its general bigger thickness offer more room to construction tolerances but perform worse in shear strength and adhesion to glass than Tec7. Concerning the type of assembly of glass, generally, float glass attained better results than cast glass, because of its flexibility in producing it in multiple shapes and additionally in the shape to optimize the connection surface (hourglass) and allow more even transfer of stresses. The saw-tooth pattern is quite useful in order to adapt to irregular connection thickness but mortars are better than glues adapting better to surface asperities. Both studies were more focused on stacked float glass assemblies connected to masonry, and therefore are not conclusive about the effect of cast glass instead. Also the effect of the interlocking cast glass was never tested in connection to existent clay masonry. About the connection principle, what becomes evident is that glass is much stiffer than the existent (decayed) clay masonry, also due to the weak state of the mortar, and in order for glass to reinforce this existent structure, the connection should behave as the weakest link, with deformation capacity in such a way to give warning and allow for repairing and not overload the decaying structure. The connection should furthermore be strong enough to hold the pieces together in case of cracking and flexible enough to allow for construction tolerances and structural movements.

2.3 Restoration theory

2.3.1 Introduction. Why to preserve/restore?

Built heritage is the set of *“physical structures inherited from the past that are publicly recognized as irreplaceable socio-cultural resources in the present. It is the combination of matter and meaning that makes the heritage buildings especially worthy of passing on to next generations”* (Barou et al., 2018b). Historical buildings are therefore, part of our cultural built heritage. They figure a travel in time to our ancestries, testifying their habits, architecture and technologies, a link to the past showing the strata of different eras, defining our tangible cultural identity as society which we seek to protect and enhance for future generations to witness. By protecting/preserving the history, the traces of our cultural societal and architectural biography are therefore, recorded for our posterity to testify.

There are different ways in order to deal with the built heritage, in how far we are intervening in the building (Stanley Price, 2009), do we have enough documentation to help in that process? ‘When should such excavated and incomplete buildings be reconstructed to a state similar to how they might once have appeared?’ (Stanley Price, 2009)

What are the widely accepted principles regarding preservation/restoration?

In order to answer these questions an overview of the historical background is put in context and subsequently the design guidelines are derived.

2.3.2 The origin of the modern restoration principles

How did the main restoration principles come about? The modern conservation movement. Preservation or Restoration?

Historical background

The care and awareness for the built heritage has given way to the modern architectural conservation movement with ideas going back to the enlightenment of the French Revolution. The wish to take control of history and the fast pace of innovations brought by the Industrial Revolution, the capitalist society and massive construction as ideal of progress, meant a whole destruction of the historical setting and a growing awareness of the protection of the built heritage as reaction, calling for a civic movement to counteract this loss (Kuipers and de Jonge, 2017).

Although conservation has been done since medieval times, this awareness, as a set of tangent and in-tangent values intrinsic to our cultural identity worth to pass on to generations to witness, the modern conservation movement was just fully acknowledged in the 19th century (van Hees, 2017) .

Two main views debated the architectural conservation movement during this century. One in which John Ruskin and William Morris, the main voice of the Arts and Crafts movement, more expressively defended the Anti-restoration (or conservation) perspective in which John Ruskin’s ‘ethical view’ valued the traditional crafts and the preservation of the old traces and authentic materials, and the other the ‘Restoration’ view by Viollet-le-Duc (in France) and Pierre Cuypers (in the Netherlands) which sought to reinstate the “former beauty” (Kuipers and de Jonge, 2017). These two conflicting perspectives had a different understanding of authenticity: on one side the ‘Anti-Restoration’ movement defended the preservation and maintenance when possible in which authenticity was the preservation of the historical layers and the ‘patina’ of the age rather than the return to its “original state”, an idealized style as it was perceived by Viollet-le-Duc by filling in the missing elements, recreating parts,

to fulfil an idealized image of completeness of a historic situation that “perhaps never had existed”.

The restoration perspective defended an “idealistic authenticity”, rather creating something new than protecting the old. (Kuipers and de Jonge, 2017)

This Conservation movement as opposed to Restoration proved to be unpractical, as any historical building to be kept and preserved as heritage should remain in use as a ‘living monument’ and that “would require some degree of adaptation to practical needs” (Kuipers and de Jonge, 2017). Some more modern approaches of the Conservation movement like the one of the Austrian Alois Riegl, characterized the built heritage as a layered qualitative set of values. According to these values one should know how to deal with the built heritage and how to proceed with its conservation intervention (Kuipers and de Jonge, 2017). A decision could be to let the ruined building decay to keep the age value and the patina of the age with the consequence that the building would continue to fall apart and finally crumble (Kuipers and de Jonge, 2017). According to Riegl, “any act of conservation is somehow a compromise between, on one hand the ideal of maintaining the historic ‘truth’ of material authenticity of the historic form and fabric as far as possible, and on the other hand the inevitable need to adapt technical and/or aesthetical performance to current needs to keep a building in daily use” (Kuipers and de Jonge, 2017). He added the use value to the concept of conservation of William Morris and John Ruskin arguing that a building would be better maintained if it stays in use, or reusing (adaptive reuse), introducing a practical characteristic that their concept was missing. Camillo Boito (1836-1914) was a critic of both movements comparing Viollet-le-Duc approach to John Ruskin issuing a paper: “Questioni pratiche di belle arti, restauri, concorsi, legislazione, professione, insegnamento”(Fine arts practical issues, restorations, competitions, legislation, profession, teaching) in which he gives practical guidelines for the restoration of historic buildings. He argued Ruskin’s view of preferring decay of the building instead of restoration, defending that each case should be evaluated individually, and opposed to Viollet-le-Duc approach fearing that the authenticity of the material/building could be lost. He presented eight principles to restore a building in which he defends that a monument should be consolidated rather than repaired, and repaired rather than restored. Also about adaptive reuse he suggests diverse ways how to deal with additions or alterations to historic buildings. His principles would leave an important legacy.

With the 20th century, new challenges arose with the two big wars and the inherent massive destruction of historical sites, calling for new ways to deal with the problem.

The Athens charter (1933) was the first international congress that strived to achieve some general international guidelines and recommendations for preservation, conservation and restoration to tackle the problem of the 1st world war destruction and the protection of the cultural heritage. The influence of the anti-restoration movement like William Morris, John Ruskin, Alois Riegl and Camillo Boito was decisive to this charter and onwards in which the conservation of the built heritage would be favoured, where possible, in detriment to the restoration, the intervention should be minimal as in contrast to the ‘stylist’ restoration of Viollet-le-Duc. The Athens charter laid the basis and pathed the way to the Venice Charter which was and still is the 20th century most important Charter (1964) for the conservation and restoration of monuments and sites.

When Giulio Carlo Argan and Cesare Brandi created the Istituto Centrale del Restauro in 1939 (ICR), the restoration acquires a scientific and technical competence character, definitely moving away from the empirical action and personal taste. In addition to the

emphasis on the physical-technical aspects of restoration, embedded with a kind of ideological and philosophical revolution, Brandi pushes it away from the empiricism and artisanal work transforming it into a critical instrument intertwined with theory, practice and didactic and interdisciplinary activities. During the 50's Brandi organized a series of courses in which future important names of the Italian modern architecture movement participated, such as Carlo Scarpa, Franco Albini e Franco Minissi. This modifying intervention, carefully and minimally invasive, demands criteria and principles that guide the restoration both on their physical (technical problems) and aesthetic and historical specificities. At the ICR, Cesare Brandi formulates a conceptual approach to the treatment of the archaeological repertoire site that rejects the decontextualization of sculptures, frescoes, mosaics and fragments of architectural elements of its intrinsic space proposing its permanence in the original site, that is, its conservation and enjoyment in situ accompanied by an adequate musealization project, instead of moving them to other places of exposure as was the practice until then. The archaeological repertoire revealed in surveys and excavations (for example, the mosaics of the Villa del Casale in Piazza Armerina), are inseparable elements of their remaining tectonic structures and determine their spatiality also in relation to the landscape in which they are inserted (Brendle, 2015).

Venice Charter came as a reaction to the 2nd world war destruction and its principles are still very actual and in use today. This Charter took the principles of the Athens Charter and actualized them to the contemporary needs, like considering for the first time the surrounding (the setting) of the historical building as important to its historical context and creating ICOMOS International Council on Monuments and Sites. This institution was created to grow the awareness and protect the international universally recognized cultural built heritage. Other important points on the Venice Charter was the concept of Authenticity as to keep not only its original state but also all alterations throughout history, "the valid contributions of all periods must be respected" (ICOMOS, 1964); Conservation rather than Restoration and Restoration rather than Reconstruction (van Hees, 2017) or the minimum intervention as possible; Compatibility in the sense that any addition to replace missing parts "must integrate harmoniously with the whole" (ICOMOS, 1964), if the building gets a new function that should be compatible with the "layout or decoration of the building" (Gazzola Piero et al, 1964). Adaptive reuse as in Art. 5 is mentioned that a function is important to give a socially useful purpose and to keep the building preserved (ICOMOS, 1964); any new addition should be "distinguishable from the original so that restoration does not falsify the artistic or historic evidence" (ICOMOS, 1964) so to not create conjecture. Although its very restrictive guidelines against new material interventions Article 10 refers that under specific circumstances to save the historic fabric, modern technology can be used: "Where traditional techniques prove inadequate, the consolidation of a monument can be achieved by the use of any modern technique for conservation and construction, the efficacy of which had been shown by scientific data and proved by experience"(ICOMOS, 1964). There is a clear distinction made between conservation and restoration in which conservation is favoured although restoration and reconstruction can be considered under certain conditions. Reconstruction is understood in the Charter as a new addition, to make the building new which loses its authenticity/ 'patina' of the age. Reconstruction through the use of Anastylis was only allowed in the case of reassembling existing "dismembered parts" and when there is enough historical documentation/evidence to support that (Gazzola Piero et al, 1964).

Since the Venice Charter some developments have been introduced as an actualization to our time like the concept of Reversibility first addressed in the Italian Charter (1972 and updated in 1987) “as a way of not limiting future interventions” (Italian Charter 1972) and its meaning extended on the Karlsruhe conference (Munich) in 1991 organized by SFB315 and ICOMOS. It was latter on improved and made more practical with the concepts of Compatibility and Retreatability, as literal Reversibility appeared almost impossible and unpractical to apply in reality. Compatibility is in the sense that any material used for Conservation/Restoration should behave in a similar way as the original one and not cause more harm to the decayed building and be as durable as possible. Retreatability is the “ability to be repairable” in the future with the least damage to the original material. The concept of Authenticity was dealt in more detail on the Nara document (1994) extending it to cultural diversity (ICOMOS, 1994). Authenticity had already been previously discussed by theoreticians from the anti-restoration movement like William Morris, John Ruskin and Alois Riegl defending that the Authenticity of the building layered history should be kept as to show its “historical truth”, the building visible age or patina and where new elements should be clearly distinguishable from the old, as mentioned in the Venice Charter and not to cause conjecture or “falsify the artistic or historic evidence” (ICOMOS, 1964).

What is also worth saying is that, the Architectural modern movement of the beginning of the XXth century took an approach of cutting with the past which in parallel with the modern restoration movement took the lead in confronting these ideas of preserving the heritage and rather build a new building. That approach brought by also a lot of destruction in the built heritage as the architects believed that the old is obsolete and should be substituted by the new in sometimes disregarding the old traces and incompatible materials or structure that instead of supporting the old building destroyed even more.

2.3.3 How is glass used in restoration?

Some architects like Franco Minissi have done some pioneering work, during the 2nd half of the XXth century, on the restoration of archaeological sites and buildings by using transparent materials such as glass in its interventions. His approach very much influenced by Cesare Brandi (the originator of the ICR institute), the museological approach (Vivio, 2017), sought the new materials as a way to deal with the heritage, to keep the old as it was and use the new techniques and materials to take the best out of the old and not to have conjecture. Unfortunately, due to execution problems, lack of ventilation or maintenance, his view and work was not fully accomplished and understood (Vivio, 2017). Most of his works had to be destroyed or repaired afterwards as consequence. There are though some nice examples such as the Roman Villa del Casale at Piazza Armerina (1958–63) made of plexiglas (poly-methyl-methacrylate) as a protective structure towards the existent (ancient) mosaics. Minissi frequently came up with transparent protections to evoke the contours of the original volume (Vivio, 2017). Other nice example is the Greek Theatre at Heraclea Minoa, Agrigento (Sicily, 1960–63) with a protective intervention also made of plexiglas, the design imitating the form of the original in a transparent way (see Fig. 26) (Vivio, 2017)

2.3.4 Conclusion

Since the end of the XIXth century an ongoing debate went on between restoration and preservation. On one side the conservation movement by John Ruskin and William Morris which sought preserving the existent, with the least possible intervention by retaining and maintaining the old as a stamp of the past with all historical layers and its story of decay enshrined for as long as possible. At the other side (contrarily) the restoration movement (stylistic) by Viollet-le-Duc, with an approach of restoring the old with an idealized, somehow aleatory version of the “former glory” which was often invented, by introducing gothic elements and forms that never existed, aiming to reveal the “true form” (Barou et al., 2018b). The conservation movement laid the basis for what would be considered the principles of modern restoration, later confirmed with the Venice Charter (ICOMOS, 1964). Herewith the importance of authenticity was underlined with respect to the original state of a historical building (as found before any restoration actions) or as the value of a historic structure is translated by all these accumulated layers of history encoded in its decay through time. Any interventions taken should be distinguishable so that to reflect their time and not a falsified interpretation of the original (authentic) building (Barou *et al.*, 2018b). The new addition should be therefore clearly recognizable from the existent so not to have conjecture and retain the authentic old traces with history written in its layers of decay. In the discussion between preserve and restore, Venice Charter is clear, that the intervention should be minimal and always based on the most relevant related information and scientific back up. Restoration or reconstruction, or the putting back of the old pieces, is only agreed upon very few situations, when the old parts are still present by recurring to anastylis in order to preserve the exact shape and material. Restoration can be done if a whole back up (exact) information is present and the new addition is compatible with the existent. Reversibility should not be taken literally and interpreted according to compatibility and retreatability, or the new additions should support and not cause any more problem to the existing one and the materials/structure should be compatible. Retreatability is the future action of replacing the new additions may those not be the most functional or compatible to the ancient structure. So all additions should be placed in a way that they can be removed or replaced in case it’s necessary. About the materiality discussion, new materials are possible and even advised because they are usually more advanced than the existent, from a time in which the construction techniques were much less modern. Glass appears in this discussion as a very good option for restoration interventions, with excellent strength properties such as the compression levels. Due to its transparency allows the ruin to be perceived in its damaged state keeping the identity and at the same time being distinguishable from the original material in a subtle and immaterial way.

To wrap up and in order to take some principles for design:

- Authenticity is important but it shouldn’t be a strict method as authenticity interpretations are very subjective
- Reversibility should also not been taken literally as very strict application are very difficult to put in practice. Reversibility should be taken in the form of compatibility, or the structural material should be compatible and even supporting the decaying structure; retreatability or the intervention made should be possible to replace or repair in the future, in the case is made superfluous or technology dictated better techniques which would function better

- Minimum Intervention: the intervention should be the least interventive as possible and just in case it's needed as to restore the structure or to avoid a collapse as not to destroy the authenticity of time
- Restoration or consolidation is needed when the decaying building is in eminent collapse
- Materiality discussion: in this issue glass and its wonderful strength capacities comes to the foreground as a perfect addition like a reflection of the past, but it should be applied respecting its features and fragilities as well as of the existent material

2.3.5 Case Study applications



Figure 28- Greek Theatre at Heraclea Minoa, Agrigento (Sicily), F. Minissi, 1960–63: Detail of the virtual rendering in Plexiglas of the shape of the tiers retrieved from (Vivio, 2017)



Figure 29- St. Francis convent church contemporary glass entrance by David Closes 2012 in Santpedor (Spain) retrieved from (BAROU ET AL., 2018B)



Figure 30- Renovation of a 150 years old castle farmhouse Blencowe Hall in Cumbria (Scotland). Tony Barton Donald Insall Associates 2008 retrieved from pinterest

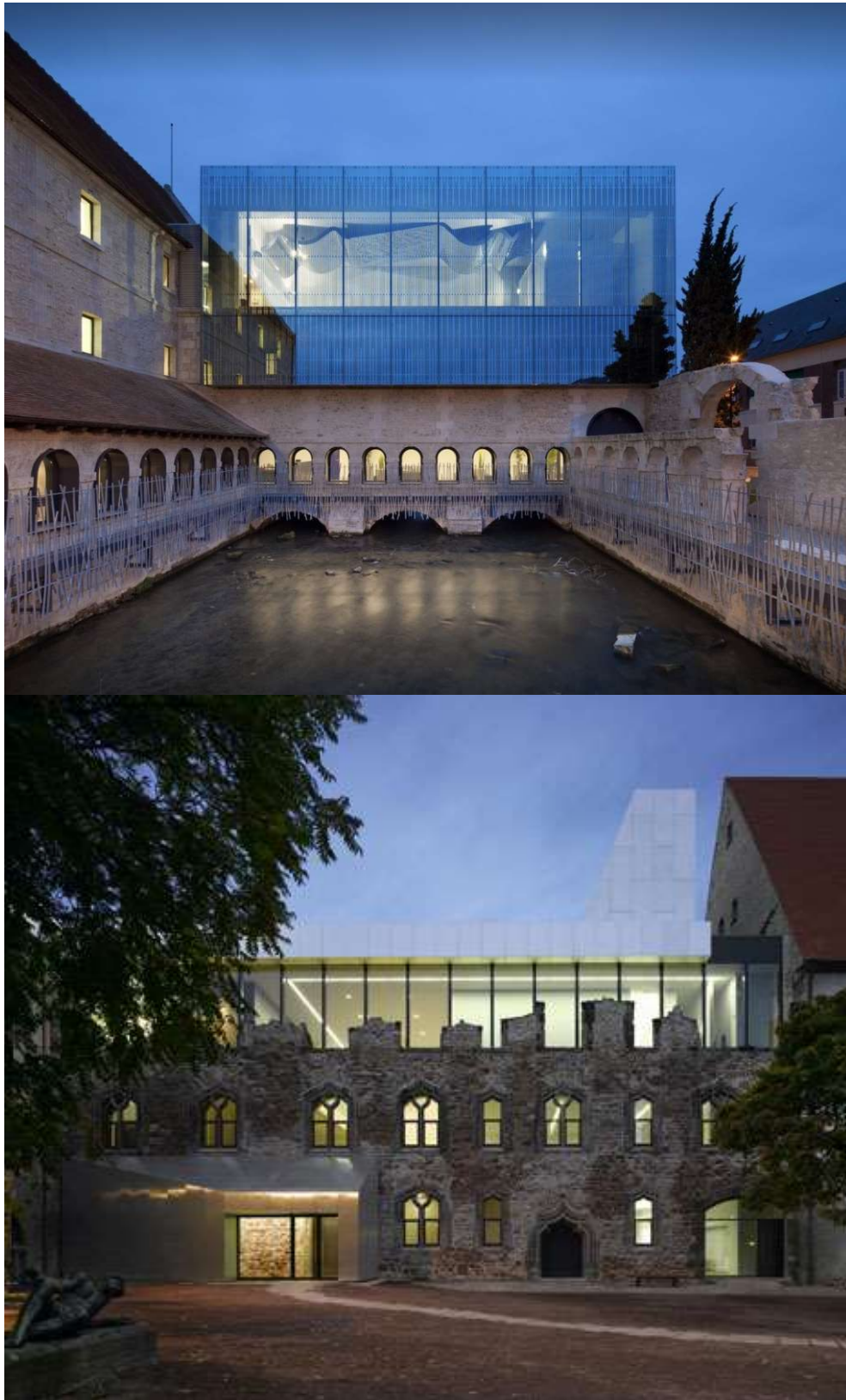

Figure 31- Above: Louviers Music School glass façade, Opus 5 architectes, 2012 retrieved from (BAROU ET AL., 2018B), below: Museum restoration, Halle Germany Nieto Sobejano arquitectos 2008, retrieved from dezeen.com



Figure 32- Restoration with glass of the ruins of the Augustan Temple in Pozzuoli (Naples Italy), Gnosis Architettura and Bardeschi 2011, retrieved from divisare.com



Figure 33- Library restoration Istanbul Turkey, Tabanlıoğlu Architects 2015 retrieved from Archdaily.com



*Figure 34- Restoration of the church of Corbera d'Ebre, Ferrán Vizoso Architecture 2017
retrieved from designboom*

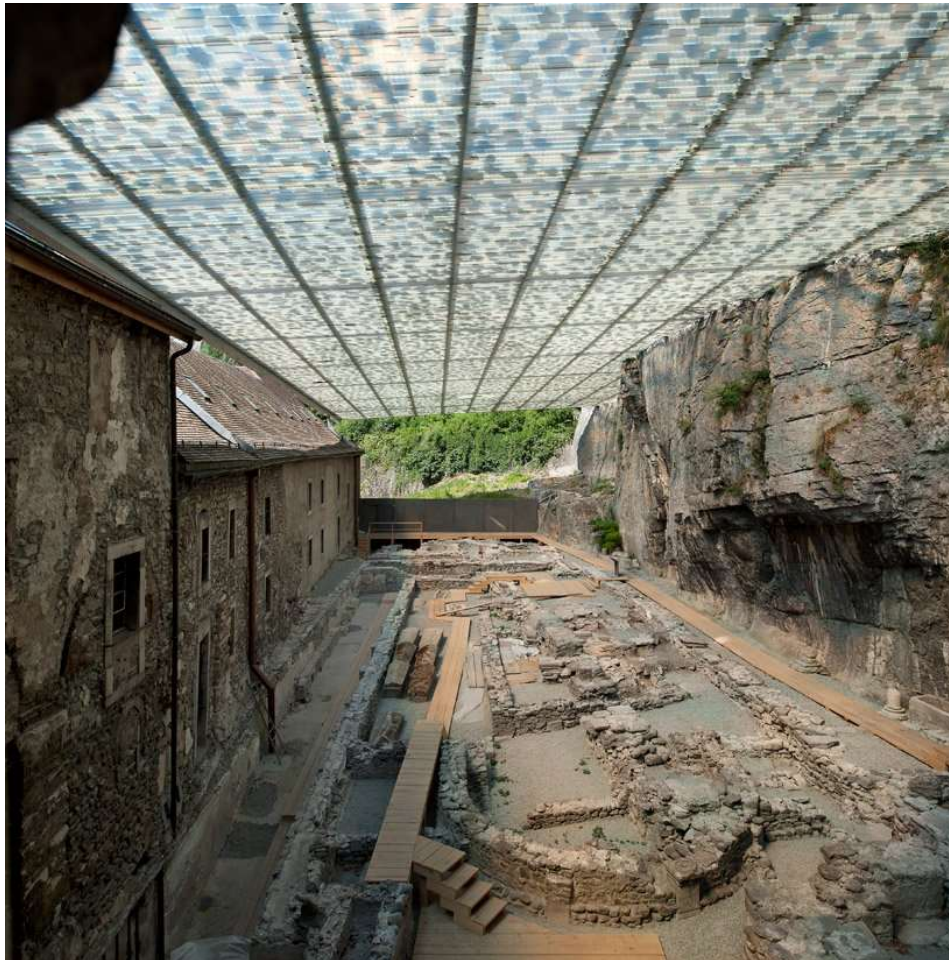

Figure 35- Above: coverage of Archaeological Ruins of the Abbey of St. Maurice Switzerland, Savioz Fabrizzi Architectes 2010, below: glass addition at the Museum in Dordrecht (Netherlands), Dirk Jan Postel of Kraaijvanger Urbis, 2010, retrieved from architectuur.org



Figure 36- Above: Juval Castle south Tirol, Italy, 1990's Vinschgau architect Karl Spitaler, below: Magdalena fountain employing stacked laminated glass CUAC Arquitectura 2018 retrieved from technicablog.com

3 Case study

3.1 Historic Overview

Schaesberg castle lies between the cities of Heerlen and Landgraaf in the province of Limburg. The remains that we see today are just a small part of what the complex used to be. The whole castle was moated consisting of two masonry residential wings and a keep. The castle was built by the Van Schaesberg family which was one of the most famous and influencing noble families of the Cologne-Lower Rhine area (Limburg). The castle was made in Mosan Renaissance style, a regional style that has little resemblance with the Renaissance style, despite its name, representing a reinterpretation of the earlier used method of timber framing in which stone (a new material) was incorporated. Stone framed windows, decorated architraves and alternating layers of brick and stone are the main characteristics of this style. The natural stone was marl a natural stone endemic from this region.

According to archaeological studies it's possible that at the same site an older castle existed probably dating back to the 14th century and made by Willem II van Reetersbeek (*Castles.nl - Schaesberg Castle*, no date). In 70's and 80's of the last century, excavation works were done by the former Technical University of Delft (TH Delft) to perform some archaeological research and some old foundations were found, together with a rectangular façade system of 15,5 by 16,5 m, made of Kunrade stone (a local natural stone) and burnt loam which probably was part of a façade timber-framing system. Possibly there was a fire and demolition of this old castle, which is believed to have taken place in 1376 (Viersen, 2014).

Although there were some important findings made on those archaeological studies, those were never published and therefore people are not completely sure about the former remains. Here, in this picture below, is a representation of what it might have been the old castle (in purple).

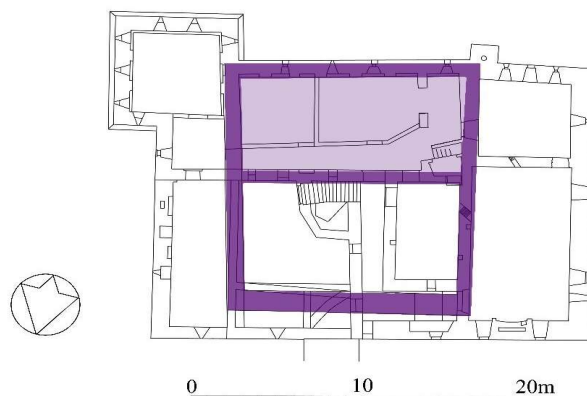

Figure 37- Representation of the old castle by Willem II van Reetersbeek (Viersen, 2014)

In 1571 Johan van Schaesberg built the first part of the castle on top of the existing foundations laying down in the channel as a moated castle. The old west facade became the dividing wall, which divided the new west wing into two parts. The new building was equipped with a basement (cellar) made of cross rib vaults. The ribs were made in marl (natural stone) and the vaults themselves in brick. In the following phase, dating back to 1616, Johan Frederik van Schaesberg extended the castle with an eastern part, where two residential wings and a square tower were belonging, becoming square centred around a courtyard. Also a large bailey was built which provided the financial support of the family

and remained in function until the 50's of last century. Here below, there is a representation of what the construction sequence was (Viersen, 2014).



Figure 38- Representation of the two phases of the castle, the blue from 1571 and the red from 1616 (Viersen, 2014)

In 1733, Frederik Sigmund Theodoor van Schaesberg (the last member of the family to have inhabited the castle) died and from there the castle was not permanently inhabited anymore and fell into decay due to a lack of maintenance. Despite the decay, the mansion remained in its almost complete structure until the end of the 19th century with roofs and floors as depicted in the pictures of Adolf Mulder of 1888 (below).

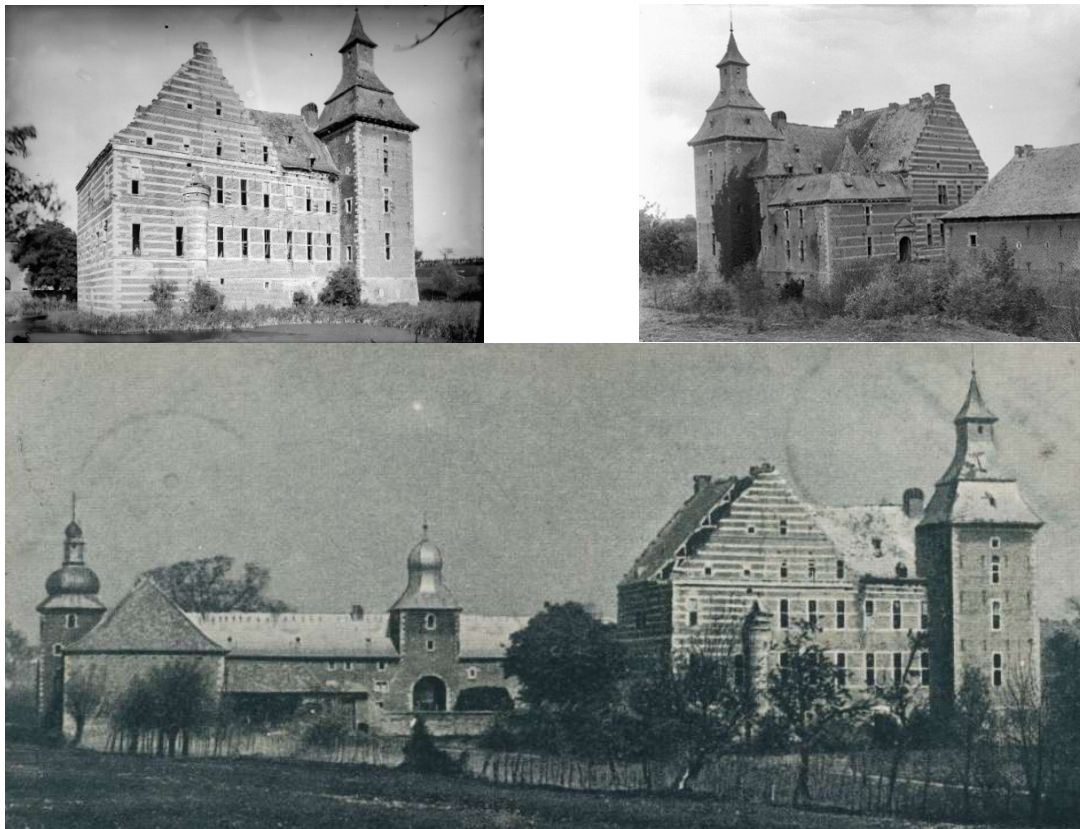

Figure 39- Overview of the Castle and bailey in 1888 retrieved from (<https://beeldbank.cultureelerfgoed.nl>, no date)

In the following years, however, there is an increasing decline. At the beginning of the 20th century most of the roofs and timber floors were lost and only the tower on the southeast corner is still equipped with its roof. The upper parts of the facades have already been lost locally. Even before the Second World War, the tower also lost its roof. Because of the loss of the floors and roofs, the declining of the castle started to go at a rapid pace, and therefore a full recovery had been considered in the pre-war period but unfortunately it was never pursued.

Around 1940, in addition to the brickwork of the tower, about three-quarters of the outer walls were still standing. In the following years, however these would be lost at a rapid pace. During the WWII the castle suffered a lot of damage. Because the Schaesberg family was from a time before the countries' borders, they became German and both the castle and the fortress became German property. After the war, the Dutch State reclaimed both the castle and the fortress under the control of the "Beheersinstituut"(Management Institute) but they never felt they were in charge of the maintenance of the castle. In the 50's an attempt was made to restore the castle for which a subsidy had already been promised. Preparation works were done like the removal of debris from the ruins and the restoration of the canals. Cleaning up the canals and removing rubble exposes the brickwork to a greater degree of weather thought. Despite these preparation works, the so wanted consolidation and/or restoration would never take place, and the measures taken have accelerated the decline rather than contributed to its preservation.

After many failed attempts to restore the castle, some archaeological studies and mining activities that contributed to the collapse of some walls, and a fire that destroyed most of the bailey, the castle was left to the vandalism as a stone quarry, many stones and anchor plates were stolen thereafter, and the building got more and more left in despair. After this several walls were torn down to prevent further collapse and a demolition permit was issued in 1968 by the local authorities to turn down the bailey. The bailey was demolished completely leaving just the foundations and the castle was left with just a few ruined remains (Fig. 38).



Figure 40- Overview of the ruins in 1953 retrieved from

At the end of the 70's finally the former technical university of Delft (TH Delft) was commissioned to perform a consolidation. In 2014 a second consolidation was done to start a full size restoration of the whole complex according to the old crafts and design. That will take 20 years to be ready

3.2 Consolidations

Two main consolidations were done recently. The first in 1975 by the former Tu Delft (TH Delft). Unfortunately they never issued a report and therefore much of the information is unsure. There was also a previous restoration done but there is however not much information available than a picture from 1974 (see Fig. 41). The second consolidation started in 2014. For this there was an archaeological research made before (Viersen, 2014) which gave information of the present state of the Castle and also of the consolidation made in 1975. The institution “Bureau voor bouwhistorie en architectuurgeschiedenis” (BBA-office for construction history and architecture history) made the assessment of all the information and produced a report where I based my research for the 1st consolidation. The pictures are also part of the report.



Figure 41- Overview of the Castle in 1974 retrieved from (Viersen, 2014)

Fig. 41 shows the overview of the castle in the late summer of 1974, just before the southeast corner of the tower collapsed on December 26. At the northeast corner it is visible that the brickwork at the height of the waterline and above had already been restored once. This photo clearly shows why so little brickwork remained at the start of the work. By cleaning the canals and omitting a protective slope on the facades, the remaining existing façade at the level of the water line was calved down, eventually resulting in collapse as it can be seen on the picture above.



Figure 42- Overview of the castle at the start of the works in 1975. It can be seen that almost nothing remained above the canal level. The fragment of the west facade is the only part of the castle, of which something has been preserved above the water level. This means that

almost all of the currently visible brickwork in this part of the castle is part of the consolidation work (Photo: Hukkelhoven, Heemkundevereniging, (Viersen, 2014))

In 1975, Dutch Castles' Foundation (NKS) started an archaeological study. First, the canal around the main castle was dug out, followed by the consolidation of the wall work. The canals had to be excavated, two bridges had to be built and the remaining parts of the castle had to be anchored, the masonry around the waterline also needed repair.

April 24 1978 was the formal start date of the consolidation. During that year the concrete coverings were applied to the walls and the construction of the bridge between the main castle and bailey is started. The existing masonry at the castle has been stacked together with concrete blocks and mortar in between, with a covering of old field fire bricks on the inside and outside. At the southeast corner of the tower, where the corner had fallen out in 1975, the brickwork was demolished until the structurally stable remaining well preserved masonry work layer, after which the same method of construction is applied as on the other walls. The method of intervention is still clearly recognizable at the corner of the tower where the core of concrete bricks is higher than the outer shell. As far as it is known, no attempt has been made to connect the core of the brickwork to the outside concrete bricks.



Figure 43- Actual overview of the castle, north façade retrieved from (Viersen, 2014)

As it is depicted in the picture above, one can see that all the brickwork visible here from the north façade was created during the consolidation. In the picture in the right corner a comparison of colours shows the difference between the consolidation and the remaining existing part (original elements). A vertical seam located at (B) suggests the location of the east façade of the west wing. By raising the foundations to the basement level, the main shape of the castle has become recognizable again. It is clear, however, that little of the original brickwork on the west and north side of the ruins has been preserved.



Figure 44- The castle in 1919, in comparison with the situation in 2014. Although the roofs and parts of the façades had been lost in the meantime, the castle was at that time in a considerably better condition than at the start of the recovery in 1975. (Photo: RCE) (Viersen, 2014)



Figure 45- Overview of the castle, west façade on 1919, (Viersen, 2014)

This picture depicts the detail of a photo taken in 1919 of the castle west facade. Light grey shows the part of the facade that was restored in 1975, dark grey shows the original brickwork. The contour of the façade was quite irregular which contrasts with the current situation, where the irregularity was made tight and straight. The size and location also deviate slightly from the original.



Figure 46- Actual overview of the castle, west façade, (Viersen, 2014)

When the façades were repaired, the brickwork was raised to the basement level. The existing remnants of the west façade have been incorporated into the new brickwork here. The part where the original façade surface is still present is shown in dark grey. Given the poor accessibility of the facade, this could not be determined at the moment of the archaeological research. Internally, a big part of the brickwork is still authentic. When reconstructing the facade, use was made of part of the original window frames that were found during the excavation of the canals. The masonry of the new facades consists of a rough stack of concrete blocks, with on both sides a covering of field fire bricks with alternating layers of marl.



Figure 47- Overview of the ruin, seen from the south at the time of the excavation. The upper part of the narrow and high fragment on the left side of the still preserved part of the south façade is no longer present. (Photo: Hukkelhoven, Heemkundevereniging, (Viersen, 2014)



Figure 48- Overview of the castle south façade, western part, (Viersen, 2014)

The picture above (Fig. 48) shows the western part of the south facade. In 1975 this part collapsed to the level of the water by then. All the brickwork visible here was created therefore during the consolidation of 1975 and afterwards. The brickwork used for erecting the walls consists of a core of concrete blocks with on both sides a half-brick heavy clamp of field fire bricks with alternating layers of marl. Due to presumably moisture and frost action on this brickwork, parts of the brick jumped off, that can be seen on the picture above. The alternating layers of marl have completely disappeared locally, making the mortar and concrete blocks of the core visible. This damage is also present on the north façade.

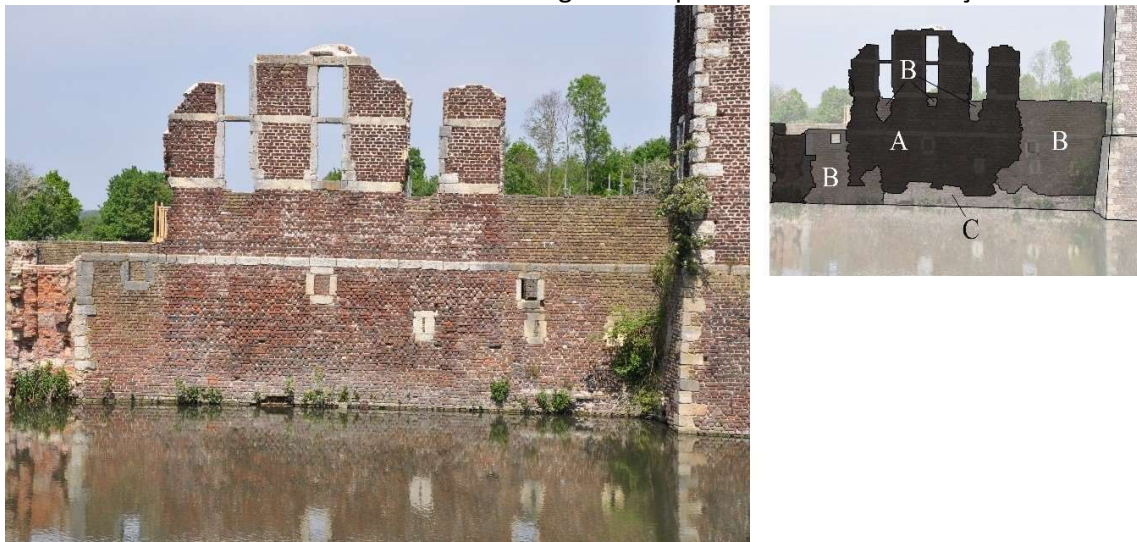

Figure 49- Overview of the castle at middle part of the south façade, photo: RCE (Viersen, 2014)

The picture above (Fig. 49) shows the middle part of the south facade in 2014. (A) and dark grey depicts the original brickwork. (B) is the masonry created during the consolidation. The masonry (C) at the level of the waterline could not be determined at the moment of the report done by BBA whether it was created during the consolidation.



Figure 50- Left: the castle, seen from the southwest. The west facade of the tower is almost entirely original. Right: the south facade of the tower before it was consolidated. Shortly before taking this photo, the southeast corner of the tower collapsed. The basement is still partly filled with debris. On the outside, the masonry was heavily damaged by watering. The masonry of the outer wall has probably been lost below the water level. On the inside, the brickwork has been preserved up to about a meter above the level of the basement. If the canal had not been dug out in the 1950s, the corner of the tower would probably not have collapsed. (Photo: Hukkelhoven, Heemkundevereniging, (Viersen, 2014))

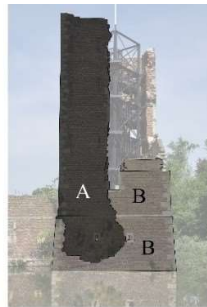

Figure 51- Overview of the castle tower, south façade, (Viersen, 2014)

The picture above (Fig. 51) shows the south facade of the tower. (A) depicts the original brickwork. (B) shows the masonry added by the consolidation works of 1975. Attending the fact that during the restoration of 1975 the field fire bricks were used up earlier than the concrete blocks, the brickwork of the concrete blocks protrudes above the rest of the

brickwork. Traces of older repairs can be recognized on the underside of the original part of the facade.



Figure 52- The lower part of the tower, viewed from the east, shortly after the southeast corner collapsed. The adjacent part of the east facade is also visible here (Photo: Hukkelhoven, Heemkundevereniging, (Viersen, 2014)



Figure 53- Overview of the castle tower, east façade, (Viersen, 2014)

The picture above shows the east facade of the tower in 2014. With dark grey, are those parts of the tower, which were assumed by BBA as part of the original design. The light grey colour indicates those parts that were created during the repair work of 1975 and thereafter. After the research carried out by TH Delft, in 1975, a recovery plan was drawn up under the leadership of the TH with Ingenieursbureau Oranjewoud. Part of it was the partial reconstruction of the recently collapsed corner of the tower, by erecting a core of concrete bricks with a half-brick cleat of field fires on both sides. Brick laying continued until the

stones were finished. It is visible that the field fire bricks were used up before the concrete blocks. No traces of anchoring or similar are visible in the protruding part of the brickwork of the concrete bricks, which means that the clamps of field fire bricks are separated from the core of concrete bricks.

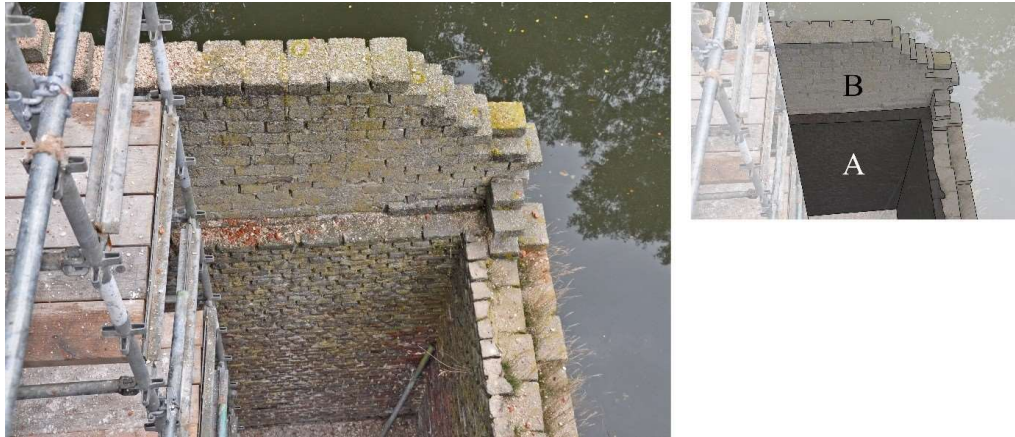

Figure 54- Overview of the castle tower, depicting the corner, (Viersen, 2014)

The picture above shows the top view of the restored southeast corner of the tower. All the brickwork visible here was created during the consolidation of 1975. On the outside of the wall a half-brick clamp has been used (A). The core of the masonry consists of concrete blocks (B). No traces were found of anchoring on both parts.



Figure 55- Overview of the castle tower ruins, north façade, (Viersen, 2014)

The picture above show the north façade of the tower remnants with the adjacent part of the east façade. As depicted on the picture, the original brickwork can be found at (A). The restoration work is indicated by (B). On the underside of the wall at the waterline, a strip of natural stone is included at the facade brickwork (C). It is not known whether this brickwork is still original or it was realized during the consolidation work. Facade (D) (east facade) has already been described previously.



Figure 56- Overview of the interior of the castle, facing south. The remaining part of the south facade is visible at the background. The formless brickwork on the far left is from the wall, which now borders the part covered with a concrete slab on the west side. The photo would have been taken in 1975. (Photo: Hukkelhoven, Heemkundevereniging, (Viersen, 2014)

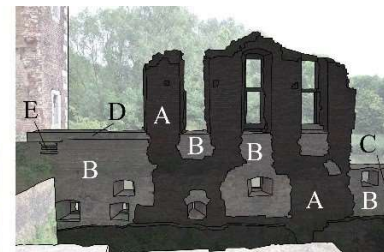

Figure 57- Overview of the south façade of the castle, eastern part seen from the north, (Viersen, 2014)

The picture above shows the overview of the eastern part of the south facade, seen from the north side. The dark grey part (A) indicates which parts of the façade's surface still belongs to the original design. The light grey part (B) concerns the brickwork, which was added during the 1st consolidation (1975). A standing tooth (C) is just visible on the right-hand side which probably gives indication that an intermediate wall was there. Also at (D) the concrete blocks can be seen, which protrude above the level of the reconstructed brickwork. At (E) a standing tooth in the south façade has been kept to indicate also the location of the intermediate wall.



Figure 58- Overview of the largely reconstructed (rebuilt) brickwork that forms the walls of the former courtyard. Only on the underside of the walls there are some layers of the original masonry. The lower steps of the stairs are also original. (Viersen, 2014). See also the following image (Fig. 60).

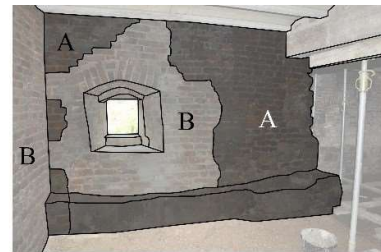

Figure 59- Overview of the tower cellar room, east wall, (Viersen, 2014)

The picture above shows the overview of the east wall of the tower cellar. At (A) the original cover of the brickwork can be seen. The brickwork at (B) is new, but partly still contains original work behind.



Figure 60- Overview of the tower cellar room, west wall, (Viersen, 2014)

The figure above shows the west wall of the cellar room with the original masonry at (A) and the masonry at (B), which was created during the consolidation.



Figure 61- Overview of the tower cellar room, north wall, (Viersen, 2014)

The figure above is the overview of the north wall of the room within the tower. This wall is mostly original. The original brickwork at (A) is depicted with dark grey. The masonry created during the consolidation is indicated by (B) light grey. The opening at the wall (C) has already been closed once in the past. This happened before the 1st consolidation (of 1975).



Figure 62- Overview of the tower cellar room, east wall, (Viersen, 2014)

The figure above shows the overview of the east wall of the tower cellar room. At (A) the brickwork that is still original is shown and (B) depicts the brickwork that was created during the consolidation work and shortly after 1975.

In 2014 the castle was consolidated for the second time. The works were a preparation for the full size restoration which will completely rebuild the castle exactly the way it was, making use of the old crafts. The consolidation consisted of a steel staircase at the tower which is a temporary construction to support the walls of the tower, and has also a structural function and a touristic new function as lookout tower besides being used as a workplace for the coming restoration works.



Figure 63- Overview of the construction of the steel staircase (on top left) and the ready done stage (at the other pictures)(Viersen, 2014)

The steel stair-case was built on top of the cellar which had in the previous consolidation (1975) a concrete floor at the top which supports the staircase. The staircase stands on top of a concrete ballast which serves as a kind of stabilizing support for the structure. The function of the staircase structurally is to substitute the former iron anchors which didn't exist anymore or were not doing any structural function anymore because the floors were not there. These iron anchors function was by fixing the floors to the walls to transmit, on this way, the horizontal force of the wind action to the floors. The iron anchors provided that the walls didn't fall in or out and therefore not only working in tension but also in compression. The floors performed the diaphragm action which was directing the load to the vertical supports (columns and outside wall). The stair-case it's in this way substituting, temporarily several load-bearing elements.



Figure 64- Overview at the left side of the prefab concrete floor at the cellar which substitutes the vaults and floors from the original construction. This consolidation was made at the 1st consolidation works of 1975. At the right side it's the overview of the concrete ballast where the steel staircase is standing on (own pictures)

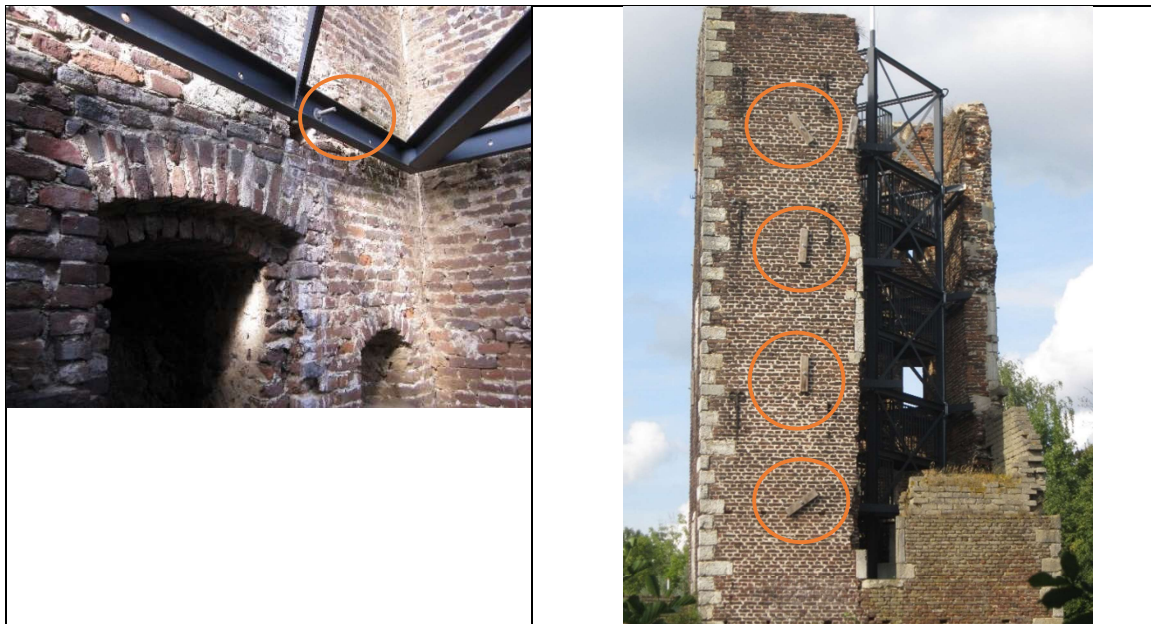

Figure 65- Overview of the anchor fixing of the steel staircase to the outside walls performing the tension and compression function of the former original iron anchors. Some of the original anchors are still at the façade, as we can see on the above picture, but are not performing any structural work but rather just for decoration (own pictures)

In 2016 an intervention was made to make the castle a touristic attraction, accessibility was made ready including platforms and staircases. The gardens were made according to the XIX century royal design and a 'kinderboerderij' (petting zoo) is still under construction. These interventions are not part of a consolidation but have the function of making the castle a touristic financial resource for the coming full size restoration which is very expensive and to which the Dutch state has made a small contribution.

The actual restoration works started in the beginning of 2019, with the reinforcing of the foundation at the entrance port, at the bailey building which will be the welcome door to the complex while under restoration. A sequence of the actual restoration can be seen on

the webpage of the Stichting Landgoed Slot Schaesberg, which is the institution responsible for the management and re-construction of the castle (<https://slotschaesberg.nl/>).

3.3 Analysis of the pathology

The analysis of the pathology is based on the site visit and on the interview with the project manager of the actual restoration, Aryan Klein. For the restoration works performed in the 70's of the last century and for the actual restoration, archaeological and geotechnical works were performed to get some insight into the state of the structure in particular the foundations. It appears that the castle is crooked because of the foundation which has settled. The reason for this settling is not clear. According to Mr. Aryan Klein possible causes were the mining coal factory which was until shortly still working on the close proximity to the castle site, another possible cause was the groundwater level which changes quite regularly because of the climate, ground porosity and running phreatic water sources and the interventions in the canal to clean the water and research on the foundations. According to a site research and visual assessment, the foundation beneath the tower doesn't seem to have suffered any settlement and therefore no further actions will be made. The foundation will be therefore assumed as stable and with enough loadbearing capacity in the consolidation design.

The consolidation materials used on both consolidations are very intrusive on the castle aesthetics and incompatible according to the conservation principles. Concrete masonry blocks of the first consolidation are not the most appropriate and the cement mortar used is also incompatible with the original brick masonry which was made of coal. The steel staircase of the second consolidation, although very effective to strengthen the tower walls, it's also very intrusive and should be substituted with a better, more compatible structural construction in glass. The concrete floor of prefab concrete is also a very heavy and intrusive construction but it's not visible and can be used as ground level diaphragm stabilization mean.

3.4 Replacement of monument interventions: design

Based on the literature review and in order to come up to a design an overview is made about the main concepts and conclusions:

In the restoration part, the main principles emphasize the **authenticity** as the main goal by respecting and keeping the old traces and **consolidating** only when needed so to avoid the risk of collapse, **intervening with minimal** traces as possible. The interventive material should be **aesthetically and structurally compatible**, not detracting from and supporting the decaying structure; **retreatability** or the intervention made should be possible to replace or repair in the future, in the case is made superfluous or technology dictated better techniques which would function better. Regarding the materiality debate whether to use the same material or a new innovative so that not to deteriorate or accelerate deterioration of the existent, any **interventions should be distinguishable** from the existent and reflect their time so not to have conjecture and retain the old traces (Barou *et al.*, 2018b). In this discussion, the glass appears as a very good alternative with its outstanding strength capacities comes to the foreground as a perfect addition like a reflection of the past, but it should be applied respecting its features and fragilities as well as of the existent decayed material (the masonry). With its transparency makes its presence subtle and (almost) invisible as a replacement of the decayed.

Glass is a very peculiar, ambivalent material in its features, strong and fragile at the same time. **Very strong in compression** and **very weak in tension**. Due to composition, manufacturing, processing and use, it's very prone to flaws which are randomly mostly present in the meso-structure, the surface and edges. These vulnerabilities tend to open in tension when glass is subjected to different loads, since impact, to own weight cause buckling or bending. Being a brittle material, a defect under the effect of load, translates into crack propagation and a complete loss of cohesion breaking in million pieces. Strategies are necessary to provide safety and reliability to structures. By transforming the structure in 3d in the form of cast blocks like standard masonry, even better in a Lego-like system (interlocked, osteomorphic), failure is limited to the element and not to the whole structure, using the compression to its full strength, employing own weight, optimizes the use of compression in combination with shear by the interlocks, transferring the horizontal loads and limiting the tension. Besides that the assembly is made easy and replaceable or recyclable. This self-weight works for the stability of the system by contributing with gravity to keep the structure in place. The 3d feature of the glass blocks counteracts the buckling problems of the usual 2d shape of the usual sheet layers of float glass. As stated in the literature review, the cast glass assembly used on the Crystal glass house relying on adhesive translates in an almost inability of the glue to take care of the construction tolerances, resulting in a very meticulous, challenge to assemble and replace structure, requiring very demanding logistics. To counteract these drawbacks, an interlocked system is studied and proposed making use of a dry system exempting the use of adhesive and only employing an interlayer and in this form avoiding glass to glass contact.

The **topological interlocking** works as the elements are held together without any adhesive, by kinematic constraints imposed by their neighbours. Each block is kept in place by its neighbours and can't be removed from the assembly. The shape and arrangement of the elements ensure the local kinematic constraints. The stability is acquired by the total weight (compression) in combination with the blocks' interlocking geometry that provide

constraints against lateral movement. Except for the peripheral elements the same cannot apply. Instead, an additional, independent constraint needs to be applied, such as frames, pre-tensioned tendons or self-weight to work as pre compression (Dyskin, Estrin and Pasternak, 2019) (see Fig.64). Instead of relying on an adhesive to transfer shear stress, shear locks can be designed where the shear transfer is needed. To prevent stress concentrations between glass elements, a transparent foil (or interlayer) is placed between the units. This dry assembled construction circumvents the use of glue and alternatively uses this interlayer (intermediate medium) which takes care, additionally, and compensates for the inevitable dimensional tolerances (Oikonomopoulou, 2019).

By introducing **osteomorphic shapes** into the interlocked system, which rely on organic smooth, non-planar concave-convex surfaces impeding relative movements in x and y planar directions and avoiding the use of key, connectors (like in lego) or sharp edges which work as stress concentrators, that may comprise the overall strength of the structure, especially when considering brittle materials like glass (Oikonomopoulou, 2019) (see Fig. 65).

Some design criteria can be drawn regarding the properties of cast glass and its manufacturing, and according to the definitions mentioned previously, as retrieved from (Oikonomopoulou, 2019):

- Limited volume in order to limit the annealing time, block size is limited to the size of the existent masonry (100x200x50).
- Rounded shape and equal mass distribution in order to avoid residual stress concentration due to inhomogeneous annealing
- Limited number of units and multifunctionality

Design criteria related to topological interlocking retrieved from (Oikonomopoulou, 2019):

- Movement constraints in two directions: To ensure local kinematic constraints mentioned above, the interlocking geometries need to be constricted in both the longitudinal and transverse direction, to account for lateral movement. Constraining only one of the two, as in the Atocha memorial, does not ensure the stability of the entire assembly.
- Self-alignment: The interlocking mechanism should account for the self-alignment of the individual components, thus enabling the assembly process.
- Shear capacity optimization: Topological interlocking does not make use of keys and connectors, as mentioned above, but instead incorporates smooth curves, which distribute the shear forces in a relatively even manner. This is particularly crucial when applied to glass, as the use of conventional interlocks, would quickly result in fractures.
- Multi-functionality: The applied geometry, preferably, should be applicable to different structural elements and volumes, i.e. walls, corners, columns etc.

Design criteria related to function and aesthetics:

- The case study, Schaesberg Castle is used as a tourist attraction nowadays and this function will be kept for this proposal.
- Only the Castle tower will be restored by glass, the proposal will be just the restoration of the tower walls without floor. The dimensions of the tower are 7x7m and 15m tall (see Fig. 68).

- The horizontal layering system by the clay masonry and design will be taken into account for the design of the glass blocks. The dimensions of the cast blocks will have the same dimensions of the existing clay masonry bricks (100x200x50mm see Fig. 65). The amplitude of the interlocked system is also an important parameter to take into account for the shear interaction of the blocks according to (Jacobs, 2017). 10 mm is used as proposal (see Fig. 66).

Structural requirements:

- The new structural system should prevent the further decaying of the existent masonry by providing support to it, and having a warning mechanism of failure away from the existent wall, replacing the missing walls and floors. To replace the diaphragm action of the floors/roof, the walls will be thicker working as shear walls for horizontal loads. The glass wall will be 300 mm thick, 3x layered with blocks connected (interlocked) in both planar directions (x and y) with English bond to avoid the use of steel anchors or buttresses to counteract the horizontal loads. The wall structure will also prevent delamination due to buckling or bending, one of the possible failing modes of the interlocked system (see Fig 67).
- The new structure should have at least the same capacity as the current intervention (steel structure) used in the consolidation.
- The current concrete floor used in the consolidation will be assumed as foundation.

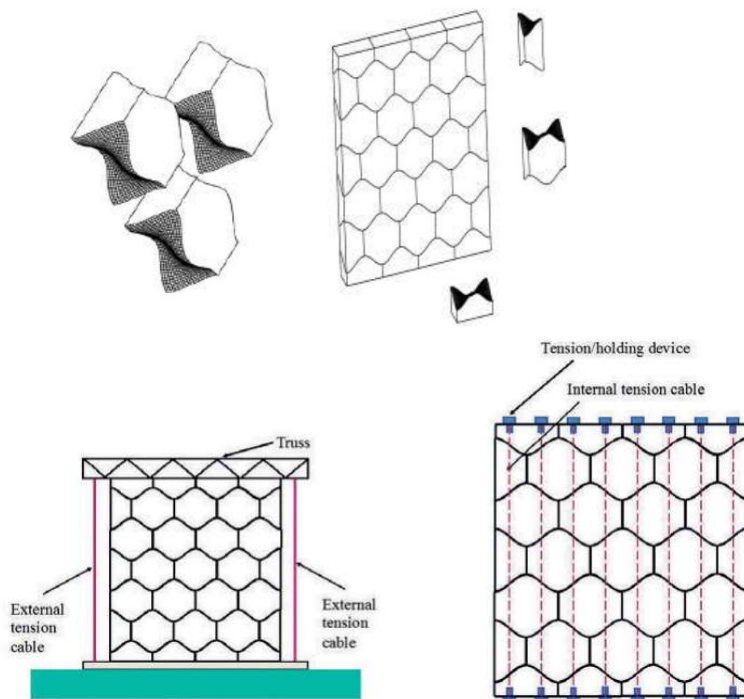

Figure 66- Topological interlocked (osteomorphic) system as proposed by (Dyskin, Estrin and Pasternak, 2019)

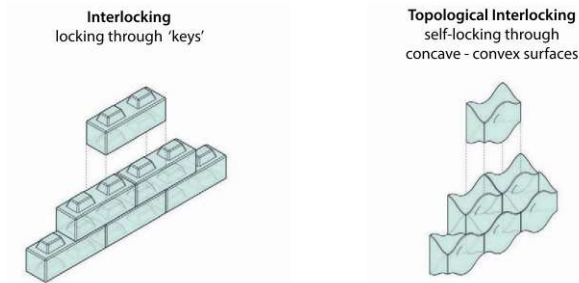

Figure 67- Principles of interlocking through keys on the left and topological interlocking by the use of concave-convex surfaces (osteomorphic) (Oikonomopoulou, 2019)

BLOCK TYPE	A	B	C	D	E
INTERLOCKING MECHANISM	Smooth curves	Smooth curves	Male and female blocks	Sliding blocks-intense curves	Semi-sphere keys for vertical stacking, ability to rotate
SHEAR CAPACITY	High	High	Moderate	Moderate	Moderate to high
SELF-ALIGNMENT	High	High	High	Low	High
MULTI-FUNCTIONAL	High	High	Moderate	Moderate	High
EQUAL MASS DISTRIBUTION/HOMOGENEOUS ANNEALING	Effective	Effective	Risk of internal residual stresses	Risk of internal residual stresses	Effective
LIM. NUMBER OF DIF. UNITS/ EASE OF ASSEMBLY	High	High	Moderate	Moderate	High

Table 10- Comparative evaluation of researched interlocked systems and choice of type B system, adapted from (Oikonomopoulou, 2019) retrieved from (Dimas, 2020)

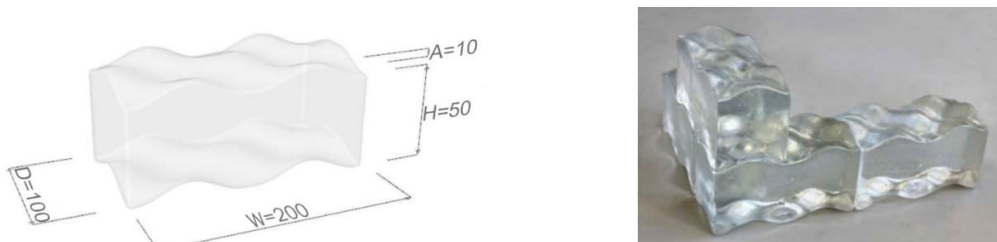

Figure 68- Overview of the chosen system and block dimensions adapted from (Jacobs, 2017) and on the right retrieved from (Oikonomopoulou, 2019)

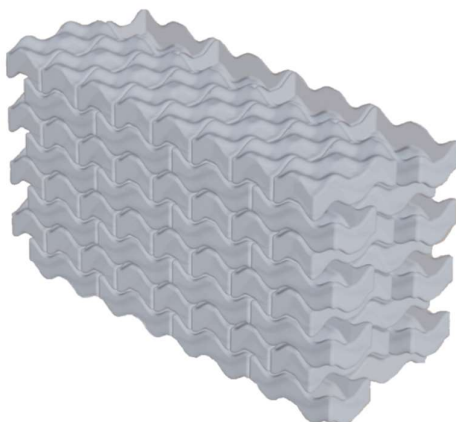

Figure 69- Overview of the assembly of the 3x layered (300mm thick) wall made of interlocked osteomorphic glass blocks according to the English bond, interlocking in both directions and avoiding the use of steel anchors to fix the blocks on the other direction

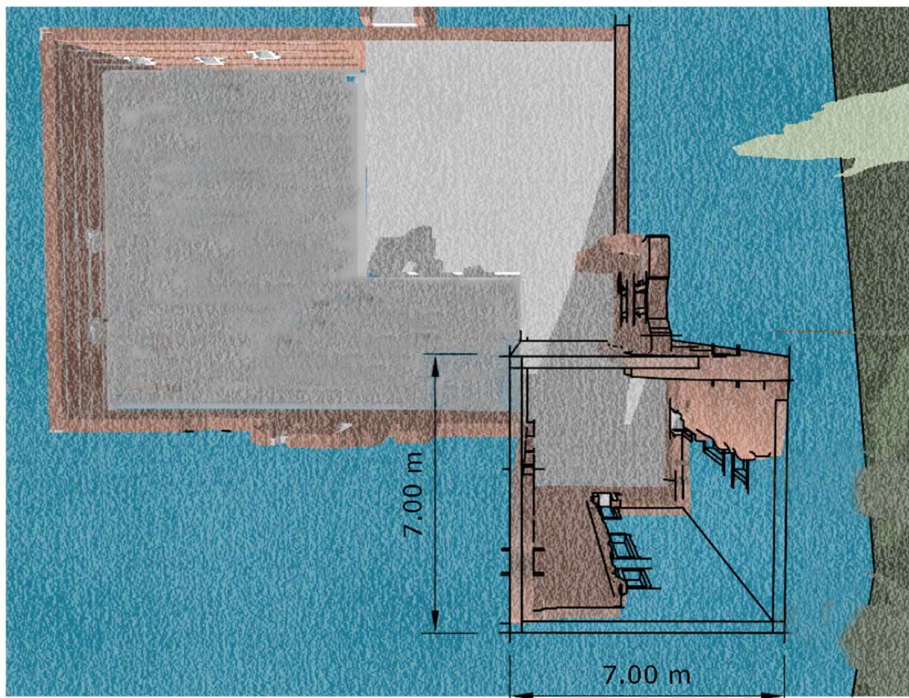
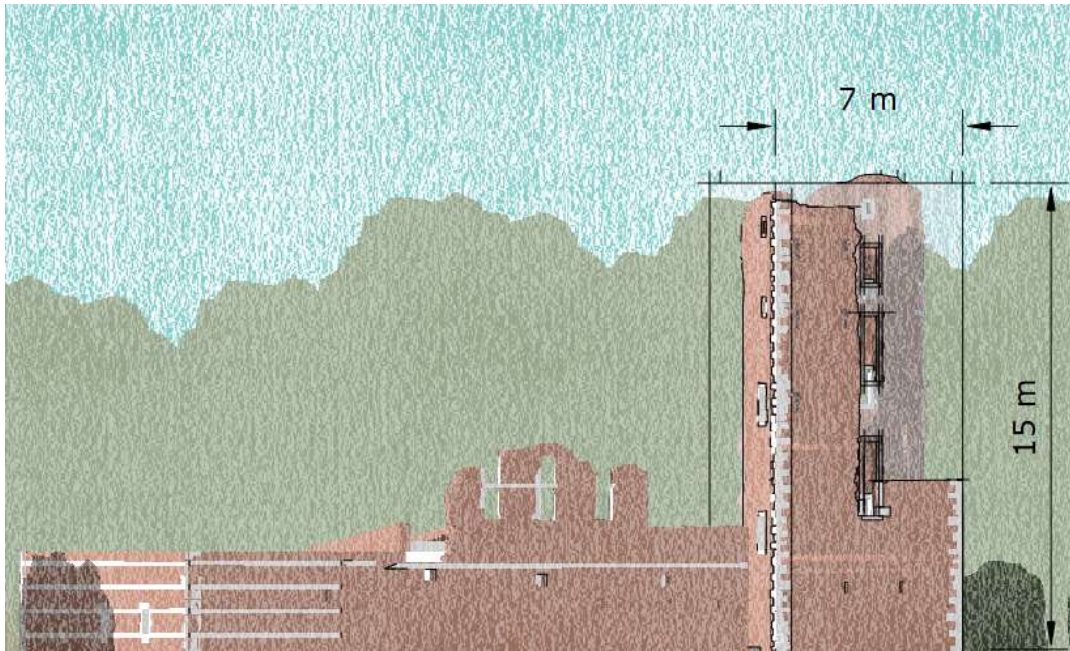

Figure 70- Above: Front view of the Castle with the intervention proposal in glass and dimensions. Below: floor plan overview and dimensions

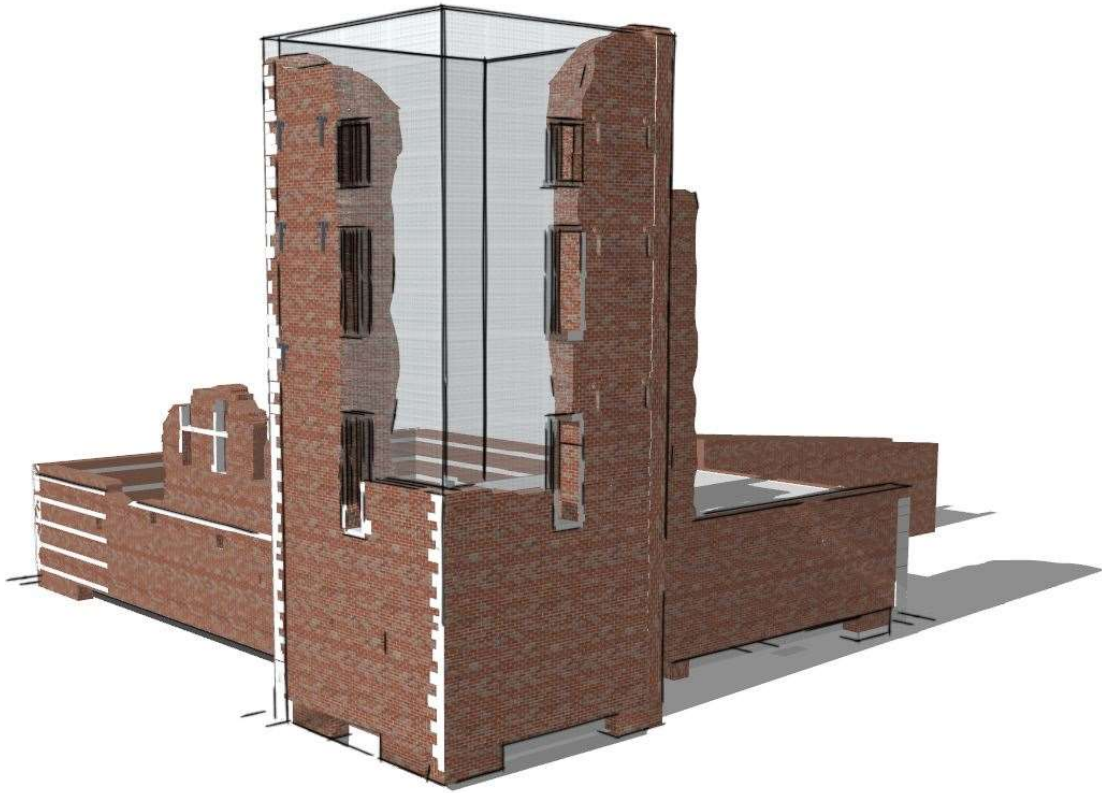

Figure 71- Proposal perspective overview with the addition of glass

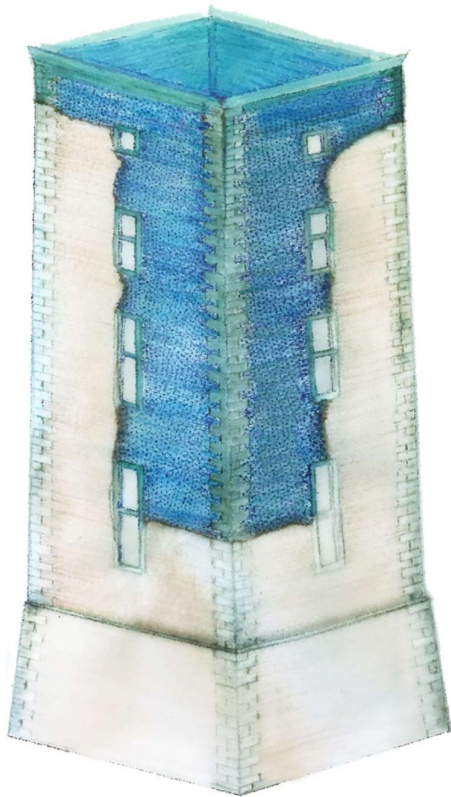

Figure 72- Intervention proposal, completion of decayed wall with glass blocks



Figure 73- Proposal 3d impressions South-East corner above and North West corner below



Figure 74- Proposal 3d impressions seen from above (Eagle eye view) above and South side impression below.

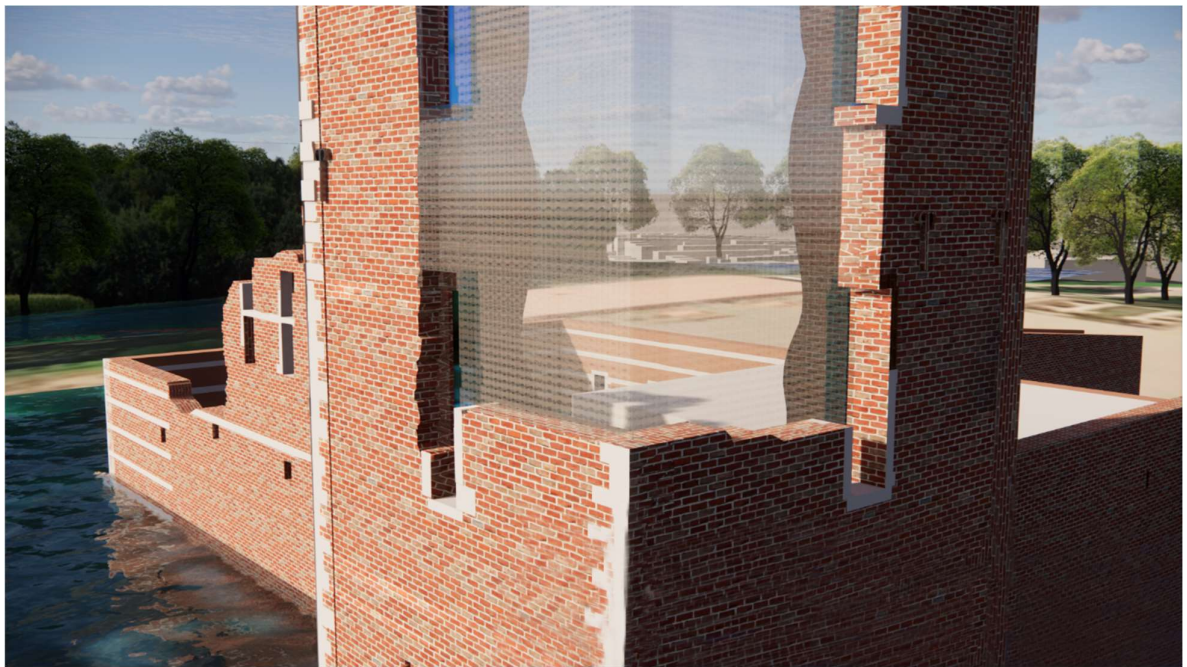
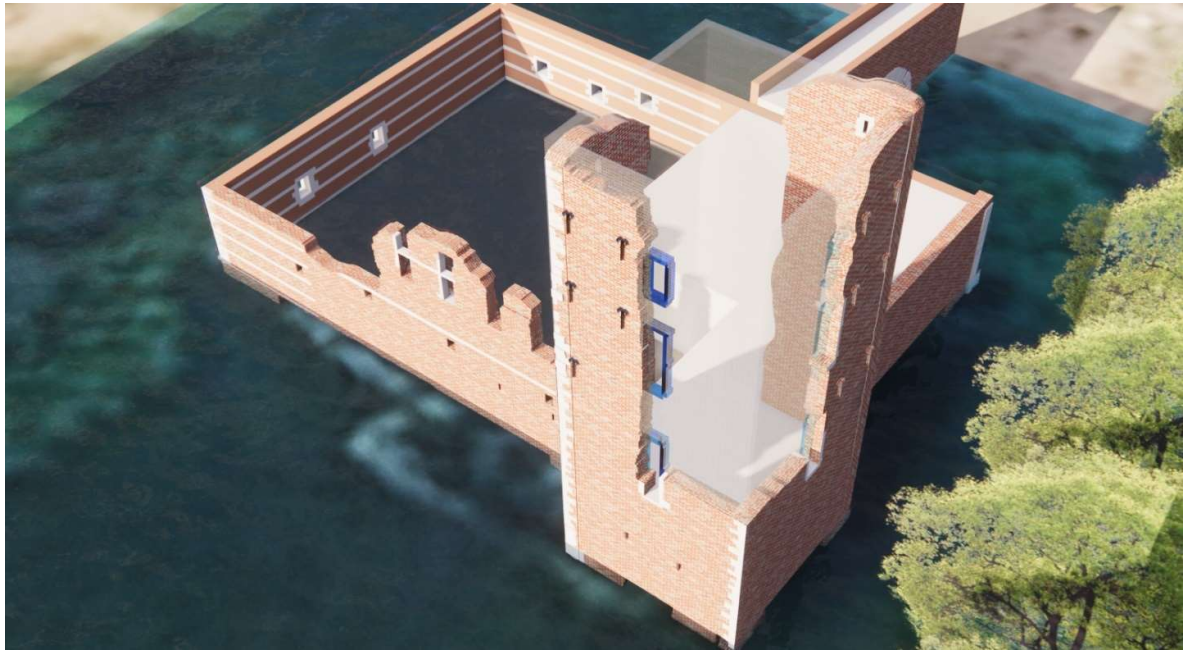

Figure 75- Above: proposal 3d impressions seen from above (Eagle eye view) South-East corner. Below: detail of the intervention seen from South-East corner.

3.6 Structural validation

3.6.1 Description and methodology

To evaluate the structure in strength and stability, a Finite Element Model in 3d was made in Diana FEA. What is important to test is whether the glass wall according to this assembly, (topological interlocking osteomorphic with dry connections by the use of the interlayer) is strong enough to consolidate the ruined masonry structure. The strength material values should then be compared against the highest stresses in the model. This kind of study with a global model in FEA was never done for a topological interlocking cast glass wall assembly and especially considering a decayed monument. Most of the research was based on the local testing or numerical analysis focused on the capacity of one single glass block assuming that the interlocks on the glass brick transfer the load by shear. The capacity of the whole system is necessary in order to evaluate if the system really fulfils its capacity according to the global boundary conditions. This system works by combining the self-weight (compression) to the shearing capacity of the interlocks (Oikonomopoulou, 2019). In here, the shape of the elements is important or the interlocking geometry, and the properties of the dry interlayer which compensates for construction or manufacturing tolerances. It is however, in this study not the focus and the properties according to the best possible solution related to the osteomorphic shape are taken as reference, as well as conservative values for the stiffness of the dry-interlayer according to (Jacobs, 2017). The focus lies on the global conditions by assuming these properties. By taking information on the local material values retrieved by these studies it's possible to use them in the global model. The strength material values of the glass units according to the chapter 2.1.6. are not enough to give a good indication of the performance of the structure. Some more research is needed in relation to the behaviour of the interlocking assembly and how the glass units collaborate with the interlayer.

Secondly, different types of connections between glass and masonry are tested in the model to see what is the influence on the integrity of the structure.

Four failure modes can be identified in regard to this assembly related to stability and strength:

- Bending failure in vertical direction (giving vertical strains) which can cause the delamination of the interlocked bricks
- Horizontal bending failure (giving horizontal strains) causing the delamination of the outside layer by tension
- Buckling failure
- Local failure of the brick by tension by bending failure or shear failure

The first three failure modes are going to be studied with the help of the global model and the strength material values. The last failure mode has been studied in previous researches, in relation to the brick shape.

But first, in order to get to the material properties related to the glass assembly, or the working of the soft dry interlayer together with glass, the latest studies are reviewed.

3.6.2 Research and material properties

An interlocked system that is dry connected exempts the use of glue to attach the glass elements. The soft dry interlayer replaces the use of glue and has the function of avoiding a glass to glass contact and spreading the stresses evenly over the glass surface. It needs to be soft enough to adapt to the shape of glass and take care of construction tolerances, but strong enough to avoid the direct contact of glass to glass by tearing up. However for this study the properties of the interlayer are just briefly discussed. Some tests can give an indication of the working of the interlayer together with glass and are consequently more interesting to use as reference for the material strength values. The interlayer chosen is PU70 with 3-4mm thickness that has been used in several studies and can be related to the study of E. Jacobs (Jacobs, 2017) which performed numerical studies. In the research by (Oikonomopoulou *et al.*, 2019) dry interlayers were tested under compression between two interlocked osteomorphic cast blocks. The failure load for the specimens of PU70 give an indication of the compressive strength of the assembly. From the three failure loads (72.5kN, 57.8kN and 63.5kN) an average is made and divided by a safety factor of 3. Dividing this 21.5kN by the area of the brick (75mmx37.5mm) gives the compressive strength value of $f_{c;d} = 7.6\text{MPa}$

For the shear tests a correlation between the tests performed by (Oikonomopoulou, 2019) and the shearing area cannot be retrieved and therefore a relation to the bricks used in this study is not possible. The research performed by E. Jacobs (Jacobs, 2017) although only numerical it can be used as assumption for the horizontal bending strength. In his research he makes a sensitivity research about the variation of the different parameters of the glass shape, by varying the amplitude of the interlocks and the height of the brick. Some design values were derived for the different parameters by using the equation used for design flexural tensile strength and adapting it for the shear capacity according to DIN 18008 (Jacobs, 2017):

$$f_{mt;u;d} = \frac{k_{mod} * k_c * f_{g;k}}{\gamma_{m;A}} \quad \text{to} \quad F_{shea} = \frac{k_{mod} * k_c * F_{shear;k}}{\gamma_{m;A}}$$

In which k_{mod} is the coefficient related to the load duration taken as 0.70 for short term loads like wind, k_c has to do with the type of structure, taken as 1 and $\gamma_{m;A}$ is the material safety factor equal to 1.8.

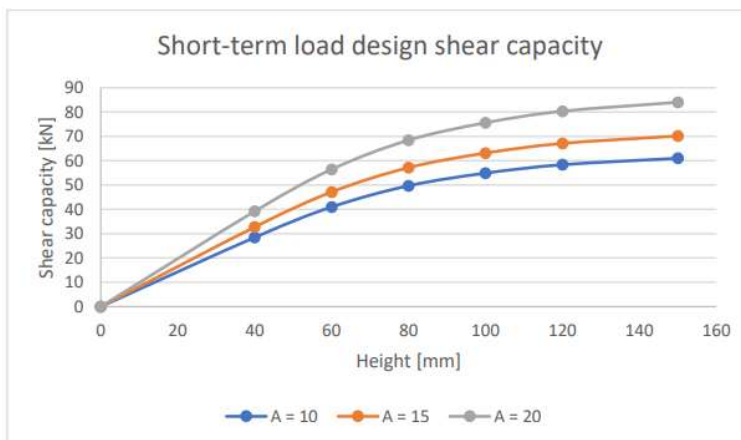

Figure 76- Design shear capacity prediction according to the numerical calculation of E. Jacobs (Jacobs, 2017)

Assuming the best possible solution of a brick of 300x150x150mm and amplitude 20mm, the design shear capacity for short term load when wind is considered prevalent, is about $F_{shear} = 83kN$. To apply it in the current situation, let's imagine the horizontal force (F) has to be transferred through the interlocks in shear. Each of the interlocks immediately above and below is transferring a force F and together 2F. This is the horizontal force that can be transferred from one brick to its neighbours. The equivalent tensile strength in the brick is then also 2F. The maximum horizontal force in a brick cannot be higher than the shear strength of two interlocks. The equivalent horizontal tensile bending strength is therefore equal to the strength of two interlocks divided by the vertical area of two bricks. The same reasoning can be applied to the out of plane direction obtaining, in this way the maximum horizontal tensile strength for both directions (see diagram on Figure 77):

$$f_{ho;d} = \frac{2F}{2 * 150 * 150} = \frac{F_{shear}}{150^2} = 3.7MPa$$

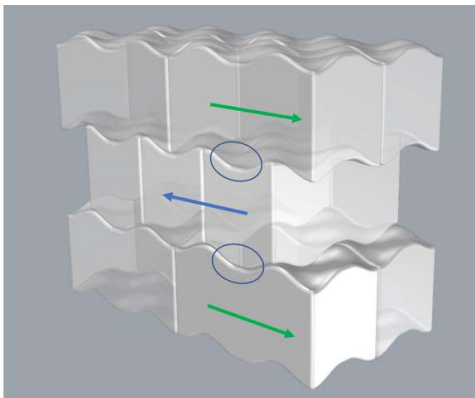

Figure 77- Acting of the shear force on the glass wall

Attending the fact that the interlocked glass wall is not monolithic but segmented and composed by two different materials (glass and interlayer) and therefore different degrees of stiffness, by using the elastic theory and Hooke's law it's possible to find an equivalent stiffness by considering an assembly composed by two glass blocks with an interlayer in between (see scheme of the Fig. 78):

$$l_{glass} = 2 * 75mm = 150mm \text{ (thickness of the two glass blocks)}$$

$$l_{int} = 3mm \text{ (thickness of the interlayer)}$$

$$l_{glass} + l_{int} = 150 + 3 = 153mm$$

$$E_{glass} = 70000N/mm^2 \text{ (glass young's modulus)}$$

$$E_{int} = 50N/mm^2 \text{ (low boundary assumption for the young's modulus of PU70 polyurethane as taken by E. Jacobs thesis (Jacobs, 2017))}$$

$$E = \frac{F * l}{A * \Delta l}, \quad E_1 = \frac{F_1 * l_1}{A_1 * \Delta l_1}, \quad E_2 = \frac{F_2 * l_2}{A_2 * \Delta l_2}, \quad F_1 = F_2 = F \quad \text{and} \quad A_1 = A_2 = A$$

$$E = \frac{F * (l_1 + l_2)}{A * (\Delta l_1 + \Delta l_2)} = \frac{F * (l_1 + l_2)}{A * \left(\frac{F * l_1}{A * E_1} + \frac{F * l_2}{A * E_2} \right)} = \frac{F * (l_1 + l_2)}{A * \frac{F}{A} \left(\frac{l_1}{E_1} + \frac{l_2}{E_2} \right)} = \frac{(l_1 + l_2)}{\left(\frac{l_1}{E_1} + \frac{l_2}{E_2} \right)}$$

$$E_{equiv} = \frac{(l_{int} + l_{glass})}{\left(\frac{l_{int}}{E_{int}} + \frac{l_{glass}}{E_{glass}} \right)} = 2462 N/mm^2$$

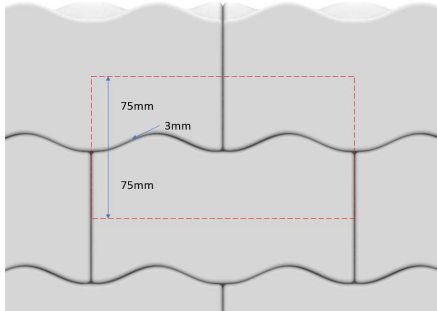

Figure 78- Schematization of the $l_{glass} = 2 * 75mm$, taking into account two glass blocks

Conclusion material values

The following table synthetizes all the material values to be used as reference in the static verifications:

Properties glass masonry	
E Young's modulus (in MPa)	70000
E_{equiv} Equivalent young's modulus (in MPa)	2462
ρ density (kg/m ³)	2500
ν poisson's ratio	0.23
$f_{c,d}$ Vertical compressive strength (in Mpa)	7.6
$f_{hor;d}$ Horizontal tensile strength (in Mpa)	3.7
Properties Interlayer PU70a	
E Young's modulus (in MPa)	50

Table 13- Overview of the material properties for cast glass and interlayer

The calculations in the models are performed in ULS according to the Eurocode (NEN-EN 1990)

$q_{d,ULS} = \gamma_G * q_G + \gamma_Q * q_Q$, where q_G is the self-weight load and q_Q is the wind load; γ_G and γ_Q are the partial coefficients with respectively 0.9 and 1.5. The self-weight works here as beneficial. These values are input in the Diana models as load combinations in ULS. For the calculations in SLS the partial coefficients are equal to 1.

3.6.3 Assumptions model and calculations

Some assumptions were made for the structure and material properties:

- The glass wall is modelled as monolithic, and not segmented like in reality as the modelling of it would result in a very heavy model. The difference in stiffness is made by calculating an equivalent stiffness (see below) which takes into account the stiffness of the glass and interlayer. Although the glass wall is modelled monolithic, in reality due to the 300mm thickness, its self-weight (compression load) would keep the structure from delaminating and the stiffness behaviour is similar to the monolithic. The façade is expected to have consequently a much higher bending stiffness than a single layered wall.
- A structural linear static analysis is performed to analyse the overall structural performance of the structure but a failure criterium is not being considered, like the Christensen failure criterium used by (Jacobs, 2017) which is specially formulated for brittle materials. This is a topic for further research.
- As there is no peripheral structure constraining the glass wall which works better to avoid delamination, the top bricks are assumed to be glued. The same goes for the window frames, which are weak points for tension. This is a topic for further research.
- Although the properties of the clay masonry are modelled as nonlinear and input in the model, to limit the scope of this thesis, an analysis of the performance of the masonry was not considered.
- Only the wind load is considered, as variable load, taking into consideration that the effect of snow or other variable loads without floors is neglectable. Wind caused a lot of damage in the past mostly on the top layers of the tower where the wind is highest and the effect of gravity is small, due to the loose decayed mortar the masonry blocks tend to detach.
- Eccentricity is not taken into account or the glass wall is considered centric in relation to the clay masonry.

Model input

Two models are made first to test if the glass assembly is strong enough and what is the influence of the connections in the strength and stability of the building.

Following schemes give an overview of the tested connection types. Although the existing clay masonry mortar is weak it's assumed to be fixed due the interlocking at the corners and the robust thickness of the walls. The first model tests all fixed connections and the second model has an hinge between glass and clay masonry. The foundation is considered to be clamped.

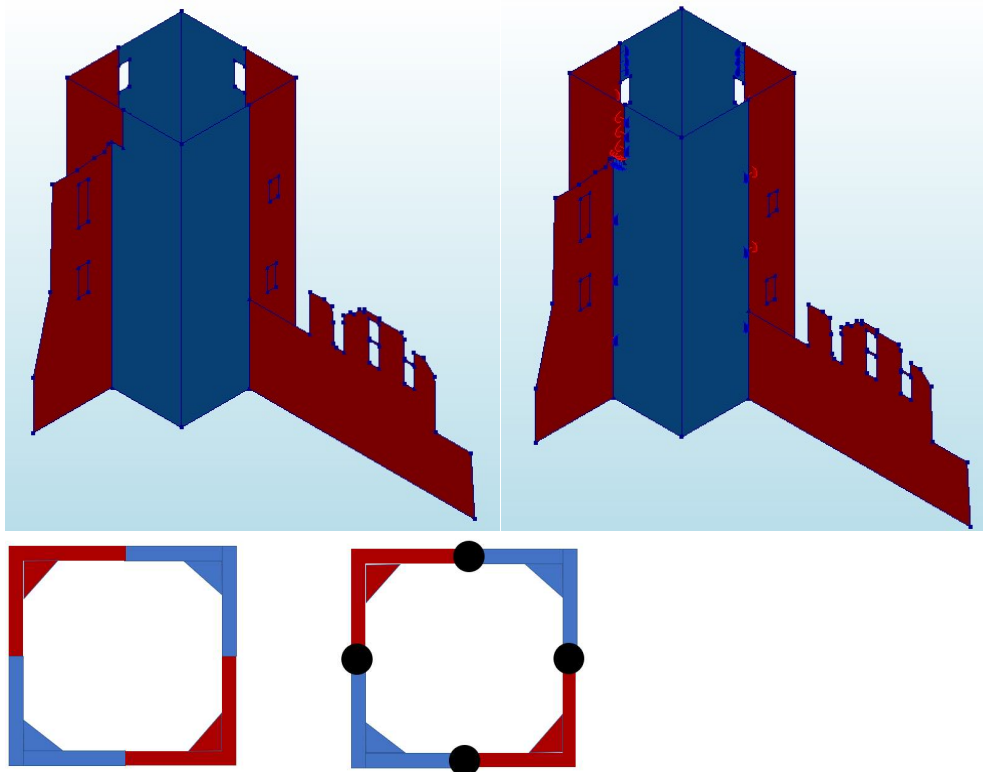

Figure 79- Schematization of the connection types: on the left all fixed connections, on the right hinged between materials.

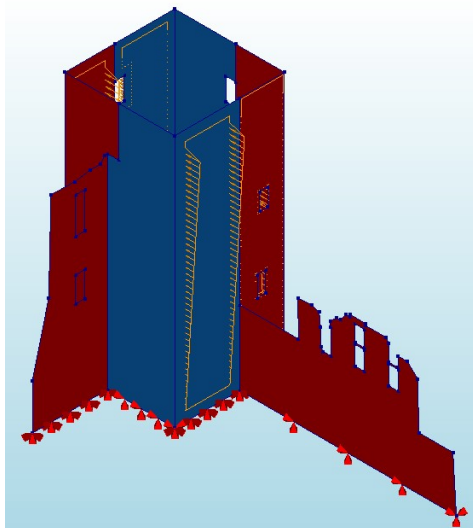

Figure 80- Overview of the clamped support connection and of the horizontal wind load considered as linear with the highest pressure on top.

3.6.4 Models results

In the following models, the vertical stresses are compared against the vertical compressive strength.

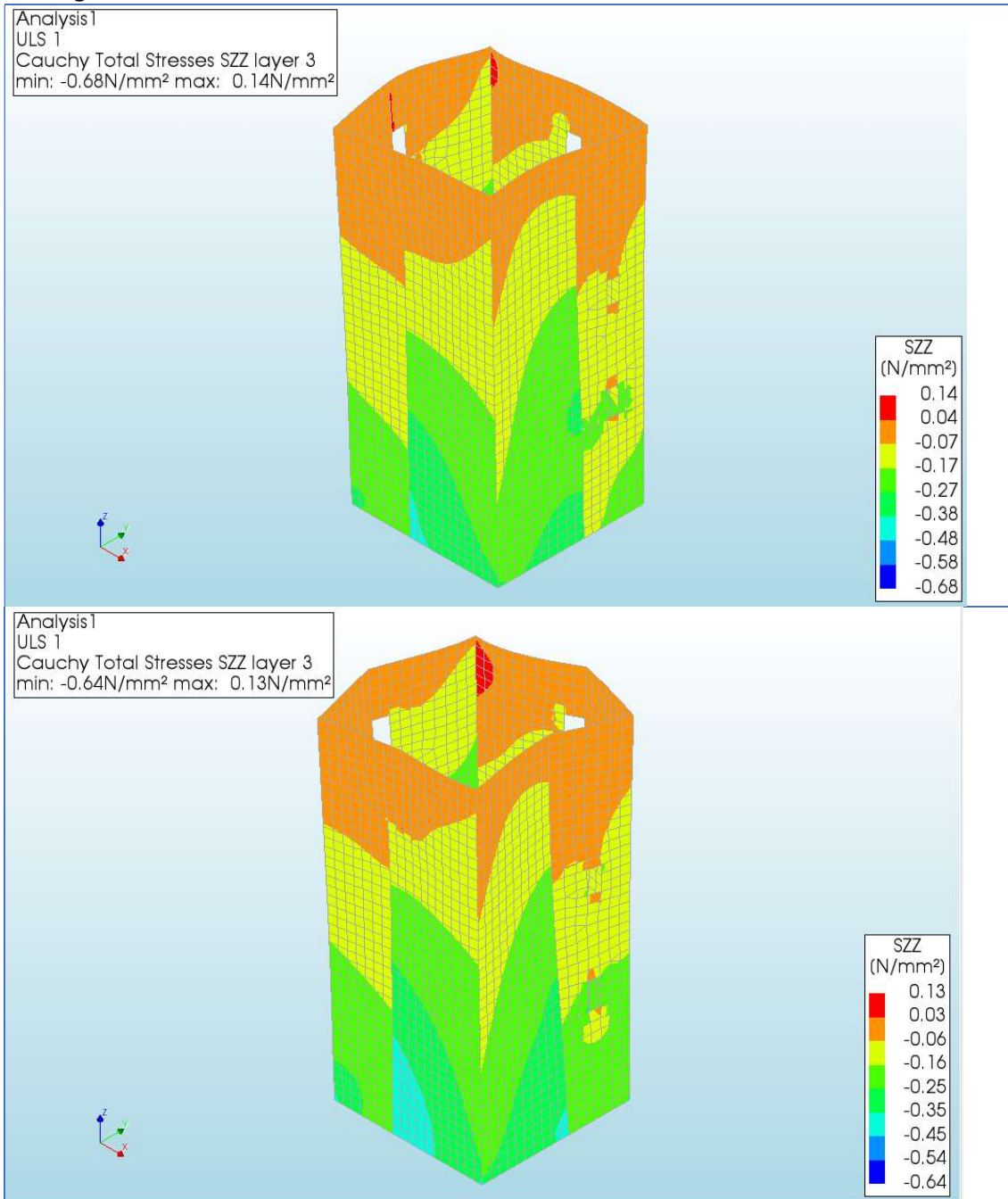

Figure 81- Overview of the vertical stress with deformation pattern. Layer 3 has the highest values for tension and compression. Above: model with fixed connections. Below: model with an hinge between materials

The two models have a quite predictable vertical stress pattern, the highest values for tension are at the top and the highest values for compression at the bottom. By comparing to the glass compressive strength value of $f_{c,d} = 7.6\text{MPa}$, one can observe that the values

for tension of 0.14MPa and the highest value for compression of -0.68MPa (for the first model) are way below the material strength. Glass usually doesn't fail in compression as it has very high strength in compression, but the compression induces tension and glass cannot take much of it. This is therefore a check, that the vertical stress is within limits.

In the following models, the horizontal stress is compared against the maximum horizontal tensile strength.

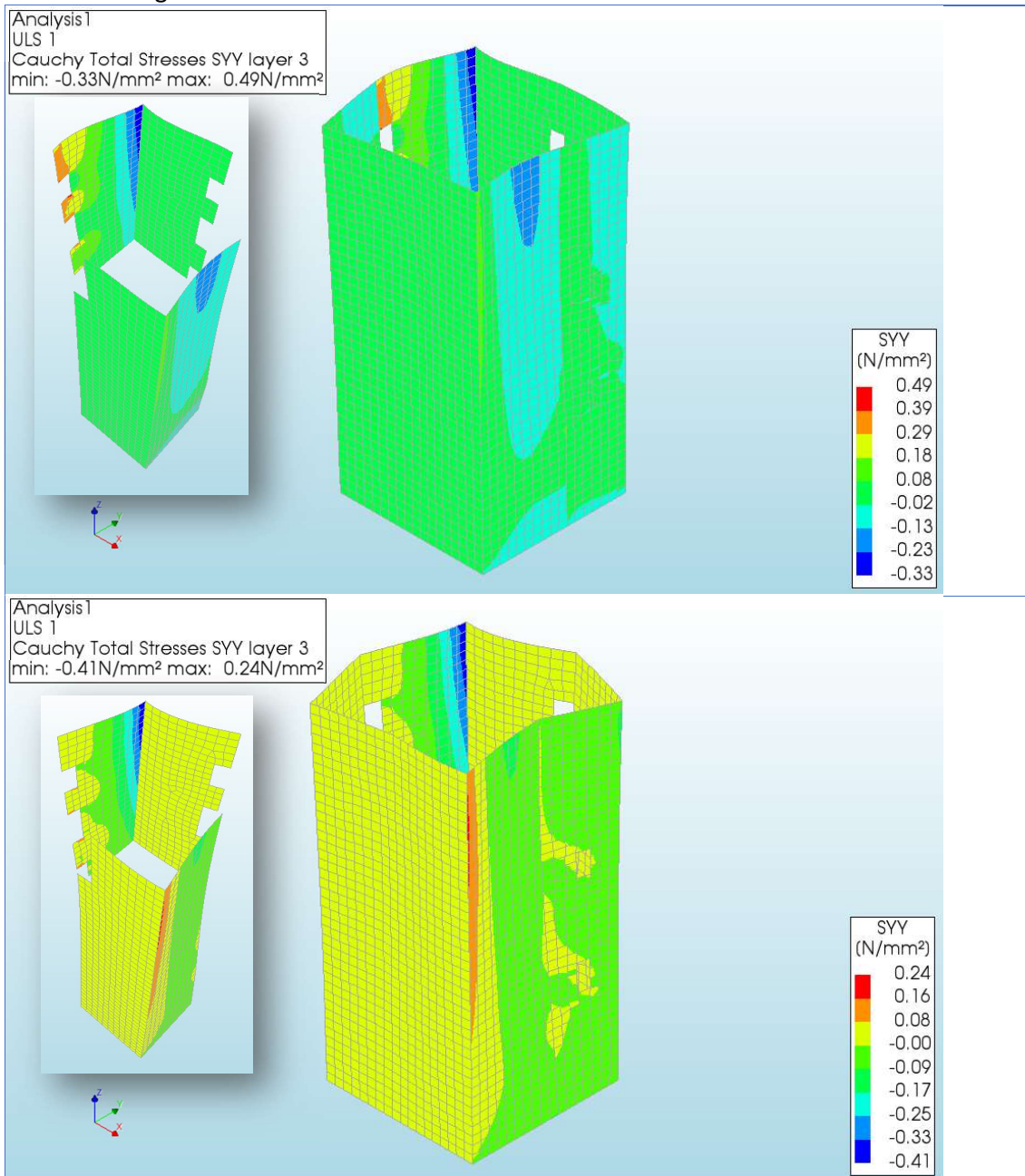

Figure 82- Overview of the horizontal stress levels. Above: model with fixed connections. Below: model with an hinge between materials. On the first model Layer 3 has the highest values for tension while on the second model Layer 3 has a higher compression than tension.

The two models have the peak of stresses on the top, corners and windows. On the first model, the peak of tension is higher than the compression and is located next to the windows. For the second model the compression value is higher than the tension. To have the highest tension value Layer 1 should be inspected with a value of 0.44MPa. By comparing to the glass horizontal strength value of $f_{hor;d} = 3.7\text{MPa}$, one can observe that the values of tension or compression are way below this and the check for horizontal stress is therefore OK.

At last, for the stability check to be complete, buckling should be examined for the glass wall because it has also the most slender thickness. Since the wall is supported at the horizontal edges, the deflection shape is not the same as for the buckling case of clamped at the bottom and free edge at the top but it can be considered somehow braced or equivalent to being supported along the height. The deflection shape would get inflection points along the height and change the direction of the deflection shape. In a case like the tower, where walls are much higher than wide, the vertical length becomes almost irrelevant for the buckling length. An approximation could be taking the unsupported length l_{buc} as the width of the tower (7m).

$$N_{cr} = \frac{\pi^2 EI}{l_{buc}^2}, \text{ where } l_{buc} \text{ can be taken as the width of the tower } 7\text{m}.$$

$$E_{equiv} = 2462\text{N/mm}^2 \text{ and } I = \frac{1}{12}bt^3, b = 1000\text{mm} \text{ and } t = 300\text{mm}, I = 2.25e^9\text{mm}^4,$$

$$N_{cr} = 1116\text{kN}$$

One wall is 15 m high and the other is 10.5m

$l = 15\text{m}$ and $l = 10.5\text{m}$ for the other walls

$$N_{Ed} = 25\text{kN/m}^3 * 15\text{m} * 0.3\text{m} * 1\text{m} * 1.2 = 135\text{kN};$$

$$N_{Ed} = 25\text{kN/m}^3 * 10.5\text{m} * 0.3\text{m} * 1\text{m} * 1.2 = 94.5\text{kN};$$

$$N_{Ed} < N_{cr} \text{ which checks OK}$$

This result shows that the structure doesn't fail in buckling which was already predictable due to the thick walls. This calculation is only a rough approximation considering the worst case scenario of the materials. In this study, it was considered that the top layers were fixed, otherwise it could be expected that local buckling due to the delamination of the top layers would be an issue. This should, however, be further researched in a future study.

For the stiffness:

The maximum deflection according to NEN-EN 1990+A1+A1/C2/NB:2019 for the whole building should not be higher than:

$$u_{max} = \frac{15000}{500} = 30\text{mm}$$

Looking at the maximum displacements on both models, it can be observed that the values are very low, with 3.03mm for the first model and 3.96mm for the second. Although the

difference of the models is quite big (approximately 30%), owing to the fact that the hinge between the two materials deforms much more on the hinge location, while for the first model the deformation is spread across the area of the wall with the clamped corners resisting on the other direction. These low values are expected for a monolithic structure with thick walls, but the exact behaviour of the interlocking geometry is not well reproduced in this model and should be studied more in detail.

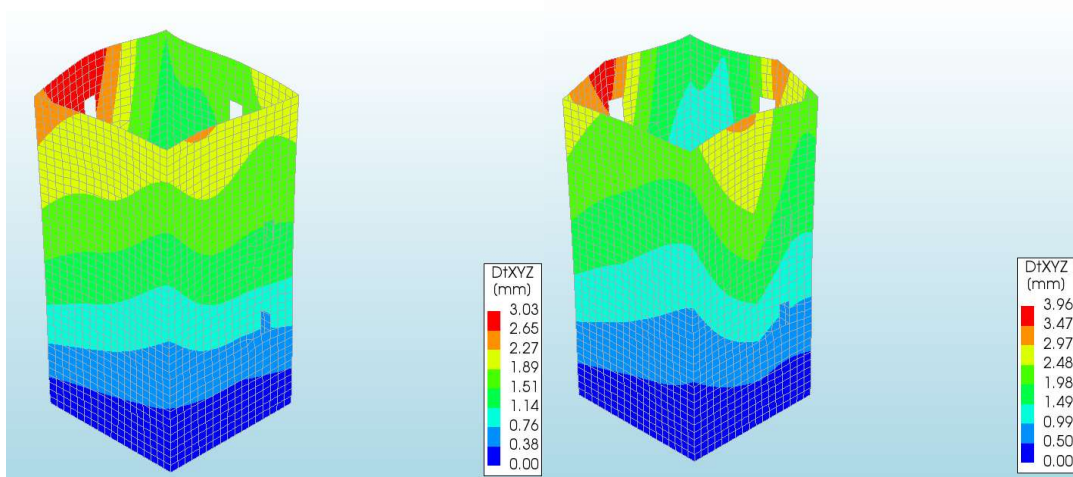

Figure 83- Maximum deflection for model 1 on the left (fixed connections) and model 2 on the right (with a hinge between materials)

4 Discussion, conclusion and recommendations

4.1 Discussion

According to the literature review and research, a design proposal was suggested which could take advantage of cast glass units as 3d elements and its optimal use as a compression structure. The design proposed a topological interlocking osteomorphic cast glass assembly, which additionally by its segmentation restricts the failure to the element and not to the whole structure, contributing to the structure safety and skips the use of an adhesive tackling the construction limitations. To attain the desired stability without the use of buttresses or floors a robust thickness of 300 mm was presented to counteract the horizontal loads and buckling turning the walls into shear walls. This system has never been realized and therefore needed to be validated.

A numerical method was researched, to validate the structure, by making use of a global Finite Element Analysis in Diana FEA and an 3d approximation of the existing building. Two models were created in Diana FEA to test the glass material strength and stability of the assembly also in relation to two different types of connections between glass and masonry. From the results it can be concluded that the assembly is strong enough and stable. By checking the horizontal and vertical stress, the first order stability is demonstrated. For a more detailed analysis of the model stability, a second order stability is checked as well, with a buckling analysis. For the purpose of this thesis, the latest studies were reviewed to get the strength values of the assembly. A rough estimation was made from the data available which do not give yet an accurate estimation of the in plane and out of plane flexural tensile strength of the assembly. More tests are needed to provide more accurate data.

Secondly the models were used to investigate how the connections influence the overall stability. Both models are stable. It can be concluded that the differences between the two models are too few to assert that one is better than the other. If it's to evaluate qualitatively, the easiest or cheapest to make would be the best choice. A fixed connection would result in the transfer of bending stresses from one material to the other. Due to the difference of thickness between the two materials, this would cause the clay masonry to crack locally. An hinge avoids the transfer of bending stresses to the weak masonry which is, in this case beneficial.

In relation to the state of art on cast glass, more specifically the dry interlocked osteomorphic system, a methodology using a global FEA model in 3d was missing to test the behaviour of the wall as a whole and in the context of the building. Most of the research is based on the local failure of the glass unit. It's therefore relevant to the knowledge in this field and can furthermore be replicated for future use by changing the different variables. It can however be noticed that this type of model cannot test with accuracy some local failure behaviour, more specifically the failure of the structure by delamination on the top layers.

4.2 Conclusion

In this chapter the conclusion will be drawn through the main research question.

In what ways can we replace the missing parts of a monument using structural (cast) glass?

The aim of this research was to find a structural cast glass assembly which could fit the structural, aesthetical and practical needs of consolidating a decaying historic monument.

The nature of the current consolidations implemented in the castle showcase very intrusive and anaesthetic interventions that deteriorate the image of the castle as a monument and are also incompatible with the international guidelines for the restoration of historic buildings. The choice of glass as a structural material for this thesis, is justified by the author sensibility, as being an architect, and aesthetics playing an important role. Glass can be perceived as a subtle and almost immaterial addition, a transparent structure. Due to the vulnerability of glass to fail in tension by the existence of flaws and in order to optimize its full strength in compression, and to limit the chance of a flaw to occur, a segmented, dry-connected topological interlocking 3d glass wall structure made of identical osteomorphic cast blocks was proposed. This system exempts the use of an adhesive and alternatively relies on a soft interlayer to avoid the glass to glass contact and compensate for the construction tolerances. To test the performance of this system in strength and stability and the integrity of the system by connecting the materials in different ways, two numerical models in Diana Fea were performed. The results suggested that the system performed well and was strong enough but are based on the assumption of a monolithic system which translates in a less accurate result unable to predict the failure mode by delamination. According to the results, this system can be implemented to replace the missing parts of a monument but a more detailed model is needed to study more accurately the local failure behaviour.

4.3 Recommendations for further research

By acknowledging the limitations of the current study, some recommendations are proposed for further study.

- In order to test the assembly capacity, data was retrieved from the latest studies. This data was however not enough to accurately assert the assembly strength material values, more specifically the in and out of plane flexure tensile strength. The research available is in relation to cast glass or/and a soft interlayer, but bigger scale assembly testing is needed to have more reliable data.
- The material properties of the soft interlayer were just considered for the calculation of the equivalent stiffness. More data is needed in relation to the creep behaviour and performance of the soft interlayer in order to judge if it can be used for this system. The long term behaviour of glass and interlayer should be studied (creep and expansion) in relation to existing material
- Some assumptions were done to simplify the model, like considering the wall as monolithic while it's segmented. In the future a more detailed FEA model is

necessary to account for the difference in spring stiffness and the possibility to test more in detail the local failure mechanisms related to the delamination of glass. A possibility could be to have two models (a global and a local) that could communicate whereas a parametric optimization could be done.

- Although the model is designed with the two materials, clay masonry and cast glass, the focus lies on the performance of the cast glass assembly more specifically the topological interlocking, osteomorphic, dry connected assembly. A rough calculation is made regarding the strength of the clay masonry, relating to the material values (appendix A) based on the current codes. It is however very difficult to have an accurate prediction of its structural performance without test samples of the existing masonry, as the current codes are only covering recent structures.
- In this study the fracture mode of the glass elements was not considered in the model and only a linear static analysis is performed. A fracture analysis like the Christensen failure criterium, the method used by E. Jacobs to test the glass element in shear, would be useful to account for the local failure of the glass elements.
- The top layers were assumed as glued to avoid delamination of the top bricks. A peripheral structure could be considered and tested in regard to the instability of the top layers. Although the gravity was assumed as a kind of pre-compression which improves the bending stiffness because the structure tend to behave as monolithic, the same cannot be said of the whole structure that has different degrees of compression due to self-weight. That effect could be controlled with the implementation of a peripheral structure like internal or external pre-tensioned cables.
- In regard to the connection design, concept connections were tested in the model to study the overall effect on the stability. This needs to be further studied in relation to the choice of the connection system and material. A more detailed model is needed to account for the behaviour of the materials and the type of connection.

List of references:

- Barou, L. *et al.* (2018a) "Dematerialization of the ruins: Glass as a promising restorative material for the consolidation of historic structures," in *Challenging Glass 6: Conference on Architectural and Structural Applications of Glass, CGC 2018 - Proceedings*. TU Delft Open, pp. 11–26. Available at: <https://doi.org/10.7480/cgc.6.2110>.
- Barou, L. *et al.* (2018b) "Structural glass: A new remedial tool for the consolidation of historic structures," in *Heron*, pp. 159–198.
- Barou, L. *et al.* (2020) *Fill-in-glass Restoration: exploring issues of compatibility for the case of Schaesberg Castle*. Available at: <http://www.tudelft.nl>.
- Bedon, C. and Santarsiero, M. (2018) "Transparency in Structural Glass Systems Via Mechanical, Adhesive, and Laminated Connections-Existing Research and Developments." Available at: <https://doi.org/10.1002/adem.201700815>.
- Belis, J. *et al.* (2019) "Architectural glass," in *Springer handbook of glass*. Springer Nature Switzerland AG 2019, pp. 1779–1817. Available at: https://doi.org/10.1007/978-3-319-93728-1_52.
- Bos, F.P. (2009) *Safety Concepts in Structural Glass Engineering-Towards an Integrated Approach*. Delft Technical University of Technology.
- Brendle, B. (2015) *Cesari Brandi e Franco Minissi: A expressão moderna do restauro arquitetônico e arqueológico na Sicília*. Available at: http://www.giuliocarloorgan.org/organ_multimedia.htm.
- Bristogianni, T. *et al.* (2018) "Structural cast glass components manufactured from waste glass: Diverting everyday discarded glass from the landfill to the building industry," 63(1). Available at: <http://heronjournal.nl/63-12/4a.pdf> (Accessed: March 1, 2022).
- Bristogianni, T. *et al.* (2020) "Investigating the flexural strength of recycled cast glass," *Glass Structures and Engineering*, 5(3), pp. 445–487. Available at: <https://doi.org/10.1007/s40940-020-00138-2>.
- Castles.nl - Schaesberg Castle* (no date). Available at: <https://www.castles.nl/schaesberg-castle> (Accessed: April 28, 2022).
- CMOG (2011) *All About Glass*. Available at: <https://www.cmog.org/article/what-is-glass> (Accessed: March 1, 2022).
- Dimas, M. (2020) *In between: An interlayer material study for interlocking cast glass blocks*.
- Dyskin, A. v., Estrin, Y. and Pasternak, E. (2019) "Topological interlocking materials," in *Springer Series in Materials Science*. Springer Verlag, pp. 23–49. Available at: https://doi.org/10.1007/978-3-030-11942-3_2.
- Haldimann, M., Luible, A. and Overend, M. (2008) *Structural use of glass*. International Association for Bridge and Structural Engineering (IABSE). Available at: <https://app.knovel.com/hotlink/toc/id:kpSUGSED09/structural-use-glass/structural-use-glass> (Accessed: March 1, 2022).
- van Hees, R. (2017) *Building Conservation AR01Ar080-Reader Observations on restoration, conservation and innovation in the light of authenticity*.
- Hiroshi Nakamura & NAP (2012) *Optical Glass House*. Available at: <https://divisare.com/projects/220226-hiroshi-nakamura-nap-nacasa-partners-inc-optical-glass-house> (Accessed: July 6, 2022).
- <https://beeldbank.cultureelerfgoed.nl> (no date). Available at: <https://beeldbank.cultureelerfgoed.nl/rce-mediabank/?mode=gallery&view=horizontal&q=Schaesberg%20kasteel&rows=1&page=1&>

ecord=893b9e65-baf7-cce5-aae9-3d67589bb94b&sort=order_s_objectnummer%20asc&reverse=0 (Accessed: March 2, 2022).

ICOMOS (1964) *International Charter for the conservation and restoration of monuments and sites (the Venice Charter 1964)*. Venice.

ICOMOS (1994) *The Nara document on Authenticity (1994) preamble*.

Jacobs, E. (2017) *Structural consolidation of historic monuments by interlocking cast glass components. A computational analysis of interlocking cast glass brickwork*. Delft University of Technology.

Kruunenberg Van der Erve Architecten (2002) *Laminata House*. Available at: <https://en.wikiarquitectura.com/building/laminata-house/> (Accessed: July 6, 2022).

Kuipers, M. and de Jonge, W. (2017) *Designing from Heritage-Strategies for Conservation and Conversion*.

Louter, P.C. (2011) *Fragile yet Ductile : structural aspects of reinforced glass beams*.

MVRDV (2016) *Crystal Houses*. Available at: <https://www.mvrdv.nl/projects/240/crystal-houses> (Accessed: July 6, 2022).

Nijse, R. (2003) *Glass in structures: elements, concepts, designs*. Birkhäuser Verlag GmbH.

Oikonomopoulou, F. et al. (2014) "A completely transparent, adhesively bonded soda-lime glass block masonry system," *Journal of Facade Design and Engineering*, 2(3–4), pp. 201–221. Available at: <https://doi.org/10.3233/fde-150021>.

Oikonomopoulou, F. et al. (2016) "Restoring and structurally reinforcing historic monuments by glass," in *Insights and Innovations in Structural Engineering, Mechanics and Computation - Proceedings of the 6th International Conference on Structural Engineering, Mechanics and Computation, SEMC 2016*. CRC Press/Balkema, pp. 1668–1673. Available at: <https://doi.org/10.1201/9781315641645-275>.

Oikonomopoulou, F. et al. (2018) "The construction of the Crystal Houses façade: challenges and innovations," *Glass Structures and Engineering*, 3(1), pp. 87–108. Available at: <https://doi.org/10.1007/s40940-017-0039-4>.

Oikonomopoulou, F. et al. (2019) "Dry interlayers out of cast polyurethane rubber for interlocking cast glass structures: Experimental exploration and validation," in *Advances in Engineering Materials, Structures and Systems: Innovations, Mechanics and Applications - Proceedings of the 7th International Conference on Structural Engineering, Mechanics and Computation, 2019*. CRC Press/Balkema, pp. 1709–1714. Available at: <https://doi.org/10.1201/9780429426506-295>.

Oikonomopoulou, F. (2019) *Unveiling the third dimension of glass Solid cast glass components and assemblies for structural applications*. Delft.

O'Reagan, C. (2015) *Structural use of glass in buildings*. 2nd edn. The Institution of Structural Engineers. Available at: <https://app-knovel-com.tudelft.idm.oclc.org/hotlink/toc/id:kpSUGBE002/structural-use-of?kpromoter=marc> (Accessed: March 1, 2022).

Pompeii - Wikipedia (no date). Available at: <https://en.wikipedia.org/wiki/Pompeii> (Accessed: July 5, 2022).

Schittich, Christian. et al. (2007) *Glass construction manual*. 2nd edn. Berlin: Birkhäuser Verlag AG.

Shelby, J.E. (2005) *Introduction to Glass Science and Technology*. Available at: https://app-knovel-com.tudelft.idm.oclc.org/web/view/khtml/show.v/rcid:kpIGSTE002/cid:kt00BZERM3/viewerType:khtml//root_slug:1-introduction/url_slug:introduction?kpromoter=marc&b-toc-

cid=kpIGSTE002&b-toc-root-slug=&b-toc-url-slug=introduction&b-toc-title=m&page=2&view=collapsed&zoom=1 (Accessed: March 1, 2022).

Stanley Price, N. (2009) *The Reconstruction of Ruins: Principles and Practice*.

Swain, M. v. (1981) "Nickel sulphide inclusions in glass: an example of microcracking induced by a volumetric expanding phase change," *Journal of Materials Science*, 16(1), pp. 151–158. Available at: <https://doi.org/10.1007/BF00552069>.

van der Velden, M. and Nijssse, R. (2019) *CIE4285 Structural Glass Reader*.

Viersen, A. (2014) *Kasteel Schaesberg gemeente Landgraaf bouwhistorische opname met waardestelling*.

Villiger, J. *et al.* (2019) "Interlocking glass spiral as building structure of the watch museum 'La Maison des Fondateurs,'" *Glass Structures and Engineering*, 4(1), pp. 3–16. Available at: <https://doi.org/10.1007/s40940-018-0077-6>.

Vivio, B. (2017) "The narrative sincerity in museums architectural and archaeological restoration of Franco Minissi Vivio B 2017."

Wiki (no date) *Spontaneous glass breakage*. Available at: https://www.conservation-wiki.com/wiki/Spontaneous_glass_breakage (Accessed: March 2, 2022).

Wikipedia (no date) *Amorphous solid*. Available at: https://en.wikipedia.org/wiki/Amorphous_solid (Accessed: March 2, 2022).

Wurm, J. (2007) *Glass Structures design and construction of self-supporting skins*.

Zachariasen, W.H. (1932) "The atomic arrangement in glass."

5 Appendices

Appendix A - Structural validation masonry

To evaluate the structure stability, a Finite Element Model in 3d was made in Diana FEA. The Diana model is subsequently compared and validated with hand calculations according to the Eurocode EN 1996-1-1.

Some assumptions were made for the material properties of masonry:

- Most of clay masonry mechanical properties are retrieved from the table C8A.2.1 of the Italian code NTC2008, as it covers much more extensively than the Dutch one, namely regarding the age and decay and the function of the structure. Some properties are taken from NPR 9998:2020 (Assessment of structural safety of buildings in case of erection, reconstruction and disapproval - Induced earthquakes - Basis of design, actions and resistance, table F.2).

Overview of the material properties:

Properties clay masonry	
$E_{ma:mm}$ Young's modulus in x and y coordinates (in MPa)	1200
E_z Young's modulus in z coordinate (in MPa)	1700
G Shear modulus (in MPa)	500
γ_M material coefficient (in MPa)	2.2
f_{ma} mean compressive strength (in MPa)	2.4
f_{x1m} flexure bending strength parallel to bed joints (in MPa)	0.15
f_{x2m} flexure bending strength perpendicular to bed joints (in MPa)	0.55
ρ density (kg/m ³)	1800
ν poisson's ratio	0.2

Table 11- Assumed clay masonry properties for the model in Diana Fea

E value or Youngs modulus is assumed as in the table C8A.2.1 of the Italian code NTC2008.

$E_{ma:mm}$ is the mean value of the Youngs modulus.

$E = E_{ma:mm} = 1200N/mm^2$ (MPa) and G the Shear modulus is assumed as

$$G = \frac{E_{ma;mm}}{2(1+\nu)} = \frac{1200}{2(1+0.2)} = 500N/mm^2 \text{ (MPa) according to NPR 9998:2020 en}$$

The mean value of compressive strength is taken from the table C8A.2.1 of the Italian code NTC2008: $f_{ma} = 2.4MPa$; according to EN 1052-1, the relation between the mean value and the characteristic is $f_k = \frac{f_{ma}}{1.2} = \frac{2.4}{1.2} = 2MPa$; the design value is obtained by dividing by γ_M the material coefficient, $f_d = \frac{f_k}{\gamma_M}$ and $\gamma_M = 2.2$ or $f_d = \frac{2}{2.2} = 0.91MPa$

The values for the flexure (bending) strength are taken from the NPR 9998 (Assessment of structural safety of buildings in case of erection, reconstruction and disapproval - Induced earthquakes - Basis of design, actions and resistances) table F.2: for plane of failure parallel to the bed joints $f_{x1m} = 0.15MPa$ and the flexure (bending) strength for plane of failure perpendicular to the bed joints $f_{x2m} = 0.55MPa$ (see Fig. 74).

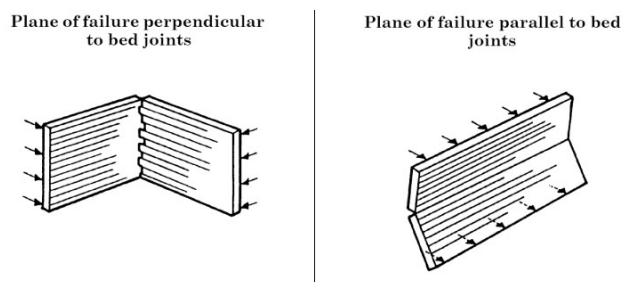

Figure 84- f_{x2m} left and f_{x1m} right

Firstly, clay masonry is checked to see whether the glass wall has a good mechanical effect on it and it's there to support the decayed clay masonry. For clay masonry of this age and without testing it's quite difficult to find the right mechanical properties as those are very decayed and consequently very weak. The Italian codes cover a bit more extensively according to age and function and are used therefore as reference. At last the connections are checked. Two models are created with concept connections and compared to see the differences. In the first model all connections are considered fixed, the second model has a hinge connection between masonry (see Fig. 79). The models are compared qualitatively and afterwards some hand calculations are performed to compare to the stresses of the Diana models after which is checked whether the yield limit of the material used for the connections is reached.



Figure 85- Overview of the Castle Ruin with the present steel staircase consolidation

The calculations are performed in ULS according to the Eurocode (NEN-EN 1990)

$q_{d,ULS} = \gamma_G * q_G + \gamma_Q * q_Q$, where q_G is the self-weight load and q_Q is the wind load; γ_G and γ_Q are the partial coefficients with respectively 1.2 and 1.5. These values are input in the Diana models as load combinations in ULS. When the own weight works as beneficial the partial coefficient is 0.9 For the calculations in SLS the partial coefficients are equal to 1.

Checks for clay masonry wall:

To check the moment resistance, the unity check should be $\frac{M_{Ed}}{M_{Rd}} \leq 1$, here the M_{Rd} is the moment resistance and M_{Ed} is the design moment. For this check, the Moment resistance should be investigated in different locations of the structure. Generally, for the bottom moment resistance the contribution of the structure own weight can be added as beneficial. At the top there is no contribution of the own weight. Furthermore there is no floor there to contribute to its stability and moment resistance. Checks should be done consequently where the moment is higher but having into account that the moment resistance is higher with the height or else at the bottom it's the highest moment resistance and at the top the lowest.

If vertical (own) load is present the equation for Moment resistance is according to EN 1996-1-1, the own load contributes to the Moment resistance:

$f_{xd1app} = f_{xd1} + \sigma_d$, and $f_{xd1} = \frac{f_{x1m}}{\gamma_M}$; $\gamma_M = 2.2$; $f_{xd} = \frac{0.15}{2.2} = 0.07MPa$; $f_{xd2} = \frac{0.55}{2.2} = 0.25MPa$; σ_d is the contribution of the masonry self-weight (beneficial effect) on the calculation of the moment resistance M_{Rd} .

$\sigma_{d,bottom} = \frac{0.9 * (F_{mas})}{1m * (t_{mas})} = 0.27 * 0.9 = 0.24MPa$; $F_{mas} = 18kN/m^3 * 15m * 0.7m * 1m = 189kN$

For the calculation of the Moment load on the wall according to EN 1996-1-1 (see Fig. 77 below), the wall is assumed to span in both horizontal and vertical direction with a free edge on top because of the absence of the floor and on the sides simply supported by the two perpendicular walls which work as shear walls. On the bottom the foundation is assumed as fully restrained.

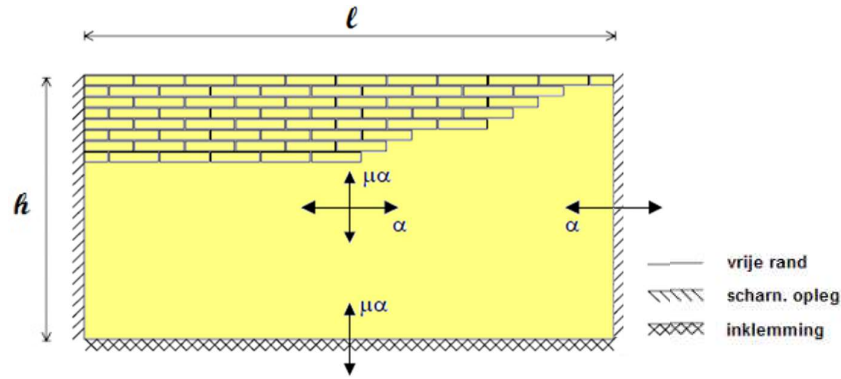

Figure 86- Schematization of the wall support system (type K): straight line means free edge, with strips simple supported and the squared clamped. In this case it's fully restrained at the bottom, simply supported on both sides and a free edge at the top (there's no floor there) retrieved from Eurocode EN 1996-1-1:2006+A1:2013

Because the wall is spanning on both directions, the moments on those directions also have an effect in each other and the calculation of the Moment load is hence according to Eurocode EN 1996-1-1:

$$M_{Ed} = \mu * \alpha * p_d * l^2 \text{ and}$$

$$M_{Ed2} = \alpha * p_d * l^2$$

According to the tables (NEN-EN 1996-1-1:2006+A1:2013) with support conditions type K (bottom fully restrained, top free edge and simply supported on both sides):

$$\mu = \frac{f_{xd1}}{f_{xd}} = \frac{0.07}{0.25} = 0.28 \text{ and } \frac{h}{l} = 2.1 \rightarrow \alpha = 0.22, h = 7m \text{ and } l = 15m \text{ and}$$

$$p_d = 0.7976 \text{ kN/m}^2 \text{ for wind load}$$

$$M_{Ed2} = 0.22 * 0.7976 * 7^2 = 13 \text{ kNm and } M_{Ed} = 0.28 * 13 = 3.51 \text{ kNm}$$

For each wall façade on top there's no contribution of the self-weight and the design bending strength is therefore:

$$\sigma_{d,top} = 0; f_{xd1app,15m} = 0.07 \text{ MPa}$$

$$M_{Rd1} = f_{xd1app} * z = 0.07 * \frac{1}{6} b h^2 = 5.71 \text{ kNm}; z \text{ is the section modulus for a rectangular profile, } b = 1000 \text{ mm width (per m wall) and } h = 700 \text{ mm is the wall thickness.}$$

To check the moment resistance $\frac{M_{Ed}}{M_{Rd}} \leq 1$ with $M_{Rd1} = 5.71 \text{ kNm}$

$$\rightarrow \frac{M_{Ed}}{M_{Rd}} = 0.61 \text{ and it's OK}$$

On the bottom the self-weight contribution is in its maximum value and therefore it can be added up as beneficial to the moment resistance

$$f_{xd1app,0m} = 0.07 + 0.24 = 0.31 \text{ MPa}$$

$$M_{Rd1} = f_{xd1app} * z = 0.31 * \frac{1}{6} b h^2 = 25.32 \text{ kNm};$$

$$M_{Rd1} = 25.32 \text{ kNm} \rightarrow \frac{M_{Ed}}{M_{Rd1}} = 0.14 \text{ and that's OK}$$

According to the Eurocode (NEN-EN 1996-1-1:2006+A1:2013) the moment resistance should be controlled on the other direction, plane of failure perpendicular to the bed joints. The flexure (bending) strength for plane of failure perpendicular to the bed joints is: $f_{x2m} = 0.55MPa$ according to the table on the Eurocode NPR 9998:2020 EN (table F2). This moment resistance doesn't have contribution of the own weight.

$f_{xd2} = \frac{0.55}{2.2} = 0.25MPa$, $M_{Rd2} = f_{xd2app} * z = 0.25 * \frac{1}{6}bh^2 = 20.4kNm$; z is the section modulus for a rectangular profile, $b = 1000mm$ width (per m wall) and $h = 700mm$ is the wall thickness.

$$M_{Ed} = 13kNm, \frac{M_{Ed2}}{M_{Rd2}} \leq 1 \rightarrow \frac{13}{20.4} = 0.64 \text{ and that's OK}$$

For the design vertical load resistance different positions of the wall should be checked. For East and South wall there's a little part of glass wall accounting to the normal force and it will be therefore added in the calculation at the bottom. The calculations for both walls are similar. At the bottom $N_{Rd} = \Phi t f_d$ and $\Phi = 1 - 2 \frac{e_i}{t}$, assuming $e_i = \frac{M_1}{N_1} + e_h + e_{init} \geq 0.05t$;

$M_1 = 2.67kNm$ taken from Diana results; $e_{init} = \frac{h_{eff}}{450}$ and $h_{eff} = \rho_n * 15m$, $\rho_n = 0.21$ and $h_{eff} = 3.15m$ and $e_{init} = \frac{3150mm}{450} = 7mm$.

$f_k = \frac{f_{mean}}{1.2}$, $f_{mean} = 2.4N/mm^2$ taken from the Italian code NTC2008 table C8A.2.1
 $f_k = \frac{2.4}{1.2} = 2N/mm^2$, $f_d = \frac{f_k}{2.2} = 0.91N/mm^2$

$$N_1 = F_{mas} + F_{glass} = 1.2 * (189 + 25kN/m^3 * 9.4m * 0.3m) = 311.4kN/m$$

$$e_i = \frac{2.67 * 10^3}{311.4} + 0 + 7mm = 15.6mm > 35mm$$

$$\Phi = 1 - 2 * \frac{35}{700} = 0.9 \text{ and } N_{Rd} = 0.9 * 700mm * 0.91N/mm^2 = 573.3kN/m$$

The Unity check is $\frac{N_1}{N_{Rd}} \leq 1 = 0.54$ and it's OK

In the middle $M_m = 3.91kNm$;

$$N_m = F_{mas7.5} = 1.2 * (18kN/m^3 * 7.5m * 0.7m) = 113kN/m$$

$$e_{mk} = \frac{M_m}{N_m} + e_h + e_{init} = \frac{3.91 * 10^3}{113} + 7 = 41.6mm > 35mm$$

$$\Phi_m = A_1 e^{-\frac{u^2}{2}} = 0.65, A_1 = 1 - 2 * \frac{e_{mk}}{t} = 0.88, u = \frac{\lambda - 0.063}{0.73 - 1.17 \frac{e_{mk}}{t}} = 0.77 \text{ and}$$

$$\lambda = \frac{h_{ef}}{t_{ef}} \sqrt{\frac{f_k}{E}} = 0.87$$

$$f_k = 2MPa, E = 1200MPa, h_{ef} = 3.15m, t_{ef} = \rho_n * t = 0.21 * 700 = 147mm$$

$$N_{Rd} = 0.65 * 700mm * 0.91N/mm^2 = 414.1kN/m$$

The Unity check is $\frac{N_m}{N_{Rd}} \leq 1 = 0.27$ and it's OK

On the top there's no normal force because there's no floor and therefore it doesn't need to be checked.

For the North and West façades, the normal force is the same and for those only the masonry part counts to the normal force distribution. On the bottom:

$$N_1 = 1.2 * F_{mas} = 1.2 * 189kN/m = 226.8kN/m$$

$M_1 = 1.26kNm$ taken from Diana results at the bottom of the wall; $e_{init} = 7mm$

$$e_i = \frac{M_1}{N_1} + e_h + e_{init} = \frac{1.26 * 10^3}{227} + 0 + 7 = 12.6mm < 35mm$$

$$\Phi = 1 - 2 * \frac{35}{700} = 0.9 \text{ and } N_{Rd} = 0.9 * 700mm * 0.91N/mm^2 = 573.3kN/m$$

The requirement for preventing tension (cracks) in ULS state according to EN 1996-1-1: the tension stress by the wind load (horizontal load), should not exceed the compressive stress due to the vertical loads. To check if there is tension going on, on the clay masonry structure the following requirement should be fulfilled:

$$\sigma_{Nd} = \frac{N_{Ed}}{A} > \sigma_{Md} = \frac{M_{Ed}}{W}$$

The effect of the wind load and the moment load on the wall structure can be schematized according to Fig. 76:

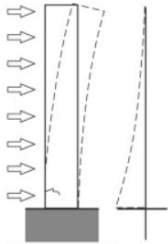

Figure 87- Mechanical scheme for bending moment due to wind

Due to own weight there's no moment but due to eccentricity by construction deviations, there's a small moment that should be added.

According to the schematization on Fig. 78 the moment by wind load is maximal at the bottom by the restrain. For the East and South wall façade on the bottom:

$$N_{Ed} = 0.9 * (F_{mas} + F_{glass}) = 0.9 * (189 + 25kN/m^3 * 9.4m * 0.3m) * 1m = 233.6kN$$

$$\sigma_{Nd} = \frac{233.6 * 10^3}{700 * 15000} = 0.022Mpa \text{ is the compression stress caused by the structure own-weight}$$

The moment load due to wind:

$$M_{Edw} = \frac{ql^2}{2} * \gamma_Q = 1.5 * 0.7976kN/m^2 * 15m^2 = 269.2kNm$$

Adding the eccentricity by construction deviations:

$$e = \frac{h_{eff}}{450} = 7mm ; h_{eff} = 3.15m \text{ (please see previous calculations), here } h_{eff} \text{ is the}$$

effective wall height.

The moment due to structure eccentricity:

$$M_{EdG} = 7mm * 233.6 = 1.6kNm$$

$$M_{Ed} = 1.6 + 269.2 = 270.8kNm, W = \frac{1}{6} * t * h^2 = \frac{1}{6} * 700mm * 15000mm^2 = 2.625 * 10^{10}mm^3$$

t is the thickness and h the wall height

$$\sigma_{Md} = \frac{M_{Ed}}{W} = \frac{270.8 * 10^6}{2.63 * 10^{10}} = 0.01Mpa \text{ is the bending stress and } \sigma_{Nd} > \sigma_{Md} \text{ and therefore the}$$

requirement that the structure has no tension checks OK

For the North and West wall façade:

$$N_{Ed} = 0.9 * (F_{mas}) * 1m = 0.9 * 189kN/m * 1m = 170.1kN$$

$$\sigma_{Nd} = \frac{170.1 * 10^3}{700 * 15000} = 0.016Mpa$$

$$M_{Edw} = 269.2kNm, M_{EdG} = 7mm * 170.1 = 1.19kNm \text{ and}$$

$$M_{Ed} = 1.19 + 269.2 = 270.4kNm$$

$$\sigma_{Md} = \frac{M_{Ed}}{W} = \frac{270.4 * 10^6}{2.63 * 10^{10}} = 0.01Mpa \text{ and } \sigma_{Nd} > \sigma_{Md} \text{ and there's no tension}$$

For the shear resistance $V_{Rd} > V_{Sd}$, the shear forces (V_{Sd}) are created by the (horizontal) wind load which also produces a moment (M_{Sd}), with normal forces present by the own weight (N_{Sd}):

$\tau_m = f_{vk0} = 0.06 \text{ N/mm}^2$ is the mean shear resistance according to the table C8A.2.1 of the Italian code NTC2008 and according to EN 1996-1-1 (6.13) $V_{Rd} = f_{vd} t l_c$

$$V_{Sd} = \frac{1}{4} * \gamma_Q * p_w * A, \text{ here is } \frac{1}{4} \text{ each direction is considered to have 4 walls (2 glasses and 2}$$

masonry), $\gamma_Q = 1.5$ the load factor for wind, $p_w = 0.7976kN/m^2$ the wind load pressure and $A = 15000 * 7000$ and $V_{Sd} = 31.4kN$

The eccentricity caused by the load in relation to the Normal centre can be found by:

$$e = \frac{M_{Sd}}{N_{Sd}}, \text{ here is the } M_{Sd} = 270.4kNm \text{ the bending moment caused by the wind load and}$$

$$N_{Sd} = 1.2 * (F_{mas}) * 1m = 227kN \text{ is the contribution of the own weight, } e = 1191mm$$

$$\sigma_{Sd} = \frac{N_{Sd}}{t * l_c}, \text{ here is } l_c \text{ the length of the compressed zone, by considering the}$$

stress σ distribution as triangular. To find l_c , $\frac{M_{Sd}}{N_{Sd}} = \frac{l}{2} - \frac{l_c}{3}, l = 3.5m,$

$$l_c = 1.677mm \text{ and } \sigma_{Sd} = 0.19MPa$$

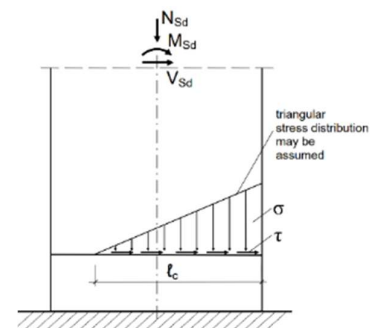

$$f_{vd} = \frac{0.5f_{vk0} + 0,4\sigma_{Sd}}{\gamma_M} = \frac{0.5 * 0.06 + 0,4 * 0.19}{2.2} = 0.049MPa$$

σ_{Sd} is the compressive stress perpendicular to the shear load,
 $V_{Rd} = f_{vd}t l_c = 0.049 * 700 * 1677 = 52.3kN$, $\gamma_M = 2.2$ is the masonry material factor

The condition $V_{Rd} > V_{Sd} \rightarrow 52.3 > 31.4$ and it's OK

The slenderness of the wall façade doesn't need to be tested as the masonry walls are very robust in thickness, and therefore the buckling won't be an issue either.

From the calculations above, it appears that the glass wall has a good effect on the clay masonry. Also the maximum deflection is 2.75mm which seems quite acceptable.

In following figures an overview of the Diana Fea results is given:

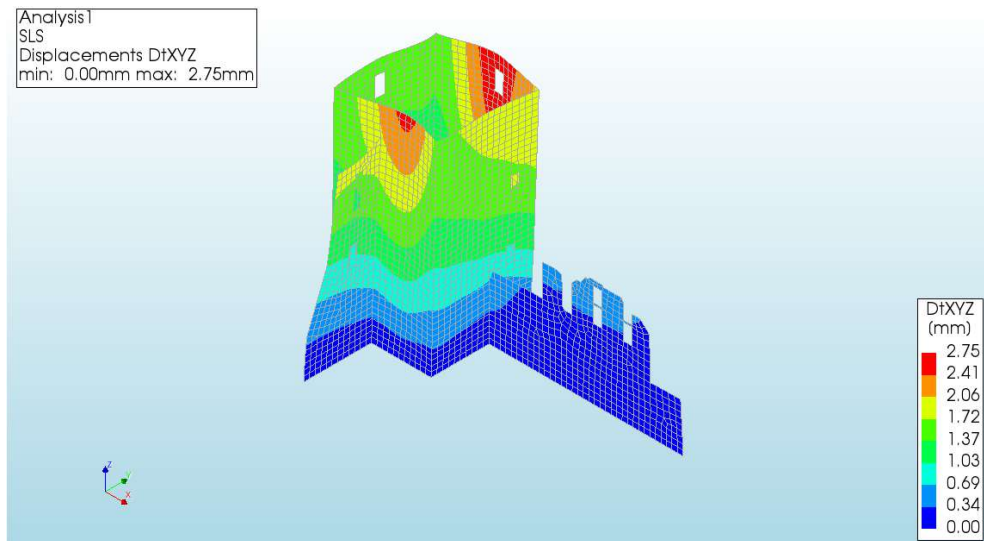

Figure 88- Diana results for the highest displacement according to SLS

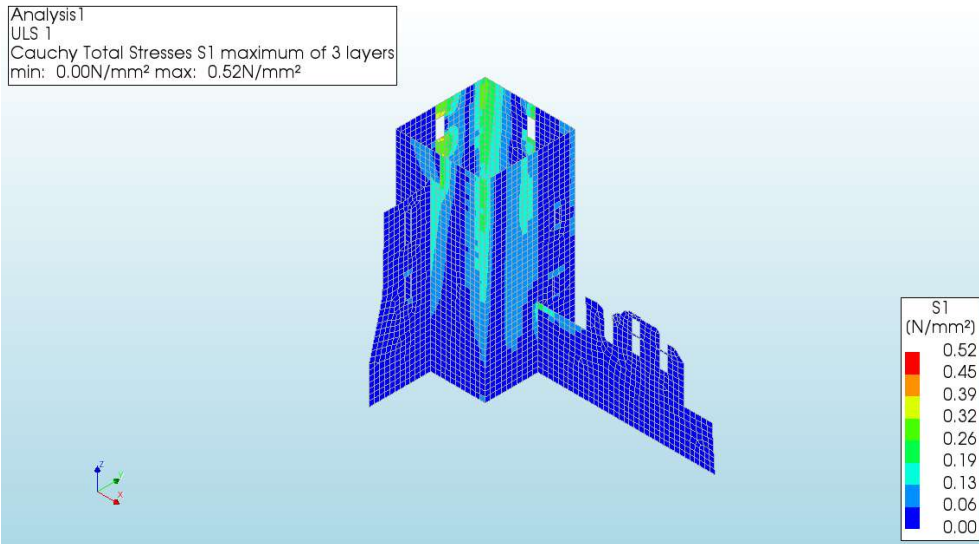

Figure 89- Diana results for the highest tension in glass S1 according to the principal direction